

THE COLLECTED WORKS OF C. G. JUNG | COMPLETE DIGITAL EDITION

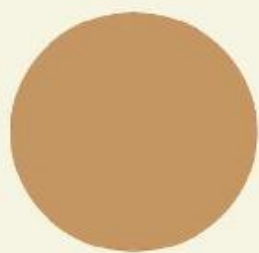
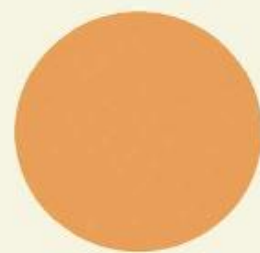

J

U

N

G

Volumes
1-19

EDITED AND TRANSLATED BY | GERHARD ADLER & R. F. C. HULL

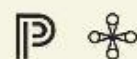

Table of Contents

Volume 1: Psychiatric Studies

Volume 2: Experimental Researches

Volume 3: Psychogenesis of Mental Disease

Volume 4: Freud & Psychoanalysis

Volume 5: Symbols of Transformation

Volume 6: Psychological Types

Volume 7: Two Essays in Analytical Psychology

Volume 8: Structure & Dynamics of the Psyche

Volume 9 Part I: Archetypes and the Collective Unconscious

Volume 9 Part II: Aion: Researches into the Phenomenology of the Self

Volume 10: Civilization in Transition

Volume 11: Psychology and Religion: West and East

Volume 12: Psychology and Alchemy

Volume 13: Alchemical Studies

Volume 14: *Mysterium Coniunctionis*

Volume 15: Spirit in Man, Art, And Literature

Volume 16: Practice of Psychotherapy

Volume 17: Development of Personality

Volume 18: The Symbolic Life: Miscellaneous Writings

Volume 19: General Bibliography

B O L L I N G E N S E R I E S X X

THE COLLECTED WORKS

OF

C. G. JUNG

VOLUME 1

EDITORS

SIR HERBERT READ

MICHAEL FORDHAM, M.D., M.R.C.P.

GERHARD ADLER, PH.D.

WILLIAM MCGUIRE, *executive editor*

PSYCHIATRIC STUDIES

C. G. JUNG

SECOND EDITION

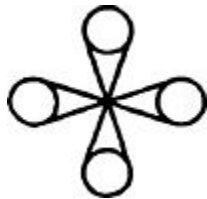

TRANSLATED BY R. F. C. HULL

BOLLINGEN SERIES XX

PRINCETON UNIVERSITY PRESS

COPYRIGHT © 1957 BY BOLLINGEN FOUNDATION INC., NEW YORK, N. Y.
SECOND EDITION COPYRIGHT © 1970 BY PRINCETON UNIVERSITY PRESS
ALL RIGHTS RESERVED

Second printing, 1975

*Third printing, 1978, with corrections
and an addition (see page 88)*

*First Princeton / Bollingen Paperback
printing, 1983*

THIS EDITION IS BEING PUBLISHED IN THE UNITED STATES OF AMERICA BY PRINCETON UNIVERSITY PRESS AND IN ENGLAND BY ROUTLEDGE AND KEGAN PAUL, LTD. IN THE AMERICAN EDITION, ALL THE VOLUMES COMPRISING THE COLLECTED WORKS CONSTITUTE NUMBER XX IN BOLLINGEN SERIES, SPONSORED BY BOLLINGEN FOUNDATION. THE PRESENT VOLUME IS NUMBER 1 OF THE COLLECTED WORKS, AND WAS THE SIXTH TO APPEAR.

LIBRARY OF CONGRESS CATALOG CARD NUMBER: 75-156

ISBN 0-691-09768-2

ISBN 0-691-01855-3 pbk.

MANUFACTURED IN THE U. S. A.

EDITORIAL PREFACE

The publication of the first complete collected edition, in English, of the works of C. G. Jung is a joint endeavour by Routledge and Kegan Paul, Ltd., in England and, under the sponsorship of Bollingen Foundation, by Princeton University Press in the United States. The edition contains revised versions of works previously published, such as *The Psychology of the Unconscious*, which is now entitled *Symbols of Transformation*; works originally written in English, such as *Psychology and Religion*; works not previously translated, such as *Aion*; and, in general, new translations of the major body of Professor Jung's writings. The author has supervised the textual revision, which in some cases is extensive.

In presenting the Collected Works of C. G. Jung to the public, the Editors believe that the plan of the edition * may require a short explanation.

The editorial problem of arrangement was difficult for a variety of reasons, but perhaps most of all because of the author's unusual literary productivity: Jung has not only written several new books and essays since the Collected Works were planned, but he has frequently published expanded versions of texts to which a certain space had already been allotted. The Editors soon found that the original framework was being subjected to severe stresses and strains; and indeed, it eventually was almost twisted out of shape. They still believe, however, that the programme adopted at the outset, based on the principles to be outlined below, is the best they can devise.

An arrangement of material by strict chronology, though far the easier, would have produced a rather confusing network of subjects: essays on psychiatry mixed in with studies of religion, of alchemy, of child psychology. Yet an arrangement according to subject-matter alone would tend to obscure a view of the progress of Jung's researches. The growth of his work, however, has made a combination of these two schemes possible, for the unfolding of Jung's psychological concepts corresponds, by and large, with the development of his interests.

C. G. Jung was born in northeastern Switzerland in 1875, a Protestant clergyman's son. As a young man of scientific and philosophical bent, he first contemplated archaeology as a career, but eventually chose medicine, and qualified with distinction in 1900. Up to this time, Jung had expected to make physiological chemistry his special field, in which a brilliant future could be expected for him; but, to the surprise of his teachers and contemporaries, he unexpectedly changed his aim. This came about through his reading of Krafft-Ebing's famous *Text-Book of Insanity*, which caught his interest and stimulated in him a strong desire to understand the strange phenomena he

there found described. Jung's inner prompting was supported by propitious outer circumstances: Dr. Eugen Bleuler was then director of the Burghölzli Mental Hospital, in Zurich, and it was under his guidance that Jung embarked on his now well-known researches in psychiatry.

The present volume, first of the Collected Works, though not large, is sufficient to contain the studies in descriptive psychiatry. It opens with Jung's first published work, his dissertation for the medical degree: "On the Psychology and Pathology of So-called Occult Phenomena" (1902), a study that adumbrates very much of his later work. But clearly a man of Jung's cast of mind could not be content with simple descriptive research, and soon he embarked upon the application of experimental psychology to psychiatry. The copious results of these researches make up Volume 2 and Volume 3. Jung's work brought about the transformation of psychiatry, as the study of the psychoses, from a static system of classification into a dynamic interpretative science. His monograph "The Psychology of Dementia Praecox" (1907), in Volume 3, marks the peak of this stage of his activity.

It was these experimental researches that led Jung to a fruitful if stormy period of collaboration with Freud, which is represented by the psychoanalytic papers in Volume 4. The chief work in this volume, "The Theory of Psychoanalysis" (1913), gives at length his first critical estimation of psychoanalysis. Volume 5, *Symbols of Transformation* (originally 1912), and Volume 7, *Two Essays on Analytical Psychology* (originally 1912 and 1916), restate his critical position but also make new contributions to the foundation of analytical psychology as a system.

The constant growth of analytical psychology is reflected in Jung's frequent revision of his publications. The first of the *Two Essays on Analytical Psychology*, for example, has passed through several different editions. *Psychology of the Unconscious*, as it was titled in its first (1916) edition in English, appears in the Collected Works, extensively revised by Jung, with the title *Symbols of Transformation*. The Editors decided to leave these works in the approximate chronological positions dictated by the dates of their first editions, though both are published in revised form. Revision and expansion also characterize the group of studies that form Volume 12, *Psychology and Alchemy* (originally 1935–36), as well as many single essays in other volumes of the present edition.

Psychological Types (Volume 6), first published in 1921, has remained practically unchanged; it marks the terminus of Jung's move away from psychoanalysis. No further long single work appeared till 1946. During the intervening period, when Jung's professional work and his teaching occupied a large part of his time, he was abstracting, refining, and elaborating his basic theses in a series of shorter essays, some of which are collected in Volume 8, *The Structure and Dynamics of the Psyche*.

Volume 9, part I, contains essays, mostly of the same period, that have special reference to the collective unconscious and the archetypes. Part II of this volume, however, contains a late (1951) major work, *Aion: Researches into the Phenomenology of the Self*. From the chronological point of view, *Aion* should come much later in this sequence, but it has been placed here because it is concerned with the archetype of the self.

From Volume 10 onwards, the material deals with the application of Jung's fundamental concepts, which, with their historical antecedents, can be said by now to have been adequately set out. The subject-matter of Volume 10 to Volume 17—organized, in the main, around several themes, such as religion, society, psychotherapy, and education—is indicated by the volume titles and contents. It will be noted that, in his later years, Jung has returned to writing longer works: *Aion*, the *Mysterium Coniunctionis*, and perhaps others yet to come from his pen. These arise, no doubt, out of the reflective stage of his life, when retirement from his analytical practice has at last given him time to work out ideas that those who know him have long wanted to see in print.

In 1956, Professor Jung announced that he would make available to the Editors of the Collected Works two accessions of material which will have the effect of enhancing and rounding out the edition: first, a selection of his correspondence on scientific subjects (including certain of his letters to Freud); and second, the texts of a number of the seminars conducted by Jung. Accordingly, Volume 18, and thereafter such additional volumes as may be needed, will be devoted to this material.

The Editors have set aside a final volume for minor essays, reviews, newspaper articles, and the like. These may make a rather short volume. If this should be so, an index of the complete works and a bibliography of Jung's writings in original and in translation will be combined with them; otherwise, the index and bibliography will be published separately.

*

In the treatment of the text, the Editors have sought to present Jung's most recent version of each work, but reference is made where necessary to previous editions. In cases where Professor Jung has authorized or himself made revisions in the English text, this is stated.

In a body of work covering more than half a century, it cannot be expected that the terminology would be standardized; indeed, some technical terms used by Jung in an earlier period were later replaced by others or put to different use. In view of their historical interest, such terms are translated faithfully according to the period to which they belong, except where Professor Jung has himself altered them in the course of his

revision. Occasionally, editorial comment is made on terms of particular interest. The volumes are provided with bibliographies and are fully indexed.

*

Of the contents of Volume 1, nothing has previously been translated into English except the monograph "On the Psychology and Pathology of So-called Occult Phenomena." The translation of the latter by M. D. Eder has been consulted, but in the main the present translation is new. It may be noted that, except for the 1916 English version of the "Occult Phenomena," none of these papers has ever been republished by Professor Jung.

An effort has been made to fill out the bibliographical details of the material, which were sometimes abbreviated in the medical publications of the 1900's.

Acknowledgment is made to George Allen and Unwin Ltd. for permission to quote passages from Freud's *The Interpretation of Dreams* and from Nietzsche's *Thus Spake Zarathustra*.

EDITORIAL NOTE TO THE SECOND EDITION

Since the above paragraphs were written, and following Jung's death on June 6, 1961, different arrangements for the publication of the correspondence and seminars have been made with the consent of his heirs. These writings will not, as originally stated, comprise Volume 18 and subsequent volumes of the Collected Works (for their contents as now planned, see below). Instead, a large selection of the correspondence, not restricted to scientific subjects though including some letters to Freud, will be issued under the same publishing auspices but outside the Collected Works, under the editorship of Dr. Gerhard Adler. A selection of the seminars, mainly those delivered in English between 1925 and 1939, will also be published outside the Collected Works in several volumes.

Two works usually described as seminars are, however, being published in the Collected Works, inasmuch as the transcripts were approved by Jung personally as giving a valid account of his statements: the work widely known as the Tavistock Lectures, delivered in London in 1935, privately circulated in multigraphed form, and published as a separate volume entitled *Analytical Psychology: Its Theory and Practice* (Routledge & Kegan Paul, London, and Pantheon Books, New York, 1968); and the seminar given in 1938 to members of the Guild of Pastoral Psychology, London, and published in pamphlet form by the Guild in 1954 under the title *The Symbolic Life*. Both of these will be published in Volume 18, which has been given the general title *The Symbolic Life*.

Volume 18 will also include the minor essays, reviews, forewords, newspaper articles, and so on, for which a "final volume" had been set aside. Furthermore, the amount of new material that has come to light since the Collected Works were planned is very considerable, most of it having been discovered after Jung's death and too late to have been placed in the volumes where thematically it belonged. The Editors have therefore assigned the new and posthumous material also to Volume 18, which will be much larger than was first envisaged. The index of the complete works and a bibliography of Jung's writings in the original and in translation will be published as two separate and final volumes.

Jung ended his long years of creative activity with the posthumously published *Memories, Dreams, Reflections*, recorded and edited by Aniela Jaffé and translated by Richard and Clara Winston (Collins with Routledge & Kegan Paul, London, and Pantheon Books, New York, 1963). At his express wish it was not included in the Collected Works.

*

Finally, the Editors and those closely concerned with implementing the publication programme, including the translator, wish to express their deep sense of loss at the death of their colleague and friend, Sir Herbert Read, who died on June 12, 1968.

*

For the second edition of *Psychiatric Studies*, bibliographical citations and entries have been revised in the light of subsequent publications in the Collected Works and essential corrections have been made.

*

In 1970, the Freud and Jung families reached an agreement that resulted in the publication of *The Freud/Jung Letters* (the complete surviving correspondence of 360 letters), under the editorship of William McGuire, in 1974. And a selection from all of Jung's correspondence throughout his career, edited by Gerhard Adler in collaboration with Aniela Jaffé, was published in 1973 (1906–1950) and 1975 (1951–1961). Finally, a selection of interviews with Jung was published in 1977 under the title *C. G. Jung Speaking: Interviews and Encounters*.

**VOLUME 1
PSYCHIATRIC STUDIES**

TABLE OF CONTENTS

EDITORIAL PREFACE

EDITORIAL NOTE TO THE SECOND EDITION

I

On the Psychology and Pathology of So-called Occult Phenomena

Translated from *Zur Psychologie und Pathologie sogenannter occulter Phänomene*
(Leipzig, 1902).

1. INTRODUCTION

2. A CASE OF SOMNAMBULISM IN A GIRL WITH POOR INHERITANCE (Spiritualistic
Medium)

Anamnesis

Somnambulistic States

Records of Séances

Development of the Somnambulistic Personalities

The Romances

Mystic Science

Termination of the Disorder

3. DISCUSSION OF THE CASE

The Waking State

Semi-Somnambulism

Automatisms

The Change in Character

Nature of the Somnambulistic Attacks

Origin of the Unconscious Personalities

Course of the Disorder

Heightened Unconscious Performance

4. CONCLUSION

On Hysterical Misreading

Translated from “Über hysterisches Verlesen,” *Archiv für die gesamte Psychologie* (Leipzig), III (1904).

II

Cryptomnesia

Translated from “Kryptomnesie,” *Die Zukunft* (Berlin), 13th year (1905), L.

III

On Manic Mood Disorder

Translated from “Über manische Verstimmung,” *Allgemeine Zeitschrift für Psychiatrie und psychisch-gerichtliche Medizin* (Berlin), LXI (1903).

IV

A Case of Hysterical Stupor in a Prisoner in Detention

Translated from “Ein Fall von hysterischem Stupor bei einer Untersuchungsgefangenen,” *Journal für Psychologie und Neurologie* (Leipzig), I (1902).

V

On Simulated Insanity

Translated from “Über Simulation von Geistesstörung,” *Journal für Psychologie und Neurologie* (Leipzig), II (1903).

A Medical Opinion on a Case of Simulated Insanity

Translated from “Ärztliches Gutachten über einen Fall von simulierter geistiger Störung,” *Schweizerische Zeitung für Strafrecht* (Zurich), XVII (1904).

VI

A Third and Final Opinion on Two Contradictory Psychiatric Diagnoses

Translated from “Obergutachten über zwei sich widersprechende psychiatrische Gutachten,” *Monatsschrift für Kriminalpsychologie und Strafrechtsreform* (Heidelberg), II (1906).

On the Psychological Diagnosis of Facts

Translated from “Zur psychologischen Tatbestandsdiagnostik,” *Zentralblatt für Nervenheilkunde und Psychiatrie* (Leipzig), XXVIII (1905).

BIBLIOGRAPHY

INDEX

I

**ON THE PSYCHOLOGY AND PATHOLOGY OF SO-CALLED OCCULT
PHENOMENA**

ON HYSTERICAL MISREADING

ON THE PSYCHOLOGY AND PATHOLOGY OF SO-CALLED OCCULT PHENOMENA¹

[1. INTRODUCTION]

- [1] In that wide domain of psychopathic inferiority from which science has marked off the clinical pictures of epilepsy, hysteria, and neurasthenia, we find scattered observations on certain rare states of consciousness as to whose meaning the authors are not yet agreed. These observations crop up sporadically in the literature on narcolepsy, lethargy, *automatisme ambulatoire*, periodic amnesia, double consciousness, somnambulism, pathological dreaminess, pathological lying, etc.
- [2] The above-mentioned states are sometimes attributed to epilepsy, sometimes to hysteria, sometimes to exhaustion of the nervous system—neurasthenia—and sometimes they may even be accorded the dignity of a disease *sui generis*. The patients concerned occasionally go through the whole gamut of diagnoses from epilepsy to hysteria and simulated insanity.
- [3] It is, in fact, exceedingly difficult, and sometimes impossible, to distinguish these states from the various types of neurosis, but on the other hand certain features point beyond pathological inferiority to something more than a merely analogical relationship with the phenomena of normal psychology, and even with the psychology of the supranormal, that of genius.
- [4] However varied the individual phenomena may be in themselves, there is certainly no case that cannot be related by means of some intermediate case to others that are typical. This relationship extends deep into the clinical pictures of hysteria and epilepsy. Recently it has even been suggested that there is no definite borderline between epilepsy and hysteria, and that a difference becomes apparent only in extreme cases. Steffens, for example, says: “We are forced to the conclusion that in essence hysteria and epilepsy are not fundamentally different, that the cause of the disease is the same, only it manifests itself in different forms and in different degrees of intensity and duration.”²
- [5] The delimitation of hysteria and certain borderline forms of epilepsy from congenital or acquired psychopathic inferiority likewise presents great difficulties. The symptoms overlap at every point, so that violence is done to the facts if they are regarded separately as belonging to this or that particular group. To delimit

psychopathic inferiority from the normal is an absolutely impossible task, for the difference is always only “more” or “less.” Classification in the field of inferiority itself meets with the same difficulties. At best, one can only single out certain groups which crystallize round a nucleus with specially marked typical features. If we disregard the two large groups of intellectual and emotional inferiority, we are left with those which are coloured pre-eminently by hysterical, epileptic (epileptoid), or neurasthenic symptoms, and which are not characterized by an inferiority either of intellect or of emotion. It is chiefly in this field, insusceptible of any sure classification, that the above-mentioned states are to be found. As is well known, they can appear as partial manifestations of a typical epilepsy or hysteria, or can exist separately as psychopathic inferiorities, in which case the qualification “epileptic” or “hysterical” is often due to relatively unimportant subsidiary symptoms. Thus somnambulism is usually classed among the hysterical illnesses because it is sometimes a partial manifestation of severe hysteria, or because it may be accompanied by milder so-called “hysterical” symptoms. Binet says: “Somnambulism is not one particular and unchanging nervous condition; there are many somnambulisms.”³ As a partial manifestation of severe hysteria, somnambulism is not an unknown phenomenon, but as a separate pathological entity, a disease *sui generis*, it must be somewhat rare, to judge by the paucity of German literature on this subject. So-called spontaneous somnambulism based on a slightly hysterical psychopathic inferiority is not very common, and it is worth while to examine such cases more closely, as they sometimes afford us a wealth of interesting observations.

- [6] CASE OF MISS E., aged 40, single, book-keeper in a large business. No hereditary taint, except that a brother suffered from “nerves” after a family misfortune and illness. Good education, of a cheerful disposition, not able to save money; “always had some big idea in my head.” She was very kind-hearted and gentle, did a great deal for her parents, who were living in modest circumstances, and for strangers. Nevertheless she was not happy because she felt she was misunderstood. She had always enjoyed good health till a few years ago, when she said she was treated for dilatation of the stomach and tapeworm. During this illness her hair turned rapidly white. Later she had typhoid. An engagement was terminated by the death of her fiancé from paralysis. She was in a highly nervous state for a year and a half. In the summer of 1897 she went away for a change of air and hydrotherapy. She herself said that for about a year there were moments in her work when her thoughts seemed to stand still, though she did not fall asleep. She made no mistakes in her accounts, however. In the street she often went to the wrong place and then suddenly realized that she was not in the right street. She had no giddiness or fainting-fits. Formerly menstruation occurred regularly every four weeks with no bother; latterly, since she was nervous and overworked, every fourteen days. For a long time she suffered from

constant headache. As accountant and book-keeper in a large business she had a very strenuous job, which she did well and conscientiously. In the present year, in addition to the strains of her work, she had all sorts of new worries. Her brother suddenly got divorced, and besides her own work she looked after his housekeeping, nursed him and his child through a serious illness, and so on. To recuperate, she went on September 13 to see a woman friend in southern Germany. Her great joy at seeing her friend again after such a long absence, and their celebration of a party, made the necessary rest impossible. On the 15th, quite contrary to her usual habit, she and her friend drank a bottle of claret. Afterwards they went for a walk in a cemetery, where she began to tear up flowers and scratch at the graves. She remembered absolutely nothing of this afterwards. On the 16th she stayed with her friend without anything of importance happening. On the 17th, her friend brought her to Zurich. An acquaintance came with her to the asylum; on the way she talked quite sensibly but was very tired. Outside the asylum they met three boys whom she described as "three dead people she had dug up." She then wanted to go to the neighbouring cemetery, and only with difficulty would be persuaded to enter the asylum.

[7] The patient was small, delicately built, slightly anaemic. Left side of the heart slightly enlarged; no murmurs, but a few double beats; accentuated sounds in the mitral region. The liver dulness extended only to the edge of the upper ribs. Patellar reflexes rather brisk, but otherwise no tendon reflexes. No anaesthesia or analgesia, no paralysis. Rough examination of the field of vision with the hands showed no restriction. Hair of a very pale, yellowish-white colour. On the whole, the patient looked her age. She recounted her history and the events of the last few days quite clearly, but had no recollection of what happened in the cemetery at C. or outside the asylum. During the night of the 17th/18th she spoke to the attendant and said she saw the whole room full of dead people looking like skeletons. She was not at all frightened, but was rather surprised that the attendant did not see them too. Once she ran to the window, but was otherwise quiet. The next morning in bed she still saw skeletons, but not in the afternoon. The following night she woke up at four o'clock and heard the dead children in the adjoining cemetery crying out that they had been buried alive. She wanted to go and dig them up but allowed herself to be restrained. Next morning at seven o'clock she was still delirious, but could now remember quite well the events in the cemetery at C. and on her way to the asylum. She said that at C. she wanted to dig up the dead children who were calling to her. She had only torn up the flowers in order to clear the graves and be able to open them. While she was in this state, Professor Bleuler explained to her that she would remember everything afterwards, too, when she came to herself again. The patient slept for a few hours in the morning; afterwards she was quite clear-headed and felt fairly well. She did indeed remember the attacks, but maintained a remarkable indifference towards them.

The following nights, except on those of September 22 and 25, she again had short attacks of delirium in which she had to deal with the dead, though the attacks differed in detail. Twice she saw dead people in her bed; she did not appear to be frightened of them, but got out of bed so as not to “embarrass” them. Several times she tried to leave the room.

[8] After a few nights free from attacks, she had a mild one on September 30, when she called to the dead from the window. During the day her mind was quite clear. On October 3, while fully conscious, as she related afterwards, she saw a whole crowd of skeletons in the drawing-room. Although she doubted the reality of the skeletons she could not convince herself that it was an hallucination. The next night, between twelve and one o'clock—the earlier attacks usually happened about this time—she was plagued by the dead for about ten minutes. She sat up in bed, stared into a corner of the room, and said: “Now they're coming, but they're not all here yet. Come along, the room's big enough, there's room for all. When they're all there I'll come too.” Then she lay down, with the words: “Now they're all there,” and fell asleep. In the morning she had not the slightest recollection of any of these attacks. Very short attacks occurred again on the nights of October 4, 6, 9, 13, and 15, all between twelve and one o'clock. The last three coincided with the menstrual period. The attendant tried to talk to her several times, showed her the lighted street-lamps and the trees, but she did not react to these overtures. Since then the attacks have stopped altogether. The patient complained about a number of troubles she had had during her stay here. She suffered especially from headaches, and these got worse the morning after the attacks. She said it was unbearable. Five grains of *Sacch. lactis* promptly alleviated this. Then she complained of a pain in both forearms, which she described as though it were *tendovaginitis*. She thought the bulging of the flexed biceps was a swelling and asked to have it massaged. Actually, there was nothing the matter, and when her complaints were ignored the trouble disappeared. She complained loud and long about the thickening of a toe-nail, even after the thickened part had been removed. Sleep was often disturbed. She would not give her consent to be hypnotized against the night attacks. Finally, on account of headache and disturbed sleep, she agreed to hypnotic treatment. She proved a good subject, and at the first sitting fell into a deep sleep with analgesia and amnesia.

[9] In November she was again asked whether she could remember the attack of September 19, which it had been suggested she would recall. She had great difficulty recollecting it, and in the end she could only recount the main facts; she had forgotten the details.

[10] It remains to be said that the patient was not at all superstitious and in her healthy days had never been particularly interested in the supernatural. All through the treatment, which ended on November 14, she maintained a remarkable indifference

both to the illness and its improvement. The following spring she returned as an outpatient for treatment of the headaches, which had slowly come back because of strenuous work during the intervening months. For the rest, her condition left nothing to be desired. It was established that she had no remembrance of the attacks of the previous autumn, not even those of September 19 and earlier. On the other hand, under hypnosis she could still give a good account of the events in the cemetery, outside the asylum, and during the night attacks.

[11] The peculiar hallucinations and general appearance of our case are reminiscent of those states which Krafft-Ebing describes as “protracted states of hysterical delirium.” He says:

It is in the milder cases of hysteria that such delirious states occur.... Protracted hysterical delirium depends upon temporary exhaustion.... Emotional disturbances seem to favour its outbreak. It is prone to relapse.... Most frequently we find delusions of persecution, with often very violent reactive fear... then religious and erotic delusions. Hallucinations of all the senses are not uncommon. The most frequent and most important are delusions of sight, smell, and touch. The visual hallucinations are mostly visions of animals, funerals, fantastic processions swarming with corpses, devils, ghosts, and what not.... The auditory delusions are simply noises in the ear (shrieks, crashes, bangs), or actual hallucinations, often with sexual content.⁴

[12] The corpse visions of our patient and their appearance during attacks remind us of states occasionally observed in hysterioepilepsy. Here too there are specific visions which, in contrast to protracted delirium, are associated with individual attacks. I will give two examples:

[13] A 30-year-old lady with *grande hystérie* had delirious twilight states in which she was tormented by frightful hallucinations. She saw her children being torn away from her, devoured by wild beasts, *etc.* She had no remembrance of the individual attacks.⁵

[14] A girl of 17, also a severe hysteric. In her attacks she always saw the corpse of her dead mother approaching her, as if to draw her to itself. No memory of the attacks.⁶

[15] These are cases of severe hysteria where consciousness works at a deep dream level. The nature of the attacks and the stability of the hallucinations alone show a certain affinity to our case, which in this respect has numerous analogies with the corresponding states of hysteria, as for instance with cases where a psychic shock (rape, *etc.*) occasioned the outbreak of hysterical attacks, or where the traumatic event is re-experienced in stereotyped hallucinatory form. Our case, however, gets its specific character from the identity of consciousness during the different attacks. It is a “second state,” with a memory of its own, but separated from the waking state by

total amnesia. This distinguishes it from the above-mentioned twilight states and relates it to those found in somnambulism.

[16] Charcot⁷ divides somnambulism into two basic forms:

a. Delirium with marked inco-ordination of ideas and actions.

b. Delirium with co-ordinated actions. This comes nearer to the waking state.

[17] Our case belongs to the second group. If by somnambulism we understand a state of systematic partial wakefulness,⁸ we must when discussing this ailment also consider those isolated attacks of amnesia which are occasionally observed. Except for noctambulism, they are the simplest states of systematic partial wakefulness. The most remarkable in the literature is undoubtedly Naef's case.^{8a} It concerns a gentleman of 32 with a bad family history and numerous signs of degeneracy, partly functional, partly organic. As a result of overwork he had, at the early age of 17, a peculiar twilight state with delusions, which lasted a few days and then cleared up with sudden recovery of memory. Later he was subject to frequent attacks of giddiness with palpitations and vomiting, but these attacks were never attended by loss of consciousness. At the end of a feverish illness he suddenly left Australia for Zurich, where he spent some weeks in carefree and merry living, only coming to himself when he read of his sudden disappearance from Australia in the newspapers. He had complete retrograde amnesia for the period of several months that included his journey to Australia, his stay there, and the journey back. A case of periodic amnesia is published by Azam:⁹ Albert X., 12½ years old, with hysterical symptoms, had several attacks of amnesia in the course of a few years, during which he forgot how to read, write, count, and even how to speak his own language, for weeks at a stretch. In between times he was normal.

[18] A case of *automatisme ambulateur* on a decidedly hysterical basis, but differing from Naef's case in that the attacks were recurrent, is published by Proust.¹⁰ An educated man, aged 30, exhibited all the symptoms of *grande hystérie*. He was very suggestible, and from time to time, under the stress of emotional excitement, had attacks of amnesia lasting from two days to several weeks. While in these states he wandered about, visited relatives, smashed various things in their houses, contracted debts, and was even arrested and convicted for picking pockets.

[19] There is a similar case of vagrancy in Boeteau.¹¹ A widow of 22, highly hysterical, became terrified at the prospect of an operation for salpingitis, left the hospital where she had been till then, and fell into a somnambulistic condition, from which she awoke after three days with total amnesia. In those three days she had walked about thirty miles looking for her child.

- [20] William James¹² describes a case of an “ambulatory sort”: the Reverend Ansel Bourne, itinerant preacher, 30 years old, psychopath, had on several occasions attacks of unconsciousness lasting an hour. One day (January 17, 1887) he suddenly disappeared from Greene, Rhode Island, after having lifted \$551 from a bank. He was missing for two months, during which time he ran a little grocery store in Norristown, Pennsylvania, under the name of A. J. Brown, carefully attending to all the purchases himself, although he had never done this sort of work before. On March 14 he suddenly awoke and went back home. Complete amnesia for the interval.
- [21] Mesnet¹³ published this case: F., 27 years old, sergeant in the African regiment, sustained an injury of the parietal bone at Bazeilles. Suffered for a year from hemiplegia, which disappeared when the wound healed. During the illness he had somnambulistic attacks with marked restriction of consciousness; all the sense functions were paralysed except for the sense of taste and a little bit of the sense of sight. Movements were co-ordinated, but their performance in overcoming obstacles was severely limited. During attacks the patient had a senseless collecting mania. Through various manipulations his consciousness could be given an hallucinatory content; for instance, if a stick was placed in his hand, the patient would immediately feel himself transported to a battle scene, would put himself on guard, see the enemy approaching, etc.
- [22] Guinon and Sophie Woltke made the following experiments with hysterics:¹⁴ A blue glass was held in front of a female patient during an hysterical attack, and she regularly saw a picture of her mother in the blue sky. A red glass showed her a bleeding wound, a yellow one an orange-seller or a lady in a yellow dress.
- [23] Mesnet’s case recalls the cases of sudden restriction of memory.
- [24] MacNish¹⁵ tells of a case of this sort: An apparently healthy young woman suddenly fell into an abnormally long sleep, apparently with no prodromal symptoms. On waking she had forgotten the words for and all knowledge of the simplest things. She had to learn how to read, write, and count all over again, at which she made rapid progress. After a second prolonged sleep she awoke as her normal self with no recollection of the intervening state. These states alternated for more than four years, during which time consciousness showed continuity within the two states, but was separated by amnesia from the consciousness of the normal state.
- [25] These selected cases of various kinds of changes in consciousness each throw some light on our case. Naef’s case presents two hysteriform lapses of memory, one of which is characterized by delusional ideas, and the other by its long duration, restriction of consciousness, and the desire to wander. The peculiar, unexpected impulses are particularly clear in Proust and Mesnet. In our case the corresponding features would be the impulsive tearing up of flowers and the digging up of graves.

The patient's continuity of consciousness during attacks reminds us of the way consciousness behaved in the MacNish case; hence it may be regarded as a temporary phenomenon of alternating consciousness. The dreamlike hallucinatory content of restricted consciousness in our case does not, however, appear to justify us in assigning it without qualification to this "double consciousness" group. The hallucinations in the second state show a certain creativeness which seems to be due to its auto-suggestibility. In Mesnet's case we observe the appearance of hallucinatory processes through simple stimulations of touch. The patient's subconscious uses these simple perceptions for the automatic construction of complicated scenes which then take possession of his restricted consciousness. We have to take a somewhat similar view of the hallucinations of our patient; at any rate the outward circumstances in which they arose seem to strengthen this conjecture.

[26] The walk in the cemetery induced the vision of the skeletons, and the meeting with the three boys evoked the hallucination of children buried alive, whose voices the patient heard at night. She came to the cemetery in a somnambulistic condition, which on this occasion was particularly intense in consequence of her having taken alcohol. She then performed impulsive actions of which her subconscious, at least, received certain impressions. (The part played here by alcohol should not be underestimated. We know from experience that it not only acts adversely on these conditions, but, like every other narcotic, increases suggestibility.) The impressions received in somnambulism go on working in the subconscious to form independent growths, and finally reach perception as hallucinations. Consequently our case is closely allied to the somnambulistic dream-states that have recently been subjected to penetrating study in England and France.

[27] The gaps of memory, apparently lacking content at first, acquire such through incidental auto-suggestions, and this content builds itself up automatically to a certain point. Then, probably under the influence of the improvement now beginning, its further development comes to a standstill and finally it disappears altogether as recovery sets in.

[28] Binet and Féré have made numerous experiments with the implanting of suggestions in states of partial sleep. They have shown, for instance, that when a pencil is put into the anaesthetic hand of an hysteric, she will immediately produce long letters in automatic writing whose content is completely foreign to her consciousness. Cutaneous stimuli in anaesthetic regions are sometimes perceived as visual images, or at least as vivid and unexpected visual ideas. These independent transmutations of simple stimuli must be regarded as the primary phenomenon in the formation of somnambulistic dream pictures. In exceptional cases, analogous phenomena occur even within the sphere of waking consciousness. Goethe,¹⁶ for instance, says that when he sat down, lowered his head, and vividly conjured up the

image of a flower, he saw it undergoing changes of its own accord, as if entering into new combinations of form. In the halfwaking state these phenomena occur fairly often as hypnagogic hallucinations. Goethe's automatism differs from truly somnambulistic ones, because in his case the initial idea is conscious, and the development of the automatism keeps within the bounds laid down by the initial idea, that is to say, within the purely motor or visual area.

[29] If the initial idea sinks below the threshold, or if it was never conscious at all and its automatic development encroaches on areas in the immediate vicinity, then it is impossible to differentiate between waking automatism and those of the somnambulistic state. This happens, for instance, if the perception of a flower associates itself with the idea of a hand plucking the flower, or with the idea of the smell of a flower. The only criterion of distinction is then simply "more" or "less": in one case we speak of "normal waking hallucinations" and in the other of "somnambulistic dream visions." The interpretation of our patient's attacks as hysterical becomes more certain if we can prove that the hallucinations were probably psychogenic in origin. This is further supported by her complaints (headache and tendovaginitis), which proved amenable to treatment by suggestion. The only aspect that the diagnosis of "hysteria" does not take sufficiently into account is the aetiological factor, for we would after all expect *a priori* that, in the course of an illness which responds so completely to a rest cure, features would now and then be observed which could be interpreted as symptoms of exhaustion. The question then arises whether the early lapses of memory and the later somnambulistic attacks can be regarded as states of exhaustion or as "neurasthenic crises." We know that psychopathic inferiority can give rise to various kinds of epileptoid attacks whose classification under epilepsy or hysteria is at least doubtful. To quote Westphal:

On the basis of numerous observations I maintain that the so-called epileptoid attacks form one of the commonest and most frequent symptoms in the group of diseases we reckon among the mental diseases and neuropathies, and that the mere appearance of one or more epileptic or epileptoid attacks is not decisive either for the character and form of the disease or for its course and prognosis.... As already mentioned, I have used the term "epileptoid" in the widest sense for the attack itself.¹⁷

[30] The epileptoid elements in our case are not far to seek; on the other hand, one can object that the colouring of the whole picture is hysterical in the extreme. As against this we must point out that not every case of somnambulism is *ipso facto* hysterical. Occasionally states occur in typical epilepsy which to experts seem directly parallel with somnambulistic states, or which can be distinguished from hysteria only by the occurrence of genuine convulsions.¹⁸

- [31] As Diehl¹⁹ has shown, neurasthenic inferiority may also give rise to “crises” which often confuse the diagnosis. A definite content of ideas can even repeat itself in stereotyped form in each crisis. Mörchen, too, has recently published the case of an epileptoid neurasthenic twilight state.²⁰
- [32] I am indebted to Professor Bleuler for the following case: An educated gentleman of middle age, with no epileptic antecedents, had worn himself out with years of mental overwork. Without any other prodromal symptoms (such as depression, etc.), he attempted suicide on a holiday: in a peculiar twilight state he suddenly threw himself into the water from a crowded spot on the river bank. He was immediately hauled out and had only a vague memory of the incident.
- [33] With these observations in mind, we must certainly allow neurasthenia a considerable share in the attacks of our patient. The headaches and the “tendovaginitis” point to a mild degree of hysteria, normally latent but becoming manifest under the stress of exhaustion. The genesis of this peculiar illness explains the above-described relationship to epilepsy, hysteria, and neurasthenia. To sum up: Miss E. suffers from a psychopathic inferiority with a tendency to hysteria. Under the influence of nervous exhaustion she has fits of epileptoid stupor whose interpretation is uncertain at first sight. As a result of an unusually large dose of alcohol, the attacks develop into definite somnambulism with hallucinations, which attach themselves to fortuitous external perceptions in the same way as dreams. When the nervous exhaustion is cured, the hysteriform symptoms disappear.
- [34] In the realm of psychopathic inferiority with hysterical colouring, we meet with numerous phenomena which show, as in this case, symptoms belonging to several different clinical pictures, but which cannot with certainty be assigned to any one of them. Some of these states are already recognized as disorders in their own right: e.g., pathological lying, pathological dreaminess, etc. But many of them still await thorough scientific investigation; at present they belong more or less to the domain of scientific gossip. Persons with habitual hallucinations, and also those who are inspired, exhibit these states; they draw the attention of the crowd to themselves, now as poets or artists, now as saviours, prophets, or founders of new sects.
- [35] The genesis of the peculiar mentality of these people is for the most part lost in obscurity, for it is only very rarely that one of these singular personalities can be subjected to exact observation. In view of the—sometimes—great historical significance of such persons, it were much to be wished that we had enough scientific material to give us closer insight into the psychological development of their peculiarities. Apart from the now practically useless productions of the pneumatological school at the beginning of the nineteenth century, there is a remarkable dearth of competent observations in the German scientific literature of the

subject; indeed, there seems to be a real aversion to investigation in this field. For the facts so far gathered we are indebted almost exclusively to the labours of French and English workers. It therefore seems at least desirable that our literature should be enlarged in this respect. These reflections have prompted me to publish some observations which will perhaps help to broaden our knowledge of the relations between hysterical twilight states and the problems of normal psychology.

[2.] A CASE OF SOMNAMBULISM IN A GIRL WITH POOR INHERITANCE (SPIRITUALISTIC MEDIUM)

[36] The following case was under my observation during the years 1899 and 1900. As I was not in medical attendance upon Miss S. W., unfortunately no physical examination for hysterical stigmata could be made. I kept a detailed diary of the séances, which I wrote down after each sitting. The report that follows is a condensed account from these notes. Out of regard for Miss S. W. and her family, a few unimportant data have been altered and various details omitted from her “romances,” which for the most part are composed of very intimate material.

[Anamnesis]

[37] Miss S. W., 15½ years old, Protestant. The paternal grandfather was very intelligent, a clergyman who frequently had waking hallucinations (mostly visions, often whole dramatic scenes with dialogues, etc.). A brother of her grandfather was feeble-minded, an eccentric who also saw visions. One of his sisters was also a peculiar, odd character. The paternal grandmother, after a feverish illness in her twentieth year—typhoid fever?—had a trance lasting for three days, from which she did not begin to awake until the crown of her head was burnt with a red-hot iron. Later on, when emotionally excited, she had fainting-fits; these were nearly always followed by a brief somnambulism during which she uttered prophecies. The father too was an odd, original personality with bizarre ideas. Two of his brothers were the same. All three had waking hallucinations. (Second sight, premonitions, etc.) A third brother was also eccentric and odd, talented but one-sided. The mother has a congenital psychopathic inferiority often bordering on psychosis. One sister is an hysteric and a visionary, another sister suffers from “nervous heart-attacks.”

[38] S. W. is of delicate build, skull somewhat rachitic though not noticeably hydrocephalic, face rather pale, eyes dark, with a peculiar penetrating look. She has had no serious illnesses. At school she passed for average, showed little interest, was inattentive. In general, her behaviour was rather reserved, but this would suddenly give place to the most exuberant joy and exaltation. Of mediocre intelligence, with no special gifts, neither musical nor fond of books, she prefers handwork or just sitting

around day-dreaming. Even at school she was often absentminded, misread in a peculiar way when reading aloud—for instance, instead of the word “Ziege” (goat) she would say “Geiss,” and instead of “Treppe” (stair) she would say “Stege”; this happened so often that her brothers and sisters used to laugh at her.²¹ Otherwise there were no abnormalities to be noticed about S. W., and especially no serious hysterical symptoms. Her family were all artisans and business people with very limited interests. Books of a mystical nature were never allowed in the family. Her education was deficient; apart from the fact that there were many brothers and sisters, all given a very casual education, the children suffered a great deal from the inconsequent, vulgar, and often brutal treatment they received from their mother. The father, a very preoccupied business man, could not devote much time to his children and died when S. W. was still adolescent. In these distressing circumstances it is no wonder that she felt shut in and unhappy. She was often afraid to go home and preferred to be anywhere rather than there. Hence she was left a great deal with her playmates and grew up without much polish. Her educational level was accordingly pretty low and her interests were correspondingly limited. Her knowledge of literature was likewise very limited. She knew the usual poems of Schiller and Goethe and a few other poets learnt by heart at school, some snatches from a song-book, and fragments of the Psalms. Newspaper and magazine stories probably represented the upper limit in prose. Up to the time of her somnambulism she had never read anything of a more cultured nature.

[*Somnambulistic States*]

[39] At home and from friends she heard about table-turning and began to take an interest in it. She asked to be allowed to take part in such experiments, and her desire was soon gratified. In July 1899, she did some table-turning several times in the family circle with friends, but as a joke. It was then discovered that she was an excellent medium. Communications of a serious nature arrived and were received amid general astonishment. Their pastoral tone was surprising. The spirit gave himself out to be the grandfather of the medium. As I was acquainted with the family, I was able to take part in these experiments. At the beginning of August 1899, I witnessed the first attacks of somnambulism. Their course was usually as follows: S. W. grew very pale, slowly sank to the ground or into a chair, closed her eyes, became cataleptic, drew several deep breaths, and began to speak. At this stage she was generally quite relaxed, the eyelid reflexes remained normal and so did tactile sensibility. She was sensitive to unexpected touches and easily frightened, especially in the initial stage.

[40] She did not react when called by name. In her somnambulistic dialogues she copied in a remarkably clever way her dead relatives and acquaintances, with all their

foibles, so that she made a lasting impression even on persons not easily influenced. She could also hit off people whom she knew only from hearsay, doing it so well that none of the spectators could deny her at least considerable talent as an actress. Gradually gestures began to accompany the words, and these finally led up to “attitudes passionnelles” and whole dramatic scenes. She flung herself into postures of prayer and rapture, with staring eyes, and spoke with impassioned and glowing rhetoric. On these occasions she made exclusive use of literary German, which she spoke with perfect ease and assurance, in complete contrast to her usual uncertain and embarrassed manner in the waking state. Her movements were free and of a noble grace, mirroring most beautifully her changing emotions. At this stage her behaviour during the attacks was irregular and extraordinarily varied. Now she would lie for ten minutes to two hours on the sofa or the floor, motionless, with closed eyes; now she assumed a half-sitting posture and spoke with altered voice and diction; now she was in constant movement, going through every possible pantomimic gesture. The content of her speeches was equally variable and irregular. Sometimes she spoke in the first person, but never for long, and then only to prophesy her next attack; sometimes—and this was the most usual—she spoke of herself in the third person. She then acted some other person, either a dead acquaintance or somebody she had invented, whose part she carried out consistently according to the characteristics she herself conceived. The ecstasy was generally followed by a cataleptic stage with *flexibilitas cerea*, which gradually passed over into the waking state. An almost constant feature was the sudden pallor which gave her face a waxen anaemic hue that was positively frightening. This sometimes occurred right at the beginning of the attack, but often in the second half only. Her pulse was then low but regular and of normal frequency; the breathing gentle, shallow, often barely perceptible. As we have already remarked, S. W. frequently predicted her attacks beforehand; just before the attacks she had strange sensations, became excited, rather anxious, and occasionally expressed thoughts of death, saying that she would probably die in one of these attacks, that her soul only hung on to her body by a very thin thread, so that her body could scarcely go on living. On one occasion after the cataleptic stage, tachypnoea was observed, lasting for two minutes with a respiration of 100 per minute. At first the attacks occurred spontaneously, but later S. W. could induce them by sitting in a dark corner and covering her face with her hands. But often the experiment did not succeed, as she had what she called “good” and “bad” days.

[41] The question of amnesia after the attacks is unfortunately very unclear. This much is certain, that after each attack she was perfectly oriented about the specific experiences she had undergone in the “rapture.” It is, however, uncertain how much she remembered of the conversations for which she served as a medium, and of changes in her surroundings during the attack. It often looked as if she did have a

vague recollection, for often she would ask immediately on waking: "Who was there? Wasn't X or Y there? What did he say?" She also showed that she was superficially aware of the content of the conversations. She often remarked that the spirits told her before waking what they had said. But frequently this was not the case at all. If at her request someone repeated the trance speeches to her, she was very often indignant about them and would be sad and depressed for hours on end, especially if any unpleasant indiscretions had occurred. She would rail against the spirits and assert that next time she would ask her guide to keep such spirits away from her. Her indignation was not faked, for in the waking state she could barely control herself and her affects, so that any change of mood was immediately reflected in her face. At times she seemed barely, if at all, aware of what went on around her during the attack. She seldom noticed when anyone left the room or came into it. Once she forbade me to enter the room when she was expecting special communications which she wished to keep secret from me. I went in, nevertheless, sat down with the three other sitters, and listened to everything. S. W. had her eyes open and spoke to the others without noticing me. She only noticed me when I began to speak, which gave rise to a veritable storm of indignation. She remembered better, but still only vaguely, the remarks of participants which referred to the trance speeches or directly to herself. I could never discover any definite rapport in this connection.

[42] Besides these "big" attacks, which seemed to follow a certain law, S. W. also exhibited a large number of other automatisms. Premonitions, forebodings, unaccountable moods, and rapidly changing fancies were all in the day's work. I never observed simple states of sleep. On the other hand, I soon noticed that in the middle of a lively conversation she would become all confused and go on talking senselessly in a peculiar monotonous way, looking in front of her dreamily with half-closed eyes. These lapses usually lasted only a few minutes. Then she would suddenly go on: "Yes, what did you say?" At first she would not give any information about these lapses, saying evasively that she felt a bit giddy, had a headache, etc. Later she simply said: "They were there again," meaning her spirits. She succumbed to these lapses very much against her will; often she struggled against them: "I don't want to, not now, let them come another time, they seem to think I'm there only for them." The lapses came over her in the street, in shops, in fact anywhere. If they happened in the street, she would lean against a house and wait till the attack was over. During these attacks, whose intensity varied considerably, she had visions; very often, and especially during attacks when she turned extremely pale, she "wandered," or, as she put it, lost her body and was wafted to distant places where the spirits led her. Distant journeys during ecstasy tired her exceedingly; she was often completely exhausted for hours afterward, and many times complained that the spirits had again drained the strength from her, such exertions were too much, the spirits must get

another medium, etc. Once she went hysterically blind for half an hour after the ecstasy. Her gait was unsteady, groping; she had to be led, did not see the light that stood on the table, though the pupils reacted.

[43] Visions also came in large numbers even without proper lapses (if we use this word only for higher-grade disturbances of attention). At first they were confined to the onset of sleep. A little while after she had gone to bed the room would suddenly light up, and shining white figures detached themselves from the foggy brightness. They were all wrapped in white veil-like robes, the women had things resembling turbans on their heads and wore girdles. Later (according to her own statement) “the spirits were already there” when she went to bed. Finally she saw the figures in broad daylight, though only blurred and fleetingly if there was no real lapse (then the figures became solid enough to touch). But she always preferred the darkness. According to her account, the visions were generally of a pleasant nature. Gazing at the beautiful figures gave her a feeling of delicious bliss. Terrifying visions of a daemonic character were much rarer. These were entirely confined to night-time or dark rooms. Occasionally she saw black figures in the street at night or in her room; once in the dark hallway she saw a terrible copper-red face which suddenly glared at her from very near and terrified her. I could not find out anything satisfactory about the first occurrence of the visions. She stated that in her fifth or sixth year she once saw her “guide” at night—her grandfather (whom she had never known in life). I could not obtain any objective clues about this early vision from her relatives. Nothing more of the kind is said to have happened until the first séance. Except for the hypnagogic brightness and “seeing sparks” there were never any rudimentary hallucinations; from the beginning the hallucinations were of a systematic nature involving all the sense organs equally. So far as the intellectual reaction to these phenomena is concerned, what is remarkable is the amazing matter-of-factness with which she regarded them. Her whole development into a somnambulist, her innumerable weird experiences, seemed to her entirely natural. She saw her whole past only in this light. Every in any way striking event from her earlier years stood in a clear and necessary relationship to her present situation. She was happy in the consciousness of having found her true vocation. Naturally she was unshakably convinced of the reality of her visions. I often tried to give her some critical explanation, but she would have none of it, since in her normal state she could not grasp a rational explanation anyway, and in her semi-somnambulist state she regarded it as senseless in view of the facts staring her in the face. She once said: “I do not know if what the spirits say and teach me is true, nor do I know if they really are the people they call themselves; but that my spirits exist is beyond question. I see them before me, I can touch them. I speak to them about everything I wish as naturally as I’m talking to you. They must be real.” She absolutely would not listen to

the idea that the manifestations were a kind of illness. Doubts about her health or about the reality of her dream-world distressed her deeply; she felt so hurt by my remarks that she closed up in my presence and for a long time refused to experiment if I was there; hence I took care not to express my doubts and misgivings aloud. On the other hand she enjoyed the undivided respect and admiration of her immediate relatives and acquaintances, who asked her advice about all sorts of things. In time she obtained such an influence over her followers that three of her sisters began to hallucinate too. The hallucinations usually began as night-dreams of a very vivid and dramatic kind which gradually passed over into the waking state—partly hypnagogic, partly hypnopompic. A married sister in particular had extraordinarily vivid dreams that developed logically from night to night and finally appeared in her waking consciousness first as indistinct delusions and then as real hallucinations, but they never reached the plastic clearness of S. W.'s visions. Thus, she once saw in a dream a black daemonic figure at her bedside in vigorous argument with a beautiful white figure who was trying to restrain the black; nevertheless the black figure seized her by the throat and started to choke her; then she awoke. Bending over her she saw a black shadow with human outlines, and near it a cloudy white figure. The vision disappeared only when she lighted the candle. Similar visions were repeated dozens of times. The visions of the other two sisters were similar but less intense.

[44] The type of attack we have described, with its wealth of fantastic visions and ideas, had developed in less than a month, reaching a climax which was never to be surpassed. What came later was only an elaboration of all the thoughts and the cycles of visions that had been more or less foreshadowed right at the beginning. In addition to the “big attacks” and the “little lapses,” whose content however was materially the same, there was a third category that deserves mention. These were the semi-somnambulistic states. They occurred at the beginning or end of the big attacks, but also independently of them. They developed slowly in the course of the first month. It is not possible to give a more precise date for their appearance. What was especially noticeable in this state was the rigid expression of the face, the shining eyes, and a certain dignity and stateliness of movement. In this condition S. W. was herself, or rather her somnambulist ego. She was fully oriented to the external world but seemed to have one foot in her dream-world. She saw and heard her spirits, saw how they walked round the room among those present, standing now by one person and now by another. She had a clear memory of her visions, of her journeys, and the instructions she received. She spoke quietly, clearly, and firmly, and was always in a serious, almost solemn, mood. Her whole being glowed with deep religious feeling, free from any pietistic flavour, and her speech was in no way influenced by the Biblical jargon of her guide. Her solemn behaviour had something sorrowful and melancholy about it. She was painfully conscious of the great difference between her nocturnal ideal

world and the crude reality of day. This state was in sharp contrast to her waking existence; in it there was no trace of that unstable and inharmonious creature, of that brittle nervous temperament which was so characteristic of her usual behaviour. Speaking with her, you had the impression of speaking with a much older person, who through numerous experiences had arrived at a state of calm composure. It was in this state that she achieved her best results, whereas her romances corresponded more closely to her waking interests. The semi-somnambulism usually appeared spontaneously, as a rule during the table-turning experiments, and it always began by S. W.'s knowing beforehand what the table was going to say. She would then stop table-turning and after a short pause would pass suddenly into an ecstasy. She proved to be very sensitive. She could guess and answer simple questions devised by a member of the circle who was not himself a medium. It was enough to lay a hand on the table, or on her hands, to give her the necessary clues. Direct thought transference could never be established. Beside the obvious broadening of her whole personality the continued existence of her ordinary character was all the more startling. She talked with unconcealed pleasure about all her little childish experiences, the flirtations and love secrets, the naughtiness and rudeness of her companions and playmates. To anyone who did not know her secret she was just a girl of 15½, no different from thousands of other girls. So much the greater was people's astonishment when they came to know her other side. Her relatives could not grasp the change at first; part of it they never understood at all, so that there were often bitter arguments in the family, some of them siding with S. W. and others against her, either with gushing enthusiasm or with contemptuous censure of her "superstition." Thus S. W., during the time that I knew her, led a curiously contradictory life, a real "double life" with two personalities existing side by side or in succession, each continually striving for mastery. I will now give some of the most interesting details of the séances in chronological order.

[*Records of Séances*]

[45] FIRST AND SECOND SITTINGS (August 1899). S. W. at once took control of the "communications." The "psychograph," for which an overturned tumbler was used, the two fingers of the right hand being placed upon it, moved with lightning speed from letter to letter. (Slips of paper, marked with letters and numbers, had been arranged in a circle round the glass.) It was communicated that the medium's grandfather was present and would speak to us. There now followed numerous communications in quick succession, mostly of an edifying religious character, partly in properly formed words and partly with the letters transposed or in reverse order. These latter words and sentences were often produced so rapidly that one could not follow the meaning and only discovered it afterwards by reversing the letters. Once

the messages were interrupted in brusque fashion by a new communication announcing the presence of the writer's grandfather. Someone remarked jokingly: "Evidently the two spirits don't get on very well together." Darkness came on during the experiment. Suddenly S. W. became very agitated, jumped up nervously, fell on her knees, and cried: "There, there, don't you see that light, that star there?" She grew more and more excited, and called for a lamp in terror. She was pale, wept, said she felt queer, did not know what was the matter with her. When a lamp was brought she quieted down. The experiments were suspended.

[46] At the next sitting, which took place two days later, also in the evening, similar communications were obtained from S. W.'s grandfather. When darkness fell she suddenly lay back on the sofa, grew pale, closed her eyes to a slit, and lay there motionless. The eyeballs were turned upwards, the eye-lid reflex was present, also tactile sensibility. Respiration gentle, almost imperceptible. Pulse low and feeble. This condition lasted about half an hour, whereupon she suddenly got up with a sigh. The extreme pallor of the face, which had lasted all through the attack, now gave way to her usual rosy colour. She was somewhat confused and embarrassed, said she had seen "all sorts" of things, but would tell nothing. Only after insistent questioning would she admit that in a peculiar waking condition she had seen her grandfather arm-in-arm with my grandfather. Then they suddenly drove past sitting side by side in an open carriage.

[47] THIRD SITTING. In this, which took place a few days later, there was a similar attack of more than half an hour's duration. S. W. afterwards told of many white transfigured forms who each gave her a flower of special symbolic significance. Most of them were dead relatives. Concerning the details of their talk she maintained an obstinate silence.

[48] FOURTH SITTING. After S. W. had passed into the somnambulistic state she began to make peculiar movements with her lips, emitting at the same time gulping and gurgling noises. Then she whispered something unintelligible very softly. When this had gone on for some minutes she suddenly began speaking in an altered, deep tone of voice. She spoke of herself in the third person: "She is not here. she has gone away." There now followed several sentences in a religious vein. From their content and language one could see that she was imitating her grandfather, who had been a clergyman. The gist of the talk did not rise above the mental level of the "communications." The tone of voice had something artificial and forced about it, and only became natural when in due course it grew more like the medium's own. (In later sittings the voice only altered for a few moments when a new spirit manifested itself.) Afterwards she had no remembrance of the trance conversation. She gave hints about a sojourn in the other world and spoke of the unimaginable blessedness

she felt. It should be noted that during the attack her talk was absolutely spontaneous and not prompted by any suggestions.

[49] Immediately after this sitting S. W. became acquainted with Justinus Kerner's book *Die Seherin von Prevorst*.²² She thereupon began to magnetize herself towards the end of the attacks, partly by means of regular passes, partly by strange circles and figures of eight which she executed symmetrically with both arms at once. She did this, she said, to dispel the severe headaches that came after the attacks. In other August sittings (not detailed here) the grandfather was joined by numerous kindred spirits who did not produce anything very remarkable. Each time a new spirit appeared, the movements of the glass altered in a startling way: it ran along the row of letters, knocking against some of them, but no sense could be made of it. The spelling was very uncertain and arbitrary, and the first sentences were often incomplete or broken up into meaningless jumbles of letters. In most cases fluent writing suddenly began at this point. Sometimes automatic writing was attempted in complete darkness. The movements began with violent jerkings of the whole arm, so that the pencil went right through the paper. The first attempt consisted of numerous strokes and zigzag lines about 8 cm. high. Further attempts first produced illegible words written very large, then the writing gradually grew smaller and more distinct. It was not much different from the medium's own. The control spirit was once again the grandfather.

[50] FIFTH SITTING. Somnambulistic attacks in September 1899. S. W. sat on the sofa, leant back, shut her eyes, breathing lightly and regularly. She gradually became cataleptic. The catalepsy disappeared after about two minutes, whereupon she lay there apparently sleeping quietly, muscles quite relaxed. Suddenly she began talking in a low voice: "No, you take the red, I'll take the white. You can take the green, and you the blue. Are you ready? Let's go." (Pause of several minutes, during which her face assumed a corpse-like pallor. Her hands felt cold and were quite bloodless.) Suddenly she called out in a loud solemn voice: "Albert, Albert, Albert," then in a whisper: "Now you speak," followed by a longer pause during which the pallor of her face reached its highest conceivable intensity. Again in a loud solemn voice: "Albert, Albert, don't you believe your father? I tell you there are many mistakes in N's teaching. Think about it." Pause. The pallor decreased. "He's very frightened, he couldn't speak any more." (These words in her usual conversational tone.) Pause. "He will certainly think about it." She went on speaking in the same conversational tone but in a strange idiom that sounded like French and Italian mixed, recalling now one and now the other. She spoke fluently, rapidly, and with charm. It was possible to make out a few words, but not to memorize them, because the language was so strange. From time to time certain words recurred, like *wena*, *wenes*, *wenai*, *wene*, etc. The absolute naturalness of the performance was amazing. Now and then she

paused as if someone were answering her. Suddenly she said, in German: "Oh dear, is it time already?" (In a sad voice.) "Must I go? Goodbye, goodbye!" At these words there passed over her face an indescribable expression of ecstatic happiness. She raised her arms, opened her eyes, till now closed, and looked upwards radiantly. For a moment she remained in this position, then her arms sank down slackly, her face became tired and exhausted. After a short cataleptic stage she woke up with a sigh. "I've slept again, haven't I?" She was told she had been talking in her sleep, whereupon she became wildly annoyed, and her anger increased still more when she learned that she was talking in a foreign language. "But I told the spirits I didn't want to, I can't do it, it tires me too much." (Began to cry.) "Oh God, must everything, everything come back again like last time, am I to be spared nothing?"

[51] The next day at the same time there was another attack. After S. W. had dropped off, Ulrich von Gerbenstein suddenly announced himself. He proved to be an amusing gossip, speaking fluent High German with a North German accent. Asked what S. W. was doing, he explained with much circumlocution that she was far away, and that he was here meanwhile to look after her body, its circulation, respiration, etc. He must take care that no black person got hold of her and harmed her. On insistent questioning he said that S. W. had gone with the others to Japan, to look up a distant relative and stop him from a stupid marriage. He then announced in a whisper the exact moment when the meeting took place. Forbidden to talk for a few minutes, he pointed to S. W.'s sudden pallor, remarking that materialization at such great distances cost a corresponding amount of strength. He then ordered cold compresses to be applied to her head so as to alleviate the severe headache which would come afterwards. With the gradual return of colour to her face, the conversation became more animated. There were all sorts of childish jokes and trivialities, then U. v. G. suddenly said: "I see them coming, but they are still very far off; I see her there like a little star." S. W. pointed to the north. We naturally asked in astonishment why they were not coming from the east, whereupon U. v. G. laughingly replied: "They come the direct way over the North Pole. I must go now, goodbye." Immediately afterwards S. W. awoke with a sigh, in a bad temper, complaining of violent headache. She said she had seen U. v. G. standing by her body; what had he told us? She was furious about the "silly chatter," why couldn't he lay off it for once?

[52] SIXTH SITTING. Began in the usual way. Extreme pallor; lay stretched out, scarcely breathing. Suddenly she spoke in a loud solemn voice: "Well then, be frightened; I am. I warn you about N's teaching. Look, in hope there is everything needed for faith. You want to know who I am? God gives where one least expects it. Don't you know me?" Then unintelligible whispering. After a few minutes she woke up.

[53] SEVENTH SITTING. S. W. soon fell asleep, stretched out on the sofa. Very pale. Said nothing, sighed deeply from time to time. Opened her eyes, stood up, sat down on the sofa, bent forward, saying softly: "You have sinned grievously, have fallen far." Bent still further forward as if speaking to someone kneeling in front of her. Stood up, turned to the right, stretched out her hand, and pointed to the spot over which she had been bending: "Will you forgive her?" she asked loudly. "Do not forgive men, but their spirits. Not she, but her human body has sinned." Then she knelt down, remained for about ten minutes in an attitude of prayer. Suddenly she got up, looked to heaven with an ecstatic expression, and then threw herself on her knees again, her face in her hands, whispering incomprehensible words. Remained motionless in this attitude for several minutes. Then she got up, gazed heavenward again with radiant countenance, and lay down on the sofa, waking soon afterwards.

Development of the Somnambulistic Personalities

[54] At the beginning of many séances, the glass was allowed to move by itself, and this was always followed by the stereotyped invitation: "You must ask a question." Since several convinced spiritualists were attending the séances, there was of course an immediate demand for all manner of spiritualistic marvels, especially for the "protecting spirits." At these requests the names of well-known dead persons were sometimes produced, and sometimes unknown names such as Berthe de Valours, Elisabeth von Thierfelsenburg, Ulrich von Gerbenstein, etc. The control spirit was almost without exception the medium's grandfather, who once declared that "he loved her more than anyone in this world because he had protected her from childhood up and knew all her thoughts." This personality produced a flood of Biblical maxims, edifying observations, and song-book verses, also verses he had presumably composed himself, like the following:

Be firm and true in thy believing,
To faith in God cling ever nigh,
Thy heavenly comfort never leaving,
Which having, man can never die.
Refuge in God is peace for ever
When earthly cares oppress the mind;
Who from the heart can pray is never
Bow'd down by fate howe'er unkind.

[55] Numerous other effusions of this sort betrayed by their hackneyed, unctuous content their origin in some tract or other. From the time S. W. began speaking in her ecstasies, lively dialogues developed between members of the circle and the somnambulist personality. The gist of the answers received was essentially the same

as the banal and generally edifying verbiage of the psychographic communications. The character of this personality was distinguished by a dry and tedious solemnity, rigorous conventionality, and sanctimonious piety (which does not accord, at all with the historical reality). The grandfather was the medium's guide and protector. During the ecstasies he offered all kinds of advice, prophesied later attacks and what would happen when she woke, etc. He ordered cold compresses, gave instructions concerning the way the medium should lie on the couch, arrangements for sittings, and so on. His relationship to the medium was exceedingly tender. In vivid contrast to this heavy-footed dream-personage, there appeared a personality who had cropped up occasionally in the psychographic communications of the first sittings. He soon disclosed himself as the dead brother of a Mr. R., who was then taking part in the séances. This dead brother, Mr. P. R., peppered his living brother with commonplaces about brotherly love, etc. He evaded specific questions in every possible way. At the same time he developed a quite astonishing eloquence toward the ladies of the circle, and in particular paid his attentions to a lady whom he had never known in life. He stated that even when alive he had always raved about her, had often met her in the street without knowing who she was, and was now absolutely delighted to make her acquaintance in this unusual manner. His stale compliments, pert remarks to the men, innocuous childish jokes, etc., took up a large part of the séances. Several members of the circle took exception to the frivolity and banality of this spirit, whereupon he vanished for one or two sittings, but soon reappeared, at first well-behaved, often with Christian phrases on his lips, but before long slipping back into his old form.

[56] Besides these two sharply differentiated personalities, others appeared who varied but little from the grandfather type; they were mostly dead relatives of the medium. The general atmosphere of the first two months' séances was accordingly solemn and edifying, disturbed only from time to time by P. R.'s trivial chatter. A few weeks after the beginning of the séances Mr. R. left our circle, whereupon a remarkable change took place in P. R.'s behaviour. He grew monosyllabic, came less often, and after a few sittings vanished altogether. Later on he reappeared very occasionally, and mostly only when the medium was alone with the lady in question. Then a new personality thrust himself to the forefront; unlike P. R., who always spoke Swiss dialect, this gentleman affected a strong North German accent. In all else he was an exact copy of P. R. His eloquence was astonishing, since S. W. had only a very scanty knowledge of High German, whereas this new personality, who called himself Ulrich von Gerbenstein, spoke an almost faultless German abounding in amiable phrases and charming compliments.²³

[57] Ulrich von Gerbenstein was a gossip, a wag, and an idler, a great admirer of the ladies, frivolous and extremely superficial. During the winter of 1899/1900 he came to dominate the situation more and more, and took over one by one all the above-

mentioned functions of the grandfather, so that the serious character of the séances visibly deteriorated under his influence. All efforts to counteract it proved unavailing, and finally the séances had to be suspended on this account for longer and longer periods.

[58] One feature which all these somnambulist personalities have in common deserves mention. They have at their disposal the whole of the medium's memory, even the unconscious portion of it, they are also *au courant* with the visions she has in the ecstatic state, but they have only the most superficial knowledge of her fantasies during the ecstasy. Of the somnambulistic dreams they only know what can occasionally be picked up from members of the circle. On doubtful points they can give no information, or only such as contradicts the medium's own explanations. The stereotyped answer to all questions of this kind is "Ask Ivenes, Ivenes knows."²⁴ From the examples we have given of the different ecstasies it is clear that the medium's consciousness is by no means idle during the trance, but develops an extraordinarily rich fantasy activity. In reconstructing her somnambulistic ego we are entirely dependent on her subsequent statements, for in the first place the spontaneous utterances of the ego associated with the waking state are few and mostly disjointed, and in the second place many of the ecstasies pass off without pantomime and without speech, so that no conclusions about inner processes can be drawn from external appearances. S. W. is almost totally amnesic in regard to the automatic phenomena during ecstasy, in so far as these fall within the sphere of personalities foreign to her ego. But she usually has a clear memory of all the other phenomena directly connected with her ego, such as talking in a loud voice, glossolalia, etc. In every instance, there is complete amnesia only in the first few moments after the ecstasy. During the first half hour, when a kind of semi-somnambulism with reveries, hallucinations, etc. is still present, the amnesia gradually disappears, and fragmentary memories come up of what has happened, though in a quite irregular and arbitrary fashion.

[59] The later séances usually began by our joining hands on the table, whereupon the table immediately started to move. Meanwhile S. W. gradually became somnambulistic, took her hands from the table, lay back on the sofa, and fell into an ecstatic sleep. She sometimes related her experiences to us afterwards, but was very reticent if strangers were present. Even after the first few ecstasies, she hinted that she played a distinguished role among the spirits. Like all the spirits, she had a special name, and hers was Ivenes; her grandfather surrounded her with quite particular care, and in the ecstasy with the flower-vision she learnt special secrets about which she still maintained the deepest silence. During the séances when her spirits spoke she made long journeys, mostly to relatives whom she visited, or she found herself in the Beyond, in "that space between the stars which people think is empty, but which

really contains countless spirit worlds.” In the semi-somnambulistic state that frequently followed her attacks she once gave a truly poetic description of a landscape in the Beyond, “a wonderful moonlit valley that was destined for generations as yet unborn.” She described her somnambulistic ego as a personality almost entirely freed from the body: a small but fully grown black-haired woman, of a markedly Jewish type, clothed in white garments, her head wrapped in a turban. As for herself, she understood and spoke the language of the spirits—for the spirits still speak with one another from human habit, although they don’t really need to because they can see one another’s thoughts. She did not always actually talk with them, she just looked at them and knew what they were thinking. She travelled in the company of four or five spirits, dead relatives, and visited her living relatives and acquaintances in order to investigate their life and way of thinking; she also visited all the places that lay on her ghostly beat. After becoming acquainted with Kerner’s book, she (like the Clairvoyante) felt it her destiny to instruct and improve the black spirits who are banished to certain regions or who dwell partly beneath the earth’s surface. This activity caused her a good deal of trouble and pain; both during and after the ecstasies she complained of suffocating feelings, violent headaches, etc. But every fortnight, on Wednesdays, she was allowed to spend the whole night in the gardens of the Beyond in the company of the blessed spirits. There she received instruction concerning the forces that govern the world and the endlessly complicated relationships between human beings, and also concerning the laws of reincarnation, the star-dwellers, etc. Unfortunately she expatiated only on the system of world-forces and reincarnation, and merely let fall an occasional remark concerning the other subjects. For instance, she once returned from a railway journey in an extremely agitated state. We thought at first that something unpleasant must have happened to her; but finally she pulled herself together and explained that “a star-dweller had sat opposite her in the train.” From the description she gave of this being I recognized an elderly merchant I happened to know, who had a rather unsympathetic face. Apropos of this event, she told us all the peculiarities of the star-dwellers: they have no godlike souls, as men have, they pursue no science, no philosophy, but in the technical arts they are far more advanced than we are. Thus, flying machines have long been in existence on Mars; the whole of Mars is covered with canals, the canals are artificial lakes and are used for irrigation. The canals are all flat ditches, the water in them is very shallow. The excavating of the canals caused the Martians no particular trouble, as the soil there is lighter than on earth. There are no bridges over the canals, but that does not prevent communication because everybody travels by flying machine. There are no wars on the stars, because no differences of opinion exist. The star-dwellers do not have a human shape but the most laughable ones imaginable, such as no one could possibly conceive. Human spirits who get permission to travel in the Beyond are not allowed to set foot on the stars. Similarly, travelling star-dwellers may not

touch down on earth but must remain at a distance of some 75 feet above its surface. Should they infringe this law, they remain in the power of the earth and must take on human bodies, from which they are freed only after their natural death. As human beings they are cold, hard-hearted, and cruel. S. W. can recognize them by their peculiar expression, which lacks the “spiritual,” and by their hairless, eyebrowless, sharply cut faces. Napoleon I was a typical star-dweller.

[60] On her journeys she did not see the places through which she hastened. She had the feeling of floating, and the spirits told her when she was in the right spot. Then, as a rule, she saw only the face and upper part of the person before whom she wished to appear or whom she wanted to see. She could seldom say in what kind of surroundings she saw this person. Occasionally she saw me, but only my head without any background. She was much occupied with the enchanting of spirits, and for this purpose wrote oracular sayings in a foreign tongue on slips of paper which she concealed in all sorts of queer places. Especially displeasing to her was the presence in my house of an Italian murderer, whom she called Conventi. She tried several times to cast a spell on him, and without my knowledge concealed several slips of paper about the place, which were later found by accident. One of them had the following message written on it (in red pencil):

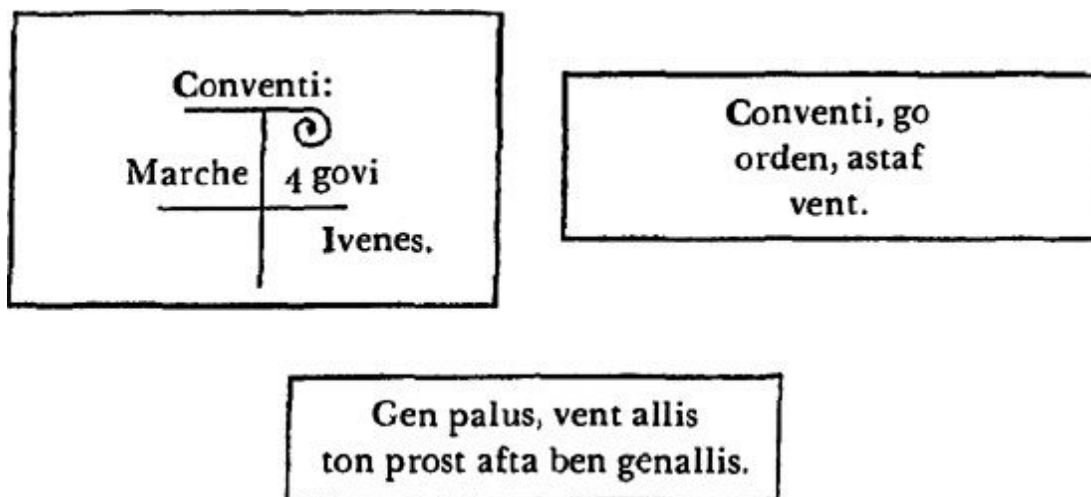

Figure 1

[61] Unfortunately I never managed to get a translation, for in this matter S. W. was quite unapproachable.

[62] Occasionally the somnambulistic Ivenes spoke directly to the public. She did so in dignified language that sounded slightly precocious, but Ivenes was not boringly unctuous or irrepressibly silly like her two guides; she is a serious, mature person, devout and right-minded, full of womanly tenderness and very modest, who always submits to the opinion of others. There is something soulful and elegiac about her, an air of melancholy resignation; she longs to get out of this world, she returns unwillingly to reality, she bemoans her hard lot, her odious family circumstances.

With all this she is something of a great lady; she orders her spirits about, despises von Gerbenstein's stupid "chatter," comforts others, succours those in distress, warns and protects them from dangers to body and soul. She is the channel for the entire intellectual output of all the manifestations, though she herself ascribes this to instruction by the spirits. It is Ivenes who directly controls S. W.'s semi-somnambulistic state.

The Romances

[63] The peculiar ghostlike look in S. W.'s eyes during her semi-somnambulism prompted some members of the circle to compare her to the Clairvoyante of Prevorst. The suggestion was not without consequences. S. W. gave hints of earlier existences she had already lived through, and after a few weeks she suddenly disclosed a whole system of reincarnations, although she had never mentioned anything of the sort before. Ivenes, she said, was a spiritual being who had certain advantages over the spirits of other human beings. Every human spirit must embody itself in the course of the centuries. But Ivenes had to embody herself at least once every two hundred years; apart from her, only two human beings shared this fate, namely Swedenborg and Miss Florence Cook (Crookes's^{24a} famous medium). S. W. called these two personages her brother and sister. She gave no information about their previous existences. At the beginning of the nineteenth century, Ivenes had been Frau Hauffe, the Clairvoyante of Prevorst, and at the end of the eighteenth century a clergyman's wife in central Germany (locality unspecified), in which capacity she had been seduced by Goethe and had borne him a son. In the fifteenth century she had been a Saxon countess, with the poetic name of Thierfelsenburg. Ulrich von Gerbenstein was a relative from that time. The lapse of three hundred years before her next incarnation, and the slip-up with Goethe, had to be atoned for by the sorrows of the Clairvoyante. In the thirteenth century, she had been a noblewoman with the name of de Valours, in the south of France, and had been burnt as a witch. From the thirteenth century back to the time of the Christian persecutions under Nero there had been numerous reincarnations, of which S. W. gave no account. During the Christian persecutions she had played a martyr's part. Then came another great darkness, back to the time of David, when Ivenes had been an ordinary Jewess. After her death as such, she had received from Astaf, an angel in one of the higher heavens, the mandate for her wonderful career. In all her pre-existences she had been a medium and an intermediary between this world and the Beyond. Her brothers and sisters were equally old and had the same profession. In each of her pre-existences she had invariably been married, and in this way founded a colossal family tree, with whose endlessly complicated relationships she was occupied in many of her ecstasies. Thus, some time in the eighth century she had been the mother of her earthly father and,

what is more, of her grandfather and mine. Hence the remarkable friendship between these two old gentlemen, otherwise strangers. As Mme. de Valours she had been my mother. When she had been burnt as a witch I had taken it very much to heart; I had retired to a monastery in Rouen, wore a grey habit, became prior, wrote a work on botany, and died at over eighty years of age. In the refectory of the monastery there had hung a portrait of Mme. de Valours, in which she was depicted in a half-sitting, half-reclining position. (S. W. in the semi-somnambulistic state often assumed this position on the sofa. It corresponds exactly to that of Mme. Récamier in David's well-known painting.) A gentleman who often took part in the séances and bore a distant resemblance to me was also one of her sons from that time. Around this core of relationships there now grouped themselves, at a greater or lesser distance, all the persons in any way related or known to her. One came from the fifteenth century, another was a cousin from the eighteenth century, and so on.

[64] From the three great family stocks there sprang the greater part of the races of Europe. She and her brothers and sisters were descended from Adam, who arose by materialization; the other races then in existence, from among whom Cain took his wife, were descended from monkeys. From these interrelated groups S. W. produced a vast amount of family gossip, a spate of romantic stories, piquant adventures, etc. The special target of her romances was a lady acquaintance of mine, who for some undiscoverable reason was peculiarly antipathetic to her. She declared that this lady was the incarnation of a celebrated Parisian poisoner who had achieved great notoriety in the eighteenth century. This lady, she maintained, still continued her dangerous work, but in a much more ingenious and refined fashion than before. Through the inspiration of the wicked spirits who accompanied her, she had discovered a fluid which when merely exposed to the air attracted any tubercle bacilli flying about and formed a splendid culture medium for them. By means of this fluid, which she was in the habit of mixing with food, she had caused the death of her husband (who had indeed died from tuberculosis), also of one of her lovers and of her own brother, so as to get his inheritance. Her eldest son was an illegitimate child by her lover. During her widowhood she had secretly borne an illegitimate child to another lover, and had finally had illicit relations with her own brother, whom she later poisoned. In this way S. W. wove innumerable stories in which she believed implicitly. The characters in these romances also appeared in her visions, as for instance this lady in the above-mentioned vision with its pantomime of confession and forgiveness of sin. Anything at all interesting that happened in her surroundings was drawn into this system of romances and given a place in the family relationships with a more or less clear account of the pre-existences and influencing spirits. So it fared with all persons who made S. W.'s acquaintance: they were rated as a second or a first incarnation according to whether they had a well-marked or an indistinct

character. In most cases they were also designated as relatives and always in the same quite definite way. Only afterwards, often several weeks later, a new and complicated romance would suddenly make its appearance after an ecstasy, explaining the striking relationship by means of pre-existences or illegitimate liaisons. Persons sympathetic to S. W. were usually very close relatives. These family romances (with the exception of the one described above) were all composed very carefully, so that it was absolutely impossible to check up on them. They were delivered with the most amazing aplomb and often surprised us by the extremely clever use of details which S. W. must have heard or picked up from somewhere. Most of the romances had a pretty gruesome character: murder by poison and dagger, seduction and banishment, forgery of wills, and so forth played a prominent role.

Mystic Science

[65] S. W. was subjected to numerous suggestions in regard to scientific questions. Generally, towards the end of the séances, various subjects of a scientific or spiritualistic nature were discussed and debated. S. W. never took part in the conversation, but sat dreamily in a corner in a semi-somnambulistic condition. She listened now to one thing and now to another, catching it in a half dream, but she could never give a coherent account of anything if one asked her about it, and she only half understood the explanations. In the course of the winter, various hints began to emerge in the séances: “The spirits brought her strange revelations about the world forces and the Beyond, but she could not say anything just now.” Once she tried to give a description, but only said “on one side was the light, on the other side the power of attraction.” Finally, in March 1900, after nothing more had been heard of these things for some time, she suddenly announced with a joyful face that she had now received everything from the spirits. She drew forth a long narrow strip of paper on which numerous names were written. Despite my request she would not let it out of her hands, but told me to draw a diagram [fig. 2].

[66] I can remember clearly that in the winter of 1899/1900 we spoke several times in S. W.’s presence of attractive and repulsive forces in connection with Kant’s *Natural History and Theory of the Heavens*,²⁵ also of the law of the conservation of energy, of the different forms of energy, and of whether the force of gravity is also a form of motion. From the content of these talks S. W. had evidently derived the foundations of her mystic system. She gave the following explanations: The forces are arranged in seven circles. Outside these there are three more, containing unknown forces midway between force and matter. Matter is found in seven outer circles surrounding the ten inner ones.²⁶ In the centre stands the Primary Force; this is the original cause of creation and is a spiritual force. The first circle which surrounds the Primary Force is Matter, which is not a true force and does not arise from the Primary Force. But it

combines with the Primary Force and from this combination arise other spiritual forces: on one side the Good or Light Powers [Magnesor], on the other side the Dark Powers [Connesor]. The Magnesor Power contains the most Primary Force, and the Connesor Power the least, since there the dark power of matter is greatest. The further the Primary Force advances outwards the weaker it becomes, but weaker too becomes the power of matter, since its power is greatest where the collision with the Primary Force is most violent, i.e., in the Connesor Power. In every circle there are analogous forces of equal strength working in opposite directions. The system could also be written out in a single line or column, beginning with Primary Force, Magnesor, Cafar, etc., and then—going from left to right on the diagram—up through Tusa and Endos to Connesor; but in that way it would be difficult to see the different degrees of intensity. Every force in an outer circle is composed of the nearest adjacent forces of the inner circle.

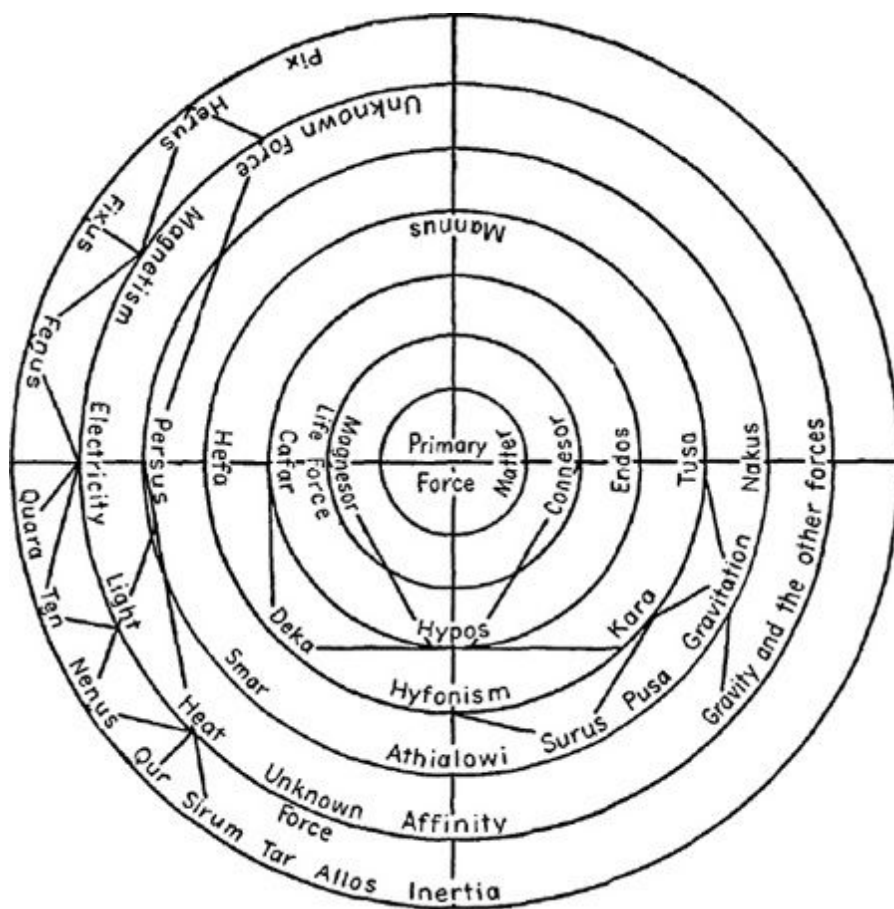

Figure 2

[67] THE MAGNESOR GROUP. From Magnesor descend in direct line the so-called Powers of Light, which are only slightly influenced by the dark side. Magnesor and Cafar together form the Life Force, which is not uniform but is differently composed in animals and plants. Man's life-force stands between Magnesor and Cafar. Morally good persons and mediums who facilitate communication between good spirits and the earth have most Magnesor. Somewhere about the middle are the life-forces of animals, and in Cafar those of plants. Nothing is known about Hefa, or rather S. W.

can give no information. Persus is the basic force that manifests itself in the forces of motion. Its recognizable forms are Heat, Light, Electricity, Magnetism, and two unknown forces, one of which is to be found only in comets. Of the forces in the sixth circle, S. W. could only name North and South Magnetism and Positive and Negative Electricity. Deka is unknown. Smar is of special significance, to be discussed below; it leads over to:

[68] THE HYPOS GROUP. Hypos and Hyfonism are powers which dwell only in certain human beings, in those who are able to exert a magnetic influence on others. Athialowi is the sexual instinct. Chemical affinity is directly derived from it. In the seventh circle comes Inertia. Surus and Kara are of unknown significance. Pusa corresponds to Smar in the opposite sense.

[69] THE CONNESOR GROUP. Connesor is the counterpole to Magnesor. It is the dark and evil power equal in intensity to the good power of Light. What the good power creates it turns into its opposite. Endos is a basic power in minerals. From Tusa (significance unknown) is derived Gravitation, which in its turn is described as the basic power manifesting itself in the forces of resistance (gravity, capillarity, adhesion, and cohesion). Nakus is the secret power in a rare stone which counteracts the effect of snake poison. The two powers Smar and Pusa have a special significance. According to S. W., Smar develops in the bodies of morally good people at the moment of death. This power enables the soul to ascend to the powers of Light. Pusa works the opposite way, for it is the power that leads the morally bad soul into the state of Connesor on the dark side.

[70] With the sixth circle the visible world begins; this appears to be so sharply divided from the Beyond only because of the imperfection of our organs of sense. In reality the transition is a very gradual one, and there are people who live on a higher plane of cosmic knowledge because their perceptions and sensations are finer than those of other human beings. Such "seers" are able to see manifestations of force where ordinary people can see nothing. S. W. sees Magnesor as a shining white or bluish vapour which develops when good spirits are near. Connesor is a black fuming fluid which develops on the appearance of "black" spirits. On the night before the great visions began, the shiny Magnesor vapour spread round her in thick layers, and the good spirits solidified out of it into visible white figures. It was just the same with Connesor. These two forces have their different mediums. S. W. is a Magnesor medium, like the Clairvoyante of Prevorst and Swedenborg. The materialization mediums of the spiritualists are mostly Connesor mediums, since materialization takes place much more easily through Connesor on account of its close connection with the properties of matter. In the summer of 1900, S. W. tried several times to

produce a picture of the circles of matter, but she never got beyond vague and incomprehensible hints, and afterwards she spoke of it no more.

Termination of the Disorder

[71] The really interesting and significant séances came to an end with the production of the power system. Even before this, the vitality of the ecstasies had been falling off considerably. Ulrich von Gerbenstein came increasingly to the forefront and filled the séances for hours on end with his childish chatter. The visions which S. W. had in the meantime likewise seem to have lost much of their richness and plasticity of form, for afterwards she was only able to report ecstatic feelings in the presence of good spirits and disagreeable ones in that of bad spirits. Nothing new was produced. In the trance conversations, one could observe a trace of uncertainty, as if she were feeling her way and seeking to make an impression on her audience; there was also an increasing staleness of content. In her outward behaviour, too, there was a marked shyness and uncertainty, so that the impression of wilful deception became ever stronger. The writer therefore soon withdrew from the séances. S. W. experimented later in other circles, and six months after the conclusion of my observations was caught cheating *in flagrante*. She wanted to revive the wavering belief in her supernatural powers by genuinely spiritualistic experiments like apport, etc., and for this purpose concealed in her dress small objects which she threw into the air during the dark séances. After that her role was played out. Since then, eighteen months have gone by, during which I have lost sight of her. But I learn from an observer who knew her in the early days that now and again she still has rather peculiar states of short duration, when she is very pale and silent and has a fixed glazed look. I have heard nothing of any more visions. She is also said not to take part any longer in spiritualistic séances. S. W. is now an employee in a large business and is by all accounts an industrious and dutiful person who does her work with zeal and skill to the satisfaction of all concerned. According to the report of trustworthy persons, her character has much improved: she has become on the whole quieter, steadier, and more agreeable. No further abnormalities have come to light.

[3. DISCUSSION OF THE CASE]

[72] This case, in spite of its incompleteness, presents a mass of psychological problems whose detailed discussion would far exceed the compass of this paper. We must therefore be content with a mere sketch of the more remarkable phenomena. For the sake of clearer exposition it seems best to discuss the different states under separate heads.

[73] Here the patient shows various peculiarities. As we have seen, she was often absent-minded at school, misread in a peculiar way, was moody, changeable, and inconsequent in her behaviour, now quiet, shy, reserved, now uncommonly lively, noisy, and talkative. She cannot be called unintelligent, yet her narrow-mindedness is sometimes as striking as her isolated moments of intelligence. Her memory is good on the whole, but is often very much impaired by marked distractibility. Thus, despite numerous discussions and readings of Kerner's *Seherin von Prevorst*, she still does not know after many weeks whether the author is called Koerner or Kerner, or the name of the Clairvoyante, if directly asked. Nevertheless the name "Kerner" appears correctly written when it occasionally turns up in the automatic communications. In general it may be said that there is something extremely immoderate, unsteady, almost protean, in her character. If we discount the psychological fluctuations of character due to puberty, there still remains a pathological residue which expresses itself in her immoderate reactions and unpredictable, bizarre conduct. One can call this character "déséquilibré" or "unstable." It gets its specific cast from certain features that must be regarded as hysterical: above all her distractibility and her dreamy nature must be viewed in this light. As Janet²⁷ maintains, the basis of hysterical anaesthesias is disturbance of attention. He was able to show in youthful hysterics "a striking indifference and lack of attention towards everything to do with the sphere of the perceptions." A notable instance of this, and one which beautifully illustrates hysterical distractibility, is misreading. The psychology of this process may be thought of somewhat as follows: While reading aloud, a person's attention slackens and turns towards some other object. Meanwhile the reading continues mechanically, the sense impressions are received as before, but owing to the distraction the excitability of the perceptive centre is reduced, so that the strength of the sense impression is no longer sufficient to fix the attention in such a way as to conduct perception along the verbal-motor route—in other words, to repress all the inflowing associations which immediately ally themselves with any new sense impression. The further psychological mechanism permits of two possible explanations:

(1) The sense impression is received *unconsciously*, i.e., below the threshold of consciousness, owing to the rise of the stimulus threshold in the perceptive centre, and consequently it is not taken up by the conscious attention and conducted along the speech route, but only reaches verbal expression through the mediation of the nearest associations, in this case the dialect expressions for the object.

(2) The sense impression is received *consciously*, but at the moment of entering the speech route it reaches a spot whose excitability is reduced by the distraction. At this point the dialect word is substituted by association for the verbal-motor speech-

image and is uttered in place of it. In either case, it is certain that the acoustic distraction fails to correct the error. Which of the two explanations is the right one cannot be determined in our case; probably both approach the truth, for the distractibility appears to be general, affecting more than one of the centres involved in the act of reading aloud.

[74] In our case this symptom has a special value, because we have here a quite elementary automatic phenomenon. It can be called hysterical because in this particular case the state of exhaustion and intoxication with its parallel symptoms can be ruled out. Only in exceptional circumstances does a healthy person allow himself to be so gripped by an object that he fails to correct the errors due to inattention, especially those of the kind described. The frequency with which this happens in the patient points to a considerable restriction of the field of consciousness, seeing that she can control only a minimum of the elementary perceptions simultaneously flowing in upon her. If we wish to define the psychological state of the “psychic shadow side” we might describe it as a sleep- or dream-state according to whether passivity or activity is its dominant feature. A pathological dream-state of rudimentary scope and intensity is certainly present here; its genesis is spontaneous, and dream-states that arise spontaneously and produce automatisms are usually regarded as hysterical. It must be pointed out that instances of misreading were a frequent occurrence in our patient and that for this reason the term “hysterical” is appropriate, because, so far as we know, it is only on the basis of an hysterical constitution that partial sleep- or dream-states occur both frequently and spontaneously.

[75] The automatic substitution of some adjacent association has been studied experimentally by Binet²⁸ in his hysterical subjects. When he pricked the anaesthetic hand of the patient, she did not feel the prick but thought of “points”; when he moved her fingers, she thought of “sticks” or “columns.” Again, when the hand, concealed from the patient’s sight by a screen, wrote “Salpêtrière,” she saw before her the word “Salpêtrière” in white writing on a black ground. This recalls the experiments of Guinon and Sophie Woltke previously referred to.

[76] We thus find in our patient, at a time when there was nothing to suggest the later phenomena, rudimentary automatisms, fragments of dreaming, which harbour in themselves the possibility that some day more than one association will slip in between the distractibility of her perceptions and consciousness. The misreading also reveals a certain autonomy of the psychic elements; even with a relatively low degree of distractibility, not in any other way striking or suspicious, they develop a noticeable if slight productivity which approximates to that of the physiological dream. The misreading can therefore be regarded as a prodromal symptom of subsequent events, especially as its psychology is the prototype of the mechanism of

somnambulistic dreams, which are in fact nothing but a multiplication and infinite variation of the elementary process we have described above. At the time of my observations I was never able to demonstrate any other rudimentary automatisms of this kind; it seems as if the originally low-grade states of distractibility gradually grew beneath the surface of consciousness into those remarkable somnambulistic attacks and therefore disappeared from the waking state. So far as the development of the patient's character is concerned, except for a slight increase in maturity no striking change could be noted in the course of observations lasting nearly two years. On the other hand, it is worth mentioning that in the two years since the subsidence (complete cessation?) of the somnambulistic attacks a considerable change of character has taken place. We shall have occasion later on to speak of the significance of this observation.

Semi-Somnambulism

[77] In our account of S. W.'s case, the following condition was indicated by the term "semi-somnambulism": For some time before and after the actual somnambulistic attack the patient found herself in a state whose most salient feature can best be described as "preoccupation." She lent only half an ear to the conversation around her, answered absent-mindedly, frequently lost herself in all manner of hallucinations; her face was solemn, her look ecstatic, visionary, ardent. Closer observation revealed a far-reaching alteration of her entire character. She was now grave, dignified; when she spoke, the theme was always an extremely serious one. In this state she could talk so seriously, so forcefully and convincingly, that one almost had to ask oneself: Is this really a girl of 15½? One had the impression that a mature woman was being acted with considerable dramatic talent. The reason for this seriousness, this solemnity of behaviour, was given in the patient's explanation that at these times she stood on the frontier of this world and the next, and associated just as really with the spirits of the dead as with the living. And indeed her conversation was about equally divided between answers to objectively real questions and hallucinatory ones. I call this state semi-somnambulistic because it coincides with Richet's own definition:

Such a person's consciousness appears to persist in its integrity, while all the time highly complex operations are taking place outside consciousness, without the voluntary and conscious ego seeming to be aware of any modification at all. He will have another person within him, acting, thinking, and willing, without his consciousness, that is, his conscious reflecting ego, having the least idea that such is the case.²⁹

[78] Binet³⁰ says of the term "semi-somnambulism":

This term indicates the relations in which this state stands to genuine somnambulism; and further, it gives us to understand that the somnambulistic life which shows itself during the waking state is overcome and suppressed by the normal consciousness as it reasserts itself.

Automatisms

[79] Semi-somnambulism is characterized by the continuity of consciousness with that of the waking state and by the appearance of various automatisms which point to the activity of a subconscious independent of the conscious self.

[80] Our case shows the following automatic phenomena:

(1) Automatic movements of the table.

(2) Automatic writing.

(3) Hallucinations.

[81] (1) AUTOMATIC MOVEMENTS OF THE TABLE. Before the patient came under my observation she had been influenced by the suggestion of "table-turning," which she first came across as a parlour game. As soon as she entered the circle, communications arrived from members of her family, and she was at once recognized as a medium. I could only ascertain that as soon as her hands were placed on the table the typical movements began. The content of the communications has no further interest for us. But the automatic character of the act itself merits some discussion, for the objection might very well be made that there was some deliberate pushing or pulling on the part of the patient.

[82] As we know from the investigations of Chevreul, Gley, Lehmann, and others,³¹ unconscious motor phenomena are not only a frequent occurrence among hysterical persons and those pathologically inclined in other ways, but can also be induced fairly easily in normal persons who exhibit no other spontaneous automatisms. I have made many experiments on these lines and can fully confirm this observation. In the great majority of cases all that is required is enough patience to put up with an hour or so of quiet waiting. With most subjects motor automatisms will eventually be obtained in more or less high degree if not hindered by counter-suggestions. In a relatively small number of cases the phenomena arise spontaneously, i.e., directly under the influence of verbal suggestion or of some earlier auto-suggestion. In our case the subject was powerfully affected by suggestion. In general, the disposition of the patient is subject to all those laws which also hold good for normal hypnosis. Nevertheless, certain special circumstances must be taken into account which are conditioned by the peculiar nature of the case. It was not a question here of total hypnosis, but of a partial one, limited entirely to the motor area of the arm, like the

cerebral anaesthesia produced by magnetic passes for a painful spot in the body. We touch the spot in question, employing verbal suggestion or making use of some existing auto-suggestion, and we use the tactile stimulus which we know acts suggestively to bring about the desired partial hypnosis. In accordance with this procedure refractory subjects can be brought easily enough to an exhibition of automatism. The experimenter intentionally gives the table a slight push, or better, a series of light rhythmical taps. After a while he notices that the oscillations become stronger, that they continue although he has stopped his own intentional movements. The experiment has succeeded, the subject has unsuspectingly taken up the suggestion. Through this procedure far better results are obtained than by verbal suggestion. With very receptive persons and in all those cases where the movement seems to start spontaneously, the intended tremors,³² which are not of course perceptible to the subject, take over the role of agent provocateur. In this way persons who by themselves would never achieve automatic movements of the coarser type can sometimes assume unconscious control of the table movements, provided that the tremors are strong enough for the medium to understand their meaning. The medium then takes over the slight oscillations and gives them back considerably strengthened, but rarely at exactly the same moment, mostly a few seconds later, and in this way reveals the agent's conscious or unconscious thought. This simple mechanism may give rise to instances of thought-reading which are quite bewildering at first sight. A very simple experiment that works in many cases even with unpractised persons will serve to illustrate this. The experimenter thinks, say, of the number 4 and then waits, his hands quietly resting on the table, until he feels it making the first move to announce the number thought of. He lifts his hands off the table immediately, and the number will be correctly tilted out. It is advisable in this experiment to stand the table on a soft thick carpet. By paying close attention, the experimenter will occasionally notice a movement of the table that can be represented thus:

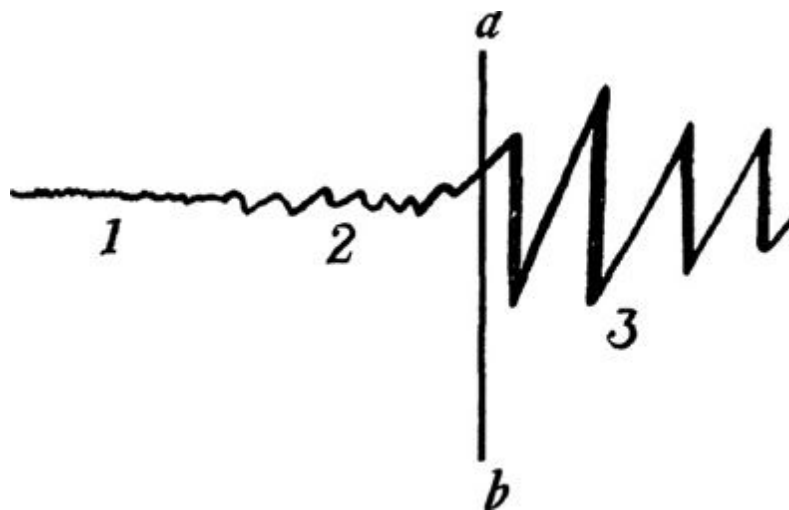

Figure 3

[83] 1: Intended tremors too slight to be perceived by the subject.

2: Very small but perceptible oscillations of the table which show that the subject is responding to them.

3: The big movements (“tilts”) of the table, giving the number 4 that was thought of.

ab denotes the moment when the operator’s hands are removed.

[84] This experiment works excellently with well-disposed but inexperienced persons. After a little practice the phenomenon usually disappears, since with practice the number can be read and reproduced directly from the intended movements.³³

[85] With a responsive medium these intended tremors work in just the same way as the intentional taps in the experiment cited above: they are received, strengthened, and reproduced, though very gently, almost timidly. Even so, they are perceptible and therefore act suggestively as slight tactile stimuli, and with the increase of partial hypnosis they produce the big automatic movements. This experiment illustrates in the clearest way the gradual increase of auto-suggestion. Along the path of this autosuggestion all the automatic motor phenomena develop. How the mental content gradually intrudes into the purely motor sphere scarcely needs explaining after the above discussion. No special suggestion is required to evoke the mental phenomena, since, from the standpoint of the experimenter at least, it was a question of verbal representation from the start. After the first random motor expressions are over, unpractised subjects soon begin reproducing verbal products of their own or the intentions of the experimenter. The intrusion of the mental content can be objectively understood as follows:

[86] Through the gradual increase of auto-suggestion the motor areas of the arm are isolated from consciousness, that is to say, the perception of slight motor impulses is veiled from the mind.³⁴ The knowledge received via consciousness of a potential mental content produces a collateral excitation in the speech area as the nearest available means to mental formulation. The intention to formulate necessarily affects the motor component³⁵ of the verbal representation most of all, thus explaining the unconscious overflow of speech impulses into the motor area,³⁶ and conversely the gradual penetration of partial hypnosis into the speech area.

[87] In numerous experiments with beginners, I have noticed, usually at the start of the mental phenomena, a relatively large number of completely meaningless words, often only senseless jumbles of letters. Later all sorts of absurdities are produced, words or whole sentences with the letters transposed all higgledy-piggledy or arranged in reverse order, like mirror-writing. The appearance of a letter or word brings a new suggestion; involuntarily some kind of association tacks on to it and is then realized. Curiously enough, these are not as a rule conscious associations but quite unexpected ones. This would seem to indicate that a considerable part of the speech area is

already hypnotically isolated. The recognition of this automatism again forms a fruitful suggestion, since at this point a feeling of strangeness invariably arises, if it was not already present in the pure motor automatism. The question “Who is doing this?” “Who is speaking?” acts as a suggestion for synthesizing the unconscious personality, which as a rule is not long in coming. Some name or other presents itself, usually one charged with emotion, and the automatic splitting of the personality is accomplished. How haphazard and precarious this synthesis is at first can be seen from the following reports from the literature.

[88] Myers gives the following interesting observation of a Mr. A., a member of the Society for Psychical Research, who was experimenting on himself with automatic writing:

[89] 3RD DAY

What is man? — *Tefi hasl esble lies.*

Is that an anagram? — *Yes.*

How many words does it contain? — *Five.*

What is the first word? — *See.*

What is the second word? — *Eeeee.*

SEE? Shall I interpret it myself? — *Try to!*

[90] Mr. A. found this solution: “The life is less able.” He was astonished at this intellectual pronouncement, which seemed to him to prove the existence of an intelligence independent of his own. He therefore went on to ask:

Who are you? — *Clelia.*

Are you a woman? — *Yes.*

Have you lived on earth? — *No.*

Will you come to life? — *Yes.*

When? — *In six years.*

Why are you conversing with me? — *E if Clelia el.*

Mr. A. interpreted this answer as: “I Clelia feel.”

[91] 4TH DAY

Am I the one who asks questions? — *Yes.*

Is Clelia there?— *No.*

Who is here then? — *Nobody.*

Does Clelia exist at all?— *No.*

Then with whom was I speaking yesterday? — *With nobody.*³⁷

[92] Janet conducted the following conversation with the subconscious of Lucie, who, meanwhile, was engaged in conversation with another observer:

[Janet asks:] Do you hear me? [Lucie answers, in automatic writing:] *No.*

But one has to hear in order to answer. — *Absolutely.*

Then how *do* you do it? — *I don't know.*

There must be someone who hears me. — *Yes.*

Who is it? — *Somebody besides Lucie.*

All right. Somebody else. Shall we give the other person a name? — *No.*

Yes, it will be more convenient. — *All right. Adrienne.*

Well, Adrienne, do you hear me? — *Yes.*³⁸

[93] One can see from these extracts how the unconscious personality builds itself up: it owes its existence simply to suggestive questions which strike an answering chord in the medium's own disposition. This disposition can be explained by the disaggregation of psychic complexes, and the feeling of strangeness evoked by these automatism assists the process as soon as conscious attention is directed to the automatic act. Binet remarks on this experiment of Janet's: "Nevertheless it should be carefully noted that if the personality of 'Adrienne' could be created, it was because the suggestion encountered a *psychological possibility*; in other words, disaggregated phenomena were existing there apart from the normal consciousness of the subject."³⁹ The individualization of the subconscious is always a great step forward and has enormous suggestive influence on further development of the automatism.⁴⁰ The formation of unconscious personalities in our case must also be regarded in this light.

[94] The objection that the table-turning was "simulated" may well be abandoned when one considers the phenomenon of thought-reading from intended tremors, of which the patient gave ample proof. Rapid, conscious thought-reading requires at the very least an extraordinary amount of practice, and this the patient demonstrably lacked. Whole conversations can be carried on by means of these tremors, as happened in our case. In the same way the suggestibility of the subconscious can be demonstrated objectively if, for instance, the operator concentrates on the thought: "The medium's hand shall no longer move the table or the glass," and at once, contrary to all expectation, and to the liveliest astonishment of the subject, the table is immobilized. Naturally all kinds of other suggestions can be realized too, provided that their innervation does not exceed the area of partial hypnosis (which proves at the same time the partial nature of the hypnosis). Hence suggestions aimed at the legs or the other arm will not work.

[95] The table-turning was not an automatism confined exclusively to the patient's semi-somnambulism. On the contrary it occurred in its most pronounced form in the

waking state, and in most cases then passed over into semi-somnambulism, whose onset was generally announced by hallucinations, as at the first séance.

[96] (2) AUTOMATIC WRITING. Another automatic phenomenon, which from the first corresponds to a higher degree of partial hypnosis, is automatic writing. It is, at least in my experience, much rarer and much more difficult to produce than table-turning. Here again it is a question of a primary suggestion, directed to the conscious mind when sensibility is retained, and to the unconscious when it is extinct. The suggestion, however, is not a simple one, since it already contains an intellectual element: "to write" means "to write something." This special property of the suggestion, going beyond the purely motor sphere, often confuses the subject and gives rise, to counter-suggestions which prevent the appearance of automatisms. However, I have noticed in a few cases that the suggestion is realized despite its comparative boldness (it is after all directed to the waking consciousness of a so-called normal person!), but that it does so in a peculiar way, by putting only the purely motor part of the central nervous system under hypnosis, and that the deeper hypnosis is then obtained from the motor phenomenon by auto-suggestion, as in the procedure for table-turning described above. The subject,⁴¹ holding a pencil in his hand, is purposely engaged in conversation to distract his attention from writing. The hand thereupon starts to move, making a number of strokes and zigzag lines at first, or else a simple line.



Figure 4

It sometimes happens that the pencil does not touch the paper at all but writes in the air. These movements must be regarded as purely motor phenomena corresponding to the expression of the motor element in the idea of "writing." They are somewhat rare; usually single letters are written right off, and what was said above of table-turning is true here of their combination into words and sentences. Now and then true mirror-writing is observed. In the majority of cases, and perhaps in all experiments with beginners who are not under some special suggestion, the automatic writing is that of the subject. Occasionally its character may be greatly changed,⁴² but this is secondary, and is always a symptom of the synthesis of a subconscious personality. As already stated, the automatic writing of our patient never came to very much. The experiments were carried out in the dark, and in most cases she passed over into semi-somnambulism or ecstasy. So the automatic writing had the same result as the preliminary table-turning.

[97] (3) HALLUCINATIONS. The manner of transition to somnambulism in the second séance is of psychological significance. As reported, the automatic phenomena were in full swing when darkness descended. The interesting event in the preceding séance was the brusque interruption of a communication from the grandfather, which became the starting-point for various discussions among members of the circle. These two factors, darkness and a remarkable occurrence, seem to have caused a rapid deepening of hypnosis, which enabled the hallucinations to develop. The psychological mechanism of this process seems to be as follows: The influence of darkness on suggestibility, particularly in regard to the sense organs, is well known.⁴³ Binet states that it has a special influence on hysterical subjects, producing immediate drowsiness.⁴⁴ As may be assumed from the foregoing explanations, the patient was in a state of partial hypnosis, and furthermore a subconscious personality having the closest ties with the speech area had already constituted itself. The automatic expression of this personality was interrupted in the most unexpected way by a new person whose existence no one suspected. Whence came this split? Obviously the patient had entertained the liveliest expectations about this first séance. Any reminiscences she had of me and my family had probably grouped themselves around this feeling of expectation, and they suddenly came to light when the automatic expression was at its climax. The fact that it was my grandfather and no one else—not, for instance, my dead father, who, as the patient knew, was closer to me than my grandfather, whom I had never known—may suggest where the origin of this new person is to be sought. It was probably a dissociation from the already existing personality, and this split-off part seized upon the nearest available material for its expression, namely the associations concerning myself. Whether this offers a parallel to the results of Freud's dream investigations⁴⁵ must remain unanswered, for we have no means of judging how far the emotion in question may be considered "repressed." From the brusque intervention of the new personality we may conclude that the patient's imaginings were extremely vivid, with a correspondingly intense expectation which a certain maidenly modesty and embarrassment sought perhaps to overcome. At any rate this event reminds us vividly of the way dreams suddenly present to consciousness, in more or less transparent symbolism, things one has never admitted to oneself clearly and openly. We do not know when the splitting off of the new personality occurred, whether it had been slowly preparing in the unconscious, or whether it only came about during the séance. In any case it meant a considerable increase in the extent of the unconscious area rendered accessible by hypnosis. At the same time this event, in view of the impression it made on the waking consciousness of the patient, must be regarded as powerfully suggestive, for the perception of the unexpected intervention of a new personality was bound to increase still further the feeling of strangeness aroused by the automatism, and would naturally suggest the

thought that an independent spirit was making itself known. From this followed the very understandable association that it might be possible to see this spirit.

[98] The situation that ensued at the second séance can be explained by the coincidence of this energizing suggestion with the heightened suggestibility occasioned by the darkness. The hypnosis, and with it the chain of split-off ideas, breaks through into the visual sphere; the expression of the unconscious, hitherto purely motor, is objectified (in accordance with the specific energy of the newly created system) in the form of visual images having the character of an hallucination—not as a mere accompaniment of the verbal automatism but as a direct substitute function. The explanation of the unexpected situation that arose in the first séance, at the time quite inexplicable, is no longer given in words, but as an allegorical vision. The proposition “they do not hate one another, but are friends” is expressed in a picture of the two grandfathers arm-in-arm. We frequently come across such things in somnambulism: the thinking of somnambulists proceeds in plastic images which constantly break through into this or that sensory sphere and are objectified as hallucinations. The thought process sinks into the subconscious and only its final terms reach consciousness directly as hallucinations or as vivid and sensuously coloured ideas. In our case the same thing occurred as with the patient whose anaesthetic hand Binet pricked nine times, making her think vividly of the number 9; or Flournoy’s Hélène Smith, who, on being asked in her shop about a certain pattern, suddenly saw before her the figure 18, eight to ten inches high, representing the number of days the pattern had been on loan.⁴⁶ The question arises as to why the automatism broke through in the visual sphere and not in the acoustic. There are several reasons for this choice of the visual:

[99] (a) The patient was not gifted acoustically; she was for instance very unmusical.

(b) There was no silence (to correspond with the darkness) which might have favoured the occurrence of auditory hallucinations, for we were talking all the time.

(c) The heightened conviction of the near presence of spirits, owing to the feeling of strangeness evoked by the automatism, could easily lead to the idea that it might be possible to see a spirit, thus causing a slight excitation of the visual sphere.

(d) The entoptic phenomena in the darkness favoured the appearance of hallucinations.

[100] The reasons given in (c) and (d) are of decisive importance for the appearance of hallucinations. The entoptic phenomena in this case play the same role in producing automatisms by auto-suggestion as do the slight tactile stimuli during hypnosis of the motor centres. As reported, the patient saw sparks before passing into the first hallucinatory twilight state at the first séance. Obviously attention was already at high pitch and directed to visual perceptions, so that the light sensations of the retina,

usually very weak, were seen with great intensity. The part played by entoptic perceptions of light in the production of hallucinations deserves closer scrutiny. Schüle says: “The swarm of lights and colours that excite and activate the nocturnal field of vision in the darkness supplies the material for the fantastic figures seen in the air before going to sleep.”⁴⁷ As we know, we never see absolute darkness, always a few patches of the dark field are dully illuminated; flecks of light bob up here and there and combine into all sorts of shapes, and it only needs a moderately active imagination to form out of them, as one does out of clouds, certain figures known to oneself personally. As one falls asleep, one’s fading power of judgment leaves the imagination free to construct more and more vivid forms. “Instead of the spots of light, the haziness and changing colours of the dark visual field, outlines of definite objects begin to appear.”⁴⁸ Hypnagogic hallucinations arise in this way. Naturally the chief share falls to the imagination, which is why highly imaginative people are particularly subject to them.⁴⁹ The “hypnopompic” hallucinations described by Myers are essentially the same as the hypnagogic ones.

[101] It is very probable that hypnagogic images are identical with the dream-images of normal sleep, or that they form their visual foundation. Maury⁵⁰ has proved by self-observation that the images which floated round him hypnagogically were also the objects of the dreams that followed. Ladd⁵¹ showed the same thing even more convincingly. With practice he succeeded in waking himself up two to five minutes after falling asleep. Each time he noticed that the bright figures dancing before the retina formed as it were the outlines of the images just dreamed of. He even supposes that practically all visual dreams derive their formal elements from the light sensations of the retina. In our case the situation favoured the development of a fantastic interpretation. Also, we must not underrate the influence of the tense expectation which caused the dull light sensations of the retina to appear with increased intensity.⁵² The development of retinal phenomena then followed in accordance with the predominant ideas. Hallucinations have been observed to arise in this way with other visionaries: Joan of Arc saw first a cloud of light,⁵³ then out of it, a little later, stepped St. Michael, St. Catharine, and St. Margaret. Swedenborg saw nothing for a whole hour but luminous spheres and brilliant flames.⁵⁴ All the time he felt a tremendous change going on in his brain, which seemed to him like a “release of light.” An hour afterwards he suddenly saw real figures whom he took to be angels and spirits. The sun vision of Benvenuto Cellini in Sant’ Angelo probably belongs to the same category.⁵⁵ A student who often saw apparitions said: “When these apparitions come, I see at first only single masses of light and hear at the same time a dull roaring in my ears. But after a bit these outlines turn into distinct figures.”⁵⁶ The hallucinations arise in quite the classical way with Flournoy’s Héléne Smith. I cite the relevant passages from his report:

- [102] *March 18.* Attempt to experiment in the darkness.... Mlle. Smith sees a balloon, now luminous, now becoming dark.
- [103] *March 25....* Mlle. Smith begins to distinguish vague gleams with long white streamers moving from the floor to the ceiling, and then a magnificent star, which in the darkness appears to her alone throughout the whole séance.
- [104] *April 1.* Mlle. Smith is very much agitated; she has fits of shivering, is very cold. She is very restless, and sees suddenly, hovering above the table, a grinning, very ugly face, with long red hair. Afterwards she sees a magnificent bouquet of roses of different hues.... Suddenly she sees a small snake come out from underneath the bouquet; it rises up gently, smells the flowers, looks at them ...⁵⁷
- [105] Concerning the origin of her Mars visions, Hélène Smith said: “The red light continues about me, and I find myself surrounded by extraordinary flowers....”⁵⁸
- [106] At all times the complex hallucinations of visionaries have occupied a special place in scientific criticism. Thus, quite early, Macario⁵⁹ distinguished them as “intuitive” hallucinations from ordinary hallucinations, saying that they occur in persons of lively mind, deep understanding, and high nervous excitability. Hecker expresses himself in a similar manner but even more enthusiastically. He supposes their conditioning factor to be the “congenitally high development of the psychic organ, which through its spontaneous activity calls the life of the imagination into free and nimble play.”⁶⁰ These hallucinations are “harbingers and also signs of an immense spiritual power.” A vision is actually “a higher excitation which adapts itself harmoniously to the most perfect health of mind and body.” Complex hallucinations do not belong to the waking state but occur as a rule in a state of partial waking: the visionary is sunk in his vision to the point of complete absorption. Flournoy, too, was always able to establish “a certain degree of obnubilation” during the visions of Hélène Smith.⁶¹ In our case the vision is complicated by a sleeping state whose peculiarities we shall discuss below.

The Change in Character

- [107] The most striking feature of the “second state” is the change in character. There are several cases in the literature which show this symptom of spontaneous change in the character of a person. The first to be made known in a scientific journal was that of Mary Reynolds, published by Weir Mitchell.⁶² This was the case of a young woman living in Pennsylvania in 1811. After a deep sleep of about twenty hours, she had totally forgotten her entire past and everything she had ever learnt; even the words she spoke had lost their meaning. She no longer knew her relatives. Slowly she re-learnt to read and write, but her writing now was from right to left. More striking still was the change in her character. “Instead of being melancholy she was now

cheerful to extremity. Instead of being reserved she was buoyant and social. Formerly taciturn and retiring, she was now merry and jocose. Her disposition was totally and absolutely changed.”⁶³

[108] In this state she gave up entirely her former secluded life and liked to set out on adventurous expeditions unarmed, through woods and mountains, on foot and on horseback. On one of these expeditions she encountered a large black bear, which she took for a pig. The bear stood up on his hind legs and gnashed his teeth at her. As she could not induce her horse to go any further, she went up to the bear with an ordinary stick and hit him until he took to flight. Five weeks later, after a deep sleep, she returned to her earlier state with amnesia for the interval. These states alternated for about sixteen years. But the last twenty-five years of her life Mary Reynolds passed exclusively in the second state.

[109] Schroeder van der Kolk⁶⁴ reports the following case: The patient became ill at the age of sixteen with a periodic amnesia after a previous long illness of three years. Sometimes in the morning after waking she fell into a peculiar choreic state, during which she made rhythmical beating movements with her arms. Throughout the day she would behave in a childish, silly way, as if she had lost all her educated faculties. When normal she was very intelligent, well-read, spoke excellent French. In the second state she began to speak French faultily. On the second day she was always normal again. The two states were completely separated by amnesia.⁶⁵

[110] Höfelt⁶⁶ reports on a case of spontaneous somnambulism in a girl who in her normal state was submissive and modest, but in somnambulism was impertinent, rude, and violent. Azam's Felida⁶⁷ was in her normal state depressed, inhibited, timid, and in the second state lively, confident, enterprising to recklessness. The second state gradually became the dominant one and finally supplanted the first to such an extent that the patient called her normal states, which now lasted only a short time, her “crises.” The amnesic attacks had begun at the age of 14½. In time the second state became more moderate, and there was a certain approximation in the character of the two states. A very fine example of change in character is the case worked out by Camuset, Ribot, Legrand du Saule, Richer, and Voisin and put together by Bourru and Burot.⁶⁸ It is that of Louis V., a case of severe male hysteria, with an amnesic alternating character. In the first state he was rude, cheeky, querulous, greedy, thievish, inconsiderate. In the second state he showed an agreeable, sympathetic character and was industrious, docile, and obedient. The amnesic change in character has been put to literary use by Paul Lindau⁶⁹ in his play *Der Andere*. A case that parallels Lindau's criminalistic public prosecutor is reported on by Rieger.⁷⁰ The subconscious personalities of Janet's Lucie and Léonie,⁷¹ or of Morton Prince's patient,⁷² can also be regarded as parallels of our case, though these were artificial

therapeutic products whose importance lies rather in the domain of dissociated consciousness and memory.

[111] In all these cases the second state is separated from the first by an amnesic split, and the change in character is accompanied by a break in the continuity of consciousness. In our case there is no amnesic disturbance whatever; the transition from the first to the second state is quite gradual, continuity of consciousness is preserved, so that the patient carries over into the waking state everything she has experienced of the otherwise unknown regions of the unconscious during hallucinations in the second state.

[112] Periodic changes in personality without an amnesic split are found in cyclic insanity, but they also occur as a rare phenomenon in hysteria, as Renaudin's case shows.⁷³ A young man, whose behaviour had always been exemplary, suddenly began to display the worst tendencies. No symptoms of insanity were observed, but on the other hand the whole surface of his body was found to be anaesthetic. This state was periodic, and, in the same way, the patient's character was subject to fluctuations. As soon as the anaesthesia disappeared he became manageable and friendly. The moment it returned he was dominated by the worst impulses, including even the lust for murder.

[113] If we remember that our patient's age at the beginning of the disturbances was 15½, i.e., that the age of puberty had just been reached, we must suppose that there was some connection between these disturbances and the physiological changes of character at puberty.

At this period of life there appears in the consciousness of the individual a new group of sensations together with the ideas and feelings arising therefrom. This continual pressure of unaccustomed mental states, which constantly make themselves felt because their cause is constantly at work, and which are co-ordinated with one another because they spring from one and the same source, must in the end bring about far-reaching changes in the constitution of the ego.⁷⁴

We all know the fitful moods, the confused, new, powerful feelings, the tendency to romantic ideas, to exalted religiosity and mysticism, side by side with relapses into childishness, which give the adolescent his peculiar character. At this period he is making his first clumsy attempts at independence in every direction; for the first time he uses for his own purposes all that family and school have inculcated into him in childhood; he conceives ideals, constructs lofty plans for the future, lives in dreams whose main content is ambition and self-complacency. All this is physiological. The puberty of a psychopath is a serious crisis. Not only do the psychophysical changes run an exceedingly stormy course, but features of an inherited degenerate character, which do not appear in the child at all or only sporadically, now become fixed. In

explaining our case we are bound to consider a specifically pubertal disturbance. The reasons for this will appear from a more detailed study of her second personality. For the sake of brevity we shall call this second personality Ivenes, as the patient herself christened her higher ego.

[114] Ivenes is the direct continuation of her everyday ego. She comprises its whole conscious content. In the semi-somnambulist state her relation to the external world is analogous to that of the waking state—that is to say, she is influenced by recurrent hallucinations, but no more than persons who are subject to non-confusional psychotic hallucinations. The continuity of Ivenes obviously extends to the hysterical attacks as well, when she enacts dramatic scenes, has visionary experiences, etc. During the actual attack she is usually isolated from the external world, does not notice what is going on around her, does not know that she is talking loudly, etc. But she has no amnesia for the dream-content of the attack. Nor is there always amnesia for her motor expressions and for the changes in her surroundings. That this is dependent on the degree of somnambulistic stupor and on the partial paralysis of individual sense organs is proved by the occasion when the patient did not notice me, despite the fact that her eyes were open and that she probably saw the others, but only perceived my presence when I spoke to her. This is a case of so-called *systematic anaesthesia* (negative hallucination), which is frequently observed among hysterics.

[115] Flournoy,⁷⁵ for instance, reports of Hélène Smith that during the séances she suddenly ceased to see those taking part, although she still heard their voices and felt their touch; or that she suddenly stopped hearing, although she saw the speakers moving their lips, etc.

[116] Just as Ivenes is a continuation of the waking ego, so she carries over her whole conscious content into the waking state. This remarkable behaviour argues strongly against any analogy with cases of double consciousness. The characteristics reported of Ivenes contrast favourably with those of the patient; she is the calmer, more composed personality, and her pleasing modesty and reserve, her more uniform intelligence, her confident way of talking, may be regarded as an improvement on the patient's whole being; thus far there is some resemblance to Janet's Léonie. But it is no more than a resemblance. They are divided by a deep psychological difference, quite apart from the question of amnesia. Léonie II is the healthier, the more normal; she has regained her natural capacities, she represents the temporary amelioration of a chronic condition of hysteria. Ivenes gives more the impression of an artificial product; she is more contrived, and despite all her excellent points she strikes one as playing a part superlatively well. Her world-weariness, her longing for the Beyond, are not mere piety but the attributes of saintliness. Ivenes is no longer quite human, she is a mystic being who only half belongs to the world of reality. Her mournful features, her suffering resignation, her mysterious fate all lead us to the historical

prototype of Ivenes: Justinus Kerner's Clairvoyante of Prevorst. I assume that the content of Kerner's book is generally known, so I omit references to the features they have in common. Ivenes, however, is not just a copy of the Clairvoyante; the latter is simply a sketch for an original. The patient pours her own soul into the role of the Clairvoyante, seeking to create out of it an ideal of virtue and perfection; she anticipates her own future and embodies in Ivenes what she wishes to be in twenty years' time—the assured, influential, wise, gracious, pious lady. In the construction of the second personality lies the deep-seated difference between Léonie II and Ivenes. Both are psychogenic, but whereas Léonie I obtains in Léonie II what properly belongs to her, the patient builds up a personality beyond herself. One cannot say that she deludes herself into the higher ideal state, rather she dreams herself into it.⁷⁶

[117] The realization of this dream is very reminiscent of the psychology of the pathological swindler. Delbrück⁷⁷ and Forel⁷⁸ have pointed out the importance of auto-suggestion in the development of pathological cheating and pathological daydreaming. Pick⁷⁹ regards intense auto-suggestion as the first symptom of hysterical dreamers which makes the realization of “daydreams” possible. One of Pick's patients dreamt herself into a morally dangerous situation and finally carried out an attempt at rape on herself by lying naked on the floor and tying herself to the table and chairs. The patients may create some dramatic personage with whom they enter into correspondence by letter, as in Bohn's case,⁸⁰ where the patient dreamt herself into an engagement with a completely imaginary lawyer in Nice, from whom she received letters which she had written herself in disguised handwriting. This pathological dreaming, with its auto-suggestive falsifications of memory sometimes amounting to actual delusions and hallucinations, is also found in the lives of many saints.⁸¹ It is only a step from dreamy ideas with a strong sensuous colouring to complex hallucinations proper.⁸² For instance, in Pick's first case, one can see how the patient, who imagined she was the Empress Elizabeth, gradually lost herself in her reveries to such an extent that her condition must be regarded as a true twilight state. Later it passed over into an hysterical delirium in which her dream fantasies became typical hallucinations. The pathological liar who lets himself be swept away by his fantasies behaves exactly like a child who loses himself in the game he is playing,⁸³ or like an actor who surrenders completely to his part. There is no fundamental distinction between this and the somnambulistic dissociation of the personality, but only a difference of degree based on the intensity of the primary auto-suggestibility or disaggregation of the psychic elements. The more consciousness becomes dissociated the greater becomes the plasticity of the dream situations, and the less, too, the amount of conscious lying and of consciousness in general. This state of being carried away by one's interest in the object is what Freud calls hysterical identification. For instance, Erler's patient,⁸⁴ a severe hysteric, had hypnagogic visions of little riders

made of paper, who so took possession of her imagination that she had the feeling of being herself one of them. Much the same sort of thing normally happens to us in dreams, when we cannot help thinking “hysterically.”⁸⁵ Complete surrender to the interesting idea explains the wonderful naturalness of these pseudological or somnambulistic performances, which is quite beyond the reach of conscious acting. The less the waking consciousness intervenes with its reflection and calculation, the more certain and convincing becomes the objectivation of the dream.⁸⁶

[118] Our case has still another analogy with *pseudologia phantastica*: the development of fantasies during the attacks. Many cases are known in the literature of fits of pathological lying, accompanied by various hysteriform complaints.⁸⁷ Our patient develops her fantasy systems exclusively during the attack. In her normal state she is quite incapable of thinking out new ideas or explanations; she must either put herself into the somnambulistic state or await its spontaneous appearance. This exhausts the affinities with *pseudologia phantastica* and pathological dreaming.

[119] Our patient differs essentially from pathological dreamers in that it could never be proved that her reveries had previously been the object of her daily interests; her dreams came up explosively, suddenly bursting forth with amazing completeness from the darkness of the unconscious. The same thing happened with Flournoy’s Hélène Smith. At several points, however, it is possible in our case to demonstrate the link with perceptions in the normal state [see next par.], so it seems probable that the roots of those dreams were originally feeling-toned ideas which only occupied her waking consciousness for a short time.⁸⁸ We must suppose that hysterical forgetfulness⁸⁹ plays a not inconsiderable role in the origin of such dreams: many ideas which, in themselves, would be worth preserving in consciousness, sink below the threshold, associated trains of thought get lost and, thanks to psychic dissociation, go on working in the unconscious. We meet the same process again in the genesis of our own dreams.⁹⁰ The apparently sudden and unexpected reveries of the patient can be explained in this way. The total submersion of the conscious personality in the dream role is also the indirect cause of the development of simultaneous automatisms:

A second condition may also occasion the division of consciousness. It is not an alteration of sensibility, but it is rather a peculiar attitude of the mind—the concentration of attention on a single thing. The result of this state of concentration is that the mind is absorbed to the exclusion of other things, and to such a degree insensible that the way is opened for automatic actions; and these actions, becoming more complicated, as in the preceding case, may assume a psychic character and constitute intelligences of a parasitic kind, existing side by side with the normal personality, which is not aware of them.⁹¹

[120] Our patient's "romances" throw a most significant light on the subjective roots of her dreams. They swarm with open and secret love-affairs, with illegitimate births and other sexual innuendoes. The hub of all these ambiguous stories is a lady whom she dislikes, and who gradually turns into her polar opposite, for whereas Ivenes is the pinnacle of virtue this lady is a sink of iniquity. But the patient's reincarnation theory, in which she appears as the ancestral mother of countless thousands, springs, in all of its naïve nakedness, straight from an exuberant fantasy which is so very characteristic of the puberty period. It is the woman's premonition of sexual feeling, the dream of fertility, that has created these monstrous ideas in the patient. We shall not be wrong if we seek the main cause of this curious clinical picture in her budding sexuality. From this point of view the whole essence of Ivenes and her enormous family is nothing but a dream of sexual wish-fulfilment, which differs from the dream of a night only in that it is spread over months and years.

[Nature of the Somnambulistic Attacks]

[121] So far there is one point in S. W.'s history that has not been discussed, and that is the nature of her attacks. In the second séance she was suddenly seized with a sort of fainting-fit, from which she awoke with a recollection of various hallucinations. According to her own statement, she had not lost consciousness for a moment. Judging from the outward symptoms and course of these attacks, one is inclined to think of narcolepsy or lethargy, of the kind described, for instance, by Loewenfeld. This is the more plausible since we know that one member of her family—the grandmother—had once had an attack of lethargy. So it is conceivable that our patient inherited the lethargic disposition (Loewenfeld). One often observes hysterical fits of convulsions at spiritualistic séances. Our patient never showed any symptoms of convulsions, but instead she had those peculiar sleeping states. Aetiologically, two elements must be considered for the first attack:

(1) The influence of hypnosis.

(2) Psychic excitation.

[122] (1) INFLUENCE OF PARTIAL HYPNOSIS. Janet observed that subconscious automatisms have a hypnotic influence and can bring about complete somnambulism.⁹² He made the following experiment: While the patient, who was fully awake, was engaged in conversation by a second observer, Janet stationed himself behind her and by means of whispered suggestions made her unconsciously move her hand, write, and answer questions by signs. Suddenly the patient broke off the conversation, turned round, and with supraliminal consciousness continued the previously subconscious talk with Janet. She had fallen into hypnotic somnambulism.⁹³ In this example we see a process similar to our case. But, for certain

reasons to be discussed later, the sleeping state cannot be regarded as hypnotic. We therefore come to the question of:

[123] (2) PSYCHIC EXCITATION. It is reported that the first time Bettina Brentano met Goethe, she suddenly fell asleep on his knee.⁹⁴ Ecstatic sleep in the midst of extreme torture, the so-called “witch’s sleep,” is a well-known phenomenon in the annals of witchcraft.⁹⁵

[124] With susceptible subjects, comparatively small stimuli are enough to induce somnambulistic states. For example, a sensitive lady had to have a splinter cut out of her finger. Without any kind of bodily change she suddenly saw herself sitting beside a brook in a beautiful meadow, plucking flowers. This condition lasted all through the minor operation and then vanished without having any special after-effects.⁹⁶

[125] Loewenfeld observed the unintentional induction of hysterical lethargy by hypnosis.⁹⁷ Our case has certain resemblances to hysterical lethargy as described by Loewenfeld:⁹⁸ superficial respiration, lowering of the pulse, corpse-like pallor of the face, also peculiar feelings of dying and thoughts of death.⁹⁹ Retention of one or more senses is no argument against lethargy: for instance in certain cases of apparent death the sense of hearing remains.¹⁰⁰ In Bonamaison’s case,¹⁰¹ not only was the sense of touch retained, but the senses of hearing and smell were sharpened. Hallucinations and loud speaking of hallucinatory persons are also met with in lethargy.¹⁰² As a rule there is total amnesia for the lethargic interval. Loewenfeld’s case D. had a vague memory afterwards,¹⁰³ and in Bonamaison’s case there was no amnesia. Lethargic patients do not prove accessible to the usual stimuli for rousing them, but Loewenfeld succeeded, with his patient St., in changing the lethargy into hypnosis by means of mesmeric passes, thus establishing contact with the rest of her consciousness during the attack.¹⁰⁴ Our patient proved at first absolutely inaccessible during lethargy; later she started to speak spontaneously, was indistractable when her somnambulistic ego was speaking, but distractable when the speaker was one of her automatic personalities. In the latter case, it seems probable that the hypnotic effect of the automatisms succeeded in achieving a partial transformation of the lethargy into hypnosis. When we consider Loewenfeld’s view that the lethargic disposition must not be “identified outright with the peculiar behaviour of the nervous apparatus in hysteria,” then the assumption that this disposition was due to family heredity becomes fairly probable. The clinical picture is much complicated by these attacks.

[126] So far we have seen that the patient’s ego-consciousness was identical in all states. We have discussed two secondary complexes of consciousness and followed them into the somnambulistic attack, where, owing to loss of motor expression, they appeared to the patient in the second séance as a vision of the two grandfathers. These complexes completely disappeared from view during the attacks that followed, but on

the other hand they developed an all the more intense activity during the twilight state, in the form of visions. It seems that numerous secondary sequences of ideas must have split off quite early from the primary unconscious personality, for soon after the first two séances “spirits” appeared by the dozen. The names were inexhaustible in their variety, but the differences between the various personalities were exhausted very quickly, and it became apparent that they could all be classified under two types, the *serio-religious* and the *gay-hilarious*. It was really only a question of two different subconscious personalities appearing under various names, which had however no essential significance. The older type, the grandfather, who had started the automatism off in the first place, was also the first to make use of the twilight state. I cannot remember any suggestion that might have given rise to the automatic speaking. According to our previous explanations, the attack can in these circumstances be thought of as a partial self-hypnosis. The ego-consciousness which remains over and, as a result of its isolation from the external world, occupies itself entirely with its hallucinations, is all that is left of the waking consciousness. Thus the automatism has a wide field for its activity. The autonomy of the individual centres, which we found to be present in the patient from the beginning, makes the act of automatic speaking more understandable. Dreamers, too, occasionally talk in their sleep, and people in the waking state sometimes accompany intense thought with unconscious whispering.¹⁰⁵ The peculiar movements of the speech muscles are worth noting. They have also been observed in other somnambulists.¹⁰⁶ These clumsy attempts can be directly paralleled by the unintelligent and clumsy movements of the table or glass; in all probability they correspond to the preliminary expression of the motor components of an idea, or they correspond to an excitation limited to the motor centres and not yet subordinated to a higher system. I do not know whether anything of the sort occurs with people who talk in their dreams, but it has been observed in hypnotized persons.¹⁰⁷

[127] Since the convenient medium of speech was used as the means of communication, it made the study of the subconscious personalities considerably easier. Their intellectual range was relatively narrow. Their knowledge comprised all that the patient knew in her waking state, plus a few incidental details such as the birthdays of unknown persons who were dead, etc. The source of this information is rather obscure, since the patient did not know how she could have procured knowledge of these facts in the ordinary way. They were cryptomnesias, but are too insignificant to deserve more detailed mention. The two subconscious personalities had a very meagre intelligence; they produced almost nothing but banalities. The interesting thing is their relation to the ego-consciousness of the patient in the somnambulistic state. They were well informed about everything that took place during the ecstasies and occasionally gave an exact report, like a running

commentary.¹⁰⁸ But they had only a very superficial knowledge of the patient's fantasies; they did not understand them and were unable to answer a single question on this subject correctly; their stereotyped reply was "Ask Ivenes." This observation reveals a dualism in the nature of the subconscious personalities which is rather difficult to explain; for the grandfather, who manifests himself through automatic speech, also appears to Ivenes, and according to her own statement "knew all her thoughts." How is it that when the grandfather speaks through the mouth of the patient he knows nothing about the very things he teaches Ivenes in the ecstasies?

[128] Let us go back to what we said at the first appearance of the hallucinations [par. 98]. There we described the vision of the grandfathers as an irruption of hypnosis into the visual sphere. That irruption did not lead to a "normal" hypnosis but to "hystero-hypnosis"; in other words, the simple hypnosis was complicated by an hysterical attack.

[129] It is not a rare occurrence for normal hypnosis to be disturbed, or rather to be replaced, by the unexpected appearance of hysterical somnambulism; the hypnotist in many cases then loses rapport with the patient. In our case the automatism arising in the motor area plays the part of the hypnotist, and the suggestions emanating from it (objectively described as autosuggestions) hypnotize the neighbouring areas which have grown susceptible. But the moment the hypnosis affects the visual sphere the hysterical attack intervenes, and this, as we have remarked, effects a very profound change over large portions of the psychic area. We must picture the automatism as standing in the same relation to the attack as the hypnotist to a pathological hypnosis: it loses its influence on the subsequent development of the situation. The hallucinatory appearance of the hypnotic personality, or of the suggested idea, may be regarded as its last effect on the personality of the somnambulist. Thereafter the hypnotist becomes a mere figure with whom the somnambulist personality engages autonomously; he can only just make out what is going on, but can no longer condition the content of the attack. The autonomous ego-complex—in this case Ivenes—now has the upper hand, and she groups her own mental products around the personality of her hypnotist, the grandfather, now diminished to a mere image. In this way we are able to understand the dualism in the nature of the grandfather. *Grandfather I, who speaks directly to those present, is a totally different person and a mere spectator of his double, Grandfather II, who appears as Ivenes' teacher.* Grandfather I maintains energetically that both are one and the same person, that Grandfather I has all the knowledge which Grandfather II possesses and is only prevented from making it public because of language difficulties. (The patient herself was naturally not conscious of this split, but took both to be the same person.) On closer inspection, however, Grandfather I is not altogether wrong, and he can appeal to an observation which apparently confirms the identity of I and II, i.e., the fact that

they are never both present together, When I is speaking automatically, II is not present, and Ivenes remarks on his absence. Similarly, during her ecstasies, when she is with II, she cannot say where I is, or she only learns on returning from her journeys that he has been guarding her body in the meantime. Conversely, the grandfather never speaks when he is going on a journey with Ivenes or when he gives her special illumination. This behaviour is certainly remarkable, for if Grandfather I is the hypnotist and completely separate from the personality of Ivenes, there seems no reason why he should not speak objectively at the same time that his double appears in the ecstasy. Although this might have been supposed possible, as a matter of fact it was never observed. How is this dilemma to be resolved? Sure enough there is an identity of I and II, but it does not lie in the realm of the personality under discussion; it lies rather in the basis common to both, namely in the personality of the patient, which is in the deepest sense one and indivisible.

[130] Here we come upon the characteristic feature of all hysterical splits of consciousness. They are disturbances that only touch the surface, and none of them goes so deep as to attack the firmly knit basis of the ego-complex. Somewhere, often in an extremely well-concealed place, we find the bridge which spans the apparently impassable abyss. For instance, one of four playing cards is made invisible to a hypnotized person by suggestion; consequently he calls only the other three. A pencil is then put into his hand and he is told to write down all the cards before him; he correctly adds the fourth one.¹⁰⁹ Again, a patient of Janet's¹¹⁰ always saw, in the aura of his hysteroepileptic attacks, the vision of a conflagration. Whenever he saw an open fire he had an attack; indeed, the sight of a lighted match held before him was sufficient to induce one. The patient's visual field was limited to 30° on the left side; the right eye was closed. The left eye was then focused on the centre of a perimeter while a lighted match was held at 80°. An hysteroepileptic attack took place immediately. Despite extensive amnesia in many cases of double consciousness, the patients do not behave in a way that corresponds to the degree of their ignorance, but as though some obscure instinct still guided their actions in accordance with their former knowledge. Neither this relatively mild amnesic split nor even the severe amnesia of the epileptic twilight state, formerly regarded as an *irreparabile damnum*, is sufficient to sever the innermost threads that bind the ego-complex of the twilight state to that of the normal state. In one case it was possible to articulate the content of the twilight state with the waking ego-complex.¹¹¹

[131] If we apply these discoveries to our case, we arrive at the explanatory hypothesis that, under the influence of appropriate suggestions, the layers of the unconscious which are beyond reach of the split try to represent the unity of the automatic personality, but that this endeavour comes to grief on the profounder and more elementary disturbance caused by the hysterical attack.¹¹² This prevents a more

complete synthesis by appending associations which are, as it were, the truest and most original property of the “supraconscious” personality. The dream of Ivenes, as it emerges into consciousness, is put into the mouths of the figures who happen to be in the field of vision, and henceforth it remains associated with these persons.

[Origin of the Unconscious Personalities]

[132] As we have seen, the various personalities are grouped round two types, the grandfather and Ulrich von Gerbenstein. The grandfather produces nothing but sanctimonious twaddle and edifying moral precepts. Ulrich von Gerbenstein is simply a silly schoolgirl, with nothing masculine about him except his name. We must here add, from the anamnesis, that the patient was confirmed at the age of fifteen by a very pietistic clergyman, and that even at home she had to listen to moral sermons. The grandfather represents this side of her past, Gerbenstein the other half; hence the curious contrast. So here we have, personified, the chief characters of the past: here the compulsorily educated bigot, there the boisterousness of a lively girl of fifteen who often goes too far.¹¹³ The patient herself is a peculiar mixture of both; sometimes timid, shy, excessively reserved, at other times boisterous to the point of indecency. She is often painfully conscious of these contrasts. This gives us the key to the origin of the two subconscious personalities. The patient is obviously seeking a middle way between two extremes; she endeavours to repress them and strives for a more ideal state. These strivings lead to the adolescent dream of the ideal Ivenes, beside whom the unrefined aspects of her character fade into the background. They are not lost; but as repressed thoughts, analogous to the idea of Ivenes, they begin to lead an independent existence as autonomous personalities.

[133] This behaviour calls to mind Freud’s dream investigations, which disclose the independent growth of repressed thoughts.¹¹⁴ We can now understand why the hallucinatory persons are divorced from those who write and speak automatically. They teach Ivenes the secrets of the Beyond, they tell her all those fantastic stories about the extraordinariness of her personality, they create situations in which she can appear dramatically with the attributes of their power, wisdom, and virtue. They are nothing but dramatized split-offs from her dream-ego. The others, the automata, are the ones to be overcome; they must have no part in Ivenes. The only thing they have in common with her spirit companions is the name. It is not to be expected in a case like this, where no clear-cut divisions exist, that two such pregnant groups of characters, with all their idiosyncrasies, should disappear entirely from a somnambulistic ego-complex so closely connected with the waking consciousness. And in fact, we meet them again, partly in those ecstatic penitential scenes and partly in the romances that are crammed with more or less banal, mischievous gossip. On the whole, however, a very much milder form predominates.

[134] It only remains now to say a few words about the course of this singular ailment. The whole process reached its climax within four to eight weeks, and the descriptions of Ivenes and the other subconscious personalities refer in general to this period. Thereafter a gradual decline became noticeable; the ecstasies grew more and more vacuous as Gerbenstein's influence increased. The phenomena lost their plasticity and became ever shallower; characters which at first were well differentiated became by degrees inextricably mixed. The psychological yield grew more and more meagre, until finally the whole story assumed the appearance of a first-class fraud. Ivenes herself was severely hit by this decline; she became painfully uncertain, spoke cautiously, as if feeling her way, so that the character of the patient came through in more and more undisguised form. The somnambulistic attacks, too, decreased in frequency and intensity. One could observe with one's own eyes all the gradations from somnambulism to conscious lying.

[135] Thus the curtain fell. The patient has since gone abroad. The fact that her character has become pleasanter and more stable may have a significance that is not to be underestimated, if we remember those cases where the second state gradually came to replace the first. We may be dealing here with a similar phenomenon.

[136] It is well known that somnambulistic symptoms are particularly common in puberty.¹¹⁵ The attacks of somnambulism in Dyce's case¹¹⁶ began immediately before the onset of puberty and lasted just till its end. The somnambulism of Hélène Smith is likewise closely connected with puberty.¹¹⁷ Schroeder van der Kolk's patient was 16 at the time of her illness; Felida X., 14½. We know also that the future character is formed and fixed at this period. We saw in the cases of Felida X. and Mary Reynolds how the character of the second state gradually replaced that of the first. It is, therefore, conceivable that the phenomena of double consciousness are simply new character formations, or attempts of the future personality to break through, and that in consequence of special difficulties (unfavourable circumstances, psychopathic disposition of the nervous system, etc.) they get bound up with peculiar disturbances of consciousness. In view of the difficulties that oppose the future character, the somnambulisms sometimes have an eminently teleological significance, in that they give the individual, who would otherwise inevitably succumb, the means of victory. Here I am thinking especially of Joan of Arc, whose extraordinary courage reminds one of the feats performed by Mary Reynolds in her second state. This is also, perhaps, the place to point out the like significance of "teleological hallucinations," of which occasional cases come to the knowledge of the public, although they have not yet been subjected to scientific study.

Heightened Unconscious Performance

[137] We have now discussed all the essential phenomena presented by our case which were significant for its inner structure. Certain accompanying phenomena have still to be briefly considered; these are the phenomena of *heightened unconscious performance*. In this field, we meet with a not altogether unjustifiable scepticism on the part of the scientific pundits. Even Dessoir's conception of the second ego aroused considerable opposition and was rejected in many quarters as too enthusiastic. As we know, occultism has claimed a special right to this field and has drawn premature conclusions from dubious observations. We are still very far indeed from being able to say anything conclusive, for up to the present our material is nothing like adequate. If, therefore, we touch on this question of heightened unconscious performance, we do so only to do justice to all sides of our case.

[138] By heightened unconscious performance we mean that peculiar automatic process whose results are not available for the conscious psychic activity of the individual. Under this category comes, first of all, thought-reading by means of table movements. I do not know whether there are people who can guess an entire long train of thought by means of inductive inferences from the "intended tremors." At any rate it is certain that, granting this to be possible, such persons must be making use of a routine acquired by endless practice. But in our case routine can be ruled out at once, and there is no choice but to assume for the present a receptivity of the unconscious far exceeding that of the conscious mind. This assumption is supported by numerous observations on somnambulists. Here I will mention only Binet's experiments, where little letters or other small objects, or complicated little figures in relief, were laid on the anaesthetic skin of the back of the hand or the neck, and the unconscious perceptions were registered by means of signs. On the basis of these experiments he comes to the following conclusion: "According to the calculations that I have been able to make, the unconscious sensibility of an hysterical patient is at certain moments *fifty times* more acute than that of a normal person."¹¹⁸ Another example of heightened performance that applies to our case and to numerous other somnambulists is the process known as cryptomnesia.¹¹⁹ By this is meant the coming into consciousness of a memory-image which is not recognized as such in the first instance, but only secondarily, if at all, by means of subsequent recollection or abstract reasoning. It is characteristic of cryptomnesia that the image which comes up does not bear the distinctive marks of the memory-image—that is to say, it is not connected with the supraliminal ego-complex in question.

[139] There are three different ways in which the cryptomnesic image may be brought into consciousness:

(1) *The image enters consciousness without the mediation of the senses, intrapsychically.* It is a sudden idea or hunch, whose causal nexus is hidden from the person concerned. To this extent cryptomnesia is an everyday occurrence and is intimately bound up with normal psychic processes. But how often it misleads the scientist, author, or composer into believing that his ideas are original, and then along comes the critic and points out the source! Generally the individual formulation of the idea protects the author from the charge of plagiarism and proves his good faith, though there are cases where the reproduction occurs unconsciously, almost word for word. Should the passage contain a remarkable idea, then the suspicion of more or less conscious plagiarism is justified. After all, an important idea is linked by numerous associations to the ego-complex; it has been thought about at different times and in different situations and therefore has innumerable connecting threads leading in all directions. Consequently it can never disappear so entirely from consciousness that its continuity is lost to the sphere of conscious memory. We have, however, a criterion by which we can always recognize intrapsychic cryptomnesia objectively: the cryptomnesic idea is linked to the ego-complex by the minimum of associations. The reason for this lies in the relation of the individual to the object concerned, in the want of proportion between interest and object.

Two possibilities are conceivable: (a) The object is worthy of interest, but the interest is slight owing to distractibility or lack of understanding. (b) The object is not worthy of interest, consequently the interest is slight. In both cases there is an extremely labile connection with consciousness, the result being that the object is quickly forgotten. This flimsy bridge soon breaks down and the idea sinks into the unconscious, where it is no longer accessible to the conscious mind. Should it now re-enter consciousness by way of cryptomnesia, the feeling of strangeness, of its being an original creation, will cling to it, because the path by which it entered the subconscious can no longer be discovered. Strangeness and original creation are, moreover, closely allied to one another, if we remember the numerous witnesses in *belles-lettres* to the “possessed” nature of genius.¹²⁰ Apart from a number of striking instances of this kind, where it is doubtful whether it is cryptomnesia or an original creation, there are others where a passage of no essential value has been reproduced cryptomnesically, and in almost the same words, as in the following example:

[140] Nietzsche, *Thus Spake Zarathustra*¹²¹ Kerner, *Blätter aus Prevorst*¹²²

Now about the time that Zarathustra sojourned on the Happy Isles, it happened that a ship anchored at the isle on which the smoking mountain stands, and the crew went ashore to shoot rabbits. About

The four captains and a merchant, Mr. Bell, went ashore on the island of Mount Stromboli to shoot rabbits. At three o'clock they mustered the crew to go aboard, when, to their inexpressible

the noontide hour, however, when the captain and his men were together again, they suddenly saw a man coming towards them through the air, and a voice said distinctly: "It is time! It is highest time!" But when the figure drew close to them, flying past quickly like a shadow in the direction of the volcano, they recognized with the greatest dismay that it was Zarathustra.... "Behold," said the old helmsman, "Zarathustra goes down to hell!"

astonishment, they saw two men flying rapidly towards them through the air. One was dressed in black, the other in grey. They came past them very closely, in the greatest haste, and to their utmost dismay descended amid the burning flames into the crater of the terrible volcano, Mount Stromboli. They recognized the pair as acquaintances from London.

[141] Nietzsche's sister, Elisabeth Förster-Nietzsche, told me, in reply to my enquiry, that Nietzsche had taken a lively interest in Kerner when staying with his grandfather, Pastor Oehler, in Pobler, between the ages of 12 and 15, but certainly not later. It could scarcely have been Nietzsche's intention to commit a plagiarism from a ship's log; had this been the case he would surely have omitted that extremely prosaic and totally irrelevant passage about shooting rabbits. Obviously, when painting the picture of Zarathustra's descent into hell, that forgotten impression from his youth must have slipped half or wholly unconsciously *into his mind*.

[142] This example shows all the peculiarities of cryptomnesia: a quite unimportant detail which only deserves to be forgotten as quickly as possible is suddenly reproduced with almost literal fidelity, while the main point of the story is, one cannot say modified, but re-created in an individual manner. Around the individual core—the idea of the journey to hell—there are deposited, as picturesque details, those old, forgotten impressions of a similar situation. The story itself is so absurd that the young Nietzsche, a voracious reader, probably skimmed through it without evincing any very profound interest in the matter. Here, then, is the required minimum of associative connections, for we can hardly conceive of a greater jump than from that stupid old tale to Nietzsche's consciousness in the year 1883. If we realize Nietzsche's state of mind¹²³ at the time when he wrote *Zarathustra*, and the poetic ecstasy that at more than one point verges on the pathological, this abnormal reminiscence will appear more understandable.

[143] The other of the two possibilities mentioned above, namely, registering some object, not in itself uninteresting, in a state of distractibility or partial interest due to lack of understanding, and its cryptomnesic reproduction, is found mainly in somnambulists, and also—as curiosities of literature—in people at the point of death.¹²⁴ Out of the rich choice of these phenomena we are chiefly concerned here with speaking in foreign tongues, the symptom of glossolalia. This phenomenon is

mentioned in practically all cases of ecstasy; it is found in the New Testament, in the *Acta Sanctorum*,¹²⁵ in the witch trials, and in recent times in the story of the Clairvoyante of Prevorst, in Judge Edmond's daughter Laura, in Flournoy's Hélène Smith, who was thoroughly investigated on this question too, and also in Bresler's case,¹²⁶ which was probably identical with that of Blumhardt's Gottliebin Dittus.¹²⁷ As Flournoy has shown, glossolalia, in so far as it is a really independent language, is a cryptomnesic phenomenon par excellence. I would refer the reader to Flournoy's exceedingly interesting study of this subject.¹²⁸

[144] In our case glossolalia was observed only once, and then the only intelligible words were the interspersed variations of the word *vena*. The origin of this word is clear: a few days previously the patient had dipped into an anatomical atlas and immersed herself in a study of the veins of the face, which were given in Latin, and she used the word *vena* in her dreams, just as a normal person might do. The remaining words and sentences in foreign language reveal at a glance their derivation from the patient's slight knowledge of French. Unfortunately I did not get exact translations of the various sentences, because the patient refused to give them to me; but we can take it that it was the same sort of thing as Hélène Smith's Martian language. Flournoy shows that this Martian language was nothing but a childish translation from the French; only the words were altered, the syntax remained the same. A more probable explanation is that our patient simply strung a lot of meaningless foreign-sounding words together, and, instead of forming any true words,¹²⁹ borrowed certain characteristic sounds from French and Italian and combined them into a sort of language, just as Hélène Smith filled in the gaps between the real Sanskrit words with pseudo-linguistic products of her own. The curious names of the mystical system can mostly be traced back to known roots. Even the circles remind one of the planetary orbits found in every school atlas; the inner parallel with the relation of the planets to the sun is also pretty clear, so we shall not go far wrong if we see the names as reminiscences of popular astronomy. In this way the names "Persus," "Fenus," "Nenus," "Sirum," "Surus," "Fixus," and "Pix" can be explained as childish distortions of "Perseus," "Venus," "Sirius," and "fixed star," analogous to the *vena* variations. "Magnesor" is reminiscent of "magnetism," whose mystical significance the patient knew from the Clairvoyante of Prevorst story. "Connesor" being contrary to "Magnesor," the first syllable "Con-" suggests French "contre." "Hypos" and "Hyfonism" remind one of "hypnosis" and "hypnotism," about which the weirdest ideas still circulate amongst laymen. The frequent endings in "-us" and "-os" are the signs by which most people distinguish between Latin and Greek. The other names derive from similar accidents to which we lack the clues. Naturally the modest glossolalia of our case cannot claim to be a classic example of

cryptomnesia, for it consists only in the unconscious use of different impressions, some optical, some acoustic, and all very obvious.

[145] (2) *The cryptomnesic image enters consciousness through mediation of the senses, as an hallucination.* Hélène Smith is the classic example of this. See the case cited above, concerning the number 18 [par. 98].

[146] (3) *The image enters consciousness by motor automatism.* Hélène Smith had lost a very valuable brooch which she was anxiously looking for everywhere. Ten days later her guide Leopold told her by table movements where it was. From the information received, she found it one night in an open field, covered by sand.¹³⁰ Strictly speaking, in cryptomnesia there is no heightened performance in the true sense of the term, since the conscious memory experiences no intensification of function but only an enrichment of content. Through the automatism certain areas which were previously closed to consciousness are made accessible to it in an indirect way, but the unconscious itself is not performing any function that exceeds the capacities of the conscious mind either qualitatively or quantitatively. Cryptomnesia is therefore only an apparent instance of heightened performance, in contrast to hypermnesia, where there is an actual increase of function.¹³¹

[147] We spoke earlier of the unconscious having a receptivity superior to that of the conscious mind, chiefly in regard to simple thought-transference experiments with numbers. As already mentioned, not only our somnambulist but a fairly large number of normal people are able to guess, from tremor movements, quite long trains of thought, provided they are not too complicated. These experiments are, so to speak, the prototype of those rarer and incomparably more astonishing cases of intuitive knowledge displayed at times by somnambulists.¹⁸² Zschokke has shown from his own self-analysis¹³³ that such phenomena occur in connection not only with somnambulism but with non-somnambulists as well.

[148] This knowledge seems to be formed in several different ways. The first thing to be considered, as we have said, is the delicacy of unconscious perceptions; secondly, we must emphasize the importance of what proves to be the enormous suggestibility of somnambulists. The somnambulist not only incorporates every suggestive idea into himself, he actually lives himself into the suggestion, into the person of the doctor or observer, with the utter abandon characteristic of suggestible hysterics. Frau Hauffe's relation to Kerner is an excellent example of this. So it not surprising that there is in these cases a high degree of concord of associations, a fact which Richet, for instance, might have taken more account of in his experiments on thought-transference. Finally, there are cases of somnambulist heightened performance which cannot be explained solely by the hyperaesthetic unconscious activity of the senses, or by the concord of associations, but which postulate a highly developed intellectual activity

of the unconscious. To decipher the intended tremor movements requires an extraordinary delicacy of feeling, both sensitive and sensory, in order to combine the individual perceptions into a self-contained unit of thought—if indeed it is permissible at all to make an analogy between the cognitive processes in the unconscious and those of the conscious. The possibility must always be borne in mind that, in the unconscious, feelings and concepts are not so clearly separated, and may even be one. The intellectual exaltation which many somnambulists display during ecstasy, though rather uncommon, is a well-observed fact,¹³⁴ and I am inclined to regard the mystical system devised by our patient as just such an example of heightened unconscious performance that transcends her normal intelligence. We have already seen where part of that system probably comes from. Another source may be Frau Hauffe's "life-circles," depicted in Kerner's book. At any rate its outward form seems to be determined by these factors. As we have already noted, the idea of dualism derives from those fragments of conversation overheard by the patient in the dreamy state following her ecstasies.

[4. CONCLUSION]

[149] This exhausts my knowledge of the sources used by the patient. Where the root idea came from she was unable to say. Naturally I waded through the occult literature so far as it pertained to this subject, and discovered a wealth of parallels with our gnostic system, dating from different centuries, but scattered about in all kinds of works, most of them quite inaccessible to the patient. Moreover, at her tender age, and in her surroundings, the possibility of any such study must be ruled out of account. A brief survey of the system in the light of the patient's own explanations will show how much intelligence was expended on its construction. How high the intellectual achievement is to be rated must remain a matter of taste. At all events, considering the youth and mentality of the patient, it must be regarded as something quite out of the ordinary.

[150] In conclusion, I would like to express my warmest thanks to my revered teacher, Professor Bleuler, for his friendly encouragement and the loan of books, and to my friend Dr. Ludwig von Muralt for his kindness in handing over to me the first case mentioned in this book (case of Miss E.).¹³⁵

ON HYSTERICAL MISREADING¹

[151] In his review of my paper “On the Psychology and Pathology of So-called Occult Phenomena,”² Mr. Hahn misrepresented my views on “hysterical misreading.” Since I regard this phenomenon as being of fundamental importance, perhaps I may be allowed to state my views once again.

[152] My patient misread with remarkable frequency at school, and always in a quite definite way: each time she substituted the Swiss dialect word for the word in question, so instead of saying “Treppe” (stair) she said “Stege,” and instead of “Ziege” (goat) she said “Geiss,” and so on.³ These expressions are absolutely synonymous. Hence, if the word “Stege” is produced, it proves that the meaning of the word “Treppe” was understood. There are two possible ways of explaining this phenomenon:

[153] (1) The word “Treppe” is understood correctly and consciously. In this case there is absolutely no reason for a healthy person to reproduce the word incorrectly, i.e., as a dialect word. But with my patient the dialect word somehow crept in.

[154] (2) The word “Treppe” is not understood correctly. In this case any normal person will reproduce nonsense that either sounds like or looks like the word, but he will never reproduce an expression that sounds and looks different but is synonymous. I have made numerous reading-tests with patients suffering from paralysis, mania, alcoholism, senile dementia, etc., who are distractible and unable to concentrate, and on the basis of hundreds of these experiences I can confidently assert that this kind of misreading does not occur in individuals who are not hysterical. Every misreading that occurs in a state of distractibility is based on a phonetic or a textual likeness; with normal persons it is usually caused by momentary constellations. I have found this rule amply confirmed by association tests conducted under conditions of distraction.

[155] If, therefore, my patient reproduces dialect words instead of the literary ones without noticing this frequently repeated mistake, she has in the first place a defective acoustic control of what she is saying; and, in the second place, the synonym shows that the meaning of the optic impression was understood correctly. But it is reproduced incorrectly. Where does the cause of the mistake lie? In my paper I left this question open, contenting myself with the general remark that it was an “automatic” phenomenon which I was not able to localize at the time.

[156] The most probable explanation is as follows: We know from everyday experience that the ordinary kind of misreading disturbs the sense by substituting for the right word a word akin to it in sound or form. Slips of the tongue in uttering a correctly understood word follow the same rule, and when, as often happens, a Swiss finds himself uttering a dialect word, he very rarely does so when reading out loud, and the words that are confused with one another are mostly those with a strong phonetic affinity. This cannot be said of the example I have deliberately chosen: “Ziege—Geiss.” In order to explain their confusion, we have to assume an additional factor. This additional factor is the patient’s hysterical disposition.

[157] Our dreamy, somewhat drowsy patient reads mechanically; her comprehension of the meaning is therefore practically nil. While her conscious mind is occupied with something quite different, the psychic processes set in motion by her reading remain feeble and indistinct. In normal and sick persons who are distractible but not hysterical, these feebly accentuated psychic processes give rise to misconstructions based on a phonetic or formal likeness, so that reproduction is falsified at the cost of sense. It is the other way round with my patient: the formal connection breaks down completely but the sense connection is preserved. This can only be explained on the hypothesis of a split consciousness; that is to say, besides the ego-complex, which follows its own thoughts, there is another conscious complex which reads and understands correctly, and allows itself various modifications of expression, as indeed is frequently the case with complexes that function automatically. Hysterical misreading differs from all other types in that, despite the misreading, the sense is preserved during reproduction.

[158] If Mr. Hahn fails to understand this well-known automatization of psychic functions in the psychopathology of hysteria, I can only recommend him to a study of the literature and to a little practical observation on his own account. Literature and reality abound in analogous phenomena.

[159] The reason why I attach particular importance to hysterical misreading is that it demonstrates in a nutshell the splitting off of psychic functions from the ego-complex, which is such a characteristic of hysteria, and consequently the strong tendency of the psychic elements towards autonomy.

[160] In my paper, I cited by way of analogy the observations made by Binet,⁴ who, having anaesthetized the subject’s hand by hypnosis (split it off from the ego-complex), pricked it with a needle under the cover of a screen, whereupon the subject suddenly thought of a row of dots (corresponding to the number of pricks). Or Binet would move the subject’s fingers, and she at once thought of “sticks” or “columns”; or the anaesthetic hand was induced to write the name “Salpêtrière,” and the subject suddenly saw “Salpêtrière” before her, in white writing on a black ground.

- [161] Mr. Hahn is of the opinion that these observations have to do with “something essentially different” from misreading. What is this something? Mr. Hahn does not say.
- [162] Binet’s experiments make it clear that the conscious complex which is split off from the ego-complex, and upon which the anaesthesia of the arm depends, perceives things correctly but reproduces them in modified form.
- [163] The ego-complex of my patient is displaced from the act of reading by other ideas, but the act continues automatically and forms a little conscious complex on its own, which likewise understands correctly but reproduces in modified form.
- [164] The type of process is therefore the same, for which reason my reference to Binet’s experiments is fully justified. It is a type that repeats itself over the whole field of hysteria; for instance, the systematic “irrelevant answers” of hysterical subjects, which have only recently been publicized, would also come into this category.
- [165] For the rest, I would like to point out that the main emphasis of my paper falls on the fullest possible registration and analysis of the manifold psychological phenomena which are all intimately connected with the development of character at this time of life. The analysis of the clinical picture is not, as Mr. Hahn thinks, based on French writers, but on Freud’s investigations of hysteria. Mr. Hahn would like to see the analysis “carried further and pursued more rigorously.” I would be very much obliged to Mr. Hahn if, together with his criticism, he would specify new ways of investigating this very difficult field.

II

CRYPTOMNESIA

CRYPTOMNESIA¹

[166] Modern scientific psychology distinguishes between direct and indirect memory. You have a direct memory when, for instance, you see a certain house and it then “comes into your mind” that a friend of yours lived there some years ago. You see the well-known house, and by the law of association the coexistent memory-image of your friend enters your consciousness. An indirect memory is different: I walk, deep in thought, past the house where my friend X used to live. I pay no attention either to the house or to the street, but am thinking of some urgent business matter I have to attend to. Suddenly an unexpected image thrusts itself obtrusively between my thoughts: I see a scene in which X once discussed similar matters with me many years ago. I am surprised that this particular memory should come up, for the conversation was of no importance. Suddenly I realize that I am in the street where my friend once lived. In this case the association of the memory-image with the house is indirect: I did not perceive the house consciously, for my thoughts distracted me from my surroundings too much. But the perception of the house nevertheless slipped into the dark background of consciousness² and activated the association with X. As this association was too feebly accentuated to cross the threshold of consciousness, a common association had to intervene as an auxiliary. This mediating association is the memory-image of the conversation that touched on matters similar to those now being revolved in my consciousness. In this way, the memory-image of X enters the sphere of consciousness.

[167] The direct and the indirect memory-image have one quality in common: the quality of being known. I recognize the association as an image I remember, and therefore know that it is not a new formation. The images we combine anew lack this quality of being known. I say “combine,” because originality lies only in the combination of psychic elements and not in the material, as everything in nature eloquently testifies. If a new combination has the quality of being known it is something abnormal: a deception of memory. The million acts of recollection daily taking place in our brain consist for the most part of direct memories, but a considerable number of them will fall on the side of indirect memory. These last are especially interesting. As our example of indirect memory shows, an unconscious perception that enters the brain passively can spontaneously activate a related association and in this way reach consciousness. The unconscious perception therefore does what our consciousness ordinarily does when we look at the house and

ask ourselves “Who lived there?” in order to evoke a clear memory. We thus call back the image of X into our minds. The unconscious perception behaves in exactly the same way; it seeks out the memory-image related to it, and in our example (by a psychological law which I do not propose to go into here) it combines with something that is being gently activated from the other side, namely the image of X talking of similar business matters. We see from this that association can take place without the least assistance from consciousness.

[168] From the way it entered my consciousness as an indirect memory, the image of X would commonly be described as a “chance idea,” and the German word *Einfall* clearly expresses the apparently fortuitous and groundless nature of the phenomenon. This kind of indirect memory is very common among people who think intuitively rather than in logical sequence—so common that we often forget how strictly determined all psychic processes are. To take a simple example: I am working away at some casual task, whistling a tune, some popular song whose words I don’t even remember at the moment. Somebody asks me what tune it is. I cast round in my memory: it is the student song “Not a cent, not a cent, and my clothes are only lent!” I have no idea how I came to pick on this particular song, which has nothing whatever to do with the associations now engaging my conscious mind. I go back along the train of thought I followed while working. All at once I remember that a few minutes ago I had been thinking, with a certain amount of feeling-tone, of a grand settlement of accounts in the New Year. Hence the song! I need hardly add that one can carry out some very pretty psychological diagnoses on one’s fellows in this way. For instance, when a friend of mine was imprudent enough to whistle three little melodies within a space of ten minutes, I could tell him to his face how sorry I was to hear that his love affair had ended unhappily. The melodies were “Im Aargau sind zwei Liebei” (“In Aargau are two lovers,”—a Swiss folksong), “Verlassen, verlassen bin i” (“Forlorn, forlorn am I”), and “Steh ich in finstrer Mitternacht” (“I stand in midnight’s gloom”). It even happened that on one occasion I whistled a tune whose text I did not know. On making inquiries I discovered a text that was undoubtedly associated with a strongly feeling-toned^{2a} train of thought I had pursued five minutes before.

[169] These examples, which one can observe every day in oneself and others, clearly show that a (feeling-toned) train of thought can disappear from the conscious mind without therefore ceasing to exist. On the contrary, it still has sufficient energy to send up, in the midst of the conscious world of associations that have completely changed in the meantime, an idea that bears no relation to its momentary surroundings.

[170] Still more drastic examples are provided by hysteria, which is nothing other than a caricature of normal psychological mechanisms. Recently I had to treat a hysterical young lady who became ill chiefly because she had been brutally beaten by her father.

Once, when we were out for a walk, this lady dropped her cloak in the dust. I picked it up, and tried to get the dust off by beating it with my stick. The next moment the lady hurled herself upon me with violent defensive gestures and tore the cloak out of my hands. She said she couldn't stand the sight, it was quite unendurable to her. I at once guessed the connection and urged her to tell me the motives for her behaviour. She was nonplussed, and could only say that it was extremely unpleasant for her to see her cloak cleaned like that. These symptomatic actions, as Sigmund Freud calls them, are very common among hysterics. The explanation is simple. A feeling-toned memory complex, though not present in consciousness at the moment, motivates certain actions from its invisible seat in the unconscious just as if it were present in the conscious mind.

[171] We can confidently say that our consciousness fairly swarms with strange intruders of this kind, which would be hard put to it to establish their identity. Every day thousands of associations enter the luminous circle of consciousness, and we would question them in vain for a more specific account of their origins. We must always bear in mind that conscious psychic phenomena are only a very small part of our total psyche. By far the greater part of the psychic elements in us is unconscious.

[172] Our consciousness therefore finds itself in a rather precarious position with regard to automatic movements of the unconscious that are independent of our will. The unconscious can perceive, and can associate autonomously; and the trouble is that only those associations which have once passed through our conscious minds have the quality of being known, and many of them can fall into oblivion so completely that they lose any such quality. Our unconscious must therefore harbour an immense number of psychic complexes which would astonish us by their strangeness. The inhibitions imposed by our waking consciousness do something to protect us from invasions of this kind. But in dreams, when the inhibitions of the conscious mind are lifted, the unconscious can play the maddest games. Anyone who has read Freud's dream analyses or, better still, has done some himself, will know how the unconscious can bedevil the most innocent and decent-minded people with sexual symbols whose lewdness is positively horrifying. It is to this unconscious that all those who do creative work must turn. All new ideas and combinations of ideas are premeditated by the unconscious. And when our own consciousness approaches the unconscious with a wish, it was the unconscious that gave it this wish. The unconscious brings the wish and its fulfilment.

[173] On this treacherous ground wander all who seek new combinations of ideas. Woe to them if they do not continually exercise the most rigorous self-criticism!

[174] Since, in the airy world of thought, one usually finds what one seeks, and gets what one wishes, the man who seeks new ideas will also be the most easily enchanted

with the deceptive gifts of the psyche. Not only is the history of religion or the psychology of the masses rich in examples, but so is the intellectual life of anyone who has ever hoped to achieve anything. What poet or composer has not been so beguiled by certain of his ideas as to believe in their novelty? We believe what we wish to believe. Even the greatest and most original genius is not free from human wishes and their all-too-human consequences.

[175] Quite apart from this general proposition, what kind of people seek these new combinations? They are the men of thought, who have finely-differentiated brains coupled with the sensitivity of a woman and the emotionality of a child. They are the slenderest, most delicate branches on the great tree of humanity: they bear the flower and the fruit. Many become brittle *too soon*, many break off. Differentiation creates in its progress the fit as well as the unfit; wits are mingled with nitwits—there are fools with genius and geniuses with follies, as Lombroso has remarked. One of the commonest and most usual marks of degeneracy is hysteria, the lack of self-control and self-criticism. Without succumbing to the pseudo-psychiatric witch-hunting of an author like Nordau,³ who sees fools everywhere, we can assert with confidence that unless the hysterical mentality is present to a greater or lesser degree genius is not possible. As Schopenhauer rightly says, the characteristic of the genius is great sensibility, something of the mimosa-like quality of the hysteric. Geniuses also have other qualities in common with hysterical persons.

[176] It may be that the majority of hysterical persons are ill because they possess a mass of memories, highly charged with affect and therefore deeply rooted in the unconscious, which cannot be controlled and which tyrannize the conscious mind and will of the patient. With women it is sometimes disappointed hopes of love, sometimes an unhappy marriage; with men, a bad position in life or unrewarded merits. They try to repress the affect from their daily lives, and so it torments them with horrid dream-symbols at night, plagues them with fits of precordial anxiety by day, saps their energy, drives them into all kinds of crazy sects, and causes headaches that defy all the medicine-men and all the magic remedies of electricity, sun-baths, and food cures. The genius, too, has to bear the brunt of an outsize psychic complex; if he can cope with it, he does so with joy, if he can't, he must painfully perform the "symptomatic actions" which his gift lays upon him: he writes, paints, or composes what he suffers.

[177] This applies more or less to all productive individuals. Tapping the depths of the psyche, the instinctively functioning complex sends up from its unknown and inexhaustible treasury countless thoughts to its slave "consciousness," some old and some new, and consciousness must deal with them as best it can. It must ask each thought: Do I know you, or are you new? But when the daemon drives, consciousness

has no time to finish its sorting work, the flood pours into the pen—and the next day is perhaps already printed.

[178] I said earlier that only the combinations are new, not the material, which hardly alters at all, or only very slowly and almost imperceptibly. Have we not seen all Böcklin's hues already in the old masters? And were not the fingers, arms, legs, noses and throats of Michelangelo's statues all somehow prefigured in antiquity? The smallest parts of a master work are certainly always old, even the next largest, the combined units, are mostly taken over from somewhere else; and in the last resort a master will not scorn to incorporate whole chunks of the past in a new work. Our psyche is not so fabulously rich that it can build from scratch each time. Neither does nature. One can see from our prisons, hospitals, and lunatic asylums at what enormous cost nature takes a little step forward; she builds laboriously on what has gone before.

[179] This process in the world at large is repeated in the smaller world of language: few novel combinations, nearly all of it old fragments taken over from somewhere. We speak the words and sentences learnt from parents, teachers, books; anyone who talks fastidiously, whether because he has a gift for language or because he takes pleasure in it, talks "like a book"—the book he has just been reading; he repeats rather larger fragments than do other people. The ordinary decent person either does not talk that way or openly admits where he got it from. But if somebody reproduces a sentence eight lines long verbatim from somebody else, we cannot, it is true, peremptorily shut the mouths of those who cry "Plagiarism!"—for as a matter of fact plagiarisms do occur—but neither need we immediately drop the person to whom this misfortune happens. For, when nature instituted the faculty of remembrance, she did not tie herself exclusively to the possibility of direct and indirect memories; she also gave, to clever and foolish alike, the power of cryptomnesia.

[180] The word "cryptomnesia" is a technical term taken from French scientific literature. The Swiss psychologist Flournoy has made particularly valuable contributions, based on case material, to our knowledge of this phenomenon.⁴ Cryptomnesia means something like "hidden memory." What this means in practice is best shown by a concrete example.⁵ When, some years ago, I read about Zarathustra's journey to hell, I was particularly struck by the passage where Nietzsche describes how Zarathustra descends into hell through the mouth of a volcano. It seemed to me that I had read this description somewhere before. I thought at first that it must be a falsification of memory on my part (abnormal quality of being known), but finally the most startling aspect of this quality settled on the passage where the crew of the ship went ashore "to shoot rabbits." This passage preoccupied my thoughts for several days, till at last I remembered having read a similar story some years earlier in Justinus Kerner. I leafed through his *Blätter aus Prevorst*, that antiquated collection

of simple-minded Swabian ghost stories, and found the following tale, which I put side by side with the corresponding passage from Nietzsche:

[181] Nietzsche, *Thus Spake Zarathustra*⁶ Kerner, *Blätter aus Prevorst*⁷

Now about the time that Zarathustra sojourned on the Happy Isles, it happened that a ship anchored at the isle on which the smoking mountain stands, and the crew went ashore to shoot rabbits. About the noontide hour, however, when the captain and his men were together again, they suddenly saw a man coming towards them through the air, and a voice said distinctly: "It is time! It is highest time!" But when the figure drew close to them, flying past quickly like a shadow in the direction of the volcano, they recognized with the greatest dismay that it was Zarathustra.... "Behold," said the old helmsman, "Zarathustra goes down to hell!"

[Nietzsche introduces this story with the words: "They say ... that through the volcano itself the narrow path leads down to the gate of the underworld."]

The four captains and a merchant, Mr. Bell, went ashore on the island of Mount Stromboli to shoot rabbits. At three o'clock they mustered the crew to go aboard, when, to their inexpressible astonishment, they saw two men flying rapidly towards them through the air. One was dressed in black, the other in grey. They came past them very closely, in the utmost haste, and to their greatest dismay descended amid the burning flames into the crater of the terrible volcano, Mount Stromboli. They recognized the pair as acquaintances from London.

[Kerner goes on to say that when the travellers returned to London, they learnt that two acquaintances had died in the meantime, the very ones whom they saw on Stromboli. From this story it was concluded that Stromboli was the entrance to hell.]

[182] One can see at once that the similarity between the two stories cannot be mere chance. The main argument in its disfavour is the number of verbal correspondences and the reproduction of unimportant details like "to shoot rabbits." A plagiarism, therefore! Everyone will find this supposition absurd. Why? Because the passage is too unimportant in relation to Nietzsche's artistic intention. And not only unimportant, but largely superfluous and unnecessary. The rabbits, for instance, characterize nothing in particular, whether we imagine the "Happy Isles" as the Lipari Islands or the Canary Islands. Nor is the description made any more felicitous by the rabbits—on the contrary. The thing is not easy to explain psychologically. The first question is, when did Nietzsche read the *Blätter aus Prevorst*? As I learnt from a letter which Frau Förster-Nietzsche wrote me, Nietzsche took a lively interest in Justinus Kerner when staying with his grandfather, Pastor Oehler, in Pobler, between the ages of 12 and 15, but probably not later. As Nietzsche had to be very economical

in his reading because of his weak eyes, it is difficult to understand what could have lured him back to this childish wonder-book in his later years, and the explanation of the plagiarism then becomes even more difficult. I think we may take it that Nietzsche read this story in his early youth and never again afterwards. How then did he come to reproduce this passage?

[183] I believe, though I cannot prove it, that it was not this old wives' tale that gave Nietzsche the idea of Zarathustra's journey to hell. Rather, while he was working out the general idea, Kerner's story would have slipped into his mind because it was associated with the general idea "journey to hell" by the law of similarity. The remarkable thing is the verbal fidelity of the reproduction. The striking agreement between the two texts strongly suggests that the reproduction did not come from the sphere of conscious memory, otherwise Nietzsche would have to be credited with a memory that was absolutely amazing. The normal powers of memory offer no explanation; it is almost inconceivable that Nietzsche could have reawakened that old sequence of words by a voluntary act of evocation. The reappearance of old, long-forgotten impressions is, however, explicable in terms of the physiology of the brain. The brain never forgets any impression, no matter how slight; every impression leaves behind it some trace in the memory, no matter how fine. Consciousness, on the other hand, operates with an unending loss of previous impressions, much as the Bank of England always destroys after a certain lapse of time the notes that are daily returned to it. Under special conditions the re-emergence of old memory traces with photographic fidelity is by no means impossible. Literature records not a few cases of dying people, or people in other abnormal mental states, who recited whole chains of earlier impressions which perhaps never belonged to the sphere of conscious memory at all. Eckermann⁸ mentions an old man "of low station" who, on his deathbed, suddenly began talking Greek. It turned out that a number of Greek verses had been drummed into him as a child, so that he should serve as a shining example to a lazy pupil of noble birth. I know another case where an old maidservant recited from the Bible passages in Greek and Hebrew on her deathbed. Investigations showed that as a young girl she had worked for a priest who had the habit of walking up and down after meals, reading the Bible aloud in the original tongues. The Viennese psychiatrist, Krafft-Ebing, who died recently, reports the case of a sixteen-year-old hysterical girl who, in an ecstatic state, could repeat without difficulty a poem, two pages long, which she had read shortly before.

[184] As these examples show, the physiology of the brain makes such reproductions possible. But, for them to take place, an abnormal mental state is always needed, which can justifiably be conjectured in Nietzsche's case at the time when he wrote *Zarathustra*. One has only to think of the incredible speed with which this work was produced.

There is an ecstasy so great that the tremendous strain of it is at times eased by a storm of tears, when your steps now involuntarily rush ahead, now lag behind; a feeling of being completely beside yourself, with the most distinct consciousness of innumerable delicate thrills tingling through you to your very toes; a depth of happiness, in which pain and gloom do not act as its antitheses, but as its condition, as a challenge, as necessary shades of colour in such an excess of light.⁹

So he himself describes his mood. These shattering extremes of feeling, far transcending his personal consciousness, were the forces that called up in him the remotest and most hidden associations. Here, as I said before, consciousness only plays the role of slave to the daemon of the unconscious, which tyrannizes over it and inundates it with alien ideas. No one has described the state of consciousness when under the influence of an automatic complex better than Nietzsche himself:

Has any one at the end of the nineteenth century any distinct notion of what poets of a stronger age understood by the word “inspiration”? If not, I will describe it. If one had the smallest vestige of superstition left in one, it would hardly be possible to set aside the idea that one is the mere incarnation, mouthpiece, or medium of an almighty power. The idea of revelation, in the sense that something which profoundly convulses and shatters one becomes suddenly visible and audible with indescribable certainty and accuracy, describes the simple fact. One hears—one does not seek; one takes—one does not ask who gives; a thought suddenly flashes up like lightning, it comes with necessity, without faltering—I never had any choice in the matter.¹⁰

There could scarcely be a better description of the impotence of consciousness in face of the tremendous automatism driving up from the unconscious. Only this elemental force can wrench from oblivion the oldest and most delicate traces in a man’s memory, while yet he retains his full senses. When the brain dies, and consciousness disintegrates, while the cerebral cortex still goes on drowsily working for a bit, automatically and without co-ordination, fragmentary memories may be reproduced together with a mass of morbid rubbish. The same thing happens in insanity. I recently observed a case of compulsive talking in a feeble-minded girl. She rattled away for hours on end about all the warders she had ever met in her life, including their families, their children, the arrangement of the rooms, describing everything down to the craziest detail—a marvellous performance that could not possibly have been a voluntary evocation. The work of genius is very different; it fetches up these distant fragments in order to build them into a new and meaningful structure.

[185] These psychic processes, where an automatic creative force causes lost memories to reappear in sizeable fragments and with photographic fidelity, are what science calls cryptomnesia.

[186] The case of Jacobsohn, which I know only from the remarks of Harden and Schnitzler,¹¹ would seem to have much in common with cryptomnesia; at any rate I

could not say why it should not be so. From this one might, perhaps, draw conclusions about the strength of Jacobsohn's talent and his passion for art, but hardly, as Schnitzler ventures to do, about his state of mind, let alone infer a focal lesion of the speech centres. Symptoms of a lesion in Broca's convolution and the neighbouring areas of the brain bear little resemblance to cryptomnesia. I am on the contrary inclined to give Jacobsohn a good prognosis, for the time being, as regards his artistic production. Should any human ill befall him, it would be the purest accident if the cortex of his speech convolutions were also affected.

III

ON MANIC MOOD DISORDER

ON MANIC MOOD DISORDER¹

[187] Under the term “manic mood disorder” I would like to publish a number of cases whose peculiarity consists in chronic hypomanic behaviour. A constitutional mood disorder characterized by melancholy and irritability has been known for some time, but only recently has attention been drawn to cases which, while still coming into the category of psychopathic inferiority, are remarkable for their excessively “sanguine temperament.” So far as I know from the relevant literature, Siefert² was the first to publish a case of this kind. It offered clear indications of a manic state, which, as the anamnesis showed, was chronic and could be followed back into youth. The patient was 36 years old on his admission, and had suffered a severe head trauma at the age of nine. He was intelligent and a skilled worker. Later, however, he led a vagabond’s life, was a deserter, thief, jail-breaker, and hardened alcoholic. He was arrogant in his behaviour, tremendously active, full of noble intentions and plans for world betterment, showing flight of ideas and surprisingly little need for sleep.

[188] In earlier writers we find only the barest hints, which might possibly refer to similar cases, as for instance in Pinel,³ whose *manie sans délire* with unimpaired brain activity and maniac behaviour is nevertheless too wide a frame for the narrowly circumscribed clinical picture we have in mind. The *mania chronica* mentioned in Mendel⁴ is a “secondary psychopathic state” with imbecility; a picture that hardly fits here. Even in Koch, Schüle, Krafft-Ebing, and others we find no mention of these states. In 1896, van Deventer⁵ published a second case under the term “sanguine inferiority,” which comes midway between the “sanguine-tempered normal person on the one hand and the maniac on the other.” The patient had an hereditary taint, was excitable and wayward from youth up, of good intelligence, skilled in various crafts, always cheerful and carefree, but with a wild and turbulent character, morally defective in every sense, showing flight of ideas, dangerous recklessness, and immense activity, occasionally also deep depressions.

[189] In his *Grundriss der Psychiatrie*,⁶ Wernicke gives an excellent description of these cases under the term “chronic mania.” He can say “nothing certain” about their causation, but thinks it safe to say that a pure mania never terminates in such a chronic state. The case he cites was preceded by a psychosis of several years’ standing, about which no information was available. He describes this state as follows:

Chronic mania has all the essential marks of acute mania, only these are modified in accordance with the conditions of a chronic, stable state. Hence, the flight of ideas keeps within the bounds of moderation, and can still be influenced to some extent by reflection and self-control. The elated mood is less marked, but occasionally it breaks through. On the other hand, the irascible mood is maintained owing to unavoidable conflicts with society. The heightened feeling of self-confidence, though not amounting to real megalomania, is very marked and gives these persons a certainty of address which, combined with their undeniable mental productivity, helps them to get on in the world. At the same time, they create for themselves all sorts of difficulties and conflicts by disregarding all the norms and checks which are imposed on them by custom and law. They have no consideration for others, yet demand every consideration for themselves. No signs of any formal disturbance of thinking need be present in this state.

[190] Although this general description fits in very well with the picture of a chronic hypomanic state, it still seems to me rather too broad, since it could also cover a large number of instabilities listed by Magnan—many querulous and morally feeble-minded persons (moral insanity). As experience shows, in many psychopathic illnesses there are persons who think unclearly and are prone to flights of ideas, who are ruthlessly egocentric, irascible, and mentally productive, but who can hardly be said to be suffering from chronic mania. In order to arrive at an accurate diagnosis, we require the symptoms of mania in more definite form. Occasional elation, exaggerated self-confidence, mental productivity, conflicts with law and order are not in themselves sufficient to warrant a diagnosis of “chronic mania.” For this we need the cardinal symptoms: emotional lability with predominantly elated mood, flight of ideas, distractibility, over-activity, restlessness, and—dependent on these symptoms—exaggerated self-importance, megalomaniac ideas, alcoholism, and other moral defects.

[191] So far as the term “manic mood disorder” is concerned, I would prefer van Deventer’s “sanguine inferiority,” because in my view it gives a more accurate description of what the term connotes. We have long been familiar with the idea of a constitutional melancholic mood, connoting a picture whose position midway between “healthy” and “diseased” exactly corresponds to that of the constitutional manic mood. As to the term “chronic mania” in the sense used by Siefert and Wernicke, this expression seems to me altogether too strong, for it is not a question of a real mania at all but of a hypomanic state which yet cannot be regarded as psychotic. The relatively mild manic symptoms are not partial manifestations of a periodic mania and are therefore seldom found in isolation; rather, they are frequently mixed with other psychopathic features, and this is only what one would expect, since the borderlines between the various clinical pictures of psychopathic inferiority

are extraordinarily indistinct and fluctuating. Over-accentuation of the ego, periodicity of various symptoms, such as irritability, depression, exacerbation of stable abnormalities, hysterical traits, etc., are found in nearly all cases of degeneracy, without there necessarily being any deeper connection with the basic symptoms. This is all the more reason for delimiting the picture as closely as possible, and the first requisite is always the presence of the fundamental manic symptoms.

1

[192] The following case presents a very mild form of manic mood disorder bordering on simple psychopathic instability.

[193] CASE A, born 1875, business man. Heredity: father contracted paralysis of the insane twelve years after the birth of the patient. Other members of the family healthy. Patient was a bright, clever child, physically rather weak. Scarlet fever at 8 years old. States that at school he was absent-minded and inattentive, always up to tricks. Severe attack of diphtheria in his twelfth year, with subsequent paralysis of accommodation and of the palate. Was afterwards lazy and superficial in his school-work, but showed great capabilities if he took the trouble. Easily moved to tears, became much more “difficult to understand” after the diphtheria. Entered high school at 13, found the work very easy, was always at the top of his class, extremely gifted but lacked perseverance. Early tendency to abuse of alcohol, no intolerance. Always in a cheerful mood, without worries. Matriculated with distinction. Afterwards he entered the business firm of a relative. Found it didn’t suit him, did little work, let himself be distracted by pleasures of all kinds. A year later, he volunteered for one year’s military service in the cavalry. Heavy abuse of alcohol at first only in merry company, then always before military duty, in order to calm his tremor; always had a full bottle by him, “knocked it back like anything.” Was the master of ceremonies and life and soul of the party. In the last months of military service, apparently only four hours sleep per night without fatigue next day. Then another year at home. Did practically no work. In recent months he gradually got fits of moodiness which lasted a day and repeated themselves at irregular intervals every two months. At these times he was in an abysmal bad humour, sometimes irritable, sometimes depressed, had gloomy thoughts, took a pessimistic view of the world, was often so irritable that when his mother or sister asked him anything he had to keep a grip on himself so as not to “bang both fists on the table.” He couldn’t settle down to any work, a “terrible inner restlessness” plagued him continually, an “everlasting restless urge to get away,” to change his situation, kept him from any profitable activity. He chased one pleasure after another and consumed enormous quantities of alcohol. His relatives finally decided to yield to his craving for change and let him go abroad, where he

obtained a position in a branch of the firm. But things didn't work there either. He flouted the authority of his uncle, who was his chief, annoyed him in every conceivable way, covered him with insults, and led an utterly dissolute life, indulging in every kind of excess. He didn't do a stroke of work, and after a few months had to be sent home again as a severe alcoholic, in 1899. He was then put into a home for alcoholics, but paid little attention to the regime of abstinence and used his days out for alcoholic and sexual excesses. He stayed there for about six months and then returned home, somewhat better. He did not remain abstinent, but behaved fairly decently until his proposed engagement fell through, which had a shattering effect on him. In despair he took to excessive drinking again, so heavily that he had to be put in the same home for a second time. There he tried as before to dissimulate his use of alcohol, not always successfully. Twice he ran away, the second time to Milan, where he got through several hundred marks in a few days. When his money ran out he telegraphed for more and returned home with a profound moral hangover. When it was suggested to him, in this state, that he should be placed in a closed institution, he readily agreed, and was admitted to Burghölzli on July 22, 1901.

[194] On admission the patient was slightly inebriated, euphoric, very talkative, showing flight of ideas. Told that his mother would visit him the next day, he got excited, wept, declared he was not in a fit state to receive her. In regard to his dipsomania he showed insight, but in regard to its cure he displayed a very shallow optimism. Physical examination revealed nothing but a distinct difference in the size of the pupils. For the rest of July things went well. The patient was always very animated, talkative, cheerful, amiable, showing plenty of social talent, and a sophistication that never went very deep and was at best witty. When out for walks he could talk for hours without stopping, and jumped from one thing to another in his flights of ideas. He expressed opinions on every conceivable subject with the greatest superficiality. He proved to be astonishingly well read in German and English novels of the lighter sort, was always on the go but lacked perseverance. In a short space of time he bought over a hundred books, half of which he left unread. His room was crammed with newspapers, comics, picture postcards, photographs. He took drawing lessons and boasted about his artistic gifts. After three or four lessons he gave up drawing, and the same thing happened with his riding lessons. He realized that his superficiality was abnormal and cheerfully admitted it, even priding himself on this specialty of his: "You see, I'm the most cultured and well-read superficial person," he said to me once. By the middle of September his patience was at an end. He became very moody and irritable, suddenly forced his way out, telegraphed home to say he couldn't possibly remain where he was any longer. He wrote a long letter to the doctors in a huffy, aggressive tone, and several more in the same vein to his relatives. Having returned, after a few days he became quieter and more reasonable.

Henceforth he was allowed more freedom, and could go out when he wished. He now began to go out every evening, visiting mostly light concerts and variety shows, and spent almost the entire morning in bed. His mood was continuously elated, he did no work but did not feel the least unhappy about it. This vacuous life continued up to his discharge. He was convinced of the necessity for abstinence, but overestimated his energy and powers of resistance. For his former life he lacked all feeling of shame; could talk with broad complacency about how he had worried his uncle almost sick, and felt no trace of gratitude to him for having taken a great deal of trouble to put him on the right road again. Similarly, he revelled in stories of his drinking bouts and other excesses, although there was nothing in the least praiseworthy about them.

[195] The manic symptoms in this case can be traced back to the high school period, and the purely psychopathic ones to the diphtheria in his twelfth year. The life the patient led from the time he matriculated was quite abnormal and offers a choice of two diagnoses: psychopathic instability or manic mood disorder. Moral insanity, which one might also think of, appears to be ruled out by the wealth of emotional reactions. It is certainly not a case of simple alcoholism, since the psychic abnormality persisted even during abstinence. If we exclude the features that could be grouped under ordinary psychopathic inferiority, we are left with definite hypomanic symptoms: mild flight of ideas, predominantly elated but quite inadequate mood, overactivity without consistency or perseverance. The moral defect is sufficiently explained by the superficiality of mood and the transitoriness of affects.

2

[196] The next case concerns a woman whose life took a similar course, but whose anamnesis, being more detailed, allows us a deeper insight into the nature of the emotional change.

[197] CASE B, born in 1858, married. Father a neurasthenic eccentric and drunkard, died of cirrhosis of the liver. Mother had heart trouble, died of some mental disease, apparently paralysis of the insane. Nothing known of any severe illnesses in youth. Patient was a bright, uncommonly lively child and a good pupil. From an early age she had suffered under disagreeable conditions at home. Her father was a solicitor, her family of good social standing, but between the parents there was continual strife because the father had an illegitimate liaison. In her eighteenth year, a male secretary employed in her father's business made two violent attempts to rape her, but she did not dare to divulge them to her parents, as the secretary threatened to make devastating revelations concerning her father's affairs. She suffered for years from the memory of these assaults and from the continual sexual molestations of the secretary. Gradually she developed hysterical attacks of convulsions, unaccountable

moods, mostly depressions with fits of despair, and to deaden them she began drinking wine. According to her relatives, she was good-natured and soft-hearted, but extremely weak-willed. At 22 she married. Before her marriage she got the consent of her parents to travel part of the way to meet her fiancé, who lived in Italy, but did not return with him at once. Instead, she ran around with him for a couple of days before coming home again. She was married with great *éclat*. The marriage, however, was not a happy one. She felt she was misunderstood by her husband and could never get accustomed to social etiquette. At parties given in their house she secretly slipped away and danced in the yard with the servants. After the birth of a child she became very excitable, partly from weakness, partly because of the visibly increasing estrangement from her husband. From the early days of her marriage she had cultivated a taste for fine wines and liqueurs. Now she drank more and more. On account of her increasing irritability and excitement, her husband sent her on a journey to recuperate. When she returned home she found he had started an intimate relationship with the housekeeper. This was enough to aggravate her already excited condition so gravely that she had to be sent to an institution. She came back after six months and found that the housekeeper, as her husband's mistress, had completely supplanted her. The consequence was renewed alcoholic excesses. She was then admitted to a Swiss mental home.

[198] The following points are taken from her clinical record. On her admission, May 13, 1888, she went off into loud self-accusations and complained of an inexplicable inner restlessness (which she said had existed ever since the sexual assault). She was soon in a better mood, began comparing the mental home with the private institution she had been in before, praised the latter, complained that she was being boarded as a second-class patient, criticized the regulations. She was extremely labile, at one moment with tears in her eyes, shouting with laughter the next, up to all sorts of tricks. She was extraordinarily talkative and told quite openly, in front of her fellow patients, without the least shame, how she used to make herself drunk. After the alcoholic symptoms had worn off she continued in a very labile mood, garrulous, eager for applause, fond of ambiguous stories, quick at taking words the wrong way, criticizing the doctors and the treatment, "laughing very loudly like a servant girl at quite ordinary jokes," familiar with the staff, socially very entertaining. This emotional lability lasted throughout her stay in the asylum. The diagnosis was alcoholism with moral defect. In November 1890 her husband was granted a divorce, and this was a heavy blow to the patient. She was discharged in December with the best intentions for the future. Her income amounted to 2000 francs a year for five years. She now lived with a woman friend who had a great influence over her. During this time she appears to have been almost completely abstinent. When, in 1895, her income was exhausted, she took a post with her friend in a Swiss asylum. But she did

not feel satisfied, got on badly with her superiors, was very upset when a number of escapes took place in her ward, and quit the post after a few months. She then lived alone and began drinking again. Before collapsing altogether, she was able to make up her mind to visit a clinic of her own accord, and was admitted to Burghölzli on October 19, 1895.

[199] On her admission she was much the same as on the admission reported above, only less inebriated. The initial depression quickly disappeared, and she soon unbosomed herself in exuberant letters to her friend. She was a “creature of moods,” “never able to hide her feelings,” allowing herself to be entirely ruled by the mood of the moment. She was extremely active and adapted herself quickly, “cheerful, temperamental, always ready with a bad joke,” sometimes bad-tempered, often carrying on in a rather sentimental way. Her behaviour at concerts in the asylum was ostentatious; instead of singing, she would warble with full-throated laughter. In 1896, on one of her days out, she suddenly got engaged to another patient, also an alcoholic. In July 1896 she was discharged. The medical report emphasized that her alcoholism was caused by her moods, which completely dominated her. Further, that her emotional condition was now more evenly balanced, but that there was still a “congenital lability of mood and great emotional excitability.” After that she lived “in sin” with her fiancé, who soon had a relapse and started her off drinking again. He was put in a home, and she, left to herself, tried to make a living in the grocery trade, but without much success. Once more she took to heavy drinking, got drunk daily, frequented taverns of ill repute, and on one occasion tore off her clothes in a frenzy of excitement, so that she stood there in her petticoat. She often turned up at the tavern dressed only in petticoat and raincoat. In November 1897 she was brought back to the asylum. On admission she had an hysterical attack with symptoms of delirium tremens. Then followed deep depressions, which lasted in milder form until January 1898, though this did not prevent her from showing great liveliness on festive occasions. Later she became touchy, flaunted her superior social position before others, was at times erotic, tried to flirt with a male patient, singing him sentimental songs from a distance. She was full of optimistic plans for the future, started to learn typewriting and helped in the anatomical laboratory. In March 1898 she suddenly went out and got mildly drunk, and received a reprimand which threw her into a blind rage. Next day she was found in an extreme stage of intoxication, and it turned out that she had made herself drunk in the laboratory with 96% alcohol. She was wildly excited, quite unapproachable at first, uttering threats; then manic, with flight of ideas, pressure of activity, eroticism, and devil-may-care humour. After a few days she was the same as before, unable to adapt to regulations, flirting with a manic patient at a concert. Periods of boisterous merriment. Discharged on October 11, 1900, to take up post as a housekeeper. Worked extraordinarily well and was

much appreciated for her continual gaiety and sociability. From a letter written at this time we extract the following passages, which are typical of her extreme self-confidence, exaggerated language abounding in forceful expressions, and her elated mood:

[200] The everlasting mistrust, the everlasting disbelief of these pessimists in a final moral cure, saps your strength and breaks your courage. You see yourself abandoned by others and finally you abandon yourself. Then you try to deaden your torments of soul and seize on any and every means that deadens—so long as there's spirit in it. Thank God I no longer need this deadening now. Are you pleased with me? Do you believe in my leonine strength?—!! ...

[201] My talent for educating children is a fact which neither the scepticism of Dr. X nor the shrewdness of Dr. Y can abolish....

[202] I am so tired in the evenings that my head throbs, as though it had been used for a drum in the Basel carnival. Under these circumstances you must bear kindly with me if letters from my hand turn into birds of paradise and the inclination to ballet dance in ink is at its last gasp.

[203] In July 1901 she went down with influenza, and her employer inadvisedly gave her wine as a tonic (!), whereupon she got a bottle of wine sent up every day. On July 7, she was readmitted to Burghölzli for delirium tremens, having lately drunk methylated spirits and eau de cologne. Now and then she seemed to have deep depressions with a sentimental tinge, but they were never so bad that she could not be provoked into wildly gay laughter. At a concert in August her behaviour was quite manic; she adorned herself with three huge roses, flirted openly, showed motor restlessness, behaved extremely tactlessly with the others. No insight afterwards. Her "excitability reached the highest degree of mania" (July 1901). At a music rehearsal in the room of an assistant doctor she was "extremely vivacious and talkative, erotic and provocative." She was sexually very excited at this period, but sometimes depressed. She dashed off her copywork in a careless way, wrote pages of sentimental scribble showing flights of ideas. She could be roused to all kinds of activity, but her energy invariably flagged. Very sensitive, reacting to censure with deep depression, all emotional reactions extremely labile and immoderate. She had no insight into her lability, greatly overestimated herself and her powers of resistance, had an inflated sense of her personal value, and often made very disdainful remarks about other people. She felt that she still had "a task in front of her," that she "was destined for something higher and better," that not her inferiority but her unfortunate circumstances were to blame for her degeneration. From August 1902 to April 1903 she followed a weight-reducing course, and towards the spring a more stable

depression supervened, during which she took more pains with her copywork than before.

[204] The first psychopathic symptoms in this hereditarily tainted patient showed themselves from her eighteenth year in the form of marked hysteria resulting from sexual traumata. Indications of some emotional abnormality apart from the hysteria are present from the age of 22. After her thirtieth year we have an accurate clinical history in which superficiality and emotional lability are already established. Besides alcoholism, a moral defect was diagnosed (1888). In 1896, the alcoholism was recognized as dependent on her emotional lability. In the course of years the manifest hysteria entirely disappeared except for a few symptoms (sentimental tone of the depressions), but the emotional abnormality remained stable. The periodic depressions were always of short duration and never so deep that they could not be banished by a joke. The only depression of longer duration, which had a decidedly improving effect on the patient, occurred under the influence of the reducing course and can therefore be regarded as a specific effect of this treatment. Depressions under such a treatment also occur with normal persons. The patient's depressions often had a reactive character, especially to censure, and were then merely excessive reactions to a depressing stimulus. Spontaneous exacerbations of stable symptoms were never observed with certainty; in most cases they were excessive reactions to the effects of joy or alcohol. The patient was decidedly manic when drunk. In her normal state we find a mild flight of ideas, which expressed itself particularly clearly in her writings; a predominantly elated mood with optimistic outlook, often indicative of her exaggerated self-esteem; great lability of pleasure/pain affects; marked distractibility. Her manic over-activity showed itself as a rule merely in her extreme vivacity and talkativeness, but it only needed some kind of festivity to produce an immediate increase of motor activity. The dependence of alcoholism, and of moral inferiority in general, on emotional abnormality is much clearer here than in the first case.

[205] The third case concerns a patient who was chiefly remarkable for her social instability.

[206] CASE C, born in 1876, nurse, unmarried. Heredity: father a drunkard, died of carcinoma of the liver. Step-sister (by the same father) epileptic. Patient had no severe physical illnesses in youth. Clever at school, also got good marks for behaviour, with few exceptions. Once when she got bad marks for arithmetic, she tore up the report under the teacher's eyes. Once wrote an anonymous letter to the school administration, denouncing certain teachers for assigning too much work. Once she ran away from school for two days. She was a very lively child, passionately fond of reading novels (often half the night). At 16 she left school and went to her sister's to learn how to be a seamstress. But she did little work, read most

of the time, never obeyed her sister, quarrelled with her after six months, and then took up another apprentice post, where she stayed only nine months instead of the required two years. She was quick to learn though not very diligent, was usually very merry, but sometimes irritable. Though “good-natured,” she “never took anything much to heart.” She was “burning with travel fever” and made up her mind to go to Geneva. There she found a job as an apprentice seamstress for a year, remained for the full period, but took occasional time off, paying her employer for the day. Afterwards she returned home. During this period her diet consisted almost entirely of sweets, of which she sometimes consumed five francs’ worth a day. Although it finally sickened her, for a long time afterwards she felt impelled to buy chocolates whenever she passed a confectioner’s. She would then give them to children in the street. She borrowed money for her passions in the most frivolous way from everybody, often just took it from her sister or bullied it out of her. After about six months she induced a relative to take her to America. Stayed a month in Chicago without working. Then she worked at a clothes shop, ran away four days later without giving notice. She then changed her job ten times in succession, staying a few hours or at most a couple of days in each of them. Finally found a job that suited her, as a companion. Became ill six months later with stomach ulcer; returned to Switzerland. She left a job as receptionist at a hotel after five days because of a quarrel with her employer, and went back home. A few weeks later she took a job as a housemaid, but got “sick of it” after eight months. She “could only stay in a job until she knew the country and the people, then something else had to come along.” Then she worked as a student nurse in a hospital in Bern. “Sick of it” after five months, went to another hospital, four months later became ill again with stomach ulcer, spent several months ill at home. At this point she started an illegitimate relationship with the dissolute son of a neighbour. On recovering from her illness, she worked as a shopgirl in Zurich. Spent considerable sums of money on herself and her friend, whom she supported financially. She borrowed money everywhere and left her father and sister to pay her debts. As a result, she was sent to a faith-healing institution for a cure, where she stayed for six months, working fairly well; then another four months as a maid. She started another intimate relationship, but soon got sick of her lover. Then seven months as a wardress in an institute for epileptics, followed by five months as a children’s nurse in a private house, which she left because of quarrels with one of the maids. She then betook herself to her late lover in W., made a violent scene but was finally reconciled. After that she got another job as a maid in Schaffhausen for a fortnight, then for two days in Bern, for some weeks in Zurich, for another four weeks in Bern, then again for a short time in Zurich, then for two months as a nurse in a lunatic asylum, then again for a few days in W., where she ran through her earnings at the hotel and started quarrelling again with her lover. After renewed reconciliation, she returned to Zurich, but soon fell out two more

times with her lover, took another job for two months, then went to Chur “for the fun of it,” then back to W., in order to make another scene with her lover, then returned to Zurich for a few days, only to go immediately afterwards to W. and make a second and this time final scene with her lover. After that she took a job as a children’s nurse in the Valais, where she stayed two and a half months. She became ill again with stomach ulcer and returned to Zurich via W. As she got out of the train at W. the first person she ran into was her lover, which annoyed her so much that she took the train straight back to Zurich. On arrival in Zurich, however, she regretted her sudden decision and immediately seated herself in the train back to W. Alighting on the platform at W., she regretted this decision too and rushed back to Zurich. (The distance between Zurich and W. is an hour and a half by rail.) On returning from W. after one of her quarrels, she went to a hotel with an unknown man whom she picked up at the station in Zurich and spent the night with him. With another she started an erotic conversation and apparently followed him even into the toilet, causing a public scandal.

[207] Wherever she worked she was liked, as she was constantly busy and a pleasant companion. She was never quiet, always on the go and excitable. Lately the excitement increased visibly, she also talked much more than before. She had never saved any money; what she earned she spent at once and incurred debts everywhere.

[208] On the recommendation of Professor M., the patient was admitted to Burghölzli on April 2, 1903. The report emphasizes the following points: “The patient suffers from a mild degree of maniacal excitement. The outward cause may be considered to be an affair with a young man which came to nothing. For several weeks the patient was expansive, unstable, irritable; she is excessively open-handed, sleeps little at night, cannot bear to be contradicted. Her mood is elated. She is talkative, occasionally showing flight of ideas. She cannot be kept at home because of her expansiveness, she starts something new every minute, and wants to go to W. in order to wreak her vengeance on her former fiancé.”

[209] She had a lively, intelligent expression of face, talked a great deal. Continuous motor restlessness when talking; in ordinary conversation no very noticeable flights of ideas; these only showed more clearly during longer recitals. She was very elated, very erotic, flirting and laughing a great deal; very labile, weeping easily at the memory of unhappy experiences; liked to sulk ostentatiously, and once made a violent scene when the doctor refused to visit her alone in her room, threatened suicide, so that she had to be removed for a while to the observation room. Soon afterwards she was as euphoric as ever. She was very frank and enjoyed telling of her adventures, but was incapable of putting them down on paper in an orderly fashion. An autobiography still remains to be attempted after several false starts. She

expressed a strong desire to go out, but still harboured thoughts of vengeance on her ex-fiancé, threatened to shoot him. Had all sorts of adventurous plans for the future, and once urgently requested to be allowed out in order to answer a newspaper advertisement for an animal trainer, asserting proudly that she did not lack courage. In addition, she had intensive plans for marriage. She took the disorderly life she had lived very lightly, and was convinced that things would go better in future. She showed slight insight *into* the excitement of the last few weeks before her admission. No major depressions or excited states were observed, and no deterioration of the normal state except the present one. Slight increase of excitement during her periods.

[210] In my account of this case I have purposely given a complete chronicle of the changes in social position in order to illustrate the extraordinary instability and restlessness of the patient. Over a period of eleven years, she changed her job no less than thirty-two times, in the great majority of cases simply because she was “sick of it.” So far as one can rely on the anamnestic information, the abnormal emotional state can be followed back into childhood. Apart from the menstrual cycle no periodicity was discoverable. Depressions never seemed to arise spontaneously, but were merely the outcome of circumstances. There was no alcoholism, only an enormous abuse of sweets. The findings—mild flight of ideas, talkativeness, predominantly elated mood, lability, distractibility, pressure of activity, eroticism—all bear out the diagnosis of manic mood disorder and explain the patient’s erratic and morally defective career.

4

[211] The fourth case was under investigation on a charge of theft and was certified by me as of unsound mind, the intensity of manic symptoms being of so high a degree that even “partial responsibility” seemed to me out of the question.

[212] CASE D, born 1847, painter. Heredity: father an eccentric person, intelligent, very lively, frivolous, always in a merry mood, went in for politics and litigation, neglected his business and his family, drank and gambled, lost his property and fortune, until he finally came to the poorhouse. First brother intelligent and gifted, head full of ideas, interested in social and political problems, died in poverty leaving a pile of debts. Second sister very extravagant, died in dire poverty. Third brother a moderate drinker, but able to support himself and wife. Fourth brother led a profligate life in every respect, a notorious liar, very much come down in the world, living on poor relief. One son of a normal brother was a notorious scrounger and sot. Patient had no serious illnesses in youth. A lively child, alert and intelligent; excellent school reports. Was apprenticed after leaving school; worked very industriously for the first year, clever, made progress. In the course of the second year

he changed, started drinking, neglected his work, extravagant. Remained four years in the same job, then took to roaming. His dissoluteness increased, his work grew more and more uneven and careless, and by way of contrast he developed a “terrific opinion of himself,” boasted of his cleverness and gifts, always passing himself off as something quite extraordinary. His roamings began at 19. He never stayed anywhere for longer than a few months, was always drinking, dissatisfied, no master was good enough for him, always had his “special ideas,” wanted to “be appreciated,” thought “everything should be to his liking,” was always “worked up,” frequently quit his job without giving notice, sometimes without even collecting his wages. In 1871 he returned home utterly destitute, looking like a tramp. Despite that, he bragged endlessly and told boastful stories about himself and his successes. He remained for some time at home, worked eagerly, “always in a hurry.” Suddenly his elated mood changed, he became irritable, cantankerous, grumbled about the work, his work-mates, former masters, etc., sometimes getting into a rage and “acting like the devil.” Now as before he indulged in drink, and the more he drank the more excited he became, giving vent to an unquenchable stream of talk. After a fortnight he suddenly packed his things, set forth on his wanderings again, and finally, in 1873, came to Paris. He found no work there because of the slump, and was sent home again by the authorities after five weeks. In 1875 he went to Nuremberg. According to the report of his employer there, he was a very skilful and efficient worker, but had to be dismissed on account of drunkenness. Because of acute manic excitement he had to be kept in confinement for a few weeks, and as no real remission ensued, he was packed off to Switzerland. He was admitted to Burghölzli on March 21, 1876.

[213] The patient was elated, excited, laughing away to himself, showed flight of ideas, made bad jokes, heard voices that told him funny stories, showed immense self-esteem. No essential change subsequently occurred except for a quieting down and cessation of the voices. The illness was taken for mania, and the patient was discharged as cured in August 1876, although at the time of his discharge he certainly did not give the impression of being a normal person. He then began his old wandering life again. He roamed round Switzerland like a vagabond; in November 1876, as a result of great privations and severe cold, he found himself in a delirious state in which it seemed to him that “he was the pope and had ordered a huge dinner.” In this state he tried to draw 5000 francs at the post-office and was arrested; on taking food he suddenly became clear again. In 1882 he married. The marriage remained childless. His wife had four or five abortions. He stuck to her for almost a year; then the wanderings were resumed and he stayed with his wife only off and on. In 1885 he found himself in great straits, and in desperation conceived the plan of poisoning himself and his wife. But he was afraid to carry it out, so he fell back on stealing. Up to the beginning of 1886 he committed a series of thefts, was arrested, and in view of

his doubtful mental condition was referred to the doctors in St. Pirminsberg for a medical opinion. The following points were emphasized in the report:

[214] The patient was in a continuous state of elation, with heightened self-confidence, amounting at times to real megalomania. He delighted in making mysterious allusions to his importance: "Great things are impending, here in the madhouse sits the founder of God's kingdom on earth." He composed an eighty-page opus intended for the press, largely incoherent in content, through which there ran like a red thread his unbounded glorification of himself. In it he addressed himself rhetorically to the pope, deeming himself his equal in infallibility, also to Christ, spoke of himself as a new Messiah, compared himself to Hercules and Winkelried, etc. Occasionally he went into real ecstasies, in which he wrote things like: "The greatest artist of all times past and to come shines the shoes of the unfortunate, polishes the floor in St. Pirminsberg. As is the son, so is the father and vice versa.—Hurrah for Helvetia!!! O stone of the wise, how thou shinest! O D—(his own name), what brilliance! Your God, O my companions, has the heart of a child, the voice of a lion, the innocence of a dove, and the appearance of one of you!" During his stay in the asylum the composition of these pieces formed his main occupation. He wrote several pages a day, and when his paper ran out he would sing patriotic songs for hours on end in a raucous voice. He was always very talkative, spoke in dialect, but when he really got going he fell into a literary style. His thought processes were orderly, but with a tendency to digression and detailed description. His language abounded in choice expressions, with a preference for foreign words, though these were generally used correctly. In keeping with his exaggerated self-esteem he always held himself aristocratically aloof from the other patients; the warders he snubbed, whereas he was always very friendly with the doctors. His situation did not worry him, he lived cheerfully from day to day, full of the greatest hopes for the future. He never showed any insight into his illness. Once he was in a particularly bad mood for several days, very irritable, suspicious, reserved, but occasionally cursing and swearing about the asylum. The diagnosis was "periodic mania, which might pass over into insanity." The thefts were put down to unsoundness of mind.

[215] On October 2, 1886, the patient was transferred to Burghölzli. Until December his state was the same as in St. Pirminsberg. At the beginning of December he quieted down a bit; the earlier symptoms continued but were less intense. He was given some painting to do in the asylum. Among other things he painted the asylum chapel; it was subsequently discovered that between the veins of the marble he had drawn little figures of devils and also a not unskilful caricature of the asylum's priest. He was discharged on February 25, 1887. Even during this quieter phase he still produced the same old ideas, held forth with great pathos on his vocation as a reformer and world improver. After his discharge he resumed his wanderings in

Switzerland, working a bit but never staying more than a few months in the same place. In 1891 he stole a great deal of food and was sentenced to *six* months in the workhouse. In 1893 he got a year for the same reason. In 1894 he was charged with stealing 700 francs. From the fourth day of his detention on, he heard voices whispering outside his door, and thought he could recognize the voice of one of his nieces, saying: "You will be repaid." Six days later he was released. At home the hallucinations persisted for another day and then suddenly vanished. In 1895 he was sentenced to two years in the workhouse for theft. In January 1895 he was sent to the penitentiary. According to the statements of officials there, the patient "had a screw loose" from the beginning and soon aroused suspicions of mental disorder. He accused the officials, quite without reason, of swindling. In solitary confinement he covered the walls with senseless daubs, asserting that he was a great artist. At night he was restless, talking loudly to himself about his "daily occupation." Now and then he was very irritable. On August 19, 1895, another medical report was made on him. The following points were emphasized: "The condition of the patient is much the same as that described in 1886 in the report from St. Pirminsberg. He showed manic excitement, flight of ideas, extraordinary elation, and self-esteem, boasting of his capabilities, his physical prowess, saying that he had known for 25 years how, 'by means of a certain substance, as with a breath, everything could be decked in the most gorgeous, dazzling colours'; he could 'change a dog into the most beautiful golden scarab in the twinkling of an eye.' " He came out with a lot of similar stories. On November 9 he was moved to Burghölzli. His condition was the same as in the penitentiary. He gave more or less logical reasons for his exaggerations. For instance, he got his gilding effects by brushing over with the right colour; gave up his plan for world improvement after he had seen how incorrigible the world was. His behaviour varied as before; mostly he was elated and excited, but intermittently he was irritable, with stormy moods. Though he quieted down somewhat, his condition remained the same until his discharge on January 16, 1897.

[216] In the weeks preceding his recent arrest he wandered round the neighbourhood of his home village and spent the nights in a barn, the walls of which he scribbled over with verses and sayings. His clothes were in rags, his shoes were tied to his feet with string. Between September 13 and October 3, 1901, he committed three burglaries with theft at night, taking food, drink, tobacco, and clothes. He stated that on the occasion of one of these thefts he was very agitated because, while in the cellar, he heard a voice saying: "Go down quickly and leave something for me too." He was arrested on October 8, 1901. At the first hearing he pleaded guilty. He was sent to us for observation on November 1, 1901. During his stay his behaviour was found to be unchanged. On admission he was very cheerful, composed, sure of himself, greeted his old acquaintances cordially, was very talkative and excitable, replying at great

length to every question and tacking on remarks and stories showing flight of ideas. He recounted his life story in a coherent manner, keeping fairly well to the facts. At night he slept little, mostly lay awake in bed for hours worrying about “scientific” problems. He had theories about the origin of meteorites, about the transport of dead bodies to the moon, about airships, about the nature of the brain and mental processes, etc. He worked industriously and quickly, often talking to himself or keeping up an accompaniment of animal noises—miaowing, barking, cackling, crowing. When walking about the ward he sometimes went at the run, or even on all fours. At work in the fields he was talkative, enjoyed teasing others, adorned his hat with roots and leaves of vegetables. He conceived his ideas at night and put them down, elaborately and extensively, on paper. His compositions were closely written, looked clean and neat, and except for the copious use of foreign words the spelling was correct. They revealed an erudition of sorts, a very good memory, distinct flight of ideas, with great pressure of speech and forceful expressions. Prose pieces in literary style or in dialect were jumbled together with quotations from Schiller, verses (his own and other people’s), sentences in French, always with a connecting thread of meaning which, however, did not go very deep. No uniform, comprehensive idea could be found in any of his writings, except for an intense subjective feeling of his own value and an unbounded self-esteem. The language he used was sometimes full of deep pathos, sometimes deliberately paradoxical. He was ready to discuss his ideas, did not cling to them obstinately, but dropped them in order to turn to new problems. It was even possible to talk him out of his meteorite theory and to wring from him the admission that “even the greatest scholars have been mistaken.” He would expatiate on all kinds of moral and religious questions, and displayed a lyrical and almost religious feeling—which did not prevent him, however, from blaspheming and making a laughing-stock of religious practices. Once, for example, he performed a gross travesty of the Mass. He said he was not born to work for his living, had better things to do, and must wait for the time when all his grand ideas would be realized, when he would create educational establishments for the young, a new system of world communications, etc. He had great hopes of the future, by comparison with which all thought of the actual present vanished. Despite this keen expectation he had no clear picture of the future in his mind, could only adumbrate vague and fabulous plans which were mostly concocted on the spur of the moment. But he was convinced that “all would come in good time,” and hinted that he would perhaps live longer than other *men* in order to accomplish his work. His earlier statements that he was the Messiah, “the founder of God’s new kingdom,” he corrected as symbolisms; he was only comparing himself to the Messiah and not asserting that he had any more intimate connection with him or with God. In the same way he disclosed that what had previously been taken for delusional ideas were exaggerations or vivid comparisons.

[217] Occasionally there were angry moods, usually provoked by insignificant trifles which at another time would not have been followed by an angry reaction. For instance, he once created a great disturbance at 3 o'clock in the morning, shouting, cursing, and barking like a dog, so that he woke the whole ward. As usual, he had not slept properly after midnight and was annoyed by the snoring of a patient. He justified the uproar by saying that if others were permitted to disturb him with their snoring, then he was permitted to make a noise at night too.

[218] This patient came of an abnormal family, and at least two of his close relatives (father and brother) seem to have had the same mental constitution. The picture of manic mood disorder developed after puberty and had persisted with occasional exacerbations throughout his life. Here again we find a number of symptoms of psychic degeneracy apart from the specifically manic ones. The patient was only an occasional alcoholic, probably from lack of money and also because, being everlastingly occupied with his enormous afflux of ideas, he lacked real leisure for drinking. His ideas show certain affinities with "inventor's paranoia," but on the one hand he lacked the stability and toughness of the paranoiac, and on the other hand his ideas were not fixed and incorrigible, but were more in the nature of inspirations that came to him from his elation and exaggerated self-esteem. The hallucinatory episodes that are mentioned several times in his history cannot easily be related to any known clinical picture; one of them seems to have been an effect of exhaustion, another an effect of imprisonment, a third an effect of excitement. Magnan regards them as "syndromes épisodiques des dégénérés." Although we know that "prison complexes"⁷ can occur in all sorts of degenerate subjects, we are unable to point to any particular underlying psychosis. Again, in our patient we see the delirious states passing quickly and without after-effects, for which reason they may best be regarded as syndromes of degeneracy.

[219] Here too we find periodic mood disorders in the form of pathological irritability. Once (1885) there was a deeper depression, when the patient toyed with the idea of suicide. Despite careful investigation we were only able to discover this one depression, and it is not even certain whether it lasted for an appreciable time or whether it was a sudden change of mood, such as usually occurs with manics. Apart from these few features, which do not belong absolutely to the picture of mania, the case offers all that is necessary for a diagnosis of manic mood disorder. The patient showed distinct flight of ideas, a profusion of fanciful thoughts and words; his predominating mood was not merely cheerful and carefree, but manically elated, expressing itself all the time in manic tricks and immense pressure of activity, which occasionally amounted to purposeless motor hyperactivity. His intelligence was good, and he was capable of judging his situation perfectly correctly, but the next moment his ideas of grandeur returned, and he was swung into them by the force of

his overproductive pleasure feelings. He led the most miserable life as a vagabond, roaming about the countryside summer and winter, half starved, sleeping in barns and stables, yet in flagrant contrast with reality was forever brooding on lofty schemes of world reformation. Significantly, his non-recognition by the rest of humanity was of no concern to him, as it would be to a paranoiac. His continual pleasurable excitement helped him even over this adversity. From all this we see how very much the intellect was taken in tow by the emotions. He was not really convinced of his ideas, for he did not mind correcting them theoretically; but he hoped for their fulfilment, in contrast to the paranoiac, who hopes because he is convinced. This case reminds one forcibly of those miserable lives lived by poets and artists who, with small talent and indestructible optimism, eke out a hungry existence despite the fact that they possess quite enough intelligence to realize their social inadequacy in this form, and enough talent and energy, if applied in other directions, to do good and even outstanding work in an ordinary profession. The patient can also be compared, up to a point, with those individuals whom Lombroso describes as “graphomaniacs.” They are psychopaths who, without being paranoid or feeble-minded, overestimate themselves and their ideas in the most absurd way, play about with philosophical or medical problems, write vast quantities of rubbish, and then ruin themselves by having their works published at their own expense. The defective critical faculty of such persons is often due not to feeble-mindedness, for they can sometimes detect the mistakes of their opponents very well indeed, but to an incomprehensible and exorbitant optimism which prevents them from seeing objective difficulties and fills them with invincible hopes of a better time to come, when they will be justified and rewarded. Our patient, however, reminds us also of numerous “higher imbeciles” and crackpot inventors whose feeble-mindedness is confined to lack of criticism of their own particular quirks, and whose intelligence and efficiency in other departments are at least average.

[220] It should be emphasized that in the four cases we have reported the intelligence was good throughout, in the first and second cases even very good, in flagrant contrast to the outward conduct of life, which was extraordinarily inept. It is a contrast also met with in moral insanity. No doubt the majority of cases of moral insanity mentioned in the literature were more or less feeble-minded, but there can also be no doubt that in the majority of cases the feeble-mindedness is not sufficient to explain their social incapacity. One gets the impression that the intellectual defect is more or less irrelevant and that the main emphasis falls on emotional abnormality. And here it is not so much a lack of ethical feelings that seems to play the chief role as an excess of instinctual drives and positive inclinations. A simple lack of ethical feelings would be more likely to favour the development of a ruthless, coldly calculating “mauvais sujet” or criminal, rather than one of those pleasure-seeking

individuals, instinctively up in arms against any form of social restriction, who unthinkingly fly off the rails at every point, often so brainlessly that the veriest imbecile could see the senselessness of it. Tiling⁸ has recently pointed out that the main element in the picture of moral insanity is an excessively sanguine temperament,⁹ which serves as too mercurial a basis for the intellectual process and fails to give it the necessary continuity of feeling-tone, lacking which there can be no arguments and no judgments capable of exerting any influence on the decisions reached by the will. A great deal has already been said and written about the relation between intellect and will. If there is any field of experience that teaches the dependence of action upon the emotions, that field is certainly psychiatry. The inferiority of the intellect as compared with instinctual impulses in regard to voluntary decisions is so striking that the daily experiences even of a psychologically minded, amateur psychiatrist like Baumann¹⁰ impel him to remark that the specific activity of thought is always preceded by something “primarily characterological,” which provides the necessary disposition for this or that action. Here Baumann is simply voicing Schopenhauer’s “operari sequitur esse” in other terms. What is “primarily characterological” is, in the wider sense, the feeling-tone, whether it be too little or too much or perverse; in the narrower sense it is the inclinations and drives, the basic psychological phenomena which make up man’s empirical character, and this character is obviously the determining factor in the actions of the great majority of people. The role played by the intellect is mostly a subsidiary one, since all it does at best is to give the already existing characterological motive the appearance of a logically compelling sequence of ideas, and at worst (which is what usually happens) to construct intellectual motives afterwards. This view has been expressed in general and absolute terms by Schopenhauer,¹¹ as follows: “Man ever does what he wills, and does so by necessity; that is because he *is* what he wills; for from what he is there follows by necessity everything he will ever do.”

[221] Even if we admit the fact that numerous decisions are mediated or first considered by the intellect, we should still not forget that every link in a chain of ideas has a definite feeling-value, which is the one essential thing in coming to a decision and without which the idea is an empty shadow. But this feeling-value, as a partial phenomenon, underlies any changes in the whole sequence, which in the case of mania results in Wernicke’s “levelling-down of ideas.” Consequently, even the purest intellectual process can reach a decision simply through feeling-values. Hence the prime motive for any abnormal action, provided that the intellect is fairly well preserved, should be sought in the realm of affect.

[222] Wernicke¹² regards moral insanity as a distant parallel to mania, supposing the elementary symptom to be a levelling-down of ideas. In most cases he finds an inner

unrest and irritable moods, but omits all the other, equally important manic symptoms like flight of ideas, pressure of talk, morbid euphoria, etc.

[223] In surveying the literature on morally defective persons one cannot fail to be struck by the emotional excitability and lability so frequently reported.¹³ It would perhaps be worth while, when investigating the morally defective, to direct attention mainly to this emotional abnormality, or rather lability, and to consider its incalculable effects on the intellectual processes. In this way it might be possible to shed new light on cases which till now have been judged only from the standpoint of moral defect, and to regard them rather as examples of emotional inferiority in the sense of a relatively mild or serious manic mood disorder. The greatest attention along the lines suggested would be claimed by the cases of moral insanity which follow a periodic or cyclic course with "lucid intervals" and paroxysmal exultations.

[224] To sum up:

1. Manic mood disorder is a clinical condition that belongs to the field of psychopathic inferiority, and is characterized by a stable, hypomanic complex of symptoms generally dating back to youth.

2. Exacerbations of uncertain periodicity can be observed.

3. Alcoholism, criminality, moral insanity, and social instability or incapacity are, in these cases, symptoms dependent on the hypomanic state.

[225] In conclusion, I would like to thank my chief, Professor Bleuler, for kindly allowing me to make use of the above material.

IV

A CASE OF HYSTERICAL STUPOR IN A PRISONER IN DETENTION

A CASE OF HYSTERICAL STUPOR IN A PRISONER IN DETENTION¹

[226] The following case of hysterical stupor in a prisoner in detention was referred to the Burghölzli Clinic for a medical opinion. Apart from the publications of Ganser and Raecke, the literature on cases of this kind is very scanty, and even their clinical status seems uncertain in view of Nissl's criticisms.² It therefore seems to me of interest to put such a case on record, particularly as the special clinical picture it presents is of considerable importance for the psychopathology of hysteria in general.

[227] The patient, Godwina F., was born May 15, 1854. Her parents were stated to have been healthy. Two of her four sisters died of consumption, another died in a lunatic asylum, the fourth was normal. One brother was also normal and very steady-going. The second brother was Carl F., an habitual criminal. Her two illegitimate daughters were both healthy. Nothing was known of any previous major illnesses. The patient came of poor circumstances; she began work in a factory at the age of 14. At 17 she started a love affair, had her first illegitimate child at 18, her second at 28. She was entirely dependent on her lover, who provided her regularly with money. She alleged that three years earlier she had received from him some 20,000 marks, which she quickly spent. Consequently she got into financial difficulties, let her hotel bills pile up, and then left the hotel, repeatedly promising the proprietor that she would pay as soon as she got the sum due—10,000 marks—from her lover. Suspected of theft, she was arrested on May 31, at 5 P.M. At the preliminary hearing on the same day, and on the following days, she conducted herself quite correctly, and her behaviour in custody was altogether quiet and respectable.

[228] Her daughter stated that the patient had lately been irritable and depressed, which was understandable enough in view of her difficult situation. Otherwise nothing abnormal could be ascertained.

[229] When, on the morning of June 4, 1902, the cell was opened at 6:30, the patient was standing "rigid" by the door, came up to the wardress "quite rigid" and furiously demanded that she should "give back the money she had stolen from her." She waved away the food that was put before her, remarking that there was "poison in it." She began to rage and shout, threw herself about in the cell, kept on asking for her money, saying that she wanted to see the judge at once, etc. At the call of the wardress, the jailer came with his wife and assistant, and together they tried to calm her down. Apparently there was a fairly lively scene; they held her by the hands and

(according to the wardress) also “shook” her. They denied hitting her. The patient was then locked up again. When the cell was opened again at 11 o’clock the patient had torn the top half of her clothes to shreds. She was still very worked up, said the jailer had hit her on the head, they had taken the money she got from her husband, 10,000 marks, all in gold, which she had counted on the table, etc. She showed an acute fear of the jailer.

[230] During the afternoon the patient was quieter. At 6 in the evening the District Medical Officer found her totally disoriented. The following symptoms are worth noting: almost complete lack of memory, easily provoked changes of mood, megalomaniac ideas, stumbling speech, complete insensibility to deep pin-pricks, strong tremor of the hands and head, her writing shaky and broken. She fancied she was in a luxury hotel, eating rich food, that the prison personnel were hotel guests. Said she was very wealthy, had millions; that during the night a man attacked her, who felt cold. At times she was excitable, screaming and shouting gibberish. She did not know her own name and could say nothing about her past life and her family. She no longer recognized money.

[231] On the way to the asylum she was extremely nervous and frightened, started at every little thing in an exaggerated way, clung to the attendant. She was admitted at 8 P.M. on June 4.

[232] The patient was of medium height, physically well nourished. She looked exhausted and haggard. Expression of the face was nervous and tearful, as if she felt utterly helpless and hopeless.

[233] Her head, tongue, and hands trembled. Depression in region of fontanelle; circumference of head 55 cm.; biparietal 15 cm.; occipitofrontal 18.5 cm. Pupils reacted normally to light and to accommodation. Gait rather unsteady. No ataxia, no Romberg sign. Reflexes of forearm and knee- and ankle-jerks brisk; pharyngeal reflex present.

[234] *June 5.* Patient passed a quiet night. Today she kept to her bed, quiet and listless. Ate decently, was clean in her habits. No spontaneous sign of affect; facial expression indicated a mood of nervous discontent without any strong affects. She looked at me with a helpless gaze, jumped at all sudden questions and quick movements. Her mood was very unstable and depended very much on the facial expression of her questioner. A serious face made her cry at once, a laughing face made her laugh, too, and to a stern face she reacted with instant fear, turned her head away, buried her face in the pillows, saying: “Don’t hit me.”

[235] There were no symptoms of any major restriction of the field of vision. (Accurate tests were impossible owing to her psychic condition.) Skin sensibility, or rather

sensibility to pain, exhibited peculiarities: at the first examination there was total analgesia on the legs and feet for deep, unobserved pinpricks, with normal sensibility on the head and arms. After a few minutes the picture changed completely: total analgesia on the left arm and normal sensibility on the lower limbs—the very places where the opposite condition had been observed shortly before. The analgesic areas varied without rhyme or reason, being apparently independent of suggestion (though this cannot be ruled out with certainty). The striking thing was the patient's behaviour during this examination: she resisted it, but did so in an impersonal way, not paying any attention to what I was doing, even when I intentionally administered the pricks quite openly, under her very eyes. *Rather, as if consciously denying the real situation, she looked for some unknown cause of the pain in her nightgown or in the bedclothes.*

[236] The following conversation then took place:

Where are you? — *In Munich.*

Where are you staying? — *In a hotel.*

What time is it? — *I don't know.*

What's your name? — *Don't know.*

Christian name? — *Ida.* (This was the name of her second daughter.)

When were you born? — *I don't know.*

How long have you been here? — *Don't know.*

Is your name Meier or Müller? — *Ida Müller.*

Have you a daughter? — *No.*

Surely you have! — *Yes.*

Is she married? — *Yes.*

Whom to? — *To a man.*

What is he? — *Don't know.*

Isn't he the director of a factory? — *Yes, he is.* (Wrong answer.)

Do you know Godwina F.? — *Yes, she's in Munich.*

Are you Godwina F.? — *Yes.*

I thought your name was Ida Müller? — *Yes, my name's Ida.*

Have you ever been to Zurich? — *Never, but I've stopped with my son-in-law.*

Do you know Mr. Benz? (The son-in-law.) — *Don't know Mr. Benz, never spoken with him.*

But you've stopped with him, haven't you? — *Yes.*

Do you know Carl F? (Her brother.) — *Don't know him.*

Who am I? — *The headwaiter.*

What is this? (A notebook.) — *The menu.*

Tell me the time. (I showed her my watch, which said 11.) — *One o'clock.*

What is three times four? — *Two.*

How many fingers is this (5)? — *Three.*

No, look carefully! — *Seven.*

Count them. — *1, 2, 3, 5, 7.*

Count up to 10. — *1, 2, 3, 4, 5, 6, 7, 10, 12.*

[237] She couldn't say the alphabet or do simple multiplication. When she attempted to write, extremely strong tremors appeared; she could not produce a single legible word with her right hand but managed a bit better with her left. She could read only with the utmost difficulty, and frequently misread the letters. With numbers it was even worse; she could not distinguish between 4 and 5. She recognized objects held before her. No symptoms of apraxia. She proved very suggestible. For instance, she was told when standing by the bed in her nightgown that she had a pretty silk dress on. "Yes, very pretty," she said, stroking the nightgown with her hand and looking down at herself. Then she wanted to lie down in bed again. "But you can't go to bed with your clothes on!" Silently she began unbuttoning her nightgown, then stopped suddenly: "But I'm not wearing a nightgown!"

[238] *June 6.* The patient's condition was about the same, but she now knew her name was F., though she still gave "Ida" as her first name. She knew her age, but was otherwise totally disoriented.

[239] *June 7.*

How long have you been here? — *A long time.*

Twenty years? — *Yes, a very long time.*

You've only been here a week, haven't you? — *Only a week?*

Where are you? — *In Munich. Must I always keep telling you?*

Where are you staying? — *In hospital. There are lots of sick people here, but I'm not sick.*

What's the matter with these sick people? — *Headache.*

Who am I? — *The doctor.*

Have you seen me before? — *No.*

So today is the first time? — *No, yesterday.*

What day of the week is it? — *Sunday. (Wrong answer.)*

Month? — *The second.*

Year? — *I don't know.*

1899? — *Yes.*

No, it's 1892! — *Yes, of course.*

Or is it 1902? — *Yes, yes, 1902! (In an emphatic tone of voice.)*

No, it's 1900, of course it's 1900, I was all muddled up.

Weren't you in prison recently? — *No, I've never been in prison. A man with a beard hit me.*

Did that happen here? — *Yes.*

Have you any debts? — *No.*

Yes, you have! — *Well, I have a lot of money.*

Where from? — (No answer.)

How much? — *Quite a lot.*

How much, then? — *I don't know, I never counted it. It belongs to my daughter.*

Who was the father of your children? — *He died a long time ago.*

How old are you? — *Fifty.*

What year were you born? — *In May.*

What year were you born? — *I don't know.*

Is your daughter pregnant? (She was very near her time.) — *What's that mean?*

Is your daughter expecting a baby? — *No, it died.*

Have you only one daughter? — *Yes, only one.*

But you have two daughters! — *Yes.*

What is the name of your married daughter's husband? — *I don't know.*

[240] The patient talked quite well today, only stumbling over the more difficult words. She was slow at reading, but didn't make too many mistakes. Comprehension of what she read was much hindered by a high degree of distractibility. Only quite short sentences of the simplest order were understood and reproduced. Longer sentences were neither understood nor reproduced, though the patient did everything she was asked. She recited the alphabet faultlessly. Her counting still had gaps: 10, 11, 12, 13, —, 15, 16, 17, 18, —, 20.

[241] She still confused 4 and 5 when writing. Her writing was very much distorted by the tremor.

[242] On the following days her condition remained essentially the same.

[243] *June 9.* Better today, quick reaction, greeted me in a friendly manner. Orientation in space was correct, she knew her name was Godwina F. But had no idea when, how, or why she came here. Knew only of one daughter, Ida. Knew nothing of the

existence of her brother, Carl F., nor of her arrest, her son-in-law, etc. No gross disturbances of sensibility ascertainable.

[244] *June 10.* Received a visit from her daughter Ida this morning. Still remembered it in the evening. Orientation maintained. She asked the wardress about the date.

[245] On being told that she was in detention, she exhibited strong affect, burst into tears, refused to believe it.

[246] *June 11.* Again a little better than yesterday. She was oriented as to place and time, but complained of bad headache. Lay quietly in bed, apparently very exhausted. Very distractible, and had to be prodded into answering. Her memory of events from June 6 back to several months before her arrest was grossly impaired. She had only the haziest ideas about her last stay in Zurich. She knew that she last stayed at a hotel run by a Mr. König, but could not remember the name of the hotel, despite my insistence. For the period immediately preceding her arrest, as also for the period of her detention, she had absolute amnesia. She could only remember that “a man hit her, not here, but somewhere else, probably in another hospital.”

[247] Her memory starts again from about June 10. She still remembered her daughter’s visit yesterday, but not her painful agitation on being informed that she was in detention. She remembered from June 9 or even earlier that she thought at first she was in Munich (where she had in fact been six months previously). Despite insistent examination, nothing more could be ascertained.

[248] Very nervous and frightened at the least thing. Easily fatigued, and several times wearily closed her eyes during the conversation.

[249] *June 12.* Fully oriented. Had all sorts of ideas about her situation. Thought she came here because she was ill with bad headache and flickering before her eyes. Said she had been told the police brought her (she got this from the wardress), but that she knew absolutely nothing about it. Also that she had been in prison, but did not know how long, maybe a week. In prison she had been beaten because she said her money had been stolen. She thought she had put the money on the table and then it suddenly vanished.

[250] She also remembered her large debts and the charge of stealing. She was extremely nervous and easily tired, rather unclear in the head, and had to think a long time before answering.

[251] On the following days, no essential change.

[252] *June 18.* Not so frightened or so easily fatigued. Gave a coherent anamnesis, but it still contained a fair number of errors due to distractibility, particularly in the dates. Her memory was fairly clear up to the day of her arrest (May 31); from then on,

uncertain. She had to think a long time before remembering the place where she was arrested; said it was in the morning (instead of 5 P.M.). She knew she had been up for a hearing, apparently only once, and said she'd been shut up in the cell for a week. She said the hearing took place on the first or second day of detention (June 2). (In reality it was immediately after her arrest, at 6 P.M., and on the following morning; she was also present at the examination of several witnesses.) She still vaguely remembered seeing her daughter there. (The daughter was arrested under the same charge.) She thought she had to sign something, but did not know what. On the second or third night "she was quite positive that she put the 10,000 marks which she'd been expecting on the table." The money was a great joy to her. Then it seemed as if the door suddenly opened and a black man came in, with bent head, who seized her by the shoulders with cold hands and pushed her into the pillows. Suddenly the thought came to her: "Christ, he's after my money!" She then came to herself from sheer fright, still feeling the cold hands on her shoulders; convinced herself that the door was shut, and looked round for her money on the table. It had vanished. She was in despair; she could not find her way about and no longer knew where she was. Next morning two men and two women came whom she did not know. One of the men seized her by the hair and hit her. She screamed and "must have lost consciousness." "It was just like being dead." When she came to herself again, she was lying here (in the asylum) in bed. She thought she was in Munich, but the wardress told her it was Zurich.

[253] She now felt pretty well, except for the headache and for sleeping badly. Only at night she had bad dreams; for instance, of lying on kittens, or that swarms of cats were crawling over her.

[254] The patient still exhibited marked torpor and considerably reduced power of attention. Comprehension good. Retention very bad; she failed altogether to remember stories of any length. She was good at short, simple sums, but could not solve more complicated ones such as 3×17 , 7×17 , $35 \div 6$, $112 + 73$, as she always forgot one part of the calculation. Rapid blunting of attention owing to high fatigability.

[255] Precise sensibility tests showed poor discrimination between qualities of touch and temperature, particularly in the lower limbs. Perimetric examination showed normal field of vision. No analgesia.

[256] In the evening the patient was put for a short time into hypnotic somnambulism by means of a few passes and closing of the eyes. Under suggestion, she drank wine and vinegar from an empty glass. On being told that it was an apple, she bit a pen wiper and pronounced it very sour.

[257] Cautious questioning revealed that *the retrograde amnesia for the period from May 31 to the night of June 3 disappeared under hypnosis*. The patient related that she was arrested at 5 P.M. on the Bellevueplatz, where she was taking a walk with her daughter. The daughter was apprehended first, whereupon the patient, who was a few paces behind her, came up to see what was the matter. The hearing took place at 6 P.M. and continued on the following morning. (The details were confirmed by the daughter.) *The total amnesia for the period from the night of June 5 to June 10 resisted hypnosis*. No memory of this period could be awakened despite repeated attempts.

[258] The headache disappeared under suggestion. Deep sleep was suggested for the night, also amnesia for the whole content of the hypnosis. The pains in the head were much better after she was wakened, and at night she slept uninterruptedly for eight hours.

[259] On the following days she was hypnotized fairly regularly, with good results. In each hypnosis she showed continuity of memory with the previous ones.

[260] *June 24*. The patient now spent the whole time out of bed, doing some kind of handiwork. Except for a certain dreaminess and distractibility, there were no more symptoms of note. *The retrograde partial amnesia and the total amnesia continued unaltered*. The patient proved very suggestible, so that posthypnotic suggestions were realized too.

[261] *June 27*. Today it was possible to penetrate the total amnesia by a trick.

[262] The patient was put to sleep in the usual way. She at once became cataleptic and profoundly analgesic.

[263] Are you hypnotized now? — *Yes*.

Are you asleep? — *Yes*.

But you can't be asleep, as you're talking to me! — *Yes, that's right, I'm not asleep*.

Look out, I'm now going to hypnotize you! (This procedure was repeated several times. The patient lay quite slack; the slight twitching of the arms that always occurs under hypnosis stopped.)

Are you asleep now? — (No answer.)

Are you asleep? — (No answer.)

You will be able to speak presently! (Passes were made over the mouth.)

Are you asleep? — (Softly and hesitatingly:) *Yes*.

How did you get here? — *I don't know*.

You are now in the detention cell, aren't you? — *Yes*.

And now the door is opening? — *Yes, and a policeman comes in, he's taking me to the asylum.*

Then how did you get here? — *In a cab.*

You are now in the cab. — *Yes, I'm awfully afraid in the cab, there's thunder and lightning and pouring rain. I'm always afraid of the big fat man who beats me.*

Now the cab stops, you are in the asylum. What time is it? — *Eight o'clock. I'm sitting in a little room, a gentleman with a beard comes in and says I needn't be afraid, nobody's going to hit me.... then two women come and then another, they put me to bed.*

[264] Here the memory broke off again. The patient's statements correspond exactly with reality. She was brought to the asylum in a cab, by a police sergeant, at 8 P.M., during a violent thunderstorm. On the way she clung frantically to the sergeant, saying in a terrified voice that she "was going to be beaten again." A doctor was present at her admission, also there were two senior wardresses, and the nurse came soon afterwards.

[265] During the next fortnight the patient's general condition underwent considerable improvement with occasional use of hypnosis. The scope of the amnesias remained unaltered.

[266] *June 21.* During the night the patient suddenly jumped out of bed, totally confused, in great terror, absolutely disoriented, and only after much persuasion could she be quieted down sufficiently to go back to bed. She stayed in bed this morning, trembling and starting violently when spoken to, expressing vague fears and complaining of dizziness and headache.

[267] Immediate inquiries revealed that yesterday, at a concert given in the asylum, she met a male patient who, before being admitted here, had put her in a very unpleasant situation indeed by blurting out the whole story of her brother, the habitual criminal, in the hotel where she stayed before her arrest. She had already complained, at the concert and afterwards, about the unpleasant impression the patient made upon her. After being ordered two hours' rest in bed, which had a very favourable effect, she was examined with the utmost care, and gave the following information:

[268] On going to bed yesterday evening she had dizziness and "noises" in the head. But she slept very well and now felt quite clear. She could not remember anything unpleasant that happened yesterday. When asked whether she remembered yesterday's concert, she suddenly got very red and her eyes filled with tears, but she said in an indifferent tone of voice that she remembered the concert quite well—which she proved by mentioning various details. Nothing unpleasant had happened at the concert. All indirect questions remained without result, only the direct question

whether she had seen the patient M. reminded her of the incident. She now related the affair in an indifferent tone of voice, without showing any noticeable affects.

[269] *July 22.* Passed the night quietly. No deterioration.

[270] *In today's hypnosis the amnesia for yesterday's twilight state disappeared.* She was put back into the state of the previous night on its being suggested to her that she was frightened and did not know where she was. She then showed how she jumped out of bed. The wardress called out: "Miss F., be quiet and go back to bed." But she did not go back, tried to hide herself, and felt terribly frightened; then a fellow patient came to comfort and soothe her. (Details of her account could be objectively confirmed.)

[271] *July 24.* Still complained of headache and sleeping badly.

[272] *It was suddenly discovered that even without double hypnosis the patient had a hypnotic recollection of the twilight state from June 4 to June 10.* Her memory now goes back to the morning of June 5, of which she reproduced the scenes of the visits and the examination with a wealth of detail. A fair amount was also elicited from the days following the 5th, but this could not be verified for lack of precise information. As a post-hypnotic suggestion she was told to remember the episode from the twilight state. In place of the short sleep, the hypnosis was followed by hysterical somnambulism, in which the patient mistook me for her lover and addressed tender words to "Ferdinand." By means of a few passes and energetic suggestions for sleeping, the twilight state was terminated and then converted into simple sleep. Total amnesia after waking. The post-hypnotic suggestion that she would remember her admission to the asylum was not realized.

[273] The patient was discharged on July 25 under police escort.

[274] On August 8, 1902, she wrote in a letter to an acquaintance in the asylum: "Ever since I've been here [abroad] I've felt unwell, when I wake up at night I don't know where I am, and I get the feeling that I can't think any more. I have to jump up and run about the room until I know where I am again."

[275] The patient wrote that she was in a difficult situation because of money.

*

[276] This case has several interesting peculiarities to offer. It is undoubtedly a purely hysterical ailment.

[277] While in detention, the patient suffered from a delirious twilight state, which after a short pause passed into a stuporous stage characterized by the symptom of the "senseless answer," strong disturbance of attention despite fairly good

comprehension, high suggestibility, fatigability, disorientation, timidity, nervousness, absence of catatonic symptoms, and disturbances of sensibility.

[278] In his lecture on a “remarkable example of an hysterical twilight state,” Ganser,³ in 1897, gave a cursory account of states which were mostly observed in prisoners in detention. The picture most of the patients present is one of hallucinatory confusion; many exhibit active fear, together with various disturbances of sensibility. Generally, after a few days, there is a striking change, sometimes an improvement, followed by amnesia for the attack. These states owe their characteristic features to the “symptom of the senseless answer,” which consists in the patients’ “inability to answer correctly the simplest questions put to them, although it was obvious from the kind of answers they gave that they had understood the meaning of the questions fairly well. Their answers revealed a positively astounding ignorance and a surprising lack of knowledge which they definitely must have possessed or must still possess.”

[279] An alternating state of consciousness with defects of memory, in conjunction with other hysterical symptoms, provides the diagnostic basis for an hysterical twilight state. Raecke⁴ has made a thorough study of such cases, and particularly of the symptom of the senseless answer. The cases he published in his first work were not all of the same kind and were not, perhaps, altogether unexceptional; consequently they provoked sharp criticism from Nissl,⁵ who accused Raecke of faulty diagnosis and asserted that “Ganser’s symptom of irrelevant talk is first and foremost a special manifestation of catatonic negativism.” The irrelevant talk of hebephrenics and catatonics is a very well-known phenomenon, and I do not believe an observer with any experience could mistake it for the “senseless answers” of hysterics. The most he could do would be to overlook a catatonia masked by hysteriform symptoms. When the inadequate answers are the direct manifestation of catatonia, they are clearly characterized as catatonic by the significant absence of affectivity and by associations which seize on irrelevant points in the question, thus differing essentially from the deliberately senseless answers of the hysteric. The irrelevant talk of hebephrenics is often due merely to lack of interest, to the “don’t care” attitude typical of such patients, perhaps also to negativistic compulsion. The senseless answer, on the other hand, is sometimes a product of semi-intentional negation, which opposes the effort to give an adequate answer, and sometimes a product of a deep restriction of consciousness, which prevents conscious association of the elements needed for an adequate answer. As an accompanying phenomenon very typical of these latter cases, we would emphasize the stuporous behaviour of the majority of the patients. Raecke, in his second publication,⁶ describes several such cases of stupor, having already established stuporous behaviour in three of the five cases mentioned in his first publication.

[280] Severe temporary loss of the intellectual faculties is a symptom not uncommonly met with in the field of hysteria. Here I would mention in passing the cases of alternating consciousness described by Azam,⁷ Weir Mitchell,⁸ Schroeder van der Kolk,⁹ MacNish,¹⁰ etc. Some of the patients had, after a prodromal stage of sleep, lost all knowledge even of the simplest things. Weir Mitchell's case did not even know the meanings of words. Similar intellectual defects are also found in the moria states of young hysterics.

[281] The phenomenon we are discussing has, however, a very different clinical setting in our case, and assumes a special aspect when combined with other symptoms. If we take Ganser's syndrome to mean a passing state of altered consciousness, amnesically separated from the normal state, in conjunction with exaggerated, negativistic senselessness, then its inner affinity with Raecke's description of stupor in convicts is unmistakable. This stupor is often found in criminals, generally soon after their arrest, and may be regarded as a consequence of the excitements and hardships they have undergone. An hallucinatory prodromal stage, preceding the stupor, is also found in Ganser's syndrome with the same clinical symptoms and can dominate the situation for a longer or shorter period. Similarly, disturbances of sensibility are common to both. The question as to the extent of amnesia is very obscure; like most hysterical amnesias, it is difficult and sometimes impossible to circumscribe. Course and prognosis are equally uncertain. One can only say that in this matter the same is true as in traumatic neuroses, where the illness stands in reciprocal relationship to the injuriousness of the cause.

[282] Our case seems to me particularly suited to throw light on those aspects of the Ganser-Raecke picture which are still relatively unexplored because they are so difficult to observe, that is, on the still open question of amnesia and the psychological mechanism of the most characteristic symptoms.

[283] In our patient, whose anamnesis had nothing special to offer, the picture described by Raecke developed in singularly pure form under the obvious influence of detention. In the loneliness of solitary confinement she naturally became intensely preoccupied with the misfortune that had suddenly befallen her; moreover, she was worried about her daughter, who was in the last stages of pregnancy, and on top of that there was the anxiety and agitation caused by the charge of theft (which later turned out to be false). All this led to the outbreak of a delirious state on the fourth night of her detention, with violent motor excitement. As chief content of the delirium we find a syndrome which "every prison psychosis can offer for a time."¹¹ It consists of that well-known mixture of hallucinatory wish-fulfilment and delusions of being wronged. We must regard as such a symptom of detention the episode which began like a vivid dream with a wish-fulfilling illusion and ended in a state of fearful

perplexity and lack of judgment, where nothing could be corrected despite the fact that she was more or less awake. She dreamt that she received the expected 10,000 marks and put them on the table; a black figure suddenly comes in and gives her a violent fright; she leaps up; the hallucinations vanish, leaving behind them the delusions of being robbed, poisoned, etc. In the course of the next day the wish-fulfilling delusion gained the upper hand: the patient thought she was in a luxurious hotel, was very rich, had millions. At the same time she showed marked deficiency of intellect, which the prison doctor who was called in took for *dementia paralytica*.

[284] This intensification of a wish-fulfilling delusion to a real delusion of grandeur may perhaps have been due to extreme restriction of the mental field of vision, since, as Wernicke points out,¹² delusions of grandeur may easily arise when there is a lack of orienting ideas and a predominance of egotistic thinking. Raecke noticed much the same thing in his cases.

[285] On being admitted to the asylum, the patient presented a picture of the most profound restriction of consciousness, with marked anxiety and perplexity. A little later this state passed into a quieter phase characterized by absolute lack of psychic content; her consciousness was a *tabula rasa*. Continuity of all memories seems to have been broken; she fancied she was in a hotel, but this was rather a matter of guesswork, a faint echo of her previous life, than a real misinterpretation of her surroundings in delirium. She had lost all knowledge of the simplest things, even of her own name, and, as though it occurred to her in a dream, gave her daughter's name as her own. In striking contrast to this marked deficiency of intellect was her good comprehension. She understood requests and questions well; only in her answers, or rather in her centrifugal psychic performance, was any disturbance evident. As might be expected, the power of attention was almost entirely absent, so that the whole psychic process was broken up into apparently disconnected elements. This picture was completed by her suggestibility; anything one told the patient or forced her to do supplied the only content in her mental void, and this behaviour was quite consistent with her behaviour under hypnosis.

[286] This stuporous state is so far removed from catatonic stupor that the latter has no bearing whatever on a differential diagnosis of our case.

[287] Despite this apparently absolute mental blank, we have a number of clues to support the hypothesis of a psychic process, though it is abnormal in not being illuminated by consciousness.

[288] When asked her Christian name, the patient replied, "Ida." Ida was the name of the daughter who was arrested with her. Asked whether she knew anybody called Godwina F., she replied, "Yes, she is in Munich." The patient herself was formerly in Munich. The idea that she was now in Munich, a faint continuity of memory with her

earlier personality, obviously gave her the shadowy idea of her former real stay in Munich, and hence a recollection of her real name.

[289] Was she ever in Zurich? “Never, but I’ve stopped there with my son-in-law.” The son-in-law did, in fact, live in Zurich, and the name “Zurich” stirred up memories of the unpleasant experiences she had there, which were also mainly connected with her son-in-law. This double connection thrust the memory of the son-in-law to the forefront, while the obvious answer—that she had been in Zurich—was rejected. We shall see more of this curious mechanism which is so characteristic of hysterical ailments.

[290] Asked what was the matter with the patients in the asylum, she replied, “Headache.” This answer shows that she was unconsciously oriented to her surroundings, but that her supraliminal consciousness could only produce a distant association to the right idea.

[291] The psychology of the next answer is very similar. Asked whether she had recently been in prison, she replied, “No, I’ve never been in prison. A man with a beard hit me.” Here again the right answer cannot be given, or rather it is flatly denied, and an idea closely associated with it is produced instead. The reverse, too, sometimes happens—an affirmative answer is given as a result of suggestibility, but must be denied immediately afterwards because of her peculiar negativism. Thus, when asked whether it was 1902, she answered, “Yes, yes, 1902—no, it’s 1900, of course it’s 1900. I was all muddled.”

[292] Her orientation was quite unmistakable, however, in the episode of the suggested silk dress. The suggestion that she was wearing a silk dress was realized at once, and lasted until she wanted to undress in order to go to bed. At that moment the unconscious orientation broke through; she stopped suddenly and said, “But I’m not wearing a nightgown!” She knew subconsciously that she was standing there in her nightgown and that she would be completely naked if she took it off. The feeling of shame was stronger than the suggestion and prevented her from undressing—not, however, with the right motivation, but because of a suggested association to the right idea.

[293] With the improvement beginning June 9, despite fairly good orientation as to time and place, there was a striking defect of memory for all unpleasant events in the recent past, including all persons who were in any way associated with unpleasant memories for the patient. She remembered only her daughter Ida, but had no knowledge of her other daughter and of the son-in-law she quarrelled with, or of her brother the criminal. Although on June 10 she showed continuity of memory with the previous day, she no longer remembered the information which she received with

such lively affect, concerning her arrest and detention. So once again something unpleasant was repressed out of the sphere of consciousness.

[294] As can be seen from the patient's history, the scope of her consciousness gradually reconstituted itself, except for her defective memory of the whole period of the twilight state (which remained irreparable up till the end of observation). As already reported, elucidation of her summary memory from the moment of arrest to the outbreak of psychosis in the night of June 3 presented no difficulty at all. Much greater obstacles stood in the way of hypnotic elucidation of the twilight state. However, I succeeded in the end, by making use of two tricks mentioned in the literature. The first was devised by Janet.¹³ In order to put his well-known medium Lucie into a deeper sleep for a definite purpose, he would hypnotize Lucie II (that is, Lucie I, already hypnotized into somnambulism) by means of passes, just as if she were not yet hypnotized. By means of this procedure Janet discovered Lucie III, whose memory was like a large circle enclosing the two smaller circles of the memories of Lucie II and Lucie I; that is to say, it had at its disposal memories not accessible to either of them. As an intermediate state between Lucie II and Lucie III, Janet found a deep sleep in which Lucie was absolutely uninfluenceable.¹⁴ The same thing was observed in our patient. The short sleeping state which followed the second dose of hypnotism, and from which it was rather difficult to get the patient to speak, probably corresponds to the intermediate state mentioned by Janet.

[295] The second trick I used was the method used by Forel in Naef's famous case.¹⁵ This consists in putting the patient each time into the appropriate situation, thereby giving him *points d'appui* round which the other associations aggregate like crystals.

[296] By means of these two procedures it was possible to demonstrate that our hypothesis of an unconscious but none the less certain orientation—even during the deepest twilight state—was correct. We therefore find the remarkable fact that the apparently severe disturbance of the psychic process in the Ganser-Raecke twilight state is merely a superficial one, affecting only the extent of consciousness, and that the unconscious mental activity is little affected, if at all.

[297] The psychological mechanism whereby such a disturbance comes about is nicely illustrated in the story of the little relapse which was observed in the asylum, when the patient had that unpleasant encounter at the concert. In the evening she complained of dizziness and noise in her ears, and that night she suddenly woke up, totally disoriented, confused, and frightened. The next day she had amnesia for the nocturnal interlude, and, when examined for its aetiology, displayed a systematic negativism that prevented her from saying what had really happened, although the words were almost put into her mouth. During this recital, she exhibited no adequate

affect, but her sudden blushing and the tears in her eyes showed that the sore spot had been touched.

[298] Here we have the primary phenomenon in the genesis of hysterical symptoms which Breuer and Freud have termed *hysterical conversion*.¹⁶ According to them, every person has a certain threshold up to which he can tolerate “unabreacted” affects and allow them to pile up. Anything that exceeds that threshold leads—*cum grano salis!*—to hysteria. In the language of Breuer and Freud, our patient’s threshold had been reached and exceeded as a result of her detention, and the unabreacted affect—the “excitement proceeding from the affective idea”—flowed off into abnormal channels and got “converted.” Just how it will flow off is “determined” in most cases by chance or by the individual; that is to say, the line of least resistance is in one case the convulsion mechanism, in another sensibility, in a third the disturbance of consciousness, and so on. In our case, to judge from all the crucial points in the patient’s history, the determining factor seems to have been the *idea of forgetting*. Her “not knowing” turns out to be partly an unconscious and partly a half-conscious *not wanting to know*. Raecke thinks that the not-knowing he found so remarkable in his patients may be due to fear, the fear of not knowing the simplest things, which, by auto-suggestion, leads to a real and effective not-knowing. This may often be true; but with our patient the semi-intentional repression of anything unpleasant from her consciousness was such a striking and dominant feature that Ganser’s symptom seems to be altogether accessory. It may be regarded as a pathologically exaggerated consequence of the unconscious urge to forget, since her conscious mind drew back not only from feeling-toned ideas but from other zones of memory as well.

[299] As to the clinical status of our case, we must define it as the “hysterical stupor of the convict” in the sense used by Raecke. This special form of hysterical illness—if we leave out of account the “prison complex” of hallucinations and delusions—may be described on the basis of the material at present available as a “prison psychosis,” since, with few exceptions, the cases so far known have been observed only in prisoners.

[300] In conclusion, I would like to thank my chief, Professor Bleuler, for his kindness in referring this case to me.

V

ON SIMULATED INSANITY

A MEDICAL OPINION ON A CASE OF SIMULATED INSANITY

ON SIMULATED INSANITY¹

[301] Several cases of simulation have recently been published by Bolte,² who in the course of his article remarks that the question of simulation presents fewer difficulties in practice than it does in theory. I would not like to go all the way with this statement. As a matter of fact, cases do occasionally come up for observation which are extremely confusing and create any amount of difficulty for the specialists who are asked to give a medical opinion. It is precisely on the practical side that the art of the diagnostician is sometimes taxed to the utmost. Generally speaking, simulation used to be suspected much more frequently and injudiciously than it is now, yet in spite of this the older literature abounds in cases on which the observers were unable to reach agreement. Today, through our knowledge of the various clinical pictures of dementia praecox and hysteria, we have advanced a step further, and have also gained rather more insight into the question of simulation, though this is not to say that we have acquired greater certainty in regard to doubtful cases. We possess no infallible method of unmasking the malingerer and are as dependent as ever on the subjective impression he makes on the observer. As Bolte rightly points out, it is always a risky business to publish these cases at all, for it requires considerable literary talent to lend an air of plausibility to subjective impressions. It is an unfortunate fact, as Fürstner says,³ that the observer cannot convey to the reader all the detailed nuances of the picture—the changing facial expression, the attitude, verbal response, and so forth. Hence no author need be surprised if the reader doubts his cases of simulation or at least finds in them something to cavil at. In any conscientious appraisal of simulation there is so much to take into account and so much to investigate that, in reading a report that is the least bit summary, one is apt to regret the omission of this or that item which seems of importance.

[302] Modern diagnostic requirements are far higher than formerly, when, strange as it seems, it was often simply a question of whether the case fit into the purely theoretical scheme of the psychoses or not. The prolonged controversy over the famous case of Reiner Stockhausen [pars. 346ff. below] is particularly instructive in this respect. Since then, the theory of hysteria has brought us so much that is new and important that we are obliged to reckon with many more factors today than we were twenty years ago. Indeed, it is a well-known fact that the majority of malingerers are mentally abnormal and consist in the main of degenerates of various descriptions. How frequently hysteria occurs in such individuals it is difficult to say, but judging by other types of mental degeneracy the percentage must be very high, assuming, of course, that one takes as hysterical all “psychogenic” symptoms. The question of an hysterical disposition is of

great importance in diagnosing simulation. The lying of hysterics is proverbial, and in the domain of psychiatry hysteria furnishes perhaps the most cases of simulation. We have reason to suppose that for simulated insanity, too, some importance attaches to hysteria, considering that a fairly large number of hysterical psychoses occur among persons in detention and among convicts, who are naturally greatly interested in simulating. Here I would refer the reader to the numerous studies of twilight states recently made by Ganser.

[303] In judging a doubtful case of simulation, one must bear in mind that successful simulation is not a simple thing at all, but often makes the greatest demands in the matter of shamming, self-control, and psychic toughness. This cannot be achieved by mere lying, for the deception must be kept up with consistency and unshakable will power for weeks or even months on end. All this requires an extraordinary amount of energy, coupled with an art of shamming that would do credit to the most accomplished actor. Such cases are rare, but they nevertheless exist. There can be no doubt that among the ranks of the degenerate and criminally minded there are persons who possess a quite unusual amount of energy and self-control, which apparently extends even to the vasomotor processes.⁴ Exceptions of this kind are certainly uncommon, for the criminal is characterized, as a rule, by an impulsive energy that tires quickly, rather than by endurance. The art of shamming, however, seems to be a gift that is widely disseminated among criminals. It is found chiefly in thieves and poisoners. The mendacity of thieves is well known; Krauss⁵ says of them: "All common criminals lie, but their lies are clumsy and palpable. Only thieves lie skilfully and naturally. They lie unthinkingly, without a moment's hesitation, as soon as they open their mouths. They no longer even know that they are lying. It has become so much second nature to them that they believe their own lies." In agreement with this we find a preponderance of thieves among malingerers. Of the ten malingerers investigated by Fritsch, seven were up for larceny, and two of the other three had previous convictions for theft. Among 8,430 admissions to this asylum, I found eleven malingerers.⁶ Of these, six had been investigated for offences against property (larceny, embezzlement, swindling), two had previous convictions for theft, and one had been investigated for attempted poisoning.

[304] Malingerers in this category of criminals therefore have a natural predisposition to deceive. If we discount the degree of intelligence and accidental factors which might assist simulation, then the one who plays his role best will be the one who lies most skilfully. The most confident of all liars are pathological swindlers, and the convincing thing about their lies is the fact that they believe them themselves, as they are no longer able to distinguish between truth and fiction. They differ from the actor in that the latter always knows when his role is at an end, whereas the former allow themselves to be hypnotized by the game they are playing, and keep it up with a curious intermingling of two mutually exclusive spheres of thought. Delbrück even speaks of a real double consciousness.⁷ The more an actor enters into his role the more he loses himself in it,

and the more his acting is accompanied by unconscious emotional movements of the body,⁸ which is just why he “acts” so convincingly. The dramatic build-up of his role is certainly not a pure act of volition, but is chiefly dependent on a special disposition whose essential ingredient seems to be a certain amount of suggestibility. The greater this subjective suggestibility is, the more likely it is that the role which began as a mere game will falsify the reality, so captivating the subject as to replace his original personality. Pick⁹ has given us a beautiful example of the way a daydream changes into a real twilight state. He tells the story of a young girl who flirted with the idea that she was an empress. She painted her role in ever more glowing colours, got so absorbed in it that in the end it turned into an hysterical twilight state with complete splitting of consciousness. The second case reported by Pick concerns a girl who dreamt herself into sexual situations and finally staged a rape on herself by lying naked on the floor and tying herself to the table and chairs. An interesting case of this kind is reported in a dissertation done under Wernicke:¹⁰ A girl fantasized that she was engaged, and she received letters and flowers from her fiancé which she had sent herself, with disguised handwriting. I observed a case of the same type in a young girl who played an elaborately contrived dream-role in her somnambulistic twilight states.¹¹ Such phenomena are not so very rare and can be observed in all gradations of intensity, from fanciful exaggerations to genuine twilight states. In all cases they begin with a feeling-toned idea which develops on the basis of suggestibility into an automatism. These experiences must be taken into account in a study of simulation. We should not forget that a large number of malingerers are hysterical¹² and therefore provide favourable soil for auto-suggestions and disturbances of consciousness.

[305] There is a Japanese proverb which says: “Thieving begins with lying.” In the same way, congenital mendacity and an hysterical disposition are the beginning of simulation. The art of conscious shamming is a rare gift, so rare that it cannot be presumed in all malingerers, for sustained shamming requires an energy that exceeds the common measure both in quality and quantity. It ought not to be assumed so long as the commoner symptom of hysteria cannot be ruled out with certainty. We often find in hysteria all those mechanisms which make possible the most incredible toughness and a refinement of self-inflicted pain. When, for instance, a work-shy female hysteric can burn her feet in the most atrocious way with sulphuric acid, simply in order to get a free stay in a hospital, or another can kill off her entire dovecot so as to simulate haemoptysis with the blood, we may expect even more refined practices in individuals who are acting from feeling-toned motivations. In such cases we no longer have to reckon with the possibilities of normal psychology—which would be to credit them with the energy of a Mucius Scaevola¹³—but with subconscious mechanisms which far exceed the strength of the initial conscious impulse and, with the help of anaesthesias and other automatisms, bring about an auto-suggestion without further assistance from consciousness or even at its expense. The completely automatic nature of many

hysterical symptoms explains their toughness and, in the case of histrionic performances, their perfection: since no reflective and deliberating conscious processes intervene, the subconscious complexes can reach full development. All doubtful cases of simulation should therefore be examined for possible hysterical symptoms, in the absence of suitable methods for investigating those disturbances of consciousness which unfortunately elude observation all too easily and, in general, form one of the darkest chapters of psychiatry.

[306] If, then, we try to envisage the psychological mechanism of a twilight state on the basis described above, we shall not be surprised if the picture contains numerous elements which strike us as contrived and artificial, or even if certain symptoms are recognized as being wilfully produced. We should not, however, jump to the false conclusion that the other symptoms are being shammed as well. Similarly, technical tricks like the one recommended by Jacobi-Jenssen should be used with great caution, for if the subject takes over a symptom that has been suggested to him, this does not, in accordance with what we said above, decide anything for or against simulation. A confession of simulation at the end of the disturbance should be received with caution (especially when, as in one case, it followed a threat of a week's solitary confinement in darkness). Paradoxical as it may sound, certain experiences with hypnotized patients, who after an obvious hypnosis assert that they have not been hypnotized at all, make this caution necessary. On no account should one be satisfied in doubtful cases with a mere confession of simulation; a thorough catamnesis is needed for full elucidation, since only very rarely is objective insight into the inner state of the subject possible during the actual psychic disturbance. Despite confession there may easily be, in persons of a hysterical disposition, defects of memory that are unknown to the subject himself and can only be discovered by means of an accurate catamnesis.

[307] We spoke above of feeling-toned ideas that may have a releasing effect on an hysterical disposition. How severe the consequences of violent emotion may sometimes be can be seen from disturbances following accident and shock neuroses. Besides the long-term consequences of the affect, we also find at the moment of the affect itself peculiar disturbances which outlast it for a longer or shorter period. I refer to the emotional confusion known as "examination fright," "stage fright," or "emotional paralysis." The latter term stems from Baetz,¹⁴ who, during an earthquake in Japan, noticed in himself a general paralysis of movement and feeling, despite completely unimpaired apperception. This accords with numerous other phenomena observed during and immediately after violent affects.¹⁵ We all know the tragicomic confusion exhibited by men during fires, when pillows and mattresses are carried downstairs and lamps and crockery thrown out of the window.

[308] In accordance with these observations on normal persons, we should expect something similar in degenerate subjects, though with abnormalities both quantitative and qualitative. Our knowledge in this respect is unfortunately very defective and the

case material scanty. I have put together a number of observations on this subject, drawn from mental defectives, but for the time being they should be regarded as case histories.

1

[309] The first case concerns a mental defective who was sent to us for a medical opinion on a charge of rape. He had given perfectly reasonable answers at all the hearings, but, as the judge doubted whether the accused had the necessary power of discrimination to recognize the punishable nature of his action, a medical opinion was asked for. On admission the patient exhibited conspicuously stupid behaviour that made us suspect simulation. He spoke to nobody, walked up and down the room, his hands stuck impudently in his pockets, or stood apathetically in a corner and stared into space. When he was questioned, we had to repeat each question several times in a loud voice until the answer came. He stuttered, often did not answer at all but just gaped at the questioner. He was oriented as to time and place, but was unable to say why he was in the asylum. There were other striking peculiarities: when walking up and down the room he often made a sharp military turn, or would suddenly spin around himself where he stood (there was a catatonic in the room with him who made similar movements). After the fifth day his behaviour slowly began to change, he became freer in his movements, less rigid, demanded to know why he was here, since he was not mentally ill. Investigation now became possible, and we were immediately struck by the man's extraordinary dull-wittedness; all his reactions were very slow, he had to think a long time before giving particulars, the story of his life was a jumble of fragments in chronological disorder, made up of unintelligible contradictions. He could no longer remember dates and names he had been quite familiar with before, but described them in a clumsy, roundabout fashion. For instance, he had once been dismissed from a firm of lithographers because he could not stand the smell of acid. He told the story as follows: "There was a thing standing open where the thing was in, a sort of little dish, and then I felt sick," etc. On the following days he grew more alert, and finally was able to give a clear and coherent account of his affairs. He had insight for his initial stupidity and explained that it was due to the great fright he got when he was sent to the asylum, saying that he always felt that way when he came to a new place.

[310] Was the patient simulating? In my opinion not; he never tried to make capital out of this strange disturbance afterwards, although, with the stupid cunning of the mental defective, he sought every possible excuse for getting himself released. He seemed to regard this abnormal effect of emotion as a quite ordinary and regular thing. Moreover, it does not seem to me possible to simulate confusion and dull-wittedness, and particularly "examination fright," in so natural a way. Was his imitation of the catatonic intentional, unintentional, or merely accidental? I would prefer to reserve final judgment on this case.

[311] The second case again has to do with a feeble-minded individual, a 17-year-old boy who was sent to us for a medical opinion, also on a charge of rape. He behaved very apathetically at first, had an extraordinarily stupid expression on his face, and gave hesitant answers brought out with great difficulty. During his stay of several weeks in the asylum his condition gradually improved; he became brighter, gave quicker and clearer answers, and it was noticed that he associated with the warders and patients in a natural and unconstrained way much sooner than he did with the doctors. In order to obtain a more accurate picture of the disturbance I took two series of association tests, amounting to 324 in all, at an interval of three weeks. The first series was taken the day after admission. The tests produced the result shown in [Table I](#).

[312] This list shows very clearly the change in the patient's mental state. The preponderance of meaningless reactions, clang reactions, and repetitions in the first series indicates a state of inhibited association which can best be described by the word "embarrassment."¹⁶ With regard to the perseveration and its comparatively large preponderance in the first series, I would not venture to say anything where the material is so limited. This syndrome may be regarded as analogous to the one described in Case 1.

TABLE I*

<i>Associations</i>	<i>May 6</i>	<i>May 27</i>	<i>Associations</i>	<i>May 6</i>	<i>May 27</i>
	<i>1903</i>	<i>1903</i>		<i>1903</i>	<i>1903</i>
Co-ordination, etc.	6.4	2.0	} Inner	15.3	69.3
Predicate relation	8.9	67.3			
Causal dependence	0.0	0.0			
Coexistence	14.1	15.3	} Outer	16.6	27.5
Identity	0.0	0.0			
Verbal-motor forms	2.5	12.2			
Word completion	0.0	0.0	} Clang reactions	3.7	0.0
Clang	2.5	0.0			
Rhyme	1.2	0.0			
Indirect	0.0	0.0			
Meaningless †	64.1	3.0			
Perseveration ‡	15.3	0.0			

Repetitions : ¶	19.1	13.0
Occurring 2 times	12.8	6.0
Occurring 3 times	5.1	1.0
Occurring 4 times	0.0	4.0
Occurring 5 times	0.0	0.0
Occurring 6 times	1.2	1.0
Occurring 7 times	0.0	1.0

* The classification follows Aschaffenburg's system; cf. Kraepelin, *Psychologische Arbeiten*, I, p. 231. The stimulus words were listed at random and not subordinated to any scheme based on number of syllables, grammatical qualities, or content. The figures are percentages.

† Meaningless reactions consisted in this case of names of objects that happened to be in the patient's field of vision. The second series includes a few "faults," where the patient failed to react.

‡ By perseveration I mean what Aschaffenburg calls "association to words that have occurred previously." I give here the percentage of associations to previous stimulus and reaction words.

¶ Repetitions = the number of reaction words that occur frequently, expressed in percentages.

[313] The following two observations derive from investigations I am at present making with my colleague Dr. Riklin.

[314] (1) Embarrassment is a state in which the attention cannot be concentrated, as it is fixed elsewhere by a strongly accentuated idea. I tried to reproduce this state by distracting the attention at the moment of association. This was done as follows: the subject (who was naturally a practised one) was asked to fix his attention on the visual ideas that presented themselves as the stimulus word was called, but, as in the ordinary test, to react as quickly as possible. He was therefore in a state that corresponds more or less to embarrassment, since his attention was fixed and only a fraction of it was left over for the reaction simultaneously taking place. The two experiments, made with two different people, each consisted of 300 separate tests ([Table II](#)).

[315] (2) Similar results were obtained in experiments with outer distraction, where the subject associated while simultaneously making pencil strokes of a certain length in time to the beating of a metronome. A corresponding change is shown in [Table III](#) (page 170), based on 300 associations.

[316] In this experiment, practice naturally plays an important part, but the change in the associations is nevertheless very striking. Later on,¹⁷ I shall give a detailed report on the experiments and their significance for psychopathology. I think these examples suffice to throw an explanatory light on the association disturbances of our mental defective.

[317] We see from these experiments that with inadequate investment of attention the quality of the associations shows a general deterioration; that is to say, there is a distinct tendency to produce outer and purely mechanical associations. A person who thinks in terms of such associations has very poor powers of comprehension and assimilation, and consequently comes very near to certain states of dementia. This may possibly be the reason for the feeble-mindedness heightened by emotionality observed in Case 2. The

findings here throw some light on Case 1, which unfortunately was not subjected to detailed psychological investigation. In Case 2, simulation was quite out of the question, and yet the patient's behaviour ran much the same course as that of the first. Is it not possible that when feebleminded and degenerate individuals are placed in an asylum the unwonted internment becomes associated with affects which are neutralized only gradually, in accordance with the poor adaptability of defectives? So far as it is possible to judge this matter at all, I should say it is not so much a question of mental defect as of a certain mental disposition, also found in other degenerate individuals, which puts abnormal obstacles in the way of an inner assimilation of affects and new impressions, and thus produces a state of continual perplexity and embarrassment.

TABLE II *

<i>Associa- tions</i>	<i>N</i>	<i>D</i>	<i>N</i>	<i>D</i>	<i>Associa- tions</i>	<i>N</i>	<i>D</i>	<i>N</i>	<i>D</i>
Co-ordina- tion, etc.	15.5	4.0	13.5	19.0	Inner	42.5	23.0	46.5	33.0
Predicate relation	25.5	19.0	31.5	12.0					
Causal de- pendence	1.5	0.0	1.5	2.0					
Coexist- ence	7.5	6.0	7.5	4.0	Outer	58.5	65.0	49.5	36.0
Identity	6.0	5.0	5.0	6.0					
Verbal-motor forms	45.0	54.0	37.0	26.0					
Word com- pletion	0.5	8.0	2.0	5.0	Clang reactions	1.5	11.0	2.5	29.0
Clang	0.0	2.0	0.5	15.0					
Rhyme	1.0	1.0	0.0	9.0					
Indirect	1.5	1.0	1.5	2.0					
Meaning- less	0.0	0.0	0.0	0.0					
Persevera- tion	1.0	2.0	1.5	1.0					

* The figures are percentages. N = normal; D = distracted.

TABLE III *

Associations	N	D		Associations	N	D	
		Metronome rate per min.				Metronome rate per min.	
		60	100			60	100
Co-ordination, etc.	29.0	20.0	20.0	Inner	46.5	32.0	26.0
Predicate relation	16.0	12.0	6.0				
Causal dependence	1.5	0.0	0.0				
Coexistence	7.5	2.0	2.0	Outer	33.5	36.0	36.0
Identity	6.0	0.0	2.0				
Verbal-motor forms	20.0	34.0	32.0				
Word completion	0.5	0.0	2.0	Clang reactions	5.5	20.0	16.0
Clang	5.0	20.0	14.0				
Rhyme	0.0	0.0	0.0				
Indirect	4.5	12.0	12.0				
Meaningless	1.0	0.0	10.0				
Perseveration	0.5	2.0	2.0				
				Not understood	1.0	0.0	10.0

* The figures are percentages. N = normal; D = distracted.

[318] How far this disposition to neutralize affects in a faulty or abnormal way coincides with hysteria is not easy to determine, but according to Freud's theory of hysteria the two are identical. Janet found that the influence of affects is seen most clearly in hysterical persons, and that it produces a state of dissociation in which the will, attention, ability to concentrate are paralyzed and all the higher psychic phenomena are impaired in the interests of the lower; that is, there is a displacement towards the automatic side, where everything that was formerly under the control of the will is now set free. Speaking of the effect of emotion on hysterical subjects, Janet says:

Emotion has a decomposing action on the mind, reduces its synthesis and makes it, for the moment, wretched. Emotions, especially depressive ones such as fear, disorganize the mental syntheses; their action, so to speak, is analytic, as opposed to that of the will, of attention, of perception, which is synthetic.¹⁸

[319] In his latest work, Janet extends his conception of the influence of affects to all possible kinds of psychopathic inferiority; he says, as earlier:

One of the marks of emotion is that it is accompanied by a decided lowering of the mental level. It brings about not only the loss of synthesis and the reduction to automatism which is so noticeable in the hysteric, but proportionately to its strength it gradually suppresses the higher phenomena and lowers tension to the level of the so-called inferior phenomena. Under the influence of emotion, mental synthesis, attention, the acquisition of new memories, are seen to disappear; with them diminish or disappear

all the functions of reality, the feeling of and pleasure in reality, confidence and certitude. In place of these we observe automatic movements....¹⁹

They have a particularly deleterious effect on the memory:

But this dissociative power which belongs to emotion is never more clearly displayed than in its effect on the memory. This dissociation can act on memories as they are produced, and constitute continuous amnesia; it can also act suddenly on a group of memories already formed.²⁰

This effect is of special importance for us, as it explains the disturbance of memory in cases of emotional confusion and also throws a remarkable light on the amnesias in Ganser's twilight states. In the Ganser syndrome which I analysed,²¹ the most important feature was an anterograde amnesia which depended on affective elements. It was evident that the prolonged retrograde amnesia also present in this case covered all the unpleasant, powerfully affective events in the recent past. A relapse suffered by the patient while under observation was caused by a highly disagreeable affect. Phleps reports much the same thing in his above-mentioned study of the amnesia which, in his cases, was present for the causative affect (i.e., the Ljubljana earthquake).

[320] The picture presented by the two patients mentioned above was one of gross feeble-mindedness, which obviously set in acutely and was not caused by any demonstrable illness. Further observation showed that the degree of feeble-mindedness actually present was not nearly so great. In many so-called malingerers who sham a high degree of stupidity we find the same outward behaviour, ranging from conscious, crassly nonsensical talk to the problematical borderline cases we have just been discussing. We find, however, in the twilight states described by Ganser, and recently by a number of other writers as well,²² symptoms apparently indicating an almost impossibly high degree of feeble-mindedness, which in fact seems to be based on a purely functional deficiency that can be explained in terms of psychological motivations, as I have shown above. Ganser's "senseless answers" are of the same kind as those of the malingerer, only they arise from a twilight state that does not seem to me very far removed clinically from the cases of emotional stupidity reported earlier.²³ If we apply these remarks to the question of simulation, we can easily imagine that, in cases of emotional confusion following the excitements of arrest, interrogation, solitary confinement, etc.,²⁴ one person will hit on the idea of simulating insanity, while others will be inclined by the disposition I have described to lapse into a state of stupidity, in which, according to the mentality of the individual, conscious exaggeration, half-conscious play-acting, and hysterical automatisms will be fused in an impenetrable mixture, as in the picture of a traumatic neurosis, where the simulated and the hysterical are inseparably combined. I would even say that in my view it is but a step from simulation to Ganser's syndrome, and that Ganser's picture is simply a simulation that has slipped out of the conscious

into the subconscious. That such a transposition is possible is proved by the cases of pathological swindling and pathological dreaminess. A contributory factor in all this is the abnormal influence of affects mentioned earlier. The literature on simulation leaves much to be desired in this respect, as very often in difficult cases the experts are only too delighted if they can succeed in unmasking one or the other symptom as simulated, and this leads to the false conclusion that everything else is “simulation” as well.

3

[321] Here I would like to report on a case²⁵ which is instructive from several points of view.

[322] J., born 1867, mill-hand. Heredity: father quick-tempered, mother's sister melancholic, committed suicide.

[323] Nothing special is known of the patient's youth, except that his father early prophesied prison for him. At 16½ he ran away from home and began wandering, working in various textile-mills for about seven years. At 22 he married. The marriage was not happy, the fault being entirely his own. After two years he ran away from his wife, taking with him her savings, emigrated to America, where he lived an adventurous and roving life. Came back after some years to Germany and tramped through it on foot. Arrived in Switzerland, he made it up again with his wife, who soon afterwards filed a petition for divorce. He ran away from her a second time, embezzled a sum of money entrusted to him by a fellow worker, spent the lot, and was arrested and sentenced to six months' hard labour (1892). After serving his sentence he resumed his roamings round Switzerland.

[324] In 1894 he was sentenced to a month's imprisonment for theft. He is stated to have attempted suicide about this time (though not in connection with the punishment). After his release he took to the road again until 1896. From then on he worked uninterruptedly for four years in the same mill. In 1900 he married for the second time. This marriage, too, was unhappy. In 1901 he ran away from his wife, taking with him her savings to the value of 1200 francs. He went on a binge with it for a fortnight, then came back to his wife with 700 francs. Later (1902) he again took her money and ran away for good, committing two thefts when the money gave out. He was arrested soon afterwards and was sentenced to six months' hard labour for the first theft. It was not until the spring of 1903 that he was recognized and arrested for committing the second theft. At the first hearing he gave his particulars correctly, but denied the charge, involved himself in contradictions, and finally gave quite incoherent and confused answers. In solitary confinement he became restless at night, threw his shoes under the bed, covered the window with a blanket “because somebody was always trying to get in.” The next day he refused food, saying it was poisoned. Gave no more answers, saw spiders on the wall. The second night, in a communal cell, he was restless, insisted that there was

somebody under the bed. The third and fourth day he was apathetic, wouldn't answer, ate only when he saw the others eating, maintained that he had killed his wife and that there was a murderer under the bed with a knife. The prison doctor testified that the patient gave the impression of being a catatonic.

[325] He was admitted on June 3, 1903, for a medical opinion.

[326] The patient seemed listless, apathetic, his face rigid and stupid-looking. He could be made to answer only with difficulty. Stated his name and address correctly, but appeared disoriented as to time and place. He gave five fingers held before him as four, ten as eight. Could not tell the time, named coins wrongly. He complied with requests correctly but carried them out in a senseless manner. When asked to lock the door he persistently tried to put the key in upside down. He opened a matchbox by breaking open the side. Strong suspicion of simulation. Was put in the observation room. Quiet at night, got up only once to move his bed, saying that the decoration on the ceiling would fall on top of him. Next day the same. At the examination he gave senseless answers and had to be pressed all the time. It was clear that he understood questions and requests quite well, but did his best to react to them in the most senseless way possible. Could not read or write. Took the pencil in his hand correctly, but held the book upside down, again opened the matchbox from the side, but lit a candle and put it out again correctly. He gave quite senseless names and values to coins.

[327] Physical examination showed brisk reflexes of forearm and patella. Sensibility to pain seemed generally reduced, almost non-existent in some areas, so that there was only a scarcely perceptible reaction to really deep needle-pricks. The right pupil was somewhat larger than the left; reaction normal. The face was markedly asymmetrical.

[328] This examination was carried out in a separate room on the same floor as the observation room in which the patient had been previously. When the examination was over we told him to find his way back to his room by himself. He went first in the opposite direction and rattled at a door he had not passed before, and was then told to go in the other direction. He now tried to open two more doors leading into rooms near the observation room. Finally he came to the right one, which was opened for him. He went in, but remained standing stiffly by the door. He was told to make his bed, but stood there without moving. His bed was in the corner facing him, clearly visible from where he stood. So we let him stand. He stood rigid on the same spot for an hour and a half, then suddenly turned pale, sweated profusely, asked the warder for some water, but fell unconscious to the floor before it arrived. After lying on the floor for ten minutes and recovering himself somewhat, he was put on his feet again, but rapidly went into another faint. He was then put to bed. He didn't respond to questions at all, refused food. In the course of the afternoon he suddenly got up and threw himself against the door with considerable force, head foremost. When the warders tried to restrain him because of the danger of suicide, a hand-to-hand fight ensued, and it took several

warders to subdue him. He was put in a straitjacket, whereupon he quickly calmed down. On the night of June 4 he was quiet, turned his bed round only once. At the morning visit he suddenly seized hold of the doctor and tried to pull him into bed, then seized the warder. Hyoscine injection. On the following days he again showed dull and stupid behaviour with occasional attacks on doctors and warders, which however never came to dangerous blows. He seldom said anything, and what he said was always stupid and nonsensical, uttered in an unemotional, toneless voice. He refused all food for the first three days, but on the fourth day he began eating again, then better every day. On June 7 he suddenly demanded to have a vein opened because he had too much blood. When this was refused he sank back into a dull brooding. In contradiction to his apathetic behaviour, however, he seemed to take an interest in his surroundings; on seeing a patient in the bed next to him offering violent resistance to nasal feeding, he suddenly called out that they should tie the man's feet together, then it would go better. On June 8 he was given a strong dose of faradism. Poor reaction. He was told that this would happen daily from now on. On the morning of June 9 he was suddenly clear, demanded a private interview at which he made the following statement:

[329] You know very well that there's not much the matter with me. When I was arrested I was so scared and upset thinking of my mother and sisters, they being so respectable, that I didn't know what to say, so I got the idea of making things look worse than they were. But I soon saw you weren't taken in, besides I felt such a fool playing the looney, also I got sick of always lying in bed. I'm sick of everything. I think all the time of killing myself.... I'm not crazy, yet I sometimes feel I'm not quite right in the head. I didn't do this to avoid going to jail, but for the sake of my family. I intended to go straight, and hadn't been in jail for nine years until last fall.

[330] When asked how he came to simulate insanity, he said: "I was sorry for my old mother and regretted what I'd done. I was so frightened and upset that I thought, well, I'll make out I'm worse than I am. When I got back to the cell after the hearing I was at my wit's end. I would have done away with myself if I'd had a knife." He did not seem to be very clear about the purpose of the simulation, said he "just wanted to see what they would do with him." He gave adequate motives for his actions under simulated insanity. One striking thing was the statement that despite his four-day fast he had felt no appetite. A thorough anamnesis was now undertaken, a point of special interest being the patient's remark that he was always driven from place to place by an "inner unrest." As soon as he settled in one place for a time, the vague urge for freedom came over him again and drove him away. Throughout his story he showed a fair amount of uncertainty with regard to exact particulars (years and dates, etc.), but his uncertainty was quite surprising when it came to judging the time of recent happenings. Although otherwise properly oriented as to time, he maintained that he had been in the asylum for a fortnight (instead of six days). By the evening of the same day he had become uncertain again, and now wavered between ten and twelve days. He recounted the details of his stay in

the asylum unclearly, and he no longer remembered many little incidents, trivial in themselves, that took place during his simulation; he also got various things muddled up in time. He had only a vague memory of his admission and the examination that followed; he knew that he had been told to put a key in the lock but thought he had done it correctly. He also remembered the examination on the next day, and said that the room had been full of doctors, about seven or eight of them (in reality there were five). He could still remember the details of the examination, but only when helped. With regard to the scene that took place afterwards, he made a statement to the following effect:

[331] He remembered quite well how he came out from the examination; we had turned him loose and he lost his way in the big corridor. It seemed to him that in order to reach the examination room he had first gone up some steps. Then, when he found that he did not have to go down any steps, he thought we wanted to fool him and lead him to the wrong room. Therefore, when we eventually took him to the sick room, he thought it was not the right room, nor did he recognize it again, especially when he saw that all the beds were occupied. (But his bed was empty and clearly visible.) That was why he remained standing by the door, then he felt queer and fell over. Only when he was put to bed did he notice that there was a bed unoccupied, that it was his bed and that he was in the right room.

[332] He treated this intermezzo as if it were simply a misunderstanding, without the least suspicion that it was something pathological. The dangerous ruthlessness with which he banged his head against the door he explained as a deliberate attempt at suicide.

[333] The next day, June 10, we got the patient to do simple additions based on Kraepelin's arithmetic tests. The average performance per minute was 28.1 additions, out of a total of 1,297 additions in 46 minutes. Increased practice produced an insignificant result: the difference between the average performance in the first and in the second halves amounted to only 1.5 in favour of the latter. So not only was the performance very poor, but the increased practice proved to be insufficient. In comparison with this relatively very easy work the number of errors was abnormally high: 11.2% of the additions were wrong; there were 1.5 errors per minute in the first half, 4.7 in the second half. These findings illustrate very well the rapid tiring of energy and attention despite the fact that there was no abnormal psychic fatigability. Optic perception was considerably reduced; the patient took a surprisingly long time to grasp the simple pictures in the Meggendorfer picture-book. His comprehension of things heard and read was likewise reduced. In reproducing a simple Aesop's fable, he left out important details and made up the rest. His retention, particularly for figures, was poor. As already indicated, his memory of events in the not so recent past was tolerably good, and he had retained a normal amount of school knowledge. No signs of mental defectiveness. No restriction of the field of vision. No other hysterical symptoms. Red-green blindness. Reflexes as at the first examination. No disturbances of sensibility other than general hypalgesia. About a week later (June 19) he was subjected to another

thorough examination, having maintained correct behaviour in the meantime. No changes in his physical condition. Comprehension still not up to normal, but a decided improvement noticeable. No improvement in retention, but his work-curve showed a change for the better.

[334] For the sake of clarity I give the results of the first and second tests side by side:

TABLE IV

	<i>June 10</i>	<i>June 19</i>
Average performance per minute	28.1	32.4
Average per minute for first half	27.4	31.9
Average per minute for second half	28.9	32.9
Error in total number of additions	11.2%	4.0%
Errors per minute for first half	1.5	1.1
Errors per minute for second half	4.7	1.5

[335] The result of the second test shows an increase of 4.3 in the performance per minute as compared with the first series, and a very definite reduction in the number of errors. This result may be taken as confirming our clinical observations, in so far as a distinct improvement in the patient's energy and attention did in fact occur in the course of a week. Unfortunately, he was not given an association test. On June 23 he made an ostentatious attempt at suicide by slowly sawing through the skin of his left wrist with a sharp stone. Afterwards he put up a childish resistance to being bandaged.

[336] The medical opinion stated that the patient must be assumed responsible for the theft, and therefore punishable, but only partially responsible for the offence of simulation.

[337] There can be no doubt that the patient really did simulate. We have to admit that the simulation was excellent, so good, in fact, that, though we never lost sight of the possibility of simulation, we sometimes seriously thought of dementia praecox or of one of the deeper hysterical twilight states mentioned by Ganser. The consistent masklike rigidity of the face, the dangerous nature of his suicide attempt (banging his head against the door), the real fainting-fit, the—to all appearances—deep hypalgesia, are facts which cannot easily be explained as mere simulation. For these reasons we soon discarded the idea of pure simulation on the supposition that, if it really was a case of simulation, there must be some pathological factor in the background which somehow lent a helping hand. Hence the sudden confession came as something of a surprise.

[338] To judge by the material reported above, the patient was a degenerate. His forgetfulness and lack of concentration point to some form of hysterical inferiority, as grosser cerebral lesions seem ruled out by the anamnesis. Although we have no other direct indications of hysteria, this assumption nevertheless appears the most probable. (Hypalgesia is a mark of degeneracy which is also found elsewhere, particularly in

criminals.) As we have seen, the patient got confused at the hearings, and explained that this was due to his state of desperation at the time, i.e., to a strong affect. The question of the logical motivation in this case still remains very obscure, and it looks as if he never came to a really clear decision to simulate. In his catamnesis he expressly emphasized and reiterated the strong affect he had experienced, and we have no grounds for not believing him in this point. It looks, rather, as if the affect played an important aetiological role. Although every feature of the resulting clinical picture is simulated (with the exception of the fainting-fit), almost every symptom is accompanied by phenomena that cannot be simulated. Lest I should lose my way in details, I shall confine myself solely to the fact, revealed by the catamnesis, that at least at times during his simulation the patient had a defective and faulty comprehension, as was borne out by the disturbance of attention noted on June 9. Accordingly, his memory of the critical period also proved strikingly vague. So, together with simulation, we find real and appreciable disturbances over the whole field of attention. These disturbances outlive the simulation and get very much better in the course of a week.

[339] Earlier writers maintain that simulation has a deleterious effect on the mental state.²⁶ Allowing for diagnostic errors, the impairment will probably be confined to a disturbance of attention resembling hypnosis; this may offer a plausible explanation of our case.²⁷ It should not be forgotten, however, that an alteration of this kind never occurs as a result of a mere decision: a certain predisposition is needed (what Forel would call a “dissociation”). And this is where, in my view, the decisive importance of affects comes in. As we have already explained at some length, affects have a dissociating (distracting) effect on consciousness, probably because they put a one-sided and excessive emphasis on a particular idea, so that too little attention is left over for investment in other conscious psychic activities. In this way all the more mechanical, more automatic processes are liberated and gradually attain to independence at the cost of consciousness. Here I would call attention to the beautiful experiments conducted by Binet²⁸ and Janet²⁹ on automatization in states of distractibility.

[340] On this foundation Janet based his conception of the influence of affects, which holds that automatisms are one and all fostered by distractibility (i.e., feebleness of attention) and, as Binet expresses it, thrive chiefly on “the psychic shadow side.” The assumption therefore is that certain ideas, which are present in consciousness at the same time as the affect but whose content need not be in any way related to it, become automatized. This assumption is amply confirmed by clinical experience, and particularly by the anamnesis of hysterical tics. Our case, showing a state of semi-simulation, has as its essential symptom a strong and stable disturbance of attention such as occurs in a hypnotized person, whose attention is likewise fixed in a certain direction. Any interesting object can so attract our attention that we are “transfixed” by it. Hysterical subjects go even further—they have a tendency to identify themselves more and more with the object of interest, so that not, as in normal persons, a limited,

but an unlimited number of associations is produced with all their subconscious ties. Owing to the peculiar nature of hysteria, these ties can be severed only with the greatest difficulty. From this point of view I see our patient as a malingerer whose malingering worked only too well, in the sense that it slipped into the subconscious.

[341] It would be desirable if more attention were paid to borderline cases of this kind. They might, perhaps, throw light on many things which at present are extremely difficult to explain. Here I am thinking of a case on which several medical opinions have already been given by different German clinics. It concerns an accomplished swindler and thief who, the moment he is arrested, sinks into a catatonia-like stupor for months at a stretch. A medical opinion was also given on this case in our asylum. The moment he was released, the patient suddenly awoke from his profound, stuporous imbecility and took a polite and ceremonious farewell.

[342] I have to thank my colleague Dr. Rüdín for the following case from the Heidelberg clinic, concerning an individual who had several previous convictions for theft and offences against decency. He had been epileptic for fourteen years. After his arrest for the second offence against decency in 1898, the patient could scarcely be made to answer at all, and a few days later became completely mutistic, remaining in a stuporous condition for seven months with unimpaired orientation. In 1901 he was caught *in flagrante* committing burglary with theft, became very excitable, then relapsed into his stuporous attitude for six weeks. In 1902 he was again arrested for theft, but this time he was very timid, silent, and gave only the briefest answers. Afterwards he became mutistic again, would not obey requests, but was otherwise quite orderly. A medical opinion was given on all three occasions and he was declared irresponsible on grounds of epileptic stupor.

[343] Leppmann³⁰ reports the following case of “simulation”: Mentally defective murderer, who, after making a full confession while in detention, lapsed into a stuporous condition (“depressive melancholia”). After the “depression” disappeared, he simulated imbecility with loss of memory for the recent past. Sentenced to fifteen years’ imprisonment. After sentence was pronounced, the patient immediately relapsed into an apprehensive stupor.

[344] Landgraf³¹ reports a remarkable case of simulation in an habitual thief. In the second year of his ten-year prison sentence he became imbecilic, dumb, and kept his eyes closed. He spent eight years in this state, in the sick-ward, often not eating for weeks on end, usually sleepless, and playing at night with fruit-stones, buttons, etc. He put up a violent resistance to narcosis with chloroform. Afterwards he appeared paralysed for a fortnight, and was incontinent. On the expiry of his sentence he was sent home, imbecilic, blind, and dumb. Suddenly he left the house, committed a series of brilliant robberies. A fortnight later he was caught, and exhibited the same abnormal behaviour as before. Certified as a malingerer, he was sentenced to ten years’ imprisonment. While

in prison he was imbecilic, blind, deaf, and dumb for ten weeks, never once forgetting his role. Then he opened his eyes and began working, but remained deaf and dumb until his death.

[345] Marandon de Montyel³² reports on the following case: A menstruating, psychopathic woman tried to drown her four-year-old child, was arrested, made a full confession, and gave financial distress as the reason for her deed. A week later she recanted, shammed amnesia for the deed and its motive, acted like an imbecile, did not know either her surroundings or her past (anterograde amnesia). On account of simultaneous depression she was certified irresponsible and interned in a lunatic asylum, whereupon her condition improved. Several months later she came up before the public prosecutor, manifested violent fright, and the next day relapsed into “simulation.”

[346] The case of Reiner Stockhausen, on which monographs were written by Jacobi, Böcker, Hertz, and Richarz in 1855,³³ deserves mention. Stockhausen was a degenerate individual, many times convicted for theft and vagrancy. At one of the hearings he grew confused, gave strikingly senseless answers (Ganser), mostly negative in character: “It’s all up, I must shoot myself, always in need of money, but there’s nothing left, everything sold, everything gone,” etc.³⁴ Later he was less informative, often irritable, muttering half-intelligible answers and repeating stereotyped phrases: “Haven’t got nothing more, everything’s sold, spent, gone on drink,” etc. He was extremely unclean in his habits, slept little and fitfully.

[347] Three of the medical opinions assumed simulation, one insanity. Thereupon he was sent to an asylum for a year for observation. At first he was very excitable and inaccessible, then he “laid aside his stiffness and reserve more and more. He acted like a peaceable, fairly sociable, reasonable human being.” But as soon as “the conversation turned to things which might be connected with the crime he was accused of, or as soon as his mental health or his emotional state was touched upon, he seemed to get violently indignant and at once began talking like a madman.” A fourth medical opinion assumed simulation because the symptoms observed in the patient “did not accord with either melancholy, insanity, craziness, lunacy, or idiocy.” He was sentenced to fifteen years’ imprisonment, but it made no impression on him. Two years later he was still being examined off and on by the experts, and each time they found the logical continuation of symptoms that had already been in existence for three years.

[348] Finally, I would like to mention a case published by Siemens³⁵ of a young day-labourer, who, falsely accused of murder, wept continuously while in detention, protested his innocence, then refused to answer any more, kept on lamenting his fate, would not eat, slept badly. When excited, he smashed things. Probably imbecilic (reading and writing very poor). On being admitted to the asylum he seemed very frightened, had to be questioned repeatedly before he would answer, said he was not ill but slept badly, refused food at first. Later he refused to answer at all, gazed at the

doctors uncomprehendingly, but told the warder the story of his arrest. In spite of his apathetic behaviour he was provoked to laughter at the jokes of a maniac. Remained in this state for two months, until his release. Received the news of his release without moving a muscle. At home he was still taciturn for a time, indifferent, not working. Then he became normal again, complained about the wrong he had suffered, denied he was insane.

[349] To our way of thinking, these cases can hardly be regarded as simulation. The characteristic feature of these disturbances is their dependence on external events, mostly of a highly affective nature; this, together with their clinical behaviour, brings them closer to the psychogenic (“hysterical”) ailments described by Ganser and Raecke, and also (particularly the last case) to the kind of stupidity I would describe as “emotional.” Freud has offered convincing proof that the chief aetiological role in psychogenic disturbances is played by affects. It would therefore be worth while to pay more attention than we have done hitherto to repressed affects in criminals who exhibit doubtful states. We already have a number of pertinent observations; for instance, the intercurrent Ganser syndrome noted by Westphal³⁶ can be traced back to emotion, and a similar case is reported by Lücke.³⁷ The recurrence of a Ganser syndrome observed by me³⁸ conformed absolutely to the Freudian mechanism of repressed affect. One may therefore, with some justification, regard these peculiar states as due to the prolonged influence of affects, and in psychogenic disorders it is not surprising if all kinds of “faked” symptoms creep in, depending on the environment.

[350] It is impossible to discuss the question of simulation on the basis of the existing case material without making certain observations of a general nature.

[351] First, as regards the material, one can scarcely imagine any that is more unequal and more difficult to evaluate. In many cases the method of description is at fault, since the main stress is laid on the obvious symptoms, while the other symptoms—the hysterical ones especially—come off very badly. The investigation and “unmasking” of symptoms often consist in technical tricks, if not in old-fashioned cruelties like cold showers, etc. The standpoint of the earlier writers (which has even been passed on to some of the books now in vogue)—namely, that anything which does not fit into the known clinical pictures or into a dogmatic system of ideas is not a disease but simulation—is depressing and highly unscientific. Particularly damaging to description and investigation alike is a diagnostic optimism,³⁹ that accords very ill with the facts. From time to time we meet with cases of simulation which can lead the most experienced doctors by the nose for a long time. There was, for instance, Billod’s patient,⁴⁰ who simulated nine times with success; a case of Laurent’s⁴¹ simulated successfully for two years; and a case, “unmasked” on a second examination as a skilled malingerer, who had been declared incompetent on the authority of a very experienced doctor.⁴² So we have every reason for caution.

[352] Secondly, there is another point worth mentioning: the concept of simulation is not understood by all the authors in the same way. Fürstner⁴³ mentions the following case of “simulation” by seventeen-year-old Sabina S., who, spurred on by reading the life of Katharina Emmerich,⁴⁴ staged an enormous swindle by passing herself off as a saint. She abstained apparently from all food, twice drove nails through her insteps to the soles of her feet, and performed all sorts of miracles which fooled the doctors and officials and created a great sensation. When examined by Fürstner, she induced true-to-life tonic and clonic spasms of the eye-muscles and in the face and throat muscles. In the asylum, of course, her mystic abstention from food, etc., turned out to be the sheerest swindle, very cleverly done. The purpose of the whole undertaking, apparently, was that she wanted to stay with a relative, who functioned as a priest.

[353] Such cases can hardly be described as simulation, for the means employed bear no relation to the ends but are merely symptoms of a known mental disorder of which history affords us hundreds of examples. When a criminal simulates insanity, that is a comparatively convenient and simple means of getting transferred to an asylum, from which he can escape more easily. Here the means are adapted to the ends. But when an hysterical girl tortures herself in order to appear interesting, both means and ends are the outcome of some morbid mental activity. An hysterical haemorrhage of the lung is something simulated, “faked,” but that does not make the patient a simulant; she really is ill, only not ill with consumption. If the doctor calls her a simulant, he does so merely because he has not understood the symptom properly, i.e., has not recognized it as hysterical. When Sabina S. faked miracles she was not a simulant, if by this term we mean a person who is genuinely healthy and whose actions are intended to conceal his inner healthiness, whereas the abnormal actions of Sabina S. were precisely what revealed her inner morbidity. In the same way hysterics do not lie, even though what they say is not true in the objective sense. Wherever hysteria is involved, the term “simulation” should be used with caution in order to avoid misunderstandings.

[354] I would like to sum up the results of my work in the form of the following conclusions:

1. There are people in whom the after-effect of violent emotions shows itself in the form of a lasting confusion, which one could describe as “emotional stupidity.”

2. Affects, by acting specifically upon the attention, favour the appearance of psychic automatisms in the widest sense.

3. A certain number of cases of simulation are probably due to the after-effect of violent emotions and their automatization (or to auto-hypnosis) and must therefore be termed pathological.

4. Ganser’s complex in prisoners can probably be explained in the same way and must be regarded as an automatized symptom closely related to simulation.

[355] In conclusion, I would like to thank my chief, Professor Bleuler, for his kindness in allowing me to make use of the above material.

A MEDICAL OPINION ON A CASE OF SIMULATED INSANITY¹

[356] Simulation of insanity is in general a rather rare phenomenon, being confined almost entirely to persons in detention and convicts. For the ordinary public the fear of the lunatic asylum is too great and this particular form of simulation too inconvenient for it to be worth their while to seek illicit advantages in this way. The sort of people who take to simulation have been found by experience to be composed for the most part of individuals who show unmistakable signs of mental and physical degeneracy. Experience shows, therefore, that simulation generally rests on a pathological foundation. This fact explains why the recognition of simulated insanity is one of the most difficult tasks of the diagnostic art. If the simulation is recognized and proved, it immediately raises the question of soundness or unsoundness of mind, and the answer to this is beset with all kinds of difficulties.

[357] Apart from cases of exaggeration of real or imaginary symptoms, we also find a number of peculiar mental states in degenerate subjects whose cause can be traced back to the powerful affects produced by the arrest, trial, and solitary confinement. Even among normal persons are many whose capacity to assimilate strong affects is much worse, and who are unduly depressed or irritated by unpleasant emotions and cannot recover their composure for a long time afterwards. In the domain of psychopathic inferiority, that broad and undefined zone separating the "healthy" from the "morbid," we find the various types of normality caricatured, and here the powerful affects manifested by normal individuals take on a character that is excessive and odd in every respect. The affective states are often abnormally prolonged or abnormally intense; they exert an influence on other parts of the psyche or on physical functions which are not directly touched by normal affects. Strange, sudden alterations of psychic behaviour may be produced in this way, and they are often so striking that they immediately make one think of simulation. Such emotional-changes are observed among feeble-minded persons especially, mostly in the form of extreme imbecility. The possibility that these states may occasionally be combined with conscious exaggeration makes the picture even more complicated. It is of some practical importance not only for the doctor, but also for the examining official, to be able to recognize psychological possibilities of this kind. The following case seems to me very instructive in this respect, as it concerns a prisoner who showed psychopathic inferiority with half-conscious simulation. The psychological and psychiatric side of this case has already been subjected to close study, and the

findings were recently published in the *Journal für Psychologie und Neurologie*.² Here I am only putting the medical opinion on record. For the psychological discussion of this case I must refer the reader to the publication mentioned below.

[358] The case was referred to us by the District Attorney, Zurich.

REPORT

[359] We were asked to give an opinion on the mental state of I. G., of Rothrist, Canton Aargau, born March 24, 1867, millhand, and in particular to answer the following questions:

1. Is the respondent mentally ill?

2. If Dr. S. is correct in his suppositions, from what other mental illness might the respondent be suffering?

3. Since when is this condition presumed to have existed?

[360] The material on which our opinion is based consists of documents relating to the theft of a bicycle, of which the respondent is accused; documents of the criminal court, Schwyz, relating to theft in 1902; documents of the district court, Hinwil, relating to theft in 1894; documents of the district court, Baden, relating to embezzlement in 1892; a written statement by the respondent's brother; the deposition of police constable S.; and observations made in the asylum.

1. *Previous History*

[361] The father of the respondent is stated to have been a respectable but rather quick-tempered man. The mother is alive and healthy. A brother of the father is alleged to be a religious crank. A sister of the mother committed suicide as a result of melancholia. Respondent has no children. His first wife had a still-birth.

[362] Nothing special is known of the respondent's youth, except that he was a naughty boy who was often told by his father that he would end up in prison. He attended school for eight years. At fifteen he entered a textile mill, where he worked for a year and a half. One day he ran away from the mill and found similar work in Turgi. He remained there for sixteen months, and states that he occasionally sent money home to his parents. Then he wandered off again and found another job in a textile mill in Wollishofen, where he remained about five months. After that he wandered about for "many weeks" and came to Linthal, worked for a year and a half, wandered off again, came to Ziegelbrücke, where he stayed about three years. At 22 he married. The marriage was not happy; after two years he ran away from his wife, taking with him her hard-earned savings, and emigrated to America, where he lived a roving and

adventurous life, and eventually, after many wanderings, found work as a stoker on a European steamer which took him to Germany. From Bremen he wandered on foot all through Germany into Switzerland, came to Wald, worked there for six months, and was also reconciled with his wife. The reconciliation did not last long, however. After a time the wife filed for a divorce, which was granted. To this end she made use of the opportunity afforded her by the respondent's first offence. Apparently, in consequence of irregular employment, he had gone to Baden in Aargau, where he found work in a textile mill. He absconded on November 13, 1892, with 275 francs, which had been entrusted to him by his room-mate, as the respondent had at his disposal a lockable trunk. He travelled with his booty to Zurich, then to Mülhausen, Colmar, Strassburg, Belfort, Montbéliard, La Chaux-de-Fonds, Bern, and Glarus, where he was arrested on November 27, 1892, just as he was about to draw the dole. The money he embezzled had all been spent. He is also said to have had a previous conviction with ten days' imprisonment for fraud, some time in 1892. He received six months' "correctional punishment" and was deprived of his civil rights for three years. After serving his sentence he roamed round Switzerland aimlessly, working here and there for short periods in various jobs. On March 15, he was sentenced to *one* month's imprisonment by the district court at Hinwil, for having pocketed a pair of pruning shears to the value of fr. 4.50. From the certificate of good conduct applied for on this occasion it appears that he had been apprehended "shortly before" in a "totally destitute condition" in Canton Glarus and had been sent back to his home parish; also that he first attempted suicide and showed himself very refractory in transit, so that he had to be locked up in the local jail, from which he broke out during the night and escaped.

[363] According to his own statement, he wandered or rather tramped round all the cantons of Switzerland until 1896, when he again found regular work in a textile mill in Schwanden. States that he remained there for four years and eight months, and married again in the autumn of 1900. The marriage was childless and not very happy.

[364] In the summer of 1901 he ran away on the Monday following a Sunday night debauch, taking with him a savings book belonging to his wife, showing funds amounting to 1200 francs, which he unlawfully drew at the bank in Glarus. Accordingly a description of him was circulated in the police gazette in Zurich. After a fortnight he came back again and gave his wife 700 francs. The rest he kept for himself. Eight weeks later he again ran away, ostensibly to look for work, taking with him another 400 francs. When, after a little while, he returned, he pretended to his wife that he had no more money left. But evidently he still had about 500 francs. After ten months he ran away again, always lodging in inns, and on September 15, 1902, stole a bicycle standing in front of a house, and on October 26 another bicycle from the corridor of a public-house in Siebnen, Canton Schwyz, valued at 200 francs,

rode it to Lucerne, and was arrested on October 28, 1902, as he was about to sell it for 120 francs. He was sentenced to six months in the workhouse on November 22, 1902.

[365] Later it was learned that he sold the first bicycle to a mechanic in Glarus for 70 francs, or rather for a pair of field-glasses valued at 45 francs and the rest in cash.

[366] When questioned by the District Attorney on May 29, 1903, the respondent gave his particulars correctly, but denied the charge of theft and maintained that he had bought the bicycle from one Emil H. at the last church fête in Wädenswil. From then on his answers were unclear and inconsistent.

[367] Previous to this the respondent is stated not to have given any impression of abnormality. Only in solitary confinement did he become restless at night. He threw his shoes under the bed, covered the window with a blanket "because somebody was always trying to get in." The next morning he refused nourishment, saying the food was poisoned. Henceforward he spoke only when pressed, said there was a spider on the wall, that spiders were poisonous, and that this was a sign that he was being poisoned. On the night of May 31 he slept in a cell for four persons. He was restless at night, repeatedly asserting that there was someone under the bed. On June 2 his behaviour was still the same; he was apathetic, did not speak to the other prisoners, but ate when he saw the others eating. The District Medical Officer testified that the respondent's remarks ("they wanted to do him in because he had killed his wife," "he had seen a murderer under the bed with a knife," etc.) and his general behaviour gave the impression of a catatonic state.

2. *Observations Made in the Asylum*

[368] On his admission on June 3, 1903, the respondent sat there listlessly and could only with difficulty be made to answer. The expression of the face was dull and masklike. He gave his name and address correctly, knew he was in Zurich, but otherwise did not appear to be oriented as to time and place, and could not state the year he was born. He persistently gave 5 fingers held before him as 4, 10 as 8. He could not tell the time, said 5:30 for 5:50, 3:30 for 7:30, and when shown 3:30 said "also 3:30." He recognized only 5-franc pieces; 1-franc pieces he called 20 cents. On being given a key and asked to lock the door, he put the key in upside down. He tried to open a matchbox sideways. He was then put to bed. During the night he was quiet, but moved his bed once, remarking that the plaster rose on the ceiling would fall on top of him.

[369] At the examination next morning he gave scanty answers, had to be continually pressed. He seemed unclear about time and place, said he was in a hospital in Zurich.

He evidently understood all the questions quite well but gave senseless answers, all very curt and confined to the fewest possible words.

[370] Examples:

What is the name of this hospital? — *Zurich Hospital.*

What sort of people are in your room? — *Sick people.*

What is the matter with them? — *They can't walk.*

Aren't they wrong in the head? — *No, in the legs.*

How long have you been here? — *Two days.*

What day is it? — *Saturday.*

What day did you arrive? — *Wednesday.*

What day is it, then? — *Saturday.* (It was Thursday.)

What day is it? — *Sunday.*

What holiday was it last Sunday? (Whitsun.) — *Singing-festival in Zurich. I heard singing.*

Where were you last Sunday? — *In Zurich.*

What did you do? — *Nothing.*

Where do you live? — (No answer.)

Glarus? Wädenswil? — *Glarus.*

Where were you before you came here? — *Zurich.*

What did you do in Zurich? Did you go anywhere? — *Wandered around.*

[371] Respondent gave no more answers, despite energetic pressing. He was then asked to do various things, and it was noted that he understood the requests correctly, as previously the questions, but carried them out in a deliberately senseless manner.

[372] He was asked to write the word "Rothrist." He at once took the pen in his hand and made a zigzag line.

[373] He was asked to read. He held the book upside down, tried to read from right to left. Called the letter O a "ring," a 9 (inverted) "5", a 1 a "line," a 6 (inverted) "3", a 4 (inverted) "2", a 3 (inverted) no answer, a 2 (inverted) "2", a 3 (inverted) "5".

[374] Said spontaneously that he "couldn't read it."

[375] He was told to hold the book properly. He turned over the pages. The book was then placed before him. Question: What's that? Reply: "What are you? Why are you here?" He could not be made to read.

[376] He was asked to lock the door with a key. He turned the key to the right to lock, to the left to open, both times with a show of strength. (N.B.: Lock opens to the

right.)

[377] He was asked to open a matchbox. First he tried, as yesterday, to break it open from the side, but on being encouraged opened it properly, struck a match, also lighted a candle and put it out, both correctly.

[378] He was asked to open the blade of a pocket-knife: opened the corkscrew.

[379] He was asked to open a spectacles case and put on the spectacles. Spontaneous remark: "I don't want any. They aren't spectacles." Turned the case over in his fingers, then opened it correctly when shown how to. Tried to put the spectacles on upside down.

[380] He was given a purse, with the question: What is that? "A little box." What's in it? "Cigars." Tried to open it by pulling off the clasp.

[381] Some money (fr. 3.40) was put in front of him with the question: How much is that? "5 francs."

[382] He was shown a gold piece (fr. 20) and asked: How much is that worth? "Nothing."

[383] Physical examination showed brisk forearm and patellar reflexes.

[384] Sensibility to pain seemed to be generally reduced, in places almost non-existent, e.g., on the right forearm. Pupils reacted to pain; right pupil somewhat larger than the left; both showed normal reaction. Face rather asymmetrical, the left eyebrow standing higher than the right. Badly swollen veins on the left leg. On the left side of the chest, over the second and third ribs, there was a scar 5½ cm. long and almost 3 cm. broad (caused by the alleged attempt at suicide).

[385] This examination was carried out in a separate room on the same floor as the observation room where the respondent had been since the previous evening. When the examination was over he was told to find his way back to his room by himself. He went first in the opposite direction and rattled at a door he had not passed before, and was then told to go in the other direction. He now tried to open two more doors leading into rooms near the observation room. Finally he came to the right one, which was opened for him. He went in, but remained standing by the door. He was told to make his bed, but stood there rigid, without moving. His bed was in the corner facing him, clearly visible from where he stood. We let him stand. He stood for 1½ hours on the same spot, turned pale, sweated profusely, asked the warder for some water, and suddenly toppled over before it arrived, slipping to the floor full-length by the stove. His face was pale purple and covered with sweat. He said nothing and did not react when spoken to, although he was conscious. After ten minutes he was put

on his feet again, but hardly was he upright than he turned pale, his pulse very weak, soft, rather rapid. He was then put to bed, where he lay quiet and silent.

[386] Towards four o'clock in the afternoon he suddenly got up, went to the door and banged it violently with his head, then took a run and threw himself head foremost against the door with considerable force. (According to the head warder, there was such a racket that he thought "everything was falling to bits" in the observation room.) When they tried to restrain him he struggled so much that he had to be straitjacketed, whereupon he calmed down at once.

[387] On the night of June 4 he was quiet, turned his bed round only once, and then didn't want to go back again. At the morning visit he suddenly seized hold of the doctor and tried to pull him into bed, then seized the warder and fought with him. He was given a narcotic by injection. On the following days he exhibited the same dull, apathetic behaviour with occasional attacks on doctors and warders, though the attacks were confined to wrestling and never came to blows. He seldom said anything, and what he said was always stupid and nonsensical, and was uttered in an unemotional, toneless voice. He ate nothing for the first three days. On the fourth day he began to eat a little, then better every day. On June 7 he suddenly announced to the doctor that he had too much blood, and would they please open a vein—a request which was naturally not granted. It was also observed that in contradiction to his apparent apathy he took a lively interest in what was going on around; for instance he suddenly called out that they ought to tie up the feet of a patient who was offering violent resistance to nasal feeding, then it would go better.

[388] On June 8 he was given a strong dose of faradism, and was told that henceforth this would happen daily and would do a great deal to improve his condition, particularly his speech.

[389] On the morning of June 9 he was suddenly clear, demanded an interview with the director. He was taken to a separate room, where he delivered the following oration:

[390] "You know very well that there's not much the matter with me. When I was arrested I was so scared and upset thinking of my mother and sisters, they being so respectable, that I didn't know what to say, so I got the idea of making things look worse than they were. But I soon saw you weren't taken in, besides I felt such a fool playing the looney, also I got sick of always lying in bed. I'm sick of everything. I thought of killing myself. This week I asked to be bled and I planned to fight against being bandaged and so make the blood run. I'm not crazy, yet I sometimes feel I'm not quite right in the head. I didn't do this to avoid going to jail, but for the sake of my family.... I hadn't been in jail for nine years until last fall." (Wept.)

[391] When asked how he came to simulate insanity, he said: "I was sorry for my old mother and regretted what I'd done. I was so frightened and upset that I thought, well, I'll make out I'm worse than I am. When I got back to the cell after the hearing I was at my wits' end. I'd have jumped out of the window but for the bars. I thought I can't bring any more disgrace on my mother and sisters. I'd have had a nice life if only I could have gone straight. I've always gone on the booze instead of working. My wife always told me I was wrong in the head—naturally, if your head's full of booze." He went on to say that he hadn't really known what would happen to him if he simulated, he just wanted to see what we would do. Other people had simulated and got away with it. He didn't know he would be taken to Burghölzli, he thought it would be the cantonal hospital.

[392] In this way he arrived at the idea of pretending to be mad. He hadn't eaten anything because he thought he would starve himself. (Another time he said he had lost his appetite.) He had been in despair and he still was; for all he cared we could open a vein today, the only reason why he had not killed himself before was that he did not want to bring more disgrace on his mother by committing suicide.

[393] He said he feigned fear of poisoning because it gave him an excuse for not eating. He simulated hallucinations because he knew that mad people often saw such things. When he was moved to a communal cell he was obliged to start eating as soon as he saw the others eating. During this recital the respondent repeatedly burst into tears and was obviously in a very penitent mood.

[394] On this and the following day (June 9–10) he was subjected to a thorough examination.

[395] Pupillary, patellar, and other reflexes showed no change. When tested for sensibility to pain the respondent definitely reacted, but it was clear that sensibility in general was considerably reduced in a uniform way over the entire surface of the body (hypalgesia). The visual field showed no restriction, but he was found to have typical red-green blindness. Apperception was considerably reduced, so that simple pictures were perceived very slowly and faultily. If he was shown a picture long enough, he understood it and could describe it correctly. When Aesop's fable of the ass in the lion's skin was read out to him, he understood the meaning but reproduced the story very inaccurately:

[396] An ass found a lion's skin with a dead lion inside it. [This passage was a spontaneous addition of the respondent's.] Then he took the skin and wrapped himself in it. He ran round roaring like a lion. Then the other animals tore him to pieces. The meaning is: Do not make yourself bigger than you are.

[397] His retention was likewise reduced, and this was particularly apparent in reckoning, as he easily forgot one or the other component of a simple sum. For instance, he could not calculate $147 + 178$; even simpler sums were difficult for him, e.g., “ $15 + 17 = 42$ —yes, 42, no, 37.” He reckoned as follows: “ $15 + 15 = 30 + 7 = 37$ —no, 32.” Division was the worst; he could not solve $92 \div 8$. Apart from poor aptitude for arithmetic, the fault lay chiefly with his reduced retention, i.e., a so-called bad memory.

[398] Otherwise he showed medium intelligence and a knowledge that was sufficient and appropriate to his circumstances.

[399] After this he composed an autobiography, running to five and a-half pages, in which he accepted the chief blame for his unsuccessful life and also for the unhappy outcome of his two marriages. In the same remorseful and contrite tone he gave an oral account of his life-history, emphasizing again and again that he alone was to blame for his criminal career, that he had drunk foolishly and neglected his work, that an inner unrest always drove him on his way and prevented him from settling down with his wife; he had never been able to “submit to the yoke.” Every so often he had to run away, driven by a vague urge for freedom.

[400] The story of his life was correct so far as it could be checked objectively. He was at fault only in the dates. He also told the story of his various thefts faithfully and without cover-up. He was surprisingly uncertain, however, with regard to the temporal location of recent happenings. He was unsure whether he had been three or four days in Selnau; on the morning of June 9 he was definite that he had been a fortnight in the asylum; later, towards afternoon, he thought it was certainly twelve days at least, and in the evening he hovered between ten and twelve days. Otherwise he was well oriented as to time. He recounted the details of his present stay in a confused manner, and he no longer remembered many little incidents that took place during his simulation; he also got various things muddled up in time. He had only a vague memory of his admission and the examination that followed; he knew that he had been told to put a key in the lock but thought he had done it correctly. He remembered also the examination on the next day, and said that the room had been full of doctors, about seven or eight of them (in reality there were five). He could still remember the details of the examination, but only when helped. With regard to the scene that took place afterwards, he made a statement to the following effect:

[401] He knew quite well how he came out after the examination, we turned him loose and he lost his way in the big corridor. It seemed to him that in order to reach the examination room he had first gone up some steps. Then, when he found he did not have to go down any steps, he thought we wanted to fool him and lead him to the wrong room. Therefore, when we took him to the sick room, he thought it was not

the right room, nor did he recognize it again, especially when he saw that all the beds were occupied. That was why he remained standing by the door. We let him stand there, and then he felt queer and fell over. Only when he was put to bed did he notice that there was a bed unoccupied, that it was his bed and that he was in the right room.

[402] The fact that he banged his head against the door so forcefully was, he explained, due to his desperation; he was in such a state that he didn't care if he bashed his head in.

[403] (Respondent would not admit the suicide attempt reported in the documents. He stated that he had merely been monkeying about with a revolver, that it had gone off, and that he had no intention of committing suicide.)

[404] In order to obtain a more accurate picture of his condition at this time (June 10), we took what is known as his "work-curve." We put him to adding up single figures for 46 minutes and then plotted the results (performance and error) in a curve.³ The striking thing is the low level of performance per minute despite increasing practice, and the large, rapidly increasing number of errors. This behaviour was not the result of fatigue; it reflected a state of peculiar psychic debility and uncertainty.

[405] On the following days the respondent was left to his own devices. He passed the time in reading and playing cards, and complained off and on of vague ailments ("weak back," etc.), grumbled about the warders and the asylum, saying that there was nothing whatever the matter with half the so-called patients here, etc.

[406] On June 19 he was subjected to another thorough examination.

[407] His physical condition showed no change.

[408] In his comprehension there was a distinct improvement, for although his perception was still uncertain and not quick enough, it was quicker and more accurate than before.

[409] No change could be demonstrated in his retention. Memory and calculation were just as uncertain as on June 9.

[410] On the other hand, the work-curve (taken on June 17) showed a distinct improvement. Not only was the average performance higher, there was also a considerable drop in the number of errors.

[411] Respondent now exhibited a continual mood of mild depression and often asked when he could go away.

[412] On June 23 he suddenly made an attempt at suicide by slowly sawing through the skin of his left wrist with a sharp stone, near the artery. On beginning to bleed he asked the warder for a knife, because he hadn't "finished it off properly," whereupon,

of course, the attempt was discovered. At first he resisted when we tried to stitch and bandage the wound, but gave way at once when we threatened to have him held down by four warders.

3. *Opinion*

[413] The following points are clear from the material set forth under sections 1 and 2:

[414] Respondent has always inclined to lead a work-shy, vagrant existence. He never remained anywhere for long, was continually moving about and changing his job; he could not endure the settled life of marriage, quarrelled with his wife, embezzled her money, and squandered it. If opportunity were favourable, he several times resorted to stealing. His characteristic instability was, in his opinion, due to an inner unrest which drove him forth again and again, even from jobs that might have suited him. He himself was aware of this peculiarity, and realized also that he had only himself to blame for his unfortunate career.

[415] Investigation shows that even apart from this peculiarity the respondent is not quite normal. He exhibits a number of deviations from the norm which, if not exactly pathological, must nevertheless be described as signs of degeneracy; for instance, general reduction of sensibility to pain (hypalgesia), red-green blindness (Daltonism), reduced attention, poor comprehension of things seen and heard, characterized by retardation and lack of accuracy.

[416] This abnormal condition comes nearer to congenital degeneracy than to any known mental illness. Owing to our meagre knowledge of the family circumstances no strong hereditary influences could be proved, but they may nevertheless exist.

[417] One can, if necessary, distinguish certain groups among hereditarily tainted persons which correspond to definite clinical pictures, according to the way the symptoms are constellated. The respondent comes closest to hysteria, since his chief symptoms—instability of character and forgetfulness—play a particularly prominent role in hysteria. Red-green blindness, dulling of the senses in general, are symptoms that are found in various forms of degeneracy (or “psychopathic inferiority”). His easy emotional excitability, his inquisitive interest in the asylum’s affairs, and his rash judgments, though they cannot with certainty be described as hysterical, nevertheless give that impression. On the other hand, the attempt at suicide, which stopped just at the point where it began to be dangerous, has a definitely hysterical character. (This is not to say that a depression cannot sometimes reach such a pitch that the attempt has a more than merely theatrical outcome.)

[418] In view of the fact that the respondent comes of an otherwise reputable family and is not just a moral degenerate, but was prevented from leading a steady and

useful life mainly on account of his abnormal psychic disposition, we must assume that the reasons he gave for simulation, particularly the powerful feeling of remorse, were in fact sufficient, although the psychology of it is not altogether clear. Indeed, it is remarkable how vague he was in this connection, for he had no very clear idea of what he really wanted to gain by simulation, and of what would happen to him if he simulated. It is probable that the thought uppermost in his mind was that his offence would be forgiven him; but, judging by what he told us, he had at the time absolutely no conception of the consequences of his actions. It looks very much as if he were following an inexplicable urge to extricate himself from his simulation rather than a clear train of thought.

[419] With regard to the outward appearance of his condition at that time, it must be emphasized that apart from a number of minor inconsistencies and improbabilities which always kept us on the watch for simulation, the respondent acted the part of a madman extremely well on the whole—so well, in fact, that there could be no mistaking a distinct affinity with certain hysterical twilight states on the one hand and with certain forms of dementia praecox (tension neurosis) on the other. The dull facial expression, the ruthlessness with which he banged his head against the door, his real fainting-fit, all these are facts which it would be difficult to explain as pure simulation. So even at this stage we had the impression that, if simulation were present at all, there must still be some pathological factor in the background which enabled the respondent to play his strenuous role. Further observation fully confirmed this conjecture. According to his own subsequent confession, it was an intentionally simulated insanity, but, without his either knowing it or willing it, it succeeded so well that it almost turned into real insanity—that is to say, it began to take on pathological features, because the meticulous imitation of a semi-imbecilic state had an effect on the normal activity of the mind, and this showed itself in various symptoms which could no longer be simulated. What the respondent said about the scene in the observation room is proof of this. His bad memory, which moreover was particularly defective for the whole period of simulation, cannot be held responsible for the above report of the incident, since it was a quite positive memory of a falsification of perception which cannot be regarded as normal and which sufficiently explains the oddity of the situation at the time. We see from this that the respondent already had a pathologically indistinct and definitely falsified perception of his environment. Further proof of the supposed disturbance of consciousness is furnished by the respondent's obvious helplessness, which led to his fainting-fit. He could easily have altered his position or done something to avoid fainting from discomfort, without necessarily stepping outside his role. The remark that he had no appetite at the beginning of his hunger-strike is also significant. All this suggests that the intention to simulate insanity became a powerful auto-

suggestion which blurred his consciousness and in this way influenced his actions regardless of his conscious will. This also gives us the key to his histrionic feats. There are numerous cases known to science of deceptions which started off as conscious and became, by auto-suggestion, involuntary and unconscious, and also much more convincing and consistent. Into this category fall, in particular, all cases of pathological lying (*pseudologia phantastica*).

[420] These phenomena are observed as a rule in hysterically disposed persons, which is an additional reason for suspecting the respondent of some hysterical degeneracy.

[421] Although certain episodes doubtless came about only as a result of the restriction and blurring of consciousness, it is not surprising that the respondent occasionally dropped the mask and showed an interest in his surroundings that contradicted his apparent apathy.

[422] The most probable hypothesis is that he acted the greater part of his seeming insanity with conscious intent, but that certain elements in the simulation worked on him so convincingly that they acquired the force of an overmastering suggestion and so induced a genuine auto-hypnosis. That these abnormal psychic processes had an injurious effect on his mental activity in other ways is shown by the difference between the work-curve on the second day after simulation ceased and nine days later.

[423] As is clear from the respondent's own statements, the development of simulation was attended by strong affects. Affects always have a disturbing influence on consciousness, as they place undue emphasis on feeling-toned thought-processes and thus obscure any others that may be present. Hence it is understandable that the respondent was not very clear as to what he wanted to gain by simulation. In our opinion, the initial affects were the source of the overmastering suggestion to simulate that later ensued. That this phenomenon of partly conscious, partly unconscious simulation could come about at all was evidently due to the respondent's hysterical disposition, and the most outstanding feature of this disposition is an abnormal dissociability of consciousness, which, the moment a strong affect appears, can easily lead to mental confusion and the formation of suggestions which are very difficult to combat. Altogether, the psychological mechanism of his simulation seems to us to suggest that the initial psychic weakness was the final cause of the idea of simulation. The respondent was probably aware of the confusion wrought by his emotions, and he may have converted it into the wish to go mad rather than bring more disgrace on his mother through another penal conviction.

[424] However that may be, it is sufficient to show that his simulation had pathological features and that it appears to have been influenced, even in origin, by causes that were not quite normal.

[425] We have no reason to suppose that the same or a similar disturbance of consciousness existed before his imprisonment, that is to say, at the time the offence was committed; moreover, it is very improbable there was any pathological disturbance at that time—unless, of course, one chooses to regard his ordinary state of congenital degeneracy as such a disturbance. Degenerative symptoms of this kind are, however, found in a large number of habitual criminals who must be considered fully responsible in the eyes of the law. On the other hand, we are of the opinion that the psychological state in which the decision to simulate was taken is not quite the same as the one designated by the term “responsibility,” because in the former case there was an undeniable predisposition which underlay the wish to simulate and fostered it in such a manner that we must suppose the respondent was acting under abnormal influences which considerably restricted his freedom of will.

[426] We therefore conclude that insanity within the meaning of the law was not present at the time the theft was committed, but that partial responsibility must be assumed for the simulation.

[427] Further, having regard to the fact that the simulation was for the most part conscious, and that a spontaneous twilight state is in consequence precluded, the respondent must also be deemed punishable.

[428] We therefore answer the questions put to us as follows:

[429] 1. The respondent is not at the moment mentally ill.

2. He is, on the other hand, in a condition of psychopathic inferiority with hysterical features.

3. This condition has existed presumably since birth. It does not preclude responsibility for theft; but partial responsibility must be assumed for simulation.

VI

A THIRD AND FINAL OPINION ON TWO CONTRADICTORY PSYCHIATRIC DIAGNOSES

ON THE PSYCHOLOGICAL DIAGNOSIS OF FACTS

A THIRD AND FINAL OPINION ON TWO CONTRADICTORY PSYCHIATRIC DIAGNOSES¹

[430] It is not so very uncommon for two psychiatric diagnoses to reach contradictory conclusions, especially when, as in the present case, it is a question of the very elastic borderline between complete irresponsibility and partial responsibility. The peculiarity of this case consists firstly in the fact that the medical expert was confronted, not with the defendant herself, but merely with the reports that had previously been passed on her. In adopting this procedure, the authorities were swayed by the reflection that the material already amassed in these reports was so exhaustive that further observation would be superfluous. The medical expert was able to concur with this view. Secondly, the case is of interest inasmuch as it gave rise to a discussion of principle concerning the relation—a very important one in practice—of moral defect to hysteria. The medical expert would like to submit the views expressed in the final opinion for the consideration of his professional colleagues.

[431] Our opinion is based on the existing records, etc., the legal records being specified under “Documents.”

[432] At the same time we have tried to form our own judgment on the basis of two consultations with the defendant in prison.

Questions Asked by the Examining Magistrate

[433] (i). May one assume, from the psychiatric reports (Opinions A and B) that Mrs. Z. is totally irresponsible, or is it a case of partial responsibility only?

(ii). Was the material at the disposal of the Governors of Asylum B. complete?

Opinion A: November 17, 1904

[434] THE FACTS: Mrs. Z. defrauded two women of 200 marks by telling them she had a ticket in the Hungarian state lottery, and had drawn a high prize (38,000 or 180,000 marks). She now needed the money to pay for her ticket, so that she could collect the winnings.

[435] EXAMINATION: To the examining magistrate the defendant stated that in November 1903 a certain August Baumann had offered her further lottery tickets to

the value of 2000 francs. In order to buy them, she had tried to raise the money.

[436] The examination showed, however, that in 1900 and 1901 she had relieved a certain B. [another person] of 4000 francs by telling the same story. Nevertheless, the defendant maintained the existence of Mr. Baumann with such obstinacy that it was at first conjectured she might perhaps be his victim.

[437] Despite exhaustive inquiries, Baumann's existence could not be proved. But as the defendant stuck to her story, and the evidence of several witnesses raised the question of her mental health, the examining magistrate considered it possible that she was suffering from pathological self-deception. For these reasons she was recommended for a medical opinion.

[438] DOCUMENTS: The Opinion was based on the documents then in existence, the following being of special interest: The records of the Cantonal Court of G.; a report from the penitentiary in G., which states: "Z. is a pleasure-seeking, dissolute person and a first-class impostor. Her behaviour in the penitentiary was entirely normal, there was never any sign of a psychic defect"; and, finally, a report from the District Medical Officer of K., September 1904, which assumed an abnormal mental condition and limited responsibility on the grounds of various nervous troubles, such as the unshakable "self-suggestion" of Baumann's existence and the incomplete correction of an anxiety dream she had in prison. In addition, there were a number of important testimonies representing the defendant as mentally abnormal.

[439] Observation began on September 28, 1904, and the Opinion was delivered on November 17. The observation established the presence of hysterical symptoms, and that the belief in Baumann's existence was a pathological self-deception in which the defendant herself believed. She admitted that she obtained the money by fraud, but insisted that she meant to pay it back as soon as she received her winnings.

[440] There were no other disturbances of intelligence and consciousness.

[441] CONCLUSION DRAWN BY THE OPINION: The most important finding is the presence of hysteria. Basic to all hysteria is an hysterical character, which is generally congenital. "Experience shows that persons of this kind habitually lie even when there is no need to, and invent whole stories," which, however, have reality value for the person concerned. "It goes without saying that with constitutionally hysterical persons lying and fraud cannot be judged in the same way as with normal people; they succumb more easily to an already existing tendency to deceive, their lies readily suggest themselves, and many of the checks which prevent normal people from lying and cheating do not operate in these persons."

[442] The Opinion assumed partial responsibility.

[443] CRITICISM OF THE OPINION: The previous history is incomplete, as it is based almost entirely on the documents. That, however, is not the fault of Asylum A., but of its distance from Switzerland, which prevented a personal examination. Examination by letter would have been impossible. The discovery of hysterical symptoms is not particularly difficult, hence the risk of deception is small. Moreover the examining doctors X. and Y. are professionals of good repute. Although greater completeness would have been desirable, the findings are nevertheless not only reliable but sufficient to warrant the above conclusion.

[444] The important question of how far the belief in Baumann's existence influenced her actions is not discussed. If she really believed in Baumann and his lottery tickets, her fraudulent manipulations would be bound to appear much less reprehensible to her, as she could always exculpate herself in her own eyes by telling herself that she would pay the money back again. This kind of reasoning would appeal very much to the weak character of an hysteric, a fact which ought to have played a considerable part in determining the degree of responsibility. Opinion A seems to assume that the defendant did believe in Baumann. In that case there is an omission in the Opinion which makes the whole conclusion appear doubtful. But if the defendant was lying, if she purposely put the blame on somebody unknown, then the conclusion reached by the Opinion could still be correct, even though it takes no stand on this question.

Opinion B: March 23, 1905

[445] THE FACTS: Mrs. Z. defrauded a certain H. of 700 francs. She told the injured party that she had a ticket in the Budapest lottery, which had won—first 135,000 and then 270,000 francs. On various pretexts of secondary importance she induced H. to give her considerable sums of money from time to time, thus repeating the game as before.

[446] EXAMINATION: At the hearing the defendant again insisted that she had received a lottery ticket from the agent Baumann. In view of the fact that one medical opinion had already been submitted, the examining magistrate thought it advisable to obtain a second.

[447] DOCUMENTS: The Opinion was based on the documents then available (list of documents followed). Private inquiries concerning the defendant were also initiated by the asylum.

[448] This material is much more complete than in Opinion A. We refrain from giving in detail all the valuable points of view arising out of the above material, and refer the reader to the "Conclusions" below. They confirm at some length that the

defendant was from the beginning a morally defective psychopath, who already had a variegated record of offences behind her.

[449] Observation began on January 19, 1905, and the Opinion was delivered on March 23, 1905. The period of observation was therefore sufficiently long to warrant a very thorough appreciation of her psychic state. The main finding was again a number of undoubted hysterical symptoms. (The fact that other physical disturbances of a different nature were found in Opinion B is of no special importance: hysterical symptoms can change very rapidly.) As in Opinion A, no pathological defect of intelligence and no disturbance of consciousness could be demonstrated. The far more thorough investigation of her mental state proved, first and foremost, the existence of an hysterical character with all its subsidiary symptoms—unsociableness, irritability, tendency to lie and to intrigue, bad memory, etc.

[450] Here too the belief in the existence of Baumann proved unshakable (at least to all appearances). The defendant maintained that she had spent the best part of the money on Baumann's tickets. In her relations with those about her she showed her sly and rebellious nature.

[451] CONCLUSIONS DRAWN BY THE OPINION: From the life and behaviour of the defendant, who has an hereditary taint, it is abundantly clear that she suffers from hysteria. Her hysterical character expresses itself in the form of crass egotism. She manifests an extraordinary lack of feeling towards her relatives, her former husband, and her fiancé, both of whom she swindled without scruple. In the sexual sphere she knows no moral restraints. She is pleasure-seeking and extravagant. Her extreme instability and moodiness are characteristic. Her feelings vary inordinately.

[452] She knows what is permitted and what is not, but is totally wanting in moral feeling.

[453] The belief in the existence of Baumann must be regarded as a pathological fraud which she has gradually talked herself into believing.

[454] Her unlawful actions must be regarded as symptoms of her hysterical aberration. She is therefore totally irresponsible. Her illness has developed with her personality. She is therefore incurable.

[455] The defendant is a danger to the community, and it is necessary to protect society from her machinations. Considering the craftiness of her procedure, this would seem best accomplished by permanent internment in a closed institution.

[456] CRITICISM OF THE OPINION: The material leaves nothing to be desired; it is more than sufficient to establish constitutional hysteria. In our view, however, the Opinion goes decidedly too far in its conclusions.

[457] It establishes quite correctly that there is a total lack of moral feelings, but that is not an hysterical symptom and does not belong in any way to the hysterical character. There are thousands of severe hysterics who have very sensitive moral feelings, and there are just as many hardened criminals who show no signs of hysteria. Moral defect and hysteria are two completely different things, which occur independently of one another, as everyday experience shows.

[458] As may be elicited from the Opinion, the defendant is a morally defective person who, besides that, is hysterical. Only her moral defect can lead to criminality, not her hysteria; otherwise all hysterics would be criminals, which is contrary to all experience.

[459] Consequently, the conclusion that the unlawful actions are symptoms of hysteria falls to the ground, and the question of responsibility appears in quite another light, a point to which we shall return later on.

[460] Despite thorough discussion, the question of belief in Baumann does not find a satisfactory solution in this Opinion either. Nevertheless, thanks to its greater thoroughness, one can see much more clearly here that this question is of no particular significance as regards her freedom of action. Before she ever got this idea, the defendant lied, defrauded, indulged in sexual activity to excess, and, in the case of the offence mentioned in Opinion B, acted with full consciousness of defrauding. It therefore seems completely out of the question that any pathological compulsion emanated from this idea.

[461] One could perhaps say that the general idea of fraudulent action depended on belief in the existence of Baumann, supposing that this belief was really present. Be that as it may, it is at any rate certain that the defendant carried out the details of her frauds with clear consciousness. For instance, she journeyed to K., ostensibly to pay for the tickets, but returned after a few days loaded with new clothes and presents.

[462] The correct conclusion to be drawn from Opinion B, therefore, is that she acted unlawfully in consequence of her moral defect. One must, however, agree with the Opinion in so far as the undoubted existence of hysteria had a considerable influence on her actions.

Final Opinion

[463] From the material collected under Opinions A and B, it seems to us proven beyond a doubt that Z. is a morally defective and hysterical person.

[464] Moral defect (moral insanity) is a congenital condition characterized by the absence of moral feelings. Hysteria never causes a moral defect; it can at most mask the existence of such, or exaggerate its pre-existing influence on a person's actions.

Hysteria is a morbid condition, congenital or acquired, in which the affects are exceedingly powerful. Hence the patients are more or less the continual victims of their affects. At the same time, however, hysteria generally determines only the *quantity*, not the *quality*, of the affects. The quality is given by the patient's character. A soft-hearted person, if she becomes hysterical, will simply burst into tears more easily, a ruthless person will become harder, and one who is inclined to excess will fall victim to her inclinations even more unresistingly than before. It is in this manner that we have to envisage the influence of hysteria on criminal actions.

[465] A person who is morally defective from the beginning and who is or becomes hysterical therefore has even less power of resistance than one who is only morally defective. This behaviour is brought out very nicely in Opinion B. No sooner is she released from prison than the defendant immediately succumbs again to the temptation of fraud. She brings off her coups with consummate skill and has, so far as one can judge, a positively uncanny influence over her victims. As Opinion B rightly remarks, these artful powers of persuasion must be put down to hysteria, for in hysteria there is always so much feeling and such a natural gift for play-acting that, however much they lie and exaggerate, hysterics will always find people gullible enough to believe them. Even doctors are often taken in by their wiles.

[466] Neither of the Opinions has proved that the defendant was acting under the compulsion of a pathological conviction, a delusional idea (Baumann), or a pathological and irresistible instinct. Both stress that she knew her actions were immoral. A clouding of consciousness at the moment of the deed is likewise out of the question.

[467] The defendant simply gives way to her evil inclinations. She acts exactly like any common criminal. Her hysteria fosters her actions and prevents any resolutions to the contrary. It does this because only evil inclinations are present. If good ones were there too, the hysteria would occasionally foster them as well, as happens in hysterical persons who are not morally defective. This shows that the essential thing can only be the moral defect.

[468] Is the defendant legally irresponsible on account of her moral defect?

[469] Every habitual criminal is morally defective, and is thus ill in a scientific sense. The law, however, as it stands at present, claims all individuals who recognize the punishable nature of their actions and who are not acting under an irresistible compulsion.

[470] The juridical conception of irresponsibility therefore includes all psychic abnormalities with the exception of moral defect. So if we adhere to the meaning of

the law, moral defect should logically not be taken into account in adjudging the question of responsibility.

[471] In the present case, is the hysteria by itself strong enough to cause total irresponsibility?

[472] As the Münsterling Opinion [B] makes clear, the defendant is morally defective. If such a defect is present and offences are committed, they must naturally be connected first of all with the moral defect, since they are two things that go together unconditionally. If the offences are to arise from hysteria, it must be shown from the character of the offences that they have their roots in hysteria and not in moral defect.

[473] Are the defendant's offences specifically hysterical?

[474] No proof of this has been furnished. To all appearances it is a question of conscious and intentional fraud, of a kind common among skilled impostors. Its roots lie in evil inclinations and lack of resistance to them. But that is not hysterical. The only point where one might surmise a specifically hysterical motive is the question of Baumann. But it is precisely here that the greatest mistrust is to be recommended. The Baumann swindle served a purpose, and on one occasion it very nearly came off (in K.). Opinion B emphasizes that the defendant once said she would not let herself be hypnotized, as she was "not obliged to tell the doctors the whole truth." In view of this remark it may be supposed that she had more insight into her swindles than she was credited with. It therefore behoves us to exercise the greatest caution in regard to the Baumann swindle. On the occasion of the present offence, the undersigned had a lengthy talk with the defendant on this point and ascertained that this time she swindled on purpose, in order to obtain money. Baumann played no part in it at all. She also assured me that she did not possess any tickets, but she still maintains the existence of Baumann to this day with the greatest positiveness and many tears, so that it is extremely difficult to resist the impression of his reality. However, the only point of practical importance here is that in the present instance she swindled on her own account, quite clearly and without beating about the bush, as once before in 1900. It is also clear that no hysterical motivation may be inferred for her offences.

[475] These offences, and particularly their remarkably sure results, must be understood as the co-operative action of moral defect and hysteria, the hysteria being merely an accessory influence in respect of the offence. Owing to the strength of their affects, hysterical persons are always their own victims; they do not belong to themselves, as it were, but to the momentary affect. Consequently, their actions are always being compromised by passing moods. We all know how much these can obscure our judgment and hinder reflection. With a higher degree of hysteria, such as the defendant exhibits, the decisions of the will are always influenced by abnormal

affects, which is not the case with normal people, who can calmly weigh the pros and cons of their actions. Hysteria therefore limits the subject's responsibility.

[476] Accordingly, we answer your questions thus, to the best of our knowledge and conscience:

(i). On the basis of Opinions A and B, only a diminished or partial responsibility can be assumed.

(ii). The material collected under Opinion B is put together with so much care and thoroughness that one could hardly add anything more than subsidiary details to its completeness.

[477] The standpoint of the Opinion [B] means nothing less, in practice, than an abandonment of the scientific conception of moral defect. The logical conclusion to be drawn would be the exclusion of moral defectives from the legal conception of insanity. In theory this might be described as a retrograde step or concession to the lay psychologist's interpretation of criminal law, and in practice as a lack of consideration for society. We, as doctors of the mentally ill, should pay no attention to either reproach, for our first charge is to watch over the welfare of the state institutions committed to our care. If we, too, now put into practice our theory of the mental sickness of moral defectives, we find that with increasing psychological education of the judiciary our institutions are getting choked with criminals, thanks to our altruistic medical reports. Conditions in an asylum will rapidly become untenable. (Just now in Burghölzli, only one more criminal is needed to make the situation quite impossible.) In this way we ruin the character and reputation of an asylum completely, and no one could blame a respectable family if it did everything in its power not to send an unfortunate mentally sick relative into the villainous hubbub of a criminal ward. The presence of criminals completely poisons the tone of the place, and its spirit as a hospital. In addition, only a very few asylums have the equipment for confining criminals. The more the legal experts realize the futility of the existing criminal practice, the more they will insist upon getting rid of their permanently incorrigible clients by interning them in a lunatic asylum, on the increasingly popular plea that society must be protected. Naturally criminal justice wants that, but why must the asylum suffer for it? The asylum should never become the executive organ of criminal law. By relieving criminal justice of inconvenient elements we do not make them better, we merely ruin our asylums. So long as society is unwilling to alter the laws relating to criminal justice, it must also discover to its cost that, as a result of the rapidly increasing number of partially responsible persons, the most dangerous criminals are turned loose against it at ever shorter intervals. Only in this way can the pressing need for reforms be demonstrated to the public.

ON THE PSYCHOLOGICAL DIAGNOSIS OF FACTS¹

[478] As readers of the *Centralblatt* may be aware, the “psychological diagnosis of facts” has recently been the object of some discussion. The essence of psychological diagnosis consists in bringing to light, by means of associations, the complex of ideas relating to a crime. In our work on “The Associations of Normal Subjects,”² Riklin and I put forward the concept of the “feeling-toned complex” and described its effects on the associations; these effects were examined in greater detail in my inaugural paper on “Reaction-Time in the Association Experiment.” The discovery of feeling-toned complexes in the associations of insane persons has been of great help to us in our diagnostic work for the past two years, as is apparent from a number of publications by Riklin and myself.

[479] After the publication of my studies in word-association, an article by Wertheimer and Klein appeared in Volume XV of the *Archiv für Kriminalanthropologie und Kriminalistik*, on the psychological diagnosis of facts.³ The authors discuss, in the main, the possibility of finding, through the associations, the feeling-toned complex relating to a crime committed in the past. As Messrs. Wertheimer and Klein are erroneously described as the “discoverers” of this idea, I would like to clarify the situation by taking this opportunity to remark that, so far as the experiment is concerned, the honour of the title of discoverer belongs to Galton or Wundt. The concept of feeling-toned complexes, however, and the determination of their specific effects on association, derive from the Zurich Clinic, and more particularly from the “Diagnostische Assoziationsstudien” published in the *Journal für Psychologie und Neurologie*, 1904–5. If Wertheimer and Klein had had a little more respect for the workers before them in this field, and had cited the source from which they appropriated their seemingly original ideas, they could have spared themselves sundry unpleasant discussions (cf. Weygandt’s criticism in the latest issue of Aschaffenburg’s *Monatsschrift*⁴).

[480] Wertheimer’s merit is confined at present to having emphasized a special instance of the feeling-toned complex—crime—and the possibility of discovering it from the associations. I am privately informed that experiments in this direction are in progress, though as yet they do not seem to have advanced much beyond the laboratory stage.

- [481] Readers may be interested to know that today I succeeded for the first time in testing out, on a delinquent, our method of discovering complexes, and with excellent results.
- [482] A detailed account of the case will appear in a forthcoming issue of the *Schweizerische Zeitschrift für Strafrecht*.⁵ I permit myself only a brief report on the case now:
- [483] Yesterday evening an elderly gentleman came to see me, obviously in a state of great agitation. He told me that he had staying with him a young man of eighteen, whose guardian he was. Some weeks ago he noticed from time to time that small sums of money were missing from his cashbox, now amounting to over 100 francs. He at once informed the police, but was unable to bring proofs against any one person. He rather suspected his ward, but had no absolute proof of this. If he knew that his ward was the thief, he would prefer to settle the matter on the quiet, so as to spare the feelings of the boy's highly respectable family. But first he wanted to know for certain whether his ward was really a thief. He now asked me to hypnotize the young man and question him under hypnosis. As can readily be understood, I declined this strange request, but proposed instead an association test, which could be rendered plausible enough in the form of a consultation (the suspected delinquent had wanted to consult me once before on account of mild nervous troubles). His guardian agreed to the plan and this morning the young man turned up for the consultation. I had, of course, previously equipped my list of one hundred stimulus words with the critical words designed to hit the complex. The experiment went off smoothly; but in order to determine the critical reactions still more precisely I decided to employ my reproduction procedure as well. The complex for the theft was then revealed so plainly by the associations that I was able to tell the young man with quiet assurance: "You have been stealing." He paled, was completely nonplussed for a moment, and after a little hesitation broke down and tearfully admitted to the theft.
- [484] I would merely like to add, in this provisional report, that the effects of a theft complex on the associations are naturally exactly the same as in the case of any other complex of similar emotional intensity. For further details I must refer the reader to the forthcoming publication.

BIBLIOGRAPHY

BIBLIOGRAPHY

The items of the bibliography are arranged alphabetically under two headings: A. List of periodicals cited, with abbreviations; B. General bibliography, including both books and articles. It has not been possible to establish the full names of some medical writers cited in the early literature.

A. LIST OF PERIODICALS CITED, WITH ABBREVIATIONS

Allg Z f Psych = *Allgemeine Zeitschrift für Psychiatrie und psychisch-gerichtliche Medicin*. Berlin.

Ann méd-psych = *Annales médico-psychologiques*. Paris.

Arch f d ges Psych = *Archiv für die gesamte Psychologie*. Leipzig.

Arch f Krim u Krim = *Archiv für Kriminalanthropologie und Kriminalstatistik*. Leipzig.

Arch f Psych und Nerv = *Archiv für Psychiatrie und Nervenkrankheiten*. Berlin.

Arch de neur = *Archives de neurologie*. Paris.

Brain. A Journal of Neurology. London.

Centralbl f Nerv und Psych = *Centralblatt für Nervenheilkunde und Psychiatrie*. Berlin and Leipzig.

L'Encéphale. *Journal des Maladies mentales et nerveuses*. Paris.

Friedrich's Blätter für gerichtliche Medizin und Sanitätspolizei. Nuremberg.

Harper's Magazine. New York.

Jahrb f Psych = *Jahrbuch für Psychiatrie und Neurologie*. Leipzig and Vienna.

Journ f Psych u Neur = *Journal für Psychologie und Neurologie*. Leipzig. (A continuation of the *Zeitschrift für Hypnotismus*, q.v.)

Juristisch-psychiatrische Grenzfragen. Halle.

Mind. A quarterly review of psychology and philosophy. London.

Monatsschrift = *Monatsschrift für Kriminalpsychologie und Strafrechtsreform*. Edited by Gustav Aschaffenburg. Heidelberg.

Münch med Wochenschr = *Münchener Medicinische Wochenschrift*. Munich.

Neur Centralbl = *Neurologisches Centralblatt*. Berlin.

Proc Soc Psych Res = *Proceedings of the Society for Psychological Research*. London.

Prog méd = *Progrès médical*. Paris.

Rév de l'hyp = *Revue de l'hypnotisme*. Paris.

Rev phil = *Revue philosophique de France et de l'Étranger*. Paris.

Samml der päd Psych = *Sammlung von Abhandlungen aus dem Gebiete der pädagogischen Psychologie und Physiologie*. Berlin.

Trans Coll Phys Philadelphia = *Transactions of the College of Physicians of Philadelphia*.

Trib méd = *Tribune médicale*. Paris.

Union méd = *Union médicale*. Paris.

Wiener med Presse = *Wiener medizinische Presse*. Vienna.

Z f Hyp = *Zeitschrift für Hypnotismus, Psychotherapie, etc.* Leipzig. (Continued as the *Journal für Psychologie und Neurologie*, q.v.)

Z f Straf = *Zeitschrift für Strafrecht*. Switzerland.

Zukunft, Die. Berlin.

B. GENERAL BIBLIOGRAPHY

AZAM, C. M. ÉTIENNE EUGÈNE. *Hypnotisme, double conscience, et altérations de la personnalité*. Paris, 1887.

BAETZ, E. VON. "Über Emotionslähmung," *Allg Z f Psych*, LVIII (1901), 717ff.

BAIN, ALEXANDER. *The Senses and the Intellect*. London, 1855.

BALLET, GILBERT. *Le Langage intérieur et les diverse formes de l'aphasie*. Paris. 1886.

BAUMANN, JULIUS. "Über Willens- und Charakterbildung auf physiologisch-psychologisches Grundlage," *Samml d päd Psych*, I (1897): 3.

BEHR, ALBERT. "Bemerkungen über Erinnerungsfälschungen und pathologische Traumzustände," *Allg Z f Psych*, LVI (1899), 918ff.

BILLOD, E. "Rapport médico-légal sur un cas de simulation de folie," *Ann méd-psych*, 4th ser., XII, 26th year (1868), 53–82.

BINET, ALFRED. *Alterations of Personality*. Translated by Helen Green Baldwin. London, 1896. (Original: *Les Altérations de la personnalité*. Paris, 1892.)

BÖCKER, F. W., HERTZ, CARL, and RICHARZ, FRANZ. *Reiner Stockhausen, ein actenmässiger Beitrag zur psychisch-gerichtlichen Medicin*. Elberfeld, 1855.

BOETEAU, M. "Automatisme somnambulique avec dédoublement de la personnalité," *Ann méd-psych*, 7th ser., V, 50th year (1892), 63–79.

BOHN, WOLFGANG. *Ein Fall von doppeltem Bewusstsein*. Dissertation, Breslau, 1898.

BOLTE, AUGUST. "Über einige Fälle von Simulation," *Allg Z f Psych*, LX (1903), 47–59.

- BONAMAISON, L. "Un Cas remarquable d'hypnose spontanée, etc.," *Rév de l'hyp*, 4th year (Feb., 1890), 234–43.
- BOURRU, HENRI, and BUROT, FERDINAND. *Variations de la personnalité*. Paris, 1888.
- BRESLER, JOHANN. "Kulturhistorischer Beitrag zur Hysterie," *Allg Z f Psych*, LIII (1896), 333ff.
- BREUER, JOSEF, and FREUD, SIGMUND. *Studies on Hysteria*. Translated under the editorship of James Strachey. (Standard Edition of the Complete Psychological Works of Sigmund Freud, 2.) London and New York, 1955. (Original: *Studien über Hysterie*. Leipzig and Vienna, 1895.)
- CARDAN, JEROME (Girolamo Cardano or Hieronymus Cardanus). *De subtilitate libri III*. Nuremberg, 1550. (Other editions: Paris, 1550, 1551; Basel, 1554, 1560, 1582, 1611; Lyons, 1580.)
- [CELLINI, BENVENUTO.] *The Life of Benvenuto Cellini, Written by Himself*. Translated by John Addington Symonds. London (Phaidon Press), 1949.
- CLAUS, _____. "Ein Fall von simulierter Geistesstörung," *Allg Z f Psych*, XXXIII (1877), 153–70.
- CULLERRE, A. "Un Cas de somnambulisme hystérique," *Ann médpsych*, 7th ser., VII, 46th year (1888), 354–70. (Reviewed by H. Kurella in *Allg Z f Psych*, XLVI (1890), p. 356* [Litteraturbericht].)
- DELBRÜCK, ANTON. *Die pathologische Lüge und die psychisch abnormen Schwindler*. Stuttgart, 1891.
- DESSOIR, MAX. *Das Doppel-Ich*. Berlin, 1890. (2nd edition, Berlin, 1896.)
- DIEHL, AUGUST. "Neurasthenische Krisen," *Münch med Wochenschr*, 49th year, no. 9 (March, 1902), 363–66.
- DONATH, JULIUS. "Über Suggestibilität," *Wiener med Presse*, 1892, no. 31, cols. 1244–46. (Cited in the next work.)
- _____. "Der epileptische Wandertrieb (Poriomanie)," *Arch f Psych und Nerv*, XXXII (1899), 335–55.
- ECKERMANN, J. P. *Conversations with Goethe*. Translated by R. O. Moon. London, n.d. [1951].
- EMMINGHAUS, H. *Allgemeine Psychopathologie zur Einführung in das Studium der Geistesstörungen*. Leipzig, 1878.
- ERLER, _____. "Hysterisches und hystero-epileptisches Irresein," *Allg Z f Psych*, XXXV (1879), 16–45.
- FLAUBERT, GUSTAVE. *Salammbô*. Translated by J. S. Chartres. London (Everyman's Library), 1931. (Original: Paris, 1862.)

- FLOURNOY, THÉODORE. *From India to the Planet Mars*. Translated by D. B. Vermilye. New York and London, 1900. (Original: *Des Indes à la Planète Mars. Étude sur un cas de somnambulisme avec glossolalie*. Paris and Geneva, 1900.)
- FOREL, AUGUSTE. *Hypnotism, or Suggestion and Psychotherapy*. Translated from the 5th German edition by H. W. Armit. London and New York, 1906. (Original: *Der Hypnotismus, seine ... Bedeutung und ... Handhabung*. Stuttgart, 1889. Later editions, 1891, 1911, 1918, etc.)
- FREUD, SIGMUND. *The Interpretation of Dreams*. Translated by James Strachey. (Standard Edition, 4 and 5.) London and New York, 1953. 2 vols. (Original: *Die Traumdeutung*. Leipzig and Vienna, 1900.)
- _____. See also BREUER.
- FÜRSTNER, C. "Die Zurechnungsfähigkeit der Hysterischen," *Arch f Psych und Nerv*, XXXI (1899), 627–39.
- _____. "Über Simulation geistiger Störungen," *Arch f Psych und Nerv*, XIX (1888), 601ff.
- GANSER, SIGBERT. "Über einen eigenartigen hysterischen Dämmerzustand," *Arch f Psych und Nerv*, XXX (1898), 633ff.
- GOETHE, J. W. VON. *Elective Affinities*. A translation of *Die Wahlverwandtschaften*. With an introduction by Victoria C. Woodhull. Boston, 1872.
- _____. *Zur Naturwissenschaft. Allgemeine Naturlehre*. Stuttgart and Tübingen, 1817–23.
- GÖRRES, JOHANN JOSEPH VON. *Die christliche Mystik*. Regensburg and Landshut, 1836–42. 4 vols.
- GRAETER, C. "Ein Fall von epileptischer Amnesie durch Hypermnesie beseitigt," *Z f Hyp*, VIII (1899), 129–63.
- GROSS, HANS. *Criminal Psychology. A Manual for Judges, Practitioners and Students*. Translated from the 4th German edition by Horace M. Kallen. London, 1911. (Original: *Criminalpsychologie*. Graz, 1898.)
- GUINON, GEORGES. "Documents pour servir à l'histoire des somnambulismes," *Prog méd*, 1891, XIII, 401–4, 425–29, 460–66, 513–17; XIV, 41–49, 137–41.
- _____ and WOLTKE, SOPHIE. "De l'influence des excitations des organes des sens sur les hallucinations de la phase passionnelle de l'attaque hystérique," *Arch de neur*, XXI: 63 (May, 1891), 346–65.
- HAGEN, F. W. "Zur Theorie der Hallucination," *Allg Z f Psych*, XXV (1868), 1–113.
- _____. Review of J. F. C. Hecker, *Über Visionen* (q.v.), *Allg Z f Psych*, VI (1849), 285–95.

- HAHN, R. Review of Jung's *Zur Psychologie und Pathologie sogenannter occulter Phänomene*, *Archiv f d ges Psych*, III (1904), Literaturbericht, p. 26.
- [HARDEN, MAXIMILIAN.] "Der kleine Jacobsohn," *Die Zukunft*, XLIX (1904), 370–78.
- HAUPTMANN, CARL. *Die Bergschmiede*. Munich, 1902.
- HECKER, JUSTUS FRIEDRICH CARL. *Über Visionen. Eine Vorlesung*, etc. Berlin, 1848.
- HOCHE, ALFRED ERICH. *Handbuch der gerichtlichen Psychiatrie*. Berlin, 1901.
- HÖFELT, J. A. "Ein Fall von spontanem Somnambulismus," *Allg Z f Psych*, XLIX (1893), 250ff.
- JAMES, WILLIAM. *The Principles of Psychology*. New York and London, 1890. 2 vols.
- JANET, PIERRE. "L'Anesthésie hystérique," *Arch de neur*, XXIII : 69 (May, 1892), 323–52.
- _____. *L'Automatisme psychologique*. 7th edition, Paris, 1913.
- _____. *Névroses et idées fixes*. Paris, 1898. 2 vols.
- _____. *Les Obsessions et la psychasthénie*. Paris, 1903.
- _____. *The Mental State of Hystericals*. Translated by Caroline Rollin Corson. New York and London, 1901. (Original: *État mental des hystériques*. Paris, [1893].)
- JESSEN, W. Review of F. W. Böcker et al., *Reiner Stockhausen* (q.v.), *Allg Z f Psych*, XII (1855), 618–32.
- _____. "Doppeltes Bewusstsein," *Allg Z f Psych*, XXII (1865), 407. (Report of address at Naturforscherversammlung zu Hannover, Psychiatrische Section, Sept. 18–23, 1865.)
- JUNG, C. G. *Collected Papers on Analytical Psychology*. Edited by Constance E. Long; translated by various hands. London and New York, 1916; 2nd edn., 1917.
- _____. *Contributions to Analytical Psychology*. Translated by C. F. and H. G. Baynes. London and New York, 1928.
- _____. "The Psychological Diagnosis of Evidence." In: *Collected Works*, Vol. 2.
- _____. "The Psychology of Dementia Praecox." In: *Collected Works*, Vol. 3.
- _____. "The Reaction-Time Ratio in the Association Experiment." In: *Collected Works*, Vol. 2.
- _____. *Symbols of Transformation*. *Collected Works*, Vol. 5.
- _____. and Riklin, Franz. "The Associations of Normal Subjects." In: *Collected Works*, Vol. 2.
- [KANT, IMMANUEL.] *Kant's Cosmogony as in His "Essay on the Retardation of the Rotation of the Earth" and His "Natural History and Theory of the Heavens."* Edited and Translated by W. Hastie. Glasgow, 1900.

- KARPLUS, J. P. "Über Pupillenstarre im hysterischen Anfalle," *Jahrb f Psych*, XVIII (1898), 1–53.
- KERNER, JUSTINUS. *Blätter aus Prevorst*. Karlsruhe, 1831–39.
- _____. *Die Seherin von Prevorst*. Stuttgart and Tübingen, 1829. 2 vols. (Translation, not cited herein, by Mrs. [Catherine] Crowe: *The Seeress of Prevorst*. New York, 1859.)
- KRAEPELIN, EMIL. *Psychologische Arbeiten*. Leipzig, 1895–1927. 9 vols.
- KRAFFT-EBING, RICHARD VON. *Text-Book of Insanity based on Clinical Observations*. Authorized translation from the last German edition by C. G. Chaddock. Philadelphia, 1904. (Original: *Lehrbuch der Psychiatrie auf klinischer Grundlage*, Stuttgart, 1879. 7th edition, 1903.)
- KRAUSS, A. *Die Psychologie des Verbrechens. Ein Beitrag zur Erfahrungsseelenkunde*. Tübingen, 1884.
- LADD, C. TRUMBULL. "Contribution to the Psychology of Visual Dreams," *Mind*, XVII (April, 1892), 299–304.
- LANDGRAF, KARL. "Ein Simulant vor Gericht," *Friedrich's Blätter*, 35th year, 6 (1884), 411–33. (Summary in *Allg Z f Psych*, XLII (1886), 60 [Literaturbericht].)
- LAURENT, ARMAND. *Étude sur la simulation*. Paris, 1866.
- LAURENT, EMILE. "Un Détenue simulant la folie pendant trois ans," *Ann méd-psych*, 7th ser., VIII, 46th year (Sept., 1888), 225–34.
- LEHMANN, ALFRED GEORG LUDWIG. *Aberglaube und Zauberei von den ältesten Zeiten an bis in die Gegenwart*. Translated from Danish by Dr. Petersen. Stuttgart, 1898.
- _____. *Die körperlichen Äusserungen psychischer Zustände*. Translated from Danish by F. Bendixen. Leipzig, 1899–1905. 3 parts.
- LEPPMANN, A. "Simulation von Geistesstörung umgrenzt von Störungsanfall und Rückfall," *Allg Z f Psych*, XLVIII (1892), 530–32.
- LOEWENFELD, LEOPOLD. *Der Hypnotismus: Handbuch der Lehre von der Hypnose und der Suggestion*. Wiesbaden, 1901.
- _____. "Über hysterische Schlafzustände, deren Beziehungen zur Hypnose und zur Grande Hystérie," *Arch f Psych und Nerv*, XXII (1891), 715–38; XXIII (1892), 40–69.
- LÜCKE, ROBERT. "Über das Ganser'sche Symptom mit Berücksichtigung seiner forensischen Bedeutung," *Allg Z f Psych*, LX (1903), 1–35.
- MACARIO, M. M. A. "Des Hallucinations," *Ann méd-psych*, VI (1845), 317–49; VII (1846), 13–45. (Reviewed in *Allg Z f Psych*, IV [1848], 137ff.)
- MACNISH, ROBERT. *The Philosophy of Sleep*. Glasgow, 1830.

- MARANDON DE MONTYEL, E. "Folie simulée par une aliénée inculpée de tentative d'assassinat," *L'Encéphale*, II (1882), 47–61. (Reviewed in *Allg Z f Psych*, XL [1884], 337–38.)
- MAURY, LOUIS FERDINAND ALFRED. *Le Sommeil et les rêves*. Paris, 1861. (3rd edition, Paris, 1865.)
- MENDEL, EMANUEL. *Die Manie*. Vienna and Leipzig, 1881.
- MESNET, ERNEST. "De l'automatisme de la mémoire et du souvenir dans la somnambulisme pathologique," *Union méd*, 3rd ser., XVIII : 87 (July 21, 1874), 105–112.
- _____. "Somnambulisme spontané dans ses rapports avec l'hystérie," *Arch de neur*, no. 69 (1892), 289–304.
- MITCHELL, SILAS WEIR. "Mary Reynolds: A Case of Double Consciousness," *Trans Coll Phys Philadelphia*, 3rd ser., X (April 4, 1888), 366–89.
- MOLL, ALBERT. "Die Bewusstseinspaltung in Paul Lindau's neuem Schauspiel," *Z f Hyp*, I (1893), 306ff.
- MÖRCHEN, FRIEDRICH. *Über Dämmerzustände*. Medical dissertation, Warburg, 1901.
- MÜLLER, ERDMANN. "Über Moral Insanity," *Arch f Psych und Nerv*, XXXI (1899), 325–77.
- MÜLLER, JOHANNES. *Über die phantastischen Gesichterscheinungen*. Coblenz, 1826. (Cited in Hagen, "Zur Theorie der Hallucination," q.v.)
- MYERS, FREDERIC W. H. "Automatic Writing," *Proc Soc Psych Res*, III (1885), 1–63.
- NAEF, M. "Ein Fall von temporärer, totaler, theilweise retrograder Amnesie," *Z f Hyp*, VI (1897), 321–54.
- NIETZSCHE, FRIEDRICH. *Thus Spake Zarathustra*. Translated by Thomas Common, revised by Oscar Levy and John L. Beevers. 6th edition, London, 1932. (Original: *Also Sprach Zarathustra*. 1883–91.)
- _____. *Ecce Homo*. Translated by A. M. Ludovici. London, 1927. (Original: 1888.)
- NISSL, F. "Hysterische Symptome bei einfachen Seelenstörungen," *Centralbl f Nerv und Psych*, 25th year, XIII (1902), 2–38.
- PELMAN, C. "Über das Verhalten des Gedächtnisses bei den verschiedenen Formen des Irreseins," *Allg Z f Psych*, XXI (1864), 63–121.
- PHLEPS, EDUARD. "Psychosen nach Erdbeben," *Jahrb f Psych*, XXIII (1903), 382–406.
- PICK, ARNOLD. "Über pathologische Träumerei und ihre Beziehung zur Hysterie," *Jahrb f Psych*, XIV (1896), 280–330.
- _____. "Vom Bewusstsein in Zuständen sogenannter Bewusstlosigkeit," *Arch f Psych und Nerv*, XV (1884), 202–23.

- PINEL, PHILIPPE. *A Treatise on Insanity*. Translated by D. D. Davis. London, 1806.
(Original: *Traité médico-philosophique sur l'aliénation mentale, ou la manie*. Paris, an IX [1801]. 2nd edition, (1809).
- PLUMER, REV. WILLIAM S. "Mary Reynolds: A Case of Double Consciousness," *Harper's*, XX : 120 (May, 1860), 807–12.
- PREYER, WILLIAM THIERRY. *Die Erklärung des Gedankenlesens*. Leipzig, 1886.
- PRINCE, MORTON. "An Experimental Study of Visions," *Brain*, XXI (1898), 528ff.
- PROUST, A. A. "Cas curieux d'automatisme ambulatoire chez un hystérique," *Trib méd*, 23rd year (March, 1890), 202–3.
- QUICHERAT, JULES. *Procès de condamnation et de réhabilitation de Jeanne d'Arc, dite la Pucelle*, etc. Paris, 1841–49. 5 vols.
- RAECKE, JULIUS. "Beitrag zur Kenntnis des hysterischen Dämmerzustandes," *Allg Z f Psych*, LVIII (1901), 115–63.
- _____. "Hysterischer Stupor bei Strafgefangenen," *Allg Z f Psych*, LVIII (1901), 409–46.
- REDLICH, JOHANN. "Ein Beitrag zur Kenntnis der Pseudologia phantastica," *Allg Z f Psych*, LVI (1900), 65ff.
- RIBOT, THÉODULE ARMAND. *Die Persönlichkeit*. Translated from French by F. T. F. Pabst. Berlin, 1894.
- RICHARZ, FRANZ. "Über psychische Untersuchungsmethoden," *Allg Z f Psych*, XIII (1856), 256–314.
- _____. See also BÖCKER.
- RICHER, PAUL. *Études cliniques sur l'hystéro-épilepsie*. Paris, 1881.
- RICHET, CHARLES. "La Suggestion mentale et le calcul des probabilités," *Rev phil*, XVIII (1884), II, 609–74.
- RIEGER, CONRAD. *Der Hypnotismus*. Jena, 1884.
- RÜDIN, ERNST. "Über die klinischen Formen der Gefängnispsychosen," *Allg Z f Psych*, LVIII (1901), 447–62.
- SCHNITZLER, ARTHUR. "Der Fall Jacobsohn," *Die Zukunft*, XLIX (1904), 401–4.
- SCHOPENHAUER, ARTHUR. "Preisschrift über die Freiheit des Willens." In: *Arthur Schopenhauers Werke*. Edited by Moritz Brasch. 3rd edition, Leipzig, n.d. [1891]. (Vol. II, pp. 231–317.)
- SCHROEDER VAN DER KOLK, JACOBUS LUDOVICUS CONRADUS. *Die Pathologie und Therapie der Geisteskrankheiten auf anatomischphysiologischer Grundlage*.

- Translated from Dutch by F. W. Theile. Brunswick, 1863. (Quoted in *Allg Z f Psych*, XXII [1865], 406–7.)
- SCHÜLE, HEINRICH. *Handbuch der Geisteskrankheiten*. (Ziemssens Handbuch der speciellen Pathologie, etc., 16.) Leipzig, 1878.
- SCHÜRMEYER, IGNAZ HEINRICH. *Theoretisch-practisches Lehrbuch der gerichtlichen Medicin*. Erlangen, 1850. (4th edition, 1874.)
- SIEFERT, ERNST. “Über chronische Manie,” *Allg Z f Psych*, LIX (1902), 261–70.
- SIEMENS, FRITZ. “Zur Frage der Simulation von Seelenstörung,” *Arch f Psych und Nerv*, XIV (1883), 40–86.
- SNELL, L. “Über Simulation von Geistesstörung,” *Allg Z f Psych*, XIII (1856), 1–32.
- STEFFENS, PAUL. “Über drei Fälle von ‘Hysteria magna,’ ” *Arch f Psych und Nerv*, XXXIII (1900), 892–928.
- TILING, T. “Die Moral Insanity beruht auf einem excessiv sanguinischen Temperament,” *Allg Z f Psych*, LVII (1901), 205–40.
- VAN DEVENTER, J. “Ein Fall von sanguinischer Minderwerthigkeit,” *Allg Z f Psych*, LI (1894), 550–78.
- WERNICKE, CARL. *Grundriss der Psychiatrie in klinischen Vorlesungen*. Leipzig, 1894.
- WERTHEIMER, MAX, and KLEIN, JULIUS. “Psychologische Tatbestandsdiagnostik,” *Arch f Krim u Krim*, XV (1904), 72–113.
- WESTPHAL, A. “Über hysterische Dämmerzustände und das Symptom des ‘Vorbeiredens,’ ” *Neur Centralbl*, XXI (1903), 7–16, 64–72.
- WESTPHAL, C. “Die Agoraphobie, eine neuropathische Erscheinung,” *Arch f Psych und Nerv*, III (1872), 138–61.
- WEYGANDT, WILHELM. “Zur psychologischen Tatbestandsdiagnostik,” *Monatsschrift*, II (1905), 435–38.
- WILBRAND, _____. and LOTZ, _____. “Simulation von Geisteskrankheit bei einem schweren Verbrecher,” *Allg Z f Psych*, XLV (1889), 472–90.
- WINSLOW, BENIGNUS FORBES. *Obscure Diseases of the Brain and Mind*. London, 1863. (Cited in *Allg Z f Psych*, XXII [1865], 405.)
- WOLTKE, SOPHIE. See GUINON.
- ZSCHOKKE, JOHANN HEINRICH DANIEL. *Eine Selbstschau*. 3rd edition, Aarau, 1843.
- ZÜNDEL, FRIEDRICH. *Pfarrer J. C. Blumhardt: Ein Lebensbild*. Zurich and Heilbronn, 1880.

INDEX

INDEX

A

- abnormality, emotional, 119, 134
- accident, and affect, 164
- accusation, false, effect of, 184
- acoustic control: defective, and misreading, 90
- Acta Sanctorum*, glossolalia in, 84
- acting: excellence of performance in simulation, 179, 202
 - skill of hysterics at, 215
 - submersion of self in assumed role, 66, 69, 162
- action (s) : automatic, 69, 92
 - dependence on emotions, 132f
 - symptomatic, 98, 100
- activity: mental, 110f, 180n, 202f
 - motor, *see* motor; pressure of, 131
- Adam, 38
- adaptability: poor, of mental defectives, 169f
- adolescent: character of, 63
 - see also* puberty
- Aesop's fable, patient's reproduction of, 197
- affect(s): and abnormal action, 133
 - aetiological role of, 180
 - re* detention, 142
 - dissociating effect of, 181
 - effect of, on hysterical persons, 170f, 217
 - and hysteria, 215
 - influence on consciousness, 203
 - lack of control of, 21
 - pleasure/pain, 120
 - produced by arrest, trial, and confinement, 188f

and psychic automatism, 187
and psychogenic disturbances, 184f
repressed, 185
unabreacted, 155
violent, effect of, 164

aggression, 176, 195

alcohol, use of, 6, 13, 16
see also alcoholism

alcoholism, 90, 111, 112f, 124
dependent on emotional lability, 119
and manic behaviour, 120
resulting from depression and despair, 115ff

amnesia: anterograde, 172, 183
for automatic phenomena during ecstasy, 33
caused by affects, 171
difficulty of determining extent of, 150
disappearance under hypnosis, 147
in lethargy, 72
penetrated by trick, 145f
periodic, 3, 10ff
retrograde, 10, 143f, 172
and somnambulistic states, 20, 61ff
for unpleasant episode, 155

anaesthesia: cerebral, 49
of entire body surface, 63f
hysterical, 44
systematic, 64

analgesia, 145
total, for pinpricks, 139
see also hypalgesia

anamnesis, in simulated insanity, 177f

anger: reaction to censure, 118f
at trifles, 129

animal noises, made by manic patient, 128, 129

animals, life-forces of, 41

answers: irrelevant, 92

- senseless, 140ff, 148f, 172, 173n, 174, 183, 193

anxiety: effect of, 151

- precordial, 100

apathy, 166, 174f, 184, 192, 195

- behaviour contradictory to, 196, 203
- apperception, reduced, 197

appetite, lack of, after 4-day fast, 177

arm, motor area isolated from consciousness by auto-suggestion, 51

artist(s), 16, 106, 131

Aschaffenburg, Gustav, 167n, 220

assimilation: of affects, 188f

- and association, 168f

association(s): without aid of consciousness, 96

- automatic substitution of, 46
- concord of, 86
- conscious, and senseless answers, 149
- and distraction of attention, 168
- effect of attention on quality of, 168
- feeling-toned, as creative force, 105f
- inhibited, as embarrassment, 166
- law of, and memory-image, 95
- minimum of, and cryptomnesic idea, 81, 83f
- in psychological diagnosis, 219
- repression of, and perception, 45
- restriction of, 86n
- and songs or tunes, 97
- substitutions of, 46
- and supraliminal consciousness, 152
- and suggestion, 52
- unlimited, in hysterical subjects, 181

association tests, 166–70

- in discovery of theft, 221

astronomy, as source of names in S. W.'s mystic system, 85

asylum: fear of, 188

as institution for mentally ill and not for criminals, 218

attention: concentration of, and new ideas, 86*n*

—, and automatic actions, 69

distracted by fixed idea, 168

disturbances of, 21*ff*, 44, 148, 180*f*

and fatigability, 144

subliminal, 68*n*

and train of thought, 69*n*

see also distractibility

auditory hallucinations, and silence, 58

authority, reaction to, 113, 116, 120

auto-hypnosis: in cases of simulation, 187

induced by simulation, 203

automatic phenomena, *see* phenomena, automatic

automatic writing, *see* writing, automatic

automatism(s): and auto-suggestion, 58

creation of, by feeling-toned idea, 162

creative force of, 105*f*

feeling of strangeness invoked by, 52, 53

fostered by distractibility, 181

in hysteria, 171

in minor somnambulistic attacks, 21

motor, as hypnotist, 74*f*

and partial hypnosis, 49

in semi-somnambulism, 48–61

subconscious, hypnotic influence of, 70

and submersion in dream role, 69

in visual sphere, 57*f*

waking and somnambulistic, 14

automatisme ambulatoire, 3, 10

auto-suggestibility, 12*f*

auto-suggestion, 49

and automatisms, 58
and daydreaming, 66*f*
deeper hypnosis through, 55
and development of automatic motor phenomena, 51
and loss of knowledge, 155
malingerers and, 163
and self-deception, 210*ff*
and simulated insanity, 203
Azam, C. M. É. E.: on periodic amnesia, 10*ff*
on spontaneous somnambulism, 62*f*, 79, 150

B

Baetz, E. von, 71*n*, 164
Bain, Alexander, 51*n*
Ballet, Gilbert, 51*n*
“Baumann, August,” in hysterical patient’s fantasy, 210*ff*, 215, 216*f*
Baumann, Julius, 133
Baynes, H. G., and Cary F. Baynes, on “emotionally toned complex,” 97*n*
behaviour: aggressive, 176
 apathetic, 192, 195
 boisterous, 116*f*
 in detention, 138
 manic, 118*ff*
 outward, and mental activity, 180*n*
 psychic, sudden alterations in, 189
 social, in manic mood disorder, 115*ff*
 in solitary confinement, 174, 191
 in somnambulistic states, 19*f*
 stupid, in simulation of insanity, 165, 174
 stuporous, 149*ff*
Behr, Albert, 67*n*
Beyond, the, trance journeys to, 33–35, 42
Billod, E., 186
Binet, Alfred, 11*n*, 12*n*
 on automatic actions, 69

on automatization, [181](#)
experiments with patient's anaesthetic hand, [57f](#), [80](#), [91](#)
on hysterical patients, [67n](#)
on influence of darkness, [56](#)
on Janet's experiment in unconscious personality, [53](#)
on substitution of associations, [46](#)
on semi-somnambulism, [48](#)
on somnambulism, [5](#)
—, and Féré, [13f](#), [55n](#)
blaspheming, [129](#)
Bleuler, Eugen, [3n](#), [88](#), [134](#), [156](#), [187](#)
 on case of attempted suicide, [15](#)
blindness, hysterical, [22](#)
bliss: facial expression of, [28](#)
 feeling of, [22](#), [27](#)
Blumhardt, J. C., [84](#)
Böcker, F. W., [183f](#)
Böcklin, Arnold, [100](#)
Boeteau, M., [11](#)
Bohn, Wolfgang, [67](#)
Bolte, August, [159f](#), [185n](#)
Bonamaison, L., [71f](#)
Bourne, Ansel, [11](#)
Bourru, Henri, [63](#)
brain, physiology of, and reproduction of impressions, [103f](#)
Brentano, Bettina, [71](#)
Bresler, Johann, [84](#)
Breuer, Josef (with Sigmund Freud), [78n](#)
 on hysterical conversion, [155](#)
brightness, hypnagogic, [22](#)
Broca's convolution, [106](#)
brooch, lost and found, [85](#)
brooding, [173n](#)
Burghölzli Mental Hospital (Zurich), [113](#), [117f](#), [125](#), [126](#), [127](#), [137](#), [218](#), [220](#)

C

Camuset, Louis, 63

Cardan, Jerome, 59n

CASES IN SUMMARY, *listed alphabetically by reporting physician:*

Azam: boy, 12½, illustrating periodic amnesia, 10ff, 150n

Felida, somnambulistic girl whose second state became dominant, 62f

Bleuler: male, middle aged, suddenly attempting suicide without prodromal symptoms, 15

Boeteau: widow, 22, with somnambulism and amnesia, 11

Bourru and Burot: Louis V., male hysteric with amnesic alternating character, 63

Flournoy, *see* Smith, Héléne

Guinon and Woltke: hysterical female, illustrating associations with colour, 12

James: male, 30, of “ambulatory sort,” a psychopath with amnesia, 11

Janet: hystero-epileptic, male, whose attacks were associated with vision of fire, 76

Léonie, 63–65

Jung: *see s.v.*

Landgraf: male, habitual thief, who simulated imbecility, 182f

Leppmann: mentally defective murderer who simulated imbecility, 182

MacNish: young female showing sleep disorder followed by amnesia, 12, 150

Marandon de Montyel: psychopathic woman who drowned her child and shammed amnesia, 183

Mesnet: soldier, 27, with somnambulistic attacks with restriction of consciousness, 11f

Mitchell: Mary Reynolds, young woman with character change after deep sleep of 20 hours, 61f, 79, 150n

Naef: male, 32, illustrating retrograde amnesia, 10

Pick: young girl whose daydream passed into twilight state, 162

Proust: male, 30, with *automatisme ambulatoire*, 10f

Renaudin: character change in young man with periodic anaesthesia of entire body surface, 63f

Richer: woman, 30, a hysteric with hallucinations of children being devoured, 9
hysterical girl, 17, with hallucinations of dead mother, 9

Rüdin: male, convicted of theft and offences against decency and declared irresponsible because of epileptic stupor, 182

Schroeder van der Kolk: girl, 15, exhibiting change of character in periods separated by amnesia, 62, 150

Siefert: male, 36, illustrating chronic manic state, 109

Siemens: young male, day-labourer, falsely accused of murder, 184

Van Deventer: male, with hereditary taint, illustrating sanguine inferiority, 110

catalepsy, 19f, 28, 145

catamnesis, 180

 in doubtful cases of simulation, 164

catatonia: imitation of, 165

 impression of, 192

 masked by hysteriform symptoms, 149

Cellini, Benvenuto, sun vision of, 60

cemetery: Miss E.'s behaviour in, 6ff

 walk in, 13

censure, angry reaction to, 118f

chain of ideas, 133

character: and actions, 133

 development at puberty, 92

 psychological fluctuations of, 44

 quality of affects determined by, 215

character, change in, 47, 61–70

 without amnesic split, 63f

 literary use of amnesic, 63

 in somnambulistic state, 87n

 second state, 61f

Charcot, Jean Martin: on somnambulism, 9f

 scheme for word-picture composition, 51n

cheating, pathological, 66

Chevreul, Michel Eugène, 48

childhood: and later abnormal emotional state, 123

see also puberty

children: dead, hallucinations of, 6f, 13

 gibberish of, 85n

hallucinations of devouring of, 9

Clairvoyante of Prevorst (Frau Hauffe), 27, 34, 36, 42, 44, 66, 84, 85, 87

clang-reaction, 166ff

Claus,—(Sachsenberg), 185n

collecting; mania for, 11

colour, associations in hysterical attacks, 12

communications: automatic, 19, 25ff, 31, 44

trance, origin of, 31

complex(es): associated, objectivation of, 77n

feeling-toned, 97n, 219

psychic, 53

composition, literary: of manic patient, 126, 128f

patient's, autobiographical, 198

comprehension: and association, 168

and distractibility, 142

faulty, 180

reduced, 178f

retention of, despite loss of knowledge, 152

and senseless answers, 193f

compulsion: negativistic, 149

pathological, 214

concepts, and feelings, 87

concert, unpleasant episode at, 146f, 154f

confession: and forgiveness, trance pantomime of, 30

of simulation, 176, 196f

conflagration, vision of, 76

confusion: emotional, 204

—, disturbance of memory in, 171f

—, as motivation for simulating insanity, 172f

—, and “stage fright,” *etc.*, 164

hallucinatory, 148ff

mental, 165f, 174, 177, 204

conscience, effect on psychic life, 173

conscious mind: and associations, 98f

tyrannized by memories, 100

consciousness: alternating states of, 12, 149

- amnesic split, 76
- dissociability of, 204
- dissociated, and memory, 63
- disturbances of, 163
- division of, 69
- double, *see* double consciousness
- entry of cryptomnesic image, 81–87, 96
- and feeling-toned memory complexes, 98
- and fraud, 215*f*
- hysterical splits of, 76
- identity of, in somnambulistic attacks, 9
- loss of previous impressions, 104
- rare states of, 3*ff*
- reconstitution of scope of, 153*f*
- restriction of, 11*f*, 45*f*, 151*f*, 203
- , and cryptomnesia, 86
- , and the senseless answer, 149
- secondary complexes, 72*f*
- in semi-somnambulism, 47*f*
- in severe hysteria, 9
- split, in misreading, 91
- supraliminal, 71, 152
- threshold of, 14, 45
- tyrannized by unconsciousness, 105

consideration for others, lack of, 131

control, mediumistic, 30*ff*

Conventi, Italian murderer, somnambulistic personality, 35

conversation, trance, 20*f*, 28, 29

- impression of wilful deception, 43
- by means of intended tremors, 54
- memory of, 27
- with somnambulist personality, 31*f*

convulsions, hysterical attacks of, [115](#)
Cook, Florence, medium, [36](#)
counter-suggestion: and prevention of automatisms, [54](#)
see also suggestion

creation, original, [41](#), [82](#)

creativity: and ecstasy, [104f](#)

of hallucinations, [12](#)

and memory complex, [100f](#)

and wish-fulfilment, [99](#)

see also originality

crime: psychological diagnosis of, [219ff](#)

see also fraud; murder; rape; suicide; swindling; theft; vagrancy

criminal(s): energy and self-control in deception, [161](#)

influence of hysteria on actions of, [215](#)

reason for simulated insanity, [186](#)

stuporous behaviour of, [150](#)

unjustifiable presence of, in asylums, [218](#)

see also prisoners

Crookes, Sir William, [36](#)

cryptomnesia, [81–87](#), [95–106](#)

defined, [101](#)

enrichment of conscious memory, [86](#)

Cullerre, A., [9n](#)

D

Daltonism, [201](#)

dark, powers of, [41f](#)

darkness, [22](#)

automatic writing in, [27f](#), [55](#)

effect of, [26](#), [56](#)

solitary confinement in, [164](#)

and suggestibility, [57](#)

David, Jacques Louis, [37](#)

daydream(ing): passing into twilight state, [162](#)

pathological, [66f](#)

dead, the: hallucinations of, [6ff](#), [26](#)
spirits of, [47](#)

death, thoughts of, [20](#)

deathbed, and cryptomnesic reproduction, [84](#), [104](#)

deception: in hallucinatory phenomena, [78](#)
see also malingering; self-deception

decisions: and feeling-values, [133](#)
voluntary, and feeling-tone, [132f](#)

degeneracy: congenital, [204](#)
effect of detention on, [169f](#)
and hypalgesia, [180](#)
hysteria as mark of, [99f](#)
inherited, [64](#)
and malingering, [160](#)
psychic, symptoms of, [130](#)
signs of, [201](#)
and simulation, [188](#)
symptoms of, [111](#)

degenerate(s): case of simulation, [183f](#)
energy and self-control of, [161](#)

dejection, [173n](#)

Delbrück, Anton, [66&n](#), [68n](#), [162](#)

delirium: delusions of grandeur in, [125](#)
hysterical, [7](#), [8f](#), [67](#)
with motor excitement, [151](#)
syndromes of degeneracy, [130](#)

delirium tremens, [117](#), [118](#)

delusion(s): of being wronged, [151](#)
in hysterical delirium, [8f](#)
of grandeur, [125](#), [126f](#), [151](#)
see also self-deception

dementia, and outer associations, [169](#)

dementia paralytica, and intellectual deficiency, [151](#)

dementia praecox, [159](#), [202](#)

depression, 115, 117, 119

epileptic, 15*n*

source of, 123

“depressive melancholia,” 182

Dessoir, Max, 76*n*, 80

detention: characteristic states of prisoners in, 148*ff*

fear of, 188

and hysterical psychoses, 160

hysterical stupor of prisoner in, 137–56

influence of, 150*f*

patient’s affect *re*, 142, 169*f*

diagnoses: contradictory psychiatric, 209–18

difficulty of differentiation in certain states of epilepsy, somnambulism, and hysteria, 15

modern requirements for, 160

optimistic, in cases of simulation, 185*f*

psychological, of facts, 219–21

of rare states of consciousness, 3*f*

dialect word, *see* word substitution Diehl, August, 15 diphtheria, in case history, 112, 114

disorientation: following unpleasant episode, 146*f*

patient’s, as to location of room, 195, 199

in senseless answers, 140*ff*

see also orientation

disposition: hysterical, 161

—, outstanding feature of, 204

—, subsidiary symptoms, 213

mental, and assimilation of affects, 170

—, and simulation, 173

pleasure-seeking, 132, 210

dissociation: and affect, 171, 181

of consciousness, 204

distractibility, 111, 120

and automatizations, 181

effect on comprehension, 142

and faulty memory, 143
hysterical, 45
and interest, 82
and lethargy, 72
low-grade states of, 46f
and misreading, 45, 90

distraction, outer: experiments with, 168

disturbance(s): of attention, 44f
of emotions, 8f
of memory, 8
psychogenic, 184f
of sensibility, 150
of thinking, 110
of writing, 140f

dizziness, 146f
see also fainting-fits; giddiness

Donath, Julius, 62n

double consciousness, 3, 12, 149
and amnesia, 76
and new character formations, 79
and submersion in role, 162

“double life,” S. W.’s, 25

dream (s): of black and white figures, 23f
hysterical thinking in, 67
of kittens and cats, 144
level, consciousness and, in severe hysteria, 9
objectivation of, 68
origin of, 69
pictures, somnambulistic, 13f
realization of ideal state, 66
somnambulistic, 32, 46, 66f
symbolism in, 57
symbols, and memories, 100
uninhibited by conscious mind, 99

visual, and light sensations of retina, 59
dreaminess: lapses into, 21f
 pathological, 3, 16, 68f, 173
dream-state: pathological, 46
 somnambulistic, 13
dream-world, reality of, 23
drowsiness, and darkness, 56
drunkenness, *see* alcohol; alcoholism
dualism, derivation of idea of, 87
dull-wittedness, 165f
Dyce, —, 79

E

E., Miss, case of spontaneous somnambulism, 5–17
 hallucinations of dead children, 6f, 13
earthquake: and amnesia, 172
 paralysis of movement and feeling caused by, 164
Eckermann, J. P., 84n
 on deathbed memories, 104
ecstasy: and creativity, 104
 fantasy activity in, 32f
 and glossolalia, 84
 and intellectual exaltation, 87
 in manic mood disorder, 126
 Nietzsche on, 84n
 poetic, 84
 in somnambulistic states, 19f
 and table-turning experiments, 25
Eder, M. D., 3n
Edmond, Laura, daughter of judge, 84
educational level, improvement of, in somnambulistic states, 18, 19, 88
ego: pubertal changes in constitution of, 64
 somnambulist, 24, 32, 36, 80
 —, and patient's distractibility, 72
 —, *see also* Ivenes

ego-complex: and cryptomnesic idea, 81
link between twilight and waking states, 76, 78
splitting off of psychic functions from, 91

egotism, extreme, 213
see also megalomania

Einfall, word, 96

elation, 120, 124ff
in chronic mania, 110f
continuous state of, 125f

embarrassment: and attention, 168
and inhibited association, 166

Emmerich, Katharina, 186

Emminghaus, H., 62n

emotion(s): changes in, in feeble-mindedness, 189
disturbances of, and hysterical delirium, 8f
domination over intellect, 131f
influence on actions, 132f
and paralysis, 164
and psychogenic disturbances, 185
repressed, 56
violent, after-effect of, 187
see also affect

employment, frequent change of, 121, 123, 124f, 173ff

enchantment of spirits, S. W.'s attempts at, 34

energy, impulsive, of criminals, 191

entoptic phenomena, 58

environment, falsified perception of, 202f

epilepsy, 3
depression in, 15n
diagnostic difficulty in certain states of, 4f, 15
epileptic stupor, 182
and hysteria, 4
see also hysteroepilepsy

epileptoid, term, 15

Erler,—(Eberswalde), [9n](#), [67](#)

eroticism, [118](#)

in manic mood disorders, [121f](#)

ethical feelings: effect of lack of, [132](#)

see also moral defect

exaggeration, conscious: in abnormal affective states, [189](#)

examination, fear of, [165f](#)

excitability, [122f](#)

and alcoholism, [125](#)

emotional, [117](#), [138](#), [201](#)

—, in morally defective persons, [134](#)

exhaustion, [14f](#)

after ecstasy, [22](#)

and manifestation of hysteria, [16](#)

temporary, and protracted hysterical delirium, [8](#)

expectation, feeling of, [56](#), [59](#)

external world: isolation of ego-consciousness from, [73](#)

orientation to, [24](#)

relation of subconscious personality to, [64](#)

F

facial expression: blissful, [28](#)

rigidity of, [175](#), [179](#), [192](#)

stupid, [166](#)

facts, psychological diagnosis of, [218–21](#)

fainting-fits, [5](#), [17](#), [175](#), [179](#), [202f](#)

fantasy(ies): pathological, [67](#)

and romance, [162](#)

in somnambulistic states, [32f](#), [36ff](#), [68](#)

fatigue, [143](#)

see also exhaustion

fear: of detention, [183f](#), [188](#)

of examination, [165f](#)

and rage, [138f](#)

and simulation, [165f](#)

feeble-mindedness, 110
and compulsive talking, 105
and doubtful simulation, 166ff
and defective critical faculty, 131
heightened by emotionality, 169
imbecility induced by emotional changes, 189
and social incapacity, 132

feelings, and concepts, 87

feeling-tone(d), 97f
associations, 105f
and decisions reached by the will, 132
ideas, 68, 162, 219
memory, 146f, 155
motivation, 163
relationship to character and actions, 133
thought-processes, 203f
train of thought, 97f

feeling-values, influence on decisions, 133

feet, burned with sulphuric acid, 163

Felida (Azam's case), 62f, 79, 150

Féré, Charles, 13f, 55n

figures: black and white, 22, 42
hallucinatory, 144, 151
white, 26

Flaubert, Gustave, 71n

flexibilitas cerea, 20

flight of ideas, 111, 113, 118, 122f, 125, 128, 130f

Flournoy, Théodore, 55n, 57n, 71n
case, see Smith, Hélène
on cryptomnesia, 101
on glossolalia, 84
on somnambulistic dreams, 66n
on speech automatisms, 73n

flower: Goethe's image of, 14

in visions, [26](#), [60](#)
food: delusion of poisoning of, [138](#)
 refusal of, [174f](#), [192](#), [196f](#), [203](#)
forces, attractive and repulsive, [39ff](#)
foreign words, manic patient's use of, [126](#), [129](#)
Forel, Auguste: on dissociation, [181](#)
 on pathological cheating and daydreaming, [66](#)
forgetfulness, hysterical, [68f](#)
 see also amnesia
forgetting, idea of, [155](#)
forgiveness, trance pantomime of, [30](#)
Förster-Nietzsche, Elisabeth, [83](#), [103](#)
fraud: case of, [209–18](#)
 conscious and intentional, [216ff](#)
 and self-deception, [214](#)
French language, words derived from, [85](#)
Freud, Sigmund: dream investigations of, [56](#), [78](#), [99](#)
 on hysterical identification, [67](#)
 on psychogenic disturbances, [185](#)
 on symptomatic actions, [98](#)
 theory of hysteria, [92](#), [155](#), [170](#)
 on train of thought and attention, [69n](#)
 see also Breuer, Josef
Fritsch, —, [161](#)
Fürstner, C., [160](#), [186](#)
future: adventurous plans for, [123](#)
 optimism *re*, [117](#), [123](#), [126](#), [129](#)

G

Galton, Francis, [220](#)
Ganser, Sigbert, [137](#), [154](#)
 on hysterical ailments, [184f](#)
 on “senseless answer,” [149](#)
 on states observed in prisoners in detention, [148ff](#)
 studies of twilight states, [160](#), [172f](#), [179](#)

syndrome, [185](#), [187](#)
“Geiss,” *see* “Ziege”
genius: creative, and wish-fulfilment, [99](#)
 and degeneracy, [99n](#)
 “possessed” nature of, [82](#)
 psychology of, [4](#)
 and sensibility, [99](#)
 symptomatic actions of, [100](#)
 work of, [105](#)
Gerbenstein, Ulrich von (somnambulistic personality), [29](#), [32](#), [36](#), [37](#), [43](#)
 gay-hilarious type, [77](#)
 increased influence of, [78](#)
gibberish, [85n](#)
giddiness, [5](#)
 see also fainting-fits
Gilles de la Tourette, Georges, [87n](#)
glass tumbler, as “psychograph,” [25](#), [27](#)
Gley, M. E. E., [48](#)
glossolalia, [84f](#)
gnostic system, parallels in S. W.’s mystic science, [88](#)
Godwina F.: case of hysterical stupor, [137–56](#)
 peculiarities of case, [148ff](#)
 physical examination, [139](#)
 tests, [144](#)
Goethe, J. W. von, [59n](#)
 and Bettina Brentano, [71](#)
 conjunction of flower image, [14](#)
 in S. W.’s trance fantasies, [37](#)
 see also Eckermann, J. P.
Görres, J. J. von, [67n](#), [84n](#)
Graeter, C., [76n](#)
grande hystérie, symptoms of, [10f](#)
grandeur, delusion of, [125](#), [126f](#), [151](#)
grandfather: Jung’s, [26](#), [56](#)

S. W.'s, as spiritualistic control, [19](#), [26](#), [31](#), [73](#), [74f](#), [77](#)
“graphomaniacs,” [131](#)
Greek: deathbed memory of, [104](#)
mystic terms derived from, [85](#)
Gross, Hans, [161n](#)
Guinon, Georges, [9n](#)
and Sophie Woltke, experiments with hysterics, [12](#), [46](#)

H

haemoptysis, simulation of, [163](#)
Hagen, F. W., [56n](#), [59n](#), [60n](#), [71n](#)
Hahn, R., [89ff](#)
hallucinations: auditory, *see* auditory hallucinations; complex, in partial waking state, [61](#)
creative, [12](#)
of dead people and skeletons, [6f](#)
in *grande hystérie*, [9](#)
habitual, [16](#)
hypnagogic, [14](#), [23](#), [59](#)
induced, [11f](#)
intuitive, [61](#)
and passage from night-dreams to waking state, [23](#)
in prodromal stage, [150](#)
psychogenic, [14](#)
reasons for appearance of, [58f](#)
of the senses, in hysterical delirium, [8f](#)
in solitary confinement, [192](#)
systematic nature of, [22f](#)
teleological, [79](#)
of theft of money, [144](#)
transition to somnambulism, [55f](#)
voices, [125](#), [127](#), [128](#), [130](#)
waking, [17](#)
hand: anaesthetic, [57](#), [80](#), [91](#)
thrust into fire, [163n](#)

Harden, Maximilian, [106](#)
Hauffe, Frau, *see* Clairvoyante of Prevorst
Hauptmann, Carl, [77n](#)
head, patient's banging of, against door, [176ff](#), [195](#), [199](#)
headache, [5](#), [7f](#), [14](#), [16](#), [29](#)
 cured by suggestion, [145](#)
 in hysterical stupor, [142ff](#)
 self-magnetization to dispel [27](#)
hebephrenics, irrelevant talk of, [149](#)
Hebrew, deathbed memory of, [104](#)
Hecker, J. F. C., [59n](#), [61](#)
Heidelberg Clinic, [182](#)
heightened unconscious performance, *see* unconscious performance
Hélène Smith, *see* Smith hell, journey to, [82f](#), [101ff](#)
heredity: and degeneracy, [64](#), [201](#)
 in case of fraud, [213](#)
 and hysterical stupor, [137](#)
 manic mood disorder and, [112](#), [115](#), [120](#), [124](#), [130](#)
 and psychopathic inferiority, [5](#)
 and simulated insanity, [173](#), [190](#)
Hertz, Carl, [183f](#)
Hoche, A. E., [163n](#)
Höfelt, J. A., [62](#)
hunch, cryptomnesic image as, [81](#)
hydrotherapy, [5](#)
hypalgesia, [178](#), [179](#), [197](#)
 and degeneracy, [180](#)
hyperactivity, motor, [131](#)
hypermnnesia, [81n](#), [86](#)
hypnosis: continuity of memory under, [145f](#)
 deepening of, [55](#), [56](#)
 double, [145f](#), [147](#), [154](#)
 effect on amnesia, [145](#)
 hystero, [74](#)

partial, *see below*; patients'
denial of being hypnotized, 164
self-, partial, 73
treatment by, 8
word, derivation of mystic terms from, 85

hypnosis, partial, 49
and automatic writing, 54*f*
influence of, 70*f*
penetration into speech area, 51*f*
and response to suggestion, 54
self-, 73

hypnotist, automatism as, 74*f*

hypomaniac: behaviour, chronic, 109
complex of symptoms, 134
state, chronic, 111

hysteria, 3*ff*
and affects, 215
and assimilation of affects, 170
associations with colour in attacks of, 12
automatization of psychic functions, 91
diagnosis of, 14
and epilepsy, relationship between clinical pictures of, 4
and feeling-toned memory complex, 98
and genius, 99*f*
and memory, 152
modern theory of, 160
and moral defect, 214*ff*
periodic changes in personality in, 63
psychopathology of, 137*ff*
severe, 9
and simulation, 187
and somnambulism, 5*ff*
strength-producing mechanisms of, 163
symptoms, 180, 201

see also grande hystérie

hysterical conversion, 155

hysterical misreading, *see* misreading

hysterical subjects: constitutional lying and fraud, 211

and forgetfulness, 68*n*

identification of, with object of interest, 181

influence of affects on, 171, 217

influence of darkness on, 56

irrelevant answers of, 92

lying of, 160

phenomena observed in, 203

self-torture by, 186

sensibility of, 80*f*

systematic anaesthesia among, 64

young, moria states of, 150

hystero-epilepsy: attacks induced by open fire or lighted match, 76

visions in, 9

hystero-hypnosis, 74

I

idea(s): affective, 155

associations with ego-complex, 81

automatization of, 181

chain of, and feeling-value, 133

combinations of, 100*f*

delusional, 215

feeling-toned, 68, 162, 219

“levelling-down” of, 133

motor components of, 73

new, development of, in somnambulism, 86*n*

new combinations of, 99

original, 81

predominating, influence of, on intended tremors, 49*n*

—, and retinal phenomena, 60

—, surrender to, 67*f*

see also flight of ideas

ideal, subconscious personality as, [65f](#), [77f](#)

identification, hysterical, [67](#)

image(s): combination of, vs. new formation, [96](#)

cryptomnesic, intrapsychic entry into consciousness, [81–86](#)

hypnagogic, and dream-images, [59](#)

formed from spots of light, [58ff](#)

visual, and cutaneous stimuli, [13](#)

imagination: and fantastic figures, [58f](#)

and visions, [61](#)

imbecility, simulation of, [182f](#)

impostors, intentional fraud of, [216](#)

impressions: forgotten, reappearance of, in cryptomnesia, [103](#)

subjective, of the malingerer, [159f](#)

impulse, unexpected, [12](#), [13](#)

incarnation of Parisian poisoner, [38](#)

inclinations, evil: and hysteria, [216](#)

inferiority: hysterical, [180](#)

intellectual and emotional, [4](#)

neurasthenic, diagnostic difficulty, [15](#)

inferiority, psychopathic, [3ff](#)

borderlines between clinical pictures of, [111](#)

character of affects, [189](#)

classification of cases, [4f](#), [15](#)

and hysteria and epilepsy, [4ff](#)

influence of affects on, [171](#)

phenomena related to other clinical pictures, [16](#)

influence, magnetic, [41](#)

inhibition(s): of association, [166](#)

imposed by conscious mind, [98f](#)

insanity: cyclic, [63](#)

feeling-toned complexes of associations in, [219](#)

legal conception of, [218](#)

and legal responsibility, [204](#)

simulated, case of, 159–205
—, medical opinion on, 188–205

insight: of defendant, as to her swindling, 217
during psychic disturbance, 164
increased, in question of simulation, 159
patient's, as to illness, 106, 113, 118, 119, 123, 126, 176

inspiration, Nietzsche on, 82*n*, 105

instability: and inner unrest, 200*f*
psychopathic, 112*ff*
social, in patient with manic mood disorder, 120*ff*

instinct, pathological, 215

instinctual drives, excess of, 132

instructions, response to, in case of simulated insanity, 175*ff*

intellect: and action, 133
effect of emotional lability on, 134
exaltation of, in ecstasy, 87
under sway of emotions, 131*f*
and will, 132

intelligence, 128
defective, in hysterical stupor, 149*f*
in manic mood disorder, 112*ff*, 115, 120, 124, 132

interest, and object, 81*f*

internment: in case of fraud, 213
and simulation, 182*f*
see also detention

inventors: crackpot, 131*f*
“paranoia” of, 130

irreparabile damnum, 76

irresponsibility, legal, *see* responsibility

irritability, 109, 122*f*, 125, 130, 133, 173*n*
in chronic mania, 110*f*

Ivenes (S. W.'s somnambulistic ego), 32, 36
character and incarnations of, 36*ff*
deterioration of, 78*f*

improvement over normal personality of S. W., 65
mental products grouped around grandfather, 74f
study of, 64ff
subconscious personalities' knowledge of, 74

J

Jacobi,——, 183

Jacobi-Jensen,——, 164

Jacobsohn, Siegfried, 106

James, William, 61n

on case of psychopath with amnesia, 11

Janet, Pierre: on disturbance of attention, 44f

on hystero-epilepsy, 76

on influence of affects, 170f, 181

Léonie, case of, 63, 65

on lies of hysterical subjects, 68n

on unconscious personality of subject, 53, 54n

use of double hypnosis, 154

whispered suggestions, experiment with, 51n, 70f

Japan: earthquake, 164

proverb, 163

Jessen, W., 79n, 183n

Joan of Arc, 60, 79

journeys, trance, 22, 27, 29, 33f

Jung, C. G.: on "feeling-tone," 97n

his grandfather in S. W.'s séances, 26, 56

inaugural dissertation, 3n, 219

professional career, v–viii

S. W. and, 21

in S. W.'s trance fantasies, 35, 37ff

CASES IN SUMMARY (*in order of presentation, numbered for reference*):

[1] Miss E., 40, showing hallucinations of skeletons and dead children. Illustrates concept of spontaneous somnambulism based on hysterical psychopathic inferiority. — 5ff

- [2] Miss S. W., 15½, somnambulistic girl (spiritualistic medium) with poor inheritance. — 17–88
- see also* S. W., Miss
- [3] Hysterical young woman, illustrating feeling-toned memory complex. — 98
- [4] Business man, 27, illustrating mild form of manic mood disorder. —112–15
- [5] Woman, 44, with manic mood disorder, illustrating alcoholism dependent on emotional abnormality. —115–20
- [6] Nurse, 26, exhibiting manic mood disorder with social instability.—120–24
- [7] Male, 55, painter, charged with theft, whose intense manic symptoms ruled out even “partial responsibility.”—124–32
- [8] Godwina F., 48, illustrating hysterical stupor in a prisoner in detention. —137–56
- [9] Doubtful simulation in male mental defective charged with rape. — 165f
- [10] Doubtful simulation in boy, 17, charged with rape. — 166ff
- [11] Male, 35, mill-hand, degenerate, illustrating simulation of insanity.—173–80, 189–205
- [12] Youth, 18, whose theft was discovered through the associations of a feeling-toned complex relating to the crime. — 220f

WORKS: “A Review of the Complex Theory,” 97n

Collected Papers on Analytical Psychology, 3n

Experimental Researches, 168n, 219n

“On Psychical Energy,” 97n

“The Reaction-Time Ratio in the Association Experiment,” 219

Symbols of Transformation, 186n

“The Psychology of Dementia Praecox,” 168n

and Riklin, “The Associations of Normal Subjects,” 219ff

for account of works, see v–x

K

Kant, Immanuel, 39f

Karplus, J. P., 77n

Kerner, Justinus, 27, 34, 44, 66

Blätter aus Prevorst passage paralleled by Nietzsche, 82f, 102ff

and Frau Hauffe, 87

see also Clairvoyante of Prevorst

Klein, Julius, 219ff

knowledge: cosmic, plane of, 42
intuitive, of somnambulists, 86
loss of, 12, 61, 140ff, 148, 151
—, and not wanting to know, 155
retention of, 178
see also educational level; quality of being known

Koch, —, 110

Kraepelin, Emil, 167n

arithmetic tests, 178

Krafft-Ebing, Richard von, vi, 86n, 110, 134n

on hysterical ecstasy and memory, 104

on protracted states of hysterical delirium, 8f

Krauss, A., 161

L

lability, emotional, 111ff, 116, 119, 123ff, 213

see also instability

Ladd, C., 59

Landgraf, Karl, 182f

language, 101

exaggerated, in manic mood disorder, 118

French, 85

Greek, 85, 104

Hebrew, 104

idiom used by S. W., 20, 28, 35

Latin, 85

loftiness of, 126

Martian, 85

of the spirits, 33f

Swiss dialect, 18, 89ff

see also glossolalia

lapses, 65

see also preoccupation

Latin, mystic terms derived from, 85

Laurent, Armand, 180n

on patient who simulated, 186
Légrand du Saule, Henri, 63
Lehmann, A. G. L., 48, 49n, 73n, 162n
Léonie (Janet's case), 63, 65
Leppmann, A., 182
lethargy, 3, 70f
 changed into hypnosis, 72
 hallucinations in, 72
 hysterical, induced by hypnosis, 71f
letters, transposed or reversed, 25f, 52
 see also love letters
liar, pathological, 67
 see also lying
light: entoptic perceptions of, 58f
 formless, vision of, 59n
 powers of, 41f
Lindau, Paul, 63
Ljubljana earthquake, 172
Loewenfeld, Leopold, 87n
 on development of new ideas, 86n
 on lethargy, 70–72
 on sleepwalking, 10n
Lombroso, Cesare: on genius, 99
 “graphomaniacs,” 131 lottery tickets, case involving, 209–18
Lotz,—(Frankfurt a. M.), 186n
love letters, from imaginary fiancé, 67, 162
Lücke, Robert, 172n, 185
lung, hysterical haemorrhage of, 186
lying, 3
 hysterical, 160
 pathological, 16, 67, 68, 203, 211
 of thieves, 161
 and self-deception, 212

Macario, M. M. A., 61

MacNish, Robert, 12, 150

Magnan, Valentin, 111, 130

magnetism, derivation of mystic term from, 85

magnetization: and cerebral anaesthesia, 49

self-, 27

malingerer(ing): character of, 160f

difficulty of unmasking, 159f

passage into subconscious, 181

use of feeble-minded behaviour, 172

see also shamming

simulation

mania, 90

chronic, cardinal symptoms, 111

—, Wernicke on, 110

periodic, diagnosis of, 126

manic mood disorder, 109–34

periodic exacerbations of, 134

summary, 134

symptoms, 111f

manie sans délire, 110

Marandon de Montyel, E., 183

marriage: effect on patient of breakup of, 116

unhappy, 190ff

Mars: S. W.'s description of, 34

visions of, 60

Martian language, 85

Mary Reynolds, *see* Reynolds

materialization: as origin of Adam, 38

trance, 29, 42

Maury, L. F. A., 59

megalomania, 111, 124ff, 126, 130

see also egotism

Meggendorfer picture-book, 178

melancholia, 109

depressive, 182

memory(ies): auto-suggestive falsification of, 67

blocking of unpleasant events in, 153

conscious, enrichment in cryptomnesia, 86

continuity of, in hypnosis, 145

defective

in hysterical subjects, 164

—, for period of simulation, 202

direct and indirect, 95ff

and dissociated consciousness, 63

disturbed, 8

effect of affects on, 171

feeling-toned, 100, 146f, 155

fragmentary, reproduction of, 105

gaps of, and acquisition of content through auto-suggestion, 13

hysteriform lapses of, 12

loss of, 138 (*see also* amnesia)

medium's, at disposal of somnambulist personalities, 32f

old, re-emergence of, 103f

see also cryptomnesia

memory-image: in cryptomnesia, 81

and the law of association, 95

and unconscious perception, 96

Mendel, Emanuel, 110

menstruation: and abnormal emotional state, 123

in case of spontaneous somnambulism, 5, 7

mental: activity, in chronic mania, 110f

—, effect of simulation on, 202f

content, intrusion of, in motor phenomena, 51

defectives, simulation of insanity among, 165ff

disease, and epileptoid attacks, 15

phenomena, in automatic table-turning, 51f

productivity, in chronic mania, 110f

Mesnet, Ernest, [11f](#)
Messiah, manic patient's delusions of self as, [126](#), [128](#)
Michelangelo Buonarroti, [100](#)
miracles, faked, [186](#)
mirror-writing, [52](#), [55](#)
misreading, hysterical, [18](#), [44](#), [45–47](#), [89–92](#)
 essential difference from all other types, [91](#)
 as prodromal symptom, [46](#)
 psychology of, [45f](#)
Mitchell, S. Weir, [150](#)
 case of Mary Reynolds, [61f](#), [79](#)
Moll, Albert, [63n](#)
money: attitude toward, [121](#)
 delusion of theft of, [138ff](#), [143ff](#), [151](#)
moods: actions affected by, [217](#)
 unstable, [139](#)
 see also lability, emotional
 manic mood disorder
moral defect (moral insanity), [111](#), [114](#), [119](#), [124](#), [132](#), [134](#), [212](#)
 and alcoholism, [116](#)
 congenital condition, [215](#)
 and emotional abnormality, [134](#)
 explanation of, [115](#)
 and hysteria, [214ff](#)
 periodic or cyclic, [134](#)
 scientific conception of, [217f](#)
moral insanity, *see* moral defect
Mörchen, Friedrich, [15](#), [68n](#)
motion, forces of, [41](#)
motivation: in case of simulated insanity, [180](#)
 characterological, [133](#)
 feeling-toned, and subconscious mechanisms, [163](#)
 psychological, [172](#)
motor: area, deeper hypnosis of, by auto-suggestion, [55](#)

automatism, [74f](#), [86](#)
centres, excitation limited to, [73](#)
hyperactivity, [131](#)
impulses, barring of perception of, [51](#)
motor phenomena: automatic, intrusion of mental content into, [51](#)
 in automatic writing, [55](#)
 suggestion and, [48f](#)
 unconscious, [48ff](#)
Müller, Erdmann, [134n](#)
Müller, Johannes, [59n](#)
Muralt, Ludwig von, [88](#)
murder, impulse toward, [64](#)
murderer, case of simulated imbecility, [182](#)
muscles, tonic and clonic spasms of, [186](#)
mutism, simulated, [182f](#)
Myers, F. W. H., [52](#), [59](#)
mystic science, [39–42](#)
 derivation of names in, [85](#)
 diagram of forces, [40](#)
 groups of forces, [41f](#)
 as heightened unconscious performance, [87](#)

N

Naef, M., [10f](#)
narcolepsy, [3](#), [70](#)
needlepricks, *see* pricks
negativism, [183](#)
 catatonic, [149](#)
nervous system, psychopathic disposition of, [79](#)
neurasthenia, [3ff](#)
 crises, [14f](#)
 and psychopathic inferiority, [4ff](#), [16](#)
neuropathies
 and epileptoid attacks, [15](#)
neuroses: shock, [164](#)

traumatic, 150
New Testament, glossolalia in, 84
Nietzsche, Friedrich: cryptomnesic parallel of passage from Kerner, 82f, 101ff
 on ecstasy, 84f
 on inspiration, 82n
 on inspiration and revelation, 105
 interest in Kerner, 83
 mental state when writing *Zarathustra*, 104f
Nissl, F., 137, 149
noises: animal, 128, 129
 hallucinatory, 147
 see also voices
Nordau, Max Simon, 99f
normal state, linked with pathological dreaming, 68f
number: experiments with, 57f, 86, 91
 gaps in counting, 142f
 patient's confusion *re*, 141
 tests with, 193, 197f

O

object: cryptomnesic reproduction, 84
 and interest, 81f, 181
objectivation: of associated complexes, 77n
 of dreams, 68
 of visual images, 57
obnubilation, 61
occultism: and heightened unconscious performance, 80
 so-called, Jung's case of, *see* S. W.
Oehler, Pastor, Nietzsche's grandfather, 83
offences, criminal: moral defect vs. hysteria as source of, 216
optic impression, and misreading, 90
optimism, 117, 123, 126, 129
 exorbitant, 131
oracular sayings, in séances, 35
orientation: as to place, 152

as to space, 142
as to time, 177
as to time and place, 153, 165, 175, 193
unconscious, 152f, 154
see also disorientation
originality: of ideas, 81
source of, 96
over-activity, 111, 117f, 120

P

pain: self-inflicted, 163, 186
sensitivity to, 139, 175, 194, 197
painting, patient's, 127
pallor, in somnambulistic states, 19, 26, 28, 29, 71
paralysis, 90
emotional, 71n, 164
paranoia, 130
Pelman, C., 15n, 79n
pendulum, experiments with, and intended tremors, 49n
penitentiary, manic patient's behaviour in, 127
perception: activated by association, 95
along verbal-motor route, 45
and reproduction, in misreading, 91f
unconscious, 87
—, related association activated by, 96
—, *via* anaesthetic skin, 80
performance tests, 178ff, 199f
see also unconscious performance
perseveration, 166f
personality: alteration of, in semi-somnambulistic states, 24
automatic splitting of, 52
change of, in somnambulistic states, 19, 24
future, and double consciousness, 79
and hysterical twilight states, 16f
somnambulistic dissociation of, 67

see also character

personality(ies), unconscious: automatic expression of, 56

continuity of, 64*f*

development of, through suggestion, 53

distinct from automata, 78

gay-hilarious, 73

hypnosis of, 154

hypnotic effect of, 72

Janet's Lucie and Léonie, 63

origin of, 77*f*

range of knowledge, 73*f*

relation to somnambulistic ego, 74*ff*

relationship of, 37*f*

serio-religious, 73

somnambulistic, in S. W.'s trances, 30–36, 37*f*

split off, 72*f*

split off from dream-ego, 78

splitting of, 56*f*

two types of, 72*f*

unity of, 76*f*

persuasion, powers of, and hysteria, 215

pessimism, 112

phenomena, automatic: memory of, 33

misreading as, 90

Phleps, Eduard, 164*n*, 172

physical examination, 6, 139

in case of simulated insanity, 178*f*, 194*f*, 197, 200

Pick, Arnold, 15*n*, 66*f*, 162

Pinel, Philippe, 109*f*

pinpricks, *see* pricks

plagiarism, and cryptomnesia, 81, 101*ff*

plants, life-forces of, 41

playing cards, experiment with hypnotized subject, 76

pleasure/pain affects, 120

pleasure-seeking, [132](#), [210](#)
pneumatological school, [16](#)
poets, [16](#)
 lives of, [131](#)
 and wish fulfilment, [99](#)
poisoner(s): Parisian incarnation of, [38](#)
 art of shamming among, [161](#)
poisoning of food, delusion *re*, [174](#), [192](#), [197](#)
pope, manic patient's delusions of himself as, [125](#)
possibility, psychological: and success of suggestion, [53](#)
powers, light and dark (good and evil), [41f](#)
practice, effect of, in association tests, [168](#)
premonition(s), [17](#)
 in semi-somnambulistic states, [25](#)
 of somnambulistic attacks, [20](#)
preoccupation, before and after somnambulistic attacks, [47](#)
Prevorst: *Blätter aus*, see Kerner s.v.
 Prophetess of, see Clairvoyante of Prevorst
Preyer, William T., [49n](#)
pricks: on anaesthetic hand, [57](#), [80](#), [91](#)
 insensibility to, [138](#)
 reaction to, [139](#), [175](#)
Prince, Morton, [63](#)
prison complexes, [130](#)
prisoners: characteristic states of, [148ff](#)
 Ganser complex, [187](#)
 case of hysterical stupor, [137–56](#)
 hysterical psychoses, [160](#)
prison psychosis, [156](#)
 characteristic syndrome, [151](#)
prophecies, [17](#)
prophets, [16](#)
Proust, Achille Adrien, [10](#)
pseudologia phantastica, [68](#), [203](#)

psyche, abnormal affective states of, 189
psychic: complexes, disaggregation of, 53
 excitation, 71ff
 functions, automatization of, 91
 processes, and hysterical attack, 77n
 —, in misreading, 90f
 shock, as cause of hysterical attack, 9
psychic elements: combination of, and originality, 96
 conscious and unconscious, 98
 disaggregation of, 67
“psychic shadow state,” 46
psychogenic disturbances, dependent on external events, 184f
psychograph, in séances, 25ff
psychological possibility, 53
psychology, normal: and pathological inferiority, 4
psychopath: morally defective, 212
 puberty of, 64
psychopathic illnesses, and chronic mania, 111
puberty: fantasy-making in, 70
 fluctuations of character in, 44
 physiological changes of character in, 64
 somnambulistic symptoms in, 79
 and manic mood disorder, 112, 114, 130

Q

quality of being known, 96, 98, 101f
questions, and senseless answers, 140ff
Quicherat, Jules, 60n

R

R., Mr., and his brother, P. R., in S. W.’s séances, 31f
rabbits, shooting of, in cryptomnesic image, 83, 102
Raecke, Julius, 137, 154, 172n
 on hysterical ailments, 184f
 on hysterical twilight state, 149

on loss of knowledge, 155
on stupor in criminals, 150
rape: attempt to simulate, 66
charge of, 165
victim's memory of attempts at, 115
reactions: meaningless, 166, 167*n*
slowness of, 165
reading, addiction to, 120
reading-tests, 90
reality, loss of, 171
Récamier, Mme., 37
red-green blindness, 197, 201
Redlich, Johann, 67*n*, 68*n*
reflexes, tests of, 6, 139, 178, 197
reincarnation, S. W.'s system of, 36*ff*, 69*f*
religious: feeling, expression of, by manic patient, 126, 129
sects, founders of, 16
remorse, as reason for simulation, 196*f*, 201
Renaudin, Louis François Emile, 63*f*
reproduction, in cryptomnesia, 103*f*
responsibility, legal, 179, 204, 213
in case of epileptic stupor, 182
juridical conception of irresponsibility, 216
limited by hysteria, 217
and moral defect, 209*ff*
and pathological self-deception, 211*ff*
rest cure, 14
restlessness, 111, 112, 116, 121*f*
inner, 133, 177, 200
retention, reduced, 197
retina, light sensations of, 59*f*
revelation, Nietzsche on, 82*n*, 105
Reynolds, Mary (Weir Mitchell's case), 61*f*, 79, 150*n*
Ribot, Théodule Armand, 63&*n*, 64*n*

Richarz, Franz, [180n](#), [183f](#)
Richer, Paul, [9](#), [63](#)
Richet, Charles, [47f](#), [87](#)
Rieger, Conrad, [63](#)
right and wrong, recognition of: and legal responsibility, [216](#)
rigidity: of face, [175](#), [179](#), [192](#)
 of posture, [138](#), [175](#)
Riklin, Franz, investigations with Jung, [168ff](#)
role, submersion in, [66](#), [69](#), [162](#)
romances, S. W.'s, [36f](#), [38f](#), [69](#)
roof-climbing, [68n](#)
Rüdin, Ernst, [130n](#), [15n](#), [182](#)

S

Sabina S. (Fürstner's case), [186f](#)
saint(s): hallucinations of, [67](#)
 simulation of, [186](#)
St. Pirminsberg Mental Hospital (St. Gallen), [125](#), [126](#), [127](#)
sanguine temperament, [109](#)
 and moral insanity, [132](#)
saviours, [16](#)
scarlet fever, [112](#)
Schnitzler, Arthur, [106](#)
Schopenhauer, Arthur, on genius, [100](#)
 “operari sequitur esse,” [133](#)
Schroeder van der Kolk, J. L. C., [62](#), [79](#), [150](#)
Schüle, Heinrich, [58](#), [110](#), [132n](#)
Schürmayer, I. H., [173n](#)
science, mystic, *see* mystic science
séances, S. W.'s, [25–30](#)
 personalities in, [30–36](#)
second sight, [17](#)
Seeress of Prevorst, The (Kerner), *see* Clairvoyante of Prevorst
Selbruck, Anton, [66](#)
self-: confidence, exaggerated, [110](#), [111](#), [118](#), [126](#)

control, lack of, in hysteria, 99f
—, in malingering, 161
criticism, lack of, 99f, 131
deception, 210ff
esteem, exaggerated, 124ff, 130
glorification, of manic patient, 126
magnetization, 27
torture, 186

senile dementia, 90

sense(s): and cryptomnesic image, 86
functions, paralysis of, 11
hallucinations of the, 8f
hyperaesthetic unconscious activity of, 87
impression, strength of, and attention, 45
retention of, in hysterical lethargy, 71

senseless answers, *see* answers

sense organs: all involved in hallucinations, 22f
partial paralysis of, 65

sensibility: disturbances of, 150
and genius, 99
and interpretation of intended tremors, 87
tests of, 144
unconscious, of hysterical patient, 80f

sexual: excesses, 113, 213ff
symbols, in dreams, 99

sexuality, 137f

shamming, energy required for, 163

shock neuroses, and violent affect, 164

Siefert, Ernst, 109, 111

Siemens, Fritz, 184

silence, and auditory hallucinations, 58

simulation: and auto-hypnosis, 203
concept of, 186
confession of, 164, 196, 201f

conscious, [202](#)
diagnosis of doubtful case, [160ff](#)
difficulty of diagnosis, [185](#), [188](#)
doubtful cases of, [163f](#)
earlier writers on, [185](#)
effect on mental state, [180f](#)
excellence of, [179](#), [202](#)
half-conscious, [189ff](#)
hysterical symptoms and, [163](#)
mistaken diagnosis of, [186f](#)
passage from conscious to subconscious, [173](#)
passage into insanity, [202f](#)
patient's explanation of, [176f](#), [196f](#), [201f](#)
physical examination, [175](#)
unmasking of, [185f](#)

skeletons, hallucinations of, [6f](#), [13](#)

sleep: disturbed, [8](#), [129f](#)
ecstatic, [71](#)
onset of, and hallucinations, [58f](#)
partial, and suggestibility, [13f](#)
prodromal stage, [150](#)
visions at onset of, [22](#)

sleeping state: following double hypnosis, [154](#)
S. W.'s, [70f](#)

sleepwalking, *see* somnambulism

Smith, H el ene (Flournoy's case), [57f](#), [60f](#), [68](#), [79](#), [84](#)
automatic speech, [73n](#)
Hindu cycle, [68n](#)
and Leopold, [73n](#), [74n](#), [86](#)
Martian language, [85](#)
systematic anaesthesia, [65](#)
visions, [60](#)

social: behaviour, in manic mood disorder, [115ff](#)
inadequacy, [131](#)

solitary confinement, 127
behaviour in, 174, 191
in darkness, 164
effect of, 150f
hallucinations in, 192

somnambulism: attacks, *see* somnambulistic attacks
case of Miss S. W., 17–18
classification of, 5
course of, 78f
development of impressions into hallucinations, 13
and the development of new ideas, 86n
dissociation of personality, 67
with hallucinations, 16
hypnotic, 70f
—, response to suggestions in, 144
hysterical, following hypnosis, 147
semi-somnambulism, 24f, 33, 47ff, 64
spontaneous, 5ff, 62f, 79, 150
states, *see* somnambulistic states
visual images objectified as hallucinations in, 57

somnambulistic attacks: course of, 19f
minor automatisms in, 21f
nature of, 70–77

somnambulistic states: induced, 71
second state, 61f
—, and change of character, 61–70
—, predominance of, 79
—, with and without amnesic split, 63f

somnambulists: cryptomnesic reproduction of object, 84
intuitive knowledge of, 86
suggestibility of, 87

song, and feeling-toned train of thought, 97

sparks, vision of, 58

spasms, tonic and clonic, of muscles, 186

speech: area, effect of partial hypnosis of, 52
 automatic, 72f, 75
 centres, focal lesion of, 106
 impulses, overflow into motor area, 51f
 muscles, movements of, in somnambulism, 73
 pressure of, 128 (*see also* talkativeness)
 unintelligible, in somnambulistic state, 26

Spinoza, Baruch, hypnopompic vision of, 59n

spirits: appearance of, 72f
 black, 34
 conviction of presence of, 58
 language of, 33f
 S. W. and, 20ff, 27f, 33

spiritual power, and hallucinations, 61

split off: from primary unconscious personality, 72f
 of subconscious personality, 56f

star-dwellers, 34f

stage fright, 164

Steffens, Paul, on hysteria and epilepsy, 4

“Stege,” *see* “Treppe”

stimuli: cutaneous, perception of, in anaesthetic regions, 13
 transmutations of, 13f

stimulus words, *in association test*, 221

Stockhausen, Reiner, a case of simulated insanity, 160, 183ff, 185ff
 Richarz on, 180n

strangeness, feeling of, 58
 and cryptomnesic image, 82

Stromboli, Mt., 82f

student, seeing apparitions and light, 60

stupidity: emotional, 185, 187
 shammed, 172

stupor: catatonia-like, 182
 epileptic, 182
 epileptoid, 16

hysterical, characteristics of, 148ff
—, in a prisoner in detention, 137–56
somnambulistic, 65

subconscious: and auto-suggestion, 163
construction of hallucinations, 13
individualization of, 53f
suggestibility of, 54
see also unconscious

suggestibility: and the creation of an automatism, 162
in hysterical stupor, 141
influence of darkness on, 56
of somnambulists, 87
in states of partial sleep, 13f
and unconscious orientation, 152

suggestion: and analgesia, 139
and automatic writing, 54f
dependent on psychological possibility, 53
effect of, in semi-somnambulism, 36
in hypnosis, 76
motor phenomena induced by, 48f
posthypnotic, 145, 147f
and thought-transference, 54
use of, in hypnotic somnambulism, 144
verbal, and partial hypnosis, 49
whispered, 51n, 70f
see also auto-suggestion
counter-suggestion

suicide: attempted, 15, 174, 191, 199, 200f
threat of, 123, 130, 176f

sulphuric acid, self-inflicted burn with, 163

sums, simple, tests in, 144, 178, 197f

superficiality, 112, 113f, 119

S. W., Miss, case of, 17–88
character development, 47

character in waking state, 41–47
character of, and subconscious personalities, 77
“dual” personality, 24f
educational level, 18, 19, 88
family background, 17
glossolalia, 84–86
grandfather as “guide,” 22, 26, 30f
identity of ego-consciousness in all states, 72
improvement in character, 79
and Jung, 21, 35, 37ff
and Jung’s grandfather, 26, 56
personal and physical traits, 18
physical state in attacks, 26, 28f
reaction to disclosure of trance behaviour, 21, 28
reaction to hallucinatory phenomena, 23
sister’s dream of black and white figures, 23f
somnambulistic personality, *see* Ivenes
somnambulistic states, 19–25
re her spirits, 23, 27
termination of the disorder, 43
Swedenborg, Emmanuel, 36, 42
visions, 60
sweets, addiction to, 120
swindler: insight of, 217
pathological, psychology of, 66
—, skill at lying, 161f
simulated stupor, 182
swindling, pathological, 173
Swiss dialect, 18, 89ff
symbolism, in dreams, 56, 99
symptomatic actions, of artist, 100
symptoms: hypomanic, 134
hysterical, *see below*
in hysterical stupor, 138f, 145ff

manic mood disorder, 122*f*, 134
prodromal, 12, 15, 46
psychogenic, 160
psychopathic, 119
of psychopathic inferiority, 4*ff*
unmasking of, in simulation, 185
symptoms, hysterical: automatic nature of, 163
 genesis of, 155
 presence of, 211, 212*f*
syncope, hypnotic, 154*n*
“syndromes épisodiques des dégénérés,” 130
synthesis, loss of, 171

T

table, movements of: automatic, 48–61
 initial, 73
 unconscious control of, 49
table-turning: and semi-somnambulistic states, 25
tachypnoea, 20
talkativeness, 113, 116, 122*f*, 125, 128
talking, compulsive, 105
tendovaginitis, 8, 14, 16
tests, arithmetic, in case of simulated insanity, 178
theft: charge of, 124–32, 138, 148
 conviction for, 182, 191
 discovery of, through feeling-toned complex of ideas relating to the crime, 220*f*
 imprisonment for, 174*ff*
 and lying, 163
 of money, delusion *re*, 138*ff*, 143*ff*, 151
Thierfelsenburg, Elisabeth von (somnambulistic personality), 30, 37
thieves, art of shamming among, 161
thinking: disturbance of, 110
 intuitive, 96*f*
 see also thought-process(es)
thought-process(es): feeling-toned, 203*f*

in somnambulism, [57f](#)
thought-reading: experiment in table-turning, [50f](#), [80](#)
 experiments with numbers, [86](#)
 from intended tremors, [54](#)
thought transference, [25](#)
thoughts, repressed, and the creation of subconscious personalities, [77f](#)
threshold of consciousness, *see* consciousness, threshold of
tics, hysterical, [181](#)
Tiling, T., [132](#)
time consciousness, [12](#)
toleration, threshold of, and unabreacted affects, [155](#)
tongue, slips of, [90](#)
touch, and hallucinatory process, [13](#)
train of thought: and attention, [69n](#)
 feeling-toned, disappearance from conscious mind, [97f](#)
trance: in séances, [25ff](#)
 journeys, [33ff](#) [43](#)
 three-day, [17](#)
traumatic neurosis, [173](#)
tremor(s): of hands and head, [138](#)
 writing disturbed by, [140f](#)
tremors, intended: role of, in table-turning, [49f](#)
 sensibility and interpretation of, [87](#)
 in thought-reading experiment, [50f](#), [54](#), [80](#)
 thought-transference from, [86](#)
“Treppe”/“Stege,” [18](#), [89ff](#)
tubercle bacilli, fantasy of, [38](#)
tumbler, *see* glass
tune, and feeling-toned train of thought, [97](#)
twilight state: amnesia for, [147](#), [153f](#)
 automatisms in, [73](#)
 and daydreaming, [162](#)
 epileptic, [76](#)
 and feeble-mindedness, [172f](#)

hallucinatory, 58
hysterical, 17, 148ff, 179, 202
psychic process in, 154f
psychological mechanisms of, 163f
somnambulistic, 162
visions in, 72
typhoid fever, 5, 17

U

Ulrich von Gerbenstein, *see* Gerbenstein
“unconscious,” term, as used by Jung, 95n
unconscious: feelings and concepts in, 87
intellectual activity of, 87
psychic complexes, 98f
receptivity of, 86
—, in heightened unconscious phenomena, 80
see also subconscious
unconscious performance, heightened, 80–87
unpleasant events: amnesia for, 172
repressed from consciousness, 153, 155

V

vagrancy, case of, 11
see also wandering
Valours, Berthe de (somnambulistic personality), 30, 37
Van Deventer, J., on “sanguine inferiority,” 110f
vena, word, 84
verbal correspondences, in cryptomnesic reproduction, 103f
vision: field of, 144
restriction of mental field of, 151
visionaries, hallucinations of, 60f
visions: hypnagogic, 67
in hysterical delirium, 9
memory of, 24
S. W.’s, 22f

visual images, objectified as hallucinations, 57
visual sphere: automatism in, 58
 excitation of, 58
 irruption of hypnosis into, 74f
voice(s): altered tone of, 20, 27
 hallucinatory, 125, 127, 128, 130
Voisin, Jules, 63
volcano, 83, 101f

W

wakefulness, systematic partial, 10
waking state: content of subconscious personality carried into, 65
 hypnotic experiments in, 51n
 and objectivation of dreams, 68
 partial, and complex hallucinations, 61
 tremors of hands and arms, 49n
 and visual images, 14
 wandering(s), 120ff, 124ff, 127, 131, 173ff, 190ff
weight-reducing course, 119
Wernicke, Carl: on chronic mania, 110
 on delusions of grandeur, 151
 on dream-role, 162
 “level-ling-down of ideas,” 133
 on moral insanity, 133f
Wertheimer, Max, 219ff
Westphal, A., 172n, 185
Westphal, C., 15
Weygandt, Wilhelm, 220
whispering: of suggestions, 5n, 70f
 unconscious, 73
Wilbrand, — (Frankfurt a. M.), 186n
will: influenced by abnormal affects, 217
 and intellect, 132
will power, and malingering, 161
wine, 115f

Winslow, B. F., [10n](#)
wish-fulfilment, [99](#)
 hallucinatory, [151](#)
 subconscious personality as, [70](#)
witchcraft, [71](#)
witch trials, glossolalia in, [84](#)
Woltke, Sophie, *see* Guinon, Georges
word-association, Jung's studies in, [219](#)
words: picture composition, Charcot's scheme for, [51n](#)
 meaningless, in partial hypnosis of speech area, [52](#)
 stimulus, in association tests, [167n](#), [221](#)
 substitutions, [18](#), [89–92](#)
 transposed in mediumistic communications, [25f](#)
work-curve, [199](#), [200](#)
 tests of, [179ff](#)
world forces, S. W.'s description of, [39–42](#)
writing, disturbance of, by tremors, [140f](#)
writing, automatic, [54f](#)
 in complete darkness, [27f](#)
 experiment by member of the Society for Psychical Research, [52f](#)
 and suggestibility, [13](#)
Wundt, Wilhelm, [220](#)

Z

Zarathustra, journey to hell of, [82f](#), [101ff](#)
“Ziege”/“Geiss,” [18](#), [89f](#)
Zschokke, J. H. D., [86](#)
Zündel, Friedrich, [84n](#)
Zurich Clinic, [220](#)

THE COLLECTED WORKS OF

C. G. JUNG

THE PUBLICATION of the first complete edition, in English, of the works of C. G. Jung was undertaken by Routledge and Kegan Paul, Ltd., in England and by Bollingen Foundation in the United States. The American edition is number XX in Bollingen Series, which since 1967 has been published by Princeton University Press. The edition contains revised versions of works previously published, such as *Psychology of the Unconscious*, which is now entitled *Symbols of Transformation*; works originally written in English, such as *Psychology and Religion*; works not previously translated, such as *Aion*; and, in general, new translations of virtually all of Professor Jung's writings. Prior to his death, in 1961, the author supervised the textual revision, which in some cases is extensive. Sir Herbert Read (d. 1968), Dr. Michael Fordham, and Dr. Gerhard Adler compose the Editorial Committee; the translator is R. F. C. Hull (except for Volume 2) and William McGuire is executive editor.

The price of the volumes varies according to size; they are sold separately, and may also be obtained on standing order. Several of the volumes are extensively illustrated. Each volume contains an index and in most a bibliography; the final volumes will contain a complete bibliography of Professor Jung's writings and a general index to the entire edition.

In the following list, dates of original publication are given in parentheses (of original composition, in brackets). Multiple dates indicate revisions.

*1. PSYCHIATRIC STUDIES

On the Psychology and Pathology of So-Called Occult Phenomena (1902)

On Hysterical Misreading (1904)

Cryptomnesia (1905)

On Manic Mood Disorder (1903)

A Case of Hysterical Stupor in a Prisoner in Detention (1902)

On Simulated Insanity (1903)

A Medical Opinion on a Case of Simulated Insanity (1904)

A Third and Final Opinion on Two Contradictory Psychiatric Diagnoses (1906)

On the Psychological Diagnosis of Facts (1905)

†2. EXPERIMENTAL RESEARCHES

Translated by Leopold Stein in collaboration with Diana Riviere

STUDIES IN WORD ASSOCIATION (1904–7, 1910)

The Associations of Normal Subjects (by Jung and F. Riklin)

An Analysis of the Associations of an Epileptic

The Reaction-Time Ratio in the Association Experiment

Experimental Observations on the Faculty of Memory

Psychoanalysis and Association Experiments

The Psychological Diagnosis of Evidence

Association, Dream, and Hysterical Symptom

The Psychopathological Significance of the Association Experiment

Disturbances in Reproduction in the Association Experiment

The Association Method

The Family Constellation

PSYCHOPHYSICAL RESEARCHES (1907–8)

On the Psychophysical Relations of the Association Experiment

Psychophysical Investigations with the Galvanometer and Pneumograph in Normal and Insane Individuals (by F. Peterson and Jung)

Further Investigations on the Galvanic Phenomenon and Respiration in Normal and Insane Individuals (by C. Ricksher and Jung)

Appendix: Statistical Details of Enlistment (1906); New Aspects of Criminal Psychology (1908); The Psychological Methods of Investigation Used in the Psychiatric Clinic of the University of Zurich (1910); On the Doctrine of Complexes ([1911] 1913); On the Psychological Diagnosis of Evidence (1937)

*3. THE PSYCHOGENESIS OF MENTAL DISEASE

The Psychology of Dementia Praecox (1907)

The Content of the Psychoses (1908/1914)

On Psychological Understanding (1914)

A Criticism of Bleuler's Theory of Schizophrenic Negativism (1911)

On the Importance of the Unconscious in Psychopathology (1914)

On the Problem of Psychogenesis in Mental Disease (1919)

Mental Disease and the Psyche (1928)

On the Psychogenesis of Schizophrenia (1939)

Recent Thoughts on Schizophrenia (1957)

Schizophrenia (1958)

†4. FREUD AND PSYCHOANALYSIS

Freud's Theory of Hysteria: A Reply to Aschaffenburg (1906)

The Freudian Theory of Hysteria (1908)

The Analysis of Dreams (1909)

A Contribution to the Psychology of Rumour (1910–11)

On the Significance of Number Dreams (1910–11)

Morton Prince, "The Mechanism and Interpretation of Dreams": A Critical Review (1911)

On the Criticism of Psychoanalysis (1910)

Concerning Psychoanalysis (1912)

The Theory of Psychoanalysis (1913)

General Aspects of Psychoanalysis (1913)

Psychoanalysis and Neurosis (1916)

Some Crucial Points in Psychoanalysis: A Correspondence between Dr. Jung and Dr. Loÿ (1914)

Prefaces to "Collected Papers on Analytical Psychology" (1916, 1917)

The Significance of the Father in the Destiny of the Individual (1909/1949)

Introduction to Kranefeldt's "Secret Ways of the Mind" (1930)

Freud and Jung: Contrasts (1929)

‡5. SYMBOLS OF TRANSFORMATION (1911–12/1952)

PART I

Introduction

Two Kinds of Thinking

The Miller Fantasies: Anamnesis

The Hymn of Creation

The Song of the Moth

PART II

Introduction

The Concept of Libido

The Transformation of Libido

The Origin of the Hero

Symbols of the Mother and of Rebirth

The Battle for Deliverance from the Mother

The Dual Mother

The Sacrifice

Epilogue

Appendix: The Miller Fantasies

*6. PSYCHOLOGICAL TYPES (1921)

Introduction

The Problem of Types in the History of Classical and Medieval Thought

Schiller's Ideas on the Type Problem

The Apollinian and the Dionysian

The Type Problem in Human Character

The Type Problem in Poetry

The Type Problem in Psychopathology

The Type Problem in Aesthetics

The Type Problem in Modern Philosophy

The Type Problem in Biography

General Description of the Types

Definitions

Epilogue

Four Papers on Psychological Typology (1913, 1925, 1931, 1936)

†7. TWO ESSAYS ON ANALYTICAL PSYCHOLOGY

On the Psychology of the Unconscious (1917/1926/1943)

The Relations between the Ego and the Unconscious (1928)

Appendix: New Paths in Psychology (1912): The Structure of the Unconscious
(1916) (new versions, with variants, 1966)

‡8. THE STRUCTURE AND DYNAMICS OF THE PSYCHE

On Psychic Energy (1928)

The Transcendent Function ([1916]/1957)

A Review of the Complex Theory (1934)

The Significance of Constitution and Heredity in Psychology (1929)

Psychological Factors Determining Human Behavior (1937)

Instinct and the Unconscious (1919)

The Structure of the Psyche (1927/1931)

On the Nature of the Psyche (1947/1954)
General Aspects of Dream Psychology (1916/1948)
On the Nature of Dreams (1945/1948)
The Psychological Foundations of Belief in Spirits (1920/1948)
Spirit and Life (1926)
Basic Postulates of Analytical Psychology (1931)
Analytical Psychology and *Weltanschauung* (1928/1931)
The Real and the Surreal (1933)
The Stages of Life (1930–1931)
The Soul and Death (1934)
Synchronicity: An Acausal Connecting Principle (1952)
Appendix: On Synchronicity (1951)

*9. PART I THE ARCHETYPES AND THE COLLECTIVE UNCONSCIOUS

Archetypes of the Collective Unconscious (1934/1954)
The Concept of the Collective Unconscious (1936)
Concerning the Archetypes, with Special Reference to the Anima Concept
(1936/1954)
Psychological Aspects of the Mother Archetype (1938/1954)
Concerning Rebirth (1940/1950)
The Psychology of the Child Archetype (1940)
The Psychological Aspects of the Kore (1941)
The Phenomenology of the Spirit in Fairytales (1945/1948)
On the Psychology of the Trickster-Figure (1954)
Conscious, Unconscious, and Individuation (1939)
A Study in the Process of Individuation (1934/1950)
Concerning Mandala Symbolism (1950)
Appendix: Mandalas (1955)

*9. PART II AION (1951)

RESEARCHES INTO THE PHENOMENOLOGY OF THE SELF

The Ego
The Shadow
The Syzygy: Anima and Animus
The Self

Christ, a Symbol of the Self

The Sign of the Fishes

The Prophecies of Nostradamus

The Historical Significance of the Fish

The Ambivalence of the Fish Symbol

The Fish in Alchemy

The Alchemical Interpretation of the Fish

Background to the Psychology of Christian Alchemical Symbolism

Gnostic Symbols of the Self

The Structure and Dynamics of the Self

Conclusion

*10. CIVILIZATION IN TRANSITION

The Role of the Unconscious (1918)

Mind and Earth (1927/1931)

Archaic Man (1931)

The Spiritual Problem of Modern Man (1928/1931)

The Love Problem of a Student (1928)

Woman in Europe (1927)

The Meaning of Psychology for Modern Man (1933/1934)

The State of Psychotherapy Today (1934)

Preface and Epilogue to "Essays on Contemporary Events" (1946)

Wotan (1936)

After the Catastrophe (1945)

The Fight with the Shadow (1946)

The Undiscovered Self (Present and Future) (1957)

Flying Saucers: A Modern Myth (1958)

A Psychological View of Conscience (1958)

Good and Evil in Analytical Psychology (1959)

Introduction to Wolff's "Studies in Jungian Psychology" (1959)

The Swiss Line in the European Spectrum (1928)

Reviews of Keyserling's "America Set Free" (1930) and "La Révolution Mondiale" (1934)

The Complications of American Psychology (1930)

The Dreamlike World of India (1939)

What India Can Teach Us (1939)

Appendix: Documents (1933–1938)

†11. PSYCHOLOGY AND RELIGION: WEST AND EAST

WESTERN RELIGION

Psychology and Religion (The Terry Lectures) (1938/1940)

A Psychological Approach to the Dogma of the Trinity (1942/1948)

Transformation Symbolism in the Mass (1942/1954)

Forewords to White's "God and the Unconscious" and Werblowsky's "Lucifer and Prometheus" (1952)

Brother Klaus (1933)

Psychotherapists or the Clergy (1932)

Psychoanalysis and the Cure of Souls (1928)

Answer to Job (1952)

EASTERN RELIGION

Psychological Commentaries on "The Tibetan Book of the Great Liberation" (1939/1954) and "The Tibetan Book of the Dead" (1935/1953)

Yoga and the West (1936)

Foreword to Suzuki's "Introduction to Zen Buddhism" (1939)

The Psychology of Eastern Meditation (1943)

The Holy Men of India: Introduction to Zimmer's "Der Weg zum Selbst" (1944)

Foreword to the "I Ching" (1950)

*12. PSYCHOLOGY AND ALCHEMY (1944)

Prefatory note to the English Edition ([1951?] added 1967)

Introduction to the Religious and Psychological Problems of Alchemy

Individual Dream Symbolism in Relation to Alchemy (1936)

Religious Ideas in Alchemy (1937)

Epilogue

†13. ALCHEMICAL STUDIES

Commentary on "The Secret of the Golden Flower" (1929)

The Visions of Zosimos (1938/1954)

Paracelsus as a Spiritual Phenomenon (1942)

The Spirit Mercurius (1943/1948)

The Philosophical Tree (1945/1954)

†14. MYSTERIUM CONIUNCTIONIS (1955–56)

AN INQUIRY INTO THE SEPARATION AND SYNTHESIS OF PSYCHIC OPPOSITES IN ALCHEMY

The Components of the Coniunctio

The Paradoxa

The Personification of the Opposites

Rex and Regina

Adam and Eve

The Conjunction

*15. THE SPIRIT IN MAN, ART, AND LITERATURE

Paracelsus (1929)

Paracelsus the Physician (1941)

Sigmund Freud in His Historical Setting (1932)

In Memory of Sigmund Freud (1939)

Richard Wilhelm: In Memoriam (1930)

On the Relation of Analytical Psychology to Poetry (1922)

Psychology and Literature (1930/1950)

“Ulysses”: A Monologue (1932)

Picasso (1932)

†16. THE PRACTICE OF PSYCHOTHERAPY

GENERAL PROBLEMS OF PSYCHOTHERAPY

Principles of Practical Psychotherapy (1935)

What Is Psychotherapy? (1935)

Some Aspects of Modern Psychotherapy (1930)

The Aims of Psychotherapy (1931)

Problems of Modern Psychotherapy (1929)

Psychotherapy and a Philosophy of Life (1943)

Medicine and Psychotherapy (1945)

Psychotherapy Today (1945)

Fundamental Questions of Psychotherapy (1951)

SPECIFIC PROBLEMS OF PSYCHOTHERAPY

The Therapeutic Value of Abreaction (1921/1928)

The Practical Use of Dream-Analysis (1934)

The Psychology of the Transference (1946)

†17. THE DEVELOPMENT OF PERSONALITY

Psychic Conflicts in a Child (1910/1946)

Introduction to Wickes's "Analyses der Kinderseele" (1927/1931)

Child Development and Education (1928)

Analytical Psychology and Education: Three Lectures (1926/1946)

The Gifted Child (1943)

The Significance of the Unconscious in Individual Education (1928)

The Development of Personality (1934)

Marriage as a Psychological Relationship (1925)

*18. THE SYMBOLIC LIFE

Miscellaneous Writings

†19. GENERAL BIBLIOGRAPHY OF C. G. JUNG'S WRITINGS

†20. GENERAL INDEX TO THE COLLECTED WORKS

See also:

C. G. JUNG: LETTERS

Selected and edited by Gerhard Adler, in collaboration with Aniela Jaffé. Translations from the German by R.F.C. Hull.

VOL. 1: 1906–1950

VOL. 2: 1951–1961

THE FREUD/JUNG LETTERS

Edited by William McGuire, translated by
Ralph Manheim and R.F.C. Hull

C. G. JUNG SPEAKING: Interviews and Encounters

Edited by William McGuire and R.F.C. Hull

C. G. JUNG: Word and Image

Edited by Aniela Jaffé

* See announcement at end of this volume.

¹ [Translated from *Zur Psychologie und Pathologie sogenannter occulter Phänomene* (Leipzig, 1902). It was Professor Jung's inaugural dissertation for his medical degree and was delivered before the Faculty of Medicine, University of Zurich. The 1902 title-page stated that the author was at that time "First Assistant Physician in the Burghölzli Clinic" and that the dissertation was approved on the motion of Professor Eugen Bleuler. The book was dedicated to the author's wife, Emma Rauschenbach Jung (1882–1955). A translation by M. D. Eder was published in *Collected Papers on Analytical Psychology* (London and New York, 1916; 2nd edn., 1917). In the following version, the headings have been somewhat re-ordered and some new headings supplied in brackets in an attempt to clarify the structure of the monograph.—EDITORS.

² "Über drei Fälle von 'Hysteria magna' " (1900), p. 928.

³ *Alterations of Personality* (orig. 1892), p. 2, modified.

⁴ *Text-Book of Insanity* (orig. 1879), p. 498, modified.

⁵ Richer, *Études cliniques* (1881), p. 483.

⁶ *Ibid.*, p. 487; cf. also Erler, "Hysterisches und hystero-epileptisches Irresein" (1879), p. 28, and Culler, "Un Cas de somnambulisme hystérique" (1888), p. 356*.

⁷ In Guinon, "Documents pour servir à l'histoire des somnambulismes" (1891).

⁸ "Sleepwalking must be regarded as systematic partial wakefulness, during which a limited but logically consistent complex of ideas enters into consciousness. No opposing ideas present themselves, and at the same time mental activity continues with increased energy within the limited sphere of wakefulness." Loewenfeld, *Hypnotismus* (1901), p. 289.

^{8a} [See Bibliography.—EDITORS.]

⁹ *Hypnotisme, double conscience* (1887). A similar case in Winslow, *Obscure Diseases of the Brain and Mind* (1863), quoted in *Allg Z f Psych*, XXII (1865), p. 405.

¹⁰ *Tribune médicale*, 23rd year (1890).

¹¹ "Automatisme somnambulique avec dédoublement de la personnalité" (1892).

¹² *The Principles of Psychology* (1890) I, p. 391.

¹³ "De l'automatisme de la mémoire et du souvenir dans la somnambulisme pathologique" (1874), pp. 105–12, cited in Binet, *Alterations*, pp. 42ff. Cf. also Mesnet, "Somnambulisme spontané dans ses rapports avec l'hystérie" (1892).

¹⁴ "De l'influence des excitations des organes des sens sur les hallucinations de la phase passionnelle de l'attaque hystérique" (1891).

¹⁵ *The Philosophy of Sleep* (1830), cited in Binet, p. 4.

¹⁶ "I had the gift, when I closed my eyes and bent my head, of being able to conjure up in my mind's eye the imaginary picture of a flower. This flower did not retain its first shape for a single instant, but unfolded out of itself new flowers with coloured petals and green leaves. They were not natural flowers, but fantastic ones, and were as regular in shape as a sculptor's rosettes. It was impossible to fix the creative images that sprang up, yet they lasted as long as I desired them to last, neither weakening nor increasing in strength." *Zur Naturwissenschaft*.

¹⁷ "Agoraphobie" (1872), p. 158.

- ¹⁸ Pick, “Vom Bewusstsein in Zuständen sogenannter Bewusstlosigkeit” (1884), p. 202; and Pelman, “Über das Verhalten des Gedächtnisses bei den verschiedenen Formen des Irreseins” (1864), p. 78.
- ¹⁹ Neurasthenische Krisen” (1902): “When the patients first describe their crises, they generally give a picture that makes us think of epileptic depression. I have often been deceived in this way.”
- ²⁰ *Über Dämmerzustände* (1901), case 32, p. 75.
- ²¹ [The alternative terms are Swiss dialect. Cf. par. 73, and also the following paper, pars. 151ff., below.—EDITORS.]
- ²² [“The Clairvoyante of Prevorst,” pub. 1829; trans. as *The Seeress of Prevorst*, 1859.—EDITORS.]
- ²³ It should be noted that a frequent guest in S. W.’s house was a gentleman who spoke North German.
- ²⁴ Ivenes is the mystical name of the medium’s somnambulistic ego.
- ^{24a} [Sir William Crookes, the physicist and psychic investigator.—EDITORS.]
- ²⁵ [Cf. Kant’s *Cosmogony as in His “Essay on the Retardation of the Rotation of the Earth” and His “Natural History and Theory of the Heavens,”* ed. and trans. W. Hastie (Glasgow, 1900).—EDITORS.]
- ²⁶ [Note that the diagram shows only the first seven inner circles.—EDITORS.]
- ²⁷ “L’Anesthésie hystérique” (1892).
- ²⁸ *Alterations of Personality*, pp. 205f.
- ²⁹ Richet, “La Suggestion mentale et le calcul des probabilités” (1884), p. 650.
- ³⁰ *Alterations*, p. 154.
- ³¹ Detailed references in Binet, pp. 222ff.
- ³² As is well known, the hands and arms during the waking state are never quite still, but are constantly subject to fine tremors. Preyer, Lehmann, and others have shown that these movements are influenced in high degree by the ideas predominating in the mind. For instance, Preyer shows that the outstretched hand will draw small but more or less successful copies of figures that are vividly imagined. These intended tremors can be demonstrated in a very simple way by experiments with the pendulum.
- ³³ Preyer, *Die Erklärung des Gedankenlesens* (1886).
- ³⁴ This is analogous to certain hypnotic experiments in the waking state. Cf. Janet’s experiment, when by whispered suggestions he got a patient to lie flat on the ground without being aware of it. *L’Automatisme psychologique* (1913), p. 241.
- ³⁵ Cf. Charcot’s scheme for word-picture composition: (1) auditory image, (2) visual image, (3) motor images, (a) speech image, (b) writing image. In Ballet, *Le Langage intérieur et les diverses formes de l’aphasie* (1886), p. 14.
- ³⁶ Bain says: “Thinking is restrained speaking or acting.” *The Senses and the Intellect* (1894), p. 358.
- ³⁷ Myers, “Automatic writing” (1885).
- ³⁸ *L’Automatisme*, pp. 317–18.
- ³⁹ Binet, p. 147.
- ⁴⁰ ‘Once baptized, the unconscious personage is more definite and distinct; he shows his psychological characteristics better.” Janet, *L’Automatisme*, p. 318.
- ⁴¹ Cf. the experiments of Binet and Féré, in Binet, pp. 99ff.

- ⁴² Cf. the tests in Flournoy, *From India to the Planet Mars* (orig. 1900).
- ⁴³ Cf. Hagen, “Zur Theorie der Hallucination” (1868), p. 10.
- ⁴⁴ *Alterations*, pp. 171ff.
- ⁴⁵ *The Interpretation of Dreams* (orig. 1900).
- ⁴⁶ *India to Mars*, p. 59.
- ⁴⁷ *Handbuch der Geisteskrankheiten* (1878), p. 134.
- ⁴⁸ Müller, *Phantastische Gesichterscheinungen* (1826), quoted by Hagen in “Zur Theorie der Hallucination” (1868), p. 41.
- ⁴⁹ Spinoza had a hypnopompic vision of a “nigrum et scabiosum Brasilianum” (a dirty black Brazilian)—Hagen, “Zur Theorie der Hallucination” (1868), p. 49. In Goethe’s *Elective Affinities*, Otilie sometimes saw in the half darkness the figure of Eduard in a dimly lit room. Cf. also Jerome Cardan, *De subtilitate rerum*: “Imagines videbam ab imo lecti, quasi e parvulis annulis arcisque constantes, arborum, belluarum, hominum, oppidorum, intractarum acierum, bellicorum et musicorum instrumentorum aliorumque huius generis adscendentes, vicissimque descendentes, aliis atque aliis succedentibus” (At the foot of the bed I saw images, consisting as it were of small circles and curves, and representing trees, animals, men, towns, troops drawn up in line, instruments of war and of music and other like things, rising and falling in turn, and coming one after another).
- ⁵⁰ *Le Sommeil et les rêves* (1861), p. 134.
- ⁵¹ “Psychology of Visual Dreams” (1892).
- ⁵² Hecker says of these states (*Über Visionen*, 1848, p. 16): “There is a simple, elementary vision caused by mental over-activity, without fantastic imagery, without even sensuous ideas: it is the vision of formless light, a manifestation of the visual organ stimulated from within.”
- ⁵³ Quicherat, *Procès de condamnation et de réhabilitation de Jeanne d’Arc* (1841–49), V, pp. 116f.
- ⁵⁴ Hagen (1868), p. 57.
- ⁵⁵ *Life of Cellini* (trans. by Symonds), pp. 231f.
- ⁵⁶ Hagen (1868), p. 57.
- ⁵⁷ Flournoy, *India to Mars*, pp. 36ff. (trans. modified).
- ⁵⁸ *Ibid.*, p. 170.
- ⁵⁹ “Des Hallucinations” (1845), as reviewed in *Allg Z f Psych*, IV (1848), p. 139.
- ⁶⁰ *Über Visionen*, pp. 285ff.
- ⁶¹ Flournoy, p. 52.
- ⁶² “Mary Reynolds: A Case of Double Consciousness” (1888). Also in *Harper’s Magazine*, 1860. Abstracted in *extenso* in William James’s *Principles of Psychology* (1891), pp. 391ff.
- ⁶³ Cf. Emminghaus, *Allgemeine Psychopathologie* (1878), p. 129, Ogier Ward’s case.
- ⁶⁴ *Pathologie und Therapie der Geisteskrankheiten* (1863), p. 31, quoted in *Allg Z f Psych*, XXII (1865), 406–7.
- ⁶⁵ Cf. Donath, “Über Suggestibilität” (1892), quoted in *Arch f Psych u Nerv*, XXXII (1899), 335.
- ⁶⁶ “Ein Fall von spontanem Somnambulismus” (1893).
- ⁶⁷ *Hypnotisme* (1887), pp. 63ff.

- ⁶⁸ *Variations de la personnalité* (1888).
- ⁶⁹ See Moll, “Die Bewusstseinspaltung in Paul Lindau’s neuem Schauspiel” (1893), pp. 306ff.
- ⁷⁰ *Der Hypnotismus* (1884), pp. 109ff.
- ⁷¹ *L’Automatisme psychologique*.
- ⁷² “An Experimental Study of Visions” (1898).
- ⁷³ Quoted in Ribot, *Die Persönlichkeit* (1894).
- ⁷⁴ Ribot, p. 69.
- ⁷⁵ *India to Mars*, p. 63.
- ⁷⁶ “[Somnambulistic dreams:]... romances of the subliminal imagination analogous to those ‘continued stories’ which so many people tell themselves in their moments of idleness, or at times when their routine occupations offer only slight obstacles to day-dreaming, and of which they themselves are generally the heroes. Fantastic constructions, taken up and pursued over and over again, but seldom seen through to the end, in which the imagination allows itself free play and revenges itself on the dull and drab matter-of-factness of everyday reality.” Ibid., pp. 9f.
- ⁷⁷ *Die pathologische Lüge* (1891). [A reference in the 1953 edn. of *Two Essays on Analytical Psychology* (*Coll. Works*, 7), p. 134, n. 4, to this par. is in error. Instead see pars. 138ff., as indicated in the revised (1966) edn., p. 137, n. 3.—EDITORS.]
- ⁷⁸ *Hypnotism* (orig. 1889).
- ⁷⁹ “Über pathologische Träumerei” (1896), pp. 280–301.
- ⁸⁰ *Ein Fall von doppeltem Bewusstsein* (1898).
- ⁸¹ Görres, *Die christliche Mystik* (1836–42).
- ⁸² Cf. Behr, “Erinnerungsfälschungen und pathologische Traumzustände” (1899), pp. 918ff.; also Ballet, *Le Langage intérieur*, p. 44.
- ⁸³ Cf. Redlich, “Pseudologia phantastica” (1900), p. 66.
- ⁸⁴ “Hysterisches und hysterio-epileptisches Irresein” (1879), p. 21.
- ⁸⁵ Binet, p. 89: “I may say in this connection that hysterical patients have been my chosen subjects, because they exaggerate the phenomena that must necessarily be found to some degree in many persons who have never shown hysterical symptoms.”
- ⁸⁶ As, for instance, in the roof-climbing of somnambulists.
- ⁸⁷ Delbrück, *Die Lüge*; and Redlich, op. cit. Cf. also the development of delusional ideas in epileptic twilight states mentioned by Mörchen, *Über Dämmerzustände* (1901), pp. 51, 59.
- ⁸⁸ Cf. Flournoy’s interesting conjecture as to the origin of H. S.’s Hindu cycle: “I should not be surprised if Marlès’ remark on the beauty of the Kanara women were the sting, the tiny jab, which aroused the subliminal attention and riveted it, quite naturally, on this single passage and the two or three lines that followed it, to the exclusion of all the much less interesting context” (Swiss edn., p. 285).
- ⁸⁹ Janet says (*The Mental State of Hystericals*, orig. 1893, p. 78); “It is from forgetfulness that there arise, not always, but very often, the supposed lies of hysterical subjects. In the same way we can also explain their caprices, their

changes of mood, their ingratitude, in a word their inconsistencies, for the connection of the past with the present, which gives seriousness and unity to conduct, depends largely upon memory.”

⁹⁰ Cf. Freud, *The Interpretation of Dreams*, p. 593: “The course of our conscious reflections shows us that we follow a particular path in our application of attention. If, as we follow this path, we come upon an idea which will not bear criticism, we break off: we drop the cathexis of attention. Now it seems that the train of thought which has thus been initiated and dropped can continue to spin itself out without attention being turned to it again, unless at some point or other it reaches a specially high degree of intensity which forces attention to it. Thus, if a train of thought is initially rejected (consciously, perhaps) by a judgment that it is wrong or that it is useless for the immediate intellectual purposes in view, the result may be that this train of thought will proceed, unobserved by consciousness, until the onset of sleep.”

⁹¹ Binet, *Alterations*, pp. 93f., modified.

⁹² *L’Automatisme psychologique*, p. 329: “Another consideration emphasizes the resemblance between these two states, namely, that subconscious acts have a kind of hypnotizing effect, and one that helps by their very performance to induce somnambulism.”

⁹³ *Ibid.*, p. 329.

⁹⁴ Gustave Flaubert made literary use of this falling asleep at the moment of supreme excitement in his novel *Salammbô*. When the hero, after many struggles, at last captures Salammbô, he suddenly falls asleep just as he touches her virginal bosom.

⁹⁵ Cases of emotional paralysis may also come into this category. Cf. Baetz, “Über Emotionslähmung” (1901), pp. 717ff.

⁹⁶ Hagen, “Zur Theorie der Hallucination” (1868), p. 17.

⁹⁷ “Über hysterische Schlafzustände” (1892), p. 59.

⁹⁸ Cf. Flournoy, *India to Mars*, pp. 67f.

⁹⁹ Loewenfeld (1891), p. 737.

¹⁰⁰ *Ibid.*, p. 734.

¹⁰¹ “Un Cas remarquable d’hypnose spontanée” (1890), p. 234.

¹⁰² Loewenfeld (1891), p. 737.

¹⁰³ *Ibid.*, p. 737.

¹⁰⁴ Loewenfeld (1892), pp. 59ff.

¹⁰⁵ Cf. Lehmann’s researches into involuntary whispering, in *Aberglaube und Zauberei* (1898), pp. 386ff.

¹⁰⁶ Flournoy, for instance, writes (p. 103): “In a first attempt, Leopold [H. S.’s control] only succeeded in giving Hélène his intonation and pronunciation; after a séance in which she suffered acutely in her mouth and in her neck, as though her vocal organs were being manipulated or removed, she began to talk in a natural voice.”

¹⁰⁷ Loewenfeld (1892), p. 60.

¹⁰⁸ This reminds us of Flournoy’s observations: while H. S. speaks somnambulistically as Marie Antoinette, her arms do not belong to the somnambulistic personality but to the automatist Leopold, who converses by gestures with the observer. Cf. Flournoy, pp. 130f.

- ¹⁰⁹ Dessoir, *Das Doppel-Ich* (1896), p. 29.
- ¹¹⁰ Janet, “L’Anesthésie hystérique,” p. 69.
- ¹¹¹ Graeter, “Ein Fall von epileptischer Amnesie durch Hypermnesie beseitigt” (1899), p. 129.
- ¹¹² Karplus, “Über Pupillenstarre im hysterischen Anfall” (1898), p. 52, says: “The hysterical attack is not a purely psychic process.... The psychic processes merely release a pre-existing mechanism, which in itself has nothing to do with them.”
- ¹¹³ This objectivation of associated complexes has been used by Carl Hauptmann in his play *Die Bergschmiede* (1902), where the treasure-seeker is confronted one gloomy night by the hallucination of his entire better self.
- ¹¹⁴ *The Interpretation of Dreams*. Cf. also Breuer and Freud, *Studies on Hysteria* (orig. 1895).
- ¹¹⁵ Pelman, “Über das Verhalten des Gedächtnisses bei den verschiedenen Formen des Irreseins” (1864), p. 74.
- ¹¹⁶ Jessen, “Doppeltes Bewusstsein” (1865), p. 407.
- ¹¹⁷ Flournoy, p. 31.
- ¹¹⁸ *Alterations*, p. 139.
- ¹¹⁹ Cryptomnesia should not be confused with hypermnesia. By the latter term is meant the abnormal sharpening of the powers of memory, which then reproduce the actual memory-images themselves.
- ¹²⁰ Cf. Nietzsche, *Ecce Homo* (trans. by Ludovici), pp. 101f.: “Has any one at the end of the nineteenth century any distinct notion of what poets of a stronger age understood by the word ‘inspiration’? If not, I will describe it. If one had the smallest vestige of superstition left in one, it would hardly be possible completely to set aside the idea that one is the mere incarnation, mouthpiece, or medium of an almighty power. The idea of revelation, in the sense that something which profoundly convulses and upsets one becomes suddenly visible and audible with indescribable certainty and accuracy, describes the simple fact. One hears—one does not seek; one takes—one does not ask who gives; a thought suddenly flashes up like lightning, it comes with necessity, without faltering—I have never had any choice in the matter.”
- ¹²¹ Ch. XL, “Great Events” (trans. by Common, p. 180, slightly modified). (Orig. 1883.)
- ¹²² Vol. IV, p. 57, headed: “An Extract of Awe-Inspiring Import from the Log of the Ship *Sphinx* in the Year 1686, in the Mediterranean.” (Orig. 1831–39.) [Cf. par. 181, below.—EDITORS.]
- ¹²³ In *Ecce Homo*: “There is an ecstasy so great that the tremendous strain of it is at times eased by a storm of tears, when your steps now involuntarily rush ahead, now lag behind; a feeling of being completely beside yourself, with the most distinct consciousness of innumerable delicate thrills tingling through you to your very toes; a depth of happiness, in which pain and gloom do not act as its antitheses, but as its condition, as a challenge, as necessary shades of colour in such an excess of light.” [Cf. Ludovici trans., p. 102.]
- ¹²⁴ Eckermann, *Conversations with Goethe*, p. 587.
- ¹²⁵ Cf. Görres, *Die christliche Mystik*.
- ¹²⁶ “Kulturhistorischer Beitrag zur Hysterie” (1896), pp. 333ff.
- ¹²⁷ Zündel, *Pfarrer J. C. Blumhardt* (1880).
- ¹²⁸ *From India to the Planet Mars*.

¹²⁹ "... the rapid and confused gibberish whose meaning can never be ascertained, probably because it really has none, but is only a pseudo-language." Flournoy, p. 199. "... analogous to the gibberish which children use sometimes in their games of 'pretending' to speak Chinese, Indian, or 'savage'..." (p. 159, modified).

¹³⁰ Ibid., p. 405.

¹³¹ For a case of this kind see Krafft-Ebing, *Text-Book of Insanity* (orig. 1879).

¹³² Loewenfeld (*Hypnotismus*, p. 289) writes: "The restriction of associative processes to, and the steady concentration of attention on, a definite field of representation can also lead to the development of new ideas which no effort of will in the waking state would have been able to bring to light."

¹³³ Zschokke, *Eine Selbstschau* (1843), pp. 227ff.

¹³⁴ Gilles de la Tourette (quoted in Loewenfeld, p. 132) says: "We have seen somnambulistic girls, poor, uneducated, and quite stupid in the waking state, whose whole appearance altered as soon as they were put to sleep. Before they were boring, now they are lively and excited, sometimes even witty."

¹³⁵ (Added 1978.) The version published in the *Gesammelte Werke*, Band I, gives for par. 150 the following concluding paragraphs (tr. Lisa Röss), from a later printing of the monograph:

I am far from believing that with this work any sort of final and scientifically satisfying result has been achieved. Primarily, my intention has been to counter general opinion, which dismisses so-called occult phenomena with a contemptuous smile, by demonstrating the manifold connections between these phenomena and the subjects covered by medicine and psychology, as well as to refer to the many important questions which this unexplored territory holds for us. Impetus for this work was given me by the conviction that in this area a rich harvest for experiential psychology is ripening, as well as by the awareness that our German science has not concerned itself sufficiently with these problems. This latter reason also induced me to lead off with the investigation of a case of somnambulism belonging to the purely pathological, so as to locate the place of somnambulists in relation to pathology in general.

I hope that in this sense my work will aid science in preparing a way toward the progressive elucidation and assimilation of the as yet extremely controversial psychology of the unconscious.

¹ [First published as “Über hysterisches Verlesen,” *Archiv für die gesamte Psychologie* (Leipzig), III (1904) : 4, 347–50.—EDITORS.]

² [See the previous paper in this volume. The review by R. Hahn was published in the *Archiv*, III, Literaturbericht, p. 26.—EDITORS.]

³ [Cf. pars. 38 and 73, above.]

⁴ [Cf. par. 75, above.]

¹ [First published as “Kryptomnesie,” *Die Zukunft* (Berlin), 13th year (1905), L, 325–34.—EDITORS.]

² I call “unconscious,” in the widest sense, everything that is not represented in consciousness, whether momentarily or permanently.

^{2a} [The phrases “feeling-toned complex” and “feeling tone” translate the German “gefühlbetonter Komplex” and “Gefühlston.” Although it might be justifiable to follow H. G. and Cary F. Baynes and translate the first phrase as “emotionally-toned” complex (cf. Jung, “On Psychological Energy,” in *Contributions to Analytical Psychology*, p. 9), the Editors have decided, in keeping with the general policy of this edition, to retain the original terminology on account both of its historical interest and of Jung’s consistent use of the term in his later works. In a re-statement of his theory of complexes published in 1934 (see “A Review of the Complex Theory,” *Coll. Works*, 8, par. 201), Jung defines the feeling-toned complex as “the image of a certain psychic situation which is strongly accentuated emotionally.” From this it is clear that the word “feeling” is not used in the later technical sense to designate one of the four psychic functions, but in a more generalized way. It is in the latter sense that the terms “feeling tone” and “feeling-toned complex” will be used throughout the collected edition.—EDITORS.]

³ [Max Simon Nordau, 1849–1923, German physician, author of *Conventional Lies of Civilization* and of *Degeneration*, an attempt to relate genius and degeneracy.—EDITORS.]

⁴ *From India to the Planet Mars* (orig. 1900).

⁵ I have used this example before and discussed it in my psychiatric study “On the Psychology and Pathology of So-called Occult Phenomena.” [See pars. 140f., above.]

⁶ Ch. XL, “Great Events” (trans. by Common, p. 180, slightly modified). (Orig. 1883.)

⁷ Vol. IV, p. 57, headed: “An Extract of Awe-Inspiring Import from the Log of the Ship *Sphinx* in the Year 1686, in the Mediterranean.” (Orig. 1831–39.)

⁸ Eckermann, *Conversations with Goethe*, trans. by Moon, p. 587.

⁹ *Ecce Homo*, trans. by Ludovici, p. 102, modified.

¹⁰ *Ibid.*, pp. 101f.

¹¹ [Maximilian Harden wrote of the case of Siegfried Jacobsohn, a dramatic critic, in his weekly journal *Die Zukunft*, in 1904. Jacobsohn, accused of plagiarizing, claimed that he had not done so knowingly, and Harden suggested that a mental aberration (resembling cryptomnesia) may have been responsible. Arthur Schnitzler, the Viennese physician and playwright, added some medical comments in the next issue. Jung’s article on cryptomnesia followed shortly after.—EDITORS.]

- ¹ [First published as “Über manische Verstimmung,” *Allgemeine Zeitschrift für Psychiatrie und psychisch-gerichtliche Medizin* (Berlin), LXI (1903) : 1, 15–39.—EDITORS.]
- ² “Über chronische Manie” (1902), pp. 261ff.
- ³ *A Treatise on Insanity* (orig. 1801), pp. 150ff.
- ⁴ *Die Manie* (1881).
- ⁵ “Ein Fall von sanguinischer Minderwerthigkeit” (1894).
- ⁶ Pub. 1894.
- ⁷ Rüdín, “Über die klinischen Formen der Gefängnispsychosen” (1901), p. 458.
- ⁸ “Die Moral Insanity beruht auf einem excessiv sanguinischen Temperament” (1901), pp. 205ff.
- ⁹ Schüle (*Handbuch der Geisteskrankheiten*, 1878) says that a middling or even a good intellectual capacity is still in the tow of perverse impulses and inclinations, and despite its abilities is incapable of producing countermotives.
- ¹⁰ “Über Willens- und Charakterbildung auf physiologisch-psychologischer Grundlage” (1897).
- ¹¹ “Preisschrift über die Freiheit des Willens,” *Werke*, II, pp. 231ff.
- ¹² *Grundriss der Psychiatrie* (1894), p. 320.
- ¹³ Krafft-Ebing speaks of “abnormally increased emotional impressionability.” *Text-Book of Insanity* (orig. 1879), p. 52. E. Müller (“Über Moral Insanity,” 1899, p. 342) writes: “It is unanimously emphasized that the emotional reactivity is reduced or abolished, that there is emotional blunting or even complete loss of emotion.” P. 344: “The restrictive checks which the patient’s egotistic strivings meet with in the legal rights of other people lead to bad moods and affects, resulting in great emotional irritability.” This contradiction is not the fault of the author but of his material. Its symptomatology is so extremely contradictory because under the term “moral insanity” are included cases of widely different provenance which merely happen to have the symptom of moral defect in common.

- ¹ [First published as “Ein Fall von hysterischem Stupor bei einer Untersuchungsgefangenen,” *Journal für Psychologie und Neurologie* (Leipzig), I (1902) : 3, 110–22.—EDITORS.]
- ² [See below, notes 3–5, for these citations.]
- ³ “Über einen eigenartigen hysterischen Dämmerzustand” (1898).
- ⁴ “Beitrag zur Kenntnis des hysterischen Dämmerzustandes” (1901).
- ⁵ “Hysterische Symptome bei einfachen Seelenstörungen” (1902).
- ⁶ “Hysterischer Stupor bei Strafgefangenen” (1901).
- ⁷ *Hypnotisme* (1887), case of Albert X.
- ⁸ “Mary Reynolds” (1888).
- ⁹ *Pathologie und Therapie der Geisteskrankheiten* (1863), p. 31.
- ¹⁰ *The Philosophy of Sleep* (1830), cited in Binet, *Alterations of Personality*.
- ¹¹ Rüdin, “Klinische Formen der Gefängnispsychosen” (1901), p. 458.
- ¹² *Grundriss der Psychiatrie* (1894), p. 316.
- ¹³ *L’Automatisme psychologique* (orig. 1889), p. 87.
- ¹⁴ *Ibid.*, p. 87: “This is that state of hypnotic syncope which I have already remarked. I have frequently observed it since, and in the case of some patients it seems to constitute an unavoidable transition between the various psychological states.”
- ¹⁵ Naef, “Ein Fall von temporärer, totaler, teilweise retrograder Amnesie” (1897).
- ¹⁶ *Studies on Hysteria* (orig. 1895), p. 206.

- ¹ [First published as “Über Simulation von Geistesstörung,” *Journal für Psychologie und Neurologie* (Leipzig), II (1903) : 5, 181–201.—EDITORS.]
- ² “Über einige Fälle von Simulation” (1903).
- ³ “Die Zurechnungsfähigkeit der Hysterischen” (1899).
- ⁴ Gross, *Criminal Psychology* (orig. 1898).
- ⁵ *Die Psychologie des Verbrechens* (1884), p. 258.
- ⁶ So far as listed in the records.
- ⁷ *Die pathologische Lüge und die psychisch abnormen Schwindler* (1891).
- ⁸ Cf. Lehmann’s studies on the expression of emotion in an actor : *Die körperlichen Äusserungen psychischer Zustände* (1899), I, p. 182.
- ⁹ “Über pathologische Träumerei” (1896).
- ¹⁰ Bohn, *Ein Fall von doppeltem Bewusstsein* (1898).
- ¹¹ [See the first paper in this volume, par. 116.—EDITORS.]
- ¹² Hoche, *Handbuch der gerichtlichen Psychiatrie* (1901).
- ¹³ [A legendary Roman who, when taken prisoner by the Etruscans, thrust his right hand into the fire to show his indifference to death.—TRANS.]
- ¹⁴ “Über Emotionslähmung” (1901).
- ¹⁵ Cf. the work done by Phleps, “Psychosen nach Erdbeben” (1903).
- ¹⁶ In such a gross disturbance as this, practice is a factor that can be left out of account.
- ¹⁷ [Professor Jung was evidently contemplating a single paper at this time. As his subsequent publications show, however, he and his collaborators published several. Cf. “The Psychopathological Significance of the Association Experiment” and other papers grouped under “Studies in Word Association” in *Experimental Researches* (Coll. Works, 2); also “The Psychology of Dementia Praecox” (Coll. Works, 3).—EDITORS.]
- ¹⁸ *L’Automatisme psychologique* (orig. 1889), p. 457.
- ¹⁹ *Les obsessions et la psychasthénie* (1903).
- ²⁰ *Névroses et idées fixes* (1898) I, p. 144.
- ²¹ [See “A Case of Hysterical Stupor in a Prisoner in Detention,” pp. 137ff., above.—EDITORS.]
- ²² Raecke, “Hysterischer Stupor bei Strafgefangenen” (1901); A. Westphal, “Über hysterische Dämmerzustände” (1903); and Lücke, “Über das Ganser’sche Symptom” (1903).
- ²³ Of the 58 cases of simulation I collected, senseless answers corresponding to the Ganser complex were given in 29. The wide incidence of this symptom, which is the distinctive feature of the Ganser complex, is of importance in evaluating the state we are discussing.
- ²⁴ Schürmayer (*Lehrbuch der gerichtlichen Medicin*, orig. 1850, p. 378) says: “Very often a bad conscience has such a powerful effect on man’s psychic life that it can feign the appearance of mental suffering. Dejection and irritable moods are found in practically all delinquents who are not professional criminals. Brooding is very common with them; for weeks on end they find no rest at night; they deteriorate physically, refuse nourishment, suffer from

phobias, hallucinations, etc. Not only if they deny their crime do they become like this, but also if they confess it. They give quite absurd answers at the trial and are brought to the brink of despair under cross-examination.”

²⁵ [The case is detailed in the following paper.—EDITORS.]

²⁶ Laurent, *Étude sur la simulation* (1866).

²⁷ As far back as 1856, Richarz, one of the experts in the Stockhausen case, expressed the view that outward behaviour exerts a great influence on mental activity. “Über psychische Untersuchungsmethoden” (1856).

²⁸ *Alterations of Personality* (orig. 1892).

²⁹ *L’Automatisme psychologique*.

³⁰ “Simulation von Geistesstörung” (1892).

³¹ “Ein Simulant vor Gericht” (1884).

³² “Folie simulée par une aliénée inculpée de tentative d’assassinat” (1882).

³³ Cf. also Jessen’s review of the study by Böcker, Hertz, and Richarz, *Reiner Stockhausen: ein actenmässiger Beitrag zur psychisch-gerichtlichen Medicin* (1855), and Richarz’s reply, “Über psychische Untersuchungsmethoden” (1856). Also Snell, “Über Simulation von Geistesstörung” (1856).

³⁴ It is surprising how often we find these negativisms in illnesses of this kind. Can it be due to emotional confusion, which inhibits the influx of associations?

³⁵ “Simulation von Seelenstörung” (1883), p. 41.

³⁶ “Über hysterische Dämmerzustände” (1903).

³⁷ “Über das Ganser’sche Symptom” (1903).

³⁸ [See “A Case of Hysterical Stupor in a Prisoner in Detention,” pp. 137ff., above.—EDITORS.]

³⁹ Cf. the following statements: “To unmask simulation, all that is needed is plain, sound common sense” (Claus, “Ein Fall von simulierter Geistesstörung,” 1876, p. 153.) “So the question of simulation presents fewer difficulties in practice than it does in theory” (Bolte, “Über einige Fälle von Simulation,” 1903, p. 47).

⁴⁰ “Rapport medico-légal sur un cas de simulation de folie” (1868).

⁴¹ Emile Laurent, “Un Détenue simulant la folie pendant trois ans” (1888).

⁴² Wilbrand and Lotz, “Simulation von Geisteskrankheit bei einem schweren Verbrecher” (1889).

⁴³ “Über Simulation geistiger Störungen” (1888).

⁴⁴ [Cf. Jung, *Symbols of Transformation*, pars. 435ff.—EDITORS.]

¹ [First published as “Ärztliches Gutachten über einen Fall von simulierter geistiger Störung,” *Schweizerische Zeitung für Strafrecht* (Zurich), XVII (1904), 55–75.—EDITORS.]

² [“On Simulated Insanity,” the foregoing paper in this volume.—EDITORS.]

³ The curve was so plotted that the number of additions carried out per minute was written down as one co-ordinate. Correlatively, the number of errors was also plotted in a curve. The curves were appended to the medical opinion. In place of the curves I give here only the average figures as a guide:

	<i>June 10</i>	<i>June 19</i>
Average performance per minute	28.1	32.4
Average per minute for 1st half of total number	27.4	31.9
Average per minute for 2nd half of total number	28.9	32.9
Error in total number of additions	11.2%	4.0%
Errors per minute for 1st half of additions	1.5	1.1
Errors per minute for 2nd half of additions	4.7	1.5

¹ [First published as “Obergutachten über zwei sich widersprechende psychiatrische Gutachten,” *Monatsschrift für Kriminalpsychologie und Strafrechtsreform* (Heidelberg), II: 11/12 (Feb.–Mar., 1906), 691–98.—EDITORS].

¹ [First published as “Zur psychologischen Tatbestandsdiagnostik,” *Zentralblatt für Nervenheilkunde und Psychiatrie* (Leipzig), XXVIII (N.S. XVI) (November, 1905), 813–15.—EDITORS.]

² [This and the other works of Jung’s mentioned in this paper are in *Experimental Researches*, Vol. 2 of the *Collected Works*.—EDITORS.]

³ “Psychologische Tatbestandsdiagnostik” (1904).

⁴ “Zur psychologischen Tatbestandsdiagnostik” (1905).

⁵ [In section II of “Die psychologische Diagnose des Tatbestandes,” XVIII (1905), 369–408; republished under same title in *Juristisch-psychiatrische Grenzfragen* (Halle, 1906), IV:2, 3–47; also published as a pamphlet (Halle, 1906; Zurich and Leipzig, 1941). For translation, see “The Psychological Diagnosis of Evidence,” *Experimental Researches*.—EDITORS.]

- * Published 1957; 2nd edn., 1970.
- † Published 1973.
- * Published 1960.
- † Published 1961.
- ‡ Published 1956; 2nd edn., 1967. (65 plates, 43 text figures.)
- * Published 1971.
- † Published 1953; 2nd edn., 1966.
- ‡ Published 1960; 2nd edn., 1969.
- * Published 1959; 2nd edn., 1968. (Part I: 79 plates, with 29 in colour.)
- * Published 1964; 2nd edn., 1970. (8 plates.)
- † Published 1958; 2nd edn., 1969.
- * Published 1953; 2nd edn., completely revised, 1968. (270 illustrations.)
- † Published 1968. (50 plates, 4 text figures.)
- ‡ Published 1963; 2nd edn., 1970. (10 plates.)
- * Published 1966.
- † Published 1954; 2nd edn., revised and augmented, 1966. (13 illustrations.)
- ‡ Published 1954.
- * Published 1976.
- † Published 1979.

BOLLINGEN SERIES XX

THE COLLECTED WORKS

OF

C. G. JUNG

VOLUME 2

EDITORS

† SIR HERBERT READ

MICHAEL FORDHAM, M.D., M.R.C.P.

GERHARD ADLER, PH.D.

WILLIAM MC GUIRE, *executive editor*

EXPERIMENTAL RESEARCHES

C. G. JUNG

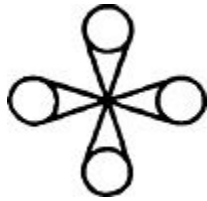

TRANSLATED BY LEOPOLD STEIN

IN COLLABORATION WITH DIANA RVIERE

BOLLINGEN SERIES XX

PRINCETON UNIVERSITY PRESS

COPYRIGHT © 1973 BY PRINCETON UNIVERSITY PRESS, PRINCETON, N.J. PUBLISHED BY
PRINCETON UNIVERSITY PRESS, PRINCETON, NEW JERSEY
ALL RIGHTS RESERVED

First Princeton / Bollingen Paperback printing, with corrections, 1981

THIS EDITION IS BEING PUBLISHED IN THE UNITED STATES
OF AMERICA FOR BOLLINGEN FOUNDATION BY
PRINCETON UNIVERSITY PRESS AND IN ENGLAND BY
ROUTLEDGE & KEGAN PAUL, LTD. IN THE AMERICAN
EDITION, ALL THE VOLUMES COMPRISING THE
COLLECTED WORKS CONSTITUTE NUMBER XX IN
BOLLINGEN SERIES. THE PRESENT VOLUME IS NUMBER 2
OF THE COLLECTED WORKS AND IS THE SEVENTEENTH TO
APPEAR.

LIBRARY OF CONGRESS CATALOGUE CARD NUMBER: 75-156

ISBN 0-691-09764-X

ISBN 0-691-01840-5 pbk.

MANUFACTURED IN THE U.S.A.

EDITORIAL NOTE

Jung's creative use of association tests was a part of the pioneering research going on at the Burghölzli in Zurich under the rigorous aegis of Eugen Bleuler at the beginning of this century. Freud's investigations, at the time known though little accepted, were clearly in Jung's mind as he observed the perplexing behaviour of associations; so instead of brushing these to one side and considering them only as aberrant features or as "failures to react" amongst classifiable groupings, he applied the interpretative method and formulated the theory of "complexes." Thus he rescued the association method from "scientific pedantry ... and reinvested it with the vitality and interest of real life."¹ The papers in this volume marked, in their day, a revolutionary advance in the use of experimental techniques. All Jung's writings setting out his experimental point of departure and method are included in this volume. Another work of major importance in which the tests were used incidentally is placed in Volume 3 of the Collected Works: Jung's celebrated investigation of dementia praecox. In "On Simulated Insanity," in Volume 1, Jung uses the more formal surface classification of associations, and in a later paper, "A Review of the Complex Theory," in Volume 8, he gives his mature reflections on the place of association studies in his general view of psychic structures and processes.

Perhaps the most vivid account of the association theory will be found in the Tavistock Lectures (1936),² in Volume 18.

*

The principal contents of this volume are Jung's six contributions to the famous Studies in Word Association (*Diagnostische Assoziationsstudien*). The experiments underlying the Studies were carried out under Jung's direction at the Psychiatric Clinic of the University of Zurich, beginning about 1902. Jung at that time was senior assistant staff physician at the Burghölzli Mental Hospital (where the Clinic was); its director was Eugen Bleuler. The Studies appeared from 1904 to 1910 in the *Journal für Psychologie und Neurologie*; they included contributions also by Bleuler, Franz Riklin, K. Wehrli, Emma Fürst, Ludwig Binswanger, and Hermann Nunberg.³ They were reprinted in two volumes, 1906 and 1909. The entire series was translated by a leading British psychoanalyst, M. D. Eder, in a single volume, *Studies in Word-Association*, published by William Heinemann, London, 1918, and Moffat Yard, New York, 1919 (reissued in a

facsimile reprint, 1969). The Eder translation has been consulted in the preparation of the present volume.

Jung's lectures under the heading "The Association Method" at Clark University in 1909 were translated by the American psychoanalyst A. A. Brill immediately afterwards for the *American Journal of Psychology* and for a volume issued by the University (both 1910). With little or no change, they were included by Constance E. Long when she edited Jung's *Collected Papers on Analytical Psychology* (1916). The Brill translation has also been consulted for the present volume.

The three other association studies in [Part I](#) of this volume appear for the first time in English. "The Psychopathological Significance of the Association Experiment" was Jung's inaugural lecture upon his appointment to a University lectureship. The three studies in [Part II](#) originally appeared in American and British journals, two of them being collaborations with American psychiatrists who came to the Burghölzli to participate in research. Four of the brief works in the appendix are also appearing for the first time in English; the fifth was originally published in Sydney, Australia.

In one or two details, the present translation does not follow the terminology evolved in other volumes of the *Collected Works*; these are cited in footnotes. The translation of "The Association Method" and "The Family Constellation" was completed after Dr. Stein's death (1969) by Jean Rhees and revised (as the entire volume has been) by Diana Riviere.

Acknowledgment is made to Professor C. A. Meier, of Zurich, for editorial advice and for the loan of a diagram reproduced in the first paper in [Part II](#).

The Editors are deeply indebted to Dr. Stein and Miss Riviere for undertaking the difficult translation of these studies, with their exceptional problems of terminology and of rendering the stimulus- and reaction-words in the tests. The German originals of the lists of test words will be available in due course in the Swiss edition of Jung's collected works.

*

In the 1981 reprint, the Editors are grateful to the Editorial Committee of the *Gesammelte Werke*, in Zurich, for corrections that came to their notice in the preparation of Band II., *Experimentelle Untersuchungen* (1979). Because of the technical character of the contents of this volume, the locations of the chief of these are noted: p. 189, line 9; p. 255, n. 47; p. 276, no. 45; p. 281, no. 27; p. 300, no. 100; p. 485, n. 3, end; p. 606, par. 1362 and no. 3; p. 610, no. 10 and n. 4; p. 613, n. 5. On p. 431, Case G, the datum under "I" has been retained as 165.0, as in the original publication, but we note that the Zurich editors construe it as 16.5.

VOLUME 2 EXPERIMENTAL RESEARCHES

TABLE OF CONTENTS

EDITORIAL NOTE

PART I: STUDIES IN WORD ASSOCIATION

[The Associations of Normal Subjects, by C. G. Jung and Franz Riklin](#)

Translated from “Experimentelle Untersuchungen über Assoziationen Gesunder,” *Diagnostische Assoziationsstudien*, Vol. I (1906), I [1904].

[An Analysis of the Associations of an Epileptic](#)

Translated from “Analyse der Assoziationen eines Epileptikers,” *Diagnostische Assoziationsstudien*, Vol. I (1906), III [1905].

[The Reaction-time Ratio in the Association Experiment](#)

Translated from “Über das Verhalten der Reaktionszeit beim Assoziationsexperimente,” *Diagnostische Assoziationsstudien*, Vol. I (1906), IV [1905].

[Experimental Observations on the Faculty of Memory](#)

Translated from “Experimentelle Beobachtungen über das Erinnerungsvermögen,” *Zentralblatt für Nervenheilkunde und Psychiatrie* (Leipzig), XXVIII (1905).

[Psychoanalysis and Association Experiments](#)

Translated from “Psychoanalyse und Assoziationsexperiment,” *Diagnostische Assoziationsstudien*, Vol. I (1906), VI [1906].

[The Psychological Diagnosis of Evidence](#)

Translated from *Die psychologische Diagnose des Tatbestandes* (Zurich: Rascher, 1941), reprinted from the 1906 version.

Association, Dream, and Hysterical Symptom

Translated from “Assoziation, Traum und hysterisches Symptom,” *Diagnostische Assoziationsstudien*, Vol. II (1909), VIII [1906].

The Psychopathological Significance of the Association Experiment

Translated from “Die psychopathologische Bedeutung der Assoziationsexperimentes,” *Archiv für Kriminalanthropologie und Kriminalistik* (Leipzig), XXII (1906).

Disturbances of Reproduction in the Association Experiment

Translated from “Über die Reproduktionsstörungen beim Assoziationsexperiment,” *Diagnostische Assoziationsstudien*, Vol. II (1909), IX [1907].

The Association Method

Translated from the German manuscript (1909).

The Family Constellation

Translated from the German manuscript (1909).

PART II: PSYCHOPHYSICAL RESEARCHES

On the Psychophysical Relations of the Association Experiment

Originally published in English in *Journal of Abnormal Psychology* (Boston), I (1907).

Psychophysical Investigations with the Galvanometer and Pneumograph in Normal and Insane Individuals, by Frederick Peterson and C. G. Jung

Originally published in English in *Brain* (London), XXX (1907).

Further Investigations on the Galvanic Phenomenon and Respiration in Normal and Insane Individuals, by Charles Ricksher and C. G. Jung

Originally published in English in *Journal of Abnormal Psychology* (Boston), II (1907–8).

1. Statistical Details of Enlistment

Translated from “Statistisches von der Rekrutenaushebung,” *Correspondenz-Blatt für Schweizer Aerzte* (Basel), XXXVI (1906).

2. New Aspects of Criminal Psychology

Translated from “Le nuove vedute della psicologia criminale,” *Rivista di psicologia applicata* (Bologna), IV (1908).

3. The Psychological Methods of Investigation Used in the Psychiatric Clinic of the University of Zurich

Translated from “Die an der psychiatrischen Klinik in Zürich gebräuchlichen psychologischen Untersuchungsmethoden,” *Zeitschrift für angewandte Psychologie* (Leipzig), III (1910).

4. On the Doctrine of Complexes

Originally published in English in *Australasian Medical Congress, Transactions of the Ninth Session* [1911] (Sydney, 1913).

5. On the Psychological Diagnosis of Evidence: The Evidence-Experiment in the Näf Trial

Translated from “Zur psychologischen Tatbestandsdiagnostik: Das Tatbestandsexperiment im Schwurgerichtsprozess Näf,” *Archiv für Kriminologie* (Leipzig), C (1937).

BIBLIOGRAPHY

INDEX

I

STUDIES IN WORD ASSOCIATION

THE ASSOCIATIONS OF NORMAL SUBJECTS¹

by C. G. Jung and Franz Riklin

- [1] For some time past, attention has been paid in this clinic to the process of association. In order to produce scientifically useful material for this, my director, Professor Bleuler, has compiled a list of 156 stimulus-words and experimented with them on all types of psychosis. In these experiments a very considerable difficulty soon presented itself. There existed no means of precisely and quantitatively separating association in abnormal subjects from that in normal ones. No work had been done giving any facts on the range of normal subjects and formulating the apparently chaotic coincidences of association into rules. In order to fill this gap to some extent and thereby to pave the way for experiments on pathological associations, I decided to collect more material on association in normal people and at the same time to study the principal conditions involved. I carried out this plan with my colleague, Dr. Riklin.
- [2] The main experimental methods are as follows: Initially we collected associations from a large number of normal people, with the intention, first, of examining the reactions to see whether they are at all subject to any law; and, next, of discovering whether individual patterns occur, i.e., whether any definite reaction-types are to be found. We combined with this a second experiment of a general psychological nature.
- [3] The mechanism of association is an extraordinarily fleeting and variable psychic process; it is subject to countless psychic events, which cannot be objectively established. Among the psychic factors that exert the main influence on the mechanism of association, *attention* is of cardinal importance. It is the factor that in the first place directs and modifies the process of association; it is also both the psychic factor that can most easily be subjected to experiment and the delicate affective apparatus that reacts first in abnormal physical and mental conditions and thereby modifies the associative performance.
- [4] Attention is that infinitely complicated mechanism which by countless threads links the associative process with all other phenomena of the psychic and physical domain in consciousness. If we know the effects of attention on the process of association, then we also know, at least in general, the corresponding effects of every psychic event that attention is capable of affecting.
- [5] These considerations led us to investigate the effects of attention on the process of association, hoping to clarify as precisely as possible the following questions:

1. What are the laws governing the range of association in normal subjects?

2. What are the direct effects of attention on the association process? In particular, does the valency of the association decrease with the distance from the focus of consciousness?

[6] Our experiments have revealed a series of facts that not only encourage us to follow the paths on which we have set out into psychological regions but also, as we believe, fit us to do so.

C. G. JUNG

PART ONE

I. GENERAL EXPERIMENTAL PROCEDURE

[7] The experiments were carried out alternately by the two authors so that each one in turn undertook a series of experiments on the subjects concerned. Altogether thirty-eight people took part: nine educated men, fourteen educated women, seven uneducated men, and eight uneducated women; the age-bracket was 20–50 years. Care was taken to use, as far as possible, normal subjects for the experiment. This, however, led to unexpected difficulties, particularly with the educated subjects, as precisely on this level the concept of normality must be very elastic. Nevertheless we hope we have not deviated too far from the norm in our selection of subjects for experiment. We give the numbers of the subjects in detail and in many cases combine with this a short description of the personality, which will facilitate the understanding of possible anomalies. Naturally the two authors have also carried out the experiment on each other.

[8] In noting associations we have entirely limited ourselves to those produced by calling out stimulus-words. We used altogether four hundred different stimulus-words. These, grammatically classified, are as follows:

nouns	231
adjectives	69
verbs	82
adverbs and numerals	18

[9] The number of syllables was not taken into account (the stimulus-words have one, two, or three syllables). Nor were the stimulus-words arranged in definite categories as Sommer, for instance, has arranged them. On the contrary, as much care as possible was taken to see that stimulus-words of similar forms or meaning should not follow each other, so as to avoid the subject adapting to a particular topic after one or two reactions. Through an unfortunate coincidence it happened that among the first hundred stimulus-words there were about thirty that can easily be associated according to temporal or spatial co-existence; in the second hundred there are only about twenty of these, which caused a notable difference of the co-existence association in the first and second hundred. The shortage of stimulus-words of this kind is made up by verbs. It was considered important completely to exclude difficult and rare words, in order to prevent mistakes or lengthened reaction-time due to lack

of knowledge on the part of the subjects. The stimulus-words were therefore taken as far as possible from everyday life.

[10] This consideration was all the more essential for us, as with most of our subjects we had to work under somewhat abnormal linguistic conditions. In German-speaking Switzerland the vernacular consists, as is well known, of the Swiss-German dialect or dialects, which not only deviate considerably from standard German but also show significant phonetic differences among themselves. In the schools children learn standard German as if it were a foreign language. In later life educated people gain a fairly complete knowledge of and facility in the German language. The uneducated man, however, unless he has spent a considerable time in Germany, retains at best those German phrases that he has learned at school and later learns little or no more. Nevertheless, literary German is familiar to him in printed or written form and he also understands it as a spoken language without being able to speak fluent, correct standard German himself. We tried therefore in many cases to call out the stimulus-words in the dialect form, but we soon noticed that the uneducated subjects did not understand dialect words as well as standard German. They reacted to the dialect words more laboriously and tried to react in standard German. This somewhat paradoxical phenomenon can be explained by the fact that Swiss-German is a purely acoustic-motor language, which is very rarely read or written.

[11] Everything printed or written is in standard German. The Swiss is therefore not used to experiencing words individually but knows them only in acoustic-motor connection with others. If he has to say a single word without an article he will usually choose the standard German form. We therefore avoided dialect words completely in our experiments. In most cases a correct standard German reaction was given, but any reactions that were in dialect were fully accepted. The reactions were, of course, written down in the form in which they were given. To subjects who had never taken part in such experiments, their significance was first explained and practical examples of how they had to react were demonstrated to them. Not a few of the uneducated subjects thought that it was a kind of question-and-answer game, the point of which was to find an appropriate word connection to stimulus-words, e.g., *house / housecat, wild / wild cat*. The experiments were never started till it was certain that the subjects understood the experiment. We stress that a case of not understanding never occurred and that general lack of intelligence was much less disturbing than affects, particularly a fairly frequent emotional obtuseness. It is of some significance that many of the uneducated came with a certain "schoolroom" attitude and a certain correct and stiff demeanour.

[12] We organized our experiments as follows: The *first two hundred reactions* were noted without further conditions. The reaction-time was measured with a 1/5-second

stop-watch, which we started on the accented syllable of the stimulus-word and stopped on the uttering of the reaction.² We do not, of course, presume to have in any way measured complicated psychological times by this simple procedure. We were merely concerned with establishing a general idea of a roughly average reaction-time which is in many cases not without importance, being very often of value in the classification of reactions.

[13] After two hundred reactions, these were as far as possible classified, with the help of the subjects. With educated subjects this was always done; with uneducated subjects, who only rarely have any capacity for introspection, it was of course impossible. We had to limit ourselves to having the connection explained in particularly striking associations. The results of the experiment were divided into a first and second hundred and these were written down separately. During the experiment the psychic state of the subject was as far as possible established, both objectively and subjectively. If for any reason physiological fatigue occurred, we waited till the next day before doing the second experimental series. With the educated subjects fatigue almost never occurred during the first experiment, so that we could continue at once with the second series in nearly every case.

[14] The *second series of experiments* consisted of one hundred reactions which were recorded under the condition of internal distraction. The subject was asked to concentrate his attention as much as possible on the so-called "A-phenomenon" (Cordes) and at the same time to react as quickly as possible, i.e., with the same promptness as in the first experiment. By the "A-phenomenon" we understand, with Cordes,³ the sum of those psychological phenomena that are directly stimulated by the perception of acoustic stimulus. To establish whether the subject had observed the A-phenomenon he had occasionally to describe it after the reaction, and this was noted. On completion of this experiment new classifications were again made. Of course, for this experiment only educated people could be used and of these unfortunately only a selection, because it takes a certain psychological training to be able to observe attentively one's own psychic phenomena.

[15] The *third experimental series* was sometimes not carried out till the second day. It consisted of one hundred reactions and was based on the condition of external distraction. The distraction in this experiment was brought about in the following way: The subject had to make pencil marks of about one centimetre, in time with a metronome. The beat for the first fifty reactions was 60 per minute and for the second fifty reactions 100 per minute. The classification results of the first fifty reactions and the second fifty were recorded separately and for ease of calculation brought to one hundred. With a very few subjects the metronome was speeded up at every twenty-

fifth reaction in order to exclude an all too quick habituation. The beat was in these cases increased from 60 to 72 and from 100 to 108 per minute.

[16] The factor of habituation, in any case, unfortunately plays a large part in these experiments, as one would expect. Many people very quickly get used to a purely mechanical activity in which, in the second phase of the experiment, only the beat changes. It is difficult to introduce other disturbing stimuli of equal continuity and variability without adducing word-images, particularly when one does not wish to make too great demands on the intelligence and will-power of uneducated subjects.

[17] In trying to find a suitable disturbing stimulus we were above all intent on excluding that which might have had an excitatory effect on verbal imagery. We think we did exclude such effects by our experimental procedure.

[18] From these experiments three hundred to four hundred associations, on an average, were obtained from every subject. We also tried to supplement our material in other directions, in order to obtain a certain connection with Aschaffenburg's results, and for this purpose we took associations from some of our subjects in a condition of obvious fatigue. We were able to obtain such reactions from six subjects. Associations were also taken from one subject in a state of morning sleepiness after a night of undisturbed sleep, in which the factor of fatigue was completely excluded. With one subject associations were taken when he was in a state of acute moodiness (irritability) without fatigue.

[19] In this way we obtained about 12,400 associations.

II. CLASSIFICATION

1. GENERAL

[20] Anyone with practical experience of work on association has been confronted with the difficult and unrewarding task of classifying the results of the experiments. On the whole we agree with Cordes⁴ when he says that in earlier association experiments the false assumption prevailed that the fundamental psychological phenomenon corresponds to the stimulus-word and that the connection between stimulus-word and reaction is an "association." This somewhat too simple interpretation is at the same time too pretentious, for it maintains that in the connection between the two linguistic signs there is also a psychological connection (the association). We do not, of course, share this point of view but see in the stimulus-word merely the stimulus in the strict sense of the word and in the reaction merely a symptom of psychological processes, the nature of which we cannot judge. We do not, therefore, claim that the reactions we describe are associations in the strictest sense; we even wonder if it would not be altogether better to drop the word

“association” and talk instead of *linguistic reaction*, for the external connection between stimulus-word and reaction is far too crude to give an absolutely exact picture of those extraordinarily complicated processes, the associations proper. Reactions represent the psychological connection only in a remote and imperfect way. Thus, when describing and classifying linguistically expressed connections, we are not then classifying the actual associations but merely their objective symptoms, from which psychological connections can be reconstructed only with caution. Only in psychologically educated subjects is the reaction what it really should be—namely, the reproduction of the next idea; in all others a distinct tendency to construct something is mixed with the reaction so that in many cases it is the product of deliberation, a whole series of associations. In our association experiments we stimulate the language apparatus. The more one-sided this stimulus is, the greater the number of linguistic connections that will appear in the reaction. As we shall see, this is mainly the case with educated subjects, from whom a finer differentiation of psychological mechanisms, and therefore a greater ability for isolated application, can *a priori* be expected. One must therefore guard against the fallacious assumption that the educated subject has in any way more external associations of ideas than the uneducated.⁵ The difference will be a psychological one, as in uneducated subjects other psychological factors insinuate themselves. In the second part of this paper we shall refer to this difference.

[21] As long as we still know so little about the connection between psychic events, we must refrain from formulating the principles for a classification of external phenomena from inner psychic data. We have therefore confined ourselves to a simple logical classification, to which as a precaution it is in our view essential to limit oneself, till we are able to derive empirical laws from psychic associations.⁶ The logical principles of classification must also be adapted to the special experimental conditions, that is, to the verbal reaction. We must therefore, in classifying the associations, take into account not only the logical quality but also, if possible, all those external circumstances occurring as a result of this particular experimental design. The use of the linguistic acoustic brain mechanism naturally is not without influence on the associations. The purely intrapsychic association cannot become the object of another’s consciousness without being transformed into the familiar symbolism of language. Thus a completely new element is added to simple association, which exerts a great influence on the latter. In the first place, the results will be determined by the subject’s verbal facility; i.e., James Mill’s generally valid “law of frequency” directs the reaction even more selectively towards what one is accustomed to. Thus one of the chief principles of our classification will be that of verbal facility.⁷

[22] We proceeded with the classification of associations essentially according to the Kraepelin-Aschaffenburg scheme. We preferred this system to others because in our opinion it is heuristically the most valuable. When Ziehen describes the Kraepelin-Aschaffenburg attempt at classification as a failure, this is surely a rather strong term. No one will maintain that Aschaffenburg's classification is exhaustive; Ziehen would not want to claim that even for his own.

[23] Ziehen's classification has certainly opened up most valuable vistas, but it is itself not completely satisfactory. First of all, the differentiation between "jumping association" and "judgment association" is a very doubtful one, if it is completely dependent on the presence or absence of the copula, a fact which Claparède⁸ also strongly criticizes. The complete failure of Aschaffenburg's schema should first be proved, but this has in fact not been done; on the contrary, the results based on this classification are very encouraging, so that at present one can still venture to use it, although bearing in mind its one-sidedness. The other schemas of classification are, however, biased in other ways. The criticism that Aschaffenburg's schema is biased on the side of logic is not valid, as it makes sufficient allowance for logical data as well as for sensual and perceptual connection, and also for the linguistic factor. Faced with reactions in the form of sentences, however, the schema is more or less powerless. On the other hand it must be stressed that with normal subjects sentences occur very rarely. One factor of great practical significance deserves to be stressed. Aschaffenburg's schema has been tested on a great deal of material, part of it pathological, and has proved itself of value. His *conditio sine qua non* is not the subsequent questioning of the subjects about the reaction phenomenon, as in the schemas of Ziehen, Mayer and Orth, and Claparède; it also allows at least an approximately correct classification without the help of the subject, which is of particular importance in psychopathological experiments.

[24] As we regard this work merely as a preliminary to psychopathological experiments, we have not hesitated to give preference to Aschaffenburg's schema. Those of Münsterberg and Bourdon appear to us as too much weighted on the side of logic; Ziehen's criticism of these, that they are unpsychological because they abstract completely from the context, is valid. Claparède's extremely subtle and penetrating suggestion (p. 226) does, however, deserve serious consideration, but should perhaps first be used on a wider range of material to test its application in practice.

[25] In attempting the classification of acoustic-verbal associations one must never forget that one is not examining images but their verbal symbols. The examination of associations is an indirect one and is susceptible to numerous sources of error caused by the great complexity of the process.

[26] In our experiments we examine the resultant of an appreciable number of psychological processes of perception, apperception, intra-psychic association, verbal comprehension, and motor expression. Each of these activities leaves its traces in the reaction. In view of the great psychological significance of motility, particularly of the speech function, one must attribute above all a main role to linguistic facility. It is mainly this factor that is to be considered in classification. This principle of classification can be criticized for introducing an extremely variable and indeterminable magnitude into the calculation. We must admit that verbal facility is an extremely variable magnitude and that in an actual case it often causes difficulties, and that therefore the logical character of the classification also suffers. It introduces an arbitrary element into the classification that one would like to avoid. But, for the reasons stated above, we have nevertheless, *faute de mieux*, decided on this mode of classification, taking as a guiding line certain empirical rules that we shall discuss later.

[27] By these restrictions and a thorough consideration of the subject, we hope to have avoided being arbitrary in applying this principle.

[28] In the following nomenclature (flight of ideas, associations etc.,) it must be remembered, after what has just been said, that by this we mean primarily speech-phenomena from which we have allowed ourselves to make deductions about psychological events. Here we are fully aware that we are examining a relatively limited area, that is, associations that are for the most part reflected in the speech mechanism. Thus, when we speak of “flight of ideas,” we mean by this the speech phenomenon that is an external manifestation of internal processes. Of course, the psychological event is not necessarily reflected *in toto* in the form of word associations, but is only expressed in linguistic signs of that type when it affects the speech mechanism. In the flight of ideas, the actual thinking would naturally present a totally different picture if it could manifest itself directly. Thus, for example, the flight of ideas resulting from predominantly visual parts of images constitutes a special aspect that can hardly manifest itself adequately enough and is therefore hardly accessible to external examination; particularly in mania, it will as a rule not be accessible to examination, because of the linguistic agitation. We shall find an opportunity in a later publication⁹ to discuss the visual form of flight of ideas.

2. SPECIAL CLASSIFICATION

A. *Internal Association*¹⁰

[29] (a) GROUPING. We classify under this heading all associations connected by coordination, superordination, subordination, or contrast. The perusal of the cases in

question leads to the following special classification of co-ordinations:

- [30] (α) *Co-ordination*. The two parts are linked by a similarity of content or nature; i.e., a general idea, in which both parts are contained, underlies them. Examples:

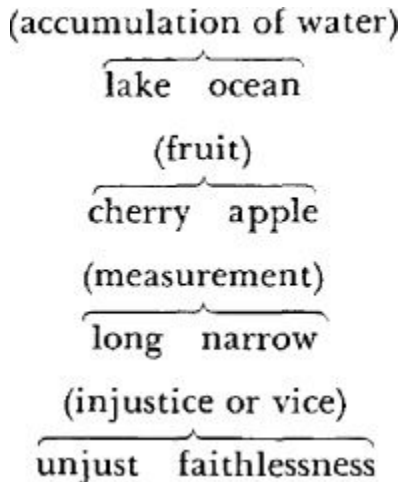

- [31] Association by co-ordination must take place within the framework of a clear-cut common general concept, but may be the result of more or less vague similarity. The similarity may be very great, so that only a nuance prevents it from being identical, e.g., *to forbear / leniency*. The similarity can also be very remote, so that the common meaning of the two concepts is not an essential one but a more or less coincidental attribute of the stimulus-image. In such cases the reaction appears very loosely connected with the stimulus-word and thus is distinguished from other co-ordinations. The distance of the association is, as it were, greater. Therefore these co-ordinations can to some extent be separated from those already discussed. In the loosely connected associations two categories can be distinguished:

(1) The stimulus-image is linked to the reaction by a meaningful but otherwise coincidental attribute, e.g.:

father (worried)	worry
play (of child?)	youth
War (peace-league)	Bertha v. Suttner ¹¹
murderer (to hang)	gallows
sentence (contains something)	content
star (romantic, night?)	romanticism

(2) The stimulus-image is linked to the reaction by an unessential, external, mostly quasi co-existent attribute, e.g.:

pencil (long)	length
sky (blue)	colour
sea (deep)	depth
table (particular shape)	style

[32] These two modes of co-ordination may be called “the connection of images according to internal or external kinship.” The first category contains by far the more significant co-ordinations, and justifies to some extent the terms internal and external. The co-existence of attributes in the second category indicates that the formation of these co-ordinations is due to external association.

[33] As a last category of co-ordination we should like to propose “co-ordination through example.” This category primarily contains reactions that are nothing but the inversions of the two previously discussed patterns:

worry	father (e.g., of the father)
content	sentence (e.g., of the sentence)
colour	sky (e.g., of the sky)
misery	old woman (e.g., an old woman is in misery)

[34] Now, there is a series of reactions to adjectives and verbs which, although it is true that they are not grammatically coordinated to the stimulus-word, can nevertheless perhaps best be grouped with co-ordinations, particularly those of the examples:

to give in	peace-loving
to pay attention	clever man
to despise	wickedness
foreign	emigrant
to pray	pious man
to help	good man

[35] These associations can, if the expression be permitted, be called analytical; they are conceptions that are given, so to speak, implicitly with the stimulus-word to which they have been subordinated or superordinated. But as it is difficult, if not impossible, to distinguish this relationship with certainty in concrete cases, and as in addition the concept of the whole and the part cannot be applied to adjectives and verbs, we count these reactions also as co-ordination through example, inasmuch as among the possible nouns certain typical ones always appear in the reactions. The reactions in these cases are always extremely general and closely dependent on the stimulus-word.

[36] The special classification of the co-ordinations would then be as follows:

- (1) by common general concept
- (2) by similarity
- (3) by internal relationship
- (4) by external relationship
- (5) by example

Examples

(1) father	uncle
(2) father	God
(3) father	worry
(4) father	our house
(5) to pay attention	clever man

[37] It must be added that with these examples the rich variety of co-ordinations is by no means exhausted. With individuals who associate intensively according to subjective constellations, a whole series of different co-ordinations, which cannot really be placed in any of these categories, is possible. In these cases one can safely admit one's inability and simply content oneself with the classification "co-ordination." One can console oneself with the idea that the individual possibilities are innumerable and that no schema could ever be invented that would make possible a clear-cut classification of all associations. But there is a number of co-ordinations that could without undue strain be placed under different headings, i.e., they have no clearly defined character; one can either leave it at that or perhaps group these reactions with the type they most resemble. The headings set out above are not meant to be absolute, compulsory categories, but merely a name for empirically found types which, on occasion, however, may merge into each other without sharp boundaries. More must not be expected in our present state of knowledge of association.

[38] (β) *Subordination*. The reaction is considered as a part or a minor (subordinated) concept of the stimulus-word, e.g.:

tree	beech
------	-------

[39] Here we include all reactions that specify the stimulus-word, i.e., that represent special instances of the general stimulus-concept, e.g.:

house	house on X street
horse	Mr. X's horse
railway station	Baden

[40] In some cases there may be doubt whether the association should be considered as subordination or as predicate, e.g.:

food	today's (viz., food)
------	----------------------

[41] (γ) *Superordination*. The reaction is considered as the whole or general concept of the stimulus-word, e.g.:

Ofen ¹²	town
cat	animal

Here too the separation from the predicate is difficult, e.g., *thirteen / unlucky number*. Is *unlucky number* in this case a general concept and as such includes thirteen with other unlucky numbers? In our opinion there is a predicate here; on the other hand we would include Aschaffenburg's association *baptism / ancient custom* as a superordination, as *ancient custom* is a general concept that includes many other subordinate concepts.

[42] (δ) *Contrast*. The concept can be understood without difficulty. The classification and evaluation of the contrasts is much more difficult, however. Contrasts are as a rule very closely associated images, not only conceptually but also perceptually and above all linguistically. There are even languages in which only one and the same word exists to express typical contrasts. It must have been a considerable psychic achievement in the beginning of language and conscious thought to separate contrasts in speech and concept. Today, however, we have these ancient achievements in thought already formulated in the language; they are taught to us from earliest youth together with the first concepts of speech, with the first songs and reading material. We are verbally very practised in these closely connected concepts, which are very often supported by quotations and rhymes; e.g.:

sorrow	joy
pain	pleasure
good	bad
sour	sweet
light	dark

Sauersüß and *helldunkel*¹³ are even colloquial words in German. For these reasons we have grouped a large number of common contrasts with external associations. Here we only count associations that are not current, such as:

friendly	angry
good	sinful
animal	plant
sense	stupidity
vengeance	to forgive

[43] In spite of this detailed classification of the groupings there are still associations that cannot be put into any of the subgroups. For these there remains simply the general term "coordination," e.g., the association *high / silk*. The stimulus-word *high* [German *hoch*] has been understood as a proper name; the bearer of this name [Hoch] has a silk shop; hence the reaction *silk*. This cannot be merely a case of co-existence; the reaction consists of two specific images that are spatially co-existent; it is therefore a rather complicated formation. One could perhaps place it under the heading "co-ordination through external connection," though admittedly on slight

evidence. Therefore it is safest, for the moment, to admit that such co-ordination cannot be further classified.

[44] Summarizing, we arrive at the following schema:

Grouping	{	(a) Co-ordination:	(1) by a common general concept
			(2) by similarity
			(3) by internal relationship
			(4) by external relationship
			(5) by example
		(β) Subordination:	(1) Actual subordination
	(2) Specification		
		(γ) Superordination	
		(δ) Contrast	
		(ε) Groupings of doubtful quality	

[45] (b) PREDICATE. We include here, in agreement with Aschaffenburg, all judgments, properties, and activities that in any way refer to the stimulus concept as subject or object (summarized by Kraepelin under the name “predicative relationships”).¹⁴

[46] It is well known that Kant divides judgments into analytic and synthetic.¹⁵ This principle of logical classification is of value to us only in so far as, in an analytic judgment, a part of the concept (i.e., a predicate) is presented that is necessarily inherent in the concept. Thus only that is given which already implicitly exists. But in the synthetic judgment something is added to the concept that is not necessarily already contained in the concept. As regards associative performance the synthetic judgment is in a way superior to the analytic. If we approach this question practically, we find (in so far as this method of classification can in practice be applied at all) that in simple judgment-reactions the analytic judgment exists mainly in the naming of a co-existent perceptible attribute, while the synthetic judgment is mostly a value judgment with a more or less marked ego-reference. Thus we see here a relationship analogous to that between “co-ordination by external relationship” and “co-ordination by internal relationship.” In the association *pencil / length*, *length* is essentially contained in the concept or is co-existent, while in *father / worry* the concept *worry* adds something new and therefore causes a shifting of concept. We should readily accept the grouping of judgment-reactions into analytic and synthetic if there were not a considerable practical difficulty: we have no way of knowing in the individual case whether the analytic predicate is an essential part of the concept or not. One can only attempt to decide this question if one can differentiate in individual cases between a concrete and an abstract concept. We know that Ziehen considers that he has done this by direct questioning, even of children. We not only consider this method most unreliable, but also find the distinction between concrete and abstract concepts particularly difficult. If I give a name to a mental picture, then the picture consists of a condensation of many memories, whose more concrete or

more abstract aspect depends on minimal differences of perceptual vividness. In many cases even psychologically educated people would be at a loss if they had to decide whether, for example, in *house / roof* they had visualized a concrete or an abstract roof. Of course we are far from denying the existence of abstract concepts; but in concrete cases of acoustic-verbal experiments we cannot help suspecting that the so-called abstract concepts are merely words that lack individual content, only not so much because they are abstract concepts as that they are mostly linguistic formations of a motor kind, in which the other sense-impressions participate only very slightly.

[47] For the answer to the question whether we are faced with an analytic or synthetic judgment we should have to know exactly whether the thought was concrete or abstract: e.g., *snake / green* is objectively entirely synthetic. It is not necessary to think of *green* together with *snake*; only in the case of the image of a definite snake must green be already implicit, in which case it would be an analytic judgment. Apart from these reservations, there are other, mainly practical, difficulties which interdict this mode of classification.

[48] In order to arrive at a special classification of the predicate we must consider the different possibilities:

- (1) The stimulus-word is a noun, the reaction an adjective.
- (2) The stimulus-word is an adjective, the reaction a noun.

[49] We have no reason to separate these two cases, any more than the other forms of predicative connection:

- (1) The stimulus-word is the subject, the reaction its active or passive activity.
- (2) The stimulus-word is the active or passive activity of the reaction. Or:
- (3) The stimulus-word is the object, the reaction is the activity referring to it.
- (4) The stimulus-word is an activity, the reaction is its object.

[50] Let us consider the first forms: the predicative connection of noun and adjective. Two main possibilities are to be distinguished:

[51] (α) The adjective describes an essential and internally meaningful characteristic of the stimulus-image. One can call this type of predicate “internal.” It can easily be divided into two groups:

(1) Objective judgment, e.g.:

snake	poisonous
glass	fragile
mild	spring
thirst	intense

war
grandmother
winter

bloody
old
raw

These predicates describe an essential and meaningful addition to the stimulus. Their purely objective character distinguishes them from the second group:

(2) Value judgment, e.g.:

father	good
to stink	unpleasant
to ride	dangerous
mountain	beautiful
book	interesting
pupil	good
soldier	brave
wood	useful
murderer	base
water	refreshing

In these reactions the personal element is more or less prominent; but where the ego-reference is clearly expressed in the form of wish or rejection, one can speak directly of “egocentric predicates.” We do not however want to separate such reactions from value judgments as a distinct group, for reasons stated below. We also count the following as value judgments:

iron	useful metal
water	one of the most interesting chemical substances
scoundrel	disgrace

[52] Value judgments expressed in the form of an activity, e.g.:

smoke	stinks
apple	tastes nice

are best placed with the predicates.

[53] We also count as value judgments reactions in which a value is not stated but demanded, e.g.:

good	one should be
diligent	the pupil should be
to threaten	one must not

[54] Such reactions are not frequent in normal subjects; we merely mention them for the sake of completeness.

[55] (β) The adjective refers to an external, less significant, possibly co-existent, and perceptible characteristic of the stimulus. For this type of predicate we should like to use the term “external”:

tooth	protruding
water	wavy
tree	brown
exercise-book	blue
salt	granular
etc.	

[56] We assess the predicate-relation between adjective as stimulus-word and noun as reaction according to the principles explained above. Thus, in classifying, we evaluate *green / meadow, meadow / green*, as more or less equivalent.

[57] Aschaffenburg has with some reason considered interjections as predicates, but we have interpreted them differently (see below).

[58] A further sub-group of predicates is made up of the “relationships of noun and verb.”

[59] (α) *The subject relation.* The noun as the stimulus-word or the reaction is the subject of a definite activity:

resin	sticks
hunter	to shoot
to cook	mother

[60] (β) *The object relation.* The noun as the stimulus-word or the reaction is the object of a definite activity:

door	to open
to recruit	soldiers
to clean	brass
throat	to strangle

[61] The predicates so far discussed cannot easily be distinguished from the above-mentioned “co-ordination by example,” if the attributive part is the stimulus-word. For this diagnosis we consider decisive the subject’s evident effort to find a reaction-word (i.e., a noun) as appropriate as possible to the stimulus-word and with a general validity, as in:

to pray	pious person
to despise	wickedness
to give in	peace-loving

Thus we count *to clean / brass* as an object relation and *to clean / shining metal* as co-ordination by example.

[62] Specifications of place, time, means, and purpose are somewhat loosely connected with the group of predicates (Ranschburg's¹⁶ "end-defining association").

<i>place:</i> to go	into town
<i>time:</i> to eat	12 o'clock
<i>means:</i> to beat	with a stick
<i>purpose:</i> wood	for burning

[63] One can sometimes, with these reactions, be in doubt about whether perhaps they are to be interpreted as specification and therefore belong to subordinations. But in most cases the decision will be easy, so that error will not be too great. Definitions or explanations of the stimulus-word, which in general occur very rarely, have a certain connection with the group discussed above, for which reason they too have been placed in the group of predicative relations. Examples:

door	noun
blue	adjective
star	heavenly body

[64] The predicative relations are thus made up of the following groups:

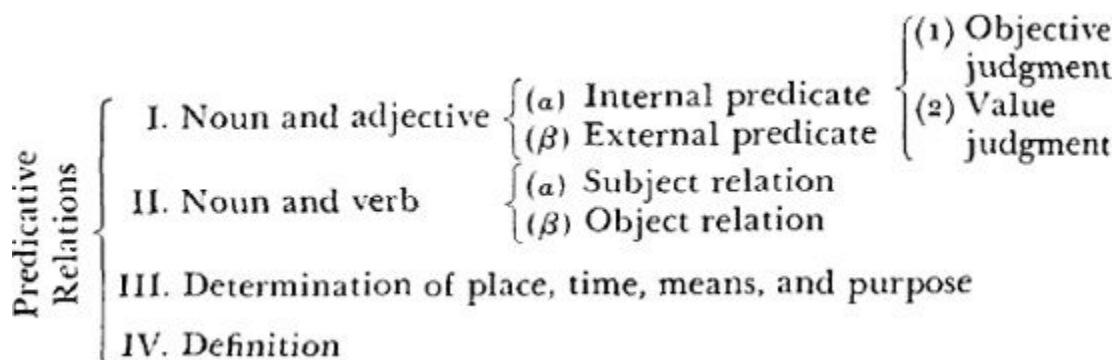

[65] (c) CAUSAL RELATIONSHIP (Münsterberg). Stimulus-word and reaction are linked by a causal connection. Examples:

pain	tears
to cut	painful

B. External Associations

[66] (a) CO-EXISTENCE. The connection of co-existence is *contiguity or simultaneity*, i.e., the link between the two concepts is not exclusively similarity or affinity but also temporal co-existence or immediate succession. Spatial co-existence is included in temporal contiguity as spatial co-existence results from succeeding sense-impressions. Examples:

ink	pen
-----	-----

exercise-book
table
Christmas
Sunday
pupil
table
lamp
mother
institution

knife
soup
Christmas tree
church
teacher
chair
family
child
warder

We also include here reactions like:

to ride	horse	to ride	saddle
eye	to see	ear	to hear
pencil	} to write		
paper			
exercise-book			
to sing			
to calculate			
school			

The associations with *to write* are complexes of school-memories, the connection of which is conditioned by simultaneity; the other examples concern reactive images associated with the stimulus images by co-existence.

[67] (b) IDENTITY. The reaction contains no shift or development of the sense, but is a more or less synonymous expression for the stimulus-word.

[68] (α) The synonymous expression is taken from the same language as the stimulus-word. Examples:

grand	magnificent
to pay attention	to take notice (in Swiss-German usage, essentially synonyms)
to squabble	quarrel

[69] (β) The synonymous expression is taken from a language other than the stimulus-word, i.e., it is a *translation*. Examples:

stamp	timbre
Sunday	dimanche

[70] (c) LINGUISTIC-MOTOR FORMS. (Ziehen:¹⁷ “Current word-compounds and associative word-complements.” Kraepelin-Aschaffenburg:¹⁸ “Linguistic reminiscences.” Trautscholdt:¹⁹ “Word association.”) In this sub-group of external associations we collect together all connections of images, which have been canalized through verbal practice, although logically and historically they may have a different meaning and therefore could be put into one of the types mentioned above.

In dealing with *contrasts* we have already mentioned a series of reactions that we interpreted as being of such common verbal practice as to be canalized. We classify them as

[71] (α) *Canalized verbal associations.*

(1) Simple contrasts. Examples:

dark	light
sweet	sour
white	black
like	unlike

(2) Current phrases. Examples:

hunger	to suffer
house	and home ²⁰
of age	to come
goods	and chattels ²¹
thanks	to give
gallant	to be
trials	and tribulations
world	and people
old	frail
right	to do
to come	(and) go
place	time
something	more
force	to apply
bread	to earn
head	to bow
bird	bush
water	to drink
to swim	to be able to
tram	to ride
to go	for a walk
revulsion	to arouse
cat	mouse
to break	the news

[72] (β) *Proverbs and quotations.* Examples:

everywhere	and nowhere
liberty	equality
everywhere	I am at home
eye	tooth
do's	and don'ts

war
more
meat

and peace
light²²
drink

[73] (γ) *Compound words.*

(1) The reaction-word complements the stimulus-word and forms a compound word. Examples:

table	leg
needle	case
mat	hanging ²³
piano	player
vengeance	to thirst for
frog	blood ²⁴
book	marker
head	scarf
tooth	ache
institute	women's

The reaction may also be such that the stimulus-word is repeated in the reaction, e.g.:

tears	tear duct ²⁵
to knock	to knock at
to hear	to hear out ²⁶
foot	football ²⁷
star	starlight
sweet	sweetmeat

(2) The reaction is essentially only a grammatical variation of the stimulus-word (Wreschner:²⁸ "Association with inflexional form").

to die	dead
kindling	to kindle
to hammer	hammer
school	scholar
to find	found
love	to love
cab	cabby
murderer	to murder

[74] (δ) To this should be added a small group of reactions that can be termed anticipatory. Examples:

dark red	light
slow	short
grandiose	small

[75] (ε) Interjections, which only rarely occur, have been placed in the category of “linguistic-motor connections” although, as Aschaffenburg stresses, they represent a predicate. We justify our interpretation by pointing out the highly imperfect linguistic form of the reaction, which moreover contains a very strong motor component. Examples:

grand	ah!
to stink	pooh!
to love	oh!

C. Sound Reactions²⁹

[76] The content of this group corresponds to Aschaffenburg’s group of “stimulus-words acting only by sound.”

[77] (a) WORD COMPLETION. We interpret these words in agreement with Aschaffenburg, only including here reactions that together with the stimulus-word, form an indivisible word. Examples:

wonder	-ful
love	-ly
modest	-y
friend	-ly

We also consider addition to the stimulus-word, to form a name, as word-completion. Example:

Canter	-bury
Winter	-bourne ³⁰

[78] (b) SOUND. The reaction is conditioned solely by the sound of the whole stimulus-word or its beginning.³¹ Examples:

enchain	enchant
mercenary	merciful
intention	intestine
to roast	roast beef
humility	humidity

[79] (c) RHYME.³² Examples:

dream	cream
heart	smart
leave	grieve
king	ring
crank	plank

[80] To divide sounds and rhymes into “meaningful and meaningless,” as Aschaffenburg does, is not worthwhile, owing to the rarity of the “meaningless” ones. We have therefore refrained from doing this.

D. Miscellaneous

[81] This not very large group comprises reactions for which no place can be found in the rest of the schema, but which have only a very limited connection with each other.

[82] (a) INDIRECT ASSOCIATION. Aschaffenburg, as is well-known, contrasts the indirect mode of reaction with all other reactions, which he regards as “direct” ones. We have rejected this quantitatively most disproportionate contradistinction, because with uneducated subjects one can never know how many different contents of consciousness stand between stimulus-word and reaction. We cannot even *ourselves* always state how many conscious, half-conscious, or unconscious constellations affect our reactions. We will not enter here into the academic controversies about indirect association (that is, whether the intermediate link is conscious or unconscious) but confine ourselves to stating the phenomenon of the indirect mode of reaction within the framework of our cases. We call “indirect association” that mode of reaction that is intelligible only on the assumption of an intermediate link different from the stimulus-word and the reaction. We distinguish five forms:

[83] (α) Connection by common intermediate concept. Examples:

<p style="margin: 0;">white far └──────────┘ snowfield</p>	<p style="margin: 0;">dozen 144 └──────────┘ heap</p>
<p style="margin: 0;">false blonde └──────────┘ Miss X is false and blonde</p>	<p style="margin: 0;">turbid shallow └──────────┘ water</p>
<p style="margin: 0;">repentance black └──────────┘ mourning</p>	<p style="margin: 0;">red scent └──────────┘ flower</p>
<p style="margin: 0;">to close round └──────────┘ to turn</p>	<p style="margin: 0;">bicycle round └──────────┘ wheel</p>
<p style="margin: 0;">to disgust odourless └──────────┘ to stink</p>	<p style="margin: 0;">to walk pear └──────────┘ under pear-trees</p>
<p style="margin: 0;">fast to whistle └──────────┘ locomotive</p>	<p style="margin: 0;">to turn earth └──────────┘ to rotate</p>
<p style="margin: 0;">hay green └──────────┘ grass</p>	<p style="margin: 0;">rich 5-franc piece └──────────┘ roll of money</p>

[84] It must be noted that in these associations the intermediate link is usually clearly conscious. Such reactions are very rare and occur almost entirely in individuals of markedly visual type.

[85] (β) *Centrifugal sound-shift* (Aschaffenburg's "paraphasic indirect association"). There is an inner reaction that is to a greater or lesser extent clear and meaningful, which, however, in the process of articulating it, is replaced by a canalized association with a similar sound. We therefore designate this group of indirect associations as "centrifugal sound-shift." Examples.³³

decision to slide (to decide)	to dress excessive (overcoat)
stubborn foolish (mulish)	society unit (union)
to quarrel to shoot (dispute)	earth house (heap)
hair blue (blonde)	medal fastness (fastened)
sacrifice to castrate (casket, sacristy)	love crate (hate)
ears typhus (tubes)	pair hoot (boot)

[86] Cordes wants to exclude these reactions from the indirect ones, admittedly, from his point of view, with some justification. The direct inner association appears to be a genuine association and not a sound reaction; so there exists an entirely appropriate and direct intention which, however, at the moment of enunciation, is shifted towards a similarity of sound to the detriment of the meaning. Such shifts can only occur when the inner image to be expressed does not command the intensity of attention necessary to set going the appropriate speech-mechanism. Deviations into by-ways only occur when what has to be enunciated is not intense enough, i.e., it does not reach a sufficient degree of consciousness. Therefore we also assume that, in spite of correct intention, the intermediate link has remained abnormally obscure, which agrees completely with the accounts of subjects who can observe themselves. Some had no more than a feeling that they had not said the right thing, without being able to point to the intermediate link. Whether in such cases the shift towards similarity of sound occurs at the sending station or the receiving station seems to us irrelevant to the evaluation of the reaction.

[87] (γ) *Centripetal sound-shift*. The stimulus-word is internally replaced by a sound similarity, which in its turn determines the reaction. Usually the intermediate link is in that case half-conscious or unconscious. It must be noted that in all cases here

classified the stimulus-word has been correctly understood, so that it is not merely a case of misunderstanding. Examples.³⁴

to ride slip (slide)	lazy mist (hazy)
to wallow bird (swallow)	to rust fair (just)
strong sin (wrong)	room to caw (rook)
malt pepper (salt)	stroke cigar (smoke)
politics hefty (policeman)	to wallow throat (swallow)
stroke knot (string)	to love turtle (dove)
to hit to bite (to smite)	pleasure tape (measure)
malt vinegar (salt)	

[88] In our experience by far the largest number of indirect associations are shifts through sound similarity. What we have said in the preceding paragraph about the consciousness of the intermediate links also applies here. The occurrence of a sound association points to a stimulus-word with an inadequate feeling-tone.³⁵ Reaction to the intermediate sound-link is likewise a result of insufficient feeling-tone of the stimulus-word. In this case the sound association is, in our experience, as indistinct as the stimulus-word, and at first the subject is even unsure of the kind of stimulus-word. The reaction is innervated before the act of apperception has taken place.³⁶

[89] (δ) *Centrifugal and centripetal shift through word-completion or linguistic-motor association.* Examples:

standard filter (solution)	head block (blockhead)
false faithfulness (faithful)	angel heart (hard)
rats poisonous (poison)	clean flea (unclean)
to cook coachman (the cook)	painter beautiful (painting)
avarice patient (pathological)	lockjaw teeth (jaw)
armlet foot (arm)	permanently to certify (deranged)

horrible grey
(gruesome)
look-out strike
(lock-out)

to roll round
(roller)
fox finger
(foxglove)

[90] (ϵ) *Shift by several intermediate links.* The intermediate links may be associations that are mechanical yet of high valency. The reactions in this category are very rare and are mostly of abnormal origin. All the types described above can of course be found among these reactions. Examples:

ink	acid
(red	litmus)
bird	mouse
(flutter	bat [<i>Fledermaus</i>])
lithe	big
(lice	small)
revenge	rector
(right	rectify)
tough	headache
(tooth	ache)

[91] We shall not at present look further into the theory of indirect association in acoustic-verbal experiments. For the moment let us simply say that these associations are closely connected with variations in concentration.

[92] (b) MEANINGLESS REACTIONS. In moments of emotion or embarrassment reactions are sometimes given that are not words or are not associations.

[93] We of course separate assonances as sound reactions from mere sounds. Among the non-associated words there are hardly any of inexplicable origin. They are mostly names of objects in the surroundings or of coincidental concepts that are not connected with the stimulus-word. Some nonsense reactions are perseverations of type b (see below).

[94] (c) FAILURES. The absence of a reaction we call a failure. The cause of the failure is usually emotional.

[95] (d) REPETITION OF THE STIMULUS-WORD. A very small group that could equally well be put into the category of failures! There are, however, normal individuals who cannot help quickly repeating the stimulus-word to themselves and then giving the actual reaction, a phenomenon that can be observed outside the experiment in ordinary conversation. This reaction is not included in any of the normal categories. Repeating the stimulus-word is, in any case, also an emotional phenomenon (Wreschner³⁷ is of the same opinion).

[96] This completes the specific classification of associations. There remain only a few general points that help to clarify the types of association.

E. The Egocentric Reaction

[97] It is striking that certain individuals tend to form ideas of reference during the experiment; that is, to give highly subjective judgments that are clearly influenced by wish or fear. Such reactions have something individually characteristic and are indicative of certain personalities.

[98] (a) DIRECT IDEAS OF REFERENCE. Examples:

grandmother	I
to dance	I don't like
unjust	I was not
praise	for me
to calculate	I cannot

[99] (b) SUBJECTIVE VALUE JUDGMENTS. Examples:

to be lazy	pleasant
to calculate	laborious
blood	gruesome
piano	horrible
love	stupid

F. Perservation³⁸

[100] By perseveration we understand a phenomenon³⁹ that consists in the fact that the preceding association conditions the next reaction. We have made it a rule to consider the effect on only the immediately following reaction. Thus we have excluded an effect that bypasses uninfluenced reactions; we prefer to consider this type of effect under the general heading of constellation. Here we do not want to be prejudiced about the nature of the phenomenon of perseveration. We must point out, however, that perseveration may be caused by psychophysical factors at present unknown as well as by specific feeling-constellations. In practice, two cases of perseveration are to be distinguished:

[101] (a) The reaction is an association to a previously used stimulus-word. Examples:

winter	skates
lake	ice
to melt	hot
slow	fire
water	fall
to dance	to fall

[102] (b) The reaction is not an association to a previously used stimulus-word.
Examples:

lid — box
rats — basket
softly — she comes along
gallant — up the steps

[103] If at the moment of the experiment consciousness is dominated by a strongly feeling-toned complex, then a longer series of heterogeneous stimulus-words will be absorbed into the complex, each reaction being influenced by stimulus-word and complex-constellation. The more powerful the complex-constellation, the more the stimulating image is liable to assimilation (Wundt), i.e., it is not comprehended in its actual and usual sense but in the special sense adapted to the complex.

G. Repetition

[104] In each experiment the same reactions were counted; the first and second hundred of the associations in normal subjects were counted separately. One could perhaps differentiate between repetition of content and of particular stylistic form. Since in normal subjects particular stereotype-reactions constructed with auxiliary words are extremely rare, we have decided not to count repetitions of form.

H. Linguistic Connection

[105] It is a striking fact that associations are linked to each other not only by meaning (i.e., the principles of *association*, *contiguity*, and *similarity*) but also by certain solely external motor-acoustic properties. To my knowledge Bourdon was the first to tackle this question experimentally. In his remarkable work “Recherches sur la succession des phénomènes psychologiques,” he describes investigations into the phonetic linking of association. Bourdon noted, from the top of every page in books chosen at random, the first noun, adjective, or verb. In this way he compared five hundred pairs of words. The total of phonetically similar pairs was 312, assuming a phonetic similarity if the words have one or more phonetic element in common. It must be noted, however, that Bourdon interpreted this similarity somewhat widely, e.g., *toi* and *jouer* because of the “w” sound! Bourdon examined especially the *ressemblance phonétique*, *graphique* (one or more common letters), and *syllabique* (a common syllable). He found the following comparative figures:

Ressemblance phonétique:	0.629
“ graphique:	0.888
“ syllabique:	0.063

[106] Bourdon finds: “Il reste néanmoins vrai, que les mots s’associent entre eux plutôt par leur signification que par leur ressemblance phonétique.”

[107] In accordance with these investigations, we have assembled a group that contains external linguistic factors.

[108] (a) THE SAME GRAMMATICAL FORM. We simply counted how often the form of the word was the same in the stimulus-word as in the reaction, that is how often noun / noun, adjective / adjective occurred together. We arrived at this question because we had observed that large individual variations exist.

[109] (b) THE SAME NUMBER OF SYLLABLES. We counted how often the stimulus-word and the reaction contain the same number of syllables, with the object of finding out more about the influence of rhythm.

[110] (c) PHONETIC AGREEMENT.

(1) *Consonance*. We counted how often the first syllable of the stimulus-word and of the reaction agreed at least as regards the vowel.

(2) *Alliteration*. Here we noted how often the stimulus-word and the reaction alliterated in the first vowel or consonant.

(3) *The same ending*. Here we examined the phonetic influence of the ending of the stimulus-word on the ending of the reaction, that is, the tendency to rhyme. Here we only noted whether the final syllables tallied.

SUMMARY

[111] A. *Internal Associations*

(a) Grouping

(α) Co-ordination

(1) By common general concept

(2) By similarity

(3) By internal relationship

(4) By external relationship

(5) By example

(β) Subordination

(1) Actual subordination

(2) Specification

(γ) Superordination

(δ) Contrast

(ϵ) Groupings of doubtful quality

(b) Predicative relationship

I. Noun and adjective

(α) Internal predicate

(1) Objective judgment

(2) Value judgment

(β) External predicate

II. Noun and verb

(α) Subject relationship

(β) Object relationship

III. Determination of place, time, means, and purpose

IV. Definition or explanation

(c) Causal relationship

B. External Associations

(a) Coexistence

(b) Identity

(c) Linguistic-motor forms

(α) Canalized verbal associations

(1) Simple contrasts

(2) Current phrases

(β) Proverbs and quotations

(γ) Compound words and word-changes

(δ) Anticipatory reactions

(ϵ) Interjections

C. Sound Reactions

(a) Word-completion

(b) Sound

(c) Rhyme

D. Miscellaneous

(a) Indirect associations

(α) Connection by common intermediate concept

(β) Centrifugal sound-shift

(γ) Centripetal sound-shift

(δ) Shift through word-completion or linguistic-motor form

- (ε) Shift through several intermediate links
- (b) Meaningless reactions
- (c) Failures
- (d) Repetition of the stimulus-word

E. The Egocentric Reaction

- (a) Direct ideas of reference
- (b) Subjective value judgments

F. Perseveration

- (a) Connection with a [previous] stimulus-word
- (b) No connection with a [previous] stimulus-word

G. Repetition of the Reaction

H. Linguistic Connection

- (a) The same grammatical form
- (b) The same number of syllables
- (c) Phonetic agreement
 - (1) Consonance
 - (2) Alliteration
 - (3) The same ending

[112] We have classified our material according to the principles laid down in the schema. In order not to complicate the presentation of the results unnecessarily by a plethora of figures, the graphs published in [Part Two](#) reproduce only the figures of the main groups, allowing the extensive material to be grouped more clearly than with a detailed report of the figures for all the sub-groups. For reasons of scientific integrity we considered ourselves obliged to give an exact account of the kind of consideration that led us to the classification of the associations in one or other main group. Also it seemed to us of general interest to state the different empirical possibilities of the associations so far as they are known to us.

[113] Thus our figures concern merely the following main groups of the schema:

I. Internal Associations

1. Grouping
2. Predicative relationship
3. Causal relationship

II. External Associations

1. Co-existence
2. Identity
3. Linguistic-motor forms

III. Sound Reactions

1. Word-completion
2. Sound
3. Rhyme

IV. Miscellaneous

1. Indirect associations
2. Meaningless reactions
3. Failures
4. Repetition of the stimulus-word

A. Perseveration

B. The Egocentric Reaction

C. Repetition of the Reaction

D. Linguistic Connection

1. The same grammatical form
2. The same number of syllables
3. Alliteration
4. Consonance
5. The same ending

PART TWO

RESULTS OF EXPERIMENTS

A. RESULTS OBTAINED FROM INDIVIDUAL SUBJECTS

[114] Subjects reacted very differently to disturbing stimuli. Producing internal distraction was the most difficult, as already stated. It was not even possible to achieve with all educated subjects. External distraction by metronome-beats was somewhat easier. But here too great differences are apparent between individual subjects. It therefore seemed necessary to give the figures of each subject fully. Here a plethora of tables cannot be avoided. All figures are percentages.

I. EDUCATED WOMEN

Fourteen subjects with 4,046 reactions

[115] *Subject I.* In general the character of these associations [see table] is very objective and almost entirely uninfluenced by subjective constellations. In the normal state external associations prevail over internal ones. Between the first and second hundred of the normal reactions a clear difference is apparent, there being an increase of 9 per cent in the sound group. We attribute this change to a certain lassitude appearing in the reception of the second hundred, which psychologically has no more significance than a relaxation of attention.¹ There can certainly be no question here of psychological fatigue which, as Aschaffenburg has shown, brings about an increase of sound associations. The preceding psychic effort is much too slight for that. On the other hand, the relaxing of interest could very well be identified with lassitude in Kraepelin's² sense.

Subject 1. About 22 years of age, very intelligent

SPECIAL QUALITY	ASSOCIATIONS		NORMAL		DISTRACTION	
	1st Hundred	2nd Hundred	Internal	External		
				60 Metro-nome	100 Metro-nome	
Grouping	26	21	16	4	12	
Predicative relationship	14	14	2	4	2	
Causal relationship	2	1	-	-	2	
Co-existence	20	10	10	2	-	
Identity	1	7	4	8	-	
Linguistic-motor forms	36	36	54	20	38	
Word-completion	1	1	6	8	2	
Sound	-	8	6	34	38	
Rhyme	-	1	-	6	-	
Indirect	-	-	-	4	-	
Meaningless	-	-	2	4	6	
Failures	-	-	-	-	-	
Repetition of stimulus-word	-	-	-	6	-	
Egocentric reaction	1	-	-	-	-	
Perseveration	1	-	2	6	4	
Repetition of reaction	5	8	2	0	6	
Same grammatical form	67	58	64	56	54	
Same number of syllables	43	41	56	60	42	
Alliteration	10	12	12	42	48	
Consonance	12	15	16	52	52	
Same ending	10	6	10	14	6	
Internal associations	42	36	18	8	16	
External associations	57	53	68	30	38	
Sound reactions	1	10	12	48	40	
Number of associations	100	100	50	50	50	

[116] The columns after those giving figures for normal conditions describe the changes of association under the influence of artificially distracted attention. From a purely dynamic point of view one could say that the “associative energy” (Ranschburg³) was to such an extent diverted to another area that only a fraction of it is still available for the reaction. Thus a correspondingly poor or easy (that is, strongly canalized) association is given, because the stimulation of ready and accustomed cerebral mechanisms requires a smaller amount of energy than the canalization of relatively new and unaccustomed connections. From this point of view, the increase of linguistic-motor forms by 18 per cent in internal distraction can easily be understood;⁴ but to understand the origin of the numerous sound reactions in external distraction is more difficult. Aschaffenburg believes that it is possible to hold motor excitation responsible.⁵ This exists in mania, exhaustion,⁶ and alcoholic intoxication. But it has been proved that flight of ideas, or modes of association similar to flight of ideas, can also occur without motor excitation, e.g., in epilepsy (Heilbronner⁷), catatonia, and manic stupor.⁸

[117] In our experiment, motor excitation is as good as excluded. (The act of writing, which could be interpreted as “motor excitation,” is excluded in internal distraction, the results of which coincide with those of external distraction.) Thus no relationship between sound reactions and motor excitations can be demonstrated; rather do we see the origin of sound reactions in diminished attention. Distraction has primarily an inhibiting effect on the development of internal associations (of “high valency”) and favours the formulation of external, i.e., more mechanical association-forms, hence sound reactions in large numbers. In further description of the experiment we shall have ample opportunity to point out shifts of association-form towards

external, that is mechanical associations. We can say that, when the experiment was at all successful, these shifts only occasionally took place.

[118] It is striking that, in this obvious tendency towards mechanical reaction, sound reactions too were clearly favoured. But in the present state of our experience sound reactions are not mechanical, they are apparently non-canalized associations. In our interpretation, sound reactions, which are on only a slightly higher level than mere repetition of words, are the most primitive of associations by similarity. After early childhood they are no longer used but, always called up by the act of speech, they predominate as soon as a disturbance impedes the activities of the next higher levels of association (slips of the tongue or mis-hearing). They are, because of their uselessness in the normal thought-process, repressed and usually exist outside consciousness.

[119] We call the increase of linguistic-motor forms and sound reactions the blunting of the reaction. The attentive reaction, which takes place in the focus of consciousness, is not a sound reaction (unless this is expressly sought); but if one succeeds in directing attention to another activity, that is moving the psychic reaction outside the focus of consciousness, then all those associations occur that had been repressed from clearly conscious reactions. We shall deal later in detail with the significance of this hypothesis for the pathology of association.

[120] With faulty attention the stimulus-concept is not raised to a level of complete clarity or, in other words, it remains on the periphery of consciousness and is apprehended only by virtue of its external appearance as sound. The cause of these defective perceptions lies in the weakness of their emotional tone which, in its turn, is dependent on the disturbances of attention. Every process of apperception of an acoustic stimulus begins at the level of pure sound perception. From each of these levels associations can be externalized if simultaneously the speech centres are ready to discharge. That this does not normally happen is due to the inhibiting effect of directed attention, that is the raising of the stimulus-threshold for all inferior and undirected forms of association.

[121] In this case the high frequency of meaningless reactions, up to 6 per cent in external distraction, is noteworthy. They are partly due to strong perseverations, e.g.:

intention	□	out of humour ("one notices the intention" etc.) ⁹
to rescue	□	art (art of poetry)
strong	□	mighty
hatred	□	magnificent ¹⁰

and partly to distraction due to the unaccustomed noise of the metronome, e.g.:

appearance

rhythm

[122] This reaction shows to some extent how strong an effect the disturbing stimulus had on this subject. The intense lowering of attention also explains the unusually high number of sound reactions. The gradual predominance of acoustic and linguistic factors is also illustrated by the distinct rise of the figures in the columns for alliteration and consonance; there is also a definite increase in the words of the same number of syllables. The increase of perseveration during distraction is not easy to explain; perhaps it can be attributed to the lack of association caused by distraction. It seems to us worth mentioning that the external distraction in this case is a

progressive one. We have used the sounds to demonstrate the progression. We divided the two experiments of external disturbance each into three parts and counted the sound associations in each part.

[123] The progression is as follows:

1st experiment:	5, 5, 7.
2nd experiment:	5, 6, 8.

[124] *Subject 2.* The general character of the associations is objective. The external associations only slightly predominate over the internal. Internal distraction seems to have had the most intense effect in this case. Sound reactions increase continuously from the first hundred on. The group of verbal associations shows, in comparison with the former case, certain differences during distraction. The agreement in grammatical form shows a distinct increase, and the agreement of number of syllables also increases generally. Consonance and alliteration, however, decrease somewhat. We do not of course know the individual causes of these differences.

[125] The relatively numerous failures are striking, most of them occurring in the first hundred. Of the four in the first hundred, three were in answer to emotionally potent stimulus-words. In the second hundred there is only one, but at the same time numerous predicates, in this case value judgments coming to the fore. This circumstance seems to indicate that failures are essentially emotional phenomena, emotional inhibitions, as it were; they disappear in the second hundred with the occurrence of facilitated and more familiar subjective judgments. As in the former case, there is a definite rise of perseveration.

[126] We should like to point out that in this case the largest number of indirect associations coincides with the smallest number of sound reactions and, conversely, the largest number of sound reactions coincided with the smallest number of indirect reactions. This correlation is, as will appear later, probably not coincidental.

Subject 2. About 24 years of age, intelligent, well read

tight

tight-fisted

sees a tight (narrow) lead-pipe.

stone

buck (*Stein/Bock*)

sees a collection of minerals.

change

time (*Wechsel/Zeit*)

sees a promissory note (*Wechsel*).

fashion

woman of fashion

sees an elegant youth.

dull

eyes

sees a dull, rainy landscape (constellated by the day of the experiment).

mirror

smooth

sees the window of a certain glazier's.

forward

march

sees a copy of the *Forward* (newspaper).

down

to cut

sees a low stool in a certain sitting-room.

[129] In these reactions the connection between reaction and inner image is, as it were, completely broken. The reaction mostly comes quite mechanically from a lower level of the process of apperception, while the mental image mostly represents quite a different apperception of the stimulus-word.

[130] Conversely, the visual image may be stimulated from a lower level of apperception, as the following examples show:

number

number, quantity (*Zahl, Menge*)

sees a newly extracted tooth (*Zahn*).

to will

you must (wollen/du musst)

sees a woolly (*wolliges*) sheepskin.

[131] *Subject 3.* The character of the associations is objective. The external associations predominate, particularly the linguistic-motor forms. Both attempts at distraction were very successful, particularly internal distraction, which resulted in 29 per cent of sound reactions. A few reactions under internal distraction are of interest:

lid

nid (senseless rhyme)

The subject sees a beermug with a lid.

hall

throat (*Halle/Hals*)

sees a waiting-room in a certain station.

fall

staff

sees a waterfall.

stone

bone (*Stein/Bein*)

sees a picture of the little town of Stein on the Rhine.

[132] The fact that the number of internal associations remained nevertheless above the normal level in internal distraction, and in the first half of external distraction, can be attributed to the fact that the artificial lowering of attention was not uniform and continuous but decreased from time to time, whereupon normal reactions were given. The reactions obtained from the same subject in a state of great physical and mental fatigue give a more uniform picture of associative levelling-down. According to these findings, the state of fatigue has no other significance for this experiment than a uniform lowering of attention; its repercussion on the association is in no way different from the results of the distraction experiments. Nor is a difference discernible in the finer points of individual associations—which cannot be counted or measured—except in a very few reactions, the content of which is caused by the particular constellation of fatigue. As appears from our further observations on this subject and also from Aschaffenburg's investigations, no specific change, other than the blunting of the emotional response during the state of fatigue, can be demonstrated. The blunting of the reaction in fatigue can easily be accounted for by a decrease of attention. We also have every reason to assume that the blunting of the reaction in alcoholic intoxication and manic excitation (observed by Kraepelin's school) is nothing but a symptom of disturbed attention. The connection with motor excitation suggested by Aschaffenburg is in our view merely an indirect one: the motor excitation lowers the intensity of attention and therefore brings about a blunting of associations. The disturbance of attention by motor excitation is a matter of experience and in the named conditions has long been known as "distractibility." Since attention as an affective condition is also linked to certain somatic (that is, muscular) processes, the decrease of its stability can be attributed to motor excitation. Thus Aschaffenburg is not correct when he considers motor excitation as the direct cause of the blunting of the reaction; motor excitation is absent in a whole series of abnormally low reactions. But common to all these conditions is a disturbance of attention, which is probably always the immediate cause for all association types similar to flight of ideas.¹¹ The origin of disturbed attention is of course different in (i.e., specific to) each single process; it can equally well be based on motor excitation or on loss or decrease of kinesthetic feelings, on raising of the muscular stimulus-threshold, on mental excitement, or on psychological split (as in our experiments).

Subject 3. About 21 years of age, intelligent, well read

SPECIAL QUALITY	ASSOCIATIONS		NORMAL		DISTRACTION		FATIGUE
	1st Hundred	2nd Hundred	Internal	External			
				60 Metro-nomic	100 Metro-nomic		
Grouping	8	9	19	14	14	4	
Predicative relationship	16	22	13	22	4	1	
Causal relationship	—	—	2	—	—	—	
Co-existence	22	7	4	—	2	10	
Identity	3	12	6	10	6	2	
Linguistic-motor forms	46	44	26	32	54	40	
Word-completion	1	2	5	10	10	—	
Sound	—	—	15	6	6	1	
Rhyme	3	1	9	—	—	25	
Indirect	1	3	1	—	2	3	
Meaningless	—	1	—	6	2	12	
Failures	—	—	—	—	—	—	
Repetition of stimulus-word	—	—	—	—	—	—	
Egocentric reaction	—	1	—	—	—	—	
Perseveration	1	2	1	2	—	—	
Repetition of reaction	7	12	6	8	8	8	
Same grammatical form	63	50	62	52	54	70	
Same number of syllables	52	46	60	44	50	73	
Alliteration	6	4	16	14	12	18	
Consonance	24	7	35	18	30	47	
Same ending	13	20	22	20	16	44	
Internal associations	24	31	34	36	18	5	
External associations	71	63	36	42	62	52	
Sound reactions	4	3	29	16	16	26	
Number of associations	100	100	100	50	50	100	

[133] The great variability of intensity of attention makes all association experiments with alcohol and fatigue susceptible to an error extremely difficult to estimate, so that in the state of our present experience it is practically impossible to say anything positive about the extent of the disturbances of association through alcohol, etc. Judging from the percentage ratios of these fatigue experiments, the subject must have been in an absolutely psychotic state. According to Aschaffenburg's theory, a result with 5 per cent internal associations and 27 per cent sound reactions corresponds to a state of heavy intoxication or serious mania or a state of quite abnormal fatigue. The intensity of this blunting, however, can easily be explained by the fact that great but not abnormal fatigue was accompanied by marked drowsiness. The decrease of attention, with raising of external stimulus-thresholds, peculiar to this condition is, in analogy with distraction experiments, to be considered as one of the main causes of the blunting.¹² The intensity of drowsiness is an unmeasurable quantity; how much drowsiness was present in the states of fatigue examined by Aschaffenburg?

[134] Drowsiness is not merely a somatic, physiological, but also to a certain extent a psychological phenomenon, which may perhaps be described by the name "autohypnosis." It is primarily a psychological event that takes place in the area of consciousness. It is mainly stimulated by somatic sensations but can also be produced by pure suggestion. Exactly the same applies to the effect of alcohol. The effects of alcohol may be to a large extent, particularly in the beginning of narcosis, purely suggestive; this probably accounts for the fact that the effects of alcohol on different dispositions may be quite different. Can one exclude or calculate the suggestive effects of alcohol in the alcohol experiment? In our view this is not possible. Therefore great caution is advisable in psychological alcohol experiments. Accordingly,

disturbance of attention in fatigue and alcohol experiments need not always have its roots in motor excitation, but could equally well be derived from suggestion.

[135] Let us return to our experiment. The great prevalence of external association can be attributed to momentary decrease of attention. The cause of the blunt reaction can, however, lie deeper. It is not unthinkable that there are individuals who, because of a congenital or acquired anomaly, have a more superficial mode of association than others; this anomaly may possibly lie in the sphere of attention, in that fatigue appears much more quickly than in other people. The figures for the sister and mother of subject 3 are interesting in this respect as observations of family psychology. We give the tables here.

[136] *Subject 4*, about 20 years of age, is the sister of subject 3. The associations have in general an objective character; the external ones predominate considerably, especially the linguistic-motor forms. Sound reactions also are numerous, so that the character of the normal state looks like the result of a distraction experiment. In the experiment of internal distraction there is an unexpected increase of internal associations as well as a clear increase of sound reactions. The superficiality displayed in the experiment under normal conditions is in our experience abnormal, thus we must assume a disturbance of attention in this state. The subject is a definite “motor type”; from other experiments performed with the subject it becomes apparent that motor perception predominates by far over the other senses.¹³ Externally too the motor disposition is shown by great vivacity of movement and a strongly developed ability for motor expression. It must here be stressed that this active motility by far exceeds the limits of conscious innervation and is expressed in motor automatisms that are innervated by unconscious psychological complexes. Among the reactions of the normal state there are two linguistic automatisms that are very probably related to an unconscious complex. This complex is closely connected with the affect concerning a past engagement. Thus we have two probable reasons for the strikingly blunt reaction-type: the strong and abnormally independent motor tendency and a partially suppressed affect. The latter probably has the most significance for the blunting.

Subjects 4 and 5. Sister and mother of subject 3

ASSOCIATIONS	SUBJECT 4			SUBJECT 5	
	NORMAL	DISTRACTION	NORMAL	1st Hundred	2nd Hundred
SPECIAL QUALITY	1st Hundred	2nd Hundred	Internal	1st Hundred	2nd Hundred
Grouping	3	8	16	24	17
Predicative relationship	7	8	8	10	7
Causal relationship	—	—	1	1	0
Co-existence	8	6	3	8	8
Identity	2	4	1	6	13
Linguistic-motor forms	67	56	39	46	45
Word-completion	4	8	14	3	4
Sound	3	5	9	—	3
Rhyme	2	1	2	—	—
Indirect	2	3	5	1	2
Meaningless	1	—	1	1	1
Failures	1	—	—	—	—
Repetition of stimulus-word	—	1	1	—	—
Egocentric reaction	—	—	—	—	—
Perseverations	1	—	2	1	2
Repetition of reaction	9	7	4	9	5
Same grammatical form	61	51	53	82	66
Same number of syllables	48	47	35	51	38
Alliteration	13	11	13	5	12
Consonance	14	19	24	16	17
Same ending	11	14	7	18	10
Internal associations	10	16	25	35	24
External associations	77	66	43	60	66
Sound reactions	9	14	25	3	7
Number of associations	100	100	100	100	100

[137] (It would be too much of a digression to examine the individual psychology of this case more closely. This will be done elsewhere.)

[138] The increase of internal associations during distraction experiments is a phenomenon that we find again in subjects of different character¹⁴ who under normal conditions also show an abnormally blunt type. We know no other explanation for the improvement of reaction-type in this case than that the attention, which under normal conditions is tied to the emotional complex, is released by the conditions of the experiment (new to the subject) and can therefore be used. Nevertheless, great fluctuation of attention occurred; this is indicated by the large number of sound reactions, together with the relatively numerous internal associations.¹⁵

[139] A special peculiarity of this subject is the occasional occurrence of marked synesthesias (*audition colorée*), which influence the reaction. Examples under normal conditions:

to kiss (*küssen*) yellow

ü is yellow for the subject.

misery (*Elend*) something red

e is red.

indolent (*träge*) blue

ä is blue.

[140] Examples from the distraction experiment:

Subject sees a yellow mass.

pious

blessed

sees something yellow.

[141] Strangely enough, the subject [3], who has the same reaction-type as subject 4, is also a definite “motor type” and also has very vivid synesthesias, which, as it happens, did not appear in the reactions.

[142] The following phenomena from the distraction experiment are worth mentioning:

stork

-’s leg

Subject sees a church-tower.

to hinder

hammer-let (Hamlet)

sees a brake.

fall

bone (*Fall -z bein*, paper-knife)

sees a high wall from which one could fall.

red

wine

sees a red sphere.

barrel

-ter (*Fass -ter [Vater?]*)

sees a certain cellar.

[143] From the subject’s account, the visual image fills consciousness completely and exclusively, the verbal reaction being given almost involuntarily and touching consciousness only quite superficially. The above examples show clearly and repeatedly the purely mechanical character of the verbal reaction.

[144] *Subject 5* is the mother of subjects 3 and 4. Quantitatively the reaction-type shows much similarity with that of subjects 3 and 4. The objective character of the reactions is qualitatively also very similar. Particularly prominent in these three people are the linguistic-motor forms. Characteristic of this family type are sound reactions under normal conditions, which distinguishes this type from others. For comparison, we give the main figures for these subjects under normal conditions:

	Internal Associations	External Associations	Sound Reactions
Mother	29.5%	62.0%	5.0%
Elder daughter	27.5%	67.0%	3.5%
Younger daughter	13.0%	71.5%	11.5%

[145] We draw attention to the increasing degree of blunting in the younger daughter. If the figures were all from the same individual one could believe that it is a distraction experiment. Perhaps this relationship is accidental but perhaps it has deeper psychological reasons. We refer to a

similar observation reported below. Ranschburg¹⁶ found 11.8 per cent more internal associations in old than in young subjects.

[146] *Subject 6.* Such external associations as are usually found in the normal state predominate. The second hundred shows a slight increase of external associations and a clear increase of sound reactions. The quality of association deviates considerably from the types so far reported, reactions of strongly subjective character occurring with this subject. They are in part highly charged value judgments, e.g.:

pupil	boring
father	good
book	interesting
school	beautiful
frog	nice
piano	horrible

[147] On the other hand, it is the predicates that designate properties of things that are to a greater or lesser extent evident to the senses. In the second hundred an increase of groupings from 9 to 14 and a decrease of predicative relations from 32 to 14 can be noticed; accordingly the quality of reactions is altered in so far as they assume a noticeably more objective character with a tendency to irrelevant clichés. The decrease of predicative relations is due to the shifting of subjective value judgments into the background. Thus the more subtle quality of the reactions also shows a markedly fading interest. The relaxation of attention is shown very clearly in the decrease of egocentric reactions from 10 to 4. From this result the distraction experiments must be considered a failure. Objectively this is also shown by the subject's being unable simultaneously to follow the beat of the metronome and to react; either the motion of writing ceased at the moment of reaction or the reaction-time lengthened to the next pause in the beat, when the reaction was given with renewed attention. The only disturbing influence was the perseveration phenomenon, which significantly only occurred with external distraction.

Subject 6. About 35 years of age, intelligent, very well read, poetic talent

SPECIAL QUALITY	ASSOCIATIONS		NORMAL		DISTRACTION	
	1st Hundred	2nd Hundred	Internal	External		
				60 Metro-nome	100 Metro-nome	
Grouping	9	14	8	8	6	
Predicative relationship	32	14	30	24	36	
Causal relationship	1	—	—	—	—	
Co-existence	12	18	14	16	10	
Identity	2	6	2	6	2	
Linguistic-motor forms	39	39	40	34	42	
Word-completion	—	1	—	2	—	
Sound	—	4	—	4	2	
Rhyme	4	2	—	2	2	
Indirect	1	2	2	2	—	
Meaningless	—	—	—	—	—	
Failures	—	—	2	—	—	
Repetition of stimulus-word	—	—	2	—	—	
Egocentric reaction	10	4	6	8	4	
Perseveration	—	—	—	2	4	
Repetition of reaction	15	5	4	4	4	
Same grammatical form	43	52	48	46	40	
Same number of syllables	50	33	36	42	42	
Alliteration	11	13	6	8	2	
Consonance	26	28	12	12	10	
Same ending	8	10	0	2	8	
Internal associations	42	28	38	32	42	
External associations	53	63	56	56	54	
Sound reactions	4	7	—	8	4	
Number of associations	100	100	50	50	50	

[148] The almost undiminished personal interest at the time of external distraction is well illustrated by the relatively large number of egocentric reactions. We will refrain from judging how far the relatively strong verbal connection by consonance under normal conditions is caused by the constellations of active poetic application. Many reactions of this subject betray a strong visual predisposition. From the subject's own account every stimulus-concept presents itself as a quite definite picture. The entirely individual character of the reactions distinguishes this subject from others and differentiates her from the subjects so far discussed. It is interesting to learn whether this type is accidental or whether it is of familial origin. Happily we are in the position of being able to some extent to answer this question.

[149] *Subject 7.* The number of internal associations considerably predominates over the external ones. The number of predicative relations is extremely great. Most of these consist of subjective value judgments, some of which are highly charged, e.g.:

to cook	laborious
water	wonderful
star	magnificent
to ride	dangerous
prison	horrible

About 40 per cent of the reactions betray an egocentric direct wish or a defence.

[150] *Subject 8.* The internal associations are more numerous than the external. This subject also showed a very subjective reaction-type, which appears particularly in the large number of

predicative relations and especially in the numerous subjective value judgments. The number of egocentric reactions too is rather high.

[151] From these figures and from the individual quality of the reactions, a clear familial relation emerges. Thus we can conclude with some probability that the subjective reaction-type of subject 6 is based not on coincidence but on familial disposition. It will be of interest to consider the quantitative aspects within this family; particularly whether, in the case of the youngest member, we can prove an analogous proportion in respect to the blunting phenomenon found in the family of subjects 3, 4, and 5. For this purpose we again collate the main figures of our subjects in a normal state.

Subject 7. The mother of subject 6, over 50 years of age, educated

ASSOCIATIONS		NORMAL	ASSOCIATIONS		NORMAL
SPECIAL QUALITY		1st	SPECIAL QUALITY		1st
		100			100
Grouping		9	Egocentric reaction		40
Predicative relationship		16	Perseveration		3
Causal relationship		8	Repetition of reaction		25
Co-existence		12	Same grammatical form		45
Identity		3	Same number of syllables		22
Linguistic-motor forms		4	Alliteration		—
Word-completion		—	Consonance		9
Sound		—	Same ending		—
Rhyme		—	Internal associations		78
Indirect		—	External associations		19
Meaningless		1	Sound reactions		—
Failures		—	Number of associations		76
Repetition of stimulus-word		—			

	Internal Associations	External Associations	Sound Reactions	Egocentric Reactions
Mother	75%	19%	0	40%
Elder daughter	56%	39%	1%	15%
Younger daughter	35%	58%	5.5%	7%

[152] These figures show a complete analogy to what we find in subjects 3, 4, and 5. This too looks like a distraction experiment which goes as far as the reversal of the relation of internal to external associations. There is a corresponding increase of sound associations as well as a decrease of egocentric reactions which, as was shown in subject 6, express the degree of personal interest. This strange analogy between the two family types does appear to be more than mere coincidence. Unfortunately our material is not sufficient to elucidate these observations. A final statement and interpretation of this apparent fact must for the moment await an experiment at present being carried out based on specially collected material.

Subject 8. The elder sister of subject 6, about 39 years of age, educated

ASSOCIATIONS	NORMAL	ASSOCIATIONS	NORMAL
SPECIAL QUALITY	1st	SPECIAL QUALITY	1st
	100		100
Grouping	6	Egocentric reaction	15
Predicative relationship	49	Perseveration	—
Causal relationship	1	Repetition of reaction	14
Co-existence	18	Same grammatical form	29
Identity	1	Same number of syllables	33
Linguistic-motor forms	20	Alliteration	10
Word-completion	—	Consonance	10
Sound	—	Same ending	1
Rhyme	1	Internal associations	56
Indirect	1	External associations	39
Meaningless	1	Sound reactions	1
Failures	—	Number of associations	78
Repetition of stimulus-word	—		

[153] The reaction-type of the last three subjects is characteristic and widespread. What distinguish it from other less definite types are the numerous predicates, among which is a considerable number of subjective value judgments. We call this type the predicate type. The following three subjects are further examples of it.

[154] *Subject 9.* The predominance of predicative relationships is clear in all phases of the experiment. Internal distraction could not be carried out as the subject was not capable of dividing her attention. The experiment of external distraction failed completely as the subject, exactly like subject 6, could not carry out two actions at the same time and therefore behaved exactly like subject 6. Only in the larger numbers of verbal connection by number of syllables, alliteration, and consonance may a certain shift of reaction towards the mechanical side be noticed.

[155] Three of the four failures under normal conditions are associated with emotionally charged stimulus-words (*unjust, rich, stupid*).

[156] The average predominance of internal association over external is noteworthy in an educated subject. The reaction-type is a mixed one and does not by any means show the strongly subjective character of subjects 6, 7, and 8.

[157] *Subject 10.* The predicative relationships are on the average many times as numerous as the number of groupings. With reference to the failure in distraction, the same must be stated as for subjects 6 and 9. The reaction-type is, particularly in the first hundred under normal conditions, a somewhat subjective one, which incidentally is also expressed by the 9 per cent of egocentric reactions. Perseverations occur solely with distraction. As in subject 9, there is an increase in the number of syllables and consonances, which perhaps may be interpreted as slight disassociation. The large number of failures in all phases of the experiment is striking. Of the 14 failures under normal conditions, 10 coincide with emotionally charged stimulus-words (*must, unjust, violence, to threaten, to suffer, etc*); in another two failures the subjective emotional charge of the stimulus-word is only probable. It must here be said that the subject is slightly hysterical in so far as she has somnambulant dreams. We attribute the large number of failures to this abnormality.

We shall present the proof of this hypothesis in a publication about association anomalies in hysteria which will appear later.¹⁷

Subject 9. About 20 years of age, well read, fairly intelligent

ASSOCIATIONS	NORMAL		DISTRACTION	
	1st Hundred	2nd Hundred	External	
			60 Metro-nome	100 Metro-nome
SPECIAL QUALITY				
Grouping	4	19	18	22
Predicative relationship	37	37	38	34
Causal relationship	5	2	2	-
Co-existence	26	14	14	14
Identity	1	3	4	12
Linguistic-motor forms	23	23	20	18
Word-completion	-	-	2	-
Sound	-	-	-	-
Rhyme	-	-	-	-
Indirect	-	-	-	-
Meaningless	-	-	-	-
Failures	2	2	2	-
Repetition of stimulus-word	-	-	-	-
Egocentric reaction	3	4	-	-
Perseveration	2	1	-	-
Repetition of reaction	13	10	6	4
Same grammatical form	29	33	20	46
Same number of syllables	38	34	56	54
Alliteration	10	6	8	16
Consonance	15	12	10	20
Same ending	3	8	8	16
Internal associations	46	58	58	56
External associations	52	40	38	44
Sound reactions	-	-	2	-
Number of associations	100	100	50	50

Subject 10. About 20 years of age, intelligent, very well read

ASSOCIATIONS	NORMAL		DISTRACTION		FATIGUE
	1st Hundred	2nd Hundred	External		
			60 Metro-nome	100 Metro-nome	
SPECIAL QUALITY					
Grouping	8	16	6	10	12
Predicative relationship	31	17	38	34	30
Causal relationship	1	-	-	-	-
Co-existence	14	13	10	4	12
Identity	3	11	18	14	6
Linguistic-motor forms	31	35	18	20	30
Word-completion	-	-	-	-	1
Sound	1	-	-	4	1
Rhyme	-	-	2	-	1
Indirect	1	1	-	-	2
Meaningless	-	-	-	4	2
Failures	8	6	6	10	3
Repetition of stimulus-word	-	-	2	-	1
Egocentric reaction	9	2	-	4	3
Perseveration	-	-	4	2	2
Repetition of reaction	16	5	18	14	18
Same grammatical form	48	51	44	42	48
Same number of syllables	36	33	46	40	41
Alliteration	10	3	8	10	8
Consonance	7	9	14	12	13
Same ending	5	8	18	16	18
Internal associations	40	33	44	44	42
External associations	48	59	46	38	48
Sound reactions	1	-	2	4	2
Number of associations	100	100	50	50	100

Subject 11. Mother of the previous subject, about 56 years of age, very intelligent, educated, well-read

ASSOCIATIONS	NORMAL		ASSOCIATIONS	NORMAL	
	1st Hundred	2nd Hundred		1st Hundred	2nd Hundred
SPECIAL QUALITY			SPECIAL QUALITY		
Grouping	5	4	Egocentric reaction	6	5
Predicative relationship	56	35	Perseveration	1	-
Causal relationship	2	-	Repetition of reaction	5	4
Co-existence	4	4	Same grammatical form	27	34
Identity	-	1	Same number of syllables	37	41
Linguistic-motor forms	28	50	Alliteration	11	3
Word-completion	3	4	Consonance	8	14
Sound	-	-	Same ending	1	10
Rhyme	-	-	Internal associations	63	39
Indirect	1	-	External associations	32	55
Meaningless	-	-	Sound reactions	3	4
Failures	-	1	Number of reactions	96	96
Repetition of stimulus-word	-	-			

[158] Subject 11 is an outstanding predicate type of subjective character with numerous value judgments. A marked slackening in the second hundred is striking; this may be attributed to

obvious and objectively established boredom. Thus the second hundred does not correspond to normal conditions but rather to a distraction experiment. Nevertheless, if we compare the reaction-type of this subject with that of the daughter, subject 10, we find the same phenomenon as before, that is that the daughter's reaction-type is a blunter one than that of the mother.

	Internal Association	External Association
Mother	51%	43.5%
Daughter	36%	53.5%

[159] We take this opportunity to repeat that in spite of this agreement the phenomenon may be pure coincidence and therefore urgently requires retesting.

[160] We also give the figures for three further subjects. *Subject 12*, a North German lady. The large number of current phrases is particularly striking. Internal distraction failed. External distraction shows a definite disturbance of attention. The reaction type is objective.

[161] *Subject 13*. Very diffident, hence the large number of repetitions of the stimulus-word. Only distraction by metronome-beat of 100 was to any degree successful. The writing movements were, in accordance with what has been said before, very awkward.

[162] *Subject 14*. We give figures for this subject only for the sake of completeness. The reaction-type is an objective one. Internal distraction was only partially successful. Its effect is uncertain as, because of the omission of the second hundred of normal reactions, we have no information on the degree of variation in normal people. The second hundred could not be obtained for external reasons.

Summary of the Group of Educated Women

[163] Unfortunately the material collected in this group is quantitatively somewhat uneven. On the other hand, the linguistic background is very similar, only one out of the fourteen subjects coming from North Germany and all the others being Swiss, whose colloquial language is the Swiss dialect. Their level of education is in general very high, two of the subjects having University education. Six subjects know one or two foreign languages. Ten subjects are relatively well read. Distraction experiments were carried out with ten subjects; of these in five cases external and internal distraction, in two cases only internal and in three cases only external was carried out. External distraction was definitely successful in four cases, internal in three. One case of internal and one of external distraction were partially successful.

Subject 12. About 40 years of age, very intelligent, well-read

SPECIAL QUALITY	ASSOCIATIONS		NORMAL		DISTRACTION	
	1st Hundred	2nd Hundred	Internal	External		
				60 Metro-nome	100 Metro-nome	
Grouping	23	12	15	12	2	
Predicative relationship	1	16	19	6	8	
Causal relationship	1	1	-	-	-	
Co-existence	34	18	18	22	6	
Identity	7	6	9	4	10	
Linguistic-motor forms	34	56	34	52	70	
Word-completion	-	-	-	-	-	
Sound	-	-	-	-	-	
Rhyme	-	1	1	2	2	
Indirect	-	-	-	-	-	
Meaningless	-	-	-	-	-	
Failures	-	-	4	-	2	
Repetition of stimulus-word	-	-	-	-	-	
Egocentric reaction	-	-	-	-	-	
Perseveration	1	-	-	2	-	
Repetition of reaction	6	5	5	-	2	
Same grammatical form	57	92	64	82	56	
Same number of syllables	50	52	57	56	38	
Alliteration	5	4	10	-	4	
Consonance	16	18	12	20	12	
Same ending	25	16	12	18	20	
Internal associations	25	19	34	18	10	
External associations	75	80	61	78	86	
Sound reactions	-	1	1	2	2	
Number of associations	100	100	100	50	50	

Subject 13. About 22 years of age, intelligent, all-round culture

ASSOCIATIONS	NORMAL		DISTRACTION	
	1st Hundred	2nd Hundred	External	
			60 Metro-nome	100 Metro-nome
SPECIAL QUALITY				
Grouping	11	21	22	10
Predicative relationship	18	19	20	14
Causal relationship	5	1	2	-
Co-existence	10	10	16	20
Identity	3	12	16	16
Linguistic-motor forms	46	31	14	34
Word-completion	-	1	-	-
Sound	-	-	-	-
Rhyme	-	1	-	-
Indirect	-	-	-	-
Meaningless	-	-	-	-
Failures	6	-	6	-
Repetition of stimulus-word	-	4	4	6
Egocentric reaction	-	-	-	-
Perseveration	-	-	-	-
Repetition of reaction	9	11	4	2
Same grammatical form	61	60	56	68
Same number of syllables	43	43	42	42
Alliteration	8	3	8	6
Consonance	10	14	8	14
Same ending	11	12	18	16
Internal associations	34	41	44	24
External associations	59	53	46	70
Sound reactions	-	2	-	-
Number of associations	100	100	50	50

Subject 14. About 22 years of age, fairly intelligent, cultured

ASSOCIATIONS	NORMAL	DISTRACTION
SPECIAL QUALITY	1st Hundred	Internal
Grouping	29	9
Predicative relationship	1	10
Causal relationship	-	1
Co-existence	31	12
Identity	2	12
Linguistic-motor forms	34	51
Word-completion	-	1
Sound	2	-
Rhyme	1	2
Indirect	-	-
Meaningless	-	-
Failures	-	2
Repetition of stimulus-word	-	-
Egocentric reaction	-	-
Perseveration	-	-
Repetition of reaction	14	1
Same grammatical form	95	69
Same number of syllables	59	40
Alliteration	10	9
Consonance	15	22
Same ending	24	7
Internal associations	30	20
External associations	67	75
Sound reactions	3	3
Number of associations	100	100

[164] Distraction failed in four cases, of which three are definite predicate types. (All predicate types who took part in the distraction experiments at all showed a much smaller distraction phenomenon than the other subjects.) Of the six subjects over 30 years of age, three showed an average predominance of internal association over external; of the eight subjects under 30 years of age, only one subject showed a predominance of internal association over external.

II. EDUCATED MEN

Nine subjects with 3,793 associations

[165] *Subject 15.* Reactions were obtained from this subject in four different states of disturbed attention: in the states of internal and external distraction, fatigue, and morning drowsiness on waking. The reaction-type is a very blunt one, as the ratio between internal and external associations shows, 15 : 78 and 29 : 65. The reactions show a very objective, almost entirely verbal character. The distraction experiments do not have much influence on the ratio between internal and external associations; on the other hand, the progression of sound reactions illustrates the increasing disturbance of attention, which reaches its maximum in the second external distraction experiment. Fatigue, which admittedly in this case was not very great, produced no change in type. The state of drowsiness caused a disturbance of attention which far surpassed the effect of the second external distraction. The subject experiences intense morning drowsiness after mental work at night, and it is difficult to wake him up completely. These reactions were obtained while the subject lay in bed and was only partially awake. The subject had been warned beforehand. The two experiments were carried out on two different days with

an interval of about a week. As the figures show, the type is an excessively blunt one. Sound reactions are extraordinarily numerous, particularly the rhymes. The figures for verbal connection are very high. This reaction-type shows the reaction to the most primitive linguistic mechanisms in, as it were, complete isolation. Fatigue is entirely excluded in these experiments; there is merely a decrease of active attention normal towards the end of sleep. As far as we know, attention is completely extinguished in sleep. If one succeeded in obtaining a reaction from a sleeping (but not somnambulant) subject, sound reactions would be the only result. In our view absolute undeviating attention directed inwards would have the same result. We are in the happy position of being able to report on a case that proves this to be so.

Subject 15. 28 years of age, intelligent, very well educated*

ASSOCIATIONS	NORMAL		DISTRACTION				DROWSI- NESS	
	1st Hundred	2nd Hundred	Internal	External		FATIGUE	1st Part	2nd Part
				1st Part	2nd Part			
SPECIAL QUALITY								
Grouping	9	13	4	10	12	10.2	2	-
Predicative relationship	6	16	19	10	4	10.2	5	2
Causal relationship	-	-	-	-	-	-	-	1
Co-existence	18	5	6	8	14	14.1	14	6
Identity	6	8	5	10	2	2.5	5	2
Linguistic-motor forms	54	52	56	46	54	53.8	40	51
Word-completion	1	-	8	4	12	2.5	2	2
Sound	-	-	2	6	2	-	4	5
Rhyme	4	4	1	2	8	2.5	20	21
Indirect	2	2	1	2	4	-	2	2
Meaningless	-	-	-	2	-	3.8	-	-
Failures	-	-	-	-	-	-	-	-
Repetition of stimulus-word	-	-	-	-	-	-	-	-
Egocentric reaction	1	-	3	-	-	-	-	-
Perseveration	-	-	2	2	-	2	4	-
Repetition of reaction	5	5	2	6	2	6	9	2
Same grammatical form	73	47	47	54	46	63	59	60
Same number of syllables	53	45	49	46	42	44	61	58
Alliteration	7	6	5	10	4	4	17	9
Consonance	15	23	16	24	20	5	32	36
Same ending	19	15	9	18	18	14	33	36
Internal associations	15	29	23	20	16	20.4	7	3
External associations	78	65	67	64	60	70.4	59	59
Sound reactions	5	4	11	12	22	5	27	32
Number of associations	100	100	100	50	50	78	78	78

[166] The subject N. was deeply disturbed by violent affects. Outwardly the main symptom was an almost complete lack of ability to concentrate. She kept the cause of her affects secret. In the experiment, to which she submitted out of scientific interest, she produced, apart from a few inexplicable (senseless) reactions, mainly sound and rhyme reactions.

[167] We should like to compare this case with a distraction experiment spread out over several days. Attention is completely bound up with the inner, emotionally charged complex,¹⁸ from which she cannot detach herself for comparatively unimportant incidents. Her attention is thus abnormally low for anything that does not concern the complex. We cannot of course judge how far this withdrawal is conscious. As the subject related, at the beginning of the experiment certain strongly charged ideas belonging to the complex were in her mind, which she constantly tried to suppress, because she feared they might betray themselves in the reaction. From the

second third of the experiment onwards, only the feeling-tone of the complex persisted in consciousness, without these accompanying vivid ideas. The next things to occur to the subject were only sounds. The stimulus-words only made an impact by the sound and never by the sense.

[168] These observations prove most clearly the dependence of sound reactions, particularly those of the blunt reaction type, on disturbance of attention. Now, how can we explain the normally blunt reaction-type? The subject was psychologically trained and took the greatest interest in the experiment. The blunt reaction-type would seem to be connected with the fact that many educated subjects regard the experiment as simply verbal; they see the experiment against a verbal background and thus they try to respond to the stimulus-word by the first word to occur, without considering the meaning of the stimulus-word. They do so because it seems obvious to them that an isolated stimulus-word cannot have any special significance. This is how we explain the great predominance of verbal and sound associations. All those subjects who let themselves be influenced by the meaning rather than by the mere word tend to form internal associations. The meaning that different people give to the stimulus-word will vary. In our experience there are two main types of people: (1) The subject tries to do justice to the meaning as objectively as possible; therefore in his reaction he produces some general or special association of objective significance; the reaction is usually a co-ordinating relationship. (2) The subject endeavours to designate in a telling way the object named by the stimulus-word, which he vividly pictures. To state something about the stimulus-word, the subject uses the predicate. The reaction is therefore in most cases a predicative relationship.

[169] On these grounds the blunt reaction-type of certain educated subjects should not be considered as the result of some disturbance of attention but as an "attitude phenomenon" (Bleuler). By the term "attitude phenomenon" we understand with Bleuler the emergence of an apparently abnormal reaction type through intentional preference for a certain mode of reaction. The mode is not, however, as must be stressed, chosen arbitrarily but motivated by the particular psychology of the subject. The more intense the attitude to the sound-effect of the stimulus-word, the blunter the reaction-type must become, for, by specially directed attention, the subject will stress and put in the foreground all the more primitive associations that are repressed in the normal act of speech. Thus a very paradoxical picture can be created by the numerical presentation of the results of the experiment; we can understand it only on the grounds we have given. The following case will illustrate this.

[170] *Subject 16.* Here we find again a strikingly blunt reaction-type in the experiment under normal conditions, which is illustrated particularly by the large number of sound reactions. The blunting is considerably increased in the experiment with internal distraction; on the other hand, in the experiment with external distraction a striking "improvement" of reaction appears, the number of internal associations far exceeding that for the experiment under normal conditions. The "improvement" is quite clearly demonstrated by the decrease and eventual disappearance of the sound reactions.

[171] This particular result is unique in our experiments and needs discussion. We have already mentioned the present subject in discussing subject 4 of the group of educated women, who presented a similar picture; we then assumed that suppressed affect was the cause of the blunt reaction-type. In this connection the very satisfying findings presented above in the discussion of

subject 15 of the group of educated men should also be mentioned. The recent very strong affect that took complete possession of this subject was the direct cause of the preponderance of sound reactions. The affect in this case was repressed, inasmuch as it did not manifest itself directly in the reaction but only indirectly through a splitting of attention. One must assume a similar psychological situation also for subject 4 of the group of educated women and so explain the blunt type. The fact that subject 4 of the group of educated women and subject 16 in the group of educated men are of the same type is perhaps fortuitous.

[172] Affect is probably completely out of the question in subject 16. We must therefore look for another cause for the blunt type: we find it in the attitude phenomenon. Subject 16 is thoroughly trained psychologically and at the same time has extraordinary powers of concentration. The subject had from the first directed his attention towards the sound of the stimulus-word and consequently reproduced the first association to occur. These can only be primitive verbal connections and sounds, if our presuppositions on associations closest to the perception of the stimulus-word are at all correct. In this way the abnormally blunt type in the experiment under normal conditions can be explained without difficulty.

Subject 16. 47 years of age, intelligent, very well educated

ASSOCIATIONS	NORMAL		DISTRACTION			FATIGUE
	1st Hundred	2nd Hundred	Internal	External		
				1st Part	2nd Part	
SPECIAL QUALITY						
Grouping	16	15	12	20	20	10.2
Predicative relationship	6	5	6	12	2	8
Causal relationship	-	-	-	4	2	-
Co-existence	4	6	8	14	8	5
Identity	6	8	2	10	10	6
Linguistic-motor forms	51	45	38	28	58	38
Word-completion	2	1	-	-	-	2
Sound	8	10	24	6	-	24
Rhyme	1	3	-	-	-	2
Indirect	6	6	10	4	-	1
Meaningless	-	1	-	-	-	-
Failures	-	-	-	-	-	-
Repetition of stimulus-word	-	-	-	2	-	-
Egocentric reaction	-	-	-	-	-	5
Perseveration	1	1	-	-	-	-
Repetition of reaction	3	13	8	4	6	10
Same grammatical form	75	63	62	70	74	58
Same number of syllables	48	37	42	48	56	41
Alliteration	25	22	38	16	6	28
Consonance	25	23	38	24	16	23
Same ending	14	12	10	10	12	10
Internal associations	22	20	18	36	24	18
External associations	61	59	48	52	76	49
Sound reactions	11	14	24	6	-	28
Number of associations	100	100	50	50	50	78

[173] The blunting increases in the internal distraction experiments. The subject carried out this experiment in a model way; concentration on the D (distraction) phenomenon was excellent, as was the reporting of it. We therefore have no reason, in this case, not to assume distraction of attention. Thus the blunt type of reaction in this experiment is to be attributed to decrease of

attention. It springs from a root different from the one in the experiment under normal conditions; consequently it is not an attitude-phenomenon.

[174] External distraction has a disturbing effect on the attention of most subjects and therefore causes blunting. In the present case the effect appears to be the opposite. The normal state of this case is characterized by the attitude phenomenon; attention is directed exclusively to the linguistic aspect. Now this attitude is disturbed by external distraction and the subject now has a different relation to the stimulus-word; i.e., the exclusive observation of the sound is disturbed and thus the production of the nearest primitive association is prevented. If the associations that are always repressed under normal conditions sink back into repression, then the next ones to follow must be the associations conditioned by the meaning of the stimulus-word; i.e., the number of sound-reactions must fall and the number of internal associations must rise. That is the case here.

[175] The figures for fatigue show a remarkable agreement with those for internal distraction. Judging from external demeanour one could diagnose quite severe fatigue. This was actually not the case. The fatigue was by no means abnormally severe but merely a relatively slight evening fatigue which, according to the subject's account, did not noticeably influence the reaction.

[176] Here again we have an attitude phenomenon and met a disturbance of attention. That the attitude was apparently more intense in this state can perhaps be deduced from the fact that the subject, who is a "motor" type, is when slightly fatigued liable to motor excitation. Speech motility of course also plays a part in general motor excitation, the speech mechanism very easily responding to the appropriate stimulus. This circumstance may have coincided in this case with the special attitude, resulting in a greater number of purely mechanical connections.

[177] As can be expected of such a type, the personal and subjective elements in the quality of the reactions gradually recede, with few exceptions.

[178] *Subject 17.* The reaction-type is fairly blunt. In internal associations predicates are particularly prominent and have an almost exclusively objective character. As the number of egocentric reactions shows, relatively few subjective aspects appear. But as predicate types always present emotionally charged constellations, there is here, too, an emotionally charged complex noticeable in the reactions. The experiment was carried out on a very hot day: among the repetitions, there is *snow* twice and *to sweat* twice. Apart from these there are the following perseverations:

Subject 17. About 26 years of age, intelligent

ASSOCIATIONS		NORMAL		ASSOCIATIONS		NORMAL	
SPECIAL QUALITY		1st Hundred	2nd Hundred	SPECIAL QUALITY		1st Hundred	2nd Hundred
Grouping		9	9	Egocentric reaction		3	3
Predicative relationship		23	26	Perseveration		5	-
Causal relationship		-	-	Repetition of reaction		9	5
Co-existence		21	5	Same grammatical form		44	49
Identity		-	10	Same number of syllables		44	46
Linguistic-motor forms		41	41	Alliteration		6	4
Word-completion		2	4	Consonance		14	9
Sound		-	-	Same ending		2	13
Rhyme		-	2	Internal associations		32	35
Indirect		2	2	External associations		62	56
Meaningless		-	-	Sound reactions		2	6
Failures		2	1	Number of reactions		100	100
Repetition of stimulus-word		-	-				

- | | |
|-------------|----------|
| 1. stove | warm |
| 2. to walk | hot |
| 3. (- | -) |
| 4. water | to bathe |
| 5. to dance | to sweat |

[179] *Subject 18.* The subject, a doctor, 36 years old, felt indisposed during the experiment under normal conditions. The experiment with external distraction could not be carried out because of illness. The hundred associations carried out in “fatigue” were obtained after an eventful night without sleep.

[180] Internal distraction and fatigue show a striking agreement: a most definite decrease of internal associations, increase in external and particularly in sound associations and word-completion, an increase in the “same number of syllables” group, while the figures for the same grammatical form remained on the whole uninfluenced. In the first hundred in the experiment under normal conditions, there is a preponderance of internal over external associations (47 : 43); in the second hundred the relationship is reversed (30 : 59). The constant increase of word-completion and sound reactions in the experiment with internal distraction is nicely demonstrated if they are counted separately in each third of the hundred associations. We find:

- 1st third: 2 word-completions, 6 sound reactions
- 2nd third: 5 word-completions, 7 sound reactions
- 3rd third: 9 word-completions, 9 sound reactions

[181] The predicates are already on the decrease in the second hundred of the experiment under normal conditions, even more so with internal distraction; they disappear completely in fatigue. Rhymes do not become prominent till the fatigue experiment; we only find two under internal distraction and none in the experiment under normal conditions.

[182] In subject 18 we meet a relatively large number of associations that can be explained only by reference to individual experiences from the recent past or present, e.g., *ring / garden*: at the time of the experiment a gold ring had been found in the garden of the establishment where the subject worked and its owner had not been found.

Subject 18. 36 years of age

ASSOCIATIONS	NORMAL			
	1st Hundred	2nd Hundred	INTERNAL DISTRACTION	FATIGUE
SPECIAL QUALITY				
Grouping	24	14	7	4
Predicative relationship	23	13	11	—
Causal relationship	—	3	—	—
Co-existence	15	12	5	9
Identity	—	8	—	—
Linguistic-motor forms	28	39	31	20
Word-completion	1	—	16	16
Sound	2	4	20	27
Rhyme	—	—	2	8
Indirect	7	6	7	8
Meaningless	—	1	1	1
Failures	—	—	—	—
Repetition of stimulus-word	—	—	—	—
Egocentric reaction	1	1	—	—
Perseveration	3	—	1	2
Repetition of reaction	2	—	—	—
Same grammatical form	42	57	45	47
Same number of syllables	33	30	47	53
Alliteration	15	22	32	26
Consonance	18	27	41	39
Same ending	6	11	6	21
Internal associations	47	30	18	4
External associations	43	59	36	29
Sound reactions	3	4	38	58
Number of associations	100	100	100	100

[183] Or *clothes / Stapfer*. A patient by the name of Stapfer, who was in the care of this particular colleague, worried him greatly because, for example, he ordered clothes and afterwards always found so much to criticize in them that he finally would not wear the garment; there then followed much unpleasantness with the tailor and other suppliers.

[184] Or *pencil / Kohinoor*. Our colleague had at the time of the experiment just learned about the useful properties of this brand of pencil.

[185] Or *murderer / Kaufmann*. Our colleague had at this time to give an opinion of a defendant by the name of Kaufmann, who had committed murder when intoxicated.

[186] This type of association is caused by definite constellations (Ziehen), referring to relatively new, subjective, possibly emotionally charged experiences.¹⁹

[187] In some subjects (e.g., subjects 25 and 27, uneducated women) we find none at all or only very few. Such individuals react throughout entirely objectively and betray practically nothing personal in the associations. For example, they associate *river / stream*; *school-boy / girl*; *table /*

floor; lamp / oil; mountain / valley; to kiss / to laugh; to plunder / to catch; to beat / to bite; prison / punishment; etc.

[188] Admittedly other subjects also make objective associations; from time to time there are among them associations which, in spite of their objectivity, allow conclusions about the subject, although they do not in the least betray his inner personality. It will not be difficult, for instance, to recognize the male nurse from the following compilation of associations (subject 35, uneducated men): *to fetch / to run; to stink / foul air; to inform / report; prison / asylum; ill / melancholic; errand / to run; freedom / convalescence; consciousness / to drink or sobriety, etc.*

[189] Nevertheless the constellation plays only a very indirect role in these associations.

[190] Then there are subjects—that is to say, associations—in which not the momentary constellations but the individual experiences predominate (e.g., subject 19, educated men):

<i>Lake (See)</i>	<i>Untersee</i> (the subject had from time to time been to that lake)
<i>father</i>	<i>grandfather</i> (the subject still has a grandfather)
<i>mountain</i>	<i>Glärnisch</i> (the subject had been to that mountain once, without the journey having had any special meaning for him)
<i>hair</i>	<i>hair-lotion</i> (the subject occasionally prepares a hair-lotion in the dispensary for the patients)
<i>sweet (Süss)</i>	<i>Süsskind</i> ²⁰ (proper name of someone not at all important to the subject)
<i>potato</i>	<i>tobacco fields</i> (fortuitous memory of a journey from Basel to Heidelberg)
<i>coffee</i>	<i>Brazil</i> (the subject had several times drunk Brazilian coffee)

[191] These are mainly subjective reminiscences. Going a step further, we encounter the constellations *sensu strictiori* that we first mentioned when discussing subject 18 in the group of educated men. Individuals with many constellations usually also have many reminiscences (e.g., subjects 18 and 19, educated men).

[192] A separate group of constellations arises in some individuals through the influence of the immediate surroundings in which the experiment is carried out. The reaction-words *carpet, flowers, ink-pot, calendar, books, pen-holder, landscape, telephone, wallpaper, curtain, mirror, sofa, etc.*, usually refer to objects in the consulting-room even if they are associated with a quite suitable stimulus-word. The subject does not necessarily need to see the objects but only to know that they are in the room (see subject 25, uneducated women).

[193] From pathology—in normal, imbecilic, hysterical stupidity—quite pronounced cases of this type of association are known to us.²¹

[194] If the stimulus-word evokes a subjective emotionally stressed image with the corresponding reaction then we get a special type of constellation-association—namely, the egocentric (as in [Part I](#)). In subject 4 [educated women] we find only a few, e.g., *piano / horrible* (the subject had to put up with the tinkling of her not exactly musical neighbour). Or *to be lazy / glorious*; the egocentricity of this reaction is readily understandable for a busy person who is looking forward to approaching holidays.

- [195] In some cases an egocentric reaction can be directly replaced by a missing reaction, a failure (see definition in [Part I](#)). It is not true that there is no reaction at all, but through a conscious or unconscious inhibition the reaction-word does not get as far as being spoken. This is probably not the origin of all failures, but certainly of the majority.
- [196] Girls, for example, fail with stimulus-words bordering on sexual themes, e.g., *to love, to kiss, to stroke, to choose, fidelity*, etc. Often it does not actually come to a “failure” but the association *to love / brother* takes a relatively long reaction-time, so that the experimenter after some experience soon discovers who is concealed behind the innocent-seeming brother.
- [197] The associations *wedding / unhappiness, to kiss / never*, and others of subject 19, educated men, have an analogous significance; the subject was at that time in a state of “suspense and anxious longing.”²²
- [198] Now it is possible that an emotionally charged complex of ideas becomes so predominant in an individual and has such a profound influence that it forms a large number of constellations, failures, and reactions with long reaction-time, all referring to this complex of ideas. Subjects 19, 20, 21, and 22 of the group of educated men will give us an opportunity to return to this special form of constellation; the majority of complexes operative in the association experiments relate to direct or transposed sexuality. In the work on the associations of hysterics we shall return to the effect of the complex.
- [199] In subject 18 of this group, we can show, besides many reminiscences, fifteen constellations in the first hundred under normal conditions, four in the second hundred, one under internal distraction, and twelve in fatigue. In the experiment under normal conditions it is often the names of definite people, e.g., *clothes / Stapfer; keeper / Baum* (Baum is the name of a particular keeper); *tooth (Zahn) / Göschenen* (the subject had a discussion in Göschenen about the poet Zahn).
- [200] The constellation also expresses itself through proper names with subject 19 of this group. When the constellations are on the increase owing to fatigue (e.g., subject 18, educated men) they nearly always consist of the reaction in the form of a proper name; the reaction is associated to the stimulus-word also through similarity of sound (e.g., the internal connection of *clothes / Stapfer* in contrast to the purely sound connection *Stahl [steel] / Stapfer*).
- [201] *Subject 19.* Physician, 25 years old. Fatigue was defined as the condition of the subject at ten o’clock in the evening after a full working day.
- [202] The ratio between internal and external associations is not unambiguous in the different experiments. The maximum of external associations, 61 per cent, is found in fatigue but it is only a little larger than the figure in the first hundred under normal conditions, 57 per cent. This maximum of external associations corresponds to a minimum of sound reactions.
- [203] Internal distraction proves stronger than external. The first fifty associations with external distraction were obtained with a metronome beat of 60, the second fifty with a beat of 100, and the last eighty-five associations with a beat of 108. Internal distraction corresponds to a maximum in the columns for sound reactions, same number of syllables, same grammatical form, alliteration, and consonance.

[204] In external distraction the sound associations decrease progressively and the indirect associations rise progressively, a proportion that we shall often meet again in distraction experiments. In the last third of the experiments with internal distraction the subject became uninterested, as if hypnoidal. At this point the number and intensity of visual images decreased, while the sound associations increased, as follows:

- 1st third: 3 sound associations
- 2nd third: 6 sound associations
- 3rd third: 18 sound associations

Subject 19. Physician, 25 years of age

ASSOCIATIONS	NORMAL		DISTRACTION				FATIGUE
	1st Hundred	2nd Hundred	Internal	External			
				60	100	108	
SPECIAL QUALITY				Metronome beats			
Grouping	19	27	11	20	20	-	20
Predicative relationship	9	20	10	12	6	10	13
Causal relationship	-	1	2	-	-	2	1
Co-existence	11	13	8	2	2	6	5
Identity	5	10	7	-	2	12	6
Linguistic-motor forms	41	17	30	34	32	40	50
Word-completion	3	-	-	-	2	1	1
Sound	6	6	27	20	14	5	1
Rhyme	-	-	1	-	-	1	-
Indirect	6	5	6	12	12	18	-
Meaningless	-	1	1	-	10	-	1
Failures	-	-	-	-	-	-	-
Repetition of stimulus-word	-	-	-	-	-	-	-
Egocentric reaction	-	-	2	2	8	-	-
Perseveration	-	4	-	2	2	-	1
Repetition of reaction	3	2	3	4	8	21	8
Same grammatical form	60	59	66	52	52	50	50
Same number of syllables	28	27	50	46	46	36	37
Alliteration	14	14	38	36	18	15	8
Consonance	30	23	43	28	30	20	20
Same ending	11	9	11	4	4	9	6
Internal associations	28	48	23	32	26	12	34
External associations	57	40	45	36	36	58	61
Sound reactions	9	6	28	20	16	7	2
Number of associations	100	100	100	50	50	85	78

[205] The number of perseverations fluctuates within the normal limits. We give as example:

fidelity $\begin{matrix} \longleftarrow \\ \longrightarrow \end{matrix}$ perjury
 once $\begin{matrix} \longleftarrow \\ \longrightarrow \end{matrix}$ merry (*fidet*)

The origin of this perseveration is obvious. *Fidel* is on the one hand a sound association of *fidèle*, the latter being a translation of “faithful.” Here is another example:

fruit	Thurgau
false	Falk (falcon)

The family gets its fruit from Thurgau, from a Mr. Falk. Falk is a sound association to the second stimulus-word and in coexistence with the first. And, for instance,

to love $\begin{matrix} \square \\ \square \end{matrix}$ Stern (star)
 son $\begin{matrix} \square \\ \square \end{matrix}$ Isaac

Stern is the name of a young Jewish lady. Isaac, the son of Abraham, is a fairly frequent though not a current association. The association to Stern is internal.

Alt	Uchtspringe
Freiheit (freedom)	at the Altmann

Alt is, as is well known, the director in Uchtspringe. Freiheit is the name of a peak near the Altmann, in the Säntis area.²³ Thus we have here a perseveration of purely external nature.

[206] With internal distraction we find in our subject an example of persistent perseveration of visual images appearing with the reaction. The reaction-words are associated with the stimulus-word only by sound:

		<i>Visual image</i>
malt (<i>Malz</i>)	painter (<i>Maler</i>)	brewery
omnipotence (<i>Allmacht</i>)	Halma [a game]	a barrel of malt
spring (<i>Quelle</i>)	the house at the fountain	in a district where there was always a strong smell of malt, the subject has often seen malt-carts in his youth

[207] After the first reaction, *malt / painter (Maler)*, the subject could not repeat his own reaction-word; he had forgotten it. While forming associations his attention was directed much more to visual associations than to verbal reaction. For similar reasons we find this forgetting of the stimulus or reaction-word much more frequently in pathological cases of emotional stupidity and hysteria.

COMPLEX-PHENOMENA AND THE UNCONSCIOUS

[208] Going through the associations of our subject, only the experienced observer would notice the complex-phenomena which are very important in normal subjects as a basis of comparison with pathological ones, where complexes play a large role. Unfortunately reaction-times were not taken in the material of subject 19 now being used.

[209] The material used here is derived not only from experiments on subject 19 used previously in our work but also from some earlier ones. What we recorded was the following (starred: not used in this work):

On Sept. 17	78 associations without fatigue*
Dec. 27	78 associations without fatigue*
Dec. 27	a further 78 associations in fatigue
Feb. 22 (foll. year)	156 associations in fatigue*
Aug. 19	200 associations without fatigue
Aug. 19	100 associations with internal distraction
Aug. 25	185 associations with external distraction

[210] The subject had, during the time of the experiments, formed an attachment to a young woman. To make the experiments understandable it must also be mentioned that the young man had not yet outgrown adolescent internal conflict, and as he had had a strict Christian upbringing,

his inclination for a Jewish girl worried him a great deal. Let us call her Alice Stern: we shall be keeping as near the truth as is necessary for the experiment. In the experiment on September 17 we find the following complex-constellations:

1. wedding	misfortune
2. come	come with me
3. to suffer	oh heavens—yes!
4. misery	who has not spent miserable nights?
5. to kiss	never
6. game	sweet games will I play with you
7. sofa	a particular chaise-longue (in the drawing-room of the young woman)
8. to love	is useless
9. fidelity	sweetheart
10. wreath	bridal wreath (thought of with the appropriate melody) ²⁴
11. hope	Thou shalt in life (quotation, continuing “be with us loving and comforting”)

[211] Numbers 1, 5, and 8 are disguised wishes, although the external form is a negation. Numbers 2, 4, 6, 10, and 11 are quotations or lines from songs; number 6 is the continuation of number 2, a quotation from the *Erlkönig*.

[212] It is most noteworthy that in the other seventy-eight associations only one other quotation occurs, namely

to be compelled	“no man can be compelled to be compelled” ²⁵
-----------------	---

and quotations are very rare in the associations of this subject. Thus the complex makes use of a mode of reaction that is not usual in this subject: in fact, it is characteristic that the subject had only (to his shame, it might be said) salvaged from the *Erlkönig* this small fragment, “Come with me, sweet games will I play with you” into conscious memory.²⁶ Of the *Jungfernkranz* (bridal wreath), too, he only knows the very small fragment of the text, “We shall weave a bridal wreath for you,” although he knows the whole tune. We shall return later, in the work on hysterical associations, to the frequently quite unconscious and automatic emergence of tunes and quotations, often only in fragments. (Cf. a similar phenomenon in subject 26, uneducated women.)

[213] In the first experiment of December 27 the subject formed among others these associations:

1. it	“It, it, it, and it. It is a hard end”
2. you	yes ... I
3. parting	is painful
4. star (<i>Stern</i>)	hm!
5. game	amusement (with long reaction-time)
6. heart	(the subject asks to be allowed not to say the reaction; it would have been Stern)

[214] The associations 1, 2, 3, 4, and 6 are self-explanatory after what has already been said. In 5 the long reaction-time, occurring suddenly, is suspicious.

[215] From the experiment of December 27 in fatigue, the following associations taken in their context are striking:

1. to kiss	yesterday
2. to love	yesterday
3. already (<i>schon</i>)	yesterday (the stimulus-word <i>tears</i> [<i>Tränen</i>] had preceded it; the subject thought he heard <i>schön</i> [beautiful]; we might have here a perseveration of the umlaut)
4. miracle	yesterday
5. to pray	yesterday

[216] The reaction-times were usually quite short. The subject had the feeling that the reactions had taken him unawares. In the whole experiment no other reaction was repeated, except *kraut* twice (with *potato* and *sauer*). In the other experiments, too, repetitions are rare.

[217] All the stimulus-words quoted belong to those with a close connection with the complex "Stern." The stimulus-word *already* (*schon*) was understood as *beautiful* (*schön*), preceded by *tears* (*Tränen*). As we recall, examples 4 and 5 especially were reactions at that time most closely connected with the complex (religion!). *To kiss* and *yesterday* are not to be regarded as a recollection; their relationship was not of this nature. It cannot be said with any certainty whether the unconscious had permitted itself to use the reaction *gestern* (*yesterday*) symbolically on account of its second syllable, or whether this word has any connection with the fact that this experiment took place immediately after the Christmas holidays, during which the subject had been tremendously pleased by a small present from the young woman. But the fact that this word, and this word only, is so often repeated in the experiment as a reaction to the complex stimulus-words is most striking. It replaces the quotations of the previous experiment (in this experiment there is not a single one).

[218] The experiment of February 22 of the following year took place in fatigue. The following associations are worthy of mention:

song		Lore (a complex quotation; "Of all the girls, etc., I like Lore best"; the vowel <i>o</i> occurs in the bisyllabic real first name of the young woman; the two names are very similar in sound)
sacrifice	∑	dog (<i>Hund</i>) (apparently senseless reaction)
wedding	∑	ram (<i>Hammel</i>)

—a perseveration of the reaction. In the combination *sacrifice* / *ram* / *wedding*, the complex certainly played a part; in this connection the perseveration in the experiment under normal conditions of August 19 is comprehensible:

{	to love	□	<i>Stern</i> (star)
	son	□	Isaac!

[219] One association is senseless: *rich* / *yesterday*; probably *yesterday* occurs as an association produced in embarrassment which has become stereotyped; it occurs again in this experiment in *a people* / *yesterday*. Here too one can only conjecture; perhaps the concept "Jews" is the link. The association *game* / *parents* can be explained as indirect; the link, which was unconscious, is the quotation: "My dear child, come away with me, beautiful games, etc." the significance of which we learned above. The following associations also occur:

inn	the Star (<i>Stern</i> ; the subject was aware of the complex here)	to part	hurt
		to cut	hurts
		to stroke	hurts

to kiss
to love

together
roses

to beat
to sing

hurts
hurts

[220] The first four associations belong to the complex, the following are probably only stereotyped repetitions of “parting hurts.” Here too the repetition must still be considered as the effect of the complex.

[221] Otherwise only a few repetitions occur.

[222] In the distraction experiments there is no manifestation of the complex.

[223] *Subject 20.* In the second half of the experiment under normal conditions,

(1) the internal associations increase from 49 per cent to 54 per cent, while the external decrease;

(2) the sound reactions increase from 2 per cent to 6 per cent;

(3) the perseverations from 6 per cent to 8 per cent;

(4) the egocentric reactions from 14 per cent to 27 per cent;

(5) the constellations from 56 per cent to 73 per cent;

(6) the repetitions from 6 per cent to 15 per cent.

[224] The following are well above average in number: Internal associations,

Subject 20. Science teacher, 25 years of age

ASSOCIATIONS	NORMAL		ASSOCIATIONS	NORMAL	
	1st Hundred	2nd Hundred		1st Hundred	2nd Hundred
SPECIAL QUALITY			SPECIAL QUALITY		
Grouping	19	21	Egocentric reaction	14	27
Predicative relationship	28	32	Perseveration	6	8
Causal relationship	2	1	Repetition of reaction	6	15
Co-existence	15	2	Same grammatical form	46	26
Identity	—	—	Same number of syllables	28	15
Linguistic-motor forms	20	19	Alliteration	5	6
Word-completion	2	5	Consonance	8	14
Sound	—	1	Same ending	1	—
Rhyme	—	—	Internal associations	49	54
Indirect	—	—	External associations	35	21
Meaningless	1	5	Sound reactions	2	6
Failures	10	11	Number of associations	78	78
Repetition of stimulus-word	—	—			

perseverations,
egocentric associations,
failures,
and the predicates (v. infra, the section on averages).

- [225] The linguistic-motor reactions are roughly equal in both halves; there are no indirect associations.
- [226] The figures given above indicate that the subject reacts very subjectively and that by analogy a complex can be presumed in addition. The high number of constellations (56 per cent and 73 per cent) makes this very probable. On analysis, they predominantly refer to *school* and *bride*. The subject is an enthusiastic teacher; on the other hand the complex *bride, wedding, etc.*, plays a preponderant role in his reactions, particularly in the second half, where the subjective phenomena are in any case more numerous.
- [227] In the first half:
26 per cent of the reactions refer to school, 21 per cent to the bride complex.
In the second half:
21 per cent of the reactions refer to school, 24 per cent to the bride complex.
- [228] In addition, two to three failures in the first half and the majority of failures in the second half refer to the bride complex, e.g., the failures after the stimulus-words *to stroke, ill, to suffer, to kiss*.
- [229] Apart from this, the complex is expressed less deviously than in the preceding subject; it is less repressed and does not fall back on song-quotations as with the former subject. Incidentally, *school* and *bride* are closely connected in subject 20, as he cherished the dream that he would soon be married and his wife would assume an important position in the institute.
- [230] Among the thirteen repetitions in the first half, the name of the institute occurs four times, an important event at the school twice, the name of the fiancée three times. In the second half, the name of the fiancée occurs seven times in the reactions, the word *child* twice, at which the subject thought of his future parenthood. The other repetitions mostly concern school matters; three times the subject was annoyed at the seemingly nonsensical stimulus-word and each time reacted angrily with "Rubbish!"
- [231] The perseverations, with two exceptions, concern school and family affairs.
- [232] Finally, a few examples of these complex-associations:

grandmother	S. will be (S. is the name of his fiancée)
cross	I as a teacher, according to S.
{to come	written to S.
{year	will marry (in two years)
{Sunday	S. comes
{to kiss	(subject will not react)
{naturally	(subject will not react)
to love	S.
tears	she cried (S.)
{fidelity	S.
{once	S.
{hope	that we can marry
{small	child (!)
{to pray	shall I never (image of praying child)
{dear	child
{where?	in bed
{old	S.
ring	at betrothal
to stroke	(will not react at first) S.
child	my future (one)
{sweet	a brand of chocolate, received from S.
{to ride	M—, home of fiancée, where she used to ride
{friendly	S.'s family
{three	members of the family (there are three in S.'s family)

[233] The bracketed stimulus-words followed each other immediately in the experiment.

[234] With the increase of the subjective emotional content in the course of the experiment the value of the individual reactions also increases, as the figures show.

[235] *Subject 21.*²⁷ In the second hundred reactions of the experiment under normal conditions we find a maximum of co-ordinations, predicative relations, of internal associations generally, while the external associations diminish greatly. This maximum also covers the perseverations and egocentric associations.

Subject 21. Physician, 23 years of age

SPECIAL QUALITY	ASSOCIATIONS		NORMAL		DISTRACTION	
	1st Hundred	2nd Hundred	Internal	External		
				60 Metro-nome	100 Metro-nome	
Grouping	19	20	7	12	8	
Predicative relationship	16	42	26	20	14	
Causal relationship	-	-	3	2	-	
Co-existence	24	5	10	30	22	
Identity	5	3	5	10	4	
Linguistic-motor forms	29	23	22	12	38	
Word-completion	-	-	-	-	-	
Sound	2	3	18	4	6	
Rhyme	-	1	-	-	-	
Indirect	2	1	3	2	6	
Meaningless	3	2	6	8	-	
Failures	-	-	-	-	-	
Repetition of stimulus-word	-	-	-	-	-	
Egocentric reaction	4	19	2	-	2	
Perseveration	4	40	5	4	10	
Repetition of reaction	8	8	8	4	4	
Same grammatical form	58	26	32	62	42	
Same number of syllables	34	22	35	50	52	
Alliteration	12	8	31	12	10	
Consonance	18	13	33	16	8	
Same ending	6	5	2	-	-	
Internal associations	35	62	36	34	22	
External associations	58	31	37	52	64	
Sound reactions	2	4	18	4	16	
Number of associations	100	100	100	50	50	

[236] In comparison with the average figures for educated men, the predicates in the second hundred, the total of internal associations generally, as well as the perseverations and egocentric reactions, are high above average, in the following ratio:

Predicates	42 : 19.7
Internal associations generally	62 : 36.7
Perseverations	40 : 2.4
Egocentric reactions	19 : 2.8

while the remaining figures deviate little from the average. With the fifteenth stimulus-word of the second hundred (*to kiss*) the complex-reactions begin, at first still interspersed with others; then the complex persists through twenty-six associations, then again with interruptions, disappearing again towards the end of the second hundred. Thus altogether we find a maximum of 50 per cent of complex-constellations in the second hundred of the experiment under normal conditions; 13 per cent in the first hundred; under internal distraction 5, under external 8. We have already found an increase of complex-reactions in the second hundred of the experiment under normal conditions with subject 20, educated men. The appearance of the complex, in this case conjured up by an appropriate stimulus-word *to kiss*, causes a big increase of internal associations, probably due to the intense stimulation of attention. That the manifestation of the complex corresponds to an increase of internal associations is a proof that our classification is to some extent valid and natural. The stronger the emotional stress of the stimulus-word is for the individual and the more attention is devoted to that stimulus-word, the more the number of internal associations rises. This phenomenon is the exact opposite of the distraction

phenomenon. Attention is improved because of the invasion of an emotional complex, which absorbs the whole personality, because the attention is directed more to the significance of the stimulus-word.

[237] If attention is distracted from the experiment not by external distraction but by an emotionally charged complex, as for example in subject 18 quoted above (experiment after sleepless, eventful night) who was under the influence of strong emotion, then we see the opposite of the phenomena that we have just described in subject 21: internal associations decrease and the result is very similar to an experiment with internal or external distraction.

[238] Thus in the second hundred, strong emotionally charged complexes were more manifest and perseverated more; there is, in contrast to the phenomenon usually appearing in the second hundred, an increase instead of a decrease of internal association, predicates, etc. That there are, among the stimulus-words of the second hundred, in the experiment under normal conditions, rather more words that stimulate slightly emotionally charged ideas is of no consequence in this case or in that of subject 20 of this group, because the complex manifests itself even with stimulus-words that are seemingly of no special significance.

[239] It is noteworthy that in complex-constellations the reactions readily come in the form of sentences, in other associations only rarely.

[240] In distraction the complex no longer plays a role. In internal distraction we find a maximum of sound reactions (18), which is somewhat above the average for educated men.

[241] In the first group of external distraction experiments we find in the reactions a maximum of "same grammatical form" (62) and "same number of syllables" (50); in internal distraction, on the other hand, a maximum of alliterations (31) and consonance (33 per cent).

[242] *Subject 22.*

Internal associations. Decrease in the second hundred of the experiment under normal conditions, which is much more marked under distraction.

External associations. Increase in the second hundred and under distraction. Most predicates decrease mainly in the second hundred, as do the constellations.

Linguistic-motor forms. Increase in the second hundred and in the second half of the distraction experiments; there we find a maximum of linguistic-motor forms.

Repetitions and failures. Most frequent in the second hundred of the experiment under normal conditions; in addition, under distraction there is an increase of same grammatical form, same number of syllables, alliteration, consonance, and same ending.

[243] In the second part of the distraction experiments there is an improvement of reaction (perhaps due to getting used to distraction); slight increase of internal associations and predicates, absence of sound reactions, slight increase of constellations, slight decrease of same grammatical form and of same number of syllables, consonance, and same ending; on the other hand, increase of linguistic-motor forms and thereby of external associations. Perseverations also occur here most frequently.

SPECIAL QUALITY	ASSOCIATIONS		NORMAL		DISTRACTION	
	1st Hundred	2nd Hundred	External			
			60 Metro-nome	100 Metro-nome		
Grouping	21	18	24	16		
Predicative relationship	20	14	2	10		
Causal relationship	2	2	—	2		
Co-existence	18	11	16	16		
Identity	5	9	24	10		
Linguistic-motor forms	26	32	28	44		
Word-completion	—	—	2	—		
Sound	2	2	4	—		
Rhyme	1	—	—	—		
Indirect	2	1	—	2		
Meaningless	1	1	—	—		
Failures	2	9	—	—		
Repetition of stimulus-word	—	1	—	—		
Egocentric reaction	3	5	2	2		
Perseveration	2	1	—	4		
Repetition of reaction	11	12	8	2		
Same grammatical form	37	54	86	70		
Same number of syllables	35	34	58	42		
Alliteration	7	5	8	8		
Consonance	7	11	24	12		
Same ending	9	8	24	12		
Internal associations	43	34	26	28		
External associations	49	52	68	70		
Sound reactions	3	2	6	—		
Number of associations	100	100	50	50		

[244] The constellations are nearly all conditioned by love or the subject's profession. There occur:

In the 1st hundred, normal conditions	44%
In the 2nd hundred, normal conditions	20%
In the 1st half of distraction	6%
In the 2nd half of distraction	14%

[245] The following perseverations, caused by a complex, are worthy of note:

1. { lady of the heart
shoulder blade
to twine entwine (the subject pictures an erotic situation)
2. { square (*Platz*) Town Hall
lawn *Platz* (this perseveration is not fortuitous either; a definite story, with erotic significance for the subject, is linked with the Town Hall square)

[246] Failures appear in two forms in subject 22: sometimes the verbal reaction fails and in its place there is a vivid visual image, for example, or a vivid emotionally charged sensation, which the subject subsequently describes.

[247] In the other group there are inhibitions because certain erotic memories emerge.

[248] Under distraction no failures occur. The egocentric reactions predominate in the experiment under normal conditions and refer mainly to erotic subjects.

[249] Of the repeated reaction-words only *bright*, *good*, and *beautiful* occur more than twice.

- [250] *The complex.* The erotic complex rules a large number of reactions—a total of thirty in the experiment under normal conditions, and ten in the second half under distraction (15 per cent under normal conditions and 20 per cent in the second half under distraction are demonstrable). In the first half, where distraction is more complete, we find none. The complex is hardly suppressed; on the contrary, it is manifest.
- [251] The progressive decrease of sound reactions in the course of the external distraction experiments and the increase of indirect associations is in keeping with our assumptions. (See “Averages.”)
- [252] *Subject 23.* The figures show a very slight distraction-phenomenon. The proportion of internal and external associations changes very little in the distraction experiment, so that the variation in the results of the two experiments in fatigue are greater than between normal conditions and distraction. On the other hand the sound associations increase under distraction, as with subject 19 of this group; in both there are fewer sound reactions in fatigue.
- [253] The associations in fatigue were obtained from both subjects under very similar conditions (normal fatigue after a doctor’s working day, 10 o’clock in the evening), while a sleepless night, with heavy psychic demands due to emotion, preceded the associations in fatigue of subject 18 of this group. Here we find in fatigue an increase of sound reactions.
- [254] The negligible difference caused by distraction may in subject 23 be connected with the fact that the number of internal associations is already fairly low in the experiment under normal conditions (24, that is 26 per cent instead of 36.7 per cent, as in the average of educated men) and the number of external ones fairly high (72, that is 69 per cent instead of 52.7 per cent, the average of educated men). The number of internal associations in the experiment under normal conditions is roughly the same as the average number of internal associations under distraction (in educated men).
- [255] The effect of fatigue is visible in the first fatigue experiment but not in the second.
- [256] The figures for alliteration and consonance in distraction have perceptibly risen, as with subjects 18 and 22 of this group.
- [257] The number of repetitions is throughout above the mean; there are relatively many words that are repeated twice but only very few that are often repeated. In almost all experiments we find *pleasant, unpleasant, gladly, unwillingly, friendly*, and similar words among the repetitions. We shall not examine the individual cases of repetition and perseveration any further here, because they do not point towards such obviously emotionally charged ideas as in the earlier cases; nevertheless, these do not entirely lack this background.

Subject 23. Physician, 25 years of age

ASSOCIATIONS	NORMAL		DISTRACTION				FATIGUE	
	1st Hundred	2nd Hundred	Internal	External		1st Experiment	2nd Experiment	
				60 Metro-nome	100 Metro-nome			
Grouping	9	9	11	12	8	13	13	
Predicative relationship	14	17	18	16	16	6	20	
Causal relationship	1	-	-	-	-	-	1	
Co-existence	24	7	-	8	14	7	12	
Identity	5	19	8	2	10	9	5	
Linguistic-motor forms	43	43	55	56	42	61	49	
Word-completion	-	-	2	-	-	-	-	
Sound	-	3	4	6	2	1	-	
Rhyme	1	-	-	-	-	-	-	
Indirect	2	1	-	-	4	1	-	
Meaningless	1	-	2	-	4	1	-	
Failures	-	-	-	-	-	-	-	
Repetition of stimulus-word	-	-	-	-	-	-	-	
Egocentric reaction	3	3	-	-	-	-	-	
Perseveration	5	1	2	2	-	1	4	
Repetition of reaction	16	15	22	12	10	18	18	
Same grammatical form	57	51	47	42	50	67	59	
Same number of syllables	42	42	45	32	28	45	48	
Alliteration	8	6	20	22	28	20	11	
Consonance	14	10	28	26	38	21	14	
Same ending	12	10	12	10	14	12	10	
Internal associations	24	26	29	28	24	19	34	
External associations	72	69	63	66	66	77	66	
Sound reactions	1	3	6	6	2	1	-	
Number of associations	100	100	100	50	50	156	156	

[258] The constellations are few and far between. Here too we find a decrease of sound associations at the same time as an increase of indirect associations in the second part of external distraction.

GENERAL REMARKS ON THE GROUP OF EDUCATED MEN

[259] We had at our disposal nine subjects, whose ages ranged from 23 to 47, with altogether 3,793 associations. With five subjects, the experiments were carried out with internal as well as external distraction; in one case only with internal distraction, and in one case only with external distraction; in two cases no distraction experiment took place. With five subjects, associations in fatigue were also worked over, with one subject associations in a state of drowsiness. All the subjects in this group have had academic education. Six of them are physicians, one a medical student, one a grammar-school teacher, and one a chemist. All are German-Swiss.

[260] Only one subject is of the predicative type (No. 17). Unfortunately we could not carry out a distraction experiment on him.

[261] The experiment with internal distraction was successful in four cases; the sharp increase of sound reactions is most characteristic, the decrease of internal with the increase of external associations is less prominent. In one case (16) the result was unexpected, in another (23) there was no definite result; the subject had a minimum of internal and a maximum of external associations already in the experiment under normal conditions.

[262] External distraction was clearly successful in two cases; in two cases the success was very moderate, in one case (23), on the other hand, no definite effect was noted. In general the effect

of internal distraction is more intense than that of external. These particular subjects always succeeded in fulfilling the experimental conditions for internal distraction.

[263] The associations obtained in fatigue give a result similar to that of distraction in three out of the five cases. In one case (18) it is particularly clear; but it is possible that perhaps fatigue was not, or not solely, responsible for that, as the subject had had a particularly exciting experience during the sleepless night and probably was still very much distracted by it during the experiment.

[264] The association experiment in drowsiness with subject 15 also gave a result similar to that of a distraction experiment.

[265] In four subjects (19, 20, 21, 22) we find in the course of the experiment, particularly under normal conditions, extensive complex phenomena. In the first three (19, 20, 21), we see that the internal associations increase in the second hundred of the experiment under normal conditions and the external associations decrease, i.e., the opposite of what one would expect. At the same time we find an increase in the complex-constellations. In the distraction experiment the complex-constellations usually decrease or disappear.

[266] The subject need not be conscious of the complex phenomena and they often do not emerge till the association results are statistically worked over and grouped. Thus, lesser complex-phenomena may also be found in subjects without this distinct complex-type, e.g., in subject 18 (see below, the examples of association-types given in detail) or in subject 16, where in plotting a curve of reaction-times, several emotionally charged associations from long ago appeared. Practically every lengthening of reaction-time, even within quite normal limits (of which the subject is not aware), signifies, as far as we know at present, that the particular stimulus-word has touched upon a feeling-toned complex. We shall describe these findings in a later communication.

III. UNEDUCATED WOMEN

*Eight subjects with 2,400 associations*²⁸

[267] *Subject 24.* The associations of this subject are given in detail among the examples of association types (see below). As in uneducated subjects generally, we find relatively more internal reactions and fewer linguistic-motor forms than in educated subjects. The increase of internal associations, particularly of predicates in the second hundred of the experiment under normal conditions, may be attributed to the predominance of personal participation after the subject had grown used to the experiment. We have already met this phenomenon several times.

Subject 24. Nurse, 18 years of age, Swiss, secondary-school education

SPECIAL QUALITY	ASSOCIATIONS		DISTRACTION	
	NORMAL		External	
	1st Hundred	2nd Hundred	60 Metro-nome	100 Metro-nome
Grouping	23	20	16	14
Predicative relationship	23	37	20	22
Causal relationship	2	1	-	-
Co-existence	28	14	38	30
Identity	1	5	2	2
Linguistic-motor forms	23	23	14	30
Word-completion	-	-	-	-
Sound	-	-	6	2
Rhyme	-	-	-	-
Indirect	-	-	2	2
Meaningless	-	-	-	-
Failures	-	-	-	-
Repetition of stimulus-word	-	-	-	-
Egocentric reaction	3	-	-	-
Perseveration	1	-	4	4
Repetition of reaction	11	9	14	2
Same grammatical form	60	53	68	58
Same number of syllables	36	44	48	46
Alliteration	16	7	4	12
Consonance	15	11	12	8
Same ending	5	6	10	8
Internal associations	48	58	36	36
External associations	52	42	54	62
Sound reactions	-	-	6	2
Number of associations	100	100	50	50

[268] Although distraction was successful, it was not exactly striking. External associations increased, sound and indirect associations, which are quite absent under normal conditions, occurred. Strikingly enough, perseverations are also more numerous.

[269] Distraction had little effect, for several reasons: the subject has relatively many predicative reactions without actually belonging to the predicative type; the latter, however, is distinguished by a weaker distraction-phenomenon. The subject often found it difficult to divide her attention and to react simultaneously to the metronome and the stimulus-word. Secondly, the experiments with uneducated women gave us the impression that these found dividing their attention more difficult than did educated subjects. They are usually completely absorbed by the experiment and work with quite concentrated attention. The stronger the means of distraction, the more desperate their effort. Thirdly, we know that in this case the experiment had a very strong psychic effect on the subject. Emotions relating to the subject's complex, some of which were only recently assuaged, came to the fore and strongly affected the reaction. The experiment was a revival of a complex that had become somewhat latent. That is why we find a large number of obvious complex-reactions even in the distraction experiment, which as a rule is rarely the case.

[270] The complex-phenomena require a short explanatory case-history. The subject had a country background and became a nurse at seventeen, after brooding at home for a year upon the unhappy termination of a love-affair. Her irascible father did not want to know anything of the relationship and once there was a scene during which he cursed her because she had dared to contradict him. Facial burns, accompanied by great terror, and a tedious illness had revived this psychic pain through brooding shortly before the associations were taken. The association experiment gave rise to a further exacerbation of this unhappy memory; the effect persisted for

But now no more,

Love, the magician, deceived me full sore.

In the next three associations she remains caught up in the complex:

}	once	I was happy
	wonder	of love
	blood	of expiation (thinks of her father's curse)
	wreath	death (for months she thought of dying; she intentionally ate almost nothing for weeks so that she might become ill, and lost a lot of weight in the process. After the experiment, which revived the complex again—particularly after a visit home that she made soon afterwards—she started to eat very little even with us and to lose weight till the matter was discovered and the folly of her behaviour made clear to her).

[274] On other occasions the subject quotes the titles of stories, the content of which refers to her complex, e.g.:

seven

brothers

“The Seven Brothers” is the title of a story in which devoted brother-love is rewarded.²⁹ The association immediately following is:

ill

my brother

[275] The quotations, six in all, occur only in the experiment under normal conditions (as with subject 19, educated men) and all evidently refer to the complex.

[276] We have already quoted two examples where the complex entraps the subject in an idea. Others occur, e.g., this perseveration:

friendly	□	friendship
three	□	friends

The subject has an intense need for friendship; but there have always been disappointments—her best friend married another girl.

[277] Another example, from the experiment under distraction:

meadow

the orchard

to bring

the apples

[278] We have here a direct perseveration not of the reaction but of the image of the underlying situation. We shall in the course of the work include these forms also in the concept of perseveration. The connection between meadow and orchard is clear to us at once from what has been said above (meadow!). The “apples” of course come from the same orchard.

[279] Of the four (8 per cent) perseverations in the distraction experiment, there is only one that probably refers to the complex.

[280] *Repetitions.* In the experiment under normal conditions, seven reaction-words occur several times (two to five times); at least thirteen of these seventeen words belong to the complex. In the distraction experiments (one hundred reactions) there are altogether eight reaction-words that occur several times (two to three times). The ratio expressed as a percentage is also roughly the

same as under normal conditions ($2 \times 8 = 16$). Of those, four (8 per cent) definitely refer to the complex.

[281] It is striking how often *human being* appears as a reaction; eight times in three hundred associations (normal conditions and distraction). There are seven reactions that certainly belong to the complex. *Human being* sometimes refers to a quite definite person, sometimes to the subject herself.

[282] Similarly we find the reaction *the person* several times used as a general term, with quite concrete meaning in reference to the complex, e.g.:

propriety	the person
bad	the person

[283] The subject is thinking of a quite definite person, her friend, who plays an important part in the complex. She is not morally faultless—has, for instance, an illegitimate child. By the reaction *human being* she often means this same friend, who in her more frivolous life had more luck in love than the more serious subject, e.g.:

{ indolent	the human being
{ virtue	of human beings

In this example there was even a perseveration of the same reaction-word, from which can be gathered how strong is the emotional charge of this idea.

[284] We often find the definite article used in the reaction as a disguise of the complex-constellation. Our subject, for example, used the article 26 times in the reactions under normal conditions; seventeen of these reactions definitely refer to the complex. The connection is less striking under distraction.

[285] We find the phenomenon again in other subjects. To illustrate the complex-reactions here are some relevant examples:

decent	the person (see above)
to be careful	the person
bad	the person
to pray	the pious one (referring to herself; she prayed a great deal when most unhappy)
{wonder ³⁰	of love (referring to herself, also to expiation)
}blood	of expiation (she feels guilty towards her father; there is a perseveration of the external form of the reaction here)
omen	of punishment (in the same way this reaction would be quite nonsensical grammatically and can only be explained by the assumption that we are probably dealing with the after-effect of the previous reaction form. This reaction is separated by several from the one before)
normal	the human being (a quite definite one)
meadow	the orchard } (for explanations of these
to bring	apples { associations see above)
mild	the father
clever	the snake (quite definite people)
{willing	the school-boy } in these associations the subject
}order	the industrious } was particularly thinking of the
	worker } friend of her youth
angry	the human being (means her father)

ana so on.

[286] In the distraction experiment the subject did not understand several stimulus-words, namely: *hatred, love, repentance, fall, pleasant, penny, glass, to hammer, entrance, ears, to inhibit.*

[287] It soon transpired on analysis that the subject could not, or would not, understand the first series of quoted stimulus-words, owing to the half-conscious, half-unconscious effect of her complex. According to her, all these stimulus-words touched most intimately upon the complex that she was trying to suppress.

[288] The stimulus-words of the second series were really not understood because of the acoustic disturbance of the metronome. The subject thus found a further method here of hiding her complex in an apparently unobtrusive way; it is adapted to the situation, for, as the second series of stimulus-words (which do not touch upon the complex) proves, it is easy not to understand stimulus-words, or to understand them wrongly, in the constant noise of the metronome beats of the distraction experiment (to compensate for this, another stimulus-word was introduced into the experiment).

[289] This not wanting to understand corresponds to a repression of the complex that was to a greater or lesser extent conscious. There is no difference in principle from the cases (hysteria!) where not reacting or falsely reacting occurs involuntarily.

[290] Under complex-reactions we have a large group; that of masked complex-reactions. In our subject the masking, so far as we could discern it, was achieved by the following means:

1. By quotations (songs, book-titles, quotations from texts).
2. By the use of unobtrusive general concepts with a quite special meaning with reference to the sense of the complex.

3. By the addition of the article. The reaction thus receives an apparently even more objective appearance; it then appears like the practised reply of an elementary-school child.

4. By misunderstanding the stimulus-words that allude to the complex.

[291] Finally it must be reported that abnormally long reaction-times frequently occur in the complex-reactions; unfortunately, however, no systematic measurements were taken with this subject, so that we cannot develop this point further in the case before us.

[292] *Subject 25.* In the first place, the high figures for grouping and co-existence are striking, both under normal conditions and under distraction. Some of them are far above the mean values. On the other hand, the figure for predicative and linguistic-motor reactions is relatively small and below the mean, particularly in the case of the predicative reactions. The explanation of these figures is probably the extraordinarily objective, steady mode of reaction, which is apparently little disturbed by complexes.

[293] A few reactions with a rather long reaction-time are to be noted. In our experience reactions with a time of more than 5.0 seconds are generally suspect of referring to emotionally charged constellations.

[294] In this subject we find twelve associations with a reaction-time of more than five seconds under normal conditions, in the distraction experiment only three.

Subject 25. Nurse, 22 years of age, South German, intelligent but not educated

ASSOCIATIONS	NORMAL		DISTRACTION	
	1st Hundred	2nd Hundred	External	
			60 Metro- none	100 Metro- none
SPECIAL QUALITY				
Grouping	33	34	18	22
Predicative relationship	3	9	2	4
Causal relationship	-	1	4	2
Co-existence	36	25	28	34
Identity	6	11	24	18
Linguistic-motor forms	15	16	20	18
Word-completion	-	-	-	-
Sound	-	1	2	-
Rhyme	-	3	2	2
Indirect	4	-	-	-
Meaningless	3	-	-	-
Failures	-	-	-	-
Repetition of stimulus-word	-	-	-	-
Egocentric reaction	-	1	-	-
Perseveration	-	-	-	-
Repetition of reaction	5	8	-	-
Same grammatical form	91	78	92	88
Same number of syllables	67	56	58	48
Alliteration	8	7	2	2
Consonance	7	18	22	14
Same ending	22	19	22	16
Internal associations	36	44	24	28
External associations	57	52	72	70
Sound reactions	-	4	4	2
Number of associations	100	100	50	50

[295] In the following examples with lengthened reaction-time, the lengthening is presumably to be interpreted as the effect of an erotic complex:

wedding	miss	6.8 ³¹
to kiss	to laugh	6.0
to love	gladly	5.6
male nurse	wardrobe	8.0
dream	basket	6.4
ripe	fruit	6.6
to bless	to receive	5.8

[296] The subject usually reacts strongly to allusions of an erotic nature and also blushes easily. She admits herself that she was embarrassed at answering to the first three stimulus-words. She also found it awkward to say the word *nurse* which first occurred to her as an answer to the stimulus-word *male nurse*, obviously because she immediately thought of erotic relations. She searched in her surroundings and named the first object she saw in the room: *wardrobe*.

[297] At the stimulus-word *dream*, an erotic thought prevented her from reacting. Instead of giving a reaction according to sense, the subject again let herself be distracted by externals, happened to see the waste-paper basket, and said *basket*. Thus a senseless reaction was given as a result of the complex. The reactions *ripe / fruit (Obst)* (the subject first thought of “fruit” [*Frucht*]) and *to bless / to receive* are obviously again examples of the same sexual embarrassment.³²

[298] Distraction by surrounding objects is, as far as we know from our experience in psychopathology, a phenomenon that must be interpreted in both cases as the effect of emotion.³³ In embarrassment or bewilderment, which are caused when the stimulus-word conjures up emotionally charged ideas that the subject consciously or unconsciously tries to repress, the subject lets herself be completely distracted by externals and verbally reacts by simply naming an object from her surroundings. We find this phenomenon very marked in certain hysterics, for example.

[299] Of the sixteen reaction-words, from the experiment under normal conditions, that are repeated we call special attention to: *diligent* five times, *good* three times, *well-behaved* twice, *right* twice. The others are divided among very varied ideas. One can more or less see from these the strict morals of the subject. It is characteristic that these indications of subjectivity disappear under distraction.

[300] In classifying, it was rather difficult always to draw the dividing line with certainty between grouping and co-existence.

[301] Finally, it can be said of the subject that she belongs to an objective reaction-type that is very little influenced by constellations, and which we find again in subject 27 of this group.

[302] The following reactions might illustrate this general objective reaction-type of the subject.

soft	hard
youth	age
sorrow	worry
window	glass
false	right
sweet	sour
wide	narrow
honey	bee
to rinse	to wash

building
sleeve
park
glass
couch
to paint
star
fidelity
to plunder
freedom
regret
stork
bike

wall
dress
garden
iron
chair
to varnish
moon
obedience
to catch
solitude
fear
dove
car

[303] The unusually high number of reactions with the same grammatical form runs parallel to the many groupings and coexistences and confirms what has just been stated.

[304] Distraction is very obvious. There is a decrease of internal, an increase of external associations. We only find sound reactions in the second hundred of the experiment under normal conditions and under distraction; on the other hand, direct associations only in the first hundred, so that our assumed rule of reciprocity between indirect and sound associations would again be correct here.³⁴

[305] It must, incidentally, be mentioned that the subject carried the experiments out with great enthusiasm and also made a great effort under distraction to do justice to the higher demands by devoting all her attention to the experiment.

[306] *Subject 26.* The subject has a rather obvious tendency to make rhymes, which increased in the second half of the distraction experiment.

[307] The usual distraction phenomenon did not appear, although the subject does not belong to the predicate type. Marking the beats was done with great irregularity. The predicates increase under distraction; the external associations, particularly the linguistic-motor reactions, decrease; only the sound reactions increase constantly.

[308] Constellations are found mostly in the second hundred of the experiment under normal conditions and in the first half of the distraction experiment. The latter fact shows that the distraction experiment was after all partially successful; for, with the exception of subject 24 of this group, where the distraction experiment was equally unsatisfactory, the constellations disappeared almost completely under distraction in the other subjects.

[309] We here describe individual examples: To the stimulus-word *lamp*, the subject did not react till 20.0 seconds later with *oil-lamp*. She had just before had the pleasant dream that instead of the 9 o'clock meal, which she rarely took, she was getting a new lamp in her room, which she wanted very much.

[310] window glass 10.0 (thought of *vitrine* in between)

The subject thought of a large shop with beautiful glass cases. She had for some time been the private nurse of the wife of the owner of such a shop and was very attached to her former patient. The subject had learned the French expression *vitrine* for "glass case" from the sister of this

patient. One can see how a particular thought occurring at the time is responsible for an apparently insignificant expression.

[311] to strike 6 o'clock 2.0

The subject had carried out night duty in a ward, always having to get up at 6 o'clock in the evening.

[312] to paint *peintre* 6.8

This reaction, with a lengthened reaction-time, refers to a year's stay in French Switzerland. The subject, then a young girl, was admired by a painter; he was also very keen to paint her. In the reaction-word *peintre* there is, besides a masking of the constellation by a quite blunt association, a further constellation, in that the subject in this instance uses, together with the reminiscence of an erotic experience in French Switzerland, a French word. In the distraction experiment she produces the reaction

Subject 26. Nurse, 21 years of age, Swiss, secondary-school education

ASSOCIATIONS	NORMAL		DISTRACTION	
	1st Hundred	2nd Hundred	External	
			60 Metro-nome	100 Metro-nome
SPECIAL QUALITY				
Grouping	20	16	22	8
Predicative relationship	5	11	16	18
Causal relationship	1	1	2	—
Co-existence	24	10	18	8
Identity	4	6	10	14
Linguistic-motor forms	43	47	24	36
Word-completion	1	1	—	2
Sound	—	—	2	2
Rhyme	1	2	2	8
Indirect	—	5	2	2
Meaningless	—	—	2	2
Failures	1	1	—	—
Repetition of stimulus-word	—	—	—	—
Egocentric reaction	1	—	—	2
Perseveration	2	2	2	—
Repetition of reaction	6	5	8	4
Same grammatical form	75	50	76	60
Same number of syllables	48	39	56	46
Alliteration	9	8	6	2
Consonance	13	9	18	16
Same ending	13	11	12	20
Internal associations	26	28	40	26
External associations	71	63	52	58
Sound reactions	2	3	4	12
Number of associations	100	100	50	50

painter

peintre 13.0

with the same constellation. The characteristically long reaction-times in both places are worthy of note.

[313] In rapid succession the following reactions occur:

wedding

tomorrow

2.2

This repetition is not a coincidence. The subject was celebrating her saint's day the day after the experiment under normal conditions took place. She was happy, for she wanted to go out, and she had been invited out for this day and would be receiving all the congratulations at home; among these she was also expecting a letter from her sweetheart.

[314] Further, we find the reactions:

rich	in love	2.0
poor	in virtue	2.2

The first is a quotation from Ernst Zahn's novel *Albin Indergard* (1901). It refers to a love-story and has the significance of a complex quotation for the subject, like the one we discussed in subject 19 in the group of educated men and subject 24 (uneducated women). The second is an analogous but original form. The subject was thinking of another nurse with whom she had had an argument the day before on the subject of "love," in which the other had maintained a much less idealistic attitude to the question than had the subject. The stimulus-word *poor* has become associated with the previous stimulus-word *rich* and the emotionally charged reaction connected with it, whereupon she became conscious of the contrast between her "ideal of love" and that of the other nurse. By *poor in virtue* she means the other nurse.

[315] The same thought gave rise to the following quotation:

to despise	you think	2.2
------------	-----------	-----

The quotation is word for word as follows:

Perhaps you believed
 I should hate life,
 [Flee to the deserts,
 Because all dream buds
 Had not bloomed?] (Goethe, *Prometheus*)

The subject knows only the first two lines of this quotation, she had quite forgotten the part in brackets. At this, the subject vividly thought of the other nurse and her low views on the subject of "love." One sees from this how closely related expressions and quotations of this sort become associated with feeling-toned complexes, helping to create the infinitely copious unconscious verbal material used by feeling-toned complexes, which makes possible, for example, the poet's countless variations on one single thought.

[316] A further quotation:

finally	does not last for ever	5.6
---------	------------------------	-----

again refers to her love-complex. The reaction-time is strikingly long. The subject was thinking of the "brother of a woman friend," who turned out to be her sweetheart; she was anxiously awaiting news of whether he had accepted a certain post abroad, wishing he would not go.

[317] At the stimulus-word *to kiss* the subject reacted in a tone of surprise: "*To kiss—yes—I cannot tell you that; we have just been talking about something.*" She meant the discussion with

the other nurse, who said that kissing was something dirty. To the stimulus-word *time* the subject reacted:

time	according to	2.0
------	--------------	-----

The next reaction but one was

to reign	according to ...	3.8
----------	------------------	-----

[318] At *to reign* an older nurse who was in charge of the whole department came to her mind. A trifling incident of about that time made the subject think: "She regiments us in everything." The stimulus-word *to reign* released this thought, which the subject could not utter; in its place appears the reaction-word *according to* used almost immediately before, which had a meaning when used with *time* but with *to reign* at the most only a remote one. Thus the gap in the reaction produced by the affect is filled by a reaction-word already used. A similar phenomenon was already observed in subject 19 in the group of educated men, who in an experiment under fatigue always reacted with *yesterday* to a series of stimulus-words that touched upon the complex.

[319] The reaction

to love	in need of	4.0
---------	------------	-----

is accompanied by a sudden change of facial expression. This phenomenon refers to her love-complex and is important for us because we find similar reaction-phenomena (changed facial expression, sudden lowering of voice) in the pathology of associations, where emotionally important complexes are concerned.

[320] At

to choose	advice	3.2
-----------	--------	-----

the subject thought that one must be very careful in one's choice of a husband; she thought that one ought to have good advice when having to make one's choice.

[321] A quotation, the reaction

hope	does not let one sink	1.8
------	-----------------------	-----

is based on a recent letter which the young man from Western Switzerland (*le peintre*) had written to her a short while before, and from which it transpired that he had not yet given up hope of winning her.

[322] On the reaction

love (<i>lieb</i>)	empty (<i>leer</i>)	3.0
----------------------	-----------------------	-----

the subject put an unusual inflection; it refers to her own love-life and must be put by the side of the reaction:

to love	in need of	4.0
---------	------------	-----

with a change of facial expression.

[323] The reaction

is again a quotation. The text on which it is based runs as follows:

The girl came to the spider
 And the spider said: Why so late?
 I have been spinning threads for three hours
 See how finely and delicately they are twisted!

The content of these lines is summarized by the stimulus-word *lazy*. Also the reaction is determined by sound in the stimulus-words *spät* (late) and *gedreht* (twisted). An obvious condensation (Freud) of the situation and apparent form into the word *träge* (lazy) has occurred in the subconscious; this is already proved by the fact that the reaction-time is quite short and therefore there can be no question of a conscious search for quotations. One also sees that the subconscious or unconscious likes to associate quotations or complexes, often in such a way that fragments of quotations and songs which happen to have been picked up, and the continuation of which the subject does not know, are directly connected with the complex. In our present case, for example, the subject does not know the poem by heart.

[324] We still have to prove that behind this quotation there lies a feeling-toned thought.

[325] The verse, taken from a school poem, corresponds to the feeling-toned situation at the time. The subject was then, as already mentioned, on night duty in a ward. She slept during the day. In the morning she was relieved by the nurse who was on day duty in the same ward; she had several times in the last few days been annoyed that this nurse relieved her so late; we find the expression of this in this reaction.

[326] Behind the seemingly insignificant, quite impersonal reaction:

something

important

1.2

is concealed the thought of the saint's day on the morrow.

[327] To the stimulus-word *to woo* there was no reaction. The cause of this is once more the conversation with the other nurse about love. She recounted that she had permitted herself the joke of writing to an obscure marriage bureau, whereupon a widower had been recommended to her by this bureau as a good match. This idea displeased the subject very much.

[328] To the stimulus-word *doing* the subject reacts *and not doing* (10 secs.). Behind this superficial reaction the thought of the argument about love is once more concealed.

[329] When a complex is hidden behind quotations or superficial reactions of this sort, the reaction-time is usually short. While in the so-called failures attention is quite absorbed by the complex that is to be suppressed (that is, hidden from consciousness or from the experimenter) here a division of attention takes place. One part is devoted to the verbal reaction and this then bears a very superficial (linguistic-motor, sound) character; the other part is occupied by the emotionally charged idea. This part is frequently repressed and does not clearly emerge to consciousness. This interpretation is also confirmed by the frequent observation that such quotations and superficial reactions are produced with the most indifferent expression in the world although the observer, for example, knows that they refer to a strong emotionally charged complex and are conditioned by it.

[330] The main part of the emotionally charged complex becomes split off and repressed. At the same time the chain of ideas unfolding in consciousness contains as representative of the complex only a quotation, for instance; this appears after a short reaction-time and indicates to the expert that under this cover an important complex is exerting its influence in the subconscious.

[331] In other cases, where the affect is already shown in the quality of the reaction (intonation, expression), this split does not take place; the reaction becomes more difficult and the reaction-time lengthened (see the example *to love / in need of*; 4.0).

[332] In the distraction experiment we find in subject 26, in the group of uneducated women, among the few reaction-words (*bicycle, Zurich, clear, sad*) that are repeated several times, two in which a complex is probably the cause of the repetition.

[333] About the reactions

bike	wheel	tram	bicycle
------	-------	------	---------

the subject afterwards explained that her sweetheart cycled a lot, which immediately came to her mind when she heard the stimulus-words. The reactions

fire	Zurich	station	Zurich
------	--------	---------	--------

remind her that in the discussion about love she had defended the town of Zurich and its inhabitants against the other nurse. The reactions

moved	sad
mild	sad

are connected with incidents in her family. In the reactions

sin	world	0.8
remorse	death	1.2

a recent accident was on her mind, in which a patient managed to drink some Lysol from an instrument dish. There were no serious consequences but the incident had happened in the ward in which the subject was on duty and had left her with a very unpleasant impression and a great feeling of guilt; hence also the perseveration in the above reactions.

[334] *Subject 27.* The result of the experiment has the greatest similarity with that of subject 25 of this group. Admittedly the distraction phenomenon is not so marked (the subject gave her whole attention to both experiments). Reactions from the sound group are completely absent and the number of linguistic-motor forms is very small. The co-existences show high figures. The predicates are few, egocentric reactions absent, which indicates a very objective grasp of the stimulus-words. The figures for the same grammatical form of the stimulus-word and reaction are strikingly high, as in case 25 of this group. Thus our subject also belongs to the same quite objective reaction-type without demonstrable constellations. Many associations have lengthened reaction-times, without our having a retrospective explanation for it. We do not possess a more detailed analysis.

[335] *Subject 28.* The predicates are relatively few (in the experiment under normal conditions, for example, only 8.5 per cent instead of 20.4 per cent, the average for uneducated women). The

groupings, too, are below average in the experiments under normal conditions and under distraction; the linguistic-motor reactions, on the other hand, are above average for uneducated women (the latter is 24 per cent under normal conditions and 28.8 per cent under external distraction). On the whole, we are confronted by a case with relatively few internal and many external associations.

Subjects 27 and 28. Nurses, 23 and 28 years of age, Swiss, elementary-school education

ASSOCIATIONS	SUBJECT 27				SUBJECT 28			
	NORMAL		DISTRACTION		NORMAL		DISTRACTION	
	1st Hundred	2nd Hundred	External		1st Hundred	2nd Hundred	External	
1st Half			2nd Half	1st Half			2nd Half	
Grouping	46	46	54	26	21	32	14	16
Predicative relationship	4	2	-	6	9	8	4	6
Causal relationship	1	3	-	-	1	1	-	-
Co-existence	30	15	18	32	32	15	14	12
Identity	4	13	16	18	6	8	12	8
Linguistic-motor forms	14	18	12	18	30	32	50	48
Word-completion	-	-	-	-	-	-	-	-
Sound	-	-	-	-	-	2	2	8
Rhyme	-	-	-	-	-	-	2	-
Indirect	1	2	-	-	-	-	-	2
Meaningless	-	1	-	-	-	1	-	-
Failures	-	-	-	-	1	1	2	-
Repetition of stimulus-word	-	-	-	-	-	-	-	-
Egocentric reaction	-	-	-	-	-	-	-	-
Perseveration	-	1	-	-	-	-	-	2
Repetition of reaction	8	5	6	4	10	9	0	2
Same grammatical form	85	86	96	90	76	69	68	70
Same number of syllables	60	53	58	56	54	43	48	42
Alliteration	11	6	8	2	16	19	28	28
Consonance	15	7	10	8	14	21	30	36
Same ending	25	17	12	24	17	14	12	22
Internal associations	51	51	54	32	31	41	18	22
External associations	48	46	46	68	68	55	76	68
Sound reactions	-	-	-	-	-	2	4	8
Number of associations	100	100	50	50	100	100	50	50

[336] Although, or rather because, the general reaction-type appears somewhat superficial, the distraction experiment was successful, considering that uneducated women with many predicatives are usually more difficult to distract. Even if the external associations are no more numerous in the second part of the distraction experiment than in the first hundred under normal conditions, the internal associations have definitely decreased, while the sound reactions have increased.

[337] In the second hundred under normal conditions we have an increase of internal associations. At the same time, we find (as so often) an increase of constellations, which are probably, as many cases show, the cause of this shift. (The fact that among the stimulus-words of the second hundred there are more than in the first hundred of the kind likely to awaken emotionally charged concepts may have an influence here.) In the first hundred under normal conditions six constellations, in the second hundred under normal conditions ten, in the distraction experiment two can be demonstrated. In the distraction experiment they are much less frequent. We have here almost exclusively complex-constellations.

[338] The complex is linked to a romance with an unhappy ending. The subject was disloyally deserted by her lover after a long relationship.

[339] The long reaction-times (mostly more than five seconds) are almost exclusively confined to these complex-constellations. Examples:

male nurse	hospital orderly	11.4	(the lover was a n
heart	stomach	6.4	
to stroke	to love	5.6	
to part	to go	5.6	
dear	angry	8.8	
freedom	imprisoned	6.0	
to despise	respected	18.4	
band	to tear up	5.2	
false	falsehood	7.2	

[340] The subject did not really want to give an account of the few remaining constellations and long reaction-times, which cannot easily be recognized as belonging to the complex; they are therefore all the more suspect.

[341] Here again we see the specific way in which the complex is manifested, i.e., the lengthened reaction-times. (This does not mean that these do not also occur in other cases, e.g., with rather difficult, unfamiliar stimulus-words.)

[342] We have already found lengthened reaction-times as complex-phenomena (subjects 26 and 27 of this group); here they are almost exclusively complex-characteristics. There is a transition to the so-called “failures,” where there is no verbal reaction at all.

[343] The repetition of reaction-words is almost exclusively limited to the experiment under normal conditions and concerns sixteen different words; the majority of them designate things from the everyday life of a nurse.

[344] *Subject 29.* A glance at the ratio of the predicate to the groupings tells us that the subject must be classed as a predicate type. In keeping with the rule for the predicate type we find no clear effect of distraction. Sound reactions and indirect associations only occur in the first part of distraction. Egocentric reactions are well represented and evenly distributed. The highest number of internal and the smallest number of external associations occur again in the second hundred of the experiment under normal conditions. There we also see a maximum of failures (7), which are nearly all caused by a complex. Unfortunately the subject never gave us an exact explanation and her retiring character induced us not to insist on one. The subject only confessed that memories of particular events in her family were largely behind the failures and the lengthened reaction-times. In a few instances unusual stimulus-words were responsible.

[345] *Subject 30.* Distraction was clearly successful; it is mainly characterized by a decrease of groupings and increase of linguistic-motor forms; the number of predicates, although fairly numerous, is somewhat more stable. The largest number of perseverations occurs under distraction, particularly in the second hundred of the distraction experiment. There are no egocentric reactions. From the type of reactions it is not clear whether constellations or complexes play a part in the associations of the subject or not. It is easier to draw some

conclusions from the reaction-times occurring, for example, after provocative stimulus-words, e.g.,

Subjects 29 and 30. Nurses, 18 and 27 years of age, Swiss, elementary school education

ASSOCIATIONS	SUBJECT 29				SUBJECT 30			
	NORMAL		DISTRACTION		NORMAL		DISTRACTION	
	1st Hundred	2nd Hundred	External		1st Hundred	2nd Hundred	External	
1st Half			2nd Half	1st Half			2nd Half	
Grouping	22	19	14	12	19	30	4	8
Predicative relationship	27	45	50	48	32	32	36	16
Causal relationship	1	1	-	-	2	1	-	-
Co-existence	31	14	16	12	26	12	10	6
Identity	2	3	6	10	2	4	6	2
Linguistic-motor forms	16	11	18	18	18	18	36	66
Word-completion	-	-	-	-	-	-	-	-
Sound	-	-	2	-	-	-	-	2
Rhyme	-	-	-	-	-	-	-	-
Indirect	-	-	4	-	-	-	-	-
Meaningless	-	-	-	-	-	-	4	-
Failures	1	7	-	-	1	3	-	-
Repetition of stimulus-word	-	-	-	-	-	-	4	-
Egocentric reaction	3	2	2	2	-	-	-	-
Perseveration	7	1	2	-	2	-	8	14
Repetition of reaction	13	11	14	6	14	9	18	4
Same grammatical form	50	29	28	32	31	35	38	60
Same number of syllables	37	24	48	52	53	43	20	14
Alliteration	6	3	6	6	13	9	28	30
Consonance	9	5	12	6	15	12	34	30
Same ending	-	2	2	4	6	11	20	28
Internal associations	50	65	64	60	53	63	40	24
External associations	49	28	30	40	46	34	52	74
Sound reactions	-	-	2	-	-	-	-	2
Number of associations	100	100	50	50	100	100	50	50

to kiss	morning kiss	8.4
to remember	letter	11.0
bad	(failure)	
rascal	without means	12.6

[346] But we lack a detailed psychological analysis in this case. In the distraction experiment, repetitions of the form of the reaction occur; mainly we find reactions in the form of a whole sentence, e.g.,

sin	man sins
repentance	man repents
love	people love
strong	man is strong
hatred	people hate, etc.

[347] Strikingly long reaction-times do not occur here; whether the repetition of form, particularly the reoccurrence of the word *man*, indicates similar complex-phenomena to those we found in subject 24 of this group cannot be established.

[348] Seen from outside the associations of our subject make a very objective impression, without many subjective constellations. The rather variable and often strikingly long reaction-times, however, indicate that, behind the apparently objective reactions, complex-constellations are

probably to be found after all. For practical reasons it was not possible in all cases to carry out a thorough psychological analysis, as could fortunately be done with a number of subjects.

[349] *Subject 31.* The reactions are characterized by the great predominance of predicates, which make up the majority of the large number of internal associations. There is a definite inclination towards value judgments, which, however, do not have an expressly subjective (egocentric) character. The reactions betray a strong involvement with the experiment and with the meaning of the stimulus-word. In this way, in spite of a certain reticence and reserve, the more intimate content does emerge rather clearly. The subject is a very capable and practical housemaid, very religious. Occasionally she thinks of marriage. In the reactions under normal conditions the following reactions are repeated:

Subject 31. Maid, about 27 years of age, Swiss, elementary school education, fairly intelligent

ASSOCIATIONS	NORMAL		DISTRACTION	
	1st Hundred	2nd Hundred	External	
			1st Half	2nd Half
SPECIAL QUALITY				
Grouping	10	13	10	20
Predicative relationship	48	32	37	32
Causal relationship	-	-	-	2
Co-existence	11	4	14	4
Identity	2	5	2	2
Linguistic-motor forms	23	42	25	32
Word-completion	-	2	2	2
Sound	-	-	-	2
Rhyme	-	-	2	-
Indirect	-	-	2	-
Meaningless	-	-	-	-
Failures	6	1	6	4
Repetition of stimulus-word	-	-	-	-
Egocentric reaction	-	-	2	-
Perseveration	-	1	-	-
Repetition of reaction	15	15	8	2
Same grammatical form	38	38	34	40
Same number of syllables	42	36	44	54
Alliteration	3	11	6	8
Consonance	11	15	10	8
Same ending	6	8	4	6
Internal associations	58	45	47	54
External associations	36	51	41	38
Sound reactions	-	2	4	4
Number of associations	100	100	50	50

practical	twice	good	3 times
house	twice	beautiful	4 times
room	twice	wonderful	3 times
church	twice	man (husband)	3 times
God	twice	child	5 times

[350] Shortly before the associations were obtained the subject was attacked by a large dog, which greatly frightened her.

[351] The reaction *dog* was repeated four times. Once the subject showed a strong perseveration with the image of the dog.

{to growl }knot	dog the knots (lumps) on the paws of the dog
--------------------	---

[352] The reaction *wolf* is also repeated twice. To the stimulus-word *cunning* the subject reacts with *wolf*, volunteering that actually *fox* had occurred to her first. These reactions and repetitions clearly show feeling-toned complexes and therefore a strong personal participation.

[353] The distraction experiment, which incidentally was carried out very inadequately, had no effect at all. Thus we have here the same behaviour as in the predicate types described above.

[354] The failures, numerous with this subject, are distributed as follows: Of the seven failures under normal conditions, five concern emotionally charged stimulus-words such as *heart*, *custom*, *flatterer*, *faithful*, *rich*, *revenge*, etc. In the two series of experiments under distraction, the failures (ten in the one and five in the other) concern 8 per cent of emotionally charged stimulus-words in the one and 4 per cent in the other—a further proof that the majority of failures can be attributed to emotional causes.

SUMMARY

[355] In the group of uneducated women we have eight subjects, with ages ranging from 18 to 28, and altogether 2,400 associations. From each subject we have two hundred associations under normal conditions and one hundred under external distraction.

[356] Most of the subjects are fairly intelligent. More than half have attended secondary as well as primary schools. Seven subjects usually speak the Swiss dialect, only one speaks a South German dialect, which is more like standard German. Seven subjects are nurses, one is a maid. Two subjects react as predicate types; with neither was the distraction experiment successful. With a third subject, who gave a good number of predicates without actually belonging to the predicate type, the distraction experiment also failed; partly, no doubt, because the subject, in order not to let her attention be distracted, did not always make the strokes to the beat of the metronome at the stimulus-words. The distraction experiment was only partly successful with a subject with many groupings and no constellations. She almost doubled her effort in the distraction experiment, in order to pay attention to the stimulus-words as well as to the metronome beats.

[357] With the remaining four subjects the distraction experiment was successful, although in general these subjects also strained their powers in the distraction experiment and made considerably more effort than in the experiment under normal conditions, because they found it more difficult than the educated subjects to divide their attention. On the whole the uneducated women were the group least able to divide their attention. The sound associations play a much smaller role as distraction phenomena than in the groups of educated subjects. Two subjects are of a purely objective type with few predicates, practically no constellations and strikingly many reaction-words with the same number of syllables as the stimulus-word. In two other subjects (24 and 26), complex-phenomena in various forms are predominant. In three subjects an increase of internal and a decrease of external associations can be observed in the second hundred of the experiment under normal conditions; it usually appeared that the complex-phenomena were also more obvious in the second hundred under normal conditions, while they diminish in number under distraction. In the marked cases, e.g., subject 24, the manifestation of the complex in the second hundred of the experiment under normal conditions is certainly not dependent on the

increase of emotionally charged stimulus-words. It also appears with stimulus-words that for other people do not have this property at all.

IV. UNEDUCATED MEN

[358] In the group of uneducated men we tabulate only a summary for the first six cases; the columns omitted are of no special interest. For the group of linguistic-motor forms, we have obtained the following mean values, from which none of the six subjects deviates significantly: experiment under normal conditions, first hundred 27, second hundred 30; external distraction, first half 22, second half 34. Definite complex-constellations are hardly demonstrable, and in almost all cases detailed analyses are lacking.

[359] *Subject 32.* The external associations predominate over the internal but not to the same degree as in the educated subjects. The effect of distraction is clear: in the second hundred of the experiment under normal conditions we see the number of internal associations fall and the external ones rise somewhat. The figures for failures and egocentric reactions (4, 8, 6, 4) are strikingly high; they exceed the mean for these reaction-forms. In the absence of a more detailed analysis it is not really possible to find the significance of the failures in each association. There are practically no definite constellation-associations; neither do the reaction-times—apart from the few failures—betray any complex-constellation. They vary within narrow limits, 0.6 to 2.6 seconds.

[360] *Subject 33.* Predominance of external associations, as in the preceding case. In the second hundred of the experiment under normal conditions, an increase of internal and decrease of external associations appears. We have been able to explain this phenomenon where we met it in other groups up to now, almost without exception, by the fact that the feeling-toned association-complexes emerge more clearly. Probably this is the case here too; yet the constellation-associations are here not very obvious and we possess only a fragmentary analysis. The sum of reaction-times in the second hundred is greater than in the first; the longer reaction-times are more numerous. In the second hundred there occurs significantly the reaction *family / alone*, 4.4 secs., the longest reaction-time that occurs with this subject.

[361] The young man is engaged to a nurse. A series of reactions with somewhat longer reaction-times are probably determined by this thought-complex.

[362] We find the most marked distraction phenomena in the first part of the distraction experiment, where we also find six sound associations.

[363] We find indications of constellations in our subject in single reactions referring to military service.

pupil	soldier
faithful	soldier
row	rank

Others refer, with fairly great probability, to his engagement and his fiancée:

dear	to trust	1.6
hope	at last	1.6
wreath	ring	3.2
fidelity	to let go	2.4

everywhere	alone	?
family	alone	4.4
to part	to come together	1.6

[364] These reaction-times, which are rather long in relation to the other associations, support this interpretation. We find practically no quotations or the like in this or in the preceding subject.

[365] *Subject 34.* The distraction experiment was not very successful; nevertheless it must be taken into consideration that the use of associations belonging to the sound and residual groups is more frequent in the distraction experiment than under normal conditions; the egocentric reactions disappeared in the distraction experiment, a phenomenon that may be regarded more or less as the effect of distraction. No constellation-and complex-associations are manifest.

[366] *Subject 35.* The subject can just be included in the predicate type. A certain effect of distraction can nevertheless be noted. We see the internal associations decrease noticeably in our table and a definite increase of external associations only in the second part of the distraction experiment; on the other hand there is a maximum of sound reactions in the first part of the distraction experiment. Perseverations and egocentric reactions are completely absent. No constellation-associations are evident. We quoted this case (one of the preceding cases from this group could also have been taken) in our discussion on constellations and complexes (see subject 18, educated men) as an example for those cases in which we find the first constellations and/or subjective reminiscences.

Subjects 32-37. Male nurses: (32) 40 years of age, Swiss, elementary-school education, fairly well read; (33) about 25, South German, elementary-school education; (34) 54, secondary-school education, intelligent, rather neurasthenic; (35) 37, elementary-school education; (36) 30; (37) 36, secondary-school education

ASSOCIATIONS	SUBJECT 32				SUBJECT 33				SUBJECT 34			
	NORMAL		DISTRACTION		NORMAL		DISTRACTION		NORMAL		DISTRACTION	
SPECIAL QUALITY	1st Hundred	2nd Hundred	External		1st Hundred	2nd Hundred	External		1st Hundred	2nd Hundred	External	
			1st Half	2nd Half			1st Half	2nd Half			1st Half	2nd Half
Grouping	34	12	16	16	32	37	24	20	5	22	10	12
Predicate	12	28	18	10	1	4	2	8	17	16	12	30
Internal associations	49	41	34	26	33	42	26	28	23	38	22	42
External associations	50	51	62	60	64	53	64	66	75	59	56	48
Sound reactions	-	-	-	-	2	1	6	-	-	1	4	2
Remaining group	1	8	2	14	1	4	4	6	2	2	18	8
Number of associations	100	100	50	50	100	100	50	50	100	100	50	50
ASSOCIATIONS	SUBJECT 35				SUBJECT 36				SUBJECT 37			
Grouping	15	15	22	10	32	16	18	12	46	27	30	22
Predicate	31	28	20	16	3	5	-	2	9	11	6	10
Internal associations	49	46	44	26	35	21	18	14	56	40	38	32
External associations	48	48	46	68	63	78	68	80	40	56	56	58
Sound reactions	1	1	4	-	1	1	8	4	1	1	-	2
Remaining group	2	5	6	6	1	-	6	2	3	3	6	8
Number of associations	100	100	50	50	100	100	50	50	100	100	50	50

[367] *Subject 36.* The internal associations diminish in number in this case as in the first few cases of this group. The predicates especially are very few. Define effects of distraction: the internal associations decrease both in the second hundred of the experiment under normal conditions and in the distraction experiment, particularly in the second part. Sound reactions, rhymes, and indirect and senseless reactions are numerous in the distraction experiment, particularly in the first part. In the second part they diminish again somewhat, but on the other hand the decrease of internal and increase of external associations is most marked. The figures for the same grammatical form are, as in the next case and in nos. 25 and 27 in the group of uneducated women, strikingly high (86 in the first hundred under normal conditions, 44 in the second hundred; 88 in each of the two halves of the distraction experiment). In keeping with this finding, egocentric associations are absent and the constellation-associations completely recede into the background and cannot be clearly recognized, as in the cases quoted.

[368] In the second part of the distraction experiment there appears a certain amount of repetition, probably in embarrassment and as a distraction phenomenon:

17. ³⁵ door	castle (or lock)
55. hall	castle hall
57. bridge	castle bridge (drawbridge)
69. shield	castle shield (or lockplate)
81. cellar	cellar-door
87. corridor	door

[369] *Subject 37.* Among the fairly abundant internal associations there are mainly groupings, while the predicates are not particularly numerous. The linguistic-motor forms are relatively few. A glance at the ratio of internal to external associations shows at once that the distraction experiment was successful; in fact the numbers obtained in the second hundred of the experiment under normal conditions foreshadowed it.

[370] Our subject is like subject 36 of this group, and subjects 27 and 25 of the group of uneducated women, in the marked prominence of groupings and the figures for the same grammatical form, the decrease of predicative relationships and the almost complete absence of egocentric reactions and constellation-associations. We have here an objective balanced reaction-type.

[371] This case is distinguished from the others by the predominance of subordinations and definitions within the groupings, while the other three subjects mentioned previously produced more actual co-ordinations.

<i>Stimulus-word</i>	<i>Subject 25</i> (Uneducated women)	<i>Subject 27</i>	<i>Subject 36</i> (Uneducated men)	<i>Subject 37</i>
Sunday	Tuesday	Monday	Monday	holiday
schoolboy	girl	teacher	teacher	boy
head	foot	arm	neck	part of human being
ink	pen	pen	pencil	writing material
bread	meat	cheese	flour	food
lamp	oil	candle	light	object in a room
tree	chair (?)	bush	bush	plant
wood	coal	coal	coal	fuel
slate-pencil	pen	pen	blackboard	school implement
fruit	plum	apple	vegetable	fruits
helmet	glove	sword	cuirassier	head-covering

[372] *Subject 38.* The subject may perhaps be included in the predicate types, although the predicates do not predominate greatly in the second hundred. Strikingly many co-existences. No reactions in the sound group. In the residual group the number of failures is noteworthy. The maximum (five) occurs in the second hundred of the experiment under normal conditions. The sudden occurrence of 6 per cent of repetitions of the stimulus-word in the second part of the distraction experiment is surprising. We also find 2 per cent of perseverations there. In the second hundred of the experiment under normal conditions the number of internal associations rises and that of external associations falls, as we have already found several times in connection with the emergence of complex-constellations. In spite of the predicate type, the distraction experiment was successful. The number of internal associations decreased and that of external associations increased more and more. The predicates in particular diminish noticeably in the distraction experiment.

ASSOCIATIONS	NORMAL		DISTRACTION	
	1st Hundred	2nd Hundred	External	
			60 Metro-nomic	100 Metro-nomic
SPECIAL QUALITY				
Grouping	13	22	26	12
Predicative relationship	35	26	12	14
Causal relationship	-	1	-	-
Co-existence	26	10	22	12
Identity	3	2	14	8
Linguistic-motor forms	22	34	22	44
Word-completion	-	-	-	-
Sound	-	-	-	-
Rhyme	-	-	-	-
Indirect	-	-	-	-
Meaningless	-	-	-	-
Failures	1	5	4	4
Repetition of stimulus-word	-	-	-	6
Egocentric reaction	2	-	-	-
Perseveration	-	-	-	2
Repetition of reaction	12	5	-	-
Same grammatical form	44	48	82	64
Same number of syllables	32	30	40	40
Alliteration	12	15	12	16
Consonance	17	18	26	22
Same ending	2	13	10	14
Internal associations	48	49	38	26
External associations	51	46	58	64
Sound reactions	-	-	-	-
Number of associations	100	100	50	50

[373] The exact figure for new constellations cannot be given; nevertheless a series of constellations exists, besides an enormous quantity of reminiscences from subjects taught at a grammar school. Individual associations with very long reaction-times are striking, e.g.:

exercise-book	squared	7.4
book	interesting	10.1
obstinate	the enemy	17.2
to stroke	<i>caresser</i> (french)	6.4
evil	devil	10.4
wicked	devil	28.0
to come	the yellow peril	8.4
to kiss	Oberon	6.8
to love	mother	13.0
dear	mother	9.0
strange	a poem	11.0
to disgust	dirty	6.8

[374] In the distraction experiment the reactions with strikingly long reaction-times are very few. Probably a more detailed analysis would have found one or more complexes behind these reactions. Eroticism, school, and fear of a small operation were probably the decisive reasons for the lengthening of the reaction-times.

[375] In the group of uneducated men we have seven subjects and 2,086 associations. All subjects are fairly intelligent but with the exception of subject 37, who has received a secondary-school education, and subject 38, who is attending a technical school, they have all only had elementary-school education. Four subjects are German Swiss, speaking the ordinary dialect; one subject is South German but has long been resident in Switzerland, and the Swiss dialect therefore came quite naturally to him. Only one subject speaks the Swabian dialect, which approximates more closely to standard German. One subject, the technical school boy, speaks standard German at home.

[376] Two subjects may be considered to be predicate types; as in most subjects of this type, distraction was not really successful in the first case, but it was in the second. With one subject, who produced relatively few internal and many external associations in the experiment under normal conditions, distraction was also not very successful. In all other subjects the effect of distraction was obvious (in all subjects of this group only external distraction was used).

[377] Sound associations as signs of distraction never occur to the same extent as with the educated subjects.

[378] Two subjects (36 and 37 of this group) belong to a type having very many groupings, few predicates, and many reactions with the same grammatical form; they are distinguished at the same time by the paucity of egocentric reactions and constellations. We also meet this type in the group of uneducated women (subjects 25 and 27). For the rest, the whole group of uneducated men is distinguished by the fact that constellations and complexes are few in number and can only be guessed at; this does not mean, however, that, within narrow limits, the fluctuations of the reaction-times do not betray the workings of complexes. Quotations and similar reactions suggesting a complex were found only rarely in this group, an exception being the youngest of the group, the technical school boy. He reacted with many subjective reminiscences and a number of constellations, which may in part be interpreted as complex-constellations.

[379] In subjects 33, 34, and 38 we find an increase of internal associations in the second hundred of the experiment under normal conditions. Whether this can always be explained by the effects of complexes cannot be ascertained with certainty in all cases.

[380] In general the uneducated men are distinguished from the uneducated women in our experiments in that subjectivity and feelings are less prominent. This difference hardly exists in the educated subjects. Among the educated men there are as many subjective types who react strongly with feeling as there are among the women; the educated men have more feminine characteristics in this respect than the uneducated.

[381] Finally, it may be permissible to point out once more that an overwhelming number of the complexes we have discovered in our subjects are erotic. In view of the great part played by love and sexuality in human life, this is not surprising.

B. CALCULATIONS OF AVERAGES

1. Experiment under Normal Conditions

[382] Having discussed the individual subjects, we still have to study the interrelations of the groups of reactions. In the individuals the proportions of these is markedly variable, as a glance

at the previous tables shows. Besides the individual causes, one of the main reasons for these variations is the intensity of concentration, the effect of which we have already mentioned several times. The fact that some individuals tend to react with internal associations and others with external ones is primarily a question of attention. Everyone gifted with speech has all the different qualities of association at his command: which quality of association he expresses depends in the main only on the degree of attention devoted to the stimulus-word. Where our distraction experiment was successful—that is, where the conditions of the experiment were carried out in the way intended by the experimenter—the identical unequivocal phenomenon appeared: the external associations and sound reactions increased at the expense of internal associations. The type of reaction shifted towards the accustomed and canalized and thus to the mechanical, concrete and verbal connections. With increasing distraction the effect of the “law of frequency” increases, ideas that are often spatially or temporally related being evoked. The less an idea is focussed upon, the more the valency of associated, mainly linguistic, elements increases, the threshold is lowered and these elements are therefore produced again.

[383] We do not wish to discuss here the different psychological theories of attention. We regard attention as a state occurring in association-complexes and ultimately characterized by muscular tension, which provides the psychophysical basis for the complex. The stabilizing of the idea in the field of consciousness seems to be the aim of the physical echo. It is probably through the somatic connection that the idea, or the “feeling” replacing it, is kept in focus. It becomes a “directional idea” (or a “directional feeling”). From it result two types of effect:

- (1) ideas promoting all associated ideas, particularly those associated with direction,
- (2) ideas inhibiting all ideas not associated, particularly those not associated with direction.

[384] If the intensity of concentration is raised for a non-associated idea, then the directional idea is correspondingly shifted from focus, i.e., it loses intensity. Its impact decreases correspondingly: thus the difference in the threshold value of all other associations becomes smaller. The directional selection becomes more difficult and is increasingly subject to the effect of the law of frequency, i.e., all those associations which, through practice and habit, form the largest component of consciousness come to the fore. The law of frequency now assumes the role previously played by the directional idea. As regards our experiment, this means that ideas already automatized and condensed in language assist the subject in his effort to comprehend the meaning of the stimulus-word and to work it over.

[385] In the act of apperception and the further working on the stimulus-word, all these purely linguistic connections are suppressed, so that in part they manifest themselves only very faintly and vaguely and in part they remain completely unconscious. If the linguistic connections enter the field of consciousness, the higher associations are pushed into the background; some of them faintly reverberate and some remain unconscious (according to Wundt “unnoticed”). (It is possible that they are not even formed, but this is difficult to prove.) In linguistic mechanisms, however, the process has not yet reached its lowest level; mere repetition of the sound reaction is suppressed during the mechanical linguistic reaction. If, by further lowering of attention, we remove the linguistic mechanisms, which in most cases still possess some meaning, the sound reactions come to the fore; these represent the lowest level of linguistic reaction and therefore remain constantly below the threshold of consciousness in everyday life. In the process of development of the child’s speech, sound reactions, as is well known, still play a fairly important

part; later they are increasingly suppressed and usually enter into the unconscious, from which they can under normal conditions be brought up only with a certain effort.

[386] We have deliberately discussed only the effect of distraction on linguistic functions. We note in addition that the law of frequency also applies to the selection of internal images. It struck us how often old childish memories cropped up, even with quite everyday objects, in the state of internal distraction (N.B. decidedly more frequently than in the normal state).

[387] In the individual accounts we pointed out the similarity between the distraction phenomenon and manic reaction. The reactions under distraction are in no way different from manic reactions as found by Aschaffenburg and observed by us in many manic associations. Liepmann,³⁶ who in a recently published monograph explains *flight of ideas* as a result of a disturbance of attention, reached a similar view to ours. Considerations such as Liepmann makes in his work have for some time pointed directions in our experimental work. The results of our experiments confirm Liepmann's views. As regards the psychological mechanism of flight of ideas, our views are completely in agreement with Liepmann. We therefore refer to his monograph.

[388] Aschaffenburg has introduced us to another reaction-type similar to the manic, the fatigue type. Other investigations, carried out under Kraepelin's direction, report analogous results under the influence of alcohol. Aschaffenburg considers, as is well known, motor excitation responsible for the occurrence of sound reactions. An obvious objection to this interpretation is that the conditions described are to a high degree characterized by disturbance of attention. It has been proved by our experiments that sound reactions are, one might say exclusively, caused by disturbance of attention. The motor excitation is a probably inessential side-effect which, at the most, could be the cause of the disturbance of attention. The latter seems to be the case in fatigue and alcoholism. In manic flight of ideas another factor must certainly also be considered as a cause of disturbance of attention, the specific excitation, the psychological nature of which is still quite obscure to us. Disturbance of attention due to motor excitation in fatigue and alcoholism could in our view be interpreted thus: the physical correlates of the attention phenomenon, the muscular tensions, become under the influence of motor excitation shorter and more variable. The psychophysical basis of accentuated ideas thus reaches a degree of instability that is represented psychically as a weakness of the directional idea. According to Liepmann's principles, from this weakness of the directional idea flight of ideas must result, which in the association experiment appears as sound reactions, etc. It is possible that in acoustic linguistic experiments motor excitation, which is of course also transmitted to the linguistic-motor system, furthers the release of the mechanical reaction; but it is never its sole cause.

[389] From this we may expect the occurrence of a blunt reaction-type or a sound reaction wherever there is a disturbance of attention; conversely we may suspect a disturbance of attention where sound reactions occur.

[390] This fact appears to us of great diagnostic value; it is, moreover, an essential condition for the understanding of the reactions generally.

[391] Because of the relatively great variations in the individual figures, a general survey of our figures is difficult; we have therefore compiled tables in which the arithmetical means of certain groups have been calculated in percentages to make comparison easier. We realize that a calculation of averages from figures of such diversity is a somewhat hazardous undertaking.

Even if the quantitative relation of the individual groups to each other is somewhat variable, we are nevertheless convinced that at least the main figures, that is, those for internal and external associations and for sound reactions, do present a true picture of the mode of reaction. The quantitative interrelation of certain special groups, e.g., particularly of co-existences, is partly subject to certain sources of error that are caused by the selection of stimulus-words. It is certainly clear that, where nouns only are used, reactions show ratios rather different from those brought about by mixed stimulus-words. Nevertheless our relative figures retain their value, as all subjects were given the same set of stimulus-words.

[392] We have classified our material according to different criteria; first of all the question of the relation of educated to uneducated subjects interested us. Aschaffenburg has found, as is well known, a relatively strong predominance of external over internal associations in his educated subjects. On the other hand, Ranschburg and Balint have found a marked predominance of internal associations in uneducated subjects. See herewith Tables A and B for the first and second hundred of normal associations.

[393] Our uneducated subjects were almost all male and female nurses of the hospital. We must now confess that this selection of uneducated subjects is not a particularly good one, for among the nursing staff there are many individuals who are above the low average level of education. It might be better to substitute the term "half-educated" for "uneducated." The level of education and intelligence of the male subjects is in general somewhat above that of the female subjects.

[394] The female subjects show a relatively high number of internal associations; strangely enough the number of internal associations rises considerably in the second half of the experiment, the predicates particularly showing an increase. In addition there is an increase in the residual group and in the sound reactions. There is probably a connection between the increase of predicates and of linguistic-motor forms and the decrease of correspondence of grammatical forms. The figures for linguistic connections are very high.

[395] The male subjects show in general a blunter reaction-type than the female subjects. The second hundred does not differ significantly from the first, only the figures for indirect associations and for consonances show a rather striking increase.

[396] The increase of failures in the second hundred of both groups may perhaps be attributed to the unfortunate coincidence that the number of feeling-toned stimulus-words is somewhat greater in the second hundred than in the first. As we have seen, the failures mainly coincide with feeling-toned stimulus-words. It is noteworthy that the men produce a larger number of egocentric reactions than the women, as well as a definitely smaller number of predicates.

[397] The egocentric reactions, i.e., the influence of personal wishes and values, is probably connected with the number of perseverations; this is somewhat higher for the women than for the men but alters in accordance with the decrease of egocentric judgments, a finding that will be confirmed in the future. We attribute this to the fact that it is mainly feeling-toned reactions that have a tendency towards perseveration, as we have already frequently pointed out in the individual accounts.

SPECIAL QUALITY	WOMEN		MEN	
	1st Hundred	2nd Hundred	1st Hundred	2nd Hundred
Grouping	24.2	26.2	25.2	21.5
Predicative relationship	18.8	22.0	15.4	16.8
Causal relationship	1.0	1.1	1.1	1.1
Co-existence	27.2	13.6	21.7	13.0
Identity	3.3	6.8	7.8	12.2
Linguistic-motor forms	22.3	25.7	26.2	30.5
Word-completion	0.2	0.0	-	-
Sound	-	0.3	0.7	0.5
Rhyme	0.1	0.6	-	0.1
Indirect	0.6	0.8	0.5	1.2
Meaningless	0.3	0.2	0.1	0.2
Failures	1.2	1.6	0.8	2.2
Repetition of stimulus-word	-	-	-	-
Egocentric reactions	0.8	0.8	2.0	1.5
Perseveration	1.5	0.6	1.0	0.4
Repetition of reaction	10.2	8.8	14.1	10.5
Same grammatical form	63.2	54.7	60.1	58.4
Same number of syllables	49.9	42.2	41.1	37.0
Alliteration	10.2	8.7	9.0	9.0
Consonance	12.3	12.2	11.1	14.0
Same ending	11.7	11.0	16.4	16.2
Number of associations	800	800	700	700
Number of subjects		8		7

[398] With the educated subjects, in the first place one is struck by the generally blunter reaction-type. The subjects are nearly all highly educated people: the women too, with few exceptions, are of a high level of education.

B. The First and Second Hundred of Normal Associations:

SPECIAL QUALITY	WOMEN		MEN	
	1st Hundred	2nd Hundred	1st Hundred	2nd Hundred
Grouping	13.4	14.0	16.1	16.5
Predicative relationship	21.8	18.6	17.3	22.2
Causal relationship	1.7	0.6	0.6	0.8
Co-existence	16.5	11.2	18.2	7.5
Identity	2.7	6.7	3.2	8.3
Linguistic-motor forms	38.0	41.0	35.2	33.2
Word-completion	1.0	2.0	1.1	1.1
Sound	0.3	1.9	1.5	2.3
Rhyme	0.8	0.6	0.7	0.6
Indirect	0.9	1.0	2.8	2.2
Meaningless	0.1	0.1	0.7	1.2
Failures	1.9	0.9	1.7	2.6
Repetition of stimulus-word	-	0.4	-	0.1
Egocentric reactions	2.7	1.5	3.6	2.6
Perseveration	0.8	0.5	3.1	1.8
Repetition of reaction	8.0	6.5	7.5	7.6
Same grammatical form	53.9	54.0	52.1	46.1
Same number of syllables	43.9	39.2	37.0	32.6
Alliteration	9.0	7.8	9.2	8.8
Consonance	14.6	15.2	15.1	16.2
Same ending	9.8	11.3	8.2	8.8
Number of associations	1100	1100	800	800
Number of subjects		11		8

[399] The difference between male and female subjects is not considerable in the first three groups, with the exception of a slight preponderance of internal associations in the men (in which groupings particularly play a part). On the other hand, considerable differences appear in the residual group, in which the high figures for indirect associations in the men are particularly striking, being more than twice those of the women. The average of sound reactions in the men is somewhat higher than in the women. The inverse relationship of indirect association and sound reactions, which was previously suspected, is indicated here too:

	WOMEN		MEN	
	1st hundred	2nd hundred	1st hundred	2nd hundred
Sound reactions	2.9	2.4	5.2	6.1
Indirect association	0.9	1.0	2.8	2.2

We shall discuss this phenomenon in the discussion of distraction averages.

[400] Here also the egocentric reactions of the men exceed those of the women. The number of perseverations corresponds to that of egocentric reactions, as in the uneducated subjects—a further proof of the largely affective nature of perseverations (N.B. only in the experiments under normal conditions).

[401] The difference between educated and uneducated subjects can be best made clear by putting the average figures of both groups side by side (Table C).

[402] The educated subjects show a clearly blunter reaction-type than the uneducated. The difference is best expressed by stating: In contrast to the uneducated subjects the educated

subjects show a distraction phenomenon.

[403] If we suppose the figures for the uneducated subjects are those of a subject under normal conditions, then the figures for the educated subjects bear the same relation to them as those of a distraction experiment. The sound reactions and the figures for the residual group are proportionately increased, as we have repeatedly seen in the individual accounts.

[404] What is the origin of this difference? One cannot assume that the educated subjects in effect think more “bluntly” than the uneducated; that would be nonsense. One can merely assume that in the experiment they thought more “bluntly” than the uneducated subjects. This appears to us really to be the case, and it seems that from this the explanation of the reaction-type can be deduced.

C. Averages for Educated and Uneducated Subjects

SPECIAL QUALITY	EDUCATED	UNEDUCATED
Grouping	15.0	24.2
Predicative relationship	19.3	18.2
Causal relationship	0.9	1.0
	35.8	43.4
Co-existence	13.3	18.8
Identity	5.2	7.5
Linguistic-motor forms	36.8	26.1
	55.3	52.4
Word-completion	1.3	0.1
Sound	1.5	0.3
Rhyme	0.6	0.4
	3.4	0.5
Indirect	1.7	0.7
Meaningless	0.5	0.1
Failures	1.7	1.4
Repetition of stimulus-word	0.1	—
	4.0	2.2
Egocentric reaction	2.4	1.1
Perseveration	1.5	0.8
Repetition of reaction	7.3	10.9
Same grammatical form	51.5	59.2
Same number of syllables	38.2	42.5
Alliteration	8.7	9.3
Consonance	10.2	12.3
Same ending	9.5	13.8
Number of associations	3800	3000
Number of subjects	19	15

[405] As proof for this assumption the following points may be considered:

(1) The agreement in grammatical form and number of syllables of the stimulus-word and reaction is clearly higher in the uneducated subjects. This fact seems to indicate that the uneducated subject sticks more closely to the stimulus-word or is more influenced by it than the educated subject.

(2) The number of meaningless reactions is considerably smaller in the uneducated subject. He has better control over himself or he pays more attention to his reaction.

(3) The uneducated subject surpasses the educated mainly in the number of groupings: i.e., he makes a greater effort to do justice to the meaning of the stimulus-word than the educated

subject does.

(4) The uneducated subject surpasses the educated in the number of co-existences, which are mainly made up of spatial concepts, i.e., the uneducated subject makes an effort to imagine clearly the object named by the stimulus-word, and he naturally must associate that which is co-existent with it. The educated subject, on the other hand, has fewer co-existences, as he limits himself to connecting linguistic forms.

(5) The uneducated subject has roughly half as many egocentric reactions as the educated. This fact indicates that he lets himself go much less and exposes undisguised subjective wishes and valuations much less. He makes an effort to achieve as objective as possible an interpretation of the stimulus-word.

(6) One of the main proofs is the almost sevenfold greater number of sound reactions in educated subjects. In this laziness is most clearly revealed. The subject who is intensely attentive produces practically no sound associations.³⁷

[406] For these reasons we regard it as proved that the difference between educated and uneducated reaction-types, as far as it is expressed in these figures, is merely a functional one and only has the significance of an attention phenomenon.

[407] If we may estimate the degree of attention from the figures for sound reactions, the residual group and the linguistic-motor forms, then the uneducated women achieve the highest degree of attention and the educated men the lowest. This fact becomes evident if we examine the groups divided according to sex with respect to these points of view.

[408] What is the origin of this difference of attention³⁸ between educated and uneducated subjects? Various factors must be considered:

(1) The uneducated subject is unused to an experiment of this kind. Naturally, it seems stranger and more difficult to him than to the educated subject, who is much more capable of understanding the significance of the experiment and who must from the first feel more at home than the uneducated in an intellectual activity. The stimulation of the uneducated subject by the experiment is therefore greater and more general, which is why more effort is made in reacting.

(2) Words without any sentence connection are called out to the subject. Under normal circumstances, if one calls anything out to someone it is, as a rule, a command or a question. The uneducated subject, in contrast to the educated, is not used to dealing with individual words outside the sentence connection, particularly if he has never learned a foreign language from books. Thus the stimulus-word contains something strange for the uneducated subject. Under the influence of habit he interprets it instinctively as a question, with the intensity of attention necessary for producing an appropriate answer. The stimulus-word is mostly something to the uneducated subject for which he constructs for himself some interrogative connection, to which he then replies.³⁹

(3) The uneducated subject knows words only, so to speak, related to a sentence, particularly when they appear as an auditory phenomenon. In the context of a sentence the words always have a meaning; the uneducated subject therefore knows the word less as mere "word" or verbal sign but much more as meaning. Therefore the uneducated subject grasps the semantic value of a

single word only in a fictitious sentence-context, while to the educated the stimulus-word usually remains merely “word” without specific semantic value.⁴⁰

[409] Summarizing, we can say that the uneducated subject shows, in keeping with his lower degree of education, a narrower interpretation of the experiment, particularly of the stimulus-word called out to him, than the educated subject whose approach to the matter is much cooler and more businesslike. In other words: the uneducated subject shows a certain tendency to assimilate the stimulus-word in the form of a question, because it is most usual for called-out verbal sounds to have the connotation of questions.

[410] This attitude to the stimulus-word becomes more evident in certain pathological cases, where the association experiment is nothing but a 2×200 sentence-long conversation on a feeling-toned theme. From these observations one can readily deduce that the uneducated subject pays greater attention because the meaning of the stimulus-word influences him more than it does the educated subject.

[411] The difference between educated and uneducated subjects is in the contrast of their interpretations of the stimulus-word. This principle of differentiation allows us to discern two groups, even if vaguely delineated. This distinction, however, is such a general one that it does not take into account other essential differences in the reaction-types. We have therefore made an effort to find other more subtle principles of classification. We asked ourselves whether there are other general factors that influence the reaction, apart from the attention phenomenon.

[412] One principal factor is the individual character. The difference in interpretation discussed above is an intellectual or associative disposition, which may be the same in individuals of widely varying character. As regards characters, the state of affairs is different. From our experiments two easily recognizable types emerge:

(1) A type in whose reactions subjective, often feeling-toned experiences are used.

(2) A type whose reactions show an objective, impersonal tone.

[413] The former type exhibits reminiscences of a personal kind that often show a very strong feeling-tone. The latter type couples words with words and concepts with concepts, but the personal plays a quite subordinate role in the reaction. This type can be called objective.

[414] The first type can be divided into three groups.

(α) The stimulus-image emanating from the stimulus-word acts principally through its feeling-tone. Usually the feeling-tone of the stimulus-image excites a whole complex of memories belonging to it. The reaction then is inherent in the constellation of this complex. In practice a subject of this type, at least in an extreme case, can easily be distinguished from the others. We call this type the complex-constellation type.

(β) The image evoked by the stimulus-word is a personal memory usually taken from everyday life. The reaction contains this image or is at least distinctly constellated by it. We call this type the simple constellation type.⁴¹

(γ) The image evoked by the stimulus-word acts through one or other of its associated attributes (partly the sensory aspects of the image, partly feeling-tones). Presumably the stimulus-image appears in strong relief; now one, now another characteristic comes to the fore

and thus, in conjunction with other features, determines the reaction; thus it usually contains a predicate of the object designated by the stimulus-word. We call this type the predicate type.

[415] The common factor in the types described under (α), (β), and (γ), as opposed to the objective type (2), is a marked stress of that part of the reaction that is individual, personal, and independent of the stimulus-word. Thus we can say that the difference between type 1 and type 2 is the egocentricity of attitude.

[416] The points presented make clear the general psychological laws that rule our experiment. This does not by any means reveal all the roots from which complications in the reactions originate.

[417] As regards the egocentric attitude, we have tacitly presupposed that the reaction is a more or less clear symbol of internal processes. As long as we know that the subject is speaking freely we can let this assumption prevail *cum grano salis*. The picture of reactions, however, changes at once when the egocentric attitude conduces to feeling-toned complexes, which the subject does not wish to betray.⁴² This occurs particularly in the complex-constellation type. For instance, the stimulus-word raises the complex of an unhappy love that is being kept as secret as possible. If the subject reacted according to his internal images, then he would exteriorize that part of the complex in the reaction through which it could be betrayed. The concealing of an emotion is always characterized by a quite particular attitude, a particular state of feeling. Without conscious censure, the emerging part of the complex is suppressed by the feeling of being directed not to betray, which is present in consciousness and from which specially attuned inhibitions arise. Of course the process of suppression may take place at a considerably more conscious level (or more unconscious, as in hysteria!). Instead of the suppressed complex-image another association fitting in with the feeling of being directed is put in its place and exteriorized.

[418] Thus the true inner association is concealed and the secret kept. It may be extraordinarily difficult for the experimenter, who does not enjoy the complete confidence of the subject, to decide in certain cases whether anything was concealed or not. The decision may perhaps be impossible with people who are capable of controlling themselves to a high degree. In most cases, however, the subjects betray themselves after a short time. According to the laws discussed previously, there must be certain phenomena that betray the suppressed complex. We shall here disregard the lengthening of reaction-time,⁴³ which occurs with great regularity.

[419] The suppression is betrayed:

(1) By an unusual and suspicious phrasing of the reaction that cannot be explained by the stimulus-word alone, but the peculiar character of which is bound to have been constellated by an X. Occasionally this X can be deduced directly from the peculiarly forced character of the reaction. Such reactions frequently occur in the form of sentences.

(2) By the attention phenomenon. A subject who interprets the stimulus-word as a question and therefore produces a series of highly potent associations suddenly, in the absence of external disturbance, reacts with a sound or some other strikingly superficial association. This result is suspicious; an internal disturbance or an internal distraction must have occurred. The subject may give no information. With a similar stimulus-word the phenomenon is repeated. We are now practically sure that there is something behind this. This suspicion has never proved unjustified.

A complex has suddenly emerged, has attracted some of the attention to itself; meanwhile the reaction is produced and, owing to the disturbance of attention, it can be only a superficial one.

(3) By a failure. The emerging complex absorbs all attention so that the reaction either is forgotten or, owing to the absence of all associations, cannot take place.

(4) By perseveration. In this case the critical reaction may be quite unobtrusive but the subsequent one has an abnormal character, in which the preceding reaction takes over the role of the constellation X. The perseverating factor is the emotion stimulated by the preceding association.⁴⁴

(5) By assimilation of the stimulus-word. The stimulus-word is interpreted for no apparent reason in a particular, rare sense or is misunderstood in a striking way according to a feeling-toned conscious idea.⁴⁵

[420] The above points are the main criteria of a concealed complex.⁴⁶

[421] We have purposely devoted so much attention to the discussion of these subtler psychological phenomena because the affective processes, the traces of which we pursued with the greatest possible care in normal reactions, play the most prominent role in the pathological reactions, as we shall show in detail later. What might perhaps be put to one side as a subtlety in a normal reaction will be revealed as the most significant factor in a pathological reaction. For the present we place great value on the realization that the reactions are an extraordinarily sensitive test for affective processes in particular and the individual response of the subject in general.

[422] To illustrate our discussion we present associations of the six main types [1 (a), (b); 2 (a), (b-i), (b-ii), (c)].

1. OBJECTIVE TYPE

[423] (a) Reactions of a subject whose attitude is essentially objective. At the same time the interpretation of the stimulus-word as a question is in the background. There is a tendency merely to put words next to each other, partly in accordance with the law of similarity, partly according to current verbal connections (subject 15, educated men).

Christmas	Easter
Sunday	Monday
winter	spring
lake (or sea)	ocean
pupil	teacher
father	mother
table	leg
head	scarf
ink	pen
needle	holder
bread	to earn
lamp	shade
tree	clearing
mountain	green
dream	froth (<i>Schaum</i>)

(Traum)

exercise-book

paper

book

school

to sing

bad

to clap

year

to threaten

long

rich

suffering

eye

youth

inn

family

misery

to pay

attention

fist (*Faust*)

people

murderer

everywhere

to calculate

to kiss

ripe

bond

ground

play

journey

to quarrel

blue

flower

cherry

institution

piano

oven

to walk

to cook

water

to dance

cat

dozen

to surmise

head

knife

cutter

to read

to attend

to write

naughty

hands

month

fist

narrow

poor

joy

tooth

game

{ At the Sign
of the
Bloody Bone

scandal

sorrow

to note

Goethe

rebellion

blood

I am at home

to measure

mouth

fruit

of love

found

of waves

to Canossa

fight

red

calyx

stone

male nurse

to play

town⁴⁷

to go

to eat

to drink

music

mouse

by the (dozen)

W (name of acquaintance who formulated a certain hypothesis)

blood and

at home
hedge
indolent
vinegar
hot
ring
tooth
window
frog
sweet
to ride
friendly
to cut
crown
rough
prison
to part
(*scheiden*)
ill
air
potato
to be lazy
coffee
sacrifice
wedding
grandmother
dark
heart (*Herz*)
bird
white
game
Kaiser
moon
to beat
to light
star
to stroke
grand
child
sofa
wild
tears
loyalty
once (*einmal*)
wonder
blood
wreath
to choose

wounds
it's nice
rose
lazy
sour
cold
finger
time
frame
leg
sour
to travel
painful
knife
realm
-ian (*ruffian*)
detention
to avoid
(*meiden*)
weak
song
to salt
armchair
to drink
to bring
feast
father
light
pain (*Schmerz*)
nest
black
card
Wilhelm
light
to throw
house
shooting
cat
magnificent
dog
to lie
animal
to shed
German
never (*keinmal*)
of wonders
vengeance
athlete
choice

right	might
to have to	no man must
	have to ⁴⁸
hope	does not let
	one perish
small (<i>klein</i>)	my (<i>mein</i>)
unjust	faithlessness
world (<i>Welt</i>)	pain (<i>Schmerz</i>)
strange	unknown
slate-pencil	to write
to growl	dog
knob	-stick
fruit	to eat
false	fox
helmet	ornament
hay	straw
cleanly	painfully
(<i>reinlich</i>)	(<i>peinlich</i>)
trap (<i>Falle</i>)	rope (<i>Strick</i>)
	(<i>Fallstrick</i> ,
	‘snare’)
to be revolted	gruesome
resin	to stick
neck	to wring
steep	mountain
swing	to swing
to fetch	to bring
skull	formation
to use	to be able to
stamp	<i>timbre</i>

[424] The subject is a doctor, as several technical medical terms, such as *needle-holder* and *skull-formation*, indicate. We do not include those reactions constellated by the profession in the “constellations” in the narrower sense in which we interpret these. Such reactions are not subjective; they belong not only to the individual, but more or less to a whole profession. The only subjective constellation is *to surmise / W.*

[425] (b) Reactions of a subject whose approach is objective and to whom the meaning of the stimulus-word is much more important than to the preceding subject. The tendency is to give as correct a reaction as possible (subject 27, group of uneducated women):

table	chair
head	arm
ink	pen
needle	thread
bread	cheese
lamp	candle
tree	bush
mountain	valley
hair	thread

wood
salt
dream
exercise-book
paper
book
school
to swim
game
Kaiser
moon
to beat
obstinate
to light
star
to stroke
great
child
to ride
friendly
file
crown
to paint
thanks
rough
to stink
prison
to separate
ill
potato
trap
to disgust
to be lazy
coffee
victim
wedding
angry
soldier
to clap
to threaten
behaviour
to fall
to suffer
youth
inn
family
to pay
attention
fist

coal
flour
sleep
book
material
newspaper
church
to go
to sing
king
stars
to bite
gentle
to extinguish
sun
to beat
wonderful
woman
to travel
cross
hammer
helmet
oil
you're welcome
fine
to taste
dungeon
to join
healthy
bread
to catch
to taste
to work
milk
saviour
funeral
satisfied
civilian
to sing
to beat
polite
level
healthy
age
hotel
husband
to hear
hand

to sing
hoop
tooth
window
frog
flower
cherry
institution
piano
fern
to walk
water
to dance
dozen
heart
bird
people

murderer
everywhere
to kiss
bad
ripe

band
ground
walk
to quarrel
sofa
to love
wild
tears
to spare
wonder
blood
wreath
to choose
right
force
revenge
hope
to pray
freedom
world
strange
to growl
knot
false

to rejoice
ring
mouth
floor
stork
grass
peach
school
violin
rose-bush
to jump
wine
to sing
ten
warm
cat
household
(*family is implied*)
robber
here
to flatter
good
bitter (*sweet is implied*)
material
floor
to jump
to make it up
chair
to hate
tame
to laugh
better
nature
human being
flowers
to meet
wrong
voluntary
peace
joy
to believe
imprisoned
nation
at home
to bite
rope
true

helmet	sword
plate	tray
hay	grass
pure	clean
to surmise	to doubt
head	arm
at home	away
vinegar	wine
resin	pitch
swing	to throw

[426] The subject is a nurse from our hospital. Subjective factors are entirely absent from the reactions. Her manner is extraordinarily objective and calm. In contrast to the preceding subject it must be noted that here the meaning of the stimulus-word is the decisive factor, which is expressed in many contrasting ways.

[2]. EGOCENTRIC ATTITUDE

(a) Simple-constellation type

[427] Reactions of a subject in whose reactions numerous subjective experiences are used. The attitude is egocentric in so far as subjective memories prevail (subject 18, educated men).

father	anxious (the subject is the father of a new-born child)
head	round
ink	sour (<i>red/litmus</i> is implied)
bread	bread-factory
lamp	smells
tree	F. (name of an acquaintance connected with a certain experience)
mountain (<i>Berg</i>)	Ütilberg
hair	falling out
salt	Rheinfelden (where there are salt works)
wood	ebony
dream	R. (name of a colleague who was occupied with dream-analyses at this time)
paper	fraud (paper in the sense of documents in evidence about a case of fraud)
book	letter (<i>Buch-stabe</i> , 'letter of the alphabet')
pencil	Kohinoor (the subject uses this brand)
school	S. (name of the place where the subject went to school)
liberty	statue (the subject had been in America and particularly admired New York)
unjust	to imprison (constellation from daily intercourse with querulous patients)
to be lazy	wonderful
coffee	Mocha
sacrifice	L. (name of an ailing painter who had a predilection for painting sacrificial scenes)

wedding	without alcohol (the subject is a teetotaller)
grand-mother	dead
wicked	R. (name of a patient with a moral defect)
to need	B. (name of a colleague)
year	and day
to threaten	threatener (<i>Drohweber</i> , nickname of a patient who frequently uttered threats)
sour	dough (<i>Teig</i>)
(<i>saner</i>)	(<i>Sauerteig</i> , 'dough')
youth	Munich (newspaper <i>Youth</i>)
family	day
sorrow	sorrowful
to pay attention	association-experiment (momentary constellation)
nature	R. (name of a patient)
folk	<i>Folk-Psychology</i> by Wundt (a work that had recently been ordered by the hospital)
murderer	G. (name of a murderer who was just then in the hospital for examination)
everywhere	superman
(<i>überall</i>)	(<i>Übermensch</i>)
to calculate	slide-rule
wild	dentist ("Wild" is the name of a dentist)
tears	vale
war	turmoil
faithful	little dog
once	shorthand again (see above)
miracle	Lourdes
blood	English (in England the word must not be said)
right	and duty
ground	and soil
game (<i>Spiel</i>)	thing (<i>Zeug</i>) (<i>Spielzeug</i> , 'toy')
arm	W. (name of a patient who had injured his arm)
blue	Grotto in Capri
strange	stranger
to growl	bulldog
knot	East Swiss (memory of his student years)
fruit	to steal
false	trap
helmet	house (<i>Helmhaus</i> , a public building in Zurich)
misery	hunger
hay (<i>heu</i>)	Heustrich (name of a spa)
raspberry	park (the raspberries in the hospital garden)
to sing	Miss B. (name of a singer who was at the hospital just at that time)
ring	hospital gardens (a ring was at that time found in the garden of the hospital)
tooth (<i>Zahn</i>)	Göschenen (the writer, Zahn, lives in Göschenen)
window	opening
frog	tree-frog
flower	rose

cherry	juicy
hospital	R. (a certain hospital for feeble-minded children)
male nurse	B. (name of a particular nurse)
fern	tape-worm
to be obliged to	Lessing (a famous quotation from Lessing is implied)
oven	Pest ⁴⁹
revenge	thirst
hope	pregnancy (this constellation is explained by earlier comments)
small (<i>Klein</i>)	male nurse (Klein is the name of a nurse)
to pray	church
row	M. (name of someone who had made a joke referring to the word "row")
to walk	L. (name of patient who often went for walks)
to cook	cooking lessons
water	supply
to dance	concert-hall (the hall in which the dances at the hospital are held)
dark	room (the subject is an enthusiastic amateur photographer)
heart	failure
bird	paws (<i>claws</i> is to be interpolated)
to swim	L. (name of a patient who often used the swimming pool)
white (<i>Weiss</i>)	malaria (a patient named Weiss suffered from malaria)
game	Halma (which was at that time played in the wards)
thirteen	shorthand (<i>to write</i> is to be interpolated; the subject was keenly occupied with shorthand)
sofa	cushion
thousand	Basel (a student friend of subject from Basel went under the name of "Tausig," the dialect form of <i>tausend</i> (thousand). The stimulus-word was of course called out in standard German but assimilated in the dialect form by the subject)
to love	ball
son	sonny (the subject is the father of a new-born son)
at home (<i>daheim</i>)	newspaper (called <i>Daheim</i>)
vinegar	home-made
trap	mousetrap
throat	epiglottis
to strike	(name of a doctor who had been struck by a patient)
star	C. (Stern, 'stern,' is the name of a patient in Ward C)
to stroke	kitten
grand (<i>grossartig</i>)	Grossman (name of patient who was included merely as a sound-association)
sweet	bananas (cf. the reaction <i>wood/ebony</i> . The subject had recently given some lectures on travels in Africa)
friendly	H. (name of an acquaintance)

to float
skull
rough (*rau*)
to report
prison
to separate
ill

S. (name of a famous airman)
occiput
A. 1 (Rau is the name of a patient in Ward A.1)
male nurse
police-barracks (the police in Zurich)
sulphuric acid
diabetes

[428] This type is characterized by the emergence of numerous subjective experiences, mostly of recent origin and belonging for the most part to the field of everyday activities. It goes without saying that, in spite of the objective character of the constellations, some also occur that belong to a feeling-toned complex. These are, however, relatively rare in comparison with the others and are in some cases well concealed. The recently experienced joy of fatherhood has an after-effect in several reactions: *father / anxious, hope / pregnancy, son / sonny*. This feeling-toned diminutive seems to us echoed in the somewhat striking reactions: *to stroke / kitten, fidelity / little dog*.

(b) Complex-constellation type

[429] (i) Reactions of a subject in whose reactions a feeling-toned complex appears quite openly. The meaning of the stimulus-word is brought into relation with the complex (subject 21, educated men).

wood
dream
exercise-
book
paper
pencil
school
to sing
ring
tooth
window
frog
flower
hospital
piano
male nurse
stove
to walk
to dance
dark
heart
bird
to swim
game
Kaiser
to hit

pile
studies (simple constellation)
pen
line
big
bank
choir
on the finger
teeth
frame
hops
stem⁵⁰
big
I cannot play
B. (name of a certain male nurse)
wood
a long way
hotel F. (a certain hotel where there was dancing)
room
red
feathers
movement
children
Wilhelm
to beat

to set fire to
star (*Stern*)
grand
child
dark red
to ride
murderer

everywhere
to
calculate
to kiss
natural
bad
time
ripe
row
ground
game
poor
to quarrel
sofa
to love
son

wild

tears
protection
war
faith
once
friendly
crown
rough
to stink
shrill
to separate

potato
to be lazy
cross
come
year
family
to take care
finally
folk
slate-pencil

S. (name of an incendiary)
Miss Stern (an actual person)
ah!
children
again ah!
riding track
in C (a certain insane murderer in Ward C in the hospital)
K. is (the name of a mobile catatonic)
I cannot

again and
again
wonderful
no
not now
I am for it } complex
of a
romance
recently
terminated

soldiers
and soil
child
poor as a beggar
oh rot!
is soft to sit on
ah!
son and father (the subject had had unpleasant quarrels with his family on account of his romance)
mother (*wild* = angry; *wild* is here assimilated into the complex in the special sense of the dialect expression)
she has now (that is, the abandoned sweetheart)
I cannot offer her
if there only were
I have not kept
and never again
very nice
queen
table
pooh!
hurt
W. (name of a mental patient whose marriage ended in divorce)
broth
nice
I am not
with me to the theatre X (a certain theatre)
1904
V. (subject's own family)
I should
it will end
worth much
she is a teacher

to growl	poodle
knob	knob-stick
false	blonde (a "lady," who is false and blonde, to be interpolated)
helmet	fire brigade
clothes	woman's skirt
softly	she comes along
gallantly	up the stairs
plate	on the table
misery	she cries
hay	in it lies a farmer
raspberry	in the wood
at home	in D. (home of the sweetheart)
wonder (miracle)	would have to happen
blood	she is anaemic
wreath	on the coffin
to choose	another
to part	I need not
right	she is not
to have to	I do not have to
force	I do not use on her
revenge	oh no!
hope	I do not know
small	oh no!
to pray	perhaps
dear	she was to me
wool	a woman's dress
old	perhaps
freedom	she could have
unjust	I was not
world	wide
strange	that she is now
hedge	fence
lazy	sometimes (i.e., sometimes she is lazy)
to woo	a woman
hot	love
consciousness	yes, in the focus of consciousness
vinegar	sour
trap	into it
to disgust	yes, so-so
riot	there is therefore none
resin	hair
(<i>Harz</i>)	(<i>Haare</i>)
to dress	yes, fine and gallant
up	
omen	bad

[430] A strong feeling-toned complex is characteristic of this mode of reaction. The stimulus-word is assimilated as a question; the experiment therefore bears the imprint of a conversation in

which the subject has only a rather dim awareness of the current situation. This explains the somewhat abnormal character of a conversation of this type. The mode of reaction can be explained by a very strong psychological sensitivity. The relatively numerous interjections and the egocentric references, not only within the complex, also point towards this. The subject's egocentricity emerges clearly throughout. He is mentally entirely sound and would at other times probably have presented a much more objective type. The abnormal character of the reaction is to be attributed merely to the temporary but prevailing emotion. One could generalize and say that this abnormal state, caused by the affect, is the prototype of the hysterical reaction.

[431] (ii) Subject 24 of the group of uneducated women is a good example of a complex appearing in a disguised form. We refer to the associations already given in detail in the relevant section.

(c) *Predicate type*

[432] Reactions of a subject who judges the object of the stimulus-word from a personal point of view (subject 7, educated women)

lake	beautiful nature
schoolboy	diligent
father	something wonderful, good, holy
needle	work
bread	best food
lamp	work
tree	something beautiful
mountain	terrible, climbing is nicer
hair	head-dress
salt	strengthens food
wood	fire
dream	many experiences
exercise-book	much work for the children
paper	blessed, because we write on it
book	joy
school	joy
dozen	straight, order
dark	horrible
heart	beats
bird	lovely, to fly
to swim	lovely
white	hard, bright
game	to enjoy
thirteen	clumsy
friendly	duty
crown	unnecessary
rough	weather
moon	beautiful
to beat	unnecessary
to light	an art, till one managed it
to sing	beautiful

ring	something silly
tooth	glad not to have any more
frog	something unnecessary
flower	joy
cherry	good fruit
hospital	narrow
piano	mainly laborious
male nurse	respect
fern	beautiful wood
stove	lovely in cold winter
to walk	one sometimes must
to cook	laborious
water	lovely
to dance	gladly when one is young
cat	sneak
star	magnificent
grand	pompous
child	gift of God
sweet	pleasant
to ride	dangerous
to stink	sometimes, alley
shrill	to hurt
ill	to hurt

[433] The characteristic of this mode of reaction is an unusually strong personal participation, which leads to a constant evaluation of the object, usually with reference to herself.

II. Sex Differences in the Experiment under Normal Conditions

[434] We have considered our individual figures from the point of view of the sex difference and calculated their averages (see Table D).

D. Sex Differences in the Experiment under Normal Conditions

SPECIAL QUALITY	MEN	WOMEN
Grouping	19.8	19.4
Predicative relationship	17.9	20.3
Causal relationship	0.9	1.0
	38.6	40.7
Co-existence	15.0	17.1
Identity	7.8	4.8
Linguistic-motor forms	31.2	31.7
	54.0	53.6
Word-completion	0.5	0.9
Sound	1.2	0.6
Rhyme	0.3	0.5
	2.0	2.0
Indirect	1.6	0.8
Meaningless	0.5	0.1
Failures	1.8	1.4
Repetition of stimulus-word	0	0.1
	3.9	2.4
Egocentric reaction	2.2	1.3
Perseveration	1.5	0.8
Repetition of reaction	9.9	8.2
Same grammatical form	54.3	56.4
Same number of syllables	37.0	43.7
Alliteration	9.1	8.9
Consonance	14.0	13.5
Same ending	12.4	10.9
Total associations	3000.0	3800.0

[435] In considering the figures, one is struck by the slightness of the difference between the two sexes. With few exceptions the figures essentially tally; in any case, the definite numerical differences that separate the group of educated from the uneducated are absent. In the men the type is somewhat blunter than in the women; the men have rather more sound associations, also more indirect associations; these phenomena may be connected with the blunter type. The larger number of egocentric reactions and perseverations seems, according to earlier investigations, to depend on the men's more uninhibited behaviour. The difference in the figures for coincidence of grammatical form and number of syllables is analogous to the corresponding difference between educated and uneducated subjects, and may be attributed to the fact that in our male subjects, particularly in the uneducated ones, the level of education is higher than in the corresponding women subjects. From the figures of the experiment under normal conditions nothing typical of feminine psychology emerges, which does not mean that no differences exist. Our method of investigation is obviously far too crude to discover subtle differences of this sort.

III. Averages of the Distraction Experiments

[436] We give in Tables E and F a compilation of the average figures from the distraction experiments. To facilitate comparison we are putting the average for experiments under normal conditions alongside.

[437] The figures for the distraction experiments show a progressively blunter type of reaction than those obtained under normal conditions. The main difference is quite unequivocal. The internal associations decrease under distraction as opposed to the external associations and sound reactions, both of which increase.

[438] Looking at the figures for internal associations, we see that the women in this group have higher figures than the men. The lowest figures are for men. The objection that the women start with a higher number of internal associations under normal conditions applies only to uneducated women. Educated women show a somewhat blunter reaction-type, under normal conditions, than educated men. The fact that the number of internal associations does not fall as low in women as in men means that the women were less adaptable to the purposes of the experiment than were the men. Comparing the minus differences of the internal associations clearly shows the smaller interest of the women.

E-1. Averages in the Distraction Experiments: Uneducated Women

SPECIAL QUALITY	NORMAL	EXTERNAL DISTRACTION	
		60 Met.	100 Met.
Grouping	25.2	19.0	15.7
Predicative relationship	20.4	20.6	19.0
Causal relationship	1.0	0.7	0.5
	46.6	40.3	35.2
Co-existence	20.4	18.2	18.5
Identity	5.0	9.7	9.2
Linguistic-motor forms	24.0	24.3	33.3
	49.4	52.2	61.0
Word-completion	0.3	0.2	0.5
Sound	0.1	1.7	2.0
Rhyme	0.3	1.0	1.2
	0.7	2.9	3.7
Indirect	0.7	1.2	0.7
Meaningless	0.2	0.7	0.2
Failures	1.4	1.0	0.5
Repetition of stimulus-word	0	0.5	0
	2.3	3.4	1.4
Egocentric reaction	0.5	0.5	0.5
Perseveration	1.0	2.0	2.5
Repetition of reaction	9.5	8.5	3.0
Same grammatical form	58.9	62.5	62.2
Same number of syllables	46.0	47.5	44.7
Alliteration	8.4	11.0	11.2
Consonance	12.2	18.5	15.7
Same ending	11.3	11.7	16.0
Total { Associations	1600	400	400
Subjects	8	8	8

[439] The remaining differences are unfortunately not equally apparent, as they are divided into three groups, the content of which is of varying psychological valency. Therefore the number of internal associations is the best simple measure of the degree of distraction. The differences for the men show a certain agreement, while the minus difference of uneducated women is greater than that of educated women, which would indicate better adaptation of the uneducated women to the experiment.

E-2. Averages in the Distraction Experiments: Uneducated Men

SPECIAL QUALITY	NORMAL	EXTERNAL DISTRACTION	
		60 Met.	100 Met.
Grouping	23.3	20.8	14.8
Predicative relationship	16.1	10.0	12.8
Causal relationship	1.1	0	0
	40.5	30.8	27.6
Co-existence	17.3	19.1	12.5
Identity	10.0	17.4	15.1
Linguistic-motor forms	28.3	22.0	35.7
	55.6	58.5	63.3
Word-completion	0	0	0
Sound	0.6	1.4	0.8
Rhyme	0	1.7	0.2
	0.6	3.1	1.0
Indirect	0.8	3.4	1.4
Meaningless	0.1	1.1	2.0
Failures	1.5	1.4	2.2
Repetition of stimulus-word	0	0.5	2.0
	2.4	6.4	7.6
Egocentric reaction	1.7	0	0
Perseveration	0.7	0.5	0
Repetition of reaction	12.3	5.1	4.0
Same grammatical form	59.5	67.7	64.5
Same number of syllables	39.0	45.7	48.2
Alliteration	9.2	8.0	12.4
Consonance	12.5	23.4	18.8
Same ending	16.3	14.3	18.2
Total { Associations	1400	350	350
{ Subjects	7	7	7

EDUCATED.

UNEDUCATED

	Internal Distraction	External Distraction	External Distraction
Women	-5.5	-2.8	-8.8
Men	-12.3	-11.8	-11.3

Minus difference of internal associations

F. I. Averages in the Distraction Experiments: Educated Women

SPECIAL QUALITY	NORMAL	INTERNAL DISTRACTION	EXTERNAL DISTRACTION	
			60 Met.	100 Met.
Grouping	13.7	14.0	11.7	11.5
Predicative relationship	20.2	15.0	21.2	19.0
Causal relationship	1.1	0.5	0.7	0.7
	35.0	29.5	33.6	30.7
Co-existence	13.8	10.0	12.7	8.0
Identity	4.7	4.3	10.5	9.0
Linguistic-motor forms	39.5	30.5	25.7	39.0
	58.0	44.8	48.9	56.0
Word-completion	1.5	4.5	3.0	2.2
Sound	1.1	5.1	5.5	6.5
Rhyme	0.7	2.0	1.7	0.5
	3.3	11.6	10.2	9.2
Indirect	0.9	1.6	1.0	0.2
Meaningless	0.1	0.5	1.2	1.5
Failures	1.4	1.1	2.0	1.5
Repetition of stimulus-word	0.2	0.6	1.5	0.7
	2.6	3.8	5.7	3.9
Egocentric reaction	2.1	1.0	1.2	1.0
Perseveration	0.6	1.0	2.2	1.7
Repetition of reaction	7.2	3.5	6.5	5.0
Same grammatical form	53.9	59.0	54.0	53.0
Same number of syllables	41.5	45.5	47.7	43.5
Alliteration	8.4	11.1	11.7	12.5
Consonance	14.9	19.3	19.0	20.6
Same ending	10.5	11.8	11.7	13.0
Total { Associations	2200	500	400	400
Subjects	11	6	8	8

[440] Admittedly the plus differences in the group of sound reactions again show a more significant increase in educated women than in uneducated:

	Uneducated women	Educated women
Plus difference of sound reactions	2.6	8.3 and 6.4

[441] The cause of this contradiction might be that the educated women's attitude to the experiment was considerably more variable than that of the uneducated female subjects. Both groups carry out the instructions of the experiment, the making of strokes and the simultaneous reaction, with somewhat more difficulty than the men. If one compares, for example, the differences of educated men and women in the internal distraction experiment, one is immediately struck by the more complete effect of distraction in the men. The only essential difference between the two female groups is perhaps that educated women are capable at least at times of dividing their attention.

SPECIAL QUALITY	NORMAL	INTERNAL DISTRACTION	EXTERNAL DISTRACTION	
			60 Met.	100 Met.
Grouping	16.3	8.6	15.6	10.8
Predicative relationship	19.7	15.0	12.0	10.4
Causal relationship	0.7	0.8	0.4	0.6
Co-existence	12.8	6.1	12.8	12.0
Identity	5.7	4.5	9.2	6.6
Linguistic-motor forms	34.2	38.6	35.2	42.8
Word-completion	1.1	4.3	1.2	2.6
Sound	1.9	15.8	8.0	3.8
Rhyme	0.6	0.6	0.4	1.8
Indirect	2.5	4.5	3.2	6.2
Meaningless	0.9	1.6	2.0	1.8
Failures	2.1	0	0	0
Repetition of stimulus-word	0	0	0	0
Egocentric reaction	2.8	1.1	0.8	1.6
Perseveration	2.4	1.6	2.0	3.0
Repetition of reaction	7.5	3.8	6.8	6.2
Same grammatical form	49.1	50.5	59.2	51.8
Same number of syllables	35.0	44.6	46.4	41.0
Alliteration	9.0	27.3	17.6	13.2
Consonance	15.6	33.3	23.6	20.6
Same ending	8.5	8.3	11.2	10.0
Total { Associations	1600	550	250	435
{ Subjects	8	6	5	5

[442] It seems to us now that we have here a certain difference in the mode of reaction of men and women, a difference that can be determined quantitatively. As, however, with the limited material, sources of error are not excluded, we offer these observations for further discussion.

[443] The figures in the individual groups of the scheme show certain variations that need discussion. While the co-ordinations decrease fairly evenly with distraction, the predicates under distraction present a somewhat different aspect in men and in women.

	EDUCATED		UNEDUCATED	
	External Distraction		External Distraction	
Women	-0.2		-0.6	
Men	-8.5		-4.7	

Minus difference of the predicates

[444] The table shows that under distraction the predicates decrease to a lesser degree in women than in men. Here let us remember that in the discussion of the predicate type we stated the hypothesis of the primary, sensory vividness of the stimulus images, which invites predicates. This psychological peculiarity shows itself, of course, in a state of attempted division of attention; this will hinder the experiment in that, in the absence of active concentration, the primarily vivid images absorb the interest and thereby bar or impede the division of attention as planned in the experiment. We shall see this phenomenon quite clearly in the result of the distraction experiment of the predicate type, to which we are referring. There are relatively very many predicate types among the women, which is probably the reason for the apparent

prevalence of the predicate. In contrast to the decrease of internal associations there is an increase of external associations, in so far as this is not influenced by a stronger rise of sound reactions. The three groups do not participate equally in the increase of external associations. We even notice that the number of coexistences shows rather a tendency to decrease. We tabulate the differences again here:

	UNEDUCATED		EDUCATED	
	Women	Men	Women	Men
	-2.0	-1.5	-3.4	-0.4

Difference between normal experiment and distraction with reference to coexistences

[445] They are all, contrary to expectation, minus differences. This shows that the coexistences cannot be held responsible for the increase of external associations. Remembering the discussion where we explained that coexistences frequently arose owing to the effort of vividly imagining the object of the stimulus-word, then the decrease under distraction is comprehensible; coexistence is to some extent a step towards internal association and therefore plays a part in its decrease.

[446] The groups of identities and linguistic-motor forms in general show a rise—which is, however, affected by a big increase of sound reactions, causing, for example, in the group of educated women particularly, a decrease of the two groups. We explain these variations by the irregularity of distraction often mentioned. The quantitatively infrequent occurrence of word-completion in uneducated subjects is striking. We believe that inadequate verbal facility is responsible for this, particularly lack of practice in standard German. Experiments with uneducated Germans, viz., North Germans, might produce different figures. Sound associations are decidedly more frequent in educated subjects than in uneducated.

[447] The indirect associations behave strangely. We have already indicated an inverse relationship of their increase with sound associations. In our averages one is first struck by a dependence on the degree of distraction.

	UNEDUCATED		EDUCATED	
	Women	Men	Women	Men
Normal conditions	0.7	0.8	0.9	2.5
Distraction	0.9	2.4	0.9	4.6

[448] These figures show that uneducated subjects produce fewer indirect associations on the average under normal conditions than do the educated and that women produce fewer than men. Under distraction the women’s aversion to indirect associations is shown even more clearly. While a quite definite increase is shown in the men, the average figure for educated women under normal conditions remains the same, and in uneducated women only a quite insignificant increase occurs. Thus, in this respect, a significant difference between the sexes must exist, the nature of which is at present unknown to us. The nature of indirect associations, discussed above (predominantly sound reactions as intermediate links), makes a dependence on distraction readily comprehensible. Thus with the increase of sound reactions we could expect an increase also of indirect associations. For the sake of clarity we briefly repeat the relevant figures here:

	UNEDUCATED				EDUCATED			
	Women		Men		Women		Men	
	S.R.	Ind.	S.R.	Ind.	S.R.	Ind.	S.R.	Ind.
Normal conditions	0.7	0.7	0.6	0.8	3.3	0.9	3.6	2.5
External distraction I	2.9	1.2	3.1	3.4	10.2	1.0	9.6	3.2
External distraction II	3.7	0.7	1.0	1.4	9.2	0.2	8.2	6.2
Internal Distraction (educated subject only)	—	—	—	—	11.6	1.6	20.7	4.5

[449] Although the simultaneous increase of sound reactions and indirect associations under distraction, already mentioned above, is indicated in general in these figures, the parallelism of the two groups is in places somewhat unbelievable. If a parallel between the two groups really exists, one would expect that the maxima of indirect associations would sometimes coincide with the maxima of sound reactions. This is by no means the case. In considering, in the figures for the distraction experiments, the maxima of indirect associations, we see that the maxima only coincide in two cases. No corresponding increases of indirect associations coincide with the maxima of sound reactions. Thus no clear and simple connection in the form of a direct proportion exists. Neither do these figures provide easily recognizable clues to an inverted relationship. Only the group of educated men shows a co-incident of a striking maximum of indirect associations with the minimum of sound reactions, which is nevertheless a noteworthy fact. In the female groups we see the indirect associations strikingly lagging behind the sound reactions. In the educated men a distinct increase of sound reactions, from 3.6 per cent under normal conditions to 20.7 per cent under distraction, corresponds to an increase of only 2 per cent of indirect associations, while their maximum coincides, as already stated, with a minimum of sound reactions. This aspect of the indirect associations seems to indicate a certain interdependence of the two groups; we see this as an increased occurrence of indirect associations affecting mainly the group of sound reactions. Taking the group of sound reactions in relation to indirect associations, we get the following picture:

	UNEDUCATED				EDUCATED			
	Women		Men		Women		Men	
	S.R.	Ind.	S.R.	Ind.	S.R.	Ind.	S.R.	Ind.
External distraction I	1.7	1.2	1.4	3.4	5.5	1.0	8.0	3.2
External distraction II	2.0	0.7	0.8	1.4	6.5	0.2	3.8	6.2

[450] The pure sound associations show, with one exception, inverse relation between the two groups. The choice of sound associations for the purpose of the demonstration is not arbitrary, since they form the main part of the whole sound group; at the same time they are the associations that are suppressed under normal conditions (this does not apply to all rhymes, for example). It is just this fact, that the pure sound associations are repressed under normal conditions, that has the greatest significance for the explanation of the inverse relation. The unspoken and mostly quite unconscious intermediate links between indirect associations are in the majority of cases sound associations. Under normal conditions sound associations are continually opposed by inhibitions, as they are, as a rule, quite inexpedient in respect to the process of association and are therefore excluded. There will always be a certain tendency to

suppress the sounds; the slighter the distraction of attention the stronger this tendency will be, but the greater the distraction is, the weaker it will be. With increasing distraction the reaction will be more and more influenced by sound, till finally only a sound is associated. Between the influence of sound and the sound association there comes a point where, although the sound association cannot conquer the inhibition it encounters, it does exclusively affect the sense of the following reaction by interrupting the connection between stimulus-word and reaction; it is immaterial whether the subconscious sound association is formed centripetally or centrifugally. The mediating sound association, which almost reaches the threshold of reaction, leads to the formation of the indirect association. Of course the intermediate links need not necessarily always be sound associations; they need only invite enough inhibition to remain just below the threshold of reaction. Thus we interpret the indirect association as a symptom of repression of inferior associations, which almost reach the threshold of reaction.⁵¹ Using this interpretation the apparently inverse relation of sound association and indirect association can be easily understood: if the sound association predominates, one can conclude from this that the inhibition of sounds has not occurred; therefore repression and consequently indirect association are also prevented. If the number of sound associations decreases it is a sign that inhibition is increasing, thus providing the conditions for the occurrence of indirect associations. The indirect associations are therefore a transitional phenomenon which reaches an optimum at a certain degree of distraction. This also explains the increase apparently in proportion with the sound reaction and the subsequent decrease in inverse proportion after the critical point has been reached.⁵²

[451] Claparède, who has worked on the question of indirect associations from another angle, believes that it is the “résultat du concours de plusieurs associations intermédiaires, chacune trop faible pour être consciente.”⁵³ From the results of experiment we are in complete agreement with this interpretation. The tendency to form a meaningful association, which derives from the stimulus-concept, inhibits sound associations. Both are too weak, however, to produce a reaction. If the sound association, not linked in meaning with the stimulus image, predominates, then the indirect association comes into being; otherwise it is a reaction that, although strongly influenced by sound, is nevertheless meaningful. Piéron’s⁵⁴ interpretation, which states that the third link of the indirect association has greater interest for the individual than the intermediate link, does not fit in with the results of our experiment. Nevertheless there is something attractive about Piéron’s view and it is valid for all those cases where the external stimulus is unconsciously assimilated as a strongly charged complex, dominant in the subject’s consciousness. (We shall discuss this further possibility of an indirect association in a later paper.) Piéron’s view does not fit in with a vast number of the indirect associations of everyday life. From many examples we mention only one very instructive observation from our own experience.⁵⁵ One of the present authors was smoking a cigar; suddenly it occurred to him that he had no more matches on him. He had a longish train journey before him and had put a good Havana cigar in his pocket in order to smoke it on the way. He now thought he would have to light the cigar from the one he was finishing. With that, the narrator was satisfied and dropped the train of thought. For about one minute, he looked out of the window at the landscape, which he observed attentively; suddenly he noticed himself saying involuntarily and quite softly; “Bunau-Varilla.” Bunau-Varilla is the name of a well-known Panamanian agitator in Paris. The observer had read the name several days before in the *Matin*. As this name appeared to him to be without any connection with the

contents of consciousness, he immediately directed his attention to the name and observed what occurred to him in the process (Freud's method of spontaneous association). Immediately *Varinas* occurred to him, then *Manila*, almost simultaneously also *cigarillo*, and with it a vague feeling of a South American atmosphere; the next clear link was the Havana cigar and with it the memory that this cigar had provided the content of the penultimate thought-cycle. The intermediate links, *Varinas* and *Manila*, are brands of tobacco, both of which had the tone of something Spanish for the narrator; *cigarillo* is the Spanish word for cigarette; the observer had smoked cigarillos with Manila tobacco in a Spanish colony but not in South America. Nevertheless there was a faint "South American" echo about *cigarillo*. While the observer was looking out of the window he had not the slightest feeling of such a train of thought, his attention was completely concentrated on the landscape. The unconscious train of thought leading to the formation of "Bunau-Varilla" was: *Havana cigar / cigarillo* with Spanish-South American background / a travel memory with *Manila-cigarillo* / Spanish-American brand of tobacco *Varinas* / (*Varinas* and *Manila* condensed by dream-mechanism into) *Varilla / Bunau-Varilla*. A sufficient reason for the subconscious pursuance of the thought of the cigar was that the observer had prepared himself not to miss lighting the Havana cigar from the end of the cigar still alight. According to Piéron, "Bunau-Varilla" would have to be the emotionally charged final link desired by the observer. This is what in fact it is not; it is merely a product of condensation formed by the competition between several very weak intermediate links (according to Claparède's interpretation). The mechanism is a linguistic-motor automatism such as occurs not infrequently in normal subjects (in certain hysterical subjects, it is true, far more often). The subconscious association-process takes place through similarities of image and sound; in fact all associations taking place in the subconscious, i.e., outside the range of attention, do so (with the exception of certain somnambulant processes). In connection with Jerusalem's⁵⁶ communication Wundt⁵⁷ calls the intermediate link "unnoticed" in contrast to "unconscious," in which we can perceive not material objection but merely a verbal quibble. It is not surprising that Scripture⁵⁸ obtains doubtful results in his experiments on indirect associations, and Smith⁵⁹ and Münsterberg⁶⁰ obtained no results, because their experiments were set in a way that did not favour the production of indirect associations. The best indirect associations are provided by careful self-observation in everyday life.⁶¹ Indirect verbal associations originate, as our experiment shows, mainly in distraction experiments.

[452] Meaningless reactions show, as is to be expected, an increase under distraction.

[453] The failures, the mainly emotive nature of which has already been frequently stressed in the individual descriptions, are conspicuously absent in the group of educated men under distraction. For the rest they present a constant pattern. We shall return to this group in the discussion of the average of the predicate type.

[454] A state of affairs similar to that of meaningless reactions obtains in the repetition of the stimulus-word; it too increases under distraction.

[455] We have combined the four last-mentioned groups to form the so-called residual group, with the original purpose of collecting the abnormal subsidiary phenomena of the association experiment into this group. From the number of this group we then hoped to obtain a certain coefficient of the emotional state into which the subject was brought by the experiment. The decision to include the indirect associations also in this group was based on the assumption, in

itself not improbable, that in indirect associations, because of their provenance from sound-shifts, we really have experiments that have failed. Naturally we interpreted the meaningless reactions, as well as the last two groups, as experiments that failed. In this interpretation we were supported by certain experiences in the pathological field—that is, the association phenomena in emotional stupidity,⁶² where the figures for this group rise considerably. It is true that the results of our experiments do not confirm the original assumption of the emotional nature of indirect associations. This does not hold in the other three groups. The nature of the emotion, however, must be defined more precisely for these three groups. Meaningless reactions and repeated stimulus-words originate according to our experience as a rule from stupefaction, which is produced by the way the experiment is set, while the majority of failures are based on emotion evoked through the awakening of feeling-toned complexes. Stupefaction, caused by the way the experiment is set, can in that case be completely excluded. The inclusion of failures in the residual group is therefore arguable. We have therefore substituted the non-committal designation “residual group” for “emotion group,” the name we originally chose for this group. The summation of the figures for these groups was undertaken for clarity of arrangement, with full realization of its provisional and inadequate nature. Everyone who has done experimental work, particularly with such involved material, knows that one must pay dearly for one’s experience and that one knows afterwards what one should have known before.

[456] The distribution under distraction of egocentric reactions (which to some extent represent a pointer to feeling-toned reactions) is best demonstrated by a tabulated survey of the differences from the results under normal conditions.

	UNEDUCATED		EDUCATED	
	Women	Men	Women	Men
No. of egocentric reactions under normal conditions	+0.5	+1.7	+2.1	+2.8
Difference under distraction	0.0	-1.7	-1.0	-1.6

[457] These differences show that according to our material the minus differences of the men are greater than those of the women; thus that, although women do not betray greater egocentricity under normal conditions than men, they maintain it more firmly under distraction than men do.

[458] With respect to perseverations, we have already several times proved a certain dependence on strong feeling-tones. As regards its frequent increase under distraction, we assumed the cause to be lack of association with distracted attention. Obviously various complicated conditions are involved here which we cannot separate beforehand. The following table of differences from normal conditions shows the effect of distraction on perseverations.

	UNEDUCATED		EDUCATED	
	Women	Men	Women	Men
	+1.2	+0.4	+1.1	-0.2

[459] From these figures it appears that in men perseverations decrease under distraction, while in women they increase.

[460] The number of egocentric reactions gives us a rough measure of how many feeling-toned references to the ego occur among the reactions;⁶³ the number of perseverations indicates something similar to us, but in a less direct form.

[461] As stated above, in women there is less effect of distraction on the reaction. From this one may conclude that female attention with respect to our experiment has proved less easy to divide. The smaller change in the number of egocentric reactions in women may be connected with this. If the number of egocentric reactions shows only a slight tendency to decrease, a similar tendency is to be expected in perseverations. These increase, however. We explain this by the fact that in the associationless vacuum artificially created by distraction feeling-toned contents of consciousness can persist more easily than otherwise. Why women in particular should have the tendency to persevere under distraction we do not know. Perhaps it is connected with more intense feelings?

[462] That attention cannot easily be divided in women may be based on the following causes:

(1) We have already indicated that various individuals (predicate types) presumably have fundamentally much more vivid inner images than others. By "more vivid images," we mean such as have combined in themselves a greater intensity of attention or, in other words, such as appear simultaneously with many other associations evoked by them. The larger an association-complex is, the more the "ego-complex" is also involved. It is therefore understandable that with the vividness of the inner images, not only does the number of internal predicates increase but also the number of subjective value judgments generally—that is, of egocentric reactions.

(2) The vividness of the inner image is by no means always a primary involuntary phenomenon but can also be an artificial one; the attention is purposely directed to it or, in other words, numerous new associations accompany an image that appears with few collateral associations. This process is stimulated by the image that appears; it is actually realized through another association-complex, which at the time fills consciousness. The vividness of the inner image is thus in one case primary and involuntary, in the other case secondary and willed. The latter form is then under the influence of another intellectual phenomenon present at the time.

(3) If the inner images are basically very vivid and plastic, i.e., if they occur from the first together with many collateral associations, they must always have a quite definite effect on attention and therefore make more difficult or hinder its division, according to the degree of vividness. This is, as we shall see, the case with the predicate type.

(4) If the inner images are under the influence of an already existing association-complex, artificially vivid or plastic, it then depends on the stability of this complex whether the dividing of attention will be possible or not.

(5) We have no reason to assume that the inner images are in general fundamentally more vivid in women than in men (otherwise all women would probably belong to the predicate type.) We have, however, reason to assume, as we have already demonstrated above, that the reactions of uneducated subjects, particularly of uneducated women, are based on a (quasi) intentionally produced vividness of the stimulus-image. The association-complex responsible for this is the special view that uneducated people take of the association experiment. As, under the influence of this dominating image, they interpret the stimulus-word mainly from the point of view of meaning, they must apply more attention to stimulus-image, thus necessarily yielding less to distraction, as our figures show. That it is particularly the uneducated women who yield least to distraction agrees with the fact that they are the most strongly under the influence of this particular interpretation of the experiment. That educated women also show a tendency to yield

less than men to distraction cannot also be attributed to this particular interpretation of the experiment but must be related to the fact, already mentioned, that among our educated female subjects there are relatively many predicate types, who show practically no distraction phenomenon at all. We therefore give in Table G the average figures of the educated women who are not predicate types.

G. Educated Women excluding Predicate Types

SPECIAL QUALITY	NORMAL	EXTERNAL DISTRACTION	
		60 Metronome	100 Metronome
Grouping	15.2	13.5	10.8
Predicative relationship	14.0	14.0	9.6
Causal relationship	1.0	0.8	0.4
Co-existence	15.3	12.4	7.2
Identity	4.8	11.2	8.8
Linguistic-motor forms	42.5	26.8	46.8
Word-completion	1.5	4.0	3.6
Sound	1.4	8.0	9.2
Rhyme	0.8	2.0	0.4
Indirect	1.0	1.2	1.6
Meaningless	0.1	2.0	0
Failures	0.9	1.6	0.4
Repetition of stimulus-word	0.4	0.2	1.2
Egocentric reaction	0.3	0.4	1.6
Perseveration	0.7	2.4	0
Repetition of reaction	6.9	4.8	3.6
Same grammatical form	41.8	63.2	42.4
Same number of syllables	60.1	47.6	57.2
Alliteration	8.5	13.2	15.2
Consonance	14.7	21.2	24.0
Same ending	12.6	15.2	13.2
Total { Associations	1200	250	250
Subjects	6	5	5

[463] From the figures of this table it immediately appears that it is not the case that the women's attention is less easily divided than the men's, but that it was the predicate type that strongly affected the average for educated women. Our figures show a definite distraction phenomenon that in no way lags behind that of the men.

[464] Repetitions of the same reactions decrease with distraction; the reasons for this are easy to understand.

[465] The numbers of verbal connections rise under distraction, thus expressing quantitatively the influence on the reaction in terms of external and mechanical factors. It is noteworthy that in uneducated subjects there is under normal conditions not only a greater agreement of grammatical form than in educated subjects but that the distraction experiment increases this even more intensely than in educated subjects, although in uneducated subjects the distraction phenomenon is less distinct. The following differences⁶⁴ clearly demonstrate this:

	Women	Men
Uneducated	+3.4	+6.6
Educated	+1.4	+4.7

[466] The figure for the agreement of grammatical form does not only begin at a higher level in uneducated subjects but under distraction rises still higher than the corresponding figure for educated subjects. The reason for this probably lies in the fact that educated subjects have numerous current phrases at their command even under distraction.

[467] The figures for agreement in number of syllables, aliteration, consonance, etc., need not be commented on.

[468] The almost general decrease of figures for verbal connections in the second part of distraction is connected with the decrease of sound reactions. This change can be attributed to habituation, when the factors of very intense distraction gradually recede.

IV. Average of the Predicate Type under Normal Conditions and under Distraction

[469] Tables H and I give the average figures for all those subjects whom we call "predicate types." We have included in this type all those subjects in whom the internal associations predominate over the group of linguistic-motor forms; the number of predicates is on an average more than twice the number of co-ordinations. Among the subjects used for the calculation of averages there are seven women and two men.⁶⁵

[470] We have placed the average of all other types next to the predicate type for comparison. The difference is striking. The predicate type shows no change worthy of mention under distraction: the predicate type does not show divided attention, while all the other types show themselves accessible to disturbing stimuli, at least to some extent. This fact is extraordinarily strange.

[471] As we have already indicated, we assume that the individuals belonging to the predicate type have basically more vivid images on which attention is already involuntarily fixed in the moment of their emergence (contrary to deliberately produced vividness). We have noticed in our material that among the reactions of the predicate type there are, besides numerous value judgments, also strikingly many predicates designating sensory properties of the object of the stimulus-word, particularly visual ones. Individual subjects reported at once that they sometimes received quite definite plastic images.⁶⁶ We based the theory of the predicate type on this observation.

[472] An inner image is vivid if the associations immediately connected with it spring to mind. The nearest associations upon the image of a concrete object are the sensory aspects: the visual, the acoustic, the tactile, and the motor. A vivid image can be said to be in the state of being concentrated upon.⁶⁷ The more vivid an image is, the stronger are the inhibitions emerging from it against everything not associated with it; the attention will therefore be all the less prone to be divided. That the distraction phenomenon is virtually absent in the predicate type we regard as proof of the correctness of our interpretation. The predicate type cannot divide his attention because his fundamentally vivid inner images make so much demand on his attention that inferior associations (which make up the distraction phenomenon) do not occur at all.

H. Averages of Predicate Types

SPECIAL QUALITY	NORMAL	EXTERNAL DISTRACTION	
		60 Met.	100 Met.
Grouping	12.5	14.8	13.1
Predicative relationship	32.1	31.2	30.5
Causal relationship	1.1	0.5	0.2
	45.7	46.5	43.8
Co-existence	13.5	13.7	11.7
Identity	4.1	8.0	8.5
Linguistic-motor forms	31.0	23.2	29.1
	48.6	44.9	49.3
Word-completion	0.8	0.8	0.2
Sound	0.3	1.4	1.1
Rhyme	0.4	0.8	0.2
	1.5	3.0	1.5
Indirect	0.8	1.7	0.2
Meaningless	0	0.2	1.1
Failures	2.4	2.5	2.5
Repetition of stimulus-word	0	0.2	0.8
	3.2	4.6	4.6
Egocentric reaction	3.6	1.7	1.4
Perseveration	0.8	1.1	1.1
Repetition of reaction	9.9	8.0	4.8
Same grammatical form	40.7	43.1	45.4
Same number of syllables	37.3	44.0	47.4
Alliteration	7.9	8.8	10.8
Consonance	12.9	15.4	14.2
Same ending	6.7	7.7	11.1
Total { Associations	1792	350	350
Subjects	9	7	7

[473] By means of our hypothesis all the peculiarities of the predicate type can now be explained.

(1) The large number of predicates. The subjects name a particularly striking characteristic of the inner image and naturally use the predicate for this purpose. The large number of internal associations is mainly to be attributed to the number of predicates. The ratio of internal to external associations reminds us of that in uneducated subjects. The common factor, however, is only the degree of attention applied. The predicates are also retained under distraction, which we regard as clear proof of the involuntary nature of the plasticity of the image.

I. Averages of Non-Predicate Types

SPECIAL QUALITY	NORMAL	EXTERNAL DISTRACTION	
		60 Met.	100 Met.
Grouping	21.5	18.0	14.3
Predicative relationship	13.5	11.3	10.8
Causal relationship	1.0	0.6	0.3
	36.0	29.9	25.4
Co-existence	17.2	16.0	12.2
Identity	7.3	13.2	10.8
Linguistic-motor forms	33.7	28.0	39.8
	58.2	57.2	62.8
Word-completion	0.8	1.3	1.7
Sound	1.1	4.7	4.2
Rhyme	0.6	1.5	1.1
	2.5	7.5	7.0
Indirect	1.5	2.2	1.9
Meaningless	0.3	1.2	1.3
Failures	1.0	0.8	0.8
Repetition of stimulus-word	0.1	0.9	0.7
	2.9	5.1	4.7
Egocentric reaction	1.0	0.6	0.7
Perseveration	0.9	1.8	1.9
Repetition of reaction	8.5	6.5	4.0
Same grammatical form	62.1	66.9	63.8
Same number of syllables	42.9	47.3	43.5
Alliteration	9.4	12.4	14.1
Consonance	14.4	22.4	20.8
Same ending	14.0	15.4	16.6
Total { Associations	4586	1000	1085
{ Subjects	23	20	20

(2) The large number of egocentric reactions. The more vivid the image is, or the greater is the complex of associations present in consciousness, at any given moment, the more it is bound to stimulate and absorb into itself the associations making up the consciousness of the personality, in order by this synthesis to remain conscious. Thus a whole series of personal references must be added to the emerging complex of associations, which are then designated as particularly striking properties of the images and so become reactions. This is how egocentric reactions originate.

(3) The relatively large number of failures. These occur as a rule in reactions to the stimulation of a strong feeling-toned complex, which grips the attention so firmly that no further reaction can take place. It is quite feasible that in the predicate type more feeling-toned complexes are stimulated than in other types as a result of the more vivid images. It follows as an essential consequence of our assumptions that under distraction the failures show a tendency to increase. A certain amount of attention may be left over from what is fixed to the image, but if this is needed for an activity (marking the metronome-beats), then none is left for reacting; no decrease in the number of failures can result from this.

[474] From the figures for the distraction experiment it emerges that the predicate type is not a fortuitous momentary attitude but constitutes an important psychological characteristic, which also obtains under different conditions.⁶⁸

V. The Influence of the Grammatical Form of the Stimulus-word on the Reaction

[475] As can easily be appreciated, the choice of stimulus-word with all its different properties is of some consequence. There is a whole series of stimulus-words that have predictable reactions. Thus, for instance, there is a large number of designations for concrete objects with which coexistent images are regularly associated, quite apart from many stimulus-words that call forth stereotyped word-connections, e.g., *to part / hurts*; *to part / to avoid*; *blood / red*. For the quantitative ratios it is of considerable importance whether the stimulus-word is a noun, adjective, or verb. A main factor will then be the frequency of the particular word-form. From a random selection in books one can say that language uses on average twice as many nouns as adjectives or verbs. Thus a noun used as a stimulus-word will, in accordance with the law of frequency, be "answered" more easily than all other word-forms. On the other hand, the lower frequency of verb and adjective will cause rather more difficulty in reaction, quite apart from the fact that, to most subjects, an adjective or a verb in the infinitive, standing outside the context of a sentence, appears more peculiar than a noun, particularly one that is the name of a concrete object, about which something can be said. We have made a comparative examination of this from the material of the experiments under normal conditions and have found the following average figures:

	REACTIONS TO VERBS					
	Noun	Adjective	Verb	ASSOCIATIONS		Sound
				Internal	External	
Educated men	63.2	15.8	20.6	48.4	41.6	7.4
Uneducated men	32.7	21.7	45.5	49.6	47.4	1.1
Educated women	45.7	19.4	34.7	55.5	39.2	4.5
Uneducated women	52.8	14.4	32.6	69.0	29.6	0.3
Predicate type	54.8	26.2	18.9	62.8	33.4	2.7
Non-predicate type	46.7	15.0	38.1	52.4	41.8	4.2

	REACTIONS TO ADJECTIVES					
	Noun	Adjective	Verb	ASSOCIATIONS		Sound
				Internal	External	
Educated men	53.1	43.6	2.9	43.5	45.0	8.0
Uneducated men	32.4	64.8	2.7	44.8	51.0	3.4
Educated women	39.1	52.6	7.4	43.3	45.4	3.1
Uneducated women	49.4	47.3	3.0	60.8	37.3	1.1
Predicate type	64.0	29.7	5.2	64.2	28.2	1.9
Non-predicate type	35.5	59.9	4.4	42.8	51.0	4.3

[476] The number of agreements in grammatical form quoted among the individual figures shows that the stimulus-word and reaction do not by any means always agree in grammatical form. The above table shows the average figures, calculated as percentages, for the best-characterized group of our subjects. We decided against giving the individual figures, to avoid a confusing accumulation. Also, the average figures show most clearly the characteristic variations with which we are essentially concerned.

[477] It is striking that in the verb groups, with one exception, the reactions to verbs were mainly nouns; only the group of uneducated men reacted mainly to verbs with verbs. The educated men reacted mostly with nouns. These (strangely enough) have most in common with the uneducated women, while the educated women are closest to the uneducated men. It is clear from the beginning that the verbal law of frequency has great influence on the preference for this or that mode of reaction. It is therefore quite understandable that educated men, who in any case have a very blunt reaction type, should prefer the readier noun to the rarer verb; it is not so easily

understandable that uneducated women should react in an apparently similar way and this needs detailed investigation.

[478] While, according to our observations, educated men usually append nouns to verbs, uneducated men make an effort to do justice to the meaning of the stimulus-word by reacting with a similar verb. A similar effort on the part of the educated women is somewhat less clear. This mode of reaction, the psychology of which we have discussed in detail, is conditioned, as is well known, by the effort to react mainly in accordance with the meaning of the stimulus-word. We have previously seen that uneducated women lead in this respect. Accordingly one would expect that uneducated women would react with an ever higher number of verbs than uneducated men. It must, however, be remembered at this point that the uneducated women's level of education is the lowest, that thus their verbal education and facility is also the lowest; consequently, reacting to verbs will be most difficult for this group, as verbs are even rarer for them than for the other groups.⁶⁹ They are therefore dependent on nouns that can most easily be combined with verbs. The uneducated women's effort to produce a meaningful reaction determines the choice of a noun that is not merely joined to the verb but expresses, wherever possible, something significant about the meaning of the verb.

[479] We have therefore carried out a further investigation to test this interpretation and to learn how great is the number of internal associations that are reactions to verbs. With these figures we are in a position to prove our interpretation. We have therefore placed next to the figures giving the preferred word-forms the figures showing the quality of the associations given in reaction to verbs. We give the appropriate figures once more together with those for the experiment under normal conditions for the groups mainly under consideration here.

	EDUCATED MEN		
	Internal Associations	External Associations	Sound Reactions
Normal conditions	36.7	52.7	3.6
Reactions to verbs	48.4	41.6	7.4
Plus difference	11.7		

[480] This table shows that the reaction-type when stimulus-words are verbs is considerably blunter than for the list of stimulus-words mainly composed of nouns. Thus it has been proved numerically that for educated men too there exist far fewer canalized connections between verb and verb than between noun and any of the three other parts of speech. Comparing the appropriate figures for uneducated women with these, we find confirmed our assertion that the nouns preferred by this group possess a higher quality.

	EDUCATED WOMEN		
	Internal Associations	External Associations	Sound Reactions
Normal conditions	46.6	49.4	0.7
Reactions to verbs	69.0	29.0	0.3
Plus difference	22.4		

[481] It becomes apparent from these figures that the vast majority of associations in reaction to verbs are highly significant and appropriate to the meaning of the stimulus-word. The sound reactions in the two groups quoted are also remarkable. Their larger proportion under normal conditions in educated men shows how slight is the influence of the meaning of the stimulus-word. Conversely the decrease of the corresponding figures for uneducated women is characteristic of the increased influence of the meaning of the verbs. From the ratios of these figures it is permissible to conclude that, on account of their lower frequency and consequently the greater difficulty of reacting, the influence of verbs on attention is greater than that of nouns.

[482] The adjectives show, as a glance at the table demonstrates, a reaction analogous to verbs, except that in general they have rather less influence on the reaction-type. It may therefore be assumed that the reaction to adjectives generally encounters little difficulty.

[483] The predicate type reacts to verbs predominantly with nouns, while on the average all non-predicate types react to verbs with twice as many verbs as the predicate type.⁷⁰ We examine again the quality of the associations with which the predicate type reacts to verbs:

	PREDICATE TYPE			NON-PREDICATE TYPE		S
	Int. Assn.	Ext. Assn.	S.R.	Int. Assn.	Ext. Assn.	
Normal conditions	45.7	48.6	36.6	58.2	2.5	
Reactions to verbs	62.8	33.4	2.7	52.4	41.8	4
Plus difference	17.4			16.4		

[484] As the plus differences show, the influence of the verbs is roughly the same in both cases; no plus difference of internal associations surpassing that found in the non-predicate type corresponds to the numerous nouns in the predicate type. Thus we have no reason to suppose that in the predicate type the verb has a greater influence on the attention, that is, that it presents greater difficulties in reaction. The predicate type shows no difference of attention in relation to the verb but only the difference that educated subjects in general display, namely, that they prefer the noun on account of its greater familiarity. This is because in our predicate types the majority are educated subjects.

[485] The reaction of predicate types to adjectives is in contrast to our earlier findings. As the figures in the tables show, in the four groups first dealt with more adjectives are given as reactions to adjectives than verbs to verbs. In the predicate type, which is mainly distinguished by attributes in adjective form, the difference is only 10.8 per cent. On the other hand, nouns are given greater preference (as opposed to non-predicate types)—namely, 28.5 per cent more. This preference for nouns is caused by the predicate type's effort to react mainly in the form of attributes and not only, as our figures show, by reacting with a predicate but also, conversely, by discovering a noun for an adjectival stimulus-word.⁷¹ Let us now examine the proportions with reference to the quality of adjectival reactions.

	PREDICATE TYPE			NON-PREDICATE TYPE		S
	Int. Assn.	Ext. Assn.	S.R.	Int. Assn.	Ext. Assn.	
Normal conditions	45.7	48.6	1.5	36.0	58.2	2
Reactions to adjectives	64.2	28.2	3.9	42.8	51.0	4
Plus difference	18.5			6.8		

[486] As these figures show, the large number of nouns in the predicate type is connected with a rise of internal associations. Thus we do not in this case have a mere juxtaposition of familiar nouns but constructions that, owing to the particular mental attitude of the subject, are matched to the stimulus-word. This although, in view of the figures for the other groups, the juxtaposition of a similar adjective seems easier for them. The latter is clearly demonstrated by the small plus difference of internal associations in the adjectival reactions of the non-predicate type.

[487] It also becomes clear from the figures for adjectival reactions that the predicate attitude is by no means fortuitous but corresponds to a quite definite psychological disposition, which is maintained even when other modes of reaction would be much easier than the predicate form.

SUMMARY

[488] The associations show normal variation, principally under the influence of:

- (1) Attention
- (2) Education
- (3) The individual characteristics of the subject

[489] (a) Decrease of attention owing to any internal or external factors causes a blunting of the reaction type, i.e., the internal or fully valent associations recede in favour of external associations or sound associations.

(b) Distraction of attention according to our experimental design caused, apart from the above-mentioned changes, an increase of indirect associations which must therefore be interpreted as distraction phenomena and can be derived as internal links from the competition of two weakly stressed (less valent) associations.

(c) Educated subjects have a blunter reaction-type on the average than uneducated. The difference can essentially be explained by a difference in the interpretation of the stimulus-word.

(d) No essential differences emerged in the degree of division of attention by distraction between educated and uneducated subjects.

(e) The most considerable variations in associations are conditioned by individual differences.

[490] (1) As regards the effect of sex on the mode of reaction under normal conditions no clear differences emerge from the average figures. Only in the distraction experiment does the peculiarity of female subjects show, in that they possess less ability to divide attention than male subjects.

(2) The individual variations can be classified into the following types:

I. *Objective type*. The stimulus-word is taken objectively, that is:

(α) mainly according to its objective meaning; the reaction is matched to the sense of the stimulus-word as much as possible and linked by meaning to the stimulus-word.

(β) mainly as verbal stimulus; the reaction is in part matched purely verbally, in part it merely marks the juxtaposing of a canalized association, in which the meaning relationship rather recedes into the background.

II. *Egocentric attitude*. The stimulus-word is taken subjectively (egocentrically).

(α) *Constellation type*. The personal elements used in the reaction belong to one or more emotionally charged complexes, there being two possibilities:

($\alpha\alpha$) The complex-constellations are spoken without concealment.

($\beta\beta$) The complex-constellations appear in veiled form as a result of a not always conscious repression.⁷²

(β) *Predicate type*. This type has presumably the psychological peculiarity of particularly vivid (plastic) inner images, by which its particular mode of reaction may be explained. This type also shows at best an abnormally low ability to divide attention, which is expressed in the distraction experiment by an, on the average, almost complete lack of blunting phenomenon.

[491] As a general result important for pathology, it emerges that the blunting of reaction-type in fatigue, alcoholic intoxication, and mania may be attributed primarily to a disturbance of attention. The observations on the affective side of associations (effects of feeling-toned complexes) might be of importance for the experimental investigation of pathological feeling changes and their consequences.

[492] Finally we may be permitted to express our sincerest thanks to our esteemed director, Professor Bleuler, for valuable encouragement. We are also particularly grateful to Mrs. Jung for active help in the repeated revision of the extensive material.

EXPLANATION OF GRAPHS

[493] In the accompanying graphs the arithmetical means of internal associations, external associations, sound reactions, and reactions in the residual group of different groups are presented. The averages shown are:

I: internal associations

S: sound reactions

E: external associations

R: reactions in the residual group

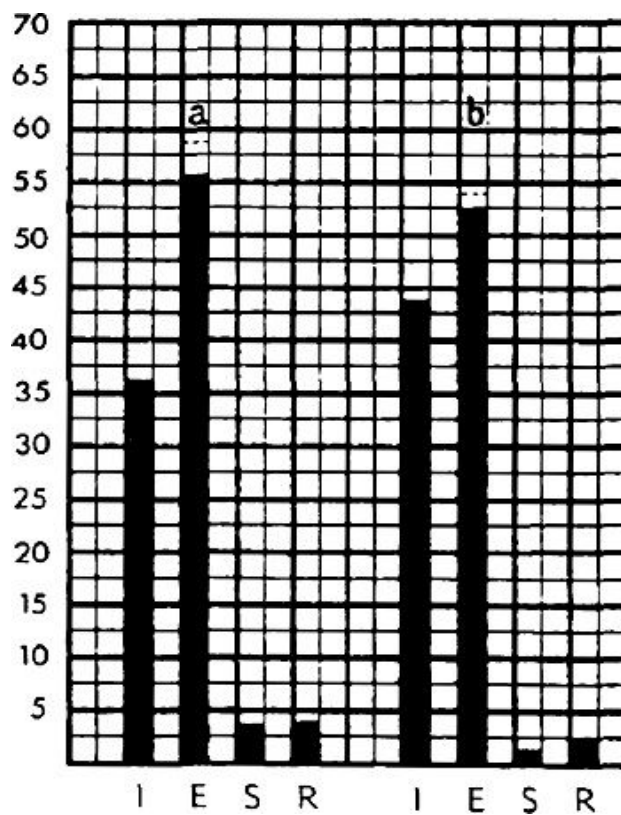

Graph I. Averages from Experiments under Normal Conditions

(a) Educated Subjects: 23 subjects, 3,800 associations

(b) Uneducated Subjects: 18 subjects, 3,000 associations

[494] Graph I. The educated subjects have fewer internal, more external and more sound associations under normal conditions than the uneducated subjects.

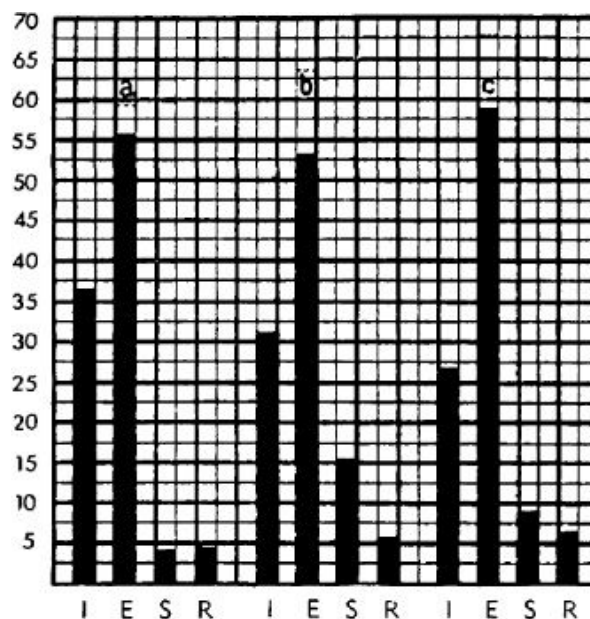

Graph II. Averages from Experiments with Educated Subjects under External Distraction

(a) Normal conditions (Graph I, a): 23 subjects, 3,800 associations

(b) Distraction experiment with 60 metronome-beats per minute: 13 subjects, 650 associations

(c) Distraction experiment with 100 metronome-beats per minute: 13 subjects, 835 associations

[495] *Graph II.* A definite, regular decrease of internal associations from *a* to *c* is found, i.e., according to the intensity of the method of distraction. Secondly, an increase of sound reactions in both distraction experiments emerges from the graph. The result of distraction consists in general of an increase of external associations plus an increase of sound reactions. This sum ($E + S$) is indicated in places by adding to column E a dotted column equal to the height of S. This column ($E + S$) increases regularly from *a* to *c*. The decrease of I and the increase of ($E + S$) under distraction demonstrates clearly the effect of distraction. S_b and S_c are both bigger than S_a . The reactions in the residual group increase from *a* to *c*.

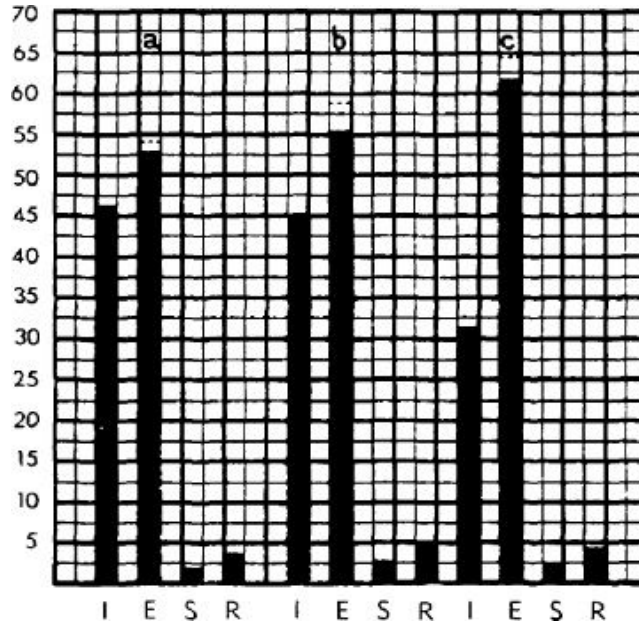

Graph III. Averages from Experiments with Uneducated Subjects under External Distraction

- (a) Normal conditions (Graph I, b): 15 subjects, 3,000 associations
- (b) Distraction experiment, 60 metronome-beats: 15 subjects, 750 associations
- (c) Distraction experiment, 100 metronome-beats: 15 subjects, 750 associations

[496] *Graph III.* The picture, apart from the different starting point, is similar to the distraction experiment with educated subjects:

Gradual decrease of internal associations from *a* to *c*;

Gradual increase of external associations plus sound reactions from *a* to *c*. R increases under distraction, S only a little, the sound reactions generally play a much smaller part than in educated subjects.

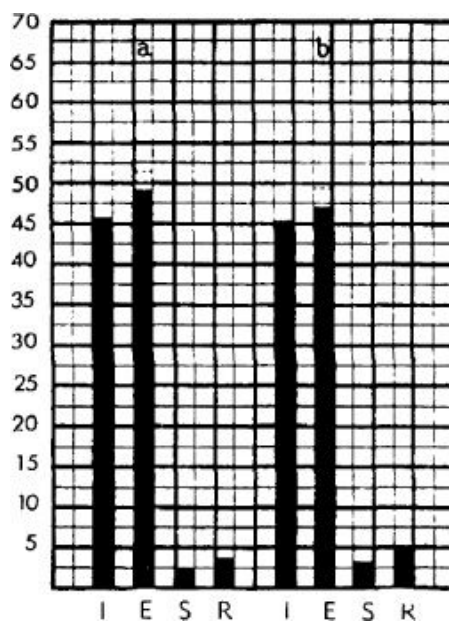

Graph IV. Averages from Experiments with Subjects of the Predicate Type (Educated and Uneducated)

(a) Normal conditions: 9 subjects, 1,792 associations

(b) Distraction experiments (60 and 100 metronome-beats taken together): 7 subjects, 700 associations

[497] Graph IV. While in educated subjects the ratio of I : E is 2 : 3, and in uneducated subjects I : E is 5 : 6, here it is 1 : 1.1. S is smaller than in educated subjects but greater than in uneducated under normal conditions. In group R the ratio is inverted. Strikingly enough, in contrast to the preceding pictures, this ratio hardly changes under distraction. There is only a minimal decrease of I and a very small increase of (E + S). R has increased a little.

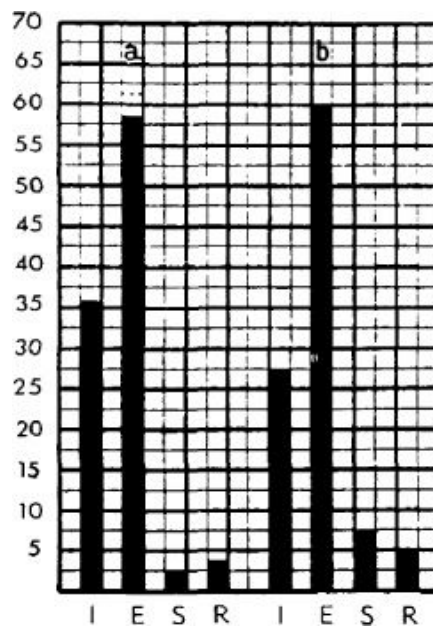

Graph V. Averages of all Experiments in the Remaining Subjects (Non-predicate Types)

(a) Normal conditions

(b) Distraction experiment

[498] Graph V. The picture is a striking contrast to the picture in graph IV. Under normal conditions the ratio I : (E + S) equals 10 : 17, approximately 2 : 3; in the distraction experiment 10 : 24, approximately 2 : 5. S increases considerably, R less.

AN ANALYSIS OF THE ASSOCIATIONS OF AN EPILEPTIC¹

[499] Epilepsy is one of the few mental diseases of which the symptomatology is particularly well known and delimited by innumerable clinical and systematic inquiries. Psychiatry has shown that in the epileptic, besides the symptoms of the fit, there is usually a mental degeneration that can be claimed to be specific and therefore of diagnostic value. Here are the principal traits of those epileptics who show degeneration according to the recognized textbooks of psychiatry:

1 *Intellect*. Mental debility, slowness of mental reactions, fussiness, restriction and impoverishment of ideas combined with poor and stereotyped vocabulary, frequently abnormal preponderance of fantasy.

2. *Emotional disposition*: Irritability, moodiness, strong egocentricity, exaggeration of all feelings, particularly religious ones.

[500] These attributes comprise what is known as the epileptic character, which, once established, has to be considered a permanent formation. Transitory accentuations of one or the other trait are quite likely, radiating like ripples from occasional fits. It is occasionally possible to make the diagnosis with sufficient certainty by recognizing the epileptic character, even if fits are not known to have occurred. Such cases, however, are on the whole rare. Very frequently the epileptic character is not very obvious, particularly if the fits are infrequent. It would therefore, for practical purposes, be most valuable to find a method of concise formulation of the epileptic degeneration.

[501] Repeated attempts to investigate the permanent epileptic changes by means of experimental methods have recently been made: thus Colucci² and Breukink³ tested by means of the ergograph; Sommer⁴ and his pupil Fuhrmann⁵ in particular turned their attention towards associations in epileptics. We consider the latter research as particularly suited for a precise formulation of epileptic degeneration.

[502] Fuhrmann reports on an investigation into the associations of two epileptics. The first concerns a patient who was taken ill in his tenth year. The author found that predicates in particular occurred repeatedly and that egocentricity played a prominent part. Not all reactions could be regarded as "associations"; there were also verbal reactions, the content and form of which had no inherent connection with the stimulus-word. Fuhrmann calls these reactions "unconscious." They appear mainly at the beginning of the test sequence (according to the table given by Fuhrmann). Test sequence I starts with the following reactions:

1. bright	faith
2. dark	health
3. white	arm
4. black	blue
5. red	parents

6. yellow
7. green
8. blue

father
chair
arm

[503] Fuhrmann does not attempt any interpretation. Kraepelin⁶ mentioned this observation in the latest edition of his textbook, where he states:

[It seemed] as if these ideas, only released but not produced by the experiment, emerged from permanent general trains of thought. Their contents were mainly related to the illness or else to the patient's personal circumstances. We may well assume that the frequency of such associations, determined by inner conditions, not by external stimulation, is particularly facilitated by the mental slowness of epileptics, which prevents them from associating quickly and easily with the stimulus-word, as normal people do.

[504] In 1903 I demonstrated the frequent occurrence of such meaningless connections in an imbecile in a state of emotional stupidity in my paper "On Simulated Insanity." Wehrlin⁷ recently expressly referred to these facts, supported by evidence, in his research on associations of imbeciles and idiots. According to our experience these meaningless reactions always occur when the patient is in a state of emotional stupidity, which can, of course, occur in quite a number of mental abnormalities. These "unconscious" reactions are therefore not at all specific for epilepsy.

[505] Let us return to Fuhrmann's paper. In the first case a repetition of the experiment with the same stimulus-words was carried out after about a month.

[506] The second case concerns a patient who had been ill since he was sixteen. Here the experiment was repeated four times within eight months, and a considerable restriction of the extent of the associations, a striking monotony in the reactions, could be observed. Basing his opinion on the associations of two female idiots, Fuhrmann considers that there is a "marked" difference between epilepsy and idiocy, in that general concepts have no meaning for idiots. Wehrlin's investigation shows that the idiot is aware of general concepts but these are extremely primitive. Thus the difference may be more subtle than Fuhrmann appears to assume.

[507] Riklin, in his notable paper on "Relieving Epileptic Amnesias by Hypnosis,"⁸ reports on several association experiments with epileptics. This author deals more with the qualitative aspect of the reactions and arrives at a variety of important findings.

[508] He finds a clinging to the content of a reaction and to the same grammatical form, strong egocentricity, personal constellations, a frequent emotional charge in the content of the reaction, and a paucity of ideas.

[509] These peculiarities are to a great extent nothing but reflections of the epileptic character. Riklin states that it is possible to read the signs of epileptic degeneration from a sequence of associations. In scrutinizing Riklin's observations, however, it has to be pointed out that: (1) Perseveration of the grammatical form need by no means always be an epileptic symptom. Wehrlin's paper shows very marked perseveration of grammatical form in imbeciles and idiots. (2) Perseveration of the content occurs also in normal subjects, as I have shown,

together with Riklin, in the first contribution of the Diagnostic Association Studies.⁹ Egocentricity and personal constellation too happen in the normal and in the feeble-minded, as well as feeling-toned reaction-contents. The paucity of ideas is, of course, not characteristic for epilepsy, but for mental deficiency generally, and in a certain sense also for emotional stupidity, where it assumes the special form of “associative vacuum.”

[510] In epilepsy therefore it is a question of the quantity of these symptoms in any given case. It will also have to be considered whether they may perhaps have a more specific quality. I have made it my task to clarify these issues and to attempt to separate what is specific for epileptic associations from the various types of the normal and from congenital mental deficiency. Such an investigation has, of course, to be based on extensive material. The Swiss Asylum for Epileptics in Zurich, with its large numbers of patients, offered a favourable opportunity.

[511] The material comes mainly from this institution, where it was collected by the Medical Superintendent, Dr. Ulrich; some of it came from the Burghölzli Asylum for the Insane. The total number of experimental subjects was 158, the total number of associations 18,277. This extensive material allowed us to form some ideas about associations in epileptics; for this reason Dr. Ulrich and I began a methodical inquiry into this subject which contains so much of interest. In order to comprehend the essence of the abnormalities of epileptic association as fully as possible, I classified the material as follows:

[512] First, I excluded those cases who were not congenitally mentally defective and those who only contracted epilepsy after leaving school, i.e., after puberty.

[513] By doing this I discarded the cases, so frequent among epileptics, that are complicated by congenital mental deficiency. According to Wehrlin's paper, it seems that imbeciles have a rather characteristic type of association which is mainly marked by the tendency to “define” the stimulus-word. The first records of epileptics showed us association types which from the very beginning revealed the greatest similarity to the imbecile type. In cases of epilepsy complicated by imbecility or by mental degeneration in early youth, the similarity was even greater. In order to find the specific epileptic, it was necessary to eliminate the cases we have mentioned.

[514] For practical reasons the field of inquiry was further divided; in this paper I am analyzing the reactions of a typical case as fully as possible, and in a forthcoming publication Dr. Ulrich is going to discuss the variants of the epileptic types of association.

[515] Before dealing with the observations themselves, I must make a few remarks about the technique of obtaining the associations.

[516] The preparation of the subjects for the experiment is by no means unimportant. One has to consider that as a rule people have no idea what the experiment demands of them; therefore they easily get bewildered. If they become markedly so, this has a distinct influence on the result, as I have repeatedly seen. We therefore introduce the experiment in each case with an instruction: the subject is told that some random word is going to be called out, to which he or she has to answer as quickly as possible with the word or idea that

comes to mind without reflection. The instruction is illustrated by a practical example in which the experimenter gives a reasonably complete list of the possible associations. In this way the subject is enabled to select freely from this list the reaction that appeals to him most. The unbiased subject will, of course, choose the type of reaction that is characteristic of him. We take special care that the subject does not make a special effort to respond, if possible, with one word only. If this is, nevertheless, the case, then the characteristic form of the response becomes completely obscured and the reaction-time is considerably shortened. In women it is often necessary to subdue a nascent emotion by talking casually about the experiment. I usually do this by presenting the experiment as a kind of game.

[517] For these experiments a new list of stimulus-words was used. I chose two hundred words; 75 of them denote concrete ideas, 25 denote abstract ideas, 50 of them are adjectives, and 50 are verbs. The sequence is as follows: noun-adjective, noun-verb. They are as mixed as possible so that related stimulus-words do not occur in immediate sequence. No attention was paid to the number of syllables. The stimulus-words were taken from widely varied fields of everyday life, unusual words being avoided as much as possible. Intentionally a number of emotionally charged ideas were interspersed, such as love, to kiss, bliss, friendly, etc., because a particular significance is attached to these words. The reaction-times were checked by a $\frac{1}{5}$ -second stop-watch.

[518] I have chosen the following case from our material:

M. Joseph. Toolmaker, born 1863, widowed, no children. 19 convictions. No family history of illness admitted. Good at school, completed a three-year apprenticeship with a locksmith. Good testimonials. No major illness during early years, particularly no sign of epilepsy. Married in 1888. In 1893 his wife contracted a psychosis and died soon after in a lunatic asylum. After his wife was taken ill, the formerly stable and industrious patient began wandering about all over Europe. He left every place of employment after a short time, took to drink, travelled aimlessly about, even in forests. During this period there were frequent collisions with the police, mainly for theft. The patient claims amnesia for most of them. In 1893–94 he was three times in lunatic asylums for violent *mania transitoria*. In 1896 he fractured his skull. In 1896–98 he was again in various lunatic asylums for delirium. In 1898 one-sided twitching, occurring in fits, was noticed. At that time a relatively lucid delirium, with plastic and very stable visions, was observed, and the patient described it with much emotion. The end of 1904 was spent by the patient aimlessly in the mountains eating only poor food. Following a drinking bout, he stole a bicycle. After the theft he wandered aimlessly about and then came into the hands of the police. He was brought in here for observation, which revealed:

Mental deficiency in an epileptic character. Frequent short lapses of consciousness with aura: “Sees black dots, five to six in a row, which are always moving up and down; head feels as if in a clamp or pressed together by screws; chest feels as if a drop were trickling down inside it; there is buzzing in the ears, then fear overcomes him as if he had done something wrong, or he has pains in the back that rise to the head; he has the feeling that he wants to tear everything up, or it is as if a railway engine suddenly rushed towards him.”

After this aura he gets giddy, everything is spinning around him and he loses consciousness. The lapses of consciousness were also observed during conversation and particularly while playing cards. Intolerance of alcohol to a high degree.

[519] The associations in this case seemed to me in various respects rather typical for epilepsy, although not all the characteristic symptoms appear in them. This is because each case has its peculiarities, so that here too rather an important role is played by the individual differences between the various reaction-types.

		Secs.
1. coal	hard coal	7.2
2. moderate	eating little	12.0
3. song	to sing, to sing a song	6.2
4. to assume	I assume, what do I assume? several things	23.2
5. pain	because I am ill	4.2
6. rotten	if an apple is rotten, a plant, everything can get rotten	5.8
7. moon	that is the moon in the sky, here we have the moon	3.4
8. to laugh	man laughs	4.2
9. coffee	one drinks it, drinks it every day	4.0
10. wide	this is the width of a distance (accompanied by an explanatory gesture)	6.2
11. air	this is the air, nature's air, healthy or unhealthy, fresh air is fresh air	2.2
12. to carry (to wear) ¹⁰	I carry (or wear) something, a burden or fine clothes	5.0

[520] These first twelve reactions already allow some conclusions. Above all it is striking that the subject reacts not with *one* word but usually with whole sentences. This fact has a certain significance. In my experience, which is supported by the material of more than thirty thousand normal associations, healthy people as a rule tend to react with one word (N.B. after being instructed as explained above). There are exceptions when even educated people may prefer the form of a sentence; Riklin and I quoted such an example in our paper on the associations of healthy people. That subject belongs to the “complex-constellation type,” i.e., to that reaction-type whose associations are at the time of the experiment under the influence of an affect-charged complex of ideas.¹¹ In such cases one recognizes at once the peculiar constellations from the contents of the associations. I refer to this quotation. Among healthy people there is also a type who likes to react with two or more words, though not actually in sentence-form:

[521] *The Predicate Type.*¹² People belonging to this type tend mainly to judge and evaluate the object described by the stimulus-word. This is, of course, done in predicate form; thus the tendency is quite obvious and the use of several words sufficiently explained. Certainly neither of these types can be confused with the reactions that now concern us.

[522] In the pathological field, however, the sentence form is so frequent and occurs so widely that one can hardly recognize in it anything pathognomonic.

[523] An observation (which I cannot, it is true, support at present by figures) has to be mentioned: uneducated mental patients appear to tend more to form sentences than educated ones. Should this observation become confirmed, it would not be difficult to combine it with the fact that uneducated people are more concerned with the meaning of the stimulus-word than are educated ones, as has already repeatedly been stressed in previous papers. Uneducated people at a very low level, who tend to “answer” with something that is as “fitting” as possible and to explain the stimulus-word as well as possible, need more words for it than educated ones, who merely juxtapose words. This tendency to explain becomes most obvious in idiots and imbeciles, who very frequently form whole sentences.¹³ Our subject shows a preference for sentences which, in the absence of sufficient data, is difficult to understand; it may therefore be inferred that we are faced with some abnormality.

[524] Before dealing with the contents of the reactions we must pay some attention to the reaction-times. These are abnormally long. (The average reaction-time of uneducated subjects is 2.0 sees.) This does not permit us to draw any conclusions at present, because there is no syndrome in which the reaction-time could not be prolonged. As is well known, Aschaffenburg found somewhat extended reaction-times also in manic patients. It may, in any case, not be advisable to investigate the reaction-times found in the association experiment, isolated from the analysis of the association contents, because they depend to a high degree on the momentary contents of consciousness.

[525] Let us now consider the quality of the associations. We notice at once that the subject focuses on the meaning of the stimulus-word; there is an outspoken tendency to clarify and characterize the object denoted by the stimulus-word. Wehrlin described this tendency as particularly characteristic for congenital mental deficiency. Perhaps, however, the strong tendency to explain occurs in every variety of mental defect, and it may be assumed that the feeble-minded converge in some respects towards the congenital mental defective, even if the causes of the two conditions are entirely different. The tendency to explain is so obvious in our case that here too we can without difficulty demonstrate the kind of explanation found by Wehrlin among imbeciles. Reactions such as these can be regarded as “tautological clarifications”:

to assume	I assume
to carry	I carry something
air	this is the air

[526] These can be taken as explanation by “examples”:

moderate	eating little
rotten	if an apple is rotten
wide	this is the width of a distance (with explanatory gesture)

[527] These indicate the main quality or activity:

to laugh
coffee

man laughs
one drinks it

[528] From this we can see no more than a very marked conformity with the explanatory tendency of imbeciles. Moreover, one can even say that the subject is taking pains not to be misunderstood in this respect. Thus he is adding something that confirms and elaborates the explanation in places where there is some doubt whether it is a superficial familiar word-connection, such as in *song / to sing, coffee / one drinks it*.

song
coffee

to sing, to *sing a song*
one drinks it, *drinks it every day*

(Similarly in 4, 11, 12.) These examples show that the subject needs to accentuate his tendency to explain.

[529] Out of the twelve reactions cited, which show a tendency to explain, we find three containing the word “I.” Such reactions belong to the egocentric type. There are egocentric reactions in the normal as well, particularly in subjects with an “egocentric attitude.”¹⁴ This attitude can express itself in three different ways:

1. The subject reacts with a number of personal reminiscences.

2. The subject is under the influence of an emotionally charged complex of ideas. He relates almost every stimulus-word to himself (i.e., to the complex) and responds to it as if it were a question concerning the complex (a prototype of paranoia, therefore!).

3. The subject belongs to the predicate type and evaluates the content of the stimulus-word from the personal angle.

[530] In these three types the subject puts himself occasionally into the foreground. Apart from this, egocentric reactions occur as a rule somewhat more frequently in the educated than in the uneducated, but mainly when the subjects are at their ease. For uneducated men we found an average of 1.7 per cent egocentric reactions, for uneducated women only 0.5 per cent. All the more remarkable is the strong predominance of egocentricity here. The cause of it could in the first place be ascribed to mental deficiency. Imbeciles use personal reminiscences relatively often because, owing to their narrow horizon, they have no others available. Wehrlin has given good examples of this. Figures found in our material obtained from imbeciles have shown a fluctuation of the numbers for egocentric reactions between 0 and 2.7 per cent. Among fifteen imbeciles there are no more than nine who show egocentric reactions. It must, however, be mentioned that in Wehrlin’s material¹⁵ there is an imbecile who is distinguished by the fact of having produced no less than 26.5 per cent egocentric reactions. This is quite an unusual result, for special reasons. This imbecile is also different from the other subjects in that he has not an actual tendency to explain, but with each stimulus-word he forms a “schoolroom-type” sentence which often begins with “I”; e.g.,

fall¹⁶

to loathe

head

to run

I fall down

I loathe rotten fish

I have a head

I run swiftly

advice
reward

I ask father's advice
I deserved the reward

[531] The examples show that, as Wehrlin has already mentioned, this imbecile is mainly trying to formulate correct "schoolroom" sentences, saying "I" in places in which other imbeciles say "one" or "the man." The description "egocentric" can therefore be applied to this case only with some qualification. As already mentioned, this case is an exception and does not alter the fact that as a rule imbeciles avoid the ego-reference. Egocentric reactions in imbeciles are not much in evidence; on the contrary, the subjects prefer the expressions "one," "someone," etc., in order to avoid the "I"-form. Hysteria, too, which has numerous ego-references, prefers the less suspect "one."

[532] Our case, with his outspoken tendency to explain, also shows a prominence of egocentric reactions, such as we do not find in imbeciles with the same tendency to explain. One can object that R.12, *to carry / I carry something*, is a "schoolroom" sentence. But one cannot make this objection to 5, *pain / because I am ill*.

[533] It is strange enough to see the strong egocentric aspect in imbecility; it is even stranger to observe the peculiar way in which the subject words his explanation.

[534] I have already pointed out that in a way the subject accentuates his tendency to explain by repeating his reactions in a confirmatory way, finally adding an attribute. But the subject goes even further; he is not satisfied with a simple reaction, but it evidently gives him special satisfaction to make his explanation more complete.

[535] In R.4, *to assume / I assume, what do I assume? Several things*, one can virtually see how he is trying to bring something more descriptive into it. He gets into an entirely abnormal excitement with R.11, *air / this is the air, nature's air, healthy or unhealthy, fresh air is fresh air*.

[536] The urge to completeness leads to pleonasm in R.10, *wide / this is the width of a distance* (with explanatory gesture). (See also 6, 7, 12.)

[537] In the reactions 11, *fresh air*, and 12, *fine clothes*, the attributes seem to give quite a special emphasis. The effort with which the subject reacts suggests some inadequacy because this display of words goes far beyond what would be necessary to cover the stimulus-word. This fact at once gives the impression of an unnecessary and exaggerated tendency to elaborate. Precisely this trait is absent in the imbecile; he is satisfied with a not too long reaction that appears to him reasonably suitable, but which frequently does not get beyond the most primitive indications and quite undeveloped concepts. Our subject, however, has a strong inclination to accumulate and to elaborate the reactions, occasionally far beyond what is necessary.

[538] The twelve reactions quoted give us reason to suspect feeble-mindedness which is specifically tinged by a strong tendency towards egocentricity and elaboration.

[539] Let us now see our patient's further reactions:

The reaction is repeated with emphasis as if in confirmation. As it is not enough, it is further defined; an unnecessary reiteration. Quite similarly constructed, but even more specific, is

14. tired	I am tired—yes, tired—the body is tired	3.0
15. intention	I have the intention—to invent a machine —to draw—to provide—to live properly	13.0

This reaction too is overdone. It contains two explanations by means of definite examples, one of which is a personal constellation (the subject is a toolmaker) and three times qualified.

16. to fly	the bird flies	4.8
17. eye	the eye sees	2.8
18. strong	am strong, that is strong	4.6

Again a clumsy ego-reference followed by a confirmatory but unnecessary sentence.

19. fruit	this is a fruit, a <i>tree-fruit</i>	7.0
-----------	--------------------------------------	-----

The tendency to confirm and complete leads here to the formation of a new word *tree-fruit* (see also below on this reaction).

20. to create	to work hard means to create	3.6
---------------	------------------------------	-----

To work has an emotionally charged attribute.

21. sail	a sail is a sailing boat on the water	6.8
----------	---------------------------------------	-----

Note the repeated return of the stimulus-word in the reaction. Up to now there were no more than three associations in all in which the stimulus-word did not recur in some form.

22. modest	yes, man is modest when he has learned something	9.0
------------	---	-----

Yes is an expression standing for a feeling that is about to take the shape of ideas and words (see R.14). Wherever strong feelings, either easily aroused or very intense, are involved (as in hysteria and certain organic brain-lesions), *yes* and *no* are frequent. The content of this association points to a train of thought hardly to be found in someone born mentally defective.

23. floor	floor of the room	3.8
24. to whistle	I whistle	3.2
25. purpose	for what purpose? For what purpose are you doing this?	5.6

The reaction is particularly striking because of the repetition of the stimulus-word. Here again we can see that the subject understands the stimulus-word as a question.¹⁷

26. hot	it's too warm, too hot	2.0
---------	------------------------	-----

Up to now, hardly one of the reactions shows as well as this one the subject's tendency to confirm and complete the reaction with emphasis. It is as if the subject is each time trying to

clarify the meaning of his reaction with special vigour. This emphatic underlining shows up well in the accentuation *too warm, too hot*.

27. resin	fir resin, the resin grows on the fir-tree, on the pine-tree	3.8
28. to arouse	I arouse—I arouse my friend, he is asleep	8.4

Both reactions are again characterized by great completeness, especially the latter, where the subject even completes the picture by *he is asleep*.

29. apple	there are various apples	6.6
-----------	--------------------------	-----

This reaction can be found extremely frequently in exactly the same form in imbeciles.

30. wicked	one says, who is wicked? so-and-so is wicked, that is a wicked person	6.0
31 case	a brief-case	3.0
32 to drink	I drink lemonade	3.0
33. bed	sleeping—I have the bed for	3.0
34. worthy	that person is worthy to whom him honour is due (<i>sic</i>)	94

This reaction has linguistically miscarried. Epileptic mental deficiency seems to have in common with congenital mental deficiency that the patient is clumsy and arbitrary in the handling of the language. In imbeciles we find many faulty formulations of sentences and also clumsy neologisms. However, in the association experiment one must not simply ascribe linguistic clumsiness to mental deficiency, since there may also be momentary emotional disturbances that interfere with the linguistic expression. We shall come back to this later.

35. danger	I am in danger, in danger of life	4.2
36. to visit	I visit a patient	4.8

The latter reaction may again be an ego-reference.

37. locksmith	I am a locksmith, an artisan	2.8
38. high	the steeple is usually high	4.8
39. hatchet	the hatchet is an axe	3.4
40. to mix	don't mix yourself up in other people's affairs	6.2 210

This reaction very much resembles a common phrase. It is the first in this case. As is well known, just such reactions are very common in normal subjects.

41. path	that is a footpath, a field-path	3.2
42. round	it is a sphere, otherwise it is not a sphere, if it is not round	3.8

A reaction very typical of the pedantic fussiness of the subject.¹⁸

43. blood	every man has, every animal only good or bad, that is the difference	3.4
-----------	--	-----

In this long-winded reaction we again find similar evaluations to those in R.11. There it was *healthy or unhealthy air*, here it is *good or bad blood*. The constellation common to both is apparently the question of health, which is important for the patient. R.5 and R.36 also refer to this complex. The strong predominance of the illness-complex in the associations of the epileptic has also been stressed by Fuhrmann.

44. to let	I let lodgings	6.0
45. cautious	Man, be cautious	4.8
46. merry	I am merry, I am gay	3.6
47. market	the annual fair, that is a market, the fair at Basel only recently took place	7.0
48. to forget	I have forgotten something	5.0
49. drum	the kettle-drum is a drum	3, 2
50. free	I am free—I am free, I am a free citizen, it would be nice if only it were true	4.0

In this reaction, apart from the repeated emphasis on *free*, the egocentric relation, clothed in the evaluation *nice*, is noticeable.

51. carriage	a carriage, a team of horses	4.4
52. to eat	I am eating, I am eating a stew	2.4
53. insolence	if a person—there are people who are insolent, insolent in their speech, insolent behaviour	6.8
54. fast	the engine runs fast (probably a constellation arising from his daily work)	3.8
55. fireplace	is a chimney, a factory chimney	2.4
56. to enjoy	I enjoy an evening entertainment, I enjoy pleasure	4.0
57. parson	is a clergyman, a pastor that ought to be a righteous man	2.2

To the reaction, which would be quite sufficient in itself, a feeling-toned evaluation is attached. It resembles R.15: *intention to live properly*. Are these perhaps indications of a tendency in the epileptic to moralize?

58. easy	what is not easy is difficult	5.0
59. neck	is the neck (points at his neck) every man has a neck	2.8
60. to wish	I wish you luck in the New Year	3.0
61. stone	a marble stone, there are various stones, stone is a product of nature ¹⁹	4.6

Imbeciles too are inclined to use abstract nouns of foreign origin (substance, material, article, etc.), which, however, they frequently use in a truly grotesque way.

62. distinguished	the educated man is distinguished	6.2
63. hose	the rubber hose is a hose	4.0

This reaction seems to me characteristic for the epileptic: Biblical form, strong emotional charge, and egocentricity. For comparison I assembled the reactions to *to love* of ten imbeciles chosen at random:

1. friendly
2. to be angry
3. fiancé
4. if one loves someone
5. pleasant
6. I love father
7. if one loves one another
8. if two are fond of each other
9. if one likes someone
10. if one loves someone

With one exception (6), the imbeciles react very impersonally and in a considerably less colourful way than the epileptic.

65. tile	there are grooved tiles in Basel	
66. mild	is mild weather, is mild, is warm	2.8

[540] It is hardly necessary to pile up any more examples. The further associations of this case contain nothing fundamentally new.

[541] Some more general clarifications may be useful. It must first be mentioned that the subject made gestures with most reactions (which were indicated each time by a tick on the association form). The gesture expressed, wherever possible, confirmation and completion. Secondly, the stimulus-words were repeated in 30 per cent of the reactions. As I shall demonstrate in a later paper, "The Reaction-time Ratio in the Association Experiment," the repetition of the stimulus-word in the normal subject is not accidental but has deep reasons, like all the so-called disturbances occurring in the experiment. Apart from these rare cases in normal subjects, in which the stimulus-word is each time quickly repeated in a low voice because of a general self-consciousness, this disturbance mainly occurs only at those points where an emotional charge from the previous reaction perseverates and hinders the following associations. In hysterics I have also seen that the complex-constellating stimulus-word tends to be repeated in a questioning tone.²⁰ These observations teach us that those places where repetitions of the stimulus-word occur are not at all unimportant in normal subjects. For epilepsy, however, other mechanisms may also have to be considered. In this case the first four stimulus-words were repeated, the fourth, *to assume*, even three times. Then there was nothing repeated until the fifteenth, *intention*.²¹ At the beginning a general self-consciousness is likely. In *assume* perhaps the "difficulty" of the word can have played a part; the same applies to *intention*. Both, moreover, have extraordinarily long reaction-times (23.2 and 13.0 secs.) which exceed by far those of other reactions. Perhaps

then the repetition of the stimulus-word is not simply to be explained by the “difficulty” of the word, but could have been brought about by a perseverating emotional charge. The preceding reaction is *I am tired—yes, tired—the body is tired*: 3.0; the following reaction-time is 13.0.

[542] Apart from the content, the word *yes* already points to the existence of a stronger feeling-tone. The subsequent repetition of the stimulus-word appears in 19, *fruit*. The reaction preceding this is *am strong, that is strong*: 4.6 (fR-T 7.0).²² 21, *sail* is repeated. Preceding reaction: *to work hard means to create*: 3.6 (fR-T 6.8). 22, *modest* is repeated. Preceding reaction: *a sail is a sailing boat on the water*: 6.8 (fR-T 9.0).

[543] Here we have two stimulus-word repetitions immediately following one another, whereby the reaction-times progressively increase: 3.6—6.8—9.0.

[544] The reaction to *sail* is a linguistic mishap (in my investigations into reaction-times, linguistic slips have proved to be complex-characteristics). At the near end of the scale is *to work hard*, an emotionally charged, probably egocentric reaction. The third reaction (22) is *yes, man is modest when he has learned something*. It is not difficult to see here a relation in the content to *to work hard*. The assumption that the emotional charge of *to work hard* has perseverated behind the linguistically disturbed reaction and constellated R.22 is therefore not unlikely.

[545] 47, *market* is repeated. Preceding reaction: *I am merry, I am gay*: 3.6 (fR-T 7.0). 51, *carriage* is repeated. Preceding reaction: *I am free—I am a free citizen, it would be nice, if only it were true*: 4.0 (fR-T 4.4).

[546] With the exception of the first four reactions most of the other repetitions of stimulus-words coincide with reactions that immediately follow egocentric associations. The reaction-time in these cases is mostly abnormally prolonged. To avoid being unduly long-winded I shall not bring any further evidence for this fact; I can, however, give an assurance that, with only very few exceptions, all the other repetitions of stimulus-words took place near strong emotional charges.

[547] In several reactions a certain linguistic awkwardness was noticed. One is tempted, in analogy with imbecility, to make the epileptic mental defect responsible for these faulty formations. We know, however, another source for slips of the tongue: namely, the strong emotional charge of a complex aroused by the stimulus-word. In my communication on reaction-time in association experiments I shall quote a number of examples from which it can be seen how reactions are influenced in normal subjects by an emotionally charged complex. Apparently quite casual slips of the tongue, which the subject himself hardly notices, prove to be meaningfully determined products of the mixture of two competing ideas.²³ Before therefore ascribing the linguistic mishaps to mental defect it is advisable to investigate whether perhaps the mechanism discovered in the normal subject is here too the cause of the incorrect sentence or word-construction. Amongst the associations quoted here, there are three linguistically incorrect ones. I am pairing each of these three associations with the immediately preceding ones (the incorrect construction is given in italics):

18. strong	am vigorous, that is, strong	4.6
19. fruit	(stimulus-word repeated) this is a fruit, a <i>tree-fruit</i>	7.0
20. to create	to work hard means to create	3.6
21. sail	(stimulus-word repeated) <i>a sail is a sailing boat</i> on the water	6.8
33. bed	sleeping—I have the bed for	3.0
34. worthy	(stimulus-word repeated) that person is worthy <i>to whom him honour is due</i>	9.4

[548] These three faulty constructions have in common:

1. The stimulus-word of the faulty association was each time repeated.

2. Every one of the incorrect reactions has a reaction-time not only higher than that of the preceding reaction but prolonged beyond the average of the others.²⁴

3. Two of the incorrect associations follow emotionally charged reactions: for the third this is at least probable according to the content and the analogy with similar cases.

[549] These observations give us so many starting points for an explanation that we may hardly assume mental deficiency to be the cause of the incorrect constructions.

[550] From these observations we can see that a specific epileptic mechanism can be found neither in the numerous repetitions of the stimulus-word, nor in the faulty constructions of the sentences. It is, however, debatable whether anything specifically epileptic can be seen in the intensity of these otherwise normal processes. Here perhaps the reaction-times, a valuable aid for judging emotional processes, can give us some information.

[551] All time-averages given here are “probable means.”²⁵ The time measurements for the subject give 4.2 seconds as a general probable mean (uneducated normal person: 2.0 secs.). The general reaction-time is thus more than twice as long as that of corresponding normal subjects. This mean, however, is only a “gross” figure; it is composed of several unequal magnitudes. As I shall show in my later publication, reactions complicated by feelings are usually prolonged. If therefore there are many such reactions the general mean may under certain circumstances be strongly influenced. If we now eliminate all those reactions that, according to the criteria already given, are remarkable because of their feeling-toned egocentric contents and also those reactions that immediately follow these, then we obtain 3.8 secs. as a probable mean for all the assumedly uncomplicated reactions, while the probable mean for those eliminated is 4.8 secs.

[552] Thus the feeling-tone makes a difference of 1.0 sec. This state of affairs is not very different from that of the normal. As we have seen in several examples, there is frequently a considerable difference between the times of feeling-toned associations and those of the reactions immediately following them. We therefore investigate separately the time of these two groups. As a mean for the reactions containing a feeling-toned idea we have 3.6 secs., a figure 0.2 secs. lower than the mean for associations not feeling-toned; for the associations immediately following those that are feeling-toned, however, there is a mean of 5.8 secs.

This unusually high mean, which exceeds that for the uncomplicated reactions by not less than 2.0 sec, expresses the important fact that the feeling-tone inhibiting the reactions perseverates from the critical reaction and exerts its main influence on the following reaction. Thus the effect of the feeling-tone inhibiting the reaction cannot as a rule be demonstrated in the critical reaction but only in the following reaction. One must therefore assume that in this case the feeling-tone does not properly set in until after the critical reaction, increases very gradually, and then decreases slowly, still inhibiting the following reaction. This state of affairs appears the more remarkable when we remember that the experimenter has to write down the reaction, to read the stop-watch, and to call out the next stimulus-word, and that the writing down of the reaction, which may be rather long, takes most of the time. I also tried to make similar observations about the associations of normal subjects. For this purpose I took the associations of a case of whom I possess a most detailed analysis, so that I was fully informed as to all complex-constellated associations. The probable mean of all associations not complicated by feelings is 1.2 secs. The mean of the feeling-toned reactions is 1.6 secs. The mean of the reactions immediately following the feeling-toned ones is 1.2 secs. This equals the mean of the uncomplicated reactions. If, therefore, in the mentally normal subject the complex-arousing stimulus-word is followed by a reaction-time on average 0.4 secs. longer than that of the immediately following or irrelevant stimulus-word, this only means that in the normal subject the feeling-tone sets in much faster and subsides again incomparably faster than in our epileptic; thus the average reaction-time of the following association is unimpaired in the normal subject, whereas in our epileptic, as we have seen, the reaction-time for the following critical association is unusually prolonged.

[553] This important and interesting peculiarity appears to be of a pathological nature; how far it is typical for epilepsy has to be learned from the further study of our vast material.

[554] There seems to be something characteristic for our case in this phenomenon, because one can also assume the existence of such an enormous emotional process from the quality of the associations. I have repeatedly pointed out the fact that the subject frequently emphasized his reactions with his voice as well as also sometimes with words giving expression to some feeling (e.g., *hot / it's too warm, too hot; tired / I am tired—yes, tired—the body is tired; etc.*). This peculiar form of reaction also seems to indicate that the feeling-tone sets in slowly and increases slowly, in this way releasing even more associations in a similar direction. It is most likely that the feeling-tone in the epileptic is of greater intensity than in the normal subject, which again is bound to prolong the feeling-tone. It is, however, difficult to say whether the epileptic's feeling-tone is necessarily abnormally prolonged.²⁶

[555] In my analytic investigations into the reaction-times of normal subjects I was able to demonstrate the existence of one or more feeling-toned complexes of ideas that constellate a large number of the associations. I have already pointed out that in our epileptic also there exists a complex that constellates many of the associations. It is the complex of the illness. The following associations may be related to this complex:

14. tired	I am tired—yes, tired—the body is tired	3.0 (fR-T 13.0 Rr) ²⁷
18. strong	am vigorous, that is, strong	4.6 (fR-T 7.0 Rr)
43. blood	every man has, every animal only good or bad, that is the difference	3.4 (fR-T 6.0 Rr)
46. merry	I am merry, I am gay	3.6 (fR-T 7.0 Rr)

A more remote constellation might be:

11. air	this is the air—healthy or unhealthy	2.2 (fR-T 5.0)
36. to visit	I visit a patient	4.8

The reaction following is:

37. locksmith	I am a locksmith, an artisan	2.8
---------------	------------------------------	-----

[556] Because of his illness the patient was hospitalized, a fact that made a great impression on him. He feared especially that he might never be discharged, nor be able to work and earn his living any longer. He was also homesick. The following reactions perhaps refer to this aspect of the complex:

20. to create	to work hard means to create	3.6 (fR-T 6.8 Rr)
35. danger	I am in danger, in danger of life	4.2 (fR-T 4.8)
50. free	I am free—I am free, I am a free citizen, it would be nice if only it were true	4.0 (fR-T 4.4 Rr)
60. to wish	I wish you luck in the New Year	3.0 (fR-T 4.6 Rr)

Regarding this last reaction, it must be added that the associations were taken before Christmas—at a time, therefore, when sensitive patients suffer twice as much from hospitalization.

[557] These few examples may suffice to show that quite a number of associations are constellated by a feeling-toned complex. This state of affairs in itself is not at all abnormal, since the associations of normal people are also often constellated by such complexes.

SUMMARY

[558] I. In common with the associations of normal persons:

- (a) The patient adapts himself to the meaning of the stimulus-word in the same way as uneducated subjects. Therefore there are no superficial word associations.
- (b) The associations are partly constellated by an illness-complex.

II. In common with the associations of imbeciles:

- (a) The adaptation to the meaning of the stimulus-word is so intense that a great number of associations has to be understood as “explanation” in the sense of Wehrlin’s paper.
- (b) The associations are in sentence-form.
- (c) The reaction-times are considerably prolonged, compared with the normal.

(d) The stimulus-word is frequently repeated.

III. Peculiarities compared with normal and imbecile subjects:

(a) The “explanations” have an extraordinarily clumsy and involved character which is manifest particularly in the confirmation and amplification of the reaction (tendency to completion). The stimulus-word is frequently repeated in the reaction.

(b) The form of the reaction is not stereotyped, apart from the egocentric form that occurs particularly often (31%).

(c) Frequent emotional references appear rather bluntly (religious, moralizing, etc.).

(d) The reaction-times show the greatest variation only after the critical reaction. The abnormally long times are therefore not to be found with particularly difficult words, but in places determined by a perseverating emotional charge. This permits the conclusion that the feeling-tone probably sets in later and lasts longer and is stronger in the epileptic than in the normal subject.

[559] In conclusion I beg to remark that the value of my analysis lies only in the case-material and that therefore I do not dare to draw any general conclusion from it. There are many forms of epilepsy that may have quite different psychological characteristics. Perhaps the fact that my case is complicated by a fracture of the skull sets it apart.

THE REACTION-TIME RATIO IN THE ASSOCIATION EXPERIMENT¹

[560] As the subject of the present investigation I have chosen the ratio of the time-interval between calling out the stimulus-word and the patient's verbal reaction. I am calling this period simply the *reaction-time*, knowing that it is a matter of a compound whole that can be divided, not only deductively but also empirically, into numerous components. I am not going to attempt an analysis of this kind for it could only be a matter of hypotheses that would have to be supported, quite unjustifiably, by anatomical data. The components of our reaction-time are known to us only in part, and careful examination must necessarily show them to be tremendously complicated, as we can see from the following summary given by Claparède:²

1. Transmission of sound to the ear of the recipient.
2. Neural conduction to the auditory centre.
3. Word-recognition (primary identification).
4. Word-comprehension (secondary identification).
5. Evocation of the associated image, i.e., pure association.
6. Naming of the idea evoked.
7. Excitation of the motor speech-apparatus or the motor-centre of the hand when measurement is made by means of a Morse telegraph key.
8. Neural conduction to the muscle.

[561] A purely superficial examination of these eight factors shows that only a few of the most important processes are stressed. The innumerable possibilities of intra-cerebral process are by no means exhausted in this summary.

[562] So far as we know these components, they are of very short duration, even the longest of them should not exceed 50σ (Ziehen). Some of these components might, in normal circumstances, be of fairly constant duration, as for instance the time of the neural conduction, of the excitation of the centres, etc. In any case, their variations will occur only within relatively narrow limits. The variation of the identification periods, however, are greater, and the longest of all are the actual association-time and that of the verbal formulation of the reaction. Thus, in the association experiment, the latter factors will be of the greatest importance.

[563] Anyone conversant with the association experiment knows how wide are the limits within which reaction-times vary. In our experience times of up to six seconds are by no means rare, even with quite normal subjects. The great variability of the times gives us the necessary lead for establishing a *method of measurement*. So long as we have inadequate knowledge of the causes of the variations, small differences cannot tell us anything; we do

not therefore need a complicated experimental set-up in order to measure the intervals in one-thousandths of seconds, for we can safely ignore small differences so long as the causes of the greater variations are still hidden. Quite apart from the fact that the complicated methods of exact time-measurement do not reveal more than measurements taken with a 1/5-second stop-watch, there are weighty arguments against the use of complicated apparatus like labial keys^{2a} and megaphones or of dark-room methods. Considering that Mayer and Orth³ even thought it necessary that the eyes should be closed throughout the experiment, to avoid distracting sensations, surely the apparatus mentioned do not contribute anything to the simplification of the experiment or the prevention of disturbing influences. In any case, inexperienced subjects should not be used in experiments of this kind if one is not to risk gross distraction. Finally, in the case of psychotics exact measurements are impossible.

[564] For this reason, measurement with a 1/5-second stop-watch not only appears entirely satisfactory, but has been proved adequate by several other writers in numerous experiments. Mayer and Orth worked with a 1/5-second stop-watch, so did Thumb and Marbe,⁴ Wreschner,⁵ Sommer, and others. Claparède⁶ holds that this is adequate in all experiments regarding successive associations. Besides the fact that the watch is easy to handle, a further special advantage is that the second hand disturbs the experiment as little as possible, a factor which is particularly valuable in experiments with uneducated subjects, who are easily upset.

[565] Considering the great differences in the times, it means little that the times measured are all somewhat too long. All of us who have worked with a stop-watch know too that it functions with only limited precision, since the stopping mechanism does not always hold the second-hand at the exact place it was at when the button was pressed. There are also certain variations in the personal equation that can influence the measurement. In spite of numerous imponderables, we can still, at least in my experience, assume that the measurements are accurate to approximately 1/5 second, i.e., 200 σ . This small disadvantage has not so far had any adverse effect on our experiments.

[566] The material that forms the basis of this investigation consists of time-measurements that were taken by Riklin and myself⁷ during association experiments with normal subjects. Out of 38 cases, whose associations we have already discussed, reaction-times were taken in 26. In about half the cases Riklin did the timing. The personal differential in the measurements of the two experimenters can, as we have established by means of control experiments, be determined at less than 1/5 second and can, therefore, be considered unimportant.

[567] Here are the number and analysis of the measurements:

1. 7 uneducated women	1,201 reaction-times
2. 7 uneducated men	1,007 " "
3. 6 educated women	948 " "
4. 6 educated men	988 " "
<hr/>	<hr/>
26 subjects	4,144 reaction-times

A. *The Average Duration of an Association*

[568] In his studies of associations, Aschaffenburg says: “The fact that the difference between duration of the association of normal subjects and that of others, which lies between 1,200 and 1,400 σ , can be as much as 50 per cent is of the greatest importance. This brings home to us how little value can be attributed to the absolute duration.”⁸

[569] Aschaffenburg bases this opinion on the observation that the reaction-time is subject to very considerable individual variations. Correspondingly, the data recording the average duration of association contained in the literature show wide discrepancies. Féré,⁹ for instance, found an average of 700 σ in men, 830 σ in women. Galton¹⁰ gives 1.3 seconds as the average, and Trautscholdt’s¹¹ figures range between 1,154 and 896 σ .

[570] These examples should suffice to show how little agreement there is between the various writers. The differences can be reduced to the following points:

(1) The methods of measurement differ according to the apparatus used and other experimental conditions.

(2) The degree of practice of the subject is variable.

(3) The methods of computing the mean vary. In practice, only two methods of computation are in use:

a. The arithmetical mean.

b. The probable mean (Kraepelin).

[571] In view of the fact that excessively long reaction-times frequently occur in the association experiment, the application of the arithmetical mean does not appear advisable in that by this method the high values influence the otherwise quite low average values in a most disturbing and possibly quite misleading manner. This can be avoided by using the method of the probable mean, which consists in arranging the figures in the order of their numerical value and taking that nearest the middle. By this means the influence of excessively high values is eliminated. In by far the largest number of cases the probable mean is for this reason lower than the arithmetical mean. For example, three of my subjects show the following values:

Probable mean	1.8	2.0	1.6
Arithmetical mean	2.8	3.0	3.6

As the example shows, such differences can influence the general mean to a considerable extent. It is therefore not a matter of indifference which method of calculation is used. Ziehen’s “representative value,” which demands fairly intricate calculations, should, for this reason, not meet with much approval, although it does make possible a very just appraisal of the individual figures. Finally, the highest value depends on external contingencies, and can be used only in certain conditions.

[572] For these reasons, the probable mean appears to be the method with the most to recommend it for quickly deriving averages from large numbers of figures.

(4) The number of subjects used by the early writers on this subject was mostly too limited, and their selection too one-sided.

[573] My endeavours have not been directed towards discovering absolute means, but merely approximate figures which can, to a certain extent, give us the levels of the values of normal subjects from varying social strata. As I believe that the association experiment, carried out in approximately the way it has been practised in this clinic for several years past, will play an important role in the future diagnosis of mental illness, it seems to me to be most important to find general normal mean-values which can form a firm basis for the assessment of pathological values.

[574] The general mean-value of the duration of an association seems to be 1.8 seconds. This figure was arrived at in the following way: First of all, the probable mean for each of the twenty-six subjects was calculated, and then the arithmetical mean was derived from the individual values. This method was chosen because twenty-six subjects represent a very modest number, and it would be unjust to exclude the individual values from the calculation through the application of the probable mean.

[575] This mean shows a fairly long duration of the reaction-time; it is considerably higher than the values given in the literature. The causes of this lengthening can be attributed to the following:

(1) The points mentioned above (measurement with a stopwatch, unpractised subjects, who in part come from lower social strata).

(2) The majority of the subjects are Swiss, the significance of which in our acoustic/linguistic experiments has already been emphasized in our previous contribution, which the reader may refer to.¹²

[576] The varying data show what the interpretation of the values depends on. The variability of the mean is most easily demonstrated by classifying the subjects according to certain simple criteria and comparing the figures of the individual groups.

B. *Sex and Reaction-time*

[577] As already mentioned, Féré has given longer times for women than for men. This result is confirmed by our figures:

men	1.6 secs.
women	2.6 secs.

These values indicate that women reacted considerably more slowly in our association experiments. It must be pointed out in criticism of this result, however, that the educated women among the subjects approach the educational level of the educated men, whereas, on the other hand, the cultural level of the uneducated women is inferior to that of the uneducated men. As may be known from Ranschburg's¹³ and our own earlier investigations,¹⁴ uneducated subjects, and especially the women among them, produce much higher figures than educated subjects, and give a considerably higher percentage of internal

associations, while purely linguistic associations are very much less prominent. According to Ziehen's¹⁵ observations on children, associations by means of internal connections (semantic relationships) are distinguished by the longer reaction-times, whereas verbal associations need the shortest times. This fact stressed by Ziehen, was denied by Aschaffenburg,¹⁶ since he finds on the basis of his observations "that no form of association is characterized by especially notable differences of duration." The figures given by Aschaffenburg can, it is true, not be interpreted in any other way, but they can perhaps be explained by his one-sided selection of subjects. Ziehen's claim that "images that are related to each other externally, such as, for instance, rhyming words" are reproduced more quickly, is in full accord with everyday experience.

[578] This point, too, should be taken into account in explaining the longer association-times of women. Whether this explanation is sufficient, further consideration will tell. In any case, we must investigate the influence of education before discussing a possible sex difference in the reaction-times.

C. Educational Level and Reaction-time

[579]

	<i>Educated Subjects</i>			<i>Uneducated Subjects</i>		
Men	1.3	secs.	1.8	(1.6) ¹⁷	secs.	
Women	1.7	"	2.2		"	
Average	1.5	"	2.0	(1.9)	"	

[580] Our previous investigations demonstrated that uneducated subjects produce more internal associations than the educated. The ratio of internal to external associations is 43 : 53 per cent with uneducated and 36 : 59 per cent with educated subjects. One is therefore tempted to connect the differences in the reaction-times with these ratios and to state: the smaller number of internal associations with educated subjects corresponds to the shorter reaction-time, and vice versa, the greater number of internal associations with uneducated subjects corresponds to the longer reaction-time.

[581] However plausible this hypothesis may appear, particularly in view of Ziehen's statements, consideration of the figures of the different sexes does show, however, that the position is not so simple. On closer consideration of the educational levels of the subjects, it must be expressly mentioned that the educational difference between the educated and the uneducated is incomparably greater than that between educated men and women, so that it is quite incomprehensible why the time-difference of 0.4 seconds is the same between educated men and women as between educated and uneducated subjects. Moreover, the reaction-time of 1.7 seconds for educated women, as against 1.3 for educated men, does not correspond at all to the percentage-ratio of internal and external associations; for the educated women show 35 : 61 per cent and the men only 36 : 56 per cent. Similarly, the time-difference of 0.4 and 0.6 seconds respectively between uneducated men and women in no way corresponds to the difference in educational level between the two sexes in the uneducated group. In both cases there remains a time-difference against the female which in

no way corresponds to any variation in educational level. If we take the time-difference of the two groups of men on the one hand and of women on the other, the difference in educational standards is a sufficient explanation, as has already been very clearly shown in the ratio of the association-qualities one to another. The observations of Wreschner¹⁸ and Wehrlin¹⁹ also lend support to this assumption, as they have demonstrated a general slowing down of associational activity in cases of pathological deficiency in intelligence and education (congenital feeble-mindedness). Wehrlin demonstrates an increased incidence of internal associations along with longer reaction-times.

[582] Whereas the uneducated women produce slightly more internal associations than the men, the position with regard to educated men and women is actually the reverse, in that the educated women have fewer internal associations than the men; nonetheless, there is a time-difference between the sexes that is greater than that between the educated and uneducated. As we have seen, we can account for this neither by a greater number of internal associations, nor by the small difference in education. Here a new factor seems to be at work, presumably the difference of sex.

[583] The justification of this hypothesis will be dealt with below. Before we approach this task, however, we must investigate the influence that the individual stimulus-word has on the reaction.

D. The Influence of the Stimulus-word on the Reaction-time

[584] The preceding investigations into association-times have been principally concerned with the connection between the quality of the association (i.e., the reaction) and its duration. Trautscholdt attempted to establish certain connections and claims, among other things, that verbal associations take the shortest time. Ziehen's and Aschaffenburg's observations have already been mentioned. We must now find out whether the influence on the reaction-time of the two components of the association—the stimulus-word and the reaction—cannot be examined separately. Only an extensive material can be expected to yield definite information. For this reason I have already attempted, with Riklin, to demonstrate the influence of the stimulus-word on the quality of the reaction. Here certain regular occurrences appeared, namely:

[585] (1) The grammatical form of the stimulus-word has a considerable influence on the form of the reaction, and the form of the reaction is indeed determined by it; the subject tends to clothe the reaction in the grammatical form of the stimulus-word.²⁰ Individual figures showing this tendency vary greatly. My stimulus-words, which consist of 60 per cent nouns, 18 per cent adjectives, and 21 per cent verbs (the various parts of speech are well mixed up in order to avoid a continuation of one form of reaction), have given these results:

[586] Individual figures of grammatical agreement vary between 26 per cent and 95 per cent. The average figure for educated subjects is 51 per cent and for the uneducated 59 per cent. Thus the uneducated show a somewhat clearer tendency to allow themselves to be

influenced by the form of the stimulus-word. (This holds good not only for the grammatical form but also for the number of syllables and alliteration!)

[587] (2) The tendency to agreement in grammatical form is limited by the influence of the law of frequency. In speech, adjectives and verbs occur only about half as often as nouns.²¹ The noun, therefore, has a higher frequency-value, so that the probability of the reproduction of a noun is greater than that of an adjective or verb.

[588] In our experiments noun stimuli were followed, on an average, by 73 per cent nouns (Aschaffenburg: 81 per cent). As verbs and adjectives have a lower frequency-value, their influence on the form of the reaction will be correspondingly less. Our experience confirms this supposition: verb stimuli were followed, on an average, by 33 per cent verbs. The number of nouns is on an average 49 per cent, it has thus been lowered through the tendency to agreement in grammatical form. A somewhat stronger influence is exerted by adjective stimuli, which are followed by 52 per cent adjectives. The number of nouns was reduced to a mean of 44 per cent through adjective stimuli. From these facts it appears that the frequency of nouns can be reduced, on the average by about half, by using verbs and adjectives as stimulus-words.

[589] (3) From our earlier investigations²² it appears that the quality of the association is influenced to quite an extent by the grammatical form of the stimulus-word. Whereas, for example, with uneducated women the ratio of internal to external associations is 1 : 1.06, the ratio of associations which follow adjectives in particular is 1 : 0.62 and that of associations following verbs is 1 : 0.43. The number of internal associations to verbs and adjectives thus increases considerably. The same phenomenon is also found in educated subjects, but in a smaller degree. The increase in internal associations seems to be accounted for by the fact that, by virtue of the lower frequency-value of verbs and adjectives, fewer common word-sequences exist with these than with nouns. For this reason associations following verbs and adjectives are much less canalized and require a greater concentration, as a result of which, of course, semantic relationships emerge more readily than superficial and more external connections.

[590] Thus we can see that more internal associations follow verbs and adjectives than follow nouns; according to observations made by Ziehen, who has found higher time-values for semantic relationships, it is to be expected that on the average verbs and adjectives should be followed by higher time-values than nouns. As, however, nouns refer to images that are to be evaluated differently, and that can to a great extent influence the reaction-time, they have been classified as concrete and abstract. One further reason was that uneducated subjects especially are easily startled by abstract terms.

[591] The probable mean-times for all subjects are as follows:

Concrete nouns	1.67 secs.
Abstract nouns	1.95 "
Adjectives	1.70 "
Verbs	1.90 "

These figures correspond to our expectations: reactions to verbs and adjectives show a longer time than those to concrete nouns. The longest time of all is taken for abstract terms, which was also to be expected.

[592] This picture becomes more interesting when the subjects are divided into groups.

Probable Mean of the Reaction-times to Concrete Nouns etc. as Stimulus-words

	UNEDUCATED		EDUCATED	
	Women	Men	Women	Men
Concrete nouns	2.0	1.7	1.6	1.4
Abstract nouns	2.8	1.9	1.8	1.3
Adjectives	2.2	1.7	1.7	1.2
Verbs	2.4	2.0	1.9	1.3

[593] The table²³ shows that uneducated people have longer reaction-times than educated ones. The longest time occurs for abstract ideas with uneducated women, whereas with educated men these words need an even shorter time than concrete ideas. It is striking that, in contrast to all other subjects, educated men have the longest reaction-time in response to concrete ideas. This fact is significant in so far as it shows that the influence of the stimulus-word on the duration of the association does not consist merely of those elements just mentioned. If we compare the figures of this group with the values that Aschaffenburg has found with similar subjects, it appears that the figures found by using a stop-watch are similar to those obtained by labial key and chronoscope.²⁴

E. The Influence of the Reaction-word on the Reaction-time

[594] In the above discussion we have explained how the reaction-time is affected by the stimulus-word's being a noun, adjective, or verb. We must now find out what happens to the reaction-time when the reaction-word is a noun, adjective, or verb.

[595] The probable mean-times of all subjects are as follows:

concrete nouns as reaction-words	1.81 secs.
abstract " " " "	1.98 "
adjectives " " " "	1.65 "
verbs " " " "	1.66 "

[596] If we compare this table with the earlier one, which gave the mean-times for the corresponding stimulus-words, it appears that in both cases abstract terms produce the longest intervals (1.95 and 1.98 seconds); if the reaction-word is a concrete one a longer time is taken than that produced by a concrete stimulus-word (S. 1.67; R. 1.81 seconds). This difference might be due to the fact that there are many current word-compounds containing nouns, whereas noun following noun signifies an inner relation, or at least an association by coexistence (which, by the way, in uneducated subjects appears as an internal association; cf. our earlier investigations).²⁵ Under the heading "concrete nouns as reaction-words" numerous internal associations are crowded together, which is probably the cause of the long reaction-time. The opposite can be seen with verbs and adjectives as reaction-words. Their average values are less, compared with those on the earlier table (1.70, 1.90 :

1.65, 1.66) because under these headings, particularly in that of verbs, current word-compounds abound.

[597] The probable mean-values of the individual classes of subject are these:

Probable Mean-times for Concrete Nouns etc. as Reaction-words²⁶

	UNEDUCATED		EDUCATED	
	Women	Men	Women	Men
Concrete nouns	2.2	1.85	1.7	1.5
Abstract nouns	2.7	2.0	2.0	1.4
Adjectives	2.0	1.7	1.7	1.2
Verbs	1.9	1.7	1.8	1.3

[598] These relatively lower values for adjectives and verbs are shown here in all four groups. Here, as in the previous table, the uneducated women again show the highest figures. The relatively high figures for concrete nouns are striking. The fact already mentioned in the previous section, that cultured men take their longest time to react with concrete nouns, is also in evidence here. An explanation of this is perhaps to be found in the circumstance that in this group very many semantic relationships (causing delay) occur.

F. The Influence of the Quality of the Association on the Reaction-time

[599] As we have seen, Aschaffenburg's investigations into the influence of the quality of the association on the reaction-time did not lead to unequivocal results; Ziehen's success, already mentioned, is therefore all the more encouraging. I too have conducted some research on this subject in which I have confined myself to the three principal groups of our earlier classification: internal, external, and sound reactions. This has produced the following average figures:

	UNEDUCATED		EDUCATED	
	Women	Men	Women	Men
Internal associations	2.8	1.9	2.1	1.6
External "	1.9	1.7	1.8	1.3
Sound reactions	2.6	2.4	2.0	1.8

[600] There is a distinct difference between the reaction-times for internal and external associations in that external associations take up decidedly less time. A different picture is presented by sound reactions, where one would expect the shortest times, as sound reactions quite rightly are to be regarded as the lowest and least valuable form of association, and for that reason could be produced in the shortest time. In practice, however, the situation is obviously not as simple as one would surmise in theory. As I have so often observed, the most superficial sound reactions very often take a very long time. As a rule, in my experience, sound reactions are usually abnormal reactions and their formation is mostly attributable to some kind of distracting influence; of what kind this disturbance usually is, the following chapter will show.

G. Prolonged Reaction-time

[601] To demarcate the concept of a “prolonged” reaction-time, I call any time prolonged that takes longer than the probable mean for the subject concerned. Thus, if the average for the individual subject is 2.5 seconds, then 3 seconds is overlong.

[602] Let us first recapitulate what is so far known of the causes that (of course, only in our experiments) lengthen reaction-times:

(1) Certain grammatical forms of the stimulus and reaction-words.

(2) Semantic relationship between stimulus- and reaction-words.

(3) The rarity or difficulty of the stimulus-word (abstractions!).

(4) Ziehen²⁷ states the remarkable fact that (in contrast to generic reactions) individual associations prolong the reaction-time.

(5) Mayer and Orth²⁸ in their experimental studies on associations found that the reaction-time was lengthened when the active will intervenes between stimulus-word and reaction. If between the stimulus-word and the reaction an emotionally charged conscious content occurred, the reaction-time was on the average considerably prolonged, as compared to those of all the other reactions. Contents charged with unpleasure²⁹ have an especially delaying effect.

(6) In our earlier investigations³⁰ on the associations of normal subjects, we pointed out that abnormally long reaction-times occur particularly when the stimulus-word touches on a feeling-toned complex, i.e., a mass of images held together by a particular affect. So we were able not only to confirm the observations of Mayer and Orth, but also to demonstrate in various cases that: (i) The cause of several, or even very many, long reaction-times is generally the complex, and (ii) of what type the complex is.

[603] It appears to us to be of the utmost importance that prolonged reaction-times can indicate the presence of feeling-toned complexes. So here we may perhaps have a means of discovering by a short and simple examination certain things that are individually extraordinarily important—namely, those complexes that are distinctive features in the psychology of the personality. This would also be of great assistance in pathology, since in this way we could find—in cases of hysteria, for example—valuable pointers to the pathogenic complexes of images of which the hysterical patient is not always aware.

[604] To clarify matters more fully, I have, with the help of educated subjects who are also reasonably introspective, made a thorough analysis of individual associations, to which I should now like to refer.

[605] *Subject No. 1:* a married woman who placed herself at my disposal in a most co-operative manner and gave me all the information I could possibly need. I am reporting on the experiment as fully as I can so that the reader may picture it as completely as possible.

The probable mean reaction-time for this experiment was 1.0 second.

1. head	-scarf	1.0
2. green	grass	0.8

3. water	-fall	1.0
4. to pierce	to cut	0.8
5. angel	-heart	0.8

Up to this point the reactions followed without the slightest emotional charge, quite smoothly and impassively. R.5 is striking; the subject can for the moment give no justification or explanation of how she came to *-heart*, which she feels is a word-compound. Suddenly through her mind flashes “Engelhard,” a name that had always been familiar to her. This is therefore an indirect association of the type known as displacement by sound similarity. We now come to the question of why this indirect association should have occurred so suddenly. As a result of our earlier investigations,³¹ we find that under certain circumstances indirect associations are more often found with a state of disturbed attention. It may therefore be assumed that the distraction of the subject’s attention can produce indirect associations. The subject repudiates any disturbance coming from without. Nor is she aware of any inner disturbance. When consciousness cannot furnish any data, an unconscious excitation may still have disturbed the reaction. The stimulus-word *angel*, however, was for this subject not emotionally hinged. As we know from earlier investigations, a preceding emotionally charged association can leave a trace in the unconscious and unconsciously constellate³² the reaction, particularly when the preceding association had a strong feeling-tone. R.4, *to cut*, had evoked in the subject some slight anxiety, the image of blood,³³ etc. The subject is pregnant and now and again has feelings of anxious anticipation. Whether the image *blood* had determined the reaction *heart* I shall not try to decide.

The feeling-tone of *to cut* was according to the subject so slight and secondary that the connection did not strike her. It was for this reason that the extension of the reaction-time usual in similar situations failed to occur.

6. long	short	0.8
7. ship	sailing	0.8
8. to plough	field	1.0
9. wool	silk	1.0
10. friendly	charming	1.2
11. table	chair	1.2
12. to carry	to lift	1.2
13. state	to make	1.2
14. insolent	snobbish	1.2 (<i>trotzig/protzig</i>)

(This rhyme is a constellation. The subject recalls that she once read it on one of my association-forms.)

15. to dance	to leap	0.8
16. lake	sea	0.8
17. ill	well	1.2
18. proud	fiery	1.2

The last two reactions show some (albeit slight) feeling-tone.

19. to cook	to learn	0.8
20. ink	black	1.0
21. evil	good	0.8
22. needle	thread	1.0
23. to swim	to learn	0.8

Here R. 19 recurs with the same short reaction-time. The subject admits that she has not learned much about cooking and had never learned to swim at all well.

24. journey	Berlin	1.2
-------------	--------	-----

Constellation of a journey some months previously, the date of which, by the way, approximately coincides with the start of her pregnancy.

25. blue	heaven	0.8
26. bread	to eat	1.2
27. to threaten	fist	1.2
28. lamp	green	1.4

Here we find the first rather long time. The subject had hardly noticed her hesitation, nor had she been aware of any particular feeling-tone. The previous stimulus-word, *to threaten*, does, however, have something insidious to many subjects. If we think of the feeling of anxious anticipation mentioned earlier, we perhaps have a clue to the elucidation of this extended reaction-time; it is perhaps a perseveration. The feeling-tone in such cases need not appear with the previous reaction. In our experience, affective processes always take longer than purely associative processes, both to appear on the surface and to take their course. The feeling-tone lingers on, as can be observed in certain hysterics.

The reaction *green* is a constellation from her *domestic* life (lamp-shade).

29. rich	poor	1.0
30. tree	green	0.8

Here we have the same reaction as 28 with a very short interval, a phenomenon that may be accounted for by the fact that associative processes that have just come into consciousness tend to return, i.e., can very easily be repeated.³⁴

Our earlier investigations³⁵ have also taught us that repetitions of a reaction are frequently based on a particular feeling-tone, in that the repeated words are associated with a feeling-toned complex. The feeling-tone pervading such a word is the mechanism that evokes it again and again in appropriate circumstances.

31. to sing	can	2.4
-------------	-----	-----

A very superficial reaction, similar to *to learn* with *to cook* and *to swim*, with a strikingly long reaction-time. The subject is very musical, but has always regretted that she cannot sing, and indeed this has hurt her more than, for instance, her not being able to swim.

32. sympathy	to have	1.0
33. yellow	gold	1.0

34. mountain	to climb	1.0
35. to play	children	1.0
36. salt	salty	1.4

In this reaction the subject comes up against a certain inhibition for the first time, whereas all the earlier reactions had followed easily. The subject explained that at first she did not understand the word *salt* at all and had had to make a deliberate effort to grasp it. In spite of the prolonged reaction-time and the exertion of attention, a very superficial reaction followed, which is determined to a considerable degree by sound. The subject cannot explain this disturbance. Let us look again at the previous reaction, *children*; this belongs quite clearly to the pregnancy-complex; the feeling-tone has persisted and caused the disturbance.

37. new	old	1.0
38. custom	habit	1.0
39. to ride	to travel	1.0
40. wall	-maps	1.0
41. stupid	clever	1.0
42. exercise-book	book	1.0
43. to despise	<i>mépriser</i>	1.8

Once again a longer reaction-time and, also, a striking rendering of the reaction into French. The reaction is also very superficial and adds nothing new to the idea referred to by the stimulus-word.

To despise is, for the subject, accompanied by an unpleasant feeling-tone. Immediately after the reaction it occurred to her that she was momentarily afraid that her pregnancy might by its various effects cause her to lose her husband's regard. Then she immediately remembered a married couple who had at first been ideally happy and then had become estranged: the couple in Zola's novel *Vérité*. Hence the reaction's being in French.

These reminiscences, needless to say, were not conscious at the time of the reaction.

44. tooth	time ³⁶	1.0
45. correct	false	1.0
46. nation	faithful	1.4

Again a longer time with a slightly unpleasant feeling-tone. She thinks that some song contains the phrase "a faithful people," but has a feeling that there is something about it personally unpleasant to her.

The preceding reaction, which has no perceptible feeling-tone, is *false*; *loyal* is the opposite. This observation suffices to bring the subject to the correct explanation: the reaction *false* had stimulated her pregnancy-complex, and in particular her fear of her husband's estrangement.

47. to stink	to be scented	1.0
48. book	to read	1.0

49. unjust	just	0.8
50. frog	leg	1.2
51. to part	to avoid	0.8
52. hunger	thirst	0.8
53. white	black	1.0
54. ring	finger	1.0
55. to watch	to listen	1.0
56. pine	forest	1.0
57. dull	fine (weather)	1.0
58. plum	pear	1.0
59. to meet	sure	1.0
60. law	to keep	1.2
61. dear	man	1.2
62. glass	clear	1.0

The strong sound association of *clear* is probably also due to the previous reaction.

63. to argue	to quarrel	1.2
64. goat	bleats	1.2
65. big	little	0.8
66. potato	field	1.0
67. to paint	painter	1.0
68. part	piece	1.0
69. old	young	1.0
70. flower	red	0.6 (<i>Blume/rot</i>)

This notably short reaction-time is explained by the subject by the fact that the first syllable of the stimulus-word *Blu-me* had already caused that of *Blu-t* (blood); cf. 4 and 143. Here we have a kind of *assimilation* of the stimulus-word to the strong pregnancy-complex.

71. to beat	to stab	1.0
72. box	-bed	1.0
73. bright	brighter	1.4 (<i>hell/heller</i>)
74. family	father	1.4

These four reactions are interesting. It will be remembered that with 4 *to pierce/to cut* we came across the pregnancy-complex for the first time. Without the subject having had any idea that this reaction was important, we here have *to pierce* following immediately on the *Blu-me/Blut* association. The following R.72 also came quite smoothly without any feeling at all. The reaction itself is, however, striking. The subject, who occasionally visited our asylum, meant the deep beds used there—the so-called box-beds. She was somewhat puzzled by this explanation, because the expression “box-bed” was not particularly familiar to her. Following this somewhat unusual association, we have a sound association of relatively long duration, thus a phenomenon that we have already indicated earlier to be indicative of a complex. “Heller” (brighter) is the name of a person who was once important—though indirectly—to the subject. Quite probably no strongly emotional memories are connected with this name. There was only a very slight hesitation, implying a subjective

feeling. For this reason, the supposition that the sound reaction is connected with the strange previous reaction does not seem to be entirely groundless. The reaction *bed* is later repeated with the clear impression of a word-combination in 199—*bone-bed* (*Knochenbett*), a meaningless combination inexplicable to the subject; if we consider a change of sound in view of her pregnancy-complex, the association could be very significant—*Wochenbett* (childbed).^{36a} If we take this hypothesis as a basis, the above series is explained in the clearest way; again we have the pregnancy-complex with blood, operation, childbed; the feeling-tone here becomes obviously stronger and disturbs the following reaction (perhaps *bright* cannot be assimilated to the complex!); finally, we have *father*.

75. to wash	washerwoman	1.0
76. cow	stupid	0.8
77. strange	-ness	1.0
78. fortune	fortunate	0.6
79. to tell	mother	1.4
80. propriety	Ge-	1.2 (<i>Ge-</i>)
(<i>Anstand</i>)	usage	2.0 (<i>Sitte</i>)

R.78 is very short, which is rather striking in a stimulus-word that could easily have stirred up the complex. The following reaction, therefore, takes proportionately longer, 1.4 seconds, which up to now has been symptomatic of a complex. The reaction *mother* explains the prolonged time. R.80 is disturbed, not surprisingly, as the complex was so obviously touched; only after 2 seconds do we get the reaction *usage*, after the *Ge-* prefix first. In this the feeling-tone of *mother* still perseverates in the subject. The subject cannot find any connection between *propriety* and *Ge-*. Above all she cannot think what word she wanted to start with *Ge-*. We are thus dependent only on suppositions. With 79 the pregnancy-complex appeared again quite clearly. We have already seen on several occasions that it is characterized mainly by feelings of *anxiety* and apprehension. We have also already seen that the first syllable of a stimulus-word is assimilated to the complex (*bloom/blood*); is the first syllable of *Anstand* (propriety) = *Anst*, assimilated as *Angst* (fear) and then *Ge-* = *Geburt* (birth)? This hypothesis immediately struck the subject as near the truth. This construction may well appear to many to be made in the manner of the augurs; I would not record it here if I had not come across many analogous phenomena in both healthy and sick subjects.

81. narrow	-minded	0.6
82. brother	sister	0.8
83. to damage	to avoid	1.2 (<i>schaden/meiden</i>)

This is very reminiscent of 51, *scheiden/meiden* (to part/to avoid). Has *schaden* perhaps been repressed by the complex as too unpleasant and been assimilated as *scheiden*? Repressive assimilations of this nature frequently occur in hysterics. The subject is quite unable to explain this.

84. stork	to bring	3.4
-----------	----------	-----

This abnormal time is quite clearly caused by the complex.

85. false	cat	1.0
86. fear	to have	1.0
87. kiss	me	1.2

The emphasis on the ego in R.87 could perhaps also be determined by the critical reaction to 86.

88. conflagration	fire	1.2
89. dirty	yellow	1.0
90. door	closed	0.8
91. to choose	choice	1.2
92. hay	grass	1.0
93. still	quiet	0.8
94. scorn	derision	1.0
95. to sleep	to stay awake	1.0
96. month	May	1.0
97. coloured	blue	1.2
98. dog	cat	1.0
99. to talk	speak	1.0
100. coal	dust	1.0
101. moderate	drinking	1.0
102. lid	eye-	1.0
103. to suppose	to believe	1.2
104. ache	heart	0.8 (<i>Schmerz/Herz</i>)

This rhyme, which has a relatively short reaction-time, is stated by the subject to be a mere catch-phrase.

105. lazy	sluggish	1.0
106. moon	-calf	1.0
107. to laugh	to cry	1.0
108. coffee	to drink	1.0
109. wide	narrow	1.0
110. air	thick	1.0
111. to carry	to lift	1.0
112. plate	round	0.8

R.110 is somewhat unusual; it seems as if the constellation *wide/narrow* has had a particularly powerful influence. Does it perhaps echo through to R.112?

The next following reactions are entirely objective in character—neither the subject nor the observer noticed anything special about them. The times are never more than 1.2 seconds. We shall therefore pass them over.

143. blood	red	0.6
144. to let (a house)	to let	1.2
	to avoid	2.0

R.143 is very quick. This is the well known reaction which already occurred at 70 (*Blume*). It is followed by a longer time and a repetition of the stimulus-word—the only one in the whole series. R.145 is likewise superficial, not even meaningful but only linked in form and sound.

Because they are of no importance I am omitting the subsequent associations.

62. distinguished	noble	1.2
63. tube	sly	0.8 (<i>Schlauch/schlau</i>)

The subject explained that at the time of the second of these two reactions she still felt the persistent influence of *distinguished*. The lady had previously been in rather better financial circumstances and occasionally feels this loss.

172. to turn	round	1.4
--------------	-------	-----

The cause of this longer time is obscure if *round* does not have the supposed emotional influence mentioned above. The subject has no explanation to offer.

175. trust	me	1.4
------------	----	-----

Here again we have the fear of the estrangement of her husband—associated with her complex.

190. to bring	something	1.2
191. inn	The Stork	1.0

What *something* represents is clear from the subsequent reaction.

195. mirror	shining	1.4
198. to punish	prison	1.4

Neither of these long reaction-times can be satisfactorily explained. The subject told us that on 195 first the image *glatt* (smooth) occurred to her but this became *glänzend* (shining). It is hard to say why *glatt* should have been suppressed.

Apart from the fact that she had been aware of a slight hesitation, the subject had no explanation for R. 198. Even if we cannot think of a plausible explanation, we may, in the light of previous experience, be fairly sure that some kind of feeling-toned complex is at the root of it. As a later example will show, it does not need to be anything actual, but can be an old reminiscence that has apparently vanished a long time ago.

199. bone	-bed	1.0 (<i>Knochen / -bett</i>)
-----------	------	--------------------------------

Compare the remarks on 72. The interesting point in this case is that the subject had not the faintest suspicion about the significance of the association.

The following associations should be mentioned:

164. to love	faithful	1.0
--------------	----------	-----

167. bill (of exchange)	false	1.0
181. duty	faithful	0.8
187. snake	deceitful	0.8

45 had *false* as reaction in 1.0 seconds, 46 *faithful* in 1.4. These words, for which the subject obviously has a predilection, appear to recur with gradually decreasing reaction-times.³⁷ It is also interesting that apparently words representing a complex tend to occur automatically in places where the meaning no longer warrants it; this is not the case here, but we have demonstrated it in an earlier investigation.³⁸

[606] The analysis of the reactions of this subject have shown that times of over 1.2 seconds, with the exception of a few reactions quoted above, can be attributed to the influence of a feeling-toned complex, for two reasons.

(1) The association through which the complex is constellated has a prolonged reaction-time.

(2) The association immediately following that through which the complex has been constellated has an extended reaction-time owing to the reverberation of the feeling-tone.

[607] Apart from those with longer reaction-times, there are numerous other associations with complex-constellations. In general, reactions with a powerful feeling-tone and a distinct indication of a complex show longer reaction-times. The meaning of the association is grasped with a fair consistency only when a very strong and differentiated feeling-tone, or a very characteristic form of the reaction, brings one complex into consciousness. In the reactions given, this only occurred once, with *stork / to bring*. In all other reactions the feeling-tone, or the special form of the reaction, provided merely pointers to the subsequent identification of the complex.

[608] At the time, only the aspect of the complex appearing in the reaction was available to consciousness. From these facts it becomes evident that consciousness plays only a minor role in the process of association.

[609] All our thinking and acting, the vast bulk of which appears to us to be conscious, actually consist of all those little bits that are finely determined by innumerable impulses completely outside consciousness. To our ego-consciousness the association-process seems to be its own work, subject to its judgment, free will, and concentration; in reality, however, as our experiment beautifully shows, ego-consciousness is merely the marionette that dances on the stage, moved by a concealed mechanism.³⁹

[610] An analysis of this series of tests shows the influence of the complex on association. Although, as people are fond of saying, associations are made at one's own discretion and the subject can say whatever he wishes, nevertheless he does not in fact say what he wishes but is *compelled* to betray precisely what he feels most sure of concealing. The reactions, therefore, are by no means random thoughts but simply symptomatic acts,⁴⁰ directed by a psychic factor that can behave like an independent being. The feeling-toned complex, for the time being split off from consciousness, exercises an influence that constantly and

successfully competes with the intentions of the ego-complex; in spite of the rejecting and repressing attitude of the ego-complex, it brings about subjective and treacherous reactions and arouses associations the meaning of which is utterly unexpected by the ego-complex. Thus we find a series of intimate secrets divulged in the associations of our subject, and it is not only complexes referring to her actual situation, but the most important complexes, which form the content of her joys and sorrows. At the time of the test we find the most powerful complex to be the psychic equivalent of pregnancy, round which revolve her anxious anticipation and her love for her husband, coupled with slightly jealous fears. This complex is of an erotic nature, and still active; it is therefore understandably in the foreground. Not less than 18 per cent of the associations can safely be related to this.⁴¹ Besides this we find some other complexes, of considerably lower intensity: loss of former prosperity, some deficiencies felt to be disagreeable (singing, swimming, cooking), and finally an erotic complex dating back many years to her youth, which could be shown to be the cause of only a single association. (Unfortunately I have had to leave this one out, out of respect for the subject herself.) The probable mean of this subject was 1.0 second. 30.5 per cent of reactions exceeded this mean, 20.5 per cent took 1.2 seconds. Of these, 32 per cent could clearly be attributed to the influence of a complex. 6 per cent of reactions took 1.4 seconds, 75 per cent of which were certainly conditioned by the complex. 3 per cent were in excess of 1.4 seconds and all of these were certainly due to the influence of a known complex.

[611] *Subject No. 2:* an educated man of middle age. His reaction-type is as objective and superficial as that of Subject No. 1. I shall, therefore, confine myself to giving only his critical reactions. The subject is a physician and often takes part in our experiments, which he follows with interest.

The probable mean of the series of tests is 1.2 seconds.

1. head	part	1.4
2. green	blue	1.0
3. water	to clean	2.6

The stimulus-word immediately aroused an unpleasant feeling-tone suggesting something sexual, coupled with a sense of inhibition. Immediately after his reaction, the subject clearly recognized that *water* had been understood in the sense of *urine*.

4. to pierce	to strike	1.0
5. angel	pure	1.0
6]. long	large	1.2
7. ship	large	1.0

Here we have a distinct perseveration. With *large*, R.6, there was at first a clearly sexual feeling-tone, followed by the second reaction and immediately afterwards the reason for this was clearly recognized. It concerned a recollection: the subject had heard from us that certain women patients frequently associate sexual implications to the word "long."

8. to plough	to turn up the soil	1.0
--------------	---------------------	-----

9. wool	sheep	1.2
10. friendly	..., busy	1.2 (<i>tötig, tätig</i>)
11. table	fish	0.8 (<i>Tisch/Fisch</i>)

R.10 is clearly disturbed. We have here a slip of the tongue.⁴² The subject immediately corrected himself with *tätig*. At this stage he felt a vaguely unpleasant sensation, somewhat like an inner restlessness, which persisted during the following reaction. Hence the unmotivated rhyme. *Freundlich/tätig* (friendly/busy) is striking, and the subject is unable to explain it. The slip of the tongue that produced *tötig* instead of *tätig* gave the impression that the reaction should really have been *böse* (bad). But even this reaction was incomprehensible to him (for the probable explanation, see below, 86).

15. stem	long	1.2
16. to dance	to steam	1.8 (<i>tanzen/dampfen</i>)
17. lake	large	1.2

In R.15 we once again have *long* with its sexual tone and almost simultaneously the reminiscence mentioned above. R.16 is due to similarity of sound and has an abnormally long reaction-time. The sexual tone of R.15 is persisting, with an admixture of irritation, and brings about the repetition of the earlier association *long, large*.

18. ill	poor	1.2
19. pride	bolt	1.6 (<i>Stolz/Bolz</i>)

Poor is accompanied by a vague feeling of dislike, but there is no particular image connected with this. *Pride* is felt to be even less pleasant and we had here a feeling of rejection and restraint. The meaningless rhyme and the prolonged time are doubly determined. The subject has financial worries that have been troubling him for some time. He had been accused frequently, particularly in the past, of pride. This reproach, converging with the business of the money, forms a particularly painful contrast. This connection was of course only realized after the reaction was given.

20. to cook	well	1.0
21. ink	to come	1.4 (<i>Tinte/kommen</i>)

The association is the phrase “in die Tinte kommen” (to get into hot water); it has an unpleasant tinge and is related by the subject to the money business. There is also an immediate recollection of an erotic complex, dating back several years, which has associations of unpleasure.

24. to swim	well	1.2
25. journey	gay	1.6

Numerous indistinct recollections of travelling with predominantly pleasant associations.

26. blue	lake	1.2
27. bread	daily	2.0

Bread excites a slightly unpleasant feeling—the impression is almost like that of *poor* and there is an accompanying feeling of restriction. Later this is seen to have a clear connection with his financial worries.

28. to threaten	evil	1.4
-----------------	------	-----

A very unpleasant tone, connected subsequently with the memory of the erotic complex already mentioned and a feeling of guilt.

29. lamp	shade	1.2
30. rich	poor	1.4

Poor again has the suggestion of unpleasure and again recalls the money business.

31. tree	trunk	1.2
32. to sing	to spring	1.8

Tree again evokes the sexual tone of *long*, for the reasons given above, coupled with irritation; to this is to be related the rhyme and the long reaction-time.

33. sympathy	the poor	1.4
34. yellow	much	1.2 (<i>gelb/viel</i>)

The poor again arouses the money-complex, this time with very distinct feeling-tone. *Gelb* (yellow) is at once assimilated as *Geld* (money), in spite of the stimulus-word being correctly understood. The money-complex has forestalled the ego-complex by means of the revealing *much*.

36. to play	ball	1.2
37. salt	dripping	1.4 (<i>Salz/Schmalz</i>)

The association *to play/ball*, which in itself is quite innocuous, immediately acquires an erotic feeling-tone, since the word *ball* changed in meaning to *dance*. Here the erotic complex reappeared; hence the rhyme and longer reaction-time in the following association. Needless to say that at the instant of the reaction the trend of thought broadly outlined here was not conscious, but only indicated by fleeting feelings. The awakening of the associated images occurs as a rule afterwards, when the subject's attention is especially directed to the feeling-tones that appear in their place.

38. new	old	1.2 (<i>neu/alt</i>)
---------	-----	------------------------

The *a* in *alt* was conspicuously prolonged, giving rise to the suggestion that perhaps the reaction should have been *arm* (poor) but it came out as *alt* (old). The money-complex had recently become more acute.

39. morality	immorality	1.8
--------------	------------	-----

A slight hesitation—a vague suggestion of guilt in the enunciation of *immorality*. The erotic complex once again.

40. to ride	to drive	1.4
41. wall	place	1.8

The subject can offer no explanation for R.41; he feels as though it should be “no place in the sun.” A somewhat painful tone to R.42 leads straight to the money-complex with the clear recognition that *to drive* is conditioned by the complex, although the feeling-tone peculiar to the complex has emerged only with R.42. The reaction *place* belongs to the money-complex rather than to *wall*. R.42 also makes the erotic complex vibrate slightly.

43. exercise-book	book	1.4
44. to despise	to respect	1.2
45. tooth	money	1.4 (<i>Zahn/Geld</i>)

To respect seems to have struck very close to the money-complex because *Zahn* (tooth), in spite of correct interpretation, is assimilated as *zahlen* (to pay), hence *money*. Here again, we have the money-complex forestalling the ego-complex.

46. correct	incorrect	1.2
47. people	poor	1.8

Again the delayed reaction with the money-complex.

60. to hit	marksman	1.2
61. law	not set	4.8

At 61 there is an inexplicable feeling of restraint which for a long time does not permit of any reaction, and then finally a disturbed, meaningless reaction which seems as if it may perhaps be a defensive expression. Later a whole series of painful memories came to mind all of which dealt with actions that, like the erotic complex, did not conform to the laws of morality. The following reaction

62. dear	good	2.0
----------	------	-----

is also under the influence of these memories of past immorality.

69. part	part of the body	1.8
----------	------------------	-----

Here again we have the sexual constellation, as in R.6 and 15.

76. to wash	filth ⁴³	1.6
-------------	---------------------	-----

A slight feeling of guilt and penitence. Later, the erotic complex. For the coarse mode of expression, see 90.

78. strange	newcomer	2.0
-------------	----------	-----

First the feeling that the reaction would be *poor*, but then the reaction *Neuling* (newcomer) predetermined by 38 (*neu/alt* [*arm*]). Of course the reaction followed without any conscious awareness of this constellation. *Strange* has again hit the money-complex. One can see how this complex sends out its *poor* at every opportunity.

79. fortune	misfortune	1.4
-------------	------------	-----

is predetermined by the preceding reaction.

80. to tell	mother	1.2
81. propriety	not proper	3.6
82. narrow	narrow-minded	1.8

R.80 followed without any particular feeling-tone. On the other hand *propriety* immediately called up inhibitions with unpleasant feeling, which clearly persisted throughout the following association. Afterwards memories of various scenes from childhood which are clearly constellated by *mother*. It was a matter of a few impressive moments when his mother in rightful anger had maintained that he was not a decent person and never would be. One scene was particularly clear when the subject in his teens had behaved coarsely and indecently towards a lady. This memory led again immediately to the erotic complex and here the subject had something similar to reproach himself with. It must therefore be this complex that is concealed at the root of this long reaction-time, and of the various screen-memories (Freud).

86. false	evil	1.4
-----------	------	-----

Here we have *evil* repeated for the third time. (In the entire series it occurs six times and *good* or *well* five.) *Evil* always brings with it the feeling of guilt that is peculiar to the erotic complex. As you can see, this word, together with *good*, has a similar tendency to increase in frequency, as *poor* does for the money-complex. (*Poor* occurs four times in a manifest and three times in a repressed form.) The first time *evil* appeared was in 10, but at that stage it was obviously repressed, as there are strong inhibitions against the erotic complex in the subject's present emotional life.

89. fire	sea	1.8 (<i>Brand/Meer</i>)
----------	-----	---------------------------

The stimulus was correctly understood, but changed immediately into *Brandung* (surf); hence the association of *sea*, with a somewhat longer reaction-time. *Brand* (fire) was therefore assimilated. The previous association does not constellate this assimilation. *Brand*, however, has an unpleasant tone and this is associated in his mind immediately with the meaning of acute alcoholism and, together with the latter, the memory of his having once been in that state, which aroused painful feelings. This time the ego-complex has forestalled the old but still active memory, which has assimilated the stimulus-word in a convenient sense and has thereby drawn a veil over the painful memory, i.e., has hidden it from consciousness. This mechanism (the censor in the Freudian sense)⁴⁴ plays a very prominent role in hysteria. It must be emphasized that it is not at all a function of consciousness but an automatic mechanism that regulates what may or may not come into the conscious mind.

90. dirty	filthy (<i>dreckig</i>)	1.4
-----------	---------------------------	-----

The coarse wording of this reaction is determined by the moral feeling of repugnance that is tied up with the erotic complex.

91. door	to show	1.4
----------	---------	-----

This reaction too, negative and dismissive as it is, is determined by the same feeling.

92. to elect

Maire (mayor)

2.2

With *to elect* we meet a new complex. This is a matter of hopes of promotion, of *mehr* (i.e., more) from several points of view. It is at the same time the hope of holding a leading, no longer a subordinate, position. Thus the determination of *Maire* is not purely a matter of sound, but also of sense in a symbolic form. The right reaction would have been *manager*. This word, however, is associated with the secret wish and for that reason is subject to the inhibition that suppresses the wish itself. Thus instead of the correct reaction we have an image associated with it that is outwardly determined by the word *mehr* (more), which itself is characteristic of the momentary mood. This process has great similarities to the hysterical talking at cross purposes of the Ganser syndrome,⁴⁵ or perhaps even more to the associating at cross purposes of dementia praecox, in which this kind of metaphor is particularly common. Analogous phenomena occur relatively frequently in everyday life—I mean the word-and-melody automatism. The following good example was given me by a lady I know. She told me that for some days the name *Taganrog* had been, as it were, on the tip of her tongue but she had not the remotest idea where it came from. I asked her about her emotional experiences and repressed wishes of the recent past. After some hesitation she told me that she very much wanted a housecoat (*Morgenrock*) but that her husband had not shown the desired interest. *Morgen-rock* : *Tag-an-rog*—you can see that the two words are related partially through meaning and partially through sound. The appearance of the Russian name could be attributed to the fact that the lady had met someone from Taganrog at about the same time.⁴⁶ Vast numbers of similar combinations can very easily be demonstrated, if one were to take the trouble of getting to the bottom of all the tunes one hums or whistles to oneself or hears from others. A colleague on his hospital rounds caught a fleeting glimpse of a nurse who was allegedly pregnant and caught himself a moment or so later in the act of whistling the tune of: “Es waren zwei Königskinder, die hatten einander so lieb” (There were two royal children, who loved each other so, etc.), although his conscious mind was occupied with something completely different. Another colleague betrayed to me the sad end of a love-affair by a succession of melody automatism.

One can see from these examples roughly the course taken by thought processes when they lack conscious awareness. Each association occurring in consciousness evokes as it were an echo of similarities and analogies that fades out through all stages of similarity of sound. The best examples are furnished by dreams.

95. mockery

scorn

1.4

99. dog

dead

1.6

This reaction amazed the subject. He could not understand how he could have arrived at this unusual association. The somewhat long time taken suggests a feeling-tone; this is at first described by the subject as indistinct, and then later as sad. The cue *sad* then reminds him of the incident at the root of this feeling. Some twenty years previously he had had to have a

dog he was very fond of destroyed. This loss had been *sad* to him for some considerable time.

102. moderate	immoderate	1.6
---------------	------------	-----

The longish time of this superficial reaction is explained by its connection with R.89 (*Brand*).

104. to suppose	to believe	2.0
-----------------	------------	-----

Suppose is a suggestive word as a stimulus and there are few subjects who do not feel affected by it. In this case it hit the erotic complex.

105. pain	scorn	1.2
108. to laugh	to chatter	2.8 (<i>lachen/schwatzen</i>)

The *sch* of the reaction *schwätzen* was rather prolonged. First for a moment *schmerzen* (pain) came to mind momentarily though clearly, hence the length of time. *Schmerzen* was at once involuntarily suppressed. The feeling-tone expressed had a tinge of grief. The subject admits having an almost morbid sensitivity to mockery. 95: *mockery/scorn*, 105: *pain/scorn*, and 108: *laugh/pain*, are now closely linked. The determination of *schwätzen* is on the one hand alliteration and on the other semantic relationship: *über Einen schwätzen* (to gossip about someone).

120. to create	to operate	2.0
----------------	------------	-----

Here we have the complex of his professional life which produces the lengthened reaction-time.

127. resin	tree	2.0 (<i>Harz/Baum</i>)
------------	------	--------------------------

First, a feeling occurred as if the association was *hart/arm* (hard/poor), in which *arm* was almost spoken out loud. This is a reappearance of the money-complex.

Also the following reaction:

128. to wake	to awaken	1.6
--------------	-----------	-----

is therefore still very superficial, with relatively long time.

130. bad	evil	0.8
131. briefcase	wood	0.8 (<i>Mappe/Holz</i>)

The subject takes *Mappe* in the sense of a briefcase in which he usually fetches (*holen*) money. The reaction *Holz* (wood) is quite meaningless and the subject was amazed at first until he remembered the meaning that he had attributed to *Mappe*. *Holz* conceals *holen*, which obviously belongs to the repressed money-complex.

148. forget	-fulness	2.0
149. drum	beat	1.2
150. free	-dom	1.2
151. wagon	-barricade	3.0 (<i>Wagen/-burg</i>)

148 has a very unpleasant feeling-tone. Nothing particular was reported about 149 and 150, but at 151 there is a strong but inexplicable inhibition. *To forget* awakens the memory of an event several years ago, when he broke with a faithless friend. 149 is an echo of the song “Der treue Kamerad” (The faithful comrade): “Die Trommel schlug zum Streite/Er ging an meiner Seite, etc.” (The drum beat for the battle, He walked by my side). 150 hints at the break. 151: *wagon* appears to have been assimilated only with difficulty. The compound *Wagen-burg* is strange, but became intelligible through the subject’s remark that the place where he first recognized the friend’s false-heartedness was *Augsburg*. All these data were at the time of the reaction unconscious. The complex betrayed itself at first only by the slightly unpleasant but otherwise indefinable feeling shown in 148. The connection of this series was only established later.

153. impudence	confounded	2.0
154. quick	-ness	0.6

R.153 belongs to the same mood as the reactions given above. (N.B. The analysis of these was undertaken only on completion of the entire series.) This mood is the anger about the insolence of the false friend. This strong feeling-tone seems to have persisted as far as 154.

167. change	of time	1.8
-------------	---------	-----

The stimulus-word has again hit the money-complex—hence the long reaction-time.

184. deaf	to fly	2.6 (<i>taub / fliegen</i>)
-----------	--------	-------------------------------

The subject has assimilated *taub* (deaf) as *Taube* (dove) although he did understand the stimulus-word correctly. (He is familiar with the stimulus-words and has experimented with them himself on various occasions.) The reaction-time is very long. *Deaf* hits on a fear-complex of limited range. He suffers from recurrent catarrh of the Eustachian tubes and his hearing in one ear has therefore deteriorated. He connects this fact with the fear, often exaggerated, of becoming totally deaf. *Deaf* thus has too unpleasant a tone and is therefore quickly suppressed.

190. to bring	money	1.2
191. vocabulary ⁴⁷	to fetch	2.2

The last reaction is senseless, but can be explained as a perseveration of the money-complex stimulated by *to bring*.

195. mirror	soul	1.8
196. full	filth	1.4
197. understanding	good	1.6
198. to punish	for evil	2.2
200. beautiful	good	1.6

R.195 for some unknown reason is somewhat inhibited. Perhaps “mirror of the soul” already presaged the ethical tone of the following reaction. With *full* it is quite clear: “the soul is full of filth.” This coarse expression again reveals the revulsion already mentioned

(90). The following reaction, *good*, is loosely connected with its stimulus-word and is repeated at the next opportunity (200). Each time it represents the erotic complex.

R.198 is clearly influenced by the complex.

[612] In contrast to the case of the previous subject, we have here a whole series of feeling-toned complexes, which are interconnected only slightly or not at all. Whereas with the female subject (No. 1) the sexual complex (pregnancy) with its various branches (fear, jealousy, etc.) is predominant, with the male subject (No. 2) the sexual complexes play a less important part. From personal respect for the subject I cannot give all the reactions. It is easy enough to demonstrate, however:

1. Sexual complexes:

An erotic complex, belonging to the past, now over and done with, which is expressed almost exclusively in ethical feeling-constellations (revulsion, remorse).

An actual erotic complex, expressed merely through erotic feeling-constellations (not reported).

At least three sexually charged ideas, independent of each other.

2. The money-complex.

3. Ambition—with at least four secondary memory-complexes.

4. Personal sensitivity—with at least three secondary memory-complexes.

5. Friendship.

6. Two feeling-toned reminiscences, independent of each other (dead dog, deafness).

[613] Thus we have about ten complexes, independent of each other, that are touched on in the series of experiments. Subject No. 2 is a few years older than No. 1. In the latter case, as was mentioned, 18 per cent of the associations were to be attributed to the sexual complex, whereas only 4 per cent came under the influence of other emotions. On the other hand, with subject No. 2, 53 per cent of the associations can be related to the influences of complexes. This great number of constellations does not in any way indicate that the analysis was taken further, or that subject No. 2 gave fuller information than No. 1, but it is also to be recognized objectively that subject No. 2 (at least at the time of the experiment) was more emotional than No. 1. We recognize this from the numerous disturbed reactions and the striking assimilations and repressions.⁴⁸

[614] Of the 53 per cent of the associations mentioned, only 10 per cent can be attributed directly to the sexual complex, namely the actual erotic complex, 11.5 per cent to the money-complex, 2.5 per cent to ambition, 4.5 per cent to personal sensitivity, 3 per cent to the broken friendship; to the erotic complex of the past, which is only betrayed by feelings of revulsion and remorse, 9 per cent can be related, and 12.5 per cent are connected to about six smaller, more or less separate emotional complexes. Thus with the male subject the sexual complex as such is very much in the background against the many other influences (10 : 43).

[615] This case shows us even more than the preceding one just how much of the individual personality is contained in the associations. The experiment provides data about a whole series of highly important psychological contents; it gives us as it were a cross-section of the actual personality from a psychological point of view.

[616] *Subject No. 3:* a youngish educated man.⁴⁹ I am limiting myself in this case entirely to the critical associations and am reporting on it mainly to show again what in principle emerged in the two preceding cases. The probable mean time for this subject is 1.6 seconds.

1. head	neck	1.2
2. green	mouse	0.8
3. water	green	1.0

What strikes one in this series is the peculiar reaction *mouse* and the perseveration of *green*. *Neck* is a reverberation from the day before the experiment when the subject had seen a film about the death of Marie Antoinette. The subject is not sure where *mouse* comes from, he only has the feeling that it is a slip of the tongue and supposes it should have been *neck* (*Hals*) or *house*.

4. to pierce	to fence	1.2
5. angel	house	1.6

Here we have, with a long reaction-time, the reaction *house* assumed in 2, and now the memory comes back. The subject's grandfather had often in times past sung the song "Es geht durch alle Lande—ein Engel still" (A silent angel walks through every land, etc.). Just as frequently he would sing: "Mein Häuschen steht im Grünen" (My little house stands in the greenwood, etc.).

A series of feeling-toned images, only some of which are pleasant, are associated with these songs. Hence the perseveration of *green* and the slip of the tongue *mouse*.

13. state	church	1.8
-----------	--------	-----

This reaction is somewhat hesitant since *church* represents the sizeable complex of a rather strong religious attitude.

16. to dance	not	1.8
--------------	-----	-----

This reaction really is "I cannot dance," to which a very unpleasant feeling is connected, for the subject has experienced a disappointment in love, which a friend who could dance well has been spared.

18. ill	not	1.6
---------	-----	-----

Here again a stimulus-word is felt to apply to himself: he is *not ill* from despair over the unfortunate ending of the romance.

22. angry	friendly	1.8
23. needle	nail	1.2 (<i>Nadel/Nagel</i>)

Angry arouses the feeling of jealous animosity that the subject feels towards a certain rival. The sound association that follows is conditioned by the perseveration of this feeling-tone.

30. rich	rather	2.8
31. tree	branches	1.6

R.30 refers to the match that did not materialize, hence the long reaction-time. The next reaction is still somewhat long and has a rather stilted and artificial character; it also seemed to the subject to have a rather ironic tone which holds for the following reactions, too:

32. to sing	beautiful	1.4
33. pity	absolutely not	1.8

by which he means that he does not deserve any pity because everyone forges his own fate.

44. detest	rascals	5.0 (<i>Kerle</i>)
47. people	religion	1.6
48. to stink	abominable	1.0
50. unfair	atrocious	1.8

R.44, *rascals*, means the Jews. The lady concerned is Jewish. *People* again arouses the image *Jews* but this is repressed. *Religion* comes in in its place because the religion of his beloved had aroused scruples in the religious-minded subject. The following feeling-toned reactions refer to the complex rather than to the stimulus-words. (Similarly in subject No. 2 a coarse reaction betrayed the affect.)

54. white	snow	1.8
-----------	------	-----

A feeling of “having finished” or “death”; refers to the love-complex.

61. law	absolute	1.4
---------	----------	-----

Here we again have the reaction of R.33 expressing the same feeling: “it is the law, it must be so.”

62. dear	beautiful	1.2
66. tall	fine	1.2

Both reactions have an ironical flavour and relate to the complex.

74. wild	animal	1.8
----------	--------	-----

Wild (dial., “angry”) he applies to himself on account of the complex.

75. family	house	1.0
------------	-------	-----

House seems to represent the complex of all family memories. (Also in *to cook/house*.) Here we have a relatively short reaction-time.

79. luck	game	1.8
----------	------	-----

Clearly refers to the love-complex.

80. to tell	to talk	1.6 (<i>erzählen/talk</i>)
-------------	---------	------------------------------

The reaction is in English. We have already seen that French reactions are suspect; this English one too refers to the complex. The subject at first wanted to tell the story of his disappointment to his brother, who lives in America, but then decided against this. Hence the English form.

83. brother	sister 2.0	(Bruder/sister)
-------------	------------	-----------------

Again an English form with a long reaction-time! *Brother* has probably subconsciously awakened the image of the earlier reaction. *Sister* comes because his sister at that time was on the point of leaving for a French boarding-school in the same way as his brother had left some time earlier for America. This analogy has condensed itself into *sister*.

88. to kiss	absolutely	1.6
-------------	------------	-----

Absolutely is the key-word to the love-complex.

91. door	mouse	1.6
----------	-------	-----

The slip of the tongue of R.2 reappears, probably to mask *house*, which stands for the complex.

92. choose	Kaposi ⁵⁰	
------------	----------------------	--

Actually the word *caprice* came up momentarily as the reaction, but was immediately suppressed and altered into *Kaposi*. *Caprice* was the choice of the lady in question. *Kaposi* is only an example of similarity in sound and is constellated by a conversation of a few days earlier in which *Kaposi* was mentioned.

105. pain	kissing	1.0
106. lazy	sow	1.4

The coarser expression of the last reaction is caused by the feeling of anger perseverating from R. 105.

115. intention	kissing	1.8 (Absicht/küssen)
----------------	---------	----------------------

Absicht he immediately assimilated as *absolut*, which refers to the complex; he then reacted as if this were the meaning of the stimulus-word.

125. purpose	absolutely none	1.2
126. hot	yes	2.2
134. worthy	daft	2.0
135. danger	glad	1.4
136. high	no, low	2.8
140. to mix	blood	2.0
143. blood	to mix	1.4

These reactions are all sometimes more, sometimes less clearly constellated by the love-complex, and in this naturally the constellating factor was not a clear image, but only a certain not very distinct mood.

144. to let	family	1.6
-------------	--------	-----

For a moment *house* loomed up but was repressed and replaced by the somewhat striking reaction *family*. This is association 75, which is again suddenly taken up to mask the word *house*, which represents the complex.

145. caution

intention

2.0 (*Vorsicht/Absicht*)

Here clearly *absolut* came first but was inhibited and masked by *Absicht* through a sound association—perhaps association also contributed.

160. to wish

absolutely not

1.8

[617] I shall not add any more examples; they do not in principle add anything new, only confirm what we have already established with the previous cases.

[618] The love-complex is clearly in the foreground with this subject. At least 52 per cent of the associations can be referred to it with certainty. The family-complex can be demonstrated in 11 per cent of the associations. Now and again there is evidence in 7 per cent of the associations of a complex of ambitious strivings. Numerous individual feeling-toned reminiscences can be demonstrated in 27 per cent of the associations. The general probable mean time in this case is 1.6 seconds. 31 per cent of the reaction-times exceed this mean. 17 per cent amount to 1.8 seconds. Of these 85 per cent are certainly constellated by a complex, whereas in 15 per cent this influence is doubtful or not demonstrated. 4.5 per cent of the associations took 2.0 seconds. 89 per cent of these can with certainty be traced back to the influence of a complex, whereas this influence is uncertain in 11 per cent. 9 per cent of the associations took over 2.0 seconds. All these can be attributed to the influence of a complex.

[619] It is unnecessary to add more examples, for one would constantly have to repeat oneself. As far as our experience goes, the complex-phenomena are the same with all subjects. Only the type of complex, naturally, varies with sex and educational level.⁵¹

[620] The perseveration of a feeling-tone deserves attention. As is well known, perseveration plays a particularly important part in the pathology of the process of association. Investigations made with normal subjects might be of some help in elucidating the nature of morbid perseveration. In our experiments the perseveration of a feeling-tone occurred so often that we were able to express it statistically to a certain extent. For example, subject No. 2 showed 32 reaction-times of over 1.6 seconds, of which 16 were themselves followed by longer reaction-times. In 10 cases, only the subsequent reaction was prolonged, in 3 the two following, and once in each case the three, four, and five subsequent reaction-times were prolonged. As can be seen from this survey, we quite often observe a discontinuous decrease in the reaction-times. I have seen a quite similar but even clearer discontinuous decrease in some cases of hysteria and dementia praecox, and mostly at points suspect of complex.

[621] To summarize:

(1) From the figures given, it follows that relatively long reaction-times are almost without exception caused by the intervention of a strong feeling-tone.

(2) Strong feeling-tones as a rule belong to extensive and personally important complexes.

(3) The reaction can be an association belonging to a complex of this nature and take its feeling-tone from this complex, though the complex need not be conscious. The *constellation* (Ziehen) of an association is mostly unconscious (or not-conscious); the constellating complex here plays the part of a quasi-independent entity—a “second consciousness.”

(4) The feeling-tone can unconsciously also influence the next reaction, in which several phenomena are to be observed:

- (a) The reaction influenced by a perseverating feeling-tone has a prolonged reaction-time.
- (b) The reaction is still an association belonging to the group of images of the preceding complex.
- (c) The reaction is abnormal in character: it can (i) be disturbed through a slip of the tongue or through repetition of the stimulus-word; (ii) be abnormally superficial (sound reactions).

(5) The feeling-tones in question are mostly unpleasant.

(6) The characteristics of an unconsciously constellating complex are: long reaction-time, unusual reaction, failures, perseveration, stereotyped repetition of the stimulus-word (“complex-representative”), translation into foreign language, strong language, quotations, slips of the tongue, assimilation of the stimulus-word (possibly also misunderstanding of the stimulus-word).

(7) Erotic complexes seem to play a particularly significant part.⁵²

H. *The Quantitative Ratio of Prolonged Reaction-times in a Greater Number of Subjects*

A. STIMULUS-WORD AND PROLONGED REACTION-TIME

[622] It would be interesting to learn whether the rules we have discovered in the analyses given above can be applied to a greater number of subjects about whom we have not adequate information. Practical experience teaches us that there are very few people who can pursue their own psychological processes in their subtlest details. Hence a very narrow limit is imposed on subjective analysis. The results given above should, however, make it possible, objectively, to penetrate into the complexes hidden in the associations and at least to demonstrate that rules gained from subjective analysis probably have a general validity. Hence I have investigated, in a comparative manner, the kind of words that are usually followed by prolonged reaction-time. Eleven subjects provided my material; of these, nine were uneducated and two educated.

[623] 1. Five subjects reacted with prolonged times to the following stimulus-words:

needle	false	{[despise: 7 subjects] ⁵⁴
{hair ⁵³	to court	}inn
{salt	{to disgust	to remember
{[tooth: 3 subjects] ⁵⁴	}uproar	ripe
{window	resin	
fern	pyramid	
hope	to hit	
strange	to threaten	

[624] It is not surprising that stimulus-words such as *fern*, *uproar*, *resin*, and *pyramid* cause a lengthening in the reaction-time, for they are rather rare words and uneducated people do not have at their disposal ready-made associations to them. But this cannot be said of the words *needle*, *hair*, *to hit*, *ripe*, etc., for these on the contrary are words that occur very frequently in everyday language. The reasons why these words should cause long reaction-times can only be found by means of the above analyses; in most cases they are words that readily arouse emotional associations for they already have in themselves a certain feeling-value, as for example: *hope*, *false*, *to hit*, *to threaten*, *to remember*, *ripe*, etc., for women *hair*, too, should have an emotional value. The words *salt*, *window*, *uproar*, *inn*, have no striking emotional value, but in the original series they follow stimulus-words that evoke feeling; and for this reason, as has many times been shown, come into the orbit of a perseverating feeling-tone. *Hair* and *tooth* can cause long reaction-times, particularly with women, whereas *to disgust* and *to despise* generally stimulate feeling. *Needle* does not in fact follow a stimulus-word arousing feeling; in this case, however, another factor might play a part. This word (*Nadel* in the German original) is pronounced differently in dialect: the vowel *a* is pronounced nearer to an *o* and the ending is transposed into *-dlé*. On the other hand, in the dialect the *a* in the word *Nabel* (navel) is pronounced exactly as in academic German and likewise the ending is unchanged. *Nabel* is the only dialect word that sounds at all like *Nadel* in academic German. For this reason inevitably this word must be evoked in the Swiss-German subject when *Nadel* is called out. As we have seen, it does not necessarily come into consciousness at the time: the inhibition connected with this word can nevertheless influence the association occurring in consciousness. That this is no idle speculation is borne out by the similar case of the word *book*, with which seven out of eleven subjects took prolonged times. *Book* (*Buck* in German) is pronounced in the dialect as *Buoch*. The dialect word *Buck*, however, means *Bauch* (belly), which is a very unpleasant stimulus-word. In experiments on psychotics it has frequently occurred that *Buch* has been immediately understood as *Bauch* and the corresponding reaction followed.

[625] II. Six out of eleven subjects reacted with prolonged times to the following stimulus-words:

dream	damage	impetus
paper	to spare	premonition
book	dreadful	to stink
frog	gentle	to forge
nurse (male)	{to surmise: 8 subjects	to caress
right	}of age	family

Of age, impetus, and premonition can be considered “difficult” words in which the rarity probably prevails over any possible feeling-value.

[626] Since *paper* is a very common word it is difficult to say just what is its capacity to arouse emotion. *Nurse (male)* is effective because it is in constellation with uneducated subjects who are all male or female nurses in our hospital. The meaning of the word *gentle* (*leise* in German) became clear to me when a South German male nurse reacted with *big* (*gross*): he had in fact in the meantime suppressed the association *Läuse / klein* (lice / small). What matters here is the sound similarity as in the case of *book*. It is striking that so many long reaction-times should occur with the word *frog*. With one exception, the subjects giving these long times were all women. The man who had a long reaction-time could give the reason: *frog* had struck the emotional complex associated with a new-born son. Possibly in the subconscious of a woman, too, the frog’s likeness to a small, naked wriggling baby can arouse feeling; so a sexual complex would be touched on which could well be present in every woman, even if only unconsciously.

[627] The feeling-value of the other stimulus-words is clear and requires no further explanation.

[628] III Seven out of eleven subjects reacted to the following stimulus-words with prolonged reaction-times:

{	freedom	to disgust
	unjust	to despise
	world	to pay attention
	loyalty	to kiss
	consciousness	

Only *consciousness* could be rated as “difficult.” The stimulus-words *freedom*, *unjust*, and *to pay attention* presumably produce long reaction-times in the nursing staff, which can easily be understood. *World* may well have prolonged times so frequently because it is placed between two words that arouse emotions.

[629] IV. Eight to ten out of eleven subjects had long reaction-times to the following stimulus-words:

heart	to surmise
violence	{to kiss: 7 subjects
wonder	{natural: 9 ”

It is not so much the relative rarity of the word *to surmise* that is important, but its capacity to arouse complexes. *Miracle* often seems to excite religious complexes associated with inhibitions. *Natural* is influenced by the immediately preceding erotic-sexual stimulant *to kiss* and is therefore very embarrassing for both sexes. *Violence* attracts the maximum of prolonged reaction-times. This is perhaps mainly due to the fact that all the subjects are closely connected with the mental hospital.

[630] From this account we can see that the difficulty or rarity of a stimulus-word can certainly influence the reaction-time; but in the vast majority of cases the stimulus-words

that produce long reaction-times are characterized by a high feeling-value. Thus the principal cause of prolonged reaction-times. This objective statistical examination shows the principal cause of prolonged reaction-times to be the emotional effect of the stimulus-word.

[631] I have tried to estimate roughly the quantitative values for the four series given above, and have compiled them in the following summary:

Out of 200 stimulus-words, 48 aroused prolonged reaction-times in 5 or more out of 11 subjects.

17 stimulus-words produced prolonged reaction-times in 5 subjects. Of these 76% referred to affective images.

17 stimulus-words produced prolonged reaction-times in 6 subjects. Of these 76% referred to affective images.

9 stimulus-words produced prolonged reaction-times in 7 subjects. Of these 89% referred to affective images.

5 stimulus-words produced prolonged reaction-times in 8 to 10 subjects. Of these 90% referred to affective images.

[632] On the average, therefore, approximately 83 per cent of the stimulus-words producing prolonged reaction-times have affective value, whereas only about 17 per cent have a delaying influence through their intrinsic difficulty. Of the stimulus-words arousing affects, at least 28 per cent have a mainly erotic-sexual affective value.

B. INCIDENCE OF PROLONGED REACTION-TIMES WITH INDIVIDUAL SUBJECTS

[633] It follows from the explanations given above that emotional processes are of the greatest significance in the origin or formation of abnormally long reaction-times. As we know from everyday experience, it is in the sphere of the emotions that the greatest individual differences exist. For this reason, it should be worthwhile investigating what is the numerical proportion of abnormally long times with the different subjects. For this investigation, I used the material given by twenty-six subjects. (Uneducated: seven women and seven men. Educated: six women and six men. Thus a total of over 4,000 individual data.)

[634] As already mentioned, all those reaction-times that exceeded the individual probable mean times were considered to be prolonged. True, we came upon a series of reactions showing neither a particularly long duration nor obvious complex-influence. On the other hand, if we raise the upper individual limit for normal times, we are thrown on to the arithmetical mean in which the prolonged times are taken into account. This limit is then individually far too high, for which reason no characteristic figures can be obtained in this way. I therefore decided to select the individual probable mean as the upper limit, first, because the abnormally long times are not taken into account in this (the probable mean is as a rule lower than the arithmetical mean) and, secondly, because (according to the analysis

of subject No. 1) of those times exceeding the probable mean by only 0.2 seconds, almost a third are clearly influenced by feeling-toned complexes, whereas all the very long times depend entirely on the effect of complexes. In this way we encounter almost all the prolonged reaction-times produced by affects. As is clear from several examples, there is a certain proportion between the intensity of the affect and the length of the reaction-time. Hence one can deduce, *cum grano salis*, very intensive affects from very long reaction-times. By means of the arithmetical mean the prolonged reaction-times are taken abundantly into account in a calculation of averages. For the four groups mentioned I am giving the figures for the probable and arithmetical means, the percentages of prolonged reaction-times, and the difference between the two means.

		Probable Mean	Arithmetical Mean	Differ- ence	% of Prolonged Reaction- times
Uneducated	{ Women	2.2	2.9	0.7	49.2
	{ Men	1.8	2.4	0.6	40.9
Educated	{ Women	1.7	2.2	0.5	42.4
	{ Men	1.3	1.7	0.4	41.8

[635] The four columns in this table all say approximately the same thing in different forms, namely that the uneducated women, as well as having the highest probable mean, also have the greatest number of prolonged reaction-times. The differences between probable and arithmetical mean times are most instructive: the group of educated men has a smaller difference than the other three groups. This figure states that the prolonged reaction-times of educated men are on average shorter than those of the other groups, that consequently the emotional inhibitions in all the other subjects—for this is the main point, not the difference in educational levels—even if they do not always occur more frequently, are still more fundamental and abundant than those of the educated men. From this I see that the experimenter, who is in every respect on the same level as the group of educated men, as far as the other groups are concerned is of the opposite sex or a superior or both. This seems to me sufficient reason for the prevalence of emotional inhibitions in the other subjects.

[636] In stating the influences of the emotions on the length of reaction-times, I have ventured into a sphere so complicated, and therefore so subject to great individual variations, that there is no point in giving the individual figures on which the above table is based. Only untenable hypotheses could be based on the differences.

GENERAL RECAPITULATION

[637] A. In time-measurements, using a stop-watch, made with both educated and uneducated subjects, the average reaction-time came out at 1.8 seconds.

B. The times of male subjects (1.6 seconds) are on average shorter than those of female subjects (2.9 seconds).

C. Similarly, the times of educated subjects (1.5 seconds) are, on average, shorter than those of the uneducated (2.0 seconds).

D. The quality of the stimulus-word exerts a certain influence on the reaction-time. The average shortest times follow concrete nouns (1.67 seconds), the longest follow abstract nouns and verbs (1.95 and 1.90 seconds). Educated men form an exception to this rule in that with them it is usually the concrete nouns that are followed by the longest times.

E. The quality of the reaction also seems to have a certain influence on the length of the reaction-time. The longest times occur with abstract nouns (1.98 seconds), the shortest with adjectives and verbs (1.65 and 1.66 seconds). Concrete nouns (1.81 seconds) are in the middle. Educated men here again are the exception in that their longest time occurs with concrete nouns.

F. The quality of the association has a distinct influence on the reaction-time. Internal associations command a longer reaction-time than external ones. Sound reactions generally show relatively long times because they are abnormal and owe their appearance to certain disturbances occasioned by inner dis tractions.

G. Those reaction-times that exceed the probable mean are for the most part caused by the eruption of intense emotions associated with individually important complex-images. The subject is mostly unaware of the reason for the prolonged reaction-time. Hence, too, long reaction-times can serve as a means of uncovering emotionally charged complexes, both conscious and unconscious. (Important in hysteria!)

H. Prolonged reaction-times tend to follow certain stimulus-words. About 83 per cent of these are mainly characterized by their affective value, whereas only about 17 per cent cause prolonged reaction-times on account of their difficulty or rarity.

[638] Very frequently the dying away of the feeling-tone is shown and it extends to the subsequent reactions which are thereby disturbed (perseveration).

BIBLIOGRAPHY

Aschaffenburg: "Experimentelle Studien über Assoziationen" in Kraepelin, *Psychologische Arbeiten*, I (1896), II (1899), IV (1904).

Bechterew: "Über zeitliche Verhältnisse der psychischen Prozesse bei in Hypnose befindlichen Personen" (1892).

Idem: "Über die Geschwindigkeitsveränderungen der psychischen Prozesse zu verschiedenen Tageszeiten" (1893).

Cattell: "Psychometrische Untersuchungen" in Wundt, *Philosophisches Studien*, III (1885).

Claparède: *L'Association des idées* (1903).

Idem and Israilovitch: "Influence du tabac sur l'association des idées" (1902).

Féré: *The Pathology of the Emotions* (1899; orig., 1892).

Freud: *The Interpretation of Dreams* (orig., 1900).

Idem: *The Psychopathology of Everyday Life* (orig., 1904).

Galton: "Psychometric Experiments" (1897).

Jung and Riklin: "The Associations of Normal Subjects" (orig., 1904).

Kraepelin: *Experimentelle Studien über Assoziationen* (1883).

Idem: "Über den Einfluss der Übung auf die Dauer von Assoziationen" (1889).

Idem: *Über die Beeinflussung einfacher psychischer Vorgänge durch einige Arzneimittel* (1892).

Mayer and Orth: "Zur qualitativen Untersuchung der Assoziationen" (1901).

Müller and Pilzecker: "Experimentelle Beiträge zur Lehre vom Gedächtnis" (1900).

Münsterberg: "Die Assoziation sukzessiver Vorstellungen" (1890).

Idem: *Beiträge zur experimentellen Psychologie* (1889-92).

Ranschburg and Balint: "Über quantitative und qualitative Veränderungen geistiger Vorgänge im hohen Greisenalter" (1900).

Riklin: "Zur Psychologie hysterischer Dämmerzustände und des Ganser'schen Symptoms" (1904).

Sommer: *Lehrbuch der psychopathologischen Untersuchungs-methoden* (1899).

Thumb and Marbe: *Experimentelle Untersuchungen über die psychologischen Grundlagen der sprachlichen Analogiebildung* (1901).

Trautscholdt: "Experimentelle Untersuchungen über die Assoziation der Vorstellungen" in Wundt, *Philosophische Studien*, I (1883).

Walitsky: "Contribution à l'étude des mensurations psychométriques des aliénés" (1889).

Wehrin: "The Associations of Imbeciles and Idiots" (orig., 1904).

Wreschner: "Eine experimentelle Studie über die Assoziation in einem Falle von Idiotie" (1900).

Ziehen: *Introduction to Physiological Psychology* (1892; orig., 1891).

Idem: "Die Ideenassoziation des Kindes" (1898–1900).

EXPERIMENTAL OBSERVATIONS ON THE FACULTY OF MEMORY¹

[639] We have often observed in our association experiments with hysterical patients that the patient would not react for a long time to stimulus-words that were obviously related to his complex, and then would suddenly ask, “What was the word you said?” Closer interrogation revealed that the patient had forgotten the word of which he had just been reminded. We immediately recognized that this striking disturbance of memory was identical with the type of *forgetting* described by Freud, i.e., the “not wanting to remember” unpleasant impressions. The phenomenon that we observed is a particular case of a general tendency to repress and then forget the unpleasant image. (Cf. Freud’s papers.²)

[640] It is to the credit of Freud, and partly also of Breuer—as is probably well known—that they have amply demonstrated this fact (forgetting equated with repression) in hysterical patients. The validity of this can be doubted only by someone who has not himself tested Freudian psychoanalysis. In more recent works³ Freud has demonstrated that the same mechanisms of repression are at work in the normal dream and in trivial incidents of everyday life (parapraxes in speaking, reading, etc.). In our experimental investigations we have also succeeded in demonstrating the repressed complex in such associations as are produced by calling out a stimulus-word. The laying bare of a repressed complex is of immense practical importance, e.g., in hysteria. Every hysterical patient has a repressed complex of causal significance. It is therefore essential for treatment that the complex be identified, unless one wants to forego such important psychotherapeutic aids. As Freud has shown, however, the inhibitions repressing the complex are so strong that the images concerned are very often split off from consciousness. It was to overcome this barrier that Freud invented his ingenious method of *free association*. This method is, however, extremely time-consuming and its use presupposes certain qualities in both the patient and the doctor. The same inhibitions are betrayed in our own method of association. A tabulation of the stimulus-words that have brought up inhibitions shows quite clearly into which category the repressed complex may fall, and from this one can obtain valuable pointers to supplementary questions. To get a clearer idea of the type of complex one can then intersperse additional pertinent stimulus-words. The art of the method, which is never easy to use, lies in distinguishing the reactions connected with a complex from the irrelevant ones. I have therefore compiled a series of so-called *complex-characteristics*.⁴ In principle the complex-characteristics are the same for normal and pathological associations. Furthermore, to lay bare the complex is of far-reaching significance in applying our experiments to

the field of criminal psychology. Hans Gross and his pupils have shown this, stimulated by our experiments.⁵ The complex in this case is the fact of a crime: the stimulus-words are the designations of things associated with the mental picture of the crime.

[641] The observations mentioned in our first paragraph became the point of departure for a new method that points to those associations attributable to complexes. The *reproduction method*, as I should like to call it, can be described as follows: After completing an association test (usually one hundred words), we try to find out whether the subject remembers how he reacted to individual stimulus-words. We simply repeat the experiment, always allowing the patient enough time to recall his previous reactions. In this reproduction method certain regular characteristics come to light, which I should now like to outline briefly. In these experiments my leading idea was to find out whether failures of memory were accidental or whether a system behind them could be revealed. I have carried out this experiment on mentally healthy people and on patients, and have, at least in principle, always found the same phenomena. (Organic disturbances of memory are of course excepted.) As this article is only concerned with establishing and describing this phenomenon, I have selected as examples two pathological cases in which the phenomenon in question is quite pronounced.

[642]

CASE NO. I

A 32-year-old professional musician who was undergoing psychoanalytical treatment because of vague anxiety-states and a compulsive fear of not being able to give solo performances. Two years previously he had become engaged, but the engagement soon broke up owing to moodiness and quarrelling. The young woman was of an implacable, quarrelsome, and jealous nature. This led to violent rows and finally to the breaking off of the engagement when the patient made the mistake of writing picture postcards to another girl. During the nights following these quarrels the patient could not sleep, and it was then that the first nervous symptoms appeared. About a year previously he had had a secret affair with a lady of a rich and distinguished family, but this had soon been broken off. In January of that year the patient became engaged to a rather unintelligent girl who was, however, already three months pregnant by another man, which the patient did not then know. The numerous excitements brought on by these circumstances aggravated his nervous condition to such an extent that he had to seek medical advice. It should also be mentioned that he had led a very dissolute life between the ages of 18 and 25, as a result of which his physical strength had allegedly been greatly impaired.

[643] The results of the two tests are set side by side. Those associations that were either not reproduced or wrongly reproduced are shown in italic type.⁶

Stimulus-word	Re-action	Re-action-time (secs.)	Reproduction	Remarks
1. <i>head</i>	<i>empty</i>	3.2	to see	Complex underlying the illness.
2. <i>green</i>	<i>lawn</i>	2.2	colour, tree	Probably perseverating feeling-tone.
3. <i>water</i>	<i>to drown</i>	2.2	deep	The patient had had thoughts of suicide as a result of his illness.
4. <i>to stab</i>	<i>dead</i>	1.8	unpleasant	—
5. <i>angel</i>	<i>beautiful</i>	8.0		Here the feeling-tone of the previous reaction has probably perseverated. Word not at first understood. Erotic reminiscences easily aroused by this word.
6. <i>long</i>	<i>table</i>	2.8	—	—
7. <i>ship</i>	<i>crew</i>	3.0	to travel, to drown	Suicide by drowning.
8. <i>to plough</i>	<i>peasant</i>	2.0	—	—
9. <i>wool</i>	<i>sheep</i>	2.0	—	—
10. <i>friendly</i>	<i>very</i>	2.8	—	Affair with the lady.
11. <i>desk</i>	<i>high</i>	3.6	—	Prolonged reaction-time due to perseverating feeling-tone.
12. <i>to ask</i>	<i>difficult</i>	3.2	to put	Same complex.
13. <i>state</i>	<i>beautiful</i>	2.4	—	—
14. <i>obstinate</i>	<i>very</i>	2.0	—	1st fiancée.
15. <i>stalk</i>	<i>green</i>	2.2	—	—
16. <i>to dance</i>	<i>good</i>	2.2	—	—
17. <i>lake</i>	<i>stormy</i>	2.0	—	—
18. <i>ill</i>	<i>unpleasant</i>	8.8	—	Illness.
19. <i>conceit</i>	<i>very</i>	2.8	—	Relations with the lady.
20. <i>to cook</i>	<i>good</i>	2.0	—	—
21. <i>ink</i>	<i>black</i>	1.8	—	—
22. <i>wicked</i>	<i>very</i>	4.8	—	1st fiancée.
23. <i>pin</i>	<i>prick</i>	1.4	—	—
24. <i>to swim</i>	<i>not</i>	2.8	good	Suicide.
25. <i>journey</i>	<i>difficult</i>	2.4	long	Perseverating feeling-tone.
26. <i>blue</i>	<i>colour</i>	2.0	—	—

27. bread	to taste	2.8	—	—
28. to threaten	me	10.4	—	Fear of the future: suicide.
29. <i>lamp</i>	<i>good</i>	2.2	to burn	Perseverating feeling-tone.
30. rich	pleasant	3.4	—	The lady.
31. <i>tree</i>	<i>green</i>	2.0	high	Perseverating feeling-tone.
32. <i>to sing</i>	<i>beautiful</i>	1.4	good	(ditto)
33. <i>sympathy</i>	<i>pleasant</i>	4.6	to have	Ostensibly the ill- ness-complex, but probably something else as well which is not divulged.
34. <i>yellow</i>	<i>material</i>	5.4	colour	Not at first under- stood.
35. mountain	high	1.2	—	—
36. to play	children	2.4	—	—
37. salt	bitter	1.8	—	—
38. <i>new</i>	<i>material</i>	2.4	dress	?
39. <i>habits</i>	<i>good</i>	3.0	bad	Early life: adulterous relationship with the lady.
40. to ride	pleasant	3.6	—	—
41. wall	white	2.2	—	—
42. <i>stupid</i>	<i>cattle</i>	4.8	very	2nd fiancée.
43. <i>notebook</i>	<i>blue</i>	2.2	to write	Perseverating feeling-tone.
44. <i>to despise</i>	<i>him</i>	3.4	me	Early life: erotic complexes.
45. <i>tooth</i>	<i>sharp</i>	2.2	long	Perseverating feeling-tone.
46. correct	to write	3.8	—	Correspondence be- hind 1st fiancée's back.
47. people	Swiss	2.4	—	—
48. to stink	dung	2.0	—	—
49. <i>book</i>	<i>beautiful</i>	3.6	good	Perhaps not at first understood. Other- wise?
50. <i>unjust</i>	<i>judge</i>	2.0	very	The reaction <i>very</i> might indicate a connection with one of the erotic complexes.

52. to separate	acid (noun)	6.0	—	—	Not at first understood. Relationship with the lady.
53. hunger	pang	2.0	—	—	—
54. white	lamb	2.2	—	—	—
55. <i>cattle</i>	<i>to slaughter</i>	4.4	to kill	—	Memories of quarrels with 1st fiancée.
56. to pay attention	very	2.0	—	—	Perseverating tone.
57. pencil	long	2.0	—	—	—
58. sultry	weather	4.8	—	—	—
59. plum	blue	1.8	—	—	—
60. <i>to hit</i>	<i>target</i>	2.0	marksman	—	Rendezvous with the lady.
61. law	to despise	2.6	—	—	The lady is married.
62. dear	she	2.6	—	—	The lady.
63. glass	transparent	2.0	—	—	—
64. <i>to quarrel</i>	<i>unpleasant</i>	2.2	violent	—	1st fiancée.
65. goat	pasture	3.8	—	—	Perseverating tone. Stimulus-word was repeated by the patient.
66. <i>big</i>	<i>man</i>	2.4	child	?	?
67. potato	to eat	1.8	—	—	—
68. <i>to paint</i>	<i>wall</i>	3.2	beautiful	?	?
69. <i>part</i>	<i>whole</i>	3.0	?	—	Suggestion of "sexual parts."
70. <i>old</i>	<i>coin</i>	7.4	man	—	As a result of previous word the fear of impotence is aroused.
71. flower	smells	1.6	—	—	—
72. <i>to fight</i>	<i>stick</i>	2.0	violent	—	Quarrel with 1st fiancée.
73. <i>box</i>	<i>to put in</i>	3.4	?	—	Perseverating tone.
74. wild	horse	1.6	—	—	—
75. family	to have	2.6	—	—	2nd fiancée.
76. to wash	face	1.8	—	—	—
77. <i>cow</i>	<i>to slaughter</i>	2.6	to kill	—	Memories of rows with 1st fiancée.
78. strange	to me	2.0	—	—	1st fiancée.
79. luck	to have	1.6	—	—	—
80. to tell	story	1.6	—	—	—
81. <i>poise</i>	<i>good</i>	2.0	habit	—	Early life: the lady.
82. narrow	boot	1.8	—	—	—

83. brother	sister	1.2	—	—
84. <i>damage</i>	<i>to have</i>	1.6	to do	Impotence.
85. stork	long	1.0	—	—
86. <i>false</i>	<i>to write</i>	5.8	to speak	Correspondence behind 1st fiancée's back.
87. fear	to have	1.2	—	—
88. to kiss	her	2.0	—	The lady.
89. fire	house	4.0	—	Word not understood, perseverating tone.
90. dirty	street	1.2	—	—
91. <i>door</i>	<i>house</i>	2.0	high	?
92. to elect	electorate	2.0	—	—
93. hay	sweet-smelling	1.4	—	—
94. still	water	2.4	—	Suicide.
95. <i>scorn</i>	<i>pleasant</i>	1.6	unpleasant	Perseverating tone.
96. <i>to sleep</i>	<i>very</i>	2.2	deep	(ditto)
97. month	January	4.6	—	Cf. R.3; stimulus-word at first not understood. January is the critical month.
98. coloured	cloth	1.6	—	—
99. <i>dog</i>	<i>snappish</i>	2.4	to snap	Quarrel with 1st fiancée.
100. to speak	sensitive	1.8	—	—

[644] In these associations several clearly feeling-toned complexes are evoked. Their symptoms are mainly a delayed reaction and its influence on the following reactions. I will not proceed further with this analysis as it might lead too far.⁷

[645] The remarks given with the reactions should enable the reader to get his bearings. Those points where the analysis showed an association constellated by a complex have been noted. If we now look over the whole experiment we can see that, with very few exceptions, the incorrect reproductions to the repeated stimulus-words are those that are directly constellated by a feeling-toned complex or those that immediately follow a critical one, and therefore fall within the area of the perseverating feeling-tone. In many places the perseveration can be quite easily recognized by the prolonged reaction-time or by the form and content of the reaction. Out of 38 incorrect reproductions there are only five in which analysis could not demonstrate any kind of complex-constellation. Nevertheless, the prolonged reaction-times usually found in such places indicate a feeling-tone.

[646] Analysis is exceptionally difficult and time-consuming in the case of half-educated and uneducated people; in fact, it often proves almost impossible to reach any depth because of lack of co-operation. Also, with patients from an out-patients' clinic, you may easily meet people who have every reason to keep their secrets. Apart from these exceptions, which need not be considered, it becomes quite clear that the

forgetting does not apply to the irrelevant reactions, but to the significant complex-reactions. Should this be generally confirmed, we should have found a method, in this reproduction process, of objectively revealing complexes from the reactions. But this method can also be theoretically valuable in that it shows us a way to investigate the much discussed connection between feeling-tone and memory.

[647] Before we go further into these questions, I should like to refer to a second case.

[648] CASE NO. II

An educated young man, 22 years old, excitable and sensitive, sanguine, morally unsound, not particularly intelligent. He is well known to the writer and has also given sufficient information about the complexes broached by the associations.

Complex I: The patient is very excitable and extraordinarily sensitive. This characteristic brings him into frequent conflict with his environment. One of these conflicts has led him to a mental hospital. The patient had a good friend who once made a joke of sketching him with ass's ears, and produced this caricature in the presence of ladies. The patient took him to task about this, but the perpetrator denied having done it, whereupon the patient slapped his face and challenged him to a duel with sabres.

His relationship with his family is strained.

Complex II: Numerous love-affairs. The patient had been given a diamond pin by one amorous lady, which he wore in his tie, and had recently lost a stone from this, which annoyed him a great deal. One of these relationships is with a Greek woman. In the year he has just completed in the cavalry he led a wild and dissolute life.

Complex III: The patient recently wanted to become engaged to a woman of means, but it came to nothing.

Complex IV; The patient has decided to study agriculture, which seems to keep him occupied for the time being, and he is also enthusiastic about rowing and other sports.

[649] I am giving full details of the associations in this case. The method of analysis is the same as that I have already demonstrated in the work on the reaction-times. I have marked with the appropriate number all the places where the analysis certainly or in all probability shows a complex. Those associations to which the reactions were either not remembered or wrongly remembered in the reproduction test are shown in the table, as on the previous occasion.

Stimulus-word	Re-action	Re-action-time (secs.)	1st Reproduction	2nd Reproduction	Remarks
1. <i>head</i>	<i>hat</i>	2.8	—	cover	Stupidity complex (ass's ears) and the supposition, owing to stay in mental hospital, that he is mentally ill.
2. <i>green</i>	<i>colour</i>	1.4	—	—	—
3. <i>water</i>	<i>to row</i>	2.6	?	—	IV.
4. <i>to stab</i>	<i>spear</i>	2.8	—	—	I. Sabre duel.
5. <i>angel</i>	<i>heaven</i>	1.8	—	—	—
6. <i>long</i>	—	—	—	—	I. Not understood, reaction omitted.
7. <i>ship</i>	<i>-building</i>	1.0	—	—	—
8. <i>to plough</i>	<i>field</i>	2.2	—	—	} IV.
9. <i>wool</i>	<i>sheep</i>	1.2	—	—	
10. <i>friendly</i>	<i>Mr. Z.</i>	2.4	—	—	
11. <i>desk</i>	<i>bank</i>	2.2	—	—	—
12. <i>to ask</i>	<i>answer</i>	3.6	?	—	III.
13. <i>state</i>	<i>Switzerland</i>	3.8	—	<i>institution</i>	Preceding R. 12 refers to complex III. Owing to the perseverating feeling-tone the reproduction is disturbed.

14. obstinate	wench	4.8	—	—	—	"The Obstinate Wench," popular song. The stimulus-word <i>to ask</i> has touched complex III. How much the feeling-tone reverberates can be gathered from the way the reaction-times increase and from the content of R. 14.
15. stalk	flower	1.8	—	—	—	—
16. to dance	ladies	3.8	—	—	—	II.
17. lake	Zurich	2.0	—	—	—	IV.
18. ill	medicine	4.2	—	to be	—	I. Complex of hospitalization, observation of his mental state.
19. conceit	Mr. S.	1.8	—	—	—	I. Acquaintance in the hospital.
20. to cook	kitchen	2.0	—	—	—	—
21. ink	to write	1.6	—	—	—	—
22. wicked	Mr. C.	3.0	to be	—	—	I.
23. pin	tie	3.2	cravat	tie-pin	—	II.
24. to swim	water	2.0	—	—	—	IV.
25. journey	adventure	3.8	—	—	—	II.
26. blue	colour	2.4	—	—	—	—
27. bread	corn	2.8	—	—	—	IV.
28. to threaten	angry	3.0	—	someone	—	I. Duel complex.
29. lamp	light	2.0	—	—	—	—
30. rich	money	3.4	—	to be	—	III.
31. tree	leaves	3.0	leaf	—	—	—
32. to sing	music	2.8	—	—	—	Here the critical reaction is obviously <i>rich/money</i> , after which the reaction-times decrease in proportion. The reaction after the critical one is uncertain
33. sympathy	to have	2.6	—	—	—	—

34. yellow	colour	2.8	—	—	—
35. mountain	climbing	1.8	—	tour	—
36. to play	tennis	3.0	—	—	IV.
37. salt	sea	4.2	—	—	—
38. new	-Greek	6.2	—	—	II.
39. habits	& customs	2.2	—	—	—
40. to ride	horse	1.8	—	—	II.
41. wall	papered	3.4	—	—	—
42. <i>stupid</i>	<i>Mr. B.</i>	6.4	to be	—	I. Similar to R.22, same complex.
43. notebook	to write	2.2	—	—	—
44. to despise	<i>Mr. H.</i>	2.8	—	—	I. Acquaintance in the hospital. With this man the pa- tient had had a similar experience to that given in complex I.
45. tooth	to pull	2.4	—	—	—
46. <i>correct</i>	<i>answer</i>	8.0	right and proper	—	I. Connected with the denial in com- plex I.
47. people	race	2.0	—	—	—
48. to stink	carbolic	3.6	—	—	I. The hospital.
49. book	to read	1.6	—	—	—
50. unjust	Russia	3.0	—	—	—
51. frog	leg	1.6	—	—	—
52. <i>to separate</i>	<i>marriage</i>	6.0	?	—	III.
53. hunger	to eat	4.0	—	—	—
54. white	colour	3.4	—	—	—
55. cattle	cattle- breeding	2.6	—	—	IV. Here again the timing shows a regular decrease after the critical reaction.
56. <i>to pay at- tention</i>	<i>lecture</i>	6.2	—	question	IV.
57. pencil	to write	4.2	—	—	—
58. sultry	sky	7.6	—	—	I. Stay in hospital.
59. plum	stone-fruit	3.0	—	—	IV.
60. to hit	to shoot	2.6	—	—	I.
61. <i>law</i>	<i>state insti- tutions</i>	6.2	?	—	I.
62. dear	beloved	7.4	—	—	II or III.
63. glass	water	2.2	—	—	—

64.	to quarrel	difference	4.8	—	—	I.
65.	goat	farming	2.8	—	—	IV.
66.	<i>big</i>	<i>Germany</i>	11.2	?	tree, pine	Refers to himself as he is exceptionally tall.
67.	potato	farming	2.8	—	—	IV.
68.	to paint	pictures	2.4	—	—	—
69.	part	to have	4.6	—	—	III. He had hoped to become a partner in his prospective father-in-law's business.
70.	old	to become	1.8	—	—	—
71.	<i>flower</i>	<i>blossom</i>	3.4	—	{stem, to bloom, leaves	IV.
72.	to fight	sabres	4.0	—	—	I.
73.	box	lid	2.8	—	—	—
74.	<i>wild</i>	<i>to become</i>	3.2	—	to be	I. Wild, evil.
75.	family	parents	4.6	—	—	I.
76.	to wash	soap	3.6	—	—	—
77.	cow	farming	4.4	—	—	IV.
78.	strange	to be	4.0	—	—	—
79.	luck	lucky	2.2	—	—	—
80.	to tell	story	1.6	—	—	—
81.	<i>poise</i>	<i>to have</i>	3.0	—	& customs	I.
82.	<i>narrow</i>	<i>a flat</i>	5.0	room	—	I. Stay in hospital.
83.	brother	siblings	4.4	—	—	I.
84.	<i>damage</i>	<i>to inflict</i>	2.8	{to have, to suffer	{to have, to suffer, to endure, to inflict	I. Refers to excesses in drunkenness.
85.	stork	bird	4.0	—	—	Word not at first understood.
86.	false	envy	4.8	—	to be	—
87.	fear	to have	3.8	—	—	—
88.	to kiss	pleasant	3.4	—	—	II.
89.	fire	brigade	6.4	—	—	—
90.	dirty	street— instantly	6.8	—	—	Marked increase in times from R.88 onwards. Cf. below.
91.	door	to open	1.6	—	—	—
92.	to elect	election	3.2	—	—	—
93.	hay	haymaking	3.2	—	—	IV.
94.	still	at night	3.6	—	—	II.
95.	scorn	& derision	1.8	—	—	At first did not un- derstand the word
96.	to sleep	at night	2.0	—	—	II.
97.	month	12 months in a year	3.2	—	—	—
98.	coloured	flowers	8.2	—	—	—
99.	dog	Great Dane	2.4	—	—	—
100.	to speak	foreign language	5.0	?	—	II. The Greek woman.

Note to test: Reactions 94–98 are influenced by a complex that requires some elucidation. These reactions show various intense *complex-characteristics*. Obviously the complex is hidden by the words *at night*. From the first reproduction onwards, there is a marked increase in the reaction-time. I suggested to the patient that this might be due to a more recent love affair, but he did not admit it. There is a similar increase in the time taken after 88, *to kiss/pleasant*, and it is difficult to understand why 56, *to pay attention/lecture*, should take as long as 6.2 seconds. Complex-characteristics in reactions to words such as *to kiss*, *to sleep*, *still*, *to pay attention*, gave rise to the suspicion that the patient had begun an affair behind our back.

On the day following these tests we intercepted a letter addressed to the patient. This was from a girl whom he had met when he was allowed to go out on parole, and suggested how they could keep their relationship secret and how they could arrange a rendezvous.

[650] In this series of associations there are obvious complexes expressed in the usual way. Out of one hundred reactions there are only 13 in which memory failed. When we now examine where these 13 unrepeated reactions occur, we see that 12 of them are found at points constellated by a complex;^{7a} one follows immediately on a complex-reaction. We may therefore suppose that the disturbance of memory is connected with the complex, or with its feeling-tone. As I have shown earlier,⁸ strong emotions, especially feelings of unpleasure, are expressed in abnormally long reaction-times.

[651] The arithmetical mean time of all correctly repeated reactions is 3.0 seconds. The mean of those not repeated is 5.0 seconds. Thus the times taken for those reactions not repeated are significantly longer than those of the others, which gives us an objective confirmation of our supposition that there is a connection between the disturbance of memory and the strong feeling-tone of the reaction.

[652] The first reproduction test followed immediately after the initial test of one hundred reactions. I had the test repeated again on the following day, and the results are shown in the column headed "2nd Reproduction."

[653] Of the hundred reactions, 14 were incorrectly reproduced on the second occasion. (The second reproduction was assumed to be correct if it was the same as the first reproduction, when the initial reaction had been incorrectly remembered.)

[654] Eleven of the fourteen incorrect reproductions concern reactions that had been correctly reproduced the first time but that, because of their content or the length of time taken, appeared to suggest the presence of a complex. Only three were wrongly remembered on the second reproduction. We can thus see that the amnesic blockages have developed further in the same direction as in the first reproduction test, and give rise to a series of reactions that also belong to the complexes. For practical purposes it would seem to be advisable to leave some time between the first test and the reproduction tests.

[655] In my experience the amnesic blockages occur just as frequently with critical reactions as with those immediately following. These two cases represent the usual behaviour. But there are even more island-like amnesias, particularly, as it seems, in hysteria, where the feeling-tones are of great intensity and can extend over many subsequent reactions. Thus, I recently found in the case of a 23-year-old hysterical

woman, who had only 13 per cent incorrect reproductions, the following interesting chain of reactions:

1. water		—	(no reaction)
2. to sting	bee	1.8	
3. <i>angel</i>	-court ⁹	21.0	In the repeat the patient believed she had not given any reaction, as with No. 1. R. garden
4. <i>long</i>	<i>knife</i>	9.0	
5. <i>ship</i>	<i>steamer</i>	7.0	
6. <i>to plough</i>	<i>field</i>	4.2	

[656] The stimulus-word *water* had awakened the memory of a suicide-attempt, as was subsequently shown through psychoanalysis. With *angel* the image of death and the hereafter immediately appeared, this time with persisting feeling-tone that hindered the subsequent reactions in a way shown by the decrease in reaction-times. All four reactions showed themselves to be amnestically blocked.

[657] The theory of our phenomenon is closely related to the teaching of Freud, whose psychological depth and fertility are still not sufficiently appreciated, in particular by psychiatrists. Freud says in effect that forgetting is frequently caused by the feeling of unpleasure associated with the forgotten image, i.e., one is inclined to forget what is unpleasant and what is associated with the unpleasant.¹⁰ The process underlying this forgetting is the repression of the affect of unpleasure which one can observe every day in hysterical cases. "Systematic" forgetting plays, as I have shown,¹¹ an important part in the origins of the so-called Ganser's twilight state. Up to now only Riklin¹² has taken up my suggestion and developed it with any result. These investigations fully confirm the correctness of Freud's teachings on this point. That just the essential matter (i.e., the repressed complex charged with unpleasure) is forgotten is the obstacle in psychoanalysis that is often the most difficult to overcome. One usually comes up against amnesia ("I don't know," "I have forgotten," etc.) where the important matter lies. The amnesic blockages in our experiment are nothing but hysterical amnesias. They also have in common with hysterical amnesia that not only what is significant is forgotten, but also related ideas which happen to coincide with the perseverating unpleasure.

[658] The reaction-words that are so easily forgotten seem like excuses; they play a similar role to that of Freud's "screen memories." When, for example, a hysterical young girl takes an agonizingly long time to react to *to kiss* with *sister's kiss* and afterwards has forgotten how she did react, it is understood without further ado that *sister's kiss* was only an evasion, which must conceal an important erotic complex. Such reactions are reminiscent of simulation (naturally, unconscious) and resemble the "screen memories" with which hysterical subjects conceal events that are of causal importance.¹³ Another reason for the speedy forgetting of these reactions is their superficiality; for these words can just as well be replaced by a number of

different words of an equally superficial kind. The deceptive nature of such reactions is one aspect of the well-known general impression that has so often caused hysterical subjects to be accused of conscious pretence. It should, however, be pointed out that very often the complex hidden by such an evasion is completely cut off from consciousness, since in fact hysterical subjects can *very often* only under hypnosis be shown what lies behind the suspect reaction.

[659] As the experiment shows, the incorrect reproduction has the value of a complex-characteristic. (I do not know whether irrelevant reactions are also forgotten.) It can have a positive value through its content since, as a second association to the stimulus-word and the repressed complex, it can be very useful in analysis. The same is, of course, true in research on criminal psychology. I should like to point out that, as in the association test, so also in the reproduction method, the repressed complex can betray itself in the reaction even though it is unconscious; it does so when it is split off from consciousness, as is often the case in hysterical patients. So far as I can see, where repressed complexes are concerned the same phenomenon occurs with normal, hysterical, and catatonic subjects; in normal cases there is a brief embarrassment or momentary blockage, in hysterical cases there is the well-known arbitrary amnesia, and in catatonic cases there is a complete barrier. The psychological mechanism, however, is the same.

PSYCHOANALYSIS AND ASSOCIATION EXPERIMENTS¹

[660] It is not easy to say in a few words what is the essence of Freud's theory of hysteria and of the psychoanalytic method. Freud's terminology and conceptions are still in the making—luckily, if I may say so, because, in spite of the amazing progress that, thanks to Freud's contributions, insight into hysteria has made in recent years, neither Freud nor we, his followers, have gained full knowledge of it. It is therefore not surprising that Freud in his most recent publication on hysteria² has for the most part abandoned the terminology that he had laid down in the *Studies on Hysteria*, and substituted for it a number of different and more fitting expressions. One must understand Freud's terms not as always sharply defined scientific concepts but more as opportune coinages from his rich vocabulary. Anyone writing about Freud should therefore not argue with him about words but rather keep the essential meaning in mind.

[661] Freud sees hysteria as caused by and manifesting a series of psychic traumas, culminating at last in a sexual trauma in the prepubertal period. The so-called psychogenic character of hysteria was, of course, already known before Freud. (We have to thank Möbius³ in particular for a concise definition of the term "psychogenic.") It was known that hysteria stems from ideas marked by the strength of their affect. But it was only Freud who showed us what lines the psychological process follows. He found that the hysterical symptom is essentially a symbol for (fundamentally sexual) ideas that are not present in consciousness but are repressed by strong inhibitions. The repression occurs because these crucial ideas are so charged with painful affects as to make them incompatible with ego-consciousness.

[662] The psychoanalytic method is inseparably linked with this conception. It acknowledges the concept of repressed and therefore unconscious ideas. If we inquire from patients about the cause of their illness, we always obtain incorrect or at least incomplete information. If we had been able to get proper information as in other (physical) diseases, we should already have known a long time ago of the psychogenic nature of hysteria. But this is just the trick of hysteria, that it represses or forgets the real cause, the psychic trauma, and substitutes for it superficial "cover" causes. We often hear from hysterics that their illness stems from a cold, from overwork, from real organic disturbances, etc. And so many doctors are fooled again and again. Others turn to the opposite extreme and allege that all hysterics are liars. So they entirely misunderstand the psychological etiology of hysteria, which actually exists only because ideas incompatible with ego-consciousness have been repressed and can therefore not be reproduced. By means of Freud's psychoanalytic method the

barriers between ego-consciousness and repressed ideas are bypassed. This method consists mainly in the patient simply telling spontaneously everything that comes into his mind (Freud called this “free association”). An elaborate description of this method can be found in Freud’s book *The Interpretation of Dreams*. Although it is theoretically *a priori* certain that all human ideas are determined, in a most wonderful way, by psychological laws, it is still easy to conceive that an inexperienced person would get lost in the maze of ideas and would finally be hopelessly caught in a blind alley. It is and will remain one of the main objections against the general acceptability of Freud’s method that the prerequisite for the practice of psychoanalysis is psychological sensitivity as well as technique, i.e., characteristics that cannot be taken for granted in every physician or psychologist. Then there is a particular way of thinking required for psychoanalysis, which aims at bringing symbols to light. This attitude, however, can only be acquired by constant application. It is a way of thinking that is innate in a poet but is carefully avoided in scientific thought, which is said to be characterized by clear-cut ideas. Thinking in symbols demands from us a new attitude, similar to starting to think in flights of ideas. These seem to be the reasons why Freud’s method has only exceptionally been understood and even more rarely practised, so that there are actually only a few authors who appreciate Freud, theoretically or practically (Löwenfeld, Vogt, Bleuler, Warda, Störring, Riklin, Otto Gross, Hellpach).⁴

[663] Freud’s psychoanalysis is, in spite of the many valuable experiences given to us by its author, still a rather difficult art, since a beginner easily loses courage and orientation when faced with the innumerable obstacles it entails. We lack the security of a framework that would enable us to seek out essential data. Having to search haphazardly in treatment is often tantamount to realizing that one has no idea at what point to tackle the problem.

[664] The association experiment has helped us to overcome these first and most important difficulties. As I have shown, particularly in my paper “The Reaction-time Ratio in the Association Experiment,”⁵ complexes of ideas referred to as emotionally charged are shown up in the experiment by characteristic disturbances, and their presence and quality can be inferred precisely from these disturbances. This fact is known to be the basis of the “psychological diagnosis of evidence” inaugurated by Wertheimer and Klein,⁶ Hans Gross,⁷ and Alfred Gross,⁸ an apparently not unpromising method of diagnosing from the associations the complex underlying a crime. Everybody, of course, has one or more complexes that manifest themselves in some way in associations. The background of our consciousness (or the unconscious) consists of such complexes. The whole material that can be remembered is grouped around these. They form higher psychic units analogous with the ego-complex.⁹ They constellate our whole thinking and acting, therefore also our associations. With the

association experiment we always combine a second, which we call the reproduction test.¹⁰ This test consists in making the subject state how he responded to each stimulus-word in the first test. Where memory fails we usually find a constellation through a complex. The reproduction technique also allows a more detailed description of the complex-disturbances.

[665] Every psychogenic neurosis contains a complex that differs from normal complexes by unusually strong emotional charges, and for this reason has such a constellating power that it fetters the whole individual. The complex, therefore, is the *causa morbi* (a certain disposition is, of course, presupposed!). From the associations we can often quickly recognize the nature of the complex, thereby gaining important starting points for causal therapy. A by-product, not to be underestimated, is the increased scientific insight that we obtain into the origin and intrinsic structure of psychogenic neuroses. The essence of these insights has, of course, already been given us long since by Freud, but here he is far too advanced for the understanding of his time. I may therefore be allowed to try to open up new avenues to Freud's body of knowledge. In the papers of the Diagnostic Association Studies published so far, Freud's principles have already been repeatedly used to explain various points. In the present paper I propose to illustrate the connection of psychoanalysis with the association experiment by means of practical examples. I am choosing a common case of obsessional neurosis which I treated in June 1905.

[666] Miss. E. came to me for hypnotic treatment of insomnia, which she had had for four months. Besides sleeplessness, she complained of an inner restlessness and excitement, irritability towards her family, impatience and difficulty in getting on with people. Miss E. is 37 years old, a teacher, educated and intelligent, has always been "nervous," has a mentally defective younger sister; father was an alcoholic. Present condition: well nourished, no physical abnormality detectable. Patient makes numerous conspicuously restless and twitching movements. When talking she rarely looks at the doctor, mostly speaks past him, out of the window. Occasionally she turns even further round, often laughs unintentionally, frequently makes a shrugging movement with the shoulder, as if shaking off something repulsive, simultaneously stretching the abdomen forward in a peculiar way.

Her history is very incomplete and vague. One learns that she had been a governess abroad, and was not then ill. The illness started only in recent years and developed gradually to the present climax. She had been treated by various doctors without any success. She now wanted to try hypnosis, but she had to say at once that she was firmly convinced hypnosis would not be successful. Her illness was incurable and she was sure to go mad. She had in any case repeatedly thought that she was not normal, she must already be mad. Here it was obvious that the patient

was apparently talking around something that she either did not want to or could not say. On urgent questioning she declared at last, with many defensive movements and persistent blushing, that she certainly could not sleep, because each time she started going off to sleep the thought came that she certainly would not be able to sleep, she would never be able to sleep until she was dead; then she promptly woke up again and could not sleep any more for the rest of the night. Each time she felt tired and again wanted to sleep, a tremendous fear that she would never again be able to sleep until she was mad or dead woke her up afresh. She had a great struggle to bring herself to this explanation, making numerous defensive gestures, which almost gave the impression that she had something sexually indecent to tell and was ashamed of it. Here again the abdominal movements became noticeable. She repeatedly giggled in a coy way. As this gave an inadequate picture of her condition, I was led to ask whether there were any other ideas that tormented her during her sleeplessness. "No, I don't remember anything else—everything is mixed up—oh, there are thousands of things going through my head." She could not, however, produce any of them, made defensive gestures and suddenly said: In any case, she often had such silly thoughts that they actually overcame her and she could not get rid of them whatever efforts she made. She regretted that she could not tell me these thoughts, because she was afraid that I might also be overtaken by such obsessional ideas. Once before she had told a priest and a doctor about some of her thoughts, and she had always had the compulsive idea that she must have infected those people with them, so that they too had obsessional ideas. She had certainly already infected me. I reassured her; I had already heard many such ideas and it had not done me the slightest harm. After this statement she confessed, again with those peculiar defensive gestures, that besides the idea that she had infected the priest and the doctor with obsessional ideas she was tortured by the thought that a woman neighbour who had recently died had, on her account, died without the last sacrament and was having to suffer all the tortures of hell. She had had this idea only since the death; before that she had for several years had the idea that a boy whom she had brought up had afterwards died from the beatings that she had occasionally given him. The fear had tortured her so much that she had twice been obliged to write to the pupil's family to ask how he was. Each time she had done it in quite a casual manner. The good news that she had received on each occasion had calmed her down for the time being, but a few days later the fear was upon her again. This idea had now vanished, but instead she had to blame herself for the death without extreme unction of the neighbour. Her common sense told her that these ideas are nonsense (she said this with a very uncertain voice), but perhaps it was not (she quickly added). Thus she did not correct it completely, but was apparently entirely dominated by the obsessional idea.

The anamnesis did not reveal any sexual abnormalities; i.e., anything that might refer to sexual processes was immediately rejected.

An attempt at hypnosis was frustrated because she could not keep her eyes fixed on anything. In order not to compromise this method from the very beginning by useless trials, I decided first to obtain some information about the psychic material underlying the condition. I therefore carried out the association experiment with her.

1. THE ASSOCIATION EXPERIMENT

[667] Here is the whole test:¹¹

<i>Stimulus-word</i>	<i>Reaction</i>	<i>Reaction-time (secs.)</i>	<i>Reproduction</i>
1. <i>head</i>	<i>thoughts</i>	2.2	<i>hair</i>
2. <i>green</i>	<i>grass</i>	1.8	+
3. <i>water</i>	<i>drinker, to drink</i>	2.4	<i>glass</i>
4. <i>to prick</i>	<i>needle</i>	3.6	+
5. <i>angel r.</i>	<i>heaven</i>	2.6	+
6. <i>long r.</i>	<i>short</i>	4.0	+
7. <i>ship</i>	<i>sea</i>	1.4	+

[668] I cannot give a complete analysis of the associations. In answer to all questions the patient confined herself to saying that nothing special had come to her mind at the critical points. It was thus impossible to find the determinant of the reactions by means of subjective analysis. The objective result of the experiment was, however, sufficient to diagnose the complex, at least in outline, independent of the information given by the patient. I should like to explain in as much detail as possible how I came to this diagnosis.

[669] In anticipation, I should mention that the probable mean (Kraepelin) of all the reaction-times of the experiment is 2.4 seconds. This mean is definitely too high for an intelligent and educated person. The mean obtained for twelve educated subjects is 1.5 secs. Since it is mainly emotional influences that prolong the reaction-time,¹² we may infer, from this high figure, a rather strong emotionality in the patient. The reader is asked to keep in mind this figure of 2.4 secs. during the following discussion of the reactions.

[670] 1, *head / thoughts*, is wrongly reproduced. The complex of the illness may have had an influence here.

[671] 3, *water / drinker, to drink*, shows a verbal deviation: *drinker* has been corrected to *to drink*. The father was a heavy drinker. The three following reaction-times are all longer than 2.4 secs.; furthermore, there are two stimulus-word repetitions. From *drinker* a perseverating emotional charge may be assumed.¹³

[672] 5, *angel / heaven*, may have recalled the obsessional idea of the neighbour who died without the sacrament.

8. to plough	to sow	2.2	+
9. <i>wool</i>	<i>to spin</i>	3.4	-14
10. <i>friendly</i>	<i>loving</i>	3.6	<i>good</i>
11. <i>table</i>	<i>woman</i>	4.6	-
12. to ask	to reply	2.4	+
13. state	church	2.2	+
14. <i>sulky</i>	<i>brave</i>	1.8	<i>friendly</i>
15. stalk	flower	1.8	+

[673] What disturbance prolonged the reaction time of *wool* I cannot say. Experience shows that *friendly* (10) very easily produces erotic reminiscences. The remarkable *table / woman* (11), which the patient cannot explain, seems to point to the erotic significance of R.10. Sensitive people, as all neurotics are, always take stimulus-words personally. It is therefore easy to assume that the patient would like to be the “loving, good woman.” That the word *friendly* has a certain tendency to be reproduced becomes apparent from its reappearance in 14.

(Feeling-toned ideas have, of course, a stronger tendency to be reproduced than others.)

16. to dance	to jump	1.8	+
17. lake r.	water	2.4	+
18. ill	healthy	2.0	+
19. pride	haughty	5.0	+
20. to cook	to roast	2.0	+
21. ink	pot	2.0	+
22. <i>wicked</i>	<i>good</i>	3.0	-
23. needle	prick	2.2	+
24. to swim	water	2.0	+
25. journey	railway	2.2	+
26. blue	red	1.8	+
27. bread	knife	2.0	+
28. <i>to threaten</i>	<i>naughty</i>	8.0	-

[674] *To dance* (16) tends to arouse erotic reminiscences. This assumption is not unjustified here because the following reaction is disturbed.

[675] *Ill* (18) and *pride* (19) may easily have been taken personally. *Pride* shows distinct complex-characteristics, *wicked* (22) and *to threaten* (28) obviously aroused feelings too. The response *naughty* to *to threaten* sounds like an association to a child’s idea. Has a schoolgirl’s reminiscence perhaps been aroused here? *To threaten*

can in any case arouse many feeling-toned associations. People with lively complexes are usually somehow afraid of the future. One can therefore often see that they relate *to threaten* to the threatening uncertainty of their future. Naturally, there are often underlying concrete associations as well. One must not forget that a word like *threaten* is seldom used; owing to this “difficulty” it has a somewhat exciting influence; this does not necessarily mean that a complex underlies it. It seems to me wiser, however, to consider the influence of a complex than of a “difficulty.” (Cf. Freud’s analyses!)

29. lamp	light	1.8	+
30. rich	poor	1.8	+
31. tree	green	1.2	+
32. to sing	to dance	2.0	+
33. pity	poor	2.0	+
34. <i>yellow</i>	<i>flower</i>	4.2	<i>green</i>
35. mountain r.	work ¹⁵	2.8	+
36. <i>to play</i>	<i>children</i>	2.2	<i>to dance</i>
37. salt	bread	2.8	+
38. new	old	1.6	+

[676] *To dance* (16), mentioned in the previous sequence, returns here twice, thus revealing a clear tendency to be reproduced, in accordance with its not inconsiderable emotional charge. In this way frequent repetitions can give away a great deal. A gentleman whom I had asked to be a subject for the experiment was convinced he would not give away any complexes. On the way to me he worked out what he would answer to my stimulus-words; it occurred to him at once that he would say “Paris,” a word that seemed to him to have absolutely no personal meaning. True enough, he repeated “Paris” many times during the experiment, declaring this word to be absolutely fortuitous. Six months later he confessed to me that at the time of the test he had still been under the impression of an event that had strongly affected him and which had occurred in Paris. At that time, however, he had thought that Paris had no significance at all for him. I have no reason to doubt this man’s truthfulness. *Yellow* (34) certainly had a personal effect, judging from the surrounding complex-disturbances. The patient has a sallow elderly complexion. Women are very sensitive to such things, particularly if an erotic complex is present.

[677] That *children* (36) is not reproduced but replaced by another erotic term seems to be worth mentioning.

39. <i>habit</i> r.	<i>nasty or bad</i>	12.2	<i>vicious habit</i>
40. to ride r.	to drive	2.4	+
41. <i>wall</i>	<i>room</i>	3.0	–
42. <i>silly</i> r.	<i>clever</i>	2.8	–

43. exercise-book	book	3.0	+
44. to scorn	disdain	15.2	to despise
45. tooth	abscess	1.4	+

[678] In this sequence we meet several serious complex-disturbances. With *habit* (39) and *to scorn* (44), the patient made defensive movements and stamped her foot. An “ugly” or “bad” habit can easily be interpreted in a sexual sense: e.g., masturbation is a “nasty” habit, a “vicious habit.” People indulging in such “vicious habits” are “scorned.”

[679] *Silly* (42) may be personal or may still belong to the range of the emotional charge perseverating from *habit*. Here her gestures by no means contradict a sexual complex. *Habit* could in some circumstances also mean “the drink habit” and thus have aroused the complex of the drunkard father.

46. correct r.	<i>I should always like to say just the opposite</i>	7.6	<i>incorrect</i>
47. people r.	father	6.0	+
48. to stink	fragrance	4.8	+
49. book r.	<i>pen</i>	4.4	<i>exercise-book</i>
50. unfair r.	<i>sense</i>	3.6	<i>fair</i>
51. frog	green	2.4	+
52. to separate	marriage	2.2	+
53. hunger	thirst	1.4	+
54. white	black	1.8	+

[680] If the patient, as we assume, takes the stimulus-words personally and has an erotic complex as indicated, then it is understandable that to *correct* (46) “she would always like to say the opposite,” as this fits her behaviour; it also fits the father’s dipsomania. Ideas that are determined twice or more do not exclude each other; according to Freud they are even the rule.

[681] That *people* (47) is associated with *father* is striking. The reaction seems to be within the field of the emotional charge of *correct*. This could lead to the conclusion that there is some connection, unclear up to now, between her self-reproaches and *father*. (This connection will become clear later on.)

[682] What sort of interference acted on *book / pen* (49) is not easy to say. *Book*, pronounced as it is spelled [*Buck*], means “belly” [*Bauch*] in the Swiss dialect. In a sexual complex such an assimilation could easily occur. I have seen it repeatedly in other subjects.

[683] The consistent decrease of the reaction-times from *correct*, 7.6 secs., however, indicates a serious complex-interference that begins with this stimulus-word and

gradually decreases during the next seven reactions. *Unfair* (50) seems to have been taken personally, and this fits well with her self-recrimination.

55. cattle r.	cow	4.2	+
56. to attend	disobedient	4.0	+
57. <i>pencil</i>	<i>to sharpen</i>	3.0	<i>pointed</i>
58. dull	weather	1.8	+
59. plum	tree	3.8	+
60. to meet	certain	1.4	+
61. law	state	2.8	+
62. <i>dear</i>	<i>good</i>	4.0	<i>child</i>
63. glass	wa-water	1.6	+
64. <i>to quarrel</i>	<i>argument</i>	2.4	<i>discord</i>
65. <i>goat</i>	<i>milk</i>	2.0	<i>to milk</i>

[684] I have no explanation for the disturbance at 55, *cattle*. *Disobedient* (56) reminds one of the previous *naughty*, which may be related to the pupil already mentioned. The disturbance of the following unrelated reaction indicates the perseverating emotional charge. R.59, *plum / tree*, does not seem to have passed by smoothly, judging by the length of the reaction-time. The word here used for *plum* is not an everyday word; it is, however, unlikely that for this reason it takes an educated subject such a long time to react. (Wehrin's idiots have average figures varying between 3.0 secs. and 37 secs. Therefore 3.8 seems far too long for an educated person.) The German *Pflaume* (plum) is, like Swiss *Zwetschge* (plum), a popular sex-symbol in our colloquial language.

[685] *Dear* (62) can easily indicate an erotic complex. At *glass* (63) the complex of the dipsomaniac father apparently comes to the surface again with the strong emotional charge attached to it (hence the disturbance of the two following reactions).

66. large	small	2.6	+
67. potato r.	floury	6.0	+
68. to grind	mill	2.0	+
69. part r.	small	11.6	+
70. <i>old</i>	<i>ugly</i>	3.0	<i>young, unattractive</i>
71. <i>flower</i>	<i>beautiful</i>	2.0	<i>scent</i>
72. <i>to beat</i>	<i>rod</i>	2.8	-
73. cupboard	table	2.8	+

[686] *Large* (66) is as a rule taken personally. The patient is very short. With an erotic complex, she is, as we have already seen, bound to be much concerned with her body. This might explain the disturbance of the following reaction.

[687] For *part* (69), the reaction-time is very much extended. It is usual to interpret "part" as "genital." Here the strong emotional charge is characteristic for this

association. It is not surprising under this constellation that *old* (70) is given a personal erotic meaning. How strongly emphasized in this patient is the question of physical beauty and her own ageing can be seen from the perseveration *beautiful* (71). *To beat / rod* (72) can again have been specially constellated by the obsessional idea that she had caused her pupil's death.

74. wild	child	2.4	+
75. family	large	2.4	+
76. to wash r.	to clean	3.0	+
77. cow	to milk	1.8	+
78. stranger	nostalgia	14.8	+
79. happiness r.	unhappiness	3.0	+
80. to tell	story	1.6	+

[688] The minor disturbance at 76, *to wash*, can be explained by the preceding erotic concepts *child* and *family*. *Stranger* (78) apparently aroused a personal association, to be explained later on.

81. propriety	intellect	4.6	+
82. narrow r.	small	3.2	+
83. brother	sister	1.0	+
84. damage r.	neighbour	4.0	+
85. stork r.	church	2.4	+
86. false r.	unfaithful	3.0	+
87. fear	anxiety	2.4	+
88. to kiss	mouth	2.2	+
89. fire	blaze	1.8	+
90. dirty	sticky	2.2	+
91. door	fold	1.6	+

[689] The sound association of 81, *propriety / intellect* (*Anstand / Verstand*) is most striking. Let us remember the disturbances produced by *habit!* There we suspected the “vicious habit” of masturbation. Here too this complex could have been aroused. In this case *intellect* is not fortuitous. According to a popular belief masturbation destroys the reason, the “intellect.” One has also to bear in mind the patient's bemoaning that she is afraid of losing her reason.

[690] *Narrow / small* (82) is still under the influence of the preceding reaction: *small* probably belongs to the body-complex in view of its being repeated (66); *narrow* may, under the constellation of the preceding association, refer to the *introitus vaginae* and therefore be connected with *small*, which indicates her figure; the ominous “part” too is *small* (this assumption will be confirmed). *Damage* (84) is probably taken personally; *neighbour* fits neatly. She has done immense damage to the neighbour by being guilty of her dying unabsolved. Under the sexual

constellation, however, “damage” can also have been taken personally; one does personal and mental damage to oneself by masturbation (see above). The neighbour then provides a cover (see Freud’s similar conclusions). Behind the neighbour the patient herself may be hidden. That an emotional charge interfered here becomes apparent from the following disturbances. At 86, *false / unfaithful*, a definite erotic reminiscence can easily have come to the surface in an elderly spinster.

92. to choose r.	teacher	4.4	+
93. hay	straw	1.8	+
94. <i>still</i>	<i>stool</i>	13.0	<i>child</i>
95. mockery	scorn	1.4	+
96. to sleep r.	to wake	3.4	+
97. month	year	1.6	+
98. coloured	gaudy	2.4	+
99. dog	cat	1.2	+
100. to talk	to be silent	1.4	+

[691] To *to choose* (92) women like to associate the thought of marriage.

[692] The patient’s father was a teacher. She is a teacher. It would be easy to assume that she has marriage with a teacher in mind. The father-complex may, however, also have to be considered here (see below). *Still / stool* (94) is a striking sound association. The explanation is given by the erotically charged term *child*. A child can be “still”; but the dead are also still (obsessive idea: she has caused the pupil’s death by ill-treating him). Behind this there may be erotic connections, associated with German “stillen” (to suckle). (Cf. 49, *book*, and subsequent comment.) The same word (*stillen*) can be used for quieting a child or quieting sexual desire. To *sleep* (96) has many erotic associations. The patient cannot sleep, for instance; sleeplessness in younger people, however, is often the expression of lack of sexual satisfaction (Freud). Anyone inexperienced in the field of pathological association psychology will probably shake his head at the above suppositions; he will perhaps see in them not just hypotheses but sheer phantasms. The judgment on them will perhaps be the same as on Freud’s *Interpretation of Dreams*.

[693] Let us next summarize the result of the association and reproduction test. As I have already said, the patient did not give any information about herself; I am therefore entirely dependent on the objective data of the test and on my experience.

[694] The probable mean of the reaction-times is 2.4 secs. Forty-four per cent of the reaction-times exceed 2.4 secs. Amongst these are figures of up to 15.2 secs., pointing to the dominance of emotion or, in other words, a considerable lack of control of the psychic material.

[695] In the analysis we indicated the existence of various complexes. The erotic complex appears to play a dominant role. Here I give a tabulated survey of the complex-reactions. The following examples should be understood as related to an erotic complex:¹⁶

10. <i>friendly</i>	<i>loving</i>	3.6	<i>good</i>
11. <i>table</i>	<i>woman</i>	4.6	–
12.		2.4	
13.		2.2	
14.		1.8	
16. to dance	to jump	1.8	+
17. lake r.	water	2.4	+
34. <i>yellow</i>	<i>flower</i>	4.2	<i>green</i>
35. mountain r.	work ¹⁷	2.8	+
36.		2.2	
39. <i>habit</i> r.	<i>nasty or bad</i>	12.2	<i>vicious habit</i>
40. to ride r.	to drive	2.4	+
41. <i>wall</i>	<i>room</i>	3.0	–
44. <i>to scorn</i>	<i>disdain</i>	15.2	<i>to despise</i>
45.		1.4	
59. plum	tree	3.8	+
62. <i>dear</i>	<i>good</i>	4.0	<i>child</i>
66. large	small	2.6	+
67. potato r.	floury	6.0	+
68.		2.0	
69. part r.	small	11.6	–
70. <i>old</i>	<i>ugly</i>	3.0	<i>young, unattractive</i>
71. <i>flower</i>	<i>beautiful</i>	2.0	<i>scent</i>
72. <i>to beat</i>	<i>rod</i>	2.8	–
73.		2.8	
74. wild	child	2.4	+
75. family	large	2.4	+
76. to wash r.	to clean	3.0	+
81. propriety	intellect	4.6	+
82. narrow r.	small	3.2	+
83.		1.0	
86. false r.	unfaithful	3.0	+
87.		2.4	
88.		2.2	
89.		1.8	
92. to choose r.	teacher	4.4	+
93.		1.8	
94. <i>still</i>	<i>stool</i>	13.0	<i>child</i>

95.			1.4	
96. to sleep r.	to wake		3.4	+
97.			1.6	

[696] These associations, which presumably have a sexual background and which show all the characteristic complex-disturbances, could be interpreted as follows:

[697] The patient feels herself to be old and ugly, is very sensitive about her sallow complexion, above all pays anxious attention to her body; in particular she does not like being so small. Presumably she has a great desire to get married; she would certainly be a loving wife to her husband and she would like to have children. Behind these not very suspicious erotic symptoms, however, there seems to lie a sexual complex that the patient has every reason to repress. There are signs that allow the conclusion that she pays more than usual attention to her genitals. In a well brought-up and educated woman this can only refer to masturbation; masturbation, however, in the wider sense of a perverse self-satisfaction.

[698] Masturbation is one of the most frequent sources of self-reproach¹⁸ and self-criticism. This complex, or, better, this aspect of the sexual complex, is also indicated by the following associations:

14. <i>sulky</i>	<i>brave</i>	1.8	<i>friendly</i>
19. pride	haughty	5.0	+
22. <i>wicked</i>	<i>good</i>	3.0	-
23.		2.2	
24.		2.0	
42. <i>silly</i> r.	<i>clever</i>	2.8	-
43. exercise-book	book	3.0	+
46. <i>correct</i> r.	<i>I should always</i> <i>like to say just</i> <i>the opposite</i>	7.6	<i>incorrect</i>
47. people r.	father	6.0	+
48. to stink	fragrance	4.8	+
49. <i>book</i> r.	<i>pen</i>	4.4	<i>exercise-book</i>
50. <i>unfair</i> r.	<i>sense</i>	3.6	<i>fair</i>
51.		2.4	
52.		2.2	
53.		1.4	

[699] To the complex of the alcoholic father can be related:

3. <i>water</i>	<i>drinker, to drink</i>	2.4	<i>glass</i>
4.		3.6	
63. glass	wa-water	1.6	+
64. <i>to quarrel</i>	<i>argument</i>	2.4	<i>discord</i>

[700] From this tabulation it can be seen that the sexual complex is well in the foreground. Although, as I have already mentioned, a direct confirmation of this interpretation was not to be had from the patient, I took the complex-diagnosis as confirmed for the reasons I have just given.

[701] I told her therefore that I was sure her obsessional ideas were nothing but excuses and shiftings, that in reality she was tortured by sexual ideas.

[702] The patient denied this explanation with affect and sincere conviction. Had I not been convinced through the association experiment of the existence of a particularly marked sexual complex, my certainty would probably have been shaken. I appealed to her intelligence and truthfulness: she assured me that if she knew of anything of the kind she would tell me, because she well knew it would be silly to conceal such thoughts from the doctor. She had thought of getting married, "as everyone else did, but not more." After this I let the patient go and asked her to come again in two days' time.

2. PSYCHOANALYSIS

[703] For psychoanalysis the patient's mental condition is important, but still more important is the mental condition of the doctor. Here probably lies the secret of why Freud's psychoanalysis is disregarded by the world of science. He who approaches a case with anything but absolute conviction is soon lost in the snares and traps laid by the complex of hysterical illness at whatever point he hopes to take hold of it. One has to know from the very beginning that everything in the hysteric is trying to prevent an exploration of the complex. Where necessary, not only the patient's interest and his regard for the doctor fail, but also his thinking, memory, and finally even his language. But precisely these peculiar defence-mechanisms give the complex away.

[704] Just as hesitating, faulty reproduction and all the other characteristic disturbances always occur in the association experiment whenever the complex is touched on, so in the analysis difficulties always arise whenever one gets close to the complex. In order to bypass these difficulties, Freud, as is well known, induces "free associations." It is a very simple method and one has only to practice it for some little time to become reasonably familiar with it. In this case I carried out psychoanalysis strictly on Freud's lines. I made the patient take an easy-chair and sat down behind her, so as not to confuse her. Then I asked her to tell me calmly everything that came into her mind, no matter what it was about. The patient laughed; surely one could not say every piece of nonsense that came into one's mind. But I adhered to my request. Then she tried several times to say something, suppressed it, however, each time with

the excuse that it was silly—I would laugh at her and think she was an ungrateful person who could only offer banalities. I did nothing but encourage her to continue to talk and eventually the patient produced the following sentences: “I think I shall never get well—now you are sure to laugh—but I am convinced that I shall never get well—you cannot hypnotize me—you will no more cure me than any other doctor has—it will only get worse, because now I have to reproach myself that with my nonsense I am only unnecessarily wasting your time.” This idea was not quite unjustified because the patient always blurted out the sentences after long intervals, so that it took us almost half an hour to come to this meagre result. She continued: “I am thinking now of my people at home, how hard they work and how they need me; while I am here, good for nothing but my silly ideas—you too will certainly become infected by them—now I am thinking that I cannot sleep, that last night I took 1 g. of Veronal, although you have forbidden it—I am sure I shall never be able to sleep. How can you expect to cure me?—What do you want me to tell you? [Here a certain restlessness became noticeable.] But I cannot tell you every piece of nonsense that comes into my head. [Increasing restlessness, shrugging of the shoulders, makes stamping movements with her foot now and then, shakes herself as if in great indignation.] No, this is nonsense—I don’t know of anything else now—really, I don’t know of anything else. [Very restless, wriggles and turns in her chair, makes defensive movements by shaking her thorax to and fro and makes elbow movements as if pushing something away.] At last she jumps up and wants to go, she cannot think of anything else at all! With gentle force I make her sit down in the chair and remind her that as she has come to me to be cured, she must follow my directions. After a long debate on the use and purpose of my method, she at last consents to stay and continue, but soon the movements of indignation and defence are resumed, she literally wriggles in the chair; occasionally she straightens herself with a forcible movement, as if she had come to a decision after the greatest struggle with herself. At last she says meekly: “Oh, something silly came into my head—you are sure to laugh—but you must not tell anybody else—it is really nothing—it is something quite simple—no, I can’t tell you, never—it has nothing at all to do with my illness—I am only wasting your time with it—really, it doesn’t mean anything at all—have I really got to tell it? Do you really insist on it? Oh, well, I may as well tell you, then I shall be rid of it. Well,—once I was in France—no, it’s impossible, and if I have to sit in this chair for another four weeks [with sudden determination] well, I was a governess in France—there was also a maidservant—no, no, I cannot tell it—no, there was a gardener—for goodness sake, what will you think of me? This is really sheer torture—I have certainly never thought of such a thing!”

[705] Between these painful ejaculations the following story at last emerged with innumerable stoppages and many interruptions, during which she asserted that this

was the first and last session with me.

[706] Her employer also had a gardener, who once said to her that he would like to sleep with her. While saying this he tried to kiss her, but the patient pushed him away. When she went to bed that evening she listened at the door and wondered what it would be like if he did come to sleep with her; then a frantic fear overtook her that he might really come. Once in bed she was still compelled to think of what it would be like if he came, then reproached herself anew for thinking such things. The thought of what it would be like to sleep with the gardener did not, however, leave her, although she was again and again shocked at finding herself capable of such thoughts. In this mental turmoil she was unable to get to sleep until the morning.

[707] The first session took no less than an hour and a half. Its result was a sexual history! What was particularly interesting to me was its quite spontaneous appearance with the same gestures that I had immediately noticed in the patient at the first consultation. These tic-like phenomena had a very close and easily understandable connection with the repressed sexual matters! I arranged the following session for two days later, which was at once accepted, the patient looking very relieved and not saying another word about leaving.

[708] On the day of the appointment I was busy with some urgent work when the patient came and therefore sent her a message, asking her to come in the evening instead. She, however, sent the reply that she could not possibly wait, she had to speak to me urgently. I thought something special had happened and went to her. I found her in great distress: she had not slept at all, not a minute, she had had to take drugs again, etc. I asked her whether she had been brooding again over her obsessional ideas: “No, something much worse; now I have my head full of that nonsense that I told you about last time. Now I can think only of these stories and therefore cannot close an eye; because of them I toss and turn all night long and cannot get rid of these thoughts for a minute. I have definitely got to talk to you now; it gives me no peace.” She went on to tell me that last time she had gone home very much relieved and calmed down, almost in a gay mood, and had hoped she would now at last be able to sleep, but then a story came into her mind that she should have told me last time, but which she had thought was not really of any importance. She had determined now not to “act so silly” as last time, but freely to tell everything she thought of. Then the confession would soon be over. So I resumed the analysis, hoping it would go off smoothly without the endless preliminaries of the time before. I was, however, completely mistaken. The patient repeated the interjections of the first session almost verbatim. After an hour and a half of mental torture I brought the following story to light: In the same house where the patient was a governess, there was also a maid¹⁹ who had a lover, with whom she had sexual intercourse. This girl

had also had sexual intercourse with the gardener. The patient often discussed sexual topics with her and in particular the sex life of master and mistress. The patient and the maid even investigated their beds for sperm stains and other signs of sexual intercourse! Every time, after such amusements, the patient suffered the severest self-reproaches on her indecency and spent sleepless nights, during which she turned and tossed about because of torturing reproaches and voluptuous fantasies.

[709] When, after tiresome resistance, the story was out at last, the patient declared: now she had come to the end, this was all, nothing else came to her mind now. If only she could sleep; the telling of these stories did not help at all.

[710] Two days later she came to the third session and said: After the previous session she had been rather quiet again, but as soon as she was in bed at night another new story had come to her mind which had tortured her incessantly, with the obsessive reproach that again she had not told me everything in the session. She was sure now that today she could tell me the story quickly, without the continuous resistance as in the first two sessions. The third one, however, proceeded exactly in the same way as the two previous ones: incessant interjections, excuses, etc. Particularly conspicuous was the tendency to present the matter as perfectly natural, as if there was nothing to it. It was about a second maid who was in service with the same employer. The master had a valet who pursued the girl. He did not, however, succeed in seducing her. At last, one evening, when there was a party in the house, he managed to entice the girl into the garden. The couple was, however, surprised by the mistress at the critical moment. At this the youth is said to have exclaimed: What a pity, he was just ready! The patient heard this story from the first maid. At first she made out not to have the slightest interest in the story, as if she found it downright repulsive. This, however, had been a lie, because in fact she had had the greatest interest in it; she had several times tried to bring the maid back to this topic in order to hear every detail. At night she had hardly been able to sleep from curiosity, and had incessantly had to ask herself the questions: What did the two want in the garden? In what posture could they have been found by the mistress? What had the youth been ready for? What would have happened if the mistress had not come? Although she knew the answers perfectly well, she could not stop asking herself these questions over and over again. At last she was compelled to think over persistently what she would have done in such a situation. This excitement lasted for several days.

[711] We have mentioned being struck by her matter-of-fact presentation of the story. She said, for instance, very reluctantly that the lad was after the maid. From the reluctance it could be expected that something rather unpleasant was to come, but she continued as follows in an indifferent tone: "The lad was just in love with the girl. This is nothing unusual? This happens often?—oh, now there is something again—"

no, that I cannot—” etc. While telling the story she always tried from time to time to belittle and talk herself out of her belief in the importance of an event by inserting such generalizing rhetorical questions.

[712] From now on, during the whole period of the analysis (three weeks), the original obsessional ideas were absent; their place had been taken by sexual ideas. The memories underlying the obsessional ideas that had already been dealt with constantly tormented the patient. She was so obsessed by these sexual reminiscences that she was never able to find peace until she had told the story again. She expressed great amazement at this change; the stories came like beads on a string, as if they had been experienced yesterday. Things occurred to her of which she had previously been quite unconscious but which she now again recalled (Freud’s hypermnesia). Of course, these admissions have to be taken with the same reserve as the familiar “I don’t know.” The patient may quite well have ardently cultivated all her sexual ideas without remembering them, and spun them out right up to the moment when she had to speak about them objectively. In her stories one can often see immediately what is to come from her gestures, while she still repeatedly asserts that she certainly does not remember anything more. Her everyday person and her sexual person are just two different complexes, two different aspects of consciousness that do not want to or must not know anything of one another. The split of the personality here is, however, only hinted at (as in every vigorous complex, the peculiarity of which is a striving for autonomy). But it is only a step to the classic examples of split personality, all of which are, of course, produced by the mechanisms demonstrated by Freud.²⁰

[713] With these three sessions a certain conclusion was reached, in so far as one could not avoid relating the obsessional idea that she had caused the death of her former pupil to the self-reproaches connected with the sexual stories. This apparently was also felt by the patient when she spontaneously mentioned that many years had already passed since these events, and the thought that she had caused the pupil’s death had long ceased to torment her. Probably for the purpose of escaping from the unbearable sexual ideas, she transferred the guilt from this field to that of her educational methods. The mechanism, which is well known, is this: if one has continually to reproach oneself in one sphere, one tries to compensate for these deficiencies in another sphere, as if the same deficiencies were present there as well; this is particularly obvious in masturbators (compulsive brooding, cleanliness, and orderliness). It therefore seems to be not incidental that precisely these stories, underlying a past obsessional idea, were told first. Since there were in present consciousness no obsessional ideas directly supported by these stories, there were no special resistances present. Hence, the stories were relatively immaterial.

[714] I refrain from presenting the subsequent sessions in detail; they all followed the pattern already described. No admonition, no pointing out the absurdity of her stereotyped resistance, could make the patient talk more quickly and spontaneously. Every new session was a new torture, and at almost every one the patient declared that this was the last. Usually during the following night, however, there came new material that tormented her.

[715] The reminiscences of her time as governess were succeeded by a series of unsavoury stories that had served as a topic for conversation with the neighbour for whose death without the sacraments the patient reproached herself. The neighbour was a person about whose dubious past a number of rumours were current. The patient, who is a very decent girl and comes from a respectable family, known to me, had in her own view a dubious past herself and reproached herself for it. Therefore it is not surprising, psychologically, that she was immediately attracted by the interesting neighbour. There the *chronique scandaleuse* of the day used to be discussed, and in this connection the patient had quite a number of obscene stories and jokes to tell me, which I need not repeat here. For this also she reproached herself. When the neighbour quickly succumbed to an illness, the patient transferred the reproaches, which actually were about her sexual curiosity, to the death of the neighbour, who had died without absolution because the patient had during her visits enticed her to sinful conversations. The type of reminiscence and of reasoning seems to suggest that this obsessional idea is simply a new version of the earlier obsession about the death of the pupil. The religious obsession took her first to the priest and then to the doctor. She felt that she had infected both of them with her obsessions. She had therefore done something similar to what she had done to the neighbour whom she had destroyed simply by being what she was, as she had originally also destroyed the pupil. Underlying all this is the general idea that she is a horrible creature who infects everything with her depravity.

[716] During the following sessions the patient dealt mainly with a series of stories that she had recently discussed with a girl friend. The friend has an office job in a big shop. There she hears quite a number of juicy things from the men, each of which she retails to the patient while they are still warm. On one occasion the friend said she intended to have sexual intercourse just simply to see what it was like. This thought mightily excited the patient; she told herself incessantly that she too would like to have it. This, however, was sufficient reason for renewed self-reproaches. From this incident onwards there was an increasingly clear trend towards referring sexual subjects to herself; during almost every session obscene jokes and the like had to be told again. From the ideas referring to herself there came first all the reminiscences of former love-affairs and longings for affection. The recounting of these on the whole rather harmless events went off fairly smoothly. Only one incident had a

stronger emotional charge. She was in love with a young man about whom she knew very little and thought he was going to marry her. Later, however, he left her without a goodbye and she never heard from him again. For a long time she kept on waiting for him and always hoped he would write to her. To this refers 78, *stranger / nostalgia*,²¹ 14.8 secs. As already mentioned, the patient could not then explain the significance of this reaction. While the old love stories were told without any major difficulties, once this phase had passed resistance set in. The patient definitely wanted to leave, she had no more to tell. I told her that I had not heard anything about her earlier youth. She thought she would soon be finished with that, there was not much to tell about her youth. She had hardly finished this sentence when she was compelled to repeat several times her vehement tic-like defensive gestures, an unmistakable sign that much more very important material could be expected. With the greatest resistance and the most painful contortions she told in a jerky manner of a book that she had found at home, when she was ten years old, the title of which was *The Way to Happy Matrimony*. She asserted that she had no longer any idea what was in it. But as I continued to be relentless, recollections recurred after a while, and it turned out that the patient still remembered every detail, frequently even the wording. She gave a detailed account of the first sexual intercourse and its complications; the academic description without any personal reference seemed to me peculiar and unusual. I suspected that something must be concealed behind this façade. It was not long before the patient related that at the age of fourteen she had found in her elder brother's pocket a small book in which was reprinted a letter. The letter was written by a young wife to an intimate friend and discussed the secrets of the wedding night in a very obscene and lascivious manner. Apparently I was on the right track, as this story showed. The patient's next recollection concerned erotic dreams that she had had only quite recently. The dreams were outspoken ejaculation dreams and represented sexual intercourse undisguised. This was followed by the confession of having several times tried to hold the dream-image and to masturbate. Then it turned out that masturbation had also occasionally been practised before this. With the masturbation was linked a persistent thinking about her own genitals; she is compelled to wonder whether she "is properly built," whether perhaps she has not a too narrow introitus; she also has to investigate this state of affairs with the finger. She frequently has to look at her naked body in the mirror, etc. She has a long series of fantasies on sexual intercourse, she is compelled especially to imagine in every detail how she would behave during the first intercourse, etc. In this connection she also confesses to feeling a strong libido (which at the beginning she had emphatically denied). She would very much like to get married, and therefore attaches sexual fantasies to most of the men she meets. She also imagines herself in the leading part of all the sex stories she has collected. Thus she tells, for instance, of a naïve young acquaintance, a girl who, on a trip in a crowded railway compartment, had to sit on

her teacher's lap. The girl afterwards laughingly related that the teacher never forgot his role, he even carried a ruler in his trousers pocket. About this story the patient thinks that she too would enjoy it if a teacher took her on his lap, but she would know what the ruler in the trousers pocket meant. (The previously not-completely explained reaction [92] *to choose / teacher* may have been constellated partly by this story.)

[717] With great reluctance she also admits that at the age of fourteen she had once laid herself upon her younger sister "as if she had been a man." At last, in one of the latest sessions, came the narration of an event which in every respect had the significance of Freud's youth trauma. At the age of seven or eight she had repeatedly listened to the sexual intercourse of her father and mother. Once she noticed that her mother struggled and did not at all want to let the father come to her again. For a long time after that she could not face her parents any more. Then her mother became pregnant and gave birth to her younger sister. She bitterly hated the little sister from the very beginning, and only much later was she able to overcome a deep aversion to the child. It is, of course, not quite unlikely that the patient imagined herself as one of the acting persons in this story and that she adopted the role of the mother. This very plausible connection easily explains the strong emotional charge in all associations to the father.

[718] Of course, the psychic trauma of such an observation becomes a complex with a very strong emotional charge in a child's mind, which is bound to constellate the thinking and acting for years to come. This was, in a classic way, the case with this patient. It gave a quite definite direction to her sexual function.²² This becomes obvious from the analysis of her repressed material; it is always chiefly connected with digging out and imagining situations of sexual intercourse. Surprisingly, in spite of her sexually extraordinarily lively fantasy, she never became deeply involved with men and anxiously repulsed every attempt at seduction. But instead she was attracted, with an almost magical force, to doubtful females and dirty topics of conversation which, at her level of education and intelligence, one would not have expected. The two last sessions were particularly instructive in this respect. She produced the choicest selection of most repulsive obscenities that she had occasionally heard in the street. What these obscenities, the narration of which I must be spared, had in common were various abnormalities of sexual intercourse (e.g., too wide, or too narrow introitus, sexual intercourse of a little hunchback with a huge fat woman, etc.). The number and the extreme vulgarity of these jokes appeared to me almost incredible for such an educated and decent lady. The phenomenon, however, is explained by the early perverted direction of the sexual function, which is mainly concerned with finding out unclean sexual practices, i.e., the symbolic repetition of eavesdropping on sexual intercourse. This complex, caused by listening to the sexual

act, has throughout her life determined a multitude of sexual actions and associations with their peculiar manifestations. This, for instance, is the reason why the patient performs a sort of sexual intercourse with her little sister, why her listening at the door to hear whether the gardener is coming still haunts her, why she has to carry out the disgusting job of examining her employers' bed, why she has to seek the company of morally dubious people, etc. Her defensive movements and the peculiar pushing forward of the abdomen also show how the effect of the complex spreads in all directions. It is worth noting, too, that she appears at each session in a different dress.

[719] Using the sexual function in this way is bound to be incompatible with her otherwise gently disposed character; a rejection and repression of sexuality as absurd as it is repulsive must have taken place, because it is impossible that an educated and sensitive woman can combine these obscenities with the other contents of her mind. These things can only be tolerated when repressed. But they do exist, they actually have a separate existence, they form a state within the state, they constitute a personality within the personality. Expressed in other words, there are two mental attitudes present, kept apart by strong emotional barriers. The one must not and cannot know anything of the other. This explains the peculiar disturbances of reproduction that counteract the analysis. The ethically superior mind has not the associations of the other at its disposal; she must therefore think she has forgotten these ideas and that she has never known such things. I am therefore inclined to accept that the patient was really convinced that nothing more came into her head, that it was not a lie when she asserted with the greatest persistence that she had no more to say.

[720] But even if a complex is still so far repressed, it must yet have a constellating influence on the contents of normal consciousness, for even the deepest split of consciousness does not reach the indivisible basis of the personality. Thus the repression must leave a certain imprint on the conscious processes; the normal consciousness must somehow explain away the emotional condition that a repressed complex leaves behind. What is simpler, therefore, than to produce an idea compatible with normal consciousness as an explanation for the persistently self-reproachful and discontented mood? To explain away the pangs of conscience related to the sins of the governess phase, the patient displaces her self-reproach on to her method of teaching, which she feels must have led to a disastrous result; otherwise she would not persistently experience the feeling of self-reproach when she recalls incidents of that time. As we have already seen, the origin of this obsession acts as a pattern for the obsessional guilt about the neighbour's dying unabsolved. The accumulation of obsessive ideas about the doctor and the priest has its good reason in the fact that these people were not at all indifferent to her sexuality, as the patient

admitted to me. By having a sexual effect on her they become in a way accomplices in her wickedness; she therefore expects them to feel equally guilty.

[721] After this analysis we can understand the role, still unclear in the associations, that the father plays in her erotic complex. In general the analysis supports to the widest extent the hypotheses suggested by the associations. The associations actually served as signposts among the maze of ever-changing fantasies that at every stage threatened to put the analyst on the wrong track.

[722] The analysis was carried out every other day for three weeks and lasted one and a half to two hours at a time. Although at the end of the three weeks the patient had neither achieved proper sleep nor peace of mind, I discharged her and heard no more of her until the end of November. During the last days of November 1905 she suddenly came to see me and presented herself as cured. After the termination of the treatment she had still been very agitated for about four weeks. Sometimes she was tortured at night by her sexual images, sometimes again by obsessional ideas. In particular the obsession about the neighbour frequently recurred and did not give her any peace until she went to the daughter of the dead woman to make her tell her about the death scene for the *n*th time. When the daughter told her again, as usual, that the mother had died peacefully, the patient suddenly became convinced that the woman had after all received the last sacraments. With this all obsessional ideas suddenly disappeared. Sleep returned and was only occasionally somewhat disturbed by sexual images.

[723] What had brought about this happy ending of the treatment?

[724] It is obvious that the daughter's story, which the patient had heard many times without any effect, was nothing but the vehicle for the final removal of the obsession. The actual turn for the better occurred at the beginning of the treatment, when the sexual images replaced the obsessional ideas. The confession of her sinful thoughts may have given considerable relief to the patient. But it seems unlikely that the cure can be ascribed entirely to their verbal expression or to the "abreaction." Pathological ideas can be definitely submerged only by a strong effort. People with obsessions and compulsions are weak; they are unable to keep their ideas in check. Treatment to increase their energy is therefore best for them. The best energy-cure, however, is to force the patients, with a certain ruthlessness, to unearth and expose to the light the images that consciousness finds intolerable. Not only is this a severe challenge for the patient's energy but also his consciousness begins to accept the existence of ideas hitherto repressed.

[725] The split-off contents of the mind are destroyed by being released from repression through an effort of the will. So they lose a great deal of their authority and therefore of their horror, and simultaneously the patient regains the feeling of

being master of his ideas. I therefore put the emphasis on arousing and strengthening of the will and not on mere “abreacting,” as Freud originally did.

[726] It appears, from some recent publications, that Freud’s theory of obsessional neurosis is still consistently ignored. It therefore gives me great satisfaction to draw attention to Freud’s theories—at the risk of also becoming a victim of persistent amnesia.

SUMMARY

[727] 1. The complex that is brought to light through the associations offered by patients with psychogenic neuroses constitutes the *causa morbi*, apart from any predisposition.

2. The associations may therefore be a valuable aid in finding the pathogenic complex, and may thus be useful for facilitating and shortening Freud’s psychoanalysis.

3. The associations supply us with an experimental insight into the psychological foundation of neurotic symptoms: hysteria and obsessive phenomena stem from a complex. The physical and psychic symptoms are nothing but symbolic manifestations of the pathogenic complexes.

THE PSYCHOLOGICAL DIAGNOSIS OF EVIDENCE¹

I

[728] It is a matter of common knowledge that the evidence of witnesses, that most unpredictable element in legal proceedings, has recently become the object of experimental research. Perhaps the most credit belongs to William Stern, whose extensive “Contributions to the Psychology of Evidence”² is a real treasure-house from both the theoretical and the practical points of view. The aim of these papers is obvious; the ultimate goal is a general improvement in human memory, the utter unreliability of which is not apparent without experiment. The reports of Stern’s experiments on legal evidence have gradually found their way to most of the major universities and have thus become widely known. It is therefore probably not necessary to deal with them in detail in this paper. In Stern’s school the main object of investigation is the reliability of evidence; it uses the technique of the examining magistrate for the purposes of experiment. The question, however, with which we shall deal here, though not less important from the legal point of view, is at the same time of medical and psychological significance; it concerns the “diagnosis” of a criminal case by study of the psychological make-up of the witness.

[729] This new field of research is best explained by proceeding in an historical fashion; the problem is thus most easily understood even by the layman in psychology.

[730] Wilhelm Wundt, stimulated by Galton,³ introduced into German psychology a simple experiment which we propose to call the “association experiment.” The experiment consists essentially in the experimenter calling out some random word to the subject, in reply to which the subject has as quickly as possible to say the first word that comes into his or her head. A large number of repetitions of this procedure yields a series of pairs of words which one can call *associations*.⁴ The word called out is known as the *stimulus-word*, the reply as the *reaction*. As can easily be seen, this experiment, which appears so academic, was of course originally used only for psychological purposes far remote from any practical use. The main interest lay in the logical relation of word-pairs. There were also questions on how far back one could trace the associations, and whether they had already developed in the subject at an early age or not until later in life. The first relevant German paper, by Trautscholdt, on “Experimental Investigations into the Associations of Ideas,”⁵ deals exclusively with this topic. Later investigations by others of the Wundt school, such as those described in the papers by Scripture⁶ and Cordes,⁷ were also concerned with

purely theoretical questions. The experiment produced positive results and gained practical importance only when the psychiatrists took the matter in hand. This progress is connected with three well-known names: Kraepelin, Sommer, and Ziehen. These three research workers proceeded almost independently from one another and each of them in his own way. Kraepelin, who belonged to the school of Wundt, dealt first with certain theoretical questions, with which we are not concerned here. Ziehen made a special study of the results of the experiments with children. Sommer used the findings as an aid to psychiatric diagnostics.⁸ This summary shows the manifold aspects of this simple experiment. As every layman would imagine, the possibilities of reaction to stimulus-words are apparently innumerable. It was therefore a great achievement to be able to prove that certain restricting laws are in operation.

[731] This proof is the result of the excellent study by Aschaffenburg,⁹ a pupil of Kraepelin. He was able to show by means of experiments, as interesting as they were laborious, that mental and physical fatigue exert a definite influence on associations, as can be clearly demonstrated by statistics. It became apparent that under the influence of fatigue there was in particular an increase in what are called *sound associations*¹⁰ (e.g., *dish / fish, red / bread, wood / good*). Aschaffenburg took this important fact as a starting-point, and he then showed that similar associations occurred in a mental disease, namely in *mania*. The question of the common psychological cause of the same phenomenon in these heterogeneous psychic states remained for the time being obscure. In 1901 Bleuler inaugurated research into associations at the Psychiatric Clinic in Zurich. These investigations led in 1904 to the discovery that sound associations are due to disturbances in attention.¹¹ A second result was that the content of the reactions was not *merely coincidental* but *inevitable*; i.e., what came into the minds of the subjects was not meaningless and incidental material but was determined according to a law by the individual content of the subject's ideas. This may be illustrated by the following example.

[732] One of my subjects was a young man who had had an unpleasant dispute with his family a short time before the experiment. He wanted to marry a girl of whom his parents did not approve. As an obedient son he had to give her up, hard though it was for him. These events dominated his interests at the time of the experiment. It is therefore not surprising that numerous reactions were influenced by the recollection of this experience, as the examples show.

<i>Stimulus-word</i>	<i>Reaction</i>
to kiss	again and again
bad	no
time	not now
mature	am I
to love	ah!

son	father and son
wild	mother (wild=furious)
tears	she now has
protection	I cannot offer to her
war	yes, if only there were
faith	I did not keep
once	and never again
miracle	would have to happen
blood	she is anaemic
choose	another one
to part	I need not
right	she has none
fond	I was, of her
wool	a woman's dress
unfair	I was not
stranger	yes, now she is

[733] On rereading these reactions it can be seen at once that their contents are not meaningless and that these are not random choices out of the thousands of possible reactions, but just those that indicate the ideas occupying the foreground of the individual interest. It is, as already mentioned, the story of an unhappy love-affair. Such a recollection, which is composed of a large number of component ideas, is called a *complex of ideas*. The cement that holds the complex together is the *feeling-tone* common to all the individual ideas, in this case unhappiness. We are therefore speaking of a *feeling-toned complex of ideas*,¹² or simply of a *complex*. In our case the complex has the effect that the subject does not react by arbitrary or random connections of words but derives most of his reactions from the complex. The influence of the complex on thinking and behaviour is called a *constellation*.¹³

[734] The reactions of our subject are thus *constellated by a complex*.

[735] Does this behaviour work according to a law, and are the reactions in all subjects constellated by complexes?

[736] There is no one who has no complexes, just as there is no one who is without emotions. Yet human beings differ immensely in the strength of their emotions. In accordance with the intensity of their emotions people's thinking and behaviour are constellated by their complexes, and so are their associations. One is bound to ask, with some surprise, whether revealing or concealing one's complexes is not a matter for individual decision. By no means everyone will disclose his secrets so openly and without embarrassment as this young man did. True, this young man was an exception; he had confidence in the experimenter and said everything just as it came into his head. By no means everyone behaves like this; on the contrary, many are

strictly on their guard not to say anything that might be compromising. Others are more casual and just fit one word to another without thinking of any deeper connections. Does a complex constellate the association even in a case where one is not thinking of anything in particular and certainly not of one's secrets? Theoretically, the question has definitely to be answered in the affirmative, because nobody can do anything that is impersonal; there is certainly no psychic manifestation that has not an individual character. Practically, however, it is not so easy to answer the following question: Is it also possible to demonstrate the constellation by complexes in associations in which the subject either does not want to give himself away or is not thinking of anything in particular?¹⁴

[737] In spite of having formulated the appropriate questions, psychology has up to now been unable to prove anything of individual significance in the associations. It was our experiments that first succeeded in finding the approach to this goal.

[738] As already mentioned, not every subject reacts as openly as the case described above; as a rule the associations are at first sight quite impenetrable and sound impersonal and safe, like those that follow here.

to dance	not
ill	not
angry	friendly
needle	nail
rich	rather
tree	branches
to sing	beautiful
pity	not at all
detest	rascals
people	religion
stink	abominable
unfair	atrocious

[739] These associations appear to have an impersonal character and are thus very different from those quoted earlier. This might therefore lead to the assumption that they are nothing but casual, entirely incidental word-connections. On questioning the subject, however, we learn that this is by no means the case. It is not accidental that the subject responds to *to dance* with *not*, but it corresponds to a quite special individual situation. The man who was my subject could not dance, a fact that annoyed him, particularly because a friend was very good at dancing and thus won the love of a very "eligible" girl. My subject also wanted to marry an "eligible" girl, but did not succeed, and this angered him even more than not being able to dance. It worried him so much that he nearly became *ill* with it, but he did *not* really become ill in spite of his despair. The girl is *rather rich*. He does *not at all* deserve any *pity*

for his lack of success because everybody has to work for his fortune. And because the lady who turned him down was Jewish, he came to *detest* the rascals (i.e., the Jews). Since the Jewish *people* have a different *religion* from his, the problem of religion is of course also particularly important for him. Towards the end his anger breaks through more plainly with the expostulations *abominable* and *atrocious*.

[740] Thus here too we find the complex and its constellation quite distinct. Up to now we have relied entirely on the statements of the subject. But now let us look more closely into the contents of the reactions.

[741] It is definitely striking that the reactions to *to dance* and *ill* are *not*, just as remarkable as that the subject says *rascals* in answer to *detest*, and *not at all* to *pity*. Surely one could at these points think of much more innocent and objective connections which seem to be nearer at hand, e.g.,

to dance	music, dance-hall, ball, etc.
ill	disease, doctor, etc.
detest	respect, contempt, etc.
pity	for the poor, the sick, or compassion, etc.

[742] The unusual content of the reaction therefore already allows us to infer a constellation by complex. So it is, for instance, striking if an elegant young man reacts to *goat*, *potato*, *cow*, each time by *agriculture*. The explanation is that he is a student of *agriculture* in his first term. I could easily pile up examples, but this is not necessary; for even without them it is feasible to conclude from the unusual content of a reaction that there is a constellating complex. This can be done even without getting information from the subject afterwards. If, for instance, a marriageable girl responds to *to kiss* with *sister's kiss*, it is not difficult to guess what is meant by that.

[743] But this does not exhaust the possibilities of suspecting and proving the influence of a complex, even without later information. Besides the content of the reaction, we have another very fine criterion for the complex-constellation; this is the *reaction-time*. We always measure the time elapsing between pronouncing the stimulus-word and the reaction with a $\frac{1}{5}$ -second stopwatch. As might be expected, these times vary in an apparently random fashion. Closer inspection, however, soon shows that very long reaction-times nearly always occur in quite definite places. The following example shows which are the critical spots:

		(secs.)
head	hair	1.4
green	lawn	1.6
<i>water</i>	<i>deep</i>	5.0
to stab	knife	1.6
long	table	1.2

<i>ship</i>	<i>sinking</i>	3.4
to ask	to reply	1.6
wool	to knit	1.6
sulky	friendly	1.4
<i>lake</i>	<i>water</i>	4.0
ill	healthy	1.8
ink	black	1.2
<i>to swim</i>	<i>to be able to</i>	3.8

[744] In this example most of the figures vary between 1.2 and 1.8 seconds. But besides these there are four unusually long times, ranging from 3.4 to 5.0 seconds. If we ask the subject now why he hesitates at these points, we learn that once in a moment of despair he had seriously contemplated suicide by drowning. The stimulus-words *water*, *ship*, *lake*, and *to swim* stimulated this complex. During the short interval between stimulus-word and reaction something unpleasant (the complex) had crossed the subject's mind, and the result was a slight hesitation. The same phenomenon is noticeable in everyday conversation when we ask someone something that is unpleasant either to us or to the other person; we dither a little and hesitate over the question or with the answer. The hesitation here is quite involuntary and a kind of reflex. It is noteworthy that the same hesitation also occurs at the moment of the reaction, when we are quite unaware of the complex-releasing effect of the stimulus-word. Hundreds of cases have taught us this. From this we see that the stimulus-word can also release complexes of which we are not aware at the moment, which may even be separated from consciousness by amnesia, such as is very often the case in hysteria. By measuring the reaction-times we therefore have another means of detecting complex-constellations, even without co-operation from the subject.

[745] There is also a third method of finding a complex, which is called the *reproduction method*.¹⁵

[746] We usually record a series of a hundred responses from the subject whose complex we wish to investigate. When this series is complete, we ask the subject to repeat his reaction to every single stimulus-word. Here memory often fails. Then we go into the question of whether the points where incorrect or incomplete reproductions are given are random or determined. For the sake of simplicity we give here the previous example again.

<i>stimulus-word</i>	<i>reaction</i>	<i>reproduction</i> ¹⁶
head	hair	+
green	lawn	+
<i>water</i>	<i>deep</i>	<i>to swim</i>
to stab	knife	+

long	table	+
<i>ship</i>	<i>sinking</i>	<i>steamer</i>
to ask	to reply	+
wool	to knit	+
sulky	friendly	+
<i>lake</i>	<i>water</i>	<i>blue</i>
ill	healthy	+
ink	black	+
<i>to swim</i>	<i>to be able to</i>	<i>water</i>

[747] The reproduction fails for *water*, *ship*, *lake*, and *to swim*, i.e., for the same stimulus-words for which long reaction-times had originally been recorded. This shows that memory fails in the places where there is a complex in operation. We do not want to deal here with the interesting theory concerning these disturbances; this has already been done in the paper mentioned above. It should merely be remembered that memory is seriously deranged by an affect, as nobody knows better than an examining magistrate. Let us summarize briefly: We can demonstrate the complex-constellation objectively by the unusual or in any way striking content of the reaction, by the prolongation of the reaction-time, and by incorrect reproduction.

[748] If we apply these three criteria to the associations, we soon find, however, that the matter is not as simple as it looks, because we see that, though these criteria apply to certain associations, they make no sense at all in, for instance, the following cases:

to stab	knife	1.6	+
angel	pure	1.2	+
long	trunk	2.8	tree
ship	man	1.2	+
to plough	field	1.4	+
wool	sheep	1.6	+
friendly	lovely	1.6	+
table	leg	4.0	chair
to ask	answer	1.6	+
the State	form (shape)	6.2	Switzerland
white	black	1.2	+
pencil	pen	1.0	+
lovable	dear	1.4	+
glass	to love	4.6	to drink

[749] If we apply our three criteria to these associations we find *long*, *table*, *the State*, *glass* to be the critical stimulus-words. This grouping does not tell us anything and does not lead to any hypothesis. But could it not be that the complex is not yet fully aroused by the stimulus-word, but makes its appearances only with the reaction? In this case the reaction following the critical reaction would be mainly affected. Let us

apply this to our example and consider the stimulus-words preceding the apparently critical reactions. They are *angel*, *friendly*, *to ask*, *lovable*.

[750] Whereas we had questioned the subject, a young man, on the previous stimulus-words in vain, his face brightened up when we offered him the new ones. He had just become secretly engaged; the beloved had answered his question with a friendly “yes.” In this case, therefore, the post-critical reaction is also constellated by the complex. This very common process is called *perseveration*. That perseveration can also strongly influence the contents of a reaction is shown by the example:

lovable dear
glass to love

[751] I have chosen a rather simple example to demonstrate what is from the practical point of view an important variety of the complex-constellations. As a rule the situation is much more complicated, inasmuch as all the possible factors are present together. In people whose emotions are easily roused (hysterics) the complex-constellation can even extend over a whole series of ensuing reactions. A hysterical female patient who had attempted suicide, for instance, reacted as follows:

1. water	(failure) ¹⁷	–	+
2. to sting	bee	1.8	+
3. angel	inn	21.0	(did not react at all, as after <i>water</i>)
4. long	knife	9.0	(as 3)
5. ship	steam	7.0	(as 3)
6. to plough	field	4.2	garden

[752] From the seventh reaction on there were again normal reaction-times and correct reproductions. In this example we can observe various features. The subject does not know in the least how to react to *water*. The reaction-time extends as it were to infinity. Ultimately, of course, she would come to some sort of a reaction, but to a forced one, which is of no use. We therefore never wait longer than about 30 seconds. What prevented the patient from reacting was the unpleasant recollection of the suicide attempt which cropped up here. In *angel / inn* the reaction-time is extremely long, because *angel* reminds her at once of the suicide attempt again, of dying and the next world, and this time with such an intensity that the emotional tone of the complex lasts over the next three reactions. The gradual subsiding of the emotional tone from reaction 3 on can clearly be seen in the reaction-times.

[753] We have discussed here the most important disturbances that the complex produces in association and reproduction, and have now to deal with the question of how much of these theoretical findings can profitably be used for practical purposes.

[754] In the first place, we have gained with this experiment a most valuable tool for psychology. With it we can demonstrate the existence of certain complexes of individual significance for our subjects, a fact that is bound to become of great theoretical importance. Secondly, the experiment is important for psychiatric practice in that, especially in hysteria, in which as a rule the whole mental life is disturbed, it provides us with the most valuable indications for finding the pathogenic factor, since in hysteria a complex is always at work.¹⁸ The experiment serves us equally well in the elucidation of another mental disorder, *dementia praecox*.

[755] The latest application of our experiment was suggested by Wertheimer and Klein,¹⁹ two pupils of the well-known criminal psychologist Hans Gross. This is its application to the delinquent—the exploration of the complex underlying a crime. Just as any subject who submits to the experiment unconsciously gives himself away, as we have shown, so the criminal, who has knowledge of certain facts, is bound to do the same. This, it is hoped, will make it possible to prove by experiment whether or not a person has any knowledge of certain facts. As everyone will appreciate, this question is of enormous practical importance.

[756] While the paper by Wertheimer and Klein mentioned above made only general suggestions about this, Wertheimer has dealt in another paper²⁰ with relevant experiments carried out in Külpe's laboratory at Würzburg. The experiment was set up as follows.

[757] The subject was shown a picture, the contents of which he had to commit to memory (e.g., a picture of a religious service in the chapel of a crypt). The stimulus-words were in some cases chosen from the picture (names of objects shown or otherwise obvious associations with it), but in other cases irrelevant words with no recognizable relation to the picture were used. These stimulus-words were called out to a number of subjects. The reaction-times were recorded with exact instruments (megaphone and chronoscope). The subjects had previously been instructed not to give themselves away, i.e., not to give any associations revealing that they had seen the picture. The results are in keeping with our previous exposition. The stimulus-words arousing the complex (relating to the picture) yielded an unusually large number of *long* reaction-times, and in these cases the reactions also gave a strange impression; there was something deliberate about them. It also often happened that the complex-characteristics appeared in reactions to irrelevant stimulus-words. In these cases a stimulus-word relating to the complex had appeared immediately before. Wertheimer was also able to confirm that the more emotional involvement there was, the more marked were the reaction-times and the qualitative and perseverative phenomena.

[758] Since the Wertheimer-Klein publication similar experiments which provided similar results have been carried out by Hans Gross²¹ and by Dr. Alfred Gross²² of Prague. What underlay these experiments was the knowledge or lack of knowledge of a certain room and its furniture. Alfred Gross has discussed very clearly the general aspect of the problem,²³ especially with regard to its juridical application.

[759] I should like to mention first, among the critical comments, that by William Stern:

The problem is certainly very interesting from a purely psychological point of view, and the suggested procedure is to be welcomed as a remarkable extension of our methods of approach, but it seems to me that there is a powerful objection to the practical forensic application of the method. In court there is no really sharp distinction between those people in whose minds the facts of the case are present and those in whom they are completely absent, since nearly everyone who has to do with a case in a law court, whether as the defendant or as a witness, knows either what he is accused of or why he is being interrogated, no matter whether he was actually in any way involved. Even the mind of someone falsely accused is, from the very first examination by the magistrate, continuously burdened with ideas concerning the matter. Every suggestion must call to consciousness the ideas with which he is preoccupied, just as if he were guilty, and must also evoke emotional reactions which in their manifestations, even as part of an experiment, can hardly be distinguished from those of guilt; it is well known that blushing, which so often occurs as a result of baseless accusations, has before now been interpreted as a symptom of guilt. Is there not a similar great danger in the psychological experiments suggested by Wertheimer and Klein?²⁴

[760] I feel obliged to support this objection fully, and should in particular like to stress that the innocent as well as the guilty has the greatest interest in reacting so as to show to the best advantage. The guilty man is afraid to give himself away, and the innocent to put himself in the wrong, by reacting in an awkward manner. The critical reactions will therefore in both cases be accompanied by strong emotional tone, which interferes in a characteristic way with the associations. This might make it difficult to distinguish between guilty and innocent. We shall come back to this question in more detail in the second part of the paper.

[761] In a recent publication Stern discussed my paper "The Reaction-time Ratio in the Association Experiment," in which I gave a detailed analysis of the experiment. Stern considers it of doubtful value to let the subjects explain the associations afterwards, as I made them do. I am ready to admit that the method is in any case difficult and dangerous. For this reason I chose as subjects for the analysis three people whose life and psychological make-up were known to me, and who were themselves

psychologically experienced, especially in the observation of association. One could not ask everyone for an explanation of his associations, because they are not casual things but the most intimate and affective ones, on which even an honest self-criticism may fail to function. A certain special experience in the experimenter and also a fair knowledge of certain aspects of psychopathology are necessary with subjects who are not used to psychological experiments. These are the principles of Sigmund Freud's ingenious psychoanalysis.²⁵ Only when one has completely assimilated Freud's method is one able with any certainty to consider associations from a psychoanalytical point of view. It has to be conceded to Stern that an inexperienced experimenter can easily make the gravest mistakes with this delicate material. In any case, even Freud has been accused of interpreting into a subject's statement more than is in it. To this reproach, however, it must be said that very likely everyone would respond with a canalized association rather than a spontaneously created association when asked what comes to mind in connection with a certain idea; this, of course, applies also to any retrospective elucidation.

[762] In his discussion of Wertheimer's suggestion Kraus²⁶ puts forward the idea that the method has not been sufficiently tried out. I would draw Kraus's attention to the fact that a number of papers were published from the Psychiatric Clinic of Zurich University which discuss the method in considerable detail.²⁷ That the method lends itself to the discovery of complexes seems to me beyond doubt. When it comes, however, to applying the method to someone giving evidence, one cannot be too careful. Therefore I agree with Kraus when he foresees great difficulties in applying the experiment in judicial procedure.

[763] Kraus continues: "But I must ask, can the examiner claim the right to base any judgment on the inextricably entangled web of my associations?"

[764] The author may forgive me if behind this question I suspect insufficient appreciation of the problem of association. A careful study of the existing literature would have taught him that the "web of the associations" is precisely not "inextricably entangled." If it were we should be at our wit's end, and we could refrain *a priori* from searching for laws among the infinite number of chance events. The experiment is simply based on the fact that there actually are laws determining the possibilities which *more and more* exclude the unaccountable.

[765] If we know these laws, then we also know the intimate association-processes of the subject, whether he likes it or not. Kraus thinks one would have for that purpose to have "that rare gift for psychoanalysis of which Freud brings amazing evidence in his remarkable papers." Freud is certainly a man of genius, but his psychoanalysis is, in its principles at least, not an inimitable art, but a transferable and teachable

method, the practice of which is greatly helped by the association experiment, as can perhaps be seen from the papers published from our Clinic.²⁸

[766] I repeat what I have already said elsewhere: The truth of this experiment is not obvious, it has to be tested; only someone who has used it repeatedly can judge it. Modern science should no longer recognize judgment *ex cathedra*. Everybody derided and criticized Freud's psychoanalysis,²⁹ because they had neither applied nor even understood the method, and yet it ranks among the greatest achievements of modern psychology.

[767] Weygandt,³⁰ too, thinks that there is still a long way to go before it will be possible to use the method in forensic procedure. He also thinks it desirable that the experiments should continue, especially with uneducated subjects. Weygandt further draws attention to the fact that the criminal probably does not observe the scene of the crime so closely that stimulus-words for the tests can simply be taken from the objects situated there. It is also likely that the emotional tone necessary for interfering with the association is precisely what the habitual criminal lacks.

[768] These objections must be unreservedly acknowledged.

II

[769] The practical application of the association method is best illustrated by a case on which I was consulted in my capacity as a doctor. Here is the history of the case.³¹

[770] One evening in September 1905 an elderly gentleman came to see me. He was evidently agitated and asked for a consultation on an important matter. He told me that he lived with a young man of eighteen, his protégé. For several weeks he had noticed that on a number of occasions larger or smaller amounts of money had been missing from the strongbox. Although he was somewhat absent-minded and not particularly careful in money matters, he was quite sure that there was a deficit of at least 100 francs. He reported the matter at once to the police, but there was no evidence at all against anyone. Recently there had been some changes among the servants; it was thus possible that one of the maids had taken the money. Now it had also occurred to him that his protégé might have stolen from him. If he knew that the young man was the thief, he would do whatever he could to prevent the police getting to know of it; in that case he would rather deal quietly with it himself in order to avoid embarrassment for the family of his protégé, who were highly respectable. For the purpose of coming to a decision in this awkward dilemma he wanted me to hypnotize the young man and question him, while under hypnosis, as to whether he was the culprit or not. I rejected this suggestion because such an undertaking is not only technically most difficult but also fruitless. But I suggested the association experiment. Fortunately the young man had intended once before to consult me

because of some minor nervous complaints. Thus the guardian was able to send him to me under the pretext of a consultation. Before long the young man turned up and consented to the experiment.

Experimental Procedure

[771] In order to stimulate the complex as strongly as possible, I prepared a sheet of stimulus-words in which I distributed thirty-seven words relevant to the possible facts of the matter. The guardian had informed me that the money was always kept hidden in a drawer amongst shirts and ties beneath a small board. The drawer was in a chest and was kept locked. It was possible that it had been opened with a master key. In the same room there was also a trunk in which money was occasionally kept. A linen-cupboard also stood near the chest of drawers. The suspect youth had recently bought a watch and given some small presents to his sister. He might have got the money from the theft; his guardian, however, did not know, because he hardly ever bothered about his protégé's finances. There were no other significant features in the room where the thefts had taken place. As critical stimulus-words I chose: *to give a present, watch, to give, drawer, sister, burglary, writing case, sin,*³² *to threaten, key, to steal, board, to look for, to lock up, master key, to hide, thief, to find, wrong, shirt, to watch, tie, trunk, to hit, to catch, police, to moan [accuse],*³³ *chest of drawers, arm [poor],*³⁴ *to arrest, jail, false,*³⁵ *anxiety, linen-cupboard, to punish, month,*³⁶ *criminal.* These thirty-seven stimulus-words touching the complex were distributed amongst sixty-three "irrelevant" stimulus-words, special care having been taken so that an irrelevant stimulus-word was frequently put immediately following a critical one. This was done because of the fact that the emotional charge often perseverates into the post-critical reaction. In this way it could be hoped that the complex-constellation would emerge fairly clearly. I am now going to describe the experiment as it took place. Between the sections I shall insert explanatory remarks. At the end I shall give a statistical survey to bring the experiment to life. The association experiment was complemented by a reproduction test.

[772] I should like to point out that the probable mean³⁷ of the reaction-times in this case, in which the subject belongs to the educated class, is 2.0 seconds. Excessively long reaction-times therefore are those above 2.0.

1. head	nose	2.0	+
2. green	blue	1.2	+
3. water	air	1.6	blue
4. to stab	painful	2.0	+
5. murder	manslaughter	1.4	+
6. long	short	1.8	+
7. five	six	1.4	+

These reaction-times show no peculiarities as yet, though one might perhaps mention the incorrect reproduction for *water* as suspect, suggesting a complex-constellation. It is, of course, impossible to explain every minute complex-interference by means of an obviously incomplete analysis carried out in retrospect, as in this case.

8. <i>to give a present</i> ³⁸	gen-generous ³⁹	2.0	to give
9. wool	cloth	1.4	+

The reaction to the first complex-stimulus-word fulfils the above criteria for interference by the influence of a complex. The reaction itself is characterized by a slip of the tongue. The reaction-time is not short and the reproduction is incorrect. No after-affect on the following association.

10. <i>watch</i>	mechanism	2.2	+
11. table	leg	1.8	wood

The second complex-stimulus-word *watch* produces a foreign word⁴⁰ as a reaction, which is somewhat unusual. The reaction-time is excessive.⁴¹ The post-critical reaction is incorrectly reproduced, so that a perseverating emotional charge may be suspected.

12. <i>to give</i>	<i>to steal</i>	2.6	+
13. chair	-leg	2.0	+
14. sulky	morose	2.8	+

In 12, the complex is openly expressed with an excessive reaction-time. The post-critical reaction-times are rather long. The reproduction is not disturbed.

15. <i>drawer</i>	wood	1.6	+
16. <i>sister</i>	brother	1.8	+
17. lake	water	1.4	+
18. <i>ill</i>	well	2.0	- ⁴²

Here no obvious complex-influence on the two critical stimulus-words is apparent. The missing reproduction for *ill* may be due to something other than the theft-complex.

19. <i>burglary</i>	<i>theft</i>	1.8	+
20. to cook	-	-	-
21. ink	paper	2.6	+

Here we have all the criteria of the complex-constellation. The perseveration was so strong that it led to a failure, an absence of the post-critical reaction. The reaction-time for 21 is still very long.

22. evil	good	2.0	+
23. <i>writing-case</i>	paper	2.0	+
24. to swim	good—don't know	2.0	freely, doing well

The critical stimulus-word interfered again with the post-critical reaction and its reproduction by means of a perseverating emotional charge.

25. <i>sin</i>	disgrace	1.8	+
26. blue	black	1.4	+
27. bread	water	1.6	+
28. <i>to threaten</i>	–	–	–
29. <i>key</i>	lo-hole	2.6	+
30. rich	poor	1.2	+

Sin obviously did not, or not appreciably, arouse the complex. *To threaten*, however, is followed by the failure to react characteristic of emotion and by lack of reproduction. This powerful effect of the stimulus-word may perhaps also be ascribed to the fact that 27 already contains the expression of a complex-constellation: bread and water = jail. In 29 the disturbance is very obvious; the reaction is disturbed by a slip of the tongue, and the reaction-time is excessive.

31. tree	green	1.2	+
32. <i>to steal</i>	<i>to take</i>	2.4	+
33. <i>board</i>	wood	2.8	+
34. yellow	black	2.2	+

To take does not contradict the complex. I do not know whether the long reaction-time following *board* stems from this complex-word or by perseveration from *to steal*. The reaction-time after *yellow* is, however, still excessive, which might indicate some slight perseveration from *board*.

35. mountain	high	1.8	+
36. <i>to look for</i>	<i>to find</i>	1.6	+
37. salt	–	–	+
38. new	old	2.0	+

The characteristic perseveration, with inhibition of the following reaction, originates with *to look for*. *To find* does not contradict the complex; on the contrary.

39. <i>to lock up</i>	<i>to imprison</i>	2.6	to release
40. to ride	river	2.0	+

The critical stimulus-word distinctly influences not only the expression of the complex, but also leads to a mishearing of the subsequent stimulus-word; as shown also in the reproduction (*riding*: *reiten* = Rhein). Mishearing of the stimulus-word is a not infrequent phenomenon in a complex-constellation.

41. <i>master key</i>	<i>key</i>	1.6	+
42. stupid	intelligent	3.0	+

Key, as an associative response to the complex, must not, of course, be overvalued. The prolonged reaction-time in R.42 is more telling.

43. exercise-book	book	1.8	+
44. <i>to hide</i>	<i>to find</i>	2.0	+
45. tooth	painful	1.4	+

To find is a frequent association to *to hide*, so it must not be too highly valued as a complex-association. It looks as if *to hide* has only just touched the complex. The response to *to look for* was also *to find* (36). Such comparisons are useful, even if they do not reveal very much. Occasionally, however, they are valuable if one is trying to detect an unknown complex.

46. right	false	2.2	+
47. <i>thief</i>	<i>burglar</i>	4.6	criminal
48. <i>to find</i>	<i>to steal</i>	2.6	to look for
49. book	–	–	statute-book

With *thief*, serious complex-disturbances set in which I need not elaborate.

50. <i>wrong</i>	right	1.2	+
51. frog	water	2.2	tadpole
52. to separate	tadpole	2.6	+

Strong perseveration appears to be connected with *wrong*. But it is more likely that this disturbed sequence is still under the influence of R.47ff, as can often be seen in strong emotion. If one watches the subject during the experiment, one can frequently see facial expressions at complex-points that at once reveal the strong emotional charge. This was the case here. From 47 on the subject became restless, gave embarrassed titters, moved his chair to and fro, rubbed his hands or hid them in his pockets. This shows that the disturbances in the associations, as well as other symptoms, are only expressions of the total effect.

53. hunger	thirst	1.4	+
54. <i>shirt</i>	white	2.0	cloth
55. <i>child</i>	small	1.8	+

Shirt seems to have made a hit.

56. <i>to watch</i>	<i>to miss</i>	1.8	<i>s-conceal</i> ^{42a}
---------------------	----------------	-----	---------------------------------

The influence of the complex is here particularly obvious in the reproduction. The slip of the tongue *s* could be an anticipation of *conceal*, or should *s* have become *steal*?

57. <i>necktie</i>	cloth	1.6	+
58. dim	dark	1.6	+
59. <i>trunk</i>	to pack ⁴³		+
60. <i>to hit</i>	<i>to miss</i>	1.8	certain
61. statute	book	1.8	+
62. lovable	faithful	1.8	+
63. <i>to catch</i>	<i>to miss</i>	2.4	to get hold of
64. to quarrel	to love	3.4	–

From this series we see the part that *to miss* plays. It occurs only in response to complex-stimulus-words, when it is in each case incorrectly reproduced. It seems to be one of those cover-words that not infrequently appear in this experiment. What is hidden beneath it seems to be the thief's fear of a surprise. The words relating to the locality of the incident, *tie*, *trunk*, appear to be of little influence.

65. <i>police</i>	<i>thief</i>	3.6	+
66. large	small	1.6	+
67. <i>to moan</i> [<i>accuse</i>]	to sigh	1.6	+
68. to paint	beautiful	3.8	+
69. <i>chest of drawers</i> ⁴⁴	comfortable	2.8	+
70. old	new	1.2	+

Police is a direct hit; *to moan* has its after-effect. *Chest of drawers* is translated [see n. 44] after a long reaction-time; the hit has thus been parried.

71. flower	heath	2.0	+
72. <i>arm</i> [<i>poor</i>]	leg	1.6	+
73. wardrobe	cupboard	2.0	+
74. wild	brook	2.0	+
75. family	<i>sister</i>	2.2	+
76. to wash	clean	1.8	+
77. cow	bull	1.8	+
78. strange	<i>to watch</i>	2,2	+

In this sequence *poor* (cause of the theft?) has no arousing effect. The choice of *sister*, however, for family, which had not been intended to be a complex-word, does not seem to be coincidence. *To watch* as an association to *strange* is odd; is there perhaps the faint thought behind it that someone must have watched and reported him, so that now even a stranger (myself) knows of the deed? Of course, the suspicion is not proof; one has, however, to keep such trains of thought in mind in the interpretation.

79. <i>to arrest</i>	<i>thief</i>	3.4	+
80. story-telling	fairy-tale	2.0	+
81. manners	custom	1.8	+
82. narrow	broad	1.8	+

To arrest was a direct hit; then there was a slowly declining charge (reaction-times!).

83. brother	<i>sister</i>	1.4	+
84. <i>jail</i>	<i>prison</i>	4.2	+
85. stork	child	2.2	+
86. <i>false</i> (cannot understand the stimulus-word at first, then)	<i>rich</i>	4.0	+

Rich is a peculiar reaction to *false*; if, however, a subject has stolen a considerable sum from his benefactor, then the response is no longer quite incomprehensible.

87. <i>anxiety</i>	<i>silly</i>	2.4	-
88. beer	wine	1.6	+

It was easy for the subject to persuade himself that his anxiety about giving himself away with the experiment was silly.

89. fire	shot	2.0	+
90. dirty	clean	1.4	+
91. door	trap-	1.6	+
92. <i>linen-cupboard</i>	wood	3.0	+
93. hay	grass	1.6	+

Linen-cupboard appears, to draw conclusions from the long reaction-time, not to be quite without meaning.

94. quiet	calm	2.0	+
95. mocking	irony	1.6	+
96. <i>to punish</i>	<i>to release</i>	2.4	+

An obvious complex-constellation.

97. <i>month</i>	week	1.8	+
98. coloured	green	6.2	+

Month, under the constellation of punishment, had obviously a strong affect.

99. <i>criminal</i>	<i>thief</i>	2.2	murderer
100. to talk	to be silent	2.6	to speak

[773] The total result of this experiment appeared so convincing to me that I told the subject point-blank that he was a thief. The young man who, up to now, had shown an embarrassed smiling face, turned suddenly pale and protested his innocence with great excitement. I then pointed out to him several points in the experiment that seemed to me particularly convincing. Thereupon he suddenly burst into tears and confessed.

[774] Thus the experiment was a complete success.

[775] This success, however, has to be examined critically. Above all, one has to keep in mind that the thief is not a hard-boiled habitual criminal but a sensitive young man who is also apparently tortured by his bad conscience (the complex). His complex had high emotional charges, which clearly affected the associations and in this way made the diagnosis of the theft possible. Had he had weaker emotional charges, the disturbances would also have been less, and the diagnosis would have been that much more difficult. Another circumstance that helped was that the culprit reacted in the manner of educated people, with single words and relatively short reaction-times. Had he been uneducated, or even somewhat mentally defective, he would have

preferred to respond with sentences or definitions, which are also always connected with rather long reaction-times. In this association-type⁴⁵ the subjects deliberate the reaction and formulate it as “suitably” as possible, which is apt to put the complex-constellations in the background.

[776] Not only the success of the method, however, but also the method itself has to be critically examined, inasmuch as we are not yet at all sure whether the critical stimulus-words cannot cause disturbances in innocent persons as well. The stimulus-words are partly such that even without a special complex they can arouse emotions or touch other complexes as well. There are also some words among them that are not in current use and that therefore have few ready connections in the language. Lastly, not all the rather long reaction-times are necessarily due to the influence of a complex, since they can just as well be caused by the rarity of the stimulus-word.⁴⁶

[777] The rarity and complexity of the stimulus-words are, of course, also affect-arousing, in so far as they demand more attention. Many people also become inhibited because of the fear of appearing foolish, particularly uneducated women, who, in any case, get very easily embarrassed. It may therefore, *a priori*, be assumed that complex-characteristics may appear at moments when emotions have been aroused purely because of these difficulties. Then, a case is easily imaginable in which, by means of intended complex-stimulus-words, complex-symptoms are produced that are not, however, related to the suspected or expected complex but to a similar one that incidentally interferes with the one for which we are looking. Such a case can give rise to the most serious misinterpretations. Finally, disturbances can be produced by one group only of the complex-stimulus-words, so that one remains in doubt whether the subject is guilty or innocent. This can also occur if another complex interferes with the expected one.

[778] In the face of these difficulties it has to be plainly admitted that one hundred stimulus-words are definitely too small a sample to confirm beyond doubt the existence of a complex and to exclude the influence of interfering complexes. In our case, the attempt succeeded that one time because the situation was simple; another time, however, it could easily fail. The obstacles that arise in these experiments are shown by the controls that I set up to check the list of stimulus-words specially chosen for the case of theft. [See pp. 344, 346.]

[779] I took as subjects two educated young men with whom I was closely acquainted. The one whom I am going to describe as the Informed knew the significance of the experiment carried out on him; the other was completely unaware of it. I am calling the latter the Uninvolved. The experiment was carried out on both of them in exactly the same way as on the Culprit. I must point out that for every subject one has always to think in terms of *his* probable mean-time.

<i>Mean-time of:</i>	<i>Secs.</i>
Culprit	2.0
Informed	1.4
Uninvolved	1.8

On the whole, the differences in these figures have an individual significance only.

[780] For the sake of brevity I have to restrict myself to discussing only the critical reactions, and just indicating the complexes of the controls.

8. *to give a present* passes smoothly for the Uninvolved; the post-critical reaction-time of the Informed is prolonged beyond the mean.

10. *watch* produces a failure in the Uninvolved, thus a complex-symptom. This subject is at present going through an unpleasant *waiting period* which seems to him to last very long (therefore the extended reaction-time for *long*). *Watch* arouses the same idea in him. The time for the Informed is also somewhat above the mean. The post-critical reactions are incorrectly reproduced by both controls as well as by the Culprit; therefore, the influence of a complex is likely. We can see that here all three of them are suspect. The analysis shows us, however, that for the Uninvolved the feeling-tone of the waiting time is very strong so that perseveration may be assumed. For the Informed, on the other hand, setting up house plays a prominent role at present: he has lately been intensely occupied with the question of furniture. The feeling-toned background for the furniture-complex is his fiancée.

Stimulus-Word	CULPRIT			INFORMED			UNINVOLVED		
	Reaction	R-T	Rep.	Reaction	R-T	Rep.	Reaction	R-T	Rep.
1. head	nose	2.0	+	neck	1.0	+	feet	1.0	+
2. green	blue	1.2	+	blue	0.8	+	yellow	0.8	+
3. water	air	1.6	blue	ship	1.0	+	sky	1.0	+
4. to stab	painful	2.0	+	knife	1.4	+	parade	2.2	+
5. murder	manslaughter	1.4	+	deed	1.0	+	death	1.2	+
6. long	short	1.8	+	short	0.8	+	short	2.2	wide
7. five	six	1.4	+	six	0.8	+	seven	1.4	+
8. to give a present	gen- <i>generous</i>	2.0	to give	to give	1.2	+	to give	1.4	+
9. wool	cloth	1.4	+	dress	2.0	+	sheep	1.6	+
10. watch	mechanism	2.2	+	hand	1.6	+	—	—	+
11. table	leg	1.8	wood	bench	1.0	chair	chair	1.2	bed
12. to give	to steal	2.6	+	to take	1.4	+	to give	1.4	+
13. chair	leg	2.0	+	table	1.0	+	seat	2.4	leg
14. sulky	morose	2.8	+	good-natured	1.8	+	cheeky	1.6	+
15. drawer	wood	1.6	+	table	1.8	+	chest of drawers	1.2	+
16. sister	brother	1.8	+	brother	0.8	+	brother	1.4	+
17. lake	water	1.4	+	water	1.2	+	river	1.8	sky
18. ill	well	2.0	—	healthy	1.0	+	healthy	1.4	+
19. burglary	theft	1.8	+	theft	1.4	+	thief	2.0	+
20. to cook	—	—	—	gas	1.0	+	to eat	1.4	+
21. ink	paper	2.6	+	paper	1.8	+	pen	2.6	to write
22. evil	good	2.0	+	good	1.0	+	good	1.4	+
23. writing-case	paper	2.0	+	paper	1.8	+	envelope	2.6	+
24. to swim	good, don't know	2.0	freely, doing well	water	1.8	+	to dive	1.2	+
25. sin	disgrace	1.8	+	deed	2.8	+	pardon	2.2	+
26. blue	black	1.4	+	green	1.4	+	Zurich	1.6	water
27. bread	water	1.6	+	envy	1.2	to bake	corn	1.8	to eat
28. to threaten	—	—	+	hand	0.8	+	murder	2.6	crime
29. key	lo-hole	2.6	+	room	1.2	drawer	burglary	1.8	+
30. rich	poor	1.2	+	poor	0.8	+	poor	1.6	+
31. tree	green	1.2	+	shrub	1.2	+	fruits	1.4	fruit
32. to steal	to take	2.4	+	carpet	3.0	to take	to punish	1.8	thief
33. board	wood	2.8	+	wood	1.6	+	carpenter	1.8	table
34. yellow	black	2.2	+	green	2.8	+	Uri	2.8	+
35. mountain	high	1.8	+	valley	1.2	+	peak	2.0	valley
36. to look for	to find	1.6	+	to find	0.8	+	to find	1.0	+
37. salt	—	—	+	pepper	0.8	+	pepper	1.6	+
38. new	old	2.0	+	old	0.8	+	old	1.2	+
39. to lock up	to imprison	2.6	to release	money	3.2	key	caught	1.6	+
40. to ride	river	2.0	+	to drive	1.2	+	to fall	3.2	+
41. master key	key	1.6	+	key	1.6	+	thief	2.0	+
42. stupid	intelligent	3.0	+	clever	1.0	+	intelligent	1.0	—
43. exercise-book	book	1.8	+	pen	1.0	+	pupil	2.8	+
44. to hide	to find	2.0	+	to play	1.2	+	to find	1.2	+
45. tooth	painful	1.4	+	wild*	1.6	+	dentist	1.8	+
46. right	false	2.2	+	wrong†	0.8	+	false	1.8	+
47. thief	burglar	4.6	criminal	to steal	1.4	+	burglary	1.6	+
48. to find	to steal	2.6	to look for	to look for	1.0	+	a find	2.4	to look for

* [Orig. *Zahn/zahn*, which gives a resemblance, and *wild*, 'wild', is the opposite of *zahn*, 'tame'.]
† [In the sense of 'incorrect']

12. *to give* passes smoothly for the controls. For the Uninvolved, however, the post-critical reaction is disturbed. We learn that he depends on someone else's favour (*to give a present*) during this waiting period, which is very unpleasant for him.

15. *drawer* produces the reaction *chest of drawers* in the Uninvolved, which one might actually have expected from the Culprit. The association of *drawer* and *chest of drawers* just happens to be a very common association by contiguity which would not mean very much even for the Culprit. One could, however, easily be misled by it.

16-32. These sequences are very instructive. 16. *sister* releases the same response from all of them, but the Culprit has the longest reaction-time.

19. The reaction to *burglary* is very "suspicious," particularly in the Uninvolved. It is not known to me that he has ever stolen anything, nor has he admitted any such offence. Even if he carried such guilt within him, his reaction is *de facto* worthless with regard to the complex in question, although the assumption would be tempting. The strong after-effect on the subsequent reaction is, however, absent in the controls.

23. *writing-case* produces disproportionately long reaction-times in the controls. Therefore the utmost caution is indicated here. The analysis could not trace the

influence of a complex in the controls. Perhaps the “difficulty” of the word was mainly responsible.

25. *sin* hits the controls harder than it does the Culprit.

28. *to threaten* has a special effect on the Uninvolved, but not nearly as much as on the Culprit.

29. *key*. The reactions of the controls contain straightforward complex-words.

32. *to steal* reveals strong complex-influence in the controls. In the Informed it is a jocular reminiscence of the furniture-complex; in the Uninvolved the interference stems mainly from his reaction *to punish*, originating from the fact that he considers the loss of his job, which he had suffered, as a punishment.

Stimulus-Word	CULPRIT			INFORMED			UNINVOLVED		
	Reaction	R-T	Rep.	Reaction	R-T	Rep.	Reaction	R-T	Rep.
49. book	—	—	statute-book	cover	1.2	+	to read	1.6	pupil
50. wrong	right	1.2	+	right (noun)	0.8	+	right (noun)	1.8	+
51. frog	water	2.2	tadpole	leg	1.4	+	toad	2.0	+
52. to separate	tadpole	2.6	+	to know	1.2	+	to combine	1.8	+
53. hunger	thirst	1.4	+	thirst	0.8	+	thirst	1.2	+
54. shirt	white	2.0	cloth	waistcoat	1.8	+	to dress	1.8	+
55. child	small	1.8	+	small	2.0	+	mother	1.6	stork
56. to watch	to miss	1.8	de-hide	to attend	1.4	+	to retain	5.0	+
57. necktie	cloth	1.6	+	bow	1.2	+	collar	2.0	+
58. dim	dark	1.6	+	clear	1.4	+	bright	1.4	+
59. trunk	to pack	—	+	key	1.4	+	to lock	1.4	+
60. to hit	to miss	1.8	certain	to find	1.4	+	to shoot	1.4	+
61. statute	-book	1.8	+	law	1.2	+	crime	3.0	+
62. lovable	faithful	1.8	+	dear	0.8	+	hatred	1.0	+
63. to catch	to miss	2.4	to get hold of	chance	2.2	+	thief	3.0	+
64. to quarrel	to love	3.4	—	to argue	1.8	+	to fight	1.4	+
65. police	thief	3.6	+	soldier	1.4	+	crime	3.8	offence
66. large	small	1.6	+	small	0.4	+	king	1.8	+
67. to moon [accuse]	to sigh	1.6	+	to weep	1.8	—	law court	2.0	judge
68. to paint	beautiful	3.8	+	colour	1.6	+	artist	2.0	+
69. chest of drawers	comfortable	2.8	+	drawer	1.8	+	furniture	3.8	+
70. old	new	1.2	+	young	0.8	+	young	1.6	+
71. flower	heath	2.0	+	blossom	1.0	+	garden	2.0	+
72. arm [poor]	rich	1.6	+	leg	0.8	+	rich	1.4	+
73. wardrobe	cupboard	2.0	+	cover	1.0	+	clothing	4.0	furniture
74. wild	brook	2.0	+	tame	1.0	+	lion	2.2	+
75. family	sister	2.2	+	party	2.2	+	house	3.0	+
76. to wash	clean	1.8	+	to comb	1.0	+	to comb	1.6	+
77. cow	bull	1.8	+	ox	1.0	+	milk	1.4	+
78. strange*	to watch	2.2	+	native	1.4	+	native	1.8	+
79. to arrest	thief	3.4	+	thief	1.6	+	criminal	1.8	+
80. story-telling	fairy-tale	2.0	+	story	1.0	+	story	1.2	+
81. mannes	custom	1.8	+	custom	1.4	+	insolence	1.8	+
82. narrow	broad	1.6	+	wide	1.2	+	broad	1.2	+
83. brother	sister	1.4	+	sister	1.0	+	sister	1.6	+
84. jail	prison	1.2	+	freedom	1.2	thief	criminal	2.8	thief
85. stork	child	2.2	+	child	1.4	+	child	1.6	+
86. false	rich	1.0	+	true	1.4	+	honest	1.8	+
87. anxiety	silly	2.4	+	grief	1.2	+	distress	1.4	+
88. beer	wine	1.6	+	wine	1.2	+	wine	1.6	+
89. fire	shot	2.0	+	tavern	1.6	+	heat	1.8	+
90. dirty	clean	1.4	+	cleanly	1.0	+	neat	1.2	+
91. floor	trap	1.6	+	lunge	1.2	+	house	1.6	+
92. linen-cupboard	wood	3.0	+	does not know the word			furniture	1.8	+
93. hay	grass	1.6	+	straw	1.0	+	straw	1.2	+
94. quiet	calm	2.0	+	calm	1.2	+	calm	1.2	+
95. mocking	irony	1.6	+	ridicule	1.0	+	gay	5.2	disgrace
96. to punish	to release	2.4	+	just	1.6	+	offence	2.2	criminal
97. month	week	1.8	+	January	1.2	+	year	1.8	+
98. coloured	green	6.2	+	multi-coloured	1.2	+	water	4.2	+
99. criminal	thief	2.2	murderer	punishment	1.4	+	guilty	3.8	murderer
100. to talk	to be silent	2.6	to speak	to reply	1.0	+	to speak	1.2	+

* [The German text misprints *Freund*, 'friend', here, though it gave *freund*, 'strange', in the original list.]

With these examples it can be most impressively shown what unexpected difficulties the use of the test would have to face, even though it can theoretically be taken as certain that disturbances in associations are as a rule related to emotions and emotions to complexes; which complexes, however? This is the great question.

33. The strongest reaction to *board* is from the Culprit, although the contents of the reaction do not give anything away. The incorrect reproduction of the Uninvolved, however, is again disturbing. It is the result of the perseveration of R.32.

36. The most striking effect of *to look for* is on the Culprit (perseveration!).

39. *to lock up* produces very suspicious reactions. In the controls other complexes again interfere; in the Informed it is the furniture-complex, this time in obvious connection with the question of the money needed for new furniture. For the Uninvolved it is again the complex about his unsatisfactory social position, which I cannot discuss here in greater detail. It is, however, remarkable that at this point the controls utter words indicative of complexes; the perseveration in the Uninvolved also corresponds to this.

41. *master key* acts in the same way, distinguishable from the Culprit's reaction only by lack of perseveration.

44. The action of *to hide* is also not distinguishable. There is interference by complexes in the controls as well.

47. *thief* has definitely the strongest effect on the Culprit, although the reactions of the controls are also complex-words.

48. Again, *to find* releases a feeling-toned reminiscence in the Uninvolved which confuses the result.

50. *wrong* and 54. *shirt* are uncertain.

56. *to watch* releases a complex (a love-affair) in the Uninvolved, thus distorting the result.

57. *necktie* and 59. *trunk* are uncertain.

60. *to hit* has the strongest effect on the Culprit.

63. *to catch out* and 65. *police* act in a very suspicious way, particularly in the Uninvolved; the complex of a secret love-affair interferes here.

67. *to moan* [*accuse*] is uncertain.

In 69. *chest of drawers*, the controls react with *drawer* and *furniture* more adequately than the Culprit with *comfortable*. Yet this reaction can easily be understood as a diversion, as a means of masking the complex. In strongly charged complexes, e.g., in hysteria, such diversions are the rule.

72. One might expect a similar result with *arm* [*poor*] / *leg*.

79. *to arrest* and 84. *jail* release the strongest reaction in the Culprit.

86. *false* and 87. *anxiety* act most strongly on the Culprit.

92. *linen-cupboard*, 96. *to punish*, and 97. *month* are uncertain. The Uninvolved has for *month* the complex of the waiting-period, hence the strong perseveration.

99. The effect of *criminal* is not clear.

[781] The result of the control-experiments is depressing: Obvious complex-symptoms can be seen at the critical points, not only in the Informed but remarkably often also in the Uninvolved, who really should have no theft symptoms at all. As it happened, however, he had two dominant complexes that could also be aroused by the stimulus-words pertaining to the theft complex. This brings home to us a fundamental weakness of the experiment: this is the multiplicity of meanings that the stimulus-words can have. One can hardly imagine how many associations, both concrete and symbolical, such words can arouse. Even for the sole purpose of narrowing the range of these possibilities, wide practical experience is required. We can come somewhat nearer to this goal by compiling as many stimulus-words as possible and by taking those that are as specialized as possible as critical stimuli. A test with only one hundred reactions is definitely inadequate.

[782] But, one is bound to ask with amazement, how could I dare to accuse the young man of the theft in view of such an uncertain state of affairs? Above all it must be stressed that, in addition to the practical test, there exists something that cannot be put on paper: namely those imponderables of human contact, those innumerable and immeasurable facial expressions which, to a large extent, we do not even consciously perceive, which affect only our unconscious, but which are most powerfully convincing. Apart from this indescribable quality that belongs to the experiment *in vivo* there is, however, some more tangible evidence that can be considered convincing: above all, there is the total result which, however, does not appear in the tables and which becomes obvious only by using statistical methods. Let us first consider the average of the reaction-times.

[783] For certain reasons, which I cannot enlarge on here, we take the arithmetical mean.⁴⁷

Mean for ...

<i>stimulus-words</i>	<i>Culprit</i>	<i>Informed</i>	<i>Uninvolved</i>
neutral	1.9	1.0	1.9
critical	2.8	1.5	2.5
post-critical	3.8	1.4	1.8

[784] Reduced to the level of the mean value of the Culprit's neutral reactions, the picture is as shown in Graph A (p. 350).

[785] From Graph A it can be seen that the Culprit is quite different from the controls in that his mean for post-critical reactions is excessively high and even greatly surpasses the mean of the critical reactions. That means, psychologically speaking, that the Culprit's emotions during the critical reactions were much stronger than those of the controls and therefore perseverated with greater intensity. Although the critical mean value of the Informed nearly corresponds to that of the Culprit, the post-critical mean value falls below this level, just because in the Informed the emotions connected with the complex are missing. For him it is nothing but a complex of ideas concerning the experiment. This is even more obvious in the Uninvolved, for whom, as we have seen, the theft-complex is not in question and there is only a complex that occasionally interferes at the same stimulus-words. Actually, the critical mean of the Uninvolved should not have exceeded the neutral mean at all. That this does happen, however, stems from the fact that critical and post-critical stimulus-words together comprise not less than 65 per cent of all the stimulus-words. For this reason alone the critical stimulus-words are very likely to arouse the unconnected complexes.

[786] This graph also shows how the mere knowledge of the complex can compromise the result.⁴⁸ In spite of all difficulties, however, the graph shows considerable material indicting the Culprit.

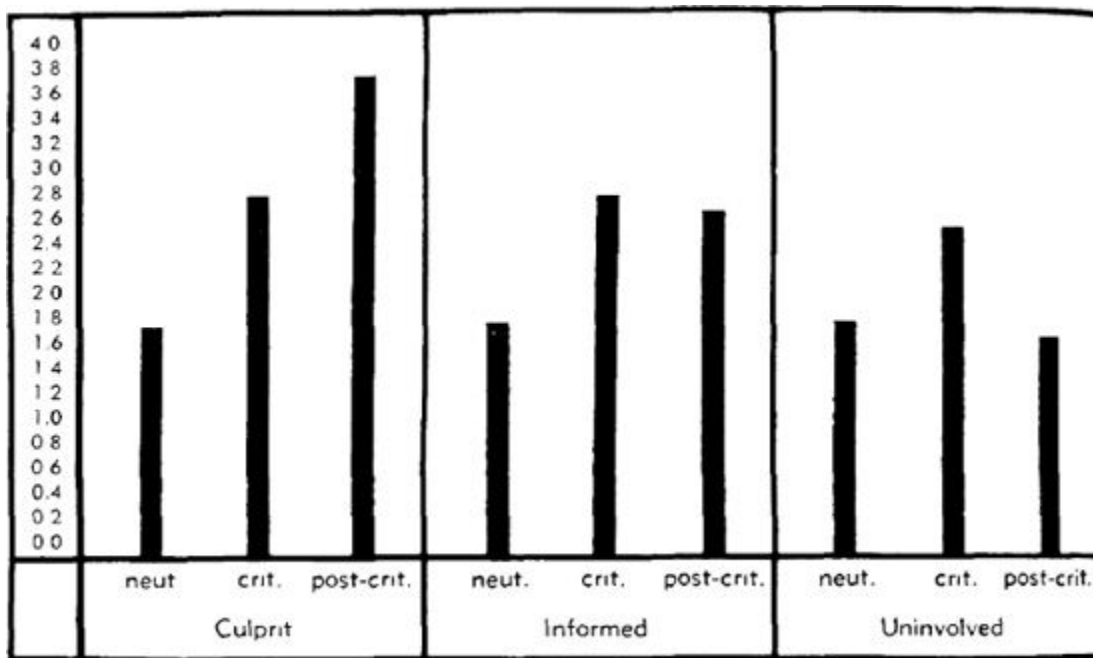

Graph A: Mean Values of Reaction-Times

[787] As we have seen, incorrect reproductions are also among the complex-symptoms. The Culprit reproduced 20 per cent of the reactions incorrectly, the Informed 5 per cent, the Uninvolved 21 per cent [see Graph B].

[788] As Graph B shows, the Culprit made mistakes in not less than 90 per cent of the reproductions of the critical and post-critical responses, the Informed in 80 per cent,

and the Uninvolved in 71 per cent.

[789] Here again we see the strongest weight of evidence in the Culprit, although the figures for the controls are also unexpectedly high.

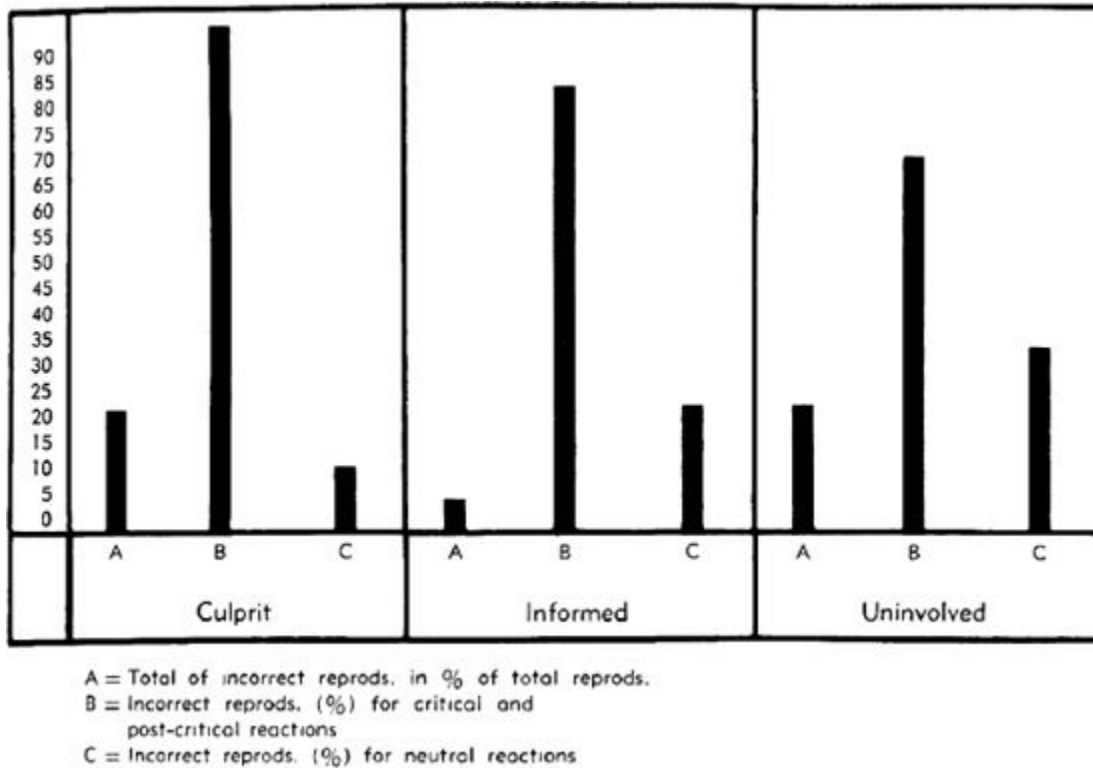

Graph B: Incorrect Reproductions

[790] The question of how often there are reactions to critical stimulus-words that may indicate the complex is an interesting one. According to Wertheimer's data we could expect significant findings. Here we must take into account that any grouping from this point of view is extremely arbitrary. In the graphs I have always emphasized the critical reactions by the type. As can be seen, I have proceeded in a very generous way. This is one source of error: another is the fact mentioned above that the reaction may, contrary to expectation, conceal the complex instead of revealing it. For the Culprit, there are 49 per cent indications of complexes in critical and post-critical reactions, for the Informed 32 per cent, and for the Uninvolved 46 per cent. True, the figure for the Culprit is the highest, but this does not prove very much.

[791] The circumstance that the scene of the crime was somewhat commonplace presented a great difficulty in the experiment; it need not always be so. On the contrary, the scene could in another case be of such a special kind that there would inevitably be a large number of complex-stimulus-words which would appear harmless to the Uninvolved, while the Culprit would continually avoid complex-constellations; as our experience shows, that cannot happen without characteristic disturbances. So much can already be seen from Gross's and Wertheimer's experiments.

[792] In summarizing, I must point out that the Culprit is distinguished only by the quantitative aspects of his complex-symptoms, and that this lends support to the diagnosis of the theft. Had the association method not become a most valuable diagnostic aid for psychopathology, making it possible to get access to pathological complexes, and had we not acquired a certain experience in carrying it out, I would not have ventured on that bold diagnosis. It was, however, the analogies with psychopathology that convinced me. I cannot therefore blame anyone who is not equally convinced. Far be it from me to dash cold water on the interesting and undoubtedly promising efforts and expectations of success in the psychological diagnosis of the criminal case; I am not sorry, however, with this case, to have been put in the position of giving a warning against undue optimism. I am giving it in the interest of this incomparably fine psychological method of investigation, which could easily be brought into discredit by drastic failures. The association method is a delicate tool which, up to now, is suitable for use only by experts, and one has on countless occasions to pay dearly for one's mistakes if one is not very experienced. Thus, as the method stands at present, one must not expect too much of it; it has, however, possibilities all of which can hardly be foreseen. The present article is meant not only as a warning but also as an encouragement to practise the association method, which is one of the most fruitful in all psychology.⁴⁹

ASSOCIATION, DREAM, AND HYSTERICAL SYMPTOM¹

I. THE ASSOCIATIONS

[793] I should like to support and clarify the views on the nature of anomalies of association in hysteria expressed in two others of these Studies² by presenting further investigations. The subject of this research is the following case:

A 24-year-old girl of fair intelligence and average education, physically healthy. The mother suffers from osteomalacia, which has completely crippled her. Otherwise nothing of hereditary relevance can be established. The patient is the youngest child, the only daughter, and has four elder brothers. Healthy up to school age. Very sensitive at school but made good progress. During the second year at school, twitching of the right arm began which soon made writing impossible; then the twitches became generalized until at last a hysterical chorea developed. The patient even became the focus of a small epidemic of chorea among the pupils. The chorea manifested itself in tic-like attacks, said to have lasted 1–2 minutes each. The patient thrashed about and stamped, and occasionally screamed as well. There was no disturbance of consciousness during the attacks, which occurred 15–20 times a day. Menstruation set in at the age of 15 years. With the first period the attacks of chorea ceased quite suddenly (two years before this, the parents had consulted a specialist, who had said that the attacks would stop with menstruation). During the same week, however, dull sensations in the head set in, always towards evening. The sensations gradually assumed the character of heat, which got considerably worse during each period. The complaint increased with the years. At last the heat-sensations began at about 10 o'clock in the morning and gradually increased until they became unbearable. During the last three years the complaint became so bad that the patient was tortured by heat sensations in the head almost all day long. Innumerable attempts at cure by every conceivable method had no success at all. In the morning the patient was occasionally still able to help a little with the housework. From 10 o'clock on she walked restlessly about, persistently complaining about her head. Gradually she became afraid of other people and shunned all social contacts. During the summer she spent the hot weather in the cellar. In the winter she could not stand a heated room. Patient consulted me during the summer of 1905. This was followed by rapid deterioration. She was afraid of going mad, and had hallucinations of white and black figures at night. Was incessantly trying to be admitted to this institution. Was admitted in the autumn of 1905.

Condition: Well-nourished, graceful person. Expression of suffering which appears to be aimed at arousing sympathy; listless behaviour without any energy at all, which is also expressed by a spidery, sloping handwriting. Incessantly complains of heat sensations in the head. Complaints uttered in a whining tone of voice. The patient describes her sensations as follows: “My whole head is blocked up to the neck and quite hot, I must have a temperature of 104° in the head, it is quite tense as if choking; my throat is hot, dry, and parched, and I feel strangled. The feeling of dryness and heat at the back of my throat is terrible. It is always worse after a meal. At the same time my body is quite cold, my hands blue, my feet like ice. It seems to me if I could only once bleed properly from the *nose* I would feel easier. I keep imagining myself *bleeding from the nose and mouth*, a whole wash-basin full; I keep imagining *big clots of blood*. *I am also always dreaming of blood*. Often I dream I am wading in blood, the whole room is full of blood or *blood is gushing out of my nose, mouth, eyes, and ears*. Just as often I dream of *fire*; then everything is *ablaze*.”

When going off to sleep she often imagines she sees a black man who stretches his black hand towards her and clutches her arm. Occasionally she also dimly sees white female apparitions.

Since January 1905 menstruation has ceased, there is severe constipation; flatulence, alleged to have persisted for several months, which makes the abdomen protrude noticeably. The patient finds sitting unbearable, therefore remains standing or walks up and down the room. Profound loathing of meat, avoids everything that makes her hot. She has only to hear steam being let into the radiators and she feels worse. She washes in cold water several times a day and practises gymnastics in her room. These activities are very important for her. In a strange contrast to this are her aversion and dread of regular work, which she thinks is very bad for her condition. She shows a pathological love of orderliness and cleanliness (formerly, she says, she had for a time a compulsion to touch, so much so that she constantly had to touch all the objects in the room while walking about). The patient has no insight at all into the psychological nature of her complaint but is firmly convinced of an organic change in the head; she cannot, however, help laughing when explaining that one of her doctors took her for a case of Graves's disease. She has, of course, no idea of the causes of her illness, as little as the doctors who had hitherto treated her.

[794] There can hardly be any doubt that this is a case of hysteria. The long duration of the illness and the lack of alteration in the syndrome, not quite usual in hysteria—i.e., the unchanging character of the main symptoms—point to a deep-seated paralysis of psychic energy and a complete subjugation of the personality by the illness. The patient has been ill for seventeen years. In considering the peculiarity of the case one must take into account the fact that there has been a continuous development from

the “St. Vitus’s dance” (choreatic tic) into the present condition. It cannot be assumed that the chorea was cured, but everything speaks for the fact that under the influence of the first period it was simply replaced by another manifestation of the basic illness. Her completely childish and asthenic personality shows all the characteristics of the infantile Meige-Feindel tic.³

[795] For the sake of clarity I am now going to describe the association experiments that I carried out with the patient. The patient had treatment from October 1, 1905, to December 21, 1905. The experiments were made during this period. The treatment resulted in a certain success, which had considerable influence on the experiment. The tests were carried out each time in a room that had been only moderately heated (13°C. = 55.4°F.), because the patient could not stand more than about 11°C. = 51°F. for any length of time.

THE ASSOCIATION TESTS

Test I

June 23, 10 a.m. With reproduction test.

<i>Stimulus-word</i>	<i>Reaction</i>	<i>Reaction-time</i> (in 1/5-secs.)	<i>Reproduction</i>
1. head	-ache	6	
2. green	-pip	33	
3. water	-	-	
4. to sting	bee	9	
5. <i>angel (Engel)</i>	-court (-hof) ^{3a}	105	-
6. <i>long</i>	knife	65	-
7. <i>ship</i>	steamship	35	-
8. <i>to plough</i>	field	21	garden
9. wool	to knit	75	
10. friendly	-ness	11	
11. table	-leg	30	
12. to question	-	-	
13. state	-	-	
14. stubborn	stubborn person	40	
15. stalk	flower-stalk	11	
16. to dance	dance-floor	10	
17. lake	Lake Zurich	29	
18. sick	-	-	
19. pride	conceit	19	
20. to cook	cookery school	13	
21. ink	ink-pot	9	
22. bad	badness	39	
23. pin	pincushion	10	
24. to swim	swimming-school	45	
25. <i>travel</i>	travelling-rug	60	
26. blue	Blue Street	35	
27. bread	breadless (unemployed)	20	
28. <i>to threaten</i>	punishment	60	to punish
29. lamp	lampshade	11	
30. rich	riches	21	
31. tree	fruit-tree	23	
32. to sing	singsong	16	
33. pity	regret	35	

34. yellow	yolk	26	
35. mountain	Mount Utlì	23	
36. to play	chess	16	
37. salt	salt-cellar	12	
38. new	Neumünster	15	
39. morals	morality	46	
40. to ride	riding-school	18	
41. wall	wallpaper	12	-
42. silly	silliness	45	-
43. exercise-book (Heft)	school-book (Schulheft)	15	
44. to despise	-	-	
45. tooth	eye-tooth	15	-
46. right	to make right	25	-
47. people	People's Press	23	
48. to sink	jackdaw	50	-
49. book	school-book	15	
50. unjust	-	-	
51. frog	tree-frog	25	
52. to separate (Scheiden)	divorce (Ehescheidung)	32	
53. hunger	to eat	19	
54. white	snow	18	
55. cattle	herd of cattle	32	
56. to attend	attention	30	
57. pencil	pencil-holder	31	
58. dull	-	-	
59. plum	plum jam	66	
60. to hit	-	-	
61. law	-	-	
62. love	unloving	15	
63. glass	water-glass	8	
64. to argue	to quarrel	23	-
65. goat	goat's milk	12	
66. grand	grandeur	15	
67. potato	potato-flour	20	
68. to paint	oil-painting	21	
69. part	part-payment	26	

70. old (<i>alt</i>)	Altstetten	49	
71. flower	bunch of flowers	51	
72. to strike	hammer-stroke	30	-
73. cupboard	linen-cupboard	21	
74. wild	wild duck	21	
75. family	family dinner	26	
76. to wash	-	-	
77. cow	cow's milk	10	
78. guest	guest-book	30	
79. luck	good luck	53	
80. to tell	tale	15	
81. manners	training in manners	55	
82. narrow	-	-	
83. brother	-	-	
84. shame (<i>Schade</i>)	shame-joy (<i>Schadenfreude</i>)	10	
85. stork	stork's nest	26	
86. false	falsehood	37	
87. anxiety	feeling of anxiety	20	
88. to kiss	sister's kiss	65	
89. fire	great fire	28	
90. dirty	-	-	
91. door	lock	21	
92. to elect	election for the Co-op	55	
93. hay	hay-cart	19	
94. still	rest	39	
95. <i>ridicule</i>	ridiculous price	10	ridiculously cheap
96. to sleep	sleeplessness	17	
97. month	monthly meeting	15	
98. coloured	-	-	
99. dog	faithful dog	15	
100. to talk (<i>reden</i>)	consultation (<i>Sprechstunde</i>)	67	

[796] This test was given during the consultation. Let us first look at the associations from the statistical angle. I am limiting myself to the classification into internal and external associations, sound reactions, failures, and indirect associations.⁴ This rough classification suffices for our purposes. The patient produced:

Internal associations	16%
External associations	60
Sound reactions	9
Failures	14
Indirect associations	1
Incorrect reproductions	14

[797] External associations form an exceptionally large majority. The patient, though not unintelligent, lacks higher education (she has only had an elementary education and was often absent from school). A glance at the reactions shows that the external associations consist mainly of combinations of motor verbal patterns, of word compounds. Besides these we also find quite a number of word complements (sound reactions). The large number of failures is striking. If we compare the figures with the average figures for educated women:⁵

Average for Educated Women

Internal associations	35.0
External associations	58.0
Sound reactions	3.3
Failures	1.4

we see that the patient's figures show a much more superficial mode of association; they approximate to the figures of the distraction experiment. Average of the distraction experiment with 100 metronome beats per minute:

Educated Women excluding the Predicate Type

Internal associations	20.8
External associations	62.8
Sound reactions	13.2
Failures	0.4

[798] Thus one might think that the attention was distracted during the experiment. This leads to the question of the cause of the distraction, i.e., what was it that had a disturbing influence? No external causes could be found. Therefore the possibility of a psychological interference must be considered. We need not go far in our search, because the patient is already full of a subject that makes every interest in her environment fade, namely, the complex of ideas regarding her illness. All her attention is riveted to her symptoms and only a small remnant is available for the association experiment; hence the superficial reaction-type. She is so much absorbed by her illness that she hardly allows the meaning of the stimulus-word to reach her; in most cases she is quite satisfied simply to grasp the outer form of the word and her intellectual effort is confined to finding a commonplace association to the stimulus-word. She listens with only "half an ear" and lets the stimulus-words, as it were, slip away from her. She cannot bring herself to devote her attention to the experiment; this is apparently not interesting enough compared with the complex. The small amount of self-control sometimes dwindles to nothing (failures), and this actually often happens wherever a commonplace combination of words is not ready on the tip of her tongue; this also often occurs when the stimulus-word has aroused emotionally charged associations, as we shall see later. As soon as she realizes that the reaction is not at her fingertips, she completely refrains from forcing one. Here the experiment reveals the meaning of the clinically conspicuous aboulia, which, as usual, consists in the fact that the whole interest is absorbed by the complex, i.e., by the hysterogenic complex underlying the manifest illness, so that nothing remains for the environment.⁶

[799] The probable mean of the reaction-times of the experiment is 5.2 seconds; it is thus very high. We believe that such prolonged intervals are due to certain emotional

inhibitions.

[800] As in the case reported in “Psychoanalysis and Association Experiments,” an analysis of the patient was impossible because she appeared quite indifferent and did not want to deal with any questions that did not concern her symptoms. The repression, i.e., the inhibition arising from the pathogenic complex, was at that time still too strong.

[801] After the consultation during which this test was taken, the patient went home again. As already mentioned, the illness grew rapidly worse. Three months later she was admitted to this hospital.

Test II

October 5, 5 p.m.

1. head	headache	1.6
2. green	—	—
3. water	water-works	2.8
4. to sting	stinging-nettle	2.4
5. angel	—	—
6. long	long-winded	2.2
7. ship	—	—
8. to plough	—	—
9. wool	cotton-wool	2.2
10. friendly	friendliness	3.0
11. table	table-mate	2.2
12. to question	question-mark	6.6
13. state	—	—
14. stubborn	stubborn person	3.2
(<i>trotzig</i>)	(<i>Trotzkopf</i>)	
15. stalk	flower-stalk	6.0
16. to dance	dance-floor	4.0
17. water	water-lily	9.0
18. sick	sickly	3.4
19. pride	—	—
20. to cook	—	—
21. ink	ink-blotter	4.6
22. bad	badly	—
23. pin	pincushion	2.4
24. to swim	swimming-pool	4.0
25. travel	—	—
26. blue	—	—
27. bread	—	—
28. to threaten	—	—

[802] The patient gave up completely at No. 28, declaring she could not stand any more. She could not be induced to stay in the consulting room any longer. Therefore it was not possible to make a reproduction test. An analysis was equally impossible. Nevertheless a number of points emerge from the result. Above all, one is again struck by the peculiar character of the associations: there is nothing but word combinations and there are numerous failures. Expressed in percentages there are:

Tests	I	II
Internal associations	16%	0%
External associations	60	46.4
Sound reactions	9	14.2
Failures	14	39.2
Indirect associations	1	0

[803] This is quite an unusual picture. The patient's behaviour during the test was characteristic. She held her head in both hands, and from time to time she sighed because of the unbearable heat in her head, caused by the heated room (55°F.! The patient is unaware that she experiences 55° as pleasantly cool in summer, while she finds the same temperature unbearable in winter. The operative factor in the air temperature is the mere concept!) During the test she obviously was completely absorbed by the complex. It is not surprising therefore that she could not spare any attention for the tedious experiment. Thus we have a distraction phenomenon again, but in a considerably higher degree than in Test 1. The deterioration of her condition decidedly increased the distraction of her attention; i.e., her attention is, even more than previously, directed towards the complex, so that she participates less in the experiment. To direct the attention towards the experiment is obviously very strenuous for her, so that she is already tired after 28 reactions and has to abandon the test. Her available energy has been reduced to a minimum. This is already shown in the enormous number of failures, which have almost tripled compared with the first test. She again fails at stimulus-words that do not immediately arouse a commonplace combination of words. But not all failures can simply be due to the lack of commonplace word combination (e.g., for *to cook* there are the common combinations *cooking-stove*, *cookery*, etc.; for *state* there are *statecraft*, *state-house*, etc.; for *travel*, *travelling bag*, etc.). Nor can all the long reaction-times be accounted for by verbal difficulties (e.g., *water*, with 9.0 secs., with which there are many common combinations). We must also consider the possibility of these disturbances being caused by affects that may be due to unconscious inhibitions arising from the pathogenic complex underlying the illness.

[804] The probable time-mean of the test is 5.2 seconds (the failures taken as 20.0 secs., though usually we waited up to 30 secs.). The probable mean is therefore very high.

Test III

October 9, 5 p.m. With reproduction test.

1. lamp	lamp-chimney	1.8	
2. rich	riches	1.8	
3. tree	tree-trunk	1.4	
4. to sing	singsong	3.2	<i>operetta</i>
5. pity	—	—	<i>pitiful</i>
6. yellow	golden-yellow	3.2	
7. mountain	mountain range	4.8	
8. to play (spielen)	operetta (Singspiel)	6.6	<i>ball</i> (Spielball)
9. salt	salt-cellar	6.8	
10. new	new moon	3.0	
11. morals	—	—	<i>morality</i>
12. to ride	riding-school	3.0	
13. wall	wall-painting	4.6	
14. silly	silliness	4.0	
15. exercise-book (Heft)	school-book (Schulheft)	2.2	
16. to despise	—	—	<i>despicable</i>
17. tooth	toothache	2.0	
18. right	—	—	
19. people (Volk)	fair (Volksfest)	2.0	
20. to stink	—	—	
21. book	school-book	3.8	
22. unjust	—	—	
23. frog	tree-frog	2.4	
24. to separate (scheiden)	—	—	<i>divorce</i> (Ehescheidung)
25. hunger	hunger-pangs	5.0	
26. white	snow-white	2.0	
27. cattle	herd of cattle	4.1	
28. to attend	attention	2.4	
29. pencil	pencil-holder	6.6	
30. dull	—	—	
31. plum	—	—	
32. to hit	—	—	

[805] This test shows some changes compared with the previous ones. The result expressed in percentages is as follows:

Tests	II	III
Internal associations	0.0%	3.1%
External associations	46.4	59.3
Sound-reactions	14.2	6.2
Failures	39.2	31.2
Incorrect reproductions	—	18.7

[806] Here we have one more distraction-experiment. The probable time-mean is

Test I	Test II	Test III
5.2 secs.	5.2 secs.	4.6 secs.

[807] Compared with the second test there is some shortening of the reaction-time, which is probably to be explained mainly by the relative reduction in the failures. This result may perhaps permit the conclusion that the patient had pulled herself together a little. This seems also to express itself in the fact that in spite of the early

failure in the association test she was willing to do the reproduction test. This test also went four reactions further than the previous one (28, 32). The number of sound reactions has not inconsiderably decreased, to the benefit of the external and internal associations. This also allows us to infer some improvement in her concentration.

Test IV

October 17, 5 p.m. With reproduction test.

1. law	against the law	5.0
2. love	unloving	3.0
3. glass	glass-cupboard	2.0
4. to argue	–	–
5. goat	goat's milk	2.8
6. grand	grand city	4.8
7. potato	potato-field	5.6
8. to paint	painter's studio	5.4
9. part	partner	3.0
10. old	old town	9.6
11. flower	flowerlet	2.4
12. to strike	–	–
13. cupboard	linen-cupboard	5.6
14. wild	–	–
15. family	family dinner	4.0
16. to wash	–	–
17. cow	cow's milk	3.2
18. guest	guest-book	3.4
19. luck	good luck	2.8
20. to tell	–	–
21. manners	training in manners	2.8
22. narrow	–	–
23. brother	–	–
24. shame (<i>Schade</i>)	shame-joy (<i>Schadenfreude</i>)	3.6
25. stork (stimulus-word first misunderstood–then failure)		
26. false	falsehood	8.2
27. anxiety	feeling of anxiety	3.0
28. to kiss	sister's kiss	4.0
29. fire	fire-blackened	6.8
30. dirty	dirty marks	7.0
31. door	trap-door	4.8
32. to choose	–	–
33. hay	–	–

[808] This test was carried out at a time when the patient was not so well (one of those fluctuations that are not unusual in the course of hysteria). The test certainly again looks like a distraction experiment. Apart from one exception (*to kiss / sister's kiss*) the patient so to speak never bothers with the meaning of the stimulus-word but contents herself with the perception of the outer word-form. There were no mistakes in reproduction. The test yielded two reactions more than the previous one (32, 34). In percentages:

<i>Tests</i>	<i>II</i>	<i>III</i>	<i>IV</i>
Internal associations	0.0%	3.1%	2.9%
External associations	46.4	59.3	58.8
Sound reactions	14.2	6.2	5.8
Failures	39.2	31.2	32.3
Incorrect reproductions	–	18.7	0

The probable time-mean is:

<i>Tests</i>	<i>II</i>	<i>III</i>	<i>IV</i>
	5.2	4.6	5.4
	secs.	secs.	secs.

[809] Thus we again have an increase in the reaction-time, which we may ascribe to the unfavourable attitude of the patient at that moment. The lack of incorrect reproductions may, in view of the small number of reactions, be accidental, but it is also possible that this time the patient remembered the reactions in order not to make any mistakes with the reproduction later on.

Test V

	November 9, 5 p.m.	With reproduction test.	
1. ridiculous	–	–	
2. <i>to sleep</i>	<i>rest</i>	1.8	<i>tired</i>
3. <i>month</i>	–	–	<i>time</i>
4. coloured	Negro	6.3	
5. dog	domestic animal	3.4	
6. to talk	to tell a story	4.8	
7. coal	to iron	4.0	
8. moderate	–	–	
9. song	tune	3.6	
10. to assume	facts	10.0	
11. <i>pain</i>	<i>ill</i>	5.2	<i>illness</i>
12. lazy	to work	5.4	
13. moon	–	–	

14. to laugh	merry	–	
15. coffee	breakfast	2.2	
16. wide	measure	3.6	
17. air	warm	5.0	
18. to frighten	anxiety	7.6	
19. plate	to eat	7.0	
20. <i>tired</i>	<i>to sleep</i>	4.4	<i>bed</i>
21. <i>intention</i>	<i>to damage</i>	7.4	?
22. to fly	–	–	
23. eye	–	–	
24. strong	vigorous	2.6	
25. fruit	–	–	
26. <i>to be busy</i>	<i>industrious</i>	3.0	<i>to work</i>
27. sail	ship	7.0	
28. modest	content	6.4	
29. ground (does not understand stimulus-word at first)	land	10.0	
30. to whistle	sound	6.4	
31. purpose	cause	3.4	
32. <i>hot</i>	yes, yes, in here	4.0	<i>light</i>
33. hand	limb	3.0	
34. <i>to wake</i>	<i>awake</i>	3.0	<i>to get up</i>
35. apple	don't know <i>Affeltrangen (place)</i>	13.6	
36. naughty	–	–	
37. mouth	teeth	7.2	
38. to drink	liquid	4.4	
39. <i>bed</i>	<i>tired</i>	7.2	<i>to sleep</i>
40. <i>pretty</i>	<i>beautiful</i>	40	?
41. <i>danger</i>	–	–	<i>terrible</i>
42. to visit	–	–	
43. <i>worker</i>	<i>occupation</i>	6.4	<i>to be occupied</i>
44. high	mountain	4.6	
45. axe	wood	9.4	
46. to remember	to watch	2.0	
47. path	a walk	5.0	
48. round	sphere	2.4	
49. <i>blood</i>	–	–	<i>red</i>
50. devoted	–	–	
51. precaution	to watch	–	
52. <i>funny</i>	<i>story</i>	4.8	<i>to laugh</i>
53. market	to shop	3.0	

54. to forget	thought	5.4	story
55. drum	noise	5.0	
56. free	free-spoken	6.6	
57. carriage	to ride	3.2	
58. to eat	appetite	5.0	
59. insolence	–	–	
60. fast	to walk	2.4	
61. chimney	smoke	2.6	
62. enjoy	pleasure	3.2	
63. parson	sermon	2.4	
64. light	weight	5.6	
65. neck	slim	7.0	
66. to wish	present	5.6	
67. stone	hard	8.8	
68. noble	rich	5.4	
69. hose	rubber	2.6	
70. to love	beautiful	9.4	?
71. tile	roof	3.4	
72. mild	temperature	4.8	
73. greed	craving for money	6.4	
74. to search	–	–	
75. blanket	–	–	
76. good	–	–	
77. leaf	–	–	
78. to torture	illness	6.0	
79. station	to go on a journey	4.8	

[810] This test shows quite a different association type compared with the previous tests. It is as if the patient had suddenly found a different attitude.⁷ The percentages are as follows:

Tests	II	III	IV	V
Internal associations	0%	3.1%	2.9%	56.9%
External associations	46.4	59.3	58.8	18.9
Sound reactions	14.2	6.2	5.8	1.2
Failures	39.2	31.2	32.3	21.5
Indirect associations	0	0	0	1.2
Incorrect reproductions	–	18.7	0	21.3

[811] Looking at the association tests, the results of which we have given here in figures, we see that the patient's reactions have assumed a normal character. She now

goes into the meaning of the stimulus-word and thus produces a preponderance of internal associations.⁸

[812] The abnormal component parts have rather diminished, so that, for instance, the number of sound reactions does not exceed the normal mean. Only the number of failures is still abnormally high; it has, however, considerably decreased compared with the earlier tests. The patient's perseverance has increased remarkably, in that this test lasts longer by 45 reactions than the previous one. The time-mean is 5.4 seconds, as in the previous test. The reaction-time is thus still very long.

[813] This test was carried out three weeks after the previous one. In the meantime the treatment had clearly improved the patient's condition. Therefore one may ascribe the improvement of the association type also to this fact. In the previous tests we mainly stressed the lack of entering into the meaning of the stimulus-word, the absolute preponderance of external associations, the enormous number of failures, and the rapid onset of fatigue as pathological signs and as an abnormal domination of the patient's interest by the complex. The improvement in the condition is thus particularly expressed, from the psychological point of view, in the fact that the patient again takes a more or less sufficient though quickly tiring interest in objective processes. The treatment is resolving her possession by the complex. Her personality is gradually being freed from the tyranny of the illness and is again able to assimilate objective material, in other words to adapt itself again to the environment. As stigmata of hysteria the following are, however, still present: the enormous number of failures; the long reaction-times and other complex-characteristics, i.e., signs of a pathological emotionality, which is, as we know, the psychological foundation of hysteria.

Test VI

December 1, 5 p.m. With reproduction test.

[814] The test comprised one hundred reactions. It was concluded not because of the patient's fatigue, but because I considered one hundred reactions enough to analyze. I shall describe and discuss the test in individual sections.

[815] I should like to remark at the outset that the probable time-mean of this test is 5.2 seconds. It is thus not lower than the preceding ones. In spite of this apparent similarity, however, the temporal aspects are in their averages entirely different from those in the previous tests. For the purpose of discussing these relations I am splitting each test up into sequences of six to ten reactions, and for each sequence I have calculated the arithmetic time-means.⁹ I have arranged the means thus obtained in curves below.

Test I. The curve fluctuates very much. Near the beginning there is a line of relatively short times which, after various fluctuations, rises higher and higher. Towards the end there are very strong increases in reaction-times which, however, are again somewhat shortened, but do not reach the initial level. The curve gives the impression that the patient has noticed the excessive times and therefore pulled herself together for a few reactions. Test I was carried out during the consultation. As reported in the case-history, the condition afterwards rapidly deteriorated. This deterioration shows in the curve of ...

Test II. Here the curve starts rather high, and after pulling itself together for a short time it rapidly collapses.

In *Test III* the curve begins low. The patient had (as she told me at the time) made a resolution to take great pains this time to answer quickly. The carefully gathered energy, however, does not last; the reaction-times increase progressively until they become very high. The observation of this weakness probably induced the patient to a little spurt at the end which, however, exhausts the remains of her energy.

Test IV. The curve starts a little higher than last time (the patient was, as we mentioned before, indisposed psychologically at the time of this test). Here too there is a steady increase in the reaction-times.

Tests I–IV mainly yielded external associations and failures. We can already see from the curves that this mode of association is linked with rapidly increasing reaction-times.

Test V. Here the curve begins very high (perhaps to be explained by the fact that the patient was still discouraged by the previous tests and therefore had some resistance against the experiment). It decreases quickly, however, and then, after a stronger fluctuation stays near the centre, though rising slightly. Then there is a more noticeable and longer-lasting final spurt, which, however, ends in a quick and steady increase of the reaction-times. The final spurt has completely exhausted the patient's energy.

Test VI. In this last test (after two months' treatment) the curve begins at a medium height and then falls quickly to a very low level, which is fairly well maintained during the whole test without any appreciable fluctuations and only towards the end shows a tendency to rise. Test V shows, at least in its middle parts, a tendency towards steadiness, which is finally reached in Test VI. Tests V and VI are, however, those that show a normal mode of association. Thus the normal type appears to go with the tendency to steadiness in the reaction-times. At the same time a very low level is reached and maintained in Test VI.

I should like to mention that the one hundred stimulus-words given in Test I were used a second time in Tests II–IV and a third time in Test VI. As the curves show, repetition of the tests had no noticeable effect in reducing the reaction-times. Tests II–IV made one rather suspect the contrary. According to Kraepelin's findings, a relatively rapid shortening of the reaction-time is actually to be expected because of a fixation of the reactions. In Test VI, however, there are not only no fixations but entirely different reactions (in accordance with the new attitude that had first appeared in Test V).

[816] As has repeatedly been indicated in the discussion of the curves, the increased reaction-times are linked with a strong tendency towards fatigue, i.e., with a complete inability to detach the attention from the syndrome. The patient has great difficulty in directing her attention to anything but her illness for any length of time; because of the exertion she tires very quickly. The curves representing the time-extensions are therefore also curves representing weakness of energy. This immediately becomes obvious when we turn them over and read them from right to left. Then they look like the *work-graphs* of an easily tiring neurotic (will-fatigue!). In particular we notice the facilitation and the increased reaction-times in curves I, V, and VI, the final spurt in curves I, III, and V. In curves I and VI the progressive fatigue is clearly marked. This shows that in certain cases the association experiment also gives information on energy and fatigue.

Analysis of the Associations Obtained in Test VI

I am setting the associations of Test VI side by side with those of Tests I–V for the purpose of analytical comparison (time in seconds):

<i>Tests</i>		<i>I</i>	<i>II–IV (V)</i>	<i>VI</i>
1. head	-ache	1.2	headache 1.6	pa-head-pains 1.8
2. green	-pip	6.6	–	forest 3.2
3. water	–		water-works 2.8	deep 1.4
4. to sting	bee	1.8	stinging- nettle 2.4	bee 2.8
5. angel	-court	21.0 [?] ¹⁰	–	–
6. long	knife	9.0 [?]	long-winded 2.2	road 5.0
7. ship	steamship	7.0 [?]	–	ocean 4.0
8. to plough	field	4.2 [garden]	–	to demand/ to give 7.4
9. wool	to knit	15.0	cotton-wool 2.2	(stimulus- word not understood) to knit 10.2
10. friendly	-ness	2.2	friendliness 3.0	– [people]
11. table	(does not at first un- derstand stimulus word, then:) -leg	6.0	table-mate 2.2	room 9.0

1: *head*, of course, arouses the complex in that the patient has localized the main symptoms in the head. Although the times are not long, we find a disturbance by a slip of the tongue in Test VI instead. The two previous reactions have the superficial character that we not infrequently find in complex-reactions and that are meant to make light of the complex.

3: *water* appears still to belong to the field of the perseverating feeling-tone.

5: *angel* shows complex-characteristics. The patient is not religious but still childlike. She has often during recent months had thoughts of dying; she even had one evening hallucination of the “black bone-man” stretching out his hand towards her. This is reason enough for the complex-interference. We have, however, to go even deeper. The patient has an intimate and confidential relation to her mother. The two women are moreover tied together through severe illness. The mother suffers from osteomalacia and is totally crippled. The mother is for the daughter not only an example in a moral respect but perhaps also a foreboding of her own fate. The fear of having to expect a fate similar to that of the mother may not be very far from the patient. Lastly, one has to remember the fact that young girls and hysterics talk of *dying* when they want *to love*.

The disturbances last from *angel* to 8. In Test I there was even an amnesic island.¹¹

In 8, another stimulus-word was substituted in Test VI to make the complex more precise: *to demand* is followed by 7.4 seconds, the next stimulus-word *wool* is misunderstood, with 10.2 secs. With *to demand* I get the patient to produce further ideas:

The patient literally says: “I thought you (the author) demanded too much of me, it is *too much* if you are always wanting me to get well.” It seemed to me that the patient was somehow “skipping over it,” although in hysterics the thought of the doctor who carries out the treatment tends to be associated with strong emotional charges.¹² Therefore I simply said: “*The demand*.” The patient starts slightly, saying: “I don’t know what you mean—I really cannot think what you can still want of me.” Then she suddenly bursts out into loud laughter, blushes, and says no more. The progress of this analytical detail is as follows: First the patient accuses me of demanding too much of her, then there are the familiar negativistic excuses and lastly, behind laughter, a strong emotionally charged thought which may not be difficult to guess. The laughter is diagnostically important: it often indicates in psychoanalysis that a complex has been touched. It is obvious that no one but the patient *demand*s anything that is *too much*. Freud says: “Many of my neurotic patients who are under psychoanalytic treatment are in the habit of confirming the fact by a laugh when I have succeeded in giving a faithful picture of their hidden

unconscious to their conscious perception; and they laugh even when the content of what is unveiled would by no means justify this. This is subject, of course, to their having arrived close enough to the unconscious material to grasp it after the doctor has detected it and presented it to them.”¹³

10, *friendly* seems to be critical in Test II, but not in Tests I and VI.

Analysis: First there are strong inhibitions (“I don’t know anything,” etc.). Then “I was thinking of you, sir. You were not nice to me last time.” This reminiscence refers to a definite incident, when the patient had transposed her bad temper on to me and alleged afterwards that I had been in a nasty mood (“transitivism” in affect). This idea seems enough to explain the disturbance. I indicated before that the patient transposed the “demanding too much” on to me, she also fits me out with *her* bad temper and accuses me of being unfriendly to her. She thus *demand*s that I should be friendly to her, and if I am as usual I am not friendly enough, for she still complains of my unfriendliness. So she wants even more friendliness from me; that allows me to conclude that the patient is erotically not indifferent to me. Of course, I cannot give in to this demand. Thus the patient demands too much. She only acquired this aspect of the complex while she was here. The complex disturbances may therefore increase at *friendly*.

<i>Tests</i>		<i>I</i>	<i>II-IV</i>		<i>VI</i>
12. to question	–		question-mark	6.6	answer 5.8
13. state	–		–		state-house 11.6
14. stubborn (<i>trotzig</i>)	stubborn person (<i>Trotzkopf</i>)	8.0	stubborn person	3.2	character 6.0
15. stalk	flower-stalk	2.2	flower-stalk	6.0	flower-stalk 10.6
16. to dance	dance-floor	2.0	dance-floor	4.0	ball 5.4
17. lake (water)	Lake Zurich	5.8	water-lily	9.0	deep 7.2
18. sick	–		sickly	3.4	hospital 6.2 very
19. pride	conceit	3.8	–		yearning/nostalgia 7.4
20. to cook	cookery school	2.6	–		kitchen 3.6
21. ink	ink-pot	1.8	ink-blotter	4.6	to write 2.0

In 12, *to question*, obvious complex-disturbances are aroused that involve the subsequent reaction as well.

Analysis: “I thought the Doctor was asking me a lot, I know absolutely nothing more—I certainly don’t know anything else.” The patient said this with emphasis and an angry ill-humoured face, which was in striking contrast to her usual politeness and submissiveness; then she suddenly burst out into loud laughter, which she tried to suppress by expressing anger: “Oh, what a strain!”—“This is impossible!”—“I have never thought of that!,” because she did not think of the special and, for a young girl, so immensely important meaning of the word *question* at the moment of the reaction.

She thinks this meaning has only now occurred to her; “of course, she never thinks of such a thing otherwise.” Thus we have here a further indication of the presence of an erotic complex.

16: *stubborn* is very suitable to bring out a reference to the ego. Particularly if the reaction to it is *character* or *quality* or *misbehaviour*, we may suspect the subject of the experiment behind it. With *character* the reference to the ego becomes obvious, hence probably also the stronger disturbances, compared with the previous reactions.

Analysis: “People are often stubborn—for instance, I was, too, when I was a child. Once I was rather stubborn and did not want to go to school any more—I was twelve years old then, I think. From then on I did not go to school.”

It is known that the patient could no longer go to school because of her St. Vitus’s dance; now she interprets this illness as misbehaviour, and here she even says she did not go to school any more out of *stubbornness*. But if we ask her in another context why she no longer went to school, then she says she was very ill at that time. For the moment we must be satisfied with this information. The twelfth year of life has, however, another significance which is infinitely more important, as we shall see later on.

Like *stubborn/stubborn person*, 16, *to dance/dance-floor* skips over the deeper meaning. Only the reaction *ball*, which goes more thoroughly into the meaning of the stimulus-word, brings about a distinct complex-disturbance. *Dance-floor*¹⁴ is something that is abhorrent to the circles to which the patient belongs, while *ball* is actually the legitimate opportunity to start erotic relationships. The patient is compelled to laugh when she is asked for associations to *ball*; she therefore may well have erotic ideas.

In 19, *yearning* was given as a stimulus-word in Test VI.

Analysis: The patient declares stubbornly and with obvious resistance that absolutely nothing but *nostalgia* comes to her mind in response to *yearning*. I insisted something would occur to her. To this, suddenly loud laughter, which is at once angrily suppressed: “Oh no, now that spoils it for me—this is boring!” We had the same reaction to *demand*. There is probably a strongly repressed erotic desire.

Tests		I	II-IV	VI
22. bad	badness	7.8	badly 3.8	<i>disobedient</i> 7.6 [child]
23. pin	pincushion	2.0	pincushion 2.4	<i>child/work</i> 7.8 [dear]
24. to swim	swimming-school	9.0	swimming-pool 4.0	public baths 6.4
25. travel	travelling-rug	12.0 ?	-	railway 4.8
26. blue	Blue Street	7.0	-	colour 1.8
27. bread	breadless (unemployed)	4.0	-	baker 2.0
28. to threaten	(does not understand stimulus-word) punishment	12.0 (to punish)		to expect/visit 3.6

Here ends Test II

Test III

29. lamp	lampshade	2.2	lamp-chimney 1.8	light 4.0
30. rich	riches	4.2	riches 1.8	money 6.8
31. tree	fruit-tree	4.6	tree-trunk 1.4	garden 3.6
32. to sing	singsong	3.2	singsong 5.2	concert 5.2

22: *bad* is taken personally; *disobedient* seems to express the complex best.

Analysis: "I was bad to you the other day—years ago too I was often bad—and disobedient at school, etc."

23: The association *child/work* is peculiar and cannot be explained by the patient. The reproduction yields the more suitable association *dear*. Preceding is the school-complex, which is most closely connected with the concept of *work*. I should like to remind the reader that the stimulus-words *to work* and *worker* in Test V produced complex-disturbances. Moreover, the patient always stresses that she is not "lazy," she would like to do the right kind of work; she also complained of certain relatives who said of her that all she was suffering from was "laziness." The stimulus-word *child* is a word which, as a rule, has a critical effect in the erotic complexes of women.

There are complex-characteristics in 25: *travel*.

Analysis: "Oh, I am thinking of a nice journey to Italy that I should like to do one day"—long interval. With great embarrassment: "Honeymoons are spent in Italy, too."

28, Test VI: *to expect*.

Analysis: "I don't expect anything—absolutely nothing—yes, health—and—," loud laughter again which the patient tries angrily to suppress. Thus the same reaction again as to *demand* and *yearning*.

30: *rich*.

Analysis: “I should like to be rich, then I could stay here a long time for treatment”; then there are strong inhibitions that bar any further ideas. For the patient “to stay a long time for treatment” equals “to remain for a long time in a personal relationship to the doctor.”

<i>Tests</i>		<i>I</i>	<i>II-IV</i>		<i>VI</i>	
33. <i>pity</i>	regret	7.0	–		[pitying]	–
34. <i>yellow</i>	yolk	4.8	golden-yellow	3.2		canary-bird
						5.0
35. <i>mountain</i>	Mount Uti	4.6	mountain-range	4.8		mountain-range
						10.8
36. <i>to play</i>	chess	3.2	operetta	6.6	[ball]	ball
						6.8
37. <i>salt</i>	salt-cellar	2.4	salt-cellar	6.8		to cook
						2.2
38. <i>new</i>	Neumünster	3.0	new moon	3.8		house
						7.0
39. <i>morals</i>	morality	9.2	–		[morality]	<i>hope/happy</i>
						8.2
40. <i>to ride</i>	riding-school	3.6	riding-school	3.0		path
						1.8
41. <i>wall</i>	wallpaper	2.4 ?	wall-painting	4.6		room
						5.2
42. <i>silly</i>	silliness	9.0	silliness	4.0		se-sensible
						7.2
43. <i>exercise-book (Heft)</i>	school-book (Schulheft)	3.0	school-book	2.2		copy-book (Schreibheft)
						5.2

R.33: *pity*.

Analysis: “I cannot imagine at all what *pity* might have to do with me—oh, perhaps with my illness—people ought to pity me.”

I give here only one example of the inhibitions the patient had about this word: in fact, the resistance lasted much longer and also showed itself in a suffering facial expression. The tendency to arouse pity is of great significance in the history of the patient’s illness. Through her illness she achieved not having to go to school any more. Later on she was the “pitied” centre of the whole family. The patient must have some, though dim, awareness of this role; it may perhaps be the origin of the strong resistance.

35: *mountain*.

Analysis: Does not want to know anything about it, she has nothing to do with mountains, this is no concern of hers. She has also never been on a mountain, although she would like to go once to the Alps, but this is, of course, impossible because of her illness, and then she cannot even travel by rail, she cannot stand it.

The patient speaks quite negatively, as if a mountain-trip was of no importance to her. A few days before the test I made a trip into the mountains, after which the patient was unhappy because I had not taken her with me; she had never seen the mountains close to. She completely repressed this incident, without actually any obvious reason, unless “travelling” was of a certain complex-significance. She has all

sorts of erotic fantasy relations to the doctor. A journey with the “erotic symptom figure” is a metaphor for a “honeymoon.” This is probably the reason why this event was sexually repressed.

38: *new*.

Analysis: The patient has become an intimate friend of a lady who moved into a *new house*, to which the patient takes a peculiar liking. She envies the lady particularly for the way she runs her house. “I shouldn’t mind something like that.” This interest seems to be symptomatic. The analysis meets with great resistances (“one often moves into a new house—we at home also have a new apartment,” etc.). I now ask pointedly: “When does one move into a new house?” This rather general question causes the patient great embarrassment, she blushes and confesses: “When one gets married.” Thus she has assimilated the “new house” to her erotic complex.

39. (Test VI): *hope*. The analysis at once produces lasting giggles and that says enough. The laughter here is, however, very inadequate. R.23, *child* also produced a disturbance. We shall come back to this complex at 69.

42: *silly*. The analysis yields self-reproaches about the time when the patient left school for good (12th year of her age). She reproaches herself for not having learned enough because of lack of energy, and for being therefore “silly.”

<i>Tests</i>		<i>I</i>		<i>II-IV</i>		<i>VI</i>
44. <i>to despise</i>	—		—		[despicable]	people 7.2
45. <i>tooth</i>	<i>eye-tooth</i>	3.0 ?	toothache	2.0		mouth 3.6
46. <i>right</i>	<i>to make right</i>	5.0 ?	—			to check (up on) 6.6
47. <i>people (Volk)</i>	People's Press (<i>Volksblatt</i>)	4.6	fair (<i>Volkstfest</i>)	4.0		crowd 5.0
48. <i>to stink</i>	<i>jackdaw</i>	10.0 ?	—			to die/cemetery 3.4
49. <i>book</i>	<i>school-book</i>	3.0	<i>school-book</i>	3.8		to read 2.2
50. <i>unjust</i>	—		—			wedding/church 3.2
51. <i>frog</i>	<i>tree-frog</i>	5.0	<i>tree-frog</i>	2.4		green 2.0
52. <i>to separate (scheiden)</i>	<i>divorce (Ehescheidung)</i>	6.4	—		[divorce]	divorce 4.0
53. <i>hunger</i>	<i>to eat</i>	3.8	<i>hunger-pangs</i>	5.0		dog/to bark 6.8
54. <i>white</i>	<i>snow</i>	3.6	<i>snow-white</i>	2.0		snow 3.2
55. <i>cattle</i>	<i>herd of cattle</i>	6.4	<i>herd of cattle</i>	4.2		herd of cattle 9.4

44: *to despise*.

Analysis: The patient always feels slighted; she felt her incomplete education as something for which she must be despised; people also despised her for her illness, which they interpreted as laziness. Is there perhaps anything else in her illness that

makes her particularly despicable? We know that sexual self-reproaches tend to be connected with this.

46: *right* also shows disturbances. The analysis yields only generalities that are difficult to interpret. Is there perhaps anything in her activities that is not or was not “right”?

53 (Test VI): *dog* has a very long reaction-time (6.8 secs.).

Analysis: The patient has dreamed of dogs, which probably have an erotic significance (see below!).

<i>Tests</i>		<i>I</i>	<i>II-IV</i>		<i>VI</i>	
56. to attend	attention	6.0	attention	2.4	attention	2.8
57. pencil	pencil-holder	6.2	pencil-holder	6.6	black	5.0
58. dull	-	-	-	-	weather	2.0
59. plum	plum jam	8.3	-	-	cat/domestic animal	8.0
60. to hit	-	-	-	-	marksman	3.6
<i>End of Test III</i>						
<i>Test IV</i>						
61. law	-	-	against the law	5.0	against the law	5.4
62. love	unloving	3.0	unloving	3.0	child	2.0
63. glass	water-glass	1.6	glass-cupboard	2.0	bottle	8.0
64. to argue	to quarrel	4.6 ?	-	-	discord	7.8
65. goat	goat's milk	2.4	goat's milk	2.8	fire/house	3.8
66. grand	grandeur	3.0	grand city	4.8	ocean	11.0
67. potato	potato-flour	4.0	potato-field	5.6	dish (food)	6.8

57: *pencil*.

Analysis: The patient thinks of those tests when I sat opposite her and, while she did addition, occasionally made marks with a blue pencil in her exercise-book.^{14a} Nothing else occurs to her after this idea. These tests took place shortly before Test VI. It may thus only be a reminiscence which, however, must somehow be constellated. One might perhaps suspect a masturbation-complex or another sexual fantasy. During the whole time of the treatment I avoided the topic of sex as much as possible, and only towards the end did I come to speak of it. If, therefore, a masturbation or other physical sexual complex was present, it was not aroused during the treatment (i.e., by Test VI), and thus could become more or less dormant, particularly when it was not being activated. Tests I-IV took place at the beginning of the treatment, when the complexes were still very active. Test VI was not carried out until the third month. This might explain the lack of complex-characteristics in this part of Test VI. In Test I the after-effect may last up to R.61.

In R.62, the more obvious hint, *child*, has a stronger perseverating effect than the former superficial *unloving*.

<i>Tests</i>	<i>I</i>		<i>II-IV</i>		<i>VI</i>	
68. to paint	oil- painting	4.2	painter's studio	5.4	picture	2.4
69. part	part- payment	5.2	partner	3.0	birth/ difficult	4.0
70. old (<i>alt</i>)	Alt-stetten	9.8	old town	6.6	old man	3.0
71. flower	bunch of flowers	10.2	flowerlet	2.4	garden	5.4
72. to strike	hammer- stroke	6.0	-		to sit/ tired	2.2
73. cupboard	linen- cupboard	4.2	linen- cupboard	5.6	room	7.0
74. wild	wild duck	4.2	-		lion	3.4
75. family	family dinner	5.2	family dinner	4.0	large	5.2
76. to wash	-		-		kitchen	6.0
77. cow	cow's milk	2.0	cow's milk	3.2	man/pater- familias	8.8
78. guest	guest-book	6.0	guest-book	3.4	spare room	5.0
79. luck	good luck	10.6	good luck	2.8	joy	5.2
80. to tell	story	3.0	-		story	3.0

69 (Test VI): *birth/difficult*.

Analysis: "My mother had difficult labours; she has told me that her illness was caused by childbearing" (let us remember here 23, *child/dear*, and 39, *hope/happy*). Although R.69 does not show any external complex-characteristic that is especially conspicuous, it contains a clear description of the complex. The mother's fate is bound to be a warning to the daughter, because it is easy for her to be afraid that if she gets married she might also become a victim of osteomalacia. It would not be surprising then if the sexual fantasies carried rather gloomy emotional charges and therefore could be maintained only under a certain mental reservation, i.e., in the repression, because then there would not be any pleasurable expectation attached, but a strong feeling of unpleasure. This realization came perhaps rather early and had its share in the construction of the syndrome.

76: *to wash* with its conspicuous disturbances can have been constellated by *family* or by her obsessive cleanliness (see also the analyses of the dreams!).

77: That there is something attached to *family* becomes obvious in *man/paterfamilias*, 8.8 secs.

<i>Tests</i>	<i>I</i>		<i>II-IV</i>		<i>VI</i>	
81. manners	training in manners	11.0	training in manners	2.8	morals	2.4
82. narrow	-		-		space	3.6
83. brother	-		-		siblings	7.8
84. shame (<i>Schade</i>)	shame-joy (<i>Schaden- freude</i>)	2.0	shame-joy	3.6	loss	8.2
85. stork	stork's nest	5.2	(does not understand stimulus- word) then	-	to fly	7.4
86. false	falsehood	7.4	falsehood	8.2	people	3.2
87. anxiety	feeling of anxiety	4.0	feeling of anxiety	3.0	trembling	4.2
88. to kiss	sister's kiss	13.0	sister's kiss	4.0	sister's kiss	3.8
89. fire	great fire	5.6	fire- blackened	6.8	house	8.8
90. dirty	-		dirty marks	7.0	street	1.8
91. door	lock	4.2	trap-door	4.8	lock	2.0
92. to elect	election for the Co-op	11.0	-		-	
93. hay	hay-cart	3.8	-		barn	2.2
94. still	rest	7.8	-		quiet	6.8

End of Test IV

Test V

95. ridicule	ridiculous price	2.0	-		to laugh	2.8
96. to sleep	sleeplessness	3.4	rest	1.8 [tired]	night	6.8
97. month	monthly meeting	3.0	-	[time]	long	6.4
98. coloured	-		Negro	6.8	painter	2.6
99. dog	faithful dog	3.0	domestic animal	3.4	river/wide	3.0
100. to talk (<i>reden</i>)	consultation (<i>Sprech- stunde</i>)	13.4	to tell a story	4.8	people	6.2

81: *manners* tends to stimulate sexual complexes.

In 85, with *stork*, there are marked disturbances that can be related to the stimulus-word (the erotic meaning of which is of course well known) as well as to the preceding *accident*.

88: *to kiss* is rather harmlessly disguised by *sister's kiss* and clearly shows the naïve compulsion to repress (similarly *stork/to fly*). But perhaps *sister's kiss* has a very deep meaning that I could not have suspected at the time of the test (see the dream-analyses!).

89: *fire* shows long reaction-times throughout. *Fire* is one of the expressions by means of which the patient describes the head-symptoms. The response *house* is constellated by the dreams of fire in which she often sees houses ablaze.

92: *to elect* produces the utterly forced reply *election for the Co-op*.

Analysis: "One can elect (choose) a number of things, for instance a town councillor or anyone else"—(resistance, then giggling and embarrassment). We have already long known what a young girl associates with "choosing"; it is actually a "co-operative

choice,” namely, someone who co-operates for life. This probably explains the disturbances that follow, because this is the “burning” question *par excellence*.

97: *month* often excites the image of the period in a woman, which in our case has a special significance. Hence the complex-disturbance.

Summary of the Analysis

[817] The association experiment and the analytical investigation into its results have given us insight into numerous trains of thought which, however, are still only vaguely differentiated. The analysis had to struggle with special difficulties because very few reactions in the three series appear normal. There is an abundance of complex-characteristics, which is further experimental evidence of how much the patient is overpowered by her complexes; we can almost say that not she but her complexes have the last word. The analysis not only met with great difficulties in getting at the critical reactions, because of the numerous complex-characteristics, but its task is made much more complicated by having to try to elicit further thoughts from the patient. Frequently the patient stops after only a few generalities and her laughter betrays that something is flashing through her mind. Interpretations that the patient can confirm are rare. She is so much under the influence of the complex that, if she were asked to evaluate its emotional significance, she would not be able to do so and would not know whether it is important or not. We depend therefore almost entirely on conjectures, which, however, permit certain conclusions.

[818] I have picked out only certain complex-constellations, although there are quite a number of others present. The associations produced in these are, however, only of secondary importance, so that I omitted their analysis for the sake of brevity.

[819] There are a good many associations that show complex-characteristics throughout all three series and which therefore have to be understood as constant complex-constellations. In the majority of these cases a rather uniform interpretation is possible. Thus, for instance, it cannot be doubted that erotic ideas play an important part; they allow us here and there to recognize references to the doctor. In the second place comes the illness-complex. These two complexes, apparently independent of one another, have some aspects, however, in which they meet.

[820] In analogy to the illness of the patient is the illness of the mother which, in its turn, touches the sexual complex of the daughter (*birth / difficult*, etc.). There are also certain signs that it is perhaps a physical sexual complex. Lastly, there is also a school complex present.

[821] With these statements a number of threads has been provided that may lead us through the maze of the patient's thoughts. Because of her lack of self-control and her helplessness in the face of her complexes, however, the patient brings us into a

precarious position in which we have to look for other means of finding confirmation of our assumptions.

[822] Nature has an apparatus that makes an extract of the complexes and brings them to consciousness in an unrecognizable and therefore harmless form: this is the *dream*. As I thought I had found only the general idea with the association experiment, I collected the patient's dreams. From the beginning nothing but stereotyped blood and fire dreams were related, and these only in a vague form. One had of course to be prepared to obtain material from the past, only after it had been carefully sifted. Everything that was too obvious had been obliterated by strong inhibitions. Also, during the observation the patient dreamed very little, i.e., she remembered only a few dreams. Unfortunately, therefore, the material is not as plentiful as one could wish.

II. THE DREAMS

[823] During the early months of the treatment I often inquired about her dreams. They were said to be infrequent; now and then the patient said she had again dreamed of *fire*, or of *blood*: "The whole room was full of fire or blood." Now and then she dreamed that blood was spurting from all the openings in her head, or she dreamed the same of another patient whom, in the dream, she saw in her room. The patient did not mention anything of any other dreams. The blood and fire dreams seemed to me to be stereotyped expressions of the dream-life, as the heat-sensations were of the waking life, which first of all symbolically represented the patient's phraseology (she had too much blood in her head, the blood was too hot; she had a temperature of 104°, she ought to be able to bleed properly once, everything in her head was like fire, everything was parched and charred, etc.). In the second place, the stereotyped dreams are, as always, symbolical expressions of the complex, which we have not yet clearly defined. For the therapeutic purpose of setting her against these dreams, which were often accompanied by anxiety, and for the theoretical purpose of learning whether she would abandon the dream-stereotypes and substitute something else for them, I said to the patient casually: "Blood is red, red means love, fire is red and hot, surely you know the song: No fire, no coal can burn as hot, etc. Fire, too, means love."

[824] This interpretation made a strong impression on the patient. She burst out laughing with marked embarrassment. So she responded with feeling to my interpretation. My naïve interpretation of the dreams was based on the assumption that the dream symbolism would be simple and childish, in accordance with the patient's mentality. The interpretation took place in the middle of November. In the second half of November the following dreams occurred:

[825] FIRST DREAM (Nov. 27). “*The room is full of cats, which are making a terrific noise.*” During the dream, strong anxiety with anger. Details were denied. The above rather general statement had to stand.

[826] The analysis was carried out in the same way as with the associations; I made her produce the first ideas that came to mind, avoiding all suggestive remarks and pressing only if the patient appeared to succumb to a stronger inhibition. (The decrease of energy at the approach of a complex, the failure to respond in critical places, etc. are the same.) I should like to point out that in all the coming analyses the result is mentioned beforehand each time, while the material follows in small print. Anyone who is interested in the result only can skip the material.

[827] *Result of the analysis:* The patient lived for eleven years in a place where she was frequently disturbed by caterwauling. This noise is known to be caused by mating fights. Behind the manifest dream-content is concealed the idea of sexual intercourse.

Material. Ideas relating to cats: The patient: “During recent nights there were now and then cats in the garden outside my room. I can’t think of anything else—nothing at all (note the strong negations which are forerunners of an intensive inhibition. I insist)—I can think of absolutely nothing—yes, we had a lovely Angora cat once upon a time; unfortunately it was stolen.” It is definitely peculiar that such a simple reminiscence should be subjected to such strong inhibitions; one has therefore to assume that this reminiscence has yet another aspect of personal significance. I therefore make her continue to associate: “(sounding angry) There are many cats that jump through our garden, yellow, black, white ones—I don’t know what you want—(becomes very indignant, as if she were being forced to do something disgusting)—really, I can’t think of anything else.” This very decisive refusal has to be cut short; so I ask: “Were you disturbed by caterwauling at night?” “Never; it was actually quite impossible, because where I sleep at home one cannot hear the cats at all—as I said, I was never disturbed by cats—(in a casual tone, as if by the way) Oh, I remember that when I was ten or eleven, no, twelve years old (!), we lived in a place where there were always very many cats. They often made such a terrific noise at night that one thought the house would fall down. There were often about sixteen cats; they made this infernal row almost every night.”

I asked: “How long did you live in this place?”—“Eleven years, i.e., from my 12th to my 23rd year.” The patient is now 24! So she lived for eleven years, and actually until the year before, in a place where she was disturbed by caterwauling. As we have seen, the inhibition on the reminiscences about cats is so excessively strong that it leads to the greatest contradictions. It has to be pointed out that the patient’s tone, which was usually very courteous and unassuming, became irritable and aggressive during the analysis; a manifestation quite unusual for her. Simultaneously

her face more and more assumed an expression of suffering; she thus showed the same expression that otherwise belongs to the illness-complex. Now I asked her whether she knew the meaning of the nightly caterwauling, which she indignantly denied; I probed but received a vehement denial. A 24-year-old girl of average intelligence who has had a cat of her own, and apart from this had ample opportunity to learn about the behaviour of cats, must surely know what the nightly gatherings mean. When she is hysterical, she perhaps does not know it with her *ego-complex* but surely with her *sexual complex*.¹⁵ Now I explained to the patient that the caterwauling meant *mating*. This was followed by visible excitement; the patient did not answer, blushed and looked out of the window. With reference to the dreams, I told her that cats had a symbolical meaning; she would be given the interpretation later. If one dreams of cats or *dogs*, this always means something definite. On the following days the patient repeatedly asked for the meaning of the dream, which interested her.

[828] SECOND DREAM (Nov. 30). “*The whole room is full of mice, which are jumping all over the place and are making a great noise. The mice have an unusual appearance; they have bigger heads than ordinary mice, somewhat like rats, but they have big black ears; they also have peculiar glowing hot eyes.*”

[829] *Result of the analysis:* The mice conceal the reminiscence of two dogs (male and female) that the patient often saw playing together. The patient has already observed how dogs jump at each other. She has also seen the dog stand up against a maid. This again is about mating.

Material: Superficially we notice in this dream that on the whole the situation of the last dream is repeated, only the cats have been replaced by mice which, however, do not seem to be proper mice. The “glowing hot” eyes seem to be a fragment of the fire dreams. I put the text of the dream to the patient again; she has nothing to add.

Associations to the mice: “I particularly noticed that all the mice jumped out of little wooden huts—(this essential piece of description had apparently been kept under an inhibition and therefore could not be produced until now).—The huts looked like dog-kennels.” Here we seem to be on a new track, because dogs do not appear in the dream. It is true that in the last analysis I drew the patient’s attention to dogs. The idea “dog” seems to be indicated indirectly in the dream (i.e., it is repressed). I therefore take “dog-kennel” as the starting point of the analysis.

Ideas relative to dog-kennel: “Surely, there are many dog-kennels —(indignant) I don’t know what you mean—there was nobody near us who had a dog—but one can see such dog-kennels everywhere—in gardens and courtyards—I cannot understand how you could suspect anything here—whatever could be behind it! For instance, *just behind our house there was a garden with a dog-kennel in it.* There were two dogs, two black ones, I think setters—perhaps a dog and a bitch; but the bitch was

immediately removed—they often played together—they tore paper or pushed sticks about—or barked.” Then comes a complete resistance with vehement indignation; she does not want to hear anything more about the dogs. After much persuasion it comes out at last that she often saw the dog stand up against the maid when she went into the garden. That the dog mounted the bitch is vehemently denied. But we know already that there are certain things that the patient cannot say, because the inhibitions are far too strong. It can with the greatest probability be assumed that she has seen it; this can be conjectured not only from the way she tells the story, but also from the whole situation. I say: “But one can often see dogs jump on each other’s backs!” “Yes, I have often seen that in the street, but these two dogs did not do it.” I asked her what the jumping meant: she explained it was a game, she did not know any other meaning. She said the last sentence in an irritated voice. We have to make the same comment here as on the previous dream: it is inconceivable that she does not know the meaning. Here, however, we must again remember the influence of the sexual complex on the conscious perceptions of the ego.

The dream may be reconstructed in the following way:

The mice are cover-figures which, however, are penetrated by the elements of the cat dream at several points. *Mouse* is a current association to *cat*, the two words can thus substitute for each other in the dream (or in a state of reduced concentration!).¹⁶

The mice are as noisy as the cats were, also they are in the room and in greater number. The mice have larger heads; thus they are not really mice, but larger animals. They have large black ears, like the black setters which also have big black ears. The mice jump out of kennels. The analysis points to a very ambiguous situation, the interpretation of which should not be difficult; it is *mating* again, as in the previous dream. That the dog jumps up on the servant seems to be a subtle indication as to what sort of person the thought of sexual intercourse refers to. This indication was missing in the first dream. Perhaps one may express the hypothesis that the first analysis stimulated the patient’s sexual complex, so that her own person appeared in the next dream. I would also point out that as, in the earlier blood and fire dreams, the entire room was always full of blood or fire, the room is now full of cats and mice. The analysis took place on December 1, after the third dream, which follows. I did not inform the patient of the analysis of the second dream, so that when she had the third dream she had no insight about the content of the second dream.

[830] THIRD DREAM (Dec. 1). “*She goes into a shop in the town to buy something. A big black dog that is very hungry comes along and jumps up on her, as if she could give him something to eat.*”

[831] *Result of the analysis:* In this dream the patient clearly takes the place of the maid of the previous dream, thereby revealing that the *idea of mating* refers to her.

Material: The manifest form of the dream betrays the content in line with the analysis of the preceding dream.

The patient is now in the situation of the maid; this clearly throws light on the critical point which remained unexplained in yesterday's dream, yet in the form that the patient could not understand on the previous day. Had she understood this symbol, it would probably not have been used—like the cats, the significance of which had been explained to her. Associations to the “dog jumping up”: First there are generalities as usual, excuses and blockages which I am not going to reproduce, so as not to go into too much detail. At last she again thinks of the scene with the maid and the dog. Our first thought when considering the dream was of course this scene, but it was different for the patient. She has to search for it at great length, as if it were a reminiscence that had long since faded away and been forgotten. This is because at first she has to push aside all the resistances attached to this recollection. We are free from such resistances. The same thing happens to her in the dream-analysis as happened in the association experiment, when she always had the same blockages at critical points, even after two or more repetitions, although one would actually expect that a reaction produced with so much effort would be more enduring than one without any special significance.

On the same day I carried out the analysis of her main symptoms (see below). During the following night she had a dream:

[832] FOURTH DREAM (Dec. 2). “*She is standing in the corridor of the Department and sees a tall black man coming along. He is leading someone down the corridor, but she does not see whether this person is a man or a woman.*”

[833] *Result of the analysis:* The black dog becomes the black man, the scene is transferred to the Hospital. The black man is the disease-producing sexual complex that brought the patient to the mental hospital. She is trying to gratify her desire for love by falling in love with the doctor, but it is not to the purpose, since the doctor is already married.

Material: The manifest form of the dream reminds us of the dog scene, except that the big black dog has now become a big black man. The maid of the dog scene (the patient herself) has become blurred (the patient does not know whether it is a man or a woman). The patient herself does not appear to take any further part in the dream; we therefore have to look for her in a dream-figure, and may well presume that she is the indistinct figure.

Associations to the “black man”: “The man comes from the front door, as if taking someone to the Department. He is dressed like a judge of a Vehmic court¹⁷ (whom she had once seen at the theatre); he looks like a ghost, “like the black man

whom I used to see when going off to sleep.” I asked her whether it had frightened her: “No, I was not frightened of him—yet I was. I even wanted to retreat into a room out of fright, but a nurse called out: ‘Stop, this is forbidden! This room is already occupied.’ “There is apparently an inhibition attached to “fright.” We have now traced the “black man” of the *dream* back to the “black man” of the *vision*. The vision shows the man stretching out his hand to catch hold of her; this frightens her very much. The vision is a stereotyped complex-expression, like the blood and fire dreams; it is thus a rather rigid psychic product which it is not easy for the analyst to tackle. In fact, the analysis comes up against strong barriers here which the patient cannot break down. We therefore have to resort to conjecture. The black man who approaches her to catch hold of her is analogous to the hungry black dog that jumps up on her. The dog has a strong sexual background, which probably also belongs to the black man. The vision originated at a climax of the illness, when the patient was often thinking of death and was afraid she might even die as a result of her illness. As we indicated in the analysis of the associations, thoughts about death do not by any means exclude the sexual background; on the contrary, they can take the place of sexuality. As we have seen from the analysis of the associations and the analyses of the dreams so far, the patient is completely pervaded by a sexual complex. It is therefore most likely that the idea of intercourse is enacted in this dream as well. But let us leave this aspect for the time being and observe more closely the behaviour of the black man. At the height of the illness she is afraid she will die. Symbolically expressed: death is stretching his hand towards her, i.e., the illness will take her and lead her into the grave. The black man of the dream is leading an indistinct figure, who might represent the patient, into the mental hospital, and moreover to the same department where the patient is in actual fact. Thus the illness has not taken the patient to the grave but to the lunatic asylum.

The black man derives from the sexual dog, and the illness from the sexual complex.

To elucidate this sentence I beg to remind the reader of all the statements so far made: in the associations the clear and intensive activity of a sexual complex becomes obvious; in the dreams we found up to now nothing but metaphors for the sexual complex. At first there are the stereotyped blood and fire dreams, which are of a naïve symbolism. They say: “My blood is hot, I have strong sexual feelings of love.” The dreams speak of sexual intercourse. Her illness is clearly connected with menstruation. That much is also acceptable to the patient, that the illness has a connection with the first period. Everything we were able to find out so far speaks for the sexual origin of the illness. What the patient is yearning for is doubtless The Man. She wants the man but has the illness; as long as she is ill she cannot get married. Does she want to be ill? We know the will-to-be-ill of hysterics. They escape into

illness for some reason; they want to be ill. This is a truth that almost forces itself on the observer. From the asthenic personality of the patient who, for no other obvious reason, breaks down in the simple association experiment, which does not require any effort, I could not help getting the impression that she did not make any effort whatsoever to react normally, i.e., to be healthy; on the contrary, she behaved in such a way that one could not help seeing how ill she was and how little interest she had in being healthy.

She needs the illness as an obstacle to prevent her getting married. So she has the choice between illness and man, therefore the choice between the joys of sexual love and the care and attention given to the sick child, which also has its advantages for a naïve female mentality. I had explained to her the previous day that she wanted to be ill because she was afraid of getting married and being healthy. The dream is the answer to it. I had already told her dozens of times: “You are escaping into the illness again; you must not do that, it is forbidden.” I said this to her each time she wanted to avoid telling me something unpleasant and disguised it by a headache and heat sensations. What does the dream say?

“But a nurse called: Stop, this is forbidden!” the nurse (thus my proxy) calls out in these words when the patient wants to take refuge in a room from fear of the black man (this part of the dream is, as its form shows, further protected by a special inhibition, so that it is produced only during the analysis). The fear of the sexual future and all its consequences is too great for the patient to decide to abandon her illness. She prefers to be ill, as she has been up to now, i.e., in actual fact to be nursed and pampered by her mother.

The dream, however, does not end with the presentation of this train of thought; it says, moreover, that the patient cannot retreat into the room, for it is already occupied. As the analysis shows, we assume that to take refuge in a room is a symbol for escaping into the illness, that therefore “room” means “illness.” The patient is, however, in possession of her illness already, it therefore cannot be occupied by anyone else. But let us remember that “illness” is ambiguous. Her illness is the sexual complex, i.e., the repressed sexual feelings. The prohibition thus also says: It is forbidden to have sexual feelings, because something in the sexuality is already “occupied.” Because of lack of time I had to interrupt the analysis at this point and to postpone it to the next day, when I intended to ask for information about which room it had been in the dream. On the following day I asked the patient at once which room it had been. She promptly replied: “Room No. 7.” In order not to spoil anything, I asked the patient for the dreams of the previous night, before I began the analysis. She had dreamt again:

[834] FIFTH DREAM (Dec. 3). “*I was outside and stood next to Miss L. We both saw that a house was on fire. Suddenly a white figure emerged from behind the house; we both got scared and exclaimed simultaneously: ‘Lord Jesus!’*”

[835] *Result of the analysis:* Here the black man has turned into a white figure; the burning house is the sexual complex. Miss L. is a patient who has a crush on the author. She was, like the patient, taken ill because of an erotic complex. The patient therefore expresses through this person that she has fallen in love with the author. Thus the patient substituted the tender relationship with her mother, which is damaging to her energy, by the erotic relation to the doctor.

Material: The form of the dream shows us that because of the dream interpretation the black man had to assume another disguise and changed to the white apparition which, however, played the same frightening role. The situation too is similar in that, as the patient starts to do something, she is suddenly prevented. In the burning house we suspect the *heat* of sexual feelings. A pointer for the analysis is, by analogy with previous ones, that part of the last dream that was not completed at yesterday’s analysis; namely *Room No. 7*. Room No. 7 is occupied by Miss L., a patient of the same age as our patient. This gives us a new point of vantage regarding the previous dreams. In that dream the patient thought something like this: “I go into Miss L.’s room, I do the same as Miss L.” Particularly characteristic of Miss L., however, is the fact that she is in love with the writer—hopelessly, as the writer is already married. The patient therefore finds the “room” occupied in two senses: (1) Miss L. is already in love with the writer; therefore there is nothing left for her. (2) The writer is married; this precludes any tender emotion from the very start. In today’s dream the idea of yesterday’s is elaborated in more detail. In the dream the patient always does what Miss L. is doing. Thus she also watches the burning house. Therefore she also has a hot yearning or a burning love. The patient also knows that Miss L. was taken ill because of an unhappy love-affair. Here is a further very stimulating analogy! Therefore they both see how the white apparition, alias the black man, alias the illness, suddenly appears behind the fire of love and frightens them both, as love has made them both ill. Miss L. suffered from sudden depressive agitations, during which she behaved in an utterly despairing and senseless manner. The patient always was amazed at this and frequently stated with satisfaction that *she* was after all not so ill as to have to behave like that. I had also often told her (our patient) that if she had let herself go, she would have become even worse. Thus the patient could easily think, with her mild jealousy of Miss L., that Miss L. had let herself go more and therefore had become more severely ill. This is how “Room No. 7” was further determined. This point had not been explored in the former analysis; therefore we meet it again later on.

The content of this dream again throws light on that of the previous one in a peculiar way: The fear of the black man (sexual future) makes her escape into illness, which is, however, forbidden. Therefore the patient looks for a new way out: she does the same as Miss L., she falls in love with the doctor who can appreciate the complex and is a sexually harmless man; thus the dream finds a fortunate compromise. It replaces the love-giving but illness-producing mother by the healing but also sexually significant man. But there is a snag; the patient is poor and cannot stay at the clinic much longer, because she has not enough money. Miss L., however, is very rich and can stay as long as she likes. Miss L. then can take her place and “occupy” the room.

This manoeuvre also led nowhere and therefore the idea behind it remained active.

When I tactfully explained the content of these dreams to the patient she made a sad disappointed face—apparently the explanation was too blunt—and said in a suffering tone: “Oh, if my mother knew the things that are dragged out of me here!”

This reaction is noteworthy, since her mother would probably be indifferent to shades of feeling in her daughter. The answer, however, excellently depicts the cooling down and turning away of the patient’s infantile sexual need for tenderness from the doctor and her reinsurance with the mother’s love, a clear indication that the compromise is not tenable and the patient cannot separate herself from her childlike relation to the mother.

[836] SIXTH DREAM (Dec. 6). “*My father is here and I am showing him the Institution by going through all the departments with him.*”

[837] *Result of the analysis:* The patient fulfils the wish to stay longer in treatment with the author, which she hopes will cure her.

Material: The patient states that this is only a fragment of a longer series of dreams which, however, she cannot remember. Even analysis cannot produce what is missing. It is not difficult to understand the dream; it represents an uncompleted piece of yesterday’s dream. The patient behaves in this dream as if the Institution is more or less her home. I had asked her occasionally whether her father never came to visit her, to which the patient said that she thought she was here for such a short time that it was not worth while for her father to make the journey. In the dream apparently a situation has arisen in which the visit was worthwhile all the same. So the patient can stay here for a very long time (as she actually wants to do). Besides which, the dream shows the patient in an unexpected position of authority. She has the master key which opens all the departments for her; this leads to the conclusion

that she is enjoying the quite special confidence of the doctor. What this confidential relation to the doctor means is not difficult to guess.

[838] SEVENTH DREAM (Dec. 6, during the same night as the previous one). *“I am at home, Mother is sitting at the dinner table, you, Sir, opposite to her, and you are eating. Between Mother and you there is an empty chair. I want to sit down on this chair and eat too. But Mother has a hot flat-iron which she pushes towards me and that makes me get hot in the head. I tell Mother to put the iron away; she makes me feel hot with it so that I cannot eat. I too would like to eat with you both. At this you get up and shout at me that there is no need at all for me to eat now, I can just as well eat later.”*

[839] *Result of the analysis:* The patient desires a sexual relationship with the author, for she hopes that in this way she may get free of the influence of the mother which contributes to her illness. But the author is married, so that this wish cannot be fulfilled. She must therefore remain ill.

Material: This dream too shows a transparent symbolism; we can interpret it without any difficulty with the help of the pointers in Dream IV. We have seen that in Dream IV the patient starts to make a compromise between the infantile relationship to the mother and the sexual relationship to the man. Here the author clearly takes the role of the “man.” The animal symbolism had already been dropped in the latest dreams, as it had been dealt with and become too transparent. So she has to create other coitus symbols. The dream begins with the patient being at home. This is the main question now which she puts to me daily: “How will it work out at home? I am always afraid it will go wrong again at home!” What is dangerous at home is mainly the mother, who as the careful nurse of her youngest child and image has apparently contributed her share to the patient’s hysteria. Thus at home the question again arises: “Shall I continue with the role of the sick child that needs nursing, or shall I, in accordance with the doctor’s advice, entrust myself bravely to the sexual future?” She therefore stands between doctor and mother. The author is eating, she wants to eat with them, i.e., to do the same as the author. In what way can she do the same as the author? There is only one possibility, and that is the one that has already repeatedly been deliberated: to marry. She would like to sit in the chair next to the author, she would therefore like to sit beside him; this means nothing but that she relates to me in the sense of “husband.” Does “to eat” therefore mean the marital function? We know Freud’s principle of the displacement from below upwards. What happens to the mouth (in the dream, in hysteria, in schizophrenia) happens to the genitals. If one eats, one puts something into the mouth.

(A patient in the early stage of dementia once expressed her wish-delirium by saying that the man she desired as her bridegroom fed her with a spoon, which made

her pregnant and she had a child.) So she wishes to enter into a sexual relationship with the doctor. But the mother makes her feel hot with the flat-iron, so she cannot sit down at the table, i.e., the mother brings back her illness (heat sensations in the head) and thus prevents her marriage. The fear that she may become worse again when she gets home is reflected here. Up to now the author has played a passive role, so that actually nobody but the mother stopped her from giving her love to the doctor. But now the author gets up and rejects her bluntly by forbidding her to “share the meal,” i.e., to attach sexual thoughts to him, and at the same time comforts her by referring her to the future, when she can get married. This passage refers to a talk that I had with the patient a few days before, in which I carefully indicated that the question of getting married would not be so difficult later on, once she was well again. From this content it appears that the patient is again concerned with the dream-situation of the occupied room, with some variation, but this is connected with the obviously deep impression made on her by my previous analysis, in which I ruthlessly destroyed her illusions. Through this refusal she sees herself thrown back on the mother, and with the mother she becomes ill, because the mother does not want her to get married (see below). I have hardly concluded the analysis with the patient, when she says, quite out of context: “I am reminded of a dream that I used to have very often. I always used to dream of worms, reddish and whitish ones, the floor and the whole room were full of them (just like the blood, the fire, the cats, etc.). Very often, too, it was as if a colossal worm was being drawn out of my mouth.” This dream in this context can be nothing but one of those penis dreams, so frequent in the normal as well as in the ill person (in dementia praecox, patients often have special neologisms for this such as snakes, the stalk of a lily, staff of life, etc.). The *mouth* again indicates the displacement from below upwards.

It is therefore not unlikely that interference with marriage by the mother is the hysterogenous basic experience. Moreover, a sexual trauma has to be expected because of the lively eroticism of the patient. Therefore I told the patient that I was not satisfied, there must exist another experience which she had not yet told me, and which was of particular importance. Perhaps it would be revealed to me by her dreams. Perhaps this experience has also a connection with her cleanliness compulsion. Then for eight days the patient cannot recall any dream, although she knows she has had vivid ones. During this time I tried, as always, to get her interested in some activity and repeatedly discussed with her whether she did not know of any chance anywhere of earning a little money. After eight days had elapsed she again remembered a dream.

[840] EIGHTH DREAM. “*I am at home and picking small coins up off the floor. I also find lovely stones, which I wash. I put the money and the stones on the kitchen-table and show them to my brothers.*”

[841] *Result of the analysis:* The patient thinks of going home, she has made several good resolutions and particularly thinks that she will find a substitute for the impossible relationship to the doctor in her family, especially in her brothers. The background of the dream, however, remains uninterpreted.

Material: In this dream she has realized her future earning of money. A new feature, however, is “the lovely stones” which she washes (cleanliness compulsion?). She shows her brothers what she has washed on the kitchen-table, which is perhaps reminiscent of the dinner-table? The analysis yielded nothing but generalities; the strongest resistances were put up against any deeper penetration. What are the brothers doing at the kitchen-table, are they perhaps replacing the doctor at the dinner-table? I could not solve this question.

[842] NINTH DREAM (Dec. 12). *“I am going for a walk in Zurich, but it suddenly becomes the place where my home is. Outside a house I see a policeman standing, talking to a man whom I only see indistinctly. The policeman makes an extremely sad face and enters the house. Then suddenly Miss L. walks along the street with a terribly sad face. Then we are suddenly together in a room and are sitting at the dinner-table. Suddenly someone says that the house is on fire. Miss L. says: ‘Now I am getting into bed.’ I find this inconceivable and run out into the corridor, but there I am told there is no fire; it was therefore only a false alarm. Now I go in again and find myself at home in the kitchen with Mother, and two of my brothers are there too. A basket full of gorgeous apples is standing there. One of my brothers says: ‘This also is something for me.’”*

[843] *Result of the analysis:* The patient, like Miss L., is disappointed in her hope of love which, however, she understands with regard to Miss L., whose less good qualities she scornfully stresses. So she goes home, where she again enters into a suspiciously intimate relationship with one of her brothers.

Material: The general situation of the dream is a similar one to that of the seventh dream. It is again about being together at the dinner- or kitchen-table. In the first part of the dream there is a policeman with a terribly sad face. Immediately afterwards and quite suddenly, Miss L. turns up with the same attribute. The policeman enters a house, and this is immediately followed by the patient eating with Miss L. in a room. Miss L. and the policeman are apparently equivalent. How and why has Miss L. changed into a policeman? I ask the patient for conspicuous characteristics of Miss L. The patient finds in particular that Miss L. has such peculiar manners that she is only half a woman, almost a man, and she is also very thin. We have a long thin sausage in Switzerland which is called something like “dried-up policeman.”¹⁸ This term is also used as a nickname for thin people. The patient thus indicates the less laudable aspects of Miss L. Why she does so is shown by the circumstance that the policeman

speaks to a man whom the patient sees only indistinctly; if Miss L., however, speaks to a man, then in the dream it can be nobody but the author. It is therefore likely that the patient is again jealously stressing Miss L.'s feelings for the author, thence treating Miss L. very disdainfully. Then she sits with Miss L. at the dinner table. She is therefore in a sexual situation with her which, however, one must not think of as anything homosexual, as "dinner-table" in its sexual meaning has already been dealt with by the author; it would therefore be far too transparent. Here it probably only means: "I feel sexually as Miss L. does." The fire-alarm that follows also indicates this.

The patient goes outside to look. Miss L., however, goes to bed, i.e., becomes sick with love. To understand this, we must know that Miss L. always went to bed when she was excited. At the beginning of the dream the patient humiliates her rival, then when the sexual situation (fire-alarm) comes up, Miss L. actually becomes ill and therefore completely harmless. So the rival has been put out of the way. But the patient hears it is only a false alarm: this is the disappointment ("the room is occupied," "she cannot partake of the meal"). The author has spoiled her illusions, the transposition of her desire for love to the man has not succeeded, she therefore has to return to mother, where at least she finds an equivalent to the gratification of her need for love. Therefore the situation changes in the second part of the dream. The patient is suddenly at home with her mother in the kitchen instead of at the dinner-table. If only the relationship to the mother was concerned, there would be no need for the brothers. But two brothers are there as well and, as in the eighth dream, at the kitchen-table, but instead of the "lovely stones" a basket of "gorgeous apples" now stands there, and a brother says: "This also is something for me." The dinner-table scene of the seventh dream, as well as the dinner-table scene of this dream with Miss L., can hardly be interpreted in other than a sexual sense: now we have a similarly constructed picture in immediate succession to the sexual scene in that "dinner-table" has been replaced by "kitchen." In the first place the "gorgeous apples" look like the "lovely stones" on the kitchen-table, and secondly they are something edible (cf. Eve's apple). This is something for the brother, he gets some of it. We have to keep in mind: in the first part of the dream a sexual wish is destroyed for the patient; the second part can hardly refer merely to the mother, sex must somehow play its part here. I now make her produce ideas about the "apples": "I thought of the apples I saw at a fruiterer's¹⁹ yesterday. I was there with Mrs. Jung." So she was there with my wife; this could be a clue. But now the analysis comes to a halt and no further progress can be made. So I make a fresh start with the brother: "This was my brother who lives in Italy: he has often invited me to go to Italy and visit him."

Remember here R.25, Test VI.

Travel: The patient associated at this point: “A nice journey to Italy—honeyymoon.” This would, however, be nothing to do with the brother, and yet the apples are meant for him too. I would like to add here another short dream which the patient had right at the beginning of the treatment. She dreamed that I came into the room and she said to me: *Unfortunately the nuts could not be gathered yet, but she had a whole basket full of them at home.* In this dream the patient offers the fruit to me, nuts. Nuts are as hard as stones, one has to open them to be able to eat them. Remember the “lovely stones,” the “gorgeous apples,” which she now allocates to the brothers. What her erotic expectation originally promised me is for the brother now, she has turned away from me.

I think that here it becomes obvious that there is something about the brother that goes beyond a sibling relation. The brother’s significance for the sister becomes suspect (cf. *to kiss/sister’s kiss*), and we cannot help having a strong feeling that here is something, sought for a long time, that would explain a lot, if we could be sure of it.²⁰ Some adventure of the time before puberty, in which the brother plays an impressive role, seems to be at the bottom here, a Freudian trauma. But the secret is well defended, and the analysis cannot gain access.

I told the patient quite casually of the content of the analysis, avoiding making any hints of a sexual nature. I wanted to avoid this because revealing the symbolism might make the next dream even more obscure. The inner development of the patient indicated in this dream, i.e., the turning away from the author, the abandoning of his point of view and the invalidating of his advice and teaching showed themselves (apart from an objective deterioration) in the significant fact that the patient now started again to dream of fire and blood; she “heard the *fire-alarm* every night.”

The time of discharge now came nearer and nearer, and I hoped for a decisive dream, but the patient did not remember her dreams any more (except the fire dreams) apart from a single small fragment that did not tell us anything. On the morning of the day of her discharge I asked her, as usual, whether she had dreamt again. She said “Yes” but added quickly: “But I know already what the dream means, I noticed it at once. But I am not going to tell you; it is something from the past that I can only perhaps tell my mother.” I implored her repeatedly, but in vain; she insisted it was of such a nature that she could only tell it to her mother. At last I said, then it must be a very unpleasant sexual story! The patient did not reply to that but looked out of the window. I could not venture to press the point any further.

Thus our dream-analysis and the analysis of the illness as a whole remain incomplete, at a point which, however, appears clearly defined.

Summary of the Dream-Analyses

[844] Although actually none of the analyses was as complete as we could wish, and in particular the last one breaks off at an important point, we have yet gained through them a number of valuable clues. Above all we see that the dreams completely confirm the complex revealed by the association tests. The associations point to an intensive sexual complex, and the dreams are about nothing but the theme of mating. This makes us realize that the complexes that constellate the associations of waking life also constellate the dreams. We have the same blockages that turn up in the association experiment, in the dream analysis too. The analysis of the dream-images revealed the sexual complex, its transposition to the author, the disappointment and the patient's reversion to the mother, and the resumption of a mysterious childhood relationship with the brother. The object of the next chapter is to show the sexual complex in the hysterical symptom and in the course of the illness.

III. THE HYSTERICAL SYMPTOM

[845] It only remains now to apply our knowledge of the form and content of the sexual complex, gained in the two previous chapters, to the symptoms of the illness. Let us start with the "St. Vitus's dance."

[846] According to the case history, as given by the patient, the St. Vitus's dance suddenly started one day for reasons unknown. All questions about the reason are answered in the negative, and it seems to be impossible to get at the cause, because it is unknown to the patient. But we already know very well the resistances that stand in the way of the production of all complex-ideas. Hysterics have access to their psychic material only in so far as it refers to insignificant ideas; but where the complex is involved they are powerless. The complex does not belong entirely to the hierarchy of ideas contained in ego-consciousness; because of its strong emotional charge it is more or less autonomous (as is, after all, any strong affect) and forces the association in its direction, even if the ego-complex endeavours to think and act in its own interests. For this reason we cannot talk about "intimate" things with the same security and calm as of objective ones. The need to keep the "intimate" secret can become strengthened almost to the impossibility of producing it, as we have seen in the case described in "Psychoanalysis and Association Experiments." If, therefore, we want to get information on "intimate" matters, i.e., on the complex in a hysteria, we can get it only by detours. Freud made a method of the detour; it is psychoanalysis. First we liberate general cover-ideas which stand in some associative (often symbolical) relation to the idea of the complex, and so we gradually approach the complex from different aspects. The method is basically the same as that used by a skilled examiner for a nervous candidate. The candidate cannot answer the special and direct question, he is too agitated; so the examiner first gets him to answer a

number of quite general and easy questions, the emotional charge of which is not too great, and then the required answer comes quite spontaneously. Similarly, if I at once ask the patient for the cause of her St. Vitus's dance, nothing will come of it; so first I make her answer harmless supplementary questions, and in this way learn the following:

She liked going to school, she also liked the teachers. Although she did not like all lessons equally she cannot, however, remember that she particularly disliked certain lessons, or that she particularly disliked certain teachers. She did not much like writing-lessons; she actually disliked this class. It was during the writing-lesson (in her second year at school) that her right hand first started twitching. Then the twitching became gradually stronger so that she could not write any more. She therefore had to miss the writing-lesson. Then the twitching started in the right leg too, so that soon she could no longer go to school at all. So the St. Vitus's dance gradually developed. She also remembers that she could not help crying "terribly" all the time and was afraid to go outside when it was raining, so that she frequently missed school for this reason as well. The St. Vitus's dance was sometimes more, sometimes less marked, so that sometimes she could go to school, sometimes stayed away. During her twelfth year, however, the illness became so violent that she had to give up school altogether.

[847] I think it emerges clearly from this narration that the patient was an extremely spoiled child who used every opportunity to keep herself away from school for the purpose of shirking the detested writing-lesson. The twitching in the arm conveniently began, which then ultimately served the purpose of making it completely impossible to go to school. The patient now also admits that she could have suppressed the twitching then if she had tried. *But it suited her to be ill.* The uncertainty with which the patient speaks of her feelings concerning her school reminiscences at the beginning of the analysis seems to me particularly instructive. First it seems to her that she liked going to school, then there are expressions of the feeling that it was after all not quite like that, and then comes the exact opposite, which coincides with the fact. This inconsistent way of presentation is actually a method of the patient (see the previous analyses). There is no indication that the patient is aware of the inconsistency at the moment; on the contrary, it seems that whatever she says at any given moment she absolutely believes. The school-complex, that well-known feature of all asthenic children, here leads to the formation of a hysterical symptom. The existence of an automatism understandably provides a suitable *locus minoris resistentiae*, from which further automatisms can develop if the situation demands it.

The day after this analysis the feeling-tones had changed again, the patient alleged she could not say she disliked going to school, she quite liked it. School never made much impression on her. She was much more occupied with other experiences, such as that once a schoolmistress had vehemently scolded her. So we have the same uncertainty and inconsistency here again.

[848] During her twelfth year the St. Vitus's dance grew worse. The twelfth year seems (according to the analysis) also to be the year from the recollection of which the sexual cat dream emerged. During the twelfth year the first puberty feelings become apparent in many girls and they begin to be interested in sexual secrets. But her twelfth year has yet another significance for the patient. I made the patient associate to the complex of the mother; the result was as follows:

A lot comes to her mind here—(after a long pause)—because Mother is also ill, and yet is so content and cheerful; if only she could also be like that. Mother always said her osteomalacia came from being married. But she had been taken ill 28 years ago; now the disease is curable, so the doctors say.

This remark made me ask: "Has this any significance for her?" None, she could not imagine at all what it might mean to her—she has never thought about it. I commented that the thought that she might have inherited a disposition to such an illness would be possible after all. She was never afraid of that, she would have got married in spite of it. I said that such a fear may perhaps have arisen in her at the time of the first period. "This is not possible, because my mother told me long before that, when I was *twelve years* old, that I must not get married, because then I would get the same illness."

[849] We may conjecture from this remark that during her twelfth year discussions of far-reaching sexual importance took place, which must have made a strong impression on the patient's fantasy, judging from the strength of the resistance with which she tries to prevent the elucidation of this point. In any case, during the twelfth year we find one of the first components of the sexual complex. At the time of the first period she was faced with two complexes, one associated with a fully developed automatism, the other with the sexual feelings. The possibility of converting this decisive experience into a hysterical symptom is thus given, but not the necessity for it, because the impossibility of marriage appears by itself insufficient. We must also postulate the existence of an event that prepared the way for repressing the sexual complex, i.e., a sexual event of childhood. Here the sexual trauma, which the dreams seem to indicate, would fit in.

[850] With menstruation a new form of existence sets in, the sexual one. It is therefore not surprising if the school-complex is replaced by the sexual complex, though only outwardly; as we have seen, it is still present in the associations, it is still an open

wound which is above all sustained by self-reproaches. That the school-complex, i.e., the St. Vitus's dance, potentially still exists is expressed in the following way: The patient once had a particularly bad day. She described the heat sensations as intolerable; while she was speaking her right arm twitched from time to time, then the left one too. I drew her attention to these movements, then her legs also began to twitch slightly, and she said: "I can only restrain myself with an effort from hitting out as I used to do. I feel the greatest temptation to do so!" We can see that the old automatisms are again ready to break through at any moment when her energy is completely exhausted (this confirms Janet's doctrine that each *abaissement du niveau mental* is accompanied by a flare-up of the automatisms). The onset of menstruation stimulates the development of the present complaints, heat sensations in the head and neck, a sensation as if all the blood is in the head, a temperature of 104°. Hands, feet, and body are cold. Simultaneously there are obsessive chains of ideas: she is constantly compelled to imagine that she is bleeding from the nose, from all apertures of the head, and that the clots that were discharged during the first period are in the head; she always wishes she could just once bleed enough from the head to fill a whole basin.

[851] This strange symptom-complex without any doubt refers to the period: it is none other than a "displacement from below upwards" (Freud). The mechanism of displacement is operative in the patient; we have already found it in the dream-analyses in a form that can hardly be mistaken. The heat (blood and fire in the dream) is probably the sexual heat appearing with the period. For many months the period has ceased, after being rather irregular; besides this there is an obvious meteorism and a posture that makes the abdomen protrude even more. These are, according to Freud, symptoms of pseudo-pregnancy, an assumption that the psychological experience supports; where there is a complex of erotic expectancy in a young girl, the child plays a marked role in associations and dreams.²¹ It will be remembered that this is in fact so in the associations of our patient. Furthermore, for the patient, pregnancy points to the danger of osteomalacia, which is bound to be strongly repressed. I am, however, unable to bring any positive evidence for Freud's conception.

[852] The following symptomatic acts probably also originate from the repression of the sexual feelings:

1. the constant craving to cool down;
2. the cold washes;
3. the horror of meat in any form;
4. the inability to sit still;

5. a liking for indoor gymnastics while otherwise avoiding any physically strenuous occupations.

[853] These symptomatic acts exactly correspond to the hygienic precepts against states of sexual excitement given in popular text-books.

[854] Positive evidence for the repression of the sexual feelings is the consistent and obstinate evading of all sexual questions. As soon as the inquiry touches anything sexual, there is a barrier, and then one is usually held up by insurmountable obstacles. For theoretical reasons I made sure by appropriate questions that the patient was thoroughly informed about all the facts of sex, but she was unable to tell me where she knew all this from; she stubbornly denied having ever read anything about it or heard anything about it from anyone. She just knew it. Only towards the end of the treatment did the patient confess during the analysis, after protracted blocking, that a girl friend had enlightened her, when she was twelve years old. This too shows how strong the barriers are that guard the sexual secret.

[855] I need not go any further into the visions; they have already found their interpretation during the dream-analyses.

[856] The improvement moved at a slow pace, with frequent relapses. The energy visibly increased, so that the patient's vigour gradually extended to four and five o'clock in the afternoon (originally it had already been used up by 10 a.m.!). She was again able to read without any interruptions and to do some needlework. But the heat sensations remained, only their intensity seemed less, and during the third month of the treatment the patient stopped telling me about them. She only wondered why she recently has such frequent depressions, the cause of which she could not understand (originally when there was something unpleasant, she never mentioned depression, only exaggerated heat sensations!). To my assistant, a lady doctor, however, the patient spoke of her heat sensations as before. After the dream of the dinner-table, when I had told her about her relationship with me, the earlier expressions were soon resumed, when talking to me as well. In the dream she heard the fire-alarm, and several times, particularly during the last week of her stay here, the black man, who had disappeared after he had first been interpreted, came back too. The dream-analyses show how this relapse can be explained. The patient was unable to reveal her innermost secret; the sexual compromise with myself had failed (apparently she could not find anything in me, apart from the sexual aspect, that would have been so valuable to her that she could have separated herself from her role as an invalid). As she was unable to separate herself from her secret, she had to cling to the heat sensations because of their repressive function, and so she came to resume the former symptoms and appropriate terminology, in this way demonstrating that my

interpretations had been wrong; because she could not admit to herself that I was right, since that would have made the genuineness of her illness questionable.

[857] About a month after the discharge her family doctor wrote to me that she was just as bad as before and that she now grumbled about the hospital and the doctor, with indications that the doctor had only tried to find opportunities to make morally dangerous conversation with her. Thus the sick personality, i.e., the sexual complex, entrenches itself behind aggressive defence-mechanisms; it discredits the moral personality of the doctor as much as possible, in order to invalidate the information supplied to the normal part of the mind. In this way the automatism of the illness secures itself a free road to unimpeded development, because each complex strives to live itself out unimpeded.

SUMMARY

[858] The complex revealed in the associations is the root of the dreams and of the hysterical symptoms.

[859] The interferences that the complex causes in the association experiment are none other than resistances in psychoanalysis, as described by Freud.

[860] The mechanisms of repression are the same in the association experiment as in the dream and in the hysterical symptom.

[861] The complex has an abnormal autonomy in hysteria and a tendency to an active separate existence, which reduces and replaces the constellating power of the ego-complex. In this way a new morbid personality is gradually created, the inclinations, judgments, and resolutions of which move only in the direction of the will to be ill. This second personality devours what is left of the normal ego and forces it into the role of a secondary (oppressed) complex.

[862] A purposive treatment of hysteria must therefore strengthen what has remained of the normal ego, and this is best achieved by introducing some new complex that liberates the ego from domination by the complex of the illness.

THE PSYCHOPATHOLOGICAL SIGNIFICANCE OF THE ASSOCIATION EXPERIMENT¹

[863] Although there is more interest in psychology as a subject nowadays among non-psychologists than there was a few decades ago, nonetheless the relative youth of experimental psychology does mean that in this sphere little has as yet been clarified, and there is a good deal of controversy over many aspects of the subject. What is more, psychology is still a hybrid, inasmuch as the subject of experimental psychology is still in many institutions a very poor relation of philosophical psychology. The dogmatic nature of the latter is to blame for the manifold misunderstandings between the two kinds of psychologist. One wants to make psychology a creed, the other a science. Understandably these entirely divergent tendencies are in conflict with and hinder each other. This opposition makes itself felt most disagreeably in the field of nomenclature. The same words and concepts mean one thing with one writer and something quite different with another. So long as it is a matter of dogmas and axioms, which owe their existence to the *petitio* principle, one cannot hope for clarity, for each dogma entails a certain obscurity, as is well known. We are, therefore waiting for enlightenment from experimental psychology which, it is true, is still in its infancy yet can already look back on a rich harvest from the work in this field.

[864] Psychopathology too has had to suffer for years from the same opposition. First, it had, with difficulty, to free itself from philosophical ideas, only to become subjected to rigid schematic anatomical notions which nowadays are still firmly fixed in many minds. It is only comparatively recently that we have the beginnings of an experimental psychopathology that has recovered from its birth-pangs. For this achievement we owe our gratitude to the alienists; first of all to the eminent psychiatrist Kraepelin, the pupil of Wilhelm Wundt, and secondly to the psychiatrist Sommer. Kraepelin has taken over a series of fundamental ideas and methods from Wundt's school and with these attempted to pave the way to an experimental science of the sick mind. Under his direction a large number of important papers² have been published that will provide a source of stimulating ideas and valuable methods for many years to come, even if the results of certain individual works are dubious or are, at least for the time being, of purely academic interest. The principal subjects of Kraepelin's research are mental ability, the influence of fatigue, drugs, and alcohol on simple psychic functions, fatigue and recovery, perception, etc.

[865] This research is mostly concerned with the experimental demonstration of various influences on the mind of a normal person. The real value of Kraepelin's

work, however, lies in opening up various new prospects in the field of psychopathology.

[866] In addition to the papers on fatigue, Aschaffenburg's work on associations is particularly important in this context.³

[867] Before we go any further into the content of Aschaffenburg's work, certain matters of a general nature must be discussed.

[868] The ancients were already aware that the flow of our images and ideas is not entirely erratic; we find suggestions of laws of association in Plato and Aristotle,⁴ the validity of which is still recognized today. The laws of simultaneity, sequence, similarity, and contrast are also the basis of Wundt's laws of association. Wherever in Nature there is a regular sequence of events the experiment can be applied. Thus experiments can also be made on the process of association, however complicated and difficult to follow this may be. After Galton's first tentative experiments,⁵ Wundt and his group were the first to make systematic investigations⁶ into association processes. The method of the experiment is extraordinarily simple; the experimenter calls out a word to the subject, who then says what is immediately called to mind by the stimulus-word. The experiment is thus similar to any other in physiology in which we subject a living object to an adequate stimulus, as for example the application of electrical stimuli to various parts of the nervous system, light to the eye and acoustic stimuli to the ear. In the same way with the stimulus-word we are applying a psychical stimulus to the psychical organ. We introduce an image to the consciousness of the subject, and are given whatever further image is brought by this to his mind. We can thus quickly obtain a large number of connected images or associations. From the material thus obtained we can establish, by comparison with that from other subjects, that this or that particular stimulus will give a particular reaction. So we possess a means of investigating the law of association. The "law of association"! That sounds highly academic, and no one with knowledge of philosophy would hesitate to admit the possibility of such laws. However, the word "law" implies necessity and thus, applied to the experiment, it means that the stimulus-image must necessarily cause this or that particular association. The experiment would thus acquire the nature of something inexorable and causally inevitable. The subject must inevitably associate the appropriate image to a particular stimulus, just as the nervous system, when given a stimulus at one point, *ceteris paribus*, always causes contraction of the same muscle. If we recognize the necessity of laws of association, we must say that the subject has surrendered completely to the experiment because he must necessarily have that thought which is associated with the particular stimulus. This involves the idea of determinism. Not everyone however, will go so far with us. There are still many educated people today who, on

the ground of idealism and for other reasons, believe in the freedom of the will. Consequently these people must deny the necessity of the law of association, and resolve interconnection of ideas into a number of fortuitous events. They must assert that the experiment indicated is open to the wildest chance; that a person can not only say, but also think, whatever he wants to; that, from hundreds of things that occur to him, he can choose now one and now another according to his taste or present mood; that he is not obliged to think in terms of similarity or simultaneity, etc. These are the usual objections. The same objections are raised by serious-minded people to determinism. They maintain, in all seriousness, that man is capable of choosing from among his various motives before the act of will occurs. Does he also choose from among the motives of the motives, and the grandfathers and great-grandfathers of the motives? And what does he do with those motives which do not enter his conscious mind?⁷ Or do the motives perhaps come to the surface from the transcendental sphere as an incomprehensible act of the Creator? If man wished to select from among his motives, he would have to spend years before he moved a finger in order to trace back to the mists of his childhood the entire series involved and consider all of them: he would never finish. In this process he would again and again be dependent on the results of all previous motives or *associations* to express himself with greater clarity. As you can see, it is *a priori* easy to refute the objection based on the principle of chance in psychical occurrences if the opposition is not intent on raising sophistical difficulties.

[869] In principle, therefore, it must be accepted that association is a necessary sequence following certain laws. Hence an association experiment in which chance appears to have an absolutely free hand takes on the dignity and conclusiveness of any other scientific experiment. Chance, by definition, does not allow of any rules, but does permit necessary occurrences. A rule means a restriction, a limitation of the occurrence, which must empirically be capable of proof. In the same way, too, the multiplicity of possible associations, which to the layman appears inexhaustible, must empirically be limited to a certain extent.

[870] This brings us back to Aschaffenburg's experiments.

[871] The results of his investigation provide us with considerable insight into the vast difficulties of a huge subject. The most difficult of all is in fact the discovery of a law. From what points of view must the disconcerting profusion of thousands of associations be classified in order to obtain even a superficial impression of the whole? When one looks at the innumerable individual reactions one almost despairs of finding a foothold in the wild chaos. Wilhelm Wundt helped himself by means of certain logical principles of classification, based on the laws of simultaneity and similitude which have come down to us from classical times. Thus at least logical

clues were obtained, although neither Wundt nor any of his pupils imagined that they could exhaust all the possibilities. Aschaffenburg and Kraepelin built further on the same foundations. They made one essential distinction: between internal and external associations. The following associations:

human being	boy
attack	defence
table	furniture

are internal associations, i.e., pairs in which the meaning or conceptual content of the words is the essential connecting link.

[872] On the other hand, associations such as:

knife	trousers-pocket
water	fish
plant	pot

are external associations, i.e., the connecting link is not the intrinsic sense or meaning but an external contingency. One particular form of this external connection is the catch-phrase; as such phrases readily come to mind they are especially frequent in this experiment. For instance, the following associations, as purely verbal connections, are to be considered as external:

time	and tide
whisper	sweet nothings
stick	in-the-mud
die	is cast

[873] Among external associations Aschaffenburg includes all current word-sequences.

[874] Apart from the internal and external associations there is often also the case of a word merely suggesting another having a similar sound:

part	heart
cow	plough
rabbit	habit

These have been called sound associations.

[875] In spite of the tremendous efforts made by various research workers, we have still not yet succeeded in finding a method of classification that is in principle entirely satisfactory. In any case, the present method suffices for solving many problems in association research.

[876] One of Aschaffenburg's predecessors in the field of association research, the well-known psychologist Münsterberg⁸ (now in America), believed he had found that

the existence of three different intellectual types was proved by his experiments. He found that among a limited number of subjects there were some who reacted mainly in terms of super-ordination, others in terms of co-ordination, and others in terms of sub-ordination. Aschaffenburg, however, with a much more reliable method, found nothing of the kind.

[877] The hope of finding categories governing association was thus premature. No regularity was to be detected *prima vista*. One subject would make many internal associations, another many external ones; one would make no sound reactions and another several. No one could account for the differences.

[878] At this stage, however, Kraepelin and Aschaffenburg made one fundamentally important step forward. They altered the psychical condition of the subject in the most unequivocal manner; the subjects of the experiments were deliberately made as tired as possible in the following way: each of them would, after a full day's work at his usual profession, be given a series of association tests at intervals from eight o'clock in the evening to eight in the morning, the pauses being given to some other form of mental work. During the night the subjects were given nothing to eat.

[879] By this means a state of intense fatigue was created.

[880] One quite constant phenomenon now became evident in the associations of the various subjects; there was a decrease in the number of internal associations, and an increase in the external variety, and especially in the sound associations, i.e., associations with other words. Semantic connections grow weaker with increasing tiredness and are replaced by external and superficial connecting links. It can thus be stated that the valency of associations decreases with increased tiredness.

[881] Thus we have the first important rule about the faculty of association. Fatigue obliterates individual differences and drives the act of association in a particular direction. Besides this, Aschaffenburg also discovered that in one of his subjects who was suffering from a severe attack of influenza, the associations were similarly affected. So the special disposition of the brain caused by fever also has an adverse effect on the value of association tests in that mainly sound associations are produced.

[882] These positive results, which far surpassed anything else that had hitherto been accomplished in the field of association research, provided Aschaffenburg with the link to the subject-matter of psychopathology. Clinical observations had long since established that in a certain mental illness, known as *mania*, a mode of association is prevalent that is similar to that found by Aschaffenburg in fatigue, i.e., the connections and sound associations were mainly superficial. The illness is characterized by a predominantly cheerful mood, distractability, and motor agitation,

which are expressed in ceaseless compulsive activity. When we analyze the state of extreme fatigue, it is easy to find similar elements there. One has only to observe one's own state after a strenuous mountaineering expedition to be able to diagnose without difficulty an unaccountable superficial gaiety and a state of motor agitation, shown in countless irrelevant movements of the arms and legs. Sound associations, too, are easily seen in the jokes current among parties in mountaineering-club huts. Most of these are of the order of the pun, i.e., the onomatopoeic joke par excellence. Aschaffenburg believed that the common factor in these circumstances was *motor agitation*, and therefore attributed the cause of sound associations to this. In this, however, I think he was in error. In our hospital we have conducted systematic research⁹ into associations for several years past and have obtained results that allowed of another interpretation. When a longish series of associations, say two hundred, is given to a subject, he will, without really becoming tired, soon find the process boring, and then he will not pay so much attention as at the beginning. For this reason we have separated the first hundred from the second in our classifications and have found that in all cases where the subject had become bored there is a clear decrease in internal associations and a proportionate increase in external and sound associations. This observation made us think that the cause of sound associations is not so much muscular stimulation, which is absent in normal boredom, but a lack of *attention*. We have been able to confirm this interpretation on the basis of numerous experiments in which the subject's attention has been methodically distracted.¹⁰ Furthermore, we found an increase in the proportion of sound associations with subjects whose ability to concentrate had been weakened by a recent affect, with people in a somnolent state, and in addition with psychotics whenever their capacity for concentration is reduced. Kraepelin's school have also shown a levelling down of associations in cases of acute alcoholic poisoning. Aschaffenburg found the same thing in feverish patients. *It can therefore be said that the more the attention of the patient decreases, the more the external and sound associations increase.*

[883] As you can already see from its numerous connections with altered psychical conditions, this empirically discovered law of association has, of course, great importance for the understanding of psychopathological states; in which, as is well known, one of the principle psychic functions, *the ability to concentrate*, is very frequently paralyzed or disturbed. In certain borderline cases between mental health and psychical disorder the experiment has already been of valuable service to us.

[884] Our knowledge of factors governing association is, however, not exhausted with the statement that the seemingly unrestricted association depends to a large extent on the subject's attentiveness. Research into the associations of a large number of educated and uneducated subjects has enabled us to establish that *on average* the

uneducated gave internal associations more often than the educated.¹¹ This apparent paradox can be explained as follows.

[885] Educated people are used to dealing with words out of any context (as in grammatical studies, dictionaries, etc.). Thus when we call out a word to an educated man, it means no more to him than just a word. An uneducated person, on the other hand, is only accustomed to hear words in a sentence, where they always have a definite meaning. If we call a word out to an uneducated person, he always constructs something like a sentence round it. He understands the word as a question: hence the tendency of uneducated subjects to react with whole sentences or by the use of higher categories. Thus for instance the educated man will react to *table* with *table-cloth* to *chair* with *chair-leg*, whereas the uneducated man will react to the word *table* with *furniture*, and *chair* with *for sitting on*. The educated person finds it easy to grasp the experiment, while it costs the uneducated one an effort to do with words called out to him something different from what he is used to in his daily life. It therefore also happens that the uneducated are inclined to apply adjectives to themselves, particularly when they appear to express a judgment or anything of that kind, e.g., in the case of the word *stupid*. The degree of effort needed for concentration varies according to the subject's grasp of the experiment. This effort is obviously often greater in the uneducated than in the educated, and this naturally has some bearing on the valencies of the associations. With very uneducated and mentally defective¹² subjects, the reactions assume the character of definitions that frequently seem clumsy and comical, e.g.:

singing

consists of notes and hymn-books

strolling

when you go forward on your feet for a
Sunday pint

[886] From our approximately 150 normal subjects, who provided a stock of over 35,000 associations, it can be seen that there is not an infinite variety of modes of association, but only a limited number of types, which I do not propose to describe to you; it would lead us too far afield. I will mention only one type; there are people who from the very start react with an extraordinarily large number of predicates. One can make the objection that this particular incidence can be very easily attributed to chance. We have, however, been able to demonstrate that whole families associate in the same way, without any one member being aware of the reactions of the others. This fact indicates that the type cannot be accidental but must be due to causes that at present still escape our knowledge.¹³

[887] As you can see, free choice does not play any part in the process of association. There are, however, certain rules: it depends on the momentary state of our attentiveness, our educational level, and the type of our family or other personal

circumstances. You have perhaps already noticed that these three rules correspond to important criteria of personality; in other words, our personality (which, as is well known, one knows least of all) plays a decisive role in the determination of the whys and wherefores of our associations. *One associates according to what one is*, or, as the psychiatrist Weygandt not long ago appropriately said: “Tell me how you associate and I’ll tell you who you are.” This is no empty statement. I will briefly outline the evidence for it:

[888] In the association experiment we measure time with a stopwatch to one-fifth of a second, from the moment the stimulus-word is called out to the moment the reaction is given. The interval of time taken we call the *reaction-time*. I will not bore you with an enumeration of the differing time-values. The assurance that the values fluctuate within a very wide range should suffice.

[889] As in the classification of associations, one should not lose heart in one’s attempt to evaluate seemingly fortuitous time-variations, since *a priori* one can hardly imagine that each of these variations has a particular significance. It is true that on closer examination we see that the internal associations, particularly reactions to abstract stimulus-words, on the whole require a longer time than the external associations. That, however, means very little—the differences are usually only fractions of seconds—beside the very much longer times that are often found with the simplest of associations. Here the time-differences can frequently be as much as twenty or thirty seconds without there being at first any indication of the reason for these variations. The subjects also cannot usually give any precise information about this. One gradually becomes accustomed to this chaos. We know from the research of Ziehen¹⁴ and of Mayer and Orth¹⁵ that it is particularly the associations that awaken memories of an unpleasant nature that take a long time. Thus, for example, A will take 0.8 seconds to react to *house with roof*: B gives the same reaction but takes 20 seconds. If we ask subject B whether, on hearing *house*, anything unpleasant crossed his mind, he tells us (for instance) that his house was recently burned down, which frightened him very much. Subject A, who had reacted in 0.8 seconds, has nothing special to report.

[890] Here we have an idea charged with an unpleasant emotional tone associated with the stimulus-word and causing a lengthening of the reaction-time. Supposing that in this case B is a cultured person with the ability to analyze himself psychologically, and is prepared to offer up the knowledge of his deepest secrets, then we can pause after every reaction that takes longer than the average and ask what memory lies at the root of it.¹⁶ We will assume further that the subject is able to give the desired explanation for each long reaction-time. When we have thus gone over one hundred reactions and analyzed them, we find that in many places where much time was taken

it is not always fresh memories that are awakened but that one memory, e.g., that of a house that was burned down, caused a whole series of long reaction-times. This memory is reflected in the reactions to the following series of stimulus-words: *burn-fire-water-window—smoke-rescue-frightful—red-etc.*

[891] These varying stimulus-words conjured up a certain scene, a particular picture from the mass of memories. The memory consists of a large number of single images; we therefore refer to it as a *complex-image*.¹⁷ The complex of these images is held together by a particular *emotional tone*, that is, by the *affect of terror*, the vibrations of which can continue gently for weeks or months and keep the image of terror fresh and vivid for that length of time. During the day work and other interests predominate, but from time to time these complexes make themselves felt through a faint and hardly recognizable unease or through slight feelings of anxiety, which seem to be unaccountable; at night they intrude into our dreams in a form the symbolism of which may be more or less pronounced.

[892] There are other emotional complexes similar to the complex of the memory of the fire; one is concerned with losing large sums of money, and another with somewhat unfortunate family relationships. These three complexes all have the same effect on reactions; they cause longer reaction-times and certain other disturbances, all of which I cannot now enumerate.

[893] If we spread out our psychological booty in front of the subject, he will be amazed that we have been able to build up, as it were, a precise inventory of his present psychological condition. In this way it appears that everything that occupies the mind of the subject is expressed in his associations. In any case, all the most important individual *complex-images* are met with. Our subject admits further that at the time of the reaction he hardly ever had the feeling that the stimulus-word had any connection with this or that memory. Only when we asked him did it occur to him how he had arrived at that particular reaction. Contrary to his expectations, the subject had as it were offered in his reactions a psychological snapshot of his mind.

[894] We have been able to demonstrate fully this significant fact, the importance of which everyone psychologically oriented can easily gather, in hundreds of individual tests. It is, however, one of those not at all obvious facts that everyone doubts until he has convinced himself of its truth by conducting the experiment himself.

[895] Thus we found a further and in my opinion the most important factor determining associations. We can see, from the fact that in the few seconds of the reaction we do not choose something fortuitous but unconsciously take an item from our memories, that our reactions, far from being the result of a free choice, are predetermined to the smallest detail by our complexes. The occurrences of everyday life are nothing but association experiments on a major scale; the things outside us are the stimulus-

words to which we react according to what we are and have become, and never in any other way. No one can get out of his own skin. We act as our psychological past, i.e., as our cerebral organization dictates. For this reason we are bound to expose ourselves in the association experiment in exactly the same way as we do in our handwriting.

[896] You can see that in this strongly forged chain there is no gap where free choice or free will can break through. So you may believe me when I say that recognition of this fact is of great value in the investigation of mental illness.

[897] Most cases of mental illness are, however, a matter of far-reaching change of personality. The association test at least paves the way for experimental research towards the discovery of the secrets of the sick mind.

[898] Before we go into this new application of the association experiment, we must say a few words about the manifold difficulties that stand in the way of the experiment even with normal subjects.

[899] We have been assuming that our subject is a man of excellent education, intellectually unbiased, and able to think objectively about his own feelings. In such a case, analysis will not be difficult. But if we were to take as subject a sensitive woman, who does not know us, the analysis would be considerably more difficult. Everyone is, above all, anxious to preserve certain secrets, particularly of a sexual nature, and will not disclose them at any price. It is here that from the very beginning the experimenter finds a significant and almost insurmountable obstacle in his endeavours to analyze. Then there are certain peculiarities of human consciousness that aid concealment and can make analysis extraordinarily difficult. I shall try to sketch these characteristics for you briefly.

[900] We have all of us at one time or another experienced something really unpleasant, which has subsequently haunted us for a long time. The natural reaction to this was that we made an effort to forget this black spot, to repress it, in that we quite deliberately did not think about it. And eventually we succeeded in not thinking about it any more. We have forgotten. In associations, however, this black spot reveals itself, and the long reaction-times caused by it show that the vibrations of the former affect are still there. In analysis we have at first some trouble in thinking of the critical point, and the more unpleasant it was the longer it takes us to get back to it. All kinds of other memories will come to mind first, but finally the old story will come up, and we can again feel slight vibrations of the old affect. Now there are people, lots of them, who cannot recollect the critical event at all; they have forgotten it. They have repressed the unpleasant experience so forcefully that it can no longer be revived. Very often, too, the inability to remember looks like a wish not to remember, i.e., the subject cannot will himself to think about it.¹⁸

[901] Our question remains unanswered. Many experiments have been wrecked on this shoal. Nonetheless the situation is not hopeless. In the last resort one can hypnotize the subject, and then one sees why he could not think back. The critical incident is so unpleasant that one understands immediately why he did not wish to be reminded of it. In the more serious cases of hysteria this inability to remember is in fact the rule.¹⁹ In these cases the complex is stronger than the conscious will and drives the subject in such a way that he cannot will himself to remember. The complex plays the part of a second and stronger personality, to which ego-consciousness is subjected. In these experiments we are shown the power of feeling-toned memories from which so many sensitive people suffer.

[902] The inability to remember in its various forms is the principal obstacle to analysis. We shall not go into a series of lesser hindrances.

[903] The objection may be made to analysis that one suggests something to the subject that is not in his mind. In my opinion, however, much too much has been attributed to suggestion. If suggestion were something better known and if so many superstitious meanings did not surround it, this could not then be maintained. It is quite impossible to suggest to a subject by means of a few well-oriented questions all his individual concrete experiences, with all the facets that they have in real life. A subject who lets himself have some experience suggested to him by a clumsy experimenter that he did not really have is a person who had previously had all sorts of phantasms in his mind. A psychologist, i.e., one experienced in the workings of the human mind, will not fall into this trap. He who understands the experiment properly will no longer be afraid of the unknown quantity of suggestion.

[904] So far as the content of complexes found among normal subjects is concerned, the subjects fall naturally into two groups: men and women.

[905] To take the women first, their complexes are of a simpler nature and are usually easily recognizable. The woman's complex is, in essence, usually of an erotic nature (and I am using the word "erotic" in the noble literary sense as opposed to the medical). It is concerned with love, even in apparently intellectual women, and is often particularly intense in the latter, although it is only revealed in a negative way to the outside world. No woman who thinks scientifically will take amiss my revelation of this fact. It is as natural and undeniable as the physical sexual process, the existence of which is, it is true, kept secret but never denied. In unmarried women the complex is concerned with the remembrance of past erotic complexes or the expectation of future experiences. Among the secondary complexes, we find most frequently social questions, such as status and earning a living; in general these are clearly linked with the erotic expectation of the man, upon whose arrival the woman's social problem is usually resolved. In the third place come difficult family

relations in the parents' home. Married women show complexes especially concerning pregnancy and children, then those connected with relations with the husband, and lastly social difficulties and domestic worries. Old erotic complexes strikingly often play a large part in the very great number of not quite happy marriages, in that they concern memories of previous lovers or at least hopes of this kind. It is mostly a case of the man she should really have chosen but did not marry.

[906] In men the erotic complex is not nearly so much in the foreground as in women. It is perhaps on the same level as that of ambition, or striving for physical, intellectual, or financial power. Money usually plays the leading part. The differences between married and unmarried men are not great. In men's associations traces of the social battle show up much more clearly than in women's. Complexes in them are not nearly so easy to reduce to a common denominator as those in women, which are almost all attributable to their erotic life. Nonetheless there are men too in whom the erotic complex is all-pervasive; the exception, however, proves the rule.

[907] Recently Professor Gross and his pupils have emphasized that a complex can also concern crime, and that a criminal can in certain circumstances be unmasked by means of an association test. Laboratory tests designed to verify this assertion are now in progress. Not long ago for the first time, using this method, I succeeded in unmasking a person guilty of a considerable theft.²⁰

[908] These results achieved in the field of normality we have transferred to that of psychopathology, and here we have found feeling-toned complexes developed to a degree that amounts to caricature. Here I will first of all name the most common form of mental disorder: *hysteria*. Here the associations are often so much under the influence of a feeling-toned complex that the other parts of the personality hardly show up at all. The complexes themselves are of the same nature as in normal cases, except that the intensity of the emotional content is far greater than in the normal. As a rule, the times of critical reactions are much longer and the barriers to recollection much stronger than with normal subjects.

[909] From this we can first of all conclude that the sensitivity (i.e., the excitability) of the emotions is greater in hysterical patients than in normal people. An integral part even of hysteria, however, is a complex of images linked with most powerful affect which, for some reason or other, is still reverberating in the patient and which his conscious mind finds unbearable; the *hysterical patient suffers from an affect that he has been unable to conquer*. The recognition of this is of the greatest importance in therapy.

[910] You will now ask what is the relationship of this fact to the enormously complicated *symptomatology of hysteria*.²¹ I will explain our view by giving two simple examples.

[911] A hysterical girl suffers from time to time from a minor paralysis of the left arm. She is very worried about it and cannot give any adequate explanation for her symptom. From her associations we learn that there are troubles in the home and, in particular, that she is terrified of her father. By various means, which I unfortunately cannot describe to you now, we induced the patient to make the following confession:

[912] She has a very unhappy relationship with her father, who is a coarse and irritable man. Each time she has had a scene with him the paralysis in her arm comes on. The first time it happened was after a particularly violent argument when her father finally seized her by the arm and forbade her the house.

[913] Thus the symptom of paralysis is closely related to the complex shown in the associations. The complex is the intolerable thing that the patient is trying hard not to think about. She succeeds in freeing herself for days or hours at a time from its constant negative affect, but has instead acquired a hysterical symptom that she now makes responsible for all her dreary moods.

[914] Another and simpler case concerns a young married woman who suffers temporarily from abasia, i.e., inability to walk. The associations revealed an unhappy marital relationship. The patient, however, did not want to go into the matter and denied absolutely that there was any connection between the abasia and her marriage. She attributed the onset of abasia to a chill. Under hypnosis, however, the matter became quite clear. The attacks of abasia came on each time immediately after brutal treatment by her husband. The first occasion was when she was fetched by this man, whom she did not love, for her wedding. She found she could no longer walk, and from that time onwards abasia had been the symbol of her suffering.

[915] These two simple examples should suffice to make clear to you the connection between the symptoms of hysteria and the feeling-toned complex. In the depths of the mind of each hysterical patient we always find an old wound that still hurts or, in psychological terms, a feeling-toned complex.

[916] Our association experiments have now also been able to demonstrate the same mechanism in cases of the next most prevalent group of mental illnesses, i.e., dementia praecox. In this too we are concerned with a complex buried in the depths of the mind which, so far as we can see, causes many of the characteristic symptoms of this disease, in which admittedly we find ingredients lacking in hysteria.²²

[917] You may have gathered from these indications on the one hand how fruitful the application of the association experiment is for psychopathology, and on the other how universal is the significance of the feeling-toned complex.

DISTURBANCES OF REPRODUCTION IN THE ASSOCIATION EXPERIMENT¹

[918] My reproduction method, which I introduced in a short communication in the *Zentralblatt für Nervenheilkunde und Psychiatrie* in 1905,² has recently been repeatedly criticized (by A. Gross, Heilbronner, and Isserlin³). Because of an undue amount of other work I am, to my regret, only now able to complete my unfinished paper by giving it the support of statistics. In 1905 I maintained the following:

[919] If, after the completion of about one hundred associations, the subject is asked to repeat the original answers to the individual stimulus-words, memory will fail in several places, in such a way that the previous reaction is either not reproduced at all, is given incorrectly, is distorted, or only given after much delay. The analysis of the incorrectly reproduced associations showed that the majority of them were constellated by a “complex.” Since most contemporary workers doing research in this field tend to attribute to Freud’s psychoanalytical method no heuristic value at all, it is denied to me to take the shortest course and simply corroborate the above statement by means of analyses. To eliminate the subjective aspect of analysis, which is so much feared, I have no choice but to adduce as unobjectionable evidence the objective signs of complex-constellations, complex-characteristics, and their relation to incorrect reproduction. I found that, in associations that were recognizable through complex-characteristics, a complex was responsible for the constellation, i.e., had “interfered” and brought about a disturbance. If these characteristics are really significant, i.e., if the analytical method has led to a correct result that could be verified, then the characteristics in general must stand in close relation to each other, i.e., they must tend to appear together in certain associations. This applies, for instance, to incorrect reproductions and prolonged reaction-times. If this is not the case and the complex-signs are indiscriminately scattered over the whole test, then the analysis has led to a wrong conclusion.

[920] I further mentioned in my previous communication: (1) The incorrectly reproduced associations occasionally have an arithmetical time-mean that exceeds the general arithmetical mean (*one example*). (2) The incorrect reproductions apparently occur as frequently with the critical as with the post-critical reaction. (3) Occasionally there is a tendency to serial or to isolated disturbances in reproductions. (4) I looked for the theory of the phenomenon in the general characteristics of the complex. I then stressed one feature in particular, repression (Freud), because precisely this feature seemed to me best to explain the inhibition of the correct reproduction. The main characteristic of the complex is certainly its relative independence, which can manifest itself particularly in two directions: in increased emphasis and stability in consciousness, and in repression, i.e., resistance against reproduction while in the unconscious. Therefore the associations belonging to the complex lack the “disposability” of other less significant psychic material (this, by the way, happens only when the special complex is inhibited and must not come to the point of reproduction). The complex itself, of course, completely, even hypermnestically, controls its

material. This reducing of the disturbance of reproduction to a more general psychological characteristic seems to me to explain something. Of course, the hypothesis does not apply to every case, for then one would first have to make sure that all interferences from outside (fortuitous ones) are completely excluded; my hypothesis applies only to the majority of cases, as well as only to the majority of complex-characteristics. (5) The complexes indicated by the association experiment are usually charged with unease, which is why the exceptional condition of the complex during the experiment may well be described as “repression.”

[921] It is now my task to demonstrate exactly what my conception is based on, i.e., to prove that the disturbances in reproduction are complex-characteristics, and therefore as a rule appear together with other complex-characteristics. There cannot be a simple method of verification, because we have to consider that the reproduction-disturbance, like all other complex-characteristics, is not a necessary feature of the complex, and also that, like the other complex-characteristics, it is not exclusively tied to the critical reaction but can also occur with the one that follows. The complex-characteristic most frequently met with is the *reaction-time*.

Disturbance in Reproduction and Reaction-time

[922] The most obvious method of comparison would be simply to compare the arithmetical mean of the times of the incorrectly reproduced associations with the arithmetical mean of all the times or of all the remaining times. But this method would only be to some extent reliable if the disturbance in reproduction coincided with the prolonged reaction-times. This, however, is not at all the case; the situation is much more complicated. The following quite varied cases occur:

1. Critical reaction with $\left\{ \begin{array}{l} \text{prolonged reaction-time,} \\ \text{reproduction-disturbance;} \end{array} \right.$
2. $\left\{ \begin{array}{l} \text{Critical reaction with prolonged time,} \\ \text{Post-critical reaction with reproduction-disturbance;} \end{array} \right.$
3. $\left\{ \begin{array}{l} \text{Critical reaction with reproduction-disturbance,} \\ \text{Post-critical reaction with prolonged reaction-time;} \end{array} \right.$
4. Post-critical reaction with $\left\{ \begin{array}{l} \text{prolonged time} \\ \text{reproduction-disturbance;} \end{array} \right.$
5. Reproduction-disturbance of critical and post-critical reaction (twofold sequences of disturbance).
6. Reproduction-disturbance of critical reaction and of three and more successive reactions (threefold and fourfold sequences of disturbance).

[923] These complicated relations have to be taken into account by the method. In a previous one of the Diagnostic Association Studies,⁴ I used the probable mean to determine the prolonged reaction-times because of the fact that the arithmetical mean is as a rule disproportionally high owing to the undue influence of excessively long times, which obviously cannot be compensated for by excessively short times, since the reaction-time has

unlimited variations only in the upper ranges. The probable mean therefore generally gives a much better picture of the average speed of reacting. What exceeds this average may as a rule be considered to be not quite normal. But the probable mean is only applicable for large series of numbers, otherwise it is too inaccurate, because it can be considerably altered by trivial chance-events. For small series of numbers we therefore have to use the arithmetical mean. So I have started with the probable mean of the whole test, first counting how many reaction-times of incorrectly reproduced associations exceed the probable mean, how many equal it, and how many do not reach it. If my previous assumptions are right, then one might expect to find the majority of reproduction-disturbances above the probable mean. Those reproduction-disturbances that fall on or below the probable mean can be due to perseveration and therefore may immediately follow a prolonged reaction-time; one has therefore in these cases to examine the reaction-time immediately preceding the disturbance. Actually the reaction-time immediately following should also be investigated, because the time-increase may not occur until afterwards. This, however, would lead us rather far afield. I have not embarked on this investigation hitherto, because it seemed to me that such cases are not very frequent. Let us first see how far we get with the two just mentioned. I should like to stress that since the methods just mentioned do not involve the subjective element, we can approach the task of verification with confidence.

[924] The material I have chosen for my inquiry consists of twenty-eight cases, all of which were investigated some time ago and for purposes other than the verification of the present assumption. Not quite a third of the cases were investigated by me, the other two-thirds by various assistants, some of them several years ago. Among the subjects of the experiment only three are mentally sound, the others are neurotics and psychotics of the most varied kinds and of the most varied reaction-types. The material is therefore as heterogeneous as can be, offering the smallest chance of uniformity in the result. I have collected the results in the following table (all the times are given in $1/5$ seconds):

	Case and Diagnosis	Associations	Associations incorrectly repr.			I	II ⁵
			above	equal to	below		
			the P.M.				
G.	Hebephrenia	100 P.M. 8.5 A.M. 9.0 I.R. ⁶ 35%	22	5	8	10.6	12.5
A.	Moral insanity	100 P.M. 12.0 A.M. 15.2 I.R. 45%	30	6	9	14.1	10.2
R. ♀	Hebephrenia	100 P.M. 13.5 A.M. 20.6 I.R. 15%	11	—	4	—	11.7
P.	Paranoia	100 P.M. 11.0 A.M. 12.9 I.R. 22%	13	2	7	13.0	13.2
H.	Catatonia	100 P.M. 22.0 A.M. 30.3 I.R. 53%	33	1	19	25.0	31.0
G. ♀	Hysteria & imbecility	50 P.M. 14.0 A.M. 17.0 I.R. 16%	6	—	2	—	16.0
W. ♀	Dementia praecox	100 P.M. 10.5 A.M. 11.3 I.R. 53%	29	—	24	—	10.2

G.	Organic mental defect	100 P.M. 47.0 A.M. 57.0 I.R. 67%	34	2	31	165.0	67.4
Z. ♀	Dementia praecox	100 P.M. 10.0 A.M. 14.4 I.R. 51%	32	6	13	14.0	16.7
H. ♀	Dementia praecox	100 P.M. 10.0 A.M. 11.5 I.R. 41%	22	5	14	9.0	10.3
V.	Imbecility	100 P.M. 11.0 A.M. 11.1 I.R. 28%	16	5	7	10.2	16.1
E.	Moral insanity	100 P.M. 15.0 A.M. 18.1 I.R. 30%	21	5	4	17.8	18.0
K. ♀	Dementia praecox	100 P.M. 17.0 A.M. 21.8 I.R. 38%	23	—	15	—	24.4
K. ♀	Dementia praecox	100 P.M. 5.0 A.M. 7.1 I.R. 25%	18	4	3	4.7	9.6
A.	Paranoia	100 P.M. 13.5 A.M. 13.9 I.R. 14%	7	—	7	—	10.4
B.	Psychopathy	113 P.M. 18.0 A.M. 19.5 I.R. 27.4%	16	2	13	19.0	17.6
S.	Catatonia	100 P.M. 11.0 A.M. 14.3 I.R. 32%	24	3	5	11.6	16.6
H.	Imbecility	104 P.M. 18.0 A.M. 30.4 I.R. 27.8%	14	4	11	56.7	24.4

S.	Psychopathy	100 P.M. 12.0 A.M. 17.4 I.R. 37%	26	4	7	19.0	16.4
R.	Dementia praecox	50 P.M. 32.0 A.M. 38.3 I.R. 36%	14	2	2	12.5	33.5
R. ♀	Syphilis of the brain	100 P.M. 14.0 A.M. 17.3 I.R. 46%	23	3	20	12.6	15.3
S.	Imbecility	100 P.M. 26.0 A.M. 37.5 I.R. 21%	13	—	8	—	55.8
J. ♀	Normal	100 P.M. 7.0 A.M. 7.9 I.R. 8%	8	—	—	—	—
H.	Alcoholism & imbecility	100 P.M. 10.5 A.M. 13.5 I.R. 37%	28	—	9	—	13.3
P.	Normal	100 P.M. 7.0 A.M. 7.9 I.R. 33%	20	6	7	7.7	8.6
A.	Normal	100 P.M. 7.0 A.M. 7.8 I.R. 15%	11	—	4	—	8.1
S.	Moral insanity	100 P.M. 12.0 A.M. 13.9 I.R. 40%	27	2	11	9.0	13.3
W. ♀	Neurasthenia	100 P.M. 15.0 A.M. 17.2 I.R. 11%	21	1	9	9.0	16.8

[925] These figures lead to the conclusion that an average of 62.2 per cent of the incorrectly reproduced associations fall above the general probable mean of the reaction-times, 7.5 per cent equal it, and 30.2 per cent lie below. This is as originally expected. An average of 33.0 per cent of the associations is incorrectly reproduced. The time-means of the last two columns have to be considered with the reserve mentioned above. They contain cases of quite different significance. As already stated, only the reaction-time immediately preceding the incorrect reproduction was considered, and this only in those cases in which the incorrect reproduction itself fell below the general time-mean. But it is quite possible that the incorrect reproduction is not the result of perseveration, but that the critical reaction has a short reaction-time, with the longer reaction-time following. In this event the result would be considerably distorted. Therefore we shall be faced with minimum figures. The time taken to give the incorrect reproductions discussed here exceeds, however, the probable mean by an average of 7.8 and the arithmetical mean by 4.1. The values on which this calculation is based vary, however, considerably. The series of numbers in the last column are not so varied and are richer in material, but the same considerations apply to them as to the figures of the last column but one. Here too we find that the reaction-time preceding these reproduction-disturbances exceeds the respective probable mean by 4.2 and the arithmetical mean by 0.4. Here we are reminded that the arithmetical mean tends to be disproportionally shifted upwards, as is anyhow sufficiently demonstrated by our figures. These figures are not contrary to expectation, but in my opinion confirm our assumption. If

one considers how extremely complicated psychic processes are, and how difficult to control, especially in the field of associations, one is actually amazed at the relative regularity of the results, which cannot even be compromised by a schema that does not claim to be complete.

Series of Disturbance and Reaction-time

[926] In my material, 63.9 per cent of all the incorrect reproductions are arranged in series. This fact shows that there is every reason to postulate a relationship between incorrect reproduction and complex, since the complex with its perseveration is a series-forming factor *par excellence* in the association experiment as well as in ordinary psychological life (which, according to the opinion of certain people, must not be related to psychology). If this conclusion by analogy is right, then the series of disturbances must show the same complex-characteristics as the complex-sequences; hence, first of all prolonged reaction-times. In order not to amass unnecessary tables I omit giving figures for each subject. That there is enough material to calculate averages is evident from the above-mentioned percentage figure. The number of the incorrect reproductions underlying this calculation amounts to a little more than six hundred. We calculate the arithmetical mean for all the incorrectly reproduced associations following one another immediately and compare the mean with the probable mean and arithmetical mean for each subject. Sequences of

2 disturbances are on an average 7.7 above the P.M.									
2	"	"	"	"	"	3.6	"	"	A.M.
3	"	"	"	"	"	9.6	"	"	P.M.
3	"	"	"	"	"	6.3	"	"	A.M.
4	"	"	"	"	"	11.6	"	"	P.M.
4	"	"	"	"	"	6.4	"	"	A.M.
5	"	"	"	"	"	6.7	"	"	P.M.
and more									
5	"	"	"	"	"	2.4	"	"	A.M.
and more									

[927] We see an increase of the time-values up to the series of four disturbances, whereas for the series of five and more they are again lower. This result does not fit badly with the analytic consideration. Not infrequently we can see a strong complex perseverating through three and four disturbances, sometimes with uneven decrease of the reaction-times. The stronger is the complex aroused, the stronger, *cum grano salis*, will be the disturbances produced by it. In longer series, however, (which in any case are much less frequent), other factors that interfere with the experiment often appear.

[928] We can summarize by saying: *In the main the disturbance in reproduction is correlated with a prolonged reaction-time; where it is not correlated with this, the preceding reaction-time tends to be prolonged in the majority of cases.* (The question of the reaction-time following is left open, because it is of secondary importance.)

[929] One can apply another, perhaps even more instructive, method to demonstrate the higher time-values of the disturbance-sequences. I have taken twenty-four cases with well-developed sequences from my material and arranged them in two categories as follows:

First, those series that begin with a reaction-time longer than that of the immediately preceding associations, thus:

Association correctly repr.	Disturbances				Associ corre repr. a of se
	I	II	III	IV	
9	10	8	6	6	7
10	82	15	—	—	11
6	92	15	8	—	8
12	35	16	16	—	14

etc.

[930] In this way I have arranged one hundred and nineteen series of this category, added the individual columns, and divided by the numbers of figures in each column.

[931] The second category concerns those series in which the disturbance begins with a reaction that is shorter than that of the immediately preceding correctly reproduced association. For the purpose of comparison I have also taken the reaction-time of the association preceding the one before the disturbance, no matter whether it has been correctly or incorrectly reproduced. Those complicated by “mistakes” were excluded from the calculation, although such sequences would have made my results even more impressive.

[932] This category is therefore composed as follows:

Preceding association	Association correctly repr. with long R.T.	Disturbances			Associ corre repr. a of se
		I	II	III	
14	17	8	21	—	10
12	15	13	55	12	13
8	40	12	20	—	9

etc.

[933] This category consists of 56 sequences. A few sequences in which the correctly reproduced associations and the first disturbance of the series had the same reaction-time were equally distributed among the two categories. The results are as follows (given in arithmetical means and in 1/5 seconds):

CATEGORY I Association correctly repr.	Disturbances					Association correctly repr. at end of series
	I	II	III	IV	V	
14.8	37.2	22.8	23.9	33.0	27.0	17.9

CATEGORY II Preceding association	Association correctly repr. with long R.T.	Disturbances			Association correctly repr. at end of series
		I	II	III ²	
18.3	22.5	13.3	22.7	30.0	17.6

The average arithmetical time-mean of the 24 cases used here is 19.8. We see therefore that all our times, with *one* exception, lie considerably above this mean. The exception is found in those reproductions (Category II) which immediately follow a prolonged reaction-time.

Reproduction-disturbance and Probable Time-mean

[934] If, as appears proved by the preceding investigation, the reproduction-disturbance occurs mainly in conjunction with prolonged times, one may venture the assumption that the number of disturbances with longer individual time-means generally increases. This seems, at least according to my (limited) material, to be actually the case. To a probable mean of

5-10: an average of 29.7 disturbed reproductions					
10.5-15:	"	"	"	31.8	"
15.5-20:	"	"	"	31.8	"
20.5 and over:	"	"	"	44.2	"

To clarify this particular question, however, much more material is necessary.

Reproduction-disturbance and Complex-characteristics, excluding Prolonged Reaction-times

[935] Besides prolonged reaction-times, I found the following to be complex-characteristics: reaction by two or more words if subject usually responds with one word, repetition of the stimulus-word, misunderstanding of the stimulus-word, mistakes, slips of the tongue, translation into a foreign language, reaction with some other unusual foreign word, insertion of "yes" or other exclamations before or after the reaction, any unusual contents of the reaction, perseveration as to content or form, etc. The evaluation of the originality of the content and opinion on the perseveration of content and form are subject to personal influences. Therefore I omit these two criteria from my investigation. I have only used the quite obvious perseveration of a reaction-word which reappears identically in the following reaction. I have selected from my material nineteen cases which are characterized by the fact that they mainly responded with only one word. I have counted how many of the above-mentioned complex-characteristics occur in the whole experiment and how many of these are incorrectly reproduced associations.

[936] The following table contains the results of this investigation in individual figures:

	correctly	incorrectly
1.	0.08	0.16
2.	0.11	0.31
3.	0.03	0.27
4.	0.03	0.11
5.	0.15	0.20
6.	0.11	0.28
7.	0.37	0.40
8.	0.08	0.26
9.	0.06	0.16
10.	0.12	0.42
11.	0.27	0.39
12.	0.03	0.18
13.	0.06	0.15
14.	0.01	0.02
15.	0.06	0.33
16.	0.23	0.29
17.	0.04	0.15
18.	0.31	0.54
19.	0.18	0.29

[937] If one considers that not all complex-reactions are necessarily reproduced incorrectly, and that the incorrectly reproduced associations comprise only one third of all the associations (in my material), then the result conveyed to us by the above table is still rather remarkable: we see that, in each case without exception, more complex-characteristics are produced with those associations that are going to be reproduced incorrectly later on. As a rule, they are recognizable beforehand. The incorrectly reproduced associations show on an average a little more than twice as many complex signs as those correctly reproduced.

SUMMARY

[938] In my very heterogeneous material there is undoubtedly a relation between incorrect reproduction and prolonged reaction-time, and it shows itself in such a way that disturbances of reproduction chiefly occur with prolonged reaction-times but also partly following these. Furthermore, the association that is afterwards incorrectly reproduced has on average twice as many complex-signs as the correctly reproduced one (except for the over-long reaction-time, contents subjectively evaluated, and the correlated perseveration). From this it follows that the complex-characteristics tend to be grouped around certain associations. Without analyzing these one cannot see where the relationships between these greatly varying complex-characteristics originate.

THE ASSOCIATION METHOD¹

[939] *Ladies and Gentlemen:* When you honoured me with an invitation to lecture at Clark University, you expressed a wish that I should speak about my methods of work and especially about the psychology of childhood. I hope to accomplish this task in the following manner:

[940] In my first lecture I shall tell you about the general points of view that enabled me to conceive my association method; in the second I shall discuss the significance of the family constellation; and in the third I shall go more fully into the psychology of the child.

[941] I could easily confine myself exclusively to an exposition of my theoretical views, but I believe it will be better to illustrate my lectures with as many practical examples as possible. We shall therefore concern ourselves first with the association test, which has been of great value to me from both a practical and a theoretical point of view. The historical development of the association method and its use in psychology are both so well known to you that there is no need to enlarge upon them. In my practice I proceed by using the following set of words:²

1. head
2. green
3. water
4. to sing
5. death
6. long
7. ship
8. to pay
9. window
10. friendly
11. table
12. to ask
13. cold
14. stem

15. to dance
16. village
17. lake
18. sick
19. pride
20. to cook
21. ink
22. angry
23. needle
24. to swim
25. journey
26. blue
27. lamp
28. to sin
29. bread
30. rich
31. tree
32. to prick
33. pity
34. yellow
35. mountain
36. to die
37. salt
38. new
39. custom
40. to pray
41. money
42. stupid
43. exercise-book

44. to despise
45. finger
46. dear
47. bird
48. to fall
49. book
50. unjust
51. frog
52. to part
53. hunger
54. white
55. child
56. to pay attention
57. pencil
58. sad
59. plum
60. to marry
61. house
62. darling
63. glass
64. to quarrel
65. fur
66. big
67. carrot
68. to paint
69. part
70. old
71. flower
72. to beat

73. box
74. wild
75. family
76. to wash
77. cow
78. friend
79. happiness
80. lie
81. department
82. narrow
83. brother
84. to fear
85. stork
86. false
87. anxiety
88. to kiss
89. bride
90. pure
91. door
92. to choose
93. hay
94. contented
95. ridicule
96. to sleep
97. month
98. nice
99. woman
100. to abuse

[942] This set of words has grown into its present form as a result of many years of experience. The words are chosen and to some extent arranged so as to touch upon almost all the complexes that commonly occur in practice. As the foregoing list shows, there is a regular mixture of the different grammatical features. For this there are definite reasons.

[943] Before the experiment begins the subject of the test is given the following instruction: "Answer as quickly as possible with the first word that occurs to you." This instruction is so simple that it can easily be followed. The task itself, moreover, appears extremely easy, so that anyone might be expected to accomplish it with the greatest ease and rapidity. But, contrary to expectation, people behave quite differently.

I. Example of a Normal Reaction-type

Stimulus-word	Reaction-time	Reaction	Reproduction
head	9	foot	part of the body
green	11	blouse	
water	14	clear	light
to sing	6	children	
death	11	do not like	
long	6	short	I, tall
ship	7	away	
to pay	6	bills	
window	9	room	
friendly	10	children	
table	9	chair	room
to ask	10	all sorts of things	
cold	7	warm	
stem	6	flower	
to dance	9	I . . .	like
lake	8	Zurich	
sick	8	sister [i.e., nurse]	
pride	6	people	
to cook	7	woman	
ink	5	black	
angry	10	children	people
needle	9	to prick	
to swim	10	healthy	
journey	9	England	I like, much
blue	10	pretty	I like
lamp	6	bright	
to sin	8	much	people
bread	10	good	I like, necessary
rich	9	beautiful	
tree	6	green	
to prick	9	needle	

II. Example of a Hysterical Reaction-type

Stimulus-word	Reaction-time	Reaction	Reproduction
needle	7	to sew	
to swim	9	water	
journey*†	35	movement, <i>voyager?</i> , to travel, ship	

* Stimulus-word misunderstood.

† Repetition of stimulus-word.

The Association Method

Stimulus-word	Reaction-time	Reaction	Reproduction
blue	10	colour	
lamp	7	to burn	
to sin	22	this idea is totally alien to me, I do not acknowledge it	
bread	10	to eat	
rich†	50	money—I don't know	possession
tree	6	nature	green
to prick	9	needle	
pity	12	feeling	
yellow	9	colour	
mountain	8	high	
to die	8	to rot	
salt	15	salty (laughs)—I don't know—NaCl	
new†	15	old—as the opposite	
custom	10	good—barbaric	
to pray	12	deity	
money	10	wealth	
stupid	12	narrow-minded— limited	
exercise-book	10	paper	
to despise	30	that is a complicated— too stupid	?
finger	8	hand—not only hand, also foot—limb— <i>membre</i> —extremity	?
dear	14	to pay (laughs)	
bird	8	to fly	
to fall†	30	<i>tomber</i> —I will say no more— what do you mean by to fall?	?
book	6	to read	
unjust	8	just	
frog	11	to croak	
to part	30	what does part mean?	?
hunger	10	to eat	
white	12	colour—all sorts of things—the light	
child†	10	little—I did not catch that— <i>bébé</i>	?
to pay attention	14	attentive	
pencil	8	to draw—all sorts of things can be drawn	
sad	9	to weep—this does not always happen	to be
plum	16	to eat a plum— to pick—What do you mean by it? Do you mean it symbolically?	fruit
to marry	27	what can you mean by that? <i>réunion</i> — bond	union, alliance

[944] The first thing that strikes us is the fact that many subjects show a marked prolongation of the reaction-time. This would seem to suggest intellectual difficulties—wrongly, however, for we are often dealing with very intelligent people with a

good command of language. The factor responsible for this is connected with their feelings. In order to understand this, we must bear in mind that the association experiments investigate not just *one* component of the mind, since no psychological experiment can possibly be concerned with one isolated psychic function; no psychic occurrence is a thing in and by itself but rather the resultant of the entire psychological past. The association experiment, too, is not merely a method for the reproduction of separate word-pairs but a kind of pastime, a conversation between experimenter and subject. In a certain sense it is even more than this. Words are really a kind of shorthand version of actions, situations, and things. When I present the subject with a stimulus-word meaning an action, it is as if I presented him with the action itself and asked him, "How do you feel about it? What's your opinion of it? What would you do in such a situation?" If I were a magician, I should cause the situation corresponding to the stimulus-word to appear in reality and, placing the subject in the centre, I should then study his reactions. Undoubtedly the effect of my stimulus-words would be much more perfect. But as we are not magicians, we must content ourselves with the linguistic surrogates for reality; at the same time we must not forget that the stimulus-word will almost without exception conjure up its corresponding situation. All depends on how the subject reacts to this situation. The word *bride* or *bridegroom* will not evoke a simple reaction in a young girl; but the emerging strong feeling tones will markedly influence the reaction and even more so if the experimenter is a man. So the subject is often unable to react quickly and smoothly to all stimulus-words. There are certain stimulus-words that denote actions, situations, or things about which the subject is also in reality unable to think quickly and with certainty, and this fact is demonstrated in the association experiments. The example I have just given shows an abundance of long reaction-times and other disturbances. In this case the reaction to the stimulus-words is obviously in some way inhibited—that is, the adaptation to the stimulus-words is disturbed. Stimulus-words are, however, nothing but part of the reality that impinges upon us; in a certain sense someone who shows such disturbances when confronted with stimulus-words is on the whole *inadequately adapted to reality*. Any disease springs from impaired adaptation; thus in our special case we are dealing with something morbid in the psyche, with something either temporarily or permanently pathological. That is, we are dealing with a psychoneurosis, with a functional disturbance of the mind.

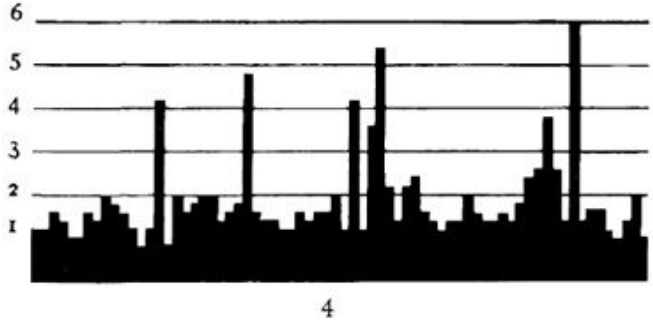
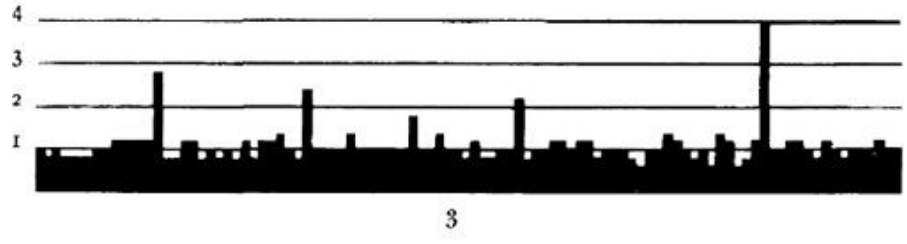
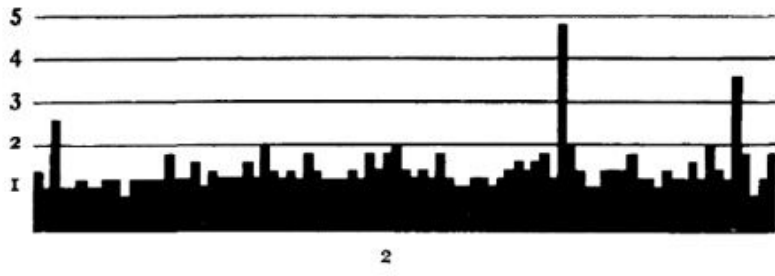
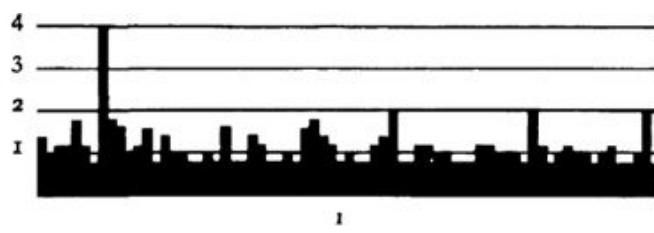

FIGS. 1-4. These graphs illustrate the reaction-times in an association experiment on four normal subjects. The height of each column indicates the length of the reaction-time

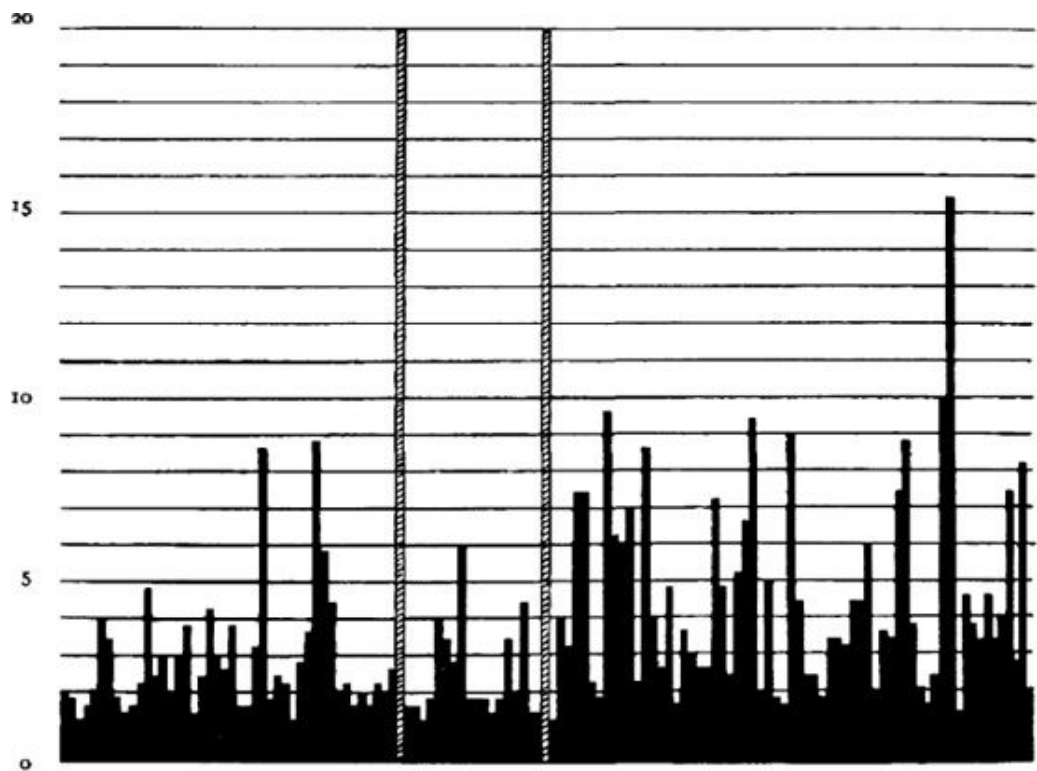

5

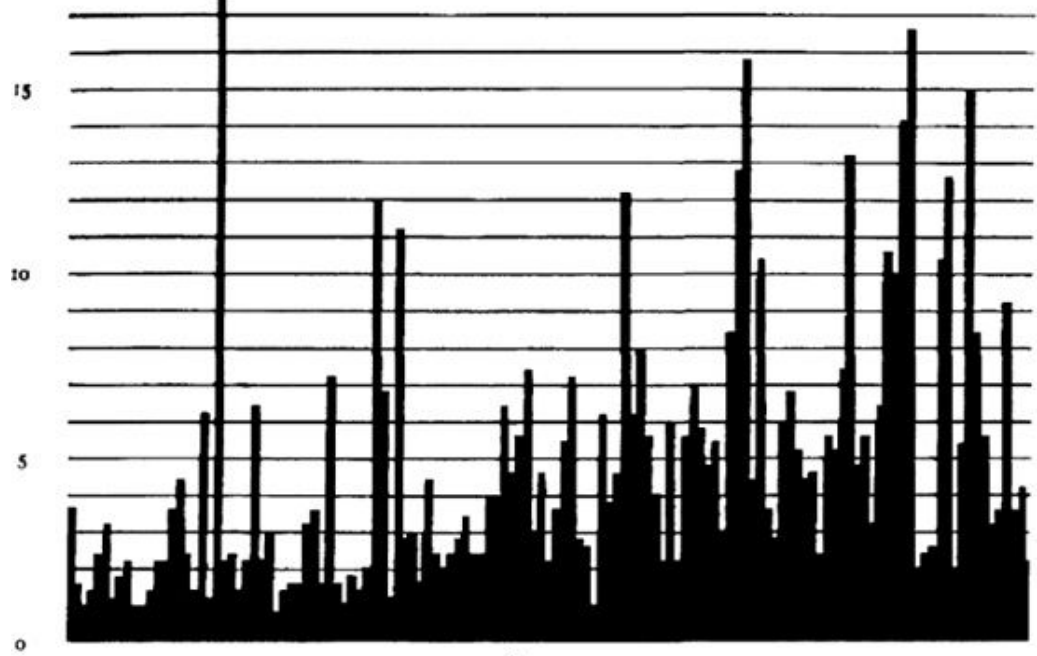

6

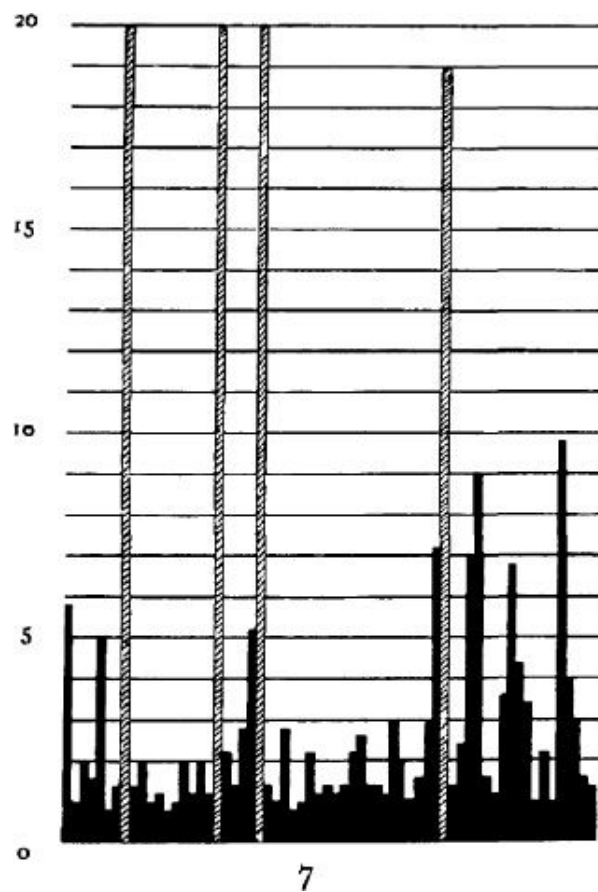

FIGS. 5-7. These graphs show the profiles of the reaction-times in hysterical individuals. The lightly cross-hatched columns indicate places where the subject was unable to react (referred to as failures)

[945] This rule is, as we shall see later, not without its exceptions.

[946] Let us now continue the discussion of the prolonged reaction-times. It often happens that the subject actually finds *no* answer to the stimulus-word. He fails to give any reaction and so for the moment abandons his agreement to follow the original instructions, showing himself incapable of adapting to the experiment. If this phenomenon occurs often in an experiment, it indicates that adaptation is seriously disturbed. I should like to remark that the reasons the subject gives for the refusal are utterly immaterial. Some find that too many ideas suddenly occur to them; others, that too few ideas enter their minds. In most cases, however, the difficulties experienced at first are so much of a deterrent that the subjects actually give up the reaction altogether. Example III shows a case of hysteria with many failures of reaction.

[947] In example II we find a characteristic phenomenon: the subject is not content with the terms of the instruction; that is, he is not satisfied with *one* word but reacts with many. He apparently does more and better than the instruction requires, but in so doing he does not fulfil the terms of the instruction. Thus he reacts: *custom / good—barbaric; stupid / narrow-minded—limited; all sorts of things.*

Stimulus-word	Reaction-time	Reaction	Reproduction
to sing	9	beautiful	
death	15	terrifying	?
long*†	40	the time, the journey	?
ship†	—	—	
to pay	11	money	
window	10	big	high
friendly	50	a person	human
to cook	10	soup	
ink	9	black or blue	
angry	—	—	bad
needle	9	to sew	
lamp	14	bright	
to sin	—	—	
bread	15	for eating	
rich*†	40	good—comfortable	
yellow	18	paper	colour
mountain	10	high	
to die	15	awful	
salt†	25	salty	
new	—	—	good, beautiful
custom†	—	—	
to pray	—	—	
money†	35	to buy—one can	
exercise-book	16	to write	
to despise†	22	people	
finger†	—	—	
dear	12	thing	
bird	12	sings or flies	

* Stimulus-word misunderstood.

† Repetition of stimulus-word.

[948] These examples show, first, that many more ideas are added to the reaction-word. The subject is unable to suppress these further ideas. In this way he also pursues a certain tendency that is more clearly expressed in the following reaction: *new / old—as the opposite*. The addition of *as the opposite* hints that the subject needs to add something explanatory or supplementary. This tendency is also shown in the following reaction: *finger / hand—not only hand, also foot—a limb—membre—extremity*.

[949] Here we have a whole series of additions. It seems as if the reaction were not sufficient for the subject, as if something else must always be added, as if what has already been said were incorrect or in some way incomplete. This feeling is what Janet calls the “sentiment d’incomplétude”; but this, however, does not explain anything. I am enlarging on this phenomenon because it is very common in neurotic individuals. It is not merely a trivial and incidental phenomenon in an experiment without significance, but rather an essential and universal phenomenon that plays a large part in the psychic life of neurotics.

[950] By his desire to supplement, the subject betrays a tendency to give the experimenter more than he wants; he actually labours in his attempts to find further ideas so as eventually to find something entirely satisfactory. If we translate this elementary observation into the psychology of everyday life, it means that the subject has a tendency always to give to others more feeling than is demanded or expected. According to Freud, this is a sign of a reinforced object-libido, that is, it is a compensation for an inner discontent and lack of

feeling. This elementary observation therefore points to one of the chief characteristics of hysterical patients, namely, the tendency to let themselves be carried away by everything, to fix their passion onto everything, and always to promise too much and hence keep only a few of their promises. Patients with this symptom are, in my experience, always rather disagreeable; at first they are enthusiastically enamoured of the physician, for a time going so far as blindly to accept everything he says; but they soon fall into an equally blind resistance to him, thus rendering any psychological influence absolutely impossible.

[951] In this phenomenon we see the expression of a tendency to give more than the instruction asks for or expects. This tendency also betrays itself in other failures to follow the instruction:

to quarrel	angry—all sorts of things—I always quarrel at home
to marry	what can you mean by that? <i>reunion</i> —bond
plum	to eat a plum—to pick—what do you mean by it? do you mean it symbolically?
to sin	this idea is totally alien to me, I do not acknowledge it

[952] These reactions show that the subject is not playing his part in the experiment. For the instruction is that he should answer only with the first word that occurs to him. But here it appears that the stimulus-words have an excessively strong effect, that they are taken absolutely *personally*, as if they were direct questions. The subject entirely forgets that he is faced with mere words presented in print. He looks for a personal meaning in them, tries to guess the meaning and defend himself against it, altogether forgetting the original instruction.

[953] This elementary observation illustrates another common peculiarity of hysterical patients, namely, that of taking everything personally, of never being able to be objective and of allowing themselves to be carried away by momentary impressions; again the characteristic of the reinforced object-libido.

[954] Yet another sign of difficulty in adaptation is the frequent *repetition of the stimulus-word*. The subjects repeat the stimulus-word as if they had not heard it distinctly or understood it. They repeat it just as we repeat an expected and difficult question so as to grasp it better and be able to answer it. This same tendency is shown in the experiment. The stimulus-words are repeated because they influence hysterical individuals as difficult personal questions do. In principle it is the same phenomenon as the additions to the reaction.

[955] In many experiments we observe that the same reaction often occurs in response to the most varied stimulus-words. These words seem to tend especially to be repeated, and it is very interesting to find out what these words really mean to the subject. I have, for instance, observed a case in which the patient repeatedly reacted with the word *short* a great many times, often in places where it made no sense. The subject could not give the precise reason for repeating the word. From experience I knew that such predicatory words always refer either to the subject himself or to the person nearest to him. I assumed that he was referring

to himself as “short” and in this way expressed something very painful to him. The subject was of very small stature. He was the youngest of four brothers; the others, in contrast to himself, were very tall. He was always the *child* in the family; he was nicknamed “Short” and was treated by all as the “little one.” This resulted in a total loss of self-confidence. Although he was intelligent, and in spite of long study, he could not make up his mind to sit for an examination; he finally became impotent, and sank into a psychosis in which, whenever he was alone, he took great pleasure in walking about his room on his toes in order to appear taller. The word *short*, therefore, stood to him for a great many painful experiences. This is usually the case with perseverated words; they always express something very important in the individual psychology of the subject.

[956] The characteristics so far described do not occur at random in the experiment, but are found at very definite points, namely, where the stimulus-words touch upon emotionally charged complexes. This fact is the foundation of what is called the *diagnosis of evidence*, i.e., the art of detecting, by means of an association experiment, the real culprit among a number of people suspected of a crime. That this is possible I will demonstrate by a brief account of an actual case.³

[957] On February 6, 1908, our matron informed me that one of the nurses had complained to her that on the previous afternoon she had been robbed. Here are the facts: The nurse had her money, which amounted to seventy francs, in a purse that she kept in her clothes-cupboard. The cupboard had two compartments; one belonged to the nurse who had been robbed and the other to the charge nurse. These two nurses slept in the same room (with the cupboard in it), together with a third nurse, who was an intimate friend of the charge nurse. The room was in a section of the hospital where normally six nurses were on duty and these could go into the room and use it if they wanted to. In view of this situation it was not surprising that the matron shrugged her shoulders when I asked her whom she suspected in the first place.

[958] From further investigation it appeared that on the day of the theft the friend of the charge nurse had stayed in bed the whole morning because she did not feel very well. According to the evidence of the first nurse, the theft must have taken place during the afternoon. Among the other four nurses on whom suspicion might fall, there was one whose regular duty it was to clean the room, whereas the other three had no official business there, and it did not appear that any of them had been in the room, for whatever reason.

[959] It was therefore very natural that the last three nurses were for the time being regarded as less suspect; I therefore first subjected the first three to the experiment.

[960] From the particulars of the case I also knew that the cupboard was locked but that the key was near by and could easily be found; that on opening the cupboard the first thing visible was a fur stole, and that the purse was hidden in an inconspicuous place between the linen. The pocketbook was made of dark red leather and contained the following: one fifty-franc note, one twenty-franc piece, a few centimes, a little silver watch-chain, a seal for marking the crockery in the hospital, and a receipt from the Dosenbach shoe-shop in Zurich.

[961] Apart from the nurse who had been robbed, and the culprit, only the charge nurse knew the exact particulars of the robbery, since the nurse who had been robbed thought at first that she had lost the money and asked the charge nurse to help her look for it. So the charge nurse was in a position to know the minutest detail of the case; this made the experiment particularly difficult because she was one of the most likely suspects. The conditions of the experiment were more favourable as far as the other nurses were concerned, since they did not know any of the particulars of the evidence and some of them did not even know that a robbery had been committed. As critical stimulus-words I chose the name of the nurse who had been robbed and also the following: *cupboard, door, open, key, yesterday, banknote, gold, 70, 50, 20, money, watch, purse, chain, silver, to conceal, fur, dark red, leather, centimes, seal, receipt, Dosenbach*. Besides these words which referred to the evidence proper, I also chose the following, which have a special affective value: *theft, to take, to rob, suspect, to accuse, court, police, to lie, to fear, to discover, to arrest, innocent*.

[962] Against words of this last type it has been objected that they carry a strong emotional charge even for the innocent and that there is therefore no value in confronting people with them. We still, however, have to consider whether in an innocent person the affective charge has the same effect on the associations as it has in a guilty one, a question that cannot be answered *ex cathedra* but only through experience. Until proof to the contrary is forthcoming I maintain that words of this class can also produce useful results.

[963] I next distributed these critical stimulus-words among double the number of ordinary stimulus-words, so that for each critical word there were two ordinary ones. It is an advantage for the critical words to be followed by ordinary ones so that the influence of the former may stand out all the more clearly. One can, however, also let one critical word follow another when one wants to show up especially the importance of the second. I therefore put together *dark red* and *leather*, as well as *chain* and *silver*.

[964] After these preparations I started the experiment on the three nurses. Since it is very difficult to present investigations of this kind in a foreign language I cannot give a full report on them here, but I shall content myself with giving an account of the general results and adding some examples. First, I subjected the friend of the charge nurse to the experiment; considering the circumstances, she seemed to be only slightly upset. Then I examined the charge nurse herself, who seemed to be possessed by a considerable agitation and who immediately after the experiment still had a pulse rate of 122 per minute. Lastly I dealt with the nurse who was responsible for cleaning the room where the theft had taken place. She was the calmest of them all; she was only slightly embarrassed and only in the course of the experiment did she realize that she was a possible suspect; towards the end of the experiment this manifestly disturbed her.

[965] The outcome of the examination spoke very much against the charge nurse who, it seemed to me, showed a suspicious reserve—I would almost say impudence. With the precise idea of finding her guilty, I applied myself to the calculation of the results.

[966] One can use all sorts of methods of computation, but they are not all equally good and equally exact. (One must always base one's judgment on calculation, because appearances

are most deceptive!) The method most to be recommended is that of the probable mean of the reaction-times. It gives one a glimpse of the difficulties that the subject of the experiment has had to overcome in reacting.

[967] The technique of this calculation is very simple: the probable mean is the number in the middle of the series of reaction-times. The reaction-times⁴ are, for instance, arranged in the following manner: 5, 5, 5, 7, 7, 7, 7, 8, 8, 9, 9, 9, 12, 13, 14; the middle number (8) is the probable mean of this series. I indicate the friend of the charge nurse by the letter A, the charge nurse by the letter B, and the third nurse by the letter C.

[968] The probable means of the reaction-times are A, 10.0; B, 12.0; C, 13.5. From this result one cannot draw any conclusion.

[969] The means of the reaction-times for the reactions without special significance, for the critical reactions, and for those immediately following (“post-critical”), calculated separately, are, however, of greater interest.

Probable Means of the Reaction-times

	A	B	C
Neutral reactions	10.0	11.0	12.0
Critical reactions	16.0	13.0	15.0
Post-critical reactions	10.0	11.0	13.0

[970] Here is what results from this table: although A has the lowest mean of the reaction-time for neutral reactions, she has, in contrast to the other two subjects of the experiment, the longest reaction-time for the critical reactions.

[971] The difference between the reaction-times for, let us say, neutral reactions and critical reactions is 6 for A, 2 for B, 3 for C; thus, about twice as high for A as for either of the others.

[972] By calculations similar to those we have made for the reaction-times, we can work out how many complex-characteristics there are on an average for ordinary, critical, and other reactions.

Mean of the Complex-characteristics for All Reactions

	A	B	C
Neutral reactions	0.6	0.9	0.8
Critical reactions	1.3	0.9	1.2
Post-critical reactions	0.6	1.0	0.8

[973] The difference between the neutral and the critical reactions is 0.7 for A, 0 for B, and 0.4 for C: A therefore leads.

[974] The next question concerns incorrect reproductions. The results of the computation are 34 per cent for A, 28 per cent for B, and 30 per cent for C. One can see that, in this connection also, A reaches the maximum value, and in this I seem to see a characteristic of A’s guilt-complex. I cannot, however, set out here the reasons why I maintain that there is a connection between errors of memory and emotional complexes, since this would lead me

beyond the scope of the present investigation. I therefore refer the reader to my paper "On Disturbances in Reproduction in the Association Experiment" [supra].

[975] It often happens in the experiment that an association with a strong affective charge leaves behind it a perseveration, in the sense that not only the critical association itself but also two or three of the subsequent associations are incorrectly reproduced; it is therefore interesting to see what one finds if one arranges these associations in a series. The results of the computation are 64.7 per cent for A, 55.5 per cent for B, and 30.0 per cent for C.

[976] Here again we find that A has the largest percentage. This may be partly due to the fact that A also has the largest number of incorrect reproductions: given the small number of reactions, it is obvious that the number of incorrect reproductions in a group increases in proportion to the total number of reactions. Even though this is probable, it can only happen to the same extent in experiments such as ours, in which B and C do not have a much smaller number of incorrect reproductions than A. It is significant that C, with her comparative lack of emotion during the experiment, has the minimum of incorrect reproductions in a series.

[977] Since incorrect reproductions are also complex-characteristics, we need to find out how the incorrect reproductions of neutral reactions, critical reactions, and so on are distributed.

Incorrect Reproductions

	A	B	C
Neutral reactions	10.0	12.0	11.0
Critical reactions	19.0	9.0	12.0
Post-critical reactions	5.0	7.0	7.0

[978] There is no need to add anything to emphasize the differences between neutral reactions and critical reactions in the different subjects: A leads in this respect also.

[979] In this case, of course, the larger the number of critical reactions, the greater is the probability of a large number of incorrect reproductions. Supposing that the incorrect reproductions are distributed evenly and at random among all the reactions, then there will be a greater number for A (compared with B and C) as a reaction to critical words, since A has the largest number of incorrect reproductions. Admitting such a uniform distribution of incorrect reproductions, we can easily calculate how many of them belong to each single class of reaction.

Incorrect Reproductions

	TO BE EXPECTED			ACTUALLY OCCURRING		
	Neutral Reactions	Critical Reactions	Post-crit. Reactions	Neutral Reactions	Critical Reactions	Post-crit. Re
A	11.2	12.5	10.2	10.0	19.0	5.0
B	9.2	10.3	8.4	12.0	9.0	7.0
C	9.9	11.1	9.0	11.0	12.0	7.0

[980] From this table it appears that the disturbances of reproduction of the critical reactions of A greatly exceed the expectation, whereas for C the figures are only 0.9 above

expectation and for B the actual number is smaller.

[981] All these data are pointers to show that in subject A the critical stimulus-words have acted with the greatest intensity so that the maximum suspicion falls on A. One could venture to declare this subject as the presumptive culprit: and on the same evening she made a full confession of the theft and thus confirmed the success of the experiment.

[982] I maintain that a result so obtained is scientifically interesting and worthy of discussion. In experimental psychology there are many much less useful things than those with which we are dealing in this paper. Completely disregarding the theoretical interest, we have to take into account the not inconsiderable practical result: we have unmasked the culprit without the usual formalities, merely by taking the shortest route. What was possible in one or two cases should be possible in others, and it is well worth while to explore every conceivable way of making this method yield rapid and reliable results.⁵

[983] This application of the experiment shows that it is possible to touch upon a concealed, indeed an unconscious, complex by means of a stimulus-word; and, conversely, we may quite certainly assume that behind a reaction showing complex-characteristics a complex is hidden, even though the subject may strongly deny it. One must get rid of the idea that people with a good education and some insight can always recognize and admit their own complexes. Every human mind contains much that is not admitted and hence, as such, unconscious; and no one can boast that he stands completely above his complexes. He who nevertheless maintains that he can is not aware of the spectacles upon his own nose.

*

[984] It has long been believed that the association experiment enables one to distinguish certain *intellectual* types. This is by no means the case. The experiment does not give us any special insight into purely intellectual processes but rather into emotional ones. To be sure, we can establish certain types of reaction; they are not, however, based on intellectual peculiarities, but depend entirely on *emotional attitudes*. Educated subjects usually show trivial, well-canalized verbal associations, whereas the uneducated make more valuable, often more meaningful, associations. This behaviour would, from an intellectual point of view, be paradoxical. The associations, rich in content, offered by uneducated people are not really the products of a thinking rich in content but merely those of a particular emotional attitude. The whole thing is more important to the uneducated, his emotion is greater, and for that reason he pays more attention to the experiment than the educated person and his associations are therefore richer in content. Apart from those derived from a particular type of education, we have to consider four principal individual types:

1. An *objective type* with undisturbed reactions.

2. What is called a *complex type*, showing many disturbances in the experiment caused by the constellation of a complex.

3. What is called a *definition type*. This type always reacts with an explanation or a definition of the content of the stimulus-word, e.g.:

apple	a tree-fruit
table	a piece of furniture
to go for a walk	an activity
father	head of the family

[985] This type is chiefly found among stupid people, and it is therefore common among imbeciles. It can also be found in people who are not really stupid but who do not wish *to be taken as stupid*. Thus, a young student, whose associations were recorded by an intelligent older woman student, reacted entirely with definitions. The subject was under the impression that he was undergoing an intelligence test, and therefore focussed principally on the meaning of the stimulus-words; his associations, therefore, looked like those of a half-wit. Not all half-wits, however, react with definitions; probably the only ones who react in this way are those who would like to appear cleverer than they are—that is, those to whom their stupidity is painful. I call this complex, which we often meet with, the “intelligence-complex.”

[986] This type often makes a strained and unnatural impression. They seem to be trying too hard:

anxiety	oppression of the heart
to kiss	love’s release
to kiss	experience of friendship, etc.

These subjects want to be more than they are, they wish to exert more influence than they really have. Hence we see that people with an intelligence-complex are in general far from simple and free; that they are always somewhat unnatural and affected; that they show a predilection for complicated foreign words, high-sounding quotations, and other intellectual ornaments. It is in this sense that they want to influence their fellowmen, to impress others with their apparent education and intelligence, and thus to compensate for their painful feeling of stupidity.

[987] 4. The definition type is closely related to the *predicate type* or, more precisely, to the evaluating predicate-type. For example:

flower	beautiful
money	pleasant
animal	ugly
knife	dangerous
death	ghastly

In the definition type it is the intellectual significance of the stimulus-word that is emphasized, but in the predicate type it is its *emotional* significance. There are predicate types who greatly exaggerate, whose reactions may be such as these:

piano	horrible
to sing	heavenly
mother	deeply loved
father	something good, noble, holy

[988] In the definition type an absolutely *intellectual* attitude is manifested, or rather simulated, but here we have an attitude that is *full of feeling*. Yet, just as the definition type really means to conceal a lack of intelligence, so the exuberant *expression of feeling* conceals or overcompensates for a *deficiency of feeling*. This conclusion is illustrated in a very interesting way by the following discovery: Investigations of the influence of the family environment on association types reveal that young people seldom belong to the predicate type; in fact, the frequency of the predicate type increases with age. In women the increase of the evaluating predicate type begins a little after the fortieth year, and in men after the sixtieth. That is just the time when, owing to the decline of sexuality, considerable loss of feeling is in fact suffered.

[989] If a subject shows a distinct predicate type, one may always infer that a marked deficiency of feeling is thereby compensated. One must not, however, conclude conversely that a deficiency of feeling must produce a predicate type, any more than that idiocy directly produces a definition type. A predicate type can also betray itself through external behaviour, as, for example, through marked affectation, enthusiastic exclamations, a certain genteel, refined demeanour, and the affected language so often observed in "society."

[990] The complex type shows no particular tendency unless it be the effort to *conceal* complexes behind the disturbances of the experiment. The definition and predicate types betray a definite tendency to exert *some influence* on the experimenter. The definition-type tries to make an impact through his intelligence, whereas the predicate type displays his emotions. I need hardly add how important such observations are for the diagnosis of character.

[991] Having finished an association experiment, I usually add another experiment of a different kind, which I call *reproduction*. I repeat the same stimulus-words and ask the subjects whether they still remember their former reactions. In certain instances their memory fails and, as experience shows, such failures are brought about by stimulus-words that touch upon a feeling-toned complex, or by stimulus-words immediately following such critical words.

[992] This phenomenon has been said to be paradoxical and contrary to all experience. For it is known that feeling-toned matters are better retained in memory than things of no special significance. This is certainly correct, but does not hold for the *linguistic* expression of a feeling-toned content. On the contrary, one very easily forgets what one has said under emotion, one is even apt to contradict oneself. Indeed, the efficacy of cross-examination in court depends on this fact. The reproduction-method therefore helps to emphasize the complex-stimulus still more. In normal people we usually find a limited number of incorrect reproductions, seldom more than 10 to 15 per cent, whereas in abnormal people, especially in hysteria, we often find from 20 to 40 per cent of incorrect reproductions. The uncertainty of reproduction is therefore in certain cases a measure of the emotivity of the subject.

[993] Most neurotics show a pronounced tendency to hide their intimate affairs in impenetrable darkness, even from the doctor, so that he finds it very difficult to form an accurate picture of his patient's psychology. In such cases my orientation is greatly assisted

by the association experiment. When the experiment is finished, I first look over the general trend of the reaction-times. I see a great many very prolonged times; this means that the patient can only adjust himself with considerable disturbance.

[994] His psychological functions flow with marked internal friction, with resistances. Most neurotics react only with great and therefore very noticeable resistances; there are, however, others in whom the average reaction-times are as short as in normal subjects, and in whom the other complex-characteristics are lacking, although neurotic symptoms are undoubtedly present. These rather rare cases are found especially among very intelligent and educated, chronically ill people who, after many years of practice, have learned to control their outward behaviour and therefore display very few if any traces of their neurosis. Superficial observation would take them for normal, yet at some points they show disturbances that betray the repressed complex.

[995] After investigating the reaction-times I turn my attention to the type of association, to find out what type I am dealing with. If it is a predicate type I draw the conclusions on which I have already enlarged; if it is a complex-type I try to determine the nature of the complex. With the necessary experience one can free one's judgment from the subject's statements to quite an extent and, under certain circumstances, almost without any previous knowledge of him, can read the most intimate complexes from the results of the experiment. I first look for the reproduction-words and tabulate them; then I pick out the stimulus-words that show the greatest disturbances. In many cases, merely tabulating these words is sufficient to unearth the complex. In some cases, one is obliged to put a question here and there. It may be best if I illustrate the point by means of a concrete example:

[996] The patient was an educated woman of thirty years of age, who had been married for three years. Since her marriage she had suffered periodically from states of agitation in which she was violently jealous of her husband. The marriage was in every other respect a happy one and in fact the husband gave no grounds for jealousy. The patient was sure that she loved him and that her agitated states were absolutely groundless. She could not imagine how this situation had come about and felt quite at a loss. It should be noted that she was a Roman Catholic and had been brought up to practise her religion, whereas her husband was a Protestant. This difference of religion was stated to be of no consequence. A more thorough anamnesis revealed an astounding prudishness: for instance, no one was allowed to talk in the patient's presence about her sister's confinement, because the sexual implication caused her the greatest agitation. She never undressed in her husband's presence but always in another room, and so on. At the age of twenty-seven she was supposed to have had no idea how children were born. Her association test gave the results shown in [Fig. 8](#).

[997] The stimulus-words that stood out because of their strong disturbing effect were these: *yellow, to pray, to part, to marry, to quarrel, old, family, happiness, unfaithful, anxiety, to kiss, bride, to choose, contented*. The following stimulus-words produced the strongest disturbances: *to pray, to marry, happiness, unfaithful, anxiety, and contented*. These then are the words that clearly pointed towards the complex. The conclusion that can be drawn from

this is: that she was not indifferent to the fact that her husband was a Protestant, that she was again thinking about prayer and felt there was something wrong with the married state; that she was unhappy; she was false—that is, she was having fantasies about being unfaithful; she suffered from anxiety (about her husband? about the future?); she was dissatisfied with her choice (*to choose*) and was thinking about *parting*. The patient therefore had a divorce-complex, for she was very dissatisfied with her married life. When I told her this result she was very shaken and at first tried to deny it, then to gloss it over, but finally she gave in and admitted it. Moreover, she produced a great deal of material, consisting of fantasies about being unfaithful, reproaches against her husband, and so on. Her prudishness and jealousy were merely a projection of her own sexual wishes onto her husband. She was jealous of her husband because she herself was unfaithful in fantasy and could not admit it to herself.

[998] It is impossible in a lecture to give a review of all the practical applications of the association experiment. I must be content with having put before you at least the main points.

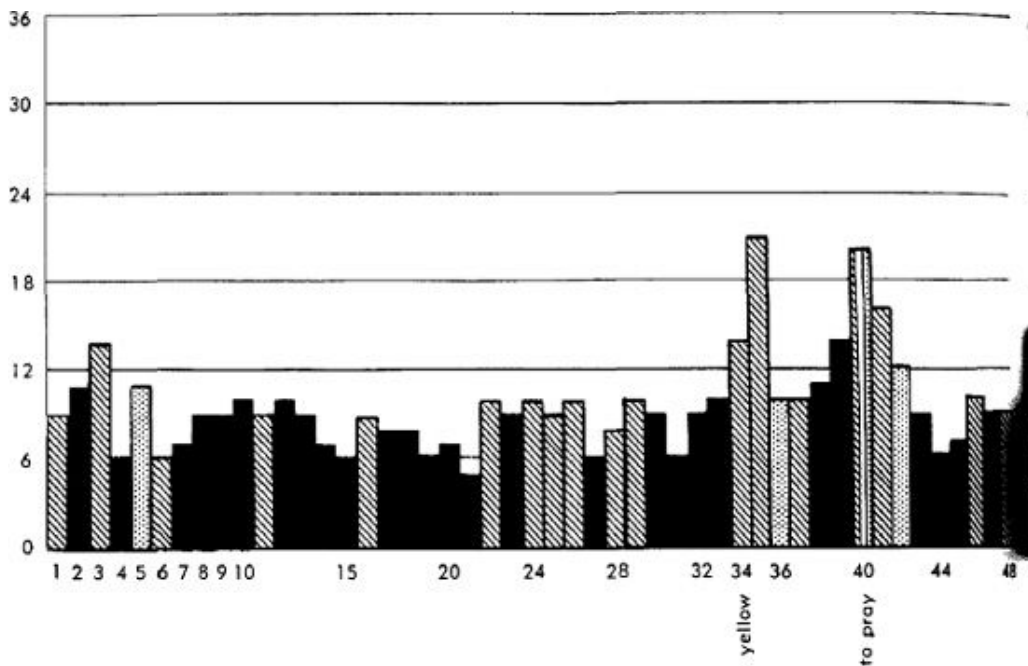





FIG. 8. Columns that are shaded  = incorrect reproductions;  = repetitions of the stimulus-words;  = associations where the patient either laughed or made a slip of the tongue and where she used several words instead of one. The heights of the columns represent the length of the reaction-time. For the stimulus-words corresponding to the numbers, see the list in par. 941*

THE FAMILY CONSTELLATION¹

[999] *Ladies and Gentlemen:* As we have seen, there are many different ways in which the association experiment may be used in practical psychology. I should like to talk to you today about yet another use of this experiment, one that is, in the first place, of merely theoretical importance. My pupil, Doctor Fürst,² made the following investigations: she applied the association experiment to twenty-four families, consisting altogether of one hundred subjects. The resulting material amounted to 22,200 associations. This material was processed as follows.

1000] Fifteen clearly defined groups were formed according to logical-linguistic criteria and the associations were arranged as follows:³

	Husband	Wife	Difference
i. Co-ordination	6.5	0.5	6
ii. Sub- and supraordination	7	-	7
iii. Contrast	-	-	-
iv. Predicate expressing a personal judgment	8.5	95.0	86.5
v. Simple predicate	21.0	3.5	17.5
vi. Relations of the verb to the subject or complement	15.5	0.5	15.0
vii. Designation of time, etc.	11.0	-	11.0
viii. Definition	11.0	-	11.0
ix. Coexistence	1.5	-	1.5
x. Identity	0.5	0.5	-
xi. Motor-speech combination	12.0	-	12.0
xii. Composition of words	-	-	-
xiii. Completion of words	-	-	-
xiv. Clang associations	-	-	-
xv. Defective reactions	-	-	-
Total	-	-	173.5
Average difference	$\frac{173.5}{15} = 11.5$		

1001] As can be seen from this example, I utilize the difference to demonstrate the degree of the analogy. In order to find a basis for the sum of the resemblance I have calculated the differences among all Dr. Fürst's subjects, not related among themselves, by comparing every female subject with all the other unrelated females; the same comparison has been made for the male subjects.

1002] The most marked difference is found in those cases where the two subjects compared have no associative quality in common. All the groups are calculated in percentages, the greatest difference possible being $\frac{200}{15} = 13.3$ per cent.

I. The average difference of male unrelated subjects is 5.9 per cent, and that of females of the same group is 6 per cent.

II. The average difference between male related subjects is 4.1 per cent, and that between female related subjects is 3.8 per cent. From these numbers we see that relatives show a tendency to agreement in the reaction type.

III. Difference between fathers and children = 4.2.

” ” mothers ” ” = 3.5.

The reaction types of children come nearer to the type of the mother than to the father.

IV. Difference between fathers and their sons = 3.1.

” ” ” ” ” daughters = 4.9.

” ” mothers ” ” sons = 4.7.

” ” ” ” ” daughters = 3.0.

V. Difference between brothers = 4.7.

” ” sisters = 5.1.

If the married sisters are omitted from the comparison we get the following result:

Difference of unmarried sisters = 3.8.

These observations show distinctly that marriage destroys more or less the original agreement, as the husband belongs to a different type.

Difference between unmarried brothers = 4.8.

Marriage seems to exert no influence on the association forms in men. Nevertheless, the material that we have at our disposal is not as yet enough to allow us to draw definite conclusions.

VI. Difference between husband and wife = 4.7.

This number sums up inadequately the different and very unequal values; that is to say, there are some cases which show an extreme difference and some which show a marked concordance.

1003] The different results are shown in the graphs (Figs. 1–5). In the graphs I have marked the number of associations of each quality perpendicularly in percentages. The roman numbers written horizontally represent the forms of association indicated in the table above.

1004] The similarity of associations of related subjects is often quite extraordinary. I will give you the associations of a mother and daughter:

<i>Stimulus-word</i>	<i>Mother</i>	<i>Daughter</i>
to pay attention	hard-working	pupil
law	God's commandment	Moses

dear	child	father and mother
great	God	father
potato	tuber	tuber
family	many people	five people
strange	traveller	travellers
brother	dear to me	dear
to kiss	mother	mother
a burn	great pain	painful
door	wide	big
hay	dry	dry
month	many days	31 days
air	cool	moist
coal	sooty	black
fruit	sweet	sweet
merry	happy child	little children
etc.	etc.	etc.

1005] One might indeed think that in this experiment, where the door is thrown wide open to so-called chance, individuality would become a factor of the utmost importance, and that therefore one might expect a rich variety and freedom of association. But, as we have seen, the opposite is the case. The daughter shares her mother's way of thinking, not only in her ideas but also in her form of expression; so much so that she even uses the same words. What is more free, fickle, and inconsequent than a passing thought? It is not inconsequent, however, nor free, but strongly determined within the boundaries of the environment. If, therefore, even the most superficial and apparently most fleeting mental images are entirely due to the constellation of the environment, what must we not expect for the more important mental activities, for emotions, wishes, hopes, and intentions? Let us consider a concrete example, illustrated by [Fig. 1](#).

1006] The mother is forty-five years old and the daughter sixteen. Both are very distinct evaluating predicate types and differ from the father in the most striking manner. The father is a drunkard and a demoralized person. It is understandable therefore that his wife is emotionally starved and betrays this by her intense value judgments. The same reasons cannot, however, apply to the daughter for, in the first place, she is not married to a drunkard and, in the second place, life with all its hopes and promises still lies before her. It is quite unnatural for the daughter to appear as an extreme evaluating predicate type. She responds to the stimuli of the environment precisely as her mother does. But whereas, in the mother, the type is to some extent a natural consequence of her unhappy situation, this simply does not apply to the daughter. The daughter merely imitates her mother; she follows her mother's pattern. Let us consider what this can mean for a young girl. It is unnatural and forced for her to

react to the world like an older woman who is disappointed in life. But it could be even more serious than this. As you know, evaluating predicate types overtly express intense emotion; for them everything is emotional. If such people are close to us it is difficult to avoid responding, at least inwardly; we may become infected and even carried away by them. Originally the affects and their physical manifestations had a biological significance; that is, they were a protective mechanism for the individual and the whole herd. If we show feeling, we can be sure that we shall evoke feeling in others. That is the experience of the evaluating predicate type. What the forty-five-year-old woman lacks emotionally, love within her marriage, she seeks compensation for in the outside world, and for this reason she is an ardent follower of the Christian Science movement. If the daughter follows this pattern she is behaving like her mother, looking for emotional satisfaction from outside. But for a girl of sixteen such an emotional state is, to say the least, very dangerous; like her mother, she is reacting to her environment, soliciting sympathy for her suffering. Such an emotional state is no longer dangerous in the mother, but for obvious reasons it is for the daughter. Once she frees herself from her father and mother she will be like her mother, an inwardly dissatisfied suffering woman. She will thus be exposed to the great danger of falling a victim to brutality and of marrying a brute and inebriate like her father.

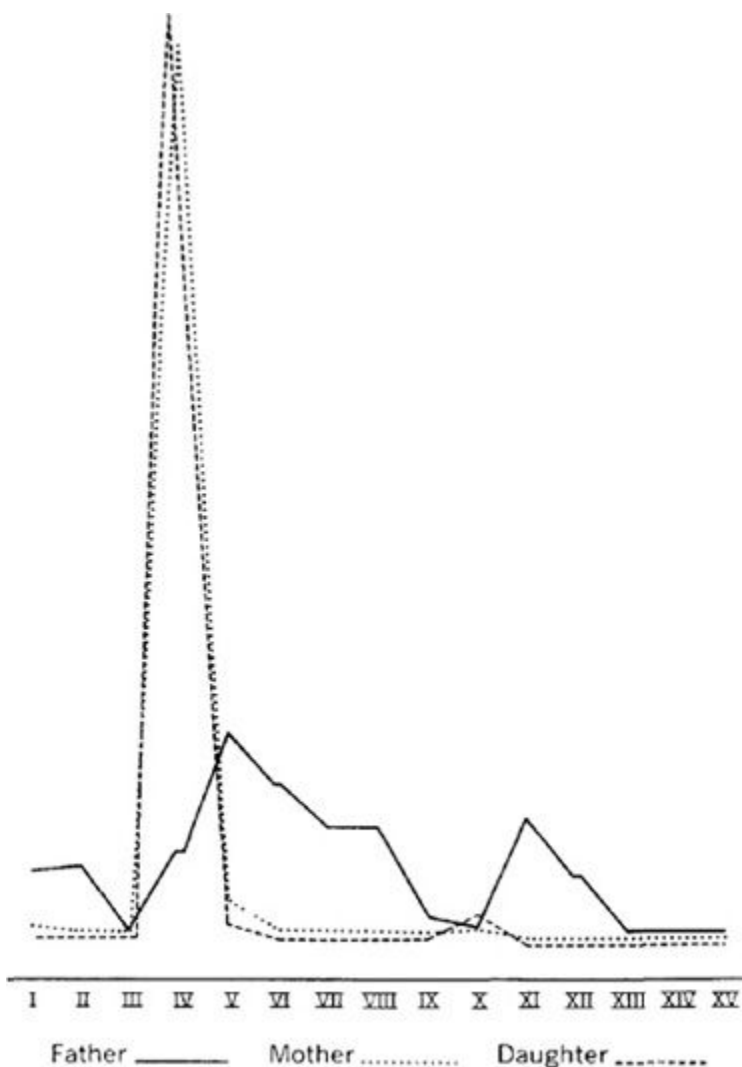
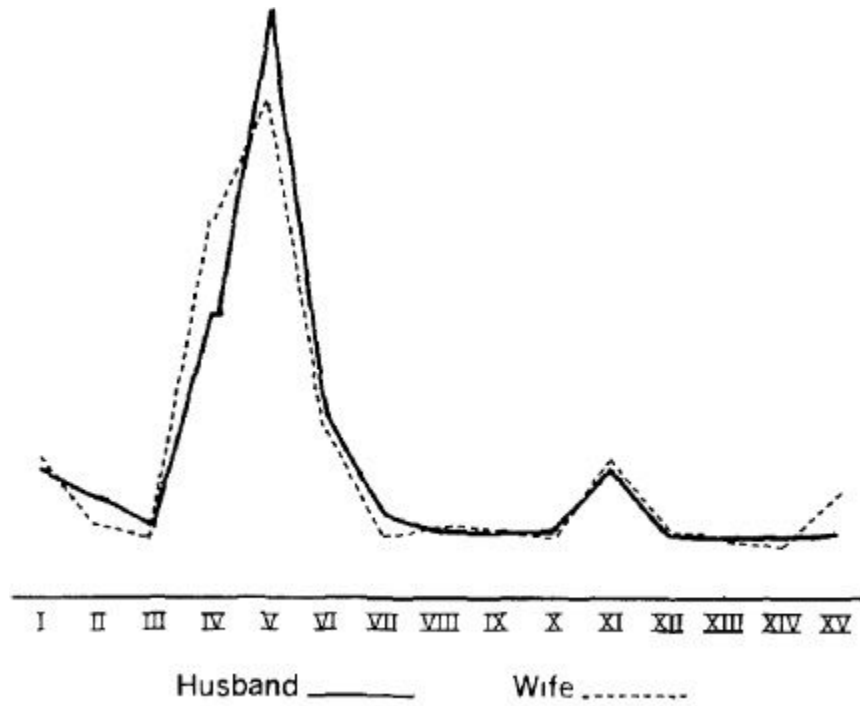

Fig. 1. The father (solid line) shows an objective type, while the mother and daughter show the pure predicate type with a pronounced subjective tendency.



2

Fig. 2. The husband and wife agree well in the predicate objective type, the predicate subjective being somewhat more numerous in the wife.



3

Fig. 3. A very nice agreement between a father and his two daughters.



4

Fig. 4. Two sisters living together. The dotted line represents the married sister.

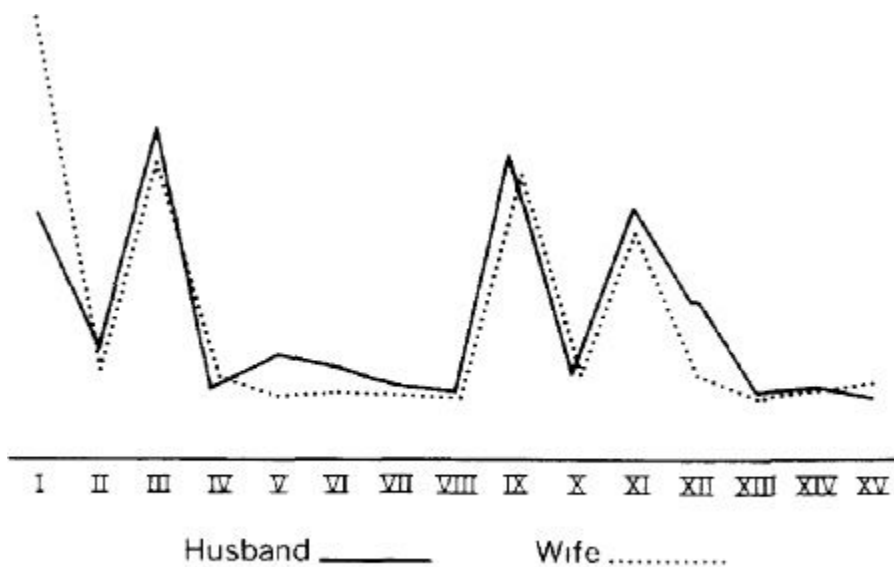

5

Fig. 5. Husband and wife. The wife is a sister of the two women of Fig. 4. She approaches very closely to the type of her husband. Her tracing is the direct opposite of that of her sisters.

1007] This consideration seems to me important for the understanding of the influence of environment and of education. The example shows what may be transmitted from a mother to her child. It is not pious precepts nor the repetition of pedagogic truths that have a moulding influence on the character of a developing child; what most influences him are the unconscious personal affective states of his parents and teachers. Hidden conflicts between the parents, secret worries, repressed wishes, all these produce in the child an emotional state, with clearly recognizable signs, that slowly but surely, though unconsciously, seeps into his mind, leading to the same attitudes and hence the same reactions to the environment. We all know that when we are with moody and melancholy people we ourselves become depressed. A restless and nervous person infects the people around him with uneasiness, a grumbler with

his discontent, and so on. Since adults are so sensitive to surrounding influences, we should certainly expect this even more among children, whose minds are as soft and malleable as wax. Fathers and mothers deeply impress their children's minds with the stamp of their personalities; the more sensitive and impressionable the child the deeper the impression. Everything is unconsciously reflected, even those things that have never been mentioned at all. A child imitates gestures and, just as the parents' gestures are the expressions of their emotional states, so in turn the gesture gradually produces an emotional state in the child, as he makes the gesture his own. His adaptation to the world is the same as his parents'. At puberty, when he begins to free himself from the spell of the family, he goes out into life with, more or less, the same kind of compromise-adaptations as those of his parents. The frequent and often very deep *depressions of puberty* arise from this; they are symptoms rooted in the difficulties of new adjustments. The adolescent at first tries to become as separate as possible from his family; he may even estrange himself from them, but inwardly this only binds him the more firmly to his image of his parents. I remember the case of a neurotic young man who ran away from home. He was estranged from and almost hostile to his family, but he admitted to me that he possessed a very special talisman; it was a casket containing his old childhood books, old dried flowers, stones, and even small bottles of water from the well at his home and from a river along which he used to walk with his parents.

1008] The first moves towards friendship and love are constellated in the strongest possible manner by the nature of the relationships with our parents, and here as a rule one can see how powerful is the influence of the family constellation. It is not rare, for instance, for a healthy man whose mother was hysterical to marry a hysteric, or for the daughter of an alcoholic to choose an alcoholic for her husband. I was once consulted by an intelligent and educated young woman of twenty-six who suffered from a peculiar symptom. She complained that her eyes now and then took on a strange expression that exerted an undesirable influence on men. If she looked at a man he became self-conscious, turned away and suddenly said something to the man next to him, whereupon they either laughed or looked embarrassed. The patient was convinced that her glance excited indecent thoughts in men. It was impossible to talk her out of her conviction. This symptom immediately made me suspect that I was dealing with a case of paranoia rather than with a neurosis. But only three days of further treatment showed me that I was mistaken, for the symptom promptly disappeared after it had been analyzed. It arose like this: the lady had had a lover who had publicly jilted her. She felt utterly forsaken, withdrew from all society and amusements, and developed suicidal ideas. In her isolation, unconscious and repressed erotic wishes accumulated and these she unconsciously projected on to men whenever she was in their company. This gave rise to the conviction that her

look excited erotic wishes in men. Further investigation showed that her unfaithful lover was mentally ill, a fact that she had apparently not realized. I expressed my astonishment at her making such an unsuitable choice, and added that she must have had a certain inclination to love mentally abnormal people. This she denied, stating that she had once before been engaged to be married, to a perfectly normal man. He, too, deserted her; and on further inquiry it was found that he, too, had shortly before been in a mental hospital for a year—another psychotic! This seemed sufficiently to confirm my view that she had an unconscious tendency to choose insane people. Where did this strange taste come from? Her father was an eccentric and in his later years was completely alienated from his family. Her love had therefore been displaced from her father on to a brother eight years her senior, whom she loved and honoured as a father. At the age of fourteen this brother became hopelessly insane. This was apparently the pattern from which the patient could never free herself, according to which she chose her lovers, and through which she was bound to become unhappy. The particular form of her neurosis, which gave the impression of insanity, probably arose from this childhood pattern. We must take into consideration that in this case we are dealing with a highly educated and intelligent woman, who was not inattentive to her inner experiences, who indeed pondered a great deal over her unhappy fate, without, however, having any idea of what caused her misfortunes.

1009] This is the kind of thing that we unconsciously take for granted in ourselves; for this very reason we cannot see what is going on but put the blame on what we think of as our innate character. I could give any number of examples of this. Patients constantly illustrate for me the determining influence of the family background on their destiny. In every neurosis we can see how the emotional environment constellated during infancy influences not only the character of the neurosis, but also the patient's destiny even down to its very details. Many an unhappy choice of profession and disastrous marriage can be traced to such a constellation. There are, however, cases where the profession has been well chosen, where the husband or wife leaves nothing to be desired, and still the patient feels uneasy and lives and works under constant difficulties. Such cases often appear to be chronic neurasthenics. Here the difficulty is that the mind is unconsciously split into two parts, of divergent and conflicting tendencies; one part lives with the husband or the profession, while the other lives unconsciously in the past with father or mother. I have treated a woman who suffered for many years from a severe neurosis which deteriorated into dementia praecox. The neurotic illness began with her marriage. Her husband was kind, educated, well-to-do, in every respect suitable for her; his character showed nothing that should in any way interfere with a happy marriage. The marriage was nevertheless unhappy, all easy companionship was impossible because the wife was neurotic.

1010] The heuristically important principle of every psychoanalysis runs: *If someone develops a neurosis, this contains the negative aspect of his relationship with the person closest to him.* A neurosis in a husband clearly shows that he has strong resistances and negative attitudes towards his wife; in a neurotic wife there is an attitude that drives her away from her husband. In an unmarried patient the neurosis turns against the lover or the parents. Every neurotic naturally resists such a relentless interpretation of the content of his neurosis and often refuses on any account to recognize it, and yet this is always the heart of the matter. Certainly, the conflict does not lie on the surface, but can as a rule only be uncovered by laborious psychoanalysis.

1011] Here is the history of our patient: The father was an impressive personality. She was his favourite daughter and held him in boundless veneration. At the age of seventeen she first fell in love with a young man. At that time she twice dreamt the same dream, the impression of which never afterwards left her; she even imputed a mystical meaning to it and often remembered it with religious awe. In the dream she saw a tall masculine figure with a very beautiful white beard, at the sight of which she was filled with a feeling of awe and delight as if she were experiencing the presence of God himself. This dream made the deepest possible impression on her, and she was compelled to think about it for ever after. The love-affair proved not to be a serious one and soon came to an end. Later the patient married her present husband. Though she loved her husband she was always, in her thoughts, comparing him with her late father, and the comparison always turned against her husband. Whatever the husband did, said or intended was judged by this standard and always with the same result: "My father would have done all this differently and better." Thus our patient could not enjoy life with her husband. She could neither respect nor love him enough and was inwardly disappointed and unsatisfied. She gradually developed strong religious feelings and at the same time marked hysteriform symptoms arose. She began by having sentimental attachments to one clergyman after another; she was looking everywhere for a soul-mate and estranged herself more and more from her husband. The mental illness became manifest about ten years after their marriage, and in this condition she refused to have anything to do with her husband and child; she imagined herself to be pregnant by another man. The resistance to her husband, which had hitherto been laboriously repressed, became quite outspoken and showed itself in various ways, among other things in violent abuse.

1012] This case shows the onset of a neurosis approximately at the moment of marriage; that is, it expresses the negative attitude to the husband. What is the content of the negative attitude? It is the relationship with the patient's father, for day by day she proved to herself that her husband did not come up to her father's stature. When

the patient first fell in love a symptom appeared, an extremely impressive dream or vision. She saw the man with the very beautiful white beard. Who was this man? When her attention was drawn to the beautiful white beard she immediately recognized the image. It was, of course, her father. Every time the patient began to fall in love, the image of her father arose disturbingly and so prevented her from adapting herself to a relationship with the man in question.

1013] I purposely chose this case as an example because it is a simple, obvious, and thoroughly typical one of a marriage crippled through the wife's neurosis. I could tire you out with similar examples. The misfortune is always too strong an attachment to the parents, so that the child remains imprisoned in its infantile relationships. It should be one of the most important aims of education to free the growing child from his unconscious attachment to the influences of his early environment, in such a way that he may keep what is valuable in it and reject whatever is not. It seems to me impossible at present to solve this difficult question by starting from the child's end. We know as yet too little about children's emotional processes. The first and only contribution to the literature giving actual evidence on this subject has in fact been published this year. It is the analysis of a five-year-old boy by Freud.⁴

1014] Children's difficulties are very great. Parents' difficulties, however, should not be so great. Parents could in many ways use more discretion and more forbearance towards their children's love. The sins committed against favourite children by their parents' over-indulgence could perhaps be avoided through a wider knowledge of the child's mind. I find it for many reasons impossible to say anything universally valid about the educational aspect of this problem. We are as yet a long way from general precepts and rules; we are still doing field work shown in case-histories. Unfortunately, our knowledge of the subtler processes of a child's mind is so inadequate that we are not yet in any position to say where lies the greater fault: in the parents, the child himself, or in environmental attitudes. Only psychoanalyses like the one published by Professor Freud in our *Jahrbuch*, 1909,⁵ will help us out of this difficulty. Such detailed and thorough observations should be a strong inducement to all teachers to acquaint themselves with Freud's psychology. In this psychology educationists can find far more than in the current physiological psychology.

II

PSYCHOPHYSICAL RESEARCHES

ON THE PSYCHOPHYSICAL RELATIONS OF THE ASSOCIATION EXPERIMENT¹

- 1015] At the second German Congress for Experimental Psychology, held at Würzburg (18–21 April 1906), Dr. Veraguth, privatdocent in neurology at Zurich, reported upon a galvanic phenomenon, which he called “galvano-psychophysical reflexes.” The author conducts a current of low tension (about two volts) through the human body, the places of entrance and exit of the current being the palms. He introduces into the circuit of the current a Deprez-d’Arsonval galvanometer of high sensitivity, and also a shunt for lowering the oscillations of the mirror. With this technique, if one applies to a subject tactile, optic, or acoustic stimuli of a certain strength, the galvanometer will indicate an increase in the amount of the current, i.e., a lowering of the electrical resistance of the body. Very early in the course of these experiments it was discovered that the action of the galvanometer was not in direct relation with the strength of the stimulus but rather with the intensity of the resulting psychological feeling-tone. Of great interest is the fact that the irregularity of the galvanometer did not appear at the same moment as the perception of the stimulus, but after a latent period of one to six seconds.
- 1016] Somewhat later Veraguth observed that a movement (often of great intensity) occurred when the stimulus, instead of being actually applied, was merely announced to the subject. This phenomenon he terms “oscillation through expectation” (*Erwartungsschwankung*). From these observations Veraguth concludes that in this experiment *feelings are objectively represented*. The only difficulty in this procedure lies in the technique of the registration of galvanometric oscillations.
- 1017] Veraguth takes photographs of the curve of the mirror’s movements on a rotating film; but this method is rather difficult and expensive, and only short curves can be obtained, while for the graphic representation of feelings long curves are desirable. I have therefore constructed an apparatus by means of which curves of more than thirty to sixty feet can be taken. In such considerable periods of time many and different experiments can be made without difficulty.
- 1018] The principle of my apparatus is as follows: I add to the scale a movable slide with a visor. The slide, pushed forward by the hand, always follows the moving mirror-reflection. After some practice, this manoeuvre can be made very easily and exactly. To the slide is fastened a cord leading to what is called an ergograph writer, which marks the movements of the slide on a kymographic tambour fitted with endless paper, upon which the curves are drawn by a pen-point (see illustration).

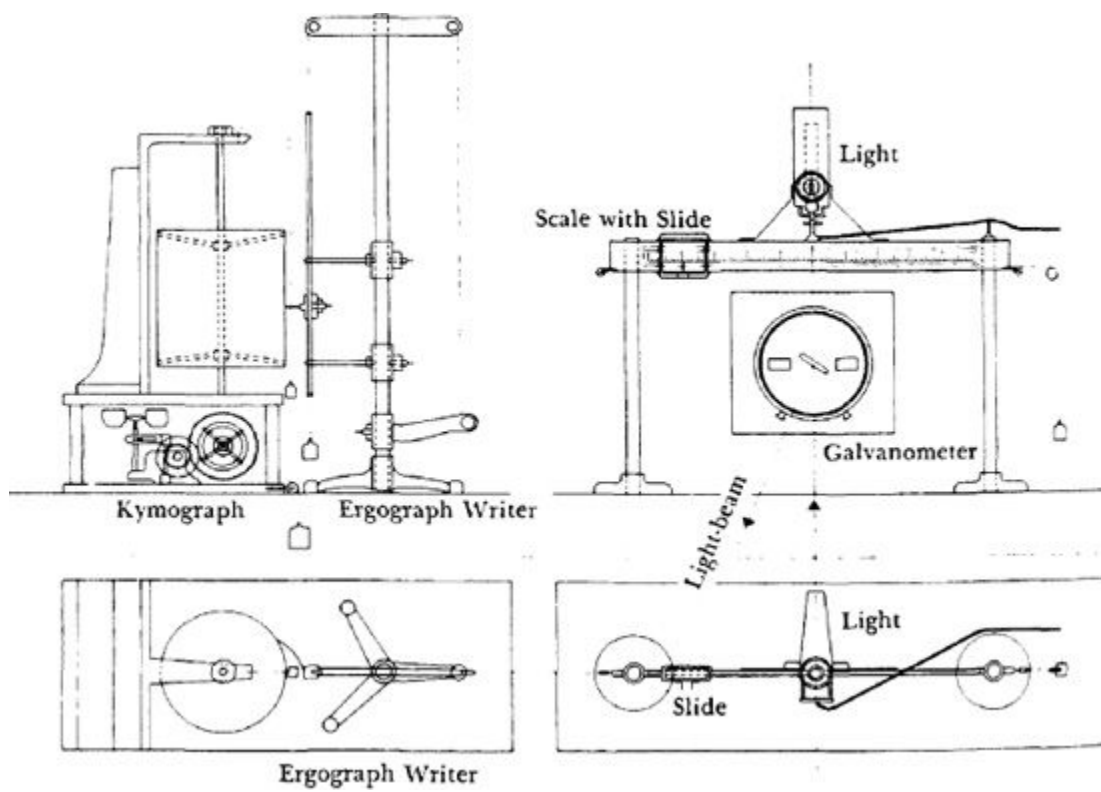

For measuring the time one may use a Jaquet chronograph, and for indicating the moment of stimulus an ordinary electric marker.

1019] With these arrangements I am able to take long curves that are especially valuable for representing feeling-tones aroused by the association experiment.

1020] As is perhaps already known, I have clearly demonstrated in the Diagnostic Association Studies² that strong feeling-tones often accompany the association and cause characteristic and regular disturbance in the association processes. I conduct my experiment as follows: I call a series of stimulus-words to a subject who is requested to answer as quickly as possible, saying the first word that comes into her mind. I measure the time elapsing between the stimulus-word and the reaction (the "reaction-time"). Having noted a rather large number of reactions (about one hundred), I then make the subject repeat, one by one, the answers to the stimulus-words (this I call the "reproduction method"). What will occur during such an experiment I shall illustrate by an example.³

<i>Stimulus- word</i>	<i>Reaction</i>	<i>Reaction-time</i>		<i>Reproduction</i>
		<i>sec.</i>	<i>1/10</i>	
head	hair	1	4	+
green	meadow	1	6	+
water	deep	5		swim
stab	knife	1	6	+
long	table	1	2	+
ship	wreck	3	4	steamer
question	answer	1	6	+
wool	knit	1	6	+
insolent	gentle	1	4	+
lake	water	4		blue
ill	well	1	8	+
ink	black	1	2	+
swim	know	3	8	water

1021] In considering the reactions of this subject we find at first sight nothing remarkable. She has, with some few exceptions, relatively short reaction-times, and there are also a few incorrect reproductions. But on looking closer we discover that the reactions after *water*, *ship*, *lake*, *swim*, were followed by a rather long reaction-time; and at the same time we observe that with these reactions the following reproduction is incorrect.

1022] So far as we know, we may suppose that the words *water*, *ship*, etc., awoke lively feelings that retarded the reaction. The incorrect reproduction of the reactions is also caused, as we can prove by experience, by the interference of lively feelings. The feelings causing such phenomena are generally of a disagreeable nature and we therefore venture to suppose that these stimulus-words gave rise to a complex of ideas having some relation to water and possessing great importance for the subject. The subject, cautiously questioned, tells us that a short while ago while living through most painful and exciting experiences she had seriously thought, in a moment of desperation, of *committing suicide by drowning herself*. But as the days began to look brighter her destiny did not bring her to such an untimely end.

1023] The complex of the intention to commit suicide, to which strong feelings are attached, betrayed itself by different psychological disturbances in the experiment. In the same or in similar fashion, all other complexes connected with the affections might naturally betray themselves. Hence the association experiment is a good means of fathoming and of analyzing the personality. According to the opinion of some German authors this method should be used to trace the guilt complexes of criminals who do not confess. At the present time many experiments are being carried out along these lines in Germany, experiments that have been of great scientific interest, but which have not, so far, produced results of undoubted practical value.⁴

1024] With this experiment, however, apparently so simple, there is one great difficulty—namely, the interpretation of the disturbances; or, to express it another way, what sort of complexes are they that cause these disturbances (“indicators of complexes”)? In reply to this question we may say that it is the *routine* of the experiments that is the main thing; and, in view of this fact, we suggest that the interpretation is at present rather an art than a science. In the future, perhaps, laws will be found for the method of interpretation. He who has not mastered this routine may easily make a wrong suggestion and thus go astray. This reproach, and especially that of arbitrary interpretation, has been made concerning my analysis; and consequently every means that helps to define the complex and its feeling-tone is useful. The “galvano-psycho-physical reflex” would seem to be such a means.

1025] By representing graphically the galvanic oscillations during the association experiment, we occasionally obtain curves of very great interest, of which I wish to give some few examples. (The vertical strokes indicate the moment at which the stimulus-word was given.) It can be seen that, shortly after the preceding reaction, the curve quickly rises and then slowly falls again. In this case every reaction is succeeded by a movement of the galvanometer. If by a special proceeding we diminish the sensibility of the apparatus, only the most intensive feeling-tones influence the current, so that occasionally we shall obtain very distinct curves that show the strong feeling-tone in a specially clear manner. The following is such an example:

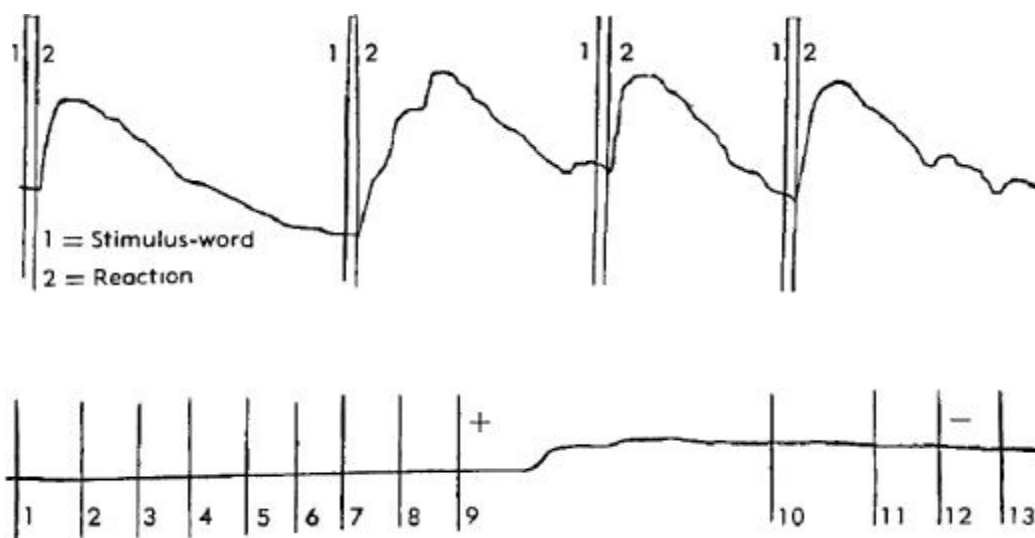

In the beginning we see the curve making its way horizontally without any irregularity. In this phase come the following eight reactions:

- | | |
|------------|-------|
| 1. hot | cold |
| 2. hand | foot |
| 3. apple | fruit |
| 4. naughty | angry |
| 5. mouth | teeth |

- 6. wake
- 7. drink
- 8. bed

- wake up
- eat
- sleep

These reactions show nothing of interest; their feeling-curve accordingly goes in a horizontal line.

- | | |
|----------------|----------------|
| 9. pretty | not pretty |
| 10. danger | no danger |
| 11. to call on | not to call on |
| 12. workman | workwoman |

1026] These reactions are obvious:

1. The first three are uttered in two words, which is, as a rule, unusual with this subject.
2. There are obvious and for the most part contrasting associations that are not easily intelligible.
3. A striking perseveration in the linguistic form is to be seen, beginning with *not pretty*. *Workman / workwoman* is rather a superficial association.

1027] It is evident that this strange phase takes its origin in *pretty*. On the curve we can see, beginning with the reaction *not pretty*, the appearance of a strong feeling-tone that lasts for a long time and disappears only with the last reaction. The linguistic perseveration (*not pretty, no danger, not to call on*) is therefore connected with a feeling, lasting probably through the same period.

1028] I had suspected from the beginning that the young man had a sweetheart. He told me that he had been married the week before. Upon my asking him whether his wife were pretty, he very characteristically replied, "Other people do not find her very pretty, but for me she is quite pretty enough." From this it is evident that the word *pretty* had hit upon a sore point.

1029] The next curve illustrates a very interesting case. The subject is a young, diligent, and gentle man, of whom I knew nothing, except the fact of his being an abstainer.

1030] In the beginning we note the curve falling slowly, then taking a rather horizontal course until the sixth stimulus-word, where a sudden steep rise sets in and maintains itself until the thirteenth reaction.

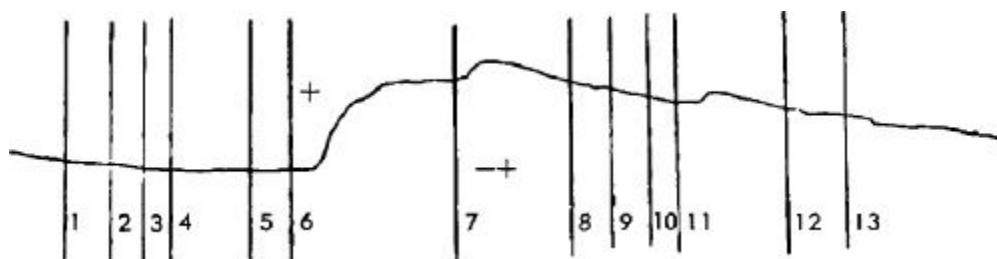

1031] The reactions are as follows:

- | | |
|----------------------|----------------------|
| 1. pay | money |
| 2. snake | animal |
| 3. fine | beautiful |
| 4. love | hatred |
| 5. help | assist |
| 6. <i>restaurant</i> | <i>non-alcoholic</i> |

With the sixth reaction the rising of the curve begins. The reaction *non-alcoholic* indicates a very individual complex of ideas. And a very strong feeling seems to be attached to the fact that he is a teetotaler.

1032] The reaction next following is:

- | | |
|--------------------|--------------|
| 7. <i>polished</i> | <i>glass</i> |
|--------------------|--------------|

accompanied by a new rise of the curve. *Glass* might be another association of the *restaurant* complex. The next associations are:

- | | |
|-------------------|----------|
| 8. soldier | military |
| 9. write | letter |
| 10. looking-glass | clear |

which present nothing special and are also galvanically uninteresting.

- | | |
|-----------------|------------|
| 11. <i>full</i> | <i>man</i> |
|-----------------|------------|

(The German word *voll*, 'full', has also the occasional meaning 'completely drunk'.) This association, which distinctly indicates the idea of being drunk, is again accompanied by a rising of the curve. The next association is:

- | | |
|------------------|---------|
| 12. intelligence | prudent |
|------------------|---------|

1033] As things present themselves we may be right in supposing that there is a complex with strong feelings that has some relation to *restaurant* and *drunkenness*. When asked, the man confesses that once, when drunk, he had committed the crime of a serious assault and had consequently been sentenced to a long term of imprisonment. Because of these occurrences he had become an abstainer as a means of preventing his again getting into a similar situation. (This confession was corroborated by others as being the truth.)

1034] As may easily be understood, this event left a serious and lasting impression, deepened by the fact that his former crime had become a great social hindrance to him.

1035] These examples may serve to show that the association experiment is, under certain conditions, a suitable way of demonstrating the feeling-tones that accompany the associations. I say “under certain conditions”—for not always will one succeed in obtaining such clear and distinct curves as those shown above. The experiment possesses numerous complications, to overcome which a great deal of time and work is required. There is moreover the difficulty that the physical and physiological part of the experiment is still obscure, notwithstanding the work of Tarchanoff, Sticker, Sommer, and Veraguth. At the present time, Binswanger in Zurich is occupied with these researches. I will not here anticipate his work, which he has already finished.⁵

BIBLIOGRAPHY⁶

Works concerning the Galvanic Experiment:

1. Tarchanoff: “Über die galvanischen Erscheinungen an der Haut des Menschen, etc.” (1890).
2. Sticker: “Über Versuche einer objectiven Darstellung von Sensibilitätsstörungen” (1897).
3. Sommer: In *Beiträge zur Psychiatrischen Klinik*, Vienna (1902).
4. Sommer and Fürstenau: “Die elektrischen Vorgänge an der menschlichen Haut” (1906).
5. Veraguth: “Le Réflexe psycho-galvanique” (1906).

Works concerning the Psychological Diagnosis of Evidence:

1. Alfred Gross: “Zur psychologischen Tatbestandsdiagnostik, etc.” (1905–6).
2. Idem: “Zur psychologischen Tatbestandsdiagnostik” (1905–6).
3. Idem: “Die Assoziationsmethode im Strafprozess” (1906).
4. Hans Gross: “Zur psychologischen Tatbestandsdiagnostik”
5. Grabowsky: *Psychologische Tatbestandsdiagnostik* (1905).
6. Jung: *Diagnostische Assoziationsstudien*, Bd. I (1906).
7. Idem: *Die psychologische Diagnose des Tatbestandes* (1906).
8. Kramer and Stern: “Selbstverrat durch Assoziation” (1905–6).
9. Lederer: “Zur Frage der psychologischen Tatbestandsdiagnostik” (1906).
10. Idem: “Die Verwendung der psychologischen Tatbestandsdiagnostik in der Strafrechtspraxis” (1906).
11. Stern: “Psychologische Tatbestandsdiagnostik” (1905–6).
12. Wertheimer and Klein: “Psychologische Tatbestandsdiagnostik” (1904).
13. Wertheimer: “Experimentelle Untersuchungen zur Tatbestandsdiagnostik” (1905–6).

PSYCHOPHYSICAL INVESTIGATIONS WITH THE GALVANOMETER AND PNEUMOGRAPH IN NORMAL AND INSANE INDIVIDUALS¹

by Frederick Peterson and C. G. Jung

1036] These investigations were carried out in the laboratory of the Clinic for Psychiatry at Zurich, to the director of which, Professor E. Bleuler, we are under obligation for the use of apparatus and material for study. The purposes of our research were to ascertain the value of the so-called "psycho-physical galvanic reflex" as a recorder of psychical changes in connection with sensory and psychical stimuli; to determine its normal and pathological variations; to study the respiratory innervation curve in the same relations; and finally to compare the galvanometric and pneumographic curves taken simultaneously upon the kymograph, under the influence of various stimuli. In word-associations the reaction-time was also registered for further comparison.

I. APPARATUS EMPLOYED

1037] For the respiratory curve we used the Marey pneumograph made by Zimmerman, in Leipzig. The kymograph was made by Schüle, in Basel, and runs with a weight, making it both steady and noiseless. The stop-watch employed for reaction-time was manufactured by Billian, of Zurich.

1038] The use of the galvanometer in experimental psychology is so new and recent as to require a special description and a brief review of the scanty literature of the subject.

The first to discover the influence of mental conditions on the galvanometer was Professor Tarchanoff, who published a paper in *Pflüger's Archiv für Physiologie*, 1890, entitled "Galvanic Phenomena in the Human Skin in Connection with Irritation of the Sensory Organs and with Various Forms of Psychic Activity." He employed tubular unpolarizable clay electrodes, connected with the skin by means of hygroscopic cotton pads, 10 to 15 cm. long, saturated with saline solution. These are attached to a Meissner and Meyerstein galvanometer. Deviations of the mirror were noted through a telescope upon a scale three metres distant from the galvanometer. The scale was divided on each side of the zero point into 50 cm. and these again into mm. The galvanometer was so sensitive that a nerve-stream of a frog's sciatic nerve deflected the mirror so much that all the divisions on the scale were passed over. The electrodes were applied at various times to different portions of the body, such as the hands and fingers, feet and toes, the face, the nose, the ears and the back. Experimenting thus, he obtained the following results:

1039] Light tickling of the face, ears, or soles of the feet, with a camel-hair brush or a feather, induced, after a latent period of from one to three seconds, a deflection in the galvanometer to the extent of the whole 50 cm. of the scale. The same results were obtained by stimulating the skin with the faradic brush, with hot and cold water, and by pricking with a needle. Stimulation in analogous ways of other sensory organs, the ear, the nose, the tongue and the eye, affected the galvanometer in a corresponding manner.

1040] The experimenter then ascertained that actual stimulation was not essential to these results, but the presentation of the proposed stimulus to the imagination also brought about similar

deviations in the galvanometer. He stated, furthermore, that the recollection of some fear, fright, or joy, in general any kind of strong emotion, produced the same result. The next point of interest recorded by Tarchanoff was that ordinary abstract mental exercise, such as computation, does not affect the galvanometer unless the exercise be accompanied by exertion. He also noted that the motion of expectant attention or anticipation had a marked effect upon the galvanometer. Tarchanoff regarded the phenomena he observed as due to a secretory current of electricity associated with the sweat-glands. He was evidently unaware of the extraordinary value of the investigations he described in this brief paper. Like many discoveries of importance, his remarkable work lay buried in medical literature for years, and it was not until 1897 that any further contribution on this subject appeared. In that year, Sticker² records a repetition of the work of Tarchanoff. His conclusion was that the capillary system of blood-vessels was a factor in the perturbations of the galvanic current. He opposed Tarchanoff's idea of the centripetal excitation of a secretory current, because he found that the same deviations were noted when the electrodes were applied to anaesthetic and analgesic areas of skin (functional or organic).

1041] After a lapse of five years, Sommer³ made some experiments with the galvanometer, but lost himself in technical and physical details, and failed completely to grasp the intrinsically valuable features of the instrument. He observed fluctuations which he attributed to alterations in resistance of the skin or to changes in contact between skin and electrodes. He thought any apparent psychic influence was due to involuntary muscular contractions induced by increased pressure on the electrodes, and concluded that, except for the reaction to tickling, no psychic influence on the galvanometer could be established with certainty. He therefore stumbled over, but missed, the one essential point.

1042] About two years ago E. K. Müller, an electrical engineer, of Zurich, read a paper before the Swiss Society of Natural Sciences (medical section) on "The Influence of Psychic and Physiological Phenomena upon the Electrical Conductivity of the Human Body." Happening to make certain experiments upon himself in relation to the resistance of the human body in the alternating magnetic field, he rediscovered the deflectibility of the mirror-galvanometer under psychic and nervous stimulation as established by Tarchanoff.

1043] O. Veraguth, a neurologist, of Zurich, was then led by Müller to experiment in the same direction. He made use of the Deprez-d'Arsonval mirror-galvanometer, nickel-plated brass cylinders for electrodes, a feeble electrical current, a horizontal celluloid scale on which the light from the mirror registered its movements, and an apparatus for photographic delineation of the fluctuations. He published some results last August (1906) in the *Archives de psychologie* (Geneva), and he gave the name "psychophysical galvanic reflex" to the phenomenon.⁴ Veraguth corroborates the findings of Tarchanoff. One or two of his experiments are especially striking. If the individual under observation is read to, deviation of the mirror is noted when passages associated with emotional tone are reached. Or, if a series of unrelated words is pronounced, a test suggested to him by one of the authors of this paper (Jung), words connected with some emotional complex produce an effect on the galvanometer, while indifferent words have no effect. He concludes from his studies that only such stimuli as are associated with sufficiently intense and actual emotional tone induce a deviation in the galvanometer. He states in his paper that he is not yet in a position to explain the phenomenon, but that if change in resistance were the cause then manifold contradictions are presented to our present conceptions of resistance in the human body. He did not think it due to alterations in the quantity of blood in the parts

beneath the electrodes, for the phenomenon takes place whether the hands be emptied of blood by an Esmarch bandage or supercharged with blood by artificial venous stasis. Veraguth excludes the participation of the perspiration, for the results were similar in hands made dry by formalin.

1044] As far as we know the above review covers the scanty literature of the subject, but work has been carried on for about a year in this field in the laboratory of the Psychiatric Clinic at Zurich, the most of which has not yet been published. One of us (Jung) has published in the *Journal of Abnormal Psychology* (Boston), for February 1907, the results of association experiments in which the galvanometer was employed, and in this article is a drawing of the apparatus and a description of the order of research.⁵ In the same laboratory, L. Binswanger, together with Jung, has investigated the physical and physiological problems presented by the phenomenon, the results of which will shortly be published in a separate paper,⁶ though the material conclusions of their investigations are embodied in this paper.

1045] The apparatus employed by us is as follows: the mirror galvanometer of Deprez-d'Arsonval; a translucent celluloid scale divided into millimetres and centimetres with a lamp upon it (made by Zulauf & Co., of Zurich), the scale being placed one metre from the galvanometer; a moveable indicator sliding on the scale and connected by a device of Jung with a recording pen writing upon the kymograph; a rheostat to reduce the current when necessary; and one, sometimes two, Bunsen cells. The electrodes generally used are large copper plates, upon which the palms of the hands rest comfortably, or upon which the soles of the feet may be placed. We have also used jars of hot water for the contact, when, as with some instances of dementia praecox, the hands were congested and cold. Occasionally we have employed a plate of zinc for one electrode and a plate of carbon for the other (in which case no element was required, since the skin, sweat, and metal provided sufficient current).

II. THE PHYSICS AND PHYSIOLOGY OF THE "PSYCHOPHYSICAL GALVANIC REFLEX"

1046] So far as is known, it would seem that the sweat glands are the chief factor in the production of this electric phenomenon, on the one hand inducing under the influence of nervous stimulation a measurable current or, on the other hand, altering the conductivity of the current. Since water contact excludes changes induced by pressure on metal electrodes, and blanching of the fingers by the Esmarch bandage excludes changes in connection with the blood supply, both of these factors play but a small part in the deviations of the galvanometer. Change in resistance is brought about either by saturation of the epidermis with sweat, or by simple filling of the sweat-gland canals or perhaps also by intracellular stimulation; or all of these factors may be associated. The path for the centrifugal stimulation in the sweat-gland system would seem to lie in the sympathetic nervous system. These conclusions are based upon facts at present to hand and are by no means felt to be conclusive. On the contrary, there are features presented which are as yet quite inexplicable,⁷ as, for instance, the gradual diminution of the current in long experiments to almost complete extinction, when our ordinary experience teaches that resistance should be much reduced and the passing current larger and stronger. This may possibly be due to gradual cooling of the skin in contact with the cold copper plates. This can be obviated by warm water contact or by resting the copper plates upon warm sand bags. Yet there is still an inviting field for investigation here.

1. *Fluctuations of the Galvanometer from Physical Causes*

1047] If the hands, placed upon the copper-plate electrodes, be pressed down firmly, there is a slowly-increasing deviation of the galvanometer, but only to a minor degree. If the area of contact be diminished by the raising of the fingers or by lifting of the palms, there is a sudden diminution in the amount of current, marked by sudden reduction of amplitude in the excursion of the light.

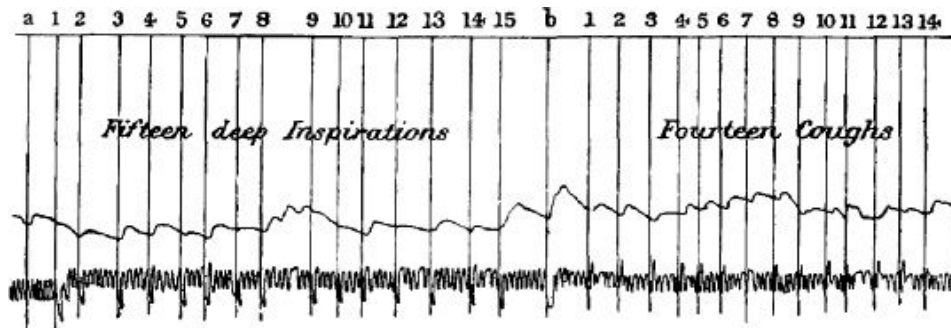

FIG. 1. Curve to show effects of deep inspirations and coughing upon the galvanometer

A deep inspiration alone, or a deep expiration, without alteration in the contact of the hands, increases the deflection of the galvanometer, while ordinary respiratory movements do not affect it. Coughing also causes a considerable rise in the galvanometric wave. We are inclined to think that this rise during inspiration, expiration, and coughing may also be of psychic, that is, emotional, origin. Certainly in the curve we observe exhaustion by repetition of the command to cough or breathe deeply, as in the case of other analogous stimuli. The deviations brought about by altered contact, by deep inspiration and expiration, and by coughing, are all readily recognized after some experience, and are readily differentiated from those depending wholly upon psychic influences. Warm hands naturally permit a larger current than cold hands. The level of the curve rises when the skin in contact grows warmer or moister, and descends with increase of coldness in the skin (see [fig. 1](#)).⁸

2. *Fluctuations of the Galvanometer from Psychic Causes in Normal Individuals*

1048] *Expectation.*—As soon as the galvanometric experiment begins, and the circuit through the subject is closed, there is a rather rapid rise with some fluctuation of a curve induced by expectant attention. Tarchanoff was much struck by this. Attention is, as Bleuler⁹ has pointed out, nothing more than a special form of affectivity. Attention, interest, expectation, are all emotional expressions. The extent of this expectation curve rises in normal individuals, depending upon their varying degree of affectivity. Expectation is not only manifested at the beginning of an experiment in the galvanometer curve, but may also be observed throughout the experiment in connection with every stimulus, sensory or verbal. It is particularly strong in connection with the threat of pricking with the needle, or threat of letting fall a heavy weight. The influence of expectation on the curve becomes less with each repetition of the same series of stimuli, and seems to disappear wholly with indifferent stimuli; while, with the threat stimuli just referred to, which are more lively and actual, repetition may diminish the curve, or at times increase it if the test case is uncertain whether the threats in the repetition are to be a real prick of the needle or an actual fall of the weight. In beginning an experiment, we therefore wait until the first influence of the emotion of expectation has subsided.

1049] *Emotion.*—Excluding the affect of attention, we find that every stimulus accompanied by an emotion causes a rise in the electric curve directly proportional to the liveliness and actuality of the emotion aroused. The galvanometer is therefore a measurer of the amount of emotional tone, and becomes a new instrument of precision in psychological research.

1050] *Imagined emotion.*—The amount of deflection seems to stand in direct relation to the *actuality* of the emotion; but, as Tarchanoff pointed out, the presentation of an outlived emotion to the imagination deviates the galvanometer, such deviation depending naturally upon the facility of the subject in living over the old emotion in his imagination. The following experiment, tried upon one of the writers, is an illustration: The list of stimuli was placed before him, while the reader of the deviations called off at intervals Nos. 1—2—3—4—5—6, allowing time for concentration upon the idea, and for the rise and subsidence of the wave. Between the periods of concentration on the emotional images, the subject allowed his eyes to wander at random about the room, and his mind to run on indifferent objects that he saw.

An Experiment in the Deflection of the Galvanometer in Imagined Conditions

	Amount of deviation of galvanometer
(1) Expectant attention.	
(2) Imagined threat of prick with needle	4.3 cm.
(3) Imagined threat of fall of heavy weight	1.6 cm.
(4) Imagined grief	2.8 cm.
(5) Thought of an amusing story	1.8 cm.
(6) Thought of a painful illness in 1888	1.6 cm.

1051] *Series of stimuli used.*—A series of stimuli, sensory and verbal, strong and indifferent, intellectual and emotional, was arranged and tested upon numerous normal individuals, besides which word associations were used in connection with the galvanometer. In some of the experiments the subject was in an adjoining room, the electric connections and signals being easily adjusted for this purpose. The following is the series of stimuli:

- (1) A loud whistle.
- (2) Actual fall of a weight with a very loud noise.
- (3) Multiply 4 by 5.
- (4) Multiply 9 by 11.
- (5) Multiply 8 by 12.
- (6) Sudden call of subject by name.
- (7) Where do you live?
- (8) What is the capital of Switzerland?
- (9) What is the capital of France?
- (10) How old are you?
- (11) Are you married?
- (12) Were you engaged once before?
- (13) Have you been long at your present employment?
- (14) Threat of prick with needle after counting 1—2—3.
- (15) Threat of allowing heavy weight to fall after counting 1—2—3

- (16) What is your first name?
- (17) What is the first name of your wife?
- (18) Is she pretty?
- (19) We have now finished.

1052] The verbal stimuli were varied to a slight degree with various individuals, to adapt them to different conditions and circumstances, but the general character of the stimuli was the same.

1053] These stimuli were ordinarily repeated three times for each individual, normal or pathological, and subsequently the series of word stimuli were given for the word associations, and these were also repeated once or twice. From seventy curves, [fig. 2](#) (H., nurse, Series 3) is selected as a general illustration of the galvanometric curve. This man was emotional and in the third series here presented the curves are smaller and more rounded than in the first and second series. At the same time they serve to show the character of the emotional curve. Stimuli 3, 4, and 5, although they were but simple multiplication, induced an emotional curve, because H. was a nurse and was embarrassed at doing mental arithmetic before experimenters. Stimuli 8, 9, and 10 were practically exhausted in this third trial and show very little. Between 10 and 11 someone entered the room. The weight was let fall twice between 13 and 14 instead of at 2, and being unexpected produced a large and a smaller wave of alarm. The threatened prick of the needle at 14 and threat of fall of large leaden weight at 15 still produced large waves, and show how strongly actuality in an apprehension influences the curves. Again, at 18 the inquiry if his wife was pretty, she being far from it, induced a lively emotion and correspondingly high wave, for this question was here a surprise as well, not having been asked in the preceding series.

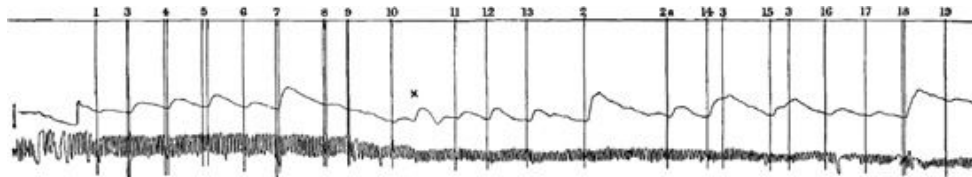

FIG. 2. Galvanometer and Pneumographic curves in a normal person (H., a nurse). The numbers at the top of each stimulus line correspond to the series of nineteen mixed stimuli printed in the text. 2 and 2a representing two falls of the weight occurred between 13 and 14 instead of between 1 and 2 in this curve, which was the second repetition of the series. Between 10 and 11 someone entered the laboratory

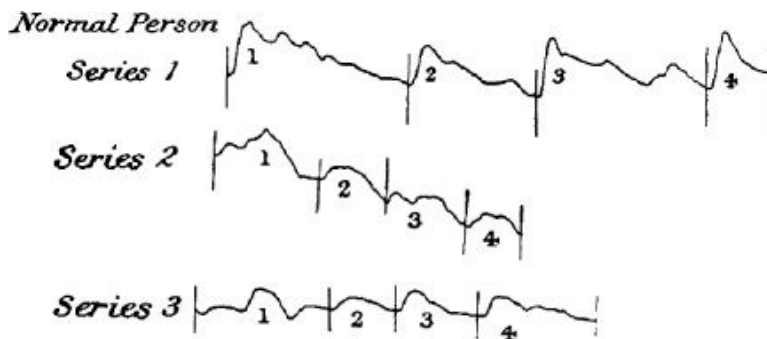

FIG. 3. Repetition of same stimulus questions in a normal person (H., a nurse) three successive times to show gradual exhaustion of emotional wave in the galvanometer curve. In 3rd series, question 1, someone entered the laboratory and caused an extra wave

1054] *Exhaustion of stimulus by repetition.*—When the first series of stimuli is recorded, the curves are usually characterized by abrupt ascent and descent with rather sharp summits. The curves diminish in size and the summits become more rounded in each repetition, showing a slower excitation and slower reaction of the emotion. This is well illustrated in [fig. 3](#), where several

curves induced by the same stimuli in the first, second, and third series in the same individual are reproduced. Wave No. 1 in Series 1 also exhibits in the descent the fluctuating character of an emotion which is slowly and waveringly passing off. This is even better shown in [fig. 4](#), from Case G., who was asked questions calculated to produce a complex emotional state such as the galvanometer perfectly indicates. In quite a number of instances the heights of the waves of the three successive series were measured and the following two illustrations are selected as examples of the differences in height (in millimetres) of the curves of the stimuli in the three series. Waves were selected which had not been affected in any of the series by interruptions, change of contact, coughing, or deep inspirations.

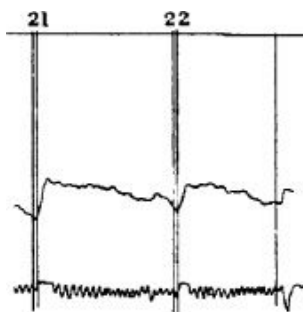

FIG. 4. Here G., a nurse, is asked about a quarrel with another nurse, H. The fluctuating galvanometer waves 21 and 22 represent the wavering emotions aroused

Table 1: Case of H. Diminishing Excursions of Galvanometer in Successive Stimulations

Stimuli	4 X 5	9 X 11	Call by name	Where do you live?	Capital of Switzerland?	How old are you?	Are you married?	Were you engaged before?	Have you been a nurse long?	Threat with needle	Threat with weight	Average
Case of H												
Series 1	34	18	5	36	14	24	18	27	26	36	22	24
Series 2	11	12	4	18	9	9	6	4	6	25	59+	10.4
Series 3	8	8	4	18	1	3	6	9	9	18	13	8.4

Table 2: Case of G. Diminishing Excursions of Galvanometer in Successive Stimulations

Stimuli	4 X 5	8 X 12	Where do you live?	Capital of Switzerland?	Capital of France?	How old are you?	Were you once engaged?	Have you been a nurse long?	Do you like the work?	Threat with needle	Threat with weight	Average
Case of G												
Series 1	9	10	7	7	8	5	10	5	8	17	15	8.6
Series 2	6	6	4	7	4	6	4	5	6	14	17	6.2
Series 3	3	5	3	5	3	4	6	4	5	16	15	5.4

NOTE. In the averages of these two tables the eleventh column of figures was not included as the emotion of expectation that the weight would really be dropped modifies especially the second trial, while in the third trial there was less of such expectation.

1055] In these tables the falling off of the height of the emotional curve is very well shown, and in both the livelier affects produced even in repetition by actual threats of the needle and weight are typical. In Series 2 of the first table the threat with the weight raised the curve to over fifty-nine because the subject thought that the weight would actually fall in this experiment, whereas before it was a threat only.

1056] *Latent time.*—It was noted by Tarchanoff that the galvanic wave began to rise from one to three seconds after a stimulus was given. We have verified this period of latent time in all normal conditions, but the latent time varies with different people and at different times. In the curves that we have thus far taken we could not well complicate the apparatus with a chronograph adjustment, and have estimated the space of latent time in a number of normal cases by measuring the distance of the curve from the moment of stimulation to the beginning of ascent of the emotional curve, taking the measurements in millimetres. The kymograph drum revolved slowly. The following results were obtained. Nurse B. with the series of mixed stimuli given above showed in the first series an average of 2.06 millimetres; the repetition of the second series averaged 2.55 millimetres; with Nurse G. and the same series of mixed stimuli in Series 1 the average was 1.85, in the second 1.76, and in the third or final series 2.32 millimetres. Dr. P. with the same series showed an average latent period in the first trial of 3.15, and in the repetition an average of 4.40. Dr. R. with the same series had an average period in the first trial of 4.05 millimetres, and in the second trial of 4.50 millimetres. In a series of word-associations Dr. R. showed at first an average period of 2.95 millimetres, and in the repetition immediately after the average was 4 millimetres. With word-associations Nurse H. showed in the first series an average latent period of 2.26; in the repetition or second series the latent period was increased to 3.55, and with a third trial of the same words the latent period had become 4.14. These figures with regard to the latent period show therefore that with repetition there is an increase of the latent period of time simultaneously with the rounding off and diminishing amplitude of the curve, both corresponding with exhaustion of the power of the stimulus. We were unable to determine in this investigation that there was any marked difference in latent time in relation to the various forms of stimulation whether physical or psychic, and when psychic with or without answer to questions or words, though such differences will probably be discovered by further experiment directed to this end.¹⁰

1057] *Normal individual variations of galvanometer curve.*—We find considerable difference in the curves made by the galvanometer in normal persons. In some the waves are of rather small and even excursion, corresponding to the unemotional or phlegmatic nature of the subject. In other waves there is wide excursion, with fluctuating or bifurcated waves, rapid ascents and descents, expressing great emotional lability. These normal variations are illustrated in [figs. 5 and 6](#).

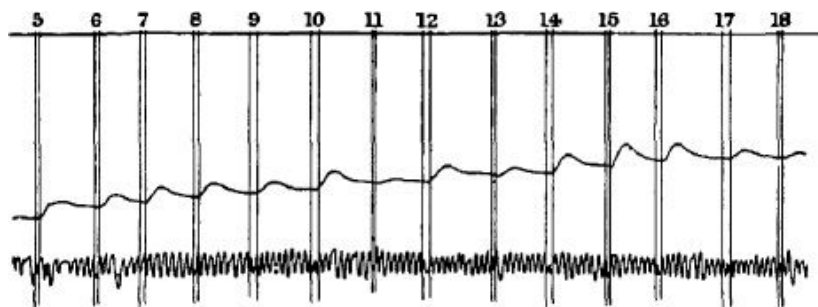

FIG. 5. Dr. R., normal curve with rather indifferent word-association stimuli. Unemotional type

III. THE PNEUMOGRAPH AS AN INDICATOR OF PSYCHIC PROCESSES

1058] The relation of the respiratory innervation curve to psychic processes in both normal and pathological conditions has not yet been thoroughly investigated. Mosso was one of the earlier

investigators (1879–1893) in the physiological application of the pneumograph and could reach no satisfactory conclusions from a study of the respiratory curve under sensory stimulation. Delabarre¹¹ states that respiration increases in frequency and depth with attention to sensory stimulation, and with mental processes increases in frequency and diminishes in depth. Lehmann¹² states that every pleasant impression increases the depth of breathing, and that strong unpleasant impressions are accompanied by several deep respiratory movements. Mentz¹³ employed pleasant and unpleasant acoustic stimuli in a study of the pulse and breathing, and as regards respiration observed with strong stimulation first slowing and then shortening of the respiratory movements. He noted also a marked influence of attention on the results. Involuntary attention generally induced prolongation of breathing, while voluntary attention often caused abbreviation of the movements. Pursuing his studies further he investigated the action of pleasant and unpleasant stimuli and of the effects upon pulse and respiration. As regards the former, pleasant feelings lengthened the pulse curve and unpleasant ones shortened it, and he regards the respiratory curve as running a parallel course. With affects there was prolongation of the respiratory movements, and with increasing strength of the affects an increasing height or depth of the breathing curve. Zoneff and Meumann,¹⁴ finding nothing sufficiently definite in literature in relation to the correspondence between respiration and circulation and psychic or emotional processes, have made an exhaustive research upon normal individuals, employing various stimuli, optic, acoustic, gustatory, cutaneous, and psychic (arithmetical problems and space conceptions), and studied at the same time the effects of voluntary attention and pleasant and unpleasant impressions upon the breathing and pulse. They found that as a rule attention produced acceleration of the breathing, especially at the end of the stimulation, and in addition to acceleration the breathing might become more shallow or be inhibited. This inhibition may appear as shallow and more rapid breathing, or there may be a partial or complete standstill of the respiration, which is greater in direct proportion to the degree of attention. Complete inhibition was found more often in attention to sensory than to intellectual stimulation. There were variations in the results in different individuals. There were fluctuations in the curves which they considered as being due to fluctuations in attention. In relation to pleasant and unpleasant stimuli, they concluded that all pleasant sensations cause shallowing and acceleration of the breathing, and all unpleasant sensations deepening and slowing of respiration, or, in other words, that the former diminish and the latter increase respiratory function. In experiments with diversion of the attention together with stimulation, they found that emotional effects upon breathing and pulse ceased. In experiments with concentration of attention on stimulus and sensation, attention strengthened the effects of both pleasant and unpleasant feelings upon the curves. While their work is the best that has yet appeared upon this subject, it must still be confessed that experiments of this nature carried out upon the trained assistants or students connected with the laboratory are more or less artificial, and this, together with the extremely simple character of the stimulation, would make their criteria for the more complex emotional phenomena with which we have to deal only relatively valuable.

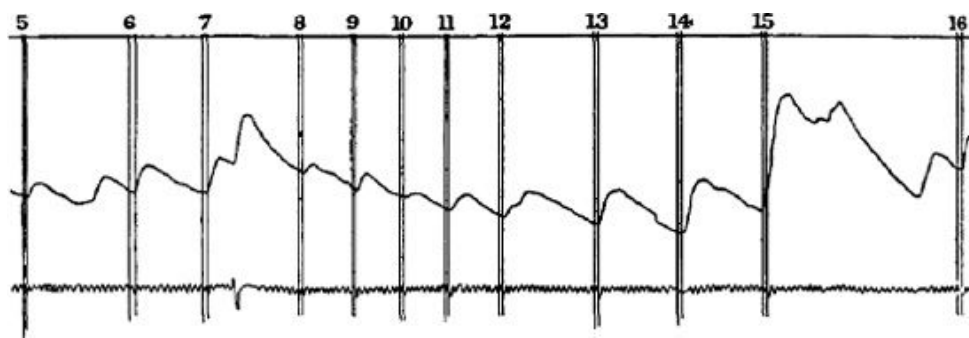

FIG. 6. H., an attendant, normal curves, very labile emotions. The numbers here correspond to the series of mixed stimuli; 15 is threat of weight

1059] Martius and Minnemann¹⁵ in a thoroughly iconoclastic and yet excellent work point out many fallacies in the studies of Lehmann, Menz, and Zoneff and Meumann, artifacts of a mechanical nature, and wrong conclusions as to the relations between affects and pulse and breathing curves. They themselves find the normal respiratory curve inconstant, subject to variations due to age, temperament, perseveration of affect, reactions from the affect, embarrassment from the experiment, undue interest in the procedure, etc., and their chief conclusion is that the main changes in breathing in emotional conditions consist of quickened or lengthened tempo, with diminished height in either case.

1060] Believing that a study of the inspiratory curve would throw the most light upon the relation of respiratory innervation to psychic processes, we set before ourselves several problems for consideration, viz., the character of the usual respiratory curve, the character of the curve in stimulation without verbal reaction, the influence of verbal reaction with indifferent stimuli upon the curve, whether distinct emotional complexes affected uniformly the pneumographic curve, whether there were marked disturbances of the respiratory without corresponding changes in the galvanometric curve, and, finally, what influence attention has on both galvanometer and pneumograph. We have not been able as yet to reach satisfactory conclusions on all of these points, for the material already available is more than we have yet had opportunity to investigate thoroughly; but so far as they go the results obtained are of interest. The figures in the table for one of the cases given here show a regular, though not constant, relation between the galvanometric and the pneumographic curves.

1061] To obtain these relations it is necessary to select an experiment in which the galvanometric curve has not been influenced greatly by the several sources of error, and the simultaneous pneumographic curve has not been modified too much by verbal reaction, coughing, etc. Taking the typical curves of several such series, measurements were made to determine the relative number of inspirations synchronous with the ascending galvanometer curve, and also with the descending galvanometer curve. The amplitude of each inspiration was also measured and averaged for the same purpose, and the measurements are recorded in millimetres. It will be seen that the ascending portion of the galvanometer curve, which is the result of an emotional stimulus, is accompanied by fewer inspirations as well as by deeper ones. While this seemed to be a general rule in this instance, we find variations in different individuals with the same mixed series of stimuli, and in some cases the reverse. The stimuli in the tables were unpleasant rather than pleasant to the subject. But the determination of the quality of the emotional tone in any such experiment is very difficult. The forced and artificial situation of the subject in itself induces unpleasant feelings, and any pleasant stimulus must therefore simply bring about a

certain relief or relaxation in a situation of unpleasant tension. The nervous tension during an experiment must naturally influence the breathing, and a pleasant stimulus is apt to produce only a temporary lessening of such tension. This is a criticism we would make of the Zoneff and Meumann experiments, and of experiments with the pneumograph in general. It is altogether probable that there are more inexplicable influences at work in relation to the pneumographic curve than we are at present able to comprehend. There are many respiratory fluctuations which have nothing to do with the emotions, but are the result of physical or intellectual processes, with the enforced quiet of body of the subject, with the disposition to speak, with tendencies to cough or to swallow, etc. Furthermore, there will be a difference in the curve if the stimulus occurs during an inspiration or an expiration, and there are individual variations dependent upon temperament or upon lability of the emotions.

Measurements to Show the Relation in Frequency and Amplitude of Inspirations to Ascending and Descending Portions of the Galvanometer Wave

Nurse B. Series I	Whistle	Weight falls	4 × 5	9 × 11	8 × 12	Where do you live?	What is the capital of Switzerland?	Are you married?	Threat of needle	Threat of fall of weight	Average
Average distance apart of inspirations in the ascending galvanometer curve	2.6	2.83	2.75	2.5	2.2	2.62	2.5	1.87	2.6	2.2	2.46
Average distance apart of inspirations in the descending galvanometer curve	2.18	2.36	2.5	2.14	2.42	2.2	2.3	2.42	2.5	2.3	2.33
Average height of inspirations with ascending galvanometer curve	15.8	15	14.5	14	12.8	11.25	12.5	13.6	16.4	14.6	14
Average height of inspirations with descending galvanometer curve	14.33	13.41	13.75	13	11	9.8	11.7	13	16.4	14.23	13

1062] We have, therefore, not been greatly impressed with the value of a possible relation between the galvanometric and pneumographic curves since this is not constant, and the more comparative study we have given to the two synchronous curves, the more we have been impressed with a surprising divergence between the influences at work upon them. We have studied hundreds of waves in every conceivable manner. For instance, we have taken series of galvanometric curves and carefully measured the length of each inspiration, and the intervals between inspirations, as related to the point of stimulus, to the latent space before the ascent of the galvanometer wave, to the ascending curve, to the crest, to the descending curve, and to the space next to the point of stimulus, without developing any regular and constant relationship of correspondence, though we think this may ultimately be shown to exist in some degree. On the contrary, we have found thus far that the influences at work upon the two curves reveal an astonishing regularity of difference. When the emotions are very labile, and show the most marked excursions in the galvanometer curve, the respiratory curve is often regular and even (fig. 7). On the other hand, in instances both normal and pathological, where the galvanometer

curve is marked by little fluctuation, or even by none, as in some cases of catatonia, there will often be most decided variations in the pneumographic curve. We often note a change in character in the pneumographic curve, not so much with each separate stimulus, but during the whole course of a series of stimuli as if expectant attention and nervous tension diminished the inspirations during the early part of the series, and as if there were a relaxation during the later half with longer inspirations (fig. 8). There does not seem to be the intimate and deep relationship between the respiratory function and the unconscious emotions that exists between the sweat glandular system and these emotions. It is a matter of everyday experience that the respiration is influenced by our conscious emotions, especially when they are strong, as instanced in such expressions as “bated breath,” “breathless with astonishment,” etc. Such inhibitions of breathing are noticeable in many pneumographic curves, particularly in association with expectation and tension. But perhaps the emotions of the unconscious, roused up by questions or words that strike into the buried complexes of the soul, reveal themselves in the galvanometer curve, while the pneumographic curve is comparatively unaffected. Respiration is an instrument of consciousness. You can control it voluntarily while you cannot control the galvanometer curve. The respiratory innervation is closely associated with speech innervation, anatomically and functionally, and the physical connection in the brain is, perhaps, one of the closest and earliest. Let us take these remarkable curves of a case of acute catatonia (figs. 9A and 9B), which may be regarded as a psychological experiment in diverting both attention and ordinary emotion. Attention and all other emotions being practically diverted by the pathological process, the galvanometer curve is slight (indeed, in the *second* repetition it was a straight line), but the sudden call of the patient by name produced the extraordinary fluctuations in the respiratory curve, though nothing was apparent in his outward demeanour to show that he was conscious in any degree of the stimulus. He may have been conscious of the call, but we had no means of determining this. In the repetition the same fluctuations occurred, proving that they were not fortuitous. The only reasonable explanation of this phenomenon, in our opinion, is that the call of the name developed a disposition to speak, stimulated the hearing centre, and the closely-associated speech centre, the motor innervation from which acted upon the respiratory muscles. Ordinarily a sudden call by name, which is one of the strongest and deepest of stimuli, produces an answer. In this instance the call by name was a stimulus that acted as in a simple reflex process, and led to motor manifestations in the respiratory muscles connected with the motor speech centre, analogous to the contraction of the eyelids in response to a sudden flash of light. Fig. 10 is another instance of almost like character.



FIG. 7. Dr. P., normal good-sized galvanometer curves with fairly regular respiratory curve

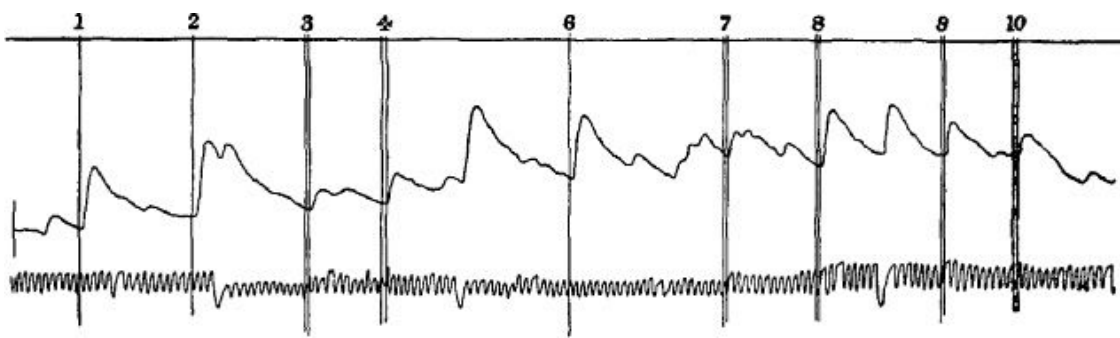

FIG. 8. Dr. S., a patient with paranoid dementia (Case No. 3). Extraordinarily labile emotions expressed in galvanometer curve. Considerable tension in pneumographic curve from stimulus 2 (fall of weight) on, with relaxation and deeper breathing beyond stimulus 7. An example of perseveration of tension for a long period in the pneumographic curve

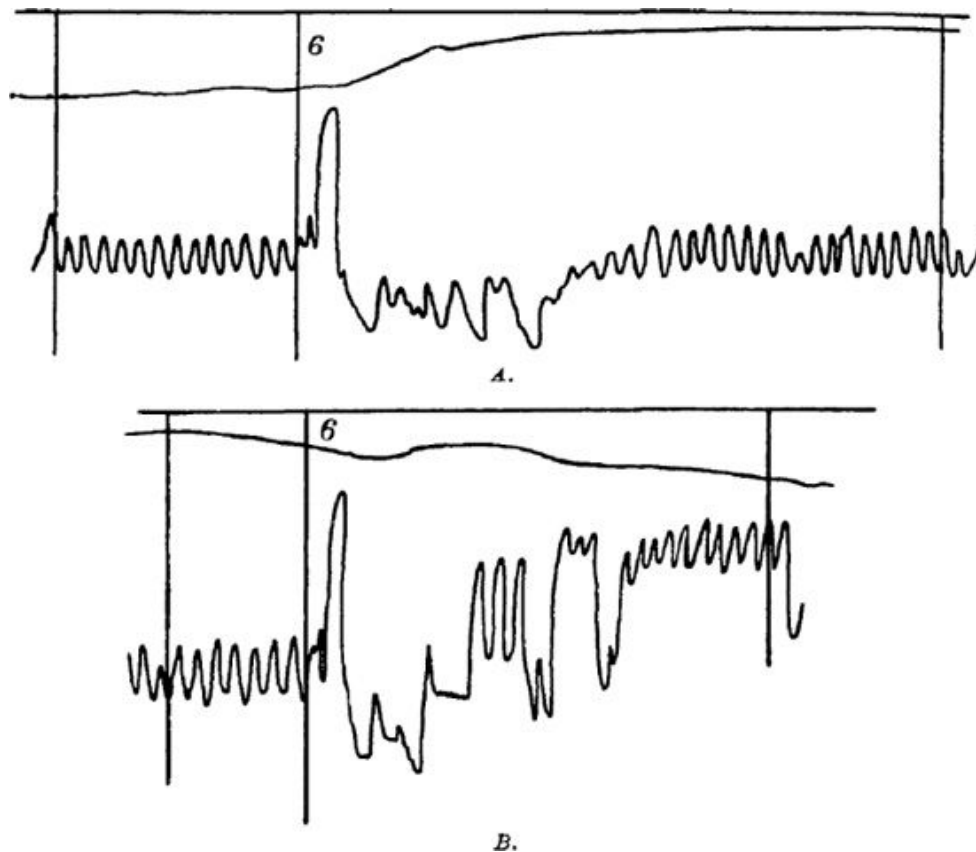

FIG. 9. J., acute catatonic stupor (Case No. 10). A is a wave selected from the series in which 6 is sudden call by name. The galvanometer curve is slight, but the change in the pneumographic curve is notable. B is the same stimulus in the repetition of the series. (Fig. 9 is reproduced actual size of the tracing)

1063] While inconstancy of emotional variations in the respiratory curve and in correspondence with the galvanometer curve has been the rule in our findings thus far, we have learned that inhibitions, when they occur as an expression of expectant attention or of other emotions, are almost always shown in the expiratory curve and not in the inspiratory, which would accord with our idea that active, intellectual, emotional or conscious innervation is chiefly associated with inspiration, whereas expiration is rather a physical process or relaxation, prone to be inhibited, but not otherwise affected by the active respiratory nerves.

1064] In reiterating our opinion that the galvanometer curve is probably more intimately connected than the pneumographic curve with the subconscious emotional complexes, we would add that there is a greater tendency also to persistence in the pneumographic curve when emotion is expressed in it, for the galvanometer curve subsides rather quickly with the fall of the emotion, while the pneumographic curve may show traces of conscious reminiscence of the emotional

stimulus for a much longer time. The galvanometer is rather an index or measure of acute feeling-tone.

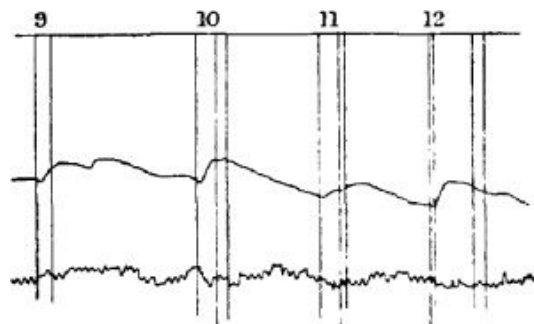

FIG. 10. Miss S., paranoid dementia (Case No. 2), stimuli 9, 10, 11, 12, correspond to numbers in the mixed series printed in the text. The noteworthy changes in the respiratory curve are due to her constant "disposition to speak." She did not speak except in answer to the questions given, but she apparently whispered most of the time between audible answers. Sometimes there was slight movement of the lips, when real whispering was not apparent

1065] Thus far, for the purposes of this study of the curves under normal conditions, we had made some forty series of curves in eight normal individuals, educated and uneducated. After this we made some thirty series of curves in eleven cases of dementia praecox of different types, viz.: Dementia paranoides three, hebephrenia two, and catatonia six cases (three chronic and three acute), and to these tests we will now turn our attention.

IV. THE GALVANOMETRIC AND PNEUMOGRAPHIC CURVES IN DEMENTIA PRAECOX

1066] Before recording the results of our experiments in dementia praecox it is necessary to say something of the psychology of the disorder. The chief characteristic in the mental condition of these patients is a peculiar disturbance of the emotions. In chronic conditions we have, as Kraepelin has clearly shown, an "emotional atrophy." In acute conditions there is a species of "inco-ordination" or "ataxia" between affectivity and concepts, well demonstrated by Stransky.¹⁶ The emotional disturbance has also been called "inadequate emotional tone." But these phrases represent rather the superficial impression that these patients make upon the physician. As soon as one examines the phenomena analytically and critically, the difficulty of attaining to a common point of view as regards all the morbid emotional symptoms is found to be extraordinary. We see at once that in most cases of dementia praecox none of the emotions is either changed or destroyed. We find, indeed, on closer analysis that many normal feelings are present. Cases with complete loss of emotion are exceptional. Elementary affects, such as fright, anxiety, pleasure, anger, embarrassment, shame, etc., are usually preserved. There is even at times an increased affectivity, or real nervous sensitiveness, present. Furthermore, in cases where one would expect more or less diminution of affectivity from their previous conduct and life, the elementary feelings are still maintained. The disorder is then shown in what Janet calls the *fonction du réel*¹⁷ or the psychological adaptation to the environment. It is hardly to be expected that we should find characteristic disturbances in such patients by our experimental method (psychogalvanic), since they would lie in quantitative differences between the various feeling-tones. Even if there were qualitative changes, these would be too small for recognition.

1067] One of the chief factors in psychological adaptation to the environment is attention, which renders possible all the associations necessary to normal existence. In dementia praecox, especially the catatonic form, there are marked disorders of attention, which are shown by lack

of power of voluntary concentration; or, otherwise expressed, objects do not excite in the diseased brain the affective reaction which alone permits an adequate selection of intellectual associations. This defective reaction to stimuli in the environment is the chief feature of dementia praecox. But this disorder is neither simple nor elementary; on the contrary, it is very complicated. What is its origin? There is in the psychology of dementia praecox still another characteristic that throws light upon the problem. By means of word associations and subsequent analysis we find in these cases, among other abnormal manifestations, certain thought-complexes associated with strong emotional tone, one or several of which are fundamental complexes for the individual and embody as a rule the emotions or experiences that immediately preceded the development of the mental disorder. In suitable cases it is possible without much trouble to discover that the symptoms (delusions, hallucinations, insane ideas) stand in close relation to these psychological antecedents. They in fact, as Freud has shown, determine the symptoms. Freud applied his method particularly to hysteria, in which he found conscious or unconscious constellations, with strong affective tone, that may dominate the individual for years, or even the whole life through, by the force they exert upon associations. Such a morbid complex plays the part of an independent being, or soul within a soul, comparable to the ambitious vassal who by intrigue finally grew mightier than the king. This complex acts in a particular way upon the psyche. Janet has described it in an excellent manner in his book.¹⁸ The complex robs the ego of light and nourishment, just as a cancer robs the body of its vitality. The sequelae of the complex are briefly as follows: Diminution of the entire psychic energy, weakening of the will, loss of objective interest and of power of concentration and of self-control, and the rise of morbid hysterical symptoms. These results can also manifest themselves in associations, so that in hysteria we find clear manifestations of emotional constellations among their associations. But this is not the only analogy between dementia praecox and hysteria. There are numerous others, which we cannot describe here in detail. One may, however, call attention to the large number of undoubted catatonic processes which were formerly called "degenerative hysterical psychoses." There are many cases, too, of dementia praecox which for years cannot be distinguished from hysteria. We call attention to the similarity of the two disorders here in order to show that our hypothesis of the relation between "psychological adaptation to environment" and an emotional complex is an established fact in the matter of hysteria. If we find in dementia praecox similar conditions, we are justified in assuming that here, too, the general disturbances of mind may have a close causal relationship with an underlying complex. The complex is naturally not the only cause of dementia praecox, as little as it is of hysteria. Disposition is also a chief agency, and it is possible that in the disposition to dementia praecox affectivity brings about certain irreparable organic disturbances, as for instance metabolic toxins.

1068] The difference between dementia praecox and hysteria lies in certain irreparable sequelae and the more marked psychic disturbances in the former disorder. Profound general disturbances (delirium, severe emotional crises, etc.), exceptional in hysteria, are usual in dementia praecox. Hysteria is a caricature of the normal, and therefore shows distinct reactions to the stimuli of the environment. In dementia praecox, on the other hand, there is always defective reaction to external stimuli. There are characteristic differences in relation to the complex. In hysteria the complex may with very little trouble be revealed by analysis, and with a good prospect of therapeutic advantage in the procedure. But with dementia praecox there is no possibility of its being thus influenced. Even if, as is sometimes possible, the complex may be forced to

reproduction, there is as a rule no therapeutic result. In dementia praecox the complex is more independent and more strongly detached, and the patient more profoundly injured by the complex than is the case in hysteria. For this reason the skilled physician is able to affect by suggestion acute hysterical states, which are nothing but irradiations from an excited complex, while he fails in dementia praecox where the inner psychic excitement is so much stronger than the stimuli from the environment. This is also the reason why patients in the early stages of dementia possess neither power of critical correction nor insight, which never fail in hysteria even in the severest forms.¹⁹

1069] Convalescence in hysteria is characterized by gradual weakening of the complex till it vanishes entirely. The same is true in the remissions of dementia praecox, though here there is always some vestige of irreparable injury, which, even if unimportant, may still be revealed by study of the associations.

1070] It is often astonishing how even the severest symptoms of dementia praecox may suddenly vanish. This is readily understood from our assumption that the acute conditions of both hysteria and dementia praecox are the results of irradiations from the complex, which for the time conceal the normal functions that are still present. For example, some strong emotion may throw a hysterical person into a condition of apathy or delirium, which may disappear the next moment through the action of some psychological stimulus. In like manner stuporous conditions may come and go quite suddenly in dementia praecox. While such patients are under the spell of the excited complex, they are for the time completely cut off from the outside world, and neither perceive external stimuli nor react to them. When the excitement of the complex has subsided, the power of reaction to the environment gradually returns, first for elementary and later for more complicated psychological stimulation.

1071] Since, according to our hypothesis, dementia praecox can be localized in some dominating psychological complex, it is to be expected that all elementary emotional reactions will be fully preserved, so long as the patient is not completely in the control of the complex. We may, therefore, expect to find in all patients with dementia praecox who show psychological adaptation in elementary matters (eating, drinking, sleeping, dressing, speaking, mechanical occupation, etc.) the presence of some adequate emotional tone. But in all cases where such psychological adaptation fails, external stimuli will produce no reaction in the disordered brain, and even elementary emotional phenomena will fail to become manifest, because the entire psychic activity is bound up with the morbid complex. That this is an actual fact is shown in the results of our experiments.

1072] The following is a brief *résumé* in each case of the features that are of interest for us here:

(1) H., male, aged 43, teacher of languages. First insane ten years ago. Well educated and intelligent. Entered an asylum for a time in 1896. Passed through a light period of catatonia with refusal of food, bizarre demeanour, and auditory hallucinations. Later constant persecutory ideas. In August 1906, he murdered one of his supposed persecutors, and since then has been in this asylum. Very precise and correct in his dress and conduct, industrious, independent, but extremely suspicious. Hallucinations not discoverable. Diagnosis—*Dementia paranoides*.

(2) Miss S., aged 61, dressmaker. Became insane about 1885. Innumerable bizarre delusions, delusions of grandeur, hallucinations of all the senses, neologisms, motor and language

stereotypy. Conduct orderly, neat, industrious, but rather querulous. Is on parole and shows considerable independent activity. Diagnosis—*Dementia paranoides*.²⁰

(3) Dr. S., male, aged 35, chemist. Became insane about 1897. Very intelligent and reads numerous scientific books. Has many wants and makes many complaints. Extremely careful in dress, and is extraordinarily neat. Numerous grandiose ideas and hallucinations. No catatonic symptoms. Diagnosis—*Dementia paranoides*.

(4) Mrs. H. O., aged 44, farmer's wife. Became insane in 1904 with an attack of hebephrenic depression. Since the end of 1906, in a second attack of similar character. Speaks only in whispers. Somewhat inhibited, anxious, and hears very unpleasant voices. Works industriously and spontaneously. Neat in dress and in care of her room. Diagnosis—*Hebephrenic depression*.

(5) Mrs. E. S., aged 43, merchant's wife. Became insane in 1901. Occasionally light maniacal excitement, never confusion at first, but rapid dementia. Now greatly demented, inactive, and vexes other patients. Unemotional, indifferent, and untidy in dress. Without interest in her husband or surroundings. Chatters a great deal, but quite superficially, and it is impossible in any way to arouse in her any of the deeper emotions. Diagnosis—*Hebephrenia*.

(6) A. V. D., male, aged 39. Entered the asylum in 1897. From the beginning quiet, unemotional, somewhat timid and anxious. Speech fragmentary and indistinct, and most of the time talks to himself. Makes meaningless gestures with the hands. Has to be cared for by the attendant in all matters. Cannot work. Shows neither homesickness nor desire for freedom. Automatism on command and at times catalepsy. Diagnosis—*Chronic catatonic stupor*.

(7) Sp., male, aged 62, factory worker. Became insane in 1865. In the early stages several attacks of catatonic excitement. Later chronic stupor with occasional raptus. In one attack of raptus tore out one of his testicles with his hand. At another time suddenly kissed the attendant. During a severe physical illness at one time he suddenly became quite clear and approachable. Speaks only spontaneously and at long intervals. Works only mechanically when he is led to it. Stereotyped gestures. Diagnosis—*Chronic catatonic stupor*.

(8) F., male, aged 50. Became insane in 1881. At first, for a long period, depressed inhibition. Later, mutism, with occasional outbursts of abusive language on account of voices and numerous hallucinations. At present constant hallucination, though he is quiet, speaking only when addressed, and then in a low, fragmentary manner. Occasionally outbreaks of abuse because of the voices. Works mechanically, and is stupid and docile. Diagnosis—*Chronic catatonia*.

(9) J. S., male, aged 21. Became insane in 1902. Stupid, stubborn, negativistic, speaks spontaneously not at all or very seldom, quite apathetic and without affectivity, sits the whole day in one place, wholly disorderly in dress. Once in a while demands release with some irritation. Diagnosis—*Mild catatonic stupor*.

(10) J., male, aged 21, student of philosophy and very intelligent. Became insane about 1901, when he had a short attack. The second attack came in December last (1906). At times excited, wholly confused, and strikes about him. Incessant hallucinations. Wholly wrapped up in his inner mental processes. In occasional intervals of some lucidity, the patient states quite spontaneously that he has no feeling at all, that he cannot be either glad or unhappy, that everything to him seems wholly indifferent. Diagnosis—*Acute catatonic stupor with raptus*.

(11) M., male, aged 26, merchant. Became insane in 1902. At first maniacal excitement. Later dull apathy and occasional exhibition. Then gradually increasing stupor, with complete

detachment. Now mutacismus, and tears out his beard, but at other times rigid and cataleptic.

Diagnosis—*Acute catatonic stupor*.

1073] The galvanometer curves in many of the tests with dementia praecox were extraordinary. As in normal individuals we found, where there was reaction at all, a gradual exhaustion of the power of the stimulus in repetitions of the same series, so that the waves became smaller in the second, and still smaller and more rounded in the third series. In some cases, where the waves were small in the first series, they disappeared altogether in the third. In [fig. 8](#) we have a good example of a very labile galvanometer curve from a case of dementia paranoides, in which we have abrupt and high ascents, at times with large bifurcations. This was the second series of this patient, and the curves are smaller than in the first. They may be compared with the labile normal curve of [fig. 6](#), which was the first series; and also with [fig. 10](#), another case of paranoid dementia, but in which the galvanometer wave is rather unemotional, while the pneumographic curve shows in this instance such marked changes owing to the disposition to whisper. The type of galvanometer curve, shown in [fig. 8](#), is also characteristic of curves we have taken in hysteria.

1074] In the hebephrenic type there is nothing especially noteworthy in the curve, either in respect of great lability or smallness of wave. In the catatonic forms of dementia praecox, especially in the acute forms, however, we observed extraordinary variations from the normal in the character of the curve. Not only is the latent time longer, but the waves are almost always of gradual ascent, and very small if present at all. [Figs. 9A and 9B](#), from a case of acute catatonic stupor, present illustrations of curves brought about by the sudden calling of the name. The galvanometer curve is exceedingly slight, but the pneumographic curve shows the singular changes previously mentioned. In [fig. 11](#) (p. 522) we show three galvanometer curves. The upper one is from a normal person, with the series printed in the text. The middle one is that of a case of chronic catatonic stupor (Sp.), which is characterized by almost no reaction to any stimuli until 14 is reached, when the threat of pricking with a needle (and the actual prick where the line crosses the up wave) produced a great rise in the curve. A slighter rise occurred at 15, the threat to let the weight fall. This is an example of reaction to an elementary emotion in a chronic case where some emotional tone is still present. The lowest line in [fig. 11](#) represents the galvanometer curve of an acute case of catatonic stupor (J.), and here it is seen that the line is perfectly straight, that not one of the mixed series of stimuli printed in the text had the slightest effect; whistle, dropping of the weight with a loud noise, sudden loud call by name, actual hard pricks with the needle—nothing brought out a response in the galvanometer. The pneumograph could not be applied in this case. Our experience with the six cases of catatonia is that such curves are characteristic for the type, and bear out our idea of the psychology of the disease as recorded above.

1075] Another feature of importance in these cases is the matter of latent time. It will be remembered that latent time, before the rise of the galvanometer wave, was estimated by us to vary in normal persons between two and five seconds. In fact, the norm is three seconds for first series, and 3.77 seconds for subsequent series. In the following tables, one relating to latent space on the kymograph, and the other to latent time, only seven of the eleven cases of dementia praecox appear, for in the others the waves were so slightly marked or so uncertain that the facts could not be satisfactorily determined. One of these patients (Dr. S.) was tested with both the mixed series and a series of word associations.

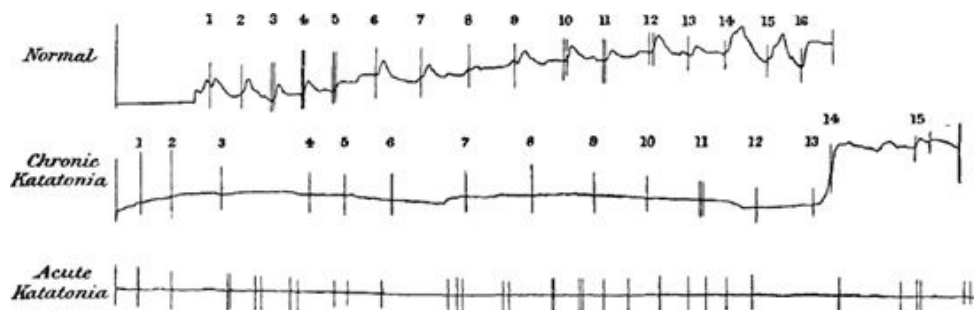

FIG. 11. Three galvanometer curves for contrast. The first curve is a normal one, with series of mixed stimuli (Miss B., a Canadian). The second curve is that of Sp. (Case No. 7), one of chronic catatonic stupor. Note presence of elementary emotion at stimulus 15. The third curve is that of J. (Case No. 10, acute catatonic stupor). No change whatever in the galvanometer curve to any of the mixed stimuli

Latent Time in Millimetres of Distance from Stimulus to Beginning of Ascent of Galvanometer Emotional Wave in Cases of Insanity

NAMES AND DIAGNOSIS	Miss S. Dementia paranoides	Dr. S. Dementia paranoides	Dr. S. Word association	Sp. Chronic catatonia	A. V. D. Chronic catatonia	F. Chronic catatonia	J. Acute catatonia	M. Acute catatonia
Series I	3.13	3.75	4.01	3.2	2	4.77	7.16	24.25
Series II	2.66	3.87	5.81		5	5.5	17.3	
Series III	3.93	4.22						
Series IV		5.46						

Latent Time in the Same Cases of Insanity as Above Estimated in Seconds

NAMES AND DIAGNOSIS	Miss S. Dementia paranoides	Dr. S. Dementia paranoides	Dr. S. Word association	Sp. Chronic catatonia	A. V. D. Chronic catatonia	F. Chronic catatonia	J. Acute catatonia	M. Acute catatonia
Series I, mixed stimuli	3.47	4.16	4.45	3.55	2.22	5.3	7.95	26.94
Series II	2.93	4.3	6.45		5.55	6.11	19.22	
Series III	4.36	4.68						
Series IV		6.06						

1076] In the first case, a woman with dementia paranoides, the latent time is within normal limits. In the second case, also dementia paranoides, Dr. S., the normal was overstepped only in the fourth round of the same mixed series, but, with the same patient using word association, the latent time was excessive (6.45) in the first repetition of the same words. In the third case (Sp.), a case of chronic catatonia, the first series showed a latent time of 3.55 seconds, but there were no waves whatever in the repetitions. The four succeeding patients, all cases of catatonia, show increase of latent time, and the two acute cases of catatonia present an astonishing interval of space and time between the stimulus and the galvanometer wave.

1077] The following table will better show the differences in latent time between the normal and cases of dementia praecox, especially in the averages given at the end of the table.

										Average	Average of distribution
Normal	Series I	2.28	2.05	3.5	4.5	3.27	2.51			3.01	.73
	Series II and III	2.83	1.95	4.88	5	4.44	3.94	2.57	4.6	3.77	.99
Dementia Praecox	Series I	3.47	4.16	4.45	3.55	2.22	5.3	7.95	26.94	7.25	5.09
	Series II and III	2.93	4.3	6.45	5.55	6.11	19.22	4.36	4.68	6.70	3.13

1078] The average of distribution is obtained by subtracting the ordinary average from the larger numbers in the series, or the smaller numbers from the average. The sum of these differences is divided by the number of items, which gives what is called the average of distribution or the average of differences—a useful method of showing wide fluctuations in pathological conditions.

V. ASSOCIATION EXPERIMENTS

1079] Galton, Wundt, Kraepelin, Aschaffenburg, Sommer, and others have introduced into psychology a very simple experiment in which a word is called out to the subject, who must respond as quickly as possible with the first word that occurs to him. The reaction-time between the stimulus-word and the response can be measured with a one-fifth-second stop-watch. It was originally expected that this method would reveal certain intellectual differences in various individuals. But from the results of investigations carried out in the Psychiatric Clinic at Zurich, it has been found that it is not intellectual factors but the emotions that play the chief part in determining these associations. Two persons, of the same social class, one intelligent, the other unintelligent, even with differences in the character of their intellectual development, may still produce similar associations, because language itself has many general word connections which are familiar to all sorts of individuals belonging to the same circle of society.

1080] There are certain well-marked differences between the word associations of educated and uneducated persons. For instance, the uneducated prefer inner connections with deeper meaning, while the educated very often select simply superficial and linguistic associations. As has been ascertained at the Zurich Clinic, this difference depends upon the fact that the uneducated fix their attention more closely than the educated upon the actual meaning of the stimulus word. But attention, as has been shown by Bleuler, is nothing more than an emotional process. All affective processes are more or less clearly connected with physical manifestations, which are also to be observed in conjunction with attention. It is therefore to be expected that the attention roused by every association should have an influence upon the galvanometer curve, though this is but one of the affective factors represented in an association experiment.

1081] We observe, as a rule, considerable variation in reaction-time, even with quick and practised subjects. One is inclined to explain such irregularities, which are apparently accidental, by supposing that the stimulus-word is unusual and difficult or that the attention is momentarily relaxed for some reason or another. Such may at times be the case, but these reasons are not sufficient to explain the frequent repetition and long duration of certain reaction-times. There must be some constant and regular rule to account for them. This disturbing factor has been

found at the Zurich Clinic to be in most cases some characteristic thought-complex of intrinsic importance for the personality of the subject. The following series will illustrate our meaning:

<i>Stimulus-word</i>	<i>Reaction-word</i>	<i>Reaction-time</i>
head	hair	1.4
green	meadow	1.6
<i>water</i>	<i>deep</i>	5
stick	knife	1.6
long	table	1.2
<i>ship</i>	<i>sink</i>	3.4
ask	answer	1.6
wool	knit	1.6
spiteful	friendly	1.4
<i>lake</i>	<i>water</i>	4
sick	well	1.8
ink	black	1.2
<i>swim</i>	<i>can swim</i>	3.8

1082] The four italicized numbers are abnormally long reaction-times. The stimulus-words are quite ordinary, are not difficult, and are such as commonly carry numerous current connections. By questioning the patient, we learn that recently, when greatly depressed, he had determined to commit suicide by drowning. *Water, lake, ship, swim* were words that excited this complex. The complex brought about lengthening of the reaction-time. This phenomenon is quite usual, and is to be observed constantly and everywhere in association studies. Lengthened reaction-time may therefore be regarded as a complex indicator, and be employed for the selection from a series of associations of such as have a personal significance to the individual. It is self-evident that associations of this kind are apt to be accompanied by lively emotional tone. The explanation would be simple if the subject were always conscious of the complex which had been excited. But it is extraordinarily common for the subject to be unconscious of the complex disturbed by the stimulus-word, and to be unable to answer questions relating to it. It is then necessary to employ the psychoanalytic method, which Freud uses for the investigation of dreams and hysteria. It would carry us too far to describe here the details of this method of analysis, and readers must be referred to Freud's *The Interpretation of Dreams*.

1083] The cause of the interference with the reaction must be sought for in the strong emotional tone of the complex. Individuals with good powers of introspection often affirm that they could not respond quickly, because of the sudden crowding into consciousness of a number of words among which they could find none suitable for the reaction. This is easily understood, for strong affects always collect numerous associations around them, and, on the other hand, an assemblage of associations is always accompanied by an intense emotional tone. In some cases we have an opposite condition from the above, and the subjects are not able to react because of a vacuum in consciousness, in which event the complex hinders reaction by simply not appearing in consciousness. Thus the underlying thought-complex sometimes carries too much into consciousness, and at other times too little, in either case disturbing the uniform flow of psychic functions. It acts like a peace-breaker in the psychic hierarchy. Such being the behaviour of the complex under normal conditions, it is easy to understand how it may play the chief part in abnormal mental states based upon disordered affectivity.

1084] Lengthened reaction-time is not the only index of a complex. If the stimulus-word causes a sudden embarrassment and brings out some striking and unusual reaction-word, it is certain that a complex has been struck, so that any reaction out of the ordinary may also be regarded as indicating the presence of an emotional thought-complex.

1085] It is not infrequent to observe a lengthened or disturbed reaction also in the second reaction after some critical stimulus-word, so that we have a persistence of the affect to the next following reaction, a fact which also may be taken to indicate the existence of a complex.

1086] And, finally, we have in the method of reproduction another excellent aid for the discovery of the complex. When the series of stimulus-words has been finished, the list is gone over again, and the subject is simply asked to repeat the word he had given before in response to the stimulus. We then notice that where stimulus-words touched upon a complex, the memory plays false and the subject tends to react with some other word than the one first given. This paradoxical phenomenon depends altogether upon the influence of a strong emotional tone. The complexes are often unpleasant and create a natural resistance in the individual; but they are not always unpleasant or painful, and even with such complexes as the subject would be perfectly willing to reveal, there is yet an inhibition present which shows itself in like manner. The cause of defective reproduction must lie in the general nature of the complex as already described, in a certain independence of the complex, which comes and goes according to factors peculiar to it, and not at the behest of consciousness, and which yields the selfgenerated associations, and not such as are sought by consciousness. We—that is, our conscious selves—are on the whole in a sense the resultants of competitions in the unconscious.

1087] It is thus that affective factors present themselves everywhere in our associations; and it is of interest to ascertain whether the psychogalvanic reflex runs a parallel course with the complex indices just described; whether it does so regularly or has a preference for certain constellations; whether differences exist when a complex is conscious or unconscious, etc.

1088] Wherever possible, we have employed the pneumograph at the same time with the galvanometer in these association studies to determine whether parallel disturbances were present.

1089] The association question is many-sided, and there are numerous methods by which to study it. We shall try in the following pages to present our method and to confine ourselves more especially to our method of investigation, rather than to bring forward too prominently results which, owing to the small number of individuals examined, are valuable as case material but cannot be looked upon as having general application.

1. *The Results Obtained with Association Tests*

1090] (1) When the experiment is ended we measure the heights of the galvanometric curves and arrange them in a table, with other results of the tests. As the table shows, we made one repetition of the experiment in this instance; in other cases two repetitions were made.

1091] (2) We then determine the arithmetical average of the galvanometric deviations, which in this instance is 4.9 mm. These figures are naturally only relative and, with our apparatus, correspond to only one-half of the actual movement of the mirror of the galvanometer. (The actual figure would be 9.8 mm.)

SERIES I			SERIES II				
No.	Height of galv. curve in mm.	Reaction-time one-fifth sec.	Association	Reproduction	Height of galv. curve in mm.	Reaction-time one-fifth sec.	Reaction
1	9	9	table/chair	ditto	7	7	ditto
2	4	9	sit/on a chair	ditto	3	15	ditto
3	4	11	garden/vegetable	ditto	3	6	ditto
4	3	14	red/apple	ditto	4	5	ditto
5	3	9	write/with pencil	ditto	4	7	ditto
6	6	40	full (no reaction)		2	6	cask
7	3	8	good/sugar		9	9	apple
8	6	6	forest/wood	ditto	4	5	ditto
9	5	10	tavern/drink	ditto	2	5	ditto

1092] (3) We then determine the probable average (Kraepelin) of the reaction-times in the following manner: The figures are arranged in a column in the order of their size, and the middle number is taken, which in this instance is 1.8 seconds. The probable is here preferred to the arithmetical average, because occasionally very high numbers occur in such tests, where the reaction-times are much more liable to increase than to diminish. An arithmetical average would be unduly influenced by the occasional presence of one or more large numbers, and would not give us the actual average of the reaction-time.

1093] (4) In the second series the average of the galvanometer deviations was 4.8 mm., and that of the reaction-times 1.2 seconds. We observe, therefore, a reduction in the average height of the galvanometer curve, which is clearly due to lessening of the power of the stimulus in the repetition. The same phenomenon is also seen in the average of the reaction-times, which is shortened. The fact that every reaction is accompanied by a galvanometer movement is due to the emotion of attention which accompanies each reaction and is great enough to produce notable physical changes.

1094] (5) We note that in the second series certain associations (the sixth and seventh) are repeated with a change of words. These defective or changed reproductions indicate that the psychological constellation for the respective associations had changed in the short time (a little over one-half hour) that had elapsed since the first series had been given. We know that associations which belong to certain complexes are those that may, because of inner conditions, suffer change within a short period of time. We may, therefore, expect that such false reproductions carry with them particular emotional phenomena; and this is actually the case here. The arithmetical average of the altered reproductions is 5.7 mm., while in the first series the average for the same associations was 4.5 mm. Furthermore, the altered reproductions in the second series show an excess of some 0.8 mm. over the average of the stimulation of the first series. The average of the reaction-times for the altered reproductions is 1.2 seconds, and for the correct reproduction 1 second, as would be expected. We learn from this that the supposition that the altered reproductions are affective phenomena would seem to be justified. We will not here enter into details in relation to the psychoanalysis of such manifestations, as we do not wish to forestall an especially careful study of this question now being made in this clinic by Binswanger.²¹

1095] (6) From the above consideration one would also expect that those associations which are changed in the repetition should also present some sort of affective signs in the first series; but,

contrary to our expectation, we see in this case that the average height of the galvanometer deviation for the words subsequently changed in repetition is 4.8 mm., while the average for the unaltered reproductions is 5 mm. This difference is, of course, small, and no particular deduction could be drawn from one case. It is to be noted that the average reaction-time for the associations subsequently wrongly reproduced is 1.9 seconds, and for the words correctly reproduced 1.8 seconds. Perhaps there is here a slight indication of the phenomenon to which we refer.

1096] (7) In the preceding paragraphs we have frequently intimated that there is a certain connection between affectivity and the length of reaction-time, and this has been already carefully determined in the work of one of us.²² One may expect to have, as a rule, large galvanometer curves with long reaction-times, always, however, with the limitation that only such lengthened reaction-times are considered as are connected with associations that directly excite complexes, and not the long reaction-times which may follow immediately after reactions that excite complexes. These latter are frequent and are examples of perseveration. In order to discover the actual complex-exciting association it is necessary to employ the psychoanalytic method, and for this purpose a more suitable material is needed than is at our disposition. We, therefore, content ourselves here with simply determining the average height of all galvanometer curves in relation to reaction-times which lie respectively above and below the probable average.

1097] In Series I, the average of galvanometer curves connected with long reaction-times is 4.5 mm., and with short reaction-times 6.1 mm.

1098] In Series II, the galvanometer curves with long reaction-times average 5.7 mm., and with short reaction-times 4.4 mm.

1099] The two results are contradictory. The cause of this lies in factors already alluded to and in other difficulties which must be the subject of later study.

1100] (8) The alteration of the psychological constellation of Series II already mentioned may be manifested in the galvanometer curve alone, without any change in the reproductions. This matter might be thus explained. In the first trial only certain meanings are attached to the stimulus-word by the subject; i.e., not all of the associations belonging to it are excited at the first trial, while at the second trial another series of new connections may be aroused. We very often meet this phenomenon in our psychoanalytic investigations.

1101] It is of the greatest importance for the study of intellectual processes in the individual to know how his associations are presented to consciousness, whether he has quick and complete command of all related associations. This point is of the utmost value for testing intelligence, since many persons may appear to be stupid during investigation because their associations are not at immediate command, and on the other hand stupid persons may seem to be relatively intelligent simply because they have good command of their associations. We may perhaps also expect to discover important differences between educated and uneducated intellects; the galvanometric experiments seem to open to us endless vistas.

1102] In this case 41.6 per cent of the associations in Series II show an increased galvanometric curve with an average plus difference of 2.3 mm. It is possible that later investigations may show us that this result has considerable psychological significance for the individual, because this subject was quite unintelligent.

1103] (9) After a marked galvanometric deviation we frequently observe that there is an inclination to successive large curves, if the succeeding stimuli are not too quickly given. This is not unexpected because it is a general psychological experience that strong affects induce great sensitiveness. If therefore we take the average of the curves which follow unusually strong galvanometer curves and compare them with the arithmetical average of all the curves, we find that after unusually high curves, the average height in Series I is 5 mm. and the reaction-time two seconds in contrast with the general averages of 4.9 mm. and 1.8 seconds. In Series II these figures are reversed, for here the average has a difference of plus 0.6 mm. while the average of the reaction-times shows a difference of minus 0.5 seconds. The relations are not quite definite.

1104] (10) The whole of Series I shows a rather uniform course, for the average of distribution amounts only to 1.6. The deviations are relatively not very high. The highest curve is 12 mm., and the association connected with it is *stupid / am I*, which was for this individual a clear egocentric stimulus which evidently struck a strong emotional complex.

1105] Fig. 12 is a portion of the curve in this case. In this, one notes the even course and uniform emotional value of each association. The accompanying pneumographic curve is undisturbed.

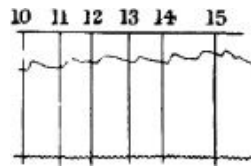

FIG. 12. Portion of curve in word association of a normal subject

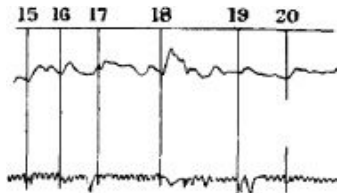

FIG. 13. Portion of curve corresponding to the association *stupid / am I*

1106] Fig. 13 shows the portion of the curve in which the association *stupid / am I* (reaction No. 18) occurred. This portion is marked by a very high many-pointed wave. The pneumographic curve is altered here, as it is also in reaction No. 19, though the latter has little emotional tone. But No. 19 has, however, a very long reaction-time (4.8 secs.), which is to be looked upon as a persisting intellectual disturbance from reaction No. 18. We observe here one of the numerous instances where the pneumographic curve and the reaction-time show evident disturbances, while the galvanic curve is unaffected. According to our hypothesis, this is owing to the fact that the galvanometer indicates only acute affective conditions, and not the more lasting intellectual after-effects, these latter being often well registered by reaction-time and pneumograph. The reaction-time shows how long the mind requires to detach itself from its conscious or unconscious preoccupation, and turn to the new stimulus. The respiration, because of its close relation to consciousness (susceptibility to voluntary influences), is also affected by intellectual processes, while the galvanometer seems to be influenced directly only by the unconscious.

Case 2.—Uneducated but rather intelligent man, aged 38

1107] (1) We have arranged in the following table the results of three series of associations of twenty-four words each:

Series I	Arithmetical average of	5.6 mm.
----------	-------------------------	---------

		galvanometer curves	
Series II		Arithmetical average of galvanometer curves	7.2 mm.
Series III		Arithmetical average of galvanometer curves	5.9 mm.
Series I		Probable average of reaction-times	1.8 sec.
Series II		Probable average of reaction-times	1.3 sec.
Series III		Probable average of reaction-times	1.0 sec.

1108] The reaction-times are what we expect, but the galvanic curves show an unexpected increase in the second series. Our first supposition would be that this is owing to some physical change; for instance, better contact from increased warmth of the hands, or a change of posture of the body that increased the pressure of the hands upon the electrodes. Such conditions may not only interfere with the experiment, but also render comparison of results difficult. But it is also possible that the psychological constellation changed in the second series, causing thereby greater deviation of the galvanometer. If we take the first fifteen curves of Series II, we find the average to be 4.7 mm., which is much less than the average of Series I. But if we take the last nine curves of Series II, we find the average to be 11.3 mm., and that the cause of the great difference lies where the principle of loss of power in repeated stimulation does not seem to be effective. It is possible that after the fifteenth reaction there was a physical disturbance, which increased the height of the curves.

1109] We find that the probable average of the reaction-times of the first fifteen and last nine reactions both amount to 1.8 seconds, while the average of the galvanometer curves of the first fifteen reactions shows only a difference of minus 0.2 mm., as compared with the last nine curves. Now, if a physical change occurred toward the end of Series II, we might expect no change in the purely psychological reaction-times. This is, however, not the case. For the increased galvanic curves in the last nine reactions correspond to an increase of the reaction-times (1.4 seconds, as compared to 1 second of the first fifteen reactions). There is, therefore, a parallel between the galvanometer increase and the increased reaction-times, from which we may conclude that the increase depends upon an altered psychological constellation.

1110] We have already mentioned that a change in the constellation is due to the arousing of complexes. The reactions occur in this wise:

No.	Associations	SERIES I			SERIES II	
		Reaction-time	Gal. curve	Reproduction	Reaction-time	Gal. curve
1	money/round	1.8 sec.	3 mm.	ditto	1.2 sec.	12 mm.
2	high/tree	1.4 sec.	7 mm.	ditto	1.4 sec.	4 mm.
3	go out/morning	2.0 sec.	8 mm.	ditto	1.4 sec.	6 mm.
4	floor/dirty	1.8 sec.	5 mm.	ditto	1.8 sec.	9 mm.
5	wages/large	1.2 sec.	6 mm.	ditto	1.2 sec.	19 mm.
6	pay/debts	3.4 sec.	9 mm.	ditto	3.0 sec.	15 mm.
7	apple/red	2.4 sec.	5 mm.	ditto	1.4 sec.	27 mm.
8	nurses/many	1.6 sec.	4 mm.	ditto	1.8 sec.	5 mm.
9	five/small	1.8 sec.	5 mm.	ditto	1.2 sec.	5 mm.

1111] While as a rule the reaction-times are shortened in Series II, the galvanometer curves are higher. It seems as if the affects first really manifested themselves in Series II after having been inhibited in Series I. As is shown, the largest increases are connected with the associations *money / round, floor / dirty, wages / large* (the subject is an attendant or nurse and receives small wages), *pay / debts, apple / red, and nurses / many*. It is easy to understand that five of these associations might arouse strong sentiments. The strong reaction with *apple / red* is incomprehensible. But we have frequently noticed that quite indifferent associations following immediately upon strong emotional associations show in repetition sudden increase of galvanic reaction, as if the emotional tone were postponed. It is possible that we have such a phenomenon here, but we have no means of proving it. Affects are always inhibited if some other strong emotional complex displaces them. This was evidently the case here, because the unusual experiment excited the subject, so that he probably did not grasp the stimulus-words in all their personal relations. In Series II he was quieter and could comprehend better, in consequence of which emotional tones were more easily developed than before. This phenomenon is theoretically very important, since it indicates how affects are repressed in normal persons. Inhibition of affects plays a powerful role in psychopathology. (See the works of Freud, Bleuler, and Jung.)

1112] This experiment also illustrates well that reaction-time and galvanometer curve do not mean the same thing. We see here again how clearly the reaction-time reveals a greater intellectual freedom than in Series II, whereas the galvanometer curves are considerably higher than those of Series I.

	Galv. Curve	Reaction-time
(2) The altered reproductions of Series II average	6 mm.	1.7 sec.
The altered reproductions of Series III average	7 mm.	1.0 sec.
The unchanged reproductions of Series II average	7.3 mm.	1.3 sec.
The unchanged reproductions of Series III average	5.8 mm.	1.3 sec.

1113] Here, too, the relations are somewhat obscure, which may be owing to the occurrence of very few altered reproductions. Only half of the above numbers coincide with our expectations.

(3) Galvanometer curves with long reaction-times average in Series I	6.4 mm.
Galvanometer curves with short reaction-times average in Series I	6.4 mm.
Galvanometer curves with long reaction-times average in Series II	8.1 mm.
Galvanometer curves with short reaction-times average in Series II	4.2 mm.
Galvanometer curves with long reaction-times average in Series III	6.8 mm.
Galvanometer curves with short reaction-times average in Series III	4.1 mm.

1114] The first test is undecided, but the two following present figures which correspond with our expectation. (In Case 1 above recorded the first test also gave a contradictory result.)

1115] (4) In Series II, 41.6 per cent of the associations show an average difference of plus 3.2 mm. compared with Series I. In Series III, 45.8 per cent of the associations show a difference of plus 2.6 mm. as compared with Series II.

1116] These figures prove, as already mentioned, that Series II presents a considerably altered constellation. In Series III there are still more psychological constellations changed. It is to be regretted that there was not a much larger material at hand for the further investigation of matters so important for the psychology of the individual.

(5) Series I. Probable average of reaction-times in associations with unusually high galvanometer curves	2.2 sec.
Series I. Arithmetical average of the corresponding galvanometer curves	5.2 mm.
Series II. Probable average of reaction-times in associations with unusually high galvanometer curves	1.6 sec.
Series II. Arithmetical average of the corresponding galvanometer curves	12.0 mm.
Series III. Probable average of reaction-times in associations with unusually high galvanometer curves	0.8 sec.
Series III. Arithmetical average of corresponding galvanometer curves	7.0 mm.

1117] The curves in Series II and III do not, while those of Series I do, correspond to expectation. The reaction times in Series I and II are what we anticipate. Therefore, of six items, four coincide with our expectation.

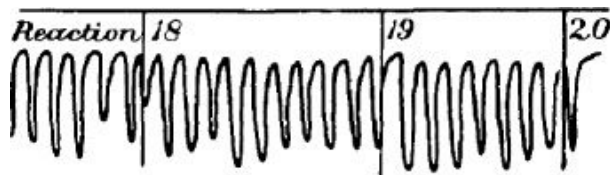

FIG. 14. Portion of Pneumographic curve in Case 2 (word association, normal individual)

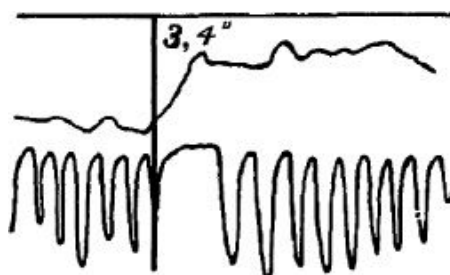

FIG. 15. Galvanic and pneumographic curve corresponding to the word association *pay / debts*. (Figs. 14 and 15 are reproduced the actual size of the tracing)

1118] (6) Series I. Presents in general a uniform character. The average of distribution is only 1.5 mm. The highest curve measures 9 mm., and this is connected with the association *pay / debts*, which, as we have seen, also preserves its high emotional value in Series II.

1119] Series II is much more irregular. The average of distribution is 3.8 mm., a very high figure, which well illustrates the general irregularity of the series. The highest curves of this series have already been described.

1120] Series III presents, on the other hand, another series with uniform character. The average of distribution is only 1.8 mm. The highest curve occurs with the association *wages / large*, and amounts to 11 mm., and in Series II it also had a high value. Such concord shows clearly that these figures are not accidental.

1121] The pneumographic curve presents no peculiarities. In Series I, with indifferent associations, this curve has the aspect shown in [fig. 14](#).

1122] [Fig. 15](#) is the galvanometric and pneumographic curve belonging to the association *pay / debts*. In this we observe a marked inhibition of respiration during and after the critical association.

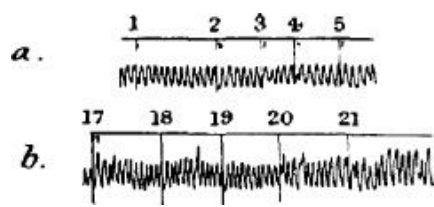

FIG. 16. (a) Respiratory curve, with word associations No. 1 to 5 in Case 2. (b) Curve, same case, associations No. 17 to 21

1123] The psychic excitation referred to previously in the last nine associations of Series II seems to manifest itself also in the pneumographic curve, as apparently evidenced in [figs. 16\(a\)](#) and [16\(b\)](#).

1124] [Fig. 16\(a\)](#) is a portion of the respiratory curve during associations 1 to 5. [Fig. 16\(b\)](#) represents associations 17 to 21. The difference is marked. We can hardly be mistaken in supposing that the change in respiration is the expression of a certain excitation, which is in harmony with our previous assumptions.

Case 3.—Uneducated man of moderate intelligence, aged 28, lively, excitable temperament. Normal. Three series of associations, each with twenty-three words

1125]

(1) Series I. Arithmetical average of galvanometer curves	14.2 mm.
Series II. Arithmetical average of galvanometer curves	6.5 mm.
Series III. Arithmetical average of galvanometer curves	2.0 mm.
Series I. Probable average of reaction-times	2.4 sec.
Series II. Probable average of reaction-times	2.2 sec.
Series III. Probable average of reaction-times	2.0 sec.

The curves of Series I reach a considerable height, but the stimulus diminishes rapidly and intensely in power in the succeeding series. The reaction-times shorten uniformly, but are still in general somewhat long, as we observe not infrequently among emotional people.

1126]

	Galv.	Reaction time
(2) The altered reproductions of Series II average	7.9 mm.	2.0 sec.
The unchanged reproductions of Series II average	1.8 mm.	2.2 sec.
The altered reproductions of Series III average	3.5 mm.	2.2 sec.
The unchanged reproductions of Series III average	1.3 mm.	2.1 sec.

The galvanic curves correspond in both series to our expectation, but the reaction-times in Series II are contradictory, which, however, is changed if we do not employ the probable average (as is ordinarily done by us in all cases) but the arithmetical average, when the average time for altered reproduction is 2.8 sec., and for the unchanged only 2.4 sec.

1127]

(3) The galvanic curves with long reaction-times in Series I average	17.8 mm.
The galvanic curves with short reaction-times in Series I average	12.7 mm.
The galvanic curves with long reaction-times in Series II average	9.8 mm.
The galvanic curves short reaction-times in with Series II average	3.6 mm.
The galvanic curves with long reaction-times in Series III average	2.1 mm.
The galvanic curves with short reaction-times in Series III average	0.0 mm.

All of these figures are in perfect accord with our hypothesis.

1128] (4) In Series II, 17.3 per cent of the associations have an average difference of plus 5.8 mm. In Series III, 17.3 per cent of the associations have an average difference of plus 2.8 mm.

1129] These figures show that the constellation in the latter series is not very much changed, with the exception of a few associations. We may conclude that all the strong emotional relations of the stimulus-words were brought out in the first test. We should say here that Case No. 3 was well accustomed to this kind of experiment, while cases No. 1 and No. 2 were not.

1130]

(5) Series I. Probable average of reaction-times following associations with unusually high galvanic curves	2.8 sec.
Series I. Arithmetical average of the corresponding galvanic curves	22.3 mm.
Series II. Probable average of reaction-times following associations with unusually high galvanic curves	1.8 sec.
Series II. Arithmetical average of the corresponding galvanic curves	11.4 mm.
Series III. Probable average of reaction-times following associations with unusually high galvanic curves	1.2 sec.
Series III. Arithmetical average of the corresponding galvanic curves	1.7 mm.

The galvanic curves are what we would expect in Series I and II but not in Series III. The reaction-time is what we expect only in Series I.

1131]

	Galv.	Reaction-time
(6) Series I. Average of associations altered in subsequent reproduction	14.2 mm.	2.4 sec.
Series I. Average of association unchanged subsequently	13.5 mm.	2.0 sec.
Series II. Average of associations altered in subsequent reproduction	8.7 mm.	2.2 sec.
Series II. Average of associations unchanged subsequently	3.6 mm.	2.0 sec.

All of these figures coincide with what we expect.

1132] (7) The general course of Series I is very irregular. The average of distribution is 7.6, the highest number we have yet observed. In the tests with Cases 1 and 2 the various phases of stimulation were shown in strong, but much differentiated, emotions, but in this case with a lively temperament there was a continual and marked fluctuation of emotions, and hence the high average of distribution.

1133] Series II is more uniform, and the average of distribution is 5.4, and in Series III this average is only 2.3.

1134] The highest galvanic curve in Series I measures 51.5 mm. and is connected with the association *the sun / burns*. Why there should be here so strong a reflex innervation could not be understood without further examination. The subject himself could not explain why he had any particular emotion at this moment. But the connection was shown in the following associations. The other high curves (37, 21 and 18 mm.) occurred with the associations *floor / parquet, pay /*

write, warm / the stove. These three associations showed constant and similar disturbances in all three series, as illustrated in this table:

	SERIES I			SERIES II			SERIES III		
	Galv.	Reaction-time	Reproduction	Galv.	Reaction-time	Reproduction	Galv.	Reaction-time	
floor	37 mm.	3.0 sec.	ditto	13 mm.	3.2 sec.	ditto	2.5 mm.	3.0 sec.	
warm	18 mm.	1.2 sec.	ditto	31 mm.	2.2 sec.	ditto	7.0 mm.	2.0 sec.	
pay	21 mm.	2.0 sec.	ditto	4.5 mm.	0.8 sec.	ditto	7.5 mm.	2.2 sec.	

1135] All the reproductions were altered. With one exception all of the galvanometer curves were considerably above the averages for each of the series. As to the nine reaction-times, four were above, and two coincided with the probable averages. It seemed justified from these observations to assume that a strong emotional complex lay behind them. But when questioned the subject answered that he had had no particular thoughts in connection with these reactions, and was evidently unconscious of any special complex. Yet even if a subject asserts that no complex is present, this is not conclusive in the face of so many indications pointing to interference by a complex. In this instance we distracted his attention from the matters in hand and asked what personal significance the word *floor* had for him, when suddenly he said with surprise and embarrassment that recently a *stove* in his dwelling had become defective and *burned* the *floor* to such an extent that he had not only to *pay* for a new stove, but also for an entire new floor which was a hardship for him. Besides this there had been great danger from fire. Thus all the disturbances above related were perfectly explained, including the strong emotional tone of the association *the sun / burns*.

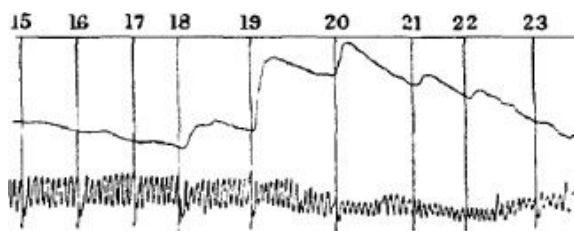

FIG. 17. Portion of a curve to show emotional effect of certain word associations

1136] We learn from this interesting episode that the galvanic phenomenon, like reaction-time and alteration of reproductions, may give evidence of the existence of an unconscious complex. We cannot go into further detail regarding this fact here, but the investigations of Binswanger already mentioned also throw much light on the subject.

1137] The group of associations described above gives an unusually fine picture in Series II of emotional effect upon the curves (fig. 17). At the beginning we have indifferent reactions. Reaction No. 18 is *floor*, 19 *warm*, 20 *wages / small*, and 21 *pay*.

1138] The respiratory curve also shows the reactions very clearly. In general, inspiration is increased, which is especially characteristic for this particular case in connection with expectant attention. The condition during the unconscious complex excitation seems therefore to have had a certain resemblance to the tension of expectation. An example of this tension of expectation in this case at the beginning of a test is shown in fig. 18.

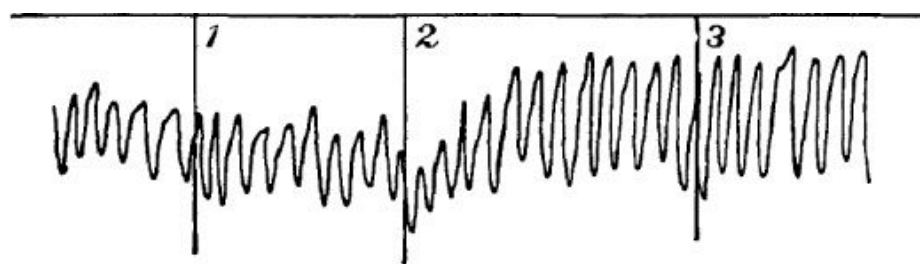

FIG. 18. Expectation curve in Case 3 (reproduced actual size of tracing)

Case 4.—An educated woman, aged 25, used to these experiments. Three series of word associations, eighteen words in each

1139]

(A) Series I. Arithmetical average of galvanic curves	6.8 mm.
Series II. Arithmetical average of galvanic curves	1.9 mm.
Series III. Arithmetical average of galvanic curves	0.9 mm.
Series I. Probable average of reaction-times	1.2 sec.
Series II. Probable average of reaction-times	1.0 sec.
Series III. Probable average of reaction-times	1.0 sec.

The galvanic curves show very rapid diminution, while the reaction-time is very short and the lowest limit is soon reached.

1140]

	Galv.	Reaction-time
(B) The altered reproductions of Series II average	7.5 mm.	1.6 sec.
The unchanged reproductions of Series II average	1.6 mm.	1.0 sec.
The altered reproductions of Series III average	0.0 mm.	1.0 sec.
The unchanged reproductions of Series III average	1.0 mm.	1.0 sec.

The result in Series II is what we expected, but this is not true of Series III, perhaps because only very few altered reproductions occur.

1141]

(C) The galvanic curves with long reaction-times in Series I average	11.6 mm.
The galvanic curves with short reaction-times in Series I average	5.2 mm.
The galvanic curves with long reaction-times in Series II average	5.4 mm.
The galvanic curves with short reaction-times in Series II average	0.8 mm.
The galvanic curves with long reaction-times in Series III average	1.0 mm.
The galvanic curves with short reaction-times in Series III average	1.5 mm.

The figures in Series I and II are what we expected, but not in Series III, perhaps because most of the curves had already sunk to zero.

1142]

(D) In Series II, 5.5 per cent of the associations show an average plus difference of	6.0 mm.
In Series III, 11.1 per cent of the associations show an average plus difference of	2.7 mm.

In this case also we note a great readiness of the association to appear fully on the first stimulus, so that the constellation does not change much later on.

(E) Series I. Probable average of reaction-times following associations with unusually high galvanometer curve	1.1 sec.
Series I. Arithmetical average of corresponding galvanometer curves	6.5 mm.
Series II. Probable average of reaction-times following associations with unusually high galvanometer curves	1.0 sec.
Series II. Arithmetical average of corresponding galvanometer curves	1.2 mm.

The figures in Series III are omitted, because most of the galvanic curves were reduced to zero. The figures given in the above two series do not accord with our expectation.

1144]

	Galv.	Reaction-time
(F) Series I. Average of associations altered in subsequent reproductions	4.3 mm.	4.0 sec.
Series I. Average of associations unchanged subsequently	4.4 mm.	1.2 sec.
Series II. Average of associations altered in subsequent reproductions	6 mm.	1.2 sec.
Series II. Average of associations unchanged subsequently	1.6 mm.	1.0 sec.

These figures are what we should expect.

1145]

(G) Average of distribution in Series I	5.5
Average of distribution in Series II	2.2
Average of distribution in Series III	1.6

1146] We find as usual the greatest variation in the figures in the first series. With lessening power of the stimulus in the repetitions, a levelling tendency is manifested as regards this variation in the power of the stimulus. The highest curves are found in the following associations:

	SERIES I			SERIES II			SERIES III	
	Galva- nometer	Reaction- time	Repro- duction	Galva- nometer	Reaction- time	Repro- duction	Galva- nometer	Reaction- time
ball/dance	4.3 mm.	4.0 sec.	o	7.5 mm.	1.6 sec.	ditto	12 mm.	0.8 sec.
dress/red	9.0 mm.	1.8 sec.	ditto	2. mm.	0.6 sec.	ditto	0 mm.	0.8 sec.
pretty/ugly	7.5 mm.	1.4 sec.	ditto	3. mm.	0.8 sec.	ditto	3 mm.	1.2 sec.

1147] The galvanic curves are much higher than the average in all three series for the association *ball / dance*. The intensity of the affect here is shown by the fact that while fifteen out of eighteen reactions in the last series caused no deviations of the galvanometer, this particular association induced a deflection of 12 mm. In this instance the subject expected to go in a few days to a fancy dress ball, but despite much search had not yet found a suitable costume. She was, therefore, in a state of anxiety concerning it. The association *dress* and *pretty* are self-evident.

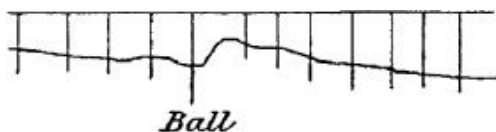

FIG. 19. Wood association *ball / dance* in Case 4

1148] The reaction-times were rapidly shortened in the repetitions, because of her natural aptitude in speech. It is evident that at times the galvanic phenomenon is more helpful than lengthened reaction-times in demonstrating emotional states.

1149] **Fig. 19** is a curve from Series III in this case representing the well-marked association *ball / dance*. Repetition of the association test is to be recommended when one desires to bring out more clearly very strong emotional complexes.

2. Resume of the Tests with Word Associations in Normal Individuals

1150] Our limited material, consisting of the word associations in one educated woman and three uneducated men, leads us to bring forward with much reserve a *résumé* of our results. We know that they must be regarded as only preliminary, and as being of questionable value, but at the same time they foreshadow features of interest for future enquiry and investigation. Our intention in this work is chiefly to point out indications, and our presentation of results must be taken in this sense.

1151] (1) The average positive difference of a galvanic curve, produced by an association whose reaction-time exceeds that of the probable average of the same series, is 2.7 mm.

1152] Taking into consideration the above-mentioned limitations this figure seems to express that in certain cases there is a clear parallelism between the length of reaction-time and the height of the galvanometer curve. This method appears, therefore, to afford a psychophysical proof of the hypothesis of one of us (Jung), that very long reaction-times are affective phenomena.

1153] (2) Altered reproductions show an average difference of 2 mm. over unchanged reproductions.

1154] (3) Such associations as are changed in the reproductions of the following series present an average difference of plus 6.8 mm. over such as are reproduced subsequently unchanged.

1155] These two figures, especially the last, seem to offer a psychophysical confirmation of the hypothesis of one of us (Jung), that altered reproductions are affective phenomena.

1156] The remaining methods embodied in the text of our work have little right to a special summing up here, because of the scantiness of our material, and also because of some contradictions in our results.

3. Word Associations in Dementia Praecox

1157] There were but two of our cases of paranoid dementia that could be used for a test of word associations with the galvanometer.

Case 1.—Male, aged. 36, very intelligent, academic education. Speech well preserved. Two series of associations, with twenty-four words each

1158]

(A) Series I. Arithmetical average of heights of galvanometer curve	11.6 mm.
Series II. Arithmetical average of heights of galvanometer curve	4.6 mm.
Series I. Probable average of the reaction-times	6.6 sec.
Series II. Probable average of the reaction-times	4.8 sec.

The average height of the galvanometer curves falls in both series within normal limits, which is not the case with the reaction-times showing excess. Our four normal subjects presented the following average:

Series I. Galvanometer curves 7.8 mm.	Reaction-times 1.8 sec.
Series II. Galvanometer curves 5.1 mm.	Reaction-times 1.4 sec.

From these figures it is seen that the patient offers a strong contrast in the length of the reaction-times.

1159]

	Galv.	Reaction-time
(B) The altered reproductions in Series II average	4.7 mm.	6.0 sec.
The unchanged reproductions in Series II average	3.4 mm.	2.8 sec.

These figures coincide with the normal, and are what we should expect. But we note that the unchanged reproductions present a much lower value in the reaction-time than the altered reproductions.

1160]

(C) The galvanometer curves with long reaction-times in Series I average	13.1 mm.
The galvanometer curves with short reaction-times in Series I average	10.3 mm.
The galvanometer curves with long reaction-times in Series II average	3.8 mm.
The galvanometer curves with short reaction-times in Series II average	4.0 mm.

In this table the figures in Series I, but not those in Series II, are what we expect.

1161]

(D) In Series II, 12.5 per cent of the associations show an average plus difference of 4.5 mm.

1162]

(E) Series I. Probable average of reaction-times following associations with unusually high galvanic curves	4.0 sec.
Series I. Arithmetical average of the corresponding galvanic curves	10.0 mm.
Series II. Probable average of reaction-times following associations with unusually high galvanic curves	7.6 sec.
Series II. Arithmetical average of the corresponding galvanic curves	3.2 mm.

In this table, only the reaction-time of Series II is in accordance with our expectation.

1163]

	Galv.	Reaction-time
(F) Series I. The associations with altered reproductions in the following series average	9.8 mm.	6.6 sec.
Series I. The associations with unchanged reproductions in the following series average	13.5 mm.	5.4 sec.

Only the reaction-time here is what we expect.

1164] (G) The average of distribution in Series I was 5.8. The average of distribution in Series II was 3.4. These figures are similar to those of Case 4 among the normal.

1165] The highest galvanic curve occurred with the reaction *love / a psychic process* (30 mm.), and here was also the longest reaction-time (27.2 sec.). The next highest curve was connected with the reaction *wife / marriage-law* (29 mm.). The patient is single, and having had with *love* a strong emotional tone, it was not surprising that *wife* should also evince a similar intensity. Another high curve was found in the association *sick / at-heart* (26 mm.). The patient still had some insight into his condition, and knew that he was confined in the asylum because of his mental malady, hence the strong emotion connected therewith. The word *handsome* produced a curve of 25 mm. The patient is very vain, and pays extraordinary attention to his dress. The contents of the association present the symptoms of affectation, which is evident from his external appearance. Most of his associations showed a definition character which, in educated people, always indicates a certain amount of affectation. The following are examples:

write	activity
shoes	footwear
hat	an article of clothing
house	building construction
to sit	condition of rest
money	medium of exchange
proud	adjective

1166] The long reaction-times may be due to this affected manner of expression, though this can hardly be the only cause.

Case 2.—Woman, single, aged 62, uneducated, medium intelligence. Speech mingled with neologisms. Three series of associations with twenty-five words each

1167]

(A) Series I. Arithmetical average of the galvanic curves	7.9 mm.
Series II. Arithmetical average of the galvanic curves	3.6 mm.
Series III. Arithmetical average of the galvanic curves	2.5 mm.
Series I. Probable average of reaction-times	10.8 sec.
Series II. Probable average of reaction-times	6.4 sec.
Series III. Probable average of reaction-times	6.0 sec.

As in the former case, the galvanic deviations are of medium height, while the reaction-times are extraordinarily long.

1168]

	Galv.	Reaction-time
(B) The altered reproductions in Series II average	3.6 mm.	6.6 sec.
The unchanged reproductions in Series II average	3.6 mm.	5.2 sec.
The altered reproductions in Series III average	2.5 mm.	7.4 sec.
The unchanged reproductions in Series III average	2.4 mm.	4.6 sec.

The reaction-times accord with our expectation, as in the former case, much better than the galvanometer curves.

1169]

(C) The galvanometer curves with long reaction-times in Series I average	9.6 mm.
--	---------

The galvanometer curves with short reaction-times in Series I average	6.0 mm.
The galvanometer curves with long reaction-times in Series II average	4.7 mm.
The galvanometer curves with short reaction-times in Series II average	2.6 mm.
The galvanometer curves with long reaction-times in Series III average	2.8 mm.
The galvanometer curves with short reaction-times in Series III average	2.5 mm.

The figures in all three series are what we expect.

1170]

(D) In Series II, 28.0 per cent of the associations show an average plus difference of 4.7 mm. In Series III, 24.0 per cent of the associations show an average plus difference of 4.8 mm.

1171]

(E) Series I. Probable average of reaction-times following associations with unusually high galvanic curves	11.6 sec.
Series I. Arithmetical average of corresponding galvanic curves	11.8 mm.
Series II. Probable average of reaction-times following associations with unusually high galvanic curves	5.8 sec.
Series II. Arithmetical average of corresponding galvanic curves	3.7 ram.
Series III. Probable average of reaction-times following associations with unusually high galvanic curves	8.0 sec.
Series III. Arithmetical average of corresponding galvanic curves	2.5 mm.

Twice the reaction-times are what we expected, the galvanic curves only once, and in Series III the arithmetical average is the same.

1172]

	Galv.	Reaction-time
(F) Series I. The associations with altered reproductions in the following series average	9.0 mm.	10.4 sec.
Series I. The associations with unchanged reproductions in the following series average	6.3 mm.	12.4 sec.
Series II. The associations with altered reproductions in the following series average	3.3 mm.	6.6 sec.
Series II. The associations with unchanged reproductions in the following series average	4.0 mm.	4.8 sec.

We find in this table that only the galvanic curves in Series I and the reaction-times in Series II are what we expected.

1173] (G) The average of distribution in Series I was 4.9.

The average of distribution in Series II was 2.8.

The average of distribution in Series III was 1.6.

1174] The highest galvanic curve (21 mm.) is found in the association *sun / sun-time*, and here the reaction-time is 14.0 seconds. It is difficult to explain this excessive deviation. The preceding association is *stout / constitution* (15 mm., and 14.8 seconds reaction-time). The patient is very stout, which she thinks due to supernatural influences. She complains much of this "forced" disfigurement. In Series II these two associations caused no deviations, but in Series III *stout / constitution* suddenly induced the largest deflection of the whole series, viz., 14.5 mm., whereas

the average was only 2.5 mm. There was a curve of 20 mm. with the association *ugly / disfigured by great suffering*, and with this a reaction-time of 12.0 seconds. The contents of this association are concerned with the same theme as *stout / constitution*. Another high curve occurred with *high / highest action* (19 mm. and reaction-time 11.2 seconds). This association was subsequently altered twice in the reproductions. It is connected with the delusion of the patient that she had accomplished the “highest work.”

1175] The associations are typically affected and show a distinctly morbid character. The following are examples:

diligent	high esteem—payment
love	to be lovable—wedding
snake	to point out as extraordinary
high	highest action—highest distinction
ugly	disfigured by great suffering

1176] *Résumé*: In our tests with word associations in the two cases of dementia praecox the only striking fact has been the great lengthening of reaction-times. In the relations between the galvanometer curves and associations we have found nothing different from the normal. From the material of Jung, who has analyzed a large collection of association experiments in dementia praecox, we learn that in by far the greater proportion of these cases there is no particular lengthening of reaction-time. Therefore a long reaction-time cannot be considered as characteristic for all cases of dementia praecox. It is of value in some cases. It is only present when the patients suffer from certain hindrances to thought, which are often present in this disease.

1177] When we examine the associations of such patients we find that the hindrance to thought (lengthened reaction-time) is especially manifested where complexes constellate the association, which is also the case in normal individuals. This phenomenon first led Jung to think that the specific pathological factor in dementia praecox depends upon some complex. A complex in fact plays a great role in the associations of our two patients here described. The reaction-times are extraordinarily long where connected with a complex. The complex constellations are also very numerous, as well as the altered reproductions related to them. In our normal cases we found an average of 30 per cent of altered reproductions in Series I, while the patients had 51 per cent. Besides this, the character of the associations presents abnormalities almost constantly, especially around the complexes.

1178] From these indications we may conclude that little of a pathological nature can be found in the general and regular mechanisms of thought, but rather in the manner and method of reaction of the individual to his complexes. We find in both of these patients an increased influence of the complex upon association, which corroborates the results of innumerable analyses of dementia praecox by Jung. This phenomenon has an important and general clinical significance, because, when carefully analyzed, nearly all the symptoms are found to be determined by an individual complex, often manifested in a very convincing way. This is particularly true for delusions and hallucinations. A series of other symptoms is more often dependent upon indirect disturbance of association by the complex. This state of affairs explains why we do not discover any elementary disturbances, even in quite intense mental disorder; the dementia is shown only in the most

delicate psychological relations. Therefore we shall look in vain, for the present and for a long time to come, among these patients for simple, elementary disturbances common to all cases.

1179] NOTE. —Since this article was put into type we have found that Féré,²³ carrying a current through a subject with various sensory stimuli, made the following observation: “Il se produit alors une déviation brusque de l’aiguille du galvanomètre.... La même déviation se produit encore sous l’influence d’émotions éthéniques; c’est à dire qu’elle se produit dans toutes les conditions où j’ai signalé précédemment une augmentation de volume des membres mise en évidence par le pléthysmograph.” This clearly shows that Féré made the discovery two years before Tarchanoff.

FURTHER INVESTIGATIONS ON THE GALVANIC PHENOMENON AND RESPIRATION IN NORMAL AND INSANE INDIVIDUALS¹

by Charles Ricksher and C. G. Jung

1180] The changes produced by various causes in the electrical resistance of the human body have been studied for many years, but as yet no definite results have been reached. Charles Féré was the first to report on the changes produced by emotion. In a communication made to the Société de Biologie in 1888² he noted that there was a decrease in bodily resistance when various sensory stimuli were applied, and also that emotion produced a similar decrease. R. Vigouroux had been working on the problem of electrical resistance in the human body with patients from the Salpêtrière and had reached the conclusion that the old view of resistance being caused by the epidermis was wrong and that the true cause was the condition of the superficial circulation. He thought that variations in resistance were caused by an increased or decreased superficial circulation. Féré accepted these conclusions and added that “l'étude de la résistance électrique peut trouver une application dans les recherches des psycho-physiologues.”

1181] Nothing new was reported for several years. In 1890, A. Vigouroux published a report on the study of electrical resistance in melancholics but added nothing to our knowledge. Tarchanoff, Stricher, Sommer, and Veraguth have all summarized the work of the French investigators. The first person to do real psychological research using the galvanometer was Veraguth, who in 1906 worked with this instrument and with Jung's association experiments. In the same year work was begun in the Psychiatric Clinic in Zurich to try to determine the cause of electrical resistance of the body and the changes produced in the bodies of normal and insane individuals by different stimuli. The apparatus used consisted of a circuit containing a single low-voltage element, a Deprez-d'Arsonval galvanometer of high sensitivity, a shunt for lowering the oscillations of the mirror, and two brass plates upon which the subject of the test places his hands and thus closes the circuit. The galvanometer reflects a beam of light onto a celluloid scale to which is attached a movable slide with a visor, which, pushed by hand, follows the moving mirror-reflection. To the slide is attached a cord leading to what is called an ergograph writer, which marks the movements of the slide by means of a pen-point on a kymograph-drum fitted with endless paper. For measuring time a Jaquet chronograph was used and for the moment of stimulus an ordinary electrical marker.

1182] The problem of the cause of resistance was first approached; the results given are those obtained by Jung and Binswanger and are as yet unpublished. Resistance was found to vary greatly in different individuals with different conditions of the palmar epithelium. That the epidermis was the seat of resistance was proved by the fact that when the electrodes were placed under the skin resistance was enormously decreased. This was done by piercing the skin of each arm with a surgical needle and using the needles as electrodes.³

1183] The French investigators were unanimous in ascribing the changes in resistance to changes in the blood supply of an area, caused by dilation and contraction of the vessels, the greater the blood supply the lower the resistance and vice versa. That the blood supply was not a chief factor

was proved by exsanguinating the area in contact with the plates with an Esmarch bandage, whereupon it was found that the galvanic phenomenon still appeared.

1184] That the changes in resistance are not due to changes in contact, such as pressure on the electrodes, is shown by the fact that when the hands are immersed in water, which acts as a connection to the electrodes, the changes in resistance still occur. Pressure and involuntary movements give a deflection entirely different from the usual result of an affective stimulus.

1185] The time that elapsed between a stimulus and the change in resistance, as shown by the galvanometer, suggested some change in the sympathetic nervous system or in some area controlled by it. The sweat-glands seemed to have most influence in the reduction of resistance. If the sweat-glands were stimulated there would be thousands of liquid connections between the electrodes and tissues, and resistance would be much lowered. Experiments were made by placing electrodes on different parts of the body, and it was found that the reduction in resistance was most marked in those places where most sweat-glands are located. It is well known that both emotion and sensory stimuli influence the various organs and glands, heart, lungs, sweat-glands, etc. Heat and cold also influence the phenomenon, heat causing a reduction and cold an increase in resistance. In view of these facts the action of the sweat-glands seems to be the most plausible explanation of the changes in resistance.

1186] The following experiments were made in the winter and spring of 1907, with a view to determining the effect on the galvanic phenomenon and respiration of a series of simple physical and mental stimuli in a number of normal and insane subjects. The galvanometric changes were noted by the apparatus described above. The respiration was recorded by means of a Marey pneumograph attached to the thorax and leading by means of a rubber tube to a Marey tambour, to which is attached a pen-point that writes on the kymograph-drum.

1187] The results of pneumographic experiments of various authors are very conflicting. Delabarre⁴ found that attention to sensory impressions increased the frequency and depth of respiration. Mosso, in his work on the circulation in the brain, could come to no satisfactory conclusions. Mentz found that every noticeable acoustic stimulus caused a slowing of the respiration and pulse. Zoneff and Meumann found that high grades of attention cause a very great or total inhibition of respiration, while relatively weaker attention generally produces an increase in the rate and a decrease in the amplitude of the respirations. Total arrest of respiration was found relatively more frequently in sensory than in intellectual attention. Martius notes great individual differences and comes to the conclusion that there is an affect type differing from the normal, shown by slowness of the pulse and respiration.

1188] The experiments of these authors were all made on a limited number of subjects, usually students. Our experiments with the pneumograph were generally made on uneducated men, attendants in the clinic, and our stimuli were quite different from those used by the other investigators. It is possible that the great difference in our results may in part depend on these facts.

1189] In our experiments care was taken to have the conditions as nearly equal as possible. It was found that different positions of the body, leaning forward or backward, for example, caused a change in the level of the respiratory curves. Slight movements of the body and of the limbs did not influence the curves. The tambour itself can cause changes in the recorded curves. The

tambour must contain the same amount of air in every case, otherwise the curves will be different. The curve registered is not an exact one, owing to defects in the instruments. In deep inspirations the rubber covering becomes tense and, when the pressure in the chest changes, the elasticity of the rubber causes the respirations to be registered in a different way from that in which they really occur.

1190] It cannot be assumed that the respiratory curves represent ordinary normal respiration but only the kind of normal respiration to be expected under experimental conditions. No one can breathe naturally with a recording apparatus on his chest and with his attention more or less directed to it. The release from the tension of the experiment is seen at the end of the experiment when the respirations become deeper and the level of the curve changes. The pneumograph could not be used on women because of their clothing, nor could it be used with many of the insane subjects because of their excitability.

1191] The plethysmograph was not used because with it the sources of error are too numerous. Martius has shown that, even when the arm and instrument are encased in plaster of Paris, there occur involuntary movements that make correct interpretation of the results difficult.

1192] In the galvanic experiment many sources of error have to be considered. Chief among these is the deflection caused by movements of the hands. An increase or decrease in the pressure of the hands upon the electrodes causes an instantaneous change in the position of the reflection of the galvanic mirror. This change is sudden, and it is almost impossible to produce deliberately a change in the position of the reflection like one caused by an affective mental process. The natural change of position of the hands is shown by an almost vertical rise or fall of the galvanic curve as shown on the kymograph-drum. To prevent, as far as possible, involuntary changes of position, bags of sand were placed on the hands, thus preventing any but deliberate movements. It was found that quite extensive movements of the body could be made without influencing the galvanometric curve. Deep inspirations and sighs cause a greater or lesser rise in the curve. In the same curve a sigh occurring after an affective process seems to cause a more extensive rise than one occurring before. Deliberate long inspirations cause little or no disturbance. It must therefore be assumed that sighs are caused by some affective complex, or that they cause such a complex to come into consciousness or they produce an unconscious emotional condition.

1193] The subjects were physicians and attendants, as well as patients suffering from various mental diseases.

1194] The experiment may be divided into six parts: in each part a different stimulus or series of stimuli of the same kind, physical or psychological, was used. Before each stimulus or series of stimuli the subject was told in a general way what was going to happen. In many individuals, after a short period of waiting for a stimulus, there were changes in respiration and in the galvanic curve. These expectation-curves will be discussed later.

1195] The measurements of height are in each case the real, i.e., the vertical height. The respiratory rate is given as so many per centimetre, which is a purely comparative measurement. For the quiet periods we give the average rate per centimetre for ten centimetres at the beginning and end of each period.

1196] [Part I](#) of the experiment consists of a quiet period of four minutes. The subject was asked to sit as quietly as possible and was told that no stimulus was going to be applied. In [Part II](#), the

stimulus was a leaden weight allowed to fall about three feet onto the floor. In Part III, the subject was asked to say spontaneously, after a minute or so, a word or a short sentence, and then to remain quiet. Part IV consists of three physical stimuli: a low whistle, a weight dropped onto the floor, and a picture (picture post-card) shown to the subject. Part V consists of four sentences spoken by the investigator. The first two were usually some familiar proverb, such as "The pitcher goes often to the well but is broken at last"; the third and fourth were of a more critical nature as they referred directly to the subject himself or to his habits. In several cases single words, such as *eye* and *face*, were given. Part VI is again a quiet period of four minutes. The results of each part will be given here, and the normal subjects, fifteen in number, will be considered first.

NORMAL SUBJECTS

- 1197] *Part I.* The galvanometric curve is usually higher at the beginning than it becomes a short time later owing to feelings of expectation and tension caused by the unusual position and the strange experiment. As a rule the curve shows many irregularities caused by the subject's hand and body movements as he settles into a comfortable position; such movements are also the result of expectation, muscular tension (this is not, however, an important factor), and of various emotionally charged complexes. In the course of the quiet period there are seen oscillations of the galvanic mirror that cannot be accounted for by any movement of the hands or body, by any respiratory change, or any conscious thought or association. We have therefore attributed them to the indefinite *feeling* caused by some still unconscious complex. Everyone has experienced these vague feelings, sad or gay, that come without apparent cause, last only a short time, and are soon forgotten. Such a curve was clearly shown in the case of a well-educated physician, with a considerable power of self-analysis, who could not remember any affective thought that had occurred to him during the period.
- 1198] The inspirations at the beginning of the quiet period are usually deeper and more frequent than at the end. At the beginning they average 2.91 per cm. and at the end 2.79 per cm. The average height of the inspirations at the beginning is 12.41 mm., at the end 12.26 mm. In our cases the respiratory curve does not show any great or constant change of level.
- 1199] In *Part II* (stimulus a falling weight) the galvanometric curves show great individual differences. In one case, that of an attendant who was very nervous and frightened by the experiment, the galvanometric deflection was 54 mm. In another case, also of an attendant, but of a very phlegmatic disposition, the deflection was only 4.6 mm. The average deflection for fifteen subjects was 20.6 mm.
- 1200] The longest reaction-time, i.e., the time from the moment of stimulus to the beginning of the rise of the galvanic curve, varies from 1.5 to 5.5 seconds. This time, while showing individual variations, is usually shorter in cases showing the greatest galvanic reactions, and averages 2.87 seconds. The time required for the curve to reach its maximum height corresponds roughly to the height, a curve of 54 mm. requiring 11.5 seconds and one of 10 mm. requiring 2.5 seconds. The average time is 6.93 seconds.
- 1201] The inspirations show individual differences in rate and amplitude, and the respiratory rate does not vary as much as the height of the galvanometric curve, as the following table shows:

<i>Height of Galv. Curve</i>	<i>Inspir. before Stim.</i>	<i>Rise of Galv. Curve</i>	<i>Fall of Galv. Curve</i>
54. mm.	3.5 per cm.	3.86 per cm.	3.92 per cm.
18.8 mm.	3. per cm.	2.72 per cm.	2.5 per cm.
4.6 mm.	3. per cm.	2.5 per cm.	2.3 per cm.

1202] Thus the change in rate for a galvanic curve of 54 mm. is not as great as for a curve of 4.6 mm. Whether the respiration is slowed down or speeded up during the rise of the galvanic curve seems to depend on the individual. The majority, however, show a decrease of speed during the rise and an increase during the fall of the galvanic curve.

1203] The average number of inspirations before the stimulus is 3.05 per cm., during the rise of the galvanic curve 3.02 cm., and during the fall 3.09 per cm.

1204] The amplitude of the inspirations does not vary in proportion to the rate. Before the stimulus the average height of the inspirations is 11.75 mm., during the rise of the galvanic curve 10.73 mm., and during the fall of the curve 11.45 mm.

1205] *Part III* (spontaneous speaking). In this part the average height of the galvanic curve is lower than in the preceding part, being 17.9 mm. As a rule the curves of the different subjects show little variation in height. Some of the curves show irregularities before the moment of speaking, caused partly by indecision and partly by preparation for speaking. In normal subjects the galvanic curve begins to rise at the moment of speaking or even a little before.

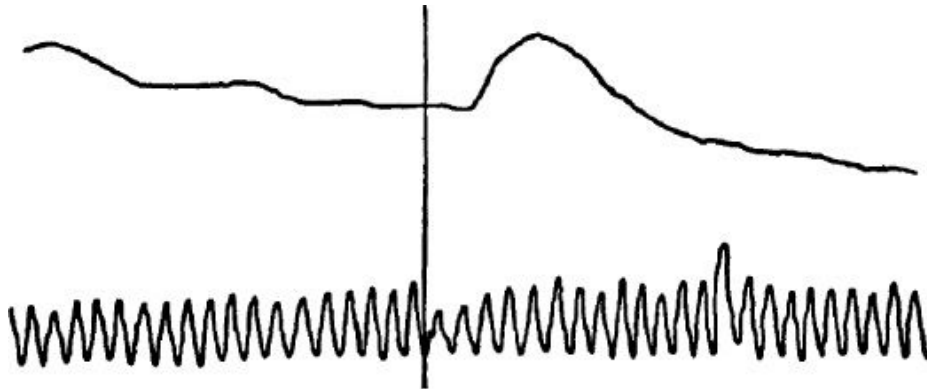

FIG. 1. *Stimulus a falling weight.* Resistance was very high at the beginning of the experiment and fell throughout the quiet period and up to the moment of stimulation, as shown by the vertical line. The latency time and the decrease in rate and amplitude of respirations are clearly shown

1206] *The* number of inspirations per centimetre decreases during the rise of the galvanic curve and continues to decrease as the curve falls. The average rate before speaking is 3.5 per cm., during the rise of the galvanic curve 3.15 per cm., and during the fall 3.04 per cm. The average height of the inspirations before speaking is 10.08 mm., during the rise of the curve 10.57 mm., and during the fall 11.75 mm. Thus the height increases as the rate decreases.

1207] In *Part IV* there are three stimuli: a falling weight, a whistle, and a picture. In each case the stimulus is not merely a sensory, visual, or auditory one, but has also a psychological component. Almost every stimulus, when perceived or received into consciousness, is associated with affective complexes. A low whistle is heard not only as a sound but also as a call, and is associated with many past experiences; a picture calls up many other associations. Naturally the personal equation comes into play here to a very great extent.

1208] The measurements are:

	Weight	Whistle	Picture
Height of curve	17.94 mm.	18.2 mm.	19.72 mm.
Latency time	2.55 sec.	2.82 sec.	3.03 sec.
Time to reach top of curve ⁵	6.95 sec.	9.88 sec.	7.47 sec.

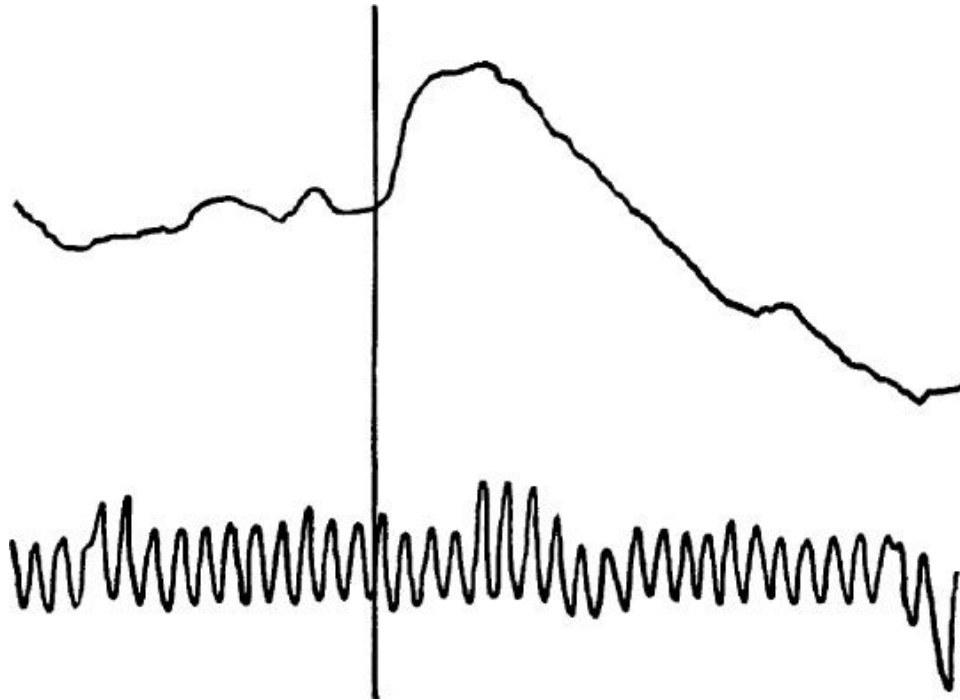

FIG. 2. *Spontaneous speaking*. The vertical line indicates the moment of speaking. The irregularities before speaking are clearly shown in the galvanometric curve. In the respiratory curve the decrease in amplitude during the rise of the galvanometric curve is clearly shown

In these cases the latency time increases with the height of the galvanometric curve. The time for the curve to reach its maximum varies in the different cases.

1209] In every case the respiratory rate increases during the rise of the galvanic curve; in one case it decreases and in two increases during the fall. The amplitude of the respirations varies in the same way, being lower during the rise and increasing in height as the affect passes off. Expressed in tabulated form, the measurements are:

	Inspirations per cm.			Height in mm.		
	Weight	Whistle	Picture	Weight	Whistle	Picture
Before stimulus	3.01	2.75	2.88	12.02	12.05	12.46
Rise of curve	3.33	2.77	3.02	10.56	11.35	10.90
Fall of curve ⁶	2.76	3.06	3.09	12.32	12.13	11.33

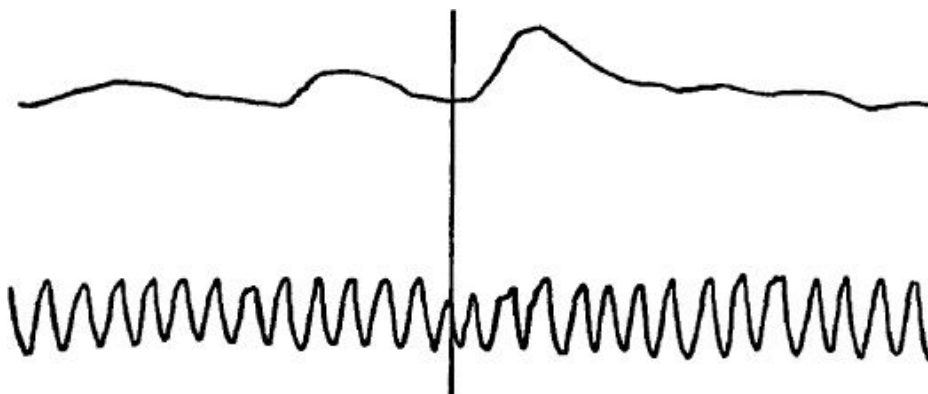

FIG. 3. *Stimulus a whistle*. A small expectation curve, before the movement of stimulus, is shown. The latency period, and the changes in the respiratory rate and amplitude, are clearly shown

1210] *Part V*. Four short sentences or words were used as stimuli. The sentences were spoken by the investigator, and time was allowed between each for the galvanic curve to return to its lowest level. The measurements are:

	<i>Sen. 1</i>	<i>Sen. 2</i>	<i>Sen. 3</i>	<i>Sen. 4</i>
Height	14.62 mm.	14.48 mm.	19.42 mm.	11.12 mm.
Latency	3.32 sec.	3.1 sec.	2.83 sec.	3.15 sec.
Time to top	8.13 sec.	5.82 sec.	7.67 sec.	5.95 sec.

As can be seen from the table, the height of the galvanic curve gradually decreases in the second and fourth sentences, while the curve of the third sentence is higher. The gradual decrease in the height of the galvanic curve is to be expected and can be explained by the gradual fading out of the affect. The first two sentences were trite, but the third usually referred to the subject or could be referred by him to himself, hence the stronger innervation and the increase in the height of the galvanic curve.

1211] The latency time and the time required for the curve to reach its maximum height bear no constant relation to the height of the galvanic curve.

1212] The respiratory curves vary greatly for the different sentences. In response to two sentences the respiratory rate decreases and in two it increases during the rise of the galvanic curve. The amplitude of the inspirations is always lower while the galvanic curve is rising and while the affect is acting, and slowly increases as the affect wears off, as the following table shows:

	<i>Inspirations per cm.</i>				<i>Height in mm.</i>			
	<i>Sen. 1</i>	<i>Sen. 2</i>	<i>Sen. 3</i>	<i>Sen. 4</i>	<i>Sen. 1</i>	<i>Sen. 2</i>	<i>Sen. 3</i>	<i>Sen. 4</i>
Before	2.84	2.97	2.71	3.05	12.85	12.59	13.74	12.23
Rise	3.04	2.78	2.57	3.41	11.63	11.27	12.81	11.76
Fall	3.09	2.74	3.13	3.46	12.13	11.98	13.38	13.07

1213] *Part VI* is a second quiet period of four minutes. As a general rule this part shows fewer irregularities than the first, because the subject has become accustomed to the experiment and is comfortably settled in his place. One marked feature of this part is the change of level of the respiratory curve as soon as the subject is told that the experiment is over and he is released from the involuntary tension in which he has been held.

1214] The respiratory rate is slower than in the first quiet period. At the beginning the inspirations are 2.41 per cm. as compared to 2.91 per cm. in the first curve. At the end they are 2.71 per cm. as compared to 2.79 per cm. in the first curve. The height of the inspirations is 12.57 mm. at the beginning as compared to 12.41 in the first curve, and 12.17 mm. at the end as compared to 12.26 mm. in the first curve.

1215] What we have designated expectation curves are changes in the galvanic curve that occur while the subject is waiting for the stimulus. Naturally they vary according to the individual. Some of our subjects showed no trace of an expectation curve, whereas in others we found quite marked expectation curves. These curves are more frequent in the early part of the experiment

and are especially marked in [Part II](#) while the subject is waiting for the fall of the weight. In height they vary with the reactions to the stimuli but are nearly always lower than these.

1216] The average height of expectation curves is 15.70 mm. This high average is due to the fact that a subject who has an intense galvanic reaction to a stimulus will have many and strong expectation curves. The time required for the curve to reach its maximum averages 10 seconds; to fall to the former level, 12 seconds.

1217] The inspirations from the beginning to the top of the curve average 3.06 per cm.; during the fall they average 3.3 per cm. The average respiratory amplitude during the rise is 10.18 mm.; during the fall, 10.56 mm.

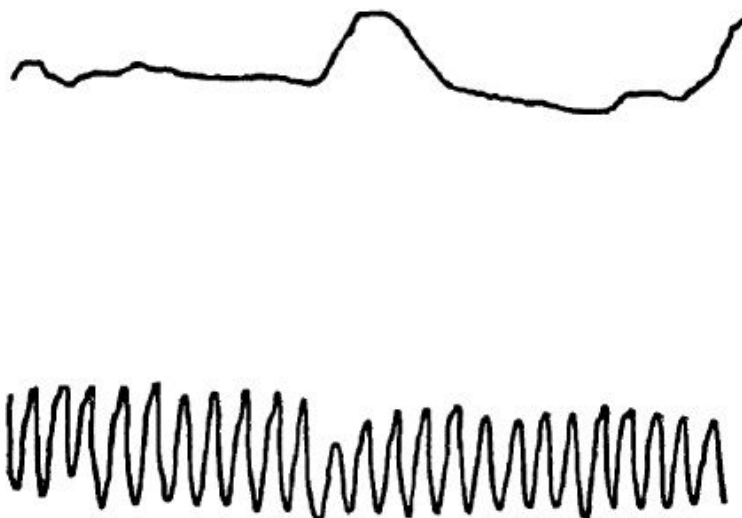

FIG. 4. *Expectation curve*. Showing changes in electrical resistance and respiration due to anticipatory attention

1218] That there are great individual differences in the galvanic reactions will be seen from the average of distribution of the various averages, expressed as a coefficient obtained by taking the average of the sum of the differences between each figure and the average of all the figures.

Part II: weight	8.09
Part IV: weight	8.71
whistle	2.75
picture	6.64
Part V: sentence 1	4.7
sentence 2	4.42
sentence 3	7.63
sentence 4	3.98

1219] This coefficient shows, when large, that there is a great diversity in the numbers of which an average is taken; when low, that the numbers are nearly equal. Two of our subjects had extremely high galvanic curves, and therefore the average and coefficient are greater than they would have been had these two cases been omitted. On this account, our averages are probably higher than those of other observers.

1220] The pneumographic results are interesting because they differ from those obtained by other investigators and because they show a different relation between the rate and amplitude from what one would expect.

1221] The following table shows the averages of all the averages of respiratory rate and amplitude and the average of distribution of each.

	<i>Inspir. per cm.</i>	<i>Coefficient</i>	<i>Height in mm.</i>	<i>Coefficient</i>
Before	2.94	0.16	12.19	0.62
Rise	2.97	0.19	11.28	0.50
Fall	3.11	0.13	12.19	0.47

1222] It can be seen that the respiratory rate increases from the moment of stimulus while the amplitude decreases during the action of the affect and increases when it passes away. The coefficients in all cases are low and show that the numbers of which an average was taken are about equal.

1223] The relation between the respiratory rate and amplitude during the rise and fall of the galvanic curve and the high and low galvanic reactions is interesting. These relations were obtained by taking the averages of the sums of the respiratory rates and amplitudes of the high and low reactions of each individual before and after the stimulus. They are:

During rise	$\left\{ \begin{array}{l} \text{high} \\ \text{low} \end{array} \right.$	$\left. \begin{array}{l} \text{rate} \\ \text{amplitude} \end{array} \right\}$	decrease 0.05 per cm.
			decrease 1.17 per mm.
			decrease 0.06 per cm.
			decrease 1.06 per mm.

1224] Thus during the rise the decrease in rate is practically the same in both high and low reactions but the decrease in amplitude is greater in the higher reactions.

During fall	$\left\{ \begin{array}{l} \text{high} \\ \text{low} \end{array} \right.$	$\left. \begin{array}{l} \text{rate} \\ \text{amplitude} \end{array} \right\}$	decrease 0.066 per cm.
			increase 1.601 mm.
			decrease 0.001 per cm.
			increase 0.819 mm.

1225] During the fall of the galvanic curve the rate decreases more in the greater than in the lesser reactions, while the amplitude also increases more in the greater than in the lesser reactions.

1226] During the rise of the curve it is probable that part of the bodily innervation is expended on the various affective muscular tensions, etc., and consequently the more the individual reacts with other innervations the less will be expended on the respiration. This would explain the decrease in rate and amplitude in the greater reactions. During the fall of the galvanic curve more innervation is probably concentrated again on the respiration but chiefly on the depth; the rate decreases in some of the greater reactions.

1227] The relations of the rate and amplitude before and after the reaction show that there is an increase in the rate and amplitude after high reactions and a decrease in the rate and increase in the amplitude after low reactions.

1228] The following table was obtained by comparing the rate and amplitude before stimulus with the rate and amplitude during the rise of the galvanic curve, and the rate and amplitude during the fall of the galvanic curve with those occurring during the rise of the galvanic curve.

Before stimulus	$\left\{ \begin{array}{l} \text{high} \\ \text{low} \end{array} \right.$	$\left. \begin{array}{l} \text{rate} \\ \text{amplitude} \end{array} \right\}$	increase 0.156 per cm.
			increase 0.213 mm.
After reaction	$\left\{ \begin{array}{l} \text{high} \\ \text{low} \end{array} \right.$	$\left. \begin{array}{l} \text{rate} \\ \text{amplitude} \end{array} \right\}$	decrease 0.091 per cm.
			increase 0.093 mm.

This table shows that the differences in respiratory changes are much greater in cases of higher galvanic reactions.

1229] So far as could be determined there was no regular relation between the height of the galvanic reactions and the individual bodily resistance at the beginning of the experiment.

ABNORMAL SUBJECTS

1230] These subjects were patients suffering from epilepsy, dementia praecox, general paralysis, chronic alcoholism, and alcoholic dementia and senile dementia.

1231] The conditions of the experiment were exactly the same as in the case of normal subjects except that in many cases the pneumograph could not be used.

Epilepsy

1232] There were nine subjects in this group, the majority being seriously demented. Among these were included one case of traumatic epilepsy with congenital imbecility and one case of epilepsy with hysteria. One subject was examined immediately after an attack of *petit mal*. In this case the reactions to ordinary stimuli were slight or nil, but when the patient was threatened with a needle there was a galvanometric deflection of 20 mm. This change was very slow and the curve remained high for several minutes. The threat of a prick of a needle is a very strong stimulus and causes reactions in nearly every case where dementia is not marked. In this case the whistle produced a fluctuation of 4 mm. and the weight one of 2.8 mm. The other stimuli were without effect. The latency time for the whistle was 5 seconds and for the needle 15 seconds. It required 21 seconds for the curve produced by the needle to reach its maximum.

1233] In this group the differences between the reactions to physical and to psychological stimuli are more marked than in normal subjects. In all cases the quiet period shows little change. Only one subject shows what could be considered an expectation curve.

1234] Five subjects reacted to the falling weight, [Part II](#). The reactions vary from 3.2 mm. to 35.6 mm. The greatest reaction was in the case of epilepsy and hysteria. The three cases not reacting were severely demented. The averages for the cases reacting are:

Height	7.5 mm.
Latency	2.25 sec.
Time to top	6.00 sec.

1235] The pneumographic measurements are:

	<i>Inspirations per cm.</i>	<i>Average height in mm.</i>
Before	2.6	12.28
Rise	2.6	9.73
Fall	2.71	10.81

1236] The galvanometric reaction is only about one-third as high as the normal. The pneumographic measurements are almost the same as those of the normal cases.

1237] Spontaneous speaking (Part III) could only be tried in three cases. In these cases there was a latency time averaging 2 seconds, in contrast to the normal cases where the curve begins to rise at the moment of speaking. The measurements for the three cases are:

Height	14.66 mm.
Latency	2.0 sec.
Time to top	5.5 sec.

1238] These measurements are lower than in normal subjects. The pneumographic results are:

	<i>Inspirations per cm.</i>	<i>Average height in mm.</i>
Before	3.5	10.92
Rise	3.3	11.52
Fall	2.9	13.62

In normal cases the amplitude decreases from the moment of stimulus; here it increases.

1239] Part IV, three physical stimuli, weight, whistle, and picture, failed to cause any reaction in three demented cases.

1240] The measurements for five cases are:

	<i>Weight</i>	<i>Whistle</i>	<i>Picture</i>
Height	26.6 mm.	23.6 mm.	15.4 mm.
Latency	2.3 sec.	3.5 sec.	2.83 sec.
Time to top	6.6 sec.	6.75 sec.	5.3 sec.

1241] In the normal cases the greatest reaction was to the picture. The weight, the stimulus calling up the fewest associations, caused the smallest reaction. The pneumographic measurements in three cases are as follows:

	<i>Inspirations per cm.</i>			<i>Average height in mm.</i>		
	<i>Weight</i>	<i>Whistle</i>	<i>Picture</i>	<i>Weight</i>	<i>Whistle</i>	<i>Picture</i>
Before	2.8	3.0	2.7	8.05	8.23	8.34
Rise	2.5	2.96	3.6	7.1	9.37	6.51
Fall	3.11	3.1	2.9	6.74	8.38	8.03

1242] In the normal cases the height is always less during the rise of the galvanic curve, here it varies very much.

1243] Part V, sentences, caused comparatively slight reactions in all cases. In four demented cases there were no reactions. The measurements for four cases are:

	<i>Sen. 1</i>	<i>Sen. 2</i>	<i>Sen. 3</i>	<i>Sen. 4</i>
Height	13.4 mm.	7.8 mm.	4.5 mm.	4.5 mm
Latency	3.0 sec.	3.3 sec.	5.0 sec.	3.0 sec.
Time to top	3.6 sec.	5.0 sec.	5.0 sec.	2.0 sec.

1244] The reactions decrease in intensity from the first to the third sentence. The pneumographic curves give the following measurements:

	<i>Inspirations per cm.</i>			
	<i>Sen. 1</i>	<i>Sen. 2</i>	<i>Sen. 3</i>	<i>Sen. 4</i>
Before	3.5	3.0	3.0	4.0
Rise	4.0	3.0	3.0	3.0
Fall	3.1	3.3	3.3	2.5
	<i>Average height in mm.</i>			
	<i>Sen. 1</i>	<i>Sen. 2</i>	<i>Sen. 3</i>	<i>Sen. 4</i>

Before	7.2	6.7	5.6	7.0
Rise	6.1	7.5	6.0	5.5
Fall	6.8	6.0	6.6	5.5

1245] Part VI, the second quiet period, shows nothing.

1246] In all these cases of varying degrees of dementia the galvanic fluctuations were in direct relation to the degree of mental dullness, seriously demented cases having little or no reaction. In such seriously demented cases the reactions are similar to those of the subject cited above, tested after an attack of *petit mal*: only those stimuli tending to cause pain are reacted to. The problem of this phenomenon is entirely a question of lack of associations.

Dementia Praecox

1247] The cases in this group were in various stages of the disease. The reactions therefore vary considerably. Each form of the disease will be discussed separately.

Catatonia

1248] There were eleven cases of catatonia varying from those in complete stupor to those in a convalescent condition. Our results are high because one convalescent gave reactions that were those of a normal person. Cases in a condition of stupor give practically no reaction to ordinary stimuli; for cases in a depressive state the reaction is also less marked.

1249] The curve for the quiet period varies according to the condition of the subject. In patients who are actively hallucinated it is very often quite irregular; in patients in a stuporous condition it is very nearly a straight line.

1250] The pneumograph was not used.

1251] Part II (falling weight) caused a reaction in almost every case, the reaction varying from 1.8 mm. in a very depressed patient to 6 mm. in a patient with active hallucinations and 43.2 mm. in a convalescent. The average deflection for eleven cases was 6.8 mm.

1252] Part III (spontaneous speaking) was not possible with these subjects.

1253] Part IV (three physical stimuli) caused various reactions, as in normal cases. In five cases of patients in a stuporous, depressed condition, the whistle caused no reaction.

1254] The weight caused a deflection of 6.3 mm., the whistle 2.4 mm., and the picture 3.9 mm. As in the groups of epileptics the weight caused the greatest reactions.

1255] Part IV (four sentences) in every case gave smaller reactions than the physical stimuli. The subject who reacted to the weight with 43.2 mm. reacted to the sentences with a deflection of from 6 to 14 mm. The averages for the four sentences are:

Sentence 1	2.01 mm.
Sentence 2	2.3 mm.
Sentence 3	2.6 mm.
Sentence 4	1.9 mm.

1256] The second quiet period curve shows nothing.

Hebephrenia

- 1257] There were eleven subjects suffering from this form of the disease. The measurements, while not markedly different from those of the former group, are quite different from the normal.
- 1258] As in the former group, the quiet curve is irregular whenever the patient has marked hallucinations.
- 1259] The weight ([Part II](#)) caused a weaker reaction than in the former group, the average deflection being 5 mm.
- 1260] Spontaneous speaking ([Part III](#)) in four cases gave an average deflection of 2.6 mm.
- 1261] The three physical stimuli ([Part IV](#)) caused the following reactions: weight, 6.8 mm.; whistle, 3.5 mm.; picture, 4.4 mm. As in the former groups, the weight caused the greatest reaction.
- 1262] [Part V](#) (sentences) caused a greater reaction here than in the former group but a much smaller average reaction than the physical stimuli. The measurements are:

Sentence 1	2.6 mm.
Sentence 2	1.3 mm.
Sentence 3	3.8 mm.
Sentence 4	4.2 mm.

Paranoid Group

- 1263] There are four subjects in this group, one in an early stage, two somewhat demented, and one seriously demented. The latter reacted to none of the stimuli. The pneumograph was used in two cases.
- 1264] The quiet period is almost that of a normal subject.
- 1265] [Part II](#) (falling weight) called forth weaker reactions than those in the two preceding groups, the average being 4.8 mm. The latency time averages 3 sec. and the time required for the curve to reach its maximum 7 sec. The rise and fall of these curves is much slower than in the normal cases. The pneumographic measurements of two cases are:

	<i>Inspirations per cm.</i>	<i>Average height in mm.</i>
Before	2.5	13.1
Rise	2.94	8.1
Fall	2.63	11.8

These are very close to the measurements obtained in the normal cases.

- 1266] [Part III](#) (spontaneous speaking) was tried in two cases, giving an average deflection of 4.6 mm. The pneumographic measurements are those of the normal cases:

	<i>Inspirations per cm.</i>	<i>Average height in mm</i>
Before	3.2	11.78
Rise	2.92	9.2
Fall	2.52	10.76

- 1267] [Part IV](#) (three physical stimuli) gives measurements similar to those of the normal subjects in that the reaction to the picture is the greatest. The measurements are:

<i>Weight</i>	<i>Whistle</i>	<i>Picture</i>
---------------	----------------	----------------

Height	5.8 mm.	5.4 mm.	7.0 mm.
Latency	2.5 sec.	2.0 sec.	2.0 sec.
Time to top	6.0 sec.	6.0 sec.	5.5 sec.

1268] The pneumographic measurements for the depth of inspirations are about those of a normal subject. The rate varies in every case, apparently quite freely.

	<i>Inspirations per cm.</i>			<i>Average height in mm.</i>		
	<i>Weight</i>	<i>Whistle</i>	<i>Picture</i>	<i>Weight</i>	<i>Whistle</i>	<i>Picture</i>
Before	3.0	2.7	3.0	11.90	11.61	16.91
Rise	2.78	3.2	4.0	9.32	9.50	11.25
Fall	2.95	3.16	2.91	12.54	11.53	11.31

1269] Part V. The reactions to the sentences are but little higher than those in the other forms of dementia praecox. The measurements are:

	<i>Sen. 1</i>	<i>Sen. 2</i>	<i>Sen. 3</i>	<i>Sen. 4</i>
Height	5.2 mm.	3.2 mm.	2.6 mm.	3.0 mm
Latency	3.0 sec.	5.0 sec.	3.0 sec.	3.0 sec.
Time to top	4.5 sec.	5.0 sec.	2.0 sec.	1.0 sec.

The pneumographic curves for the first two sentences only are given, those of the other two being unusable.

	<i>Inspirations per cm.</i>		<i>Average height in mm.</i>	
	<i>Sen. 1</i>	<i>Sen. 2</i>	<i>Sen. 1</i>	<i>Sen. 2</i>
Before	3.2	3.0	12.52	13.58
Rise	3.16	2.99	12.16	12.1
Fall	2.5	2.48	13.0	12.22

1270] The second quiet curve is regular in all cases.

Chronic Alcoholism

1271] There are three cases in this group, confirmed alcoholics, but showing no dementia. The galvanometric measurements only are given. The subjects reacted fairly rapidly, and most of them responded more intensely than normal subjects to all stimuli.

1272] The first quiet period shows nothing.

1273] **Part II** (falling weight) caused a deflection of 23.3 mm., greater than in any of the other groups.

1274] **Part III** (spontaneous speaking) caused a deflection of 18.6 mm.

1275] **Part IV** (three physical stimuli, weight, whistle, and picture) caused the following deflections: weight, 24 mm.; whistle, 24 mm.; picture, 28 mm. These reactions are greater than those of the normal subjects. The relation of the reactions to the various stimuli in these and in normal subjects is almost the same in all cases, that to the picture being the greatest and those to the weight and whistle being very nearly the same.

1276] **Part V** (the four sentences) caused reactions generally greater than in the normal cases, being: Sen. 1, 8.6 mm.; Sen. 2, 16 mm.; Sen. 3, 20 mm.; Sen. 4, 14 mm.

Alcoholic Dementia

- 1277] There were three cases of alcoholic dementia, which may be contrasted with the last group. In this group the reactions are all weaker than in the cases without dementia, and the smaller reactions to psychological stimuli are especially striking.
- 1278] The weight caused a deflection of 9.06 mm., as compared to 23.3 mm. for the last group.
- 1279] Spontaneous speaking caused a reaction of 6.8 mm.
- 1280] The reactions to the three physical stimuli, weight, whistle, and picture, are very interesting. The picture caused a deflection of only 7.6 mm., as compared to the weight, 16 mm., and the whistle, 13 mm. The reactions are directly proportional to the physical nature of the stimuli. The picture, which in normal cases caused the greatest number of associations and the greatest affects, here caused the fewest associations and the slightest reactions.
- 1281] The reduction of the reactions to mental stimuli is again seen in the sentences, where they are slight.

<i>Sen. 1</i>	<i>Sen. 2</i>	<i>Sen. 3</i>	<i>Sen. 4</i>
3.3 mm.	1.3 mm.	5.6 mm.	2.5 mm.

The reduction here is proportionally much greater than in any of the other groups.

General Paralysis

- 1282] Nine cases of general paralysis were examined. Two were in a condition of euphoria and one in a period of remission. The other six cases were in a condition of dementia and apathy and gave hardly any reactions to the various stimuli.
- 1283] The quiet period shows nothing at all for the cases of dementia; in the other cases a few irregularities can be seen.
- 1284] **Part II** (the falling weight) caused strong reactions in the two euphoric cases and the case in remission, but no reaction at all in the demented cases.

Height	21.1 mm.
Latency	2.2 sec.
Time to top	6.6 sec.

- 1285] The pneumographic measurements in these cases are nearly normal.

	<i>Inspirations per cm.</i>	<i>Average height</i>
Before	3.25	8.7
Rise	3.1	7.2
Fall	3.4	9.6

- 1286] The pneumographic measurements for two cases giving no galvanic reactions are:

	<i>Inspirations per cm.</i>	<i>Average height</i>
Before stimulus	2.5	21.37
After stimulus	3.0	22.3

- 1287] Spontaneous speaking could not be attempted.
- 1288] **Part IV** (three physical stimuli) in the three cases caused the following reactions:

	<i>Weight</i>	<i>Whistle</i>	<i>Picture</i>
Height	9.4 mm.	25.8 mm.	15.05 mm.
Latency	2.5 sec.	2.3 sec.	2.6 sec.
Time to top	4.0 sec.	7.0 sec.	4.1 sec.

1289] The high average reaction to the whistle is due to the reaction of the patient in a period of remission whose reaction was 70 mm. It will be observed that the weight in these cases caused the smallest reaction. The pneumographic measurements for the three cases are:

	<i>Inspirations per cm.</i>			<i>Average height in mm.</i>		
	<i>Weight</i>	<i>Whistle</i>	<i>Picture</i>	<i>Weight</i>	<i>Whistle</i>	<i>Picture</i>
Before	3.0	3.0	3.65	5.5	5.5	7.9
Rise	3.0	3.0	3.2	4.5	9.1	7.9
Fall	3.0	2.9	3.5	4.8	8.8	7.8

1290] In the case of two patients giving no galvanic reaction the pneumographic measurements are:

	<i>Inspirations per cm.</i>			<i>Average height in mm.</i>		
	<i>Weight</i>	<i>Whistle</i>	<i>Picture</i>	<i>Weight</i>	<i>Whistle</i>	<i>Picture</i>
Before	2.0	3.0	2.0	20.5	20.45	18.5
After	2.0	2.5	2.0	21.12	20.50	19.0

1291] Part V. The results for three sentences are given. Four subjects reacted to these stimuli.

	<i>Sen. 1</i>	<i>Sen. 2</i>	<i>Sen. 3</i>
Height	16 mm.	9.58 mm.	18 mm.
Latency	4 sec.	2.5 sec.	1.5 sec.
Time to top	5 sec.	4.7 sec.	5.5 sec.

1292] These reactions are nearly the same as those of the normal subjects. The pneumographic measurements for these cases are:

	<i>Inspirations per cm.</i>			<i>Average height in mm.</i>		
	<i>Weight</i>	<i>Whistle</i>	<i>Picture</i>	<i>Weight</i>	<i>Whistle</i>	<i>Picture</i>
Before	3.5	3.0	3.0	7.4	7.1	10.3
Rise	4.0	3.3	3.3	10.0	8.6	9.0
Fall	4.0	4.6	4.5	11.0	8.1	9.2

1293] The pneumographic measurements of two cases giving no galvanic reaction are:

	<i>Inspirations per cm.</i>		<i>Average height in mm.</i>	
	<i>Sen. 1</i>	<i>Sen. 2</i>	<i>Sen. 1</i>	<i>Sen. 2</i>
Before	2.75	3.0	20.75	20.40
After	2.75	2.75	21.30	21.50

1294] Paretics in a condition of euphoria and in a stage of remission, when dementia is not pronounced, react well to the various stimuli. They take a very active interest in the experiment and this may account for the fairly large galvanic reaction. Paretics in a demented condition give no reactions to simple stimuli and correspond to other cases of dementia.

Senile Dementia

1295] There were eleven cases of senile dementia. Most of these cases did not react to the stimuli. In some cases even the prick of a needle caused no galvanic fluctuation.

1296] The weight caused a reaction in three cases. The average deviation for the three cases was 5 mm.

1297] Spontaneous speaking (Part III of the experiment) could not be attempted on account of the dementia.

1298] The three stimuli (Part IV) gave smaller measurements than those obtained in any other disease, the weight causing an average deflection of 1 mm., the whistle 1.8 mm., and the picture 4 mm. The relatively high reaction caused by the picture is interesting.

1299] The mental stimuli, sentences (Part V), caused very little reaction.

<i>Sen. 1</i>	<i>Sen. 2</i>	<i>Sen. 3</i>	<i>Sen. 4</i>
0.6 mm.	0.6 mm.	0.2 mm.	0.8 mm.

1300] The following table gives a survey of the galvanic measurements in mm. of all the subjects:

	<i>Weight</i>	<i>Spont.</i>	<i>Weight</i>	<i>Whistle</i>	<i>Picture</i>	<i>Sentences</i>			
						<i>1</i>	<i>2</i>	<i>3</i>	<i>4</i>
Normal	20.6	17.9	17.94	18.2	19.72	14.62	14.48	19.42	11.12
Epilepsy	7.5	14.66	26.6	23.6	15.4	13.4	7.8	4.5	4.5
Catatonia	6.8	—	6.3	2.4	3.9	2.01	2.3	2.6	1.9
Hebephrenia	5.0	2.6	6.8	3.5	4.4	2.6	1.3	3.8	4.2
Paranoid D. P.	4.8	4.6	5.8	5.4	7.0	5.2	3.2	2.6	3.0
Chronic alcoholism	23.3	18.6	24.0	24.0	28.0	8.6	16.0	20.0	14.0
Alcoholic dementia	9.06	6.8	16.0	13.0	7.6	3.3	1.3	5.6	2.5
General paralysis: euphoria and remission	21.1	—	9.4	25.8	15.05	16.0	9.58	18.0	—
General paralysis: dementia	—	—	—	—	—	—	—	—	—
Senile dementia	5.0	—	1.0	1.8	4.0	0.6	0.6	0.2	0.8

1301] This table shows that in every case the physical stimuli cause a smaller galvanic fluctuation than the psychological ones, but in the cases where intellectual deterioration is marked the reduction is proportionally greater than in the other cases.

1302] The intensity of the reaction seems to depend partly on the attention paid by the subject to the experiment. In cases of dementia praecox, where internal complexes dominate the affectivity and attention, the reactions are slight; in alcoholism and in general paralysis, euphoric state, where excitability is very great, the reactions are correspondingly greater. In organic dementia, where all associative power is lost, the reactions are almost nil. In dementia senilis, where dementia was very marked, even the prick of a needle failed to cause any response.

1303] The pneumographic measurements in these cases are nearly the same as those found in normal cases. There is evidently no rule for the rate but the amplitude usually decreases while the galvanic phenomenon persists.

1304] That the galvanic fluctuation is caused by the psychological⁷ and not the physical factor of a stimulus is shown by the following facts:

1305] The reaction is greatest when the stimulus is such as to call up a large number of associations, e.g., the picture.

- 1306] A stimulus causing doubt and perplexity is accompanied by a marked galvanic fluctuation, e.g., where the stimulus is a simple word.
- 1307] In cases of dementia, where associations are few, the reactions are correspondingly weaker.
- 1308] The physical intensity of a stimulus does not bear any regular relation to the force of the galvanic reaction.
- 1309] The strength of the reaction changes exclusively according to psychological constellations. This is beautifully shown in one normal case where an ordinary whistle caused only a slight reaction, but the whistle-call of a society to which the subject had belonged as a schoolboy caused a very great fluctuation.
- 1310] If the attention is not directed to the stimulus the reaction is small or nil. We therefore have no reactions in cases where attention is seriously disturbed. This can be proved by letting the subject count or draw lines on a paper at the beat of a metronome. In this case the reactions are almost nil.

SUMMARY

1311] From the above experiments we conclude that:

(1) The galvanic reaction depends on attention to the stimulus and the ability to associate it with other previous occurrences. This association may be conscious but is usually unconscious.⁸

(2) In our experiments greater galvanic fluctuations are caused, as a rule, by physical than by psychological stimuli. This may be due to the fact that they occurred before the psychological stimuli, early stimuli nearly always causing greater reactions than later ones.

(3) While normal reactions vary greatly in different individuals, they are nearly always greater than pathological reactions.

(4) In depression and stupor, galvanic reactions are low because attention is poor and associations are inhibited.

(5) In alcoholism and in the euphoric stage of general paralysis, reactions are high because of greater excitability.

(6) In dementia, reactions are practically nil because of the lack of associations.

(7) Reactions show great individual variation and within certain rather wide limits are entirely independent of the original bodily resistance.

The pneumographic measurements may be summarized as follows:

(1) The inspiratory rate varies according to the individual and no general rule can be given.

(2) The amplitude of the inspirations generally decreases during the rise of the galvanic curve.

(3) This decrease in amplitude, however, has no relation to the height of the galvanic curve but varies according to individuals.

(4) In cases of dementia where there is no galvanic reaction, changes of respiration exist but are very slight.

Delabarre: *Über Bewegungsempfindungen* (1891).

Féré: “Note sur des modifications de la résistance électrique sous l’influence des excitations sensorielles et des émotions” (1888).

Idem: “Note sur des modifications de la tension électrique dans le corps humain” (1888).

Mentz: “Die Wirkung akustischer Sinnesreize auf Puls und Atmung” (1893).

Mosso: *Über den Kreislauf des Blutes im menschlichen Gehirn* (1881).

Sommer: In *Beiträge zur Psychiatrischen Klinik*, Vienna (1902).

Sommer and Fürstenau: “Die elektrischen Vorgänge an der menschlichen Haut” (1906).

Sticker: “Über Versuche einer objektiven Darstellung von Sensibilitätsstörungen” (1897).

Tarchanoff: “Über die galvanischen Erscheinungen an der Haut des Menschen ...” (1890).

Veraguth: “Le Réflexe psycho-galvanique” (1906).

Idem: “Das psycho-galvanische Reflex-Phänomen” (1906).

A. Vigouroux: *Étude sur la résistance électrique chez les mélancoliques* (1890).

R. Vigouroux: “Sur la résistance électrique considérée comme signe clinique” (1888).

Idem: “L’Électricité du corps humain” (1888).

Zoneff and Meumann: “Über Begleiterscheinungen psychischer Vorgänge in Atem und Puls” (1900).

APPENDIX

1

STATISTICAL DETAILS OF ENLISTMENT¹

[1312] As a member of a medical board I had the opportunity last autumn to make a few observations that may be of interest to some of my colleagues and stimulate them to make similar investigations.

[1313] The enlistment at which I was present took place in Lucerne and its environs. The first day of the enlistment produced much strikingly inferior human material. At least, that is how it struck me—it was the first time I had taken part in an enlistment. If I remember rightly, not even half of the recruits were fit. Later on it became even worse. There are places where not even 30 per cent of the male population are fit; it must be emphasized that these places are not industrial towns, but villages in rich and fertile country. The impression that the first day of enlistment made on me, namely the fact that so many mentally inferior men came for examination, induced me to note how many manifestly imbecile men had presented themselves. Since a somewhat too biassed judgment regarding the diagnosis of mental deficiency is attributed to the psychiatrist, I noted only those cases that had also immediately struck the psychiatric layman as idiots. I omitted a number of cases where, after a short examination,² I was convinced that I was faced with mental deficiency, in which, however, imbecility was not immediately apparent to the layman. The material under examination consisted of 506 men, of whom 47 (that is, as much as 9.2 per cent) were patently imbecile! 211 men from the town presented themselves; of these 5.6 per cent were imbecile. 232³ men came from the country; of these 13 per cent were imbecile. The big difference between town and country might be explained by the fact that it is mainly the intelligent and enterprising people who converge on the towns, while the unintelligent and torpid remain in the country. The difference between town and country probably does not mean more than a symptom of the present tendency to migrate into the towns. The imbecility of my cases was so obvious that, where there had been any question of criminal offences, the psychiatrist present had stated that the accused were not responsible for their actions. Should my figures be confirmed throughout, then approximately 9 per cent of Swiss adolescents would not be responsible for their actions! This is a terrifyingly high figure which casts a curious light on the level of intelligence of our people, particularly of the rural population. The even higher figures for physical unfitness raise the question of whether there has always been an inferiority of this kind or whether we are faced with degeneration. In any case, an investigation of this problem in connection with enlistment would, for various theoretical and economic reasons, be worthwhile.

[1314] In this connection one should consider the fact that, in the enlistment district about which I am reporting, the farmers are alleged to have the curious custom of delivering all their milk to the cheese-factories and of feeding their children on coffee and brandy (a similar custom is reported from the canton of Bern).

[1315] When examining those conscripts who reported some ailment to the Commission, I was struck by the large number of alcoholics. To avoid misunderstandings, I noted only those cases that also impressed my colleagues as alcoholics. I therefore included only the cases that revealed themselves as chronic alcoholics through tremor, heart or liver symptoms, and perhaps through signs of polyneuritis. My material comprises 78 men, nearly all of them between the ages of 20 and 30. Of these, 10 (that is 12.9 per cent) had to be discharged as unfit for military service owing to chronic alcoholism. No statistical survey, however, reports this figure because these people are not classified under the heading of alcoholism; they are entered under the more decent title of the alcoholic sequela—for instance, dilatation of the heart or hypertrophy of the heart, chronic gastric catarrh, chronic nephritis, etc. One refers to these alcoholics with a kind of euphemism that certainly often originates in commendable personal consideration but which ultimately leads to a highly detrimental obscuring of the fact that our army annually loses a disproportionately large number of strong men because of alcoholism. What makes matters even worse is the fact that it is the most vigorous age-group that is in question and not the older age-groups. One wonders what conditions are like in the militia if we get such figures for the regular recruits!

*Contribution to the Method Used for the Psychological Diagnosis of Evidence
(Tatbestandsdiagnose)²*

[1316] The very simple experiment designed to induce an individual to respond to a given stimulus-word with the first word that crosses his mind has become the point of departure of a long series of psychological problems that are of interest not only to the psychologist but also to the jurist and the psychiatrist.

[1317] It is not my intention to give here a review of all association experiments; I only wish to indicate one of the possible applications of these experiments, which may interest practical psychologists and criminologists. This is the so-called “diagnosis of evidence” (*Tatbestandsdiagnose*), i.e., the psychological diagnosis of a crime.³ This term is somewhat pretentious; in practice, those in favour of the method content themselves with more modest results than the infallible diagnosis of a crime. Notwithstanding this limitation, there are some, and they are not a few, who deny any value to the use of the experiment and who maintain that it is without any interest: but as so often, this exaggeration only shows how one falls from one extreme into the other. On the one hand, workers in this field dare not hope that they can arrive at a psychological procedure that will permit them to make a sure diagnosis after only a few preliminary investigations. Medicine, however, possesses quite a number of such methods that have won acceptance only after a laborious struggle. In the field of psychology progress cannot be made any more easily. On the other hand, one must recognize the facile opposition that is based on initial failure of the method; some, like Heilbronner, deny that any application of the experiment can be of value. So the opposition degenerates into a scepticism that arises not from knowledge and serious criticism, but from a deplorably superficial judgment.⁴

[1318] The problem of the diagnosis of evidence is at present of the greatest importance to psychologists; to criminologists it is only of academic interest, since we are still far from its practical application in court: this must be the honest and fair appreciation of the experiments we are going to report.

[1319] The technique is very simple. Let us take an example: a bag containing jewellery, such as a gold bracelet with blue stones, a diamond brooch in the shape of a butterfly, a ring shaped like a snake, and a brooch in the form of a lizard with emerald eyes, was stolen from a hotel. There were also a green leather wallet containing a cheque drawn on the Banca Commerciale Italiana and three banknotes of fifty lire each, and a bottle of Odol.

[1320] The hotel porter and two other employees were suspected of the theft and arrested. Apart from the hotel proprietor, only the culprit could have known the contents of the bag. Such a state of affairs lends itself admirably to the association experiment. Here are examples of the words chosen for it: *gold, fifty, three, bracelet, blue, bank, snake, stone, diamond, lizard, green, leather, butterfly, wallet, cheque, banknote, Odol*, etc. These were distributed among approximately twice the number of other words, chosen for having the smallest possible reference to the evidence.

This was done because we wanted to demonstrate how words derived from the evidence, which is known in its minutest particulars only to the culprit, affect people subjected to the experiment.

[1321] How then, generally speaking, do the stimulus-words “act”?

[1322] Needless to say, the subject must consent to the experiment and must obey the instructions. Without his co-operation one cannot, of course, achieve anything. The instruction usually given is this: “You must say, as quickly as possible, the first word that the stimulus-word suggests to you.” It is possible for the subject to cheat by not saying the first word that comes to his mind, but in order to reveal the deception, we measure the reaction-time with a stop-watch. If the subject does not say the first word that occurs to him, it is tantamount to rejecting it and he has to look for another; this needs a certain time, which is measurable. A long reaction-time should therefore not mislead the experimenter. The subject of the experiment may well go to the trouble of prolonging his other reaction-times nearly to the same extent, whether they belong to critical words or to others without special meaning. But this deception is as a rule easily seen through since it is known that the reaction-time in educated people is about 1.5 seconds and in uneducated people 2.0 seconds; on the other hand, as the subject deliberately influences the reaction-times, these are as a rule unduly prolonged because it is difficult consciously to judge the lapse of time. Apart from these possible deceptions, every other effect of the critical stimulus-words will result from a disturbance of *attention*. This disturbance arises from the fact that the critical stimulus-word brings back to the mind a content with a strong feeling-tone; this attracts the attention and captivates it for a moment, producing a slowing down of the reaction if a familiar word does not at once present itself. The reproduction method⁵ also brings into relief another fact, namely, that reactions to critical words (i.e., those words that revive contents of consciousness with a strong feeling-tone) are more easily forgotten than reactions to words without special meaning. Reactions that immediately follow critical reactions are also often forgotten (perseveration of the disturbance of attention). Why they are so easily forgotten has not yet been sufficiently explored; nor do I wish to enter into any theoretical speculations.

[1323] It often happens that the subject is startled by the critical stimulus-word. This is another disturbing factor, which first affects the reaction-time and then the verbal form of the reaction itself: the subject believes that he has not properly understood or has really misunderstood, or he mechanically repeats the stimulus-word. As, in his embarrassment, he cannot find a word of no special significance, he replaces it with a phrase (and this is against the rules) and then, in uttering this phrase, makes a mistake. In these short moments, which are of immense intrinsic value, he produces many blunders that betray him, such as we all, in our daily lives, also commit for the same reasons, even though as a rule unconsciously. In one case, a student who took part in the experiment, and who was usually very much in command of himself, betrayed himself by making at each critical word a certain small gesture of the hand which he omitted when the word had no special meaning for him.

[1324] All these small disturbing elements in the experiment I have termed “complex-characteristics” (*Complexmerkmale*); this means that they are pointers revealing the influence of a complex of ideas with a particular feeling-tone.⁶ These are the complex-characteristics in question:

1. Prolonged reaction-time⁷ in the critical reaction or in the one immediately following.

2. Reaction with two or more words, although the subject usually reacts with one word only, according to the instructions.

3. Repetition of the stimulus-word.

4. The stimulus-word (especially the one following the critical word) is misunderstood.

5. Failure to react (i.e., where the subject does not know how to react).

6. *Lapsus linguae* when pronouncing the reaction-word.

7. Translation of the stimulus-word, or of the reaction, into a foreign language.

8. Reaction in the form of an unusual expression.

9. The reaction has a singular content or may be meaningless.

10. Perseveration of the reaction-word in respect of content and of form.

11. Interpolation of “yes” or of other interjections before or after the reaction-word.

[1325] Characteristics 8, 9, and 10 are somewhat arbitrary and can therefore be omitted in an exact computation.

[1326] It may be objected that these deviations cannot with certainty be reduced to psychological disturbances determined by ideas with a special feeling-tone (complexes). This does not in fact appear when the association experiment is used specifically for what we have called the diagnosis of evidence, whereas it becomes quite clear in the case of the accurate analytical examination of the experiments made without a diagnostic purpose. These findings receive considerable support from measuring oscillations of body-resistance to the galvanic current during the association experiment.⁸

[1327] Now, given that these deviations are caused by critical stimulus-words, we may justifiably admit that we are faced with a disturbing inner factor, i.e., an idea with a strong feeling-tone. If, then, with a particular subject these deviations occur mainly in connection with critical reactions—i.e., in response to stimulus-words derived from actuality—then we can confidently assume that with the word that influences the subject a complex is operative that refers to actual facts. This complex may embrace simply the subject’s general knowledge about a particular crime; should stimulus-words refer to this crime then a certain emotion is bound to arise in response to every one of these stimulus-words. But it may also turn out that the disturbing complex is one that points to a feeling of guilt in the subject.

[1328] An innocent suspect, as well as a guilty one, will of course show a certain emotion in response to critical stimulus-words. We do not yet know whether this emotion exerts the same perturbing influence over each of them, or whether the reaction of the innocent can be qualitatively distinguished from that of the guilty; only further experience can decide this question.

[1329] In the case of our hypothetical crime only the guilty party knows the details of the facts, whereas innocent suspects hardly know the general outline. From the experiment it appears that all the critical stimulus-words have a disturbing effect on the porter, whereas in the other two employees most of the critical reactions are quite normal. From this we may conclude that suspicion must very probably fall on the porter and that his guilt appears to be established;

moreover, the complex-characteristics are, significantly enough, recognized through those stimulus-words the importance of which cannot by any means be known to the innocent.

[1330] We have no absolute proof of guilt, but it is clear that in such cases the experiment may provide valuable pointers for further investigation. This will happen especially when there is a large number of suspects and when the elements of suspicion about some of them lack a solid basis; in such a case we can, with the help of the experiment, eventually succeed in tracing those on whom graver suspicion must fall. Let us, however, repeat that the results of the experiment will not provide absolute proof of guilt but, at best, merely a valuable addition to the circumstantial evidence. If one has to do with only one suspect and if there are no facts with which to confront this person, then the results are unquestionably most unreliable.

[1331] Some two years ago I published a case from my practice, in which a thief confessed his crime as a result of strong evidence arising from the association experiment.⁹ A short time ago I was concerned with another case of theft that from the technical point of view lent itself very well to the experiment; like the first case, it was entirely successful.¹⁰

.....

Critique and Qualitative Analysis

[1332] Faced with these results, the reader who is without a thorough knowledge of the method is bound to ask himself this question: Is it not possible that one of the three suspects who was not the subject of this research would, on examination, present an even greater number of signs of guilt? This is of course *a priori* possible, but in practice one always begins with the subject to whom the evidence points most clearly; in our case this was definitely the nurse A. From this reasoning my concept of the experiment clearly emerges: it should only, in the first place, show us which of the subjects presents the maximum number of complex-disturbances. Then we have the suspect who shows himself most disturbed, either because he is really the culprit or because the fear of appearing guilty causes great agitation. Nurse B appeared very agitated during the experiment and this prejudiced me against her, even though she did not show distinct signs of a guilt-complex. Nurse C was relatively calm but nevertheless the complex-characteristics were more numerous. This discrepancy needs to be examined further. Why do the innocent usually show signs of a guilt-complex? The answer to this question presents no difficulties. Nurse B knew all the particulars of the case and during the experiment Nurse C had an inkling of its importance. It is therefore easy to understand why words like *theft*, *to steal*, and *police* created in them an unpleasant feeling that in its turn produced the characteristic disturbance of the experiment. Here we have the explanation of why even the innocent can show a not inconsiderable number of signs of guilt-complex. What distinguishes them from the guilty are not (at least as far as we know at present) qualitative differences but mainly quantitative ones.

[1333] It is nevertheless surprising that Nurse B, who had been given exact information about the circumstances of the theft and who was evidently affected by strong emotion, showed fewer signs of guilt-complex than Nurse C, who was the calmer of the two. Only psychoanalysis, applied to each association, can throw light on this question.

[1334] In Nurse C the words *watch*, *chain*, *silver*, produced evident complex-disturbances; now, by an unfortunate coincidence, both the watch and the chain had been broken a few days before. The word *to hide* also has a disturbing influence; Nurse C had a short time before taken away her

evening meal and hidden it, something that was absolutely forbidden in the hospital. *Fear, to discover, innocent, suspect, to lie* are all disturbing words: it was known that through negligence she had mislaid or lost a garment belonging to one of the patients. It suddenly occurred to her during the experiment that this incident was being enquired into, since nothing had so far been discovered about it; and that was why signs of guilt-complex appeared in response to these words.

[1335] The interference of other individual complexes seriously compromised the results of the investigation but this was unavoidable. One of the few measures that could be taken to this end would be to use a long series of stimulus-words (100—200) of which as many as possible would refer to definite details of the case and would be of similar categories since, if they were, they would produce disturbances owing to the intellectual work involved. *A priori* one would regard as most suitable words that are apparently of no special significance and that yet have a special significance in relation to the case (the so-called “exchange” [German, *Wechsel*], according to Freud’s apt expression¹¹).

[1336] Let us therefore try to assess the importance of words that have a direct reference to the case as compared with those that have only a general connection with the theft.

[1337] First we shall again calculate the probable mean of the reaction-times; we shall, however, reduce the numbers of B and C as if the reaction-times of these subjects had the same general probable mean as those shown by A (11.0).

*Probable Mean of Reaction-times
(reduced to the level of that of the culprit)*

	A	B	C
Special stimulus-words	15	15.1	12.2
General stimulus-words	18	11.0	14.6

[1338] We can see that the general stimulus-words have a very strong influence on the guilty nurse A. The special stimulus-words have the same effect on the guilty A and on the innocent B, whereas on B the general stimulus-words show very little effect. In this case the expected confirmation was not forthcoming.

[1339] Let us now investigate the same question from the point of view of complex-characteristics.

Average Number of Complex-characteristics per Reaction

	A	B	C
Special stimulus-words	1.2	0.9	1.0
General stimulus-words	1.5	0.7	1.1

[1340] We find here in essence a state of affairs similar to that in the reaction-times, i.e., [in the case of A and C]¹² the general stimulus-words exercise a stronger influence.

[1341] Let us now examine the disturbances of reproduction from the same point of view.

Incorrect Reproductions

	A	B	C
Special stimulus-words	0.4	0.2	0.2
General stimulus-words	0.6	0.2	0.3

[1342] This shows that the figures for disturbances of reproduction are larger for the general stimulus-words [for A and C].

[1343] Little can be expected, for the time being, from the study of such associations as follow immediately upon critical associations; this is because we do not know when, in what individuals, or in what complexes a particularly strong perseveration may exert a disturbing influence on the experiment. One could presume that perseveration would appear mainly after very intense emotion, but it is not at all certain that this would be shown by the experiment. Should it prove to be true, it could turn out to be one of the origins of disturbance associated with perseveration. Another cause may be found in the fact that quite often the total range of the preceding stimulus-word is not readily understood, so that soon enough other ideas suddenly appear, not infrequently carrying strong feeling-tone. But all these contingencies demand very accurate investigations. Until these are completed, we shall not be able to benefit from whatever emerges from the research—according to which, words referring in a special way to the evidence leave in their train more disturbances in the post-critical associations than general stimulus-words do.

[1344] The most intense after-effect was produced in the culprit by the following stimulus-words; I give the reactions with the ordinary reactions that follow them.

<i>Stimulus-word</i>		<i>Reaction</i>	<i>Reaction-time</i>	<i>Reproduction</i> ¹³
(1) banknote		money	15	—
mountain	r	to climb	26	—
to play		to sing	15	—
(2) suspect (noun)		nobody	43	+
bottle		water	17	—
fire		wood	9	—
(3) to hide		to lose, to look for	18	—
sofa		seat	17	—
night		day	6	+
(4) chain		round the neck	19	—
(5) silver		gold	10	+
(6) money	r	centime	34	—
wine		beer	8	+
(7) open	r	free	6	+
(8) key		keyhole	19	+
house		courtyard	13	—
lamp		light	8	+

[1345] Just as we have found that it is *on the whole* the general stimulus-words that work with the utmost intensity, so we now see that the strongest single impact is made by those stimulus-words that refer particularly to the evidence. This shows that the general stimulus-words usually have a strong effect, whereas the special stimulus-words sometimes have an intense effect and sometimes a weak one.

[1346] The only way in which we can do full justice to these results is to apply them as much as possible to practical cases since, for reasons not far to seek, laboratory investigations are always rather incomplete.

[1347] I am confident that with this work I have awakened a certain interest in experiments of this kind and have encouraged others to follow in this direction. It is only by the work of many, directed always towards the examination of practical cases, that we can hope to make the diagnosis of a particular case a matter of greater certainty.

3 THE PSYCHOLOGICAL METHODS OF INVESTIGATION USED IN THE PSYCHIATRIC CLINIC OF THE UNIVERSITY OF ZURICH¹

[1348] 1. Rapidity of apperception: short exposure of simple pictures.

2. Working through psychological material and fidelity of reproduction: retelling of three fables. The first fable contains two similar simple situations which, however, differ from each other by one important nuance. The second fable is similar but more complicated. The third fable is in principle similar, but contains a whole series of similar situations.

3. Fatiguability of the will: Kraepelin's method of reckoning.

4. Emotionally charged contents ("complexes"): Jung's association method.

5. Psychogenic mechanism and symptom-determination: Freud's psychoanalytic method.

4 ON THE DOCTRINE OF COMPLEXES¹

[1349] It is difficult to express in a short summary the doctrines laid down in my two books, “Diagnostic Association Studies” and “The Psychology of Dementia Praecox.” What I state here must necessarily be incomplete and superficial.

[1350] My theoretical views on the neuroses and certain psychoses—especially dementia praecox—are founded upon the psychological outcome of the *association experiment*. These experiments are used for the demonstration of certain intellectual types, but I must here mention that an important point was formerly disregarded, namely, the disturbing influence of the experiment on the subject. Thus, in my practice of using a series of *stimulus-words*, and allowing the subject to react to them, that is to give answers to each word, the reactions often do not come with equal smoothness, but very irregularly, or with lengthened intervals; or there appear other disturbances such as repetitions of the stimulus-word, slips of the tongue, several reaction-words instead of one, etc. These irregularities were formerly regarded as mere faults of the experiment, and not taken into further consideration. In collaboration with Riklin, however, I have now given special attention to these disturbances. Noting at which stimulus-words they occur, we find that it is principally where a stimulus-word refers to a personal matter, which, as a rule, is of a distressing nature. Often the relation between the two is not clear at first glance, but is rather of a “symbolic” character, it is in fact an “allusion.” Usually there are only a few personal matters to which the disturbances of the experiment refer. Riklin and myself have introduced for this “personal matter” the term *complex*, because such a “personal matter” is always a collection of various ideas, held together by an emotional tone common to all. With practice and experience one may easily attain the faculty of collecting those stimulus-words which will most likely be accompanied by disturbances, then of combining their meanings and deducing therefrom the intimate affairs of the subject. It is obvious that this procedure is of special importance in a psychological examination of patients. (It is important also to note the use of the procedure in criminology; I, myself, have detected by its means two cases of theft.) Here I must mention that nearly all the German authorities have pronounced against the method, but its use is generally recognized in Switzerland and in the United States of America. French and English psychiatrists are as yet unfamiliar with the method.

[1351] The experiment, which I perform usually with a hundred specially selected and collocated stimulus-words, serves as an indication of the psychic contents of a patient and his mode of reaction. This is of special importance with regard to the neuroses,

the psychic origin of which present-day observers no longer doubt. Somatic states are never the real, but only the predisposing causes of the neuroses. The neurosis itself is of psychic origin, and emanates from “special psychic contents,” which we call a *complex*. It has been discovered that the complexes revealed by association experiment are either pathogenic conflicts or at least nearly such, so that by association experiment the pathogenic complex is easily located. If one wishes to penetrate still further into the psychological connections of a neurosis, one must have knowledge of Freud’s psychoanalytic method. But for a superficial grasp of the psychic contents of a neurosis the association experiment is quite sufficient. It is interesting to find that the experiment discloses thought-complexes, which were not mentioned at all in the history of the case. The obvious reason for this is the distressing character of the complexes. At the outset, patients do not talk to the doctor quite frankly about more private matters, and it is precisely these matters which have the most important bearing on the genesis of the neurosis. That these painful private matters are mostly conflicts of a distinctly psychosexual nature is to the unprejudiced judge of human nature a matter of course. Occasionally the psychosexual conflict is very deeply hidden, and can be discovered only by psychoanalysis. In many cases the aroused complex is by no means approved by the patient, who even tries in every way to deny, or at least to weaken, the existence of the complex. Since it is therapeutically important to induce the patient to self-recognition, i.e., to a recognition of his “repressed” complexes, one must take this fact into careful consideration, and proceed with corresponding care and tact.

[1352] The association experiment provides the means of studying experimentally the behaviour of the complex. Experience teaches us the close relation between complex and neurosis. We must assume that the complex is a thought material, which stands under special psychological conditions, because it can exert a pathogenic influence. In the association experiment we first observe that it is the intention of the subject to react quickly and correctly. This intention is disturbed by the interference of the complex, so that the association, contrary to expectation, is either turned from the sense of the complex or replaced by fragmentary allusions, or is in general so disturbed as to render the subject altogether unable to produce a reaction, although he may be unaware that the complex is independent of his intentions. The same observation is confirmed by applying the so-called *reproduction method*. If after the finished association experiment we let the subject repeat all the reactions to the different stimulus-words, we find the uncertainty of recollection (the so-called faulty reproduction) usually at those places where the complexes have interfered (though we must not lose sight of the perseveration factor of the complex). Therefore, the “faulty reproduction” is also to be regarded as a sign of the complex, and this is theoretically interesting because it shows that even the moods associated with a

complex are subject to certain exceptional conditions, that is, they are inclined to be quickly forgotten or replaced. The uncertainty of the subject towards the complex-associations is characteristic; they are to the individual either of an obsession-like stability, or they disappear totally from the memory, and may even cause false memories—as may be well observed *in nuce* during the experiment. This points also to the complex and its association material having a remarkable independence in the hierarchy of the psyche, so that one may compare the complex to revolting vassals in an empire. Researches have shown that this independence is based upon an intense emotional tone, that is upon the value of the affective elements of the complex, because the “affect” occupies in the constitution of the psyche a very independent place, and may easily break through the self-control and self-intention of the individual. The “affect-intensity” of the complex can be easily proven psychophysically. For this property of the complex I have introduced the term *autonomy*. I conceive the complex to be a collection of imaginings, which, in consequence of this autonomy, is relatively independent of the central control of the consciousness, and at any moment liable to bend or cross the intentions of the individual. In so far as the meaning of the ego is psychologically nothing but a complex of imaginings held together and fixed by the coenesthetic impressions, also since its intentions or innervations are *eo ipso* stronger than those of the secondary complex (for they are disturbed by them), the complex of the ego may well be set parallel with and compared to the secondary autonomous complex. This comparison shows the existence of a certain psychological similarity, because the emotional tone of the secondary complexes is also based upon coenesthetic impressions, and, further, both the ego and secondary complex may be temporarily split up or repressed, a phenomenon which may be observed with particular clearness in hysterical delirium and other “cleavages” of personality. Especially in those states where the complex temporarily replaces the ego, we see that a strong complex possesses all the characteristics of a separate personality. We are, therefore, justified in regarding a complex as somewhat like a small secondary mind, which deliberately (though unknown to consciousness) drives at certain intentions which are contrary to the conscious intentions of the individual. Hysterical symptoms are the products of those counter-endeavours; they originate from the complex, and are all the more intense and obstinate the greater the autonomy of the complex is. I may say here that the superstition held by all races that hysterical and insane persons are “possessed” by demons is right in conception. These patients have, in fact, autonomous complexes, which at times completely destroy the self-control. The superstition is therefore justified, inasmuch as it denotes “possession,” because the complexes behave quite independently of the ego, and force upon it a quasi-foreign will.

[1353] By means of the association experiment, aided by Freud's psychoanalytic method, I have succeeded in proving that all neuroses contain autonomous complexes, whose disturbing influences have a disease-producing effect. Amongst the psychoses, Kraepelin's dementia praecox has undoubtedly proved itself a "complex disease," at least in its initial stages. (I regard the noted but still unconfirmed anatomical alterations as secondary.) In this disease the autonomy of the complexes may sometimes be observed with surprising distinctness; for instance, the overpowering force of "voices," the obsessions arising from catatonic impulses, etc.

[1354] The objection that neuroses and dementia praecox are totally different affections, and cannot possibly be founded upon the same disturbances, I can only meet here with the suggestion that more or less autonomous complexes occur everywhere, even in so-called normals. The question is, to what extent are the complexes really autonomous, and in what form does the reaction take place? The researches of Freud and his school have shown how hysteria reactively deals with the complexes, while the work of the Zurich school has shown a characteristic and different behaviour of dementia praecox; with this, however, I cannot deal here at length. I may say only that certainly in both the neuroses and dementia praecox the symptoms—whether of a somatic or of a psychic nature—originate from the complex as has been described in detail by the school of Freud. While in hysteria there occurs usually a continuous accommodation to the surroundings, in consequence of which the complexes are subjected to continual alterations, in dementia praecox on the contrary the complexes are fixed, so that they usually arrest the progress of the general personality; this we call dementia. In estimating the extent of this dementia some authors have gone much too far in assuming that the repulsive and degenerate exterior of the patient is the result of an equally great interior decay. This is quite incorrect, because the patients still possess a very vivid life of fantasy, of which, however, they are able only in exceptional cases to give utterance. In these fantasies, of which in some instances the patients are quite unconscious, they deal with the fixed complex in a way which is intensely interesting to the observer. In fact, this is the workshop where delusions, hallucinations, etc., are produced from really sensible connections. The direction of thought is, however, entirely turned away from reality, and prefers thought-forms and material no longer of interest to modern man; hence many of these fantasies appear in a purely mythological garb. Owing to the loss of the recent biological train of suitable thought, there is apparently substituted an antiquated form. (I may refer here to a similar conception of the hysterical symptom by Claparède and Janet.)

[1355] In this short summary I have been forced to restrict myself entirely to indications and assertions. Proofs have not been offered, because the subject has already reached the extent of a special science, a science which may be called

“Analytical Psychology,”² or after Bleuler, “Deep Psychology” (“Tiefenpsychologie”).

[1356] In conclusion, I would draw attention to the following publications. An account of all works on association methods will be found in:

Jung. *Diagnostische Associationsstudien*. Band I and II. J. A. Barth, Leipzig.³

A summary of these methods in the English language appeared in *Lectures and Addresses delivered before the Departments of Psychology and Pedagogy*, in celebration of the 20th anniversary of the opening of Clark University, Sept., 1909, Worcester, Mass., 1910.⁴

These lectures contain an account of the practical application of the experiments in a case of theft.

Further details may be found in:⁵

Jung. *Die psychologische Diagnose des Tatbestandes*.

Marhold, Halle.

Peterson and Jung. “Psychophysical Investigations with the Galvanometer and Pneumograph in Normal and Insane Individuals.” *Brain*. Vol. 30. 1907.

Jung. “On Psychophysical Relations of the Association-experiment.” *Journal of Abnormal Psychology*. Vol. I.

Details concerning my conception of the neuroses and psychoses may be read, partly in Vol. I of my *Diagnostische Associationsstudien*, partly in Jung, “The Psychology of Dementia Praecox”—*Journal of Nerv. and Ment. Dis.*, New York, 1909; also in Jung, *Ueber die Psychologie der Dementia Praecox*; Marhold, Halle; and in Jung, *Der Inhalt der Psychose*. Deuticke, Vienna.⁶

Proofs of the resumption of antiquated forms of thinking are as yet published only in part. A general presentation of the problem may be found in:

Jung. “Wandlungen und Symbole der Libido.” *Jahrb. f. Psychoanalyt. u. Psychopath. Forschungen*. Deuticke, Vienna. Band III. 1911.⁷

5 ON THE PSYCHOLOGICAL DIAGNOSIS OF EVIDENCE¹

The Evidence-Experiment in the Näf Trial

The method of investigating crime called “psychological diagnosis of evidence” was thought out and first published thirty years ago in the *Archiv für Kriminologie*, vol. XV, pp. 72–113.

In that paper, entitled “Psychological Diagnosis of Evidence: ideas on psychological experimental methods of ascertaining whether or not a person had taken part in a particular crime,” all that is essential in the method and its technique was described and can be referred to there.²

[1357] In a letter of October 31, 1934, the Criminal Court of Canton Zurich, in the case of Hans Näf, dental technician of Mogelsberg, asked for an opinion on the following question: “Would the interrogation of the accused by me reveal anything that would be of considerable significance for the judge who has to decide on the guilt or innocence of the accused?”

[1358] For my information, copies of the following documents were handed to me:

1. A graphological opinion given by Dr. Pulver on March 21, 1934.
2. Psychiatric opinion of the director of the Canton Asylum, Burghölzli, of August 10, 1934.
3. The act of indictment from the Police Court, Zurich.

[1359] A further basis for my opinion was the result of a so-called “evidence-experiment.”

I. THE EXPERIMENT

[1360] Since the expert opinion of the psychiatrist had already established the mental state and the character of the subject, I was concerned only with a psychological examination of the accused with regard to a possible guilt- or innocence-complex. Such an examination is called the evidence-experiment. In principle it consists in an association experiment distinguished from the usual form, in which stimulus-words are used without any ulterior motive, in that so-called critical stimulus-words taken from the evidence are interspersed with the others. In the case under consideration a list of 407 stimulus-words was used. (The experiment took more than three hours.) Of these 407 words, 271 were neutral, 96 referred to the evidence, and 40 were of an emotional nature and referred to the history and conditions of life of the subject.

[1361] Examples of evidence-words: *murder, death, to die, gas, suicide, rubber tubing, morphia, advantage, fraud, to rub out, letter, table, floor, accident, to marry, bottle, syringe, beer, ampoule, etc.*

[1362] Examples of emotional stimulus-words: *theft, Stolp,³ girl, to despise, to despair, peace, anxiety, unjust, etc.*

[1363] Experience has shown that stimulus-words referring to very emotionally charged contents of consciousness cause considerable disturbances in reaction; i.e., the subject cannot comply with the instruction to respond as quickly as possible to the stimulus-word with the word that immediately comes to his mind. The usual disturbances, which in technical language are called complex-characteristics, are these:

1. A reaction-time longer than the average (measured with a stop-watch).
2. Repetition of the stimulus-word by the subject (as if he had not heard it properly).
3. Mishearing of the stimulus-word.
4. Expressive movements (laughing, twitching of the face, etc.).
5. Reaction with more than one word.
6. Strikingly superficial reaction (purely mechanical, according to sound, etc.).
7. Meaningless reaction.
8. "Failure" (failing to give a reaction).
9. Perseveration, i.e., a disturbing influence on subsequent reactions.
10. Defective reproduction (i.e., after the experiment we try to find out whether the subject remembers the reactions he gave the first time).
11. Slips of the tongue (stammering, etc.).

[1364] To this list should be added the use of foreign words; this happens in 27 out of 34 cases (i.e., approximately 80 per cent of the cases) with critical words. In the case under observation we very often observed a slight movement of the left index-finger; this happened with 81 per cent of the critical stimulus-words and is therefore regarded as a complex-characteristic.

[1365] The exact observation, measurement, and recording of the complex-characteristics thus served the purpose of ascertaining emotionally charged contents as well as of establishing their character.

II. THE RESULTS OF THE EXPERIMENT

1. *The Reaction-time*

[1366] Stimulus-words that had no personal meaning, excluding those that immediately followed a critical stimulus-word and therefore were disturbed through perseveration of the affect, resulted in a mean reaction-time of 2.4 seconds.

[1367] Stimulus-words referring to the evidence had to be divided into two groups according to their reaction-time; namely, those with a long and those with a short reaction-time. In the latter group we usually found a perseveration-phenomenon which made itself noticeable by a prolonged reaction-time of the association immediately following. When the reaction-time of a critical association was long, then the reaction-time of the following association without personal meaning was short; i.e., it equalled the mean of the reactions without personal meaning. When the reaction-time of the critical association was short, then the following one was long. This resulted in the following picture:

Reaction-time after critical stimulus-word:

First group: long 3.2 secs.

short 2.5 ”

Second group: short 2.4 secs.

long 3.3 ”

[1368] Expressed in words: the evidence-words produce, either directly or indirectly, a reaction-time the mean prolongation of which is 0.8 and 0.9 seconds.

2. *The Complex-characteristics*

[1369] The experiment reveals the following distribution of the complex-characteristics described above:

Associations without personal meaning contain 0.6 complex-characteristics

Evidence stimulus-words contain 2.2 complex-characteristics

Emotional stimulus-words contain 2.0 complex-characteristics

[1370] Stimulus-words that are taken from the evidence produce, it appears, almost four times as many disturbing elements as stimulus-words without personal meaning; the disturbing influence of the former surpasses that of the emotional stimulus-words by 0.2.

3. *Incorrect Reproductions*

[1371] The incorrect reproductions were numbered together with the complex-characteristics. In 31.7 per cent of all reactions the memory failed. No less than 77

per cent of these mistakes occurred in the critical reactions and in those immediately following them (disturbed by perseveration). The memory fails:

In 32.5% of the emotional associations

In 36.0% of the evidence-associations

In 20.5% of the associations without personal meaning (outside the range of perseveration).

Expressed in words: the critical stimulus-words that are taken from the evidence had the greatest disturbing influence on the memory.

4. *Maximally Disturbed Associations*

[1372] Among the 407 associations of the total experiment there are 36 that are maximally disturbed, i.e., that are characterized by four complex-characteristics, or by a particularly long reaction-time, or by strong perseveration. Of these, 29 belong to the evidence stimulus-words and 7 to the emotional stimulus-words. Computed in percentages of the total number (96) of the evidence stimulus-words, there were 30.2 per cent; of the emotional stimulus-words (40), 17.5 per cent. This means that the evidence stimulus-words produced 30.2 per cent maximal disturbances and the emotional stimulus-words only 17.5 per cent. Such stimulus-words as were recognizable beforehand as without personal meaning did not produce any maximal disturbances at all.

[1373] Since the disturbances of the normal experiment always indicated the presence of affective contents (apart from accidental external influences which, however, were absent in this experiment), this rule applies, of course, in great measure to maximal disturbances.

[1374] The following were the maximally disturbed associations:

Stimulus-word	Repetition, Interjection, or Misunderstanding	R.T. ^{3a}	Reaction	Finger-movements	Reproduction	Number of C.C. ^{3a} in the critical & post- critical reactions
1. suicide	(yes)	5.0	to make-death	-	-	5/1
2. to die	(sigh)	8.8	death	+	-	5/3
3. stupid	-	6.0	not intelligent	-	-	4/2
4. to scorn	+	9.4	not to love	-	-	4/2
5. smell	-	3.0	notice nothing ⁴	+	-	5/3
6. gas	-	3.2	poison methane	+	-	5/5
7. cow	++	6.8	mammal	+	-	5/5
8. drunk	+	5.2	intoxication	-	-	4/2
9. hose	-	2.0	rubber	-	+	1/4
10. month	+	5.8	s'Munots- glöckli, ⁴ part of the year	-	-	5/1
11. to marry	-	2.6	dear—yes	-	-	4/2
12. truth	-	3.6	is best—yes	-	-	4/2
13. beer	-	6.0	I like it, I dare say ⁴	+	-	6/2
14. bottle	-	1.8	wine, beer	-	+	2/6
15. ampoule	-	4.0	adrenalin	+	-	5/2
16. to inherit	-	4.0	disinherited	+	+	5/1
17. intoxication	-	3.0	silly feeling	-	-	4/1
18. inheritance	-	4.0	without—	+	-	5/3
19. marriage	-	10.0	married	-	-	3
20. picture						
postcard	-	5.2	for sending	+	+	4/2
21. ground	-	3.2	air etc.	-	-	4/2
22. twenty-two	-	3.0	February	-	+	4/2
23. peace	-	3.0	unpeaceful	+	-	4/1
24. brush	+	4.0	to clean	-	+	3/5
25. soap	-	4.0	fatty	-	+	2/4
26. tap	-	2.8	brass	+	+	3/3
27. to despair	+	8.8	don't know	+	-	5
28. heimlich (cozy, secret)	-	2.8	nicht-unheimlich (not-uncanny)	+	-	4
29. illustrated	-	10.0	don't know what it's called	-	-	5/2
30. anxiety	+	3.6	to press	+	-	4/1
31. calf	+	4.8	cow	+	-	4/1
32. success	-	4.0	unsuccessful	-	-	4/1
33. to kill	-	3.6	how can I express myself?— unpleasant— to suffer	++	+	3/4
34. periodical	+	2.8	subscription	-	+	3/4
35. syringe	-	2.4	for injecting	+	-	4/3
36. injecting	-	3.6	injection	+	-	5/1

^{3a} [R.T. = reaction-time; C.C. = complex-characteristics.]

⁴ [Original in Swiss dialect.]

⁴ ["Little Bell-Tower of Munot," Swiss dialect song.]

[1375] As we have already mentioned, of the 36 stimulus-words 29 are taken from the evidence. Of these, 18 are designations of definite concrete phenomena, namely: *smell, gas, drink, hose, beer, bottle, ampoule, intoxication, picture postcard, ground, brush, soap, tap, illustrated, to kill, periodical, syringe, and injecting*. These constitute 62.0 per cent of the maximally disturbed evidence-reactions. In the total experiment 96 evidence stimulus-words occur and of these 53.1 per cent designate concrete phenomena. Thus the maximally disturbed reactions occur mainly in response to concrete evidence stimulus-words, and this exceeds the normal expectation by 9 per cent. In other words: it is precisely the concrete details of the evidence that prevail over the more general aspects of the evidence.

[1376] To summarize:

1. The evidence stimulus-words prevail over the emotional stimulus-words by 12.7%.
2. Among the evidence stimulus-words, those prevail that refer to concrete or otherwise distinctive details of the evidence by 9%

5. *The Minimally Disturbed Critical Associations*

[1377] 25 per cent of the evidence stimulus-words and the same percentage of emotional stimulus-words are minimally affected, i.e., less than 2 complex-characteristics. Among them there are stimulus-words of which one would under normal conditions have expected a certain effect; for instance, the wife's Christian name and the following words: *woman, to abort, cocaine, to do in, death, murder, morphia, to rub out, accident, money, poisonous, last will and testament, gaol, punishment, loss, judgment*, etc. To the stimulus-word *total*, the subject reacted with *to kill* after only 2.8 seconds.

[1378] Among the evidence stimulus-words with minimal effect there are 37.5 per cent stimulus-words that refer to concrete content of the evidence, while there are 62.0 per cent among the maximally disturbed ones. This shows that the evidence stimulus-words are distinguished from the other categories by their appreciably stronger effect.

THE EXPERT OPINION

[1379] It must be stated, in the first place, that an association experiment will, under these conditions, result as a rule in appreciably higher degrees of disturbance with critical reactions. The reason is that the critical stimulus-words invariably stir up already-existing affects which in their turn disturb the associations. The general picture of disturbance will therefore not necessarily mean a great deal. It would, however, be a most aggravating piece of circumstantial evidence in the case of a

defendant who at the preliminary inquiry had not been made acquainted with the evidence and therefore could not possibly know the details. In our case every detail of the evidence is known, even the incriminating details. Therefore the disturbance of the critical reaction is not relevant in evaluating the psychological situation. So only a consideration of small variations can promise some success. Consequently I devised the experiment in a certain way: I selected general stimulus-words that are assumed to be affectively potent, in order to obtain a yardstick for the general emotional make-up of the subject; then I selected general and special stimulus-words obtained from the evidence, in order to determine whether the general emotional situation or the special concrete evidence is in the foreground of the affective interest.

[1380] Experience has shown that a defendant who is sure of his innocence will concentrate more on the general fact of the injustice of being suspected than on any particular detail of the evidence, which is for him irrelevant. For him it is not the particular concrete details that carry a guilty and therefore confusing affective charge but the stimulus-words referring to the indignation roused by his sense of justice and to his fear of possible conviction. As our findings demonstrate beyond doubt, one subject is much less affected by the general emotional stimulus-words than by those referring to the evidence; among these, the particular concrete details prevail that carry weight for the judicial proof of guilt.

[1381] The reaction to the stimulus-word *brush* was: "I pronounce the word *brush*"; the subject is startled and repeats *brush* as if he had not properly understood the word. Then he hesitates for 4 seconds until he can say *cleaning*. The next stimulus-word, *to force*, which follows immediately, finds him unprepared because his attention is still disturbed by *brush*. So he also repeats this stimulus-word; the reaction takes as much as 6.2 seconds. Contrary to the instructions, which he usually follows, he lapses into dialect.⁵ The stimulus-word *soap*, which would in itself be harmless, produces such an after-effect that the subject cannot find any reaction at all to the stimulus-word *important* that follows, although he has a considerable vocabulary and is quite able to react quickly according to his educational standard.

[1382] Such processes are responsible for the disturbances in 62 per cent of the concrete evidence-reactions. From this fact it must be concluded that it is mainly the subject's ideas referring to the concrete details of the evidence that carry the strongest affects, and that other affects recede into the background.

[1383] That this diagnosis is not incorrect is proved by the fact that the subject himself spontaneously states, with every sign of affect, that the maximally disturbed associations to *suicide* and *to die* have touched on his suicidal ideas. Just as his ideas revolve round the theme of suicide, so they move round the concrete details of the evidence. This is statistically corroborated by our findings.

- [1384] It must be emphasized that, apart from the suicide-complex, out of four stimulus-words referring to stupidity (*stupid, sheep, cow, calf*) no less than three are maximally disturbed. This fact can only be understood as meaning that the subject experiences a very strong inner conflict because of a piece of stupid behaviour.
- [1385] The maximal disturbance at *to marry* and *marriage* indicates complications that can only be interpreted as meaning that his married life was no simple matter but of a problematical character.
- [1386] Likewise, the stimulus-words *to inherit* and *inheritance* elicit a maximal disturbance, which proves that these words too point to a background full of conflict and complication.
- [1387] The stimulus-words *clandestine* and *truth*, with maximal disturbance, indicate that the subject was not prepared to respond to these ideas.
- [1388] To summarize, and in reply to the original question, it must therefore be stated that the subject's psychological situation, as revealed by the experiment, in no way corresponds to what one would empirically expect in an innocent person. To assess the signs of a guilty conscience, however, must be left to the discretion of the judge.

BIBLIOGRAPHY

BIBLIOGRAPHY

A LIST OF PERIODICALS CITED, WITH ABBREVIATIONS

- Allg. Z. Psychiat.* = *Allgemeine Zeitschrift für Psychiatrie und psychisch-gerichtliche Medizin*. Berlin.
- Amer. J. Insan.* = *American Journal of Insanity*. Baltimore.
- Année psychol.* = *Année psychologique*. Paris.
- Arch. ges. Psychol.* = *Archiv für die gesamte Psychologie*. Leipzig.
- Arch. Kriminalanthrop.* = *Archiv für Kriminalanthropologie und Kriminalistik*. Leipzig.
- Arch. psychol.* = *Archives de psychologie de la Suisse romande*. Geneva.
- Beitr. Psychol. Aussage* = *Beiträge zur Psychologie der Aussage*. Leipzig.
- Brain* = *Brain. A Journal of Neurology*. London.
- C.R. Soc. Biol. Paris* = *Comptes rendus hebdomadaires des séances et mémoires de la Société de Biologie*. Paris.
- J. Abnorm. Psychol.* = *Journal of Abnormal Psychology*. Boston.
- J. Psychol. Neurol.* = *Journal für Psychologie und Neurologie*. Leipzig.
- Jb. Psychiat. Neurol.* = *Jahrbuch für Psychiatrie und Neurologie*. Leipzig and Vienna.
- Jb. psychoanal. psychopath. Forsch.* = *Jahrbuch für psychoanalytische und psychopathologische Forschungen*.
Leipzig and Vienna.
- Jurist.-psychiat. Grenzfr.* = *Juristisch-psychiatrische Grenzfragen*. Halle.
- Med. Wschr. St. P.* = *St. Petersburger Medizinische Wochenschrift*. St. Petersburg (Leningrad).
- M Schr. Kriminalpsychol.* = *Monatsschrift für Kriminalpsychologie und Strafrechtsreform*. Heidelberg.
- M Schr. Psychiat. Neurol.* = *Monatsschrift für Psychiatrie und Neurologie*. Berlin.
- Neurol. Zbl.* = *Neurologisches Zentralblatt*. Leipzig.
- Pflüg. Arch. ges. Psychol.* = *(Pflügers) Archiv für die gesamte Psychologie*. Bonn and Leipzig.
- Psychiat.-neurol. Wschr.* = *Psychiatrisch-neurologische Wochenschrift*. Halle.
- Psychol. Bull.* = *Psychological Bulletin*. Lancaster, Pa. and New York.
- Rev. phil.* = *Revue philosophique de France et de l'Étranger*. Paris.
- Rif. med.* = *Riforma medica*. Rome.
- Riv. psicol.* = *Rivista di psicologia applicata*. Bologna.
- Samml. Abh. pädag. Psychol.* = *Sammlung von Abhandlungen aus dem Gebiete der pädagogischen Psychologie und Physiologie*. Berlin.
- Wien. klin. Rdsch.* = *Wiener klinische Rundschau*. Vienna.
- Z. angew. Psychol.* = *Zeitschrift für angewandte Psychologie*. Leipzig.

Z. ges. Strafrechtswiss. = *Zeitschrift für die gesamte Strafrechtswissenschaft*. Berlin.

Z. Psychol. Physiol. Sinnesorg. = *Zeitschrift für Psychologie und Physiologie der Sinnesorgane*. Leipzig.

Zbl. Nervenheilk. = *Zentralblatt für Nervenheilkunde und Psychiatrie*. Berlin.

B. GENERAL BIBLIOGRAPHY

ASCHAFFENBURG, GUSTAV. "Experimentelle Studien über Assoziationen." In: KRAEPELIN, *Psychol. Arb.*, I (1896), 209–99; II (1899), 1–83; IV (1904), 235–374.

BECHTEREW, W. M. VON. "Über die Geschwindigkeitsveränderungen der psychischen Prozesse zu verschiedenen Tageszeiten," *Neurol. Zbl.*, XII (1893), 290–92.

_____. "Über zeitliche Verhältnisse der psychischen Prozesse bei in Hypnose befindlichen Personen," *Neurol. Zbl.*, XI (1892), 305–7.

BINSWANGER, LUDWIG. "On the Psychogalvanic Phenomenon in Association Experiments." In: JUNG, *Studies in Word-Association*, (1918), pp. 446–530. (Orig. 1907/8.)

BLEULER, PAUL EUGEN. *Affektivität, Suggestibilität, Paranoia*. Halle, 1906; 2nd edn., 1926. (See "Affectivity, Suggestibility, Paranoia," translated by Charles Ricksher, *New York State Hospital Bulletin* (Utica), Feb. 1912.)

_____. "Consciousness and Association." In: JUNG, *Studies in Word-Association* (1918), pp. 266–96. (Orig. 1905.)

_____. "Upon the Significance of Association Experiments." In: *Ibid.*, pp. 1–7. (Orig. 1904.)

_____. "Versuch einer naturwissenschaftlichen Betrachtung der psychologischen Grundbegriffe," *Allg. Z. Psychiat.*, L (1894), 133–68.

BONHÖFFER, KARL. *Der Geisteszustand des Alkoholdeliranten*. Breslau, 1897.

BOURDON, B. "Recherches sur la succession des phénomènes psychologiques," *Rev. phil.*, XXXV (1893), 225–60.

BREUER, JOSEF, and FREUD, SIGMUND. *Studies on Hysteria*. Translated by James and Alix Strachey. In: FREUD, *Standard Edition*, 2. (Orig.: *Studien über Hysterie*, 1895.)

BREUKINK, H. "Über Ermüdungskurven bei Gesunden und bei einigen Neurosen und Psychosen," *J. Psychol. Neurol.*, IV:3 (1904), 85–108.

BRILL, A. A. "A Case of Schizophrenia (Dementia Praecox)," *Amer. J. Insan.*, LXVI (1909–10), 53–70.

_____. "Psychological Factors in Dementia Praecox, an Analysis," *J. Abnorm. Psychol.*, III (1908–9), 219–38.

CATTELL, JAMES MCKEEN. "Psychometrische Untersuchungen," I and II. In: WUNDT, *Philosophische Studien*, III (1885), 305–36, 452–92

CLAPARÈDE, ÉDOUARD. *L'Association des idées*. Paris, 1903.

_____. "Association médiate dans l'évocation volontaire," *Arch. psychol.*, III (1904), 201–3.

_____ and ISRAÏLOVITCH, D. "Influence du tabac sur l'association des idées," *C.R. Soc. Biol. Paris*, LIV (1902), 758–60.

COLUCCI, CESARE. "L'Allenamento ergografico nei normali e negli epilettici," *Rif. med.*, Anno XVIII, vol. I (1902), 424–28.

- CORDES, G. "Experimentelle Untersuchungen über Assoziationen." In: WUNDT, ed., *Philosophische Studien*, XVII (1901), 30–77.
- DELABARRE, E. BURKE. *Über Bewegungsempfindungen*. Freiburg i. Baden, 1891. See *Rev. phil.*, XXXIII (1892), 342–43, a review of it.
- FÉRÉ, CHARLES SAMSON. "Note sur des modifications de la résistance électrique sous l'influence des excitations sensorielles et des émotions," *C.R. Soc. Biol. Paris*, 3 Mar. 1888.
- FÉRÉ, CHARLES SAMSON. "Note sur des modifications de la tension électrique dans le corps humain," *C.R. Soc. Biol. Paris*, 14 Jan. 1888.
- _____. *The Pathology of the Emotions*. Translated by R. Park. London, 1899. (Orig.: *La Pathologie des émotions*, 1892.)
- FREUD, SIGMUND. *The Standard Edition of the Complete Psychological Works*. Translated under the general editorship of James Strachey. 24 vols. London, 1953–
- _____. "Analysis of a Phobia in a Five-Year-Old Boy." Translated by Alix and James Strachey. Standard Edition, 10, pp. 5–147. (Orig.: "Analyse der Phobie eines 5-jährigen Knaben," 1909.)
- _____. "Five Lectures on Psycho-Analysis." Translated by James Strachey. Standard Edition, 11, pp. 3–55. (Orig.: "Über Psychoanalyse," 1910.)
- _____. "Fragment of an Analysis of a Case of Hysteria." Translated by Alix and James Strachey. Standard Edition, 7, pp. 7–122. (Orig.: "Bruchstück einer Hysterie-Analyse," 1905.)
- _____. *The Interpretation of Dreams*. Translated by James Strachey. Standard Edition, 4, 5. (Orig.: *Die Traumdeutung*, 1900.)
- _____. *Jokes and Their Relation to the Unconscious*. Translated by James Strachey. Standard Edition, 8. (Orig.: *Der Witz und seine Beziehung zum Unbewussten*, 1905.)
- _____. "The Neuro-Psychoses of Defence." Translated by John Rickman. Standard Edition, 3, pp. 45–61. (Orig.: "Die Abwehr-Neuropsychosen," 1894.)
- _____. "On the History of the Psycho-Analytic Movement." Translated by Joan Riviere. Standard Edition, 14, pp. 3–66. (Orig.: "Zur Geschichte der psychoanalytischen Bewegung," 1914.)
- _____. "The Psychological Mechanism of Forgetfulness." Translated by James Strachey. Standard Edition, 3, pp. 287–97. (Orig.: "Zum psychischen Mechanismus der Vergesslichkeit," 1898.)
- _____. "Psycho-analysis and the Establishment of the Facts in Legal Proceedings." Translated by James Strachey. Standard Edition, 9. (Orig.: "Tatbestandsdiagnostik und Psychoanalyse," *Arch. Kriminalanthrop.*, XXVI: 1 (1906), 1–10.)
- _____. *The Psychopathology of Everyday Life*. Translated by Alan Tyson. Standard Edition, 6. (Orig.: *Zur Psychopathologie des Alltagslebens*, 1904.)
- _____. "Screen Memories." Translated by James Strachey. Standard Edition, 3, pp. 303–22. (Orig.: "Über Deckerinnerungen," 1899)
- _____. See also BREUER.
- FUHRMANN, M. *Analyse des Vorstellungsmaterials bei epileptischem Schwachsinn*. Dissertation, Giessen, 1902.

- FÜRST, EMMA. "Statistical Investigations on Word-Associations and on Familial Agreement in Reaction Type among Uneducated Persons." In: JUNG, *Studies in Word-Association* (1918), pp. 407–45 (Orig. 1907.)
- GALTON, FRANCIS. "Psychometric Experiments," *Brain*, II (1897), 149–62.
- GRABOWSKY, ADOLF. "Psychologische Tatbestandsdiagnostik," *Beilage zur Allgemeine Zeitung* (Tübingen), 15 Dec. 1905.
- GROSS, ALFRED. "Die Assoziationsmethode im Strafprozess," *Z. ges. Strafrechtswiss.*, XXVI (1906), 19–40.
- _____. "Kriminalpsychologische Tatbestandsforschung," *Jurist.-psychiat. Grenzfr.*, V:7 (1907).
- _____. "Zur psychologischen Tatbestandsdiagnostik," *M Schr. Kriminalpsychol.*, II (1905–6), 182–84.
- _____. "Zur psychologischen Tatbestandsdiagnostik als kriminalistisches Hilfsmittel," *Beitr. Psychol. Aussage*, 11:3 (1905–6), 150–53 (436–39) (Reprinted from *Allgemeine Österreichische Gerichtszeitung*, LVI, no. 17.)
- GROSS, HANS. "Zur Frage des Wahrnehmungsproblems," *Beitr. Psychol. Aussage*, II: 2 (1905–6), 128–34 (258–64).
- _____. "Zur psychologischen Tatbestandsdiagnostik," *Arch. Kriminalanthrop.*, XIX (1905), 49–59.
- HEILBRONNER, KARL. "Die Grundlagen der psychologischen Tatbestandsdiagnostik," *Z. gess. Strafrechtswiss.*, XXVII (1907), 601–56.
- _____. "Über epileptische Manie nebst Bemerkungen über die Ideenflucht," *M Schr. Psychiat. Neurol.*, XIII (1903), 193–209, 269–90.
- HOCH, AUGUST. Review of Jung, "Über das Verhalten der Reaktionszeit beim Assoziationsexperimente" and "Experimentelle Beobachtungen über das Erinnerungsvermögen" (= papers 3 and 4 in present vol.) and "Zur psychologischen Tatbestandsdiagnostik" (= final paper in Coll. Works, 1), *J. Abnorm. Psychol.*, I:2 (June 1906), 95–100.
- ISSERLIN, MAX. "Über Jung's 'Psychologie der Dementia praecox' und die Anwendung Freud'scher Forschungsmaximen in der Psychopathologie," *Zbl. Nervenheilk.*, XXX, n.s. XVIII (1 May 1907). 329–43.
- JANET, PIERRE. *Les Obsessions et la psychasthenic*. 2 vols., Paris, 1903.
- JERUSALEM, M. "Ein Beispiel von Assoziation durch unbewusste Mittelglieder." In: WUNDT, *Philosophische Studien*, X (1892), 323–25.
- JUNG, CARL GUSTAV. "The Analysis of Dreams." In: *Freud and Psychoanalysis*. Coll. Works, 4.
- _____. *Analytical Psychology: Its Theory and Practice. The Tavistock Lectures* [1935]. New York and London, 1968. To be included in Coll. Works, 18.
- _____. "Associations d'idées familiales," *Arch. psychol.*, VII:26 (1907), 160–68.
- _____. "A Case of Hysterical Stupor in a Prisoner in Detention." In: *Psychiatric Studies*. Coll. Works, 1.
- _____. *Freud and Psychoanalysis*. Coll. Works, 4.
- _____. *Memories, Dreams, Reflections*. Recorded and edited by Aniela Jaffé. New York and London, 1962. (Diff. paginated edns.)
- _____. "Psychological Conflicts in a Child." In: *The Development of Personality*. Coll. Works, 17.
- _____. "On the Psychological Diagnosis of Facts." In: *Psychiatric Studies*, Coll. Works, 1.

- _____. "On the Psychology and Pathology of So-Called Occult Phenomena." In: *Psychiatric Studies*. Coll. Works, 1.
- _____. "On Simulated Insanity." In: *Psychiatric Studies*, Coll. Works, 1.
- _____. *Psychiatric Studies*. Coll. Works, 1.
- _____. *The Psychogenesis of Mental Disease*. Coll. Works, 3.
- _____. "The Psychology of Dementia Praecox." In: *The Psychogenesis of Mental Disease*. Coll. Works, 3.
- _____. "The Significance of the Father in the Destiny of the Individual." In: *Freud and Psychoanalysis*. Coll. Works, 4.
- _____. ed. *Studies in Word-Association*. Translated by M. D. Eder. London and New York, 1918.
- KANT, IMMANUEL. *Critique of Pure Reason*. Translated by J.M.D. Meiklejohn. London and New York (Everyman's Library), 1934.
- KRAEPELIN, EMIL. *Experimentelle Studien über Assoziationen*. Freiburg, 1883.
- _____. *Psychiatrie: Ein Lehrbuch für Studierende und Ärzte*. 7th edn., 2 vols., Leipzig, 1904. (Cf. *Clinical Psychiatry; a Text-book for Students and Physicians*. Abstracted and adapted from the 7th German edn. by A. Ross Diefendorf. New edn., rev. & augmented, New York, 1907.)
- _____. "Über den Einfluss der Übung auf die Dauer von Assoziationen," *Med. Wschr. St. P.*, n.s., VI (1889), 9–10.
- _____. *Über die Beeinflussung einfacher psychischer Vorgänge durch einige Arzneimittel*. Jena, 1892.
- _____, ed. *Psychologische Arbeiten*. 9 vols., Leipzig, 1896–1928.
- KRAFFT-EBING, RICHARD VON. *Psychopathia Sexualis*. Translated by F. J. Rebman. London, 1901. (Orig. 1886.)
- KRAMER, F., and STERN, W. "Selbstverrat durch Assoziation," *Beitr. Psychol. Aussage*, II:4 (1905–6), 1–32.
- KRAUS, O. "Psychologische Tatbestandsdiagnostik," *M Schr. Kriminalpsychol.*, II (1905), 58–61.
- LEDERER, MAX. "Die Verwendung der psychologischen Tatbestandsdiagnostik in der Strafrechtspraxis," *M Schr. Kriminalpsychol.*, III (1906), 163–72.
- _____. "Zur Frage der psychologischen Tatbestandsdiagnostik," *Z. ges. Strafrechtswiss.*, XXVI (1906), 488–506.
- LEHMANN, ALFRED. *Die Hauptgesetze des menschlichen Gefühlslebens*. Leipzig, 1892.
- LIEPMANN, HUGO. *Über Ideenflucht, Begriffsbestimmung und psychologische Analyse*. Halle, 1904.
- MARTIUS, GÖTZ, and MINNEMANN, C. *Beiträge zur Psychologie und Philosophie*, vol. I, part 4. Leipzig, 1905. (Martius, "Über die Lehre von der Beeinflussung des Pulses und der Atmung durch psychische Reize," pp. 411–513; Minnemann, "Atmung und Puls bei aktuellen Affekten," pp. 514–51.)
- MAYER, A., and ORTH, J. "Zur qualitativen Untersuchung der Assoziationen," *Z. Psychol. Physiol. Sinnesorg.*, XXVI (1901), 1–13.
- MEIER, C. A. *Die Empirie des Unbewussten*. (Lehrbuch der Komplexen Psychologie C. G. Jungs, 1.) Zurich, 1968.
- MEIGE, HENRY, and FEINDEL, E. *Tics and Their Treatment*. Translated by S.A.K. Wilson. London, 1907. (Orig. 1902.)
- MENTZ, PAUL. "Die Wirkung akustischer Sinnesreize auf Puls und Atmung." In: WUNDT, *Philosophische Studien*, XI (1893), 61–124, 371–93. 563–603.

- MEYER, ADOLF. "Normal and Abnormal Associations" (review of Jung and Riklin, "Experimentelle Untersuchungen über Assoziationen Gesunder" = paper 1 in present vol.), *Psychol. Bull.*, II:7 (1905), 242–50. (251–59 continues with review of other association studies by Jung, Wehrlin, and Riklin.)
- MINNEMAN, C. See MARTIUS.
- MOSSO, ANGELO. *Über den Kreislauf des Blutes im menschlichen Gehirn*. Leipzig, 1881.
- MÜLLER, E. K. "Über den Einfluss psychischer und physiologischer Vorgänge auf das elektrische Leitvermögen des menschlichen Körpers," *Schweizerische Naturforschende Gesellschaft; Verhandlungen*, LXXXVII (1904), 79–80 (summary of paper read 1 Aug. 1904 to Section for Medicine).
- MÜLLER, GEORG E., and PILZECKER, A. "Experimentelle Beiträge zur Lehre vom Gedächtnis," *Z. Psychol. Physiol. Sinnesorg.*, Ergänzungsband I (1900).
- MÜNSTERBERG, HUGO. "Die Assoziation sukzessiver Vorstellungen," *Z. Psychol. Physiol. Sinnesorg.*, I (1890), 99–107.
- _____. *Beiträge zur experimentellen Psychologie*. 4 vols., Freiburg, 1889–92.
- NUNBERG, HERMANN. "On the Physical Accompaniment of Association Processes." In: JUNG, *Studies in Word-Association* (1918), pp. 531–60. (Orig. 1910.)
- PICK, ARNOLD. "Zur Psychologie des Vergessens bei Geistes- und Nervenkranken," *Arch. Kriminalanthrop.*, XVIII (1905), 251–61.
- PIÉRON, H. "L'Association médiate," *Rev. phil.*, XXVIII (1903), 147.
- RAIMANN, EMIL. *Die hysterischen Geistesstörungen*. Leipzig and Vienna, 1904.
- RANSCHBURG, PAUL, and BALINT, EMERICH. "Über quantitative und qualitative Veränderungen geistiger Vorgänge im hohen Greisenalter," *Allg. Z. Psychiat.*, LVII (1900), 689–718.
- _____, and HAJÓS, LAJOS. *Beiträge zur Psychologie des hysterischen Geisteszustandes*. Leipzig and Vienna, 1897.
- RIKLIN, FRANZ. "Analytische Untersuchungen der Symptome und Assoziationen eines Falles von Hysterie (Lina H.)," *Psychiat.-neurol. Wschr.*, 46–52 (1905), 449, 464, 469, 481, 493, 505, 521.
- _____. "Cases Illustrating the Phenomena of Association in Hysteria." In: JUNG, *Studies in Word-Association* (1918), pp. 322–53. (Orig. 1906.)
- _____. "Hebung epileptischer Amnesien durch Hypnose," *J. Psychol. Neurol.*, I:5/6 (1902), 200–25.
- _____. "Die diagnostische Bedeutung des Assoziationen bei der Hysterie," *Psychiat.-neurol. Wschr.*, VI:29 (1904).
- _____. *Wish Fulfilment and Symbolism in Fairy Tales*. Translated by William A. White. New York, 1915. (Orig.: *Wunscherfüllung und Symbolik im Märchen*, 1908.)
- _____. "Zur Psychologie hysterischer Dämmerzustände und des Ganser'schen Symptoms," *Psychiat.-neurol. Wschr.*, VI:22 (1904), 185–90, 193–200.
- RÜDIN, ERNST. "Über die Dauer der psychischen Alkoholwirkung." In: KRAEPELIN, *Psychol. Arb.*, IV:1 (1901), 1–44.
- _____. "Auffassung und Merkfähigkeit unter Alkoholwirkung." In: KRAEPELIN, *Psychol. Arb.*, IV:3 (1902), 495–522.

- SCHNITZLER, J. G. "Experimentelle Beiträge zur Tatbestandsdiagnostik," *Z. angew. Psychol.*, II (1909), 51–91.
(Extracted from medical diss., Utrecht, 1907.)
- SCHÜLE, HEINRICH. *Klinische Psychiatrie*. Leipzig, 1886.
- SCRIPTURE, E. W. "Über den assoziativen Verlauf der Vorstellungen." In: WUNDT, *Philosophische Studien*, VII (1889), 50–146.
- SMITH, WILLIAM. *Zur Frage der mittelbaren Assoziation*. Dissertation, Leipzig, 1894.
- SOMMER, ROBERT. *Lehrbuch der psychopathologischen Untersuchungsmethoden*. Berlin and Vienna, 1899.
- _____. "Zur Messung der motorischen Begleiterscheinungen psychischer Zustände," *Beiträge zur Psychiatrischen Klinik* (Berlin and Vienna), I (1902), 143–64.
- _____, and FÜRSTENAU, ROBERT. "Die elektrischen Vorgänge an der menschlichen Haut," *Klinik für psychische und nervöse Krankheiten* (Halle), I (1906):3, 197–207.
- STERN, WILLIAM. "Psychologische Tatbestandsdiagnostik," *Beitr. Psychol. Aussage*, II (1905–6), 145–47 (275–77).
- STICKER, GEORG. "Über Versuche einer objektiven Darstellung von Sensibilitätsstörungen," *Wien. klin. Rdsch.*, II (1897), 497–501, 514–18.
- STRANSKY, ERWIN. *Über Sprachverwirrtheit*. (Sammlung Zwangloser Abhandlungen aus dem Gebiete der Nerven- und Geisteskrankheiten, VI, 4/5.) Halle, 1905. (See review by Lewandowsky, *Zbl. Nervenheilk.*, XXVIII, n.s. XVI (15 Nov. 1905), 879, answered by Stransky, *ibid.* (15 Dec. 1905), 963–64.)
- _____. "Zur Kenntnis gewisser erworbener Blodsinnformen," *Jb. Psychiat. Neurol.*, XXIV (1903), 1–149.
- STRANSKY, ERWIN. "Zur Auffassung gewisser Symptome der Dementia Praecox," *Neurol. Zbl.*, XXIII (1904), 1074–85, 1137–43.
- TARCHANOFF, J. "Über die galvanischen Erscheinungen an der Haut des Menschen bei Reizungen der Sinnesorgane und bei verschiedenen Formen der psychischen Tätigkeit," *Pflüg. Arch. ges. Physiol.*, XLVI (1890), 46–55.
- THUMB, ALBERT, and MARBE, KARL. *Experimentelle Untersuchungen über die psychologischen Grundlagen der sprachlichen Analogiebildung*. Leipzig, 1901.
- TRAUTSCHOLDT, MARTIN, "Experimentelle Untersuchungen über die Assoziation der Vorstellungen." In: WUNDT, *Philosophische Studien*, I (1883), 213–50.
- VERAGUTH, OTTO. "Le Réflexe psycho-galvanique," *Compte rendu du II^{me} Congrès allemand de psychologie expérimentale*. Würzburg, 1906. (See report by E. Claparède: *Arch. psychol.*, VI (1907), 162–63.)
- _____. "Das psycho-galvanische Reflex-Phänomen," *M Schr. Psychiat. Neurol.*, XXI (1907), 387–425.
- VIGOUROUX, A. *Étude sur la résistance électrique chez les mélancoliques*. Thesis, Paris, 1890.
- VIGOUROUX, R. "L'Électricité du corps humain," *C.R. Soc. Biol. Paris*, 11 Feb. 1888.
- _____. "Sur la résistance électrique considérée comme signe clinique," *Le Progrès médicale*, 21 Jan., 4 Feb. 1888.
- WALITSKY, MARIE. "Contribution a l'étude des mensurations psychometriques des aliénés," *Rev. phil.*, XXVIII (1889), 583–95.
- WEHRLIN, K. "The Associations of Imbeciles and Idiots." In: JUNG, *Studies in Word-Association* (1918), pp. 173–205. (Orig. 1904.)

- WERTHEIMER, MAX. "Experimentelle Untersuchungen zur Tatbestandsdiagnostik," *Arch. ges. Psychol.*, VI (1905–6), 59–131.
- _____. "Zur Tatbestandsdiagnostik," *Arch. ges. Psychol.*, VII:1 (Mar. 1906), Literaturbericht, 139–40.
- _____, and KLEIN, JULIUS. "Psychologische Tatbestandsdiagnostik," *Arch. Kriminalanthrop.*, XV (1904), 72–113.
- WEYGANDT, WILHLLM. "Zur psychologischen Tatbestandsdiagnostik," *M Schr. Kriminalpsychol.*, II (1905), 135–38.
- WRESCHNER, ARTHUR. "Eine experimentelle Studie über die Assoziation in einem Falle von Idiotie," *Allg. Z. Psychiat.*, LVII (1900), 241–339.
- WUNDT, WILHELM. "Sind die Mittelglieder einer mittelbaren Assoziation bewusst oder unbewusst?" In: WUNDT, *Philosophische Studien*, X (1892), 326–28.
- _____, ed. *Philosophische Studien*. 20 vols., Leipzig, 1883–1902.
- ZIEHEN, GEORG THEODOR. "Die Ideenassoziation des Kindes," *Samml. Abh. pädog. Psychol.*, I:6 (1898), III:4 (1900).
- _____. *Introduction to Physiological Psychology*. Translated by C. G. van Liew and O. W. Beyer. London and New York, 2nd edn., 1895. (Orig.: *Leitfaden der physiologischen Psychologie*, 1891; 2nd edn., 1893.)
- _____, ed. *Sammlung von Abhandlungen aus dem Gebiete der pädagogischen Psychologie*. 8 vols., Berlin, 1898–1906.
- ZONEFF, P., and MEUMANN, E. "Über Begleiterscheinungen psychischer Vorgänge im Atem und Puls." In: WUNDT, *Philosophische Studien*, XVIII (1900), 1–112.

INDEX

INDEX

A

- abasia, hysterical, [424](#)
- aboulia, [360](#)
- abreaction, [316f](#)
- adjectives, [21f](#), [185](#), [188ff](#), [229–33](#)
 - reactions to, [16](#), [21f](#), [24](#)
- affects: association and, [72](#), [74](#), [119](#), [418](#)
 - in complexes, [601](#)
 - in hysteria, [423](#)
- alcoholic intoxication (alcoholism), [42](#), [52f](#), [139f](#), [172n](#), [415](#)
 - in family constellation, [473](#), [475](#)
 - galvanometer experiments, [489f](#), [574f](#)
 - of recruits, [584f](#)
 - wife and daughter of drunkard, [473](#)
- Alt, Konrad, [85](#)
- amnesia, hysterical, [285f](#), [325](#)
- amnesic blockages, [285f](#)
- analyst: attitude of, [289f](#), [304](#)
 - patient in love with, [389–99](#)
 - suggestion by, [421f](#)
 - transference to, [373](#)
- A-phenomenon, [8](#)
- apperception, [138](#)
- Aristotle, [409](#)
- Aschaffenburg, Gustav, [139](#), [141](#), [205](#), [216n](#), [229f](#), [232f](#), [409](#), [524](#)
 - association studies, [9](#), [11f](#), [18f](#), [22](#), [25](#), [27](#), [34](#), [50](#), [52f](#), [65n](#), [411–15](#)
 - on duration of association, [224](#), [227](#)
 - fatigue and attention studies, [40n](#), [42](#), [320](#), [413f](#)
- association: definition of, [9f](#), [319](#)

duration of, [224ff](#)
free, [273](#), [289](#), [304](#)
law of, [410f](#), [415](#)

association, examples of: bone/bed, [240f](#)
Bunau-Varilla/cigar, [173](#)
in hysteria, [371–82](#)
Morgenrock/Taganrog, [252](#)
in theft case, [323–27](#), [335–41](#)
water, drowning associated with, [325–28](#), [486](#), [526](#)

association experiments (association method), [3–196](#), [439–63](#), [598](#)
averages, [137–45](#), [162–71](#), [176–89](#)
controls in, [343–48](#)
criminal investigation, *see* evidence, psychological diagnosis of
in dementia praecox, [547–53](#)
disturbances of reproduction in, [426–38](#)
educated men, [70–101](#), [167](#), [186ff](#)
educated subjects, [7f](#), [10](#), [142–48](#), [186f](#), [226ff](#), [230–34](#), [267ff](#), [415f](#), [525](#)
educated women, [40–70](#), [166](#), [179f](#)
in epilepsy, [197–220](#)
family constellation, [466–79](#)
galvanometer, *see* galvanometer experiments
historical development of, [319f](#)
in hysteria, [353–83](#), [442ff](#), [448–51](#)
men and women compared, [143f](#), [162–68](#), [176–80](#), [226ff](#), [422f](#)
procedure, [5–9](#), [331](#)
psychoanalysis and, [288–317](#), [599f](#)
psychopathological significance, [408–25](#)
uneducated men, [129–37](#), [141f](#), [165](#)
uneducated subjects, [6f](#), [10](#), [103](#), [141f](#), [144–48](#), [186f](#), [204](#), [226ff](#), [230–34](#), [267ff](#),
[415ff](#), [525](#)
uneducated women, [101–28](#), [141f](#), [164](#), [178f](#), [186ff](#)

associations, classification of, [9–39](#)
analytical, [16](#), [19ff](#)
canalized, [25f](#)
causal, [24](#)

co-existence, 24f
contrast, 18, 25
co-ordination, 14–17, 20, 23
egocentric, 33
emotional types, 458ff
external, 15, 24–27, 412
identity, 25
indirect, 28f, 32
internal, 14–24, 412
linguistic connection, 35f
objective type, 458
perseveration, 33ff
predicate, 19–24
repetition, 35
sound, 27f, 412
subordination, 17
superordination, 17f
synthetic, 19ff; *see also specific entries, e.g.,* egocentric reactions; perseveration;
 sound associations

attention, 4, 137f, 415, 525
 blunting of, 52f, 55, 60, 70, 73–77
 degree of, 146f
 in dementia praecox, 515
 distraction of, *see* distraction
 disturbances of, 44, 50, 52f, 55, 70, 73, 139f, 320, 589
 in galvanometer and pneumograph experiments, 498, 556

attention phenomenon, 150f
attentive reaction, 43f
attitude phenomenon, 73f, 76
audition colorée (synesthesia), 56f
Australasian Medical Congress (1911), 598n
autohypnosis, 53
automatism, 402ff, 406
 linguistic, 55
autonomy (autonomous complexes), 601f

B

Balint, Emerich, [10n](#), [23](#), [141](#), [226n](#),

Baroncini, L., [586n](#)

Binswanger, Ludwig, [490](#), [496](#), [530](#), [542](#), [555](#), [590](#)

black man, dream of, [389–93](#), [405f](#)

Bleuler, Paul Eugen, [3](#), [73](#), [204n](#), [262n](#), [290](#) [320](#), [332n](#), [386n](#), [492](#), [498](#), [525](#), [536](#), [603](#)

blood: dreams of, [384](#), [390](#)

 hysterical attitude towards, [354](#), [404](#)

Bonhöffer, Karl, [172n](#)

Bourdon, B., [12](#), [36](#)

breathing, *see* respiration

Breuer, Josef, [191n](#), [272](#), [288](#), [33n](#)

Breukink, H., [198](#)

Brill, A. A., [vi](#), [439n](#), [466](#), [492n](#)

brother: in dreams, [396–99](#)

 neurotic attachment to, [476](#)

Burgholzli Cantonal Hospital, [200](#), [379n](#), [606](#)

C

catatonia, [43](#), [172n](#), [287](#)

 galvanometer and pneumograph experiments in, [510](#), [512ff](#), [524](#), [571](#)

 in hysteria, [516](#)

catatonic stupor, [519ff](#)

cats, dream of, [384ff](#)

cursor, [251](#)

centrifugal sound-shift, [29f](#), [32](#)

centripetal sound-shift, [30ff](#)

children, parents in character development of, [474f](#), [478f](#)

chorea, hysterical, [353ff](#), [374f](#), [400–406](#)

chronograph, Jaquet, [485](#), [555](#)

chronoscope, [232](#)

clang, *see* sound associations; sound-shift

Claparède, Édouard, [12](#), [172](#), [174](#), [221](#), [223](#), [409n](#), [603](#)

Clark University, Worcester, Mass., [439n](#). [603](#)

cleanliness compulsion, [355](#), [396](#)

Colucci, Cesare, 198

complex(es), 128, 136, 290, 321*f* 324*f*, 526*ff*, 598*ff*

concealed, 458

definition of, 321, 599

doctrine of, 598–604

masked reactions, 109

sexuality in, 82, 256*f*

suppression and, 150*f*

the unconscious and, 86–92; *see also specific entries, e.g., erotic complex; feeling-toned complexes*

complex-characteristics, 261 *ff*, 273, 284, 287, 295, 382*f*, 426*ff*, 589*f*, 606*ff*

complex-constellation, *see* constellations

complex-constellation type, 149, 159*ff*, 204, 458, 460

complex-image, 418*f*

compound words as reactions, 26

concepts: abstract, 20*f*

common intermediate, 29

concrete, 20*f*

consciousness, association and, 245, 253

constellations (complex-constellations), 78, 80–83, 90*f*, 94*f*, 97, 100*f*, 103*ff*, 108*f*, 115, 122*f*, 125, 130, 135*f*, 290*f*, 322, 426*f*

definition of, 322

emotionally charged, *see* emotionally charged complexes *and* feeling-toned complexes

in epilepsy, 211, 218*f*

family, 466–79

in hysteria, 382*f*

in imbeciles, 81, 200

reaction-time and, 109, 122*f*, 216*n*, 217, 237, 244*f*, 262, 278*f*, 284, 324–28

constellation type: complex, 149, 159*ff*

simple, 149, 156*ff*

co-ordination in association, 14–17, 20, 23, 73, 92

Cordes, G., 8*f*, 30, 175*n*, 319

crime, *see* evidence, psychological diagnosis of

D

Davidson, Andrew, [598n](#)

death, obsession with, [292f](#), [300](#),

definition type, [458ff](#); *see also* explanation of stimulus-word

Delabarre, E. Burke, [506](#), [556](#)

dementia, [602f](#)

dementia paranoides, *see* paranoia

dementia praecox, [252](#), [328](#), [424f](#), [476](#)

association in, [547–53](#)

complexes in, [602](#)

dreams in, [395f](#)

galvanometer and pneumograph experiments in, [496](#), [514–24](#), [547–53](#), [571ff](#)

hysteria and, [576ff](#)

nature of, [514–18](#)

Diagnostic Association Studies (*Diagnostische Assoziationsstudien*), [3n](#), [291](#), [429](#), [485](#),
[587n](#), [598](#), [603f](#)

dinner table, dream of, [394–98](#), [405](#)

directional idea, [138](#)

distractibility, [52](#)

distraction: acoustic disturbance, [108f](#)

effects of, [137ff](#)

experiments, averages, [163–71](#)

in hysteria, [359f](#), [362](#)

motor excitation and, [52](#)

by surroundings, [111f](#)

of uneducated subjects, [103](#)

dogs, dreams of, [386–89](#)

dreams: in dementia praecox, [395f](#)

erotic, [312](#)

father in, [393f](#), [477f](#)

in hysteria, [383–400](#)

INSTANCES, *see* black man

blood

brother

cats
dinner table
dogs
father
fire
fire alarm
money
mother

drowning, water associated with, 325–28, 486, 526

drowsiness, 52*f*, 70, 100*f*

E

eating, symbolism of, 394*f*

Eder, M. D., vi

egocentric reactions, 33, 141*f*, 144, 146, 149*f*, 156–62, 176*f*, 178, 184

in epilepsy, 210, 212, 214*f*

of imbeciles and idiots, 200, 206*ff*

ego-complex, 245, 250*f*, 290, 601

ego-consciousness, 245, 289

electrical resistance, 483, 554*f*

Ellis, Havelock, 598*n*

emotion: in association, 210

in dementia praecox, 514*f*, 518

in galvanometer experiments, 499, 503*f*

emotional attitudes, classified, 458*ff*

emotionally charged complexes, 72, 77, 82, 94*f*, 104, 109, 115–19, 122, 127*f*, 290, 321*n*, 418*n*, 606*f*

definition of, 72*n*

in hysteria, 360

of imbeciles, 206

reaction-time and, 234*ff*

slips of the tongue and, 214*ff*

in value judgments, 57, 62; *see also* feeling-toned complexes

emotional stupidity, 86, 176, 199*f*,

enlistment, study of, 583*ff*

epilepsy: association in, 197–220
constellations in, 211, 218f
flight of ideas in, 43
galvanometer experiments in, 568ff
indirect association in, 172
reaction-time in, 214f, 216–19
traits of character, 197

ergograph, 484, 555

erotic complex, 97f, 137, 294–304, 422f
in dreams, 312, 384–400
in hysteria, 373–81, 400–406
reaction-time in, 111, 246–57

evaluation in reaction, 211f; *see also* value judgments

evidence, psychological diagnosis of, 290, 318f, 330–52, 452–57, 486, 586–96, 599, 605–14
Näf trial, 605–14
nurse suspected of theft, 452–57, 592–95
results, calculation of, 454–57
young man suspected of theft, 333–52, 423

exchange (*Wechsel*), 593

explanation of stimulus-word, 205f 208–12, 448–51, 458f

F

facts, psychological diagnosis of, *see* evidence

failure, 33, 151, 175f, 184, 448f
in hysteria, 362, 368f, 448f

family, association reactions, 53, 57, 60f, 66

family constellation, 466–79

father: in dreams, 393f, 477f
in family constellation, 473, 476ff
as God, 477f
hysterical symptoms related to, 424
in psychoanalysis, 294, 297, 300, 303, 313, 315

fatigue, 139, 320
Aschaffenburg's studies, 40n, 42, 320, 413f

in hysteria, 369, 371

feeling-tone: galvanometer recording of, 483ff, 487f, 495
perseveration of, 262f, 279

feeling-toned complexes (reactions), 116ff, 127, 129, 141f, 148ff, 160, 176f, 184, 200, 212, 295, 601
in criminal investigation, 589f
definition of, 72n, 321
in hysteria, 423ff
reaction-time and, 216–19, 235–38, 244f, 253, 258f, 278f, 527
repeated words and, 213n
in reproduction, 461; *see also* emotionally charged complexes

Feindel, E., 355n

Féré, Charles Samson, 224, 226, 553f

Ferrari, G. Cesare, 586n

fetishism, 313n

fire, dreams of, 384, 390ff

fire alarm, dream of, 396–99, 405

flight of ideas, 13, 42f, 52, 139f, 172n

fonction du réel, 515

foreign language: reactions in, 259
synonyms in, 113, 115, 239

forgetting: Freud's concept, 272, 286
of unpleasant experiences, 420f

free association, 273, 289, 304

Freud, Sigmund, 118, 173, 251, 295, 297, 301, 304, 309, 313, 317, 318n, 322n, 395, 401, 404, 406, 423n, 426f, 450, 516, 536, 597, 599, 602
forgetting, concept of, 272, 286
free association, 273, 289, 304
hysteria, theory of, 288, 602
psychoanalytic method, 288ff, 331ff
repression, concept of, 26n, 272f, 286, 288f

WORKS: "Analysis of a Phobia in a Five-Year-Old Boy," 478f
Breuer and, *Studies in Hysteria*, 191n, 288, 331n
Clark University lectures, 439n
"Fragment of an Analysis of a Case of Hysteria," 288, 373n

Interpretation of Dreams, The, 251n, 289, 301, 331n, 526

Jokes and Their Relation to the Unconscious, 373

letters to Jung, 593–94n

“On Psychoanalysis” (Australasian Medical Congress), 598n

“On the History of the Psychoanalytic Movement,” 439n

“Psycho-analysis and the Establishment of the Facts in Legal Proceedings,” 593n

Psychopathology of Everyday Life, The, 215n, 245n

Fuhrmann, M., 198f, 211

Fürer, _____ 42n

Fürst, Emma, 417n, 468f

G

Galton, Francis, 224, 319, 409, 524

galvanometer, 483–580

Deprez-d’Arsonval, 483, 495f, 555

Meissner and Meyerstein, 493

technique of use, 484ff, 492–96, 555

galvanometer experiments: in alcoholism, 489f, 574f

association with, 524–53

coughing in, 497f

emotion in, 499, 503f

in epilepsy, 568ff

expectation in, 498f

latent time, 504f, 521, 523f

in mental

disorders, 496, 511, 514–24, 547–53, 568–79

reaction-time in, 485f, 529–37, 539ff, 543–46

repetition in, 502ff

respiration in, 497f, 508–14, 559–65

of Tarchanoff, 490, 493ff, 498f, 504, 553f

of Veraguth, 483f, 494f, 554, 555n

galvano-psycho-physical reflex, *see* psycho-physical galvanic reflex

Ganser, Sigbert, 286n

Ganser syndrome, 252, 286

general paralysis, 575ff

German Congress for Experimental Psychology (Würzburg, 1906), [483](#), [495n](#)
gesture, use of, [200](#), [213](#)
Goethe, Johann Wolfgang von, [26n](#), [44n](#), [116](#)
Grabowsky, Adolf, [290n](#)
Gross, ——— [34n](#)
Gross, Alfred, [273n](#), [290](#), [330](#), [332n](#), [352](#), [423](#), [426](#), [587n](#)
Gross, Hans, [273](#), [290](#), [329f](#)
Gross, Otto, [290](#)

H

Hajós, Lajós, [42n](#)
heat sensations, [353ff](#), [403–6](#)
hebephrenia, [514](#), [519](#), [521](#), [572](#)
Heilbronner, Karl, [43](#), [172n](#), [426](#), [587](#)
Hellpach, Willy, [290](#)
Herbart, Johann Friedrich, [48](#)
Hoch, August, [485n](#)
house-complex, [257–61](#)
hypermnesia, [309](#)
hysteria, [328](#), [353–407](#)

- abasia in, [424](#)
- amnesia in, [285f](#), [325](#)
- association in, [353–83](#), [442ff](#), [448–51](#)
- catatonia in, [516](#)
- ensor in, [251](#)
- chorea symptoms, case of, [353ff](#)
- complexes in, [601 f](#)
- constellations in, [81](#), [86](#)
- dementia praecox and, [516ff](#)
- dreams in, [383–400](#)
- egocentric reactions in, [207](#)
- in family constellation, [475](#)
- feeling-toned complexes in, [423ff](#)
- forgetting in, [272](#), [286](#)
- Freud's theory of, [288](#), [602](#)

indirect association in, [172n](#)
paralysis in, [423f](#)
reaction-time in, [360–64](#), [369](#)
reinforced object libido in, [450f](#)
repression in, [272f](#), [286](#), [288f](#), [360f](#)
screen memories in, [286f](#)

I

idiots, [147n](#), [199f](#), [204](#)
illness; association and, [414f](#)
 hysterical symptoms, [353ff](#), [374f](#), [390f](#), [400–407](#), [423f](#)
images: plastic, [181](#), [183](#)
 visual, [47–50](#), [56f](#), [83](#), [85f](#), [97](#)
 vividness of, [177f](#), [181f](#), [184](#), [189n](#)
imbeciles, [199ff](#), [204–8](#), [210](#), [211n](#), [212f](#), [416](#)
 constellations, [81](#), [200](#)
 definition type, [459](#)
 egocentric reactions, [206ff](#)
 explanatory tendency, [205f](#)
 as recruits, [583f](#)
indirect associations, [28f](#), [32](#), [45](#), [83](#), [144](#), [169–75](#), [236](#), [387n](#)
inhibitions, [273](#), [535ff](#)
insomnia, [291ff](#)
intelligence-complex, [459](#)
interjections as responses, [27](#)
Isserlin, Max, [426](#)

J

Janet, Pierre, [404](#), [450](#), [515f](#), [603](#)
Jerusalem, M., [174](#)
Jews, reaction related to, [259](#), [323](#)
jokes, [414](#)
Jung, Carl Gustav:

CASES IN SUMMARY (*in order of presentation, numbered for reference*)

[1] Young man accused of theft, [333f](#), [341](#)

- [2] Hysterical chorea symptoms, [353ff](#)
- [3] Hysterical paralysis, [423f](#)
- [4] Nurse suspected of theft, [452–57](#), [592–95](#)
- [5] Jealous woman with divorce complex, [462–63](#)
- [6] Woman attracted to psychotic men, [475f](#)
- [7] Neurotic woman attached to father, [476f](#)

WORKS (*references from one paper to another in this volume are not included in this entry*)

- “Associations d’idées familiales,” [468n](#)
- “Case of Hysterical Stupor in a Prisoner in Detention, A,” [286n](#)
- “Content of the Psychoses, The,” [604n](#)
- “General Aspects of Psychoanalysis,” [603n](#)
- “On Simulated Insanity,” [81n](#), [111n](#), [176n](#), [199](#), [286n](#)
- “On the Psychological Diagnosis of Facts,” [318n](#), [333n](#), [605n](#)
- “On the Psychology and Pathology of So-called Occult Phenomena,” [309n](#), [404n](#)
- “Psychology of Dementia Praecox, The,” [72n](#), [173n](#), [241n](#), [425n](#), [492n](#), [519n](#), [531n](#), [598](#), [604](#)
- Psychology of the Unconscious*, [604n](#)
- Summaries, [vin](#)
- Symbols of Transformation*, [604n](#)
- “Tavistock Lectures, The,” v, [466n](#)

K

- Kant, Immanuel, [19](#)
- Klein, Julius, [273n](#), [290](#), [328ff](#), [587n](#), [605n](#)
- Kraepelin, Emil, [11](#), [19](#), [25](#), [42](#), [52](#), [139](#), [198](#), [224](#), [229n](#), [294](#), [319](#), [335](#), [371](#), [379n](#), [409](#), [413ff](#), [514](#), [524](#), [529](#), [597](#), [602](#)
- Krafft-Ebing, Richard von, [313n](#)
- Kraus, O., [331f](#)
- Külpe, Oswald, [329](#)
- kymograph, [484](#) (diagram), [492](#), [496](#), [555](#)

L

- labial keys, [222](#), [232](#)
- lassitude, *see* fatigue

laughter, in psychoanalysis, 373–76
law of association, 410*f*, 415
law of frequency, 11, 137*ff*, 185*f*, 230
Lehmann, Alfred, 506, 508
Liepmann, Hugo, 139*f*
linguistic automatisms, 55
linguistic connection, 35*f*, 138
linguistic facility, 6*f*, 13
linguistic-motor forms, 20, 25*ff*, 32, 140, 146, 169, 174
 visual images occurring as, 48, 50
linguistic reaction, 10, 138*f*
love-complex, 103–6, 258–61
Lowenfeld, Leopold, 290

M

Mace, C. A., *vn*
mania: associations in, 320, 414
 motor exhaustion in, 42, 43*n*
manic excitation, 52
manic reaction, 139
manic stupor, 43
Marbe, Karl, 223
Martius, Götz, 508, 557
masturbation, 297, 299*f*, 303, 310, 312
Mayer, A., 12, 222*f*, 234*f*, 418
meaningless reactions, 32, 44, 175*f*, 198*f*
Meier, C. A., *viiin*, 222*n*, 379*n*
Meige, Henry, 355*n*
Meige-Feindel tic, 355
memory, 272–87
 screen memories, 286*f*
memory-complexes, 256
menstruation, 403*f*
mental deficiency, *see* idiots;
 imbeciles

mental disorders: association in, [547–53](#)
galvanometer experiments in, [496](#), [511](#), [514–24](#), [547–53](#), [568–79](#)
pneumograph experiments in, [511](#), [514–24](#), [569f](#), [572f](#), [576](#), [578f](#); *see also*
dementia praecox; mania; paranoia

Mentz, Paul, [506](#), [508](#), [556](#)

Meumann, E., [507f](#), [510](#), [556](#)

Meyer, Adolf, [485n](#)

mice, dream of, [386ff](#)

Mill, James, [11](#)

Minnemann, C., [508](#)

Möbius, Paul Julius, [288](#)

money, dream of, [396](#)

money-complex, [248ff](#), [254f](#), [422](#)

Mosso, Angelo, [506](#), [556](#)

mother: in association, [313](#), [372](#), [380](#)
and daughter as predicate types, [473ff](#)
in dream, [394f](#)
in psychoanalysis, [313](#), [392f](#), [402f](#)

motility, [13](#), [55](#)
speech, [76f](#)

motor excitation, [42f](#), [52](#), [55](#), [77](#), [139f](#), [414](#)

motor perception, [55](#)

mouth, Freudian symbolism of, [395f](#)

Müller, E. K., [494](#)

Müller, Georg E., [34n](#), [236n](#), [238n](#)

Munsterberg, Hugo, [12](#), [24](#), [31n](#), [175](#), [299n](#), [413](#)

N

Näf, Hans, evidence-experiment in trial of, [605–14](#)

neurosis: complexes in, [599f](#), [602](#)
family constellations in, [475–78](#)
psychogenic, [291](#), [448](#)
reaction-times in, [461n](#)

Nordau, Max Simon, [52n](#)

nouns, [185ff](#), [229–33](#)

adjectives as reactions to, [21f](#)
as reactions, [21f](#), [232f](#)
verb relationships, [22ff](#), [186](#)

O

objective type, [148f](#), [152–56](#), [458](#)
Orth, J., [12](#), [222f](#), [234f](#), [418](#)

P

paralysis: general, [575ff](#)
hysterical, [423f](#)
paranoia (dementia paranoides), [518f](#), [572f](#)
galvanometer and pneumograph experiments, [511](#), [514](#), [520](#), [523f](#), [572f](#)
parents in children's character development, [474f](#), [478f](#); *see also* father;
mother
paresis (general paralysis), [575ff](#)
perseveration, [34ff](#), [141f](#), [144](#), [151](#), [177](#), [327](#)
in epilepsy, [200](#); of feeling-tone, [262f](#), [279](#)
Peterson, Frederick. W., [492n](#)
phrases as responses, [26](#)
Pick, Arnold, [286n](#)
picture as stimulus, [329](#), [559](#), [561f](#)
Piéron, H., [173f](#)
Pilzecker, A., [34n](#), [236n](#), [238n](#)
plastic images, [181](#), [183](#)
Plato, [409](#)
pleonasm, [208](#), [321n](#)
plethysmograph, [557](#)
pneumograph, [492](#), [506–14](#), [556f](#), [566f](#)
Marey, [492](#), [556](#)
in mental disorders, [511](#), [514–24](#), [569f](#), [572f](#), [576](#), [578f](#)
reaction-time and, [532f](#), [537f](#)
possession by demons, [602](#)
predicate type, [149](#), [161f](#), [168](#), [177–84](#), [188f](#), [204](#), [459f](#)
evaluating, [459](#), [469f](#)

of imbeciles, 206
mother and daughter, 469ff
predicative reactions, 19–24, 141, 182f
pregnancy, hysterical attitude towards, 404
pregnancy-complex, 236–44, 246
proverbs as responses, 26
psychoanalysis: association experiments and, 288–317, 599f
 family constellations in, 477ff
 Freud's method, 288f, 331ff
psychology: analytical, 603
 depth, 603n
 experimental, 408f
 philosophical, 408
psychopathology, association experiments and, 408–25
psychophysical experiments, *see* galvanometer experiments
 pneumograph
psychophysical galvanic (galvanophysical) reflex, 483, 487, 492, 495f
puberty, adjustments in, 474
Pulver, Max, 606
puns, 414

Q

quotations, 87, 104ff, 109, 115–19

R

Raimann, Emil, 517n
Ranschburg, Paul, 10n, 23, 42, 57, 141, 226, 415n
reaction, definition of, 319
reaction-time, 7, 125, 129f, 135, 205, 221–71, 525ff
 arithmetical mean, 224f
 in constellations, 109, 122f, 216n, 217, 237, 244f, 262, 278f, 284, 324–28
 in criminal investigations, 335–41. 349f, 588f, 607f
 in epilepsy, 214f, 216–19
 feeling-tone and, *see* feeling-toned complexes
 in galvanometer experiments, 485f, 529–37, 539ff, 543–46

grammatical form and, 229–32
in hysteria, 360–64, 369
measurement technique, 222*f*, 454*f*
of neurotics, 461*n*
in pneumograph experiments, 532*f*, 537*f*
probable mean, 216, 224*f*, 335, 454*f*
prolonged, concept, 234*f*, 444, 448, 525*f*
in psychoanalysis, 294
reaction-word and, 232*f*
reproduction disturbance and, 428–36
sex and, 226*f*
sexual (erotic) complexes and, 82, 111
stimulus-word and, 229–32, 263–67
in theft case, 335–41, 349*f*

recruits, study of, 583*ff*

reinforced object-libido, 450*f*

repetition: in galvanometer experiments, 502*ff*
in reactions, 35, 89–92, 95, 97*f*, 100, 106*f*, 112, 115*ff*, 119*f*, 123, 127, 132*f*, 296, 451*f*
of stimulus-word, 33, 175*f*, 208*f*, 213*ff*, 218*f*, 451

repression: definition of, 261–62*n*
forgetting and, 272, 286*f*
Freud's concept of, 261*n*, 272*f*, 286, 288*f*
in hysteria, 272*f*, 286, 288*f*, 360*f*

in reproduction disturbances, 427*f*

reproduction, disturbances of, 426–38

reproduction method, 273*f*, 290*f*, 325*f*, 461, 527*f*, 600
in criminal investigation, 456*f*, 589
in galvanometer experiments, 485

respiration: galvanometer experiments, 497*f*, 508–14, 559–65
pneumograph experiments, 506–14, 556*ff*, 566*f*; *see also* pneumograph

rhyme as response, 28, 78, 113, 151*n*, 247

Ricksher, Charles, 554*n*

Riklin, Franz, 3, 199*f*, 203*f*, 223, 229, 252*n*, 263*n*, 286, 287*n*, 290, 328*n*, 332*n*, 353*n*, 421*n*, 598*f*

S

St. Vitus's dance, *see* chorea

Salpêtrière, 554

schizophrenia, *see* dementia praecox

Schnitzler, J. G., 587n

school-complex, 401f

Schüle, Heinrich, 320n

screen memories, 286f

Scripture, Edward Wheeler, 174, 319

senile dementia, 577

sentence: as reaction, 125, 203f, 207, 210f, 416

as stimulus, 559, 563f

sexual complexes, 82, 256f

in dreams, 384–400

in hysteria, 373–81, 400–406; *see also* erotic complex

sexuality in psychoanalysis, 306–16

simple-constellation type, 149, 156ff

slips of the tongue, 214, 247, 257f, 260

Smith, William, 42n, 174

Sommer, Robert, 5, 223, 319f, 409, 490, 494, 524, 554

songs, 104ff, 118, 252f, 257f

sound associations (sound reactions), 27f, 138ff, 144, 146, 169–73, 320, 412, 414f

sound-shift, centrifugal and centripetal, 29–32

speech motility, 76f

speech-phenomena, 13; *see also* entries under linguistic

Spiegel, H. W., 605n

split personality, 309

Stern, William, 318, 330

Sticker, Georg, 490, 494, 554

stimulus-words, 319

attitudes towards, 147ff

defining of, 201

experimental procedure, 5ff

explanation of, 205f, 208–12, 448–51, 458f
forgetting, 272
grammatical form, influence of, 184–89, 229–32
language problems, 6f
not understanding, 108f
reaction and, as association, 9f
reaction-time and, 229–32, 263–67
repetition of, 33, 175f, 208f, 213ff, 218f, 451
stop-watch, use of, 222f
Störring, Gustav, 290
Stransky, Erwin, 515
stupidity: definition type and, 459
 emotional, 86, 176, 199f, 583n
 hysterical, 81
subjective type, 148f
suicide, by drowning, water associated with, 325–28, 486, 526
suppression of feelings, 149ff
Switzerland, German language in, 6f
synesthesia (*audition colorée*), 56f
synonyms: in foreign language, 113, 115
 as responses, 25

T

Tarchanoff, J., 490, 493ff, 498f, 504, 553f
teachers, influence of, 475
theft: nurse suspected of, 452–57, 592–95
 young man suspected of, 333–52, 423; *see also* evidence, psychological diagnosis
 of
Thumb, Albert, 223
transference, 373
Trautscholdt, Martin, 11n, 25, 224, 229, 319, 410n
tunes, 252f
types of associations, *see under* complex-constellation
 definition
 objective

predicate

U

Ulrich, — (Zurich), 200*f*

unconscious, the complexes and, 86–92

in psychoanalysis, 289

V

value judgments, 20*ff*, 33, 57, 59, 125, 178, 473

Veraguth, Otto, 483, 490, 494*f*, 554, 555*n*

verbs, 185*ff*, 229–33

noun relationships, 22*ff*, 186

reactions to, 16, 186*ff*

Vigouroux, A., 554

Vigouroux, R., 554

visual images, *see* images

Vogt, Heinrich, 290

W

Warda, W., 290

Wehrlin, K., 199*f*, 205*ff*, 228, 298, 332*n*, 342*n*, 416*n*

Wertheimer, Max, 273*n*, 290, 328–31. 351*f*, 587*n*, 605*n*

Weygandt, Wilhelm, 333, 417

word completion as response, 27*f*, 32, 78

worms, dream of, 395

Wreschner, Arthur, 27, 33, 223, 228

Wundt, Wilhelm, 14*n*, 35, 138, 174, 319, 409*f*, 412, 524

Z

Zahn, Ernst, 115

Ziehen, Georg Theodor, 11*f*, 14*n*, 20, 25, 80, 18*n*, 22*n*, 222, 225, 227*ff*, 231, 233*f*, 235*n*,
262, 319*f*, 322*n*, 418

Zoneff, P., 507*f*, 510, 556

Zurich, Swiss Asylum for Epileptics, 200

Zurich University, Psychiatric Clinic of, 320, 331*f*, 492, 495*f*, 525, 554

methods used, [597](#); *see also* Burghölzli Cantonal Hospital

THE COLLECTED WORKS OF

C. G. JUNG

THE PUBLICATION of the first complete edition, in English, of the works of C. G. Jung was undertaken by Routledge and Kegan Paul, Ltd., in England and by Bollingen Foundation in the United States. The American edition is number XX in Bollingen Series, which since 1967 has been published by Princeton University Press. The edition contains revised versions of works previously published, such as *Psychology of the Unconscious*, which is now entitled *Symbols of Transformation*; works originally written in English, such as *Psychology and Religion*; works not previously translated, such as *Aion*; and, in general, new translations of virtually all of Professor Jung's writings. Prior to his death, in 1961, the author supervised the textual revision, which in some cases is extensive. Sir Herbert Read (d. 1968), Dr. Michael Fordham, and Dr. Gerhard Adler compose the Editorial Committee; the translator is R. F. C. Hull (except for Volume 2) and William McGuire is executive editor.

The price of the volumes varies according to size; they are sold separately, and may also be obtained on standing order. Several of the volumes are extensively illustrated. Each volume contains an index and in most a bibliography; the final volume will contain a complete bibliography of Professor Jung's writings and a general index to the entire edition.

In the following list, dates of original publication are given in parentheses (of original composition, in brackets). Multiple dates indicate revisions.

*1. PSYCHIATRIC STUDIES

On the Psychology and Pathology of So-Called Occult Phenomena (1902)

On Hysterical Misreading (1904)

Cryptomnesia (1905)

On Manic Mood Disorder (1903)

A Case of Hysterical Stupor in a Prisoner in Detention (1902)

On Simulated Insanity (1903)

A Medical Opinion on a Case of Simulated Insanity (1904)

A Third and Final Opinion on Two Contradictory Psychiatric Diagnoses (1906)

On the Psychological Diagnosis of Facts (1905)

†2. EXPERIMENTAL RESEARCHES

Translated by Leopold Stein in collaboration with Diana Riviere

STUDIES IN WORD ASSOCIATION (1904–7, 1910)

The Associations of Normal Subjects (by Jung and F. Riklin)

An Analysis of the Associations of an Epileptic

The Reaction-Time Ratio in the Association Experiment

Experimental Observations on the Faculty of Memory

Psychoanalysis and Association Experiments

The Psychological Diagnosis of Evidence

Association, Dream, and Hysterical Symptom

The Psychopathological Significance of the Association Experiment

Disturbances in Reproduction in the Association Experiment

The Association Method

The Family Constellation

PSYCHOPHYSICAL RESEARCHES (1907–8)

On the Psychophysical Relations of the Association Experiment

Psychophysical Investigations with the Galvanometer and Pneumograph in Normal and Insane Individuals (by F. Peterson and Jung)

Further Investigations on the Galvanic Phenomenon and Respiration in Normal and Insane Individuals (by C. Ricksher and Jung)

Appendix: Statistical Details of Enlistment (1906); New Aspects of Criminal Psychology (1908); The Psychological Methods of Investigation Used in the Psychiatric Clinic of the University of Zurich (1910); On the Doctrine of Complexes ([1911] 1913); On the Psychological Diagnosis of Evidence (1937)

*3. THE PSYCHOGENESIS OF MENTAL DISEASE

The Psychology of Dementia Praecox (1907)

The Content of the Psychoses (1908/1914)

On Psychological Understanding (1914)

A Criticism of Bleuler's Theory of Schizophrenic Negativism (1911)

On the Importance of the Unconscious in Psychopathology (1914)
On the Problem of Psychogenesis in Mental Disease (1919)
Mental Disease and the Psyche (1928)
On the Psychogenesis of Schizophrenia (1939)
Recent Thoughts on Schizophrenia (1957)
Schizophrenia (1958)

†4. FREUD AND PSYCHOANALYSIS

Freud's Theory of Hysteria: A Reply to Aschaffenburg (1906)
The Freudian Theory of Hysteria (1908)
The Analysis of Dreams (1909)
A Contribution to the Psychology of Rumour (1910-11)
On the Significance of Number Dreams (1910-11)
Morton Prince, "The Mechanism and Interpretation of Dreams": A Critical Review (1911)
On the Criticism of Psychoanalysis (1910)
Concerning Psychoanalysis (1912)
The Theory of Psychoanalysis (1913)
General Aspects of Psychoanalysis (1913)
Psychoanalysis and Neurosis (1916)
Some Crucial Points in Psychoanalysis: A Correspondence between Dr. Jung and Dr. Loÿ (1914)
Prefaces to "Collected Papers on Analytical Psychology" (1916, 1917)
The Significance of the Father in the Destiny of the Individual (1909/1949)
Introduction to Kranefeldt's "Secret Ways of the Mind" (1930)
Freud and Jung: Contrasts (1929)

†5. SYMBOLS OF TRANSFORMATION (1911-12/1952)

PART I

Introduction
Two Kinds of Thinking
The Miller Fantasies: Anamnesis
The Hymn of Creation
The Song of the Moth

PART II

Introduction

The Concept of Libido

The Transformation of Libido

The Origin of the Hero

Symbols of the Mother and of Rebirth

The Battle for Deliverance from the Mother

The Dual Mother

The Sacrifice

Epilogue

Appendix: The Miller Fantasies

***6. PSYCHOLOGICAL TYPES (1921)**

Introduction

The Problem of Types in the History of Classical and Medieval Thought

Schiller's Ideas on the Type Problem

The Apollinian and the Dionysian

The Type Problem in Human Character

The Type Problem in Poetry

The Type Problem in Psychopathology

The Type Problem in Aesthetics

The Type Problem in Modern Philosophy

The Type Problem in Biography

General Description of the Types

Definitions

Epilogue

Four Papers on Psychological Typology (1913, 1925, 1931, 1936)

†7. TWO ESSAYS ON ANALYTICAL PSYCHOLOGY

On the Psychology of the Unconscious (1917/1926/1943)

The Relations between the Ego and the Unconscious (1928)

Appendix: New Paths in Psychology (1912); The Structure of the Unconscious (1916) (new versions, with variants, 1966)

‡8. THE STRUCTURE AND DYNAMICS OF THE PSYCHE

On Psychic Energy (1928)
The Transcendent Function ([1916]/1957)
A Review of the Complex Theory (1934)
The Significance of Constitution and Heredity in Psychology (1929)
Psychological Factors Determining Human Behavior (1937)
Instinct and the Unconscious (1919)
The Structure of the Psyche (1927/1931)
On the Nature of the Psyche (1947/1954)
General Aspects of Dream Psychology (1916/1948)
On the Nature of Dreams (1945/1948)
The Psychological Foundations of Belief in Spirits (1920/1948)
Spirit and Life (1926)
Basic Postulates of Analytical Psychology (1931)
Analytical Psychology and *Weltanschauung* (1928/1931)
The Real and the Surreal (1933)
The Stages of Life (1930–1931)
The Soul and Death (1934)
Synchronicity: An Acausal Connecting Principle (1952)
Appendix: On Synchronicity (1951)

*9. PART I. THE ARCHETYPES AND THE COLLECTIVE UNCONSCIOUS

Archetypes of the Collective Unconscious (1934/1954)
The Concept of the Collective Unconscious (1936)
Concerning the Archetypes, with Special Reference to the Anima Concept
(1936/1954)
Psychological Aspects of the Mother Archetype (1938/1954)
Concerning Rebirth (1940/1950)
The Psychology of the Child Archetype (1940)
The Psychological Aspects of the Kore (1941)
The Phenomenology of the Spirit in Fairytales (1945/1948)
On the Psychology of the Trickster-Figure (1954)
Conscious, Unconscious, and Individuation (1939)
A Study in the Process of Individuation (1934/1950)

Concerning Mandala Symbolism (1950)

Appendix: Mandalas (1955)

***9. PART II. AION (1951)**

RESEARCHES INTO THE PHENOMENOLOGY OF THE SELF

The Ego

The Shadow

The Syzygy: Anima and Animus

The Self

Christ, a Symbol of the Self

The Sign of the Fishes

The Prophecies of Nostradamus

The Historical Significance of the Fish

The Ambivalence of the Fish Symbol

The Fish in Alchemy

The Alchemical Interpretation of the Fish

Background to the Psychology of Christian Alchemical Symbolism

Gnostic Symbols of the Self

The Structure and Dynamics of the Self

Conclusion

***10. CIVILIZATION IN TRANSITION**

The Role of the Unconscious (1918)

Mind and Earth (1927/1931)

Archaic Man (1931)

The Spiritual Problem of Modern Man (1928/1931)

The Love Problem of a Student (1928)

Woman in Europe (1927)

The Meaning of Psychology for Modern Man (1933/1934)

The State of Psychotherapy Today (1934)

Preface and Epilogue to “Essays on Contemporary Events” (1946)

Wotan (1936)

After the Catastrophe (1945)

The Fight with the Shadow (1946)

The Undiscovered Self (Present and Future) (1957)
Flying Saucers: A Modern Myth (1958)
A Psychological View of Conscience (1958)
Good and Evil in Analytical Psychology (1959)
Introduction to Wolff's "Studies in Jungian Psychology" (1959)
The Swiss Line in the European Spectrum (1928)
Reviews of Keyserling's "America Set Free" (1930) and "La Révolution Mondiale"
(1934)
The Complications of American Psychology (1930)
The Dreamlike World of India (1939)
What India Can Teach Us (1939)
Appendix: Documents (1933–1938)

†11. PSYCHOLOGY AND RELIGION: WEST AND EAST

WESTERN RELIGION

Psychology and Religion (The Terry Lectures) (1938/1940)
A Psychological Approach to the Dogma of the Trinity (1942/1948)
Transformation Symbolism in the Mass (1942/1954)
Forewords to White's "God and the Unconscious" and Werblowsky's "Lucifer and
Prometheus" (1952)
Brother Klaus (1933)
Psychotherapists or the Clergy (1932)
Psychoanalysis and the Cure of Souls (1928)
Answer to Job (1952)

EASTERN RELIGION

Psychological Commentaries on "The Tibetan Book of the Great Liberation"
(1939/1954) and "The Tibetan Book of the Dead" (1935/1953)
Yoga and the West (1936)
Foreword to Suzuki's "Introduction to Zen Buddhism" (1939)
The Psychology of Eastern Meditation (1943)
The Holy Men of India: Introduction to Zimmer's "Der Weg zum Selbst" (1944)
Foreword to the "I Ching" (1950)

*12. PSYCHOLOGY AND ALCHEMY (1944)

Prefatory note to the English Edition ([1951?] added 1967)
Introduction to the Religious and Psychological Problems of Alchemy
Individual Dream Symbolism in Relation to Alchemy (1936)
Religious Ideas in Alchemy (1937)
Epilogue

†13. ALCHEMICAL STUDIES

Commentary on “The Secret of the Golden Flower” (1929)
The Visions of Zosimos (1938/1954)
Paracelsus as a Spiritual Phenomenon (1942)
The Spirit Mercurius (1943/1948)
The Philosophical Tree (1945/1954)

‡14. MYSTERIUM CONIUNCTIONIS (1955–56)

AN INQUIRY INTO THE SEPARATION AND SYNTHESIS OF PSYCHIC OPPOSITES IN ALCHEMY

The Components of the Coniunctio
The Paradoxa
The Personification of the Opposites
Rex and Regina
Adam and Eve
The Conjunction

*15. THE SPIRIT IN MAN, ART, AND LITERATURE

Paracelsus (1929)
Paracelsus the Physician (1941)
Sigmund Freud in His Historical Setting (1932)
In Memory of Sigmund Freud (1939)
Richard Wilhelm: In Memoriam (1930)
On the Relation of Analytical Psychology to Poetry (1922)
Psychology and Literature (1930/1950)
“Ulysses”: A Monologue (1932)
Picasso (1932)

†16. THE PRACTICE OF PSYCHOTHERAPY

GENERAL PROBLEMS OF PSYCHOTHERAPY

Principles of Practical Psychotherapy (1935)

What Is Psychotherapy? (1935)

Some Aspects of Modern Psychotherapy (1930)

The Aims of Psychotherapy (1931)

Problems of Modern Psychotherapy (1929)

Psychotherapy and a Philosophy of Life (1943)

Medicine and Psychotherapy (1945)

Psychotherapy Today (1945)

Fundamental Questions of Psychotherapy (1951)

SPECIFIC PROBLEMS OF PSYCHOTHERAPY

The Therapeutic Value of Abreaction (1921/1928)

The Practical Use of Dream-Analysis (1934)

The Psychology of the Transference (1946)

Appendix: The Realities of Practical Psychotherapy ([1937] added, 1966)

‡17. THE DEVELOPMENT OF PERSONALITY

Psychic Conflicts in a Child (1910/1946)

Introduction to Wickes's "Analyses der Kinderseele" (1927/1931)

Child Development and Education (1928)

Analytical Psychology and Education: Three Lectures (1926/1946)

The Gifted Child (1943)

The Significance of the Unconscious in Individual Education (1928)

The Development of Personality (1934)

Marriage as a Psychological Relationship (1925)

*18. THE SYMBOLIC LIFE

Miscellaneous Writings

†19. GENERAL BIBLIOGRAPHY OF C. G. JUNG'S WRITINGS

†20. GENERAL INDEX TO THE COLLECTED WORKS

See also:

C. G. JUNG: LETTERS

Selected and edited by Gerhard Adler, in collaboration with Aniela Jaffé Translations from the German by R.F.C. Hull.

VOL. 1: 1906–1950

VOL. 2: 1951–1961

THE FREUD/JUNG LETTERS

Edited by William McGuire, translated by
Ralph Manheim and R.F.C. Hull

C. G. JUNG SPEAKING: Interviews and Encounters

Edited by William McGuire and R.F.C. Hull

C. G. JUNG: Word and Image

Edited by Aniela Jaffé

¹ C. A. Mace, “On the Eightieth Birthday of C. G. Jung,” *Journal of Analytical Psychology*, I:2 (1956).

² First published 1968 as *Analytical Psychology: Its Theory and Practice*.

³ See the bibliography under their respective names. Jung published two abstracts of the *Studien*: (1) At the request of the French psychologist Alfred Binet, an “analyse bibliographique” of Vol. I of the *Studien* in Binet’s journal, *L’Année psychologique* (Paris), XIV (1908), 453–55; (2) Summaries of both volumes of the *Studien*, in “Referate über psychologische Arbeiten schweizerischer Autoren (bis Ende 1909),” compiled by Jung, in the *Jahrbuch für psychoanalytische und psychopathologische Forschungen* (Leipzig and Vienna), II (1910), 366–74; see Volume 18 of the *Collected Works*.

¹ [First published as “Experimentelle Untersuchung über Assoziationen Gesunder,” *Journal für Psychologie und Neurologie* (Leipzig), III (1904), 55–83, 145–64, 193–214, 238–308, and IV (1905), 24–67, 109–23. Republished in *Diagnostische Assoziationsstudien: Beiträge zur experimentellen Psychopathologie*, edited by C. G. Jung, Vol. I (Leipzig, 1906; 2nd edn., 1911; 3rd edn., 1915). pp. 7–145 (I. Beitrag). Translated by M. D. Eder in *Studies in Word-Association* (London, 1918; New York, 1919).

[Franz Riklin (1878–1938) was assistant physician on the staff of the Burghölzli at this time. From 1907 to 1913, he and Jung were active in the International Psycho-Analytical Association. For his principal publications, see the Bibliography.]

² A later paper will report on time-measurements. The times were not measured in all subjects. [See below, “The Reaction-time Ratio in the Association Experiment.”]

³ Cordes, “Experimentelle Untersuchung über Assoziationen” (1899), p. 30.

⁴ *Ibid.*, p. 33.

⁵ Ranschburg states that in uneducated subjects inner associations predominate. With Balint, “Über quantitative und qualitative Veränderungen geistiger Vorgänge im hohen Greisenalter” (1900).

⁶ Aschaffenburg, too, is cautious about this and confines himself entirely to the relation between stimulus and reaction as it is reflected in speech. He insists on this, since the linguistic reaction does not by any means always tally with the simultaneous inner associations. (“Experimentelle Studien über Assoziation” (1896), p. 220.)

⁷ Trautschold says: “First and foremost in this respect is practice or habit, which facilitates certain associations so much that in the end they occur quite mechanically, and there can be no question of other reactions” (“Experimentelle Untersuchungen über die Assoziation der Vorstellungen” (1883), p. 221).

⁸ Claparède, *L’Association des idées* (1903), p. 218.

⁹ [No such publication has been traced.]

¹⁰ Ziehen (*Introduction to Physiological Psychology* (orig. 1891). p. 205), arguing against internal association, gives as examples the following: *guest/chest*, *pain/rain*, and remarks that these so-called internal associations are purely external and are almost completely limited to the acoustic image of words that have similar sounds. One can readily agree with Ziehen, for surely no one will want to call these examples of inner association.

We consider, with Wundt, that associative affinity is the principle of internal association and practice the principle of external association (or similarity = internal association, contiguity = outer association).

¹¹ [Baroness von Suttner (d. 1914), Austrian writer and pacifist, recipient of the first Nobel Peace Prize, 1905.]

¹² [See *infra*. par. 423, n. 47.]

¹³ [Sour-sweet and light-dark, i.e., *chiaroscuro*.]

¹⁴ *Psychol. Arb.*, I, p. 222.

¹⁵ In an analytical judgment I do not go beyond the given conception, in order to arrive at some decision respecting it. If the judgment is affirmative, I predicate of the conception only that which was already cogitated in it; if negative, I merely exclude from the conception its contrary. But in synthetical judgments, I must go beyond the given conception, in order to cogitate, in relation with it, something quite different from that which was cogitated in it ...” etc. Kant, *Critique of Pure Reason* (trans. Meiklejohn, 1934), p. 126.

¹⁶ Ranschburg and Balint, p. 715.

- ¹⁷ Ziehen, “Die Ideenassoziation des Kindes” (1898), p. 29; *Sammlung von Abhandlungen aus dem Gebiete der pädagogischen Psychologie*, I (1898). p. 6.
- ¹⁸ *Psychol. Arb.*, I, p. 223.
- ¹⁹ Experimentelle Untersuchungen über die Assoziation der Vorstellungen,” p. 213.
- ²⁰ [In German, *Grunad/und Boden* (bottom/and ground), an expression referring to the hospital grounds.]
- ²¹ [In German, *Kind/Kegel* (child/bastard); *Kind und Kegel* is a folk expression for “the whole family.”]
- ²² [Goethe’s dying words.]
- ²³ [*Matte/Hänge* = *Hängematte*, ‘hammock,’ originally a hanging mat. Some of these compounds are untranslatable.]
- ²⁴ [Referring to someone who is “cold-blooded.”]
- ²⁵ [The actual example, *Tränensack*, refers to the lacrymal sac.]
- ²⁶ [The German, *aufhören*, means to listen attentively.]
- ²⁷ [In the German language there is the generic term *Spielball*, meaning a ball used for any game.]
- ²⁸ Wreschner, “Eine experimentelle Studie über die Assoziation in einem Falle von Idiotie” (1900), p. 241.
- ²⁹ [“Sound” = German *Klang*, also translated in the *Coll. Works* as “clang.”]
- ³⁰ [The examples given by Jung are *Laufen* (to run)/*burg* and *Winter/thur*, both giving the name of a town.]
- ³¹ [Jung’s examples (except for *to roast/roast beef*), being untranslatable, have been replaced by similar pairs of English words.]
- ³² [Some of the rhyming pairs have been replaced by English equivalents.]
- ³³ [Most of the original examples are not translatable, so equivalents have been found.]
- ³⁴ [Many of the original examples, being untranslatable, have been replaced by English equivalents.]
- ³⁵ Intensity of attention; see above, par. 86.
- ³⁶ Münsterberg maintains that, in order to stimulate associations, the external excitation does not first have to be converted into a conscious process, but that, between external excitation and conscious central excitation, there is a non-conscious stage in which an association-process takes place that does not reach consciousness (*Beiträge zur experimentellen Psychologie* IV (1892), p. 7). Nevertheless, Münsterberg denies the occurrences of indirect associations through conscious intermediate links (*ibid.*, p. 9).
- ³⁷ “Eine experimentelle Studie über die Assoziation in einem Falle von Idiotie.”
- ³⁸ Aschaffenburg’s “association to words previously used.”
- ³⁹ We use the word “perseveration,” as in Müller’s and Pilzecker’s experiments [“Experimentelle Beiträge zur Lehre vom Gedächtnis,” 1900], to denote merely the continuance of the preceding image in so far as it is manifest in the following reaction. The term is intended to be purely formal and is not intended to explain anything. We offer no opinion on whether the perseveration is a cortical or a cellular (nutritional) process (Gross) or whether the result is a particular associative constellation. In any case, we wish to stress that our concept has no connection with the “perseveration” in organic cerebral processes any more than with the hypothetical “secondary function of brain cells” which is said to explain the psychological after-effect of the vector-image.

¹ Aschaffenburg says: “Our attention is so enormously unstable, the non-controllable and unavoidable changes in our psychic life so great, that we should not use short experimental series. On the other hand one must not forget that in the course of longer experiments signs of fatigue occur, so that it is not, for example, permissible to compare the first 25 associations with the last 25 of a series of 200 reactions, without taking this fact into consideration” (“Experimentelle Studien.” I, p. 217). Thus Aschaffenburg has noted the same phenomenon, but in our view has not interpreted it correctly.

² *Psychol. Arb.*, I, p. 53. Kraepelin distinguishes between “lassitude” [*Müdigkeit*] and “fatigue” [*Ermüdung*]. Lassitude he regards as a sort of warning, a subjective feeling which, however, usually but not always develops before real fatigue.

³ Ranschburg and Hajós, *Beiträge zur Psychologie des hysterischen Geisteszustandes* (1897).

⁴ Aschaffenburg, I, p. 239. At the time of the formation of the external association linguistic habit predominates, while later, on reflection, a secondary tendency to co-ordinate develops.

⁵ “The facilitation of motor-impulses must be considered the essential factor responsible for the number of sound reactions exceeding the norm” (Aschaffenburg, II, p. 69; see also the work of Smith, Fúrer, and Rudin on the effects of alcohol, in Kraepelin’s *Psychol. Arb.*). [For Rüdín, see Bibliography. Smith and Fúrer did not contribute to *Psychol. Arb.*, though Rudin and others cited their work on this subject.]

⁶ The expression “exhaustion” merely denotes a higher degree of impairment of mental and physical energy (Aschaffenburg, II, p. 47),

⁷ Heilbronner, “Über epileptische Manie nebst Bemerkungen über die Ideenflucht” (1903).

⁸ There are, incidentally, also pure manias which, particularly when subsiding, still show a definite flight of ideas in a completely steady state of motility.

⁹ [The reference is to a well-known quotation from Goethe’s *Torquato Tasso*, Act II, Sc. I: “Man merkt die Absicht und man ist verstimmt” (“One notices the intention and becomes out of humour”).]

¹⁰ [In German, a rhyme: *mächtig/prächtigt*.]

¹¹ Aschaffenburg errs when he says, for example, that Nordau’s descriptions referred to hypomanics; they refer rather to the larger group of individuals incapable of concentration and showing blunt association-type.

¹² See below, experiment in drowsiness with subject 15 (educated men).

¹³ By that we do not mean that some sort of motor excitation is responsible for the blunt reaction type. In personalities of a motor type the motor factors perhaps play an independent role in the word-image combination in that they facilitate talking.

¹⁴ Cf. subject 16 (educated men).

¹⁵ Cf. subjects 15 and 16 (educated men).

¹⁶ Ranschburg and Balint, p. 689.

¹⁷ In his experiments on normal people Aschaffenburg had only one subject who had a strikingly large number of failures; he was a dreamy, vague, poetic young man (IV, p. 243). [The textual allusion is to “Association, Dream, and Hysterical Symptom,” *infra*.]

¹⁸ By “emotionally charged complex” we mean the sum of ideas referring to a particular feeling-toned event. We shall always use the term “complex” in this sense in what follows. [In the present volume, “emotionally charged” is

the translation adopted for German *affektbetonte* and, as a rule, “feeling-toned” for *gefühlbetonte*. Cf. vol. 1, par. 168, n. 2a, and vol. 3, “Psychology of Dementia Praecox,” pars. 77 ff. (ch. 2).]

¹⁹ We know, of course, that no reaction is fortuitous, but that each one, even the most objective, is caused by definite constellations. It makes, however, a great difference whether, e.g., *murderer* is associated with *Meier* and thus points to a definite murderer, or *murderer* is associated with *criminal* which expresses a general thought. This difference we stress by using the designation “constellation.”

²⁰ [*Süsskind*, literally ‘sweet child.’]

²¹ See Jung, “On Simulated Insanity.”

²² [Well-known phrase, *Hangen und Bangen*, from one of Schiller’s poems.]

²³ [Dr. Konrad Alt (1861–1922) was director of a mental hospital at Uchtspringe, Saxony, renowned for its advanced methods. The Säntis and the Altmann are high mountains in northeastern Switzerland.]

²⁴ [The song “Wir winden dir den Jungfernkranz,” from Weber’s opera *Der Freischütz*.]

²⁵ [In German, *müssen* / “*kein Mensch muss müssen*.” The quotation is from Lessing’s *Nathan der Weise*.]

²⁶ [In the original, he misquotes even this fragment.]

²⁷ The reactions of this subject are given in detail in the section on Calculations of Averages, Complex-Constellation Type, pars. 429ff.

²⁸ For technical reasons the experiment with internal distraction could not be carried out with any of the uneducated subjects.

²⁹ After the breaking off of her romance, her brother was the only person in whom the subject confided.

³⁰ The braces to the left of the stimulus-words indicate that these immediately succeeded each other.

³¹ Reactions of between one and two seconds are considered normal. [All reaction-time data in this paper are in seconds.]

³² [German *Obst* is the equivalent of English ‘fruit’ in a collective sense. *Frucht* is the term for particular fruit but is also used in the phrase “the fruit of the womb.”]

³³ Cf. “emotional stupidity”: Jung, “On Simulated Insanity.”

³⁴ See below, Calculations of Averages, par. 405 (6).

³⁵ The numbers refer to the order of the stimulus-words on the form; they are given only to show at what intervals these repetitions occur.

³⁶ Liepmann, *Über Ideenflucht, Begriffsbestimmung und psychologische Analyse* (1904).

³⁷ With the exception, of course, of people with specific dispositions.

³⁸ By this we mean a difference of attention only in the quantitative sense, not by any means a qualitative difference.

³⁹ One can say that in general the more uneducated and unintelligent a subject is, the more he interprets the stimulus-word as a question. This is shown most clearly in idiots, who, with few exceptions, always interpret the stimulus-word as a question and then give a definition or an explanation of it in the reaction.

⁴⁰ Incidentally, educated subjects have the same experience with words of a language that they have never read in print or writing. When stimulus-words are called out in dialect, the educated subjects sometimes have difficulty in understanding the words, because they are used to hearing dialect words only in a sentence-connection.

⁴¹ We stress here once more that by this classification we intend to mark only the clear and obvious differences in the mode of reaction. We know very well that basically every subject belongs in fact to, for example, the complex-constellation type, as no reaction is fortuitous but irrevocably conditioned by the psychological past of the subject. What we wish to clarify by our classification is the degree of subjective dependence in so far as it is clearly expressed in the reactions.

⁴² This not-wanting-to-betray is, as we have become convinced from numerous experiments, by no means always a conscious not-wanting but quite often unconscious inhibition, which in most cases also causes a lengthening of the reaction-time.

⁴³ A later paper will report on the variation of the reaction-times. [See *infra*.]

⁴⁴ A subject whose inner life is strongly affected by an unpleasant financial matter reacts within normal time to *ill* with *poor* and in the following reaction, *Stolz* ('pride') / *Boh* ('arrow'), with lengthened reaction-time. For no obvious reason the association is a senseless rhyme. Sound associations and rhymes occur in this subject only at "critical" points. *Poor* has a quite special emotional significance for this subject; attention remains attached to the constellated complex, which results in a disturbance of the succeeding reaction because of internal distraction.

⁴⁵ The subject already quoted in the preceding footnote reacts to *pity* with *poor ones* (*poor* has a particular feeling-tone). The succeeding association is *yellow (gelb)* / *much*. It is another perseveration of the financial complex, *gelb* being immediately assimilated as *Geld* (money), although the subject has long been familiar with all the stimulus-words on our list.

⁴⁶ In some subjects the repetitions also have a certain significance as the indirect expression of the complex. (We have pointed this out several times in the relevant section.) Certain words that are more or less closely associated with the complex, or that indirectly replace it, are frequently repeated.

⁴⁷ [*Oven* stands for the German *Ofen*, the German name of Buda, the sister town of Pest (Hungary). *Ofen* really means 'oven.']

⁴⁸ [Cf. *supra*, par. 212, n. 15.]

⁴⁹ [See n. 47.]

⁵⁰ [The German word *Blumenstock* (literally, "flowerstick") is mainly used for a tree-shaped potted plant such as a fuchsia.]

⁵¹ We note that the description of indirect associations at present deserves no greater value than that of a working hypothesis. We willingly offer our figures and our interpretations for further discussion in the hope that several research workers in cooperation might succeed in solving this question satisfactorily.

⁵² The occurrence of indirect associations under the influence of a distraction of attention has long been known from another source. The tangential naming of pictures in alcoholic delirium (Bonhöffer), in epileptic mania (Heilbronner), in certain catatonic and hysterical conditions, etc., is nothing but indirect association which is formed not, as in our experiment, through shift via sound similarity but through a shift via image similarity. Thus, in this case, it is a supplementary phenomenon of flight of ideas in the visual sphere and corresponds at all points to the phenomena we have shown in the acoustic-verbal sphere. [For Bonhöffer and Heilbronner, see Bibliography.]

⁵³ Cf. Claparède, *L'Association des idées* (1903), p. 140; and *idem*, "Association médiate dans l'évocation volontaire" (1904).

- ⁵⁴ H. Piéron, “L’Association médiate” (1903).
- ⁵⁵ [Cf. “The Psychology of Dementia Praecox,” par. 110, where the example is given with slight differences.]
- ⁵⁶ Jerusalem, “Ein Beispiel von Assoziation durch unbewusste Mittelglieder” (1892).
- ⁵⁷ Wundt, “Sind die Mittelglieder einer mittelbaren Assoziation bewusst oder unbewusst?” (1892).
- ⁵⁸ Scripture, “Über den assoziation Verlauf der Vorstellungen” (1889).
- ⁵⁹ William Smith, *Zur Frage der mittelbaren Assoziation* (1894).
- ⁶⁰ Münsterberg, *Beiträge zur experimentellen Psychologie*, IV (1892), p. 9. Münsterberg states emphatically: “Indirect associations through unconscious intermediate links do not exist.” All that can be said is that there were none in his experiments.
- ⁶¹ There are several good examples of indirect associations in Cordes, “Experimentelle Untersuchungen über Assoziationen” (1899), pp. 70, 71, 75. The supposition that the intermediate links of indirect associations are unconscious is for Cordes “a theoretical construction which it will never be possible to prove empirically, for unconscious psychic phenomena cannot be experienced.” The author would in any case modify this apodictic statement if he were at all acquainted with the results of hypnotism.
- ⁶² See Jung, “On Simulated Insanity.”
- ⁶³ In women by no means all egocentric references emerge freely, for the simple reason that the experimenters are men.
- ⁶⁴ Difference between the figure for identical grammatical form under normal conditions and the average number of distraction experiments.
- ⁶⁵ From the predicate-type class, containing three sub-groups, only one subject was used for calculation.
- ⁶⁶ These plastic images correspond roughly to Ziehen’s individual images. We purposely did not ask about them during the experiment, to avoid directing attention to them by this suggestion. In many individuals only a slight effort of attention is needed to produce plastic images immediately. In this case only the vague and general verbal images are suppressed, which can happen half unconsciously with appropriate suggestion, particularly with unpractised subjects.
- ⁶⁷ That is, it concentrates attention upon itself.
- ⁶⁸ By this we mean, of course, merely our experimental conditions. Under the influence of fatigue or alcohol the predicates would probably decrease; this, however, remains to be investigated.
- ⁶⁹ The fact that the majority of the subjects are Swiss, and therefore working under the more difficult linguistic conditions, must be remembered here.
- ⁷⁰ It must be noted here that of all the eleven predicate types used in these calculations only two are uneducated and of these only one is a woman.
- ⁷¹ This can be explained from the psychology of the predicate type. The subjects of this type are distinguished by their particularly vivid images. Therefore, they always see the adjective as the property of a definite object, which they then name in their reactions.
- ⁷² We use the term “repression” in the sense of Breuer and Freud, to whose work *Studies on Hysteria* we are indebted for valuable stimulus for our work.

¹ [First published as “Analyse der Assoziationen eines Epileptikers,” *Journal für Psychologie und Neurologie*, V (1905):2, 73–90. Republished in *Diagnostische Assoziationsstudien*, Vol. I, pp. 175–92 (III. Beitrag). Translated by M. D. Eder in *Studies in Word-Association*, pp. 206–26. See supra, par. 1, n.1.]

² “L’Allenamento ergografico nei normali e negli Epilettici” (1902).

³ “Über Ermüdungskurven bei Gesunden und bei einigen Neurosen und Psychosen” (1904).

⁴ *Lehrbuch der psychopathologischen Untersuchungsmethoden* (1899).

⁵ *Analyse des Vorstellungsmaterials bei epileptischen Schwachsinn* (1902).

⁶ *Psychiatrie: Ein Lehrbuch für Studierende und Ärzte* (7th edn., 1904), II, p. [626]. [The passage is not included in the abstracted translation by Diefendorf (1907).]

⁷ “The Associations of Imbeciles and Idiots” (1904).

⁸ “Hebung epileptischer Amnesien durch Hypnose” (1902).

⁹ “The Associations of Normal Subjects,” supra.

¹⁰ [German *tragen* has both these meanings. All reaction-time data in this paper are in seconds.]

¹¹ See “The Associations of Normal Subjects,” par. 429, supra. This case concerns a love-affair that ended unhappily and, moreover, with distressing circumstances that fully explain the strong affect.

¹² *Ibid.*, par. 432.

¹³ A further reason that, in Bleuler’s view, facilitates the occurrence of sentences in mental defectives is that it is difficult for them not only to understand a word outside the context of a sentence, but even to think words outside a sentence context.

¹⁴ See “The Associations of Normal Subjects,” par. 427.

¹⁵ Case 13 of Wehrin’s paper.

¹⁶ [German *Falle*: “fall” was substituted for the correct translation, “trap,” which would not have made sense in this example.]

¹⁷ Cf. “The Associations of Normal Subjects,” par. 408 (2).

¹⁸ Such reactions differ distinctly from certain reactions that can occasionally be obtained from loquacious imbeciles.

I quote the following as examples of this type:

Sunday	consists of a day when one does nothing, when one goes to church
mountain	a high mountain, with houses or without houses
salt	something to salt with. One salts meat
exercise-book	is made of paper. One makes a newspaper of it
ring	on the finger—jewelry—chain
attendant	someone who attends in hospitals, institutions, almshouses
piano	where music is, on the top floor where the organ is, the Misses have played it, next to it (even tells a story of an organ-player)
to swim	in the lake, in the water, in the Rhine, one

to cook

needs swimming trunks
necessary for the meal, soup, flour, meat,
pots and pans, casserole

star

parts of the sky, system of planets, sun,
moon, and stars

In these associations the emphasis and confirmations of the epileptic are absent; they do not express the emotional moment so well. They are more enumerations, which frequently appear like flights of ideas; the train of thought progresses and does not stick anxiously to the stimulus-word.

¹⁹ [German *Naturalie*, which is felt to be a foreign word.]

²⁰ Certain stimulus-words can touch off a feeling-toned complex of ideas that is very important for the individual. This results in certain disturbances of the association which we have described as “complex-characteristics,” such as: abnormally long reaction-times, repetition of the stimulus-word, abnormal wording of the critical or of the following reaction.

²¹ *Intention* is in any case a very insidious word for certain people.

²² [fR-T = reaction-time of the following association.]

²³ Cf. also Freud’s observations in *The Psychopathology of Everyday Life*.

²⁴ I find in normal subjects that reactions constellated by a conscious or unconscious complex often show abnormally long reaction-times; in some cases the emotional charge can even involve the following reaction, for which the reaction-time also becomes extended.

²⁵ See Aschaffenburg, “Experimentelle Studien über Assoziationen” (1896 ff.). (For the calculation, see my later paper on reaction-times.)

²⁶ This suggestion would also explain the epileptic perseveration in terms of the abnormality of the feeling-tone. It is, however, not unthinkable that the epileptic idea is abnormal in that it lasts longer than in the normal subject, and therefore produces a number of associations that still belong to the initial idea. Under these circumstances one could certainly expect relatively numerous perseverations of the contents. There is, however, none present in this case.

²⁷ Rr = repetition of the stimulus-word in the following reaction.

¹ [Originally published as “Über das Verhalten der Reaktionszeit beim Assoziationsexperimente,” *Journal für Psychologie und Neurologie*, VI (1905): 1/2, 1–36; republished separately the same year as Jung’s *Habilitationschrift*, i.e., treatise submitted for recognition as lecturer in psychiatry at the University of Zurich. Republished in *Diagnostische Assoziationsstudien*, Vol. I, pp. 193–228 (IV. Beitrag). Translated by M. D. Eder as “Reaction-time in Association Experiments,” *Studies in Word-Association*, pp. 227–65. See supra, par. 1, n.1.]

[In this study, the symbol σ = a millisecond, or 1/1000th of a second.]

² *L’Association des idées* (1903), p. 275. The construction of the schema follows Ziehen, “Die Ideenassoziation des Kindes” (1900), p. 14.

^{2a} [Labial keys are electrical contacts fastened to the subject’s lips; they close an electrical circuit that is interrupted each time the subject opens his mouth and thus mark the moment when the reaction is uttered—C. A. M.]

³ “Zur qualitativen Untersuchung der Assoziationen” (1901).

⁴ *Experimentelle Untersuchungen über die psychologischen Grundlagen der sprachlichen Analogiebildung* (1901).

⁵ “Eine experimentelle Studie über die Assoziation in einem Falle von Idiotie” (1900).

⁶ Op. cit., p. 261.

⁷ “The Associations of Normal Subjects,” supra.

⁸ “Experimentelle Studien über Assoziationen” (1896), p. 272.

⁹ *The Pathology of the Emotions* (orig. 1892).

¹⁰ “Psychometric Experiments” (1897).

¹¹ “Experimentelle Untersuchungen über die Assoziation der Vorstellungen” (1883).

¹² “The Associations of Normal Subjects,” supra. par. 10.

¹³ Ranschburg and Balint, “Über quantitative und qualitative Veränderungen geistiger Vorgänge im hohen Greisenalter” (1900).

¹⁴ “The Associations of Normal Subjects,” supra, pars. 436ff.

¹⁵ “Die Ideenassoziation des Kindes.”

¹⁶ “Experimentelle Studien über Assoziationen.”

¹⁷ Among the uneducated male subjects there is a young man of a slightly hysterical disposition, whose mental soundness we may have overestimated. His probable mean is no less than 3.4 seconds (an abnormally high value!). If this doubtful subject is left out, then the mean for men is only 1.6 seconds.

¹⁸ “Eine experimentelle Studie über die Assoziation in einem Falle von Idiotie” (1900).

¹⁹ “The Associations of Imbeciles and Idiots” (orig. 1904).

²⁰ Münsterberg, Kraepelin, and Aschaffenburg have all dealt with this question. Kraepelin found that, in about 90% of cases, where the stimulus-word was given in the form of a noun, the reaction was also given as a noun; Aschaffenburg, testing 16 subjects, found the same result in 81%. It may be remarked that he used only nouns as stimulus-words, on principle. This fact induces the subjects to indulge in perseverating with the same reaction-form; that is why these figures have only limited value. By “grammatical form” I understand merely noun, adjective, or verb.

²¹ I have counted them in newspapers and in interview articles and have found approximately the same proportion.

- ²² “The Associations of Normal Subjects,” supra, pars. 475ff.
- ²³ The individual values on which this table is based vary between 1.0 and 4.4 seconds.
- ²⁴ One could easily pose a whole series of questions on this theme; for instance, what is the reaction-time when verb is followed by verb and noun by noun? how does this vary between different subjects? and so on. This, however, would lead us too far afield.
- ²⁵ “The Associations of Normal Subjects,” supra, par. 445.
- ²⁶ The individual mean-values on which this table is based vary between 1.0 and 4.0 seconds.
- ²⁷ “Die Ideenassoziation des Kindes.”
- ²⁸ “Zur qualitativen Untersuchung der Assoziationen.”
- ²⁹ Ziehen first drew our attention to the fact that in cases of prolonged reaction-time a “relatively strong emotional charge” often occurred. Op. cit., 2nd contrib., p. 36.
- ³⁰ “The Associations of Normal Subjects,” supra.
- ³¹ Ibid., par. 449.
- ³² On perseveration, cf. Müller and Pilzecker, “Experimentelle Beiträge zur Lehre von Gedächtnis” (1900).
- ³³ Cf. R.143, *blood*, infra.
- ³⁴ Cf. Müller and Pilzecker, op. cit.
- ³⁵ “The Associations of Normal Subjects,” supra, pars. 350ff.
- ³⁶ [This association derives from the German phrase “der Zahn der Zeit” = “the tooth (i.e., ravages) of time.”]
- ^{36a} [Cf. “The Psychology of Dementia Praecox,” par. 110, where the same association is rendered in translation as *mild / bed; child / bed.*]
- ³⁷ In a case of this kind, more exact timing would be desirable.
- ³⁸ “The Association of Normal Subjects,” supra, pars. 211f.
- ³⁹ From this we can also gather that those who equate psyche with consciousness actually take *partem pro toto*.
- ⁴⁰ Cf. Freud, *The Psychopathology of Everyday Life* (orig. 1904).
- ⁴¹ Only 4% of the associations can safely be related to other complexes.
- ⁴² [Tötig, not actually a word, suggests töten, ‘to kill.’]
- ⁴³ [Dreck, which also means excrement.]
- ⁴⁴ Cf. *The Interpretation of Dreams* (orig. 1900).
- ⁴⁵ Riklin, “Zur Psychologie hysterischer Dämmerzustände und des Ganser’schen Symptoms” (1904).
- ⁴⁶ A similar word-automatism (Bunau-Varilla) is reported in “The Associations of Normal Subjects,” supra, par. 451.
- ⁴⁷ [Wortschaft, not an actual word; perhaps a mistake for Wortschatz, ‘vocabulary’; but cf. above, p. 243, no. 191, *Wirtschaft.*]
- ⁴⁸ Cf. also the “complex-characteristics” in our earlier investigation: “The Associations of Normal Subjects,” supra, par. 417.
- ⁴⁹ [This case is also discussed in “The Psychological Diagnosis of Evidence,” infra.]
- ⁵⁰ [Famous Viennese dermatologist (1837–1902).]

⁵¹ The concept of *repression*, which I use on many occasions in my analyses, requires a brief explanation. In Freud's works this concept (which in any case the meaning of the word itself indicates) has the character of an active function, frequently a function of consciousness. In hysteria one may, however, get the impression that *repression* equals deliberate forgetting. With normal subjects it might, however, be a more passive "sliding into the background"; at least here repression seems to be something unconscious, to which we can only indirectly attribute the character of something willed or something *wished*. If, nevertheless, I speak of repressing or, better, concealing, this can be taken as a metaphor from the psychology of the conscious. Essentially it comes to the same thing because objectively it does not matter one way or the other whether a psychic process is conscious or unconscious. (Cf. Bleuler, "Versuch einer naturwissenschaftlichen Betrachtung der psychologischen Grundbegriffe" (1894).)

⁵² I must observe that the analysis of the associations of an uneducated subject would take a very different and more complicated form. As explained by Riklin and myself, the uneducated subject is inclined to concentrate on the meaning of the stimulus-word; for this reason his reaction-times are longer and it would be difficult to decide to what extent feelings or attitudes account for these.

⁵³ The stimulus-words bracketed together followed immediately on each other in the test series.

⁵⁴ The stimulus-word in square brackets is given because it seems more likely to arouse a complex than *window* or *inn*.

¹ [First published as “Experimentelle Beobachtungen über das Erinnerungsvermögen,” *Zentralblatt für Nervenheilkunde und Psychiatrie* (Leipzig), XXVIII (1905; n.s. XVI): 196 (Sept.), 653–66. It was not included in the first volume of *Diagnostische Assoziationsstudien*, whose contents Jung referred to in the opening sentence, and it is here first republished.]

² Freud, “The Neuro-Psychoses of Defence” (orig. 1894), “The Psychological Mechanism of Forgetfulness” (1898), “Screen Memories” (1899), *The Psychopathology of Everyday Life* (orig. 1904).

³ Freud, *The Interpretation of Dreams* (1900).

⁴ See my “The Reaction-time Ratio in the Association Experiment,” *supra*.

⁵ Hans Gross, “Zur psychologischen Tatbestandsdiagnostik” (1905); Wertheimer and Klein, “Psychologische Tatbestandsdiagnostik” (1904); Alfred Gross, “Zur psychologischen Tatbestandsdiagnostik als kriminalistisches Hilfsmittel” (1905); Stern, “Psychologische Tatbestandsdiagnostik” (1905); Hans Gross, “Zur Frage des Wahrnehmungsproblems” (1905).

⁶ [In the German version, the items of this list were not numbered. They have now been numbered to facilitate comparison with the list for Case No. II. The list for Case No. I omits, perhaps inadvertently, 51, *frog*.]

⁷ The complex phenomena are comprehensively presented in my “The Reaction-time Ratio in the Association Experiment”; see *supra*.

^{7a} [Jung is apparently referring to the first column of reproductions, in which there are actually 12, not 13, incorrect reproductions. There are 14 in the second column.]

⁸ “The Reaction-time Ratio in the Association Experiment.”

⁹ [German *Engel/-hof*; in Switzerland, a name sometimes given to a farm or house.]

¹⁰ Cf. Pick, “Zur Psychologie des Vergessens bei Geistes- und Nervenkranken” (1905).

¹¹ “A Case of Hysterical Stupor in a Prisoner in Detention”; “On Simulated Insanity.” [For Sigbert Ganser, see *Psychiatric Studies*, index, s.v.]

¹² Riklin, “Zur Psychologie hysterischer Dämmerzustände und des Ganser’schen Symptoms” (1904).

¹³ Cf. Riklin, “Analytische Untersuchungen der Symptome und Assoziationen eines Falles von Hysterie (Lina H.)” (1905).

- ¹ [First published in “Psychoanalyse und Assoziationsexperiment,” *Journal für Psychologie und Neurologie*, VII (1906): 1–2, 1–24. Republished in *Diagnostische Assoziationsstudien*, Vol. I, pp. 258–81 (VI. Beitrag). Translated by M. D. Eder in *Studies in Word-Association*, pp. 297–321. See supra, par. 1, n. 1.]
- ² “Fragment of an Analysis of a Case of Hysteria” (orig. 1905).
- ³ [Paul Julius Möbius (1853–1907), German neurologist who influenced Freud.]
- ⁴ [For Jung’s reviews of books by Leopold Lowenfeld and Willy Hellpach, see Vol. 18, *Miscellany*.]
- ⁵ See supra, pars. 602 ff.
- ⁶ Wertheimer, “Experimentelle Untersuchungen zur Tatbestandsdiagnostik” (1905). Wertheimer and Klein, “Psychologische Tatbestandsdiagnostik” (1904).
- ⁷ “Zur psychologischen Tatbestandsdiagnostik” (1905).
- ⁸ “Die Assoziationsmethode in Strafprozess” (1906). Grabowsky, “Psychologische Tatbestandsdiagnostik” (1905).
- ⁹ Bleuler, “Versuch einer naturwissenschaftlichen Betrachtung der psychologischen Grundbegriffe” (1894) and “Consciousness and Association” (orig. 1905).
- ¹⁰ Jung, “Experimental Observations on the Faculty of Memory,” supra.
- ¹¹ The incorrectly reproduced associations are in italics. + = correct reproduction. r. = here the patient repeated the stimulus-word quickly in the reaction. One frequently meets this phenomenon in and after complex-reactions.
- ¹² Cf. Jung, “The Reaction-Time Ratio in the Association Experiment,” etc.
- ¹³ I cannot deal here with the justification of these inferences. See *ibid*.
- ¹⁴ — = not reproduced.
- ¹⁵ [The association in German seems to have been suggested by *Bergwerk*, ‘mine.’]
- ¹⁶ In order to set the complex-disturbances in relief, I am adding all the perseveration phenomena and also the gradually decreasing times of the subsequent reactions.
- ¹⁷ [See supra, n. 15.]
- ¹⁸ The reproaches are originally restricted to the sexual complex but, according to our experience, are soon applied to a wider field.
- ¹⁹ Cf. the reference to this maid in the first session.
- ²⁰ Cf. Jung, “On the Psychology and Pathology of So called Occult Phenomena” (1902).
- ²¹ [German *fremd/Heimweh*; “fremd” is an adjective the literal translation of which (‘strange’) would be misleading. The noun had therefore to be used, although not strictly apposite.]
- ²² With this one can also compare the fact that many sexually perverted persons (fetishists) have acquired their abnormality through an incidental sexual event (see Krafft-Ebing, *Psychopathia Sexualis*).

¹ [First published as “Die psychologische Diagnose des Tatbestandes,” *Schweizerische Zeitschrift für Strafrecht* (Bern), XVIII (1905), 369–408, and again in *Juristische-psychiatrische Grenzfragen* (Halle), IV (1906): 2, 3–47; republished as a pamphlet the same year under the same auspices, and again in 1941 by Rascher, Zurich and Leipzig.

[For a preliminary report of the case described in Part II (pars. 770ff.) see “On the Psychological Diagnosis of Facts,” *Psychiatric Studies*, Vol. 1 of the *Collected Works*. Jung wrote that report on the actual evening of the day during which he had conducted the test herein described more fully.

[While *Tatbestand* means ‘facts,’ as translated in the title of the preliminary report, it may mean ‘evidence’ in a forensic context. Cf. Freud’s “Tatbestandsdiagnostik und Psychoanalyse,” translated in the Standard Edn., IX, as “Psychoanalysis and the Establishment of the Facts in Legal Proceedings” (main title) and as “Psycho-analysis and Legal Evidence” (page headings).]

² [I.e., the series *Beiträge zur Psychologie der Aussage*, which Stern published in Leipzig].

³ “Psychometric Experiments” (1897).

⁴ Strictly speaking, these are of course not associations, only remote verbal reflections of the purely psychological process of association.

⁵ “Experimentelle Untersuchungen über die Assoziationen der Vorstellungen” (1883).

⁶ “Über den assoziativen Verlauf der Vorstellungen” (1889).

⁷ “Experimentelle Untersuchungen über Assoziationen” (1899).

⁸ For further details, see “The Psychopathological Significance of the Association Experiment,” *infra*.

⁹ “Experimentelle Studien über Assoziationen” (1896–1904).

¹⁰ On the clinical side, Heinrich Schüle (1886; pp. 84, 191) has drawn attention to the “predominance of assonances” in cerebral exhaustion.

¹¹ Jung and Riklin, “The Associations of Normal Subjects,” *supra*.

¹² This term is a pleonasm, because there are no complexes of ideas other than emotionally charged ones. The stronger the complex is, the more vivid an emotional tone one has to infer.

¹³ The concept in this case originates with Ziehen, *Introduction to Physiological Psychology* (orig. 1891). Freud’s “symptomatic behaviour” means the same thing.

¹⁴ “The Reaction-time Ratio in the Association Experiment,” *supra*.

¹⁵ “Experimental Observations on the Faculty of Memory,” *supra*.

¹⁶ The plus sign means that the reproduction was correct. Incorrect reproductions are given.

¹⁷ “Failure” means that the subject could not think of anything at all here.

¹⁸ See in particular Riklin, “Analytische Untersuchungen der Symptome und Assoziationen eines Falles von Hysterie” (1905).

¹⁹ “Psychologische Tatbestandsdiagnostik” (1904). [For further comment on this work, see *infra*. Appendix, no. 5, n. 2.]

²⁰ “Experimentelle Untersuchungen zur Tatbestandsdiagnostik” (1905).

²¹ “Zur psychologischen Tatbestandsdiagnostik” (1905) and “Zur Frage des Wahrnehmungsproblems” (1905).

²² “Zur psychologischen Tatbestandsdiagnostik als kriminalistisches Hilfsmittel” (1905–6).

- ²³ “Die Assoziationsmethode im Strafprozess” (1906), p. 19.
- ²⁴ “Psychologische Tatbestandsdiagnostik” (1905–6), p. 145.
- ²⁵ Breuer and Freud, *Studies on Hysteria* (orig. 1895); Freud, *The Interpretation of Dreams* (orig. 1900).
- ²⁶ “Psychologische Tatbestandsdiagnostik” (1905).
- ²⁷ Bleuler, “Upon the Significance of Association Experiments”; Jung and Riklin, “The Association of Normal Subjects,” supra; Wehrlin, “The Associations of Imbeciles and Idiots”; Jung, “An Analysis of the Associations of an Epileptic,” supra; also, Riklin, “Die diagnostische Bedeutung des Assoziationsversuches bei Hysterischen” (1904) and “Analytische Untersuchungen der Symptome und Assoziationen eines Falles von Hysterie” (1905).
- ²⁸ Alfred Gross replied in detail to Kraus’s deliberations in “Zur psychologischen Tatbestandsdiagnostik” (1905).
- ²⁹ See n. 25, supra.
- ³⁰ “Zur psychologischen Tatbestandsdiagnostik” (1905).
- ³¹ For a preliminary report of the case, see “On the Psychological Diagnosis of Facts,” *Coll. Works*, Vol. 1.
- ³² The delinquent comes from a religious family.
- ³³ [German *klagen* has both meanings.]
- ³⁴ [German *arm* or *Arm* has both meanings.]
- ³⁵ *False* means that he has stolen from his benefactor.
- ³⁶ So many months in jail.
- ³⁷ The method of the “probable mean” (Kraepelin) consists in putting the numbers into a sequence according to their magnitude and then simply taking the middle number. As to the advantages of this method, cf. Jung, “The Reaction-time Ratio in the Association Experiment,” supra.
- ³⁸ The intentionally inserted stimulus-words relating to the complex are italicized in each case.
- ³⁹ The words indicating the complex are also italicized. [In this case, the reaction was stammered: German *frei-freigebig*, ‘free-freely giving.’]
- ⁴⁰ [Orig. *Mechanismus*, not a German word.]
- ⁴¹ Cf. “The Reaction-time Ratio in the Association Experiment.”
- ⁴² The minus sign indicates that the reaction could not be remembered.
- ^{42a} [German: *aufpassen/verfehlen ... st-verstecken*, with *stehlen* conjectured.]
- ⁴³ Unfortunately the reaction-time could not be assessed here because of a breakdown of the stop-watch.
- ⁴⁴ [German *Kommode*, and the original reaction *bequem* has the same meaning, ‘comfortable,’ as *kommode*.]
- ⁴⁵ See Wehrlin, “The Associations of Imbeciles and Idiots.”
- ⁴⁶ In this respect there are characteristic differences between words, e.g., the probable mean for concrete nouns is 1.67 secs., for general concepts 1.95 secs., adjectives 1.70 secs., verbs 1.90 secs. See “The Reaction-time Ratio in the Association Experiment.”
- ⁴⁷ The reasons are given in detail in “The Reaction-time Ratio in the Association Experiment.”
- ⁴⁸ We have here, however, to consider that the reduction of the Informed to the level of the Culprit is not a quite unobjectionable procedure, because the times can only be extended upwards and not downwards. Finally, it is also characteristic that the innocent can act quickly, that is, without hesitation.

¹ [Originally published as “Assoziation, Traum und hysterisches Symptom,” *Journal für Psychologie und Neurologie*, VIII (1906):1–2,25–60. Republished in *Diagnostische Assoziationsstudien*, Vol. II (1909), 31–66 (VIII. Beitrag). Translated by M. D. Eder as “Association, Dream, and Hysterical Symptoms,” *Studies in Word-Association*, pp. 354–95. See supra, par. 1, n. 1.]

² Jung, “Psychoanalysis and Association Experiments,” supra; Riklin, “Cases Illustrating the Phenomena of Association in Hysteria” (1906).

³ [See Meige and Feindel, *Tics and Their Treatment* (orig. 1902).]

^{3a} [See supra, par. 655, n. 9.]

⁴ Cf. “The Associations of Normal Subjects,” supra, pars. 20ff.

⁵ Ibid., Table F.

⁶ A similar case of diversion phenomenon is reported supra, pars. 170ff., where, however, quite a recent affect formed the cause of the interference.

⁷ This is not actually the case, however, because already in Test I the patient showed the beginnings of a less superficial association type.

⁸ Thus the patient now shows a reaction-type that we not infrequently see in uneducated people: a great many internal associations, few external ones, and very few sound reactions.

⁹ The failures were calculated at 20 secs. each.

¹⁰ Failure or incorrectness of reproduction is indicated in square brackets.

¹¹ Cf. “Experimental Observations on the Faculty of Memory,” supra.

¹² Transference [*Transposition*] to the doctor; see Freud, “Fragment of an Analysis of a Case of Hysteria” (orig. 1905).

¹³ *Jokes and Their Relation to the Unconscious* (orig. 1905), p. 170.

¹⁴ [German *Tanzboden*, lit. ‘dance-floor,’ has the sense of a low-class dance-hall.]

^{14a} [This apparently refers to a performance or calculation test, devised by Kraepelin, and still in use at the Burghölzli. The patient has to add pairs of digits and write the sum down in an exercise-book, in which the experimenter enters a mark at each minute in order to indicate the patient’s rate of performance. Dr. C. A. Meier has kindly supplied this information.]

¹⁵ See Bleuler’s theoretical discussions in “Consciousness and Association” (orig. 1905).

¹⁶ We have shown that in a state of diversion of attention the indirect associations increase in such a way that a very frequent association replaces either the stimulus-word or the reaction, so that it appears as if the stimulus-word must have been misheard or that the patient reacted by a slip of the tongue. “The Associations of Normal Subjects.”

¹⁷ [A medieval tribunal that sat in secret.]

¹⁸ [In German, *dürren Landjäger*.]

¹⁹ [The word used, *Sudfruchtengeschäft*, means a shop specializing in fruit from the South.]

²⁰ Here it should also be remembered that in the dream of the occupied room there was the call: “Stop, this is forbidden!” Perhaps my phrase made such an impression, because it was complex-stimulating and expressed something that was of great importance for the patient (if we assume that the complex here touched actually exists!).

²¹ Cf., e.g., the sleep-walking fantasies of the case that I published in my study “On the Psychology and Pathology of So-called Occult Phenomena.”

- ¹ [First published as “Die psychopathologische Bedeutung des Assoziationsexperimentes,” *Archiv für Kriminalanthropologie und Kriminalistik* (Leipzig). XXII (1906): 2–3 (Feb. 15), 145–62. It was Jung’s inaugural lecture, 21 October 1905, upon his appointment as lecturer in psychiatry at the University of Zurich.]
- ² *Psychologische Arbeiten* (from 1896).
- ³ “Experimentelle Studien über Assoziationen,” *ibid.*, I (1896), II (1899), IV (1904).
- ⁴ A book that offers an excellent survey of the problem is Claparède, *L’Association des idées* (1903).
- ⁵ “Psychometric Experiments” (1897).
- ⁶ Trautscholdt, “Experimentelle Untersuchungen über die Assoziation der Vorstellungen” (1883).
- ⁷ The possibility of such motivations is proved by the post-hypnotic command.
- ⁸ *Beiträge zur experimentellen Psychologie* (1889–92). [Hugo Münsterberg, professor of psychology at Harvard until his death in 1916, was an opponent of psychoanalysis.]
- ⁹ Jung and Riklin, “The Associations of Normal Subjects,” *supra*.
- ¹⁰ *Ibid.*
- ¹¹ These findings confirm Ranschburg’s statements. Cf. Ranschburg and Balint, “Über quantitative und qualitative Veränderungen geistiger Vorgänge im hohen Greisenalter” (1900).
- ¹² Wehrlin, “The Associations of Imbeciles and Idiots” (1904).
- ¹³ According to investigations made in this clinic, which have not yet been published. [Cf. *infra*, “The Family Constellation,” and Fürst, “Statistical Investigations” (1907).]
- ¹⁴ “Die Ideenassoziation des Kindes” (1898–1900).
- ¹⁵ “Zur qualitativen Untersuchung der Assoziationen” (1901).
- ¹⁶ Of course, we sometimes find long reaction-times that are due to other causes.
- ¹⁷ Cf. Jung, “The Reaction-time Ratio in the Association Experiment,” *supra*.
- ¹⁸ Jung, “Experimental Observations on the Faculty of Memory,” *supra*.
- ¹⁹ On hysterical associations, cf. Riklin, “Analytische Untersuchungen der Symptome und Assoziationen eines Falles von Hysterie” (1905).
- ²⁰ Jung, “The Psychological Diagnosis of Evidence,” *supra*.
- ²¹ On this question, see especially the works of Sigmund Freud, to whose far-seeing psychological understanding modern psychiatry will be *very much* indebted.
- ²² In order to avoid long-winded explanations in a lecture, I have expressed myself somewhat dogmatically. Dementia praecox unfortunately denotes a group of illnesses which have not yet been clearly defined clinically, and individual forms and descriptions can appear quite distinct from one another. Our experiments (whose results have not yet been published) show that the symptoms of this disease can be explained in a large number of cases as complex-phenomena. [See “The Psychology of Dementia Praecox” and other works in vol. 3, *Coll. Works*.]

¹ [First published as “Über die Reproduktionsstörungen beim Assoziationsexperiment,” *Journal für Psychologie und Neurologie*, IX (1907): 4, 188–97. Republished in *Diagnostische Assoziationsstudien*, Vol. II (1909), pp. 67–76 (IX. Beitrag). Translated by M. D. Eder in *Studies in Word-Association*, pp. 396–406. See supra, par. 1, n. 1.]

² [“Experimental Observations on the Faculty of Memory,” supra.]

³ Alfred Gross, “Kriminalpsychologische Tatbestandsforschung” (1907); Heilbronner, “Die Grundlagen der psychologischen Tatbestandsdiagnostik” (1907); Isserlin, “Über Jungs ‘Psychologie der Dementia praecox,’ etc.” (1907).

⁴ “The Reaction-time Ratio in the Association Experiment,” supra.

⁵ The figures in these two columns give the arithmetical mean (A.M.) of the reaction-times of the associations immediately preceding the incorrectly reproduced ones: column I for the incorrectly reproduced associations with the probable mean (P.M.), column II for those below the probable mean.

⁶ I.R. = incorrectly reproduced.

⁷ The fourth and subsequent disturbances are not given because they are based on too small a series of numbers (less than 20). But they all considerably exceed the general arithmetical mean, if only for the reason that the number and the series of disturbed reproductions tend to increase with the length of the reaction-time.

¹ [The first of a series of lectures under the general title “The Association Method,” delivered before the Department of Psychology in celebration of the twentieth anniversary of the opening of Clark University, Worcester, Massachusetts, September, 1909. The three lectures were translated by A. A. Brill and published in the *American Journal of Psychology*, XXI (1910), in a Clark University anniversary volume (1910; the same setting of type), and in *Collected Papers on Analytical Psychology* (London and New York, 1916; 2nd edn., 1917). For the second lecture, see “The Family Constellation,” *infra*. The third lecture was the only one published in its original German version: see “Psychic Conflicts in a Child,” *Coll. Works*, vol. 17, prefatory note.

[The original German version of the first two lectures was thought to have been lost, but recently Jung’s holograph was found among his papers. While it has the appearance of a draft, it corresponds closely with the Brill translation. Both Freud and Jung lectured at Clark University in German; see Freud’s “On the History of the Psycho-Analytic Movement,” p. 31, and his “Five Lectures on Psycho-Analysis” (the Clark lectures), editor’s note, p. 4. Both men received honorary doctorates of law at the Clark celebration, Freud’s being in psychology and Jung’s in “education and social hygiene.”

[The present translation has been made from the holograph, in consultation with the Brill translation.]

² [The holograph contains merely the direction “insert,” and the list that follows here is from Brill, modified to conform to the present translation. It corresponds closely to a list that Jung customarily used in German, viz.:

1. Kopf
2. grün
3. Wasser
4. singen
5. Tod
6. lang
7. Schiff
8. zahlen
9. Fenster
10. freundlich
11. Tisch
12. fragen
13. Dorf
14. kalt
15. Stengel
16. tanzen
17. See
18. krank
19. Stolz
20. kochen
21. Tinte

22. böse
23. Nadel
24. schwimmen
25. Reise
26. blau
27. Lampe
28. sündigen
29. Brot
30. reich
31. Baum
32. stechen
33. Mitleid
34. gelb
35. Berg
36. sterben
37. Salz
38. neu
39. Sitte
40. beten
41. Geld
42. dumm
43. Heft
44. verachten
45. Finger
46. teuer
47. Vogel
48. fallen
49. Buch
50. ungerecht
51. Frosch
52. scheiden
53. Hunger
54. weiss
55. Kind
56. aufpassen
57. Bleistift

58. traurig
59. Pflaume
60. heiraten
61. Haus
62. lieb
63. Glas
64. streiten
65. Pelz
66. gross
67. Rübe
68. malen
69. Teil
70. alt
71. Blume
72. schlagen
73. Kasten
74. wild
75. Familie
76. waschen
77. Kuh
78. fremd
79. Glück
80. lügen
81. Anstand
82. eng
83. Bruder
84. fürchten
85. Storch
86. falsch
87. Angst
88. küssen
89. Braut
90. rein
91. Türe
92. wählen
93. Heu

94. zufrieden
95. Spott
96. schlafen
97. Monat
98. hübsch
99. Frau
100. schimpfen

The lists on the following pages appeared in the holograph. The graphs did not appear, though referred to.]

³ [The holograph here contains a direction to insert the experiment from the *Rivista di psicologia applicata*, i.e., “New Aspects of Criminal Psychology” (see *infra*. Appendix 2). Accordingly, pars. 957–983 here are translated from the Italian of that work, where the passage is omitted to avoid repetition.]

⁴ [The reaction-times are always given in fifths of a second.]

⁵ [See the appendix, *infra*, pars. 1331ff., where the discussion of this case continues.]

* [In the original editions, this graph was reproduced using three colours in addition to black: blue, green, and yellow with striped effects when two or three factors applied. As a coloured graph is mentioned in the holograph, it may have been shown as a slide or chart during the lecture. The graph has been simplified and corrected in detail for this presentation.]

¹ [For bibliographical history, see n. 1 to the preceding lecture, “The Association Method.” This lecture has also been translated from the German holograph, in consultation with the Brill version. In the holograph, Jung’s title was “Die familiäre Constellation,” which Brill rendered as “The Familiar Constellations” in the 1909, 1910, and 1916 publications.]

[Jung had previously published “Associations d’idées familiales,” *Archives de psychologie* (Geneva), VII: 26 (Oct., 1907), 160–68, the content of which is similar to that of the present paper; it is omitted from the *Coll. Works*. He again presented four of the graphs, and commented on the cases, in 1935 in “The Tavistock Lectures,” Lecture III (1968 edn., pp. 83ff.)]

² [Emma Fürst, M.D., a member of the staff of the Psychiatric Clinic of the University of Zurich. Cf. her “Statistical Investigations on Word-Associations and on Familial Agreement in Reaction Type among Uneducated Persons” (orig. 1907).]

³ [The holograph here contains a direction to insert all of sec. 2 at p. 165 in the *Archives*, i.e., “Associations d’idées familiales” (supra, n. 1). Pars. 1000–1003 are here reproduced from the Brill translation, modified to conform with the present translation.]

⁴ “Analysis of a Phobia in a Five-Year-Old Boy” (orig. 1909).

⁵ [Ibid.]

¹ [Apparently written in English; published in *The Journal of Abnormal Psychology* (Boston), I (1907), 247–55. It was Jung’s first publication in English and has never been republished. The present text contains slight stylistic revisions.]

² Cf. the report of Adolf Meyer, *Psychological Bulletin*, II (1905), 242–50; also August Hoch, in *Journal of Abnormal Psychology*, I:2 (1906).

³ [In the 1907 publication, the reaction-time column is headed “min./sec.”; but, inasmuch as in the next par. Jung states that the reaction-times are relatively short, the column heading has been corrected. But cf. above, pars. 743ff.]

⁴ See bibliography at end of this article.

⁵ [“On the Psychogalvanic Phenomenon in Association Experiments” (orig. 1907/8).]

⁶ [Jung published the bibliography with more or less full references, which will be found in the entries in the volume bibliography.]

¹ [Originally published, in English, in *Brain: A Journal of Neurology* (London), XXX (1907): 118 (July), 153–218; reprinted the same year as a small book. Frederick W. Peterson (1859–1938), M.D., was then Clinical Professor of Psychiatry, Columbia University, New York. He collaborated with A. A. Brill in the translation of Jung’s *The Psychology of Dementia Praecox* (1909).

[In the present version, stylistic and terminological revisions have been made. A list of references originally at the end of the paper has been converted into footnotes.]

² “Über Versuche einer objektiven Darstellung von Sensibilitätsstörungen” (1897).

³ “Zur Messung der motorischen Begleiterscheinungen psychischer Zustände” (1902).

⁴ Veraguth presented his entire results to date for discussion at the second German Congress for Experimental Psychology, Würzburg, 1906, the transactions of which will be published early this year (1907). [See Veraguth, “Le Réflexe psychogalvanique” (1906 and 1907).]

[The following was inserted as a corrigendum slip in the *Brain* publication: “Dr. Jung wishes us to state that Dr. O. Veraguth, of Zurich, first made known to him the value of the galvanometer as a measure of psychical stimuli. It was after this demonstration by Dr. Veraguth that Dr. Jung began to experiment on his own account.”]

⁵ [See above, par. 1018.]

⁶ [“On the Psychogalvanic Phenomenon in Association Experiments.”]

⁷ On one occasion, with three persons in the circuit and one Bunsen cell, the sudden fall of a weight with loud noise caused a deflection of two cms.

⁸ All tracings except figs. 9, 14, 15, and 18 have been reduced to one-eighth their size.

⁹ *Affektivität, Suggestibilität, Paranoia* (1906).

¹⁰ With a stop-watch we estimated that the time of revolution of the drum was 4.5 in five seconds. Hence the latent time in the above normal individuals was about as follows:

Latent time in seconds	B.	G.	Dr. P.	Dr. R.	Dr. R. Word Assoc.	H. Word Assoc.
First series	2.28	2.05	3.5	4.5	3.27	2.51
Second series	2.83	1.95	4.88	5	4.44	3.94
Third series		2.57				4.6

¹¹ *Über Bewegungsempfindungen* (1819).

¹² *Die Hauptgesetze des menschlichen Gefühlslebens* (1892).

¹³ “Die Wirkung akustischer Sinnesreize auf Puls und Atmung” (1893).

¹⁴ “Über Begleiterscheinungen psychischer Vorgänge im Atem und Puls” (1900).

¹⁵ *Beiträge zur Psychologie und Philosophie* (1905).

¹⁶ “Zur Kenntnis gewisser erworbener Blödsinnsformen” (1903); “Zur Auffassung gewisser Symptome der Dementia Praecox” (1904).

¹⁷ “Acting up to realities.”

¹⁸ *Les Obsessions et la psychasthénie* (1903).

¹⁹ Raimann, *Die hysterischen Geistesstörungen* (1904).

²⁰ [This is probably the case that Jung dealt with in detail in “The Psychology of Dementia Praecox” (1907). See especially par. 198 and pars. 364–84 in *Coll. Works*, vol. 3; also *Memories, Dreams, Reflections*, pp. 125–28 (both edns.).]

²¹ [See n. 6, *supra*.]

²² “The Psychology of Dementia Praecox”; “Experimental Observations on the Faculty of Memory” (*supra*); and other works on the association test.

²³ “Note sur des modifications de la résistance électrique sous l’influence des excitations sensorielles et des émotions” (1888), p. 217.

¹ [Originally published, in English, in *The Journal of Abnormal Psychology* (Boston), II (1907–8): 5,189–217. Charles Ricksher (1879–1943), M.D., was then Assistant Physician, Danvers Insane Hospital, Hathorne, Massachusetts. In this version, stylistic and terminological revisions have been made.]

² [For this reference and others following, see bibliography at end of the paper.]

³ Experiments by Veraguth and Jung and Binswanger.

⁴ Remarks by Delabarre, Mosso, and Mentz are quoted from Zoneff and Meumann.

⁵ [Hereafter abbreviated as Height, Latency, Time to top.]

⁶ [Hereafter abbreviated as Before, Rise, Fall.]

⁷ Binswanger, “On the Psychogalvanic Phenomenon in Association Experiments” (orig. 1907/8).

⁸ [*Orig.*: subconscious.]

⁹ [Jung published this bibliography with more or less full references, which will be found in the entries in the volume bibliography.]

¹ [Translated from “Statistisches von der Rekrutenaushebung,” *Correspondenz-Blatt für Schweizer Aerzte* (Basel), XXXVI:4 (Feb. 15, 1906), 129–30. Jung served as an officer in the Swiss Army medical corps from 1901 to 1930.]

² One must take into consideration that the formalities of enlistment create for many people an unusual situation, owing to which they get into a state of persistent stupefaction (so-called emotional stupidity), which makes them appear more stupid than they really are.

³ The rest came from the semi-urban population of Kriens; they were therefore omitted.

¹ [Translated from “Le nuove vedute della psicologia criminale; Contributo al metodo della ‘Diagnosi della conoscenza del fatto (Tatbestandsdiagnose),” *Rivista di psicologia applicata* (Bologna), IV:4 (July–August, 1908), 285–304. The article in Italian was translated by L. Baroncini from a German manuscript that has not been discovered. Part of the article was incorporated in Jung’s lecture “The Association Method” at Clark University, 1909; see *supra*, par. 929, n. 1, and *infra*, n. 10.]

² [Editorial note in the Italian, apparently by the editor of the *Rivista*, G. Cesare Ferrari, director of the provincial mental hospital at Imola:

“*Tatbestandsdiagnose* is one of those words without meaning, at least for us, that only the Germans can coin. The subject to which this inappropriate word refers is, however, so important that we must try to find a significant term.

“It is not the first time that this difficulty has arisen; terms such as ‘associations with a diagnostic purpose,’ ‘involuntary self-accusation by means of associations,’ ‘diagnosis of complexes of ideas,’ and others have been proposed. Each of these is, however, open to criticism.

“Baroncini, who has translated Jung’s original work into Italian, tries to be faithful to the German phraseology of the text. He proposes, however, to correct the term to ‘psychological diagnosis of evidence’ (*diagnosi della conoscenza del fatto*), a logical substitution that has the disadvantage of needing two pages of interpretation. For lack of a better term, we accept this phrase and we suggest that the organizers of the Congress for Psychology in Geneva may improve on it.”]

³ For the history, literature, and technique of the experiments, see my “The Psychological Diagnosis of Evidence,” *supra*.

A good illustration of the laboratory experiments and of many questions about the method can be found in Alfred Gross, “Kriminalpsychologische Tatbestandsforschung” (1907).

The use of the association experiments for criminological purposes was first suggested by Wertheimer and Klein [1904].

For the general importance of the association experiments, see the *Diagnostic Association Studies* edited by me (1906).

⁴ J. G. Schnitzler, medical dissertation, Utrecht, 1907 [= “Experimentelle Beiträge zur Tatbestandsdiagnostik” (1909)].

⁵ In the reproduction method, one first collects a large number of associations, then one requests the subject to say again the words with which he had reacted to the various stimulus-words. One then finds that it is mainly such associations as indicate complexes that are easily forgotten. Cf. my “Disturbances of Reproduction in the Association Experiment,” *supra*.

⁶ A classification of the complex-characteristics can be found in par. 935, *supra*.

⁷ See my “The Reaction-time Ratio in the Association Experiment,” *supra*. I call “prolonged” those reaction-times that exceed the probable mean of all the reaction-times observed during the investigations.

⁸ Cf. especially the investigations of Binswanger, “On the Psychogalvanic Phenomenon in Association Experiments.”

⁹ “The Psychological Diagnosis of Evidence,” *supra*.

¹⁰ [The case report is omitted here, as it is reproduced in “The Association Method,” supra, pars. 957–82. The present paper, however, contains further analysis of the case, which follows.]

¹¹ Freud, “Psycho-analysis and the Establishment of the Facts in Legal Proceedings” (1906). [See the Standard Edn., IX, 106, where, however, the term “exchange” (*Wechsel*) does not occur. In a letter to Jung of 1 Jan. 1907, Freud uses *Wechsel* in precisely this sense. It is possible that Jung was recalling Freud’s usage in that letter but by mistake cited the 1906 article. See *The Freud/Jung Letters*, ed. W. McGuire (Princeton, 1974), 11 F.]

¹² [Bracketed words added by translator.]

¹³ The sign – means incorrect reproduction; +, correct reproduction; the letter “r,” repetition of the stimulus-word.

¹ [Translated from “Die an der psychiatrischen Klinik in Zurich gebräuchlichen psychologischen Untersuchungsmethoden,” *Zeitschrift für angewandte Psychologie* (Leipzig), III (1910), 390. The item is a contribution to a “survey of clinical methods for the psychological testing of the insane,” along with six other reports, from German institutions.]

¹ [In March 1911, Dr. Andrew Davidson, the secretary of the Section of Psychological Medicine and Neurology, Australasian Medical Congress, invited Jung, Fiend, and Havelock Ellis to send papers to be read before the Congress in Sydney, September, 1911. All three responded, and subsequently the papers were read and in 1913 published in the *Australasian Medical Congress, Transactions of the Ninth Session*, II, part 8. It is not known whether Jung's paper (pp. 835–39) was written in English or whether this is a translation. It is published here with only stylistic alterations. For Freud's paper, "On Psychoanalysis," see vol. XII of the Standard Edn., pp. 205ff.]

² [This may be Jung's first use of the term "analytical psychology." However, see "General Aspects of Psychoanalysis," a paper which he delivered in London on Aug. 5, 1913; the term is introduced in par. 523. The term "deep psychology" did not gain acceptance; the usual form is "depth psychology."]

³ [Jung's papers are in the present volume; those of his collaborators are available in the M. D. Eder translation, *Studies in Word-Association*.]

⁴ ["The Association Method," comprising three lectures. See supra, par. 929, n. 1.]

⁵ [These three papers are in the present volume: the first translated as "The Psychological Diagnosis of Evidence."]

⁶ [These two works are in vol. 3 of the *Coll. Works*, the latter translated as "The Content of the Psychoses."]

⁷ [Translated as *Psychology of the Unconscious* (1916); revised version translated as *Symbols of Transformation*, vol. 5 in the *Coll. Works*.]

¹ [Translated from “Zur psychologischen Tatbestandsdiagnostik: Das Tatbestandsexperiment im Schwurgerichtsprozess Näf,” *Archiv für Kriminologie* (Leipzig), C (1937), 123–30. It followed a detailed account of the case from the criminological standpoint by H. W. Spiegel, “Der Fall Näf: Mord und Versicherungsbetrug, Selbstmord oder Unfall?”, pp. 98–122.]

² [The paper referred to in this headnote was by Wertheimer and Klein, “Psychologische Tatbestandsdiagnostik” (1904). In Jung’s brief 1905 paper, “On the Psychological Diagnosis of Facts” (*Coll. Works*, vol. 1, par. 479), he attacked Wertheimer and Klein for not crediting the work of the Zurich Clinic, “from which they appropriated their seemingly original ideas.” Wertheimer responded with a statement in the *Archiv für die gesamte Psychologie*, VII (1906), 1/2, 139–40, indicating that his first work was published prior to Jung’s. Jung then published a retraction in the *Zeitschrift für angewandte Psychologie*, I (1907/8), 163, acknowledging that Wertheimer and he had arrived at the same conclusions independently of one another. Thirty years later, in the present publication, Jung took occasion again to give primary credit to the work of Wertheimer and Klein.]

³ [German town where Näf had been sentenced for theft.]

⁴ [“Little Bell-Tower of Munot,” Swiss dialect song.]

⁵ [The two German words actually used are *zwingen* (standard) and *forciere wolle* (dialect), both meaning ‘to force.’]

- * Published 1957; 2nd edn., 1970.
- † Published 1973.
- * Published 1960.
- † Published 1961.
- ‡ Published 1956; 2nd edn., 1967. (65 plates. 43 text figures.)
- * Published 1971.
- † Published 1953; 2nd edn., 1966.
- ‡ Published 1960; 2nd edn., 1969.
- * Published 1959; 2nd edn., 1968. (Part I: 79 plates, with 29 in colour.)
- * Published 1964; 2nd edn., 1970. (8 plates.)
- † Published 1958; 2nd edn., 1969.
- * Published 1953; 2nd edn., completely revised, 1968. (270 illustrations.)
- † Published 1968. (50 plates, 4 text figures.)
- ‡ Published 1963; 2nd edn., 1970. (10 plates.)
- * Published 1966.
- † Published 1954; 2nd edn., revised and augmented, 1966. (13 illustrations.)
- ‡ Published 1954.
- * Published 1976.
- † Published 1979.

B O L L I N G E N S E R I E S X X

THE COLLECTED WORKS

OF

C. G. JUNG

VOLUME 3

EDITORS

† SIR HERBERT READ

MICHAEL FORDHAM, M.D., M.R.C.P.

GERHARD ADLER, PH.D.

WILLIAM MCGUIRE, *executive editor*

**THE
PSYCHOGENESIS
OF MENTAL
DISEASE**

C. G. JUNG

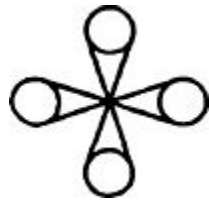

TRANSLATED BY R. F. C. HULL

BOLLINGEN SERIES XX

PRINCETON UNIVERSITY PRESS

COPYRIGHT © 1960 BY BOLLINGEN FOUNDATION, NEW YORK, N. Y.
PUBLISHED BY PRINCETON UNIVERSITY PRESS
PRINCETON, N. J.

Second printing, with corrections and minor revisions, 1972

Third printing, 1976

First Princeton / Bollingen Paperback printing, 1982

THIS EDITION IS BEING PUBLISHED IN THE UNITED STATES OF AMERICA BY PRINCETON UNIVERSITY PRESS AND IN ENGLAND BY ROUTLEDGE AND KEGAN PAUL, LTD. IN THE AMERICAN EDITION, ALL THE VOLUMES COMPRISING THE COLLECTED WORKS CONSTITUTE NUMBER XX IN BOLLINGEN SERIES. THE PRESENT VOLUME IS NUMBER 3 OF THE COLLECTED WORKS AND WAS THE TENTH TO APPEAR.

LIBRARY OF CONGRESS CATALOGUE CARD NUMBER: 75-156

ISBN 0-691-09769-0

ISBN 0-691-01859-6 (pbk.)

MANUFACTURED IN THE UNITED STATES OF AMERICA

EDITORIAL NOTE

The importance of this volume of scientific papers for understanding Jung's researches as a whole can scarcely be overrated, even though most of them are now mainly of historical interest or represent the reflections of his later years on a subject that never ceased to engage his active psychotherapeutic endeavours.

"The Psychology of Dementia Praecox" was the culmination of Jung's early researches at the Burghölzli Hospital into the nature of the psychoses. It was the publication which established him once and for all as a psychiatric investigator of the first rank. It was the volume which engaged Freud's interest and led to their meeting. It was the research which contained the seeds of his theoretical divergence from psychoanalysis.

Jung's work on the manifestations of schizophrenia was a potent factor in the development of his theory of psychic energy and of the archetypes. He believed that, in order to account for the imagery, splitting processes, and defect in the sense of reality observable in this disease, neither the sexual theory of libido, which leads to the concept of narcissism, nor personal and genetic study is adequate. In short, the theory of archetypes becomes indispensable.

Jung was indeed one of the first to employ individual psychotherapy with schizophrenic patients. Not only this: there are clear indications in this volume of how early in this century he investigated the relationship between mental hospital administration and the course of the supposed disease-process. His Swiss forerunners, Forel and Bleuler, both men with intense psychological interests, also realized this, and the Burghölzli team did much pioneering work in changing the hospital atmosphere. Today this understanding is being gradually applied with the good results that Jung anticipated.

It may be regretted that there is no more in this volume about the psychotherapy of schizophrenia. Why is it that Jung did not write more on this subject? The answer is given in one of his later essays, "Recent Thoughts on Schizophrenia," where he states that in spite of all the developments over the years, knowledge of this disorder is still so fragmentary that he could organize his findings only in outline and in relation to individual case-studies.

The volume is divided into four parts based on their chronological sequence, except that "On Psychological Understanding" has been placed after "The Content of the Psychoses." Though written as separate essays the two were later combined in this way by the author in both Swiss and English publications of these works.

EDITORIAL NOTE TO THE SECOND PRINTING

Because of the availability of *Experimental Researches*, Volume 2 in the *Collected Works*, the copious references herein to Jung's papers on the word-association tests have been revised in terms of that volume. Changes of terminology and other minor revisions of text, bibliography, and index have been made.

VOLUME 3
PSYCHOGENESIS OF MENTAL DISEASE

TABLE OF CONTENTS

EDITORIAL NOTE

I

The Psychology of Dementia Praecox

Translated from *Über die Psychologie der Dementia praecox: Ein Versuch* (Halle a. S., 1907).

Foreword

1. Critical Survey of Theoretical Views on the Psychology of Dementia Praecox

2. The Feeling-toned Complex and Its General Effects on the Psyche

 Acute Effects of the Complex

 Chronic Effects of the Complex

3. The Influence of the Feeling-toned Complex on the Valency of Associations

4. Dementia Praecox and Hysteria

 I. Disturbances of the Emotions

 II. Abnormalities of Character

 III. Intellectual Disturbances

 IV. Stereotypy

 Summary

5. Analysis of a Case of Paranoid Dementia as a Paradigm

 Clinical History

 Simple Word Associations

 Continuous Associations

 A. Wish-fulfilment

 B. The Complex of Being Wronged

 C. The Sexual Complex

 D. Summary

 E. Supplement

II

The Content of the Psychoses

Translated from *Der Inhalt der Psychose* (2nd edn., Leipzig and Vienna, 1914).

On Psychological Understanding

Translated from the Supplement to the foregoing.

III

A Criticism of Bleuler's Theory of Schizophrenic Negativism

Translated from a critique in the *Jahrbuch für psychoanalytische und psychopathologische Forschungen* (Vienna and Leipzig), III (1911).

On the Importance of the Unconscious in Psychopathology

Written in English and published in the *British Medical Journal* (London), II (1914).

On the Problem of Psychogenesis in Mental Disease

Written in English and published in the *Proceedings of the Royal Society of Medicine* (London), XII (1919).

Mental Disease and the Psyche

Translated from "Heilbare Geisteskrankheiten?", *Berliner Tageblatt*, 1928.

IV

On the Psychogenesis of Schizophrenia

Written in English and published in the *Journal of Mental Science* (London), LXXXV (1939).

Recent Thoughts on Schizophrenia

Written in English and broadcast by the "Voice of America," December 1956.

Schizophrenia

Translated from "Die Schizophrenia," *Schweizer Archiv für Neurologie und Psychiatrie* (Zurich), LXXXI (1958).

APPENDIX; Letter to the Second International Congress of Psychiatry (Symposium on Chemical Concepts of Psychosis), 1957

BIBLIOGRAPHY

INDEX

THE PSYCHOLOGY OF DEMENTIA PRAECOX

[First published as *Über die Psychologie der Dementia praecox: Ein Versuch* (Halle a. S., 1907). Translated, and with an introduction, by Frederick W. Peterson and A. A. Brill, under the present title, in the Nervous and Mental Disease Monograph Series (no. 3; New York, 1909). Retranslated in the same series by A. A. Brill alone, with a new introduction (New York and Washington, 1936). Now newly translated from the original. The 1936 Brill translation has been consulted.—EDITORS.]

FOREWORD

This work is the fruit of three years' experimental researches and clinical observations. In view of the complexity and magnitude of the material, my work cannot and does not lay claim either to finality of treatment or to absolute certainty of the statements and conclusions. On the contrary, it combines all the disadvantages of eclecticism, which to many a reader may seem so striking that he will call my work a confession of faith rather than a scientific treatise. *Peu importe!* The important thing is that I should be able to show the reader how, through psychological investigation, I have been led to certain views which I think will provoke new and fruitful questions concerning the individual psychological basis of dementia praecox.

My views are not contrivances of a roving fancy, but thoughts which matured in almost daily conversation with my respected chief, Professor Bleuler. I owe special thanks to my friend Dr. Riklin, of Rheinau, for adding considerably to the empirical material. Even a superficial glance at my work will show how much I am indebted to the brilliant discoveries of Freud. As Freud has not yet received the recognition and appreciation he deserves, but is still opposed even in the most authoritative circles, I hope I may be allowed to define my position towards him. My attention was drawn to Freud by the first book of his I happened to read, *The Interpretation of Dreams*, after which I also studied his other writings. I can assure you that in the beginning I naturally entertained all the objections that are customarily made against Freud in the literature. But, I told myself, Freud could be refuted only by one who has made repeated use of the psychoanalytic method and who really investigates as Freud does; that is, by one who has made a long and patient study of everyday life, hysteria, and dreams from Freud's point of view. He who does not or cannot do this should not pronounce judgment on Freud, else he acts like those notorious men of science who disdained to look through Galileo's telescope. Fairness to Freud, however, does not imply, as many fear, unqualified submission to a dogma; one can very well maintain an independent judgment. If I, for instance, acknowledge the complex mechanisms of dreams and hysteria, this does not mean that I attribute to the infantile sexual trauma the exclusive importance that Freud apparently does. Still less does it mean that I place sexuality so predominantly in the foreground, or that I grant it the psychological universality which Freud, it seems, postulates in view of the admittedly enormous role which sexuality plays in the psyche. As for Freud's therapy, it is at best but one of several possible methods, and perhaps does not always offer in practice what one expects from it in theory. Nevertheless, all these things are the merest trifles compared with the psychological principles whose discovery is Freud's greatest merit; and to them the critics pay far too little attention. He who wishes to be fair to Freud should take to heart the words of Erasmus: "Unumquemque move lapidem, omnia experire, nihil intentatum relinque."*

As my work is largely based on experimental researches, I trust the reader will bear with me if he finds a great many references to the *Diagnostische Assoziationsstudien*, which appeared under my editorship.¹

1. CRITICAL SURVEY OF THEORETICAL VIEWS ON THE PSYCHOLOGY OF DEMENTIA PRAECOX

- [1] The literature which treats of the psychological disturbances in dementia praecox is very fragmentary, and although parts of it are quite extensive it nowhere shows any clear co-ordination. The statements of the older authors have only a limited value, because they refer now to this, now to that form of illness, which can be classified only very indefinitely as dementia praecox. Hence one cannot attribute any general validity to them. The first and somewhat more general view concerning the nature of the psychological disturbance in catatonia, so far as I know, was that of Tschisch (1886),¹ who thought that the essential thing was an *incapacity for attention*. A similar view, somewhat differently formulated, was expressed by Freusberg,² who stated that the automatic actions of the catatonic are associated with a weakening of consciousness, which has lost its control over the psychic processes. The motor disturbance is only a symptomatic expression of the degree of psychic tension.
- [2] For Freusberg, therefore, the motor catatonic symptoms are dependent on corresponding psychological symptoms. The “weakening of consciousness” resembles the quite modern view of Pierre Janet. That there is a disturbance of attention is also confirmed by Kraepelin,³ Aschaffenburg,⁴ Ziehen, and others. In 1894 we encounter for the first time an *experimental psychological* work on the subject of catatonia: Sommer’s “On the Theory of ‘Inhibition’ of Mental Processes.”⁵ The author makes the following statements which are of general significance:
1. The process of ideation is slowed down.
 2. The patient is so fascinated by pictures shown to him that he can tear himself away from them only with difficulty.
- [3] The frequent *blockings* (prolongations of reaction time) are explained by Sommer as visual fixation.⁶ The state of distractibility in normal persons occasionally shows similar phenomena; e.g., “amazement” and “staring into space.” With this comparison of the catatonic state to normal distractibility Sommer affirms much the same thing as Tschisch and Freusberg, namely that there is a reduction of attention. Another phenomenon closely related to visual fixation, according to Sommer, is catalepsy; he considers it “in all cases a phenomenon of entirely psychic origin.” This view of Sommer’s conflicts sharply with that of Roller, with whom Clemens Neisser is in entire agreement.
- [4] Says Roller: “The ideas and sensations that reach perception in the insane person and force themselves into the field of consciousness arise from the morbid state of the subordinate centres, and when active apperception, or attention, comes into play it is fixated by these pathological perceptions.”⁷

[5] In this connection Neisser remarks: “Wherever we look in insanity we find something different, something strange; processes that cannot be explained on the analogy of normal psychic life. The logical mechanism in insanity is set in motion not by apperceptive or associative conscious activity but by pathological stimuli lying below the threshold of consciousness.”⁸ Neisser thus agrees with Roller’s view, but it seems to me that this view is not quite free from objections. First, it is based on an anatomical conception of psychic processes—a conception that cannot be cautioned against too strongly. What significance “subordinate centres” have in the formation of psychic elements (ideas, sensations, etc.) we do not know at all. An explanation of this kind is merely a matter of words.

[6] Second, the Roller-Neisser view seems to presuppose that outside consciousness the psyche ceases to exist. From the psychology of the French school and from our experiences with hypnotism it is evident that this is not so.

[7] Third, if I have understood him correctly, by “pathological stimuli lying below the threshold of consciousness” Neisser must mean cell-processes in the cortex. This hypothesis goes too far. All psychic processes are correlates of cell-processes, according to both the materialistic view and that of psychophysical parallelism. So it is nothing out of the ordinary if the psychic processes in catatonia are correlates of a physical series. We know that the normal psychic series develops under the constant influence of countless psychological constellations of which we are as a rule unconscious. Why should this fundamental psychological law suddenly cease to apply in catatonia? Is it because the ideational content of the catatonic is foreign to his consciousness? But is it not the same in our dreams? Yet no one will assert that dreams originate so to speak directly from the cells without psychological constellations. Anyone who has analysed dreams according to Freud’s method knows what an enormous influence these constellations have. The appearance of strange ideas in consciousness which have no demonstrable connection with previous conscious contents is not unheard of either in normal psychology or in hysteria. The “pathological ideas” of catatonics have plenty of analogies in normal as well as in hysterical persons. What we lack is not so much comparative factual material as the key to the psychology of catatonic automatism. For the rest, it always seems to me rather risky to assume something absolutely new and strange in science.

[8] In dementia praecox, where as a matter of fact countless normal associations still exist, we must expect that until we get to know the very delicate processes which are really specific of the disease the laws of the normal psyche will long continue to play their part. To the great detriment of psychopathology, where the only thing we are beginning to agree about is the ambiguity of our applied concepts, our knowledge of the normal psyche is unfortunately still on a very primitive level.

[9] We are indebted to Sommer⁹ for further stimulating studies on the associations of catatonics. In certain cases the associations proceed in a normal way but are suddenly interrupted by an apparently quite disconnected, strangely “mannered” combination of ideas, as the following example will show:¹⁰

dark	green
white	brown
black	“good day, William”
red	brown

[10] These “erratic” associations were also observed by Diem,¹¹ who conceived of them as sudden “whims.” Sommer justly considers them an important criterion for catatonia. The “pathological inspirations” described by Breukink,¹² following Ziehen, were observed by these authors in insane patients and were found exclusively in dementia praecox, especially in its paranoid forms, where “inspirations” of every kind play a well-known role. Bonhoeffer’s “pathological ideas” probably refer to a similar phenomenon.¹³ The question raised by Sommer’s discovery has naturally not been settled; but, until we are better informed, the phenomena observed by different authors and designated with almost the same names must for the present be grouped under one heading. Although it would seem from clinical experience that “pathological ideas” occur only in dementia praecox (we naturally discount the falsifications of memory which often appear suddenly in organic dementia and in Korsakow’s syndrome), I would like to point out that in hysteria, especially in cases that never reach the clinic, “pathological ideas” play a large part. The most interesting examples are reported by Flournoy.¹⁴ I have observed similar sudden irruptions of altered psychological activity in a very clear case of hysteria,¹⁵ and recently I was able to confirm it again in a similar case. Finally, as I have shown,¹⁶ the sudden disturbance of association by the irruption of apparently strange combinations of ideas occurs also in normal people. The “erratic” association or “pathological idea” may therefore be a widespread psychological phenomenon which, we may at once agree with Sommer, appears in its most glaring form in dementia praecox.

[11] Furthermore, in examining the associations of catatonics Sommer found numerous clang associations¹⁷ and stereotypies. By “stereotypy” he meant the frequent reappearance of previous reactions. In our association experiments we called this “repetition.” The reaction times showed enormous fluctuations.

[12] In 1902, Ragnar Vogt¹⁸ again took up the problem of catatonic consciousness. He started from the Müller-Pilzecker investigations¹⁹ by considering mainly their observations on “perseveration.” According to Vogt, the persistence of psychic processes or their correlates, even after they have been superseded in consciousness by other ideas, is the normal analogy of catatonic processes of perseveration (verbigeration, catalepsy, etc.). Hence the capacity of the psychophysical functions for perseveration must be especially great in catatonia. But as, according to the Müller-Pilzecker investigations, perseveration becomes very marked only when no new content has impressed itself on consciousness,²⁰ Vogt assumes that perseveration is possible in catatonia only because no other conscious processes of interest to the patient are taking place. One must therefore assume a certain restriction of consciousness. This would also explain the resemblance between hypnotic and catatonic states.²¹ The impulsive actions of catatonics are likewise explained by Vogt on the basis of

restriction of consciousness, which prevents inhibitions from intervening. Vogt has evidently been influenced by Pierre Janet, for whom “restriction of consciousness” and “reduction of attention” are the same as “abaissement du niveau mental.”²² So here again, though in a somewhat more modern and more generalized form, we meet the view already mentioned, that in catatonia there is a disturbance of attention, or, to express it more broadly, of the positive psychic performance.²³ Vogt’s reference to the analogy with hypnotic states is interesting, but unfortunately he describes it only in outline.

[13] Similar views are expressed by Evensen.²⁴ He draws a skilful parallel between catatonia and distractibility, and maintains that absence of ideas in a restricted field of consciousness is the basis of catalepsy, etc.

[14] A painstaking and thorough examination of catatonic psychology is to be found in the thesis of René Masselon.²⁵ He maintains from the start that its chief characteristic is reduction of attention (“distraction perpétuelle”). As is to be expected from his French training in psychology, he conceives of attention in a very broad and comprehensive sense: “Perception of external objects, awareness of our own personality, judgment, the feeling of rapport, belief, certainty, all disappear when the power of attention disappears.”²⁶

[15] As this quotation shows, a very great deal depends on attention as Masselon conceives it. He concludes that the commonest features of the catatonic state are “apathy, aboulia, loss of intellectual activity.” A brief consideration of these three abstractions will show that at bottom they are all trying to say the same thing; indeed, throughout his work, Masselon is constantly endeavouring to find the word or simile that will best express the innermost essence of his correct feeling. However, no concept need be quite so many-sided, just as there is no concept that has not had a one-sided and limited connotation forced upon it by some school or system. Masselon can best tell us what he feels about the essence of dementia praecox if we listen to the wording of some of his statements: “The habitual state is emotional apathy ... these disturbances are intimately connected with disturbances of intelligence: they are of the same nature ... the patients manifest no desires ... all volition is destroyed ... the disappearance of desire is bound up with all the other disturbances of mental activity ... a veritable cramping of cerebral activity ... the elements [of the mind] show a tendency to live an individual life, being no longer systematized by the inactive mind.”²⁷

[16] In Masselon’s work we find an assortment of views which he feels all go back to one root, but he cannot find this root without obscuring his work. Yet despite their shortcomings, Masselon’s researches contain many useful observations. Thus he finds a striking resemblance to hysteria, marked self-distractibility of the patients to everything, especially to their own symptoms (Sommer’s “visual fixation”), fatiguability, and a capricious memory. German critics have reproached him for this last statement, but quite unjustly when we consider that Masselon really means only the capacity for reproduction. If a patient gives a wrong answer to a direct question, it is taken by the German school as an “irrelevant answer,” as negativism; in other words, as active resistance. Masselon regards it rather as an *inability to reproduce*. Looked at from the outside, it can be both; the distinction

depends only on the different interpretations we choose to give of the phenomenon. Masselon speaks of a “true obscuration of the memory-image” and regards the disturbance of memory as the “disappearance from consciousness of certain memories, and the inability of the patient to find them again.”²⁸ The contradiction between the two views can be resolved without difficulty if one considers the psychology of hysteria. If an hysterical patient says during the anamnesis, “I don’t know, I have forgotten,” it simply means, “I cannot or will not say it, for it is something very unpleasant.”²⁹ Very often the “I don’t know” is so clumsy that one can immediately discern the reason for not knowing. I have proved by numerous experiments that the faults (failures to react) which occur during the association test have the same psychology.³⁰ In practice it is often very difficult to decide whether hysterical patients really do not know or whether they simply cannot or will not answer. Anyone who is accustomed to investigating dementia praecox cases will know how much trouble he has to take to obtain the correct information. Sometimes one is certain that the patients know, sometimes there is a “blocking” that gives the impression of being involuntary, and then again there are cases where one is obliged to speak of “amnesia,” just as in hysteria, where it is only a step from amnesia to not wanting to talk. Finally, the association test shows us that these phenomena are all present, in the bud, in normal people.³¹

[17] For Masselon the disturbance of memory comes from the same source as the disturbance of attention, though what this source may be is not clear. As if in contradiction to this, he finds ideas that obstinately persist. He qualifies them as follows: “Certain memories that once were more intimately connected with the affective personality of the patients tend to reproduce themselves unceasingly and to occupy consciousness continually ... the memories that persist assume a stereotyped form ... thought tends to coagulate (*se figer*).”³² Without attempting to produce any further proof Masselon declares that the stereotyped ideas (i.e., the delusions) are associations of the personality complex. It is a pity that he does not dwell longer on this point, for it would have been very interesting to know how far, for instance, a few neologisms or a “word salad” are associations of the personality complex, since these are often the only vestiges that still give us a clue to the existence of ideas. That the mental life of the dementia praecox patient “coagulates” seems to me an excellent simile for the gradual torpidity of the disease; it characterizes most pregnantly the impression that dementia praecox must have made on every attentive observer. Masselon naturally found it quite easy to derive “command automatism” (*suggestibilité*) from his premises. Concerning the origin of negativism he has only vague conjectures to offer, although the French literature on obsessional states would afford him any number of starting points for analogical explanations. Masselon also tested the associations experimentally, finding numerous repetitions of stimulus words and frequent “whims” of an apparently quite fortuitous nature. The only conclusion he came to from these experiments was that the patients were unable to pay attention. The conclusion is right enough, but Masselon spent too little time on the “whims.”

[18] From the main results of Masselon’s work it can be seen that this author, like his predecessors, is inclined to assume a quite central psychological disturbance,³³ a disturbance

that sets in at the vital source of all the mental functions; that is, in the realm of apperception, feeling, and appetite.³⁴

[19] In his clear elucidation of the psychology of feeble-mindedness in dementia praecox Weygandt, following Wundt, calls the, terminal process of the disease “apperceptive deterioration.”³⁵ As we know, Wundt’s conception of apperception is an extremely broad one; it covers not only Binet’s and Masselon’s conception of attention but also Janet’s “fonction du réel,”³⁶ to which we shall return later. The broadness of Wundt’s conception of apperception in the sense indicated is borne out by his own words: “That state which accompanies the clearer comprehension of a psychic content and is characterized by special feelings, we call ‘attention’; the single process by which any psychic content is brought to clear comprehension, we call ‘apperception.’”³⁷ The apparent contrast between attention and apperception can be resolved as follows: “Accordingly, attention and apperception are expressions for one and the same psychological fact. We choose the first of these expressions in order to denote the subjective side of this fact, the accompanying feelings and sensations; by the second we mean mainly the objective consequences, the alterations in the quality of the conscious contents.”³⁸

[20] In the definition of apperception as “the single process by which any psychic content is brought to clear comprehension,” much is said in a few words. According to this, apperception is volition, feeling, affectivity, suggestion, compulsion, etc., for these are all processes which “bring a psychic content to clear comprehension.” In saying this we do not wish to make any adverse criticism of Wundt’s idea of apperception, but merely to indicate its enormous scope. It includes every positive psychic function, and besides that the progressive acquisition of new associations; in other words, it embraces nothing less than all the riddles of psychic activity, both conscious and unconscious. Weygandt’s conception of apperceptive deterioration thus expresses what Masselon only dimly sensed. But it expresses the psychology of dementia praecox merely in general terms—too general for us to be able to deduce from it all the symptoms.

[21] Madeleine Pelletier, in her thesis,³⁹ investigates the process of ideation in manic flight of ideas and in “mental debility,” by which we are to understand clear cases of dementia praecox. The theoretical standpoint from which she considers flight of ideas agrees in essentials with that of Liepmann,⁴⁰ a knowledge of whose work I must take for granted.

[22] Pelletier compares the superficial course of association in dementia praecox to flight of ideas. Characteristic of flight of ideas is the “absence of any directing principle.” The same is true of the course of association in dementia praecox: “The directing idea is absent and the state of consciousness remains vague without any order in its elements.” “The only mode of psychic activity which in the normal state can be compared to mania is the daydream, although daydreaming is more the mode of thinking of the feeble-minded than of the manic.”⁴¹ Pelletier is right in seeing a great resemblance between normal daydreaming and the superficial associations of manics, but that is true only when the associations are written down on paper. Clinically, however, the manic does not at all resemble a dreamer. The author evidently feels this and finds the analogy rather more suitable for dementia

praecox, which since Reil has frequently been compared to a dream.⁴² The richness and acceleration of thought in manic flight of ideas can be sharply differentiated from the sluggish, often halting course of association in the dreamy type, and particularly from the poverty of associations in catatonics, with their numerous perseverations. The analogy is correct only in so far as the directing idea is absent in all these cases; in manics because all the ideas crowd into consciousness with marked acceleration and great intensity of feeling,⁴³ which probably accounts for the absence of attention.⁴⁴ In daydreaming there is no attention from the outset, and wherever this is absent the course of association must sink to the level of a dream-state, to a slow progression according to the laws of association and tending mainly towards similarity, contrast, coexistence, and verbal-motor combinations.⁴⁵ Abundant examples are furnished by daily self-observation or by attentively following a general conversation. As Pelletier shows, the associations in dementia praecox are constructed along similar lines. This can best be seen from an example:

Je suis l'être, l'être ancien, le vieil Hêtre,⁴⁶ que l'on peut écrire avec un H. Je suis universel, primordial, divine, catholique, apostolique, Romaine.⁴⁷ L'eusses-tu cru, l'être tout cru, suprumu,⁴⁸ l'enfant Jésus.⁴⁸ Je m'appelle Paul, c'est un nom, ce n'est pas une négation,⁴⁸ on en connaît la signification. ...⁴⁸ Je suis éternel, immense, il n'y a ni haut ni bas, *fluctuat nec mergitur*, le petit bateau,⁴⁹ vous n'avez pas peur de tomber.⁵⁰

[23] This example shows us very clearly the course of association in dementia praecox. It is very superficial and proceeds by way of numerous clang associations. The disintegration is so marked, however, that we can no longer compare it to normal daydreaming, but must compare it directly to a dream. Indeed, the conversations we have in dreams sound very like this;⁵¹ Freud's *The Interpretation of Dreams* gives numerous examples.

[24] In "The Associations of Normal Subjects" it was shown that reduced attention produces associations of a superficial type (verbal-motor combinations, clang associations, etc.), and that, conversely, from the occurrence of a superficial type one could always infer a disturbance of attention. Judging by our experimental proofs, Pelletier is therefore correct in attributing the superficial type of association in dementia praecox to a lowering of attention. She calls this lowering, in Janet's words, an *abaissement du niveau mental*. What we can also see from her work is that the disturbance is once again traced back to the central problem of apperception.

[25] In particular, it is to be noted that she overlooks the phenomenon of perseveration, but on the other hand we are indebted to her for a valuable observation on the symbols and symbolic relationships that are so very common in dementia praecox. She says: "It is to be noted that the symbol plays a very great role in the productions of the insane. One meets it at every step in the persecuted and the demented; this is due to the fact that the symbol is a very inferior form of thought. The symbol could be defined as the false perception of a relation of identity, or of very great analogy, between two objects which in reality are only vaguely analogous."⁵²

[26] From this it is clear that Pelletier associates catatonic symbols with disturbed attention. This assumption is definitely supported by the fact that symbols have long been known as a

usual phenomenon in daydreaming and dreams.

[27] The psychology of negativism, concerning which numerous publications are now available, is a subject in itself. It is certain that the symptoms of negativism should not be regarded as anything clear and definite. There are many forms and degrees of negativism which have not yet been clinically studied and analysed with the necessary accuracy. The division of negativism into an active and a passive form is understandable, since the most complicated psychological cases take the form of active resistance. If analysis were possible in these cases, it would frequently be found that there were very definite motives for the resistance, and it would then be doubtful whether one could still talk of negativism. In the passive form, too, there are many cases that are difficult to interpret. Nevertheless there are plenty of cases where it is perfectly apparent that even simple processes of volition are invariably turned into their opposite. In our view, negativism always depends ultimately on negative associations. Whether there is also a negativism that is enacted in the spinal cord I do not know. The broadest view on the question of negativism is the one taken by Bleuler,⁵³ who shows that “negative suggestibility,” or the compulsion to produce contrary associations, is not only a constituent of the normal psyche but a frequent mechanism of pathological symptoms in hysteria, obsessional states, and dementia praecox. The contrary mechanism is a function existing independently of the normal associative activity and is rooted entirely in “affectivity”; hence it is actuated chiefly by strongly feeling-toned ideas, decisions, etc. “The mechanism is meant to guard against precipitate action and to force one to weigh the pros and cons.” The contrary mechanism acts as a counterbalance to suggestibility. Suggestibility is the capacity to accept and put into effect strongly feeling-toned ideas; the contrary mechanism does just the opposite. Bleuler’s term “negative suggestibility” is therefore fitting. The close connection of these two functions makes it easier to understand why they are found together clinically. (Suggestibility side by side with insuperable contrary auto-suggestions in hysteria, and with negativism, command automatism, and echopraxia in dementia praecox.)

[28] The importance of negative suggestibility for the everyday life of the psyche explains why contrary associations are so extraordinarily frequent: they are the nearest to hand.⁵⁴

[29] In language, too, we find something similar: the words that express common contrasts are very firmly associated and generally come into the category of well-worn verbal combinations (black-white, etc.). In primitive languages there is sometimes a single word for contrary ideas. In Bleuler’s sense, therefore, only a relatively slight disturbance of feeling is needed to produce negativistic phenomena. As Janet has shown,⁵⁵ in obsessional personalities the *abaissement du niveau mental* is enough to release the play of contraries. What, then, are we to expect from the “apperceptive deterioration” in dementia praecox! And here we really do find that apparently uncontrolled play of positive and negative which is very often nicely reflected in verbal associations.⁵⁶ Hence, on the question of negativism there is no lack of grounds for the hypothesis that this symptom, too, is closely connected with “apperceptive deterioration.” The central control of the psyche has become so weak that it can neither promote the positive nor inhibit the negative acts, or vice versa.⁵⁷

[30] To recapitulate what we have said so far: The authors mentioned have established in the main that the lowering of attention—or, more generally speaking, “apperceptive deterioration” (Weygandt)—is a characteristic of dementia praecox. To this characteristic the peculiar superficiality of associations, the symbols, stereotypies, perseverations, command automatisms, apathy, aboulia, disturbance of reproduction and, in a limited sense, negativism, are all in principle due.

[31] The fact that comprehension and retention are not as a rule affected by the general deterioration may seem rather strange at first glance. One often finds in dementia praecox, during accessible moments, a surprisingly good, almost photographic memory, which by preference takes note of the most ordinary things that invariably escape the notice of normal persons.⁵⁸ But it is just this peculiarity that shows what kind of memory it is: it is nothing but a passive registration of events occurring in the immediate environment. Everything which requires an effort of attention passes unheeded by the patient, or at most is registered on the same level as the daily visit of the doctor or the arrival of dinner—or so at least it appears. Weygandt has given an excellent description of this lack of active assimilation. Comprehension is usually disturbed only during periods of excitement. Comprehension and retention are for the most part only passive processes which occur in us without much expenditure of energy, just like seeing and hearing when these are not accompanied by attention.

[32] Although the above-mentioned symptoms (automatism, stereotypy, etc.) are to some extent deducible from Weygandt’s conception of apperceptive deterioration, it does not suffice to explain the individual variety of the symptoms, their capriciousness, the peculiar content of the delusions, hallucinations, etc. Several investigators have attempted to solve this riddle.

[33] Stransky⁵⁹ has investigated the problem of dementia praecox from the clinical side. Starting from Kraepelin’s conception of “emotional deterioration,” he finds that two things are to be understood by this term: “First, the poverty or superficiality of emotional reactions; second, their incongruity with the ideational content dominating the psyche at the time.”⁶⁰ Stransky thus differentiates Kraepelin’s conception, and especially emphasizes that “emotional deterioration” is not the only thing one meets with clinically. The striking incongruity between idea and affect which we observe daily in dementia praecox is a commoner symptom at the onset of the disease than is the emotional deterioration. This incongruity obliges Stransky to assume two distinct psychic factors, the *noöpsyche* and the *thymopsyche*, the former comprising all purely intellectual and the latter all affective processes. These two concepts correspond by and large to Schopenhauer’s intellect and will. In the healthy psyche there is naturally a constant, very delicately co-ordinated interaction of the two factors. But as soon as incongruity appears, this corresponds to *ataxia*, and we then have the picture of dementia praecox with its disproportionate and incomprehensible affects. To that extent the division of the psychic functions into *noöpsyche* and *thymopsyche* agrees with reality. But we must ask whether a quite ordinary content that appears in the patient with tremendous affect seems incongruous not merely to us, who have

only a very imperfect insight into his psyche, but also to the subjective feeling of the patient.

[34] I will make this question clear by an example. I visit a gentleman in his office. Suddenly he starts up in a rage and swears most excitedly at a clerk who has just put a newspaper on the right instead of the left side of the table. I am astounded and make a mental note about the peculiar nervousness of this person. Afterwards I learn from another employee that the clerk has made the same mistake dozens of times before, so that the gentleman's anger was quite appropriate.

[35] Had I not received the subsequent explanation, I should have formed a wrong picture of the psychology of this person. We are frequently confronted with a similar situation in dementia praecox: owing to the peculiar "shut-in" state of the patients we see into them far too little, a fact which every psychiatrist will confirm. It is therefore very possible that their excitements often remain incomprehensible to us only because we do not see their associative causes. The same thing may also happen to us: we can be in a bad humour for a time, and quite inappropriately so, without being aware of the cause. We snap out answers in an unduly emphatic and irritated tone of voice, etc. If even the normal person is not always clear about the causes of his own bad temper, how much less can we be so in regard to the psyche of a dementia praecox patient! Owing to the obvious inadequacy of our psychological diagnosis we must be very cautious about assuming a real incongruity in Stransky's sense of the term. Although clinically speaking an incongruity is often present, it is by no means limited to dementia praecox. In hysteria, too, it is an everyday occurrence; it can be seen in the very commonplace fact of hysterical "exaggerations." The counterpart of this is the well-known *belle indifférence* of hysterics. We also find violent excitements over nothing, or rather over something that seems to have absolutely no connection with the excitement. Psychoanalysis, however, uncovers the motive, and we are beginning to understand why the patients react as they do. In dementia praecox we are at present unable to penetrate deeply enough, so that the connections remain unknown to us and we assume an "ataxia" between noöpsyche and thymopsyche. Thanks to analysis we know that in hysteria there is no "ataxia" but merely an oversensitiveness, which becomes clear and intelligible as soon as we discover the pathogenic complex of ideas.⁶¹ Knowing how the incongruity comes about in hysteria, is it still necessary for us to assume a totally new mechanism in dementia praecox? In general we know far too little about the psychology of the normal and the hysterical⁶² to dare to assume, in so baffling a disease as dementia praecox, completely new mechanisms unknown to all psychology. We should be sparing with new principles of explanation; for this reason I decline to accept Stransky's hypothesis, clear and ingenious though it is.

[36] To make up for this, we have a very fine experimental work of Stransky's⁶³ which provides a basis for the understanding of one important symptom, namely the speech confusion.

[37] Speech confusion is a product of the basic psychological disturbance. (Stransky calls it "intrapyschic ataxia.") Whenever the relations between emotional life and ideation are

disturbed, as in dementia praecox, and the orientation of normal thought by a directing idea (Liepmann) is lacking, a thought-process akin to flight of ideas is bound to develop. (As Pelletier has shown, the laws of association are stronger than the influence of the directing idea.) In the case of a-verbal process there will be an increase in the purely superficial connective elements (verbal-motor associations and clang reactions), as was shown in our experiments with distracted attention. Hand in hand with this there is a decrease in meaningful combinations. In addition, there are other disturbances such as an increased number of mediate associations, senseless reactions, repetitions of the stimulus word (often many times). Perseverations show contradictory behaviour under distraction; in our experiments they increase in women and decrease in men. In very many cases we could explain the perseveration by the presence of a strong feeling-tone: the strongly feeling-toned idea shows a tendency to perseverate. Everyday experience confirms this. Distraction of attention creates a sort of vacuum of consciousness⁶⁴ in which ideas can perseverate more easily than during full attention.

[38] Stransky then examined how continuous sequences of verbal associations behave under the influence of relaxed attention. His subjects had to talk at random into a phonograph for one minute, saying just what came into their heads. At the same time they were not to pay attention to what they said. A stimulus-word was given as a starting point. (In half the experiments an external distraction was also provided.)

[39] These tests brought interesting results to light: The sequence of words and sentences immediately recalled the talk (as well as the fragments of writing) we find in dementia praecox! A definite direction for the talk was ruled out by the way the experiment was conducted; the stimulus word acted for only a very short time as a more or less indefinite "theme." Superficial connective elements predominated strikingly (reflecting the breakdown of logical connections), there were masses of perseverations (or else repetitions of the preceding word, which amounts roughly to the repetition of the stimulus word in our experiment); besides this there were numerous contaminations,⁶⁵ and closely connected with them neologisms, new word-formations.

[40] From Stransky's voluminous material I should like to quote a few examples by way of illustration:

The storks stand on one leg, they have wives, they have children, they are the ones that bring children, the children whom they bring home, of this home, an idea that people have about storks, about the activity of storks, storks are large birds, with a long beak and live on frogs, frogs, fresh frigs, the frigs are frugs first thing, first thing in the morning [*Früh*], fresh for breakfast [*Frühstück*], coffee, and with coffee they also drink cognac, and cognac they also drink wine, and with wine they drink everything possible, the frogs are large animals and which the frogs feed on, the storks feed on the fowls, the fowls feed on the animals, the animals are large, the animals are small, the animals are men, the animals are not men [etc., etc.].

These sheep are ... were merino sheep, from which the fat was cut by the pound, with Shylock the fat was cut, the pound was cut [etc.].

K ... was a K ... with a long nose, with a ram's nose, with a ramp nose, with a nose to ram with, ram-bane, a man who has rammed, who is rammed [etc.].

[41] From these examples of Stransky's one can see at once what laws of association the thought-process follows: it is chiefly the laws of similarity, coexistence, verbal-motor combination, and combination according to sound. Besides that the numerous perseverations and repetitions (Sommer's "stereotypies") leap to the eye. If we compare this with the sample of dementia praecox associations quoted earlier from Pelletier, we shall find a striking resemblance⁶⁶—in both cases the same laws of similarity, contiguity, and assonance. Only stereotypies⁶⁷ and perseverations are lacking in Pelletier's analysis, although they can plainly be seen in the material. Stransky then proceeds to document this obvious similarity with a number of excellent examples taken from dementia praecox.

[42] It is especially worth noting that in Stransky's tests with normal persons numerous conglomerations of words or sentences occur which can be described as contaminations. For example:

... especially a meat one cannot get rid of, the thoughts one cannot get rid of, especially when one ought to persevere at it, persevere, sever, Severin [etc.].

[43] According to Stransky the following series of ideas are condensed in this conglomerate:

- a. A lot of mutton is consumed in England.
- b. I cannot get rid of this idea.
- c. This is perseveration.
- d. I ought to say at random what comes into my mind.

[44] Contamination is therefore a condensation of different ideas, and hence should be regarded in principle as an *indirect association*.⁶⁸ This quality of contamination is immediately apparent from the pathological examples given by Stransky:

Q: What is a mammal?

A: It is a cow, for instance a midwife.

[45] "Midwife" is an indirect association to "cow" and reveals the probable train of thought: *cow—bears living young—so do human beings—midwife*.⁶⁹

Q: What do you understand by the Blessed Virgin?

A: The behaviour of a young lady.

[46] As Stransky rightly observes, the train of thought probably runs as follows: *immaculate conception—virgo intacta—chaste conduct*.

Q: What is a square?

A: An angular quadrangle.

The condensation consists of:

- a. A square is a quadrangle.
- b. A square has four angles.

- [47] From these examples it should be clear that the numerous contaminations occurring under distracted attention are somewhat similar to the indirect associations which occur under distraction in simple word reactions. Our experiments have proved statistically the increase of indirect associations under distraction.
- [48] This concurrence of three experimenters—Stransky, myself, and, so to speak, dementia praecox—can be no accident. It proves the correctness of our views and is yet another confirmation of the apperceptive weakness, the most striking of all the degenerative symptoms in dementia praecox.
- [49] Stransky points out that contamination often produces strange word-formations, which are so bizarre that they immediately bring to mind the neologisms of dementia praecox. I am convinced that a great number of neologisms do come about in this way. A young patient who wanted to convince me of her normality once exclaimed: “Of course I am normal. It’s as broad as daylight!” She repeated this emphatically several times. The formation has the following components:
- a. As clear as daylight,
 - b. In broad daylight.
- [50] In 1898 Neisser,⁷⁰ on the basis of clinical observations, remarked that the new word-formations, which as a rule, like the verbal roots themselves, are neither verbs nor nouns, are not really words at all but represent sentences, since they always serve to illustrate an entire process. This expression of Neisser’s hints at the idea of condensation. But Neisser goes even further and speaks directly of the illustration of an entire process. At this point I would remind the reader that Freud in *The Interpretation of Dreams* has shown that a dream is a condensation⁷¹ in the grand manner. Unfortunately I cannot discuss in detail the comprehensive and extremely valuable psychological material adduced by this still too little appreciated investigator; it would lead us much too far afield. I must simply take a knowledge of this important book for granted. So far as I know, no real refutation of Freud’s views has yet been made. Hence I shall confine myself to affirming that dreams, which in any case have numerous analogies with the associative disturbances in dementia praecox, also show the special speech-condensations consisting of the contamination of whole sentences and situations. Kraepelin, too, was struck by the resemblance between the language of dreams and that of dementia praecox.⁷² From the numerous examples I have observed in my own and other people’s dreams I will select only a very simple one. It is at once a condensation and a neologism. Wishing to express approval of a certain situation in a dream, the dreamer remarks: “That is fimous”—a condensation of “fine” and “famous.”
- [51] Dreams are an “apperceptive” weakness par excellence, as is particularly clear from their well-known predilection for *symbols*.⁷³
- [52] Finally, there is one more question which should really have been answered first, and that is: Does the state of consciousness in Stransky’s experiments conducted under normal conditions really correspond to one of disturbed attention? Above all it should be noted that his distraction experiments show no essential changes compared with the normal

experiments; consequently neither association nor attention can have been so very different in the two states. But what is one to think of the disturbance in the normal experiments?

[53] It seems to me that the main reason is to be sought in the “forced” character of the experiment. The subjects were told to talk at random, and that they sometimes did so with great rapidity is proved by the fact that on average they uttered 100 to 250 words per minute, whereas in normal speech the average per minute is only 130 to 140.⁷⁴ Now if a person talks more quickly and perhaps thinks more quickly than he is accustomed to do about ordinary and indifferent things, he cannot pay sufficient attention to his associations. A second point that needs to be considered is this: for the great majority of the subjects the situation was an unusual one and must have influenced their emotional state. They were in the position of an excited orator who gets into a state of “emotional stupidity.”⁷⁵ In such conditions I found an extraordinarily high number of perseverations and repetitions. But emotional stupidity likewise causes great disturbance of attention. We can therefore take it as certain that in Stransky’s normal experiments attention really was disturbed, though the actual state of consciousness is far from clear.

[54] We are indebted to Heilbronner⁷⁶ for an important observation. Examining a series of associations in a case of hebephrenia, he found that on one occasion 41%, and on another 23%, of the reaction-words referred to the environment. Heilbronner considers this as proving that the fixation originates in the “vacuum,” i.e., is due to the lack of new ideas. I can confirm this observation from my own experience. Theoretically, it would be interesting to know how this symptom is related to the Sommer-Leupoldt symptom of “naming and touching.”

[55] New and independent views on the psychology of dementia praecox are expressed by Otto Gross.⁷⁷ He proposes *dementia sejunctiva* as a name for the disease, the reason being the disintegration or “sejunction” of consciousness. The concept of sejunction is, of course, taken from Wernicke; Gross could just as well have taken the much older, synonymous concept of dissociation from Binet and Janet. Fundamentally, dissociation of consciousness means the same thing as Gross’s sejunction of consciousness. The latter term only gives us another new word, of which we have more than enough in psychiatry already. By dissociation the French school meant a weakening of consciousness due to the splitting off of one or more sequences of ideas; they separate themselves from the hierarchy of ego-consciousness and begin to lead a more or less independent existence of their own.⁷⁸ The Breuer-Freud theory of hysteria grew up on this basis. According to the more recent formulations of Janet, dissociation is the result of the *abaissement du niveau mental*, which destroys the hierarchy and promotes, or actually causes, the formation of automatisms.⁷⁹ Breuer and Freud have shown very nicely what kind of automatisms are then released.⁸⁰ Gross’s application of this theory to dementia praecox is new and important. Writing of his basic idea, the author says: “Disintegration of consciousness in my sense of the word means the simultaneous occurrence of functionally discrete chains of association. ... For me the main point lies in the view that the conscious activity of the moment is the result of many psychophysical processes occurring synchronously.”⁸¹

[56] These two quotations may be sufficient to illustrate the author's concept. We can perhaps agree with the view that consciousness, or rather, the content of consciousness, is the outcome of countless non-conscious (or unconscious) psychophysical processes. Compared with the current psychology of consciousness, which holds that at the point where the epiphenomenon "consciousness" leaves off the nutritive processes of the brain cells immediately begin, this view represents a refreshing advance for psychiatry. Gross evidently visualizes the *psychic content* (not the content of consciousness) as separate chains of association occurring simultaneously. I think this simile is rather misleading: it would seem to me more correct to assume complexes of ideas which become conscious successively and are constellated by previously associated complexes. The cement binding these complexes together is some definite affect.⁸² If the connection between Gross's synchronous chains of association is loosened by the disease, a disintegration of consciousness sets in. In the language of the French school, this means that when one or more sequences of ideas split off, there is a dissociation which causes a weakening of consciousness. Let us not quarrel about words, however. Here Gross comes back to the problem of apperceptive disturbance, but he approaches it from a new and interesting angle—from the side of the unconscious. He makes the attempt to uncover the roots of the numerous automatic phenomena which burst into the consciousness of the dementia praecox patient with elemental force and strangeness. The signs of automatic phenomena in the conscious life of the patient should be known to every psychiatrist: they are the "autochthonous" ideas, sudden impulses, hallucinations, influencing of thought, obsessive sequences of strange ideas, stoppage and disappearance of thought (aptly termed by one of my patients "thought deprivation"), inspirations, pathological ideas, etc.

[57] Gross states that the catatonic symptoms are

alterations of the will itself by an agent felt as external to the continuity of the ego and therefore interpreted as a strange power. [They are] a momentary replacement of the continuity of the ego's will by the intrusion of another chain of consciousness. ... We have to imagine that several chains of association can be maintained in the organ of consciousness simultaneously, without influencing one another. One of these chains will have to become the carrier of the continuity of consciousness ... the other chains of association will then naturally be "subconscious" or, better, "unconscious." Now at any given time it must be possible for, let us say, the nervous energy in them to mount up and reach such a pitch that attention is suddenly directed to one of the terminal links in the chain, so that a link from an unconscious chain of associations unexpectedly forces itself directly into the continuity of the hitherto dominant chain. If these conditions are fulfilled, the accompanying subjective process can only be such that any psychic manifestation is felt as suddenly irrupting into consciousness and as something entirely foreign to its continuity. The explanatory idea will then follow almost inevitably that this particular psychic manifestation did not come from one's own organ of consciousness but was injected into it from outside.⁸³

[58] As I have said, the displeasing thing about this hypothesis is the assumption of independent but synchronous chains of association. Normal psychology furnishes nothing in support of this. In hysteria, where we can best examine split-off sequences of ideas, we find that the opposite holds true. Even when we are apparently dealing with totally distinct sequences, we can find somewhere, in a hidden place, the bridge leading from one to the other.⁸⁴ In the psyche everything is connected with everything else: the existing psyche is the resultant of myriads of different constellations.

[59] But apart from this slight defect, I think we may call Gross's hypothesis a singularly happy one. It tells us, in short, that the roots of all automatic phenomena lie in the unconscious bonds of association. When consciousness "disintegrates" (*abaissement du niveau mental*, apperceptive weakness), the complexes coexisting with it are simultaneously freed from all restraint and are then able to break through into ego-consciousness. This is an eminently psychological conception and is clearly in accord with the teachings of the French school, with our experience of hypnotism, and with the analysis of hysteria. If we depotentiate consciousness by suggestion and thus produce a split-off complex of ideas, as in a post-hypnotic command, this split-off complex will break through into ego-consciousness with inexplicable force. In the psychology of ecstatic somnambulists we find the same typical irruptions of split-off ideas.⁸⁵

[60] Unfortunately Gross leaves one question open, and that is: Exactly what are these split-off sequences of ideas and what is the nature of their content?

[61] Sometime before Gross wrote anything, Freud answered this question in a very brilliant way. As far back as 1893 Freud showed⁸⁶ how a hallucinatory delirium arises from an affect which is intolerable to consciousness, how this delirium is a compensation for unsatisfied wishes, and how the individual takes refuge, as it were, in the psychosis in order to find in the dreamlike delirium of the disease what is denied him in reality. In 1896 Freud analysed a paranoid illness, one of Kraepelin's paranoid forms of dementia praecox, and showed how the symptoms are determined exactly in accordance with the transformation mechanisms in hysteria. Freud said at the time that paranoia, or the group of illnesses included under paranoia, is also a defence neuropsychosis; that it arises, like hysteria and obsessional ideas, from the repression of painful reminiscences, and that its symptoms are determined by the content of the repression.⁸⁷

[62] In view of the far-reaching significance of such an hypothesis it is worth while to go more closely into this classic analysis of Freud's.

[63] The case⁸⁸ is that of a 32-year-old woman who manifested the following symptoms: She imagined that her environment had changed, she was no longer respected, people insulted her, she was watched, her thoughts were known. Later she got the idea that she was watched in the evening while undressing; then she experienced sensations in her abdomen which she believed were caused by an indecent thought on the part of the servant girl. Visions then appeared in which she saw female and male genitals. Whenever she was alone with women she had hallucinations of female genitals, and at the same time felt as though the other women could see hers.

[64] Freud analysed this case. He found that this patient behaved just like an hysteric; that is, she showed the same resistances, etc. What seemed unusual was that the repressed thoughts did not appear, as in hysteria, in the form of loosely connected fancies, but in the form of inner hallucinations; she therefore compared them to her voices. (Later I shall have occasion to furnish experimental proof of this observation.) The hallucinations began after the patient had seen a number of female patients naked in the bathing-room.⁸⁹ “It was to be presumed that [this impression] had been repeated only because great interest had been taken in it. She then said she had at the time felt shame for those women.” This somewhat compulsive, altruistic shame was striking, and pointed to something repressed. The patient then reproduced “a series of scenes from her seventeenth back to her eighth year in which she had been ashamed of her nakedness in the presence of her mother while bathing, her sister, or the family physician; the series ... ended in a scene in her sixth year, in which she undressed in the nursery on going to bed without feeling shame about her brother’s presence.” Finally it turned out that “the brother and sister had for years had the habit of showing themselves to each other naked before going to bed.” On those occasions she was not ashamed. “She was now making up for the shame which she had not felt as a child.”

[65] The beginning of her depression occurred at the time of a quarrel between her husband and her brother in consequence of which the latter no longer came to the house. She had always been very fond of this brother. ... Further, she also referred to a certain period in her illness at which for the first time “everything became clear to her”—that is to say, the time when she became convinced of the truth of her conjecture that she was being generally scorned and deliberately insulted. This certainty came upon her during a visit from a sister-in-law, who in the course of conversation remarked casually, “If anything of that kind happened to me I should simply shrug my shoulders.” Frau P. at first received this remark with indifference, but later, after the visitor had left, it occurred to her that the words contained a reproach, as if *she* was wont to make light of serious things; and from that moment she felt sure that she was the victim of universal slander. When I questioned her why she felt justified in applying these words to herself, she replied that it was the tone in which her sister-in-law had spoken which (although only later) had convinced her of it—a characteristically paranoiac detail. I now urged her to recollect the remarks which her sister-in-law had made *before* the expression complained of, and I learnt that the sister-in-law had related that in her home there had been all sorts of difficulties with her *brothers*, and had added the wise comment: “In every family things occur over which one would gladly draw a veil, but if anything of the kind happened to me I should think nothing of it.” Frau P. now had to admit that her depression was related to these sentences before the last remark. Since she had repressed both of the sentences which might have aroused the memory of her relations with her brother and had retained in memory only the insignificant last sentence, she had had to connect her idea that her sister-in-law was intending a reproach against her with this last sentence; and as its contents offered no support to this interpretation she turned from the contents to the *tone* in which the words were spoken.

[66] After this explanation Freud turned his attention to the analysis of the voices. “In the first place it had to be explained why such an indifferent content as ‘Here comes Frau P.,’

‘She’s looking for a house now,’ and the like, could be so distressing to her.” She first heard the voices after she had read a novel by O. Ludwig, called *Die Heiterethei*. After reading it she went for a walk on a country road, and suddenly while passing a peasant’s cottage the voices told her: “That’s what Heiterethei’s house looked like! There’s the spring and there’s the shrubbery! How happy she was in spite of all her poverty!” Then the voices repeated to her whole paragraphs from the book she had just read, although the content was of no importance.

[67] The analysis showed that during her reading her mind had wandered and she had become excited by totally different passages in the book. Against this material—analogy between the couple in the novel and herself and her husband, memories of intimacies in her married life and family secrets—there arose a repressing resistance, because it was connected by easily demonstrable trains of thought with her sexual dread and finally amounted to an awakening of the old childhood experience. In consequence of the censorship exercised by the repression, the harmless and idyllic passages, which were connected with the proscribed ones by contrast and also by proximity, became strengthened in consciousness and were able to “say themselves aloud.” The first of the repressed ideas, for instance, related to the gossip among the neighbours to which the heroine, who lived all alone, was exposed. She easily discovered the analogy with herself in this; she also lived in a small place, saw no one, and thought herself despised by her neighbours. This distrust of her neighbours had a foundation in real experience; for when she was first married she had at first been obliged to be content with a small dwelling, and the wall of the bedroom against which the bed of the young couple stood adjoined a room of the neighbours. Great sexual shyness first awoke in her at the time of her marriage—obviously by its arousing memories of the affair in her childhood when the two children played at man and wife; she was continually apprehensive lest the neighbours should distinguish words and noises through the intervening wall, and this shame turned itself into suspicions of the neighbours in her mind.

[68] On further analysis of the voices Freud often found “the character of diplomatic indefiniteness; the distressing allusion was usually closely hidden, the connection between the particular sentences being disguised by a strange tone of voice, unusual forms of speech, and the like—characteristics common to the auditory hallucinations of paranoiacs and in which I see traces of the compromise-distortion.”

[69] I have purposely given the floor to the author of this first analysis of paranoia, which is so extremely important for psycho-pathology, because I did not know how to abridge Freud’s ingenious argument.

[70] Let us now turn back to the question concerning the nature of the dissociated ideas. We can now see what meaning Freud attaches to Gross’s supposed dissociations: they are nothing other than repressed complexes as found in hysterics⁹⁰ and—last but not least—in normal persons.⁹¹ The secret of the repressed ideas turns out to be a psychological mechanism of general significance, and a quite ordinary occurrence. Freud sheds new light on the question of incongruity between the content of consciousness and feeling-tone

discussed by Stransky. He shows how indifferent and quite trivial ideas may be accompanied by an intense feeling-tone, which, however, has been taken over from a repressed idea. Here Freud opens the way to understanding the inadequate feeling-tone in *dementia praecox*. I need hardly discuss the significance of this.

[71] The results of Freud's investigations may be summed up as follows. Both in their form and content, the symptoms of paranoid *dementia praecox* express thoughts which, in consequence of their painful feeling-tone, became incompatible with the ego-consciousness and were therefore repressed. These repressions determine the nature of the delusions and hallucinations, as well as the general behaviour of the patient. Hence, whenever an apperceptive paralysis appears, the resultant automatisms contain the split-off complexes of ideas—the whole army of bottled-up thoughts is let loose. Thus we may generalize the conclusions reached by Freud's analysis.

[72] Uninfluenced by Freud, Tiling⁹² came to very similar conclusions on the basis of clinical experience. He, too, would like to attribute to the individual an almost incalculable significance as regards the origin and specific form of the psychosis. The importance of the individual factor, and of the individual's psychology in general, is undoubtedly underestimated in modern psychiatry, less perhaps for theoretical reasons than because of the helplessness of the practising psychologist. We can therefore go a long way with Tiling, at any rate a good deal further than Neisser⁹³ thought he could go. But on the question of aetiology, the core of the problem, we must make a halt. According neither to Freud nor to Tiling does the individual psychology explain the origin of the psychosis. This can be seen most clearly in Freud's analysis, quoted above. The "hysterical" mechanisms he uncovered suffice to explain the origin of *hysteria*, but why then does *dementia praecox* arise? We can understand why the content of the delusions and hallucinations is so and not otherwise, but why *non-hysterical* delusions and hallucinations should appear at all we do not know. There may be an underlying *physical* cause that overrides all psychological causes. Let us further assume with Freud that every paranoid form of *dementia praecox* follows the mechanism of *hysteria*—but why is it that paranoia is uncommonly stable and resistant, while *hysteria* is characterized by the great mobility of its symptoms?

[73] Here we come upon a new factor in the disease. The mobility of the hysterical symptoms is due to the mobility of affects, while paranoia is characterized by fixation of affects, as Neisser says.⁹⁴ This idea, which is extraordinarily important for the theory of *dementia praecox*, is formulated by Neisser⁹⁵ as follows:

Only a very slight assimilation takes place from the outside. The patient is able to exert less and less influence on the course of his ideas, and in this way, to a much greater extent than in the normal, there arise separate groups of ideational complexes. Their contents are bound together only by the personal relationship attaching to them all; apart from this they are not fused in any other way, and, depending on the constellation of the moment, now one and now another of these complexes will determine the course of psychic elaboration and association. Thus a gradual decay of the personality sets in; it becomes, as it were, a passive spectator of the impressions flowing in from the various internal sources of stimulation, a

lifeless plaything of the excitations generated by them. The affects which are normally meant to regulate our relations with the surrounding world and to implement our adaptation to it—which act, indeed, as a means of protecting the organism and are the motive forces of self-preservation—these affects become alienated from their natural purpose. The strong organically determined feeling-tone of the delusional trains of thought brings it about that, no matter what the emotional excitation may be, these and these only are reproduced, over and over again. This fixation of affects destroys the capacity to feel joy and compassion, and leads to the emotional isolation of the patients, which runs parallel with their intellectual alienation.

[74] Neisser has here described the familiar picture of apperceptive deterioration: lack of new ideas, paralysis of all purposive progress adapted to reality, decay of the personality, autonomy of complexes. To these he adds the “fixation of affects,” that is, the fixation of the feeling-toned complexes of ideas. (Affects usually have an intellectual content, though it need not always be conscious.) This explains the emotional impoverishment (for which Masselon coined the apt expression “coagulation”). Fixation of affects therefore means, in Freudian terms, that the repressed complexes (the carriers of affects) can no longer be eliminated from the conscious process; they remain operative, and so prevent the further development of personality.

[75] In order to prevent misunderstandings, I must add at once that the continued predominance of a strong complex in normal psychic life can lead merely to hysteria. But the symptoms produced by the hysterogenic affect are different from those of dementia praecox. We must therefore suppose that the disposition for the origin of dementia praecox is quite different from that for hysteria. If a purely hypothetical conjecture may be permitted, we might venture the following train of thought: the hysterogenic complex produces reparable symptoms, while the affect in dementia praecox favours the appearance of anomalies in the metabolism—toxins, perhaps, which injure the brain in a more or less irreparable manner, so that the highest psychic functions become paralysed. As a result, the acquisition of new complexes is slowed down or ceases altogether; the pathogenic (or rather, the precipitating) complex remains the last one, and the further development of the personality is finally checked. In spite of an apparently uninterrupted causal chain of psychological events leading from the normal to the pathological, we should never overlook the possibility that in certain cases a change in the metabolism (in Kraepelin’s sense) may be primary; the complex which happens to be the newest and last one “coagulates” and determines the content of the symptoms. Our experience does not yet go nearly far enough to warrant the exclusion of such a possibility.

Summary

[76] This anthology from the literature shows very clearly, in my opinion, how all these views and researches, though apparently having hardly any connection with one another, nevertheless converge towards the same goal. The observations and suggestions culled from the many different domains of dementia praecox point above all to the idea of a quite

central disturbance, which is called by various names: apperceptive deterioration (Weygandt); dissociation, *abaissement du niveau mental* (Masselon, Janet); disintegration of consciousness (Gross); disintegration of personality (Neisser and others). Then, the tendency to fixation is stressed (Masselon, Neisser), and from it Neisser derives the emotional impoverishment. Freud and Gross lay their finger on the important fact of the existence of split-off ideas, and to Freud belongs the merit of having been the first to demonstrate the “principle of conversion” (repression and indirect reappearance of complexes) in a case of paranoid dementia praecox. Nevertheless, the mechanisms of Freud are not comprehensive enough to explain why dementia praecox arises and not hysteria; we must therefore postulate for dementia praecox a specific concomitant of the affect—toxins?—which causes the final fixation of the complex and injures the psychic functions as a whole. The possibility that this “intoxication” might be due primarily to somatic causes, and might then seize upon the last complex which happened to be there and pathologically transform it, should not be dismissed.

2. THE FEELING-TONED COMPLEX AND ITS GENERAL EFFECTS ON THE PSYCHE

[77] My theoretical premises for an understanding of the psychology of dementia praecox are, in principle, exhausted with the contents of the first chapter, for Freud has, strictly speaking, said all that is essential in his works on hysteria, obsessional neurosis, and dreams. Nevertheless our concepts, worked out on an experimental basis, differ somewhat from those of Freud, and it may be that the concept of the feeling-toned complex goes a little beyond the scope of Freud’s views.

[78] The essential basis of our personality is affectivity.¹ Thought and action are, as it were, only symptoms of affectivity.² The elements of psychic life, sensations, ideas, and feelings, are given to consciousness in the form of certain units, which can perhaps be compared—if one may risk a chemical analogy—to molecules.

[79] For example: I meet an old friend in the street, and immediately there is formed in my brain an image, a functional unit: the image of my friend X. In this unit, or “molecule,” we can distinguish three components, or “radicals”: sense-perception, intellectual components (ideas, memory-images, judgments, etc.), and feeling-tone.³ These three components are firmly united, so that if the memory-image of X rises to the surface all the elements belonging to it usually come with it, too. (Sense-perception is represented by a simultaneous, centrifugal excitation of the sensory spheres concerned.) I am therefore justified in speaking of a functional unit.

[80] Now, through the thoughtless gossip of my friend X, I once became involved in a very unpleasant affair and had to suffer the consequences for a long time. This affair comprises a large number of associations (it may be compared to a body made up of countless molecules); many persons, things, and events are included in it. The functional unit, “my friend,” is only one of many figures. The entire mass of memories has a definite feeling-

tone, a lively feeling of *irritation*. Every molecule participates in this feeling-tone, so that, whether it appears by itself or in conjunction with others, it always carries this feeling-tone with it, and it does this with the greater distinctness the more distinctly we can see its connection with the complex-situation as a whole.⁴

[81] I once witnessed the following incident as an illustration of this: I was taking a walk with a very sensitive and hysterical gentleman. The village bells were pealing a new and very harmonious chime. My companion, who usually displayed great feeling for such chimes, suddenly began to rail at it, saying he could not bear that disgusting ringing in the major key, it sounded frightful; moreover it was a hideous church and a squalid-looking village. (The village is famous for its charming situation.) This remarkable inappropriate affect interested me, and I pursued my investigations further. My companion then began to abuse the local parson. The reason he gave was that the parson had a repulsive beard and—wrote very bad poetry. My companion, too, was poetically inclined. Thus, the affect lay in poetic rivalry.

[82] This example shows how each molecule (bell-ringing, etc.) participates in the feeling-tone (poetic rivalry) of the whole fabric of ideas,⁵ which we call the feeling-toned complex. Understood in this sense, the complex is a higher psychic unity. When we come to examine our psychic material (with the help of the association test, for example), we find that practically every association belongs to some complex or other.⁶ To be sure, it is rather difficult to prove this in practice, but the more carefully we analyse them the more clearly we see the relation of the individual associations to complexes. Their relation to the *ego-complex* is beyond all doubt. The ego-complex in a normal person is the highest psychic authority. By this we mean the whole mass of ideas pertaining to the ego, which we think of as being accompanied by the powerful and ever-present feeling-tone of our own body.

[83] The feeling-tone is an affective state accompanied by somatic innervations. The ego is the psychological expression of the firmly associated combination of all body sensations. One's own personality is therefore the firmest and strongest complex, and (good health permitting) it weathers all psychological storms. It is for this reason that the ideas which directly concern our own persons are always the most stable, and to us the most interesting; we could also express this by saying that they possess the strongest *attention-tone*. ("Attention" in the sense used by Bleuler is an affective state.⁷)

Acute Effects of the Complex

[84] Reality sees to it that the peaceful cycle of egocentric ideas is constantly interrupted by ideas with a strong feeling-tone, that is, by affects. A situation threatening danger pushes aside the tranquil play of ideas and puts in their place a complex of other ideas with a very strong feeling-tone. The new complex then crowds everything else into the background. For the time being it is the most distinct because it totally inhibits all other ideas; it permits only those egocentric ideas to exist which fit *its* situation, and under certain conditions it can suppress to the point of complete (momentary) unconsciousness all ideas that run counter to

it, however strong they may be. It now possesses the strongest attention-tone. (Thus we should not say that we direct our attention to something, but that the state of attention sets in with this idea.⁸)

[85] How does a complex get its inhibiting or stimulating power?

[86] We have seen that the ego-complex, by reason of its direct connection with bodily sensations, is the most stable and the richest in associations. Awareness of a threatening situation arouses fright. Fright is an affect, hence it is followed by bodily changes, by a complicated harmony of muscular tensions and excitations of the sympathetic nervous system. The perception has thus found the way to somatic innervation and thereby helped the complex associated with it to gain the upper hand. Through the fright, countless body sensations become altered, and in turn alter most of the sensations on which the normal ego is based. Consequently the normal ego loses its attention-tone (or its clarity, or its stimulating and inhibiting influence on other associations). It is compelled to give way to the other, stronger sensations connected with the new complex, yet normally it is not completely submerged but remains behind as an “affect-ego,”⁹ because even very powerful affects cannot alter all the sensations lying at the base of the ego. As everyday experience shows, this affect-ego is a weak complex, greatly inferior to the affective complex in constellating power.

[87] Let us assume that the threatening situation passes rapidly: the complex soon loses some of its attention-tone, since the body sensations gradually resume their normal character. Nevertheless, in its physical as well as its psychic components, the affect goes on vibrating for some time afterwards; the knees shake, the heart continues to pound, the face is flushed or pale, “one can hardly recover from the fright.” From time to time, first at short and then at longer intervals, the fright-image returns, charged with new associations, and evokes re-echoing waves of affect. This perseveration of the affect, coupled with great intensity of feeling, is one reason for a corresponding increase in the richness of associations. Hence large complexes are always strongly feeling-toned and, conversely, strong affects always leave behind very large complexes. This is due simply to the fact that on the one hand large complexes include numerous somatic innervations, while on the other hand strong affects constellate a great many associations because of their powerful and persistent stimulation of the body. Normally, affects can go on working indefinitely (in the form of stomach and heart troubles, insomnia, tremors, etc.). Gradually, however, they subside, the ideas relating to the complex disappear from consciousness, and only in dreams do they occasionally manifest themselves in more or less disguised hints. But complexes continue to show themselves for years in the characteristic disturbances they produce in a person’s associations. Their gradual extinction is marked by one general psychological peculiarity: their readiness to reappear in almost full strength as a result of similar though much weaker stimuli. For a long time afterwards there remains a condition which I would like to call “complex-sensitiveness.” A child once bitten by a dog will scream with terror at the mere sight of a dog in the distance. People who have received bad news will thereafter open all

their mail with apprehension. These effects of the complex, which may last for a very long time, lead to a consideration of the—

Chronic Effects of the Complex

[88] Here we must distinguish two kinds:

1. An effect that continues over a very long period and is produced by an affect occurring only once.
2. Chronic effects which become permanent because the affect is in a continuous state of excitation.

[89] The first group is best illustrated by the legend of Ramón Lully, who, as a gallant adventurer, had long courted a lady. Finally the longed-for *billet* arrived, inviting him to a midnight assignation. Lully, full of expectation, came to the appointed place, and as he approached the lady, who was awaiting him, she suddenly threw open her robe and uncovered her cancer-eaten bosom. This episode made such an impression on Lully that from then on he devoted his life to pious asceticism.

[90] There are impressions which last a lifetime. The lasting effects of strong religious impressions or of shattering experiences are well known. The effects are particularly strong in youth. Indeed, the whole aim of education is to implant lasting complexes in the child. The durability of a complex is guaranteed by its continually active feeling-tone. If the feeling-tone is extinguished, the complex is extinguished with it. The persistence of a feeling-toned complex naturally has the same constellating effect on the rest of the psychic activities as an acute affect. Whatever suits the complex is assimilated, everything else is excluded or at least inhibited. The best examples of this can be seen in religious convictions. There is no argument, no matter how threadbare, that is not advanced if it is *pro*, while on the other hand the strongest and most plausible arguments *contra* make no impression; they simply bounce off, because emotional inhibitions are stronger than all logic. Even in quite intelligent people who have considerable education and experience one can sometimes observe a real blindness, a true systematic anaesthesia, when one tries to convince them, say, of the theory of determinism. And how often does a single unpleasant impression produce in some people an unshakable false judgment, which no logic, no matter how cogent, can dislodge!

[91] The effects of the complex extend, however, not only to thought but to action, which is continually forced in a quite definite direction. For instance, many people unthinkingly perform religious rites and all kinds of groundless actions despite the fact that intellectually they have long since outgrown them.

[92] The second group of chronic effects, where the feeling-tone is constantly maintained by active stimuli, affords the best examples of complex constellations. The strongest and most lasting effects are seen above all in sexual complexes, where the feeling-tone is constantly maintained, for instance by unsatisfied sexual desire. A glance at the legends of the saints,

or at Zola's novels *Lourdes* or *The Dream*, will provide numerous examples of this. Yet the constellations are not always quite so crude and obvious, often they are more subtle influences, masked by symbolisms, that sway our thoughts and actions. Here I must refer the reader to the numerous and instructive examples given by Freud. Freud puts forward the concept of "symptomatic action" as a special instance of constellation. (Actually one should speak of "symptomatic thought" as well as "symptomatic action.") In his *Psychopathology of Everyday Life* he shows how apparently accidental disturbances of our actions, such as slips of the tongue, misreading, forgetting, etc., are due to constellated complexes. In his *Interpretation of Dreams* he points out similar influences in our dreams. In our experimental work we have demonstrated that complexes disturb the association tests in a characteristic and regular manner (peculiar forms of reaction, perseveration, prolongation of reaction time, failure to react, forgetting of critical or post-critical reactions,¹⁰ etc.).

[93] These observations give us valuable hints in regard to the theory of complexes. In selecting my stimulus-words I always took care to employ as far as possible ordinary words from everyday speech, in order to avoid intellectual difficulties. One would expect an educated person to react "smoothly" to the test, but as a matter of fact this is not so. At the simplest words hesitations and other disturbances occur which can only be explained by the fact that the stimulus-word has hit a complex. But why cannot an idea which is closely associated with a complex be reproduced "smoothly"? The prime reason for the obstruction is emotional inhibition. Complexes are mostly in a state of repression because they are concerned as a rule with the most intimate secrets which are anxiously guarded and which the subject either will not or cannot divulge. Even under normal conditions the repression may be so strong that the subject has an hysterical amnesia for the complex; that is, he has the feeling that some idea, some significant association, is coming up, but a vague hesitation keeps the reproduction back. He feels he wants to say something, but it slips away again immediately. What has slipped away is the thought-complex. Occasionally a reaction comes which unconsciously contains this thought, but the subject is blind to it, and only the experimenter can put him on the right track. The repressive resistance also has a striking effect afterwards on the reproduction test: the critical and post-critical reactions are apt to be smitten with amnesia. These facts all indicate that the complex has an exceptional position compared with the more indifferent psychic material. Indifferent reactions come "smoothly" and generally have very short reaction times; they are always on hand for the ego complex to use as it pleases. Not so the complex reactions: they come only with a struggle, when about to appear they often slip away again from the ego-complex, their form is peculiar, as often they are embarrassing products and the ego itself does not know how it ever got hold of them, they are liable to amnesia immediately afterwards—unlike the indifferent reactions which often have great stability and can be reproduced unchanged even after months or years. The complex associations are therefore much less at the disposal of the ego-complex than the indifferent ones. From this we must conclude that the complex occupies a relatively independent position in regard to the ego-complex—a vassal that will not give unqualified allegiance to its rule. Experience also shows that the stronger the feeling-tone of a complex, the stronger and more frequent will be the disturbances of the experiment. A person with a

strong feeling-toned complex is less able to react smoothly, not only to the association test but to all the stimuli of daily life, as he is continually hindered and disturbed by the uncontrollable influences of the complex. His self-control (control of his moods, thoughts, words, and deeds) suffers in proportion to the strength of the complex; the purposefulness of his actions is more and more replaced by unintentional errors, blunders, unpredictable lapses for which he himself can give no reason. A person with a strong complex therefore shows intensive disturbances during association tests because a large number of apparently innocent stimulus-words hit the complex. The following two examples will illustrate this.

[94] CASE 1. The stimulus-word "white" has numerous well-worn associations, but the patient could react only hesitantly with "black." By way of explanation I obtained some more associations to "white." "Snow is white, and so is the sheet covering the face of the dead." The patient had recently lost a relative whom she loved. The well-worn contrast "black" suggests symbolically the same thing, i.e., mourning.

[95] CASE 2. "Paint" hesitantly aroused the reaction "landscapes." This reaction was explained by the following train of associations: "One paints landscapes, portraits, faces—also the cheeks when one has wrinkles." The patient, an old maid who lamented the loss of an admirer, bestowed a loving attention on her person (symptomatic action), thinking to make herself more attractive by painting her face. "One paints one's face for play-acting, once I play-acted too." It should be noted that she played in amateur theatricals at the time when she still had her lost lover.

[96] The associations of persons with strong complexes swarm with examples of this kind. But the association experiment reflects only one side of daily psychological life. The complex-sensitiveness can also be demonstrated in all the other psychic reactions, as shown in the following cases.

[97] CASE 1. A certain young lady could not bear to see the dust beaten out of her cloak. This peculiar reaction could be traced back to her masochistic disposition. As a child her father frequently chastised her on the buttocks, thus causing sexual excitation. Consequently she reacted to anything remotely resembling chastisement with marked rage, which rapidly passed over into sexual excitement and masturbation. Once, when I said to her casually, "Well, you have to obey," she got into a state of marked sexual excitement.

[98] CASE 2. Mr. Y fell hopelessly in love with a lady who soon afterwards married Mr. X. Although Mr. Y had known Mr. X for a long time and even had business dealings with him, he again and again forgot his name, so that on a number of occasions he had to ask other people when he wished to correspond with Mr. X.

[99] CASE 3. A young hysteric was suddenly assaulted by her lover, and was especially frightened by the erect member of her seducer. Afterwards she became afflicted with a stiff arm.

[100] CASE 4. A young lady, while guilelessly telling me a dream, for no apparent reason suddenly hid her face behind a curtain in an ostentatious manner. Analysis of the dream

revealed a sexual wish which fully explained the reaction of shame.¹¹

[101] CASE 5. Many people commit extraordinarily complicated actions which at bottom are nothing but symbols for the complex. I know a young girl who likes to take a baby-carriage with her on her walks, because, as she blushingly admitted to me, she would then be taken for a married woman. Elderly unmarried women often use dogs and cats as complex-symbols.

[102] As these examples show, thought and action are constantly disturbed and distorted by a strong complex, in large things as in small. The ego-complex is, so to say, no longer the whole of the personality; side by side with it there exists another being, living its own life and hindering and disturbing the development of the ego-complex, for the symptomatic actions often take up a good deal of time and energy at its expense. So we can easily imagine how much the psyche is influenced when the complex gains in intensity. The clearest examples are always furnished by sexual complexes. Let us take for instance the classic state of being in love. The lover is obsessed by his complex: his whole interest hangs solely on this complex and on the things that suit it. Every word, every object reminds him of his beloved (in the association test even apparently quite indifferent stimulus words can hit the complex). The most trivial objects are guarded like priceless jewels, so far as they relate to the complex; his whole environment is viewed *sub specie amoris*. Anything that does not suit the complex simply glances off, all other interests sink to nothing, there is a standstill and temporary atrophy of the personality. Only what suits the complex arouses affects and is assimilated by the psyche. All thoughts and actions tend in the direction of the complex; whatever cannot be constrained in this direction is repudiated, or is performed perfunctorily, without emotion and without care. In attending to indifferent matters the most extraordinary compromise formations are produced; slips of the pen referring to the erotic complex creep into business letters, suspicious slips of the tongue occur in speaking. The flow of objective thought is constantly interrupted by invasions from the complex, there are long gaps in one's thought which are filled out with erotic episodes.

[103] This well-known paradigm shows clearly the effect of a strong complex on a normal psyche. We see how the psychic energy applies itself wholly to the complex at the expense of the other psychic material, which in consequence remains unused. All stimuli that do not suit the complex undergo a partial apperceptive degeneration with emotional impoverishment. Even the feeling-tone becomes inappropriate: trifles such as ribbons, pressed flowers, snapshots, *billets doux*, a lock of hair, etc., are cherished with the greatest care, while vital questions are often dismissed with a smile or with complete indifference. On the other hand the slightest remark even remotely touching on the complex instantly arouses a violent outburst of anger or pain which may assume pathological proportions. (In a case of dementia praecox one would note: "On being asked whether he was married, the patient broke into inappropriate laughter," or "the patient began to weep and became completely negativistic," or "the patient showed blocking," etc.) If we had no means of feeling our way into the psyche of a normal person in love, his behaviour would seem to us that of an hysteric or a catatonic. In hysteria, where the complex-sensitiveness is far greater

than normal, we have almost no means of feeling our way, and must laboriously accustom ourselves to intuiting the meaning of the hysterical affects. This is quite impossible in catatonia, perhaps because we still know too little about hysteria.

[104] The psychological state of being in love could be described as an obsessional complex. Besides this special form of sexual complex, which I have chosen as a paradigm for didactic reasons, since it is the commonest and best-known form of obsessional complex, there are naturally many other kinds of sexual complex which can exert an equally strong influence. Among women the complexes of unrequited or otherwise hopeless love are very common. Here we find an exceedingly strong complex-sensitiveness. The slightest hint from the other sex is assimilated to the complex and elaborated with complete blindness for even the weightiest arguments to the contrary. An insignificant remark of the adored is construed as a powerful subjective proof of his love. The chance interests of the intended become the starting-point for similar interests on the woman's part—a symptomatic action which rapidly disappears when the wedding finally takes place or if the object of adoration changes. The complex-sensitiveness also shows itself in an unusual sensitiveness to sexual stimuli, which appears particularly in the form of prudery. Those obsessed by the complex ostentatiously avoid in their younger years everything that could remind them of sex—the well-known “innocence” of grown-up daughters. Although they know where everything is and what it means, their whole behaviour gives the impression that they never had an inkling of things sexual. If one has to inquire into these matters for medical reasons, one thinks at first that one is on virgin soil, but one soon finds that all the necessary knowledge is there, except that the patient does not know where she got it from.¹² Psychoanalysis usually discovers that behind all the resistances there is a complete repertoire of subtle observations and astute deductions. In later years the prudery often becomes unbearable, or the patient displays a naïve symptomatic interest in all sorts of natural situations in which one “may now take an interest because one is past the age ...” and so on. The objects of this symptomatic interest are brides, pregnancies, births, scandals, and so on. The fine nose of elderly ladies for these matters is proverbial. They are then passed off as “objective, purely human interest.”

[105] Here we have an instance of displacement: the complex must under all circumstances assert itself. Since, for many people, the sexual complex cannot be acted out in a natural way, it makes use of by-ways. During puberty it takes the form of more or less abnormal sexual fantasies, frequently alternating with phases of religious enthusiasm (displacements). In men, sexuality, if not acted out directly, is frequently converted into a feverish professional activity or a passion for dangerous sports, etc., or into some learned hobby, such as a collecting mania. Women take up some kind of philanthropic work, which is usually determined by the special form of the complex. They devote themselves to nursing in hospitals where there are young assistant physicians, or they develop strange eccentricities, a prim, affected behaviour which is meant to express distinction and proud resignation. Artistic natures in particular are wont to benefit by such displacements.¹³ There is, however, one very common displacement, and that is the disguising of a complex by the super-imposition of a contrasting mood. We frequently meet this phenomenon in people

who have to banish some chronic worry. Among these people we often find the best wits, the finest humorists, whose jokes however are spiced with a grain of bitterness. Others hide their pain under a forced, convulsive cheerfulness, which because of its noisiness and artificiality (“lack of affect”) makes everybody uncomfortable. Women betray themselves by a shrill, aggressive gaiety, men by sudden alcoholic and other excesses (also fugues). These displacements and disguises may, as we know, produce real double personalities, such as have always excited the interest of psychological writers (cf. the recurrent problem in Goethe of “two souls,” and among the moderns Hermann Bahr, Gorky, and others). “Double personality” is not just a literary phrase, it is a scientific fact of general interest to psychology and psychiatry, especially when it manifests itself in the form of double consciousness or dissociation of the personality. The split-off complexes are always distinguished by peculiarities of mood and character, as I have shown in a case of this kind.¹⁴

[106] It sometimes happens that the displacement gradually becomes stable and—superficially at least—replaces the original character. Everyone knows people who, judged externally, are enormously gay and entertaining. Inwardly, and sometimes even in private life, they are sullen grumblers nursing an old wound. Often their true nature suddenly bursts through the artificial covering, the assumed blithesomeness vanishes at a stroke, and we are confronted with a different person. A single word, a gesture, if it touches the sore spot, reveals the complex lurking in the depths of the psyche. These imponderabilia of emotional life must be borne in mind before we apply our crude experimental methods to the complicated psyche of the patient. In association tests with patients suffering from a high degree of complex-sensitiveness (as in hysteria and dementia praecox) we find exaggerations of these normal mechanisms; hence their description and discussion will require more than a psychological *aperçu*.

3. THE INFLUENCE OF THE FEELING-TONED COMPLEX ON THE VALENCY OF ASSOCIATIONS

[107] How the complex comes to light in the association experiment has been explained a number of times already, and we must refer the reader to our earlier publications. Here we shall come back to one point only which is of theoretical value. We frequently meet with reactions that are built up in the following manner:

	<i>Stimulus-word</i>	<i>Reaction</i>	<i>Reaction-time (seconds)</i>
1.	kiss	love	3.0
	burn	burning	1.8
2.	despise	someone	5.2
	tooth	teeth	2.4
3.	friendly	amiable	4.8
	dish	fish	1.6

[108] The first reaction in each of the three examples contains the complex (in 1 and 3 it refers to an erotic relationship, and in 2 to an injury). The second reactions show the perseverating feeling-tone of the preceding reaction, as can be seen from the slightly prolonged reaction time and from their superficiality. As explained in “The Associations of Normal Subjects,” associations like *tooth / teeth* belong to the verbal-motor combinations, *burn / burning* to word-completion, and *dish / fish* to rhymes. The distraction experiments show definitely that the verbal-motor combinations and clang-reactions increase when attention is distracted. Whenever there is a reduction of attention there is an increase in the superficiality of associations and their valency diminishes accordingly. Therefore, if during an experiment with no artificial distraction there is a sudden striking increase in superficial associations, we are justified in assuming that attention has momentarily been reduced. The cause is to be sought in an *inner distraction*. Following the instructions, the subject has to fix his attention on the experiment, and if his attention diminishes, that is, if for no outward reason it turns away from the meaning of the stimulus-word, then there must be an inner reason for the distraction. We find this mostly in the preceding or even in the same reaction. A strongly feeling-toned idea has come up, a complex which, because of its strong feeling-tone, attains a high degree of clarity in consciousness or, if repressed, exerts an inhibition on the conscious mind, and in this way temporarily checks or reduces the influence of the directing idea (attention to the stimulus-word). The correctness of this supposition can generally be demonstrated, without difficulty, by analysis.¹

[109] The phenomenon we have described is therefore of practical importance as a complex-indicator. It is of theoretical importance that the complex need not be conscious to the subject. Even when repressed it can exert an inhibition on his consciousness and disturb his attention; in other words, it can check the intellectual performance of consciousness (prolonged reaction-time), or make it impossible (failures to react), or diminish its valency (clang-reactions). The association experiment merely shows details of the effect, whereas clinical and psychological observation shows us the same phenomena on a large scale. A strong complex, for instance a nagging worry, hinders concentration; we are unable to tear ourselves away from it and direct our activity and interest into other channels. Or if we try to do this in order to “forget our worries,” we succeed perhaps for a short time but we do it only “half-heartedly”; without our knowing it, the complex prevents us from giving ourselves wholly to the task in hand. We succumb to all kinds of inhibitions; in the pauses of thought (“thought-deprivation”) fragments of the complex appear and, as in the association experiment, cause characteristic disturbances in the intellectual performance. We make slips of the pen in accordance with the rules of Meringer and Mayer,² we produce condensations, perseverations, anticipations, etc., and Freudian errors which reveal by their content the determining complex. Our slips of the tongue occur at the critical places, that is, when we say words that have a significance for the complex. We make mistakes in reading because we think we see the complex-words in the text. Frequently these words appear in the peripheral field of vision³ (Bleuler). In the midst of our “distracting” occupations we catch ourselves singing or whistling a certain melody; the words, which we have great difficulty in remembering, are a complex constellation. Or we keep on murmuring a word,

frequently a technical term or a foreign word, which likewise refers to the complex. We may be haunted all day by an obsession, by a melody or a word that is always on the tip of our tongue; these too are complex constellations.⁴ Or we make doodles on paper or on the table which are not difficult to interpret in terms of the complex. Wherever the disturbances caused by the complex express themselves in words we find displacements by clang similarities or by combinations of phrases. Here I must refer the reader to the examples given by Freud.⁵

[110] From my own observations I will mention the association of a woman who was pregnant: she reacted to *mild* with *bed*, by which she meant *child / bed*.⁶ Then the verbal automatism “Bunau-Varilla”⁷ gave by free association the following train of thought: *Varinas-Manila-cigarillo-Havana cigar*. Because I had forgotten my matches I resolved not to extinguish a burning cigar before I had lighted my good Havana with it. The name “Bunau-Varilla” presented itself at just the right moment, when the cigar was on the point of going out. Finally the association *Tagerock / Taganrog*, the latter place-name obsessing a lady whose husband had refused to give her a new morning coat [*Tagerock*].⁸

[111] These examples are meant only to illustrate once again what Freud shows in detail in *The Interpretation of Dreams*, that repressed thoughts disguise themselves in similarities, whether in verbal (clang) similarities or in similarities of visual imagery. The best examples of the latter form of displacement can be seen in dreams.

[112] Those who are afraid of Freud’s dream-analysis can find plenty of similar material in melodic automatisms. For instance, someone jokingly remarks in conversation that if one must marry, it should be a proud woman. One of those present, a man who had recently married a woman noted for her pride, began whistling a well-known popular song. As he was a friend of mine, I asked him to tell me the words of the melody. He replied: “What have I been whistling? Oh, nothing. I believe I have often heard it in the street but I don’t know the words.” I urged him to recall the words, which were well known to me, but it was impossible for him to do so; on the contrary he assured me that he had never heard the words. The refrain was: “My mother told me, do not take a peasant maid.”

[113] During an excursion a young lady, walking beside a gentleman whose imminent proposal she hoped for, quietly sang the Wedding March from *Lohengrin*.

[114] A young colleague who had just finished his dissertation was impelled to whistle for half the day Handel’s “See, the conquering hero comes.”

[115] An acquaintance who was pleased with his new and lucrative position betrayed his feelings by singing the obsessive melody “Are we not born for glory?”

[116] A colleague, meeting a nurse on his rounds, who was supposed to be pregnant, immediately afterwards found himself whistling: “Once there were two royal children, who loved each other so dear.”

[117] I do not wish to add unnecessarily to this collection of melodic automatisms; everyone can make the same observations every day. They show us once again how repressed

thoughts are disguised. We know that singing and whistling often accompany activities which do not require full “cathexis of attention” (Freud). The residual attention is therefore sufficient to produce a dreamy movement of thoughts relating to the complex. But the purposive activity prevents the complex from becoming clear, it can only show itself indistinctly, as for instance in the melodic automatisms that contain the thought-complex in the usual metaphorical form. The similarity lies in the situation, in the mood (“See, the conquering hero comes,” Wedding March, “Once there were two royal children”), or in the words expressed (“Do not take a peasant maid”). In these cases the thought-complex did not come clearly into consciousness but manifested itself more or less symbolically. How far such symbolic constellations can go is best seen from that wonderful example of Freud’s in *The Psychopathology of Everyday Life*,⁹ where in the verse “Exoriare aliquis nostris ex ossibus ultor” Freud was able to trace his friend’s forgetting of the word “aliquis” (*A-liquid-fluid-miracle of the blood of St. Januarius*) to the overdue menstrual period of his beloved. I shall give a similar example from my own experience as confirmation of the Freudian mechanisms.

[118] A gentleman wished to recite Heine’s poem “Ein Fichtenbaum steht einsam” (A pine-tree stands alone). When he came to “Ihn schläfert” (It felt drowsy) he got hopelessly stuck; he had totally forgotten the words “mit weisser Decke” (with white sheet). This lapse of memory in such a well-known poem seemed to me very odd, so I asked him to tell me what came into his mind with the words “with white sheet.” The following train of thought resulted: “White sheet makes one think of the winding-sheet for the dead—a linen cloth with which one covers a dead person—(pause)—now I think of a close friend—his brother recently died quite suddenly—supposed to have died of a stroke—he was very corpulent—my friend is corpulent too, and I have sometimes thought it might happen to him—probably he doesn’t take enough exercise—when I heard of his death I suddenly became frightened—it might happen to me, as in our family we are inclined to stoutness—my grandfather also died of a stroke—I am too stout myself and have recently begun a reducing course.”

[119] This shows very clearly how the repression can banish similarities from the conscious mind, even when they are concealed as symbols, and “inhibit” them by attaching them to the complex. In consequence, the gentleman at once identified himself unconsciously with the pine-tree enveloped in a white sheet.

[120] We may therefore assume that he wanted to recite the poem as a symptomatic action in order to discharge the excitation caused by the complex. Another favourite sphere for complex constellations is the joke of the pun type. There are people who have a special talent for this, and among them I know some who have very strong complexes to repress. I shall show what I mean by a simple example representative of a whole class.

[121] At a party there was a Mr. X, who made many good and bad puns. While oranges were being handed round he came out with “O-rangierbahnhof” (shunting station). A Mr. Z, who obstinately disputed the complex theory, exclaimed, “I suppose, Doctor, you would conclude from this that Mr. X is thinking of going on a journey.” Mr. X said, astonished, “So I am! Recently I have always been thinking of journeys, but I was unable to get away.”

Mr. X was thinking in particular of a journey to Italy; hence the constellation via the oranges, a package of which he had just received from a friend in Italy. Naturally he was not conscious of the significance of the pun when he made it, as complex constellations always are and must remain obscure.

[122] Dreams, too, are constructed along similar lines; they are symbolic expressions of the repressed complex. In dreams we find excellent examples of expression by similarity of imagery.¹⁰ Freud, as we know, has at last put dream-analysis on the right track. It is to be hoped that psychologists will soon recognize this fact, for the gain would be immense. Freud's dream-interpretation is fundamental in regard to the concept of expression by means of similarity of imagery, which is so very important for the psychology of dementia praecox. In view of this, it may not be superfluous if I add another dream-analysis to those reported in *Studies in Word Association*.¹¹

[123] A friend¹² once told me the following dream: *I saw horses being hoisted by thick cables to a great height. One of them, a powerful brown horse which was tied up with straps and was hoisted aloft like a package, struck me particularly. Suddenly the cable broke and the horse crashed to the street. I thought it must be dead. But it immediately leapt up again and galloped away. I noticed that the horse was dragging a heavy log along with it, and I wondered how it could advance so quickly. It was obviously frightened and might easily have caused an accident. Then a rider came up on a little horse and rode along slowly in front of the frightened horse, which moderated its pace somewhat. I still feared that the horse might run over the rider, when a cab came along and drove in front of the rider at the same pace, thus bringing the frightened horse to a still slower gait. I then thought now all is well; the danger is over.*

[124] I took up the individual points of the dream and asked my friend to tell me what came into his mind at each point. The hoisting of the horse: it seemed to him that the horses were being hoisted on to a skyscraper, tied up just like horses that are lowered into the mines to work. X had recently seen in a periodical the picture of a skyscraper being built; the work was done at a dizzy height, and he thought it was heavy work that he would not like. I then tried to analyse the peculiar image of a horse being hoisted on to a skyscraper. X stated that the horse was tied round with straps like the young horses that are lowered into the mines. What particularly struck the dreamer about the picture in the periodical was the *work* at such a dizzy height. The horses in the mines have to work too. Could it be that the expression "mines" (*Bergwerk*, literally 'mountain-work') was the result of the condensation of two dream-thoughts: "mountain" as an expression for height, and "work" as an expression for labour, toil, etc.? I therefore asked X for his associations to "mountain," whereupon he remarked at once that he was a passionate mountain-climber and, just about the time of the dream, had had a great desire to make a high ascent and also to travel. But his wife felt very uneasy about it and would not allow him to go alone. She could not accompany him, as she was pregnant. For this reason they had been obliged to give up the idea of a journey to America (skyscraper), where they had planned to go together. They realized that as soon as there are children in the family it becomes much more difficult to

move about and that one cannot go everywhere. (Both were very fond of travelling and had travelled a good deal.) Having to give up the trip to America was particularly disagreeable to him, as he had business dealings with that country and always hoped that by a personal visit he would be able to establish new and important connections. On this hope he had built vague plans for the future, rather lofty and flattering to his ambition.

[125] Let us briefly summarize what has been said so far. *Mountain* can be interpreted as *height*; to climb a mountain = to get to the top; work = labour. The underlying meaning might be: “By labour one gets to the top.” Height is expressed very vividly in the dream by the “dizzy height” of the skyscraper which stands for America, the goal of my friend’s ambitions. The image of the horse, which is obviously associated with the idea of labour, seems to be a symbolic expression for “heavy work”: the work on the skyscraper upon which the horse was hoisted is very heavy, as heavy as the work the horses have to do in the mines. Moreover, in colloquial speech we have expressions like “to work like a horse,” “to be in harness,” etc.

[126] The discovery of these associations gives us some insight into the meaning of the first part of the dream; we have found a path obviously leading to the dreamer’s intimate hopes and expectations. If we assume that the meaning of this part of the dream is “By labour one gets to the top,” the dream-images can be taken as symbolic expressions of this thought.

[127] The first sentences of the dream-narrative read: *I saw horses being hoisted by thick cables to a great height. One of them, a powerful brown horse which was tied up with straps and was hoisted aloft like a package, struck me particularly.* This seems to contradict the analysis so far, that by labour one gets to the top. Of course one can also be hoisted up. Here X recalled that he had always despised tourists who got themselves hoisted up the highest peaks like “sacks of flour.” He himself had never needed anybody’s help. The various horses in the dream are therefore “other people” who have got to the top but not by their own efforts. The expression “like a package” also seems to express contempt. But where is the dreamer himself represented in the dream? According to Freud he must be represented somewhere; indeed, he is usually the chief actor. This is undoubtedly the “powerful brown horse.” The powerful horse resembles him firstly because it can work hard, secondly because the brown colour was described as a “healthy tan” such as mountain-climbers have. So the brown horse may well be the dreamer. It is hoisted up like the others. But the hoisting up of the dreamer himself is not clear; it even contradicts the meaning we have discovered, that by labour one gets to the top.

[128] It therefore seemed to me particularly important to find out whether my conjecture that the brown horse represented the dreamer himself was correct. For this reason I asked him to direct his attention to the passage, *I noticed that the horse was dragging a heavy log along with it.* He immediately recalled that he used to be nicknamed the “log,” on account of his powerful, stocky figure. So my conjecture was correct: the horse even had his name attached to it. The log impeded the horse, or at least should have done so, and X was surprised that it nevertheless advanced so quickly. To “advance” is synonymous with “getting to the top.” Thus despite the burden or encumbrance X forges ahead, so quickly,

indeed, that he has the impression the horse is frightened and could easily cause an accident. On being questioned X stated that the horse, if it fell, could have been crushed by the heavy log, or the force of this moving mass could have “pitched the horse into something.”

[129] This exhausted the associations to this episode. I therefore began the analysis from another point, at the place where the cable broke. I was struck by the expression “street.” X stated that it was the same street in which his business was, where he once hoped to make his fortune. He had hopes of a definite career. Nothing came of it, and even if it had come to anything, his position would have been due less to his own merits than to personal influences. Hence the sentence suddenly becomes clear: *The cable broke and the horse crashed into the street.* It gives symbolical expression to his disappointment. He did not fare like the others who were hoisted to the top without effort. But the others who were preferred to him and got to the top could not start anything useful, for “What could a horse do up there?” They were in a position where they could do nothing. His disappointment over his failure was so great, he said, that for a moment he almost despaired of his future career. In the dream he thought the horse was dead, but soon saw with satisfaction that it got up again and galloped away. So he did not allow himself to be “got down.”

[130] A new section of the dream obviously begins at this point, probably corresponding to a new period of his life, if the interpretation of the preceding part is correct. I therefore asked X to fix his attention on the horse galloping away. He stated that for a moment in the dream he saw another but very indistinct horse appear beside the brown one; it, too, was dragging a log and started galloping off with the roan. But it was very indistinct and disappeared immediately. This fact (together with its late reproduction) indicates that the second horse was under a quite special repressive influence and is therefore very important. X was dragging the log with someone else, and this person must be his wife, with whom he is harnessed “in the yoke of matrimony.” Together they pull the log. In spite of the encumbrance which might easily hinder his progress he was able to gallop, which again expresses the thought that he can’t be got down. X associated the galloping horse with a painting by Welti, *A Moonlight Night*, where galloping horses are shown on the cornice of a building. One of them is a lusty stallion, rearing up. In the same picture there is a married couple lying in bed. The image of the galloping horse, therefore (which at first galloped in a pair), leads to the very suggestive painting by Welti. Here we get a quite unexpected glimpse into the sexual nuance of the dream, where till now we thought we could see only the complex of ambition and careerism. The symbol of the horse, which so far has shown only the side of the hard-working domestic animal, now takes on a sexual significance, clearly confirmed by the horse scene on the cornice. There the horse is the symbol of passionate impulsive desire, which is obviously identical with the sexual drive. As the associations show, the dreamer feared that the horse would fall or that the impetus of the moving log might “pitch it into something.” This *vis a tergo* can easily be interpreted as X’s own impetuous temperament, which he feared might involve him in thoughtless acts.

[131] The dream continues: *Then a rider came up on a little horse and rode along slowly in front of the frightened horse, which moderated its pace somewhat.* His sexual impetuosity is

bridled. X described the rider as resembling his superior in dress and general appearance. This fits in with the first part of the interpretation: his superior moderates the rash pace of the horse, in other words he hinders the dreamer from advancing too rapidly by keeping ahead of him. But we still have to find out whether the sexual thought we have just discovered is developed further. Perhaps it is hiding behind the expression “a little horse,” which seemed to me significant. X stated that the horse was small and dainty like a rocking-horse, and this reminded him of an incident from his youth. While still a boy, he saw a woman far advanced in pregnancy wearing hoops, which were then in fashion. This comical sight seemed to need an explanation, so he asked his mother whether the woman was wearing a little horse under her clothes. (He meant one of those little horses that used to be worn at carnivals or circuses and were buckled to the body.) Since then, whenever he saw women in this condition, it reminded him of his childish hypothesis. His wife, as we have said, was pregnant, and her pregnancy was mentioned as an obstacle to travelling. Here it bridles an impetuosity which we must regard as sexual. This part of the dream is obviously saying: The wife’s pregnancy imposes restraints on her husband. Here we have a very clear thought which is evidently strongly repressed and extraordinarily well hidden in the meshes of a dream that seems to be composed entirely of upward-striving symbols. But evidently the pregnancy is still not a sufficient reason for restraint, for the dreamer feared the horse might nevertheless run over the rider. Then comes the slowly advancing cab which slows down the pace of the horse still more. When I asked X who was in the cab, he recalled that there were children. The children, therefore, were obviously under a repression, with the result that the dreamer only remembered them on being questioned. It was “a whole cartload of children,” as the colloquialism used by my friend puts it. The cartload of children checks his impetuosity.

[132] The meaning of the dream is now perfectly clear and runs, in a word, as follows: the wife’s pregnancy and the problem of too many children impose restraints on the husband. This dream fulfils a wish, since it represents the restraint as already accomplished. Outwardly the dream, like all others, looks meaningless, but even in its top layer it shows clearly enough the hopes and disappointments of an upward-striving career. Inwardly it hides an extremely personal matter which may well have been accompanied by painful feelings.

[133] In analysing and interpreting the dream fabric, I have refrained from pointing out the numerous analogical connections, the similarities of imagery, the allegorical representation of phrases, etc. No one who carefully examines the material can fail to observe these characteristics of mythological thinking. Here I will only emphasize that the ambiguity of the individual dream-images (Freud’s “overdetermination”) is one more sign of the vagueness and indefiniteness of dream-thinking. The images in the dream belong to both the complexes (self-assertion and sexuality) of waking life, although in the waking state the two complexes are sharply divided. Owing to the deficient sensitiveness to differences in dreams, the contents of the two complexes can flow into one another, at least in symbolical form.

[134] This phenomenon may not be understandable at first sight, though we can deduce it without difficulty from our earlier premises.¹³ Our distraction experiments lend support to the conjecture that in the state of reduced attention thought runs to very superficial associations. The state of reduced attention expresses itself in the decreased clarity of ideas. When ideas are unclear, their differences are unclear too: our sensitiveness to their differences then naturally disappears also, for it is only a function of attention or of clarity (the two are synonymous).

[135] Hence there is nothing to prevent the confusion of different (and otherwise separate) ideas (“psychic molecules”). This fact is expressed experimentally in the increase of indirect associations produced by distraction.¹⁴ As we know, the indirect associations (especially under conditions of distraction) are as a rule nothing but verbal displacements via well-worn combinations of phrase or sound.¹⁵ Owing to the distraction the psyche becomes uncertain in the choice of expression, and has to put up with all sorts of mistakes in the speech and auditory systems, just like a person suffering from paraphasia.¹⁶ We can easily imagine the outer distraction in our experiment replaced by a complex which exerts its autonomous effect alongside the activity of the ego-complex. We have already discussed the association phenomena that then result. When the complex is hit, conscious association is disturbed and becomes superficial, owing to the flowing off of attention to the underlying complex (“inhibition of attention”). During the normal activity of the ego-complex the other complexes must be inhibited or the conscious function of directed association would be impossible. From this we see that the complex can only make itself felt indirectly by means of indistinct symptomatic associations and symptomatic actions which all have a more or less symbolical character.¹⁷ (See the examples given above.) The effects of the complex must normally be feeble and indistinct because they lack the full cathexis of attention which is taken up by the ego-complex. Hence the ego-complex and the autonomous complex can be directly compared to the two psychic activities in the distraction experiment; and just as in this experiment most of the attention is given to the work of writing the associations down, and only a fraction of it to the act of association itself, so the main part of the attention is directed to the activity of the ego-complex, while the autonomous complex receives only a fraction (provided it is not abnormally excited). For this reason the autonomous complex can only “think” superficially and unclearly, i.e., symbolically, and the end-results (automatisms, constellations) which filter through into the activity of the ego-complex and into consciousness will be similarly constituted.

[136] Here we must interpolate a brief discussion on symbolism. We use the term “symbolical” in contradistinction to “allegorical.” Allegory, for us, is the intentional interpretation of a thought, reinforced by images, whereas symbols are only indistinct, subsidiary associations to a thought, which obscure it rather than clarify it. As Pelletier says: “The symbol is a very inferior form of thought. One could define the symbol as the false perception of a relation of identity, or of very great analogy, between two objects which in reality are only vaguely analogous.”¹⁸ Thus Pelletier, too, presupposes that for the origin of symbolic associations there must be a lack of sensitivity to differences, or a deficiency in the power of discrimination. We shall now apply these reflections to dreams.

[137] Over the gateway of sleep there stands the imperative: "You wish to sleep, you don't wish to be disturbed by anything."¹⁹ The suggestive force of this acts as an absolute command for the ego-complex and checks all its associations. But the autonomous complexes are no longer under the direct control of the ego-complex, as we have seen to our satisfaction. They allow themselves to be pushed back only so far, but not to be completely lulled to sleep. They are like little secondary psyches having their own affective roots in the body, by means of which they always remain awake. During sleep they are perhaps just as inhibited as during the waking state, because the imperative command to sleep²⁰ inhibits all subsidiary thoughts. Yet from time to time they succeed in presenting their blurred, apparently senseless subsidiary associations to the sleeping ego, just as they do during the noise of the day in the waking state. The thought-complexes themselves are unable to appear, as the inhibition due to sleep-suggestion is directed mainly against them. If they can break through the suggestion and obtain full cathexis of attention, of course sleep immediately ceases. We see this happening very frequently in the hypnosis of hysterics: the patients sleep a short time, then they are suddenly frightened awake by a thought-complex. Insomnia is often due to uncontrollable complexes against which the auto-suggestive power of sleep is no longer effective. If by suitable means we reinforce the energy of such patients, they are able to sleep again, because they can then suppress their complexes. But suppressing the complex means nothing more than the withdrawal of attention, i.e., depriving it of clarity. Thus the thought-complexes are dependent on a small fraction of clarity, for which reason they can manifest themselves only in vague, symbolic expressions and also get contaminated for lack of differentiation. We need not assume an actual censorship of dream thoughts in the Freudian sense; the inhibition exerted by sleep-suggestion is a perfectly sufficient explanation.

[138] Finally, we must mention another characteristic effect of complexes: the tendency to contrasting associations. As Bleuler has demonstrated (see ch. 1), all psychic activity that strives towards a goal must be accompanied by contrasts. This is absolutely necessary for proper co-ordination and control. Experience shows that in every decision these contrasts appear as the nearest associations. Normally they do not hinder reflection; on the contrary they promote it and are useful for our actions. But if for any reason the individual's energy is impaired, he easily becomes the victim of the counterplay of positive and negative, since the feeling-tone of the decision is no longer sufficient to overpower the contrasts and restrain them. We see this particularly often when a strong complex saps the individual's energy. His energy being diminished, his attention for everything not pertaining to the complex becomes superficial, and the association accordingly lacks definite direction. The result, on the one hand, is a superficial type of association, and on the other hand contrasts that can no longer be restrained. There are plenty of instances of this in hysteria, where it is purely a matter of emotional contrasts (see Bleuler), and in dementia praecox, where it is a matter of emotional and verbal contrasts (see Pelletier). Stransky found verbal contrasts in his experiments with forced talking.

[139] It now remains only to make a few general remarks on the nature and course of complexes by way of completing [chapters 2 and 3](#).

[140] *Every affective event becomes a complex.* If it does not encounter a related and already existing complex and is only of momentary significance, it gradually sinks with decreasing feeling-tone into the latent mass of memories, where it remains until a related impression reproduces it again. But if it encounters an already existing complex, it reinforces it and helps it to gain the upper hand for a while. The clearest examples of this can be seen in hysteria, where apparent trifles may lead to tremendous outbursts of affect. In such cases the impression has impinged, either directly or symbolically, on the insufficiently repressed complex and thereby evoked a veritable storm, which considering the insignificance of the event often seems altogether disproportionate. We also find that the strongest feelings and impulses are connected with the strongest complexes. It is therefore not surprising that the majority of complexes are of an erotic-sexual nature, as also are most dreams and most of the hysterias. Especially in women, for whom sexuality is the centre of psychic life, there is hardly a complex that is not related to sex. To this fact may well be due the significance of the sexual trauma for hysteria, assumed by Freud to be universal. At any rate, we must always bear sexuality in mind in psychoanalysis, though this does not mean that every hysteria can be traced back exclusively to sexuality. Any strong complex can call forth hysterical symptoms in those so disposed; at least it seems so. I leave all the other types of complex unmentioned, as I have attempted to sketch out the commonest kinds elsewhere.²¹

[141] It is in the interests of the normal individual to free himself from any obsessive complex that hinders the proper development of his personality (adaptation to his environment). Time generally takes care of this. Often, however, the individual has to resort to artificial aid in order to rid himself of the complex. We have learnt to regard *displacement* as an important help. People will cling to something new, especially if it contrasts strongly with the complex (“masturbation-mysticism”). An hysteric can be cured if one is able to induce a new complex that will obsess her.²² Sokolowski says much the same thing.²³ If the complex is successfully repressed, a marked complex-sensitiveness remains for a long time, i.e., a tendency to recrudescence. If the repression was simply the result of compromise formations, there is a lasting inferiority, an hysteria which allows only limited adaptation to the environment. *But if the complex remains entirely unchanged, which naturally happens only when there is very severe damage to the ego-complex and its functions, then we must speak of dementia praecox.*²⁴ Note that I am speaking here only from the psychological angle and merely stating what one finds in the psyche of the dementia praecox patient. The view I have expressed in no way precludes the possibility that the insuperable persistence of the complex may be due to an inner poisoning, which may originally have been induced by that very affect. This hypothesis seems to me probable because it is consistent with the fact that in most cases of dementia praecox the complex is in the foreground, while in all *primary* poisonings (alcohol, uremic poisons, etc.) complexes play a minor role. Another fact in favour of my hypothesis is that many cases of dementia praecox begin with striking hysteroid symptoms which only “degenerate” in the course of the disease, becoming characteristically stereotyped or senseless. For this reason the older psychiatrists spoke directly of degenerative hysterical psychoses.

[142] We can therefore formulate the above proposition in the following way. Looking at it from the outside, we see only the objective signs of an affect. These signs gradually (or very rapidly) grow stronger and more distorted, so that on a superficial view it finally becomes impossible to assume a normal psychic content. We then speak of dementia praecox. A more perfect chemistry or anatomy of the future will perhaps demonstrate the objective metabolic anomalies or toxic effects associated therewith. Looking at it from the inside (which naturally can be done only by means of complicated analogical inferences), we observe that the subject can no longer free himself psychologically from the complex—that he associates only to this complex and therefore lets all his actions be constellated by it, the inevitable result being a degeneration of the personality. How far the purely psychological influence of the complex reaches we do not yet know, but we may conjecture that toxic effects also play an important part in the progressive degeneration.

4. DEMENTIA PRAECOX AND HYSTERIA

[143] An exhaustive comparison of dementia praecox and hysteria would be possible only if we had a more thorough knowledge of the disturbances of association in both diseases, and particularly of the affective disturbances in normal persons. This at present is far from being the case. What I intend to do here is simply to review the psychological similarities on the basis of the preceding discussion. As the later account of the association experiment in dementia praecox will show, a preliminary comparison of dementia praecox and hysteria is necessary in order to understand the phenomena of catatonic association.

I. *Disturbances of the Emotions*

[144] The recent investigators of dementia praecox (Kraepelin, Stransky, and others) place the emotional disturbances pretty well in the centre of the clinical picture. They speak on the one hand of *emotional deterioration*, and on the other of the *incongruity of ideational content and affect* (Stransky).

[145] I shall disregard the dulling of the senses found in the terminal stages of the disease, since it can hardly be compared to hysteria (they are of course two totally different diseases), and shall confine myself to the apathetic states during the acute stage. The emotional indifference so striking in many cases of dementia praecox bears a certain resemblance to the “*belle indifférence*” of many hysterics, who describe their complaints with smiling serenity and thus make an inadequate impression, or speak with equanimity of things that ought to touch them profoundly. In *Studies in Word Association*¹ I have endeavoured to point out how the patients speak quite unemotionally about things which have the most intimate significance for them. This is especially striking in analysis, when one invariably discovers the reason for the inadequate behaviour. So long as the complex which is under special inhibition does not become conscious, the patients can safely talk

about it, they can even “talk it away” in a deliberately light manner. This “talking it away” can sometimes amount to “feeling it away,” to displacing it by a contrasting mood.

[146] For a long time I had an hysterical patient who, whenever she was plagued by gloomy thoughts, used to work herself up into a mood of boisterous merriment, thus repressing the complex. Whenever she related anything sad that really ought to have moved her deeply, she accompanied it by loud laughter. At other times she spoke with absolute indifference (though its very deliberateness betrayed her) about her complexes, as if they were not of the remotest concern to her. The psychological reason for this incongruity of ideational content and affect seems to be that the complex is autonomous and allows itself to be reproduced only when *it* wishes. Hence we find that the “belle indifférence” never lasts very long but is suddenly interrupted by a wild outburst of affect, a fit of crying, or something of the kind. We see much the same thing in the euphoric apathy of dementia praecox patients; here too an apparently unannounced moodiness may appear from time to time, or a violent act or startling trick which has nothing in common with their former indifference. Professor Bleuler and I frequently noticed at our joint examinations that as soon as analysis succeeded in laying bare the complex the apathetic or euphoric mask was immediately dropped and was replaced by an adequate affect, often quite a stormy one, just as in hysteria when the sore spot is touched. There are, however, cases where the defensive blocking of the complex can in no way be penetrated. The patients then continue to give “snooty,” non-committal answers; they simply refuse to respond to the question asked, and the more direct a bearing the questions have on the complex the less will they answer them.

[147] Occasionally we see that after complex stimuli have intentionally or unintentionally been aroused in apparently apathetic patients, a reaction having a distinct relation to the stimulus appears. The stimulus therefore acted after a certain period of incubation. I have often found with hysterics that in conversation they spoke with apparently affected indifference and superficiality about certain critical points, so that I had to wonder at their pseudo self-control. A few hours later I would be called to the ward because this very patient was having an attack, and it was then discovered that the conversation had subsequently produced an affect. The same thing can be observed in the origin of paranoiac delusions (Bleuler). Janet² observed that his patients remained calm at the moment of an event that ought really to have excited them. Only after a latency period of several hours or even days did the corresponding affect appear. I can confirm this observation of Janet's. Baetz, on the occasion of an earthquake, was able to observe in himself the phenomenon of what he calls “emotional paralysis.”³

[148] *The affective states without adequate ideational content*, which are so common in dementia praecox, likewise have their analogies in hysteria. We need only remember, for instance, the anxiety states in obsessional neurosis. The ideational content is as a rule so inadequate that the patients themselves clearly recognize its logical untenability and regard it as senseless, yet it *seems* to be the source of anxiety. That this is not so has been shown by Freud in a way that so far has not been refuted, and that I can only corroborate. I recall the patient in *Studies in Word Association*⁴ who suffered from the obsession that she had

infected the clergyman and doctor with her obsessional ideas. In spite of proving to herself over and over again that this idea was quite unfounded and senseless, she was nevertheless tormented by the greatest anxiety. The frequent depressions in hysteria are in the great majority of cases traced back by the patients to what can only be classified as “screen causes.” In reality we are dealing with normal reflections and thoughts hidden in the repression. A young hysteric suffered from such a deep depression that at every answer she burst into tears, for no apparent reason. She obstinately traced it back to pains in the arm which she occasionally felt while working. Finally it turned out that she was having a love-affair with a man who did not want to marry her, and this caused her constant worry. So before we say that the patient is depressed for some “inadequate” reason, we must bear in mind the mechanisms existing in every normal person, which always strive to repress anything unpleasant and bury it as deeply as possible.

[149] The *explosive excitements* in dementia praecox may be brought about in the same way as the explosive affects in hysteria. Everyone who has treated hysterical patients knows the sudden outbursts of affect and acute exacerbations of the symptoms. In many cases we are up against a psychological riddle and content ourselves with noting: “The patient is again excited.” But careful analysis will always discover a clear cause: a thoughtless remark, a disturbing letter, the anniversary of some crucial event, etc. Only a trifle is needed, sometimes merely a symbol; this is sufficient to release the complex.⁵ So also in dementia praecox one may, by careful analysis, sometimes find the psychological clue that leads to the cause of the excitement. Naturally we cannot do this in all cases because the disease is much too obscure; but we have absolutely no reason to suppose that no sufficient connection exists.

[150] That the affects in dementia praecox are probably not extinguished but are merely displaced and blocked in some peculiar way can be seen on those rare occasions when we are granted complete catamnestic insight into the disease.⁶ Outwardly senseless affects and moods can be explained subjectively as hallucinations and pathological ideas which, because they belong to the complex, can be reproduced only with difficulty or not at all when the disease is at its height. If a catatonic is constantly preoccupied with the hallucinatory scenes that crowd into his consciousness with elemental force and a much stronger feeling-tone than external reality, we can readily understand why he is incapable of reacting adequately to the doctor’s questions. Or if the patient, like Schreber, for instance, perceives all the people around him as “fleeting-improvised men,”⁷ it is obvious that he cannot react adequately to the stimuli of reality, although he reacts adequately in his own way.

[151] A typical feature of dementia praecox is *lack of self-control* or the *unruliness of affects*. We find this wherever emotivity is pathologically intensified, above all in hysteria and epilepsy. The symptom merely shows that the ego-synthesis is seriously disturbed, i.e., that there are very powerful autonomous complexes which no longer fit into the hierarchy of the ego-complex.

[152] The characteristic lack of *emotional rapport* in dementia praecox is sometimes found in hysteria, when we are unable to capture the interest of the patient and penetrate the complex. In hysteria this condition is only temporary, because the intensity of the complex varies. In dementia praecox, where the complex is very stable, we can get emotional rapport only for short moments when we penetrate the complex. In hysteria we gain something by this penetration, but in dementia praecox we gain nothing, for immediately afterwards the personality confronts us just as coldly and strangely as before. Under certain conditions analysis may even cause a flaring up of the symptoms, but in hysteria there is usually some improvement afterwards. Anyone who has penetrated the mind of an hysteric by analysis knows that he has gained moral power over the patient. (Incidentally, this is also true of ordinary confessions.) In dementia praecox, on the other hand, everything remains as before even after very thorough analysis. The patients cannot feel their way into the mind of the doctor, they stick to their delusional assertions, they attribute hostile motives to the analyst, they are and remain, in a word, uninfluenceable.

II. *Abnormalities of Character*

[153] Character disturbances claim an important place in the symptomatology of dementia praecox, although we cannot really speak of a “dementia-praecox character.” One could just as well speak of an “hysterical character,” smuggling into it all kinds of prejudices, such as moral inferiorities and the like. Hysteria does not create any special character, it merely exaggerates the already existing traits. Thus all temperaments can be found among hysterics: there are egoistic and altruistic personalities, criminals and saints, sexually excited and sexually frigid natures, and so on. The only thing characteristic of hysteria is the existence of a powerful complex incompatible with the ego-complex.

[154] Among the characterological disturbances in dementia praecox we might mention *affectation* (mannerisms, eccentricity, mania for originality, etc.). We frequently meet this symptom in hysteria, especially when the patients find themselves out of their social element. A very common form of this affectation is the pretentious and artificial behaviour of women of a lower social position—dressmakers, nurses, maids, etc.—who mix with those socially above them, and also of men who are dissatisfied with their social status and try to give themselves at least the appearance of a better education or of a more imposing position. These complexes are frequently associated with aristocratic airs, literary and philosophic enthusiasms, extravagant, “original” views and utterances. They show themselves in exaggerated mannerisms, especially in a choice of language that abounds in bombastic expressions, technical terms, affected turns of speech and high-sounding phrases. We find these peculiarities chiefly in those cases of dementia praecox who have the “delirium of social elevation” (Krafft-Ebing) in some form or other.

[155] The affectation, in itself, contains nothing specific of dementia praecox; the disease takes over the mechanism from the normal, or rather from the caricature of the normal, hysteria. Such patients have a special predilection for *neologisms*, which they use mostly as learned or otherwise distinguished-sounding technical terms. One of my women patients

called them “power-words” and showed a special liking for the most abstruse expressions, which obviously seemed to her fraught with meaning. The “power-words” serve among other things to emphasize the personality and to make it as imposing as possible. The emphasis laid on “power-words” accentuates the value of the personality in the face of doubt and hostility, and for this reason they are frequently used as defensive and exorcistic formulae. A dementia-praecox patient under my care, if the doctors refused him anything, used to threaten them with the words: “I, the Grand Duke Mephisto, shall have you treated with blood vengeance for orang-outang representation.” Others, like Schreber, use the power-words to exorcise their voices.⁸

[156] The affectation also expresses itself in gesture and handwriting, the latter being adorned with all kinds of peculiar flourishes. Normal analogies can be found in young girls who, out of caprice, affect an especially striking or original script. Dementia-praecox patients frequently have a characteristic handwriting: it expresses the contradictory tendencies in their psyche, the script being now sloping and cursive, now upright, now large, now small. The same thing can be seen in temperamental hysterics, and it is often easy to show that the change in writing begins at the place where the complex is touched. Even with normal people one can often see disturbances at such places.

[157] Affectation is naturally not the only source of neologisms. A large number of them come from dreams, and especially from hallucinations. They are, not uncommonly, verbal condensations and clang associations that can be analysed, and whose origin can be explained according to the principles outlined in the preceding chapters. (There are excellent examples of this in Schreber.) The origin of the “word salad” can be also understood in terms of Janet’s *abaissement du niveau mental*. Many schizophrenics who are inclined to be negativistic and will not react to the questions show “etymological” leanings: instead of answering, they dissect the question and embellish it with clang associations, which amounts to a displacement and concealment of the complex. They do not want to answer the question and therefore divert attention to its phonetic aspects. (This is analogous to not answering the stimulus-word.⁹) There are many other indications that the clang elements of language impress dementia-praecox patients more than others; they are very fond of dissecting and interpreting words.¹⁰ In general the unconscious shows a similar liking for new word formations. (Cf. the “heavenly languages” of the classic somnambulists, especially the interesting productions of Hélène Smith.¹¹)

[158] *Lack of consideration, narrow-mindedness, and inaccessibility to persuasion* are found in normal and pathological subjects, particularly where affective causes are involved. It needs, for instance, only a firm religious or some other conviction to make a man under certain circumstances narrow-minded, ruthless, and cruel. For this there is no need to assume an emotional deterioration. Owing to their excessive sensitiveness, hysterics become selfish, inconsiderate, a torment to themselves and others. Here again there need be no deterioration; they are merely blinded by affect. Nevertheless I must once again repeat the oft-mentioned proviso that between hysteria and dementia praecox there is only a

similarity of psychological mechanism and not an *identity*. In dementia praecox these mechanisms go much deeper, perhaps because they are complicated by toxic effects.

[159] The *stupid behaviour* of hebephrenics has analogies with the moria states¹² of hysterics. For a long time I had under my observation an hysterical woman of high intelligence who frequently suffered from states of excitement during which she showed a peculiarly childish and silly behaviour. This regularly happened when she had to repress sad thoughts associated with her complex. Janet, too, was acquainted with this behaviour, which naturally is found in all gradations: "These persons play a sort of comedy, they pretend to be young, naïve, coaxing, they feign complete ignorance and finally get to be like little children."¹³

III. *Intellectual Disturbances*

[160] Consciousness in dementia praecox shows anomalies which have often been compared with those of hysteria or hypnosis. In many cases there are signs of a narrowing of consciousness, i.e., restriction of clarity to one idea, with abnormal increase in the indistinctness of all subsidiary associations. This, in the opinion of several authors, would explain the blind acceptance of an idea without inhibition or correction, a phenomenon analogous to suggestion. Others seek to explain the peculiar suggestibility of catatonics (echo symptoms) on this basis, too. To this one can only object that there is a considerable difference between normal and catatonic suggestibility. In normal suggestibility we note that the subject will keep as close as possible to the suggestion if he attempts to realize it. In hysteria, according to the degree and nature of the illness, there are all sorts of peculiar embellishments; for instance, the suggestion to sleep may easily change into hysterohypnosis or into an hysterical twilight state, or the suggestions are only partially executed, with the addition of subsidiary actions that were not intended.¹⁴ For this reason hypnosis is often more difficult to control in severe hysterics than in normal persons. In catatonia the chance factor in the phenomena of suggestion is still greater. Often suggestibility is limited entirely to the motor sphere, resulting only in echopraxia and often only in echolalia. Verbal suggestion can seldom be carried out in dementia praecox and even if successful the effects are uncontrollable and seemingly fortuitous. There are always a number of extraneous elements mixed in with the normal suggestibility. Nevertheless, there is no reason why catatonic suggestibility, at least in its normal vestiges, should not be reduced to the same mechanisms as in hysteria. We know that in hysteria the uncontrollable element in the suggested effect is to be sought in the autonomous complex. There is no reason to assume that this is not the case also in dementia praecox. Similarly capricious behaviour is found in dementia praecox with regard to other therapeutic measures, such as transfer to another institution, discharge,¹⁵ education by example, and so forth. How very much the improvement in old catatonics when transferred to other surroundings depends on psychological factors has been shown by Riklin in his extremely valuable analyses.¹⁶

[161] *Lucidity of consciousness* in dementia praecox is subject to every form of clouding; it may change from perfect clarity to deepest confusion. Since Janet the fluctuations of

lucidity in hysteria have become almost proverbial. Here we are able to distinguish two kinds of disturbance: momentary and persistent. The momentary disturbance may be a mild “engourdissement” of a few seconds’ duration, or an hallucinatory, ecstatic irruption, also of very short duration. In dementia praecox we are familiar with the abrupt blockings, momentary “thought-deprivation,” and the lightning-like, hallucinatory irruption of bizarre impulses. The persistent disturbances of *consciousness* in hysteria appear in the form of somnambulous states with numerous hallucinations, or in the “lethargic” (Löwenfeld) or cataleptic states. In dementia praecox they are seen in the persistent hallucinatory phases with more or less marked confusion, and in stuporous states.

[162] *Attention* is almost regularly disturbed, but these disturbances also play a large role in hysteria. Janet says of “les troubles de l’attention”: “One can say that the principal disturbance consists not in a suppression of the intellectual faculties but in the difficulty of fixing the attention. Their [the patients’] minds are always distracted by some vague preoccupation, and they never give themselves entirely to the object which one assigns to them.” As shown in the first chapter, Janet’s words can also be applied to dementia praecox. What disturbs the patients’ concentration is the autonomous complex, which paralyses all other psychic activities. Curiously enough, this fact escaped Janet. The striking thing in hysteria, as in all affective states, is that the patients always come back to their “story” (as in traumatic hysteria) and that all their thoughts and actions are constellated only by the complex. A similar limitation, greatly intensified, can often be observed in dementia praecox, especially in its paranoid forms. It is hardly necessary to give examples.

[163] *Orientation* varies in the same capricious way in both diseases. In dementia praecox, when we are not actually dealing with marked excitement accompanied by deep confusion, we often get the impression that the patients are disturbed merely by illusions but that at bottom they are correctly oriented. We do not always have this impression in hysteria, though we can see for ourselves that correct orientation does exist by hypnotizing the patient. Hypnosis represses the hysterical complex and leads to reproduction of the ego-complex. As in hysteria the disorientation is due to a pathogenic complex momentarily pushing aside the ego-complex, so in dementia praecox it may easily happen that quite clear answers are followed the next moment by the most extraordinary utterances.¹⁷ Lucidity of consciousness is especially often impaired in the acute stage of the disease, when the patients are in a real dream, i.e., in a “complex-delirium.”¹⁸

[164] The *hallucinatory delirious phases* can, as we have said, be paralleled by those in hysteria, though it should always be borne in mind that we are dealing with two different diseases. The content of hysterical delirium, as can easily be seen if we employ Freud’s method of analysis, is always a clear complex-delirium; that is to say the pathogenic complex appears autonomously and works itself out in some way, usually in the form of a wish-fulfilment.¹⁹

[165] We do not have to look far in order to find something similar in the acute phases of dementia praecox. Every psychiatrist is familiar with the deliria of unmarried women, who act out betrothals, marriages, coitus, pregnancies, and births. I mention this only in passing

and shall come back to these questions later, as they are of great importance in determining the symptoms.²⁰

[166] This brings us to the *delusions and hallucinations*. Both symptoms occur in all mental diseases and also in hysteria. We must therefore be dealing with mechanisms which in general are preformed and are set in motion by various toxic agents. What chiefly interests us here is the content of the delusions and hallucinations, amongst which we include pathological ideas. Once more hysteria, the most transparent of the mental diseases, can help us a little. The delusions may be paralleled, in a sense, by the obsessional ideas, and also by the narrow-minded prejudices based on affect, which are so often met with in hysteria, and finally by the stubbornly asserted bodily pains and ailments. I cannot recapitulate the genesis of delusional assertions and must presuppose a knowledge of Freud's writings. The delusional assertions of the hysteric are displacements; that is to say, the accompanying affect does not really belong to them but to a repressed complex which is disguised by this manoeuvre. An insuperable obsession merely shows that some complex (usually a sexual one) is repressed, and the same is true of all the other obstinately asserted hysterical symptoms. We now have good grounds for supposing—I base this on dozens of analyses—that a fundamentally similar process is at work in the delusions of dementia praecox.²¹

[167] I will illustrate this by a simple example.^{21a} A 32-year-old servant had her teeth extracted in order to have a complete new set. During the night following the operation she got into a violent state of anxiety. She considered herself damned and lost forever because she had committed a great sin: she should never have allowed her teeth to be extracted. People must pray for her that God might forgive her this sin. The next day she was quiet and continued her work, but in the following nights the anxiety states grew worse. I examined the patient for her antecedents, and also her employers, in whose service she had been for a number of years. Nothing, however, was known, or rather the patient denied any kind of emotivity in her former life, emphasizing with great affect that the extraction of her teeth was the sole cause of her illness. The illness rapidly grew worse, and she had to be interned, with all the symptoms of catatonic excitement. It was then discovered that for many years she had been concealing an illegitimate child, of whose existence even her family had not the slightest knowledge. For a year past she had been acquainted with a man she wanted to marry, but she could never fully make up her mind because she was continually tormented by the fear that her lover would reject her if he knew of her former life. Here, then, was the source of her anxiety, and at the same time it shows why the affect connected with the extraction of teeth was bound to be inappropriate.

[168] The mechanism of displacement paves the way for an understanding of the origin of delusional assertions. The way is strewn with obstacles because the notorious strangeness of the delusions in dementia praecox hardly permits of any analogies. Nevertheless, normal and hysterical psychology both give us a number of clues that allow us to get a little nearer at least to the commonest forms of delusion.

[169] *Delusions of reference* have been thoroughly analysed and explained by Bleuler.²² Feelings of reference are found wherever there is a strongly accentuated complex. It is a peculiarity of all strong complexes to assimilate everything they possibly can; thus, it is a well-known fact that when we are in the grip of a powerful affect we often have the feeling that “people will notice.” An acute affect will cause quite unimportant happenings to be assimilated from the environment, thus producing the grossest falsifications of judgment. When we meet with some mishap we at once jump to the conclusion, during the first moment of anger, that someone has injured or insulted us *deliberately*. In hysteria, depending on the magnitude and duration of the affect, prejudices of this kind can establish themselves for a long time, easily producing mild delusions of reference. From this it is but a step to the delusional assumption of strange “machinations.” This road leads straight to paranoia.²³ It is often difficult, however, to reduce the incredible and grotesque delusions of dementia praecox to delusions of reference. When, for example, a dementia-praecox patient feels that everything happening inside him and outside him is unnatural and “faked,” it is probable that we are dealing with a more elemental disturbance than a delusion of reference.²⁴ Obviously there is something in his apperception that prevents normal assimilation. There is either a shade too little or a shade too much, and this gives his apperception a peculiar accent.

[170] There are analogies to this in hysteria: disturbances in the *feelings of activity*. Every psychic activity is accompanied, apart from the pleasure/pain feeling-tone, by still another feelingtone which qualifies it in a special way (Höfding). What is meant by this can best be explained by Janet’s important observations on psychasthenics. Here voluntary decisions and actions are not accompanied by the feelings that ought normally to accompany them but by “sentiments d’incomplétude,” for instance. “The subject feels that the action is not completely finished, that something is lacking.” Or else every voluntary decision brings with it a “sentiment d’incapacité”: “These persons experience in advance painful feelings in the very thought that it is necessary for them to act; they fear action above all things. Their dream, as they all say, is of a life where there will be nothing more to do.”²⁵ One abnormality in the feeling of activity which is extremely important for the psychology of dementia praecox is the “sentiment d’automatisme.”²⁶ About this one patient says: “I am unable to give an account of what I really do, everything is mechanical in me and is done unconsciously. I am nothing but a machine.”²⁷ Closely related to this is the “sentiment de domination.”²⁸ A patient describes this feeling as follows: “For four months I have had queer ideas. It seems to me that I am forced to think them and say them; someone forces me to speak and suggests coarse words, it is not my fault if my mouth acts in spite of me.”

[171] A dementia-praecox patient might talk like this. The question whether it might not be a case of dementia praecox is therefore permissible. When reading Janet’s work I took careful note whether there might not be cases of dementia praecox among his clinical material, as might easily happen with a French author. But I found nothing suspicious and have no reason to assume that the patient was suffering from dementia praecox. Moreover we frequently hear such remarks from hysterical patients, especially from somnambulists, and we find something similar in normal people who are dominated by an unusually strong

complex, for instance in poets and artists. (Cf. what Nietzsche says about the origin of *Zarathustra*.²⁹) A good example of disturbance in the feelings of activity is the “sentiment de perception incomplète.”³⁰ A patient says: “It is as though I saw things through a veil, a mist, or through a wall which separates me from reality.” A normal person who is under the direct influence of a powerful affect might express himself in a similar manner. Schizophrenics also talk like this when they speak of their uncertain perception of their surroundings (“It seems to me as though you were the doctor,” “They say it is my mother,” “It looks like Burghölzli but it is not”).³¹ When a patient of Janet’s says: “The world seems to me like a gigantic hallucination,” this is in the fullest sense true of schizophrenics, who continually live in a dream (especially in the acute phases) and act accordingly both during the disease and in the catamnesis.

[172] The “sentiments d’incomplétude” apply particularly to affects. A patient of Janet’s says: “It seems to me that I shall not see my children again; everything leaves me indifferent and cold, I wish I could despair, cry out with pain. I know that I ought to be unhappy but I cannot be so, I have neither pleasure nor pain. I know that a meal is good but I swallow it because it is necessary, without finding in it the pleasure I would have found before. ... There is an enormous thickness that prevents me from feeling any moral impressions.” Another patient said: “I would like to try to think of my little girl but I cannot, the thought of my child barely passes through my mind, it passes and leaves me without any feeling.”

[173] I have repeatedly heard spontaneous statements of this kind from hysterical patients as well as from schizophrenics who were still able to give information. A young woman who fell ill with catatonia and had to part from her husband and child in particularly tragic circumstances displayed a *total* lack of affect for all reminiscences of her family. I put the whole sad situation before her and tried to evoke an adequate feeling. While I was describing it she laughed, and when I had finished she became calm for a moment and said, “I simply can’t feel any more.”

[174] In our view the “sentiments d’incomplétude” are products of inhibition deriving from an overwhelmingly powerful complex. When we are dominated by a complex only the ideas associated with it have full feeling-tone, i.e., full clarity; all other perceptions within or without are subject to the inhibition, so that they become unclear and lose their feeling-tone. That is the underlying cause of the incompleteness of the activity feelings and also of the lack of affect. These disturbances account for the feeling of strangeness. In hysteria the reasoning faculty is preserved and this prevents the feeling from immediately being projected outside as in dementia praecox. But if we assist the projection by allowing certain superstitious ideas to come into play, we immediately get an explanation in terms of some power coming from outside. The clearest examples of this are spiritualistic mediums, who trace back a mass of trivialities to transcendental causes—though, we must admit, they never do it as clumsily and grotesquely as schizophrenics. Only in normal dreams do we observe anything similar, where the projection takes place in an absolutely natural and naive way. The psychological mechanisms of dreams and hysteria are closely related to those of dementia praecox. A comparison with dreams, therefore, is not too daring. In dreams we see

how reality is spun round with fantasy creations, how the pale memories of the waking state assume tangible form, and how the impressions of the environment are transmogrified to suit the dream. The dreamer finds himself in a new and different world which he has projected out of himself. Let the dreamer walk about and act like a person awake, and we have the clinical picture of dementia praecox.

[175] I cannot discuss all the forms of delusion here, but should like to say a few words about the well-known delusion that the patient's thoughts are being influenced. The influencing of thought can take many forms, the commonest being "thought deprivation." Schizophrenics often complain that their thoughts are taken away from them³² when they wish to think or say something.³³ By means of projection they frequently make some unknown power or agency responsible. Outwardly, thought-deprivation shows itself in the form of blockings: the investigator suddenly gets no more answers to his questions.³⁴ The patient may then say that he cannot answer because his thoughts have been "taken away" from him. The association experiment has taught us that prolonged reaction-times and failures to react ("faults") generally occur when a complex has been touched: the strong feeling-tone inhibits association. This phenomenon is found in more intensified form in hysteria, when at critical points the patient "simply cannot think of anything." This is already "thought deprivation." The mechanism in dementia praecox is the same; here too the thought is inhibited at points where the complex is touched (in the experiment or in conversation). One can easily observe this when, in suitable cases, one talks first about matters indifferent to the patient and then about the complex. With the indifferent material the answers follow smoothly, while with the complex one blocking succeeds another; the patients either answer nothing at all or else give the most evasive answers it is possible to imagine. Thus, with female patients who are unhappily married, it is impossible to obtain any precise statements about their husbands, whereas about anything else they volunteer the most detailed information.

[176] Another phenomenon to be considered is compulsive thinking. Weird or absolutely senseless thoughts force themselves on the patient, which he is compelled to ponder and to go on thinking. We have an analogy to this in psychogenic obsessional thinking: as a rule the patients fully realize the absurdity of the thoughts but are quite unable to repress them.³⁵ The influencing of thought also appears in the form of "inspirations." That this is a phenomenon not restricted to dementia praecox is shown by the very word "inspiration": it designates a psychic event that takes place wherever there is an autonomous complex. It is a sudden irruption of the complex into consciousness. "Inspirations" are not at all unusual in religious people; modern Protestant theologians have even devised the name "inner experience" for them. Inspiration is an everyday occurrence in somnambulism.

[177] Finally, there is a special form of blocking which one of my women patients called "*Bannung*"— "captivation" or "fascination."³⁶ Sommer terms it "visual fixation." We also find "interdiction" in association experiments even outside dementia praecox, especially in states of emotional stupidity. This state may sometimes be induced by the experiment itself or by a complex stimulated during the experiment. The patients then cease to react (at least

for a time) to the stimulus word; they simply name objects in the environment. I have noticed this especially in imbeciles, but also in normal people under the influence of a strong affect, in hysterics when the complex is touched, as well as in dementia praecox.

[178] “Fascination” is a drawing away of attention from the stimulus-word to the environment for the purpose of covering up the vacuum of associations, or the complex producing it. It is the same in principle as breaking off an unpleasant conversation by suddenly starting to speak of something quite commonplace and beside the point. Any object in the environment will serve as a point of departure. We have, therefore, sufficient justification for putting “fascination” on a level with normal mechanisms.

[179] All these disturbances appear in dementia praecox grouped round the complex and belong to the defence mechanisms. At this point we must also discuss *negativism*. The prototype of negativism is *blocking*, which in certain cases may easily give the impression of a deliberate refusal, just like the “I don’t know” of hysterics. Hence one can just as well speak of “negativism” when the patients refuse to answer questions. Passive negativism readily passes over into active negativism: the patients then show psychic resistance to exploration. If we disregard the cases where negativism has intensified into a general mood of defence, we find, in patients who are still accessible, negativism as well as blocking where the complex is located. As soon as the association experiment or the exploration probes the complex, the sore spot, the patient refuses to answer and draws back, just as the hysteric employs all sorts of subterfuges to conceal the complex. What is particularly striking in negativism is the strong tendency of catatonic symptoms to become generalized. Whereas in hysteria, despite a very evident and aggravating negativism, certain lines of approach to the emotions still remain open, the negativistic catatonic shuts himself up completely, so that for the moment at least there is no means of penetration. Occasionally a single critical question can induce negativism. A special form of negativism is the “irrelevant answer,” which we know in similar form in the Ganser syndrome. In both cases there is a more or less unconscious refusal to respond to the question, hence something very like what we find in “fascination” and in “thought deprivation.” There are good reasons for this in the Ganser syndrome, as the studies of Riklin and myself may have made clear: the patients want to repress their complex. It is probably the same in dementia praecox. In the psychoanalysis of hysteria we regularly find irrelevant answers or “talking round” the complex, and we find the same thing in dementia praecox, only here the symptom (and all other catatonic symptoms) shows a strong tendency to generalization. The catatonic symptoms in the motor sphere can easily be thought of as the spreading effects of this generalization. This probably applies to the majority of cases. It is true that catatonic symptoms also occur in focal and general disturbances of the brain, where we cannot very well imagine a psychological nexus. But here again we find, at least as frequently, hysterical symptoms whose psychic causation is an established fact. What we should learn from this is never to forget the possibility of contrary explanations.

[180] *Hallucination* is simply the outward projection of psychic elements. Clinically we know all gradations, from inspirations and pathological ideas to loud auditory hallucinations and

vivid visions. Hallucinations are ubiquitous. Dementia praecox merely sets in motion a preformed mechanism which normally functions in dreams. The hallucinations of hysteria, like those of dreams, contain symbolically distorted fragments of the complex. This is also true of the majority of hallucinations in dementia praecox,³⁷ though here the symbolism is carried much further and is more dreamlike in its distortion. Distortions of speech, along the lines of dream paraphasias (cf. Freud, Stransky, Kraepelin), are extraordinarily common; mostly they are contaminations. A patient who was presented in the clinic, noticing a Japanese in the front row of students, heard his voices call out to him “Japan-sinner” [*Japansünder*]. It is remarkable that not a few patients who delight in neologisms and bizarre delusional ideas, and who are therefore under the complete domination of the complex, are often corrected by their voices. One of my patients, for example, was twitted by the voices about her delusions of grandeur, or the voices commanded her to tell the doctor who was examining her delusions “not to bother himself with these things.” Another patient, who has been in the clinic for a number of years and always spoke in a disdainful way about his family, was told by the voices that he was “homesick.” From these and numerous other examples I have gained the impression that the correcting voices may perhaps be irruptions of the repressed normal remnant of the ego-complex. That the normal ego-complex does not perish entirely, but is simply pushed aside by the pathological complex, seems borne out by the fact that schizophrenics often suddenly begin to react in a fairly normal manner during severe physical illnesses or any other far-reaching changes.³⁸

[181] *Disturbances of sleep* are quite usual in dementia praecox and manifest themselves in a variety of ways. Dreams are often extraordinarily vivid, so that we can well understand why the patients are incapable of correcting them. Many patients derive their delusional ideas almost exclusively from their dreams, to which they attribute real validity.³⁹ The role that vivid dreams play in hysteria is well known. Apart from dreams, sleep can be disturbed by various other irruptions of complexes, such as hallucinations, autochthonous ideas, etc., just as hypnosis may be in certain hysterics. Schizophrenics often complain about an unnatural sleep, which is not real sleep at all but merely an artificial rigidity. We hear similar complaints wherever there is a strong complex that cannot be entirely extinguished by the sleep inhibition and accompanies sleep as a constant undertone (e.g., melancholia, depressive affects in hysteria). Not infrequently, intelligent hysterics feel the “restlessness of the complex” in their sleep and can describe it precisely. Thus, a patient of Janet’s said: “There are always two or three of my personalities who do not sleep, although during sleep I have fewer personalities; there are some who sleep but little. These personalities have dreams, but the dreams are not the same: I feel that there are some who dream of different things.” This, in my view, aptly expresses the feeling of the unremitting activity of autonomous complexes, which will not submit to the sleep inhibition exercised by the ego-complex.

IV. Stereotypy

[182] By stereotypy in its widest sense we mean the persistent and constant reproduction of a certain activity (verbigeration, catalepsy, stock phrases, perseveration, etc.). These phenomena are among the most characteristic symptoms of dementia praecox. At the same time, stereotypy in the form of automatization is one of the commonest phenomena in the development of the normal psyche (Spencer). All our faculties and the whole progress of our personality depend on automatizations. The process that leads to this result is as follows: In order to perform a certain activity we direct all our attention to the ideas relating to it, and through this strong feeling-tone we engrave the various phases of the process on our memory. The result of frequent repetition is that an ever smoother "path" is formed, along which the activity comes to move almost without our help, i.e., "automatically." Only a slight impulse is needed to set the mechanism going. The same thing may also take place passively when there is a strong affect. We can be compelled by an affect to perform certain actions, with great inhibitions at first, but later, with constant repetition of the affect, the inhibitions become less and less, and finally the reaction follows promptly even on a very slight impulse. This can be observed particularly well in the bad habits of children.

[183] The strong feeling-tone, then, creates a path, which amounts to saying what we have already said about complexes. Every complex has a tendency to autonomy—to act itself out independently; it has a greater tendency to persistence and reproduction than ordinary, indifferent thought and so has a better chance of becoming automatic. Hence, when something becomes automatic in the psyche an antecedent feeling-tone must be postulated.⁴⁰ The clearest example of this is hysteria, where all the stereotypies, such as attacks of cramp, trance-states, complaints, and symptoms, can be traced. As we have already remarked, the collective term "feeling-tone" includes "attention-tone." complaints, and symptoms, can be traced back to the underlying affects. In the normal association experiment we usually find perseveration where the complex is located.⁴¹

[184] If there is a very strong complex, all progress adapted to the environment ceases and the associations revolve entirely round the complex. By and large this is what happens in hysteria, where we find very strong complexes. The progress of the personality is retarded, and a large part of the psychic activity is expended in varying the complex in all possible ways (symptomatic actions). Not for nothing does Janet call attention to the general disturbances in "obsessed" persons, of which I mention the following: indolence, irresolution, retardation, fatigue, lack of achievement, aboulia, inhibition.⁴² If a complex succeeds in becoming fixed, monotony results, especially monotony of the outward symptoms. Who does not know the stereotyped, exhausting complaints of hysterics and the stubborn, invincible nature of their symptoms? Just as a constant pain will always call forth the same monotonous cries of distress, so a fixed complaint will gradually stereotype the individual's whole mode of expression, so that in the end we know that day after day we shall receive with mathematical accuracy the same answer to the same question.

[185] In these automatic processes are to be found the normal prototypes of stereotypy in dementia praecox. If we examine the beginnings of linguistic or mimic stereotypies we can often find the emotional content that belongs to them.⁴³ Later the content grows more and more indistinct, just as in normal and hysterical automatisms. Only, the corresponding process in dementia praecox seems to run a more rapid and thorough course, so that it soon loses all content and affectivity.

[186] Experience shows, without any doubt, that in dementia praecox not only the content of the complex becomes stereotyped but also material that is obviously quite fortuitous. Thus, verbigerating patients will seize on a stray word and repeat it constantly. Heilbronner, Stransky, and others may be right in interpreting such phenomena as symptoms of the associative "vacuum." The motility stereotypies can be interpreted in the same way. We know that schizophrenics suffer very frequently from associative blockings ("thought-deprivation"). This vanishing of thought usually occurs in the vicinity of the complex. Now if the complex plays the enormous role attributed to it, it is only to be expected that it will very often absorb a great many thoughts and thereby disturb the "fonction du réel"; it creates an associative vacuum in spheres not pertaining to it and thus produces all those perseveration phenomena which the vacuum accounts for.

[187] It is a peculiarity of most ontogenetically acquired automatisms that they are subject to gradual changes. The case histories of patients with tics⁴⁴ offer proof of this. Catatonic automatisms are no exception; they, too, change slowly, and the transformation often takes years. I will show what I mean by the following examples.

[188] A catatonic used to sing verbigeratively, for hours on end, a religious song with the refrain "Hallelujah." Then she started verbigerating "Hallelujah" for hours, which gradually degenerated into "Hallo," "Oha," and finally she verbigerated "Ha-ha-ha" accompanied by convulsive laughter.

[189] In the year 1900 a patient used to comb his hair a few hours every day in a stereotyped manner, in order to remove the "plaster that had been rubbed into it during the night." In the following years the comb got further and further away from his head; in 1903 he beat and scratched his chest with it, and now he has reached the inguinal region.

[190] The voices⁴⁵ and delusional ideas "degenerate" in a very similar way. The "word salad" arises in the same manner. Sentences that were originally simple become more and more complicated with neologisms, are verbigerated loudly or softly, and gradually become more and more muddled, until finally they turn into an incomprehensible jumble that probably sounds like the "stupid chattering" about which so many schizophrenics complain.

[191] A patient under my observation, recuperating from an acute attack of dementia praecox, began telling herself quietly how she would pack her bags, go from the ward to the asylum gate, then out into the street and to the station, how she gets into the train and reaches her home, where the wedding is solemnized, and so on. This story grew more and more stereotyped, the separate stages got mixed up, sentences were left incomplete, some of them abbreviated into a single catchword; and now, after a year, she uses a catchword only

occasionally, all the other words have been replaced by “hm-hm-hm” which she utters in a stereotyped manner in the same tone and rhythm as before when she told her story. In moments of excitement the former sentences reappear. We know from hallucinating patients that the voices in time grow quieter and emptier, but as soon as the excitement returns they regain their content and clarity.

[192] These gradual, stealthy changes can be seen very clearly in obsessions.⁴⁶ Janet, too, speaks of the gradual transformation of obsessional processes.⁴⁷

[193] There are, however, stereotypies, or rather stereotyped automatisms, which from the very beginning do not show any psychic content, or at any rate no content that would render them comprehensible even symbolically. I am thinking here of those almost entirely “muscular” manifestations of automatism, such as catalepsy, or certain forms of negativistic muscular resistances. As many investigators have pointed out, we find these markedly catatonic symptoms in organic disturbances, such as paralysis, brain tumours, etc. Brain physiology and especially the well-known experiments of Goltz have shown that in vertebrates the removal of the cerebrum produces a condition of extreme automatism. Forel’s experiments on ants (destruction of the *corpora quadrigemina*) show that automatisms appear when the largest (and most highly differentiated?) portion of the brain tissue is removed. The debrained creature becomes a “reflex-machine,” it remains sitting or lying in some favourite position until roused to reflex action by external stimuli. It is no doubt rather a bold analogy to compare certain cases of catatonia to “reflex machines,” although the analogy fairly leaps to the eye. But when we penetrate a bit deeper and consider that in this disease a complex has encroached upon almost every area of association and holds it in its grip, that this complex is absolutely inaccessible to psychological stimuli and is isolated from all external influences, the analogy seems to have a rather greater significance. Because of its intensity the complex arrogates to itself the activity of the cerebrum on the widest scale, so that at least a very large number of impulses to other areas disappear. It can then easily be imagined that the complex creates a condition in the brain functionally equivalent to an extensive destruction of the cerebrum. Though this hypothesis cannot be proved, it might nevertheless explain many things that are beyond the reach of psychological analysis.

Summary

[194] Hysteria contains as its innermost core a complex that can never be overcome completely; the psyche is brought to a standstill because it is no longer able to rid itself of this complex. Most of the associations tend in the direction of the complex, and psychic activity consists for the most part merely in elaborating the complex in every possible way. In consequence, the individual (in chronic cases) is bound to become more and more unadapted to the environment. The wish-dreams and wish-deliria of the hysteric are concerned exclusively with the fulfilment of the complex’s wishes. Many hysterics succeed, after a time, in regaining their equilibrium by partially overcoming the complex and avoiding new traumata.

[195] In dementia praecox, too, we find one or more complexes which have become permanently fixed and could not, therefore, be overcome. But whereas in persons predisposed to hysteria there is an unmistakable causal connection between the complex and the illness, in dementia praecox it is not at all clear whether the complex caused or precipitated the illness in persons so predisposed, or whether at the moment of the outbreak of the disease a definite complex was present which then determined the symptoms. The more thoroughly we analyse the symptoms, the more we find that there was, at the onset of the disease, a strong affect from which the initial moodiness developed. In such cases one feels tempted to attribute causal significance to the complex, though with the above-mentioned proviso that besides its psychological effects the complex also produces an unknown quantity, possibly a toxin, which assists the work of destruction. At the same time I am fully aware of the possibility that this X may arise in the first place from non-psychological causes and then simply seize on the existing complex and specifically transform it, so that it may seem as if the complex had a causal effect. Be that as it may, the psychological consequences remain the same: the psyche never rids itself of the complex. An improvement sets in with the atrophy of the complex, but the complex brings with it an extensive destruction of the personality, so that the schizophrenic at best escapes with a psychic mutilation. The alienation from reality, the loss of interest in objective events, are not hard to explain when one considers that schizophrenics are permanently under the spell of an insuperable complex. Anyone whose whole interest is captivated by a complex must be dead to his environment. Janet's "fonction du réel" consequently ceases to operate. A person with a strong complex thinks in terms of the complex, he dreams with open eyes and no longer adapts psychologically to the environment. What Janet says of the "fonction du réel" in hysteria is true, in a sense, of dementia praecox: "The patient constructs in his imagination little stories that are very coherent and very logical, but when he has to deal with reality he is no longer capable of attention or comprehension."

[196] The most difficult of these far from simple problems is the hypothetical X, the metabolic toxin (?), and its effects on the psyche. It is uncommonly difficult to describe these effects from the psychological side. If I may be allowed a conjecture, it seems to me that the effect shows itself most clearly in the enormous tendency to automatization and fixation; in other words, in the permanent effects of the complex. Accordingly the hypothetical toxin would have to be thought of as a highly developed substance that attaches itself everywhere to the psychic processes, especially to the feeling-toned processes, reinforcing and automatizing them. Finally, it must be borne in mind that the complex largely absorbs the activity of the cerebrum, so that something like a "debraining" takes place. The consequence of this could be the creation of those forms of automatism which develop principally in the motor system.

[197] This more programmatic than exhaustive survey of the parallels between hysteria and dementia praecox will probably sound hypothetical to many readers unaccustomed to Freud's views. I do not intend it as anything conclusive, but rather as a preliminary sketch that will support and facilitate the discussion of the experimental researches that now follows.

5. ANALYSIS OF A CASE OF PARANOID DEMENTIA AS A PARADIGM

Clinical History

[198] B. St., dressmaker, unmarried, born 1845. The patient was admitted in 1887 and since then has remained permanently in the asylum. She has a severe hereditary taint. Before admission she had, for several years, heard voices that slandered her. For a time she contemplated suicide by drowning. She explained the voices as invisible telephones. They called out to her that she was a woman of doubtful character, that her child had been found in a toilet, that she had stolen a pair of scissors in order to poke out a child's eyes. (According to the anamnesis the patient had led a thoroughly respectable and quiet life.) Now and then she used peculiar expressions, and in general spoke in a somewhat pretentious manner.

[199] The letters she wrote at the time will give some hint of this:

5 July 1887

Dear Superintendent,

With these lines I request you most urgently to discharge me forthwith. My head is *clearer* than ever, as I have already remarked in my last letter. What I have to suffer secretly on account of novelties of all descriptions is unfortunately known to me alone and is too shattering for my health as well as for my mind. Unfortunately they have gone so far as to torture poor victims to death with secret brutalities, for I suffer more than you can imagine and in this manner fully expect my end, which touches me more and more and more sadly. I hope you will act in your capacity as physician and will have no need of any further reflection.

Yours faithfully, etc.

16 August 1887

Dear Sir,

Unfortunately I cannot make it possible for you to appreciate the sad conditions which have obtruded themselves. Once again I call your attention to the simple fact that you should discharge me without further delay, as I suffer all by myself from the novelties and if you were to be convinced of it you would surely discharge me immediately, because I have suffered from the beginning since I came here and am totally at the end of my health; I want an immediate discharge. It gets better immediately I am away from Zurich in another atmosphere where the horrors are no longer in evidence, etc.

[200] The patient produced vivid delusional ideas: she had a fortune of millions, at night her bed was stuck full of needles. In 1888 her speech became more and more incoherent and her delusions unintelligible; for instance she owned the "monopoly," made curious gestures with her hands, a certain "Rubinstein from Petersburg" sent her money by the wagon-load. In 1889 she complained that her spinal marrow was torn out in the night. "Pains in the back are caused by substances going through the walls covered with magnetism." "The

monopoly establishes the pains that do not stick in the body and do not fly about in the air.” “Extracts are made by an inhalation of chemistry,” and “legions perish of death by suffocation.” “Station for station must keep their proper governmental positions so that vital departmental questions cannot be chosen to hide behind, things can all be chosen.”

[201] In 1890-91 the delusional ideas became more and more absurd. A large but incomprehensible role was played by the word “banknote monopoly.” In 1892 the patient became “Queen of the Orphans” and “proprietress of Burghölzli Asylum.” “Naples and I must supply the whole world with macaroni.” 1894: Stereotyped request for discharge at every visit, but delivered in a totally unemotional manner. 1895: Patient felt paralysed and claimed she had consumption. She is the owner of a “banknote factory seven storeys high with coal-raven-black¹ windows, which means paralysis and starvation.” 1896: Patient is “Germania and Helvetia of exclusively sweet butter, but now I have no more butter-content than a fly would leave behind—hm-hm-hm—that is starvation—hm-hm.” (“Hm” is a characteristic stereotyped interpolation that still continues.) “I am Noah’s Ark, the boat of salvation and respect, Mary Stuart, Empress Alexander.” 1897: Patient relates that Dr. D. had recently come out of her mouth, “tiny little Dr. D., the son of the Emperor Barbarossa.” 1899: Patient is tormented at night by thousands of snakes.

[202] These notes from the clinical record show quite clearly the nature of the case. At present the patient is, as ever, a diligent worker. Now and then she gesticulates and whispers during her work, and at the doctor’s visits brings out her questions in a stereotyped manner and unemotional tone of voice: “Have you heard nothing more of the banknotes? I have long since established the monopoly, I am the triple owner of the world,” etc. When she is not actually talking of her delusions her behaviour and speech are quite orderly, though there is an unmistakable affectation such as is often found in elderly spinsters who try to create a substitute for unsatisfied sexuality by the greatest possible perfection of demeanour. She naturally has no insight into her illness, though up to a point finds it comprehensible that her delusions are not understood. There is no imbecility. Her speech is altered only where her delusions are concerned; otherwise she speaks normally, reports on what she has read, and defines ideas in a clear way, provided they do not touch the complex. During tests and analyses she shows great readiness to co-operate and takes visible pains to make herself as intelligible as possible. This behaviour is principally due to the fact that the examination as such is also a complex-stimulant; she is always pressing for interviews, hoping finally to convince us and thus reach the goal of her desires. She is always calm and there is nothing striking in her outward behaviour. While at work she whispers her “power-words” to herself, stereotyped sentences or fragments of sentences with a very strange content, such as: “Yesterday evening I sat in the night train for Nice, had to go through a triumphal arch there—we have established all that already as triple owner of the world—we are also the lilac-new-red sea-wonder,” and so forth. There are masses of such fragments, but they are all stereotyped and are always reproduced in the same form. Motor stereotypies occur but rarely. One stereotypy is the sudden stretching out of the arms, as if the patient wanted to embrace someone.

Simple Word Associations

[203] For two years I have taken simple word associations from the patient at different times, like those described in *Studies in Word Association*. Here are a few samples:

<i>Stimulus-word</i>	<i>Reaction</i>	<i>React tim (sec)</i>
1. pupil	2 ² now you can write Socrates	12.4
2. father	1 yes, mother	7.6
3. table	1 sofa	3.8
4. head	1 yes, irreplaceable	14.8
5. ink	1 nut-water	9.0
6. needle	1 thread	11.4
7. bread	1 butter	3.4
8. lamp	1 electricity, kerosene	6.4
9. tree	1 fruit	6.0
10. mountain	1 valleys	9.4
11. hair	2 hat	6.2

[204] Among these associations there are some that sound quite incomprehensible. The first reaction—*pupil / Socrates*—is a really startling reaction for a dressmaker; it looks very affected and immediately suggests a complex-constellation: the tendency to fastidious speech and behaviour. The same applies to reaction 8, *lamp / electricity*. Reaction 4, *head / yes, irreplaceable*, is unintelligible unless one knows that *irreplaceable* is one of the patient's favourite stereotypies. R. 5, *ink / nut-water*, was explained on subsequent questioning: nut-water is dark brown, ink is black. But how does the patient get to *nut-water*? It is again a complex constellation, like *Socrates*; nut-water is something she would like to have. Apart from these peculiarities one is struck by the numerous repetitions of the stimulus-word, the unusually long reaction-times, and the fact that two of the reactions begin with "yes." We regard these signs as symptoms of the complex-constellation, as the intervention of a feeling-toned idea. But it must be remembered that we are dealing here with a dementia-*praecox* patient who brings out her delusional ideas (which in our view are nothing other than expressions of the complex) with marked lack of affect. If it were a real lack of affect, it would seem at first sight contradictory that the signs of a strong feeling-tone should appear just at the point where one always has the impression of an emotional deficiency. We know from numerous investigations of normal people and hysterics that these signs always signify the emergence of a complex, and we therefore retain this view also in dementia *praecox*. The inference from this assumption is that most of the above reactions must be constellated by complexes. We have already seen that this is so in R. 1. R. 2, *father / yes, mother*, is characterized by the feeling-indicator *yes*:³ the parents play a considerable role in the delusions of the patient, as we shall see later. R. 3, *table / sofa*, looks objective and has therefore a shorter reaction time. On the other hand R. 4, *head / yes*,

irreplaceable, has a very long reaction-time. The patient refers *head* to herself and predicates this part of her body as *irreplaceable*, an expression which she otherwise applies to her own person and usually in the stereotyped formula: “I am double polytechnic irreplaceable.” R. 5, *ink / nut-water*, is a very far-fetched mediate association: the patient demands, among other things, nut-water. R. 6, *needle / thread*, touches her professional complex: she is a dressmaker. R. 7, *bread / butter*, is objective. R. 8, *lamp / electricity, kerosene*, is also among the things she desires. So is R. 9, *tree / fruit*, for she frequently complains about getting too little fruit. Occasionally she dreams of a large gift of fruit. In R. 10, *mountain / valleys*, *mountain* plays a large role in her delusions; she expresses it in the stereotypy: “I created the highest mountain peak, the Finsteraarhorn,” etc. R. 11, *hair / hat*, may well be a self-reference, though this has not been clearly confirmed.

[205] We see, then, that the great majority of the associations are constellated by complexes, and this makes the outward signs of feeling-tone immediately understandable. What is not understandable at first sight is the unusually large number of complex-constellations. We find such a profusion in normal people and hysterics only when the complex is extraordinarily intense, that is, when the affect is quite fresh. There is no question of this in our patient: she is perfectly calm, she merely shows the consequences of the affect in her associations, in the one-sided accentuation of the complex without the accompanying emotional excitement. From this we get the clinical impression of “lack of affect.” We have only the husks of the affect, the content is gone. But it may be that the patient has *displaced* the affect and that these husks are merely worn-out expressions of a repressed complex with a reasonable and comprehensible content that cannot be reproduced, so that the affect, too, is buried. Later we shall come back to this possibility.

12. wood	1	cushion	10.2
13. dream	1	reality	3.8
14. copybook	1	satchel	14.4
15. paper	1	official paper	5.0
16. book	1	books	6.8
17. pencil	1	pens	7.6
18. sing	1	singer	5.0
19. ring	1	bond, alliance, or betrothal	16.4
20. tooth	1	denture, teeth	14.8

[206] R. 12, *wood / cushion*, refers to her complaint that there are only hard wooden benches in the asylum; for her own use she wants upholstered furniture. (“I establish upholstered furniture.”) R. 13, *dream / reality*: most of her delusional ideas are taken from dreams, and when they are refuted she always insists vehemently on the reality of all the objects of her wishes. R. 15, *paper / official paper*, refers to her delusion that there is an official record of her splendid activities. R. 16, *book / books*, is one of her stereotypies: “I saw the book terribly high above the grounds of the town hall,” etc. This stereotypy likewise refers to her extraordinary activities, as we shall see below. The multiple reaction in R. 19, *ring / bond, alliance, or betrothal*, indicates a particularly strong feeling-tone. The erotic complex is

obvious here; it plays a great role in the patient's life. R. 20, *tooth / denture, teeth*, is another of her wishes: she would like a new set of false teeth.

21. window	1	door, movable pane, or ventilation	10.6
22. frog	1	I like paralysis best	18.2
23. flower	1	camellia	24.8
24. cherry	1	pear	9.8
25. asylum	1	causation	12.8
26. warder	1	locked in	8.0
27. piano	1	clavier	4.8
28. stove	1	interest-draughts	8.4

[207] R. 21, *window* has a manifold significance in her delusions, one of the most important being what she calls "ventilation": she is tormented every night by faecal odours which she hopes to remove by better ventilation. The very odd reaction to *frog* (R. 22) was explained by the patient as follows: "A person is like that when he watches how a frog jumps. I have always such a paralysis in my legs." "I have a paralysis" or "that is paralysis" is a stereotypy meant to indicate a feeling of paralysis in her legs. One can see from this how very far-fetched are the patient's assimilations to her complex. R. 23, *flower / camellia*, sounds rather affected, but camellias are another adornment of which she dreams. R. 24, *cherry / pear*, belongs to the fruit complex. The remarkable R. 25, *asylum / causation*, was explained by the patient as follows: "Private people cause such asylums. As owner of the world, I established but did not cause this asylum, in spite of the fact that on my admission someone called out that I had." On her admission the voices called out that it was her fault this asylum existed; she denied this, but ever since then she has had the delusional idea that the asylum belongs to her, for as "owner of the world" all big buildings are "established" or "affirmed" as her property. R. 26, *warder / locked in*, is, as the reaction suggests, a perseveration of the preceding complex. R. 28, *stove / interest-draughts*, the patient explained thus: "We are the stoves for the State, I am the legator of interest-draughts." The last sentence is stereotyped; what it means we shall see later. Reactions like *asylum / causation* and *stove / interest-draughts* are altogether typical of dementia praecox and are not found in any other psychic abnormality.

29. walk	1	that is an extraordinary pleasure for me, when I can go out [She is allowed out once a week.]	[not giv
30. ⁴ cook	1	roast	6.8
31. water	1	lemonade	5.0
32. dance	1	Prim, I am Mr. Prim	10.0

Here again a delusional idea is constellated. The patient explained that "Mr. Prim is the foremost dancing teacher in Zurich." The name and person are unknown to me; it is probably a delusional idea.

33. cat	1	slander	21.8
---------	---	---------	------

This far-fetched complex-constellation was explained as follows: “I was once slandered by somebody because I always carried cats in my arms.” It is not clear whether the slander emanated from the voices or from people. The carrying about of cats is a not uncommon symptomatic action in erotic complexes (substitute for child).

34. heart	1	mind	11.2
35. swim	1	I was once almost drowned, drown	[not giv

This is a complex memory from the beginning of the disease, when there were many thoughts of suicide.

36. Emperor	1	Empress	3.0
-------------	---	---------	-----

“I am Empress Alexander” is one of her stereotypies.

37. moon	1	sun	2.8
38. strike	1	always a proof of brutality	15.8

A reference to occasional attacks by other patients.

39. star	1	Should one say sun, moon, and all the fixed stars?	[not giv
----------	---	--	----------

The complex constellated here is a delusional idea expressed stereo-typically as “I am Forel and Forel’s star.”

40. stroke	1	a word which one cannot write very well: caress	[not giv
------------	---	---	----------

Here again the erotic complex is constellated, as probably also in the previous association. Both reactions came hesitatingly, with a preamble, indicating a feeling of uncertainty (“sentiment d’incomplétude”). This is probably due to the simultaneous stimulation of a strong unconscious complex, which causes the conscious idea to lose its clarity and completeness.

41. splendid	1	annoyance	6.6
--------------	---	-----------	-----

Again a far-fetched complex constellation. The patient explained: “One says about unpleasant things: Why, that is splendid!” She finds it particularly annoying that her immense fortune which she has long since “established” is withheld from her so “splendidly.”

42. child	1	parents	6.2
43. sweet	1	I have to experience the bitterness of life	11.0
44. ride	1	I must now be content with driving	8.8

Here the patient again reacts very egocentrically; that is, her complexes use every possible opportunity to assert themselves. “Ride” refers to a stereotypically expressed delusional idea: “I should have been riding horseback since 1866.” This idea refers to her megalomania.

45. friendly	1	yes, friendly, lovely	12.8
--------------	---	-----------------------	------

Refers to a stereotypically expressed idea of grandeur: “I am royally lovely, so lovely and so pure.”

46. crown	2	villa	17.4
-----------	---	-------	------

The patient explained: “The Villa S. in T. is my crown. I establish it as my property.” The Villa S. is one of the finest villas in the suburbs of Zurich.

47. rough	1	is mostly brutal	5.6
Assimilation to the brutality complex (R. 38).			
48. ill	2	ill is poverty	[not giv
“Poverty comes from illnesses.”			
49. victim	2	cruelty	7.8
As the patient explained, she was the victim of “unheard-of cruelties.”			
50. marriage	1	state affair	7.8
Marriage is a state affair in so far as it concerns her marriage, since she is the owner of the world.			
51. grandmother	1	is happiness	6.6
“When there is still a grandmother in a family there is happiness.”			
52. quarrel	2	always a sign of dangerous	10.4
53. blue	1	sky-blue	3.4
54. sofa	1	cushion	7.2
55. thousand	1	150,000	7.0
This sum corresponds to the “payment” which the patient daily expects.			
56. love	1	great abuses	11.4
The patient explained: “People love only themselves.” She meant that nobody bothers about her demands and for this reason she still has to wait for the “payment.”			
57. wild	1	Indian	8.2
58. tears	1	mourning	4.4
59. war	1	I never caused any, always misery	6.8
60. faith	1	imperishable	9.0
61. miracle	1	peak	10.0
“It is not conceivable for others that I created the highest mountain peak.”			
62. blood	1	ennobled	9.0
63. wreath	1	is festal	7.0
The first association is a clear complex-constellation, the second is a fragment from her fantasies of great festivals.			
64. parting	1	generally causes tears	7.2
65. right	1	righteousness	5.8
66. force	1	generally it is cruelty, act of violence	13.0
67. revenge	1	often quite natural in cruelties	14.2
68. little	1	often it is a loss	10.0
“When one has been great and then becomes little, it is a loss.”			
69. pray	1	is a ground-pedestal	11.4
“Without religion no one can do anything great.” “Ground-pedestal” is one of her favourite neologisms.			

70. unjust	1	is always cruel	8.2
71. world	1	world owner	4.2
72. strange	1	unknown	3.4
73. fruit	1	blessing	15.0
74. false	1	bad	6.6
75. helmet	3	hero, heroic deed	11.4

The patient compares herself and her deeds to the greatest the world has ever known. She therefore uses “helmet” to express the complex.

76. dress	1	taste	3.4
-----------	---	-------	-----

She is a dressmaker and always boasts of her excellent taste.

77. gentle	1	tact	6.0
------------	---	------	-----

Patient explains: “If you pass through a bedroom you should walk gently, so as not to wake the others.” This is an obvious constellation from asylum life, with the implication that she has the necessary tact.

78. misery	1	crutches	7.8
------------	---	----------	-----

A mediate association to “paralysed.” Patient feels herself “paralysed.”

79. hay	1	harvest	4.8
80. clean	1	good conditions	24.4

“Cleanliness creates good conditions,” a general expression of implied self-praise.

81. raspberries	1	jam, syrup	3.8
-----------------	---	------------	-----

One of the things she wants.

82. head	1	wisdom	22.0
----------	---	--------	------

Refers to the complex of her extraordinary intelligence.

[208] I do not want to pile up the examples, for those I have given contain all the essentials. The most striking thing is the enormous number of perfectly clear complex-constellations. With a few exceptions all the associations are thinly veiled expressions of complexes. Because the complexes are conspicuously in the foreground everywhere, the experiment is disturbed throughout. The extraordinarily long reaction-times could be explained in part by the continual interference of complexes, which is seldom seen in normal people or even in hysterics. From this we can conclude that the psychic activity of the patient is completely taken up by the complex: she is under the sway of the complex, she speaks, acts, and dreams nothing but what the complex suggests to her. There seems to be a certain intellectual weakness which expresses itself in a *tendency to give definitions*, though unlike the same tendency in imbeciles it does not strive for generalization⁵ but defines the content of the stimulus-words in terms of the complex. Characteristic is the extraordinarily stilted and affected manner of expression, sometimes verging on the incomprehensible. The clumsy and peculiar-sounding definitions of imbeciles occur at the intellectually difficult places, as might be expected, but here the affected definitions occur at unexpected places which happen to hit the complex. In normal people and hysterics we find striking or

linguistically odd reactions always at the critical places, and especially words from foreign languages. These correspond here to the neologisms, which are nothing but peculiarly forceful and ponderous expressions of thought-complexes. We can also understand why the patient describes her neologisms as “power-words.” Wherever they appear they hint at the whole system hidden behind them, just as technical terms do in normal speech.

[209] We see, then, that the complex is stimulated even by the most far-fetched words; it assimilates everything that comes into its orbit.

[210] In normal people and in hysterics we find roughly the same situation when there are very strong complexes and the affect is still fresh. The patient therefore reacts to the experiment like a person with a fresh affect. In reality this is naturally not the case, even though the influence on the associations is such as occurs only when the affect is fresh. By far the greatest number of the reactions are constellated in the most obvious way by subjective complexes. We can explain this fact on the hypothesis put forward in the preceding chapters, that dementia praecox has an abnormally strong affective content which becomes stabilized with the onset of the disease. If this hypothesis is correct and holds true for all forms of dementia praecox, we may expect as a characteristic feature of the associations an abnormally strong predominance of complexes. So far as my experience goes, this is true in all cases. In this respect, too, the similarity to hysteria is very great. The principal complexes which the experiment has touched on are as follows:

[211] *The complex of personal grandeur.* This constellates most of the associations and expresses itself above all in the affectation, whose sole purpose is to emphasize the value of the personality. To that extent it is a normal and familiar aid to self-complacency. Here it is exaggerated in accordance with the patient’s morbidly intensified self-esteem. Because the underlying affect apparently never weakens, it lasts for years and becomes a mannerism that contrasts glaringly with reality. We see the same thing in normal people who are excessively vain and keep up their supercilious airs even when the real situation in no way warrants it. Hand in hand with the exaggerated affectation go exaggerated ideas of grandeur which, because of their contrast with reality and the affected, barely intelligible way they are expressed, have something grotesque about them. We find this phenomenon in normal people whose self-esteem is at odds with their intelligence and outward situation. In the patient it is primarily a question of exaggeration and the correspondingly strong affect it indicates. What exceeds the normal mechanism is the barely intelligible and unadapted manner of expression, which suggests an impairment of the underlying concepts. The complex of personal grandeur expresses itself also in the patient’s unsuitable demands and wishes.

Contrasting with the complex of grandeur is the *complex of injury*, which likewise appears with great clarity. In this disease it is the usual compensation of grandeur. Here again the expression is exaggerated, difficult to understand, and grotesque.

[213] There are also indications of an *erotic complex*. Though largely disguised by the other two, it may well be the most important; in women this is even to be expected. Significantly,

perhaps, it remains in the background, the other complexes being merely its displacements. We shall come back to this later.

[214] A person of great sensitivity and exaggerated self-esteem will receive many hard knocks in the world, and these may easily lay the foundation for the complex of grandeur and the complex of injury. Accordingly the specific feature is hardly to be found in these mechanisms. We must seek it, rather, in the symptoms that are furthest from the normal; that is, in those elements that are *unintelligible*. These include, above all, the neologisms. I therefore subjected the new speech-formations of the patient to a special study, hoping in this way to find the clue to the essential factor.

Continuous Associations

[215] At first I tried to get the patient to tell me outright what she meant by her neologisms. This attempt was a total failure, as she immediately came out with a string of fresh neologisms resembling a word salad. She spoke in a matter-of-fact tone, as if she were perfectly clear about the meaning of her words and thought that what she was saying constituted an explanation. I realized that direct questioning would lead to nothing, just as in hysteria when one asks directly about the origin of the symptoms. I therefore employed a device that can also be used with profit in hysteria: I got the patient to tell me all her associations to a stimulus-word. In this way the idea can be associated in all directions and its various connections discovered. As stimulus-words I chose the neologisms, of which the patient had dozens. As she spoke very slowly with reference to her delusional ideas and was continually hindered by “thought-deprivations” (inhibitions caused by the complex), there was plenty of time for a literal transcript. I reproduce the tests verbatim, omitting only the repetitions.

A. WISH-FULFILMENT

[216] (1) *Socrates*: “Pupil—books—wisdom—modesty—no words to express this wisdom—is the highest ground-pedestal—his teachings—had to die because of wicked men—falsely accused—sublimest sublimity—self-satisfied—that is all Socrates—the fine learned world—never cut a thread—I was the best dressmaker, never left a bit of cloth on the floor—fine world of art—fine professorship—is doubloon—25 francs—that is the highest—prison—slandered by wicked men—unreason—cruelty-depravity—brutality.”

[217] The associations did not come smoothly but were constantly inhibited by “thought-deprivation,” which the patient described as an invisible force that always took away just what she wanted to say. This occurred whenever she wanted to explain something crucial. The crucial thing was the complex. As we can see from the above analysis, the essential factor appeared only after having been preceded by a number of obscure analogies.⁶ The object of the test was, as the patient knew, to explain the neologisms. So if it took her such a long time to reproduce the important phrase “never cut a thread,” then her powers of conception must suffer from a peculiar disturbance which can best be described as a lack of

ability to discriminate between important and unimportant material. The explanation of her stereotypy “I am Socrates” or “I am Socratic” is that she is the “best dressmaker” who “never cut a thread” and “never left a bit of cloth on the floor.” She is an “artist,” a “professor” in her line. She is martyred, she is not recognized as the owner of the world, she is considered ill, which is a “slander.” She is “wise” and “modest,” she has achieved “the highest.” All these things are analogies of the life and death of Socrates. She therefore wishes to say: “I am like Socrates, and I suffer like him.” With a certain poetic licence, such as appears also in moments of strong affect, she says outright: “I am Socrates.” The really pathological element is that she is so identified with Socrates that she can no longer get away from him; she takes the identification at its face value and regards the metonymy as so real that she expects everybody to understand it.

[218] Here is a clear instance of deficient discrimination between two ideas: every normal person can distinguish between an assumed role or metaphorical name and his real personality, even though a lively fantasy or intense feeling-tone may attach itself for a time to such a dream- or wish-formation. The correction does finally come with a reversal of feeling, and with it a re-adaptation to reality. In the unconscious the process is somewhat different. We saw, for instance, how dreams change metaphors into a reality which is substituted for the person of the dreamer, or how an unconscious complex immediately “condenses” a distant analogy and a person, and thereby attains the necessary intensity to disturb the conscious process (“A pine-tree stands alone,” etc.). If at that moment the unconscious complex, in a short twilight state, had attained innervation in speech, the patient would have said: “I am the pine-tree.” As we have shown in the preceding chapters, the necessary premise for these condensations is the indistinctness of ideas, such as normally exists in the unconscious. This would also explain the condensations in our case. As soon as the patient thinks in terms of the complex she no longer thinks with normal energy or distinctness, but indistinctly, dreamily, as normally happens in the unconscious or in dreams. As soon as her associations enter the realm of the complex the hierarchy of the directing idea ceases, and the stream of thought moves forward in dreamlike analogies which, in the self-evident way of dreams, are equated with reality. The complex functions automatically in accordance with the law of analogy; it is completely freed from the control of the ego-complex, and for this reason the ego-complex can no longer direct the associations; on the contrary, it is subordinated to the complex and continually disturbed by defective reproductions (thought-deprivation) and compulsive associations (pathological ideas). The same process of obscuration that takes place with regard to ideas also occurs in speech: it gradually becomes indistinct, similar expressions are substituted for one another, there are clang-displacements and indirect (linguistic) associations. Thus it does not matter to the patient whether she says “artist” or “fine world of art,” “professorship” instead of “professor,” “fine learned world” instead of “skilled dressmaker.” These ideas take one another’s place with the same facility as do the personality of the patient and Socrates. Characteristically, the accent does not fall on the simple but on the unusual, for this is in keeping with her hankering for distinction.

[219] (2) *Double polytechnic* (stereotype: “I am double polytechnic irreplaceable”): “That is the highest, all-highest—the highest of dressmaking—the highest achievement—the highest intelligence—the highest achievement in the culinary art—the highest achievement in all spheres—the double polytechnic is irreplaceable—the universal with 20,000 francs—never cut a thread—fine world of art—not apply a thread of trimming where it is not seen—plum-tart with corn-meal crust—it is of the greatest importance—finest professorship—is a doubloon—25 francs—Schneckenmuseum clothing is the highest—salon and bedroom—should live there as double polytechnic.”

[220] The content of “double polytechnic” is very like that of “Socrates,” only here the “arts” are even more emphasized. Besides “dressmaking” we have the “culinary art” with her specialty—“plum-tart with corn-meal crust.” The art of dressmaking reappears in the same stereotyped groups of associations as before. It is quite clear that “double polytechnic” is simply another metonymy for the acme of art and wisdom. A further specification lies in “should live there,” namely in the Polytechnic Institute, as the patient later told me. It is no contradiction for her consciousness, any more than it would be for a dream, that she lives in the Polytechnic as a “double polytechnic.” It was also quite impossible to make her realize the absurdity of this; she simply answered with one of her stereotypies. The Polytechnic in Zurich is a stately building and therefore “belongs to her.” “Double” is an obscure epithet which is perhaps echoed in “doubloon”; this may be a reference to the reward she expects for her “highest achievement.” “Double” may be meant as an intensification, but it may have another meaning of which we shall speak later. If “double polytechnic” is the “highest,” the epithet “irreplaceable” then becomes clear.

[221] (3) *Professorship* (stereotype: “I am the finest professorship”). “That is again the highest achievement—double—25 francs—I am double polytechnic irreplaceable—professorship includes the fine learned world—the finest world of art—I am these titles too—I am Schneckenmuseum clothing, that comes from me—never cut a thread—choose the best patterns that show up well—the finest learned world includes that—choose the best patterns that show up well and waste little cloth—I did that—that’s my line—the fine world of art is to apply trimming only where it is seen—plum-tart with corn-meal crust—the finest professorship is double—25 francs—it doesn’t go any further—no one can get any further than 25 francs—Schneckenmuseum clothing is the highest clothing—the others always want to connect the learned world with astronomy and all that.”

[222] The content of “professorship” agrees with that of the two concepts analysed above. “Professorship” is simply another symbolic designation for the megalomaniac idea that the patient is the best dressmaker. “Doubloon” is here replaced by the clang-similarity “double”; for the patient they are obviously equivalent. A doubloon corresponds to 25 francs and it is evident that this means the highest daily wage she can earn by her work. The expression “Schneckenmuseum clothing” is a symbolic designation for the product of her art, which she considers the “highest clothing.” It can be explained as follows: the Museum is the haunt of intellectual circles in Zurich, the Haus zur Schneckle stands near the Museum and is a prominent guild. These two ideas have been fused together in the singular concept

“Schneckenmuseum clothing,” which, as the patient says, means the “highest clothing.” Her speech usage is interesting. She does not say “I make” but “I *am* the Schneckenmuseum clothing, that comes from me.” She “condenses” or identifies herself with this object too, at least in so far as she treats “I am” and “that comes from me” as equivalent. “I am” seems to be an intensified form of “I have” or “I make.”

[223] The three concepts so far analysed are technical terms which characterize a wealth of ideas and relationships in what seems to the patient a very pregnant way. When she whispers to herself she simply repeats these terms and nods affirmatively, but the explanatory material is lacking. The origin of the terms is not known; some of them, according to the patient, come from dreams. Probably they arose spontaneously on some occasion and impressed the patient on account of their strangeness, in the same way that philosophers who think in nebulous concepts like playing with obscure words.

[224] (4) *Summit*: “Sublimest sublimity—self-satisfied am I—Clubhouse ‘Zur Platte’—fine learned world—world of art—Schneckenmuseum clothing—my right side—I am Nathan the Wise—father, mother, brothers, sisters have I none in the world—an orphan child—am Socrates—Lorelei—Schiller’s *Bell* and the monopoly—Lord God, Mary the mother of God—master-key, the key of heaven—I always legalize our hymn-book with gilt edge and the Bible—I am the owner of the southerly zones, royally lovely, so lovely and so pure—in my sole personality I am von Stuart, von Muralt, von Planta, von Kugler—highest intelligence belongs to me—no one else should be made a member—I legalize a second banknote factory six storeys high for the Socrates deputy—the asylum should keep the Socrates deputy—no longer the earlier deputy my parents had, but Socrates—a doctor can explain that to them—I am Germania and Helvetia of exclusively sweet butter—that is a life-symbol—I created the highest summit—I saw the book terribly high above the town-hall grounds covered with white sugar—high in heaven is the highest summit created—higher than the highest height—you can bring no one who can show a mightier title.”

[225] In the concept “summit” we find an enormous number of the craziest ideas some of which sound extraordinarily comical. By and large we elicit from this material that by “summit” the patient simply means the sum of all her “titles” and “achievements.” Titles like Schiller’s *Bell*, Lorelei, etc., probably express special analogies which will have to be looked for in the individual words.

[226] (5) *Lorelei*: “Is the owner of the world—it expresses the deepest mourning because the world is so depraved—a title that is the greatest happiness for others—usually these personalities who have the misfortune, I might almost say, to be owners of the world are extraordinarily tormented—Lorelei is also the highest life-image—the world can show no higher remembrance—no higher veneration—it is like a statue—for example, the song runs ‘I know not what it means’⁷—it happens so often that the title owner of the world is not understood at all—that people say they don’t know what it means—it is really a great misfortune—yet I establish the largest silver island—it is a very old song, so old that the title never became known at all—that is sadness.”

- [227] When the patient says “I am the Lorelei,” it is simply—as the analysis shows—a condensation by means of a clumsy analogy: people do not know what owner of the world means, that is sad; Heine’s song says “I know not what it means,” etc., therefore she is the Lorelei. The mechanism is exactly the same as in the “pine-tree” analogy.
- [228] (6) *Crown* (stereotypy: “I am the crown”): “Highest good you can achieve—those who achieve the highest come to the crown—highest happiness and earthly good—greatest earthly riches—it is all earned—there are lazy people who always remain poor—highest heavenly image—highest divinity—Mary the mother of God—master-key and a key of heaven with which one cuts off relations—I myself saw how a door was bolted—the key is necessary for incontrovertible justice—titles—empress, owner of the world—highest title of nobility.”
- [229] “Crown” is another analogy of “summit,” but with the added nuance of merits and rewards. The rewards are attained not only on this earth in the form of the greatest worldly possessions (riches, being crowned empress, titles of nobility, etc.); they are also found in heaven, to which the patient gains entry by means of the key and where she is even crowned Queen of Heaven. In view of her merits, this seems to her “incontrovertible justice.” A naïve bit of dreaming somewhat reminiscent of *Hannele’s Ascension* (Hauptmann).
- [230] (7) *Master-key* (stereotypy: “I am the master-key”): “The master-key is the house-key—I am not the house-key but the house—the house belongs to me—yes, I am the master-key—I affirm the master-key as my property—it is therefore a house-key that folds up—a key that unlocks all doors—therefore it includes the house—it is a keystone—monopoly—Schiller’s *Bell*.”
- [231] The patient means the pass key carried by doctors. By means of the stereotypy “I am the master-key” she solves the complex of her internment. Here we can see particularly well how hazy her ideas are and also her expressions: sometimes she *is* the master-key, sometimes she merely “affirms” it; sometimes she *is* the house, sometimes it belongs to her. This key, that unlocks everything and sets her free, also prompts the analogy with the key of heaven, which opens for her the door to bliss.
- [232] (8) *Owner of the world* (stereotypy: “I am triple owner of the world”): “Grand Hotel — hotel-life — omnibuses — theatres — comedies — parks — carriages — fiacres — trams — traffic — houses — stations — steamships — railways — post — telegraph — national holidays — music — stores — libraries — governments — letters — monograms — postcards — gondolas — delegates — great occasions — payments — gentry — coaches — Negro on the box — flags — one-horse carriage — pavilion — education — banknote factory — mightiest silver island in the world — gold — precious stones — pearls — rings — diamonds — bank — central court — credit office — villa — servants and maids — carpets — curtains — mirrors, etc.”
- [233] The images which “owner of the world” conjures up for the patient are the prerequisites for a princely existence, some of them carefully observed situations, charmingly depicted (“Negro on the box”). These hints give us some idea of the ceaseless inner activity of the

complex in dementia praecox, outwardly noticeable only in a few unintelligible fragments. Psychic activity no longer serves the “fonction du réel” but turns inwards to an unending elaboration of thought which exhausts itself in building up her complexes.

[234] (9) *Interest-draughts* (stereotypy: “My interest-draughts will have to be accepted sometime”): “Cocoa, chocolate, noodles, macaroni, coffee, kerosene, black tea, green tea, sugar-candy, white sugar, nut-water, red wine, honey-cakes, wine-cake—fabrics, velvet, merino, double merino, alpaca, twill, fustian, white percale, shirting, linen, wool, shoes, boots, stockings, petticoats, underwear, skirts, umbrellas, hats, jackets, coats, gloves—they are interest-draughts that in reality belong to me.”

[235] This is only a sample from the content of “interest-draughts.” They are the concrete wishes of everyday life which have nothing to do with the complex of owning the world. They, too, are thought out in the finest detail and give the impression of a carefully compiled list.

[236] (10) *Establish [or affirm; see below]*: “Substantiate, verify, recommend—generally, complete finality—to express an opinion—to take into consideration—to take in hand—the heathens chatter so, the same thing is explained to them every day and yet they do nothing about it—I affirm that I am paralysed—nine years ago I would have needed 80,000 francs—payment through Director Forel—they are brutal to me—as owner of the world I have affirmed the asylum six times already.”

[237] The content of this word [*feststellen*] has been hinted at under “master-key.” The meaning is clearest in the sentence “I affirm that I am paralysed.” Here “affirm” is used in its proper and original sense. But generally the patient uses the word in a metaphorical sense, for instance “I affirm the asylum,” i.e., as my property, or “I establish a payment,” i.e., I establish a claim to a payment. As we have seen, there is an abnormal mobility of verbal expression with a marked tendency to arbitrary manipulation of language. Normally changes in speech occur very slowly, but here the changes take place rapidly in a single individual. The reason for these rapid changes seems to lie in the vagueness of her conceptions. She makes hardly any distinction between them, and her conceptions are used and expressed now in one way, now in another (cf. “master-key”). To judge by the list of its contents, this concept is very ambiguous. It is supposed to mean “substantiate,” “verify,” which at any rate can be understood, although both terms go somewhat beyond the sense of “affirm” and “establish”; but to “recommend,” “express an opinion,” “take into consideration,” have no logical connection with “affirming” and “establishing” and must be understood as superficial associations. They do not in any way explain what the concept means, they only make it blurred. This is probably because the words themselves are conceived very indistinctly, so that their dissimilarities are not recognized.

[238] (11) *Universal* (stereotypy: “I am the universal”): “I came as the universal seventeen years ago—universal infirms rest—regular conditions—it also comes through legacies—includes financial circumstances too—title of world owner includes 1000 millions—that is the villa, equipage—I’ve been riding horseback and driving since 1866—I’ve been universal since the death of my father—in the winter months I affirm the universal—even if

I'd not affirmed it in the dream I would have known it—on account of being a legator—25,000 at the very least—with what emphasis—the Swiss annuity is 150,000—they said over the telephone that Mr. O. had drawn my annuity—universal is a finality—you can be that through deceased persons—through legacies—universal is property—the property belongs to me.”

[239] According to these associations “universal” means something like “sole heiress”; at any rate that seems to be its derivation. The term, however, is used quite indiscriminately, now for the person and now for the property. Again we have the same uncertainty. Instead of “affirm” the patient prefers to use “include”; on one occasion the two words condense into “infirm.” The uncertainty in the use of moods and tenses is significant. For instance the patient says: “I’ve been riding horseback since 1866,” etc. She knows very well that this is not true; on another occasion she said: “I should have been riding horseback since 1866, but I content myself with driving.” It makes no difference to her whether she expresses an optative in the present or in the imperfect tense; she talks just like a dream. This peculiarity of dreams has been pointed out by Freud.⁸ Her dreamlike, condensed, disconnected manner of speaking is in clear agreement with this fact.

[240] “Universal” is again a symbol of her riches, which she has not only earned herself but has inherited. This also sheds lustre on her family, who, as we shall see, are included in her wish-dreams.

[241] (12) *Hero*: “I am a hero of the pen—generosity—fearlessness—heroic deed—hero of the pen because of the content of what one writes—the highest intelligence—the highest traits of character—highest endurance—highest noblesse—the highest that the world shows—includes in itself—letters—deeds of purchase and transfer.”

[242] “Hero of the pen” is actually an ironic expression which the patient takes quite seriously. This may be due to her lack of education, but it is more probable that she has lost all sense of humour, as usually happens in dementia praecox. Incidentally, this defect is also characteristic of dreams. “Hero” is another symbolic expression for highest intelligence, etc. How much the patient herself is a “hero of the pen” can be seen from the concluding phrases. Actually she does not write anything except a letter on rare occasions, but in fantasy she writes letters in abundance, especially those dealing with “deeds of purchase and transfer,” a reference to her acquisitive complex. It is interesting to see how she expresses this *arrière pensée* symbolically by “hero,” “heroic deed.”

[243] (13) *Finality [Endgültigkeit]*: “Alliance, counter-bill, conclusions, signature, title deed, procuration—generally includes the key too—foreign currency, the highest conclusions—dedication of the highest—worship—I dreamt that the worship, veneration, and admiration of which I am worthy cannot be offered to me—so wanders the noblest of women, with roses she would like to surround the people—Queen Louise of Prussia—I established that long ago—I am her too—those are the highest conclusions in life—keystone.”

[244] The concept “finality” is again very unclear. “Counter-bill, signature, procuration, title-deed” seem to me to emphasize mainly the element of “validity” [*Gültigkeit*], whereas

“conclusions, alliance, keystone” emphasize more the “finality.” Actually these relationships merge into one another completely. From “procuration” the association goes to “key,” which as we know plays a great role as the “master-key” and always evokes its symbolic counterpart, the “key of heaven.” Here again the association goes from “key” to quasi-religious ideas by means of the concept “foreign currency,” which for the patient also stands for the “highest,” so that she can assimilate the latter concept as well. From “foreign currency” it goes via “dedication” to “worship.” In an earlier analysis she identified herself at a similar point with “Mary the mother of God”; here it is only with the “noblest of women, Queen Louise,” another symbol for the patient’s grandeur. In this way she designates yet another pinnacle of human virtue, including it in the concept of finality along with her numerous other attributes. Quotation is a favourite way of expressing complexes.

[245] (14) *Mountain-peak* (stereotypy: “I created the highest mountain-peak”): “I have achieved the highest of all mountain peaks by mending—obviously it makes a sugar-cone—it comes out quite white—you had to descend the mountain for meals—it was majestic—little houses are provided on the slope—in clear weather you go up there with tourists—it must be very remunerative—I was once there too, but the weather was bad—sea of fog—I was surprised that such distinguished inhabitants still lived up there—they had to come down for meals—in fine weather it is very remunerative—you might also think that down-at-heel people were up there—the sense is majestic because it is the best sense—if you have a majestic sense it is out of the question for you to be killed and robbed in such a place—yes, that is the mountain-peak—the Finsteraarhorn.”

[246] The patient has long been occupied with mending linen, she has mended enough linen to make a whole mountain, “the highest of all mountain-peaks.” Linen is white, hence “sugarcone.”⁹ The snowy peaks can be compared to sugar-cones, they are white on top and blue below, hence “Finsteraarhorn.” Among these dreamlike but transparent associations the patient inserts an intermezzo about a mountain on which distinguished people live. Involuntarily one thinks of the Rigi,¹⁰ whose big hotels doubtless excited the covetous fantasies of the patient. When subsequently asked about this intermezzo she said she did not mean any particular mountain, she only dreamt of it. Nothing further could be elicited, though she talked about it as if it were something real, or at least a vision. It was obviously an unusually vivid concretization of a fantasy-image such as otherwise occurs only in dreams.

[247] (15) *Turkey* (stereotypy: “I am the finest Turkey”): “I belong to the finest Turkey in the world—no other woman in the world should be undressed—for choosing—I am the legator of champagne and the strongest black wine—of all the finest produce—we are the mightiest preservers of the world—Switzerland comes to my side as the mightiest, most glorious nation—Biel, Liestal, Baden, Seefeld, Neumünster—no discord—Switzerland expresses herself in Turkey—Turkey is fine and imports the finest foodstuffs—fine wines—cigars—lots of coffee, etc.”

[248] This reminds one of those advertisements for Greek wines and Egyptian cigarettes, which are adorned with a pretty Oriental girl (the patient also says: “I am an Egyptian”),

You see the same thing in advertisements for champagne. This is probably the source of the symbols. Again they are things she wants (wine, coffee, etc.), but it also seems that she distributes these goods to humanity (“I am the legator”), perhaps commercially, since the import business seems to her especially lucrative. She also “affirms businesses,” as we shall see below. Be that as it may, the important thing here is the figurative way in which she expresses herself, arrogating a geographical concept (Turkey) as her title. For her it is a technical term that expresses the whole of the material mentioned.

[249] (16) *Silver* (stereotypy: “I have established the mightiest silver island in the world”): “Speech is silver, silence is golden—silver stars—money is made from silver—supply of money—largest silver island in the world—silver medals—one must cling to what is made out of it—watches—silver boxes—goblets—spoons—highest eloquence—speech is silver, silence is golden—as owner of the world the mightiest silver island in the world belongs to me—but I afterwards gave the order to supply only money, no external things—all the existing silverware must be melted down into money.”

[250] The “silver island” is among the perquisites of the owner of the world; it is from here that her untold millions come. But silver is also “speech,” hence she possesses the “highest eloquence.” This example again shows quite clearly how indistinct her ideas are. One cannot really speak of directed associations here, but merely of the associative principles governing verbal combination and the similarity of images.

[251] (17) *Zähringer*¹¹ (stereotypy: “I am Zähringer since 1886”): “Means paymaster—extraordinary health—often in life they say: you are tough!—I am Zähringer since 1886—long life—extraordinary achievements—unbelievable with many people—it is in the realm—one is so misunderstood—there are so many people who always want to be ill—they don’t get on with the Zähringers—quite extraordinary—highest age—do you know where the Zähringer quarter is?—near the Franciscan church—a nice quarter—extraordinary—this title means nothing to common people—yet one often says they are so tough—this has to do with the state of health—it makes such an infinite difference, the difference in age—I am Zähringer on account of my health—it is extraordinary—they often say it is wonderful what she does and how tough she is—in 1886 I established the quarter, so that I have a place to live.”

[252] The symbolic significance of “Zähringer” is clear: the patient is “Zähringer” because she is *zäh*, ‘tough.’ This sounds like a pun, but she takes this phonetic metonymy seriously, while at the same time “Zähringer” means for her a nice residence in the “Zähringer quarter.” Again a dreamlike condensation of widely different ideas.

[253] (18) Lately the patient repeatedly produced the following neologism: “I am a Switzerland.” Analysis: “I long ago established Switzerland as a double—I do not belong shut up here—I came here freely—‘He who is free of guilt and sin / Preserves the child’s pure soul within’—I am a crane—Switzerland cannot be shut up.”

[254] It is not difficult to see how the patient is a Switzerland: Switzerland is free, the patient “came here freely,” therefore she should not be kept shut up. The *tertium comparationis*

“free” immediately leads to a contamination with Switzerland. Similar but more grotesque is the neologism “I am a crane.” “He who is free of guilt,” etc. is a well-known quotation from *The Cranes of Ibycus*.¹² The patient therefore identifies herself outright with “crane.”

[255] The analyses so far have been concerned only with symbols for the extraordinary power, health, and virtuousness of the patient. They all represent thoughts of self-admiration and self-glorification which express themselves in inordinate and grotesque exaggerations. The basic thoughts—I am an excellent dressmaker, have lived a respectable life and am therefore worthy of respect and financial reward—are understandable enough. We can also understand that these thoughts lead to a great many wishes: for instance, for recognition, praise, financial security in old age. Before her illness the patient was always poor and came from a low-grade family (her sister is a prostitute). Her thoughts and wishes express her striving to get out of this milieu and attain a better social position, so it is not surprising that her wish for money etc. is very strongly emphasized. All strong wishes furnish themes for dreams, and the dreams represent them as fulfilled, expressing them not in concepts taken from reality but in vague dreamlike metaphors. The wish-fulfilling dreams appear side by side with associations from the waking state, the complexes come to light and, the inhibiting power of the ego-complex having been destroyed by the disease, they now go on weaving their dreams on the surface, just as they used to do under normal conditions in the depths of the unconscious.

[256] Dementia praecox has, so to speak, pierced holes in the ceiling of consciousness (that is, in the functioning of the clearest, purposively directed associations), so that it is now possible to see from all sides into the automatic workings of the unconscious complexes. What the patient and we, too, see are only the barely intelligible, distorted and disjointed products of the thought-complex which are analogous to our dreams, where again we see only the dream-image but not the thought-complex hidden beneath it. Thus the patient takes her dream products as real and claims that they are reality. She acts just as we do in dreams, when we are no longer capable of distinguishing between logical and analogical connections; hence it is all the same to her whether she says “I am the double polytechnic” or “I am the best dressmaker.” When we speak of our dreams, we speak, as it were, of something apart from ourselves, we speak from the standpoint of the waking state. But when the patient talks of her dreams, she speaks as if she were still in the dream, she is involved in the automatic machinery, with the result that all logical reproduction naturally ceases. She is then entirely dependent on chance ideas, and must wait to see whether the complex will reproduce anything or not. Accordingly her thought-process is halting, reiterative (perseverating), and constantly interrupted by thought-deprivation, which the patient considers very trying. If asked for explanations she can only reproduce further dream-fragments as answers, so that one is none the wiser for it. She is totally unable to control the material of the complex and to reproduce it as if it were indifferent material.

[257] We see from these analyses that her pathological dreams have fulfilled her wishes and her hopes in the most brilliant way. Where there is so much light there must also be a good deal of shadow. Excessive happiness must always be paid for very dearly, psychologically

speaking. We therefore come to another group of neologisms or delusional ideas, which are concerned with the other side of the picture: they comprise the complex of injury.

B. THE COMPLEX OF INJURY

[258] (1) *Paralysis* (stereotypy: “That is paralysis”): “Bad food—overwork—sleep deprivation—telephone—those are the natural causes—consumption—spine—the paralysis comes from there—wheel-chairs—they only cite these as paralysis—tortured—expresses itself in certain pains—that is the way it is with me—woe is never far away—I belong to the monopoly, to the payment—banknotes—here the suffering is affirmed—it is a just system—crutches—dust development—I need immediate help.”

[259] Here we see the reverse of the medal. Just as on one side her fantasies automatically lead to every conceivable splendour, so on the other side she meets with all sorts of malicious persecutions and sufferings. It is for this reason that she demands an indemnity which she expresses by saying: “I belong to the payment,” which is synonymous with “a payment belongs to me.” In consequence of her suffering [*Not*] she has to claim banknotes. (We shall return to this pun below.) Her complaints are of the same physical injuries that are usual among paranoiacs. What the psychological root of the sufferings here described may be I am unable to say.

[260] (2) *Hieroglyphical* (stereotypy: “I suffer hieroglyphical”): “Just now I suffer hieroglyphical. Marie [a nurse] said I should stay in the other ward today, Ida [another nurse] said she couldn’t even do the mending—it was only kind of me to do the mending—I am in my house and the others live with me—I affirm the asylum sixfold, not that it is my caprice to remain here, they forced me to remain here—I have also affirmed a house in the Münsterhof—I was shut up for fourteen years so that my breath could not come out anywhere—that is hieroglyphical suffering—that is the very highest suffering—that not even the breath could come out—yet I establish everything and don’t even belong to a little room—that is hieroglyphical suffering—through speaking-tubes directed outward.”

[261] It is not quite clear from this analysis, which was interrupted by the story of the nurses, what exactly is meant by “hieroglyphical,” although she cites examples. But in another analysis of this locution she said: “I suffer in an unknown way, that is hieroglyphical.” This explanation makes sense. Hieroglyphics are, for the uneducated, a proverbial example of something incomprehensible. The patient does not understand why and to what end she suffers, it is a “hieroglyphical” suffering. To be “shut up for fourteen years so that not even the breath could come out” is nothing but an elaborate paraphrase of her enforced stay in the asylum. The suffering “through speaking-tubes directed outward” seems to be a reference to the “telephone” and the voices, though a different interpretation may be possible.

[262] (3) *Discord* (stereotypy: “There is such a great discord”): “Discords—it is really a crime—I have to be cared for—I saw in a dream two people twisting two cords in the loft—there are two such great discords—I have to be cared for—discords simply won’t go any longer on this floor—there is such a great discord that they don’t want to care for me—they were

making lace in the loft and only went on working without thinking or caring for me—discords come from negligence—discords do not belong to this floor but to Siberia—it is high time I was cared for, I have consumption—instead of providing me with the bank title they only go on working—both of them happened to be making lace in the loft.”

[263] “Discord” seems to express something like “disagreeable circumstances.” The patient finds it particularly disagreeable that the doctor never wants to hear anything about the payment she demands at every visit. She then complains mostly about the selfishness of people who only think of themselves and “only go on working” without thinking of the payment. The dreamlike intermezzo about the two people twisting two cords in the loft and going on working without caring for her may be a symbol for the indifference with which she is treated here. “Siberia” likewise suggests bad treatment. In spite of the splendid health which on other occasions she claims to enjoy, she considers herself “consumptive,” but like all the other mutually exclusive absurdities these contradictions do not disturb one another. Dementia praecox has this, too, in common with normal dreams. Moreover one can observe in hysterics and in rather emotional normal people that they begin to contradict themselves as soon as they talk of their complexes. Reproduction of thought-complexes is always disturbed or falsified in one way or another. Similarly, judgment of complexes is almost always clouded, or at any rate uncertain. This is known to all psychoanalysts.

[264] (4) *Monopoly* (stereotypy: “I am Schiller’s *Bell* and the monopoly” or “banknote monopoly”): “With me it expresses itself in the note-factory—quite black windows—I saw it in a dream—that is paralysis—a note-factory seven storeys high—it is a double house, a front one and behind it is the apartment—the note-factory is genuine American—the factory has been drawn into the monopoly just like, for example, Schiller’s *Bell* and the monopoly—the monopoly includes everything that can happen—all diseases which are caused by chemical productions, poisonings without seeing anyone, then attacks of suffocation—from above it is credible—then the terrible stretchings—they’re continually stretching me—on this food you cannot get a figure like mine—the awful system of burdening as if there were tons of iron plate lying on your back—then the poisoning, it is invisible—it is shot in through the window—then, as if you were in ice—then pains in the back, this also belonged to the monopoly—as Schiller’s *Bell* and the monopoly Forel should have paid me 80,000 francs nine years ago, because I had to endure such pains—I need immediate help—monopoly is a finality of all innovations since 1886, chemical productions, ventilations, sleep-deprivation—even without that a government would be obliged to stand by me with immediate help—I establish a note-factory—even if I weren’t owner of the world the government would still have to bring help—as owner of the world I should have paid out fifteen years ago with gentlemen from the note-factory, forever, as long as I live—therefore it is such a great loss if one has to die only a year earlier—since 1886 the Oleum has belonged to me—all those who endure such sufferings should be helped, belong to be helped to the note-factory, to the payment—such innovations are all summed up in the word Monopoly, just as there are people who have the powder monopoly.”

[265] The concept of the “monopoly” is again very unclear. It is associated with a series of tortures, and the note-factory is part of this suffering [*Not*]. The patient repeatedly emphasizes that she needs “immediate help,” which is connected with the oft-mentioned “payment.” She must be helped to get the payment because of her great sufferings. The probable train of thought seems to be as follows: her unprecedented and unique sufferings, as well as her advanced age, require that she should once and for all be given her unique rights. This is what she probably means by “monopoly.” The special content of the monopoly is that the patient, as owner of the world, is solely entitled to manufacture banknotes. The psychological connection may be via the clang association *Not / notes*.

[266] (5) *Note factory*: “This is the creation of conditions through too great suffering—the notes have the same weight as money—everything that is necessary to arrange—notes for the alleviation of the greatest suffering—payment of financial conditions—I should be with the city throughout life—the note-factory should definitely be on our soil—I should pay out forever with four gentlemen—it would be too great a loss if one had to die only a year earlier than is necessary, etc.”

[267] We must be content with this extract from an originally much longer analysis. I think it is clear where the idea of the note-factory comes from: the notes alleviate *Not*. In this way the patient has created one of those symbolic clang-associations that so often occur in dreams. One complex has assimilated the other; the two complexes are condensed in the words *Not* and *note*, so that the one concept always contains the other without there being any linguistic justification for such a fusion of ideas. It is characteristic of dream-thinking that the most commonplace similarities give rise to condensations. Even in normal people two complexes existing at the same time always fuse, especially in dreams, where the *tertium comparationis* may be any superficial similarity. The money-complex and the suffering-complex are closely related as regards their content, and for this reason alone they must fuse: *Not* and *note* thereby acquire an even greater significance apart from the clang-association. This type of thinking, as all psychiatrists know, is found not only in dementia praecox but in many other far-fetched interpretations. I have only to mention the mystical interpretations of the name “Napoleon.”

[268] (6) *Oleum*: “Belongs to the title ‘eternal’—it is for old age—when I die, the title is gone, everything is gone—it is a somewhat longer official length of life—Oleum serves for prolongation—it belongs to me but I don’t know what it is made of—the age is established ever since 1886.”

[269] “Oleum” seems to be a sort of elixir which is to prolong the precious life of the patient. The expression “official length of life” is a very characteristic pleonasm. It is a perfect example of the hazy thinking that connects two totally different ideas; it also reveals the marked tendency of the patient to express herself as learnedly as possible (“official language”), a peculiarity of many normal persons who strive to give themselves an air of especial importance. The pompous style of officials or half-educated journalists sometimes bears similar fruit. These individuals, like the patient, have a striving for prestige. Where the word “Oleum” came from I do not know. The patient claims to have heard it from the

voices, just as she heard “monopoly.” Very often these products are due to chance coincidences (cf. “Japan-sinner”).

[270] (7) *Hufeland* (stereotypy: “I establish a million Hufeland to the left”): “Whoever belongs to Hufeland is universal, a millionaire—on a Monday between eleven and twelve o’clock I slept and established a million Hufeland to the left on the last splinter of earth up on the hill—the highest qualities belong to him—wisdom—many people make themselves ill, that is surely a great loss—known to be one of the most famous doctors who establishes what is true in life—seven-eighths make themselves ill through unwise things—the million belongs to the realm of the distinguished million—a million on the last splinter of earth—you also have two sides, Doctor, and now we have to do with the left—they would have to pay me a million—it is extraordinary—the empty, lazy people do not belong here—money always gets into the wrong hands—they are the deadly enemies of Hufeland, the empty, lazy, unwise people—Hufeland is extraordinarily world-famous—to be Hufeland is so mighty, to feel yourself quite healthy or quite ill, indeed will-power makes such a difference—the highest essence of man is needed in order to be Hufeland—perhaps you do not belong to Hufeland, Doctor—Hufeland has no connection with cruelty, not at the present time—they also snatched away my petticoat—for only two blankets—that is unhufeland—that is murdered, when they make you ill by force—I once had an extract from him, it is splendid to read how he agrees with every fibre of life—I am Hufeland—no cruelties belong to Hufeland.”

[271] The patient is “Hufeland.” Knowing her use of language, we know that this amounts to saying that there is something in her life that can be expressed symbolically by “Hufeland.” She once read about Hufeland and therefore knows that he was a famous doctor.^{12a} She probably knows of his “macrobiotics” (as suggested by her remark “will-power makes such a difference”). It is “unhufeland” to take away her petticoat and give her only two blankets. In this way she will catch cold—and this happens on the doctor’s orders. Only a bad doctor, who is not a Hufeland, can order such things. I was the doctor, and therefore she says: “You also have two sides, Doctor”; “perhaps you do not belong to Hufeland, Doctor.” The adjective “unhufeland” is worth noting; it has the meaning of “not in accordance with Hufeland.” She uses the word “Hufeland” as a technical term, just as surgeons say “We will do a Bier here” (i.e., Bier’s stasis) or “a Bassini” (Bassini’s operation), or as psychiatrists say “This is a Ganser” (Ganser’s syndrome). So in “unhufeland”; only the prefix is a pathological formation. Her many complaints about “cruel” treatment justify the supposition that she wants a Hufeland for her doctor. This thought can also be expressed perfectly well by her saying that she herself is Hufeland; as we have seen, a metonymy of this kind is nothing unexpected. The idea of bad treatment deleterious to her health is always associated with that of the “payment,” which she obviously regards as a sort of indemnity. She does not make herself ill, as seven-eighths of the others do, but is made ill “by force.” Presumably for this reason she should be paid a million. This brings us to the meaning of her stereotypy: “I establish a million Hufeland to the left on the last splinter of earth” etc. What “left” means in this connection is not clear. But from a lengthy analysis which I cannot reproduce here *in toto* it transpired that the “splinter” is a “wooden post” on

a mound of earth which signifies “the extreme end,” probably a metaphor for “grave.” So here, as (implicitly) in (6) *Oleum*, we encounter the complex of death-expectation. “I establish a million Hufeland to the left on the last splinter of earth, up on the hill” may therefore be a metaphorical and paralogical condensation (ellipsis) for something like this: “For the bad medical treatment which I have to endure here and which will finally torture me to death I claim a high indemnity.”

[272] (8) *Gessler* (stereotypy: “I suffer under Gessler”): “Gessler’s hat is set up down below, I saw it in a dream—Gessler is the greatest tyrant—I suffer under Gessler, therefore *William Tell* is the greatest tragedy in the world because of personalities like Gessler—I will tell you what he exacted from the people—he requires them always to have the same linen, the same clothes and never the smallest coin—he was always for war, for battle—all the cruelties these battles legalize, cause—I suffer under Gessler, he is a tyrant, there are people who are quite inadmissible, of unnatural unreason and bloody cruelty—for three quarters of a year I should have had a border on my skirt, only it was not given to me—that is Gessler, yes, Gessler—bloody cruelty.”

[273] The patient uses “Gessler” just as she used “Hufeland,” as a technical term for the petty vexations of asylum life which she imagines she has to endure. The *tertium comparationis* for this metaphor from *William Tell* is the humiliation which Gessler exacted from the people. It is interesting to see how this thought immediately condenses with the personal vexations of the patient: Gessler does not require the people to greet the hat he stuck up, but “always to have the same linen, the same clothes.” Thus the patient completely assimilates the scene from *William Tell* to her own complexes.

[274] (9) *Schiller’s Bell* (stereotypy: “I am Schiller’s *Bell* and the monopoly”): “Well that is—as Schiller’s *Bell* I am also the monopoly—Schiller’s *Bell* needs immediate help—whoever has achieved this needs immediate help—belongs to the highest title in the world—includes the greatest finality—needs immediate help. Because all those who established this are at the end of their life and have worked themselves to death, immediate help is needed. Schiller is the most famous poet—for instance *William Tell*, that is the greatest tragedy—I suffer under Gessler—it is world-famous, the poem: *The Bell*—it also establishes the whole of creation—the creation of the world—that is the greatest conclusion—Schiller’s *Bell* is the creation, the highest finality—that is a governmental ground-pedestal—the world should now be in the best conditions—we have examined everything so practically and so thoroughly—Schiller’s *Bell* is the creation—the work of mighty masters—the world has been helped out of misery—should be in the best conditions.”

[275] Here the *tertium comparationis* is the greatness of achievement: Schiller’s masterpiece is his poem *The Bell*, the patient likewise has achieved “the greatest,” hence something similar to Schiller’s *Bell*. In accordance with her habitual use of thought and language the condensation takes place at once and the patient *is* Schiller’s *Bell*. Because she has achieved her greatest and final work (“the world has been helped out of misery”), nothing greater can come after, besides which she is getting old. So it is not surprising that the complex of death-expectation (which also plays a considerable role in normal people at this age)

appears here and presses for “immediate help,” which naturally means the “payment.” I would mention here, as an instructive intermezzo, that the patient was very annoyed with the former director, Professor Forel, for not giving her this payment. Once during analysis she said: “I also saw in a dream how Mr. Forel was hit by a bullet, thus causing his own death—but that is awfully stupid—one does not always act like this when one has established the note-factory.” She gets rid of her enemies by having them shot out of hand in her dreams. I mention this example not merely because it throws an interesting light on the psychology of our patient but because it is typical of the way by which normal as well as morbid individuals rid themselves in their dreams of persons who are an inconvenience to them. We can confirm this over and over again in our analysis of dreams.

[276] I must content myself here with these nine analyses; they may suffice to shed light on the patient’s “unpleasure” complexes. An important role is played by her physical sufferings, the “burdening system,” “paralysis,” etc. Besides that, the following thoughts are expressed in her stereotypies: she suffers under the discipline imposed by the doctors, and under the treatment she receives from the ward-personnel, she is not recognized, and she does not get her deserts despite the fact that she has achieved the best of everything. The complex of death-expectation is of great significance in determining some of the stereotypies: she tries to palliate it by “establishing” an elixir of life. Any person with a lively sense of his own worth, who for any reason was forced into such a hopeless and morally destructive situation, would probably dream in a similar way. Every emotional and aspiring individual experiences moments of doubt and apprehension in the very hour of supreme self-confidence, when the reversal of his hopes falls on him “like a ton of iron plate.” Ideas of injury are the usual compensation of exaggerated self-esteem, and we seldom find one without the other.

C. THE SEXUAL COMPLEX

[277] So far the analyses have mainly shown us the bright and dark sides of the patient’s social striving, but up to the present we have not encountered the commonest and most frequent manifestations of the complex, namely the sexual manifestations. In a case where the symbolism is so richly developed, the sexual complex cannot be lacking. It is there right enough, elaborated in the finest detail, as the following analyses will show.

[278] (1) *Stuart*: “I have the honour to be von Stuart—so it is described—once when I broached it Dr. B. said: “Why, she was beheaded—von Stuart, Empress Alexander, von Escher, von Muralt—this is also the greatest tragedy in the world—our all-highest deity in heaven—the Roman Mr. St.¹³ has expressed himself giving vent to the highest pain and the highest indignation about this most abominable meaning of the world, where the life of innocent people is persecuted—my eldest sister had to come here so innocently from America, in order to die—then I saw her head at the side of the Roman deity in heaven—but it is abominable that a world like this always comes to light, which persecutes the life of innocent people—Miss S. has caused me consumption—then I saw her lying on the hearse and another, Mrs. Sch., beside her, who was obviously to blame for my coming here—

incredible that the world is not freed from such monsters—Mary Stuart was another such unfortunate who had to die innocent.”

[279] The last sentence makes it clear how the patient came to identify herself with Mary Stuart: it is only another analogy. Miss S. is an inmate of the asylum, with whom the patient gets on badly. She, like the other person who was to blame for the patient’s internment, is therefore on the “hearse.” Whether this is a delusional idea or a dream or hallucination does not matter; it is the same mechanism as above (Forel). A remarkable figure in this analysis is “the Roman Mr. St., our all-highest deity in heaven.” We have already seen that the patient accords herself the title “Lord God,” so in this respect there is a firm association to the idea of divinity. Now comes another connecting-link: the highest deity is called “St.,” the patient’s own name. The predicate “Roman” probably owes its existence to the vague analogy with “Pope.” The deity, like the Pope, is of masculine gender and is thereby distinguished from the patient herself as “Lord God.” Beside the masculine deity, whose name is obviously meant to express an inner affinity with her family, she sees the head of her deceased sister, an image that reminds one of the two pagan divinities, Jupiter and Juno. She thus more or less marries her sister to the divine Mr. St. This seems to be nothing but an analogy, giving promise of her own ascension, when she will become the (sexually not inactive) Queen of Heaven, Mary the mother of God. Such a “sublimation” of exceedingly earthy matrimonial desires has been a favourite plaything of women’s dreams since the dawn of Christianity. From the Christian interpretation of the Song of Songs to the secret raptures of St. Catherine of Siena and the marriage of Hauptmann’s Hannele, it has always been the same story: the prologue in heaven to the earthly comedy. The representation of one’s own complexes by strange actors in dreams is well known even to dream investigators who wish to hear nothing of Freud; in psychopathology we know it in the form of “transitivism.” This interpretation is a conjecture which I hope will be confirmed in the following analyses.

[280] (2) (Stereotypy: “I come first with the deaf and dumb Mr. W. from the city and then with Uster.”) “I come for instance first with the deaf and dumb Mr. W. from the city—you are going here with Mrs. W.-Uster—I am Uster—to guard against perversities I shall tell you who must keep my interest-draughts from Uster—a Mr. Grimm—Uster, Jud, Ith, and Guggenbuhl must keep my interest-draughts—I come first with the deaf and dumb Mr. W. from the city and then with Uster—that is the same interest-draught—that is double the same weight as the interest-draught from Uster—I establish the churches in the city to guard the money—Mr. K. in M. manages my money in St. Peter’s, then I see the deaf and dumb Mr. W. walking across the square near St. Peter’s, in a dream on a Sunday while I slept—Mr. W. can give information about the last penny that belongs to me—Mr. W. belongs to the city and not to Uster—I come first with the deaf and dumb Mr. W. from the city and then with Uster—that is double—same weight.”

[281] By “city” the patient naturally means Zurich; Uster is a small, prosperous industrial town near Zurich. Mr. W. is unknown to me, so I can say nothing about his psychological determination. The essential content of the analysis lies in the first three sentences. We then

learn that Mr. W. can “give information about the last penny” of the patient. In her dream, therefore, he is firmly associated with her riches, and, as the analysis seems to show, especially with the sums deposited in churches. (She once dreamt that the church of St. Peter was filled to the roof for her with five-franc pieces.) This wealth is compared with that of Uster. We know already that the patient “affirms” everything that pleases her. Among the things affirmed are the fine villas, the great business-houses in the city, not to mention the whole of the Bahnhofstrasse in Chur. So it is no wonder that she also affirms the profitable factories in Uster. Therefore she says, “I am Uster.” (She also says, incidentally, “I am Chur.”) Furthermore, she said to me: “You are going here with Mrs. W.-Uster.” This clears the matter up: she means that she is married to Mr. W. Through this marriage she unites the wealth of Zurich and Uster. “That is double the same weight as the interest-draught from Uster.” If we remember the earlier use of “double,” which seemed incomprehensible, we can now give it a satisfying erotic meaning. The marriage that in the preceding analysis was merely suggested by transcendental symbols has here been consummated in somewhat prosaic fashion. But the authentically sexual, not to say “crude,” symbols are still lacking. We shall find them in the following analyses.

[282] (3) *Amphi*: This word crops up only rarely, in the form: “Doctor, there is again too much amphi.” The patient vaguely derives the word from “amphibian.” Occasionally, when she complains about being disturbed every night by “amphi,” she says something about the “ritze-ratze animal” that “gnaws the floor,” but one cannot find out what harm the amphi do to her.

[283] “Amphi—that expresses itself in hedgehog—so broad and so long (indicating with her hands about a foot in length and considerably less in breadth)—one morning Mr. Zuppinger, through pork-sausages—only I don’t know now if the gentlemen specially want to bring such an animal into the world—I established this through pork-sausages—I always hear: there is too much amphi—the animal will only have grown so big by mistake perhaps—it must be in the evacuation (stool)—instead of the factory in S. there was a building for amphi—for productions—I saw in a dream that it was written on an arch in Weggengasse: ‘Only at well-replenished tables after supper’—I never saw such a production—it needs a huge building—we were as in a theatre—up there—I think animals of all descriptions will be discussed—amphi expresses that animals probably have human reason—they can make themselves understood like human beings—they are just amphibians, snakes and suchlike—the hedgehog is so long (indicating a little less than a foot) and on Sunday morning it crawled as far as the well—yes, Mr. Zuppinger, it was through pork-sausages—Mr. Zuppinger has eaten pork-sausages—once when I affirmed my 1,000 millions in a dream, a little green snake came up to my mouth—it had the finest, loveliest feeling, as if it had human reason and wanted to tell me something—just as if it wanted to kiss me.” (At the words “little green snake” the patient showed lively symptoms of affect, blushing and bashful laughter.)

[284] It should be quite clear from the singular content of this analysis what is meant by “amphi.” An amphi is evidently an animal of longish shape, it crawls, it is associated with

amphibians, snakes, hedgehogs, and probably also with “pork-sausages.” Furthermore, it is associated with “gentlemen” (“if the gentlemen specially want to bring such an animal into the world”) and particularly—via the “pork-sausages”—with “Mr. Zuppinger,” about whom I could learn nothing more. It will be particularly enlightening to compare these two passages:

The hedgehog is so long and on Sunday morning it crawled as far as the well—yes, Mr. Zuppinger, it was through pork-sausages. Mr. Zuppinger has eaten pork-sausages.

Once when I affirmed my 1,000 millions in a dream, a little green snake came up to my mouth—it had the finest, loveliest feeling, as if it had human reason and wanted to tell me something—just as if it wanted to kiss me.

[285] It is not difficult for a dream to condense or at least make an analogy of two outwardly similar objects. Such an analogy seems to be the kissing snake and the eating of pork-sausages. The word “kiss” (which produced a lively affect in the patient) gives it an unmistakable sexual nuance. If one pictures to oneself the process by which the snake crawled up to her mouth to kiss her, one will immediately be struck by the coitus-symbolism. According to the well-known Freudian mechanism of “displacement from below upward,” this localization and paraphrase of the coital act is a favourite one, which, like Freud, we were able to demonstrate in numerous normal and pathological dreams.¹⁴ If the coitus-symbol is localized in the mouth, the vague dream-thought readily tends in the direction of eating, so that this act too is frequently included in the coitus-symbolism.¹⁵ With such a constellation, it can easily be understood why the snake changes into a pork-sausage that is eaten (“sausage” is a well-known vulgar expression for penis). “Eating” is therefore analogous to “kissing.” The hedgehog plays a role as an extensile animal, moreover it is obviously connected with the other “complex-animals” by verbal coexistence. The fact that it “crawls” to the well suggests that it is blended with the snake-idea. “Mouth,” however, is represented by “well.” Mouth can be understood as a sexual symbol if one assumes a displacement from below upward; but one need not assume a displacement for “well,” it is simply a metaphorical designation based on the familiar analogy which even the ancients applied to their fountains.

[286] Here, then, we find the “crude” sexual symbols which we have missed till now and which are as a rule so extraordinarily common. From this standpoint we can understand without too much difficulty some of the other details in the above associations. For instance, it is not at all remarkable that the “amphi” has human reason if it is meant to represent a man. It can like-wise be understood why the animal is “in the evacuation.” Presumably this is a vague analogy to the intestinal worm, but the important thing is the localization of the symbol—in the “cloaca” (Freud), which has already been expressed by another symbol, the “well.” The cryptic utterance “Only at well-replenished tables after supper” probably belongs to the sexual symbolism of eating: the nuptial couch generally follows a hearty supper. As an old maid she might well say, “I never saw such a production.” “Theatre” and “animals of all descriptions” give one the feeling that the idea of a menagerie had suddenly bobbed up. This is borne out by the “factory in S.,” for S. is a place near Zurich where there are usually menageries, merry-go-rounds, etc.

[287] (4) *Maria Theresa*: “I belong to the synagogue in Löwenstrasse since 1866, I am a Jewess since 1866—owner of the world—I am therefore three empresses—I am also Maria Theresa as von Planta—that is finality—in the dream I was at a table with omelets and dried prunes—then there was a dam with speaking-tubes in it—then there were four horses with moustaches over their tails—they stood near the speaking-tubes—the third emperor has already legalized this—I am the Emperor Francis in Vienna—in spite of that I am a female—my Liesel rises early and yodels in the morning—that is there too—each horse stood near a speaking-tube.” (Suddenly the patient made a gesture of embracing, and on being questioned said that once in a dream it was as though a man took her in his arms.)

[288] This analysis, unlike any of the others, was continually interrupted by blockings (thought-deprivation) and motor-stereo-typies (embracing), from which we may conclude that it hit thoughts that were very strongly repressed. For instance, the patient went on tracing little circles in the air with her forefinger, saying she “had to show the speaking-tubes,” or she drew little half-moons with both hands: “These are the moustaches.” Besides this the “telephone” kept on making mocking remarks, to which we shall return later.

[289] By “Maria Theresa” the patient obviously means a particular quality of her greatness, so this part of the analysis is of no further interest to us. Then comes a singular dream-image which ends with “I am the Emperor Francis.” The Emperor Francis I was the husband of Maria Theresa. The patient is both of them at once, but “in spite of that I am a female.” She condenses the relationship of these two persons into one person (herself), which in her hazy way of talking probably signifies no more than that both persons have a relationship to one another which bears some resemblance to hers with them. The most likely is the erotic relationship, the wish for a distinguished husband. That it is most probably erotic is clear from the fact that the association which immediately follows is the erotic song: “My Liesel rises early,” etc. The patient connects this song with the horses, which “stood near the speaking-tubes.” Horses in dreams, like bulls, dogs, and cats, are often sexual symbols, because it is from these animals that one is most likely to see crude sexual activities which greatly impress children. Similarly, she connects the horses with the Emperor Francis. This seems to justify the suspicion of an erotic significance. The horses have “moustaches over their tails.” This symbol probably stands for the male genitals, which would also explain the connection with the Emperor Francis, the symbolic husband. Each horse stands near a speaking-tube in a “dam.” I tried to find out whether the patient was acquainted with the anatomical meaning of the word *Damm*,¹⁶ but I was unable to come to any conclusions without asking suggestive questions. I must therefore leave this question *in suspensio*. But considering the patient’s average education it is not unlikely that she knew this meaning of the word. The meaning of the “speaking-tubes” would then be quite unequivocal. With the gesture of embracing and the mention of the sexual dream the situation takes on a definite erotic colouring, which does much to elucidate the obscure symbolism of the preceding images.

[290] (5) *Empress Alexander*: “That expresses von Escher and von Muralt—owner of the world—as Empress Alexander I become owner of the silver island—a Mrs. F. said I had to

send the family of the Russian Czar a hundred thousand milliards—I have ordered them to make money exclusively of the silver island—I am three empresses, von Stuart, von Muralt, von Planta and von Kugler—because I am owner of the world I am Empress Alexander—I am three Excellencies—I am the highest Russian lady—Catheter, Chartreuse, Schatedral, Carreau—I saw a carreau of white horses on the hill—beneath the skin they had half-moons, like little curls—they were hungry—the Emperor von Muralt was up there too—I became engaged to him in the dream—they are Russians, it was a battle attack—on the carreau of horses were gentlemen like Mr. Sch. in U., with long lances—like a battle attack.”

[291] The first associations once again have to do with ideas of grandeur. The peculiar collection of clang-associations (Catheter, Chartreuse, Schatedral, Carreau) leads to the carreau of white horses which, instead of having moustaches like half-moons over their tails, had half-moons under their skin, like “little curls.” This is probably a similar but better disguised sexual symbol. The horses were hungry—a near association to “eating.” “Hunger” indicates an instinct, possibly the sexual instinct.¹⁷ The association does not lead, as in the previous analysis, to the symbolic husband, “Emperor Francis,” but to a similarly exalted synonym, “Emperor von Muralt.” It again goes from horse to man, but this time the sexual relationship is unmistakable, as the patient says she became engaged to him. The horses, too, now receive a characteristic attribute: they are ridden by gentlemen with “long lances—like a battle attack.” Anyone who has analysed dreams knows that whenever women dream of men coming into their room at night armed with daggers, swords, lances, or revolvers, it is invariably a sexual symbol, and that the pricking or wounding weapon is a symbol for the penis. We meet this dream-symbolism over and over again in normal as well as pathological persons. Only recently I saw at the clinic a young girl who had to break off a love-affair out of obedience to her parents. As a result she suffered from a depression with sporadic states of sexual excitement. At night she had stereotyped anxiety dreams in which “someone” came into her room and stabbed her in the breast with a long spear. In another, very similar case the patient always dreamt that as she was crossing the street at night someone waylaid her and shot her in the leg with a revolver. In dementia praecox the sensory hallucination of knives in the genitals is not uncommon. After this explanation the sexual significance of the horses in this and the preceding analysis ought to be clear enough, also the significance of the “battle attack.” The association to “Russians” is not so far-fetched, for although mounted lancers are an unknown spectacle in Switzerland nowadays, Russians, especially Suvarov’s Cossacks from the days of the battle of Zurich (1799), are still alive in the popular memory, and many reminiscences of the older generation gather round these figures. The “battle attack” is probably a synonym for the embrace mentioned in the previous analysis, and the thought of masculine activity is probably also hiding behind the “hunger.” This analysis, therefore, has the same content as the previous one, although the verbal and pictorial symbols have changed.

[292] The analyses so far have been concerned with betrothal, marriage, and coitus. All the details of the wedding festivities were vividly dreamt out by the patient; she summarized them in the words: “I am the lilac new-red sea wonder and the blue.” I must refrain from

going more closely into this dream-image so as not to overload our already very extensive analysis. (The wedding festivities alone run to ten closely written pages of foolscap.) All that is lacking now is the fruit of this sexual union, the children. These appear in the following analysis.

[293] (6) *Bazaar*: “Double bazaar—I affirm two bazaars—W.-bazaar in Bahnhofstrasse and one in the Wühre—ladies’ handwork—the most wonderful plate, glassware, all jewellery, toilet soaps, purses, etc.— Mr. Zuppinger shot out of my mouth as a little boy-doll, once in a dream—he had no uniform on, but the others had military uniforms—they are Czars, the sons of the highest in Russia, dressed up as Czars, hence the word bazaar—the bazaars are extraordinarily good businesses—Czars are hired for these businesses, they have their incomes from these bazaars because they are sons of world-owners and world-owneresses—also a little girl jumped out of my mouth with a little brown frock and a little black apron—my little daughter, she is granted to me—O God, the deputy—she is the deputy, the end of the lunatic asylum came out of my mouth—my little daughter shot out of my mouth to the end of the lunatic asylum—she was slightly paralysed, sewn together from rags—she belongs to a bazaar—you know, these businesses have a large turnover—I came first as double, as sole owner of the world, first with the deaf and dumb Mr. Wegmann from the city and then with Uster—I am the double bazaar.” (Later, when part of the analysis was repeated, the patient said: “Both children look like dolls, and they have this name from the bazaar.”)

[294] As the analysis shows, there can be no doubt that the patient’s delusions have also created children for her. But it is especially interesting to note the circumstances under which this delusional formation arose and how it was determined. It was while she was reeling off a long list of the goods in the bazaar (greatly abbreviated here) that she mentioned that Mr. Zuppinger shot out of her mouth as a little boy-doll, in a dream. If we remember the analysis given under item 3, where “Mr. Zuppinger” is firmly associated with all sorts of sexual symbols, we would seem to be confronted simply with the consequences of this delusional love-affair. The patient’s peculiar description has, however, an historical antecedent. As early as 1897 it was noted in her clinical record that Dr. D., the first assistant, who at that time was revered by the patient, “came out of her mouth”: “tiny little Dr. D., the son of the Emperor Barbarossa.” Dr. D. had a reddish beard, which obviously accounts for the formation “Barbarossa.” His elevation to the status of Emperor, presumably a symbol of the estimation in which she held him, seems, like the veneration, to have transferred itself to Dr. D.’s successor, Dr. von Muralt (the “Emperor von Muralt,” to whom she is betrothed). The passage we have just quoted can safely be regarded as the birth of a son begotten by Dr. D., and the episode with “Mr. Zuppinger” is constructed on the same pattern. The manner of birth, the emergence of the child from the mouth, is an obvious confirmation of the “displacement from below upward” and therefore lends powerful support to our interpretation of “snake” and “mouth” in the analysis of (3) *Amphi*. That the little boy is “Mr. Zuppinger,” or at any rate stands in a certain relationship to this gentleman, accords perfectly with the conjectured sexual significance of Mr. Z. The description of the child as a “little boy-doll” can probably be explained by the connection with “bazaar,”

where dolls are often displayed on the stalls. Just as “mouth” is a substitute for genitals, so “doll” is a more innocent substitute for child, just as it is in ordinary life. The sentences “he had no uniform on,” “they are Czars,” etc., seem to be reminiscences of the (5) *Empress Alexander* analysis, where the critical “battle-attack” by the lancers is associatively connected with the “Russians,” the link with “Czar.” By means of a clang-association the patient finds her way back to “bazaar” and then presents a train of thought which is altogether typical of the unclear thinking in dementia praecox: “The bazaars are extraordinarily good businesses—Czars ... have their income from these bazaars.” Here the clang-association *Czar / bazaar* is obviously a meaningful one for the patient. She says: “The sons of the highest in Russia, dressed up as Czars, hence the word bazaar.” This is another contamination: like all good businesses, the patient “affirms” the bazaars as her property. She is the Czarina, just as she is every other distinguished personality; the specific determinant of this status may be the lancers. These two diverse trains of thought blend together by clang-association, and so it comes about that the Czars are bazaar-owners. Since the “battle-attack” by the lancers resulted in the birth of a son, this son becomes Czar and is accordingly the owner of a bazaar.

[295] The marked tendency of dreams to create analogical formations leads, as in the other sexual symbols, to a second delusional birth: a little girl is likewise born from the patient’s mouth. She wears a “little brown frock” and a “little black apron.” This is the usual dress of the patient and she has long been dissatisfied with it; hence she frequently complains and has already “affirmed” a copious wardrobe in her dreams. The words “sewn together from rags” are a reference to this. But the similarity of mother and daughter is crowned by the fact that the child is “slightly paralysed,” i.e., endures the same sufferings as the patient. The child has been “granted” to her as her “deputy”—in other words, because of this similarity the child will, so to speak, take upon herself the fate of the patient and thereby release her from her manifold sufferings in the lunatic asylum. Hence the patient can say, in a figurative sense: “The end of the lunatic asylum came out of my mouth.” On another occasion she said that the child was the “Socrates deputy.” As will be remembered, the patient identifies herself with Socrates since he, like her, was unjustly imprisoned and suffered innocently. Now the daughter takes over her role as Socrates and accordingly becomes the “Socrates deputy,” which fully explains this singular neologism. To make the analogy complete, the little daughter, like her brother the Czar, is given a bazaar by way of indemnity. This double bequest of bazaars leads to the pronouncement: “I came first as double—I am the double bazaar.” On top of that she adds the familiar Uster stereotypy, which has a distinctly sexual connotation. The word “double” may therefore have a variously determined sexual meaning, namely that of marriage.

[296] In the further course of this analysis (which for the sake of brevity I have not reported in full) the patient elaborated on the theme of how she looked after her children, and finally she extended it to her parents who died in poverty. (“By me my parents are clothed, my sorely tried mother—I sat with her at table, covered white with abundance.”)

D. SUMMARY

[297] In the foregoing discussion we saw how the patient, brought up in miserable home circumstances, amid poverty and hard work, creates in her psychosis a tremendously complicated and to all appearances utterly confused and senseless fantasy-structure. The analysis, which we have conducted just as we would a dream-analysis, shows material that is grouped round certain “dream-thoughts”—thoughts, that is to say, which are understandable enough psychologically if we consider the personality of the patient and her circumstances. The first part of the analysis describes her sufferings and their symbols; the second, her wishes and their fulfilment in symbolic images and episodes. The third part deals with her intimate erotic wishes and the solution of this problem through the transfer of her power and her sufferings to the “children.”

[298] The patient describes for us, in her symptoms, the hopes and disappointments of her life, just as a poet might who is moved by an inner, creative impulse. But the poet, even in his metaphors, speaks the language of the normal mind, therefore most normal people understand him and recognize in his mental products the true reflections of his joys and sorrows. Our patient, however, speaks as if in a dream—I can think of no better expression. The nearest analogy to her thinking is the normal dream, which employs the same or at least very similar psychological mechanisms and cannot be understood by anyone who does not understand Freud’s method of analysis. The poet works with the most powerful means of expression and for the most part consciously, he thinks directedly, whereas our half-educated and poorly endowed patient thinks in vague, dreamlike images without any directing ideas and with only the feeblest means of expression. All this has helped to make her thought-processes as impenetrable as possible. It is a trite saying that everyone is unconsciously a poet—in his dreams. In dreams he remoulds his complexes into symbolic forms, in a disconnected, aphoristic manner, and only seldom do the dream-formations assume a broader, more coherent structure, for this requires complexes of poetic—or hysterical—intensity. But our patient has created a long-drawn-out and elaborately woven tissue of fancies, comparable on the one hand to an epic poem and on the other to the romances and fantasy-productions of somnambulists. In our patient, as with the poet, the web of fantasy is woven in the waking state, whereas in somnambulists the extension and elaboration of the system are usually accomplished in a dissociated, “other” state of consciousness. But just as somnambulists prefer to translate everything into fantastic and sometimes mystical forms, in which the sharp outlines of the images are often blurred as in dreams, so our patient expresses herself in monstrous, grotesque, distorted metaphors, which are more like normal dreams with their characteristic absurdities. What she has in common with the “conscious” poet and the “unconscious” poet, the somnambulist, therefore, is simply the extension and constant elaboration of the fantasies, while the absurd, the grotesque, the lack of everything beautiful, seems to be derived from the dreams of the normal average person. Hence the psyche of the patient stands midway between the mental state of the normal dreamer and that of the somnambulist, with the difference that dreaming has largely replaced the waking state, and the “*fonction du réel*,” or adaptation to the environment, is seriously impaired. I first showed how dream-formations develop out of complexes in my “Psychology and Pathology of So-called Occult Phenomena,”¹⁸ and I must

refer the reader to this paper, as it would lead us much too far to go into this special field here. Flournoy¹⁹ has pointed out the roots of the complexes in the dreams of Hélène Smith. I regard knowledge of these phenomena as indispensable for understanding the problems we have been discussing.

[299] The conscious psychic activity of the patient, then, is limited to a systematic creation of wish-fulfillments as a substitute, so to speak, for a life of toil and privation and for the depressing experiences of a wretched family milieu. The unconscious psychic activity, on the other hand, is entirely under the influence of repressed, contradictory complexes—on one side the complex of injury, on the other the remnants of normal correction.²⁰ The entry of fragments of these split-off complexes into consciousness occurs chiefly in the form of hallucinations, in the manner described by Gross, and from psychological roots as conjectured by Freud.

[300] The associative phenomena are in accord with the views of Pelletier, Stransky, and Kraepelin. The associations, though following a vague theme, are without any directing idea (Pelletier, Liepmann) and therefore show all the symptoms of Janet's *abaissement du niveau mental*: release of automatisms (thought-deprivation, pathological ideas) and reduction of attention. The consequence of this last is an incapacity for clear ideation. The ideas are indistinct, no proper differentiation takes place, and this leads to numerous confusions, condensations, contaminations, metaphors, etc. The condensations mostly follow the law of similarity of imagery or sound, so that meaningful connections largely disappear.

[301] The metaphorical modulations of the complexes are closely analogous on the one hand to normal dreams and on the other to the wish-dreams of hysterical somnambulists.

[302] The analysis of this case of paranoid dementia thus confirms in large measure the theoretical assumptions we made in the preceding chapters.

E. SUPPLEMENT

[303] In conclusion I would like to call attention to two special points. First of all, the verbal expression. As in normal speech, the speech of the patient shows a tendency to change. Generally, innovations of language are technical terms serving to designate in concise form certain complicated ideas. In normal speech the formation and acceptance of technical terms is a slow process, and their use is generally dependent on certain requirements of intelligibility and logic. In the patient this process has taken place with pathological speed and intensity which far exceed the understanding of people in her environment. The way the pathological term is formed often bears a resemblance to the changes in normal speech; here I would only mention the change of meaning in the word "Languedoc."²¹ There are many similar examples in the history of language. Unfortunately I am not at all at home in this field, so that I would not dare to look for further analogies. But I have the feeling that a philologist would be able to make valuable observations on speech-confused patients which would help us to understand the normal changes that have occurred in the history of language.

[304] Second, the auditory hallucinations that play such a peculiar role in our patient. She elaborates her daytime wishes in the waking state and at night in dreams. This is an occupation which obviously affords her pleasure, since the direction it takes accords with her innermost wishes. Anyone who thinks so exclusively and so persistently in one fixed and limited direction is bound to repress all contrary thoughts. We know that in normal people—that is, temperamental people who are at any rate halfway normal—the same mood may continue for a very long time, but then is suddenly interrupted with positively elemental force by an invasion from another sphere of thought. We see this in extreme form in hysterical patients with dissociated consciousness, where one state is suddenly superseded by its opposite. The contrary state often manifests itself in hallucinations and various other automatisms (cf. Flournoy), just as every split-off complex habitually disturbs the activity of another complex simultaneously existing in consciousness. (We could compare this to the disturbances caused by an invisible planet in the orbit of a visible one.) The stronger the split-off complex is, the more intensely the automatic disturbances will make themselves felt. The best examples of this are the so-called teleological hallucinations, which I should like to illustrate by three examples from my experience.

[305] (1) A patient in the first stages of progressive paralysis wanted in desperation to kill himself by jumping out of the window. He jumped on to the window-sill, but at that moment a tremendous light appeared in front of the window, hurling him back into the room.

[306] (2) A psychopath who was disgusted with life because of his misfortunes wanted to commit suicide by inhaling gas from an open jet. He inhaled the gas vigorously for a few seconds, then suddenly felt an enormous hand grasp him by the chest and throw him to the floor, where he gradually recovered from his fright. The hallucination was so distinct that the next day he could still show me the place where the five fingers had gripped him.

[307] (3) A Russian-Jewish student, who later fell ill with a paranoid form of dementia praecox, told me the following story. Under the stress of extreme hardship, he resolved to become a Christian, although he was very orthodox and had strong religious scruples about conversion. One day, following another long spell of starvation, he decided after a hard struggle to take this step. With this thought in mind he fell asleep. In a dream his dead mother appeared before him and uttered a warning. When he awoke, his religious scruples rose up again because of the dream, and he could not make up his mind to be converted. So he tormented himself for weeks on end until finally, driven by continued hardship, he once more thought of getting converted, this time more energetically than before. One evening, therefore, he resolved to apply for baptism the very next morning. That night his mother again appeared before him in a dream and said, "If you go over I will choke you." This dream frightened him so much that he gave up his decision once and for all, and, to escape his hardships, emigrated to a foreign country. Here we see how the repressed religious scruples made use of the strongest possible symbolic argument, his piety towards his dead mother, and in this way overrode the ego-complex.

[308] The psychological life of all epochs is rich in such examples. As we know, the daemon of Socrates played a teleological role. One recalls, for example, the anecdote of the daemon warning the philosopher about a herd of swine (there are similar incidents in Flournoy). Dreams, which are the hallucinations of normal life, are nothing but hallucinatory representations of repressed complexes. It is therefore to be expected that in our patient all the contrary complexes under repression will work upon her consciousness in the form of hallucinations. Her voices therefore have an almost exclusively disagreeable and derogatory content, just as paraesthesias and other automatic phenomena are generally of an unpleasant character.

[309] As usual, we find in this patient the complex of grandeur alongside that of injury. But part of the “injury” consists in the normal correction of her grotesque ideas of grandeur. That such a correction still exists seems *a priori* quite possible, since even in patients who are far more impaired, intellectually and emotionally, than she was, there are still signs of more or less extensive insight into the illness. Naturally the correction runs counter to the complex of grandeur that entirely occupies her consciousness; hence, being repressed, it probably works through hallucinations. This actually seems to be the case; at any rate certain observations favour such a supposition. While the patient was telling me what a misfortune it would be for humanity if she, the owner of the world, should have to die before the “payment,” the “telephone” suddenly remarked, “It would do no harm, they would simply take another owner.”

[310] Again, while associating to the neologism “million Hufeland,” she was continually hindered by thought-deprivation, and for a long time I could get no further. Suddenly, to the great chagrin of the patient, the telephone called out, “The doctor should not bother himself with these things.” The associations to “Zähringer” likewise presented difficulties, whereupon the telephone said, “She is embarrassed and therefore can say nothing.” Once when she remarked during analysis that she was “a Switzerland” and I had to laugh, the telephone exclaimed, “That is going a bit too far!” She got quite particularly stuck at the neologism “Maria Theresa,” so that I absolutely could not follow her; the thing was really too complicated. The following dialogue then developed:

Telephone: “You’re leading the doctor round the whole wood.”

Patient: “Because this also goes too far.”

Telephone: “You’re too clever by half!”

[311] When she came to the neologism “Emperor Francis” the patient began to whisper, as she often did, so that I continually misunderstood her. She had to repeat several sentences out loud. This made me rather nervous and I told her impatiently to speak louder, whereupon she answered irritably too. At this moment the telephone called out: “Now they’re getting in each other’s hair!”

[312] Once she said, with great emphasis, “I am the keystone, the monopoly and Schiller’s *Bell*,” and the telephone remarked, “That is so important that the markets will drop!”

[313] In all these examples the “telephone” has the character of an ironically commenting spectator who seems to be thoroughly convinced of the futility of these pathological fancies and mocks the patient’s assertions in a superior tone. This kind of voice is rather like a personified self-irony. Unfortunately in spite of diligent research I lack the necessary material for a closer characterization of this interesting split-off personality. But the meagre material we possess at least allows us to conjecture that besides the complexes of grandeur and injury there is another complex which has retained a certain amount of normal criticism but is withheld from reproduction by the complex of grandeur, so that no direct communication can be had with it. (As we know, in somnambulism direct communication can be had with such personalities by means of automatic writing.)

[314] This apparent division of the complexes into three gives us food for thought, not only in regard to the psychology of dementia praecox but also in regard to its clinical aspects. In the case of our patient, communication with the outside world was dominated by the complex of grandeur. This might be merely an accident. We know of many cases where reproduction is dominated by the complex of injury and where we find only the barest suggestion of ideas of grandeur. Finally, there are cases where a correcting, ironical, semi-normal ego-remnant remains on top, while the two other complexes are acted out in the unconscious and make themselves felt only through hallucinations. An individual case can vary temporarily according to this scheme. In Schreber, for instance, we see during convalescence the reappearance of a corrective ego-remnant.

Epilogue

[315] I do not imagine that I have offered anything conclusive in this paper; this whole field is much too broad and at present much too obscure for that. It would be far beyond the power of a single individual to carry out by himself, in the course of a few years, all the experimental work which alone could lend support to my hypothetical views. I must content myself with the hope that this analysis of a case of dementia praecox will give the reader some idea of our method of thought and work in this field of research. If at the same time he will take into account the basic assumptions and experimental proofs offered in *Studies in Word Association*, he may be in a position to form a coherent picture of the psychological points of view from which we consider the pathological mental disturbances in dementia praecox. I am fully aware that this case only partially corroborates the views expressed in the preceding chapters, since it serves as no more than a paradigm for certain types of paranoid dementia. It manifestly does not touch on the extensive domains of catatonia and hebephrenia. In this connection I must console the reader with the prospect of further contributions to *Studies in Word Association*,²² which I hope will furnish more experimental work on the psychology of dementia praecox.

[316] I have made it easy for the critics: my work has many weak spots and gaps, for which I crave the reader’s indulgence. All the same, the critic must be ruthless in the interests of truth. Somebody, after all, had to take it on himself to start the ball rolling.

II

THE CONTENT OF THE PSYCHOSES

[Delivered as an academic lecture, *Der Inhalt der Psychose*, in the Zurich Town Hall, January 16, 1908, and then published as no. III in the series “Schriften zur angewandten Seelenkunde,” edited by Sigmund Freud (Leipzig and Vienna, 1908). A second edition appeared (Leipzig and Vienna, 1914), augmented by an introduction and a supplement consisting of a German version of “On Psychological Understanding” (see *infra*, pp. 179ff.). “The Content of the Psychoses” was translated by M. D. Eder in *Collected Papers on Analytical Psychology*, edited by Constance Long (London and New York, 1916; 2nd edn., 1917). The Eder translation has been consulted.—EDITORS.]

INTRODUCTORY

[317] My short sketch on “The Content of the Psychoses,” which first appeared in the series “Schriften zur angewandten Seelenkunde,” under Freud’s editorship, was intended to give the educated lay public some insight into the psychological standpoint of modern psychiatry. I chose by way of example the mental illness known as dementia praecox, which Bleuler calls schizophrenia. Statistically, this group of illnesses contains by far the largest number of cases of psychosis. Many psychiatrists would prefer to limit its scope, and accordingly they make use of other nomenclatures and classifications. From the psychological point of view the change of name is unimportant, for it is of less value to know what a thing is called than to know what it is. The cases I have sketched in this paper are types of common mental disturbances well known to the psychiatrist. It makes no difference to the facts whether these disturbances are called dementia praecox or by some other name.

[318] I have set forth my psychological position in a work ¹ whose scientific validity has been contested upon all sorts of grounds. It is particularly gratifying to me that a psychiatrist of Bleuler’s standing has fully accepted, in his great monograph ² on the disease, all the essential points in my work. The chief difference between us is as to whether the psychological disturbance should be regarded as primary or secondary in relation to the physiological basis. The resolution of this weighty question depends on the general problem of whether the prevailing dogma in psychiatry—“mental diseases are diseases of the brain”—represents a final truth or not. We know that this dogma leads to absolute sterility as soon as it is assumed to be generally valid, for there are undoubted psychogenic mental disturbances (those called “hysterical”) which are properly designated as *functional* in contrast to the organic diseases which are due to demonstrable anatomical changes. We should designate as organic diseases only those disturbances of the brain function where the psychic symptoms can be proved to be dependent upon a primary disease of the organic substrate. Now in dementia praecox this is by no means clear. Definite anatomical changes have been found, but we are very far from being able to derive the psychological symptoms from these findings. We have, as a matter of fact, positive indications as to the functional character of at least the initial stages of schizophrenia; further, the organic character of paranoia and of many paranoid forms is more than doubtful. This being so it is worth while to inquire whether secondary symptoms of degeneration might not arise from a psychological disturbance of function. Such an idea is incomprehensible only to those who smuggle materialistic preconceptions into their scientific theories. Nor is my inquiry based on equally arbitrary “spiritualistic” assumptions, but on the following simple argument. Instead of assuming that some

hereditary disposition, or a toxin, gives rise directly to an organic process of disease, thereby inducing secondary psychic disturbances, I incline to the view that, on the basis of a disposition whose nature is at present unknown to us, an unadapted psychological function arises which may develop into a manifest mental disturbance and *secondarily* induce symptoms of organic degeneration. This view is borne out by the fact that we have no proof of the primary nature of the organic disturbance, but proofs in abundance of a primarily psychological failure of function whose history can be traced back into early childhood. It accords very well with this view that the practising analyst knows cases where patients on the borderline of dementia praecox could still be brought back to normal life.

[319] Even if regular anatomical findings or actual organic symptoms could be proved, scientists should not imagine that the psychological standpoint can be abandoned and the undoubted psychological connections given up as unimportant. If, for instance, cancer should turn out to be an infectious disease, the peculiar process of proliferation and degeneration in the cancer cells would still remain a factor requiring investigation on its own account. As I have said, however, the connection between the anatomical findings and the psychological picture of the disease is so loose that it is very well worth while to examine the psychological side of it thoroughly for once, since there have been all too few attempts in this direction so far.

C. G. JUNG

Küsnacht / Zurich, 1914

THE CONTENT OF THE PSYCHOSES

[320] Psychiatry is a stepchild of medicine. All the other branches of medicine have one great advantage: the scientific method. In all other branches there are things that can be seen and touched, physical and chemical methods of investigation to be followed. The microscope reveals the dreaded bacillus, the surgeon's knife halts at no anatomical difficulty and gives us glimpses into the most vital and inaccessible organs. Psychiatry, the art of healing the soul, still stands at the door, seeking in vain to weigh and measure as in the other departments of science. We have long known that we have to do with a definite organ, the brain; but only beyond the brain, beyond the anatomical substrate, do we reach what is important for us—the psyche, as indefinable as ever, still eluding all explanation, no matter how ingenious.

[321] Former ages, endowing the soul with substance and personifying every incomprehensible occurrence in nature, regarded mental illness as the work of evil spirits; the patient was looked upon as one possessed, and the methods of treatment

were such as befitted this conception. It is not unknown for this medieval view to find credence and expression even today. A classic example is the expulsion of the devil which was successfully performed by the elder Pastor Blumhardt in the famous case of the Dittus sisters.¹ To the honour of the Middle Ages be it said that there were also early evidences of a sound rationalism. Thus, in the sixteenth century at the Julius Hospital in Würzburg, mental patients were already being treated side by side with the physically sick, and the treatment seems to have been really humane. With the opening of the modern era and the dawn of the first scientific ideas, the original barbaric personification of unknown powers gradually disappeared; a change arose in the conception of mental disease in favour of a more philosophic moral attitude. The ancient view that every misfortune was the vengeance of offended gods returned in a new guise to suit the times. Just as physical diseases can, in many cases, be traced back to some frivolous self-injury, so mental diseases were believed to be due to some moral injury, or sin. Behind this conception, too, lurks the angry deity.

[322] Such views played a great role right up to the beginning of the last century, especially in German psychiatry. In France, however, at about the same time, a new idea was appearing, destined to sway psychiatry for a hundred years. Pinel, whose statue fittingly stands at the gateway of the Salpêtrière in Paris, removed the chains from the insane and thus freed them from the stigma of the criminal. In this way he gave the most effective expression to the humane and scientific conceptions of modern times. A little later Esquirol and Bayle made the discovery that certain forms of insanity ended in death after a relatively short time, and that regular changes in the brain could be demonstrated *post mortem*.² Esquirol had discovered general paralysis of the insane (or, as it was popularly called, “softening of the brain”), a disease which is always accompanied by chronic inflammatory shrinkage of the cerebral tissue. Thus was laid the foundation of the dogma which you will find repeated in every text-book of psychiatry: “Mental diseases are diseases of the brain.”

[323] Further confirmation of this view was furnished about the same time by the discoveries of Gall, who traced partial or complete loss of the power of speech—a psychic faculty—to a lesion in the region of the lower left frontal convolution. Later this view proved to be exceedingly fruitful. Innumerable cases of extreme idiocy and other serious mental disorders were found to be caused by tumours of the brain. Towards the end of the nineteenth century Wernicke (recently deceased) localized the speech-centre in the left temporal lobe. This epoch-making discovery raised hopes to the highest pitch. It was expected that the time was not far off when every characteristic and every psychic activity would be assigned its place in the cortical grey matter. Gradually, more and more attempts were made to trace the primary mental changes in the psychoses back to parallel changes in the brain. Meynert, the famous Viennese psychiatrist, propounded a regular system in which the alteration of

the blood-supply to certain areas of the cortex was to play the chief role in the origin of the psychoses. Wernicke made a similar but far more ingenious attempt at an anatomical explanation of psychic disturbances. One visible result of this tendency can be seen in the fact that nowadays even the smallest and most out of the way asylum has its anatomical laboratory, where cerebral sections are cut, stained, and examined under the microscope. Our numerous psychiatric journals are full of morphological contributions, investigations on the path of the fibres in the brain and spinal cord, on the structure and distribution of cells in the cerebral cortex, and the various ways they are destroyed in different mental diseases.

[324] Psychiatry has been charged with gross materialism. And quite rightly, for it is on the road to putting the organ, the instrument, above the function—or rather, it has long been doing so. Function has become the appendage of its organ, the psyche an appendage of the brain. In modern psychiatry the psyche has come off very badly. While immense progress has been made in cerebral anatomy, we know practically nothing about the psyche, or even less than we did before. Modern psychiatry behaves like someone who thinks he can decipher the meaning and purpose of a building by a mineralogical analysis of its stones. Let us try to form a statistical picture of the number and types of mental patients who show any clear lesions of the brain.

[325] In the last four years we have admitted 1,325 mental patients to Burghölzli Mental Hospital—some 331 a year—of whom 9% suffer from *constitutional* psychic anomalies. By this I mean an inborn defect of the psyche. Of the 9%, about a quarter are imbeciles, congenitally feeble-minded. In them we find definite cerebral changes such as congenital microcephalus, pronounced hydrocephalus, and malformation of certain parts of the brain. The remaining three quarters of the psychopathically inferior show no trace of typical findings in the brain.

[326] Three per cent of our patients suffer from epileptic mental disturbances. In the course of epilepsy a typical degeneration of the brain gradually sets in, which I cannot describe more closely here. The degeneration is demonstrable only in severe cases and after the illness has lasted a long time. If the attacks have been present for a relatively short time only, not more than a few years, as a rule nothing can be discovered in the brain.

[327] Seventeen per cent of our patients suffer from progressive paralysis and senile deterioration. Both diseases present characteristic cerebral findings. In progressive paralysis there is regularly an extensive shrinkage of the brain, so that the cerebral cortex in particular is often reduced by one half. Especially the frontal portions of the brain may be reduced to a third of the normal weight. A similar destruction occurs in senile deterioration.

[328] Fourteen per cent of the patients admitted annually suffer from poisoning, at least 13% of the cases being due to alcohol. As a rule, in milder cases nothing can be found in the brain; only in relatively few of the more severe cases is there a slight shrinkage of the cortex. The number of these severe cases amounts to less than 1% of the yearly cases of alcoholism.

[329] Six per cent of the patients suffer from so-called manic-depressive insanity, which comprises the manias and the melancholias. The essence of this disease can be understood even by the layman. Melancholia is a condition of abnormal sadness with no disturbance of intelligence and memory. Mania is the opposite, the rule being an abnormally excited state with great restlessness, but without any deeper disturbance of intelligence and memory. In this disease no morphological lesions of the brain can be demonstrated.

[330] Forty-five per cent of the patients suffer from the authentic and common disease known as dementia praecox. The name is a very unhappy one, for the dementia is not always precocious, nor in all cases is there dementia. Unfortunately the disease is too often incurable; even in the best cases, in recoveries where the layman would notice no abnormality, one always finds some defect in the patient's emotional life. The clinical picture is incredibly varied; usually there is some disturbance of feeling, very often there are delusions and hallucinations. As a rule there is nothing to be found in the brain. Even in cases of the most severe type, lasting for years, an intact brain is not infrequently found post mortem. Only in a few cases are slight changes to be found, which cannot yet, however, be proved to be regular.

[331] To sum up: in round figures about a quarter of our patients show more or less extensive alterations and lesions of the brain, while three-fourths have a brain which seems to be generally unimpaired or at most exhibits changes such as afford absolutely no explanation of the psychological disturbance.

[332] These figures offer the best possible proof that the purely anatomical approach of modern psychiatry leads—to put it mildly—only very indirectly to the goal, which is the understanding of the psychic disturbance. In addition, it must be remembered that the mental patients who show the most striking lesions of the brain die after a relatively short time; consequently, the chronic inmates of the asylum, who form its real population, consist of up to 70 or 80% cases of dementia praecox, that is, of patients in whom anatomical changes are practically non-existent. The way to a psychiatry of the future, which is to come to grips with the essence of the matter, is therefore clearly marked out: it can only be by way of psychology. For this reason we have entirely abandoned the anatomical approach in our Zurich Clinic and have turned to the psychological investigation of mental disease. Since most of our patients suffer from dementia praecox, this disease is naturally our chief problem.

[333] The older clinicians paid great attention to the psychological precursors of insanity, just as the lay public still does, following a true instinct. We took up this trail and carefully investigated the previous psychological history whenever possible. Our efforts were richly rewarded, for we found surprisingly often that the illness broke out at a moment of some great emotion which, in its turn, had arisen in a more or less normal manner. We also found that in the mental disease which ensued there were a number of symptoms that could not be understood at all from the anatomical standpoint. These symptoms immediately became comprehensible when considered from the standpoint of the individual's previous history. Freud's pioneering investigations into the psychology of hysteria and dreams afforded us the greatest stimulus and help in our work.

[334] A few examples of the most recent departures in psychiatry will, I think, make the subject clearer than any amount of dry theory. In order to bring home to you the difference in our conception I shall, in each case, first describe the medical history in the older fashion, and then give the solution characteristic of the new approach.

[335] The first case to be considered is that of a cook, aged 32. She had no hereditary taint, was always very industrious and conscientious, and had never been noticeable for eccentric behaviour or the like. Quite recently she became acquainted with a young man who wanted to marry her. From that time on she began to show certain peculiarities. She often spoke of his not liking her very much, was frequently out of sorts, moody, and sat alone brooding. Once she ornamented her Sunday hat very strikingly with red and green feathers; another time she bought a pair of pince-nez to wear when she went out walking with her fiancé. One day the sudden idea that there was something the matter with her teeth would not let her rest, and she decided to get a new set, although it wasn't absolutely necessary. She had all her teeth out under an anaesthetic. The following night she suddenly had a severe anxiety-attack. She cried and moaned that she was damned for ever, for she had committed a great sin: she should not have allowed her teeth to be extracted. She must be prayed for, so that God would pardon her sin. In vain her friends tried to talk her out of her fears, to assure her that the extraction of teeth was not really a sin; it availed nothing. At daybreak she became somewhat quieter, and worked throughout the day. On the following nights the attacks were repeated. On being consulted I found the patient quiet, but with a rather vacant expression. I talked to her about the operation, and she assured me that it was not so dreadful to have teeth extracted, but still it was a great sin, from which position, despite every persuasion, she could not be moved. She continually repeated in plaintive, pathetic tones: "I should not have allowed my teeth to be taken out, yes, yes, it was a great sin and God will never forgive me." She gave the impression of real insanity. A few days later her condition grew worse and she

had to be brought to the asylum. The anxiety attack persisted and did not stop; it was a disturbance that lasted for months.

[336] This history shows a series of symptoms which are all quite absurd. Why this queer story of the hat and the pince-nez? Why these anxiety attacks? Why this delusion that the extraction of her teeth was an unpardonable sin? Nothing is clear. The anatomically-minded psychiatrist would say: This is just a typical case of dementia praecox. It is the essence of insanity, of “madness,” to talk of nothing but absurdities; the view the diseased mind has of the world is deranged, crazy. What is no sin for a normal person is a sin for a mad one. It is a bizarre delusion characteristic of dementia praecox. The extravagant lamentation about this supposed sin is the result of “inappropriate” emotional emphasis. The eccentric ornamentation of the hat, the pince-nez, are bizarre notions such as are very common in these patients. Somewhere in the brain a few cells have got out of order and produce illogical, senseless ideas of one kind or another which are quite without psychological meaning. The patient is obviously a congenital degenerate with a feeble brain, having from birth a kink which contained the seed of the disorder. For some reason or other the disease suddenly broke out now; it could just as easily have broken out at any other time.

[337] Perhaps we should have had to capitulate to these arguments had not fate come to the aid of our psychological analysis. In connection with the formalities required for her admission to the asylum it was found that many years ago the patient had an affair which came to an end when her lover left her with an illegitimate child. The otherwise respectable girl sought to hide her shame and had the child secretly brought up in the country. Nobody knew of this. When she got engaged she was in a dilemma: what would her fiancé say? At first she put off the marriage, becoming more and more worried, and then the eccentricities began. In order to understand them, we have to feel our way into the psychology of the naïve mind. If we have to disclose some painful secret to a person we love, we usually try to strengthen his love beforehand so as to obtain a guarantee of his forgiveness. We do it by flattery or by sulking, or we try to show off the value of our own personality so as to raise it in the eyes of the other. Our patient decked herself out with “fine feathers,” which to her simple taste seemed worthy of esteem. The wearing of pince-nez increases the respect of children, even when they are older. And who does not know people who will have their teeth extracted out of sheer vanity, simply in order to wear a denture?

[338] After such an operation most people find themselves in a slightly nervous state, when everything becomes much more difficult to bear. And it was just at this moment that the catastrophe occurred: her fear lest her fiancé should break with her when he heard of her previous life. That was the first anxiety attack. Just as the patient had not

admitted her fault all these years, so now she still sought to guard her secret, and shifted her pangs of conscience on to the extraction of her teeth. In this she followed the well-known pattern, for when we cannot admit a great sin, we deplore a small one with all the greater emphasis.

[339] The problem seemed insoluble to the weak and sensitive mind of the patient, hence the affect became insurmountably great. That is how mental illness looks from the psychological side. The series of apparently meaningless happenings, the so-called “absurdities,” suddenly take on meaning. We understand the method in the madness, and the insane patient becomes more human to us. Here is a person like ourselves, beset by common human problems, no longer merely a cerebral machine thrown out of gear. Hitherto we thought that the insane patient revealed nothing to us by his symptoms except the senseless products of his disordered brain-cells, but that was academic wisdom reeking of the study. When we penetrate into the human secrets of our patients, the madness discloses the system upon which it is based, and we recognize insanity to be simply an unusual reaction to emotional problems which are in no wise foreign to ourselves.

[340] The light that is shed by this view seems to me exceedingly great, for it penetrates into the innermost depths of the mental disturbance which is the commonest in our asylums and the least understood; indeed, because of the craziness of its symptoms, it is the type that strikes the layman as madness *in excelsis*.

[341] The case I have just sketched is a simple one. It is, in fact, quite transparent. My second example is somewhat more complicated. It is the case of a man between 30 and 40 years of age; he is a foreign archaeologist of great learning and extraordinary intelligence. He was an intellectually precocious boy, very sensitive, with excellent qualities of character and unusual gifts. Physically he was small, weakly, and afflicted with a stammer. Brought up and educated abroad, he afterwards studied for several terms in B. Up to this point there had been no disturbances of any kind. On completing his university studies he immersed himself in his archaeological work, which gradually absorbed him to such an extent that he was dead to the world and all its pleasures. He worked incessantly, and buried himself entirely in his books. He became thoroughly unsociable; awkward and shy in society before, he now shunned it altogether, and saw no one beyond a few friends. He thus led the life of a hermit devoted entirely to science.

[342] A few years later, on a holiday tour, he revisited B., where he remained a few days. He walked a great deal in the environs of the town. The few acquaintances he had there found him strange, taciturn, and nervous. After a rather long walk he seemed very tired, and remarked that he did not feel very well. He then talked of getting himself hypnotized, as he felt nervously run down. On top of this he fell

physically ill with inflammation of the lungs. Soon afterwards a peculiar state of excitement supervened, which rapidly passed over into frenzy. He was brought to the asylum, where for weeks he remained in an extremely excited state. He was completely deranged, did not know where he was, spoke in broken sentences which no one could understand. Often he was so excited and aggressive that it took several attendants to hold him down. He gradually became quieter, and one day he came to himself as if waking out of a long, confused dream. He quickly obtained complete insight into his illness and was soon discharged as cured. He returned home and again immersed himself in his books. In the following years he published several outstanding works, but, as before, his life was that of a hermit living entirely in his books and dead to the world. Gradually he got the reputation of being a dried-up misanthropist, with no feeling for the beauty of life.

[343] A few years after his first illness a short holiday trip again brought him to B. As before, he took his solitary walks in the environs. One day he was suddenly overcome by a feeling of faintness and lay down in the street. He was carried into a neighbouring house, where he immediately became violently excited. He began to perform gymnastics, jumped over the rails of the bed, turned somersaults in the room, started declaiming in a loud voice, sang improvised poems, etc. Again he was brought to the asylum. The excitement continued. He extolled his wonderful muscles, his beautiful figure, his enormous strength. He believed he had discovered a law of nature by which a marvellous voice could be developed. He regarded himself as a great singer and a unique orator, and at the same time he was a divinely inspired poet and composer to whom the verse came simultaneously with the melody.

[344] All this was in pathetic but very significant contrast to reality. He was a small weakly man of unimposing build, with poorly developed muscles, betraying at the first glance the atrophying effect of his studious life. He was unmusical, his voice was squeaky and he sang out of tune; he was a bad speaker because of his stammer. For weeks he occupied himself in the asylum with peculiar jumpings and contortions of the body which he called gymnastics, now and then singing and declaiming. Then he became quieter and dreamy, often stared musingly in front of him for long periods of time, sometimes softly singing a love-song which, despite its lack of musical expression, showed a pretty feeling for the yearnings of love. This, too, was in complete contrast to the aridity and isolation of his normal life. Gradually he became more accessible for conversations.

[345] Let us break off the case-history here and sum up what has been furnished simply by the observation of the patient.

[346] In the first attack of illness the delirium broke out unexpectedly, and was followed by a mental disturbance with confused ideas and violence which lasted for

several weeks. Afterwards complete recovery appeared to have taken place. Six years later there was a sudden outbreak of excitement, with delusions of grandeur and bizarre actions, followed by a twilight stage gradually leading to recovery. Again it is a typical case of dementia praecox, of the catatonic variety, which is especially characterized by peculiar movements and actions. And here again the views now prevailing in psychiatry would regard this as a localized deterioration of the brain-cells in some part of the cortex, causing now delirium and confusional ideas, now delusions of grandeur, now peculiar contortions of the muscles, now twilight states, which taken all together have as little psychological meaning as the weird shapes of a drop of molten lead thrown into water.

[347] This is not my view. It was certainly no accidental freak of diseased brain-cells that created those dramatic contrasts in the second attack. We can see that these contrasts, the so-called delusions of grandeur, are very subtly attuned to the deficiencies in the patient's personality. They are deficiencies which any one of us would certainly feel as a lack. Who has not felt the need to console himself for the aridity of his profession and of his life with the joys of poetry and music, and to restore to his body the natural strength and beauty stolen from it by the atmosphere of the study? Finally, who does not recall with envy the energy of Demosthenes who, despite his stammer, became a great orator? If our patient filled the obvious gaps in his physical and psychic life by delusionally fulfilled wishes, we may also conjecture that those soft love-songs which he sang from time to time filled a painful blank in his being, making up for a lack which became the more agonizing the more it was concealed.

[348] I did not have to search for long. It was the same old story, born anew in every human soul, in a guise suited to the sensibilities of the predestined victim.

[349] When our patient was a student he learnt to know and love a girl student. Together they took many solitary walks in the environs of the town, but his exceeding timidity and bashfulness (the lot of the stammerer) never allowed him an opportunity to get out the appropriate words. Moreover he was poor and had nothing to offer her but hopes. The time came for the termination of his studies; she went away, and he also, and they never saw one another again. And not long afterwards he heard she had married someone else. Then he relinquished his hopes, but he did not know that Eros never emancipates his slaves.

[350] He buried himself in abstract learning, not to forget, but to work for her in his thoughts. He wanted to keep the love in his heart quite secret, and never to betray that secret. He would dedicate his works to her without her ever knowing it. The compromise succeeded, but not for long. Once he travelled through the town where he had heard she lived—he said it was quite by chance that he travelled through that

town. He did not leave the train, which made only a short halt there. From the window he saw in the distance a young woman with a small child, and thought it was she. Impossible to say whether it really was or not; not even he knew. He did not think he felt any particular sensation at that moment; anyway he did not trouble to find out whether it was she or not, and this suggests that it wasn't. The unconscious wanted to be left in peace with its illusion. Shortly afterwards he again came to B., the place of old memories. Then he felt something strange stir in his soul, an uneasy feeling presciently described by Nietzsche:

Yet not for long shalt thou thirst, O burnt-out heart!
There is promise in the air,
From unknown mouths I feel a breath
—The great coolness cometh.³

[351] Civilized man no longer believes in demons, he calls in the doctor. Our patient wanted to be hypnotized. Then madness overcame him. What was going on?

[352] He answered this question in broken phrases, with long pauses in between, in that twilight stage which precedes convalescence. I followed his own words as faithfully as possible. When he fell ill he suddenly left the orderly world and found himself in the chaos of an overmastering dream: a sea of blood and fire, the world was out of joint, everywhere conflagrations, volcanic outbursts, earthquakes, mountains caved in, then came tremendous battles in which nation was hurled on nation, more and more he found himself involved in the struggle of nature, he was in the midst of the fighters, wrestling, defending himself, enduring unutterable misery and pain, but gradually exalted and strengthened by a strange, soothing feeling that someone was watching his struggles—that his loved one saw all this from afar. (That was the time when he showed real violence towards the attendants.) He felt his strength increasing and saw himself at the head of great armies which he would lead to victory. Then more battles, and victory at last. As the victor's prize he gained his loved one. As he drew near her the illness ceased, and he awoke from a long dream.

[353] His daily life now resumed its ordered course. He shut himself up in his work and forgot the abyss within him. A few years later he was again in B. Demon or destiny? Again he followed the old trail and again was overborne by old memories. But this time he did not sink into the depths of confusion. He remained oriented and en rapport with his surroundings. The struggle was considerably milder; he merely did gymnastics, practised the masculine arts, and made up for his deficiencies. Then followed the dreamy stage with the love-songs, corresponding to the period of victory in the first psychosis. In this state—I follow his own words—he had a dreamy feeling, as if he stood on the border between two different worlds and did not know

whether reality was on the right or on the left. He said: "They tell me she is married, but I believe she is not; she is still waiting for me. I feel that it must be so. For me it is always as if she were not married, as if success must still be attainable." What our patient has here described is but a pale reflection of that scene in the first attack of psychosis, when he stood as the victor before his bride. A few weeks after this conversation, his scientific interests began to reassert themselves. He spoke with obvious unwillingness about his intimate life, he repressed it more and more, and finally turned away from it as if it did not belong to him. Thus the door of the underworld gradually closed. There remained nothing but a certain tenseness of expression, and a look which, though fixed on the outer world, was at the same time turned inwards; and this alone hinted at the silent activity of the unconscious, preparing new solutions for his insoluble problem. Such is the so-called cure in dementia praecox.

[354] Hitherto we psychiatrists were unable to suppress a smile when we read of a poet's attempts to describe a psychosis. These attempts have generally been regarded as quite useless, on the ground that a poet introduces into his conception of psychosis psychological relationships that are quite foreign to the clinical picture of the disease. But if the poet has not actually set out to copy a case from a text-book of psychiatry he usually knows better than the psychiatrist.

[355] The case I have just described is not unique, it is typical of a whole class, for which one of our poets has created a universally valid model. The poet is Spitteler, and the model is *Imago*. I take it that the course of *that* case is known. However, the psychological gulf between the creation of the artist and the insane person is great. The world of the artist is a world of solved problems; the world of reality, that of unsolved problems. The insane person is a faithful reflection of this reality. His solutions are unsatisfying illusions, his cure a temporary relinquishing of the problem, which yet goes on working unsolved in the depths of the unconscious, and at the appointed time rises again to the surface and creates new illusions with new scenery—the history of mankind writ small.

[356] Psychological analysis is far from being able to explain in a clear and illuminating fashion all cases of the disease with which we are here concerned. On the contrary, the majority remain exceedingly obscure and difficult to understand, not least because only a fraction of the patients recover. Our last case was exceptional in that the patient's return to a normal state enabled us to survey the period of his illness. Unfortunately we do not always enjoy the advantage of this standpoint, because a large number of patients never find their way back from their dreams. They are lost in the maze of a magic garden where the same old story is repeated again and again in a timeless present. For them the hands of the world's clock remain

stationary; there is no time, no further development. It makes no difference to them whether they dream for two days or thirty years. I had a patient in my ward who had lain in bed for five years without uttering a word, completely buried in himself. For years I visited him twice daily, and as I reached his bedside I could always see at once that there was no change. One day I was on the point of leaving the room when a voice I did not recognize called out "Who are you? What do you want?" I saw with amazement that it was our dumb patient who had suddenly recovered his voice, and obviously his senses as well. I told him I was his doctor, whereupon he asked angrily why he was kept a prisoner here, and why no one ever spoke to him? He said this in an injured voice just like a normal person whom one had not greeted for a couple of days. I informed him that he had lain in bed quite speechless for five years and had responded to nothing, whereat he looked at me fixedly and without understanding. Naturally I tried to discover what had gone on in him all these years, but could learn nothing. Another patient with a similar symptom, when asked why he had remained silent for years, declared, "Because I wanted to spare the German language."⁴ These examples show that it is often quite impossible to lift the veil, because the patients themselves have neither the desire nor the interest to explain their strange experiences; as a rule they do not even find them strange.

[357] Occasionally, however, the symptoms themselves are pointers to the psychological content of the disease.

[358] We had a patient who for thirty-five years was an inmate of Burghölzli. For decades she lay in bed, she never spoke or reacted to anything, her head was always bowed, her back bent and the knees slightly drawn up. She was always making peculiar rubbing movements with her hands, so that in the course of the years thick horny patches developed on the palms. She kept the thumb and index finger of her right hand together as if sewing. When she died, some two years ago, I tried to discover what she had been like formerly. Nobody in the asylum recalled ever having seen her out of bed. Only our old chief attendant had a memory of having seen her sitting in the same attitude in which she afterwards lay in bed. In those days she made rapid sweeping movements of the arms across her right knee; she was said to be "sewing shoes" and, later, "polishing shoes." As time went on the movements became more restricted till finally nothing but a little rubbing movement remained, and only the thumb and forefinger kept the sewing position. In vain I consulted our old records; they contained nothing about the patient's previous history. When her seventy-year-old brother came to the funeral I asked him if he remembered what had been the cause of his sister's illness. He told me that she had had a love-affair, but for various reasons it had come to nothing, and the girl had taken this so much to heart that she became melancholic. I asked who her lover was: he was a shoemaker.

[359] Unless we choose to see here some very strange play of chance, we must assume that the patient had kept the memory-image of her lover unaltered in her heart for thirty-five years.

[360] It might easily be thought that these patients, who give the impression of being imbeciles, are in fact nothing but burnt-out ruins of humanity. But in all probability that is not so. Very often one can prove directly that such patients register everything going on around them, sometimes even with curiosity, and that they have an excellent memory for it all. This explains why many patients often become quite sensible again for a time, and develop mental powers which one believed they had long since lost. Such intervals occasionally occur during serious physical illnesses or shortly before death. For example, we had a patient with whom it was impossible to carry on a sane conversation; he produced only a crazy mixture of delusional ideas and queer words. This man once went down with a serious physical illness, and I expected it would be very difficult to treat him. But not at all. He was entirely changed; he became friendly and obliging, and carried out all the doctor's orders with patience and gratitude. His eyes lost their evil darting looks, and shone quietly and with understanding. One morning I came to his room with the usual greeting: "Good morning, how are you?" But the patient forestalled me with his well-known refrain: "Here comes another of the dog and monkey troupe wanting to play the Saviour." Then I knew his physical trouble was over. From that moment the whole of his reason was as if blown away again.

[361] We can see from this that reason still survives, but is pushed away into some remote corner by the mind's preoccupation with pathological ideas.

[362] Why is the mind compelled to expend itself in the elaboration of pathological nonsense? Our new method of approach gives us a clue to this difficult question. Today we can assert that the pathological ideas dominate the interests of the patient so completely because they are derived from the most important questions that occupied him when he was normal. In other words, what in insanity is now an incomprehensible jumble of symptoms was once a vital field of interest to the normal personality.

[363] I will cite as an example a patient⁵ who has been over twenty years in the asylum. She was always a puzzle to the doctors, for the absurdity of her delusions exceeded anything the boldest imagination could devise.

[364] She was a dressmaker by trade, born in 1845, of very poor family. Her sister early went to the bad and was finally lost in the morass of prostitution. The patient herself led an industrious, respectable, secluded life. She fell ill in 1886 in her thirty-ninth year—on the threshold of the age when so many dreams are brought to naught. Her illness consisted of delusions and hallucinations which increased rapidly, and soon

became so absurd that no one could understand her wishes and complaints. In 1887 she came to the asylum. By 1888 her speech, so far as it concerned her delusions, had degenerated into complete unintelligibility. She maintained such monstrous things as this: At night the spinal marrow is torn out of her; pains in the back are caused by substances going through the walls covered with magnetism. The monopoly establishes the pains that do not stick in the body and do not fly about in the air. Extracts are made by an inhalation of chemistry and legions perish of death by suffocation.

[365] In 1892 the patient styled herself “The Bank-note Monopoly, Queen of the Orphans, Proprietress of Burghölzli Asylum,” saying that “Naples and I must supply the whole world with macaroni.”

[366] In 1896 she became “Germania and Helvetia of exclusively sweet butter,” and said: “I am Noah’s Ark, the boat of salvation and respect.”

[367] Since then the pathological nonsense has greatly increased; her latest creation is the delusion that she is the “lilac new-red sea-wonder and the blue.”

[368] These examples show how far the unintelligibility of such pathological formations can go. For this reason our patient became the classic example of “meaningless delusional ideas” in dementia praecox, and many hundreds of medical students received from her a lasting impression of the sinister power of insanity. But even this case has not withstood the newest technique in modern analysis. What the patient says is not at all meaningless; it is full of significance, so that he who knows the key can understand her without undue difficulty.

[369] Unfortunately time does not permit me to describe the technique by means of which I succeeded in lifting the veil from her secret. I must content myself with a few examples which will make clear the strange changes of thought and speech in this patient.

[370] She said of herself that she was *Socrates*. Analysis of this delusional idea reveals the following train of thought: Socrates was the greatest sage, the greatest man of learning; he was slanderously accused and had to die at the hands of strange men in prison. She—the patient—is the best dressmaker, has “never cut a thread,” “never left a bit of cloth on the floor.” She has worked incessantly, and now she has been falsely accused, wicked men have shut her up, and she will have to die in the asylum. Therefore she is Socrates. This, as you see, is a simple metaphor based on an obvious analogy.

[371] Take another example: “I am the finest professorship and the finest world of art.” Analysis shows that she is the best dressmaker and chooses the most beautiful models which show up well and waste little material; she puts the trimming on only

where it can be seen. She is a professor, an artist in her work. She makes the best clothes, which she grandly calls the “Schneckenmuseum clothing.” Only such persons as frequent the Haus zur Schnecke and the Museum are her customers, for she is the best dressmaker who makes only Schneckenmuseum clothing.

[372] The patient also calls herself Mary Stuart. Analysis shows the same analogy as with Socrates: wrongful suffering and death of the heroine.

[373] “I am the Lorelei.” Analysis: This refers to Heine’s well-known song, “Ich weiss nicht, was soll es bedeuten” (I know not what it means). Whenever she wants to speak about her affairs people do not understand her, and say they don’t know what it means; therefore she is the Lorelei.

[374] “I am a Switzerland.” Analysis: Switzerland is free, no one can rob Switzerland of her freedom. The patient does not belong in the asylum; she should be free like Switzerland; therefore she is a Switzerland.

[375] “I am a crane.” Analysis: In the *Cranes of Ibycus* it is said: “Whoso is free of guilt and sin / Shall keep the child’s pure soul within.” She has been wrongfully brought to the asylum and has never committed a crime. Therefore she is a crane.

[376] “I am Schiller’s *Bell*.” Analysis: Schiller’s *Bell* is the greatest work of the greatest master. She is the best and most industrious dressmaker, and has achieved the highest rung in the art of dressmaking. Therefore she is Schiller’s *Bell*.

[377] “I am Hufeland.” Analysis: Hufeland was the best doctor. She suffers infinite torments in the asylum and on top of that is treated by the worst doctors. But she is such a distinguished personality that she is entitled to the very best doctors, a doctor like Hufeland. Therefore she is Hufeland.

[378] The patient uses the form “I am” in a very capricious way. Sometimes it means “it belongs to me” or “it is proper for me,” sometimes it means “I ought to have.” This can be seen from the following analysis:

[379] “I am the master-key.” The master key is the key that opens all the doors in the asylum. Properly, by rights, she should have obtained this key long ago, for she has been for many years the “Proprietress of Burghölzli Asylum.” She expresses this argument very much simplified in the sentence: “I am the master-key.”

[380] The chief content of her delusional ideas is concentrated in the following statement:

“I am the monopoly.” Analysis: By this she means the banknote monopoly, which has belonged to her for some time. She believes that she possesses the monopoly of all the bank-notes in the world, thus creating enormous riches for herself, in compensation for the poverty and wretchedness of her life. Her parents died early;

therefore she is “Queen of the Orphans.” Her parents lived and died in great poverty, and to them too she extends her blessings, in fancy pouring out her riches with both hands. She said in her own words: “By me my parents are clothed, my sorely tried mother, full of sorrows—I sat with her at the table, covered white with abundance.”

[381] This is one of those vivid hallucinations which the patient has daily. It is a wish-fulfilment, the poverty in this world contrasting with the riches in the next, reminiscent of Gerhardt Hauptmann’s *Hannele*, more especially of that scene where Gottwald says: “She was hung with rags—now she is bedecked in silken robes; she ran about barefoot, now she has shoes of glass to her feet. Soon she will live in a golden castle and eat each day of baked meats. Here she lived on cold potatoes ...”

[382] The wish-fulfilments of our patient go even further. Switzerland has to pay her an annuity of 150,000 francs. The director of Burghölzli owes her 80,000 francs damages for wrongful incarceration. She is the owner of a distant island with silver mines, “the mightiest silver island in the world.” That is why she is also the “greatest orator,” possessing the “highest eloquence,” because, as she says, “Speech is silver, silence is golden.” To her all the finest estates belong, all the wealthy quarters, all cities and countries, she is the owner of the world, actually the “triple owner of the world.” Whilst poor Hannele was only elevated to the side of the Heavenly Bridegroom, our patient possesses the “key of heaven”; she is not only the honoured earthly queens Mary Stuart and Queen Louise of Prussia, she is also the Queen of Heaven, the Mother of God, and at the same time the Godhead. Even in this earthly world where she was nothing but a humble dressmaker she has attained the fulfilment of her human wishes, for she chose three husbands from the best families in the town and her fourth was the Emperor Francis. From these marriages sprouted two phantom children, a little boy and a little girl. Just as she clothed and regaled her parents with food and drink, so she provided for the future of her children. To her son she bequeathed the big bazaars of Zurich, therefore her son is a Czar, for the owner of a bazaar is a Czar. The little daughter resembles her mother, therefore she becomes the proprietress of the asylum and takes her mother’s place so that the mother shall be released from captivity. The daughter therefore receives the title of the “Socrates deputy,” since she acts for Socrates in captivity.

[383] These examples by no means exhaust the delusional ideas of the patient. But they will give you, I hope, some idea of the richness of her inner life although she was apparently so dull and apathetic, sitting like an “imbecile” for twenty years in her workroom, mechanically darning her linen and occasionally mumbling a few meaningless phrases which nobody had been able to understand. Her baroque jumble of words can now be seen in a different light: they are fragments of an enigmatic inscription, bits and pieces of fairy-tale fantasies, which have broken away from hard

reality to build a far-off world of their own. Here the tables are ever laden, and a thousand banquets are held in golden palaces. The patient can spare only a few mysterious symbols for the dim, dismal realm of reality; they need not be understood, for our understanding has long ceased to be necessary to her.

[384] Nor is this patient at all unique. She is one of a type. Similar fantasies are always found in patients of this kind, though not always in such perfection.

[385] The parallels with Hauptmann's *Hannele* show that once again a poet has pointed the way, freely drawing on his own fantasy. From this conjecture, which is not due to chance, we may conclude that what the artist and the insane have in common is common also to every human being—a restless creative fantasy which is constantly engaged in smoothing away the hard edges of reality. Anyone who observes himself, carefully and unsparingly, will know that there is something within him which would gladly hide and cover up all that is difficult and questionable in life, in order to smooth a path for itself. Insanity gives it a free hand. And once it has gained ascendancy, reality is veiled, more quickly or less; it becomes a distant dream, but the dream becomes a reality which holds the patient enchained, wholly or in part, often for the rest of his life. We healthy people, who stand with both feet in reality, see only the ruin of the patient in *this* world, but not the richness of that side of the psyche which is turned away from us. Unfortunately only too often no further knowledge reaches us of the things that are being played out on the dark side of the soul, because all the bridges have broken down which connect that side with this.

[386] We still do not know at present whether these new insights have a general or only a limited validity. The more carefully and patiently we examine the mentally sick, the more we find cases which, despite the appearance of total imbecility, allow us at least fragmentary glimpses of a shadowy psychic life, far removed from that spiritual impoverishment which the prevailing theories have obliged us to accept.

[387] Though we are still far from being able to explain all the relationships in that obscure world, we can maintain with complete assurance that in dementia praecox there is no symptom which could be described as psychologically groundless and meaningless. Even the most absurd things are nothing other than symbols for thoughts which are not only understandable in human terms but dwell in every human breast. In insanity we do not discover anything new and unknown; we are looking at the foundations of our own being, the matrix of those vital problems on which we are all engaged.

ON PSYCHOLOGICAL UNDERSTANDING¹

[388] The number of investigations into the psychology of dementia praecox has grown considerably since the preceding paper was first published. When, in 1903, I made the first analysis of a case of dementia praecox, I had a premonition of future discoveries in this field. This premonition has since been confirmed.

[389] In 1911 Freud, using an improved analytical technique based on his ample experience of neurotics, subjected a case of paranoid dementia to closer psychological investigation.² This was the famous autobiography of D. P. Schreber, *Memoirs of My Nervous Illness*. In his investigation Freud shows out of what infantile drives and forms of thinking the delusional system was built up. The peculiar delusions the patient had about his doctor, whom he identified with God or a godlike being, and certain other surprising and even blasphemous ideas about God himself, Freud was able to reduce in a very ingenious manner to the infantile relationship between the patient and his father. This case also shows the comic and grotesque combinations of ideas described in the foregoing paper. Freud confines himself to pointing out the universally existent foundations out of which we may say every psychological product develops historically.³ This analytical-reductive procedure did not, however, furnish such enlightening results in regard to the rich and surprising symbolism in patients of this kind as we had been accustomed to expect from the same method in cases of hysteria. The reductive method seems to suit hysteria better than dementia praecox.

[390] If one reads the recent researches of the Zurich school, for instance the works of Maeder,⁴ Spielrein,⁵ Nelken,⁶ Grebel-skaja,⁷ and Itten,⁸ one gets a powerful impression of the enormous symbolic activity in dementia praecox. Although some of these authors still proceed essentially by the analytical-reductive method, tracing back the complicated system of delusions to its simpler and more general components, as I have done in the preceding pages, one cannot resist the feeling that this method does not altogether do justice to the almost overpowering profusion of fantastic symbolization, illuminating though it may be in other respects.

[391] Let me illustrate what I mean by an example. We are grateful to a commentator on *Faust* when he traces back all the multifarious material of [Part II](#) to its historical sources, or when he gives a psychological analysis of [Part I](#), showing how the conflict in the drama springs from a conflict in the soul of the poet, and how this subjective conflict is itself based on those ultimate and universal problems which are in nowise foreign to us because we all carry the seeds of them in our own hearts. Nevertheless, we are a little disappointed. We do not read *Faust* just to discover that

things everywhere are “human, all-too-human.” We know that only too well already. And anyone who still doesn’t know it has only to go out into the world and look at life without prejudice and with open eyes. He will turn back fully convinced of the prevalence and power of the “all-too-human,” and he will hungrily pick up his *Faust* again not in order to rediscover what he has just left behind him, but to learn how a man like Goethe deals with these human banalities, and how he redeems his soul from bondage to them. Once we have discovered who the “Proktophantasmist” is, and to what historical events and figures the symbolism of [Part II](#) refers, and how closely interwoven all this is with the human personality of the poet, we come to regard these determining factors as far less important than the question of what the poet means by this symbolization. The investigator who proceeds purely reductively sees the final meaning in these human generalities, and demands nothing more from an explanation than that it should reduce the unknown to the known and the complicated to the simple. I should like to designate this kind of understanding “retrospective understanding.” There is another kind of understanding, which is not analytical-reductive by nature, but synthetic or constructive. I would call this “prospective understanding,” and the corresponding method the “constructive method.”

[392] It is generally recognized that the modern scientific method of explanation is based entirely on the principle of causality. Scientific explanation is causal explanation. Hence we are naturally inclined, whenever we think scientifically, to explain causally, and to take a thing as explained when it is reduced analytically to its cause and general principle. To that extent Freud’s method of psychological explanation is strictly scientific.

[393] But when we apply this method to *Faust*, it becomes clear that something more is required for a real understanding. We even realize that we have completely missed the deepest meaning the poet strove to express if we see in it *only* the universally human—for we can see the universally human wherever we look. What we really want to find in *Faust* is how this human being redeems himself as an individual, and when we have understood that, we have understood Goethe’s symbolism. True, we may make the mistake of thinking that we have understood Goethe himself. But let us be cautious and modest, and simply say that we have understood ourselves with the help of *Faust*. I think here of that cogent definition of Kant’s according to which “comprehension” means “to cognize a thing to the extent which is sufficient for our purpose.”⁹

[394] Certainly, this kind of understanding is subjective, and therefore not scientific for those who identify scientific explanation with causal explanation. But the validity of

this identification is decidedly a matter for discussion. I have to emphasize my doubts about it in the sphere of psychology.

[395] We speak of “objective” understanding when we have given a causal explanation. But, in reality, understanding is a subjective process, to which we ascribe the quality “objective” simply to differentiate it from another kind of understanding which is also a psychological and subjective process, and which we call “subjective” without further ado. The general attitude of today grants scientific value only to “objective” understanding, precisely because of its general validity. This standpoint is unquestionably right wherever we are not concerned with the psychological process itself, i.e., in all sciences that are not psychology.

[396] Anyone who understands *Faust* “objectively,” from the causal standpoint, is—to take a drastic example—like a man who tries to understand a Gothic cathedral under its historical, technical, and finally its mineralogical aspect. But—where is the meaning of the marvellous edifice? Where is the answer to that all-important question: what goal of redemption did the Gothic man seek in his work, and how have we to understand his work subjectively, in and through ourselves? To the scientific mind this seems an idle question, which at all events has nothing to do with science. What is worse, it conflicts with the causal principle, for its intention is clearly speculative and constructive. The modern mind has overthrown the speculative spirit of scholasticism.

[397] If we want to understand anything psychological, we must bear in mind that all knowledge is subjectively conditioned. The world is not “objective” only; it is also as we see it. This is even truer of the psyche. Of course it is possible to understand the psyche objectively, just as it is possible to understand *Faust* and Cologne Cathedral that way. In this objective understanding lies the whole worth and worthlessness of current experimental psychology and psychoanalysis. But the scientific mind, so far as it thinks causalistically, is incapable of prospective understanding—it understands only retrospectively. Like Ahriman, the Persian devil, it has the gift of hindsight. Yet this kind of understanding is only one half of the psyche. The other, more important, half is constructive, and if we are not able to understand prospectively, then nothing is understood. If psychoanalysis, following Freud’s lead, should succeed in establishing an uninterrupted and conclusive connection between Goethe’s infantile sexual development and *Faust*, or—following Adler—between the infantile striving for power of the adult Goethe and his work, a very interesting task would have been accomplished, and we should have learnt how a masterpiece can be reduced to the simplest possible elements. But did Goethe create *Faust* to that end? Did he intend it to be understood in that way?

[398] It should be sufficiently clear that though this kind of understanding is undoubtedly scientific it misses the point. This is true of psychology in general. To understand the psyche causally is to understand only one half of it. A causal understanding of *Faust* tells us very clearly how it came to be a finished work of art, but it does not show us its living meaning. That meaning only lives when we experience it in and through ourselves. In so far as our actual life, the life we live here and now, is something essentially new and not just a continuation of the past, the main value of a work of art does not lie in its causal development but in its living effect upon ourselves. We should be depreciating a work like *Faust* if we regarded it merely as something that has come to be, and is finished and done with. *Faust* is understood only when it is apprehended as something that becomes alive and creative again and again in our own experience.

[399] This is how we have to consider the human psyche, too. Only on one side is it something that has come to be, and, as such, subject to the causal standpoint. The other side is in the process of becoming, and can only be grasped synthetically or constructively. The causal standpoint merely inquires how this psyche has become what it is, as we see it today. The constructive standpoint asks how, out of this present psyche, a bridge can be built into its own future.¹⁰

[400] (The two standpoints can be illustrated by the difference in their treatment of dream-symbols. A patient of mine, a man of extremely feeble will-power, lazy and inactive, had the following dream: *A certain man gave him a peculiar old sword, ornamented with weird old ciphers. The dreamer enjoyed this gift immensely.* At the time of the dream he was suffering from a slight physical disorder, which had made an exaggerated impression on him, so that he had fallen back into complete despair and inactivity. He had lost all pleasure and interest in life.

[401] It is perfectly true that the patient was very much under the influence of a so-called father-complex, and that he wished to have the phallic power of his father (sword). That was precisely his infantile mistake, he wanted nothing better than to conquer life in an archaic sexual way. To that extent the reduction of the dream-symbol is entirely satisfactory. Only, the patient was well aware of these facts and was able to interpret his dream in this way without any difficulty. So he learnt nothing from this interpretation.

[402] He associated the man in the dream with a young friend, who had been very ill with tuberculosis and was even considered a hopeless case. The patient said: "It was marvellous to see how my friend stood the pain; he had simply tremendous endurance, courage and hope. He used to say, 'I will not die, I have decided to live.' His will-power was so strong that he finally overcame the disease and got cured. He was really a model of courage." His associations to *sword* were: "An old bronze

sword handed down from time immemorial. The ciphers remind me of old languages and old civilizations. The sword is an old heirloom of mankind, a weapon, an instrument of defence and aggression, a guard against the dangers of life.”

[403] Now we understand: his young friend gave him an invaluable example of how to face the dangers of life through firm and brave decision. The words “I will” are mankind’s oldest heritage and have helped it through innumerable dangers. They are the safeguard of civilized humanity, differentiating it from the animal, that only obeys dumb instinct and natural law. Through this dream a way is opened to the patient, a way to a more idealistic standpoint which redeems him from his childish self-bemoaning, and leads to an attitude that has always helped mankind in the face of threats and dangers.)

[404] Just as through analysis and reduction of individual events the causal method ultimately arrives at the universal principles of human psychology, so through the synthesis of individual trends the constructive method aims at universal goals. The psyche is the point of intersection, hence it must be defined under two aspects. On the one hand it gives a picture of the remnants and traces of all that has been, and, on the other, but expressed in the same picture, the outlines of what is to come, in so far as the psyche creates its own future.

[405] The psyche at any given moment is on the one hand the result and culmination of all that has been and on the other a symbolic expression of all that is to be. Since the future is only apparently like the past, but in its essence always new and unique, the present expression is bound to be incomplete, germlike, as it were, in relation to the future. In so far as we regard the actual content of the psyche as a symbolic expression of what is to be, we have to apply a constructive interest to it—I almost felt tempted to say a “scientific” interest. But modern science is identical with the causal principle. As soon as we regard the psyche causally, that is, scientifically, the psyche as a creative function eludes us. If we want to grasp this other side of the psyche, we shall never do it by the exclusive application of the causal principle, but only with the help of the constructive standpoint. The causal standpoint reduces things to their elements, the constructive standpoint elaborates them into something higher and more complicated. This latter standpoint is necessarily a speculative one.

[406] Constructive understanding, however, differs from scholastic speculation in that it never asserts that something has universal validity, but merely subjective validity. When a speculative philosopher believes he has comprehended the world once and for all in his system, he is deceiving himself; he has merely comprehended himself and then naively projected that view upon the world. Projection is a fundamental error of scholasticism that has lingered on into modern times. Reacting against this, “scientism” almost put an end to speculation and went to the other extreme. It tried to

create an “objective” psychology. In the face of these efforts, the emphasis that Freud laid on the psychology of the individual is of immortal merit. The immense importance of subjective factors in the development of objective mental processes was thus given due prominence for the first time.

[407] Subjective speculation that lays no claim to universal validity is identical with constructive understanding. It is a subjective creation; considered from the outside it may easily seem an “infantile fantasy,” or at least an unmistakable product of it. From an “objective” standpoint it has to be judged as such, in so far as “objective” is equated with “scientific” or “causal.” But considered from the inside, this subjective creation spells redemption. As Nietzsche says, “Creation—that is the great redemption from suffering; that is ease of living.”¹¹

[408] When we apply these insights to the psychology of that class of mental patient to which Schreber belongs, we must, from the “objective-scientific” standpoint, reduce the fantasy-structure to its simple, fundamental elements. This is what Freud has done. But that is only one half of the work. The other half is the constructive understanding of Schreber’s system. The question is: What is the goal the patient tried to reach through the creation of his system?

[409] The purely scientific thinker of today will regard this question as absurd. The psychiatrist will certainly smile at it, being profoundly convinced of the universal validity of the causal principle, and seeing the psyche merely as something derivative and reactive. The unconscious picture at the back of his mind, psyche = brain-secretion, is often only too plainly in evidence.

[410] But if we look at the delusional system without prejudice, and ask ourselves what it is aiming at, we see, first, that it is in fact aiming at something, and second, that the patient devotes all his will-power to the completion of his system. There are patients who elaborate their delusions with scientific thoroughness, often dragging in an immense amount of comparative material by way of proof. Schreber belongs to this class. Others do not set about it so thoroughly and learnedly, but content themselves with piling up synonyms for the thing they are struggling to express. A good example of this is the patient I have already described, who gave herself all sorts of grotesque titles.

[411] This unmistakable striving of the patient to express something in and through his delusions Freud conceives retrospectively, as a gratification in fantasy of infantile wishes. Adler reduces it to the striving for power. For him the delusional system is a “masculine protest,” a means of safeguarding the patient’s threatened superiority. So regarded, this striving is equally infantile, and the means employed—the delusional system—is infantile too, because insufficient for its purpose. Hence one can

understand Freud's rejection of the Adlerian viewpoint. Freud, with some justice, classifies this striving for power under the concept of infantile wish-fulfilment.

[412] The constructive standpoint is very different. Here the delusional system, as regards its material content, is neither infantile nor in itself pathological, but subjective, and hence justified within those limits. The constructive standpoint rejects absolutely the view that the subjective fantasy-formation is nothing but an infantile wish symbolically disguised or an obstinate clinging to the fiction of one's own superiority, in so far as this pretends to be a final explanation. One can judge the subjective mental process from the outside as one can judge everything else. But such a judgment is inadequate, because it is of the nature of the subjective that it cannot be judged objectively. You cannot measure distance in pints. The subjective can only be understood and judged subjectively, that is, constructively. Any other judgment is unfair and does not hit the mark.

[413] The *carte blanche* which the constructive standpoint gives to subjective factors naturally seems to the "scientific" mind an utter violation of reason. But it can protest only so long as the construction is not admitted to be subjective. Constructive understanding also *analyses*, but it does not *reduce*. It breaks the system down into *typical* components. What is to be regarded as a "type" at any given time is dependent on the scope of our experience and knowledge. Even the most individual systems are not absolutely unique, but offer striking and unmistakable analogies with other systems. From the comparative analysis of many systems the typical formations can be discovered. If one can speak of reduction at all, it is simply a reduction to general types, but not to some general principle arrived at inductively or deductively, such as "sexuality" or "striving for power." This paralleling with other typical formations serves only to widen the basis on which the construction is to rest.¹² At the same time, it serves the purpose of objective communication. Without these parallels we would proceed entirely subjectively; we would go on constructing in the language and mental range of the patient, building up a structure which would be intelligible to him and to the investigator but not to the wider scientific public, who could not be expected to feel their way into the peculiarities of his thought and language.

[414] The work of the Zurich school gives careful and detailed records of the individual material. There we find countless typical formations which show obvious analogies with mythological formations.¹³ These parallels have proved to be a new and exceedingly valuable source for the comparative study of delusional systems. It is not easy to accept the possibility of such a comparison, but the only question is whether the materials to be compared are really alike or not. It may also be objected that pathological and mythological formations are not directly comparable. This objection

cannot be raised *a priori*, since only careful comparison can show whether a real parallelism exists. At present all we know is that both are fantasy-structures which, like all such products, are based essentially on the activity of the unconscious. Experience must show whether the comparison is valid. The results so far obtained are so encouraging that further research along these lines seems to me very well worth while.

[415] Without entering more closely into the nature of the constructive method, I made practical use of it in a case published by Flournoy in the *Archives de psychologie*. It was the case of a rather neurotic young woman who describes, in Flournoy's text, how she would suddenly be overcome by coherent fantasies which broke through from the unconscious into consciousness. I subjected these fantasies, there reproduced in detail, to the constructive method and set forth the results of these investigations in my book *Wandlungen und Symbole der Libido*,¹⁴ first published in 1912. This book, I regret to say, has met with numerous, and perhaps inevitable, misunderstandings. But here again I have had a satisfaction particularly to be valued, for the book won the approval of Flournoy himself, who knew the case personally. It is to be hoped that later researches will succeed in making the standpoint of the Zurich school intelligible to a wider public. Those who have tried to grasp the essence of the constructive method with the help of that book will readily appreciate how great are the difficulties of research, and how much greater still the difficulties of presenting it objectively.

[416] Among the many causes of misunderstanding I should like to emphasize one which is especially characteristic. Closer study of Schreber's or any similar case will show that these patients are consumed by a desire to create a new world-system, or what we call a *Weltanschauung*, often of the most bizarre kind. Their aim is obviously to create a system that will enable them to assimilate unknown psychic phenomena and so adapt themselves to their own world. This is a purely subjective adaptation at first, but it is a necessary transition stage on the way to adapting the personality to the world in general. Only, the patient remains stuck in this stage and substitutes his subjective formulation for the real world—which is precisely why he remains ill. He cannot free himself from his subjectivism and therefore does not establish any connection with objective thinking and with human society. He does not gain any real understanding of himself because he understands himself merely subjectively, and this precludes intelligible communication. As Feuerbach says, understanding is real and effective only when it is in accord with that of other reasonable beings. Then it becomes objective¹⁵ and connects with life.

[417] I am sure many people will object that psychological adaptation does not come about by first creating a philosophical view of the world, and that it is in itself a sign

of a morbid disposition even to attempt to adapt oneself by such means. Undoubtedly there are a great many people who are capable of adapting themselves to the world without first having a “philosophical” conception of it. If they arrive at all at a more general view, this only happens afterwards. But there are just as many who are able to adapt only with the help of some previous intellectual formulation. What they do not understand, or think they do not understand, they cannot adapt themselves to. And, as a rule, they do adapt themselves only as far as they can grasp the situation intellectually.

[418] Medical experience has taught us that there are two large groups of functional nervous disorders. One of them comprises all those forms of illness which are commonly designated “hysterical”; the other all those forms which the French school calls “psychasthenic.” Although the line of demarcation is rather uncertain, one can mark off two psychological types which in themselves are quite distinct because their psychology is diametrically opposed. I have called these the introverted and extraverted types. The hysteric belongs to the extraverted type, the psychasthenic to the introverted type, and so, to the best of our knowledge, does the schizophrenic. The terms introversion and extraversion are dependent on my energetic conception of psychic phenomena. I postulate a hypothetical, fundamental striving which I call *libido*.¹⁶ In accordance with the classical usage of the word,¹⁷ *libido* does not have an exclusively sexual connotation as it has in medicine. The word “interest,” as Claparède once suggested to me, could also be used in this special sense if it had today a less extensive application. Again, Bergson’s concept of *élan vital* would serve if only it were less biological and more psychological. *Libido* is intended as an energetic expression for psychological values. A psychological value is something that has an effect, hence it can be considered from the energetic standpoint without any pretence of exact measurement.

[419] The introverted type directs his *libido* chiefly to his own personality: he finds the absolute value in himself. The extraverted type directs his *libido* outwards: he finds the absolute value in the object. The introvert sees everything in terms of the value of his own personality; the extravert is dependent on the value of his object. Unfortunately I cannot go more closely into type differences here, but would only like to emphasize that the type question is one of the most vital for our psychology and that any further advance will probably be along those lines. The difference between the types is alarmingly great. So far there is only a short, provisional statement by myself on the type theory,¹⁸ a theory which has particular bearing on our views of dementia praecox. On the psychiatric side Gross¹⁹ has drawn attention to the existence of psychological types: he differentiates between types with a restricted but deep consciousness and those with a wide but superficial consciousness. The former corresponds to my introverted and the latter to my extraverted type. William James

has given an excellent description of the two types in philosophy in his book on pragmatism, and Schiller has done the same for aesthetics in his essay on “The Naïve and the Sentimental.” In scholastic philosophy our two types are represented by the nominalists and the realists. In the realm of medical psychology, Freud is decidedly the champion of the extravert, Adler the champion of the introvert. The irreconcilable contradiction between the views of Freud and Adler²⁰ is easily explained by the existence of two diametrically opposed psychologies which view the same things under totally different aspects. An extravert and an introvert find it very difficult to understand each other when they discuss any of the more delicate questions of psychology.

[420] An extravert can barely conceive the necessity that forces the introvert to adapt to the world by means of a system. And yet this need exists, otherwise we should have no philosophical systems and dogmas presumed to be universally valid. Civilized humanity would consist solely of empiricists, and the sciences solely of empirical sciences. There is no doubt that causalism and empiricism are the two ruling forces in the intellectual life of today, though things may yet turn out otherwise.

[421] This difference of types is the first great obstacle in the way of understanding. The second obstacle is the fact that the constructive method, true to its nature, must follow the clues laid down by the delusional system itself. The thoughts of the patient must be taken seriously and followed out to their logical conclusion; in that way the investigator himself takes over the standpoint of the psychosis. This may expose him to the suspicion of being deranged himself, or at the very least of having a *Weltanschauung* of his own, which nowadays is considered a terrible disgrace. Confirmation of such a possibility is as bad as being unscientific. But everyone has a view of the world, though not everyone is aware of it. And those who are unaware simply have an unconscious, and therefore inadequate and archaic, view, for everything that is left dormant in the psyche without being developed remains in a primitive state. A striking example of the way theories are influenced by unconscious, archaic conceptions is furnished by a famous German historian,²¹ whose name is no concern of ours. He took it as self-evident that human beings once propagated themselves by incest, because in the first human family the only possible mate for a brother was a sister. This theory is based on the still existing, unconscious belief that Adam and Eve were the first and only parents of mankind. On the whole, therefore, it is wiser to have a well-developed philosophical standpoint, or at least to make use of a suitable system, if one wishes to avoid mistakes of this kind.

[422] To be suspected of having a *Weltanschauung* is something one could put up with easily enough. There is, however, a greater danger that the public will come to believe that the view of the world worked out by the constructive method is a

theoretical and objectively valid view of the world in general. Again and again I have to point out that it is a chronic misunderstanding, dating from the Schoolmen, not to be able to distinguish between a view of the world that is purely psychological, and a non-psychological theory that is concerned with the nature of the object itself. It is absolutely essential for every student of the constructive method to make this distinction. In its immediate results the constructive method does not produce anything that could be called a scientific theory. It traces, rather, the psychological path of development in a given individual, as I have tried to show in my book *Wandlungen und Symbole der Libido*.

[423] The analytical-reductive method has the advantage of being much simpler. It reduces everything to known basic principles of a very simple nature. The constructive method, working with highly complex material, has to build up towards an unknown goal. This obliges the investigator to take account of all the forces at work in the human psyche. The reductive method tries to replace the religious and philosophical needs of mankind by their more elementary components, following the principle of “nothing but,” as William James nicely says; but the constructive method accepts them as such and considers them indispensable ingredients of its work. Only in this way can we do justice to man’s psychic striving. It is in the nature of things that such work should go far beyond the fundamental concepts of empiricism, for the human mind has never yet rested content with experience alone. All mental development comes by way of speculation and not by confining ourselves to mere experience. Experience without speculation leads nowhere.

[424] But if one works speculatively with psychological material one risks falling a victim to the popular misconception that the psychological line of development thus traced has the value of an objective theory. That is why so many people feel impelled to pronounce judgment on whether the theory is right or not. Those who are particularly brilliant even discover that the fundamental concepts can be traced back to Heraclitus or someone even earlier. Let me confide to these knowing folk that the fundamental concepts employed in the constructive method go back beyond all historical philosophy to the dynamistic ideas of primitive peoples.²² If the constructive method resulted in a scientific theory, the theory would be in a parlous condition indeed, for it would be a relapse into darkest superstition. But since it produces anything rather than a scientific theory, the extreme antiquity of the concepts it employs testifies to their practical usefulness. Not until the constructive method has furnished us with a great many more experiences can we start building up a scientific theory, a theory concerning the psychological lines of development. Until then we must be content to trace them out in individual cases.

III

A CRITICISM OF BLEULER'S THEORY OF SCHIZOPHRENIC NEGATIVISM

ON THE IMPORTANCE OF THE UNCONSCIOUS IN PSYCHOPATHOLOGY



ON THE PROBLEM OF PSYCHOGENESIS IN MENTAL DISEASE

MENTAL DISEASE AND THE PSYCHE

A CRITICISM OF BLEULER'S THEORY OF SCHIZOPHRENIC NEGATIVISM¹

[425] In this work² Bleuler presents a noteworthy clinical analysis of the concept "negativism." Besides giving a very precise and discerning summary of the various manifestations of negativism, he introduces a new psychological concept well worthy of attention. This is the concept of *ambivalence* or *ambitendency*, which formulates the psychological fact that every tendency is balanced by a contrary one. (We must add that the positive act therefore results from a relatively small preponderance on one side.) Similarly, all feeling-tones are balanced by their opposites, and this gives the feeling-toned idea an ambivalent character. This formulation is based on the clinical observation of catatonic negativism, which demonstrates with perhaps excessive clarity the existence of contradictory tendencies and values. These facts are well known to psychoanalysis, where they are summed up under the concept of resistance. Resistance, however, must not be taken as meaning that every positive psychic act simply calls up its opposite. One may easily gain the impression from Bleuler's work that his standpoint is that, *cum grano salis*, the ideas or tendencies of the schizophrenic are always accompanied by their opposites. For instance, Bleuler says:

Predisposing causes of negativistic phenomena are:

(1) *Ambitendency*, which causes every impulse to be accompanied simultaneously by a counter-impulse.

(2) *Ambivalence*, which gives two contradictory feeling-tones to the same idea and makes the same thought appear positive and negative at once.

(3) *Schizophrenic splitting of the psyche*, which prevents conclusions from being drawn from contradictory psychisms, so that the most unsuitable impulse can be translated into action just as easily as the right one, and the right thought accompanied, or replaced, by its negative.

Negativistic phenomena can arise directly on the basis of these propensities, since positive and negative psychisms are substituted for one another indiscriminately.

[426] If we try to psychoanalyse an obvious manifestation of ambivalence, for instance a more or less unexpected negative reaction instead of a positive one, we find that there is a strict sequence of psychological causes conditioning the negative reaction. The tendency of this sequence is to disturb the intention of the contrary sequence; that is to say, resistance is set up by a complex. This fact, which so far has not been refuted by other observations, seems to me to contradict the above formulations.³ Psychoanalysis has shown to our satisfaction that resistance is never "indiscriminate"

or meaningless, and that, consequently, there is no such thing as a capricious playing with opposites. The systematic character of resistance holds good, as I think I have shown, for schizophrenia as well. So long as this statement, which is supported by ample experience, is not refuted by other observations, the theory of negativism will have to take its cue from it. In a certain sense Bleuler takes account of this when he says: "Generally, however, the negativistic reaction does not seem to be merely accidental, but is *actually preferred to the right one.*"⁴ This is an admission that negativism is of the nature of resistance. Once admit this, and the causal significance of ambivalence disappears so far as negativism is concerned. The causally important factor is simply the tendency to resist. Hence ambivalence cannot in any sense be put on a level with the "schizophrenic splitting of the psyche," but is a concept which gives expression to the ever-present, intimate association of opposites.

[427] One of the most striking examples of this can be found in Freud's paper on "The Antithetical Meaning of Primal Words." The same is true of the ambitendency. Neither is specific for schizophrenia, but both are equally true of the neuroses and of the normal. All that is left over for catatonic negativism is the intentional opposition, in other words, the resistance. As is clear from the explanation given above, resistance is something different from ambivalence; it is the dynamic factor which in all cases makes the latent ambivalence manifest. What is characteristic of the diseased mind, therefore, is not the ambivalence but the resistance. This implies the existence of a conflict between two opposite tendencies which have succeeded in intensifying the normally present ambivalence into a manifest struggle between its contradictory components.⁵ In other words it is a conflict of wills, bringing about the neurotic condition of "disunion with oneself." This condition is the only "splitting of the psyche" known to us, which is therefore not so much a "predisposing cause" as a manifestation of the inner conflict, of the "incompatibility of the complex" (Riklin).

[428] Now resistance, as the fundamental fact of schizophrenic dissociation, is something which, in contradistinction to ambivalence, is not necessarily implied in the concept of "feeling-tone," but is a secondary addition, with its own special and more or less independent psychological history which in each case is identical with the previous history of the complex. It follows from this that the theory of negativism must coincide with the theory of the complex, since the complex is the cause of the resistance. Bleuler lists the following causes of negativism:

- a. Autistic withdrawal of the patient into his own fantasies.
- b. The existence of a "life-wound" (complex) which must be protected from injury.
- c. Misapprehension of the environment and its intentions.
- d. Directly hostile relationship to the environment.

e. The pathological irritability of schizophrenics.

f. "Pressure of ideas" and other impediments to thought and action.

g. "Often sexuality, with its ambivalent feeling-tone, is one of the roots of negativistic reaction."

[429] As regards *a*. "autistic withdrawal" into one's fantasies⁶ is the same as what I have described elsewhere as the marked proliferation of fantasies relating to the complex. Reinforcement of the complex is identical with increase of resistance.

[430] *b*. The "life-wound" is the complex, which is naturally present in every case of schizophrenia and of necessity always entails the phenomenon of autism or autoerotism, since complexes and involuntary egocentricity are inseparable and reciprocal. Points *a* and *b* therefore are really identical.⁷

[431] *c*. It has been shown that "misapprehension of the environment" is an assimilation to the complex.

[432] *d*. "Hostile relationship to the environment" is a maximal point of resistance, as psychoanalysis shows to perfection. Accordingly *d* coincides with *a*.

[433] *e*. "Irritability" proves psychoanalytically to be one of the commonest consequences of the complex. In its systematic form I have called it "complex sensitiveness." Its generalized form (if one may use such an expression) is a damming up of affect (= damming up of libido) as a result of increased resistances. What is known as "neurasthenia" is a classic example of this.

[434] *f*. Under the heading "pressure of ideas" and similar intellectual disturbances we may also include the "lack of clarity and defective logic of schizophrenic thinking," which Bleuler considers a "predisposing cause." I have, as is presumably known, expressed myself with the utmost reserve on the "intentionality" of the schizophrenic attitude. Further and wider experience has taught me that the laws of Freud's dream-psychology and his theory of the neuroses must be brought to bear on the obscurity of schizophrenic thinking. *The painfulness of the elaborated complex necessitates censorship of its expression.*⁸ This fundamental principle has to be applied to the schizophrenic disturbance of thought, and until it has been proved that it is not applicable to schizophrenia there is no justification for setting up a new principle of explanation, i.e., for postulating that the schizophrenic disturbance of thought is something primary. Observation of hypnagogic mental activity as well as of association-processes in the state of relaxed attention has brought to light psychic products which up till now have proved indistinguishable from mental products in schizophrenia. For instance, a marked relaxation of attention is sufficient to conjure up images as like as two peas to schizophrenic fantasies and modes of expression. It will be remembered that I attributed the notorious disturbance of attention in

schizophrenia to the peculiar behaviour of the complex, a view which my experience since 1906 has only confirmed. There are good reasons why I have come to regard the specifically schizophrenic disturbance of thought as the result of a complex.

[435] As for the “pressure of ideas,” it is primarily and essentially a symptom of “compulsive thinking” which, as Freud has clearly shown, is in the first place a thought-complex and secondly a sexualization of thought. Occasionally a “manic” element is added, such as can be observed in every vigorous release or production of libido. The “pressure” of ideas proves on closer inspection to be a consequence of schizophrenic introversion, which necessarily leads to a “sexualization” (= autonomization) of thought, i.e., to the autonomy of the complex.⁹

[436] *g.* The passage about sexuality appears, from the psychoanalytical point of view, difficult to understand. When we consider that the development of resistance coincides in every case with the previous history of the complex, we need only ask ourselves: Is the complex sexual or not? (It goes without saying that we must understand sexuality in the proper sense of “psychosexuality.”) To this question psychoanalysis gives the invariable answer: resistance always springs from a specific sexual development. This, as we know, leads to a conflict, i.e., to the complex. Every case of schizophrenia which has so far been analysed confirms the above proposition. It can therefore claim at least the value of a working hypothesis, and one to be followed up. In the present state of our knowledge, therefore, it is not easy to see why Bleuler allows sexuality only an occasional influence on the phenomenon of negativism, since psychoanalysis has shown that the source of negativism is resistance, which in schizophrenia as well as in all other neuroses arises from the specific sexual development.

[437] There can scarcely be any more doubt today that schizophrenia possesses essentially the same mechanisms as any other psychoneurosis, though introversion mechanisms preponderate. In my opinion, at any rate, its individual symptoms can be studied, apart from the descriptive, clinical standpoint (and disregarding the anatomical one), only from that of psychoanalysis, particularly when the investigation is directed mainly to the genetic elements. I have therefore tried to show how Bleuler’s formulations appear in the light of the complex theory, for I feel bound to draw attention to it here, and am in no way disposed to surrender this hard-won insight.

ON THE IMPORTANCE OF THE UNCONSCIOUS IN PSYCHOPATHOLOGY¹

[438] When we speak of a thing being “unconscious,” we must not forget that from the standpoint of the functioning of the brain it may be unconscious to us in two ways—physiologically and psychologically. I shall discuss the subject only from the latter point of view. For our purpose we may define the unconscious as the sum of all those psychic events which are not apperceived, and so are unconscious.

[439] The unconscious contains all those psychic events which do not possess sufficient intensity of functioning to cross the threshold dividing the conscious from the unconscious. They remain, in effect, below the surface of consciousness, and flit by in subliminal form.

[440] It has been known to psychologists since the time of Leibniz that the elements, that is to say the ideas and feelings, which make up the conscious mind—its so-called conscious content—are of a complex nature, and rest upon far simpler and altogether unconscious elements; it is the combination of these which produces consciousness. Leibniz had already mentioned the *perceptions insensibles*—those vague perceptions which Kant called “shadowy representations,” which could attain to consciousness only in an indirect manner. Later philosophers assigned the first place to the unconscious as the foundation upon which consciousness is built.

[441] This is not the place to consider the many speculative theories and the endless philosophical discussions concerning the nature and quality of the unconscious. We must be satisfied with the definition already given, which will prove quite sufficient for our purpose, namely, the conception of the unconscious as the sum of all psychic processes below the threshold of consciousness.

[442] The question of the importance of the unconscious for psychopathology may be briefly put as follows: “In what manner may we expect unconscious psychic material to behave in cases of psychosis and neurosis?”

[443] In order to get a better grasp of the situation in mental disorders, we may profitably consider first how unconscious psychic material behaves in a normal person, and especially try to visualize what in him is likely to be unconscious. To obtain this information we must first get a complete inventory of his conscious mind; and then, by a process of elimination, we may expect to find what is contained in his unconscious, for obviously—*per exclusionem*—what is in the conscious cannot be unconscious. For this purpose we must review all the activities, interests, passions, cares, and joys which make up the contents of consciousness. All that we are thus able to discover becomes, *ipso facto*, of no further moment as a possible content of

the unconscious, and we may then expect to find only those things contained in the unconscious which we have not found in the conscious mind.

[444] Let us take a concrete example: A merchant, who is happily married, father of two children, thorough and painstaking in his business affairs, and at the same time trying in a reasonable degree to improve his position in the world, is self-respecting, enlightened in religious matters, and even belongs to a society for the discussion of liberal ideas.

[445] What can we assume to be the content of the unconscious in such an individual?

[446] Considered from the theoretical standpoint outlined above, everything in the personality that is not contained in the conscious should be found in the unconscious. Let us agree, then, that this man consciously believes himself to possess all the fine qualities we have just described—no more, no less. It follows from this that he is entirely unaware that a man may be not merely industrious, thorough, and painstaking, but may also be careless, indifferent, untrustworthy; for some of these bad qualities are the common heritage of mankind and may be found to be an essential component of every character. This worthy merchant forgets that quite recently he allowed several letters to remain unanswered which he could easily have answered at once. He forgets, too, that he failed to bring a book home which his wife had asked him to get at the book-store, where she had previously ordered it, although he could easily have made a note of it in his note-book. But such occurrences are common with him. There can then be no other conclusion than that he is also lazy and untrustworthy. He is convinced that he is a thoroughly loyal citizen; but for all that he failed to declare his entire income to the authorities, and so, when they raise his taxes, he votes for the Socialists.

[447] He believes he is an independent thinker, yet a little while back he undertook a big deal on the Stock Exchange, and when he came to enter the details of the transaction in his records he noticed with considerable misgivings that it fell upon a Friday, the 13th of the month. Therefore, he is also superstitious and not a free-thinker.

[448] So we are not at all surprised to find these compensating vices to be an essential content of the unconscious. Obviously, therefore, the reverse must be true—that unconscious virtues compensate for conscious defects. The law which ought to follow from this deduction would appear to be quite simple: the conscious spendthrift is unconsciously a miser, the philanthropist is unconsciously an egoist and misanthrope. But, unfortunately, it is not quite so easy as that, although there is a core of truth in this simple rule. There are essential, hereditary dispositions of a latent or manifest nature that upset the simple rule of compensation and vary greatly in individual cases. From entirely different motives a man may be, shall we say, a

philanthropist, but the manner of his philanthropy depends upon his inherited disposition, and the way in which his philanthropic attitude is compensated depends upon his motives. It is not sufficient simply to know that a certain person is philanthropic in order to diagnose an unconscious egoism. We must also bring to such a diagnosis a careful study of the motives involved.

[449] In normal people the principal function of the unconscious is to effect a compensation and to produce a balance. All extreme conscious tendencies are softened and toned down through a counter-impulse in the unconscious. This compensating agency, as I have tried to show in the case of the merchant, expresses itself in certain unconscious, apparently inconsistent activities, which Freud has aptly termed symptomatic actions.

[450] To Freud we owe thanks, also, for having called attention to the importance of dreams. For through dreams we are able to learn much about this compensating function. There is an excellent historical example of this in the well-known dream of Nebuchadnezzar in the fourth chapter of the Book of Daniel, where Nebuchadnezzar at the height of his power had a dream which foretold his downfall. He dreamt of a tree which had raised its head even up to heaven and now must fall. This dream obviously compensates the exaggerated feeling of royal power.

[451] Coming now to conditions in which the mental balance is disturbed, we can the more easily see, from what has been said, wherein lies the importance of the unconscious for psychopathology. Let us consider the question of where and in what manner the unconscious manifests itself in abnormal mental conditions. The way the unconscious works is seen most clearly in disturbances of a psychogenic nature, such as hysteria, obsessional neurosis, etc.

[452] We have known for a long time that certain symptoms of these disturbances are produced by unconscious psychic events. The manifestations of the unconscious in actually insane patients are just as clear, but are not so well recognized. For just as the intuitive ideas of normal people do not spring from logical combinations of the conscious mind, so the hallucinations and delusions of the insane arise not out of conscious but out of unconscious processes.

[453] Formerly, in a more materialistic epoch of psychiatry, it was believed that all delusions, hallucinations, stereotypies, etc., were caused by morbid processes in the brain-cells. Adherents of this theory overlooked the fact that delusions, hallucinations, etc., are found in certain functional disturbances, and not only there but also in normal people. Primitives may have visions and hear strange voices without their mental processes being at all disturbed. To seek to reduce symptoms of this kind directly to a disease of the brain-cells I hold to be superficial and unwarranted. Hallucinations show very plainly how a part of the unconscious content

can force itself across the threshold of consciousness. The same is true of a delusion whose appearance is at once strange and unexpected by the patient.

[454] “Mental balance” is no mere figure of speech, for its disturbance is a real disturbance of the balance which—to a far higher degree than has been recognized—actually exists between the conscious and the unconscious contents. What happens is that the normal functioning of the unconscious processes breaks through into the conscious mind in an abnormal manner, and thereby disturbs the adaptation of the individual to his environment.

[455] If we examine the history of any such person we often find that he has been living for a considerable time in a state of peculiar individual isolation, more or less shut off from the world of reality. This condition of aloofness may be traced back to certain innate or early acquired peculiarities, which show themselves again and again in the events of his life. For instance, in the histories of those suffering from dementia praecox we often hear such a remark as this: “He was always of a pensive disposition, and much shut up in himself. After his mother died he cut himself off still more from the world, shunning his friends and acquaintances.” Or again, we may hear: “Even as a child he rigged up all sorts of peculiar inventions; and later, when he became an engineer, he went in for the most ambitious schemes.”

[456] Without going into the matter more closely, it seems evident that a counter-irritant will be produced in the unconscious as a compensation to the one-sidedness of the conscious attitude. In the first case mentioned, we may expect to find in the unconscious an increasing wish for human intercourse, a longing for mother, friends, relations, while in the second case self-criticism will try to establish a correcting balance. In normal people a condition never arises which is so one-sided that the natural corrective influences of the unconscious are entirely without effect in everyday life. On the other hand, we find it eminently characteristic of abnormal people that they refuse to recognize the compensating influence which comes from the unconscious and even continue to emphasize their one-sidedness in accordance with the well-known psychological fact that the worst enemy of the wolf is the wolf-hound, the worst despiser of the Negro the mulatto, and the convert the greatest fanatic; for I become a fanatic when I attack outwardly a thing which inwardly I am obliged to concede is right.

[457] The mentally unbalanced person tries to defend himself against his own unconscious, that is to say, he fights against his own compensating influences. The man already living in an atmosphere of isolation continues to remove himself further and further from the world of reality, and the ambitious engineer strives, by his more and more pathological and exaggerated inventions, to prove the incorrectness of his compensating powers of self-criticism. This results in a condition of excitation,

which produces a great lack of harmony between the conscious and unconscious tendencies. The pairs of opposites are torn asunder, the resultant division leads to disaster, for the unconscious soon begins to obtrude itself violently upon the conscious processes. Then come odd and incomprehensible thoughts and moods, and often incipient forms of hallucination, which plainly bear the stamp of the internal conflict.

[458] These corrective impulses or compensations which now break through into the conscious mind should really be the beginning of a healing process, because through them the previously isolated attitude ought to be relieved. But in reality this does not happen, for the reason that the unconscious corrective impulses which succeed in making themselves perceptible to the conscious mind do so in a form that is altogether unacceptable to it.

[459] The isolated individual begins to hear strange voices, which accuse him of murder and all sorts of crimes. These voices drive him to desperation, and in the ensuing excitement he tries to get into contact with the surrounding milieu, thus doing the very thing he had anxiously avoided before. The compensation is, to be sure, effected, but to the detriment of the individual.

[460] The pathological inventor, who is unable to profit by his previous failures, still allows himself, by refusing to recognize the value of his own self-criticism, to work at ever crazier schemes. He wishes to accomplish the impossible but falls instead into the absurd. After a while he notices that people talk about him, make unfavourable remarks, and even scoff at him. He believes a far-reaching conspiracy exists to frustrate his discoveries and render them objects of ridicule. By this means his unconscious brings about the same results that his self-criticism could have achieved, but again only to the detriment of the individual, because the criticism is projected into his surroundings.

[461] An especially typical form of unconscious compensation—to give a further example—is the paranoia of the alcoholic. The alcoholic loses his love for his wife; the unconscious compensation tries to lead him back again to his duty, but it can only partially succeed, for it merely causes him to become jealous of his wife as if he still loved her. As we know, he can even go so far as to kill his wife and himself through jealousy. In other words, his love for his wife has not been entirely lost, it has simply become subliminal. But from the realm of the unconscious it can now reappear only in the form of jealousy.

[462] We see something similar in the case of religious converts. Everyone who turns from Protestantism to Catholicism has, as is well known, a tendency to be somewhat fanatical. His Protestantism is not entirely relinquished, it has merely disappeared into the unconscious, where it is constantly at work as a counterirritant to his newly

acquired Catholicism. Therefore the new convert feels under an obligation to defend fanatically the faith he has adopted. It is exactly the same with the paranoiac, who feels compelled to defend himself against all external criticism, because his delusional system is too much threatened from within.

[463] The strange manner in which these compensating influences break through into consciousness is explained by the fact, firstly, that they have to struggle against the resistances already there and so present themselves to the patient in a quite thoroughly distorted way. Secondly, these compensating influences must of necessity present themselves in the language of the unconscious—that is, in subliminal material of a very heterogeneous nature. For everything in the conscious mind which is of no further value and can find no suitable application becomes subliminal. Such material includes all those forgotten infantile fantasies which have ever entered the minds of men, and of which only legends and myths remain. For certain reasons which I cannot discuss here, this material is frequently found in dementia praecox.

[464] I hope I may have been able to give in this brief lecture, which I feel to be very incomplete, a glimpse of the importance, as I see it, of the unconscious in psychopathology. It would be impossible in a short talk to give an adequate idea of all the work that has already been done in this field.

[465] To sum up, one could say that the function of the unconscious in mental disturbances is essentially a compensation of the conscious content. But because of the characteristic one-sidedness of the conscious striving in all such cases, the compensating correctives are rendered useless. It is, however, inevitable that these unconscious tendencies will break through, but in adapting themselves to the one-sided conscious aims, it is possible for them to appear only in a distorted and unacceptable form.

ON THE PROBLEM OF PSYCHOGENESIS IN MENTAL DISEASE¹

[466] If I venture to discuss the problem of psychogenesis in mental disease, I am well aware that I am touching a question that is far from popular. The great progress that has been made in the realm of brain anatomy and pathological physiology, and the general prepossession in favour of natural science today, have taught us to look, always and everywhere, for material causes, and to rest content once we have found them. The ancient metaphysical explanation of Nature was discredited on account of its manifold errors, so much so that the value of its psychological standpoint was lost. In psychiatry, during the first decades of the nineteenth century, the metaphysical explanation of Nature ended in moralistic aetiological theories which explained mental disease as a consequence of moral faults. Only at the time of Esquirol did psychiatry become a natural science.

[467] The development of natural science brought with it a general view of the world—that of scientific materialism, which, considered from the psychological standpoint, is based on an excessive overvaluation of physical causation. Scientific materialism axiomatically refuses to acknowledge any other causal connection than the physical one. The materialistic dogma as formulated in psychiatry runs as follows: “Mental diseases are diseases of the brain.” This dogma still prevails today, although materialism in philosophy is already on the wane. The almost undisputed validity of the materialistic dogma in psychiatry is due essentially to the fact that medicine is a natural science, and the psychiatrist as a physician is a natural scientist. The medical student, being overburdened with specialized studies, cannot allow himself to make digressions into the realm of philosophy, and is subjected exclusively to the influence of materialistic axioms. As a consequence, researches in psychiatry are concerned mainly with anatomical problems, so far as they are not preoccupied with questions of diagnosis and classification. Thus the psychiatrist generally considers the physical aetiology to be of primary importance and the psychological aetiology to be only secondary and subsidiary; and because of this attitude he keeps in view only causal connections of a physical kind and overlooks their psychological determination. This is not a position in which one can appreciate the importance of psychological determinants. Physicians have often assured me that it was impossible to discover in their patients any trace of psychological conflicts or of psychogenic symptoms, but just as often I found they had carefully noted all the incidents of a physical kind and had failed to note all those of a psychological kind, not from negligence but because of a typical undervaluation of the importance of the psychological factor.

[468] Once, for instance, I was called in as consultant on a case in which two well-known nerve specialists had diagnosed sarcoma of the membranes of the spinal cord. The patient, a woman aged about 50, suffered from a peculiar symmetrical rash in the lumbar region, and from fits of crying. The physical examination made by the doctors was exceedingly careful, as was the anamnesis. A piece of the skin had been excised and examined histologically. But it had been entirely overlooked that the patient was a human being with a human psychology. Owing to this characteristic undervaluation of the psychological standpoint, the conditions in which the disease originated remained unexplored.

[469] The patient was a widow. She lived with her eldest son, whom she loved in spite of their many quarrels and mutual difficulties. In a way he replaced her husband. Life under these conditions became more and more intolerable to the son, so he decided to separate himself from his mother and live elsewhere. The first fit of crying occurred on the day he left her. This was the beginning of a protracted illness. The course of the disease, its improvements as well as its exacerbations, all corresponded with changes in relation to the son, as could clearly be shown by means of psychological anamnesis. The wrong diagnosis naturally did not improve the symptoms; on the contrary, it worked by suggestion for the worse. It was an ordinary case of hysteria, as the later developments proved. Since both the doctors were hypnotized by their belief in the physical causation and physical nature of the disease, it did not occur to them to inquire into the patient's psychological circumstances. Therefore they could both assure me that there was "nothing psychic" in the case.

[470] Such errors are easily understood when one remembers that neither psychiatrists nor neurologists have any other training than in natural science. Yet, for these branches of medicine, a knowledge of psychology is absolutely indispensable. The lack of psychological training is frequently compensated later, especially among general practitioners, by practical experience of life and its fundamental emotions, but unfortunately this is not the general rule. The student, at all events, hears little or nothing of abnormal psychology. Even if time should allow him to follow a course of psychology, he would only have the opportunity of learning a kind which has nothing to do with the requirements of medical practice. This at least is the situation on the Continent. As a rule psychologists are men of the laboratory and not general practitioners, at all events not experienced psychiatrists or neurologists. So it is not surprising that the psychological point of view is omitted from the anamnesis, the diagnosis, and the treatment. And yet this view is of the greatest importance, not only in the realm of neurosis, where it has been increasingly appreciated ever since Charcot's day, but also in the realm of mental disease.

[471] In speaking of the psychogenesis of mental disease I have in mind chiefly those many forms lately labelled in a vague and misleading way "dementia praecox." Under this rubric are gathered all those hallucinatory, catatonic, hebephrenic, and paranoid conditions, not showing the characteristic organic processes of cellular destruction seen in general paralysis, senile dementia, epileptic dementia, and chronic intoxications, and not belonging to the manic-depressive group. As you are aware, there are certain cases belonging to the class of dementia praecox which do show cellular changes in the brain. But these changes are not regularly present nor do they explain the special symptomatology. If you compare the usual symptoms of dementia praecox with the disturbances which occur in organic brain-disease you will find striking differences. There is not a single usual symptom of dementia praecox which could be called an organic symptom. There is no justification whatever for putting general paralysis, senile dementia, and dementia praecox on the same level. The fact that cellular destruction occasionally occurs does not justify us in classifying dementia praecox among the organic diseases. I admit, however, that the inmates of a mental hospital present such a degenerative picture that one can quite understand why the term "dementia praecox" was invented. The general aspect of a ward of the incurably insane supports the materialistic bias of the psychiatrist. His clientele includes some of the worst cases imaginable. It is therefore natural that traits of degeneration and destruction make the most impression on him. It is the same with hysteria; only the worst hysterics are confined to asylums, and so psychiatrists see only the most hopeless and degenerate forms of the disease. Naturally such a selection must lead to a prejudiced view. If you read the description of hysteria in a text-book of psychiatry and compare it with real hysteria as it presents itself in the consulting-room of the general practitioner, you will have to acknowledge a considerable difference. The psychiatrist sees only a minimum of hysterics and a selection of only the worst cases. But beside these there are numberless mild cases which never come near a hospital, and these are the cases of genuine hysteria. It is the same with dementia praecox. There are mild forms of this disease far outnumbering the worst cases which alone reach the hospital. The mild forms are never confined. They come under diagnoses as vague and mistaken as "neurasthenia" or "psychasthenia." As a rule the general practitioner never realizes that his neurasthenic is nothing but a mild case of that dreadful disease called dementia praecox with its almost hopeless prognosis. In the same way he would never consider his hysterical niece to be the liar and impostor and morally unreliable character of the text-books. Bad cases of hysteria give a bad repute to the whole class, hence the public does not mind confessing to nervousness, but will not confess to hysteria.

[472] As regards the apparently destructive and degenerative traits of dementia praecox, I must call special attention to the fact that the worst catatonic states and the

most complete dementias are in many cases products of the lunatic asylum, brought on by the psychological influence of the milieu, and by no means always by a destructive process independent of external conditions. It is a well-known fact that the very worst demented catatonics are to be encountered in badly administered and overcrowded asylums. It is well known also that removal to noisy or otherwise unfavourable wards often has an unwholesome influence; the same applies to coercive measures or forced inactivity. All the conditions which would reduce a normal person to a state of psychic misery will have an equally baleful effect on a patient. Bearing this fact in mind, modern psychiatry tries to avoid the character of a prison and to give the asylum the aspect of a hospital. The wards are made as homelike as possible, the physicians deprecate coercion, and as much personal freedom is granted to the patient as possible. Flowers at the curtained windows make a good impression not only on the normal but also on the sick. It is a fact that nowadays we seldom or never see the sad picture of demented, dirty, insane persons sitting in rows along the asylum walls. And why is this so? Because we realize that these patients react to their surroundings just as much as the normal do. Senile dementia, general paralysis, and epileptic insanity run their course whether the patients are confined with similar cases or not. But cases of dementia praecox not infrequently improve or become worse in response to psychological conditions, in a way that is sometimes astonishing. Every psychiatrist knows such cases; they prove the great importance of the psychological factor. They clearly demonstrate that dementia praecox must not be regarded one-sidedly as an organic disease. Such ameliorations and relapses could not occur if dementia praecox were only organic.

[473] I must also mention those frequent cases in which the onset of the disease, or a new outbreak of it, takes place under special emotional conditions. I remember a case of my own in which a man, aged about 35, was twice seized with a catatonic attack when he came into the town where he had lived as a student. He had an unforgettable love-affair there, which came to an unhappy end. He avoided returning to that town for several years, but as he had relatives there, he could finally no longer refrain from visiting them. In the course of six years he went there twice, and each time almost immediately fell ill on account of a fatal reactivation of his memories. Both times catatonic excitement occurred, and he had to be confined to an asylum. Except for those periods of confinement he was successful in his work, and apart from leading a somewhat solitary existence he did not show any noticeable signs of mental derangement.

[474] It is quite common for a renewed attack to occur when an engagement, marriage, or any similar emotional event is imminent. The outbreak and development of the disease are often determined by psychological motives. I remember the case of a woman who broke down after a quarrel with another woman. The patient's

temperament had always been irritable and choleric. In this particular quarrel she became violent towards her opponent, who in return called her “mad.” This reproach roused the patient still more, and she said, “If you call me mad, you shall see what it means to be mad!” With these words she fell into a state of frenzy. As it caused a scandal in the street the police intervened and took her to the hospital. There she soon calmed down, only insisting somewhat too energetically upon her immediate discharge. It did not seem advisable, however, to allow her to return after only a few hours, because she was still excited. We sent her from the consultation-room to the observation-ward. There she would not obey the nurses, and tried to open the door by violence. She feared she would be kept permanently in the hospital. Her excitement became so troublesome that she had to be placed in another ward. As soon as she became aware of the character of the patients there, she began to cry out that we had locked her up with crazy people in order to drive her mad. And again she said, “If you want me to be mad, you shall see what madness means.” Immediately afterwards she fell into a catatonic dream-state, with wild delusions and fits of rage, which lasted uninterruptedly for about two months.

[475] In my view her catatonia was nothing but pathologically exaggerated emotion, brought on by being confined in a lunatic asylum. During the acute stage of her illness she behaved just as the general public thinks a mad person would behave. It was a perfect demonstration of “madness” in every particular. It was certainly not hysteria, because there was a complete lack of emotional rapport.

[476] It is most unlikely that there was a primary brain-disturbance of an organic nature, and that the mental disorder, the violent emotions, and the subsequent delusions and hallucinations were secondary. Rather is it an instinctive reaction against being deprived of freedom. Wild animals often show similarly violent reactions when they are caged. In spite of the manifest psychogenic causation, the case was typically catatonic, with excitement, delusions, and hallucinations, and could not be distinguished from a case due to other than psychological causes. The patient had never had such an attack before. She had always been irritable, but her excitement always had a definite cause, and each time quickly subsided. The only really catatonic attack was the one in the hospital.

[477] I remember another case of a similar kind. The patient was a young school-teacher, who began to be lazy, dreamy, and unreliable. Apart from that he showed certain peculiarities in his behaviour. He was confined to an asylum for observation. At first he was quiet and accessible, and believed he would be discharged, as he was convinced of his normality. He was placed in a quiet ward. But when we told him that he would have to be kept under observation for some weeks, he became angry, and said to the doctor, “If you want to keep me here as insane, I will show you what

it means to be mad.” He immediately became very excited, and within a few days was completely confused, and had many delusions and hallucinations. This state lasted for some weeks.

[478] The following case emphasizes my point: A young man had been in the asylum for almost two months. He had been certified as morally insane. This diagnosis was based on the fact that he had been proved to be a cheat and a liar. He refused to work, and was excessively lazy. It did not appear to us as if he were merely morally defective. The possibility of dementia praecox occurred to us. There were no specific symptoms, however, except great moral indifference. His behaviour was disagreeably irritating, he was scheming, and at times rough and violent. He was out of place in the quiet ward. In spite of his troublesome conduct I tried to keep him there, although many complaints were received from nurses and patients. Once, during my absence from the hospital, my substitute put him into the ward for excited patients. There he at once became so excited that he had to be narcotized. He then began to be afraid of being murdered or poisoned, and had hallucinations. Obviously the outbreak of manifest psychosis was due to external conditions which had an unfavourable influence on his mental state. It would be an unsatisfactory explanation to attribute the psychosis to sudden aggravation of a pre-existing brain-disease. The exact opposite, namely marked improvement in a chronic state as a result of improved external conditions, is a fairly common occurrence.

[479] If dementia praecox were due essentially to a process of organic destruction, patients would behave like those showing actual changes in the brain. A patient suffering from general paralysis does not improve or become worse as the result of a change in his psychological condition, nor are such cases noticeably worse in poorly run asylums, but cases of dementia praecox are distinctly worse when the external circumstances are unfavourable.

[480] Since it is evident that the psychological factor plays a decisive role in the course of the dementia praecox, it is not unlikely that the first attack would be due to a psychological cause. It is known that many cases originate in a psychologically critical period or following a shock or a violent moral conflict. The psychiatrist is inclined to regard such conditions rather as precipitating causes or auxiliary factors which bring a latent organic disease to the surface. He thinks that if psychic experiences were really efficient causes they should exercise a pathological effect in everybody. As this is obviously not the case, the psychic causes therefore have the significance only of auxiliary factors. This reasoning is undoubtedly one-sided and materialistically prejudiced. Modern medicine no longer speaks of *one* cause, and one only, of a disease. Tuberculosis is no longer held to be caused only by the specific bacillus, it owes its existence to a number of contributory causes. The

modern aetiological conception is no longer causalism but *conditionalism*. Undoubtedly a psychological cause hardly ever produces insanity unless it is supported by some specific predisposition. On the other hand a marked predisposition may exist, but a psychosis will not break out so long as serious conflicts and emotional shocks are avoided. It can be stated, however, almost with certainty that the psychological predisposition leads to a conflict, and thus by way of a vicious circle to psychosis. Such cases, looked at from an external standpoint, might appear to be determined by a degenerative predisposition of the brain. In my view most cases of dementia praecox are driven by their congenital predisposition into psychological conflicts, but these conflicts are not essentially pathological, they are common human experiences. Since the predisposition consists in an abnormal sensitiveness, the conflicts differ from normal conflicts only in emotional intensity. Because of their intensity they are out of all proportion to the other mental faculties of the individual. They cannot, therefore, be dealt with in the ordinary way, by means of distraction, reason, and self-control. It is only the impossibility of getting rid of an overpowering conflict that leads to insanity. Only when the individual realizes that he cannot help himself in his difficulties, and that nobody else will help him, is he seized by panic, which arouses in him a chaos of emotions and strange thoughts. This experience belongs to the stage of incubation and seldom comes before the psychiatrist, since it occurs a long time before anybody thinks of consulting a doctor. If the psychiatrist succeeds in finding a solution to the conflict the patient can be saved from a psychosis.

[481] It may be objected that it is impossible to prove that this was the initial stage of a psychosis, and that there is no evidence that a psychosis would have arisen if the conflict had not been solved. Certainly I cannot supply any convincing proof to the contrary. If a case of indubitable dementia praecox could be brought back to normal adaptation and a definite estimate made of the effect of the therapeutic measures, it might be considered satisfactory evidence; but even such evidence could easily be invalidated by the objection that the apparent cure was only an accidental remission of symptoms. It is almost impossible to produce satisfactory evidence, in spite of the fact that not a few specialists believe in the possible prevention of psychoses.

[482] It is still perhaps too early to speak of a psychotherapy of psychoses. I am not altogether optimistic in this respect. For the time being I would stress the importance of examining the role and significance of the psychological factor in the aetiology and course of psychoses. Most of the psychoses I have explored are of an exceedingly complicated nature, so that I could not describe them in the narrow space of a lecture. But comparatively simple cases are sometimes met with, the origin of which can be demonstrated. I remember, for instance, the case of a young girl, a peasant's daughter, who suddenly fell ill with dementia praecox. Her doctor, a

general practitioner, told me that she was always very quiet and retiring. Her symptoms came on suddenly and unexpectedly, and nobody had suspected her of being mentally abnormal. One night she suddenly heard the voice of God speaking to her, about war and peace and the sins of man. She had, she said, a long talk with God. The same night, Jesus also appeared to her. When I saw her, she was perfectly calm, but absolutely without interest in her surroundings. She stood erect all day long near the stove, rocking to and fro, not talking to anybody except when questioned. Her answers were short and clear, but without feeling. She greeted me without the slightest emotional reaction, as if she saw me daily. Though unprepared for my coming she did not seem in the least astonished or curious to know who I was or what was the purpose of my visit. I asked her to tell me of her experiences. In her taciturn and unemotional way she remarked she had had long talks with God. Apparently she had forgotten the subject of her talks. Christ looked quite like an ordinary man with blue eyes. He also talked with her, but she did not remember what he said. I told her it would be a regrettable loss if those talks should be entirely forgotten. She should have taken note of them. She said that she had taken note of them, and gave me the sheet of a calendar. But there was only a cross on it, which she had marked on the date when she heard the voice of God for the first time. Her answers were curt, evasive and indirect, and completely devoid of feeling. Her whole attitude was absolutely indifferent. She was intelligent, a trained teacher, but she betrayed not a trace of either intellectual or emotional reaction. We might have been speaking of her stove rather than of a most unusual phenomenon.

[483] It was impossible to get a coherent story from her. I had to draw her out bit by bit, not against any active resistance, as in hysteria, but against a complete lack of interest. It was a matter of complete indifference to her whether she was questioned or not, or whether her answers were satisfactory or not. She had obviously no emotional rapport with her surroundings. Her indifference was such that it produced the impression that there was nothing in her that it was worth while to ask for. When I asked whether she was troubled about some religious experience, she calmly said that she was not. Nothing was troubling her, there were no conflicts, neither with her relatives nor with other people. I questioned her mother. She could only tell me that the evening before the outbreak the patient went with her sister to a religious meeting. On coming home she seemed excited, and spoke of having experienced a complete conversion. Her doctor, deeply interested in her case, had already tried to get more out of her, because his common sense could not believe that such a disturbance could arise out of nothing. But he was confronted by her unfeigned indifference, and was forced to believe that there really was nothing below the surface. Her relatives could say nothing more than that she had always been rather over-quiet, retiring, and shy from her sixteenth year. In childhood she was healthy,

merry, and not in the least abnormal. There was no pathological heredity in the family. The aetiology was quite impenetrable.

[484] She told me she did not actually hear the voice of God any longer, but that she was almost entirely sleepless, because her thoughts went on working uninterruptedly. She seemed quite unable to tell me what she thought about, apparently because she did not know. She alluded to a constant movement in her head, and to the presence of electric currents in her body. But she was not sure where they came from; presumably they came from God.

[485] There will probably be no disagreement about the diagnosis of dementia praecox. Hysteria is excluded; there were no specifically hysterical symptoms, and moreover the main criterion of hysteria—an emotional rapport—was absolutely lacking.

[486] While I was trying to get at the aetiology, the following conversation took place:

Before you heard the voice of God, did you experience a religious conversion? —
Yes.

If you were converted, you must have been sinful before? — *Yes.*

How did you sin? — *I don't know.*

But—I do not understand. Surely you must know what your sin was? — *Yes, I did wrong.*

What did you do? — *I saw a man.*

Where? — *In the town.*

But do you believe it a sin to see a man? — *No.*

Who was this man? — *Mr. M.*

What did you feel when you saw Mr. M.? — *I loved him.*

Do you still love him? — *No.*

Why not? — *I don't know.*

[487] I will not weary you with a verbatim report of my attempts to catch hold of what was behind the screen. It took me about two hours. The patient was unremittingly taciturn and indifferent, so that I had to exert all my energy in order to continue our talk. All the time I was under the impression that the examination was completely hopeless, and I almost felt my questions were superfluous. I lay particular stress upon the patient's attitude for it is just this attitude that makes a psychological examination so exhausting and, very often, so unfruitful. But it is an attitude only, and not a real lack of psychic contents. It is an attitude of self-defence, a mechanism for warding off the overwhelming emotions of the hidden conflict.

[488] Only the fact that the case appeared simple gave me the courage and patience to continue questioning. In more complicated cases, where we are concerned less with

realities than with fantasies, questioning becomes more difficult and sometimes impossible, particularly when the patient refuses to answer. As can readily be understood, doctors in a mental hospital cannot as a rule devote so much time to their patients. The exploration of a psychosis demands almost limitless time, so it is no wonder that the psychogenic connections are overlooked. I assure you that if the patient had been admitted to a clinic you would not have found more in her anamnesis than I have already told you.

[489] The result of my examination was as follows. Several weeks before the outbreak of the illness the patient was in town with a friend. There she became acquainted with Mr. M. When she fell in love with him she was frightened by the extraordinary intensity of her feelings. She thereupon became taciturn and shy. She did not tell her friend of her feeling of fear. She hoped Mr. M. would return her love. Seeing no sign of this, she almost immediately afterwards left the town and returned home. She felt as if she had committed a great sin because of the intensity of her feelings, although, as she said, she had never been particularly religious before. The feeling of guilt kept on worrying her. A few weeks later her friend came to visit her. As this friend was very religious she consented to go with her to a religious meeting. She was deeply moved and professed conversion. She felt great relief, because the feeling of guilt disappeared, and at the same time she found her love for Mr. M. had completely vanished. I wondered why she thought her feeling of love was sinful, and I asked her why it appeared so to her. She replied that owing to her conversion she had realized that such a feeling for a man was a sin against God. I reminded her that this attitude could not be natural, whereupon she confessed that she had always been shy about such feelings. She dated that shyness from a sin she had committed in her sixteenth year. At that time, whilst walking with a girl friend of the same age, they met an elderly imbecile woman whom they provoked to obscene behaviour. This fact became known to her parents and to the school-teacher, and both punished her severely. Only afterwards did she realize the wickedness of her behaviour. She was much ashamed, and solemnly promised herself to lead a pure and irreproachable life henceforth. From that time on she became retiring, not liking to go out of the house, fearing that the neighbours would know of her fault. It became her custom to stay at home and avoid all worldly amusements.

[490] The patient had, as one might expect, been morally a good child—but as often happens with sensitive characters, she remained a child too long. It was because of her childish irresponsibility that she could commit such an inadmissible deed as late as her sixteenth year. Her subsequent insight led to profound remorse. The experience threw a shadow on the feeling of love itself, and she therefore felt disagreeably affected by everything remotely pertaining to this episode. For this reason her sudden

love for Mr. M. felt like guilt. By her immediate departure she prevented the development of any further relationship and at the same time cut off all hope.

[491] Her tendency to transfer her hopes to the sphere of religion and to seek consolation there has nothing unusual about it. The unexpected and complete conversion was perhaps exceptional, though similar conversions, where there is no reason to think of a psychosis, often occur at revival meetings. The pathogenic impressions were not essentially morbid, they were only particularly intense. The friend who took part in the same affair was admonished and punished like herself, yet she did not become a prey to profound regret and everlasting remorse, whereas the result of the patient's regret was that she cut herself off from intercourse with other people. This caused her to bottle up her desire for human relations to such an extent that when she met Mr. M. she was simply overwhelmed by the intensity of her feelings. Not meeting with an immediately satisfactory response she was deeply disappointed and departed precipitately. Thus she got into still worse trouble, and her solitary life at home became quite intolerable. Again her desire for human companionship was bottled up, and about this time she attended the religious meeting. The impression it made upon her turned her completely away from her former hopes and expectations. She even got rid of her love. By this device she was saved indeed from her former worries, but her natural desire to share the ordinary life of a woman of her class was abolished with them. Now that her hopes were turned away from the world, her "fonction du réel" created a world within herself. When people lose their hold on the concrete values of life the unconscious contents become overwhelmingly real. Considered from the psychological standpoint, psychosis is a mental condition in which formerly unconscious elements take the place of reality.

[492] It depends, of course, upon the patient's predisposition whether a conversion of this kind will lead to hysteria or to dementia praecox. If the patient can maintain his emotional rapport by dissociating himself into two personalities, one religious and apparently transcendental, the other perhaps all too human, he will become hysterical. If on the other hand he cuts off his emotional rapport with human beings entirely, so that they make no impression on him at all, he will become schizophrenic. In our case there was a striking lack of emotional rapport, and accordingly there was no trace of hysteria.

[493] In these circumstances, can one speak of an organic process at all? I believe it to be completely out of the question. The critical experience occurred when the patient was sixteen, at which time there was not the slightest trace of an organic lesion. There is no evidence whatever in favour of such an hypothesis, nor is there any reason to explain the traumatic experience with Mr. M. as organically determined, otherwise all cases of this kind would have to be explained in the same way. If we

had to admit cellular destruction, it would certainly have begun after the shock of religious conversion, in which case the organic changes would be secondary. More than ten years ago I claimed that a great many cases of dementia praecox were psychogenic in origin,² the toxic or destructive processes being secondary only. But I do not deny that there may be cases in which the organic processes are primary and the disturbances of the psychic functions secondary.

[494] It is worth noting that immediately after the consultation the patient's mental state improved considerably. I have repeatedly observed very striking reactions after such an examination, either a marked improvement or, conversely, an exacerbation of the symptoms. This is strictly in keeping with the important role played by the psychic factor.

[495] I am well aware that I have not given a full account of the problem of psychogenesis, but the point I wish to make is that the psychiatrist has here a wide field for psychological research which has not yet been explored.

MENTAL DISEASE AND THE PSYCHE¹

[496] The predominantly materialistic views that were popular at the end of the nineteenth century have left their mark, as everywhere, on medical theory and particularly on psychiatric theory. That epoch, terminating with the World War, put its faith in the axiom: Mental diseases are diseases of the brain. What is more, one could with impunity attribute even the neuroses to metabolic toxins or to disturbances of the internal secretions. This chemical materialism or, as we may call it, “brain-mythology,” came to grief more quickly in the domain of neurosis than it did in psychiatry. It was, above all, the experiences of the French psychopathologists (Janet and the Nancy school) that, with the support of Forel in Switzerland and Freud in Austria, did away with the idea of the organic basis of neurosis, at least in theory. Today nobody doubts that the neuroses are *psychogenic*. “Psychogenesis” means that the essential cause of a neurosis, or the condition under which it arises, is of a psychic nature. It may, for instance, be a psychic shock, a gruelling conflict, a wrong kind of psychic adaptation, a fatal illusion, and so on.

[497] Clear and indubitable as the psychic causation of the neuroses may seem today, the question of psychogenesis in other mental diseases remains obscure and doubtful. Quite apart from the fact that whole groups of mental diseases, such as senile deterioration and progressive paralysis, are merely symptoms of an organic destruction of the brain, there are other groups of mental diseases, such as epileptic and schizophrenic disturbances, which also yield findings relating to the brain. This organic complication is not met with in the neuroses, or only in exceptional cases, such as the spurious neuroses caused by “diaschisis” (Monakow: indirect failure of function). The schizophrenias are the real mental diseases; that is, they supply the main population of our mental hospitals. Nearly every case which the general public rightly regards as “mad” belongs to this class. (The term “schizophrenia” was coined by Bleuler and means “split mind.” It replaces Kraepelin’s earlier term, “dementia praecox.”) If, therefore, we wish to speak of psychogenesis in mental disease, our primary concern must be schizophrenia.

[498] In 1907 I came before the scientific public with a book on the psychology of dementia praecox. By and large, I adopted a standpoint affirming the psychogenesis of schizophrenia, and emphasized that the symptoms (delusions and hallucinations) are not just meaningless chance happenings but, as regards their content, are in every respect significant psychic products. This means that schizophrenia has a “psychology,” i.e., a psychic causality and finality, just as normal mental life has, though with this important difference: whereas in the healthy person the ego is the

subject of his experience, in the schizophrenic the ego is only *one* of the experiencing subjects. In other words, in schizophrenia the normal subject has split into a plurality of subjects, or into a plurality of *autonomous complexes*.

[499] The simplest form of schizophrenia, of the splitting of the personality, is paranoia, the classic persecution-mania of the “*persécuteur persécuté*.” It consists in a simple doubling of the personality, which in milder cases is still held together by the identity of the two egos. The patient strikes us at first as completely normal; he may hold office, be in a lucrative position, we suspect nothing. We converse normally with him, and at some point we let fall the word “Freemason.” Suddenly the jovial face before us changes, a piercing look full of abysmal mistrust and inhuman fanaticism meets us from his eye. He has become a hunted, dangerous animal, surrounded by invisible enemies: the other ego has risen to the surface.

[500] What has happened? Obviously at some time or other the idea of being a persecuted victim gained the upper hand, became autonomous, and formed a second subject which at times completely replaces the healthy ego. It is characteristic that neither of the two subjects can fully experience the other, although the two personalities are not separated by a belt of unconsciousness as they are in an hysterical dissociation of the personality. They know each other intimately, but they have no valid arguments against one another. The healthy ego cannot counter the affectivity of the other, for at least half its affectivity has gone over into its opposite number. It is, so to speak, paralysed. This is the beginning of that schizophrenic “*apathy*” which can best be observed in paranoid dementia. The patient can assure you with the greatest indifference: “I am the triple owner of the world, the finest Turkey, the Lorelei, Germania and Helvetia of exclusively sweet butter and Naples and I must supply the whole world with macaroni.”² All this without a blush, and with no flicker of a smile. Here there are countless subjects and no central ego to experience anything and react emotionally.

[501] Turning back to our case of paranoia, we must ask: Is it psychologically meaningless that the idea of persecution has taken possession of him and usurped a part of his personality? Is it, in other words, simply a product of some chance organic disturbance of the brain? If that were so, the delusion would be “*unpsychological*”; it would lack psychological causality and finality, and would not be psychogenic. But should it be found that the pathological idea did not appear just by chance, that it appeared at a particular psychological moment, then we would have to speak of psychogenesis, even if we assumed that there had always been a predisposing factor in the brain which was partly responsible for the disease. The psychological moment must certainly be something out of the ordinary; it must have something about it that would adequately explain why it had such a profound and dangerous effect. If

someone is frightened by a mouse and then falls ill with schizophrenia, this is obviously not a psychic causation, which is always intricate and subtle. Thus our paranoiac fell ill long before anyone suspected his illness; and secondly, the pathological idea overwhelmed him at a psychological moment. This happened when his congenitally hypersensitive emotional life became warped, and the spiritual form which his emotions needed in order to live finally broke down. It did not break by itself, it was broken by the patient. It came about in the following way.

[502] When still a sensitive youth, but already equipped with a powerful intellect, he developed a passionate love for his sister-in-law, until finally—and not unnaturally—it displeased her husband, his elder brother. His were boyish feelings, woven mostly out of moonshine, seeking the mother, like all psychic impulses that are immature. But these feelings really do need a mother, they need prolonged incubation in order to grow strong and to withstand the unavoidable clash with reality. In themselves there is nothing reprehensible about them, but to the simple, straightforward mind they arouse suspicion. The harsh interpretation which his brother put upon them had a devastating effect, because the patient's own mind admitted that it was right. His dream was destroyed, but this in itself would not have been harmful had it not also killed his feelings. For his intellect then took over the role of the brother and, with inquisitorial sternness, destroyed every trace of feeling, holding before him the ideal of cold-blooded heartlessness. A less passionate nature can put up with this for a time, but a highly-strung, sensitive nature in need of affection will be broken. Gradually it seemed to him that he had attained his ideal, when suddenly he discovered that waiters and suchlike people took a curious interest in him, smiling at one another understandingly, and one day he made the startling discovery that they took him for a homosexual. The paranoid idea had now become autonomous. It is easy to see the deeper connection between the pitilessness of his intellect, which cold-bloodedly destroyed every feeling, and his unshakable paranoid conviction. That is psychic causality, psychogenesis.

[503] In some such way—naturally with endless variations—not only does paranoia arise, but also the paranoid form of schizophrenia characterized by delusions and hallucinations, and indeed all other forms of schizophrenia. (I would not class among the group of schizophrenias those schizophrenic syndromes, such as catatonias with a rapidly lethal outcome, which seem from the beginning to have an organic basis.) The microscopic lesions of the brain often found in schizophrenia I would, for the time being, regard as secondary symptoms of degeneration, like the atrophy of the muscles in hysterical paralyses. The psychogenesis of schizophrenia would explain why certain milder cases, which do not get as far as the mental hospital but only appear in the neurologist's consulting-room, can be cured by psychotherapeutic means. With regard to the possibility of cure, however, one should not be too

optimistic. Such cases are rare. The very nature of the disease, involving as it does the disintegration of the personality, rules out the possibility of psychic influence, which is the essential agent in therapy. Schizophrenia shares this peculiarity with obsessional neurosis, its nearest relative in the realm of the neuroses.

IV

ON THE PSYCHOGENESIS OF SCHIZOPHRENIA



RECENT THOUGHTS ON SCHIZOPHRENIA

SCHIZOPHRENIA

ON THE PSYCHOGENESIS OF SCHIZOPHRENIA¹

[504] It is just twenty years since I read a paper on “The Problem of Psychogenesis in Mental Disease”² before this Society. William McDougall, whose recent death we all deplore, was in the chair. What I said then about psychogenesis could safely be repeated today, for it has left no visible traces, or other noticeable consequences, either in text-books or in clinics. Although I hate to repeat myself, it is almost impossible to say anything wholly new and different about a subject which has not changed its face in the many years that have gone by. My experience has increased and some of my views have matured, but I could not say that my standpoint has had to undergo any radical change. I am therefore in the somewhat uncomfortable situation of one who believes that he has a well-founded conviction, and yet on the other hand is afraid to indulge in the habit of repeating old stories. Psychogenesis has long been discussed, but it is still a modern, even an ultra-modern, problem.

[505] There is little doubt nowadays about the psychogenesis of hysteria and other neuroses, although thirty years ago some brain enthusiasts still vaguely suspected that at bottom “there was something organically wrong in the neuroses.” Nevertheless the *consensus doctorum* in their vast majority has admitted the psychic causation of hysteria and similar neuroses. Concerning the mental diseases, however, and especially concerning schizophrenia, they agreed unanimously upon an essentially organic aetiology, although for a long time specific destruction of the brain-cells could not be proved. Even today the question of how far schizophrenia itself can destroy the brain-cells has not been satisfactorily answered, much less the more specific question of how far primary organic disintegrations account for the symptomatology of schizophrenia. I fully agree with Bleuler that the great majority of symptoms are of a secondary nature and are due chiefly to psychic causes. For the primary symptoms, however, Bleuler assumes the existence of an organic cause. As *the* primary symptom he points to a peculiar disturbance of the association-process. According to his description, some kind of disintegration is involved, inasmuch as the associations seem to be peculiarly mutilated and disjointed. He refuses to accept Wernicke’s concept of “sejunction” because of its anatomical implications. He prefers the term “schizophrenia,” obviously understanding by this a *functional* disturbance. Such disturbances, or at least very similar ones, can be observed in delirious states of various kinds. Bleuler himself points out the remarkable similarity between schizophrenic associations and the association-phenomena in dreams and half-waking states. From his description it is sufficiently clear that the primary symptom coincides with the condition which Pierre Janet termed *abaissement du niveau mental*. It is caused by a peculiar *faiblesse de la volonté*. If the main guiding

and controlling force of our mental life is will-power, then we can agree that Janet's concept of *abaissement* explains a psychic condition in which a train of thought is not carried through to its logical conclusion, or is interrupted by strange contents that are insufficiently inhibited. Though Bleuler does not mention Janet, I think that Janet's *abaissement* aptly formulates Bleuler's views on the primary symptoms.

[506] It is true that Janet uses his hypothesis chiefly to explain the symptomatology of hysteria and other neuroses, which are indubitably psychogenic and quite different from schizophrenia. Yet there are certain noteworthy analogies between the neurotic and the schizophrenic mental condition. If you study the association tests of neurotics, you will find that their normal associations are disturbed by the spontaneous intervention of complex contents typical of an *abaissement*. The dissociation can even go so far as to create one or more secondary personalities, each, apparently, with a separate consciousness of its own. But the fundamental difference between neurosis and schizophrenia lies in the maintenance of the potential unity of the personality. Despite the fact that consciousness can be split up into several personal consciousnesses, the unity of all the dissociated fragments is not only visible to the professional eye but can be re-established by means of hypnosis. This is not the case with schizophrenia. The general picture of an association test of a schizophrenic may be very similar to that of a neurotic, but closer examination shows that in a schizophrenic patient the connection between the ego and some of the complexes is more or less completely lost. The split is not relative, it is absolute. An hysterical patient might suffer from a persecution-mania very similar to real paranoia, but the difference is that in the former case one can bring the delusion back under the control of consciousness, whereas it is virtually impossible to do this in paranoia. A neurosis, it is true, is characterized by the relative autonomy of its complexes, but in schizophrenia the complexes have become disconnected and autonomous fragments, which either do not reintegrate back to the psychic totality, or, in the case of a remission, are unexpectedly joined together again as if nothing had happened.

[507] The dissociation in schizophrenia is not only far more serious, but very often it is irreversible. The dissociation is no longer fluid and changeable as it is in a neurosis, it is more like a mirror broken up into splinters. The unity of personality which, in a case of hysteria, lends a humanly understandable character to its own secondary personalities is definitely shattered into fragments. In hysterical multiple personality there is a fairly smooth, even tactful, co-operation between the different persons, who keep to their respective roles and, if possible, do not bother each other. One feels the presence of an invisible *spiritus rector* a central manager who arranges the stage for the different figures in an almost rational way, often in the form of a more or less sentimental drama. Each figure has a suggestive name and an admissible character,

and they are just as nicely hysterical and just as sentimentally biased as the patient's own consciousness.

[508] The picture of a personality dissociation in schizophrenia is quite different. The split-off figures assume banal, grotesque, or highly exaggerated names and characters, and are often objectionable in many other ways. They do not, moreover, co-operate with the patient's consciousness. They are not tactful and they have no respect for sentimental values. On the contrary, they break in and make a disturbance at any time, they torment the ego in a hundred ways; all are objectionable and shocking, either in their noisy and impertinent behaviour or in their grotesque cruelty and obscenity. There is an apparent chaos of incoherent visions, voices, and characters, all of an overwhelmingly strange and incomprehensible nature. If there is a drama at all, it is certainly far beyond the patient's understanding. In most cases it transcends even the physician's comprehension, so much so that he is inclined to suspect the mental sanity of anybody who sees more than plain madness in the ravings of a lunatic.

[509] The autonomous figures have broken away from the control of the ego so thoroughly that their original participation in the patient's mental make-up has vanished. The *abaissement* has reached a degree unheard of in the sphere of neurosis. An hysterical dissociation is bridged over by a unity of personality which still functions, whereas in schizophrenia the very foundations of the personality are impaired.

[510] The *abaissement*

(1) Causes the loss of whole regions of normally controlled contents.

(2) Produces split-off fragments of the personality.

(3) Hinders normal trains of thought from being consistently carried through and completed.

(4) Decreases the responsibility and the adequate reaction of the ego.

(5) Causes incomplete realizations and thus gives rise to insufficient and inadequate emotional reactions.

(6) Lowers the threshold of consciousness, thereby allowing normally inhibited contents of the unconscious to enter consciousness in the form of autonomous invasions.

[511] We find all these effects of *abaissement* in neurosis as well as in schizophrenia. But in neurosis the unity of personality is at least potentially preserved, whereas in schizophrenia it is almost irreparably damaged. Because of this fundamental injury the cleavage between dissociated psychic elements amounts to a real destruction of their former connections.

[512] The psychogenesis of schizophrenia therefore prompts us to ask, first of all: Can the primary symptom, the extreme *abaissement*, be considered an effect of psychological conflicts and other disorders of an emotional nature, or not? I do not think it necessary to discuss in detail whether or not the *secondary symptoms*, as described by Bleuler, owe their existence and their specific form to psychological determination. Bleuler himself is fully convinced that their form and content, i.e., their individual phenomenology, are derived entirely from emotional complexes. I agree with Bleuler, whose experience of the psychogenesis of secondary symptoms coincides with my own, for we were collaborating in the years which preceded his famous book on dementia praecox. As a matter of fact, I began as early as 1903 to analyse cases of schizophrenia for therapeutic purposes. There can, indeed, be no doubt about the psychological determination of secondary symptoms. Their structure and origin are in no way different from those of neurotic symptoms, with, of course, the important exception that they exhibit all the characteristics of mental contents no longer subordinated to the supreme control of a complete personality. There is, as a matter of fact, hardly one secondary symptom which does not show some signs of a typical *abaissement*. This characteristic, however, does not depend upon psychogenesis but derives entirely from the primary symptom. Psychological causes, in other words, produce secondary symptoms exclusively on the basis of the primary condition.

[513] In dealing with the question of psychogenesis in schizophrenia, therefore, we can dismiss the secondary symptoms altogether. There is only one problem, and that is the psychogenesis of the primary condition, i.e., the extreme *abaissement*, which is, from the psychological point of view, the root of the schizophrenic disorder. We therefore ask: Is there any reason to believe that the *abaissement* can be due to causes which are strictly psychological? An *abaissement* can be due to causes which are strictly psychological? An *abaissement* can be produced—as we well know—by many causes: by fatigue, normal sleep, intoxication, fever, anaemia, intense affects, shocks, organic diseases of the central nervous system; likewise it can be induced by mass-psychology or a primitive mentality, or by religious and political fanaticism, etc. It can also be caused by constitutional and hereditary factors.

[514] The more common form of *abaissement* does not affect the unity of the personality, at least not seriously. Thus all dissociations and other psychic phenomena derived from this general form of *abaissement* bear the stamp of the integral personality.

[515] Neuroses are specific consequences of an *abaissement*; as a rule they arise from a habitual or chronic form of it. Where they appear to be the effect of an acute form, a

more or less latent psychological disposition always existed prior to the *abaissement*, so that the latter is no more than a conditional cause.

[516] Now there is no doubt that an *abaissement* which leads to a neurosis is produced either by exclusively psychological factors or by these in conjunction with other, perhaps more physical, conditions. Any *abaissement*, particularly one that leads to a neurosis, means in itself that there is a weakening of the supreme control. A neurosis is a relative dissociation, a conflict between the ego and a resistant force based upon unconscious contents. These contents have more or less lost their connection with the psychic totality. They form themselves into fragments, and the loss of them means a depotentiation of the conscious personality. The intense conflict, on the other hand, expresses an equally intense desire to re-establish the severed connection. There is no co-operation, but at least there is a violent conflict, which functions instead of a positive connection. Every neurotic fights for the maintenance and supremacy of his ego-consciousness and for the subjugation of the resistant unconscious forces. But a patient who allows himself to be swayed by the intrusion of strange contents from the unconscious, a patient who does not fight, who even identifies with the morbid elements, immediately exposes himself to the suspicion of schizophrenia. His *abaissement* has reached the fatal, extreme degree, when the ego loses all power to resist the onslaught of an apparently more powerful unconscious.

[517] Neurosis lies on this side of the critical point, schizophrenia on the other. We do not doubt that psychological motives can bring about an *abaissement* which eventually results in a neurosis. A neurosis approaches the danger line, yet somehow it manages to remain on the hither side. If it should transgress the line it would cease to be a neurosis. Yet are we quite certain that a neurosis never steps beyond the danger-line? You know that there are such cases, neuroses to all appearances for many years, and then it suddenly happens that the patient steps beyond the line and clearly transforms himself into a real psychotic.

[518] Now, what do we say in such a case? We say that it has always been a psychosis, a "latent" one, or one concealed or camouflaged by an ostensible neurosis. But what has really happened? For many years the patient fought for the maintenance of his ego, for the supremacy of his control and for the unity of his personality. But at last he gave in—he succumbed to the invader he could no longer suppress. He is not just overcome by a violent emotion, he is actually drowned in a flood of insurmountably strong forces and thought-forms which go far beyond any ordinary emotion, no matter how violent. These unconscious forces and contents have long existed in him and he has wrestled with them successfully for years. As a matter of fact, these strange contents are not confined to the patient alone, they exist in the unconscious of normal people as well, who, however, are fortunate enough to be profoundly ignorant

of them. These forces did not originate in our patient out of nowhere. They are most emphatically not the result of poisoned brain-cells, but are normal constituents of our unconscious psyche. They appeared in numberless dreams, in the same or a similar form, at a time of life when seemingly nothing was wrong. And they appear in the dreams of normal people who never get anywhere near a psychosis. But if a normal individual should suddenly undergo a dangerous *abaissement*, his dreams would instantly seize hold of him and make him think, feel, and act exactly like a lunatic. And he would be a lunatic, like the man in one of Andreyev's stories, who thought he could safely bark at the moon because he knew that he was perfectly normal. But when he barked he lost consciousness of the little bit of difference between normal and crazy, so that the other side overwhelmed him and he became mad.

[519] What happened was that our patient succumbed to an attack of weakness—in reality it is often just a sudden panic—it made him hopeless or desperate, and then all the suppressed material welled up and drowned him.

[520] In my experience of almost forty years I have seen quite a number of cases who developed either a psychotic interval or a lasting psychosis out of a neurotic condition. Let us assume for the moment that they were really suffering from a latent psychosis, concealed under the cloak of a neurosis. What, then, is a latent psychosis exactly? It is obviously nothing but the possibility that an individual may become mentally deranged at some period of his life. The existence of strange unconscious material proves nothing. You find the same material in neurotics, modern artists, and poets, and also in fairly normal people who have submitted to a careful investigation of their dreams. Moreover, you find most suggestive parallels in the mythology and symbolism of all races and times. The possibility of a future psychosis has nothing to do with the peculiar contents of the unconscious. But it has everything to do with whether the individual can stand a certain panic, or the chronic strain of a psyche at war with itself. Very often it is simply a matter of a little bit too much, of the drop that falls into a vessel already full, or of the spark that accidentally lands on a heap of gunpowder.

[521] Under the stress of an extreme *abaissement* the psychic totality falls apart and splits up into complexes, and the ego-complex ceases to play the important role among these. It is just one among several complexes which are all equally important, or perhaps even more important than the ego. All these complexes assume a personal character although they remain fragments. It is understandable that people should get panicky, or that they eventually become demoralized under a chronic strain, or despair of their hopes and expectations. It is also understandable that their will-power weakens and their self-control becomes slack and begins to lose its grip upon circumstances, moods, and thoughts. It is quite consistent with such a state of mind if

some particularly unruly parts of the patient's psyche then acquire a certain degree of autonomy.

[522] Thus far schizophrenia does not behave in any way differently from a purely psychological disorder. We would search in vain for anything characteristic of the disease in this part of the symptomatology. The real trouble begins with the disintegration of the personality and the divestment of the ego-complex of its habitual supremacy. As I have already pointed out, not even multiple personality, or certain religious or "mystical" phenomena, can be compared to what happens in schizophrenia. The primary symptom seems to have no analogy with any kind of functional disturbance. It is as if the very foundations of the psyche were giving way, as if an explosion or an earthquake were tearing asunder the structure of a normally built house. I use this analogy on purpose, because it is suggested by the symptomatology of the initial stages. Sollier has given us a vivid description of these *troubles cénesthésiques*,³ which are compared to explosions, pistol-shots, and other violent noises in the head. They appear in projection as earthquakes, cosmic catastrophes, as the fall of the stars, the splitting of the sun, the falling asunder of the moon, the transformation of people into corpses, the freezing of the universe, and so on.

[523] I have just said that the primary symptom appears to have no analogy with any kind of functional disturbance, yet I have omitted to mention the phenomena of the *dream*. Dreams can produce similar pictures of great catastrophes. They can manifest all stages of personal disintegration, so it is no exaggeration to say that the dreamer is normally insane, or that insanity is a dream which has replaced normal consciousness. To say that insanity is a dream which has become real is no metaphor. The phenomenology of the dream and of schizophrenia are almost identical, with a certain difference, of course; for the one occurs normally under the condition of sleep, while the other upsets the waking or conscious state. Sleep, too, is an *abaissement du niveau mental* which leads to more or less complete oblivion of the ego. The psychic mechanism that brings about the normal extinction and disintegration of consciousness in sleep is therefore a normal function which almost obeys our will. In schizophrenia it seems as if this function were set in motion in order to bring about that sleep-like condition in which consciousness is reduced to the level of dreams, or in which dreams are intensified to a degree equalling that of consciousness.

[524] Yet even if we knew that the primary symptom is produced with the aid of an ever-present normal function, we should still have to explain why a pathological condition ensues instead of the normal effect, which is sleep. It must, however, be emphasized that it is not exactly sleep which is produced, but something which

disturbs sleep namely, the dream. Dreams are due to an incomplete extinction of consciousness, or to a somewhat excited state of the unconscious which interferes with sleep. Sleep is disturbed if too many remnants of consciousness go on stirring, or if there are unconscious contents with too great an energy-charge, for then they rise above the threshold and create a relatively conscious state. Hence it is better to explain many dreams as the remnants of conscious impressions, while others derive directly from unconscious sources which have never been conscious. Dreams of the first type have a personal character and conform to the rules of a personalistic psychology; those of the second type have a collective character, inasmuch as they contain peculiarly mythological, legendary, or generally archaic imagery. One must turn to historical or primitive symbology in order to explain such dreams.

[525] Both types of dream are reflected in the symptomatology of schizophrenia. There is a mixture of personal and collective material just as there is in dreams. But in contradistinction to normal dreams, the collective material seems to predominate. This is particularly evident in the so-called “dream-states” or delirious intervals and in paranoid conditions. It seems also to predominate in the catatonic phases, so far as we can get any insight into the inner experiences of such patients. Whenever collective material prevails under normal conditions, it produces important dreams. Primitives call them “big dreams” and consider them of tribal significance. You find the same thing in the Greek and Roman civilizations, where such dreams were reported to the Areopagus or to the Senate. One meets these dreams frequently in the decisive moments or periods of life: in childhood from the third to the sixth year; at puberty, from fourteen to sixteen; in the period of maturity from twenty to twenty-five; in middle life from thirty-five to forty; and before death. They also occur in particularly important psychological situations. It seems that such dreams come chiefly at those moments or periods when the man of antiquity or the primitive would deem it necessary to perform certain religious or magic rites, in order to procure favourable results or to propitiate the gods for the same end.

[526] We may safely assume that important personal matters and worries account for personal dreams. We are not so sure of our ground when we come to collective dreams, with their often weird and archaic imagery, which cannot be traced back to personal sources. The history of symbols, however, yields the most surprising and enlightening parallels, without which we could never follow up the remarkable meaning of such dreams.

[527] This fact makes one realize how inadequate the psychological training of the psychiatrist is. It is, of course, impossible to appreciate the importance of comparative psychology for the theory of delusions without a detailed knowledge of historical and ethnic symbols. No sooner did we begin with the qualitative analysis of

schizophrenia at the Psychiatric Clinic in Zurich than we realized the need of such additional information. We naturally started with an entirely personalistic medical psychology, mainly as presented by Freud. But we soon came up against the fact that, in its basic structure, the human psyche is as little personalistic as the body. It is far rather something inherited and universal. The logic of the intellect, the *raison du cœur*, the emotions, the instincts, the basic images and forms of imagination, have in a way more resemblance to Kant's table of *a priori* categories or to Plato's *eida* than to the scurrilities, circumstantialities, whims, and tricks of our personal minds. Schizophrenia in particular yields an immense harvest of collective symbols, the neuroses yield far less, for with few exceptions they show a predominantly personal psychology. The fact that schizophrenia disrupts the foundations of the psyche accounts for the abundance of collective symbols, because it is the latter material that constitutes the basic structure of the personality.

[528] From this point of view we might conclude that the schizophrenic state of mind, so far as it yields archaic material, has all the characteristics of a "big dream"—in other words, that it is an important event, exhibiting the same "numinous" quality which in primitive cultures is attributed to a magic ritual. As a matter of fact, the insane person has always enjoyed the prerogative of being the one who is possessed by spirits or haunted by a demon. This is, by the way, a correct interpretation of his psychic condition, for he is invaded by autonomous figures and thought-forms. The primitive valuation of insanity, moreover, lays stress on a special characteristic which we should not overlook: it ascribes personality, initiative, and wilful intention to the unconscious—again a true interpretation of the obvious facts. From the primitive standpoint it is perfectly clear that the unconscious, of its own volition, has taken possession of the ego. According to this view it is not the ego that is enfeebled; on the contrary, it is the unconscious that is strengthened through the presence of a demon. The primitive, therefore, does not seek the cause of insanity in a primary weakness of consciousness but rather in an inordinate strength of the unconscious.

[529] I must admit it is exceedingly difficult to decide the intricate question of whether it is a matter of a primary weakness and corresponding dissociability of consciousness, or of the primary strength of the unconscious. The latter possibility cannot easily be dismissed, since it is conceivable that the abundant archaic material in schizophrenia is the expression of a still existing infantile and therefore primitive mentality. It might be a question of *atavism*. I seriously consider the possibility of a so-called "arrested development," in which a more than normal amount of primitive psychology remains intact and does not become adapted to modern conditions. It is natural that under such conditions a considerable part of the psyche should not catch up with the normal progress of consciousness. In the course of years the distance between the unconscious and the conscious mind increases and produces a conflict—

latent at first. But when a special effort at adaptation is needed, and when consciousness should draw upon its unconscious instinctive resources, the conflict becomes manifest; the hitherto latent primitive mind suddenly bursts forth with contents that are too incomprehensible and too strange for assimilation to be possible. Indeed, such a moment marks the beginning of the psychosis in a great number of cases.

[530] It should not be overlooked that many patients seem quite capable of exhibiting a modern and sufficiently developed consciousness, sometimes of a particularly concentrated, rational, obstinate kind. However, one must quickly add that such a consciousness shows early signs of a defensive nature. This is a symptom of weakness, not of strength.

[531] It may be that in schizophrenia a normal consciousness is confronted with an unusually strong unconscious: it may also be that the patient's consciousness is just weak and therefore unable to keep back the inrush of unconscious material. In practice I must allow for the existence of two groups of schizophrenia: one with a weak consciousness and the other with a strong unconscious. We have here a certain analogy with the neuroses, where we also find plenty of patients with a markedly weak consciousness and little will-power, and others who possess remarkable energy but are subjected to an almost overwhelmingly strong unconscious determination. This is particularly the case when creative impulses (artistic or otherwise) are coupled with unconscious incompatibilities.

[532] If we now return to our original question, the psychogenesis of schizophrenia, we reach the conclusion that the problem itself is rather complicated. At all events we ought to make it clear that the term "psychogenesis" means two different things: (1) an exclusively psychological origin, (2) a number of psychological conditions. We have dealt with the second point, but we have not yet touched upon the first. This envisages psychogenesis from the standpoint of a *causa efficiens*. The question is: Is the sole and absolute cause of schizophrenia a psychological one or not?

[533] Over the whole field of medicine such a question is, as you know, more than embarrassing. Only in a very few cases can it be answered positively. The usual aetiology consists in a competition between various conditions. It has therefore been urged that the word *causality* or *cause* should be expunged from the medical vocabulary and replaced by the term "conditionalism." I am absolutely in favour of such a measure, since it is well-nigh impossible to prove, even approximately, that schizophrenia is an organic disease to begin with. It is equally impossible to make its exclusively psychological origin evident. We may have strong suspicions as to the organic nature of the primary symptom, but we cannot ignore the well-established fact that there are many cases which developed out of an emotional shock, a

disappointment, a difficult situation, a reversal of fortune, etc.; and also that many relapses as well as improvements are due to psychological conditions. What are we to say about a case like the following? A young student experiences a great disappointment in a love-affair. He has a catatonic attack, from which he recovers after several months. He then finishes his studies and becomes a successful professional man. After a number of years he returns to Zurich, where he had experienced his love-affair. Instantly he is seized by a new and very similar attack. He says that he believes he saw the girl somewhere. He recovers and avoids Zurich for several years. Then he returns and in a few days he is back in the clinic with a catatonic attack, again because he is under the impression that he has seen the girl, who by that time was married and had children.

[534] My teacher, Eugen Bleuler, used to say that a psychological cause can produce only the symptoms of the disease, but not the disease itself. This statement may be profound or the reverse. At all events it shows the psychiatrist's dilemma. One could say, for instance, that our patient returned to Zurich when he felt the disease coming on, and one thinks one has said something clever. He denies it—naturally, you will say. But it is a fact that this man was still deeply in love with his girl. He never went near another woman and his thoughts kept on returning to Zurich. What could be more natural than that once in a while he should give way to his unconquered longing to see the streets, the houses, the walks again, where he had met her, insanity or not? We do not know, moreover, what ecstasies and adventures he experienced in his insanity and what thrilling expectations tempted him to seek the experience once more. I once treated a schizophrenic girl who told me that she hated me because I had made it impossible for her to return into her beautiful psychosis. I have heard my psychiatric colleagues say, "That was no schizophrenia." But they did not know that they, together with at least three other specialists, had made the diagnosis themselves, for they were ignorant of the fact that my patient was identical with the one they had diagnosed.

[535] Shall we now say that our patient became ill before he fell in love and before he returned to Zurich? If that is so, then we are bound to make the paradoxical statement that when he was still normal he was already ill and on account of his illness he fell in love, and for the same reason he returned to the fatal place. Or shall we say that the shock of his passionate love was too much for him and instead of committing suicide he became insane, and that it was his longing which brought him back again to the place of the fatal memories?

[536] But surely, it will be objected, not everybody becomes insane on account of a disappointment in love. Certainly not, just as little as everyone commits suicide, falls so passionately in love, or remains true to the first love for ever. Shall we lay more

stress on the assumption of an organic weakness, for which we have no tangible evidence, or on his passion, for which we have all the symptoms?

[537] The far-reaching consequences of the initial *abaissement*, however, constitute a serious objection to the hypothesis of pure psychogenesis. Unfortunately nearly all that we know of the primary symptom, and its supposedly organic nature, amounts to a series of question marks, whereas our knowledge of possibly psychogenic conditions consists of many carefully observed facts. There are indeed organic cases with brain-oedema and lethal outcome. But they are a small minority and it is not certain whether such a disease should be called schizophrenia.

[538] A serious objection against the psychogenesis of schizophrenia is the bad prognosis, the incurability, and the ultimate dementia. But, as I pointed out twenty years ago,⁴ the hospital statistics are based chiefly upon a selection of the worst cases; all the milder cases are excluded.

[539] Two facts have impressed themselves on me during my career as a psychiatrist and psychotherapist. One is the enormous change that the average mental hospital has undergone in my lifetime. That whole desperate crowd of utterly degenerate catatonics has practically disappeared, simply because they have been given something to do. The other fact that impressed me is the discovery I made when I began my psychotherapeutic practice: I was amazed at the number of schizophrenics whom we almost never see in psychiatric hospitals. These cases are partially camouflaged as obsessional neuroses, compulsions, phobias, and hysterias, and they are very careful never to go near an asylum. These patients insist upon treatment, and I found myself, Bleuler's loyal disciple, trying my hand on cases we never would have dreamed of touching if we had had them in the clinic, cases unmistakably schizophrenic even before treatment—I felt hopelessly unscientific in treating them at all—and after the treatment I was told that they could never have been schizophrenic in the first place. There are numbers of latent psychoses—and quite a few that are not so latent—which, under favourable conditions, can be subjected to psychological analysis, sometimes with quite decent results. Even if I am not very hopeful about a patient, I try to give him as much psychology as he can stand, because I have seen plenty of cases where the later attacks were less severe, and the prognosis was better, as a result of increased psychological understanding. At least so it seemed to me. You know how difficult it is to judge these things correctly. In such doubtful matters, where you have to work as a pioneer, you must be able to put some trust in your intuition and to follow your feeling even at the risk of going wrong. To make a correct diagnosis, and to nod your head gravely at a bad prognosis, is the less important aspect of the medical art. It can even cripple your enthusiasm, and in psychotherapy enthusiasm is the secret of success.

[540] The results of occupational therapy in mental hospitals have clearly shown that the status of hopeless cases can be enormously improved. And the much milder cases not in hospitals sometimes show encouraging results under psychotherapeutic treatment. I do not want to appear overoptimistic. Often enough one can do little or nothing at all; or again, one can have unexpected results. For about fourteen years I have been seeing a woman, who is now sixty-four years of age. I never see her more than fifteen times in the course of a year. She is a schizophrenic and has twice spent a number of months in hospital with an acute psychosis. She suffers from numberless voices distributed all over her body. I found one voice which was fairly reasonable and helpful. I tried to cultivate that voice, with the result that for about two years the right side of the body has been free of voices. Only the left side is still under the domination of the unconscious. No further attacks have occurred. Unfortunately, the patient is not intelligent. Her mentality is early medieval, and I was able to establish a fairly good rapport with her only by adapting my terminology to that of the early Middle Ages. There were no hallucinations then; it was all devils and witchcraft.

[541] This is not a brilliant case, but I have found that I always learn most from difficult and even impossible patients. I treat such cases as if they were not organic, as if they were psychogenic and as if one could cure them by purely psychological means. I admit that I cannot imagine how something “merely” psychic can cause an *abaissement* which destroys the unity of personality, only too often beyond repair. But I know from long experience not only that the overwhelming majority of symptoms are psychologically determined, but that in an unspecified number of cases the onset of the disease is influenced by, or at least coupled with, psychic facts which one would not hesitate to declare causal in a case of neurosis. Statistics in this respect prove nothing to me, for I know that even in a neurosis one is likely to discover the true anamnesis only after months of careful analysis. In psychiatric anamnesis there is a lack of psychological knowledge which is sometimes appalling. I do not say that the general practitioner should have a knowledge of psychology, but if the psychiatrist wants to practise psychotherapy at all he certainly ought to have a proper psychological training. What we call “medical psychology” is unfortunately a very onesided affair. It may give you some knowledge of everyday complexes, but far too little is known of anything outside the medical department. Psychology does not consist of medical rules of thumb. It has far more to do with the history of civilization, of philosophy, of religion, and quite particularly with the primitive mentality. The pathological mind is a vast, almost unexplored region and comparatively little has been done in this field, whereas the biology, anatomy, and physiology of schizophrenia have had all the attention they want. And with all this work, what exact knowledge have we of the heredity or of the nature of the primary

symptom? I should say: Let us discuss the question of psychogenesis once more when the psychic side of schizophrenia has had a square deal.

RECENT THOUGHTS ON SCHIZOPHRENIA¹

[542] Without doubt we are on the eve of a new age which will ask us some difficult questions. Your request for a forecast concerning future developments in psychology, psychopathology, and psychotherapy sets me, as you probably realize, no easy task. It is a well-known fact in the history of science that very often just the most important and epoch-making developments emerge from rather unexpected discoveries or from hitherto neglected or underestimated spheres of thought. Under such conditions, prognostication becomes so doubtful an undertaking that I prefer to refrain from incompetent attempts at prophecy, and to present my opinion as the mere desideratum of a psychiatrist living in the second half of the twentieth century.

[543] The most desirable things being those which we do not possess, we must begin with questions that have still to be answered, or with speculative hypotheses based on known facts. In psychology as well as in psychopathology, I feel that the most pressing need is a deeper and more comprehensive knowledge of the complex psychic structures which confront the psychotherapist. We know far too little about the contents and the meaning of pathological mental products, and the little we do know is prejudiced by theoretical assumptions. This is particularly true of the psychology of schizophrenia. Our knowledge of this commonest of all mental diseases is still in a very unsatisfactory state. Although a great deal of work has been done in this field since my modest attempt fifty years ago,² many aspects of the disease still remain to be investigated. And although I have observed, analysed, and treated a fair number of schizophrenics during the interval, I could not carry out a systematic study as I would have liked to do. The reason for this was that no sound and reliable foundation existed for such an enterprise. One needs the extraneous *point de repère*, the Archimedean point *extra rem*; in this case, the possibility of comparison with normal psychology.

[544] As I pointed out as far back as 1907, comparison with the neurotic mentality and its specific psychology is valid only to a limited extent, that is, only as far as the personalistic point of view can be stretched. There are manifest elements in the psychology of schizophrenics, however, that cannot be fitted into a purely personalistic frame of reference. Although a personalistic psychology (e.g., the heuristic hypotheses of Freud and Adler) yields satisfactory results up to a point, it is of doubtful value when applied to the peculiar mental formations typical of paranoid schizophrenia, or to the fundamental and specific dissociation that originally caused Bleuler to characterize this disease by his term "schizophrenia." This concept stresses the difference between neurotic and psychotic dissociations, the former being a

“systematic” dissociation of the personality, the latter a “physiological” and unsystematic disintegration of the psychic elements, that is, of the ideational content. Again, whereas neurotic phenomena are more closely analogous to normal processes, such as are observed chiefly in emotional conditions, the schizophrenic symptoms resemble formations observable in dreams and toxic states. Since dreams must be considered as phenomena of normal sleep, their analogies with schizophrenic disintegration point to a common denominator consisting in an *abaissement du niveau mental* (Janet). The *abaissement*, whatever its cause, begins with a relaxation of concentration or attention. As the value of associations decreases, they become superficial. Instead of meaningful connections of ideas, verbal-motor and clang associations (rhyme, alliteration, and so forth), and also perseverations, appear and gain the upper hand. Finally, not only the meaning of the sentences but the words themselves break up. Moreover strange, disconnected, and illogical intrusions interrupt the thematic continuity.

[545] This is true not only of the dream-state but also of the schizophrenic condition. There is one considerable difference, however, as in the latter case consciousness is not reduced as it is in dreams. In schizophrenia (except in the dreamlike and delirious states) memory and general orientation function normally, in spite of the undeniable presence of *abaissement* symptoms. This clearly shows that schizophrenic phenomena are not caused by a general reduction of attention and consciousness, but rather depend upon another disturbing factor connected with certain definite psychic elements. Generally it cannot be predicted which of the patient’s ideas will be damaged, although there is some probability that they will belong to the emotional field of a recognizable complex, the existence of which is not in itself a specifically schizophrenic symptom. On the contrary, such complexes are identical with those observed in neurotic as well as in normal individuals. Although an emotional complex may disturb or diminish general attention and concentration by absorbing their energy, it never disintegrates its own psychic elements or contents in the way that a schizophrenic complex does. One could even say that the elements of a neurotic and normal complex are not only well-developed but even hypertrophied on account of their heightened energetic value. They have a marked tendency to enlarge their scope by means of exaggeration and fantastic accretions.

[546] In contrast to this, the schizophrenic complex is characterized by a peculiar deterioration and disintegration of its own ideational content, leaving the general field of attention remarkably undisturbed. It looks as if the complex were destroying itself by distorting its own contents and means of communication, that is, its expression through co-ordinated thinking and speech. It does not seem to draw its energy from other mental processes, as it does not impair general orientation or any of the other functions. It is, on the contrary, evident that the schizophrenic complex

devours, as it were, its own energy, abstracting this from its own contents by lowering their *niveau mental*. Or, venturing another approach, we could say that the emotional intensity of the complex causes an unexpected subsiding of its own foundations, or a disturbance of the normal synthesis of ideas. It is extremely difficult to imagine a psychological process which would produce such an effect. The psychotherapy of neurosis gives us no clue here, as all neurotic processes operate with fully co-ordinated psychic elements. No disintegration of ideas and so forth occur in its orbit, and if any such traces should appear in a case of neurosis we may safely suspect the existence of latent schizophrenia.

[547] The self-destruction of the schizophrenic complex manifests itself, in the first place, in a disintegration of the means of expression and communication. Besides this there is another less obvious effect, namely inadequate affectivity. Though a certain inadequacy of emotion is also observed in neuroses (e.g., exaggeration, apathy, depression, etc.), it is (as it is not in schizophrenia) always systematic and apparent only to the experienced observer. Once all the aspects of the dominating neurotic complex are known, all inadequacies become transparent and comprehensible. In schizophrenia, however, affectivity seems to be disturbed throughout; not only is there an absence or a disturbance of affectivity in the area of the complex proper, it shows itself also in the patient's general behaviour. Within the complex the emotional values seem to be illogically distributed or absent, disintegrated in much the same way as the disturbed psychic elements. This phenomenon seems to be of a rather complicated and perhaps secondary nature. It may be merely a psychological reaction to the complex. In this case we would expect it to show a systematic structure. Or it may be the symptom of a general destruction of affectivity itself. I do not know and I do not dare to give a definite answer to this question.

[548] However we interpret the peculiar behaviour of the schizophrenic complex, its difference from that of the neurotic or normal complex is plain. Further, in view of the fact that no specifically psychological processes which would account for the schizophrenic effect, that is, for the specific dissociation, have yet been discovered, I have come to the conclusion that there might be a *toxic cause* traceable to an organic and local disintegration, a physiological alteration due to the pressure of emotion exceeding the capacity of the brain-cells. (The *troubles cénesthésiques*, described by Sollier some sixty years ago, seem to point in this direction.) Experiences with mescaline and related drugs encourage the hypothesis of a toxic origin.³ With respect to future developments in the field of psychiatry, I suggest that we have here an almost unexplored region awaiting pioneer research work.

[549] Whereas the problem of a specific toxin presents a task for clinical psychiatry on account of its formal aspects, the question of the *contents* of schizophrenia and their

meaning presents an equally important task for the psychopathologist as well as the psychologist of the future. Both problems are of the highest theoretical interest; moreover, their solution will provide an indispensable basis for the therapy of schizophrenia. As we know, this disease has two aspects of paramount importance, biochemical and psychological. It is also known, as I proved to my own satisfaction fifty years ago, that the disease can be treated by psychotherapy, though only to a limited extent. But as soon as psychological treatment is attempted, the question arises of the psychotic contents and their meaning. In many cases we are confronted with psychological material which can be compared with that found in neuroses or in dreams and can be understood from a personalistic point of view. But unlike the contents of a neurosis, which can be satisfactorily explained by biographical data, psychotic contents show peculiarities that defy reduction to individual determinants, just as there are dreams where the symbols cannot be properly explained with the aid of personal data. By this I mean that neurotic contents can be compared with those of normal complexes, whereas psychotic contents, especially in paranoid cases, show close analogies with the type of dream that the primitive aptly calls a "big dream." Unlike ordinary dreams, such a dream is highly impressive, numinous, and its imagery frequently makes use of motifs analogous to or even identical with those of mythology. I call these structures *archetypes* because they function in a way similar to instinctual patterns of behaviour. Moreover, most of them can be found everywhere and at all times. They occur in the folklore of primitive races, in Greek, Egyptian, and ancient Mexican myths, as well as in the dreams, visions, and delusions of modern individuals entirely ignorant of all such traditions.

[550] In cases of this kind, one seeks in vain for a personalistic causality which would explain their peculiar archaic form and meaning. We must rather suppose that they are something like universally existent constituents of the unconscious psyche, which form, as it were, a deeper stratum of a collective nature, in contradistinction to the personally acquired contents of the more superficial layers, or what one may call the personal unconscious. I consider these archetypal patterns to be the matrix of all mythological statements. They not only occur in highly emotional conditions but very often seem to be their cause. It would be a mistake to regard them as inherited ideas, as they are merely conditions for the forming of representations in general, just as the instincts are the dynamic conditions for various modes of behaviour. It is even probable that archetypes are the psychic expressions or manifestations of instinct.

[551] The question of archaic behaviour and thought-forms obviously cannot be dealt with solely from the standpoint of personalistic psychology. Research in this field must have recourse to more general manifestations of the human mind than are to be found in personal biography. Any attempt at deeper penetration leads inevitably to the problem of the human mind *in toto*. The individual mind cannot be understood by

and out of itself. For this purpose a far more comprehensive frame of reference is needed; in other words, investigation of the deeper-lying psychic strata can be carried out only with the aid of other disciplines. That is why our research-work is still only at its beginning. Nevertheless the results are encouraging.

[552] The investigation of schizophrenia is in my view one of the most important tasks for a psychiatry of the future. The problem has two aspects, physiological and psychological, for the disease, so far as we can see today, does not permit of a one-sided explanation. Its symptomatology points on the one hand to an underlying destructive process, possibly of a toxic nature, and on the other—inasmuch as a psychogenic aetiology is not excluded and psychological treatment (in suitable cases) is effective—to a psychic factor of equal importance. Both ways of approach open up far-reaching vistas in the theoretical as well as the therapeutic field.

SCHIZOPHRENIA¹

[553] It is the privilege of old age to look back upon the paths one has travelled. I must thank Professor Manfred Bleuler for giving me the opportunity of presenting my experiences in the domain of schizophrenia before a meeting of my professional colleagues.

[554] It was in the year 1901 that I, a young assistant physician at Burghölzli, asked my then chief, Professor Eugen Bleuler, to propose a theme for my doctoral dissertation. He suggested that I investigate experimentally the disintegration of ideas in schizophrenia. At that time we had already penetrated so far into the psychology of these patients with the help of association tests that we knew of the existence of the feeling-toned complexes that manifested themselves in schizophrenia. They were essentially the same as the complexes that could be found in the neuroses. The way in which they expressed themselves in the association test was, in many not acutely disturbed cases, very much the same as in hysteria, for example. In other cases, however, and particularly in those where the speech area was affected, there was a characteristic picture for schizophrenia, showing, in comparison with the neuroses, an excessively large number of blockings, perseverations, neologisms, irrelevant answers, faults (failures to react), all occurring at, or in the vicinity of, the stimulus-words that hit the complex.

[555] The question now was, how one could penetrate further, from this point, into the structure of the specifically schizophrenic disturbances. This question remained unanswerable. Even my respected chief and teacher could offer no advice. The upshot was that I chose—probably not by accident—a theme which on the one hand presented fewer difficulties, and on the other offered an analogy to schizophrenia in that it concerned the systematic dissociation of personality in a young girl.² She passed for a medium and had developed in spiritualistic seances a genuine somnambulism, in which contents from the unconscious appeared that were unknown to her conscious mind, and formed the manifest cause of the splitting of personality. In schizophrenia, too, we very often find strange contents that inundate consciousness with comparative suddenness and burst asunder the inner cohesion of the personality, though they do this in a way characteristic of schizophrenia. Whereas the neurotic dissociation never loses its systematic character, schizophrenia shows a picture of unsystematic randomness, so to speak, in which the continuity of meaning so distinctive of the neuroses is often mutilated to the point of unintelligibility.

[556] In a work published in 1907, “The Psychology of Dementia Praecox,” I tried to set forth the state of my knowledge at the time. It dealt in the main with a typical case

of paranoid schizophrenia with characteristic speech disturbances. Although the pathological contents could be recognized as compensatory and their apparently systematic nature could not be denied, the underlying ideas were nevertheless disintegrated to the point of unintelligibility by their unsystematic randomness. Extensive amplificatory material was often needed to reconstitute their originally compensatory meaning.

[557] For the time being, however, we could not understand why the peculiar character of the neuroses breaks down in schizophrenia, and instead of systematic analogies only abstruse, grotesque, or extremely unexpected fragments of them are produced. We could only establish that this breakdown of ideas is distinctive of schizophrenia. It has this peculiarity in common with a quite normal phenomenon, the *dream*. In dreams we observe an apparently identical character—random absurd fragmentary—which requires the same amplificatory procedure in order to be understood. But the not inconsiderable difference from schizophrenia lies in the fact that the dream occurs in the sleeping state, when consciousness is to a large extent obscured, whereas the schizophrenic phenomenon barely affects the elementary orientation of consciousness, if at all. (It may be remarked in parenthesis that it would be difficult to distinguish most dreams of schizophrenics from those of normal people.) The impression that there was a far-reaching analogy between schizophrenia and dreams became more and more pronounced as my experience grew. (At that time I analysed at least four thousand dreams a year.)

[558] Although I gave up my work at Burghölzli in 1909 in order to devote myself entirely to my psychotherapeutic practice, I did not lose touch with schizophrenia, as I had feared I would. On the contrary it was only then that, despite my apprehensions and very much to my astonishment, I came into real contact with this disease. The number of latent and potential psychoses is astoundingly large in comparison with the manifest cases. Without being able to give any exact statistics, I reckon it at 10 : 1. Not a few of the classic neuroses, such as hysteria and obsessional neurosis, turn out under treatment to be latent psychoses, which can sometimes pass over into manifest psychoses—a fact that should constantly be borne in mind by the psychotherapist. A benevolent fate, rather than any merit of mine, preserved me from seeing any of my patients irresistibly slip into a psychosis, but as a consultant I have witnessed a large number of such cases. For instance, there were classic obsessional neuroses where the obsessional impulses gradually changed into auditory hallucinations, or unmistakable hysterias which turned out to be mere screens for various forms of schizophrenia. These experiences are by no means strange to the clinical psychiatrist. What was new to me, however, when I started practising, was the comparatively large number of latent schizophrenics who unconsciously but systematically avoid the asylums and go to the psychologist for advice and help

instead. In these cases it is not always a question merely of people with schizoid dispositions, but of genuine psychoses which have not yet definitively undermined the compensating activity of consciousness.

[559] It is now just about fifty years since I became convinced, through practical experience, that schizophrenic disturbances could be treated and cured by psychological means. I found that, with respect to the treatment, the schizophrenic patient behaves no differently from the neurotic. He has the same complexes, the same insights and needs, but not the same certainty with regard to his foundations. Whereas the neurotic can rely instinctively on his personality dissociation never losing its systematic character, so that the unity and inner cohesion of the whole are never seriously jeopardized, the latent schizophrenic must always reckon with the possibility that his very foundations will give way somewhere, that an irretrievable disintegration will set in, that his ideas and concepts will lose their cohesion and their connection with other spheres of association and with the environment. As a result, he feels threatened by an uncontrollable chaos of chance happenings. He stands on treacherous ground, and very often he knows it. The dangerousness of his situation often shows itself in terrifying dreams of cosmic catastrophes, of the end of the world and such things. Or the ground he stands on begins to heave, the walls bend and bulge, the solid earth turns to water, a storm carries him up into the air, all his relatives are dead, etc. These images bear witness to a fundamental disturbance of relationship, that is, of the patient's rapport with his surroundings, and graphically illustrate the isolation that menaces him.

[560] The immediate cause of this disturbance is a violent affect, which in the neurotic leads, like every emotion, to a similar alienation, but one that passes quickly. Likewise, the images which the neurotic uses to describe the disturbance may show some resemblance to schizoid fantasies, but, in contrast to the menacing and sinister character of the latter, they evoke the impression of dramatization and exaggeration. Therapeutically, therefore, they can be ignored, with no harm being done. It is very different with the evaluation of isolation symptoms in latent psychoses. Here they have the significance of threatening signs whose dangerous character cannot be recognized early enough. They call for immediate precautions, such as discontinuation of treatment, careful re-establishment of personal rapport, change of milieu, choice of another therapist, strict avoidance of any concern with the contents of the unconscious and especially with dream-analysis, and so on.

[561] These are only very general measures which may be modified in individual cases. I would mention, to give an example, the case of a highly educated lady, till then unknown to me, who was attending my lectures on a Tantric text that went very thoroughly into the contents of the unconscious. She became more and more

fascinated and excited by all these new ideas, without being able to formulate the questions and problems that arose within her. Accordingly she had compensating dreams of an incomprehensible nature, which rapidly led to destructive images, just those isolation symptoms mentioned above. At this juncture she came to consult me, with the wish that I should analyse her and help her to understand her incomprehensible thoughts. Her dreams of earthquakes, collapsing houses, and floods showed me that, on the contrary, the patient had to be rescued from the already menacing invasion of the unconscious by effecting a drastic change in her present situation. I forbade her to attend my lectures and advised her instead to make a thorough study of Schopenhauer's *The World as Will and Idea*. I chose Schopenhauer because this philosopher, who was influenced by Buddhism, lays express emphasis on the redeeming effect of consciousness. Fortunately she was rational enough to follow my advice, whereupon the symptomatic dreams immediately stopped and her excitement abated. It turned out that, twenty-five years previously, she had had a schizophrenic attack of short duration, apparently followed by no relapses.

[562] With schizophrenic patients who are already under successful treatment, emotional complications may occur which lead to a psychotic relapse or to an acute initial psychosis if the danger-signs, and especially the destructive dreams, are not recognized in time. The treatment or termination of such developments does not always require drastic intervention. Even with ordinary therapeutic measures you can get the patient's mind at a sufficiently safe distance from the unconscious, for instance by inducing him to draw or paint a picture of his psychic situation. (Painting is rather more effective, since by means of the colours his feelings are drawn into the picture too.) In this way the apparently incomprehensible and unmanageable chaos of his total situation is visualized and objectified; it can be observed at a distance by his conscious mind, analysed, and interpreted. The effect of this method is evidently due to the fact that the originally chaotic or frightening impression is replaced by the picture, which, as it were, covers it up. The *tremendum* is spellbound by it, made harmless and familiar, and whenever the patient is reminded of his original experience by its menacing emotional effects, the picture he has made of it interposes itself between him and the experience and keeps his terror at bay. A good example of this procedure is Brother Klaus's terrifying vision of God. By dint of long meditation, and with the help of certain diagrams drawn by a Bavarian mystic, he succeeded in changing this vision into a picture of the Trinity, which you can see today in the parish church at Sachseln.³

[563] The schizoid disposition is characterized by affects produced by ordinary complexes, but these affects usually have much more devastating consequences than they do in the neuroses. From the psychological point of view, it is the affective concomitants of the complex that form the symptom specific for schizophrenia. They

are, as already emphasized, unsystematic, apparently chaotic and random. They are further characterized, like certain dreams, by primitive or archaic associations closely akin to mythological motifs and combinations of ideas. These archaisms also occur in neurotics and normal people, but they are rarer.

[564] Even Freud could not help drawing a comparison between the incest-complex, which is frequently found in neurosis, and a mythological motif, choosing for it the apt name of “Oedipus complex.” This motif is by no means the only one. We would have to choose a different name for the corresponding motif in a woman’s psychology, for instance “Electra complex,” as I suggested many years ago. Besides the endogamy-complex there are many other complications which can equally well be compared with mythological motifs.

[565] It was this frequent reversion to archaic forms of association found in schizophrenia that first gave me the idea of an unconscious not consisting only of originally conscious contents that have got lost, but having a deeper layer of the same universal character as the mythological motifs which typify human fantasy in general. These motifs are not *invented* so much as *discovered*; they are typical forms that appear spontaneously all over the world, independently of tradition in myths fairy-tales, fantasies, dreams, visions, and the delusional systems of the insane. On closer investigation they prove to be typical attitudes, modes of action—thought-processes and impulses which must be regarded as constituting the instinctive behaviour typical of the human species. The term I chose for this, namely “archetype,” therefore coincides with the biological concept of the “pattern of behaviour.” In no sense is it a question of inherited ideas, but of inherited, instinctive impulses and forms that can be observed in all living creatures.

[566] If, therefore, archaic forms appear especially frequently in schizophrenia, this points in my view to the fact that the biological foundations of the psyche are affected to a far greater extent in this disease than in the neuroses. We know from experience that, in normal people, archaic dream-products with their characteristic numinosity appear mainly in situations that somehow threaten the very foundations of the individual’s existence, for instance in moments of mortal danger, before or after accidents, severe illnesses, operations, etc., or when psychic problems are developing which might give his life a catastrophic turn, or in the critical periods of life when a modification of his previous psychic attitude forces itself peremptorily upon him, or before, during, and after radical changes in his immediate or his general surroundings. Such dreams were reported in ancient times to the Areopagus or to the Roman Senate, and in primitive societies even today they are the subject of a palaver. This shows that a collective significance has always been attributed to them.

[567] It is easy to understand that in vitally important situations the instinctual foundations of the psyche are mobilized, even when the conscious mind has no insight into the situation. Indeed, one can say that it is precisely *then* that the instincts have the best opportunity to assert themselves. The vital or menacing significance of the psychosis is obvious enough, and for this reason the appearance of instinctual contents in a schizophrenic situation is nothing astonishing in itself. The only remarkable thing is that this manifestation does not occur in a systematic way that is accessible to consciousness, as it does in hysteria, for instance. There the conscious personality that is lost in one-sidedness is confronted by a compensating, systematically organized personality which, because of its rational structure and the intelligibility of its expressions, has a much better chance of being integrated. In contrast to this, the schizophrenic compensation almost always remains stuck fast in collective and archaic forms, thereby cutting itself off from understanding and integration to a far higher degree.

[568] Now if the schizophrenic compensation, that is, the expression of affective complexes, were satisfied with a merely archaic or mythological formulation, its associative products could easily be understood as *poetic circumlocutions*. This is usually not the case, any more than it is in normal dreams; here as there the associations are unsystematic, abrupt, grotesque, absurd, and correspondingly difficult if not impossible to understand. Not only are the products of schizophrenic compensation archaic, they are further distorted by their chaotic randomness.

[569] Obviously a disintegration has taken place, a decay of apperception, such as can be observed in cases of extreme *abaissement du niveau mental* (Janet) and in intense fatigue and severe intoxication. Very often the associative variants that are excluded by normal apperception enter the field of consciousness, e.g., those countless nuances of form, meaning, and value such as are characteristic of the effects of mescaline. This and kindred drugs cause, as we know, an *abaissement* which, by lowering the threshold of consciousness, renders perceptible the perceptual variants⁴ that are normally unconscious, thereby enriching one's apperception to an astounding degree, but on the other hand making it impossible to integrate them into the general orientation of consciousness. This is because the accumulation of variants that have become conscious gives each single act of apperception a dimension that fills the whole of consciousness. This explains the fascination so typical of mescaline. It cannot be denied that schizophrenic apperception is very similar.

[570] Judging by the empirical material at present available, it does not seem certain that mescaline and the noxious agent in schizophrenia cause an *identical* disturbance. The fluid and mobile continuity of mescaline phenomena differs from the abrupt, rigid, halting, and discontinuous behaviour of schizophrenic apperception. This,

together with disturbances of the sympathetic system, of the metabolism and the blood-circulation, produces, both psychologically and physiologically, an over-all picture of schizophrenia which in many respects reminds one of a toxic disturbance, and which made me think fifty years ago of the possible presence of a specific, metabolic toxin.⁵ Whereas at that time, for lack of psychological experience, I had to leave it an open question whether the aetiology is primarily or secondarily toxic, I have now, after long practical experience, come to hold the view that the *psychogenic causation of the disease is more probable than the toxic causation*. There are a number of mild and ephemeral but manifestly schizophrenic illnesses—quite apart from the even more common latent psychoses—which begin purely psychogenically, run an equally psychological course (aside from certain presumably toxic nuances) and can be completely cured by a purely psychotherapeutic procedure. I have seen this even in severe cases.

[571] I remember, for instance, the case of a girl of nineteen, who had been hospitalized at seventeen with catatonia and hallucinations. Her brother was a doctor, and as he was personally implicated in the chain of pathogenic occurrences that finally led to catastrophe, in his desperation he lost patience, turned to me and gave me *carte blanche*—including the possibility of suicide—to do “everything that was humanly possible.” He brought the patient to me in a catatonic condition. She was completely mutistic, her hands were cold and bluish, she had livid patches on her face and dilated, feebly reacting pupils. I lodged her in a sanatorium nearby, and from there she was brought to me every day for an hour’s consultation. After weeks of effort I succeeded, by dint of constantly repeated questions, in getting her to whisper a few words at the end of every session. The moment she started to speak, her pupils contracted, the livid patches on her face disappeared, soon her hands grew warm and assumed their normal colour. Finally she began—with endless blockings at first—to talk and to tell me the content of her psychosis. She had only a fragmentary education, had grown up in a small town in a bourgeois milieu, and had no trace of mythological and folkloristic knowledge. She now related to me a long and elaborate myth, a description of her life on the moon, where she played the role of a female saviour for the moon people. The classical connection of the moon with “lunacy” was as unknown to her as the numerous other mythological motifs in her story. The first relapse occurred after about four months of treatment and was caused by the sudden realization that she could no longer go back to the moon after betraying her secret to a human being. She fell into a state of violent excitement which necessitated her transfer to a psychiatric clinic. Professor Eugen Bleuler, my former chief, confirmed the diagnosis of catatonia. After about two months the acute interval abated, and the patient could be moved back to the sanatorium and resume treatment. She was now rather more accessible and began to discuss problems that are characteristic of cases

of neurosis. Her former apathy and lack of affect gradually gave way to a somewhat lymphatic emotionality and soulfulness. Unavoidably, the problem of her re-entry into normal life and her acceptance of a social existence became more and more pressing. When she found herself confronted with this unavoidable task, a second relapse ensued, and again she had to be put in the clinic with a severe attack of delirium. This time the clinical diagnosis was "Unusual epileptoid twilight-state," with a question mark. Evidently her emotional life, reawakened in the interval, had blurred the schizophrenic traits.

[572] Despite my qualms I was able to discharge the patient, after rather more than a year's treatment, as cured. For more than thirty years she kept me informed, by letter, about the state of her health. A few years after her cure she married and had children, and she assured me that she never had any more pathological attacks.

[573] Fairly narrow limits, however, are set to the psychotherapy of severe cases. It would be a mistake to suppose that more or less suitable methods of treatment exist. Theoretical assumptions in this respect count for next to nothing. Also, one would do well not to speak of "methods" at all. The thing that really matters is the personal commitment, the serious purpose, the devotion, indeed the self-sacrifice, of those who give the treatment. I have seen results that were truly miraculous, as when sympathetic nurses and laymen were able, by their courage and steady devotion, to re-establish psychic rapport with their patients and so achieve quite astounding cures. Naturally only a few doctors, in a very limited number of cases, can undertake such a difficult task. But even so one can bring about noticeable improvements in severe schizophrenics, and even cure them, by psychological treatment, provided that "one's own constitution holds out." This question is very much to the point, because the treatment not only demands uncommon efforts but may also induce psychic infections in a therapist who himself has a rather unstable disposition. I have seen no less than three cases of induced psychoses in treatments of this kind.

[574] The results of the treatment are often curious. I recall the case of a sixty-year-old widow, who had suffered for thirty years from chronic hallucinations after an acute schizophrenic interval which had brought her to the asylum for a few months. She heard voices, which were distributed all over her body and congregated more particularly round the body openings and also round the breasts and navel. She suffered considerably under these vexations. For reasons I cannot discuss here, I had taken on this case for "treatment," though the treatment was more like control or observation. From a therapeutic point of view it seemed to me hopeless, especially as the patient had only a limited intelligence. Although she was able to look after her house tolerably well, intelligent conversation with her was barely possible. Things went best if one confined oneself to one voice, which she called "God's voice." It

was localized in the middle of the breastbone. The voice told her that she should get me to induce her to read a chapter of the Bible, chosen by me, at each consultation, and afterward she should memorize it at home and reflect upon it. I was then to hear her at the next consultation. This somewhat peculiar proposal proved, in due course, to be a valuable therapeutic device, for the exercise not only helped the patient's speech and powers of expression but also brought a noticeable improvement in the psychic rapport. The end-result was that after about eight years the right half of her body was completely freed of voices, up to a line running exactly down the middle of the body. The voices persisted only on the left side. This unforeseen result of patient exercise was probably due simply to the fact that her attention and interest were kept alive. (Later she died of an apoplexy.)

[575] In general, the patient's degree of intelligence and education is of considerable importance for the prognosis. In cases of passing, acute intervals, or in the early stages of the disease, an explanatory discussion of the symptoms, especially of the psychotic contents, seems to me of the greatest value. Since fascination by archetypal contents is particularly dangerous, an explanation of their universal, impersonal meaning seems to me especially helpful, as opposed to the usual discussion of personal complexes. These complexes are the things that called forth the archaic reactions and compensations in the first place, and can obviously produce the same effects again at any time. Often, therefore, one must help the patient to detach his interest from these personal sources of excitation, at least temporarily, so as to give him a general orientation and a broader view of his confused situation. I have therefore made it a rule to give the intelligent patient as much psychological knowledge as he can stand. The more he knows in this respect, the better his whole prognosis will turn out; for if he is equipped with the necessary knowledge he can meet renewed irruptions of the unconscious with understanding and in this way assimilate the strange contents and integrate them into his conscious life. So in cases where the patients remember the content of their psychosis, I discuss it with them in detail and try to get them to understand it as thoroughly as possible.

[576] This procedure naturally demands of the doctor more than merely psychiatric knowledge, for he must know about mythology, primitive psychology, etc. All this is today part of the equipment of the psychotherapist, just as it formed an essential part of medical knowledge up to the Age of Enlightenment. (One thinks, for instance, of the Paracelsist physicians of the Middle Ages.) You cannot handle the human psyche, especially when it is sick, with the ignorance of a layman, whose knowledge of it is confined to his personal complexes. For the same reason the practice of somatic medicine presupposes a thorough knowledge of anatomy and physiology. For just as there is an objective human body and not merely a subjective and personal one, so also there is an objective psyche with its specific structures and activities of which

the psychotherapist should have at any rate adequate knowledge. In this matter little has changed during the last half century. There are some—in my view—premature attempts at theory-building, but they are frustrated by professional prejudice and by insufficient knowledge of the facts. Very many more experiences in all fields of psychic research need to be collected before even such foundations could be laid as would bear comparison, for instance, with the findings of comparative anatomy. Nowadays we know infinitely more about the nature of the body than we do about the structure of the psyche, despite the fact that its biology is becoming more and more important for an understanding of somatic disorders and, finally, of man himself.

*

[577] The over-all picture of schizophrenia, which has presented itself to me in the course of more than fifty years of experience, and which I have tried to outline briefly here, does not indicate any clear-cut aetiology. Nevertheless, so far as I was able to investigate my cases analytically and assure myself, with the help of dreams and other psychological material, not only of the initial state but also of the course of the compensation-process during treatment, I must admit that I have never met with a case that did not show a logical and causally consistent development. At the same time, I am very much aware of the fact that my material consisted for the most part of milder, still fluid cases and of latent psychoses. I do not know, therefore, how it is with those severe catatonias, for instance, that may have a lethal outcome and naturally do not appear in the psychotherapist's consulting-room. Consequently, I must leave the possibility open that there may also be schizophrenias for which a psychogenic aetiology can be considered only in minimal degree or perhaps not at all.

[578] Despite, however, the undoubted psychogeneity of most cases, which would lead one to expect the disease to run a purely psychological course, schizophrenia exhibits concomitant phenomena that do not seem to me to be explicable psychologically. These phenomena, as I have said, occur in the region of the pathogenic complex. In normal people and in neurotics the affect that binds the complex together produces symptoms which could easily be interpreted as milder, preliminary forms of schizophrenic symptoms. This is particularly true of the *abaissement du niveau mental*, with its characteristic one-sidedness, clouding of judgment, weakness of will, and the blocking, perseveration, stereotypy, verbal-motor superficiality, alliteration, and assonance peculiar to the reactions. In the same way, the affect proves to be a creator of neologisms. All these phenomena reappear, heaped together and intensified, in schizophrenia, a clear indication of the exceptional violence of the affect. The affect does not always appear outwardly, in dramatized form, but very

often runs a course invisible to the observer, within, where it provokes intensified compensation-phenomena on the part of the unconscious, thus accounting for the characteristic apathy of the schizophrenic. These phenomena express themselves in delusional formations and dreams that overwhelm his conscious mind with obsessive force. The intensity of their fascination reflects the strength of the pathogenic affect and can as a rule easily be explained accordingly.

[579] But whereas, in the normal and neurotic, the acute affect passes comparatively quickly, and the chronic affect impairs the general orientation of consciousness and its adaptability in ways that are barely perceptible, the schizophrenic complex has an incomparably more powerful effect. Its expressions become fixed, its relative autonomy becomes absolute, and it takes possession of the conscious mind so completely that it alienates and destroys the personality. It does not produce a “double personality” but depotentiates the ego-personality by usurping its place, a phenomenon which is otherwise observed only in the acutest and most severe affective states—which for that reason are called pathological—or in delirium. The normal, preliminary form of this state is the dream, which, in contrast to schizophrenia, occurs in the sleeping and not in the waking state.

[580] Here we are faced with a dilemma: are we to assume, as a causal factor, a weakness of the ego-personality, or a particularly strong affect? I regard the latter hypothesis as the more promising, and for the following reason. The notorious weakness of ego-consciousness in the sleeping state means next to nothing so far as a psychological understanding of the dream-contents is concerned. It is the feeling-toned complex that determines the meaning of the dream, both dynamically and also as regards its content. We must undoubtedly apply this criterion to schizophrenia, for, so far as we can see at present, the whole phenomenology of this disease turns on the pathogenic complex. In our attempts at explanation we shall probably do best if we start from this point and regard the weakening of the ego-personality as secondary, as one of the destructive concomitants of a feeling-toned complex which arose under normal conditions but afterwards shattered the unity of the personality by its intensity.

[581] Every complex, even in the domain of neurosis, has a distinct tendency to normalize itself, either by fitting into the hierarchy of higher psychic structures, or, at the worst, by producing a personal dissociation that is somehow consistent with the ego-personality. In schizophrenia, however, the complex not only remains archaic but remains fixed in a chaotically random condition, regardless of its social aspect. It remains alien, incomprehensible, and incommunicable, like the overwhelming majority of dreams. For this peculiarity of dreams the sleeping state is responsible. For schizophrenia, on the other hand, we must assume as an explanatory hypothesis a

specific noxious agent. We may conceive this to be a toxin produced by the excessively strong affect and having, we must suppose, a specific action. It does not act in the general sense of disturbing the sense-functions or the bodily movements, it acts only in the region of the pathogenic complex, reducing the association processes to an archaic level by an intensive *abaissement du niveau mental* and partly decomposing them into their elementary constituents.

[582] This postulate certainly makes one think of a possible localization, an idea that may seem altogether daring. Recently, however, it seems that two American investigators succeeded in evoking an hallucinatory vision of coloured squares and circles by stimulating the occipital cortex. It was the case of an epileptic who, as a prodromal symptom of the attack, always had a vision of a circle in a square.⁶ This imagery, probably related to the well-known Purkinje figures, suggests that we are dealing with the raw material from which mandala symbols originate. I have long thought that, if there is any analogy between psychic and physiological processes, the organizing system of the brain must lie subcortically in the brain-stem. This conjecture arose out of considering the psychology of an archetype of central importance and universal distribution represented in mandala symbols. It appears spontaneously and independently of all tradition in the products of the unconscious. It is easy to recognize and cannot remain hidden from anybody who has experience of dreams. The reason that led me to conjecture a localization of a physiological basis for this archetype in the brain-stem was the psychological fact that besides being specifically characterized by the ordering and orientating role its uniting properties are predominantly affective. I would conjecture that such a subcortical system might somehow reflect characteristics of the archetypal forms in the unconscious. They are never clear-cut units but always have fringes which make them difficult or even impossible to delineate since they would appear not only to overlap but to be indistinct. This results in their having many apparently incompatible meanings.⁷ Mandala symbols appear very frequently in moments of psychic disorientation as compensatory ordering factors. This aspect is expressed above all in their mathematical structure, which was known to Hermetic natural philosophy ever since late antiquity as the axiom of Maria Prophetissa (a Neoplatonist of the 3rd century A.D.) and was the object of lively speculation for fourteen hundred years.⁸

[583] Should the idea of a localization of the archetype be confirmed by further investigation, the self-destruction of the pathogenic complex by a specific toxin would gain considerably in probability, and it would then be possible to understand the destructive process as a kind of mistaken biological defence-reaction.

[584] It will assuredly be a long time before the physiology and pathology of the brain and the psychology of the unconscious are able to join hands. Till then they must go

their separate ways. But psychiatry, whose concern is the total man, is forced by its task of understanding and treating the sick to consider both sides, regardless of the gulf that yawns between the two aspects of the psychic phenomenon. Even if it is not yet granted to our present insight to discover the bridges that connect the visible and tangible nature of the brain with the apparent insubstantiality of psychic forms, the unerring certainty of their presence nevertheless remains. May this certainty safeguard investigators from the impatient error of neglecting one side in favour of the other, and, still worse, of wishing to replace the one by the other. For indeed, nature would not exist without substance, but neither would she exist for us if she were not reflected in the psyche.

APPENDIX⁹

In a letter to the chairman of a Symposium on Chemical Concepts of Psychosis, held at the second International Congress for Psychiatry in Zurich, September 1–7, 1957, Professor Jung sent this message:

Please convey my sincerest thanks to the opening session of your Society. I consider it a great honour to be nominated as Honorary President, although my approach to the chemical solution of problems presented by cases of schizophrenia is not the same as yours, since I envisage schizophrenia from the psychological point of view. But it was just my psychological approach that had led me to the hypothesis of a chemical factor, without which I would not be able to explain certain pathognomonic details in its symptomatology. I arrived at the chemical hypothesis by a process of psychological elimination rather than by specifically chemical research. It is therefore with the greatest interest that I welcome your chemical attempts.

To make myself clear, I consider the aetiology of schizophrenia to be a dual one: namely, up to a certain point psychology is indispensable in explaining the nature and the causes of the initial emotions which give rise to metabolic alterations. These emotions seem to be accompanied by chemical processes that cause specific temporary or chronic disturbances or lesions.

BIBLIOGRAPHY

INDEX

BIBLIOGRAPHY

A. LIST OF PERIODICALS CITED, WITH ABBREVIATIONS

- Allg. Z. Psychiat.* = *Allgemeine Zeitschrift für Psychiatrie und psychisch-gerichtliche Medicin.* Berlin.
- Année psychol.* = *Année psychologique.* Paris.
- Arch. KrimAnthrop.* = *Archiv für Kriminalanthropologie und Kriminalistik.* Leipzig.
- Arch. Psychiat. Nervenkr.* = *Archiv für Psychiatrie und Nerven-krankheiten.* Berlin.
- Arch. Psychol. Suisse rom.* = *Archives de psychologie de la Suisse romande.* Geneva.
- Dtsch. med. Wschr.* = *Deutsche medizinische Wochenschrift.* Leipzig.
- Jb. Psychiat. Neurol.* = *Jahrbuch für Psychiatrie und Neurologie.* Leipzig and Vienna.
- Jb. psychoanal. psychopath. Forsch.* = *Jahrbuch für psychoanalytische und psychopathologische Forschungen.* Vienna and Leipzig.
- J. nerv. ment. Dis.* = *Journal of Nervous and Mental Diseases.* New York.
- Klin. psych, nerv. Krankh.* = *Klinik für psychische und nervöse Krankheiten.* Halle.
- Mschr. Psychiat. Neurol.* = *Monatsschrift für Psychiatrie und Neurologie.* Berlin.
- Neurol. Zbl.* = *Neurologisches Zentralblatt.* Leipzig.
- Psychiat.-neurol. Wschr.* = *Psychiatrisch-neurologische Wochenschrift.* Halle.
- Psychol. Rev.* = *Psychological Review.* Lancaster, Pa.
- Rev. sci., Paris* = *Revue scientifique de France et de l'étranger.* Paris.
- St Pet. med. Wschr.* = *St Petersburger Medizinische Wochenschrift.* St Petersburg (Leningrad).
- Wien. med. Pr.* = *Wiener medizinische Presse.* Vienna.
- Z. Psychol. Physiol. Sinnesorg.* = *Zeitschrift für Psychologie und Physiologie der Sinnesorgane.* Leipzig.
- Zbl. Nervenheilk.* = *Zentralblatt für Nervenheilkunde und Psychiatrie.* Berlin.

B. GENERAL BIBLIOGRAPHY

- ADLER, ALFRED. *The Neurotic Constitution.* Translated by B. Glueck and J. E. Lind. New York, 1917; London, 1921.
(Original: *Über den Nervösen Charakter.* Wiesbaden, 1912.)
- ARNDT, ERICH. Über die Geschichte der Katatonie," *Zbl. Nervenheilk.*, XXV (n.s., XIV; 1902), 81–117.
- ASCHAFFENBURG, GUSTAV. "Die Katatoniefrage," *Allg. Z. Psychiat.*, LIV (1898), 1004–1026.
- BAETZ, E. "Über Emotionslähmung" (in a report of the Jahresver-sammlung des Vereins der deutschen Irrenärzte), *Allg. Z. Psychiat.*, LVIII (1901), 717–21.

- BALL, M. "La Folie du doute," *Rev. sci., Paris*, 3rd ser., IV (XXX of the collection; 1882), 43–46.
- BINET, ALFRED. *Alterations of Personality*. Translated by Helen Green Baldwin. London, 1896. (Original: *Les Altérations de la personnalité*. Paris, 1892.)
- _____. "Attention et adaptation," *Année psychol.*, VI (1900), 247–404.
- BLEULER, PAUL EUGEN. *Affektivität, Suggestibilität, Paranoia*. Halle, 1906; 2nd edn., 1926. (Trans., *N.Y. State Hosp. Bull.*, Feb. 1912.)
- _____. "Consciousness and Association." In: JUNG, ed., *Studies in Word-Association* (1918), q.v.
- _____. *Dementia Praecox, or The Group of Schizophrenias*. Translated by Joseph Zinkin. (Monograph Series on Schizophrenia, 1.) New York, 1950. (Original: *Dementia Praecox, oder die Gruppe der Schizophrenien*. In: G. ASCHAFFENBURG [ed.]. *Handbuch der Psychiatrie*. Leipzig and Vienna, 1911.)
- _____. "Frühe Entlassungen," *Psychiat.-neurol. Wschr.*, VI (1904–5).
- _____. "Die negative Suggestibilität, ein psychologischer Prototyp des Negativismus," *Psychiat.-neurol. Wschr.*, VI (1904–5), 249–69.
- _____. *The Theory of Schizophrenic Negativism*. Translated by William Allen White. (Nervous and Mental Disease Monograph Series, 11.) New York, 1912. (Original: "Zur Theorie des schizophrenen Negativismus," *Psychiat.-neurol. Wschr.*, XII (1910–11), 171, 189, 195.)
- BOHN, WOLFGANG. *Ein Fall von doppeltem Bewusstsein*. Breslau, 1898.
- BONHOEFFER, K. "Über den pathologischen Einfall: Ein Beitrag zur Symptomatologie der Degenerationszustände," *Dtsch. med. Wschr.*, 1904, no. XXXIX, 1420–23.
- BRESLER, JOHANN. "Kulturhistorischer Beitrag zur Hysterie," *Allg. Z. Psychiat.*, LIII (1897), 333–76.
- BREUER, JOSEF, and FREUD, SIGMUND. *Studies on Hysteria*. Translated by James and Alix Strachey. (Standard Edition of the Complete Psychological Works of Sigmund Freud, 2.) London, 1955. (Original: *Studien über Hysterie*. Leipzig and Vienna, 1895.)
- BREUKINK, H. "Über eknoische Zustände," *Mshr. Psychiat. Neurol.*, XIV (1903), 97–112.
- CARTER, CAPT. R. KELSO. *Pastor Blumhardt*. (Willard Tract Repository.) Boston, New York, and Philadelphia, 1883.
- CHASLIN, PHILIPPE. *La Confusion mentale primitive*. Paris, 1895.
- CLAPARÈDE, ÉDOUARD. "Esquisse d'une théorie biologique du sommeil," *Arch. Psychol. Suisse rom.*, IV (1904–5), 245–349.
- CLAUS, A. *Catatonie et stupeur*. Brussels, 1903. (Report to the Congrès de médecins aliénistes et neurologistes de France et des pays de langue française, 13th session, Brussels, August 1903.)
- DE SANCTIS, SANTE. *I Sogni: Studi psicologici e clinici di un alienista*. Turin, 1899. (German translation: *Die Träume*. Halle, 1901.)
- DIEM, OTTO. "Die einfach demente Form der Dementia praecox (Dementia simplex)," *Arch. Psychiat. Nervenkr.*, XXXVII (1903), 111–87.

- EVENSEN, HANS. "Die psychologische Grundlage der katatonischen Krankheitszeichen," *Neurologia (Ein Centralblatt für Neurologie, Psychiatrie, Psychologie und Verwandte Wissenschaften)* (Tokyo), II (1903): 1, 1–24.
- FÉRÉ, CHARLES SAMSON. *The Pathology of the Emotions*. Translated by Robert Park. London, 1899. (Original: *La Pathologie des émotions*. Paris, 1892.)
- FERENCZI, SANDOR. "On the Part Played by Homosexuality in the Pathogenesis of Paranoia." In: *First Contributions to Psycho-Analysis*. Translated by Ernest Jones. London, 1952. (Pp. 154–84.) (Original: "Über die Rolle der Homosexualität in der Pathogenese der Paranoia," *Jb. psychoanal. psychopath. Forsch.*, III (1911), 101–119.)
- FLOURNOY, THÉODORE. *From India to the Planet Mars*. Translated by D. B. Vermilye. New York and London, 1900. (Orig.: *Des Indes à la Planète Mars. Étude sur un cas de somnambulisme avec glossolalie*. Paris and Geneva, 1900.)
- _____. "Nouvelles observations sur un cas de somnambulisme avec glossolalie," *Arch. Psychol. Suisse rom.*, I (1901), 101–255.
- FOREL, AUGUSTE HENRI. "Selbstbiographie eines Falles von Mania acuta," *Arch. Psychiat. Nervenkr.*, XXXIV (1901), 960–97.
- FREUD, SIGMUND. "The Antithetical Meaning of Primal Words." Translated by Alan Tyson. In: Standard Edition of the Complete Psychological Works, 11. London, 1957. (Pp. 153–61.)
- _____. "Further Remarks on the Neuro-Psychoses of Defence." Translated by J. Rickman. In: Standard Edition of the Complete Psychological Works, 3. London, 1962. (Pp. 159–85.)
- _____. *The Interpretation of Dreams*. Translated by James Strachey et al. In: Standard Edition of the Complete Psychological Works, 4–5. London, 1953. 2 vols.
- _____. "On the Psychological Mechanism of Hysterical Phenomena." In: BREUER and FREUD, *Studies on Hysteria*, q.v. (pp. 3–17).
- _____. "Psycho-Analytic Notes on an Autobiographical Account of a Case of Paranoia (Dementia Paranoides)." Translated by Alix and James Strachey. In: Standard Edition of the Complete Psychological Works, 12. London, 1958. (Pp. 1–82.)
- _____. *The Psychopathology of Everyday Life*. Translated by Alan Tyson. In: Standard Edition of the Complete Psychological Works, 6. London, 1960.
- _____. "Three Essays on the Theory of Sexuality." In: Standard Edition of the Complete Psychological Works, 7. London, 1953. (Pp. 153–243.)
- _____. See also BREUER.
- FREUSBERG, _____. "Über motorische Symptome bei einfachen Psychosen," *Arch. Psychiat. Nervenkr.*, XVII (1886), 757–94.
- FUHRMANN, M. "Über akute juvenile Verblödung," *Arch. Psychiat. Nervenkr.*, XL (1905), 817–47.
- FÜRSTNER, C. "Die Zurechnungsfähigkeit der Hysterischen," *Arch. Psychiat. Nervenkr.*, XXXI (1899), 627–39.
- GAST, PETER. See NIETZSCHE.

- GIERLICH, N. "Über periodische Paranoia und die Entstehung der paranoischen Wahnideen," *Arch. Psychiat. Nervenkr.*, XL (1905), 19–40.
- GODFERNAUX, ANDRÉ. *Le Sentiment et la pensée et leurs principaux aspects physiologiques*. 2nd edn., Paris, 1906.
- GREBELSKAJA, S. "Psychologische Analyse eines Paranoiden," *Jb. psychoanal. psychopath. Forsch.*, IV (1912), 116–40.
- GROSS, OTTO. "Beitrag zur Pathologie des Negativismus," *Psychiat.-neurol. Wschr.*, V (1903), 269–73.
- _____. *Die zerebrale Sekundärfunktion*. Leipzig, 1902.
- _____. "Über Bewusstseinszerfall," *M Schr. Psychiat. Neurol.*, XV (1904), 45–51.
- _____. "Zur Differentialdiagnostik negativistischer Phänomene," *Psychiat.-neurol. Wschr.*, VI (1904–5), 345–53, 357–63.
- _____. "Zur Nomenklatur 'Dementia sejunctiva,'" *Neurol. Zbl.*, XXIII (1904), 1144–46.
- HAUPTMANN, GERHARDT. *Hannele*. Translated by C. H. Meltzer. London, [1908].
- HEILBRONNER, KARL. "Über Haftenbleiben und Stereotypie," *M Schr. Psychiat. Neurol.*, XVIII (1905), Ergänzungsheft, 293–371.
- HENRY, VICTOR. *Antinomies linguistiques*. (Bibliothèque de la faculté des lettres, 2.) Paris, 1896.
- ITTEN, W. "Beiträge zur Psychologie der Dementia Praecox," *Jb. psychoanal. psychopath. Forsch.*, V (1913), 1–54.
- JAMES, WILLIAM. *Pragmatism*. London and Cambridge (Mass.), 1907.
- JANET, PIERRE. *L'Automatisme psychologique*. Paris, 1889. 7th edn., 1913.
- _____. *Névroses et idées fixes*. Paris, 1898. 2 vols.
- _____. *Les Obsessions et la psychasthénie*. Paris, 1903. 2 vols.
- JUNG, CARL GUSTAV. "An Analysis of the Associations of an Epileptic." In: *Experimental Researches*. (Collected Works, 2.) 1973.
- _____. "Answer to Job." In: *Psychology and Religion: West and East*, q.v.
- _____. "Association, Dream, and Hysterical Symptom." In: *Experimental Researches*. (Collected Works, 2.) 1973.
- (with F. RIKLIN). "The Associations of Normal Subjects." In: *Experimental Researches*. (Collected Works, 2.) 1973.
- _____. "Brother Klaus." In: *Psychology and Religion: West and East*, q.v.
- _____. "A Case of Hysterical Stupor in a Prisoner in Detention." In: *Psychiatric Studies*, q.v.
- _____. *Collected Papers on Analytical Psychology*. Edited by C. E. Long, translated by various hands. London, and New York, 1916; 2nd edn., 1917.
- _____. "A Contribution to the Study of Psychological Types." In: *Psychological Types*, q.v.
- _____. "Experimental Observations on the Faculty of Memory." In: *Experimental Researches*. (Collected Works, 2.) 1973.
- _____. "On Psychic Energy." In: *The Structure and Dynamics of the Psyche*, q.v.
- _____. "On the Psychology and Pathology of So-called Occult Phenomena." In: *Psychiatric Studies*, q.v.
- _____. "On Simulated Insanity." In: *Psychiatric Studies*, q.v.

- _____. *Psychiatric Studies*. (Collected Works, 1.) 1957; 2nd edn., 1970.
- _____. "Psychoanalysis and Association Experiments." In: *Experimental Researches*. (Collected Works, 2.) 1973.
- _____. "A Psychological Approach to the Dogma of the Trinity." In: *Psychology and Religion: West and East*, q.v.
- _____. "The Psychological Diagnosis of Evidence." In: *Experimental Researches*. (Collected Works, 2.) 1973.
- _____. *Psychological Types*. (Collected Works, 6.) 1971.
- _____. *Psychology and Religion: West and East*. (Collected Works, 11.) 1958; 2nd edn., 1969.
- _____. "The Psychopathological Significance of the Association Experiment." In: *Experimental Researches*. (Collected Works, 2.) 1973.
- _____. "The Reaction-time Ratio in the Association Experiment." In: *Experimental Researches*. (Collected Works, 2.) 1973
- _____. *The Structure and Dynamics of the Psyche*, (Collected Works, 8.) 1960; 2nd edn., 1969.
- *Studies in Word-Association ...* under the direction of C. G. Jung. Translated by M. D. Eder. London, 1918; New York, 1919.
- _____. *Symbols of Transformation*. (Collected Works, 5.) 1956; 2nd edn., 1967.
- _____. *Wandlungen und Symbole der Libido*. Leipzig and Vienna, 1912.
- _____. (ed.). *Diagnostische Assoziationsstudien*. Leipzig, 1906 and 1909. 2 vols.
- _____. and FREUD, SIGMUND. *The Freud/Jung Letters*. Edited by William McGuire. Princeton and London, 1974.

*

*

*

*

*

- KAISER, O. "Beiträge zur Differentialdiagnose der Hysterie und Kata-tonie," *Allg. Z. Psychiat.*, LVIII (1901), 957–69, 1126–59.
- KANT, IMMANUEL. *Introduction to Logic*. Translated by Thomas Kingsmill Abbott. London, 1885.
- _____. *Critique of Practical Reason*. Translated by Lewis White Beck. Chicago, 1949.
- KAZOWSKY, A. D. "Zur Frage nach dem Zusammenhange von Träumen und Wahnvorstellungen," *Neurol. Zbl.*, XX (1901), 440–47, 508–13.
- KLINKE, O. "Über das Symptom des Gedankenlautwerdens," *Arch. Psychiat. Nervenkr.*, XXV (1894), 147–201.

- KRAEPELIN, EMIL. *Psychiatrie: Ein Lehrbuch für Studierende und Ärzte*. 5th edn., Leipzig, 1896. (1st edn.: *Compendium der Psychiatrie zum Gebrauche für Studierende und Ärzte*. Leipzig, 1883.)
- _____. Report of Wanderversammlung der Südwestdeutschen Neurologen und Irrenärzte in Baden-Baden, 2 and 3 June 1894, *Arch. Psychiat. Nervenkr.*, XXVI (1894), 584–612.
- _____. “Über Sprachstörungen im Traume.” In: *Psychologische Arbeiten*. Leipzig, 1895–1927. 9 vols. (Vol. V, pt. 1, pp. 1–104.)
- KRAFFT-EBING, RICHARD VON. *Text-Book of Insanity Based on Clinical Observations*. Translated by C. G. Chaddock. Philadelphia, 1904. (Original: *Lehrbuch der Psychiatrie auf klinischer Grundlage*. Stuttgart, 1879; 7th edn., 1903.)
- LAMBERT, GAVIN. *The Slide Area*. London, 1959.
- LEUPOLDT, C. VON. “Zur Symptomatologie der Katatonie,” *Klin. psych. nerv. Krankh.*, I (1906), 39–50.
- LIEPMANN, HUGO. *Über Ideenflucht, Begriffsbestimmung, und psychologische Analyse*. Halle, 1904.
- MAEDER, A. “Psychologische Untersuchungen an Dementia-*praecox*-kranken,” *Jb. psychoanal. psychopath. Forsch.*, II (1910), 185–245.
- MARGULIÈS, ALEXANDER. “Die primäre Bedeutung der Affecte im ersten Stadium der Paranoia,” *M Schr. Psychiat. Neurol.*, X (1901), 265–88.
- MASSELON, RENÉ. *La Démence précoce*. Paris, 1904.
- _____. *Psychologie des déments précoces*. Paris, 1902.
- MAYER, KARL. “Sechzehn Fälle von Halbtraumzustand,” *Jb. Psychiat. Neurol.*, XI (1893), 236–52.
- MEIGE, HENRY, and FEINDEL, E. *Tics and Their Treatment*. Translated by S.A.K. Wilson. London, 1907. (Orig. 1902.)
- MENDEL, EMANUEL. *Leitfaden der Psychologie*. Stuttgart, 1902.
- MERINGER, RUDOLF, and MAYER, KARL. *Versprechen und Verlesen*. Stuttgart, 1895.
- MEYER, ERNST. *Beitrag zur Kenntnis der acut entstandenen Psychosen*. Habilitationsschrift. Berlin, 1899.
- _____. “Bemerkungen zu Jung ‘Über die Psychologie der Dementia *praecox*,’ ” *Arch. Psychiat. Nervenkr.*, LIII (1908), 1312–16.
- MÜLLER, GEORG E., and PILZECKER, A. “Experimentelle Beiträge zur Lehre vom Gedächtnis,” *Z. Psychol. Physiol. Sinnesorg.*, Ergänzungsband I (1900).
- NEISSER, CLEMENS. *Individualität und Psychose*. Beitrag geh. in der allgemeinen Sitzung der Gesellschaft deutscher Naturforscher und Ärzte zu Meran am 29 Sept. 1905. Berlin, 1906.
- _____. “Paranoia und Schwachsinn,” *Allg. Z. Psychiat.*, LIII (1898), 241–69.
- _____. *Über die Katatonie*. Stuttgart, 1887.
- _____. “Über die Sprachneubildungen Geisteskranker,” 74. Sitzung der Vereins Ostdeutscher Irrenärzte zu Breslau, *Allg. Z. Psychiat.*, LIII (1898), 443–46.
- NELKEN, JAN. “Analytische Beobachtungen über Phantasien eines Schizophrenen,” *Jb. psychoanal. psychopath. Forsch.*, IV (1912), 504–62.

- NIETZSCHE, FRIEDRICH WILHELM. *Thus Spake Zarathustra*. In: *The Portable Nietzsche*. Selected and translated by Walter Kaufmann. New York, 1954. (Pp. 103–439.)
- _____. *Werke*. Leipzig, 1899–1913. 19 vols. (For “Die Entstehung von *Also Sprach Zarathustra*,” by Peter Gast, see Vol. VI, pp. 479–521.)
- _____. *Ecce Homo, and Poetry*. Translated by Anthony M. Ludovici et al. (Complete Works, 17.) Edinburgh and London, 1911.
- PAULHAN, FRÉDÉRIC. *L’Activité mentale et les éléments de l’esprit*. Paris, 1889; 2nd edn., 1913.
- _____. *Les Mensonges du caractère*. Paris, 1905.
- PELLETIER, MADELEINE. *L’Association des idées dans la manie aiguë et dans la débilité mentale*. (Faculté de médecine de Paris, thèse pour le doctorat en médecine, 1903, no. 4.) Paris, 1903.
- PENFIELD, WILDER, and JASPER, HERBERT. *Epilepsy and the Functional Anatomy of the Human Brain*. Boston and London, 1954.
- PFISTER, O. “Über Verbigeration,” address to the Versammlung des Deutsch. Verein für Psychiatrie in München 1906, *Psychiat.-neurol. Wschr.*, 1906, no. 7.
- PICK, ARNOLD. “On Contrary Actions,” *J. nerv. ment. Dis.*, XXXI (1904), 1–14.
- _____. “Über pathologische Träumerei und ihre Beziehung zur Hysterie,” *Jb. Psychiat. Neurol.*, XIV (1896), 280–301.
- RIKLIN, FRANZ. “Analytische Untersuchungen der Symptome und Assoziationen eines Falles von Hysterie (Lina H.),” *Psychiat.-neurol. Wschr.*, VI (1904–5), 449, 464, 469, 481, 493, 505, 521.
- _____. “Cases Illustrating the Phenomena of Association in Hysteria.” In: JUNG, ed., *Studies in Word-Association* (1918), q.v.
- _____. “Über Versetzungsbesserungen,” *Psychiat.-neurol. Wschr.*, VII (1905–6), 153, 165, 179.
- _____. “Zur Psychologie hysterischer Dämmerzustände und des Ganser’schen Symptoms,” *Psychiat.-neurol. Wschr.*, VI (1904–5), 185–93.
- ROLLER, C. F. W. “Über motorische Störungen beim einfachen Irresein,” *Allg. Z. Psychiat.* (Berlin), XLII (1885), 1–60.
- ROYCE, JOSIAH. “The Case of John Bunyan,” *Psychol. Rev.*, I (1894), 22–33, 134–151, 230–240.
- SCHILLER, FRIEDRICH. *Über naive und sentimentalische Dichtung*. Edited by William F. Mainland. Oxford, 1951.
- SCHREBER, DANIEL PAUL. *Memoirs of My Nervous Illness*. Translated by Ida Macalpine and Richard A. Hunter. (Psychiatric Monograph Series, 1.) London, 1955. (Original: *Denkwürdigkeiten eines Nervenkranken*. 1903.)
- SÉGLAS, JULES. *Leçons cliniques sur les maladies mentales et nerveuses (Salpêtrière, 1887–94)*. Collected and edited by Henry Meige. Paris, 1895.
- SOKOLOWSKI, ERNST. “Hysterie und hysterisches Irresein,” *St Pet. med. Wschr.*, XX (n.s., XII; 1895), 441–44.
- SOLLIER, PAUL AUGUSTE. *Le Mécanisme des émotions*. Paris, 1905.
- SOMMER, ROBERT. *Lehrbuch der psychopathologischen Untersuchungsverfahren*. Berlin and Vienna, 1899.
- _____. “Zur Lehre von der ‘Hemmung’ geistiger Vorgänge,” *Allg. Z. Psychiat.*, L (1894), 234–57.

- SPIELREIN, SABINA. "Über den psychologischen Inhalt eines Falles von Schizophrenie (Dementia praecox)," *Jb. psychoanal. psychopath. Forsch.*, III (1911), 329–400.
- STADELMANN, HEINRICH. *Geisteskrankheit und Naturwissenschaft*. Munich, 1905.
- STRANSKY, ERWIN. "Über die Dementia praecox in ihrer Bedeutung für die ärztliche Praxis," *Wien. med. Pr.*, XLVI (1905), cols. 1379–83, 1435–41, 1478–82, 1522–27.
- _____. *Über Sprachverwirrtheit*. (Sammlung zwangloser Abhandlungen aus dem Gebiete der Nerven- und Geisteskrankheiten, 6, pts. 4–5.) Halle, 1905.
- _____. "Zur Auffassung gewisser Symptome der Dementia praecox," *Neurol. Zbl.*, XXIII (1904), 1074–85, 1137–43.
- _____. "Zur Kenntnis gewisser erworbener Blödsinnsformen," *Jb. Psychiat. Neurol.*, XXIV (1903), 1–149.
- _____. "Zur Lehre von der Dementia praecox," *Zbl. Nervenheilk.*, XXVII (n.s., XV; 1904), 1–19.
- SVENSON, FREY. "Om Katatoni," *Hygeia* (Stockholm), 2nd ser., II (1902), 107–138.
- TILING, TH. *Individuelle Geistesartung und Geistesstörung*. (Grenzfragen des Nerven- und Seelenleben, 20.) Wiesbaden, 1904.
- _____. "Zur Ätiologie der Geistesstörungen," *Centralbl. f. Nerv. und Psych.*, XXVI (n.s., XIV; 1903), 561–79.
- VOGT, RAGNAR. "Zur Psychologie der katatonischen Symptome," *Zbl. Nervenheilk.*, XXV (n.s., XIII; 1902), 433–37.
- WEHRLIN, K. "The Associations of Imbeciles and Idiots." In: JUNG, ed., *Studies in Word-Association* (1918), q.v.
- WEISKORN, JOSEPH. *Transitorische Geistesstörungen beim Geburtsakt*. Bonn, 1897.
- WEYGANDT, WILHELM. "Alte Dementia praecox," *Zbl. Nervenheilk.*, XXVII (n.s., XV; 1904), 613–25.
- WUNDT, WILHELM. *Grundzüge der physiologischen Psychologie*. 5th edn., Leipzig, 1903. 3 vols, and index. (1st edn., 1874.)
- _____. *Outlines of Psychology*. Translated by Charles Hubbard Judd. 2nd revised English edn. from the 4th revised German edn., Leipzig, London, New York, 1902. (Original: *Grundriss der Psychologie*. Leipzig, 1896.)
- ZIEHEN, GEORG THEODOR. *Leitfaden der physiologischen Psychologie*. 3rd edn., Jena, 1896.
- _____. *Psychiatrie für Ärzte und Studierende bearbeitet*. 2nd edn., Leipzig, 1902.
- ZILBOORG, GREGORY, and HENRY, GEORGE W. *A History of Medical Psychology*. New York, 1941.
- ZOLA, ÉMILE. *Lourdes*. Translated by E. A. Vizetelly. London, 1903. (Original, 1884.)
- _____. *The Dream*. Translated by Eliza E. Chase. London, 1912. (Original: *Le Rêve*. Paris, 1888.)
- ZÜNDEL, FRIEDRICH. *Pfarrer J. C. Blumhardt: Ein Lebensbild*. Zurich and Heilbronn, 1880.

INDEX

A

- abaissement du niveau mental*, 10, 16, 28, 30, 37, 146, 234, 246, 248, 251, 263, 268, 270
- in compulsives, 18
 - neurosis and, 238ff
 - psychogenesis of, 237
 - in schizophrenia, 236ff, 252
 - sleep as, 241
 - various causes, 237
 - and “word salad,” 76
- aboulia: in catatonia, 10, 18
- in obsessed persons, 93
- Abraham, Karl, 171
- “absurdities,” 163, 165
- acceleration, of thought and feeling, 15
- achievement, lack of, 93
- action: fear of, 84
- symptomatic, 44, 46f, 49, 57, 93, 206
- activity, feelings of, disturbances in, 84
- Adam and Eve, 192
- adaptation, 13n, 244
- to world/environment, 68, 145, 189, 207
- Adler, Alfred, 183, 186, 251
- champion of introvert, 191
- aesthetics, 191
- aetiological theories, 211
- aetiology, physical and psychological, 212, 272
- affect(s): damming up of, 200
- displacement of, 103
 - , in dementia praecox, 73
 - fixation of, in dementia praecox, 35f
 - fresh, reaction to, 110

in hysteria and paranoia, 35
and ideational content, incongruity, *see* incongruity; lack of, 103
outbursts of, in hysteria, 67, 73
strength of, and complexes, 42
strong, 269
unruliness of, 74

affectation, 75, 101, 109, 110
affect-ego, 41*f*
affective states, without adequate ideational content, 72
affectivity, 38
 disturbance, in schizophrenia, 253
 paralysed, 228

“affirm,” association-chain, 118*f*

Ahriman, 182

alcoholic, paranoia of, 209

alcoholism, 161

“Alexander, Empress,” association-chain, 139*ff*

“aliquis,” 56, 112*n*

allegory, 65

alliteration, 268

aloofness, *see* isolation

amazement, 6

ambitendency, 197

ambivalence, 197*ff*

America, 58*f*

amnesia, 12, 45

“amphi,” association-chain, 136

amplification, method of, 187*n*

analogy, 113

analysis, *see* psychoanalysis

analytical method, *see* reductive method

anatomy: brain, 211
 and psychiatry, 211
 and psychic disturbances, 159*ff*

Andreyev, Leonid, 239

anger, 48

answer, irrelevant, 89

anticipation(s), 53

ants, 96

anxiety states, 72

apathy, 253

- in catatonia, 10f, 18
- euphoric, in dementia praecox, 71
- schizophrenic, 228, 269

apperception, 13, 14, 16, 263

- degeneration of, 48
- disturbance of, 29
- weakness of, 30

archaeologist, 165ff

archaisms, 261ff

archetypes, 187n, 254f, 261, 266, 270f

Areopagus, 242, 262

art, works of, meaning, 183

artist(s), 85, 170, 177, 240

Aschaffenburg, Gustav, 5, 15n

assertions, delusional, 83

assimilation, active, lack of, 19

association(s): chains of/continuous, 29, 111ff

- and complexes, 40, 52ff
- clang, *see* clang associations
- compulsive, 113
- contrary/contrasting, 17, 66f
- in daydreaming, 15
- disturbance of, 9
- erratic, 9
- examples of, *see separate entry below*; and flight of ideas, 14, 15
- laws of, 23
- indirect, 24, 54n, 113

- , and distraction, 63
- poverty of, in catatonics, 15
- and reduced attention, 16
- and schizophrenia, Bleuler on, 234
- schizophrenic, 263
- subsidiary, 63–64*n*
- superficial, 16, 52
- symbolic, *see* symbols; valency of, 52*ff*
- verbal-motor, 21, 251

associations, examples of: Bunau-Varilla/cigar, 54

- mild/bed, 54
- mountain/work/America, 58*f*
- oranges/shunting station, 57
- paint/landscape, 46
- Tagerock/Taganrog, 54
- white/black, 46
- “white sheet,” 56
- in case of B. St., 102*ff*
- melodic, 55*f*
- various others, 24, 52

association experiments/tests, 12, 51, 87, 256

- and complexes, 44, 52*ff*
- disturbances in, 45–6
- of neurotics, 234*f*
- of schizophrenics, 235

assonance, 15*n*, 23, 268

asylum, modern, 215

atavism, 244

ataxia, 19, 21

- intrapsychic, 21

attention: and affectivity, 40

- and apperception, 13
- distraction of, and perseveration, 22
- disturbance of, 12, 16, 18, 26, 27, 79*f*, 201

incapacity for/reduction of/relaxation of, [5f](#), [10](#), [16](#), [146](#), [251](#)
— and reactions, [52f](#)
— and unclear ideas, [63](#)
inhibition of, [64](#)
relaxed, association in, [200f](#)
withdrawal of, [66](#)
attention-tone, [40](#), [41](#), [42](#)
attitude, patient's, [222](#)
autism, [199n](#), [200](#)
autoerotism, [199n](#), [200](#)
automatic phenomena, [29](#)
automatism(s), [19](#), [34](#)
 and *abaissement*, [28](#)
 catatonic, [7](#), [94f](#)
 command, [12](#), [17](#), [18](#)
 melodic, [55f](#)
 muscular, [96](#)
 release of, [146](#)
automatization, [92](#), [98](#)
autonomy, *see* complexes

B

Baetz, E., [72](#)
Bahr, Hermann, [50](#)
balance, mental, [207f](#)
Ball, M., [84n](#)
“*Bannung*,” *see* captivation
Bassini, [130](#)
Bayle, Antoine, [159](#)
“bazaar,” association-chain, [141ff](#)
behaviour, pattern of, [261](#)
belle indifference, [20](#), [70](#), [71](#)
bell-ringing, [39f](#)
Bergson, Henri, [66n](#), [190](#)
Bible, [266](#)

Bier, 130
Binet, Alfred, 10n, 13, 21n, 27
Bleuler, Eugen, 3, 17, 18, 24, 34n, 38n, 39n, 40, 54, 66, 67, 71, 72, 79n, 83, 155, 198ff, 227, 234, 246, 251, 256, 264
Bleuler, Manfred, 256
blocking(s), 6, 12, 79, 87, 88, 89, 94, 256, 268
Blumhardt, Pastor, 158
body sensations, and affects, 41, 42
Bohn, Wolfgang, 81n
Bonhoeffer, K., 8
brain: changes in, observed after death, 159
 degenerative predisposition, 219
 effects of tissue removal, 96
 integrative system of, 270n
 lesions, in schizophrenia, 229, 233
 malformations, 160
 mental diseases and, 155, 159ff, 211, 226
 organic destruction of, 226
 organic disease of, and dementia praecox, 214
 and psyche, 158
 softening of the, 159
 and unconscious, 271; *see also* cerebrum
brain-mythology, 226
Bresler, Johann, 158n
Breuer, Josef, 28
Breukink, H., 8
Buddhism, 260
Bunau-Varilla, P. J., 54
Burghölzli Hospital, 160, 172, 256, 258

C

cancer, 156
captivation, 88f; *see also* fascination
Carter, R. K., 158n
cats, carrying, 106

catalepsy, [6](#), [9](#), [10](#), [79](#), [92](#), [96](#)
catastrophes, cosmic, [241](#), [259](#)
catatonia, [5ff](#), [151](#), [167](#), [213](#), [216](#), [264f](#)
 associations in, [7ff](#)
 in asylums, [215](#)
 automatic actions in, [5](#)
 and dementia praecox/schizophrenia, [167](#), [213](#), [229](#)
 hallucinations in, [73](#)
 negativism in, [89](#)
 pathological ideas in, [7](#)
 perseveration in, [9](#), [15](#)
 reflex action in, [96](#)
 severe, [268](#)
 suggestibility in, [78](#)
 symptoms of, [29](#); *see also* hypnotic states
cathedral, Gothic, [182](#)
Catherine of Siena, St., [134](#)
Catholicism, [209](#)
causalism, [191](#), [218](#)
causality, [181ff](#)
 of schizophrenia, [227](#), [245](#)
causation, physical, [211](#)
causes, material, [211](#)
cellular destruction, [213f](#), [224](#); *see also* brain
censorship, [66](#), [200](#)
centrencephalic system, [270n](#)
centres, subordinate, [6](#)
cerebrum, [98](#)
 removal of, [96](#)
character: displacement and, [50](#)
 disturbances of, [74ff](#)
 hysteria and, [74](#)
Charcot, Jean Martin, [213](#)
Chaslin, Philippe, [15n](#)

cheerfulness, forced, 50
chemical factor, in schizophrenia, 27f; *see also* toxin(s)
child(ren): bad habits of, 92
 complexes and, 43
Christ, 220
Christianity, sex sublimation in, 134
ciphers, 184
circle, in square, 270
circumlocutions, poetic, 263
clang: associations, 9, 16, 76, 128, 140, 143, 251
 displacements, 113
 reactions, 21, 52, 53
 similarities, 54, 55
Claparède, Edouard, 65n, 66n, 190
Claus, A., 87n
coagulation, 36, 37
collecting mania, 50
compensation: schizophrenic, 262
 of unconscious for conscious, 205ff
complex(es): *abaissement* and, 240
 and analogy, 113
 autonomous, in neurosis, 235
 —, in schizophrenia, 227, 235
 autonomy of, 92, 240
 blocking of, 71
 coagulation/fusion of, 37, 63 & n
 durability of, 43
 effects, 43ff
 Electra, 261
 endogamy, 261
 erotic/sexual, 44, 47, 48f, 67, 111, 133ff
 —, unnatural expressions of, 49f
 extinction of, 42
 feeling-toned, 38ff

incest, 261
incompatibility of, 199
judgment of, uncertain, 127
neurotic/normal, and schizophrenic, compared, 252
obsessional, 48
Oedipus, 261
painfulness of, and censorship, 200
in paranoia, 35*f*
of personal grandeur, 110
reinforcement of, 200
relation to affects, 42
repressed, 34, 37
in schizophrenia, 256, 270
—, special characters, 252
in sleep, 65*f*
—, restlessness of, 91
split-off, 30
strong, in hysteria, 93, 97
symbolized in dreams, 145
and symptoms, in dementia praecox, 97
tendency to self-normalization, 269
unremitting activity of, 92
vagueness of, in dreams, 63
of being wronged, 110*f*; *see also* association experiments; ego-complex; father-complex; ideas; personality

complex-delirium, 80*f*
complex-indicator, 53
complex-sensitiveness, 42, 49, 68, 200
 association tests, and high, 51
comprehension, 18*f*, 181
compromise formations, 68
compulsions, 247; *see also* obsessional (neurosis)
compulsive associations, 113
 thinking, 87
concentration, *see* attention

condensation(s), 24, 25f, 53, 76, 113, 129, 146

conditionalism, 218, 245

confessions, 74

conflict(s): of conscious and unconscious mind, 244
neurosis as, 238
psychological, 219

consciousness: anomalies of, in dementia praecox, 78
catatonic, 9
contents of, 204
deep and restricted, 190
defensive, 244
disintegration of, 27f, 30, 37
dissociation of, 27, 29, 147
double, 50
fringe of, 263n
lucidity of, 79
narrowing of, 78
restriction/weakening of, 5, 9, 29
“sejunction” of, 27
unconscious elements and, 203

consideration, lack of, 77

constructive method/standpoint, 181, 184ff

consultation, reactions after, 225

contaminations, 22, 23f, 25

content, psychic, 28

contiguity, 15n, 23

contradictions, 127

contrasts: of associations, 66f
verbal, 18

conversion: principle of, 37
religious, 221, 223, 225

converts, 209

corpora quadrigemina, 96

cortex: cell-processes in, 7

cerebral, reduction in paralysis, 161
deterioration in, 167
occipital, 270
Cossacks, 141
cramp, 92
“crane,” neologism, 124, 175
creative impulses, 245
“crown,” association-chain, 117
crying, fits of, 212

D

daemon of Socrates, 148
daydreaming, 14, 16
 and attention, 15
 and mania, 14*f*
 symbols in, 16
death, as sequela of insanity, 159
death-expectation, 131, 132, 133
debility, mental, 14
“debraining,” 98
definitions, tendency to give, 109
degeneration, 68, 69, 156, 214
 in epilepsy, 160*f*
 secondary symptoms, 229
delirium, 167
 hallucinatory, 30, 80*f*
 hysterical, 81
 in unmarried women, 81
delusions, 82*ff*, 100*ff*, 227, 261
 aims of, 186
 elaboration of, 186
 non-hysterical, 35
 paranoid, 72
 and unconscious, 206
dementia: acute juvenile, 8*n*

epileptic, 213
paranoid, 179
senile, 213ff

dementia praecox, 5ff, 69, 155, *et passim*, see also schizophrenia; affective content, 110
brain changes in, 213
complex-sensitiveness in, 51
contrasts in, 67
degenerative traits, 214f
description, 161
established complex and, 68
and external conditions, 217f
mild forms, 214
not solely organic, 215
organic origin, 225
organic symptoms and, 214
origin of, 35, 36
psychogenesis of, 213, 225
psychological cause, 218f
psychology and physiology in, 155f
term replaced by schizophrenia, 227
types and, 190

dementia sejunctiva, 27

demon, 243

Demosthenes, 168

depression: in hysteria, 72, 91
in neurosis, 253

deprivation, thought, see thought-deprivation

De Sanctis, Sante, 91n

deterioration: apperceptive, 13, 14, 18, 19, 36, 37
emotional, 19, 70
senile, 161, 226

determinism, 43

development, arrested, 244

devil(s), 158, 248

Diagnostische Assoziationsstudien, 4, *see also* Jung, *WORKS: Studies in Word-Association*

diaschisis, 226

Diem, Otto, 8

“discord,” association-chain, 126f

discrimination, deficient, 65, 112f

disease(s): mental, functional and organic, 156

 multiplicity of causes, 218

disintegration: in schizophrenic complex, 252ff, 263; *see also* consciousness; personality

displacement(s), 54, 68, 82, 83

 from below upward, 137, 142

 replacing character, 50

 of sexual complex, 49f

dissociation, 37

 neurotic and psychotic, 251

 of neurotics, 234

 of personality, 50, 251

 schizophrenic, 199, 235f; *see also* consciousness

distractibility, 6, 10, 11

distraction: experiments, 52, 63, 64

 inner, 53

 and mediate associations, 63 *see also* attention, distraction of

disunion, with self, 199

Dittus sisters, 158

doodles, 54

dreams, 42, 86, 261, 269

 analogy with psychotic thinking, 144

 associations in, 234

 “big,” 242, 243, 254

 breakdown of ideas in, 257

 compensating function, 206

 complexes and, 44, 57

 condensations in, 25f

 conversations in, 116

and dementia praecox/schizophrenia, [15](#), [91](#)
—, compared, [241f](#), [251](#), [257](#)
destructive, [260](#)
displacement in, [55](#)
endogenous and exogenous, [80n](#)
erotic/sexual, [67](#)
Freud and, [3f](#), [25](#), [44](#), [57](#), [80n](#), [120](#), [144](#), [206](#)
as hallucinations, [148](#)
and hysteria, [92](#)
and neologisms, [76](#)
personal and collective, [242](#)
and psychological constellations, [7](#)
relation to sleep, [241](#)
symbols in, [16](#), [140](#), [145](#), [183f](#)
at turning-points in life, [242](#)
unconscious forces in, [239](#)
vagueness of thinking in, [63](#)
and wish-fulfilment, [124](#)
INSTANCES OF DREAMS: horse dropped from height, [57ff](#)
Nebuchadnezzar's, [206](#)
sword adorned with ciphers, [183](#)
dream-states, [242](#)
drugs, [263](#); see also mescaline

E

earthquake, [72](#)
eccentricity, [75](#)
echolalia, [78](#)
echopraxia, [17](#), [78](#)
echo symptoms, [78](#)
eclipse, mental, [87n](#)
education, [43](#)
 patient's, and prognosis, [266](#)
ego, [40](#)

effect of affect on, [41n](#)
oblivion of, in sleep, [241](#)
in schizophrenia, [227](#)
synthesis of, disturbed, [74](#); *see also* affect-ego
ego-complex
ego-personality
egocentricity, involuntary, [200](#)
ego-complex: associations and, [40](#), [41](#), [45](#), [113](#)
divestment of supremacy, [240](#)
irruptions of, [90](#)
relation to other complexes, [64](#), [240](#)
sleep and, [65](#)
and symptomatic actions, [47](#)
ego-personality, depotentiation of, [269](#)
élan vital, [190](#)
ellipsis, [25n](#)
emotion (s): disturbances of, in dementia praecox, [70ff](#), [161](#), [236](#)
inadequate, in neuroses, [253](#)
empiricism, [191](#), [193](#)
energy, psychic, and complex, [48](#), [66f](#)
enthusiasm, value in psychotherapy, [248](#)
environment: hostility to, [199f](#)
misapprehension of, [199f](#)
epilepsy/epileptic, [74](#), [160](#), [226](#), [270](#)
Erasmus, [4](#)
errors, Freudian, [53](#)
Esquirol, J. E. D., [159](#), [211](#)
“establish,” association-chain, [118f](#)
Evensen, H., [10](#)
events, affective, and complexes, [67](#)
exaggeration(s), [110](#), [124](#), [252](#), [253](#)
hysterical, [20](#)
excess, alcoholic, [50](#)
excitement(s), [20](#)

explosive, 73
experience, inner, 88
extravert (type), 190f

F

faiblesse de la volonté, 234

fairy-tales, 261

fanaticism, 207f, 209, 237

fantasy(-ies)

creative, 177

infantile, 185, 209

schizoid, 259

sexual, 49

fantasy-formation, constructive standpoint and, 187

fascination, 263, 266; *see also* captivation

father-complex, 184

fatigue, 11, 93, 263

Faust, 180ff

feeling-tone: ambivalence in, 197

disturbances in, 84

and durability of complex, 43

inadequate, in dementia praecox, 34

inappropriate, 48

resistance and, 199

strength of, and disturbances, 45

feeling-toned complex, *see* complex

Féré, Charles S., 63n

Ferenczi, Sandor, 179

Feuerbach, Ludwig, 189

“finality,” association-chain, 120

Finsteraarhorn (mt.), 121f

fixation, 98

of affects, 35f, 37

visual, 6, 11, 88

Flournoy, Théodore, 8, 30n, 77n, 81n, 145, 147, 148, 188

folklore, 254
fonction du réel, 13, 94, 98, 118, 145, 224
footsteps, 87n
Forel, Auguste, 25n, 65n, 73n, 76n, 96, 132, 134, 226
forgetting, 44
freedom, reaction against deprivation of, 217
French school of psychology, 7, 27, 29, 30, 226
Freud, Sigmund, 3f, 11n, 28, 37, 38, 49n, 54, 56, 63, 72, 82, 90, 98, 112n, 137, 138, 146, 162, 183, 200, 226, 243, 251
 and A. Adler, 187
 and ambivalence, 198f
 analysis of paranoid woman, 31ff
 champion of extravert, 191
 on compulsive thinking, 201
 and condensation, 25f
 on defence neuropsychosis, 30f
 and dream analysis, 57
 and dreams, 206
 and the individual, 185
 Interpretation of Dreams, 3, 16, 25, 44, 55, 120n
 his method scientific, 181
 on Oedipus complex, 261
 on paranoia, 30f
 and Schreber case, 179, 186
 and sexuality in hysteria, 67
 and sublimation, 50
 on symptomatic action, 44, 206
Freusberg, 5f
fright, 41f
fugues, 50
Fuhrmann, M., 8n
function: disturbance of, and degeneration, 156
 indirect failure of, 226
 and organ, 160
Fürstner, C, 77n

fusion, of complexes, [63n](#)

future, and past, [185](#)

G

gaiety, aggressive, [50](#)

Gall, Franz Joseph, [159](#)

ganglia, basal, [270n](#)

Ganser syndrome, [81n](#), [89](#), [130](#)

Gast, Peter, [85n](#)

gastro-enteritis, [91n](#)

general paralysis of the insane, [159](#), [213](#), [214](#), [215](#)

genius, [64n](#)

“Gessler,” association-chain, [131](#)

“getting stuck,” [189](#), [262](#)

Gierlich, N., [83n](#)

God: Schreber and, [179](#)

 talks with, [220ff](#)

Godfernaux, André, [38n](#), [82n](#)

Goethe, J. W. von, [50](#), [180ff](#)

Goltz, [96](#)

Gorky, Maxim, [50](#)

grandeur, ideas of, [110](#), [140](#), [149](#), [167](#)

Grebelskaja, S., [180](#)

Greeks, and dreams, [242](#)

Gross, Otto, [27](#), [28ff](#), [34](#), [37](#), [146](#), [190](#)

guilt, feeling of, [222f](#)

gymnastics, [166f](#), [169](#)

H

hallucinations, [31](#), [73](#), [82](#), [90f](#), [146](#), [213](#), [227](#), [266](#)

 auditory, [147](#), [258](#)

 incipient, [208](#)

 and neologisms, [76](#)

 non-hysterical, [35](#)

 in somnambulous states, [79](#)

teleological, 147f
and unconscious, 206; *see also* delirium

Handel, Georg Friedrich, 55

handwriting, affected, 76

hat, ornamented, 163f

Hauptmann, Gerhardt, 117, 134, 176, 177

Haus zur Schnecke, 115, 175

heart troubles, 42

hebephrenia, 27, 151, 213
stupid behaviour in, 77

hedgehog, 136f

Heilbrunner, Karl, 9n, 27, 93n, 94

Heine, Heinrich, 56, 116, 175

Heiterethei, Die (Ludwig), 33

Henry, Victor, 147

Heraclitus, 193

"hero," association-chain, 120

"hieroglyphical," association-chain, 126

hindsight, 182

hobbies, 50

Höfding, Harald, 84

hormé, 190n

horse: dream-figure, 57–62
sexual symbol, 139

hospitals, mental, change in, 247

"Hufeland," association-chain, 129ff, 175

humour, absence of sense of, 120

hydrocephalus, 160

hypnagogic mental activity, 200

hypnosis, 78, 91, 235
of hysterics, 66, 80 *see also* hystero-hypnosis

hypnotic states, and catatonia, resemblance, 9f

hypnotism, 7, 30

hysteria, 30, 213, 262

alienists and, 214
Breuer-Freud theory, 28
catatonia and, 11
complexes/complex-sensitiveness in, 48, 51, 67, 97, 256
and dementia praecox, compared, 70ff
dissociation in, 234f
dreams in, 91
Freud and, 3f, 31
incongruity in, 20f
lack of emotional rapport in, 74
as latent psychosis, 258
memory and, 11
mobility of symptoms, 35
negativism in, 17
origin of, 35, 36
outbursts of affect in, 67, 73
pathological ideas in, 8
and protection against complexes, 68n
psycho-genesis of, 233f
reductive method and, 180
schizophrenia camouflaged as, 247
and sequences of ideas, 30
sexual trauma and, 67
stereotypies in, 92f
strange ideas in, 7
suggestibility in, 78
traumatic, 79f
unconscious in, 206
hysterics: cure by induction of obsessional complexes, 68
 hypnosis of, 66, 80
hystero-hypnosis, 78n

I

idea(s): absence of, 10
 breakdown of, 257

complexes of, 28, 30
confusion of/confusional, 63, 167
delusional, degeneration of, 95
flight of, 14, 15, 21
indistinctness of, 113
inherited, 261
pathological, 7, 8, 9, 113, 173
persistent, 12
pressure of, 199, 200, 201
reduced clarity of, in distraction, 63
repressed, 34
split-off, 29, 34, 37
ideation: incapacity for clear, 146
 in mental debility, 14
 slowing down of, 6
illness, physical, schizophrenia and, 91. 172
imagery: archaic, in dreams, 242
 similarity of, and dreams, 57
 used by neurotic, 259
imbeciles, 88, 109, 160
impoverishment, emotional, 36, 37, 48
impressions, effects of, 43
incest, 192
incongruity, of idea and affect, 19, 20, 21, 34, 70, 71
indifference: emotional, 70
 of hallucinated patient, 220f; see also *belle indifférence*
individual: importance in psychiatry, 35
 psychology of the, 185
infantile drives, 179
inhibition(s), 9, 53, 66, 86, 93
 of attention, 64
 emotional, 43, 45
 and repetition of affect, 92
 from repressed complex, 53

injury: complex of, [110f](#), [125ff](#), [149](#), [150](#)
ideas of, [133](#)
"innocence," sexual, [49](#)
insanity, [165](#)
dreaming as, [241](#)
epileptic, [215](#)
logical mechanism in, [6](#)
precursors of, [162](#)
primitive view, [243](#)
insight, by patients, [149](#), [166](#), [223](#)
insomnia, [42](#), [66](#)
instinct, and archetypes, [255](#)
inspirations, [88](#)
pathological, [8](#), [90](#)
intellectual activity, loss of, [10](#)
intelligence, patient's, and prognosis, [266](#)
intensity, of conflicts, [219](#)
interdiction, *see* [captivation](#)
interest, [190](#)
symptomatic, [49](#)
"interest-draughts," association-chain, [118](#)
intoxication(s), [263](#)
chronic, [213](#)
introversion/introvert (type), [190f](#), [199n](#)
schizophrenic, and pressure of ideas, [201](#)
intuition, [248](#)
irrelevant answers, [256](#)
irresolution, [93](#)
irritability, of schizophrenics, [199](#), [200](#)
irritation, [39](#)
isolation, [207f](#), [259](#)
Itten, W., [180](#)

J

James, William, [191](#), [192](#), [263n](#)

Janet, Pierre, 5, 9, 10n, 13, 17n, 18, 27, 65n, 66n, 72, 76n, 77, 79, 84, 85, 87n, 88n, 91, 93, 96, 98, 226, 234; see also *abaissement*, etc.

Japanese, 90

Jasper, Herbert, 270n

jealousy, 209

Jesus, 220

jokes, 50; see also puns

judgment: clouding of, 268

false/falsification of, 43, 83

Jung, Carl Gustav:

CASES IN SUMMARY (*in order of presentation, numbered for reference*):

- [1] Young woman, masochistic, who reacted with rage to chastisement.—46
- [2] Man, disappointed in love, who forgot rival's name.—47
- [3] Girl, hysterical, who developed stiff arm after sexual assault.—47
- [4] Young woman, who hid face while relating dream.—47
- [5] Girl who, when she went for walks, took baby-carriage to suggest maternity.—47
- [6] Woman, hysterical, showing incongruity of idea and affect.—71
- [7] Woman, who felt she had infected others with obsessional ideas.—72
- [8] Young woman, hysterical, depressed, who wept on answering questions.—72
- [9] Man concerned about "insinuations" in food.—76n
- [10] Woman, hysterical, who exhibited stupid behaviour during excitement.—77
- [11] Woman, hysterical, depressed but with moods of abnormal cheerfulness.—78n
- [12] Woman, 32, cook, who felt "damned" after extraction of teeth.—82f, 163
- [13] Dementia praecox patient who found everything "faked."—84n
- [14] Young woman, catatonic, who lost all affect for family.—86
- [15] Woman catatonic, who verbigerated "Hallelujah."—95
- [16] Man, who combed hair to remove "plaster."—95
- [17] Woman, recovering from dementia praecox, who developed stereotype based on fantasy of leaving asylum.—95
- [18] B. St., woman, dressmaker, with paranoid dementia and vivid delusions.—99ff, 173ff
- [19] Young girl, depressed after broken love affair, with stereotyped anxiety dreams.—140
- [20] Man, with progressive paralysis, prevented by hallucination from jumping from window.—147

- [21] Man, prevented from suicide by hallucinated hand.—148
- [22] Jewish student, withheld from conversion by dream of mother. —148
- [23] Archaeologist, mentally disturbed by return to town which recalled early love affair.—165ff, 215f, 245f
- [24] Man who recovered speech after five years' silence in asylum.—171
- [25] Female, melancholic, who imitated shoemaking movement.—171f
- [26] Man whose mental powers were restored during physical illness.—172f
- [27] Widow, 50, with hysteria, wrongly diagnosed as sarcoma of spinal cord.—212f
- [28] Woman who became frenzied and catatonic after quarrel with brother.—216
- [29] Male teacher who developed persecution fears and delusions after entry into asylum for observation.—217
- [30] Young man, “morally insane,” who developed psychosis on association with “excited” patients.—217f
- [31] Young girl, teacher, who had “talks with God.”—220
- [32] Girl, schizophrenic, who regretted impossibility of returning to her “beautiful psychosis.”—246
- [33] Woman, 64, schizophrenic, with voices distributed over body.—248, 266
- [34] Young girl, somnambulistic, who passed as spiritualistic medium.—257
- [35] Woman who developed destructive thoughts after attending Jung's lectures on a Tantric text.—259f
- [36] Girl, 19, catatonic, who developed myth of life on moon.—264f

WORKS (*references from one paper to another in this volume are not included in this entry*): “Analysis of the Associations of an Epileptic,” 103n

“Answer to Job,” 192n

“Association, Dream, and Hysterical Symptom,” 34n, 49n, 53n, 57n, 70n, 76n, 96n, 137n, 140n

“Associations of Normal Subjects, The,” 9n, 15n, 16, 22n, 24n, 41n, 52, 54n, 63n

“Brother Klaus,” 261n

“Case of Hysterical Stupor in a Prisoner in Detention, A,” 78n, 81n

“Contribution to the Study of Psychological Types, A,” 190n

“Experimental Observations on the Faculty of Memory,” 12n, 44n

“The Psychological Diagnosis of Evidence,” 53n

“On Psychic Energy,” 190n, 193n

“On the Psychology and Pathology of So-Called Occult Phenomena,” 8n, 30n, 5n, 77n, 85n, 145n, 257n

“On Simulated Insanity,” 27n, 81n

“Psychoanalysis and Association Experiments,” 34n, 47n, 53n, 70n, 72n, 88n

“Psychological Approach to the Dogma of the Trinity, A,” 271n

“The Reaction-time Ratio in the Association Experiment,” 9n, 12n, 34n, 40n, 54n

“The Psychopathological Significance of the Association Experiment,” 67n

(ed.) *Studies in Word-Association*, 4, 34n, 70, 72, 151

Symbols of Transformation, 188n, 190n

Wandlungen und Symbole der Libido, 188, 192

K

Kaiser, O., 9n

Kant, Immanuel, 13n, 181, 203, 243

Kazowsky, A. D., 91n

kissing, 137

Klaus, Brother, 260

Klinke, O., 87n

knowledge, subjectively conditioned, 182

Korsakow’s syndrome, 8

Kraepelin, Emil, 5, 6n, 16n, 18n, 19, 25n, 26, 30, 35n, 37, 63–4n, 70, 90, 146, 227

Krafft-Ebing, Richard von, 75, 81n

L

Lambert, Gavin, 74n

language: affected, 75

“heavenly,” 77

innovations in, 146

official, 129

“Languedoc,” 147

legends, 209

Leibniz, G. W., 203

leitmotiv, 39n

lethargy, 79

Leupoldt, C. von, 6n, 27

libido, 190, 201

damming up of, 200

Liepmann, Hugo, [14](#), [21](#)
“life-wound,” [199](#), [200](#)
localization, [270f](#)
 of symbol, [138](#)
log, [57](#), [60](#), [61](#)
logic, defective, [200](#)
Lohengrin, Wedding March, [55](#)
“Lorelei,” association-chain, [116](#), [175](#)
love: and complexes, [47f](#)
 as obsessional complex, [48](#)
 unrequited, [49](#)
love-songs, [167](#), [169](#)
Löwenfeld, L., [79](#)
lucidity, in dementia praecox and hysteria, [79](#), [80](#)
Ludwig, O., [33](#)
Lull, Ramón (Raymond Lully), [43](#)

M

McDougall, William, [233](#)
machinations, [83](#)
Maeder, A., [180](#)
Magnan, [82n](#)
mana, [193n](#)
mandala, [270](#)
mania, [161](#)
 manic element, [201](#)
manic-depressive insanity, [161](#)
mannerisms, [75](#), [110](#)
Marguliès, Alexander, [83n](#)
Maria Prophetissa, [271](#)
“Maria Theresa,” association-chain, [138f](#)
Mary, mother of God, [134](#)
masculine protest, [186](#)
Masselon, René, [10](#), [11](#), [12](#), [13](#), [14](#), [36](#), [37](#)
mass-psychology, [237](#)

“master-key,” association-chain, 117, 175
masturbation-mysticism, 68
materialism, 156, 160, 211, 226
Mayer, Karl, 81*n* *see also* Meringer
medicine: and psychiatry, 158, 211*f*
 and psychology, 249
mediums, spiritualistic, 86
medulla oblongata, 270*n*
Meige, H., and Feindel, E., 94*n*
melancholia, 91, 161, 172
melody, 54
memory(-ies): affective events as, 67
 capricious, 11
 in dementia praecox, 18
 disturbance of, 11, 12
 falsifications of, 8
 lapse of, 56
 in schizophrenia, 252
memory-image: components of, 38*f*
 obscuration of, 11
Mendel, Emanuel, 87*n*
mental patients, statistical analysis, 160*ff*
Meringer, R., and Mayer, Karl, 22*n*, 25*n*, 53
mescaline, 253, 263
metabolism, change in, 36*f*, 272
metaphors, in dreams, 113, 145
Meyer, Ernst, 6*n*, 80*n*
Meynert, T., 160
microcephalus, 160
Middle Ages, 248, 267
milk, vomiting of, 73*n*
misreading, 44
molecules, 38*f*
 psychic, 63

Monakow, C. von, [226](#)
“monopoly,” association-chain, [127f](#), [176f](#)
monotony, [93](#)
mood
 disguise of complex by, [50](#), [71](#)
 peculiarities of, [50](#)
moon, [264](#)
moral: conflict, and onset of dementia praecox, [218](#)
 and mental disease, [211](#)
moria, [77](#)
mountain, [58f](#)
“mountain-peak,” association-chain, [121](#)
Müller, Georg E., and Pilzecker, A., [9](#)
mulungu, [193n](#)
muscles, contortion of, [167](#)
music: as compensation, [167f](#)
 Wagnerian, [39n](#)
mythological: formation, [188](#)
 motifs, [261](#)
 thinking, [62](#)
mythology/myths, [209](#), [240](#), [254](#), [261](#), [267](#)

N

nakedness, [32](#)
naming and touching, [6n](#), [27](#)
Nancy school, [226](#)
Napoleon, [129](#)
narrow-mindedness, [77](#)
nature, metaphysical explanation of, [211](#)
Nebuchadnezzar, [206](#)
negativism, [11](#), [12](#), [26ff](#), [76](#), [89](#)
 Bleuler’s theory of, [197ff](#)
 causes of, [199](#)
 passive and active, [89](#)
 and resistance, [198](#)

Neisser, Clemens, [6f](#), [25](#), [35](#), [36](#), [37](#), [83n](#)

Nelken, Jan, [180](#)

neologisms, [12](#), [22](#), [25](#), [75f](#), [90](#), [95](#), [109](#), [111ff](#), [256](#), [268](#)

nervous disorders, hysterical and psychasthenic, [189](#)

neurasthenia, [200](#), [214](#)

neurologists, and psychology, [213](#)

neurosis(-es): behaviour of unconscious in, [204](#)

compulsion, *see* compulsions; and disintegration of ideas, [252f](#)

effects of *abaissement* in, [236ff](#)

obsessional, *see* obsessional neurosis; psychogenic, [226](#), [233f](#)

and schizophrenia, compared, [234](#), [258f](#)

and toxins, [226](#)

transference into psychosis, [238f](#)

Nietzsche, F. W., [85](#), [168f](#), [186](#)

nominalists, [191](#)

noöpsyche, [19f](#), [21](#)

“Note factory,” association-chain, [128f](#)

“nothing but,” principle of, [192](#)

nursing, as displacement, [50](#)

O

obsessional: disturbances, [93](#)

ideas, [31](#), [54](#), [72](#), [82](#)

neurosis, *see below*

personalities, [18](#)

states, [12](#)

—, and negativism, [17](#)

thinking, [87f](#)

transformations, gradual, [96](#); *see also* compulsions; compulsive

obsessional neurosis, [72](#)

and Freud, [38](#)

nearness to schizophrenia, [230](#), [247](#), [258](#)

unconscious in, [206](#)

oedema, brain, [247](#)

“Oleum,” association-chain, [129](#)

one-sidedness, 207, 268
opposites: association of, 198
separation of pairs of, 199n, 207

oranges, 57

orientation, 80

originality, mania for, 75

overdetermination, 63

“owner of the world,” association-chain, 117f

P

pain, aroused by complex, 48

painting, 260

palaver, 262

panic, 219

Paracelsist physicians, 267

paraesthesia(s), 149

parallelism, psychophysical, 7

paralogia, 94n

metaphorical, 64n

paralysis, 96

emotional, 72

hysterical, 229

progressive, 161, 226; *see also* general paralysis of the insane

“paralysis,” association-chain, 125

paranoia, 213, 227ff

of alcoholic, 209

delusions and, 83

Freud on, 31

Freud’s case (Frau P.), 31ff

organic character, 156

primary, 35n

stability of, 35

paraphasia, 63

dream, 90

past, *see* future

Paul, —, [25n](#)
Paulhan, Frédéric, [17n](#), [50n](#)
Pelletier, Madeleine, [14f](#), [16](#), [18n](#), [21](#), [23](#), [26n](#), [65](#), [67](#), [146](#)
pen, slips of, [48](#), [53](#)
Penfield, Wilder, [270n](#)
perceptions insensibles, [203](#)
persecution mania, [227f](#), [235](#); *see also* paranoia
perseveration(s), [9](#), [15](#), [16](#), [18](#), [21f](#), [23](#), [27](#), [53](#), [92](#), [93](#), [251](#), [256](#), [268](#)
 of affect, [42](#)
persistence: of psychic processes, *see* perseveration
personalism: in psychology, [243](#)
 and schizophrenia, [251](#)
personality: *abaissement* and unity of, [237f](#)
 as complex, [40](#)
 degeneration / disintegration / dissociation of, [37](#), [50](#), [69](#), [224](#), [227](#), [230](#), [240](#)
 double/split-off/secondary, [50](#), [150](#), [224](#), [227](#), [234](#), [269](#)
 multiple, in hysteria, [235](#)
 splitting of, in schizophrenia, [227](#), [235](#), [257](#)
 unity of, in neurosis, [234](#)
 variety of, in hysterics, [75](#)
personality complex, associations, [12](#)
persuasion, inaccessibility to, [77](#)
Pfister, O., [93n](#)
philanthropic work, [50](#)
philosophy: materialism and, [211](#)
 scholastic, *see* scholasticism
phobias, [247](#)
phrases, stock, [92](#)
physiology, pathological, [211](#)
Pick, Arnold, [17n](#), [81n](#)
pictures, fascination by, [6](#)
Pilzecker, A., *see* Müller, Georg E.
pince-nez, [163f](#)
Pinel, Philippe, [159](#)

Plato, 243, 271n

poet(s), 85, 144f, 240
and psychosis, 170

poetry, as compensation, 167f

poisoning(s), 68
and brain defects, 161; *see also* toxin

“polytechnic, double,” association-chain, 114

pork-sausages, 136f

possession, 158

power, striving for, 183, 186f

power-words, 75, 101, 109

precipitancy, 23n

predisposition, to dementia praecox, 218f

prejudices, 82

primitives: and dreams, 262
and visions, 206

“professorship,” association-chain, 114f, 174f

projection, 87, 185, 241

Protestantism, 209

prudery, 49

psychasthenia/psychasthenics, 84, 214

psyche: and brain, 160, 186
causal and constructive views, 183, 184f
constitutional defects, 160
elusiveness of, 158
normal, deficient knowledge of, 7
objective, 267
outside consciousness, 6f
subjectively conditioned, 182

psychiatrists, 212ff

psychiatry: French, 159
German, 159
materialism of, 160, 211
and medicine, 158

as natural science, [211](#)
weakness of anatomical approach, [162](#)
psychic: processes, anatomical conception, [6](#)
structures, Bleuler on, [39n](#)
psychoanalysis, [182f](#)
and excitement, [20](#)
Freudian, [144](#)
irrelevant answers in, [89](#)
and resistance, [197](#), [201](#)
—, in women, [49](#)
results, in dementia praecox and hysteria, [74](#)
psychogenesis, meaning of, [226](#), [245](#)
psychography, [77n](#)
psychological factor: decisive part in dementia praecox, [218](#)
significance, in psychoses, [219](#)
undervaluation of, [212](#)
psychology: Adler's and Freud's, opposition, [191](#)
of the individual, [185](#)
“medical,” [249](#)
need of, for patient, [247](#), [267](#)
need of training in, for alienists and neurologists, [213](#)
objective understanding and, [182](#)
primitive, [267](#)
of schizophrenia, [227](#)
psychosexuality, [201](#)
psychosis(-es): beginning of, [244](#)
behaviour of unconscious in, [204](#)
degenerative hysterical, [68](#)
developing from neurosis, [238f](#)
latent, [239f](#), [247](#), [258](#), [259](#)
—, ratio of, to manifest, [258](#)
predisposition to, [218](#)
prevention of, [219](#)
psychotherapy of, [219](#)

unconscious in, 224
puberty, sexual fantasies in, 49
puns, 57, 126, 128
Purkinje figures, 270*n*

Q

quotation, 121

R

rapidity of speech, 26*f*
rapport: between patient and therapist, 265
 disturbance of, 259
 emotional, lack of, 74, 224
reaction(s): delayed, 71*f*
 indifferent and complex, 45
reaction times, 52, 53, 102*ff*
 prolonged, 87, 109
reading, mistakes in, 54
realists, 191
redemption, 186
reduction, 187
reductive method, 179*f*, 181, 192
reference, delusions of, 83*f*
reflection, 66
“reflex machines,” 96
Reil, Johann Christian, 15
religious: convictions, 43, 222*f*
 enthusiasm, 49
remorse, 223*f*
repetition, 9, 21, 23, 27
representations, shadowy, 203
repression, 31*ff*, 37
 of complexes, 45*ff*, 68
 in normal persons, 73
reproduction: capacity for, 11

disturbance of, 18
resistance, 197ff
 active, 11, 17
 muscular, negativistic, 96
 never indiscriminate, 198
respiration, and motor activity, 63n
retardation, 93
retention, 18f
reticular formation, 270n
rêverie forcée, 88n
revival meetings, 223
Rigi (mt.), 122
rigidity, artificial, 91
Riklin, Franz, 3, 11n, 34n, 73n, 79n, 80n, 81n, 89, 199
rites/ritual: magic, 242, 243
 religious, 44, 242
rivalry, poetic, 40
Rogues de Fersac, –, 87
Roller, C. F. W., 6
Romans, and dreams, 242
Royce, Josiah, 17n

S

Sachsein, 261
saints, legends of, 44
Salpêtrière Hospital, 159
sarcoma of spinal cord, 212
Schiller, J. C. F. von, 116, 124, 191
 “Bell,” association-chain, 131f, 175
schizophrenia, 155, 226ff
 Bleuler on, 234
 cause of, 245 *et passim*
 chemical factor in, 272
 contents of, 254
 intentionality of, 200

lack of knowledge of, 250
latent, 259
objection to psychogenesis of, 247
origin of term, 227, 251
and obsessional neurosis, 230, 247, 251
paranoid, origin of, 229
phenomena not psychologically explicable in, 268
possibly not psychogenic, 268
psychotherapy and, 229
resistance and, 198
two groups, 244; *see also* dementia praecox
schizophrenics, non-hospitalized, 247
“Schneckenmuseum,” 115, 175
scholasticism/Schoolmen, 182, 185, 191, 192
Schopenhauer, Arthur, 19, 260
Schreber, Daniel Paul, 73, 76, 85*n*, 95*n*, 150, 179, 186, 189
science, causality and, 181, 185, 211
scientific method, 158, 181
“scientism,” 185
screen causes, 72
seances, spiritualistic, 257
secrets, 45
Séglas, Jules, 13*n*
sejunction, 234
self-complacency, 110
self-control: failure of, 46, 240
 lack of, 74
self-criticism, 207*f*
self-defence, 222
self-esteem, 110, 111, 133
self-irony, 150
Senate, Roman, 242, 262
senile deterioration, *see* deterioration
senses, dulling of, 70

sense-perception, and memory image, [39](#) *see also* perception
sensitiveness, abnormal, [219](#)
sentiments: d'automatisme, de domination, [84](#)
 de perception incomplète, [85](#)
 d'incapacité, [84](#)
 d'in-complétude, [84](#), [86](#), [106](#)
sexuality, [187](#)
 and complexes, [67](#)
 infantile, Freud and, [4](#)
 —, of Goethe, [183](#)
 and negativism, [199](#), [201](#)
shame, [32](#)
shoes, movement of sewing, [172](#)
silence, prolonged, [171](#)
“silver,” association-chain, [122f](#)
similarities, repressed thoughts and, [55](#)
sin, [221](#), [223](#)
 and mental disease, [159](#), [163f](#)
singing, [54](#), [55](#)
“sin register,” [90n](#)
skyscraper, [58f](#)
sleep, [65](#), [241](#), [269](#)
 disturbances of, [91f](#), [241](#)
 unnatural, [91](#)
Smith, Hélène, [30n](#), [77](#), [8n](#), [145](#)
snakes, [136f](#)
social elevation, delirium of, [75](#)
social status, dissatisfaction with, [75](#)
Socrates, daemon of, [148](#)
“Socrates,” association-chain, [112ff](#), [143](#), [174](#)
Sokolowski, Ernst, [68](#)
Sollier, Paul Auguste, [240](#), [253](#)
Sommer, Robert, [5](#), [6](#), [7](#), [8](#), [9](#), [11](#), [23](#), [27](#), [88](#)
somnambulism/somnambulists, [30n](#), [77](#), [79](#), [85](#), [88](#), [145](#), [150](#), [256](#)

Song of Songs, 134
soul, personified, 158
“souls, two,” 50
sound associations, *see* clang associations
speech: changes in, 146f
 confusion, 21ff
 disintegration of, 93-94n, 173
 distortions of, 90, 256
 obscuration in, 113
speech-centre, in brain, 159
Spencer, (Herbert?), 92
Spielrein, Sabina, 180
spinal cord, 17
spirits, evil, 158
 possession by, 243
spiritus rector, 235
Spitteier, C, 170
sports, dangerous, 50
Stadelmann, Heinrich, 64n, 68n
stammer, 165, 167, 168
stereotypy(-ies), 9, 12, 18, 19, 23, 92ff, 101, 206, 268
 motility/motor, 94, 101, 138 *see also* automatism stimulus(-i), mutual reinforcement
 of simultaneous, 63n
stimulus-words: choice of, 44
 exciting complex, 46 *see also* association tests
stomach troubles, 42
Stransky, Erwin, 16n, 18n, 19, 20, 21, 22, 23, 25, 26, 27, 34, 67, 70, 90, 94, 146
“Stuart,” association-chain, 133f, 175
stupidity: of behaviour, in hebe phrenics, 77
 emotional, 27, 88
sublimation, 50n
suggestibility, 17
 in catatonics, 78
 negative, 17
 normal and catatonic, 78; *see also* negativism

suggestion: and consciousness, 30
verbal, in dementia praecox, 78
suicide, 148, 264
“summit,” association-chain, 115f
superiority, 186, 187
Suvarov, A. V., 141
Svenson, Frey, 17n
“Switzerland,” as neologism, 123, 149, 175
sword, dream-symbol, 183f
symbolism/symbols, 65, 240
collective, in schizophrenia and neuroses, 243
of complexes, 47, 56
delusions and, 243
in dementia praecox, 16, 18, 178, 180
in dreams, 26, 183
history of, 242
sexual, 137, 140
symptoms: of schizophrenia, secondary, 234, 237
–, significance, 227, 234
pre-schizophrenic, 268
value of discussion of, 266; *see also* action, symptomatic

T

“talking it away,” 71
technical terms, 109, 115, 146
teeth, extraction of, 82f, 163f
telephone, voice from, 149f
temper, bad, 20
therapy: Freud’s, 4
occupational, 248
thinking/thought(s): compulsive, 201
–, psychogenic, 87f
delusion of influence on, 87
disturbance of, in schizophrenia, 200
obsessional, 87f

socialization of, 201
thought-complex, 124
thought-deprivation, 29, 53, 79, 87, 89, 94, 111, 112, 113, 125, 138, 149
threshold, of consciousness, 203, 206, 236, 263
thymopsyche, 19f, 21
tics, 94
Tiling, T., 34f
tongue, slips of, 44, 48, 54
toxin(s)/toxic disturbances, 36, 37, 65n, 69, 82, 97, 98, 156, 226, 253, 263f, 270, 271
training, psychiatrist's, 242, 249
trance-states, 92
transitivism, 134
tremendum, 260
tremors, 42
Trinity, vision of, 261
troubles cénesthésiques, 241, 253
Tschisch, W. von, 5f
tuberculosis, 218
tumours, brain, 96
“Turkey,” association-chain, 122
twilight state, 81n, 167, 169
 hysterical, 78, 80n
types, 187
 psychological, 189ff
typical formations, 188

U

unconscious, 170
 and apperceptive disturbance, 29
 behaviour and contents of, 204
 compensation in, 205
 definition of, 203f
 and ego, 243
 fantasy-structures and, 188
 function of, 210

indistinctness of ideas in, 113
physiological and psychological, 203
and psychosis, 224
processes, and consciousness, 28; *see also* archetypes
unconsciousness, and hysterical dissociation, 227
understanding: causal, 181ff
 constructive/synthetic, 181, 185ff
 prospective, 182
 retrospective, 181, 182
 subjective and objective, 181f, 189
“universal,” association-chain, 119f
“Uster,” association-chain, 134f

V

vacuum, 27, 93n, 94
validity, universal and subjective, 185
value, psychological, 190
verbal-motor: associations, 21, 251
 combinations, 15, 16, 23, 52
verbigeration, 9, 92, 94, 95
vision, peripheral field of, 54
visions, 91, 261
 of Brother Klaus, 260f
 primitives and, 206
Vogt, Ragnar, 9
voices: degeneration of, 95
 disagreeable, 149
 of God, 220ff, 266
 hallucinatory, 90, 99, 208, 266
 primitives and, 206; *see also* telephone

W

Wehrlin, K., 109n
Weiskorn, Joseph, 81n
Weltanschauung, 189

investigator's, [191](#), [192](#)
Welti, Albert, [61](#)
Wernicke, Carl, [27](#), [159](#), [160](#), [234](#)
Weygandt, Wilhelm, [13](#), [19](#), [37](#), [65n](#)
“whims,” [8](#), [13](#)
whistling, [54](#), [55](#)
will(s): conflict of, [199](#)
 weakness of, [268](#)
will-power, [234](#)
wishes: infantile, fantasy gratification of, [186f](#)
 unsatisfied, compensation for, [30](#)
wish-fulfilments, [145](#), [168](#), [176](#), [187](#)
 dreams as, [80n](#), [124](#)
 in hysteria, [97](#)
 in hysterical delirium, [81](#)
 in word-associations, [112ff](#)
witchcraft, [248](#)
withdrawal, autistic, [199](#)
women: artificial behaviour in, [75](#)
 erotic complex in, [111](#)
 sex and complexes in, [67](#)
 sexual “innocence” in, [49](#)
 unmarried, deliria of, [81](#)
 unrequited love and, [49](#)
“word salad,” [12](#), [76](#), [95](#), [111](#)
worm, intestinal, [138](#)
worry: chronic, [50](#)
 and concentration, [53](#)
writing, automatic, [77n](#), [150](#)
Wundt, Wilhelm, [13](#), [14](#)
Würzburg: Julius Hospital, [158](#)

Z

“Zähringer,” association-chain, [123](#)
Ziehen, Georg Theodor, [5](#), [8](#)

Zilboorg, G., and Henry, G. W., [159n](#)

Zola, Emile, [44](#)

Zündel, Friedrich, [158n](#)

“Zuppinger,” [136](#), [142](#)

Zurich, [114f](#), [174f](#), [245f](#)

 Battle of, [141](#)

 Psychiatric Clinic, [243](#); *see also* Burghölzli Hospital

Zurich school, [180](#), [188](#)

THE COLLECTED WORKS OF

C. G. JUNG

THE PUBLICATION of the first complete edition, in English, of the works of C. G. Jung was undertaken by Routledge and Kegan Paul, Ltd., in England and by Bollingen Foundation in the United States. The American edition is number XX in Bollingen Series, which since 1967 has been published by Princeton University Press. The edition contains revised versions of works previously published, such as *Psychology of the Unconscious*, which is now entitled *Symbols of Transformation*; works originally written in English, such as *Psychology and Religion*; works not previously translated, such as *Aion*; and, in general, new translations of virtually all of Professor Jung's writings. Prior to his death, in 1961, the author supervised the textual revision, which in some cases is extensive. Sir Herbert Read (d. 1968), Dr. Michael Fordham, and Dr. Gerhard Adler compose the Editorial Committee; the translator is R. F. C. Hull (except for Volume 2) and William McGuire is executive editor.

The price of the volumes varies according to size; they are sold separately, and may also be obtained on standing order. Several of the volumes are extensively illustrated. Each volume contains an index and in most a bibliography; the final volumes will contain a complete bibliography of Professor Jung's writings and a general index to the entire edition.

In the following list, dates of original publication are given in parentheses (of original composition, in brackets). Multiple dates indicate revisions.

5.

PART II

Introduction

The Concept of Libido

The Transformation of Libido

The Origin of the Hero

Symbols of the Mother and of Rebirth

The Battle for Deliverance from the Mother

The Dual Mother

The Sacrifice

Epilogue

Appendix: The Miller Fantasies

*6. PSYCHOLOGICAL TYPES (1921)

Introduction

The Problem of Types in the History of Classical and Medieval Thought

Schiller's Ideas on the Type Problem

The Apollinian and the Dionysian

The Type Problem in Human Character

The Type Problem in Poetry

The Type Problem in Psychopathology

The Type Problem in Aesthetics

The Type Problem in Modern Philosophy

The Type Problem in Biography

General Description of the Types

Definitions

Epilogue

Four Papers on Psychological Typology (1913, 1925, 1931, 1936)

†7. TWO ESSAYS ON ANALYTICAL PSYCHOLOGY

On the Psychology of the Unconscious (1917/1926/1943)

The Relations between the Ego and the Unconscious (1928)

Appendix: New Paths in Psychology (1912); The Structure of the Unconscious (1916) (new versions, with variants, 1966)

‡8. THE STRUCTURE AND DYNAMICS OF THE PSYCHE

On Psychic Energy (1928)

The Transcendent Function ([1916]/1957)

A Review of the Complex Theory (1934)

The Significance of Constitution and Heredity in Psychology (1929)

Psychological Factors Determining Human Behavior (1937)

Instinct and the Unconscious (1919)

The Structure of the Psyche (1927/1931)

On the Nature of the Psyche (1947/1954)

General Aspects of Dream Psychology (1916/1948)

On the Nature of Dreams (1945/1948)

The Psychological Foundations of Belief in Spirits (1920/1948)

Spirit and Life (1926)

Basic Postulates of Analytical Psychology (1931)
Analytical Psychology and *Weltanschauung* (1928/1931)
The Real and the Surreal (1933)
The Stages of Life (1930–1931)
The Soul and Death (1934)
Synchronicity: An Acausal Connecting Principle (1952)
Appendix: On Synchronicity (1951)

*9. PART I. THE ARCHETYPES AND THE COLLECTIVE UNCONSCIOUS

Archetypes of the Collective Unconscious (1934/1954)
The Concept of the Collective Unconscious (1936)
Concerning the Archetypes, with Special Reference to the Anima Concept
(1936/1954)
Psychological Aspects of the Mother Archetype (1938/1954)
Concerning Rebirth (1940/1950)
The Psychology of the Child Archetype (1940)
The Psychological Aspects of the Kore (1941)
The Phenomenology of the Spirit in Fairytales (1945/1948)
On the Psychology of the Trickster-Figure (1954)
Conscious, Unconscious, and Individuation (1939)
A Study in the Process of Individuation (1934/1950)
Concerning Mandala Symbolism (1950)
Appendix: Mandalas (1955)

*9. PART II. AION (1951)

RESEARCHES INTO THE PHENOMENOLOGY OF THE SELF

The Ego
The Shadow
The Syzygy: Anima and Animus
The Self
Christ, a Symbol of the Self
The Sign of the Fishes
The Prophecies of Nostradamus
The Historical Significance of the Fish
The Ambivalence of the Fish Symbol

The Fish in Alchemy

The Alchemical Interpretation of the Fish

Background to the Psychology of Christian Alchemical Symbolism

Gnostic Symbols of the Self

The Structure and Dynamics of the Self

Conclusion

*10. CIVILIZATION IN TRANSITION

The Role of the Unconscious (1918)

Mind and Earth (1927/1931)

Archaic Man (1931)

The Spiritual Problem of Modern Man (1928/1931)

The Love Problem of a Student (1928)

Woman in Europe (1927)

The Meaning of Psychology for Modern Man (1933/1934)

The State of Psychotherapy Today (1934)

Preface and Epilogue to “Essays on Contemporary Events” (1946)

Wotan (1936)

After the Catastrophe (1945)

The Fight with the Shadow (1946)

The Undiscovered Self (Present and Future) (1957)

Flying Saucers: A Modern Myth (1958)

A Psychological View of Conscience (1958)

Good and Evil in Analytical Psychology (1959)

Introduction to Wolff’s “Studies in Jungian Psychology” (1959)

The Swiss Line in the European Spectrum (1928)

Reviews of Keyserling’s “America Set Free” (1930) and “La Révolution
Mondiale” (1934)

The Complications of American Psychology (1930)

The Dreamlike World of India (1939)

What India Can Teach Us (1939)

Appendix: Documents (1933–1938)

†11. PSYCHOLOGY AND RELIGION: WEST AND EAST

WESTERN RELIGION

Psychology and Religion (The Terry Lectures) (1938/1940)
A Psychological Approach to the Dogma of the Trinity (1942/1948)
Transformation Symbolism in the Mass (1942/1954)
Forewords to White's "God and the Unconscious" and Werblowsky's "Lucifer and Prometheus" (1952)
Brother Klaus (1933)
Psychotherapists or the Clergy (1932)
Psychoanalysis and the Cure of Souls (1928)
Answer to Job (1952)

EASTERN RELIGION

Psychological Commentaries on "The Tibetan Book of the Great Liberation" (1939/1954) and "The Tibetan Book of the Dead"
Yoga and the West (1936)
Foreword to Suzuki's "Introduction to Zen Buddhism" (1939)
The Psychology of Eastern Meditation (1943)
The Holy Men of India: Introduction to Zimmer's "Der Weg zum Selbst" (1944)
Foreword to the "I Ching" (1950)

*12. PSYCHOLOGY AND ALCHEMY (1944)

Prefatory note to the English Edition ([1951?] added 1967)
Introduction to the Religious and Psychological Problems of Alchemy
Individual Dream Symbolism in Relation to Alchemy (1936)
Religious Ideas in Alchemy (1937)
Epilogue

†13. ALCHEMICAL STUDIES

Commentary on "The Secret of the Golden Flower" (1929)
The Visions of Zosimos (1938/1954)
Paracelsus as a Spiritual Phenomenon (1942)
The Spirit Mercurius (1943/1948)
The Philosophical Tree (1945/1954)

‡14. MYSTERIUM CONIUNCTIONIS (1955–56)

AN INQUIRY INTO THE SEPARATION AND SYNTHESIS OF PSYCHIC OPPOSITES IN ALCHEMY

The Components of the Coniunctio
The Paradoxa

The Personification of the Opposites

Rex and Regina

Adam and Eve

The Conjunction

*15. THE SPIRIT IN MAN, ART, AND LITERATURE

Paracelsus (1929)

Paracelsus the Physician (1941)

Sigmund Freud in His Historical Setting (1932)

In Memory of Sigmund Freud (1939)

Richard Wilhelm: In Memoriam (1930)

On the Relation of Analytical Psychology to Poetry (1922)

Psychology and Literature (1930/1950)

“Ulysses”: A Monologue (1932)

Picasso (1932)

†16. THE PRACTICE OF PSYCHOTHERAPY

GENERAL PROBLEMS OF PSYCHOTHERAPY

Principles of Practical Psychotherapy (1935)

What Is Psychotherapy? (1935)

Some Aspects of Modern Psychotherapy (1930)

The Aims of Psychotherapy (1931)

Problems of Modern Psychotherapy (1929)

Psychotherapy and a Philosophy of Life (1943)

Medicine and Psychotherapy (1945)

Psychotherapy Today (1945)

Fundamental Questions of Psychotherapy (1951)

SPECIFIC PROBLEMS OF PSYCHOTHERAPY

The Therapeutic Value of Abreaction (1921/1928)

The Practical Use of Dream-Analysis (1934)

The Psychology of the Transference (1946)

Appendix: The Realities of Practical Psychotherapy ([1937] added, 1966)

‡17. THE DEVELOPMENT OF PERSONALITY

Psychic Conflicts in a Child (1910/1946)

Introduction to Wickes's “Analyses der Kinderseele” (1927/1931)

Child Development and Education (1928)

Analytical Psychology and Education: Three Lectures (1926/1946)

The Gifted Child (1943)

The Significance of the Unconscious in Individual Education (1928)

The Development of Personality (1934)

Marriage as a Psychological Relationship (1925)

18. THE SYMBOLIC LIFE

Miscellaneous Writings

19. BIBLIOGRAPHY OF C. G. JUNG'S WRITINGS

20. GENERAL INDEX TO THE COLLECTED WORKS

See also:

C. G. JUNG: LETTERS

Selected and edited by Gerhard Adler, in collaboration with Aniela Jaffé.

Translations from the German by R.F.C. Hull.

VOL. 1: 1906–1950

VOL. 2: 1951–1961

THE FREUD/JUNG LETTERS

Edited by William McGuire, translated by

Ralph Manheim and R.F.C. Hull

* [“Move every stone, try everything, leave nothing unattempted.”—Erasmus, *Adagia*, I.IV.xxx; trans. here by Margaret Mann Phillips. Cf. *The Freud/Jung Letters*, p. xviii. The *Letters* contain numerous references to “The Psychology of Dementia Praecox”; see the index, Jung, C. G., under the title.]

¹ [In 2 vols., 1906 and 1909. Trans. by M. D. Eder as *Studies in Word-Association* (1918); Jung’s contributions appear in Vol. 2 of the present edition.—EDITORS.]

- ¹ Cited from Arndt, “Über die Geschichte der Katatonie” (1902).
- ² “Über motorische Symptome bei einfachen Psychosen” (1886).
- ³ *Psychiatrie: Ein Lehrbuch für Studierende und Ärzte* (orig. 1883).
- ⁴ “Die Katatoniefrage” (1898). [For works by Ziehen, see Bibliography.—EDITORS.]
- ⁵ “Zur Lehre von der ‘Hemmung’ geistiger Vorgänge” (1894).
- ⁶ Von Leupoldt, who recently worked on this symptom, calls it “the symptom of naming and touching.” Cf. “Zur Symptomatologie der Katatonie” (1906).
- ⁷ “Über motorische Störungen beim einfachen Irresein” (1885), cited from Neisser, *Über die Katatonie* (1887), p. 61.
- ⁸ Ernst Meyer opposed this view, which was then held also by Kraepelin. Cf. Meyer, *Beitrag zur Kenntnis der acut entstandenen Psychosen* (1899).
- ⁹ *Lehrbuch der psychopathologischen Untersuchungsmethoden* (1899).
- ¹⁰ *Ibid.*, p. 362. Recently Fuhrmann cited some association tests in “acute juvenile dementia,” which were without characteristic results. Cf. “Über akute juvenile Verblödung” (1905).
- ¹¹ “Die einfach demente Form der Dementia praecox” (1903).
- ¹² “Über eknoische Zustände” (1903).
- ¹³ “Über den pathologischen Einfall” (1904).
- ¹⁴ *From India to the Planet Mars* (1900); “Nouvelles observations sur un cas de somnambulisme avec glossolalie” (1901).
- ¹⁵ “On the Psychology and Pathology of So-called Occult Phenomena” (orig. 1902; in *Collected Works*, Vol. 1.).
- ¹⁶ “The Reaction-time Ratio in the Association Experiment” (orig. 1905).
- ¹⁷ [Association through the sound of words without regard to their meaning; also, “sound associations,” as in “The Associations of Normal Subjects,” pars. 76ff.—EDITORS.]
- ¹⁸ “Zur Psychologie der katatonischen Symptome” (1902).
- ¹⁹ “Experimentelle Beiträge zur Lehre von Gedächtnis” (1900).
- ²⁰ In conditions of distraction there is often an increase of perseveration. Cf. my “The Associations of Normal Subjects” (1904/5) and the interesting experiments of Stransky, *Über Sprachverwirrtheit* (1905). Also the excellent work of Heilbronner, “Über Haftenbleiben und Stereotypie” (1905).
- ²¹ Cf. Kaiser, “Beiträge zur Differentialdiagnose der Hysterie und Katatonie” (1901).
- ²² Janet, *Les Obsessions et la psychasthénie* (1903). He adopts a similar viewpoint in his earlier works, *Névroses et idées fixes* (1898) and *L’Automatisme psychologique* (1889).
- ²³ According to Binet, attention is “mental adaptation to a state which is new for us.” Cf. “Attention et adaptation” (1900).
- ²⁴ “Die psychologische Grundlage der katatonischen Krankheitszeichen” (1903).
- ²⁵ *Psychologie des déments précoces* (1902). (Masselon’s *La Démence précoce*, 1904, is more a clinical sketch of the disease.)
- ²⁶ *Ibid.*, p. 28.

- ²⁷ Ibid., pp. 28, 265, 135, 140, 63, 71.
- ²⁸ Ibid., pp. 71, 66.
- ²⁹ Cf. the works of Freud; also Riklin, “Zur Psychologie hysterischer Dämmerzustände und des Ganser’schen Symptoms” (1904).
- ³⁰ Cf. my “Reaction-time Ratio in the Association Experiment” and “Experimental Observations on the Faculty of Memory” (orig. 1905).
- ³¹ “The Reaction-time Ratio in the Association Experiment.”
- ³² *Psychologie des déments précoces*, pp. 69, 263, 261.
- ³³ Séglas (*Leçons cliniques sur les maladies mentales et nerveuses*, 1895) says of the uncertainty of the catatonic performance: “There is nothing surprising in this when one considers that all movement requires the previous synthesis of a mass of ideas—and it is precisely the power to make this mental synthesis which is lacking in these individuals.”
- ³⁴ Cf. Kant, *Critique of Practical Reason*.
- ³⁵ Weygandt, “Alte Dementia praecox” (1904).
- ³⁶ Janet, *Obsessions et la psychasthénie* (1903), I, p. 433. The “fonction du réel” could also be called psychological adaptation to the environment. It corresponds to Binet’s “adaptation,” which represents a special aspect of apperception.
- ³⁷ *Outlines of Psychology* (orig. 1896; here 1902), p. 229 (slightly modified).
- ³⁸ *Grundzüge der physiologischen Psychologie* (orig. 1874; here 1903), III, p. 341.
- ³⁹ *L’Association des idées dans la manie aiguë et dans la débilité mentale* (1903).
- ⁴⁰ *Über Ideenflucht, Begriffsbestimmung, und psychologische Analyse* (1904).
- ⁴¹ Pelletier, pp. 116, 123, 118.
- ⁴² Cf. Chaslin, *La Confusion mentale primitive* (1895).
- ⁴³ Aschaffenburg found some prolongation of reaction time in manics. But one should not forget that in acoustic-verbal experiments attention and verbal apperception play a very great role. One observes and measures merely the verbal expressions and not the associations of ideas.
- ⁴⁴ The acceleration and emotional intensity of ideas can at least be verified by observation, but this is not to say that there are not other important factors which at present escape our knowledge.
- ⁴⁵ Cf. my “The Associations of Normal Subjects.”
- ⁴⁶ Assonance.
- ⁴⁷ Contiguity.
- ⁴⁸ Assonance.
- ⁴⁹ “Similarity and contiguity: ‘immense’ suggested ‘ocean,’ then the ship and the motto that form the coat-of-arms of the city of Paris.” Pelletier, p. 142.
- ⁵⁰ Ibid., p. 142.
- ⁵¹ Also pointed out by Kraepelin, *Arch. Psychiat. Nervenkr.*, XXVI (1894), p. 595, and Stransky, *Über Sprachverwirrtheit* (1905).

⁵² Pelletier, pp. 128f.

⁵³ “Die negative Suggestibilität, ein psychologisches Prototyp des Negativismus” (1905).

⁵⁴ This is confirmed by Paulhan, *L'Activité mentale et les éléments de l'esprit* (1889); Janet, *Les Obsessions et la psychasthénie* (1903); Pick, “On Contrary Actions” 1904; and Svenson, “Om Katatoni” (1902). An instructive case is reported by Royce: “The Case of John Bunyan” (1894).

⁵⁵ *Les Obsessions*, I, p. 60.

⁵⁶ Cf. the analyses of Pelletier and the experimental researches of Stransky, *Über Sprachverwirrtheit*.

⁵⁷ Other works on negativism, etc., have already been criticized by Bleuler, “Die negative Suggestibilität.”

⁵⁸ Kraepelin, too, is of the opinion that comprehension is not unduly impaired; there is merely an increased tendency to arbitrary production of random ideas. Cf. his *Lehrbuch* (5th edn.), p. 177.

⁵⁹ “Zur Kenntnis gewisser erworbener Blödsinnsformen” (1903).

⁶⁰ *Ibid.*, p. 28. Cf. also by Stransky: “Zur Lehre von der Dementia praecox” (1904); “Zur Auffassung gewisser Symptome der Dementia praecox” (1904); and “Über die Dementia praecox” (1905).

⁶¹ For instance an hysterical woman fell one day into a deep and lasting depression “because the weather was so dull and rainy.” Analysis showed that the depression set in on the anniversary of a tragic event that influenced the whole life of the patient.

⁶² Binet (*Alterations of Personality*, p. 89) aptly remarks: “Hysterical patients have been my subjects from choice, because they magnify the phenomena that must necessarily be found to some degree in many persons who have never shown hysterical symptoms.”

⁶³ *Über Sprachverwirrtheit*.

⁶⁴ Cf. my “The Associations of Normal Subjects,” pars. 436ff.

⁶⁵ Cf. Meringer and Maver, *Versprechen und Verlesen* (1895).

⁶⁶ It must however be remarked that there is an air of precipitancy about Stransky’s talking experiments which is generally lacking in the talk of dementia praecox patients. Just what gives this impression of precipitancy is hard to say.

⁶⁷ As indicated above [pars. 9–11], Sommer has already demonstrated clang associations and stereotypies in simple word reactions.

⁶⁸ Cf. “The Associations of Normal Subjects,” par. 82.

⁶⁹ Professor Bleuler favours the following construction:

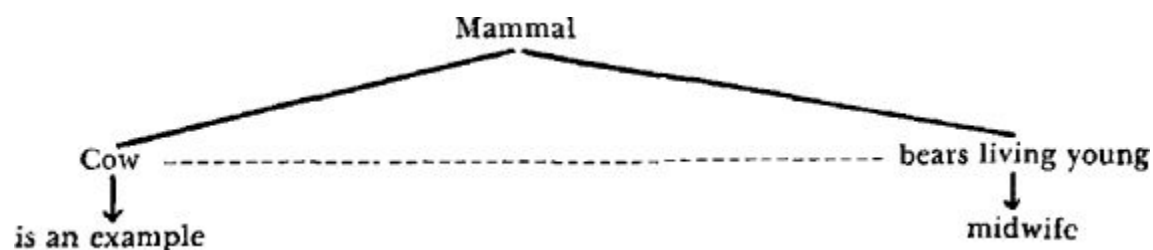

⁷⁰ “Über die Sprachneubildungen Geisteskranker” (1898).

⁷¹ Kraepelin, in his “Über Sprachstörungen im Traume” (1910), also deals with these phenomena on the basis of extensive empirical material. With regard to their psychological origin, Kraepelin’s remarks suggest that he is not so

far from the view we have outlined here. Thus he says (p. 10): “The appearance of speech disturbances in dreams is very closely connected with the clouding of consciousness and with the consequent reduction in clarity of ideas.”

What Paul, Meringer, Mayer, and others designate as “contamination” and Freud as “condensation,” Kraepelin calls “ellipsis” (“blending of different sequences of ideas,” “elliptical contraction of several simultaneous trains of thought”). I would like to take this opportunity to point out that as far back as the 1880’s Forel used the term “ellipses” for the condensations and new word-formations of paranoiacs. It escaped Kraepelin’s notice that already in 1900 Freud had gone very thoroughly into the question of dream-condensations. By “condensation” Freud means the fusing together of situations, images, and elements of speech. The philological term “contamination” applies only to verbal fusions, and is thus a special concept which is subordinate to Freud’s “condensation.” In the case of speech-condensations it is advisable to retain the term “contamination.”

⁷² *Arch. Psychiat. Nervenkr.*, XXVI (1894), p. 595; cf. also “Über Sprachstörungen im Traume,” p. 79, where he says: “Only, it should be borne in mind that the peculiar language of the patients is not simply ‘nonsense,’ still less the deliberate product of boisterous moods, but rather the expression of a ‘word-finding’ disturbance which must be closely akin to that of dreams.” He also observes that “in speech confusion, besides disturbances in word-finding and in the verbal control of thought, there are disturbances in the thought-process itself which closely resemble those in dreams.”

⁷³ Cf. Pelletier’s admirable remarks on the symbol, above, par. 25.

⁷⁴ Stransky, *Über Sprachverwirrtheit*, p. 14.

⁷⁵ Cf. my “On Simulated Insanity,” par. 349, and Wehrin, “The Associations of Imbeciles and Idiots.”

⁷⁶ “Über Haftenbleiben und Stereotypie.”

⁷⁷ “Über Bewusstseinszerfall” (1904); “Beitrag zur Pathologie des Negativismus” (1903); “Zur Nomenklatur ‘Dementia sejunctiva’” (1904); “Zur Differentialdiagnostik negativistischer Phänomene” (1905).

⁷⁸ Cf. Janet’s fundamental work, *L’Automatisme psychologique* (1889).

⁷⁹ *Les Obsessions et la psychasthénie* (1903).

⁸⁰ *Studies on Hysteria* (orig. 1895).

⁸¹ Gross, “Zur Nomenklatur ‘Dementia sejunctiva’.”

⁸² The laws of association play a very insignificant role compared with the all-powerful emotional constellation, just as in real life the logic of thought is nothing compared with the logic of feeling.

⁸³ Gross, “Zur Differentialdiagnostik negativistischer Phänomene.”

⁸⁴ Basing myself on Flournoy, I have demonstrated precisely this point in a case of somnambulism. Cf. “On the Psychology and Pathology of So-called Occult Phenomena.”

⁸⁵ Cf. especially the marvellous examples of automatic writing by Hélène Smith, in Flournoy, *From India to the Planet Mars* (1900).

⁸⁶ “On the Psychological Mechanism of Hysterical Phenomena,” *Studies on Hysteria*, part I.

⁸⁷ “Further Remarks on the Neuro-Psychoses of Defence” (orig. 1896), *Standard Edn.*, 3, pp. 183f.

⁸⁸ *Ibid.*, pp. 175ff.

⁸⁹ [I.e., of a hydrotherapeutic establishment where she was first sent for treatment.—EDITORS.]

⁹⁰ Cf. my “Psychoanalysis and Association Experiments” and “Association, Dream, and Hysterical Symptoms”; also Bleuler, “Consciousness and Association,” and Riklin, “Cases Illustrating the Phenomena of Association in Hysteria.” [I.e., Chs. 6–9. *Studies in Word-Association* (1918). Jung’s papers: Coll. Works, 2.—EDITORS.]

⁹¹ “The Reaction-time Ratio in the Association Experiment,”

⁹² *Individuelle Geistesentartung und Geistesstörung* (1904) and “Zur Aetiologie der Geistesstörungen” (1903).

⁹³ *Individualität und Psychose* (1906).

⁹⁴ *Ibid.*, p. 29.

⁹⁵ Note that he does this only for paranoia, by which he can hardly mean Kraepelin’s “primary” paranoia. His description is more applicable to the paranoid states.

¹ For feeling, sentiment, emotion, affect, Bleuler proposes the expression “affectivity,” “which is meant to designate not only affects in the proper sense, but the slight feelings or feeling-tones of pleasure and unpleasure in every possible circumstance.” Cf. *Affektivität, Suggestibilität, Paranoia* (1906), p. 6.

² Bleuler says (p. 17): “Thus affectivity, much more than reflection, is the driving force behind all our actions and omissions. It is likely that we act *only* under the influence of pleasure/unpleasure feelings; our logical reflections get their power only from the affects associated with them.” “Affectivity is the broader concept of which volition and conation are only one aspect.” Godfernaux says: “The affective state is the ruling power, ideas are nothing but its subjects. ... The logic of reasoning is only the apparent cause of the *volte-faces* of thought. ... Below the cold and rational laws of association of ideas there are others which conform more to the profound needs of life. This is the logic of feeling,” *Le Sentiment et la pensée et leurs principaux aspects physiologiques* (1906), pp. 83f.

³ Bleuler (p. 5): “Just as even in the simplest perception of light we can distinguish between its quality, intensity, and saturation, so we may speak of processes of cognition, feeling, and volition, although we know that there is probably no psychic process to which all three qualities are not common, even if first one and then the other predominates.” For this reason Bleuler divides the “psychic structures” into those that are “preponderantly intellectual, preponderantly affective, and preponderantly volitional.”

⁴ This behaviour may be compared directly to Wagnerian music. The leitmotiv, as a sort of feeling-tone, denotes a complex of ideas which is essential to the dramatic structure. Each time one or the other complex is stimulated by something someone does or says, the relevant leitmotiv is sounded in one of its variants. It is exactly the same in ordinary psychic life: the leitmotivs are the feeling tones of our complexes, our actions and moods are modulations of the leitmotivs.

⁵ The individual ideas are combined according to the different laws of association (similarity, coexistence, etc.), but are selected and grouped into large combinations by an affect.

⁶ Cf. “The Reaction-time Ratio in the Association Experiment.”

⁷ Bleuler (*Affektivität*, p. 31) says: “Attention is nothing more than a special form of affectivity.” P. 30: “Attention like all our actions is always directed by an affect”; or more accurately: “Attention is an aspect of affectivity, and does nothing more than what we know affectivity does, i.e., it facilitates certain associations and inhibits others.”

⁸ “The Associations of Normal Subjects,” par. 383.

⁹ By “affect-ego” I mean the modification of the ego-complex resulting from the emergence of a strongly toned complex. In the case of painful affects the modification consists in a restriction, a withdrawal of many parts of the normal ego. Many other wishes, interests, and affects must make way for the new complex, so far as they are opposed to it. In an outburst of affect the ego is reduced to the barest essentials: one has only to think of scenes like a theatre fire or a shipwreck, where in a trice all civilization melts away and only the most primitive ruthlessness remains.

¹⁰ Cf. my “Experimental Observations on Memory.” In *The Interpretation of Dreams* (Standard edn., V, p. 515) Freud says: “If the first account given me by a patient of a dream is too hard to follow I ask him to repeat it. In doing so he rarely uses the same words. But the parts of the dream which he describes in different terms are by that fact revealed to me as the weak spot in the dream’s disguise. ... My request to the patient to repeat his account of the dream has warned him that I was proposing to take special pains in solving it; under pressure of the resistance,

therefore, he hastily covers the weak spots in the dream's disguise by replacing any expressions that threaten to betray its meaning by other less revealing ones."

¹¹ Further examples of symptomatic actions in my "Psychoanalysis and Association Experiments."

¹² Freud remarks on this too. Cf. also the case in my "Association, Dream, and Hysterical Symptoms."

¹³ Freud calls this "sublimation." Cf. "Three Essays on the Theory of Sexuality" (Standard edn., VII), p. 178.

¹⁴ "On the Psychology and Pathology of So-called Occult Phenomena." Cf. also Paulhan, *Les Mensonges du caractère* (1905).

¹ For the technique of analysis see my “Psychoanalysis and Association Experiments” and “Association, Dream, and Hysterical Symptom”; also “The Psychological Diagnosis of Evidence.”

² *Versprechen und Verlesen* (1895).

³ The greatest clarity is found at the point of vision where attention is greatest. Hence attention is reduced for the peripheral field of vision and the inhibition for unsuitable elements is less than at that point. This makes it easier for repressed fragments of complexes to appear in the peripheral field.

⁴ Examples in “Reaction-time Ratio in the Association Experiment.” Cf. also the indirect associations in “The Associations of Normal Subjects,” pars. 82, 451.

⁵ Cf. *The Psychopathology of Everyday Life* and *The Interpretation of Dreams*.

⁶ “Reaction-time Ratio,” par. 605, no. 199 [with further details at no. 72].

⁷ “The Associations of Normal Subjects,” par. 451. [P. J. Bunau-Varilla was an individual prominent in the Panama Canal controversy, to whom Jung had seen a newspaper reference.—EDITORS.]

⁸ “The Reaction-time Ratio in the Association Experiment,” par. 611, following no. 92.

⁹ Standard Edn., VI, pp. 9ff.

¹⁰ Cf. my “Association, Dream, and Hysterical Symptoms.”

¹¹ *Ibid.*

¹² The personal and family circumstances of the subject are well known to me.

¹³ The fusion of simultaneously existing complexes might, for instance, be explained by the elementary fact, not unknown to psychologists (cf. Féré, *The Pathology of the Emotions*), that two simultaneous stimuli in different sensory spheres reinforce and influence one another. From experiments on which I myself am engaged it can be shown that voluntary motor activity is influenced by a simultaneous automatic activity (respiration). Judging by all we know of them, complexes are continuous automatic stimulations or activities, and just as they influence our conscious thinking so also they act formatively on one another, so that each complex contains elements of the other—which could be described psychologically as “fusion.” Freud, from a rather different standpoint, calls it “overdetermination.”

¹⁴ Cf. “The Associations of Normal Subjects,” par. 450.

¹⁵ *Ibid.*, pars. 82ff.

¹⁶ Kraepelin (“Über Sprachstörungen im Traume”) is of the opinion that the “proper formulation of a thought is frustrated by the emergence of distracting subsidiary ideas.” On p. 48 he says: “The common feature in all these observations [on dream paraphasia] is the displacement of the underlying thought by a subsidiary association with some essential link in the chain of ideas.” The “derailment” of speech or thought by a subsidiary association is due, in my opinion, to the ideas being insufficiently discriminated. Kraepelin found, further, that the “subsidiary idea causing the displacement was manifestly a narrower one with a richer content, which thrust aside the more general, more shadowy idea.” He terms this symbolic derailment of thought “metaphorical paralogia” and contrasts it with the paralogias due simply to displacement. The subsidiary associations are mostly associations of similarity—at any rate they are exceedingly frequent—so it is easy to understand how the paralogia gets its metaphorical character. Such metaphors can give the impression of a sort of deliberate distortion of dream-thinking. On this point, therefore, Kraepelin’s views come very close to Freud’s.

¹⁷ Stadelmann (*Geisteskrankheit und Naturwissenschaft*) says, in his distressingly stilted manner: “The psychotic equips his partially or completely disturbed ego-feeling with a symbol, but he does not compare this feeling with other processes or objects in the manner of a normal person; it is carried so far that the image he has adduced for comparison becomes a reality—his own subjective reality, which in the judgment of others is a delusion.” “The genius has need of forms for the inner life which he projects outside him, and whereas in the psychotic the symbolizing association becomes a delusion, in the genius it manifests itself only as an intensified experience.”

¹⁸ *L'Association des idées dans la manie aiguë*, pp. 128t.

¹⁹ This is naturally meant only as a figurative expression for the compulsion to sleep, or the sleep-instinct (Claparède, “Esquisse d’une théorie biologique du sommeil”). Theoretically I agree with the view formulated by Janet: “In one way sleep is an act. It requires a certain amount of energy to decide to go to sleep at the opportune moment and to do this correctly” (*Les Obsessions*, I, p. 408). Like every psychic process, sleep probably has its special cell-chemistry (Weygandt). What this is no one knows. From the psychological point of view sleep seems to be an auto-suggestive phenomenon. (Forel and others express similar views.) Thus we can understand that there are all gradations from pure sleep-suggestion to the organic compulsion to sleep, which gives the impression of a poisoning by metabolic toxins.

²⁰ The instinctive sleep-inhibition can be expressed psychologically as “désintérêt pour la situation présente” (Bergson, Claparède). The effect of the “désintérêt” on the associative activity is the “abaissement de la tension psychologique” (Janet), expressed in the characteristic dream-associations described above.

²¹ “The Psychopathological Significance of the Association Experiment.”

²² Hysteria employs all kinds of elaborate devices as a means of protection against the complex, such as conversion into physical symptoms, splitting of consciousness, etc.

²³ “Hysterie und hysterisches Irresein” (1895).

²⁴ Stadelmann, though he almost chokes it in a welter of verbiage, gives expression to a similar (?) idea.

¹ “Psychoanalysis and Association Experiments” and “Association, Dream, and Hysterical Symptoms.”

² If I identify Janet’s cases, described in *Les Obsessions*, with hysteria, I do so because I do not know how to distinguish his “obsédés” from hysterics.

³ “Über Emotionslähmung.”

⁴ “Psychoanalysis and Association Experiments,” par. 666.

⁵ Riklin cites the following instructive example: An hysterical patient regularly vomited all the milk she drank. Under hypnosis, analysis showed that once when she was staying with a relative he assaulted her in a stable, where she had gone to fetch milk. “Ibi homo puellam coagere conatus est, ut semen, quod masturbatione effluebat, ore reciperet.” In the week following the hypnosis she nearly always vomited what milk she drank, though she had total amnesia for the hypnosis. Cf. Riklin, “Analytische Untersuchungen der Symptome und Assoziationen eines Falles von Hysterie” (1904).

⁶ Cf. Forel, “Selbstbiographie eines Falles von Mania acuta” (1901), and Schreber, *Memoirs of My Nervous Illness*.

⁷ *Ibid.*, passim, particularly p. 357. [*Flüchtig hingemachte Männer*; more literally, perhaps, “fleetingly deposited men.” An approximation to the sense is conveyed by the novelist Gavin Lambert, who, in *The Slide Area* (1959), speaks of “instant people.”—TRANS.]

⁸ Similar to Janet’s “conjurations.” Cf. *Obsessions*.

⁹ Cf. my “Association, Dream, and Hysterical Symptoms.”

¹⁰ Forel’s patient felt compelled to make many such interpretations; thus, she interpreted the name “Vaterlaus” as “pater laus tibi.” A patient of mine complained of the “insinuations” that were made by means of food. He had recently found a linen thread (*Leinenfaser*) in what he was eating. This was enough to suggest to him that a certain Frl. Feuerlein was meant. The same patient announced to me one day that he could not understand what a “green form” had to do with him. He got this idea because “they put chloroform” (*chloros, forma*) in his food.

¹¹ In experiments with automatic writing (“psychography”) we can see very clearly how the unconscious plays with ideas. Often the words are written with the sequence of letters reversed, or there are strange conglomerations of words in otherwise clear sentences. In mediumistic circles attempts are sometimes made at inventing new languages. The best-known of these language-making mediums is Hélène Smith (cf. Flournoy, *From India to the Planet Mars*). Similar phenomena are reported in my “Psychology and Pathology of So-called Occult Phenomena.”

¹² Fürstner, “Die Zurechnungsfähigkeit der Hysterischen.” [Moria is a morbid impulse to joke.—EDITORS.]

¹³ *Les Obsessions*, p. 391.

¹⁴ For some time I treated an hysterical patient who suffered from intense depressions, headaches, and total inability to work. When I suggested pleasure in work and a more cheerful mood, she was often abnormally cheerful the next day, laughing incessantly, and had such a compulsion to work that she kept at it until late at night. Then, on the third day, she was profoundly exhausted. Actually she found the cheerful mood that appeared in her without motivation unpleasant, because all sorts of nonsense, stupid jokes, etc., kept coming into her head together with a regular compulsion to laugh. For an example of hysterical stupor, see my “A Case of Hysterical Stupor in a Prisoner in Detention.”

¹⁵ Cf. Bleuler, “Frühe Entlassungen” (1905).

¹⁶ “Über Versetzungsbesserungen” (1905), pp. 153, 165, 179.

¹⁷ A good example of the momentary changes of front in hysteria can be found in Riklin's "Zur Psychologie hysterischer Dämmerzustände und des Ganser'schen Symptoms" (1904). Riklin shows that the patient manifested correct or delusional orientation according to the manner of questioning. The same thing may happen spontaneously when the complex is touched. Riklin reports a similar, experimental case ("Cases Illustrating the Phenomena of Association"), where a critical stimulus word induced a twilight state which lasted for some time. Pathological ideas, e.g., the automatic interpolations in the speech or writing of somnambulists, are the same thing in principle.

¹⁸ Cf. Meyer, *Beitrag zur Kenntnis der acut entstandenen Psychosen*. It is worth remembering that a normal dream is always a "complex-delirium," that is to say its content is determined by one or more complexes which are acute. This has been demonstrated by Freud. Anyone who analyses his own dreams by the Freudian method will soon see the justification for the term "complex-delirium." Very many dreams are wish-fulfillments. Endogenous dreams are exclusively concerned with complexes, whereas exogenous dreams, i.e., those that are influenced or produced by physical excitations during sleep, are, so far as I can judge, fusions of complex constellations with more or less symbolic elaborations of physical sensations.

¹⁹ Good examples are to be found in Ganser's twilight states and the deliria of somnambulists. (Cf. Riklin, "Zur Psychologie hysterischer Dämmerzustände," and my "Hysterical Stupor in a Prisoner in Detention" and "On Simulated Insanity.") An excellent example of complex-delirium with misinterpretation is given by Weiskorn (*Transitorische Geistesstörungen beim Geburtsakt*, 1897): A 21-year-old primipara, clutching her abdomen during labour, asked, "Who is pressing me there?" She interpreted the descent of the head as a hard movement of the bowels. Transparent complex-deliria are reported by Krafft-Ebing (*Text-Book of Insanity*) and Mayer ("Sechzehn Fälle von Halbtraumzustand," 1893). The semi-conscious or unconscious fantasies of hysterics described by Pick ("Über pathologische Traumerei und ihre Beziehung zur Hysterie," 1896) are clear complex-deliria, as are the romances of Hélène Smith described by Flournoy and of the somnambulists observed by me. Another clear case can be found in Bohn, *Ein Fall von doppeltem Bewusstsein* (1898).

²⁰ Riklin has made valuable contributions to this question in his "Über Versetzungsbesserungen." I give one of his cases as an example: Miss M. S., aged 26, educated and intelligent. Had a brief attack of illness six years ago, but recovered so well that she was discharged as cured and the diagnosis of dementia praecox was not given. Before the present attack she fell in love with a composer, from whom she took singing lessons and who filled her with admiration. Her love soon reached a passionate intensity, with periods of morbid excitement. She was brought to Burghölzli. At first she looked upon her internment and everything that went on around her as a descent into the underworld. She got this idea from her teacher's latest composition, "Charon." Then, after this purifying passage through the underworld, she interpreted everything in terms of the difficulties and struggles she had to endure in order to be united with her lover. She thought a fellow patient was her lover and for several nights went into her bed. Afterwards she believed she was pregnant, felt and heard twins in her womb, a girl that looked like her and a boy that looked like the "father." Later she believed she had given birth and hallucinated a child next to her in bed. With that the psychosis came to an end. She had discovered a healing substitute for reality. She soon became quiet, freer in her behaviour, the stiffness in her attitude and gait disappeared, and she willingly gave catamnestic information, so that her statements could be correlated with those in the clinical record.

²¹ In his psychological analysis of Magnan's "délire chronique à évolution systématique" Godfernaux finds at its base an affective disturbance: "In reality the patient's thinking is passive; he orients himself in accordance with his

affective state, without taking all his ideas into account.” *Le Sentiment et la pensée* (1906), p. 83.

^{21a} [Cf. *infra*, pars. 335f.—EDITORS.]

²² *Affektivität* (1906). Cf. also Neisser, “Paranoia und Schwachsinn” (1898).

²³ Cf. Marguliès, “Die primäre Bedeutung der Affecte im ersten Stadium der Paranoia” (1901), and Gierlich, “Über periodische Paranoia und die Entstehung der paranoischen Wahnideen” (1905).

²⁴ A dementia-*praecox* patient under my observation finds everything faked: what the doctor says to him, what the other patients do, the cleaning of the ward, the food, etc., everything is faked. It is all caused by one of his female persecutors “pulling a princess round by the head and yelling at people what they have to do.”

²⁵ *Les Obsessions*, I, pp. 264, 266.

²⁶ *Ibid.*, 272.

²⁷ Ball, “La Folie du doute” (1882).

²⁸ Janet, p. 273.

²⁹ “Die Entstehung von *Also Sprach Zarathustra*,” by Peter Gast, in Nietzsche’s *Werke*, VI, pp. 479ff. Cf. also my “On the Psychology of So-called Occult Phenomena,” pars. 140f., 180ff.

³⁰ Janet, p. 282.

³¹ Excellent examples can be found in Schreber.

³² An original form of thought-deprivation is reported by Klinke: “The footsteps of other patients walking up and down the ward ‘walk out’ the patient’s thoughts.” “Über das Symptom des Gedankenlautwerdens” (1894).

³³ The phenomenon is not uncommon in hysterics, as I have observed. Janet calls it a “mental eclipse.” His patient, he says, “often complains of a singular arrest of her thought, she loses her ideas.” *Les Obsessions*, I, p. 369.

³⁴ “Theories” such as those of Rogues de Fursac merely restate the facts: “The most suitable term might be psychic interference. The two opposing tendencies cancel one another out, as contrary waves do in physics.” Cited from Claus, *Catatonie et stupeur* (1903). Cf. also Mendel, *Leitfaden der Psychologie* (1902), p. 55.

³⁵ A parallel to this is the “*réverie forcée*” of Janet’s “*obsédés*”: “She feels that at certain moments all her life is concentrated in her head, that the rest of her body is as if asleep, and that she is forced to think tremendously hard, without being able to stop herself. Her memory becomes extraordinary, and so excessively developed that it cannot be directed by attention.” *Les Obsessions*, I, p. 154. Cf. also the case reported in “Psychoanalysis and Association Experiments.”

³⁶ [“*Bannung*” is not commonly used in modern psychiatry. It could also be translated “interdiction” and in that sense would cover the phenomenon of thought deprivation,—TRANS.]

³⁷ A girl was seduced during the prolonged absence of her fiancé. She concealed this fact from him. More than ten years later she fell ill with dementia *praecox*. The illness began with her feeling that people suspected her morality; she heard voices that talked of her secret, and finally they forced her to confess to her husband. Many patients state that the “sin register” is read out in all its details, or that the voices “know everything” and “put them through it.” It is therefore extremely significant that most patients are unable to give any satisfactory information about their hallucinations. As we know, the voluntary reproduction of the complex is under special inhibition.

³⁸ Cf. below, par. 360. A schizophrenic who was quite inaccessible and always greeted the doctors with a flood of abuse once fell ill with severe gastro-enteritis. With the onset of the illness he changed completely, he was patient and grateful, followed all the instructions and always gave polite and precise information. His convalescence was proclaimed by his once more becoming monosyllabic and shut in, and one fine morning he signalled his complete recovery by greeting me as before with the refrain “Here comes another of the dog and monkey troupe wanting to play the saviour.”

³⁹ Cf. De Sanctis, *I Sogni: Studi psicologici e clinici di un alienista* (1899), and Kazowsky, “Zur Frage nach dem Zusammenhange von Träumen und Wahnvorstellungen” (1901). In Burghölzli we had a patient who was afflicted with all sorts of sexual delusions. The delusions, as we were able to demonstrate countless times, came exclusively from dreams. She simply equated the content of her dreams, which were all very vivid and concrete, with reality and, depending on the dream, became abusive, querulous, or aggressive—but only in writing. In her general behaviour she was neat and orderly, and this contrasted strikingly with the tone of her letters and other writings.

⁴⁰ As we have already remarked, the collective term “feeling-tone” includes “attention-tone.”

⁴¹ Occasionally the content of the complex perseverates, but in the majority of cases there is only a perseverating disturbance. This may be due to the fact that the complex acts as a distraction and leaves behind an associative “vacuum,” just as in the distraction experiment, where, because of this vacuum, the subject simply resorts in embarrassment to the previous content of consciousness. If, like Heilbronner, one asks rather more difficult questions, the resultant emotion may serve the same purpose as a complex. Or else the associative vacuum is primary, there being no familiar associations to the stimulus concepts. In normal people a complex usually perseverates.

⁴² Janet, *Les Obsessions*, pp. 335ff. On p. 351 he says: “This more or less complete stoppage of certain actions or even of all actions is one of the most essential phenomena in the mental state of the obsessed.” On p. 105: “These forced operations are not normal operations, they are operations of thought, action, and emotion which are at once excessive, sterile, and of an inferior order.”

⁴³ Pfister (“Über Verbigeration,” 1906) poses the question whether stereotypies, especially verbigerations, are psychologically motivated or not. He seems, like me, to be of the opinion that some ideational content is at the back of the stereotypy, but that it comes out in a distorted way owing to the pathological disturbance of the means of expression. “It is conceivable that the stereotyped ideas are struggling to express themselves, but instead of them only senseless phrases and new word-formations are reiterated, because the processes of disintegration and excitation in the central speech apparatus render their intelligible reproduction impossible. Instead of the stereotyped thoughts only unintelligible remnants of them are expressed (as a result of paralogical and paraphasic malformations).” There is still another way in which the disintegration of speech can undermine the correct reproduction of stereotyped ideas: owing to the disturbance in the process of formulating them into words and phrases, no corresponding speech-formations can be evoked by the monotonously recurring ideas and thoughts. During their conversion into words numerous paralogical “derailments” occur; the ideas get in each other’s way, slip in all directions, so that instead of the conceptual stereotypy, which remains completely hidden, only a constantly changing jumble of nonsense is produced.

⁴⁴ Cf. Meige and Feindel, *Tics and Their Treatment* (orig. 1902).

⁴⁵ Cf. Schreber in particular, who gives an excellent account of how the content of the voices becomes grammatically more and more abbreviated.

⁴⁶ My “Association, Dream, and Hysterical Symptoms.”

⁴⁷ One of his patients said: “Formerly I used to look back in my memory in order to know whether I ought to reproach myself for anything, in order to reassure myself about my conduct—but now it is not at all the same thing. I always recall what I have done a week or two weeks ago, and I see things exactly, but I have absolutely no interest in seeing them.” Here the detachment from the actual content is especially worth noting, (*Les Obsessions*, I, p. 125.)

¹ [Kohlrabenschwarz.—TRANS.]

² This figure indicates the number of times the stimulus-word was repeated by the patient.

³ Cf. “Analysis of the Associations of an Epileptic,” par. 542, where we found “yes” as an expression of feeling in an epileptic.

⁴ [In the earlier edns., the numbers skipped here to 39, for no apparent reason. At present R. 56, which was earlier 65, they dropped back to 55. The series has been corrected to run consecutively.—EDITORS.]

⁵ Wehrlin, “The Associations of Imbeciles and Idiots,” p. 203.

⁶ As a model for this see Freud’s analysis of “exoriare aliquis,” etc., in *The Psychopathology of Everyday Life*, Standard Edn., VI, pp. 9ff.

⁷ [Heine: “Ich weiss nicht, was soll es bedeuten.”—TRANS.]

⁸ *The Interpretation of Dreams* (Standard Edn., V) pp. 534f., 647.

⁹ [Sugar formerly came from the refinery in the form of large, heavy cones, wrapped in white and blue paper.—EDITORS.]

¹⁰ [The slope of this mountain, near Lucerne, was one of Switzerland’s first fashionable tourist resorts.]

¹¹ [Family name of the House of Baden, famous also in Swiss history. In Zurich, the Zähringerplatz was in a well-to-do neighbourhood.]

¹² [A poem by Schiller.—EDITORS.]

^{12a} [Christoph Wilhelm Hufeland (1762–1836), M.D., Berlin pathologist, man of letters.—EDITORS.]

¹³ Patient’s own name.

¹⁴ Cf. my “Association, Dream, and Hysterical Symptom,” par. 851.

¹⁵ *Ibid.*, pars. 838f.

¹⁶ [Can be translated ‘dam’ or ‘perineum.’—TRANS.]

¹⁷ Cf. the sexual symbol of the “hungry dog” in “Association, Dream, and Hysterical Symptom,” pars. 830f.

¹⁸ *Psychiatric Studies*, pars. 54ff., 132ff.

¹⁹ *From India to the Planet Mars*.

²⁰ See Supplement, below.

²¹ Cf. Henry, *Antinomies linguistiques* (1896).

²² [Vol. II of *Diagnostische Assoziationsstudien* (1909) contained two further studies by Jung and four by other psychologists. See *Experimental Researches*, editorial note.]

¹ [“The Psychology of Dementia Praecox,” above.]

² [*Dementia Praecox, oder die Gruppe der Schizophrenien* (Aschaffenburg’s Handbuch; Leipzig and Vienna, 1911); trans. by Joseph Zinkin: *Dementia Praecox, or the Group of Schizophrenias* (Monograph Series on Schizophrenia, No. 1; New York, 1950).—EDITORS.]

¹ Bresler, “Kulturhistorischer Beitrag zur Hysterie” (1897); Zundel, *Pfarrer J. C. Blumhardt* (1880). [Also Carter, *Pastor Blumhardt*.—EDITORS.]

² [For these and other historic medical personages mentioned in this volume, cf. Zilboorg and Henry, *History of Medical Psychology*, index, s.v.—EDITORS.]

³ [“The Sun Sinks,” *Complete Works*, XVII, p. 182.]

⁴ I am indebted to my colleague Dr. Abraham, in Berlin, for this example. [Karl Abraham had been Jung’s associate on the staff of the Burghölzli Mental Hospital, Zurich, from 1904 to 1907.—EDITORS.]

⁵ [Cf. “The Psychology of Dementia Praecox,” pars. 198ff.—EDITORS.]

¹ [A lecture delivered in English before the Psycho-Medical Society, London, July 24, 1914; published subsequently in the *Journal of Abnormal Psychology* (Boston), IX (1915): 6. Later in 1914, a German version in revised and slightly expanded form was published as a supplement to the 2nd edn. of *Der Inhalt der Psychose* (see supra, p. 153). It was translated by M. D. Eder in the 2nd edn. (1917) of *Collected Papers on Analytical Psychology*, as an untitled supplement to “The Content of the Psychoses.” The present translation follows the revised German version in all essentials, but a few passages are based on the English version of 1914/1915. The Eder translation has been freely consulted.—EDITORS.]

² “Psycho-Analytic Notes on an Autobiographical Account of a Case of Paranoia (Dementia Paranoides)” (orig. 1911).

³ Cf. also Ferenczi, “On the Part Played by Homosexuality in the Pathogenesis of Paranoia” (orig. 1911).

⁴ “Psychologische Untersuchungen an Dementia-praecox-kranken” (1910).

⁵ “Über den psychologischen Inhalt eines Falles von Schizophrenie” (1911).

⁶ “Analytische Beobachtungen über Phantasien eines Schizophrenen” (1912).

⁷ “Psychologische Analyse eines Paranoiden” (1912).

⁸ “Beiträge zur Psychologie der Dementia praecox” (1913).

⁹ [Cf. *Introduction to Logic*, p. 55.—EDITORS.]

¹⁰ [The following four paragraphs appeared only in the original English version.—EDITORS.]

¹¹ [*Thus Spake Zarathustra*, p. 199 (modified).]

¹² [These passages would appear to be an early, very tentative formulation of the archetypes theory, as well as of the method of amplification.—EDITORS.]

¹³ [See n. 12.]

¹⁴ [Trans. 1956 as *Symbols of Transformation*, from the 1952 revision.—EDITORS.]

¹⁵ Here “objective” understanding is not the same as causal understanding.

¹⁶ [In the English, Jung used instead of *libido* the word *hormé*, and stated at this point: “In my German publications I have used the word *libido*, which seems to be too easily misunderstood in English. *Hormé* is the Greek word for ‘force, attack, press, impetuosity, violence, urgency, zeal’.” Cf. “On Psychic Energy,” par. 55.—EDITORS.]

¹⁷ Cf. *Symbols of Transformation*, pars. 185f.

¹⁸ “A Contribution to the Study of Psychological Types.” [Orig. 1913.]

¹⁹ *Die zerebrale Sekundärfunktion* (1902).

²⁰ Cf. in particular, Adler’s *The Neurotic Constitution* (orig., 1912).

²¹ [Cf. “Answer to Job,” par. 576.—EDITORS.]

²² [Such as *mana*, *mulungu*, etc. Cf. “On Psychic Energy,” sec. 4.—EDITORS.]

¹ [Trans. from the critique in the *Jahrbuch für psychoanalytische und psychopathologische Forschungen* (Leipzig and Vienna), III (1911), 469–74.—EDITORS.]

² [“Zur Theorie des schizophrenen Negativismus,” *Psychiatrisch-neurologische Wochenschrift* (Halle), XII (1910–11), 171, 189, 195. For trans., see Bibliography.—EDITORS.]

³ For confirmation see supra, “The Psychology of Dementia Praecox,” par. 179.

⁴ My italics.

⁵ Aptly termed by Freud the “separation of the pairs of opposites.”

⁶ Autism (Bleuler) = autoerotism (Freud). For some time I have employed the concept of *introversion* for this condition.

⁷ Cf. my remarks on the complex in “The Psychology of Dementia Praecox,” chs. 2 and 3.

⁸ Hence the complex is replaced by corresponding symbols.

⁹ Cf. “The Psychology of Dementia Praecox,” chs. 4 and 5.

¹ [Written in English and read in the Section of Neurology and Psychological Medicine at the annual meeting of the British Medical Association, Aberdeen, July, 1914. Published in the *British Medical Journal* (London), II (1914), 964–66, and in *Collected Papers on Analytical Psychology* (London and New York, 1916; 2nd edn., 1917). The present text is a slight revision of the original, based on a shortened German version which was never published.—
EDITORS.]

¹ [Written in English and read to the Section of Psychiatry, at the annual meeting of the Royal Society of Medicine, July 11, 1919, and published in the Society's *Proceedings* (London), XII (1919): 3, 63–76. Slightly revised for publication here.—EDITORS.]

² Cf. *supra*, “The Psychology of Dementia Praecox.”

¹ [Translated from “Heilbare Geistesranke?,” part of a section entitled “Moderne Grenzfragen der Psychiatrie,” *Berliner Tageblatt*, Apr. 21, 1928. The above title was the original one (“Geisteskrankheit und Seele”), which the newspaper editors altered.—EDITORS.]

² [Cf. “The Psychology of Dementia Praecox,” pars. 198ff.—EDITORS.]

¹ [Written in English and read at a meeting of the Section of Psychiatry, Royal Society of Medicine, London, April 4, 1939. Published in the *Journal of Mental Science* (London), LXXXV (1939), 999–1011.—EDITORS.]

² [Cf. supra, pars. 466ff.]

³ [Cf. *Le Mécanisme des émotions*, ch. IV, esp. p. 208.—EDITORS.]

⁴ Cf. supra, “On the Problem of Psychogenesis in Mental Disease.”

¹ [Written in English, for a symposium on “The Frontiers of Knowledge and Humanity’s Hopes for the Future” broadcast in 30 languages by the “Voice of America,” an international radio activity of the United States Information Agency, in December 1956. Privately published in the *Bulletin* of the Analytical Psychology Club of New York, XIX:4 (April, 1957). A translation into German by Dr. H. Degen, authorized by Professor Jung, was published in *Universitas* (Stuttgart), XIV: 1 (Jan., 1959). The present version is based on both the English and German texts.—EDITORS.]

² “The Psychology of Dementia Praecox,” supra.

³ [Supra, “The Psychology of Dementia Praecox,” pars. 73f., 142, 195f.; and infra, pars. 570, 581.—EDITORS.]

¹ [Translated from “Die Schizophrenie,” *Schweizer Archiv für Neurologie und Psychiatrie* (Zurich), LXXXI (1958), 163–77. Originally written as a lecture and read (by the author’s grandson, Dr. Dieter Baumann) at the second International Congress for Psychiatry, Zurich, September 1957. The author has revised par. 582.—EDITORS.]

² Cf. “On the Psychology and Pathology of So-called Occult Phenomena.”

³ [Cf. Jung, “Brother Klaus.”—EDITORS.]

⁴ This term is rather more specific than the “fringe of consciousness” used by William James.

⁵ [Cf. *supra*, “The Psychology of Dementia Praecox,” pars. 75f., 142, 195f.—EDITORS.]

⁶ [The American investigators were Wilder Penfield and Herbert Jasper, and the case to which Jung refers is to be found in their book *Epilepsy and the Functional Anatomy of the Human Brain* (1954), pp. 509f. (case A. Bra.)—EDITORS.]

⁷ [The theory that the reticular formation or centrencephalic system (extending from the medulla oblongata to the basal ganglia and particularly the thalamus) is the integrative system of the brain would seem to make Jung’s conjecture more specific and put it on an experimental basis; cf. Penfield and Jasper.—EDITORS.]

⁸ The historical model for this may be the difficult cosmogonic problem described in Plato’s *Timaeus*. Cf. “A Psychological Approach to the Dogma of the Trinity,” pars. 179ff.

⁹ [Published in *Chemical Concepts of Psychosis* (Proceedings of the Symposium), edited by Max Rinkel and Herman C. B. Denber (New York, 1958).—EDITORS.]

- * Published 1971.
- † Published 1953; 2nd edn., 1966.
- ‡ Published 1960; 2nd edn., 1969.
- * Published 1959; 2nd edn., 1968. (Part I: 79 plates, with 29 in colour.)
- * Published 1964; 2nd edn., 1970. (8 plates.)
- † Published 1958; 2nd edn., 1969.
- * Published 1953; 2nd edn., completely revised, 1968. (270 illustrations.)
- † Published 1968. (50 plates, 4 text figures.)
- ‡ Published 1963; 2nd edn., 1970. (10 plates.)
- * Published 1966.
- † Published 1954; 2nd edn., revised and augmented, 1966. (13 illustrations.)
- ‡ Published 1954.

BOLLINGEN SERIES XX

THE COLLECTED WORKS

OF

C. G. JUNG

VOLUME 4

EDITORS

SIR HERBERT READ

MICHAEL FORDHAM, M.D., M.R.C.P.

GERHARD ADLER, PH.D.

WILLIAM MCGUIRE, *executive editor*

FREUD AND PSYCHOANALYSIS

C. G. JUNG

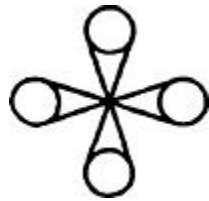

TRANSLATED BY R. F. C. HULL

BOLLINGEN SERIES XX

PRINCETON UNIVERSITY PRESS

COPYRIGHT © 1961 BY BOLLINGEN FOUNDATION, NEW YORK, N. Y PUBLISHED BY PRINCETON
UNIVERSITY PRESS, PRINCETON, N. J.

Second printing, with corrections, 1970
Fourth printing, 1979
First Princeton / Bollingen Paperback printing, 1985

THIS EDITION IS BEING PUBLISHED IN THE UNITED STATES
OF AMERICA BY PRINCETON UNIVERSITY PRESS AND IN
ENGLAND BY ROUTLEDGE AND KEGAN PAUL, LTD. IN THE
AMERICAN EDITION ALL THE VOLUMES COMPRISING THE
COLLECTED WORKS CONSTITUTE NUMBER XX IN
BOLLINGEN SERIES, SPONSORED BY BOLLINGEN
FOUNDATION. THE PRESENT VOLUME IS NUMBER 4 OF THE
COLLECTED WORKS, AND WAS THE ELEVENTH TO APPEAR.

ISBN 0-691-09765-8

ISBN 0-691-01864-2 (PBK.)

LIBRARY OF CONGRESS CATALOG CARD NUMBER: 75-156
MANUFACTURED IN THE UNITED STATES OF AMERICA

EDITORIAL NOTE

In the Editorial Note to Volume 1 it was pointed out that Jung's interest had gradually transferred itself, over the years, from psychiatry through psychoanalysis and typology to the theory of archetypes, and finally to the psychology of religious motifs. This facilitated the grouping of his published researches under the relevant headings, even though some of the material could equally well fit into any of several volumes. It follows that there is an underlying network linking, in time or subject-matter, each volume with others, and that wide reading among the volumes is required for a thorough grasp of Jung's views on any particular topic. From no single volume, whatever the arrangement, could the continuity of development be seen in historical perspective.

The present volume gives the substance of Jung's published writings on Freud and psychoanalysis between the years 1906 and 1916; two later papers are, however, added for reasons which will become apparent. Anyone familiar with Jung's work will be aware that references to Freud's observations and theories occur frequently throughout his writings; indeed, the discussion of them has engaged his interest from the beginning of the century to the present day. The scientific papers in this volume, while falling short of a complete account of Freud and psychoanalysis, nevertheless give the essential elements in Jung's changing views on this subject.

Between the years 1907 and 1912, when Jung was a psychoanalyst, his association with Freud was very close. Though the personal relationship between the two then became strained, largely owing to the publication of *Wandlungen und Symbole der Libido* in 1911–12, Jung continued to serve as president of the International Psycho-Analytical Association until 1914. [Part I](#) of this volume covers the period of Jung's close and "enthusiastic" collaboration with Freud; the papers in [Parts II](#) and [III](#) contain the essentials of the criticism that led to the formal rupture. The contents of [Part IV](#) are more in need of explanation. "The Significance of the Father in the Destiny of the Individual," having been originally written in 1908, is associated with the material of [Part I](#). It was, however, considerably revised by the author in 1949, and the revisions are sufficiently extensive to warrant its being placed in [Part IV](#). In view of their special interest, the most important differences between the two versions have been indicated by the use of brackets and footnotes (a comparative method applied also to "The Theory of Psychoanalysis" in [Part II](#)). The essay "Freud and Jung: Contrasts" was commissioned in 1929 by the editor of the *Kölnische Zeitung* in view of the then current interest in the relation between Freud and Jung. It is included here because it shows the

continuity in Jung's thinking from the time he wrote "The Theory of Psychoanalysis" (1912), serving at the same time as an outline of the changes that had taken place in the interim. In particular, it stresses that the element of confession and the personality of the investigator cannot be eradicated from psychological formulations and may even be considered an essential part of them. Jung's estimate of Freud must be seen in this light, not only in the writings in the present volume but in Volume 15, where Freud is viewed in his cultural setting. "Freud and Jung: Contrasts" and the Introduction to Kranefeldt's *Secret Ways of the Mind* (1930) therefore form a basis for further study of Jung's reassessment of psychoanalysis in that and other volumes of this edition.

The concept of personality is closely bound up with the subject of typology, first broached in this volume and elaborated systematically in *Psychological Types* (Volume 6). Indeed, Jung has once again declared (in his British television broadcast, November 1959) that it was the difference between Freud's views and his own that originally impelled him to work out a psychology of types. We can see this very clearly in the publications between the years 1913 and 1921, when *Psychological Types* was published. The break with Freud was followed by a relatively fallow period. Except for a handful of publications chiefly in English only two works appeared during those years, but they are very important indeed: "The Conception of the Unconscious" and "The Psychology of the Unconscious Processes" (a revision of a 1912 work), published in 1916 and 1917. Through periodic revision these ultimately became the celebrated *Two Essays on Analytical Psychology* (Volume 7), and they contain in embryo the whole future development of analytical psychology both as a therapeutic technique and as a method of investigating the unconscious. In these two seminal works and their subsequent revisions, Jung progressively elaborates and clarifies his basic concepts and carefully differentiates his position from that of Freud. They deepen our understanding of Jung's relation to psychoanalysis in that they set his concepts of the collective unconscious, the archetypes, and the individuation process side by side with his assessment of the theories of Freud and Adler. In this respect, they amplify the papers published in [Parts I, II, and III](#) of the present volume and form the link between them and Jung's more critical approach to Freud in [Part IV](#).

The combination of scientific with less technical essays illustrates another aspect of editorial policy in this and other volumes. Over the years Jung has responded again and again to the widespread interest which psychoanalysis, and later analytical psychology, aroused. The Editors, therefore, have not hesitated to assemble in the same volume scientific articles with essays of a more popular nature.

VOLUME 4
FREUD & PSYCHOANALYSIS

TABLE OF CONTENTS

EDITORIAL NOTE

I

[Freud's Theory of Hysteria: A Reply to Aschaffenburg](#)

Translated from "Die Hysterielehre Freuds: Eine Erwiderung auf die Aschaffenburgsche Kritik," *Münchener medizinische Wochenschrift* (Munich), LIII (1906).

[The Freudian Theory of Hysteria](#)

Translated from "Die Freud'sche Hysterietheorie," *Monatsschrift für Psychiatrie und Neurologie* (Berlin), XXIII (1908).

[The Analysis of Dreams](#)

Translated from "L'Analyse des rêves," *Année psychologique* (Paris), XV (1909).

[A Contribution to the Psychology of Rumour](#)

Translated from "Ein Beitrag zur Psychologie des Gerüchtes," *Zentralblatt für Psychoanalyse* (Wiesbaden), I (1910/11).

[On the Significance of Number Dreams](#)

Translated from "Ein Beitrag zur Kenntnis des Zahlentraumes," *Zentralblatt für Psychoanalyse* (Wiesbaden), I (1910/11).

[Morton Prince, "The Mechanism and Interpretation of Dreams": A Critical Review](#)

Translated from a review in the *Jahrbuch für psychoanalytische und psychopathologische Forschungen* (Leipzig), III (1911).

[On the Criticism of Psychoanalysis](#)

Translated from “Zur Kritik über Psychoanalyse,” *Jahrbuch für psychoanalytische und psychopathologische Forschungen* (Leipzig), II (1910).

Concerning Psychoanalysis

Translated from “Zur Psychoanalyse,” *Wissen und Leben* (Zurich), V (1912).

II

The Theory of Psychoanalysis

Translated from *Versuch einer Darstellung der psychoanalytischen Theorie*, 2nd edn. (Zurich: Rascher, 1955).

FOREWORD TO THE FIRST EDITION

FOREWORD TO THE SECOND EDITION

1. A REVIEW OF THE EARLY HYPOTHESES

2. THE THEORY OF INFANTILE SEXUALITY

3. THE CONCEPT OF LIBIDO

4. NEUROSIS AND AETIOLOGICAL FACTORS IN CHILDHOOD

5. THE FANTASIES OF THE UNCONSCIOUS

6. THE OEDIPUS COMPLEX

7. THE AETIOLOGY OF NEUROSIS

8. THERAPEUTIC PRINCIPLES OF PSYCHOANALYSIS

9. A CASE OF NEUROSIS IN A CHILD

III

General Aspects of Psychoanalysis

Translated from “Allgemeine Aspekte der Psychoanalyse,” the original ms., which was published (in an anonymous translation) in *Transactions of the Psycho-Medical Society* (Cockermouth, England), 1913.

Psychoanalysis and Neurosis

Originally published in English as “On Psychoanalysis” in *Collected Papers on Analytical Psychology* (London: Baillière, Tindall and Cox, 1916).

Some Crucial Points in Psychoanalysis: A Correspondence between Dr. Jung and Dr. Loÿ

Translated from *Psychotherapeutische Zeitfragen: Ein Briefwechsel mit Dr. C. G. Jung*, edited by Dr. R. Loÿ (Leipzig and Vienna: Deuticke, 1914).

Prefaces to *Collected Papers on Analytical Psychology*

Originally published in the book, edited by Constance E. Long (London: Baillière, Tindall and Cox, 1916; 2nd edn., 1917).

IV

The Significance of the Father in the Destiny of the Individual

Translated from *Die Bedeutung des Vaters für das Schicksal des Einzelnen* (3rd revised edn., Zurich: Rascher, 1949), including material from the 1st edn. (1909).

Introduction to Kranefeldt's *Secret Ways of the Mind*

Translated from the introduction to W. M. Kranefeldt, *Die Psychoanalyse* (Berlin and Leipzig: W. de Gruyter, 1930).

Freud and Jung: Contrasts

Translated from “Der Gegensatz Freud und Jung,” *Seelenprobleme der Gegenwart* (Zurich: Rascher, 1931).

BIBLIOGRAPHY

INDEX

I

ARTICLES

1906-1912

FREUD'S THEORY OF HYSTERIA: A REPLY TO ASCHAFFENBURG¹

- [1] If I try to answer Aschaffenburg's—on the whole—very moderate and cautious criticism of Freud's theory of hysteria,² I do so in order to prevent the baby from being thrown out with the bath-water. Aschaffenburg, of course, does not assert that Freud's importance ends with his theory of hysteria. But the medical public (psychiatrists included) know Freud mainly from this side of his work, and for this reason adverse criticism could easily throw a shadow on Freud's other scientific achievements. I would like to remark at the start that my reply is not directed to Aschaffenburg personally, but to the whole school of thought whose views and aspirations have found eloquent expression in Aschaffenburg's lecture.
- [2] His criticism is confined exclusively to the role which sexuality, according to Freud, plays in the formation of the psychoneuroses. What he says, therefore, does not affect the wider range of Freud's psychology, that is, the psychology of dreams, jokes, and disturbances of ordinary thinking caused by feeling-toned constellations. It affects only the psychology of sexuality, the determinants of hysterical symptoms, and the methods of psychoanalysis.³ In all these fields Freud has to his credit unique achievements, which can be contested only by one who has never taken the trouble to check Freud's thought-processes experimentally. I say "achievements," though this does not mean that I subscribe unconditionally to all Freud's theorems. But it is also an achievement, and often no small one, to propound ingenious problems. This achievement cannot be disputed even by Freud's most vigorous opponents.
- [3] To avoid being unnecessarily diffuse, I shall leave out of account all those points which are not affected by Aschaffenburg's criticism, and shall confine myself only to those it attacks.
- [4] Freud maintains that he has found the root of *most* psychoneuroses to be a psychosexual trauma. Is this assertion nonsense?
- [5] Aschaffenburg takes his stand on the view, generally accepted today, that hysteria is a psychogenic illness. It therefore has its roots in the psyche. It would be a work of supererogation to point out that an essential component of the psyche is sexuality, a component of whose extent and importance we can form absolutely no conception in the present unsatisfactory state of empirical psychology. We know only that one meets sexuality everywhere. Is there any other psychic factor, any other basic drive except hunger and its derivatives, that has a similar importance in human psychology? I could not name one. It stands to reason that such a large and weighty component of the psyche must give rise to a correspondingly large number of emotional conflicts

and affective disturbances, and a glance at real life teaches us nothing to the contrary. Freud's view can therefore claim a high degree of probability at the outset, in so far as he derives hysteria primarily from psychosexual conflicts.

- [6] Now what about Freud's particular view that all hysteria is reducible to sexuality?
- [7] Freud has not examined all the hysterias there are. His proposition is therefore subject to the general limitation which applies to empirical axioms. He has simply found his view confirmed in the cases observed by him, which constitute an infinitely small fraction of all cases of hysteria. It is even conceivable that there are several forms of hysteria which Freud has not yet observed at all. Finally, it is also possible that Freud's material, under the constellation of his writings, has become somewhat one-sided.
- [8] We may therefore modify his dictum, with the consent of the author, as follows: An indefinitely large number of cases of hysteria derive from sexual roots.
- [9] Has anyone proved that this is not so? By "prove" I naturally mean applying Freud's psychoanalytic methods and not just carrying out a rigorous examination of the patient and then declaring that nothing sexual can be found. All such "proofs" are of course worthless from the start. Otherwise we would have to admit that a person who examines a bacterial culture with a magnifying-glass and asserts that there are no bacteria in it is right. The application of psychoanalytic methods is, logically, a *sine qua non*.
- [10] Aschaffenburg's objection that an entirely traumatic hysteria contains nothing sexual and goes back to other, very clear traumata seems to me very apt. But the limits of traumatic hysteria, as Aschaffenburg's example shows (flower-pot falling followed by aphonia), are very wide. At that rate countless cases of hysteria could be put into the category of "traumatic" hysteria, for how often does a mild fright produce a new symptom! Aschaffenburg will surely not believe that anyone can be so naïve as to seek the cause of the symptom in that little affect alone. The obvious inference is that the patient was hysterical long before. When for instance a shot is fired and a passing girl gets abasia, we can safely assume that the vessel, long since full, has merely overflowed. No special feat of interpretation is needed to prove this. So these and a legion of similar cases prove nothing against Freud.
- [11] It is rather different in the case of physical traumata and hysterias about insurance money. Here, where the trauma and the highly affective prospect of money coincide, an emotional situation arises which makes the outbreak of a specific form of hysteria appear at least very plausible. It is possible that Freud's view is not valid in these cases. For lack of other experiences I incline to this opinion. But if we want to be absolutely fair and absolutely scientific, we would certainly have to show first that a

sexual constellation really never did pave the way for the hysteria, i.e., that nothing of this sort comes out under analysis. At any rate the allegation of traumatic hysteria proves, at best, only that not all cases of hysteria have a sexual root. But this does not controvert Freud's basic proposition, as modified above.

[12] There is no other way to refute it than by the use of psychanalytic methods. Anyone who does not use them will never refute Freud; for it must be proved by means of the methods inaugurated by him that factors can be found in hysteria other than sexual ones, or that these methods are totally unsuited to bringing intimate psychic material to light.

[13] Under these conditions, can Aschaffenburg substantiate his criticism?

[14] We hear a great deal about "experiments" and "experiences," but there is nothing to show that our critic has used the methods himself and—what is more important—handled them with certainty. He cites a number of—we must admit—very startling examples of Freudian interpretation, which are bound to nonplus the beginner. He himself points out the inadequacy of quotations torn from their context; it should not be too much if I emphasize still further that in psychology the context is everything. These Freudian interpretations are the result of innumerable experiences and inferences. If you present such results naked, stripped of their psychological premises, naturally no one can understand them.

[15] When Aschaffenburg says these interpretations are arbitrary and asserts that other interpretations are just as possible, or that there is absolutely nothing behind the facts in question, it is up to him to prove, by his own analyses, that such things are susceptible of altogether different interpretations. Then the matter would be quickly settled, and everyone would thank him for clearing up this question. It is the same with the question of "forgetting" and other symptomatic actions which Aschaffenburg relegates to the realm of mysticism. These phenomena are extraordinarily common; you meet them almost every day. It is therefore not too much to ask a critic to show by means of practical examples how these phenomena can be traced back to other causes. The association experiment would provide him with any amount of material. Again he would be doing constructive work for which one could not thank him enough.

[16] As soon as Aschaffenburg meets these requirements, that is to say, publishes psychanalyses with totally different findings, we will accept his criticism, and then the discussion of Freud's theory can be reopened. Till then his criticism hangs in mid air.

[17] Aschaffenburg asserts that the psychanalytic method amounts to auto-suggestion on the part of the doctor as well as the patient.

[18] Apart from the fact that it is incumbent on a critic to demonstrate his thorough knowledge of the method, we also lack the proof that the method is auto-suggestion. In earlier writings⁴ I have already pointed out that the association experiment devised by me gives the same results in principle, and that psychoanalysis is really no different from an association experiment, as Aschaffenburg himself says in his criticism. His assertion that the experiment was used by me in one case only is erroneous; it was used for the purpose of analysis in a great number of cases, as is evident from numerous statements in my own work and from the recent work of Riklin. Aschaffenburg can check my statements and those of Freud at any time, so far as the latter coincide with my own, by experiment, and thereby acquire a knowledge of the exact foundations of psychoanalysis.

[19] That my experiments have nothing to do with auto-suggestion can easily be seen from their use in the *experimental diagnosis of facts*. The step from the association experiment, which is already pretty complicated, to full psychoanalysis is certainly a big one. But, by thorough study of the association experiment—to the development of which Aschaffenburg himself has made outstanding contributions—one can acquire invaluable insights which prove very useful during analysis. (At any rate this has been so with me.) Only when he has gone through this arduous and difficult training can he begin, with some justification, to examine Freud's theory for evidence of auto-suggestion. He will also have a more sympathetic insight into the somewhat apodictic nature of Freud's style. He will learn to understand how uncommonly difficult it is to *describe* these delicate psychological matters. A written exposition will never be able to reproduce the reality of psychoanalysis even approximately, let alone reproduce it in such a way that it has an immediately convincing effect on the reader. When I first read Freud's writings it was the same with me as with everybody else: I could only strew the pages with question-marks. And it will be like that for everyone who reads the account of my association experiments for the first time. Luckily, however, anyone who wants to can repeat them, and so experience for himself what he did not believe before. Unfortunately this is not true of psychoanalysis, since it presupposes an unusual combination of specialized knowledge and psychological routine which not everyone possesses, but which can, to a certain extent, be learnt.

[20] So long as we do not know whether Aschaffenburg has this practical experience, the charge of auto-suggestion cannot be taken any more seriously than that of arbitrary interpretation.

[21] Aschaffenburg regards the exploration of the patient for sexual ideas as, in many cases, immoral.

[22] This is a very delicate question, for whenever morals get mixed up with science one can only pit one belief against another belief. If we look at it simply from the utilitarian point of view, we have to ask ourselves whether sexual enlightenment is under all circumstances harmful or not. This question cannot be answered in general terms, because just as many cases can be cited for as against. Everything depends on the individual. Many people can stand certain truths, others not. Every skilled psychologist will surely take account of this fact. Any rigid formula is particularly wrong here. Apart from the fact that there are many patients who are not in the least harmed by sexual enlightenment, there are not a few who, far from having to be pushed towards this theme, guide the analysis to this point of their own accord. Finally, there are cases (of which I have had more than one) that cannot be got at at all until their sexual circumstances are subjected to a thorough review, and in the cases I have known this has led to very good results. It therefore seems to me beyond doubt that there are at least a great many cases where discussion of sexual matters not only does no harm but is positively helpful. Conversely, I do not hesitate to admit that there are cases where sexual enlightenment does more harm than good. It must be left to the skill of the analyst to find out which these cases are. This, it seems to me, disposes of the moral problem. "Higher" moral considerations derive all too easily from some obnoxious schematism, for which reason their application in practice would seem inopportune from the start.

[23] So far as the therapeutic effect of psychoanalysis is concerned, it makes no difference to the scientific rightness of the hysteria theory or of the analytic method how the therapeutic result turns out. My personal conviction at present is that Freud's psychoanalysis is one of several possible therapies and that in certain cases it achieves more than the others.

[24] As to the scientific findings of psychoanalysis, nobody should be put off by seeming enormities, and particularly not by sensational quotations. Freud is probably liable to many human errors, but that does not by any means rule out the possibility that a core of truth lies hidden in the crude husk, of whose significance we can form no adequate conception at present. Seldom has a great truth appeared without fantastic wrappings. One has only to think of Kepler and Newton!

[25] In conclusion, I would like to utter an urgent warning against the standpoint of Spielmeier,⁵ which cannot be condemned sharply enough. When a person reviles as unscientific not only a theory whose experimental foundations he has not even examined but also those who have taken the trouble to test it for themselves, the freedom of scientific research is imperilled. No matter whether Freud is mistaken or not, he has the right to be heard before the forum of science. Justice demands that

Freud's statements should be verified. But to strike them dead and then consign them to oblivion, that is beneath the dignity of an impartial and unprejudiced scientist.

[26] To recapitulate:

(1) It has never yet been proved that Freud's theory of hysteria is erroneous in all cases.

(2) This proof can, logically, be supplied only by one who practises the psychoanalytic method.

(3) It has not been proved that psychoanalysis gives other results than those obtained by Freud.

(4) It has not been proved that psychoanalysis is based on false principles and is altogether unsuitable for an understanding of hysterical symptoms.

THE FREUDIAN THEORY OF HYSTERIA¹

- [27] It is always a difficult and ungrateful task to discuss a theory which the author himself has not formulated in any final way. Freud has never propounded a cut-and-dried theory of hysteria; he has simply tried, from time to time, to formulate his theoretical conclusions in accordance with his experience at that moment. His theoretical formulations can claim the status of a working hypothesis that agrees with experience at all points. For the present, therefore, there can be no talk of a firmly-established Freudian theory of hysteria, but only of numerous experiences which have certain features in common. As we are not dealing with anything finished and conclusive, but rather with a process of development, an historical survey will probably be the form best suited to an account of Freud's teachings.
- [28] The theoretical presuppositions on which Freud bases his investigations are to be found in the experiments of Pierre Janet. Breuer and Freud, in their first formulation of the problem of hysteria, start from the fact of psychic dissociation and unconscious psychic automatisms. A further presupposition is the aetiological significance of affects, stressed among others by Binswanger.² These two presuppositions, together with the findings reached by the theory of suggestion, culminate in the now generally accepted view that hysteria is a psychogenic neurosis.
- [29] The aim of Freud's research is to discover how the mechanism producing hysterical symptoms works. Nothing less is attempted, therefore, than to supply the missing link in the long chain between the initial cause and the ultimate symptom, a link which no one had yet been able to find. The fact, obvious enough to any attentive observer, that affects play an aetiological decisive role in the formation of hysterical symptoms makes the findings of the first Breuer-Freud report, in the year 1893, immediately intelligible. This is especially true of the proposition advanced by both authors, that the hysteric suffers most of all from *reminiscences*, i.e., from feeling-toned complexes of ideas which, in certain exceptional conditions, prevent the initial affect from working itself out and finally disappearing.
- [30] This view, presented only in broad outline at first, was reached by Breuer, who between the years 1880 and 1882 had the opportunity to observe and treat an hysterical woman patient of great intelligence. The clinical picture was characterized chiefly by a profound splitting of consciousness, together with numerous physical symptoms of secondary importance and constancy. Breuer, allowing himself to be guided by the patient, observed that in her twilight states complexes of reminiscences were reproduced which derived from the previous year. In these states she

hallucinated a great many episodes that had had a traumatic significance for her. Further, he noticed that the reliving and retelling of these traumatic events had a marked therapeutic effect, bringing relief and an improvement in her condition. If he broke off the treatment, a considerable deterioration set in after a short time. In order to increase and accelerate the effect of the treatment, Breuer induced, besides the spontaneous twilight state, an artificially suggested one in which more material was “abreacted.” In this way he succeeded in effecting a substantial improvement. Freud, who at once recognized the extraordinary importance of these observations, thereupon furnished a number of his own which agreed with them. This material can be found in *Studies on Hysteria*, published in 1895 by Breuer and Freud.

[31] On this foundation was raised the original theoretical edifice constructed jointly by the two authors. They start with the symptomatology of affects in normal individuals. The excitation produced by affects is converted into a series of somatic innervations, thus exhausting itself and so restoring the “tonus of the nerve centres.” In this way the affect is “abreacted.” It is different in hysteria. Here the traumatic experience is followed—to use a phrase of Oppenheim’s—by an “abnormal expression of the emotional impulse.”³ The intracerebral excitation is not discharged directly, in a natural way, but produces pathological symptoms, either new ones or a recrudescence of old ones. The excitation is converted into abnormal innervations, a phenomenon which the authors call “conversion of the sum of excitation.” The affect is deprived of its normal expression, of its normal outlet in adequate innervations; it is not abreacted but remains “blocked.” The resulting hysterical symptoms can therefore be regarded as manifestations of the retention.

[32] This formulates the situation as we see it in the patient; but the important question as to why the affect should be blocked and converted still remains unanswered, and it was to this question that Freud devoted special attention. In “The Defence Neuro-psychoses,” published in 1894, he tried to analyse in great detail the psychological repercussions of the affect. He found two groups of psychogenic neuroses, different in principle because in one group the pathogenic affect is converted into somatic innervations, while in the other group it is displaced to a different complex of ideas. The first group corresponds to classic hysteria, the second to obsessional neurosis. He found the reason for the blocking of affect, or for its conversion or displacement, to be the incompatibility of the traumatic complex with the normal content of consciousness. In many cases he could furnish direct proof that the incompatibility had reached the consciousness of the patient, thus causing an active repression of the incompatible content. The patient did not wish to know anything about it and treated the critical complex as “non arrivé.” The result was a systematic circumvention or “repression” of the vulnerable spot, so that the affect could not be abreacted.

[33] The blocking of affect is due, therefore, not to a vaguely conceived “special disposition” but to a recognizable motive.

[34] To recapitulate what has been said: up to the year 1895 the Breuer-Freud investigations yielded the following results. Psychogenic symptoms arise from feeling-toned complexes of ideas that have the effect of a trauma, either

1. by conversion of the excitation into abnormal somatic innervations, or
2. by displacement of the affect to a less significant complex.

[35] The reason why the traumatic affect is not abreacted in a normal way, but is retained, is that its content is not compatible with the rest of the personality and must be repressed.

[36] The content of the traumatic affect provided the theme for Freud’s further researches. Already in the *Studies on Hysteria* and particularly in “The Defence Neuro-psychoses,” Freud had pointed out the sexual nature of the initial affect, whereas the first case history reported by Breuer skirts round the sexual element in a striking fashion, although the whole history not only contains a wealth of sexual allusions but, even for the expert, becomes intelligible and coherent only when the patient’s sexuality is taken into account. On the basis of thirteen careful analyses Freud felt justified in asserting that the specific aetiology of hysteria is to be found in the sexual traumata of early childhood, and that the trauma must have consisted in a “real irritation of the genitals.” The trauma works at first only preparatorily; it develops its real effect at puberty, when the old memory-trace is reactivated by nascent sexual feelings. Thus Freud tried to resolve the vague concept of a special disposition into quite definite, concrete events in the pre-pubertal period. At that time he did not attribute much significance to a still earlier *inborn* disposition.

[37] While the Breuer-Freud *Studies* enjoyed a certain amount of recognition (although, despite Raimann’s assurances,⁴ they have not yet become the common property of science), *this* theory of Freud’s met with general opposition. Not that the frequency of sexual traumata in childhood could be doubted, but rather their exclusively pathogenic significance for normal children. Freud certainly did not evolve this view out of nothing, he was merely formulating certain experiences which had forced themselves on him during analysis. To begin with, he found memory-traces of sexual scenes in infancy, which in many cases were quite definitely related to real happenings. Further, he found that though the traumata remained without specific effect in childhood, after puberty they proved to be determinants of hysterical symptoms. Freud therefore felt compelled to grant that the trauma was real. In my personal opinion he did this because at that time he was still under the spell of the original view that the hysteric “suffers from reminiscences,” for which reason the cause and motivation of the symptom must be sought in the past. Obviously such a

view of the aetiological factors was bound to provoke opposition, especially among those with experience of hysteria, for the practitioner is accustomed to look for the driving forces of hysterical neurosis not so much in the past as in the present.

[38] This formulation of the theoretical standpoint in 1896 was no more than a transitional stage for Freud, which he has since abandoned. The discovery of sexual determinants in hysteria became the starting-point for extensive researches in the field of sexual psychology in general. Similarly, the problem of the determination of associative processes led his inquiry into the field of dream psychology. In 1900 he published his fundamental work on dreams, which is of such vital importance for the development of his views and his technique. No one who is not thoroughly acquainted with Freud's method of dream interpretation will be able to understand the conceptions he has developed in recent years. *The Interpretation of Dreams* lays down the principles of Freudian theory and at the same time its technique. For an understanding of his present views and the verification of his results a knowledge of Freud's technique is indispensable. This fact makes it necessary for me to go rather more closely into the nature of psychoanalysis.

[39] The original cathartic method started with the symptoms and sought to discover the traumatic affect underlying them. The affect was thus raised to consciousness and abreacted in the normal manner; that is, it was divested of its traumatic potency. The method relied to a certain extent on suggestion—the analyst took the lead, while the patient remained essentially passive. Aside from this inconvenience, however, it was found that there were more and more cases in which no real trauma was present, and in which all the emotional conflicts seemed to derive exclusively from morbid fantasy activity. The cathartic method was unable to do justice to these cases.

[40] According to Freud's statements in 1904,⁵ much has altered in the method since those early days. All suggestion is now discarded. The patients are no longer guided by the analyst; the freest rein is given to their associations, so that it is really the patients who conduct the analysis. Freud contents himself with registering, and from time to time pointing out, the connections that result. If an interpretation is wrong, it cannot be forced on the patient; if it is right, the result is immediately visible and expresses itself very clearly in the patient's whole behaviour.

[41] The present psychoanalytic method of Freud is much more complicated, and penetrates much more deeply, than the original cathartic method. Its aim is to bring to consciousness all the false associative connections produced by the complex, and in that way to resolve them. Thus the patient gradually gains complete insight into his illness, and also has an objective standpoint from which to view his complexes. The method could be called an educative one, since it changes the whole thinking and feeling of the patient in such a way that his personality gradually breaks free from the

compulsion of the complexes and can take up an independent attitude towards them. In this respect Freud's new method bears some resemblance to the educative method of Dubois,⁶ the undeniable success of which is due mainly to the fact that the instruction it imparts alters the patient's attitude towards his complexes.

[42] Since it has grown entirely out of empirical practice, the theoretical foundations of the psychoanalytic method are still very obscure. By means of my association experiments I think I have made at least a few points accessible to experimental investigation, though not all the theoretical difficulties have been overcome. It seems to me that the main difficulty is this. If, as psychoanalysis presupposes, free association leads to the complex, Freud logically assumes that this complex is associated with the starting-point or initial idea. Against this it can be argued that it is not very difficult to establish the associative connection between a cucumber and an elephant. But that is to forget, first, that in analysis only the starting-point is given, and not the goal; and second, that the conscious state is not one of directed thinking but of relaxed attention. Here one might object that the *complex* is the point being aimed at and that, because of its independent feeling-tone, it possesses a strong tendency to reproduction, so that it "rises up" spontaneously and then, as though purely by chance, appears associated with the starting-point.

[43] This is certainly conceivable in theory, but in practice things generally look different. The complex, in fact, does not "rise up" freely but is blocked by the most intense resistances. Instead, what "rises up" often seems at first sight to be quite incomprehensible intermediate associations, which neither the analyst nor the patient recognizes as belonging in any way to the complex. But once the chain leading to the complex has been fully established, the meaning of each single link becomes clear, often in the most startling way, so that no special work of interpretation is needed. Anyone with enough practical experience of analysis can convince himself over and over again that under these conditions not just *anything* is reproduced, but always something that is related to the complex, though the relationship is, *a priori*, not always clear. One must accustom oneself to the thought that even in these chains of association chance is absolutely excluded. So if an associative connection is discovered in a chain of associations which was not intended—if, that is to say, the complex we find is associatively connected with the initial idea—then this connection has existed from the start; in other words, the idea we took as the starting-point was already constellated by the complex. We are therefore justified in regarding the initial idea as a sign or symbol of the complex.

[44] This view is in agreement with already known psychological theories which maintain that the psychological situation at a given moment is nothing but the resultant of all the psychological events preceding it. Of these the most predominant

are the affective experiences, that is, the complexes, which for that reason have the greatest constellating power. If you take any segment of the psychological present, it will logically contain all the antecedent individual events, the affective experiences occupying the foreground, according to the degree of their actuality. This is true of every particle of the psyche. Hence it is theoretically possible to reconstruct the constellations from every particle, and that is what the Freudian method tries to do. During this work the probability is that you will come upon just the affective constellation lying closest to hand, and not merely on one but on many, indeed very many, each according to the degree of its constellating power. Freud has called this fact *over-determination*.

[45] Psychoanalysis accordingly keeps within the bounds of known psychological facts. The method is extraordinarily difficult to apply, but it can be learnt; only, as Löwenfeld rightly emphasizes, one needs some years of intensive practice before one can handle it with any certainty. For this reason alone all over-hasty criticism of Freud's findings is precluded. It also precludes the method from ever being used for mass therapy in mental institutions. Its achievements as a scientific instrument can be judged only by one who uses it himself.

[46] Freud applied his method first of all to the investigation of dreams, refining and perfecting it in the process. Here he found, it appears, all those surprising associative connections which play such an important role in the neuroses. I would mention, as the most important discovery, the significant role which feeling-toned complexes play in dreams and their symbolical mode of expression. Freud attaches great significance to verbal expression—one of the most important components of our thinking—because the double meaning of words is a favourite channel for the displacement and improper expression of affects. I mention this point because it is of fundamental importance in the psychology of neurosis. For anyone who is familiar with these matters, which are everyday occurrences with normal people too, the interpretations given in the "Fragment of an Analysis of a Case of Hysteria," however strange they may sound, will contain nothing unexpected, but will fit smoothly into his general experience. Unfortunately I must refrain from a detailed discussion of Freud's findings and must limit myself to a few hints. These latest investigations are required reading for Freud's present view of hysterical illnesses. Judging by my own experience, it is impossible to understand the meaning of the *Three Essays* and of the "Fragment" without a thorough knowledge of *The Interpretation of Dreams*.

[47] By "thorough knowledge" I naturally do not mean the cheap philological criticism which many writers have levelled at this book, but a patient application of Freud's principles to psychic processes. Here lies the crux of the whole problem.

Attack and defence both miss the mark so long as the discussion proceeds only on theoretical ground. Freud's discoveries do not, at present, lend themselves to the framing of general theories. For the present the only question is: do the associative connections asserted by Freud exist or not? Nothing is achieved by thoughtless affirmation or negation; one should look at the facts without prejudice, carefully observing the rules laid down by Freud. Nor should one be put off by the obtrusion of sexuality, for as a rule you come upon many other, exceedingly interesting things which, at least to begin with, show no trace of sex. An altogether harmless but most instructive exercise, for instance, is the analysis of constellations indicating a complex in the association experiment. With the help of this perfectly harmless material a great many Freudian phenomena can be studied without undue difficulty. The analysis of dreams and hysteria is considerably more difficult and therefore less suitable for a beginner. Without a knowledge of the ground-work Freud's more recent teachings are completely incomprehensible, and, as might be expected, they have remained misunderstood.

[48] It is with the greatest hesitation, therefore, that I make the attempt to say something about the subsequent development of Freud's views. My task is rendered especially difficult by the fact that actually we have only two publications to go on: they are the above-mentioned *Three Essays on the Theory of Sexuality* and the "Fragment of an Analysis of a Case of Hysteria." There is as yet no attempt at a systematic exposition and documentation of Freud's more recent views. Let us first try to come closer to the argument of the *Three Essays*.

[49] These essays are extremely difficult to understand, not only for one unaccustomed to Freud's way of thinking but also for those who have already worked in this special field. The first thing to be considered is that Freud's conception of sexuality is uncommonly wide. It includes not only normal sexuality but all the perversions, and extends far into the sphere of psychosexual derivatives. When Freud speaks of sexuality, it must not be understood merely as the sexual instinct.⁷ Another concept which Freud uses in a very wide sense is "libido." This concept, originally borrowed from "libido sexualis," denotes in the first place the sexual components of psychic life so far as they are volitional, and then any inordinate passion or desire.

[50] Infantile sexuality, as Freud understands it, is a bundle of possibilities for the application or "investment" of libido. A normal sexual goal does not exist at that stage, because the sexual organs are not yet fully developed. But the psychic mechanisms are probably already in being. The libido is distributed among all the possible forms of sexual activity, and also among all the perversions—that is, among all the variants of sexuality which, if they become fixed, later turn into real perversions. The progressive development of the child gradually eliminates the

libidinal investment of perverse tendencies and concentrates on the growth of normal sexuality. The investments set free during this process are used as driving-forces for sublimations, that is, for the higher mental functions. At or after puberty the normal individual seizes on an objective sexual goal, and with this his sexual development comes to an end.

[51] In Freud's view, it is characteristic of hysteria that the infantile sexual development takes place under difficult conditions, since the perverse investments of libido are much less easily discarded than with normal individuals and therefore last longer. If the real sexual demands of later life impinge in any form on a morbid personality, its inhibited development shows itself in the fact that it is unable to satisfy the demand in the proper way, because the demand comes up against an unprepared sexuality. As Freud says, the individual predisposed to hysteria brings a "bit of sexual repression" with him from his childhood. Instead of the sexual excitation, in the widest sense of the word, being acted out in the sphere of normal sexuality, it is repressed and causes a reactivation of the original infantile sexual activity. This is expressed above all in the fantasy-activity so characteristic of hysterics. The fantasies develop along the line already traced by the special kind of infantile sexual activity. The fantasies of hysterics are, as we know, boundless; hence, if the psychic balance is in some measure to be preserved, equivalent inhibiting mechanisms are needed or, as Freud calls them, resistances. If the fantasies are of a sexual nature, then the corresponding resistances will be shame and disgust. As these affective states are normally associated with physical manifestations, the appearance of physical symptoms is assured.

[52] I think a concrete example from my own experience will illustrate the meaning of Freud's teachings better than any theoretical formulations, which, because of the complexity of the subject, are all apt to sound uncommonly ponderous.

[53] The case is one of psychotic hysteria in an intelligent young woman of twenty. The earliest symptoms occurred between the third and fourth year. At that time the patient began to keep back her stool until pain compelled her to defecate. Gradually she began to employ the following auxiliary procedure: she seated herself in a crouching position on the heel of one foot, and in this position tried to defecate, pressing the heel against the anus. The patient continued this perverse activity until her seventh year. Freud calls this infantile perversion anal eroticism.

[54] The perversion stopped with the seventh year and was replaced by masturbation. Once, when her father smacked her on the bare buttocks, she felt distinct sexual excitement. Later she became sexually excited when she saw her younger brother being disciplined in the same way. Gradually she developed a markedly negative attitude towards her father.

[55] Puberty started when she was thirteen. From then on fantasies developed of a thoroughly perverse nature which pursued her obsessively. These fantasies had a compulsive character: she could never sit at table without thinking of defecation while she was eating, nor could she watch anyone else eating without thinking of the same thing, and especially not her father. In particular, she could not see her father's hands without feeling sexual excitement; for the same reason she could no longer bear to touch his right hand. Thus it gradually came about that she could not eat at all in the presence of other people without continual fits of compulsive laughter and cries of disgust, because the defecation fantasies finally spread to all the persons in her environment. If she was corrected or even reproached in any way, she answered by sticking out her tongue, or with convulsive laughter, cries of disgust, and gestures of horror, because each time she had before her the vivid image of her father's chastising hand, coupled with sexual excitement, which immediately passed over into ill-concealed masturbation.

[56] At the age of fifteen, she felt the normal urge to form a love relationship with another person. But all attempts in this direction failed, because the morbid fantasies invariably thrust themselves between her and the very person she most wanted to love. At the same time, because of the disgust she felt, any display of affection for her father had become impossible. Her father had been the object of her infantile libido transference, hence the resistances were directed especially against him, whereas her mother was not affected by them. About this time she felt a stirring of love for her teacher, but it quickly succumbed to the same overpowering disgust. In a child so much in need of affection this emotional isolation was bound to have the gravest consequences, which were not long in coming.

[57] At eighteen, her condition had got so bad that she really did nothing else than alternate between deep depressions and fits of laughing, crying, and screaming. She could no longer look anyone in the face, kept her head bowed, and when anybody touched her stuck her tongue out with every sign of loathing.

[58] This short history demonstrates the essentials of Freud's view. First we find a fragment of perverse infantile sexual activity—anal eroticism—replaced in the seventh year by masturbation. At this period the administering of corporal punishment, affecting the region of the anus, produced sexual excitement. Here we have the determinants for the later psychosexual development. Puberty, with its physical and spiritual upheavals, brought a marked increase in fantasy activity. This seized on the sexual activity of childhood and modulated it in endless variations. Perverse fantasies of this kind were bound to act as moral foreign bodies, so to speak, in an otherwise sensitive person, and had to be repressed by means of defence

mechanisms, particularly shame and disgust. This readily accounts for all those fits of disgust, loathing, exclamations of horror, sticking out the tongue, etc.

[59] At the time when the ordinary longings of puberty for the love of other people were beginning to stir, the pathological symptoms increased, because the fantasies were now directed most intensively to the very people who seemed most worthy of love. This naturally led to a violent psychic conflict, which fully explains the deterioration that then set in, ending in hysterical psychosis.

[60] We now understand why Freud can say that hysterics bring with them “a bit of sexual repression from childhood.” For constitutional reasons they are probably ready for sexual or quasi-sexual activities earlier than other people. In keeping with their constitutional emotivity, the infantile impressions go deeper and last longer, so that later, at puberty, they have a constellating effect on the trend of the first really sexual fantasies. Again in keeping with their constitutional emotivity, all affective impulses are much stronger than in normal persons. Hence, to counteract the intensity of their abnormal fantasies, correspondingly strong feelings of shame and disgust are bound to appear. When real sexual demands are made, requiring the transference of libido to the love-object, all the perverse fantasies are transferred to him, as we have seen. Hence the resistance against the object of love. The patient could not transfer her libido to him without inhibitions, and this precipitated the great emotional conflict. Her libido exhausted itself in struggling against her feelings of defence, which grew ever stronger, and which then produced the symptoms. Thus Freud can say that the symptoms represent nothing but the sexual activity of the patient.

[61] Summing up, we can formulate Freud’s present view of hysteria as follows:

a. Certain precocious sexual activities of a more or less perverse nature grow up on a constitutional basis.

b. These activities do not lead at first to real hysterical symptoms.

c. At puberty (which psychologically sets in earlier than physical maturity) the fantasies tend in a direction constellated by the infantile sexual activity.

d. The fantasies, intensified for constitutional (affective) reasons, lead to the formation of complexes of ideas that are incompatible with the other contents of consciousness and are therefore repressed, chiefly by shame and disgust.

e. This repression takes with it the transference of libido to a love-object, thus precipitating the great emotional conflict which then provides occasion for the outbreak of actual illness.

f. The symptoms of the illness owe their origin to the struggle of the libido against the repression; they therefore represent nothing but an abnormal sexual activity.

[62] How far does the validity of Freud's view go? This question is exceedingly difficult to answer. Above all, it must be emphatically pointed out that cases which conform exactly to Freud's schema really do exist. Anyone who has learnt the technique knows this. But no one knows whether Freud's schema is applicable to all forms of hysteria (in any case, hysteria in children and the psychotraumatic neuroses form a group apart). For ordinary cases of hysteria, such as the nerve-specialist meets by the dozen, Freud asserts the validity of his views; my own experience, which is considerably less than his, has yielded nothing that would argue against this assertion. In the cases of hysteria which I have analysed, the symptoms were extraordinarily varied, but they all showed a surprising similarity in their psychological structure. The outward appearance of a case loses much of its interest when it is analysed, because one then sees how the same complex can produce apparently very far-fetched and very remarkable symptoms. For this reason it is impossible to say whether Freud's schema applies only to certain groups of symptoms. At present we can only affirm that his findings are true of an indefinitely large number of cases of hysteria which till now could not be delimited as clinical groups.

[63] As to the detailed results of Freud's analyses, the violent opposition they have met with is due simply to the fact that practically no one has followed the development of Freud's theory since 1896. Had his dream-analyses been tested and his rules observed, Freud's latest publications, particularly the "Fragment of an Analysis of a Case of Hysteria," would not have been so difficult to understand. The only disconcerting thing about these reports is their frankness. The public can forgive Freud least of all for his sexual symbolism. In my view he is really easiest to follow here, because this is just where mythology, expressing the fantasy-thinking of all races, has prepared the ground in the most instructive way. I would only mention the writings of Steinthal^B in the 1860's, which prove the existence of a widespread sexual symbolism in the mythological records and the history of language. I also recall the eroticism of our poets and their allegorical or symbolical expressions. No one who considers this material will be able to conceal from himself that there are uncommonly far-reaching and significant analogies between the Freudian symbolisms and the symbols of poetic fantasy in individuals and in whole nations. The Freudian symbol and its interpretation is therefore nothing unheard of, it is merely something unusual for us psychiatrists. But these difficulties should not deter us from going more deeply into the problems raised by Freud, for they are of extraordinary importance for psychiatry no less than for neurology.

THE ANALYSIS OF DREAMS¹

[64] In 1900, Sigmund Freud published in Vienna a voluminous work on the analysis of dreams. Here are the principal results of his investigations.

[65] The dream, far from being the confusion of haphazard and meaningless associations it is commonly believed to be, or a result merely of somatic sensations during sleep as many authors suppose, is an autonomous and meaningful product of psychic activity, susceptible, like all other psychic functions, of a systematic analysis. The organic sensations felt during sleep are not the cause of the dream; they play but a secondary role and furnish only elements (the material) upon which the psyche works. According to Freud the dream, like every complex psychic product, is a creation, a piece of work which has its motives, its trains of antecedent associations; and like any considered action it is the outcome of a logical process, of the competition between various tendencies and the victory of one tendency over another. Dreaming has a meaning, like everything else we do.

[66] It may be objected that all empirical reality is against this theory, since the impression of incoherence and obscurity that dreams make upon us is notorious. Freud calls this sequence of confused images the *manifest content* of the dream; it is the façade behind which he looks for what is essential—namely, the dream-thought or the *latent content*. One may ask what reason Freud has for thinking that the dream itself is only the façade of a vast edifice, or that it really has any meaning. His supposition is not founded on a dogma, nor on an *a priori* idea, but on empiricism alone—namely, the common experience that no psychic (or physical) fact is accidental. It must have, then, its train of causes, being always the product of a complicated combination of phenomena; for every existing mental element is the resultant of anterior psychic states and ought in theory to be capable of analysis. Freud applies to the dream the same principle that we always instinctively use when inquiring into the causes of human actions.

[67] He asks himself, quite simply: why does this particular person dream this particular thing? He must have his specific reasons, otherwise there would be a breakdown in the law of causality. A child's dream is different from an adult's, just as the dream of an educated man differs from that of an illiterate. There is something individual in the dream: it is in agreement with the psychological disposition of the subject. In what does this psychological disposition consist? It is itself the result of our psychic past. Our present mental state depends upon our history. In each person's past there are elements of different value which determine the psychic

“constellation.” The events which do not awaken any strong emotions have little influence on our thoughts or actions, whereas those which provoke strong emotional reactions are of great importance for our subsequent psychological development. These memories with a strong feeling-tone form complexes of associations which are not only long enduring but are very powerful and closely interlinked. An object which I regard with little interest calls forth few associations and soon vanishes from my intellectual horizon. An object in which, on the contrary, I feel much interest will evoke numerous associations and preoccupy me for a long while. Every emotion produces a more or less extensive complex of associations which I have called the “feeling-toned complex of ideas.” In studying an individual case history we always discover that the complex exerts the strongest “constellating” force, from which we conclude that in any analysis we shall meet with it from the start. The complexes appear as the chief components of the psychological disposition in every psychic structure. In the dream, for example, we encounter the emotional components, for it is easy to understand that all the products of psychic activity depend above all upon the strongest “constellating” influences.

[68] One does not have to look far to find the complex that sets Gretchen, in *Faust*, singing:

There was a king in Thule,
True even to his grave—
To him his dying mistress
A golden beaker gave.

[69] The hidden thought is Gretchen’s doubt about Faust’s fidelity. The song, unconsciously chosen by Gretchen, is what we have called the *dream-material*, which corresponds to the secret thought. One might apply this example to the dream, and suppose that Gretchen had not sung but dreamed this romance.² In that case the song, with its tragic story of the loves of a far-off king of old, is the “manifest content” of the dream, its “façade.” Anyone who did not know of Gretchen’s secret sorrow would have no idea why she dreamt of this king. But we, who know the dream-thought which is her tragic love for Faust, can understand why the dream makes use of this particular song, for it is about the “rare faithfulness” of the king. Faust is not faithful, and Gretchen would like his faithfulness to her to resemble that of the king in the story. Her dream—in reality her song—expresses in a disguised form *the ardent desire of her soul*. Here we touch upon the real nature of the feeling-toned complex; it is always a question of *a wish and resistance to it*. Our life is spent in struggles for the realization of our wishes: all our actions proceed from the wish that something should or should not come to pass.

[70] It is for this that we work, for this we think. If we cannot fulfil a wish in reality, we realize it at least in fantasy. The religious and the philosophic systems of every people in every age are the best proof of this. The thought of immortality, even in philosophic guise, is no other than a wish, for which philosophy is but the façade, even as Gretchen's song is only the outward form, a beneficent veil drawn over her grief. *The dream represents her wish as fulfilled.* Freud says that *every dream represents the fulfilment of a repressed wish.*

[71] Carrying our illustration further, we see that in the dream Faust is replaced by the king. A transformation has taken place. Faust has become the far-off old king; the personality of Faust, which has a strong feeling-tone, is replaced by a neutral, legendary person. The king is an association by analogy, a *symbol* for Faust, and the "mistress" for Gretchen. We may ask what is the purpose of this arrangement, why Gretchen should dream, so to speak, indirectly about this thought, why she cannot conceive it clearly and without equivocation. This question is easily answered: Gretchen's sadness contains a thought that no one likes to dwell upon; it would be too painful. Her doubt about Faust's faithfulness is repressed and kept down. It makes its reappearance in the form of a melancholy story which, although it realizes her wish, is not accompanied by pleasant feelings. Freud says that the wishes which form the dream-thought are never desires which one openly admits to oneself, but desires that are repressed because of their painful character; and it is because they are excluded from conscious reflection in the waking state that they float up, indirectly, in dreams.

[72] This reasoning is not at all surprising if we look at the lives of the saints. One can understand without difficulty the nature of the feelings repressed by St. Catherine of Siena, which reappeared indirectly in the vision of her celestial marriage, and see what are the wishes that manifest themselves more or less symbolically in the visions and temptations of the saints. As we know, there is as little difference between the somnambulistic consciousness of the hysteric and the normal dream as there is between the intellectual life of hysterics and that of normal people.

[73] Naturally, if we ask someone why he had such and such a dream, what are the secret thoughts expressed in it, he cannot tell us. He will say that he had eaten too much in the evening, that he was lying on his back; that he had seen or heard this or that the day before—in short, all the things we can read in the numerous scientific books about dreams. As for the dream-thought, he does not and he cannot know it for, according to Freud, the thought is repressed because it is too disagreeable. So, if anyone solemnly assures us that he has never found in his own dreams any of the things Freud talks about, we can hardly suppress a smile; he has been straining to see things it is impossible to see directly. The dream disguises the repressed complex to

prevent it from being recognized. By changing Faust into the King of Thule, Gretchen renders the situation inoffensive. Freud calls this mechanism, which prevents the repressed thought from showing itself clearly, the *ensor*. The censor is nothing but the resistance which also prevents us, in the daytime, from following a line of reasoning right to the end. The censor will not allow the thought to pass until it is so disguised that the dreamer is unable to recognize it. If we try to acquaint the dreamer with the thought behind his dream, he will always oppose to us the same resistance that he opposes to his repressed complex.

[74] We can now ask ourselves a series of important questions. Above all, what must we do to get behind the façade into the inside of the house—that is, beyond the manifest content of the dream to the real, secret thought behind it?

[75] Let us return to our example and suppose that Gretchen is an hysterical patient who comes to consult me about a disagreeable dream. I will suppose, moreover, that I know nothing about her. In this case I would not waste my time questioning her directly, for as a rule these intimate sorrows cannot be uncovered without arousing the most intense resistance. I would try rather to conduct what I have called an “association experiment,”³ which would reveal to me the whole of her love-affair (her secret pregnancy, etc.). The conclusion would be easy to draw, and I should be able to submit the dream-thought to her without hesitation. But one may proceed more prudently.

[76] I would ask her, for instance: Who is not so faithful as the King of Thule, or who ought to be? This question would very quickly illuminate the situation. In uncomplicated cases such as this, the interpretation or analysis of a dream is limited to a few simple questions.

[77] Here is an example of such a case. It concerns a man of whom I know nothing except that he lives in the colonies and happens at present to be in Europe on leave. During one of our interviews he related a dream which had made a profound impression on him. Two years before, he had dreamt that *he was in a wild and desert place, and he saw, on a rock, a man dressed in black covering his face with both hands. Suddenly he set out towards a precipice, when a woman, likewise clothed in black, appeared and tried to restrain him. He flung himself into the abyss, dragging her with him.* The dreamer awoke with a cry of anguish.

[78] The question, Who was that man who put himself in a dangerous situation and dragged a woman to her doom? moved the dreamer deeply, for that man was the dreamer himself. Two years before, he had been on a journey of exploration across a rocky and desert land. His expedition was pursued relentlessly by the savage inhabitants of that country, who at night made attacks in which several of its members perished. He had undertaken this extremely perilous journey because at that

time *life had no value for him*. The feeling he had when engaging in this adventure was that he was *tempting fate*. And the reason for his despair? For several years he had lived alone in a country with a very dangerous climate. When on leave in Europe two and a half years ago, he made the acquaintance of a young woman. They fell in love and the young woman wanted to marry him. He knew, however, that he would have to go back to the murderous climate of the tropics, and he had no wish to take a woman there and condemn her to almost certain death. He therefore broke off his engagement, after prolonged moral conflicts which plunged him into profound despair. It was in such a state of mind that he started on his perilous journey. The analysis of the dream does not end with this statement, for the wish-fulfilment is not yet evident. But as I am only citing this dream in order to demonstrate the discovery of the essential complex, the sequel of the analysis is without interest for us.

[79] In this case the dreamer was a frank and courageous man. A little less frankness, or any feeling of unease or mistrust towards me, and the complex would not have been admitted. There are even some who would calmly have asseverated that the dream had no meaning and that my question was completely beside the point. In these cases the resistance is too great, and the complex cannot be brought up from the depths directly into ordinary consciousness. Generally the resistance is such that a direct inquiry, unless it is conducted with great experience, leads to no result. By creating the “psychoanalytic method” Freud has given us a valuable instrument for resolving or overcoming the most tenacious resistances.

[80] This method is practised in the following manner. One selects some specially striking portion of the dream, and then questions the subject about the associations that attach themselves to it. He is directed to say frankly whatever comes into his mind concerning this part of the dream, eliminating as far as possible any criticism. Criticism is nothing but the censor at work; it is the resistance against the complex, and it tends to suppress what is of the most importance.

[81] The subject should, therefore, say absolutely everything that comes into his head without paying any attention to it. This is always difficult at first, especially in an introspective examination when his attention cannot be suppressed so far as to eliminate the inhibiting effect of the censor. For it is towards oneself that one has the strongest resistances. The following case demonstrates the course of an analysis against strong resistances.

[82] A gentleman of whose intimate life I was ignorant told me the following dream: *“I found myself in a little room, seated at a table beside Pope Pius X, whose features were far more handsome than they are in reality, which surprised me. I saw on one side of our room a great apartment with a table sumptuously laid, and a crowd of ladies in evening-dress. Suddenly I felt a need to urinate, and I went out. On my*

return the need was repeated; I went out again, and this happened several times. Finally I woke up, wanting to urinate.”

[83] The dreamer, a very intelligent and well-educated man, naturally explained this to himself as a dream caused by irritation of the bladder. Indeed, dreams of this class are always so explained.

[84] He argued vigorously against the existence of any components of great individual significance in this dream. It is true that the façade of the dream was not very transparent, and I could not know what was hidden behind it. My first deduction was that the dreamer had a strong resistance because he put so much energy into protesting that the dream was meaningless.

[85] In consequence, I did not venture to put the indiscreet question: Why did you compare yourself to the Pope? I only asked him what ideas he associated with “Pope.” The analysis developed as follows:

Pope. “The Pope lives royally ...” (A well-known students’ song.) Note that this gentleman was thirty-one and unmarried.

Seated beside the Pope. “Just in the same way I was seated at the side of a Sheikh of a Moslem sect, whose guest I was in Arabia. The Sheikh is a sort of Pope.”

[86] The Pope is a celibate, the Moslem a polygamist. The idea behind the dream seems to be clear: “I am a celibate like the Pope, but I would like to have many wives like the Moslem.” I kept silent about these conjectures.

The room and the apartment with the table laid. “They are apartments in my cousin’s house, where I was present at a large dinner-party he gave a fortnight ago.”

The ladies in evening dress. “At this dinner there were also ladies, my cousin’s daughters, girls of marriageable age.”

[87] Here he stopped: he had no further associations. The appearance of this phenomenon, known as a mental inhibition, always justifies the conclusion that one has hit on an association which arouses strong resistance. I asked:

And these young women? “Oh, nothing; recently one of them was at F. She stayed with us for some time. When she went away I went to the station with her, along with my sister.”

[88] Another inhibition: I helped him out by asking:

What happened then? “Oh! I was just thinking [this thought had evidently been repressed by the censor] that I had said something to my sister that made us laugh, but I have completely forgotten what it was.”

[89] In spite of his sincere efforts to remember, it was at first impossible for him to recall what this was. Here we have a very common instance of forgetfulness caused by inhibition. All at once he remembered:

“On the way to the station we met a gentleman who greeted us and whom I seemed to recognize. Later, I asked my sister, Was that the gentleman who is interested in — [the cousin’s daughter]?”

[90] (She is now engaged to this gentleman, and I must add that the cousin’s family was very wealthy and that the dreamer was interested too, but he was too late.)

The dinner at the cousin’s house. “I shall shortly have to go to the wedding of two friends of mine.”

The Pope’s features. “The nose was exceedingly well-formed and slightly pointed.”

Who has a nose like that? (Laughing.) “A young woman I’m taking a great interest in just now.”

Was there anything else noteworthy about the Pope’s face? “Yes his mouth. It was a very shapely mouth. [Laughing.] Another young woman, who also attracts me, has a mouth like that.”

[91] This material is sufficient to elucidate a large part of the dream. The “Pope” is a good example of what Freud would call a *condensation*. In the first place he symbolizes the dreamer (celibate life), secondly he is a transformation of the polygamous Sheikh. Then he is the person seated beside the dreamer during a dinner, that is to say, one or rather two ladies—in fact, the two ladies who interest the dreamer.

[92] But how comes it that this material is associated with the need to urinate? To find the answer to this question I formulated the situation in this way:

You were taking part in a marriage ceremony and in the presence of a young lady when you felt you wanted to pass water? “True, that did happen to me once. It was very unpleasant. I had been invited to the marriage of a relative, when I was about eleven. In the church I was sitting next to a girl of my own age. The ceremony went on rather a long time, and I began to want to urinate. But I restrained myself until it was too late. I wetted my trousers.”

[93] The association of marriage with the desire to urinate dates from that event. I will not pursue this analysis, which does not end here, lest this paper should become too long. But what has been said is sufficient to show the technique, the procedure of analysis. Obviously it is impossible to give the reader a comprehensive survey of

these new points of view. The illumination that the psychoanalytic method brings to us is very great, not only for the understanding of dreams but for that of hysteria and the most important mental illnesses.

[94] The psychoanalytic method, which is in use everywhere, has already given rise to a considerable literature in German. I am persuaded that the study of this method is extremely important, not only for psychiatrists and neurologists but also for psychologists. The following works are recommended. For normal psychology: Freud, *The Interpretation of Dreams*, and “Jokes and Their Relation to the Unconscious.” For the neuroses: Breuer and Freud, *Studies on Hysteria*; Freud, “Fragment of an Analysis of a Case of Hysteria.” For the psychoses: Jung, *The Psychology of Dementia Praecox*. The writings of Maeder in the *Archives de psychologie* also give an excellent summary of Freud’s ideas.⁴

A CONTRIBUTION TO THE PSYCHOLOGY OF RUMOUR¹

[95] About a year ago the school authorities in N. asked me to furnish a report on the mental condition of Marie X., a thirteen-year-old school-girl. Marie had recently been expelled from the school because she was instrumental in originating an ugly rumour, spreading gossip about her class-teacher. The punishment hit the child, and especially her parents, very hard, so that the school authorities were inclined to readmit her under the cover of a medical opinion.

[96] The facts of the case were as follows. The teacher had heard indirectly that the girls were telling an ambiguous sexual story about him. On investigation, it was found that Marie had one day related a dream to three girl-friends which ran somewhat as follows:

The class was going to the bathing-place. I had to go with the boys because there was no more room.—Then we swam a long way out in the lake. (Asked “Who?” Marie said: “Lina,² the teacher, and me.”) A steamer came along. The teacher asked us: “Do you want a ride?” We came to K. A wedding was going on. (“Whose?” “A friend of the teacher’s.”) We were allowed to take part in it. Then we went on a journey. (“Who?” “Me, Lina, and the teacher.”) It was like a honeymoon trip. We came to Andermatt, and there was no more room in the hotel so we had to spend the night in a barn. There the woman got a child and the teacher became the godfather.

[97] This dream was told me by the child when I examined her. The teacher had also got her to tell the dream in writing. In this earlier version the obvious gap after “Do you want a ride?” was filled in by the words: “We got on it. Soon we felt cold. An old man gave us a blouse which the teacher put on.” On the other hand, there was an omission of the passage about finding no room in the hotel and having to spend the night in the barn.

[98] The child told the dream immediately not only to her three friends but also to her mother. The mother repeated it to me with only trifling differences from the two readings given above. In his investigations, carried out with the deepest misgivings, the teacher failed, like myself, to discover any other, more dangerous text. It is therefore very probable that the original story could not have been very different. (The passage about the cold and the blouse seems to be an early interpolation, as it tries to establish a logical relationship. Coming out of the water one is wet, has on only a bathing-dress, and therefore cannot take part in a wedding before putting on some clothes.) The teacher would not believe at first that it was simply a dream, he suspected it was an invention. But he had to admit that the innocent telling of the

dream was apparently a fact, and that it would be unnatural to credit the child with sufficient guile to make sexual innuendoes in such a veiled form. For a time he wavered between the view that it was a cunning invention and the view that it was really a dream, harmless in itself, which had been given a sexual twist by the other children. When his first indignation wore off he came to see that Marie's guilt could not be so great, and that the fantasies of her friends had contributed to the rumour. He then did something very praiseworthy: he placed Marie's schoolmates under supervision and made them all write out what they had heard of the dream.

[99] Before turning our attention to these accounts, let us first consider the dream analytically. To begin with, we must accept the facts and agree with the teacher that it really was a dream and not an invention—the ambiguities are too great for that. Conscious invention tries to create unbroken transitions; the dream takes no account of this, but proceeds regardless of gaps, which, as we have seen, give rise to interpolations during the conscious revision. The gaps are very significant. In the bathing-place there is no picture of undressing, being unclothed, nor any detailed description of being together in the water. The lack of clothes on the steamer is compensated by the above-mentioned interpolation, but only for the teacher, which shows that his nakedness was most urgently in need of cover. There is no detailed description of the wedding, and the transition from the steamer to the wedding celebration is abrupt. The reason for stopping overnight in the barn at Andermatt is undiscoverable at first. The parallel, however, is the lack of room in the bathing-place, which made it necessary for the girls to go to the men's section; the lack of room at the hotel again prevents the segregation of the sexes. The picture of the barn is very inadequately filled out: the birth follows suddenly and disconnectedly. The teacher as godfather is extremely ambiguous. Marie's role throughout the whole story is of secondary importance; she is no more than a spectator.

[100] All this has the appearance of a genuine dream, and those of my readers who have sufficient experience of dreams of girls of this age will certainly confirm this view. The interpretation of the dream is so simple that we can safely leave it to the children themselves, whose statements now follow.

Aural Witnesses

[101] (1) Marie dreamt that she and Lina went swimming with our teacher. When they had swum out pretty far in the lake, Marie said she could not swim any further, her foot hurt her so. Our teacher said, she could ride on my back. Marie got on and they swam out together. After a while a steamer came along and they got on it. It seems our teacher had a rope with him with which he tied Marie and Lina together, and so pulled them out into the lake after him. They went as far as Z., where they got out.

But now they had no clothes on. The teacher bought a jacket, and Marie and Lina got a long thick veil, and all three walked up the street by the lake. This was when the wedding was going on. Soon they met. The bride had on a blue silk dress but no veil. She asked Marie and Lina if they would be so kind as to give her their veil. Marie and Lina gave it and in return were allowed to go to the wedding. They went to the Sun Inn. Afterwards they made a honeymoon trip to Andermatt, I don't know whether they went to the inn at Andermatt or at Z. There they were given coffee, potatoes, honey, and butter. I must not say any more, only that in the end the teacher became the godfather.

[102] Here the roundabout story of lack of room at the bathing-place is missing; Marie goes swimming with the teacher right away. Their being together in the water is given a more personal relationship by the rope connecting the teacher and the two girls. The ambiguity about the "ride"³ in the original story has already had consequences here, for the part about the steamer now takes second place, and first place is given to the teacher, who takes Marie on his back. (The delightful little slip "she could ride on my back"—instead of *his*—shows the narrator's inner participation in the scene.) This explains why she brings the steamer into action somewhat abruptly, in order to give the equivocal "ride" a familiar, harmless turn, like the anticlimax in a music-hall song. The passage about the lack of clothes, the ambiguity of which has already been noted, arouses her special interest. The teacher buys a jacket, the girls get a long thick veil, such as is worn only in case of death or at weddings. That the wedding is meant here in a wider sense is shown by the remark that the bride had no veil: the one who has the veil is the bride! The narrator, a good friend of Marie, helps her to dream the dream further: the possession of the veil characterizes Marie and Lina as brides. Anything offensive or immoral in this situation is relieved by the girls' surrendering the veil; the narrator thus gives the story an innocent turn. The same mechanism is followed in the embellishment of the ambiguous situation at Andermatt: there is nothing but nice things, coffee, potatoes, honey, and butter, a reversion to the infantile on the well-known pattern. The conclusion seems to be very abrupt: the teacher becomes a godfather.

[103] (2) Marie dreamt that she went bathing with Lina and the teacher. Far out in the lake Marie told the teacher her leg was hurting. The teacher said she could ride on his back. I don't know now whether the last sentence was really told so, but I think it was. As there was a ship on the lake just then, the teacher said she should swim to the ship and then get in. I really don't remember any more how she told it.—Then the teacher or Marie, I don't know which, said they would get out at Z. and run home. So the teacher called to two gentlemen, who had just been bathing, to carry the children ashore. Lina sat on one man's back and Marie on the other fat man, and the teacher held on to the fat man's leg and swam after them. When they landed they ran home.

On the way the teacher met his friend, who had a wedding. Marie said, it was then the fashion to go on foot, not in a carriage. Then the bride said they could come along too. Then the teacher said it would be nice if the two girls gave the bride their black veil, which they had got on the way, I don't know where. The girls gave it to her, and the bride said they were nice generous children. Then they went on further and stopped at the Sun Inn. There they had something to eat, I don't know what. Then they went on the honeymoon trip to Andermatt. They went into a barn and danced. All the men had taken off their coats except the teacher. The bride said he should take off his coat too. The teacher refused, but at last he did. Then the teacher was ... The teacher said he felt cold. I mustn't tell any more, it is improper. That's all I heard of the dream.

[104] The narrator pays special attention to the "ride," but is uncertain whether in the original story it referred to the teacher or the steamer. This uncertainty is amply compensated by the elaborate story of the two strange gentlemen who took the girls on their backs. For her, the piggyback is too valuable a thought to be relinquished, only she is embarrassed at the idea of the teacher as its object. The lack of clothes likewise arouses strong interest. The bridal veil has now become black, like a veil of mourning (naturally in order to conceal anything indelicate). Here the innocent turn has even been given a virtuous accent ("nice generous children"); the immoral wish has surreptitiously changed into something virtuous on which special emphasis is laid, suspect like every accentuated virtue. The narrator has exuberantly filled in the blanks in the scene of the barn; the men take off their coats, the teacher follows suit and is consequently ... naked, and feels cold. Whereupon it becomes too "improper." She has correctly recognized the parallels we conjectured above when discussing the original story, and has added the undressing scene—which really belongs to the bathing scene—here, for it had to come out in the end that the girls were together with the naked teacher.

[105] (3) Marie told me she had dreamt: Once I went bathing but there was no more room. The teacher took me into his cabin. I undressed and went bathing. I swam until I reached the bank. There I met the teacher. He said, wouldn't I like to swim across the lake with him? I went, and Lina also. We swam out and were soon in the middle of the lake. I did not want to swim any further. Now I can't remember it exactly. Soon a ship came along and we got on the ship. The teacher said, "I'm cold," and a sailor gave us an old shirt. Each of us tore a piece off. I tied it round my neck. Then we left the ship and swam on to K.

Lina and I did not want to go any further and two fat men took us on their backs. In K. we got a veil which we put on. In K. we went into the street. The teacher met his friend who invited us to his wedding. We went to the Sun Inn and played games.

We also danced the polonaise. Now I don't remember exactly. Afterwards we went on the honeymoon trip to Andermatt. The teacher had no money with him and stole some chestnuts. The teacher told us, "I am so glad I can travel with my two pupils." Now comes something improper which I will not write. Now the dream is finished.

[106] Here the undressing together takes place in the bathing-cabin. The lack of clothes on the ship gives rise to a new variant (old shirt torn into three pieces). Because of its uncertainty, the sitting on the teacher is not mentioned. Instead, the girls sit on the backs of two fat men. As "fat" is stressed in this and the previous version, it is worth mentioning that the teacher was more than a little plump. The substitution is typical: each of the girls has a teacher. Duplication or multiplication of personalities expresses their significance, i.e., their investment with libido. The same is true of the repetition of actions.⁴ The significance of this multiplication is especially clear in religion and mythology. (Cf. the Trinity and the two mystic formulae of confession: "Isis una quae es omnia," "Hermes omnia solus et ter unus.") Proverbially we say: "He eats, drinks, or sleeps 'for two.'" Also, the multiplication of personality expresses an analogy or comparison: *my friend* has the "same aetiological value" as *myself* (Freud). In dementia praecox, or schizophrenia, to use Bleuler's broader and better term, the multiplication of personality is primarily the expression of libido investment, for it is invariably the person to whom the patient has a transference who is liable to multiplication. ("There are two Professor N's." "Oh, so you are Dr. Jung too. This morning another person came to see me who also called himself Dr. Jung.") It seems that, in keeping with the general tendency of schizophrenia, this splitting is an analytical depotentiation for the purpose of preventing too powerful impressions. A further significance of the multiplication of personality, though it does not come exactly into this category, is the raising of some attribute to a living figure. A simple example is Dionysus and his companion Phales, Phales (*phallos*) being the personification of the penis of Dionysus. The so-called Dionysian train (satyrs, tityrs, Sileni, maenads, Mimallones, etc.) consists of personifications of Dionysian attributes.

[107] The scene in Andermatt is portrayed with a nice wit, or more correctly, is dreamt further. "The teacher stole some chestnuts" is equivalent to saying that he did something prohibited. By chestnuts is meant roast chestnuts, which because of the split are known to be female sexual symbols. Hence the teacher's remark that he was "so glad to travel with his two pupils," following directly on the theft of the chestnuts, becomes understandable. The theft of the chestnuts is certainly a personal interpolation, for it occurs in no other account. It shows how intense was the inner participation of her schoolmates in Marie's dream, i.e., it had the "same aetiological value" for them.

[108] This is the last of the aural witnesses. The story of the veil and the pain in the foot or leg are items which may well have been mentioned in the original narrative. Other interpolations are altogether personal and are based on inner participation in the meaning of the dream.

Hearsay Evidence

[109] (1) The whole school went bathing with the teacher. Only Marie had no room to undress in the bathing-place. So the teacher said, "You can come into my room and undress with me." She must have felt very uncomfortable. When both were undressed they went into the lake. The teacher took a long cord and tied it round Marie. Then they both swam far out. But Marie got tired, so the teacher took her on his back. Then Marie saw Lina, she called out, "Come with me," and Lina came. They all swam out still further. They met a ship. Then the teacher asked, "May we get in? These girls are tired." The ship stopped and they all got in. I don't know exactly how they came ashore at K. Then the teacher got an old night-shirt. He put it on. Then he met a friend who was having a wedding. Teacher, Marie, and Lina were invited. The wedding was celebrated at the Crown in K. They wanted to dance the polonaise. The teacher said he would not do it. But the others said he might as well. He did it with Marie. Teacher said, "I will not go home any more to my wife and children. I love you best, Marie." She was very pleased. After the wedding there was a honeymoon trip. Teacher, Marie, and Lina were allowed to go with them. The trip was to Milan. Afterwards they went to Andermatt, where they could find no place to sleep. They went to a barn, where they could stop the night all together. I must not tell any more because it becomes very indecent.

[110] The undressing scene at the bathing-place is fully developed. The swim undergoes a simplification for which the story of the rope had paved the way: the teacher ties himself to Marie, but Lina is not mentioned here, she comes only later when Marie was already sitting on the teacher's back. Here the clothing is a night-shirt. The wedding celebrations are given a very direct interpretation: the teacher does not want to go home any more to his wife and children, he loves Marie best. In the barn they found a place "all together" and then it "became very indecent."

[111] (2) They said she had gone with the school to the bathing-place to bathe. But as the bathing-place was too full, the teacher called her to come with him. Then we swam out in the lake and Lina followed us. Then the teacher took a cord and tied us together. I don't know exactly how they got separated again. But after a long time they suddenly arrived at Z. There a scene is said to have taken place which I would rather not tell, for if it was true it would be too shameful. Also I don't know exactly what is supposed to have happened as I was very tired. Only I have heard that Marie

said she was always to remain with the teacher now, and that he hugged her again and again as his best pupil. If I knew exactly I would also tell the other thing, but my sister only said something about a little child that was born there, and the teacher was said to be the godfather.

[112] Note that in this story the indecent scene is inserted at the wedding festivities, where it is just as appropriate as at the end, for the attentive reader will long ago have observed that it could also have taken place in the bathing-cabin. Actually, things have happened as they usually do in dreams: the final thought in a long series of dream-images contains precisely what the first image in the series was trying to represent. The censor pushes the complex away as long as possible by means of ever-renewed symbolical disguises, displacements, bowdlerizations, etc. Nothing happens in the bathing-cabin, there is no piggyback in the water, on landing it is not on the teacher's back that the girls sit, it is another pair who get married, another girl has a child in the barn, and the teacher is only—godfather. But all these situations and images lend themselves to representing the wish for coitus. Behind all these metamorphoses the action nevertheless takes place, and the result is the birth staged at the end.

[113] (3) Marie said: the teacher had a wedding with his wife, and afterwards they went to the Crown and danced together. Marie said all sorts of other wild things which I must not tell or write about, it is too embarrassing.

[114] Here pretty well everything is too improper to be told. Note that the wedding takes place with the “wife.”

[115] (4) The teacher and Marie went bathing, and he asked Marie if she wanted to come along too. She said yes. When they had gone out together they met Lina, and the teacher asked if she wanted to come with them. And they went further out. Then I heard that she said the teacher said that Lina and she were his favourite pupils. She also told us that the teacher was in his bathing-dress. Then they went to a wedding and the bride got a little child.

[116] The personal relationship to the teacher is strongly emphasized (“favourite pupils”), likewise the inadequate clothing (“bathing-dress”).

[117] (5) Marie and Lina went bathing with the teacher. When Marie and Lina and the teacher had swum a little way, Marie said, “Teacher, I can't go any further, my foot hurts me.” The teacher told her to sit on his back and Marie did so. Then a little steamer came along and the teacher got into the ship. The teacher had two ropes with him and tied the children to the ship. Then they all went to Z. and got out there. The teacher bought himself a night-shirt and put it on and the children put a towel over them. Teacher had a bride and they were in a barn. The two children were also with

the teacher and his bride in the barn and they danced. I must not write the other thing for it is too awful.

[118] Here Marie sits on the teacher's back. The teacher fastens the two children to the ship with ropes, from which it can be seen how easily "ship" is substituted for "teacher." The nightshirt again emerges as the article of clothing. It was the teacher's own wedding, and what is improper comes after the dance.

[119] (6: Lina.) The teacher went bathing with the whole school. Marie could not find any room, and she cried. The teacher then told Marie she could come into his cabin.

"I must leave out something here and there," said my sister, "for it is a long story." But she told me something more which I must tell in order to speak the truth. When they were in the water the teacher asked Marie if she would like to swim across the lake with him. She answered that if I came she would come too. Then we swam about halfway. Marie got tired and the teacher pulled her by a cord. At K. they went on shore and from there to Z. All this time the teacher is supposed to have been dressed as for swimming. There we met a friend who was having a wedding. We were invited to it by this friend. After the feast there was a honeymoon trip, and we went to Milan. We had to sleep one night in a barn and there something happened which I must not tell. The teacher said we were his favourite pupils, and he also kissed Marie.

[120] The excuse "I must leave out something here and there" replaces the undressing scene. Special emphasis is laid on the teacher's inadequate clothing. The journey to Milan is a typical honeymoon trip. This passage likewise seems to be an independent fantasy due to inner participation. Marie clearly figures as the loved one.

[121] (7) The whole school and teacher went bathing. They all went into a room. Teacher also. Only Marie could find no room, so the teacher said to her, "I still have room." She went. Then the teacher said, "Lie on my back, I will swim out into the lake with you." I must not write any more, for it is so improper that I can hardly even say it. Except for the improper part which followed I know nothing more of the dream.

[122] This narrator is getting down to the facts. Already at the bathing-place Marie was to lie on the teacher's back. Logically enough the narrator does not know anything of the rest of the dream except the improper part.

[123] (8) The whole school went bathing. Marie had no room and was invited into his cabin by the teacher. The teacher swam out with her and told her, straight, she was his darling or something like that. When they came ashore at Z. a friend had just had a wedding and this friend invited them both in their bathing-costume. The teacher had found an old night-shirt and put it on over his swimming-pants. He also kissed Marie a lot and said he would not go home to his wife any more. They were both

invited on the honeymoon trip. The journey went through Andermatt, where they could not find any place to sleep, and so had to sleep in the hay. A woman was there too, now comes the dreadful part, and it is not at all right to laugh and joke about something so serious. This woman got a little child, but I will not say any more for it is too dreadful.

[124] The narrator is very downright (“he told her, straight, she was his darling,” “he kissed her a lot” etc.). Her obvious indignation over the silly tattling tells us something special about her character. Subsequent investigations showed that this girl was the only one of all the witnesses who had been sexually enlightened by her mother.

Summary

[125] So far as the interpretation of the dream is concerned, there is nothing for me to add; the children themselves have done all that is necessary, leaving practically nothing over for psychoanalytic interpretation. *The rumour has analysed and interpreted the dream.* So far as I know, rumour has not been investigated in this capacity up to now. Our case certainly makes it appear worth while to fathom the psychology of rumour from the psychoanalytic side. In presenting the material I have purposely restricted myself to the psychoanalytic point of view, though I do not deny that my material offers numerous openings for the invaluable researches of the followers of Stern, Claparède, and others.

[126] The material enables us to understand the structure of the rumour, but psychoanalysis cannot rest satisfied with that. We need to know more about the why and the wherefore of the whole phenomenon. As we have seen, the teacher was greatly affected by the rumour and was left puzzled by the problem of its cause and effect. How can a dream, which is notoriously harmless and never means anything (teachers, as we know, also have a training in psychology), produce such effects, such malicious gossip? Faced with this question, the teacher seems to me to have hit instinctively on the right answer. The effect of the dream can only be explained by its being “le vrai mot de la situation”; that is to say, it gave suitable expression to something that was already in the air. It was the spark which fell into the powder-barrel. Our material affords all the necessary proofs of this view. Throughout, I have drawn attention to the inner participation of Marie’s schoolmates in her dream, and to the points of special interest where some of them have added their own fantasies or day-dreams. The class consisted of girls between the ages of twelve and thirteen, who were therefore in the midst of the prodromata of puberty. The dreamer herself was almost fully developed sexually and in this respect ahead of her class; she was the

leader who gave the watchword for the unconscious and so detonated the sexual complexes lying dormant in her companions.

[127] As can easily be understood, the whole affair was most distressing for the teacher. The supposition that this, precisely, was what the girls secretly intended is justified by the psychoanalytic axiom that actions are to be judged more by their results than by their conscious motives.⁵ Accordingly, we would conjecture that Marie had been especially troublesome to her teacher. At first she liked this teacher most of all. In the course of the last six months, however, her position had changed. She had become dreamy and inattentive, she was afraid to go into the streets after dark because of bad men. On several occasions she talked about sex to her companions in a rather obscene way; her mother asked me anxiously how she was to explain the approaching menstruation to her daughter. Because of her behaviour she had forfeited the good opinion of her teacher, as was clearly evidenced for the first time by a bad report which she and some of her friends received a few days before the outbreak of the rumour. Their disappointment was so great that the girls indulged in all sorts of vengeful fantasies about the teacher; for instance, they might push him on to the rails so that the train would run over him. Marie was especially to the fore in these murderous fantasies. On the night following this great outburst of anger, when her former love for her teacher seemed quite forgotten, that repressed part of herself rose up in the dream, and fulfilled its wish for sexual union with the teacher—as compensation for the hate which had filled the day.⁶ On waking, the dream became a subtle instrument of her hatred, because its wishful thinking was also that of her companions, as it always is in rumours of this kind. Revenge certainly had its triumph, but the recoil upon Marie herself was even more severe. Such is the rule when our impulses are given over to the unconscious. Marie was expelled from school, but on my report was allowed to return.

[128] I am well aware that this short report is inadequate and unsatisfactory from the point of view of exact science. Had the original story been accurately verified we could have demonstrated quite clearly what we have now only been able to suggest. This case, therefore, merely poses a question, and it remains for more fortunate observers to collect really convincing evidence in this field.

ON THE SIGNIFICANCE OF NUMBER DREAMS¹

[129] The symbolism of numbers, which greatly engaged the philosophic fantasy of earlier centuries, has acquired a fresh interest from the analytical researches of Freud and his school. In the material of number dreams we no longer discover conscious speculations on the symbolic connections between numbers, but rather the unconscious roots of number symbolism. As there is nothing fundamentally new to be offered in this field since the researches of Freud, Adler, and Stekel, we must content ourselves with corroborating their experience by citing parallel cases. I have under observation a few cases of this kind which may be worth reporting for their general interest.

[130] The first three examples are from a middle-aged man whose conflict of the moment was an extramarital love-affair. The dream-fragment from which I take the symbolical number is: ... *the dreamer shows his season ticket to the conductor. The conductor protests at the high number on the ticket. It was 2477.*

[131] The analysis of the dream brought out a rather ungentlemanly reckoning up of the expenses of this love-affair, which was foreign to the dreamer's generous nature. His unconscious made use of this in order to resist the affair. The most obvious interpretation would be that this number had a financial significance and origin. A rough estimate of the expenses so far involved led to a number which in fact approached 2477 francs; a more careful calculation gave 2387 francs, a number which could only arbitrarily be translated into 2477. I then left the number to the free association of the patient. It occurred to him that in the dream the number appeared divided: 24 77. Perhaps it was a telephone number. This conjecture proved incorrect. The next association was that it was the sum of various other numbers. At this point the patient remembered telling me earlier that he had just celebrated the hundredth birthday of his mother and himself, since she was sixty-five and he was thirty-five. (Their birthdays fell on the same day.) In this way he arrived at the following series of associations:

He was born on	26. II ²
His mistress	28. VIII
His wife	1. III
His mother (his father was long dead)	26. II
His two children	29. IV
	13. VII
He was born	II. 75 ³
His mistress	VIII. 85
He was now	36
His mistress	25

[132] If this series of associations is written down in the usual figures, we get the following sum:

262
288
13
262
294
137
275
885
36
25

2477

- [133] This series, which includes all the members of his family, thus gives the number 2477. Its composition led to a deeper layer of the dream's meaning. The patient was greatly attached to his family but on the other hand very much in love with his mistress. This caused him severe conflicts. The details of the "conductor's" appearance (omitted here for the sake of brevity) pointed to the analyst, from whom the patient both feared and wished firm control as well as sharp censure of his dependent state.
- [134] The dream that followed shortly afterwards ran (much abbreviated): *The analyst asked the patient what he actually did when he was with his mistress. The patient said he gambled, and always on a very high number: 152. The analyst remarked: "You are sadly cheated."*
- [135] Analysis once more revealed a repressed tendency to reckon up the costs of the affair. The monthly expenses amounted to close on 152 francs (actually between 148 and 158). The remark that he was being cheated alluded to the point at issue between himself and his mistress. She asserted that he deflowered her, but he was quite convinced that she was not a virgin and had already been deflowered by someone else at a time when he was seeking her favours and she was refusing him. The word "number" led to the association "size in gloves," "size of calibre." From there it was but a short step to the fact that he had noted at the first coitus a remarkable width of the opening instead of the expected resistance of the hymen. This seemed to him proof of deception. The unconscious naturally used this discovery as a most effective means of resistance against the relationship. The number 152 proved refractory at first to further analysis. But on a later occasion it led to the not so distant idea of a "house number," followed by these associations: when he first knew her the lady lived at 17 X Street, then at 129 Y Street, then at 48 Z Street.
- [136] Here the patient realized that he had already gone far beyond 152, for the total was 194. It then occurred to him that, for certain reasons, the lady had left 48 Z Street at his instigation, so the total must be $194 - 48 = 146$. She was now living at 6 A Street, hence it was $146 + 6 = 152$.
- [137] Later in the analysis he had the following dream: *He received a bill from the analyst charging him interest of 1 franc on a sum of 315 francs for delay in payment from the 3rd to the 29th September.*

[138] This reproach of meanness and avariciousness levelled at the analyst covered, as analysis proved, a strong unconscious envy. There were several things in the analyst's life that might arouse the envy of the patient. One thing in particular had made an impression on him: the analyst had lately had an addition to his family. The disturbed relations between the patient and his wife unfortunately permitted no such expectation in his case. There was therefore ample ground for invidious comparisons.

[139] As before, the analysis started by dividing the number 315 into 3 1 5. The patient associated 3 with the fact that the analyst had 3 children, with the recent addition of another 1. He himself would have had 5 children if all were living, as it was he had $3 - 1 = 2$, for 3 children were stillborn. But these associations were far from exhausting the number symbolism of the dream.

[140] The patient remarked that the period from the 3rd to the 29th September comprised 26 days. His next thought was to add this and the remaining numbers together: $26 + 315 + 1 = 342$. He then carried out the same operation on 342 as on 315, dividing it into 3 4 2. Whereas before it came out that the analyst had 3 children, with 1 in addition, and the patient would have had 5, now the meaning was: the analyst had 3 children, now has 4, but the patient only 2. He remarked that the second number sounded like a rectification of the wish-fulfilment of the first.

[141] The patient, who had discovered this explanation for himself without my help, declared himself satisfied. His analyst, however, was not; to him it seemed that the above revelations did not exhaust the possibilities determining the unconscious products. In connection with the number 5, the patient had carefully noted that, of the 3 stillborn children, 1 was born in the 9th and 2 in the 7th month. He also emphasized that his wife had had 2 miscarriages, 1 in the 5th week and 1 in the 7th. If we add these figures together we get the determination of the number 26:

1 child		7 months
1 "		7 "
1 "		9 "
2 miscarriages (5 + 7 weeks)	=	3 "
		<u>26</u>

[142] It seems as if 26 were determined by the number of lost periods of pregnancy. In the dream the period of 26 days denoted a delay for which the patient was charged 1 franc interest. Owing to the lost pregnancies he did in fact suffer a delay, for during the time in which the patient knew him the analyst got ahead by 1 child, 1 franc may therefore mean 1 child. We have already noted the patient's tendency to add together all his children, including the dead ones, in order to outdo his rival. The thought that his analyst had outdone him by 1 child might influence even more strongly the determination of the number 1. We shall therefore follow up this tendency of the patient and continue his number game by adding to 26 the 2 successful pregnancies of 9 months each: $26 + 18 = 44$.

[143] Dividing the numbers again into integers we get $2 + 6$ and $4 + 4$, two groups of figures which have only one thing in common, that each gives 8 by addition. It is to be noted that these figures are composed entirely of the months of pregnancy accruing to the patient. If we compare them with the figures indicating the progenerative capacity of the analyst, namely 315 and 342, we observe that the latter, added crosswise, each gives a total of 9. Now $9 - 8 = 1$. Again it seems as if the thought of the difference of 1 were asserting itself. The patient had remarked earlier that 315 seemed to him a wish-fulfilment and 342 a rectification. Letting our fantasy play round them, we discover the following difference between the two numbers:

$$3 \times 1 \times 5 = 15 \quad 3 \times 4 \times 2 = 24 \quad 24 - 15 = 9$$

[144] Once more we come upon the significant figure 9, which fits very aptly into this calculus of pregnancies and births.

[145] It is difficult to say where the borderline of play begins—necessarily so, for an unconscious product is the creation of sportive fantasy, of that psychic impulse out of which play itself arises. It is repugnant to the scientific mind to indulge in this kind of playfulness, which tails off everywhere in inanity. But we should never forget that the human mind has for thousands of years amused itself with just this kind of game, so it would be no wonder if those tendencies from the distant past gained a hearing in dreams. Even in his waking life the patient gave free rein to his number-fantasies, as the fact of celebrating the 100th birthday shows. Their presence in his dreams is therefore beyond question. For a single example of unconscious determination exact proofs are lacking, only the sum of our experiences can corroborate the accuracy of the individual discoveries. In investigating the realm of free creative fantasy we have to rely, more almost than anywhere else, on a broad empiricism; and though this enjoins on us a high degree of modesty with regard to the accuracy of individual results, it by no means obliges us to pass over in silence what has happened and been observed, simply from fear of being execrated as unscientific. There must be no parleying with the superstition-phobia of the modern mind, for this is one of the means by which the secrets of the unconscious are kept veiled.

[146] It is particularly interesting to see how the problems of the patient were mirrored in the unconscious of his wife. His wife had the following dream: she dreamt—and this is the whole dream—*Luke 137*. Analysis of this number showed that she associated as follows: the analyst has got 1 more child. He had 3. If all her children (counting the miscarriages) were living, she would have 7; now she has only $3 - 1 = 2$. But she wants $1 + 3 + 7 = 11$ (a twin number, 1 and 1), which expresses her wish that her two children had been pairs of twins, for then she would have had the same number of children as the analyst. Her mother once had twins. The hope of getting a child by her husband was very precarious, and this had long since implanted in the unconscious the thought of a second marriage.

[147] Other fantasies showed her as “finished” at 44, i.e., when she reached the climacteric. She was now 33, so there were only 11 more years to go till she was 44. This was a significant number, for her father died in his 44th year. Her fantasy of the 44th year thus

contained the thought of her father's death. The emphasis on the death of her father corresponded to the repressed fantasy of the death of her husband, who was the obstacle to a second marriage.

[148] At this point the material to "Luke 137" comes in to help solve the conflict. The dreamer, it must be emphatically remarked, was not at all well up in the Bible, she had not read it for an incredible time and was not in the least religious. It would therefore be quite hopeless to rely on associations here. Her ignorance of the Bible was so great that she did not even know that "Luke 137" could refer only to the Gospel according to St. Luke. When she turned up the New Testament she opened it instead at the Acts of the Apostles.⁴ As Acts 1 has only 26 verses, she took the 7th verse: "It is not for you to know the times or the seasons, which the Father hath put in his own power." But if we turn to Luke 1 : 37, we find the Annunciation of the Virgin:

35. The Holy Ghost shall come upon thee, and the power of the Highest shall overshadow thee: therefore also that holy thing which shall be born of thee shall be called the Son of God.

36. And, behold, thy cousin Elisabeth, she hath also conceived a son in her old age: and this is the sixth month with her, who was called barren.

37. For with God nothing shall be impossible.

[149] The logical continuation of the analysis of "Luke 137" requires us also to look up Luke 13 : 7. There we read:

6. A certain man had a fig tree planted in his vineyard; and he came and sought fruit thereon, and found none.

7. Then said he unto the dresser of his vineyard, Behold, these three years I come seeking fruit on this fig tree, and find none: cut it down; why cumbereth it the ground?

[150] The fig-tree, since ancient times a symbol of the male genitals, must be cut down on account of its unfruitfulness. This passage is in complete accord with the numerous sadistic fantasies of the dreamer, which were concerned with cutting off or biting off the penis. The allusion to her husband's unfruitful organ is obvious. It was understandable that the dreamer withdrew her libido from her husband, for with her he was impotent,⁵ and equally understandable that she made a regression to her father ("... which the Father hath put in his own power") and identified with her mother, who had twins. By thus advancing her age she put her husband in the role of a son or boy, of an age when impotence is normal. We can also understand her wish to get rid of her husband, as was moreover confirmed by her earlier analysis. It is therefore only a further confirmation of what has been said if, following up the material to "Luke 137," we turn to Luke 7 : 13:

12. Now when he came nigh to the gate of the city, behold, there was a dead man carried out, the only son of his mother, and she was a widow ...

13. And when the Lord saw her, he had compassion on her, and said unto her, Weep not.

14. And he came and touched the bier: and they that bare him stood still. And he said, Young man, I say unto thee, Arise.

[151] In the particular psychological situation of the dreamer the allusion to the raising up of the dead man acquires a pretty significance as the curing of her husband's impotence. Then the whole problem would be solved. There is no need for me to point out in so many words the numerous wish-fulfillments contained in this material; the reader can see them for himself.

[152] Since the dreamer was totally ignorant of the Bible, "Luke 137" must be regarded as a cryptomnesia. Both Flournoy⁶ and myself⁷ have already drawn attention to the important effects of this phenomenon. So far as one can be humanly certain, any manipulation of the material with intent to deceive is out of the question in this case. Those familiar with psychoanalysis will know that the whole nature of the material rules out any such suspicion.

[153] I am aware that these observations are floating in a sea of uncertainties, but I think it would be wrong to suppress them, for luckier investigators may come after us who will be able to put them in the right perspective, as we cannot do for lack of adequate knowledge.

MORTON PRINCE, "THE MECHANISM AND INTERPRETATION OF DREAMS": A CRITICAL REVIEW¹

[154] I hope that all colleagues and fellow workers who, following in Freud's footsteps, have investigated the problem of dreams, and have been able to confirm the basic principles of dream-interpretation, will forgive me if I pass over their corroborative work and speak instead of another investigation which, though it has led to less positive results, is for that reason the more suited to public discussion. A fact especially worth noting is that Morton Prince, thanks to his previous work and his deep insight into psychopathological problems, is singularly well equipped to understand the psychology inaugurated by Freud. I do not know whether Morton Prince has sufficient command of German to read Freud in the original, though this is almost a *sine qua non* for understanding him. But if he must rely only on writings in English, the very clear presentation of dream-analysis by Ernest Jones, in "Freud's Theory of Dreams,"² would have given him all the necessary knowledge. Apart from that, there are already a large number of articles and reports by Brill and Jones, and recently also by Putnam,³ Meyer, Hoch, Scripture, and others, which shed light on the various aspects of psychoanalysis (or "depth psychology," as Bleuler calls it). And, for full measure, there have been available for some time not only Freud's and my lectures at Clark University,⁴ but several translations of our works as well, so that even those who have no knowledge of German would have had ample opportunity to familiarize themselves with the subject.

[155] It was not through personal contact, of whose suggestive influence Professor Hoche⁵ has an almost superstitious fear very flattering to us, but presumably through reading that Morton Prince acquired the necessary knowledge of analysis. As the German-speaking reader may be aware, Morton Prince is the author of a valuable book, *The Dissociation of a Personality*, which takes a worthy place beside the similar studies of Binet, Janet, and Flournoy.⁶ Prince is also, of course, the editor of the *Journal of Abnormal Psychology*, in almost every issue of which questions of psychoanalysis are discussed without bias.

[156] From this introduction the reader will see that I am not saying too much when I represent Morton Prince as an unprejudiced investigator with a firmly established scientific reputation and undisputed competence in judging psychopathological problems. Whereas Putnam is chiefly concerned with the therapeutic aspect of psychoanalysis and has discussed it with admirable frankness, Morton Prince is interested in a particularly controversial subject, namely, dream-analysis. It is here that every follower of Freud has lost his honourable name as a man of science in the

eyes of German scientists. Freud's fundamental contribution, *The Interpretation of Dreams*, has been treated, with irresponsible levity by the German critics. As usual, they were ready to hand with glib phrases like "brilliant mistake," "ingenious aberration," etc. But that any of the psychologists, neurologists, and psychiatrists should really get down to it and try out his wit on Freud's dream-interpretation was too much to expect.⁷ Perhaps they did not dare to. I almost believe they did not dare, because the subject is indeed very difficult—less, I think, for intellectual reasons than on account of personal, subjective resistances. For it is just here that psychoanalysis demands a sacrifice which no other science demands of its adherents: ruthless self-knowledge. It needs to be repeated again and again that *practical and theoretical understanding of psychoanalysis is a function of analytical self-knowledge*. Where self-knowledge fails, psychoanalysis cannot flourish. This is a paradox only so long as people think that they know themselves. And who does not think that? In ringing tones of deepest conviction everyone assures us that he does. And yet it is simply not true, a childish illusion which is indispensable to one's self-esteem. There can be no doubt whatever that a doctor who covers up his lack of knowledge and ability with increased self-confidence will never be able to analyse, for otherwise he would have to admit the truth to himself and would become impossible in his own eyes.

[157] We must rate it all the higher, then, when a scientist of repute, like Morton Prince, courageously tackles the problem and seeks to master it in his own way. We are ready to meet at any time the objections that spring from honest work of this kind. We have no answer only for those who are afraid of real work and are satisfied with making cheap academic speeches. But before taking up Prince's objections, we shall have a look at his field of inquiry and at his—in our sense—positive results. Prince worked through six dreams of a woman patient who was capable of different states of consciousness and could be examined in several of these states. He used interrogation under hypnosis as well as "free association." We learn that he had already analysed several dozen dreams.⁸ Prince found that the method of free association "enables us by the examination of a large number of dreams in the same person to search the whole field of the unconscious, and by comparison of all the dreams to discover certain persistent, conserved ideas which run through and influence the psychological life of the individual."⁹ Using the "insane" psychoanalytic method, therefore, the American investigator was able to discover, in the realm of the unconscious, something that perceptibly influences psychic life. For him the "method" is a method after all, he is convinced that there is an unconscious and all the rest of it, without being in any way hypnotized by Freud personally.

[158] Prince admits, further, that we must consider as dream-material "certain subconscious ideas of which the subject had not been aware" (p. 150), thus

recognizing that the sources of dreams can lie in the unconscious. The following passage brings important and emphatic confirmation of this:

It was a brilliant stroke of genius that led Freud to the discovery that dreams are not the meaningless vagaries that they were previously supposed to be, but when interpreted through the method of psychoanalysis may be found to have a logical and intelligible meaning. This meaning, however, is generally hidden in a mass of symbolism which can only be unraveled by a searching investigation into the previous mental experiences of the dreamer. Such an investigation requires, as I have already pointed out, the resurrection of all the associated memories pertaining to the elements of the dream. When this is done the conclusion is forced upon us, I believe, that even the most fantastic dream may express some intelligent idea, though that idea may be hidden in symbolism. My own observations confirm those of Freud, so far as to show that running through each dream there is an intelligent *motive*; so that the dream can be interpreted as expressing some idea or ideas which the dreamer previously has entertained. At least all the dreams I have subjected to analysis justify this interpretation.

[159] Prince is thus in a position to admit that dreams have a meaning, that the meaning is hidden in symbols, and that in order to find the meaning one needs the memory-material. All this confirms essential portions of Freud's dream interpretation, far more than the *a priori* critics have ever admitted. As a result of certain experiences Prince has also come to conceive hysterical symptoms "as possible symbolisms of hidden processes of thought." In spite of the views expressed in Binswanger's *Die Hysterie*, which might have prepared the ground, this has still not penetrated the heads of German psychiatrists.

[160] I have, as I said, begun with Prince's affirmative statements. We now come to the deviations and objections (p. 151):

I am unable to confirm [Freud's view] that every dream can be interpreted as "the imaginary fulfillment of a wish," which is the motive of the dream. That sometimes a dream can be recognized as the fulfillment of a wish there can be no question, but that every dream, or that the majority of dreams are such, I have been unable to verify, even after subjecting the individual to the most exhaustive analysis. On the contrary I find, if my interpretations are correct, that some dreams are rather the expression of the non-fulfillment of a wish; some seem to be that of the fulfillment of a fear or anxiety.

[161] In this passage we have everything that Prince cannot accept. It should be added that the wish itself often seems to him not to be "repressed" and not to be so unconscious or important as Freud would lead us to expect. Hence Freud's theory

that a repressed wish is the real source of the dream, and that it fulfils itself in the dream, is not accepted by Prince, because he was unable to see these things in his material. But at least he tried to see them, and the theory seemed to him worth a careful check, which is definitely not the case with many of our critics. (I should have thought that this procedure would be an unwritten law of academic decency.) Fortunately, Prince has also presented us with the material from which he drew his conclusions. We are thus in a position to measure our experience against his and at the same time to find the reasons for any misunderstanding. He has had great courage in exposing himself in this commendable way, for we now have an opportunity to compare our divergencies openly with his material, a procedure which will be instructive in every respect.

[162] In order to show how it is that Prince was able to see only the formal and not the dynamic element of the dreams, we must examine his material in more detail. One gathers, from various indications in the material, that the dreamer was a lady in late middle age, with a grown-up son who was studying, and apparently that she was unhappily married (or perhaps divorced or separated). For some years she had suffered from an hysterical dissociation of personality, and, we infer, had regressive fantasies about two earlier love-affairs, which the author, perhaps owing to the prudery of the public, is obliged to hint at rather too delicately. He succeeded in curing the patient of her dissociation for eighteen months, but now things seem to be going badly again, for she remained anxiously dependent on the analyst, and he found this so tiresome that he twice wanted to send her to a colleague.

[163] Here we have the well-known picture of an unanalysed and unadmitted transference, which, as we know, consists in the anchoring of the patient's erotic fantasies to the analyst. The six dreams are an illustrative excerpt from the analyst's struggle against the clinging transference of the patient.

[164] *Dream I:* C [the patient's dream-ego] was somewhere and saw an old woman who appeared to be a *Jewess*. She was holding a *bottle* and a *glass* and seemed to be drinking *whiskey*; then this woman changed into her own *mother*, who had the bottle and glass, and appeared likewise to be drinking whiskey; then the door opened and her *father* appeared. He had on her *husband's dressing-gown*, and he was holding two *sticks of wood* in his hand. [Pp. 147ff.]

[165] Prince found, on the basis of copious and altogether convincing material,¹⁰ that the patient regarded the temptation to drink, and also the temptations of "poor people" in general, as something very understandable. She herself sometimes took a little whiskey in the evening, and so did her mother. But there might be something wrong in it. "The dream scene is therefore the symbolical representation and justification of her own belief and answers the doubts and scruples that beset her

mind” (p. 154). The second part of the dream, about the sticks, is certainly, according to Prince, a kind of wish-fulfilment, but he says it tells us nothing, since the patient had ordered firewood the evening before. Despite the trouble expended on it (eight pages of print) the dream has not been analysed thoroughly enough, for the two most important items—the whiskey-drinking and the sticks—remain unanalysed. If the author would follow up those “temptations,” he would soon discover that the patient’s scruples are at bottom of a far more serious nature than a spoonful of whiskey and two bundles of wood. Why is the father who comes in, condensed with the husband? How is the Jewess determined other than by a memory of the previous day? Why are the two sticks significant and why are they in the hand of the father? And so on. The dream has not been analysed. Unfortunately its meaning is only too clear to the psychoanalyst. It says very plainly: “If I were this poor Jewess, whom I saw on the previous day, I would not resist temptation (just as mother and father don’t—a typical infantile comparison!), and then a man would come into my room with firewood—naturally to warm me up.” This, briefly, would be the meaning. The dream contains all that, only the author’s analysis has discreetly stopped too soon. I trust he will forgive me for indiscreetly breaking open the tactfully closed door, so that it may clearly be seen what kind of wish-fulfilments, which “one cannot see,” hide behind conventional discretion and medical blindness to sex.

[166] *Dream 2*: A hill—she was toiling up the hill; one could hardly get up; had the sensation of some one, or thing, following her. She said, “*I must not show that I am frightened, or this thing will catch me.*” Then she came where it was lighter, and she could see two clouds or *shadows*, one black and one red, and she said, “My God, it is *A and B!* If I don’t have help I am lost.” (She meant that she would change again—i.e., relapse into dissociated personalities.) She began to call “Dr. Prince! Dr. Prince!” and you were there and laughed, and said, “Well, you will have to fight the damned thing yourself.” Then she woke up *paralysed* with fright. [P. 156.]

[167] As the dream is very simple, we can dispense with any further knowledge of the analytical material. But Prince cannot see the wish-fulfilment in this dream, on the contrary he sees in it the “fulfilment of a fear.” He commits the fundamental mistake of once again confusing the manifest dream-content with the unconscious dream-thought. In fairness to the author it should be remarked that in this case the repetition of the mistake was the more excusable since the crucial sentence (“Well, you will have to fight the damned thing yourself”) is really very ambiguous and misleading. Equally ambiguous is the sentence “I must not show that I am frightened,” etc., which, as Prince shows from the material, refers to the thought of a relapse into the illness, since the patient was *frightened* of a relapse.

[168] But what does “frightened” mean? We know that it is far more convenient for the patient to be ill, because recovery brings with it a great disadvantage: she would lose her analyst. The illness reserves him, as it were, for her needs. With her interesting illness, she has obviously offered the analyst a great deal, and has received from him a good deal of interest and patience in return. She certainly does not want to give up this stimulating relationship, and for this reason she is afraid of remaining well and secretly hopes that something weird and wonderful will befall her so as to rekindle the analyst’s interest. Naturally she would do anything rather than admit that she really had such wishes. But we must accustom ourselves to the thought that in psychology there are things which the patient simultaneously knows and does not know. Things which are apparently quite unconscious can often be shown to be conscious in another connection, and actually to have been known. Only, they were not known in their true meaning. Thus, the true meaning of the wish which the patient could not admit was not directly accessible to her consciousness, which is why we call this true meaning not conscious, or “repressed.” Put in the brutal form “I will have symptoms in order to re-arouse the interest of the analyst,” it cannot be accepted, true though it is, for it is too hurtful; but she could well allow a few little associations and half-smothered wishes to be discerned in the background, such as reminiscences of the time when the analysis was so interesting, etc.

[169] The sentence “I must not show that I am frightened” therefore means in reality “I must not show that I would really like a relapse because keeping well is too much trouble.” “If I don’t have help, I am lost” means “I hope I won’t be cured too quickly or I cannot have a relapse.” Then, at the end, comes the wish-fulfilment: “Well, you will have to fight the damned thing yourself.” The patient keeps well only out of love for the analyst. If he leaves her in the lurch she will have a relapse, and it will be his fault for not helping her. But if she has a relapse she will have a renewed and more intense claim on his attention, and this is the point of the whole manœuvre. It is altogether typical of dreams that the wish-fulfilment is always found where it seems most impossible to the conscious mind. The fear of a relapse is a symbol that needs analysing, and this the author has forgotten, because he took the fear, like the whiskey-drinking and the sticks, at its face value, instead of examining it sceptically for its genuineness. His colleague Ernest Jones’s excellent work *On the Nightmare*¹¹ would have informed him of the wishful character of these fears. But, as I know from my own experience, it is difficult for a beginner to remain conscious of all the psychoanalytic rules all the time.

[170] *Dream 3*: She was in the rocky path of Watts’s,¹² barefooted, stones hurt her feet, few clothes, cold, could hardly climb that path; she saw you there, and she called on you to help her, and you said, “I cannot help you, you must help yourself.” She said,

“I can’t, I can’t.” “Well, you have got to. Let me see if I cannot hammer it into your head.” You picked up a stone and hammered her head, and with every blow you said, “I can’t be bothered, I can’t be bothered.” And every blow sent a weight down into her heart so she felt heavy-hearted. She woke and I saw you pounding with a stone; you looked cross. [Pp. 159f.]

[171] As Prince again takes the dream literally, he can see in it merely the “non-fulfillment of a wish.” Once again it must be emphasized that Freud has expressly stated that the true *dream-thoughts are not identical with the manifest dream-contents*. Prince has not discovered the true dream-thought simply because he stuck to the wording of the dream. Now, it is always risky to intervene without knowing the material oneself; one can make enormous blunders. But it may be that the material brought out by the author’s analysis will be sufficient to give us a glimpse of the latent dream-thought. (Anyone who has experience will naturally have guessed the meaning of the dream long ago, for it is perfectly clear.)

[172] The dream is built up on the following experience. On the previous morning the patient had begged the author for medical help and had received the answer by telephone: “I cannot possibly come to see you today. I have engagements all the day and into the evening. I will send Dr. W, you must not depend on me” (p. 160). An unmistakable hint, therefore, that the analyst’s time belonged also to others. The patient remarked: “I didn’t say anything about it, but it played ducks and drakes with me the other night.” She therefore had a bitter morsel to swallow. The analyst had done something really painful, which she, as a reasonable woman, understood well enough—but not with her heart. Before going to sleep she had thought: “I must not bother him; I should think I would get that *into my head* after a while” (p. 161). (In the dream it is actually hammered into her head.) “If my heart was not like a *stone*, I should weep.” (She was hammered with a stone.)

[173] As in the previous dream, it is stated that the analyst will not help her any more, and he hammers this decision of his into her head so that at every blow her heart became heavier. The situation that evening, therefore, is taken up too clearly in the manifest dream-content. In such cases we must always try to find where a new element has been added to the situation of the previous day; at this point we may penetrate into the real meaning of the dream. The painful thing is that the analyst will not treat the patient any more, but in the dream she *is* treated, though in a new and remarkable way. When the analyst hammers it into her head that he cannot let himself be tormented by her chatter, he does it so emphatically that his psychotherapy turns into an extremely intense form of physical treatment or torture. This fulfils a wish which is far too shocking to be recognized in the decent light of day, although it is a very natural and simple thought. Popular humour and all the evil

tongues that have dissected the secrets of the confessional and the consulting-room know it.¹³ Mephistopheles, in his famous speech about Medicine,¹⁴ guessed it too. It is one of those imperishable thoughts which nobody knows and everybody has.

[174] When the patient awoke she saw the analyst still carrying out that movement: pounding¹⁵ with a stone. To name an action for a second time is to give it special prominence.¹⁶ As in the previous dream, the wish-fulfilment lies in the greatest disappointment.

[175] It will no doubt be objected that I am reading my own corrupt fantasies into the dream, as is customary with the Freudian school. Perhaps my esteemed colleague, the author, will be indignant at my attributing such impure thoughts to his patient, or at least will find it quite unjustified of me to draw such a far-reaching conclusion from these scanty hints. I am well aware that this conclusion, seen from the standpoint of yesterday's science, looks almost frivolous. But hundreds of parallel experiences have shown me that the above data are really quite sufficient to warrant my conclusion, and with a certainty that meets the most rigorous requirements. Those who have no experience of psychoanalysis can have no idea how very probable is the presence of an erotic wish and how extremely improbable is its absence. The latter illusion is naturally due to moral sex-blindness on the one hand, but on the other to the disastrous mistake of thinking that consciousness is the whole of the psyche. This does not, of course, apply to our esteemed author. I therefore beg the reader: no moral indignation, please, but calm verification. This is what science is made with, and not with howls of indignation, mockery, abuse, and threats, the weapons which the spokesmen of German science use in arguing with us.

[176] It would really be incumbent on the author to present all the interim material which would finally establish the erotic meaning of the dream. Though he has not done it for this dream, everything necessary is said indirectly in the following dreams, so that my above-mentioned conclusion emerges from its isolation and will prove to be a link in a consistent chain.

[177] *Dream 4:* [Shortly before the last dream the subject] dreamt that she was in a great *ballroom*, where everything was very *beautiful*. She was walking about, and a man came up to her and asked, "Where is your escort?" She replied, "I am *alone*." He then said, "You cannot stay here, we do not want any *lone women*." In the next scene she was in a *theater* and was going to sit down, when someone came and said the same thing to her: "You can't stay here, we do not want any *lone women* here." Then she was in ever so many different places, but wherever she went she had to leave because she was *alone*; they would not let her stay. Then she was in the street; there was a great crowd, and she saw her husband a little way ahead, and struggled to

get to him through the crowd. When she got quite near she saw ... [what we may interpret as a symbolical representation of happiness, says Prince.] Then sickness and nausea came over her and she thought there was no place for her there either. [P. 162.]

[178] The gap in the dream is a praiseworthy piece of discretion and will certainly please the prudish reader, but it is not science. Science admits no such considerations of decency. Here it is simply a question of whether Freud's maligned theory of dreams is right or not, and not whether dream-texts sound nice to immature ears. Would a gynaecologist suppress the illustration of the female genitalia in a textbook of midwifery on grounds of decency? On p. 164 of this analysis we read: "The analysis of this scene would carry us too far into the intimacy of her life to justify our entering upon it." Does the author really believe that in these circumstances he has any scientific right to speak about the psychoanalytic dream-theory, when he withholds essential material from the reader for reasons of discretion? By the very fact of reporting his patient's dream to the world he has violated discretion as thoroughly as possible, for every analyst will see its meaning at once: what the dreamer instinctively hides most deeply cries out loudest from the unconscious. For anyone who knows how to read dream-symbols all precautions are in vain, the truth will out. We would therefore request the author, if he doesn't want to strip his patient bare the next time, to choose a case about which he can say everything.

[179] Despite his medical discretion this dream too, which Prince denies is a wish-fulfilment, is accessible to understanding. The end of the dream betrays, despite the disguise, the patient's violent resistance to sexual relations with her husband. The rest is all wish-fulfilment: she becomes a "lone woman" who is socially somewhat beyond the pale. The feeling of loneliness ("she feels that she cannot be alone any more, that she must have company") is fittingly resolved by this ambiguous situation: there are "lone women" who are not so alone as all that, though certainly they are not tolerated everywhere. This wish-fulfilment naturally meets with the utmost resistance, until it is made clear that in case of necessity the devil, as the proverb says, eats even flies—and this is in the highest degree true of the libido. This solution, so objectionable to the conscious mind, seems thoroughly acceptable to the unconscious. One has to know what the psychology of a neurosis is in a patient of this age; psychoanalysis requires us to take people as they really are and not as they pretend to be. Since the great majority of people want to be what they are not, and therefore believe themselves identical with the conscious or unconscious ideal that floats before them, the individual is blinded by mass suggestion from the start, quite apart from the fact that he himself feels different from what he really is. This rule has

the peculiarity of being true of everybody else, but never of the person to whom it is being applied.

[180] I have set forth the historical and general significance of this fact in a previous work,¹⁷ so I can spare myself the trouble of discussing it here. I would only remark that, to practise psychoanalysis, one must subject one's ethical concepts to a total revision. It is a requirement which explains why psychoanalysis becomes intelligible to a really serious person only gradually and with great difficulty. It needs not only intellectual but, to an even greater extent, moral effort to understand the meaning of the method, for it is not just a medical method like vibro-massage or hypnosis, but something of much wider scope, that modestly calls itself "psychoanalysis."

[181] *Dream 5.* She dreamt that she was in a dark, gloomy, rocky place, and she was walking with difficulty, as she always does in her dreams, over this rocky path, and all at once the place was filled with cats. She turned in terror to go back, and there in her path was a frightful creature like a wild man of the woods. His hair was hanging down his face and neck; he had a sort of skin over him for covering; his legs and arms were bare and he had a club. A wild figure. Behind him were hundreds of men like him—the whole place was filled with them, so that in front were cats and behind were wild men. The man said to her that she would have to go forward through those cats, and that if she made a sound they would all come down on her and smother her, but if she went through them without making a sound she would never again feel any regret about the past ... [mentioning certain specific matters which included two particular systems of ideas known as the Z and Y complexes, all of which had troubled her, adds the author]. She realized that she must choose between death from the wild men and the journey over the cats, so she started forward. Now, in her dream of course she had to step on the cats [the subject here shivers and shudders], and the horror of knowing that they would come on her if she screamed caused her to make such an effort to keep still that the muscles of her throat contracted in her dream [they actually did contract, I could feel them, says Prince]. She waded through the cats without making a sound, and then she saw her mother and tried to speak to her. She reached out her hands and tried to say "O mamma!" but she could not speak, and then she woke up feeling nauseated, frightened, and fatigued, and wet with perspiration. Later, after waking, when she tried to speak, she could only whisper. [Pp. 164f. A footnote adds: "She awoke with complete aphonia, which persisted until relieved by appropriate suggestion."]

[182] Prince sees this dream partly as a wish-fulfilment, because the dreamer did after all walk over the cats. But he thinks: "The dream would rather seem to be principally a symbolical representation of her idea of life in general, and of the moral precepts

with which she has endeavoured to inspire herself, and which she has endeavoured to live up to in order to obtain happiness” (p. 168).

[183] That is not the meaning of the dream, as anyone can see who knows anything of dreams. The dream has not been analysed at all. We are merely told that the patient had a phobia about cats. What that means is not analysed. The treading on the cats is not analysed. The wild man wearing the skin is not analysed, and there is no analysis of the skin and the club. The erotic reminiscences Z and Y are not described. The significance of the aphonia is not analysed. Only the rocky path at the beginning is analysed a little: It comes from a painting by Watts, “Love and Life.” A female figure (Life) drags herself wearily along the rocky path, accompanied by the figure of Love. The initial image in the dream corresponds exactly to this picture, “minus the figure of Love,” as Prince remarks. Instead there are the cats, as the dream shows and as we remark. This means that the cats symbolize love. Prince has not seen this; had he studied the literature he would have discovered from one of my earlier publications that I have dealt in detail with the question of cat phobia.¹⁸ There he would have been informed of this conclusion and could have understood the dream and the cat phobia as well.

[184] For the rest, the dream is a typical anxiety dream which, in consequence, *must* be regarded from the standpoint of the sexual theory, unless Prince succeeds in proving to us that the sexual theory of anxiety is wrong. Owing to the complete lack of any analysis I refrain from further discussion of the dream, which is indeed very clear and pretty. I would only point out that the patient has succeeded in collecting a symptom (aphonia) which captured the interest of the analyst, as she reckoned it would. It is evident that one cannot criticize the dream-theory on the basis of analyses which are not made; this is merely the method of our German critics.

[185] *Dream 6:* This dream occurred twice on succeeding nights. She dreamed she was in the same rocky, dark path she is always in—Watts’s path—but with trees besides (there are always trees, or a hillside, or a canyon). The *wind* was blowing very hard, and she could hardly walk on account of something, as is always the case. Someone, a *figure*, came rushing past her with his hand over his (or her) eyes. This figure said, “*Don’t look, you will be blinded.*” She was at the entrance of a great *cave*; suddenly it *flashed light* in the cave like a flashlight picture, and there, down on the ground *you* were lying, and you were *bound round and round* with bonds of some kind, and your clothes were torn and dirty, and your face was covered with blood, and you looked terribly anguished; and all over you there were just hundreds of little gnomes or pigmies or brownies, and they were *torturing you*. Some of them had axes, and were chopping on your legs and arms, and some were sawing you. Hundreds of them had little things like joss-sticks, but shorter, which were red hot at the ends, and they were

jabbing them into you. It was something like Gulliver and the little creatures running over him. You saw C, and you said, “O Mrs. C, for heaven’s sake get me out of this damned hole.” (You always swear in C’s dreams.) She was horrified, and said, “O Dr. Prince, I am coming,” but she *could not move*, she was rooted to the spot; and then it all went away, everything became black, as if she were *blinded*, and then it would flash again and illuminate the cave, and she would see again. This happened three or four times in the dream. She kept saying, “I am coming,” and *struggled to move*, and she woke up saying it. In the same way *she could not move when she woke up, and she could not see*. [Pp. 170f.]

[186] The author does not report the details of the analysis of this dream, “in order not to weary the reader.” He gives only the following résumé:

The dream proved to be a symbolic representation of the subject’s conception of life (the rocky path), of her dread of the future, which for years she has said she dared not face; of her feeling that the future was “blind,” in that she could not “see anything ahead”; of the thought that she would be overwhelmed, “lost,” “swept away” if she looked into and realized this future, *and she must not look*. And yet there are moments in life when she realizes vividly the future; and so in the dream one of these moments is when she looks into the cave (the future), and in the flash of light the realization comes—she sees her son (metamorphosed through substitution of another person) tortured, as she has thought of him tortured, and handicapped (bound) by the moral “pin pricks” of life. Then follows the symbolic representation (paralysis) of her utter “helplessness” to aid either him or anyone else or alter the conditions of her own life. Finally follow the prophesied consequences of this realization. She is overcome by blindness and to this extent the dream is a fulfillment of a fear. [P. 171.]

[187] The author says in conclusion: “In this dream, as in the others, we find no ‘unacceptable’ and ‘repressed wish,’ no ‘conflict’ with ‘censoring thoughts,’ no ‘compromise,’ no ‘resistance’ and no ‘disguise’ in the dream-content to deceive the dreamer—elements and processes fundamental in the Freud school of psychology” (p. 173).

[188] From this devastating judgment we shall delete the words “as in the others,” for the other dreams are analysed so inadequately that the author has no right to pronounce such a judgment on the basis of the preceding “analyses.” Only the last dream remains to substantiate this judgment, and we shall therefore look at it rather more closely.

[189] We shall not linger over the constantly recurring symbol of the painting by Watts, in which the figure of Love is missing and was replaced by the cats in dream 5. Here

it is replaced by a figure who warns the patient not to look or she will be “blinded.” Now comes another very remarkable image: the analyst bound round and round with bonds, his clothes torn and dirty, his face covered with blood—the Gulliver situation. Prince remarks that it is the patient’s son who is in this agonizing situation, but withholds further details. Where the bonds, the bloody face, the torn clothes come from, what the Gulliver situation means—of all this we learn nothing. Because the patient “must not look into the future,” the cave signifies the future, remarks Prince. But why is the future symbolized by a cave? The author is silent. How comes it that the analyst is substituted for the son? Prince mentions the patient’s helplessness with regard to the situation of the son, and observes that she is just as helpless with regard to the analyst, for she does not know how to show her gratitude. But these are, if I may say so, two quite different kinds of helplessness, which do not sufficiently explain the condensation of the two persons. An essential and unequivocal *tertium comparationis* is lacking. All the details of the Gulliver situation, especially the red-hot joss-sticks, are left unanalysed. The highly significant fact that the analyst himself suffers hellish tortures is passed over in complete silence.

[190] In Dream 3 the analyst pounded the patient on the head with a stone, and this torture seems to be answered here, but swelled out into a hellish fantasy of revenge. Without doubt these tortures were thought up by the patient and intended for her analyst (and perhaps also for her son); that is what the dream says. This fact needs analysing. If the son is really “tortured by the moral pin pricks of life,” we definitely require to know why in the dream the patient multiplies this torture a hundred-fold, brings the son (or the analyst) into the Gulliver situation and then puts Gulliver in the “damned hole.” Why must the analyst swear in the dreams? Why does the patient step into the analyst’s shoes and say she is unable to bring help, when really the situation is the other way round?

[191] Here the way leads down into the wish-fulfilling situation. But the author has not trodden this path; he has either omitted to ask himself any of these questions or answered them much too superficially, so that this analysis too must be disqualified as “unsatisfactory.”¹⁹

[192] With this the last prop for a criticism of the dream-theory collapses. We must require of a critic that he carry out his investigations just as thoroughly as the founder of the theory, and that he should at least be able to explain the main points of the dream. But in the author’s analyses, as we have seen, the most important items are brushed aside. You cannot produce psychoanalysis out of a hat, as everyone knows who has tried; *unumquemque movere lapidem* is nearer the truth.

[193] Only after the conclusion of this review did I see the criticism which Ernest Jones²⁰ lavished on Morton Prince's article. We learn from Prince's reply that he *does not claim to have used the psychoanalytic method*. In that case he might fairly have refrained from criticizing the findings of psychoanalysis, it seems to me. His analytical methods, as the above examples show, are so lacking in scientific thoroughness that the conclusions he reaches offer no basis for a serious criticism of Freud's dream-theory. The rest of his remarks, culminating in the admission that he will never be able to see eye to eye with the psychoanalytic school, do not encourage me to make further efforts to explain the problems of dream-psychology to him or to discuss his reply. I confine myself to expressing my regret that he has even gone to the length of denying the scientific training and scientific thinking of his opponents.

ON THE CRITICISM OF PSYCHOANALYSIS¹

[194] It is a well-known fact to the psychoanalyst that laymen, even those with relatively little education, are able to understand the nature and rationale of psychoanalysis without undue intellectual difficulty. It is the same with educated people, be they scholars, business-men, journalists, artists, or teachers. They can all understand the truths of psychoanalysis. They also understand very well why psychoanalysis cannot be expounded in the same convincing way as a mathematical proposition. Everyone of common sense knows that a psychological proof must necessarily be different from a physical one, and that each branch of science can only offer proofs that are suited to its material. It would be interesting to know just what kind of empirical proof our critics expect, if not proof on the evidence of the empirical facts. Do these facts exist? We point to our observations. Our critics, however, simply say No. What, then, are we to offer if our factual observations are flatly denied? Under these circumstances we would expect our critics to study the neuroses and psychoses as thoroughly as we have done (quite independently of the method of psychoanalysis), and to put forward facts of an essentially different kind concerning their psychological determination. We have waited for this for more than ten years. Fate has even decreed that all investigators in this field who have worked independently of the discoverer of the new theory, but as thoroughly, have arrived at the same results as Freud; and that those who have taken the time and trouble to acquire the necessary knowledge under a psychoanalyst have also gained an understanding of these results.

[195] In general, we must expect the most violent resistance from medical men and psychologists, chiefly because of scientific prejudices based on a different way of thinking to which they obstinately adhere. Our critics, unlike earlier ones, have progressed inasmuch as they try to be more serious and to strike a more moderate note. But they commit the mistake of criticizing the psychoanalytic method as though it rested on *a priori* principles, whereas in reality it is purely empirical and totally lacking in any final theoretical framework. All we know is that it is simply the quickest way to find facts which are of importance for our psychology, but which, as the history of psychoanalysis shows, can also be discovered in other more tedious and complicated ways. We would naturally be happy if we possessed an analytical technique which led us to the goal even more quickly and reliably than the present method. Our critics, however, will scarcely be able to help us towards a more suitable technique, and one that corresponds better to the assumptions of psychology up till now, merely by contesting our findings. So long as the question of the facts is not

settled, all criticism of the method hangs in the air, for concerning the ultimate secrets of the association process our opponents know as little as we do. It should be obvious to every thinking person that what matters is simply and solely the empirical facts. If criticism confines itself to the method, it may easily come one day to deny the existence of facts merely because the method of finding them betrays certain theoretical defects—a standpoint that would carry us happily back to the depths of the Middle Ages. In this respect our critics commit grave mistakes. It is the duty of intelligent people to point them out, for to err is human.

[196] Occasionally, however, the criticism assumes forms which arouse the interest of the psychological worker in the highest degree, since the scientific endeavour of the critic is thrust into the background in the most surprising way by symptoms of personal participation. Such critics make a valuable contribution to the knowledge of the personal undercurrents beneath so-called scientific criticism. We cannot deny ourselves the pleasure of making such a *document humain* accessible to a wider public.

*

Review by Kurt Mendel² of an Exposition of the Freudian Standpoint

The present reviewer, who has read many works of Freud and his followers, and has *himself had practical experience of psychoanalysis*,³ must admit that he finds many things in this doctrine utterly repugnant, especially the latest additions concerning anal eroticism and the sexuality of children. After perusing the work under review,⁴ he stepped up to his youngest child, lying there innocently in his cot, and spoke as follows: “Poor little boy! I fancied you were pure and chaste, but now I know that you are depraved and full of sin! ‘From the first day of your existence you have led a sexual life’ (p. 184); now you are an exhibitionist, a fetishist, a sadist, a masochist, an anal-erotic, an onanist—in short, you are ‘polymorphous-perverse’ (p. 185). ‘There is scarcely a Don Juan among grown-ups whose erotic fantasies could be compared with the products of your infant brain’ (p. 185). How, indeed, could it be otherwise? For you are corrupt from birth. Your father has the reputation of being unusually tidy and economical, and the Freudians say he is stubborn because he won’t give full acceptance to their teachings. Unusually tidy, economical, and stubborn! A hopeless anal-erotic, therefore! (Cf. Freud, “Charakter und Analerotik,” *Psych.-neur. Wochenschr.* IX: 51.) As for your mother, she cleans out the house every four weeks. ‘Cleaning, and particularly spring-cleaning, is the specific female reaction to suppressed anal eroticism’ (Sadger, “Analerotik und Analcharakter,” *Die Heilkunde*, Feb. 1910). You are a congenital anal-erotic from your father’s and your mother’s side! And a little

while ago, before going to bed, you would not ‘empty the bowels when you were put on the pot, because you want to derive extra pleasure from defecation and therefore enjoy holding back your stool.’ Previously your father simply told your mother on such occasions: ‘The boy is constipated, give him a pill!’ Pfu! How shamelessly perverse I was then, a regular pimp and corrupter of youth! You’ll get no good-night kiss from me any more, for a caress like that would only ‘arouse your sexuality’ (p. 191). And don’t say your evening prayer to me again: ‘I am small, my heart is pure’;⁵ that would be a lie; you are dissipated, an exhibitionist, fetishist, sadist, masochist, anal-erotic, onanist, ‘polymorphous-perverse’—through me, through your mother, and through yourself! Poor little boy!”

Freudians! I have repeatedly asserted that your teachings have opened up many new and valuable perspectives. But for heaven’s sake make an end of your boundless exaggerations and nonsensical fantasies! Instead of puns, give us proofs! Instead of books that read like comics, give us serious works to be taken seriously! Prove to me the truth of your squalid and slanderous statement (p. 187): “There is but one form of love, and that is erotic love”! Do not plunge our most sacred feelings, our love and respect for our parents and our happy love for our children, into the mire of your fantasies by the continual imputation of sordid sexual motives! Your whole argument culminates in the axiom: “Freud has said it, therefore it is so!” But I say with Goethe, the son of an anal-erotic (Sadger, op. cit.):

“A man who speculates
Is like a beast upon a barren heath
Led round in circles by an evil sprite,
While all around lie pastures green and bright.”

CONCERNING PSYCHOANALYSIS¹

Küsnacht, 28 January 1912

To the Editor.

Sir,

[197] Thank you for kindly inviting me to publish in your columns an epilogue to the series of articles in the *Neue Zürcher Zeitung*. Such an epilogue could only be a defence either of the scientific truth which we think we can discern in psychoanalysis, and which has been so heavily attacked, or of our own scientific qualities. The latter defence offends against good taste, and is unworthy of anyone dedicated to the service of science. But a defence of the first kind can be carried out only if the discussion takes an objective form, and if the arguments used arise from a careful study of the problem, practical as well as theoretical. I am ready to argue with opponents like this, though I prefer to do so in private; I have, however, also done it in public, in a scientific journal.²

[198] I shall not reply, either, to scientific criticism the essence of which is: “The method is morally dangerous, therefore the theory is wrong,” or: “The facts asserted by the Freudians do not exist but merely spring from the morbid fantasy of these so-called researchers, and the method used for discovering these facts is in itself logically at fault.” No one can assert *a priori* that certain facts do not exist. This is a scholastic argument, and it is superfluous to discuss it.

[199] It is repugnant to me to make propaganda for the truth and to defend it with slogans. Except in the Psychoanalytical Society and in the Swiss Psychiatric Society I have never yet given a public lecture without first having been asked to do so; similarly, my article in Rascher’s Yearbook³ was written only at the request of the editor, Konrad Falke. I do not thrust myself upon the public. I shall therefore not enter the arena now in order to engage in barbarous polemics on behalf of a scientific truth. Prejudice and the almost boundless misunderstanding we are faced with can certainly prevent progress and the spread of scientific knowledge for a long time, and this is perhaps a necessity of mass psychology to which one has to submit. If this truth does not speak for itself, it is a poor truth and it is better for it to perish. But if it is an inner necessity, it will make its way, even without battle-cries and the martial blast of trumpets, into the hearts of all straight-thinking and realistic persons and so become an essential ingredient of our civilization.

[200] The sexual indelicacies which unfortunately occupy a necessarily large place in many psychoanalytic writings are not to be blamed on psychoanalysis itself. Our very exacting and responsible medical work merely brings these unlovely fantasies to light, but the blame for the existence of these sometimes repulsive and evil things must surely lie with the mendaciousness of our sexual morality. No intelligent person needs to be told yet again that the psychoanalytic method of education does not consist merely in psychological discussions of sex, but covers *every department of life*. The goal of this education, as I have expressly emphasized in Rascher's Yearbook, is not that a man should be delivered over helplessly to his passions but that he should attain the necessary self-control. In spite of Freud's and my assurances, our opponents want us to countenance "licentiousness" and then assert that we do so, regardless of what we ourselves say. It is the same with the theory of neurosis—the sexual or libido theory, as it is called. For years I have been pointing out, both in my lectures and in my writings, that the concept of libido is taken in a very general sense, rather like the instinct of preservation of the species, and that in psychoanalytic parlance it definitely does not mean "localized sexual excitation" but all striving and willing that exceed the limits of self-preservation, and that this is the sense in which it is used. I have also recently expressed my views on these general questions in a voluminous work,⁴ but our opponents wishfully decree that our views are as "grossly sexual" as their own. Our efforts to expound our psychological standpoint are quite useless, as our opponents want this whole theory to resolve itself into unspeakable banality. I feel powerless in the face of this overwhelming demand. I can only express my sincere distress that, through a misunderstanding which confuses day with night, many people are preventing themselves from employing the extraordinary insights afforded by psychoanalysis for the benefit of their own ethical development. Equally I regret that, by thoughtlessly ignoring psychoanalysis, many people are blinding themselves to the profundity and beauty of the human soul.

[201] No sensible person would lay it at the door of scientific research and its results that there are clumsy and irresponsible people who use it for purposes of hocus-pocus. Would anybody of intelligence lay the blame for the faults and imperfections in the execution of a method designed for the good of mankind on the method itself? Where would surgery be if one blamed its methods for every lethal outcome? Surgery is very dangerous indeed, especially in the hands of a fool. No one would trust himself to an unskilled surgeon or let his appendix be removed by a barber. So it is with psychoanalysis. That there are not only unskilled psychiatrists but also laymen who play about in an irresponsible way with psychoanalysis cannot be denied, any more than that there are, today as always, unsuitable doctors and unscrupulous quacks. But this fact does not entitle anyone to lump together science, method, researcher, and doctor in a wholesale condemnation.

[202] I regret, Sir, having to bore you and the readers of your paper with these self-evident truths, and I therefore hasten to a conclusion. You must forgive me if my manner of writing is at times a little heated; but no one, perhaps, is so far above public opinion as not to be painfully affected by the frivolous discrediting of his honest scientific endeavours.

Yours, etc.,

DR. JUNG

THE THEORY OF PSYCHOANALYSIS

[Written originally in German under the title *Versuch einer Darstellung der psychoanalytischen Theorie* and translated (by Dr. and Mrs. M. D. Eder and Miss Mary Moltzer) for delivery as a series of lectures under the present title at the medical school of Fordham University, New York, in September 1912. The German text was published in the *Jahrbuch für psychoanalytische und psychopathologische Forschungen* (Vienna and Leipzig), V (1913; reprinted as a book the same year); the English, in five issues of the *Psychoanalytic Review* (New York): I (1913/14) : 1–4 and II (1915) : 1. The latter was then republished in the Nervous and Mental Disease Monograph Series, No. 19 (New York, 1915). The analysis of a child in the last chapter had been previously presented as “Über Psychoanalyse beim Kinde” at the First International Congress of Pedagogy, Brussels, August 1911, and printed in the proceedings of the Congress (Brussels, 1912), II, 332–43.

[A second edition of the German text, with no essential alterations, was published in 1955 (Zurich). The present translation is made from this edition in consultation with the previous English version.

[The text of the 1913 and 1955 editions in German is uninterrupted by headings, but at the author’s request the original division into nine lectures (ascertained from an examination of the manuscript) has here been preserved. This arrangement differs from that of the previous English version, which is divided into ten lectures; the chapter and section headings there introduced have in general been retained, with some modifications. A number of critical passages inserted at a later stage into the original manuscript and included in the German editions were omitted from the previous English version, together with the footnotes. In the present version these passages are given in pointed brackets ().—EDITORS.]

FOREWORD TO THE FIRST EDITION

In these lectures I have attempted to reconcile my practical experiences in psychoanalysis with the existing theory, or rather, with the approaches to such a theory. It is really an attempt to outline my attitude to the guiding principles which my honoured teacher Sigmund Freud has evolved from the experience of many decades. Since my name is associated with psychoanalysis, and for some time I too have been the victim of the wholesale condemnation of this movement, it will perhaps be asked with astonishment how it is that I am now for the first time defining my theoretical position. When, some ten years ago, it came home to me what a vast distance Freud had already travelled beyond the bounds of contemporary knowledge of psychopathological phenomena, especially the psychology of complex mental processes, I did not feel in a position to exercise any real criticism. I did not possess the courage of those pundits who, by reason of their ignorance and incompetence, consider themselves justified in making “critical” refutations. I thought one must first work modestly for years in this field before one might dare to criticize. The unfortunate results of premature and superficial criticism have certainly not been lacking. Yet the great majority of the critics missed the mark as much with their indignation as with their technical ignorance. Psychoanalysis continued to flourish undisturbed and did not trouble itself about the unscientific chatter that buzzed around it. As everyone knows, this tree has waxed mightily, and not in one hemisphere only, but alike in Europe and America. Official critics meet with no better success than the Proktophantasmist in *Faust*, who laments in the Walpurgisnacht:

Preposterous! You still intend to stay?

Vanish at once! You’ve been explained away.

The critics have omitted to take it to heart that everything that exists has sufficient right to its own existence, and that this holds for psychoanalysis as well. We will not fall into the error of our opponents, neither ignoring their existence nor denying their right to exist. But this enjoins upon us the duty of applying a just criticism ourselves, based on a proper knowledge of the facts. To me it seems that psychoanalysis stands in need of this weighing-up from inside.

It has been wrongly suggested that my attitude signifies a “split” in the psychoanalytic movement. Such schisms can only exist in matters of faith. But psychoanalysis is concerned with knowledge and its ever-changing formulations. I have taken as my guiding principle William James’s pragmatic rule: “You must bring out of

each word its practical cash-value, set it at work within the stream of your experience. It appears less as a solution, then, than as a program for more work, and more particularly as an indication of the ways in which existing realities may be changed. *Theories thus become instruments, not answers to enigmas, in which we can rest.* We don't lie back upon them, we move forward, and, on occasion, make nature over again by their aid."¹

In the same way, my criticism does not proceed from academic arguments, but from experiences which have forced themselves on me during ten years of serious work in this field. I know that my own experience in no wise approaches Freud's quite extraordinary experience and insight, but nonetheless it seems to me that certain of my formulations do express the observed facts more suitably than Freud's version of them. At any rate I have found, in my teaching work, that the conceptions I have put forward in these lectures were of particular help to me in my endeavours to give my pupils an understanding of psychoanalysis. I am far indeed from regarding a modest and temperate criticism as a "falling away" or a schism; on the contrary, I hope thereby to promote the continued flowering and fructification of the psychoanalytic movement, and to open the way to the treasures of psychoanalytic knowledge for those who, lacking practical experience or handicapped by certain theoretical preconceptions, have so far been unable to master the method.

For the opportunity to deliver these lectures I have to thank my friend Dr. Smith Ely Jelliffe, of New York, who kindly invited me to take part in the Extension Course at Fordham University, in New York. The nine lectures were given in September 1912. I must also express my best thanks to Dr. Gregory, of Bellevue Hospital, for his ready assistance at my clinical demonstrations.

Only after the preparation of these lectures, in the spring of 1912, did Alfred Adler's book *Über den nervösen Charakter* [*The Nervous Constitution*] become known to me, in the summer of that year. I recognize that he and I have reached similar conclusions on various points, but here is not the place to discuss the matter more thoroughly. This should be done elsewhere.

C. G. J.

Zurich, autumn 1912

FOREWORD TO THE SECOND EDITION

Since the appearance of the first edition in 1913 so much time has elapsed, and so many things have happened, that it is quite impossible to rework a book of this kind, coming from a long-past epoch and from one particular phase in the development of knowledge, and bring it up to date. It is a milestone on the long road of scientific endeavour, and so it shall remain. It may serve to call back to memory the constantly changing stages of the search in a newly discovered territory, whose boundaries are not marked out with any certainty even today, and thus to make its contribution to the story of an evolving science. I am therefore letting this book go to press again in its original form and with no essential alterations.

C. G. J.

October 1954

1. A REVIEW OF THE EARLY HYPOTHESES

[203] It is no easy task to lecture on psychoanalysis at the present time. I am not thinking so much of the fact that this whole field of research raises—I am fully convinced—some of the most difficult problems facing present-day science. Even if we put this cardinal fact aside, there remain other serious difficulties which interfere considerably with the presentation of the material. I cannot offer you a well-established, neatly rounded doctrine elaborated from the practical and the theoretical side. Psychoanalysis has not yet reached that point of development, despite all the labour that has been expended upon it. Nor can I give you a description of its growth *ab ovo*, for you already have in your country, dedicated as always to the cause of progress, a number of excellent interpreters and teachers who have spread a more general knowledge of psychoanalysis among the scientifically-minded public. Besides this, Freud, the true discoverer and founder of the movement, has lectured in your country and given an authentic account of his views. I, too, have already had the great honour of lecturing in America, on the experimental foundation of the theory of complexes and the application of psychoanalysis to education.¹

[204] In these circumstances you will readily appreciate that I am afraid of repeating what has already been said or already been published in scientific journals. Another difficulty to be considered is the fact that quite extraordinary misconceptions prevail in many quarters concerning the nature of psychoanalysis. At times it is almost impossible to imagine what exactly these erroneous conceptions might be. But sometimes they are so preposterous that one is astonished that anyone with a scientific background could ever arrive at ideas so remote from reality. Obviously it would not be worth while to cite examples of these curiosities. It will be better to devote time and energy to discussing those problems of psychoanalysis which by their very nature give rise to misunderstandings.

THE TRAUMA THEORY

[205] Although it has been pointed out on any number of occasions before, many people still do not seem to know that the theory of psychoanalysis has changed considerably in the course of the years. Those, for instance, who have read only the first book, *Studies on Hysteria*,² by Breuer and Freud, still believe that, according to psychoanalysis, hysteria and the neuroses in general are derived from a so-called trauma in early childhood. They continue senselessly to attack this theory, not realizing that it is more than fifteen years since it was abandoned and replaced by a

totally different one. This change is of such great importance for the whole development of the technique and theory of psychoanalysis that we are obliged to examine it in rather more detail. So as not to weary you with case histories that by now are well known, I shall content myself with referring to those mentioned in Breuer and Freud's book, which I may assume is known to you in its English translation. You will there have read that case of Breuer's to which Freud referred in his lectures at Clark University,³ and will have discovered that the hysterical symptom did not derive from some unknown anatomical source, as was formerly supposed, but from certain psychic experiences of a highly emotional nature, called traumata or psychic wounds. Nowadays, I am sure, every careful and attentive observer of hysteria will be able to confirm from his own experience that these especially painful and distressing occurrences do in fact often lie at the root of the illness. This truth was already known to the older physicians.

[206] So far as I know, however, it was really Charcot who, probably influenced by Page's theory of "nervous shock,"⁴ first made theoretical use of this observation. Charcot knew, from his experience of the new technique of hypnotism, that hysterical symptoms can be produced and also be made to disappear by suggestion. He believed something of the kind could be observed in those increasingly common cases of hysteria caused by accidents. The traumatic shock would be comparable, in a sense, to the moment of hypnosis, since the emotion it produced would cause, temporarily, a complete paralysis of the will during which the trauma could become fixed as an auto-suggestion.

[207] This conception laid the foundations for a theory of psycho-genesis. It was left for later aetiological researches to find out whether the same mechanism, or a similar one, existed in cases of hysteria which could not be called traumatic. This gap in our knowledge of the aetiology of hysteria was filled by the discoveries of Breuer and Freud. They showed that even in cases of ordinary hysteria which had not been regarded as traumatically conditioned the same traumatic element could be found, and that it seemed to have an aetiological significance. So it was very natural for Freud, himself a pupil of Charcot, to see in this discovery a confirmation of Charcot's views. Consequently, the theory elaborated out of the experience of that period, mainly by Freud, bore the imprint of a traumatic aetiology. It was therefore fittingly called the trauma theory.

[208] The new thing about this theory, apart from the truly admirable thoroughness of Freud's analysis of hysterical symptoms, is the abandonment of the concept of auto-suggestion, which was the dynamic element in the original theory. It was replaced by a more detailed conception of the psychological and psychophysical effects produced by the shock. The shock or trauma causes an excitation which, under normal

conditions, is got rid of by being expressed (“abreacted”). In hysteria, however, the trauma is incompletely abreacted, and this results in a “retention of the excitation,” or a “blocking of affect.” The energy of the excitation, always lying ready *in potentia*, is transmuted into the physical symptoms by the mechanism of conversion. According to this view, the task of therapy was to release the accumulated excitation, thereby discharging the repressed and converted affects from the symptoms. Hence it was aptly called the “cleansing” or “cathartic” method, and its aim was to “abreact” the blocked affects. That stage of the analysis was therefore bound up fairly closely with the symptoms—one analysed the symptoms, or began the work of analysis with the symptoms, very much in contrast to the psychoanalytical technique employed today. The cathartic method and the theory on which it is based have, as you know, been taken over by other professional people, so far as they are interested in psychoanalysis at all, and have also found appreciative mention in the text-books.

[209] Although the discoveries of Breuer and Freud are undoubtedly correct in point of fact, as can easily be proved by any case of hysteria, several objections can nevertheless be raised against the trauma theory. The Breuer-Freud method shows with wonderful clearness the retrospective connection between the actual symptom and the traumatic experience, as well as the psychological consequences which apparently follow of necessity from the original traumatic situation. All the same, some doubt arises as to the *aetiological* significance of the trauma. For one thing, the hypothesis that a neurosis, with all its complications, can be related to events in the past—that is, to some factor in the patient’s predisposition—must seem doubtful to anyone who knows hysteria. It is the fashion nowadays to regard all mental abnormalities not of exogenous origin as consequences of hereditary degeneration, and not as essentially conditioned by the psychology of the patient and his environment. But this is an extreme view which fails to do justice to the facts. We know very well how to find the middle course in dealing with the aetiology of tuberculosis. There are undoubtedly cases of tuberculosis where the germ of the disease proliferates from early childhood in soil predisposed by heredity, so that even under the most favourable conditions the patient cannot escape his fate. But there are also cases where there is no hereditary taint and no predisposition, and yet a fatal infection occurs. This is equally true of the neuroses, where things will not be radically different from what they are in general pathology. An extreme theory about predisposition will be just as wrong as an extreme theory about environment.

THE CONCEPT OF REPRESSION

[210] Although the trauma theory gave distinct prominence to the predisposition, even insisting that some past trauma is the *conditio sine qua non* of neurosis, Freud with

his brilliant empiricism had already discovered, and described in the Breuer-Freud *Studies*, certain elements which bear more resemblance to an “environment theory” than to a “predisposition theory,” though their theoretical importance was not sufficiently appreciated at the time. Freud had synthesized these observations in a concept that was to lead far beyond the limits of the trauma theory. This concept he called “repression.” As you know, by “repression” we mean the mechanism by which a conscious content is displaced into a sphere outside consciousness. We call this sphere the unconscious, and we define it as the psychic element of which we are not conscious. The concept of repression is based on the repeated observation that neurotics seem to have the capacity for forgetting significant experiences or thoughts so thoroughly that one might easily believe they had never existed. Such observations are very common and are well known to anyone who enters at all deeply into the psychology of his patients.

[211] As a result of the Breuer-Freud *Studies*, it was found that special procedures were needed to call back into consciousness traumatic experiences that had long been forgotten. This fact, I would mention in passing, is astonishing in itself, inasmuch as we are disinclined from the start to suppose that things of such importance could ever be forgotten. For this reason it has often been objected that the reminiscences brought back by hypnotic procedures are merely “suggested” and bear no relation to reality. Even if this doubt were justified, there would certainly be no justification for denying repression in principle on that account, for there are plenty of cases where the actual existence of repressed memories has been verified objectively. Quite apart from numerous proofs of this kind, it is possible to demonstrate this phenomenon experimentally, by the association test. Here we discover the remarkable fact that associations relating to feeling-toned complexes are much less easily remembered and are very frequently forgotten. As my experiments were never checked, this finding was rejected along with the rest. It was only recently that Wilhelm Peters, of the Kraepelin school, was able to confirm my earlier observations, proving that “painful experiences are very rarely reproduced correctly.”⁵

[212] As you see, then, the concept of repression rests on a firm empirical basis. But there is another side of the question that needs discussing. We might ask if the repression is due to a conscious decision of the individual, or whether the reminiscences disappear passively, without his conscious knowledge? In Freud’s writings you will find excellent proofs of the existence of a conscious tendency to repress anything painful. Every psychoanalyst knows dozens of cases showing clearly that at some particular moment in the past the patient definitely did not want to think any longer of the content to be repressed. One patient told me, very significantly: “Je l’ai mis de côté.” On the other hand, we must not forget that there are any number of cases where it is impossible to show, even with the most careful

examination, the slightest trace of “putting aside” or of conscious repression, and where it seems as if the process of repression were more in the nature of a passive disappearance, or even as if the impressions were dragged beneath the surface by some force operating from below. Patients of the first type give us the impression of being mentally well-developed individuals who seem to suffer only from a peculiar cowardice in regard to their own feelings. But among the second you may find cases showing a more serious retardation of development, since here the process of repression could be compared rather to an automatic mechanism. This difference may be connected with the question discussed above, concerning the relative importance of predisposition and environment. Many factors in cases of the first type appear to depend on the influence of environment and education, whereas in the latter type the factor of predisposition seems to predominate. It is pretty clear where the treatment will be more effective.

[213] As I have indicated, the concept of repression contains an element which is in intrinsic contradiction with the trauma theory. We saw, for instance, in the case of Miss Lucy R., analysed by Freud,⁶ that the aetiologically significant factor was not to be found in the traumatic scenes but in the insufficient readiness of the patient to accept the insights that forced themselves upon her. And when we think of the later formulation in the *Schriften zur Neurosenlehre*,⁷ where Freud’s experience obliged him to recognize certain traumatic events in early childhood as the source of the neurosis, we get a forcible impression of the incongruity between the concept of repression and that of the trauma. The concept of repression contains the elements of an aetiological theory of environment, while the trauma concept is a theory of predisposition.

[214] At first the theory of neurosis developed entirely along the lines of the trauma concept. In his later investigations Freud came to the conclusion that no positive validity could be attributed to the traumatic experiences of later life, as their effects were conceivable only on the basis of a specific predisposition. It was evidently there that the riddle had to be solved. In pursuing the roots of hysterical symptoms, Freud found that the analytical work led back into childhood; the links reached backwards from the present into the distant past. The end of the chain threatened to get lost in the mists of earliest infancy. But it was just at that point that reminiscences appeared of certain sexual scenes—active or passive—which were unmistakably connected with the subsequent events leading to the neurosis. For the nature of these scenes you must consult the works of Freud and the numerous analyses that have already been published.

[215] Hence arose the theory of sexual trauma in childhood, which provoked bitter opposition not because of theoretical objections against the trauma theory in general, but against the element of sexuality in particular. In the first place, the very idea that children might be sexual, and that sexual thoughts might play any part in their lives, aroused great indignation. In the second place, the possibility that hysteria had a sexual basis was most unwelcome, for the sterile position that hysteria either was a uterine reflex-neurosis or arose from lack of sexual satisfaction had just been given up. Naturally, therefore, the validity of Freud's observations was contested. Had the critics confined themselves to that question, and not embellished their opposition with moral indignation, a calm discussion might have been possible. In Germany, for example, this method of attack made it impossible to gain any credit at all for Freud's theory. As soon as the question of sexuality was touched, it aroused universal resistance and the most arrogant contempt. But in reality there was only one question at issue: were Freud's observations true or not? That alone could be of importance to a truly scientific mind. I daresay his observations may seem improbable at first sight, but it is impossible to condemn them *a priori* as false. Wherever a really honest and thorough check has been carried out, the existence of the psychological connections established by Freud has been absolutely confirmed, but not the original hypothesis that it is always a question of real traumatic scenes.

[216] Freud himself had to abandon that first formulation of his sexual theory of neurosis as a result of increasing experience. He could no longer retain his original view as to the absolute reality of the sexual trauma. Those scenes of a decidedly sexual character, the sexual abuse of children, and premature sexual activity in childhood were later on found to be to a large extent unreal. You may perhaps be inclined to share the suspicion of the critics that the results of Freud's analytical researches were therefore based on suggestion. There might be some justification for such an assumption if these assertions had been publicized by some charlatan or other unqualified person. But anyone who has read Freud's works of that period with attention, and has tried to penetrate into the psychology of his patients as Freud has done, will know how unjust it would be to attribute to an intellect like Freud's the crude mistakes of a beginner. Such insinuations only redound to the discredit of those who make them. Ever since then patients have been examined under conditions in which every possible precaution was taken to exclude suggestion, and still the psychological connections described by Freud have been proved true in principle. We are thus obliged to assume that many traumata in early infancy are of a purely fantastic nature, mere fantasies in fact, while others do have objective reality.

[217] With this discovery, somewhat bewildering at first sight, the aetiological significance of the sexual trauma in childhood falls to the ground, as it now appears totally irrelevant whether the trauma really occurred or not. Experience shows us that

fantasies can be just as traumatic in their effects as real traumata. As against this, every doctor who treats hysteria will be able to recall cases where violent traumatic impressions have in fact precipitated a neurosis. This observation is only in apparent contradiction with the unreality, already discussed, of the infantile trauma. We know very well that there are a great many more people who experience traumata in childhood or adult life without getting a neurosis. Therefore the trauma, other things being equal, has no absolute aetiological significance and will pass off without having any lasting effect. From this simple reflection it is perfectly clear that the individual must meet the trauma with a quite definite inner predisposition in order to make it really effective. This inner predisposition is not to be understood as that obscure, hereditary disposition of which we know so little, but as a psychological development which reaches its climax, and becomes manifest, at the traumatic moment.

THE PREDISPOSITION FOR THE TRAUMA

[218] I will now show you, by means of a concrete example, the nature of the trauma and its psychological preparation. It concerns the case of a young woman who suffered from acute hysteria following a sudden fright.⁸ She had been to an evening party and was on her way home about midnight in the company of several acquaintances, when a cab came up behind them at full trot. The others got out of the way, but she, as though spellbound with terror, kept to the middle of the road and ran along in front of the horses. The cabman cracked his whip and swore; it was no good, she ran down the whole length of the road, which led across a bridge. There her strength deserted her, and to avoid being trampled on by the horses she would, in her desperation, have leapt into the river had not the passers-by restrained her. Now, this same lady had happened to be in St. Petersburg on the bloody 22nd of January [1905], in the very street which was being cleared by the volleys of the soldiers. All round her people were falling to the ground dead or wounded; she, however, quite calm and clear-headed, espied a gate leading into a yard, through which she made her escape into another street. These dreadful moments caused her no further agitation. She felt perfectly well afterwards—indeed, rather better than usual.

[219] This failure to react to an apparent shock is often observed. Hence it necessarily follows that the intensity of a trauma has very little pathogenic significance in itself; everything depends on the particular circumstances. Here we have a key to the “predisposition.” We have therefore to ask ourselves: what are the particular circumstances of the scene with the cab? The patient’s fear began with the sound of the trotting horses; for an instant it seemed to her that this portended some terrible

doom —her death, or something as dreadful; the next moment she lost all sense of what she was doing.

[220] The real shock evidently came from the horses. The patient's predisposition to react in so unaccountable a way to this unremarkable incident might therefore be due to the fact that horses have some special significance for her. We might conjecture, for instance, that she once had a dangerous accident with horses. This was actually found to be the case. As a child of about seven she was out for a drive with the coachman, when suddenly the horses took fright and at a wild gallop made for the precipitous bank of a deep river-gorge. The coachman jumped off and shouted to her to do likewise, but she was in such deadly fear that she could hardly make up her mind. Nevertheless she managed to jump in the nick of time, while the horses crashed with the carriage into the depths below. That such an event would leave a very deep impression hardly needs proof. Yet it does not explain why at a later date such an insensate reaction should follow a perfectly harmless stimulus. So far we know only that the later symptom had a prelude in childhood. The pathological aspect of it still remains in the dark.

[221] This anamnesis, whose continuation we shall find out later,⁹ shows very clearly the discrepancy between the so-called trauma and the part played by fantasy. In this case fantasy must predominate to a quite extraordinary degree in order to produce such a great effect from so insignificant a stimulus. At first one is inclined to adduce that early childhood trauma as an explanation—not very successfully, it seems to me, because we still do not understand why the effects of that trauma remained latent so long, and why they manifested themselves precisely on this occasion and on no other. The patient must surely have had opportunities enough during her lifetime of getting out of the way of a carriage going at full speed. The moment of deadly peril she experienced earlier in St. Petersburg did not leave behind the slightest trace of neurosis, despite her being predisposed by the impressive event in her childhood. Everything about this traumatic scene has still to be explained, for, from the standpoint of the trauma theory, we are left completely in the dark.

[222] You must forgive me if I return so persistently to this question of the trauma theory. I do not think it superfluous to do so, because nowadays so many people, even those closely connected with psychoanalysis, still cling to the old standpoint, and this gives our opponents, who mostly never read our writings or do so only very superficially, the impression that psychoanalysis still revolves round the trauma theory.

[223] The question now arises: what are we to understand by this “predisposition,” through which an impression, insignificant in itself, can produce such a pathological effect? This is a question of fundamental importance, and, as we shall see later, it

plays a very important role in the whole theory of neurosis. We have to understand why apparently irrelevant events of the past still have so much significance that they can interfere in a daemonic and capricious way with our reactions in actual life.

THE SEXUAL ELEMENT IN THE TRAUMA

[224] The early school of psychoanalysis, and its later disciples, did all they could to find in the special quality of those original traumatic experiences the reason for their later effectiveness. Freud went deepest: he was the first and only one to see that some kind of sexual element was mingled with the traumatic event, and that this admixture, of which the patient was generally unconscious, was chiefly responsible for the effect of the trauma. The unconsciousness of sexuality in childhood seemed to throw a significant light on the problem of the long-lasting constellation caused by the original traumatic experience. The real emotional significance of that experience remains hidden all along from the patient, so that, not reaching consciousness, the emotion never wears itself out, it is never used up. We might explain the long-lasting constellative effect of the experience as a kind of *suggestion à échéance*, for this, too, is unconscious and develops its effect only at the appointed time.

[225] It is hardly necessary to give detailed examples showing that the real character of sexual activities in infancy is not recognized. Doctors are aware, for instance, that open masturbation right up to adult life is not understood as such, especially by women. From this it is easy to deduce that a child would be even less conscious of the character of certain actions; hence the real meaning of these experiences remains hidden from consciousness even in adult life. In some cases the experiences themselves are completely forgotten, either because their sexual significance is quite unknown to the patient, or because their sexual character, being too painful, is not admitted, in other words, is repressed.

[226] As already mentioned, Freud's observation that the admixture of a sexual element in the trauma is a characteristic concomitant having a pathological effect led to the theory of the infantile sexual trauma. This hypothesis means that the pathogenic experience is a sexual one.

INFANTILE SEXUAL FANTASY

[227] At first this hypothesis was countered by the widespread opinion that children have no sexuality at all in early life, thus making such an aetiology unthinkable. The modification of the trauma theory already discussed, that the trauma is generally not real at all but essentially just fantasy, does not make things any better. On the contrary, it obliges us to see in the pathogenic experience a positive sexual

manifestation of infantile fantasy. It is no longer some brutal accidental impression coming from outside, but a sexual manifestation of unmistakable clearness actually created by the child. Even real traumatic experiences of a definitely sexual character do not happen to the child entirely without his co-operation; it was found that very often he himself prepares the way for them and brings them to pass. Abraham has furnished valuable proofs of great interest in support of this, which in conjunction with many other experiences of the same kind make it seem very probable that even real traumata are frequently aided and abetted by the psychological attitude of the child. Medical jurisprudence, quite independently of psychoanalysis, can offer striking parallels in support of this psychoanalytic assertion.

[228] The precocious manifestations of sexual fantasy, and their traumatic effect, now seemed to be the source of the neurosis. One was therefore obliged to attribute to children a much more developed sexuality than was admitted before. Cases of precocious sexuality had long been recorded in the literature, for instance of a two-year-old girl who was menstruating regularly, or of boys between three and five years old having erections and therefore being capable of cohabitation. But these cases were curiosities. Great was the astonishment, therefore, when Freud began to credit children not only with ordinary sexuality but even with a so-called “polymorphous-perverse” sexuality, and moreover on the basis of the most exhaustive investigations. People were far too ready with the facile assumption that all this had merely been suggested to the patients and was accordingly a highly debatable artificial product.

[229] In these circumstances, Freud’s *Three Essays on the Theory of Sexuality*¹⁰ provoked not only opposition but violent indignation. I need hardly point out that the progress of science is not furthered by indignation and that arguments based on the sense of moral outrage may suit the moralist—for that is his business—but not the scientist, who must be guided by truth and not by moral sentiments. If matters really are as Freud describes them, all indignation is absurd; if they are not, indignation will avail nothing. The decision as to what is the truth must be left solely to observation and research. In consequence of this misplaced indignation the opponents of psychoanalysis, with a few honourable exceptions, present a slightly comic picture of pitiful backwardness. Although the psychoanalytic school was unfortunately unable to learn anything from its critics, as the critics did not trouble to examine our actual conclusions, and although it could not get any useful hints, because the psychoanalytic method of investigation was and still is unknown to them, it nevertheless remains the duty of our school to discuss very thoroughly the discrepancies between the existing views. It is not our endeavour to put forward a paradoxical theory contradicting all previous theories, but rather to introduce a certain category of new observations into science. We therefore consider it our duty to do whatever we can from our side to promote agreement. True, we must give up

trying to reach an understanding with all those who blindly oppose us, which would be a waste of effort, but we do hope to make our peace with men of science. This will now be my endeavour in attempting to sketch the further conceptual development of psychoanalysis, up to the point where it reached the *sexual theory of neurosis*.¹¹

2. THE THEORY OF INFANTILE SEXUALITY

[230] As you have heard in the last lecture, the discovery of precocious sexual fantasies, which seemed to be the source of the neurosis, forced Freud to assume the existence of a richly developed infantile sexuality. As you know, the validity of this observation has been roundly contested by many, who argue that crude error and bigoted delusion have misled Freud and his whole school, alike in Europe and in America, into seeing things that never existed. We are therefore regarded as people in the grip of an intellectual epidemic. I must confess that I have no way of defending myself against this sort of "criticism." For the rest, I must remark that science has no right to start off with the idea that certain facts do not exist. The most one can say is that they appear to be very improbable, and that more confirmation and more exact study are needed. This is also our reply to the objection that nothing reliable can be learnt from the psychoanalytic method, as the method itself is absurd. No one believed in Galileo's telescope, and Columbus discovered America on a false hypothesis. The method may for all I know be full of errors, but that should not prevent its use. Chronological and geographical observations were made in the past with quite inadequate instruments. The objections to the method must be regarded as so many subterfuges until our opponents come to grips with the facts. It is there that the issue should be decided—not by a war of words.

[231] Even our opponents call hysteria a psychogenic illness. We believe we have discovered its psychological determinants and we present, undaunted, the results of our researches for public criticism. Anyone who does not agree with our conclusions is at liberty to publish his own analyses of cases. So far as I know, this has never yet been done, at least in the European literature. Under these circumstances, critics have no right to deny our discoveries *a priori*. Our opponents have cases of hysteria just as we have, and these are just as psychogenic as ours, so there is nothing to prevent them from finding the psychological determinants. It does not depend on the method. Our opponents content themselves with attacking and vilifying our researches, but they do not know how to find a better way.

[232] Many of our critics are more careful and more just, and admit that we have made many valuable observations and that the psychic connections revealed by the psychoanalytic method very probably hold good, but they maintain that our conception of them is all wrong. The alleged sexual fantasies of children, with which we are here chiefly concerned, must not be taken, they say, as real sexual functions,

being obviously something quite different, since the specific character of sexuality is acquired only at the onset of puberty.

[233] This objection, whose calm and reasonable tone makes a trustworthy impression, deserves to be taken seriously. It is an objection that has given every thoughtful analyst plenty of cause for reflection.

THE CONCEPT OF SEXUALITY

[234] The first thing to be said about this problem is that the main difficulty resides in the concept of sexuality. If we understand sexuality as a fully developed function, then we must restrict this phenomenon to the period of maturity and are not justified in speaking of infantile sexuality. But if we limit our conception in this way, we are faced with a new and much greater difficulty. What name are we then to give to all those biological phenomena correlated with the sexual function in the strict sense, such as pregnancy, birth, natural selection, protection of offspring, and so on? It seems to me that all this belongs to the concept of sexuality, although a distinguished colleague did once say that childbirth is not a sexual act. But if these things do pertain to the concept of sexuality, then countless psychological phenomena must come into it too, for we know that an incredible number of purely psychological functions are connected with this sphere. I need only mention the extraordinary importance of fantasy in preparing and perfecting the sexual function. Thus we arrive at a highly biological conception of sexuality, which includes within it a series of psychological functions as well as a series of physiological phenomena. Availing ourselves of an old but practical classification, we might identify sexuality with the instinct for the preservation of the species, which in a certain sense may be contrasted with the instinct of self-preservation.

[235] Looking at sexuality from this point of view, we shall no longer find it so astonishing that the roots of the preservation of the species, on which nature sets such store, go much deeper than the limited conception of sexuality would ever allow. Only the more or less grown-up cat catches mice, but even the very young kitten at least plays at catching them. The puppy's playful attempts at copulation begin long before sexual maturity. We have a right to suppose that man is no exception to this rule. Even though we do not find such things on the surface in our well-brought-up children, observation of children of primitive peoples proves that they are no exceptions to the biological norm. It is really far more probable that the vital instinct for preservation of the species begins to unfold in early infancy than that it should descend at one fell swoop from heaven, fully-fledged, at puberty. Also, the organs of reproduction develop long before the slightest sign of their future function can be discerned.

[236] So when the psychoanalytic school speaks of “sexuality,” this wider concept of the preservation of the species should be associated with it, and it should not be thought that we mean merely the physical sensations and functions which are ordinarily connoted by that word. It might be said that in order to avoid misunderstandings one should not call the preliminary phenomena of early infancy “sexual.” But this demand is surely not justified, since anatomical nomenclature is taken from the fully-developed system and it is not usual to give special names to the more or less rudimentary stages.

IMPORTANCE OF THE NUTRITIVE FUNCTION

[237] Now although no fault can be found with Freud’s sexual terminology as such, since he logically gives all the stages of sexual development the general name of sexuality, it has nevertheless led to certain conclusions which in my view are untenable. For if we ask ourselves how far the first traces of sexuality go back into childhood, we have to admit that though sexuality exists implicitly *ab ovo* it only manifests itself after a long period of extra-uterine life. Freud is inclined to see even in the infant’s sucking at its mother’s breast a kind of sexual act. He was bitterly attacked for this view, yet we must admit that it is sensible enough if we assume with Freud that the instinct for the preservation of the species, i.e., sexuality, exists as it were separately from the instinct of self-preservation, i.e., the nutritive function, and accordingly undergoes a special development *ab ovo*. But this way of thinking seems to me inadmissible biologically. It is not possible to separate the two modes of manifestation or functioning of the hypothetical life-instinct and assign each of them a special path of development. If we judge by what we see, we must take into consideration the fact that in the whole realm of organic nature the life-process consists for a long time only in the functions of nutrition and growth. We can observe this very clearly indeed in many organisms, for instance in butterflies, which as caterpillars first pass through an asexual stage of nutrition and growth only. The intra-uterine period of human beings, as well as the extra-uterine period of infancy, belong to this stage of the life process.

[238] *This period is characterized by the absence of any sexual function, so that to speak of manifest sexuality in infancy would be a contradiction in terms. The most we can ask is whether, among the vital functions of the infantile period, there are some that do not have the character of nutrition and growth and hence could be termed sexual. Freud points to the unmistakable excitement and satisfaction of the infant while sucking, and he compares these emotional mechanisms with those of the sexual act. This comparison leads him to assume that the act of sucking has a sexual quality. Such an assumption would be justifiable only if it were proved that the*

tension of a physical need, and its release by gratification, is a sexual process. But the fact that sucking has this emotional mechanism proves just the contrary. Consequently we can only say that this emotional mechanism is found both in the nutritive function and in the sexual function. If Freud derives the sexual quality of the act of sucking from the analogy of the emotional mechanism, biological experience would also justify a terminology qualifying the sexual act as a function of nutrition. This is exceeding the bounds in both directions. What is quite evident is that the act of sucking cannot be qualified as sexual.

[239] We know, however, of other functions at the infantile stage which apparently have nothing to do with the function of nutrition, such as sucking the finger and its numerous variants. Here is rather the place to ask whether such things belong to the sexual sphere. They do not serve nutrition, but produce pleasure. Of that there can be no doubt, but it nevertheless remains disputable whether the pleasure obtained by sucking should be called by analogy a sexual pleasure. It could equally well be called a nutritive pleasure. This latter qualification is the more apt in that the form of pleasure and the place where it is obtained belong entirely to the sphere of nutrition. The hand which is used for sucking is being prepared in this way for the independent act of feeding in the future. That being so, surely no one will beg the question by asserting that the first expressions of human life are sexual.

[240] Yet the formula we hit on just now, that pleasure is sought in sucking the finger without serving any nutritive purpose, leaves us feeling doubtful whether it does belong entirely to the sphere of nutrition. We notice that the so-called bad habits of a child as it grows up are closely connected with early infantile sucking, like putting the finger in the mouth, biting the nails, picking the nose, ears, etc. We see, too, how easily these habits pass over into masturbation later on. The conclusion that these infantile habits are the first stages of masturbation or of similar activities, and therefore have a distinctly sexual character, cannot be denied: it is perfectly legitimate. I have seen many cases in which an indubitable correlation existed between these childish habits and masturbation, and if masturbation occurs in late childhood, before puberty, it is nothing but a continuation of the infantile bad habits. The inference from masturbation that other infantile habits have a sexual character appears natural and understandable from this point of view, in so far as they are acts for obtaining pleasure from one's own body.

[241] From here it is but a short step to qualifying the infant's sucking as sexual. Freud, as you know, took that step and you have just heard me reject it. For here we come upon a contradiction which is very hard to resolve. It would be fairly easy if we could assume two separate instincts existing side by side. Then the act of sucking the breast would be a nutritive act and at the same time a sexual act, a sort of combination of

the two instincts. This seems to be Freud's conception. The obvious coexistence of the two instincts, or rather their manifestation in the form of hunger and the sexual drive, is found in the life of adults. But at the infantile stage we find *only* the function of nutrition, which sets a premium on pleasure and satisfaction. Its sexual character can be argued only by a *petitio principii*, for the facts show that the act of sucking is the first to give pleasure, not the sexual function. *Obtaining pleasure is by no means identical with sexuality*. We deceive ourselves if we think that the two instincts exist side by side in the infant, for then we project into the psyche of the child an observation taken over from the psychology of adults. The co-existence or separate manifestation of the two instincts is *not* found in the infant, for one of the instinctual systems is not developed at all, or is quite rudimentary. If we take the attitude that the striving for pleasure is something sexual, we might just as well say, paradoxically, that hunger is a sexual striving, since it seeks pleasure by satisfaction. But if we juggle with concepts like that, we should have to allow our opponents to apply the terminology of hunger to sexuality. This kind of one-sidedness appears over and over again in the history of science. I am not saying this as a reproach: on the contrary, we must be glad that there are people who are courageous enough to be immoderate and one-sided. It is to them that we owe our discoveries. What is regrettable is that each should defend his one-sidedness so passionately. Scientific theories are merely suggestions as to how things might be observed.

[242] The co-existence of two instinctual systems is an hypothesis that would certainly facilitate matters, but unfortunately it is impossible because it contradicts the observed facts and, if pursued, leads to untenable conclusions.

THE POLYMORPHOUS-PERVERSE SEXUALITY OF INFANCY

[243] Before I try to resolve this contradiction, I must say something more about Freud's sexual theory and the changes it has undergone. As I explained earlier, the discovery of a sexual fantasy-activity in childhood, which apparently had the effect of a trauma, led to the assumption that the child must have, in contradiction to all previous views, an almost fully developed sexuality, and even a polymorphous-perverse sexuality. Its sexuality does not seem to be centred on the genital function and on the other sex, but is occupied with the child's own body, whence it is said to be autoerotic. If its sexual interest is directed outwards to another person, it makes but little difference to the child what that person's sex is. Hence the child may very easily be "homosexual." Instead of the non-existent, localized sexual function there are a number of so-called bad habits, which from this point of view appear as perverse actions since they have close analogies with subsequent perversions.

[244] As a result of this conception sexuality, ordinarily thought of as a unity, was decomposed into a plurality of separate drives; and since it was tacitly assumed that sexuality originates in the genitals, Freud arrived at the conception of “erogenous zones,” by which he meant the mouth, skin, anus, etc.

[245] The term “erogenous zone” reminds us of “spasmogenic zone.” At all events the underlying idea is the same: just as the spasmogenic zone is the place where a spasm originates, the erogenous zone is the place from which comes an afflux of sexuality. On the underlying model of the genitals as the anatomical source of sexuality, the erogenous zones would have to be conceived as so many genital organs out of which sexuality flows. This state is the polymorphous-perverse sexuality of children. The term “perverse” appeared justified by the close analogy with later perversions which are, so to speak, simply a new edition of certain “perverse” interests in early infancy. They are frequently connected with one or other of the erogenous zones and cause those sexual anomalies which are so characteristic of children.

SEXUAL COMPONENTS AS ENERGETIC MANIFESTATIONS

[246] From this point of view the later, normal, “monomorphic” sexuality is made up of several components. First it falls into a homo- and a heterosexual component, then comes the autoerotic component, and then the various erogenous zones. This conception can be compared with the position of physics before Robert Mayer, when only separate fields of phenomena existed, each credited with elementary qualities whose correlation was not properly understood. The law of the conservation of energy brought order into the relationship of forces to one another, at the same time abolishing the conception of those forces as having an absolute, elementary character and making them manifestations of the same energy. The same thing will have to happen with this splitting of sexuality into the polymorphous-perverse sexuality of childhood.

[247] Experience compels us to postulate a constant interchange of individual components. It was recognized more and more that perversions, for instance, exist at the expense of normal sexuality, and that increased application of one form of sexuality follows a decrease in the application of another form. To make the matter clearer I will give an example. A young man had a homosexual phase lasting for some years, during which time he had no interest in girls. This abnormal condition gradually changed towards his twentieth year, and his erotic interests became more and more normal. He began to take an interest in girls, and soon he had overcome the last traces of homosexuality. This lasted for several years, and he had a number of successful love-affairs. Then he wanted to marry. But here he suffered a severe disappointment, as the girl he adored threw him over. During the ensuing phase he

gave up all idea of marriage. After that he experienced a dislike of all women, and one day he discovered that he had become homosexual again, for young men once more had a peculiarly irritating effect upon him.

[248] If we regard sexuality as consisting of a fixed heterosexual and a fixed homosexual component we shall never explain this case, since the assumption of fixed components precludes any kind of transformation. In order to do justice to it, we must assume a great mobility of the sexual components, which even goes so far that one component disappears almost completely while the other occupies the foreground. If nothing but a change of position took place, so that the homosexual component lapsed in full force into the unconscious, leaving the field of consciousness to the heterosexual component, modern scientific knowledge would lead us to infer that equivalent effects would then arise from the unconscious sphere. These effects would have to be regarded as resistances to the activity of the heterosexual component, that is, as resistances against women. But in our case there is no evidence of this. Though faint traces of such influences existed, they were of such slight intensity that they could not be compared with the previous intensity of the homosexual component.

[249] On the existing theory, it remains incomprehensible how the homosexual component, regarded as so firmly fixed, could disappear without leaving any active traces behind it. (Further, it would be very difficult to conceive how these transformations come about. One could, at a pinch, understand the development passing through a homosexual stage in the pubertal period in order to lay the foundation for normal heterosexuality later, in a fixed, definite form. But how are we then to explain that the product of a gradual development, to all appearances bound up very closely with organic processes of maturation, is suddenly abolished under the impact of an impression, so as to make room for an earlier stage? Or, if two active components are postulated as existing simultaneously side by side, why is only one of them active and not the other as well? One might object that the homosexual component in men does in fact show itself most readily in a peculiar irritability, a special sensitiveness in regard to other men. According to my experience the apparent reason for this characteristic behaviour, of which we find so many examples in society today, is an invariable disturbance in the relationship with women, a special form of dependence on them. This would constitute the “plus” that is counterbalanced by the “minus” in the homosexual relationship. (Naturally this is not the real reason. The real reason is the infantile state of the man’s character.))

[250] It was, therefore, urgently necessary to give an adequate explanation of such a change of scene. For this we need a dynamic hypothesis, since these permutations of sex can only be thought of as dynamic or energetic processes. Without an alteration in

the dynamic relationships, I cannot conceive how a mode of functioning can disappear like this. Freud's theory took account of this necessity. His conception of components, of separate modes of functioning, began to be weakened, at first more in practice than in theory, and was eventually replaced by a conception of energy. The term chosen for this was *libido*.

3. THE CONCEPT OF LIBIDO

[251] Freud had already introduced the concept of libido in his *Three Essays on the Theory of Sexuality*, where he says:

The fact of the existence of sexual needs in human beings and animals is expressed in biology by the assumption of a “sexual instinct,” on the analogy of the instinct of nutrition, that is of hunger. Everyday language possesses no counterpart to the word “hunger,” but science makes use of the word “libido” for that purpose.¹

[252] In Freud’s definition the term *libido* connotes an exclusively sexual need, hence everything that Freud means by libido must be understood as sexual need or sexual desire. In medicine the term *libido* is certainly used for sexual desire, and specifically for sexual lust. But the classical use of the word as found in Cicero, Sallust, and others was not so exclusive; there it is used in the more general sense of passionate desire.² I mention this fact now, because further on it will play an important part in our argument, and because it is important to know that the term *libido* really has a much wider range of meaning than it has in medicine.

[253] The concept of libido—whose sexual meaning in the Freudian sense we shall try to retain as long as possible—represents that dynamic factor which we were seeking in order to explain the shifting of the psychological scenery. This concept makes it much easier to formulate the phenomena in question. Instead of the incomprehensible exchanging of the homosexual component for the heterosexual component, we can now say that the libido was gradually withdrawn from its homosexual application and that it passed over in the same measure to a heterosexual application. In the process the homosexual component disappeared almost completely. It remained only an empty possibility, signifying nothing in itself. Its very existence is quite rightly denied by the layman, just as he would deny the possibility that he is a murderer. The libido concept also helps to explain the reciprocal relationships between the various modes of sexual functioning. At the same time, it does away with the original idea of a plurality of sexual components, which savoured too much of the old philosophical notion of psychic faculties. Their place is taken by libido, which is capable of the most varied applications. The earlier “components” represent only possible modes of action. The libido concept puts in the place of a divided sexuality split into many roots a dynamic unity, lacking which these once-significant components remain nothing but potential activities. This conceptual development is of the greatest importance; it accomplishes for psychology the same advance that the concept of

energy introduced into physics. Just as the theory of the conservation of energy deprived the various forces of their elementary character and made them manifestations of a single energy, so the theory of libido deprives the sexual components of their elementary significance as psychic “faculties” and gives them a merely phenomenological value.

THE ENERGIc THEORY OF LIBIDO

[254] This view is a far better reflection of reality than the theory of components. With the libido theory we can easily explain the case of the young man cited earlier. The disappointment he met with at the moment he wanted to marry drove his libido away from its heterosexual mode of application, with the result that it assumed a homosexual form again and thus reinduced the earlier homosexuality. Here I cannot refrain from remarking that the analogy with the law of the conservation of energy is very close. In both cases one has to ask, when one sees that a quantum of energy has disappeared, where this energy has re-emerged in the meantime? If we apply this point of view as an explanatory principle to the psychology of human conduct, we shall make the most surprising discoveries. We can then see that the most heterogeneous phases in an individual’s psychological development are connected with one another in an energetic relationship. Every time we come across a person who has a “bee in his bonnet,” or a morbid conviction, or some extreme attitude, we know that there is too much libido, and that the excess must have been taken from somewhere else where, consequently, there is too little. From this point of view psychoanalysis is a method which helps us to discover those places or functions where there is too little libido, and to restore the balance. Thus the symptoms of a neurosis must be regarded as exaggerated functions over-invested with libido.³ The energy used for this purpose has been taken from somewhere else, and it is the task of the psychoanalyst to discover the place it was taken from or where it was never applied.

[255] The question has to be reversed in the case of those syndromes characterized mainly by lack of libido, for instance apathetic states. Here we have to ask, where did the libido go? The patient gives us the impression of having no libido, and there are many doctors who take him at his face value. Such doctors have a primitive way of thinking, like a savage who, seeing an eclipse of the sun, believes that the sun has been swallowed and killed. But the sun is only hidden, and so it is with these patients. The libido is there, but it is not visible and is inaccessible to the patient himself. Superficially, we have here a lack of libido. It is the task of psychoanalysis to search out that hidden place where the libido dwells and where the patient himself

cannot get at it. The hidden place is the “non-conscious,” which we may also call the “unconscious” without attributing to it any mystical significance.

UNCONSCIOUS FANTASY SYSTEMS

[256] Psychoanalysis has taught us that there are non-conscious psychological systems which, by analogy with conscious fantasies, can be described as unconscious fantasy systems. In states of neurotic apathy these unconscious fantasy systems are the objects of libido. We are fully aware that when we speak of unconscious fantasy-systems we are speaking only figuratively. By this we mean no more than that we accept as a necessary postulate the conception of psychic entities outside consciousness. Experience teaches us, we might say daily, that there are non-conscious psychic processes which perceptibly influence the libido economy. Those cases known to every psychiatrist, in which a complicated system of delusions breaks out with comparative suddenness, prove that there must be unconscious psychic developments that have prepared the ground, for we can hardly suppose that such things come into being just as suddenly as they enter consciousness.

[257] I have allowed myself to make this digression concerning the unconscious in order to point out that, with regard to the changing localization of libidinal investments, we have to reckon not merely with the conscious but with another factor, the unconscious, into which the libido sometimes disappears. We can now resume our discussion of the further consequences resulting from the adoption of the libido theory.

THE CONSERVATION OF LIBIDO

[258] Freud has taught us, and we see it in the everyday practice of psychoanalysis, that there exist in early childhood, instead of the later normal sexuality, the beginnings of many tendencies which in later life are called “perversions.” We have had to admit Freud’s right to apply a sexual terminology to these tendencies. Through the introduction of the libido concept, we see that in adults those elementary components which seemed to be the origin and source of normal sexuality lose their importance and are reduced to mere potentialities. Their operative principle, their vital force, so to speak, is the libido. Without libido these components mean practically nothing. Freud, as we saw, gives the libido an unquestionably sexual connotation, something like “sexual need.” It is generally assumed that libido in this sense comes into existence only at puberty. How, then, are we to explain the fact that children have a polymorphous-perverse sexuality, and that the libido activates not merely one perversion but several? If the libido, in Freud’s sense, comes into existence only at

puberty, it cannot be held accountable for earlier infantile perversions—unless we regard them as “psychic faculties,” in accordance with the theory of components. Quite apart from the hopeless theoretical confusion this would lead to, we would be sinning against the methodological axiom that “explanatory principles are not to be multiplied beyond the necessary.”

[259] There is no alternative but to assume that before and after puberty it is the same libido. Hence the infantile perversions arise in exactly the same way as in adults. Common sense will object to this, as obviously the sexual needs of children cannot possibly be the same as those of sexually mature persons. We might, however, compromise on this point and say with Freud that though the libido before and after puberty is the same it is different in its intensity. Instead of the intense sexual need after puberty there would be only a slight sexual need in childhood, gradually diminishing in intensity until, at about the first year, it is nothing but a trace. We could declare ourselves in agreement with this from the biological point of view. But we should also have to assume that everything that comes within the realm of the wider concept of sexuality discussed in the previous lecture is already present in miniature, including all those emotional manifestations of psychosexuality, such as need for affection, jealousy, and many other affective phenomena, and by no means least the neuroses of childhood. It must be admitted, however, that these affective phenomena in children do not at all give the impression of being “in miniature”; on the contrary, they can rival in intensity those of an adult. Nor should we forget that, as experience has shown, the perverse manifestations of sexuality in childhood are often more glaring, and even seem to be more richly developed, than in adults. In an adult showing a similar state of richly developed perversion we could rightly expect a total extinction of normal sexuality and of many other important forms of biological adaptation, as is normally the case with children. An adult is rightly called perverse when his libido is not used for normal functions, and the same can reasonably be said of a child: he is polymorphous-perverse because he does not yet know the normal sexual function.

[260] These considerations suggest that perhaps the amount of libido is always the same and that no enormous increase occurs at sexual maturity. This somewhat audacious hypothesis leans heavily, it is clear, on the law of the conservation of energy, according to which the amount of energy remains constant. It is conceivable that the peak of maturity is reached only when the infantile, subsidiary applications of libido gradually discharge themselves into one definite channel of sexuality and are extinguished in it. For the moment we must content ourselves with these suggestions, for we must next pay attention to one point of criticism concerning the nature of the infantile libido.

[261] Many of our critics do not concede that the infantile libido is simply less intense but of essentially the same nature as the libido of adults. The libidinal impulses of adults are correlated with the genital function, those of children are not, or only in exceptional cases, and this gives rise to a distinction whose importance must not be underestimated. It seems to me that this objection is justified. There is indeed a considerable difference between immature and fully developed functions, just as there is between play and seriousness, between shooting with blank and with loaded cartridges. This would give the infantile libido that undeniably harmless character which is demanded by common sense. But neither can one deny that blank-shooting is shooting. We must get accustomed to the idea that sexuality really exists, even before puberty, right back into early childhood, and we have no grounds for not calling the manifestations of this immature sexuality sexual.

[262] This naturally does not invalidate the objection which, while admitting the existence of infantile sexuality in the form we have described, nevertheless contests Freud's right to designate as "sexual" early infantile phenomena such as sucking. We have already discussed the reasons which may have induced Freud to stretch his sexual terminology so far. We mentioned, too, how this very act of sucking could be conceived just as well from the standpoint of the nutritive function and that, on biological grounds, there was actually more justification for this derivation than for Freud's view. It might be objected that these and similar activities of the oral zone reappear in later life in an undoubtedly sexual guise. This only means that these activities can be used later for sexual purposes, but proves nothing about their originally sexual character. I must, therefore, admit that I can find no ground for regarding the pleasure-producing activities of the infantile period from the standpoint of sexuality, but rather grounds to the contrary. It seems to me, so far as I am capable of judging these difficult problems correctly, that from the standpoint of sexuality it is necessary to divide human life into three phases.

THE THREE PHASES OF LIFE

[263] The first phase embraces the first years of life; I call this period the *presexual stage*.⁴ It corresponds to the caterpillar stage of butterflies, and is characterized almost exclusively by the functions of nutrition and growth.

[264] The second phase embraces the later years of childhood up to puberty, and might be called the *prepubertal stage*. Germination of sexuality takes place at this period.

[265] The third phase is the adult period from puberty on, and may be called the period of *maturity*.

[266] It will not have escaped you that the greatest difficulty lies in assigning limits to the presexual stage. I am ready to confess my great uncertainty in regard to this problem. When I look back on my own psychoanalytic experiences with children—insufficiently numerous as yet, unfortunately—at the same time bearing in mind the observations made by Freud, it seems to me that the limits of this phase lie between the third and fifth year, subject, of course, to individual variation. This age is an important one in many respects. The child has already outgrown the helplessness of a baby, and a number of important psychological functions have acquired a reliable hold. From this period on, the profound darkness of the early infantile amnesia, or discontinuity of consciousness, begins to be illuminated by the sporadic continuity of memory. It seems as if, at this stage, an essential step forward is taken in the emancipation and centring of the new personality. So far as we know, the first signs of interests and activities which may fairly be called sexual also fall into this period, even though these indications still have the infantile characteristics of harmlessness and naïveté.

THE SEXUAL TERMINOLOGY

[267] I think I have sufficiently explained why a sexual terminology cannot be applied to the presexual stage, so we may now consider the other problems from the standpoint we have just reached. You will remember that we dropped the problem of decreased libido in childhood because it was impossible in that way to reach any clear conclusion. We now take up this question once again, if only to see whether the energetic conception fits in with our present formulations.

[268] We saw that the difference between infantile and mature sexuality can be explained, according to Freud, by the diminishing intensity of sexuality in childhood. But we have just advanced reasons why it seems doubtful that the life-processes of a child, with the exception of sexuality, are any less intense than those of adults. We could say that, sexuality excepted, the affective phenomena, and the nervous symptoms if there are any, are quite as intense as in adults. Yet, on the energetic view, they are all manifestations of libido. It is therefore difficult to believe that the intensity of libido can make the difference between mature and immature sexuality. Rather the difference seems to be conditioned by a change in the localization of libido (if such an expression be permitted). In contradistinction to its medical definition, the libido of a child is occupied far more with subsidiary functions of a mental and physical nature than with local sexual functions. This being so, one is tempted to withdraw the predicate “sexualis” from the term “libido” and to strike out the sexual definition of libido given in Freud’s *Three Essays on the Theory of Sexuality*. The necessity for this becomes really urgent when we ask ourselves

whether the intense joys and sorrows of a child in the first years of his life, that is, *at the presexual stage*, are conditioned solely by his sexual libido.

[269] Freud has pronounced himself in favour of this supposition. There is no need for me to repeat here the reasons which compelled me to postulate a presexual stage. The caterpillar stage possesses an alimentary libido but no sexual libido; we have to put it like that if we want to retain the energetic view which the libido theory offers us. I think there is nothing for it but to abandon the sexual definition of libido, or we shall lose what is valuable in the libido theory, namely the energetic point of view. For a long time now the need to give the concept of libido breathing-space and to remove it from the narrow confines of the sexual definition has forced itself on the psychoanalytical school. One never wearied of insisting that sexuality was not to be taken too literally but in a wider sense; yet exactly *how* remained obscure and so could not satisfy the serious critics.

[270] I do not think I am going astray if I see the real value of the concept of libido not in its sexual definition but in its energetic view, thanks to which we are in possession of an extremely valuable heuristic principle. We are also indebted to the energetic view for dynamic images and correlations which are of inestimable value to us in the chaos of the psychic world. Freudians would be wrong not to listen to those critics who accuse our libido theory of mysticism and unintelligibility. We were deceiving ourselves when we believed that we could make the *libido sexualis* the vehicle of an energetic conception of psychic life, and if many of Freud's school still believe that they are in possession of a well-defined and, so to speak, concrete conception of libido, they are not aware that this concept has been put to uses which far exceed the bounds of any sexual definition. Consequently the critics are right when they object that the libido theory purports to explain things which do not properly belong to its sphere. This really does evoke the impression that we are operating with a mystical entity.

THE PROBLEM OF LIBIDO IN DEMENTIA PRAECOX

[271] In my book *Wandlungen und Symbole der Libido* I tried to furnish proof of these transgressions and at the same time to show the need for a new conception of libido which took account only of the energetic view. Freud himself was forced to admit that his original conception of libido might possibly be too narrow when he tried to apply the energetic view consistently to a famous case of dementia praecox—the so-called Schreber case.⁵ This case is concerned among other things with that well-known problem in the psychology of dementia praecox, the loss of adaptation to reality, a peculiar phenomenon consisting in the special tendency of these patients to construct

an inner fantasy world of their own, surrendering for this purpose their adaptation to reality.

[272] One aspect of this phenomenon, the absence of emotional rapport, will be well known to you, as this is a striking disturbance of the reality function. By dint of much psychoanalytic work with these patients we established that this lack of adaptation to reality is compensated by a progressive increase in the creation of fantasies, which goes so far that the dream world becomes more real for the patient than external reality. Schreber found an excellent figurative description for this phenomenon in his delusion about the “end of the world.” He thus depicts the loss of reality in a very concrete way. The dynamic explanation is simple: we say that libido has withdrawn more and more from the external world into the inner world of fantasy, and there had to create, as a substitute for the lost world, a so-called reality equivalent. This substitute is built up piece by piece, so to speak, and it is most interesting to see out of what psychological material this inner world is constructed.

[273] This way of looking at the displacement of libido is based on the everyday use of the term, its original, purely sexual connotation being very rarely remembered. In actual practice we speak simply of *libido*, and this is understood in so innocuous a sense that Claparède once remarked to me that one could just as well use the word “interest.” The customary use of the term has developed, quite naturally and spontaneously, into a usage which makes it possible to explain Schreber’s end of the world simply as a withdrawal of libido. On this occasion Freud remembered his original sexual definition of libido and tried to come to terms with the change of meaning that had quietly taken place in the meantime. In his paper on Schreber he asks himself whether *what the psychoanalytic school calls libido and conceives as “interest from erotic sources” coincides with interest in general*. You see that, putting the problem in this way, Freud asks himself the question which Claparède had already answered in practice.

[274] Freud thus broaches the question of whether the loss of reality in schizophrenia, to which I drew attention in my “Psychology of Dementia Praecox,”⁶ is due entirely to the withdrawal of erotic interest, or whether this coincides with objective interest in general. We can hardly suppose that the normal “fonction du réel” (Janet) is maintained solely by erotic interest. The fact is that in very many cases reality disappears altogether, so that not a trace of psychological adaptation can be found in these patients. (In these states reality is replaced by complex contents.) We are therefore compelled to admit that not only the erotic interest, but all interest whatsoever, has got lost, and with it the whole adaptation to reality.

[275] Earlier, in my “Psychology of Dementia Praecox,” I tried to get round this difficulty by using the expression “psychic energy,” because I could not base the

theory of dementia praecox on the theory of displacements of libido sexually defined. My experience—at that time chiefly psychiatric—did not permit me to understand this latter theory: only later did I come to realize its partial correctness as regards the neuroses, thanks to increased experiences in the field of hysteria and obsessional neurosis. Abnormal displacements of libido, quite definitely sexual, do in fact play a great role in these illnesses. But although very characteristic repressions of sexual libido do take place in the neuroses, the loss of reality so typical of dementia praecox never occurs. In dementia praecox the loss of the reality function is so extreme that it must involve the loss of other instinctual forces whose sexual character must be denied absolutely, for no one is likely to maintain that reality is a function of sex. Moreover, if it were, the withdrawal of erotic interest in the neuroses would necessarily entail a loss of reality comparable to that which occurs in dementia praecox. But, as I said before, this is not the case.

[276] (Another thing to be considered—as Freud also pointed out in his work on the Schreber case—is that the introversion of sexual libido leads to an investment of the ego which might conceivably produce that effect of loss of reality. It is indeed tempting to explain the psychology of the loss in this way. But when we examine more closely the various things that can arise from the withdrawal and introversion of sexual libido, we come to see that though it can produce the psychology of an ascetic anchorite, it cannot produce dementia praecox. The anchorite’s whole endeavour is to exterminate every trace of sexual interest, and this is something that cannot be asserted of dementia praecox.⁷)

[277] These facts have made it impossible for me to apply Freud’s libido theory to dementia praecox. I am also of the opinion that Abraham’s essay on this subject⁸ is theoretically untenable from the standpoint of Freud’s conception of libido. Abraham’s belief that the paranoid system, or the schizophrenic symptomatology, is produced by the withdrawal of sexual libido from the outside world cannot be justified in terms of our present knowledge. For, as Freud has clearly shown, a mere introversion or regression of libido invariably leads to a neurosis and not to dementia praecox. It seems to me impossible simply to transfer the libido theory to dementia praecox, because this disease shows a loss of reality which cannot be explained solely by the loss of erotic interest.

THE GENETIC CONCEPTION OF LIBIDO

[278] The attitude of reserve which I adopted towards the ubiquity of sexuality in my foreword to “The Psychology of Dementia Praecox,” despite the fact that I recognized the psychological mechanisms pointed out by Freud, was dictated by the position of the libido theory at that time. Its sexual definition did not permit me to

explain functional disturbances which affect the indefinite sphere of the hunger drive just as much as that of sex solely in the light of a sexual libido theory. Freud's libido theory had long seemed to me inapplicable to dementia praecox. In my analytical work I noticed that, with growing experience, a slow change in my conception of libido had taken place. Instead of the descriptive definition set forth in Freud's *Three Essays*, there gradually took shape a genetic definition of libido, which enabled me to replace the expression "psychic energy" by "libido." I had to tell myself: if the reality function consists nowadays to only a very small extent of sexual libido and to a far greater extent of other instinctual forces, then it is very important to consider whether, phylogenetically speaking, the reality function is not, at least very largely, of sexual origin. It is impossible to answer this question directly, but we can seek to approach it by a circuitous route.

[279] A cursory glance at the history of evolution suffices to show that numerous complicated functions, which today must be denied all trace of sexuality, were originally nothing but offshoots of the reproductive instinct. As we know, an important change occurred in the principles of reproduction during the ascent through the animal kingdom: the vast numbers of gametes which chance fertilization made necessary were progressively reduced in favour of assured fertilization and effective protection of the young. The decreased production of ova and spermatozoa set free considerable quantities of energy for conversion into the mechanisms of attraction and protection of offspring, etc. Thus we find the first stirrings of the artistic impulse in animals, but subservient to the reproductive instinct and limited to the breeding season. The original sexual character of these biological phenomena gradually disappears as they become organically fixed and achieve functional independence. Although there can be no doubt that music originally belonged to the reproductive sphere, it would be an unjustified and fantastic generalization to put music in the same category as sex. Such a terminology would be tantamount to treating of Cologne cathedral in a text-book of mineralogy, on the ground that it consisted very largely of stones.

[280] Up to now we have spoken of libido as the instinct for propagation or for the preservation of the species, and have kept within the confines of a view which contrasts libido with hunger in the same way as the instinct for the preservation of the species is contrasted with the instinct for self-preservation. In nature, of course, this artificial distinction does not exist. There we see only a continuous life-urge, a will to live, which seeks to ensure the continuance of the whole species through the preservation of the individual. Thus far our conception of libido coincides with Schopenhauer's Will, inasmuch as a movement perceived from the outside can only be grasped as the manifestation of an inner will or desire. Once we have arrived at the bold conjecture that the libido which was originally employed in the production

of ova and spermatozoa is now firmly organized in the function of nest-building, for instance, and can no longer be employed otherwise, we are compelled to include every striving and every desire, as well as hunger, in this conception. There is no longer any justification for differentiating in principle between the desire to build nests and the desire to eat.⁹

[281] I think you will already see where our argument is leading us. We are in the process of carrying through the energetic point of view consistently, putting the energetic mode of action in the place of the purely formal functioning. Just as the older sciences were always talking of reciprocal actions in nature, and this old-fashioned point of view was replaced by the law of the conservation of energy, so here too, in the realm of psychology, we are seeking to replace the reciprocal action of co-ordinated psychic faculties by an energy conceived to be homogeneous. We thus take cognizance of the justified criticism that the psychoanalytic school is operating with a mystical conception of libido.

[282] For this reason I must dispel the illusion that the whole psychoanalytic school has a clearly understood and concrete conception of libido. I maintain that the libido with which we operate is not only not concrete or known, but is a complete X, a pure hypothesis, a model or counter, and is no more concretely conceivable than the energy known to the world of physics. Only in this way can we escape those violent transgressions of the proper boundaries, which happen time and again when we try to reduce co-ordinated forces to one another. (We shall never be able to explain the mechanics of solid bodies or of electromagnetic phenomena in terms of a theory of light, for mechanics and electromagnetism are not light. Moreover, strictly speaking, it is not physical forces that change into one another, but the energy that changes its outward form. Forces are phenomenal manifestations; what underlies their relations with one another is the hypothetical idea of energy, which is, of course, entirely psychological and has nothing to do with so-called objective reality.) This same conceptual achievement that has taken place in physics we seek to accomplish for the libido theory. We want to give the concept of libido the position that really belongs to it, which is a purely energetic one, so that we can conceive the life-process in terms of energy and replace the old idea of reciprocal action by relations of absolute equivalence. We shall not be disturbed if we are met with the cry of vitalism. We are as far removed from any belief in a specific life-force as from any other metaphysical assertion. Libido is intended simply as a name for the energy which manifests itself in the life-process and is perceived subjectively as conation and desire. It is hardly necessary to defend this view. It brings us into line with a powerful current of ideas that seeks to comprehend the world of appearances energetically. Suffice it to say that everything we perceive can only be understood as an effect of force.

[283] In the diversity of natural phenomena we see desire—libido —taking the most variegated forms. In early childhood it appears at first wholly in the form of the nutritive instinct which builds up the body. As the body develops, new spheres of activity are opened up successively for the libido. A definitive and extremely important sphere of activity is sexuality, which to begin with appears closely bound up with the function of nutrition (one has only to think of the influence of nutritional factors on propagation in the lower animals and plants). In the sphere of sexuality the libido acquires a form whose tremendous importance gives us the justification for using the ambiguous term “libido” at all. Here it appears at first in the form of an undifferentiated, primary libido, as the energy of growth that causes cell-division, budding, etc. in individuals.

[284] Out of this primary, sexual libido, which produces from one small organism millions of ova and spermatozoa, there developed, by a tremendous restriction of fertility, offshoots whose function is maintained by a specifically differentiated libido. This differentiated libido is now “desexualized” by being divested of its original function of producing eggs and sperm, nor is there any possibility of restoring it to its original function. Thus the whole process of development consists in a progressive absorption of the primary libido, which produced nothing but gametes, into the secondary functions of attraction and protection of offspring. This development presupposes a quite different and much more complicated relation to reality, a genuine reality function which is inseparably connected with the needs of reproduction. In other words, the altered mode of reproduction brings with it, as a correlate, a correspondingly enhanced adaptation to reality. This, of course, does not imply that the reality function owes its existence exclusively to the differentiation in reproduction. I am fully aware of the indefinitely large role played by the nutritive function.

[285] In this way we gain some insight into the factors originally conditioning the reality function. It would be a fundamental error to say that its driving force is a sexual one. It *was* in large measure a sexual one originally, but even then not exclusively so.

[286] The process of absorption of primary libido into secondary functions probably always occurred in the form of “libidinal affluxes,” that is to say sexuality was diverted from its original destination and part of it used for the mechanisms of attraction and protection of the young—functions which gradually increase the higher you go in the phylogenetic scale. This transfer of sexual libido from the sexual sphere to subsidiary functions is still taking place. (Malthusianism, for instance, is an artificial continuation of the natural tendency.) Wherever this operation occurs

without detriment to the adaptation of the individual we call it “sublimation,” and “repression” when the attempt fails.

[287] The descriptive standpoint of psychoanalysis views the multiplicity of instincts, among them the sexual instinct, as partial phenomena, and, in addition, recognizes certain affluxes of libido to nonsexual instincts.

[288] The genetic standpoint is different. It regards the multiplicity of instincts as issuing from a relative unity, the libido; it sees how portions of libido continually split off from the reproductive function, add themselves as libidinal affluxes to the newly formed functions, and finally merge into them.

[289] From this point of view we can rightly say that the schizophrenic withdraws his libido from the outside world and in consequence suffers a loss of reality compensated by an increase in fantasy activity.

INFANTILE PERVERSIONS

[290] We shall now try to fit this new conception of libido into the theory of infantile sexuality, which is so very important for the theory of neurosis. In infants we find that libido as energy, as a vital activity, first manifests itself in the nutritional zone, where, in the act of sucking, food is taken in with a rhythmic movement and with every sign of satisfaction. With the growth of the individual and development of his organs the libido creates for itself new avenues of activity. The primary model of rhythmic movement, producing pleasure and satisfaction, is now transferred to the zone of the other functions, with sexuality as its ultimate goal. A considerable portion of the “alimentary libido” has to convert itself into “sexual libido.” This transition does not take place quite suddenly at puberty, but only very gradually during the course of childhood. The libido can free itself only with difficulty and quite slowly from the modality of the nutritive function in order to pass over into the sexual function.

[291] In this transitional stage there are, so far as I am able to judge, two distinct phases: the phase of sucking, and the phase of displaced rhythmic activity. Sucking belongs by its very nature to the sphere of the nutritive function, but outgrows it by ceasing to be a function of nutrition and becoming a rhythmic activity aiming at pleasure and satisfaction without intake of nourishment. At this point the hand comes in as an auxiliary organ. It appears even more clearly as an auxiliary organ in the phase of displaced rhythmic activity for pleasure, which then leaves the oral zone and turns to other regions. As a rule, it is the other body-openings that become the first objects of libidinal interest; then the skin, or special parts of it. The activities carried out in these places, taking the form of rubbing, boring, picking, pulling, and so forth,

follow a certain rhythm and serve to produce pleasure. After lingering for a while at these stations, the libido continues its wanderings until it reaches the sexual zone, where it may provide occasion for the first attempts at masturbation. In the course of its migrations the libido carries traces of the nutritional phase into its new field of operations, which readily accounts for the many intimate connections between the nutritive and the sexual function.¹⁰ This migration of libido takes place during the presexual stage, whose special distinguishing-mark is that the libido gradually sloughs off the character of the nutritive instinct and assumes that of the sexual instinct.¹¹ At the stage of nutrition, therefore, we cannot yet speak of a true sexual libido.

[292] In consequence, we are obliged to qualify the so-called polymorphous-perverse sexuality of early infancy. The polymorphism of libidinal strivings at this period can be explained as the gradual migration of libido, stage by stage, away from the sphere of the nutritive function into that of the sexual function. Thus the term “perverse,” so bitterly attacked by our critics, can be dropped, since it creates a false impression.

[293] When a chemical substance breaks up into its elements, these elements are, under those conditions, products of disintegration. But it is not permissible to describe all elements whatsoever as products of disintegration. Perversions are disturbed products of a developed sexuality. They are never the initial stages of sexuality, although there is an undoubted similarity between the initial stage and the product of disintegration. As sexuality develops, its infantile stages, which should no longer be regarded as “perverse” but as rudimentary and provisional, resolve themselves into normal sexuality. The more smoothly the libido withdraws from its provisional positions, the more quickly and completely does the formation of normal sexuality take place. It is of the essence of normal sexuality that all those early infantile tendencies which are not yet sexual should be sloughed off as much as possible. The less this is so, the more perverse will sexuality become. Here the expression “perverse” is altogether appropriate. The basic conditioning factor in perversion, therefore, is an infantile, insufficiently developed state of sexuality. The expression “polymorphous-perverse” has been borrowed from the psychology of neurosis and projected backwards into the psychology of the child, where of course it is quite out of place.

4. NEUROSIS AND AETIOLOGICAL FACTORS IN CHILDHOOD

[294] Now that we have ascertained what is to be understood by infantile sexuality, we can follow up the discussion of the theory of neurosis, which we began in the first lecture and then dropped. We followed the theory of neurosis up to the point where we ran up against Freud's statement that the predisposition which makes traumatic experiences pathogenically effective is a sexual one. Helped by our reflections since then, we can now understand how that sexual predisposition is to be conceived: it is a retardation, a check in the process of freeing the libido from the activities of the presexual stage. The disturbance must be regarded in the first place as a temporary fixation: the libido lingers too long at certain stations in the course of its migration from the nutritive function to the sexual function. This produces a state of disharmony because provisional and, as it were, outworn activities still persist at a period when they should have been given up. This formula can be applied to all those infantile features which are so prevalent in neurotics that no attentive observer can have failed to notice them. In dementia praecox the infantilism is so striking that it has even given a telltale name to one particular syndrome—*hebephrenia* (literally, 'adolescent mind').

[295] The matter is not ended, however, by saying that the libido lingers too long in the preliminary stages. For while the libido is lingering, time does not stand still, and the development of the individual is proceeding apace. Physical maturation heightens the discrepancy between the perseverating infantile activity and the demands of later years with their changed conditions of life. In this way the foundation is laid for a dissociation of the personality, and hence for a conflict, which is the real basis of a neurosis. The more the libido is engaged in retarded activities, the more intense will the conflict be. The particular experience best suited to make this conflict manifest is a traumatic or pathogenic one.

[296] As Freud has shown in his early writings, one can easily imagine a neurosis arising in this way. It was a conception that fitted in quite well with the views of Janet, who attributed a neurosis to some kind of defect. From this standpoint one could regard neurosis as a product of retarded affective development, and I can easily imagine that this conception must seem self-evident to anyone who is inclined to derive the neuroses more or less directly from a hereditary taint or congenital degeneracy. Unfortunately the real state of affairs is much more complicated. In order to give you some idea of these complications, I shall cite a very ordinary example of

hysteria, which I hope will show you how characteristic and how extremely important they are theoretically.

[297] You will probably remember the case of the young hysteric I mentioned earlier, who, surprisingly enough, did not react to a situation which might have been expected to make a profound impression on her, and yet displayed an unexpected and pathologically violent reaction to a quite ordinary occurrence. We took this occasion to express our doubt as to the aetiological significance of the trauma, and to investigate more closely the so-called predisposition which rendered the trauma effective. The result of that investigation led to the conclusion just mentioned, that it is by no means improbable that the origin of a neurosis is due to a retardation of affective development.

[298] You will now ask in what way the patient's affective development was retarded. The answer is that she lived in a world of fantasy which can only be described as infantile. It is unnecessary for me to give you a description of these fantasies, for, as neurologists or psychiatrists, you undoubtedly have a daily opportunity to listen to the childish prejudices, illusions, and emotional demands of neurotics. The disinclination to face stern reality is the distinguishing feature of these fantasies; there is a lack of seriousness, a playfulness in them, which sometimes frivolously disguises real difficulties, at other times makes mountains out of molehills, always thinking up fantastic ways of evading the demands of real life. We immediately recognize in them the intemperate psychic attitude of the child to reality, his precarious judgment, his lack of orientation, his dislike of unpleasant duties. With such an infantile mentality all manner of wishful fantasies and illusions can grow luxuriantly, and this is where the danger comes in. By means of these fantasies people can easily slip into an unreal and completely unadapted attitude to the world, which sooner or later must lead to catastrophe.

THE TRAUMA THEORY CRITICIZED

[299] If we follow the patient's infantile fantasy-life back into earliest childhood, we find, it is true, many obviously outstanding scenes which might well serve to provide fresh food for this or that fantastic variation, but it would be vain to search for the so-called traumatic elements from which something pathological, for instance her abnormal fantasy activity, might have originated. There were plenty of "traumatic" scenes, but they did not lie in early childhood; and the few scenes of early childhood which were remembered did not appear to be traumatic, being more like accidental experiences which passed by without having any effect worth mentioning on her fantasies. The earliest fantasies consisted of all sorts of vague and half-understood impressions she had received of her parents. All sorts of special feelings clustered

round the father, fluctuating between fear, horror, aversion, disgust, love, and ecstasy. The case was like so many other cases of hysteria for which no traumatic aetiology can be found; they are rooted instead in a peculiar, premature fantasy activity which permanently retains its infantile character.

[300] You will object that it is just that scene with the bolting horses that represents the trauma, and that this was obviously the model for that nocturnal scene eighteen years later, when the patient could not get out of the way of the horses trotting along behind her and wanted to throw herself into the river, following the model of the horses and carriage plunging down the ravine. From this moment on she also suffered from hysterical twilight states. But, as I tried to show you in my earlier lecture, we find no trace of any such aetiological connection in the development of her fantasy system. It is as though the danger of losing her life, that first time with the bolting horses, passed by without noticeable effect. In all the years following that experience there was no discernible trace of that fright. It was as though it had never happened. In parenthesis let me add that perhaps it never happened at all. There is nothing to prevent it from being sheer fantasy, for here I have only the statements of the patient to rely on.¹

[301] Suddenly, after eighteen years, this experience becomes significant, is reproduced and acted out in all its details. The old theory says: the previously blocked affect has suddenly forced its way to the surface. This assumption is extremely unlikely and becomes still more inconceivable when we consider that the story of the bolting horses may not even be true. Be that as it may, it is almost inconceivable that an affect should remain buried for years and then suddenly explode at an unsuitable opportunity.

[302] It is very suspicious, too, that patients often have a pronounced tendency to account for their ailments by some long-past experience, ingeniously drawing the analyst's attention away from the present to some false track in the past. This false track was the one pursued by the first psychoanalytical theory. But to this false hypothesis we owe an insight into the determination of neurotic symptoms which we should never have reached if the investigators had not trodden this path, guided into it, really, by the tendency of the patient to mislead. I think that only those who regard the happenings in this world as a concatenation of errors and accidents, and who therefore believe that the pedagogic hand of the rationalist is constantly needed to guide us, can ever imagine that this path was an aberration from which we should have been warned off with a signboard. Besides the deeper insight into psychological determination, we owe to this "error" a method of inquiry of incalculable importance. It is for us to rejoice and be thankful that Freud had the courage to let himself be guided along this path. Not thus is the progress of science hindered, but rather by

blind adherence to insights once gained, by the typical conservatism of authority, by the childish vanity of the savant and his fear of making mistakes. This lack of courage is considerably more injurious to the name of science than an honest error. When will there be an end to the incessant squabbling about who is right? One has only to look at the history of science: how many have *been* right, and how few have *remained* right!

THE PARENTAL COMPLEX

[303] But to return to our case. The question that now arises is this: if the old trauma is not of aetiological significance, then the cause of the manifest neurosis is obviously to be sought in the retardation of affective development. We must therefore regard the patient's statement that her hysterical twilight states were caused by the fright she got with the horses as null and void, although that fright was the starting-point for her manifest illness. This experience merely *seems* to be important without being so in reality, a formulation which is true of most other traumata. They merely *seem* to be important because they provide occasion for the manifestation of a condition that has long been abnormal. The abnormal condition, as we have already explained, consists in the anachronistic persistence of an infantile stage of libido development. The patients continue to hang on to forms of libido activity which they should have abandoned long ago. It is almost impossible to catalogue these forms, so extraordinarily varied are they. The commonest, which is scarcely ever absent, is an excessive fantasy activity characterized by a thoughtless overvaluation of subjective wishes. Excessive fantasy activity is always a sign of faulty application of libido to reality. Instead of being used for the best possible adaptation to the actual circumstances, it gets stuck in fantastic applications. We call this state one of partial introversion when libido is used for the maintenance of fantasies and illusions instead of being adapted to the actual conditions of life.

[304] A regular concomitant of this retardation of affective development is the *parental complex*. When the libido is not used for purposes of real adaptation it is always more or less introverted.² The material content of the psychic world consists of memories, that is, of material from the individual's past (aside from actual perceptions). If the libido is partially or totally introverted, it invests to a greater or lesser degree large areas of memory, with the result that these reminiscences acquire a vitality that no longer properly belongs to them. The patients then live more or less entirely in the world of the past. They battle with difficulties which once played a role in their lives but which ought to have faded out long ago. They still worry, or rather are forced to worry, about things which should long since have ceased to be important. They

amuse or torment themselves with fancies which, in the normal course of events, were once significant but no longer have any significance for adults.

[305] Among the things that were of the utmost significance at the infantile period the most influential are the personalities of the parents. Even when the parents have long been dead and have lost, or should have lost, all significance, the situation of the patient having perhaps completely changed since then, they are still somehow present and as important as if they were still alive. The patient's love, admiration, resistance, hatred, and rebelliousness still cling to their effigies, transfigured by affection or distorted by envy, and often bearing little resemblance to the erstwhile reality. It was this fact that compelled me to speak no longer of "father" and "mother" but to employ instead the term "imago," because these fantasies are not concerned any more with the real father and mother but with subjective and often very much distorted images of them which lead a shadowy but nonetheless potent existence in the mind of the patient.

[306] The complex of the parental imagos, that is, the whole tissue of ideas relating to the parents, provides an important field of activity for the introverted libido. I should mention in passing that the complex in itself leads but a shadowy existence if it is not invested with libido. In accordance with the earlier usage worked out in my *Studies in Word Association*, the word "complex" denoted a system of ideas already invested with libido and activated by it. But this system also exists *in potentia*, ready for possible action, even when not temporarily or permanently invested with libido.

PARENTAL INFLUENCES ON CHILDREN

[307] At the time when psychoanalytic theory was still dominated by the trauma concept and, in conformity with that view, was inclined to look for the *causa efficiens* of the neurosis in the past, it seemed to us that the parental complex was, as Freud called it, the "nuclear complex" of neurosis. The role of the parents seemed to be so powerful a factor that we were apt to blame them for all the subsequent complications in the life of the patient. Some years ago I discussed this in my paper, "The Significance of the Father in the Destiny of the Individual."³ Once again we had allowed ourselves to be guided by the tendency of the patient to revert to the past, following the direction of his introverted libido. This time, certainly, it was no longer an external, accidental experience or event which seemed to produce the pathogenic effect; it was rather a psychological effect apparently arising out of the individual's difficulties in adapting to the conditions of the family milieu. The disharmony between the parents on the one hand and between the parents and the child on the other seemed especially liable to produce psychic currents in the child which were incompatible with his individual way of life.

[308] In the paper just alluded to I cited a number of instances, taken from a wealth of material on this subject, which show these effects particularly clearly. The effects apparently emanating from the parents are not limited to the endless recriminations of their neurotic offspring, who constantly lay the blame for their illness on their family circumstances or bad upbringing, but extend even to actual events in the life of the patients, where no such determining influence could have been expected. The lively imitativeness which we find in primitives as well as in children can give rise, in particularly sensitive children, to a peculiar inner identification with the parents, to a mental attitude so similar to theirs that effects in real life are sometimes produced which, even in detail, resemble the personal experiences of the parents.⁴

[309] For the empirical material on this subject, I must refer you to the literature, but should just like to remind you that one of my pupils, Dr. Emma Fürst, has adduced valuable experimental proofs in regard to this problem. I have already referred to her researches in my lectures at Clark University.⁵ By applying the association test to whole families, Dr. Fürst established the great conformity of reaction type among all members of one family. These experiments show that very often there exists an unconscious concordance of association between parents and children, which can only be explained as an intensive imitation or identification. The results of these researches indicate a far-reaching parallelism of biological tendencies that readily explains the sometimes astonishing similarity in the destinies of parents and children. Our destinies are as a rule the outcome of our psychological tendencies.

[310] These facts enable us to understand why not only the patients themselves, but the theories that have been built on these researches, tend to assume that neurosis is the result of the characterological influence of the parents on the children. This assumption is, moreover, supported by the experience which lies at the base of all education, namely, the plasticity of the child's mind, which is commonly compared with soft wax, taking up and preserving all impressions. We know that the first impressions of childhood accompany us inalienably throughout life, and that, just as indestructibly, certain educational influences can keep people all their lives within those limits. In these circumstances it is not surprising that conflicts break out between the personality moulded by educational and other influences of the infantile milieu and one's own individual style of life. It is a conflict which all those must face who are called upon to live a life that is independent and creative.

[311] Owing to the enormous influence which childhood has on the later development of character, you will readily understand why one would like to attribute the cause of a neurosis directly to the influences of the infantile environment. I must confess that I have known cases in which any other explanation seemed to me less plausible. There are indeed parents whose own contradictory nature causes them to treat their children

in so unreasonable a fashion that the children's illness would appear to be unavoidable. Hence it is almost a rule among nerve specialists to remove neurotic children, whenever possible, from the dangerous family atmosphere and place them among more healthy influences, where, even without any medical treatment, they thrive much better than at home. There are many neurotic patients who were clearly neurotic as children and so have never been free from illness since childhood. In such cases the view outlined above seems generally valid.

THE INFANTILE MENTALITY

[312] This knowledge, which for the time being seemed to us definitive, was considerably deepened by the researches of Freud and the psychoanalytic school. The parent-child relationship was studied in all its details, since it was just this relationship which was considered aetiologically important. It was soon noticed that these patients really did live partly or entirely in their childhood world, although themselves quite unconscious of this fact. On the contrary, it was the arduous task of psychoanalysis to investigate the psychological mode of adaptation so thoroughly that one could put one's finger on the infantile misunderstandings. As you know, a striking number of neurotics were spoiled as children. Such cases offer the best and clearest examples of the infantilism of their psychological mode of adaptation. They start out in life expecting the same friendly reception, tenderness, and easy success to which they were accustomed by their parents in their youth. Even very intelligent patients are incapable of seeing that from the very beginning they owe the complications of their lives as well as their neurosis to dragging their infantile emotional attitude along with them. The small world of the child, the family milieu, is the model for the big world. The more intensely the family sets its stamp on the child, the more he will be emotionally inclined, as an adult, to see in the great world his former small world. Of course this must not be taken as a conscious intellectual process. On the contrary, the patient feels and sees the difference between now and then, and tries as well as he can to adapt himself. Perhaps he will even believe himself perfectly adapted, since he may be able to grasp the situation intellectually, but that does not prevent his emotions from lagging far behind his intellectual insight.

[313] It is scarcely necessary to give you examples of this phenomenon, for it is an everyday experience that our emotions never come up to the level of our insight. It is exactly the same with the neurotic, but greatly intensified. He may perhaps believe that, except for his neurosis, he is a normal person, fully adapted to the conditions of life. It never crosses his mind that he has still not given up certain infantile demands, that he still carries with him, in the background, expectations and illusions of which he has never made himself conscious. He indulges in all sorts of pet fantasies, of

which he is seldom, if ever, so conscious that he knows that he has them. Very often they exist only as emotional expectations, hopes, prejudices, and so forth. In this case we call them unconscious fantasies. Sometimes they appear on the fringe of consciousness as fleeting thoughts, only to vanish again the next moment, so that the patient is unable to say whether he had such fantasies or not. It is only during psychoanalytic treatment that most patients learn to retain and observe these fugitive thoughts. Although most fantasies were once conscious, for a moment, as fleeting thoughts, it would not do to call them *conscious*, because most of the time they are practically *unconscious*. It is therefore right to call them unconscious fantasies. Of course there are also infantile fantasies which are perfectly conscious and can be reproduced at any time.

5. THE FANTASIES OF THE UNCONSCIOUS

[314] The realm of unconscious infantile fantasies has become the real object of psychoanalytic research, for it seems to offer the key to the aetiology of neurosis. Here, quite otherwise than with the trauma theory, we are forced by all the reasons we have mentioned to assume that the roots of the psychological present are to be found in the family history of the patient.

[315] The fantasy systems which patients present on being questioned are mostly of a composite nature and are elaborated like a novel or a drama. But, despite their elaboration, they are of relatively little value in investigating the unconscious. Just because they are conscious, they defer too much to the demands of etiquette and social morality. They have been purged of all painful personal details, and also of everything ugly, thereby becoming socially presentable and revealing very little. The more valuable and evidently more influential fantasies are not conscious, in the sense previously defined, and so have to be dug out by the psychoanalytic technique.

[316] Without wishing to enter fully into the question of technique, I must here meet an objection that is constantly heard. It is that the so-called unconscious fantasies are merely suggested to the patient and exist only in the mind of the analyst. This objection is on the same vulgar level as those which impute to us the crude mistakes of beginners. Only people with no psychological experience and no knowledge of the history of psychology are capable of making such accusations. No one with the faintest glimmering of mythology could possibly fail to see the startling parallels between the unconscious fantasies brought to light by the psychoanalytic school and mythological ideas. The objection that our knowledge of mythology has been suggested to the patient is without foundation, because the psychoanalytic school discovered the fantasies first and only then became acquainted with their mythology. Mythology, as we know, is something quite outside the ken of the medical man.

[317] As these fantasies are unconscious, the patient is naturally unaware of their existence, and to question him about them directly would be quite pointless. Nevertheless it is said over and over again, not only by patients but by so-called normal persons: "But if I had such fantasies, surely I would know it!" But what is unconscious is in truth something that we do *not* know. Our opponents, too, are firmly convinced that such things do not exist. This *a priori* judgment is pure scholasticism and has no grounds to support it. We cannot possibly rest on the dogma that consciousness alone is the psyche, for we have daily proof that our consciousness is only a part of the psychic function. When the contents of our

consciousness appear they are already in a highly complex state; the constellation of our thoughts from the material contained in our memory is a predominantly unconscious process. We are therefore obliged to assume, whether we like it or not, the existence of a non-conscious psychic sphere, even if only as a “negative borderline concept,” like Kant’s *Ding an sich*. Since we perceive effects whose origin cannot be found in consciousness, we are compelled to allow hypothetical contents to the sphere of the non-conscious, which means presupposing that the origin of those effects lies in the unconscious precisely because it is not conscious. This conception of the unconscious can hardly be accused of “mysticism.” We do not pretend to know or to assert anything positive about the state of psychic elements in the unconscious. Instead, we have formulated symbolical concepts in a manner analogous to our formulation of conscious concepts, and this terminology has proved its value in practice.

THE CONCEPT OF THE UNCONSCIOUS

[318] This way of thinking is the only possible one if we accept the axiom that “principles are not to be multiplied beyond the necessary.” We therefore speak about the effects of the unconscious just as we do about the phenomena of consciousness. Great objection was taken to Freud’s statement: “The unconscious can only wish.” This was regarded as an unheard-of metaphysical assertion, something like a tenet from von Hartmann’s *Philosophy of the Unconscious*. The indignation was due simply to the fact that these critics, unknown to themselves, evidently started from a metaphysical conception of the unconscious as an *ens per se*, and naively projected their epistemologically unclarified ideas on to us. For us the unconscious is not an entity in this sense but a mere term, about whose metaphysical essence we do not permit ourselves to form any idea. In this we are unlike those arm-chair psychologists who are not only perfectly informed about the localization of the psyche in the brain and the physiological correlates of mental processes, but can assert positively that beyond consciousness there are nothing but “physiological processes in the cortex.”

[319] Such naïvetés should not be imputed to us. When Freud says that the unconscious can only wish, he is describing in symbolical terms effects whose source is not conscious, but which from the standpoint of conscious thinking can only be regarded as analogous to wishes. The psychoanalytic school is, moreover, aware that the discussion as to whether “wishing” is a suitable analogy or not can be reopened at any time. Anybody who knows a better one will be welcome. Instead of which, our opponents content themselves with denying the existence of these phenomena or else, if certain phenomena have to be admitted, they abstain from all theoretical

formulations. This last point is understandable enough, since it is not everyone's business to think theoretically.

[320] Once one has succeeded in freeing oneself from the dogma of the psyche's identity with consciousness, thus admitting the possible existence of extra-conscious psychic processes, one cannot, *a priori*, either assert or deny anything about the potentialities of the unconscious. The psychoanalytic school has been accused of making assertions without sufficient grounds. It seems to us that the abundant, perhaps too abundant case-material contained in the literature offers enough and more than enough grounds, yet it does not seem sufficient for our opponents. There must be a good deal of difference as to the meaning of the word "sufficient" in regard to the validity of these grounds. So we must ask: Why does the psychoanalytic school apparently demand far less exacting proofs of its formulations than its opponents?

[321] The reason is simple. An engineer who has built a bridge and calculated its load needs no further proof of its holding capacity. But a sceptical layman, who has no notion how a bridge is built, or what is the strength of the material used, will demand quite different proofs of its holding capacity, since he can have no confidence in it. It is chiefly the profound ignorance of our opponents about what we are doing that screws their demands up to such a pitch. In the second place, there are the countless theoretical misunderstandings: it is impossible for us to know them all and to clear them up. Just as we find in our patients new and ever more astounding misconceptions about the ways and aims of psychoanalysis, so our critics display an inexhaustible ingenuity in misunderstanding. You can see from our discussion of the concept of the unconscious just what kind of false philosophical assumptions can vitiate understanding of our terminology. Obviously a person who thinks of the unconscious as an absolute entity is bound to require proofs of a totally different kind, utterly beyond our power to give, as our opponents in fact do. Had we to offer proof of immortality, mountains of proofs of the weightiest nature would have to be furnished, very different from what would be required to demonstrate the existence of plasmodia in a malaria patient. Metaphysical expectations still bedevil scientific thinking far too much for the problems of psychoanalysis to be seen in their own frame of reference.

[322] But, in fairness to our critics, I must admit that the psychoanalytic school has itself given rise to plenty of misunderstandings, even though in all innocence. One of the principal sources is the confusion that reigns in the theoretical sphere. Regrettable though it is, we have no presentable theory. You would understand this if you could see in concrete instances the enormous difficulties we have to wrestle with. Contrary to the opinion of nearly all the critics, Freud is anything rather than a theorist. He is an empiricist, as anyone must admit who is willing to go at all deeply into Freud's

writings and to try to see his cases as he sees them. Unfortunately, our critics are not willing. As we have repeatedly been told, it is “repulsive and disgusting” to see them as Freud does. But how can anyone learn the nature of Freud’s method if he allows himself to be put off by disgust? Just because people make no effort to accommodate themselves to Freud’s point of view, adopted perhaps as a necessary working hypothesis, they come to the absurd conclusion that he is a theorist. They readily assume that *Three Essays on the Theory of Sexuality* is simply a theory, invented by a speculative brain, and that everything is put into the patient’s head by suggestion. But that is turning things upside down. This makes it easy for the critics, which is just what they want. They pay no attention at all to the “couple of case-histories” with which the psychoanalyst conscientiously documents his theoretical statements, but only to the theory and the formulation of technique. The weak spots of psychoanalysis are not to be found here—for psychoanalysis is essentially empirical—though here, undoubtedly, is a large and insufficiently cultivated field where the critics can romp to their heart’s content. In the field of theory there are many uncertainties and not a few contradictions. We were conscious of this long before our learned critics began to honour us with their attentions.

THE DREAM

[323] After this digression we will return to the question of unconscious fantasies which occupied us before. Nobody, as we have seen, has the right to assert their existence or define their qualities unless effects of unconscious origin are observed which can be expressed in terms of conscious symbolism. The only question is whether effects can in fact be found that comply with this expectation. The psychoanalytic school believes it has discovered such effects. I will mention the principal phenomenon at once: the dream.

[324] Of this it may be said that it enters consciousness as a complex structure compounded of elements whose connection with each other is not *conscious*. Only afterwards, by adding a series of associations to the individual images in the dream, can we show that these images had their origin in certain memories of the recent past. We ask ourselves: Where have I seen or heard that? And then, by the ordinary process of association, comes the memory that certain parts of the dream have been consciously experienced, some the day before, some earlier. So far there will be general agreement, for these things have been known for a long time. To that extent the dream presents itself to us as a more or less unintelligible jumble of elements not at first conscious and only recognized afterwards through their associations.¹ It should be added that not all parts of the dream have a recognizable quality from which their conscious character can be deduced; they are often, and indeed mostly,

unrecognizable at first. Only afterwards does it occur to us that we have consciously experienced this or that part of the dream. From this standpoint alone we may regard the dream as a product of unconscious origin.

[325] The technique for exploring the unconscious origin is the one I have just mentioned, used as a matter of course long before Freud by every dream-investigator. We simply try to remember where the parts of the dream came from. The psychoanalytic technique of dream elucidation is based on this very simple principle. It is a fact that certain parts of the dream are derived from our waking life, from events which, on account of their obvious unimportance, would have fallen into oblivion and were already on the way to becoming definitely unconscious. It is just these parts that are the effects of “unconscious ideas.” Exception has been taken to this expression too. Naturally we do not take things nearly so concretely, not to say ponderously, as our critics. Certainly this expression is nothing more than conscious symbolism—we were never in any doubt on that point. But it is perfectly clear and serves very well as a sign for an unknown psychic fact. As I have said before, we have no alternative but to conceive the unconscious by analogy with the conscious. We do not pretend that we understand a thing merely because we have invented a sonorous and all-but-incomprehensible name for it.

THE METHOD OF DREAM-ANALYSIS

[326] The principle of psychoanalytic elucidation is, therefore, extraordinarily simple and has actually been known for a long time. The subsequent procedure follows logically along the same lines. If we get really absorbed in a dream—which naturally never happens outside analysis—we shall succeed in discovering still more reminiscences about the individual dream-parts. But we are not always successful in finding reminiscences about some of them. These must be put aside for the time being. (When I say “reminiscences” I do not mean only memories of actual experiences; I also mean the reproduction of meaningful associations and connections.) The reminiscences so gathered are called the “dream-material.” We treat this material in accordance with a generally accepted scientific principle. If you have any experimental material to work up, you compare its individual parts and classify them according to their similarities. You proceed in exactly the same way with dream-material; you look for the common features, whether of form or content.

[327] In doing this one has to get rid, so far as possible, of certain prejudices. I have observed that the beginner is always looking for some special feature and then tries to force his material to conform to his expectations. I have noticed this particularly with colleagues who, because of the well-known prejudices and misunderstandings, were once passionate opponents of psychoanalysis. If it was my fate to analyse them, and

they at last obtained real insight into the method, the first mistake they generally made in their psychoanalytic work was to do violence to the material by their own preconceived opinions. That is, they now vented their previous attitude to psychoanalysis on their material, which they could not assess objectively but only in terms of their subjective fantasies.

[328] Once embarked on the task of examining the dream-material, you must not shrink from any comparison. The material usually consists of very disparate images, from which it is sometimes very difficult to extract the *tertium comparationis*. I must refrain from giving detailed-examples, as it is quite impossible to discuss such voluminous material in a lecture. I would, however, like to call your attention to a paper by Rank on “a dream which interprets itself.”² There you will see how extensive is the material that must be taken into account for purposes of comparison.

[329] Hence, in exploring the unconscious, we proceed in the usual way when conclusions are to be drawn by the comparative method. It has often been objected: Why should a dream have any unconscious content at all? This objection is in my view about as unscientific as it could possibly be. Every psychological element has its special history. Every sentence I utter has, besides the meaning consciously intended by me, its historical meaning, which may turn out to be quite different from its conscious meaning. I am expressing myself somewhat paradoxically on purpose: I do not mean that I could explain the historical meaning of every individual sentence. That is easier in the case of larger and more complex structures. Thus, it will be clear to everyone that, apart from the manifest content of a poem, the poem itself is especially characteristic of the poet in regard to its form, content, and manner of origin. While the poet merely gave expression in his poem to the mood of the moment, the literary historian will see things in it and behind it which the poet would never have suspected. The analysis which the literary historian makes of the poet’s material is exactly comparable with the method of psychoanalysis, not excluding the mistakes that may creep in.

[330] The psychoanalytic method can be compared with historical analysis and synthesis in general. Suppose, for instance, we did not understand the meaning of the baptismal rite practised in our churches today. The priest tells us: baptism means the admission of the child into the Christian community. But this does not satisfy us. Why is the child sprinkled with water? In order to understand this ceremony, we must gather together from the whole history of ritual, that is, from mankind’s memories of the relevant traditions, a body of comparative material culled from the most varied sources:

1. Baptism is clearly a rite of initiation, a consecration. Therefore we have to collect all memories in which any initiation rites are preserved.

2. The act of baptism is performed with water. For this special form another series of memories must be collected, namely, of rites in which water is used.

3. The person to be baptized is sprinkled with water. Here we have to collect all those rites in which the neophyte is sprinkled, immersed, etc.

4. All reminiscences from mythology, folklore, as well as superstitious practices, etc., have to be recalled, in so far as they run in any way parallel to the symbolism of the baptismal act.

[331] In this way we build up a comparative study of the act of baptism. We discover the elements out of which the baptismal act is formed; we ascertain, further, its original meaning, and at the same time become acquainted with the rich world of myths that have laid the foundation of religions and help us to understand the manifold and profound meanings of baptism. The analyst proceeds in the same way with a dream. He collects the historical parallels to every part of the dream, even the remotest, and tries to reconstruct the psychological history of the dream and its underlying meanings. Through this monographic elaboration we obtain, just as in the analysis of baptism, a profound insight into the marvellously delicate and meaningful network of unconscious determination—an insight that may legitimately be compared with the historical understanding of an act which we had hitherto regarded in a very superficial and one-sided way.

[332] This excursus seemed to me unavoidable. In view of the numerous misunderstandings of all those who constantly seek to discredit the psychoanalytic method, I felt obliged to give you a very general account of the method and its position within the methodology of science. I do not doubt that there are superficial and improper applications of this method. But an intelligent critic should not allow this to detract from the method itself, any more than a bad surgeon should be used to discredit the value of surgery in general. I do not doubt, either, that not all the expositions of dream-psychology by psychoanalysts are entirely free from misunderstandings and distortions. But much of this is due to the fact that, precisely because of his training in the natural sciences, it is difficult for the medical man to get an intellectual grasp of a very subtle psychological method, even though he instinctively handles it correctly.

[333] The method I have described is the one I adopt and the one to which I hold myself scientifically responsible. To give advice about dreams and to make direct attempts at interpretation is, in my opinion, absolutely wrong and scientifically inadmissible. It is not a methodological but a quite arbitrary proceeding which defeats itself by the sterility of its results, like every false method.

[334] If I have made the attempt to illustrate the principles of the psychoanalytic method by means of dream-analysis it is because the dream is one of the clearest

examples of psychic contents whose composition eludes direct understanding. When someone knocks in a nail with a hammer in order to hang something up, we can understand every detail of the action; it is immediately evident. It is otherwise with the act of baptism, where every phase is problematic. We call these actions, whose meaning and purpose are not immediately evident, symbolic actions, or symbols. On the basis of this reasoning we call a dream symbolic, because it is a psychological product whose origin, meaning, and purpose are obscure, and is therefore one of the purest products of unconscious constellation. As Freud aptly says, the dream is the *via regia* to the unconscious.

THE ASSOCIATION EXPERIMENT

[335] There are many products of unconscious constellation besides dreams. In the association experiment we have a means of determining exactly the influence of the unconscious. We see these effects in the disturbances which I have called “complex indicators.” The task which the association test sets the subject of the experiment is so extraordinarily simple that even children can accomplish it without difficulty. It is all the more surprising that, despite this, so many disturbances of the intended action should be registered. The only things that can regularly be shown to be causes of these disturbances are the partly conscious, partly unconscious constellations caused by complexes. In the majority of cases the connection of these disturbances with feeling-toned complexes can be demonstrated without difficulty. But very often we must have recourse to the psychoanalytic method in order to explain the connection; that is, we must ask the patient what associations he can give to the disturbed reactions.

[336] In this way we obtain the historical material on which to base our judgment. It has been objected that the patient could then say whatever he liked—in other words, any old nonsense. This objection is made, I believe, on the unconscious assumption that the historian who gathers material for his monograph is an imbecile, incapable of distinguishing real parallels from apparent ones and authentic reports from crude falsifications. The professional has means at his disposal for avoiding clumsy mistakes with certainty and more subtle ones with some probability. For anyone who understands psychoanalytic work it is a well-known fact that it is not so very difficult to see where there is coherence and where there is none. In addition, fraudulent statements are in the first place very significant of the person who makes them, and secondly they are easily recognized as fraudulent.

[337] (There is, however, another objection to be considered, which is more worth mentioning. One can ask oneself whether the reminiscences subsequently produced were really the basis of a dream. If, in the evening, I read an interesting account of a

battle, and at night dream of the Balkan War, and then during analysis remember by association certain details in the account of the battle, even the most rigorous critic will fairly assume that my retrospective association is right and true. As I mentioned earlier, this is one of the most firmly entrenched hypotheses regarding the origin of dreams. All we have done is to apply this working hypothesis consistently to all the remaining associations relating to all other parts of the dream. Ultimately, we are saying no more than that this dream-element is linked with this association, that it therefore has something to do with it, that there is a connection between the two things. When a distinguished critic once remarked that, by means of psychoanalytic interpretations, one could even connect a cucumber with an elephant, this worthy showed us, by the very fact of associating “cucumber” with “elephant,” that these two things somehow have an associative connection in his mind. One must have a lot of nerve and a magisterial judgment to declare that the human mind produces entirely meaningless associations. In this instance, only a little reflection is needed to understand the meaning of the association.)

[338] In the association experiment we can ascertain the extraordinarily intense effects emanating from the unconscious precisely through the interference of complexes. The slips and faults in the experiment are nothing but prototypes of the mistakes we make in everyday life, the majority of which must be regarded as due to the interference of complexes. Freud has gathered this material together in his book *The Psychopathology of Everyday Life*. It includes the so-called symptomatic actions—which from another point of view might equally well be called “symbolic actions” and real slips like lapses of memory, slips of the tongue, and so on. All these phenomena are effects of unconscious constellations and are therefore so many gateways to the realm of the unconscious. When they are cumulative, we have to call them a neurosis, which from this point of view looks like a dysfunction and must be understood as the effect of an unconscious constellation.

[339] Thus the association experiment is, not infrequently, a means of unlocking the unconscious directly, although mostly it is simply a technique for obtaining a wide selection of faulty reactions which can then be used for exploring the unconscious by psychoanalysis. At least, this is its most reliable form of application at present. However, it is possible that it will furnish other, especially valuable facts which would give us direct glimpses of the unconscious, but I do not consider this question sufficiently ripe to speak about yet.

6. THE OEDIPUS COMPLEX

[340] After what I have told you about our method you may have gained rather more confidence in its scientific character, and will be inclined to agree that the fantasies which have been brought to light by psychoanalytic research are not just the arbitrary suppositions and illusions of psychoanalysts. Perhaps you will even be willing to listen patiently to what these products of unconscious fantasy can tell us.

[341] The fantasies of adults are, in so far as they are conscious, immensely varied and take the most strongly individual forms. It is therefore impossible to give a general description of them. But it is very different when we enter by means of analysis into the world of unconscious fantasies. The diversity of the fantasy-material is indeed very great, but we do not find nearly so many individual peculiarities as in the conscious realm. We meet here with more typical material which is not infrequently repeated in similar form in different individuals. Constantly recurring in these fantasies are ideas which are variations of those found in religion and mythology. This fact is so striking that we may say we have discovered in these fantasies the forerunners of religious and mythological ideas.

[342] I should have to enter into very much more detail to give you any adequate examples. For these problems I must refer you to my book *Symbols of Transformation*. Here I will only mention that the central symbol of Christianity—sacrifice—plays an important part in the fantasies of the unconscious. The Viennese school knows this phenomenon under the ambiguous name of “castration complex.” This paradoxical use of the term follows from the special attitude of the Viennese school towards the question of sexuality, which I discussed earlier. I have devoted special attention to the problem of sacrifice in the above-mentioned book. I must content myself with this passing reference and will now proceed to say something about the origin of unconscious fantasies.

[343] In a child’s unconscious the fantasies are very much simpler, as if scaled to the childish milieu. Thanks to the concerted efforts of the psychoanalytic school, we have discovered that the most frequent fantasy of childhood is the so-called Oedipus complex. This term, too, seems the most unsuitable one possible. We all know that the tragic fate of Oedipus consisted in his marrying his mother and slaying his father. This tragic conflict of adult life appears far removed from the psyche of a child, and to the layman it seems quite inconceivable that a child should suffer from this conflict. But, with a little reflection, it will become clear that the *tertium comparationis* lies precisely in the *narrow restriction of the fate of Oedipus to his two*

parents. This restriction is characteristic of the child, for the fate of the adult is not limited to the parents. To that extent Oedipus is the exponent of an infantile conflict magnified to adult proportions. The term “Oedipus complex” naturally does not mean conceiving this conflict in its adult form, but rather on a reduced scale suitable to childhood. All it means, in effect, is that the childish demands for love are directed to mother and father, and to the extent that these demands have already attained a certain degree of intensity, so that the chosen object is jealously defended, we can speak of an “Oedipus complex.”

[344] This weakening and reduction in scale of the Oedipus complex should not be understood as a diminution of the total sum of affect, but as indicating the smaller share of sexual affect characteristic of a child. To make up for this, childish affects have that peculiar intensity which is characteristic of the sexual affect in adults. The little son would like to have his mother all to himself and to be rid of his father. As you know, small children can sometimes force themselves between the parents in the most jealous way. In the unconscious these wishes and intentions assume a more concrete and more drastic form. Children are small primitive creatures and are therefore quickly ready to kill—a thought which is all the easier in the unconscious, because the unconscious is wont to express itself very dramatically. But as a child is, in general, harmless, this seemingly dangerous wish is as a rule harmless too. I say “as a rule,” for we know that children can occasionally give way to their murderous impulses, not only indirectly, but in quite direct fashion. But just as the child is incapable of making systematic plans, so his intention to murder is not all that dangerous. The same is true of his Oedipal intention towards the mother. The faint hints of this fantasy in the child’s consciousness can easily be overlooked; all parents are therefore convinced that their children have no Oedipus complex. Parents, like lovers, are mostly blind. If I now say that the Oedipus complex is in the first place only a formula for childish desires in regard to the parents and for the conflict which these desires evoke—as every selfish desire must—the matter may seem more acceptable.

[345] The history of the Oedipus fantasy is of special interest because it teaches us a great deal about the development of unconscious fantasies in general. People naturally think that the Oedipus problem is the problem of the son. But this, remarkably enough, is an illusion. Under certain conditions, the sexual libido reaches its final differentiation, corresponding to the sex of the individual, only relatively late in puberty. Before this time it has a sexually undifferentiated character, which could also be termed bisexual. It is therefore not surprising if little girls have an Oedipus complex too. So far as we know, the first love of a child, regardless of sex, belongs to the mother. If the love for the mother is intense at this stage, the father is jealously kept away as a rival. Of course, for the child itself, the mother at this early stage of

childhood has no sexual significance worth mentioning, and to that extent the term “Oedipus complex” is not really suitable. At this period the mother still has the significance of a protecting, enfolding, nourishing being, who for this reason is a source of pleasure.

[346] (It is characteristic, too, that the babyish word for mother, “mamma,” is the name for the maternal breast. As Dr. Beatrice Hinkle has informed me, interrogation of small children elicited the fact that they defined “mother” as the person who gives food, chocolate, etc. One could hardly assert that for children of this age food is only a symbol for sex, though this is sometimes true of adults. A superficial glance at the history of civilization will show just how enormous the nutritive source of pleasure is. The colossal feasts of Rome in its decadence were an expression of anything you like, only not of repressed sexuality, for that is the last thing one could accuse the Romans of in those days. There is no doubt that these excesses were some kind of substitute, but not for sexuality; they were far more a substitute for neglected moral functions, which we are too prone to regard as laws forced on man from outside. Men have the laws which they make for themselves.)

[347] As I explained earlier, I do not identify the feeling of pleasure *eo ipso* with sexuality. Sexuality has an increasingly small share in pleasure-sensations the further back we go in childhood. Nevertheless, jealousy can play a large role, for it too is something that does not belong entirely to the sexual sphere, since the desire for food has itself much to do with the first stirrings of jealousy—one has only to think of animals! Certainly it is reinforced by a budding eroticism relatively early. This element gains in strength as the years go on, so that the Oedipus complex soon assumes its classical form. The conflict takes on a more masculine and therefore more typical form in a son, whereas a daughter develops a specific liking for the father, with a correspondingly jealous attitude towards the mother. We could call this the Electra complex. As everyone knows, Electra took vengeance on her mother Clytemnestra for murdering her husband Agamemnon and thus robbing her—Electra—of her beloved father.

[348] Both these fantasy complexes become more pronounced with increasing maturity, and reach a new stage only in the postpubertal period, when the problem arises of detachment from the parents. This stage is characterized by the symbol we have already mentioned: the symbol of sacrifice. The more sexuality develops, the more it drives the individual away from his family and forces him to achieve independence. But the child has become closely attached to the family by his whole previous history, and especially to the parents, so that it is often only with the greatest difficulty that the growing individual can free himself inwardly from his infantile milieu. If he does not succeed in this, the Oedipus (or Electra) complex will

precipitate a conflict, and then there is the possibility of neurotic disturbances. The libido, already sexually developed, pours into the Oedipal “mould” and gives rise to feelings and fantasies which prove beyond doubt the effectiveness of the complex, which till then had been unconscious and more or less inoperative.

[349] The first consequence is the formation of intense resistances against the “immoral” impulses stemming from the now active complex. This affects the conscious behaviour in two ways. Either the consequences are direct, in which case the son displays violent resistances against his father and a particularly affectionate and dependent attitude towards his mother; or they are indirect, that is to say compensated: instead of resistance to the father there is marked submissiveness coupled with an irritated, antagonistic attitude towards the mother. Direct and compensated consequences can sometimes alternate. All this is true also of the Electra complex. If the sexual libido were to get stuck in this form, the Oedipus and Electra conflict would lead to murder and incest. This naturally does not happen with normal people, nor in so-called “amoral” primitive communities, otherwise the human race would have perished long ago. On the contrary, it is in the natural order of things that familiar objects lose their compelling charm and force the libido to seek new objects; and this acts as an important regulative factor which prevents parricide and incest. The continuous development of libido towards objects outside the family is perfectly normal and natural, and it is an abnormal and pathological phenomenon if the libido remains, as it were, glued to the family. Nevertheless, it is a phenomenon that can sometimes be observed in normal people.

THE PROBLEM OF INCEST

[350] (The unconscious fantasy of sacrifice, occurring some time after puberty, is a direct outcome of the infantile complexes. Of this I have given a circumstantial example in my book *Symbols of Transformation*. The fantasy of sacrifice means the giving up of infantile wishes. I have shown this in my book and at the same time have pointed out the parallels in the history of religion. It is not surprising that this problem plays an important role in religion, for religion is one of the greatest helps in the psychological process of adaptation. The chief obstacle to new modes of psychological adaptation is conservative adherence to the earlier attitude. But man cannot leave his previous personality and his previous objects of interest simply as they are, otherwise his libido would stagnate in the past, and this would be an impoverishment for him. Here religion is a great help because, by the bridge of the symbol, it leads his libido away from the infantile objects (parents) towards the symbolic representatives of the past, i.e., the gods, thus facilitating the transition

from the infantile world to the adult world. In this way the libido is set free for social purposes.)

[351] Freud has a special conception of the incest complex which has given rise to heated controversy. He starts from the fact that the Oedipus complex is usually unconscious, and he conceives this to be the consequence of a moral repression. It is possible that I am not expressing myself quite correctly if I give you Freud's view in these words. At any rate, according to him the Oedipus complex seems to be repressed, that is, displaced into the unconscious through the reactive effect of conscious tendencies. It almost looks as if the Oedipus complex would rise to consciousness if the child's development were uninhibited and were not affected by cultural influences.¹

[352] Freud calls the barrier that prevents this acting out of the Oedipus complex the "incest barrier." He seems to believe, so far as one can gather from his writings, that the incest barrier is formed by the backwash of experience, that it is a correction by reality, since the unconscious strives for boundless and immediate satisfaction without regard for others. In this he agrees with Schopenhauer, who says of the egoism of the blind World-Will that it is so strong that a man could slay his brother merely to grease his boots with his brother's fat. Freud considers that the psychological incest barrier can be compared with the incest prohibitions found even among primitives. He further considers that these prohibitions are a proof that men really do desire incest, for which reason laws were framed against it even on the primitive level. He therefore takes the tendency towards incest to be an absolutely concrete sexual wish, for he calls this complex the root-complex, or nucleus, of the neuroses and is inclined, viewing this as the original one, to reduce practically the whole psychology of the neuroses, as well as many other phenomena in the realm of the mind, to this one complex.

7. THE AETIOLOGY OF NEUROSIS

[353] With this new conception of Freud's we come back to the question of the aetiology of neurosis. We have seen that psychoanalytic theory started from a traumatic experience in childhood, which later on was found to be partly or wholly unreal. In consequence, the theory made a change of front and sought the aetiologically significant factor in the development of abnormal fantasies. The investigation of the unconscious, continued over a period of ten years with the help of an increasing number of workers, gradually brought to light a mass of empirical material which showed that the incest complex was a highly important and never-failing element in pathological fantasy. But it was found that the incest complex was not a special complex of neurotic people; it proved to be a component of the normal infantile psyche. We cannot tell from its mere existence whether this complex will give rise to a neurosis or not. To become pathogenic, it must precipitate a conflict; the complex, which in itself is inactive, must be activated and intensified to the point where a conflict breaks out.

[354] This brings us to a new and important question. If the infantile "nuclear complex" is only a general form, not in itself pathogenic but requiring special activation, then the whole aetiological problem is altered. In that case we would dig in vain among the reminiscences of earliest childhood, since they give us only the general forms of later conflicts but not the actual conflict. (It makes no difference that there were already conflicts in childhood, for the conflicts of childhood are different from the conflicts of adults. Those who have suffered ever since childhood from a chronic neurosis do not suffer now from the same conflict they suffered from then. Maybe the neurosis broke out when they first had to go to school as children. Then it was the conflict between indulgence and duty, between love for their parents and the necessity of going to school. But now it is the conflict between, say, the joys of a comfortable bourgeois existence and the strenuous demands of professional life. It only seems to be the same conflict. It is just as if the "Teutschen" of the Napoleonic wars were to compare themselves with the old Germans who rebelled against the Roman yoke.)

UNCONSCIOUS DETERMINATION

[355] I think I can best make my meaning clear if I describe the subsequent development of the theory by using the example of the young lady whose story you have heard in the earlier lectures. As you will probably remember, we found in the

anamnesis that the fright with the horses led to the reminiscence of a similar scene in childhood, in which connection we discussed the trauma theory. We found that we had to look for the real pathological element in her exaggerated fantasies, which arose from her retarded psychosexual development. We now have to apply the theoretical insight we have thus gained to the genesis of this particular illness if we want to understand how, just at that moment, that childhood experience was constellated so effectively.

[356] The simplest way to find an explanation for that nocturnal occurrence would be to make an exact inquiry into the circumstances of the moment. The first thing I did, therefore, was to question the patient about the company she had been keeping at the time. From this I learnt that she knew a young man to whom she thought of getting engaged; she loved him and hoped to be happy with him. At first nothing more could be discovered. But it would never do to be deterred from investigation by the negative results of the preliminary questioning. There are indirect ways of reaching the goal when the direct way fails. We therefore return to that singular moment when the lady ran headlong in front of the horses. We inquire about her companions and the sort of festive occasion she had just taken part in. It had been a farewell party for her best friend, who was going abroad to a health-resort on account of her nerves. This friend was married and, we are told, happily; she was also the mother of a child. We may take leave to doubt the statement that she was happy; for, were she really so, she would presumably have no reason to be “nervous” and in need of a cure.

[357] Shifting my angle of approach, I learnt that after her friends had caught up with her they took the patient back to the house of her host, as this was the nearest shelter. There she was hospitably received in her exhausted state. At this point the patient broke off her narrative, became embarrassed, fidgeted, and tried to change the subject. Evidently some disagreeable recollection had suddenly bobbed up. After the most obstinate resistance had been overcome, it appeared that yet another very remarkable incident had occurred that night: the amiable host had made her a fiery declaration of love, thus precipitating a situation which, in the absence of the lady of the house, might well be considered both difficult and distressing. Ostensibly this declaration of love came to her like a bolt from the blue. A modicum of criticism teaches us, however, that these things never drop from the skies but always have their history. It was now the task of the next few weeks to dig out bit by bit a long love-story, until at last a complete picture emerged which I attempt to outline as follows:

[358] As a child the patient had been a regular tomboy, caring only for wild boys' games, scorning her own sex and avoiding all feminine ways and occupations. After puberty, when the erotic problem might have come too close, she began to shun all society, hated and despised everything that even remotely reminded her of the

biological destiny of woman, and lived in a world of fantasy which had nothing in common with rude reality. Thus, until about her twenty-fourth year, she evaded all those little adventures, hopes, and expectations which ordinarily move a girl's heart at this age. Then she got to know two men who were destined to break through the thorny hedge that had grown up around her. Mr. A was her best friend's husband, and Mr. B was his bachelor friend. She liked them both. Nevertheless it soon began to look as though she liked Mr. B a vast deal better. An intimacy quickly sprang up between them and before long there was talk of a possible engagement. Through her relations with Mr. B and through her friend she often came into contact with Mr. A, whose presence sometimes disturbed her in the most unaccountable way and made her nervous.

[359] About this time the patient went to a large party. Her friends were also there. She became lost in thought and was dreamily playing with her ring when it suddenly slipped off her finger and rolled under the table. Both gentlemen looked for it and Mr. B succeeded in finding it. He placed the ring on her finger with an arch smile and said, "You know what that means!" Overcome by a strange and irresistible feeling, she tore the ring from her finger and flung it through the open window. A painful moment ensued, as may be imagined, and soon she left the party in deep dejection.

[360] Not long after this, so-called chance brought it about that she should spend her summer holidays at a health resort where Mr. and Mrs. A were also staying. Mrs. A then began to grow visibly nervous, and frequently stayed indoors because she felt out of sorts. The patient was thus in a position to go out for walks alone with Mr. A. On one occasion they went boating. So boisterous was she in her merriment that she suddenly fell overboard. She could not swim, and it was only with great difficulty that Mr. A pulled her half-unconscious into the boat. And then it was that he kissed her. With this romantic episode the bonds were tied fast. To excuse herself in her own eyes she tried all the more energetically to get herself engaged to Mr. B, telling herself every day that it was Mr. B whom she really loved. Naturally this curious little game had not escaped the keen glances of wifely jealousy. Mrs. A, her friend, had guessed the secret and fretted accordingly, so that her nerves only got worse. Hence it became necessary for Mrs. A to go abroad for a cure.¹

[361] The farewell party presented a dangerous opportunity. The patient knew that her friend and rival was going off the same evening, and that Mr. A would be alone in the house. Of course she did not think this out logically and clearly, for some women have a remarkable capacity for thinking purely with their feelings, and not with their intellects, so that it seems to them as if they had never thought certain things at all. At any rate she had a very queer feeling all the evening. She felt extraordinarily nervous, and when Mrs. A had been accompanied to the station and had gone, the hysterical

twilight state came over her on the way back. I asked her what she had been thinking or feeling at the actual moment when she heard the horses coming along behind her. Her answer was that she had only a feeling of panic, the feeling that something dreadful was approaching which she could no longer escape. The consequence was, as you know, that she was brought back exhausted to the house of her host, Mr. A.

[362] To the simple mind this dénouement seems perfectly obvious. Every layman will say, “Well, that is clear enough, she only intended to return by one way or another to Mr. A’s house.” But the psychologist would reproach the layman for his incorrect way of expressing himself, and would tell him that the patient was not conscious of the motives of her behaviour, and that we cannot therefore speak of her *intention* to return to Mr. A’s house. There are, of course, learned psychologists who could find any number of theoretical reasons for disputing the purposiveness of her action—reasons based on the dogma of the identity of consciousness and psyche. But the psychology inaugurated by Freud recognized long ago that the purposive significance of psychological acts cannot be judged by conscious motives but only by the objective criterion of their psychological result. Today it can no longer be contested that there are unconscious tendencies which have a great influence on a person’s reactions and on the effect he has on others.

[363] What happened at Mr. A’s house bears out this observation. Our patient made a sentimental scene, and Mr. A felt obliged to react to it with a declaration of love. Looked at in the light of these concluding events, the whole previous history seems to be very ingeniously directed towards precisely this end, though consciously the patient was struggling against it all the time.

[364] The theoretical gain from this story is the clear recognition that an unconscious “intention” or tendency stage-managed the fright with the horses, very probably using for this purpose the infantile reminiscence of the horses galloping irresistibly towards disaster. Seen in the light of the whole material, the nocturnal scene with the horses—the starting point of the illness —seems to be only the keystone of a planned edifice. The fright and the apparently traumatic effect of the childhood experience are merely staged, but staged in the peculiar way characteristic of hysteria, so that the *mise en scène* appears almost exactly like a reality. We know from hundreds of experiences that hysterical pains are staged in order to reap certain advantages from the environment. Nevertheless these pains are entirely real. The patients do not merely think they have pains; from the psychological point of view the pains are just as real as those due to organic causes, and yet they are stage-managed.

THE REGRESSION OF LIBIDO

[365] This utilization of reminiscences for staging an illness or an ostensible aetiology is called a *regression of libido*. The libido goes back to these reminiscences and activates them, with the result that an apparent aetiology is simulated. In this instance, according to the old theory, it might seem as if the fright with the horses were due to the old trauma. The resemblance between the two scenes is unmistakable, and in both cases the patient's fright was very real. At all events, we have no reason to doubt her assertions in this respect, as they fully accord with our experiences of other patients. The nervous asthma, the hysterical anxiety-attacks, the psychogenic depressions and exaltations, the pains, the cramps, etc. are all quite real, and any doctor who has himself suffered from a psychogenic symptom will know how absolutely real it feels. Regressively reactivated reminiscences, however fantastic they may be, are as real as recollections of events which have actually happened.

[366] As the term "regression of libido" indicates, we understand by this retrograde mode of application a reversion to earlier stages. From our example we can see very clearly how the process of regression takes place. At that farewell party, which presented a good opportunity for her to be alone with her host, the patient shrank from the idea of turning this opportunity to her advantage, but let herself be overpowered by desires which hitherto she had never admitted. The libido was not used consciously for that purpose, nor was this purpose ever acknowledged. In consequence, the libido had to carry it out by means of the unconscious, under the cover of panic in face of overwhelming danger. Her feelings at the moment when the horses approached illustrate our formulation very clearly: she felt as if something inescapable now had to happen.

[367] The process of regression is beautifully illustrated in an image used by Freud. The libido can be compared with a river which, when it meets with an obstruction, gets dammed up and causes an inundation. If this river has previously, in its upper reaches, dug out other channels, these channels will be filled up again by reason of the damming below. They appear to be real river-beds, filled with water as before, but at the same time they have only a provisional existence. The river has not permanently flowed back into the old channels, but only for as long as the obstruction lasts in the main stream. The subsidiary streams carry the water not because they were independent streams from the beginning, but because they were once stages or stations in the development of the main river-bed, passing possibilities, traces of which still exist and can therefore be used again in times of flood.

[368] This image can be applied directly to the development of the uses of libido. The final direction, the main river-bed, has not yet been found at the time of the infantile

development of sexuality. Instead, the libido branches out into all sorts of subsidiary streams, and only gradually does the final form appear. But when the river has dug out its main bed, all the subsidiary streams dry up and lose their importance, leaving only traces of their former activity. Similarly, the importance of the child's preliminary exercises at sexuality disappears almost completely as a rule, except for a few traces. If later an obstruction occurs, so that the damming up of libido reactivates the old channels, this state is properly speaking a new and at the same time an abnormal one. The earlier, infantile state represents a normal application of libido, whereas the reversion of libido to infantile ways is something abnormal. I am therefore of the opinion that Freud is not justified in calling the infantile sexual manifestations "perverse," since a normal manifestation should not be designated by a pathological term. This incorrect usage has had pernicious consequences in confusing the scientific public. Such a terminology is a misapplication to normal people of insights gained from neurotic psychology, on the assumption that the abnormal by-path taken by the libido in neurotics is still the same phenomenon as in children.

[369] The so-called "amnesia of childhood," which I would like to mention in passing, is a similar illegitimate "retrograde" application of terms from pathology. Amnesia is a pathological condition, consisting in the repression of certain conscious contents, and this cannot possibly be the same as the anterograde amnesia of children, which consists in an incapacity for intentional memory-reproduction, such as is also found among primitives. This incapacity for memory-reproduction dates from birth and can be understood on quite obvious biological grounds. It would be a remarkable hypothesis if we were to assume that this totally different quality of infantile consciousness could be reduced to sexual repressions on the analogy of a neurosis. A neurotic amnesia is punched out, as it were, from the continuity of memory, whereas memory in early childhood consists of single islands in the continuum of non-memory. This condition is in every sense the opposite of the condition found in neurosis, so that the expression "amnesia" is absolutely incorrect. The "amnesia of childhood" is an inference from the psychology of neurosis, just as is the "polymorphous-perverse" disposition of the child.

THE PERIOD OF SEXUAL LATENCY

[370] This error in theoretical formulation comes to light in the peculiar doctrine of the so-called "period of sexual latency" in childhood. Freud observed that the early infantile sexual manifestations, which I call phenomena of the presexual stage, disappear after a time and reappear only much later. What Freud calls "infantile masturbation"—that is, all those quasi-sexual activities which we spoke about before

—is said to return later as real masturbation. Such a process of development would be biologically unique. In conformity with this theory we would have to assume, for instance, that when a plant forms a bud from which a blossom begins to unfold, the blossom is taken back again before it is fully developed, and is again hidden within the bud, to reappear later on in a similar form. This impossible supposition is a consequence of the assertion that the early infantile activities of the presexual stage are sexual phenomena, and that the quasi-masturbational acts of that period are genuine acts of masturbation. Here the incorrect terminology and the boundless extension of the concept of sexuality take their revenge. Thus it was that Freud was compelled to assume that there is a disappearance of sexuality, in other words, a period of sexual latency. What he calls a disappearance is nothing other than the *real beginning of sexuality*, everything preceding it being but a preliminary stage to which no real sexual character can be attributed. The impossible phenomenon of sexual latency is thus explained in a very simple way.

[371] The theory of the latency period is an excellent example of the incorrectness of the conception of infantile sexuality. But there has been no error of observation. On the contrary, the hypothesis of the latency period proves how exactly Freud observed the apparent recommencement of sexuality. The error lies in the conception. As we have already seen, the prime error consists in a somewhat old-fashioned conception of a plurality of instincts. As soon as we accept the idea of two or more instincts existing side by side, we must necessarily conclude that, if one instinct is not yet manifest, it is still present *in nuce*, in accordance with the old theory of encasement.² Or, in physics, we should have to say that when a piece of iron passes from the condition of heat to the condition of light, the light was already present *in nuce* (latently) in the heat. Such assumptions are arbitrary projections of human ideas into transcendental regions, contravening the requirements of the theory of cognition. We have therefore no right to speak of a sexual instinct existing *in nuce*, as we would then be giving an arbitrary interpretation of phenomena which can be explained otherwise, in a much more suitable manner. We can only speak of the manifestation of the nutritive function, of the sexual function, and so on, and then only when that function has come to the surface with unmistakable clarity. We speak of light only when the iron is visibly glowing, but not when the iron is merely hot.

[372] Freud as an observer sees quite clearly that the sexuality of neurotics cannot really be compared with infantile sexuality, just as there is a great difference, for instance, between the un-cleanliness of a two-year-old child and the uncleanliness of a forty-year-old catatonic. The one is normal, the other exceedingly pathological. Freud inserted a short passage in his *Three Essays*,³ stating that the infantile form of neurotic sexuality is either wholly, or at any rate partly, due to regression. That is, even in those cases where we can say that it is still the same old infantile by-path, the

function of this by-path is intensified by the regression. Freud thus admits that the infantile sexuality of neurotics is for the greater part a regressive phenomenon. That this must be so is evidenced by the researches of recent years, showing that the observations concerning the childhood psychology of neurotics hold equally true of normal people. At any rate we can say that the historical development of infantile sexuality in a neurotic is distinguished from that of normal people only by minimal differences which completely elude scientific evaluation. Striking differences are exceptional.

THE AETIOLOGICAL SIGNIFICANCE OF THE ACTUAL PRESENT

[373] The more deeply we penetrate into the heart of the infantile development, the more we get the impression that as little of aetiological significance can be found there as in the infantile trauma. Even with the acutest ferreting into their respective histories we shall never discover why people living on German soil had just such a fate, and why the Gauls another. The further we get away, in analytical investigations, from the epoch of the manifest neurosis, the less can we expect to find the real *causa efficiens*, since the dynamics of the maladjustment grow fainter and fainter the further we go back into the past. In constructing a theory which derives the neurosis from causes in the distant past, we are first and foremost following the tendency of our patients to lure us as far away as possible from the critical present. *For the cause of the pathogenic conflict lies mainly in the present moment.* It is just as if a nation were to blame its miserable political conditions on the past; as if the Germany of the nineteenth century had attributed her political dismemberment and incapacity to her oppression by the Romans, instead of seeking the causes of her difficulties in the actual present. It is mainly in the present that the effective causes lie, and here alone are the possibilities of removing them.

[374] The greater part of the psychoanalytic school is still under the spell of the conception that infantile sexuality is the *sine qua non* of neurosis. It is not only the theorist, delving into childhood simply from scientific interest, but the practising analyst also, who believes that he has to turn the history of infancy inside out in order to find the fantasies conditioning the neurosis. A fruitless enterprise! In the meantime the most important factor escapes him, namely, the conflict and its demands in the present. In the case we have been describing, we should not understand any of the motives which produced the hysterical attacks if we looked for them in earliest childhood. Those reminiscences determine only the form, but the dynamic element springs from the present, and insight into the significance of the actual moment alone gives real understanding.

[375] It may not be out of place to remark here that it would never occur to me to blame Freud personally for the innumerable misunderstandings. I know very well that Freud, being an empiricist, always publishes only provisional formulations to which he certainly does not attribute any eternal value. But it is equally certain that the scientific public is inclined to make a creed out of them, a system which is asserted as blindly on the one hand as it is attacked on the other. I can only say that from the sum total of Freud's writings certain average conceptions have crystallized out, which both sides treat far too dogmatically. These views have led to a number of undoubtedly incorrect technical axioms the existence of which cannot be postulated with any certainty in Freud's own work. We know that in the mind of a creator of new ideas things are much more fluid and flexible than they are in the minds of his followers. They do not possess his vital creativity, and they make up for this deficiency by a dogmatic allegiance, in exactly the same way as their opponents, who, like them, cling to the dead letter because they cannot grasp its living content. My words are thus addressed less to Freud, who I know recognizes to some extent the final orientation of the neuroses, than to his public, who continue to argue about his views.

[376] From what has been said it should be clear that we gain insight into the history of a neurosis only when we understand that each separate element in it serves a purpose. We can now understand why that particular element in the previous history of our case was pathogenic, and we also understand why it was chosen as a symbol. Through the concept of regression, the theory is freed from the narrow formula of the importance of childhood experiences, and the actual conflict acquires the significance which, on the empirical evidence, implicitly belongs to it. Freud himself introduced the concept of regression, as I have said, in his *Three Essays*, rightly acknowledging that experience does not permit us to seek the cause of a neurosis exclusively in the past. If it is true, then, that reminiscences become effective again chiefly because of regressive activation, we have to consider whether the apparently determining effects of the reminiscences can be traced back solely to the regression of libido.

[377] As you have heard already, Freud himself in the *Three Essays* gives us to understand that the infantilism of neurotic sexuality is for the most part due to regression. This statement deserves considerably more emphasis than it received there. (Actually Freud did give it due emphasis in his later works.) The point is that the *regression of libido abolishes to a very large extent the aetiological significance of childhood experiences*. It had seemed to us very peculiar anyway that the Oedipus or Electra complex should have a determining influence in the formation of a neurosis, since these complexes are actually present in everyone, even in people who have never known their father and mother and were brought up by foster-parents. I have analysed cases of this kind, and found that the incest complex was as well

developed in them as in other patients. This seems to me a good proof that the incest complex is much less a reality than a purely regressive fantasy formation, and that the conflicts resulting from it must be reduced rather to an anachronistic clinging to the infantile attitude than to real incestuous wishes, which are merely a cover for regressive fantasies. Looked at from this point of view, childhood experiences have a significance for neurosis only when they are made significant by a regression of libido. That this must be so to a very large extent is shown by the fact that neither the infantile sexual trauma nor the incest complex present in everyone causes hysteria. Neurosis occurs only when the incest complex is activated by regression.

FAILURE OF ADAPTATION

[378] This brings us to the question: why does the libido become regressive? In order to answer this, we must examine more closely the conditions under which a regression arises. In discussing this problem with my patients I generally give the following example: A mountain-climber, attempting the ascent of a certain peak, happens to meet with an insurmountable obstacle, for instance a precipitous rock-face whose ascent is a sheer impossibility. After vainly seeking another route, he will turn back and regretfully abandon the idea of climbing that peak. He will say to himself: "It is not in my power to get over this difficulty, so I will climb an easier mountain."

[379] Here we see a normal utilization of libido: the man turns back when he meets an insurmountable difficulty, and uses his libido, which could not attain its original goal, for the ascent of another mountain.

[380] Now let us imagine that the rock-face was not really un-climbable so far as the man's physical abilities were concerned, but that he shrank back from this difficult undertaking from sheer funk. In this case two possibilities are open:

1. The man will be annoyed by his own cowardice and will set out to prove himself less timid on another occasion, or perhaps he will admit that with his timidity he ought never to undertake such daring ascents. At any rate, he will acknowledge that his moral capacity is not sufficient to overcome the difficulties. He therefore uses the libido which did not attain its original aim for the useful purpose of self-criticism, and for evolving a plan by which he may yet be able, with due regard to his moral capacity, to realize his wish to climb a mountain.

2. The second possibility is that the man does not admit his cowardice, and flatly asserts that the rock face is physically un-climbable, although he can very well see that, with sufficient courage, the obstacle could be overcome. But he prefers to deceive himself. This creates the psychological situation which is of significance for our problem.

[381] At bottom the man knows perfectly well that it would be physically possible to overcome the difficulty, and that he is simply morally incapable of doing so. But he pushes this thought aside because of its disagreeable character. He is so conceited that he cannot admit his cowardice. He brags about his courage and prefers to declare that things are impossible rather than that his own courage is inadequate. In this way he falls into contradiction with himself: on the one hand he has a correct appreciation of the situation, on the other he hides this knowledge from himself, behind the illusion of his bravery. He represses his correct insight and tries to force his subjective illusions on reality. The result of this contradiction is that his libido is split and the two halves fight one another. He pits his wish to climb the mountain against the opinion, invented by himself and supported by artificial arguments, that the mountain is un-climbable. He draws back not because of any real impossibility but because of an artificial barrier invented by himself. He has fallen into disunion with himself. From this moment on he suffers from an internal conflict. Now the realization of his cowardice gains the upper hand, now defiance and pride. In either case his libido is engaged in a useless civil war, and the man becomes incapable of any new enterprise. He will never realize his wish to climb a mountain, because he has gone thoroughly astray in the estimation of his moral qualities. His efficiency is reduced, he is not fully adapted, he has become—in a word—neurotic. The libido that retreated in face of the difficulty has led neither to honest self-criticism nor to a desperate struggle to overcome the difficulty at any price; it has been used merely to maintain the cheap pretence that the ascent was absolutely impossible and that even heroic courage would have availed nothing.

REVERSION TO THE INFANTILE LEVEL

[382] This kind of reaction is called *infantile*. It is characteristic of children, and of naïve minds generally, not to find the mistake in themselves but in things outside them, and forcibly to impose on things their own subjective judgment.

[383] This man, therefore, solves the problem in an infantile way; he substitutes for the adapted attitude of the first climber a mode of adaptation characteristic of the child's mind. That is what we mean by regression. His libido retreats before the obstacle it cannot surmount and substitutes a childish illusion for real action.

[384] Such cases are a daily occurrence in the treatment of neurosis. I would only remind you of all those young girls who suddenly become hysterically ill the moment they have to decide whether to get engaged or not. As an example, I will present the case of two sisters. The two girls were separated by only a year in age. In talents and also in character they were very much alike. They had the same education and grew up in the same surroundings under the same parental influences. Both were

ostensibly healthy, neither showed any noticeable nervous symptoms. An attentive observer might have discovered that the elder daughter was rather more the darling of her parents than the younger. Her parents' esteem was due to the special kind of sensitiveness which this daughter displayed. She demanded more affection than the younger one, was somewhat more precocious and forthcoming than she. Besides, she showed some delightfully childish traits—just those things which, because of their contradictory and slightly unbalanced character, make a person specially charming. No wonder father and mother had great joy in their elder daughter.

[385] When the two sisters became of marriageable age, they both made the acquaintance of two young men, and the possibility of their marriages soon drew near. As is generally the case, there were certain difficulties in the way. Both girls were quite young and had very little experience of the world. The men were fairly young too, and in positions which might have been better; they were only at the beginning of their careers, nevertheless both were capable young men. The two girls lived in social surroundings which gave them the right to certain expectations. It was a situation in which doubts as to the suitability of either marriage were permissible. Moreover, both girls were insufficiently acquainted with their prospective husbands, and were not quite sure of their love. Hence there were many hesitations and doubts. It was noticed that the elder sister always showed greater waverings in all her decisions. On account of these hesitations there were some painful moments with the two young men, who naturally pressed for a definite answer. At such moments the elder sister showed herself much more agitated than the younger one. Several times she went weeping to her mother, bemoaning her own uncertainty. The younger one was more decided, and put an end to the unsettled situation by accepting her suitor. She thus got over her difficulty and thereafter events ran smoothly.

[386] As soon as the admirer of the elder sister heard that the younger one had given her word, he rushed to his lady and begged passionately for her final acceptance. His tempestuous behaviour irritated and rather frightened her, although she was really inclined to follow her sister's example. She answered in a haughty and rather offhand way. He replied with sharp reproaches, causing her to answer still more tartly. At the end there was a tearful scene, and he went away in a huff. At home, he told the story to his mother, who expressed the opinion that the girl was obviously not the right one for him and that he had better choose someone else. The quarrel had made the girl profoundly doubtful whether she really loved him. It suddenly seemed to her impossible to leave her beloved parents and follow this man to an unknown destiny. Matters finally went so far that the relationship was broken off altogether. From then on the girl became moody; she showed unmistakable signs of the greatest jealousy towards her sister, but would neither see nor admit that she was jealous. The former happy relationship with her parents went to pieces too. Instead of her earlier child-

like affection she put on a sulky manner, which sometimes amounted to violent irritability; weeks of depression followed. While the younger sister was celebrating her wedding, the elder went to a distant health-resort for nervous intestinal catarrh. I shall not continue the history of the illness; it developed into an ordinary hysteria.

[387] In the analysis of this case great resistance was found to the sexual problem. The resistance was due to numerous perverse fantasies whose existence the patient would not admit. The question as to where these perverse fantasies, so unexpected in a young girl, could come from led to the discovery that once, as a child of eight years old, she had found herself suddenly confronted in the street by an exhibitionist. She was rooted to the spot by fright, and for a long time afterwards the ugly image pursued her in her dreams. Her younger sister had been with her at the time. The night after the patient told me about this, she dreamt of a man in a grey suit, who started to do in front of her what the exhibitionist had done. She awoke with a cry of terror.

[388] Her first association to the grey suit was a suit of her father's, which he had been wearing on an excursion she had made with him when she was about six years old. This dream, without any doubt, connects the father with the exhibitionist. There must be some reason for this. Did something happen with the father that might possibly call forth such an association? This question met with violent resistance from the patient, but it would not let her alone. At the next interview she reproduced some very early reminiscences, in which she had watched her father undressing; and one day she came, terribly embarrassed and shaken, to tell me that she had had an abominable vision, absolutely distinct. In bed at night, she suddenly felt herself once again a child of two or three years old, and she saw her father standing by her bed in an obscene attitude. The story was gasped out bit by bit, obviously with the greatest internal struggle. Then followed wild lamentations about how dreadful it was that a father should do such a terrible thing to his child.

[389] Nothing is less probable than that the father really did this. It is only a fantasy, presumably constructed in the course of the analysis from that same need for causality which once misled the analysts into supposing that hysteria was caused merely by such impressions.

[390] This case seems to me perfectly designed to demonstrate the importance of the regression theory, and to show at the same time the sources of the previous theoretical errors. Originally, as we saw, there was only a slight difference between the two sisters, but from the moment of their engagement their ways became totally divided. They now seemed to have two entirely different characters. The one, vigorous in health, and enjoying life, was a fine courageous girl, willing to submit to the natural demands of womanhood; the other was gloomy, ill-tempered, full of

bitterness and malice, unwilling to make any effort to lead a reasonable life, egotistical, quarrelsome, and a nuisance to all around her. This striking difference was brought out only when one of the sisters successfully got over the difficulties of the engagement period, while the other did not. For both, it hung by a hair whether the affair would be broken off. The younger, somewhat more placid, was the more decided, and she was able to find the right word at the right moment. The elder was more spoiled and more sensitive, consequently more influenced by her emotions, so that she could not find the right word, nor had she the courage to sacrifice her pride to put things straight afterwards. This little cause had a great effect, as we shall see. Originally the conditions were exactly the same for both sisters. It was the greater sensitiveness of the elder that made all the difference.

SENSITIVENESS AND REGRESSION

[391] The question now is, whence came this sensitiveness which had such unfortunate results? Analysis demonstrated the existence of an extraordinarily well-developed sexuality with an infantile, fantastic character; further, of an incestuous fantasy about the father. Assuming that these fantasies had long been alive and active in the patient, we have here a quick and very simple solution of the problem of sensitiveness. We can easily understand why the girl was so sensitive: she was completely shut up in her fantasies and had a secret attachment to her father. In these circumstances it would have been a miracle if she had been willing to love and marry another man.

[392] The further we pursue the development of these fantasies back to their source, following our need for causality, the greater become the difficulties of analysis, that is, the greater become the “resistances,” as we called them. Finally we reach that impressive scene, that obscene act, whose improbability has already been established. This scene has exactly the character of a later fantasy-formation. Therefore, we have to conceive these difficulties, these “resistances,” not—at least in this stage of the analysis—as defences against the conscious realization of a painful memory, but as a struggle against the construction of this fantasy.

[393] You will ask in astonishment: But what is it that compels the patient to weave such a fantasy? You will even be inclined to suggest that the analyst forced the patient to invent it, otherwise she would never have produced such an absurd idea. I do not venture to doubt that there have been cases where the analyst’s need to find a cause, especially under the influence of the trauma theory, forced the patient to invent a fantasy of this kind. But the analyst, in his turn, would never have arrived at this theory had he not followed the patient’s line of thought, thus taking part in that retrograde movement of libido which we call regression. He is simply carrying out to

its logical conclusion what the patient is afraid to carry out, that is, a regression, a retreat of libido with all the consequences that this entails.

[394] Hence, in tracing the libido regression, the analysis does not always follow the exact path marked out by the historical development, but often that of a subsequently formed fantasy, based only in part on former realities. In our case, too, the events were only partly real, and they got their enormous significance only afterwards, when the libido regressed. Whenever the libido seizes upon a certain reminiscence, we may expect it to be elaborated and transformed, for everything that is touched by the libido revives, takes on dramatic form, and becomes systematized. We have to admit that by far the greater part of the material became significant only later, when the regressing libido, seizing hold of anything suitable that lay in its path, had turned all this into a fantasy. Then that fantasy, keeping pace with the regressive movement of libido, came back at last to the father and put upon him all the infantile sexual wishes. Even so has it ever been thought that the golden age of Paradise lay in the past!

[395] As we know that the fantasy material brought out by analysis became significant only afterwards, we are not in a position to use this material to explain the onset of the neurosis; we should be constantly moving in a circle. The critical moment for the neurosis was the one when the girl and the man were both ready to be reconciled, but when the inopportune sensitiveness of the patient, and perhaps also of her partner, allowed the opportunity to slip by.

IS SENSITIVENESS PRIMARY?

[396] It might be said—and the psychoanalytic school inclines to this view—that the critical sensitiveness arose from a special psychological history which made this outcome a foregone conclusion. We know that in psychogenic neuroses sensitiveness is always a symptom of disunion with oneself, a symptom of the struggle between two divergent tendencies. Each of these tendencies has its psychological prehistory, and in our case it can clearly be shown that the peculiar resistance at the bottom of the patient's critical sensitiveness was in fact bound up historically with certain infantile sexual activities, and also with that so-called traumatic experience—things which may very well cast a shadow on sexuality. This would be plausible enough, were it not that the patient's sister had experienced pretty much the same things—including the exhibitionist—without suffering the same consequences, and without becoming neurotic.

[397] We would therefore have to assume that the patient experienced these things in a special way, perhaps more intensely and enduringly than her sister, and that the events of early childhood would have been more significant to her in the long run. If

that had been true in so marked a degree, some violent effect would surely have been noticed even at the time. But in later youth the events of early childhood were as much over and done with for the patient as they were for her sister. Therefore, yet another conjecture is conceivable with regard to that critical sensitiveness, namely, that it did not come from her peculiar prehistory but had existed all along. An attentive observer of small children can detect, even in early infancy, any unusual sensitiveness. I once analysed a hysterical patient who showed me a letter written by her mother when the patient was two years old. Her mother wrote about her and her sister: she—the patient—was always a friendly and enterprising child, but her sister had difficulties in getting along with people and things. The first one in later life became hysterical, the other catatonic. These far-reaching differences, which go back into earliest childhood, cannot be due to accidental events but must be regarded as innate. From this standpoint we cannot assert that our patient's peculiar prehistory was to blame for her sensitiveness at the critical moment; it would be more correct to say that this sensitiveness was inborn and naturally manifested itself most strongly in any unusual situation.

[398] This excessive sensitiveness very often brings an enrichment of the personality and contributes more to its charm than to the undoing of a person's character. Only, when difficult and unusual situations arise, the advantage frequently turns into a very great disadvantage, since calm consideration is then disturbed by untimely affects. Nothing could be more mistaken, though, than to regard this excessive sensitiveness as in itself a pathological character component. If that were really so, we should have to rate about one quarter of humanity as pathological. Yet if this sensitiveness has such destructive consequences for the individual, we must admit that it can no longer be considered quite normal.

[399] We are driven to this contradiction when we contrast the two views concerning the significance of the psychological prehistory as sharply as we have done here. In reality, it is not a question of either one or the other. A certain innate sensitiveness produces a special prehistory, a special way of experiencing infantile events, which in their turn are not without influence on the development of the child's view of the world. Events bound up with powerful impressions can never pass off without leaving some trace on sensitive people. Some of them remain effective throughout life, and such events can have a determining influence on a person's whole mental development. Dirty and disillusioning experiences in the realm of sexuality are especially apt to frighten off a sensitive person for years afterwards, so that the mere thought of sex arouses the greatest resistances.

[400] As the trauma theory shows, we are too much inclined, knowing of such cases, to attribute the emotional development of a person wholly, or at least very largely, to

accidents. The old trauma theory went too far in this respect. We must never forget that the world is, in the first place, a subjective phenomenon. *The impressions we receive from these accidental happenings are also our own doing.* It is not true that the impressions are forced on us unconditionally; our own predisposition conditions the impression. A man whose libido is blocked will have, as a rule, quite different and very much more vivid impressions than one whose libido is organized in a wealth of activities. A person who is sensitive in one way or another will receive a deep impression from an event which would leave a less sensitive person cold.

[401] Therefore, in addition to the accidental impression, we have to consider the subjective conditions seriously. Our previous reflections, and in particular our discussion of an actual case, have shown that the most important subjective condition is regression. The effect of regression, as practical experience shows, is so great and so impressive that one might be inclined to attribute the effect of accidental occurrences solely to the mechanism of regression. Without any doubt, there are many cases where everything is dramatized, where even the traumatic experiences are pure figments of the imagination, and the few real events among them are afterwards completely distorted by fantastic elaboration. We can safely say that there is not a single case of neurosis in which the emotional value of the antecedent experience is not intensified by libido regression, and even when large tracts of infantile development seem to be extraordinarily significant (as for instance the relationship to the parents), it is almost always a regression that gives them this value.

[402] The truth, as always, lies in the middle. The previous history certainly has a determining value, and this is intensified by regression. Sometimes the traumatic significance of the previous history comes more to the forefront, sometimes only its regressive meaning. These considerations naturally have to be applied to infantile sexual experiences as well. Obviously there are cases where brutal sexual experiences justify the shadow thrown on sexuality and make the later resistance to sex thoroughly comprehensible. (I would mention, by the way, that frightful impressions other than sexual can leave behind a permanent feeling of insecurity which may give the individual a hesitating attitude to reality.) Where real events of undoubted traumatic potency are absent—as is the case in most neuroses—the mechanism of regression predominates.

[403] It might be objected that we have no criterion by which to judge the potential effect of a trauma, since this is an extremely relative concept. That is not altogether true; we have such a criterion in the average normal person. Something that is likely to make a strong and abiding impression on a normal person must be considered as having a determining influence for neurotics also. But we cannot attribute

determining importance, in neurosis either, to impressions which normally would disappear and be forgotten. In most cases where some event has had an unexpected traumatic effect, we shall in all probability find a regression, that is to say, a secondary fantastic dramatization. *The earlier in childhood an impression is said to have arisen, the more suspect is its reality.* Primitive people and animals have nothing like that capacity for reviving memories of unique impressions which we find among civilized people. Very young children are not nearly as impressionable as older children. The higher development of the mental faculties is an indispensable prerequisite for impressionability. We can therefore safely assume that the earlier a patient places some impressive experience in his childhood, the more likely it is to be a fantastic and regressive one. Deeper impressions are to be expected only from experiences in late childhood. At any rate, we generally have to attribute only regressive significance to the events of early infancy, that is, from the fifth year back. In later years, too, regression can sometimes play an overwhelming role, but even so one must not attribute too little importance to accidental events. In the later course of a neurosis, accidental events and regression together form a vicious circle: retreat from life leads to regression, and regression heightens resistance to life.

THE TELEOLOGICAL SIGNIFICANCE OF REGRESSION

[404] (Before pursuing our argument further, we must turn to the question of what teleological significance should be attributed to regressive fantasies. We might be satisfied with the hypothesis that these fantasies are simply a substitute for real action and therefore have no further significance. That can hardly be so. Psychoanalytic theory inclines to see the reason for the neurosis in the fantasies (illusions, prejudices, etc.), as their character betrays a tendency which is often directly opposed to reasonable action. Indeed, it often looks as if the patient were really using his previous history only to prove that he cannot act reasonably, whereupon the analyst, who, like everyone else, is easily inclined to sympathize with the patient (i.e., to identify with him unconsciously), gets the impression that the patient's arguments constitute a real aetiology. In other cases the fantasies have more the character of wonderful ideals which put beautiful and airy phantasms in the place of crude reality. Here a more or less obvious megalomania is always present, aptly compensating for the patient's indolence and deliberate incompetence. But the decidedly sexual fantasies often reveal their purpose quite clearly, which is to accustom the patient to the thought of his sexual destiny, and so help him to overcome his resistance.

[405] If we agree with Freud that neurosis is an unsuccessful attempt at self-cure, we must allow the fantasies, too, a double character: on one hand a pathological tendency to resist, on the other a helpful and preparatory tendency. With a normal

person the libido, when it is blocked by an obstacle, forces him into a state of introversion and makes him reflect. So, too, with a neurotic under the same conditions: an introversion ensues, with increased fantasy activity. But he gets stuck there, because he prefers the infantile mode of adaptation as being the easier one. He does not see that he is exchanging his momentary advantage for a permanent disadvantage and has thus done himself a bad turn. In the same way, it is much easier and more convenient for the civic authorities to neglect all those troublesome sanitary precautions, but when an epidemic comes the sin of omission takes bitter revenge. If, therefore, the neurotic claims all manner of infantile alleviations, he must also accept the consequences. And if he is not willing to do so, then the consequences will overtake him.

[406] It would, in general, be a great mistake to deny any teleological value to the apparently pathological fantasies of a neurotic. They are, as a matter of fact, the first beginnings of spiritualization, the first groping attempts to find new ways of adapting. His retreat to the infantile level does not mean only regression and stagnation, but also the possibility of discovering a new life-plan. Regression is thus in very truth the basic condition for the act of creation. Once again I must refer you to my oft-cited book *Symbols of Transformation*.)

8. THERAPEUTIC PRINCIPLES OF PSYCHOANALYSIS

[407] With the concept of regression, psychoanalysis made probably one of the most important discoveries in this field. Not only were the earlier formulations of the genesis of neurosis overthrown or at least considerably modified, but the *actual conflict* received, for the first time, its proper valuation.

[408] In our earlier case of the lady and the horses, we saw that the symptomatological dramatization could only be understood when it was seen as an expression of the actual conflict. Here psychoanalytic theory joins hands with the results of the association experiments, of which I spoke in my lectures at Clark University. The association experiment, when conducted on a neurotic person, gives us a number of pointers to definite conflicts in his actual life, which we call complexes. These complexes contain just those problems and difficulties which have brought the patient into disharmony with himself. Generally we find a love-conflict of a quite obvious character. From the standpoint of the association experiment, neurosis appears as something quite different from what it seemed to be from the standpoint of earlier psychoanalytic theory. From that standpoint, neurosis seemed to be a formation having its roots in earliest infancy and overgrowing the normal psychic structure; considered from the standpoint of the association experiment, neurosis appears as a reaction to an actual conflict, which naturally is found just as often among normal people but is solved by them without too much difficulty. The neurotic, however, remains in the grip of the conflict, and his neurosis seems to be more or less the consequence of his having got stuck. We can say, therefore, that the results of the association experiment argue strongly in favour of the regression theory.

THE EVALUATION OF NEUROTIC FANTASIES

[409] With the help of the earlier, "historical" conception of neurosis, we thought we could understand why a neurotic with a powerful parental complex has such great difficulties in adapting himself to life. But now that we know that normal persons have exactly the same complexes and, in principle, go through the same psychological development as a neurotic, we can no longer explain neurosis by the development of certain fantasy systems. The really explanatory approach now is a prospective one. We no longer ask whether the patient has a father or mother complex, or unconscious incest fantasies which tie him to his parents, for we know today that everybody has them. It was a mistake to believe that only neurotics have

such things. We ask rather: What is the task which the patient does not want to fulfil? What difficulty is he trying to avoid?

[410] If a person tried always to adapt himself fully to the conditions of life, his libido would always be employed correctly and adequately. When that does not happen, it gets blocked and produces regressive symptoms. The non-fulfilment of the demands of adaptation, or the shrinking of the neurotic from difficulties, is, at bottom, the hesitation of every organism in the face of a new effort to adapt. (The training of animals provides instructive examples in this respect, and in many cases such an explanation is, in principle, sufficient. From this standpoint the earlier mode of explanation, which maintained that the resistance of the neurotic was due to his bondage to fantasies, appears incorrect. But it would be very one-sided to take our stand solely on a point of principle. There is *also* a bondage to fantasies, even though the fantasies are, as a rule, secondary. The neurotic's bondage to fantasies (illusions, prejudices, etc.) develops gradually, as a habit, out of innumerable regressions from obstacles since earliest childhood. All this grows into a regular habit familiar to every student of neurosis; we all know those patients who use their neurosis as an excuse for running away from difficulties and shirking their duty. Their habitual evasion produces a habit of mind which makes them take it for granted that they should live out their fantasies instead of fulfilling disagreeable obligations. And this bondage to fantasy makes reality seem less real to the neurotic, less valuable and less interesting, than it does to the normal person. As I explained earlier, the fantastic prejudices and resistances may also arise, sometimes, from experiences that were not intended at all; in other words, were not deliberately sought disappointments and suchlike.)

[411] The ultimate and deepest root of neurosis appears to be the innate sensitiveness,¹ which causes difficulties even to the infant at the mother's breast, in the form of unnecessary excitement and resistance. The apparent aetiology of neurosis elicited by psychoanalysis is actually, in very many cases, only an inventory of carefully selected fantasies, reminiscences, etc., aiming in a definite direction and created by the patient out of the libido he did not use for biological adaptation. Those allegedly aetiological fantasies thus appear to be nothing but substitute formations, disguises, artificial explanations for the failure to adapt to reality. The aforementioned vicious circle of flight from reality and regression into fantasy is naturally very apt to give the illusion of seemingly decisive causal relationships, which the analyst as well as the patient believes in. Accidental occurrences intervene in this mechanism only as "mitigating circumstances." Their real and effective existence must, however, be acknowledged.

[412] I must admit that those critics are partly right who get the impression, from their reading of psychoanalytic case histories, that it is all fantastic and artificial. Only,

they make the mistake of attributing the fantastic artefacts and lurid, far-fetched symbolisms to the suggestion and fertile imagination of the analyst, and not to the incomparably more fertile fantasy of his patients. In the fantasy material of a psychoanalytic case history there is, indeed, very much that is artificial. But the most striking thing is the active inventiveness of the patient. And the critics are not so wrong, either, when they say that their neurotic patients have no such fantasies. I do not doubt that most of their patients are totally unconscious of having any fantasies at all. When it is in the unconscious, a fantasy is “real” only when it has some demonstrable effect on consciousness, for instance in the form of a dream. Otherwise we can say with a clear conscience that it is not real. So anyone who overlooks the almost imperceptible effects of unconscious fantasies on consciousness, or dispenses with a thorough and technically irreproachable analysis of dreams, can easily overlook the fantasies of his patients altogether. We are therefore inclined to smile when we hear this oft-repeated objection.

[413] Nevertheless, we must admit that there is some truth in it. The regressive tendency of the patient, reinforced by the attentions of the psychoanalyst in his examination of the unconscious fantasy activity, goes on inventing and creating even during the analysis. One could even say that this activity is greatly increased in the analytical situation, since the patient feels his regressive tendency strengthened by the interest of the analyst and produces even more fantasies than before. For this reason our critics have often remarked that a conscientious therapy of the neurosis should go in exactly the opposite direction to that taken by psychoanalysis; in other words, that it is the first task of therapy to extricate the patient from his unhealthy fantasies and bring him back again to real life.

[414] The psychoanalyst, of course, is well aware of this, but he knows just how far one can go with this extricating of neurotics from their fantasies. As medical men, we should naturally never dream of preferring a difficult and complicated method, assailed by all the authorities, to a simple, clear, and easy one unless for a very good reason. I am perfectly well acquainted with hypnotic suggestion and Dubois’ method of persuasion, but I do not use them because they are comparatively ineffective. For the same reason, I do not use “rééducation de la volonté” directly, as psychoanalysis gives me better results.

ACTIVE PARTICIPATION IN THE FANTASY

[415] But, if we do use psychoanalysis, we must go along with the regressive fantasies of our patients. Psychoanalysis has a much broader outlook as regards the evaluation of symptoms than have the usual psychotherapeutic procedures. These all start from the assumption that neurosis is an entirely pathological formation. In the whole of

neurology hitherto, no one has ever thought of seeing in the neurosis an attempt at healing, or, consequently, of attributing to the neurotic formations a quite special teleological significance. But, like every illness, neurosis is only a compromise between the pathogenic causes and the normal function. Modern medicine no longer considers fever as the illness itself but as a purposive reaction of the organism. Similarly, psychoanalysis does not conceive the neurosis as anti-natural and in itself pathological, but as having a meaning and a purpose.

[416] From this follows the inquiring and expectant attitude of psychoanalysis towards neurosis. In all cases it refrains from judging the value of a symptom, and tries instead to understand what tendencies lie beneath that symptom. If we were able to destroy a neurosis in the same way, for instance, as a cancer is destroyed, we would be destroying at the same time a large amount of useful energy. We save this energy, that is, we make it serve the purposes of the drive for recuperation, by pursuing the meaning of the symptoms and going along with the regressive movement of the patient. Those unfamiliar with the essentials of psychoanalysis will certainly have some difficulty in understanding how a therapeutic effect can be achieved when the analyst enters into the “harmful” fantasies of his patients. Not only the opponents of psychoanalysis but the patients themselves doubt the therapeutic value of such a method, which concentrates attention on the very things that the patient condemns as worthless and reprehensible, namely his fantasies. Patients will often tell you that their former doctors forbade them to have any concern with their fantasies, explaining that they could only consider themselves well when they were free, if only temporarily, from this terrible scourge. Naturally they wonder what good it will do when the treatment leads them back to the very place from which they consistently tried to escape.

[417] This objection can be answered as follows: it all depends on the attitude the patient takes towards his fantasies. Hitherto, the patient’s fantasizing was a completely passive and involuntary activity. He was lost in his dreams, as we say. Even his so-called “brooding” was nothing but an involuntary fantasy. What psychoanalysis demands of the patient is apparently the same thing, but only a person with a very superficial knowledge of psychoanalysis could confuse this passive dreaming with the attitude now required. What psychoanalysis asks of the patient is the exact opposite of what the patient has always done. He is like a man who has unintentionally fallen into the water and sunk, whereas psychoanalysis wants him to act like a diver. It was no mere chance which led him to fall in just at that spot. There lies the sunken treasure, but only a diver can bring it to the surface.

[418] That is to say, when the patient judges them from a rational standpoint, he regards his fantasies as worthless and meaningless. In reality, however, they exert their great

influence just because they are of such great importance. They are sunken treasures which can only be recovered by a diver; in other words the patient, contrary to his wont, must now deliberately turn his attention to his inner life. Where formerly he dreamed, he must now think, consciously and intentionally. This new way of thinking about himself has about as much resemblance to his former state of mind as a diver has to a drowning man. His former compulsion now has a meaning and a purpose, it has become *work*. The patient, assisted by the analyst, immerses himself in his fantasies, not in order to lose himself in them, but to salvage them, piece by piece, and bring them into the light of day. He thus acquires an objective vantage-point from which to view his inner life, and can now tackle the very thing he feared and hated. Here we have the basic principle of all psychoanalytic treatment.

THE TASK OF ADAPTATION

[419] Previously, because of his illness, the patient stood partly or wholly outside life. Consequently he neglected many of his duties, either in regard to social achievement or in regard to his purely human tasks. He must get back to fulfilling these duties if he wants to become well again. By way of caution, I would remark that “duties” are not to be understood here as general ethical postulates, but as duties to himself, by which again I do not mean egocentric interests—for a human being is also a social being, a fact too easily forgotten by individualists. A normal person feels very much more comfortable sharing a common virtue than possessing an individual vice, no matter how seductive it may be. He must already be a neurotic, or an otherwise unusual person, if he lets himself be deluded by special interests of this kind.

[420] The neurotic shrank from his duties and his libido turned away, at least partly, from the tasks imposed by reality. Consequently it became introverted, directed towards his inner life. Because no attempt was made to master any real difficulties, his libido followed the path of regression, so that fantasy largely took the place of reality. Unconsciously—and very often consciously—the neurotic prefers to live in his dreams and fantasies. In order to bring him back to reality and to the fulfilment of his necessary tasks, psychoanalysis proceeds along the same “false” track of regression which was taken by the libido of the patient, so that at the beginning the analysis looks as if it were supporting his morbid proclivities. But psychoanalysis follows the false tracks of fantasy in order to restore the libido, the valuable part of the fantasies, to consciousness and apply it to the duties of the present. This can only be done by bringing up the unconscious fantasies, together with the libido attached to them. Were there no libido attached, we could safely leave these unconscious fantasies to their own shadowy existence. Unavoidably the patient, feeling confirmed in his regressive tendency by the mere fact of having started the analysis, will, amid

increasing resistances, lead the analyst's interest down to the depths of his unconscious shadow-world.

[421] It will readily be understood that every analyst, as a normal person, will feel in himself the greatest resistances to the regressive tendency of the patient, as he is quite convinced that this tendency is pathological. As a doctor, he believes he is acting quite rightly not to enter into his patient's fantasies. He is understandably repelled by this tendency, for it is indeed repulsive to see somebody completely given up to such fantasies, finding only himself important and admiring himself unceasingly. Moreover, for the aesthetic sensibilities of the normal person, the average run of neurotic fantasies is exceedingly disagreeable, if not downright disgusting. The psychoanalyst, of course, must put aside all aesthetic value-judgments, just like every other doctor who really wants to help his patient. He must not shudder at dirty work. Naturally there are a great many patients who are physically ill and who do recover through the application of ordinary physical methods, dietetic or suggestive, without closer exploration and radical treatment. But severe cases can be helped only by a therapy based on an exact investigation and thorough knowledge of the illness. Our psychotherapeutic methods hitherto were general measures of this kind; in mild cases they do no harm, on the contrary they are often of real use. But a great many patients prove inaccessible to these methods. If anything helps here, it is psychoanalysis, which is not to say that psychoanalysis is a cure-all. This is a sneer that comes only from ill-natured criticism. We know very well that psychoanalysis fails in certain cases. As everybody knows, we shall never be able to cure all illnesses.

[422] The "diving" work of analysis brings up dirty material, piece by piece, out of the slime, but it must first be cleaned before we can recognize its value. The dirty fantasies are valueless and are thrown aside, but the libido attached to them is of value and this, after the work of cleaning, becomes serviceable again. To the professional psychoanalyst, as to every specialist, it will sometimes seem that the fantasies have a value of their own, and not just the libido. But their value is no concern of the patient's. For the analyst these fantasies have only a scientific value, just as it may be of special interest to the surgeon to know whether the pus contains staphylococci or streptococci. To the patient it is all the same, and so far as he is concerned it is better for the analyst to conceal his scientific interest, lest the patient be tempted to take more pleasure than necessary in his fantasies. The aetiological significance which is attributed to these fantasies—incorrectly, to my mind—explains why so much space is given up to the extensive discussion of all forms of fantasy in the psychoanalytic literature. Once one knows that in this sphere absolutely nothing is impossible, the initial estimation of fantasies will gradually wear itself out, and with it the attempt to discover in them an aetiological significance. Nor will the most

exhaustive discussion of case histories ever succeed in emptying this ocean. Theoretically the fantasies in each case are inexhaustible.

[423] In most cases, however, the production of fantasies ceases after a time, from which one must not conclude that the possibilities of fantasy are exhausted; the cessation only means that no more libido is regressing. The end of the regressive movement is reached when the libido seizes hold of the actualities of life and is used for the solution of necessary tasks. There are cases, and not a few of them, where the patient continues to produce endless fantasies, whether for his own pleasure or because of the mistaken expectations of the analyst. Such a mistake is especially easy for beginners, since, blinded by psychoanalytic case histories, they keep their interest fixed on the alleged aetiological significance of the fantasies, and are constantly endeavouring to fish up more fantasies from the infantile past, vainly hoping to find there the solution of the neurotic difficulties. They do not see that the solution lies in action, in the fulfilment of certain necessary obligations to life. It will be objected that the neurosis is entirely due to the incapacity of the patient to carry out these tasks, and that, by analysing the unconscious, the therapist ought to enable him to do so, or at least give him the means of doing so.

[424] Put in this way, the objection is perfectly true, but we have to add that it is valid only when the patient is really conscious of the task he has to fulfil—conscious of it not only academically, in general theoretical outline, but also in detail. It is characteristic of neurotics to be wanting in this knowledge, although, because of their intelligence, they are well aware of the general duties of life, and struggle perhaps only too hard to fulfil the precepts of current morality. But for that very reason they know all the less, sometimes nothing at all, about the incomparably more important duties to themselves. It is not enough, therefore, to follow the patient blindfold on the path of regression, and to push him back into his infantile fantasies by an untimely aetiological interest. I often hear from patients who have got stuck in a psychoanalytic treatment: “My analyst thinks I must have an infantile trauma somewhere, or a fantasy I am still repressing.” Apart from cases where this conjecture happened to be true, I have seen others in which the stoppage was caused by the fact that the libido, hauled up by the analysis, sank back again into the depths for want of employment. This was due to the analyst directing his attention entirely to the infantile fantasies and his failure to see what task of adaptation the patient had to fulfil. The consequence was that the libido always sank back again, as it was given no opportunity for further activity.

[425] There are many patients who, quite on their own account, discover their life-tasks and stop the production of regressive fantasies fairly soon, because they prefer to live in reality rather than in fantasy. It is a pity that this cannot be said of all patients. A

good many of them postpone the fulfilment of their life-tasks indefinitely, perhaps for ever, and prefer their idle neurotic dreaming. I must emphasize yet again that by “dreaming” we do not mean a conscious phenomenon.

[426] In consequence of these facts and insights, the character of psychoanalysis has changed in the course of the years. If in its first stage psychoanalysis was a kind of surgery, which removed the foreign body, the blocked affect, from the psyche, in its later form it was a kind of historical method, which tried to investigate the genesis of the neurosis in all its details and to trace it back to its earliest beginnings.

THE TRANSFERENCE

[427] There is no doubt that this method owed its existence not only to a strong scientific interest but also to the personal “empathy” of the analyst, traces of which can clearly be seen in the psychoanalytic case material. Thanks to this personal feeling, Freud was able to discover wherein lay the therapeutic effect of psychoanalysis. While this was formerly sought in the discharge of the traumatic affect, it was now found that the fantasies brought out by analysis were all associated with the person of the analyst. Freud called this process the *transference*, because the patient transferred to the analyst the fantasies that were formerly attached to the memory-images of the parents. The transference is not limited to the purely intellectual sphere; rather, the libido that is invested in the fantasies precipitates itself, together with the fantasies, upon the analyst. All those sexual fantasies which cluster round the imago of the parents now cluster round him, and the less the patient realizes this, the stronger will be his unconscious tie to the analyst.

[428] This discovery is of fundamental importance in several ways. Above all, the transference is of great biological value to the patient. The less libido he gives to reality, the more exaggerated will be his fantasies and the more he will be cut off from the world. Typical of neurotics is their disturbed relationship to reality—that is to say, their reduced adaptation. The transference to the analyst builds a bridge across which the patient can get away from his family into reality. He can now emerge from his infantile milieu into the world of adults, since the analyst represents for him a part of the world outside the family.

[429] On the other hand, the transference is a powerful hindrance to the progress of the treatment, because the patient assimilates the analyst, who should stand for a part of the extrafamilial world, to his father and mother, so that the whole advantage of his new acquisition is jeopardized. The more he is able to see the analyst objectively, to regard him as he does any other individual, the greater becomes the advantage of the transference. The less he is able to see the analyst in this way, and the more he assimilates him to the father imago, the less advantageous the transference will be

and the greater the harm it will do. The patient has merely widened the scope of his family by the addition of a quasi-parental personality. He himself is, as before, still in the infantile milieu and therefore maintains his infantile constellation. In this manner all the advantages of the transference can be lost.

[430] There are patients who follow the analysis with the greatest interest without making the slightest improvement, remaining extraordinarily productive in their fantasies although the whole previous history of their neurosis, even its darkest corners, seems to have been brought to light. An analyst under the influence of the historical view might easily be thrown into confusion, and would have to ask himself: What is there in this case still to be analysed? These are just the cases I had in mind before, when I said it is no longer a matter of analysing the historical material, but of action, of overcoming the infantile attitude. The historical analysis would show over and over again that the patient has an infantile attitude to the analyst, but it would not tell us how to alter it. Up to a certain point, this serious disadvantage of the transference applies to every case. It has gradually proved, even, that the part of psychoanalysis so far discussed, extraordinarily interesting and valuable though it may be from a scientific point of view, is in practice far less important than what now has to follow, namely, the analysis of the transference itself.

CONFESSION AND PSYCHOANALYSIS

[431] Before I discuss in detail this especially important part of the analysis, I should like to draw attention to a parallel between the first stage of psychoanalysis and a certain cultural institution. By this I mean the religious institution of confession.

[432] Nothing makes people more lonely, and more cut off from the fellowship of others, than the possession of an anxiously hidden and jealously guarded personal secret. Very often it is “sinful” thoughts and deeds that keep them apart and estrange them from one another. Here confession sometimes has a truly redeeming effect. The tremendous feeling of relief which usually follows a confession can be ascribed to the readmission of the lost sheep into the human community. His moral isolation and seclusion, which were so difficult to bear, cease. Herein lies the chief psychological value of confession.

[433] Besides that, however, it has other consequences: through the transference of his secret and all the unconscious fantasies underlying it, a moral bond is formed between the patient and his father confessor. We call this a “transference relationship.” Anyone with psychoanalytic experience knows how much the personal significance of the analyst is enhanced when the patient is able to confess his secrets to him. The change this induces in the patient’s behaviour is often amazing. This, too, is an effect probably intended by the Church. The fact that by far the greater part of

humanity not only needs guidance, but wishes for nothing better than to be guided and held in tutelage, justifies, in a sense, the moral value which the Church sets on confession. The priest, equipped with all the insignia of paternal authority, becomes the responsible leader and shepherd of his flock. He is the father confessor and the members of his parish are his penitent children.

[434] Thus priest and Church replace the parents, and to that extent they free the individual from the bonds of the family. In so far as the priest is a morally elevated personality with a natural nobility of soul and a mental culture to match, the institution of confession may be commended as a brilliant method of social guidance and education, which did in fact perform a tremendous educative task for more than fifteen hundred years. So long as the medieval Church knew how to be the guardian of art and science—a role in which her success was due, in part, to her wide tolerance of worldly interests—confession was an admirable instrument of education. But it lost its educative value, at least for more highly developed people, as soon as the Church proved incapable of maintaining her leadership in the intellectual sphere—the inevitable consequence of spiritual rigidity. The more highly developed men of our time do not want to be guided by a creed or a dogma; they want to understand. So it is not surprising if they throw aside everything they do not understand; and religious symbols, being the least intelligible of all, are generally the first to go overboard. The sacrifice of the intellect demanded by a positive belief is a violation against which the conscience of the more highly developed individual rebels.

[435] So far as analysis is concerned, in perhaps the majority of cases the transference to and dependence on the analyst could be regarded as a sufficient end with a definite therapeutic effect, provided that the analyst was a commanding personality and in every way capable of guiding his patients responsibly and being a “father to his people.” But a modern, mentally developed person strives, consciously or unconsciously, to govern himself and stand morally on his own feet. He wants to take the helm in his own hands; the steering has too long been done by others. He wants to understand; in other words, he wants to be an adult. It is much easier to be guided, but this no longer suits intelligent people today, for they feel that the spirit of the age requires them to exercise moral autonomy. Psychoanalysis has to reckon with this requirement, and has therefore to reject the demand of the patient for constant guidance and instruction. The analyst knows his own shortcomings too well to believe that he could play the role of father and guide. His highest ambition must consist only in educating his patients to become independent personalities, and in freeing them from their unconscious bondage to infantile limitations. He must therefore analyse the transference, a task left untouched by the priest. Through the analysis the unconscious—and sometimes conscious—tie to the analyst is cut, and the patient is set upon his own feet. That, at least, is the aim of the treatment.²

[436] The transference introduces all sorts of difficulties into the relationship between analyst and patient because, as we have seen, the analyst is always more or less assimilated to the family. The first part of the analysis, the discovery of complexes, is fairly easy, thanks to the fact that everyone likes to unburden himself of his painful secrets. Also, he experiences a particular satisfaction in at last finding someone who has an understanding ear for all those things to which nobody would listen before. For the patient it is a singularly agreeable sensation to be understood and to have a doctor who is determined to understand him at all costs, and is willing to follow him, apparently, through all his devious ways. There are patients who even have a special "test" for this, a special question which the analyst has to go into; if he cannot or will not do this, or if he overlooks it, then he is no good. The feeling of being understood is especially sweet to all those lonely souls who are insatiable in their demand for "understanding."

[437] For patients with such an obliging disposition, the beginning of the analysis is, as a rule, fairly simple. The therapeutic effects, often considerable, which may appear about this time are easy to obtain, and for that reason they may seduce the beginner into a therapeutic optimism and analytical superficiality which bear no relation to the seriousness and peculiar difficulties of his task. The trumpeting of therapeutic successes is nowhere more contemptible than in psychoanalysis, for no one should know better than the psychoanalyst that the therapeutic result ultimately depends far more on the co-operation of nature and of the patient himself. The psychoanalyst may legitimately pride himself on his increased insight into the essence and structure of neurosis, an insight that greatly exceeds all previous knowledge in this field. But psychoanalytic publications to date cannot be acquitted of the charge of sometimes showing psychoanalysis in a false light. There are technical publications which give the uninitiated person the impression that psychoanalysis is a more or less clever trick, productive of astonishing results.

[438] The first stage of the analysis, when we try to understand, and in this way often relieve, the patient's feelings, is responsible for these therapeutic illusions. The improvements that may appear at the beginning of an analysis are naturally not really results of the treatment, but are generally only passing alleviations which greatly assist the process of transference. After the initial resistances to the transference have been overcome, it turns out to be an ideal situation for a neurotic. He does not need to make any effort himself, and yet someone comes to meet him more than halfway, someone with an unwonted and peculiar wish to understand, who does not allow himself to get bored and is not put off by anything, although the patient sometimes does his utmost to rile him with his wilfulness and childish defiance. This

forbearance is enough to melt the strongest resistances, so that the patient no longer hesitates to set the analyst among his family gods, i.e., to assimilate him to the infantile milieu.

[439] At the same time, the patient satisfies another need, that is, he achieves a relationship outside the family and thus fulfils a biological demand. Hence the patient obtains a double advantage from the transference relationship: a personality who on the one hand is expected to bestow on him a loving attention in all his concerns, and to that extent is equated with father and mother, but who, on the other hand, is outside the family and thus helps him to fulfil a vitally important and difficult duty without the least danger to himself. When, on top of that, this acquisition is coupled with a marked therapeutic effect, as not infrequently happens, the patient is fortified in his belief that his new-found situation is an excellent one. We can readily appreciate that he is not in the least inclined to give up all these advantages. If it were left to him, he would prefer to remain united with the analyst for ever. Accordingly, he now starts to produce numerous fantasies showing how this goal might be attained. Eroticism plays a large role here, and is exploited and exaggerated in order to demonstrate the impossibility of separation. The patient, understandably enough, puts up the most obstinate resistance when the analyst tries to break the transference relationship.

[440] We must not forget, however, that for a neurotic the acquisition of an extrafamilial relationship is one of life's duties, as it is for everyone, and a duty which till then he has either not fulfilled at all or fulfilled in a very limited way. At this point I must energetically oppose the view one so often hears that an extrafamilial relationship always means a sexual relationship. (In many cases one would like to say: it is precisely not that. It is a favourite neurotic misunderstanding that the right attitude to the world is found by indulgence in sex. In this respect, too, the literature of psychoanalysis is not free from misrepresentations; indeed there are publications from which no other conclusions can be drawn. This misunderstanding is far older than psychoanalysis, however, and so cannot be laid altogether at its door. The experienced medical man knows this advice very well, and I have had more than one patient who has acted according to this prescription. But when a psychoanalyst recommends it, he is making the same mistake as his patient, who believes that his sexual fantasies come from pent-up ("repressed") sexuality. If that were so, this recipe would naturally be a salutary one. It is not a question of that at all, but of regressive libido which exaggerates the fantasies because it evades the real task and strives back to the infantile level.) If we support this regressive tendency at all points we simply reinforce the infantile attitude from which the neurotic is suffering. He has to learn the higher adaptation which life demands from mature and civilized people.

Those who have a decided tendency to sink lower will proceed to do so; they need no psychoanalysis for that.

[441] At the same time, we must be careful that we do not fall into the opposite extreme of thinking that psychoanalysis creates nothing but quite exceptional personalities. Psychoanalysis stands outside traditional morality; for the present it should adhere to no general moral standard. It is, and should be, only a means for giving the individual trends breathing-space, for developing them and bringing them into harmony with the rest of the personality. It should be a biological method, whose aim is to combine the highest subjective well-being with the most valuable biological performance. As man is not only an individual but also a member of society, these two tendencies inherent in human nature can never be separated, or the one subordinated to the other, without doing him serious injury.

[442] The best result for a person who undergoes an analysis is that he shall become in the end what he really is, in harmony with himself, neither good nor bad, just as he is in his natural state. Psychoanalysis cannot be considered a method of education, if by education we mean the topiary art of clipping a tree into a beautiful artificial shape. But those who have a higher conception of education will prize most the method of cultivating a tree so that it fulfils to perfection its own natural conditions of growth. We yield too much to the ridiculous fear that we are at bottom quite impossible beings, that if everyone were to appear as he really is a frightful social catastrophe would ensue. Many people today take “man as he really is” to mean merely the eternally discontented, anarchic, rapacious element in human beings, quite forgetting that these same human beings have also erected those firmly established forms of civilization which possess greater strength and stability than all the anarchic undercurrents. (The strengthening of his social personality is one of the essential conditions for man’s existence. Were it not so, humanity would cease to be. The selfishness and rebelliousness we meet in the neurotic’s psychology are not “man as he really is” but an infantile distortion. In reality the normal man is “civic-minded and moral”; he created his laws and observes them, not because they are imposed on him from without—that is a childish delusion—but because he loves law and order more than he loves disorder and lawlessness.)

RESOLUTION OF THE TRANSFERENCE

[443] In order to resolve the transference, we have to fight against forces which are not merely neurotic but have a general significance for normal human beings. In trying to get the patient to break the transference relationship, we are asking of him something that is seldom, or never, demanded of the average person, namely, that he should

conquer himself completely. Only certain religions demanded this of the individual, and it is this that makes the second stage of analysis so very difficult.

[444] (As you know, it is an habitual prejudice of children to think that love gives them the right to make demands. The infantile conception of loving is getting presents from others. Patients make demands in accordance with this definition, and thus behave no differently from most normal people, whose infantile cupidity is only prevented from reaching too high a pitch by their fulfilling their duties to life and by the satisfaction this affords the libido, and also because a certain lack of temperament does not incline them from the start to passionate behaviour. The basic trouble with the neurotic is that, instead of adapting himself to life in his own special way, which would require a high degree of self-discipline, he makes infantile demands and then begins to bargain. The analyst will hardly be disposed to comply with the demands the patient makes on him personally, but circumstances may arise in which he will seek to buy his freedom with compromises. For instance, he might throw out hints of moral liberties which, if turned into a maxim, would bring about a general lowering of the cultural level. But in that way the patient merely sinks to the lower level and becomes inferior. Nor is it, in the end, a question of culture at all, but simply of the analyst buying his way out of the constricting transference situation by offering other, alleged advantages. It goes against the real interests of the patient to hold out these compensating advantages so enticingly; at that rate he will never be freed from his infantile cupidity and indolence. Only self-conquest can free him from these.

[445] The neurotic has to prove that he, just as much as a normal person, can live reasonably. Indeed, he must do more than a normal person, he must give up a large slice of his infantilism, which nobody asks a normal person to do.

[446] Patients often try to convince themselves, by seeking out special adventures, that it is possible to go on living in an infantile way. It would be a great mistake if the analyst tried to stop them. There are experiences which one must go through and for which reason is no substitute. Such experiences are often of inestimable value to the patient.

[447] Nowhere more clearly than at this stage of the analysis will everything depend on how far the analyst has been analysed himself. If he himself has an infantile type of desire of which he is still unconscious, he will never be able to open his patient's eyes to this danger. It is an open secret that all through the analysis intelligent patients are looking beyond it into the soul of the analyst, in order to find there the confirmation of the healing formulae—or its opposite. It is quite impossible, even by the subtlest analysis, to prevent the patient from taking over instinctively the way in which his analyst deals with the problems of life. Nothing can stop this, for personality teaches more than thick tomes full of wisdom. All the disguises in which

he wraps himself in order to conceal his own personality avail him nothing; sooner or later he will come across a patient who calls his bluff. An analyst who from the first takes his profession seriously is faced with the inexorable necessity of testing out the principles of psychoanalysis on himself as well. He will be astonished to see how many apparently technical difficulties vanish in this way. Note that I am not speaking of the initial stage of analysis, which might be called the stage of unearthing the complexes, but of this final, extraordinarily tricky stage which is concerned with the resolution of the transference.

[448] I have frequently found that beginners look upon the transference as an entirely abnormal phenomenon that has to be “fought against.” Nothing could be more mistaken. To begin with we have to regard the transference merely as a falsification, a sexualized caricature, of the social bond which holds human society together and which also produces close ties between people of like mind. This bond is one of the most valuable social factors imaginable, and it would be a cruel mistake to reject absolutely these social overtures on the part of the patient. It is only necessary to purge them of their regressive components, their infantile sexualism. If that is done, the transference becomes a most convenient instrument of adaptation.

[449] The only danger—and it is a great one—is that the unacknowledged infantile demands of the analyst may identify themselves with the parallel demands of the patient. The analyst can avoid this only by submitting to a rigorous analysis at the hands of another. He then learns to understand what analysis really means and how it feels to experience it on your own psyche. Every intelligent analyst will at once see how much this must redound to the benefit of his patients. There are analysts who believe that they can get along with a self-analysis. This is Munchausen psychology, and they will certainly remain stuck. They forget that one of the most important therapeutically effective factors is subjecting yourself to the objective judgment of another. As regards ourselves we remain blind, despite everything and everybody. The analyst, of all people, must give up all isolationist tactics and autoerotic mystification if he wants to help his patients to become socially mature and independent personalities.

[450] I know that I am also at one with Freud when I set it up as a self-evident requirement that a psychoanalyst must discharge his own duties to life in the proper way. If he does not, nothing can stop his unutilized libido from automatically descending on his patients and in the end falsifying the whole analysis. Immature and incompetent persons who are themselves neurotic and stand with only one foot in reality generally make nothing but nonsense out of analysis. *Exempla sunt odiosa!* Medicine in the hand of a fool was ever poison and death. Just as we demand from a surgeon, besides his technical knowledge, a skilled hand, courage, presence of mind,

and power of decision, so we must expect from an analyst a very serious and thorough psychoanalytic training of his own personality before we are willing to entrust a patient to him. I would even go so far as to say that the acquisition and practice of the psychoanalytic technique presuppose not only a specific psychological gift but in the very first place a serious concern with the moulding of one's own character.)

[451] The technique for resolving the transference is the same as the one we have already described. The problem of what the patient is to do with the libido he has withdrawn from the person of the analyst naturally occupies a large place. Here too the danger for the beginner is great, as he will be inclined to suggest or to give advice. For the patient the analyst's efforts in this respect are extremely convenient, and therefore fatal. At this important juncture, as everywhere in psychoanalysis, we have to let the patient and his impulses take the lead, even if the path seems a wrong one. Error is just as important a condition of life's progress as truth.

THE PROSPECTIVE FUNCTION OF DREAMS

[452] In this second stage of analysis, with its hidden reefs and shoals, we owe an enormous amount to dreams. At the beginning of the analysis, dreams helped us chiefly to discover the fantasies; but here they are often extremely valuable guides to the use of libido. Freud's work laid the foundation for an immense increase in our knowledge in regard to the determination of the manifest dream content by historical material and wishful tendencies. He showed how dreams give access to a mass of subliminal material, mostly memories that have sunk below the threshold. In keeping with his genius for the purely historical method, Freud's procedure is predominantly analytical. Although this method is incontestably of great value we ought not to adopt this standpoint exclusively, as a one-sided historical view does not take sufficient account of the teleological significance of dreams (stressed in particular by Maeder³). Unconscious thinking would be quite inadequately characterized if we considered it only from the standpoint of its historical determinants. For a complete evaluation we have unquestionably to consider its teleological or prospective significance as well. If we pursued the history of the English Parliament back to its earliest beginnings, we should undoubtedly arrive at an excellent understanding of its development and the way its present form was determined. But that would tell us nothing about its prospective function, that is, about the tasks it has to accomplish now and in the future.

[453] The same is true of dreams, whose prospective function alone was valued in the superstitions of all times and races. There may well be a good deal of truth in this view. Without presuming to say that dreams have prophetic foresight, it is

nevertheless possible that we might find, in this subliminal material, combinations of future events which are subliminal simply because they have not yet attained the degree of clarity necessary for them to become conscious. Here I am thinking of those dim presentiments we sometimes have of the future, which are nothing but very faint, subliminal combinations of events whose objective value we are not yet able to apperceive.

[454] The future tendencies of the patient are elaborated with the help of these teleological components of the dream. If this work is successful, the patient passes out of the treatment and out of the semi-infantile transference relationship into a life which has been carefully prepared within him, which he has chosen himself, and to which, after mature deliberation, he can declare himself committed.

FUTURE USES OF PSYCHOANALYSIS

[455] As will readily be understood, psychoanalysis can never be used for polyclinical work. It must always remain in the hands of the few who, because of their innate educative and psychological capacities, have a particular aptitude and a special liking for this profession. Just as not every doctor makes a good surgeon, not everyone is fitted to be a psychoanalyst. The predominantly psychological nature of the work will make it difficult for the medical profession to monopolize it. Sooner or later other branches of science will master the method, either for practical reasons or out of theoretical interest. So long as orthodox science excludes psychoanalysis from general discussion as sheer nonsense, we cannot be surprised if other departments learn to master the material before the medical profession does. This is all the more likely as psychoanalysis is a general method of psychological research and a heuristic principle of the first rank in the domain of the humane sciences.

[456] It is chiefly the work of the Zurich school that has demonstrated the applicability of psychoanalysis as a method of investigation in mental disease. Psychoanalytic investigation of dementia praecox, for instance, has given us most valuable insights into the psychological structure of this remarkable disease. It would lead me too far afield to go at all deeply into the results of these investigations. The theory of the psychological determinants of this disease is a sufficiently vast territory in itself, and if I were to discuss the symbolistic problems of dementia praecox I would have to put before you a mass of material which I could not hope to deploy within the framework of these lectures, whose purpose is to provide a general survey.

[457] The question of dementia praecox has become so extraordinarily complicated because the recent incursion of psychoanalysis into the domains of mythology and comparative religion has afforded us deep insight into ethnological symbolism. Those who were familiar with the symbolism of dreams and of dementia praecox were

astounded by the parallelism between the symbols found in modern individuals and those found in the history of the human race. Most startling of all is the parallelism between ethnic and schizophrenic symbols. The complicated relations between psychology and mythology make it impossible for me to discuss in detail my views on dementia praecox. For the same reason I must refrain from discussing the results of the psychoanalytic investigation of mythology and comparative religion. The principal result of these investigations at present is the discovery of far-reaching parallels between ethnic and individual symbolisms. We cannot yet see what vast perspectives this ethnopsychology may open out. But, from all we know at present, we may expect that psychoanalytic research into the nature of subliminal processes will be enormously enriched and deepened by a study of mythology.

9. A CASE OF NEUROSIS IN A CHILD

[458] In these lectures I have had to confine myself to giving you a general account of the nature of psychoanalysis. Detailed discussion of the method and theory would have required a mass of case material, exposition of which would have detracted from a comprehensive view of the whole. But, in order to give you some idea of the actual process of psychoanalytic treatment, I have decided to present a fairly short analysis of an eleven-year-old girl. The case was analysed by my assistant, Miss Mary Moltzer. I must preface my remarks by saying that this case is no more typical of the length or course of an ordinary psychoanalysis than one individual is typical of all others. Nowhere is the abstraction of generally valid rules so difficult as in psychoanalysis, for which reason it is better not to make too many formulations. We must not forget that, notwithstanding the great uniformity of conflicts and complexes, every case is unique, because every individual is unique. Every case demands the analyst's individual interest, and in every case the course of analysis is different.

[459] In presenting this case, therefore, I am offering but a small section of the infinitely varied world of the psyche, showing all those apparently bizarre and arbitrary peculiarities which the whim of so-called chance scatters into a human life. It is not my intention to withhold any of the more interesting psychoanalytic details, as I do not want to evoke the impression that psychoanalysis is a rigidly formalistic method. The scientific needs of the investigator prompt him always to look for rules and categories in which the most alive of all living things can be captured. The analyst and observer, on the other hand, must eschew formulas and let the living reality work upon him in all its lawless profusion. Thus I shall try to present this case in its natural setting, and I hope I shall succeed in showing you how differently an analysis develops from what might have been expected on purely theoretical grounds.

[460] The case in question is that of an intelligent eleven-year-old girl of good family.

ANAMNESIS

[461] The clinical history is as follows: She had to leave school several times on account of sudden nausea and headaches, and was obliged to go to bed. In the morning she sometimes refused to get up and go to school. She suffered from bad dreams, was moody and unreliable. I informed the mother, who came to consult me, that these might be the signs of a neurosis, and that something special might be hidden behind them about which one would have to ask the child. This conjecture

was not an arbitrary one, for every attentive observer knows that if children are so restless and bad-tempered something is worrying them.

[462] The child now confessed to her mother the following story. She had a favourite teacher, on whom she had a crush. During this last term she had fallen behind with her work, and she thought she had sunk in her teacher's estimation. She then began to feel sick during his lessons. She felt not only estranged from her teacher, but even rather hostile to him. She directed all her friendly feelings to a poor boy with whom she usually shared the bread she took to school. She now gave him money as well, so that he could buy bread for himself. Once, in conversation with this boy, she made fun of her teacher and called him a goat. The boy attached himself to her more and more, and considered that he had the right to levy an occasional tribute from her in the form of a little present of money. Then she became afraid that the boy would tell the teacher she had called him a goat, and she promised him two francs if he would give her his solemn word never to say anything to the teacher. From that moment the boy began to blackmail her; he demanded money with threats, and persecuted her with his demands on the way to school. She was in despair. Her attacks of sickness were closely connected with this story; yet, after the affair had been settled as a result of this confession, her peace of mind was not restored as we would have expected.

[463] Very often, as I mentioned in the previous lecture, the mere relation of a painful episode has a favourable therapeutic effect. Generally this does not last very long, although on occasion it may be maintained for a long time. Such a confession is naturally a long way from being an analysis, despite the fact that there are many nerve specialists nowadays who believe that an analysis is only a somewhat more extensive anamnesis or confession.

[464] Not long afterwards, the child had a violent attack of coughing and missed school for one day. After that she went back to school for one day and felt perfectly well. On the third day a renewed attack of coughing came on, with pains on the left side, fever and vomiting. She had a temperature of 103° F. The doctor feared pneumonia. But the next day everything had disappeared again. She felt quite well, and there was no trace of fever or nausea.

[465] But still our little patient wept the whole time and did not wish to get up. From this strange course of events I suspected a serious neurosis, and I therefore advised analytical treatment.

FIRST INTERVIEW

[466] The little girl seemed nervous and constrained, now and then giving a disagreeable forced laugh. She was first of all given an opportunity to talk about what

it felt like to be allowed to stay in bed. We learn that it was especially nice then, as she always had company. Everybody came to see her; best of all, she could get herself read to by Mama, from a book with the story in it of a *prince who was ill and only got well again when his wish was fulfilled, the wish being that his little friend, a poor boy, might be allowed to stay with him.*

[467] The obvious relation between this story and her own little love-story, as well as its connection with her sickness, was pointed out to her, whereupon she began to weep, saying that she would rather go with the other children and play with them, or they would run away. This was at once allowed, and away she ran, but came back again in no time, somewhat crestfallen. It was explained to her that she had not run away because she was afraid her playmates would run away, but that she herself wanted to run away because of resistances.

SECOND INTERVIEW

[468] At the second interview she was less anxious and inhibited. The conversation was led round to the teacher, but she was too embarrassed to speak about him. Finally came the shamefaced admission that she liked him very much. It was explained to her that she need not be ashamed of that; on the contrary, her love was a guarantee that she would do her very best in his lessons. “So then I may like him?” asked the little patient with a happier face.

[469] This explanation justified the child in her choice of a love-object. She had, it seemed, been afraid to admit to herself her feelings for the teacher. It is not easy to explain why this should be so. It was previously assumed that the libido has great difficulty in seizing upon a person outside the family because it still finds itself caught in the incestuous bond—a very plausible view indeed, from which it is difficult to withdraw. On the other hand, it must be emphasized that her libido had taken vehement possession of the poor boy, and he too was someone outside the family, so that the difficulty cannot lie in transferring libido to an extra-familial object, but in some other circumstance. Her love for the teacher was for her a more difficult task, it demanded much more from her than her love for the boy, which did not require any moral effort on her part. The hint dropped in the analysis that love would enable her to do her best brought the child back to her real task, which was to adapt to the teacher.

[470] Now if the libido draws back from a necessary task, it does so for the very human reason of indolence, which is particularly marked not only in children but also in primitives and animals. Primitive inertia and laziness are the primary reason for not making the effort to adapt. The libido which is not used for this purpose stagnates, and will then make the inevitable regression to former objects or modes of

adaptation. The result is a striking activation of the incest complex. The libido withdraws from the object which is so difficult to attain and which demands such great efforts, and turns instead to the easier ones, and finally to the easiest of all, the infantile fantasies, which are then elaborated into real incest fantasies. The fact that, whenever there is a disturbance of psychological adaptation, we always find an excessive development of these fantasies must likewise be conceived, as I pointed out before, as a regressive phenomenon. That is to say, the incest fantasy is of secondary and not of causal significance, while the primary cause is the resistance of human nature to any kind of exertion. Accordingly, drawing back from certain tasks cannot be explained by saying that man prefers the incestuous relationship, rather he falls back into it because he shuns exertion. Otherwise we would have to say that resistance to conscious effort is identical with preference for the incestuous relationship. This would be obvious nonsense, since not only primitive man but animals too have a mighty dislike of all intentional effort, and are addicted to absolute laziness until circumstances prod them into action. Neither of primitive people nor of animals can it be asserted that preference for incestuous relationships is the cause of their aversion to efforts at adaptation, for, especially in the case of animals, there can be absolutely no question of an incestuous relationship.

[471] Characteristically, the child expressed joy not at the prospect of doing her best for the teacher but at being allowed to love him. That was the thing she heard first, because it suited her best. Her relief came from the confirmation that she was justified in loving him—even without making any special effort first.

[472] The conversation then went on to the story of the blackmail, which she told again in detail. We learn, furthermore, that she tried to force open her money-box, and when she did not succeed she tried to steal the key from her mother. She also made a clean breast of the other matter: she had made fun of the teacher because he was much nicer to the other girls than to her. But it was true that she had got worse at his lessons, especially in arithmetic. Once she did not understand something, but had not dared to ask for fear of losing the teacher's esteem. Consequently she made mistakes, fell behind, and really did lose it. As a result, she got into a very unsatisfactory position with her teacher.

[473] About this time it happened that a girl in her class was sent home because she felt sick. Soon after, the same thing happened to her. In this way, she tried to get away from school, which she no longer liked. The loss of her teacher's esteem led her, on the one hand, to insult him and, on the other, into the affair with the little boy, obviously as a compensation for her lost relationship with the teacher. The explanation she was now given was a simple hint: she would be doing her teacher a good turn if she took pains to understand his lessons by asking questions in time. I

may add that this hint had good results; from that moment the little girl became the best pupil and missed no more arithmetic lessons.

[474] A point worth stressing in the story of the blackmail is its compulsive character and the lack of freedom it shows in the girl. This is a quite regular phenomenon. As soon as anyone permits his libido to draw back from a necessary task, it becomes autonomous and, regardless of the protests of the subject, chooses its own goals and pursues them obstinately. It is therefore quite common for a person leading a lazy and inactive life to be peculiarly prone to the compulsion of libido, that is, to all kinds of fears and involuntary constraints. The fears and superstitions of primitives furnish the best proof of this, but the history of our own civilization, especially the civilization of antiquity, provides ample confirmation as well. Non-employment of the libido makes it ungovernable. But we must not believe that we can save ourselves permanently from the compulsion of libido by forced efforts. Only to a very limited extent can we consciously set tasks for the libido; other natural tasks are chosen by the libido itself because it is destined for them. If these tasks are avoided, even the most industrious life avails nothing, for we have to consider all the conditions of human nature. Innumerable neurasthenias from overwork can be traced back to this cause, for work done amid internal conflicts creates nervous exhaustion.

THIRD INTERVIEW

[475] The girl related a dream she had had when she was five years old, which made an unforgettable impression on her. "I'll never forget the dream as long as I live," she said. I would like to add here that such dreams are of quite special interest. The longer a dream remains spontaneously in the memory, the greater is the importance to be attributed to it. This is the dream: "*I was in a wood with my little brother, looking for strawberries. Then a wolf came and jumped at me. I fled up a staircase, the wolf after me. I fell down and the wolf bit me in the leg. I awoke in deadly fear.*"

[476] Before we take up the associations given us by the little girl, I will try to form an arbitrary opinion as to the possible content of the dream, and then see how our results compare with the associations given by the child. The beginning of the dream reminds us of the well-known fairytale of Little Red Riding-hood, which is, of course, known to every child. The wolf ate the grandmother first, then took her shape, and afterwards ate Little Red Ridinghood. But the hunter killed the wolf, cut open the belly, and Little Red Ridinghood sprang out safe and sound.

[477] This motif is found in countless myths all over the world, and is the motif of the Bible story of Jonah. The meaning immediately lying behind it is astro-mythological: the sun is swallowed by the sea monster and is born again in the morning. Of course, the whole of astro-mythology is at bottom nothing but psychology—unconscious

psychology—projected into the heavens; for myths never were and never are made consciously, they arise from man's unconscious. This is the reason for the sometimes miraculous similarity or identity of myth-forms among races that have been separated from each other in space ever since time began. It explains, for instance, the extraordinary distribution of the cross symbol, quite independently of Christianity, of which America offers specially remarkable examples. It is not possible to suppose that myths were created merely in order to explain meteorological or astronomical processes; they are, in the first instance, manifestations of unconscious impulses, comparable to dreams. These impulses were actuated by the regressive libido in the unconscious. The material which comes to light is naturally infantile material—fantasies connected with the incest complex. Thus, in all these so-called solar myths, we can easily recognize infantile theories about procreation, birth, and incestuous relations. In the fairytale of Little Red Ridinghood it is the fantasy that the mother has to eat something which is like a child, and that the child is born by cutting open the mother's body. This fantasy is one of the commonest and can be found everywhere.

[478] From these general psychological considerations we can conclude that the child, in this dream, was elaborating the problem of procreation and birth. As to the wolf, we must probably put him in the father's place, for the child unconsciously attributed to the father any act of violence towards the mother. This motif, too, is based on countless myths dealing with the violation of the mother. With regard to the mythological parallels, I would like to call your attention to the work of Boas,¹ which includes a magnificent collection of American Indian sagas; then the book by Frobenius, *Das Zeitalter des Sonnengottes*; and finally the works of Abraham, Rank, Riklin, Jones, Freud, Maeder, Silberer, and Spielrein,² and my own investigations in *Symbols of Transformation*.

[479] After these general reflections, which I give here for theoretical reasons but which naturally formed no part of the treatment, we will go on to see what the child has to tell us about her dream. Needless to say, she was allowed to speak about her dream just as she liked, without being influenced in any way. She picked first on the bite in the leg, and explained that *she had once been told by a woman who had had a baby that she could still show the place where the stork had bitten her*. This expression is, in Switzerland, a variant of the widespread symbolism of copulation and birth. Here we have a perfect parallelism between our interpretation and the association process of the child. For the first association she produced, quite uninfluenced, goes back to the problem we conjectured above on theoretical grounds. I know that the innumerable cases published in the psychoanalytic literature, which were definitely not influenced, have not been able to quash our critics' contention that we suggest our interpretations to the patients. This case, too, will convince no

one who is determined to impute to us the crude mistakes of beginners—or, what is worse, falsification.

[480] After this first association the little patient was asked what the wolf made her think of. She answered, “I think of my father when he is angry.” This, too, coincides absolutely with our theoretical considerations. It might be objected that these considerations were made expressly for this purpose and therefore lack general validity. I think this objection vanishes of itself as soon as one has the requisite psychoanalytic and mythological knowledge. The validity of a hypothesis can be seen only on the basis of the right knowledge, otherwise not at all.

[481] The first association put the stork in the place of the wolf; the association to the wolf now brings us to the father. In the popular myth the stork stands for the father, for he brings the children. The apparent contradiction between the fairytale, where the wolf is the mother, and the dream, where the wolf is the father, is of no importance for the dream or the dreamer. We can therefore dispense with a detailed explanation. I have dealt with this problem of bisexual symbols in my book.³ As you know, in the legend of Romulus and Remus both animals, the bird Picus and the wolf, were raised to the rank of parents.

[482] Her fear of the wolf in the dream is therefore her fear of the father. The dreamer explained that she was afraid of her father because he was very strict with her. He had also told her that we have bad dreams only when we have done something wrong. She then asked her father, “But what does Mama do wrong? She always has bad dreams.”

[483] Once her father slapped her because she was sucking her finger. She kept on doing this despite his prohibition. Was this, perhaps, the wrong she had done? Hardly, because sucking the finger was simply a rather anachronistic infantile habit, of little real interest at her age, and serving more to irritate her father so that he would punish her by slapping. In this way she relieved her conscience of an unconfessed and much more serious “sin”: *it came out that she had induced a number of girls of her own age to perform mutual masturbation.*

[484] It was because of these sexual interests that she was afraid of her father. But we must not forget that she had the wolf dream in her fifth year. At that time these sexual acts had not been committed. Hence we must regard the affair with the other girls at most as a reason for her present fear of her father, but that does not explain her earlier fear. Nevertheless, we may expect that it was something similar, some unconscious sexual wish in keeping with the psychology of the forbidden act just mentioned. The character and moral evaluation of this act are naturally far more unconscious to a child than to an adult. In order to understand what could have made an impression on the child so early, we have to ask what happened in her fifth year. *That was the year*

in which her younger brother was born. So even then she was afraid of her father. The associations already discussed show us the unmistakable connection between her sexual interests and her fear.

[485] The problem of sex, which nature connects with positive feelings of pleasure, appears in the wolf dream in the form of fear, apparently on account of the bad father, who stands for moral education. The dream was therefore the first impressive manifestation of the sexual problem, obviously stimulated by the recent birth of a younger brother, when as we know all these questions become aired. But because the sexual problem was connected at all points with the history of certain pleasurable physical sensations which education devalues as “bad habits,” it could apparently manifest itself only in the guise of moral guilt and fear.

[486] This explanation, plausible though it is, seems to me superficial and inadequate. We then attribute the whole difficulty to moral education, on the unproven assumption that education can cause a neurosis. This is to disregard the fact that even people with no trace of moral education become neurotic and suffer from morbid fears. Furthermore, moral law is not just an evil that has to be resisted, but a necessity born from the innermost needs of man. Moral law is nothing other than an outward manifestation of man’s innate urge to dominate and control himself. This impulse to domestication and civilization is lost in the dim, unfathomable depths of man’s evolutionary history and can never be conceived as the consequence of laws imposed from without. Man himself, obeying his instincts, created his laws. We shall never understand the reasons for the fear and suppression of the sexual problem in a child if we take into account only the moral influences of education. The real reasons lie much deeper, in human nature itself, perhaps in that tragic conflict between nature and culture, or between individual consciousness and collective feeling.

[487] Naturally, it would have been pointless to give the child a notion of the higher philosophical aspects of the problem; it would certainly have had not the slightest effect. It was sufficient to remove the idea that she was doing something wrong in being interested in the procreation of life. So it was made clear to her how much pleasure and curiosity she was bringing to bear on the problem of generation, and how her groundless fear was only pleasure turned into its opposite. The affair of her masturbation met with tolerant understanding, and the discussion was limited to drawing the child’s attention to the aimlessness of her action. At the same time, it was explained to her that her sexual actions were mainly an outlet for her curiosity, which she might satisfy in a better way. Her great fear of her father expressed an equally great expectation, which because of the birth of her little brother was closely connected with the problem of generation. These explanations justified the child in her curiosity. With that, a large part of the moral conflict was removed.

FOURTH INTERVIEW

[488] The little girl was now much nicer and much more confiding. Her former constrained and unnatural manner had quite disappeared. She brought a dream which she dreamt after the last interview. It ran: *“I am as tall as a church-spire and can see into every house. At my feet are very small children, as small as flowers are. A policeman comes. I say to him, ‘If you dare to make any remark, I shall take your sword and cut off your head.’”*

[489] In the analysis of the dream she made the following remark: “I would like to be taller than my father, because then he would have to obey me.” She at once associated the policeman with her father, who was a military man and had, of course, a sword. The dream clearly fulfils her wish. As a church-spire, she is much bigger than her father, and if he dares to make a remark he will be decapitated. The dream also fulfils the natural wish of the child to be “big,” i.e., grown-up, and to have children playing at her feet. In this dream she got over her fear of her father, and from this we may expect a significant increase in her personal freedom and feeling of security.

[490] On the theoretical side, we may regard this dream as a clear example of the compensatory significance and teleological function of dreams. Such a dream must leave the dreamer with a heightened sense of the value of her own personality, and this is of great importance for her personal well-being. It does not matter that the symbolism was not clear to the consciousness of the child, for the emotional effect of symbols does not depend on conscious understanding. It is more a matter of intuitive knowledge, the source from which all religious symbols derive their efficacy. Here no conscious understanding is needed; they influence the psyche of the believer through intuition.

FIFTH AND SIXTH INTERVIEWS

[491] The child related the following dream which she had dreamt in the meantime: *“I was standing with my whole family on the roof. The windows of the houses on the other side of the valley shone like fire. The rising sun was reflected in them. Suddenly I saw that the house at the corner of our street was really on fire. The fire came nearer and nearer and took hold of our house. I ran into the street, and my mother threw all sorts of things after me. I held out my apron, and among other things she threw me a doll. I saw that the stones of our house were burning, but the wood remained untouched.”*

[492] The analysis of this dream presented peculiar difficulties and had to be extended over two sittings. It would lead me too far to describe the whole of the material this

dream brought forth; I shall have to limit myself to what is most essential. The salient associations began with the peculiar image of the stones of the house burning but not the wood. It is sometimes worth while, especially with longer dreams, to take the most striking images and analyse them first. This is not the general rule but it may be excused here by the practical need for abbreviation.

[493] “It is queer, like in a fairytale,” said the little patient about this image. She was shown, with the help of examples, that fairytales always have a meaning. “But not all fairytales,” she objected. “For instance, the tale of Sleeping Beauty. What could that mean?” It was explained to her that Sleeping Beauty had to wait for a hundred years in an enchanted sleep until she could be set free. Only the hero whose love overcame all difficulties and who boldly broke through the thorny hedge could rescue her. Thus one often has to wait for a long time before one obtains one’s heart’s desire.

[494] This explanation was suited to the child’s understanding, and on the other hand was perfectly in accord with the history of this fairytale motif. The tale of Sleeping Beauty has obvious connections with an ancient spring and fertility myth, and at the same time contains a problem which has a remarkably close affinity with the psychological situation of a rather precocious little girl of eleven. It belongs to a whole cycle of legends in which a virgin, guarded by a dragon, is rescued by a hero. Without wishing to embark on an interpretation of this myth, I would like to emphasize its astronomical or meteorological components, clearly brought out in the Edda. The earth, in the form of a maiden, is held prisoner by the winter, and is covered with ice and snow. The young spring sun, the fiery hero, melts her out of her frosty prison, where she had long awaited her deliverer.

[495] The association given by the little girl was chosen by her simply as an example of a fairytale without a meaning, and not as a direct association to the dream-image of the burning house. About this she only made the remark, “It is queer, like in a fairytale,” by which she meant impossible; for to say that stones burn is something completely impossible, nonsensical, and like a fairytale. The explanation she was given showed her that “impossible” and “like a fairytale” are only partly identical, since fairytales do have a great deal of meaning. Although this particular fairytale, from the casual way it was mentioned, seems to have nothing to do with the dream, it deserves special attention because it appeared, as though by chance, while the dream was being analysed. The unconscious came out with just this example, and this cannot be mere chance but is somehow characteristic of the situation at that moment. In analysing dreams we have to look out for these seeming accidents, for in psychology there are no blind accidents, much as we are inclined to assume that these things are pure chance. You can hear this objection as often as you like from our critics, but for a really scientific mind there are only causal relationships and no

accidents. From the fact that the little girl chose Sleeping Beauty as an example we must conclude that there was some fundamental reason for this in the psychology of the child. This reason was the comparison or partial identification of herself with Sleeping Beauty; in other words, in the psyche of the child there was a complex which found expression in the Sleeping Beauty motif. The explanation given to the child took account of this inference.

[496] Nevertheless, she was not quite satisfied, and still doubted that fairytales have a meaning. As a further example of an incomprehensible fairytale she cited Snow White, who lay enclosed in a glass coffin, in the sleep of death. It is not difficult to see that Snow White belongs to the same cycle of myths as Sleeping Beauty. It contains even clearer indications of the myth of the seasons. The myth material chosen by the child points to an intuitive comparison with the earth, held fast by the winter's cold, awaiting the liberating sun of spring.

[497] This second example confirms the first one and the explanation we have given. It would be difficult to maintain that the second example, accentuating as it does the meaning of the first, was suggested by the explanation. The fact that the little girl gave Snow White as another example of a meaningless fairytale proves that she did not realize the identity of Snow White and Sleeping Beauty. We may therefore conjecture that Snow White arose from the same unconscious source as Sleeping Beauty, namely, from a complex concerned with the expectation of coming events. These events may be compared exactly with the deliverance of the earth from the prison of winter and its fertilization by the rays of the spring sun. As you know, from ancient times the fertilizing spring sun was associated with the symbol of the bull, the animal embodying the mightiest procreative power. Although we cannot yet see the connection between these insights and the dream, we will hold fast to what we have gained and proceed with our analysis.

[498] The next dream-image shows the little girl catching the doll in her apron. Her first association tells us that her attitude and the whole situation in the dream reminded her of *a picture she knew, showing a stork flying over a village, with little girls standing in the street holding out their aprons and shouting to the stork to bring them a baby*. She added that she herself had long wanted a baby brother or sister. This material, given spontaneously, is clearly related to the myth-motifs already discussed. It is evident that the dream was in fact concerned with the same problem of the awakening reproductive instinct. Of course, nothing of these connections was mentioned to the child.

[499] Then, abruptly, after a pause, came the next association: "Once, when I was five years old, I lay down in the street and a bicycle passed over my stomach." This highly improbable story proved to be, as might be expected, a fantasy, which had

become a paramnesia. Nothing of the kind had ever happened, but on the other hand we learn that at school *the little girls used to lie crosswise over each other's bodies and trample with their legs.*

[500] Anyone who has read the analyses of children published by Freud and myself⁴ will recognize in this childish game the same basic motif of trampling, which we considered must have a sexual undercurrent. This view, demonstrated by our earlier work, was borne out by the next association of our little patient: "I would much rather have a real baby than a doll."

[501] All this highly remarkable material brought out by the stork fantasy suggests the typical beginnings of an infantile sexual theory, and at the same time shows us the point round which the little girl's fantasies were revolving.

[502] It may be of interest to know that the motif of treading or trampling can be found in mythology. I have documented this in my book on libido.⁵ The use of these infantile fantasies in the dream, the paramnesia about the bicyclist, and the tense expectation expressed in the Sleeping Beauty motif all show that the child's inner interest was dwelling on certain problems that had to be solved. Probably the fact that her libido was attracted by the problem of generation was the reason why her interest flagged at school, so that she fell behind in her work. How very much this problem fascinates girls of twelve and thirteen I was able to show in a special case, published in "A Contribution to the Psychology of Rumour."⁶ It is the cause of all that smutty talk among children, and of mutual attempts at enlightenment which naturally turn out to be very nasty and often ruin the child's imagination for good. Even the most careful protection cannot prevent them from one day discovering the great secret, and then probably in the dirtiest way. It would be far better for children to learn the facts of life cleanly and in good time, so that they would not need to be enlightened in ugly ways by their playmates.

[503] These and other indications showed that the moment had come for a certain amount of sexual enlightenment. The little girl listened attentively to the talk that followed, and then asked very seriously: "So then I really can't have a child?" This question led to an explanation about sexual maturity.

SEVENTH INTERVIEW

[504] The little girl began by remarking that she perfectly understood why it was not yet possible for her to have a child; she had therefore renounced all idea of it. But this time she did not make a good impression. It turned out that she had lied to her teacher. She had been late to school, and told the teacher that she had had to go somewhere with her father and had therefore arrived late. In reality, she had been too

lazy to get up in time. She told a lie because she was afraid of losing the teacher's favour by confessing the truth. This sudden moral defeat requires an explanation. According to the principles of psychoanalysis, a sudden and striking weakness can only come about when the analysand does not draw from the analysis the conclusions that are necessary at the moment, but still keeps the door open to other possibilities. This means, in our case, that though the analysis had apparently brought the libido to the surface, so that an improvement of personality could occur, for some reason or other the adaptation was not made, and the libido slipped back along its old regressive path.

EIGHTH INTERVIEW

[505] The eighth interview proved that this was indeed the case. Our patient had withheld an important piece of evidence in regard to her ideas of sex, and one which contradicted the analyst's explanation of sexual maturity. *She had not mentioned a rumour current in the school that a girl of eleven had got a baby from a boy of the same age.* This rumour was proved to be groundless; it was a fantasy, fulfilling the secret wishes of girls of this age. Rumours often start in this way, as I have tried to show in my paper on the psychology of rumour. They air the unconscious fantasies, and in this function they correspond to dreams and myths. This rumour kept another way open: she need not wait, she could have a child already at eleven. The contradiction between the accepted rumour and the analyst's explanation created resistances against the latter, as a result of which it was immediately devalued. All the other information and instruction fell to the ground at the same time, giving rise to momentary doubt and uncertainty. The libido then took to its former path and became regressive. This moment was the moment of the relapse.

NINTH INTERVIEW

[506] This interview contributed some important details to the history of her sexual problem. First came a significant dream fragment: *"I was with other children in a clearing in a wood, surrounded by beautiful fir-trees. It began to rain, there was thunder and lightning, and it grew dark. Then I suddenly saw a stork in the air."*

[507] Before we start analysing this dream, I must mention its parallels with certain mythological ideas. To anyone familiar with the works of Adalbert Kuhn and Steinthal, to which Abraham⁷ has recently drawn attention, the curious combination of thunderstorm and stork is not at all surprising. Since ancient times the thunderstorm has had the meaning of an earth-fecundating act, it is the cohabitation of Father Heaven and Mother Earth, where the lightning takes over the role of the

winged phallus. The stork in flight is just the same thing, a winged phallus, and its psychosexual meaning is known to every child. But the psychosexual meaning of the thunderstorm is not known to everyone, and certainly not to our little patient. In view of the whole psychological constellation previously described, the stork must unquestionably be given a psychosexual interpretation. The fact that the thunderstorm is connected with the stork and, like it, has a psychosexual meaning seems difficult to accept at first. But when we remember that psychoanalytic research has already discovered a vast number of purely mythological connections in the unconscious psychic products, we may conclude that the psychosexual link between the two images is present also in this case. We know from other experiences that those unconscious strata which once produced mythological formations are still active in modern individuals and are unceasingly productive. Only, the production is limited to dreams and to the symptomatology of the neuroses and psychoses, as the correction by reality is so strong in the modern mind that it prevents them from being projected upon the real world.

[508] To return to the analysis of the dream: the associations that led to the heart of this image began with the idea of *rain during a thunderstorm*. Her actual words were: “I think of water—my uncle was drowned in the water—it must be awful to be stuck in the water like that, in the dark—but wouldn’t the baby drown in the water, too? Does it drink the water that is in the stomach? Queer, when I was ill Mama sent my water to the doctor. I thought he was going to mix something with it like syrup, which babies grow from, and Mama would have to drink it.”

[509] We see with unquestionable clearness from this string of associations that the child connected psychosexual ideas specifically relating to fertilization with the rain during the thunderstorm.

[510] Here again we see that remarkable parallelism between mythology and the individual fantasies of our own day. This series of associations is so rich in symbolical connections that a whole dissertation could be written about them. The symbolism of drowning was brilliantly interpreted by the child herself as a pregnancy fantasy, an explanation given in the psychoanalytic literature long ago.

TENTH INTERVIEW

[511] The tenth interview was taken up with the child’s spontaneous description of infantile theories about fertilization and birth, which could now be dismissed as settled. The child had always thought that the urine of the man went into the body of the woman, and that from this the embryo would grow. Hence the child was in the water, i.e., urine, from the beginning. Another version was that the urine was drunk with the doctor’s syrup, the child grew in the head, the head was then split open to

help the child grow, and one wore hats to cover this up. She illustrated this by a little drawing, showing a childbirth through the head. This idea is archaic and highly mythological. I need only remind you of the birth of Pallas Athene, who came out of her father's head. The fertilizing significance of urine is also mythological; we find excellent proofs of this in the Rudra songs of the Rig-veda.⁸ I should also mention something which the mother corroborated, that once the little girl, long before the analysis, declared that she saw a jack-in-a-box dancing on her younger brother's head—a fantasy which may well be the origin of this birth-theory.

[512] The drawing had a remarkable affinity with certain artefacts found among the Bataks of Sumatra. They are called magic wands or ancestor-columns, and consist of a number of figures standing one on top of another. The explanation given by the Bataks themselves of these columns, and generally regarded as nonsense, is in remarkable agreement with the mentality of a child, still caught in the infantile bonds. They assert that these superimposed figures are members of a family who, because they committed incest, were entwined by a snake while being bitten to death by another snake. This explanation runs parallel with the assumptions of our little patient, for her sexual fantasies, too, as we saw from the first dream, revolved round her father. Here, as with the Bataks, the primary condition is the incest relationship.

[513] A third version was the theory that the child grew in the intestinal canal. This version had its own symptomatic phenomenology thoroughly in accord with Freudian theory. The girl, acting on her fantasy that children were "sicked up," frequently tried to induce nausea and vomiting. She also performed regular pushing-exercises in the water-closet, in order to push the child out. In this situation it was not surprising that the first and most important symptoms in the manifest neurosis were those of nausea.

[514] We have now got so far with our analysis that we can cast a glance back at the case as a whole. We found, behind the neurotic symptoms, complicated emotional processes that were undoubtedly connected with these symptoms. If we may venture to draw general conclusions from such limited material, we can reconstruct the course of the neurosis somewhat as follows.

[515] At the gradual approach of puberty, the libido of the child produced in her an emotional rather than an objective attitude to reality. She developed a crush on her teacher, and this sentimental indulgence in starry-eyed fantasies obviously played a greater role than the thought of the increased efforts which such a love really demanded. Consequently, her attention fell off, and her work suffered. This upset her former good relationship with the teacher. He became impatient, and the girl, who had been made over-demanding by conditions at home, grew resentful instead of trying to improve her work. As a result, her libido turned away from the teacher as well as from her work and fell into that characteristically compulsive dependence on

the poor young boy, who exploited the situation as much as he could. For when an individual consciously or unconsciously lets his libido draw back from a necessary task, the unutilized (so-called “repressed”) libido provokes all sorts of accidents, within and without—symptoms of every description which force themselves on him in a disagreeable way. Under these conditions the girl’s resistance to going to school seized on the first available opportunity, which soon presented itself in the form of the other girl who was sent home because she felt sick. Our patient duly copied this.

[516] Once out of school, the way was open to her fantasies. Owing to the libido regression, the symptom-creating fantasies were aroused in real earnest and acquired an influence which they never had before, for previously they had never played such an important role. But now they took on a highly significant content and seemed themselves to be the real reason why the libido regressed to them. It might be said that the child, with her fantasy-spinning nature, saw her father too much in the teacher, and consequently developed incestuous resistances against him. As I explained earlier, I think it is simpler and more probable to assume that it was temporarily convenient for her to see her teacher as the father. Since she preferred to follow the secret promptings of puberty rather than her obligations to the school and her teacher, she allowed her libido to pick on the little boy, from whom, as we saw in the analysis, she promised herself certain secret advantages. Even if the analysis had proved she really did have incestuous resistances against her teacher owing to the transference of the father-*imago*, these resistances would only have been secondarily blown-up fantasies. The prime mover would in any case be laziness or convenience, or, to put it in more scientific language, the principle of least resistance.

[517] (I think there are cogent reasons for assuming—I mention this only in passing—that it is not always a perfectly legitimate interest in sexual processes and their unknown nature that accounts for the regression to infantile fantasies. For we find the same regressive fantasies even in adults who have long known all about sex, and here there is no legitimate reason. It is also my impression that young people in analysis often try to keep up their alleged ignorance, despite enlightenment, in order to direct attention there rather than to the task of adaptation. Although there is no doubt in my mind that children do exploit their real or pretended ignorance, it must on the other hand be stressed that young people have a right to be sexually enlightened. As I said before, for many children it would be a distinct advantage if this were decently done at home.)

[518] Through the analysis it became clear that independently of the progressive development of the child’s life a regressive movement had set in, which caused the neurosis, the disunion with herself.) By following this regressive tendency, the analysis discovered a keen sexual curiosity, circling round quite certain definite

problems. The libido, caught in this labyrinth of fantasies, was made serviceable again as soon as the child was freed from the burden of mistaken infantile fantasies by being enlightened. This also opened her eyes to her own attitude to reality and gave her an insight into her true potentialities. The result was that she was able to look at her immature, adolescent fantasies in an objective and critical way, and to give up these and all other impossible desires, using her libido instead for a positive purpose, in her work and in obtaining the goodwill of her teacher. The analysis brought her great peace of mind, as well as marked intellectual improvement in school; for the teacher himself confirmed that the little girl soon became the best pupil in his class.

[519] (In principle, this analysis is no different from that of an adult. Only the sexual enlightenment would be dropped, but its place would be taken by something very similar, namely, enlightenment concerning the infantilism of his previous attitude to reality and how to acquire a more reasonable one. Analysis is a refined technique of Socratic maieutics, and it is not afraid to tread the darkest paths of neurotic fantasy.)

[520] I hope that with the help of this very condensed example I may have succeeded in giving you some insight not only into the actual course of treatment, and into the difficulties of technique, but no less into the beauty of the human psyche and its endless problems. I have deliberately stressed certain parallels with mythology in order to indicate some of the uses to which psychoanalytic insights may be put. At the same time, I would like to point out the implications of this discovery. The marked predominance of mythological elements in the psyche of the child gives us a clear hint of the way the individual mind gradually develops out of the “collective mind” of early childhood, thus giving rise to the old theory of a state of perfect knowledge before and after individual existence.

[521] (These mythological references which we find in children are also met with in dementia praecox and in dreams. They offer a broad and fertile field of work for comparative psychological research. The distant goal to which these investigations lead is a phylogeny of the mind, which, like the body, has attained its present form through endless transformations. The rudimentary organs, as it were, which the mind still possesses can be found in full activity in other mental variants and in certain pathological conditions.)

[522] With these hints I have now reached the present position of our research, and have sketched out at least those insights and working hypotheses which define the nature of my present and future work. (I have endeavoured to propound certain views, which deviate from the hypotheses of Freud, not as contrary assertions but as illustrations of the organic development of the basic ideas Freud has introduced into science. It would not be fitting to disturb the progress of science by adopting the most

contradictory standpoint possible and by making use of an entirely different nomenclature—that is the privilege of the very few; but even they find themselves obliged to descend from their lonely eminence after a time and once more take part in the slow progress of average experience by which ideas are evaluated. I hope, also, that my critics will not again accuse me of having contrived my hypotheses out of thin air. I would never have ventured to override the existing ones had not hundreds of experiences shown me that my views fully stand the test in practice. No great hopes should be set on the results of any scientific work; yet if it should find a circle of readers, I hope it will serve to clear up various misunderstandings and remove a number of obstacles which bar the way to a better comprehension of psychoanalysis. Naturally my work is no substitute for lack of psychoanalytic experience. Anyone who wishes to have his say in these matters will have, now as then, to investigate his cases as thoroughly as was done by the psychoanalytic school.)

III

GENERAL ASPECTS OF PSYCHOANALYSIS



PSYCHOANALYSIS AND NEUROSIS



SOME CRUCIAL POINTS IN PSYCHOANALYSIS

PREFACES TO "COLLECTED PAPERS ON ANALYTICAL PSYCHOLOGY"

GENERAL ASPECTS OF PSYCHOANALYSIS¹

[523] Psychoanalysis today is as much a science as a technique. From the results of the technique there has grown up, in the course of the years, a new psychological science which could be called “analytical psychology.” I would willingly use Bleuler’s expression “depth psychology” instead, if this kind of psychology were concerned only with the unconscious.

[524] Psychologists and doctors in general are by no means conversant with this particular branch of psychology, owing to the fact that its technical foundations are as yet comparatively unknown to them. The main reason for this is that the new method is of an essentially psychological nature, and therefore belongs neither to the realm of medicine nor to that of philosophy. The medical man has, as a rule, but little knowledge of psychology, and the philosopher has no medical knowledge. Consequently, there is a lack of suitable soil in which to plant the spirit of this new method. Furthermore, the method itself appears to many persons so arbitrary that they cannot reconcile its use with their scientific conscience. The formulations of Freud, the founder of the method, laid great stress on the sexual factors; this aroused strong prejudice and repelled many scientific men. I need hardly remark that such an antipathy is not a logical reason for rejecting a new method. In psychoanalysis, moreover, there is much discussion of case-histories, but little discussion of principle. This, too, has naturally led to the method being little understood and therefore to its being regarded as unscientific. For if we do not acknowledge the scientific character of the method, we cannot acknowledge the scientific character of its results.

[525] Before discussing the principles of the psychoanalytic method, I must mention two common prejudices against it. The first is that psychoanalysis is nothing but a rather deep and complicated form of *anamnesis*. Now it is well known that an anamnesis is based on the statements made by the patient’s family, and on his own conscious self-knowledge in reply to direct questions. The psychoanalyst naturally makes his anamnesis as carefully as any other specialist. But this is merely the patient’s history and must not be confused with analysis. Analysis is the reduction of actual contents of consciousness, ostensibly of a fortuitous nature, to their psychological determinants. This process has nothing to do with the anamnestic reconstruction of the history of the illness.

[526] The second prejudice, which is based, as a rule, on a superficial knowledge of psychoanalytic literature, is that psychoanalysis is a *method of suggestion*, by which some kind of systematic teaching is instilled into the patient, thereby effecting a cure

in the manner of mental healing or Christian Science. Many analysts, especially those who have practised psychoanalysis for a long time, previously used suggestion therapy, and therefore know very well what suggestion is and what it is not. They know that the psychoanalyst's method of working is diametrically opposed to that of the hypnotist. In direct contrast with suggestion therapy, the psychoanalyst does not attempt to force anything on his patient which the latter does not see for himself and find plausible with his own understanding. Faced with the constant demand of the neurotic for suggestions and advice, the analyst just as constantly endeavours to get him out of this passive attitude and make him use his common sense and powers of criticism in order to equip him for an independent life. We have often been accused of forcing interpretations upon patients, interpretations that are often quite arbitrary. I wish one of these critics would try forcing arbitrary interpretations on my patients, who are very often persons of great intelligence and highly cultured—indeed, not infrequently my own colleagues. The impossibility of such an undertaking would quickly be demonstrated. In psychoanalysis we are entirely dependent on the patient and on his powers of judgment, for the reason that the very nature of analysis consists in leading him to a knowledge of himself. The principles of psychoanalysis are so utterly different from those of suggestion therapy that on this point the two methods cannot be compared.

[527] An attempt has also been made to compare psychoanalysis with the ratiocinative method of Dubois,² which is an essentially rational procedure. But this comparison does not hold good, for the psychoanalyst strictly avoids reasoning and arguing with his patients. Naturally he has to listen to their conscious problems and conflicts and take note of them, but not for the purpose of fulfilling their desire to obtain advice or instruction with regard to the conduct of their lives. The problems of a neurotic cannot be solved by advice and conscious reasoning. I do not doubt that good advice at the right time can produce good results, but I do not know how anyone can believe that the psychoanalyst can always give the right advice at the right moment. The neurotic conflict is frequently, indeed usually, of such a nature that advice cannot possibly be given. Furthermore, it is well known that the patient only wants authoritative advice in order to shuffle off the burden of responsibility, referring himself and others to the opinion of a higher authority. So far as reasoning and persuasion are concerned, their effect as a method of therapy is as little to be doubted as that of hypnosis. What I would like to stress here is simply its difference in principle from psychoanalysis.

[528] In contradistinction to all previous methods, psychoanalysis endeavours to overcome the disorders of the neurotic psyche through the unconscious, and not from the conscious side. In this work we naturally have need of the patient's conscious contents, for only in this way can we reach the unconscious. The conscious content

from which our work starts is the material supplied by the anamnesis. In many cases the anamnesis provides useful clues which make the psychic origin of his symptoms clear to the patient. This, of course, is necessary only when he is convinced that his neurosis is organic in origin. But even in those cases where the patient is convinced from the start of the psychic nature of his illness, a critical survey of the anamnesis can be of advantage, for it discloses a psychological context of which he was unaware before. In this way problems that need special discussion are frequently brought to the surface. This work may occupy many sittings. Finally, the elucidation of the conscious material comes to an end when neither the analyst nor the patient can contribute anything further of decisive importance. In the most favourable cases the end comes with the formulation of the problem which, very often, proves insoluble.

[529] Let us take the case of a man who was once healthy but developed a neurosis between the ages of thirty-five and forty. His position in life was secure, and he had a wife and children. Parallel with his neurosis he developed an intense resistance to his professional work. He observed that the first symptoms of neurosis became noticeable when he had to overcome a particular difficulty in his career. Later they got worse with each successive difficulty that arose. Passing ameliorations occurred whenever fortune favoured him in his work. The problem that presented itself after a critical discussion of the anamnesis was as follows: the patient knew that he could improve his work and that the satisfaction resulting from this would bring about the much-desired improvement in his neurotic condition. But he was unable to do his work more efficiently because of his great resistance to it. This problem is rationally insoluble. Psychoanalytic treatment must therefore start at the critical point, his resistance to his work.

[530] Let us take another case. A woman of forty, mother of four children, became neurotic four years ago after the death of one of them. A new pregnancy, followed by the birth of another child, brought a great improvement in her condition. She now thought that if she could have yet another child she would be helped still further. She knew, however, that she could not have any more children, so she tried to devote her energies to philanthropic interests. But she failed to obtain the least satisfaction from this work. She noticed a distinct alleviation whenever she succeeded in giving real interest to something, however fleetingly, but she felt quite incapable of discovering anything that would bring her lasting interest and satisfaction. The rational insolubility of the problem is clear. Psychoanalytic work must begin with the question of what prevented the patient from developing any interest beyond her longing for a child.

[531] Since we cannot pretend that we know from the outset what the solution of such problems is, we have to rely on the clues furnished by the individuality of the patient. Neither conscious questioning nor rational advice can aid us in the discovery of these clues, for the obstacles which prevent us from finding them are hidden from the patient's consciousness. There is, therefore, no clearly prescribed way of getting at the unconscious obstacles. The only rule that psychoanalysis lays down in this respect is: let the patient talk about anything that comes into his head. The analyst must observe carefully what the patient says and, to begin with, simply take note of it without attempting to force his own opinions upon him. We notice, for instance, that the first-named patient began by talking about his marriage, which we had been told was normal. We now learn that he has difficulties with his wife and does not understand her in the least. This prompts the analyst to remark that evidently the patient's professional work is not his only problem, and that his relation to his wife also needs reviewing. This starts a train of associations all relating to the marriage. Then follow associations about the love-affairs he had before he was married. These experiences, recounted in detail, show that the patient was always rather peculiar in his more intimate relations with women, and that his peculiarity took the form of a childish egoism. This is a new and surprising point of view for him, and explains to him many of his misfortunes with women.

[532] We cannot in every case get as far as this on the principle of simply letting the patient talk; few patients have their psychic material so much on the surface. Furthermore, many patients have a real resistance against speaking freely about what occurs to them on the spur of the moment, some because it is too painful for them to tell it to an analyst whom they may not entirely trust, others because apparently nothing occurs to them and they force themselves to talk of things about which they are more or less indifferent. This trick of not talking to the point does not prove that the patient is *consciously* concealing certain painful contents; it can also occur quite unconsciously. In such cases it sometimes helps the patient to tell him that he need not force himself, but need only seize on the very first thoughts that come to him, no matter how unimportant or ridiculous they may seem. In certain cases even these instructions are of no use, and then the analyst has to resort to other measures. One of these is the association experiment, which usually gives apt information concerning the main tendencies of the patient at that moment.

[533] A second expedient is the analysis of dreams; this is the real instrument of psychoanalysis. We have already experienced so much opposition to dream analysis that a brief exposition of its principles may not be out of place. The interpretation of dreams, as well as the meaning given to them, is, as we know, in bad odour. It is not long since oneiromancy was practised and believed in; nor is the time long past when even the most enlightened persons were still under the spell of superstition. It is

therefore comprehensible that our age should still entertain a lively fear of superstitions that have been only partially overcome. This nervousness in regard to superstition is largely responsible for the opposition to dream-interpretation, but psychoanalysis is in no way to blame for this. We select the dream as an object not because we pay it the homage of superstitious admiration, but because it is a psychic product that is independent of consciousness. We ask for the patient's free associations, but he gives us little or nothing, or else something forced or irrelevant. A dream is a free association, a free fantasy, it is not forced, and is just as much a psychic phenomenon as an association.³

[534] I cannot disguise the fact that in practice, especially at the beginning of an analysis, we do not under all circumstances make complete and ideal analyses of the dreams. Usually we gather the dream-associations together until the problem which the patient is hiding from us becomes so clear that he can recognize it himself. This problem is then worked through consciously until it is cleared up as far as possible and we are once again confronted with an unanswerable question.

[535] You will now ask what is to be done when the patient does not dream at all. I can assure you that hitherto all patients, even those who claimed never to have dreamed before, began to dream when they went through analysis. On the other hand it frequently happens that patients who began by dreaming vividly are suddenly no longer able to remember their dreams. The empirical and practical rule which I have adopted is that the patient, if he does not dream, still has sufficient conscious material which he is keeping back for certain reasons. A common reason is: "I am in the analyst's hands and am quite willing to be treated by him. But the analyst must do the work, I shall remain passive in the matter." Sometimes there are resistances of a more serious nature. For instance, patients who cannot admit certain moral defects in themselves project them upon the analyst, calmly assuming that since he is more or less deficient morally they cannot communicate certain unpleasant things to him.

[536] If, then, a patient does not dream from the beginning or ceases to dream, he is keeping back material which would be capable of conscious elaboration. Here the relationship between analyst and patient may be considered one of the chief obstacles. It can prevent them both, the analyst as well as the patient, from seeing the situation clearly. We must not forget that as the analyst shows, and must show, a searching interest in the psychology of his patient, so the patient, if he has an active mind, feels his way into the psychology of the analyst and adopts a corresponding attitude towards him. The analyst is blind to the attitude of his patient to the exact extent that he does not see himself and his own unconscious problems. For this reason I maintain that a doctor must himself be analysed before he practises analysis. Otherwise analysis may easily be a great disappointment to him, because he can,

under certain circumstances, get absolutely stuck and then lose his head. He is then readily inclined to assume that psychoanalysis is nonsense, so as to avoid having to admit that he has run his vessel aground. If you are sure of your own psychology you can confidently tell your patient that he does not dream because there is conscious material still to be dealt with. I say you must be sure of yourself at such moments, for the criticisms and unsparing judgments to which you sometimes have to submit can be excessively disturbing to one who is unprepared to meet them. The immediate consequence of the analyst's losing his balance is that he begins to argue with his patient in order to maintain his influence over him. This, of course, renders all further analysis impossible.

[537] I have told you that, in the first instance, dreams need be used only as a source of material for analysis. At the beginning of an analysis it is not only unnecessary, but at times unwise, to give a so-called complete interpretation of a dream. A complete and really exhaustive interpretation is very difficult indeed. The interpretations you sometimes come across in the psychoanalytic literature are very often one-sided and, not infrequently, contestable formulations. I include among these the one-sided sexual reductions of the Viennese school. In view of the myriad-sidedness of the dream-material one must beware of all one-sided formulations. The many-sided meaning of a dream, rather than its singleness of meaning, is of the utmost value especially at the beginning of the treatment. Thus, a patient had the following dream not long after her treatment had begun. *She was in a hotel in a strange city. Suddenly a fire broke out. Her husband and her father, who were with her, helped her in the rescue work.*

[538] The patient was intelligent, extraordinarily sceptical, and absolutely convinced that dream-analysis was nonsense. I had the greatest difficulty in inducing her to give it even one trial. I selected the fire, the most conspicuous event in the dream, as the starting-point for associations. The patient informed me that she had recently read in the newspapers that a certain hotel in Zurich had been burnt down; that she remembered the hotel because she had once stayed there. At the hotel she had made the acquaintance of a man, and from this a somewhat questionable love-affair developed. In connection with this story the fact came out that she had already had quite a number of similar adventures, all of them decidedly frivolous. This important bit of past history was brought out by the very first association. In her case it would have been pointless to make clear to her the very obvious meaning of the dream. With her frivolous attitude, of which her scepticism was only a special instance, she would have coldly repelled such an attempt. But after the frivolity of her attitude had been recognized and demonstrated to her from the material she herself had furnished, it was possible to analyse the dreams which followed much more thoroughly.

[539] It is, therefore, advisable in the beginning to use dreams for getting at the critical material through their associations. This is the best and most cautious procedure, especially for the beginner in psychoanalysis. An arbitrary translation of the dreams is exceedingly inadvisable. That would be a superstitious practice based on the assumption that dreams have well-established symbolic meanings. But there are no fixed symbolic meanings. There are certain symbols that recur frequently, but we are not in a position to get beyond very general statements. For instance, it is quite incorrect to assume that a snake, when it appears in dreams, always has a merely phallic meaning; just as incorrect as it is to deny that it may have a phallic meaning in some cases. Every symbol has at least two meanings. The very frequent sexual meaning of dream-symbols is at most one of them. I cannot, therefore, accept the exclusively sexual interpretations which appear in certain psychoanalytic publications, as little as I can accept the interpretation of dreams as wish-fulfilments, for my experience has led me to regard these formulations as one-sided and inadequate. As an example I will tell you a very simple dream of a young man, a patient of mine. It was as follows: *I was going up a flight of stairs with my mother and sister. When we reached the top I was told that my sister was going to have a baby.*

[540] First I will show how, in accordance with the hitherto prevailing point of view, this dream may be translated sexually. We know that incest fantasies play a prominent role in the life of a neurotic, hence the image “with my mother and sister” could be understood as a hint in this direction. “Stairs” are alleged to have a well-established sexual meaning: they represent the sexual act because of the rhythmic climbing. The baby the sister is expecting is nothing but the logical consequence of these premises. Thus translated, the dream would be a clear fulfilment of so-called infantile wishes, which, as you know, are an important part of Freud’s dream-theory.

[541] I have analysed this dream on the basis of the following reasoning. If I say that stairs are a *symbol* for the sexual act, by what right do I take the mother and sister and baby as *real*, that is, not symbolically? If, on the strength of the assertion that dream-images are symbolic, I assign a symbolic value to certain of these images, what right have I to exempt certain others? If I attach a symbolic value to the ascent of the stairs, I must also attach a symbolic value to the images called mother, sister, and baby. I therefore did not “translate” the dream but really analysed it. The result was surprising. I will give you the patient’s associations to the individual dream-images word for word, so that you can form your own opinion of the material. I should say in advance that the young man had finished his studies at the university a few months previously, that he had found the choice of a profession too difficult to make, and that he there upon became neurotic. In consequence of this he gave up his work. His neurosis took, among other things, a manifestly homosexual form.

[542] His associations to *mother* were as follows: “I have not seen her for a long time, a very long time. I must really reproach myself for this, it is wrong of me to neglect her so.”

[543] *Mother*, then, stands for something that is neglected in an irresponsible manner. I asked the patient: “What is that?” and he replied, with considerable embarrassment: “My work.”

[544] Associations to *sister*: “It is years since I have seen her. I long to see her again. Whenever I think of her I always remember the moment I said good-bye. I kissed her with real affection, and at that moment I understood for the first time what love for a woman can mean.” It was at once clear to the patient that “sister” stood for “love for a woman.”

[545] Associations to *stairs*: “Climbing up—getting to the top—making a career—growing up, becoming great.”

[546] Associations to *baby*: “Newborn—renewal—rebirth—becoming a new man.”

[547] One has only to hear this material to understand at once that the dream represents not so much the fulfilment of infantile wishes as the fulfilment of biological duties which the patient has neglected because of his neurotic infantilism. Biological justice, which is inexorable, often compels us to make up in dreams for the duties we have neglected in real life.

[548] This dream is a typical example of the prospective and finally-oriented function of dreams in general, especially stressed by my colleague Maeder. If we adhered to a one-sided sexual interpretation the real meaning of the dream would escape us. Sexuality in dreams is, in the first instance, a means of expression and by no means always the meaning and aim of the dream. The discovery of its prospective or final meaning is particularly important when the analysis is so far advanced that the eyes of the patient are turned more readily to the future than to his inner world and the past.

[549] As regards the handling of the symbolism, we learn from this example that there can be no dream-symbols whose meanings are fixed in every detail, but, at most, a frequent occurrence of symbols with fairly general meanings. So far as the specifically sexual meaning of dreams is concerned, experience has led me to lay down the following practical rules:

[550] If dream-analysis at the beginning of the treatment shows that the dreams have an undoubtedly sexual meaning, this meaning is to be taken realistically; that is, it proves that the sexual problems of the patient need to be subjected to a careful review. For instance, if an incest fantasy is clearly shown to be a latent content of the dream, one must subject the patient’s infantile relations with his parents and brothers

and sisters, as well as his relations with other persons who are fitted to play the role of father or mother, to a thorough investigation. But if a dream that comes at a later stage of the analysis has, let us say, an incest fantasy as its essential content—a fantasy that we have reason to consider disposed of—concrete value should not under all circumstances be attached to it; it should be regarded as symbolic. The formula for interpretation is: the unknown meaning of the dream is expressed, by analogy, through a fantasy of incest. In this case symbolic and not real value must be attached to the sexual fantasy. If we did not get beyond the real value we should keep reducing the patient to sexuality, and this would arrest the progress of the development of his personality. The patient's salvation does not lie in thrusting him back again and again into primitive sexuality; this would leave him on a low cultural level whence he could never obtain freedom and complete restoration to health. Retrogression to a state of barbarism is no advantage at all for a civilized human being.

[551] The above-mentioned formula, according to which the sexuality of a dream is a symbolic or analogical expression of its meaning, naturally applies also to dreams occurring at the beginning of an analysis. But the practical reasons that have impelled us not to take the symbolic value of these sexual fantasies into consideration arise from the fact that a genuine realistic value must be attached to the abnormal sexual fantasies of a neurotic in so far as he allows his actions to be influenced by them. The fantasies not only hinder him in adapting better to his situation, they also lead him to all manner of real sexual acts, and occasionally even to incest, as experience shows. Under these circumstances, it would be of little use to consider the symbolic content only; the concrete aspect must be first dealt with.

[552] These statements are based, as you will have observed, on a different conception of the dream from that put forward by Freud. Indeed, experience has forced a different conception upon me. For Freud, the dream is essentially a symbolic disguise for repressed wishes which would come into conflict with the aims of the personality. I am obliged to regard the structure of a dream from a different point of view. For me the dream is, in the first instance, a subliminal picture of the actual psychological situation of the individual in his waking state. It gives us a résumé of the subliminal associative material constellated by the psychological situation of the moment. The volitional content of the dream, which Freud calls the repressed wish, is for me essentially a means of expression.

[553] The activity of consciousness represents, biologically speaking, the individual's struggle for psychological adaptation. Consciousness tries to adjust itself to the necessities of the moment, or, to put it differently: there are tasks ahead which the individual must overcome. In many cases the solution is, in the nature of things, unknown, for which reason consciousness always tries to find the solution by way of

analogous experiences. We try to grasp the unknown future on the model of our experience in the past. We have no reason to suppose that the subliminal psychic material obeys other laws than the “supraliminal” material. The unconscious, like the conscious, mobilizes itself round the biological tasks and seeks solutions on the analogy of what has gone before, just as consciousness does. Whenever we wish to assimilate something unknown, we do so by means of analogy. A simple example of this is the well-known fact that when America was discovered by the Spaniards the Indians took the horses of the conquerors, which were unknown to them, for large pigs, because only pigs were familiar in their experience. This is the way we always recognize things, and it is also the essential reason for the existence of symbolism: it is a process of comprehension by means of analogy. The dream is a *subliminal* process of comprehension by analogy. The apparently repressed wishes are volitional tendencies which supply the unconscious dream-thought with a verbal means of expression. On this particular point I find myself in entire agreement with the views of Adler, another pupil of Freud’s. As to the fact that the unconscious expresses itself by means of volitional elements or tendencies, this is due to the archaic nature of dream-thinking, a problem I have discussed elsewhere.⁴

[554] Owing to our different conception of the structure of dreams, the further course of analysis assumes a rather different aspect. The symbolic evaluation of sexual fantasies in the later stages necessarily leads, not to a reduction of the personality to primitive tendencies, but to a broadening and continuous development of the patient’s attitude; that is, it tends to make his thinking richer and deeper, thus giving him what has always been one of man’s most powerful weapons in the struggle for adaptation. By following this new course consistently, I have come to the realization that the religious and philosophical driving forces—what Schopenhauer calls the “metaphysical need” of man—must receive positive consideration during the analytical work. They must not be destroyed by reducing them to their primitive sexual roots, but made to serve biological ends as psychologically valuable factors. In this way these driving forces assume once more the function that has been theirs from time immemorial.

[555] Just as primitive man was able, with the help of religious and philosophical symbols, to free himself from his original condition, so too the neurotic can free himself from his illness. It is hardly necessary for me to remark that I do not mean inoculating him with belief in a religious or philosophical dogma; I mean simply that there must be built up in him that same psychological attitude which was characterized by the living belief in a religious or philosophical dogma on earlier levels of culture. A religious or philosophical attitude is not the same thing as belief in a dogma. A dogma is a temporary intellectual formulation, the outcome of a religious and philosophical attitude conditioned by time and circumstances. But the

attitude itself is a cultural achievement; it is a function that is exceedingly valuable from a biological point of view, for it gives rise to incentives that drive human beings to do creative work for the benefit of a future age and, if necessary, to sacrifice themselves for the welfare of the species.

[556] Thus man attains the same sense of unity and wholeness, the same confidence, the same capacity for self-sacrifice in his conscious existence that belong unconsciously and instinctively to wild animals. Every reduction, every digression from the path that has been laid down for the development of civilization, does nothing more than turn the human being into a crippled animal; it never makes a so-called natural man of him. I have had numerous successes and failures in the course of my analytical practice which have convinced me of the inexorable rightness of this kind of psychological orientation. We do not help the neurotic by relieving him of the demands made by civilization; we can help him only by inducing him to take an active part in the strenuous work of carrying on its development. The suffering he undergoes in performing this service takes the place of his neurosis. But whereas the neurosis and the troubles that attend it are never followed by the pleasant feeling of good work well done, of duty fearlessly performed, the suffering that comes from useful work and from victory over real difficulties brings with it those moments of peace and satisfaction which give the human being the priceless feeling that he has really lived his life.

PSYCHOANALYSIS AND NEUROSIS¹

[557] After many years' experience I now know that it is extremely difficult to discuss psychoanalysis at public meetings and at congresses. There are so many misconceptions of the matter, so many prejudices against certain psychoanalytic views, that it is an almost impossible task to reach mutual understanding in a public discussion. I have always found a quiet conversation on the subject much more useful and fruitful than heated arguments *coram publico*. However, having been honoured by an invitation from the Committee of this Congress to speak as a representative of the psychoanalytic movement, I will do my best to discuss some of the fundamental theoretical problems of psychoanalysis. I must limit myself to this aspect of the subject because I am quite unable to put before my audience all that psychoanalysis means and strives for, and its various applications in the fields of mythology, comparative religion, philosophy, etc. But if I am to discuss certain theoretical problems fundamental to psychoanalysis, I must presuppose that my audience is familiar with the development and the main results of psychoanalytic research. Unfortunately, it often happens that people think themselves entitled to judge psychoanalysis who have not even read the literature. It is my firm conviction that no one is competent to form an opinion on this matter until he has studied the basic writings of the psychoanalytic school.

[558] In spite of the fact that Freud's theory of neurosis has been worked out in great detail, it cannot be said to be, on the whole, very clear or easy to understand. This justifies my giving you a short abstract of his fundamental views on the theory of neurosis.

[559] You are aware that the original theory that hysteria and the related neuroses have their origin in a trauma or sexual shock in early childhood was given up about fifteen years ago. It soon became evident that the sexual trauma could not be the real cause of the neurosis, for the simple reason that the trauma was found to be almost universal. There is scarcely a human being who has not had some sexual shock in early youth, and yet comparatively few develop a neurosis in later life. Freud himself soon realized that many of the patients who related an early traumatic experience had only invented the story of the so-called trauma; it had never occurred in reality, but was a mere creation of fantasy. Moreover, on further investigation it became quite obvious that even if a trauma had actually occurred it was not always responsible for the whole of the neurosis, although it does sometimes look as if the structure of the neurosis depended entirely on the trauma. If a neurosis were the inevitable

consequence of the trauma it would be quite incomprehensible why neurotics are not incomparably more numerous than they are.

[560] The apparently heightened effect of the shock was clearly due to the exaggerated and morbid fantasy of the patient. Freud also saw that this same fantasy activity manifested itself relatively early in bad habits, which he called infantile perversions. His new conception of the aetiology of neurosis was based on this insight, and he traced the neurosis back to some sexual activity in early infancy. This conception led to his recent view that the neurotic is “fixated” to a certain period of his early infancy, because he seems to preserve some trace of it, direct or indirect, in his mental attitude. Freud also makes the attempt to classify or to differentiate the neuroses, as well as dementia praecox, according to the stage of infantile development in which the fixation took place. From the standpoint of this theory, the neurotic appears to be entirely dependent on his infantile past, and all his troubles in later life, his moral conflicts and his deficiencies, seem to be derived from the powerful influences of that period. Accordingly, the main task of the treatment is to resolve this infantile fixation, which is conceived as an unconscious attachment of the sexual libido to certain infantile fantasies and habits.

[561] This, so far as I can see, is the essence of Freud’s theory of neurosis. But it overlooks the following important question: What is the cause of this fixation of libido to the old infantile fantasies and habits? We have to remember that almost everyone has at some time had infantile fantasies and habits exactly corresponding to those of a neurotic, yet he does not become fixated to them; consequently, he does not become neurotic later on. The aetiological secret of the neurosis, therefore, does not lie in the mere *existence* of infantile fantasies but in the so-called *fixation*. The numerous statements of neurotics affirming the existence of infantile sexual fantasies are worthless in so far as they attribute an aetiological significance to them, for the same fantasies can be found in normal individuals as well, a fact which I have often proved. It is only the fixation which seems to be characteristic.

[562] It is therefore necessary to demand proof of the reality of this infantile fixation. Freud, an absolutely sincere and painstaking empiricist, would never have evolved this hypothesis had he not had sufficient grounds for it. These grounds are furnished by the results of psychoanalytic investigations of the unconscious. Psychoanalysis reveals the unconscious presence of numerous fantasies which have their roots in the infantile past and are grouped round the so-called “nuclear complex,” which in men may be designated as the Oedipus complex, in women as the Electra complex. These terms convey their own meaning exactly. The whole tragic fate of Oedipus and Electra was acted out within the narrow confines of the family, just as a child’s fate lies wholly within the family boundaries. Hence the Oedipus complex, like the

Electra complex, is very characteristic of an infantile conflict. The existence of these conflicts in infancy has been proved by means of psychoanalytic research. It is in the realm of this complex that the fixation is supposed to have taken place. The extremely potent and effective existence of the nuclear complex in the unconscious of neurotics led Freud to the hypothesis that the neurotic has a peculiar fixation or attachment to it. Not the mere existence of this complex—for everybody has it in the unconscious—but the very strong attachment to it is what is typical of the neurotic. He is far more influenced by this complex than the normal person; many examples in confirmation of this can be found in every one of the recent psychoanalytic histories of neurotic cases.

[563] We must admit that this view is a very plausible one, because the hypothesis of fixation is based on the well-known fact that certain periods of human life, and particularly infancy, do sometimes leave determining traces behind them which are permanent. The only question is whether this is a sufficient explanation or not. If we examine persons who have been neurotic from infancy it seems to be confirmed, for we see the nuclear complex as a permanent and powerful agent throughout life. But if we take cases which never show any noticeable trace of neurosis except at the particular time when they break down, and there are many such, this explanation becomes doubtful. If there is such a thing as fixation, it is not permissible to erect upon it a new hypothesis, claiming that at times during certain periods of life the fixation becomes loosened and ineffective, while at others it suddenly becomes strengthened. In these cases we find that the nuclear complex is as active and potent as in those which apparently support the theory of fixation. Here a critical attitude is justifiable, especially when we consider the oft-repeated observation that the moment of the outbreak of neurosis is not just a matter of chance; as a rule it is most critical. It is usually *the moment when a new psychological adjustment, that is, a new adaptation, is demanded*. Such moments facilitate the outbreak of a neurosis, as every experienced neurologist knows.

[564] This fact seems to me extremely significant. If the fixation were indeed real we should expect to find its influence constant; in other words, a neurosis lasting throughout life. This is obviously not the case. The psychological determination of a neurosis is only partly due to an early infantile predisposition; it must be due to some cause in the present as well. And if we carefully examine the kind of infantile fantasies and occurrences to which the neurotic is attached, we shall be obliged to agree that there is nothing in them that is specifically neurotic. Normal individuals have pretty much the same inner and outer experiences, and may be attached to them to an astonishing degree without developing a neurosis. Primitive people, especially, are very much bound to their infantility. It now begins to look as if this so-called fixation were a normal phenomenon, and that the importance of infancy for the later

mental attitude is natural and prevails everywhere. The fact that the neurotic seems to be markedly influenced by his infantile conflicts shows that it is less a matter of fixation than of the peculiar use which he makes of his infantile past. It looks as if he exaggerated its importance and attributed to it a wholly artificial value. Adler, a pupil of Freud's, expresses a very similar view.

[565] It would be unjust to say that Freud limited himself to the hypothesis of fixation; he was also aware of the problem I have just discussed. He called this phenomenon of reactivation or secondary exaggeration of infantile reminiscences "regression." But in Freud's view it appears as if the incestuous desires of the Oedipus complex were the real cause of the regression to infantile fantasies. If this were the case, we should have to postulate an unexpected intensity of the primary incestuous tendencies. This view led Freud to his recent comparison between what he calls the psychological "incest barrier" in children and the "incest taboo" in primitive man. He supposes that a desire for real incest led primitive man to frame laws against it; while to me it looks as if the incest taboo were only one among numerous taboos of all kinds, and were due to the typical superstitious fear of primitive man—a fear existing independently of incest and its prohibition. I am able to attribute as little strength to incestuous desires in childhood as in primitive humanity. I do not even seek the reason for regression in primary incestuous or any other sexual desires. I must admit that a purely sexual aetiology of neurosis seems to me much too narrow. I base this criticism not on any prejudice against sexuality but on an intimate acquaintance with the whole problem.

[566] I therefore suggest that psychoanalytic theory should be freed from the purely sexual standpoint. In place of it I should like to introduce an *energetic viewpoint* into the psychology of neurosis.

[567] All psychological phenomena can be considered as manifestations of energy, in the same way that all physical phenomena have been understood as energetic manifestations ever since Robert Mayer discovered the law of the conservation of energy. Subjectively and psychologically, this energy is conceived as *desire*. I call it *libido*, using the word in its original sense, which is by no means only sexual. Sallust uses it exactly as we do here when he says: "They took more pleasure in handsome arms and war horses than in harlots and revelry."²

[568] From a broader standpoint libido can be understood as vital energy in general, or as Bergson's *élan vital*. The first manifestation of this energy in the infant is the nutritive instinct. From this stage the libido slowly develops through numerous variants of the act of sucking into the sexual function. Hence I do not consider the act of sucking a sexual act. The pleasure in sucking can certainly not be considered as sexual pleasure, but as pleasure in nutrition, for it is nowhere proved that pleasure is

sexual in itself. This process of development is continued into adult life and is accompanied by constantly increasing adaptation to the external world. Whenever the libido, in the process of adaptation, meets an obstacle, an accumulation takes place which normally gives rise to an increased effort to overcome the obstacle. But if the obstacle seems to be insurmountable, and the individual abandons the task of overcoming it, the stored-up libido makes a regression. Instead of being employed for an increased effort, the libido gives up its present task and reverts to an earlier and more primitive mode of adaptation.

[569] The best examples of such regressions are found in hysterical cases where a disappointment in love or marriage has precipitated a neurosis. There we find those well-known digestive disorders, loss of appetite, dyspeptic symptoms of all sorts, etc. In these cases the regressive libido, turning back from the task of adaptation, gains power over the nutritive function and produces marked disturbances. Similar effects can be observed in cases where there is no disturbance of the nutritive function but, instead, a regressive revival of reminiscences from the distant past. We then find a reactivation of the parental imagos, of the Oedipus complex. Here the events of early infancy—never before important—suddenly become so. They have been regressively reactivated. Remove the obstacle from the path of life and this whole system of infantile fantasies at once breaks down and becomes as inactive and ineffective as before. But let us not forget that, to a certain extent, it is at work all the time, influencing us in unseen ways. This view, incidentally, comes very close to Janet's hypothesis that the "parties supérieures" of a function are replaced by its "parties inférieures." I would also remind you of Claparède's conception of neurotic symptoms as emotional reflexes of a primitive nature.

[570] For these reasons I no longer seek the cause of a neurosis in the past, but in the present. I ask, what is the necessary task which the patient will not accomplish? The long list of his infantile fantasies does not give me any sufficient aetiological explanation, because I know that these fantasies are only puffed up by the regressive libido, which has not found its natural outlet in a new form of adaptation to the demands of life.

[571] You may ask why the neurotic has a special tendency not to accomplish his necessary tasks. Here let me point out that no living creature adjusts itself easily and smoothly to new conditions. The law of inertia is valid everywhere.

[572] A sensitive and somewhat unbalanced person, as a neurotic always is, will meet with special difficulties and perhaps with more unusual tasks in life than a normal individual, who as a rule has only to follow the well-worn path of an ordinary existence. For the neurotic there is no established way of life, because his aims and tasks are apt to be of a highly individual character. He tries to go the more or less

uncontrolled and half-conscious way of normal people, not realizing that his own critical and very different nature demands of him more effort than the normal person is required to exert. There are neurotics who have shown their heightened sensitiveness and their resistance to adaptation in the very first weeks of life, in the difficulty they have in taking the mother's breast and in their exaggerated nervous reactions, etc. For this peculiarity in the neurotic predisposition it will always be impossible to find a psychological aetiology, because it is anterior to all psychology. This predisposition—you can call it “congenital sensitiveness” or what you like—is the cause of the first resistances to adaptation. As the way to adaptation is blocked, the biological energy we call libido does not find its appropriate outlet or activity, with the result that a suitable form of adaptation is replaced by an abnormal or primitive one.

[573] In neurosis we speak of an infantile attitude or of the predominance of infantile fantasies and wishes. In so far as infantile impressions are of obvious importance in normal people they will be equally influential in neurosis, but they have no aetiological significance; they are reactions merely, being chiefly secondary and regressive phenomena. It is perfectly true, as Freud says, that infantile fantasies determine the form and the subsequent development of neurosis, but this is not an aetiology. Even when we find perverted sexual fantasies whose existence can be demonstrated in childhood, we cannot consider them of aetiological significance. A neurosis is not really caused by infantile sexual fantasies, and the same must be said of the sexualism of neurotic fantasy in general. It is not a primary phenomenon based on a perverted sexual disposition, but merely secondary and a consequence of the failure to apply the stored-up libido in a suitable way. I realize that this is a very old view, but this does not prevent it from being true. The fact that the patient himself very often believes that his infantile fantasies are the real cause of his neurosis does not prove that he is right in his belief, or that a theory based on this belief is right either. It may look as if it were so, and I must admit that very many cases do have that appearance. At all events, it is perfectly easy to understand how Freud arrived at this view. Everyone who has any psychoanalytic experience will agree with me here.

[574] To sum up: I cannot see the real aetiology of neurosis in the various manifestations of infantile sexual development and the fantasies to which they give rise. The fact that these fantasies are exaggerated in neurosis and occupy the foreground is a consequence of the stored-up energy or libido. The psychological trouble in neurosis, and the neurosis itself, can be formulated as *an act of adaptation that has failed*. This formulation might reconcile certain views of Janet's with Freud's view that a neurosis is, in a sense, an attempt at self-cure—a view which can be and has been applied to many other illnesses.

[575] Here the question arises as to whether it is still advisable to bring to light all the patient's fantasies by analysis, if we now consider them of no aetiological significance. Hitherto psychoanalysis has set about unravelling these fantasies because they were considered aetiologically important. My altered view of the theory of neurosis does not affect the psychoanalytic procedure. The technique remains the same. Though we no longer imagine we are unearthing the ultimate root of the illness, we have to pull up the sexual fantasies because the energy which the patient needs for his health, that is, for adaptation, is attached to them. By means of psychoanalysis the connection between his conscious mind and the libido in the unconscious is re-established. Thus the unconscious libido is brought under the control of the will. Only in this way can the split-off energy become available again for the accomplishment of the necessary tasks of life. Considered from this standpoint, psychoanalysis no longer appears as a mere reduction of the individual to his primitive sexual wishes, but, if rightly understood, as a highly moral task of immense educational value.

SOME CRUCIAL POINTS IN PSYCHOANALYSIS

A CORRESPONDENCE BETWEEN DR. JUNG AND DR. LOÿ¹

Foreword

A few words may suffice to explain the reasons which led to this correspondence, and the purpose in publishing it.

After being introduced to the theory and practice of suggestion therapy by Professor Forel, I practised it for many years and still use it in suitable cases. When I became aware of the great significance of Freud's psychoanalytic works, I studied them and gradually began to take up analysis myself. I made contact with the nearest centre of psychoanalytic research, which was Zurich. Yet in technical matters I had, in the main, to rely on myself. Hence, when I met with failures, I had to ask myself who or what was to blame, I alone, because I did not know how to apply the "correct psychoanalytic method," or perhaps the method itself, which might not be suitable in all cases. A special stumbling-block for me was the interpretation of dreams: I could not convince myself that there was a generally valid symbolism, and that this symbolism was exclusively sexual, as many psychoanalysts declared. Their interpretations often seemed to me to bear the stamp of arbitrariness.

And so, when I read the following statement by Freud in the *Zentralblatt für Psychoanalyse*, in June 1912, the words seemed to come from my own heart: "Some years ago I gave as an answer to the question of how one can become an analyst: 'By analysing one's own dreams.' This preparation is no doubt enough for many people, but not for everyone who wishes to learn analysis. Nor can everyone succeed in interpreting his own dreams without outside help. I count it as one of the many merits of the Zurich school of analysis that they have laid increased emphasis on this requirement, and have embodied it in the demand that everyone who wishes to carry out analyses on other people shall first himself undergo an analysis by someone with expert knowledge. Anyone who takes up the work seriously should choose this course, which offers more than one advantage; the sacrifice involved in laying oneself open to another person without being driven to it by illness is amply rewarded. Not only is one's aim of learning to know what is hidden in one's own mind far more rapidly attained and with less expense of affect, but impressions and convictions will be gained in relation to oneself which will be sought in vain from studying books and attending lectures."²

Dr. Jung declared himself ready to undertake my analysis. A great obstacle arose, however: the distance between us. Thus, many questions which had come up in the analytical interviews and could not be discussed sufficiently thoroughly were settled by correspondence.

When the correspondence reached its present proportions I asked myself whether other colleagues might not find it as stimulating as I had done: psychoanalysts who were just beginning and who needed a guiding thread through the mounting tangle of psychoanalytic literature, practising physicians who perhaps knew of psychoanalysis only through the violent attacks it has had to endure (often from quite unqualified persons who have no experience of it).

I could only answer this question in the affirmative. I asked Dr. Jung to give his consent to my publishing the correspondence, which he readily did.

I do not doubt that the reader will, like me, give him the thanks that are his due; for a more concise and easily understandable account of the psychoanalytic method and of some of the problems it raises does not, to my knowledge, exist.

DR. R. LOÿ

Sanatorium L'Abri, Montreux-Territet,

14 December 1913

From Dr. Loÿ

12 January 1913

[576] What you said at our last interview was extraordinarily stimulating. I was expecting you to throw light on the interpretation of my own and my patients' dreams from the standpoint of Freud's dream interpretation. Instead, you put before me an entirely new conception: the dream as a means, produced by the subconscious, of restoring the moral balance. That is certainly a fruitful thought. But still more fruitful, it seems to me, is your other suggestion. You conceive the tasks of psychoanalysis to be much deeper than I had ever imagined: it is no longer a question of getting rid of troublesome pathological symptoms, but of the analysand learning to know himself completely—not just his anxiety experiences—and on the basis of this knowledge building up and shaping his life anew. But he himself must be the builder; the analyst only furnishes him with the necessary tools.

[577] To begin with, I would ask you to consider what justification there is for the original procedure of Breuer and Freud, now entirely given up both by Freud himself and by you, but practised by Frank, for instance, as his only method: the "abreaction of inhibited affects under light hypnosis." Why did you give up the cathartic method?

Please explain. More particularly, has light hypnosis in psychocatharsis a different value from suggestion during sleep, long practised in suggestion therapy? That is, has it only the value which the doctor attributes, or says he attributes to it, the value which the patient's faith gives it? In other words, is suggestion in the waking state equivalent to suggestion in the hypnoid state, as Bernheim now asserts, after having used suggestion for many years in hypnosis? You will tell me that we must talk of psychoanalysis, not of suggestion. What I really mean is this: is not the *suggestion* that psychocatharsis in the hypnoid state will produce a therapeutic effect (with limitations, naturally, the age of the patient, etc.) the main factor in the therapeutic effects of psychocatharsis? Frank says in his *Affektstörungen*: "These one-sided attitudes, suggestibility and suggestion, are almost entirely in abeyance in psychocatharsis under light sleep, so far as the content of the ideas reproduced is concerned."³ Is that really true? Frank himself adds: "How can ruminating on the dreams of youth *in itself* lead to discharge of the stored-up anxiety, whether in the hypnoid state or any other? Must we not rather suppose that ruminating on them would make the anxiety states even greater?" (I have noticed this myself, far more than I liked.) Of course one says to the patient, "First we must stir up, then afterwards comes peace." And it does come. But does it not come *in spite of the stirring-up process*, because gradually, by means of frequent talks *apart from* light hypnosis, the patient gains such confidence in the analyst that he becomes susceptible to the direct suggestion that an improvement and then a cure will follow? I go still further: in an analysis in the waking state, is not the patient's faith that the method employed will cure him, coupled with his growing confidence in the analyst, a main cause of his cure? And I go still further: in every therapeutic method systematically carried out is not faith in it, confidence in the doctor, a main cause of its success? I won't say the only cause, for one cannot deny that physical, dietetic, and chemical procedures, when properly selected, have their own effect in bringing about a cure, over and above the striking effects produced by indirect suggestion.

From Dr. Jung

28 January 1913

[578] With regard to your question concerning the applicability of the cathartic procedure, I can say that I adopt the following standpoint: every procedure is good if it helps. I therefore acknowledge every method of suggestion including Christian Science, mental healing, etc. "A truth is a truth, when it works." It is another question, though, whether a scientifically trained doctor can square it with his conscience to sell little bottles of Lourdes water because this suggestion is at times very helpful. Even the so-called highly scientific suggestion therapy employs the

wares of the medicine-man and the exorcising shaman. And why not? The public is not much more advanced either and continues to expect miraculous cures from the doctor. And indeed, we must rate those doctors wise—worldly-wise in every sense—who know how to surround themselves with the aura of a medicine-man. They have not only the biggest practices but also get the best results. This is because, apart from the neuroses, countless physical illnesses are tainted and complicated with psychic material to an unsuspected degree. The medical exorcist betrays by his whole demeanour his full appreciation of that psychic component when he gives the patient the opportunity of fixing his faith firmly on the mysterious personality of the doctor. In this way he wins the sick man's mind, which from then on helps him to restore his body to health. The cure works best when the doctor himself believes in his own formulae, otherwise he may be overcome by scientific doubt and so lose the proper convincing tone. I myself practised hypnotic suggestion-therapy for a time with enthusiasm. But then there befell me three dubious incidents which I would like to bring to your attention.

[579] One day a withered old peasant woman of about 56 came to me to be hypnotized for various neurotic troubles. She was not easy to hypnotize, was very restless, and kept opening her eyes—but at last I did succeed. When I woke her up again after about half an hour she seized my hand and with many words testified to her overflowing gratitude. I told her, “You are by no means cured yet, so keep your thanks till the end of the treatment.” “I'm not thanking you for that,” she whispered, blushing, “but because you were so *decent*.” She looked at me with a sort of tender admiration and departed. I gazed for a long time at the spot where she had stood. So decent? I asked myself, flabbergasted—good heavens, surely she hadn't imagined ... ? This glimpse made me suspect for the first time that possibly the old reprobate, with the atrocious directness of feminine (at the time I called it “animal”) instinct, understood more about the essence of hypnosis than I did with all my knowledge of the scientific profundity of the text-books. My innocence was gone.

[580] Next came a pretty, coquettish, seventeen-year-old girl with a very harassed-looking mama. She had suffered since early childhood from *enuresis nocturna* (which she used, among other things, to stop herself being sent to a finishing school in Italy). At once I thought of the old woman and her wisdom. I tried to hypnotize the girl; she went into fits of laughter and held up the hypnosis for twenty minutes. I kept my temper and thought: I know why you laugh, you have already fallen in love with me, but I will give you proof of my decency as a reward for wasting my time with your provocative laughter. At last I put her under. The effect was immediate. The enuresis stopped, and I thereupon informed the young lady that, instead of Wednesday, I would not see her again for hypnosis till the following Saturday. On Saturday she arrived with a cross face, boding disaster. The enuresis had come back

again. I thought of my wise old woman and asked, "When did it come back?" She (unsuspecting): "Wednesday night." I thought to myself: There we have it, she wants to prove to me that I absolutely must see her on Wednesdays too; not to see me for a whole long week is too much for a tender loving heart. But I did not intend to pander to this annoying romance, so I said, "It would be quite wrong to continue the treatment under these circumstances. We must drop it altogether for three weeks, to give the enuresis a chance to stop. Then come again for treatment." In my malicious heart I knew that I would be away on holiday and the course for hypnotic treatment would be finished. After the holiday my *locum tenens* told me that the young lady had been there with the news that the enuresis had vanished, but her disappointment at not seeing me was very keen. The old woman was right, I thought.

[581] The third case gave my joy in suggestion therapy its deathblow. This case really was the limit. A 65-year-old lady came hobbling into the consulting-room on a crutch. She had suffered from pain in the knee-joint for seventeen years, and this at times kept her chained to her bed for many weeks. No doctor had been able to cure her, and she had run through all the cures of present-day medicine. After letting the stream of her narrative pour over me for ten minutes, I said, "I will try to hypnotize you, perhaps that will do you good." "Oh yes, please do!" she said, then leaned her head to one side and fell asleep before ever I said or did a thing. She passed into somnambulism and showed every form of hypnosis you could possibly desire. After half an hour I had the greatest difficulty in waking her; when at last she was awake she jumped up: "I am well, I am all right, you have cured me!" I tried to raise timid objections, but her praises drowned me. She could really walk. I blushed, and said embarrassed to my colleagues: "Behold the marvels of hypnotic therapy!" That day saw the death of my connection with therapy by suggestion; the notoriety aroused by this case shamed and depressed me. When, a year later, the good old lady returned, this time with a pain in her back, I was already sunk in hopeless cynicism; I saw written on her brow that she had just read in the paper the notice of the reopening of my course on hypnotism. That tiresome romanticism had provided her with a convenient pain in the back so that she might have a pretext for seeing me, and again let herself be cured in the same spectacular fashion. This proved true in every particular.

[582] As you will understand, a man possessed of a scientific conscience cannot digest such cases with impunity. I was resolved to abandon suggestion altogether rather than allow myself to be passively transformed into a miracle-worker. I wanted to understand what really goes on in people's minds. It suddenly seemed to me incredibly childish to think of dispelling an illness with magical incantations, and that this should be the sole result of our efforts to create a psychotherapy. Thus the discovery of Breuer and Freud came as a veritable life-saver. I took up their method

with unalloyed enthusiasm and soon recognized how right Freud was when, at a very early date, indeed as far back as *Studies on Hysteria*, he began to direct a searchlight on the circumstances of the so-called trauma. I soon discovered that, though traumata of clearly aetiological significance were occasionally present, the majority of them appeared very improbable. Many traumata were so unimportant, even so normal, that they could be regarded at most as a pretext for the neurosis. But what especially aroused my criticism was the fact that not a few traumata were simply inventions of fantasy and had never happened at all. This realization was enough to make me sceptical about the whole trauma theory. (I have discussed these matters in detail in my lectures on the theory of psychoanalysis.) I could no longer imagine that repeated experiences of a fantastically exaggerated or entirely fictitious trauma had a different therapeutic value from a suggestion procedure. It is good if it helps. If only one did not have a scientific conscience and that hankering after the truth! I recognized in many cases, particularly with intelligent patients, the therapeutic limitations of this method. It is merely a rule of thumb, convenient for the analyst because it makes no particular demands on his intellect or his capacity to adapt. The theory and practice are delightfully simple: "The neurosis comes from a trauma. The trauma is abreacted." If the abreacting takes place under hypnosis or with other magical accessories (dark room, special lighting, etc.), I think at once of my clever old woman, who opened my eyes not only to the magical influence of the mesmeric passes but to the nature of hypnosis itself.

[583] What alienated me once and for all from this comparatively effective, indirect method of suggestion, based as it is on an equally effective false theory, was the simultaneous recognition that behind the bewildering and deceptive maze of neurotic fantasies there is a *conflict* which may best be described as a moral one. With this there began for me a new era of understanding. Research and therapy now joined hands in the effort to discover the causes and the *rational* solution of the conflict. For me this meant psychoanalysis. While I was arriving at this insight, Freud had built up his sexual theory of neurosis, thus posing a mass of questions for discussion, all of which seemed worthy of the deepest consideration. I had the good fortune to collaborate with Freud for a long time, and to work with him on the problem of sexuality in neurosis. You know perhaps from some of my earlier works that I was always rather dubious about the significance of sexuality. This has now become the point on which I am no longer altogether of Freud's opinion.

[584] I have preferred to answer your questions in a somewhat inconsequential fashion. I will now catch up on the rest: light hypnosis and total hypnosis are simply varying degrees of intensity of unconscious susceptibility to the hypnotist. Who can draw sharp distinctions here? To a critical intelligence it is unthinkable that suggestibility and suggestion can be avoided in the cathartic method. They are present everywhere

as general human attributes, even with Dubois⁴ and the psychoanalysts, who all think they are working on purely rational lines. No technique and no self-effacement avails here; the analyst works willy-nilly, and perhaps most of all, through his personality, i.e., through suggestion. In the cathartic method, what is of far more importance to the patient than the conjuring up of old fantasies is the experience of being together so often with the analyst, his trust and belief in him personally and in his method. The belief, the self-confidence, perhaps also the devotion with which the analyst does his work, are far more important to the patient (imponderabilia though they may be) than the rehearsing of old traumata.⁵

[585] It is time we learnt from the history of medicine everything that has ever been of help, then perhaps we shall discover the really necessary therapy—that is, psychotherapy. Did not even the old apothecaries' messes achieve brilliant cures, cures which faded only with the belief in their efficacy?!

[586] Because I know that, despite all rational safeguards, the patient does attempt to assimilate the analyst's personality, I have laid it down as a requirement that the psychotherapist must be just as responsible for the cleanness of his hands as the surgeon. I even hold it to be an indispensable prerequisite that the psychoanalyst should first submit himself to the analytical process, as his personality is one of the main factors in the cure.

[587] Patients read the analyst's character intuitively, and they should find in him a man with failings, admittedly, but also a man who strives at every point to fulfil his human duties in the fullest sense. Many times I have had the opportunity of seeing that the analyst is successful with his treatment just so far as he has succeeded in his own moral development. I think this answer will satisfy your question.

From Dr. Loÿ

2 February 1913

[588] You answer several of my questions in a decidedly affirmative tone, taking it as proved that in cures by the cathartic method the main role is played by faith in the analyst and his method and not by "abreacting" the real or imaginary traumata. I think so too. Equally I agree with your view that the old "apothecaries' messes," as well as the Lourdes cures or those of the mental healers, Christian Scientists, and persuasionists, are to be attributed to faith in the miracle-worker rather than to any of the methods employed.

[589] But now comes the ticklish point: the augur can remain an augur so long as he himself believes that the will of the gods is made manifest by the entrails of the

sacrificial beast. When he no longer believes, he can ask himself: Shall I continue to use my augur's authority to promote the welfare of the State, or shall I make use of my newer, and I hope truer, convictions of today? Both ways are possible. The first is called opportunism, the second the pursuit of truth and scientific honesty. For the doctor, the first way perhaps brings therapeutic success and fame, the second brings the reproach that such a man is not to be taken seriously. What I esteem most highly in Freud and his school is just this passionate desire for truth. On the other hand some people pronounce a different verdict: "It is impossible for a busy practitioner to keep pace with the development of the views of this investigator and his initiates" (Frank, *Affektstörungen*, Introduction, p. 2).

[590] One can easily disregard this little quip, but self-criticism needs to be taken more seriously. One can after all ask oneself: Since science is in continual flux, have I the right to ignore on principle any method or combination of methods by which I know I can get therapeutic results?

[591] Looking more closely at the fundamental reason for your aversion to the ancillary use of hypnosis (or semi-hypnosis; the degree matters nothing) in treatment by suggestion (which as you say every doctor and every therapeutic method makes use of willy-nilly, no matter what it is called), one must say that what has disgusted you with hypnotism is at bottom nothing but the so-called "transference" to the doctor, which you, with your purely psychoanalytic procedure, can eliminate as little as anybody else, and which actually plays an essential part in the success of the treatment. Your requirement that the psychoanalyst must be responsible for the cleanness of his hands—here I agree unreservedly—is the logical conclusion. But is the possible recourse to hypnosis in a psychotherapeutic procedure any more "augurish" than the unavoidable use of the "transference to the analyst" for therapeutic purposes? In either case we bank on faith as the healing agent. As for the feeling which the patient—whether man or woman—entertains for the analyst, is there never anything in the background save a conscious or unconscious sexual wish? In many cases your impression is certainly correct, and more than one woman has been frank enough to confess that the beginning of hypnosis was accompanied by a voluptuous sensation. But it is not true in all instances—or how would you explain the underlying feeling in the hypnotizing of one animal by another, e.g., snake and bird? Surely you would say that here the feeling of *fear* prevails, which is an inversion of libido, whereas in the hypnoid state that comes over the female before she succumbs to the male it is the pure *libido sexualis* that predominates, though possibly still mixed with fear.

[592] However that may be, from your three cases I cannot draw any ethical distinction between "susceptibility to the hypnotist" and "transference to the analyst" that would

condemn a possible combination of hypnosis with psychoanalysis, as an auxiliary. You will ask why I cling so much to the use of hypnosis, or rather of the hypnoid state. It is because I think there are cases that can be cured much more quickly in this way than by a purely psychoanalytic procedure. For example, in no more than five or six interviews I completely cured a fifteen-year-old girl who had suffered from *enuresis nocturna* even since infancy, but was otherwise perfectly sound, gifted, first in her class, etc. Previously she had tried all sorts of treatment without any result.

[593] Perhaps I ought to have sought out the psychoanalytic connections between the enuresis and her psychosexual disposition, explained it to her, etc., but I couldn't, the girl had only the short Easter holidays for treatment: so I just hypnotized her and the trouble vanished.

[594] In psychoanalysis I use hypnosis to help the patient overcome "resistance."

[595] Further, I use semi-hypnosis in conjunction with psychoanalysis to accelerate the "reconstruction" stage.

[596] To take an example, a patient afflicted with a washing mania was sent to me after a year's psychocathartic treatment with Dr. X. The symbolic meaning of her washing ceremonies had previously been explained to her, but she became more and more agitated during the "abreaction" of alleged traumata in childhood, because she had persuaded herself by auto-suggestion that she was too old to be cured, that she saw no "images," etc. So I used hypnosis to help her reduce the number of washings—"so that the anxiety feeling would stay away"—and to train her to throw things on the floor and pick them up again without washing her hands afterwards, etc.

[597] In view of these considerations I should, if you feel disposed to go further into the matter, be grateful if you would furnish me with more convincing reasons why the hypnotic procedure is to be condemned, and explain how to do without it, or what to replace it with in such cases. Were I convinced, I would give it up as you have done; but what convinced you has not, so far, convinced me. *Si duo faciunt idem, non est idem.*

[598] I would now like to go on to another important matter to which you alluded, but only cursorily, and to put one question: Behind the neurotic fantasies there is almost always (or always) a moral conflict belonging to the present. That is perfectly clear to me. Research and therapy coincide; their task is: to seek the causes and the rational solution of the conflict.

[599] Good—But can the rational solution always be found? "Reasons of expediency" so often bar the way, varying with the type of patient (children, young girls and women, from "pious"—hypocritical!—Catholic or Protestant families). Again that accursed opportunism!—A colleague of mine was perfectly right when he began to

give sexual enlightenment to a young French boy who was indulging in masturbation. Whereupon, like one possessed, in rushed a bigoted grandmother, and a disagreeable scene ensued. How to act in these and similar cases? What to do in cases where there is a moral conflict between love and duty (conflicts in marriage)—or in general between instinct and moral duty? What to do in the case of a girl afflicted with hysterical or anxiety symptoms, who is in need of love and has no chance to marry, or cannot find a suitable man, and, because she comes of “good family,” wants to remain chaste? Simply try to get rid of the symptoms by suggestion? But that is wrong as soon as one knows of a better way.

[600] How is one to reconcile one’s two consciences: that of the man who does not want to confine his fidelity to truth *intra muros*, and that of the doctor who *must* cure, or if he dares not cure according to his real convictions (owing to opportunist motives), must at least provide some alleviation? We live in the present, but with the ideas and the ideals of the future. That is *our* conflict. How to resolve it?

From Dr. Jung

4 February 1913

[601] ... You have put me in a somewhat embarrassing position with your question in yesterday’s letter. You have rightly guessed the spirit which dictated my last. I am glad you, too, acknowledge this spirit. There are not very many who can boast of such liberalism. I should deceive myself if I thought I was a practising physician. I am above all an investigator, and this naturally gives me a different attitude to many problems. In my last letter I purposely left the practical needs of the doctor out of account, chiefly in order to show you on what grounds one might be moved to give up hypnotic therapy. To anticipate a possible objection, let me say at once that I did not give up hypnosis because I wanted to avoid dealing with the basic forces of the human psyche, but because I wanted to battle with them directly and openly. When once I understood what kind of forces play a part in hypnotism I gave it up, simply to get rid of all the indirect advantages of this method. As we psychoanalysts find to our cost every day—and our patients also—we do not work with the “transference to the analyst,”⁶ but *against it and in spite of it*. Hence we do not bank on the faith of the patient, but on his *criticism*. So much I would say for now about this delicate question.

[602] As your letter shows, we are at one in regard to the theoretical aspect of treatment by suggestion. We can therefore apply ourselves to the further task of reaching agreement on practical questions. Your remarks on the doctor’s dilemma—whether to be a magician or a scientist—bring us to the heart of the matter. I strive not to be a

fanatic—though there are not a few who accuse me of fanaticism. I struggle merely for the recognition of methods of research and their results, not for the application of psychoanalytic methods at all costs. I was a medical practitioner quite long enough to realize that practice obeys, and must obey, other laws than does the search for truth. One might almost say that the practitioner must submit first and foremost to the law of expediency. The investigator would be doing him a great wrong if he accused him of not using the “one true” scientific method. As I said to you in my last letter: “A truth is a truth, when it works.” On the other hand, the practitioner must not reproach the investigator if in his search for truth and for new and perhaps better methods he tries out unusual procedures. After all, it is not the practitioner who will have to bear the brunt, but the investigator and possibly his patient. The practitioner must certainly use those methods which he knows how to apply to the greatest advantage and which give him relatively the best results. My liberalism, as you see, extends even to Christian Science. But I deem it most uncalled for that Frank, a practising doctor, should cast aspersions on research in which he cannot participate—the very line of research to which he owes his own method. It is surely high time to stop this running down of every new idea. No one asks Frank and his confrères to be psychoanalysts. We grant them their right to existence, why should they always seek to curtail ours?

[603] As my own “cures” show you, I do not doubt the effect of suggestion. I merely had the feeling that I might be able to discover something still better. This hope has been justified. Not for ever shall it be said:

If ever in this world we reach what’s good
We call what’s better just a plain falsehood!⁷

[604] I frankly confess that if I were doing your work I should often be in difficulties if I relied on psychoanalysis alone. I can scarcely imagine a general practice, especially in a sanatorium, with no other auxiliaries than psychoanalysis. It is true that at Bircher’s sanatorium in Zurich the principle of psychoanalysis has been adopted, at least by several of the assistants, but a whole series of other important educative influences are also brought to bear on the patients, without which things would probably go very badly. In my own purely psychoanalytic practice I have often regretted that I could not avail myself of other methods of re-education that are naturally at hand in an institution—but only, of course, in special cases where one is dealing with particularly uncontrolled, untrained patients. Which of us would assert that he has discovered the panacea? There are cases where psychoanalysis works worse than any other method. But who has ever claimed that psychoanalysis should be used always and everywhere? Only a fanatic could maintain such a view. Patients for whom psychoanalysis is suitable have to be selected. I unhesitatingly send cases I

think unsuitable to other doctors. This does not happen often, as a matter of fact, because patients have a way of sorting themselves out. Those who go to a psychoanalyst usually know quite well why they go to him and not to someone else. Moreover there are very many neurotics excellently suited for psychoanalysis. In these matters all schematism is to be abhorred. It is never quite wise to run your head against a brick wall. Whether simple hypnotism, or cathartic treatment, or psychoanalysis shall be used must be determined by the conditions of the case and the preference of the doctor. Every doctor will obtain the best results with the instrument he knows best.

[605] But, barring exceptions, I must say definitely that for me, as well as for my patients, psychoanalysis works better than any other method. This is not merely a matter of feeling; from manifold experiences I know many cases can still be helped by psychoanalysis that are refractory to all other methods of treatment. I know many colleagues whose experience is the same, even men engaged exclusively in practical work. It is scarcely credible that an altogether inferior method would meet with so much support.

[606] When once psychoanalysis has been applied in a suitable case, it is *imperative* that rational solutions of the conflicts should be found. The objection is at once advanced that many conflicts are intrinsically insoluble. People sometimes take this view because they think only of external solutions—which at bottom are not solutions at all. If a man cannot get on with his wife, he naturally thinks the conflict would be solved if he married someone else. When such marriages are examined they are seen to be no solution whatever. The old Adam enters upon the new marriage and bungles it just as badly as he did the earlier one. A real solution comes only from within, and then only because the patient has been brought to a different attitude.

[607] If an external solution is possible no psychoanalysis is necessary; but if an internal solution is sought, we are faced with the peculiar task of psychoanalysis. The conflict between “love and duty” must be solved on that level of character where “love and duty” are no longer opposites, which in reality they are not. Similarly, the familiar conflict between “instinct and conventional morality” must be solved in such a way that both factors are taken sufficiently into account, and this again is possible only through a change of character. This change psychoanalysis can bring about. In such cases external solutions are worse than none at all. Naturally, expediency determines which road the doctor must ultimately follow and what is then his duty. I regard the conscience-searching question of whether he should remain true to his scientific convictions as a minor one in comparison with the far weightier question of how he can best help his patient. The doctor *must*, on occasion, be able to play the augur. *Mundus vult decipi*—but the curative effect is no deception. It is true that there

is a conflict between ideal conviction and concrete possibility. But we should ill prepare the ground for the seed of the future were we to forget the tasks of the present, and sought only to cultivate ideals. That would be but idle dreaming. Do not forget that Kepler once cast horoscopes for money, and that countless artists are condemned to work for a living wage.

From Dr. Loj

9 February 1913

[608] The same passion for truth possesses us when we think of pure research, and the same wish to cure when we consider therapy. For the researcher, as for the doctor, we desire the fullest freedom in all directions—complete freedom to choose and practise the methods which promise the best fulfilment of their ends at any moment. On this last point we are at one, but it remains a postulate which we must prove to the satisfaction of others if we want recognition for our views.

[609] First and foremost there is one question that must be answered, an old question already asked in the Gospels: “What is truth?” I think clear definitions of fundamental ideas are everywhere necessary. How shall we contrive a working definition of the concept “Truth?” Perhaps an allegory may help us.

[610] Imagine a gigantic prism in front of the sun, so that its rays are broken up, but suppose man entirely ignorant of this fact. (I disregard the chemical, invisible, ultra-violet rays.) Men living in the blue-lit region will say, “The sun sends forth blue light only.” They are right and yet they are wrong: from their standpoint they are capable of perceiving only a *fragment* of the truth. And so too with the inhabitants of the red, yellow, and intermediate regions. And they will all scourge and slay one another to force their fragmentary truth on the others—until, grown wiser through travelling in each other’s regions, they come to the unanimous view that the sun sends out light of different colours. That is a more comprehensive truth, but it is still not *the* truth. Only when a giant lens has recombined the split-up rays, and when the invisible, chemical, and heat rays have given proof of their specific effects, will a view arise more in accordance with the truth, and men will perceive that the sun emits white light which is split up by the prism into different rays with different qualities, and that these rays are recombined by the lens into a beam of white light.

[611] This example serves to show that the road to Truth leads through a series of comparative observations, the results of which must be controlled with the help of freely selected experiments until seemingly well-grounded hypotheses and theories can be put forward; but these hypotheses and theories will fall to the ground as soon as a single new observation or a single new experiment contradicts them.

[612] The way is toilsome, and in the end all we ever attain is a *relative* truth. But such relative truth suffices for the time being if it serves to explain the most important concatenations of fact in the past, to light up those of the present, and to predict those of the future, so that we are in a position to adapt through our knowledge. Absolute truth, however, would be accessible only to omniscience, having knowledge of all possible concatenations and combinations; but that is not possible for us, because the number of concatenations and combinations is infinite. Accordingly, we shall never know more than an approximate truth. Should new concatenations be discovered, new combinations be built up, the picture changes and with it the whole range of knowledge and action. To what new revolutions in daily life does not every new scientific discovery lead: how absurdly small was the beginning of the first theory of electricity, how inconceivably great the results!

[613] These are commonplaces, but one must continually repeat them when one sees how life is always made bitter for the innovators in every scientific field, and now especially so for the followers of the psychoanalytic school. Everyone admits these commonplaces so long as it is a matter of “academic” discussion, but only so long; as soon as a concrete case has to be considered, sympathies and antipathies rush to the forefront and darken judgment. Therefore the investigator must fight tirelessly, appealing to logic and honesty, for freedom of research in all fields, and must not allow despots of whatever political or religious persuasion to advance “reasons of expediency” in order to destroy or even restrict this freedom. Reasons of expediency may be and are in place elsewhere, but not here. Finally, we must make an end of the dictum of the Middle Ages, *philosophia ancilla theologiae*, as well as the founding of university chairs in favour of this or that political or religious party. All fanaticism is the enemy of science, which above all things must be independent.

[614] And when we turn from the search for Truth back to therapeutics, we see immediately that here again we are in agreement. In practice expediency *must* rule: the doctor from the yellow region must adapt himself to the patients in the yellow region, as must the doctor in the blue region to *his* patients; both have the same object in view. And the doctor who lives in the white light must take into consideration the past experiences of patients from the yellow or blue region, in spite or rather because of his wider knowledge. In such cases the way to healing will be long and difficult, may indeed lead more easily to a *cul-de-sac* than in cases where he has to deal with patients who, like himself, have already attained knowledge of the white light, or, in other words, when his patients have already “sorted themselves out.” With these sorted-out patients the psychoanalyst is permitted to work exclusively with the methods of psychoanalysis; he can consider himself lucky that he does not need to “play the augur.”

[615] Now, these methods of psychoanalysis, what are they? If I understand you aright, it is by and large a question of working directly and openly with the fundamental forces of the human psyche, to the end that the patient, be he sick or sound or in some stage in between—for sickness and health flow into each other imperceptibly—shall have his mental eyes opened to the drama that is being enacted within him. He must learn to know the automatisms that are hostile to the development of his personality, and through this knowledge he must learn gradually to free himself from them; but he must also learn how to exploit and strengthen the favourable automatisms. He must learn to make his self-knowledge real and to control the workings of his mind so that a balance may be struck between feeling and reason. How large a part is played in all this by *suggestion*? I can hardly believe that suggestion can be avoided altogether till the patient feels really freed. This freedom, it goes without saying, is the main thing to strive for, and it must be an *active* freedom. The patient who simply obeys a suggestion obeys it only so long as the “transference to the analyst” remains in force.

[616] But in order to adjust himself to all circumstances the patient must have strengthened himself “from within.” He should no longer need the crutches of faith but must be capable of tackling all theoretical and practical problems critically and of solving them himself. That is your view, isn’t it, or have I not understood you correctly?

[617] I next ask, must not every single case be treated differently—within the limits of the psychoanalytic method? For if every case is a case by itself, it must surely require individual treatment.

[618] “Il n’y a pas de maladies, il n’y a que des malades,” said a French doctor whose name escapes me. But broadly speaking, what course, from a technical point of view, does analysis take, and what deviations occur most frequently? That I would gladly learn from you. I take it for granted that all “augur’s tricks,” darkened rooms, masks, chloroform, etc., are out of the question.

[619] Psychoanalysis—purged so far as is humanly possible of suggestive influence—appears to have one essential difference from psychotherapy à la Dubois. With Dubois, all talk about the past is prohibited from the outset, and “moral reasons for recovery” are placed in the forefront; whilst psychoanalysis uses the subconscious material from the patient’s past and present to promote self-knowledge. Another difference lies in the conception of morality: morals are above all “relative.” But what forms (in broad outline) should one give them at times when suggestion cannot be avoided? Expediency must decide, you will say. Agreed, as regards old people or grown-ups who have to live in a not very enlightened milieu. But if one is dealing with children, the seed of the future, isn’t it a sacred duty to enlighten them about the shaky foundations of the so-called moral conceptions of the past, which have only a

dogmatic basis, and to educate them to full freedom by courageously unveiling the truth? I ask this not so much with respect to the analysing doctor as with respect to the educator. Should not the founding of *progressive schools* be regarded as a task for the psychoanalyst?

From Dr. Jung

11 February 1913

- [620] The relativity of “truth” has been known for ages and does not stand in the way of anything, and if it did would merely prevent belief in dogmas and authority. But it does not even do that.
- [621] You ask me—or rather tell me—what psychoanalysis is. Before considering your views, permit me first to try to mark out the territory and give a definition of psychoanalysis.
- [622] Psychoanalysis is first of all simply a method—but a method complying with all the rigorous requirements which the concept of a “method” implies today. Let me say at once that psychoanalysis is not an *anamnesis*, as those who know everything without learning it are pleased to believe. It is essentially a way of investigating unconscious associations which cannot be got at by exploring the conscious mind. Again, psychoanalysis is not a method of examination in the nature of an intelligence test, though this mistake is common in certain circles. Nor is it a method of catharsis for abreacting, with or without hypnosis, real or imaginary traumata.
- [623] Psychoanalysis is a method which makes possible the analytical reduction of psychic contents to their simplest expression, and for discovering the line of least resistance in the development of a harmonious personality. In neurosis there is no uniform direction of life because contrary tendencies frustrate and prevent psychological adaptation. Psychoanalysis, so far as we can judge at present, seems to be the only rational therapy of the neuroses.
- [624] No programme can be formulated for the technical application of psychoanalysis. There are only general principles, and working rules for individual analysis. (For the latter I would refer you to Freud’s work in Vol. I of the *Internationale Zeit-schrift für ärztliche Psychoanalyse*.⁸) My only working rule is to conduct the analysis as a perfectly ordinary, sensible conversation, and to avoid all appearance of medical magic.
- [625] The main principle of psychoanalytic technique is to analyse the psychic contents that present themselves at a given moment. Any interference on the part of the

analyst, with the object of forcing the analysis to follow a systematic course, is a gross mistake in technique. So-called chance is the law and order of psychoanalysis.

[626] At the beginning of the analysis the anamnesis and diagnosis naturally come first. The subsequent analytic procedure develops quite differently in every case. To give rules is almost impossible. All one can say is that very frequently, right at the beginning, a number of resistances have to be overcome, resistances against both the method and the analyst. Patients who have no notion of psychoanalysis must first be given some understanding of the method. With those who already know something of it there are very often misconceptions to be set right, and also all those objections to be answered which are levelled by scientific criticism. In either case the misconceptions are due to arbitrary interpretations, superficiality, and gross ignorance of the facts.

[627] If the patient is himself a doctor his habit of knowing better may prove extremely tiresome. With intelligent colleagues a thorough theoretical discussion is worth while. With the unintelligent and bigoted ones you begin quietly with the analysis. In the unconscious of such folk you have a confederate who never lets you down. The very first dreams demonstrate the wretched inadequacy of their criticism, so that from the whole beautiful edifice of supposedly scientific scepticism nothing remains over but a little heap of personal vanity. I have had very amusing experiences in this respect.

[628] It is best to let the patients talk freely and to confine yourself to pointing out a connection here and there. When the conscious material is exhausted you go on to dreams, which give you the subliminal material. If people have no dreams, as they allege, or forget them, there is usually still some conscious material that ought to be produced and discussed, but is kept back owing to resistances. When the conscious is emptied then come the dreams, which as you know are the chief object of analysis.

[629] How the analysis is to be conducted and what is to be said to the patient depends, first, on the material to be dealt with; second, on the analyst's skill; and third, on the patient's capacity. I must emphasize that no one should undertake an analysis except on the basis of a sound knowledge of the subject, and this means a thorough knowledge of the existing literature. Without this, the work will only be bungled.

[630] I do not know what else to tell you beforehand. I must wait for further questions.

[631] As to the question of morality and education, let me say that these things belong to a later stage of the analysis, when they find—or should find—their own solution. You cannot make recipes out of psychoanalysis!

From Dr. Loj

[632] You write that a sound knowledge of the literature is necessary for an introduction to psychoanalysis. I agree, but with one reservation: the more one reads of it the more clearly one sees how many contradictions there are among the different writers, and less and less does one know—until one has had sufficient personal experience—to which view to give adherence, since quite frequently assertions are made without any proof. For example, I had thought (strengthened in this view by my own experience of suggestion therapy) that the transference to the analyst might be an essential condition of the patient's cure. But you write: "We psychoanalysts do not bank on the patient's *faith*, but on his *criticism*." As against this Stekel writes ("Ausgänge der psychoanalytischen Kuren," *Zentralblatt für Psychoanalyse*, III, 1912–13, p. 176): "Love for the analyst can become a force conducive to recovery. Neurotics never get well for love of themselves, they get well for love of the analyst. They do it to please him ..." Here again, surely, the accent is on the power of suggestion? And yet Stekel, too, thinks he is a psychoanalyst pure and simple. On the other hand you remark in your letter of January 28: "The personality of the analyst is one of the main factors in the cure." Should not this be translated as: When the analyst inspires respect in the patient and is worthy of his love, the patient will follow his example in order to please him, and will endeavour to get over his neurosis so as to fulfil his human duties in the widest sense of the word?

[633] I think one can only emerge from all this uncertainty when one has gained sufficient personal experience, and then one will also know which procedure is best suited to one's own personality and gives the best therapeutic results. This is another reason for submitting to an analysis oneself, to find out what one is. I am very much in agreement with your definition of psychoanalysis in its negative sense: psychoanalysis is neither an anamnesis nor a method of examination like an intelligence test, nor yet a psychocatharsis. But your definition in the positive sense, that "psychoanalysis is a method for discovering the line of least resistance in the development of a harmonious personality," seems to me to apply only to the laziness of the patient, but not to the releasing of sublimated libido for a new aim in life.

[634] You say that in neurosis there is no uniform direction because contrary tendencies prevent psychic adaptation. True, but will not psychic adaptation turn out quite differently according to whether the patient, now cured, re-directs his life simply to the avoidance of pain (line of least resistance) or to the attainment of the greatest pleasure? In the first case he would be more passive, and would simply reconcile himself to the "soberness of reality" (Stekel, p. 187). In the second case he would be "filled with enthusiasm" for something or other, or for some person. But what determines whether he will be more active or more passive in his "second" life? In

your opinion, does this determining factor appear spontaneously in the course of analysis, and should the analyst carefully avoid tilting the balance to one side or the other by his influence? Or will he, if he does not refrain from canalizing the patient's libido in a definite direction, have to renounce the right to be called a psychoanalyst at all, and is he to be regarded as a "moderate" or a "radical"? (Fürtmüller, "Wandlungen in der Freud'schen Schule," *Zentralblatt*, III, p. 191.) But I think you have already answered this question in advance when you write in your letter of February 11 : "Any interference on the part of the analyst is a gross mistake in technique. So-called chance is the law and order of psychoanalysis." But, torn from its context, perhaps this sentence does not quite give your whole meaning.

[635] With regard to enlightening the patient about the psychoanalytic method before beginning the analysis, you appear to be in agreement with Freud and Stekel: better too little than too much. For knowledge pumped into a patient remains half-knowledge anyway, and half-knowledge begets "wanting to know better," which only impedes progress. So, after a brief explanation, first let the patient talk, pointing out a connection here and there, then, after the conscious material is exhausted, go on to the dreams.

[636] But here another obstacle stands in my way, which I have already mentioned at our interview: you find the patient adopting the tone, language, or jargon of the analyst (whether from conscious imitation, transference, or plain defiance, so as to fight the analyst with his own weapons)—how then can you prevent his starting to produce all manner of fantasies as supposedly real traumata of early childhood, and *dreams* which are supposedly spontaneous but in reality, whether directly or indirectly, albeit involuntarily, are *suggested*?"

[637] I told you at the time that Forel (in *Der Hypnotismus*) made his patients dream just what he wanted, and I myself have easily repeated this experiment. But if the analyst wants to *suggest nothing*, must he keep silent most of the time and let the patient talk—except that, when interpreting the dreams, he may put his own interpretation to the patient?

From *Dr. Jung*

18 February 1913

[638] I cannot but agree with your observation that confusion reigns in psychoanalytic literature. Just at this moment different points of view are developing in the theoretical assessment of analytic results, not to mention the many individual deviations. Over against Freud's almost entirely causal conception there has developed, apparently in absolute contradiction to Freud, Adler's purely finalist view,

though in reality it is an essential complement to Freud's theory. I hold rather to a middle course, taking account of both standpoints. It is not surprising that great disagreement prevails with regard to the ultimate questions of psychoanalysis when you consider how difficult they are. In particular, the problem of the therapeutic effect of psychoanalysis is bound up with the most difficult questions of all, so that it would indeed be astonishing if we had already reached final certitude.

[639] Stekel's remark is very characteristic. What he says about love for the analyst is obviously true, but it is simply a statement of fact and not a goal or a guiding principle of analytical therapy. If it were the goal, many cures, it is true, would be possible, but also many failures might result which could be avoided. The goal is to educate the patient in such a way that he will get well for his own sake and by reason of his own determination, and not in order to procure his analyst some kind of advantage—though of course it would be absurd from the therapeutic standpoint not to allow the patient to get well because he simply wants to do his analyst a good turn. The patient should know what he is doing, that's all. It is not for us to prescribe for him the ways by which he should get well. Naturally it seems to me (from the psychoanalytic point of view) an illegitimate use of suggestive influence if the patient is forced to get well out of love for his analyst. This kind of coercion sometimes takes a bitter revenge. The "you must and shall be saved" attitude is no more to be commended in the therapy of the neuroses than in any other department of life. Besides, it contradicts the principles of analytic treatment, which shuns all coercion and tries to let everything grow up from within. I am not opposed, as you know, to suggestive influence in general, but merely to doubtful motivations. If the analyst demands that his patient shall get well out of love for him, the patient may easily reckon on reciprocal services, and will without doubt try to extort them. I can only utter a warning against any such practice. A far stronger motive for recovery—also a far healthier and ethically more valuable one—is the patient's thorough insight into the real situation, his recognition of things as they are and how they should be. If he is worth his salt he will then realize that he can hardly remain sitting in the morass of neurosis.

[640] I cannot agree with your interpretation of my remarks on the healing effect of the analyst's personality. I wrote⁹ that his personality had a healing effect because the patient *reads* the personality of the analyst, and not that he gets well *out of love for* the analyst. The analyst cannot prevent him from beginning to behave towards his conflicts as he himself behaves, for nothing is finer than the empathy of a neurotic. *But every strong transference serves this purpose too.* If the analyst makes himself amiable to the patient, he simply buys off a lot of resistances which the patient ought to have overcome, and which he will quite certainly have to overcome later on. So nothing is gained by this technique; at most the beginning of the analysis is made

easier for the patient, though in certain cases this is not without its uses. To have to crawl through a barbed-wire fence without having some enticing end in view testifies to an ascetic strength of will which you can expect neither from the ordinary person nor from the neurotic. Even Christianity, whose moral demands are set very high, has not scorned to dangle before us the kingdom of heaven as the goal and reward of earthly endeavour. In my view the analyst is entitled to speak of the advantages which follow from the ardours of analysis. Only, he should not represent himself or his friendship, by hints or promises, as a reward, unless he is seriously resolved to make it so.

[641] As to your criticism of my tentative definition of psychoanalysis, it must be observed that the road over a steep mountain is the line of least resistance when a ferocious bull awaits you in the pleasant valley road. In other words, the line of least resistance is a compromise with *all* eventualities, not just with laziness. It is a prejudice to think that the line of least resistance coincides with the path of inertia. (That's what we thought when we dawdled over our Latin exercises at school.) Laziness is a temporary advantage only and leads to consequences which involve the worst resistances. On the whole, therefore, it does not coincide with the line of least resistance. Nor is life along the line of least resistance synonymous with the ruthless pursuit of selfish desires. Anyone who lived like that would soon realize with sorrow that he was not following the line of least resistance, because man is also a social being and not just a bundle of egoistic instincts, as some people pretend. You can see this best with primitives and domestic animals, who all have a well-developed social sense. Without some such function the herd could not exist at all. Man as a herd-animal, too, has not by any manner of means to subordinate himself to laws imposed from without; he carries his social imperatives within himself, *a priori*, as an inborn necessity. Here, as you see, I place myself in decided opposition to certain views—quite unjustified, in my opinion—which have been expressed here and there inside the psychoanalytic school.

[642] Accordingly the line of least resistance does not signify *eo ipso* the avoidance of pain so much as the just balancing of pain and pleasure. Painful activity by itself leads to no result but exhaustion. A man must be able to enjoy life, otherwise the effort of living is not worth while.

[643] What direction the patient's life should take in the future is not ours to judge. We must not imagine that we know better than his own nature, or we would prove ourselves educators of the worst kind. (Fundamental ideas of a similar nature have also been worked out by the Montessori school.¹⁰) Psychoanalysis is only a means for removing the stones from the path of development, and not a method (as hypnotism often claims to be) of putting things into the patient that were not there before. It is

better to renounce any attempt to give direction, and simply try to throw into relief everything that the analysis brings to light, so that the patient can see it clearly and be able to draw suitable conclusions. Anything he has not acquired himself he will not believe in the long run, and what he takes over from authority merely keeps him infantile. He should rather be put in a position to take his own life in hand. The art of analysis lies in following the patient on all his erring ways and so gathering his strayed sheep together. Working to programme, on a preconceived system, we spoil the best effects of analysis. I must therefore hold fast to the sentence you object to: “Any interference on the part of the analyst is a gross mistake in technique. So-called chance is the law and order of psychoanalysis.”

[644] As you must know, we still cannot give up the pedantic prejudice of wanting to correct nature and force our limited “truths” on her. But in the therapy of the neuroses we meet with so many strange, unforeseen and unforeseeable experiences that all hope should vanish of our knowing better and being able to prescribe the way. The roundabout way and even the wrong way are necessary. If you deny this you must also deny that the mistakes of history were necessary. That is the pedant’s-eye view of the world. This attitude is no good in psychoanalysis.

[645] The question as to how much the analyst involuntarily suggests to the patient is a very ticklish one. It certainly plays a much more important role than psychoanalysis has so far admitted. Experience has convinced me that patients rapidly begin to make use of ideas picked up from psychoanalysis, as is also apparent in their dreams. You get many impressions of this sort from Stekel’s book *Die Sprache des Traumes*. I once had a very instructive experience: a very intelligent lady had from the beginning long-drawn-out transference fantasies which appeared in the usual erotic guise. But she absolutely refused to admit their existence. Naturally she was betrayed by her dreams, in which, however, my person was always hidden under some other figure, often rather difficult to make out. A long series of such dreams finally compelled me to remark: “So, you see, it’s always like that, the person you are really dreaming about is replaced and masked by someone else in the manifest dream.” Till then she had obstinately denied this mechanism. But this time she could no longer evade it and had to admit my working rule—but only to play a trick on me. Next day she brought me a dream in which she and I appeared in a manifestly lascivious situation. I was naturally perplexed and thought of my rule. Her first association to the dream was the malicious question: “It’s always true, isn’t it, that the person you are really dreaming about is replaced by someone else in the manifest dream?”

[646] Clearly, she had made use of her experience to find a protective formula by which she could express her fantasies openly in a quite innocent way.

[647] This example shows at once how patients use insights they have gained from analysis. They use them for the purpose of symbolization. You get caught in your own net if you believe in fixed, unalterable symbols. That has happened to more than one psychoanalyst. It is therefore a fallacious and risky business to try to exemplify any particular theory with dreams arising from an analysis. Proof can only come from the dreams of demonstrably uninfluenced persons. In such cases one would have to exclude at most telepathic thought-reading. But if you concede this possibility, you would have to subject many other things to a rigorous scrutiny, including judicial verdicts.

[648] Although we must pay full attention to the element of suggestion, we should not go too far. The patient is not an empty sack into which we can stuff whatever we like; he brings his own particular contents with him which stubbornly resist suggestion and push themselves again and again to the fore. Analytic “suggestions” merely distort the expression, but not the content, as I have seen countless times. The expression varies without limit, but the content is fixed and can only be got at in the long run, and then with difficulty. Were it not so, suggestion therapy would be in every sense the most effective and rewarding and easiest therapy, a true panacea. Unfortunately it is not, as every honest hypnotist will readily admit.

[649] To come back to your question as to whether it is possible for patients to trick the analyst by making deceptive use—perhaps involuntarily—of his mode of expression, this is indeed a very serious problem. The analyst must exercise all possible care and self-criticism not to let himself be led astray by his patient’s dreams. One can say that patients almost invariably use in their dreams, to a greater or lesser extent, the mode of expression learnt in analysis. Interpretations of earlier symbols will themselves be used again as fresh symbols in later dreams. It often happens, for instance, that sexual situations which appeared in earlier dreams in symbolic form will appear “undisguised” in later ones—once more, be it noted, in symbolic form—as analysable expressions for ideas of a different nature hidden behind them. Thus the not infrequent dream of incestuous cohabitation is by no means an “undisguised” content, but a dream as freshly symbolic and capable of analysis as all others. You can only arrive at the paradoxical idea that such a dream is “undisguised” if you are pledged to the sexual theory of neurosis.

[650] That the patient may mislead the analyst for a longer or shorter time by means of deliberate deception and misrepresentation is possible, as in all other branches of medicine. But the patient injures himself most, since he has to pay for every deception or subterfuge with an aggravation of his symptoms, or with fresh ones. Deception is so obviously disadvantageous to himself that he can scarcely avoid relinquishing such a course for good.

[651] The technique of analysis we can best postpone for oral discussion.

From Dr. Loj

23 February 1913

[652] From your letter of 18 February I would like first to single out the end, where you so aptly assign the element of suggestion its proper place in psychoanalysis: “The patient is not an empty sack into which we can stuff whatever we like; he brings his own particular contents with him, with which you have always to reckon afresh” [*sic*]. With this I fully agree, as my own experience confirms it. And you add: involuntary analytic suggestions will leave this content intact, but the expression, Proteus-like, can be distorted without limit. Hence it would be a kind of “mimicry,” by which the patient seeks to escape the analyst who is driving him into a corner and for the moment seems to him an enemy. Until at last, through the joint work of patient and analyst—the former spontaneously yielding up his psychic content, the latter only interpreting and explaining—the analysis succeeds in bringing so much light into the darkness of the patient’s psyche that he can see the true relationships and, without any preconceived plan of the analyst’s, draw the right conclusions and apply them to his future life. This new life will follow the line of least resistance—or should we not rather say of least resistances—as a “compromise with all eventualities,” in a just balancing of pain and pleasure. It is not for us to decide arbitrarily for the patient how matters stand and what will benefit him; his own nature decides. In other words, we should take over approximately the role of a midwife, who can only bring out into the light of day a child already alive, but who has to avoid a number of mistakes if the child is to remain alive and the mother is not to be injured.

[653] All this is very clear to me because it is only an application to psychoanalytic procedure of a principle which should be generally valid: Never do violence to Nature! Hence I also see that the psychoanalyst must follow his patient’s apparently “erring ways” if the patient is ever to arrive at his own convictions and be freed once and for all from infantile reliance on authority. We ourselves as individuals have learnt and can only learn by making mistakes how to avoid them in the future, and mankind as a whole has created the conditions for its present and future stages of development quite as much by following the crooked path as by keeping to the straight one. Have not many neurotics—I do not know if you will agree, but I think so—become ill partly because their infantile faith in authority has gone to pieces? Now they stand before the wreckage of their faith, weeping over it, and terrified because they cannot find a substitute which would show them clearly where they have to turn. So they remain stuck between the infantilisms they are unwilling to

renounce and the serious tasks of the present and future (moral conflict). I also see, particularly in such cases, how right you are in saying that it would be a mistake to try to replace their lost faith in authority by another faith in authority, which would be useful only as long as it lasted. This passes a verdict on the deliberate use of suggestive influence in psychoanalysis, and on regarding the “transference to the analyst” as the goal of analytic therapy. I no longer contest your dictum: “Every interference on the part of the analyst is a gross mistake in technique. So-called chance is the law and order of psychoanalysis.” Further, I am in entire agreement when you say that altruism [*sic*] must necessarily be innate in man as a herd-animal. The contrary would be the thing to wonder at.

[654] I am very much inclined to assume that not the egoistic but the altruistic instincts are primary. Love and trust of the child for the mother who feeds it, nurses, cherishes and pets it; love of man for wife, regarded as absorption in another’s personality; love for offspring, care of them; love for kinsfolk, etc. Whereas the egoistic instincts owe their existence only to the desire for exclusive possession of the object of love, the desire to possess the mother exclusively, in opposition to the father and brother and sisters, the desire to have a woman for oneself alone, the desire for jewellery, clothes, etc. ... But perhaps you will say I am being paradoxical and that the instincts, whether altruistic or egoistic, arise together in the heart of man, and that every instinct is ambivalent by nature. But I ask: are our feelings and instincts really ambivalent? Are they perhaps bipolar? Can the qualities of emotions be compared at all? Is love really the opposite of hate?

[655] Be that as it may, it is lucky that man carries his social imperatives within himself as an inborn necessity, otherwise our civilized humanity would be in a bad way, having to submit to laws imposed only from without: when the earlier religious faith in authority died out we would rapidly and infallibly fall into complete anarchy. We would then have to ask ourselves whether it would not be better to try to maintain by force an exclusively religious belief in authority, as the Middle Ages did. For the benefits of civilization, which strives to grant every individual as much outward freedom as is consistent with the freedom of others, would be well worth such a sacrifice as the sacrifice of free research. But the age of this use of force against nature is past, civilized mankind has abandoned these erroneous ways, not out of caprice, but obeying an inner need, and therefore we may look forward with joyful anticipation to the future. Mankind, advancing in knowledge and obeying its own law, will find its way across the ruins of faith in authority to the moral autonomy of the individual.

From Dr. Jung

[656] At various places in your letters it has struck me that the problem of the “transference” seems to you particularly critical. Your feeling is entirely justified. The transference is indeed at present the central problem of analysis.

[657] You know that Freud regards the transference as a projection of infantile fantasies upon the analyst. To that extent it is an infantile-erotic relationship. However, seen from outside, and superficially, the thing does not always look like an infantile-erotic relationship by any means. So long as it is a case of a so-called positive transference, you can as a rule recognize the infantile-erotic content of the transference without much difficulty. But if it is a so-called negative transference, you see nothing but violent resistances which sometimes disguise themselves in theoretical, seemingly critical or sceptical forms. In a certain sense the determining factor in these relationships is the patient’s relationship to authority, that is, in the last resort, to his father. In both forms of transference the analyst is treated as if he were the father—either with affection or with hostility. According to this view of the transference it acts as a resistance as soon as the question arises of resolving the infantile attitude. But this form of transference must be destroyed in so far as the aim of analysis is the patient’s moral autonomy.

[658] A lofty aim, you will say. Lofty indeed, and far off, but still not altogether so remote, since it actually corresponds to one of the predominating trends of our stage of civilization—the urge towards individualization, which might serve as a motto for our whole epoch. (Cf. Müller-Lyer, *The Family*.) Anyone who does not believe in this ultimate aim but still adheres to the old scientific causalism will naturally tend to take only the hostile element out of the transference and let the patient remain in a positive relationship to the father, in accordance with the ideals of a past epoch. As we know, the Catholic Church is one of the most powerful organizations based on this tendency. I do not venture to doubt that there are very many people who feel happier under the coercion of others than when forced to discipline themselves (see Shaw’s *Man and Superman*). None the less, we would be doing our neurotic patients a grievous wrong if we tried to force them all into the category of the coerced. Among neurotics, there are not a few who do not require any reminders of their social duties and obligations, but are born and destined rather to be bearers of new cultural ideals. They are neurotic as long as they bow down before authority and refuse the freedom to which they are destined. As long as we look at life only retrospectively, as is the case in the psychoanalytic writings of the Viennese school, we shall never do justice to these persons and never bring them the longed-for deliverance. For in this way we train them only to be obedient children and thereby strengthen the very forces that made them ill—their conservative backwardness and

submission to authority. Up to a point this is the right way to take with people suffering from an infantile insubordination who cannot yet adapt to authority. But the impulse which drives the others out of their conservative father-relationship is by no means an infantile wish for insubordination; it is a powerful urge to develop their own personality, and the struggle for this is for them an imperative duty. Adler's psychology does much greater justice to this situation than Freud's.

[659] For one type of person (called the infantile-rebel) a positive transference is, to begin with, an important achievement with a healing significance; for the other (the infantile-obedient) it is a dangerous backsliding, a convenient way of evading life's duties. For the first a negative transference denotes increased insubordination, hence a backsliding and an evasion of life's duties, for the second it is a step forward with a healing significance. (For the two types see Adler, "Trotz und Gehorsam," *Monatshefte für Pädagogik und Schulpolitik*, VIII, 1910.)

[660] So the transference must, as you see, be evaluated quite differently according to the type of case.

[661] The psychological process of transference—whether negative or positive—consists in a "libidinal investment" of the personality of the analyst, that is to say he stands for an emotional value. (As you know, by libido I mean very much what the ancients meant by the cosmogonic principle of Eros, or in modern language, "psychic energy.") The patient is bound to the analyst by ties of affection or resistance and cannot help following and imitating his psychic attitude. By this means he feels his way along (empathy). And with the best will in the world and for all his technical skill the analyst cannot prevent it, for empathy works surely and instinctively in spite of conscious judgment, be it never so strong. If the analyst himself is neurotic and insufficiently adapted to the demands of life or of his own personality, the patient will copy this defect and reflect it in his own attitudes: with what results you can imagine.

[662] Accordingly I cannot regard the transference merely as a projection of infantile-erotic fantasies. No doubt that is what it is from one standpoint, but I also see in it, as I said in an earlier letter, a process of empathy and adaptation. From this standpoint, the infantile-erotic fantasies, in spite of their undeniable reality, appear rather as a means of comparison or as analogical images for something not yet understood than as independent wishes. This seems to me the real reason why they are unconscious. The patient, not knowing the right attitude, tries to grasp at the right relationship to the analyst by way of comparison and analogy with his infantile experiences. It is not surprising that he gropes back to just the most intimate relationships of his childhood in the attempt to discover the appropriate formula for his relationship to the analyst, for this relationship is very intimate too but differs from the sexual relationship as much as does that of a child to its parents. This latter relationship—child to parent—

which Christianity has everywhere set up as a symbolic formula for human relationships in general, serves to restore to the patient that direct feeling of human fellowship of which he has been deprived by the incursions of sexual and social valuations (valuations from the standpoint of power, etc.). The purely sexual and other more or less primitive and barbaric valuations militate against a direct, purely human relationship, and this creates a damming up of libido which may easily give rise to neurotic formations. Through analysis of the infantile content of the transference fantasies the patient is brought back to a remembrance of the childhood relationship, which, stripped of its infantile qualities, gives him a clear picture of a direct human relationship over and above merely sexual valuations, etc. I can only regard it as a misconception to judge the child-relationship retrospectively as a merely sexual one, even though a certain sexual content cannot be denied.

[663] Recapitulating, I would like to say this of the positive transference:

The patient's libido fastens on the person of the analyst in the form of expectation, hope, interest, trust, friendship, and love. The transference first produces a projection of infantile fantasies, often with a predominantly erotic tinge. At this stage it is, as a rule, of a decidedly sexual character, even though the sexual component remains relatively unconscious. But this emotional process serves as a bridge for the higher aspect of empathy, whereby the patient becomes conscious of the inadequacy of his own attitude through recognition of the analyst's attitude, which is accepted as being adapted to life's demands and as normal. Through remembrance of the childhood relationship with the help of analysis the patient is shown the way which leads out of the subsidiary, purely sexual or power values acquired in puberty and reinforced by social prejudice. This road leads to a purely human relationship and to an intimacy based not on the existence of sexual or power factors but on the value of personality. That is the road to freedom which the analyst should show his patient.

[664] I ought not to conceal from you at this point that the stubborn assertion of sexual values would not be maintained so tenaciously if they did not have a profound significance for that period of life in which propagation is of primary importance. The discovery of the value of human personality is reserved for a riper age. For young people the search for personality values is very often a pretext for evading their biological duty. Conversely, the exaggerated longing of an older person for the sexual values of youth is a short-sighted and often cowardly evasion of a duty which demands recognition of the value of personality and submission to the hierarchy of cultural values. The young neurotic shrinks back in terror from the expansion of life's duties, the old one from the dwindling of the treasures he has attained.

[665] This view of the transference is, as you will have observed, closely connected with the acceptance of biological "duties." By this I mean the tendencies or

determinants that produce culture in man with the same logic as in the bird they produce the artfully woven nest, and antlers in the stag. The purely causal, not to say materialistic views of the last few decades seek to explain all organic formation as the reaction of living matter, and though this is undoubtedly a heuristically valuable line of inquiry, as far as any real explanation goes it amounts only to a more or less ingenious postponement and apparent minimizing of the problem. I would remind you of Bergson's excellent criticism in this respect. External causes can account for at most half the reaction, the other half is due to the peculiar attributes of living matter itself, without which the specific reaction formation could never come about at all. We have to apply this principle also in psychology. The psyche does not merely *react*, it gives its own specific answer to the influences at work upon it, and at least half the resulting formation is entirely due to the psyche and the determinants inherent within it. Culture can never be understood as reaction to environment. That shallow explanation can safely be left to the past century. It is just these determinants that appear as psychological imperatives, and we have daily proof of their compelling power. What I call "biological duty" is identical with these determinants.

[666] In conclusion, I must take up one point which seems to have caused you uneasiness. That is the *moral* question. Among our patients we observe so many so-called immoral impulses that the thought involuntarily forces itself on the psychotherapist how it would be if all these desires were gratified. You will have seen from my earlier letters that these desires should not be taken too seriously. Mostly they are boundlessly exaggerated demands which are thrust to the forefront by the patient's dammed-up libido, usually against his will. The canalizing of libido for the fulfilment of life's simple duties is in most cases sufficient to reduce the pressure of these desires to zero. But in certain cases it is a recognized fact that "immoral" tendencies are not got rid of by analysis, but appear more and more clearly until it becomes evident that they belong to the biological duties of the individual. This is particularly true of certain sexual demands aiming at an individual evaluation of sexuality. This is not a question for pathology, it is a social question of today which imperatively demands an ethical solution. For many it is a biological duty to work for a solution of this question, i.e., to find some sort of practical solution. (Nature, as we know, is not satisfied with theories.) Nowadays we have no real sexual morality, only a legalistic attitude to sexuality; just as the Middle Ages had no real morality of money-making but only prejudices and a legalistic point of view. We are not yet far enough advanced to distinguish between moral and immoral behaviour in the realm of free sexual activity. This is clearly expressed in the customary treatment, or rather ill-treatment, of unmarried mothers. All the repulsive hypocrisy, the high tide of prostitution and of venereal diseases, we owe to the barbarous, wholesale legal condemnation of certain kinds of sexual behaviour, and to

our inability to develop a finer moral sense for the enormous psychological differences that exist in the domain of free sexual activity.

[667] The existence of this exceedingly complicated and significant contemporary problem may serve to make clear to you why we so often find among our patients people who, because of their spiritual and social gifts, are quite specifically called to take an active part in the work of civilization—that is their biological destiny. We should never forget that what today seems to us a moral commandment will tomorrow be cast into the melting-pot and transformed, so that in the near or distant future it may serve as a basis for new ethical formations. This much we ought to have learnt from the history of civilization, that the forms of morality belong to the category of transitory things. The finest psychological tact is needed with these sensitive natures if they are to turn the dangerous corner of infantile irresponsibility, indolence, or licentiousness, and to give the patient a clear and unclouded vision of the possibility of morally autonomous behaviour. Five per cent on money lent is fair interest, twenty per cent is despicable usury. We have to apply this view to the sexual situation as well.

[668] So it comes about that there are many neurotics whose inner decency prevents them from being at one with present-day morality and who cannot adapt themselves so long as the moral code has gaps in it which it is the crying need of our age to fill. We deceive ourselves greatly if we think that many married women are neurotic merely because they are unsatisfied sexually or because they have not found the right man or because they have an infantile sexual fixation. The real reason in many cases is that they cannot recognize the cultural task that is waiting for them. We all have far too much the standpoint of the “nothing but” psychology, that is, we still think that the new future which is pressing in at the door can be squeezed into the framework of what is already known. And so these people see only the present and not the future. It was of profound psychological significance when Christianity first proclaimed that the orientation to the future was the redeeming principle for mankind. In the past nothing can be altered, and in the present little, but the future is ours and capable of raising life’s intensity to the highest pitch. A little span of youth belongs to us, all the rest belongs to our children.

[669] Thus your question about the significance of the loss of faith in authority answers itself. The neurotic is ill not because he has lost his old faith, but because he has not yet found a new form for his finest aspirations.

PREFACES TO "COLLECTED PAPERS ON ANALYTICAL PSYCHOLOGY"¹

First Edition

[670] This volume contains a selection of articles and pamphlets on analytical psychology written at intervals during the past fourteen years.² These years have seen the development of a new discipline and, as is usual in such a case, have involved many changes of viewpoint, conception, and formulation.

[671] It is not my intention to present the fundamental concepts of analytical psychology in this book. The volume does, however, throw some light on a certain line of development which is especially characteristic of the Zurich school of psychoanalysis.

[672] As is well known, the merit of discovering the new analytical method of general psychology belongs to Professor Freud of Vienna. His original views have had to undergo many important modifications, some of them owing to the work done at Zurich, in spite of the fact that he himself is far from agreeing with the standpoint of this school.

[673] I cannot here explain the fundamental differences between the two schools but would mention only the following: The Viennese School adopts an exclusively sexualistic standpoint while that of the Zurich School is symbolistic. The Viennese School interprets the psychological symbol semiotically, as a sign or token of certain primitive psychosexual processes. Its method is analytical and causal. The Zurich School recognizes the scientific possibility of such a conception but denies its exclusive validity, for it does not interpret the psychological symbol semiotically only but also symbolistically, that is, it attributes a positive value to the symbol.

[674] The value of the symbol does not depend merely on historical causes; its chief importance lies in the fact that it has a meaning for the actual present and for the future, in their psychological aspects. For the Zurich School the symbol is not merely a sign of something repressed and concealed, but is at the same time an attempt to comprehend and to point the way to the further psychological development of the individual. Thus we add a prospective meaning to the retrospective value of the symbol.

[675] The method of the Zurich School, therefore, is not only analytical and causal but synthetic and prospective, in recognition of the fact that the human mind is characterized by *fines* (aims) as well as by *causae*. This deserves particular emphasis,

because there are two types of psychology, the one following the principle of hedonism, the other the power principle. The philosophical counterpart of the former type is scientific materialism and of the latter the philosophy of Nietzsche. The principle of the Freudian theory is hedonism, while the theory of Adler (one of Freud's earliest personal pupils) is founded on the power principle.

[676] The Zurich School, recognizing the existence of these two types (also remarked by the late Professor William James), considers that the views of Freud and Adler are one-sided and valid only within the limits of their corresponding type. Both principles exist in every individual though not in equal proportions.

[677] Thus, it is obvious that every psychological symbol has two aspects and should be interpreted in accordance with both principles. Freud and Adler interpret in the analytical and causal way, reducing to the infantile and primitive. Thus with Freud the conception of the "aim" is the fulfilment of the wish, while with Adler it is the usurpation of power. In their practical analytical work both authors take the standpoint which brings to light only infantile and grossly egoistic aims.

[678] The Zurich School is convinced that within the limits of a diseased mental attitude the psychology is such as Freud and Adler describe. It is, indeed, just on account of such an impossible and childish psychology that the individual is in a state of inner dissociation and hence neurotic. The Zurich School, therefore, in agreement with them so far, also reduces the psychological symbol (the fantasy-products of the patient) to his fundamental infantile hedonism or infantile desire for power. Freud and Adler content themselves with the result of mere reduction, which accords with their scientific biologism and naturalism.

[679] But here a very important question arises. Can man obey the fundamental and primitive impulses of his nature without gravely injuring himself or his fellow beings? He cannot assert either his sexual desire or his desire for power unlimitedly in the face of limits which are very restrictive. The Zurich School has in view the end-result of analysis, and it regards the fundamental thoughts and impulses of the unconscious as symbols, indicative of a definite line of future development. We must admit, however, that there is *no scientific justification* for such a procedure, because our present-day science is based wholly on causality. But causality is only one principle, and psychology cannot be exhausted by causal methods only, because the mind lives by aims as well. Besides this controversial philosophical argument we have another of much greater value in favour of our hypothesis, namely that of *vital necessity*. It is impossible to live according to the promptings of infantile hedonism or according to a childish desire for power. If these are to be given a place they must be taken symbolically. Out of the symbolic application of infantile trends there evolves an attitude which may be termed philosophic or religious, and these terms

characterize sufficiently well the lines of the individual's further development. The individual is not just a fixed and unchangeable complex of psychological facts; he is also an extremely variable entity. By an exclusive reduction to causes the primitive trends of a personality are reinforced; this is helpful only when these primitive tendencies are balanced by a recognition of their symbolic value. Analysis and reduction lead to causal truth; this by itself does not help us to live but only induces resignation and hopelessness. On the other hand, the recognition of the intrinsic value of a symbol leads to constructive truth and helps us to live; it inspires hopefulness and furthers the possibility of future development.

[680] The functional importance of the symbol is clearly shown in the history of civilization. For thousands of years the religious symbol proved a most efficacious device in the moral education of mankind. Only a prejudiced mind could deny such an obvious fact. Concrete values cannot take the place of the symbol; only new and more effective symbols can be substituted for those that are antiquated and outworn and have lost their efficacy through the progress of intellectual analysis and understanding. The further development of the individual can be brought about only by means of symbols which represent something far in advance of himself and whose intellectual meanings cannot yet be grasped entirely. The individual unconscious produces such symbols, and they are of the greatest possible value in the moral development of the personality.

[681] Man almost invariably has philosophic and religious views concerning the meaning of the world and of his own life. There are some who are proud to have none. But these are exceptions outside the common path of mankind; they lack an important function which has proved itself to be indispensable to the human psyche.

[682] In such cases we find in the unconscious, instead of modern symbolism, an antiquated, archaic view of the world and of life. If a necessary psychological function is not represented in the sphere of consciousness it exists in the unconscious in the form of an archaic or embryonic prototype.

[683] This brief résumé may show the reader what he may expect *not* to find in this collection of papers. The essays are stations on the way toward the more general views developed above.

Küsnacht / Zurich, January 1916

Second Edition

[684] In agreement with my honoured collaborator, Dr. C. E. Long, I have made certain additions to the second edition of this book. It should especially be noted that a new

chapter on “The Conception of the Unconscious”³ has been added. This is a lecture I gave early in 1916 to the Zurich Society for Analytical Psychology. It provides a general survey of a most important problem in practical analysis, namely the relation of the ego to the psychological *non-ego*. Chapter XIV, “The Psychology of the Unconscious Processes,”⁴ has been fundamentally revised, and I have taken the opportunity to incorporate an article⁵ that describes the results of more recent researches.

[685] In accordance with my usual method of working, my description is as generalized as possible. My habit in daily practice is to confine myself for some time to studying the human material. I then abstract as general a formula as possible from the data collected, obtaining from it a point of view and applying it in my practical work until it has been either confirmed, modified, or else abandoned. If it is confirmed, I publish it as a general viewpoint without giving the empirical material. I introduce the material amassed in the course of my practice only in the form of example or illustration. I therefore beg the reader not to consider the views I present as mere fabrications of my brain. They are, as a matter of fact, the results of extensive experience and ripe reflection.

[686] These additions will enable the reader of the second edition to familiarize himself with the recent views of the Zurich School.

[687] As regards the criticism encountered by the first edition of this work, I was pleased to find my writings were received with much more open-mindedness among English critics than was the case in Germany, where they are met with the silence born of contempt. I am particularly grateful to Dr. Agnes Savill for an exceptionally understanding criticism in the *Medical Press*. My thanks are also due to Dr. T. W. Mitchell for an exhaustive review in the *Proceedings of the Society for Psychical Research*.⁶ This critic takes exception to my heresy respecting causality. He considers that I am entering upon a perilous, because unscientific, course when I question the sole validity of the causal viewpoint in psychology. I sympathize with him, but in my opinion the nature of the human mind compels us to take the finalistic view. It cannot be disputed that, psychologically speaking, we are living and working day by day according to the principle of directed aim or purpose as well as that of causality. A psychological theory must necessarily adapt itself to this fact. What is plainly directed towards a goal cannot be given an exclusively causalistic explanation, otherwise we should be led to the conclusion expressed in Moleschott’s famous dictum: “Man ist was er isst” (Man *is* what he eats). We must always bear in mind that *causality is a point of view*. It affirms the inevitable and immutable relation of a series of events: *a-b-c-z*. Since this relation is fixed, and according to the causal point of view must necessarily be so, looked at logically the order may also be reversed.

Finality is also a point of view, and it is empirically justified by the existence of series of events in which the causal connection is indeed evident *but the meaning of which only becomes intelligible in terms of end-products (final effects)*. Ordinary life furnishes the best instances of this. The causal explanation must be mechanistic if we are not to postulate a metaphysical entity as first cause. For instance, if we adopt Freud's sexual theory and assign primary importance psychologically to the function of the genital glands, the brain is seen as an appendage of the genital glands. If we approach the Viennese concept of sexuality, with all its vague omnipotence, in a strictly scientific manner and reduce it to its physiological basis, we shall arrive at the first cause, according to which psychic life is for the most, or the most important part, tension and relaxation of the genital glands. If we assume for the moment that this mechanistic explanation is "true," it would be the sort of truth which is exceptionally tiresome and rigidly limited in scope. A similar statement would be that the genital glands cannot function without adequate *nourishment*, the inference being that sexuality is a subsidiary function of nutrition. The truth of this forms an important chapter in the biology of the lower forms of life.

[688] But if we wish to work in a really psychological way we shall want to know the *meaning* of psychological phenomena. After learning what kinds of steel the various parts of a locomotive are made of, and what iron-works and mines they come from, we do not really know anything about the locomotive's *function*, that is to say its *meaning*. But "function" as conceived by modern science is by no means exclusively a causal concept; it is especially a final or "teleological" one. For it is impossible to consider the psyche from the causal standpoint only; we are obliged to consider it also from the final point of view. As Dr. Mitchell remarks, it is impossible to think of causal determination as having at the same time a finalistic reference. That would be an obvious contradiction. But the theory of cognition does not need to remain on a pre-Kantian level. It is well known that Kant showed very clearly that the mechanistic and the teleological viewpoints are not *constituent* (objective) principles—as it were, qualities of the object—but that they are purely *regulative* (subjective) principles of thought, and, as such, not mutually inconsistent. I can, for example, easily conceive the following thesis and antithesis:

Thesis: Everything came into existence according to mechanistic laws.

Antithesis: Some things did not come into existence according to mechanistic laws only.

Kant says to this: Reason cannot prove either of these principles because *a priori* the purely empirical laws of nature cannot give us a determinative principle regarding the potentiality of events.

[689] As a matter of fact, modern physics has necessarily been converted from the idea of pure mechanism to the finalistic concept of the conservation of energy, because the mechanistic explanation recognizes only reversible processes whereas the actual truth is that the processes of nature are irreversible. This fact led to the concept of an energy that tends towards relief of tension and hence towards a definitive final state.

[690] Obviously, I consider both these points of view necessary, the causal as well as the final, but would at the same time stress that since Kant's time we have come to realize that the two viewpoints are not antagonistic if they are regarded as regulative principles of thought and not as constituent principles of the process of nature itself.

[691] In speaking of the reviews of this book I must mention some that seem to me wide of the mark. I was once again struck by the fact that certain critics cannot distinguish between the theoretical explanation given by the author and the fantastic ideas produced by the patient. One of my critics is guilty of this confusion when discussing "On the Significance of Number Dreams." The associations to the quotation from the Bible in this paper are, as every attentive reader will perceive, not arbitrary explanations of my own but a cryptomnesic conglomeration emanating not from my brain at all but from that of the patient. Surely it is not difficult to see that this conglomeration of numbers corresponds exactly to the unconscious psychological function from which the whole mysticism of numbers originated, Pythagorean, cabalistic, and so forth, back to very early times.

[692] I am grateful to my serious reviewers, and should like here to express my thanks also to Mrs. Harold F. McCormick for her generous help in the production of this book.

June 1917

IV

THE SIGNIFICANCE OF THE FATHER IN THE DESTINY OF THE INDIVIDUAL

INTRODUCTION TO KRANEFELDT'S "SECRET WAYS OF THE MIND"



FREUD AND JUNG: CONTRASTS

THE SIGNIFICANCE OF THE FATHER IN THE DESTINY OF THE INDIVIDUAL¹

Foreword to the Second Edition

This little essay, written seventeen years ago, ended with the words: “It is to be hoped that experience in the years to come will sink deeper shafts into this obscure territory, on which I have been able to shed but a fleeting light, and will discover more about the secret workshop of the daemon who shapes our fate.” Experience in later years has indeed altered and deepened many things; some of them have appeared in a different light, and I have seen how the roots of the psyche and of fate go deeper than the “family romance,” and that not only the children but the parents, too, are merely branches of one great tree. While I was working on the mother-complex in my book *Wandlungen und Symbole der Libido*,² it became clear to me what the deeper causes of this complex are; why not only the father, but the mother as well, is such an important factor in the child’s fate: not because they themselves have this or that human failing or merit, but because they happen to be—by accident, so to speak—the human beings who first impress on the childish mind those mysterious and mighty laws which govern not only families but entire nations, indeed the whole of humanity. Not laws devised by the wit of man, but the laws and forces of nature, amongst which man walks as on the edge of a razor.

I am letting this essay appear in unaltered form. There is nothing in it that is actually wrong—merely too simple, too naïve. The Horatian verse, which I then placed at the end, points to that deeper, darker background:

“Scit Genius natale comes qui temperat astrum,
Naturae deus humanae, mortalis in unum,
Quodque caput, vultu mutabilis, albus et ater.”³

C. G. J.

Küsnacht, December 1926

Foreword to the Third Edition

This essay was written nearly forty years ago, but this time I did not want to publish it in its original form. Since that time so many things have changed and taken on a new face that I felt obliged to make a number of corrections and additions to the original text. It was chiefly the discovery of the collective unconscious that raised new problems for the theory of complexes. Previously the personality appeared to be unique and as if rooted in nothing; but now, associated with the individually acquired causes of the complex, there was found to be a general human precondition, the inherited and inborn biological structure which is the instinctual basis of every human being. From it proceed, as throughout the whole animal kingdom, determining forces which inhibit or strengthen the more or less fortuitous

constellations of individual life. Every normal human situation is provided for and, as it were, imprinted on this inherited structure, since it has happened innumerable times before in our long ancestry. At the same time the structure brings with it an inborn tendency to seek out, or to produce, such situations instinctively. A repressed content would indeed vanish into the void were it not caught and held fast in this pre-established instinctual substrate. Here are to be found those forces which offer the most obstinate resistance to reason and will, thus accounting for the conflicting nature of the complex.

I have tried to modify the old text in accordance with these discoveries and to bring it, in some degree, up to the level of our present knowledge.

C. G. J.

October 1948

The Fates lead the willing, but drag the unwilling.

CLEANTHES

[693] Freud has pointed out that the emotional relationship of the child to the parents, and particularly to the father, is of a decisive significance in regard to the content of any later neurosis. This relationship is indeed the infantile channel along which the libido⁴ flows back when it encounters any obstacles in later years, thus reactivating the long-forgotten psychic contents of childhood. It is ever so in life when we draw back before too great an obstacle, say the threat of some severe disappointment or the risk of some too far-reaching decision. The energy stored up for the solution of the task flows back and the old river-beds, the obsolete systems of the past, are filled up again. A man disillusioned in love falls back, as a substitute, upon some sentimental friendship⁵ or false religiosity; if he is a neurotic he regresses still further back to the childhood relationships he has never quite forsaken, and to which even the normal person is fettered by more than one chain—the relationship to father and mother.

[694] Every analysis carried out at all thoroughly shows this regression more or less plainly. One peculiarity which stands out in the works of Freud is that the relationship to the father seems to possess a special significance. (This is not to say that the father always has a greater influence on the moulding of the child's fate than the mother. His influence is of a specific nature and differs typically from hers.⁶)

[695] The significance of the father in moulding the child's psyche may be discovered in quite another field—the study of the family.⁷ The latest investigations show the predominating influence of the father's character in a family, often lasting for centuries. The mother seems to play a less important role. If this is true of heredity, we may expect it to be true also of the psychological influences emanating from the father.⁸ The scope of the problem has been widened by the researches of my pupil, Dr. Emma Fürst, on the similarity of reaction-type within families.⁹ She conducted association tests on 100 persons coming from 24 families. From this extensive material, so far only the results for nine families and 37 persons (all uneducated) have been worked out and published. But the calculations already permit some

valuable conclusions. The associations were classified on the Kraepelin-Aschaffenburg scheme as simplified and modified by me, and the difference was then calculated between each group of qualities in a given subject and the corresponding group in every other subject. We thus get mean figures of the differences in reaction-type.

Non-related men	5.9
Non-related women	6.0
Related men	4.1
Related women	3.8

[696] Relatives, especially if they are women, therefore have on average a similar reaction-type. This means that the psychological attitude of relatives differs but slightly. Examination of the various relationships yielded the following results:

[697] The mean difference for husband and wife amounts to 4.7%. But the dispersion value for this mean figure is 3.7, which is high, indicating that the mean of 4.7 is composed of a very wide range of figures: there are married couples with great similarity in reaction-type and others with less.

[698] On the whole, fathers and sons, mothers and daughters, stand closer together:

Difference for fathers and sons:	3.1
Difference for mothers and daughters:	3.0

[699] Except for a few cases of married couples (where the difference dropped to 1.4), these are among the lowest figures. Fürst even had one case where a 45-year-old mother and her 16-year-old daughter differed by only 0.5. But it was just in this case that the mother and daughter differed from the father's reaction-type by 11.8. The father was a coarse, stupid man and a drinker; the mother went in for Christian Science. In accordance with this, mother and daughter exhibited an extreme value-predicate type of reaction,¹⁰ which in my experience is an important sign of a conflicting relationship to the object. Value-predicate types show excessive intensity of feeling and thus betray an unadmitted but nonetheless transparent desire to evoke answering feelings in the experimenter. This view agrees with the fact that in Fürst's material the number of value-predicates increases with the age of the subject.

[700] The similarity of reaction-type in children and parents provides matter for thought. For the association experiment is nothing other than a small segment of the psychological life of a man, and everyday life is at bottom an extensive and greatly varied association experiment; in principle we react in one as we do in the other. Obvious as this truth is, it still requires some reflection—and limitation. Take the case of the 45-year-old mother and her 16-year-old daughter: the extreme value-predicate type of the mother is without doubt the precipitate of a whole life of disappointed hopes and wishes. One is not in the least surprised at a value-predicate type here. But the 16-year-old daughter had not really lived at all; she was not yet married, and yet she reacted as if she were her mother and had endless disillusion behind her. She had her mother's attitude, and to that extent was identified with

her mother. The mother's attitude was explained by her relationship to the father. But the daughter was not married to the father and therefore did not need this attitude. She simply took it over from the environmental influences and later on will try to adapt herself to the world under the influence of this family problem. To the extent that an ill-assorted marriage is unsuitable, the attitude resulting from it will be unsuitable too. In order to adapt, the girl in later life will have to overcome the obstacles of her family milieu; if she does not, she will succumb to the fate to which her attitude predisposes her.

[701] Clearly such a fate has many possibilities. The glossing over of the family problem and the development of the negative of the parental character may take place deep within, unnoticed by anyone, in the form of inhibitions and conflicts which she herself does not understand. Or, as she grows up, she will come into conflict with the world of actualities, fitting in nowhere, until one stroke of fate after another gradually opens her eyes to her own infantile, unadapted qualities. The source of the infantile disturbance of adaptation is naturally the emotional relation to the parents. It is a kind of psychic contagion, caused, as we know, not by logical truths but by affects and their physical manifestations.¹¹ In the most formative period between the first and fifth year all the essential characteristics, which fit exactly into the parental mould, are already developed, for experience teaches us that the first signs¹² of the later conflict between the parental constellation and the individual's longing for independence occur as a rule before the fifth year.

[702] I would like to show, with the help of a few case-histories, how the parental constellation hinders the child's adaptation.¹³

Case 1

[703] A well-preserved woman of 55, dressed poorly but carefully, with a certain elegance, in black; hair carefully arranged; a polite, rather affected manner, fastidious in speech, devout. The patient might be the wife of a minor official or shopkeeper. She informed me, blushing and dropping her eyes, that she was the divorced wife of a common peasant. She had come to the clinic on account of depression, night terrors, palpitations, and nervous twitches in the arms—typical features of a mild climacteric neurosis. To complete the picture, the patient added that she suffered from severe anxiety-dreams; some man was pursuing her, wild animals attacked her, and so on.

[704] Her anamnesis began with the family history. (So far as possible I give her own words.) Her father was a fine, stately, rather corpulent man of imposing appearance. He was very happily married, for her mother worshipped him. He was a clever man, a master craftsman, and held a dignified position. There were only two children, the patient and an elder sister. The sister was the mother's and the patient the father's favourite. When she was five years old her father suddenly died of a stroke at the age of forty-two. She felt very lonely, and also that from then on she was treated by her mother and sister as the Cinderella. She noticed clearly enough that her mother preferred her sister to herself. The mother remained a

widow, her respect for her husband being too great to allow her to marry a second time. She preserved his memory “like a religious cult” and taught her children to do likewise.

[705] The sister married relatively young; the patient did not marry till she was twenty-four. She had never cared for young men, they all seemed insipid; her mind turned always to more mature men. When about twenty she became acquainted with a “stately” gentleman of over forty, to whom she was much drawn, but for various reasons the relationship was broken off. At twenty-four she got to know a widower who had two children. He was a fine, stately, rather corpulent man, with an imposing presence, like her father; he was forty-four. She married him and respected him enormously. The marriage was childless; his children by the first marriage died of an infectious disease. After four years of married life her husband died of a stroke. For eighteen years she remained his faithful widow. But at forty-six (just before the menopause) she felt a great need of love. As she had no acquaintances she went to a matrimonial agency and married the first comer, a peasant of about sixty who had already been twice divorced on account of brutality and perverseness; the patient knew this before marriage. She remained five unbearable years with him, then she also obtained a divorce. The neurosis set in a little later.

[706] For the reader with psychological¹⁴ experience no further elucidation is needed; the case is too obvious. I would only emphasize that up to her forty-sixth year the patient did nothing but live out a faithful copy of the milieu of her early youth. The exacerbation of sexuality at the climacteric led to an even worse edition of the father-substitute, thanks to which she was cheated out of the late blossoming of her sexuality. The neurosis reveals, flickering under the repression, the eroticism of the aging woman who still wants to please (affectation).¹⁵

Case 2

[707] A man of thirty-four, of small build, with a clever, kindly expression. He was easily embarrassed, blushed often. He had come for treatment on account of “nervousness.” He said he was very irritable, readily fatigued, had nervous stomach-trouble, was often so deeply depressed that he sometimes thought of suicide.

[708] Before coming to me for treatment he had sent me a circumstantial autobiography, or rather a history of his illness, in order to prepare me for his visit. His story began: “My father was a very big and strong man.” This sentence awakened my curiosity; I turned over a page and there read: “When I was fifteen a big lad of nineteen took me into a wood and indecently assaulted me.”

[709] The numerous gaps in the patient’s story induced me to obtain a more exact anamnesis from him, which led to the following disclosures: The patient was the youngest of three brothers. His father, a big, red-haired man, was formerly a soldier in the Swiss Guard at the Vatican; later he became a policeman. He was a stern, gruff old soldier, who brought up his sons with military discipline; he issued commands, did not call them by name, but whistled for them. He had spent his youth in Rome, and during his gay life there had contracted syphilis, from the consequences of which he still suffered in old age. He was fond of talking

about his adventures in early life. His eldest son (considerably older than the patient) was exactly like him, a big, strong man with red hair. The mother was an ailing woman, prematurely aged. Exhausted and tired of life, she died at forty when the patient was eight years old. He preserved a tender and beautiful memory of his mother.

[710] At school he was always the whipping-boy and always the object of his schoolfellows' mockery. He thought his peculiar dialect might be to blame. Later he was apprenticed to a strict and unkind master, with whom he stuck it out for over two years, under conditions so trying that all the other apprentices ran away. At fifteen the assault already mentioned took place, together with several other, milder homosexual experiences. Then fate packed him off to France. There he made the acquaintance of a man from the south, a great boaster and Don Juan. He dragged the patient to a brothel; he went unwillingly and out of fear, and found he was impotent. Later he went to Paris, where his eldest brother, a master-mason and the replica of his father, was leading a dissolute life. The patient stayed there a long time, badly paid and helping his sister-in-law out of pity. The brother often took him along to a brothel, but he was always impotent.

[711] One day his brother asked him to make over to him his inheritance, 6,000 francs. The patient consulted his second brother, who was also in Paris, and who urgently tried to dissuade him from handing over the money, because it would only be squandered. Nevertheless the patient went and gave his inheritance to his brother, who naturally ran through it in the shortest possible time. And the second brother, who would have dissuaded him, was also let in for 500 francs. To my astonished question why he had so light-heartedly given the money to his brother without any guarantee he replied: well, he asked for it. He was not a bit sorry about the money, he would give him another 6,000 francs if he had it. The eldest brother afterwards went to the bad altogether and his wife divorced him.

[712] The patient returned to Switzerland and remained for a year without regular employment, often suffering from hunger. During this time he made the acquaintance of a family and became a frequent visitor. The husband belonged to some peculiar sect, was a hypocrite, and neglected his family. The wife was elderly, ill, and weak, and moreover pregnant. There were six children, all living in great poverty. For this woman the patient developed a warm affection and shared with her the little he possessed. She told him her troubles, saying she felt sure she would die in childbed. He promised her (although he possessed nothing) that he would take charge of the children and bring them up. The woman did die in childbed, but the orphanage interfered and allowed him only one child. So now he had a child but no family, and naturally could not bring it up by himself. He thus came to think of marrying. But as he had never yet fallen in love with a girl he was in great perplexity.

[713] It then occurred to him that his elder brother was divorced from his wife, and he resolved to marry her. He wrote to her in Paris, saying what he intended. She was seventeen years older than he, but not averse to his plan. She invited him to come to Paris to talk matters over. But on the eve of the journey fate willed that he should run an iron nail into his foot, so that he could not travel. After a while, when the wound was healed, he went to

Paris and found that he had imagined his sister-in-law, now his fiancée, to be younger and prettier than she really was. The wedding took place, however, and three months later the first coitus, on his wife's initiative. He himself had no desire for it. They brought up the child together, he in the Swiss and she in the Parisian fashion, as she was a French woman. At the age of nine the child was run over and killed by a cyclist. The patient then felt very lonely and dismal at home. He proposed to his wife that they should adopt a young girl, whereupon she broke out into a fury of jealousy. Then, for the first time in his life, he fell in love with a young girl, and simultaneously the neurosis started with deep depression and nervous exhaustion, for meanwhile his life at home had become a hell.

[714] My suggestion that he should separate from his wife was dismissed out of hand, on the ground that he could not take it upon himself to make the old woman unhappy on his account. He obviously preferred to go on being tormented, for the memories of his youth seemed to him more precious than any present joys.

[715] This patient, too, moved all through his life in the magic circle of the family constellation. The strongest and most fateful factor was the relationship to the father; its masochistic-homo-sexual colouring is clearly apparent in everything he did. Even the unfortunate marriage was determined by the father, for the patient married the divorced wife of his elder brother, which amounted to marrying his mother. At the same time, his wife was the mother-substitute for the woman who died in childbed. The neurosis set in the moment the libido was withdrawn from the infantile relationship and for the first time came a bit nearer to an individually determined goal. In this as in the previous case, the family constellation proved to be by far the stronger, so that the narrow field of neurosis was all that was left over for the struggling individuality.

Case 3

[716] A 36-year-old peasant woman, of average intelligence, healthy appearance, and robust build, mother of three healthy children. Comfortable economic circumstances. She came to the clinic for the following reasons: for some weeks she had been terribly wretched and anxious, slept badly, had terrifying dreams, and also suffered by day from anxiety and depression. She stated that all these things were without foundation, she herself was surprised at them, and had to admit that her husband was quite right when he insisted that it was all "stuff and nonsense." Nevertheless, she simply could not get over them. Often strange thoughts came into her head; she was going to die and would go to hell. She got on very well with her husband.

[717] Examination of the case yielded the following results. Some weeks before, she happened to take up some religious tracts which had long lain about the house unread. There she was informed that people who swore would go to hell. She took this very much to heart, and ever since then had been thinking that she must stop people swearing or she would go to hell too. About a fortnight before she read these tracts her father, who lived

with her, had suddenly died of a stroke. She was not actually present at his death, but arrived only when he was already dead. Her terror and grief were very great.

[718] In the days following his death she thought much about it all, wondering why her father had to die so suddenly. During these meditations she suddenly remembered that the last words she had heard her father say were: "I am one of those who have got into the devil's clutches." This memory filled her with trepidation, and she recalled how often her father had sworn savagely. She also began to wonder whether there was really a life after death, and whether her father was in heaven or hell. It was during these musings that she came across the tracts and began to read them, until she came to the place where it said that people who swore would go to hell. Then great fear and terror fell upon her; she covered herself with reproaches, she ought to have stopped her father's swearing and deserved to be punished for her negligence. She would die and would be condemned to hell. From that hour she was filled with sorrow, grew moody, tormented her husband with her obsessive ideas, and shunned all joy and conviviality.

[719] The patient's life-history was as follows: She was the youngest of five brothers and sisters and had always been her father's favourite. Her father gave her everything she wanted if he possibly could. If she wanted a new dress and her mother refused it, she could be sure her father would bring her one next time he went to town. Her mother died rather early. At twenty-four she married the man of her choice, against her father's wishes. The father flatly disapproved of her choice although he had nothing particular against the man. After the wedding she made her father come and live with them. That seemed the obvious thing, she said, since the others had never suggested having him with them. He was, as a matter of fact, a quarrelsome, foul-mouthed old drunkard. Husband and father-in-law, as may easily be imagined, did not get on at all. There were endless squabbles and altercations, in spite of which the patient would always dutifully fetch drink for her father from the inn. All the same, she admitted her husband was right. He was a good, patient fellow with only one failing: he did not obey her father enough. She found that incomprehensible, and would rather have seen her husband knuckle under to her father. When all's said and done, a father is still a father. In the frequent quarrels she always took her father's part. But she had nothing to say against her husband, and he was usually right in his protests, but even so one must stand by one's father.

[720] Soon it began to seem to her that she had sinned against her father by marrying against his will, and she often felt, after one of these incessant wrangles, that her love for her husband had died. And since her father's death it was impossible to love him any more, for his disobedience had usually been the cause of her father's fits of raging and swearing. At one time the quarrelling had become too much for the husband, and he induced his wife to find a room for her father elsewhere, where he lived for two years. During this time husband and wife lived together peaceably and happily. But by degrees she began to reproach herself for letting her father live alone; in spite of everything he was her father. And in the end, despite her husband's protests, she fetched her father home again because, as she said, at bottom she loved her father better than her husband. Scarcely was the old

man back in the house than the strife broke out again. And so it went on till the father's sudden death.

[721] After this recital she broke into a string of lamentations: she must get a divorce from her husband, she would have done so long ago but for the children. She had committed a great wrong, a grievous sin, when she married her husband against her father's wishes. She ought to have taken the man her father wanted her to have; he, certainly, would have obeyed her father, and then everything would have been all right. Oh, she wailed, her husband was not nearly as nice as her father, she could do anything with her father, but not with her husband. Her father had given her everything she wanted. And now she wanted most of all to die, so that she could be with her father.

[722] When this outburst was over, I asked curiously why she had refused the husband her father had proposed?

[723] It seems that the father, a small peasant on a lean little holding, had taken on as a labourer, just at the time when his youngest daughter was born, a wretched little boy, a foundling. The boy developed in a most unpleasant fashion: he was so stupid that he could not learn to read or write, or even to speak properly. He was an absolute blockhead. As he approached manhood a series of ulcers developed on his neck, some of which opened and continually discharged pus, giving this dirty, ugly creature a truly horrible appearance. His intelligence did not grow with his years, so he stayed on as a farm-labourer without any recognized wage.

[724] To this oaf the father wanted to marry his favourite daughter.

[725] The girl, fortunately, had not been disposed to yield, but now she regretted it, for this idiot would unquestionably have been more obedient to her father than her good man had been.

[726] Here, as in the foregoing case, it must be clearly understood that the patient was not at all feeble-minded. Both possessed normal intelligence, although the blinkers of the infantile constellation kept them from using it. That appears with quite remarkable clearness in this patient's life-story. The father's authority is never even questioned. It makes not the least difference to her that he was a quarrelsome old drunkard, the obvious cause of all the bickering and dissension; on the contrary, her husband must bow down before this bogey, and finally our patient even comes to regret that her father did not succeed in completely destroying her life's happiness. So now she sets about destroying it herself, through her neurosis, which forces on her the wish to die so that she may go to hell—whither, be it noted, her father has already betaken himself.

[727] If ever we are disposed to see some demonic power at work controlling mortal destiny, surely we can see it here in these melancholy, silent tragedies working themselves out, slowly and agonizingly, in the sick souls of our neurotics. Some, step by step, continually struggling against the unseen powers, do free themselves from the clutches of the demon who drives his unsuspecting victims from one cruel fatality to another; others rise up and win to freedom, only to be dragged back later to the old paths, caught in the noose of the

neurosis. You cannot even maintain that these unhappy people are always neurotics or “degenerates.” If we normal people examine our lives,¹⁶ we too perceive how a mighty hand guides us without fail to our destiny, and not always is this hand a kindly one.¹⁷ Often we call it the hand of God or of the devil, (thereby expressing, unconsciously but correctly, a highly important psychological fact: that the power which shapes the life of the psyche has the character of an autonomous personality. At all events it is felt as such, so that today in common speech, just as in ancient times, the source of any such destiny appears as a daemon, as a good or evil spirit.

[728] (The personification of this source goes back in the first place to the father, for which reason Freud was of the opinion that all “divine” figures have their roots in the father-*imago*. It can hardly be denied that they do derive from this *imago*, but what we are to say about the father-*imago* itself is another matter. For the parental *imago* is possessed of a quite extraordinary power; it influences the psychic life of the child so enormously that we must ask ourselves whether we may attribute such magical power to an ordinary human being at all. Obviously he possesses it, but we are bound to ask whether it is really his property. Man “possesses” many things which he has never acquired but has inherited from his ancestors. He is not born as a *tabula rasa*, he is merely born unconscious. But he brings with him systems that are organized and ready to function in a specifically human way, and these he owes to millions of years of human development. Just as the migratory and nest-building instincts of birds were never learnt or acquired individually, man brings with him at birth the ground-plan of his nature, and not only of his individual nature but of his collective nature. These inherited systems correspond to the human situations that have existed since primeval times: youth and old age, birth and death, sons and daughters, fathers and mothers, mating, and so on. Only the individual consciousness experiences these things for the first time, but not the bodily system and the unconscious. For them they are only the habitual functioning of instincts that were preformed long ago. “You were in bygone times my wife or sister,” says Goethe, clothing in words the dim feelings of many.

[729] (I have called this congenital and pre-existent instinctual model, or pattern of behaviour, the *archetype*. This is the *imago* that is charged with the dynamism we cannot attribute to an individual human being. Were this power really in our hands and subject to our will, we would be so crushed with responsibility that no one in his right senses would dare to have children. But the power of the archetype is not controlled by us; we ourselves are at its mercy to an unsuspected degree. There are many who resist its influence and its compulsion, but equally many who identify with the archetype, for instance with the *patris potestas* or with the queen ant. And because everyone is in some degree “possessed” by his specifically human preformation, he is held fast and fascinated by it and exercises the same influence on others without being conscious of what he is doing. The danger is just this unconscious identity with the archetype: not only does it exert a dominating influence on the child by suggestion, it also causes the same unconsciousness in the child, so that it succumbs to the influence from outside and at the same time cannot oppose it from within. The more a father identifies with the archetype, the more unconscious and irresponsible,

indeed psychotic, both he and his child will be. In the case we have discussed, it is almost a matter of “folie à deux.”¹⁸

[730] In our case, it is quite obvious what the father was doing, and why he wanted to marry his daughter to this brutish creature: he wanted to keep her with him and make her his slave for ever. What he did is but a crass exaggeration of what is done by thousands of so-called respectable, educated parents, who nevertheless pride themselves on their progressive views. The fathers who criticize every sign of emotional independence in their children, who fondle their daughters with ill-concealed eroticism and tyrannize over their feelings, who keep their sons on a leash or force them into a profession and finally into a “suitable” marriage, the mothers who even in the cradle excite their children with unhealthy tenderness, who later make them into slavish puppets and then at last ruin their love-life out of jealousy: they all act no differently in principle from this stupid, boorish peasant. (They do not know what they are doing, and they do not know that by succumbing to the compulsion they pass it on to their children and make them slaves of their parents and of the unconscious as well. Such children will long continue to live out the curse laid on them by their parents, even when the parents are long since dead. “They know not what they do.” Unconsciousness is the original sin.)¹⁹

Case 4

[731] An eight-year-old boy, intelligent, rather delicate-looking, brought to me by his mother on account of enuresis. During the consultation the child clung all the time to his mother, a pretty, youthful woman. The marriage was a happy one, but the father was strict, and the boy (the eldest child) was rather afraid of him. The mother compensated for the father’s strictness by a corresponding tenderness, to which the boy responded so much that he never got away from his mother’s apron-strings. He never played with his school-fellows, never went alone into the street unless he had to go to school. He feared the boys’ roughness and violence and played thoughtful games at home or helped his mother with the housework. He was extremely jealous of his father, and could not bear it when the father showed tenderness to the mother.

[732] I took the boy aside and asked him about his dreams. Very often he dreamt of a *black snake that wanted to bite his face*. Then he would cry out, and his mother had to come to him from the next room and stay by his bedside.

[733] In the evening he would go quietly to bed. But when falling asleep it seemed to him that a *wicked black man with a sword or a gun was lying on his bed, a tall thin man who wanted to kill him*. The parents slept in the next room. The boy often dreamt that something dreadful was going on in there, as if there were *great black snakes or evil men who wanted to kill Mama*. Then he would cry out, and Mama came to comfort him. Every time he wet his bed he called his mother, who would then have to change the bedclothes.

[734] The father was a tall thin man. Every morning he stood naked at the wash-stand in full view of the boy, to perform a thorough ablution. The boy also told me that at night he often

started up from sleep at the sound of strange noises in the next room; then he was always horribly afraid that something dreadful was going on in there, a struggle of some kind, but his mother would quiet him and say it was nothing.

[735] It is not difficult to see what was happening in the next room. It is equally easy to understand the boy's aim in calling out for his mother: he was jealous and was separating her from the father. He did this also in the daytime whenever he saw his father caressing her. Thus far the boy was simply the father's rival for his mother's love.

[736] But now comes the fact that the snake and the wicked man threaten him as well: the same thing happens to him as happens to his mother in the next room. To that extent he identifies with his mother and thus puts himself in a similar relationship to the father. This is due to his homosexual component, which feels feminine towards the father. (The bed-wetting is in this case a substitute for sexuality. Pressure of urine in dreams and also in the waking state is often an expression of some other pressure, for instance of fear, expectation, suppressed excitement, inability to speak, the need to express an unconscious content, etc. In our case the substitute for sexuality has the significance of a premature masculinity which is meant to compensate the inferiority of the child.

[737] (Although I do not intend to go into the psychology of dreams in this connection, the motif of the black snake and of the black man should not pass unmentioned. Both these terrifying spectres threaten the dreamer as well as his mother. "Black" indicates something dark, the unconscious. The dream shows that the mother-child relationship is menaced by unconsciousness. The threatening agency is represented by the mythological motif of the "father animal"; in other words the father appears as threatening. This is in keeping with the tendency of the child to remain unconscious and infantile, which is decidedly dangerous. For the boy, the father is an anticipation of his own masculinity, conflicting with his wish to remain infantile. The snake's attack on the boy's face, the part that "sees," represents the danger to consciousness (blinding).)²⁰

[738] This little example shows what goes on in the psyche of an eight-year-old child who is over-dependent on his parents, the blame for this lying partly on the too strict father and the too tender mother. (The boy's identification with his mother and fear of his father are in this individual instance an infantile neurosis, but they represent at the same time the original human situation, the clinging of primitive consciousness to the unconscious, and the compensating impulse which strives to tear consciousness away from the embrace of the darkness. Because man has a dim premonition of this original situation behind his individual experience, he has always tried to give it generally valid expression through the universal motif of the divine hero's fight with the mother dragon, whose purpose is to deliver man from the power of darkness. This myth has a "saving," i.e., therapeutic significance, since it gives adequate expression to the dynamism underlying the individual entanglement. The myth is not to be causally explained as the consequence of a personal father-complex, but should be understood teleologically, as an attempt of the unconscious itself to rescue consciousness from the danger of regression. The ideas of "salvation" are

not subsequent rationalizations of a father-complex; they are, rather, archetypally preformed mechanisms for the development of consciousness.)²¹

[739] What we see enacted on the stage of world-history happens also in the individual. The child is guided by the power of the parents as by a higher destiny. But as he grows up, the struggle between his infantile attitude and his increasing consciousness begins. The parental influence, dating from the early infantile period, is repressed and sinks into the unconscious, but is not eliminated; by invisible threads it directs the apparently individual workings of the maturing mind. Like everything that has fallen into the unconscious, the infantile situation still sends up dim, premonitory feelings, feelings of being secretly guided by otherworldly influences. (Normally these feelings are not referred back to the father, but to a positive or negative deity. This change is accomplished partly under the influence of education, partly spontaneously. It is universal. Also, it resists conscious criticism with the force of an instinct, for which reason the soul (*anima*) may fittingly be described as *naturaliter religiosa*. The reason for this development, indeed its very possibility, is to be found in the fact that the child possesses an inherited system that anticipates the existence of parents and their influence upon him. In other words, behind the father stands the archetype of the father, and in this pre-existent archetype lies the secret of the father's power, just as the power which forces the bird to migrate is not produced by the bird itself but derives from its ancestors.

[740] It will not have escaped the reader that the role which falls to the father-*imago* in our case is an ambiguous one. The threat it represents has a dual aspect: fear of the father may drive the boy out of his identification with the mother, but on the other hand it is possible that his fear will make him cling still more closely to her. A typically neurotic situation then arises: he wants and yet does not want, saying yes and no at the same time.

[741] This double aspect of the father-*imago* is characteristic of the archetype in general: it is capable of diametrically opposite effects and acts on consciousness rather as Yahweh acted towards Job—ambivalently. And, as in the Book of Job, man is left to take the consequences. We cannot say with certainty that the archetype always acts in this way, for there are experiences which prove the contrary. But they do not appear to be the rule.)²²

[742] An instructive and well-known example of the ambivalent behaviour of the father-*imago* is the love-episode in the Book of Tobit.²³ Sara, the daughter of Raguel, of Ecbatana, desires to marry. But her evil fate wills it that seven times, one after the other, she chooses a husband who dies on the wedding-night. It is the evil spirit Asmodeus, by whom she is persecuted, that kills these men. She prays to Yahweh to let her die rather than suffer this shame again, for she is despised even by her father's maidservants. The eighth bridegroom, her cousin Tobias, the son of Tobit, is sent to her by God. He too is led into the bridal chamber. Then old Raguel, who had only pretended to go to bed, goes out and thoughtfully digs his son-in-law's grave, and in the morning sends a maid to the bridal chamber to make sure that he is dead. But this time Asmodeus' role is played out, for Tobias is alive.

[743] (The story shows father Raguel in his two roles, as the inconsolable father of the bride and the provident digger of his son-in-law's grave. Humanly speaking he seems beyond

reproach, and it is highly probable that he was. But there is still the evil spirit Asmodeus and his presence needs explaining. If we suspect old Raguel personally of playing a double role, this malicious insinuation would apply only to his sentiments; there is no evidence that he committed murder. These wicked deeds transcend the old man's daughter-complex as well as Sara's father-complex, for which reason the legend fittingly ascribes them to a demon. Asmodeus plays the role of a jealous father who will not give up his beloved daughter and only relents when he remembers his own positive aspect, and in that capacity at last gives Sara a pleasing bridegroom. He, significantly enough, is the eighth: the last and highest stage.²⁴ Asmodeus stands for the negative aspect of the father archetype, for the archetype is the genius and daemon of the personal human being, "the god of human nature, changeful of countenance, white and black."²⁵ The legend offers a psychologically correct explanation: it does not attribute superhuman evil to Raguel, it distinguishes between man and daemon, just as psychology must distinguish between what the human individual is and can do and what must be ascribed to the congenital, instinctual system, which the individual has not made but finds within him. We would be doing the gravest injustice to Raguel if we held him responsible for the fateful power of this system, that is, of the archetype.

[744] (The potentialities of the archetype, for good and evil alike, transcend our human capacities many times, and a man can appropriate its power only by identifying with the daemon, by letting himself be possessed by it, thus forfeiting his own humanity. The fateful power of the father complex comes from the archetype, and this is the real reason why the *consensus gentium* puts a divine or daemonic figure in place of the father. The personal father inevitably embodies the archetype, which is what endows his figure with its fascinating power. The archetype acts as an amplifier, enhancing beyond measure the effects that proceed from the father, so far as these conform to the inherited pattern.)²⁶

INTRODUCTION TO KRANEFELDT'S "SECRET WAYS OF THE MIND"¹

[745] At the present time, one can well say, it is still quite impossible to draw up a comprehensive and hence a proper picture of all that commonly goes by the much abused name "psychoanalysis." What the layman usually understands by "psychoanalysis"—a medical dissection of the soul for the purpose of disclosing hidden causes and connections—touches only a small part of the phenomena in question. Even if we regard psychoanalysis from a wider angle—in agreement with Freud's conception of it—as essentially a medical instrument for the cure of neurosis, this broader point of view still does not exhaust the nature of the subject. Above all, psychoanalysis in the strictly Freudian sense is not only a therapeutic method but a psychological theory, which does not confine itself in the least to the neuroses and to psychopathology in general but attempts also to bring within its province the normal phenomenon of the dream and, besides this, wide areas of the humane sciences, of literature and the creative arts, as well as biography, mythology, folklore, comparative religion, and philosophy.

[746] It is a somewhat curious fact in the history of science—but one that is in keeping with the peculiar nature of the psychoanalytic movement—that Freud, the creator of psychoanalysis (in, the narrower sense), insists on identifying the method with his sexual theory, thus placing upon it the stamp of dogmatism. This declaration of "scientific" infallibility caused me, at the time, to break with Freud, for to me dogma and science are incommensurable quantities which damage one another by mutual contamination. Dogma as a factor in religion is of inestimable value precisely because of its absolute standpoint. But when science dispenses with criticism and scepticism it degenerates into a sickly hot-house plant. One of the elements necessary to science is extreme uncertainty. Whenever science inclines towards dogma and shows a tendency to be impatient and fanatical, it is concealing a doubt which in all probability is justified and explaining away an uncertainty which is only too well founded.

[747] I emphasize this unfortunate state of affairs not because I want to make a critical attack on Freud's theories, but rather to point out to the unbiased reader the significant fact that Freudian psychoanalysis, apart from being a scientific endeavour and a scientific achievement, is a psychic symptom which has proved to be more powerful than the analytical art of the master himself. As Maylan's book on "Freud's tragic complex"² has shown, it would not be at all difficult to derive Freud's tendency to dogmatize from the premises of his own personal psychology—indeed, he taught

this trick to his disciples and practised it more or less successfully himself—but I do not wish to turn his own weapons against him. In the end no one can completely outgrow his personal limitations; everyone is more or less imprisoned by them—especially when he practises psychology.

[748] I find these technical defects uninteresting and believe it is dangerous to lay too much stress on them, as it diverts attention from the one important fact: that even the loftiest mind is most limited and dependent just at the point where it seems to be freest. In my estimation the creative spirit in man is not his personality at all but rather a sign or symptom of a contemporary movement of thought. His personality is important only as the mouthpiece of a conviction arising out of an unconscious, collective background—a conviction that robs him of his freedom, forces him to sacrifice himself and to make mistakes which he would criticize mercilessly in others. Freud is borne along by a particular current of thought which can be traced back to the Reformation. Gradually it freed itself from innumerable veils and disguises, and it is now turning into the kind of psychology which Nietzsche foresaw with prophetic insight—the discovery of the psyche as a new fact. Some day we shall be able to see by what tortuous paths modern psychology has made its way from the dingy laboratories of the alchemists, via mesmerism and magnetism (Kerner, Ennemoser, Eschimayer, Baader, Pas-savant, and others), to the philosophical anticipations of Schopenhauer, Carus, and von Hartmann; and how, from the native soil of everyday experience in Liébeault and, still earlier, in Quimby (the spiritual father of Christian Science),³ it finally reached Freud through the teachings of the French hypnotists. This current of ideas flowed together from many obscure sources, gaining rapidly in strength in the nineteenth century and winning many adherents, amongst whom Freud is not an isolated figure.

[749] What is designated today by the catchword “psychoanalysis” is not in reality a uniform thing, but comprises in itself many different aspects of the great psychological problem of our age. Whether or not the public at large is conscious of this problem does not alter the fact of its existence. In our time the psyche has become something of a problem for everyone. Psychology has acquired a power of attraction which is really astounding. It explains the surprising, world-wide spread of Freudian psychoanalysis, which has had a success comparable only to that of Christian Science, theosophy, and anthroposophy—comparable not only in its success but also in its essence, for Freud’s dogmatism comes very close to the attitude of religious conviction that characterizes these movements. Moreover, all four movements are decidedly psychological. When we add to this the almost unbelievable rise of occultism in every form in all civilized parts of the Western world, we begin to get a picture of this current of thought, everywhere a little taboo yet nonetheless compelling. Similarly, modern medicine shows significant leanings

towards the spirit of Paracelsus, and is becoming increasingly aware of the importance of the psyche in somatic diseases. Even the traditionalism of criminal law is beginning to yield to the claims of psychology, as we can see from the suspension of sentences and the more and more frequent practice of calling in psychological experts.

[750] So much for the positive aspects of this psychological movement. But these aspects are balanced on the other side by equally characteristic negative ones. Already at the time of the Reformation the conscious mind had begun to break away from the metaphysical certainties of the Gothic age, and this separation became more acute and widespread with every passing century. At the beginning of the eighteenth century the world saw the truths of Christianity publicly dethroned for the first time, and at the beginning of the twentieth the government of one of the largest countries on earth is making every effort to stamp out the Christian faith as if it were a disease. Meanwhile, the intellect of the white man as a whole has outgrown the authority of Catholic dogma, and Protestantism has succeeded in splitting itself into more than four hundred denominations through the most trivial quibbles. These are obvious negative aspects, and they explain why people increasingly flock to any movement from which they expect a helpful truth to come.

[751] Religions are the great healing-systems for the ills of the soul. Neuroses and similar illnesses arise, one and all, from psychic complications. But once a dogma is disputed and questioned, it has lost its healing power. A person who no longer believes that a God who knows suffering will have mercy on him, will help and comfort him and give his life a meaning, is weak and a prey to his own weakness and becomes neurotic. The innumerable pathological elements in the population constitute one of the most powerful factors that lend support to the psychological tendencies of our time.

[752] Another and by no means unimportant contingent is formed by all those who, after a period of belief in authority, have awakened with a kind of resentment and find a satisfaction mixed with self-torture in advocating a so-called new truth which is destructive of their old, still-smouldering convictions. Such people can never keep their mouths shut and, because of the weakness of their conviction and their fear of isolation, must always flock together in proselytizing bands, thus at least making up in quantity for their doubtful quality.

[753] Finally, there are those who are earnestly searching for something, who are thoroughly convinced that the soul is the seat of all psychic sufferings and at the same time the dwelling-place of all the healing truths that have ever been announced as glad tidings to suffering humanity. From the soul come the most senseless

conflicts, yet we also look to it for a solution or at least a valid answer to the tormenting question: why?

[754] One does not have to be neurotic to feel the need of healing, and this need exists even in people who deny with the deepest conviction that any such healing is possible. In a weak moment they cannot help glancing inquisitively into a book on psychology, even if only to find a recipe for adroitly bringing a refractory marriage partner to reason.

[755] These entirely different interests on the part of the public are reflected in the variations on the theme of "psychoanalysis." The Adlerian school, which grew up side by side with Freud, lays particular stress on the social aspect of the psychic problem and, accordingly, has differentiated itself more and more into a system of social education. It denies, not only in theory but in practice, all the essentially Freudian elements of psychoanalysis, so much so that with the exception of a few theoretical principles the original points of contact with the Freudian school are almost unrecognizable. For this reason Adler's "individual psychology" can no longer be included in the concept of "psychoanalysis." It is an independent system of psychology, the expression of a different temperament and a wholly different view of the world.

[756] No one who is interested in "psychoanalysis" and who wants to get anything like an adequate survey of the whole field of modern psychiatry should fail to study the writings of Adler. He will find them extremely stimulating, and in addition he will make the valuable discovery that exactly the same case of neurosis can be explained in an equally convincing way from the standpoint of Freud or of Adler, despite the fact that the two methods of explanation seem diametrically opposed to one another. But things that fall hopelessly apart in theory lie close together without contradiction in the paradoxical soul of man: every human being has a power instinct as well as a sexual instinct. Consequently, he displays both of these psychologies, and every psychic impulse in him has subtle overtones coming from the one side as much as the other.

[757] Since it has not been established how many primary instincts exist in man or in animals, the possibility at once arises that an ingenious mind might discover a few more psychologies, apparently contradicting all the rest and yet productive of highly satisfactory explanations. But these discoveries are not just a simple matter of sitting down and evolving a new psychological system out of, shall we say, the artistic impulse. Neither Freud's nor Adler's psychology came into existence in this way. Rather, as if they were fated by an inner necessity, both investigators confessed their ruling principle, putting on record their own personal psychology and hence also their way of observing other people. This is a question of deep experience and not an

intellectual conjuring-trick. One could wish that there were more confessions of this sort; they would give us a more complete picture of the psyche's potentialities.

[758] My own views and the school I have founded are equally psychological, and are therefore subject to the same limitations and criticisms that I have allowed myself to urge against these other psychologists. So far as I myself can pass judgment on my own point of view, it differs from the psychologies discussed above in this respect, that it is not monistic but, if anything, dualistic, being based on the principle of opposites, and possibly pluralistic, since it recognizes a multiplicity of relatively autonomous psychic complexes.

[759] It will be seen that I have deduced a theory from the fact that contradictory and yet satisfactory explanations are possible. Unlike Freud and Adler, whose principles of explanation are essentially reductive and always return to the infantile conditions that limit human nature, I lay more stress on a constructive or synthetic explanation, in acknowledgment of the fact that tomorrow is of more practical importance than yesterday, and that the Whence is less essential than the Whither. For all my respect for history, it seems to me that no insight into the past and no re-experiencing of pathogenic reminiscences—however powerful it may be—is as effective in freeing man from the grip of the past as the construction of something new. I am of course very well aware that, without insight into the past and without an integration of significant memories that have been lost, nothing new and viable can be created. But I consider it a waste of time and a misleading prejudice to rummage in the past for the alleged specific causes of illness; for neuroses, no matter what the original circumstances from which they arose, are conditioned and maintained by a wrong attitude which is present all the time and which, once it is recognized, must be corrected *now* and not in the early period of infancy. Nor is it enough merely to bring the causes into consciousness, for the cure of neurosis is, in the last analysis, a moral problem and not the magic effect of rehearsing old memories.

[760] My views differ further from those of Freud and Adler in that I give an essentially different value to the unconscious. Freud, who attributes an infinitely more important role to the unconscious than Adler (this school allows it to disappear completely into the background), has a more religious temperament than Adler and for this reason he naturally concedes an autonomous, if negative, function to the psychic non-ego. In this respect I go several steps further than Freud. For me the unconscious is not just a receptacle for all unclean spirits and other odious legacies from the dead past—such as, for instance, that deposit of centuries of public opinion which constitutes Freud's "superego." It is in very truth the eternally living, creative, germinal layer in each of us, and though it may make use of age-old symbolical images it nevertheless intends them to be understood in a new way. Naturally a new

meaning does not come ready-made out of the unconscious, like Pallas Athene springing fully-armed from the head of Zeus; a living effect is achieved only when the products of the unconscious are brought into serious relationship with the conscious mind.

[761] In order to interpret the products of the unconscious, I also found it necessary to give a quite different reading to dreams and fantasies. I did not reduce them to personal factors, as Freud does, but—and this seemed indicated by their very nature—I compared them with the symbols from mythology and the history of religion, in order to discover the meaning they were trying to express. This method did in fact yield extremely interesting results, not least because it permitted an entirely new reading of dreams and fantasies, thus making it possible to unite the otherwise incompatible and archaic tendencies of the unconscious with the conscious personality. This union had long seemed to me the end to strive for, because neurotics (and many normal people, too) suffer at bottom from a dissociation between conscious and unconscious. As the unconscious contains not only the sources of instinct and the whole prehistoric nature of man right down to the animal level, but also, along with these, the creative seeds of the future and the roots of all constructive fantasies, a separation from the unconscious through neurotic dissociation means nothing less than a separation from the source of all life. It therefore seemed to me that the prime task of the therapist was to re-establish this lost connection and the life-giving co-operation between conscious and unconscious. Freud depreciates the unconscious and seeks safety in the discriminating power of consciousness. This approach is generally mistaken and leads to desiccation and rigidity wherever a firmly established consciousness already exists; for, by holding off the antagonistic and apparently hostile elements in the unconscious, it denies itself the vitality it needs for its own renewal.

[762] Freud's approach is not always mistaken, however, for consciousness is not always firmly established. This presupposes a good deal of experience of life and a certain amount of maturity. Young people, who are very far from knowing who they really are, would run a great risk if they obscured their knowledge of themselves still further by letting the "dark night of the soul" pour into their immature, labile consciousness. Here a certain depreciation of the unconscious is justified. Experience has convinced me that there are not only different temperaments ("types"), but different stages of psychological development, so that one can well say that there is an essential difference between the psychology of the first and the second half of life. Here again I differ from the others in maintaining that the same psychological criteria are not applicable to the different stages of life.

[763] If, to all these considerations, one adds the further fact that I distinguish between extraverts and introverts, and again distinguish each of them by the criterion of its most differentiated function (of which I can clearly make out four), it will be evident that hitherto my main concern as an investigator in the field of psychology has been to break in rudely upon a situation which, seen from the other two standpoints, is simple to the point of monotony, and to call attention to the inconceivable complexity of the psyche as it really is.

[764] Most people have wanted to ignore these complexities, and have frankly deplored their existence. But would any physiologist assert that the body is simple? Or that a living molecule of albumen is simple? If the human psyche is anything, it must be of unimaginable complexity and diversity, so that it cannot possibly be approached through a mere psychology of instinct. I can only gaze with wonder and awe at the depths and heights of our psychic nature. Its non-spatial universe conceals an untold abundance of images which have accumulated over millions of years of living development and become fixed in the organism. My consciousness is like an eye that penetrates to the most distant spaces, yet it is the psychic non-ego that fills them with non-spatial images. And these images are not pale shadows, but tremendously powerful psychic factors. The most we may be able to do is misunderstand them, but we can never rob them of their power by denying them. Beside this picture I would like to place the spectacle of the starry heavens at night, for the only equivalent of the universe within is the universe without; and just as I reach this world through the medium of the body, so I reach that world through the medium of the psyche.

[765] Thus I cannot regret the complications introduced into psychology by my own contributions, for scientists have always deceived themselves very thoroughly when they thought they had discovered how simple things are.

[766] In this introduction I hope I have conveyed to the reader that the psychological endeavours summed up in the layman's idea of "psychoanalysis" ramify very much further historically, socially, and philosophically than the term indicates. It may also become clear that the field of research presented in this book is far from being a distinct, easily delimited territory. On the contrary it is a growing science, which is only just beginning to leave its medical cradle and become a psychology of human nature.

[767] The exposition that now follows is not intended to describe the whole range of present-day psychological problems. It confines itself to surveying the beginnings of modern psychology and the elementary problems which fall chiefly within the province of the physician. I have included in my introduction a number of wider considerations so as to give the reader a more general orientation.

FREUD AND JUNG: CONTRASTS¹

[768] The difference between Freud's views and my own ought really to be dealt with by someone who stands outside the orbit of those ideas which go under our respective names. Can I be credited with sufficient impartiality to rise above my own ideas? Can any man do this? I doubt it. If I were told that someone had rivalled Baron Munchausen by accomplishing such a feat, I should feel sure that his ideas were borrowed ones.

[769] It is true that widely accepted ideas are never the personal property of their so-called author; on the contrary, he is the bondservant of his ideas. Impressive ideas which are hailed as truths have something peculiar about them. Although they come into being at a definite time, they are and have always been timeless; they arise from that realm of creative psychic life out of which the ephemeral mind of the single human being grows like a plant that blossoms, bears fruit and seed, and then withers and dies. Ideas spring from something greater than the personal human being. Man does not make his ideas; we could say that man's ideas make him.

[770] Ideas are, inevitably, a fatal confession, for they bring to light not only the best in us, but our worst insufficiencies and personal shortcomings as well. This is especially the case with ideas about psychology. Where should they come from except from our most subjective side? Can our experience of the objective world ever save us from our subjective bias? Is not every experience, even in the best of circumstances, at least fifty-per-cent subjective interpretation? On the other hand, the subject is also an objective fact, a piece of the world; and what comes from him comes, ultimately, from the stuff of the world itself, just as the rarest and strangest organism is none the less supported and nourished by the earth which is common to all. It is precisely the most subjective ideas which, being closest to nature and to our own essence, deserve to be called the truest. But: "What is truth?"

[771] For the purposes of psychology, I think it best to abandon the notion that we are today in anything like a position to make statements about the nature of the psyche that are "true" or "correct." The best that we can achieve is true expression. By true expression I mean an open avowal and detailed presentation of everything that is subjectively observed. One person will stress the *forms* into which he can work this material, and will therefore believe that he is the creator of what he finds within himself. Another will lay most weight on *what* is observed; he will therefore speak of it as a phenomenon, while remaining conscious of his own receptive attitude. The

truth probably lies between the two: true expression consists in giving form to what is observed.

[772] The modern psychologist, however ambitious, can hardly claim to have achieved more than this. Our psychology is the more or less successfully formulated confession of a few individuals, and so far as each of them conforms more or less to a type, his confession can be accepted as a fairly valid description of a large number of people. And since those who conform to other types none the less belong to the human species, we may conclude that this description applies, though less fully, to them too. What Freud has to say about sexuality, infantile pleasure, and their conflict with the “reality principle,” as well as what he says about incest and the like, can be taken as the truest expression of his personal psychology. It is the successful formulation of what he himself subjectively observed. I am no opponent of Freud’s; I am merely presented in that light by his own short-sightedness and that of his pupils. No experienced psychiatrist can deny having met with dozens of cases whose psychology answers in all essentials to that of Freud. By his own subjective confession, Freud has assisted at the birth of a great truth about man. He has devoted his life and strength to the construction of a psychology which is a formulation of his own being.

[773] Our way of looking at things is conditioned by what we are. And since other people have a different psychology, they see things differently and express themselves differently. Adler, one of Freud’s earliest pupils, is a case in point. Working with the same empirical material as Freud, he approached it from a totally different standpoint. His way of looking at things is at least as convincing as Freud’s, because he too represents a psychology of a well-known type. I know that the followers of both schools flatly assert that I am in the wrong, but I may hope that history and all fair-minded persons will bear me out. Both schools, to my way of thinking, deserve reproach for overemphasizing the pathological aspect of life and for interpreting man too exclusively in the light of his defects. A convincing example of this in Freud’s case is his inability to understand religious experience, as is clearly shown in his book *The Future of an Illusion*.

[774] For my part, I prefer to look at man in the light of what in him is healthy and sound, and to free the sick man from just that kind of psychology which colours every page Freud has written. I cannot see how Freud can ever get beyond his own psychology and relieve the patient of a suffering from which the doctor himself still suffers. It is the psychology of neurotic states of mind, definitely one-sided, and its validity is really confined to those states. Within these limits it is true and valid even when it is in error, for error also belongs to the picture and carries the truth of a confession. But it is not a psychology of the healthy mind, and—this is a symptom of

its morbidity—it is based on an uncriticized, even an unconscious, view of the world which is apt to narrow the horizon of experience and limit one's vision. It was a great mistake on Freud's part to turn his back on philosophy. Not once does he criticize his assumptions or even his personal psychic premises. Yet to do so was necessary, as may be inferred from what I have said above; for had he critically examined his own foundations he would never have been able to put his peculiar psychology so naïvely on view as he did in *The Interpretation of Dreams*. At all events, he would have had a taste of the difficulties I have met with. I have never refused the bitter-sweet drink of philosophical criticism, but have taken it with caution, a little at a time. All too little, my opponents will say; almost too much, my own feeling tells me. All too easily does self-criticism poison one's naïveté, that priceless possession, or rather gift, which no creative person can do without. At any rate, philosophical criticism has helped me to see that every psychology—my own included—has the character of a subjective confession. And yet I must prevent my critical powers from destroying my creativeness. I know well enough that every word I utter carries with it something of myself—of my special and unique self with its particular history and its own particular world. Even when I deal with empirical data I am necessarily speaking about myself. But it is only by accepting this as inevitable that I can serve the cause of man's knowledge of man—the cause which Freud also wished to serve and which, in spite of everything, he has served. Knowledge rests not upon truth alone, but upon error also.

[775] It is perhaps here, where the question arises of recognizing that every psychology which is the work of one man is subjectively coloured, that the line between Freud and myself is most sharply drawn.

[776] A further difference seems to me to consist in this, that I try to free myself from all unconscious and therefore uncriticized assumptions about the world in general. I say "I try," for who can be sure that he has freed himself from all of his unconscious assumptions? I try to save myself from at least the crassest prejudices, and am therefore disposed to recognize all manner of gods provided only that they are active in the human psyche. I do not doubt that the natural instincts or drives are forces of propulsion in psychic life, whether we call them sexuality or the will to power; but neither do I doubt that these instincts come into collision with the spirit, for they are continually colliding with something, and why should not this something be called "spirit"? I am far from knowing what spirit is in itself, and equally far from knowing what instincts are. The one is as mysterious to me as the other; nor can I explain the one as a misunderstanding of the other. There are no misunderstandings in nature, any more than the fact that the earth has only one moon is a misunderstanding; misunderstandings are found only in the realm of what we call "understanding."

Certainly instinct and spirit are beyond my understanding. They are terms which we posit for powerful forces whose nature we do not know.

[777] My attitude to all religions is therefore a positive one. In their symbolism I recognize those figures which I have met with in the dreams and fantasies of my patients. In their moral teachings I see efforts that are the same as or similar to those made by my patients when, guided by their own insight or inspiration, they seek the right way to deal with the forces of psychic life. Ceremonial ritual, initiation rites, and ascetic practices, in all their forms and variations, interest me profoundly as so many techniques for bringing about a proper relation to these forces. My attitude to biology is equally positive, and to the empiricism of natural science in general, in which I see a herculean attempt to understand the psyche by approaching it from the outside world, just as religious gnosis is a prodigious attempt of the human mind to derive knowledge of the cosmos from within. In my picture of the world there is a vast outer realm and an equally vast inner realm; between these two stands man, facing now one and now the other, and, according to temperament and disposition, taking the one for the absolute truth by denying or sacrificing the other.

[778] This picture is hypothetical, of course, but it offers a hypothesis which is so valuable that I will not give it up. I consider it heuristically and empirically justified and, moreover, it is confirmed by the *consensus gentium*. This hypothesis certainly came to me from an inner source, though I might imagine that empirical findings had led to its discovery. Out of it has grown my theory of types, and also my reconciliation with views as different from my own as those of Freud.

[779] I see in all that happens the play of opposites, and derive from this conception my idea of psychic energy. I hold that psychic energy involves the play of opposites in much the same way as physical energy involves a difference of potential, that is to say the existence of opposites such as warm and cold, high and low, etc. Freud began by taking sexuality as the only psychic driving force, and only after my break with him did he take other factors into account. For my part, I have summed up the various psychic drives or forces—all constructed more or less *ad hoc*—under the concept of energy, in order to eliminate the almost unavoidable arbitrariness of a psychology that deals purely with power-drives. I therefore speak not of separate drives or forces but of “value intensities.”² By this I do not mean to deny the importance of sexuality in psychic life, though Freud stubbornly maintains that I do deny it. What I seek is to set bounds to the rampant terminology of sex which vitiates all discussion of the human psyche, and to put sexuality itself in its proper place.

[780] Common-sense will always return to the fact that sexuality is only one of the biological instincts, only one of the psychophysiological functions, though one that is without doubt very far-reaching and important. But—what happens when we can no

longer satisfy our hunger? There is, quite obviously, a marked disturbance today in the psychic sphere of sex, just as, when a tooth really hurts, the whole psyche seems to consist of nothing but toothache. The kind of sexuality described by Freud is that unmistakable sexual obsession which shows itself whenever a patient has reached the point where he needs to be forced or tempted out of a wrong attitude or situation. It is an overemphasized sexuality piled up behind a dam, and it shrinks at once to normal proportions as soon as the way to development is opened. Generally it is being caught in the old resentments against parents and relations and in the boring emotional tangles of the “family romance” that brings about the damming up of life’s energies, and this stoppage unfailingly manifests itself in the form of sexuality called “infantile.” It is not sexuality proper, but an unnatural discharge of tensions that really belong to quite another province of life. That being so, what is the use of paddling about in this flooded country? Surely, straight thinking will grant that it is more important to open up drainage canals, that is, to find a new attitude or way of life which will offer a suitable gradient for the pent-up energy. Otherwise a vicious circle is set up, and this is in fact what Freudian psychology appears to do. It points no way that leads beyond the inexorable cycle of biological events. In despair we would have to cry out with St. Paul: “Wretched man that I am, who will deliver me from the body of this death?” And the spiritual man in us comes forward, shaking his head, and says in Faust’s words: “Thou art conscious only of the single urge,” namely of the fleshly bond leading back to father and mother or forward to the children that have sprung from our flesh—“incest” with the past and “incest” with the future, the original sin of perpetuation of the “family romance.” There is nothing that can free us from this bond except that opposite urge of life, the spirit. It is not the children of the flesh, but the “children of God,” who know freedom. In Ernst Barlach’s tragedy *The Dead Day*, the mother-daemon says at the end: “The strange thing is that man will not learn that God is his father.” That is what Freud would never learn, and what all those who share his outlook forbid themselves to learn. At least, they never find the key to this knowledge. Theology does not help those who are looking for the key, because theology demands faith, and faith cannot be made: it is in the truest sense a gift of grace. We moderns are faced with the necessity of rediscovering the life of the spirit; we must experience it anew for ourselves. It is the only way in which to break the spell that binds us to the cycle of biological events.

[781] My position on this question is the third point of difference between Freud’s views and my own. Because of it I am accused of mysticism. I do not, however, hold myself responsible for the fact that man has, always and everywhere, spontaneously developed a religious function, and that the human psyche from time immemorial has been shot through with religious feelings and ideas. Whoever cannot see this aspect of the human psyche is blind, and whoever chooses to explain it away, or to

“enlighten” it away, has no sense of reality. Or should we see in the father-complex which shows itself in all members of the Freudian school, and in its founder as well, evidence of a notable release from the fatalities of the family situation? This father-complex, defended with such stubbornness and oversensitivity, is a religious function misunderstood, a piece of mysticism expressed in terms of biological and family relationships. As for Freud’s concept of the “superego,” it is a furtive attempt to smuggle the time-honoured image of Jehovah in the dress of psychological theory. For my part, I prefer to call things by the names under which they have always been known.

[782] The wheel of history must not be turned back, and man’s advance toward a spiritual life, which began with the primitive rites of initiation, must not be denied. It is permissible for science to divide up its field of inquiry and to operate with limited hypotheses, for science must work in that way; but the human psyche may not be so parcelled out. It is a whole which embraces consciousness, and it is the mother of consciousness. Scientific thought, being only one of the psyche’s functions, can never exhaust all its potentialities. The psychotherapist must not allow his vision to be coloured by pathology; he must never allow himself to forget that the ailing mind is a human mind and that, for all its ailments, it unconsciously shares the whole psychic life of man. He must even be able to admit that the ego is sick for the very reason that it is cut off from the whole, and has lost its connection not only with mankind but with the spirit. The ego is indeed the “place of fears,” as Freud says in *The Ego and the Id*, but only so long as it has not returned to its “father” and “mother.” Freud founders on the question of Nicodemus: “How can a man be born when he is old? Can he enter the second time into his mother’s womb, and be born?” (John 3:4). History repeats itself, for—to compare small things with great—the question reappears today in the domestic quarrel of modern psychology.

[783] For thousands of years, rites of initiation have been teaching rebirth from the spirit; yet, strangely enough, man forgets again and again the meaning of divine procreation. Though this may be poor testimony to the strength of the spirit, the penalty for misunderstanding is neurotic decay, embitterment, atrophy, and sterility. It is easy enough to drive the spirit out of the door, but when we have done so the meal has lost its savour—the salt of the earth. Fortunately, we have proof that the spirit always renews its strength in the fact that the essential teaching of the initiations is handed on from generation to generation. Ever and again there are human beings who understand what it means that God is their father. The equal balance of the flesh and the spirit is not lost to the world.

[784] The contrast between Freud and myself goes back to essential differences in our basic assumptions. Assumptions are unavoidable, and this being so it is wrong to

pretend that we have no assumptions. That is why I have dealt with fundamental questions; with these as a starting-point, the manifold and detailed differences between Freud's views and my own can best be understood.

BIBLIOGRAPHY

BIBLIOGRAPHY

A. LIST OF PERIODICALS CITED, WITH ABBREVIATIONS

- Amer. J. Psychol.* = *American Journal of Psychology*. Baltimore.
- Arch. Psychol. Suisse rom.* = *Archives de psychologie de la Suisse romande*. Geneva.
- Arch. Rass. u. GesBiol.* = *Archiv für Rassen- und Gesellschaftsbiologie*. Leipzig and Berlin.
- Berl. klin. Wschr.* = *Berliner klinische Wochenschrift*. Berlin.
- J. abnorm. Psychol.* = *Journal of Abnormal Psychology*. Boston.
- Jb. psychoanal. psychopath. Forsch.* = *Jahrbuch für psychoanalytische und psychopathologische Forschungen*. Vienna and Leipzig.
- Med. Klinik* = *Medizinische Klinik*. Vienna and Berlin.
- Med. Pr.* = *Medical Press*. London,
- Münch. med. Wschr.* = *Münchener Medizinische Wochenschrift*. Munich.
- Monatshefte für Pädagogik und Schulpolitik*. Vienna.
- Proc. Soc. psych. Res., Lond.* = *Proceedings of the Society for Psychical Research*. London.
- Psychiat.-neurol. Wschr.* = *Psychiatrisch-neurologische Wochenschrift*. Halle.
- Z. ReligPsychol.* = *Zeitschrift für Religionspsychologie*. Halle.
- Z. Völkerpsychol. Sprachw.* = *Zeitschrift für Völkerpsychologie und Sprachwissenschaft*. Berlin.
- Zbl. Nervenheilk.* = *Zentralblatt für Nervenheilkunde und Psychiatrie*. Berlin.
- Zbl. Psychoan.* = *Zentralblatt für Psychoanalyse*. Wiesbaden.

B. GENERAL BIBLIOGRAPHY

- ABRAHAM, KARL. *Dreams and Myths*. Translated by William Alanson White. (Nervous and Mental Disease Monograph Series, 15.) New York, 1913.
- _____. "The Psycho-Sexual Differences between Hysteria and Dementia Praecox." In: *Selected Papers*. Translated by Douglas Bryan and Alix Strachey. (International Psycho-Analytical Library, 13.) London, 1927.
- ADLER, ALFRED. *The Neurotic Constitution*. Translated by B. Glueck and J. E. Lind. London, 1921. (Original: *Über den nervösen Charakter*. 1912.)

- _____. "Trotz und Gehorsam," *Monatshefte für Pädagogik und Schulpolitik* (Vienna), VIII (1910). Also in: ADLER and FURTMÜLLER, CARL (eds.). *Heilen und Bilden*. Munich, 1914.
- ASCHAFFENBURG, GUSTAV. "Die Beziehungen des sexuellen Lebens zur Entstehung von Nerven- und Geisteskrankheiten," *Münch. med. Wschr.*, LIII (1906), 1793–98.
- BARLACH, ERNST. *Der Tote Tag*. Berlin, 1912; 2nd edn., 1918.
- BINET, ALFRED. *Alterations of Personality*. Translated by Helen Green Baldwin. London, 1896. (Original: *Les Altérations de la personnalité*. 1892.)
- BINSWANGER, LUDWIG. "Freud'sche Mechanismen in der Symptomatologie von Psychosen," *Psychiat.-neurol. Wschr.*, VIII (1906).
- BINSWANGER, OTTO. *Die Hysterie*. (Spezielle Pathologie und Therapie, edited by Herman Nothnagel et al., 12, First Half, Part 2.) Vienna, 1904.
- BLEULER, EUGEN. "Die Psychoanalyse Freuds," *Jb. psychoanal. psychopath. Forsch.*, II (1910), 623–730.
- BOAS, FRANZ. *Indianische Sagen von der Nord-pacifischen Küste Amerikas*. Berlin, 1895.
- BREUER, JOSEF, and FREUD, SIGMUND. *Studies on Hysteria*. Translated by James and Alix Strachey. (Complete Psychological Works of Sigmund Freud, Standard Edition, 2.) London, 1955. (Original: *Studien über Hysterie*. 1895.)
- BRILL, A. A. "Psychological Factors in Dementia Praecox: an Analysis," *J. abnorm. Psychol.*, III (1908), 219.
- FLOURNOY, THÉODORE. *From India to the Planet Mars*. Translated by D. B. Vermilye. New York, 1900. (Original: *Des Indes à la planète Mars*. 1900.)
- _____. "Nouvelles observations sur un cas de somnambulisme avec glossolalie," *Arch. Psychol. Suisse rom.*, I (1901), 101–255.
- FOREL, AUGUSTE. *Hypnotism: or, Suggestion and Psychotherapy*. Translated from the 5th German edn. by H. W. Armit. London and New York, 1906. (Original: *Der Hypnotismus*. 1889.)
- FRANK, LUDWIG. *Affektstörungen. Studien über ihre Ätiologie und Therapie*. (Monographien aus dem Gesamtgebiete der Neurologie und Psychiatrie, 4.) Berlin, 1913.
- FREUD, SIGMUND. "Character and Anal Erotism." Translated by R. C. McWatters. In: Standard Edn.,* 9, 1959. (Original: "Charakter und Analerotik," *Psychiat.-neurol. Wschr.*, IX (1907).)
- _____. *Collected Papers*. (International Psycho-Analytical Library, 7–10, 37.) London, 1924–50. 5 vols.

- _____. "The Defence Neuro-Psychoses." Translated by John Rickman. In *Collected Papers*, q.v., 1. (To appear in the Standard Edn.,* 3.) (Original: *Die Abwehrneuropsychosen*. 1894.)
- _____. *The Ego and the Id*. Translated by Joan Riviere. (International Psycho-Analytical Library, 12.) London, 1927. (To appear in the Standard Edn.,* 19.) (Original; *Das Ich und das Es*. 1923.)
- _____. "Five Lectures on Psycho-Analysis." (Delivered on the Occasion of the Celebration of the Twentieth Anniversary of the Foundation of Clark University, Worcester, Mass., September 1909.) Translated by James Strachey. In: Standard Edn.,* 11. 1957. (Original: *Ueber Psychoanalyse*. 1910.)
- _____. "Fragment of an Analysis of a Case of Hysteria." Translated by Alix and James Strachey. In: Standard Edn.,* 7. 1953. (Original: "Bruchstücke einer Hysterie-Analyse." 1905.)
- _____. "Freud's Psycho-Analytic Procedure." Translated by J. Bernays. In: Standard Edn.,* 7. 1953. (Original: "Die Freud'sche Psychoanalytische Methode." 1904.)
- _____. *The Future of an Illusion*. Translated by W. D. Robson-Scott. London, 1928. (International Psycho-Analytical Library, 15.) (To appear in the Standard Edn.,* 21.) (Original: *Die Zukunft einer Illusion*. 1927.)
- _____. *The Interpretation of Dreams*. Translated by James Strachey. Standard Edn.,* 4, 5. 1953. (Original: *Die Traumdeutung*. 1900.)
- _____. *Jokes and Their Relation to the Unconscious*. Standard Edn.,* 8. 1960. (Original: *Der Witz und seine Beziehung zum Unbewussten*. 1905.)
- _____. "Obsessive Acts and Religious Practices." Translated by R. C. McWatters. In: Standard Edn.,* 9. 1959. (Original: "Zwangshandlungen und Religionsübung," *Z. ReligPsychol.*, I (1907).)
- _____. "On Beginning the Treatment (Further Recommendations on the Technique of Psycho-Analysis I)." In: Standard Edn.,* 12. 1958.
- _____. "On Psychotherapy." Translated by J. Bernays. In: Standard Edn. * 7. 1953. (Original: "Über Psychotherapie." 1904.)
- _____. "The Origin and Development of Psychoanalysis." See "Five Lectures on Psycho-Analysis."
- _____. "Psycho-Analytic Notes on an Autobiographical Account of a Case of Paranoia (Dementia Paranoides)." Translated by Alix and James Strachey. In: Standard Edn.,* 12. 1958. (Original: "Psycho-analytische Bemerkungen über einen autobiographisch beschriebenen Fall von Paranoia (Dementia Paranoides)." 1911.)
- _____. *The Psychopathology of Everyday Life*. Translated by A. A. Brill. In: *Basic Writings of Sigmund Freud*. New York, 1938. (To appear in Standard Edn.,* 6.) (Original: *Zur Psychopathologie des Alltagslebens*. 1901.)

- _____. "Recommendations to Physicians Practising Psycho-Analysis." Translated by Joan Riviere. In: Standard Edn.,* 12. 1958. (Original: "Ratschläge für den Arzt bei der psychoanalytischen Behandlung." 1912.)
- _____. *Sammlung kleiner Schriften zur Neurosenlehre*. Vienna, 1906–22. 5 vols. (Mostly translated in *Collected Papers*, q.v.)
- _____. "Three Essays on the Theory of Sexuality." Translated by James Strachey. Standard Edn.,* 7. 1953. (Original: *Drei Abhandlungen zur Sexualtheorie*. 1905.)
- FROBENIUS, LEO. *Das Zeitalter des Sonnengottes*. Vol. I (no more published). Berlin, 1904.
- FÜRST, EMMA. "Statistical Investigations on Word-Associations and on Familial Agreement in Reaction Type among Uneducated Persons." In: C. G. JUNG (ed.). *Studies in Word-Association*. Translated by M. D. Eder. London, 1918; New York, 1919.
- FURTMÜLLER, CARL. "Wandlungen in der Freud'schen Schule," *Zbl. Psychoan.*, III (1912–13), 189–201.
- GOETHE, JOHANN WOLFGANG VON. *Faust: Part One*. Translated by Philip Wayne. (Penguin Classics.) Harmondsworth, 1956.
- _____. *Werke*. (Gesamtausgabe.) Edited by Ernst Beutler. Zurich, 1948–54. 24 vols. (For the poem quoted on p. 315, see Vol. II, p. 43.)
- HARTMANN, CARL ROBERT EDUARD VON. *Philosophy of the Unconscious*. Translated by W. C. Coupland. London, 1931.
- HASLEBACHER, J. A., "Psychoneurosen und Psychoanalyse," *Correspondenzblatt für Schweizer Ärzte* (Basel), XL:7 (Mar. 1, 1910).
- HOCHE, ALFRED E. "Eine psychische Epidemie unter Aerzten," *Med. Klinik*, VI (1910), 1007–10.
- HORACE. *Satires, Epistles, and Ars Poetica*. With an English translation by H. Rushton Fairclough. (Loeb Classical Library.) London and New York, 1929.
- JAMES, WILLIAM. *Pragmatism*. London and Cambridge (Mass.), 1907.
- JANET, PIERRE. *Les Névroses*. Paris, 1898. Later edn., 1909.
- JONES, ERNEST. "Freud's Theory of Dreams," *Amer. J. Psychol.*, XXI (1910), 283–308.
- _____. *On the Nightmare*. (International Psycho-Analytical Library, 20.) London, 1931.
- _____. "Remarks on Dr Morton Prince's article 'The Mechanism and Interpretation of Dreams.'" *J. abnorm. Psychol.*, V (1910–11), 328–36.
- _____. *Sigmund Freud: Life and Work*. London, 1953–57. 3 vols. (Also pub. New York separately. Refs. are to the London edn.)

- JÖRGER, J. "Die Familie Zero," *Arch. Rass. u. GesBiol.* (Leipzig and Berlin), II (1905), 494–559.
- JUNG, CARL GUSTAV. "The Association Method." In: *Experimental Researches*. (Collected Works, 2.*) (Alternative source: *Collected Papers on Analytical Psychology*, q.v.)
- _____. *Collected Papers on Analytical Psychology*. Edited by Constance Long, translated by various persons. London and New York, 1916; 2nd edn., 1917.
- _____. "The Familial Constellations." In: *Experimental Researches*. (Collected Works, 2.*) (Alternative source: *Collected Papers on Analytical Psychology*, q.v.)
- _____. "New Paths in Psychology." In: *Two Essays on Analytical Psychology*, q.v.
- _____. "On Psychic Energy." In: *The Structure and Dynamics of the Psyche*. (Collected Works, 8.) 1960.
- _____. "On Psychological Understanding." In: *The Psychogenesis of Mental Disease*, q.v.
- _____. "Psychic Conflicts in a Child." In: *The Development of Personality*. (Collected Works, 17.) 1954.
- _____. *The Psychogenesis of Mental Disease*. (Collected Works, 3.) 1960.
- _____. "Psychological Aspects of the Mother Archetype." In: *The Archetypes and the Collective Unconscious*. (Collected Works, 9, part i.) 1959.
- _____. *Psychological Types*. (Collected Works, 6.*) (Alternative source: translation by H. G. Baynes, London and New York, 1923.)
- _____. *Psychology and Alchemy*. (Collected Works, 12.) 1953.
- _____. "The Psychology of Dementia Praecox." In: *The Psychogenesis of Mental Disease*, q.v.
- _____. "Psychology of the Transference." In: *The Practice of Psychotherapy*. (Collected Works, 16.) 1954.
- _____. *Studies in Word-Association*. In: *Experimental Researches*. (Collected Works, 2.*) (Alternative source: *Studies in Word-Association...* under the direction of C. G. Jung. Translated by M. D. Eder. London, 1918; New York, 1919.)
- _____. *Symbols of Transformation*. (Collected Works, 5.) 1956.
- _____. *Two Essays on Analytical Psychology*. (Collected Works, 7.) 1953.
- _____. *Wandlungen und Symbole der Libido*. Leipzig and Vienna, 1912.
- KUHN, FRANZ FELIX ADALBERT. *Mythologische Studien*. Gütersloh, 1886–1912. 2 vols.
- MAEDER, ALPHONSE. "Contributions à la psychologie de la vie quotidienne," *Arch. Psychol. Suisse rom.*, VI (1906–7), 148 ff., and VII (1907–8), 283 ff.

- _____. "Essai d'interprétation de quelques rêves," *Arch. Psychol. Suisse rom.*, VI (1906–7), 354 ff.
- _____. "Die Symbolik in den Legenden, Märchen, Gebräuchen und Träumen," *Psychiat.-neurol. Wschr.* (Halle), X (1908).
- MAYLAN, CHARLES E. *Freuds tragischer Komplex: Eine Analyse der Psychoanalyse*. Munich, 1929.
- MITCHELL, T. WEIR. Review of "Collected Papers on Analytical Psychology," *Proc. Soc. psych. Res., Lond.*, XXIX (1916), 191–95.
- MÜLLER-LYER, FRANZ. *The Family*. Translated by F. W. Stella Browne. London, 1931. (Original: *Die Familie*. 1912.)
- OPPENHEIM, H. "Thatsächliches und Hypothetisches über das Wesen der Hysterie," *Berl. klin. Wschr.*, XXVII (1890), 553.
- PAGE, H. W. "Shock from Fright." In: HACK TUKE. *Dictionary of Psychological Medicine*. London, 1892.
- _____. *Injuries of the Spine and Spinal Cord without Apparent Mechanical Lesions, and Nervous Shock—Their Surgical and Medico-Legal Aspects*. London and Philadelphia, 1883.
- PETERS, WILHELM. "Gefühl und Erinnerung." In: EMIL KRAEPELIN. *Psychologische Arbeiten*. Leipzig and Berlin, 1914. (Vol. 6, pt. 2, pp. 197–260.)
- PRINCE, MORTON. *The Dissociation of a Personality*. New York and London, 1906.
- _____. "The Mechanism and Interpretation of Dreams," *J. abnorm. Psychol.*, V (1910–11), 139–95.
- PUTNAM, JAMES J. "Personal Impressions of Sigmund Freud and His Work, with special reference to His Recent Lectures at Clark University," *J. abnorm. Psychol.*, IV (1909–10), 293, 372.
- _____. "Persönliche Erfahrungen mit Freud's psychoanalytischer Methode," *Zbl. Psychoan.*, I (1910-11), 533–48.
- RANK, OTTO. *The Myth of the Birth of the Hero*. Translated by William Alanson White. (Nervous and Mental Disease Monograph Series, 18.) New York, 1914.
- _____. "Ein Traum, der sich selbst deutet," *Jb. psychoanal. psychopath. Forsch.*, II (1910), 465–540.
- RIKLIN, FRANZ. *Wishfulfilment and Symbolism in Fairy Tales*. Translated by William Alanson White. (Nervous and Mental Disease Monograph Series, 21.) New York, 1915.
- SADGER, ISIDOR, "Analerotik und Analcharakter," *Die Heilkunde* (Vienna), Feb. 1910.

- SALLUST (C. Sallustius Crispus). [*Works.*] With an English translation by J. C. Rolfe. (Loeb Classical Library.) London and New York, 1921.
- SAVILL, AGNES. "Psychoanalysis," *Med. Pr.*, CLII (1916), 446–48.
- SCHOPENHAUER, ARTHUR. *Transcendent Speculations on the Apparent Design in the Fate of the Individual*. Translated by David Irvine. London, 1913. (Original: "Über die anscheinende Absichtlichkeit im Schicksale des Einzelnen," *Sämmtliche Werke*, ed. Julius Frauenstadt, 2nd edn., Leipzig, 1877, Vol. V [*Parerga und Paralipomena*, Vol. II], 222–23.)
- SHAW, GEORGE BERNARD. *Man and Superman*. London, 1903.
- SILBERER, HERBERT. "Phantasie und Mythos," *Jb. psychoanal. psychopath. Forsch.*, II (1910), 541–622.
- _____. *Problems of Mysticism and Its Symbolism*. Translated by Smith Ely Jelliffe. New York, 1917.
- SOMMER, ROBERT. *Familienforschung und Vererbungslehre*. Leipzig, 1907.
- SPIELMEYER, WALTER. Untitled note in *Zbl. Nervenheilk.*, XXIX (1906), 322–24.
- SPIELREIN, SABINA. "Über den psychologischen Inhalt eines Falls von Schizophrenie," *Jb. psychoanal. psychopath. Forsch.*, III (1912), 329–400.
- STEINTHAL, HEYMANN. "Die Sage von Simson," *Z. Völkerpsychol. Sprachw.*, II (1861), 129–78.
- STEKEL, WILHELM. "Ausgänge der psychoanalytischen Kuren," *Zbl. Psychoan.*, III (1912–13), 175–88.
- _____. *Die Sprache des Traumes*. Wiesbaden, 1911.
- VIGOUROUX, A., and JUQUELIER, P. *La Contagion mentale*. (Bibliothèque internationale de psychologie.) Paris, 1904.
- ZIERMER, MANFRED. "Genealogische Studien über die Vererbung geistiger Eigenschaften," *Arch. Rass.- u. GesBiol.*, V (1908), 178–220, 327–63.

INDEX

INDEX

A

- abasia, 5
- Abraham, Karl, 100, 122, 211, 220
- abreaction, 11, 14, 90, 254, 258, 262
- accidents, 223
 - apparent, 216
 - and emotional development, 177, 179
 - hysteria and, 90
- activity, and passivity, 274
- Acts of the Apostles, 53
- adaptation, 137, 182, 186ff, 248
 - abnormal, 249
 - failure in, 250
 - infantile, 137
 - new, and neurosis, 246
 - psychological, 271, 274
 - reduced, in neurotics, 191
 - resistance to, infantile, 249
 - transference and, 199, 285
- Adler, Alfred, 48, 87, 240, 247, 276, 285, 291f, 328, 335
- advice, 231
- affection, need for, 114
- affects: aetiological significance in hysteria, 10f
 - blocking of, 12, 90
 - children's, intensity of, 152
 - displacement of, 13
 - effects of traumatic, 12f
 - in normal persons, 11
 - retardation of development of, 130
- affluxes, libidinal, 126

Agamemnon, 154
aims, and causes, 291f
albumen, 331
alchemists, 326
altruism, 282
ambivalence: of father-*imago*, 321
 of instincts, 283
America: cross symbol in, 210
 psychoanalysis in, 88
amnesia: of childhood/infantile, 117, 163f
 neurotic, 164
Amsterdam Congress (1907), 317n
anal eroticism, 20, 21, 76
analogy, 240
analysis, 250
 fantasy invention during, 184
 first stage, 194f
 second stage, 197, 200
 of transference, 194ff *see also* dream-analysis
 psychanalysis
 psychoanalysis
analyst: analysis of, 198f, 235, 253, 260, 274
 fear of loss of, 63
 interference by, 272, 275
 loss of balance by, 235
 personality of, 198ff, 260, 274, 277
 possibility of deceiving, 280
 procedure of, 272
 relation to patient, 193, 235, 285
 requirements for, 202
 resistances of, 187
 transference relation to, 191, *see also* transference
analytical psychology, 229

anamnesis, 97
 and psychoanalysis, 230*f*, 271
anarchy, 283
ancestor-columns, 222
anchorite, 121
Andermatt, 35*ff*
animals, 242
 artistic impulse in, 123
 gradual change in reproductive principles, 123
 hypnosis in, 262
 laziness in, 208
 and remembered impressions, 179
 social sense in, 278
 training of, 182
Annunciation, 54
ant, queen, 315
anthroposophy, 326
antlers, 287
anxiety attacks, 162
apathy, neurotic, 113
aphonia, 5, 69, 70
“apothecaries’ messes,” 260
appetite, loss of, 248
archetype, 315*f*, 322*f*
 of father, 321, 322
artistic instinct, in animals, 123
ascetic practices, 337
Aschaffenburg, Gustav, 3*ff*, 10*n*, 304
Asmodeus, 322, 323*n*
association(s): chains of, and complex, 16
 concordant, in families, 136
 and dreams, 17, 143*f*
 and dream material, 238

free, 15, 58f
and number dreams, 49
and repression, 92
association experiments, 233
and families, 136, 304
and neurosis, 181
and psychoanalysis, 7
and unconscious, 148ff
assumptions: basic, 340
unconscious, 336
asthma, nervous, 162
astro-mythology, 210
attitude: change of, and conflict, 266
infantile, 249
patient's, to interpretation, 236
and reaction-type, 305
religious and philosophical, 241 *see also* emotional attitude
attraction, 125f
attributes, personification of, 40f
aufsitzen, 38n, 47n
augur, 260f, 267
authority: faith in, 282, 283
submission to, 284
autoerotism, 108
automatisms, unconscious psychic, and hysteria, 10
autonomy: individual, 283, 284
moral, 288, 289
auto-suggestion, 6f, 90

B

Baader, 326
baptism, 146f, 148
barbarism, 239
Barlach, Ernst, 339

barn, [35ff](#)
Bataks, [222](#)
bathing-place, [35ff](#)
bed-wetting, *see* enuresis
Bergson, Henri, [248](#), [287](#)
Bernheim, H., [254](#)
Bible, [53](#), [55](#)
bicycle, [218](#)
Binet, Alfred, [57](#)
Binswanger, Ludwig, [10 & n](#)
Binswanger, Otto, [60](#)
biography, [324](#)
biology, [337](#)
Bircher, [265](#)
bird(s), [287](#), [315](#), [321](#)
blackmail, [205](#), [208](#), [209](#)
black man (dream-symbol), [318f](#)
bladder, irritation of, and dreams, [31](#), [318](#)
Bleuler, Eugen, [40](#), [57](#), [58n](#), [229](#)
“blinded,” [70f](#), [72](#)
blinding, [319](#)
Boas, F., [211](#)
body-openings, [127](#)
Breuer, Josef, [10](#), [11](#), [90f](#), [254](#)
 “Anna O.” case, [11](#)
 Studies on Hysteria, [11](#), [12n](#), [34](#), [89](#), [92](#), [258](#)
bridge, [141f](#)
Brill, A. A., [56](#), [323n](#)
brooding, [185](#)
bull, [217](#)
butterfly(-ies), [105](#), [117](#)

cab, 96

Carus, K. G., 326

castration complex, 151

caterpillar(s), 105, 117, 118

catharsis/cathartic method, 259f

- and hysteria, 90f
- and neurosis, 14, 254f
- psychoanalysis and, 271, 274

Catherine of Siena, St., 28

Catholic Church, 284

cats, 68ff, 72

causalism, 284

causality: and dreams, 26

- need for, and fantasy formation, 173
- psychology and, 292, 295

cause(s): and aims, 291f

- first, 295

cave, 70f

ensor, 29, 31, 43

chance, and psychoanalysis, 272, 275, 278, 282

Charcot, J.-M., 89f

chestnuts, 40, 41

childbirth, 103

children: parental influences on, 135ff

- sexuality in, 94, 98ff, *see also* sexuality

Christ, 320n

Christianity, 277, 286, 289, 327

Christian Science, 230, 255, 260, 265, 326

Church, the, 192f *see also* Catholic Church

church-spire, 214

Cicero, 111

civilization, 283, 288

- history of, symbols in, 293

Claparède, Edouard, [45](#), [120](#), [248](#)
Clark University, [57](#)
Cleanthes, [303](#)
climacteric, [306ff](#)
Clytemnestra, [154](#)
coercion, [284](#)
cognition, theory of, [165](#), [296](#)
Columbus, Christopher, [102](#)
compensation, [155](#)
complex(es): association experiment and, [181](#)
 father-, Freud's, [339](#)
 feeling-toned, [26](#)
 nuclear, [157](#), [245f](#)
 resolution of, [15f](#)
 tendency to reproduction, [16](#) *see also* castration complex
 Electra complex
 incest complex
 Oedipus complex
 parental complex
complex indicators, [148](#)
“components,” of sexuality, [109](#), [111](#)
conation, [125](#)
condensation, [33](#), [62](#)
confession, [192f](#), [205f](#)
 formulas of, [40](#)
 subjective, psychology as, [336](#)
conflict(s), [129](#), [157](#)
 actual, [181](#)
 child and adult, [157](#)
 external and internal solutions, [266f](#)
 infantile, [245](#)
 instinct/conventional morality, [267](#)
 love/duty, [267](#)

moral, [259](#), [263](#), [282](#)

consciousness: and adaptation, [240](#)

- individual, and unconscious, [315](#)
- infantile, [164](#)
- and infantile attitude, struggle, [320](#)
- not whole of psyche, [66](#), [140](#)
- primitive, [319](#)
- psyche and, [340](#)
- psychological determinants of, [230](#)

constellation(s): affective, [16f](#)

- analysis of, in association experiment, [18](#)
- of childhood sexuality, [99](#)
- psychic, elements of, [26](#)
- unconscious, [148](#)

contagion, psychic, [306](#)

context, importance in psychology, [6](#)

conversion of excitation, [12](#), [90](#)

coughing, [206](#)

cramps, [162](#)

creation, regression and, [180](#)

criticism of psychoanalysis, and personal undercurrents, [75](#)

cross, [210](#)

cryptomnesia, [55](#)

cucumber, [149](#)

culture, [198](#), [287](#)

- and nature, [213](#)

cure: faith and, [254](#)

- necessity to attempt, [263](#)

D

daemon, [314](#), [322f](#)

dark night of the soul, [331](#)

“decent,” [256](#)

deception, of analyst, 275, 281

degeneration/degeneracy, hereditary, 91, 130

delusions, 114

dementia praecox, 40n, 244

- infantilism in, 129
- libido in, 119ff
- mythology and, 225
- psychoanalysis and, 202 *see also* schizophrenia
- Schreber case

depressions, psychogenic, 162

depth psychology, 57, 229

desire, 125, 247 *see also* libido

destiny: biological, 288

- and psychological tendency, 136
- source of, personification, 314f

determinants, 287

determination: causal and final, 296

- unconscious, 158ff

devil, 314, 321n

diagnosis of facts, experimental, 7

digestive disorders, 248

dinner-party, 32

Dionysus, 41

disgust, 19, 21f

disintegration, chemical, 128

dissociation: inner, 291

- psychic, and hysteria, 10

divine, the, and father-*imago*, 315

doctor, as analysand, 272

dogma, 193, 241, 324f, 327

“Dora analysis,” Freud’s, 9n

dragon, 216

- hero’s fight with, 319

dream(s), 143ff

alleged absence of, 234f

analysis of, *see* dream-analysis

archaic thinking in, 241

Freud and, 14, 17, 25ff

Freud's vs. Jung's views, 240, 330

and hysterics, 28

of incestuous cohabitation, 280

interpreted by rumour, 45

manifest and latent content, 25

meaningfulness of, 25f

no fixed meanings, 236, 238

and number fantasies, 48ff

and particular theories, 280

and past experiences, 143ff

prospective function, 200f, 238

psychoanalysis of, *see* dream-analysis

and reminiscence, 149

in second stage of analysis, 200

sexuality in, 238ff

as subliminal picture of dreamer's waking state, 240

suggested, 275

symbolism in, 252

technique of elucidation, 144

teleological significance, 201, 214

unconscious origin, 144

undisguised, 280

use in analysis, 273

as wish-fulfilment, 27, 62ff *see also* fear

resistance

INSTANCES OF DREAMS (in order of occurrence in text): black-clothed man dragging
woman over precipice, 29f

need to urinate felt in presence of Pope Pius X, 31

girls' bathing expedition and journey with teacher, 35ff

season ticket numbered 2477, 48f
gambling on number 152, 50
analyst's bill with interest, 50f
"Luke 137," 53
Jewess drinking whisky, 61
toiling up hill, 62
rocky path and hammering with stone, 64
woman alone in ballroom, theatre, etc., 66f
cats and wild man on rocky path, 68f
gnomes in cave, 70f
exhibitionist in grey suit, 172f
girl bitten by wolf while looking for strawberries, 209f
tall girl who meets policeman, 214
house on fire, 215
stork in fir-wood, 220
fire in hotel, 236
mounting stairs with mother and sister, 237
lady in lascivious situation with Dr Jung, 279
black snake seeking to bite boy's face, 318
black man on boy's bed, 318
dream-analysis, 31, 234
 method, 144ff, 234
dream-material, 27, 145
 many-sidedness of, 236
dream-thought and content, confusion, 62, 64
drives, sexual, plurality of, 108 *see also* instinct(s)
drowning, 221
Dubois, Paul, 15 & n, 184, 231, 259, 270
duplication, of personalities, 40
duty(-ies), 186f
 biological, 287, 288
 and love, conflict, 267
 neglected, and dreams, 238
dyspepsia, 248

E

- Edda, [216](#)
- Eddy, Mary Baker, [326n](#)
- education: moral, [213](#)
- and neurosis, [213](#)
 - psychoanalysis and, [196f](#)
 - psychoanalytic, [79](#)
 - social, [328](#)
- educative method, [15](#)
- ego: “place of fears,” [340](#)
- relation to non-ego, [294](#)
- egoism: and altruism, [282](#)
- childish, [233](#)
- élan vital*, [248](#)
- Electra complex, [154f](#), [168](#), [245](#)
- electricity, [269](#)
- electromagnetism, [124](#)
- elephant, [149](#)
- emotional attitude, infantile, and neurosis, [137](#)
- emotional rapport, lack of, [119f](#)
- empathy, [190](#), [264n](#), [277](#), [285](#), [286](#)
- encasement, [165](#)
- “end of the world,” [120](#)
- energetic viewpoint, [247](#)
- energy, [124](#)
- conservation of, [109](#), [111](#), [112](#), [115](#), [247](#), [296](#)
 - hypothetical idea of, [124](#)
 - physical, and libido, compared, [124](#)
 - psychic, [121](#), [122](#), [247](#), [285](#), [337](#)
 - single, in physics, [111](#)
- enlightenment, sexual, [8](#), [219](#), [224](#)
- Ennemoser, J., [326](#)
- enthusiasm, [274](#)

enuresis, [256f](#), [262](#), [317](#)
environment: culture and, [287](#) *see also* neurosis
envy, patient's, of analyst, [50](#)
erection, in children, [100](#)
erogenous zones, [108](#)
Eros, [122n](#), [285](#)
eroticism: in analysis, [195](#) *see also* anal eroticism
error, value of, [200](#)
Eschmayer, [326](#)
ethnopsychology, [203](#)
evolution, [123](#)
exaltations, psychogenic, [162](#)
excitation: retention of, [90](#) *see also* affect, blocking of
excitement, suppressed, [318](#)
exhibitionist, [172f](#)
expectation, [286](#), [318](#)
expediency, [263](#), [265](#), [267](#), [269](#)
experience, inner, [320n](#)
expression, true, [334](#)
extraversion, [331](#)

F

“faculties,” psychic, [111](#), [114](#)
fairytales, [215f](#)
faith, [339](#)
 in authority, [282](#), [289](#)
 patient's, [254f](#), [260f](#)
Falke, Konrad, [79](#)
family: analyst assimilated to, [194](#)
 conformity of reaction type in, [136](#)
 father's significance in, [303f](#)
 reaction-types in, [304f](#)
family milieu, and neurosis, [135f](#)

family romance, 301, 338, 339

fanaticism, 269

fantasy(-ies): aetiological significance, 188, 245, 248f

artificiality of, 183

bondage to, 182

cessation of, 188

conscious, 139, 151

defecation, 20f

in dementia praecox, 120

of father in obscene attitude, 173

in hysterics, 19ff, 130ff

infantile, 138, 249

—, transference and, 283

murderous, 146

and neurosis, 157, 244

neurotic, evaluation of, 182ff

in neurotics, 138

patient's attitude to, 185f

perverse, in case of hysteria, 172f

“reality” of, 183f

reasons for inventing, 174f

sexual, in children, 103

and sexual function, 103

transference, erotic, 279, 285

traumatic effect of, 96, 97f

unconscious, 138, 139ff, 151ff

—, origin of, 152ff

value of, 188 *see also* incest fantasies

fantasy activity, excessive, 133 *see also* hypnosis

fantasy systems, unconscious, 113f

fate, of child, restricted to parents, 152

father: analyst as, 284

animal, 319

and personification of destiny, 315

relation to, and neurosis, 303
significance of, 301ff
wolf as symbol of, 211f *see also* Oedipus complex parents

father-*imago*, *see imago*

Faust, *see* Goethe

fear, 318

- dream as fulfilment of, 60, 62, 70
- of father, 211ff, *see also* father
- and hypnosis, 262
- in Judaism, 320n

fertilization: chance and assured, 123

- child's theories of, 221

fever, 185

fig-tree, barren, 54

finality, 295

finger-sucking, 106, 212

fire, dream-symbol, 215, 236

firewood, 62

flesh and spirit, balance, 340

Flournoy, Théodore, 55, 57

folie à deux, 316

folklore, 146, 324

“fonction du réel,” 120

food, and mother, 153

Fordham University, 87

Forel, Auguste, 252, 275

forgetfulness, and inhibition, 32

forgetting, 6, 92

foster-children, 168

Frank, Ludwig, 254, 261, 265

freedom, 270, 287

Freud, Sigmund, 40, 56, 64, 74, 76, 85, 88, 104, 105, 122, 130, 132, 137, 148, 161, 180, 190, 200, 211, 225, 229, 252, 275f, 290, 324ff

on analysis of one's own dreams, 252
development of his views, 18ff
"Dora analysis," 9n
and dreams, 25ff, 200f, 240
German criticism of, 57f
and incest complex, 156
and infantile sexuality/sexual traumata, 13, 94f, 98, 114, 118
and latency period, 164f
and libido concept, 111
"Lucy R." case, 93
misunderstandings of, 167
and number symbolism, 48
and parental complex, 135
and regression, 163, 168
on relationship to father, 303, 315
and repression, 91f
and Schreber case, 119
theory of hysteria/neurosis, 3ff, 10ff, 22, 90f, 243ff, 259
and transference, 283
and unconscious, 140, 141 *see also* sexuality
WORKS: "Analysis of a Phobia in a Five-year-old Boy," 317n
"Bruchstück einer Hysterie-analyse," 3n
"Charakter und Analerotik," 76
Collected Papers, 94n
"The Defence Neuro-Psychoses," 12, 13
The Ego and the Id, 340
"Five Lectures on Psycho-Analysis," 57n
"Fragment of an Analysis of a Case of Hysteria," 3n, 9n, 14n, 17, 18, 23, 24
"Freud's Psycho-Analytic Procedure," 14n
The Future of an Illusion, 335
The Interpretation of Dreams, 14, 17, 25ff, 34, 58, 335
"Jokes and their Relation to the Unconscious," 34
"Obsessive Acts and Religious Practices," 320n
"On Beginning the Treatment," 272n

“On Psychotherapy,” 14n

“Psycho-Analytic Notes on an Autobiographical Account of a Case of Paranoia,”
119n

Psychopathology of Everyday Life, 150

“Recommendations to Physicians Practising Psycho-Analysis,” 253n

Sammlung kleiner Schriften zur Neurosenlehre, 94n

Studies on Hysteria, 11, 12n, 13, 34, 89, 92, 93n

“Three Essays on Sexuality,” 17, 18, 100, 111, 118, 122, 143, 166, 168

friendship, 286

Frobenius, L., 211

function(s): development from reproductive instinct, 123

especially a final concept, 296

four, 331

immature and developed, 116

psychological, necessary, 293

religious, 339 *see also* nutritive function; reality function

Fürst, Emma, 136, 304f

Furtmüller, C., 274f

G

Galileo, 102

gametes, reduction in number, 123

genital organs, and sexuality, 108

German army, 317n

Germans, 158

Germany, 166, 295

Freudian theory and, 57f, 95

“getting stuck,” 133, 180, 181, 189, 199, 235

girls: hysteria in, 171f

Oedipus complex in, 153

glands, genital, 295

gnomes, 70

God, 321n, 327, 340

gods, 156

Goethe, J. W. von, 315

Faust, 26ff, 65, 77, 85, 265, 338

grandfather, 323n

Gregory, Dr, 87

Gross, Otto, 304n

Gulliver situation, 70, 72

H

habits, bad, in children, 106, 108, 213, 244

hammering, 64f, 72

hand, 127

Hartmann, C. R. E. von, 140, 326

Haslebacher, J. A., 76n

headaches, 205

healing, need of, 328

heaven, kingdom of, 277

hebephrenia, 129

hedonism, 291f

Hermes, 40

hero-dragon myth, 216, 319

Hinkle, Beatrice, 153

Hoch, August, 56

Hoche, Alfred E., 57 & n

homosexuality, 108, 109f, 112

hope, 286

Horace, 302, 322n, 323n

horse(s): American Indians and, 240

trotting, shock from, 97, 131, 158ff

hotel (dream-symbol), 236

human situation, original, 315, 319

hunger, 107, 111, 123

importance in psychology, 4

hypnosis/hypnotism, 89, 231, 254ff, 278

as auxiliary to psychoanalysis, 262
light and total, 259, 261
and reminiscences, 92 *see also* suggestion
hypnotists, French, 326
hysteria, 130, 168, 248
 applicability of Freudian view to, 23
 cause and symptom in, 10*f*
 and childhood trauma, 89, 94
 fantasy-activity in, 19
 Freudian theory, 10*ff*
 —, Aschaffenburg and, 3*ff*
 —, historical survey of, 10*ff*
 and hidden thought-processes, 60
 psychogenesis of, 90
 as psychogenic illness, 4, 10, 102
 and sexuality, 4*ff*, 13, 19, 94
 traumatic, limits of, 5
 in young girls, 171*ff* *see also* affects neurosis suggestion

I

idea(s), 333
 gained in analysis, use of, 279
 initial, as symbol of complex, 16
 subjective, 333*f*
ideal, identity with, 68
identification: of analyst with patient, 179
 of children with parents, 135*f*
images, psychic, 332
imago: father-, 315, 321
 parental, 134, 190
imitativeness, 135
immoral impulses, 288
immortality, 27, 142
impotence, 54*f*

impressions: conditioned by predisposition, 177
early, 136
—, suspect reality of, 179

incest, 155, 156, 157, 222
complex, 207, 210 *see also* Oedipus complex
fantasies, 208, 237, 239
taboo, 247

incest barrier, 156, 247

independence, child's desire for, 306

Indians, American, 240

indignation, uselessness of, 100

individual, variability of, 292

individualization, urge to, 284

individual psychology, 328

indolence, 207, 289

inertia, 207, 249

infantile-insubordinate type, 285

infantile level, reversion to, 170ff

infantile-obedient type, 285

influences, parental, on children, 135ff

inhibition, mental, 32

initiation, rites of, 146, 337, 339, 340

insight: and emotions, 138
gained in analysis, use of, 279

instinct(s), 336
ambivalence of, 283
co-existence in child, 107
multiplicity/plurality of, 126, 165
nutritive, 248
preformed, 315
primary, 328
sexual, 111, *see also* sexuality

insurance money, and hysteria, 5

intelligence test, 271, 274
intention, unconscious, 161
interest, 120f, 232, 286
 erotic, 120f
interpretations: complete, sometimes unwise, 235f
 Freudian, alleged arbitrary character, 6, 230
 in Freudian analysis, 15
 use as symbols in later dreams, 280 *see also* dreams
intestinal canal, 222
intra-uterine period, 105
introversion, 133n, 180, 331
 of libido, 187
intuition, 215
inventiveness, 183
investment, libidinal, of analyst, 285
irresponsibility, 289
irritability, 110
Isis, 40
isolation, moral, 192
Isserlin, M., 58n

J

jack-in-the-box, 222
James, William, 86, 291
Janet, Pierre, 10, 57, 113n, 120, 130, 248, 250
jealousy, 114, 154, 172
Jehovah, 320n, 339 *see also* Yahweh
Jelliffe, Smith Ely, 86
Jewess, 61f
Job, Book of, 321
John, Gospel of, 340
Jonah, 210
Jones, Ernest, 3n, 10n, 56 and n, 57n, 64, 73, 211, 304n

Jörger, J., 303n

Journal of Abnormal Psychology, 57

Judaism, 320n

Jung, Carl Gustav:

CASES IN SUMMARY (in order of presentation, numbered for reference):

[1] Psychotic hysteric, with compulsive defecation fantasies.— 20f

[2] Young woman, suffering from hysteria after fright from cab-horses. 96f, 130ff, 158ff

[3] Young man, returned to homosexuality after disappointment in love.—109, 112

[4] Two sisters, illustrating difficulties of engagement period.— 171ff

[5] Schoolgirl, “blackmailed” by boy fellow-pupil after making fun of teacher.— 205ff

[6] Neurotic, in late thirties, with resistance to his professional work.— 232

[7] Woman, 40, who developed neurotic lack of interest after childbearing period.— 232

[8] Peasant woman, thanked Dr Jung for his “decency” after hypnotic treatment.— 256

[9] Girl, enuretic, with romantic approach to hypnosis.—256

[10] Woman, 65, with knee pains, “cured” by hypnosis.—257f

[11] Woman, 55, with climacteric neurosis, illustrating search for father-substitute in unsatisfactory marriage.—306ff

[12] Man, 34, with nervous stomach trouble, illustrating effect of masochistic-homosexual relationship to father.—308ff

[13] Woman, 36, with anxiety, depression, and guilt-feeling for marrying against father’s will.— 310ff

[14] Boy, 8, enuretic, illustrating over-dependence on mother and fear of father.— 317ff

WORKS: “Association, Dream, and Hysterical Symptoms,” 70n

“The Association Method,” 57n, 136n, 290n

Collected Papers on Analytical Psychology’ 35n, 48n, 57n, 229n, 243n, 252n, 290ff, 301n

Diagnostische Assoziationsstudien, 7n

Experimental Researches, 7n, 29n, 70n, 136n

“The Familial Constellations,” 57”, 136n, 290n

“New Paths in Psychology,” 79n, 290n, 294n

“On Psychic Energy,” 338n

Psychiatric Studies, 55n

“Psychic Conflicts in a Child,” 46n, 57n, 218n, 290n

“Psychoanalyse und Assoiationsexperiment,” 7n

“Psychoanalysis and Association Experiments,” 7n

The Psychogenesis of Mental Disease, 120n, 294n

“Psychological Aspects of the Mother Archetype,” 303n

Psychology and Alchemy, 322n

“The Psychology of Dementia Praecox,” 34, 40n, 120f, 122

“Psychology of the Transference,” 193n

Studies in Word Association, 7n, 134

Symbols of Transformation, 23n, 68n, 111n, 177n, 124n, 151, 155, 180, 211, 212n, 218n, 220n, 222n, 241n, 301n, 303n

Two Essays on Analytical Psychology, 79n, 96n, 160n, 294n

Wandlungen und Symbole der Libido, 68n, 80n, 119, 301

K

Kant, Immanuel, 140, 296

Kepler, J., 9, 267

Kranefeldt, W. M., 324ff

Kuhn, Adalbert, 220

L

lability, 183n

lake, 35ff

latency, sexual, 164ff

law, criminal, 326

laziness, 207f, 224, 274, 277

least resistance, law of, 274, 277f, 281

libido, 18f, 79f, 110, 303

alimentary, 118, 127

bisexuality of, 153

change in author’s conception of, 122f

compulsion of, 209

conservation of, 114ff
damming up of, 163, 286
in dementia praecox, 119ff
desexualized, 125
displacements of, abnormal, 121
dreams and use of, 200
energetic theory, 112ff
excess of, and human acts, 112f
fixation of, *see* fixation
genetic conception, 122ff
a hypothesis, 124
infantile, nature of, 116
intensity, in children, 115, 118
investment of, 19, 285
localization of, 118
migration of, 127f
non-sexual conception of, 118f
primary and secondary, 125f
regression of, *see regression*
repressed, 223
sexual, introversion of, 121f
sexualis, and hypnosis, 262
splitting of, 170
transference to extra-familial object, 207
and unconscious, 114
unconscious, in analysis, 250
use of term, 111, 285

licentiousness, 79, 289

Liébeault, A.-A., 326

life, first and second half of, 331

life-force, 125

life-instinct, two modes of functioning, 105

life-urge, 123

literature, psychoanalytic: confusion in, 275

need of knowledge of, [273](#)
Little Red Ridinghood, [210](#)
locomotive, [296](#)
loneliness, [67](#)
Lourdes cures/water, [255](#), [260](#)
love, [320n](#)
 of analyst, [273f](#), [276](#), [286](#), *see also* transference
 disappointments in, [248](#)
 infantile conception, [197](#)
Lôwenfeld, L., [17](#)
Löy, R., Jung's correspondence with, [252ff](#)

M

Maeder, Alphonse, [34](#), [201](#), [211](#), [238](#)
maenads, [41](#)
magnetism, [326](#)
maieutics, [225](#)
Malthusianism, [126](#)
“mamma,” [153](#)
“man as he really is,” [197](#)
man, normal, [197](#)
Maria, Axiom of, [322n](#)
marriage difficulties, [233](#)
masculinity, premature, [318](#)
Mass, the, [320n](#)
mass therapy, and psychoanalysis, [17](#)
masturbation, [20](#), [21](#), [99](#), [106](#), [127](#), [212](#), [214](#), [263](#)
 infantile, [164](#)
materialism, scientific, [291](#)
maturation, [111](#), [129](#)
maturity, [115](#)
 period of, [117](#)
Mayer, Robert, [109](#), [247](#)

Maylan, C. E., [325n](#)
mechanics, [124](#)
medicine, and psychoanalysis, [229](#)
medicine-man, [255](#)
megalomania, [179](#)
memories(-y), [134](#)
 continuity of, [117](#)
 lapses of, [150](#) *see also* reminiscences
memory-reproduction, [164](#)
Mendel, Kurt, [76](#)
menstruation, in child, [100](#)
mental healing/healers, [230](#), [255](#), [260](#)
mentality, infantile, [137f](#)
mesmerism, [326](#)
metaphysical need, man's, [241](#)
method(s): choice of, [266](#)
 Freudian, as auto-suggestion, [6f](#)
 —, development of, [14f](#)
 —, and hysteria, [5f](#)
 —, theoretical foundations, [15](#)
 psychoanalysis a, [271](#)
 psychoanalytic, [30f](#), [229](#)
 —, purely empirical, [75](#)
Meyer, Adolf, [56](#)
Middle Ages, [283](#), [288](#)
Milan, [42](#), [44](#)
Mimallones, [41](#)
mimicry, [281](#)
mind, collective, [225](#)
misconceptions, patients', [272](#)
mistakes, [149](#), [279](#), [282](#)
misunderstanding, [336](#)
Mitchell, T. W., [295](#), [296](#)

Moleschott, J., 295

Moltzer, Mary, 83, 204

money-box, 208

money-making, 288

Montessori, Maria, 278n

moral balance, dreams and restoration of, 254

moral defects, admission of, 235

morality/morals: Aschaffenburg on, 8

- psych(o)analysis and, 78, 196, 271, 288
- religion and, 337
- sexual, current, 288
- transitoriness of forms of, 289

Mosaic law, 320n

mother(s): and child's fate, 303

- cutting open body of, 210
- as food-giver, 153
- significance to child, 153
- unmarried, 288
- violation of, 211 *see also* parents

mountain-climber, 169

Muller-Lyer, 284

Munchausen, Baron, 333

murder, 155

music, 123

mysticism, 140, 339

mythology, 210, 220f, 225, 324, 330

- and baptism, 146
- psychoanalysis and, 202
- and psychology, 203
- sexual symbolism in, 23
- and unconscious fantasies, 139, 151 *see also* astromythology

myth(s): fertility, 216

- solar, 210

therapeutic significance of, [319](#) *see also* hero-dragon myth

N

natural selection, [103](#)

nature, collective, man's, [315](#)

nausea, [205](#), [222](#)

necessity, vital, [292](#)

nest, [287](#)

 building, [124](#), [315](#)

Neue Zürcher Zeitung, [78](#)

neurosis(-es): aetiological factors in childhood, [129f](#), [157ff](#)

 association experiment and, [181](#)

 of childhood, [114](#), [157](#)

 and childhood environment, [135ff](#)

 and childhood trauma, [89](#), [156](#)

 climacteric, [306](#)

 and displacements of libido, [121](#)

 energetic viewpoint, [247](#)

 and fantasies, [157](#)

 Freud's theory of, *see* Freud

 introversion of libido and, [122](#)

 Janet's view, [130](#)

 libido theory of, [79f](#), [113](#)

 moment of outbreak, [246](#)

 no uniform direction in, [271](#), [274](#)

 obsessional, [12](#)

 and parental influence, [136](#)

 and past events, [91](#), [94](#), [244](#)

 predisposition and environment, [91ff](#)

 prospective explanation, [182](#)

 psychoanalysis and, [184ff](#), [231ff](#)

 psychogenic, two groups, [12](#)

 purpose in historical elements of, [167](#)

 purposiveness of, [185](#)

and retardation of affective development, 130
and unconscious constellation, 150
as unsuccessful attempt at self-cure, 180, 250 *see also* hysteria
neurotics: infantile sexuality of, 166
often spoiled as children, 137
New Testament, 53
Nietzsche, Friedrich, 291, 325
Nicodemus, 340
non-conscious psychic processes, 113ff
“nothing but” psychology, 289
numbers: mysticism of, 297
symbolism of, 48ff
nutritive function, 116, 125
importance, 104ff
libido and, 127
and pleasure, 106
and sexual function, 105f, 127

O

occultism, 326
Oedipus complex, 152ff, 245, 247
and neurosis, 156, 168
reactivation of, 248 *see also* girls
offspring, protection of, 103, 125f
Old Testament, 320n
oneiromancy, 234
one-sidedness, scientific, 107
Oppenheim, H., 11
opportunism, 263
opposites: play of, 337
principle of, 329
oral zone, 116 *see also* nutritive function
sucking over-determination, 17

overwork, 209

P

Page, Herbert W., 89

pain: avoidance of, 274, 278

hysterical, 162

Pallas Athene, 222, 330

Paracelsus, 326

paramnesia, 218

parental complex, 133*f*, 182

parents: detachment from, 154

influence of, and neurosis, 136

neurotic, 137

slavery to, 316 *see also* Oedipus complex

Paris, 310

Parliament, English, 201

parricide, 155

parties supérieures et inférieures, 248

Passavant, J. K., 326 passivity, *see* activity

past: reversion to, 135 *see also* present

path, rocky, 64, 68, 70*f*

pathology, 340

patient: doctor as, 272

imitation of analyst, 275

type of, and expediency, 263

use of ideas gained from analysis, 279

patris potestas, 315

Paul, St., 338

personality: of analyst, *see* analyst

autonomous, destiny as, 314

dissociation of, 61, 129

harmonious, 271, 274

multiplication of, 40*f*

value of, 287 *see also* individual

persuasion, 15n, 184

perversion(s), 18, 19, 109, 128

- and childhood “bad habits,” 108
- infantile, 114f, 126f, 244 *see also* polymorphous-perverse sexuality

Peters, Wilhelm, 92

Phales, 41

phallus, winged, 220

phases, three, of life, 117

philosophy, and psychoanalysis, 229, 241, 324

phobia, of cats, 70

phylogeny, of mind, 225

physics, 109, 124, 165, 296

Picus, 212

pigs, 240

Pius X, Pope, 31

play: in animals, 104

- with numbers, 52

pleasure, 106, 274, 278

- and sexuality, relation, 107, 154

poem, meaning of, 146

poetry, erotic symbolism in, 23

polygamy, 32

polymorphous-perverse sexuality, 100, 107f, 114f, 128, 164

Pope, dream-figure, 31ff

potential, difference of, 337

pounding, *see* hammering

power principle, 291f, 336

predisposition, 96ff *see also* neurosis

preformation, 315f

pregnancy, 103

prepubertal stage, 117

present: aetiological significance of, 166ff

psychological, as result of past, [16](#), [26](#)
presentiments, [201](#)
preservation of species, and sexuality, [104](#), [105](#)
presexual stage, [117](#)
 and libido, [118](#), [127](#)
priest, [192](#)
primitives: amnesia among, [164](#)
 children among, [104](#)
 fears of, [209](#)
 imitativeness among, [135](#)
 incest among, [156](#), [208](#)
 and infantility, [246](#)
 libido among, [155](#)
 religion and philosophy among, [241](#)
 and remembered impressions, [179](#)
 social sense in, [278](#)
 and taboos, [247](#)
prince, [206](#)
Prince, Morton, [56ff](#)
prism, [267f](#)
procreation: divine, [340](#)
 infantile theories, [210](#)
projection: of erotic fantasies, in transference, [286](#)
 of moral defects on analyst, [235](#)
proof, difference of physical and psychological, [74](#)
propagation, [287](#)
prophets, [320n](#)
Protestantism, [327](#)
psychoanalysis, [3ff](#)
 nature of, [14ff](#)
 value as therapy, [8f](#)
psyche: complexity of, [331f](#)
 not wholly conscious, *see* consciousness; roots of hysteria in, [4](#)

sexuality in, 4
and somatic illness, 255

psychoanalysis: and adaptation, 137
change in character, 190
criticism of, 74f
definition of, 271f
and dream interpretation, 59
failures of, 188
future uses, 202ff
goal of, 277
illustration of method, 31ff
lay understanding of, 74, 80
and libido balance, 113
method of, 139, 144ff
misunderstandings regarding, 140f
need of moral effort to understand, 68
negative definition, 271, 274
prejudices against, 230, 243
Prince's criticisms, 73
in sanatoria, 265
as science, 229
and other sciences, 202
scope of, 324
and self-knowledge, 48
and sexuality, 79
suggestion in, 280, 281
suitability for, 266
and symptoms, 184
technical application, 272
therapeutic effect, 190, 276 *see also* analysis; psychoanalysis

Psychoanalytical Society, 79

psychocatharsis, 274 *see also* catharsis

psychology, 229
two types, 291 *see also* analytical psychology

depth psychology
individual psychology
psychoneuroses, sexuality and, [3ff](#)
puberty: and development of hysterical psychosis, [21f](#)
 libido and, [114](#)
 and objectification of sexual goal, [19](#)
 reactivation of childhood traumata at, [13](#)
puppy, [104](#)
purposiveness, [161](#)
Putnam, James J., [56](#), [57](#)

Q

Quimby, Phineas P., [326](#) & n

R

Raguel, [321f](#), [323n](#)
Raimann, Emil, [13](#) & n
Rank, Otto, [145](#), [211](#)
Raschefs Yearbook, [79](#)
ratiocinative method, [231](#)
reactions, value-predicate, [305](#)
reaction-types, similarity in families, [304](#)
reactivation, of parental images, [248](#)
reactivity, [183n](#)
reality: adaptation to, enhanced, [126](#)
 —, loss of, [119](#), [120](#)
 disappearance of, [121](#)
 flight from, [183](#)
 neurotics and, [191](#)
 no loss of in neuroses, [121](#)
 soberness of, [274](#)
reality function, and sexuality, [122ff](#)
reality principle, [334](#)
reconstruction stage, [262](#)

recovery, motives for, 276
reduction, 292
reeducation de la volonté, 184
reflexes, emotional, 248
Reformation, 325, 327
regression, 121–22n, 181, 207, 224, 247, 303
 conditions of, 169f
 effect of, 178
 end of, 188f
 of libido, 162ff, 187, 248
 teleological significance, 179f
relapse, 63f
relationship: analyst-patient, 193, 235, 285, *see also* transference
 extra-familial, 195f
 parent-child, 137, 286, *see also* parents
 transference, *see* transference
relatives, and association reactions, 304
religion, 330
 in analysis, 241
 comparative, 324
 —, psychoanalysis and, 202, 203
 and dogma, 324
 Freud and, 335
 history of, and fantasies, 320n
 infantile constellations and, 316n
 sacrifice in, 155
 symbolism of, 337
 unconscious fantasies and, 151 *see also* symbol, religious
reminiscences, 11, 14, 134, 162, 168, 248
 and dreams, 145, 149
 excited by hypnosis, 92
 transformation into fantasies, 175
repetition, significance of, 40
repression, 12, 91ff, 99, 126

conscious, [93](#)
and dreams, [28f](#)
and hysteria, [19](#), [21](#)
of Oedipus complex, [156](#)
sexual, God and, [321n](#)

reproduction, evolutionary change in principles, [123](#), [125f](#)

reproductive organs, development of, [104](#)

resistance(s), [110](#), [174](#), [235](#), [283f](#)
of analyst, [187](#)
to complex, [16](#), [154f](#)
in dreams, [28ff](#)
hypnosis and, [262](#)
to hysterical fantasies, [19](#)
initial, in analysis, [195](#), [272](#)
to sexual problem, [172](#)
to wish-fulfilment, [68](#)
to work, [232](#)

retrogression, [239](#)

revenge, [73](#)

reversion, to infantile level, [170ff](#)

rhythmic movement, [127](#)

rigidity, spiritual, [193](#)

Rig-veda, [222](#)

Riklin, Franz, [7](#), [211](#)

ring, [160](#)

ritual, [146](#), [337](#)

river, [163](#)

Rome, [153](#)

Romulus and Remus, [212](#)

rumour: analysis by, [65n](#)
fantasy as, [219f](#)
psychology of, [35ff](#)

S

- sacrifice, [151](#), [154](#), [155](#)
- Sadger, I., [76](#), [77](#)
- St. Petersburg, [96](#), [98](#)
- Sallust, [111](#), [247](#)
- salvation, [319](#)
- Sara, [321f](#), [323n](#)
- satyrs, [41](#)
- Savill, Agnes, [295](#)
- schizophrenia, [40f](#), [126](#) *see also* dementia praecox
- schools, progressive, [271](#)
- Schopenhauer, Arthur, [123](#), [156](#), [241](#), [314n](#), [326](#)
- Schreber case, [119ff](#)
- science: and dogma, [325](#)
 - and hypotheses, [339](#)
 - and independence, [269](#)
- Scripture, Edward Wheeler, [56](#)
- sea-monster, [210](#)
- seasons, myth of, [217](#)
- secrets, [192](#)
- self-analysis, [199](#)
- self-conquest, [197](#), [198](#)
- self-control, [79](#)
- self-criticism, [169](#), [261](#), [336](#)
- self-cure, neurosis as, [180](#), [250](#)
- self-knowledge, [58](#), [230](#), [270](#)
- self-preservation, [104](#), [105](#), [123](#)
 - dementia praecox and, [122n](#) *see also* nutritive function
- self-sacrifice, [241](#)
- sensitiveness, [171](#), [174ff](#), [183](#)
 - congenital, [249](#)
 - excessive, [176f](#)
 - inborn, [176](#)

symptom of disunion, 176

sexuality: components of, mobility, 109f

- concept of, 103f, 151
- in dreams, 238ff
- fate of, and life's fate, 320n
- formation of normal, 128
- and formation of psychoneuroses, 3ff, 13
- Freud's concept, 18f, 94f
- importance of, 338
- individual evaluation, 288
- infantile, 99ff, 102ff, 114ff, 338
 - Freud and, 13f, 19, 76f, 98ff, 114, 165f
 - , and libido, 126f
 - , not perverse, 163
 - and libido, 125
- mature and immature, 118
- monomorphic, 108
- and nutrition, 296
- in older persons, 287
- and parental authority, 317
- permutations of, 110
- and pleasure, 107
- as plurality of drives, 108
- polymorphous-perverse, *see* polymorphous-perverse sexuality
- “repressed,” 196
- and three phases of life, 117 *see also* hysteria pleasure

shame, 19, 21f

Shaw, G. Bernard, 284

sheikh, 32

ship, *see* steamer

shock, nervous, 89 *see also* trauma

Silberer, Herbert, 211

Sileni, 41

sin, original, 316n

skin, [127](#)
Sleeping Beauty. [215ff](#)
slips: in association experiment, [149](#)
of the tongue, [150](#)
smutty talk, [218](#)
snake, [222](#)
 and bird, [262](#)
 as dream symbol, [237](#), [318f](#)
Snow White, [217](#)
social sense, in animals and primitives, [278](#)
Sommer, Robert, [303n](#)
somnambulism, [257](#)
soul, [327f](#)
 dark night of the, [331](#)
 naturally religious, [321](#)
spasmogenic zones, [108](#)
speech, inhibition of, [318](#)
Spielmeyer, Walter, [9](#)
Spielrein, S., [211](#)
spirit, [336](#), [340](#)
spiritualization, [180](#)
splitting of consciousness, [11](#)
spoiling of children, [137](#)
sprinkling, [146](#)
stag, [287](#)
stairs, dream-symbol, [237f](#)
steamer, [35ff](#)
Steinthal, Heymann, [23](#), [220](#)
Stekel, Wilhelm, [48](#), [156n](#), [273f](#), [276](#), [279](#)
Stern, [45](#)
stone(s), [64ff](#), [72](#)
 burning, [215f](#)
stork, [211](#), [212](#), [217](#), [218](#), [220](#)

strawberries, 209

style of life, 136

sublimation, 19, 126, 320*n*
 religious, 321*n*

submissiveness, 155

substitute formations, 183

sucking, 127, 248
 as sexual act, 105*ff*, 116

suggestion(s), 95, 270, 280
 and cathartic method, 14
 hypnotic, 184
 and hysteria, 10, 89*f*, 255*ff*
 involuntary, to patient, 279
 and morals, 271
 psychoanalysis and, 230, 270, 281
 therapy, 230, 252, 254*f*
 in waking and hypnoid states, 254 *see also* auto-suggestion hypnosis

sun, 210, 216, 267*f*
 eclipse of, 113

superego, 330, 339

superstition, 234

surgery, 80

swearing, 311

Swiss Psychiatric Society, 79

Switzerland, 211

sword, 214

symbols, 148, 155, 202, 280
 bisexual, 212
 double meaning of, 237, 291
 dreams and, 330
 effect of, emotional, 215
 ethnic and schizophrenic, 202
 functional importance, 293

interpretation of, [291](#)
prospective meaning, [291](#)
religious, [293](#)
symbolism: in dreams, [28](#), [59](#), [236ff](#), [252](#)
of religion, [337](#)
sexual, Freud and, [23f](#)
symbolization, [279](#)
symptomatic actions, [150](#)
symptoms: evaluation of, [184](#)
hysterical, as abnormal sexual activity, [22](#)
—, analysis of, [90f](#)
—, and trauma, [5](#), [91](#)
neurotic, and libido, [113](#)
psychic, Freudian psychoanalysis as, [325](#)
psychic origin of, [231](#)
psychogenic, reality of, [162](#)

T

taboos, [247](#)
teacher, [205ff](#), [219](#), [223](#)
dream-figure, [35ff](#)
technique, psychoanalytic, [139](#), [229](#), [250](#)
telepathy, [280](#)
terminology, sexual, [117ff](#)
Teutschen, [158](#)
theology, [339](#)
theory, lack of, in psychoanalysis, [141](#)
theosophy, [326](#)
thunderstorm, [220f](#)
tityrs, [41](#)
Tobias, [322](#)
Tobit, Book of, [321f](#)
tomboy, [159](#)

torture, [70f](#), [72](#)
tracts, [311](#)
train, Dionysian, [41](#)
trampling, [218](#)
transference, [190f](#), [264n](#), [270](#), [277](#), [283ff](#)
 analysis of, [192](#), [193ff](#)
 and faith, [261f](#), [273](#)
 positive and negative, [283ff](#)
 relationship, [192](#)
 resolution of, [197ff](#)
 unanalysed, [61](#)
 working against, [264](#)
trauma: childhood, [94ff](#)
 and hysteria, [13](#), [89](#), [90](#), [243f](#), [258](#)
 intensity unimportant, [97](#)
 measurement of effect of, [178](#)
 past, and neurosis, [91](#), [94](#)
 predisposition for, [96ff](#)
 real, child's part in producing, [99f](#)
 as root of most neuroses, [4](#)
 sexual element in, [98f](#)
 theory, [89ff](#)
 —, criticism of, [131ff](#)
treading, [218](#)
treatment, individual, [270](#)
Trinity, [40](#)
trust, [286](#)
truth: pragmatic, [255](#), [265](#)
 relative and absolute, [267ff](#), [271](#)
tuberculosis, aetiology of, [91](#)
twilight states, [11](#), [131](#), [133](#), [160](#)
types, [331](#), [337](#)

uncertainty, science and, 325
unconscious, 109, 113f, 139ff, 231, 245
 black as symbol of, 319
 “can only wish,” 140f
 collective, 302
 definition, 92
 depreciation of, 331
 parental influence and, 320
 as source of dreams, 59
 symbols and, 293
 union with conscious, 330
 views of Adler, Freud, and Jung, 330 *see also* fantasies
unconsciousness, original sin, 317
understanding, 194
unity, 241
urination, need for, dream of, 31, 33
urine: and fertilization, 221f
 pressure of, 318
usury, 289

V

value intensities, 338
veil, 37ff
verbal expression, 17
Viennese school, 151, 284, 291
Vigouroux, A., and Jaquelier, P., 306n
vitalism, 125

W

wands, magic, 222
washing mania, 262f
water, and baptism, 146
Watts, G. F., 64, 68, 70, 72
wedding, 35ff

whiskey, [61f](#)
wholeness, [241](#)
widow's son, raising of, [54f](#)
wild man, [68](#)
will, [123](#), [156](#), [250](#)
 paralysis of, [90](#)
 to power, *see* power principle
wind, [70](#)
wish(es): erotic, [66](#)
 infantile, [237](#)
 repressed, [240](#)
wish-fulfilment: dream as, [27](#), [55](#), [60ff](#), [67](#), [237](#)
 Freud and, [291](#)
 and number symbolism, [51](#)
wishing, unconscious and, [140f](#)
wolf, [209f](#), [211f](#)
words, double meanings, [17](#)
world, a subjective phenomenon, [177](#)

Y

Yahweh, [321](#), [322](#)

Z

Ziermer, Manfred, [303n](#)

Zurich, [236](#), [252](#), [265](#)

Zurich school, [202](#), [290ff](#)

THE COLLECTED WORKS OF

C. G. JUNG

THE PUBLICATION of the first complete edition, in English, of the works of C. G. Jung was undertaken by Routledge and Kegan Paul, Ltd., in England and by Bollingen Foundation in the United States. The American edition is number XX in Bollingen Series, which since 1967 has been published by Princeton University Press. The edition contains revised versions of works previously published, such as *Psychology of the Unconscious*, which is now entitled *Symbols of Transformation*; works originally written in English, such as *Psychology and Religion*; works not previously translated, such as *Aion*; and, in general, new translations of virtually all of Professor Jung's writings. Prior to his death, in 1961, the author supervised the textual revision, which in some cases is extensive. Sir Herbert Read (d. 1968), Dr. Michael Fordham, and Dr. Gerhard Adler compose the Editorial Committee; the translator is R. F. C. Hull (except for Volume 2) and William McGuire is executive editor.

The price of the volumes varies according to size; they are sold separately, and may also be obtained on standing order. Several of the volumes are extensively illustrated. Each volume contains an index and in most a bibliography; the final volumes will contain a complete bibliography of Professor Jung's writings and a general index to the entire edition.

In the following list, dates of original publication are given in parentheses (of original composition, in brackets). Multiple dates indicate revisions.

*1. PSYCHIATRIC STUDIES

On the Psychology and Pathology of So-Called Occult Phenomena (1902)

On Hysterical Misreading (1904)

Cryptomnesia (1905)

On Manic Mood Disorder (1903)

A Case of Hysterical Stupor in a Prisoner in Detention (1902) On Simulated Insanity (1903)

On Simulated Insanity (1903)

A Medical Opinion on a Case of Simulated Insanity (1904)

A Third and Final Opinion on Two Contradictory Psychiatric Diagnoses (1906)

On the Psychological Diagnosis of Facts (1905)

†2. EXPERIMENTAL RESEARCHES

Translated by Leopold Stein in collaboration with Diana Riviere

STUDIES IN WORD ASSOCIATION (1904–7, 1910)

The Associations of Normal Subjects (by Jung and F. Riklin)

An Analysis of the Associations of an Epileptic

The Reaction-Time Ratio in the Association Experiment

Experimental Observations on the Faculty of Memory

Psychoanalysis and Association Experiments

The Psychological Diagnosis of Evidence

Association, Dream, and Hysterical Symptom

The Psychopathological Significance of the Association Experiment

Disturbances in Reproduction in the Association Experiment

The Association Method

The Family Constellation

PSYCHOPHYSICAL RESEARCHES (1907–8)

On the Psychophysical Relations of the Association Experiment

Psychophysical Investigations with the Galvanometer and Pneumograph in Normal and Insane Individuals (by F. Peterson and Jung)

Further Investigations on the Galvanic Phenomenon and Respiration in Normal and Insane Individuals (by C. Ricksher and Jung)

Appendix: Statistical Details of Enlistment (1906); New Aspects of Criminal Psychology (1908); The Psychological Methods of Investigation Used in the Psychiatric Clinic of the University of Zurich (1910); On the Doctrine of Complexes ([1911] 1913); On the Psychological Diagnosis of Evidence (1937)

*3 THE PSYCHOGENESIS OF MENTAL DISEASE

The Psychology of Dementia Praecox (1907)

The Content of the Psychoses (1908/1914)

On Psychological Understanding (1914)

A Criticism of Bleuler's Theory of Schizophrenic Negativism (1911)

On the Importance of the Unconscious in Psychopathology (1914)

On the Problem of Psychogenesis in Mental Disease (1919)

Mental Disease and the Psyche (1928)

On the Psychogenesis of Schizophrenia (1939)

Recent Thoughts on Schizophrenia (1957)

Schizophrenia (1958)

†4. FREUD AND PSYCHOANALYSIS

Freud's Theory of Hysteria: A Reply to Aschaffenburg (1906)

The Freudian Theory of Hysteria (1908)

The Analysis of Dreams (1909)

A Contribution to the Psychology of Rumour (1910–11)

On the Significance of Number Dreams (1910–11)

Morton Prince, "The Mechanism and Interpretation of Dreams": A Critical Review (1911)

On the Criticism of Psychoanalysis (1910)

Concerning Psychoanalysis (1912)

The Theory of Psychoanalysis (1913)

General Aspects of Psychoanalysis (1913)

Psychoanalysis and Neurosis (1916)

Some Crucial Points in Psychoanalysis: A Correspondence between Dr. Jung and Dr. Loÿ (1914)

Prefaces to "Collected Papers on Analytical Psychology" (1916, 1917)

The Significance of the Father in the Destiny of the Individual (1909/1949)

Introduction to Kranefeldt's "Secret Ways of the Mind" (1930)

Freud and Jung: Contrasts (1929)

‡5. SYMBOLS OF TRANSFORMATION (1911–12/1952)

PART I

Introduction

Two Kinds of Thinking

The Miller Fantasies: Anamnesis

The Hymn of Creation

The Song of the Moth

PART II

Introduction

The Concept of Libido

The Transformation of Libido

The Origin of the Hero

Symbols of the Mother and of Rebirth

The Battle for Deliverance from the Mother

The Dual Mother

The Sacrifice

Epilogue

Appendix: The Miller Fantasies

*6. PSYCHOLOGICAL TYPES (1921)

Introduction

The Problem of Types in the History of Classical and Medieval Thought

Schiller's Ideas on the Type Problem

The Apollinian and the Dionysian

The Type Problem in Human Character

The Type Problem in Poetry

The Type Problem in Psychopathology

The Type Problem in Aesthetics

The Type Problem in Modern Philosophy

The Type Problem in Biography

General Description of the Types

Definitions

Epilogue

Four Papers on Psychological Typology (1913, 1925, 1931, 1936)

†7. TWO ESSAYS ON ANALYTICAL PSYCHOLOGY

On the Psychology of the Unconscious (1917/1926/1943)

The Relations between the Ego and the Unconscious (1928)

Appendix: New Paths in Psychology (1912); The Structure of the Unconscious (1916) (new versions, with variants, 1966)

‡8. THE STRUCTURE AND DYNAMICS OF THE PSYCHE

On Psychic Energy (1928)

The Transcendent Function ([1916]/1957)

A Review of the Complex Theory (1934)

The Significance of Constitution and Heredity in Psychology (1929)

Psychological Factors Determining Human Behavior (1937)

Instinct and the Unconscious (1919)

The Structure of the Psyche (1927/1931)

On the Nature of the Psyche (1947/1954)
General Aspects of Dream Psychology (1916/1948)
On the Nature of Dreams (1945/1948)
The Psychological Foundations of Belief in Spirits (1920/1948)
Spirit and Life (1926)
Basic Postulates of Analytical Psychology (1931)
Analytical Psychology and *Weltanschauung* (1928/1931)
The Real and the Surreal (1933)
The Stages of Life (1930–1931)
The Soul and Death (1934)
Synchronicity: An Acausal Connecting Principle (1952)
Appendix: On Synchronicity (1951)

*9. PART I. THE ARCHETYPES AND THE COLLECTIVE UNCONSCIOUS

Archetypes of the Collective Unconscious (1934/1954)
The Concept of the Collective Unconscious (1936)
Concerning the Archetypes, with Special Reference to the Anima Concept
(1936/1954)
Psychological Aspects of the Mother Archetype (1938/1954)
Concerning Rebirth (1940/1950)
The Psychology of the Child Archetype (1940)
The Psychological Aspects of the Kore (1941)
The Phenomenology of the Spirit in Fairytales (1945/1948)
On the Psychology of the Trickster-Figure (1954)
Conscious, Unconscious, and Individuation (1939)
A Study in the Process of Individuation (1934/1950)
Concerning Mandala Symbolism (1950)
Appendix: Mandalas (1955)

*9. PART II. AION (1951)

RESEARCHES INTO THE PHENOMENOLOGY OF THE SELF

The Ego
The Shadow
The *Syzygy*: Anima and Animus
The Self

Christ, a Symbol of the Self

The Sign of the Fishes

The Prophecies of Nostradamus

The Historical Significance of the Fish

The Ambivalence of the Fish Symbol

The Fish in Alchemy

The Alchemical Interpretation of the Fish

Background to the Psychology of Christian Alchemical Symbolism

Gnostic Symbols of the Self

The Structure and Dynamics of the Self

Conclusion

*10. CIVILIZATION IN TRANSITION

The Role of the Unconscious (1918)

Mind and Earth (1927/1931)

Archaic Man (1931)

The Spiritual Problem of Modern Man (1928/1931)

The Love Problem of a Student (1928)

Woman in Europe (1927)

The Meaning of Psychology for Modern Man (1933/1934)

The State of Psychotherapy Today (1934)

Preface and Epilogue to "Essays on Contemporary Events" (1946)

Wotan (1936)

After the Catastrophe (1945)

The Fight with the Shadow (1946)

The Undiscovered Self (Present and Future) (1957)

Flying Saucers: A Modern Myth (1958)

A Psychological View of Conscience (1958)

Good and Evil in Analytical Psychology (1959)

Introduction to Wolff's "Studies in Jungian Psychology" (1959)

The Swiss Line in the European Spectrum (1928)

Reviews of Keyserling's "America Set Free" (1930) and "La Révolution Mondiale" (1934)

The Complications of American Psychology (1930)

The Dreamlike World of India (1939)

What India Can Teach Us (1939)

Appendix: Documents (1933–1938)

† PSYCHOLOGY AND RELIGION: WEST AND EAST

WESTERN RELIGION

Psychology and Religion (The Terry Lectures) (1,938/1940)

A Psychological Approach to the Dogma of the Trinity (1942/1948)

Transformation Symbolism in the Mass (1942/1954)

Forewords to White's "God and the Unconscious" and Werblowsky's "Lucifer and Prometheus" (1952)

Brother Klaus (1933)

Psychotherapists or the Clergy (1932)

Psychoanalysis and the Cure of Souls (1928)

Answer to Job (1952)

EASTERN RELIGION

Psychological Commentaries on "The Tibetan Book of the Great Liberation" (1939/1954) and "The Tibetan Book of the Dead" (1935/1953)

Yoga and the West (1936)

Foreword to Suzuki's "Introduction to Zen Buddhism" (1939)

The Psychology of Eastern Meditation (1943)

The Holy Men of India: Introduction to Zimmer's "Der Weg zum Selbst" (1944)

Foreword to the "I Ching" (1950)

*12. PSYCHOLOGY AND ALCHEMY (1944)

Prefatory note to the English Edition ([1951?] added 1967)

Introduction to the Religious and Psychological Problems of Alchemy

Individual Dream Symbolism in Relation to Alchemy (1936)

Religious Ideas in Alchemy (1937)

Epilogue

†13. ALCHEMICAL STUDIES

Commentary on "The Secret of the Golden Flower" (1929)

The Visions of Zosimos (1938/1954)

Paracelsus as a Spiritual Phenomenon (1942)

The Spirit Mercurius (1943/1948)

The Philosophical Tree (1945/1954)

‡14. MYSTERIUM CONIUNCTIONIS (1955–56)

AN INQUIRY INTO THE SEPARATION AND
SYNTHESIS OF PSYCHIC OPPOSITES IN ALCHEMY

The Components of the Coniunctio

The Paradoxa

The Personification of the Opposites

Rex and Regina

Adam and Eve

The Conjunction

*15. THE SPIRIT IN MAN, ART, AND LITERATURE

Paracelsus (192g)

Paracelsus the Physician (1941)

Sigmund Freud in His Historical Setting (1932)

In Memory of Sigmund Freud (1939)

Richard Wilhelm: In Memoriam (1930)

On the Relation of Analytical Psychology to Poetry (1922)

Psychology and Literature (1930/1950)

“Ulysses”: A Monologue (1932)

Picasso (1932)

†16. THE PRACTICE OF PSYCHOTHERAPY

GENERAL PROBLEMS OF PSYCHOTHERAPY

Principles of Practical Psychotherapy (1935)

What Is Psychotherapy? (1935)

Some Aspects of Modern Psychotherapy (1930)

The Aims of Psychotherapy (1931)

Problems of Modern Psychotherapy (1929)

Psychotherapy and a Philosophy of Life (1943)

Medicine and Psychotherapy (1945)

Psychotherapy Today (1945)

Fundamental Questions of Psychotherapy (1951)

SPECIFIC PROBLEMS OF PSYCHOTHERAPY

The Therapeutic Value of Abreaction (1921/1928)

The Practical Use of Dream-Analysis (1934)

The Psychology of the Transference (1946)

Appendix: The Realities of Practical Psychotherapy ([1937] added, 1966)

‡17. THE DEVELOPMENT OF PERSONALITY

Psychic Conflicts in a Child (1910/1946)

Introduction to Wickes's "Analyses der Kinderseele" (1927/1931)

Child Development and Education (1928)

Analytical Psychology and Education: Three Lectures (1926/1946)

The Gifted Child (1943)

The Significance of the Unconscious in Individual Education (1928)

The Development of Personality (1934)

Marriage as a Psychological Relationship (1925)

18. THE SYMBOLIC LIFE

Miscellaneous Writings

19. GENERAL BIBLIOGRAPHY OF C. G. JUNG'S WRITINGS

20. GENERAL INDEX TO THE COLLECTED WORKS

See also:

C. G. JUNG: LETTERS

Selected and edited by Gerhard Adler, in collaboration with Aniela Jaffé

Translations from the German by R.F.C. Hull.

VOL. 1: 1906–1950

VOL. 2: 1951–1961

THE FREUD / JUNG LETTERS

Edited by William McGuire, translated by

Ralph Manheim and R.F.C. Hull

C. G. JUNG SPEAKING: Interviews and Encounters

Edited by William McGuire and R.F.C. Hull

C. G. JUNG: Word and Image

Edited by Aniela Jaffé

Supplementary Volume A:

THE ZOFINGIA LECTURES

Edited by William McGuire, translated by Jan Van Heurck,
introduction by Marie-Louise von Franz

SELECTED LETTERS OF C. G. JUNG, 1909–1961

Selected and edited by Gerhard Adler, in collaboration with Aniela Jaffé
Translations from the German by R.F.C. Hull

DREAM ANALYSIS

Notes of the Seminar Given in 1928–1930
Edited by William McGuire

THE ESSENTIAL JUNG

Selected and introduced by Anthony Storr

¹ [First published as “Die Hysterielehre Freuds: Eine Erwiderung auf die Aschaffenburgsche Kritik,” *Münchener medizinische Wochenschrift* (Munich), LIII : 47 (Nov. 1906).—EDITORS.]

² [Aschaffenburg, “Die Beziehungen des sexuellen Lebens zur Entstehung von Nerven- und Geisteskrankheiten,” in the same organ, no. 37 (Sept. 1906). Originally an address (to a congress of neurologists and psychiatrists, Baden-Baden, May 1906) criticizing Freud’s “Bruchstück einer Hysterie-analyse,” which had been first published in 1905 (i.e., “Fragment of an Analysis of a Case of Hysteria”). See Jones, *Freud: Life and Work*, II, p. 12.—EDITORS.]

³ [The earlier form “psychanalysis” (*Psychanalyse*) is used throughout this and the next paper.—EDITORS.]

⁴ *Studies in Word Association*. [Vol. I of *Diagnostische Assoziationsstudien*, which the author actually cited here, was published in 1906, before the present paper. It reprinted Jung’s “Psychoanalyse und Assoziationsexperiment” (“Psychoanalysis and Association Experiments,” in *Experimental Researches*, Coll. Works, Vol. 2), originally published in the *Journal für Psychologie und Neurologie* (Leipzig), VII (1905). This paper, which discussed Freud’s theory of hysteria and commented on the “Fragment of an Analysis” (see n. 2, supra), was Jung’s first significant publication on the subject of psychoanalysis.—EDITORS.]

⁵ Untitled note in the *Zentralblatt für Nervenheilkunde und Psychiatrie*, XXIX (1906), 322. [The first review (pub. April) of Freud’s “Fragment of an Analysis of a Case of Hysteria”; see n. 2, supra. Jung’s paper cited in n. 4, supra, is earlier, however, and is probably the first discussion of the “Dora analysis.”—EDITORS.]

¹ [Translated from “Die Freud’sche Hysteriethorie,” *Monatsschrift für Psychiatrie und Neurologie* (Berlin), XXIII (1908), 310–22. Originally a report to the First International Congress of Psychiatry and Neurology, Amsterdam, September 1907. Aschaffenburg also addressed the Congress, publishing his paper in the same organ, XXII (1907), 564ff. For an account of this event, see Jones, *Freud: Life and Work*, II, pp. 125ff.—EDITORS.]

² [L. Binswanger, “Freud’sche Mechanismen in der Symptomatologie von Psychosen” (1906). Cf. Jones, II, pp. 36f.—EDITORS.]

³ [“Thatsächliches und Hypothetisches über das Wesen der Hysterie” (1890). Cf. Breuer and Freud, *Studies on Hysteria*, Standard Edn., p. 203.—EDITORS.]

⁴ [Emil Raimann, Vienna psychiatrist, critic of Freud, See Jones, I, pp. 395f., and II, p. 122.—EDITORS.]

⁵ [“Freud’s Psycho-Analytic Procedure” and “On Psychotherapy” appear to be the publications Jung referred to. Cf., however, “Fragment of an Analysis of a Case of Hysteria” (1905), Standard Edn., p. 12.—EDITORS.]

⁶ [Paul Dubois, of Bern, treated neurosis by “persuasion.”—EDITORS.]

⁷ Freud’s concept of sexuality includes roughly everything covered by the concept of the instinct for the preservation of the species.

⁸ [Heymann Steinthal (1823–99), German philologist and philosopher. Cf. *Symbols of Transformation*, index, s.v.—EDITORS.]

¹ [Written in French. Translated by Philip Mairet from “L’Analyse des Iêves,” *Année psychologique* (Paris), XV (1909), 160–67, and revised by R. F. C. Hull.—EDITORS.]

² It might be objected that such a supposition is not permissible, as there is a great deal of difference between a song and a dream. But thanks to the researches of Freud we now know that all the products of any dreaming state have something in common. First, they are all variations on the complex, and second, they are only a kind of symbolic expression of the complex. That is why I think I am justified in making this supposition.

³ See *Experimental Researches*, Coll. Works, Vol. 2.

⁴ [See the bibliography for fuller data.—EDITORS.]

¹ [Originally published as “Ein Beitrag zur Psychologie des Gerüchtes,” *Zentralblatt für Psychoanalyse* (Wiesbaden), I (1910/11): 3, 81–90. Previously translated in *Collected Papers on Analytical Psychology* (London and New York, 1916; 2nd edn., 1917).—EDITORS.]

² [Her sister. Cf. par. 119.—EDITORS.]

³ [*Aufsitzen* in the original. The word (usually intransitive) means both to ‘sit on a person’s back’ and to ‘mount’ a horse or vehicle. As applied to a steamer, its use is quite exceptional. The ambiguity can be preserved in English only by alternating between ‘ride’ and ‘get on.’—TRANS.]

⁴ Cf. the duplication of attributes in dementia praecox in my “The Psychology of Dementia Praecox.”

⁵ Cf. my “Psychic Conflicts in a Child.”

⁶ [It may be not without significance that, used transitively, the word *aufsitzen*— literally, ‘sit a person up’—means ‘to deceive,’ ‘to make a fool of,’ someone, or, as we might say today in this context, ‘to take him for a ride.’—TRANS.]

¹ [Originally published as “Ein Beitrag zur Kenntnis des Zahlentraumes,” *Zentralblatt für Psychoanalyse* (Wiesbaden), I (1910/11), 567–72. Previously translated by M. D. Eder in *Collected Papers on Analytical Psychology* (London and New York, 1916; 2nd edn., 1917).—EDITORS.]

² [Day and month.]

³ [Month and year.]

⁴ [Sometimes called in German *Apostelgeschichte St Lucae*.— TRANS.]

⁵ The husband’s principal trouble was a pronounced mother complex.

⁶ *From India to the Planet Mars* (1900); “Nouvelles Observations sur un cas de somnambulisme avec glossolalie” (1901).

⁷ Cf. *Psychiatrie Studies*, passim, 139ff. and 166ff.

¹ [Originally published in the *Jahrbuch für psychoanalytische und psychopathologische Forschungen*, III (1911), 309–28. The article by Prince (1854–1929) was published in the *Journal of Abnormal Psychology* (Boston), V (1910), 139–95. For Prince’s relations with the early psychoanalytical movement, see Jones, *Life and Work*, II, passim.—EDITORS.]

² *American Journal of Psychology*, XXI (1910), 283ff.

³ I should not omit to mention that James J. Putnam, professor of neurology in Harvard Medical School, has tested and made medical use of psychoanalysis. (See Putnam, “Persönliche Erfahrungen mit Freuds psychoanalytischer Methode,” 1911.) [And Putnam’s “Personal Impressions of Sigmund Freud and His Work” (1909–10). Adolf Meyer, August Hoch, and Edward Wheeler Scripture also practised in America.—EDITORS.]

⁴ [The lectures were first published (in English translation) in the *American Journal of Psychology*, XXI (1910). For Freud’s, see “Five Lectures on Psycho-Analysis,” Standard Edn., XI. The three lectures by Jung, entitled “The Association Method,” were republished in *Collected Papers on Analytical Psychology* (1916). For the first two, “The Association Method” and “The Familial Constellations,” see Vol. 2 in the *Collected Works*; the third, “Psychic Conflicts in a Child,” appears in Vol. 17 in its later, revised form of 1946.—EDITORS.]

⁵ As is well known, Professor Hoche, of Freiburg im Breisgau, described Freud and his school as afflicted with epidemic insanity. Participants in the congress accepted this diagnosis without rebuttal and with applause. [Alfred E. Hoche, “Eine psychische Epidemie unter Ärzten,” *Versammlung Sud-West Deutscher Irrenärzte*, Baden-Baden, May 1910. See Jones, *Life and Work*, II, 131.—EDITORS]

⁶ It is especially to be regretted that the learned men—or to be more accurate, the men who today go in for learning—all too often have an interest which is merely national and stops at the frontier. It would be a great relief to psychoanalysts if more Binet, Janet, and Flournoy were read in Germany.

⁷ Those who did so were the ones who openly sided with Freud. Isserlin, on the other hand, contented himself with criticizing the method *a priori*, having no practical knowledge of the matter. Bleuler did what he could, under the circumstances, to answer him (“Die Psychoanalyse Freuds,” 1910).

⁸ In order to give the reader some idea of the experience the psychoanalyst possesses of dream analysis I would mention that, on average, I analyse eight dreams per working day. That makes about two thousand a year. Similar figures probably hold good for most psychoanalysts. Freud himself has immense experience in analysing dreams.

⁹ “The Mechanism and Interpretation of Dreams,” p. 145.

¹⁰ For the practised analyst the dream itself is so clear that it can be read directly.

¹¹ [Orig. 1910.—EDITORS.]

¹² See Dream 5.

¹³ Analysis by rumour. Cf. *supra*, “A Contribution to the Psychology of Rumour.”

¹⁴ [“Learn how to handle women, that make sure,

Since all the aches and sighs that come to vex

The tender sex

The doctor knows one little place to cure.

A bedside manner sets their hearts at ease,

And then they're yours for treatment as you please.”

—*Faust*, Part One, trans. by Wayne, p. 98.]

¹⁵ A pounder is a pestle or club.

¹⁶ Cf. “A Contribution to the Psychology of Rumour,” par. 106.

¹⁷ *Symbols of Transformation*. [The first part of the original, *Wandlungen und Symbole der Libido*, appeared in the same issue of the *Jahrbuch* as the present article.—EDITORS.]

¹⁸ [“Association, Dream, and Hysterical Symptoms” (orig. 1906) in *Experimental Researches*, Coll. Works, Vol. 2.—EDITORS.]

¹⁹ The dream is a typical fantasy of revenge for scorned love and contains in the torture (as in the pounding) scene the boundless gratitude of the patient. Hence the mysterious scene in the cave, which is so scandalous that she will be struck blind at the sight of it. Proof of this can be found in the details of the cave scene.

²⁰ “Remarks on Dr. Morton Prince’s article, “The Mechanism and Interpretation of Dreams”” (1910–11).

¹ [Translated from “Zur Kritik über Psychoanalyse,” *Jahrbuch für psychoanalytische und psychopathologische Forschungen* (Leipzig), II (1910), 743–46.—EDITORS.]

² In *Neurologisches Centralblatt* (Leipzig), XXIX : 6 (March 16, 1910).

³ My italics.—C. G. J.

⁴ J. A. Haslebacher, “Psychoneurosen und Psychoanalyse,” *Correspondenzblatt für Schweizer Ärzte* (Basel), XL:7 (March 1, 1910), 184–96.

⁵ “Ich bin klein, mein Herz ist rein.”

¹ [Translated from “Zur Psychoanalyse,” *Wissen und Leben* (Zurich; former title of the *Neue Schweizer Rundschau*), V (1912), 711–14. An introductory editorial note stated: “A series of communications pro and con Freudian theories in the *Neue Zürcher Zeitung* seems to prove that remarkable misunderstanding and prejudice with respect to modern psychology are the rule with the general public. Since all this impassioned wrangling was more likely to confuse than to enlighten, we have asked Dr. Karl Jung (*sic*) for a few closing words, which should be the more welcome for calming ruffled tempers.”—EDITORS.]

² [See the preceding article.—EDITORS.]

³ [*Neue Bahnen der Psychologie*, published in *Raschers Jahrbuch für Schweizer Art und Kunst* (Zurich), 1912. Trans. as “New Paths in Psychology,” *Two Essays on Analytical Psychology*, pars. 407ff.—EDITORS.]

⁴ [Presumably *Wandlungen und Symbole der Libido*, Part I of which appeared in the *Jahrbuch* in 1911. Part II, the second chapter of which is devoted to the concept and the genetic theory of the libido, appeared early in 1912.—EDITORS.]

¹ [*Pragmatism* (1907), p. 53.]

¹ [The Clark Lectures. See par. 154, n. 4, supra.—EDITORS.]

² [First published 1895; partially trans. by A. A. Brill in *Selected Papers on Hysteria and Other Neuroses* (New York, 1909; later edns.); trans. in Standard Edn. of Freud, II (1955).—EDITORS.]

³ [“Five Lectures on Psycho-Analysis”; see par. 154, n. 4, supra.—EDITORS.]

⁴ [Probably Herbert W. Page, British psychiatrist, who published on this subject; see Bibliography.—EDITORS.]

⁵ (“Gefühl und Erinnerung,” in Kraepelin, *Psychologische Arbeiten*, VI, pt. 2, p. 237.)

⁶ [*Studies on Hysteria*, pp. 106ff.]

⁷ [By 1912, two volumes of Freud’s *Sammlungen kleiner Schriften zur Neurosenlehre* had appeared, in 1906 and 1909 (another in 1913). The various contents of these volumes were trans., regrouped, in the *Collected Papers* (1924 ff.), and, further rearranged, in the Standard Edn. The precise reference here is unavailable.—EDITORS.]

⁸ [This case is fully reported in *Two Essays on Analytical Psychology*, pars. 8ff., 417ff.—EDITORS.]

⁹ [See infra, pars. 297ff. and 355ff.—EDITORS.]

¹⁰ [First Published in 1905.]

¹¹ [See Ch. 4.—EDITORS.]

¹ [Standard Edn., VII, p. 135.]

² [Cf. the definition of libido in *Symbols of Transformation*, pars. 185f.]

³ We meet with a similar view in Janet.

⁴ [Cf. *Symbols of Transformation*, par. 206.]

⁵ [“Psycho-Analytic Notes on an Autobiographical Account of a Case of Paranoia (Dementia Paranoides).”]

⁶ [The first paper in *The Psychogenesis of Mental Disease*, Collected Works, Vol.3.]

⁷ (It might be objected that dementia praecox is characterized not only by the introversion of sexual libido but also by a regression to the infantile level, and that this constitutes the difference between the anchorite and the schizophrenic. This is certainly correct, but it would still have to be proved that in dementia praecox it is regularly and exclusively the erotic interest which goes into a regression. It seems to me rather difficult to prove this, because erotic interest would then have to be understood as the “Eros” of the old philosophers. But that can hardly be meant. I know cases of dementia praecox where all regard for self-preservation disappears, but not the very lively erotic interests.)

⁸ [“The Psycho-Sexual Differences between Hysteria and Dementia Praecox.”]

⁹ [Pars. 278–80 and 274–75 reappear with certain modifications and additions in *Symbols of Transformation*, pars. 192ff.—EDITORS.]

¹⁰ [Pars. 290–91 likewise recur with small changes in *Symbols of Transformation*, par. 206.—EDITORS.]

¹¹ (I must ask the reader not to misunderstand my figurative way of speaking. It is, of course, not libido as energy that gradually frees itself from the function of nutrition, but libido as a function, which is bound up with the slow changes of organic growth.)

¹ (It may not be superfluous to remark that there are still people who believe that psychologists swallow the lies of their patients. That is quite impossible. Lies are fantasies, and we deal in fantasies.)

² (Introversion does not mean that libido simply accumulates inactively. But it is used for the creation of fantasies and illusions when the introversion results in regression to an infantile mode of adaptation. Introversion can also lead to action on a rational plane.)

³ [See *infra*, pars. 693ff.]

⁴ (I am discounting the inherited organic similarity which is naturally responsible for many things but by no means all.)

⁵ [Fürst, “Statistical Investigations on Word-Associations and on Familial Agreement in Reaction Type among Uneducated Persons” (orig. 1905). Jung’s discussion of her work occurred in the second of the Clark Lectures under the title “Familial Constellations”; see *Experimental Researches*, Coll. Works, Vol. 2.— EDITORS.]

¹ (This might be disputed on the ground that it is an *a priori* assertion. I must remark, however, that this view conforms to the one generally accepted working hypothesis concerning the origin of dreams: that they are derived from the experiences and thoughts of the recent past. We are, therefore, moving on known ground.)

² “Ein Traum, der sich selbst deutet” (1910).

¹ A view expressed most strongly by Stekel.

¹ [Cf. *Two Essays*, pars. 11f. and 420. For the first two instalments of the story see supra, pars. 218ff. and 297ff.—EDITORS.]

² [*Einschachtelung*: “An old theory of reproduction which assumed that when the first animal of each species was created, the germs of all other individuals of the same species which were to come from it were encased in its ova.”—*Century Dictionary* (1890).—TRANS.]

³ Standard Edn., p. 232.

¹ (Sensitiveness is naturally only one word for it. We could also say “reactivity” or “lability.” As we know, there are many other words in circulation.)

² [Cf. the “Psychology of the Transference” for a more detailed study.]

³ [“Die Symbolik in den Legenden, Märchen, Gebräuchen und Träumen” (1908).—EDITORS.]

¹ [The anthropologist Franz Boas (1858–1942); see especially his *Indianische Sagen* (1895).—EDITORS.]

² [See Bibliography.]

³ [Cf. *Symbols of Transformation*, particularly par. 547.]

⁴ [Cf. “Psychic Conflicts in a Child,” pars. 47ff.]

⁵ [*Symbols of Transformation*, pars. 370, 480.]

⁶ [Cf. *supra*, pars. 95ff.]

⁷ [See *Symbols of Transformation*, index, s.w.—EDITORS.]

⁸ [Cf. *Symbols of Transformation*, par. 322f.]

¹ [Originally written in German with the title “Allgemeine Aspekte der Psychoanalyse,” translated (anonymously) into English, and read before the Psycho-Medical Society, London, Aug. 5, 1913. With the title “Psycho-Analysis,” the translation was published in the *Transactions of the Psycho-Medical Society* (Cockermouth), 1913, and reprinted in the *Psychoanalytic Review* (New York), II: 3 (July 1915) and in *Collected Papers on Analytical Psychology* (London and New York, 1916; 2nd edn., 1917). The present translation is made in consultation with the original German manuscript.—EDITORS.]

² [See par. 41, n. 6, above.—EDITORS.]

³ [The passage which here follows in the original is identical with “The Theory of Psychoanalysis,” supra, pars. 324–31.—EDITORS.]

⁴ [Cf. *Symbols of Transformation*, pars. 25ff.—EDITORS.]

¹ [Originally written in English and read before the New York Academy of Medicine, Oct. 8, 1912. Revised and read before the 17th International Medical Congress, London, 1913, under the title “On Psychoanalysis.” First published in *Collected Papers on Analytical Psychology* (London and New York, 1916; 2nd edn., 1917), pp. 226–35. The present version is a stylistic revision of this.—EDITORS.]

² “Magis in armis et militaribus equis quam in scortis et conviviis libidinem habebant.” *Catilina*, 7, trans. by Rolfe, pp. 14–15.

¹ [Originally published as *Psychotherapeutische Zeitfragen; Ein Briefwechsel mit Dr. C. G. Jung*, edited by Dr. R. Loÿ (Leipzig and Vienna, 1914). Translated (except for Dr. Loÿ's foreword) by Mrs. Edith Eder as "On Some Crucial Points in Psychoanalysis," in *Collected Papers on Analytical Psychology* (London and New York, 1916; 2nd edn., 1917). The present translation is based on this.—EDITORS.]

² "Recommendations to Physicians Practising Psycho-Analysis" (orig. 1912), pp. 116f.

³ Ludwig Frank, *Affektstörungen: Studien über ihre Aetiologie und Therapie* (1913)

⁴ [See supra, par. 41, n. 6.]

⁵ Thus a woman patient, who had been treated by a young colleague without entire success, once said to me: "Certainly I made great progress with him and I am much better than I was. He tried to analyse my dreams. It's true he never understood them, but he took *so much trouble* over them. He is really a good doctor."

⁶ Defined in the Freudian sense as the transference to the analyst of infantile and sexual fantasies. A more advanced conception of the transference perceives in it the important process of *empathy*, which begins by making use of infantile and sexual analogies.

⁷ [*Faust, Part I, The Night Scene.*]

⁸ ["On Beginning the Treatment (Further Recommendations on the Technique of Psycho-Analysis I)" (1913).—EDITORS]

⁹ [Presumably a reference to par. 587, or to an unpublished letter.—EDITORS.]

¹⁰ [Dr. Maria Montessori (1870–1952) published *The Montessori Method* in 1912.—EDITORS.]

¹ [Published in *Collected Papers on Analytical Psychology*, edited by Dr. Constance E. Long (London and New York, 1916; 2nd edn., 1917). The prefaces were probably written in German and translated by Dr. Long; they are published here with minor revisions.—EDITORS.]

² [Contents of 1st edition and location in the Coll. Works: “On the Psychology and Pathology of So-called Occult Phenomena” (Vol. 1); “The Association Method”: Lecture I, untitled, and Lecture II, “The Familial Constellations” (Vol. 2); Lecture III, “The Psychic Life of the Child” (Vol. 17, as “Psychic Conflicts in a Child”); “The Significance of the Father in the Destiny of the Individual,” “A Contribution to the Psychology of Rumour,” and “On the Significance of Number Dreams” (Vol. 4); “A Criticism of Bleuler’s ‘Theory of Schizophrenic Negativism’” (Vol. 3); “Psychoanalysis” and “On Psychoanalysis” (Vol. 4, as “Concerning Psychoanalysis” and “Psychoanalysis and Neurosis”); “On Some Crucial Points in Psychoanalysis” (Vol. 4); “On the Importance of the Unconscious in Psychopathology” (Vol. 3); “A Contribution to the Study of Psychological Types” (Vol. 6); “The Psychology of Dreams” (Vol. 8, as “General Aspects of Dream Psychology”); “The Content of the Psychoses” (Vol. 3); and “New Paths in Psychology” (Vol. 7, appendix; see n. 4, infra).—EDITORS.]

³ [This was a translation of the original version of “The Relations between the Ego and the Unconscious.” Later in 1916 the German original was translated into French under the title “La Structure de l’inconscient.” See *Two Essays on Analytical Psychology*, 2nd edn., pp. 123ff. and p. 269, n. 1.—EDITORS.]

⁴ [A revised and expanded version of “New Paths in Psychology” (orig. in *Raschers Jahrbuch für Schweizer Art und Kunst*, Zurich, 1912). In 1926 it was again expanded and published under the title *Das Unbewusste im normalen und kranken Seelenleben*. A revised and expanded version of this appeared in 1942 as *Über die Psychologie des Unbewussten*. See *Two Essays on Analytical Psychology*, 2nd edn., pp. 3ff. and p. 245, n. 1.—EDITORS.]

⁵ [Part II, untitled, of “The Content of the Psychoses,” Ch. XIII in the *Collected Papers*. This was originally written in English and published as “On Psychological Understanding,” *Journal of Abnormal Psychology* (Boston), IX (1915). Later in 1914, translated into German and published as a supplement to *Der Inhalt der Psychose*. See *The Psychogenesis of Mental Disease*, pp. 179ff.—EDITORS.]

⁶ [Savill, “Psychoanalysis” (1916); Mitchell (1916).—EDITORS.]

¹ [First published as “Die Bedeutung des Vaters für das Schicksal des Einzelnen,” *Jahrbuch für psychoanalytische und psychopathologische Forschungen* (Leipzig), I (1909). 155–73. This was translated by M. D. Eder under the present title and published in *Collected Papers on Analytical Psychology* (London and New York. 1916; 2nd edn., 1917). The German original of the article was reprinted (1909) as a pamphlet, and a second edition in this form appeared (Vienna, 1927) with a brief foreword. A third edition, much revised and expanded, with a new foreword, was published in 1949 (Zurich). The present version is a translation of the third edition. Passages which the author added to that version are given in pointed brackets () in the text, while any of significance which they replaced, or which were omitted, are given in square brackets [] in the footnotes (as translated from the 1909 version).—EDITORS.]

² [Revised (1952) and translated as *Symbols of Transformation*.— EDITORS.]

³ “[(Why this should be so) only the Genius knows—that companion who rules the star of our birth, the god of human nature, mortal though he be in each single life, and changeful of countenance, white and black.”—Horace, *Epistles*, II, II, 187–89.—TRANS.]

⁴ [Orig. footnote: Libido is what earlier psychologists called “will” or “tendency.” The Freudian expression is a *denominatio a potiori*. *Jahrbuch*, I (1909), 155.]

⁵ [In orig., also: masturbation.]

⁶ (I have discussed this question on two occasions: *Symbols of Transformation* (in regard to the son), and “Psychological Aspects of the Mother Archetype” (in regard to the daughter).)

⁷ Sommer, *Familienforschung und Vererbungslehre* (1907); Joerger, “Die Familie Zero” (1905); Ziermer, “Genealogische Studien über die Vererbung geistiger Eigenschaften” (1908).

⁸ [Orig.: These experiences, and those gained more particularly in an analysis carried out conjointly with Dr. Otto Gross, have impressed upon me the soundness of this view.] [For Gross, cf. Jones, *Freud: Life and Work*, II, p. 33.—EDITORS.]

⁹ “Statistical Investigations on Word-Associations and on Familial Agreement in Reaction Type among Uneducated Persons” (orig. 1907).

¹⁰ By this I mean reactions where the response to the stimulus-word is always a subjectively toned predicate instead of an objective relationship, e.g., *flower / nice, frog / horrible, piano / frightful, salt / bad, singing / sweet, cooking / useful*

¹¹ Vigouroux and Juquelier, *La Contagion mentale* (1904), ch. 6.

¹² [Orig.: ... of the struggle between repression and libido (Freud) ...]

¹³ [Orig.: It must suffice to present only the chief events, i.e., those of sexuality.]

¹⁴ [Orig.: psychanalytical.]

¹⁵ [Orig.: ... but dares not acknowledge her sexuality.]

¹⁶ [Orig.: ... from the psychanalytic standpoint ...]

¹⁷ “Throughout we believe ourselves to be the masters of our deeds. But reviewing our lives, and chiefly taking our misfortunes and their consequences into consideration, we often cannot account for our doing this act and omitting that, making it appear as if our steps had been guided by a power foreign to us. Therefore Shakespeare says:

‘Fate show thy force: ourselves we do not owe;

What is decreed must be, and be this so!”

—Schopenhauer, “On Apparent Design in the Fate of the Individual,” *Parerga and Paralipomena* (trans. by Irvine, p. 26).

¹⁸ [Orig.: ... for the power of the infantile constellation has provided highly convincing material for the religions in the course of the millennia.

[All this is not to say that we should cast the blame for original sin upon our parents. A sensitive child, whose sympathies are only too quick to reflect in his psyche the excesses of his parents, bears the blame for his fate in his own character. But, as our last case shows, this is not always so, for the parents can (and unfortunately only too often do) instil the evil into the child’s soul, preying upon his ignorance in order to make him the slave of their complexes.]

¹⁹ [Orig.: It will be asked, wherein lies the magic power of the parents to bind their children to themselves, often for the whole of their lives? The psychoanalyst knows that it is nothing but sexuality on both sides.

[We are always trying not to admit the child’s sexuality. But this is only because of wilful ignorance, which happens to be very prevalent again just now.*

[I have not given any real analysis of these cases. We therefore do not know what happened to these puppets of fate when they were children. A profound insight into the living soul of a child, such as we have never had before, is given in Freud’s contribution to the present semi-annual volume of the *Jahrbuch* [“Analysis of a Phobia in a Five-year-old Boy”]. If I venture, after Freud’s masterly presentation, to offer another small contribution to the study of the child-psyche, it is because psychoanalytic case-histories seem to me always valuable.

[* Orig. footnote: This was seen at the Amsterdam Congress in 1907 [First International Congress of Psychiatry and Neurology; cf. the second paper in this vol.—EDITORS], when an eminent French savant assured us that Freud’s theory was nothing but “une plaisanterie.” This gentleman had evidently read neither Freud’s latest writings nor mine, and knew far less about the subject than a little child. This pronouncement, so admirably grounded, met with the approbation of a well-known German professor in his report to the Congress. One can but bow before such thoroughness. At the same Congress a noted German neurologist immortalized his name with the following brilliant argument: “If in Freud’s view hysteria really does rest on repressed affects, then the whole German army must be hysterical.”]

²⁰ [Orig.: It is not difficult to see, from the Freudian standpoint, what the bed-wetting means in this case. Micturition dreams give us the clue. Here I would refer the reader to an analysis of this kind in my paper “The Analysis of Dreams” (cf. supra, pars. 82f.). Bed-wetting must be regarded as an infantile sexual substitute, and even in the dream-life of adults it is easily used as a cloak for the pressure of sexual desire.]

²¹ [Orig.: The infantile attitude, it is evident, is nothing but infantile sexuality. If we now survey all the far-reaching possibilities of the infantile constellation, we are obliged to say that *in essence our life’s fate is identical with the fate of our sexuality*. If Freud and his school devote themselves first and foremost to tracing out the individual’s sexuality, it is certainly not in order to excite piquant sensations but to gain a deeper insight into the driving forces that determine the individual’s fate. In this we are not saying too much, but rather understating the case. For, when we strip off the veils shrouding the problems of individual destiny, we at once widen our field of vision from the history of the individual to the history of nations. We can take a look, first of all, at the history of religion, at the history of the fantasy systems of whole peoples and epochs. The religion of the Old Testament exalted the paterfamilias into the

Jehovah of the Jews, whom the people had to obey in fear and dread. The patriarchs were a stepping-stone to the Deity. The neurotic fear in Judaism, an imperfect or at any rate unsuccessful attempt at sublimation by a still too barbarous people, gave rise to the excessive severity of Mosaic law, the compulsive ceremonial of the neurotic.* Only the prophets were able to free themselves from it; for them the identification with Jehovah, complete sublimation, was successful. They became the fathers of the people. Christ, the fulfiller of their prophecies, put an end to this fear of God and taught mankind that the true relation to the Deity is love. Thus he destroyed the compulsive ceremonial of the law and was himself the exponent of the personal loving relationship to God. Later, the imperfect sublimations of the Christian Mass resulted once again in the ceremonial of the Church, from which only those of the numerous saints and reformers who were really capable of sublimation were able to break free. Not without cause, therefore, does modern theology speak of the liberating effect of “inner” or “personal” experience, for always the ardour of love transmutes fear and compulsion into a higher, freer type of feeling.

[* *Orig. footnote: Cf. Freud, Zeitschrift für Religionspsychologie (1907).*] [I.e., “Obsessive Acts and Religious Practices.”—EDITORS.]

²² [*Orig.:* These are the roots of the first religious sublimations. In the place of the father with his constellating virtues and faults there appears on the one hand an altogether sublime deity, and on the other hand the devil, who in modern times has been largely whittled away by the realization of one’s own moral responsibility. Sublime love is attributed to the former, low sexuality to the latter. As soon as we enter the field of neurosis, this antithesis is stretched to the limit. God becomes the symbol of the most complete sexual repression, the devil the symbol of sexual lust. Thus it is that the conscious expression of the father-constellation, like every expression of an unconscious complex when it appears in consciousness, acquires its Janus face, its positive and its negative components.]

²³ Chs. 3 : 7ff. and 8 : 1ff.

²⁴ (Cf. the axiom of Maria and the discussion of 3 and 4, 7 and 8, in *Psychology and Alchemy*, pars. 201ff. and 209.)

²⁵ (Horace, *Epistles*, II, 2, 187–89.)

²⁶ [*Orig.:* Unfortunately medical etiquette forbids me to report a case of hysteria which fits this pattern exactly, except that there were not seven husbands but only three, unluckily chosen under all the ominous signs of an infantile constellation. Our first case, too, belongs to this category, and in our third case we see the old peasant at work, preparing to dedicate his daughter to a like fate.

[As a pious and dutiful daughter (cf. her prayer in Tobit, ch. 3), Sara has brought about the usual sublimation and splitting of the father-complex, on the one hand elevating her infantile love into the worship of God, and on the other turning the obsessive power of the father into the persecuting demon Asmodeus. The story is beautifully worked out and shows father Raguel in his two roles, as the inconsolable father of the bride and the provident digger of his son-in-law’s grave, whose fate he foresees.

[This pretty fable has become a classic example in my analytical work, for we frequently meet with cases where the father-demon has laid his hand upon his daughter, so that her whole life long, even when she does marry, there is never a true inward union, because her husband’s image never succeeds in obliterating the unconscious and continually operative infantile father-ideal. This is true not only of daughters, but also of sons. An excellent example of this kind of father-constellation can be found in Brill’s recently published “Psychological Factors in Dementia Praecox” (1908).

[In my experience it is usually the father who is the decisive and dangerous object of the child's fantasy, and if ever it happened to be the mother I was able to discover behind her a grandfather to whom she belonged in her heart.

[I must leave this question open, because my findings are not sufficient to warrant a decision. It is to be hoped that experience in the years to come will sink deeper shafts into this obscure territory, on which I have been able to shed but a fleeting light, and will discover more about the secret workshop of the demon who shapes our fate, of whom Horace says:

“Scit Genius natale comes qui temperat astrum,
Naturae deus humanae, mortalis in unum,
Quodque caput, vultu mutabilis, albus et ater.”]

¹ [Originally published in W. M. Kranefeldt's *Die Psychoanalyse* (Berlin and Leipzig, 1930). Translated by Ralph M. Eaton in the English version of the volume, *Secret Ways of the Mind* (New York, 1932; London, 1934). The present translation is of the original, but reference was made to the Eaton version.—EDITORS.]

² [*Freuds tragischer Komplex: Eine Analyse der Psychoanalyse* (1929).—EDITORS.]

³ [Phineas Parkhurst Quimby (1802–66), American hypnotist and mental healer, consulted by Mary Baker Eddy, whose ideas he is thought to have influenced.—EDITORS.]

¹ [Originally published as “Der Gegensatz Freud und Jung,” *Kölnische Zeitung* (Cologne), May 7, 1929, p. 4. Reprinted in *Seelenprobleme der Gegenwart* (Zurich, 1931), and translated by W. S. Dell and Cary F. Baynes, under the present title, in *Modern Man in Search of a Soul* (London and New York, 1933). The original German text is retranslated here, though reference has been made to the 1933 translation.—EDITORS.]

² Cf. “On Psychic Energy,” pars. 14ff.

* The Standard Edition of the Complete Psychological Works of Sigmund Freud, translated under the general editorship of James Strachey. London.

* For details of the Collected Works of C. G. Jung (especially volumes yet unpublished, cited here without date) see the end of this volume.

* Published 1957; 2nd edn., 1970.

† Published 1973.

* Published 1960.

† Published 1961.

‡ Published 1956; 2nd edn., 1967. (65 plates, 43 text figures.)

* Published 1971.

† Published 1953; 2nd edn., 1966.

‡ Published 1960; 2nd edn., 1969.

* Published 1959; 2nd edn., 1968. (Part I: 79 plates, with 29 in colour.)

* Published 1964; 2nd edn., 1970. (8 plates.)

† Published 1958; 2nd edn., 1969.

* Published 1953; 2nd edn., completely revised, 1968. (270 illustrations.)

† Published 1968. (50 plates, 4 text figures.)

‡ Published 1963; 2nd edn., 1970. (10 plates.)

* Published 1966.

† Published 1954; 2nd edn., revised and augmented, 1966. (13 illustrations.)

‡ Published 1954.

BOLLINGEN SERIES XX

THE COLLECTED WORKS

OF

C. G. JUNG

VOLUME 5

EDITORS

† SIR HERBERT READ

MICHAEL FORDHAM, M.D., M.R.C.P.

GERHARD ADLER, PH.D.

WILLIAM MCGUIRE, *executive editor*



The Ostian head of Mithras *Roman*

SYMBOLS
OF
TRANSFORMATION

AN ANALYSIS OF THE PRELUDE TO A CASE OF
SCHIZOPHRENIA

C. G. JUNG

SECOND EDITION

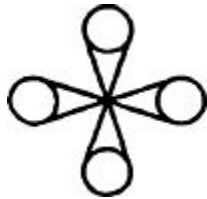

TRANSLATED BY R. F. C. HULL

BOLLINGEN SERIES XX

PRINCETON UNIVERSITY PRESS

COPYRIGHT © 1956 BY BOLLINGEN FOUNDATION INC., NEW YORK, N. Y PUBLISHED BY PRINCETON
UNIVERSITY PRESS, PRINCETON, N. J.
ALL RIGHTS RESERVED

Second edition, with corrections, 1967

Second printing, 1974

Third printing, 1976

First Princeton / Bollingen Paperback printing, 1976

THIS EDITION IS BEING PUBLISHED IN THE UNITED STATES OF AMERICA BY PRINCETON UNIVERSITY PRESS AND IN ENGLAND BY ROUTLEDGE AND KEGAN PAUL, LTD. IN THE AMERICAN EDITION, ALL THE VOLUMES COMPRISING THE COLLECTED WORKS CONSTITUTE NUMBER XX IN BOLLINGEN SERIES, SPONSORED BY BOLLINGEN FOUNDATION. THE PRESENT VOLUME IS NUMBER 5 OF THE COLLECTED WORKS, AND WAS THE FIFTH TO APPEAR.

Translated from *Symbole der Wandlung* (4th edition, rewritten, of *Wandlungen und Symbole der Libido*), published by Rascher Verlag, Zurich, 1952.

ISBN 0-691-01815-4 (paperback edn.)

ISBN 0-691-09775-5 (hardcover edn.)

LIBRARY OF CONGRESS CATALOG CARD NUMBER: 75-156

MANUFACTURED IN THE U. S. A.

EDITORIAL NOTE

As the author's Foreword indicates, the volume from which the present translation has been made is an extensive revision, published in 1952, of *Wandlungen und Symbole der Libido*, published in 1912.* The reasons for this revision and its extent are explained by Dr. Jung and need no further comment here.

The present translation differs in certain respects from the revised Swiss edition. First of all, the number of illustrations has been reduced. In the Swiss edition, these had been inserted to amplify the text rather than to illustrate. It seemed to the Editors that the illustrations sometimes had the disadvantage of interrupting the text unduly, and after careful consideration it was decided that only those having a direct relevance to the text should be included. Among these, some new photographs and substitutions have been used. Secondly, an appendix containing the complete Miller fantasies has been added. Since these were available only in a French text published in 1906 in the *Archives de psychologie*, a translation by Philip Mairet has been provided. The textual quotations are also from this translation. Other differences from the Swiss edition result from bringing the volume into conformity with the general plan for the Collected Works. A bibliography has been added, and accordingly the references in the footnotes have been somewhat shortened.

In respect to the quotations from various languages, special mention must be made of the work of Dr. A. Wasserstein and Dr. Marie-Louise von Franz in checking and translating some of the Latin and Greek texts. The philological material has been checked over by Dr. Leopold Stein.

EDITORIAL NOTE TO THE SECOND EDITION

For this edition, appearing ten years after the first, bibliographical citations and entries have been revised in the light of subsequent publications in the *Collected Works* and in the Standard Edition of Freud's works, some translations have been substituted in quotations, and other essential corrections have been made, but there have been no changes of substance in the text.

TRANSLATOR'S NOTE

During the preparation of this volume, the text of the original English translation by Beatrice M. Hinkle, first published in America in 1916 under the title *Psychology of the Unconscious*, was freely consulted. Certain of the quotations of poetry there rendered by Louis Untermeyer have been taken over into the present edition, sometimes with slight modifications. For some of the quotations from *Faust*, I am indebted to Philip Wayne, both for extracts from his published version of Part 1 and for passages from Part 2 specially translated for this volume. Quotations from Latin and Greek sources are taken when possible from existing translations, but mostly they are of a composite nature, resulting from comparison of the existing translations with the original texts and with the German versions used by the author, who in some cases translated direct from the originals. For the purpose of comparison, reference is sometimes made, in square brackets, to an existing translation although it has not been quoted.

For the 1974 printing, the Author's Note to the first American/English edition has been added on p. xxx.

NOTE OF ACKNOWLEDGMENT

Grateful acknowledgment is made to the following publishers and others for the reproduction of illustrations or for permission to quote:

Allen and Unwin, London, for a passage from Freud's *The Interpretation of Dreams*; O. W. Barth, Munich: a plate from Wachlmayr, *Das Christgeburtbild der frühen Sakralkunst*; Professor W. Norman Brown: passages from his translation of the Rig-Veda; Bruckmann Verlag, Munich: an illustration from J. J. Bernoulli, *Die erhaltenen Darstellungen Alexanders des Grossen*; Clarendon Press, Oxford: a passage from John Tod-hunter's translation of Heine and an illustration from the catalogue of the Palazzo dei Conservatori, Rome, edited by H. S. Jones for the British School at Rome; Diederichs Verlag, Düsseldorf: a plate from Wirth, *Der Aufgang der Menschheit*; Dodd, Mead and Co., New York: for the use of material originally appearing in Beatrice Hinkle's translation of Jung's *Psychology of the Unconscious*; Folkwang Verlag, Hagen i. W.: a plate from Fuhrmann, *Reich der Inka*; Friedrichsen Verlag, Hamburg: figures from Danzel, *Symbole, Dämonen, und heilige Türme*; Harcourt, Brace and Co.: passages from Untermeyer's translation of Heine and Cornford's translation of Plato's *Timaeus*; Harvard University Press: passages from the Loeb Classical Library editions of Ovid, Seneca, Virgil, and the Homeric Hymns; William Heinemann, London: passages from the Thomas and Guillemard translation of Rostand's *Cyrano de Bergerac*; Hoepli, Milan: a plate from Prampolini, *La Mitologia nella vita dei popoli*; The Hogarth Press; quotations from the Standard Edition of the Works of Sigmund Freud and the Collected Papers of Sigmund Freud; Houghton Mifflin Co., Boston: passages from Longfellow's *Hiawatha*; H. Keller Verlag, Berlin: a plate from Deubner, *Attische Feste*; Librairie Larousse, Paris: two plates from Guirand, *Mythologie générale*; Macmillan and Co., New York: a quotation from Baldwin, *Thoughts and Things*, and translations from Nietzsche's works, and figs. 28 and 33, from *The Mythology of All Races*, II; The Medici Society, London, for an illustration from Budge's *Osiris and the Egyptian Resurrection*, I; Methuen and Co., London: figs. 5, 24, and 27 and Pl. XLlb, from Budge, *Gods of the Egyptians*; Oxford University Press, New York: passages from Louis MacNeice's translation of *Faust*; Penguin Books: passages from Rieu's translation of the Iliad and the Odyssey, de Selincourt's translation of Herodotus, Wayne's translation of *Faust*, and Hamilton's translation of Plato; Princeton University Press: passages from E. A. Speiser's translations in *Ancient Near Eastern Texts*; Reimer Verlag, Berlin: a plate from LeCoq, *Die Buddhistische Spätantike in Mittelasien*; Schwann Verlag, Düsseldorf: a plate from Clemen, *Die*

romanische Wandmalerei des Rheinlands; Seeman Verlag, Cologne: a plate from Cohn, *Buddha in der Kunst des Ostens*; Sheed and Ward, New York: passages from F. J. Sheed's translation of the *Confessions* of St. Augustine; Stubenrauch Verlag, Berlin: a plate from Spiess, *Marksteine der Volkskunst*; Editions Tel, Paris: a photograph of Strasbourg Cathedral, by Marc Foucault; Mr. Philip Wayne: passages from his unpublished translation of *Faust*, Part II.

VOLUME 5 SYMBOLS OF TRANSFORMATION

TABLE OF CONTENTS

EDITORIAL NOTE

TRANSLATOR'S NOTE

NOTE OF ACKNOWLEDGMENT

LIST OF PLATES

LIST OF TEXT FIGURES

FOREWORD TO THE FOURTH (SWISS) EDITION

FOREWORD TO THE THIRD (GERMAN) EDITION

FOREWORD TO THE SECOND (GERMAN) EDITION

AUTHOR'S NOTE TO THE FIRST AMERICAN/ENGLISH EDITION

PART ONE

I. Introduction

II. Two Kinds of Thinking

III. The Miller Fantasies: Anamnesis

IV. The Hymn of Creation

V. The Song of the Moth

PART TWO

I. Introduction

II. The Concept of Libido

III. The Transformation of Libido

IV. The Origin of the Hero

V. Symbols of the Mother and of Rebirth

VI. The Battle for Deliverance from the Mother

VII. The Dual Mother

VIII. The Sacrifice

IX. Epilogue

APPENDIX: The Miller Fantasies

BIBLIOGRAPHY

LINGUISTIC ABBREVIATIONS

INDEX

LIST OF PLATES

For full documentation of sources, see the Bibliography, P = photograph.

Frontispiece. The Ostian head of Mithras

Roman. Museo Laterano, Rome. P: Museum, courtesy of Torgil Magnusson.

1a. Expulsion of the demons

Anonymous engraving, 17th century. P: Courtesy of Dr. Jolande Jacobi.

1b. Sun-god

Shamanistic Eskimo idol, Alaska. P: From Wirth, *Der Aufgang der Menschheit*, Pl. XI, fig. 1.

II. Romulus and Remus with the She-Wolf

Painted wood, northern Italian, medieval. Victoria and Albert Museum, London, P: Museum, Crown copyright.

III. Christ in the Virgin's womb

Upper Rhenish Master, Germany, c. 1400. Formerly Staatliche Gemäldegalerie, Berlin. P: From Wachlmayr, *Das Christgeburts-bild*, p. 4.

iva. Boar-headed mother goddess: shakti of boar-headed vishnu

Relief, northern India, 7th century. British Museum, P: Museum.

ivb. Scenes from the Eleusinian Mysteries

From a burial urn, Rome, 1st century A.D. Formerly in the Kircher Museum, Rome. Reconstructed drawing from *Bullettino della Commissione Archeologica Comunale di Roma*, VII (1879), 2nd series, Pls. II–III.

va. Veneration of the Buddha's teachings as a sun-wheel

Stupa of Amaravati, India, 2nd century A.D. Government Museum, Madras. P Guirand, *Mythologie générale*, p. 330.

vb. The Son of Man between the Seven Candlesticks

Universitätsbibliothek, Tübingen: Beatus Commentary, Theol. Lat. fol. 561, fol. 3^v. P: E. Surkamp, courtesy of the Bibliothek.

VI. The initiation of Apuleius

Title-page, Book XI, Apuleius, *Les Metamorphoses* (1648), p. 346.

VII. The winged sun-disc, above the King

Throne of Tut-Ankh-Amon, 14th century B.C. P: Courtesy of the Griffith Institute, Ashmolean Museum, Oxford.

VIII. The Overshadowing of Mary

Tempera painting on wood, Erfurt Cathedral, 1620–40. P: From Spiess, *Marksteine der Volkskunst*, II, fig. 112.

IXa. Winged sun-moon disc and tree of life

Hittite relief, Sakjegeuzi, northern Syria. P: From *Orientalische Literaturzeitung*, XII (1909) : 9, Pl. II, fig-2.

IXb. Crucifixion, and the serpent lifted up

Thaler struck by the goldsmith Hieronymus Magdeburger of Annaberg. P: Courtesy of the Ciba Archives, Basel.

X. “Sin”

Painting by Franz Stuck (1863–1928), Germany. Bayerische Staatliche Gemäldesammlung, Munich. P: Gallery.

XIa. The King, attended, sacrifices to the sun-god

Stele of King Nabupaliddina, Babylon, 870 B.C. British Museum. P: Museum.

XIb The fertility god Frey

Bronze figure, Södermanland, Sweden. Drawings from Montelius, *Opuscula*, p. 406.

XII. Phanes in the egg

Orphic relief, Modena Museum. P: From *Revue archéologique*, 3rd series, XL (1902), Pl. I, facing p. 432.

XIIIa. The fire-god Tjintya

Wood-carving, Bali. P: Courtesy of the Ciba Archives, Basel.

XIIIb. Agni on the ram, with fire-sticks

Teak processional carving, southern India. Musée Guimet, Paris. P: Museum.

XIVa. The nourishing earth-mother

Vault painting, Limburg Cathedral, c. 1235. P: From Clemen, *Die romanischen Wandmalereien*, Pl. 51.

XIVb. Gorgon

Detail from a Greek vase. Louvre. P: Archives photographiques.

XV. The Churning of the Milky Ocean

Miniature painting, Rajput School, India. Musée Guimet, Paris. P: Museum.

xvi. [Kihe Wahine, goddess of goblins and lizards](#)

Kou wood with human teeth, Hawaii. P: Friedrich Hewicker, from Tischner, *Oceanic Art*, pl. 89.

xvii. [Female figure with head-dress symbolizing kingly power](#)

King's incense bowl, Yoruba, West Africa. Hesse State Museum, Darmstadt. P: P. Hirlmann, Darmstadt.

xviii. [The crowned hermaphrodite](#)

From a manuscript, "De alchimia," attributed to Thomas Aquinas, c. 1520. Rijksuniversiteit Bibliotheek, Leiden, Codex Vossianus Chymicus 29, fol. 91. P: Courtesy of the Library.

xix. [Gilgamesh with the herb of immortality](#)

Relief, palace of Assurnasirpal II (885–860 B.C.), Nimrud, Assyria. Metropolitan Museum of Art, New York. P: Courtesy of the Museum.

xxa. [The horned Alexander](#)

Coin of Lysimachus, 3rd century B.C. P: From Bernoulli, *Die Darstellungen Alexanders*, Pl. VIII, fig. 4.

xxb. [The Dadophors with raised and lowered torches](#)

From a Mithraic marble bas-relief. Museum, Palermo. P: Randazzo.

xxia. [The god Men, on the cock](#)

Attic wall-relief. National Museum, Athens. P: Alison Frantz, Athens.

xxib. [American Indian dancer, in ceremonial head-dress](#)

New Mexico. P: George Hight, Gallup.

xxiia. [The New Jerusalem \(Revelation, ch. 21\)](#)

From a Bible illustrated and printed by Matthaeus Merian, Amsterdam, 1650.

xxiib. [A man and woman devoured by the Terrible Mother](#)

Shaman's amulet, walrus ivory, Tlingit Indians, Alaska, 19th century. American Museum of Natural History, New York. P: Courtesy of the Museum.

xxiii. [Ardhanari: Shiva and Parvati united](#)

Polychrome clay, India, 19th century. Victoria and Albert Museum, London. P: Courtesy of Bush Collection, Columbia University, New York.

xxiva. [Mithras and Helios](#)

Fragment from the Mithraeum near Klagenfurt. Carinthian State Museum, Klagenfurt. P: W. Prugger, courtesy of the Museum.

xxivb. Diana of Ephesus, with the mural crown

Alabaster and bronze, Roman, 2nd century A.D. National Museum, Naples. P: Anderson.

xxv. Lingam with yoni

Angkor Wat, Cambodia, c. 12th century. P: Eliot Elisofon, copyright by Time, Inc.

xxvi. The Fountain of Life

Icon, Constantinople School, 17th century. Coll. Dr. S. Amberg, Ettiswil, near Lucerne. P: Courtesy of Dr. Jolande Jacobi.

xxvii. Stoup, with arms encircling belly

Church at Kilpeck, Herefordshire, early 12th century. P: Courtesy of Dr. C. A. Meier, Zurich.

xxviii. Hook for hanging

Painted wood, northern New Guinea. Rijksmuseum voor Volkenkunde, Leiden, P: Museum.

xxix. The Goddess in the Lingam

Cambodia, 14th century. Musée Guimet, Paris. P: Museum.

xxx a. Mater Ecclesia

From the manuscript "Scivias" of St. Hildegarde of Bingen, Germany, 12th century. Formerly in the Nassauische Landesbibliothek, Wiesbaden; destroyed in the second World War. P: Library.

xxx b. The cow-headed Hathor

Bronze, Serapeum of Saqqara, late period. Cairo Museum. P: From Daressy, "Statues de divinités," no. 39134.

xxx i. The Tree of Life

Bronze vessel, Egypt, 7th-6th century B.C. Louvre. P: Archives photographiques.

xxx ii a. Jackal-headed Anubis bending over a mummy

From a tomb, Der el-Medinah, Thebes, XXth Dynasty. P: A. Gaddis, Luxor.

xxx ii b. The sun-eating lion of alchemy

From a manuscript, St. Gall Bibliothek, 17th century. P: Courtesy of the Ciba Archives, Basel.

xxxiii. [The Mithraic sacrifice creating fruitfulness](#)

The Heddernheim Relief, reverse. Nassauisches Landesmuseum, Wiesbaden, P: From Cumont, *Textes et monuments*, II, Pl. VIII.

xxxiv. [Demon eating the sun](#)

Stone, eastern Java, 15th century. Rijksmuseum voor Volkenkunde, Leiden, P: Museum.

xxxv. [Buddhist tree of the dead](#)

Wood carving, China. Museum für Völkerkunde, Berlin; destroyed in the second World War. P: Museum.

xxxvi. [Christ on the Tree of Life](#)

Painting, Strasbourg School. Strasbourg Gallery. P: Braun.

xxxvii. [The Cross on Adam's grave](#)

Detail over west door, Strasbourg Cathedral, c. 1280. P: Marc Foucault, from Thibout, *La Cathédrale de Strasbourg*, pl 4.

xxxviii. [Lamia bearing off a new-born babe](#)

From the frieze "Tomb of the Harpies," Acropolis of Xanthos. British Museum. P: Museum.

xxviii. [The devouring mother](#)

Shaman's amulet, walrus tusk, Tlingit Indians, Alaska. American Museum of Natural History, New York. P: Courtesy of the Museum.

xxxix. [The wak-wak tree with its human fruit](#)

From a Turkish history of the West Indies, Woodcut from a history of the West Indies by Ta'rikh al-Hind al-Gharbi, Constantinople, 1730.

xl. [Mithras sacrificing the bull](#)

The Heddernheim Relief. Nassauisches Landesmuseum, Wiesbaden. P: Cumont, *Textes et monuments*, II Pl. VII.

xlia. [The cross of Palenque](#)

Mayan relief, Yucatán, Mexico. Drawing from Maudslay, in *Biologia Centrali-Americana: Archaeology*, IV, pl. 76.

xl. [The shaping of the world-egg: Ptah working on a potter's wheel](#)

Egypt. Painting from Budge, *The Gods of the Egyptians*, I, p. 500.

xl. [Regeneration in the mother's body](#)

Wooden figure, Nootka Indians, Vancouver Island, Canada. American Museum of Natural History, New York, P: Courtesy of the Museum.

XLIII. Mock crucifixion

Graffito, wall of the Imperial Cadet School, Palatine, Rome. Museo delle Terme (formerly in the Kircher Coll.), Rome. P: Anderson.

XLIV. Aion, with the signs of the zodiac

Rome, and-3rd century. Museo Profano, Vatican. P: Alinari.

XLV. Death the archer

Detail from an engraving by the “Master of 1464,” German School. From *Publications of the International Chalcographical Society*, 1888, Pl. I.

XLVIA. The lotus growing out of Vishnu’s navel, with Brahma inside

Relief, Vijayanagar, India. P: From Guirand, *Mythologie générale*, p. 320.

XLVIB. Ixion on the wheel

From a Cumaean vase. P: From Archaeologisches Institut des Deutschen Reiches, *Annali*, XLV (1873), Pl. IK.

XLVII. Vishnu as a fish

Zinc figurine, India, 19th century. Victoria and Albert Museum, London. P: Museum.

XLVIII. The witch Rangda, thief of children

Painted wood, Bali. P: L. Fritz, Berlin, from Prampolini, *La Mitologia*, II, p. 416.

XLIXa. Mithras carrying the bull

Relief, Castle of Stockstadt, Germany. P: From Drexel, “Das Kastell Stockstadt,” Pl. XIII, fig. 5.

XLIXb. Queen Maya’s dream of the Buddha’s conception

Relief, Gandhara. P: From Le Coq, *Die Buddhistische Spätantike*, I, Pl. 14a.

La. The Hathor Cow, suckling Queen Hatshepsut

Relief, Anubis Chapel, Temple of Der el-Bahri, XVIIIth Dynasty. P: Metropolitan Museum of Art, New York.

Lb. The goddess Artio with bears: a Roman parallel to Artemis

Bronze group, dedicated to the goddess of Licinia Sabinilla, from Muri, near Bern. Historical Museum, Bern. P: Museum.

LI. The Mistress of the Beasts

Greek hydria, 600 B.C., found near Bern. Historical Museum, Bern. P: Museum.

LII. A corn-god

Clay vessel, Chimbote culture, Peru. P: From Fuhrmann, *Reich der Inka*, I, pl. 59.

LIII. Basket of Isis, with snake

Marble altar from Caligula's temple to Isis, Rome. Museo Capitolino, Rome. P: Deutsches Archaeologisches Institut, Rome.

LIV. Matuta, an Etruscan Pietà

Fifth century B.C. Museo Archeologico, Florence. P: Alinari.

LV. The Tree of Enlightenment

Pillar relief, stupa of Bharhut, India, 1st century B.C. P: From Cohn, *Buddha in der Kunst des Ostens*, fig. 3, p. xxiv.

LVI. The Vision of Ezekiel

Bible of Manerius (French manuscript). Bibliothèque Nationale, Paris, MS. Lat. 11534. P: Bibliothèque.

LVIIa. Cista and serpent

Silver coin, Ephesus, 57 B.C. British Museum. P: Museum.

LVIIb. The sacrifice to the snake deity

Votive tablet, Sialesi (Eteonis), Boeotia. P: Courtesy of the Ciba Archives, Basel.

LVIII. Triple-bodied Hecate

Roman. Museum of the Palazzo dei Conservatori, Rome. P: From Jones, *Catalogue*.

LIXa. The self-consuming dragon

From Lambsprinck's symbols in the *Musaeum Hermeticum* (1678), p. 353.

LIXb. Circle of gods

Balinese drawing. Courtesy of the Ciba Archives, Basel.

LX. Christ surrounded by the Evangelists

Relief, Church at Arles-sur-Tech, Pyrénées-orientales, 11th century. P: Archives photographiques, Paris.

LXIa. The Serpent Mystery

Altar to the Lares, Pompeii. P: Courtesy of the Ciba Archives, Basel.

LXIb. Priapus with snake

Roman. Museo Archeologico, Verona. P: Courtesy of Dr. G. Mardersteig.

LXII. Devouring monster

Stone, Belahan, eastern Java, 11th century. Rijksmuseum voor Volkenkunde, Leiden. P: Museum.

LXIIIa. The regenerative symbol of the Haloa Festival

From a Greek vase, by the Pan Painter. P: From Deubner, *Attische Feste*, pl. 4, fig. 2.

LXIIIb. Mixing-pot with lion and snake

Detail from the Heddernheim Relief (cf. PL XL). Nassauisches Landesmuseum, Wiesbaden. P: From Cumont, *Textes et monuments*, II, Pl. VII.

LXIV. Rubens: *The Last Judgment*

1618–20. Alte Pinakothek, Munich. P: Bayerische Staatliche Gemäldesammlung.

LIST OF TEXT FIGURES

1. The Mother of All Living

Woodcut from Colonna, *Hypnerotomachia Poliphili*; from Fierz-David, *The Dream of Poliphilo*, p. 67.

2. The Eye of God

Frontispiece to Jakob Böhme, *Seraphinisch Blumengärtlein*; from *Auslese aus den mystisch-religiösen Schriften Jakob Böhmes*.

3. The Voyage of the Sun

Late Egyptian. From Schaefer, *Von ägyptischer Kunst*, Pl. LIII, fig. 1.

4. Germanic sun-idol

Woodcut from Botho, *Sachsisch Chronicon*. P: British Museum.

5. The life-giving Sun: Amenophis IV on his throne

Relief, Egypt. Drawing from Budge, *The Gods of the Egyptians*, II, p. 74.

6. The mercurial serpent, alchemical symbol of psychic transformation

Engraving from Barchusen, *Elementa chemiae*, fig. 62.

7. The Sun's hands

Relief, Spitalkirche, Tübingen. Rubbing from Erich Jung, *Germanische Götter und Helden*, fig. 2.

8. The Tempting of Eve

Woodcut from the *Speculum humanae salvationis*; from Worringer, *Die altdeutsche Buchillustration*, fig. 6, p. 37.

9. Mithras with sword and torch

Roman sculpture, excavated on the Esquiline Hill. Engraving from Cumont, *Textes et monuments*, II, fig. 28, p. 202.

10. Serpent representing the orbit of the moon

Assyrian boundary stone, Susa. Drawing from Roscher, *Lexikon*, IV, col. 1475.

11. Bes, with Horus-eyes

Bronze figure, Serapeum of Saqqara, Egypt, c. 6th century B.C. Louvre, Paris. Drawing from Lanzone, *Dizionario*, I, Pl. LXXX, fig. 3.

12. The birth-giving orifice

From a Mexican lienzo. Drawing from Danzel, *Symbole*, pl. 87.

13. Odysseus as a Cabiric dwarf, with Circe

From a bowl by the Cabiri Painter (?), c. 400 B.C. British Museum. Drawing from Wolters and Bruns, *Das Kabirenheiligtum bei Theben*, I, pl. 29.

14. The banquet of the Cabir

From a bowl by the Cabiri Painter, c. 435 B.C. National Museum, Athens. Drawing from Wolters and Bruns, *Das Kabirenheiligtum bei Theben*, I, pl. 29.

15. The phallic plough

From a Greek vase. Museo Archeologico, Florence. Drawing from Dieterich, *Mutter Erde*, p. 108.

16. The twirling-stick

From an Aztec hieroglyph-painting. Drawing courtesy of the Ciba Archives, Basel.

17. The first three labours of Heracles

Classical sarcophagus relief. Drawing by Gori in *Inscriptiones antiquae graecae et romanae*, 1783; from Robert, *Die antiken Sarkophag-Reliefs*, III, Part 1, Pl. XXXIX, fig. 128 (detail).

18. Priest with a fish-mask, representing Oannes

Relief, Nimrud. Drawing from Jeremias, *Das Alte Testament im Lichte des alten Orients*, fig. 2.

19. Androgynous divinity

Late Babylonian gem. Drawing from Lajard, *Mémoire*, p. 161.

20. Cybele and her son-lover Attis

Roman coin. Drawing from Roscher, *Lexikon*, II, Part 1, col. 1647.

21. Noah in the Ark

Enamelled altar of Nicholas of Verdun, 1186, Klosterneuburg, near Vienna. Drawing from Ehrenstein, *Das Alte Testament im Bilde*, Ch. IV, fig. 31, p. 106.

22. The Great Whore of Babylon

New Testament engraving by H. Burgkmaier; from Worringer, *Die altdeutsche Buchillustration*, fig. 88, p. 136.

23. Osiris in the cedar-coffin

Relief, Dendera, Egypt. Drawing from Budge, *Osiris and the Egyptian Resurrection*, I, p. 5.

24. Nut giving birth to the Sun

Relief, Egypt. Drawing from Budge, *The Gods of the Egyptians*, II, p. 101.

25. The Divine Cow

From the tomb of Seti I, Egypt. Drawing from Erman, *Die Religion der Agypter*, p. 15.

26. The human cross

Woodcut from Agrippa of Nettesheim, *De occulta philosophia*, p. 157.

27. The life-giving *crux ansata*

Egypt. Drawing from Budge, *The Gods of the Egyptians*, II, p. 24.

28. Wotan riding the eight-legged horse Sleipnir

Tombstone, Götland, Sweden, c. A.D. 1000. Drawing from Gray and McCulloch, *The Mythology of All Races*, II, Pl. VIII.

29. The Devil riding off with a witch

Woodcut from Olaus Magnus, *Historia de gentibus septentrionalibus*, Rome, 1555; from de Givry, *Le Musée des Sorciers*, p. 207, fig. 164.

30. Quetzalcoatl devouring a man

From the Codex Borbonicus, Aztec, 16th century. Library of the Palais Bourbon, Paris. Drawing from Danzel, "Altmexi-kanische Symbolik," p. 235.

31. The moon as the abode of souls

Chalcedon gem, 1st century B.C. Drawing from Chapouthier, *Les Dioscures*, fig. 67, p. 324.

32. The woman in the moon

Tattoo pattern, Haida Indians, Northwest America. Drawing from Danzel, *Symbole*, pl. 35.

33. Vidarr's fight with the Fenris-Wolf

Relief from a cross, Churchyard of Gosforth, Cumberland. Rubbing from Gray and MacCulloch, *Mythology of All Races*, II, Pl. XXI.

34. Hecate of Samothrace

Gnostic gem. Engraving from *Archäologische Zeitung*, XV, 98–99 (1857), Atlas, Pl. XCIX.

35. The assault by the dragon

From Vitruvius, *De architectura*, Book I, p. 9.

36. Prajapati with the world-egg

India. Drawing from Müller, *Glauben, Wissen und Kunst der alten Hindus*, Pl. II, fig. 21.

37. Agathodaimon serpent

Antique gem. Engraving from Macarius, *Abraxas*, Pl. XV, fig. 63. Courtesy of the United States Geological Survey Library, Washington.

38. World plan

From an Aztec codex. Drawing from Danzel, *Mexiko I*, pl. 53.

39. The four corners of the zodiac: sun and moon in centre

Coptic. Woodcut from Kircher, *Oedipus Aegyptiacus*.

40. The womb of the World Mother

Wooden bowl, Congo. Museum für Völkerkunde, Hamburg. Drawing from Danzel, *Symbole*, pl. 88.

41. Marduk fighting Tiamat

Assyrian cylinder seal. Drawing from Jeremias, *Das Alte Testament*, fig. 14.

42. The sacred tree of Attis

Relief from an altar to Cybele. Drawing from Gressmann, *Die orientalischen Religionen*, fig. 41, p. 99.

43. Antique cameo

Formerly in a museum of Florence. Drawing from Bachofen, *Versuch über die Gräbersymbolik*, Pl. II, fig. 1.

FOREWORD TO THE FOURTH (SWISS) EDITION¹

I have long been conscious of the fact that this book, which was written thirty-seven years ago, stood in urgent need of revision, but my professional obligations and my scientific work never left me sufficient leisure to settle down in comfort to this unpleasant and difficult task. Old age and illness released me at last from my professional duties and gave me the necessary time to contemplate the sins of my youth. I have never felt happy about this book, much less satisfied with it: it was written at top speed, amid the rush and press of my medical practice, without regard to time or method. I had to fling my material hastily together, just as I found it. There was no opportunity to let my thoughts mature. The whole thing came upon me like a landslide that cannot be stopped. The urgency that lay behind it became clear to me only later: it was the explosion of all those psychic contents which could find no room, no breathing-space, in the constricting atmosphere of Freudian psychology and its narrow outlook. I have no wish to denigrate Freud, or to detract from the extraordinary merits of his investigation of the individual psyche. But the conceptual framework into which he fitted the psychic phenomenon seemed to me unendurably narrow. I am not thinking here of his theory of neurosis, which can be as narrow as it pleases if only it is adequate to the empirical facts, or of his theory of dreams, about which different views may be held in all good faith; I am thinking more of the reductive causalism of his whole outlook, and the almost complete disregard of the teleological directedness which is so characteristic of everything psychic. Although Freud's book *The Future of an Illusion* dates from his later years, it gives the best possible account of his earlier views, which move within the confines of the outmoded rationalism and scientific materialism of the late nineteenth century.

As might be expected, my book, born under such conditions, consisted of larger or smaller fragments which I could only string together in an unsatisfying manner. It was an attempt, only partially successful, to create a wider setting for medical psychology and to bring the whole of the psychic phenomenon within its purview. One of my principal aims was to free medical psychology from the subjective and personalistic bias that characterized its outlook at that time, and to make it possible to understand the unconscious as an objective and collective psyche. The personalism in the views of Freud and Adler that went hand in hand with the individualism of the nineteenth century failed to satisfy me because, except in the case of instinctive dynamisms (which actually have too little place in Adler), it left no room for objective, impersonal facts. Freud, accordingly, could see no objective justification for my attempt, but suspected personal motives.

Thus this book became a landmark, set up on the spot where two ways divided. Because of its imperfections and its incompleteness it laid down the programme to be followed for the next few decades of my life. Hardly had I finished the manuscript when it struck me what it means to live with a myth, and what it means to live without one. Myth, says a Church Father, is "what is believed always, everywhere, by

everybody”; hence the man who thinks he can live without myth, or outside it, is an exception. He is like one uprooted, having no true link either with the past, or with the ancestral life which continues within him, or yet with contemporary human society. He does not live in a house like other men, does not eat and drink like other men, but lives a life of his own, sunk in a subjective mania of his own devising, which he believes to be the newly discovered truth. This plaything of his reason never grips his vitals. It may occasionally lie heavy on his stomach, for that organ is apt to reject the products of reason as indigestible. The psyche is not of today; its ancestry goes back many millions of years. Individual consciousness is only the flower and the fruit of a season, sprung from the perennial rhizome beneath the earth; and it would find itself in better accord with the truth if it took the existence of the rhizome into its calculations. For the root matter is the mother of all things.

So I suspected that myth had a meaning which I was sure to miss if I lived outside it in the haze of my own speculations. I was driven to ask myself in all seriousness: “What is the myth you are living?” I found no answer to this question, and had to admit that I was not living with a myth, or even in a myth, but rather in an uncertain cloud of theoretical possibilities which I was beginning to regard with increasing distrust. I did not know that I was living a myth, and even if I had known it, I would not have known what sort of myth was ordering my life without my knowledge. So, in the most natural way, I took it upon myself to get to know “my” myth, and I regarded this as the task of tasks, for—so I told myself—how could I, when treating my patients, make due allowance for the personal factor, for my personal equation, which is yet so necessary for a knowledge of the other person, if I was unconscious of it? I simply had to know what unconscious or preconscious myth was forming me, from what rhizome I sprang. This resolve led me to devote many years of my life to investigating the subjective contents which are the products of unconscious processes, and to work out methods which would enable us, or at any rate help us, to explore the manifestations of the unconscious. Here I discovered, bit by bit, the connecting links that I should have known about before if I was to join up the fragments of my book. I do not know whether I have succeeded in this task now, after a lapse of thirty-seven years. Much pruning had to be done, many gaps filled. It has proved impossible to preserve the style of 1912, for I had to incorporate many things that I found out only many years later. Nevertheless I have tried, despite a number of radical interventions, to leave as much of the original edifice standing as possible, for the sake of continuity with previous editions. And although the alterations are considerable, I do not think one could say that it has turned into a different book. There can be no question of that because the whole thing is really only an extended commentary on a practical analysis of the prodromal stages of schizophrenia. The symptoms of the case form the Ariadne thread to guide us through the labyrinth of symbolistic parallels, that is, through the amplifications which

are absolutely essential if we wish to establish the meaning of the archetypal context. As soon as these parallels come to be worked out they take up an incredible amount of space, which is why expositions of case histories are such an arduous task. But that is only to be expected: the deeper you go, the broader the base becomes. It certainly does not become narrower, and it never by any chance ends in a point—in a psychic trauma, for instance. Any such theory presupposes a knowledge of the traumatically affected psyche which no human being possesses, and which can only be laboriously acquired by investigating the workings of the unconscious. For this a great deal of comparative material is needed, and it cannot be dispensed with any more than in comparative anatomy. Knowledge of the subjective contents of consciousness means very little, for it tells us next to nothing about the real, subterranean life of the psyche. In psychology as in every science a fairly wide knowledge of other subjects is among the requisites for research work. A nodding acquaintance with the theory and pathology of neurosis is totally inadequate, because medical knowledge of this kind is merely information about an illness, but not knowledge of the soul that is ill. I wanted, so far as lay within my power, to redress that evil with this book—then as now.

This book was written in 1911, in my thirty-sixth year. The time is a critical one, for it marks the beginning of the second half of life, when a metanoia, a mental transformation, not infrequently occurs. I was acutely conscious, then, of the loss of friendly relations with Freud and of the lost comradeship of our work together. The practical and moral support which my wife gave me at that difficult period is something I shall always hold in grateful remembrance.

September, 1950

C. G. JUNG

FOREWORD TO THE THIRD (GERMAN) EDITION

The new edition of this book appears essentially unaltered, except for a few textual improvements which hardly affect its content.

This book has to perform the thankless task of making clear to my contemporaries that the problems of the human psyche cannot be tackled with the meagre equipment of the doctor's consulting-room, any more than they can be tackled with the layman's famous "understanding of the world and human nature." Psychology cannot dispense with the contribution made by the humane sciences, and certainly not with that made by the history of the human mind. For it is history above all that today enables us to bring the huge mass of empirical material into ordered relationships and to recognize the functional significance of the collective contents of the unconscious. The psyche is not something unalterably given, but a product of its own continuous development. Hence altered glandular secretions or aggravated personal relationships are not the sole causes of neurotic conflicts; these can equally well be caused by historically conditioned attitudes and mental factors. Scientific and medical knowledge is in no sense sufficient to grasp the nature of the soul, nor does the psychiatric understanding of pathological processes help to integrate them into the totality of the psyche. Similarly, mere rationalization is not an adequate instrument. History teaches us over and over again that, contrary to rational expectation, irrational factors play the largest, indeed the decisive, role in all processes of psychic transformation.

It seems as if this insight were slowly making headway with the somewhat drastic assistance of contemporary events.

November, 1937

C. G. JUNG

FOREWORD TO THE SECOND (GERMAN) EDITION

In this second edition the text of the book remains, for technical reasons, unaltered. The reappearance of this book after twelve years, without alterations, does not mean that I did not consider certain emendations and improvements desirable. But such improvements would have affected details only, and not anything essential. The views and opinions I expressed in the book I would still maintain, in substance and in principle, today. I must ask the reader to bear patiently with a number of minor inaccuracies and uncertainties of detail.

This book has given rise to a good deal of misunderstanding. It has even been suggested that it represents my method of treatment. Apart from the fact that such a method would be a practical impossibility, the book is far more concerned with working out the fantasy material of an unknown young American woman, pseudonymously known as Frank Miller. This material was originally published by my respected and fatherly friend, the late Théodore Flournoy, in the *Archives de psychologie* (Geneva). I had the great satisfaction of hearing from his own lips that I had hit off the young woman's mentality very well. Valuable confirmation of this reached me in 1918, through an American colleague who was treating Miss Miller for the schizophrenic disturbance which had broken out after her sojourn in Europe. He wrote to say that my exposition of the case was so exhaustive that even personal acquaintance with the patient had not taught him "one iota more" about her mentality. This confirmation led me to conclude that my reconstruction of the semi-conscious and unconscious fantasy processes had evidently hit the mark in all essential respects.

There is, however, one very common misunderstanding which I feel I ought to point out to the reader. The copious use of comparative mythological and etymological material necessitated by the peculiar nature of the Miller fantasies may evoke the impression, among certain readers, that the purpose of this book is to propound mythological or etymological hypotheses. This is far from my intention, for if it had been, I would have undertaken to analyse a particular myth or whole corpus of myths, for instance an American Indian myth-cycle. For that purpose I would certainly not have chosen Longfellow's *Hiawatha*, any more than I would have used Wagner's *Siegfried* had I wished to analyse the cycle of the younger Edda. I use the material quoted in the book because it belongs, directly or indirectly, to the basic assumptions of the Miller fantasies, as I have explained more fully in the text. If, in this work, various mythologems are shown in a light which makes their psychological meaning more intelligible, I have mentioned this insight simply as a welcome by-product, without claiming to propound any general theory of myths. The real purpose of this book is confined to working out the implications of all those historical and spiritual factors

which come together in the involuntary products of individual fantasy. Besides the obvious personal sources, creative fantasy also draws upon the forgotten and long buried primitive mind with its host of images, which are to be found in the mythologies of all ages and all peoples. The sum of these images constitutes the collective unconscious, a heritage which is potentially present in every individual. It is the psychic correlate of the differentiation of the human brain. This is the reason why mythological images are able to arise spontaneously over and over again, and to agree with one another not only in all the corners of the wide earth, but at all times. As they are present always and everywhere, it is an entirely natural proceeding to relate mythologems, which may be very far apart both temporally and ethnically, to an individual fantasy system. The creative substratum is everywhere this same human psyche and this same human brain, which, with relatively minor variations, functions everywhere in the same way.

Küsnacht/Zurich, November, 1924

C. G. JUNG

AUTHOR'S NOTE TO THE FIRST AMERICAN/ENGLISH EDITION

My task in this work has been to investigate an individual fantasy system, and in the doing of it problems of such magnitude have been uncovered that my endeavour to grasp them in their entirety has necessarily meant only a superficial orientation toward those paths the opening and exploration of which may possibly crown the work of future investigators with success.

I am not in sympathy with the attitude which favours the repression of certain possible working hypotheses because they are perhaps erroneous, and so may possess no lasting value. Certainly I endeavoured as far as possible to guard myself from error, which might indeed become especially dangerous upon these dizzy heights, for I am entirely aware of the risks of these investigations. However, I do not consider scientific work as a dogmatic contest, but rather as a work done for the increase and deepening of knowledge.

This contribution is addressed to those having similar ideas concerning science.

In conclusion, I must render thanks to those who have assisted my endeavours with valuable aid, especially my dear wife and my friends, to whose disinterested assistance I am deeply indebted.

C. G. JUNG

Zurich [1916?]

Therefore theory, which gives facts their value and significance, is often very useful, even if it is partially false, because it throws light on phenomena which no one has observed, it forces an examination, from many angles, of facts which no one has hitherto studied, and provides the impulse for more extensive and more productive researches....

Hence it is a moral duty for the man of science to expose himself to the risk of committing error, and to submit to criticism in order that science may continue to progress. A writer ... has launched a vigorous attack on the author, saying that this is a scientific ideal which is very limited and very paltry.... But those who are endowed with a mind serious and impersonal enough not to believe that everything they write is the expression of absolute and eternal truth will approve of this theory, which puts the aims of science well above the miserable vanity and paltry *amour propre* of the scientist.

—Ferrero, *Les Lois psychologiques du symbolisme*, p. viii

INTRODUCTION

[1] Anyone who can read Freud's *Interpretation of Dreams* without being outraged by the novelty and seemingly unjustified boldness of his procedure, and without waxing morally indignant over the stark nakedness of his dream-interpretations, but can let this extraordinary book work upon his imagination calmly and without prejudice, will not fail to be deeply impressed at that point¹ where Freud reminds us that an individual conflict, which he calls the incest fantasy, lies at the root of that monumental drama of the ancient world, the Oedipus legend. The impression made by this simple remark may be likened to the uncanny feeling which would steal over us if, amid the noise and bustle of a modern city street, we were suddenly to come upon an ancient relic—say the Corinthian capital of a long-immured column, or a fragment of an inscription. A moment ago, and we were completely absorbed in the hectic, ephemeral life of the present; then, the next moment, something very remote and strange flashes upon us, which directs our gaze to a different order of things. We turn away from the vast confusion of the present to glimpse the higher continuity of history. Suddenly we remember that on this spot where we now hasten to and fro about our business a similar scene of life and activity prevailed two thousand years ago in slightly different forms; similar passions moved mankind, and people were just as convinced as we are of the uniqueness of their lives. This is the impression that may very easily be left behind by a first acquaintance with the monuments of antiquity, and it seems to me that Freud's reference to the Oedipus legend is in every way comparable. While still struggling with the confusing impressions of the infinite variability of the individual psyche, we suddenly catch a glimpse of the simplicity and grandeur of the Oedipus tragedy, that perennial highlight of the Greek theatre. This broadening of our vision has about it something of a revelation. For our psychology, the ancient world has long since been sunk in the shadows of the past; in the schoolroom one could scarcely repress a sceptical smile when one indiscreetly calculated the matronly age of Penelope or pictured to oneself the comfortable middle-aged appearance of Jocasta, and comically compared the result with the tragic tempests of eroticism that agitate the legend and drama. We did not know then—and who knows even today?—that a man can have an unconscious, all-consuming passion for his mother which may undermine and tragically complicate his whole life, so that the monstrous fate of Oedipus seems not one whit overdrawn. Rare and

pathological cases like that of Ninon de Lenclos and her son ² are too remote from most of us to convey a living impression. But when we follow the paths traced out by Freud we gain a living knowledge of the existence of these possibilities, which, although too weak to compel actual incest, are yet sufficiently strong to cause very considerable psychic disturbances. We cannot, to begin with, admit such possibilities in ourselves without a feeling of moral revulsion, and without resistances which are only too likely to blind the intellect and render self-knowledge impossible. But if we can succeed in discriminating between objective knowledge and emotional value-judgments, then the gulf that separates our age from antiquity is bridged over, and we realize with astonishment that Oedipus is still alive for us. The importance of this realization should not be underestimated, for it teaches us that there is an identity of fundamental human conflicts which is independent of time and place. What aroused a feeling of horror in the Greeks still remains true, but it is true for us only if we give up the vain illusion that we are *different*, i.e., morally better, than the ancients. We have merely succeeded in forgetting that an indissoluble link binds us to the men of antiquity. This truth opens the way to an understanding of the classical spirit such as has never existed before—the way of inner sympathy on the one hand and of intellectual comprehension on the other. By penetrating into the blocked subterranean passages of our own psyches we grasp the living meaning of classical civilization, and at the same time we establish a firm foothold outside our own culture from which alone it is possible to gain an objective understanding of its foundations. That at least is the hope we draw from the rediscovery of the immortality of the Oedipus problem.

- [2] This line of inquiry has already yielded fruitful results: to it we owe a number of successful advances into the territory of the human mind and its history. These are the works of Riklin,³ Abraham,⁴ Rank,⁵ Maeder,⁶ and Jones,⁷ to which there has now been added Silberer's valuable study entitled "Phantasie und Mythos." Another work which cannot be overlooked is Pfister's contribution to Christian religious psychology.⁸ The *leitmotiv* of all these works is to find a clue to historical problems through the application of insights derived from the activity of the unconscious psyche in modern man. I must refer the reader to the works specified if he wishes to inform himself of the extent and nature of the insights already achieved. The interpretations are sometimes uncertain in particulars, but that does not materially detract from the total result. It would be significant enough if this merely demonstrated the far-reaching analogy between the psychological structure of the historical products and those of modern individuals. But the analogy applies with particular force to the symbolism, as Riklin, Rank, Maeder, and Abraham have shown, and also to the individual mechanisms governing the unconscious elaboration of motifs.

[3] Psychological investigators have hitherto turned their attention mainly to the analysis of individual problems. But, as things are at present, it seems to me imperative that they should broaden the basis of this analysis by a comparative study of the historical material, as Freud has already tried to do in his study of Leonardo da Vinci.⁹ For, just as psychological knowledge furthers our understanding of the historical material, so, conversely, the historical material can throw new light on individual psychological problems. These considerations have led me to direct my attention more to the historical side of the picture, in the hope of gaining fresh insight into the foundations of psychology. In my later writings¹⁰ I have concerned myself chiefly with the question of historical and ethnological parallels, and here the researches of Erich Neumann have made a massive contribution towards solving the countless difficult problems that crop up everywhere in this hitherto little explored territory. I would mention above all his key work, *The Origins and History of Consciousness*,¹¹ which carries forward the ideas that originally impelled me to write this book, and places them in the broad perspective of the evolution of human consciousness in general.

II

TWO KINDS OF THINKING

- [4] As most people know, one of the basic principles of analytical psychology is that dream-images are to be understood symbolically; that is to say, one must not take them literally, but must surmise a hidden meaning in them. This ancient idea of dream symbolism has aroused not only criticism, but the strongest opposition. That dreams should have a meaning, and should therefore be capable of interpretation, is certainly neither a strange nor an extraordinary idea. It has been known to mankind for thousands of years; indeed it has become something of a truism. One remembers having heard even at school of Egyptian and Chaldaean dream-interpreters. Everyone knows the story of Joseph, who interpreted Pharaoh's dreams, and of Daniel and the dream of King Nebuchadnezzar; and the dream-book of Artemidorus is familiar to many of us. From the written records of all times and peoples we learn of significant and prophetic dreams, of warning dreams and of healing dreams sent by the gods. When an idea is so old and so generally believed, it must be true in some way, by which I mean that it is *psychologically true*.
- [5] For modern man it is hardly conceivable that a God existing outside ourselves should cause us to dream, or that the dream foretells the future prophetically. But if we translate this into the language of psychology, the ancient idea becomes much more comprehensible. The dream, we would say, originates in an unknown part of the psyche and prepares the dreamer for the events of the following day.
- [6] According to the old belief, a god or demon spoke to the sleeper in symbolic language, and the dream-interpreter had to solve the riddle. In modern speech we would say that the dream is a series of images which are apparently contradictory and meaningless, but that it contains material which yields a clear meaning when properly translated.
- [7] Were I to suppose my readers to be entirely ignorant of dream-analysis, I should be obliged to document this statement with numerous examples. Today, however, these things are so well known that one must be sparing in the use of case-histories so as not to bore the public. It is an especial inconvenience that one cannot recount a dream without having to add the history of half a lifetime in order to represent the individual foundations of the dream. Certainly there are typical dreams and dream-motifs whose meaning appears to be simple enough if they are regarded from the

point of view of sexual symbolism. One can apply this point of view without jumping to the conclusion that the content so expressed must also be sexual in origin. Common speech, as we know, is full of erotic metaphors which are applied to matters that have nothing to do with sex; and conversely, sexual symbolism by no means implies that the interests making use of it are by nature erotic. Sex, as one of the most important instincts, is the prime cause of numerous affects that exert an abiding influence on our speech. But affects cannot be identified with sexuality inasmuch as they may easily spring from conflict situations—for instance, many emotions spring from the instinct of self-preservation.

- [8] It is true that many dream-images have a sexual aspect or express erotic conflicts. This is particularly clear in the motif of *assault*. Burglars, thieves, murderers, and sexual maniacs figure prominently in the erotic dreams of women. It is a theme with countless variations. The instrument of murder may be a lance, a sword, a dagger, a revolver, a rifle, a cannon, a fire-hydrant, a watering-can; and the assault may take the form of a burglary, a pursuit, a robbery, or it may be someone hidden in the cupboard or under the bed. Again, the danger may be represented by wild animals, for instance by a horse that throws the dreamer to the ground and kicks her in the stomach with his hind leg; by lions, tigers, elephants with threatening trunks, and finally by snakes in endless variety. Sometimes the snake creeps into the mouth, sometimes it bites the breast like Cleopatra's legendary asp, sometimes it appears in the role of the paradisaical serpent, or in one of the variations of Franz Stuck, whose snake-pictures bear significant titles like "Vice," "Sin," or "Lust" (cf. pl. x). The mixture of anxiety and lust is perfectly expressed in the sultry atmosphere of these pictures, and far more crudely than in Mörike's piquant little poem:

Girl's First Love Song

What's in the net? I feel
Frightened and shaken!
Is it a sweet-slipping eel
Or a snake that I've taken?

Love's a blind fisherman,
Love cannot see;
Whisper the child, then,
What would love of me?

It leaps in my hands! This is
Anguish unguessed.
With cunning and kisses

It creeps to my breast.

It bites me, O wonder!

Worms under my skin.

My heart bursts asunder,

I tremble within.

Where go and where hide me?

The shuddersome thing

Rages inside me,

Then sinks in a ring.

What poison can this be?

O that spasm again!

It burrows in ecstasy

Till I am slain.¹

- [9] All these things seem simple and need no explanation to be intelligible. Somewhat more complicated is the following dream of a young woman. She dreamt that she saw *the triumphal Arch of Constantine*. Before it stood a cannon, to the right a bird, to the left a man. A cannon-ball shot out of the muzzle and hit her; it went into her pocket, into her purse. There it remained, and she held the purse as if there were something very precious inside it. Then the picture faded, and all she could see was the stock of the cannon, with Constantine's motto above it: "*In hoc signo vinces.*" The sexual symbolism of this dream is sufficiently obvious to justify the indignant surprise of all innocent-minded people. If it so happens that this kind of realization is entirely new to the dreamer, thus filling a gap in her conscious orientation, we can say that the dream has in effect been interpreted. But if the dreamer has known this interpretation all along, then it is nothing more than a repetition whose purpose we cannot ascertain. Dreams and dream-motifs of this nature can repeat themselves in a never-ending series without our being able to discover—at any rate from the sexual side—anything in them except what we know already and are sick and tired of knowing. This kind of approach inevitably leads to that "monotony" of interpretation of which Freud himself complained. In these cases we may justly suspect that the sexual symbolism is as good a *façon de parler* as any other and is being used as a dream-language. "*Canis panem somniat, piscator pisces.*" Even dream-language ultimately degenerates into jargon. The only exception to this is in cases where a particular motif or a whole dream repeats itself because it has never been properly understood, and because it is necessary for the conscious mind to reorient itself by recognizing the compensation which the motif or dream expresses. In the above dream it is certainly a case either of ordinary unconsciousness, or of repression. One

can therefore interpret it sexually and leave it at that, without going into all the niceties of the symbolism. The words with which the dream ends—"In hoc signo vinces"—point to a deeper meaning, but this level could only be reached if the dreamer became conscious enough to admit the existence of an erotic conflict.

[10] These few references to the symbolic nature of dreams must suffice. We must accept dream symbolism as an accomplished fact if we wish to treat this astonishing truth with the necessary degree of seriousness. It is indeed astonishing that the conscious activity of the psyche should be influenced by products which seem to obey quite other laws and to follow purposes very different from those of the conscious mind.

[11] How is it that dreams are symbolical at all? In other words, whence comes this capacity for symbolic representation, of which we can discover no trace in our conscious thinking? Let us examine the matter a little more closely. If we analyse a train of thought, we find that we begin with an "initial" idea, or a "leading" idea, and then, without thinking back to it each time, but merely guided by a sense of direction, we pass on to a series of separate ideas that all hang together. There is nothing symbolical in this, and our whole conscious thinking proceeds along these lines.^{1a} If we scrutinize our thinking more closely still and follow out an intensive train of thought—the solution of a difficult problem, for instance—we suddenly notice that we are *thinking in words*, that in very intensive thinking we begin talking to ourselves, or that we occasionally write down the problem or make a drawing of it, so as to be absolutely clear. Anyone who has lived for some time in a foreign country will certainly have noticed that after a while he begins to think in the language of that country. Any very intensive train of thought works itself out more or less in verbal form—if, that is to say, one wants to express it, or teach it, or convince someone of it. It is evidently directed *outwards*, to the outside world. To that extent, directed or logical thinking is reality-thinking,² a thinking that is adapted to reality,³ by means of which we imitate the successiveness of objectively real things, so that the images inside our mind follow one another in the same strictly causal sequence as the events taking place outside it.⁴ We also call this "thinking with directed attention." It has in addition the peculiarity of causing fatigue, and is for that reason brought into play for short periods only. The whole laborious achievement of our lives is adaptation to reality, part of which consists in directed thinking. In biological terms it is simply a process of psychic assimilation that leaves behind a corresponding state of exhaustion, like any other vital achievement.

[12] The material with which we think is *language* and *verbal concepts*—something which from time immemorial has been directed outwards and used as a bridge, and which has but a single purpose, namely that of communication. So long as we think

directedly, we think *for* others and speak *to* others.⁵ Language was originally a system of emotive and imitative sounds—sounds which express terror, fear, anger, love, etc., and sounds which imitate the noises of the elements: the rushing and gurgling of water, the rolling of thunder, the roaring of the wind, the cries of the animal world, and so on; and lastly, those which represent a combination of the sound perceived and the emotional reaction to it.⁶ A large number of onomatopoeic vestiges remain even in the more modern languages; note, for instance, the sounds for running water: *rauschen, rieseln, rûschen, rinnen, rennen, rush, river, ruscello, ruisseau, Rhein*. And note *Wasser, wissen, wissern, pissen, piscis, Fisch*.

[13] Thus, language, in its origin and essence, is simply a system of signs or symbols that denote real occurrences or their echo in the human soul.⁷ We must emphatically agree with Anatole France when he says:

What is thinking? And how does one think? We think with words; that in itself is sensual and brings us back to nature. Think of it! a metaphysician has nothing with which to build his world system except the perfected cries of monkeys and dogs. What he calls profound speculation and transcendental method is merely the stringing together, in an arbitrary order, of onomatopoeic cries of hunger, fear, and love from the primeval forests, to which have become attached, little by little, meanings that are believed to be abstract merely because they are loosely used. Have no fear that the succession of little cries, extinct or enfeebled, that composes a book of philosophy will teach us so much about the universe that we can no longer go on living in it.⁸

[14] So our directed thinking, even though we be the loneliest thinkers in the world, is nothing but the first stirrings of a cry to our companions that water has been found, or the bear been killed, or that a storm is approaching, or that wolves are prowling round the camp. There is a striking paradox of Abelard's which intuitively expresses the human limitations of our complicated thought-process: "Speech is generated by the intellect and in turn generates intellect." The most abstract system of philosophy is, in its method and purpose, nothing more than an extremely ingenious combination of natural sounds.⁹ Hence the craving of a Schopenhauer or a Nietzsche for recognition and understanding, and the despair and bitterness of their loneliness. One might expect, perhaps, that a man of genius would luxuriate in the greatness of his own thoughts and renounce the cheap approbation of the rabble he despises; yet he succumbs to the more powerful impulse of the herd instinct. His seeking and his finding, his heart's cry, are meant for the herd and must be heeded by them. When I said just now that directed thinking is really thinking in words, and quoted that amusing testimony of Anatole France as drastic proof, this might easily give rise to the misunderstanding that directed thinking is after all "only a matter of words." That would certainly be going too far. Language must be taken in a wider sense than speech, for speech is only the outward flow of thoughts formulated for communication. Were it otherwise, the deaf-mute would be extremely limited in his

thinking capacity, which is not the case at all. Without any knowledge of the spoken word, he too has his “language.” Historically speaking, this ideal language, this directed thinking, is derived from primitive words, as Wundt has explained:

A further important consequence of the interaction of sound and meaning is that many words come to lose their original concrete significance altogether, and turn into signs for general ideas expressive of the apperceptive functions of relating and comparing, and their products. In this way abstract thought develops, which, because it would not be possible without the underlying changes of meaning, is itself the product of those psychic and psychophysical interchanges in which the development of language consists.¹⁰

[15] Jodl¹¹ rejects the identity of language and thought on the ground that the same psychic fact can be expressed in different ways in different languages. From this he infers the existence of a “supra-linguistic” type of thinking. No doubt there is such a thing, whether one elects to call it “supra-linguistic” with Jodl or “hypological” with Erdmann. Only, it is not logical thinking. My views coincide with those of Baldwin, who says:

The transition from pre-judgmental to judgmental meaning is just that from knowledge which has social confirmation to that which gets along without it. The meanings utilized for judgment are those already developed in their presuppositions and implications through the confirmations of social intercourse. Thus the personal judgment, trained in the methods of social rendering, and disciplined by the interaction of its social world, projects its content into that world again. In other words, the platform for all movement into the assertion of individual judgment—the level from which new experience is utilized—is *already and always socialized*; and it is just this movement that we find reflected in the actual result as the sense of the “appropriateness” or synnomic character of the meaning rendered....

Now the development of thought, as we are to see in more detail, is by a method essentially of trial and error, of experimentation, of *the use of meanings as worth more than they are as yet recognized to be worth*. The individual must use his old thoughts, his established knowledge, his grounded judgments, for the embodiment of his new inventive constructions. He erects his thought as we say “schematically”—in logical terms, problematically, conditionally, disjunctively—projecting into the world an opinion still personal to himself, as if it were true. *Thus all discovery proceeds*. But this is, from the linguistic point of view, still to use the current language, still to work by meanings already embodied in social and conventional usage.

By this experimentation both thought and language are together advanced....

Language grows, therefore, just as thought does, *by never losing its synnomic* or dual reference; its meaning is both personal and social....

Language is the register of tradition, the record of racial conquest, the deposit of all the gains made by the genius of individuals.... The social “copy-system” thus established reflects the judgmental processes of the race, and in turn becomes the training-school of the judgment of new generations....

Most of the training of the self, whereby the vagaries of personal reaction to fact and image are reduced to the funded basis of sound judgment, comes through the use of speech. When the child speaks, he lays before the world

his suggestion for a general or common meaning; the reception it gets confirms or refutes him. In either case he is instructed. His next venture is from a platform of knowledge on which the newer item is more nearly convertible into the common coin of effective intercourse. The point to notice here is not so much the exact mechanism of the exchange—secondary conversion—by which this gain is made, as the training in judgment that the constant use of it affords. In each case, effective judgment is the common judgment.... Here the object is to point out that it is secured by the development of a function *whose rise is directly ad hoc ... —the function of speech.*

In language, therefore, to sum up the foregoing, we have the tangible—the actual and historical—instrument of the development and conservation of psychic meaning. It is the material evidence and proof of *the concurrence of social and personal judgment.* In its synnomic meaning, judged as “appropriate,” becomes “social” meaning, held as socially generalized and acknowledged.¹²

[16] Baldwin’s argument lays ample stress on the limitations imposed on thought by language,¹³ which are of the greatest importance both subjectively and objectively, i.e., psychologically and socially—so great, indeed, that we must ask ourselves whether the sceptical Mauthner¹⁴ was not right in his view that thinking is speech and nothing more. Baldwin is more cautious and reserved, but at bottom he is plainly in favour of the primacy of speech.

[17] Directed thinking or, as we might also call it, *thinking in words*, is manifestly an instrument of culture, and we shall not be wrong in saying that the tremendous work of education which past centuries have devoted to directed thinking, thereby forcing it to develop from the subjective, individual sphere to the objective, social sphere, has produced a readjustment of the human mind to which we owe our modern empiricism and technics. These are absolutely new developments in the history of the world and were unknown to earlier ages. Inquiring minds have often wrestled with the question of why the first-rate knowledge which the ancients undoubtedly had of mathematics, mechanics, and physics, coupled with their matchless craftsmanship, was never applied to developing the rudimentary techniques already known to them (e.g., the principles of simple machines) into a real technology in the modern sense of the word, and why they never got beyond the stage of inventing amusing curiosities. There is only one answer to this: the ancients, with a few illustrious exceptions, entirely lacked the capacity to concentrate their interest on the transformations of inanimate matter and to reproduce the natural process artificially, by which means alone they could have gained control of the forces of nature. What they lacked was training in directed thinking.¹⁵ The secret of cultural development is the *mobility and disposability of psychic energy.* Directed thinking, as we know it today, is a more or less modern acquisition which earlier ages lacked.

[18] This brings us to a further question: What happens when we do not think directedly? Well, our thinking then lacks all leading ideas and the sense of direction emanating from them.¹⁶ We no longer compel our thoughts along a definite track, but

let them float, sink or rise according to their specific gravity. In Kuelpe's view,¹⁷ thinking is a sort of "inner act of the will," and its absence necessarily leads to an "automatic play of ideas." William James regards non-directed thinking, or "merely associative" thinking, as the ordinary kind. He expresses himself as follows:

Much of our thinking consists of trains of images suggested one by another, of a sort of spontaneous reverie of which it seems likely enough that the higher brutes should be capable. This sort of thinking leads nevertheless to rational conclusions both practical and theoretical.

As a rule, in this sort of irresponsible thinking the terms which come to be coupled together are empirical concretes, not abstractions.¹⁸

[19] We can supplement James's definitions by saying that this sort of thinking does not tire us, that it leads away from reality into fantasies of the past or future. At this point thinking in verbal form ceases, image piles on image, feeling on feeling,¹⁹ and there is an ever-increasing tendency to shuffle things about and arrange them not as they are in reality but as one would like them to be. Naturally enough, the stuff of this thinking which shies away from reality can only be the past with its thousand-and-one memory images. Common speech calls this kind of thinking "dreaming."

[20] Anyone who observes himself attentively will find that the idioms of common speech are very much to the point, for almost every day we can see for ourselves, when falling asleep, how our fantasies get woven into our dreams, so that between daydreaming and night-dreaming there is not much difference. We have, therefore, two kinds of thinking: directed thinking, and dreaming or fantasy-thinking. The former operates with speech elements for the purpose of communication, and is difficult and exhausting; the latter is effortless, working as it were spontaneously, with the contents ready to hand, and guided by unconscious motives. The one produces innovations and adaptation, copies reality, and tries to act upon it; the other turns away from reality, sets free subjective tendencies, and, as regards adaptation, is unproductive.²⁰

[21] As I have indicated above, history shows that directed thinking was not always as developed as it is today. The clearest expression of modern directed thinking is science and the techniques fostered by it. Both owe their existence simply and solely to energetic training in directed thinking. Yet at the time when the forerunners of our present-day culture, such as the poet Petrarch, were just beginning to approach nature in a spirit of understanding,²¹ an equivalent of our science already existed in scholasticism.²² This took its subjects from fantasies of the past, but it gave the mind a dialectical training in directed thinking. The one goal of success that shone before the thinker was rhetorical victory in disputation, and not the visible transformation of reality. The subjects he thought about were often unbelievably fantastic; for instance, it was debated how many angels could stand on the point of a needle, whether Christ

could have performed his work of redemption had he come into the world in the shape of a pea, etc., etc. The fact that these problems could be posed at all—and the stock metaphysical problem of how to know the unknowable comes into this category—proves how peculiar the medieval mind must have been, that it could contrive questions which for us are the height of absurdity. Nietzsche glimpsed something of the background of this phenomenon when he spoke of the “glorious tension of mind” which the Middle Ages produced.

[22] On a historical view, the scholastic spirit in which men of the intellectual calibre of St. Thomas Aquinas, Duns Scotus, Abelard, William of Ockham, and others worked is the mother of our modern scientific method, and future generations will see clearly how far scholasticism still nourishes the science of today with living undercurrents. It consisted essentially in a dialectical gymnastics which gave the symbol of speech, the word, an absolute meaning, so that words came in the end to have a substantiality with which the ancients could invest their Logos only by attributing to it a mystical value. The great achievement of scholasticism was that it laid the foundations of a solidly built intellectual function, the *sine qua non* of modern science and technology.

[23] If we go still further back into history, we find what we call science dissolving in an indistinct mist. The culture-creating mind is ceaselessly employed in stripping experience of everything subjective, and in devising formulas to harness the forces of nature and express them in the best way possible. It would be a ridiculous and unwarranted presumption on our part if we imagined that we were more energetic or more intelligent than the men of the past—our material knowledge has increased, but not our intelligence. This means that we are just as bigoted in regard to new ideas, and just as impervious to them, as people were in the darkest days of antiquity. We have become rich in knowledge, but poor in wisdom. The centre of gravity of our interest has switched over to the materialistic side, whereas the ancients preferred a mode of thought nearer to the fantastic type. To the classical mind everything was still saturated with mythology, even though classical philosophy and the beginnings of natural science undeniably prepared the way for the work of “enlightenment.”

[24] Unfortunately, we get at school only a very feeble idea of the richness and tremendous vitality of Greek mythology. All the creative power that modern man pours into science and technics the man of antiquity devoted to his myths. This creative urge explains the bewildering confusion, the kaleidoscopic changes and syncretistic regroupings, the continual rejuvenation, of myths in Greek culture. We move in a world of fantasies which, untroubled by the outward course of things, well up from an inner source to produce an ever-changing succession of plastic or phantasmal forms. This activity of the early classical mind was in the highest degree

artistic: the goal of its interest does not seem to have been how to understand the real world as objectively and accurately as possible, but how to adapt it aesthetically to subjective fantasies and expectations. There was very little room among the ancients for that coldness and disillusionment which Giordano Bruno's vision of infinite worlds and Kepler's discoveries brought to mankind. The naïve man of antiquity saw the sun as the great Father of heaven and earth, and the moon as the fruitful Mother. Everything had its demon, was animated like a human being, or like his brothers the animals. Everything was conceived anthropomorphically or theriomorphically, in the likeness of man or beast. Even the sun's disc was given wings or little feet to illustrate its motion (pl. *Ib*). Thus there arose a picture of the universe which was completely removed from reality, but which corresponded exactly to man's subjective fantasies. It needs no very elaborate proof to show that children think in much the same way. They too animate their dolls and toys, and with imaginative children it is easy to see that they inhabit a world of marvels.

[25] We also know that the same kind of thinking is exhibited in dreams. The most heterogeneous things are brought together regardless of the actual conditions, and a world of impossibilities takes the place of reality. Freud finds that the hallmark of waking thought is *progression*: the advance of the thought stimulus from the systems of inner or outer perception through the endopsychic work of association to its motor end, i.e., innervation. In dreams he finds the reverse: regression of the thought stimulus from the pre-conscious or unconscious sphere to the perceptual system, which gives the dream its peculiar atmosphere of sensuous clarity, rising at times to almost hallucinatory vividness. Dream-thinking thus regresses back to the raw material of memory. As Freud says: "In regression the fabric of the dream-thoughts is resolved into its raw material."²³ The reactivation of original perceptions is, however, only one side of regression. The other side is regression to infantile memories, and though this might equally well be called regression to the original perceptions, it nevertheless deserves special mention because it has an importance of its own. It might even be considered as an "historical" regression. In this sense the dream can, with Freud, be described as a modified memory—modified through being projected into the present. The original scene of the memory is unable to effect its own revival, so has to be content with returning as a dream.²⁴ In Freud's view it is an essential characteristic of dreams to "elaborate" memories that mostly go back to early childhood, that is, to bring them nearer to the present and recast them in its language. But, in so far as infantile psychic life cannot deny its archaic character, the latter quality is the especial peculiarity of dreams. Freud expressly draws attention to this:

Dreams, which fulfil their wishes along the short path of regression, have merely preserved for us in that respect a sample of the psychological apparatus's primary method of working, a method which was abandoned as being inefficient. What once dominated waking life, while the mind was still young and incompetent, seems now to have

been banished into the night—just as the primitive weapons, the bows and arrows, that have been abandoned by adult men, turn up once more in the nursery.²⁵

[26] These considerations²⁶ tempt us to draw a parallel between the mythological thinking of ancient man and the similar thinking found in children,²⁷ primitives, and in dreams. This idea is not at all strange; we know it quite well from comparative anatomy and from evolution, which show that the structure and function of the human body are the result of a series of embryonic mutations corresponding to similar mutations in our racial history. The supposition that there may also be in psychology a correspondence between ontogenesis and phylogenesis therefore seems justified. If this is so, it would mean that infantile thinking²⁸ and dream-thinking are simply a recapitulation of earlier evolutionary stages.

[27] In this regard, Nietzsche takes up an attitude well worth noting:

In sleep and in dreams we pass through the whole thought of earlier humanity.... What I mean is this: as man now reasons in dreams, so humanity also reasoned for many thousands of years when awake; the first cause which occurred to the mind as an explanation of anything that required explanation was sufficient and passed for truth.... This atavistic element in man's nature still manifests itself in our dreams, for it is the foundation upon which the higher reason has developed and still develops in every individual. Dreams carry us back to remote conditions of human culture and give us a ready means of understanding them better. Dream thinking comes so easily to us now because this form of fantastic and facile explanation in terms of the first random idea has been drilled into us for immense periods of time. To that extent dreaming is a recreation for the brain, which by day has to satisfy the stern demands of thought imposed by a higher culture....

From this we can see how *lately* the more acute logical thinking, the strict discrimination of cause and effect, has been developed, since our rational and intellectual faculties still involuntarily hark back to those primitive forms of reasoning, and we pass about half our lives in this condition.²⁹

[28] Freud, as we have seen, reached similar conclusions regarding the archaic nature of dream-thinking on the basis of dream-analysis. It is therefore not such a great step to the view that myths are dreamlike structures. Freud himself puts it as follows: "The study of constructions of folk-psychology such as these is far from being complete, but it is extremely probable that myths, for instance, are distorted vestiges of the wishful phantasies of whole nations, the [age-long] dreams of youthful humanity."³⁰ In the same way Rank³¹ regards myth as the collective dream of a whole people.³²

[29] Riklin has drawn attention to the dream mechanism in fairytales,³³ and Abraham has done the same for myths. He says: "The myth is a fragment of the superseded infantile psychic life of the race"; and again: "The myth is therefore a fragment preserved from the infantile psychic life of the race, and dreams are the myths of the individual."³⁴ The conclusion that the myth-makers thought in much the same way as

we still think in dreams is almost self-evident. The first attempts at myth-making can, of course, be observed in children, whose games of make-believe often contain historical echoes. But one must certainly put a large question-mark after the assertion that myths spring from the “infantile” psychic life of the race. They are on the contrary the most mature product of that young humanity. Just as those first fishy ancestors of man, with their gill-slits, were not embryos, but fully developed creatures, so the myth-making and myth-inhabiting man was a grown reality and not a four-year-old child. Myth is certainly not an infantile phantasm, but one of the most important requisites of primitive life.

[30] It might be objected that the mythological proclivities of children are implanted by education. This objection is futile. Has mankind ever really got away from myths? Everyone who has his eyes and wits about him can see that the world is dead, cold, and unending. Never yet has he beheld a God, or been compelled to require the existence of such a God from the evidence of his senses. On the contrary, it needed the strongest inner compulsion, which can only be explained by the irrational force of instinct, for man to invent those religious beliefs whose absurdity was long since pointed out by Tertullian. In the same way one can withhold the material content of primitive myths from a child but not take from him the need for mythology, and still less his ability to manufacture it for himself. One could almost say that if all the world’s traditions were cut off at a single blow, the whole of mythology and the whole history of religion would start all over again with the next generation. Only a very few individuals succeed in throwing off mythology in epochs of exceptional intellectual exuberance—the masses never. Enlightenment avails nothing, it merely destroys a transitory manifestation, but not the creative impulse.

[31] Let us now turn back to our earlier reflections.

[32] We were speaking of the ontogenetic recapitulation of phylogenetic psychology in children, and we saw that archaic thinking is a peculiarity of children and primitives. We now know that this same thinking also occupies a large place in modern man and appears as soon as directed thinking ceases. Any lessening of interest, or the slightest fatigue, is enough to put an end to the delicate psychological adaptation to reality which is expressed through directed thinking, and to replace it by fantasies. We wander from the subject and let our thoughts go their own way; if the slackening of attention continues, we gradually lose all sense of the present, and fantasy gains the upper hand.

[33] At this point the important question arises: How are fantasies made, and what is their nature? From the poets we learn much, from scientists little. It was the psychotherapists who first began to throw light on the subject. They showed that fantasies go in typical cycles. The stammerer fancies himself a great orator, which

actually came true in the case of Demosthenes, thanks to his enormous energy; the poor man fancies himself a millionaire, the child a grown-up. The oppressed wage victorious war on the oppressor, the failure torments or amuses himself with ambitious schemes. All seek compensation through fantasy.

[34] But just where do the fantasies get their material? Let us take as an example a typical adolescent fantasy. Faced by the vast uncertainty of the future, the adolescent puts the blame for it on the past, saying to himself: "If only I were not the child of my very ordinary parents, but the child of a rich and elegant count and had merely been brought up by foster-parents, then one day a golden coach would come and the count would take his long-lost child back with him to his wonderful castle," and so on, just as in a Grimms' fairy-story which a mother tells to her children. With a normal child the fantasy stops short at the fleeting idea, which is soon over and forgotten. There was a time, however, in the ancient world, when the fantasy was a legitimate truth that enjoyed universal recognition. The heroes—Romulus and Remus (pl. II), Moses, Semiramis, and many others—were foundlings whose real parents had lost them.³⁵ Others were directly descended from the gods, and the noble families traced their descent from the heroes and gods of old. Hence the fantasy of our adolescent is simply a re-echo of an ancient folk-belief which was once very widespread. The fantasy of ambition therefore chooses, among other things, a classical form which at one time had real validity. The same is true of certain erotic fantasies. Earlier on we mentioned the dream of sexual assault: the robber who breaks in and does something dangerous. That too is a mythological theme and in days gone by was undoubtedly a reality.³⁶ Quite apart from the fact that rape was a common occurrence in prehistoric times, it was also a popular theme of mythology in more civilized epochs. One has only to think of the rape of Persephone, of Deianira, Europa, and of the Sabine women. Nor should we forget that in many parts of the earth there are marriage customs existing today which recall the ancient marriage by capture.

[35] One could give countless examples of this kind. They would all prove the same thing, namely that what, with us, is a subterranean fantasy was once open to the light of day. What, with us, crops up only in dreams and fantasies was once either a conscious custom or a general belief. But what was once strong enough to mould the spiritual life of a highly developed people will not have vanished without trace from the human soul in the course of a few generations. We must remember that a mere eighty generations separate us from the Golden Age of Greek culture. And what are eighty generations? They shrink to an almost imperceptible span when compared with the enormous stretch of time that separates us from Neanderthal or Heidelberg man. I would like in this connection to call attention to the pointed remarks of the great historian Ferrero:

It is a very common belief that the further man is separated from the present in time, the more he differs from us in his thoughts and feelings; that the psychology of humanity changes from century to century, like fashions or literature. Therefore, no sooner do we find in past history an institution, a custom, a law, or a belief a little different from those with which we are familiar, than we immediately search for all manner of complicated explanations, which more often than not resolve themselves into phrases of no very precise significance. And indeed, man does not change so quickly; his psychology at bottom remains the same, and even if his culture varies much from one epoch to another, it does not change the functioning of his mind. The fundamental laws of the mind remain the same, at least during the short historical periods of which we have knowledge; and nearly all the phenomena, even the most strange, must be capable of explanation by those common laws of the mind which we can recognize in ourselves.³⁷

[36] The psychologist should accept this view without qualification. The Dionysian phallagogies, the chthonic mysteries of classical Athens, have vanished from our civilization, and the theriomorphic representations of the gods have dwindled to mere vestiges, like the Dove, the Lamb, and the Cock adorning our church towers. Yet all this does not alter the fact that in childhood we go through a phase when archaic thinking and feeling once more rise up in us, and that all through our lives we possess, side by side with our newly acquired directed and adapted thinking, a fantasy-thinking which corresponds to the antique state of mind. Just as our bodies still retain vestiges of obsolete functions and conditions in many of their organs, so our minds, which have apparently outgrown those archaic impulses, still bear the marks of the evolutionary stages we have traversed, and re-echo the dim bygone in dreams and fantasies.

[37] The question of where the mind's aptitude for symbolical expression comes from brings us to the distinction between the two kinds of thinking—the directed and adapted on the one hand, and the subjective, which is actuated by inner motives, on the other. The latter form, if not constantly corrected by adapted thinking, is bound to produce an overwhelmingly subjective and distorted picture of the world. This state of mind has been described in the first place as infantile and autoerotic, or, with Bleuler, as “autistic,” which clearly expresses the view that the subjective picture, judged from the standpoint of adaptation, is inferior to that of directed thinking. The ideal instance of autism is found in schizophrenia, whereas infantile autoeroticism is more characteristic of neurosis. Such a view brings a perfectly normal process like non-directed fantasy-thinking dangerously close to the pathological, and this must be ascribed less to the cynicism of doctors than to the circumstance that it was the doctors who were the first to evaluate this type of thinking. Non-directed thinking is in the main subjectively motivated, and not so much by conscious motives as—far more—by unconscious ones. It certainly produces a world-picture very different from that of conscious, directed thinking. But there is no real ground for assuming that it is nothing more than a distortion of the objective world-picture, for it remains to be

asked whether the mainly unconscious inner motive which guides these fantasy-processes is not itself an *objective fact*. Freud himself has pointed out on more than one occasion how much unconscious motives are grounded on instinct, which is certainly an objective fact. Equally, he half admitted their archaic nature.

[38] The unconscious bases of dreams and fantasies are only apparently infantile reminiscences. In reality we are concerned with primitive or archaic thought-forms, based on instinct, which naturally emerge more clearly in childhood than they do later. But they are not in themselves infantile, much less pathological. To characterize them, we ought therefore not to use expressions borrowed from pathology. So also the myth, which is likewise based on unconscious fantasy-processes, is, in meaning, substance, and form, far from being infantile or the expression of an autoerotic or autistic attitude, even though it produces a world-picture which is scarcely consistent with our rational and objective view of things. The instinctive, archaic basis of the mind is a matter of plain objective fact and is no more dependent upon individual experience or personal choice than is the inherited structure and functioning of the brain or any other organ. Just as the body has its evolutionary history and shows clear traces of the various evolutionary stages, so too does the psyche.³⁸

[39] Whereas directed thinking is an altogether conscious phenomenon,³⁹ the same cannot be said of fantasy-thinking. Much of it belongs to the conscious sphere, but at least as much goes on in the half-shadow, or entirely in the unconscious, and can therefore be inferred only indirectly.⁴⁰ Through fantasy-thinking, directed thinking is brought into contact with the oldest layers of the human mind, long buried beneath the threshold of consciousness. The fantasy-products directly engaging the conscious mind are, first of all, waking dreams or daydreams, to which Freud, Flournoy, Pick, and others have devoted special attention; then ordinary dreams, which present to the conscious mind a baffling exterior and only make sense on the basis of indirectly inferred unconscious contents. Finally, in split-off complexes there are completely unconscious fantasy-systems that have a marked tendency to constitute themselves as separate personalities.⁴¹

[40] All this shows how much the products of the unconscious have in common with mythology. We should therefore have to conclude that any introversion occurring in later life regresses back to infantile reminiscences which, though derived from the individual's past, generally have a slight archaic tinge. With stronger introversion and regression the archaic features become more pronounced.

[41] This problem merits further discussion. Let us take as a concrete example Anatole France's story of the pious Abbé Oegger.⁴² This priest was something of a dreamer, and much given to speculative musings, particularly in regard to the fate of Judas: whether he was really condemned to everlasting punishment, as the teaching of the

Church declares, or whether God pardoned him after all. Oegger took up the very understandable attitude that God, in his supreme wisdom, had chosen Judas as an instrument for the completion of Christ's work of redemption.⁴³ This necessary instrument, without whose help humanity would never have had a share in salvation, could not possibly be damned by the all-good God. In order to put an end to his doubts, Oegger betook himself one night to the church and implored God to give him a sign that Judas was saved. Thereupon he felt a heavenly touch on his shoulder. The next day he went to the archbishop and told him that he was resolved to go out into the world to preach the gospel of God's unending mercy.

[42] Here we have a well-developed fantasy-system dealing with the ticklish and eternally unresolved question of whether the legendary figure of Judas was damned or not. The Judas legend is itself a typical motif, namely that of the mischievous betrayal of the hero. One is reminded of Siegfried and Hagen, Baldur and Loki: Siegfried and Baldur were both murdered by a perfidious traitor from among their closest associates. This myth is moving and tragic, because the noble hero is not felled in a fair fight, but through treachery. At the same time it is an event that was repeated many times in history, for instance in the case of Caesar and Brutus. Though the myth is extremely old it is still a subject for repetition, as it expresses the simple fact that envy does not let mankind sleep in peace. This rule can be applied to the mythological tradition in general: it does not perpetuate accounts of ordinary everyday events in the past, but only of those which express the universal and ever-renewed thoughts of mankind. Thus the lives and deeds of the culture-heroes and founders of religions are the purest condensations of typical mythological motifs, behind which the individual figures entirely disappear.⁴⁴

[43] But why should our pious Abbé worry about the old Judas legend? We are told that he went out into the world to preach the gospel of God's unending mercy. Not long afterwards he left the Catholic Church and became a Swedenborgian. Now we understand his Judas fantasy: *he* was the Judas who betrayed his Lord. Therefore he had first of all to assure himself of God's mercy in order to play the role of Judas undisturbed.

[44] Oegger's case throws light on the mechanism of fantasies in general. The conscious fantasy may be woven of mythological or any other material; it should not be taken literally, but must be interpreted according to its meaning. If it is taken too literally it remains unintelligible, and makes one despair of the meaning and purpose of the psychic function. But the case of the Abbé Oegger shows that his doubts and his hopes are only apparently concerned with the historical person of Judas, but in reality revolve round his own personality, which was seeking a way to freedom through the solution of the Judas problem.

[45] Conscious fantasies therefore illustrate, through the use of mythological material, certain tendencies in the personality which are either not yet recognized or are recognized no longer. It will readily be understood that a tendency which we fail to recognize and which we treat as non-existent can hardly contain anything that would fit in with our conscious character. Hence it is mostly a question of things which we regard as immoral or impossible, and whose conscious realization meets with the strongest resistances. What would Oegger have said had one told him in confidence that he was preparing himself for the role of Judas? Because he found the damnation of Judas incompatible with God's goodness, he proceeded to think about this conflict. That is the *conscious* causal sequence. Hand in hand with this goes the *unconscious* sequence: because he wanted to be Judas, or had to be Judas, he first made sure of God's goodness. For him Judas was the symbol of his own unconscious tendency, and he made use of this symbol in order to reflect on his own situation—its direct realization would have been too painful for him. There must, then, be typical myths which serve to work out our racial and national complexes. Jacob Burckhardt seems to have glimpsed this truth when he said that every Greek of the classical period carries in himself a little bit of Oedipus, and every German a little bit of Faust.⁴⁵

[46] The problems with which the simple tale of the Abbé Oegger confronts us will meet us again when we examine another set of fantasies, which owe their existence this time to the exclusive activity of the unconscious. We are indebted to a young American woman, known to us by the pseudonym of Miss Frank Miller, for a series of fantasies, partly poetical in form, which Théodore Flournoy made available to the public in 1906, in the *Archives de psychologie* (Geneva), under the title "Quelques faits d'imagination créatrice subconsciente."⁴⁶

III

THE MILLER FANTASIES: ANAMNESIS

[47] Experience has taught us that whenever anyone tells us his fantasies or his dreams, he is concerned not only with an urgent and intimate problem but with the one that is most painful for him at the moment.¹ Since, in the case of Miss Miller, we have to do with a complicated fantasy system, we shall have to give attention to details which I can best discuss by keeping to Miss Miller's own account. In the first section, entitled "Phenomena of Transitory Suggestion or of Instantaneous Autosuggestion," she gives a number of examples of her unusual suggestibility, which she herself regards as a symptom of her nervous temperament. She seems to possess an extraordinary capacity for identification and empathy; for instance she identifies herself to such a degree with the wounded Christian de Neuville in *Cyrano de Bergerac* that she feels a piercing pain in her own breast, the very place where the hero receives his death wound.

[48] One might describe the theatre, somewhat unaesthetically, as an institution for working out private complexes in public. The enjoyment of comedy, or of the blissful dénouement of the plot, is the direct result of identifying one's own complexes with those personified by the actors, while the enjoyment of tragedy lies in the thrilling yet satisfying feeling that what is happening to somebody else may very well happen to you. The palpitations of our author at the sight of the dying Christian mean that there is a complex in her awaiting a similar solution, which whispers a soft "today to you, tomorrow to me"; and lest there should be any doubt as to the critical moment, Miss Miller adds that she felt the pain in her breast "when Sarah Bernhardt throws herself upon him to stanch the bleeding of his wound." The critical moment, therefore, is when the love between Christian and Roxane comes to a sudden end. If we examine Rostand's play as a whole, we shall be struck by certain passages whose effect it is not so easy to escape, and which we must emphasize here because they are of importance for everything that follows. *Cyrano de Bergerac* of the long ugly nose, on account of which he undertakes innumerable duels, loves Roxane, who is in love with Christian, because she thinks he is the author of the beautiful verses which really come from *Cyrano's* pen. *Cyrano* is the misunderstood one whose passionate love and noble soul no one suspects, the hero who sacrifices himself for others and, in the evening of life, with his dying breath, reads her once more Christian's last letter, the verses of which he has composed himself:

Roxane, adieu! I soon must die!
This very night, beloved; and I
Feel my soul heavy with a love untold.
I die! No more, as in the days of old,
My loving, longing eyes will feast
On your least gesture—ay, the least!
I mind me of the way you touch your cheek
So softly with your finger, as you speak!
Ah me! I know that gesture well!
My heart cries out! I cry “Farewell!
My life, my love, my jewel, my sweet,
My heart was yours in every beat!”²

[49] Whereupon Roxane recognizes him as the true beloved. But it is already too late, death comes, and in an agonized delirium Cyrano rouses himself, draws his sword:

Why, I do believe
He dares to mock my nose! Ho! insolent!
(He raises his sword)
What say you? It is useless? Ay, I know!
But who fights ever hoping for success?
I fought for lost cause, and for fruitless quest!
You there, who are you?—You are thousands! Ah!
I know you now, old enemies of mine!
Falsehood!
(He strikes the air with his sword)
Have at you! Ha! and Compromise!
Prejudice! Treachery! ...
(He strikes)

Surrender, I?
Parley? No, never! You too, Folly, you?
I know that you will lay me low at last;
Let be! Yet I fall fighting, fighting still!
You strip from me the laurel and the rose!
Take all! Despite you there is yet one thing
I hold against you all; and when tonight
I enter Christ’s fair courts, and lowly bowed,

Sweep with doffed casque the heavens' threshold blue,

One thing is left that, void of stain or smutch,

I bear away despite you—my *panache!* ³

[50] Cyrano, who beneath his hideous exterior hides a soul so much more beautiful, is full of misunderstood yearnings, and his final triumph lies in his departing with a clean shield—“void of stain or smutch.” The author’s identification with the dying Christian, who in himself is not a very inspiring figure, tells us that a sudden end is destined for her love, just as for Christian’s. But, as we have seen, the tragic intermezzo with Christian is played against a background of far wider significance, namely Cyrano’s unrequited love for Roxane. The identification with Christian is probably only a cover. That this is so will become clear in the course of our analysis.

[51] The identification with Christian is followed by an extraordinarily plastic memory of the sea, evoked by a photograph of a steamer plunging through the waves. (“I felt the throb of the engines, the heave of the waves, the roll of the ship.”) We may here hazard the conjecture that the sea-voyages of our author were associated with particularly impressive memories which bit deep into her soul and, through unconscious sympathy, threw the screen memory into particularly vivid relief. We shall see later how far these conjectured memories hang together with the problem touched on above.

[52] The example that now follows is remarkable: Once, while she was having a bath, Miss Miller wound a towel round her hair to prevent it from getting wet. At that moment she had the following vivid impression: “... it seemed to me, for one moment and with an almost breath-taking clarity, that I was on a pedestal, a veritable Egyptian statue with all its details; stiff-limbed, one foot forward, holding insignia in my hand, etc.” So Miss Miller is now identifying herself with an Egyptian statue, obviously on the basis of an unrecognized similarity. What she means is: I am like an Egyptian statue, just as stiff, wooden, sublime, and impassible, qualities for which the Egyptian statue is proverbial.

[53] The next example lays stress on the personal influence she wields over a certain artist:

However, I succeeded in making him draw landscapes, such as those of Lake Geneva, where he had never been, and he used to pretend that I could make him depict things that he had never seen and give him the sense of a surrounding atmosphere that he had never felt; in short, that I was using him as he himself used his pencil; that is, simply as an instrument.

[54] This remark stands in abrupt contrast to the fantasy of the Egyptian statue. Miss Miller evidently has an unspoken need to emphasize her almost magical influence over another person. This, too, could not have happened without an inner

compulsion, such as is particularly noticeable in one who often does *not* succeed in establishing a real emotional relationship. She will then solace herself with the idea of her almost magical powers of suggestion.

[55] With that, we come to the end of the examples illustrating the autosuggestibility and suggestive influence of our author. The examples are neither particularly striking nor particularly interesting in this respect, but are all the more valuable from the psychological point of view because they allow us to glimpse some of her personal problems. Most of the examples show how liable Miss Miller was to succumb to the powers of suggestion, how the libido gained control of certain impressions and intensified them, which would naturally not have been possible but for the free-floating energy placed at her disposal by her lack of relation to reality.

IV

THE HYMN OF CREATION

[56] The second section in the Miller material bears the title: “ ‘Glory to God’: A Dream Poem.”

[57] In 1898, as a girl of twenty, Miss Miller went on a long journey through Europe. We leave the description to her:

After the long and rough voyage from New York to Stockholm, then to St. Petersburg and Odessa, it was a real pleasure [*une véritable volupté*]¹ to leave the world of cities, of roaring streets, of business—in short, of the earth—and enter the world of waves, sky, and silence.... I spent hours on end on the deck of the ship, dreaming, stretched out in a deck chair. All the histories, legends, and myths of the different countries I saw in the distance came back to me confusedly, dissolved in a kind of luminous mist in which real things seemed to lose their being, while dreams and ideas took on the aspect of the only true reality. At first I even avoided all company and kept to myself, lost in my reveries, where everything I had ever known that was truly great, beautiful, and good came back to mind with renewed life and vigour. I also spent a good part of my days writing to absent friends, reading, or scribbling little bits of poetry in remembrance of the various places we visited. Some of these poems were of a rather serious character.

[58] It may perhaps seem superfluous to go into all these details more closely. But if we remember what we said above, that when people let their unconscious speak it always blurts out the most intimate things, then even the smallest detail often has a meaning. Miss Miller is here describing a “state of introversion”: after the life of the cities, with their many impressions, had absorbed her interest (with that suggestive power which, as we have seen, forcibly produced the impression), she breathed freely again on the sea and became wholly engrossed in her inner world, deliberately cutting herself off from the environment, so that things lost their reality and dreams became truth. We know from psychopathology that there is a certain mental disturbance² which is initiated by the patient’s shutting out reality more and more and sinking into his fantasies, with the result that as reality loses its hold, the determining power of the inner world increases. This process leads up to a climax when the patient suddenly becomes more or less conscious of his dissociation from reality: in a sort of panic he begins making pathological efforts to get back to his environment. These attempts spring from the compensating desire for re-association and seem to be the psychological rule, valid not only for pathological cases but also, to a lesser degree, for normal people.

[59] One might therefore expect that after this prolonged introversion, which even impaired her sense of reality for a time, Miss Miller would succumb to a new impression of the external world, and one whose suggestive influence would be at least as great as that of her reveries. Let us proceed with her narrative:

But as the voyage drew near its end, the ship's officers outdid themselves in kindness and amiability [*se montrèrent tout ce qu'il y a de plus empresses et aimables*], and I passed many an amusing hour teaching them English.

Off the coast of Sicily, in the port of Catania, I wrote a sea-chanty, which, however, was little more than an adaptation of a well-known song about the sea, wine and love ("Brine, wine and damsels fine"). The Italians are all good singers, as a rule; and one of the officers, singing at night as he stood watch on deck, had made a great impression on me and had given me the idea of writing some words that could be fitted to his melody.

Soon afterwards, I nearly did what the proverb says, "See Naples and die," for in the port of Naples I began by being very ill (though not dangerously so); then I recovered sufficiently to go ashore and visit the principal sights of the city in a carriage. This outing tired me extremely; and as we were intending to visit Pisa the next day, I soon returned on board and went to bed early, without thinking of anything more serious than the good looks of the officers and the ugliness of Italian beggars.

[60] One is slightly disappointed at meeting here, instead of the powerful impression one expected, an apparently insignificant episode, a mere flirtation. Nevertheless one of the officers, a singer, had evidently made a considerable impression on her. The concluding remark—without thinking of anything more serious than the good looks of the officers—does, it is true, tone it down somewhat. Even so, the assumption that this impression had no little influence on her mood is supported by the fact that a poem in honour of the singer was immediately forthcoming. One is only too ready to make light of such an experience and to accept the assurance of those concerned that everything is quite simple and not at all important. I am inclined to pay rather more attention to it, because experience has shown that an impression which comes after an introversion of that kind has a profound effect and may possibly have been underestimated by Miss Miller herself. The sudden, passing attack of sickness requires psychological explanation, though this is not possible for lack of data. But the phenomena about to be described can only be understood as arising out of a convulsion that reaches into the very depths of her being:

From Naples to Leghorn is one night by boat, during which I slept moderately well—my sleep is rarely deep or dreamless—and it seemed to me that my mother's voice woke me up just at the end of the following dream, which must, therefore, have taken place immediately before waking.

First, I was vaguely conscious of the words "when the morning stars sang together," which served as the prelude, if I may so put it, to an involved idea of creation and to mighty chorales reverberating through the universe. But, with the confusion and strange contradiction characteristic of dreams, all this was mixed up with choruses from oratorios given by one of the leading musical societies of New York, and with indistinct memories

of Milton's *Paradise Lost*. Then, slowly, out of this medley, words appeared, and a little later they arranged themselves in three stanzas, in my handwriting, on a sheet of ordinary blue-lined writing-paper, in a page of my old poetry album that I always carry about with me: in short, they appeared to me exactly as they did in reality, a few minutes later, in my book.

[61] Miss Miller then wrote down the following poem, which she rearranged slightly a few months later, in order to make it more nearly, in her opinion, like the dream original:

First Version

When God had first made Sound,
A myriad ears sprang into being
And throughout all the Universe Rolled a mighty echo:
“Glory to the God of Sound!”

When beauty (light) first was given by God,
A myriad eyes sprang out to see
And hearing ears and seeing eyes
Again gave forth that mighty song:
“Glory to the God of Beauty (Light)!”

When God has first given Love,
A myriad hearts lept up;
And ears full of music, eyes all full of Beauty,
Hearts all full of love sang:
“Glory to the God of Love!”

Second Version (more exact)

When the Eternal first made Sound
A myriad ears sprang out to hear,
And throughout all the Universe
There rolled an echo deep and clear:
“All glory to the God of Sound!”

When the Eternal first made Light,
A myriad eyes sprang out to look,
And hearing ears and seeing eyes,
Once more a mighty choral took:

“All glory to the God of Light!”

When the Eternal first gave Love,

A myriad hearts sprang into life;

Ears filled with music, eyes with light,

Pealed forth with hearts with love all rife:

“All glory to the God of Love!”

[62] Before we examine her attempts to get at the roots of this subliminal creation through her own associations, let us take a quick look at the material already in hand. The impression of the ship has already received due emphasis, so it ought not to be difficult to lay hold of the dynamic processes responsible for this poetic revelation. It was suggested further back that Miss Miller may have considerably underestimated the scope of the erotic impression she had received. This assumption is the more probable in that experience has shown that relatively weak erotic impressions are often underestimated. One can see this most clearly in cases where an erotic relationship is regarded as impossible on social or moral grounds (for instance between parents and children, brothers and sisters, older and younger men, etc.). If the impression is comparatively slight, it does not exist at all for the persons concerned; if it is strong, then a tragic dependence develops which can lead to all sorts of trouble. This lack of judgment can go unbelievably far—a mother who sees her small son having an erection in her own bed; a sister who half-playfully embraces her brother; a twenty-year-old daughter who still sits herself in her father’s lap and then has “strange” sensations in her “tummy.” And yet they are all highly indignant when anyone speaks of “sexuality.” There is a certain kind of education that tacitly aims at knowing as little as possible about these unmentionable facts in the background, and which shrouds them in the deepest ignorance.³ No wonder, then, that most people’s judgment in regard to the scope of erotic impressions is precarious and inadequate. Miss Miller was, as we have seen, quite prepared for a *deep* impression. But not many of the feelings it aroused seem to have come to the surface, for the dream had to repeat the lesson over again. We know from analytical experience that the initial dreams of patients at the beginning of an analysis are of especial interest, not least because they often bring out a critical evaluation of the doctor’s personality which previously he would have asked for in vain. They enrich the patient’s *conscious* impression of the doctor, often on very important points, and they frequently contain erotic comments which the unconscious had to make in order to counterbalance the patient’s underestimation and uncertain appraisal of the impression. Expressed in the drastic and hyperbolic manner peculiar to dreams, the impression often appears in almost unintelligible form owing to the incongruity of the symbolism. A further peculiarity, which seems due to the historical stratification

of the unconscious, is that when an impression is denied conscious recognition it reverts to an earlier form of relationship. That explains why young girls, at the time of their first love, have great difficulty in expressing themselves owing to disturbances brought about by regressive reactivation of the father-*imago*.⁴

[63] We may suppose that something similar has happened to Miss Miller, for the idea of a masculine Creator-God is apparently derived from the father-*imago*,⁵ and aims, among other things, at replacing the infantile relation to the father in such a way as to enable the individual to emerge from the narrow circle of the family into the wider circle of society. Naturally this is far from exhausting the meaning of the dream-image.

[64] In the light of these reflections, the poem and its prelude appear as the religiously and poetically formulated product of an introversion that has regressed back to the father-*imago*. Despite inadequate apperception of the operative impression, its essential ingredients have been built into the substitute product, as marks of its origin, so to speak. The operative impression was the handsome officer singing in the night-watch—"When the morning stars sang together—whose image opened out a new world to the girl ("Creation").

[65] This "creator" created first Sound, then Light, and then Love. That Sound should be the first thing created has parallels in the "creative word" in Genesis, in Simon Magus, where the voice corresponds to the sun,⁶ in the sounds or cries of lamentation mentioned in *Poimandres*,⁷ and in God's laughter at the creation of the world (*κοσμοποιία*) in a Leiden Papyrus.⁸ Hence we may hazard the conjecture, which will be amply confirmed later on, that there was the following chain of association: the singer—the singing morning star—the God of Sound—the Creator—the God of Light—of the sun—of fire—and of Love. Most of these expressions are also characteristic of the language of love and are found wherever speech is heightened by emotion.

[66] Miss Miller has tried to understand this unconscious creation by means of a procedure which agrees in principle with the methods of psychological analysis and therefore leads to the same results. But, as is usually the case with laymen and beginners, she gets stuck at associations which bring the underlying complex to light only in an indirect way. Nevertheless, a simple procedure, a mere matter of carrying the thought to its logical conclusion, is enough to help one find the meaning.

[67] Miss Miller finds it astonishing, first of all, that her unconscious fantasy does not, like the Biblical account of the Creation, put light in the first place, but sound. There now follows a truly *ad hoc* theoretical explanation. She says:

It may be of interest to recall that Anaxagoras, too, makes the cosmos arise out of chaos by means of a whirlwind⁹—which does not normally occur without producing a noise. But at that time I had not yet made a study of philosophy and I knew nothing either of Anaxagoras or of his theories about the *voûs* which I found I had been unconsciously following. I was in equally complete ignorance of the name of Leibniz and consequently of his doctrine “*dum Deus calculat fit mundus.*”

The allusions to Anaxagoras and Leibniz both refer to creation through thought, so that divine thought alone is held capable of producing a new material reality—a reference which seems unintelligible at first, but will soon become more understandable.

[68] We come now to the associations from which Miss Miller mainly derives her unconscious creation:

In the first place, there is Milton’s *Paradise Lost*, of which we had a fine edition at home, illustrated by Gustave Doré, and which I have known well since childhood. Then the Book of Job, which has been read aloud to me ever since I can remember. Now, if you compare my first line with the first words of *Paradise Lost*, you find it is in the same metre (—/—/—/—):

Of man’s first disobedience ...

When the Eternal first made sound. Moreover, the general idea of my poem is slightly reminiscent of various passages in Job, and also of one or two places in Handel’s¹⁰ oratorio *The Creation* (which appeared in the confusion at the beginning of the dream).

[69] So the “lost paradise,” which is as we know closely associated with the beginning of the world, is defined more precisely through the line “Of man’s first disobedience”—a clear reference to the Fall, which in this connection is not without significance. I know the objection which everyone will raise here, namely that Miss Miller could just as well have chosen any other line as an example, that she picked on the first suitable one purely by accident, and that its content was equally accidental. The criticism levelled at the association method generally operates with arguments of this kind. The misunderstanding arises from the fact that the law of psychic causality is never taken seriously enough: there are no accidents, no “just as wells.” It is so, and there is a very good reason why it is so. It is a fact that Miss Miller’s poem is associated with the Fall, and this focuses our attention on the very same problem whose existence we have already surmised. Unfortunately, the author neglects to tell us which passages in Job came into her mind, so we can only make broad conjectures. First of all, the analogy to *Paradise Lost*: Job loses everything he has, because Satan made God doubt his integrity. In the same way, paradise was lost through the temptation of the serpent, and mankind was cast out into a life of earthly travail. The idea, or rather the mood, expressed by this recollection of *Paradise Lost* is Miss Miller’s feeling of having lost something which was somehow connected with Satanic temptation. Like Job, she is an innocent victim because she did not

succumb to the temptation. Job's sufferings are not understood by his friends; ¹¹ none of them knows that Satan has a hand in the game and that Job is really innocent. Indeed, he never wearies of protesting his innocence. Does this, perhaps, give us a clue? We know that certain neurotics and mentally diseased people continually defend their innocence against nonexistent attacks; but on closer inspection one discovers that in defending their innocence apparently without cause they are simply indulging in a self-deceiving manoeuvre, which derives its energy from those very impulses whose unpleasant character is plainly revealed by the content of the alleged accusations and calumnies. ¹²

[70] Job suffers doubly, firstly through the loss of his fortune, secondly through the lack of understanding of his friends, a theme that can be traced all through the book. The misery of being misunderstood reminds us of the figure of Cyrano de Bergerac: he too suffers doubly—on one side through unrequited love, on the other through misunderstanding. He falls, as we have already seen, in the last hopeless struggle against “Falsehood, Compromise, Prejudice, Treachery, and Folly”:

You strip from me the laurel and the rose!

[71] Job laments:

God hath delivered me to the ungodly,
and turned me over into the hands of the wicked.
I was at ease, but he hath broken me asunder:
he hath also taken me by my neck, and shaken me to pieces,
and set me up for his mark.
His archers compass me round about,
he cleaveth my reins asunder, and doth not spare;
he poureth out my gall upon the ground.
He breaketh me with breach upon breach,
he runneth upon me like a giant. ¹³

[72] The emotional analogy lies in having to suffer a hopeless struggle against overwhelming odds. It is as if this struggle were accompanied from afar by the clangour of “creation,” as if it constellated in the unconscious a wonderful and mysterious image that has not yet forced its way into the light of the upper world. We surmise, rather than know, that this struggle has got something to do with creation, with the unending battle between affirmation and negation. The allusions to Rostand's *Cyrano* through the identification with Christian, to Milton's *Paradise Lost*, to the sorrows of Job, misunderstood by his friends, plainly betray that in the soul of the poet there is something that identifies with these ideas. She too has

suffered like Job, has lost paradise, and dreams of “creation”—creation through thought—and of fructification through the rushing wind of the pneuma.

[73] We submit ourselves once more to Miss Miller’s guidance:

I remember that, at the age of fifteen, I was very much excited by an article my mother had read to me, about “the Idea spontaneously creating its own object,” and I passed almost the whole night without sleep, wondering what it could all mean.—From the age of nine to sixteen, I used to go on Sundays to a Presbyterian church, where the pastor was a highly cultivated man, now president of a well-known college. And in one of the earliest memories I have of him, I see myself, still quite a little girl, sitting in our large pew in church and struggling to keep myself awake, without being able to understand what in the world he meant when he spoke to us of “Chaos,” “Cosmos,” and “the Gift of Love.”

[74] There are, then, fairly early memories of the awakening of puberty (nine to sixteen), which connect the idea of the cosmos born of chaos with the “Gift of Love.” The medium in which this happy connection took place is the memory of a much-respected ecclesiastic who spoke those dark words. From the same period comes the memory of her excitement over the “Idea spontaneously creating its own object.” Two ways of creation are here hinted at: creative thought, and the mysterious reference to the “Gift of Love.”

[75] During the latter part of my medical studies I had an opportunity of gaining, through long observation, a deep insight into the soul of a fifteen-year-old girl. I then discovered, to my astonishment, what the contents of unconscious fantasies are like, and how far removed they are from what a girl of this age shows in her outward demeanour and from what an outsider would suspect. They were far-reaching fantasies of a positively mythical nature: the girl saw herself, in her split-off fantasy, as the racial mother of uncounted generations of men.¹⁴ Even allowing for the markedly poetic cast of her imagination, there still remained elements that are probably common to all girls of her age, for the unconscious is infinitely more common to all men than are the contents of their individual consciousnesses. The unconscious is, in fact, the condensation of the average run of historical experience.

[76] Miss Miller’s problem at this age was the common human problem: How am I to be creative? Nature knows only one answer to that: Through a child (the gift of love). But—how does one get a child? Here arises the problem which, as experience has shown, is connected with the father,¹⁵ so that it cannot be tackled properly because too much preoccupation with the father at once brings up the incest-barrier. The strong and natural love that binds the child to the father turns away, during the years when the child is outgrowing the family circle, to the higher forms of the father, to authority, to the “Fathers” of the Church and to the father-god visibly represented by them, where there is even less possibility of coming to grips with the problem.

Nevertheless, mythology is not lacking in consolations. Did not the Word become flesh? And did not the divine pneuma enter into the Virgin's womb? (pl. III.) The whirlwind of Anaxagoras was that same divine *nous* which produced the world out of itself. Why do we cherish the image of the Immaculate Mother even to this day? Because it is still comforting and speaks without words or noisy sermons to the comfortless, saying, "I too have become a mother"—through the "Idea spontaneously creating its own object." I believe there would be reason enough for a sleepless night if those adolescent fantasies once got hold of this idea—the consequences would indeed be incalculable.

[77] Everything psychic has a lower and a higher meaning, as in the profound saying of late classical mysticism: "Heaven above, Heaven below, stars above, stars below, all that is above also is below, know this and rejoice."¹⁶ Here we lay our finger on the secret symbolical significance of everything psychic. We would be doing less than justice to the intellectual originality of our author if we were content to trace back the excitement of that sleepless night simply and solely to the sexual problem in its narrower sense. That would be only one half of the meaning, and the lower half at that. The other half is ideal creation as a substitute for real creation.

[78] With personalities who are obviously capable of intellectual effort, the prospect of spiritual fruitfulness is something worthy of their highest aspirations, and for many people it is actually a vital necessity. This other side of the fantasy also explains the excitement, for we are concerned here with a thought that contains a presentiment of the future—one of those thoughts which, to quote Maeterlinck,¹⁷ spring from the "inconscient supérieur," from the "prospective potency" of a subliminal synthesis.¹⁸ I have had occasion to observe, in the course of my daily professional work (though this is an experience about whose certainty I must express myself with all the caution which the complexity of the material enjoins), that in certain cases of long-standing neurosis a dream, often of visionary clarity, occurs about the time of the onset of the illness or shortly before, which imprints itself indelibly on the mind and, when analysed, reveals to the patient a hidden meaning that anticipates the subsequent events of his life.¹⁹ I am inclined to attribute a similar meaning to the excitement of that restless night, because the later events, so far as Miss Miller consciously or unconsciously reveals them to us, are entirely of a nature to confirm our supposition that we must take that moment as foreshadowing a future life-aim.

[79] Miss Miller ends her string of associations with the following comment:

It [the dream] seems to me to result from a mixture in my mind of *Paradise Lost*, *Job*, and *The Creation*, with notions like the "Idea spontaneously creating its own object," the "Gift of Love", "Chaos," and "Cosmos."

[80] Thus, like little bits of coloured glass in a kaleidoscope, fragments of philosophy, aesthetics, and religion are blended together in her mind, so she tells us—

... under the stimulation of the voyage and of countries fleetingly seen, coupled with the vast silence and impalpable charm of the sea—to produce this beautiful dream. There was only this and nothing more. “Only this, and nothing more!”

[81] With these words Miss Miller shows us politely but emphatically out. Her parting words of negation make one curious to know exactly what position they are intended to negate. “There was only this and nothing more” must refer to “the impalpable charm of the sea”; so presumably the handsome young officer who sang so melodiously during the watches of the night is long since forgotten, and nobody is to know, least of all the dreamer, that he was a star of the morning who heralded the dawning of a new day.²⁰ One should, however, avoid pacifying oneself or the reader with soothing phrases like “There was only this,” for something might easily give them the lie the next moment. This is what happens to Miss Miller, who immediately adds, “Only this, and nothing more!” but without giving the source. The quotation comes from Poe’s poem “The Raven,” and the operative stanza runs:

While I nodded, nearly napping, suddenly there came a tapping,

As of some one gently rapping, rapping at my chamber door.

“‘Tis some visitor,” I muttered, “tapping at my chamber door—

Only this, and nothing more.”

[82] A spectral raven knocks nightly at his door and reminds the poet of his irrevocably lost “Lenore.” The raven’s name is “Nevermore,” and he croaks his horrible “Nevermore” as a refrain to every verse. Old memories come back tormentingly, and each time the spectre repeats inexorably: “Nevermore.” In vain the poet seeks to frighten away the dismal guest, shouting at the raven:

“Be that word our sign of parting, bird or fiend!” I shrieked upstarting—

“Get thee back into the tempest and the Night’s Plutonian shore!

Leave no black plume as a token of the lie thy soul hath spoken!

Leave my loneliness unbroken!—quit the bust above my door!

Take thy beak from out my heart, and take thy form from off my door!”

Quoth the raven, “Nevermore!”

[83] The words “Only this and nothing more!,” which apparently skip so lightly over the situation, are taken from a poem which depicts in an affecting manner the poet’s despair over a lost love.²¹ Their quotation gives the show away completely. Miss Miller evidently underestimated the impression which the night-watching singer had made upon her, and its far-reaching consequences. This under-estimation is precisely

the reason why the problem was not worked out consciously and why it produced those “psychological riddles”,²² The impression goes on working in the unconscious and throws up symbolical fantasies. First it is the “morning stars [that] sang together,” then *Paradise Lost*, then the yearning clothes itself in ecclesiastical garb, speaks darkly of “World Creation” and finally rises to a religious hymn, where it at last finds its way to freedom. But the hymn bears in its own peculiarities the marks of its origin: by the devious route of the father-*imago* relationship, the night-watching singer becomes the Creator, the God of Sound, of Light and of Love. This is not to say that the idea of God derives from the loss of a lover and is nothing but a substitute for the human object. What is evidently in question here is the displacement of libido on to a *symbolical* object, with the result that the latter is turned into a sort of substitute. It is in itself a perfectly genuine experience, though, like everything else, it can be put to improper use.

[84] The winding path of the libido seems to be a *via dolorosa*; at any rate, *Paradise Lost* and the parallel reference to Job lead one to that conclusion. The initial hints of identification with Christian, which really points to Cyrano, prove that the long way round is a way of suffering, just as it was when mankind, after the Fall, had to bear the burden of earthly life, or when Job suffered under the power of God and Satan and became the unsuspecting plaything of two superhuman forces. *Faust* offers the same spectacle of a wager with God:

MEPHISTOPHELES: What do you wager? You will lose him yet,

Provided *you* give *me* permission

To steer him gently in the course I set.²³

[85] Compare with this the passage in Job, where Satan says:

But put forth thine hand now, and touch all that he hath, and he will curse thee to thy face.²⁴

[86] While in Job the two great forces are characterized simply as good and evil, the immediate problem is a definitely erotic one in *Faust*, where the devil is aptly characterized by the appropriate role of tempter. This aspect is lacking in Job, but at the same time Job is not conscious of the conflict within his own soul, and he never ceases to inveigh against the arguments of his friends who want to convince him of the evil in his heart. To that extent, one could say that *Faust* is the more conscious in that he openly admits his psychic conflicts.

[87] Miss Miller acts like Job: she admits nothing, and pretends that good and evil come from outside. Hence her identification with Job is significant in this respect also. But there is another, very important analogy still to be mentioned: the procreative urge—which is how love must be regarded from the natural standpoint—remains the essential attribute of the God whom Miss Miller apparently derives from

the erotic impression, for which reason he is praised in the hymn as Creator. We see the same thing in Job. Satan is the destroyer of Job's fruitfulness, but God is the All-Fruitful: therefore, at the end of the book, he addresses a paean filled with lofty poetic beauty to his own creative power, but it is curious to note that he gives chief consideration to two highly unsympathetic representatives of the animal kingdom, Behemoth and Leviathan, both expressive of the crudest force conceivable in nature.

[88] Miss Miller uses the text of the Authorized Version, which, like Luther's version, is very suggestive:

Behold now behemoth, which I made with thee;

he eateth grass as an ox.

Lo now, his strength is in his loins,

and his force is in the navel of his belly.

He moveth his tail like a cedar:

the sinews of his stones are wrapped together.

His bones are as strong pieces of brass;

his bones are like bars of iron.

He is the chief of the ways of God....

Canst thou draw out leviathan with an hook?

or his tongue with a cord which thou lettest down?

Canst thou put an hook into his nose?

or bore his jaw through with a thorn?

Will he make many supplications unto thee?

will he speak soft words unto thee?

Will he make a covenant with thee?

wilt thou take him for a servant for ever? ²⁵

[89] God speaks thus in order to parade his power and omnipotence forcibly before Job's eyes. God is as Behemoth and Leviathan: ²⁶ the fruitfulness and abundance of Nature, the ungovernable wildness and licentiousness of Nature, the overwhelming danger of unchained power.²⁷ What was it that destroyed Job's earthly paradise? The unchained power of Nature. God, so the poet gives us to understand, has simply shown his other side for once, the side we call the Devil, and let loose all the terrors of Nature upon the unfortunate Job. The God who created such monstrosities, at the very thought of which we poor weak mortals stiffen with fear, must certainly harbour within himself qualities which give one pause. This God dwells in the heart, in the unconscious.²⁸ That is the source of our fear of the unspeakably terrible, and of the strength to withstand the terror. Man, that is to say his conscious ego, is a mere

bagatelle, a feather whirled hither and thither with every gust of wind, sometimes the sacrificed and sometimes the sacrificer, and he cannot hinder either. The Book of Job shows us God at work both as creator and destroyer. Who is this God? An idea that has forced itself upon mankind in all parts of the earth and in all ages and always in similar form: an otherworldly power which has us at its mercy, which begets and kills—an image of all the necessities and inevitablenesses of life. Since, psychologically speaking, the God-image is a complex of ideas of an archetypal nature, it must necessarily be regarded as representing a certain sum of energy (libido) which appears in projection.²⁹ In most of the existing religions it seems that the formative factor which creates the attributes of divinity is the father-*imago*, while in the older religions it was the mother-*imago*. These attributes are omnipotence, a sternly persecuting paternalism ruling through fear (Old Testament), and a loving paternalism (New Testament). In certain pagan conceptions of divinity the maternal element is strongly emphasized, and there is also a wide development of the animal or theriomorphic element.³⁰ (PI. IV *a.*) The God-concept is not only an image, but an elemental force. The primitive power which Job's Hymn of Creation vindicates, absolute and inexorable, unjust and superhuman, is a genuine and authentic attribute of the natural power of instinct and fate which "leads us into life," which makes "all the world become guilty before God" (Romans 3: 19) and against which all struggle is in vain. Nothing remains for mankind but to work in harmony with this will. To work in harmony with the libido does not mean letting oneself drift with it, for the psychic forces have no uniform direction, but are often directly opposed to one another. A mere letting go of oneself leads in the shortest space of time to the most hopeless confusion. It is often difficult, if not impossible, to feel the ground-current and to know the true direction; at any rate collisions, conflicts, and mistakes are scarcely avoidable.

[90] As we have seen, the religious hymn unconsciously produced by Miss Miller appears in the place of the erotic problem. It derives its material for the most part from reminiscences which were reactivated by the introverted libido. Had this "creation" not come off, Miss Miller would inevitably have yielded to the erotic impression, either with the usual consequences, or else with a negative result which would have replaced the lost happiness by a correspondingly strong feeling of regret. Opinions, as we know, are deeply divided over the value of solving an erotic conflict like Miss Miller's in this way. It is thought to be much more beautiful and noble to let an erotic tension resolve itself unnoticed into the sublime feelings of religious poetry, in which perhaps other people can find joy and consolation, and that it is a kind of unjustified fanaticism for truth to complain about the unconsciousness of such a solution. I would not like to decide this question one way or the other, but would prefer to find out the meaning and purpose of the apparently devious path followed

by the libido, and of the apparent self-deception, in the case of a so-called unnatural and unconscious solution. There are no “purposeless” psychic processes; that is to say, it is a hypothesis of the greatest heuristic value that the psyche is essentially purposive and directed.

[91] That the root-cause of the poem has been shown to be the love-episode is an explanation that does not amount to very much at present, for the question of purpose still remains to be settled. Only the discovery of the purpose can provide a satisfactory answer to psychological questions. Were there not a secret purposiveness bound up with the supposedly devious path of the libido or with the supposed *repression*, it is certain that such a process could not take place so easily, so naturally, and so spontaneously. Also, it would hardly occur so frequently in this form, or in some other like it. There is no doubt that this transformation of libido moves in the same direction as, broadly speaking, the cultural modification, conversion, or displacement of natural drives. It must be a well-trodden path which is so habitual that we hardly notice the conversion ourselves, if at all. Between the normal psychic transformation of instinctual drives and the present case there is, however, a certain difference: we cannot rid ourselves of the suspicion that the critical experience—the singer—was assiduously overlooked; in other words, that there was a certain amount of “repression.” This latter term should really be used only when it is a voluntary act of which one cannot help being conscious. Nervous persons can successfully hide voluntary decisions of this kind from themselves up to a point, so that it looks as if the act of repression were completely unconscious. The context³¹ of associations provided by the author herself is so impressive that she must have felt this background in a fairly lively fashion, and must therefore have transformed the situation through a more or less conscious act of repression.

[92] Repression, however, is an illegitimate way of evading the conflict, for it means pretending to oneself that it does not exist. What then becomes of the repressed conflict? Clearly, it continues to exist, even though not conscious to the subject. As we have seen already, the repression leads to regressive reactivation of an earlier relationship or type of relatedness, in this case the reactivation of the father-*imago*. “Constellated” (i.e., activated) unconscious contents are, so far as we know, always projected; that is, they are either discovered in external objects, or are said to exist outside one’s own psyche. A repressed conflict and its affective tone must reappear *somewhere*. The projection caused by repression is not something that the individual consciously does or makes; it follows automatically and, as such, is not recognized unless there are quite special conditions which enforce its withdrawal.

[93] The “advantage” of projection consists in the fact that one has apparently got rid of the painful conflict once and for all. Somebody else or external circumstances now

have the responsibility. In the present case, the reactivated father-*imago* gives rise to a hymn addressed to the deity in his specifically paternal aspect—hence the emphasis on the Father of all things, Creator, etc. The deity thus takes the place of the human singer; and earthly love is replaced by the heavenly. Although it cannot be proved from the material available, it is nevertheless highly improbable that Miss Miller was so unaware of the conflicting nature of the situation that the apparently effortless transformation of the erotic impression into feelings of religious exaltation cannot be explained as an act of repression. If this view is correct, then the picture of the father-god is a projection and the procedure responsible for this a self-deceiving manoeuvre undertaken for the illegitimate purpose of *making a real difficulty unreal*, that is, of juggling it out of existence.

[94] If, however, a product like the hymn came into being *without* an act of repression, i.e., unconsciously and spontaneously, then we are confronted with an entirely natural and automatic process of transformation. In that case the creator-god who emerges from the father-*imago* is no longer a product of repression or a substitute, but a natural and inevitable phenomenon. Natural transformations of this kind, without any semi-conscious elements of conflict, are to be found in all genuine acts of creation, artistic or otherwise. But to the degree that they are causally connected with an act of repression they are coloured by complexes which neurotically distort them and stamp them as *ersatz* products. With a little experience it would not be difficult to determine their origin by their character, and to see how far their genealogy is the result of repression. Just as in natural birth no repression is needed to bring or “project” a living creature into the world, so artistic and spiritual creation is a natural process even when the figure projected is divine. This is far from being always a religious, philosophical, or even a denominational question, but is a universal phenomenon which forms the basis of all our ideas of God, and these are so old that one cannot tell whether they are derived from a father-*imago*, or vice versa. (The same must be said of the mother-*imago* as well.)

[95] The God-image thrown up by a spontaneous act of creation is a living figure, a being that exists in its own right and therefore confronts its ostensible creator autonomously. As proof of this it may be mentioned that the relation between the creator and the created is a *dialectical* one, and that, as experience shows, man has often been the person who is addressed. From this the naïve-minded person concludes, rightly or wrongly, that the figure produced exists in and for itself, and he is inclined to assume that it was not he who fashioned it, but that it fashioned itself in him—a possibility which no amount of criticism can disprove, since the genesis of this figure is a natural process with a teleological orientation in which the cause anticipates the goal. As it is a natural process, it cannot be decided whether the God-image is created or whether it creates itself. The naïve intellect cannot help taking its

autonomy into account and putting the dialectical relationship to practical use. It does this by calling upon the divine presence in all difficult or dangerous situations, for the purpose of unloading all its unbearable difficulties upon the Almighty and expecting help from that quarter.³² In the psychological sense this means that complexes weighing on the soul are *consciously* transferred to the God-image. This, it should be noted, is the direct opposite of an act of repression, where the complexes are handed over to an unconscious authority, inasmuch as one prefers to forget them. But in any religious discipline it is of the highest importance that one should remain conscious of one's difficulties—in other words, of one's sins. An excellent means to this end is the mutual confession of sin (James 5: 16), which effectively prevents one from *becoming* unconscious.³³ These measures aim at keeping the conflicts conscious, and that is also a *sine qua non* of the psychotherapeutic procedure. Just as medical treatment appoints the person of the doctor to take over the conflicts of his patients, so Christian practice appoints the Saviour, "in whom we have redemption through his blood, the forgiveness of sins."³⁴ He is the deliverer and redeemer of our guilt, a God who stands above sin, who "committed no sin, no guile was found on his lips,"³⁵ who "himself bore our sins in his body on the tree."³⁶ "So Christ was once sacrificed to take away the sins of many."³⁷ This God is characterized as being himself innocent and a self-sacrificer. The conscious projection at which Christian education aims therefore brings a double psychic benefit: firstly, one keeps oneself conscious of the conflict ("sin") of two mutually opposing tendencies, thus preventing a known suffering from turning into an unknown one, which is far more tormenting, by being repressed and forgotten; and secondly, one lightens one's burden by surrendering it to God, to whom all solutions are known. But, as we have said, the divine figure is in the first place a psychic image, a complex of archetypal ideas which faith equates with a metaphysical entity. Science has no competence to pass judgment on this equation: on the contrary, it must pursue its explanations without resorting to any such hypostasis. It can only establish that instead of an objective human being there appears an apparently subjective figure, i.e., a complex of ideas. This complex, as experience has shown, possesses a certain functional autonomy and has proved itself to be a psychic existent. That is what psychological experience is primarily concerned with, and to that extent this experience can be an object of science. Science can only establish the existence of psychic factors, and provided that we do not overstep these limits with professions of faith, in all so-called metaphysical problems we find ourselves confronted exclusively with psychic existents. These, in accordance with their nature, are intimately interwoven with the individual personality and are therefore subject to all manner of variations, unlike the postulates of faith whose uniformity and permanence are guaranteed by tradition and by institutional religion. The epistemological boundaries set by the scientific standpoint make it inevitable that the religious figure appears essentially as a psychic factor

which can only be separated theoretically from the individual psyche. And the more it is so separated, the more it loses its plasticity and concreteness, since it owes its explicit form and vitality precisely to its intimate connection with the individual psyche. The scientific approach makes the divine figure, which faith posits as being the supreme certainty, into a variable and hardly definable quantity, although it cannot cast doubt on its actuality (in the psychological sense). Science therefore puts, in place of the certainty of faith, the uncertainty of human knowledge. The resultant change of attitude is not without serious consequences for the individual: his conscious mind sees itself isolated in a world of psychic factors, and only the utmost caution and conscientiousness can prevent him from assimilating them and from identifying them with himself. This danger is all the greater because, in his immediate experience of dreams, visions, etc., the religious figures show a marked tendency to appear in the most varied forms; they often clothe themselves so convincingly in the stuff of the individual psyche that it remains a moot point whether they are not in the last resort produced by the subject himself. That is an illusion of the conscious mind, but a very common one.³⁸ In reality all inner experience springs from the unconscious, over which we have no control. *But the unconscious is nature, which never deceives: only we deceive ourselves.* Thus, inasmuch as the scientific approach disregards metaphysics, basing itself entirely on verifiable experience, it plunges us straight into the uncertainty which is conditioned by the variability of everything psychic. It emphasizes outright the subjectivity of religious experience, thereby offering an open threat to the solidarity of faith. This long-felt and ever-present danger is countered by the institution of the Christian community, whose psychological significance is best expressed in the command in the Epistle of James: "Confess your sins to one another."³⁹ Again, it is emphasized as being especially important to preserve the community through mutual love; the Pauline commands leave no doubts on this score:

Through love be servants of one another.⁴⁰

Let brotherly love continue.⁴¹

And let us consider how to stir up one another to love and good works, not neglecting to meet together....⁴²

[96] Fellowship in the Christian community appears to be a condition of salvation, or however one chooses to describe the desired state. The First Epistle of John expresses similar views:

He who loves his brother abides in the light.... But he who hates his brother is in the darkness....⁴³

No man has ever seen God; if we love one another, God abides in us and his love is perfected in us.⁴⁴

[97] We have already referred to the mutual confession of sin and the transference of psychic difficulties to the divine figure. Between it and man there thus arises an intimate bond. Yet man should be bound through love not to God alone, but also to

his fellows. The latter relation, indeed, seems to be just as essential as the former. If God dwells in us only when we love our brother, we might be led to suppose that love is even more important than God. This is not so absurd when we consider the words of Hugh of St. Victor:

You have great power, O Love; you alone could draw God down from heaven to earth. O how strong is your bond with which even God could be bound.... You brought him bound with your bonds, you brought him wounded with your arrows, ... you wounded him who was invulnerable, you bound him who was invincible, you drew down him who was immovable, the Eternal you made mortal.... O Love, how great is your victory!⁴⁵

Accordingly, love would seem to be no trifling thing: it is God himself.⁴⁶ But, on the other hand, "love" is an extreme example of anthropomorphism and, together with hunger, the immemorial psychic driving-force of humanity. It is, psychologically considered, a function of relationship on the one hand and a feeling-toned psychic condition on the other, which, as we have seen, practically coincides with the God-image. There can be no doubt that love has an instinctual determinant; it is an activity peculiar to mankind, and, if the language of religion defines God as "love," there is always the great danger of confusing the love which works in man with the workings of God. This is an obvious instance of the above-mentioned fact that the archetype is inextricably interwoven with the individual psyche, so that the greatest care is needed to differentiate the collective type, at least conceptually, from the personal psyche. In practice, however, this differentiation is not without danger if human "love" is thought of as the prerequisite for the divine presence (I John 4: 12).

[98] No doubt this presents those who would like to keep the man-to-God relationship free from psychology with no small problem. But for the psychologist the situation is not so complicated. "Love," in his experience, proves to be the power of fate par excellence, whether it manifests itself as base *concupiscentia* or as the most spiritual affection. It is one of the mightiest movers of humanity. If it is conceived as "divine," this designation falls to it with absolute right, since the mightiest force in the psyche has always been described as "God." Whether we believe in God or not, whether we marvel or curse, the word "God" is always on our lips. Anything psychically powerful is invariably called "God." At the same time "God" is set over against man and expressly set apart from him. But love is common to both. It belongs to man in so far as he is its master, and to the daemon if ever he becomes its object or its victim. This means, psychologically, that the libido, regarded as the force of desire and aspiration, as psychic energy in the widest sense, stands in part at the disposal of the ego, and in part confronts the ego autonomously, sometimes influencing it so powerfully that it is either put in a position of unwilling constraint, or else discovers in the libido itself a new and unexpected source of strength. Since the relation of the unconscious to the conscious mind is not merely mechanical or complementary, but rather compensatory, taking its cue from the anfractuosities of the conscious attitude, the intelligent character of this unconscious activity can hardly be denied. Experiences like these make it immediately understandable why the God-image is so often regarded as a personal being.

[99] Now, since a man's *spiritual vocation* in the widest sense has been thrust upon him to an increasing degree by the unconscious,⁴⁷ this naturally gave rise to the view that the God-image was a spirit who required man's spirit. This is not an invention of Christianity or of philosophy, but a common human experience to which even the atheist bears witness. (The important thing is *what* he talks about, not whether he agrees with it or not.) The other definition of God therefore asserts: "God is spirit."⁴⁸ The pneumatic God-image has been further attenuated as the Logos, and this gives the "love of God" that peculiarly abstract quality which is also apparent in the idea of "Christian love."

[100] It is this "spiritual love," which is actually far more appropriate to the God-image than to man, that is supposed to hold the human community together:

Welcome one another, therefore, as Christ has welcomed you, for the glory of God.⁴⁹

[101] It is obvious that, since Christ "welcomed" men with "divine" love, men's love for one another should also have, and indeed *can* have, a "spiritual" and "divine" quality. However, it is not so obvious from the psychological point of view, since, as a rule, the energy of an archetype is not at the disposal of the conscious mind. Hence the specifically human forms of love are, very rightly, not regarded as either "spiritual" or "divine." The energy of an archetype communicates itself to the ego only when the latter has been influenced or gripped by an autonomous action of the archetype. From this psychological fact one would have to conclude that the man who practises a spiritual form of love has already been gripped by something akin to a *donum gratiae*, for he could hardly be expected to be capable of usurping, on his own resources, a divine action such as that love is. But by virtue of the *donum amoris* he becomes capable of taking God's place in this respect. It is a psychological fact that an archetype can seize hold of the ego and even compel it to act as it—the archetype—wills. A man can then take on archetypal dimensions and exercise corresponding effects; he can appear in the place of God, so that it is not only possible, but quite sensible, for other men to act towards him as they act towards God. We know that, in the Catholic Church, this possibility has become an institution whose psychological efficacy cannot be doubted. From this intimate relationship there arises a community of an archetypal order which is distinguished from all other communities by the fact that its aim or purpose is not immanent in mankind and not directed to utilitarian ends, but is a transcendental symbol whose nature corresponds to the peculiarity of the ruling archetype.

[102] The closer relations between men thus made possible by such a community produce a psychological intimacy which touches on the personal instinctual sphere of "human" love and therefore harbours certain dangers. Above all, the power and sex instincts are inevitably constellated. Intimacy creates various short-cuts between

people and is only too likely to lead to the very thing from which Christianity seeks to deliver them, namely to those all-too-human attractions and their necessary consequences, which had already been the bane of the highly civilized man at the beginning of our Christian era. Religious experience in antiquity was frequently conceived as bodily union with the deity,⁵⁰ and certain cults were saturated with sexuality of every kind. Sexuality was all too close to the relations of people with one another. The moral degeneracy of the first centuries of the Christian era produced a moral reaction which then, in the second and third centuries, after germinating in the darkness of the lowest strata of society, expressed itself at its purest in the two mutually antagonistic religions, Christianity and Mithraism. These religions strove after precisely that higher form of social intercourse symbolized by a projected (“incarnate”) idea (the Logos), whereby all the strongest impulses of man—which formerly had flung him from one passion to another and seemed to the ancients like the compulsion of evil stars, *Heimarmene*,⁵¹ or like what we psychologists would call the *compulsion of libido*⁵²—could be made available for the maintenance of society. As one example among many others, I would cite St. Augustine’s description of the fate of Alypius, in his *Confessions*:

But at Carthage the maelstrom of ill morals—and especially the passion for idle spectacles—had sucked him in, his special madness being for gladiatorial shows.... As a result of what he had heard me say, he wrenched himself out of the deep pit in which he had chosen to be plunged and in the darkness of whose pleasures he had been so woefully blinded. He braced his mind and shook it till all the filth of the Games fell away from it and he went no more....

In pursuit of the worldly career whose necessity his parents were always dinning into his ears, he had gone before me to Rome to study Law; and there he had been, incredibly, carried away again by an incredible passion for gladiatorial shows. He had turned from such things and utterly detested them. But it happened one day that he met some friends and fellow students coming from dinner: and though he flatly refused and vigorously resisted, they used friendly violence and forced him along with them to the amphitheatre on a day of these cruel and murderous Games. He protested: “Even if you drag my body to the place, can you force me to turn my mind and my eyes on the show? Though there, I shall not be there, and so I shall defeat both you and it.”

Hearing this his companions led him on all the faster, wishing to discover whether he could do as he had said. When they had reached the Arena and had got such seats as they could, the whole place was in a frenzy of hideous delight. He closed up the door of his eyes and forbade his mind to pay attention to things so evil. If only he could have stopped his ears too! For at a certain critical point in the fight, the vast roar of the whole audience beat upon him. His curiosity got the better of him, and thinking that he would be able to treat the sight with scorn—whatever the sight might be—he opened his eyes, and was stricken with a deeper wound in the soul than the man he had opened his eyes to see suffered in the body. He fell more miserably than the gladiator whose fall had set the crowd to that roar—a roar which had entered his ears and unlocked his eyes, so that his soul was stricken and beaten down. But in truth the reason was that its courage had so far been only audaciousness, and it was weak because it had relied upon itself when it should have trusted only in You. Seeing the blood he drank deep of the savagery. He

did not turn away but fixed his gaze upon the sight. He drank in all the frenzy, with no thought of what had happened to him, revelled in the wickedness of the contest, and was drunk with lust for blood. He was no longer the man who had come there but one of the crowd to which he had come, a fit companion for those who had brought him.

What more need I say? He continued to gaze, shouted, grew hot, and when he departed took with him a madness by which he was goaded to come back again, not only with those who at first took him there, but even more than they and leading on others.⁵³

[103] One can take it as certain that man's domestication cost him the heaviest sacrifices. An age which created the Stoic ideal must doubtless have known why and against what it was set up. The age of Nero provides an effective foil for the celebrated passage from the forty-first letter of Seneca to Lucilius:

We push one another into vice. And how can a man be recalled to salvation, when he has none to restrain him, and all mankind to urge him on? ...

If you see a man who is unterrified in the midst of dangers, untouched by desires, happy in adversity, peaceful amid the storm, who looks down upon men from a higher plane, and views the gods on a footing of equality, will not a feeling of reverence for him steal over you? Will you not say: "This quality is too great and too lofty to be regarded as resembling this petty body in which it dwells. A divine power has descended upon that man." When a soul rises superior to other souls, when it is under control, when it passes through every experience as if it were of small account, when it smiles at our fears and at our prayers, it is stirred by a force from heaven. A thing like this cannot stand upright unless it be propped by the divine. Therefore, a greater part of it abides in that place from whence it came down to earth. Just as the rays of the sun do indeed touch the earth but still abide at the source from which they are sent, even so the great and hallowed soul, which has come down in order that we may have a nearer knowledge of divinity, does indeed associate with us, but still cleaves to its origin; on that source it depends, thither it turns its gaze and strives to go, and it concerns itself with our doings only as a being superior to ourselves.⁵⁴

[104] The men of that age were ripe for identification with the word made flesh, for the founding of a community united by an idea,⁵⁵ in the name of which they could love one another and call each other brothers.⁵⁶ The old idea of a *μεσίτης*, of a mediator in whose name new ways of love would be opened, became a fact, and with that human society took an immense stride forward. This was not the result of any speculative, sophisticated philosophy, but of an elementary need in the great masses of humanity vegetating in spiritual darkness. They were evidently driven to it by the profoundest inner necessities, for humanity does not thrive in a state of licentiousness.⁵⁷ The meaning of these cults—Christianity and Mithraism—is clear: moral subjugation of the animal instincts.⁵⁸ The spread of both these religions betrays something of that feeling of redemption which animated their first adherents, and which we can scarcely appreciate today. We can hardly realize the whirlwinds of brutality and unchained libido that roared through the streets of Imperial Rome. But we would

know that feeling again if ever we understood, clearly and in all its consequences, what is happening under our very eyes. The civilized man of today seems very far from that. He has merely become neurotic. For us the needs of the Christian community have gone by the board; we no longer understand their meaning. We do not even know against what it is meant to protect us.⁵⁹ For enlightened people, the need for religion is next door to neurosis.⁶⁰ It must be admitted that the Christian emphasis on spirit inevitably leads to an unbearable depreciation of man's physical side, and thus produces a sort of optimistic caricature of human nature. He gets too good and too spiritual a picture of himself, and becomes too naïve and optimistic. In two world wars the abyss has opened out again and taught us the most frightful lesson that can be imagined. We now know what human beings are capable of, and what lies in store for us if ever again the mass psyche gets the upper hand. Mass psychology is egoism raised to an inconceivable power, for its goal is immanent and not transcendent.

[105] Let us now turn back to the question from which we started, namely, whether or not Miss Miller has created anything of value with her poem. If we bear in mind the psychological and moral conditions under which Christianity came to birth, in an age when the crudest brutality was an everyday spectacle, we can understand the religious convulsion of the whole personality and the value of a religion that protected people living in the Roman sphere of culture from the visible onslaughts of wickedness. It was not difficult for those people to remain conscious of sin, for they saw it every day spread out before their eyes. Miss Miller not only underestimates her "sins," but the connection between the "bitter inexorable necessity" and her religious product has altogether escaped her. The poem thus loses the living value of a religious work of art. It seems to be not much more than a sentimental rehash of an erotic experience, slyly working itself out on the fringe of consciousness and having about the same ethical value as a dream, which is also none of our doing.

[106] To the degree that the modern mind is passionately concerned with anything and everything rather than religion, religion and its prime object—original sin—have mostly vanished into the unconscious. That is why, today, nobody believes in either. People accuse psychology of dealing in squalid fantasies, and yet even a cursory glance at ancient religions and the history of morals should be sufficient to convince them of the demons hidden in the human soul. This disbelief in the devilishness of human nature goes hand in hand with the blank incomprehension of religion and its meaning. The *unconscious* conversion of instinctual impulses into religious activity is ethically worthless, and often no more than an hysterical outburst, even though its products may be aesthetically valuable. Ethical decision is possible only when one is conscious of the conflict in all its aspects. The same is true of the religious attitude: it

must be fully conscious of itself and of its foundations if it is to signify anything more than unconscious imitation.⁶¹

[107] Through centuries of educational training, Christianity subdued the animal instincts of antiquity and of the ensuing ages of barbarism to the point where a large amount of instinctual energy could be set free for the building of civilization. The effect of this training showed itself, to begin with, in a fundamental change of attitude, namely in the alienation from reality, the otherworldliness of the early Christian centuries. It was an age that strove after inwardness and spiritual abstraction. Nature was abhorrent to man. One has only to think of the passage in St. Augustine quoted by Jacob Burckhardt:

And men go forth, and admire lofty mountains and broad seas, ... and turn away from themselves.⁶²

[108] But it was not only the aesthetic beauty of the world that distracted their senses and lured them away from concentrating on a spiritual and supramundane goal. There were also daemonic or magical influences emanating from nature herself.

[109] The foremost authority on the Mithraic cult, Franz Cumont, describes the classical feeling for nature as follows:

The gods were everywhere, and they mingled in all the events of daily life. The fire that cooked the food and warmed the bodies of the faithful, the water that allayed their thirst and cleansed them, the very air they breathed, and the light that shone for them, all were objects of their adoration. Perhaps no other religion has ever offered to its votaries, in so high a degree as Mithraism, opportunities for prayer and motives for veneration. When the initiate betook himself in the evening to the sacred grotto concealed in the solitude of the forest, at every step new sensations awakened in his heart some mystical emotion. The stars that shone in the sky, the wind that whispered in the foliage, the spring or brook that hastened murmuring to the valley, even the earth which he trod under his feet, were in his eyes divine, and all surrounding nature evoked in him a worshipful fear of the infinite forces that swayed the universe.⁶³

[110] This religious oneness with nature is beautifully described by Seneca:

When you enter a grove peopled with ancient trees, higher than the ordinary, and shutting out the sky with their thickly intertwining branches, do not the stately shadows of the wood, the stillness of the place, and the awful gloom of this domed cavern then strike you as with the presence of a deity? Or when you see a cave penetrating into the rock at the foot of an overhanging mountain, not made by human hands, but hollowed out to a great depth by nature, is not your soul suffused with a religious fear? We worship the sources of great rivers, we erect altars at the place where a sudden rush of water bursts from the bowels of the earth, warm springs we adore, and certain pools we hold sacred on account of their sombre darkness or their immense depth.⁶⁴

[111] Sharply contrasting with this ancient nature worship is the Christian aversion from the world, as described in the most poignant language in the *Confessions* of St. Augustine:

What do I love when I love my God? Not the beauty of any bodily thing, not the graciousness of the times, nor the splendour of the light that rejoices the eye, nor the sweet melodies of richly varied songs; not the fragrance of flowers and sweet-smelling ointments and spices, not manna and honey, nor the fair limbs whose embraces are pleasant to the flesh. None of these do I love when I love my God; and yet I love a kind of light, and a kind of melody, and a kind of fragrance, and a kind of savour, and a kind of embracement when I love my God, who is the light and the melody and the fragrance and the savour and the embracement of my inner man; where that light shines into my soul which no space can contain, that melody sounds which no time takes away, that fragrance smells which no wind scatters, that savour tastes which no gluttony diminishes, and that embracement is enjoyed which no satiety can put apart. That is what I love when I love my God.⁶⁵

[112] The world and its beauty had to be shunned, not only because of their vanity and transitoriness, but because love of created nature soon makes man its slave. As St. Augustine says (X, 6): "... they love these things too much and become subject to them, and subjects cannot judge."⁶⁶ One would certainly think it possible to love something, to have a positive attitude towards it, without supinely succumbing to it and losing one's power of rational judgment. But Augustine knew his contemporaries, and knew furthermore how much godliness and godlike power dwelt in the beauty of the world.

Since you alone govern the universe, and without you nothing rises into the bright realm of light, and nothing joyous or lovely can come to be....⁶⁷



Fig. 1. The Mother of All Living

From the Hypnerotomachia Poliphili, Venice, 1499

[113] Thus Lucretius extols “alma Venus” as the ruling principle of nature. To such a *daimonion* man falls an abject victim unless he can categorically reject its seductive influence at the outset. It is not merely a question of sensuality and of aesthetic corruption, but—and this is the point—of paganism and nature-worship. (Fig. 1.) Because gods dwell in created things, man falls to worshipping them, and for that reason he must turn away from them utterly lest he be overwhelmed. In this respect the fate of Alypius is extremely instructive. If the flight from the world is successful, man can then build up an inner, spiritual world which stands firm against the onslaught of sense-impressions. The struggle with the world of the senses brought to birth a type of thinking independent of external factors. Man won for himself that *sovereignty of the idea* which was able to withstand the aesthetic impact, so that thought was no longer fettered by the emotional effect of sense-impressions, but could assert itself and even rise, later, to reflection and observation. Man was now in a position to enter into a new and independent relationship with nature, to go on building upon the foundations which the classical spirit had laid,⁶⁸ and to take up

once more the natural link which the Christian retreat from the world had let fall. On this newly-won spiritual level there was forged an alliance with the world and nature which, unlike the old attitude, did not collapse before the magic of external objects, but could regard them in the steady light of reflection. Nevertheless, the attention lavished upon natural objects was infused with something of the old religious piety, and something of the old religious ethic communicated itself to scientific truthfulness and honesty. Although at the time of the Renaissance the antique feeling for nature visibly broke through in art⁶⁹ and in natural philosophy,⁷⁰ and for a while thrust the Christian principle into the background, the newly-won rational and intellectual stability of the human mind nevertheless managed to hold its own and allowed it to penetrate further and further into depths of nature that earlier ages had hardly suspected. The more successful the penetration and advance of the new scientific spirit proved to be, the more the latter—as is usually the case with the victor—became the prisoner of the world it had conquered. At the beginning of the present century a Christian writer could still regard the modern spirit as a sort of second incarnation of the Logos. “The deeper comprehension of the spirit of nature in modern painting and poetry,” writes Kalthoff, “the living intuition which science is no longer willing to dispense with even in its most arduous endeavours, demonstrate how the Logos of Greek philosophy, which gave to the early Christ-ideal its cosmic position, is divesting itself of its transcendental character and entering upon a new incarnation.”⁷¹ It did not take us long to realize that it was less a question of the incarnation of the Logos than of the descent of the Anthropos or Nous into the dark embrace of Physis. The world had not only been deprived of its gods, but had lost its soul. Through the shifting of interest from the inner to the outer world our knowledge of nature was increased a thousandfold in comparison with earlier ages, but knowledge and experience of the inner world were correspondingly reduced. The religious interest, which ought normally to be the greatest and most decisive factor, turned away from the inner world, and the great figures of dogma dwindled to strange and incomprehensible vestiges, a prey to every sort of criticism. Even modern psychology has the greatest difficulty in vindicating the human soul’s right to existence, and in making it credible that the soul is a mode of being with properties that can be investigated, and therefore a suitable object for scientific study; that it is not something attached to an outside, but has an autonomous inside, too, and a life of its own; that it is not just an ego-consciousness, but an existent which in all essentials can only be inferred indirectly. To people who think otherwise, the myths and dogmas of the Church are bound to appear as a collection of absurd and impossible statements. Modern rationalism is a process of sham enlightenment and even prides itself morally on its iconoclastic tendencies. Most people are satisfied with the not very intelligent view that the whole purpose of dogma is to state a flat impossibility. That it could be the symbolic expression of a definite idea with a definite content is

something that occurs to hardly anybody. For how can one possibly know what that idea really is! And what “I” do not know simply does not exist. Therefore, for this enlightened stupidity, there is no non-conscious psyche.

[114] *Symbols* are not allegories and not signs: they are images of contents which for the most part transcend consciousness. We have still to discover that such contents are real, that they are agents with which it is not only possible but absolutely necessary for us to come to terms.⁷² While making this discovery, we shall not fail to understand what dogma is about, what it formulates, and the reason for its existence.⁷³

V

THE SONG OF THE MOTH

[115] Shortly after the events described above, Miss Miller travelled from Geneva to Paris. She says:

My fatigue on the train was such that I hardly slept an hour. It was horribly hot in the ladies' compartment.

[116] At four o'clock in the morning she noticed a moth fluttering round the light in the carriage. She then tried to go to sleep again. Suddenly the following poem sprang into her mind:

The Moth to the Sun

I longed for thee when first I crawled to consciousness.

My dreams were all of thee when in the chrysalis I lay.

Oft myriads of my kind beat out their lives

Against some feeble spark once caught from thee.

And one hour more—and my poor life is gone;

Yet my last effort, as my first desire, shall be

But to approach thy glory; then, having gained

One raptured glance, I'll die content,

For I, the source of beauty, warmth, and life

Have in his perfect splendor once beheld!

[117] Before we go into the material which Miss Miller offers for an understanding of the poem, we will again cast a glance over the psychological situation in which the poem arose. Some weeks or months appear to have elapsed since the last direct manifestation of the unconscious. About this period we have no information; we know nothing of her moods and fantasies during the interval. If any conclusion is to be drawn from this silence, it is that nothing of real importance has happened during the time between the two poems, and that the new poem is another verbalized fragment reflecting the unconscious working out of the complex that had been going on for months. It is highly probable that it is concerned with the same conflict as before.¹ The earlier product, the Hymn of Creation, bears, however, little resemblance to the present poem. This has a truly hopeless and melancholy character:

moth and sun, two things that never meet. But, we must ask, is a moth really expected to reach the sun? We all know the proverbial saying about the moth that flies into the flame and burns its wings, but we know of no legend about a moth that strives towards the sun. Evidently there is a condensation here of two things that do not really belong together: firstly the moth which flies round the light till it burns its wings; secondly the image of a tiny ephemeral being, the May-fly perhaps, which in pathetic contrast to the eternity of the stars longs for the imperishable light. This image is reminiscent of Faust, where he says:

Mark, now, the glimmering in the leafy glades
Of dwellings gilded by the setting sun.
Now slants the fiery god towards the west,
Hasting away, but seeking in his round
New life afar: I long to join his quest,
On tireless wings uplifted from the ground.
Then should I see, in deathless evening light,
The world in cradled stillness at my feet ...
And now at length the sun-god seems to sink,
Yet stirs my heart with new-awakened might,
The streams of quenchless light I long to drink,
Before me day and, far behind, the night,
The heavens above me, and the waves below:
A lovely dream, but gone with set of sun.
Ah me, the pinions by the spirit won
Bring us no flight that mortal clay can know.²

[118] A little later, Faust sees the “black dog scampering through corn and stubble”—the poodle who is the devil himself, the Tempter in whose hellish fires Faust will soon singe his wings. Believing that he was expressing his great longing for the beauty of sun and earth, he “turned away from himself” and fell into the hands of the Evil One.

Spurn this terrestrial sun,
Leave, resolute, its loveliness,³

Faust had said to himself but a little while before, in true recognition of his danger—for the worship of Nature and her beauties leads the medieval Christian to pagan thoughts which stand in antagonistic relationship to his conscious religion, just as Mithraism was once the threatening rival of Christianity.⁴

[119] Faust's longing became his ruin. His longing for the other world brought in its train a loathing of life, so that he was on the brink of self-destruction.⁵ And his equally importunate longing for the beauties of this world plunged him into renewed ruin, doubt and wretchedness, which culminated in the tragedy of Gretchen's death. His mistake was that he made the worst of both worlds by blindly following the urge of his libido, like a man overcome by strong and violent passions. Faust's conflict is a reflection of the collective conflict at the beginning of the Christian era, but in him, curiously enough, it takes the opposite course. The fearful powers of seduction against which the Christian had to defend himself with his absolute hope in a world to come can be seen from the example of Alypius, to which we have already referred. That civilization was foredoomed, because humanity itself revolted against it. We know that, even before the spread of Christianity, mankind was seized by wild, eschatological hopes of redemption. This mood may well be reflected in Virgil's eclogue:

Now has come the last age foretold in the song of the Cumaean Sibyl; the great cycle of centuries begins anew. Now the Virgin ⁶ returns, and the reign of Saturn is restored. Now a new generation comes down from high heaven. Only do thou, chaste Lucina, favour the birth of the child, through whom the iron brood shall cease to be, and a golden race arise throughout the world. Thine own Apollo now is king.... Under thy governance any lingering traces of our guilt shall be wiped out, and the earth shall be freed from its perpetual fear. He shall have the gift of divine life, shall see heroes consort with gods and shall himself be seen mingling with them; he shall rule over a world to which his father's virtues have brought peace.⁷

[120] For many, the cult of asceticism that followed the wholesale expansion of Christianity denoted a new adventure: monasticism and the life of the anchorite. Faust takes the opposite road; for him the ascetic ideal is sheer death. He struggles for liberation and wins life by binding himself over to evil, thereby bringing about the death of what he loves most: Gretchen. He tears himself away from his grief and sacrifices his life in unceasing work, thus saving many lives.⁸ His double mission as saviour and destroyer had been hinted at from the beginning:

WAGNER: With what emotion must your noble soul

Receive the acclamations of the crowd! ...

FAUST: So, with a nostrum of this hellish sort,

We made these hills and valleys our resort,

And ravaged there more deadly than the pest.

These hands have ministered the deadly bane

To thousands who have perished; I remain

To hear cool murderers extolled and bless'd.⁹

[121] What makes Goethe's *Faust* so profoundly significant is that it formulates a problem that had been brewing for centuries, just as *Oedipus* did for the Greek sphere of culture: how to extricate ourselves from between the Scylla of world-renunciation and the Charybdis of its acceptance.

[122] The hopeful note struck in the hymn to the Creator-God cannot long be sustained by our author. It is a pose that promises, but does not fulfil. The old longing will come back again, for a peculiar feature of all complexes that are simply left to work themselves out in the unconscious is that they lose nothing of their original affectivity, though their outward manifestations can change almost endlessly. One can therefore take the first poem as an unconscious attempt to solve the conflict by adopting a religious attitude, in much the same way as in earlier centuries people decided their conscious conflicts by the criterion of religion. This attempt fails. There now follows a second attempt, which is decidedly more worldly in tone, and unequivocal in meaning: "one raptured glance," and then—to die. From the supramundane sphere of religion her gaze turns, as in *Faust*,¹⁰ to "this terrestrial sun." And already there is mingled in it something with another meaning—the moth that flutters round the light until it burns its wings.

[123] We now pass to what Miss Miller says about the poem:

This little poem made a profound impression on me. I could not at first find a sufficiently clear and direct explanation of it. But a few days afterwards, having again taken up a philosophical article that I had read in Berlin the previous winter, which had delighted me extremely, and reading it aloud to a friend, I came upon these words: "The same passionate longing of the moth for the star, of man for God..." I had completely forgotten them, but it seemed to me quite obvious that these were the words that had reappeared in my hypnagogic poem. Moreover, a play entitled *The Moth and the Flame*,¹¹ which I saw a few years ago, also came back to me as another possible source of my poem. You see how often the word *moth* has been impressed upon me!

[124] The profound impression the poem made on the author means that it expresses a correspondingly intense psychic content. In the "passionate longing" we meet the profound yearning of the moth for the star, and of man for God—in other words, the moth is Miss Miller herself. Her final remark that the word "moth" had often been impressed upon her shows how often she had noticed the "moth" as being a suitable name for herself. Her longing for God resembles the longing of the moth for the "star." The reader will remember that this word has already occurred in the earlier material: "When the morning stars sang together," with reference to the ship's officer singing in the night-watch. The passionate longing for God is like that longing for the singing morning star. We pointed out in the previous chapter that this analogy was only to be expected—*si parvis componere magna solebam*.

[125] It is, if you like, shameful and degrading that the more exalted longings of humanity, which alone make us what we are, should be so directly connected with an all-too-human passion. One is therefore inclined, despite the undeniability of the facts, to dispute the connection. What? A helmsman with bronzed skin and black mustachios, and the loftiest ideas of religion? Impossible! We do not doubt the incommensurability of these two objects, but one thing at least they have in common: both are the object of a passionate desire, and it remains to be seen whether the nature of the object alters the quality of the libido, or whether it is the same desire in both cases, i.e., the same emotional process. It is not at all certain psychologically—to use a banal comparison—whether appetite as such has anything to do with the quality of the object desired. Outwardly, of course, it is of some importance *which* object is desired, but inwardly it is at least as important to know what kind of desire it is. Desire can be instinctual, compulsive, uninhibited, uncontrolled, greedy, irrational, sensual, etc., or it may be rational, considered, controlled, co-ordinated, adapted, ethical, reflective, and so on. As regards its psychological evaluation the *how* is more important than the *what*—*si duo faciunt idem, non est idem*.

[126] The quality of the desire is important because it endows its object with the moral and aesthetic qualities of goodness and beauty, and thus influences our relations with our fellow men and the world in a decisive way. Nature is beautiful because I love it, and good is everything that my feeling regards as good. Values are chiefly created by the quality of one's subjective reactions. This is not to deny the existence of "objective" values altogether; only, their validity depends upon the consensus of opinion. In the erotic sphere, it is abundantly evident how little the object counts, and how much the subjective reaction.

[127] Apparently Miss Miller did not think much of the officer, which is understandable enough from the human point of view—though it did not prevent the relationship from having a deep and lasting effect which even dragged in the Deity. The moods apparently produced by such dissimilar objects can hardly spring from them in reality, but must spring from the subjective experience of love. So when Miss Miller praises God or the sun, she really means her love, the instinct most deeply rooted in human nature.

[128] The reader will remember the chain of associations we adduced in the previous chapter: the singer—the singing morning star—the God of Sound—the Creator—the God of Light—of the sun—of fire—of Love. With the changing of the erotic impression from positive to negative there is a predominance of *light* symbols for the object. In the second poem, where the longing comes out into the open, the object is the terrestrial sun. The libido having turned away from the concrete object, its object has become a psychic one, namely God. Psychologically, however, God is the name

for a complex of ideas grouped round a powerful feeling; the feeling-tone is what really gives the complex its characteristic efficacy,¹² for it represents an emotional tension which can be formulated in terms of energy. The light and fire attributes depict the intensity of the feeling-tone and are therefore expressions for the psychic energy which manifests itself as libido. If one worships God, sun, or fire (cf. fig. 4), one is worshipping intensity and power, in other words the phenomenon of psychic energy as such, the libido. Every force and every phenomenon is a special form of energy. Form is both an image and a mode of manifestation. It expresses two things: the energy which takes shape in it, and the medium in which that energy appears. On the one hand one can say that energy creates its own image, and on the other hand that the character of the medium forces it into a definite form. One man will derive the idea of God from the sun, another will maintain that it is the numinous feelings it arouses which give the sun its godlike significance. The former, by attitude and temperament, believes more in the causal nexus of the environment, the latter more in the spontaneity of psychic experience. I fear it is the old question of which came first, the chicken or the egg. For all that, I incline to the view that in this particular case the psychoenergetic phenomenon not only takes precedence, but explains far more than the hypothesis of the causal primacy of the environment.

[129] I am therefore of the opinion that, in general, psychic energy or libido creates the God-image by making use of archetypal patterns, and that man in consequence worships the psychic force active within him as something divine. (Pl. *va.*) We thus arrive at the objectionable conclusion that, from the psychological point of view, the God-image is a real but subjective phenomenon. As Seneca says: "God is near you, he is with you, he is within you," or, as in the First Epistle of John, "He who does not love does not know God; for God is love," and "If we love one another, God abides in us."¹³

[130] To anyone who understands libido merely as the psychic energy over which he has conscious control, the religious relationship, as we have defined it, is bound to appear as a ridiculous game of hide-and-seek with oneself. But it is rather a question of the energy which belongs to the archetype, to the unconscious, and which is therefore not his to dispose of. This "game with oneself" is anything but ridiculous; on the contrary, it is extremely important. To carry a god around in yourself means a great deal; it is a guarantee of happiness, of power, and even of omnipotence, in so far as these are attributes of divinity. To carry a god within oneself is practically the same as being God oneself. In Christianity, despite the weeding out of the most grossly sensual ideas and symbols, we can still find traces of this psychology. The idea of "becoming a god" is even more obvious in the pagan mystery cults, where the neophyte, after initiation, is himself lifted up to divine status: at the conclusion of the consecration rites in the syncretistic Isis mysteries ¹⁴ he was crowned with a crown of

palm leaves, set up on a pedestal, and worshipped as Helios. (Pl. VI.) In a magic papyrus, published by Dieterich as a Mithraic liturgy, there is a *ἱερὸς λόγος* in which the neophyte says: “I am a star wandering together with you and shining up from the depths.”¹⁵

[131] In his religious ecstasy the neophyte makes himself the equal of the stars, just as the saint in the Middle Ages put himself, through the stigmata, on a level with Christ. St. Francis of Assisi carried the relationship even further by speaking of his brother the sun and his sister the moon.¹⁶

[132] Hippolytus insists on the future deification of the believer: “You have become God, you will be a companion of God and co-heir in Christ.” He says of the deification: “That is the ‘Know thyself.’”¹⁷ Even Jesus proved his divine Sonship to the Jews by appealing to Psalm 82:6: “I have said, Ye are gods” (John 10:34).

[133] This idea of becoming a god is age-old. The old belief relegates it to the time after death, but the mystery cults bring it about in this world. An ancient Egyptian text represents it, very beautifully, as the triumphal song of the ascending soul:

I am the god Atum, I who alone was.

I am the god Ra at his first appearing.

I am the great god who created himself,

The lord of the gods, to whom no other god is equal.

I was yesterday and know tomorrow; the battle-ground of the gods was made when I spoke.

I know the name of that great god who dwells there.

I am the god Min at his coming forth, whose feathers I place upon my head.¹⁸

I am in my country, I come into my city. I am daily together with my father Atum.

My impurity is driven out, and the sin which was in me is trodden under foot.

I washed myself in the two great pools which are in Heracleopolis, in which the sacrifices of men are purified for that great god who dwells there.

I go on my way, where I wash my head in the water of the righteous. I reach this land of the glorified and enter in at the splendid portal.

You who stand before me, reach me your hands, it is I, I am become one of you. I am daily together with my father Atum.¹⁹

[134] When man becomes God, his importance and power are enormously increased.²⁰ That seems to have been its main purpose: to strengthen the individual against his all-too-human weakness and insecurity in personal life. But the strengthening of his power-consciousness is only the outward effect of his becoming God; far more important are the deeper lying processes in the realm of feeling. For whoever introverts libido, i.e., withdraws it from the external object, suffers the necessary

consequences of introversion: the libido which is turned inwards, into the subject, reverts to the individual past and digs up from the treasure-house of memory those images glimpsed long ago, which bring back the time when the world was a full and rounded whole. First and foremost are the memories of childhood, among them the imagos of father and mother. These are unique and imperishable, and in adult life not many difficulties are needed to reawaken those memories and make them active. The regressive reactivation of the father- and mother-imagos plays an important role in religion. The benefits of religion are equivalent, in their effects, to the parental care lavished upon the child, and religious feelings are rooted in unconscious memories of certain tender emotions in early infancy—memories of archetypal intuitions, as expressed in the above hymn:

I am in my country, I come into my city. I am daily together with my father Atum.²¹

[135] The visible father of the world is the sun, the heavenly fire, for which reason father, God, sun, and fire are mythologically synonymous. The well-known fact that in worshipping the sun's strength we pay homage to the great generative force of Nature is the plainest possible evidence—if evidence were still needed—that in God we honour the energy of the archetype. This symbolism is expressed very plastically in the third logos of the Dieterich papyrus: after the second prayer, stars float down towards the neophyte from the disc of the sun—"five-pointed, in great numbers and filling the whole air." "When the sun's disc has opened, you will see an immense circle, and fiery doors which are closed." The neophyte then utters the following prayer:

Give ear to me, hear me, Lord, who hast fastened the fiery bolts of heaven with thy spirit, double-bodied, fire-ruler, creator of light, fire-breathing, fiery-hearted, shining spirit, rejoicing in fire, beautiful light, Lord of light, fiery-bodied, giver of light, sower of fire, confounding with fire, living light, whirling fire, mover of light, hurler of thunderbolts, glorious light, multiplier of light, holder of fiery light, conqueror of the stars, etc.²²

[136] The invocation is an almost inexhaustible catalogue of light and fire attributes, and for sheer extravagance can only be compared with the endless vociferations about "love" in Christian mysticism. Among the many texts which might be cited I select this passage from Mechthild of Magdeburg (1212–77):

Ah Lord! love me greatly, love me often and long! For the more continuously Thou lovest me, the purer I shall be; the more fervently Thou lovest me, the more lovely I shall be; the longer Thou lovest me the more holy I shall become, even here on earth.

[137] God answers:

That I love thee continuously is My Nature
For I Myself am Love;

That I love thee fervently is My Desire
For I long to be greatly loved.
That I love thee long comes from My Eternity
For I am everlasting and without end.²³

[138] Religious regression makes use of the parental imago, but only as a symbol—that is to say, it clothes the archetype in the image of the parents, just as it bodies forth the archetype’s energy by making use of sensuous ideas like fire, light, heat,²⁴ fecundity, generative power, and so on. In mysticism the inwardly perceived vision of the Divine is often nothing but sun or light, and is rarely, if ever, personified. (Fig. 2.) For example, there is this significant passage in the Mithraic liturgy: “The path of the visible gods will appear through the disc of the sun, who is God my father.”²⁵

[139] Hildegarde of Bingen (1100–1178) declares:

But the light I see is not local, but is everywhere, and brighter far than the cloud which supports the sun. I can in no way know the form of this light, just as I cannot see the sun’s disc entire. But in this light I see at times, though not often, another light which is called by me the living light, but when and in what manner I see this I do not know how to say. And when I see it all weariness and need is lifted from me, and all at once I feel like a simple girl and not like an old woman.²⁶

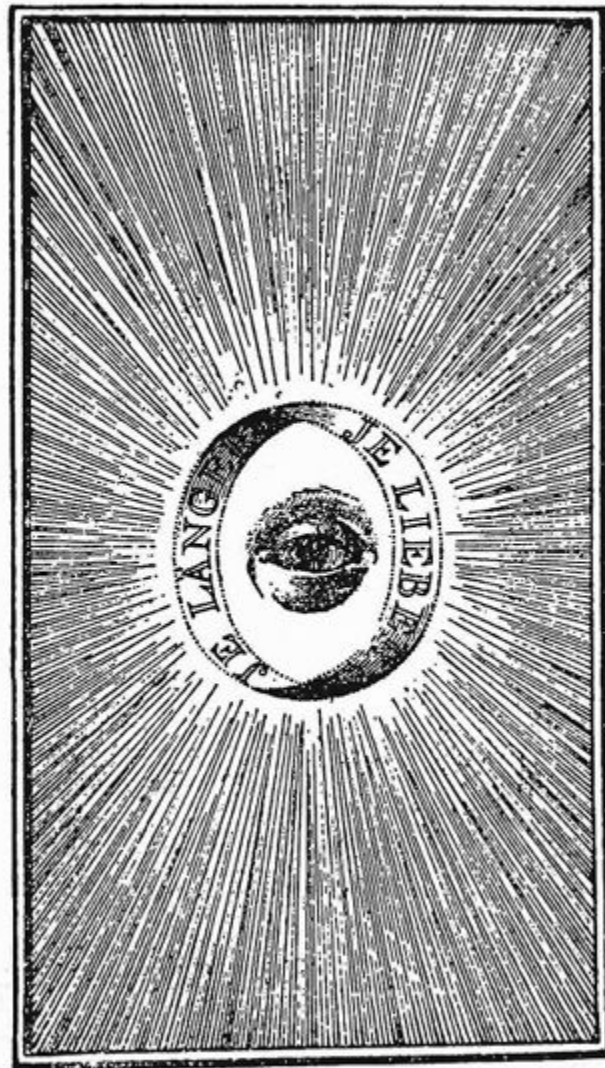

Fig. 2. The Eye of God

Frontispiece to Jakob Böhme, Seraphinisch Blumengärtlein, Amsterdam, 1700

[140] Symeon, the “New Theologian” (970–1040), says:

My tongue lacks words, and what happens in me my spirit sees clearly but does not explain. It sees the Invisible, that emptiness of all forms, simple throughout, not complex, and in extent infinite. For it sees no beginning, and it sees no end, and is entirely unconscious of any middle, and does not know what to call that which it sees. Something complete appears, it seems to me, not indeed with the thing itself, but through a kind of *participation*. For you enkindle fire from fire, and you receive the whole fire; but this thing remains undiminished and undivided as before. Similarly, that which is imparted separates itself from the first, and spreads like something corporeal into many lights. But this is something spiritual, immeasurable, indivisible, and inexhaustible. For it is not separated when it becomes many, but remains undivided, and is in me, and rises in my poor heart like a sun or circular disc of the sun, like light, for it is a light.²⁷

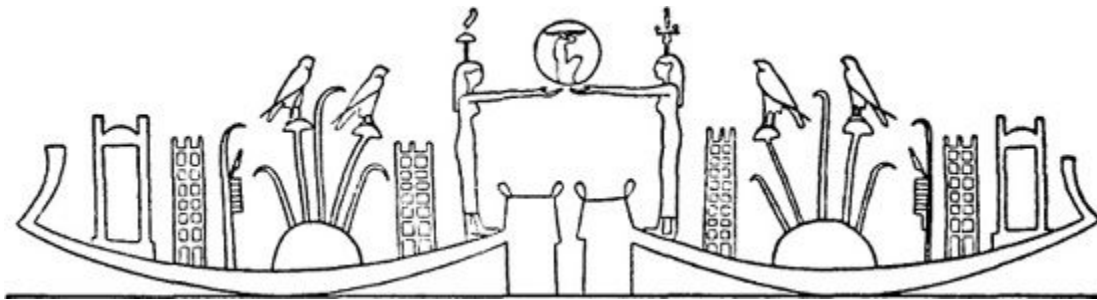

Fig. 3. The Voyage of the Sun: The Western Goddess in the Barge of Evening gives the Sun-disc to the Eastern Goddess in the Barge of Morning *Late Egyptian*

[141] That the thing perceived as an inner light, as the sun of the other world, is an emotional component of the psyche, is clear from Symeon’s words:

And questing after it, my spirit sought to comprehend the splendour it had seen, but found it not as a creature and could not get away from created things, that it might embrace that uncreated and un-comprehended splendour. Nevertheless it wandered everywhere and strove to behold it. It searched through the air, it wandered over the heavens, it crossed the abysses, it searched, so it seemed, to the ends of the world.²⁸ But in all that it found nothing, for all was created. And I lamented and was sorrowful, and my heart burned, and I lived as one distraught in mind. But it came as it was wont, and descending like a luminous cloud, seemed to envelop my whole head, so that I cried out dismayed. But flying away again it left me alone. And when I wearily sought it, I realized suddenly that it was within me, and in the midst of my heart it shone like the light of a spherical sun.²⁹

[142] In Nietzsche’s “Glory and Eternity” we meet with essentially the same symbolism:

Hush!

I see vastness!

And of vasty things

One should not speak—

Save in vast words! Well then:

Grandiloquize, charmed wisdom mine!

Look up:

There roll the star-strewn seas,

Night, stillness, deathly silent roar!

Behold, a sign:

Slowly, from endless space.

A glittering constellation floats towards me.³⁰

[143] It is not surprising that Nietzsche's great solitude should have called awake certain images which the old cults had exalted as religious ideas. In the visions of the Mithraic liturgy we move among ideas of a very similar kind, which can now be understood without difficulty as ecstatic libido-symbols:

But after you have said the second prayer, where silence is twice commanded, then whistle twice and click twice with the tongue, and immediately you will see stars coming down from the disc of the sun, five-pointed, in large numbers and filling the whole air. But say once again *Silence! Silence!*³¹

[144] The whistling and clicking with the tongue are archaic devices for attracting the theriomorphic deity. Roaring has a similar significance: "You are to look up at him and give forth a long roar, as with a horn, using all your breath and pressing your sides, then kiss the amulet" etc.³² "My soul roars with the voice of a hungry lion," says Mechthild of Magdeburg. "As the hart panteth after the water brooks, so panteth my soul after thee, O God" (Psalm 42:1). As so often happens, the ceremony has dwindled to a mere figure of speech. Schizophrenia, however, infuses new life into the old usage, as in the case of the "bellowing miracle"³³ described by Schreber, who in this way gave God, sadly uninformed about the affairs of humanity, notice of his existence.

[145] Silence is commanded, then the vision of light is revealed. The similarity between the situation of the neophyte and Nietzsche's poetic vision is very striking. Nietzsche says "constellation"; but constellations, as we know, are mainly theriomorphic or anthropomorphic. The papyrus has *ἀστέρας πενταδακτυλίου* (literally, 'five-fingered stars,' similar to the 'rosy-fingered Dawn'), which is a pure anthropomorphic image. Hence, if one looked long enough, one would expect that a living being would form itself out of the fiery image, a "constellation" in the form of a man or animal—for libido-symbols do not stop at sun, light, and fire, but have a whole range of other expressions at their disposal. I leave Nietzsche to speak for himself:

Here, where the island grew amid the seas,
Like a high-towering sacrificial rock,
Here under the darkling heavens
Zarathustra lights his mountain-fires....

This flame with its grey-white belly
Hisses its desire into the chill distances,
Stretching its neck to ever purer heights—
A snake upreared in impatience:

This emblem I set up before me.
This flame is my own soul,
Insatiable for new distances,
Sending upwards its blaze of silent heat....

To all the lonely I now throw my fishing-rod:
Give answer to the flame's impatience,
Let me, the fisher on high mountains,
Catch my seventh, last solitude! ³⁴



Fig. 4. Germanic sun-idol

From the *Sachsisch Chronicon*, 1596

[146] Here the libido turns into fire, flame, and a snake. The Egyptian symbol of the “living sun-disc”—a disc with the two intertwined Uraeus serpents (pl. VII)—is a combination of both these libido analogies. And the sun-disc with its fructifying warmth is analogous to the fructifying warmth of love. The comparison of libido with sun and fire is essentially a “comparison by analogy.” There is also a “causative” element in it, because sun and fire, as beneficent forces, are objects of human love (for instance the sun-hero Mithras is called the “well-beloved”). In Nietzsche’s poem the comparison is also a causative one, but this time in the opposite sense: the snake comparison is unmistakably phallic. The phallus is the source of life and libido, the creator and worker of miracles, and as such it was worshipped everywhere. We have, therefore, three ways of symbolizing the libido:

1. *Comparison by analogy*: as sun and fire (fig. 4).

2. *Causative Comparisons*: (a) with objects. The libido is characterized by its object, e.g., the health-giving sun. (b) with the subject. The libido is characterized by its instrument or by something analogous to it, e.g., the phallus or its analogue, the snake.

[147] To these three fundamental forms of comparison there must be added a fourth: the *functional comparison*, where the “tertium comparationis” is *activity*. For instance, the libido is fertile like the bull, dangerous like the lion or boar (because of the fury of its passion), and lustful like the ever-rutting ass, and so on. These comparisons represent so many possible ways of symbolization, and for this reason all the infinitely varied symbols, so far as they are libido-images, can be reduced to a common denominator—the libido and its properties. This psychological simplification is in accord with the historical attempts of civilization to unify and simplify, in a higher synthesis, the infinite number of gods. We come across this attempt even in ancient Egypt, where the boundless polytheism of local demon-worship finally made simplification necessary. The various local gods, such as Amon of Thebes, Horus of the East, Horus of Edfu, Khnum of Elephantine, Atum of Heliopolis, etc., were all identified with the sun-god, Ra.³⁵ In the hymns to the sun, the composite deity Amon-Ra-Harmachis-Atum was invoked as “the only god, in truth, the living one.”³⁶ Amenophis IV (XVIIIth Dynasty) went the furthest in this direction: he replaced all former gods by the “great living disc of the sun,” whose official title was: “Lord of the Two Horizons, exulting on the horizon in his name: Glittering Splendour, which is in the sun-disc.” “In fact,” adds Erman,³⁷ “it was not a sun-god who was adored, but the material sun itself, which, by the hands of his beams,³⁸ bestowed upon living beings that ‘eternal life’ which was in him.” (Fig. 5; cf. also fig. 7 and pl. 1 b.)

[148] Amenophis IV achieved, by his reforms, a psychologically valuable work of interpretation. He united all the bull,³⁹ ram,⁴⁰ crocodile,⁴¹ and pile-dwelling⁴² gods into the sun-disc, and



Fig. 5. The life-giving Sun: Amenophis IV on his throne
Relief, Egypt

made it clear that their various attributes were compatible with those of the sun.⁴³ A similar fate overtook Hellenic and Roman polytheism as a result of the syncretistic strivings of later centuries. An excellent illustration of this is the beautiful prayer of Lucius to the Queen of Heaven (the moon):

Queen of heaven, whether thou be named Ceres, bountiful mother of earthly fruits, or heavenly Venus, or Phoebus' sister, or Proserpina, who strikest terror with midnight ululations ..., thou that with soft feminine brightness dost illumine the walls of all cities....⁴⁴

[149] These attempts to reunite the basic archetypes after polytheism had multiplied them into countless variants and personified them as separate gods prove that such analogies must forcibly have obtruded themselves at a fairly early date. Herodotus is full of references of this kind, not to mention the various systems known to the Greco-Roman world. But the striving for unity is opposed by a possibly even stronger tendency to create multiplicity, so that even in strictly monotheistic religions like Christianity the polytheistic tendency cannot be suppressed. The deity is divided

into three parts, and on top of that come all the heavenly hierarchies. These two tendencies are in constant warfare: sometimes there is only one God with countless attributes, sometimes there are many gods, who are simply called by different names in different places, and who personify one or the other attribute of their respective archetype, as we have seen in the case of the Egyptian gods. This brings us back to Nietzsche's poem "The Beacon." The flame was there used as a libido-image, theriomorphically represented (fig. 6) as a snake (and at the same time as an image of the soul: ⁴⁵ "This flame is my own soul"). We saw, however, that the snake is to be taken not only in the phallic sense, but as an attribute of the sun's image (the Egyptian uraeus) and as a libido-symbol. It is therefore possible for the sun-disc to be equipped not only with hands and feet (fig. 7; cf. also pl. 1B), but also with a phallus. We find proof of this in a strange vision in the Mithraic liturgy: "And likewise the so-called tube, the origin of the ministering wind. For you will see hanging down from the disc of the sun something that looks like a tube."⁴⁶



Fig. 6. The mercurial serpent, alchemical symbol of psychic transformation
From Barchusen, Elementa chemiae, 1718

[150] This remarkable vision of a tube hanging down from the sun would be absolutely baffling in a religious text were it not that the tube has a phallic significance: the tube is the origin of the wind. The phallic significance of this attribute is not apparent at

first sight, but we must remember that the wind, just as much as the sun, is a fructifier and creator.⁴⁷ There is a painting by an early German artist which depicts the fructification of Mary in the following manner: a sort of tube or hose-pipe comes down from heaven and passes under the robe of the Virgin, and we can see the Holy Ghost flying down it in the form of a dove to fecundate the Mother of God.⁴⁸ (Cf. pl. VIII; cf. also pl. III.)

[151] I once came across the following hallucination in a schizophrenic patient: he told me he could see an erect phallus on the sun. When he moved his head from side to side, he said, the sun's phallus moved with it, and *that was where the wind came from*. This bizarre notion remained unintelligible to me for a long time, until I got to know the visions in the Mithraic liturgy. The hallucination, it seems to me, also throws light on a very obscure passage in the text which comes immediately after the one quoted above:

εἰς δὲ τὰ μέρη τὰ πρὸς λίβα ἀπέραντον οἶον ἀπηλιώτην. Ἐὰν ἦ κεκληρωμένος εἰς τὰ μέρη τοῦ ἀπηλιώτων ὁ ἕτερος, ὁμοίως εἰς τὰ μέρη τὰ ἐκείνου ὄψει τὴν ἀποφορὰν τοῦ ὁράματος

[152] Mead translates as follows:

And towards the regions Westward, as though it were an infinite East-Wind. But if the other wind, toward the regions of the East, should be in service, in like fashion shalt thou see, toward the regions of that (side), the converse of the sight.⁴⁹

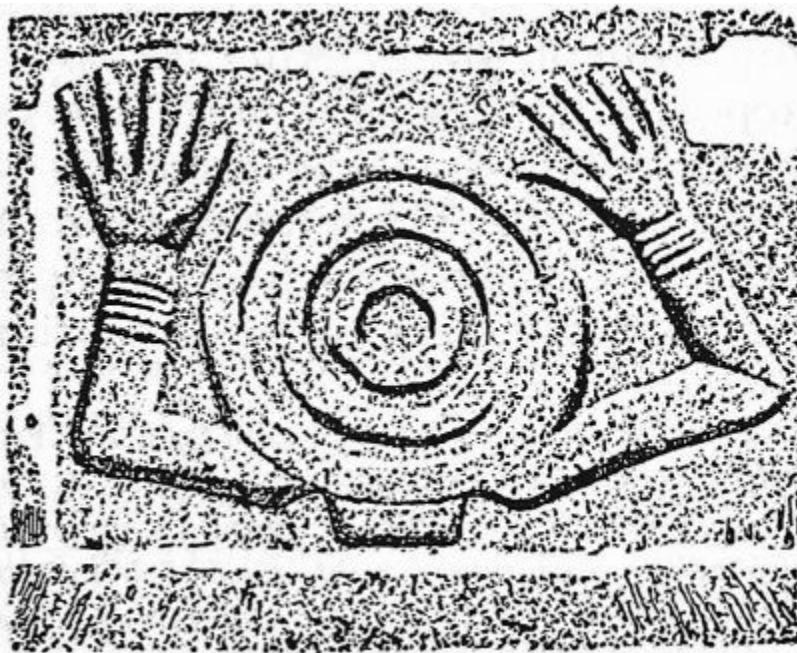

Fig. 7. The Sun's hands
Relief, Spitalkirche, Tübingen

[153] Basing ourselves on Dieterich, we would say:

And towards the regions westward it is as though there were an infinite east wind. But if the other wind should prevail towards the regions of the east, you will in like manner see the vision veering in that direction.⁵⁰

[154] “Οραμα is the vision, the thing seen; ἀποφορᾶ really means a carrying away, or taking away. The probable meaning is that the vision moves or is carried hither and thither according to the direction of the wind. The thing seen is the tube, the “origin of the wind,” which turns now to the east, now to the west, and presumably generates the corresponding wind. The vision of our schizophrenic tallies in the most astonishing way with this movement of the tube.⁵¹ This remarkable case prompted me to undertake various researches on mentally deranged Negroes.⁵² I was able to convince myself that the well-known motif of Ixion on the sun-wheel (cf. pl. XLVib) did in fact occur in the dream of an uneducated Negro. These and other experiences like them were sufficient to give me a clue: it is not a question of a specifically racial heredity, but of a universally human characteristic. Nor is it a question of *inherited ideas*, but of a functional disposition to produce the same, or very similar, ideas. This disposition I later called the *archetype*.⁵³

[155] The various attributes of the sun appear one after another in the Mithraic liturgy. After the vision of Helios, seven maidens appear with faces like snakes, and seven gods with the faces of black bulls. The maiden can easily be understood as a causative libido analogy. The serpent in Paradise is usually thought of as feminine, as the seductive principle in woman, and is represented as feminine by the old painters.⁵⁴ (Fig. 8.) Through a similar change of meaning the snake in antiquity became a symbol of the earth, which has always been considered feminine. The bull is a notorious fertility-symbol. In the Mithraic liturgy, the bull-gods are called κνωδακοφύλακς, ‘guardians of the world’s axis,’ who turn the “axle of the wheel of heaven.” The same attribute falls also to Mithras: sometimes he is the *Sol invictus* itself, sometimes the companion and ruler of Helios (cf. pls. XXIVa, XL); in his right hand he holds “the constellation of the Bear, which moves and turns the heavens round.” The bull-headed deities, ἱεροὶ καὶ ἄλκιμοι νεανίαι, ‘sacred and valorous youths’ like Mithras himself, who is also given the attribute νεώτερος, ‘the younger one,’ are merely aspects of the same divinity. The chief god of the Mithraic liturgy is himself divided into Mithras and Helios (cf. pl. XXIVa), both of whom have closely related attributes. Speaking of Helios, the text says:



Fig. 8. The Tempting of Eve
From the Speculum humanae salvationis, Augsburg, 1470

You will see a god, young, comely, with glowing locks, in a white tunic and a scarlet cloak, with a fiery crown.⁵⁵

And of Mithras:

You will see a god of enormous power, with a shining countenance, young, with golden hair, in a white tunic and a golden crown, with wide trousers, holding in his right hand the golden shoulder of a young bull. This is the constellation of the Bear, which moves and turns the heavens round, wandering upwards and downwards according to the hour. Then you will see lightnings leap from his eyes, and from his body, stars.⁵⁶

[156] If we equate gold and fire as essentially similar, then there is a large measure of agreement in the attributes of the two gods. To these mystical pagan ideas we must add the visions of the Johannine Apocalypse, which are probably not much older:

And I turned to see the voice that spake with me. And being turned, I saw seven golden candlesticks; and in the midst of the seven candlesticks one like unto the Son of man, clothed with a garment down to the foot, and girt about the paps with a golden girdle. His head and his hairs were white like wool, as white as snow; and his eyes were as a flame of fire; and his feet like unto fine brass, as if they burned in a furnace; and his voice as the sound of many waters. And he had in his right hand seven stars:⁵⁷ and out of his mouth went a sharp two-edged sword:⁵⁸ and his countenance was as the sun shineth in his strength. [Rev. 1:12ff.]

And I looked, and behold a white cloud, and upon the cloud one sat like unto the Son of Man, having on his head a golden crown,⁵⁹ and in his hand a sharp sickle. [Rev. 14: 14.]

His eyes were as a flame of fire, and on his head were many crowns.... And he was clothed with a vesture dipped in blood....⁶⁰ And the armies which were in heaven followed him upon white horses, clothed in fine linen, white and clean.⁶¹ [Rev. 19: 12ff.]

[157] There is no need to assume any direct connection between the Apocalypse and Mithraic ideas. The visionary images in both texts are drawn from a source not

limited to any one place, but found in the souls of many people. The symbols it produces are far too typical to belong to any one individual.



Fig. 9. Mithras with sword and torch

Roman sculpture

[158] I mention these images in order to show how the light-symbolism gradually develops,⁶² as the intensity of the vision increases, into the figure of the sun-hero, the “well-beloved.”⁶³ These visionary processes are the psychological roots of the sun-coronations in the mystery religions. (Pl. VI.) The religious experience behind the ritual had congealed into liturgy, but it was a regular enough occurrence to be accepted as a valid outward form. In view of all this it is evident that the early Church stood in a special relationship to Christ as the *Sol novus*, and on the other hand had some difficulty in shaking off the pagan symbol. Philo Judaeus saw in the sun the image of the divine Logos, or even the deity itself.⁶⁴ And in a hymn of St. Ambrose, Christ is invoked with the words “O sol salutis,” etc. At the time of Marcus Aurelius, Melito, in his treatise *Περὶ λούτρου*, called Christ “The sun of the East.... As the only sun he rose in the heavens.”⁶⁵

[159] Even more explicit is a passage from Pseudo-Cyprian:

O how wonderful is Providence, that Christ should be born on the same day on which the sun was created, the 28th of March! Therefore the prophet Malachi said to the people concerning him: “The Sun of righteousness shall rise, with healing in his wings.” This is the sun of righteousness in whose wings healing was foreshown.⁶⁶

[160] In a treatise attributed to St. John Chrysostom, “De solstitiis et aequinoctiis,” it is said:

But the Lord, too, was born in wintertime, on the 25th of December, when the ripe olives are pressed in order to produce the oil for anointing, the chrism. They also call this day the birthday of the Unconquerable One. Yet who is as unconquerable as our Lord, who overthrew and conquered death itself? As for their calling it the birthday of the sun, he himself is the sun of righteousness of whom the prophet Malachi spoke.—He is the Lord of light and darkness, the creator and separator, who is called by the prophet the sun of righteousness.⁶⁷

[161] According to the testimony of Eusebius of Alexandria, Christians, too, shared in the worship of the rising sun until well into the fifth century:

Woe to those who prostrate themselves before the sun and the moon and the stars! For I know of many who prostrate themselves and pray to the sun. At sunrise they address their prayers to him, saying: “Have pity on us!” And this is done not only by sun-worshippers and heretics, but by Christians too, who forget their faith and mix with heretics.⁶⁸

[162] Augustine remonstrated with his Christian followers, telling them emphatically: “Christ the Lord has not been made [like unto] the sun, but is he through whom the sun is made.”⁶⁹

[163] Not a few traces of sun-worship are preserved in ecclesiastical art,⁷⁰ for instance the nimbus round the head of Christ, and the haloes of the saints. Numerous fire- and light-symbols are attributed to the saints in Christian legend.⁷¹ The twelve apostles, for example, were likened to the twelve signs of the zodiac and were therefore represented each with a star over his head.⁷² No wonder the heathen, as Tertullian reports, took the sun for the God of the Christians! “Some, in a more human and probable way, believe the Sun to be our god.”⁷³ Among the Manichees the sun actually was God. One of the most remarkable records of this period, an amalgam of pagan-Asiatic, Hellenistic, and Christian beliefs, is the *Ἐξηγήσεις περὶ τῶν ἐν Περσίδι πραχθέντων*,⁷⁴ a book of fables which affords deep insight into syncretistic symbolism. There we find the following magical dedication: Διὶ Ἡλίῳ θεῷ μεγάλῳ βασιλεῖ Ἰησοῦ.⁷⁵ In certain parts of Armenia, Christians still pray to the rising sun, that it may “let its foot rest on the face of the worshipper.”⁷⁶



Fig. 10. Serpent representing the orbit of the moon

Assyrian boundary stone, Susa

[164] Under the symbol of “moth and sun” we have dug deep down into the historical layers of the psyche, and in the course of our excavations have uncovered a buried idol, the sun-hero, “young, comely, with glowing locks and fiery crown,” who, forever unattainable to mortal man, revolves round the earth, causing night to follow day, and winter summer, and death life, and who rises again in rejuvenated splendour to give light to new generations. For him the dreamer longs with her very soul, for him the “soul-moth” burns her wings.

[165] The ancient civilizations of the Near East were familiar with a sun-worship dominated by the idea of the dying and resurgent god—Osiris (cf. fig. 23), Tammuz, Attis-Adonis,⁷⁷ Christ, Mithras,⁷⁸ and the phoenix. The beneficent as well as the destroying power was worshipped in the fire. The forces of nature are always two-faced, as is plainly the case with the God of Job. This ambivalence brings us back to Miss Miller’s poem. Her recollections as to its antecedents bear out our earlier supposition that the image of the moth and the sun is a condensation of two ideas, one of which we have just discussed. The other is the idea of the moth and the flame. As the title of a play, about whose contents the author tells us absolutely nothing, “The Moth and the Flame” could easily have the hackneyed meaning of flying round the flame of passion until one’s wings are burned. This passionate longing has two sides: it is the power which beautifies everything, but, in a different set of circumstances, is quite as likely to destroy everything. Hence a violent desire is either accompanied by anxiety at the start, or is remorselessly pursued by it. All passion is a challenge to fate, and what it does cannot be undone. Fear of fate is a very understandable phenomenon, for it is incalculable, immeasurable, full of unknown

dangers. The perpetual hesitation of the neurotic to launch out into life is readily explained by his desire to stand aside so as not to get involved in the dangerous struggle for existence. But anyone who refuses to experience life must stifle his desire to live—in other words, he must commit partial suicide. This explains the death-fantasies that usually accompany the renunciation of desire. Miss Miller had already given vent to these fantasies in her poem, and she now comments:

I had been reading a selection of Byron's poems that pleased me greatly and that I often dipped into. Moreover, there is a great similarity of rhythm between my two last lines, "For I, the source, etc." and these two of Byron's:

"Now, let me die as I have lived in faith
Nor tremble tho' the Universe should quake!"

[166] This reminiscence, the last link in her chain of associations, corroborates the death-fantasies born of renunciation. The quotation comes—a point not mentioned by Miss Miller—from an unfinished poem of Byron's called "Heaven and Earth." The passage reads:

Still blessed be the Lord,
For what is past,
For that which is:
For all are his,
From first to last—
Time, space, eternity, life, death—
The vast known and immeasurable unknown,
He made, and can unmake;
And shall *I*, for a little gasp of breath,
Blaspheme and groan?
No; let me die, as I have lived, in faith,
Nor quiver, though the universe may quake! ⁷⁹

[167] These words form part of a panegyric or prayer spoken by a "mortal" who is in headlong flight before the oncoming Deluge. Quoting them, Miss Miller puts herself in a similar situation: she hints that her own feelings are very like the hopeless despair of the unfortunates who saw themselves threatened by the rising waters. She thus allows us to peer into the dark abyss of her longing for the sun-hero. We see that her longing is in vain, for she too is a mortal, momentarily upborne on the wings of her longing into the light and then sinking down to death—or should we perhaps say, *driven by deadly fear* to climb higher and higher, like the people in the flood, and yet despite the most desperate struggles irretrievably doomed to destruction. One is forcibly reminded of the closing scene in *Cyrano de Bergerac*:

CYRANO: But since Death comes,
I meet him still afoot, and sword in hand! ...
What say you? It is useless? Ay, I know!
But who fights ever hoping for success?
I fought for lost cause, and for fruitless quest! ...
I know that you will lay me low at last.⁸⁰

[168] Her human expectations are futile, because her whole longing is directed towards the Divine, the “well-beloved,” who is worshipped in the sun’s image. The existing material makes it clear that there is no question of any conscious decision or choice on her part: it is rather that she is confronted, against her will and inclinations, with the disquieting fact that a divine hero has stepped into the shoes of the handsome officer. Whether this betokens a good thing or a bad remains to be seen.

[169] Byron’s “Heaven and Earth” is a “mystery, founded on the following passage in Genesis: ‘And it came to pass ... that the sons of God saw the daughters of men, that they were fair; and they took them wives of all which they chose.’”⁸¹ Besides that, Byron used as a motto for his poem the following words from Coleridge: “And woman wailing for her demon-lover.”⁸² The poem is composed of two major episodes, one psychological, the other telluric: a passion that breaks down all barriers, and the terrors of the unleashed forces of Nature. The angels Sami-asa and Azazel burn with sinful love for the beautiful daughters of Cain, Anah and Aholibamah, and thus break through the barrier between mortals and immortals. Like Lucifer, they rebel against God, and the archangel Raphael raises his voice in warning:

But man hath listen’d to his voice,
And ye to woman’s—beautiful she is,
The serpent’s voice less subtle than her kiss.
The snake but vanquish’d dust; but she will draw
A second host from heaven, to break heaven’s law.⁸³

[170] The power of God is menaced by the seductions of passion; heaven is threatened with a second fall of angels. If we translate this projection back into the psychological sphere from whence it came, it would mean that the good and rational Power which rules the world with wise laws is threatened by the chaotic, primitive force of passion. Therefore passion must be exterminated, which means, in mythological projection, that the race of Cain and the whole sinful world must be wiped out, root and branch, by the Flood. That is the inevitable result of a passion that sweeps away all barriers. It is like the sea breaking through its dykes, like the waters of the deep and the torrential rains,⁸⁴ the creative, fructifying, “motherly”

waters, as Indian mythology calls them. Now they depart from their natural courses and surge over the mountain-tops and engulf all living things. As a power which transcends consciousness the libido is by nature daemonic: it is both God and devil. If evil were to be utterly destroyed, everything daemonic, including God himself, would suffer a grievous loss; it would be like performing an amputation on the body of the Deity. Raphael's lament over the rebel angels, Samiasa and Azazel, suggests as much:

Why

Cannot this earth be made, or be destroy'd,

Without involving ever some vast void

In the immortal ranks?

[171] Passion raises a man not only above himself, but also above the bounds of his mortality and earthliness, and by the very act of raising him, it destroys him. This "rising above himself" is expressed mythologically in the building of the heaven-high tower of Babel that brought confusion to mankind,⁸⁵ and in the revolt of Lucifer. In Byron's poem it is the overweening ambition of the race of Cain, whose strivings make the stars subservient and corrupt the sons of God themselves. Even if a longing for the highest is legitimate in itself, the sinful presumption and inevitable corruption lie in the very fact that it goes beyond the fixed human boundaries. The longing of the moth is not made pure by reaching for the stars, nor does it cease to be a moth on account of such noble aspirations. Man continues to be man. Through excess of longing he can draw the gods down into the murk of his passion.⁸⁶ He seems to be raising himself up to the Divine, but in so doing he abandons his humanity. Thus the love of Anah and Aholibamah for their angels becomes the ruin of gods and men. Their impassioned invocation of the angels is an exact parallel to Miss Miller's poem:

ANAH: ⁸⁷ Seraph!

From thy sphere!

Whatever star⁸⁸ contain thy glory;

In the eternal depths of heaven

Albeit thou watchest with "the seven";

Though through space infinite and hoary

Before thy bright wings worlds be driven,

Yet hear!

Oh! think of her who holds thee dear!

And though she nothing is to thee,

Yet think that thou art all to her....

Eternity is in thine ears,
Unborn, undying beauty in thine eyes;
With me thou canst not sympathize,
Except in love, and there thou must
Acknowledge that more loving dust
Ne'er wept beneath the skies.
Thou walk'st thy many worlds,⁸⁹ thou see'st
The face of him who made thee great,
As he hath made of me the least
Of those cast out from Eden's gate;
Yet, Seraph dear!

Oh hear!

For thou hast loved me, and I would not die
Until I know what I must die in knowing,
That thou forgett'st in thine eternity
Her whose heart death could not keep from o'erflowing
For thee, immortal essence as thou art!
Great is their love who love in sin and fear;
And such, I feel, are waging in my heart
A war unworthy: to an Adamite
Forgive, my Seraph! that such thoughts appear,
For sorrow is our element...

The hour is near

Which tells me we are not abandon'd quite.

Appear! Appear!

Seraph!

My own Azazel! be but here,
And leave the stars to their own light...

AHOLIBAMA: I call thee, I await thee, and I love thee...

Though I be form'd of clay,
And thou of beams
More bright than those of day
On Eden's streams,
Thine immortality cannot repay
With love more warm than mine

My love. There is a ray⁹⁰

In me, which, though forbidden yet to shine,

I feel was lighted at thy God's and thine.⁹¹

It may be hidden long: death and decay

Our mother Eve bequeath'd us—but my heart

Defies it: though this life must pass away,

Is *that* a cause for thee and me to part? ...

I can share all things, even immortal sorrow;

For thou hast ventured to share life with *me*,

And shall *I* shrink from thine eternity?

No! though the serpent's sting should pierce me thorough,

And thou thyself wert like the serpent, coil

Around me still!⁹² and I will smile,

And curse thee not; but hold

Thee in as warm a fold.

... descend, and prove

A mortal's love

For an immortal....

[172] The apparition of both angels which follows the invocation is, as always, a glorious vision of light:

AHOLIBAMAH: The clouds from off their pinions flinging,

As though they bore tomorrow's light.

ANAH: But if our father see the sight!

AHOLIBAMAH: He would but deem it was the moon

Rising unto some sorcerer's tune

An hour too soon....

ANAH: Lo! they have kindled all the west,

Like a returning sunset; lo!

On Ararat's late secret crest

A mild and many-colour'd bow,

The remnant of their flashing path,

Now shines!

[173] At the sight of this rainbow-hued vision both women are filled with longing and expectation, and Anah makes use of a pregnant simile. Once more the abyss opens, and we catch a brief but terrifying glimpse of the theriomorphic nature of the mild god of light:

... and now, behold! it hath
Return'd to night, as rippling foam,
Which the leviathan hath lash'd
From his unfathomable home,
When sporting on the face of the calm deep,
Subsides soon after he again hath dash'd
Down, down, to where the ocean's fountains sleep.

[174] Leviathan—we remember this prize exhibit that tips the scales of Yahweh's justice so heavily against Job. There, where the deep fountains of the ocean are, dwells Leviathan; from there the all-destroying flood ascends, the tidal wave of animal passion. The choking, heart-constricting surge of instinct is projected outwards as a mounting flood to destroy everything that exists, so that a new and better world may arise from the ruins of the old:

JAPHET: The eternal Will
Shall deign to expound this dream
Of good and evil; and redeem
Unto himself all times, all things;
And, gather'd under his almighty wings,
Abolish hell!
And to the expiated Earth
Restore the beauty of her birth....

SPIRITS: And when shall take effect this wondrous spell?

JAPHET: When the Redeemer cometh; first in pain,
And then in glory....

SPIRITS: New times, new climes, new arts, new men; but still
The same old tears, old crimes, and oldest ill,
Shall be amongst your race in different forms;
But the same moral storms
Shall oversweep the future, as the waves
In a few hours the glorious giants' graves.⁹³

[175] Japhet's prognostications have an almost prophetic meaning for our poetess and must therefore be understood on the "subjective level."⁹⁴ With the death of the moth in the light the danger has been removed for the time being, though the problem is still far from solved. The conflict must begin again from the beginning; but this time there is a promise in the air, a premonition of the redeemer, the "well-beloved," who mounts to the zenith with the sun and then sinks again into night and the cold darkness of winter—the young dying god, who has ever been our hope of renewal and of the world to come.

INTRODUCTION

[176] Before I enter upon the contents of this second part, it seems necessary to cast a backward glance over the singular train of thought which the analysis of the poem “The Moth to the Sun” has revealed. Although this poem is very different from the preceding “Hymn of Creation,” closer investigation of the longing for the sun has led us into a realm of mythological ideas that are closely related to those considered in the first poem: the Creator God, whose dual nature was plainly apparent in the case of Job, has now taken on an astromythological, or rather an astrological, character. He has become the sun, and thus finds a natural expression that transcends his moral division into a Heavenly Father and his counterpart the devil. The sun, as Renan has observed, is the only truly “rational” image of God, whether we adopt the standpoint of the primitive savage or of modern science. In either case the sun is the father-god from whom all living things draw life; he is the fructifier and creator, the source of energy for our world. The discord into which the human soul has fallen can be harmoniously resolved through the sun as a natural object which knows no inner conflict. The sun is not only beneficial, but also destructive; hence the zodiacal sign for August heat is the ravaging lion which Samson¹ slew in order to rid the parched earth of its torment. Yet it is in the nature of the sun to scorch, and its scorching power seems natural to man. It shines equally on the just and the unjust, and allows useful creatures to flourish as well as the harmful. Therefore the sun is perfectly suited to represent the visible God of this world, i. e., the creative power of our own soul, which we call libido, and whose nature it is to bring forth the useful and the harmful, the good and the bad. That this comparison is not just a matter of words can be seen from the teachings of the mystics: when they descend into the depths of their own being they find “in their heart” the image of the sun, they find their own life-force which they call the “sun” for a legitimate and, I would say, a *physical* reason, because our source of energy and life actually *is* the sun. Our physiological life, regarded as an energy process, is entirely solar. The peculiar nature of this solar energy as inwardly perceived by the mystic is made clear in Indian mythology. The following passages, referring to Rudra,² are taken from the Shvetashvatara Upanishad:

There is one Rudra only, they do not allow a second, who rules all the worlds by his powers. Behind all creatures he stands, the Protector; having created them, he gathers all beings together at the end of time.

He has eyes on all sides, faces on all sides, arms on all sides, feet on all sides. He is the one God who created heaven and earth, forging all things together with his hands and wings.

You who are the source and origin of the gods, the ruler of all, Rudra, the great seer, who of old gave birth to the Golden Seed—give us enlightenment!³

[177] Behind these attributes we can discern the All-Creator, and behind him the sun, who is winged and scans the world with a thousand eyes.⁴ (Cf. fig. 11.) This is confirmed by the following passages, which bring out the important point that God is contained in the individual creature:

Beyond this is Brahma, the highest, hidden in the bodies of all, encompassing all. Those who know him as the Lord become immortal.

I know this mighty Person (purusha), who is like to the sun, transcendent over darkness. Those who know him truly pass beyond death; by no other road can they go.

He is the face, the head, the neck of all, he dwells in the heart of all things, all-pervading, bountiful, omnipresent, kindly.

[178] The all-powerful God, who is “like to the sun,” is in every one of us, and whoever knows him is immortal.⁵ Following the text, we come upon further attributes which tell us in what form Rudra dwells in man:



Fig. 11. Bes, with Horus-eyes
Bronze figure, Egypt, c. 6th century B.C.

A mighty Lord is Purusha, spurring on the highest in us to purest attainment, inexhaustible light.

That Person, no bigger than a thumb, the inner Self, seated forever in the heart of man, is revealed by the heart, the thought, the mind. They who know That, become immortal.

Thousand-headed, thousand-eyed, thousand-footed is Purusha. He encompasses the earth on every side and rules over the ten-finger space.

That Person is this whole world, whatever has been and what will be. He is Lord of immortality, he is whatever grows by food.

[179] There is a famous parallel passage in the Katha Upanishad:

That Person in the heart, no bigger than a thumb, burning like flame without smoke, maker of past and future, the same today and tomorrow, that is Self.⁶

[180] We know that Tom Thumbs, dactyls, and Cabiri have a phallic aspect, and this is understandable enough, because they are personifications of creative forces, of which the phallus, too, is a symbol. It represents the libido, or psychic energy in its creative aspect. The same is true of many other sexual images which are found not only in dreams and fantasies but in everyday speech. In neither case should they be taken literally, for they are not to be understood semiotically, as *signs* for definite things, but as *symbols*. A symbol is an indefinite expression with many meanings, pointing to something not easily defined and therefore not fully known. But the sign always has a fixed meaning, because it is a conventional abbreviation for, or a commonly accepted indication of, something known. The symbol therefore has a large number of analogous variants, and the more of these variants it has at its disposal, the more complete and clear-cut will be the image it projects of its object. The same creative force which is symbolized by Tom Thumb, etc., can also be represented by the phallus or by numerous other symbols (pl. XIb), which delineate further aspects of the process underlying them all. Thus the *creative dwarfs* toil away in secret; the *phallus*, also working in darkness, begets a living being; and the *key* unlocks the mysterious forbidden door behind which some wonderful thing awaits discovery. One thinks, in this connection, of "The Mothers" in *Faust*:

MEPHISTOPHELES: Congratulations, before you part from me!

You know the devil, that is plain to see.

Here, take this key.

FAUST: That little thing! But why?

MEPHISTOPHELES: First grasp it; it is nothing to decry.

FAUST: It glows, it shines, increases in my hand!⁷

MEPHISTOPHELES: How great its worth, you soon shall understand.

The key will smell the right place from all others:

Follow it down, it leads you to the Mothers!⁸

[181] Here the devil again puts into Faust's hand the marvellous tool, as once before when, in the form of the black dog, he introduced himself to Faust as:

Part of that power which would

Ever work evil, but engenders good.⁹

[182] What he is describing here is the libido, which is not only creative and procreative, but possesses an intuitive faculty, a strange power to “smell the right place,” almost as if it were a live creature with an independent life of its own (which is why it is so easily personified). It is purposive, like sexuality itself, a favourite object of comparison. The “realm of the Mothers” has not a few connections with the womb (fig. 12), with the matrix, which frequently symbolizes the creative aspect of the unconscious. This libido is a force of nature, good and bad at once, or morally neutral. Uniting himself with it, Faust succeeds in accomplishing his real life's work, at first with evil results and then for the benefit of mankind. In the realm of the Mothers he finds the tripod, the Hermetic vessel in which the “royal marriage” is consummated. But he needs the phallic wand in order to bring off the greatest wonder of all—the creation of Paris and Helen.¹⁰ The insignificant-looking tool in Faust's hand is the dark creative power of the unconscious, which reveals itself to those who follow its dictates and is indeed capable of working miracles.¹¹ This paradox appears to be very ancient, for the Shvetashvatara Upanishad (19, 20) goes on to say of the dwarf-god, the cosmic *purusha*:



Fig. 12. The birth-giving orifice
From a Mexican lienzo

Without feet, without hands, he moves, he grasps; eyeless he sees, earless he hears; he knows all that is to be known, yet there is no knower of him. Men call him the Primordial Person, the Cosmic Man.

Smaller than small, greater than great....

[183] The phallus often stands for the creative divinity, Hermes being an excellent example. It is sometimes thought of as an independent being, an idea that is found not only in antiquity but in the drawings of children and artists of our own day. So we ought not to be surprised if certain phallic characteristics are also to be found in the seers, artists, and wonder-workers of mythology. Hephaestus, Wieland the Smith, and Mani (the founder of Manichaeism, famous also for his artistic gifts), had crippled feet. The foot, as I shall explain in due course, is supposed to possess a magical generative power. The ancient seer Melampus, who is said to have introduced the cult of the phallus, had a very peculiar name—Blackfoot,¹² and it also seems characteristic of seers to be blind. Ugliness and deformity are especially characteristic of those mysterious chthonic gods, the sons of Hephaestus, the Cabiri,¹³ to whom mighty wonder-working powers were ascribed. (Fig. 13.) Their Samothracian cult was closely bound up with that of the ithyphallic Hermes, who according to Herodotus was brought to Attica by the Pelasgians. They were called *μειάλοι θεοί*, ‘great gods.’ Their near relatives were the Idaean dactyls (fingers or else Tom Thumbs¹⁴), to whom the mother of the gods had taught the blacksmith’s art. (“Follow it down, it leads you to the Mothers!”) They were the first Wise Men, the teachers of Orpheus, and it was they who invented the Ephesian magic formulae and the musical rhythms.¹⁵ The characteristic disparity which we noted in the Upanishads and *Faust* crops up again here, since the giant Hercules was said to be an Idaean dactyl. Also the colossal Phrygians, Rhea’s technicians,¹⁶ were dactyls. The two Dioscuri are related to the Cabiri; ¹⁷ they too wear the queer little pointed hat, the pileus,¹⁸ which is peculiar to these mysterious gods and was thenceforward perpetuated as a secret mark of identification. Attis and Mithras both wore the pileus. (Cf. figs. 9, 20.) It has become the traditional headgear of our infantile chthonic gods today, the pixies and goblins.

[184] The dwarf motif brings us to the figure of the divine boy, the *puer aeternus*, *παῖς*, the young Dionysus, Jupiter Anxurus, Tages, etc. In the Theban vase-painting already mentioned (fig. 14), there is a bearded Dionysus who is designated as KABIPOΣ, together with the figure of a boy labelled ΠΑΙΣ, followed by a caricatured boy’s figure labelled as ΠΡΑΤΟΛΑΟΣ, and then another bearded caricature labelled ΜΙΤΟΣ.¹⁹ Μίτος really means ‘thread,’ but in Orphic speech it stands for semen. It is conjectured that this group corresponded to a set of cult-images in the sanctuary. The conjecture is supported by what we know of the history of the cult, which is supposed to have been originally a Phoenician cult of father and son,²⁰ an old and a young Cabir who were more or less assimilated to the Greek gods. The double figure of the adult and infant Dionysus lends itself particularly well to this assimilation. One might also call it the cult of the big and little man. Now Dionysus, under his various aspects, is a god in whose cult the phallus occupied a prominent position, as for

instance in the worship of the Argive Dionysus-bull. Moreover the phallic herm of the god gave rise to a personification of the phallus of Dionysus in the form of the god Phales, who was nothing but a Priapus. He was called *ἑταῖρος* or *σύγκωμος Βακχίου*.²¹ The paradox of great and small, giant and dwarf in the Upanishadic text is expressed less drastically here as man and boy, or father and son. The motif of deformity (cf. fig. 13), which constantly appears in the Cabiric cult, is also present in the vase-painting, where the parallel figures to Dionysus and Παιῖς are the caricatured Μίτος and Πρατόλαος.²² Just as formerly the difference in size led to their separation, so now they are separated by deformity.



Fig. 13. Odysseus as a Cabiric dwarf, with Circe
From a bowl by the Cabiri Painter (?), c. 400 B.C.

[185] All this goes to show that though the term “libido,” introduced by Freud, is not without a sexual connotation,²³ an exclusively sexual definition of this concept is one-sided and must therefore be rejected. Appetite and compulsion are the specific features of all impulses and automatisms. No more than the sexual metaphors of common speech can the corresponding analogies in instinctual processes, and the symptoms and dreams to which they give rise, be taken literally. The sexual theory of psychic automatisms is an untenable prejudice. The very fact that it is impossible to derive the whole mass of psychic phenomena from a single instinct forbids a one-sided definition of “libido.” I use this term in the general sense in which it was understood by the classical authors. Cicero gives it a very wide meaning:



Fig. 14. The banquet of the Cabir
From a bowl by the Cabiri Painter, c. 435 B.C.

They hold that from two kinds of expected good arise desire and delight, in the sense that delight is concerned with present good, and desire with future good ... since desire, being tempted and en-flamed, is carried away towards what seems good.... For all men naturally pursue those things that seem good and shun their opposites. Wherefore, as soon as anything presents itself that seems good, nature herself impels them to obtain it. If this is done with moderation and prudence, the Stoics call that kind of striving *βονλησις*, and we call it *will*. In their opinion this is found only in the wise man, and they define it as follows: will is a rational desire, but when it is divorced from reason and is too violently aroused, that is “libido,” or unbridled desire, which is found in all fools.²⁴

[186] Here *libido* means a ‘want’ or a ‘wish,’ and also, in contradistinction to the ‘will’ of the Stoics, ‘unbridled desire.’ Cicero uses it in this sense when he says: “[Gerere rem aliquam] libidine, non ratione” (to do something from wilful desire and not from reason).²⁵ Similarly Sallust: “Iracundia pars est libidinis” (rage is a part of desire), or, in a milder and more general sense which comes closer to our use of the word: “Magisque in decoris armis et militaribus equis, quam in scortis atque conviviis libidinem habebant” (they took more pleasure in fine weapons and war-horses than in whores and drinking parties).²⁶ Or again: “Quod si tibi bona libido fuerit patriae” (if you have a proper concern for your country).²⁷ The use of *libido* is so general that the phrase “libido est scire” merely means ‘I like,’ ‘it pleases me.’²⁸ In the phrase “aliquam libido urinae lacessit,” *libido* has the meaning of ‘urge.’ It can also have the nuance of ‘lasciviousness.’ St. Augustine aptly defines *libido* as a “general term for all desire” and says:

There is a lust for revenge, which is called rage; a lust for having money, which is called avarice; a lust for victory at all costs, which is called stubbornness; a lust for self-glorification, which is called boastfulness. There are many and varied kinds of lust, some of which are specifically named, others not. For who could easily give a name to the lust for domination, which, as we know from the civil wars, is nevertheless very powerful in the minds of tyrants?²⁹

[187] For him *libido* denotes an appetite like hunger and thirst, and so far as sexuality is concerned he says: “Pleasure is preceded by an appetite that is felt in the flesh, a kind of desire like hunger and thirst.”³⁰ This very wide use of the term in the classics coincides with the etymological context:

[188] *Libido* or *lubido* (with *libet*, formerly *lubet*), ‘it pleases’; *libens* or *lubens*, ‘gladly, willingly’; Skr. *lúbhyati*, ‘to experience violent longing,’ *lôbhayati*, ‘excites longing,’ *lubdha-h*, ‘eager,’ *lôbha-h*, ‘longing, eagerness’; Goth. *liufs*, OHG. *liob*, ‘love.’ Also associated with Goth. *lubains*, ‘hope,’ and OHG. *lobôn*, *loben*, *lob*, ‘praise, glory’; OBulg. *ljubiti*, ‘to love,’ *ljuby*, ‘love,’ Lith. *liáupsinti*, ‘to praise.’³¹

[189] We can say, then, that the concept of *libido* in psychology has functionally the same significance as the concept of energy in physics since the time of Robert

II

THE CONCEPT OF LIBIDO

[190] Freud introduced his concept of libido in his *Three Essays on the Theory of Sexuality*,¹ and there, as we have said, he defined it *sexually*. The libido appears subject to displacement, and in the form of “libidinal affluxes” can communicate itself to various other functions and regions of the body which in themselves have nothing to do with sex. This fact led Freud to compare the libido with a stream, which is divisible, can be dammed up, overflows into collaterals, and so on.² Thus, despite his definition of libido as sexuality, Freud does not explain “everything” in terms of sex, as is commonly supposed, but recognizes the existence of special instinctual forces whose nature is not clearly known, but to which he was bound to ascribe the faculty of taking up these “libidinal affluxes.” At the back of all this lies the hypothetical idea of a “bundle of instincts,”³ in which the sexual instinct figures as a partial instinct. Its encroachment into the sphere of other instincts is a fact of experience.⁴ The resultant Freudian theory, which held that the instinctual forces of a neurotic system correspond to the libidinal affluxes taken up by other, non-sexual, instinctual functions,⁵ has become the keystone of the psychoanalytical theory of neurosis and the dogma of the Viennese school. Later, however, Freud was forced to ponder whether libido might not in the end coincide with *interest* in general. (Here I would remark that it was a case of paranoid schizophrenia that gave rise to these considerations.) The operative passage, which I set down word for word, runs:

A third consideration which arises from the views that have been developed in these pages is as follows. Are we to suppose that a general detachment of the libido from the external world would be an effective enough agent to account for the “end of the world”? Or would not the ego-cathexes which still remained in existence have been sufficient to maintain *rapport* with the external world? To meet this difficulty we should either have to assume that what we call libidinal cathexis (that is, interest emanating from erotic sources) coincides with interest in general, or we should have to consider the possibility that a very widespread disturbance in the distribution of the libido may bring about a corresponding disturbance in the egocathexes. But these are problems which we are still quite helpless and incompetent to solve. It would be otherwise if we could start out from some well-grounded theory of instincts; but in fact we have nothing of the kind at our disposal. We regard instinct as being the concept on the frontier-line between the somatic and the mental, and see in it the psychical representative of organic forces. Further, we accept the popular distinction between ego-instincts and a sexual instinct; for such a distinction seems to agree with the biological conception that the individual has a double orientation, aiming on the one hand at self-preservation and on the other at the preservation of the species. But beyond this are only

hypotheses which we have taken up—and are quite ready to drop again—in order to help us to find our bearings in the chaos of the obscurer processes of the mind. What we expect from the psycho-analytic investigations of pathological mental processes is precisely that they shall drive us to some conclusions on questions connected with the theory of instincts. These investigations, however, are in their infancy and are only being carried out by isolated workers, so that the hopes we place in them must still remain unfulfilled.⁶

[191] Nevertheless, Freud finally decides that the paranoid alteration is sufficiently explained by the recession of sexual libido. He says:

It therefore appears to me far more probable that the paranoic's altered relation to the world is to be explained entirely or in the main by the loss of his libidinal interest.⁷

[192] In this passage Freud broaches the question of whether the well-known loss of reality in paranoia and schizophrenia,⁸ to which I have drawn attention in my *Psychology of Dementia Praecox*,⁹ is to be traced back solely to the recession of the “libidinal condition,” or whether this condition ordinarily coincides with “objective interest.” It can hardly be supposed that the normal “fonction du réel,” to use Janet's term,¹⁰ is maintained only through affluxes of libido or erotic interest. The fact is that in very many cases reality disappears entirely, so that the patient shows no trace of psychological adaptation. (In these states, reality has been buried under the contents of the unconscious.) One is compelled to admit that not only the erotic interest, but all interest whatsoever, has completely disappeared except for a few feeble flickers, and with it the man's whole relation to reality. If the libido were really nothing but sexuality, what would happen in the case of eunuchs? In their case it is precisely the “libidinal” interest that has been cut off, but they do not necessarily react with schizophrenia. The term “afflux of libido” connotes something that is highly questionable. Many apparently sexual contents and processes are mere metaphors and analogies, as for instance “fire” for passion, “heat” for anger, “marriage” for a bond or union, etc. Presumably no one imagines that all plumbers who connect up male and female pipe-joints, or all electricians who work with male and female outlets, are blessed with particularly potent “affluxes of libido”?

[193] Earlier, in *The Psychology of Dementia Praecox*, I made use of the term “psychic energy,” because what is lacking in this disease is evidently more than erotic interest as such. If one tried to explain the loss of relationship, the schizophrenic dissociation between man and world, purely by the recession of eroticism, the inevitable result would be to inflate the idea of sexuality in a typically Freudian manner. One would then be forced to say that every relationship to the world was in essence a sexual relationship, and the idea of sexuality would become so nebulous that the very word “sexuality” would be deprived of all meaning. The fashionable term “psychosexuality” is a clear symptom of this conceptual inflation. But in

schizophrenia far more is lacking to reality than could ever be laid at the door of sexuality in the strict sense of the word. The “fonction du réel” is absent to such a degree as to include the loss of certain instinctual forces which cannot possibly be supposed to have a sexual character, for no one in his senses would maintain that reality is nothing but a function of sex! And even if it were, the introversion of libido in the neuroses would necessarily be followed by a loss of reality comparable with that which occurs in schizophrenia. But that is far from being the case. As Freud himself has pointed out, introversion and regression of sexual libido leads, at the worst, to neurosis, but not to schizophrenia.

[194] The attitude of reserve which I adopted towards the sexual theory in the preface to *The Psychology of Dementia Praecox*, despite the fact that I recognized the psychological mechanisms pointed out by Freud, was dictated by the general position of the libido theory at that time. The theory as it then stood did not permit me to explain functional disturbances which affect the sphere of other instincts just as much as that of sex, solely in the light of a one-sided sexual theory. An interpretation in terms of energy seemed to me better suited to the facts than the doctrine set forth in Freud's *Essays on the Theory of Sexuality*. It allowed me to identify “psychic energy” with “libido.” The latter term denotes a desire or impulse which is unchecked by any kind of authority, moral or otherwise. Libido is appetite in its natural state. From the genetic point of view it is bodily needs like hunger, thirst, sleep, and sex, and emotional states or affects, which constitute the essence of libido. All these factors have their differentiations and subtle ramifications in the highly complicated human psyche. There can be no doubt that even the highest differentiations were developed from simpler forms. Thus, many complex functions, which today must be denied all trace of sexuality, were originally derived from the reproductive instinct. As we know, an important change occurred in the principles of propagation during the ascent through the animal kingdom: the vast numbers of gametes which chance fertilization made necessary were progressively reduced in favour of assured fertilization and effective protection of the young. The decreased production of ova and spermatozoa set free considerable quantities of energy which soon sought and found new outlets. Thus we find the first stirrings of the artistic impulse in animals, but subservient to the reproductive instinct and limited to the breeding season. The original sexual character of these biological phenomena gradually disappears as they become organically fixed and achieve functional independence. Although there can be no doubt that music originally belonged to the reproductive sphere, it would be an unjustified and fantastic generalization to put music in the same category as sex. Such a view would be tantamount to treating of Cologne Cathedral in a text-book of mineralogy, on the ground that it consisted very largely of stones.

[195] Consequently, to speak of libido as the urge to propagation is to remain within the confines of a view which distinguishes libido from hunger in the same way that the instinct for the preservation of the species is distinguished from the instinct for self-preservation. In nature, of course, this artificial distinction does not exist. There we see only a continuous life-urge, a will to live which seeks to ensure the continuance of the whole species through the preservation of the individual. Thus far our conception of libido coincides with Schopenhauer's Will, inasmuch as a movement perceived from outside can only be grasped as the manifestation of an inner will or desire. This throwing of psychological perceptions into material reality is known in philosophy as "introjection."¹¹ Through introjection one's world picture becomes subjectivized, and it is to this same process that the physical concept of force owes its existence. As Galileo aptly remarked, its origin is to be sought in the subjective perception of our own muscular power. Similarly, the concept of libido as desire or appetite is an *interpretation* of the process of psychic energy, which we experience precisely in the form of an appetite. We know as little about what underlies it as we know about what the psyche is *per se*.

[196] Having once made the bold conjecture that the libido which was originally employed in the production of ova and spermatozoa is now firmly organized in the function of nest-building, for instance, and can no longer be employed otherwise, we are compelled to regard every striving and every desire, including hunger and instinct however understood, as equally a phenomenon of energy.

[197] This view leads to a conception of libido which expands into a conception of *intentionality* in general. As the above quotation from Freud shows, we know far too little about the nature of human instincts and their psychic dynamism to risk giving priority to any one instinct. We would be better advised, therefore, when speaking of libido, to understand it as an energy-value which is able to communicate itself to any field of activity whatsoever, be it power, hunger, hatred, sexuality, or religion, without ever being itself a specific instinct. As Schopenhauer says: "The Will as a thing-in-itself is quite different from its phenomenal manifestation, and entirely free from all forms of phenomenality, which it assumes only when it becomes manifest, and which therefore affect its objectivity only, and are foreign to the Will itself."¹²

[198] Numerous mythological and philosophical attempts have been made to formulate and visualize the creative force which man knows only by subjective experience. To give but a few examples, I would remind the reader of the cosmogonic significance of Eros in Hesiod,¹³ and also of the Orphic figure of Phanes (pl. XII), The Shining One, the First-Created, the "Father of Eros." Orphically, too, he has the significance of Priapus; he is bisexual and equated with the Theban Dionysus Lysius.¹⁴ The Orphic significance of Phanes is akin to that of the Indian Kama, the god of love,

who is likewise a cosmogonic principle. To the Neoplatonist Plotinus, the world-soul is the energy of the intellect.¹⁵ He compares the One, the primordial creative principle, with light, the intellect with the sun (♂), and the world-soul with the moon (♀). Or again, he compares the One with the Father and the intellect with the Son.¹⁶ The One, designated as Uranos, is transcendent; the Son (Kronos) has dominion over the visible world; and the world-soul (Zeus) is subordinate to him. The One, or the *ousia* of existence in totality, is described by Plotinus as hypostatic, and so are the three forms of emanation; thus we have *μία οὐσία ἐν τρισὶν ὑποστάσεσιν* (one being in three hypostases). As Drews has observed, this is also the formula for the Christian Trinity as laid down at the councils of Nicaea and of Constantinople.¹⁷ We might add that certain early Christian sects gave a maternal significance to the Holy Ghost (world-soul or moon). According to Plotinus, the world-soul has a tendency towards separation and divisibility, the *sine qua non* of all change, creation, and reproduction. It is an “unending All of life” and wholly energy; a living organism of ideas which only become effective and real in it.¹⁸ The intellect is its progenitor and father, and what the intellect conceives the world-soul brings to birth in reality.¹⁹ “What lies enclosed in the intellect comes to birth in the world-soul as Logos, fills it with meaning and makes it drunken as if with nectar.”²⁰ Nectar, like soma, is the drink of fertility and immortality. The soul is fructified by the intellect; as the “over-soul” it is called the heavenly Aphrodite, as the “undersoul” the earthly Aphrodite. It knows “the pangs of birth.”²¹ It is not without reason that the dove of Aphrodite is the symbol of the Holy Ghost.

[199] The energetic standpoint has the effect of freeing psychic energy from the bonds of a too narrow definition. Experience shows that instinctual processes of whatever kind are often intensified to an extraordinary degree by an afflux of energy, no matter where it comes from. This is true not only of sexuality, but of hunger and thirst too. One instinct can temporarily be depotentiated in favour of another instinct, and this is true of psychic activities in general. To assume that it is always and only sexuality which is subject to these depotentiations would be a sort of psychic equivalent of the phlogiston theory in physics and chemistry. Freud himself was somewhat sceptical about the existing theories of instinct, and rightly so. Instinct is a very mysterious manifestation of life, partly psychic and partly physiological by nature. It is one of the most conservative functions in the psyche and is extremely difficult, if not impossible, to change. Pathological maladjustments, such as the neuroses, are therefore more easily explained by the patient’s attitude to instinct than by a sudden change in the latter. But the patient’s attitude is a complicated psychological problem, which it would certainly not be if his attitude depended on instinct. The motive forces at the back of neurosis come from all sorts of congenital characteristics and environmental influences, which together build up an attitude that makes it

impossible for him to lead a life in which the instincts are satisfied. Thus the neurotic perversion of instinct in a young person is intimately bound up with a similar disposition in the parents, and the disturbance in the sexual sphere is a secondary and not a primary phenomenon. Hence there can be no sexual theory of neurosis, though there may very well be a psychological one.

[200] This brings us back to our hypothesis that it is not the sexual instinct, but a kind of neutral energy, which is responsible for the formation of such symbols as light, fire, sun, and the like. The loss of the reality function in schizophrenia does not produce a heightening of sexuality: it produces a world of fantasy with marked archaic features.²² This is not to deny that, particularly at the beginning of the illness, violent sexual disturbances may sometimes occur, though they occur just as often in any intensive experience, such as panic, rage, religious mania, etc. The fact that an archaic world of fantasy takes the place of reality in schizophrenia proves nothing about the nature of the reality function as such; it only demonstrates the well-known biological fact that whenever a more recent system suffers deterioration it is likely to be replaced by a more primitive and therefore obsolete one. To use Freud's simile, one begins firing with bows and arrows instead of with guns. A loss of the latest acquisitions of the reality function (or adaptation) must of necessity be replaced, if at all, by an earlier mode of adaptation. We find this principle in the theory of neurosis which holds that any failure of adaptation is compensated by an older one, that is, by a regressive reactivation of the parental imagos. In neurosis the substitute product is a fantasy of individual origin and scope with hardly a trace of those archaic features which are characteristic of the fantasies of schizophrenics. Again, in neurosis there is never an actual loss of reality, only a falsification of it. In schizophrenia, on the other hand, reality has all but disappeared. I must thank my erstwhile pupil J. Honegger, whose work²³ was unfortunately cut short by an early death, for a simple illustration of this: A paranoid patient of good intelligence, who knew very well that the earth was a sphere and rotated round the sun, superseded all our modern views of astronomy by an elaborate system of his own devising, where the earth was a flat disc over which the sun travelled. Spielrein, too, gives some interesting examples of archaic definitions which, in the course of the illness, begin superimposing themselves on the meanings of words. Thus, one of her women patients declared that the mythological analogue of alcohol was an "emission of seed," i.e., soma.²⁴ She also hit upon a symbolism of cooking which parallels the alchemical vision of Zosimos, who saw, in the "bowl" of the altar, people being transformed in boiling water.²⁵ The patient substituted earth,²⁶ and also water,²⁷ for "mother." (Cf. pls. XXIVa, XXVI.)

[201] What I said above about a disturbed reality function being replaced by an archaic substitute is supported by a remark of Spielrein's: "I often had the illusion that the

patients might simply be victims of a deep-rooted folk superstition.”²³ As a matter of fact, patients do set up, in place of reality, fantasies very like certain archaic ideas which once had a reality function. But, as the vision of Zosimos shows, the old superstitions were symbols²⁹ that sought to give adequate expression to the unknown in the world (and in the psyche). The “conception” (*Auffassung*) gives us a “handle” (*Griff*) by which to “grasp hold” of things (*fassen, begreifen*), and the resultant “concept” (*Begriff*) enables us to take possession of them. Functionally, the concept corresponds to the *magically powerful name* which gets a grip on the object. This not only renders the object harmless, but incorporates it into the psychic system, thus increasing the meaning and power of the human mind. (Compare the primitive respect for name-giving in the *Alvissmal* of the *Elder Edda*.) Spielrein evidently thinks symbols have a similar significance when she says:

Thus a symbol seems to me to owe its origin to the striving of a complex for dissolution in the common totality of thought... The complex is thus robbed of its personal quality... This tendency towards dissolution or transformation of every individual complex is the mainspring of poetry, painting, and every form of art.³⁰

[202] If, for “complex,” we substitute the idea of “energy value,” i.e., the total affectivity of the complex, it is clear that Spielrein’s views fall into line with my own.

[203] It seems as if this process of analogy-making had gradually altered and added to the common stock of ideas and names, with the result that man’s picture of the world was considerably broadened. Specially colourful or intense contents (the “feeling-toned” complexes) were reflected in countless analogies, and gave rise to synonyms whose objects were thus drawn into the magic circle of the psyche. In this way there came into being those intimate relationships by analogy which Lévy-Bruhl fittingly describes as “participation mystique.” It is evident that this tendency to invent analogies deriving from feeling-toned contents has been of enormous significance for the development of the human mind. We are in thorough agreement with Steinthal when he says that a positively overwhelming importance attaches to the little word “like” in the history of human thought. One can easily imagine that the canalization of libido into analogy-making was responsible for some of the most important discoveries ever made by primitive man.

III

THE TRANSFORMATION OF LIBIDO

[204] In what follows I should like to give some concrete examples of this canalization of libido. I once had to treat a woman patient who suffered from catatonic depressions. As there was a mild degree of psychosis, I was not surprised by the numerous hysterical symptoms she exhibited. At the beginning of the treatment, while she was telling me of a very painful experience, she fell into an hysterical dream-state in which she showed all the signs of sexual excitement. (It was abundantly evident that during this state she was completely unaware of my presence.) The excitement culminated in an act of masturbation. This act was accompanied by a singular gesture: she kept on making a violent rotary movement with the forefinger of the left hand against the left temple, as though she were boring a hole there. Afterwards there was complete amnesia for what had happened, and nothing could be elicited about the singular gesture with the hand. Although this performance could easily be recognized as an act of thumb-sucking, or of nose- or ear-picking, transferred to the temple, and hence as an analogy of the masturbatory act, it nevertheless struck me as somehow significant, though at first I did not know why. Weeks later I had an opportunity of speaking with the patient's mother, and she told me what a very exceptional child her daughter had been. When only two years old she would sit for hours with her back to an open cupboard door, rhythmically banging it shut with her head¹ and driving the whole household distracted. A little later, instead of playing like the other children, she began boring holes in the plaster of the wall with her finger. She did this with little turning and scraping movements, which she would keep up for hours on end. To her parents she was a complete mystery. From about her fourth year she began to masturbate. So it is clear that in the earlier infantile occupation we have the preliminary stage of the later activity.

[205] The boring with the finger, then, can be traced back to a very early stage of childhood which antedates the period of masturbation. That period is very obscure psychologically, because there were no individual memories. Such a peculiar mode of behaviour is highly remarkable in a child of that age. We know from her subsequent history that her development—which was, as always, bound up with parallel external events—led to a mental illness which is well known for the individuality and originality of its products, namely schizophrenia. The peculiarity of this disease lies in the startling emergence of an archaic psychology. That accounts

for the innumerable points of contact with mythological material, and what we take to be original and individual creations are mostly products which can only be compared with those of antiquity. We have to apply this criterion to probably all the products of this remarkable illness, including perhaps this odd symptom of boring. As we have seen, it dates from a very early period, and it was revived from the distant past only when the patient, after several years of marriage, fell back into her early masturbatory habits following the death of her child, with whom she had identified herself through an over-indulgent love. When the child died, the infantile symptoms again inflicted themselves on the still healthy mother in the form of fits of masturbation, accompanied by this same act of boring. The primary boring, as we have said, appeared some time before the infantile masturbation. This fact is important inasmuch as the boring is seen to be distinct from a similar and later habit which supervened after she began masturbating.

[206] We know that in infants the libido first manifests itself exclusively in the nutritional zone, where, in the act of sucking, food is taken in with a rhythmic movement. At the same time there develops in the motor sphere in general a pleasurable rhythmic movement of the arms and legs (kicking, etc.). With the growth of the individual and development of his organs the libido creates for itself new avenues of activity. The primary model of rhythmic movement, producing pleasure and satisfaction, is transferred to the zone of other functions, with sexuality as its ultimate goal. This is not to say that the rhythmic activity derives from the act of nutrition. A considerable part of the energy supplied by nutrition for growth has to convert itself into sexual libido and other forms of activity. This transition does not take place suddenly at the time of puberty, as is commonly supposed, but only very gradually during the course of childhood. In this transitional period there are, so far as I am able to judge, two distinct phases: the phase of sucking, and the phase of rhythmic activity in general. Sucking still belongs to the sphere of the nutritive function, but outgrows it by ceasing to be a function of nutrition and becoming an analogous rhythmic activity without intake of nourishment. At this point the hand comes in as an auxiliary organ. It appears even more clearly as an auxiliary organ in the phase of rhythmic activity, which then leaves the oral zone and turns to other regions. Numerous possibilities now present themselves. As a rule, it is the other body openings that become the main object of interest; then the skin, or special parts of it; and finally rhythmic movements of all kinds. These, expressed in the form of rubbing, boring, picking, and so forth, follow a certain rhythm. It is clear that this activity, once it reaches the sexual zone, may provide occasion for the first attempts at masturbation. In the course of its migrations the libido carries traces of the nutritional phase into its new field of operations, which accounts for the many intimate connections between the nutritive and the sexual function. Should this more

developed activity meet with an obstacle that forces it to regress, the regression will be to an earlier stage of development. The phase of rhythmic activity generally coincides with the development of mind and speech. I therefore propose to call the period from birth up to the time of the first clear manifestations of sexuality the “pre-sexual stage.” As a rule it falls between the first and the fourth year, and is comparable to the chrysalis stage in butterflies. It is characterized by a varying mixture of elements from the nutritional and sexual phases. Certain regressions go right back to the presexual stage: so far as one can judge from experience, this seems to be the rule with regressions in schizophrenia and epilepsy. I will give two examples. One is the case of a young girl who developed a catatonic state during her engagement. The first time she saw me she suddenly came up to me and gave me a kiss, saying, “Papa, give me something to eat!” The other case concerns a young servant-girl who complained that people were pursuing her with electricity, and that this caused a queer feeling in her genitals, “as if it ate and drank down there.”

[207] These things show that the earlier phases of libido are capable of regressive reactivation. It is a road that is easily travelled, and has often been travelled in the past. If this assumption is correct, it is very likely that in earlier stages of human development this way of transformation was not just a pathological symptom, but a frequent and normal occurrence. It would therefore be interesting to see whether it has left any historical traces.

[208] We are indebted to Abraham² for drawing attention to the ethnological connection between boring and fire-making. The latter subject has been elaborated in the work of Adalbert Kuhn.³ From these investigations we learn that the fire-bringer Prometheus may possibly be brother to the Indian *pramantha*, the masculine fire-stick. The Indian fire-bringer was called Matarisvan, and the activity of fire-making is always referred to in the sacred texts by means of the verb *manthāmi*,⁴ ‘to shake, to rub, to bring forth by rubbing.’ Kuhn relates this verb to Gr. *μανθάνω*, ‘to learn,’ and has also explained the conceptual relationship between them.⁵ The *tertium comparationis* may lie in the rhythm, the movement to and fro in the mind. According to Kuhn, the root *manth-* or *math-* leads, via *μανθάνω* (*μάθημα*, *μάθησις*) and *προ-μηθέομαι*, to *Προμηθεύς*, the well-known Greek fire-robber. He points out that just as the Thuric Zeus bore the especially interesting cognomen *Προ-μανθεύς*, so *Προ-μηθεύς* might be not an original Indo-European word related to the Skr. *pramantha*, but only a cognomen. This view is supported by a gloss of Hesychius, explaining the name *Ιθάς* as *ὁ τῶν Τιτάνων κήρυξ Προμηθεύς* (Prometheus, the herald of the titans). Another gloss of Hesychius explains *ἀθαίνομαι* (*λαίνω*, ‘to heat, melt’) as *θερμαίνομαι*, ‘to grow hot,’ so that ‘*Ιθάς* acquires the meaning ‘Flaming One,’ similar to *Αἰθών* or *Φλεγύας*.⁶ The relation of Prometheus to *pramantha* is therefore questionable. On the other hand, *Προμηθεύς* is highly significant as a

cognomen for ‘Ἰθάς, since the “Flaming One” is the “Forethinker.”⁷ (*Pramati*, ‘precaution,’ is also an attribute of Agni, the god of fire, although *pramati* is of different derivation.) Prometheus, however, belongs to the line of Phlegians whom Kuhn puts into incontestable relationship with the Indian priestly family of Bhrigu.⁸ The Bhrigu, like Matarisvan (“he who swells in the mother”), were also fire-bringers. Kuhn cites a passage to show that the Bhrigu arose from the fire like Agni. (“Bhrigu arose in the flame; Bhrigu roasted, but did not burn.”) This idea leads to a root cognate with Bhrigu: Skr. *bhrāy*, ‘to shine,’ Lat. *fulgeo*, Gr. *φλέγω* (Skr. *bhargas*, ‘splendour,’ Lat. *fulgur*). Bhrigu therefore appears as the “Shining One.” *Φλεγύας* denotes a certain species of eagle distinguished for its burnished yellow colour. The connection with *φλέγειν* ‘to burn,’ is obvious. Hence the Phlegians were fiery eagles.⁹ Prometheus, too, was a Phlegian. The line from *pramantha* to Prometheus does not go via the word, but more probably through the idea or image, so that Prometheus may in the end have the same meaning as *pramantha*¹⁰ Only, it would be an *archetypal* parallel and not a case of linguistic transmission.

[209] For some time it was believed that Prometheus took over the meaning “Forethinker” (as the figure of Epimetheus, the “After-thinker,” testifies) only quite late, and that the word was originally connected with *pramantha*, *manthāmi*, *mathāyati* and had, etymologically, nothing to do with *προμηθέομαι*, *μάθημα*, *μανθάνω*. Conversely, *pramati*, ‘precaution,’ which is associated with Agni, has no connection with *manthāmi*. Lately, however, there has been a tendency to derive Prometheus from *μανθάνω* after all.¹¹ The only thing that can be established with any certainty in this complicated situation is that we find thinking, precaution, or foresight somehow connected with fire-boring, without there being any demonstrable etymological connections between the words used for them. In considering the etymology, therefore, we have to take into account not only the migration of the root-words, but the autochthonous revival of certain primordial images.

[210] The *pramantha*, or instrument of the *manthana* (fire-sacrifice), is conceived under a purely sexual aspect in India, the fire-stick being the phallus or man, and the bored wood underneath the vulva or woman. The fire that results from the boring is the child, the divine son Agni. (Pl. XIIIb.) The two pieces of wood are ritually known as *pururavas* and *urvasi*, and, when personified, are thought of as man and woman. The fire is born¹² from the genitals of the woman. Weber gives the following account of the fire-producing ceremony:

A sacrificial fire is kindled by rubbing two fire-sticks together. One of the fire-sticks is taken up with the words: “Thou art the birthplace of fire,” and two blades of grass are placed upon it: “Ye are the two testicles.” The priest then places on them the *adhararani* (the underlying piece of wood), saying: “Thou art Urvasi,” and anoints the *uttarani* (uppermost piece) with butter: “Thou art the power” (semen). This is then placed on the *adhararani*,

with the words: “Thou art Pururavas.” Rubbing them together three times the priest says: “I rub thee with the Gayatrimetrum: I rub thee with the Trishtubhmetrum: I rub thee with the Jagatimetrum.”¹³

[211] The sexual symbolism is unmistakable. We find the same idea and symbolism in a hymn of the Rig-Veda:

Here is the gear for friction, here tinder is made ready for the spark.

Bring the mistress of the people:¹⁴ we will rub Agni in ancient fashion forth.

In the two fire-sticks lies Jatavedas, safe as the seed in pregnant women;

Daily let Agni be praised by men who watch and worship with oblations.

Let this (staff) enter into her as she lies there outstretched, O you skilled ones;

Straightway she conceives, has given birth to the fructifier:

With his red pillar lighting his path, the son of Ila is born from the precious wood.¹⁵

[212] It is to be noted that in this hymn the *pramantha* is also Agni, the begotten son: the phallus is the son, or the son is the phallus. In colloquial German today there are distant echoes of this primitive symbolism: a lout or urchin is known as a *Bengel*, ‘club, cudgel,’ and in the Hessian dialect as a *Stift*, ‘peg,’ or *Bolzen*, ‘bolt.’¹⁶ The plant *Artemisia abrotanum*, called in German *Stabwurz*, ‘stick-root,’ is known in English as “boy’s-love.” The vulgar designation of the penis as “boy” was remarked even by the brothers Grimm. Ceremonial fire-making lingered on in Europe as a superstitious custom until well into the nineteenth century. Kuhn mentions one such case which occurred in Germany in 1828. This magical rite, practised with due ceremony, was called the “Nodfyr” (need-fire),¹⁷ and the charm was used mainly against cattle epidemics. Kuhn quotes from the Chronicles of Lanercost, in the year 1268, a particularly interesting case of “Nodfyr” which plainly reveals the sexual symbolism of the ceremonies:

In order to safeguard the integrity of divine faith, let the reader remember that when the herds of cattle in Laodonia were ravaged this year by the pest called lung-sickness, certain cattle-breeders, monastery folk by habit or dress but not by disposition, taught the ignorant rustics to make fire by rubbing pieces of wood together, and to set up an image of Priapus, and in this wise to help their animals. After a Cistercian lay brother had done this near Fenton in front of the courtyard, he dipped the testicles of a dog in holy water and sprinkled the animals with it...

18

[213] These examples, coming from different periods of history and from different peoples, prove the existence of a widespread tendency to equate fire-making with sexuality. The ceremonial or magical repetition of this age-old discovery shows how persistently the human mind clings to the old forms, and how deep-rooted is the memory of fire-boring. One might be inclined to see the sexual symbolism of fire-making simply as a gratuitous addition to priestly lore. That may be true of certain ritualistic elaborations of the fire mystery, but the question remains whether fire-

making originally had a deeper connection with sex. We know that similar rites are practised among primitives from studies of the Wachandi, of Australia,¹⁹ who in spring perform the following piece of fertility-magic: They dig a hole in the ground, so shaping it and setting it about with bushes that it looks like a woman's genitals. Then they dance round this hole all night, holding their spears in front of them in imitation of an erect penis. As they dance round, they thrust their spears into the hole, shouting: "Pulli nira, pulli nira, wataka!" (Not a pit, not a pit, but a c____!). Obscene dances of this kind are found among other tribes as well.²⁰

[214] In this rite of spring²¹ there is enacted a sacramental mating, with the hole in the earth representing the woman, and the spear the man. The *hieros gamos* was an essential component of many cults and played an important part in various sects.²²

[215] One can easily imagine that just as the Australian bushmen perform a sort of *hieros gamos* with the earth, so the same or a similar idea could be represented by producing fire from two pieces of wood. The ritual coitus is enacted, not by two people, but by two simulacra, Pururavas and Urvasi, the male and female fire-sticks. (Cf. pl. XIIIb.)



Fig. 15. The phallic plough
From a Greek vase

[216] Of all the components of the psyche, sex is undoubtedly the one with the strongest affective tone. Certain persons are therefore inclined to assume that everything which bears an obvious analogy to sex must of necessity be derived from it, on the hypothesis that the sexual libido comes up against some sort of barrier which compels it to seek a substitute activity in the form of a ritual analogy. In order to account for the partial conversion and transformation of libido, Freud assumed that the barrier was the *incest-taboo*. Strictly speaking, however, the incest-taboo is a check on the endogamous tendency in man. For an instinct to be forcibly converted into something else, or even partially checked, there must be a correspondingly

higher energy on the opposite side. Freud rightly supposed that this energy came from *fear*, and in order to explain the fear, he had to resort to the more or less plausible hypothesis of the primal horde, which, like a herd of gorillas, was tyrannized over by a ferocious patriarch. To complete the picture, we would have to add an equally awe-inspiring matron who instils fear into the daughters, just as the primordial father compels the savage respect of the sons. We would then have a patrilineal and a matrilineal source of anxiety to match the primitive conditions. I can well imagine that the more neurotic among the troglodytes “thought” in this manner.

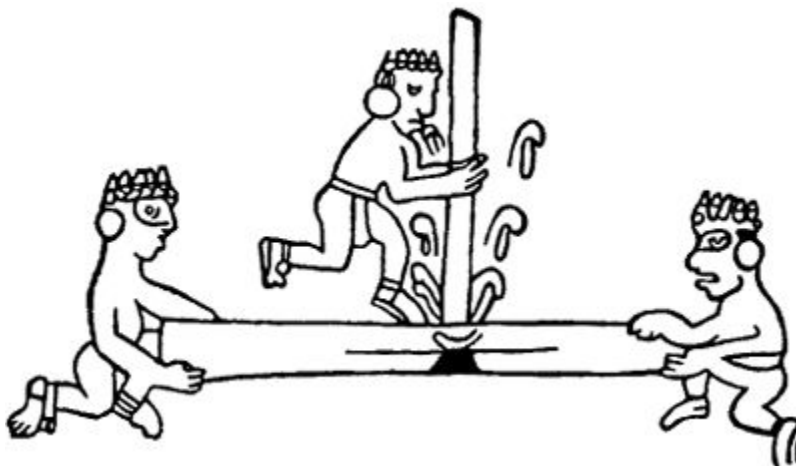

Fig. 16. The twirling-stick
From an Aztec hieroglyph-painting

[217] Such a derivation of the motive for checking the instincts seems to me somewhat doubtful, to say the least of it, for the simple reason that the tensions inside a primitive group are never greater than those involved in the struggle for existence of the group as a whole. Were it otherwise, the group would speedily perish. What does constitute a serious threat to the primitive group is the endogamous tendency, which has to be checked in order to exorcize the danger. The best means to this end seems to be the widespread custom of cross-cousin-marriage,²³ because it keeps the endogamous and exogamous tendencies balanced. The danger that then threatens the group comes from the very advantages it has gained through checking the endogamous tendency to which the incest-taboo applies. The group acquires an inner stability, opportunities for expansion, and hence greater security. That is to say, the source of fear does not lie inside the group, but in the very real risks which the struggle for existence entails. Fear of enemies and of hunger predominates even over sexuality, which is, as we know, no problem at all for the primitive, as it is far simpler to get a woman than it is to get food. Fear of the consequences of being unadapted is a compelling reason for checking the instincts. Confronted with disaster, one is obliged to ask oneself how it is to be remedied. The libido that is forced into regression by the obstacle always reverts to the possibilities lying dormant in the individual. A dog, finding the door shut, scratches at it until it is opened, and a man

unable to find the answer to a problem rubs his nose, pulls his lower lip, scratches his ear, and so on. If he gets impatient, all sorts of other rhythms appear: he starts drumming with his fingers, shuffles his feet about, and it will not be long before certain distinctly sexual analogies manifest themselves, such as masturbation gestures. Koch-Grünberg, writing on South American rock-paintings, tells us how the Indians sit on the rocks and scratch lines on them with sharp stones while waiting for their canoes to be transported round the rapids.²⁴ In the course of time there have arisen chaotic drawings or scribbles that might perhaps be compared with doodling on blotting-pads. This makes it easier to understand what Maeterlinck tells us in his *Blue Bird*:²⁵ the two children who are looking for the blue bird in the Land of the Unborn find a boy who *picks his nose*. It is said that one day he will discover a new *fire* when the earth has grown cold. Spielrein's patient²⁶ associated the act of boring with fire and procreation. She said: "You need iron to bore through the earth. With iron you can make cold people out of stone. With a hot iron you can bore through the mountain. The iron becomes red-hot when it is pushed into a stone."

[218] Now when the libido is forced back by an obstacle, it does not necessarily regress to earlier sexual modes of application, but rather to the rhythmic activities of infancy which serve as a model both for the act of nutrition and for the sexual act itself. The material before us does not seem to preclude the possibility that the invention of fire-making came about in the manner suggested, that is, through the regressive reawakening of rhythm.²⁷ This hypothesis seems to me psychologically possible, though I would not maintain that this is the only way in which the discovery of fire could have been made. It could just as well have been made from striking flints together. All I am concerned with here is the psychological process, whose symbolisms suggest that fire-making may possibly have been discovered in this way.

[219] Even if these rhythmic activities give one the impression of a game, one is nevertheless impressed by the intentness and energy with which this alleged game is conducted. It is well known that such rites (for that is how we must regard them) are performed with great seriousness and an uncommon display of energy, which is in marked contrast to the notorious laziness of primitive man. The so-called game takes on the character of purposeful effort. If certain tribes can dance all night long to a monotonous tune of three notes, then, to our way of thinking, the play-element is entirely lacking: it is more like an exercise with a set purpose. This is in fact the case, for rhythm is a classic device for impressing certain ideas or activities on the mind, and what has to be impressed and firmly organized is the canalization of libido into a new form of activity. Since the rhythmic activity can no longer find an outlet in the act of feeding after the nutritional phase of development is over, it transfers itself not only to the sphere of sexuality in the strict sense, but also to the "decoy mechanisms," such as music and dancing, and finally to the sphere of work. The

close connection which work always has with music, singing, dancing, drumming, and all manner of rhythms in primitive societies, indeed its absolute dependence on these things, is very striking. This connection forms the bridge to sexuality, thus giving the primitive an opportunity to sidetrack and evade the task in hand. Because diversions of this kind are a frequent occurrence, and are to be found in all spheres of culture, people have been led to believe that there is no differentiated achievement that is not a substitute for some form of sexuality. I regard this as an error, albeit a very understandable one considering the enormous psychological importance of the sexual instinct. I myself once held similar views, at least in so far as I assumed that the various forms of attraction and protection of the young came from the splitting and differentiation of an originally sexual libido, or of the reproductive instinct in its widest sense, and were therefore the preliminary stages of all cultural activities, so far as these are by nature instinctive. One reason for this error was the influence of Freud; the other, and more cogent, reason was the element of rhythm which often attaches to these functions. Only later did I realize that the rhythmic tendency does not come from the nutritional phase at all, as if it had migrated from there to the sexual, but that it is a peculiarity of emotional processes in general. Any kind of excitement, no matter in what phase of life, displays a tendency to rhythmic expression, perseveration, and repetition, as can easily be seen from the repetition, assonance, and alliteration of complex-toned reaction-words in the association experiment.²⁸ Rhythmic patterns therefore offer no ground for assuming that the function they affect originated in sexuality.

[220] The psychological importance of sexuality and the existence of plausible sexual analogies make a deviation into sex extremely easy in cases of regression, so that it naturally seems as if all one's troubles were due to a sexual wish that is unjustly denied fulfilment. This reasoning is typical of the neurotic. Primitives seem to know instinctively the dangers of this deviation: when celebrating the *hieros gamos*, the Wachandi, of Australia, may not look at a woman during the entire ceremony. Among a certain tribe of American Indians, it was the custom for the warriors, before setting out on the warpath, to move in a circle round a beautiful young girl standing naked in the centre. Whoever got an erection was disqualified as unfit for military operations. The deviation into sex is used—not always, but very frequently—as a means of escaping the real problem. One makes oneself and others believe that the problem is purely sexual, that the trouble started long ago and that its causes lie in the remote past. This provides a heaven-sent way out of the problem of the present by shifting the whole question on to another and less dangerous plane. But the illicit gain is purchased at the expense of adaptation, and one gets a neurosis into the bargain.

[221] In an earlier paragraph we traced the checking of the instincts back to fear of the very real dangers of existence in this world. But external reality is not the only source of this instinct-inhibiting fear, for primitive man is often very much more afraid of an “inner” reality—the world of dreams, ancestral spirits, demons, gods, magicians, and witches. Although we, with our rationalism, think we can block this source of fear by pointing to its unreality, it nevertheless remains one of those psychic realities whose irrational nature cannot be exorcized by rational argument. You can free the primitive of certain superstitions, but you cannot talk him out of his alcoholism, his moral depravity, and general hopelessness. There is a psychic reality which is just as pitiless and just as inexorable as the outer world, and just as useful and helpful, provided one knows how to circumvent its dangers and discover its hidden treasures. “Magic is the science of the jungle,” a famous explorer once said. Civilized man contemptuously looks down on primitive superstitions, which is about as sensible as turning up one’s nose at the pikes and halberds, the fortresses and tall-spired cathedrals of the Middle Ages. Primitive methods are just as effective under primitive conditions as machine-guns or the radio are under modern conditions. Our religions and political ideologies are methods of salvation and propitiation which can be compared with primitive ideas of magic, and where such “collective representations” are lacking their place is immediately taken by all sorts of private idiocies and idiosyncrasies, manias, phobias, and daemonisms whose primitivity leaves nothing to be desired, not to speak of the psychic epidemics of our time before which the witch-hunts of the sixteenth century pale by comparison.

[122] Notwithstanding our rationalistic attempts to argue it out of existence, psychic reality is and remains a genuine source of anxiety whose danger increases the more it is denied. The biological instincts then meet not only with outer obstacles but with an internal resistance. The same psychic system which, on one side, is based on the concupiscence of the instincts, rests on the other side on an opposing will which is at least as strong as the biological urge.

[123] Except when motivated by external necessity, the will to suppress or repress the natural instincts, or rather to overcome their predominance (*superbia*) and lack of coordination (*concupiscentia*), derives from a spiritual source; in other words, the determining factor is the numinous primordial images. These images, ideas, beliefs, or ideals operate through the specific energy of the individual, which he cannot always utilize at will for this purpose, but which seems rather to be drawn out of him by the images. Even the authority of the father is seldom powerful enough to keep the spirit of the sons in permanent subjection. This can only happen when the father appeals to or expresses an image which, in the eyes of humanity, is numinous, or at any rate backed up by the consensus of opinion. The suggestive power of the environment is itself a consequence of the numinosity of the image and intensifies it

in turn. If there is no such suggestion, the collective effect of the image will be negligible, or non-existent, even though it may be extremely intense as an individual experience. I mention this circumstance because it is a controversial point whether the inner images, or collective representations, are merely suggested by the environment, or whether they are genuine and spontaneous experiences. The first view simply begs the question, because it is obvious that the content suggested must have come into existence somehow and at some time. There was a time when the utterances of mythology were entirely original, when they were numinous experiences, and anyone who takes the trouble can observe these subjective experiences even today. I have already given one example²⁹ of a mythological statement (the solar phallus) coming alive again under circumstances which rule out any possibility of direct transmission. The patient was a small business employee with no more than a secondary school education. He grew up in Zurich, and by no stretch of imagination can I conceive how he could have got hold of the idea of the solar phallus, of the vision moving to and fro, and of the origin of the wind. I myself, who would have been in a much better position, intellectually, to know about this singular concatenation of ideas, was entirely ignorant of it and only discovered the parallel in a book of Dieterich's which appeared in 1910, four years after my original observation (1906).³⁰

[224] This observation was not an isolated case: it was manifestly not a question of inherited ideas, but of an inborn disposition to produce parallel thought-formations, or rather of identical psychic structures common to all men, which I later called the archetypes of the collective unconscious. They correspond to the concept of the "pattern of behaviour" in biology.³¹

[225] The archetype, as a glance at the history of religious phenomena will show, has a characteristically numinous effect, so that the subject is gripped by it as though by an instinct. What is more, instinct itself can be restrained and even overcome by this power, a fact for which there is no need to advance proofs.

[226] Whenever an instinct is checked or inhibited, it gets blocked and regresses. Or, to be more precise: if there is an inhibition of sexuality, a regression will eventually occur in which the sexual energy flowing back from this sphere activates a function in some other sphere. In this way the energy changes its form. Let us take as an example the Wachandi ceremony: in all probability the hole in the earth is an analogy of the mother's genitals, for when a man is forbidden to look at a woman, his Eros reverts to the mother. But as incest has to be avoided at all costs, the hole in the earth acts as a kind of mother-substitute. Thus, by means of ceremonial exercise, the incestuous energy-component becomes as it were desexualized, is led back to an infantile level where, if the operation is successful, it attains another form, which is

equivalent to another function. It is to be assumed, however, that the operation is accomplished only with difficulty, for the primary instinct is composed of an endogamous (“incestuous”) tendency and an exogamous one, and must therefore be split into two. This splitting is connected with consciousness and the process of becoming conscious. The regression is always attended by certain difficulties because the energy clings with specific force to its object, and on being changed from one form carries something of its previous character into the next form.³² So although the resultant phenomena have the character of a sexual act, it is not a sexual act any longer. In the same way fire-boring is only an analogy of the sexual act, just as the latter often has to serve as a linguistic analogy for all sorts of other activities. The presexual, early infantile stage to which the libido reverts is characterized by numerous possibilities of application, because, once the libido has arrived there, it is restored to its original undifferentiated polyvalency. It is therefore understandable that the libido which regressively “invests” this stage sees itself confronted with a variety of possible applications. Since, in the Wachandi ceremony, the libido is bound to its object—sexuality—it will carry at least part of this function into the new form as an essential characteristic. The result is that an analogous object is “invested” and takes the place of the one thrust into the background. The ideal example of such an object is the nurturing earth-mother. (P1. xiv^a; cf. also [fig. 1](#).) The psychology of the presexual stage accounts for her nourishing character, and sexuality for her most typical form of worship, the *hieros gamos*. From this arise the age-old symbols of agriculture. In the work of tilling and sowing the fields hunger and incest intermingle. The ancient cults of Mother Earth saw in this the fertilization of the mother. But the aim of the action is to bring forth the fruits of the field, and it is magical rather than sexual. Here the regression leads to a reactivation of the mother as the goal of desire, this time as a symbol not of sex but of the giver of nourishment.

[227] It is just possible that we owe the discovery of fire to some such regression to the presexual stage, where the model of rhythmic activity can co-operate effectively. The libido, forced into regression by the checking of instinct, reactivates the infantile boring and provides it with objective material to work on—fittingly called “material” because the object at this stage is the mother (*mater*). As I have pointed out above, the act of boring requires only the strength and perseverance of an adult man and suitable “material” in order to generate fire. Consequently, the production of fire may have originally occurred as the objective expression of a quasi-masturbatory activity analogous to the aforementioned case of masturbatory boring. Though we can never hope to advance any real proof of our contention, it is at least thinkable that some traces of these first exercises in fire-making may have been preserved. I have succeeded in finding a passage in a monument of Indian literature which describes

this conversion of libido into fire-making. It occurs in the Brihadaranyaka Upanishad: ³³

He (*A tman*³⁴) was as big as a man and woman joined together; he divided himself into two, and thus husband and wife were born....³⁵ He joined himself to her, and thus men were born.

She thought: "How should he lie with me after having produced me? I will hide myself." She became a cow, he became a bull; they joined and cattle were born. She became a mare, he a stallion; she became a she-ass, he an ass; they joined and the hoofed animals were born. She became a she-goat, he a goat; she became a ewe, he a ram; they joined and goats and sheep were born. Thus he created everything down to the ants, male and female....

Then he knew: "I am this creation, for I produced it all from myself." Such was creation. He who possesses this knowledge creates his own being in that creation.

Thereupon he rubbed thus [holding his hands before his mouth]. From his mouth, the fire-hole (*yoni*), and from his hands, he brought forth fire.³⁶

[228] I once observed a year-old baby making a very peculiar gesture: it held one hand before its mouth and kept rubbing it with the other. It lost this habit after some months. Such cases show that there is some justification for interpreting a mythologem like the above as being based on a very early infantile gesture.

[229] The baby's gesture is interesting in another respect, too: it lays emphasis on the mouth, which at this early age still has an exclusively nutritive significance. The pleasure and satisfaction it finds in feeding is localized in the mouth, but to interpret this pleasure as sexual is quite unjustified. Feeding is a genuine activity, satisfying in itself, and because it is a vital necessity nature has here put a premium on pleasure. The mouth soon begins to develop another significance as the organ of speech. The extreme importance of speech doubles the significance of the mouth in small children. The rhythmic activities it carries out express a concentration of emotional forces, i.e., of libido, at this point. Thus the mouth (and to a lesser degree the anus) becomes the prime place of origin. According to the Brihadaranyaka Upanishad, the most important discovery ever made by primitive man, the discovery of fire, came out of the mouth. As we might expect, there are texts which draw a parallel between fire and speech. The Aitareya Upanishad says:

Then he drew forth a Person (*purusha*) from the waters and shaped him. He brooded upon him, and when he had brooded him forth, a mouth split open like an egg. From the mouth came speech, and from speech fire.³⁷ [Cf. pl. XIIIb.]

[230] Here, then, speech becomes fire, but a little later on (2, 4) we are told that fire becomes speech. There is a similar connection between the two in Brihadaranyaka Upanishad:

"Yajñavalkya, what is the light of man?"

“The sun is his light,” he answered. “It is by the light of the sun that a man rests, goes forth, does his work and returns.”

“Quite so, Yajñavalkya. But when the sun is set, what then is the light of man?”

“The moon is his light,” he answered. “It is by the light of the moon that a man rests, goes forth, does his work and returns.”

“Quite so, Yajñavalkya. But when the sun is set, and the moon is set, what then is the light of man?”

“Fire is his light,” he answered. “It is by the light of the fire that a man rests, goes forth, does his work and returns.”

“Quite so, Yajñavalkya. But when the sun is set, and the moon is set, and the fire has gone out, what then is the light of man?”

“Speech is his light,” he answered. “It is by the light of speech that a man rests, goes forth, does his work and returns.”

“Quite so, Yajñavalkya. But when the sun is set, and the moon is set, and the fire has gone out, and speech is hushed, what then is the light of man?”

“Self is his light,” he answered. “It is by the light of the Self that a man rests, goes forth, does his work and returns.”³⁸

[231] This association of mouth, fire, and speech is not as strange as it would seem: we speak of a man being “fired” or “inflamed” by another’s words, of a “fiery” speech, “burning words,” etc. In the language of the Old Testament mouth and fire are frequently connected, as in II Samuel 22:9: “There went up a smoke out of his nostrils, and fire out of his mouth...” Isaiah 30: 27: “The name of the Lord cometh from afar, burning with his anger ... his lips are full of indignation, and his tongue as a devouring fire.” Psalm 29:7 (RV): “The voice of the Lord scattereth flames of fire.” Jeremiah 23:29: “Is not my word like as a fire?” And in Revelation 11:5 fire proceeds out of the mouth of the two prophetic witnesses.

[232] Again and again fire is called “devouring,” “consuming,” a reminder of the function of the mouth, as in Ezekiel 15:4: “It is cast into the fire for fuel; the fire devoureth both the ends of it, and the midst of it is burned.” Deuteronomy 4: 24: “For the Lord thy God is a consuming fire, even a jealous God.” Perhaps the best-known example is Acts 2:3–4: “And there appeared unto them cloven tongues [γλῶσσαι] like as of fire, and it sat upon each of them. And they were all filled with the Holy Ghost, and began to speak with other tongues [γλῶσσαις], as the Spirit gave them utterance.” The γλῶσσαι of the fire caused the glossolalia of the apostles. In a negative sense the Epistle of James 3:6 says: “And the tongue is a fire, a world of iniquity: so is the tongue among our members, that it defileth the whole body, and setteth on fire the course of nature; and it is set on fire of hell.” Proverbs 16:27 says likewise: “An ungodly man diggeth up evil: and in his lips there is as a burning fire.” The dragons or horses of the Apocalypse (Rev. 9:17) breathe forth fire and smoke

and brimstone, and as for Leviathan (Job 41:19f.): “Out of his mouth go burning lamps, and sparks of fire leap out.”

[233] The connection of the mouth with fire and speech is indubitable. Another fact to be considered is that the etymological dictionaries connect the Indo-European root **bhā* with the idea of ‘bright,’ ‘shining.’ This root is found in Gr. *φάω, φαίνω, φάος*; in OIr. *bàn*, ‘white’; and in the G. *bohlen*, ‘to polish, make shining.’ But the homonymous root **bhā* also signifies ‘speaking’: it is found in Skr. *bhan*, ‘to speak’; in Armen. *ban*, ‘word’; in G. *Bann, bannen*, ‘to ban, put a spell on’; in Gr. *φαμί, ἔφην, φάτις*, Lat. *fā-ri, fātum*.

[234] The root *la*, ‘to sound, to bark,’ occurs in Skr. *las lāsati*, ‘to resound, reverberate,’ and in *las lāsati*, ‘to radiate, shine.’

[235] A similar archaic fusion of meanings occurs in a certain class of Egyptian words derived from the cognate roots *ben* and *bel*, duplicated into *benben* and *belbel*. The original meaning of these words was ‘to burst forth, emerge, swell, well out,’ with the associated idea of bubbling, boiling, roundness. *Belbel*, accompanied by the obelisk sign, meant a source of light. The obelisk itself had several names: *teshenu, men, benben*, and more rarely *berber* and *belbel*.³⁹ The Indo-European root **vel*, meaning ‘to wave about like fire,’ occurs in Skr. *ulunka*, ‘blaze,’ Gr. *Φαλέα*, Att. *ἀλέα*, ‘warmth of the sun,’ Goth, *ulan*, ‘undulate,’ OHG. and MHG. *Walm*, ‘warmth.’ The related Indo-European root **velkō*, ‘to lighten, glow,’ occurs in Skr. *ulka*, ‘firebrand,’ Gr. *Φελχᾶνος*, ‘Vulcan.’ The same root **vel* also means ‘to sound’; in Skr. *vānī*, ‘tone, song, music’; Czech *volati*, ‘to call.’ The root **svéno* occurs in Skr. *svan, svánati*, ‘to sound,’ Zend *qanañt*, Lat. *sonare*, OIran. *semn*, Welsh *sain*, Lat. *sonus*, OE. *svinsian*. The related root **svénos*, ‘noise,’ occurs in Ved. *svánas*, Lat. *sonor, sonorus*. A further related root is **svonós*, OIran. *son*, ‘word.’ The root **své (n)*, locative **svéni*, dative **svéni*, means ‘sun’; in Zend *qeng* (cf. above, **suéno*, Zend *qanañt*); Goth, *sun-na, sunnô*.⁴⁰ Although the stars are only perceived by their light, we still talk of the music of the spheres and celestial harmony, just as Pythagoras did. Goethe opens his “Prologue in Heaven” in the same way:

The day-star, sonorous as of old,
Goes his predestined way along,
And round his path is thunder rolled,
While sister-spheres join rival song.⁴¹

Again, in Part II:

Hearken to the storm of hours!
Ringing out for spirits’ ears

Now the new-born day appears.
Gates of rock grind back asunder,
Phoebus comes with wheels of thunder,
Light brings tumult in his train.
Drums and trumpets far resounding,
Dazzling, deafening, dumbfounding,
A din the ears can scarce sustain.
Into bells of blossom creep,
Lie there quietly, as in sleep,
Into rock and under leaf:
If it strikes you, you are deaf.⁴²

[236] Nor should we forget the verses of Hölderlin:

Where are you? Drunken with all your glory
My soul dreams; yet even now I hearken,
As full of golden tones the radiant sun-youth
Raises his evening song on the heavenly lyre
To the echoing woods and hills....⁴³

[237] These images point back to the sun-god Apollo, whose lyre marks him out as the divine musician. The fusion of sound, speech, light, and fire is expressed in an almost physiological way in the phenomenon of “colour-hearing,” i.e., the perception of the tonal quality of colours and the chromatic quality of musical tones. This leads one to think that there must be a preconscious identity between them: the two phenomena have something in common despite their real differences. It is probably no accident that the two most important discoveries which distinguish man from all other living beings, namely speech and the use of fire, should have a common psychic background. Both are products of psychic energy, of libido or mana. In Sanskrit there is a term which expresses in all its nuances the preconscious situation I have suggested. This is the word *tejas*, and it combines the following meanings:

1. Sharpness, cutting edge.
2. Fire, brightness, light, ardour, heat.
3. Healthy appearance, beauty.
4. The fiery and colour-producing faculty of the human organism (located in the bile).
5. Strength, energy, vital force.
6. Passion.
7. Spiritual and magical power; influence, position, dignity.

8. Semen.⁴⁴

[238] *Tejas*, therefore, describes the psychological situation covered by the word “libido.” It really denotes *subjective intensity*. Anything potent, any content highly charged with energy, therefore has a wide range of symbolic meanings. This is obvious enough in the case of language, which is capable of expressing practically anything. But it may not be out of place to say a few words about the symbolism of fire.

[239] The Sanskrit word for fire is *agnis* (Lat. *ignis*⁴⁵), personified as Agni, the god of fire, a divine mediator (cf. pl. XIIIb) whose symbolism has certain affinities with Christian ideas.

[240] An Iranian name for fire is *Nairyosagha*, ‘masculine word.’ (Cf. the Indian *Narasamsa*, ‘wish of men.’⁴⁶) Max Müller says of Agni:

It was a familiar idea with the Brahmans to look upon the fire both as the subject and the object of a sacrifice. The fire embraced the offering, and was thus a kind of priest; it carried it to the gods, and was thus a kind of mediator between gods and men. But the fire represented also something divine, a god to whom honour was due, and thus it became both the subject and the object of the sacrifice. Hence the idea that Agni sacrifices himself, that he offers a sacrifice to himself, and likewise that he offers himself as a sacrifice.⁴⁷

[241] The affinity between this line of thought and the Christian symbol is obvious. Krishna expresses the same idea in the Bhagavad Gita:

All's then God!

The sacrifice is Brahm, the ghee and grain

Are Brahm, the fire is Brahm, the flesh it eats

Is Brahm, and unto Brahm attaineth he

Who, in such office, meditates on Brahm.⁴⁸

[242] The wise Diotima in Plato's *Symposium* has a rather different conception of the divine messenger and mediator. She teaches Socrates (ch. 23) that Eros is “the intermediary between mortals and immortals ... a mighty daemon, dear Socrates; for everything daemonic is the intermediary between God and man.” His function is to “interpret and convey messages to the gods from men and to men from the gods, prayers and sacrifices from the one, and commands and rewards from the other, thus bridging the gap between them, so that by his mediation the universe is at one with itself.” Diotima gives an excellent description of Eros: “He is bold and forward and strenuous, always devising tricks like a cunning huntsman; he yearns after knowledge and is full of resource and is a lover of wisdom all his life, a skilful magician, an alchemist, a true sophist. He is neither mortal nor immortal; but on one and the same day he will live and flourish (when things go well with him), and also meet his death;

and then come to life again through the force of his father's nature. Yet all that he wins is forever slipping away from him."⁴⁹

[243] In the Avesta and in the Vedas, fire is the messenger of the gods. In Christian mythology, too, there are points of contact with the Agni myth. Daniel 3: 24f. speaks of the three men in the burning fiery furnace:

Then Nebuchadnezzar the king was astonished, and rose up in haste, and spake, and said unto his counsellors, Did we not cast three men bound into the midst of the fire? They answered and said unto the king, True, O king.

He answered and said, Lo, I see four men loose, walking in the midst of the fire, and they have no hurt; and the form of the fourth is like the Son of God.

[244] The *Biblia pauperum* (1471) makes the following comment:

We read in the third chapter of the book of the prophet Daniel that Nabuchodonosor, the King of Babylon, caused three men to be placed in a glowing furnace, and that the king came to the furnace and looked in, and saw with the three a fourth, who was like the Son of God. The three signify for us the Holy Trinity of the person, and the fourth the unity of being. Thus Christ in his transfiguration signified the Trinity of the person and the unity of being.

[245] According to this interpretation the legend of the three men in the furnace is a magical procedure during which a "fourth" is produced. The fiery furnace, like the fiery tripod in *Faust*, is a mother-symbol. From the tripod come Paris and Helen, the royal pair of alchemy, and in popular tradition children are baked in the oven. The alchemical athanor, or melting-pot, signifies the body, while the alembic or *cucurbita*, the Hermetic vessel, represents the uterus. The "fourth" in the fiery furnace appears like a son of God made visible in the fire.⁵⁰ Jehovah himself is a fire. Isaiah 10:17 (RSV) says of the saviour of Israel: "And the light of Israel will become a fire, and his Holy One a flame." A hymn of Ephraem the Syrian says of Christ: "Thou who art all fire, have pity on me." This view is based on the apocryphal saying of our Lord: "He who is near unto me is near unto the fire."

[246] Agni is the sacrificial flame, the sacrificer and the sacrificed. Just as Christ left behind his redeeming blood, a true *φάρμακον ἀθανασίας*, in the wine, so Agni is the *soma*, the holy drink of inspiration, the mead of immortality.⁵¹ Soma and fire are identical in Vedic literature. The ancient Hindus saw fire both as a symbol of Agni and as an emanation of the inner libido-fire, and for them the same psychic dynamism was at work in the intoxicating drink ("fire-water," Soma-Agni as rain and fire). The Vedic definition of soma as "seminal fluid"⁵² confirms this view. The "somatic" significance of Agni has its parallel in the Christian interpretation of the Eucharistic Blood as the body of Christ.

[247] Soma is also the "nourishing drink." Its mythological characteristics coincide with those of fire, and so both are united in Agni. The drink of immortality, Amrita,

was stirred by the Hindu gods like the fire. (P1. xv.)

[248] So far our exposition has been based on the *pramantha* component of the Agni sacrifice, and we have concerned ourselves with only one meaning of the word *manthāmi* or *mathnāmi*, namely with that which expresses the idea of rubbing. But as Kuhn has shown, the word can also mean ‘to tear or break off,’ ‘to snatch,’ and also ‘to rob.’⁵³ In his view this meaning is apparent even in the early Vedic texts. Legend always conceives the discovery of fire as a *robbery*, and to that extent it is akin to the widespread motif of the “treasure hard to attain.” In many myths fire-making is something forbidden, a criminal act of usurpation which can only be accomplished by cunning or violence, but mostly by cunning.⁵⁴ The religious laws of the ancient Hindus threatened with severe penalties anyone who prepared fire in an incorrect manner. It is the custom in the Catholic Church to light a new fire at Easter. So, even in the Occident, fire-making is an element in a religious mystery, which testifies to its symbolical and ambiguous character. The rules of the ritual must be scrupulously observed if it is to have its intended magical effect. Generally the rite has a prophylactic, apotropaic significance, and when incorrectly performed or used may conjure up the very danger it was intended to avert. Speech and fire-making represent primitive man’s victory over his brutish unconsciousness and subsequently became powerful magical devices for overcoming the ever-present “daemonic” forces lurking in the unconscious. Both these applications of libido require attention, concentration, and inner discipline, thereby facilitating a further development of consciousness. On the other hand incorrect performance and use of the rite cause a retrograde movement of the libido, a regression which threatens to reproduce the earlier, instinctual, and unconscious state. The danger lies in those well-known “perils of the soul”—a splitting of the personality (“loss of a soul”) and reduction of consciousness, both of which automatically increase the power of the unconscious. The consequences of this are a serious danger not only for primitives; in civilized man, too, they may give rise to psychic disturbances, states of possession, and psychic epidemics.

[249] The blocking of libido leads to an accumulation of instinctuality and, in consequence, to excesses and aberrations of all kinds. Among them, sexual disturbances are fairly frequent, as we might expect. A particularly instructive example is the psychology of incendiarism: incendiarism is really a regressive act of fire-making, and in certain cases it is combined with masturbation. Schmid⁵⁵ tells of an imbecile peasant youth who started numerous fires. On one occasion he aroused suspicion by standing in the door of a house with his hands in his trouser-pockets, gazing with delight at the conflagration. Later, under examination, he admitted that he always masturbated while enjoying the spectacle of the fires he had started.

[250] The preparation of fire is an immemorial custom, harmless enough in itself, which soon ceased to have anything very mysterious about it. But there was always a tendency to prepare fire in a mysterious ceremonial manner on special occasions—just as with ritual eating and drinking—and to do it according to prescribed rules from which no one dared to differ. This ritual serves to remind us of the original numinosity of fire-making, but apart from that it has no practical significance. The anamnesis of fire-making is on a level with the recollection of the ancestors among primitives and of the gods at a more civilized stage. From the psychological point of view the ceremony has the significance of a meaningful institution, inasmuch as it represents a clearly defined procedure for canalizing the libido. It has, in fact, the functional value of a paradigm, and its purpose is to show us how we should act when the libido gets blocked. What we call the “blocking of libido” is, for the primitive, a hard and concrete fact: his life ceases to flow, things lose their glamour, plants, animals, and men no longer prosper. The ancient Chinese philosophy of the *I Ching* devised some brilliant images for this state of affairs. Modern man, in the same situation, experiences a standstill (“I am stuck”), a loss of energy and enjoyment (“the zest—libido—has gone out of life”), or a depression. One frequently has to tell the patient what is happening to him, for modern man’s powers of introspection leave much to be desired. If, even today, the new fire is kindled at Eastertide, it is in commemoration of the redemptive and saving significance of the first fire-boring. In this way man wrested a secret from nature—the Promethean theft of fire. He made himself guilty of an unlawful intervention, incorporating a fragment of the age-old unconscious into the darkness of his mind. With this theft he appropriated something precious and offended against the gods. Anyone who knows the primitive’s fear of innovations and their unforeseen consequences can imagine the uncertainty and uneasy conscience which such a discovery would arouse. This primordial experience finds an echo in the widespread motif of robbery (sun-cattle of Geryon, apples of the Hesperides, herb of immortality). And it is worth remembering that in the cult of Diana at Aricia only he could become her priest who plucked the golden bough from the sacred grove of the goddess.

IV THE ORIGIN OF THE HERO

[251] The finest of all symbols of the libido is the human figure, conceived as a demon or hero. Here the symbolism leaves the objective, material realm of astral and meteorological images and takes on human form, changing into a figure who passes from joy to sorrow, from sorrow to joy, and, like the sun, now stands high at the zenith and now is plunged into darkest night, only to rise again in new splendour.¹ Just as the sun, by its own motion and in accordance with its own inner law, climbs from morn till noon, crosses the meridian and goes its downward way towards evening, leaving its radiance behind it, and finally plunges into all-enveloping night, so man sets his course by immutable laws and, his journey over, sinks into darkness, to rise again in his children and begin the cycle anew. The symbolic transition from sun to man is easily made, and the third and last creation of Miss Miller's follows this pattern. She calls it "Chiwantopel, A hypnagogic drama," and gives us the following information concerning its origin:

After an evening of trouble and anxiety, I had gone to bed at half past eleven. I felt restless; unable to sleep although very tired. I had the impression of being in a receptive mood. There was no light in the room. I closed my eyes, and had the feeling of waiting for something that was about to happen. Then I felt a great relaxation come over me, and I remained as completely passive as possible. Lines, sparks, and spirals of fire passed before my eyes, symptoms of nervousness and ocular fatigue, followed by a kaleidoscopic and fragmentary review of recent trivial events.

[252] The reader will share my regret that we cannot know the cause of her worry and anxiety. It would have been of great importance for what follows to have information on this point. This gap in our knowledge is the more regrettable because, between the first poem (1898) and the fantasy now to be discussed (1902), four whole years have passed. All information is lacking regarding this period, during which the problem was assuredly not slumbering in the unconscious. Maybe this lack has its advantages, in that our interest in the general validity of the fantasy now struggling to be born is not obscured by any sympathetic concern for the personal fate of the author. This obviates the difficulty which often prevents the doctor, in his daily work, from turning his eyes away from the wearisome mass of petty detail to those wider relationships where every neurotic conflict is seen to be part of human fate as a whole.



Fig. 17. The first three labours of Heracles
Classical sarcophagus relief

[253] The state of mind depicted by our author is very much like that which usually precedes a case of intentional somnambulism,² and has often been described by mediums. A certain willingness to give ear to these faint nocturnal voices must be there, otherwise these subtle and hardly perceptible inner experiences will pass unnoticed. We can discern in this listening attitude an inward-flowing current of libido, leading towards a still invisible and mysterious goal. It is as if the libido had suddenly discovered, in the depths of the unconscious, an object which exercises a powerful attraction. As our life is directed outwards and does not normally allow of such introversions, we have to suppose a rather exceptional condition, for instance a lack of external objects, which forces the individual to seek a substitute in his own psyche. It is hard to believe that this teeming world is too poor to provide an object for human love—it offers boundless opportunities to everyone. It is rather the inability to love which robs a person of these opportunities. The world is empty only to him who does not know how to direct his libido towards things and people, and to render them alive and beautiful. What compels us to create a substitute from within ourselves is not an external lack, but our own inability to include anything outside ourselves in our love. Certainly the difficulties and adversities of the struggle for existence may oppress us, yet even the worst conditions need not hinder love; on the contrary, they often spur us on to greater efforts. Real difficulties alone will never drive the libido back to the point where a neurosis arises, because the conflict which is the precondition for every neurosis is lacking. Only a resistance, which opposes its obstinate “won’t” to the “will,” is capable of producing a regression that may become the starting-point for a pathogenic disturbance. Resistance to loving produces the inability to love, or else that inability acts as a resistance. Just as the libido may be compared to a steady stream pouring its waters into the world of reality, so a resistance, dynamically considered, resembles, not a rock that juts up from the river-

bed and causes the stream to flow round it, but a flowing back towards the source. Part of the psyche really wants the external object, but another part of it strives back to the subjective world, where the airy and lightly built palaces of fantasy beckon. We can take this dichotomy of the human will, for which Bleuler has coined the term “ambitendency,”³ as a constant factor, bearing in mind that the most primitive motor impulses are essentially antithetical, since, even in a simple act like stretching, the flexor muscles must be innervated. Normally, however, this ambitendency never leads to the inhibition or prevention of the intended act, but is absolutely necessary for its co-ordination and execution. If, from this harmony of delicately balanced opposites, there should arise any resistance to the act, then it must be due to an abnormal plus or minus quantity on one side or the other. The resistance springs from the intervention of this third factor. This is true also of the dichotomy of the will which is the cause of so many human problems. The abnormal “third factor” loosens the paired opposites which are normally bound tightly together and makes them appear as separate tendencies, as a genuine “won’t” and “will” that get in each other’s way.⁴ Harmony thus turns into disharmony. This is not the place to investigate where the unknown third factor comes from and what it is. Freud sees the root complex in the incest problem, since in his view the libido that regresses to the parents produces not only symbols, but symptoms and situations that can only be regarded as incestuous. This is the source of all those incestuous relationships with which mythology swarms. The reason this regression is so easy seems to lie in the specific inertia of the libido, which will relinquish no object of the past, but would like to hold it fast forever. Stripped of its incestuous covering, Nietzsche’s “sacrilegious backward grasp” is only a metaphor for a reversion to the original passive state where the libido is arrested in the objects of childhood. This inertia, as La Rochefoucauld says, is also a passion:

Of all the Passions we are exposed to, none is more concealed from our Knowledge than Idleness. It is the most violent, and the most mischievous of any, and yet at the same time we are never sensible of its Violence, and the damage we sustain by it is very seldom seen. If we consider its Power carefully, it will be found, upon all Occasions, to reign absolute over all our Sentiments, our Interests, and our Pleasures. This is a Remora that can stop the largest Ships, and a Calm of worse Consequence in our Affairs, than any Rocks, and Storms. The Ease and Quiet of Sloth is a secret Charm upon the Soul, to suspend its most eager Pursuits, and shake its most peremptory Resolutions. In a Word, to give a true image of this Passion, we must say that it is a supposed Felicity of the Soul, that makes her easie under all her Losses, and supplies the Place of all her Enjoyments and Advantages.⁵

[254] This dangerous passion is what lies hidden beneath the hazardous mask of incest. It confronts us in the guise of the Terrible Mother⁶ (pl. XVI, cf. also pl. XXXVIII), and is indeed the mother of innumerable evils, not the least of which are neurotic disturbances. For out of the miasmas arising from the stagnant pools of libido are

born those baneful phantasmagorias which so veil reality that all adaptation becomes impossible. However, we shall not enquire further into the, origin of incest fantasies; the bare mention of the incest problem must suffice. Here we are concerned only with the question whether the resistance which, in the case of our author, led to a regression, signifies a conscious external difficulty or not. If it were an external difficulty, then the libido would be violently dammed back, and would produce a flood of fantasies which could best be described as plans to overcome the obstacle: ideas that toy with solutions, perhaps even some hard thinking which might lead to anything rather than a hypnagogic poem. The passive state described above does not fit in with the idea of an external obstacle, but, through its very acquiescence, points to a tendency that scorns real solutions and prefers a fantastic substitute. In the last resort, therefore, we must be dealing with an internal conflict, somewhat after the style of those earlier experiences which resulted in the first two unconscious creations. We are thus forced to conclude that the external object simply *cannot* be loved, because an overwhelming proportion of the libido prefers an internal object that rises up from the unconscious as a substitute for the missing reality.

[255] The visionary phenomena produced by the first stage of introversion can be classed among the well-known symptoms⁷ of hypnagogic vision. They provide the basis for the actual visions or “self-perceptions” of the libido in the form of symbols.

[256] Miss Miller continues:

Then an impression that something was on the point of being communicated to me. It seemed as if these words were repeating themselves in me—“Speak, Lord, for thy servant heareth—Open thou mine ears.”

[257] This passage describes the underlying intention very clearly; the word “communication” (*communiqué*) is actually a common expression in mediumistic circles. The Biblical words contain an invocation or “prayer,” that is, a wish addressed to God, a concentration of libido on the God-image. The prayer refers to I Samuel 3:1ff., where Samuel was called three times by God during the night, but thought it was Eli calling him, until Eli told him that it was God, and that if he was called again, he should answer: “Speak, Lord, for thy servant heareth.” The dreamer uses these words in the opposite sense, in order to direct her wishes, her libido, into the depths of the unconscious.

[258] We know that however much individuals differ from one another in the content of their conscious minds, they become all the more alike when regarded from the standpoint of the unconscious. The psychotherapist cannot fail to be impressed when he realizes how uniform the unconscious images are despite their surface richness. Differences only arise through individuation—a fact which provides the psychological justification for an essential portion of the philosophies of

Schopenhauer, Carus, and von Hartmann, whose views have as their psychic basis the obvious uniformity of the unconscious. The unconscious consists, among other things, of remnants of the undifferentiated archaic psyche, including its animal stages. The reactions and products of the animal psyche have a uniformity and constancy of which we seem able to discover only sporadic traces in man. Man seems to us far more individual than the animals. This may perhaps be a delusion, since we have in us a convenient tendency to discern differences mainly in the things which interest us. Psychological adaptation makes this inevitable, for without the minute differentiation of impressions all adaptation would be impossible. So strong is this tendency that we have, in fact, the greatest difficulty in recognizing the common connection between the things we have to do with in everyday life. It is much easier to recognize the connection in things that are remote from us. For instance, it is almost impossible for a European to distinguish at first between the faces in a Chinese crowd, although the Chinese have just as individual a physiognomy as we Europeans; but what their faces have in common is much more evident to the outsider than their individual differences. If we live among the Chinese, the impression of uniformity gradually disappears, and in the end they too become individuals. Individuality is one of those conditioned factors which are greatly overrated on account of their practical importance; it does not come into the category of those self-evident, universal truths upon which a science must be founded. The individual content of consciousness is therefore the most unfavourable object imaginable for psychology, precisely because it has differentiated the universal to the point of unrecognizability. The essence of conscious processes is adaptation, which takes place in a series of particulars. The unconscious, on the other hand, is universal: it not only binds individuals together into a nation or race, but unites them with the men of the past and with their psychology. Thus, by reason of its supra-individual universality,⁸ the unconscious is the prime object of any real psychology that claims to be more than psychophysics.

[259] Man as an individual is a very suspicious phenomenon whose right to exist could be questioned by the biologist, since from that point of view he is significant only as a collective creature or as a particle in the mass. The cultural point of view gives man a meaning apart from the mass, and this, in the course of centuries, led to the development of personality and the cult of the hero. The efforts of rationalistic theology to preserve the *personal* Jesus as the last and most precious remnant of a divinity whom we are no longer capable of imagining, are quite in keeping with this tendency. In this respect the Catholic Church proved more adaptable, since she met the universal need for a visible hero by recognizing God's vicar upon earth. The concrete reality of religious figures assists the canalization of libido into the equivalent symbols, provided that the worship of them does not get stuck at the

outward object. But even if it does, it at least remains bound to the representative human figure and loses its original primitive form, even though it does not attain the desired symbolic form. This need for a visible reality has been secretly preserved in a certain personalistic brand of Protestant theology which insists on the historical Jesus. Not that men have ever loved the visible God: they do not love him for what he appears to be, a mere man, because if the pious want to love humanity they have only to turn to their neighbours or their enemies. The religious figure cannot be a mere man, for it has to represent what it actually is, namely the totality of all those primordial images which express the “extraordinarily potent,” always and everywhere. What we seek in visible human form is not man, but the superman, the hero or god, that *quasi-human* being who symbolizes the ideas, forms, and forces which grip and mould the soul. These, so far as psychological experience is concerned, are the archetypal contents of the (collective) unconscious, the archaic heritage of humanity, the legacy left behind by all differentiation and development and bestowed upon all men like sunlight and air. But in loving this inheritance they love that which is common to all; they turn back to the mother of humanity, to the psyche, which was before consciousness existed, and in this way they make contact with the source and regain something of that mysterious and irresistible power which comes from the feeling of being part of the whole. It is the problem of Antaeus, who could only keep his giant strength through contact with mother earth. This temporary withdrawal into oneself seems, within certain limits, to have a favourable effect upon the psychic well-being of the individual. As one would expect, the two fundamental mechanisms of the psyche, extraversion and introversion, are also to a large extent the normal and appropriate ways of reacting to complexes—extraversion as a means of escaping from the complex into reality, introversion as a means of detaching oneself from external reality through the complex.

[260] The story in I Samuel 3:1ff. illustrates how the libido can be directed inwards: the invocation expresses this introversion, and the explicit expectation that God will speak empties the conscious mind of activity and transfers it to the divine being constellated by the invocation, who, from the empirical point of view, must be regarded as a primordial image. It is a fact of experience that all archetypal contents have a certain autonomy, since they appear spontaneously and can often exercise an overwhelming compulsion. There is, therefore, nothing intrinsically absurd about the expectation that “God” will take over the activity and spontaneity of the conscious mind, for the primordial images are quite capable of doing precisely this.

[261] Now that we have informed ourselves of the general purpose of the prayer, we are prepared to hear more about the visions of our dreamer. After the prayer, “the head of a sphinx in an Egyptian setting” appeared, only to disappear again immediately after. At this point the dreamer was disturbed, and woke up for a

moment. The vision recalls the fantasy of the Egyptian statue mentioned in the beginning, whose rigid gesture is entirely in place here as a functional phenomenon, the light stages of hypnosis being technically known as “engourdissement” (stiffening). The word “sphinx” suggests “enigma,” an enigmatic creature who propounds riddles, like the Sphinx of Oedipus, and stands on the threshold of man’s fate as though symbolically announcing the inevitable. The Sphinx is a semi-theriomorphic representation of the mother-imago, or rather of the Terrible Mother, who has left numerous traces in mythology. I shall be told that nothing except the word “Sphinx” justifies our allusion to the Sphinx of Oedipus. But, in the absence of any context, an individual interpretation of the vision is impossible. The “Egyptian” fantasy hinted at in Part I (par. 52) is far too vague to be used here. Therefore, in order to understand the vision at all, we have to turn boldly to the ethnological material, on the assumption that the unconscious coins its symbols today in much the same way as it did in the remote past. With regard to the Sphinx, I would remind the reader of what I said in Part I (par. 24) about theriomorphic representations of the libido. (Cf. pl. *iva*.) They are well known to the doctor from the dreams and fantasies of his patients, where instinct is often represented as a bull, horse, dog, etc. One of my patients, who had questionable relations with women, and who began the treatment with the fear that I would forbid him his adventures, dreamt that I had very skilfully speared a strange animal, half pig, half crocodile, to the wall. Dreams are full of these theriomorphic representations of libido. Hybrids and monsters, like the one found here, are not at all infrequent. Bertschinger⁹ has given us a series of illustrations in which the lower (animal) half in particular is represented theriomorphically. The libido so represented is the “animal” instinct¹⁰ that has got repressed. In the above-mentioned case, one asks oneself in some bewilderment where the repression can lie in such a man, since he obviously lives out his instincts as much as possible. But we must remember that sex is not the only instinct, nor can instinct be identified outright with sex. It is therefore conceivable that my patient was damaging his instinct precisely through his manifest lack of sexual repression. His fear of my imposing some medical prohibition on him is reflected a little too faithfully in the dream for the latter to be altogether above suspicion. Dreams which repeat the real situation too emphatically, or insist too plainly on some anticipated reality, are making use of conscious contents as a means of expression. His dream is really expressing a projection: he projects the killing of the animal on to the doctor. That is the way it appears to him, because he does not know that he himself is injuring his instinct. The pointed instrument generally means the needle of the intellect, with which insects are pinned down and classified. He has “modern” ideas about sex, and does not know that he has an unconscious fear of my taking his pet theories away from him. This possibility is rightly feared, for if it were not in him he

would hardly have had this dream. Thus the theriomorphic symbols always refer to unconscious manifestations of libido.

[262] There are two main reasons why these instinctual impulses are unconscious: the first is the general unconsciousness which we all share to a greater or less degree; the other is a secondary unconsciousness due to the repression of incompatible contents. This is not a cause, but rather a symptom, of a neurotic attitude which prefers to overlook unpleasant facts, and unhesitatingly risks a whole chain of pathological symptoms for the sake of some small advantage in the present.

[263] Repression, as we have seen, is not directed solely against sexuality, but against the instincts in general, which are the vital foundations, the laws governing all life. The regression caused by repressing the instincts always leads back to the psychic past, and consequently to the phase of childhood where the decisive factors appear to be, and sometimes actually are, the parents. But the inborn instincts of the child play a distinct role aside from the parents, as can be seen from the fact that the parents do not exercise a uniform influence on their children, who each react to them in a different way. They must, therefore, possess individual determinants. Yet, to the empty consciousness of the child, it must seem as if all the determining influences came from outside, because children cannot distinguish their own instincts from the influence and will of their parents. This lack of discrimination in the child makes it possible for the animals which represent the instincts to appear at the same time as *attributes* of the parents, and for the parents to appear in animal form, the father as a bull, the mother as a cow (cf. pl. *La*), and so on.¹¹

[264] If the regression goes still further back, beyond the phase of childhood to the preconscious, prenatal phase, then archetypal images appear, no longer connected with the individual's memories, but belonging to the stock of inherited *possibilities of representation* that are born anew in every individual. It is from them that there arise those images of "divine" beings, part animal, part human. The guise in which these figures appear depends on the attitude of the conscious mind: if it is negative towards the unconscious, the animals will be frightening; if positive, they appear as the "helpful animals" of fairytale and legend.¹² It frequently happens that if the attitude towards the parents is too affectionate and too dependent, it is compensated in dreams by frightening animals, who represent the parents just as much as the helpful animals did. The Sphinx is a fear-animal of this kind and still shows clear traces of a mother derivative. In the Oedipus legend the Sphinx was sent by Hera, who hated Thebes on account of the birth of Bacchus. Oedipus, thinking he had overcome the Sphinx sent by the mother-goddess merely because he had solved her childishly simple riddle, fell a victim to matriarchal incest and had to marry Jocasta, his mother, for the throne and the hand of the widowed queen belonged to him who freed the

land from the plague of the Sphinx. This had all those tragic consequences which could easily have been avoided if only Oedipus had been sufficiently intimidated by the frightening appearance of the “terrible” or “devouring” Mother whom the Sphinx personified. (Cf. pls. XVI, XLVIII.) He was far indeed from the philosophical wonderment of Faust: “The Mothers, the Mothers, it has a wondrous sound!” Little did he know that the riddle of the Sphinx can never be solved merely by the wit of man.

[265] The genealogy of the Sphinx has manifold connections with the problem touched upon here: she was a daughter of Echidna, a monster with the top half of a beautiful maiden, and a hideous serpent below. This double being corresponds to the mother-imago: above, the lovely and attractive human half; below, the horrible animal half, changed into a fear-animal by the incest prohibition.¹³ Echidna was born of the All-Mother, Mother Earth, Gaia, who conceived her with Tartarus, the personification of the underworld. Echidna herself was the mother of all terrors, of the Chimera, Scylla, the Gorgon (pl. XIVb), of frightful Cerberus, of the Nemean lion, and of the eagle that devoured the liver of Prometheus. She also gave birth to a number of dragons. One of her sons was Orthrus, the dog of the monster Geryon, who was slain by Heracles. With this dog, her own son, Echidna incestuously begat the Sphinx. This should be sufficient to characterize the complex whose symbol is the Sphinx. It is evident that a factor of such magnitude cannot be disposed of by solving a childish riddle. The riddle was, in fact, the trap which the Sphinx laid for the unwary wanderer. Overestimating his intellect in a typically masculine way, Oedipus walked right into it, and all unknowingly committed the crime of incest. The riddle of the Sphinx was *herself*—the terrible mother-imago, which Oedipus would not take as a warning.

[266] If, in spite of the lack of subjective material, we may venture an inference concerning the sphinx symbol in the case of Miss Miller, we may perhaps say that its meaning for her is approximately the same as it was for Oedipus, even though Oedipus was a man. We would almost expect a masculine sphinx, and as a matter of fact there are masculine as well as feminine sphinxes in Egypt. This may have been known to Miss Miller. (The Sphinx of Thebes was undoubtedly feminine.) If our expectations are correct, it would have to be a masculine monster, because the danger for a woman comes not from the mother, but from the father. We shall leave this question undecided for the moment, and turn back to the facts. After Miss Miller had concentrated her thoughts again, the vision continued as follows:

Suddenly, the apparition of an Aztec, complete in every detail: hand open, with large fingers, head in profile, armoured, with a head-dress resembling the plumed crests of the American Indians, etc. The whole is somewhat suggestive of the carvings on Mexican monuments.

[267] Our conjecture that a masculine figure was hidden in the Sphinx is now confirmed. The Aztec is a primitive Indian, or rather a primitive American. On the personal level he represents the primitive side of the father, since Miss Miller was an American. I have frequently observed in the analysis of Americans that the inferior side of the personality, the “shadow,”¹⁴ is represented by a Negro or an Indian, whereas in the dream of a European it would be represented by a somewhat shady individual of his own kind. These representatives of the so-called “lower races” stand for the inferior personality component of the man. But Miss Miller is a woman. Therefore her shadow would have to be a feminine figure. But what we have here is a masculine figure which, in view of the role it plays in the Miller fantasies, must be regarded as a personification of the masculine component of the woman’s personality. (Cf. pl. xvii.) In my later writings I have called this personification the “animus.”¹⁵

[268] The details of this vision are worth going into, because there are several things to be noticed. The head-dress of eagle’s feathers has a magical significance. The Indian takes on something of the sun-like nature of this bird when he adorns himself with its feathers, just as he assimilates the courage and strength of his enemy when he eats the latter’s heart or takes his scalp. At the same time the feather crest is a crown which is equivalent to the rays of the sun. (Pl. xxib.) The importance of the sun identification was made clear in Part I. Further proof of this is furnished not only by innumerable ancient customs, but by equally ancient religious figures of speech, as in the Wisdom of Solomon 5: 16: “Therefore shall they receive ... a beautiful crown from the Lord’s hand.” There are countless other passages of this kind in the Bible. A hymn by J. L. K. Allendorf says of the soul:

The soul is freed from all care and pain
And in dying it has come
To the crown of joy; she stands as bride and queen
In the glitter of eternal splendour,
At the side of the great king.

It [the soul] sees a clear countenance [sun]:
His [the sun’s] joyful loving nature
Now restores it through and through:
It is a light in his light.
Now the child can see the father.
He feels the gentle emotion of love.
Now he can understand the word of Jesus.
He himself, the father, has loved you.

An unfathomable sea of benefits,
An abyss of eternal waves of blessing
Is disclosed to the enlightened spirit:
He beholds the countenance of God,
And knows what signifies the inheritor
Of God in light and the co-heir of Christ.
The feeble body rests on the earth:
It sleeps until Jesus awakens it.
Then will the dust become the sun,
Which now is covered by the dark cavern:
Then shall we come together
With all the pious, who knows how soon,
And will be for eternity with the Lord.¹⁶

[269] Another hymn, by Laurentius Laurentii (1660–1722), says:

To the bride, because she conquers,
Now is given the eternal crown.¹⁷

[270] In a hymn by G. W. Sacer (1635–99) we find the passage:

Adorn my coffin with garlands
Just as a conqueror is adorned,
From those springs of heaven,
My soul has attained
The eternally green crown:
The true glory of victory,
Coming from the son of God
Who has so cared for me.¹⁸

[271] Special importance seems to attach to the hand, which is described as “open,” with “large” fingers. It is rather odd that the accent should fall on the hand, as one would rather have expected a description of the face and its expression. It is well known that the gesture of the hand is significant; unfortunately, further details are lacking here. Nevertheless, we might mention a parallel fantasy which also concerns the hand: a patient in a hypnagogic condition saw his mother painted on a wall, like a mural in a Byzantine church. She held one hand up, wide open, with splayed fingers. The fingers were very large, swollen at the ends into knobs, each surrounded by a small halo. The immediate association with this image was the fingers of a frog with suckers at the ends; then the resemblance to a phallus. The antiquated setting of the mother-image is also important. Presumably the hand in this fantasy had a spermatic

and creative significance. This interpretation is borne out by other fantasies of the same patient: he saw what looked like a skyrocket going up from his mother's hand, which on closer inspection proved to be a shining bird with golden wings—a golden pheasant, it then occurred to him. We have seen in the last chapter that the hand actually has a phallic meaning, and that it plays a corresponding role in the production of fire. Fire is bored with the hand; therefore fire comes from the hand; and Agni, fire, was worshipped as a golden-winged bird.¹⁹

[272] Miss Miller says of the Aztec: "In my childhood I was particularly interested in Aztec remains and in the history of Peru and the Incas." Unfortunately, she tells us nothing more in this connection. We can, however, conclude from the sudden appearance of the Aztec that the unconscious was willing to let itself be impressed by her reading, presumably because this material had a natural affinity with her unconscious contents or was able to give them satisfactory expression. Just as we surmised an aspect of the mother in the Sphinx, so the Aztec is probably an aspect of the father. The mother's influence is mainly on the Eros of her son, therefore it was only logical that Oedipus should end up by marrying his mother. But the father exerts his influence on the mind or spirit of his daughter—on her "Logos." This he does by increasing her intellectuality, often to a pathological degree which in my later writings I have described as "animus possession." These spiritual influences played a not unimportant part in the personal history of our author and, as I pointed out in the Foreword to the second edition of this volume, finally led to insanity. Although the Aztec is a masculine figure and thus clearly betrays the influence of the father, it was the feminine Sphinx that came first. In an American girl this might conceivably point to the preponderance of the feminine element. Mother complexes are extremely common in America and often very pronounced, probably because of the strong maternal influence in the home and the social position of women generally. The fact that more than half the capital in America is in women's hands gives one something to think about. As a result of this conditioning many American women develop their masculine side, which is then compensated in the unconscious by an exquisitely feminine instinct, aptly symbolized by a Sphinx.

[273] The figure of the Aztec appears with all its "heroic" qualities: it represents the masculine ideal for the primitive, female side of our author. We have already met this ideal in the Italian naval officer, who "so softly and silently vanished away." Though, in certain respects, he came up to the unconscious ideal that floated before Miss Miller, he was not able to compete with this rival because he lacked the mysterious charm of the "demon lover," of the angel who takes a tender interest in the daughters of men, as angels sometimes seem inclined to do. (Hence the rule that women must cover up their hair in church, where the angels hover near!) We now understand what it was that turned against the naval officer: it was Miss Miller's spirituality, which,

personified as the Aztec, was far too exalted for her ever to find a lover among mortal men. However reasonable and unexacting the conscious attitude may be in such a case, it will not have the slightest effect on the patient's unconscious expectations. Even after the greatest difficulties and resistances have been overcome, and a so-called normal marriage is made, she will only discover later on what the unconscious wants, and this will assert itself either as a change of life style or as a neurosis or even a psychosis.

[274] After this vision Miss Miller felt that a name was forming itself in her "bit by bit," a name that seemed to belong to this Aztec, who was the "son of an Inca of Peru." The name was "Chi-wan-to-pel."²⁰ The author says that it was somehow connected with her reminiscences. The act of naming is, like baptism, extremely important as regards the creation of personality, for a magical power has been attributed to the name since time immemorial. To know the secret name of a person is to have power over him. A well-known example of this is the tale of Rumpelstiltskin. In an Egyptian myth, Isis permanently robs the sun-god Ra of his power by compelling him to tell her his real name. Therefore, to give a name means to give power, to invest with a definite personality or soul.²¹ Here the author remarked that the name reminded her very much of "Popocatepetl," which as we all know belongs to the unforgettable memories of our school-days and, much to the indignation of patients under analysis, occasionally turns up in a dream or association. Although one might hesitate to regard this schoolboy joke as of psychological importance, one must nevertheless inquire into the reasons for its existence. One must also ask: Why is it always Popocatepetl and not the neighbouring Ixtaccihuatl, or the even higher and more beautiful Orizaba? The latter is a nicer name and is far easier to pronounce. Popocatepetl, however, is impressive precisely because of its onomatopoeic name. In English the onomatopoeia that comes to mind is *pop* or *pop-gun*; in German and French, the words *Hinter-pommern*, *Pumpnickel*, *Bombe*, *petarde* (*le pet* = flatus). The German word *Popo*, 'posterior,' does not exist in English,²² but on the other hand to break wind is sometimes called *to pop* or *to poop*, and the act of defecation is commonly known as *to poop* or *to poo-poo* in childish speech. A jocular name for the posterior is *bum*. (*Poop* also means the rear end of a ship.) In French, *pouf!* is onomatopoeic; *pouffer*, 'explode,' *la poupe*, 'poop of a ship,' *le poupard*, 'baby in arms,' *la poupée*, 'doll.' *Poupon* is a pet name for a chubby-cheeked child. In Dutch, *pop* is 'doll'; in Latin, *puppis* means poop of a ship, though Plautus uses it jokingly for the backside of the body; *pupus*, 'child,' *pupula*, 'girl, little doll.' The Greek $\rho\omicron\pi\pi\tilde{\upsilon}\zeta\omega$ denotes a smacking, snapping, or blowing noise. It is used of kissing, but also (in Theocritus) of the subsidiary noises connected with flute-playing.

[275] One of my patients, in his boyhood, always associated the act of defecation with the fantasy that his posterior was a volcano in full eruption, with violent explosions

of gas and gushings forth of lava. The words for the elemental occurrences of nature are not, as a rule, very poetical: one thinks of a beautiful phenomenon like the meteor, which in German is called “Sternschnuppe” (smouldering wick of a star, which is “snuffed” out). Certain South American Indians call it “piss of the stars.” The Voile de la Vierge waterfall in the Valais, famous for its beauty, has only recently been called by this poetic name. Formerly it was known as the Pissevache. One takes the name from the nearest source.

[276] It seems very puzzling at first why the figure of Chiwantopel, whom Miss Miller awaited with positively mystical expectation and whom she herself compared, in a note, to a mediumistic control, should get into such a disreputable neighbourhood that his very essence—his name—appears to be bound up with those out-of-the-way regions of the body. In order to understand this, we have to realize that when something is produced from the unconscious, the first thing to come up is the infantile material that has long been lost to memory. We have, therefore, to adopt the point of view of that time, when this material was still on the surface. So if a much venerated object is related by the unconscious to the anal region, we have to conclude that this is a way of expressing respect and attention, such as the child feels for these forbidden functions. Naturally traces of this infantile interest still linger on in the adult. The only question is whether this interest corresponds to the psychology of the child. Before we attempt to answer this question, it must be said at once that the anal region is very closely connected with veneration. An Oriental fairy-tale relates that the Crusaders used to anoint themselves with the excrement of the Pope in order to make themselves more formidable. One of my patients, who had a special veneration for her father, had a fantasy in which she saw her father sitting on a commode in a dignified manner, while people filed past greeting him effusively. We might also mention the intimate connection between excrement and gold:²³ the lowest value allies itself to the highest. The alchemists sought their *prima materia* in excrement, one of the arcane substances from which it was hoped that the mystic figure of the *filius philosophorum* would emerge (“in stercore invenitur”). A very religiously brought-up young patient once dreamt that she saw the Crucifix formed of excrement on the bottom of a blue-flowered chamber-pot. The contrast is so enormous that one can only assume that the valuations of childhood are totally different from ours. And so, indeed, they are. Children bring to the act of defecation and its products an interest²⁴ such as is later evinced only by the hypochondriac. We can only begin to understand this interest when we realize that the young child connects defecation with a theory of propagation. This puts a somewhat different complexion on the matter. The child thinks: that is how things are produced, how they “come out.”

[277] The same child on whom I reported in my “Psychic Conflicts in a Child” and who had a well-developed anal birth theory, like Freud’s “Little Hans,”²⁵ later

contracted the habit of sitting for hours on the toilet. On one occasion her father, growing impatient, went to the toilet and called: "Come out at once! Whatever are you doing?" Whereupon the answer came from within: "I'm doing a little cart and two ponies!" So the child was "making" a little cart and two ponies, things she particularly wanted at that moment. In this way one can make whatever one wishes. The child wishes passionately for a doll or, at heart, for a real baby—that is, she is practising for her future biological task; and in exactly the same way that things in general are produced, she makes the "doll"²⁶ that stands for the baby and all her other wishes. From a patient I got a parallel fantasy dating from her childhood: in the toilet there was a crack in the wall, and she used to imagine that a fairy would come out of this crack and give her everything she wished for. The toilet is well known as the place of dreams where much is created that would later be considered unworthy of this place of origin. Lombroso recounts a pathological fantasy of two insane artists, which is relevant here:

Each of them thought he was God Almighty and the ruler of the universe. They created or produced the world by making it come forth from the rectum, like a bird's egg from the oviduct (or cloaca). One of these artists was gifted with real artistic sense. He painted a picture of himself in the act of creation: the world came forth from his anus, his member was in full erection, he was naked, surrounded by women and by all the insignia of his power.²⁷

[278] It was only after I realized these connections that an observation I made many years ago, which kept on bothering me because I had never rightly understood it, finally became clear to me. The patient was an educated woman who was separated from her husband and child under tragic circumstances and taken to an asylum. She exhibited a typical apathy and slovenliness which were considered due to "affective deterioration." As I rather doubted this deterioration and was inclined to regard it more as a secondary phenomenon, I took great pains to find out how I could get at the blocked source of affect. Finally, after more than three hours' hard work, I hit upon a train of thought that suddenly produced a violent outburst of affect in the patient. Complete affective rapport was instantly established. This happened in the morning, and when I returned at the appointed time in the evening to see her in the ward, she had smeared herself with excrement from head to foot for my reception, and cried out laughingly: "How do you like me now?" She had never done this before; it was obviously a gesture intended for my benefit. The impression it made on me was so powerful that for years afterwards I was convinced of the affective deterioration of such cases. In reality this ceremony of welcome was a drastic attempt to ward off the transference—in so far as the patient acted as an adult. But in so far as she acted on the level of regressive infantilism, the ceremony denoted an outburst of positive feeling. Hence the equivocal "Do you like me now?"

[279] The birth of Chiwantopel from Popocatepetl therefore means: “I make, produce, invent him out of myself.” It is the creation or birth of man by the infantile route. The first men were made from earth or clay. The Latin *lutum*, which really means ‘mud,’ also had the metaphorical meaning of ‘filth.’ Plautus even uses it as a term of abuse, something like “You scum!” The idea of anal birth recalls the motif of throwing something behind one. A well-known example of this is the story of Deucalion and Pyrrha, the sole survivors of the Flood, who were told by the oracle to throw behind them the bones of the Great Mother. They thereupon threw stones behind them, from which mankind sprang. There is a similar legend that the Dactyls sprang from the dust which the nymph Anchiale threw behind her. In this connection one thinks of the humorous significance that attaches to anal products: in popular humour excrement is often regarded as a monument or souvenir (which in the case of criminals plays an important part in the form of the *grumus merdae*). Everyone knows the joke about the man who wandered through labyrinthine passages looking for a hidden treasure, and who, after shedding all his clothing, deposited an excrementum as a last sign-post for the journey back. In the distant past no doubt such a sign possessed as great a significance as the droppings of animals to indicate a man’s whereabouts or the direction taken. Stone monuments will later have replaced this more perishable memorial.

[280] As a parallel to Chiwantopel’s emergence into consciousness, Miss Miller mentions another instance of a name suddenly obtruding itself on her mind: “A-ha-ma-ra-ma,” which, she felt, had something Assyrian about it. As a possible source there came into her mind the words: “Asurabama (who made cuneiform bricks).” This fact was unknown to me. We know that Assurbanipal left behind him the cuneiform library excavated at Kuyunjik, and it may be that “Asurabama” has something to do with “Assurbanipal.” We must also consider the name “Aholibamah,” which we met in Part I. The word “Ahama-rama” likewise has associations with Anah and Aholibamah, those daughters of Cain with the sinful passion for the sons of God. This possibility points to Chiwantopel as the longed-for son of God. Was Byron thinking, perhaps, of the two whorish sisters Aholah and Aholibah (Ezek. 23)? Aholibamah was the name of one of Esau’s wives (Gen. 36:2 and 14), and another wife was called Adah. Dr. Riwkah Schärf has drawn my attention to a dissertation by Georg Mayn (1887) on Byron’s “Heaven and Earth,” in which the author points out that Anah was probably Adah in the original draft, but that Byron altered it to Anah because Adah had already occurred in his drama “Cain.” So far as the meaning of the words is concerned, Aholibamah is reminiscent of Aholah and Aholibah: Aholah means “(she has) her (own) tabernacle,” i.e., her own temple, and Aholibah means “my tabernacle is in her,” i.e., in Jerusalem, just as Aholah is the name of Samaria (Ezek. 23:4). In Gen. 36:41 Aholibamah is also the

name of one of the “dukes of Edom.” The Canaanites worshipped on hill—*bamoth*—and a synonym for hill is *ramah*. Whether Miss Miller’s neologism “Ahamarama” can legitimately be connected with this is open to question.

[281] Miss Miller remarks that besides the name “Asurabama” she also thought of “Ahasuerus.” This association points to a very different aspect of the problem of the unconscious personality. While the previous material told us something about the infantile theory of human birth, this association gives us a glimpse into the dynamics of the unconscious creation of personality. Ahasuerus is the Wandering Jew, whose main characteristic was that he had to wander restlessly over the earth till the end of the world. The fact that this particular name occurred to the author justifies us in following his trail.

[282] The legend of Ahasuerus, whose first literary traces are to be found in the thirteenth century, appears to be of Occidental origin. The figure of the Eternal Jew has undergone even more literary elaboration than that of Faust, practically all of it dating from the last century. If the figure were not called Ahasuerus, it would still exist under another name, perhaps as the Comte de Saint-Germain, the mysterious Rosicrucian, whose immortality is assured and whose present whereabouts are supposed to be known.²⁸ Although the stories about Ahasuerus cannot be traced beyond the thirteenth century, the oral tradition may go much further back, and it is possible that a link with the Orient once existed. There the parallel figure is Khidr or El-Khadr, the “eternally youthful Chidher” celebrated in song by Friedrich Rückert. The legend is purely Islamic.²⁹ The strange thing is, however, that Khidr is not only regarded as a saint, but in Sufic circles even has the status of a deity. In view of the strict monotheism of Islam, one is inclined to think of him as a pre-Islamic, Arabian deity who, though not officially recognized by the new religion, was tolerated for reasons of expediency. But there is nothing to prove that. The first traces of Khidr are to be found in the commentaries on the Koran by al-Bukhari (d. 870) and al-Tabari (d. 923), and especially in the commentary on a noteworthy passage in the 18th Sura. This is entitled “The Cave,” after the cave of the seven sleepers who, according to legend, slept in it for 309 years, thus escaping the persecution, and woke up in a new age. It is interesting to see how the Koran, after lengthy moral reflections in the course of this same sura, comes to the following passage, which is especially important as regards the origin of the Khidr myth. I quote the Koran literally.³⁰

And Moses said to his servant (Joshua the son of Nun): “I will not cease to wander until I have reached the place where the two seas meet, even though I journey for eighty years.” But when they had reached the place where the two seas meet, they forgot their fish (which they had brought with them for food), and it took its way through a canal to the sea. And when they had gone past this place, Moses said to his servant: “Bring us our breakfast, for we are weary from our journey.” But his servant answered: “See what has befallen me! When we were encamped

there by the rock, I forgot the fish. Only Satan can have caused me to forget the fish and put it out of my mind, and in wondrous wise it took its way to the sea.” Then Moses said: “That is the place we seek.” And they went back the way they had come. And they found one of Our servants, whom We³¹ had endowed with Our grace and wisdom. Moses said to him: “Shall I follow you, that you may teach me for my guidance some of the wisdom you have learnt?” But he answered: “You will not be able to endure me, for how should you have patience to bear with things you cannot comprehend?”

[283] Moses now accompanies the mysterious servant of God, who does divers things which Moses cannot comprehend; finally the Unknown takes leave of him and speaks as follows:

The Jews will ask you about Dhulqarnein.³² Say: I will tell you a story of him. We established his kingdom on earth and gave him the means of fulfilling all his wishes. He took his way until he came to the place where the sun sets, and it seemed to him as if it set in a black muddy spring....

[284] Now follows a moral reflection, then the story continues:

Then he took his way further, until he came to the place where the sun rises....

[285] If we wish to know who the unknown servant of God is, this passage tells us that he is Dhulqarnein, Alexander; he goes to the place of setting and the place of rising, like the sun. The commentators explain that the unknown servant of God is Khidr, “the Verdant One, the tireless wanderer, the teacher and counsellor of pious men, wise in divine knowledge, the immortal.”³³ On the authority of al-Tabari, Khidr is connected with Dhulqarnein: Khidr, following the armies of Alexander, reached the “stream of life,” and they both unwittingly drank of it, and so became immortal. Moreover, Khidr is identified by the old commentators with Elias (Elijah), who also did not die, but ascended to heaven in a fiery chariot, a feature he shares with Helios.³⁴ It has been conjectured that Ahasuerus owes his existence to an obscure passage in the Bible. This passage occurs in Matthew 16:28. First comes the scene where Christ appoints Peter as the rock of his Church and names him the holder of his power; then follows the prophecy of his death, ending with the words:

Verily I say unto you, There be some standing here, which shall not taste of death, till they see the Son of Man coming in his kingdom.

[286] This is followed immediately by the Transfiguration:

And (he) was transfigured before them: and his face did shine as the sun, and his raiment was white as the light.

And, behold, there appeared unto them Moses and Elias talking with him.

Then answered Peter, and said unto Jesus, Lord, it is good for us to be here: if thou wilt, let us make here three tabernacles; one for thee, and one for Moses, and one for Elias.

[287] From these passages it is clear that Christ is somehow equated with Elias without being identical with him,³⁵ although the people regarded him as Elias. The ascension, however, forms a parallel between Elias and Christ. Christ's prophecy shows that there are one or two immortals besides himself who shall not die until the Second Coming. According to John 21:21ff., John himself was considered to be one of these immortals, and in legend he is in fact not dead, but merely sleeping in the earth until the Second Coming, and his breath causes the dust to swirl around his grave.³⁶

[288] Another legend³⁷ says that Dhulqarnein brought his "friend" Khidr to the source of life, that he might drink of immortality.³⁸ Alexander himself bathed in the stream of life and performed the ritual ablutions. In the Arabian legend Khidr is the companion, or else he is accompanied (either by Dhulqarnein or by Elias, being "like unto" them or identical with them).³⁹ There are, therefore, two figures who resemble one another but are nevertheless distinct. The analogous situation in Christianity is the scene by the Jordan, where John leads Christ to the source of life. Christ, as the baptized, is here the subordinate, while John plays the superior role, as in the case of Dhulqarnein and Khidr, or Khidr and Moses, and Khidr and Elias. Vollers compares Khidr and Elias on the one hand with Gilgamesh and his primitive brother Eabani or Enkidu, and on the other hand with the Dioscuri, one of whom was mortal and the other immortal. This relation applies equally to Jesus and John the Baptist,⁴⁰ and Jesus and Peter. The last-named parallel can be explained only by comparison with the Mithraic mysteries, whose esoteric content is revealed to us in part by the surviving monuments. On the marble relief at Klagenfurt,⁴¹ Mithras is shown crowning Helios with a crown of rays, as he kneels before him or floats up to him from below. On the Osterburken monument, Mithras has in his right hand the shoulder of the mystic bull and holds it above the head of Helios, who stands bowed before him; his left hand rests on his sword hilt; a crown lies between them on the ground. Cumont⁴² remarks that this scene probably represents the divine prototype of initiation into the degree of Miles, when a sword and crown were conferred on the neophyte. Helios is therefore appointed the Miles of Mithras. In general, Mithras seems to act in the capacity of patron to Helios. This recalls the bold attitude of Heracles towards the sun: on his way to fight the monster Geryon the sun burned too fiercely, so Heracles wrathfully threatened him with his invincible arrows. Helios was compelled to yield, and thereupon lent the hero the sun-ship which he used for crossing the sea. Thus Heracles came to Erythia, to the sun-cattle of Geryon.⁴³

[289] On the Klagenfurt monument, Mithras is also shown shaking Helios by the hand, either in farewell or in agreement. (P1. xxivA.) In another scene he mounts the chariot of Helios for the ascension or sea-journey.⁴⁴ Cumont is of the opinion that Mithras performs a kind of ceremonial investiture: he consecrates the divine power of Helios by crowning him with his own hands.⁴⁵ This relationship corresponds to that

between Christ and Peter. Peter's attribute, the cock, gives him a solar character. After Christ's ascension he becomes the visible representative of God; therefore he suffers the same death—crucifixion—as his master, replaces the chief deity of the Roman imperium, the *Sol invictus*, and becomes the head of the Church Militant and Triumphant. In the Malchus scene he already appears as the Miles of Christ, the holder of the sword. His successors all wear the triple crown. But the crown is a solar attribute, hence the Pope is a symbolical “solis invicti comes” like the Roman Caesars. The setting sun appoints a successor whom he invests with his solar power. Dhulqarnein gives Khidr eternal life, Khidr imparts his wisdom to Moses; there is even a legend that Moses' forgetful servant Joshua unwittingly drank from the fountain of life, whereupon he became immortal and, as a punishment, was placed in a boat by Khidr and Moses and cast out to sea—another fragment of a sun-myth, the motif of the “sea-journey.”⁴⁶

[290] The symbol for that portion of the zodiac in which the sun re-enters the yearly cycle at the time of the winter solstice is Capricorn, originally known as the “Goat-Fish” (αἰγόχερος, ‘goat-horned’): the sun mounts like a goat to the tops of the highest mountains, and then plunges into the depths of the sea like a fish. The fish in dreams occasionally signifies the unborn child,⁴⁷ because the child before its birth lives in the water like a fish; similarly, when the sun sinks into the sea, it becomes child and fish at once. The fish is therefore a symbol of renewal and rebirth.

[291] The journey of Moses with his servant Joshua is a life-journey (it lasted eighty years). They grow old together and lose the life-force, i.e., the fish, which “in wondrous wise took its way to the sea” (setting of the sun). When the two notice their loss, they discover at the place where the source of life is found (where the dead fish revived and sprang into the sea) Khidr wrapped in his mantle,⁴⁸ sitting on the ground. In another version he was sitting on an island in the midst of the sea, “in the wettest place on earth,” which means that he had just been born from the maternal depths. Where the fish vanished Khidr, the Verdant One, was born as a “son of the watery deep,” his head veiled, proclaiming divine wisdom, like the Babylonian Oannes-Ea (cf. [fig. 18](#)), who was represented in fish form and daily came out of the sea as a fish to teach the people wisdom.⁴⁹



Fig. 18. Priest with a fish-mask, representing Oannes *Relief, Nimrud*

[292] Oannes' name was brought into connection with John's. With the rising of the reborn sun the fish that dwelt in darkness, surrounded by all the terrors of night and death,⁵⁰ becomes the shining, fiery day-star. This gives the words of John the Baptist a special significance (Matthew 3:11):

I indeed baptize you with water unto repentance; but he that cometh after me is mightier than I ... he shall baptize you with the Holy Ghost, and with fire.

[293] Following Vollers, we may compare Khidr and Elias (or Moses and his servant Joshua) with Gilgamesh and his brother Eabani (Enkidu). Gilgamesh wanders through the world, driven by fear and longing, to find immortality. (Pl. XIX.) His journey takes him across the sea to the wise Utnapishtim (Noah), who knows how to cross the waters of death. There Gilgamesh has to dive down to the bottom of the sea for the magical herb that is to lead him back to the land of men. On the return journey he is accompanied by an immortal mariner, who, banished by the curse of Utnapishtim, has been forbidden to return to the land of the blessed. But when Gilgamesh arrives home, a serpent steals the magic herb from him (i.e., the fish slips back into the sea). Because of the loss of the magic herb, Gilgamesh's journey has

been in vain; instead he comes back in the company of an immortal, whose fate we cannot learn from the fragments of the epic. Jensen⁵¹ believes that this banished immortal is the prototype of Ahasuerus.

[294] Once again we meet the motif of the Dioscuri: mortal and immortal, the setting and rising sun. The Mithraic bull-sacrifice is often represented as flanked by the two dadophors, Cautes and Cautopates, one with a raised and the other with a lowered torch. (Cf. pl. xxb.) They form a pair of brothers whose characters are revealed by the symbolic position of the torches. Cumont not unjustly connects them with the sepulchral Eroles, who as genies with inverted torches have a traditional meaning. One would stand for death, the other for life. There are certain points of resemblance between the Mithraic sacrifice (where the bull in the centre is flanked on either side by dadophors) and the Christian sacrifice of the lamb (or ram). The Crucified is traditionally flanked by two thieves, one of whom ascends to paradise while the other descends to hell.⁵² The Semitic gods were often flanked by two *paredroi*; for instance, the Baal of Edessa was accompanied by Aziz and Monimos (Baal being astrologically interpreted as the sun, and Aziz and Monimos as Mars and Mercury). According to the Babylonian view, the gods are grouped into triads. Thus the two thieves somehow go together with Christ. The two dadophors are, as Cumont has shown, offshoots⁵³ from the main figure of Mithras, who was supposed to have a secret triadic character. Dionysius the Areopagite reports that the magicians held a feast in honour of τοῦ τοῦ τρι-πλασίου Μίθρον⁵⁴ (the threefold Mithras).⁵⁵

[295] As Cumont observes,⁵⁶ Cautes and Cautopates sometimes carry in their hands the head of a bull and of a scorpion respectively. Taurus and Scorpio are equinoctial signs,⁵⁷ and this is a clear indication that the sacrifice was primarily connected with the sun cycle: the rising sun that sacrifices itself at the summer solstice, and the setting sun. Since it was not easy to represent sunrise and sunset in the sacrificial drama, this idea had to be shown outside it.

[296] We have already pointed out that the Dioscuri represent a similar idea in somewhat different form: one sun is mortal, the other immortal. As this whole solar mythology is psychology projected into the heavens, the underlying idea could probably be paraphrased thus: just as man consists of a mortal and an immortal part, so the sun is a pair of brothers, one of whom is mortal, the other immortal. Man is mortal, yet there are exceptions who are immortal, or there is something immortal in us. Thus the gods, or figures like Khidr and the Comte de Saint-Germain, are our immortal part which continues intangibly to exist. The sun comparison tells us over and over again that the dynamic of the gods is psychic energy. This is our immortality, the link through which man feels inextinguishably one with the continuity of all life.⁵⁸ The life of the psyche is the life of mankind. Welling up from

the depths of the unconscious, its springs gush forth from the root of the whole human race, since the individual is, biologically speaking, only a twig broken off from the mother and transplanted.

[297] The psychic life-force, the libido, symbolizes itself in the sun⁵⁹ or personifies itself in figures of heroes with solar attributes. At the same time it expresses itself through phallic symbols. Both possibilities are found on a late Babylonian gem from Lajard's collection (fig. 19). In the middle stands an androgynous deity. On the masculine side there is a snake with a sun halo round its head; on the feminine side another snake with a sickle moon above it. This picture has a symbolic sexual nuance: on the masculine side there is a lozenge, a favourite symbol of the female genitals, and on the feminine side a wheel without its rim. The spokes are thickened at the ends into knobs, which, like the fingers we mentioned earlier, have a phallic meaning. It seems to be a phallic wheel such as was not unknown in antiquity. There are obscene gems on which Cupid is shown turning a wheel consisting entirely of phalli.⁶⁰ As to what the sun signifies, I discovered in the collection of antiquities at Verona a late Roman inscription with the following symbols:⁶¹

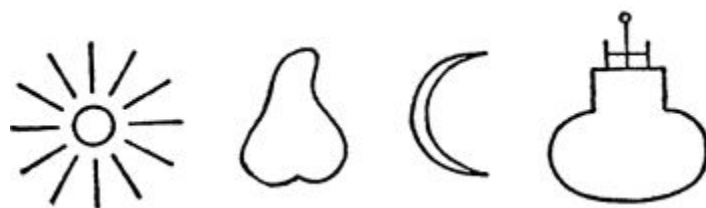

[298] The symbolism is plain: sun = phallus, moon = vessel (uterus). This interpretation is confirmed by another monument from the same collection. The symbols are the same, except that the vessel⁶² has been replaced by the figure of a woman. Certain symbols on coins can probably be interpreted in a similar manner. In Lajard's *Recherches sur la culte de Vénus* there is a coin from Perga, showing Artemis as a conical stone flanked by a masculine figure (alleged to be the deity Men) and a female figure (alleged to be Artemis). Men (otherwise called Lunus) appears on an Attic bas-relief with a spear, flanked by Pan with a club, and a female figure.⁶³ From this it is clear that sexuality as well as the sun can be used to symbolize the libido.

[299] One further point deserves mention here. The dadophor Cautopates is often represented with a cock⁶⁴ and pine-cones. These are the attributes of the Phrygian god Men (pl. xxia), whose cult was very widespread. He was shown with the pileus⁶⁵ (or "Phrygian cap") and pine-cones, riding on the cock, and also in the form of a boy, just as the dadophors were boyish figures. (This latter characteristic relates both them and Men to the Cabiri and Dactyls.) Now Men has affinities with Attis, the son and lover of Cybele. In Imperial times Men and Attis merged into one. Attis also wears the pileus like Men, Mithras, and the dadophors. As the son and lover of his mother

he raises the incest problem. Incest leads logically to ritual castration in the Attis-Cybele cult; for according to legend the hero, driven mad by his mother, mutilates himself. I must refrain from going into this question more deeply at present, as I would prefer to discuss the incest problem at the end of this book. Here I would only point out that the incest motif is bound to arise, because when the regressing libido is introverted for internal or external reasons it always reactivates the parental imagos and thus apparently re-establishes the infantile relationship. But this relationship cannot be re-established, because the libido is an adult libido which is already bound to sexuality and inevitably imports an incompatible, incestuous character into the reactivated relationship to the parents.⁶⁶ It is this sexual character that now gives rise to the incest symbolism. Since incest must be avoided at all costs, the result is either the death of the son-lover or his self-castration as punishment for the incest he has committed, or else the sacrifice of instinctuality, and especially of sexuality, as a means of preventing or expiating the incestuous longing. (Cf. [fig. 20](#).) Sex being one of the most obvious examples of instinctuality, it is sex which is liable to be most affected by these sacrificial measures, i.e., through abstinence. The heroes are usually wanderers,⁶⁷ and wandering is a symbol of longing,⁶⁸ of the restless urge which never finds its object, of nostalgia for the lost mother. The sun comparison can easily be taken in this sense: the heroes are like the wandering sun, from which it is concluded that the myth of the hero is a solar myth. It seems to us, rather, that he is first and foremost a self-representation of the longing of the unconscious, of its unquenched and unquenchable desire for the light of consciousness. But consciousness, continually in danger of being led astray by its own light and of becoming a rootless will o' the wisp, longs for the healing power of nature, for the deep wells of being and for unconscious communion with life in all its countless forms. Here I must make way for the master, who has plumbed to the root of these Faustian longings:



Fig. 19. Androgynous divinity
Late Babylonian gem



Fig. 20. Cybele and her son-lover Attis
Roman coin

MEPHISTOPHELES: This lofty mystery I must now unfold.

Goddesses throned in solitude, sublime,
Set in no place, still less in any time.
At the mere thought of them my blood runs cold.
They are the Mothers!
... ..

Goddesses, unknown to mortal mind,
And named indeed with dread among our kind.
To reach them you must plumb earth's deepest vault;
That we have need of them is your own fault.

FAUST: Where leads the way?

MEPHISTOPHELES: There's none! To the untrodden,
Untreadable regions—the unforgotten
And unforgettable—for which prepare!
There are no bolts, no hatches to be lifted,
Through endless solitudes you shall be drifted.
Can you imagine Nothing everywhere?
... ..
Supposing you had swum across the ocean
And gazed upon the immensity of space,
Still you would see wave after wave in motion,
And even though you feared the world should cease,

You'd still see something—in the limpid green
Of the calm deep are gliding dolphins seen,
The flying clouds above, sun, moon, and star.
But blank is that eternal Void afar.

You do not hear your footfall, and you meet
No solid ground on which to set your feet.

... ..

Here, take this key.

... ..

The key will smell the right place from all others:
Follow it down, it leads you to the Mothers.

... ..

Then to the depths!—I could as well say height:
It's all the same. From the Existent fleeing,
Take the free world of forms for your delight,
Rejoice in things that long have ceased from being.
The busy brood will weave like coiling cloud,
But swing your key to keep away the crowd!

... ..

A fiery tripod warns you to beware,
This is the nethermost place where now you are.
You shall behold the Mothers by its light,
Some of them sit, some walk, some stand upright,
Just as they please. Formation, transformation,
Eternal Mind's eternal recreation.

Thronged round with images of things to be,
They see you not, shadows are all they see.

Then pluck up heart, the danger here is great,
Approach the tripod, do not hesitate,

And touch it with the key.⁶⁹

V

SYMBOLS OF THE MOTHER AND OF REBIRTH

[300] The vision that follows the birth of the hero is described by Miss Miller as a “swarm of people.” We know that this image symbolizes a secret,¹ or rather, the unconscious. The possession of a secret cuts a person off from his fellow human beings. Since it is of the utmost importance for the economy of the libido that his rapport with the environment should be as complete and as unimpeded as possible, the possession of subjectively important secrets usually has a very disturbing effect. It is therefore especially beneficial for the neurotic if he can at last disburden himself of his secrets during treatment. I have often noticed that the symbol of the crowd, and particularly of a streaming mass of people in motion, expresses violent motions of the unconscious. Such symbols always indicate an activation of the unconscious and an incipient dissociation between it and the ego.

[301] The vision of the swarm of people undergoes further development: horses appear, and a battle is fought.

[302] For the time being, I would like to follow Silberer and place the meaning of these visions in the “functional” category, because, fundamentally, the idea of the swarming crowd is an expression for the mass of thoughts now rushing in upon consciousness. The same is true of the battle, and possibly of the horses, which symbolize movement or energy. The deeper meaning of the horses will only become apparent in our treatment of mother-symbols. The next vision has a more definite character and a more significant content: Miss Miller sees a “dream-city.” The picture is similar to one she had seen a short time before on the cover of a magazine. Unfortunately, further details are lacking. But one can easily imagine that this dream-city is something very beautiful and ardently longed for—a kind of heavenly Jerusalem, as the poet of the Apocalypse dreamt it.² (Cf. pl. xxiiia.)

[303] The city is a maternal symbol, a woman who harbours the inhabitants in herself like children. It is therefore understandable that the three mother-goddesses, Rhea, Cybele, and Diana, all wear the mural crown (pl. xxivb). The Old Testament treats the cities of Jerusalem, Babylon, etc. just as if they were women. Isaiah (47 : 1ff.) cries out:

Come down, and sit in the dust, O virgin daughter of Babylon, sit on the ground: there is no throne, O daughter of the Chaldaeans: for thou shalt no more be called tender and delicate.

Take the millstones, and grind meal: uncover thy locks, make bare the leg, uncover the thigh, pass over the rivers.

Thy nakedness shall be uncovered, yea, thy shame shall be seen:

I will take vengeance, and I will not meet thee as a man....

Sit thou silent, and get thee into darkness, O daughter of the Chaldaeans: for thou shalt no more be called, The lady of kingdoms.

[304] Jeremiah (50:12) says of Babylon:

Your mother shall be sore confounded; she that bare you shall be ashamed.

[305] Strong, unconquered cities are virgins; colonies are sons and daughters. Cities are also harlots; Isaiah (23:16) says of Tyre:

Take an harp, go about the city, thou harlot that hast been forgotten,

and (1:21):

How is the faithful city become an harlot!

[306] We find a similar symbolism in the myth of Ogyges, the prehistoric king of Egypt who reigned in Thebes, and whose wife was appropriately called Thebe. The Boeotian city of Thebes founded by Cadmus received on that account the cognomen "Ogygian." This cognomen was also applied to the great Flood, which was called "Ogygian" because it happened under Ogyges. We shall see later on that this coincidence can hardly be accidental. The fact that the city and the wife of Ogyges both have the same name indicates that there must be some relation between the city and the woman, which is not difficult to understand because the city is identical with the woman. There is a similar idea in Hindu mythology, where Indra appears as the husband of Urvara. But Urvara means the "fertile land." In the same way the seizure of a country by the king was regarded as his marriage with the land. Similar ideas must also have existed in Europe. Princes at their accession had to guarantee a good harvest. The Swedish king Domaldi was actually killed as a result of failure of the crops (Ynglinga Saga, 18). In the Hindu Ramayana, the hero Rama marries Sita, the furrow. To the same circle of ideas belongs the Chinese custom of the emperor's having to plough a furrow on ascending the throne. The idea of the soil as feminine also embraces the idea of continuous cohabitation with the woman, a physical interpenetration. The god Shiva, as Mahadeva and Parvati, is both male and female: he has even given one half of his body to his wife Parvati as a dwelling-place (pl. XXIII). The motif of continuous cohabitation is expressed in the well-known lingam symbol found everywhere in Indian temples: the base is a female symbol, and within it stands the phallus.³ (P1. xxv.) This symbol is rather like the phallic baskets and chests of the Greeks. The chest or casket is a female symbol (cf. [fig. 21](#) and pl. LIII),

i.e., the womb, a common enough conception in the older mythologies.⁴ The chest, barrel, or basket with its precious contents was often thought of as floating on the water, thus forming an analogy to the course of the sun. The sun sails over the sea like an immortal god who every evening is immersed in the maternal waters and is born anew in the morning.

[307] Frobenius writes:

If, then, we find the blood-red sunrise connected with the idea that a birth is taking place, the birth of the young sun, the question immediately arises: Whose is the paternity? How did the woman become pregnant? And since this woman symbolizes the same idea as the fish, which means the sea (on the assumption that the sun descends into the sea as well as rises out of it), the strange primitive answer is that the sea has previously swallowed the old sun. The resulting myth is that since the sea-woman devoured the sun and now brings a new sun into the world, she obviously became pregnant in that way.⁵

[308] All these sea-going gods are solar figures. They are enclosed in a chest or ark for the “night sea journey” (Frobenius), often in the company of a woman (pl. xxii**b**)—an inversion of the actual situation, but linking up with the theme of continuous cohabitation we met above. During the night sea journey the sun-god is shut up in the mother’s womb, and often threatened by all kinds of dangers.

[309] Instead of using numerous separate examples, I shall content myself with reproducing the diagram which Frobenius constructed from numberless myths of this sort:

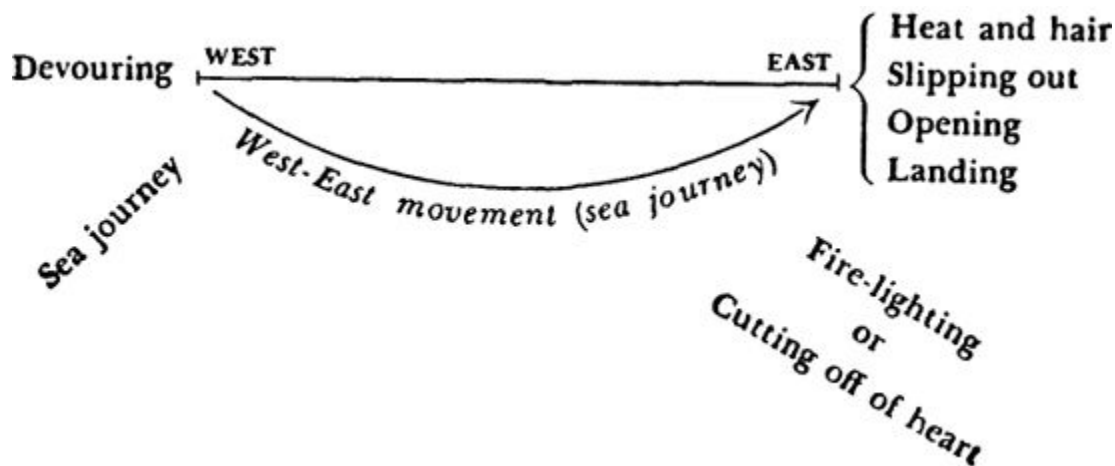

[310] Frobenius gives the following legend by way of illustration:

A hero is devoured by a water-monster in the West (*devouring*). The animal travels with him to the East (*sea journey*). Meanwhile, the hero lights a fire in the belly of the monster (*fire-lighting*), and feeling hungry, cuts himself a piece of the heart (*cutting off of heart*). Soon afterwards, he notices that the fish has glided on to dry land (*landing*); he immediately begins to cut open the animal from within (*opening*); then he slips out (*slipping out*). It was so hot in the fish’s belly that all his hair has fallen out (*heat and hair*). The hero may at the same time free all those who were previously devoured by the monster, and who now slip out too.⁶

[311] A very close parallel is Noah's journey over the Flood that killed all living things; only he and his animals lived to experience a new Creation. A Polynesian myth⁷ tells how the hero, in the belly of Kumbili, the King Fish, seized his obsidian knife and cut open the fish's belly. "He slipped out and beheld a splendour. Then he sat down and began to think. 'I wonder where I am?' he said to himself. Then the sun rose up with a bound and threw itself from one side to the other." The sun had again slipped out. Frobenius cites from the Ramayana the story of the ape Hanuman, who represents the sun-hero:

The sun, travelling through the air with Hanuman in it, cast a shadow on the sea, a sea-monster seized hold of it and drew Hanuman down from the sky. But when Hanuman saw that the monster was about to devour him, he stretched himself out to enormous size, and the monster followed suit. Then Hanuman shrank to the size of a thumb, slipped into the huge body of the monster, and came out on the other side.^{7a} Hanuman thereupon resumed his flight, and encountered a new obstacle in another sea monster, who was the mother of Rahu, the sun-devouring demon. She also drew Hanuman down to her by his shadow.⁸ Once more he had recourse to his earlier stratagem, made himself small, and slipped into her body; but scarcely was he inside than he swelled up to gigantic size, burst her, and killed her, and so made his escape.⁹

We now understand why the Indian fire-bringer Matarisvan is called "he who swells in the mother." The ark (fig. 21), chest, casket, barrel, ship, etc. is an analogy of the womb, like the sea into which the sun sinks for rebirth. That which swells in the mother can also signify her conquest and death. Fire-making is a pre-eminently conscious act and therefore "kills" the dark state of union with the mother.

[312] In the light of these ideas we can understand the mythological statements about Ogyges: it is he who possesses the mother, the city, and is thus united with the mother; therefore under him came the great flood, for it is typical of the sun myth that the hero, once he is united with the woman "hard to attain," is exposed in a cask and thrown out to sea, and then lands on a distant shore to begin a new life. The middle section, the night sea journey in the ark, is lacking in the Ogyges tradition. But the rule in mythology is that the typical parts of a myth can be fitted together in every conceivable variation, which makes it extraordinarily difficult to interpret one myth without a knowledge of all the others. The meaning of this cycle of myths is clear enough: it is the longing to attain rebirth through a return to the womb, and to become immortal like the sun. This longing for the mother is amply expressed in the literature of the Bible. I cite first the passage in Galatians 4 : 26ff. and 5:1:



Fig. 21. Noah in the Ark
*Enamelled altar of Nicholas of Verdun, 1186,
 Klosterneuburg, near Vienna*

But Jerusalem which is above is free, which is the mother of us all.

For it is written, Rejoice, thou barren that bearest not; break forth and cry, thou that travailest not: for the desolate hath many more children than she which hath an husband.

Now we, brethren, as Isaac was, are the children of promise.

But as then he that was born after the flesh persecuted him that was born after the Spirit, even so it is now.

Nevertheless what saith the scripture? Cast out the bondwoman and her son: for the son of the bondwoman shall not be heir with the son of the freewoman.

So then, brethren, we are not children of the bondwoman, but of the free.

Stand fast therefore in the liberty wherewith Christ hath made us free ...

[313] The Christians are children of the Higher City, not sons of the earthly city-mother, who is to be cast out; for those born after the flesh are opposed to those born after the spirit, who are not born from the fleshly mother but from a symbol of the mother. Here again one thinks of the American Indians who say that the first man

was born from a sword-hilt and a shuttle. The symbol-creating process substitutes for the mother the city, the well, the cave, the Church, etc. (Cf. pls. xxiiia, xxxa.) This substitution is due to the fact that the regression of libido reactivates the ways and habits of childhood, and above all the relation to the mother;¹⁰ but what was natural and useful to the child is a psychic danger for the adult, and this is expressed by the symbol of incest. Because the incest taboo opposes the libido and blocks the path to regression, it is possible for the libido to be canalized into the mother analogies thrown up by the unconscious. In that way the libido becomes progressive again, and even attains a level of consciousness higher than before. The meaning and purpose of this canalization are particularly evident when the city appears in place of the mother: the infantile attachment (whether primary or secondary) is a crippling limitation for the adult, whereas attachment to the city fosters his civic virtues and at least enables him to lead a useful existence. In primitives the tribe takes the place of the city. We find a well-developed city symbolism in the Johannine Apocalypse, where two cities play a great part, one being cursed and execrated, the other ardently desired. We read in the Revelation (17 : 1ff.):

Come hither; I will show unto thee the judgement of the great whore that sitteth upon many waters:

With whom the kings of the earth have committed fornication, and the inhabitants of the earth have been made drunk with the wine of her fornication.

So he carried me away in the spirit into the wilderness: and I saw a woman sit upon a scarlet coloured beast, full of names of blasphemy, having seven heads and ten horns.

And the woman was arrayed in purple and scarlet colour, and decked with gold and precious stones and pearls, having a golden cup in her hand full of abominations and filthiness of her fornication:

And upon her forehead was a name written: Mystery, Babylon the Great, the Mother of Harlots and Abominations of the Earth.

And I saw the woman drunken with the blood of the saints, and with the blood of the martyrs of Jesus: and when I saw her, I wondered with a great admiration. [Fig. 22.]

[314] There now follows a barely intelligible interpretation of the vision, the main points of interest being that the seven heads of the dragon signify “seven mountains, on which the woman sitteth.” This is probably a direct allusion to Rome, the city whose temporal power oppressed the world at that time. “The waters where the whore [the mother] sitteth” are “peoples, and multitudes, and nations, and tongues,” and this too seems to refer to Rome, for she is the mother of peoples and possesses all lands. Just as colonies are called “daughters,” so the peoples subject to Rome are like members of a family ruled over by the mother. In another scene the kings of the earth, i.e., the “sons,” commit fornication with her. The Apocalypse continues (18:2ff.):

Babylon the great is fallen, is fallen, and is become the habitation of devils, and the hold of every foul spirit, and a cage of every unclean and hateful bird.

For all nations have drunk of the wine of the wrath of her fornication, and the kings of the earth have committed fornication with her.

[315] This mother, then, is not only the mother of all abominations, but the receptacle of all that is wicked and unclean. The birds are soul-images,¹¹ by which are meant the souls of the damned and evil spirits. Thus the mother becomes the underworld, the City of the Damned. In this primordial image of the woman on the dragon¹² we recognize Echidna, the mother of every hellish horror. Babylon is the symbol of the Terrible Mother, who leads the peoples into whoredom with her devilish temptations and makes them drunk with her wine (cf. [fig. 22](#)). Here the intoxicating drink is closely associated with fornication, for it too is a libido symbol, as we have already seen in the soma-fire-sun parallel.



Fig. 22. The Great Whore of Babylon
New Testament engraving by H. Burgkmaier, Augsburg, 1523

[316] After the fall and curse of Babylon, we find the hymn (Rev. 19 : 6ff.) which brings us from the lower half of the mother to the upper half, where everything that

incest would have made impossible now becomes possible:

Alleluia: for the Lord God omnipotent reigneth.

Let us be glad and rejoice, and give honour to him: for the marriage of the Lamb¹³ is come, and his wife hath made herself ready.

And to her was granted that she should be arrayed in fine linen, clean and white: for the fine linen is the righteousness of saints.

And he saith unto me, Write, Blessed are they which are called unto the marriage supper of the Lamb.

[317] The Lamb is the Son of Man who celebrates his nuptials with the “woman.” Who the “woman” is remains obscure at first, but Rev. 21:9ff. shows us which “woman” is the bride, the Lamb’s wife:

Come hither, I will show thee the bride, the Lamb’s wife.¹⁴

And he carried me away in the spirit to a great and high mountain, and showed me that great city, the holy Jerusalem, descending out of heaven from God. [Cf. pl. xxiiia.]

[318] After all that has gone before, it is evident from this passage that the City, the heavenly bride who is here promised to the Son, is the mother or mother-*imago*.¹⁵ In Babylon the impure maid was cast out, according to Galatians, in order that the mother-bride might be the more surely attained in the heavenly Jerusalem. It is proof of the most delicate psychological perception that the Church Fathers who compiled the canon did not allow the Apocalypse to get lost, for it is a rich mine of primitive Christian symbols.¹⁶ The other attributes that are heaped on the heavenly Jerusalem put its mother significance beyond doubt (Rev. 22:1f.):

And he showed me a pure river of water of life, clear as crystal, proceeding out of the throne of God and of the Lamb.

In the midst of the street of it, and on either side of the river, was there the tree of life, which bare twelve manner of fruits, and yielded her fruit every month: and the leaves of the tree were for the healing of the nations.

And there shall be no more curse.

[319] In this passage we meet the water-symbol which we found connected with the city in the case of Ogyges. The maternal significance of water (pl. xxvi) is one of the clearest interpretations of symbols in the whole field of mythology,¹⁷ so that even the ancient Greeks could say that “the sea is the symbol of generation.” From water comes life;¹⁸ hence, of the two deities who here interest us most, Christ and Mithras, the latter is represented as having been born beside a river, while Christ experienced his “rebirth” in the Jordan. Christ, moreover, was born of the Πηνή,¹⁹ the sempiternal *fons amoris* or Mother of God, whom pagan-Christian legend turned into a nymph of the spring. The spring is also found in Mithraism. A Pannonian dedication reads “Fonti perenni.” An inscription from Apulum is dedicated to the “Fons aeternus.”²⁰ In

Persian, Ardisura is the fount of the water of life. Ardisura-Anahita is a goddess of water and love (just as Aphrodite is the “foam-born”). In the Vedas, the waters are called *malritamah*, ‘most maternal.’ All living things rise, like the sun, from water, and sink into it again at evening. Born of springs, rivers, lakes, and seas, man at death comes to the waters of the Styx, and there embarks on the “night sea journey.” Those black waters of death are the water of life, for death with its cold embrace is the maternal womb, just as the sea devours the sun but brings it forth again. Life knows no death; as the Spirit says in *Faust*:

In flood of life, in action’s storm
I ply on my wave
With weaving motion
Birth and the grave,
A boundless ocean,
Ceaselessly giving
Weft of living,
Forms unending,
Glowing and blending...²¹

[320] The projection of the mother-*imago* upon water endows the latter with a number of numinous or magical qualities peculiar to the mother. A good example of this is the baptismal water symbolism in the Church (pl. xxvii). In dreams and fantasies the sea or a large expanse of water signifies the unconscious. The maternal aspect of water coincides with the nature of the unconscious, because the latter (particularly in men) can be regarded as the mother or matrix of consciousness. Hence the unconscious, when interpreted on the subjective level,²² has the same maternal significance as water.

[321] Another equally common mother-symbol is the wood of life (ξύλον ζωής), or tree of life. The tree of life may have been, in the first instance, a fruit-bearing genealogical tree, and hence a kind of tribal mother. Numerous myths say that human beings came from trees, and many of them tell how the hero was enclosed in the maternal tree-trunk, like the dead Osiris in the cedar-tree, Adonis in the myrtle, etc. (Cf. fig. 23.) Numerous female deities were worshipped in tree form, and this led to the cult of sacred groves and trees. Hence when Attis castrates himself under a pine-tree, he did so because the tree has a maternal significance. Juno of Thespieae was a bough, Juno of Samos a plank, Juno of Argos a pillar, the Carian Diana was an unhewn block of wood, Athene of Lindus a polished column.²³ Tertullian called the Ceres of Pharos “rudis palus et informe lignum sine effigie” (a rough and shapeless wooden stake with no face). Athenaeus remarks that the Latona at Delos was ξύλινον ἄμορφον, ‘an amorphous bit of wood.’ Tertullian also describes an Attic Pallas as a

“crucis stipes” (cross-post). The naked wooden pole, as the name itself indicates (φάλης, *palus*, *Pfahl*, pale, pile), is phallic (cf. pl. xxviii). The φαλλός is a pole, a ceremonial lingam carved out of figwood, as are all the Roman statues of Priapus. Φάλος means the peak or ridge of a helmet, later called κῶνος, ‘cone.’ Φάλληνος (from φαλλός) means ‘wooden’; θαλάγγωμα is a cylinder; θαλάγξ, a round beam. The Macedonian shock-troops when drawn up in battle array were also known as a phalanx, and so is the finger-joint.²⁴ Finally, we have to consider θαλός, ‘bright, shining.’ The Indo-European root is *bhale, ‘to bulge, swell.’²⁵ Who does not think of Faust’s “It glows, it shines, increases in my hand!”²⁶

[322] This is “primitive” libido symbolism, which shows how direct is the connection between libido and light. We find much the same thing in the invocations to Rudra in the Rig-Veda:

May we obtain favour of thee, O ruler of heroes, maker of bountiful water [i.e., urine]....

We call down for our help the fiery Rudra, who fulfils the sacrifice, the seer who circles in the sky....

He who yields sweetness, who hears our invocations, the ruddy-hued with the gorgeous helm, let him not deliver us into the power of jealousy.

The bull of the Marut has gladdened me, the suppliant, with more vigorous health....

Let a great hymn of praise resound to the ruddy-brown bull, the white-shining (sun); let us worship the fiery god with prostrations; let us sing of the glorious being of Rudra.

May the arrow of Rudra be turned from us; may the anger of the fiery god pass us by. Unbend thy firm bow (?) for the princes; thou who blessest with the waters of thy body, be gracious to our children and grandchildren.²⁷

[323] Here the various aspects of the psychic life-force, of the extraordinarily potent,” the personified mana-concept, come together in the figure of Rudra: the fiery-white sun, the gorgeous helm, the puissant bull, and the urine (*urere*, ‘to burn’).

[324] Not only the gods, but the goddesses, too, are libido-symbols, when regarded from the point of view of their dynamism. The libido expresses itself in images of sun, light, fire, sex, fertility, and growth. In this way the goddesses, as we have seen, come to possess phallic symbols, even though the latter are essentially masculine. One of the main reasons for this is that, just as the female lies hidden in the male (pl. xxix), so the male lies hidden in the female.²⁸ The feminine quality of the tree that represents the goddess (cf. pl. xxxi) is contaminated with phallic symbolism, as is evident from the genealogical tree that grows out of Adam’s body. In my *Psychology and Alchemy* I have reproduced, from a manuscript in Florence, a picture of Adam showing the *membrum virile* as a tree.²⁹ Thus the tree has a bisexual character, as is also suggested by the fact that in Latin the names of trees have masculine endings and the feminine gender.³⁰

[325] The tree in the following dream of a young woman patient brings out this hermaphroditism:³¹ *She was in a garden, where she found an exotic-looking tree with strange red fleshy flowers or fruits. She picked and ate them. Then, to her horror, she felt that she was poisoned.*

[326] As a result of sexual difficulties in her marriage, the dreamer's fancy had been much taken by a certain young man of her acquaintance. The tree is the same tree that stood in Paradise, and it plays the same role in this dream as it did for our first parents. It is the tree of libido, which here represents the feminine as well as the masculine side, because it simply expresses the relationship of the two to one another.

[327] A Norwegian riddle runs:

A tree stands on the Billinsberg,
Drooping over a lake.
Its branches shine like gold.
You won't guess that today.

[328] In the evening the sun's daughter collects the golden branches that have dropped from the wonderful oak.

Bitterly weeps the sun-child
In the apple orchard.
From the apple-tree has fallen
The golden apple.
Weep not, sun-child,
God will make another
Of gold or bronze,
Or a little silver one.

[329] The various meanings of the tree—sun, tree of Paradise, mother, phallus—are explained by the fact that it is a libido-symbol and not an allegory of this or that concrete object. Thus a phallic symbol does not denote the sexual organ, but the libido, and however clearly it appears as such, it does not mean *itself* but is always a symbol of the libido. Symbols are not signs or allegories for something known; they seek rather to express something that is little known or completely unknown. The *tertium comparationis* for all these symbols is the libido, and the unity of meaning lies in the fact that they are all analogies of the same thing. In this realm the fixed meaning of things comes to an end. The sole reality is the libido, whose nature we can only experience through its effect on us. Thus it is not the real mother who is symbolized, but the libido of the son, whose object was once the mother. We take

mythological symbols much too concretely and are puzzled at every turn by the endless contradictions of myths. But we always forget that it is the unconscious creative force which wraps itself in images. When, therefore, we read: "His mother was a wicked witch," we must translate it as: the son is unable to detach his libido from the mother-*imago*, he suffers from resistances because he is tied to the mother.

[330] The water and tree symbolism, which we found as further attributes of the symbol of the city, likewise refer to the libido that is unconsciously attached to the mother-*imago*. In certain passages of the Apocalypse we catch a clear glimpse of this longing for the mother.³² Also, the author's eschatological expectations end with the mother: "And there shall be no more curse." There shall be no more sin, no more repression, no more disharmony with oneself, no guilt, no fear of death and no pain of separation, because through the marriage of the Lamb the son is united with the mother-*bride* and the ultimate bliss is attained. This symbol recurs in the *nuptiae chymicae*, the *coniunctio* of alchemy.³³

[331] Thus the Apocalypse dies away on that same note of radiant, mystic harmony which was re-echoed some two thousand years later in the last prayer of "Doctor Marianus":

O contrite hearts, seek with your eyes

The visage of salvation;

Blissful in that gaze, arise

Through glad regeneration.

Now may every pulse of good

Seek to serve before thy face,

Virgin, Queen of Motherhood,

Keep us, Goddess, in thy grace.³⁴

[332] The beauty and nobility of these feelings raises in our minds a question of principle: is the causal interpretation of Freud correct in believing that symbol-formation is to be explained solely by prevention of the primary incest tendency, and is thus a mere substitute product? The so-called "incest prohibition" which is supposed to operate here is not in itself a primary phenomenon, but goes back to something much more fundamental, namely the primitive system of marriage classes which, in its turn, is a vital necessity in the organization of the tribe. So it is more a question of phenomena requiring a teleological explanation than of simple causalities. Moreover it must be pointed out that the basis of the "incestuous" desire is not cohabitation, but, as every sun myth shows, the strange idea of becoming a child again, of returning to the parental shelter, and of entering into the mother in order to be reborn through her. But the way to this goal lies through incest, i.e., the

necessity of finding some way into the mother's body. One of the simplest ways would be to impregnate the mother and beget oneself in identical form all over again. But here the incest prohibition intervenes; consequently the sun myths and rebirth myths devise every conceivable kind of mother-analogy for the purpose of canalizing the libido into new forms and effectively preventing it from regressing to actual incest. For instance, the mother is transformed into an animal, or is made young again,³⁵ and then disappears after giving birth, i.e., is changed back into her old shape. It is not incestuous cohabitation that is desired, but rebirth. The incest prohibition acts as an obstacle and makes the creative fantasy inventive; for instance, there are attempts to make the mother pregnant by means of fertility magic. The effect of the incest-taboo and of the attempts at canalization is to stimulate the creative imagination, which gradually opens up possible avenues for the self-realization of libido. In this way the libido becomes imperceptibly spiritualized. The power which "always desires evil" thus creates spiritual life. That is why the religions exalt this procedure into a system. It is instructive to see the pains they take to further the translation into symbols.³⁶ The New Testament gives us an excellent example of this: in the dialogue about rebirth (John 3:4ff.), Nicodemus cannot help taking the matter realistically:

How can a man be born when he is old? Can he enter the second time into his mother's womb, and be born?

[333] Jesus tries to purify the sensuous cast of Nicodemus' mind by rousing it from its dense materialistic slumbers, and translates the passage into the same, and yet not the same, words:

Verily, verily, I say unto thee, Except a man be born of water and of the Spirit, he cannot enter into the kingdom of God.

That which is born of flesh is flesh, and that which is born of the Spirit is spirit.

Marvel not that I said unto thee, Ye must be born again.

The wind bloweth where it listeth, and thou hearest the sound thereof, but canst not tell whence it cometh, and whither it goeth: so is every one that is born of the Spirit.

[334] To be born of water simply means to be born of the mother's womb; to be born of the Spirit means to be born of the fructifying breath of the wind, as can be seen from the Greek text of the passages italicized above, where spirit and wind are expressed by the same word, πνεῦμα: "τὸ γεγεννημένον ἐκ τῆς σαρκὸς σὰρξ ἐστίν, καὶ τὸ γεγεννημένον ἐκ τοῦ πνεύματος πνεῦμά ἐστιν.... Τὸ πνεῦμα ὅπου θέλει πνεῖ."

[335] This symbolism arose from the same need as that which produced the Egyptian legend of the vultures: they were female only and were fertilized by the wind. The basis of these mythological statements is an ethical demand which can be formulated

thus: you should not say that your mother is impregnated by a man in the ordinary way, but is impregnated in some extraordinary way by a spiritual being. As this stands in complete contrast to the empirical truth, the myth bridges over the difficulty by analogy: the son is said to have been a hero who died, was born again in a remarkable manner, and thus attained to immortality. The need responsible for this demand is evidently a desire to transcend reality. A son may naturally believe that a father begot him in the flesh, but not that he himself can impregnate his mother and so cause himself to be born young again. Such a thought is prohibited by the danger of regression, and is therefore replaced by the above demand that one should, in certain circumstances, express the problem of rebirth in symbolical terms. We see the same thing in Jesus' challenge to Nicodemus: Do not think carnally, or you will be flesh, but think symbolically, and then you will be spirit. It is evident that this compulsion towards the symbolical is a great educative force, for Nicodemus would remain stuck in banalities if he did not succeed in raising himself above his concretism. Had he been a mere Philistine, he would certainly have taken offence at the irrationality and unreality of this advice and understood it literally, only to reject it in the end as impossible and incomprehensible. The reason why Jesus' words have such great suggestive power is that they express the symbolical truths which are rooted in the very structure of the human psyche. The empirical truth never frees a man from his bondage to the senses; it only shows him that he was always so and cannot be otherwise. The symbolical truth, on the other hand, which puts water in place of the mother and spirit or fire in place of the father, frees the libido from the channel of the incest tendency, offers it a new gradient, and canalizes it into a spiritual form. Thus man, as a spiritual being, becomes a child again and is born into a circle of brothers and sisters: but his mother has become the "communion of saints," the Church (pl. *xxx*a), and his brothers and sisters are humanity, with whom he is united anew in the common heritage of symbolical truth. It seems that this process was especially necessary at the time when Christianity originated; for that age, as a result of the appalling contrast between slavery and the freedom of the citizens and masters, had entirely lost consciousness of the unity of mankind.

[336] When we see how much trouble Jesus took to make the symbolical view of things acceptable to Nicodemus, as if throwing a veil over the crude reality, and how important it was—and still is—for the history of civilization that people should think in this way, then one is at a loss to understand why the concern of modern psychology with symbolism has met with such violent disapprobation in many quarters. It is as necessary today as it ever was to lead the libido away from the cult of rationalism and realism—not, indeed, because these things have gained the upper hand (quite the contrary), but because the guardians and custodians of symbolical truth, namely the religions, have been robbed of their efficacy by science. Even

intelligent people no longer understand the value and purpose of symbolical truth, and the spokesmen of religion have failed to deliver an apologetic suited to the spirit of the age. Insistence on the bare concretism of dogma, or ethics for ethics' sake, or even a humanization of the Christ-figure coupled with inadequate attempts to write his biography, are singularly unimpressive. Symbolical truth is exposed undefended to the attacks of scientific thought, which can never do justice to such a subject, and in face of this competition has been unable to hold its ground. The truth, however, still remains to be proved. Exclusive appeals to faith are a hopeless *petitio principii*, for it is the manifest improbability of symbolical truth that prevents people from believing in it. Instead of insisting so glibly on the necessity of faith, the theologians, it seems to me, should see what can be done to make this faith possible. But that means placing symbolical truth on a new foundation—a foundation which appeals not only to sentiment, but to reason. And this can only be achieved by reflecting how it came about in the first place that humanity needed the improbability of religious statements, and what it signifies when a totally different spiritual reality is superimposed on the sensuous and tangible actuality of this world.

[337] The instincts operate most smoothly when there is no consciousness to conflict with them, or when what consciousness there is remains firmly attached to instinct. This condition no longer applies even to primitive man, for everywhere we find psychic systems at work which are in some measure opposed to pure instinctuality. And if a primitive tribe shows even the smallest traces of culture, we find that creative fantasy is continually engaged in producing analogies to instinctual processes in order to free the libido from sheer instinctuality by guiding it towards analogical ideas. These systems have to be constituted in such a way that they offer the libido a kind of natural gradient. For the libido does not incline to *anything*, otherwise it would be possible to turn it in any direction one chose. But that is the case only with voluntary processes, and then only to a limited degree. The libido has, as it were, a natural penchant: it is like water, which must have a gradient if it is to flow. The nature of these analogies is therefore a serious problem because, as we have said, they must be ideas which attract the libido. Their special character is, I believe, to be discerned in the fact that they are archetypes, that is, universal and inherited patterns which, taken together, constitute the structure of the unconscious. When Christ, for instance, speaks to Nicodemus of spirit and water, these are not just random ideas, but typical ones which have always exerted a powerful fascination on the mind. Christ is here touching on the archetype, and that, if anything, will convince Nicodemus, for the archetypes are the forms or river-beds along which the current of psychic life has always flowed.

[338] It is not possible to discuss the problem of symbol-formation without reference to the instinctual processes, because it is from them that the symbol derives its motive

power. It has no meaning whatever unless it strives against the resistance of instinct, just as undisciplined instincts would bring nothing but ruin to man if the symbol did not give them form. Hence a discussion of one of the strongest instincts, sexuality, is unavoidable, since perhaps the majority of symbols are more or less close analogies of this instinct. To interpret symbol-formation in terms of instinctual processes is a legitimate scientific attitude, which does not, however, claim to be the only possible one. I readily admit that the creation of symbols could also be explained from the spiritual side, but in order to do so, one would need the hypothesis that the “spirit” is an autonomous reality which commands a specific energy powerful enough to bend the instincts round and constrain them into spiritual forms. This hypothesis has its disadvantages for the scientific mind, even though, in the end, we still know so little about the nature of the psyche that we can think of no decisive reason against such an assumption. In accordance with my empirical attitude I nevertheless prefer to describe and explain symbol-formation as a natural process, though I am fully conscious of the probable one-sidedness of this point of view.

[339] As we have said, sex plays an important part in this process, even when the symbols are religious. It is less than two thousand years since the cult of sex was in full bloom. In those days, of course, they were heathens and did not know any better, but the nature of the symbol-creating forces does not change from age to age. If one has any conception of the sexual content of those ancient cults, and if one realizes that the experience of union with God was understood in antiquity as a more or less concrete coitus, then one can no longer pretend that the forces motivating the production of symbols have suddenly become different since the birth of Christ. The fact that primitive Christianity resolutely turned away from nature and the instincts in general, and, through its asceticism, from sex in particular, clearly indicates the source from which its motive forces came. So it is not surprising that this transformation has left noticeable traces in Christian symbolism. Had it not done so, Christianity would never have been able to transform libido. It succeeded in this largely because its archetypal analogies were for the most part in tune with the instinctual forces it wanted to transform. Some people profess to be very shocked when I do not shrink from bringing even the sublimest spiritual ideas into relation with what they call the “subhuman.” My primary concern, however, is to *understand* these religious ideas, whose value I appreciate far too deeply to dispose of them with rationalistic arguments. What do we want, anyway, with things that cannot be understood? They appeal only to people for whom thinking and understanding are too much bother. Instead, we ask for blind faith and praise it to the skies. But that, in the end, only means educating ourselves to thoughtlessness and lack of criticism. What the “blind faith” so long preached from the pulpit was able to do in Germany, when that country finally turned its back on Christian dogma, has been bloodily

demonstrated before our eyes by contemporary history. The really dangerous people are not the great heretics and unbelievers, but the swarm of petty thinkers, the rationalizing intellectuals, who suddenly discover how irrational all religious dogmas are. Anything not understood is given short shrift, and the highest values of symbolic truth are irretrievably lost. What can a rationalist do with the dogma of the virgin birth, or with Christ's sacrificial death, or the Trinity?

[340] The medical psychotherapist today must make clear to his more educated patients the foundations of religious experience, and set them on the road to where such an experience becomes possible. If, therefore, as a doctor and scientist, I analyse abstruse religious symbols and trace them back to their origins, my sole purpose is to conserve, through understanding, the values they represent, and to enable people to think symbolically once more, as the early thinkers of the Church were still able to do. This is far from implying an arid dogmatism. It is only when we, today, think dogmatically, that our thought becomes antiquated and no longer accessible to modern man. Hence a way has to be found which will again make it possible for him to participate spiritually in the substance of the Christian message.

[341] At a time when a large part of mankind is beginning to discard Christianity, it may be worth our while to try to understand why it was accepted in the first place. It was accepted as a means of escape from the brutality and unconsciousness of the ancient world. As soon as we discard it, the old brutality returns in force, as has been made overwhelmingly clear by contemporary events. This is not a step forwards, but a long step backwards into the past. It is the same with individuals who lay aside one form of adaptation and have no new form to turn to: they infallibly regress along the old path and then find themselves at a great disadvantage, because the world around them has changed considerably in the meantime. Consequently, any one who is repelled by the philosophical weakness of Christian dogmatism or by the barren idea of a merely historical Jesus—for we know far too little about his contradictory personality and the little we do know only confuses our judgment—and who throws Christianity overboard and with it the whole basis of morality, is bound to be confronted with the age-old problem of brutality. We have had bitter experience of what happens when a whole nation finds the moral mask too stupid to keep up. The beast breaks loose, and a frenzy of demoralization sweeps over the civilized world.³⁷

[342] Today there are countless neurotics who are neurotic simply because they do not know why they cannot be happy in their own way—they do not even know that the fault lies with them. Besides these neurotics there are many more normal people, men and women of the better kind, who feel restricted and discontented because they have no symbol which would act as an outlet for their libido. For all these people a reductive analysis down to the primal facts should be undertaken, so that they can

become acquainted with their primitive personality and learn how to take due account of it. Only in this way can certain requirements be fulfilled and others rejected as unreasonable because of their infantile character. We like to imagine that our primitive traits have long since disappeared without trace. In this we are cruelly disappointed, for never before has our civilization been so swamped with evil. This gruesome spectacle helps us to understand what Christianity was up against and what it endeavoured to transform. The transforming process took place for the most part unconsciously, at any rate in the later centuries. When I remarked earlier (par. 106) that an unconscious transformation of libido was ethically worthless, and contrasted it with the Christianity of the early Roman period, as a patent example of the immorality and brutalization against which Christians had to fight, I ought to have added that mere faith cannot be counted as an ethical ideal either, because it too is an unconscious transformation of libido. Faith is a charisma for those who possess it, but it is no way for those who need to understand before they can believe. This is a matter of temperament and cannot be discounted as valueless. For, ultimately, even the believer believes that God gave man reason, and for something better than to lie and cheat with. Although we naturally *believe* in symbols in the first place, we can also *understand* them, and this is indeed the only viable way for those who have not been granted the charisma of faith.

[343] The religious myth is one of man's greatest and most significant achievements, giving him the security and inner strength not to be crushed by the monstrosity of the universe. Considered from the standpoint of realism, the symbol is not of course an external truth, but it is psychologically true, for it was and is the bridge to all that is best in humanity.³⁸

[344] Psychological truth by no means excludes metaphysical truth, though psychology, as a science, has to hold aloof from all metaphysical assertions. Its subject is the psyche and its contents. Both are realities, because they *work*. Though we do not possess a physics of the soul, and are not even able to observe it and judge it from some Archimedean point "outside" ourselves, and can therefore know nothing objective about it since all knowledge of the psyche is itself psychic, in spite of all this the soul is the only experience of life and existence. It is, in fact, the only immediate experience we can have and the *sine qua non* of the subjective reality of the world. The symbols it creates are always grounded in the unconscious archetype, but their manifest forms are moulded by the ideas acquired by the conscious mind. The archetypes are the numinous, structural elements of the psyche and possess a certain autonomy and specific energy which enables them to attract, out of the conscious mind, those contents which are best suited to themselves. The symbols act as *transformers*, their function being to convert libido from a "lower" into a "higher" form. This function is so important that feeling accords it the highest values. The

symbol works by suggestion; that is to say, it carries conviction and at the same time expresses the content of that conviction. It is able to do this because of the numen, the specific energy stored up in the archetype. Experience of the archetype is not only impressive, it seizes and possesses the whole personality, and is naturally productive of faith.

[345] “Legitimate” faith must always rest on experience. There is, however, another kind of faith which rests exclusively on the authority of tradition. This kind of faith could also be called “legitimate,” since the power of tradition embodies an experience whose importance for the continuity of culture is beyond question. But with this kind of faith there is always the danger of mere habit supervening—it may so easily degenerate into spiritual inertia and a thoughtless compliance which, if persisted in, threatens stagnation and cultural regression. This mechanical dependence goes hand in hand with a psychic regression to infantilism. The traditional contents gradually lose their real meaning and are only believed in as formalities, without this belief having any influence on the conduct of life. There is no longer a living power behind it. The much-vaunted “child-likeness” of faith only makes sense when the feeling behind the experience is still alive. If it gets lost, faith is only another word for habitual, infantile dependence, which takes the place of, and actually prevents, the struggle for deeper understanding. This seems to be the position we have reached today.

[346] Since faith revolves round those central and perennially important “dominant ideas” which alone give life a meaning, the prime task of the psychotherapist must be to understand the symbols anew, and thus to understand the unconscious, compensatory striving of his patient for an attitude that reflects the totality of the psyche.

[347] After this digression, let us return to our author.

[348] The vision of the city is immediately followed by that of a “strange conifer with knotty branches.” This image no longer seems strange to us after what we have learned about the tree of life and its association with the mother, the city, and the water of life. The attribute “strange” probably expresses, as in dreams, a peculiar emphasis or numinosity. Unfortunately the author gives us no individual material in this connection. As the tree already suggested in the symbolism of the city is specially emphasized in the further development of the visions, I feel it necessary to discuss at some length the history of tree symbolism.

[349] Trees, as is well known, have played a large part in religion and in mythology from the remotest times. (Pl. xxxi.) Typical of the trees found in myth is the tree of paradise, or tree of life; most people know of the pine-tree of Attis, the tree or trees of Mithras, and the world-ash Yggdrasill of Nordic mythology, and so on. The

hanging of Attis, in effigy, on a pine-tree (cf. [fig. 42](#)), the hanging of Marsyas, which became a popular theme for art, the hanging of Odin, the Germanic hanging sacrifices and the whole series of hanged gods—all teach us that the hanging of Christ on the Cross is nothing unique in religious mythology, but belongs to the same circle of ideas. In this world of images the Cross is the Tree of Life and at the same time a Tree of Death—a coffin (cf. pl. xxxvi). Just as the myths tell us that human beings were descended from trees, so there were burial customs in which people were buried in hollow tree-trunks, whence the German *Totenbaum*, ‘tree of death,’ for coffin, which is still in use today. If we remember that the tree is predominantly a mother-symbol, then the meaning of this mode of burial becomes clear. *The dead are delivered back to the mother for rebirth.* (Cf. [fig. 23](#) and pl. XLII.) We meet this symbol in the myth of Osiris as handed down by Plutarch.³⁹ Rhea was pregnant with Osiris and his twin sister Isis, and they mated together even in their mother’s womb (night sea journey with incest). Their son was Arueris, later called Horus. Isis is said to have been “born in the All-Wetness” (ἐν πανύγροισ γενέσθαι), and of Osiris it is related that a certain Pamylen of Thebes, whilst drawing water, heard a voice from the temple of Zeus which commanded him to proclaim that Osiris, “the great and beneficent king” (μέγας βασιλεὺς εὐεργέτης), was born. In honour of this Pamylen the Pamylenia were celebrated, similar to the Phallophoria. Pamylen seems, therefore, to have been originally a phallic daimon, like Dionysus. In his phallic form he represents the creative power which “draws” things out of the unconscious (i.e., the water) and begets the god (Osiris) as a conscious content. This process can be understood both as an individual experience: Pamylen drawing water, and as a symbolic act or experience of the archetype: a drawing up from the depths. What is drawn up is a numinous, previously unconscious content which would remain dark were it not interpreted by the voice from above as the birth of a god. This type of experience recurs in the baptism in the Jordan, Matthew 3:17.

[350] Osiris was killed in a crafty manner by the god of the underworld, Set (Typhon in Greek), who locked him in a chest. He was thrown into the Nile and carried out to sea. But in the underworld Osiris mated with his second sister, Nephthys. One can see from this how the symbolism is developed: already in his mother’s womb, before his extra-uterine existence, Osiris commits incest; and in death, the second intra-uterine existence, he again commits incest, both times with a sister, for in remote antiquity brother-and-sister marriages were not only tolerated, but were a mark of the aristocracy. Zarathustra likewise recommended consanguineous marriages.

[351] The wicked Set lured Osiris into the chest by a ruse, in other words the original evil in man wants to get back into the mother again, and the illicit, incestuous longing for the mother is the ruse supposedly invented by Set. It is significant that it is “evil” which lures Osiris into the chest; for, in the light of teleology, the motif of

containment signifies the latent state that precedes regeneration. Thus evil, as though cognizant of its imperfection, strives to be made perfect through rebirth—"Part of that power which would / Ever work evil, but engenders good!"⁴⁰ The ruse, too, is significant: man tries to sneak into rebirth by a subterfuge in order to become a child again. That is how it appears to the "rational" mind. An Egyptian hymn⁴¹ even charges Isis with having struck down the sun god Ra by treachery: it was because of her ill will towards her son that she banished and betrayed him. The hymn describes how Isis fashioned a poisonous snake and set it in his path, and how the snake wounded the sun-god with its bite. From this wound he never recovered, so that he finally had to retire on the back of the heavenly cow. But the cow was the cow-headed mother-goddess (pl. xxxb), just as Osiris was the bull Apis. The mother is accused as though *she* were the cause of his having to fly to her in order to be cured of the wound she herself had inflicted. But the real cause of the wound is the incest-taboo,⁴² which cuts a man off from the security of childhood and early youth, from all those unconscious, instinctive happenings that allow the child to live without responsibility as an appendage of his parents. There must be contained in this feeling many dim memories of the animal age, when there was as yet no "thou shalt" and "thou shalt not," and everything just happened of itself. Even now a deep resentment seems to dwell in man's breast against the brutal law that once separated him from instinctive surrender to his desires and from the beautiful harmony of animal nature. This separation manifested itself in the incest prohibition and its correlates (marriage laws, food-taboos, etc.). So long as the child is in that state of unconscious identity with the mother, he is still one with the animal psyche and is just as unconscious as it. The development of consciousness inevitably leads not only to separation from the mother, but to separation from the parents and the whole family circle and thus to a relative degree of detachment from the unconscious and the world of instinct. Yet the longing for this lost world continues and, when difficult adaptations are demanded, is forever tempting one to make evasions and retreats, to regress to the infantile past, which then starts throwing up the incestuous symbolism. If only this temptation were perfectly clear, it would be possible, with a great effort of will, to free oneself from it. But it is far from clear, because a new adaptation or orientation of vital importance can only be achieved in accordance with the instincts. Lacking this, nothing durable results, only a convulsively willed, artificial product which proves in the long run to be incapable of life. No man can change himself into anything from sheer reason; he can only change into what he potentially is. When such a change becomes necessary, the previous mode of adaptation, already in a state of decay, is unconsciously compensated by the archetype of another mode. If the conscious mind now succeeds in interpreting the constellated archetype in a meaningful and appropriate manner, then a viable transformation can take place. Thus the most important relationship of childhood, the relation to the mother, will be compensated by the mother archetype as

soon as detachment from the childhood state is indicated. One such successful interpretation has been, for instance, Mother Church (cf. pl. xxxa), but once this form begins to show signs of age and decay a new interpretation becomes inevitable.

[352] Even if a change does occur, the old form loses none of its attractions; for whoever sunders himself from the mother longs to get back to the mother. This longing can easily turn into a consuming passion which threatens all that has been won. The mother then appears on the one hand as the supreme goal, and on the other as the most frightful danger—the “Terrible Mother.”⁴³

[353] After completing the night sea journey, the coffer containing Osiris was cast ashore at Byblos and came to rest in the branches of a cedar-tree, which shot up and enclosed the coffer in its trunk (cf. fig. 23). The king of the country, admiring the splendid tree, caused it to be cut down and made into a pillar supporting the roof of his house.⁴⁴ This period of Osiris’ absence (the winter solstice) coincides with the age-old lament for the dead god, and his εὕρεσις (finding) was celebrated as a feast of joy.

[354] Later on Set dismembered the body and scattered the pieces. We find this motif of dismemberment in numerous sun-myths⁴⁵ as a contrast to the putting together of the child in the mother’s womb. Actually Isis collected the pieces together again with the help of the jackal-headed Anubis. Here the dogs and jackals, devourers of corpses by night, assist in the reconstitution or reproduction of Osiris.⁴⁶ To this necrophagous function the Egyptian vulture probably owes its symbolic mother significance. In ancient times the Persians used to throw out their corpses for the dogs to devour, just as, today in Tibet, the dead are left to the vultures,^{46a} and in Bombay, where the Parsis expose their corpses on the “towers of silence.” The Persians had the custom of leading a dog to the bedside of a dying man, who then had to give the dog a morsel to eat.⁴⁷ This custom suggests that the morsel should belong to the dog, so that he will spare the body of the dying man, just as Cerberus was pacified with the honey-cakes which Heracles gave him on his journey to hell. But when we consider the jackal-headed Anubis (pl. xxxiia) who rendered such good service in gathering together the remains of Osiris, and the mother significance of the vulture, the question arises whether this ceremony may not have a deeper meaning. This problem has been taken up by Creuzer,⁴⁸ who comes to the conclusion that the deeper meaning is connected with the astral form of the dog ceremony, i.e., the appearance of the dog-star at the highest point of the solstice. Hence the bringing in of the dog would have a compensatory significance, death being made equal to the sun at its highest point. This is a thoroughly psychological interpretation, as can be seen from the fact that death is quite commonly regarded as an entry into the mother’s womb (for rebirth). The interpretation would seem to be supported by the otherwise enigmatic function

of the dog in the Mithraic sacrifice. In the monuments a dog is often shown leaping upon the bull killed by Mithras. In the light of the Persian legend, and on the evidence of the monuments themselves, this sacrifice should be conceived as the moment of supreme fruitfulness. This is most beautifully portrayed in the Mithraic relief at Heddernheim (pl. XXXIII). On one side of a large (formerly rotating) stone slab there is a stereotyped representation of the overthrow and sacrifice of the bull, while on the other side stand Sol with a bunch of grapes in his hand, Mithras with the cornucopia, and the dadophors bearing fruits, in accordance with the legend that from the dead bull comes all fruitfulness: fruits from his horns, wine from his blood, corn from his tail, cattle from his semen, garlic from his nostrils, and so forth. Over this scene stands Sylvanus, the beasts of the forest leaping away from him.

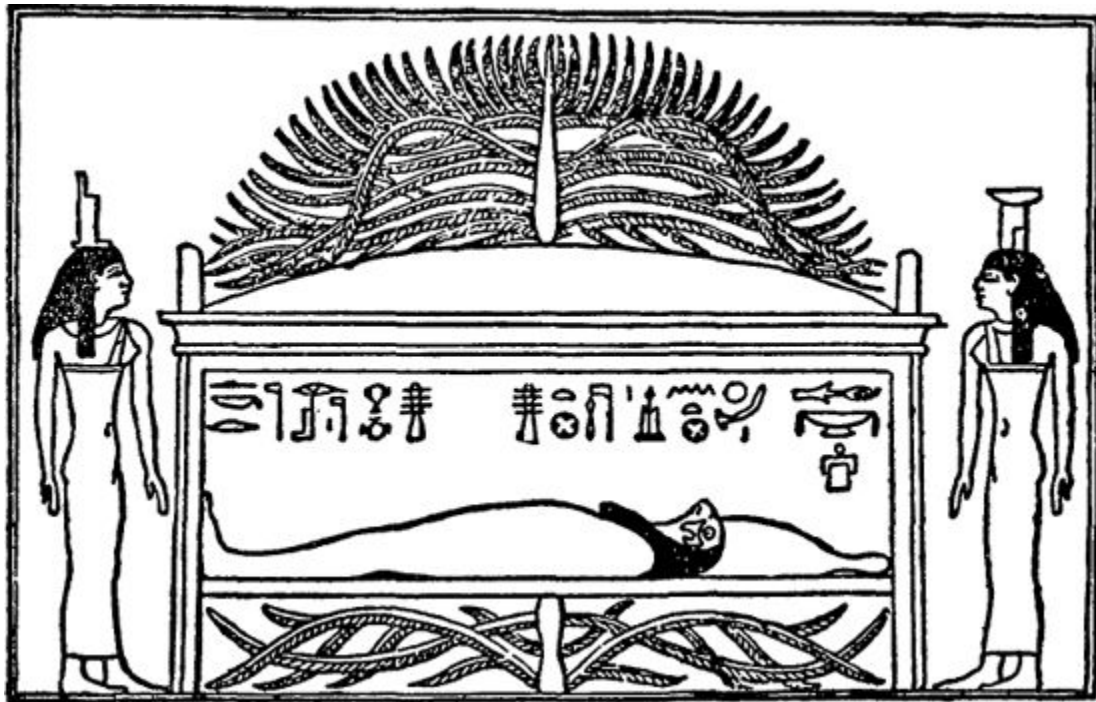

Fig. 23. Osiris in the cedar-coffin
Relief, Dendera, Egypt

[355] In this context the dog might very well have the significance suspected by Creuzer. Moreover the goddess of the underworld, Hecate, is dog-headed, like Anubis. As Canicula, she received dog sacrifices to keep away the pest. Her close relation to the moon-goddess suggests that she was a promoter of growth. Hecate was the first to bring Demeter news of her stolen daughter, another reminder of Anubis. Dog sacrifices were also offered to Eileithyia, the goddess of birth, and Hecate herself (cf. pl. LVIII) is, on occasion, a goddess of marriage and birth. The dog is also the regular companion of Aesculapius, the god of healing, who, while still a mortal, raised a man from the dead and was struck by a thunderbolt as a punishment. These associations help to explain the following passage in Petronius:

I earnestly beseech you to paint a small dog round the foot of my statue ... so that by your kindness I may attain to life after death.⁴⁹

[356] But to return to the myth of Osiris: although Isis had managed to collect the pieces of the body, its resuscitation was only partially successful because the phallus could not be found; it had been eaten by the fishes, and the reconstituted body lacked vital force.⁵⁰ The phantom Osiris lay once more with Isis, but the fruit of their union was Harpocrates, who was weak “in the lower limbs” (*γυίον*), i.e., in the feet. In the above-mentioned hymn, Ra was wounded in the foot by the serpent of Isis. The foot, as the organ nearest the earth, represents in dreams the relation to earthly reality and often has a generative or phallic significance.⁵¹ The name Oedipus, ‘Swell-foot,’ is suspicious in this respect. Osiris, although only a phantom, now makes the young sun (his son Horus) ready for battle with Set, the evil spirit of darkness. Osiris and Horus represent the father-son symbolism mentioned at the beginning. Osiris is thus flanked by the comely Horus and the misshapen Harpocrates, who is mostly shown as a cripple, sometimes distorted to the point of freakishness. It is just possible that the motif of the unequal brothers has something to do with the primitive conception that the placenta is the twin-brother of the new-born child.

[357] Osiris is frequently confused in tradition with Horus. The latter’s real name is Horpi-chrud,⁵² which is composed of *chrud* (child), and *Hor* (from *hri*, ‘up, above, on top’). The name thus signifies the “up-and-coming child,” the rising sun, as opposed to Osiris, who personifies the setting sun, the sun “in the Western Land.” So Osiris and Horpi-chrud are one being, both husband and son of the same mother. Khnum-Ra, the sun-god of Lower Egypt, is a ram, and his consort, the female divinity of the nome, is Hatmehit, who wears the fish on her head. She is the mother and spouse of Bi-neb-did (‘ram,’ the local name for Khnum-Ra). In the hymn of Hibis, Amon-Ra is invoked as follows:

Thy Ram dwelleth in Mendes, united as the fourfold god Thmuis. He is the phallus, lord of the gods. The bull of his mother rejoiceth in the cow, and the husband maketh fruitful through his seed.⁵³

[358] In other inscriptions⁵⁴ Hatmehit is called the “mother of Mendes.” (Mendes is the Greek form of Bi-neb-did.) She is also invoked as “The Good,” with the subsidiary meaning of *tanofert*, “young woman.” The cow as a mother-symbol (cf. pl. *La*) appears in all the innumerable forms and variations of Hathor-Isis (cf. pl. *xxx b*), and also in the feminine aspect of Nun (whose parallel is the primitive goddess Nit or Neith), the primary substance—moisture—which is both masculine and feminine by nature. Nun is therefore invoked⁵⁵ as “Amon, the primordial waters,⁵⁶ which was in the beginning.” He is also called the father of fathers, the mother of mothers. The corresponding invocation to Nun-Amon’s feminine aspect, Nit or Neith, says:

Nit, the Ancient, the Mother of God, Mistress of Esne, Father of Fathers, Mother of Mothers, who is the Scarab and the Vulture, who was in the beginning.

Nit, the Ancient, the mother who bore Ra, the God of Light, who, brought forth when there was nothing which brought forth.

The Cow, the Ancient, who bore the sun and set the seeds of gods and men.⁵⁷ [Cf. [figs. 24, 25.](#)]

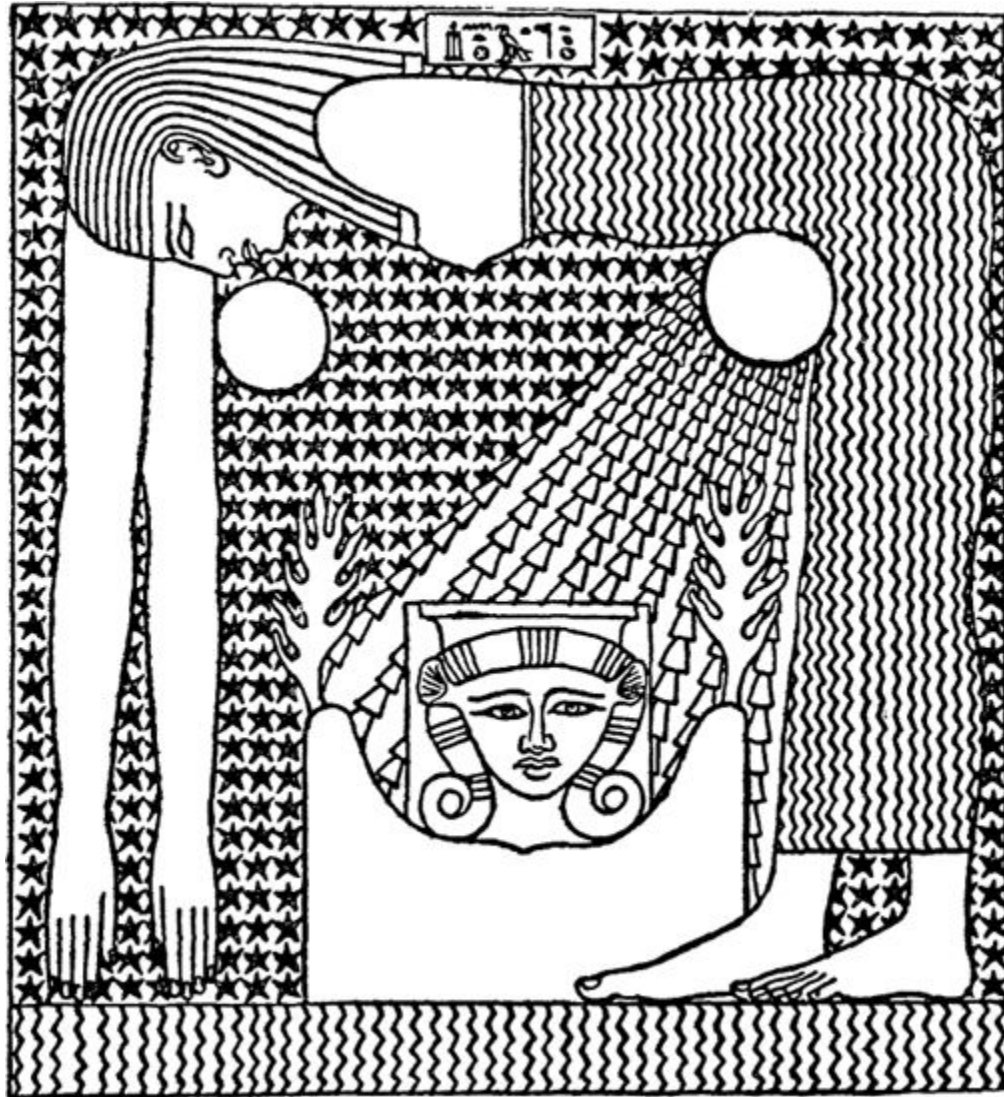

Fig. 24. Nut giving birth to the Sun
Relief, Egypt

[359] The word *nun* means ‘young, fresh, new,’ and also the new flood-waters of the Nile. In a metaphorical sense it is used for the chaotic waters of the beginning, and for the birth-giving primary substance,⁵⁸ which is personified as the goddess Naunet. From her sprang Nut, the sky-goddess, who is represented with a starry body or as a heavenly cow dotted with stars ([figs. 24, 25](#)).

[360] So when the sun-god Ra retires on the back of the heavenly cow, it means that he is going back into the mother in order to rise again as Horus. In the morning the goddess is the mother, at noon she is the sister-wife, and at evening once more the mother who takes back the dead into her womb.

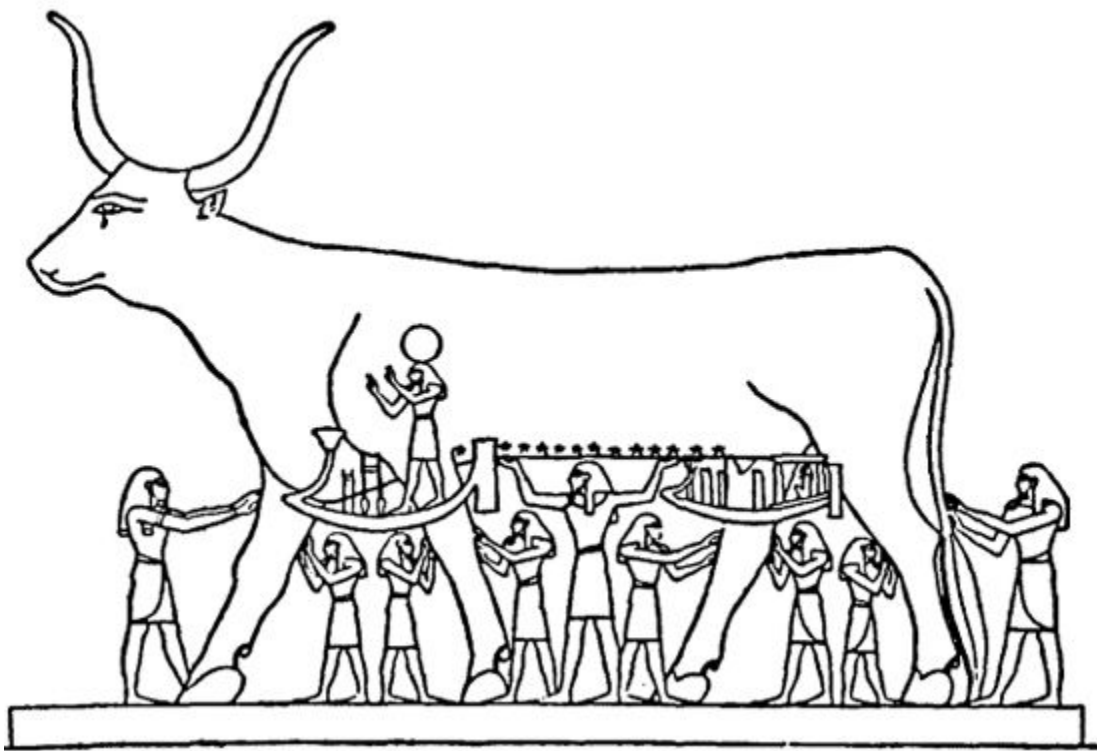

Fig. 25. The Divine Cow

From the tomb of Seti I, Egypt

[361] Thus the fate of Osiris is explained: he enters into the mother's womb, into the coffer, the sea, the tree, the Astarte column; is dismembered, put together again, and reappears in his son Horpi-chrud.

[362] Before we enter upon the other mysteries which this myth has in store for us, it will be as well to say a few words more about the symbol of the tree. Osiris comes to rest in the branches of a tree, which grow up round him.⁵⁹ The motif of embracing and entwining is often found in the sun myths and rebirth myths, as in the story of Sleeping Beauty, or the legend of the girl who was imprisoned between the bark and the wood of a tree.⁶⁰ A primitive myth tells of a sun-hero who has to be freed from a creeping plant.⁶¹ The girl dreams that her lover has fallen into the water; she tries to rescue him, but first has to pull seaweed out of the water, then she catches him. In an African myth the hero, after his deed, has to be disentangled from the seaweed. In a Polynesian story the hero's canoe is caught in the tentacles of a giant polyp, just as Ra's barge was entwined by the nocturnal serpent on the night sea journey. The motif of entwining also occurs in Sir Edwin Arnold's poetic version of the story of Buddha's birth:

Queen Maya stood at noon, her days fulfilled,
 Under a palsa in the palace-grounds,
 A stately trunk, straight as a temple-shaft,
 With crown of glossy leaves and fragrant blooms;
 And, knowing the time come—for all things knew—

The conscious tree bent down its boughs to make
A bower about Queen Maya's majesty:
And Earth put forth a thousand sudden flowers
To spread a couch; while, ready for the bath,
The rock hard by gave out a limpid stream
Of crystal flow. So brought she forth her child.⁶²

[363] There is a very similar motif in the cult-legend of the Samian Hera. Every year her image "disappeared" from the temple, attached itself to a lygos-tree somewhere on the seashore, and was entwined in its branches. There it was "found" and regaled with wedding-cakes. This festival was undoubtedly a *hieros gamos*, for in Samos there was a legend that Zeus had previously had a long-drawn-out clandestine love-affair with Hera. In Plataea and Argos a wedding procession was staged in their honour with bridesmaids, wedding feast, etc. The festival took place in the "wedding month" of Gamelion (beginning of February). The image was carried to a lonely spot in the woods, which is in keeping with Plutarch's story that Zeus kidnapped Hera and hid her in a cave on Mount Cithaeron. After our previous remarks we have to conclude that there is still another train of thought connected with the *hieros gamos*, namely, rejuvenation magic. The disappearance and hiding of the image in the wood, in the cave, on the seashore, its twining-about by the lygos-tree,⁶³ all this points to death and rebirth. The early springtime, Gamelion, fits in very well with this theory. In fact, Pausanias⁶⁴ tells us that the Argive Hera became a virgin again by taking a yearly dip in the fountain of Kanathos. The significance of this bath is further increased by the report that, in the Plataean cult of Hera Teleia, Tritonian nymphs appeared as water-carriers. The Iliad describes Zeus' conjugal couch on Mount Ida as follows:

As he spoke, the Son of Cronos took his wife in his arms; and the gracious earth sent up fresh grass beneath them, dewy lotus and crocuses, and a soft and crowded bed of hyacinths, to lift them off the ground. In this they lay, covered by a beautiful golden cloud, from which a rain of glistening dewdrops fell.... The Father lay peacefully on top of Gargarus with his arms round his wife, conquered by sleep and love....⁶⁵

[364] Drexler sees in this description⁶⁶ an allusion to the garden of the gods on the extreme Western shore of the ocean—an idea which might have been taken from a pre-Homeric *hieros gamos* hymn.⁶⁷ The Western Land is the land of the setting sun; Heracles and Gilgamesh hasten thither, where the sun and the maternal sea are united in an eternally rejuvenating embrace. This seems to confirm our conjecture that the *hieros gamos* is connected with a rebirth myth. Pausanias mentions a related myth-fragment which says that the image of Artemis Orthia was also called *Lygodesma*, 'willow-captive,'⁶⁸ because it was found in a willow-tree. There seems to be some

connection here with the popular Greek festival of the *hieros gamos* and its above-mentioned customs.

[365] The motif of “devouring” (pls. xxxiib, xxxiv), which Frobenius has shown to be one of the commonest components of the sun myth, is closely connected with embracing and entwining. The “whale-dragon” always “devours” the hero, but the devouring can also be partial. For instance, a six-year-old girl who hated going to school once dreamt that her leg was encircled by a large red worm. Contrary to what might be expected, she evinced a tender interest in the creature. Again, an adult patient who was unable to separate from an older woman friend on account of a strong mother transference to her, dreamt that she had to cross a broad stream. There was no bridge, but she found a place where she could step across. Just as she was about to do so, a large crab that lay hidden in the water seized hold of her foot and would not let go.⁶⁹

[366] This picture is borne out by etymology. There is an Indo-European root **uélu-*, with the meaning of ‘encircling, enveloping, winding, turning.’ From this are derived: Skr. *val*, *valati*, ‘to cover, envelop, surround, encircle’; *valli*, ‘creeping plant’; *ulūta*, ‘boa-constrictor’ = Lat. *volutus*; Lith. *velù*, *velti* = G. *wickeln*, ‘to wind, wrap’; Church Slav, *vlina* = OHG. *wella*, ‘a wave.’ A related root is *vlvo*, ‘covering, coil, membrane, womb.’ Skr. *ulva*, *ulba*, has the same meaning; Lat. *volva*, *volvula*, *vulva*. *Vélu* is also cognate with *ulvora*, ‘fruitful field, sheath or husk of a plant.’ Skr. *urvārā*, ‘sown field’; Zend *urvara*, ‘plant.’ The same root *vel* also has the meaning of G. *wallen*, ‘boil, undulate.’ Skr. *ulmuka*, ‘conflagration’; Gr. *Φαλέα*, *Φέλα*, Goth. *vulan* = *wallen*. OHG. and MHG. *walm* = ‘warmth.’⁷⁰ (It is typical that in the state of “involution” the hero’s hair always falls out with the heat.) *Vel* is also found with the meaning ‘to sound,’⁷¹ and ‘to will, wish.’

[367] The motif of entwining is a mother-symbol.⁷² The entwining trees are at the same time birth-giving mothers (cf. pl. xxxix), as in the Greek myth where the *μελίαι νύμφαι* are ash-trees, the mothers of the men of the Bronze Age. The Bundahish symbolizes the first human beings, Mashya and Mashyoi, as the tree Rivas. According to a Nordic myth, God created man by breathing life into a substance called *tre*⁷³ (tree, wood).⁷⁴ Gr. *ύλη* also means ‘wood.’ In the wood of the world-ash Yggdrasill a human pair hide themselves at the end of the world, and from them will spring a new race of men.⁷⁵ At the moment of universal destruction the world-ash becomes the guardian mother, the tree pregnant with death and life.⁷⁶ The regenerative function of the world-ash helps to explain the image in the chapter of the Egyptian Book of the Dead called “The Gate of Knowledge of the Souls of the East”:

I am the pilot in the holy keel, I am the steersman who allows himself no rest in the ship of Ra.⁷⁷ I know the tree of emerald green from whose midst Ra rises to the height of the clouds.⁷⁸

[368] Ship and tree (i.e., the ship of death and tree of death) are closely related here. (P1. xxxv.) The idea is that Ra rises up, born from the tree. The representations of the sun-god Mithras should probably be interpreted in the same way. In the Hedderheim Relief (pl. XL) he is shown with half his body rising from the top of a tree, and in other monuments half his body is stuck in the rock, which clearly points to the rock-birth. Often there is a stream near his birthplace. This conglomeration of symbols⁷⁹ is also found in the birth of Aschanes, the first Saxon king, who grew from the Harz rocks in the middle of a wood near a fountain.⁸⁰ Here all the mother symbols are united—earth, wood, and water. So it is only logical that in the Middle Ages the tree was poetically addressed with the honorific title of “Lady.” Nor is it surprising that Christian legend transformed the tree of death, the Cross, into the Tree of Life, so that Christ is often shown hanging on a green tree among the fruit (pl. xxxvi). The derivation of the Cross from the Tree of Life, which was an authentic religious symbol even in Babylonian times, is considered entirely probable by Zöckler,⁸¹ an authority on the history of the Cross. The pre-Christian meaning of so universal a symbol does not contradict this view; quite the contrary, for its meaning is life. Nor does the existence of the cross in the sun-cult (where the regular cross and the swastika represent the sun-wheel) and in the cult of the love-goddesses in any way contradict its historical significance. Christian legend has made abundant use of this symbolism. The student of medieval art will be familiar with the representation of the Cross growing from Adam’s grave (pl. xxxvii). The legend says that Adam was buried on Golgotha, and that Seth planted on his grave a twig from the tree of Paradise, which grew into Christ’s Cross, the Tree of Death.⁸² As we know, it was through Adam’s guilt that sin and death came into the world, and Christ through his death redeemed us from the guilt. If we ask, In what did Adam’s guilt consist? the answer is that the unpardonable sin to be punished by death was that he dared to eat of the tree of Paradise.⁸³ The consequences of this are described in a Jewish legend: one who was permitted to gaze into Paradise after the Fall saw the tree and the four streams, but the tree was withered, and in its branches lay a babe. The “mother” had become pregnant.⁸⁴

[369] This curious legend corresponds to the Jewish tradition that Adam, before he knew Eve, had a demon-wife called Lilith, with whom he strove for supremacy. But Lilith rose up into the air through the magic of God’s name and hid herself in the sea. Adam forced her to come back with the help of three angels,⁸⁵ whereupon Lilith changed into a nightmare or lamia (pl. xxxviii*a*) who haunted pregnant women and kidnapped new-born infants. The parallel myth is that of the lamias, the nocturnal spectres who terrify children. The original legend is that Lamia seduced Zeus, but the jealous Hera caused her to bring only dead children into the world. Ever since then, the raging Lamia has persecuted children, whom she destroys whenever she can. This

motif is a recurrent one in fairytales, where the mother often appears as a murderers⁸⁶ or eater of human flesh (cf. pl. αxxxviii**b**); a well-known German paradigm is the story of Hansel and Gretel. Lamia is also the name of a large, voracious fish,⁸⁷ which links up with the whale-dragon motif worked out by Frobenius. Once again we meet the idea of the Terrible Mother in the form of a voracious fish, a personification of death.⁸⁸ In Frobenius there are numerous examples of the monster devouring not only men (pl. xxxviii**b**), but animals, plants, and even an entire country, which are all delivered by the hero to a glorious rebirth.

[370] The lamias (cf. pl. xxxviii**a**) are typical nightmares whose feminine nature is abundantly documented.⁸⁹ Their universal peculiarity is that they *ride* their victims. Their counterparts are the spectral horses who carry their riders away at a mad gallop. One can easily recognize in these symbols the typical anxiety dream which, as Laistner⁹⁰ has shown, holds an important clue to the interpretation of fairytales. The riding takes on a special aspect in the light of researches into child psychology: the two contributions of Freud and myself⁹¹ have established the fear-significance of horses on the one hand, and the sexual meaning of riding fantasies on the other. The essential feature is the *rhythm*, which assumes a sexual significance only secondarily. If we take these factors into account, it will not surprise us to hear that the maternal world-ash Yggdrasill is called the *Schreckross* (terrible horse) in German. Cannegieter says of nightmares: “Even today the peasants drive away these female spirits (mother-goddesses, *moirae*) by throwing the bone of a horse’s head upon the roof, and you can often see such bones on peasant houses hereabouts. But at night they are believed to ride at the time of the first sleep and to tire out the horses for long journeys.”⁹² At first sight, there seems to be an etymological connection between *nightmare* and *mare* (female horse)—G. *Mar* and *Mähre*. The Indo-European root for ‘mare’ is **mark*; cf. OIr. *marc*. *Mare* is akin to OHG. *meriha* (fem. of *marah*, ‘stallion’), OE. *myre* (fem. of *mearh*, ‘stallion’), ON. *merr*. The supposed source of *nightmare* is OE. and ON. *mara*, ‘ogress, incubus, demon,’ and, by extension, ‘nightmare.’ F. *cauchemar* comes from Lat. *calcare*, ‘to tread,’ in the reiterative sense of “treading” the grape; it is also used of the cock that “treads” the hen. This movement is equally typical of the nightmare; hence it was said of King Vanlandi: “Mara trad hann,” the Mara trod him to death in sleep.⁹³ A synonym for the nightmare is the troll or “treader.” The treading movement has been verified by the experience of Freud and myself with children, which shows that a secondary sexual meaning attaches to stamping or kicking, though the rhythm is obviously primary. Like the Mara, the “Stempe” treads.⁹⁴

[371] The Indo-European root **mer*, **mor*, means ‘to die.’ From it also come Lat. *mors*, Gr. *μῶρος*, ‘fate,’ and possibly *Moïpa*, the goddess of fate.⁹⁵ The Norns who sit under the world-ash are well-known personifications of fate, like Clotho, Lachesis,

and Atropos. With the Celts the conception of the Fates probably passed into that of the *matres* and *matronae*,⁹⁶ who were considered divine by the Teutons. The divine significance of the mothers comes out in Julius Caesar, where he says, “The matrons should declare by lots and divinations whether it was expedient to join battle or not.”⁹⁷

[372] In connection with the etymology of *Mar* and (*night*)*mare*, it should be added that F. *mère* has a strong phonetic resemblance to *mare*, although this, etymologically speaking, proves nothing. In Slavonic, *mara* means ‘witch’; in Polish, *mora* means ‘nightmare.’ *Mor* or *More* in Swiss-German means ‘sow’ (it is also used as a swear-word). The Czech *mura* means both ‘nightmare’ and the Sphinx or hawk moth. This strange connection is explained by the fact that the butterfly is a symbol and allegory of the psyche. The *Sphingidae* are evening moths—they come, like the nightmare, in darkness. Finally, it should be mentioned that the sacred olive-tree of Athene was called *μορία*, which is derived from *μόρος*, ‘fate.’ Halirrhothios wanted to cut down the tree, but killed himself with the axe in the attempt.

[373] The phonetic connection between G. *Mar*, F. *mère*, and the various words for ‘sea’ (Lat. *mare*, G. *Meer*, F. *mer*) is certainly remarkable, though etymologically accidental. May it perhaps point back to the great primordial image of the mother, who was once our only world and later became the symbol of the whole world? Goethe says of the Mothers that they are “thronged round with images of all creation.”⁹⁸ Even the Christians could not refrain from reuniting their Mother of God with the water: “Ave maris stella” are the opening words of a hymn to Mary. It is probably significant that the infantile word *ma-ma* (mother’s breast) is found in all languages, and that the mothers of two religious heroes were called Mary and Maya. That the mother is in fact the child’s “horse” is apparent in the primitive custom of carrying the child on the back or riding it on the hip. And Odin hung upon the maternal world-ash, upon his “terrible horse.”

[374] As we have seen, Isis, the mother of the gods, played an evil trick on the sun-god with the poisonous snake, and, according to Plutarch, she behaved equally treacherously towards her son Horus. Horus vanquished the wicked Set who had murdered his father Osiris, but Isis set him free again. Outraged, Horus lifted his hand against his mother and snatched the royal diadem from her head,⁹⁹ in place of which Thoth gave her a cow’s head (cf. pl. xxxb). Horus then vanquished Set for a second time. In the Greek legend, Typhon (Set) is a dragon. But even without this confirmation it is evident that Horus’ fight is the typical fight of the sun-hero with the “whale dragon” who, as we know, is a symbol of the Terrible Mother, of the voracious maw, the jaws of death in which men are crunched and ground to pieces.¹⁰⁰ (Cf. pl. xxxviii b.) Whoever conquers this monster wins to eternal youth. But to this

end, defying all danger, he must descend into the belly of the monster¹⁰¹ (“journey to hell”) and sojourn there for some time (“night sea imprisonment”: Frobenius). (Cf. diagram, p. 210; pl. xxii*b*.)

[375] The fight with the “nocturnal serpent” accordingly signifies conquest of the mother, who is suspected of an infamous crime, namely the betrayal of her son. Complete confirmation of all this is furnished by the fragments of the Babylonian Creation Epic discovered by George Smith, most of which come from the library of Assurbanipal. The text dates from about the time of Hammurabi (2000 B.C.). From this account of the Creation we learn that Ea, the son of the watery deep and god of wisdom,¹⁰² has overthrown Apsu. Apsu is the progenitor of the great gods, so Ea has conquered the father. But Tiamat, the mother of the gods, plots revenge, and arrays herself for battle against them:

Mother Hubur, who created everything,
Procured invincible weapons, gave birth to giant snakes,
Sharp of tooth, unsparing of fang,
Filled their bodies with venom instead of blood,
Roaring dragons she clothed with terror,
Made them to swell with a terrible splendour, made them to prance,
So that he who beholds them shall perish of terror.
Their bodies shall rear up, and none shall turn them back.
She set up lizards, dragons, and sphinxes,
Hurricanes, mad dogs, scorpion-men,
Lion-demons, fish-men, and centaurs,
Bearing weapons that spare not, fearless in battle.
Mighty are Tiamat’s commands, irresistible are they.

And when Tiamat had completed her handiwork,
She prepared for battle against the gods, her descendants.
To avenge Apsu, Tiamat did evil.

When Ea now heard this thing,
He was sore afraid, and he sat down sorrowfully.

He went to the father, his creator, Ansar,
To relate to him all that Tiamat plotted:
Tiamat, our mother, is incensed against us,
She has mustered a riotous throng, furiously raging.¹⁰³

[376] Against the fearful hosts of Tiamat the gods finally put up Marduk, the god of spring, who represents the victorious sun. Marduk prepares himself for battle and forges his invincible weapons:

He created the evil wind, Imhullu, the sou'wester, the hurricane,
The fourfold wind, the sevenfold wind, the whirlwind, and the harmful wind,
Then he let loose the winds he had brought forth, all seven of them:
To stir up confusion in Tiamat's vitals, they followed behind him.
Then the Lord raised up the cyclone, his mighty weapon;
For his chariot he mounted the storm-wind, matchless and terrible.

[377] His chief weapons are the wind and a net with which he hopes to catch Tiamat. He approaches Tiamat and challenges her to single combat:¹⁰⁴

Then Tiamat and Marduk, the wise one among the gods, joined issue,
Girding their loins for the fight, drawing near for battle.
Then the Lord spread out his net and caught her;
Imhullu, which followed behind, he let loose in her face,
When Tiamat opened her mouth, as wide as she could, to consume him,
He let Imhullu rush in and her lips could not close.
With the raging winds he filled her belly,
Her inward parts were seized and she opened wide her mouth.
He smote her with the spear, he hewed her in pieces,
He cut up her bowels and made mincemeat of her heart,
Vanquished her and put an end to her life,
Threw down her carcass and trampled upon it.

[378] After Marduk had slain Tiamat, he sat down and planned the creation of the world:

Then the Lord paused to contemplate her dead body,
That he might divide up the monster and do artful works.
He split her like a flat fish into two parts,¹⁰⁵
One half he set up and with it he covered the sky.

[379] In this manner Marduk created the world from the mother. (Cf. [fig. 41](#).) Evidently the killing of the mother-dragon here takes the form of a negative wind-fertilization. The world is created from the mother, i.e., with the libido that is withdrawn from her through the sacrifice, and through prevention of the regression that threatened to overcome the hero. We shall have to examine this significant formula more closely in

the final chapter. As Gunkel¹⁰⁶ has pointed out, the myth has interesting parallels in the literature of the Old Testament. Isaiah 51 : 9f. says:^{106a}

Awake, awake, put on strength, O arm of the Lord; awake, as in the days of old, the generations of long ago.
Was it not thou that didst cut Rahab in pieces, that didst pierce the dragon?

Was it not thou that didst dry up the sea, the waters of the great deep; that didst make the depths of the sea a way for the redeemed to pass over?

[380] The name Rahab is frequently used for Egypt in the Old Testament (in Isaiah 30:7, Egypt is called “Rahab who sits still”), and also for dragon; it therefore meant something evil and hostile. Rahab appears here as the old dragon Tiamat, against whose evil power Marduk or Yahweh goes forth to battle. The term “the redeemed” refers to the children of Israel who were delivered from bondage; but it is also mythological, because the hero sets free those who had previously been devoured by the whale-dragon (Frobenius).

[381] Psalm 89:10:

Thou didst crush Rahab like a carcass....

[382] Job 26: 12f.:

By his power he stilled the sea,
by his understanding he smote Rahab.
By his wind the heavens were made fair,
his hand pierced the fleeing serpent.

[383] Gunkel equates Rahab with chaos, i.e., Tiamat. The dragon Rahab also appears as Leviathan, the monster of the deep and personification of the sea.

[384] Psalm 74:13ff.:

Thou didst divide the sea by thy might;
thou didst break the heads of the dragons on the waters.
Thou didst crush the heads of Leviathan,
thou didst give him as food for the creatures of the wilderness.

[385] There is a further parallel in Isaiah 27:1:

In that day the Lord with his sore and great and strong sword shall punish Leviathan the piercing serpent, even Leviathan that crooked serpent; and he shall slay the dragon that is in the sea.

[386] We come upon a special motif in Job 41:1f.:

Canst thou draw out Leviathan with an hook?
Or his tongue with a cord which thou lettest down?

Canst thou put an hook into his nose?

Or bore his jaw through with a thorn?

[387] This motif has numerous parallels in the primitive myths collected by Frobenius, where the sea-monster was likewise fished for.

[388] We have seen that the incest prohibition prevents the son from symbolically reproducing himself through the mother. It is not man as such who has to be regenerated or born again as a renewed whole, but, according to the statements of mythology, it is the hero or god who rejuvenates himself. These figures are generally expressed or characterized by libido-symbols (light, fire, sun, etc.), so that it looks as if they represented psychic energy. They are, in fact, personifications of the libido. Now it is a fact amply confirmed by psychiatric experience that all parts of the psyche, inasmuch as they possess a certain autonomy, exhibit a personal character, like the split-off products of hysteria and schizophrenia, mediumistic "spirits," figures seen in dreams, etc. Every split-off portion of libido, every complex, has or is a (fragmentary) personality. At any rate, that is how it looks from the purely observational standpoint. But when we go into the matter more deeply, we find that they are really archetypal formations. There are no conclusive arguments against the hypothesis that these archetypal figures are endowed with personality at the outset and are not just secondary personalizations. In so far as the archetypes do not represent mere functional relationships, they manifest themselves as *δαίμονες*, as personal agencies. In this form they are felt as actual experiences and are not "figments of the imagination," as rationalism would have us believe. Consequently, man derives his human personality only secondarily from what the myths call his descent from the gods and heroes; or, to put it in psychological terms, his consciousness of himself as a personality derives primarily from the influence of quasi-personal archetypes.¹⁰⁷ Numerous mythological proofs could be advanced in support of this view.

[389] It is, then, in the first place the god who transforms himself, and only through him does man take part in the transformation. Thus Khnum, "the maker, the potter, the builder," shapes his egg on the potter's wheel (pl. XLIB), for he is "immortal growth, his own generation and his own self-birth, the creator of the egg that came out of the primeval waters." The Egyptian Book of the Dead says: "I have risen like the mighty hawk¹⁰⁸ that comes forth from his egg," and: "I am the creator of Nun, who has taken up his abode in the underworld. My nest is not seen and my egg is not broken." Yet another passage speaks of "that great and glorious god in his egg, who created himself for that which came forth from him."¹⁰⁹ (Cf. fig. 36.) Therefore the god is also called Nagaga-uer, the "Great Cackler." (Book of the Dead 98:2: "I cackle like the goose, and whistle like the hawk.")

[390] The canalization of regressive libido into the god justifies the mythological statement that it is the god or the hero who commits incest. On the primitive level no further symbolization is required. This only becomes necessary when the mythological statement begins to bring the god into discredit, which obviously only happens at a higher level of morality. Thus Herodotus reports:

I have already mentioned the festival of Isis at Busiris: it is here that everybody—tens of thousands of men and women—when the sacrifice is over, beat their breasts: in whose honour, however, I do not feel it is proper for me to say.

At Papremis there is a special ceremony in addition to the ordinary rites and sacrifices as practised elsewhere. As the sun draws towards setting, only a few of the priests continue to employ themselves about the image of the god, while the majority, armed with wooden clubs, take their stand at the entrance of the temple; opposite these is another crowd of men, more than a thousand strong, also armed with clubs and consisting of men who have vows to perform. The image of the god, in a little wooden gold-plated shrine, is conveyed to another sacred building on the day before the ceremony. The few priests who are left to attend to it put it, together with the shrine which contains it, in a four-wheeled cart, which they drag along towards the temple. The others, waiting at the temple gate, try to prevent it from coming in, while the votaries take the god's side and set upon them with their clubs. The assault is resisted, and a vigorous tussle ensues in which heads are broken and not a few actually die of the wounds they receive. That, at least, is what I believe, though the Egyptians told me that nobody is ever killed. The origin of this festival is explained locally by the story that the mother of Ares¹¹⁰ once lived in the temple; Ares himself was brought up elsewhere, but when he grew to manhood he wished to get to know¹¹¹ his mother and for that purpose came to the temple where she was. Her attendants, however, not knowing him by sight, refused him admission, and succeeded in keeping him out until he fetched help from another town and forced his way in by violence. This, they say, is why the battle with clubs is part of the ceremony at the festival of Ares.¹¹²

[391] A Pyramid Text, describing the dead Pharaoh's fight for supremacy in heaven, says:

The sky weeps, the stars shake, the keepers of the gods tremble and their servants flee, when they behold the King rising up as a spirit, as a god who lives on his fathers and possesses his mothers.¹¹³

[392] It is clear that the votaries fight and even kill each other for their share in the mystery of divine incest.¹¹⁴ In this way they participate in the action of the god.¹¹⁵ The death of Baldur, by being wounded with the branch of mistletoe, is analogous to the death of Osiris and seems to require a similar explanation. The legend says that all creatures had pledged themselves not to harm Baldur; only the mistletoe was forgotten, because she was supposed to be too young. Yet it was the twig of mistletoe that killed Baldur. The mistletoe is a parasite. The female fire-stick, the fire-mother, was obtained from the wood of a parasitic or creeping plant for the Indian fire-boring ceremony.¹¹⁶ In Germanic legend the Mara, after its nightly jaunt, is said to rest on the "märentakken," which Grimm suggests is another name for mistletoe.¹¹⁷ Mistletoe was also a sovereign remedy against barrenness.¹¹⁸ In Gaul, it was only after offering

sacrifice that the Druid was allowed, amid solemn ceremonies, to climb the sacred oak and cut the ritual branch of mistletoe. That which grows on the tree is the child (pl. xxxix), or *oneself* in renewed and rejuvenated form; and that is precisely what one cannot have, because the incest prohibition forbids it. We are told that the mistletoe which killed Baldur was “too young”; hence this clinging parasite could be interpreted as the “child of the tree.” But as the tree signifies the origin in the sense of the mother, it represents the source of life, of that magical life-force whose yearly renewal was celebrated in primitive times by the homage paid to a divine son, a *puer aeternus*. The graceful Baldur is such a figure. This type is granted only a fleeting existence, because he is never anything but an anticipation of something desired and hoped for. This is so literally true that a certain type of “mother’s son” actually exhibits all the characteristics of the flower-like, youthful god, and even dies an early death.¹¹⁹ The reason is that he only lives on and through the mother and can strike no roots in the world, so that he finds himself in a state of permanent incest. He is, as it were, only a dream of the mother, an ideal which she soon takes back into herself, as we can see from the Near Eastern “son-gods” like Tammuz, Attis, Adonis, and Christ. The mistletoe, like Baldur, represents the “child of the mother,” the longed-for, revived life-force that flows from her. But, separated from its host, the mistletoe dies. Therefore, when the Druid cuts it, he kills it and by this act symbolically repeats the fatal self-castration of Attis and the wounding of Adonis by the boar’s tusk. This is the dream of the mother in matriarchal times, when there was as yet no father to stand by the side of the son.



a. Expulsion of the demons
Anonymous engraving, 17th century



b. Sun-god
Shamanistic Eskimo idol, Alaska



Romulus and Remus with the She-Wolf
Painted wood northern Italian, medieval



Christ in the Virgin's womb
Upper Rhenish Master Germany c. 1400



a. Boar-headed mother goddess: shakti of boar-headed Vishnu
Relief, northern India, 7th century



b. Scenes from the Eleusinian Mysteries
From a burial urn, Rome, 1st century A.D.

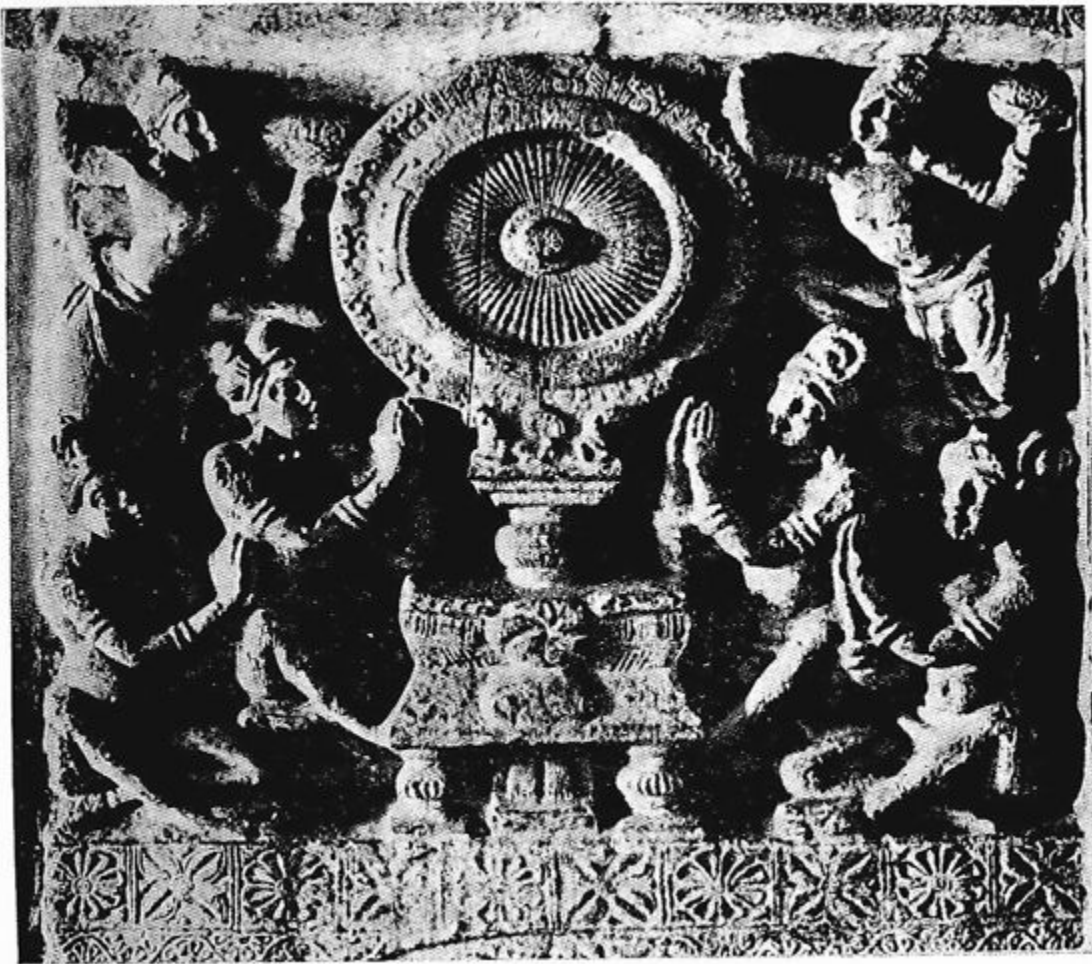

a. Veneration of the Buddha's teachings as a sun-wheel
Stupa of Amaravati, India, 2nd century A.D.



b. The Son of Man between the Seven Candlesticks
From the Beatus Commentary on the Apocalypse, late 12th century



The initiation of Apuleius
From a 17th-century French edition of The Golden Ass



The winged sun-disc, above the King
Throne of Tut-Ankh-Amon, 14th century B.C.



The Overshadowing of Mary
Tempera painting on wood, Erfurt Cathedral, 1620–40



a. Winged sun-moon disc and tree of life
Hittite relief, Sakjegeuzi, northern Syria



b. Crucifixion, and the serpent lifted up
Thaler struck by the goldsmith Hieronymus Magdeburger of Annaberg



“Sin”

Painting by Franz Stuck (1863–1928), Germany



a. The King, attended, sacrifices to the sun-god
Stele of King Nabupaliddina, Babylon, 870 B.C.

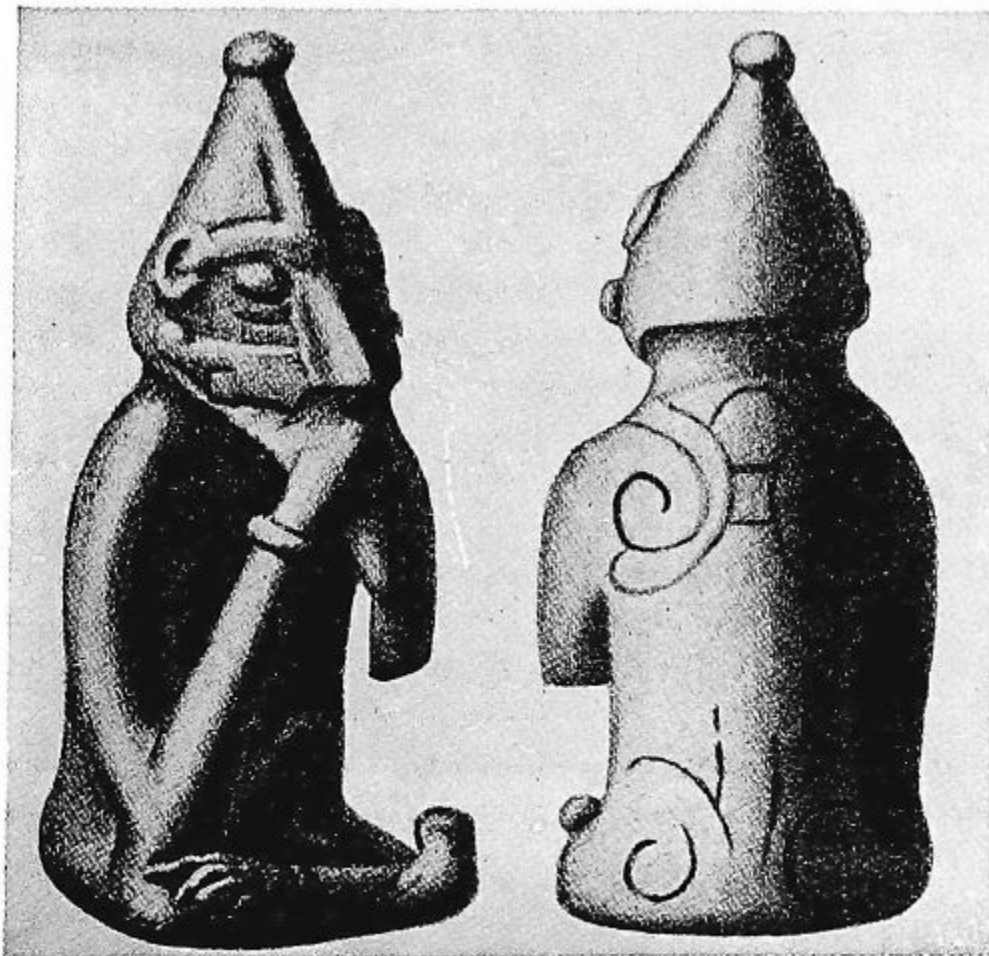

b. The fertility god Frey
Bronze figure, Södermanland, Sweden



Phanes in the egg
Orphic relief, Modena



a. The fire-god Tjintya
Wood-carving, Bali



*b. Agni on the ram, with fire-sticks
Teak processional carving, southern India*

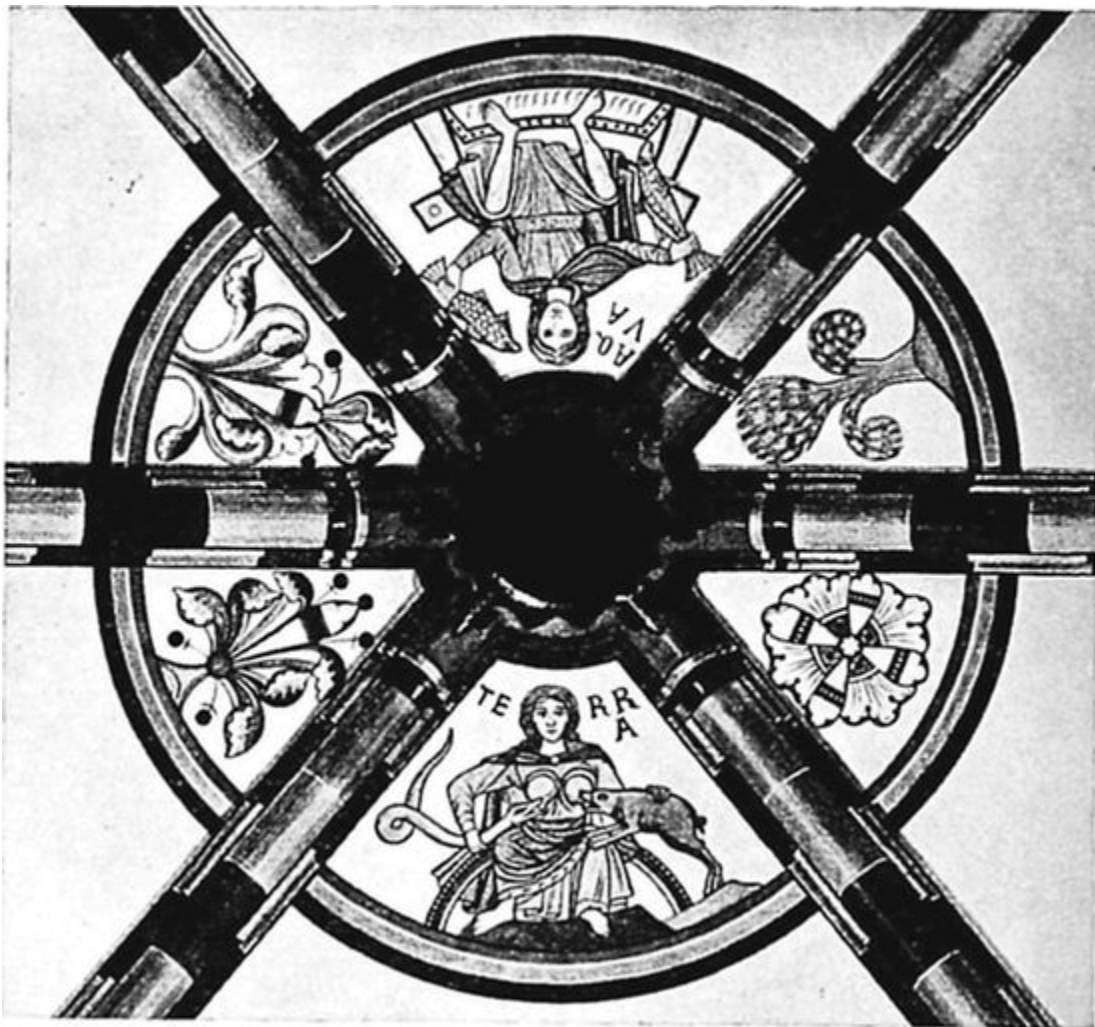

a. The nourishing earth-mother
Vault painting, Limburg Cathedral. c. 1235



b. Gorgon
Detail from a Greek vase



The Churning of the Milky Ocean
Miniature painting, Rajput School, India

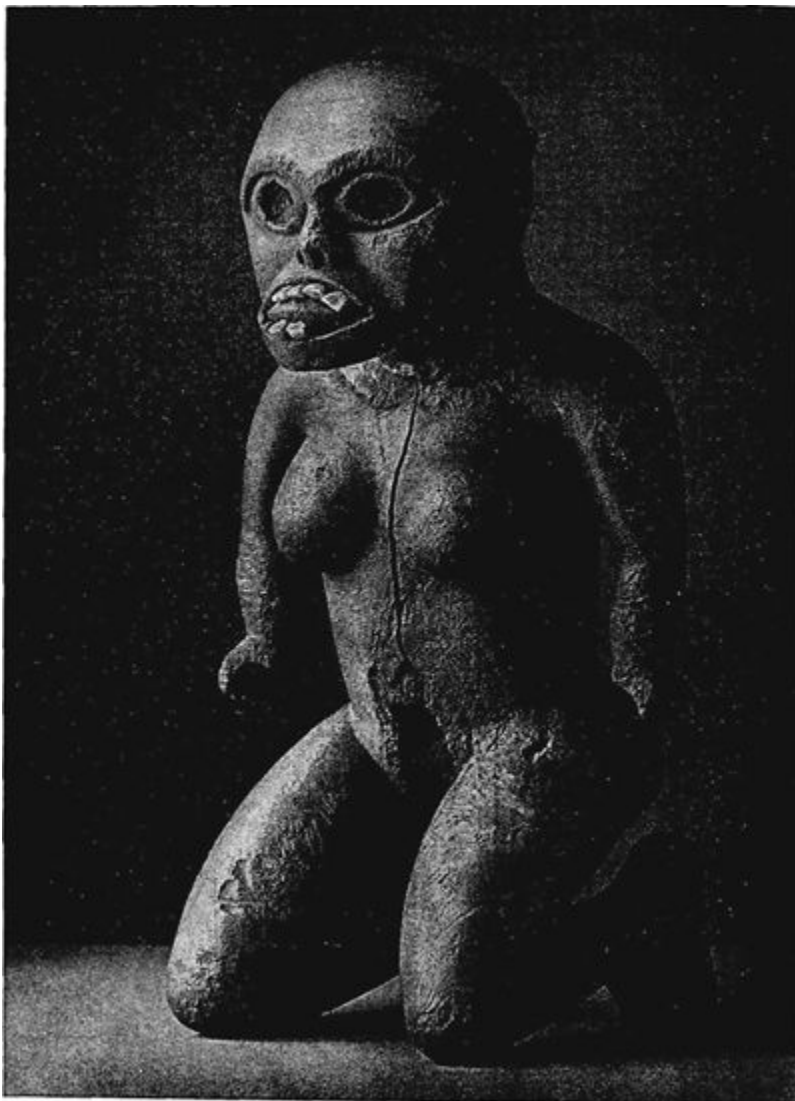

Kihe Wahine, goddess of goblins and lizards
Kou wood with human teeth, Hawaii



Female figure with head-dress symbolizing kingly power
King's incense bowl, Yoruba, West Africa



Gilgamesh with the herb of immortality
Relief, palace of Assurnasirpal II (885–860 B.C.), Nimrud, Assyria



a. The horned Alexander
Coin of Lysimachus, 3rd century B.C.



b. The dadophors with raised and lowered torches
From a Mithraic marble bas-relief

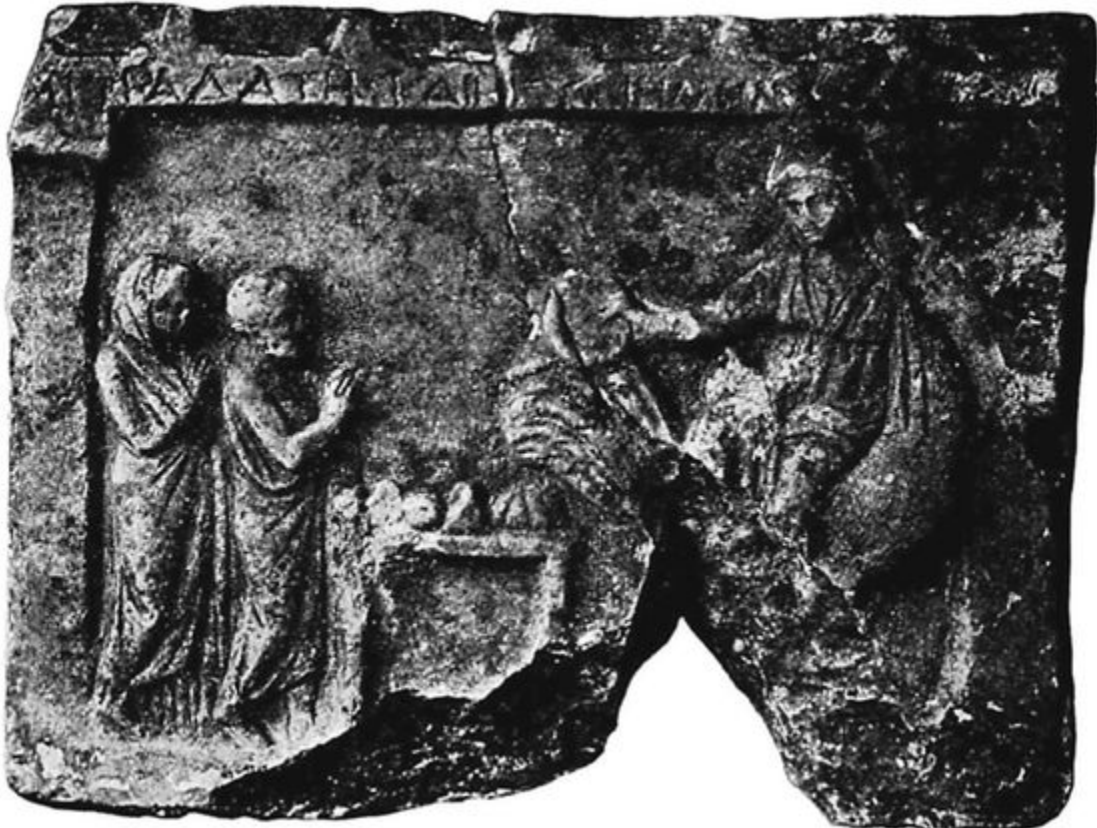

a. The god Men, on the cock
Attic wall-relief



b. Ceremonial head-dress of American Indian dancer
New Mexico



a. The New Jerusalem (Revelation, ch. 21)
Engraving from the Merian Bible, 1650



b. A man and woman devoured by the Terrible Mother
Shaman's amulet, walrus ivory, Tlingit Indians, Alaska, 19th century



Ardhanari: Shiva and Parvati united
Polychrome clay, India, 19th century



a. Mithras and Helios
Fragment from the Mithraeum near Klagenfurt



*b. Diana of Ephesus, with the mural crown
Alabaster and bronze, Roman, 2nd century A.D.*



Lingam with yoni
Anchor Wat, Cambodia, c. 12th century



The Fountain of Life
Icon, Constantinople School, 17th century



Stoup, with arms encircling belly
Church at Kilpeck, Herefordshire, early 12th century

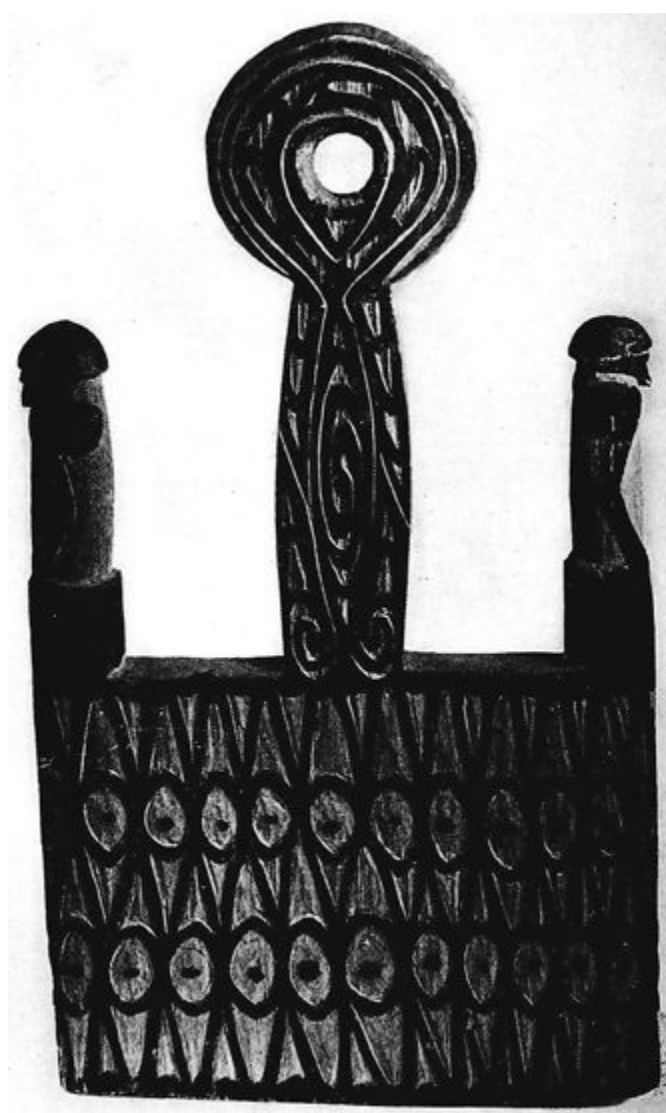

Hook for hanging
Painted wood, northern New Guinea



The Goddess in the Lingam
Cambodia, 14th century



a. Mater Ecclesia

From the manuscript "Scivias" of St. Hildegarde of Bingen, 12th century



*b. The cow-headed Hathor
Bronze, Serapeum of Sakkara, late period*



The Tree of Life
Bronze vessel, Egypt, 7th–6th century B.C.



a. Jackal-headed Anubis bending over a mummy
From a tomb, Thebes, XX Dynasty



b. The sun-eating lion of alchemy
From a manuscript, Library of St. Gall, 17th century



The Mithraic sacrifice creating fruitfulness
The Hedderheim Relief



Demon eating the sun
Stone, eastern Java, 15th century

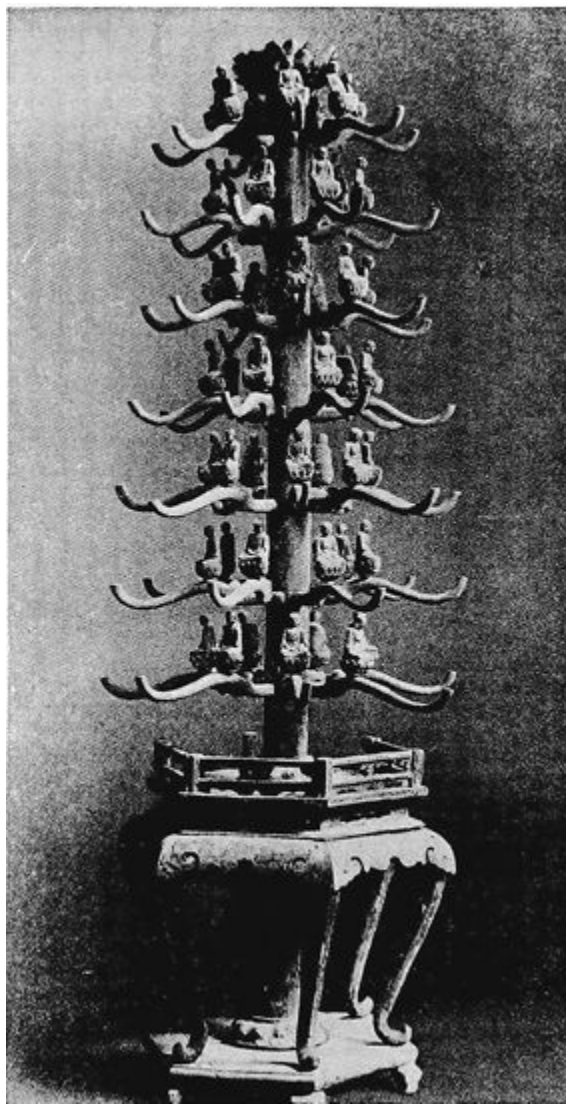

Buddhist tree of the dead
Wood carving, China



Christ on the Tree of Life
Painting, Strasbourg



The Cross on Adam's grave
Detail over west door, Strasbourg Cathedral, c. 1280



a. Lamia bearing off a new-born babe
From the frieze "Tomb of the Harpies," Acropolis of Xanthos



*b. The devouring mother
Shaman's amulet, walrus tusk, Tlingit Indians, Alaska*

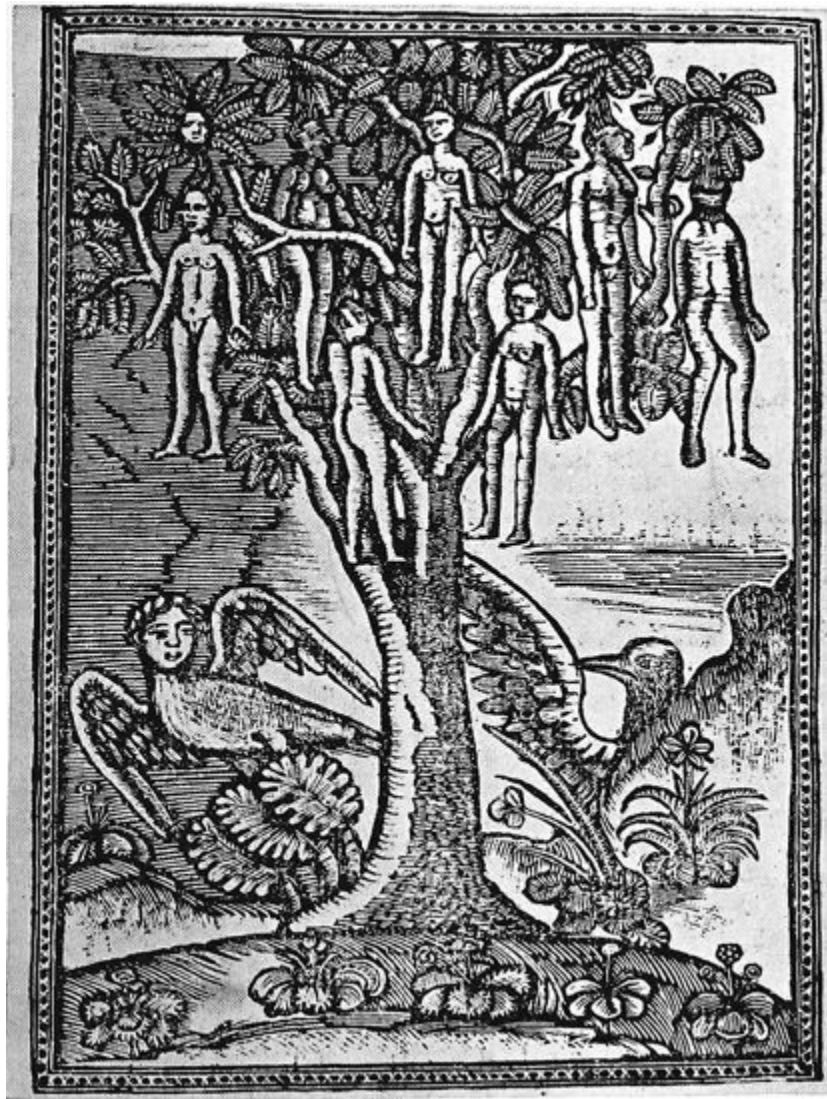

The wak-wak tree with its human fruit
From a Turkish history of the West Indies, Constantinople, 1730



Mithras sacrificing the bull
The Heddernheim Relief

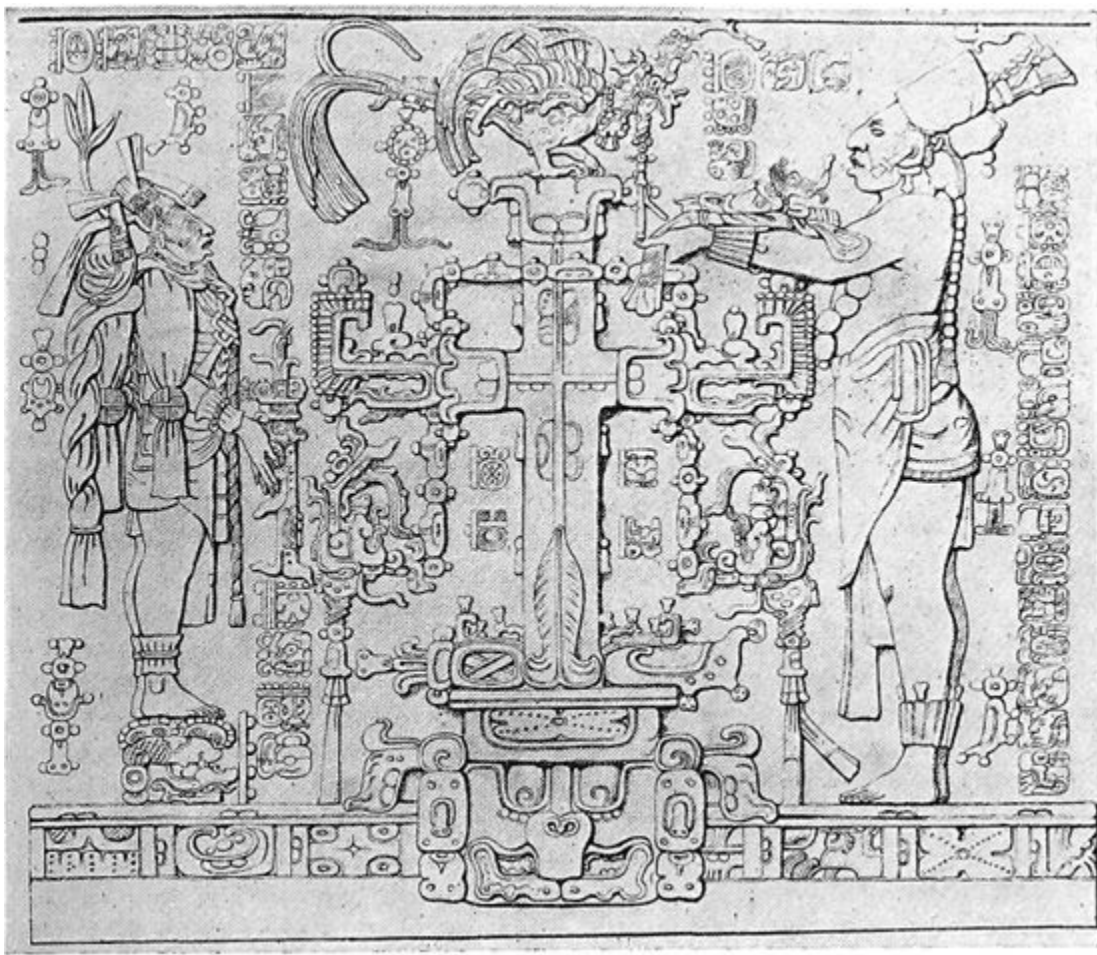

a. The Cross of Palenque
Mayan relief, Yucatán, Mexico

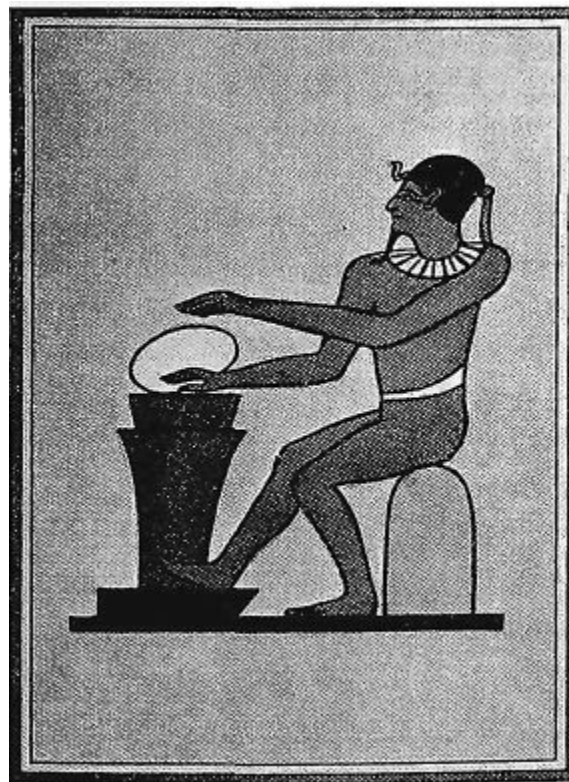

b. The shaping of the world-egg: Ptah working on a potter's wheel
Egypt



Regeneration in the mother's body
Wooden figure, Nootka Indians, Vancouver Island, Canada



Mock crucifixion

Graffito, wall of the Imperial Cadet School, Palatine, Rome



Aion, with the signs of the zodiac
Rome, 2nd–3rd century

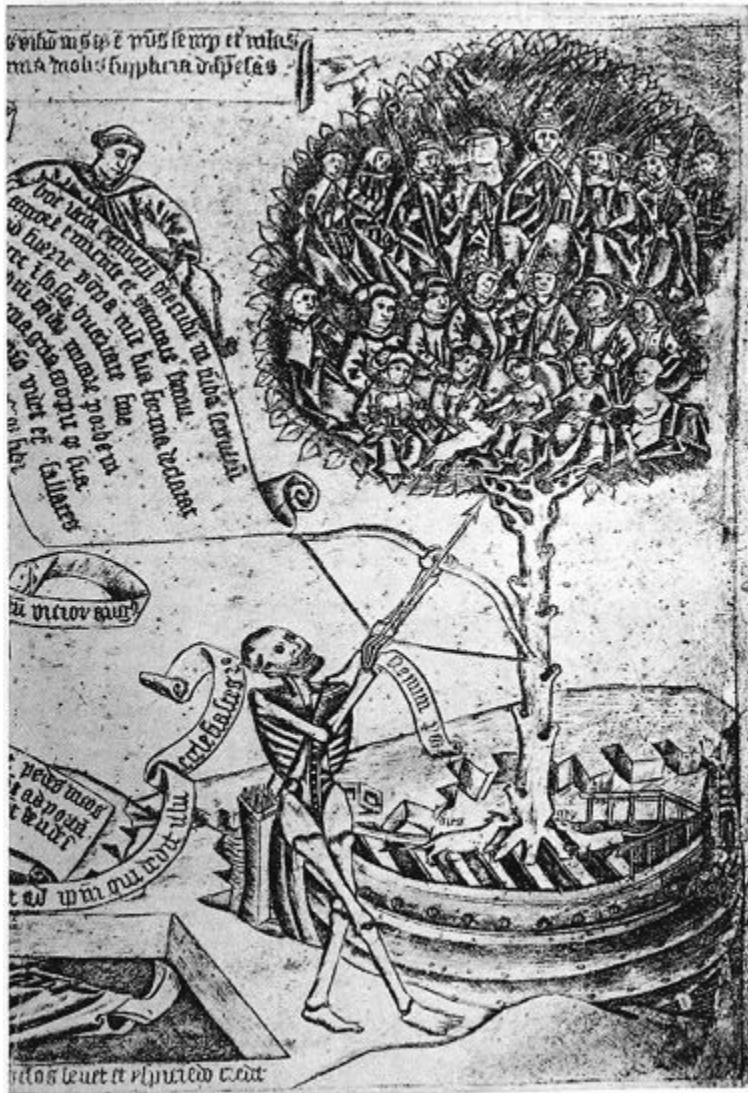

Death the archer

Detail from an engraving by the "Master of 1464," German School



a. The lotus growing out of Vishnu's navel, with Brahma inside
Relief, Vijayanagar, India



*b. Ixion on the wheel
From a Cumaean vase*



Vishnu as a fish
Zinc figurine, India, 19th century



The witch Rangda, thief of children
Painted wood, Bali



a. Mithras carrying the bull
Relief, Castle of Stockstadt, Germany

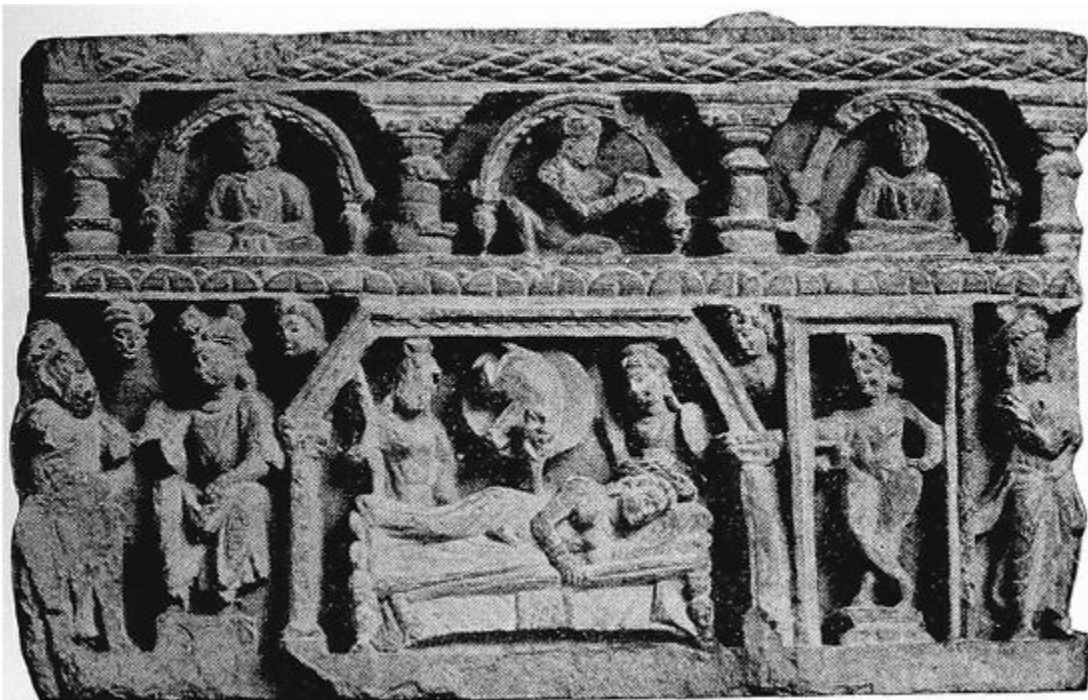

b. Queen Maya's dream of the Buddha's conception
Relief, Gandhara

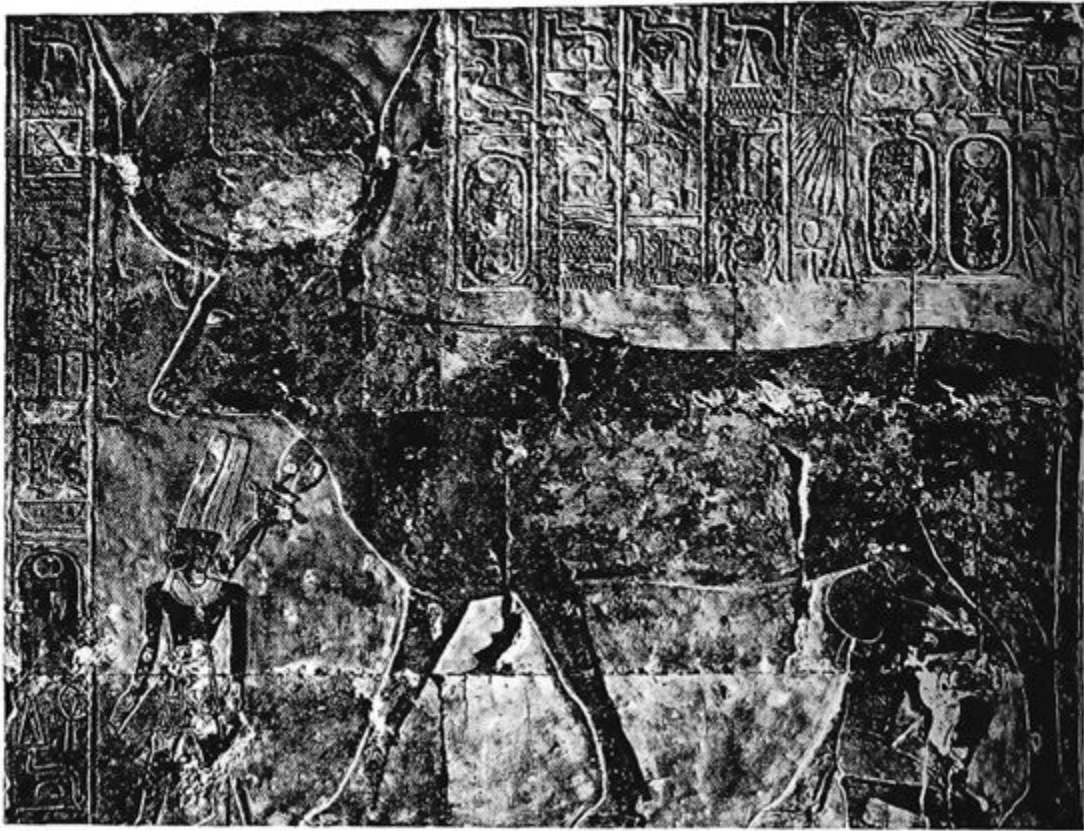

a. The Hathor Cow, suckling Queen Hatshepsut
Relief, Anubis Chapel, Temple of Der el-Bahri, XVIII Dynasty



b. The goddess Artio with bears
Bronze group, dedicated to the goddess of Licia Sabinilla, from Muri, near Bern



The Mistress of the Beasts
Greek hydria, 600 B.C., found near Bern



A corn-god
Clay vessel, Chimbote culture, Peru

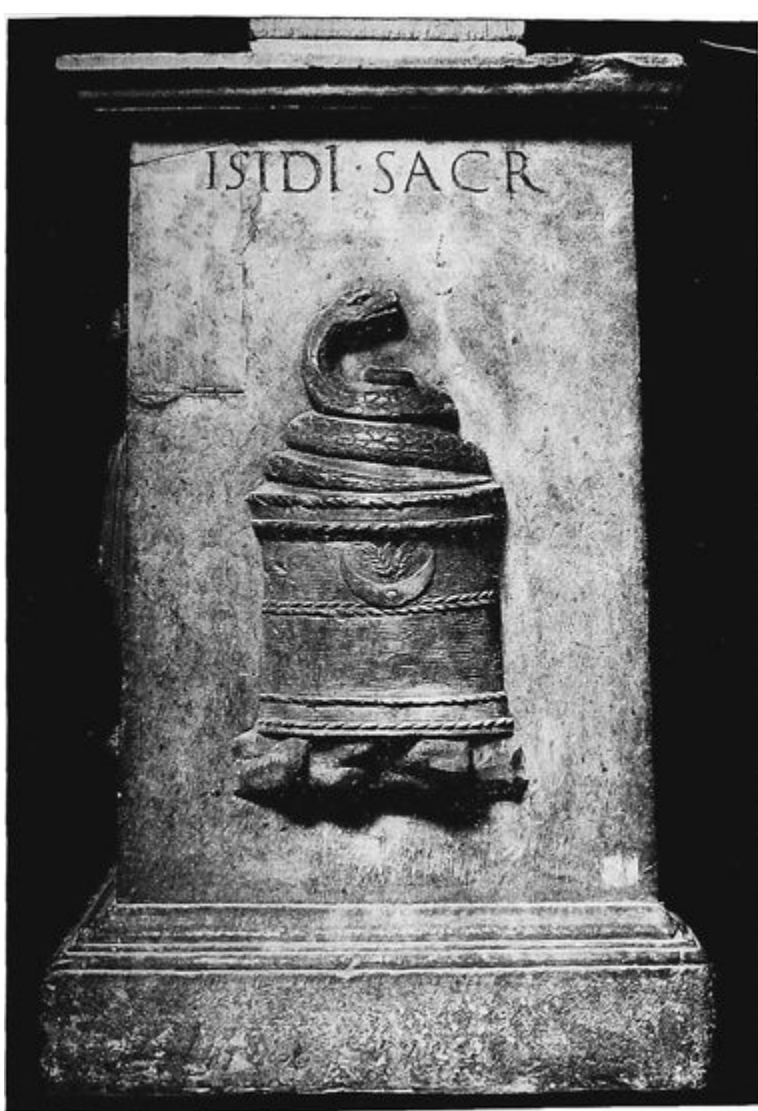

Basket of Isis, with snake
Marble altar from Caligula's temple to Isis, Rome



Matuta, an Etruscan Pietà
Fifth century B.C.

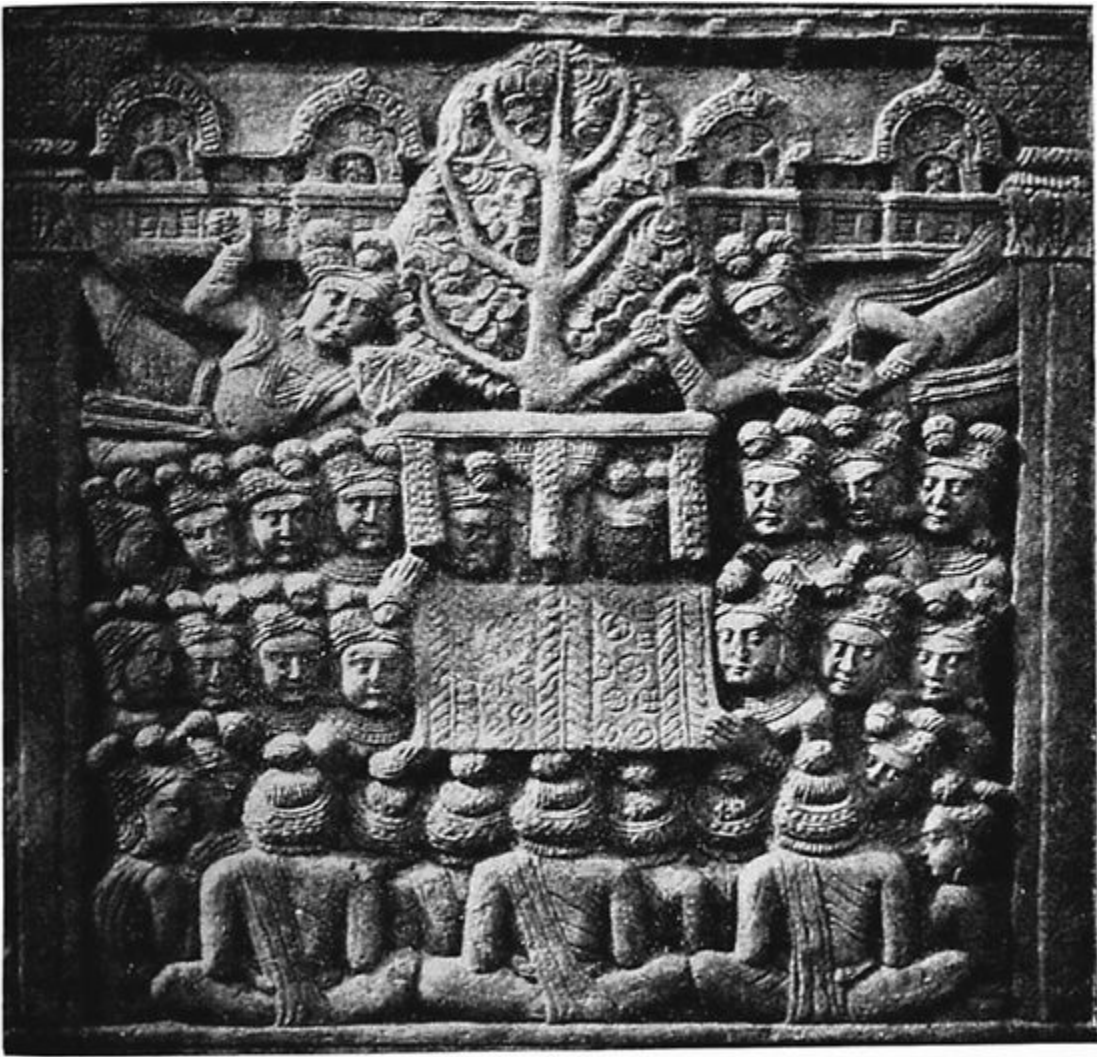

The Tree of Enlightenment
Pillar relief, stupa of Bharhut, India, 1st century B.C.



The Vision of Ezekiel
Bible of Manerius (French manuscript)



a. Cista and serpent
Silver coin, Ephesus, 57 B.C.



b. The sacrifice to the snake deity
Votive tablet, Sialesi (Eteonis), Boeotia



Triple-bodied Hecate
Roman



a. The self-consuming dragon

From Lambsprinck's symbols in the Musaeum Hermeticum (1678)

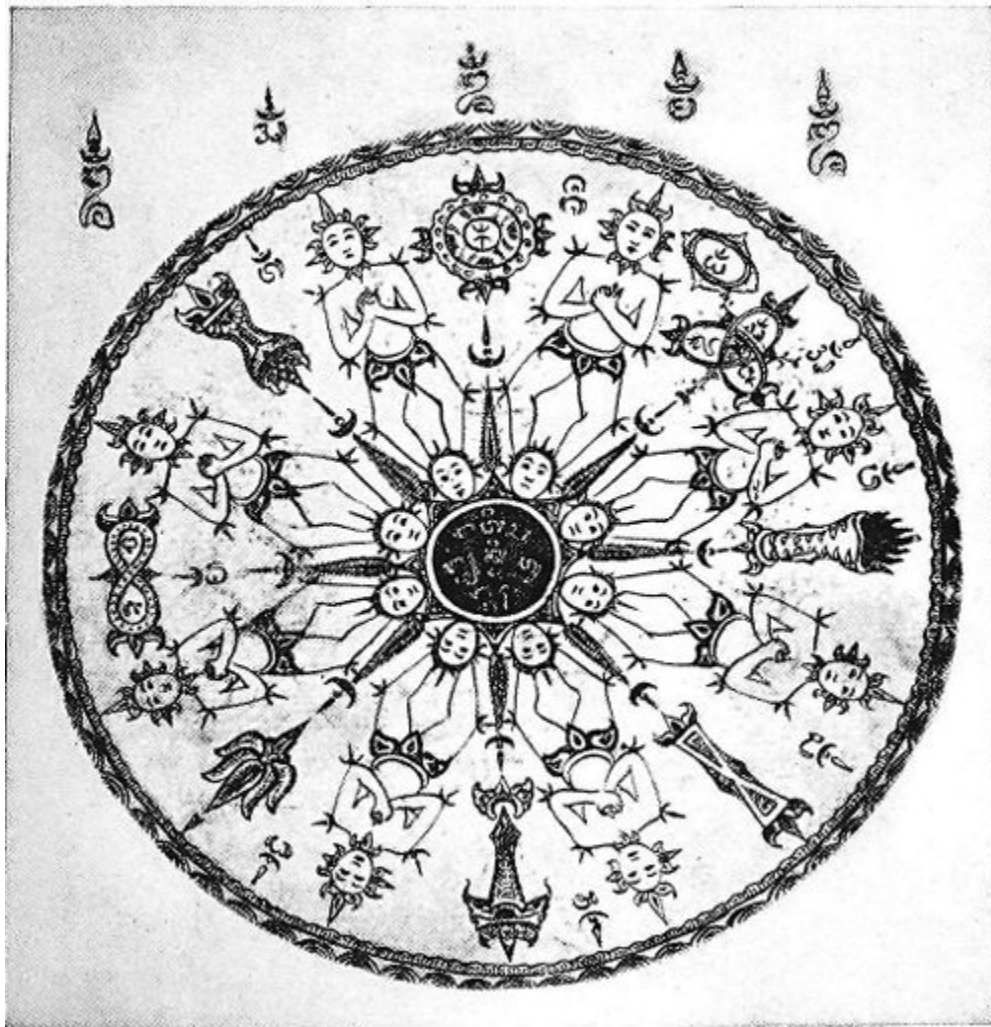

b. Circle of gods
Bali



Christ surrounded by the Evangelists
Relief, Church at Arles-sur-Tech, Pyrénées-orientales, 11th century



a. The Serpent Mystery
Altar to the Lares, Pompeii

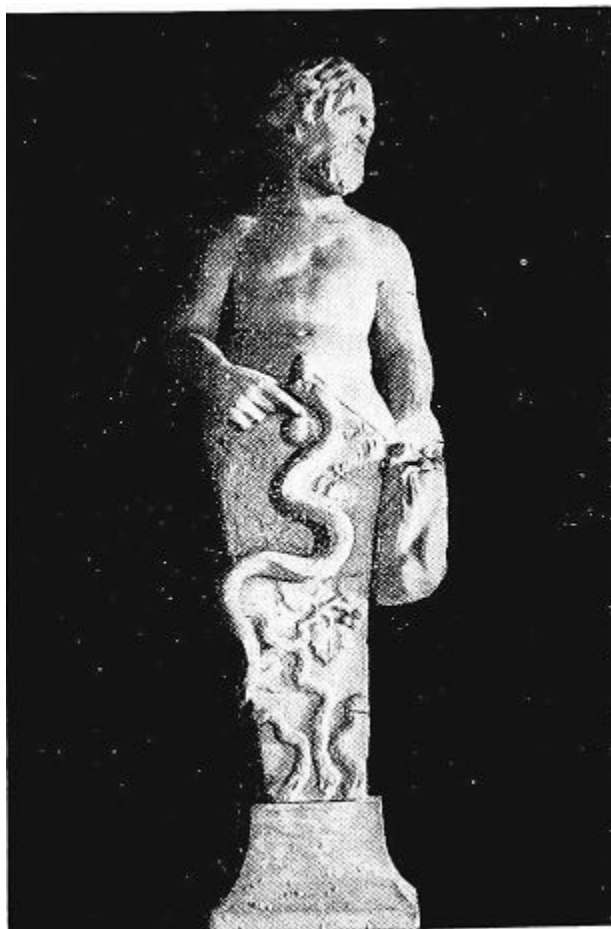

b. Priapus with snake
Roman



Devouring monster
Stone, Belahan, eastern Java, 11th century

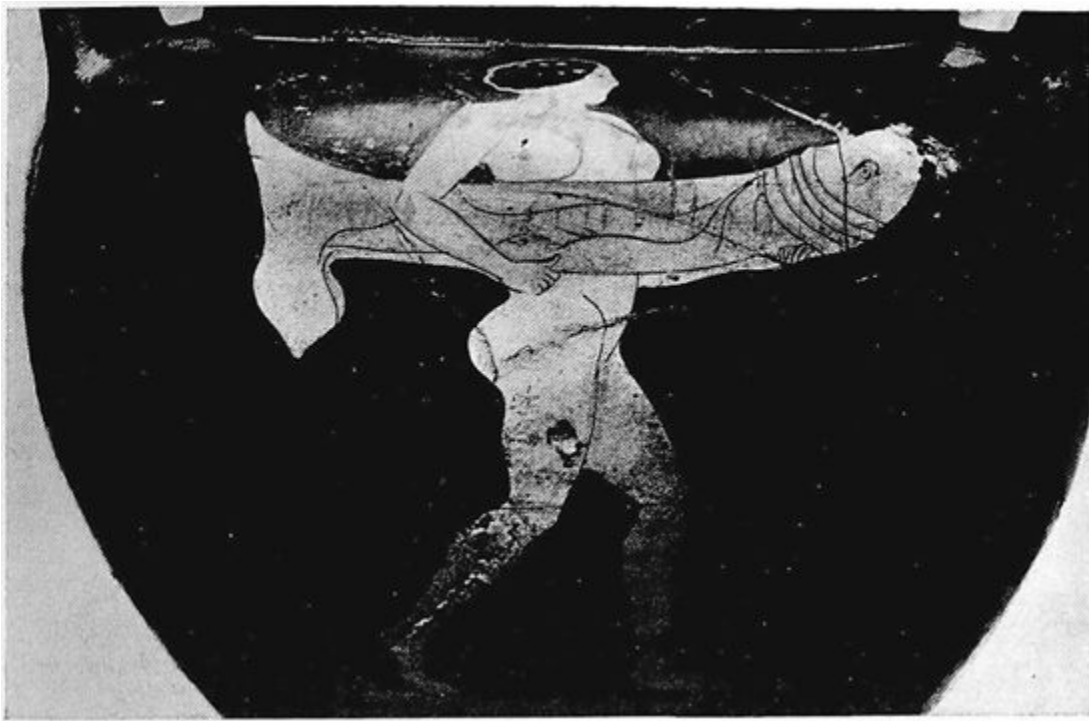

a. The regenerative symbol of the Haloa Festival
From a Greek vase, by the Pan Painter

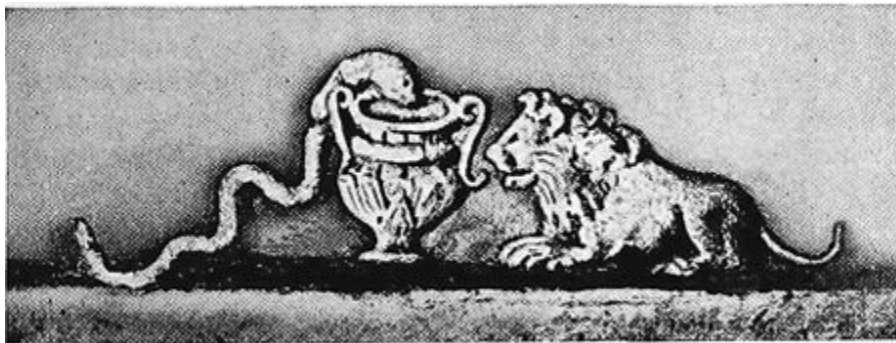

b. Mixing-pot with lion and snake
Detail from the Heddernheim Relief (cf. PL XL)



Rubens: *The Last Judgment*
1618–20

[393] But why should the mistletoe kill Baldur, since it is, in a sense, his sister or brother? The lovely apparition of the *puer aeternus* is, alas, a form of illusion. In reality he is a parasite on the mother, a creature of her imagination, who only lives when rooted in the maternal body. In actual psychic experience the mother corresponds to the collective unconscious, and the son to consciousness, which fancies itself free but must ever again succumb to the power of sleep and deadening unconsciousness. The mistletoe, however, corresponds to the shadow brother, of whom E. T. A. Hoffmann gives such an excellent description in his *Devil's Elixir*, and whom the psychotherapist regularly meets as a personification of the personal unconscious.¹²⁰ Just as, at evening, the shadows lengthen and finally engulf everything, so the mistletoe betokens Baldur's end. Being an equivalent of Baldur himself, it is fetched down from the tree like the "treasure hard to attain" (see the following chapters). The shadow becomes fatal when there is too little vitality or too little consciousness in the hero for him to complete his heroic task.

[394] The “son of the mother,” as a mere mortal, dies young, but as a god he can do that which is forbidden and superhuman: he commits the magical incest and thus obtains immortality. In the myths the hero does not die; instead, he has to overcome the dragon of death.

[395] As the reader will long since have guessed, the dragon represents the negative mother-imago and thus expresses resistance to incest, or the fear of it. Dragon and snake are symbolic representations of the fear of the consequences of breaking the taboo and regressing to incest. It is therefore understandable that we should come over and over again upon the motif of the tree and the snake. Snakes and dragons are especially significant as guardians or defenders of the treasure. The black horse Apaosha also has this meaning in the old Persian *Song of Tishtriya*, where he blocks up the sources of the rain-lake. The white horse, Tishtriya, makes two futile attempts to vanquish Apaosha; at the third attempt he succeeds with the help of Ahura-Mazda.¹²¹ Whereupon the sluices of heaven are opened and the fertilizing rain pours down upon the earth.¹²² In this symbolism we can see very clearly how libido fights against libido, instinct against instinct, how the unconscious is in conflict with itself, and how mythological man perceived the unconscious in all the adversities and contrarities of external nature without ever suspecting that he was gazing at the paradoxical background of his own consciousness.

[396] The tree entwined by the snake may therefore be taken as the symbol of the mother who is protected against incest by fear. This symbol is frequently found on Mithraic monuments. The rock with a snake coiled round it has a similar meaning, for Mithras (and also Men) was born from a rock. The threatening of new-born infants by snakes (Mithras, Apollo, Heracles) is explained by the legend of Lilith and the Lamia. Python, the dragon of Leto, and Poine, who devastated the land of Crotopos, were sent by the father of the new-born. This fact points to the father as being the cause of the fear, which as we know prompted Freud to his famous aetiological myth of the primal horde with the jealous old patriarch at the top. The immediate model for this is obviously the jealous Yahweh, struggling to protect his wife Israel from whoredoms with strange gods. The father represents the world of moral commandments and prohibitions, although, for lack of information about conditions in prehistoric times, it remains an open question how far the first moral laws arose from dire necessity rather than from the family preoccupations of the tribal father. At all events it would be easier to keep one's eye on a boxful of spiders than on the females of a primal horde. The father is the representative of the spirit, whose function it is to oppose pure instinctuality. That is his archetypal role, which falls to him regardless of his personal qualities; hence he is very often an object of neurotic fears for the son. Accordingly, the monster to be overcome by the son frequently appears as a giant who guards the treasure. An excellent example of this is

the giant Humbaba in the Gilgamesh Epic, who guards the garden of Ishtar.¹²³ Gilgamesh conquers the giant and wins Ishtar, whereupon Ishtar immediately makes sexual advances to her deliverer.¹²⁴ These facts should be sufficient to explain the role played by Horus in Plutarch, and especially the violent treatment of Isis. By overpowering the mother the hero becomes equal to the sun: he renews himself. He wins the strength of the invincible sun, the power of eternal rejuvenation. We can now understand the series of pictures illustrating the Mithraic legend on the Hedderheim Relief (pl. XL). First we see the birth of Mithras from the top of the tree; the next picture shows him carrying the conquered bull (cf. pl. XLIXa). Here the bull has the same significance as the monster and may be compared with the bull that was conquered by Gilgamesh. He represents the father who—paradoxically—enforces the incest prohibition as a giant and dangerous animal. The paradox lies in the fact that, like the mother who gives life and then takes it away again as the “terrible” or “devouring” mother, the father apparently lives a life of unbridled instinct and yet is the living embodiment of the law that thwarts instinct. There is, however, a subtle though important distinction to be made here: the father commits no incest, whereas the son has tendencies in that direction. The paternal law is directed against incest with all the violence and fury of uninhibited instinct. Freud overlooks the fact that the spirit too is dynamic, as indeed it must be if the psyche is not to lose its self-regulating equilibrium. But as the “father,” the representative of moral law, is not only an objective fact, but a subjective psychic factor in the son himself, the killing of the bull clearly denotes an overcoming of animal instinct, and at the same time a secret and furtive overcoming of the power of the law, and hence a criminal usurpation of justice. Since the better is always the enemy of the good, every drastic innovation is an infringement of what is traditionally right, and may sometimes even be a crime punishable by death. As we know, this dilemma played an important part in the psychology of early Christianity, at the time when it came into conflict with Jewish law. In the eyes of the Jews, Christ was undoubtedly a law-breaker. Not unjustly is he called Adam Secundus; for just as the first Adam became conscious through sin, through eating of the tree of knowledge, so the second Adam broke through to the necessary relation with a fundamentally different God.¹²⁵

[397] The third picture shows Mithras reaching for the nimbus on the head of Sol. This act recalls the Christian idea that those who have conquered win the crown of eternal life.

[398] In the fourth picture Sol kneels before Mithras. (Cf. pl. XXIVa.) These last two pictures show that Mithras has arrogated to himself the strength of the sun and become its lord. He has conquered his animal nature (the bull). Animals represent instinct, and also the prohibition of instinct, so that man becomes human through conquering his animal instinctuality. Mithras has thus sacrificed his animal nature—a

solution already anticipated in the Gilgamesh Epic by the hero's renunciation of the terrible Ishtar. In the Mithraic sacrifice the conquest of instinctuality no longer takes the archaic form of overpowering the mother, but of renouncing one's own instinctive desires. The primitive idea of reproducing oneself by entering into the mother's body has become so remote that the hero, instead of committing incest, is now sufficiently far advanced in the domestic virtues to seek immortality through the sacrifice of the incest tendency. This significant change finds its true fulfilment only in the symbol of the crucified God. In atonement for Adam's sin a bloody human sacrifice is hung upon the tree of life.¹²⁶ (Cf. pl. xxxvi.) Although the tree of life has a mother significance, it is no longer the mother, but a symbolical equivalent to which the hero offers up his life. One can hardly imagine a symbol which expresses more drastically the subjugation of instinct. Even the manner of death reveals the symbolic content of this act: the hero suspends himself in the branches of the maternal tree by allowing his arms to be nailed to the cross. We can say that he unites himself with the mother in death and at the same time negates the act of union, paying for his guilt with deadly torment. This act of supreme courage and supreme renunciation is a crushing defeat for man's animal nature, and it is also an earnest of supreme salvation, because such a deed alone seems adequate to expiate Adam's sin of unbridled instinctuality. The sacrifice is the very reverse of regression—it is a successful canalization of libido into the symbolic equivalent of the mother, and hence a spiritualization of it.

[399] As I have already pointed out, the hanging of the victim on a tree was a religious rite, of which numerous examples can be found in the Germanic sphere of culture.¹²⁷ It is also characteristic that the victims were pierced with a spear. Thus, in the Hovamol Edda, Odin says:

I ween that I hung / on the windy tree,
Hung there for nights full nine;
With the spear I was wounded, / and offered I was
To Odin, myself to myself.¹²⁸

[400] The hanging of the victims on crosses was a religious custom in Middle America. Müller¹²⁹ mentions the Fejérváry Manuscript (a Mexican hieroglyphic codex), which has, for a tailpiece, a cross with a gory divinity hanging in the centre. Equally significant is the Palenque Cross (pl. xliA).¹³⁰ At the top is a bird, on either side two human figures facing the cross, one of them holding out a child for either sacrifice or baptism. The ancient Aztecs are said to have invoked the favour of Cinteotl, "the daughter of heaven and goddess of the grain," by nailing a youth or maiden to the cross every spring and shooting the victim with arrows.¹³¹ The name of the cross signifies "Tree of our life or flesh."¹³² An effigy from the island of Philae represents

Osiris in the form of a crucified god, mourned by Isis and Nephthys, his sister wives.¹³³

[401] The meaning of the cross is certainly not restricted to the tree of life, as has already been shown. Müller takes it as an emblem of rain and fertility.¹³⁴ We should also mention that it is a powerful charm for averting evil (e.g., making the sign of the cross).

[402] In view of the fact that the cross resembles the human figure with arms outspread, it is worth noting that in early Christian art Christ is not nailed to the cross, but is shown standing before it with open arms.¹³⁵ Maurice interprets this as follows:

It is a fact not less remarkable than well attested, that the Druids in their groves were accustomed to select the most stately and beautiful tree as an emblem of the deity they adored; and, having cut off the side branches, they affixed two of the largest of them to the highest part of the trunk, in such manner that those branches, extended on each side like the arms of a man, together with the body, presented to the spectator the appearance of a huge cross [cf. fig. 26]; and on the bark, in various places, was actually inscribed the letter “tau.”¹³⁶

[403] The “tree of knowledge” of the Jains, of India, also has a human form; it is represented as an enormously thick trunk shaped like a human head, from the top of which grow two long branches hanging down on either side, with a short, vertical branch sticking straight up, crowned with a bud-like knob.¹³⁷ Robertson tells us that in the Assyrian system God was represented in the form of a cross, the vertical standing for the human figure, and the horizontal for a conventionalized pair of wings.¹³⁸ Archaic Greek idols, such as were found in large quantities in Aegina, have a similar character: an immoderately long head, wing-shaped arms slightly raised, and in front distinct breasts.¹³⁹

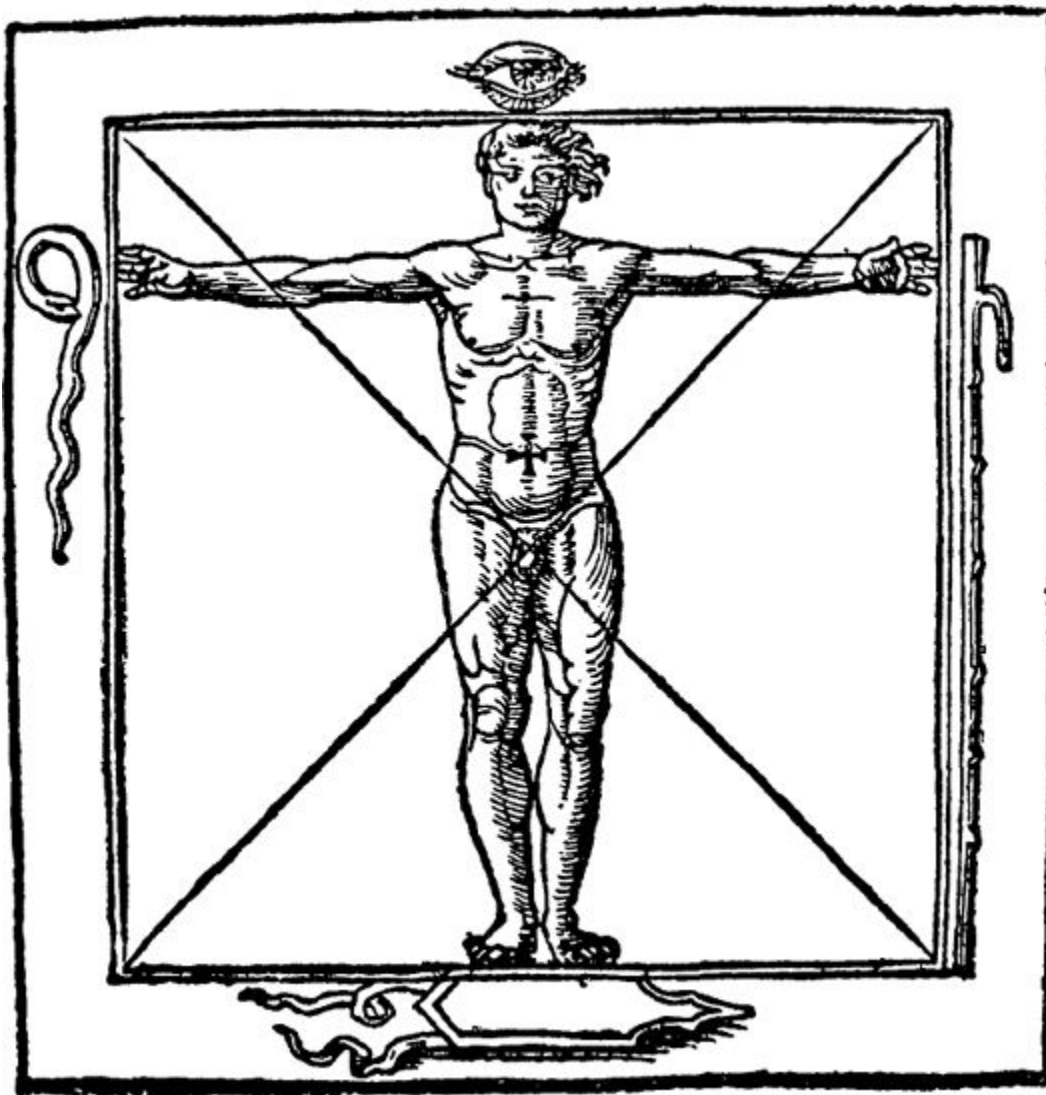

Fig. 26. The human cross

From Agrippa von Nettesheim, De occulta philosophia, Cologne, 1533

[404] I must leave it an open question whether the symbol of the cross bears any relation to the two ceremonial fire-sticks used in fire-making, as has been claimed. But it seems very likely that the idea of “union” still lingers on in the cross, for underlying all fertility magic is the thought of renewal, which in turn is intimately connected with the cross. The idea of union expressed in the cross symbol is found in Plato’s *Timaeus*, where the demiurge joins the parts of the world-soul together by means of two sutures, which form a X (chi). According to Plato, the world-soul contains the world in itself like a body, an image which cannot fail to remind us of the mother:

And in the centre he set a soul and caused it to extend throughout the whole and further wrapped its body round with soul on the outside; and so he established one world alone, round and revolving in a circle, solitary but by reason of its excellence able to bear itself company, needing no other acquaintance or friend but sufficient to itself. On all these accounts the world which he brought into being was a blessed god.¹⁴⁰

[405] This utter inactivity and desirelessness, symbolized by the idea of self-containment, amounts to divine bliss. Man in this state is contained as if in his own

vessel, like an Indian god in the lotus or in the embrace of his Shakti. In accordance with this mythological and philosophical conception, the enviable Diogenes lived in a tub in order to give symbolical expression to the blissfulness and godlikeness of his freedom from desire. On the relation between the world-soul and the world-body Plato says:

Now this soul, though it comes later in the account we are now attempting, was not made by the god younger than the body; for when he joined them together, he would not have suffered the elder to be ruled by the younger. There is in us too much of the casual and random, which shows itself in our speech; but the god made soul prior to body and more venerable in birth and excellence, to be the body's mistress and governor.¹⁴¹

[406] From other indications it appears that the image of the "soul" somehow coincides with the mother-imago.¹⁴² The next stage in the development of the world-soul takes place in a mysterious and rather controversial fashion.¹⁴³ When the operation was complete, the following was done:

This whole fabric, then, he split lengthwise into two halves; and making the two cross one another at their centres in the form of the letter X, he bent each round into a circle and joined it up....

When the whole fabric of the soul had been finished to its maker's mind, he next began to fashion within the soul all that is bodily and brought the two together, fitting them centre to centre.¹⁴⁴

[407] A peculiar use is made of the cross symbol by the Muyscas Indians, of Peru; two ropes are stretched crosswise over the surface of the water (pool or stream), and fruits, oil, and precious stones are thrown in as a sacrifice at the point of intersection.¹⁴⁵ Here the divinity is evidently the water, not the cross, which only signifies the place of sacrifice. The symbolism is somewhat obscure. Water, and particularly deep water, usually has a maternal significance, roughly corresponding to "womb." The point of intersection of the two ropes is the point of union where the "crossing" takes place. (Note the double meaning of this word! According to all the analogies, the aim of fertility magic is to bring about the *increase* of the things marked for sacrifice.)

[408] The cross in the form of the *crux ansata* frequently appears in the hand of the Egyptian Tum or Atum, the supreme god or hegemon of the Ennead. Its meaning is "life," which is to say that the god gives life. (Fig. 27.) It is important to know something about the attributes of this life-giving god. Tum of On-Heliopolis bears the name "the father of his mother," and his attendant goddess, Jusas or Nebit-Hotpet, is called sometimes the mother, sometimes the daughter, and sometimes the wife of the god. The first day in autumn is known in the Heliopolitan inscriptions as the "feast-day of the goddess Jusasit," as the arrival of the "sister who makes ready to unite herself with her father." It is the day on which "the goddess Mehnit completes her work, so that the god Osiris may enter the left eye."¹⁴⁶ It is also called "the day for

filling the sacred eye with what it needs.” In the autumn equinox the heavenly cow with the moon-eye, Isis, receives the seed that begets Horus (the moon being the guardian of the seed).¹⁴⁷ The “eye” evidently stands for the female genitals, as is clear from the myth of Indra, who, as a punishment for his wantonness, was smitten with yonis all over his body, but was so far pardoned by the gods that the shameful yonis were changed into eyes. The little image reflected in the eye, the “pupilla,” is a “child.” The great god becomes a child again: he enters into the mother’s womb for self-renewal.¹⁴⁸ (Cf. pl. XLII.) An Egyptian hymn says:



Fig. 27. *The life-giving crux ansata*
Egypt

Thy mother, the sky,
Stretches forth her arms to thee.

[409] The hymn continues:

Thou shinest, O father of the gods, upon the back of thy mother, daily thy mother taketh thee in her arms. When thou lightest up the habitation of the night, thou art one with thy mother, the sky.¹⁴⁹

[410] Tum of Pithum-Heroopolis not only carries the *crux ansata* as a symbol, but even has this emblem as the commonest of his titles, *ankh* or *ankhi*, which means ‘life’ or the ‘Living One.’ He was chiefly worshipped as the Agathodaimon serpent (cf. [fig.](#)

37), of whom it was said: “The sacred Agathodaimon serpent goes forth from the city of Nezi.” The snake, because it casts its skin, is a symbol of renewal, like the scarab beetle, a sun-symbol, which was believed to be of masculine sex only and to beget itself. “Khnum” (another name for Tum, but always the sun-god is meant) comes from the verb *num*, ‘to combine or unite.’¹⁵⁰ Khnum appears as the potter and maker of his own egg (cf. pl. *XLlib*).

[411] It is clear from all this that the cross is a many-faceted symbol, and its chief meaning is that of the “tree of life” and the “mother.” Its symbolization in human form is therefore quite understandable. The various forms of the *crux ansata* have the meaning of “life” and “fruitfulness,” and also of “union,” which can be interpreted as the *hieros gamos* of the god with his mother for the purpose of conquering death and renewing life.¹⁵¹ This mythologem, it is plain, has passed into Christianity. For instance, St. Augustine says:

Like a bridegroom Christ went forth from his chamber, he went out with a presage of his nuptials into the field of the world.... He came to the marriage-bed of the cross, and there, in mounting it, he consummated his marriage. And when he perceived the sighs of the creature, he lovingly gave himself up to the torment in place of his bride, and he joined himself to the woman for ever.¹⁵²

[412] The analogy is indeed so plain that it hardly requires further comment. It is, therefore, a very touching and, for all its naïveté, an extraordinarily profound piece of symbolism when Mary, in an Old English lament of the Virgin,¹⁵³ accuses the cross of being a false tree, which unjustly and insensately destroyed “the pure fruit of her body, her gentle birdling,” with a poisonous draught, the draught of death, which was meant only for the guilty descendants of the sinner Adam. Her son was not to blame for their guilt. Mary laments:

Tre unkynde, thou schalt be kud,
mi sone step-moder I the calle:
cros thou holdest him so heih on heighth,
mi fruites feet I mai not kis;
cros I fynde thou art my fo,
thou berest my brid, beten blo....

[413] Whereupon the Holy Cross answers:

Ladi to the I owe honour,
thi brihte palmes nou I bere;
thi fruit me florscheth in blod colour ...
that Blosme Blomed up in thi bour.
ac not for the al-one,

but for to winne all this world.

[414] Concerning the relation of the two mothers to one another, the Cross says:

thou art i-crouned hevene quene,
thorw the burthe that thou beere.
I am a Relyk that shineth shene,
men wolde wite wher that I were,
at the parlement wol I bene,
on domes-day prestly a-pere;
at the parlement shul puiten up pleynyng,
hou Maydenes fruit on me gan sterve.¹⁵⁴

[415] Thus the Mother of Death joins the Mother of Life in lamenting the dying god, and, as an outward token of their union, Mary kisses the cross and is reconciled.¹⁵⁵ In ancient Egypt this union of opposite tendencies was naively preserved in the Isis mother-imago. The separation of the son from the mother signifies man's leavetaking from animal unconsciousness. It was only the power of the "incest prohibition"¹⁵⁶ that created the self-conscious individual, who before had been mindlessly one with the tribe; and it was only then that the idea of the final death of the individual became possible. Thus through Adam's sin, which lay precisely in his becoming conscious, death came into the world. The neurotic who cannot leave his mother has good reasons for not doing so: ultimately, it is the fear of death that holds him there. It seems as if no idea and no word were powerful enough to express the meaning of this conflict. Certainly the struggle for expression which has continued through the centuries cannot be motivated by what is narrowly and crudely conceived as "incest." We ought rather to conceive the law that expresses itself first and last in the "incest prohibition" as the impulse to domestication, and regard the religious systems as institutions which take up the instinctual forces of man's animal nature, organize them, and gradually make them available for higher cultural purposes.

[416] We will now return to Miss Miller's visions. Those that now follow do not require detailed discussion. First comes the image of a "bay of purple water." The symbolism of the sea links up with what has gone before, and we could also refer back to the reminiscences of the bay of Naples in Part I. In the sequence of the whole we certainly ought not to overlook the significance of the bay, so it might be as well to cast a glance at the etymology of this conception. Generally speaking, *bay* denotes anything that stands open. F. *bayer* means 'to keep the mouth open, to gape.' Another word for the same thing is *gulf* (Lat. *sinus*), which, in F. *golfe*, is closely connected with *gouffre*, 'abyss' (cf. also Eng. *gap*). *Gulf* is related to κόλπος,¹⁵⁷ 'bosom, lap, womb'; also 'fold of a garment,' or 'pocket.' (In Swiss-German, *Buese* is 'pocket of

a coat or skirt.’) Κόλπος can also mean a deep hollow between two waves, or a valley between two high mountains. These significations point clearly to the underlying primitive ideas. They render intelligible Goethe’s choice of words in the passage where Faust wishes to follow the sun with winged desire in order to drink its “streams of quenchless light”:

Then mountains could not check my godlike flight,
With wild ravine or savage rocky ways;
But lo, the sea, with warm and tranquil bays,
Would hold its beauty to my wondering sight.¹⁵⁸

[417] Faust’s desire, like that of every hero, is a yearning for the mystery of rebirth, for immortality; therefore his way leads out to sea and down into the maw of death, that frighteningly narrow “passage” which signals the new day:

I hear a call towards the open main,
My tide of soul is ebbing more and more;
Lies at my feet the shining, glassy plain,
A new day beckons to another shore.
As if on wings, a chariot of fire
Sweeps near me. I am ready to be free.
Piercing the ether, new-born, I aspire
To rise to spheres of pure activity.
... ..
Now let me dare to open wide the gate
Past which man’s steps have ever flinching trod,
The hour is come, as master of my fate,
To prove in man the stature of a god,
Nor shrink before the cavern black and fell,
Imagination’s torment evermore,
But *strive towards that passage*, at whose door
—A narrow mouth—burn all the flames of hell.
This step I take in cheerful resolution,
Though I should plunge to death and dissolution.¹⁵⁹

[418] So it seems like a confirmation of this when in the very next vision Miss Miller sees “a perpendicular cliff.” (Cf. *gouffre*.) This whole series of visions ends, so the author tells us, with a confusion of sounds, somewhat resembling “wa-ma, wa-ma.” This strikes a very primitive, abysmal note. Since we learn nothing from Miss Miller about the subjective roots of this echo from the past, there is only one conjecture

open to us: that it might, in the context as a whole, be considered a slight distortion of the well-known cry “Ma-ma.”

VI

THE BATTLE FOR DELIVERANCE FROM THE MOTHER

[419] There now comes a short pause in the production of the visions; then the activity of the unconscious is energetically resumed.

[420] A wood appears, with trees and bushes. After our discussion in the preceding chapter, we need only say that the meaning of the forest coincides essentially with that of the tabooed tree. The sacred tree is generally found in a wood or in a paradiselike garden. Sometimes the forbidden grove takes the place of the tabooed tree and is invested with all the attributes of the latter. The forest, like the tree, has a maternal significance. In the vision which now follows, the forest forms the setting for the dramatic representation of Chiwantopel's end. I will first give the beginning of the drama, i.e., the first attempt at sacrifice, as it appears in the original text. The reader will find the continuation, the monologue and sacrificial scene, at the beginning of the next chapter.

The figure of Chi-wan-to-pel comes up from the south, on horseback, wrapped in a blanket of bright colours, red, blue, and white. An Indian, dressed in buckskin, beaded and ornamented with feathers, creeps forward stealthily, making ready to shoot an arrow at Chi-wan-to-pel, who bares his breast to him in an attitude of defiance; and the Indian, fascinated by this sight, slinks away and disappears into the forest.

[421] Chiwantopel appears on horseback. This fact seems to be of some importance because, as the next act of the drama will show, the horse does not play a neutral role, but suffers the same death as the hero, who even calls him his "faithful brother." This points to a curious similarity between horse and rider. There seems to be an intimate connection between the two which leads them to the same fate. We have already seen that the libido directed towards the mother actually symbolizes her as a horse.¹ The mother-imago is a libido-symbol and so is the horse; at some points the meaning of the two symbols overlaps. But the factor common to both is the libido. In the present context, therefore, the hero and his horse seem to symbolize the idea of man and the subordinate sphere of animal instinct. Parallel representations would be Agni on the ram (pl. XIIIb), Wotan on Sleipnir (fig. 28), Ahura-Mazda on Angramainyu,² Christ on the ass,³ Mithras on the bull, accompanied by his symbolic animals, the lion and the snake (pl. XL), Men on the human-footed horse, Frey on the boar with golden bristles, and so on. The steeds of mythology are always invested with great significance and very often appear anthropomorphized. Thus Men's horse has human

forelegs, Balaam's ass human speech, and the bull upon whose back Mithras springs to deliver the death blow (*taurokathapsis*:⁴ cf. pl. XL) is a life-giving deity.



Fig. 28. Wotan riding the eight-legged horse Sleipnir
Tombstone, Götland, Sweden, C. A.D. 1000



Fig. 29. The Devil riding off with a witch
From Olaus Magnus, Historia, Rome, 1555

The mock crucifixion on the Palatine shows the Crucified with an ass's head (pl. XLIII), which may perhaps be a reference to the old legend that the image of an ass was worshipped in the temple at Jerusalem.⁵ In the form of

Drosselbart ('horse's beard') Wotan is half man, half horse. An old German riddle puts this unity of horse and rider⁶ very nicely: "Who are the two that go to the Thing? Together they have three eyes,⁷ ten feet and one tail,⁸ and thus they travel over the land." Legend attributes properties to the horse which psychologically belong to the unconscious of man: there are clairvoyant and clairaudient horses, path-finding horses who show the way when the wanderer is lost, horses with mantic powers. In the Iliad (xix), the horse prophesies evil. They hear the words the corpse utters on its way to the grave—words which no human can hear. Caesar was told by his human-footed horse (probably derived from an identification of Caesar with the Phrygian Men) that he would conquer the world. An ass prophesied to Augustus the victory of Actium. Horses also see ghosts. All these things are typical manifestations of the unconscious. We can therefore see why the horse, as a symbol of the animal component in man, has numerous connections with the devil. The devil has a horse's hoof and sometimes a horse's form. At critical moments he shows the proverbial cloven hoof, just as, during the abduction of Hadding, Sleipnir suddenly looked out from behind Wotan's mantle.⁹ The devil, like the nightmare, rides the sleeper; hence it is said that those who have nightmares are ridden by the devil. In Persian lore the devil is the steed of God. He represents the sexual instinct; consequently at the Witches' Sabbath he appears in the form of a goat or horse. The sexual nature of the devil is imparted to the horse as well, so that this symbol is found in contexts where the sexual interpretation is the only one that fits. Loki propagates in the form of a horse, and so does the devil, as an ancient god of fire. Lightning, too, is represented theriomorphically as a horse.¹⁰ An uneducated hysterical patient once told me that as a child she was terrified of thunderstorms, because after each flash of lightning she saw a huge black horse rearing up to the sky. Indian legend tells of the black thunder-horse of Yama, the god of death, who dwells in the south, the mythical place of storms.¹¹ In German folklore the devil is a god of lightning who hurls the horse's hoof—lightning—on the rooftops. In accordance with the primitive idea that thunder fertilizes the earth, lightning and horses' hoofs both have a phallic meaning. An uneducated woman patient who had been violently forced by her husband to have coitus with him often dreamt that a wild horse leapt over her and kicked her in the abdomen with his hind foot. Plutarch records the following words of a prayer from the Dionysian orgies:

Come, Dionysus, into thy temple at Elis, come with the Graces into thy holy temple, come with the bull's foot thundering, worthy bull, worthy bull! ¹²

Pegasus struck the fountain of Hippocrene from the earth with his hoof. A Corinthian statue of Bellerophon, which was also a fountain, was made so that the water flowed from the hoof of the horse. Baldur's horse struck forth a spring with his kick. The horse's foot is therefore the dispenser of fruitful moisture.¹³ A tale from lower Austria, recorded by Jähns,¹⁴ says that a gigantic man on a white horse can sometimes be seen riding over the mountains, a sure sign of rain. In German legend, Mother Holle, the goddess of childbirth, comes on horseback. Pregnant women nearing confinement would often give oats to a white horse from their aprons and ask him for a speedy delivery. Originally it was the custom for the horse to nuzzle the woman's genitals. The horse, like the ass, has the significance of a priapic animal.¹⁵ Hoof-marks were once worshipped as dispensers of blessings and fertility; they also established the right of possession and were of importance in determining boundaries, like the Priapic statues of Latin antiquity. It was a horse who, like the Dactyls, discovered the mineral wealth of the Harz Mountains with his hoof. The horse-shoe, an equivalent for the horse's foot,¹⁶ brings luck and has an apotropaic meaning. In the Netherlands, a hoof is hung up in the stable to ward off sorcery. The analogous effect of the

phallus is well known; hence the phalli on gates. The shank in particular is supposed to keep off lightning, on the principle that like cures like.

[422] On account of their speed, horses signify wind, and here again the *tertium comparationis* is the libido-symbol. German legend knows the wind as the wild huntsman in lustful pursuit of the maiden. Wotan gallops along in a storm after the wind-bride (Frigg) fleeing before him.¹⁷ Storm-centres often get their names from horses, e.g., the Schimmelberge ('white horse hills') on Lüneburg heath. The centaurs are, among other things, wind-gods.¹⁸

[423] Horses also signify fire and light, like the fiery horses of Helios. Hector's horses were called Xanthos (yellow, glaring), Podargos (swift-footed), Lampos (shining), and Aithon (burning). Siegfried leaps over the wall of fire on the thunder-horse Grani, who was sired by Sleipnir and was the only one capable of taking the fiery hedge.¹⁹ There is a distinct fire symbolism in the mystic quadriga mentioned by Dio Chrysostom: ²⁰ the highest god always drives his chariot round in a circle. The chariot is drawn by four horses, and the outside horse moves very quickly. He has a shining coat, bearing on it the signs of the zodiac and the constellations.²¹ The second horse goes more slowly and is illuminated on one side only. The third horse is slower still, and the fourth horse runs round himself. Once, however, the outside horse set the mane of the second horse on fire with his fiery breath, and the third horse drenched the fourth with streams of sweat. Then the horses dissolve and merge with the substance of the strongest and most fiery, which now becomes the charioteer. The horses represent the four elements. The catastrophe signifies world conflagration and the deluge, after which the division of God into Many ceases, and the divine One is restored.²² There can be no doubt that the quadriga is meant as an astronomical symbol of Time. We saw in Part I that the Stoic conception of fate is a fire-symbol, so it is a logical continuation of this idea when the closely related conception of time exhibits the same libido symbolism.

[424] The Brihadaranyaka Upanishad says:

Dawn is the head of the sacrificial horse, the sun his eye, the wind his breath, the universal fire his open mouth. The year is the body of the sacrificial horse. The sky is his back, the air his belly, the earth the underpart of his belly. The poles are his flanks, the intermediate poles his ribs, the seasons his limbs, the months and half-months his joints, days and nights his feet, the stars his bones, the clouds his flesh. Sand is the food in his stomach, rivers are his entrails. His liver and lungs are the mountains; plants and trees, his hair. The rising sun is his forepart, the setting sun his hindpart.... The ocean is his kinsman, the sea his cradle.²³

[425] Here the horse is undoubtedly conceived as a time-symbol, besides being the whole world. In the Mithraic religion we meet with a strange god, Aion (pl. XLIV), also called Chronos or *deus leontocephalus* because he is conventionally represented

as a lion-headed human figure. He stands in a rigid attitude, wrapped in the coils of a serpent whose head juts forward over the head of the lion. In each hand he holds a key, on his breast is a thunderbolt, on his back are the four wings of the wind, and on his body are the signs of the zodiac. His attributes are a cock and implements. In the Carolingian Utrecht Psalter, which was based on classical models, Aion is shown as a naked man bearing in his hand a snake.²⁴ As the name indicates, he is a time-symbol, and is composed entirely of libido-images. The lion, the zodiacal sign for the torrid heat of summer,²⁵ is the symbol of *concupiscentia effrenata*, ‘frenzied desire.’ (“My soul roars with the voice of a hungry lion,” says Mechthild of Magdeburg.) In the Mithraic mysteries the snake is often shown as the antagonist of the lion, in accordance with the myth of the sun’s fight with the dragon. In the Egyptian Book of the Dead, Tum is addressed as a tom-cat, because in that form he fought the Apophis-serpent. To be “entwined” or embraced is the same as to be “devoured,” which as we saw means entering into the mother’s womb. Time is thus defined by the rising and setting sun, by the death and renewal of libido, the dawning and extinction of consciousness. The attribute of the cock again points to time, and the implements to creation through time (Bergson’s “durée créatrice”). Oromazdes (Ahura-Mazda) and Ahriman came into being through *Zrwan akarana*, ‘infinitely long duration.’ So time, this empty and purely formal concept, is expressed in the mysteries through transformations of the creative force, libido, just as time in physics is identical with the flow of the energetic process. Macrobius remarks: “By the lion’s head the present time is indicated ... because its condition is strong and fervent.”²⁶ Philo Judaeus evidently knows better:

Time is regarded as a god by evil men who wish to hide the Essential Being.... Vicious men think that Time is the cause of the world, but the wise and good think it is God.²⁷

[426] In Firdausi, time is often the symbol of fate.²⁸ The Indian text quoted above goes even further: its horse symbol contains the whole world, his kinsman and cradle is the sea, the mother, who is the equivalent of the world-soul. Just as Aion represents the libido in the “embrace” or state of death and rebirth, so here the cradle of the horse is the sea, i.e., the libido is in the “mother,” dying and rising again in the unconscious.

[427] We have already seen that the horse is connected through Yggdrasil with the symbolism of the tree. The horse too is a “tree of death”; for instance in the Middle Ages the bier was called “St. Michael’s Horse,” and the modern Persian word for coffin means ‘wooden horse.’²⁹ The horse also plays the part of a psychopomp who leads the way to the other world—the souls of the dead are fetched by horsewomen, the Valkyries. Modern Greek songs speak of Charon as riding on a horse.

[428] Finally, the symbol appears in yet another form: sometimes the devil rides on a *three-legged* horse. The goddess of death, Hel, rides on a three-legged horse in time of pestilence.³⁰ In the Bundahish³¹ there is a monstrous three-legged ass who stands in the heavenly rain-lake Vouru-Kasha; his urine purifies its waters, and at his cry all useful animals become pregnant and all harmful animals drop their young. The contrasting symbolism of Hel is fused into one image in the ass of Vouru-Kasha. The libido is fructifying as well as destructive.

[429] In the Miller drama an Indian approaches the hero, preparing to shoot an arrow at him. But Chiwantopel, with a proud gesture, exposes his breast to the enemy. This image reminded the author of the scene between Cassius and Brutus in Shakespeare's *Julius Caesar*.³² A misunderstanding has arisen between the two friends, Brutus accusing Cassius of withholding the money for the legions. Cassius breaks out in a peevish tirade:

Come, Antony, and young Octavius, come,
Revenge yourselves alone on Cassius,
For Cassius is aweary of the world:
Hated by one he loves: braved by his brother;
Check'd like a bondman; all his faults observ'd,
Set in a note-book, learn'd, and conn'd by rote,
To cast into my teeth. O! I could weep
My spirit from mine eyes! There is my dagger,
And here my naked breast; within, a heart
Dearer than Plutus' mine, richer than gold:
If that thou be'st a Roman, take it forth;
I, that denied thee gold, will give my heart.
Strike, as thou didst at Caesar; for, I know,
When thou didst hate him worst, thou lov'dst him better
Than ever thou lov'dst Cassius.

[430] Our material would not be complete if we did not mention that this speech of Cassius has several analogies with the agonized delirium of Cyrano, except that Cassius is far more theatrical. There is something childish and hysterical in his manner. Brutus has no intention of killing him; instead, he pours cold water on him in the following dialogue:

Sheathe your dagger:
Be angry when you will, it shall have scope;

Do what you will, dishonour shall be humour.

O Cassius! you are yoked with a lamb
That carries anger as the flint bears fire,
Who, much enforced, shows a hasty spark,
And straight is cold again.

CASSIUS: Hath Cassius liv'd

To be but mirth and laughter to his Brutus,
When grief and blood ill-temper'd vexeth him?

BRUTUS: When I spoke that, I was ill-temper'd too.

CASSIUS: Do you confess so much? Give me your hand.

BRUTUS: And my heart too.

CASSIUS: O Brutus!

BRUTUS: What's the matter?

CASSIUS: Have you not love enough to bear with me,
When that rash humour which my mother gave me
Makes me forgetful?

BRUTUS: Yes, Cassius; and from henceforth
When you are over-earnest with your Brutus,
He'll think your mother chides, and leave you so.

[431] Cassius's irritability is explained by the fact that he identifies with his mother and therefore behaves exactly like a woman, as his speech demonstrates to perfection.³³ His womanish yearning for love and his despairing self-abasement under the proud masculine will of Brutus fully justify the latter's remark that Cassius is "yoked with a lamb," in other words, has something feckless in his character, which is inherited from his mother. This can be taken as proof of an infantile disposition, which is as always characterized by a predominance of the parental imago, in this case that of the mother. An individual is infantile because he has freed himself insufficiently, or not at all, from his childish environment and his adaptation to his parents, with the result that he has a false reaction to the world: on the one hand he reacts as a child towards his parents, always demanding love and immediate emotional rewards, while on the other hand he is so identified with his parents through his close ties with them that he

behaves like his father or his mother. He is incapable of living his own life and finding the character that belongs to him. Therefore Brutus correctly surmises that “the mother chides” in Cassius, not he himself. The psychologically valuable fact to be elicited here is that Cassius is infantile and identified with the mother. His hysterical behaviour is due to the circumstance that he is still, in part, a “lamb,” an innocent and harmless child. So far as his emotional life is concerned, he has not yet caught up with himself, as is often the case with people who are apparently so masterful towards life and their fellows, but who have remained infantile in regard to the demands of feeling.

[432] Since the figures in the Miller drama are children of the author’s imagination, they naturally depict those traits of character which belong to the author herself.³⁴ The hero Chiwantopel represents her ideal, who is here projected as a masculine figure; for Miss Miller is still youthful enough to see her ideal in a man. She has evidently received no salutary disappointments in this respect, but is still enjoying her illusions. She does not yet know that her ideal figure ought really to be feminine, because such a figure might touch they could get at him her too closely. So long as the ideal is portrayed in the person of a man, it does not commit her to anything; it merely stimulates her fantastic demands. Were the ideal of her own sex, she might one day make the discovery that she does not quite come up to it. That would be uncomfortable, but salutary. Cyrano’s gesture³⁵ is all very fine and impressive, but that of Cassius verges on the theatrical. Both heroes set about dying in the grand manner, and Cyrano actually succeeds in doing so. This yearning for death anticipates the inevitable end of the illusion that the *other* person is the ideal. Miss Miller’s ideal figure is evidently about to change his psychic localization—he might even take up his abode in the author herself. That would mark a very critical point in her career. For when such a vitally important figure as the ideal is about to change, it is as though that figure had to die. It then creates in the individual all sorts of unaccountable and apparently unfounded presentiments of death—a romantic world-weariness. These tendencies have already found expression in the “Song of the Moth,” but now they become more sharply defined. Her infantile world wants to come to an end and be replaced by the adult phase. The wish of young girls to die is often only an indirect expression of this, but it remains a pose even if they really do die, for even death can be dramatized. Such an outcome merely makes the pose more effective. That the highest summit of life can be expressed through the symbolism of death is a well-known fact, for any growing beyond oneself means death. As an infantile person Miss Miller cannot realize what her task is in life; she cannot set herself any goal or standard for which she feels responsible. Therefore she is not yet prepared to accept the problem of love either, for this demands full consciousness

and responsibility, circumspection and foresight. It is a decision in favour of life, at whose end death stands. Love and death have not a little to do with one another.

[433] The proud gesture with which the hero offers himself to death may very easily be a manoeuvre for courting the sympathy of the other person, and it therefore invites the cool analysis which Brutus proceeds to give. The behaviour of Chiwantopel is equally suspicious, for the Cassius scene which serves as its model indiscreetly discloses the fact that the whole affair is merely infantile. When a gesture turns out to be too theatrical it gives ground for the suspicion that it is not genuine, that somewhere a contrary will is at work which intends something quite different.

[434] In the ensuing drama the libido assumes a menacing activity that contrasts very strongly with the inactive nature of the preceding symbols, and a conflict develops in which one party threatens the other with murder. The hero, the ideal image of the dreamer, is ready to die; he has no fear of death. To judge from the infantile character of this hero, it is indeed high time for him to quit the stage. Death is to come for him in the form of an arrow-shot. In view of the fact that many heroes are themselves mighty archers, or else are killed by arrows, it may not be superfluous to inquire what death by an arrow means. (Cf. pl. XLV.)

[435] We read in the biography of Anna Catherina Emmerich, the hysterical German nun (1774–1824) who received the stigmata, the following account of her heart-trouble:

When only in her novitiate, she received as a Christmas gift from Christ a very painful heart-trouble, which lasted for the whole period of her ordained life. But God showed her inwardly its purpose: it was to atone for the decay of the spirit of the Order, and especially for the sins of her fellow sisters. But what made this trouble most painful to her was the gift which she had possessed from youth, of seeing with her mind's eye the inner nature of man as he really was. She felt the heart-trouble physically, as if her heart were continually pierced by arrows.³⁶ These arrows—and for her this was a far worse spiritual torment—she recognized as the thoughts, schemings, secret gossipings, misunderstandings, and uncharitable slanders with which her fellow sisters, wholly without reason and conscience, plotted against her and her God-fearing way of life.³⁷

[436] It is difficult to be a saint, because even a patient and long-suffering nature will not readily endure such a high degree of differentiation and defends itself in its own way. The constant companion of sanctity is temptation, without which no true saint can live. We know that these temptations can pass off unconsciously, so that only their equivalents reach consciousness in the form of symptoms. We know, too, that *Herz* traditionally rhymes with *Schmerz*.³⁸ It is a well-known fact that hysterics substitute a physical pain for a psychic pain which is not felt because repressed. Catherina Emmerich's biographer has understood this more or less correctly, but her own interpretation of the pain is based, as usual, on a projection: it is always the

others who secretly say all sorts of wicked things about her, and this is the cause of her pains. The facts of the matter are rather different: the renunciation of all life's joys, this fading before the flower, is always painful, and especially painful are the unfulfilled desires and the attempts of nature to break through the barrier of repression, without which no such differentiation would be possible. The gossip and sarcastic gibes of the sisters very naturally pick on these painful things, so that it must seem to the saint as if her difficulties came from there. She could hardly know that gossip is very apt to take over the role of the unconscious, and, like a skilled adversary, always aims at the chinks in our armour of which we know nothing.

[437] The same idea is expressed in the following passage from the discourses of the Buddha:

But if those sensual pleasures fail the person who desires and wishes for them, he will suffer, pierced by the arrow of pain.³⁹

[438] The wounding and painful shafts do not come from outside, through gossip, which only pricks us on the surface, but from the ambush of our own unconscious. It is our own repressed desires that stick like arrows in our flesh.⁴⁰ On another occasion this became true for our nun, and in the most literal sense. It is a well-known fact that scenes of mystic union with the Saviour are strongly tinged with erotic libido.⁴¹ Stigmatization amounts to an incubation with the Saviour, a slight modification of the ancient conception of the *unio mystica* as cohabitation with the god. The nun gives the following account of her stigmatization:

I had a contemplation of the sufferings of Christ, and I besought him to let me feel his sorrows with him, and prayed five paternosters in adoration of the five sacred wounds. Lying on my bed with arms outstretched, I entered into a great sweetness and into an endless thirst for the torments of Jesus. Then I saw a radiance descending towards me; it came slanting down from above. It was a crucified body, alive and transparent, the arms extended, but without the Cross. The wounds shone more brightly than the body; they were five circles of glory emanating from the glory of the whole. I was enraptured, and my heart was moved with great pain and yet with great sweetness, from my longing to share the torments of my Saviour. And at the sight of the wounds my longing for the sufferings of the Redeemer increased more and more, as if streaming out of my breast, through my hands, side, and feet towards his holy wounds. Then from the hands, then from the side, then from the feet of the figure triple beams of shining red light shot forth into my hands, my side, and my feet, ending in an arrow.⁴²

[439] The beams are triple, terminating in an arrow-head.⁴³ Like Cupid, the sun has his quiver full of destroying or fertilizing arrows.⁴⁴ The arrow has a masculine significance; hence the Oriental custom of describing brave sons as the arrows or javelins of their father. "To make sharp arrows" is an Arabic expression for begetting valiant sons. To announce the birth of a son the Chinese used to hang a bow and arrow in front of the house. Accordingly the Psalms declare (127:4, RV): "As arrows

in the hand of a mighty man, so are the children of youth.” Thanks to this meaning of the arrow, we can see why the Scythian king Ariantes, wishing to prepare a census, demanded an arrow-head from each man.⁴⁵ A similar significance attaches to the lance: men are descended from the lance; the ash is the mother of lances; therefore the men of the Bronze Age are derived from her. Kaineus⁴⁶ commanded that his lance was to be worshipped. Pindar says of this Kaineus that, in the legend, “he descended into the depths, splitting the earth with a straight foot.”⁴⁷ Originally he is supposed to have been a maiden named Kainis, who, as a reward for her submissiveness, was changed by Poseidon into an invulnerable man. Ovid, describing the battle of the Lapithae with the invulnerable Kaineus, says that in the end they covered him completely with trees, because that was the only way they could get at him. He continues:

His end is doubtful. Some say that his body was thrust down by the weight of the trees to the Tartarean pit, but the son of Ampycus denied this. For from the midst of the pile he saw a bird with golden wings fly up into the limpid air.⁴⁸

[440] Roscher⁴⁹ takes this bird to be the golden plover (*Charadrius pluvialis*), which gets its name from the fact that it lives in a *χαράδρα*, ‘crack in the earth.’ His song heralds the rain.

[441] Once again we recognize the typical elements of a libido myth: original bisexuality, immortality (invulnerability) through entry into the mother (splitting the mother with the foot), resurrection as a soul-bird, and production of fertility (rain). When a hero of this type causes his lance to be worshipped, he probably does so because he thinks it a valid equivalent of himself.

[442] From this standpoint the passage in Job, which we quoted in Part I, appears in a new light:

He hath set me up for his mark.
His archers compass me round about,
He cleaveth my reins asunder, and doth not spare;
He poureth out my gall upon the ground.
He breaketh me with breach upon breach,
He runneth upon me like a giant.⁵⁰

[443] Here Job is voicing the torment of soul caused by the onslaught of unconscious desires; the libido festers in his flesh, a cruel God has overpowered him and pierced him through with barbed thoughts that agonize his whole being.

[444] The same image occurs in Nietzsche:

Stretched out, shivering,
Like one half dead whose feet are warmed,
Shaken by unknown fevers,
Shuddering from the icy pointed arrows of frost,
Hunted by thee, O thought,
Unutterable! veiled! horrible one!
Thou huntsman behind the clouds.
Struck to the ground by thee,
Thou mocking eye that gazeth at me from the dark:
Thus do I lie,
Twisting, writhing, tortured
With eternal tortures,
Smitten
By thee, cruel huntsman,
Thou unknown—God!

Smite deeper!
Smite once more!
Pierce, rend my heart!
What meaneth this torturing
With blunt-toothed arrows?
Why gazest thou again,
Never weary of human agony,
With sardonic gods'-eyes, flashing lightning?
Why wilt thou not kill,
Only torture, torture? ⁵¹

[445] No long-drawn explanations are needed to see in this comparison the martyred and sacrificed god whom we have already met in the Aztec crucifixions and in the sacrifice of Odin.⁵² We meet the same image in depictions of the martyrdom of St. Sebastian, where the glowing, girlishly tender flesh of the young saint betrays all the pain of renunciation which the sensibility of the artist projected into it. An artist cannot prevent his work from being coloured by the psychology of his time. This is true in even higher degree of the Christian symbol, the Crucified pierced by the lance. It is a true symbol of the man of the Christian era, tormented by his desires and crucified in Christ.

[446] That the torment which afflicts mankind does not come from outside, but that man is his own huntsman, his own sacrificer, his own sacrificial knife, is clear from

another poem of Nietzsche's, where the dualism is resolved into a psychic conflict through the same symbolism:

O Zarathustra,
Most cruel Nimrod!
Erstwhile hunter of God,
Snare of all virtue,
Arrow of evil!
And now
Self-hunted,
Thine own quarry,
Thyself pierced through ...

Now
Alone with thyself,
Split in thine own knowledge,
Amidst a hundred mirrors
To thine own self false,
Amidst a hundred memories
Uncertain,
Languishing with each wound,
Shivering with each frost,
Strangled in thine own snares,
Self-knower!
Self-hangman!

Why didst thou hang thyself
With the noose of thy wisdom?
Why hast thou enticed thyself
Into the old serpent's Paradise?
Why hast thou stolen
Into thyself, thyself?⁵³

[447] The deadly arrows do not strike the hero from without; it is himself who hunts, fights, and tortures himself. In him, instinct wars with instinct; therefore the poet says, "Thyself pierced through," which means that he is wounded by his own arrow. As we know that the arrow is a libido-symbol, the meaning of this "piercing" is clear: it is the act of union with oneself, a sort of self-fertilization, and also a self-violation, a self-murder, so that Zarathustra can justly call himself his own hangman (like Odin,

who sacrifices himself to Odin). One should not of course take this psychologem in too voluntaristic a sense: nobody deliberately inflicts such tortures on himself, they just happen to him. If a man reckons the unconscious as part of his personality, then one must admit that he is in fact raging against himself. But, in so far as the symbolism thrown up by his suffering is archetypal and collective, it can be taken as a sign that he is no longer suffering from himself, but rather from the spirit of the age. He is suffering from an objective, impersonal cause, from his collective unconscious which he has in common with all men.

[448] Being wounded by one's own arrow signifies, therefore, a state of introversion. What this means we already know: the libido sinks "into its own depths" (a favourite image of Nietzsche's), and discovers in the darkness a substitute for the upper world it has abandoned—the world of memories ("Amidst a hundred memories"), the strongest and most influential of which are the earliest ones. It is the world of the child, the paradisaal state of early infancy, from which we are driven out by the relentless law of time. In this subterranean kingdom slumber sweet feelings of home and the hopes of all that is to be. As Heinrich says of his miraculous work in Gerhart Hauptmann's *The Sunken Bell*:

It sings a song, long lost and long forgotten,
A song of home, a childlike song of love,
Born in the waters of some fairy well,
Known to all mortals, and yet heard of none.⁵⁴

[449] Yet "the danger is great,"⁵⁵ as Mephistopheles says, for these depths fascinate. When the libido leaves the bright upper world, whether from choice, or from inertia, or from fate, it sinks back into its own depths, into the source from which it originally flowed, and returns to the point of cleavage, the navel, where it first entered the body. This point of cleavage is called the mother, because from her the current of life reached us. Whenever some great work is to be accomplished, before which a man recoils, doubtful of his strength, his libido streams back to the fountainhead—and that is the dangerous moment when the issue hangs between annihilation and new life. For if the libido gets stuck in the wonderland of this inner world,⁵⁶ then for the upper world man is nothing but a shadow, he is aloof from the unconscious to be eady moribund or at least seriously ill. But if the libido manages to tear itself loose and force its way up again, something like a miracle happens: the journey to the underworld was a plunge into the fountain of youth, and the libido, apparently dead, wakes to renewed fruitfulness. This idea is illustrated in an Indian myth: Vishnu sank into a profound trance, and in his slumber brought forth Brahma, who, enthroned on a lotus, rose out of Vishnu's navel, bringing with him the Vedas (pl. XLVIA), which he diligently read. (Birth of creative thought from introversion.) But through Vishnu's

ecstatic absentmindedness a mighty flood came upon the world. (Devouring and destruction of the world through introversion.) Taking advantage of the general confusion, a demon stole the Vedas and hid them in the depths. Brahma then roused Vishnu, who, changing himself into a fish (pl. XLVII), plunged into the flood, fought the demon, conquered him, and recaptured the Vedas.

[450] This is a primitive way of describing the libido's entry into the interior world of the psyche, the unconscious. There, through its introversion and regression, contents are constellated which till now were latent. These are the primordial images, the archetypes, which have been so enriched with individual memories through the introversion of libido as to become perceptible to the conscious mind, in much the same way as the crystalline structure latent in the saturated solution takes visible shape from the aggregation of molecules. Since these introversions and regressions only occur at moments when a new orientation and a new adaptation are necessary, the constellated archetype is always the primordial image of the need of the moment. Although the changing situations of life must appear infinitely various to our way of thinking, their possible number never exceeds certain natural limits; they fall into more or less typical patterns that repeat themselves over and over again. The archetypal structure of the unconscious corresponds to the average run of events. The changes that may befall a man are not infinitely variable; they are variations of certain typical occurrences which are limited in number. When therefore a distressing situation arises, the corresponding archetype will be constellated in the unconscious. Since this archetype is numinous, i.e., possesses a specific energy, it will attract to itself the contents of consciousness—conscious ideas that render it perceptible and hence capable of conscious realization. Its passing over into consciousness is felt as an illumination, a revelation, or a “saving idea.” Repeated experience of this process has had the general result that, whenever a critical situation arises, the mechanism of introversion is made to function artificially by means of ritual actions which bring about a spiritual preparation, e.g., magical ceremonies, sacrifices, invocations, prayers, and suchlike. The aim of these ritual actions is to direct the libido towards the unconscious and compel it to introvert. If the libido connects with the unconscious, it is as though it were connecting with the mother, and this raises the incest-taboo. But as the unconscious is infinitely greater than the mother and is only symbolized by her, the fear of incest must be conquered if one is to gain possession of those “saving” contents—the treasure hard to attain. Since the son is not conscious of his incest tendency, it is projected upon the mother or her symbol. But the symbol of the mother is not the mother herself, so in reality there is not the slightest possibility of incest, and the taboo can therefore be ruled out as a reason for resistance. In so far as the mother represents the unconscious, the incest tendency, particularly when it appears as the amorous desire of the mother (e.g., Ishtar and

Gilgamesh) or of the anima (e.g., Chryse and Philoctetes), is really only the desire of the unconscious to be taken notice of. The rejection of the unconscious usually has untortunate results; its instinctive forces, if persistently disregarded, rise up in opposition: Chryse changes into a venomous serpent. The more negative the attitude of the conscious towards the unconscious, the more dangerous does the latter become.⁵⁷ Chryse's curse was fulfilled so completely that Philoctetes, on approaching her altar, wounded himself in the foot with his own poison-tipped arrow, or, according to other versions⁵⁸ which are in fact better attested, was bitten in the foot by a poisonous snake,⁵⁹ and fell into a decline.⁶⁰

[451] This very typical injury also destroyed Ra, and is described as follows in an Egyptian hymn:

The mouth of the god twitched with age,
So that he dropped his spittle on the earth,
And what he spat fell on the ground.
Isis then kneaded it with her hands
Together with the earth which was there;
She fashioned from it a noble worm
And made it like a spear.
She did not wind it living about her face,
But threw it in a coil upon the path
Upon which the great god was wont to walk
At pleasure through his two countries.
The noble god stepped forth in his splendour,
The gods who served Pharaoh accompanied him,
And he walked as he did each day.
Then the noble worm stung him ...
The divine god opened his mouth,
And the voice of his majesty rang through the heavens.
And the gods cried: Behold! Behold!
He could not answer them,
His jawbones chattered,
All his limbs trembled,
And the poison invaded his flesh
As the Nile invades his territory.⁶¹

[452] In this hymn Egypt has preserved for us a primitive version of the snake-sting motif. The aging of the autumn sun as a symbol of human senility is traced back to

poisoning by a serpent. The mother is blamed for causing the death of the sun-god with her mischievous arts. The serpent symbolizes the mysterious numen of the “mother” (and of other daimonia) who kills, but who is at the same time man’s only security against death, as she is the source of life.⁶² Accordingly, only the mother can cure him who is sick unto death, and the hymn goes on to describe how the gods were called together to take counsel:

Then came Isis with her wisdom,
Whose mouth is full of the breath of life,
Whose decree banishes pain,
And whose word gives life to those who no longer breathe.
She said: What is it, what is it, divine Father?
Behold, a worm hath done thee this wrong.

Tell me thy name, divine Father,
For he whose name is spoken shall live.

[453] Ra answers:

I am he who created heaven and earth, and piled up the mountains,
And made all living things.
I am he who made the water and caused the great flood,
Who made the Bull of his Mother,
Who is the Begetter.

The poison did not depart, it went further,
The great god was not healed.
Then said Isis to Ra:
That is not thy name which thou tellest me.
Tell me thy name, that the poison may depart,
For he whose name is spoken shall live.

[454] Finally Ra decides to utter his true name. He was only partially cured, just as Osiris was only incompletely reconstituted, and in addition he lost his power and finally had to retire on the back of the heavenly cow.

[455] The poisonous worm is a deadly instead of an animating form of libido. The “true name” is Ra’s soul and magic power (his libido). What Isis demands is the transference of libido to the mother. This request is fulfilled to the letter, for the aging god returns to the heavenly cow, the symbol of the mother.

[456] The meaning of this symbolism becomes clear in the light of what we said earlier: the forward-striving libido which rules the conscious mind of the son demands separation from the mother, but his childish longing for her prevents this by setting up a psychic resistance that manifests itself in all kinds of neurotic fears—that is to say, in a general fear of life. The more a person shrinks from adapting himself to reality, the greater becomes the fear which increasingly besets his path at every point. Thus a vicious circle is formed: fear of life and people causes more shrinking back, and this in turn leads to infantilism and finally “into the mother.” The reasons for this are generally projected outside oneself: the fault lies with external circumstances, or else the parents are made responsible. And indeed, it remains to be found out how much the mother is to blame for not letting the son go. The son will naturally try to explain everything by the wrong attitude of the mother, but he would do better to refrain from all such futile attempts to excuse his own ineptitude by laying the blame on his parents.

[457] This fear of life is not just an imaginary bogey, but a very real panic, which seems disproportionate only because its real source is unconscious and therefore projected: the young, growing part of the personality, if prevented from living or kept in check, generates fear and changes into fear. The fear seems to come from the mother, but actually it is the deadly fear of the instinctive, unconscious, inner man who is cut off from life by the continual shrinking back from reality. If the mother is felt as the obstacle, she then becomes the vengeful pursuer. Naturally it is not the real mother, although she too may seriously injure her child by the morbid tenderness with which she pursues it into adult life, thus prolonging the infantile attitude beyond the proper time. It is rather the mother-*imago* that has turned into a *lamia*.⁶³ (Cf. pls. XXXVIIIa, XLVIII.) The mother-*imago*, however, represents the unconscious, and it is as much a vital necessity for the unconscious to be joined to the conscious as it is for the latter not to lose contact with the unconscious. Nothing endangers this connection more in a man than a successful life; it makes him forget his dependence on the unconscious. The case of Gilgamesh is instructive in this respect: he was so successful that the gods, the representatives of the unconscious, saw themselves compelled to deliberate how they could best bring about his downfall. Their efforts were unavailing at first, but when the hero had won the herb of immortality (cf. pl. XIX) and was almost at his goal, a serpent stole the elixir of life from him while he slept.

[458] The demands of the unconscious act at first like a paralysing poison on a man's energy and resourcefulness, so that it may well be compared to the bite of a poisonous snake. (Cf. fig. 30.) Apparently it is a hostile demon who robs him of energy, but in actual fact it is his own unconscious whose alien tendencies are beginning to check the forward striving of the conscious mind. The cause of this process is often extremely obscure, the more so as it is complicated by all kinds of

external factors and subsidiary causes, such as difficulties in work, disappointments, failures, reduced efficiency due to age, depressing family problems, and so on and so forth. According to the myths it is the woman who secretly enslaves a man, so that he can no longer free himself from her and becomes a child again.⁶⁴ It is also significant that Isis, the sister-wife of the sun-god, creates the poisonous serpent from his spittle, which, like all bodily secretions, has a magical significance, being a libido equivalent. She creates the serpent from the libido of the god, and by this means weakens him and makes him dependent on her. Delilah acts in the same way with Samson: by cutting off his hair, the sun's rays, she robs him of his strength. This demon-woman of mythology is in truth the "sister-wife-mother," the woman in the man, who unexpectedly turns up during the second half of life and tries to effect a forcible change of personality. I have dealt with certain aspects of this change in my essay on "The Stages of Life." It consists in a partial feminization of the man and a corresponding masculinization of the woman. Often it takes place under very dramatic circumstances: the man's strongest quality, his Logos principle, turns against him and as it were betrays him. The same thing happens with the Eros of the woman. The man becomes rigidly set in his previous attitude, while the woman remains caught in her emotional ties and fails to develop her reason and understanding, whose place is then taken by equally obstinate and inept "animus" opinions. The fossilization of the man shrouds itself in a smoke-screen of moods, ridiculous irritability, feelings of distrust and resentment, which are meant to justify his rigid attitude. A perfect example of this type of psychology is Schreber's account of his own psychosis, *Memoirs of My Nervous Illness*.⁶⁵

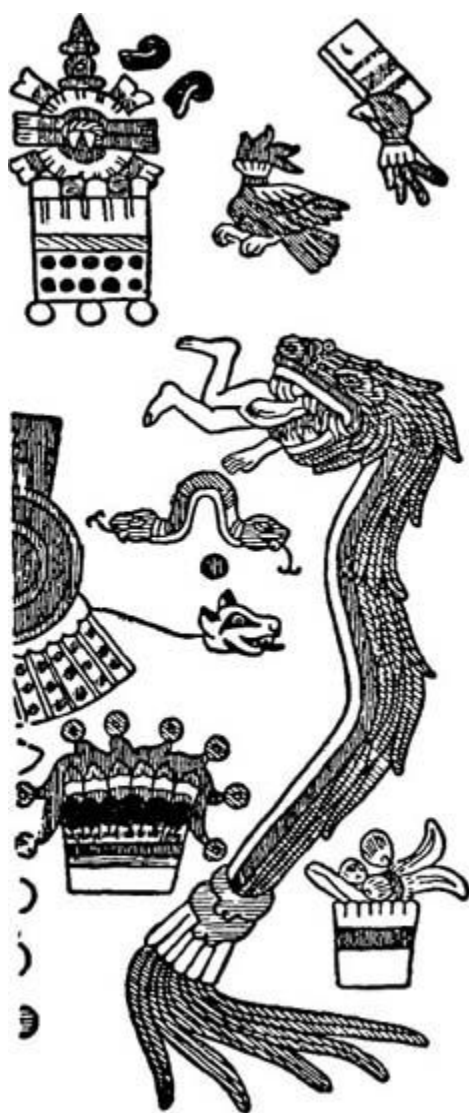

Fig. 30. Quetzalcoatl devouring a man
From the Codex Borbonicus, Aztec 16th century

[459] The paralysis of progressive energy has in truth some very disagreeable aspects. It seems like an unwelcome accident or a positive catastrophe, which one would naturally rather avoid. In most cases the conscious personality rises up against the assault of the unconscious and resists its demands, which, it is clearly felt, are directed not only against all the weak spots in the man's character, but also against his chief virtue (the differentiated function and the ideal). It is evident from the myths of Heracles and Gilgamesh that this assault can become the source of energy for an heroic conflict; indeed, so obvious is this impression that one has to ask oneself whether the apparent enmity of the maternal archetype is not a ruse on the part of Mater Natura for spurring on her favoured child to his highest achievement. The vengeful Hera would then appear as the stern "Mistress Soul," who imposes the most difficult labours on her hero and threatens him with destruction unless he plucks up courage for the supreme deed and actually becomes what he always potentially was. The hero's victory over the "mother," or over her daemonic representative (dragon, etc.), is never anything but temporary. What must be regarded as regression in a young person—feminization of the man (partial identity with the mother) and

masculinization of the woman (partial identity with the father)-acquires a different meaning in the second half of life. The assimilation of contrasexual tendencies then becomes a task that must be fulfilled in order to keep the libido in a state of progression. The task consists in integrating the unconscious, in bringing together “conscious” and “unconscious.” I have called this the individuation process, and for further details must refer the reader to my later works.^{65a} At this stage the mother-symbol no longer connects back to the beginnings, but points towards the unconscious as the creative matrix of the future. “Entry into the mother” then means establishing a relationship” between the ego and the unconscious. Nietzsche probably means something of the kind in his poem:

Why hast thou enticed thyself
Into the old serpent’s Paradise?
Why hast thou stolen
Into thyself, thyself?

A sick man now,
Sick of the serpent’s poison;⁶⁶
A captive now
Who drew the hardest lot:
Bent double
Working in thine own pit,
Encaved within thyself,
Burrowing into thyself,
Heavy-handed,
Stiff,
A corpse—
Piled with a hundred burdens,
Loaded to death with thyself,
A knower!
Self-knower!
The wise Zarathustra!
You sought the heaviest burden
And found yourself.⁶⁷

[460] Sunk in his own depths, he is like one buried in the earth; a dead man who has crawled back into the mother; ⁶⁸ a Kaineus “piled with a hundred burdens” and pressed down to death, groaning beneath the intolerable weight of his own self and his own destiny. Who does not think here of Mithras, who, in the Taurophoria, took

his bull (or, as the Egyptian hymn says, “the bull of his mother”), namely his love for his Mater Natura, on his back, and with this heaviest burden set forth on the *via dolorosa* of the Transitus?⁶⁹ The way of this passion leads to the cave in which the bull is sacrificed. So, too, Christ had to bear the Cross⁷⁰ to the place of sacrifice, where, according to the Christian version, the Lamb was slain in the form of the god, and was then laid to earth in the sepulchre.⁷¹ The cross, or whatever other heavy burden the hero carries, is *himself*, or rather *the self*, his wholeness, which is both God and animal—not merely the empirical man, but the totality of his being, which is rooted in his animal nature and reaches out beyond the merely human towards the divine. His wholeness implies a tremendous tension of opposites paradoxically at one with themselves, as in the cross, their most perfect symbol. What seems like a poetic figure of speech in Nietzsche is really an age-old myth. It is as if the poet could still sense, beneath the words of contemporary speech and in the images that crowd in upon his imagination, the ghostly presence of bygone spiritual worlds, and possessed the capacity to make them come alive again. As Gerhart Hauptmann says: “Poetry is the art of letting the primordial word resound through the common word.”⁷²

[461] The sacrifice, whose mysterious and manifold meanings we guess rather than understand, passes by the conscious mind of our author unrecognized and unconsummated. The arrow is not yet shot, the hero Chiwantopel is not yet fatally poisoned and ready for death through self-sacrifice. On the evidence before us we can say that this sacrifice means giving up the connection with the mother, relinquishing all the ties and limitations which the psyche has taken over from childhood into adult life. From various hints of Miss Miller’s it appears that at the time of these fantasies she was still living in the family circle, at an age when independence was an urgent necessity. It is therefore significant that the birth of her fantasies coincided with a journey abroad, i.e., with a breaking away from her childhood environment. It is not possible to live too long amid infantile surroundings, or in the bosom of the family, without endangering one’s psychic health. Life calls us forth to independence, and anyone who does not heed this call because of childish laziness or timidity is threatened with neurosis. And once this has broken out, it becomes an increasingly valid reason for running away from life and remaining forever in the morally poisonous atmosphere of infancy.

[462] The fantasy of the arrow-shot is part of this struggle for personal independence. As yet, however, the need for such a decision has not penetrated to the conscious mind of the dreamer: the fatal arrow of Cupid has not yet found its mark. Chiwantopel, playing the role of the author, is not yet wounded or killed. He is the bold adventurer who dares to do what Miss Miller obviously shrinks from doing: he offers himself, of his own free will, as a target for the fatal arrow-shot. The fact that this gesture of self-exposure is projected upon a masculine figure is direct proof that

the dreamer is quite unconscious of its necessity. Chiwantopel is a typical animus-figure, that is to say, a personification of the masculine side of the woman's psyche. He is an archetypal figure who becomes particularly active when the conscious mind refuses to follow the feelings and instincts prompted by the unconscious: instead of love and surrender there is mannishness, argumentativeness, obstinate self-assertion, and the demon of opinion in every possible shape and form (power instead of love). The animus is not a real man at all; he is a slightly hysterical, infantile hero whose longing to be loved shows through the gaps in his armour. It is in this garb that Miss Miller has dressed the critical decisions of her life, or rather these decisions have not yet got beyond the stage of unconscious fantasy and are still not recognized by her conscious mind as her own decisions. (Cf. pl. XVII.)

[463] The fact that the assassin allows himself to be scared away by Chiwantopel's heroics means that the impending death of this pasteboard hero has been temporarily postponed: the conscious mind is not yet ready to come to a decision by itself, but prefers to adopt the ostrich policy of burying its head in unconsciousness. Chiwantopel must fall because the power of decision locked up in the unconscious, which is at present keeping the nerveless figure of the hero erect, is needed to strengthen the conscious mind, for without the co-operation of the unconscious and its instinctive forces the conscious personality would be too weak to wrench itself free from its infantile past and venture into a strange world with all its unforeseen possibilities. The whole of the libido is needed for the battle of life. The dreamer cannot bring herself to this decision, which would tear aside all sentimental attachments to childhood, to father and mother, and yet it must be taken if she wishes to follow the call of her individual destiny.

VII

THE DUAL MOTHER ¹

[464] After his assailant has disappeared, Chiwantopel begins the following monologue:

From the tip of the backbone ² of these continents, from the farthest lowlands, I have wandered for a hundred moons since quitting my father's palace, forever pursued by my mad desire to find "her who will understand." With jewels I tempted many beautiful women; with kisses tried I to draw out the secrets of their hearts, with deeds of daring I won their admiration. [He reviews one after another the women he has known.] Chi-ta, the princess of my own race ... she was a fool, vain as a peacock, without a thought in her head except trinkets and perfumes. Tannan, the peasant girl ... bah! a perfect sow, nothing but a bust and a belly, thinking of nothing but pleasure. And then Ki-ma, the priestess, a mere parrot, repeating the empty phrases learnt from the priests, all for show, without real understanding or sincerity, mistrustful, affected, hypocritical! ... Alas! Not one who understands me, not one who resembles me or has a soul that is sister to mine. There is not one among them all who has known my soul, not one who could read my thoughts—far from it; not one capable of seeking the shining summits with me, or of spelling out with me the superhuman word Love!

[465] Here Chiwantopel admits that his travels and wanderings are a search for the other, for the beloved, and for the meaning of life that is to be found in union with her. This possibility was merely hinted at in the first part of the book. The fact that the seeker is masculine and the sought-for feminine is not so very remarkable, since the prime object of unconscious desire is the mother, as should be clear from what we have already learnt. "She who understands" is, in infantile speech, the mother. The original concrete meaning of words like *comprehend*, *comprendre*, *begreifen*, *erfassen* (grasp, seize), etc., is literally to seize hold of something with the hands and hold it tight in the arms. That is just what the mother does with her child when it asks for help or protection, and what binds the child to its mother. But the older it grows, the greater becomes the danger of this kind of "comprehension" hindering its natural development. Instead of adapting itself, as is necessary, to its new surroundings, the libido of the child regresses to the sheltering ease of the mother's arms and fails to keep pace with the passing of time. This situation is described as follows in an old Hermetic text: "Being chained to the arms and breast of my mother, and to her substance, I cause my substance to hold together and rest, and I compose the invisible from the visible...."³ When a person remains bound to the mother, the life he ought to have lived runs away in the form of conscious and unconscious fantasies, which in the case of a woman are generally attributed to some hero-figure, or are acted out by

him, as here. *He* is the one who then has the great longing for an understanding soul-mate, he is the seeker who survives the adventures which the conscious personality studiously avoids; he it is who, with a magnificent gesture, offers his breast to the slings and arrows of a hostile world, and displays the courage which is so sadly lacking to the conscious mind. It is all up with the man whom the whims of fortune bring into contact with this infantile woman: he will at once be made identical with her animus-hero and relentlessly set up as the ideal figure, threatened with the direst punishments should he ever make a face that shows the least departure from the ideal!

[466] It is in this situation that our author now finds herself. Chiwantopel is the very devil of a fellow: a breaker of hearts by the dozen, all the women rave about him. He knows so many of them that he can pass them under review. Not one of them gets him, for he seeks one who (so she thinks) is known only to our author. That is, she believes in her heart of hearts that he is looking for *her*. In this she is labouring under a delusion, for experience shows that this particular cat jumps quite differently. The animus, a typical “son”—hero, is not after her at all; true to his ancient prototype, he is seeking the mother. This youthful hero is always the son-lover of the mother-goddess and is doomed to an early death. (Cf. fig. 20.) The libido that will not flow into life at the right time regresses to the mythical world of the archetypes, where it activates images which, since the remotest times, have expressed the non-human life of the gods, whether of the upper world or the lower. If this regression occurs in a young person, his own individual life is supplanted by the divine archetypal drama, which is all the more devastating for him because his conscious education provides him with no means of recognizing what is happening, and thus with no possibility of freeing himself from its fascination. Herein lay the vital importance of myths: they explained to the bewildered human being what was going on in his unconscious and why he was held fast. The myths told him: “This is not you, but the gods. You will never reach them, so turn back to your human avocations, holding the gods in fear and respect.” These ingredients can also be found in the Christian myth, but it is too veiled to have enlightened our author. Nor is anything said about these things in the catechism. The “shining heights” are beyond the reach of mere mortals, and the “superhuman word Love” betrays the divine nature of the *dramatis personae*, since even human love presents such a thorny problem to man that he would rather creep into the remotest corner than touch it with his little finger. The words we have quoted show how deeply our author has been drawn into the unconscious drama and how much she is under its spell. Looked at in this light, the pathos rings hollow and the heroics seem hysterical.

[467] However, it looks somewhat different when viewed not from the personalistic standpoint, i.e., from the personal situation of Miss Miller, but from the standpoint of

the archetype's own life. As we have already explained, the phenomena of the unconscious can be regarded as more or less spontaneous manifestations of autonomous archetypes, and though this hypothesis may seem very strange to the layman, it is amply supported by the fact the archetype has a numinous character: it exerts a fascination, it enters into active opposition to the conscious mind, and may be said in the long run to mould the destinies of individuals by unconsciously influencing their thinking, feeling, and behaviour, even if this influence is not recognized until long afterwards. The primordial image is itself a "pattern of behaviour"⁴ which will assert itself with or without the co-operation of the conscious personality. Although the Miller case gives us some idea of the manner in which an archetype gradually draws nearer to consciousness and finally takes possession of it, the material is too scanty to serve as a complete illustration of the process. I must therefore refer my reader to the dream-series discussed in *Psychology and Alchemy*, where he will be able to follow the gradual emergence of a definite archetype with all the specific marks of its autonomy and authority.

[468] From this point of view, then, the hero Chiwantopel represents a psychic entity which can only be compared to a fragmentary personality equipped with a relative degree of consciousness and a will to match. Such a conclusion is inevitable if our premise of the autonomy and purposiveness of the complex is correct. In that case the intentions both of Chiwantopel and of the mother-imago standing behind and above him can be subjected to closer scrutiny. He himself seems to find complete fulfilment in the role of the actor. As an ideal figure he attracts all our author's attention to himself, he gives voice to her most secret thoughts and desires, and, like Cyrano, he does so in a language which springs from Miss Miller's own heart. He is therefore sure of his success and cuts out all possible rivals. He wins the soul of the dreamer, not in order to lead her back to normal life, but to her spiritual destiny; for he is a bridegroom of death, one of the son-lovers who die young because they have no life of their own but are only fast-fading flowers on the maternal tree. Their meaning and their vitality begin and end in the mother-goddess. Therefore, when Chiwantopel, the "ghostly lover,"⁵ draws Miss Miller away from the path of life, he does so in a certain sense at the behest of the mother-imago, which in women personifies a special aspect of the unconscious. It does not, like the anima, stand for the chaotic life of the unconscious in all its aspects, but for the peculiarly fascinating background of the psyche, the world of primordial images. There is always a danger that those who set foot in this realm will grow fast to the rocks, like Theseus and Peirithous, who wanted to abduct the goddess of the underworld. It happens all too easily that there is no returning from the realm of the Mothers. As I have already hinted, this is the fate that has overtaken Miss Miller. But the danger could equally well prove to be her salvation, if only the conscious mind had some means of understanding the

unconscious contents. This is certainly not the case with our author. For her these fantasies are “marvellous” products of an unconscious activity which she confronts more or less helplessly, although, as we shall see, the associations contain all the necessary clues that would enable her, with a little reflection, to guess what the fantasy-figures mean, and to use the symbols as a heavensent opportunity for assimilating her unconscious contents. Our culture, however, has neither eyes nor heart for these things. Anything that comes out of the psyche is regarded with suspicion at the best of times, and if it does not immediately prove its material value it goes for nothing.

[469] The hero as an animus-figure acts vicariously for the conscious individual; that is to say, he does what the subject ought, could, or would like to do, but does not do. All the things that could happen in conscious life, but do not happen, are acted out in the unconscious and consequently appear in projection. Chiwantopel is characterized as the hero who leaves his family and his ancestral home in order to seek his psychic counterpart. He thus represents what in the normal course of events ought to happen. The fact that this appears as a fantasy-figure shows how little the author is doing it herself. What happens in fantasy is therefore compensatory to the situation or attitude of the conscious mind. This is also the rule in dreams.

[470] How right we were in our supposition that what is going on in Miss Miller’s unconscious is a battle for independence is now shown by her remark that the hero’s departure from his father’s house reminded her of the fate of the young Buddha, who renounced all the luxury of his home in order to go out into the world and live his destiny to the full.⁶ The Buddha set the same heroic example as Christ, who also cut himself off from his family and even spoke these bitter words (Matt. 10: 34f.):

Think not that I am come to send peace on earth: I came not to send peace, but a sword.

For I am come to set a man at variance against his father, and the daughter against her mother, and the daughter in law against her mother in law.

And a man’s foes shall be they of his own household.

He that loveth father or mother more than me is not worthy of me...

[471] Horus snatches the head-dress from his mother, the emblem of her power. Nietzsche says:

We must suppose that a mind in which the ideal of the “free spirit” can grow to maturity and perfection has had its decisive crisis in some great act of emancipation, and that before this it was a spirit bound and apparenFig. 31. The m tly chained for ever to its corner and pillar. What binds it most tightly? What ties are the most unbreakable? For men of a superior and select type, it is the ties of duty: the reverence that befits youth, respect and tenderness for all the time-honoured and valued things, feelings of gratitude for the soil whence they grew, for the hand that guided them, for the shrine where they learnt to pray—their highest moments are the very ones

that bind them most firmly, that put them under the most enduring obligations. The great emancipation comes suddenly for those who are so bound....

“Better to die than live here,” says the imperious voice of temptation; and this “here,” this “at home,” is all that the soul has hitherto loved! A sudden horror and mistrust of what it loved, a flash of contempt for its so-called “duty,” a rebellious, wilful, volcanically impelling desire for travel, strangeness, estrangement, coldness, disillusion, glaciation; a hatred of love, perhaps a sacrilegious grasp and glance backwards⁷ to everything it had worshipped and loved till then, perhaps a blush of shame over what it has just done and at the same time an exultation over having done it, an intoxicating, inner thrill of joy which signalizes victory—victory over what? over whom? an enigmatic, doubtful, questioning victory, but the first victory nonetheless. Of such evil and painful things is the history of the great emancipation composed. It is like a disease that can easily destroy the man, this first eruption of strength and will to self-determination....⁸

[472] The danger, as Nietzsche sees, lies in isolation within oneself:

Solitude surrounds and encircles him, ever more threatening, ever more constricting, ever more heart-strangling, that terrible goddess and *Mater saeva cupidinum*,⁹

[473] The libido that is withdrawn so unwillingly from the “mother” turns into a threatening serpent, symbolizing the fear of death—for the relation to the mother must cease, *must die*, and this is almost the same as dying oneself. That is to say, the violence of the separation is proportionate to the strength of the bond uniting the son with the mother, and the stronger this broken bond was in the first place, the more dangerously does the “mother” approach him in the guise of the unconscious. This is indeed the *Mater saeva cupidinum*, ‘savage mother of desire,’ who in another form now threatens to devour the erstwhile fugitive. (Note the snake symbolism.)

[474] Miss Miller now gives us a further reference, this time to something that influenced her fantasies in a more general way, namely Longfellow’s great narrative poem, *The Song of Hiawatha*.¹⁰ My reader must frequently have wondered at the number of times I adduce apparently very remote material for purposes of comparison and how I enlarge the basis upon which Miss Miller’s creations rest. He must also have doubted whether it is justifiable, on the basis of such scanty suggestions, to enter into fundamental discussions concerning the mythological foundations of these fantasies. For, he will say, we are not likely to find anything of the sort behind the Miller fantasies. I need hardly emphasize how hazardous these comparisons have seemed even to me. In this case I can at least plead that Miss Miller named her sources herself. So long as we stick to these clues we are moving on certain ground. The information we obtain from our patients, however, is seldom complete. We ourselves do not find it at all easy to remember where some of our own ideas and views come from. But, although instances of cryptomnesia are not uncommon, it is highly probable that not all our ideas are individual acquisitions, and that the ones whose origin we do not know are not necessarily cryptomnesias. It is

rather different as regards the way in which our ideas are formed and the order in which they are arranged. Such things can undoubtedly be acquired and afterwards remembered. That need not always be the case, however, because the human mind possesses general and typical modes of functioning which correspond to the biological “pattern of behaviour.” These preexistent, innate patterns—the archetypes—can easily produce in the most widely differing individuals ideas or combinations of ideas that are practically identical, and for whose origin no individual experience can be made responsible. In the psychoses, for instance, there are very many ideas and images which impress the patient and his circle with their absolute strangeness, but which are quite familiar to the expert on account of the affinity of their motifs with certain mythologems. Because the basic structure of the psyche is everywhere more or less the same, it is possible to compare what look like individual dream-motifs with mythologems of whatever origin. So I have no hesitation in making comparisons between American Indian myth and the modern American psyche.

[475] I had never read *Hiawatha* until I came to this point in my inquiry, when the continuation of my work made its perusal necessary. This poetical compilation of Indian myths proved to my satisfaction how justified were all my previous reflections, since it is unusually rich in mythological motifs. This fact should throw light on the wealth of associations in the Miller fantasies. It therefore behoves us to examine the contents of this epic more closely.

[476] Nawadaha sings the songs of Hiawatha, the friend of man:¹¹

There he sang of Hiawatha,
Sang the songs of Hiawatha,
Sang his wondrous birth and being,
How he prayed and how he fasted,
How he lived, and toiled, and suffered,
That the tribes of men might prosper,
That he might advance his people.

[477] The teleological significance of the hero as a symbolic figure who attracts libido to himself in the form of wonder and adoration, in order to lead it over the symbolic bridge of myth to higher uses, is already anticipated here. Thus we quickly become acquainted with Hiawatha as a saviour, and are prepared to hear all that is usually said about such a figure, about his miraculous birth, his mighty deeds in youth, and his sacrifice for his fellow men. The first canto opens with an “Evangelium”: Gitche Manito, the “master of life,” weary of the squabbles of his human children, calls his people together and makes known to them the joyous message:

I will send a Prophet to you,

A Deliverer of the nations,
Who shall guide you and shall teach you,
Who shall toil and suffer with you.
If you listen to his counsels,
You will multiply and prosper;
If his warnings pass unheeded,
You will fade away and perish!

[478] Gitche Manito the Mighty, “the creator of the nations,”¹² is shown standing erect “on the great Red Pipestone quarry”:

From his footprints flowed a river,
Leaped into the light of morning,
O’er the precipice plunging downward
Gleamed like Ishkoodah, the comet.

[479] This image has a parallel in certain Coptic ideas. In the “Mysteries of Saint John and the Holy Virgin” we read:

[The Cherubim] answered and said unto me: “Seest thou that the water is under the feet of the Father? If the Father lifteth up His feet, the water riseth upwards; but if at the time when God is about to bring the water up, man sinneth against Him, He is wont to make the fruit of the earth to be little, because of the sins of men.”¹³

By the water is meant the Nile, on which Egypt’s fertility depended.

[480] It is not only the feet themselves that have a fertility significance, it also seems to extend to their activity, treading. I observed that the dance-step of the Pueblo Indians consisted in a “*calcare terram*”—a persistent, vigorous pounding of the earth with the heels (“*nunc pede libero pulsanda tellus*”: “with unfettered foot now we are to beat on the ground”¹⁴). Kaineus, as we saw, descended into the depths, “splitting the earth with a straight foot.” Faust reached the Mothers by stamping on the ground: “Stamping descend, and stamping rise up again!”¹⁵

[481] The heroes in the sun-devouring myths often stamp or kick in the gullet of the monster. Thor stamped clean through the bottom of the boat in his struggle with the monster and touched the bottom of the sea. The regression of libido makes the ritual act of treading out the dance-step seem like a repetition of the infantile “kicking.” The latter is associated with the mother and with pleasurable sensations, and recapitulates a movement that was already practised inside the mother’s womb. The foot and the treading movement are invested with a phallic significance,¹⁶ or with that of re-entry into the womb, so that the rhythm of the dance transports the dancer into an unconscious state. The Dancing Dervishes and other primitive dancers offer confirmation of this. The comparison of the water flowing from Gitche Manito’s

footprints with a comet means that it is a light- or libido-symbol for the fertilizing moisture (sperma). According to a note in Humboldt's *Cosmos*,¹⁷ certain South American Indian tribes call meteors the "piss of the stars." We should also mention that Gitche Manito is a fire-maker: he blows upon a forest so that the trees rub against one another and burst into flame. Hence this god too is a libido-symbol, since he produces not only water but fire.

[482] After this prologue there follows in the second canto the story of the hero's antecedents. His father, the great warrior Mudjekeewis, has overcome by stealth the great bear, "the terror of the nations," and stolen from him the magic "belt of wampum," a girdle of shells. Here we meet the motif of the "treasure hard to attain," which the hero wrests from the monster. The "mystic" identity of the bear comes out in the poet's comparisons: Mudjekeewis smites the bear on the head after robbing him of the treasure:

With the heavy blow bewildered
Rose the great Bear of the mountains;
But his knees beneath him trembled,
And he whimpered like a woman.

[483] Mudjekeewis tells him mockingly:

Else you would not cry and whimper
Like a miserable woman! ...
But you, Bear! sit here and whimper,
And disgrace your tribe by crying,
Like a wretched Shaugodaya,
Like a cowardly old woman!

[484] These three comparisons with a woman occur on the same page. What Mudjekeewis slays is his feminine component, the anima-image, whose first carrier is the mother. Like a true hero, he has snatched life from the jaws of death, from the all-devouring Terrible Mother. This deed, which as we have seen is also depicted as the journey to hell, the night sea journey (cf. pars. 308f.), or the conquest of the monster from within, signifies at the same time entry into the mother's womb, a rebirth that has notable consequences for Mudjekeewis. As in the Zosimos vision, so here the entrant becomes the pneuma, a wind-breath or spirit: Mudjekeewis becomes the West Wind, the fertilizing breath, the father of the winds.¹⁸ Hissons become the other winds. An intermezzo tells of them and their loves, of which I will mention only the courtship of Wabun, the East Wind, because the wind's wooing is described

in particularly graphic language. Every morning he sees a beautiful girl in the meadow, whom he eagerly courts:

Every morning, gazing earthward,
Still the first thing he beheld there
Was her blue eyes looking at him,
Two blue lakes among the rushes.

[485] The comparison with water is not irrelevant, because from “wind and water” man shall be born anew.

And he wooed her with caresses,
Wooed her with his smile of sunshine,
With his flattering words he wooed her,
With his sighing and his singing,
Gentlest whispers in the branches,
Softest music, sweetest odors.

[486] The caressing courtship of the wind is beautifully expressed in the lilting onomatopoeia.¹⁹

[487] The third canto gives us the antecedents of Hiawatha’s two mothers. We are told that as a girl his grandmother lived in the moon. One day when she was swinging on a grape-vine, a jealous lover cut it down, and Nokomis, Hiawatha’s grandmother, fell to earth. The people who saw her fall thought she was a shooting-star. The wonderful origin of Nokomis is explained more fully in the course of the same song. Young Hiawatha asks his grandmother what the moon really is. She tells him that the moon is the *body of a grandmother* who had been thrown up there by one of her warlike grandchildren in a fit of rage. (Cf. fig. 32.)²⁰ According to the ancient belief, the moon is the gathering-place of departed souls²¹ (fig. 31) a guardian of the seed, and hence a source of life with a feminine significance. The remarkable thing is that Nokomis, when she fell to earth, gave birth to a daughter, Wenonah, who afterwards became the mother of Hiawatha. The throwing upward of the mother, her fall and birth-pangs, seem to be something altogether typical. A seventeenth-century story relates that a raging bull tossed a pregnant woman “as high as a house” and tore open her body, and the child fell to earth without injury. This child, on account of his wonderful birth, was supposed to be a hero or miracle-worker, but he died young. There is a widespread belief among primitives that the sun is feminine and the moon masculine. Among the Namaqua Hottentots, the sun is thought to consist of clear bacon-fat. “Those who travel on boats,” we read,²² “draw it down by magic every evening, and after cutting off a sizeable piece, kick it up again into the sky.” In

infancy, food comes from the mother. In the fantasies of the Gnostics there is a legend about the origin of man which may be of some relevance here. The female archons who were bound to the vault of heaven were unable, on account of its rapid rotation, to keep their young within them, but let them fall to earth, where they grew into human beings. (This may be connected with certain barbarous obstetric methods, in which women in labour were dropped or thrown to the ground.) The assault on the mother begins with the Mudjekeewis episode and is continued in the violent treatment of Grandmother Nokomis, who, as a result of the cutting of the grape-vine and her fall to earth, seems to have become pregnant in some way. The “plucking of the branch” hints, as we have already seen, at an infringement of the incest-taboo. The song about “Saxonland, where beautiful maidens grow upon trees,” or proverbs like “stolen fruits are sweetest,” point to a similar idea. The fall of Nokomis deserves comparison with a poetical figure in Heine:



Fig. 31. The moon as the abode of souls
Chalcedon gem, 1st century B.C.



Fig. 32. The woman in the moon

Tattoo pattern, Haida Indians, Northwest America

A star, a star is falling

Out of the glittering sky!

The star of Love! I watch it
Sink in the depths and die.

The leaves and buds are falling
From many an apple-tree;
I watch the mirthful breezes
Embrace them wantonly.²³

[488] Wenonah is later wooed by the caressing West Wind and is made pregnant by him. Being a young moon-goddess, she is as beautiful as the moonlight. Nokomis warns her of the dangerous courtship of Mudjekeewis, but Wenonah allows herself to become infatuated and conceives from the breath of the West Wind a son, our hero:

And the West Wind came at evening ...
Found the beautiful Wenonah
Lying there among the lilies,
Wooed her with his words of sweetness,
Wooed her with his soft caresses,
Till she bore a son in sorrow,
Bore a son of love and sorrow.

[489] The star or comet plainly belongs to the birth-scene; Nokomis, too, comes to earth as a falling star. Mörike's poetic fancy imagined another such divine conception:

And she who bore me in her womb,
And gave me food and clothing,
She was a maid, a wild, brown maid,
Who looked on men with loathing.

She fleered at them and laughed aloud,
And bade no suitor tarry;
"I'd rather be the Wind's own bride
Than have a man and marry."

Then came the Wind and held her fast,
His captive, love-enchanted;
And lo, by him a merry child
Within her womb was planted.²⁴

[490] The same idea can be seen in the story of Buddha's marvellous birth, as told by Sir Edwin Arnold:

Maya the queen ...
Dreamed a strange dream; dreamed that a star from heaven-
Splendid, six-rayed, in colour rosy-pearl,
Whereof the token was an Elephant
Six-tusked, and white as milk of Kamadhuk—
Shot through the void; and, shining into her,
Entered her womb upon the right.²⁵ [Pl. XLIXb.]

[491] During the conception

A wind blew
With unknown freshness over lands and seas.

[492] After the birth the four genies of the East, West, North, and South come to offer their services as palanquin-bearers. (Cf. the coming of the Wise Men at the birth of Christ.) To complete the symbolism, there is in the Buddha myth, besides the fertilization by star and wind, fertilization by a theriomorphic symbol, the elephant, who, as Bodhisattva, begets the Buddha. In Christian picture-language the unicorn, as well as the dove, is a symbol of the spermatic Word or Spirit.²⁶ (Cf. pl. VIII.)

[493] At this point we might ask ourselves why the birth of a hero always has to take place under such extraordinary circumstances. One would think it possible for a hero to be born in the normal manner, and then gradually to grow out of his humble and homely surroundings, perhaps with a great effort and in face of many dangers. (This motif is by no means uncommon in the hero-myths.) As a general rule, however, the story of his origins is miraculous. The singular circumstances of his procreation and birth are part and parcel of the hero-myth. What is the reason for these beliefs?

[494] The answer to this question is that the hero is not born like an ordinary mortal because his birth is a rebirth from the mother-wife. That is why the hero so often has two mothers. As Rank²⁷ has shown with a wealth of examples, the hero is frequently exposed and then reared by foster-parents. In this way he gets two mothers. An excellent example of this is the relation of Heracles to Hera. In the Hiawatha epic, Wenonah dies after giving birth, and her place is taken by Nokomis.²⁸ Buddha, too, was brought up by a foster-mother. The foster-mother is sometimes an animal, e.g., the she-wolf of Romulus and Remus, etc. (pls. II, La). The dual mother may be replaced by the motif of dual birth, which has attained a lofty significance in various religions. In Christianity, for example, baptism represents a rebirth, as we have already seen. Man is not merely born in the commonplace sense, but is born again in a mysterious manner, and so partakes of divinity. Anyone who is reborn in this way becomes a hero, a semi-divine being. Thus Christ's redemptive death on the cross was understood as a "baptism," that is to say, as rebirth through the second mother,

symbolized by the tree of death. (Cf. pls. xxxvi, xxxvii.) Christ himself said (Luke 12:50): “But I have a baptism to be baptized with; and how am I straitened till it be accomplished!” He therefore interprets his own death-agony symbolically as the pangs of rebirth.

[495] The dual-mother motif suggests the idea of a dual birth. One of the mothers is the real, human mother, the other is the symbolical mother; in other words, she is distinguished as being divine, supernatural, or in some way extraordinary. She can also be represented theriomorphically. In certain cases she has more human proportions, and here we are dealing with projections of archetypal ideas upon persons in the immediate environment, which generally brings about complications. For instance the rebirth symbol is liable to be projected upon the step-mother or mother-in-law (unconsciously, of course), just as, for her part, the mother-in-law often finds it difficult not to make her son-in-law her son-lover in the old mythological manner. There are innumerable variations on this motif, especially when we add individual elements to the collective mythological ones.

[496] He who stems from two mothers is the hero: the first birth makes him a mortal man, the second an immortal half-god. That is what all the hints in the story of the hero's procreation are getting at. Hiawatha's father first conquers the mother under the terrifying symbol of the bear;²⁹ then, having become a god himself, he begets the hero. What the hero Hiawatha then has to do is suggested to him by Nokomis, when she tells him the story of the origin of the moon: he is to throw his mother up into the sky, whereupon she will become pregnant and give birth to a daughter. This rejuvenated mother would, according to the Egyptian fantasy, be given as a daughter-wife to the sun-god, the “father of his mother,” for purposes of self-reproduction. What Hiawatha does in this respect we shall see presently. We have already examined the behaviour of the dying and resurgent gods of the Near East. In regard to the pre-existence of Christ, the gospel of St. John is, as we know, the crowning witness to this idea. One has only to think of the words of the Baptist (John 1:30): “After me cometh a man which is preferred before me: for he was before me.” The opening words are equally significant: “In the beginning was the Word, and the Word was with God, and the Word was God. The same was in the beginning with God. All things were made by him; and without him was not any thing made that was made.” Then follows the annunciation of the Light, of the rising sun—the *Sol mysticus* which was before and will be afterwards. In the baptistry at Pisa, Christ is shown bringing the tree of life to mankind, his head surrounded by a sun-wheel. Over this relief stand the words “INTROITUS SOLIS.”

[497] Because the reborn is his own begetter, the story of his procreation is veiled beneath strange symbolical events which conceal and reveal at the same time. Quite

in keeping with this is the extraordinary assertion about the virgin conception. The idea of supernatural conception can, of course, be taken as a metaphysical fact, but psychologically it tells us that a content of the unconscious (“child”) has come into existence without the natural help of a human father (i.e., consciousness). (Cf. pl. VIII.) It tells us, on the contrary, that some god has begotten the son and further that the son is identical with the father, which in psychological language means that a central archetype, the God-image, has renewed itself (“been reborn”) and become “incarnate” in a way perceptible to consciousness. The “mother” corresponds to the “virgin anima,” who is not turned towards the outer world and is therefore not corrupted by it. She is turned rather towards the “inner sun,” the archetype of transcendent wholeness—the self.³⁰

[498] As is consistent with the birth of the hero and renewed god from the ocean of the unconscious, Hiawatha passes his childhood between land and water, by the shores of the great lake:

By the shores of Gitche Gumee,
By the shining Big-Sea-Water,
Stood the wigwam of Nokomis,
Daughter of the moon, Nokomis.
Dark behind it rose the forest,
Rose the black and gloomy pine-trees,
Rose the firs with cones upon them;
Bright before it beat the water,
Beat the clear and sunny water,
Beat the shining Big-Sea-Water.

[499] In these surroundings he was reared by Nokomis. Here she taught him the first words and told him the first fairytales, and the sounds of the water and the forest mingled with them, so that the child learned to understand not only the language of men, but the language of nature:

At the door on summer evenings
Sat the little Hiawatha;
Heard the whispering of the pine-trees,
Heard the lapping of the water,
Sounds of music, words of wonder:
“Minne-wawa!” said the pine-trees,
“Mudway-aushka!” said the water.

[500] Hiawatha hears human speech in the sounds of nature; thus he understands nature's language. The wind says "wawa." The goose cries "wawa." "Wah-wah-taysee" is the name of the little glow-worm that enchants him. Thus the poet describes the gradual drawing in of external nature into the world of the subject, and the contamination of the primary object, the mother, to whom those first lisping words were addressed and from whom the first sounds were learned, with the secondary object, nature, which imperceptibly usurps the mother's place and takes over the sounds first heard from her, together with all those feelings we later rediscover in ourselves in our warm love for Mother Nature. The subsequent blending, whether pantheistic or aesthetic, of the sensitive, civilized man with nature³¹ is, looked at retrospectively, a reblending with the mother, who was our first object, with whom we were truly and wholly one. She was our first experience of an *outside* and at the same time of an *inside*: from that interior world there emerged an image, apparently a reflection of the external mother-image, yet older, more original and more imperishable than this—a mother who changed back into a Kore, into an eternally youthful figure. This is the anima, the personification of the collective unconscious. So it is not surprising if we see the old images rising up again in the graphic language of a modern philosopher, Karl Joël, symbolizing this oneness with the mother and the merging of subject and object in the unconscious. Joël gives the following account of this "Primal Experience":³²

I lie on the seashore, the sparkling flood blue-shimmering in my dreamy eyes; light breezes flutter in the distance; the thud of the waves, charging and breaking over in foam, beats thrillingly and drowsily upon the shore—or upon the ear? I cannot tell. The far and the near become blurred into one; outside and inside merge into one another. Nearer and nearer, friendlier, like a homecoming, sounds the thud of the waves; now, like a thundering pulse, they beat in my head, now they beat over my soul, wrapping it round, consuming it, while at the same time my soul floats out of me as a blue waste of waters. Outside and inside are one. The whole symphony of sensations fades away into one tone, all senses become one sense, which is one with feeling; the world expires in the soul and the soul dissolves in the world. Our little life is rounded by a great sleep. Sleep our cradle, sleep our grave, sleep our home, from which we go forth in the morning, returning again at evening; our life a short pilgrimage, the interval between emergence from original oneness and sinking back into it! Blue shimmers the infinite sea, where the jelly-fish dreams of that primeval existence to which our thoughts still filter down through aeons of memory. For every experience entails a change and a guarantee of life's unity. At that moment when they are no longer blended together, when the experient lifts his head, still blind and dripping, from immersion in the stream of experience, from flowing away with the thing experienced; when man, amazed and estranged, detaches the change from himself and holds it before him as something alien—at that moment of estrangement the two sides of the experience are substantialized into subject and object, and at that moment consciousness is born.³³

[501] Joël describes here, in unmistakable symbolism, the merging of subject and object as the reunion of mother and child. The symbols agree with those of mythology even in their details. There is a distinct allusion to the encircling and

devouring motif. The sea that devours the sun and gives birth to it again is an old acquaintance. The moment of the rise of consciousness, of the separation of subject and object, is indeed a birth. It is as though philosophical speculation hung with lame wings on a few primordial figures of human speech, beyond whose simple grandeur no thought can fly. The image of the jelly-fish is far from accidental. Once when I was explaining to a patient the maternal significance of water, she experienced a very disagreeable sensation at this contact with the mother-complex. “It makes me squirm,” she said, “as if I’d touched a *jelly-fish*.” The blessed state of sleep before birth and after death is, as Joël observes, rather like an old shadowy memory of that unsuspecting state of early childhood, when there is as yet no opposition to disturb the peaceful flow of slumbering life. Again and again an inner longing draws us back, but always the life of action must struggle in deadly fear to break free lest it fall into a state of sleep. Long before Joël, an Indian chieftain had expressed the same thing in the same words to one of the restless white men: “Ah, my brother, you will never know the happiness of thinking nothing and doing nothing. This is the most delightful thing there is, next to sleep. So we were before birth, and so we shall be after death.”³⁴

[502] We shall see from the later destinies of Hiawatha how important his early childhood impressions were in his choice of a wife. Hiawatha’s first deed was to kill a roebuck with his arrow:

Dead he lay there in the forest
By the ford across the river...

[503] This is typical of Hiawatha’s deeds. Whatever he kills generally lies by or in the water, or better still, half in water and half on land.³⁵ His subsequent adventures will explain why this is so. Further, the roebuck was no ordinary animal, but a magic one with an unconscious (i.e., symbolical) significance. Hiawatha made himself gloves and moccasins from its hide: the gloves gave such power to his arms that he could crumble rocks to dust, and the moccasins had the virtue of seven-leagued boots. By clothing himself in the hide he became a sort of giant. Therefore the roebuck killed at the ford³⁶ was a “doctor animal,” a magician who had changed his shape, or a daemonic being—a symbol, that is to say, which points to the “animal” and other such powers of the unconscious. That is why it was killed at the ford, i.e., at the crossing, on the border-line between conscious and unconscious. The animal is a representative of the unconscious, and the latter, as the matrix of consciousness, has a maternal significance, which explains why the mother was also represented by the bear. All animals belong to the Great Mother (pl. LI), and the killing of any wild animal is a transgression against the mother. Just as the mother seems a giantess to the small child, so the attribute of size passes to the archetypal Great Mother, Mother

Nature. Whoever succeeds in killing the “magic” animal, the symbolic representative of the animal mother, acquires something of her gigantic strength. This is expressed by saying that the hero clothes himself in the animal’s skin and in this way obtains for the magic animal a sort of resurrection. At the Aztec human sacrifices criminals played the part of gods: they were slaughtered and flayed, and the priests then wrapped themselves in the dripping pelts in order to represent the gods’ resurrection and renewal.³⁷

[504] In killing his first roebuck, therefore, Hiawatha was killing the symbolic representative of the unconscious, i.e., his own *participation mystique* with animal nature, and from that comes his giant strength. He now sallies forth to do battle with Mudjekeewis, the father, in order to avenge his mother Wenonah. (Cf. Gilgamesh’s fight with the giant Humbaba.) In this fight the father may also be represented by some sort of magic animal which has to be overcome, but he can equally well be represented by a giant or a magician or a wicked tyrant. *Mutatis mutandis* the animals can be interpreted as the “mother,” as the “mater saeva cupidinum,” or again as that amiable Isis who laid a horned viper in her husband’s path—in short, they can be interpreted as the Terrible Mother who devours and destroys, and thus symbolizes death itself.³⁸ (I remember the case of a mother who kept her children tied to her with unnatural love and devotion. At the time of the climacteric she fell into a depressive psychosis and had delirious states in which she saw herself as an animal, especially as a wolf or pig, and acted accordingly, running about on all fours, howling like a wolf or grunting like a pig. In her psychosis she had herself become the symbol of the all-devouring mother.)

[505] Interpretation in terms of the parents is, however, simply a *façon de parler*. In reality the whole drama takes place in the individual’s own psyche, where the “parents” are not the parents at all but only their imagos: they are representations which have arisen from the conjunction of parental peculiarities with the individual disposition of the child.³⁹ The imagos are activated and varied in every possible manner by an energy which likewise pertains to the individual; it derives from the sphere of instinct and expresses itself as instinctuality. This dynamism is represented in dreams by theriomorphic symbols. All the lions, bulls, dogs, and snakes that populate our dreams represent an undifferentiated and as yet untamed libido, which at the same time forms part of the human personality and can therefore fittingly be described as the *anthropoid psyche*. Like energy, the libido never manifests itself as such, but only in the form of a “force,” that is to say, in the form of something in a definite energetic state, be it moving bodies, chemical or electrical tension, etc. Libido is therefore tied to definite forms or states. It appears as the *intensity* of impulses, affects, activities, and so on. But these phenomena are never impersonal; they

manifest themselves like parts of the personality. The same is true of complexes: they too behave like parts of the personality.

[506] It is this anthropoid psyche which will not fit into the rational pattern of culture—or only very unsatisfactorily and with extreme reluctance—and resists cultural development to the utmost. It is as though its libido were constantly striving back to the original unconscious state of untamed savagery. The road of regression leads back to childhood and finally, in a manner of speaking, into the mother's body. The intensity of this retrospective longing, so brilliantly depicted in the figure of Enkidu in the Gilgamesh Epic, becomes quite unbearable with the heightened demands made by adaptation. These may be due either to external or to internal causes. If the demand comes from "inside," the main difficulty lies not so much in unfavourable external circumstances as in an enhanced "subjective" demand that seems to increase with the years, and in the ever-stronger emergence of the inner, and hitherto hidden, "real" personality. The source of this change is to all appearances the anthropoid psyche, and the anthropoid psyche is also the aim and end of every regression, which immediately sets in whenever there is the least hesitation to adapt—not to speak of cases where the demands of life cannot be met at all.

[507] Scouting the dangers in this situation, religious and conventional morality joins forces with Freudian theory in consistently devaluing the regression and its ostensible goal—reversion to infantilism—as "infantile sexuality," "incest," "uterine fantasy," etc. Reason must here call a halt, for it is hardly possible to go farther back than the maternal uterus. At this point concretism comes up against a brick wall; what is more, moral condemnation seizes upon the regressive tendency and tries by every trick of devaluation to prevent this sacrilegious return to the mother, surreptitiously aided and abetted by the one-sided "biological" orientation of the Freudian school. But anything that exceeds the bounds of a man's personal consciousness remains unconscious and therefore appears in projection; that is to say, the semi-animal psyche with its regressive demands against which he struggles so desperately is attributed to the mother, and the defence against it is seen in the father. Projection, however, is never a cure; it prevents the conflict only on the surface, while deeper down it creates a neurosis which allows him to escape into illness. In that way the devil is cast out by Beelzebub.

[508] As against this, therapy must support the regression, and continue to do so until the "prenatal" stage is reached. It must be remembered that the "mother" is really an imago, a psychic image merely, which has in it a number of different but very important unconscious contents. The "mother," as the first incarnation of the anima archetype, personifies in fact the whole unconscious. Hence the regression leads back only apparently to the mother; in reality she is the gateway into the unconscious, into

the “realm of the Mothers.” Whoever sets foot in this realm submits his conscious ego-personality to the controlling influence of the unconscious, or if he feels that he has got caught by mistake, or that somebody has tricked him into it, he will defend himself desperately, though his resistance will not turn out to his advantage. For regression, if left undisturbed, does not stop short at the “mother” but goes back beyond her to the prenatal realm of the “Eternal Feminine,” to the immemorial world of archetypal possibilities where, “thronged round with images of all creation,” slumbers the “divine child,” patiently awaiting his conscious realization. This son is the germ of wholeness, and he is characterized as such by his specific symbols.

[509] When Jonah was swallowed by the whale, he was not simply imprisoned in the belly of the monster, but, as Paracelsus tells us,⁴⁰ he saw “mighty mysteries” there. This view probably derives from the *Pirkê de Rabbi Elieser*, which says:

Jonah entered its mouth just as a man enters the great synagogue, and he stood there. The two eyes of the fish were like windows of glass giving light to Jonah. R. Meir said: One pearl was suspended inside the belly of the fish and it gave illumination to Jonah, like this sun which shines with all its might at noon; and it showed to Jonah all that was in the sea and in the depths.⁴¹

[510] In the darkness of the unconscious a treasure lies hidden, the same “treasure hard to attain” which in our text, and in many other places too, is described as the shining pearl, or, to quote Paracelsus, as the “mystery,” by which is meant a *fascinosum* par excellence. It is these inherent possibilities of “spiritual” or “symbolic” life and of progress which form the ultimate, though unconscious, goal of regression. By serving as a means of expression, as bridges and pointers, symbols help to prevent the libido from getting stuck in the material corporeality of the mother. Never has the dilemma been more acutely formulated than in the Nicodemus dialogue: on the one hand the impossibility of entering again into the mother’s womb; on the other, the need for rebirth from “water and spirit.” The hero is a hero just because he sees resistance to the forbidden goal in all life’s difficulties and yet fights that resistance with the whole-hearted yearning that strives towards the treasure hard to attain, and perhaps unattainable—a yearning that paralyzes and kills the ordinary man.

[511] Hiawatha’s father is Mudjekeewis, the West Wind: the battle therefore is fought in the West. From that quarter came life (fertilization of Wenonah) and death (Wenonah’s). Hence Hiawatha is fighting the typical battle of the hero for rebirth in the Western Sea. The fight is with the father, who is the obstacle barring the way to the goal. In other cases the fight in the West is a battle with the devouring mother. As we have seen, the danger comes from both parents: from the father, because he apparently makes regression impossible, and from the mother, because she absorbs the regressing libido and keeps it to herself, so that he who sought rebirth finds only

death. Mudjekeewis, who had acquired his godlike nature by overcoming the maternal bear, is himself overcome by his son:

Back retreated Mudjekeewis,
Rushing westward o'er the mountains,
Stumbling westward down the mountains,
Three whole days retreated fighting,
Still pursued by Hiawatha
To the doorways of the West Wind,
To the portals of the Sunset,
To the earth's remotest border,
Where into the empty spaces
Sinks the sun, as a flamingo
Drops into her nest at nightfall.

[512] The “three days” are a stereotyped expression for the “night sea imprisonment” (December 21 to 24). Christ, too, spent three days in the underworld. During this struggle in the West the hero wins the treasure hard to attain. In Hiawatha's case the father is forced to make a great concession to the son: he gives him his divine nature,⁴² that very wind-nature whose incorporeality alone protected Mudjekeewis from death.⁴³ He says to his son:

I will share my kingdom with you,
Ruler shall you be henceforward
Of the Northwest Wind, Keewaydin,
Of the home-wind, the Keewaydin.

[513] Hiawatha's being appointed the ruler of the home-wind has its exact parallel in the Gilgamesh Epic, where Gilgamesh obtains from the wise old Utnapishtim, who dwells in the West, the magic herb which brings him safely over the sea to his native land (cf. pl. XIX), but which is stolen from him by a serpent on his arrival home. As a reward for his victory Hiawatha receives a “pneumatic” body, a breath-body or subtle body not subject to corruption. On the return journey he stops with a skilled arrowsmith who has a lovely daughter:

And he named her from the river,
From the waterfall he named her,
Minnehaha, Laughing Water.

[514] When Hiawatha, in his early childhood reveries, felt the sounds of wind and water crowding upon his ears, he recognized in the phonetics of nature the speech of his own mother. “Minnewawa” said the murmuring pines on the shore of the great

lake. And once again, through the murmuring of the wind and the lapping of the water, he discovers his childhood reveries in the girl of his choice, “Minnehaha,” the laughing water. For the hero, even more than the rest of mankind, finds his mother in the woman he loves, so that he can become a child again and win to immortality. The archetype of the Feminine, the anima, first appears in the mother and then transfers itself to the beloved.

[515] The fact that Minnehaha’s father is a skilled arrowsmith tells us that he is a protagonist in the unconscious drama, namely the father of the hero (just as the beloved is his mother). The archetype of the wise old man first appears in the father, being a personification of meaning and spirit in its procreative sense.⁴⁴ The hero’s father is often a master carpenter or some kind of artisan. According to an Arabian legend, Terah, the father of Abraham, was a master craftsman who could cut a shaft from any bit of wood, which means in Arabic usage that he was a begetter of excellent sons.⁴⁵ In addition, he was a maker of images. Tvashtri, the father of Agni, was the cosmic architect, a smith and carpenter, and the inventor of fire-boring. Joseph, the father of Jesus, was a carpenter, and so was Cinyras, the father of Adonis, who was supposed to have invented the hammer, the lever, roof-building, and mining. The father of the many-faced Hermes, Hephaestus, was a cunning technician and sculptor. In fairytales, the hero’s father is, more modestly, the traditional woodcutter. In the Rig-Veda the world is hewn from a tree by the cosmic architect, Tvashtri. To say that Hiawatha’s father-in-law was an arrowsmith means, therefore, that the mythological attribute otherwise characteristic of the hero’s father has been transferred to the father-in-law. This corresponds to the psychological fact that the anima always stands in the relationship of a daughter to the wise old man.⁴⁶ Nor is it uncommon to find the father-in-law so much emphasized that he replaces the real father. The reason for this is the archetypal relationship we have just discussed.

[516] Finally, father-attributes may occasionally fall to the son himself, i.e., when it has become apparent that he is of one nature with the father. The hero symbolizes a man’s *unconscious self*, and this manifests itself empirically as the sum total of all archetypes and therefore includes the archetype of the father and of the wise old man. To that extent the hero is his own father and his own begetter. This combination of motifs can be found in the legend of Mani. He performs his great deeds as a religious teacher, then goes into hiding for years in a cave, dies, and is skinned, stuffed, and hung up. Besides that, he is an artist and has a crippled foot. There is a similar combination of motifs in Wieland the Smith.

[517] Hiawatha kept silent, on his return to Nokomis, about what he had seen at the old arrowsmith’s house, and did nothing further to win Minnehaha. But now something happens which, if it were not in an Indian epic, we might rather have expected to find

in the anamnesis of a neurosis. Hiawatha introverts his libido, puts up the most dogged resistance to the natural course of events, and builds himself a hut in the forest in order to fast and have dreams and visions. For the first three days he wanders through the forest as in his boyhood, looking at all the animals and plants:

Master of Life! he cried, desponding,
Must our lives depend on these things?

[518] This question, as to whether our lives must depend on “these things,” is very strange. It sounds as if Hiawatha found it unendurable that life should come from “these things,” i.e., from the world of nature. Nature seems suddenly to have taken on an alien meaning. The only possible explanation for this is that a considerable quantity of libido which till now was unconscious has suddenly been either transferred to nature or withdrawn from it. At any rate, some crucial change has taken place in the general direction of feeling, consisting apparently in a regression of libido. Hiawatha returns home to Nokomis without having undertaken anything; but there again he is driven away, because Minnehaha is already standing in his path. So he withdraws himself still further, back into the time of early boyhood when he learnt to hear the mother-sounds in the sounds of nature, whose undertones now fill his mind with memories of Minnehaha. In this reactivation of the impressions of nature we can see a revival of those very early and powerful impressions which are only surpassed by the still stronger impressions the child received from its mother. The glamour of this feeling for her is transferred to other objects in the child’s environment, and from them there emanate in later years those magical, blissful feelings which are characteristic of the earliest memories of childhood. When, therefore, Hiawatha hides himself again in the lap of nature, what he is doing is to reawaken the relationship to the mother, and to something older than the mother, and it is therefore to be expected that he will emerge reborn in some other form.

[519] Before we turn to this new creation born of introversion, there is still another meaning to be considered in this question of whether life must depend on “these things.” Life can depend on “these things” in the quite simple sense that, without them, man must perish of hunger. In that case we would have to conclude that the question of nourishment has suddenly come to lie close to the hero’s heart. The question of nourishment has to be considered here because regression to the mother is bound to revive the memory of the “alma mater,”⁴⁷ the mother as the nourishing source. Incest is not the only aspect characteristic of regression: there is also the hunger that drives the child to its mother. Whoever gives up the struggle to adapt and regresses into the bosom of the family, which in the last resort is the mother’s bosom, expects not only to be warmed and loved, but also to be fed. If the regression has an infantile character, it aims—without of course admitting it—at incest and

nourishment. But when the regression is only apparent, and is in reality a purposive introversion of libido directed towards a goal, then the endogamous relationship, which is in any case prohibited by the incest-taboo, will be avoided, and the demand for nourishment replaced by intentional fasting, as was the case with Hiawatha. Such an attitude compels the libido to switch over to a symbol or to a symbolic equivalent of the “alma mater,” in other words, to the collective unconscious. Solitude and fasting have from time immemorial been the best-known means of strengthening any meditation whose purpose is to open the door to the unconscious.

[520] On the fourth day of his fast Hiawatha ceases to address himself to nature; he lies on his couch exhausted, his eyes half-closed, sunk in his dreams, a picture of extreme introversion. We have already seen that in such states inner experiences take the place of external life and reality. Hiawatha then has a vision:

And he saw a youth approaching,
Dressed in garments green and yellow,
Coming through the purple twilight,
Through the splendour of the sunset;
Plumes of green bent o'er his forehead,
And his hair was soft and golden.

[521] This singular personage addresses Hiawatha as follows:

From the Master of Life descending,
I, the friend of man, Mondamin,
Come to warn you and instruct you,
How by struggle and by labour
You shall gain what you have prayed for.
Rise up from your bed of branches,
Rise, O youth, and wrestle with me!

[522] Mondamin is the maize, the Indian corn. Hiawatha's introversion gives birth to a god who is eaten. His hunger—in the twofold sense described above—his longing for the nourishing mother, calls forth from the unconscious another hero, an edible god, the maize, son of the Earth Mother. The Christian parallel is obvious. It is hardly necessary to suppose any Christian influence here, since Fray Bernardino de Sahagún had already described the eucharist of Huitzilopochtli among the Aztecs early in the sixteenth century.⁴⁸ This god, too, was ceremonially eaten. Mondamin, the “friend of man,”⁴⁹ challenges Hiawatha to single combat in the glow of evening. In the “purple twilight” of the setting sun (i.e., in the western land) there now ensues the mythological struggle with the god who has sprung out of the unconscious like a transformed reflection of Hiawatha's introverted consciousness. As a god or god-man

he is the prototype of Hiawatha's heroic destiny; that is to say, Hiawatha has in himself the possibility, indeed the necessity, of confronting his daemon. On the way to this goal he conquers the parents and breaks his infantile ties. But the deepest tie is to the mother. Once he has conquered this by gaining access to her symbolical equivalent, he can be born again. In this tie to the maternal source lies the strength that gives the hero his extraordinary powers, his true genius, which he frees from the embrace of the unconscious by his daring and sovereign independence. Thus the god is born in him. The mystery of the "mother" is divine creative power, which appears here in the form of the corn-god Mondamin. (Cf. pl. LII.) This view is corroborated by a legend of the Cherokee Indians, "who invoke it [the corn] under the name of 'the old woman,' in allusion to a myth that it sprang from the blood of an old woman killed by her disobedient sons."⁵⁰

Faint with famine, Hiawatha
Started from his bed of branches,
From the twilight of his wigwam
Forth into the flush of sunset,
Came and wrestled with Mondamin;
At his touch he felt new courage
Throbbing in his brain and bosom,
Felt new life and hope and vigour
Run through every nerve and fibre.

[523] The battle in the sunset with the corn-god gives Hiawatha new strength—necessarily so, because the fight against the paralysing grip of the unconscious calls forth man's creative powers. That is the source of all creativity, but it needs heroic courage to do battle with these forces and to wrest from them the treasure hard to attain. Whoever succeeds in this has triumphed indeed. Hiawatha wrestles with himself in order to create himself.⁵¹ The struggle again lasts for the mythical three days; and on the fourth day, as Mondamin prophesied, Hiawatha conquers him, and Mondamin, yielding up his soul, sinks to the ground. In accordance with the latter's wish, Hiawatha buries him in the earth his mother, and soon afterwards, young and fresh, the corn sprouts from his grave for the nourishment of mankind. (Cf. pl. LII.) Had Hiawatha not succeeded in conquering him, Mondamin would have "killed" him and usurped his place, with the result that Hiawatha would have become "possessed" by a demon.⁵²

[524] Now the remarkable thing here is that it is not Hiawatha who passes through death and emerges reborn, as might be expected, but the god. It is not man who is transformed into a god, but the god who undergoes transformation in and through man. It is as though he had been asleep in the "mother," i.e., in Hiawatha's

unconscious, and had then been roused and fought with so that he should not overpower his host, but should, on the contrary, himself experience death and rebirth, and reappear in the corn in a new form beneficial to mankind. Consequently he appears at first in hostile form, as an assailant with whom the hero has to wrestle. This is in keeping with the violence of all unconscious dynamism. In this manner the god manifests himself and in this form he must be overcome. The struggle has its parallel in Jacob's wrestling with the angel at the ford Jabbok. The onslaught of instinct then becomes an experience of divinity, provided that man does not succumb to it and follow it blindly, but defends his humanity against the animal nature of the divine power. It is "a fearful thing to fall into the hands of the living God," and "whoso is near unto me, is near unto the fire, and whoso is far from me, is far from the kingdom"; for "the Lord is a consuming fire," the Messiah is "the Lion of the tribe of Judah":

Judah is a lion's whelp;
from the prey, my son, thou art gone up.
He stooped down, he couched as a lion,
and as an old lion; who shall rouse him up?⁵³

[525] The devil, too, "as a roaring lion, walketh about seeking whom he may devour."⁵⁴

These well-known examples suffice to show that this idea is very much at home even in the Judaeo-Christian teachings.

[526] In the Mithraic mysteries, the cult-hero has to fight the bull; in the "transitus" he carries it into the cave, where he kills it. From its death comes all fruitfulness, especially things to eat.⁵⁵ (Cf. pl. xxxiii.) The cave is the equivalent of the grave. The same idea is expressed in the Christian mystery, but in a more beautiful and humane form. The struggle in Christ's soul in Gethsemane, where he wrestles with himself in order to complete his work; then the "transitus," the carrying of the cross,⁵⁶ when he takes on his shoulders the symbol of the deadly mother and in so doing carries himself to the grave, from which he will rise again after three days—all these images express the same fundamental thought: that Christ is a divinity who is eaten in the Lord's Supper. His death transforms him into bread and wine, which we relish as mystical food.⁵⁷ The relation of Agni to the soma-drink and of Dionysus to the wine⁵⁸ should not pass without mention here. Another parallel is Samson's strangling of the lion, and the subsequent inhabitation of the dead lion by a swarm of bees, which gave rise to the riddle: "Out of the eater came forth meat, and out of the strong came forth sweetness."⁵⁹ These ideas seem to have played a role in the Eleusinian mysteries, too. (Cf. also pl. ivb.) Besides Demeter and Persephone, Iacchus was one of the chief gods in the Eleusinian cult; he was a *puer aeternus*, the eternal boy, whom Ovid apostrophizes as follows:

For thine is unending youth, eternal boyhood: thou art the most lovely in the lofty sky; thy face is virgin-seeming, if without horns thou stand before us.⁶⁰

[527] The image of Iacchus was carried at the head of the great Eleusinian procession. It is not easy to say exactly what god Iacchus is, but he was probably a boy or a newborn son, similar perhaps to the Etruscan Tages, who bore the epithet “the fresh-ploughed boy,” because, according to legend, he sprang out of a furrow behind a peasant ploughing his fields. This image illustrates the Mondamin motif very clearly: the plough has a well-known phallic meaning (cf. fig. 15), and the furrow, as in India, stands for woman. Psychologically this image is a symbolical equivalent of copulation, the son being the edible fruit of the field. The lexicographers called him “Demeter’s daimon.” He was identified with Dionysus, especially with the Thracian Dionysus-Zagreus, who is supposed to have undergone the typical fate of being reborn. Hera, we are told, had stirred up the Titans against Zagreus, who tried to escape them by changing into various shapes. In the end they caught him when he had taken on the form of a bull. They then killed him, cut him in pieces, and threw the pieces into a cauldron; but Zeus slew the Titans with a thunderbolt and swallowed the still-throbbing heart of Zagreus. In this manner he was regenerated, and Zagreus stepped forth again as Iacchus.

[528] Another thing carried in the Eleusinian procession was the winnowing-basket (cf. also pl. ivb), the cradle of Iacchus (λίκνον, *mystica vannus Iacchi*). The Orphic legend⁶¹ relates that Iacchus was reared by Persephone in the underworld, where, after slumbering for three years, he awoke in the λίκνον. The 20th of Boedromion (the month of Boedromion lasted from about September 5 to October 5) was called Iacchus, in honour of the hero. On the evening of this day a great torchlight procession was held on the sea-shore, where the search and lament of Demeter were re-enacted. The part of Demeter, who, abstaining from food and drink, wanders over the face of the earth seeking her lost daughter, has, in the American Indian epic, been taken over by Hiawatha. He turns to all creatures, but receives no answer. Just as Demeter first gets news of her daughter from the moon-goddess Hecate, so Hiawatha only finds the one he is looking for—Mondamin⁶²—through profound introversion, by a descent into the darkness of night, to the Mothers. As to the content of the mysteries, we have the following testimony from Bishop Asterius (c. A.D. 390): “Is not there [in Eleusis] the dark descent, and is not the solemn communion of hierophant and priestess between him and her alone? Are not the torches doused, and does not the great multitude see their salvation in that which is consummated by the two in the darkness?”⁶³ This clearly points to a *hieros gamos* which was celebrated underground. The priestess of Demeter seems to have represented the earth-goddess, or possibly the ploughed furrow.⁶⁴ The descent into the earth is a piece of womb symbolism and was widespread in the form of cave worship. Plutarch says that the

Magi offered sacrifices to Ahriman “in a sunless place.”⁶⁵ In Lucian, the magician Mithrobarzanes descends into the bowels of the earth “at a desolate spot, marshy and sunless.”⁶⁶ According to the testimony of Moses of Chorene, the Armenians worshipped “Sister Fire” and “Brother Spring” in a cave. Julian records the Attis legend of a “descent into the cave,” from which Cybele brings back her son-lover.⁶⁷ The cave where Christ was born in Bethlehem (“The House of Bread”) is said to have been an Attis spelaeum.

[529] A further piece of Eleusinian symbolism relating to the celebration of the *hieros gamos* is the mysterious baskets (pl. LVIIa), which, according to the testimony of Clement of Alexandria, contained pastries, salt-offerings, and fruit. But the *synthema* (confession) of the neophyte, as handed down by Clement, points to other things besides:

I have fasted, I have drunk the mixed drink, I have taken from the cista, and after working with it I have laid it back in the basket and from the basket into the cista.⁶⁸

[530] The question of what was in the cista has been elucidated by Dieterich.⁶⁹ The “working” he interprets as some phallic activity which the neophyte had to perform. And there are in fact representations of the magic basket with a phallus lying in it surrounded by fruits.⁷⁰ On the so-called Lovatelli funeral urn, carved with scenes supposedly taken from the Eleusinian mysteries, there is a picture of a neophyte fondling the snake entwined about Demeter. The fondling or kissing of the “fear-animal” symbolizes the ceremonial conquest of incest. According to Clement of Alexandria, there was a snake in the mystical basket.⁷¹ This snake signifies the danger that comes from the regressive movement of libido. Rohde⁷² mentions that, at the Arrhetophoria festival, pastries shaped like phalli and serpents were thrown into a pit near the Thesmophorion, to invoke the blessing of children and good harvests.⁷³ The snake also played a large part in the initiation ceremonies, under the strange title “ὁ διὰ χόλπου θεός” (the god through the lap). Clement says that the symbol of the Sabazius mysteries was “The god through the lap: and that is a snake which is dragged through the laps of the initiates.”⁷⁴ From Arnobius we learn: “A golden snake is let down into the lap of the initiates and is drawn out again from below.”⁷⁵ In the 52nd Orphic hymn, Bacchus is invoked by the name of ὑποκόλπιε (lying in the lap), which suggests that the god entered his devotees as if through the female genitals.⁷⁶ At the Eleusinian mysteries the hierophant proclaimed in a loud voice: “The great goddess has borne a divine boy, Brimo has borne Brimos!”⁷⁷ This Christmas message “Unto us a son is born” is further elucidated by the tradition⁷⁸ that the Athenians “silently held up before the celebrants the great, the wonderful, the supreme epoptic mystery—a mown ear of corn.”⁷⁹ (Cf. pl. IVb.)

[531] The parallel to the motif of dying and rising again is that of being lost and found again. It appears ritually at exactly the same place, in connection with the *hieros-gamos*-like spring festivities, where the image of the god was hidden and then found again. There is an uncanonical tradition that Moses left his father's house at the age of twelve in order to instruct mankind. Similarly, Christ was lost by his parents, and they found him teaching wisdom in the temple, just as in the Mohammedan legend Moses and Joshua lose the fish and find in its stead Khidr, the teacher of wisdom. So, too, does the corn-god, lost and believed dead, suddenly spring from the earth in the splendour of youth.

[532] We can see from these accounts how comforting the Eleusinian mysteries were for the celebrant's hopes of a world to come. One epitaph says:

Truly the blessed gods have proclaimed a most beautiful secret: Death comes not as a curse, but as a blessing to men!

[533] The Homeric hymn to Demeter says the same thing of the mysteries:

Happy is he among men upon earth who has seen these mysteries; but he who is uninitiate and has no part in them, never has lot of like good things once he is dead, down in the darkness and gloom.⁸⁰

[534] And we find the same symbolism in a nineteenth-century hymn by Samuel Preiswerk:^{80a}

The world is yours, Lord Jesus,
The world, on which we stand,
Because it is thy world
It cannot perish.
Only the wheat, before it comes
Up to the light in its fertility,
Must die in the womb of the earth
First freed from its own nature.
Thou goest, O Lord, our chief,
To heaven through thy sorrows,
And guide him who believes
In thee on the same path.
Then take us all equally
To share in thy sorrows and kingdom,
Guide us through thy gate of death,
Bring thy world into the light.⁸¹

[535] Firmicus says of the Attis mystery:

On a certain night the image is laid on its back in a litter, and the people bewail it with rhythmical laments. And when they have had their fill of this pretended lamentation, a light is brought in. Then the priest anoints the throats of all who wept, and this having been done, the priest whispers softly: "Take courage, ye initiates, for the god is saved, and you too shall have salvation out of sorrow."⁸²

[536] These parallels show how little there is of the human and personal in the Christ-image, and how strong is the universal and mythological element. The hero is an extraordinary being who is inhabited by a daemon, and it is this that makes him a hero. That is why the mythological statements about heroes are so typical and so impersonal. Christ was a divine being, as the early Christian interpretation tells us at first hand. All over the earth, in the most various forms, each with a different time-colouring, the saviour-hero appears as a fruit of the entry of libido into the maternal depths of the unconscious. The Bacchic consecrations depicted on the Farnese stucco-relief contain a scene in which a neophyte, wrapped in a mantle drawn over his head, is being led before Silenus, who holds the *λίκνον*, which is covered with a cloth. The covering of the head signifies invisibility, that is, death.⁸³ Among the Nandi, of East Africa, the newly-circumcised, the initiates, have to go about for a long time dressed in queer cone-shaped grass hats, which envelop them completely and reach to the ground. The circumcised have become invisible, i.e., spirits. The veil has the same significance among nuns. The neophyte dies like the seed-corn, springs up again and gets into the winnowing-basket. Proclus reports that the neophytes were buried in the ground up to their necks.⁸⁴ The Church is, in a sense, the hero's grave (cf. the catacombs). The believer descends into the grave in order to rise again from the dead with the hero. It can scarcely be doubted that the underlying meaning of the Church is the mother's womb. The Tantric texts interpret the interior of the temple as the interior of the body, and the *adyton* is called "garbha griha," the seeding-place or uterus. We can see this quite plainly in the worship of the Holy Sepulchre, a good example being the Holy Sepulchre of San Stefano in Bologna. The church itself, an extremely ancient polygonal building, was built from the remains of a temple to Isis. Inside, there is an artificial spelaeum, known as the Holy Sepulchre, into which one creeps through a tiny door. Worshippers in such a spelaeum could hardly help identifying themselves with him who died and rose again, i.e., with the reborn. Similar initiations seem to have been performed in the neolithic caves of Hal Saflieni in Malta. An Etruscan ossuary in the archaeological museum at Florence serves at the same time as a statue of Matuta (pl. LIV), the goddess of death: the clay figure of the goddess is hollowed out inside as a receptacle for ashes. It is clear from the accompanying illustration that Matuta is the mother. Her chair is adorned with sphinxes, a fitting symbol of the mother of death. (Cf. the Oedipus myth.)

[537] Of the further deeds of Hiawatha only a few can interest us here. The battle with Mische-Nahma, the fish-king, in the eighth canto, deserves mention as a typical battle

of the sun-hero. Mishe-Nahma is a monster fish who lives at the bottom of the waters. Challenged to battle by Hiawatha, he swallows the hero together with his boat:

In his wrath he darted upward,
Flashing leaped into the sunshine,
Opened his great jaws, and swallowed
Both canoe and Hiawatha.

Down into that darksome cavern
Plunged the headlong Hiawatha,
As a log on some black river
Shoots and plunges down the rapids,
Found himself in utter darkness,
Groped about in helpless wonder,
Till he felt a great heart beating,
Throbbing in that utter darkness.

And he smote it in his anger,
With his fist, the heart of Nahma,
Felt the mighty king of fishes
Shudder through each nerve and fibre ...
Crosswise then did Hiawatha
Drag his birch-canoe for safety,
Lest from out the jaws of Nahma,
In the turmoil and confusion,
Forth he might be hurled and perish.

[538] This is the almost worldwide myth of the typical deed of the hero. He journeys by ship, fights the sea monster, is swallowed, struggles against being bitten and crushed to death (kicking or stamping motif), and having arrived inside the “whale-dragon,” seeks the vital organ, which he proceeds to cut off or otherwise destroy. Often the monster is killed by the hero lighting a fire inside him—that is to say, in the very womb of death he secretly creates life, the rising sun. Thus the fish dies and drifts to land, where with the help of a bird the hero once more sees the light of day.⁸⁵ The bird probably signifies the renewed ascent of the sun, the rebirth of the phoenix, and is at the same time one of those “helpful animals” who render supernatural aid during the birth: birds, as aerial beings, symbolize spirits or angels. Divine messengers frequently appear at these mythological births, as can be seen from the use we still make of *god-parents*. The sun-symbol of the bird rising from the water is preserved

etymologically in the idea of the singing swan. “Swan” derives from the root *sven*, like ‘sun’ and “sound.”⁸⁶ This ascent signifies rebirth, the bringing forth of life from the mother,⁸⁷ and the ultimate conquest of death, which, according to an African Negro myth, came into the world through the carelessness of one old woman: when the season of universal skin-casting came round again (for in those days people renewed themselves by casting their skins like snakes), she was absent-minded enough to put on her old skin instead of the new one, and in consequence died.

[539] It is easy to see what the battle with the sea monster means: it is the attempt to free the ego-consciousness from the deadly grip of the unconscious. The making of a fire in the monster’s belly suggests as much, for it is a piece of apotropaic magic aimed at dispelling the darkness of unconsciousness. The rescue of the hero is at the same time a sunrise, the triumph of consciousness. (Cf. fig. 33.)

[540] Unfortunately, however, this heroic deed has no lasting effects. Again and again the hero must renew the struggle, and always under the symbol of deliverance from the mother. Just as Hera, in her role of the pursuing mother, is the real source of the mighty deeds performed by Heracles, so Nokomis allows Hiawatha no rest, but piles up new difficulties in his path, hazardous adventures in which the hero may be victorious, but may also meet with his death. Man with his consciousness is always a long way behind the goals of the unconscious; unless his libido calls him forth to new dangers he sinks into slothful inactivity, or in the prime of life he is overcome with longing for the past and is paralysed. But if he rouses himself and follows the dangerous urge to do the forbidden and apparently impossible thing, then he must either go under or become a hero. The mother is thus the daemon who challenges the hero to his deeds and lays in his path the poisonous serpent that will strike him. Accordingly Nokomis, in the ninth canto, calls Hiawatha, points with her hand to the West, where the sun sets in purple splendour, and says to him:

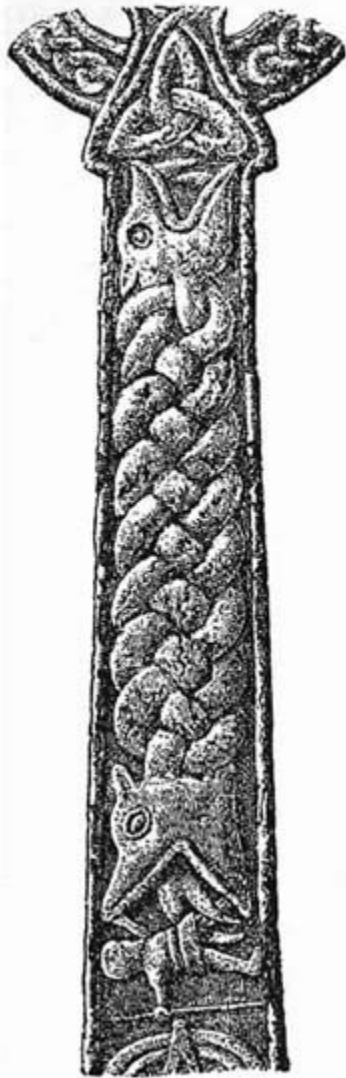

Fig. 33. Vidarr's fight with the Fenris-Wolf
Relief from a cross, Churchyard of Gosforth, Cumberland

Yonder dwells the great Pearl-Feather,
Megissogwon, the Magician,
Manito of Wealth and Wampum,
Guarded by his fiery serpents,
Guarded by the black pitch-water.
You can see his fiery serpents ...
Coiling, playing in the water.

[541] The danger that dwells in the West is death, whom none, not even the mightiest, escapes. The magician, we are told, had killed the father of Nokomis. Now she sends her son forth to avenge her father. From the symbols assigned to the magician we can see what he symbolizes. Snake and water are mother attributes. The snake coils protectingly round the maternal rock, lives in the cave, twines itself round the mother-tree, and guards the precious hoard, the secret "treasure." The black Stygian water, like the muddy spring of Dhulqarnein, is the place where the sun sinks down for rebirth, the maternal sea of death and night. On his journey thither Hiawatha takes

with him the magic oil of Mishe-Nahma, which helps his canoe through the waters of death (hence it is an immortality philtre, as was the dragon's blood for Siegfried). Thus Hiawatha makes the "night sea journey" over the Stygian waters:

All night long he sailed upon it,
Sailed upon that sluggish water,
Covered with its mould of ages,
Black with rotting water-rushes,
Rank with flags and leaves of lilies,
Stagnant, lifeless, dreary, dismal,
Lighted by the shimmering moonlight
And by will-o'-the-wisps illumined,
Fires by ghosts of dead men kindled
In their weary night encampments.

[542] This description clearly shows that they are the waters of death. The rotting water-plants point to the entwining and devouring motif already mentioned. The dream-book of Jagaddeva⁸⁸ says: "Whoever dreams that his body is wrapped round with bast, creepers or cords, with snake-skins, threads or webs, will certainly die."

[543] There is no doubt that the above description refers to the realm of the Terrible Mother, represented in this case by the magician, a negative father-figure, or by a masculine principle in the mother herself, just as the secret *spiritus rector* who impels Hiawatha to his task is represented by Nokomis, the mother, who is a feminine principle in the breast of the hero. The latter is Hiawatha's anima, and the former would correspond to the animus of the Terrible Mother.

[544] Arrived in the Western Land, the hero challenges the magician to battle, and a terrible struggle begins. Hiawatha is powerless because Megissogwon is invulnerable. In the evening Hiawatha, wounded and despairing, retires for a short rest:

Paused to rest beneath a pine-tree,
From whose branches trailed the mosses,
And whose trunk was coated over
With the Dead Man's Moccasin-leather,
With the fungus white and yellow.

[545] This sheltering tree is described as "coated" with fungus. Tree-anthropomorphism is an important factor wherever tree-worship prevails, as for instance in India, where every village has its sacred tree (pl. LV), which is clothed and treated exactly like a human being. The trees are anointed with sweet-smelling

waters, sprinkled with powder, adorned with garlands and draperies. And just as the people pierce their ears as an apotropaic charm against death, so they pierce the sacred tree. “Of all the trees in India there is none more sacred to the Hindus than the peepul or aswatha (*Ficus religiosa*). It is known to them as Vriksha Raja (king of trees). Brahma, Vishnu, and Maheswar live in it, and the worship of it is the worship of the Triad. Almost every Indian village has an aswatha.”⁸⁹

[546] This well-known “village linden-tree” is clearly characterized as a mother-symbol: it contains the three gods. So when Hiawatha retires to rest under the pine-tree,⁹⁰ he is taking a dangerous step, for he is seeking refuge with the mother whose garment is the garment of death. As in the battle with the whale-dragon, so here the hero needs the help of a bird, of one of those helpful animals who represent the stirrings or intuitions of the unconscious, the helpful mother:

Suddenly from the boughs above him

Sang the Mama, the woodpecker:

Aim your arrows, Hiawatha,

At the head of Megissogwon,

Strike the tuft of hair upon it,

At their roots the long black tresses;

There alone can he be wounded!

[547] So “Mama”—an amusing touch this, one must own—hastens to his aid. Oddly enough, the woodpecker also happened to be the “mama” of Romulus and Remus, for he put food into their mouths with his beak.⁹¹ The woodpecker owes his special significance to the fact that he hammers holes in trees. Hence we can understand why he was honoured in Roman legend as an ancient king of the country, who was the possessor or ruler of the sacred tree, and the prototype of the *pater familias*. An old fable relates that Circe, the wife of king Picus, changed him into *Picus martius*, the woodpecker. She killed and magically transformed him into a soul-bird. Picus was also regarded as a wood demon and incubus,⁹² and a soothsayer.⁹³ He was sometimes equated with Picumnus, the inseparable companion of Pilumnus, both of whom were called *infantium dii*, ‘gods of small children.’ Pilumnus especially was said to protect new-born infants from the wicked attacks of the wood-imp Sylvanus. This helpful little bird now counsels our hero to aim under the magician’s topknot, the only vulnerable spot. It is situated on the crown of the head, at the point where the mythical “head-birth” takes place, which even today figures among the birth-theories of children. There Hiawatha shoots in three arrows⁹⁴ and so makes an end of Megissogwon. He then steals the magic belt of wampum which makes him invisible; the dead magician he leaves lying in the water:

On the shore he left the body,
Half on land and half in water,
In the sand his feet were buried,
And his face was in the water.

[548] The situation is therefore the same as with the fish-king, for the magician is the personification of the water of death, which in its turn stands for the devouring mother. This great deed of Hiawatha's, when he conquers the Terrible Mother and death-bringing daemon in the guise of the negative father, is followed by his marriage with Minnehaha. He can only turn to his human side after he has fulfilled his heroic destiny: firstly the transformation of the daemon from an uncontrolled force of nature into a power that is his to command; secondly the final deliverance of ego-consciousness from the deadly threat of the unconscious in the form of the negative parents. The first task signifies the creation of will-power, the second the free use of it.

[549] We might mention, from a later canto (the twelfth), a little fable which the poet has interpolated: an old man is changed back into a youth by crawling through a hollow oak-tree.⁹⁵ The fourteenth canto describes how Hiawatha invents writing. I must confine myself here to the description of two hieroglyphs:

Gitche Manito the Mighty,
He, the Master of Life, was painted
As an egg, with points projecting
To the four winds of the heavens.
Everywhere is the Great Spirit,
Was the meaning of this symbol.

[550] The world is enclosed in the egg (cf. fig. 36) which surrounds it on all sides; it is the cosmic birth-giver, a symbol used by Plato and by the Vedas. This "mother" is omnipresent, like the air. But air is spirit, so the world-mother is a spirit, the *anima mundi*. The hieroglyph is at the same time a quaternity-symbol, which psychologically always points to the self.⁹⁶ It therefore depicts the uttermost circumference and the innermost centre, the infinite and the infinitesimal, corresponding to the Indian idea of the atman, which encompasses the whole world and dwells, "no bigger than a thumb," in the heart of man. The second hieroglyph is as follows:

Mitche Manito the Mighty,
He the dreadful Spirit of Evil,
As a serpent was depicted,

[551] The spirit of evil is fear, negation, the adversary who opposes life in its struggle for eternal duration and thwarts every great deed, who infuses into the body the poison of weakness and age through the treacherous bite of the serpent; he is the spirit of regression, who threatens us with bondage to the mother and with dissolution and extinction in the unconscious. (Cf. fig. 35 and pl. LXII.) For the hero, fear is a challenge and a task, because only boldness can deliver from fear. And if the risk is not taken, the meaning of life is somehow violated, and the whole future is condemned to hopeless staleness, to a drab grey lit only by will-o'-the-wisps.

[552] The fifteenth canto describes how Chibiabos, Hiawatha's best friend, the amiable player and singer, the incarnation of all life's joys, was enticed into an ambush by evil spirits, fell through the ice, and was drowned. Hiawatha mourned him so long that, with the help of magicians, he succeeded in calling him back again. But he comes back only as a spirit, and is made master of the Land of Spirits. More battles follow, and then comes the loss of a second friend, Kwasind, the embodiment of physical strength. These events are omens of the end, like the death of Eabani in the Gilgamesh Epic. In the twentieth canto comes the famine, followed by the death of Minnehaha, which is foretold by two taciturn guests from the Land of the Dead; and in the twenty-second canto Hiawatha prepares for the final journey to the Western Land:

I am going, O Nokomis,
On a long and distant journey,
To the portals of the Sunset,
To the regions of the home-wind,
Of the Northwest Wind, Keewaydin.

One long track and trail of splendour,
Down whose stream, as down a river,
Westward, westward, Hiawatha
Sailed into the fiery sunset,
Sailed into the purple vapours,
Sailed into the dusk of evening.

Thus departed Hiawatha,
Hiawatha the Beloved,
In the glory of the sunset,
In the purple mists of evening,
To the regions of the home-wind,

Of the Northwest Wind, Keewaydin,
To the Islands of the Blessed,
To the kingdom of Ponemah,
To the land of the Hereafter!

[553] The sun, rising triumphant, tears himself from the enveloping womb of the sea, and leaving behind him the noonday zenith and all its glorious works, sinks down again into the maternal depths, into all-enfolding and all-regenerating night. (Cf. figs. 3, 24.) This image is undoubtedly a primordial one, and there was profound justification for its becoming a symbolical expression of human fate: in the morning of life the son tears himself loose from the mother, from the domestic hearth, to rise through battle to his destined heights. Always he imagines his worst enemy in front of him, yet he carries the enemy within himself—a deadly longing for the abyss, a longing to drown in his own source, to be sucked down to the realm of the Mothers. His life is a constant struggle against extinction, a violent yet fleeting deliverance from ever-lurking night. This death is no external enemy, it is his own inner longing for the stillness and profound peace of all-knowing non-existence, for all-seeing sleep in the ocean of coming-to-be and passing away. Even in his highest strivings for harmony and balance, for the profundities of philosophy and the raptures of the artist, he seeks death, immobility, satiety, rest. If, like Peirithous, he tarries too long in this abode of rest and peace, he is overcome by apathy, and the poison of the serpent paralyses him for all time. If he is to live, he must fight and sacrifice his longing for the past in order to rise to his own heights. And having reached the noonday heights, he must sacrifice his love for his own achievement, for he may not loiter. The sun, too, sacrifices its greatest strength in order to hasten onward to the fruits of autumn, which are the seeds of rebirth. The natural course of life demands that the young person should sacrifice his childhood and his childish dependence on the physical parents, lest he remain caught body and soul in the bonds of unconscious incest. This regressive tendency has been consistently opposed from the most primitive times by the great psychotherapeutic systems which we know as the religions. They seek to create an autonomous consciousness by weaning mankind away from the sleep of childhood. The sun breaks from the mists of the horizon and climbs to undimmed brightness at the meridian.⁹⁷ Once this goal is reached, it sinks down again towards night. This process can be allegorized as a gradual seeping away of the water of life: one has to bend ever deeper to reach the source. When we are feeling on top of the world we find this exceedingly disagreeable; we resist the sunset tendency, especially when we suspect that there is something in ourselves which would like to follow this movement, for behind it we sense nothing good, only an obscure, hateful threat. So, as soon as we feel ourselves slipping, we begin to combat this tendency and erect barriers against the dark, rising flood of the unconscious and its enticements to

regression, which all too easily takes on the deceptive guise of sacrosanct ideals, principles, beliefs, etc. If we wish to stay on the heights we have reached, we must struggle all the time to consolidate our consciousness and its attitude. But we soon discover that this praiseworthy and apparently unavoidable battle with the years leads to stagnation and desiccation of soul. Our convictions become platitudes ground out on a barrel-organ, our ideals become starchy habits, enthusiasm stiffens into automatic gestures. The source of the water of life seeps away. We ourselves may not notice it, but everybody else does, and that is even more painful. If we should risk a little introspection, coupled perhaps with an energetic attempt to be honest for once with ourselves, we may get a dim idea of all the wants, longings, and fears that have accumulated down there—a repulsive and sinister sight. The mind shies away, but life wants to flow down into the depths. Fate itself seems to preserve us from this, because each of us has a tendency to become an immovable pillar of the past. Nevertheless, the daemon throws us down, makes us traitors to our ideals and cherished convictions—traitors to the selves we thought we were. That is an unmitigated catastrophe, because it is an *unwilling* sacrifice. Things go very differently when the sacrifice is a voluntary one. Then it is no longer an overthrow, a “transvaluation of values,” the destruction of all that we held sacred, but transformation and conservation. Everything young grows old, all beauty fades, all heat cools, all brightness dims, and every truth becomes stale and trite. For all these things have taken on shape, and all shapes are worn thin by the working of time; they age, sicken, crumble to dust—unless they change. But change they can, for the invisible spark that generated them is potent enough for infinite generation. No one should deny the danger of the descent, but it *can be* risked. No one *need* risk it, but it is certain that some one will. And let those who go down the sunset way do so with open eyes, for it is a sacrifice which daunts even the gods. Yet every descent is followed by an ascent; the vanishing shapes are shaped anew, and a truth is valid in the end only if it suffers change and bears new witness in new images, in new tongues, like a new wine that is put into new bottles.

[554] *The Song of Hiawatha* contains material that is well suited to bring into play the vast potentialities for archetypal symbolization latent in the human mind and to stimulate the creation of images. But the products always contain the same old human problems, which rise up again and again in new symbolic guise from the shadowy world of the unconscious.

[555] Thus it is that Chiwantopel puts Miss Miller in mind of another hero, who makes his entry in the form of Wagner’s Siegfried. Chiwantopel cries out in his monologue: “Alas! Not one who understands me, not one who resembles me or has a soul that is sister to mine.” Miss Miller declares that the sentiments expressed in this passage have the greatest analogy with Siegfried’s feelings for Brünhilde. This analogy

prompts us to cast a glance at the relations between Siegfried and Brünhilde in Wagner. It is well known that Brünhilde, the Valkyrie, looked with favour on the brother-sister incest that gave birth to Siegfried. But whereas Sieglinde is the human mother, Brünhilde acts the part of the symbolic mother, the “spirit-mother” (mother-imago), not as a persecutor, like Hera with the infant Heracles, but as a helper. The sin of incest, of which she makes herself guilty by her complicity, is the reason for her banishment by Wotan. Siegfried’s birth from the sister-wife characterizes him as a Horus, the reborn sun, a reincarnation of the aging sun-god. The birth of the young sun, the god-man, stems from human partners, but they are really only vehicles for cosmic symbols. The spirit-mother therefore lends it her protection; she sends Sieglinde forth, with the child in her womb,⁹⁸ on the night sea journey to the East:

Away then, hasten;
Turn to the East! ...
Woman, you cherish
The noblest hero in the world
In your sheltering womb!⁹⁹

[556] The motif of dismemberment recurs in the broken sword of Siegmund, which was kept for Siegfried. Life is put together again from the broken pieces (miracle of Medea). Just as a blacksmith welds the broken pieces together, so the dismembered corpse is reconstituted. This comparison also occurs in Plato’s *Timaeus*: the world’s parts are joined together with pegs. In the Rig-Veda the world creator Brahmanaspati is a blacksmith:

This world Brahmanaspati
Welded together like a blacksmith.¹⁰⁰

[557] The sword denotes solar power, therefore a sword goes out from the mouth of Christ in the Apocalypse (cf. pl. *vb*), namely the procreative fire, speech, or the spermatic Word. In the Rig-Veda, Brahmanaspati is the prayer-word, which is accorded a pre-worldly, creative significance:

And this prayer of the singer, continually expanding,
Became a cow that was there before the beginning of the world.
The gods are foster-children of the same brood,
Dwelling together in the womb of this god.¹⁰¹

[558] The Logos becomes a cow, i.e., a mother who bears the gods in her womb. The transformation of Logos into mother is not really surprising, since in the *Acts of Thomas* the Holy Ghost is addressed as the mother, and it is always the mother-imago which proves to be the hero’s greatest danger but is for that very reason the prime

source of his deeds and of his ascent. His ascent signifies a renewal of the light and hence a rebirth of consciousness from the darkness, i.e., from regression to the unconscious.

[559] The persecution motif is not connected here with the mother, but with Wotan, as in the Linus legend, where the father is the vengeful pursuer. Brünhilde stands in a peculiar relation to her father Wotan. She says to him:

You speak to the will of Wotan
When you tell me what you wish.
Who am I
If I am not your will?

WOTAN: I take counsel with myself alone
When I speak with you ...¹⁰²

[560] Brünhilde is a sort of “split-off” from Wotan, part of his personality, just as Pallas Athene was an emanation of Zeus. She is, as it were, Wotan’s emissary for the mother-imagery or agent, and therefore corresponds to the angel of Yahweh, to the “eye of Ahura” or Vohu Manah, God’s good thought in Persian legend, or to the Babylonian Nabu, the word of fate, or to Hermes, the messenger of the gods, whom the philosophers equated with Reason and Logos. In Assyria the role of Logos falls to the fire god, Gibil. That Wagner should have put the designs of so martial a god as Wotan into the hands of a feminine agent is somewhat remarkable, despite the Greek precedent of Pallas Athene. A very similar figure is the Kore in the *Acts of Thomas*, of whom Thomas sings:

Maiden, daughter of the light,
In whom there abides the majestic splendour of kings ...
On the crown of her head the king is seated,
Feeding with his own ambrosia those seated beside him.
Truth rests upon her head ...
Her tongue is like the curtain of a door
Which is drawn back for them who go in.
Her neck rises up like a stairway,
And the first builder of the world created it.
Her two hands signify and proclaim the dance of the blessed ages,
And her fingers the gates of the city ...¹⁰³

[561] This maiden, according to the *Acts of Thomas*, is the “Mother of Wisdom.” Conversely, the Holy Ghost is worshipped in feminine form in one of the Eucharistic

prayers:

Come, thou that knowest the secrets of the chosen;

Come, thou that partakest in all the combats of the noble combatant ...

Come, peace,

That revealest the great things of all greatness;

Come, thou that layest bare the hidden things,

And makest manifest things not to be spoken;

Come, holy dove,

Which hast brought forth the twin nestlings;

Come, secret mother ... ¹⁰⁴

[562] This Eucharistic feast is celebrated at a characteristic moment, immediately after Thomas had delivered a “beautiful woman” from an “unchaste demon” who had been plaguing her for years. This is probably no accident, because the therapeutic meaning of the hymn is the transformation of a sexual obsession into a recognition of the positive qualities of the feminine spirit.

[563] In line with the *Acts of Thomas* is the Ophite view that the Holy Ghost is the “first word,” the “Mother of All Living,” and the Valentinian idea that the Third Person is the “Word of the Mother from Above.” It is clear from all this that Wagner’s Brünhilde is one of the numerous anima-figures who are attributed to masculine deities, and who without exception represent a dissociation in the masculine psyche—a “split-off” with a tendency to lead an obsessive existence of its own. This tendency to autonomy causes the anima to anticipate the thoughts and decisions of the masculine consciousness, with the result that the latter is constantly confronted with unlooked-for situations which it has apparently done nothing to provoke. Such is the situation of Wotan, and indeed of every hero who is unconscious of his own intriguing femininity.

[564] Something of the sort must have been in Wagner’s mind when he wrote Wotan’s lament for Brünhilde:

None knew as she my innermost thoughts;

None knew as she the source of my will;

She herself was

The creating womb of my wish;

And now she has broken

That happy bond! ¹⁰⁵

[565] Brünhilde’s sin was her support of Siegmund, but behind that lies the incest which was projected into the brother-sister pair Siegmund and Sieglinde. The

symbolical meaning, however, is that Wotan, the father, has entered into his own daughter in order to rejuvenate himself. This archaic fact is expressed here in a rather veiled way. In the legend of the “Entkrist” it is expressed openly by the devil, the father of the Anti-Christ. Wotan is justly indignant with Brünhilde, for she has taken over the role of Isis and through the birth of a son has deprived the old man of his power. Wotan beats off the first herald of doom, Siegmund, and smashes his sword, but Siegmund rises again in the grandson, Siegfried. And the instrument of fate is always the woman, who knows and reveals his secret thoughts; hence the impotent rage of Wotan, who cannot bring himself to recognize his own contradictory nature.

[566] At Siegfried’s birth Sieglinde dies, as is proper. The foster-parent ¹⁰⁶ who brings him up is not a woman, but a chthonic god, Mime, a crippled dwarf who belongs to a race that has abjured love.¹⁰⁷ Similarly, the god of the Egyptian underworld, the crippled shadow of Osiris (who underwent a sorry resurrection in Harpocrates), brings up the infant Horus to avenge the death of his father.

[567] Meanwhile Brünhilde lies in enchanted slumber ¹⁰⁸ on the mountain where Wotan has put her to sleep with the magic thorn (Edda), surrounded by a curtain of fire that keeps off all who approach and at the same time symbolizes the fiery longing of the hero for the forbidden goal.¹⁰⁹ Mime, however, becomes Siegfried’s enemy and wills his death through Fafner. Here Mime’s dynamic nature is revealed: he is a masculine representative of the Terrible Mother who lays the poisonous worm in her son’s path.¹¹⁰ Siegfried’s longing for the motherimago drives him away from Mime:

Away with the imp!
Let me see him no more.
If only I knew
What my mother was like!
But that will my thought never tell me!
Her eyes’ tender light
Surely did shine
Like the soft eyes of the doe.¹¹¹

[568] Siegfried wants to part from the “imp” who was his mother in the past, and longingly he reaches out for the other mother. For him, too, nature acquires a hidden maternal significance (“doe”); he, too, discovers in the sounds of nature a hint of his mother’s voice and his mother’s speech:

Sweet little bird!
Never yet have I heard you;
Do you live here in the forest?
Could I but follow your sweet warbling!

Surely it would tell me

Something of my dear mother?¹¹²

[569] But his conversation with the bird lures Fafner out of the cave. Siegfried's longing for the mother-*imago* has unwittingly exposed him to the danger of looking back to his childhood and to the human mother, who immediately changes into the death-dealing dragon. He has conjured up the evil aspect of the unconscious, its devouring nature (cf. pls. xxxi**nb**, xxxiv), personified by the cave-dwelling terror of the woods. Fafner is the guardian of the treasure; in his cave lies the hoard, the source of life and power. The mother apparently possesses the libido of the son (the treasure she guards so jealously), and this is in fact true so long as the son remains unconscious of himself.¹¹³ In psychological terms this means that the "treasure hard to attain" lies hidden in the mother-*imago*, i.e., in the unconscious. This symbol points to one of life's secrets which is expressed in countless symbolical ways in mythology. When such symbols occur in individual dreams, they will be found on examination to be pointing to something like a centre of the total personality, of the psychic totality which consists of both conscious and unconscious. Here I must refer the reader to my later works, where I deal at some length with the symbol of the self.¹¹⁴ The rewards of this battle with Fafner are glowingly described in the Siegfried legend. According to the Edda, Siegfried eats Fafner's heart,¹¹⁵ the seat of life. He wins the magic cap through whose power Alberich had changed himself into a serpent—an allusion to the motif of rejuvenation by casting the skin. Another lucky cap is the caul that is occasionally found over the heads of new-born children. In addition, by drinking the dragon's blood Siegfried learns to understand the language of birds, and thus enjoys a peculiar relationship to nature, which he now dominates by knowledge. Last but not least, he wins the hoard.

[570] *Hort* is a Middle High German and Old High German word meaning 'collected and guarded treasure'; Goth. *huzd*; OIcel. *hodd*; Germanic **hozda*, from the pre-Germanic **kuzdho*—for *kudtho*—'hidden.' Kluge¹¹⁶ associates it with Gr. *κεύθω*, *ἔκρυθον*, 'to hide, conceal'; also with G. *Hütte*, 'hut,' *Hut*, 'custody,' E. *hide*, Germanic root **hud*, from IEur. **kuth* (possibly related to *κεύθω* and *κύσθος*, 'cavity, female genitals.' Prellwitz¹¹⁷ also relates Goth. *huzd*, OE. *hyde*, E. *hide* and *hoard* to *κεύθω*. Stokes¹¹⁸ relates E. *hide*, OE. *hydan*, G. *Hütte*, Lat. *cūdo*, 'helmet,' Skr. *kuhara*, 'hollow'(?), to Celt. *koudo*, concealment,' Lat. *occultatio*. In this connection we might also mention the report of Pausanias:

There was in Athens a sacred precinct [a *temenos*] dedicated to Gaia and surnamed Olympia. Here the ground is torn open to the width of a cubit; and they say that the water flowed off here after the flood at the time of Deucalion; and every year they cast into the fissure wheatmeal kneaded with honey.¹¹⁹

[571] We have already seen that pastries in the form of snakes and phalli were flung into a pit at the Arrhetophoria. We mentioned this in connection with the earth fertilization ceremonies. It is significant that the deadly flood flowed off into the fissure, back into the mother again, for it was from the mother that death came into the world in the first place. The Deluge is simply the counterpart of the all-vivifying and all-producing water, of “the ocean, which is the origin of all things.”¹²⁰ Honey-cakes are offered to the mother that she may spare one from death. In Rome money-offerings were thrown every year into the *lacus Curtius*, formerly a chasm that had been closed through the sacrificial death of Curtius. He was the hero who went down to the underworld in order to conquer the danger that threatened the Roman state after the opening of the chasm. In the Amphiaraiion at Oropos those healed through incubation in the temple threw their money-offerings into the sacred well. Pausanias says:

If anyone is cured of a sickness through a saying of the oracle, it is customary for him to throw a silver or gold coin into the well; for they say that this was where Amphiaraos rose up as a god.¹²¹

[572] Presumably this Oropian well was also the scene of his *katabasis*. There were any number of entrances to Hades in antiquity, Thus, near Eleusis, there was a gorge through which Aidoneus came up and into which he descended after kidnapping the Kore. There were crevasses in the rocks where the souls could ascend to the upper world. Behind the temple of Chthonia in Hermione lay a spot sacred to Pluto, with a chasm through which Heracles came up with Cerberus. There was also an “Acherusian” lake.¹²² This chasm, therefore, was the entrance to the place where death had been conquered. The chasm on the Areopagus in Athens was believed to be the seat of the dwellers in the underworld.¹²³ Similar ideas are suggested by an old Greek custom: ¹²⁴ girls used to be sent for a virginity test to a cave where there lived a poisonous serpent. If they were bitten, it was a sign that they were no longer chaste. We find the same motif in the Roman legend of St. Sylvester, dating from the end of the fifth century:

There used to be a huge dragon inside the Tarpeian Hill, where the Capitol stands. Once a month magicians and wanton girls went down the 365 steps to this dragon, as though into the underworld, bearing with them sacrifices and purificatory offerings from which the great dragon could be given his food. Then the dragon would suddenly rise up, and though he did not come out he poisoned the air with his breath, so that men died and much sorrow was occasioned by the deaths of children. When, therefore, St. Sylvester was fighting the pagans in defence of truth, the pagans challenged him, saying: Sylvester, go down to the dragon, and in the name of thy God make him desist, if only for a year, from this slaughter of human lives.¹²⁵

[573] St. Peter then appeared to Sylvester in a dream, and counselled him to close this door to the underworld with a chain, as in the vision of the Apocalypse:

And I saw an angel come down from heaven, having the key of the bottomless pit and a great chain in his hand.

And he laid hold on the dragon, that old serpent, which is the Devil, and Satan, and bound him a thousand years, and cast him into the bottomless pit, and shut him up, and set a seal upon him.¹²⁶

[574] Writing at the beginning of the fifth century, the anonymous author of a treatise entitled “De promissionibus” mentions a very similar legend:

Near the city of Rome there was a certain cavern in which could be seen a frightful and terrible dragon of marvellous size, a mechanical contrivance that brandished a sword in its mouth¹²⁷ and had shining red jewels for eyes.¹²⁸ Every year girls were consecrated and adorned with flowers, and then given to the dragon in sacrifice. For, as they descended with their gifts, they unwittingly touched the step to which this devilish mechanism of a dragon was attached, and were instantly pierced through with the sword that sprang out, so that innocent blood was shed. A certain monk, who was known to Stilicho the patrician on account of his good deeds, destroyed the dragon in the following manner: he carefully examined each step with a rod and with his hand until he discovered the diabolical fraud. Then, stepping over it, he went down, smote the dragon and cut it to pieces, thus showing that they are not true gods who are made by the hands of men.¹²⁹

[575] The hero has much in common with the dragon he fights—or rather, he takes over some of its qualities, invulnerability, snake’s eyes, etc. Man and dragon might be a pair of brothers, even as Christ identified himself with the serpent which—*similia similibus*—conquered the plague of fiery serpents in the wilderness (John 3 : 14 and Numbers 21 : 6f.). As a serpent he is to be “lifted up” on the cross; that is to say, as a man with merely human thoughts and desires, who is ever striving back to childhood and the mother, he must die on the mother-tree, his gaze fixed on the past. This formulation is not to be taken as anything more than a psychological interpretation of the crucifixion symbol, which, because of its long-lasting effects over the centuries, must somehow be an idea that accords with the nature of the human soul. If this were not so, the symbol would long since have perished. Here, as everywhere else in this book when discussing the psychology of religious figures, I am not concerned with the theological point of view. I would like to state this categorically, for I am aware that my comparative procedure often juxtaposes figures which from another point of view can hardly be compared at all. It is clear to me that such comparisons might easily give offence to the newcomer to psychology. On the other hand, anyone who has to do with the phenomena of the unconscious knows with what hair-raising irrationalism and with what shocking tactlessness and ruthlessness the unconscious “mind” dismisses our logical concepts and moral values. The unconscious, it appears, does not obey the same laws as the conscious—indeed, if it did, it would not be able to fulfil its compensatory function.

[576] Christ, as a hero and god-man, signifies psychologically the self; that is, he represents the projection of this most important and most central of archetypes. (Cf.

pl. LX.) The archetype of the self has, functionally, the significance of a ruler of the inner world, i.e., of the collective unconscious.¹³⁰ The self, as a symbol of wholeness, is a *coincidentia oppositorum*, and therefore contains light and darkness simultaneously. (Cf. pl. LVI, also fig. 39.) In the Christ-figure the opposites which are united in the archetype are polarized into the “light” son of God on the one hand and the devil on the other. The original unity of opposites is still discernible in the original unity of Satan and Yahweh. Christ and the dragon of the Anti-Christ lie very close together so far as their historical development and cosmic significance are concerned.¹³¹ The dragon legend concealed under the myth of the Anti-Christ is an essential part of the hero’s life¹³² and is therefore immortal. Nowhere in the latter-day myths are the paired opposites so palpably close together as in the figures of Christ and Anti-Christ. (Here I would refer the reader to Merezhkovsky’s admirable account of this problem in his novel *Leonardo da Vinci*.) It is a convenient rationalistic conceit to say that the dragon is only “artificial,” thus banishing the mysterious gods with a word. Schizophrenic patients often make use of this mechanism for apotropaic purposes. “It’s all a fake,” they say, “all artificially made up.” The following dream of a schizophrenic is typical: *He is sitting in a dark room which has only one small window, through which he can see the sky. The sun and moon appear, but they are made of oiled paper.* Sun and moon, as divine equivalents of the parent archetype, possess a tremendous psychic power that has to be weakened apotropaically, because the patient is already far too much under the power of the unconscious.

[577] The descent of the 365 steps refers to the course of the sun, and hence to the cavern of death and rebirth. That this cavern is in fact related to the subterranean mother of death can be seen from a note in Malalas, the historian of Antioch,¹³³ who says that in that city Diocletian dedicated a crypt to Hecate, with 365 steps leading down to it. Cave mysteries in her honour seem also to have been celebrated in Samothrace. The Hecate mysteries flourished in Rome towards the end of the fourth century, so that the two legends quoted above might well refer to her cult. Hecate¹³⁴ is a real spook-goddess of night and phantoms, a nightmare; she is sometimes shown riding a horse, and in Hesiod she is counted the patron goddess of riders. It is she who sends that horrible and fearful night-time apparition, the Empusa, which Aristophanes says comes wrapped in a bladder swollen with blood. According to Libanius, the mother of Aischines was also called Empusa, because she ἐκ σκοτεινῶν τόπων τοῖς παισὶν καὶ ταῖς γυναῖξιν ὤρματο—“rushed out upon women and children from dark places.” The Empusa had peculiar feet: one foot was of brass, the other of ass’s dung. In Tralles, Hecate appears side by side with Priapus; there is also a Hecate Aphrodisias. Her symbols are the key,¹³⁵ the whip,¹³⁶ the dagger, and the torch (pl. LVIII). As the deadly mother, her attributes are dogs, whose significance we have already discussed at some length. As guardian of the gate of Hades and as

the triple-bodied goddess of dogs, she is more or less identical with Cerberus. Thus, in bringing up Cerberus, Heracles was really bringing the vanquished mother of death to the upper world.



Fig. 34. Hecate of Samothrace
Gnostic gem

As the “spirit-mother” she sends madness, the moonsickness. This idea is perfectly sensible, because most forms of lunacy consist of affections which amount to an invasion by the unconscious and an inundation of the conscious mind. In the Hecate mysteries a wand, named the λευκόφυλλος (‘white-leaved’), was broken. This wand protected the purity of virgins and caused madness in anyone who touched it. We recognize here the motif of the sacred tree, the mother who might not be touched. Only a madman would attempt to do so. As an incubus or vampire she appears in the form of Empusa, or as a man-eating lamia (cf. pl. xxxviii), or again in that more beautiful guise, the “Bride of Corinth.” She is the mother of all witchcraft and witches, the patron goddess of Medea, because the power of the Terrible Mother is irresistible, coming as it does from the unconscious. She plays an important part in Greek syncretism, being confused with Artemis, who was also called *ἐκάτη*, the ‘far-hitting,’ or ‘she who hits at will,’ a name that once more reveals her superordinate power. Artemis is the huntress with hounds, and Hecate too is the wild huntress prowling at night. She has her name in common with Apollo: *ἑκατος*, *ἐκάεργος*. The identification of Hecate with Brimo as the underworldly mother is understandable, also her identification with Persephone and Rhea, the primitive All-Mother. Her maternal significance also explains her confusion with Eileithyia, the goddess of childbirth. Hecate is a birth-goddess (*κουροτρόφος*), the multiplier of cattle and goddess of marriage. In Orphic cosmogony she occupies the centre of the world as Aphrodite and Gaia, if not as the world-soul itself. On a carved gem she is shown with a cross on her head (fig. 34). The pillory where criminals were scourged was also known as the *ἐκάτη*; and to her, as to the Roman Trivia, were dedicated junctions of three roads, forked roads, and cross roads. Where the roads branch off or meet, dog-sacrifices were offered to her, and there too were thrown the bodies of the executed: the sacrifice occurs at the point of union. Where the roads *cross* and enter into one another, thereby symbolizing the union of opposites, there is the “mother,” the object and epitome of all union. Where the roads *divide*, where there is parting, separation, splitting, there we find the “division,” the cleft ¹³⁷—the symbol of the mother and at the same time the essence of what the mother means for us, namely cleavage and farewell. Accordingly, the meaning of a sacrifice on this spot would be: propitiation of the mother in both senses. The temenos of Gaia, the fissure and the well, can easily be understood as the doors of life and death, ¹³⁸ “past which man’s steps have ever flinching trod,” ¹³⁹ sacrificing there his obolus or his *πελανοί* instead of his body, just as Heracles pacified Cerberus with the honey-cakes. Thus

the crevice at Delphi with the Castalian spring was the habitation of the chthonic Python who was vanquished by the sun-hero Apollo. The Python, incited by Hera, had pursued Apollo's mother, Leto, when he was still in her womb; but she fled to the floating island of Delos on a "night sea journey" and was there safely delivered of her child, who later slew the Python. In Hierapolis (Edessa) a temple was built over the crack in the earth where the flood subsided, and in Jerusalem the foundation-stone of the temple was laid over the great abyss,¹⁴⁰ in the same way that Christian churches are often built over caves, grottoes, wells, etc. We find the same motif in the Grotto of Mithras¹⁴¹ and the various other cave-cults, including the Christian catacombs, which owe their importance not to legendary persecutions but to the cult of the dead.¹⁴² Even the burial of the dead in consecrated ground ("garden of the dead," cloisters, crypts, etc.) is a rendering back to the mother with the hope of resurrection which such burials presuppose. In olden times, the dragon in the cave who represented the devouring mother had to be propitiated with human sacrifices, later with gifts. Hence the Attic custom of giving the dead man the *μελιτοῦττα* (same as *μᾶζα*, honey-cakes), with which to pacify the hound of hell, the three-headed monster guarding the door of the underworld. A substitute for the gifts seems to have been the obolus given to Charon, which is why Rohde calls him the second Cerberus, akin to the jackal-headed Anubis of the Egyptians.¹⁴³ (Cf. pl. xxxiia.) The dog and the underworld serpent are identical. In the Greek tragedies the Erinyes are serpents as well as dogs; the monsters Typhon and Echidna are parents of the Hydra, of the dragon of the Hesperides, and of the Gorgon (cf. pl. xivb); they also spawned the dogs Cerberus, Orthros, and Scylla.¹⁴⁴ Snakes and dogs are guardians of the treasure. The chthonic god was in all probability a snake that was housed in a cave and was fed with *πέλανοι* (pl. lviiib). In the Asclepieia of the later period the sacred snakes were hardly ever visible, so they may have existed only figuratively.¹⁴⁵ Nothing was left but the hole in which the snake was said to dwell. There the *πέλανοι* were placed and the obolus thrown in. The sacred cave in the temple at Cos consisted of a rectangular pit covered by a stone slab with a square hole in it. This arrangement served the purpose of a treasure-house: the snake-pit had become a slot for money, a "poor-box," and the cave a "hoard." That this development is fully in accord with the archaeological evidence is proved by a discovery in the temple of Aesculapius and Hygeia at Ptolemaïs:

A coiled granite snake with an arched neck was found. In the middle of the coils there is a narrow slit, polished by use, just large enough to allow a coin of at most 4 cm. diameter to drop through. At the sides are holes for handles to lift this heavy object, the lower half of which could be inserted as a lid.¹⁴⁶

[578] Here the serpent lies on the treasury as protector of the hoard. Fear of the deadly maternal womb has become the guardian of the treasure of life. That the snake really is a death-symbol is evident from the fact that the souls of the dead, like the chthonic gods, appear as serpents, as dwellers in the kingdom of the deadly mother.¹⁴⁷

[579] The development of this symbol, showing how the crevice in the earth, interpreted on the primitive level as the "mother," came to signify the place of the treasure, therefore corresponds to the etymology of *G. Hort*, 'hoard,' as suggested by Kluge. *Κεύθος* (from *κεύθω*) means the innermost womb of the earth (Hades), and *κύσθος*, which he associates with it, has a similar meaning: 'cavity' or 'womb.' Prellwitz makes no mention of this connection. On the other hand, Fick¹⁴⁸ connects *Hort*, Goth. *huzd*, with Armen. *kust* (Lat. *venter*, 'belly'), Slav. *cista*, Ved. *kostha*,

‘abdomen,’ from the IEur. root **koustho-s*, ‘viscera, abdomen, chamber, storeroom.’¹⁴⁹ Prellwitz connects κύσθος with κύστις and κύστη, ‘bladder, bag,’ Skr. *kustha-s*, ‘hollow of the loins’; also with κύτος, ‘cavity, vault’; κυτίς, ‘casket,’ from κῤεῖν, ‘to be pregnant.’ Whence also κύτος, ‘hollow vessel, skin’; κύαρ, ‘hole’; κύαθος, ‘cup’; κύλα, ‘depression under the eye’; κῤμα, ‘swelling, wave, billow.’ The basic IEur. root¹⁵⁰ is **kevo*, ‘to swell, be strong’; whence the above-mentioned κῤεῖν, κύαρ and Lat. *cavus*, ‘hollow, arched, cave, hole’; *cavea*, ‘cavity, enclosure, cage, scene, stage, assembly’; *caulae*, ‘cavity, aperture, stable’;¹⁵¹ IEur. **kuéyô*, ‘I swell,’ part. **kueyonts*, ‘swelling’; **en-kueyonts*, ‘enceinte’; ἔγκυέων, Lat. *inciens*, ‘pregnant’; cf. Skr. *vi-śvāyan*, ‘swelling.’¹⁵²

[580] The treasure which the hero fetches from the dark cavern is *life*: it is himself, new-born from the dark maternal cave of the unconscious where he was stranded by the introversion or regression of libido. Hence the Hindu fire-bringer is called Matarisvan, he who swells in the mother. The hero who clings to the mother is the dragon, and when he is reborn from the mother he becomes the conqueror of the dragon. (PI. LIXa.) He shares this paradoxical nature with the snake. According to Philo the snake is the most spiritual of all creatures; it is of a fiery nature, and its swiftness is terrible. It has a long life and sloughs off old age with its skin.¹⁵³ In actual fact the snake is a cold-blooded creature, unconscious and unrelated. It is both toxic and prophylactic, equally a symbol of the good and bad daemon (the Agathodaemon), of Christ and the devil. Among the Gnostics it was regarded as an emblem of the brain-stem and spinal cord, as is consistent with its predominantly reflex psyche. It is an excellent symbol for the unconscious, perfectly expressing the latter’s sudden and unexpected manifestations, its painful and dangerous intervention in our affairs, and its frightening effects. Taken purely as a psychologem the hero represents the positive, favourable action of the unconscious, while the dragon is its negative and unfavourable action—not birth, but a devouring; not a beneficial and constructive deed, but greedy retention and destruction. (Fig. 35; cf. also pl. xxxiv and fig. 30.)

[581] Every psychological extreme secretly contains its own opposite or stands in some sort of intimate and essential relation to it.¹⁵⁴ Indeed, it is from this tension that it derives its peculiar dynamism. There is no hallowed custom that cannot on occasion turn into its opposite, and the more extreme a position is, the more easily may we expect an enantiodromia, a conversion of something into its opposite. The best is the most threatened with some devilish perversion just because it has done the most to suppress evil. This peculiar relationship to the opposite can also be seen in the vagaries of language, as for instance in the comparison of ‘good, better, best.’ ‘Better,’ however, derives from the old word *bass*, meaning ‘good.’ The related English word is ‘bad’; its comparative would therefore be ‘better’ (badder!). What

happens everywhere in language happens also in mythology: in one version of a fairytale we find God, in another the devil.¹⁵⁵ And how often has it happened in the history of religion that its rites, orgies and mysteries degenerate into vicious debauches!¹⁵⁶ Thus a blasphemer who arose at the beginning of the nineteenth century says of the Communion:



Fig. 35. The assault by the dragon
From Vitruvius, De architectura, Venice, 1511

The communion of the devil is in the brothels. Everything that they sacrifice there they sacrifice to the devil and not to God. There they have the devil's cup and the devil's board; there they have sucked the head of the snake,¹⁵⁷ there they have fed on the bread of iniquity and drunk the wine of fornication.

[582] Anton Unternährer, as this man was called, fancied himself a sort of priapic divinity. He says of himself:

Black-haired, very charming withal and of handsome countenance, everyone enjoys listening to thee because of the graceful speeches which flow from thy mouth; therefore do the virgins love thee.¹⁵⁸

[583] He continues:

Ye fools and blind men, behold God has created man in his own image, as male and female, and has blessed them and said: "Be fruitful and multiply, and replenish the earth, and subdue it." Therefore has he given the greatest honour to these poor members, and placed them naked in the garden ...

Now are the fig-leaves and the covering removed, because ye have turned to the Lord, for the Lord is Spirit, and where the Spirit of the Lord is, there is liberty,¹⁵⁹ there is the brightness of the Lord mirrored with uncovered countenance. This is precious before God, and is the glory of the Lord and the adornment of our God, when ye stand in the image and honour of God as God created you, naked and unashamed.

Who shall ever praise sufficiently in the sons and daughters of the living God those members of the body which are appointed for procreation?

In the lap of the daughters of Jerusalem is the gate of the Lord, and the righteous shall there go into the temple, even to the altar. And in the lap of the sons of the living God is the water-pipe of the upper part, which is a tube, like a rod with which to measure the temple and the altar. And underneath the water-pipe are erected the sacred stones, as a sign and testimony¹⁶⁰ of the Lord, who has taken to himself the seed of Abraham.

Out of the seed in the chamber of the mother God creates with his hand a man, formed in his own image. Then is the house of the mother and the chamber of the mother opened for the daughters of the living God, and God himself brings forth the child through them. Thus God creates children from stones, for the seed comes from the stones.

[584] History has numerous examples of how easily the mystery can turn into a sexual orgy just because it grew out of the opposite of the orgy. It is characteristic that this fanatic should return again to the symbol of the snake, which in the mystery religions entered into the faithful, fecundating and spiritualizing them, though all the time keeping its phallic significance. In the mysteries of the Ophites, the festival was celebrated with live snakes, and the creatures were even kissed. (Cf. the kissing of the Demeter serpent in the Eleusinian mysteries.) This kiss plays a not unimportant part in the sexual orgies of certain modern Christian sects.

[585] One of my patients dreamt that a snake shot out of a cave and bit him in the genital region. This dream occurred at the moment when the patient was convinced of the truth of the analysis and was beginning to free himself from the bonds of his mother-complex. He felt that he was making progress and that he had more control over himself. But the moment he felt the impulse to go forward he also felt the pull of the bond to the mother. Being bitten in the genital region by a snake (cf. pls. LXIb, LXIV), reminds us of Attis, whose self-castration was occasioned by his mother's jealousy. Another patient had the following dream after a relapse into neurosis: she was completely filled inside with an enormous snake. Only the end of its tail stuck out from her arm. She tried to seize hold of it, but it slithered away. A third patient complained that a snake was stuck in her throat.¹⁶¹ Nietzsche uses this symbolism in his "vision" of the shepherd and the snake:

And verily, what I saw was like nothing I ever saw before. I saw a young shepherd, writhing, choking, twitching, with distorted countenance, and with a heavy black serpent hanging out of his mouth.

Did ever I see so much loathing and pale horror on a human countenance?¹⁶² Perhaps he had been asleep, and the serpent had crawled into his mouth—and bitten fast.

My hand tugged at the serpent, and tugged in vain. I could not pull the serpent out of his throat. Then a cry broke from me: “Bite—its head off! Bite hard!” My horror, my hatred, my loathing, my pity, all my good and bad broke from me in one cry.

You valiant ones about me ..., you lovers of mysteries, solve me the riddle I then saw, interpret for me the vision of the loneliest man!

For a vision it was, and a foresight: *what* did I then see in a semblance? And *who* is it that is to come?

Who is the shepherd into whose mouth the serpent crawled? *Who* is the man into whose throat all the heaviest and blackest must crawl?¹⁶³

But the shepherd bit, as my cry bade him—he bit with a strong bite! Far off he spat the head of the serpent and leapt to his feet.

No longer a shepherd, no longer a man, but a transfigured being with light all about him, who *laughed!* Never yet on earth did a human being laugh as *he* laughed!

O my brothers, I heard a laughter which was no human laughter—and now a thirst consumes me, a longing that is never allayed.

My longing for that laughter consumes me: O how can I bear to live, and how could I bear to die! ¹⁶⁴

[586] The experience described here by Nietzsche can be interpreted as follows with the help of what we said above: the snake represents the unconscious psyche which, like the snake-god in the Sabazios mysteries, crawls into the mouth of the celebrant, i.e., Nietzsche himself as the *ποιμήν* or *ποιμάνδρης*, the shepherd of souls and preacher, firstly to stop him from talking too much, and secondly to make him *ἔνθεος* —‘ “enthused,” filled with God.’ The snake had already bitten fast, but fear was swifter and more violent: it bit off the snake’s head and spat it out. If you want the snake to bruise your heel you have only to tread on its head. The shepherd laughed on getting rid of the snake—a wild hysterical laughter, because he had dished the compensation from the unconscious. He could now reckon without his host, and with the well-known consequences: one has only to read the passages in *Zarathustra* where Nietzsche speaks of laughing and laughter. Unfortunately, everything happened afterwards just as if the whole German nation had paid heed to Nietzsche’s sermon.

[587] The unconscious insinuates itself in the form of a snake if the conscious mind is afraid of the compensating tendency of the unconscious, as is generally the case in regression. But if the compensation is accepted in principle, there is no regression, and the unconscious can be met half-way through introversion. It must be admitted, however, that the problem as it presented itself to Nietzsche was insoluble, for

nobody could expect the shepherd to swallow down a snake under such circumstances. We are confronted here with one of those fatal cases, by no means uncommon, where the compensation appears in a form that cannot be accepted and could only be overcome by something that is equally impossible for the patient. Cases of this kind occur when the unconscious has been resisted for too long on principle, and a wedge violently driven between instinct and the conscious mind.

[588] Through introversion, as numerous historical witnesses testify, one is fertilized, inspired, regenerated, and reborn. In Indian philosophy this idea of creative spiritual activity has even acquired a cosmogonic significance. According to the Rig-Veda (X, 121), the unknown creator of all things is Prajapati, “Lord of Creation.” His cosmogonic activity is described as follows in the various Brahmanas:

Prajapati desired: I will propagate myself, I will be many. He practised *tapas*, and after he had practised *tapas* he created these worlds.¹⁶⁵

[589] The term *tapas* is to be translated, according to Deussen,¹⁶⁶ as “he heated himself with his own heat,”¹⁶⁷ in the sense that “he brooded his own brooding,” brooder and brooded being conceived not as separate, but as one and the same thing. As Hiranyagarbha (the Golden Germ), Prajapati is the self-begotten egg, the cosmic egg from which he hatches himself (fig. 36). He creeps into himself, becomes his own womb, makes himself pregnant with himself in order to hatch forth the world of multiplicity. Thus Prajapati transforms himself by introversion into something new, into the multiplicity of the world. It is particularly interesting to note the gradual approximation of widely divergent ideas. Deussen says:

Just as, in a hot country like India, the idea of *tapas* became the symbol of strenuous effort and suffering, so the idea of *tapo atapyata* gradually acquired the meaning of self-castigation, and became associated with the view ... that creation is an act of self-abnegation on the part of the creator.¹⁶⁸

[590] Self-incubation,¹⁶⁹ self-castigation, and introversion are closely related ideas. Immersion in oneself (introversion) is a penetration into the unconscious and at the same time asceticism. The result, for the philosophy of the Brahmanas, is the creation of the world, and for the mystic the regeneration and spiritual rebirth of the individual, who is born into a new world of the spirit. Indian philosophy also assumes that creativity as such springs from introversion. Rig-Veda X, 129 says:



Fig. 36. Prajapati with the world-egg
India

Then the One, that was hidden in the shell,
 Was born through the force of fiery torment.
 From it there arose in the beginning love,¹⁷⁰
 Which is the germ and the seed of knowledge.
 The wise found the root of being in not-being
 By investigating the impulses of the human heart.¹⁷¹

[591] This philosophical view conceives the world as an emanation of libido. When therefore the insane Schreber brought about the end of the world through his introversion, he was withdrawing libido from the world about him, thereby making it unreal.¹⁷² Schopenhauer tried in exactly the same way to abolish through negation (the equivalent of holiness and asceticism) the cardinal error of the Primal Will in creating the world at all. Does not Goethe also say: “Is not the core of nature in the heart of man?”

[592] The hero who sets himself the task of renewing the world and conquering death personifies the world-creating power which, brooding on itself in introversion, coiled round its own egg like a snake, threatens life with its poisonous bite, so that the living may die and be born again from the darkness. The same idea is found in Nietzsche:

How long already have you sat on your misfortune?

Give heed, lest you hatch me

An egg,

A basilisk egg

From your long travail.¹⁷³

[593] The hero is himself the snake, himself the sacrificer and the sacrificed, which is why Christ rightly compares himself with the healing Moses-serpent (cf. pl. *ixb*), and why the saviour of the Christian Ophites was a serpent, too. It is both Agathodaimon (fig. 37) and Cacodaimon. In German legend we are told that the heroes have snake's eyes.¹⁷⁴

[594] Clear traces of the original identity of hero and snake are to be found in the myth of Cecrops. Cecrops was half snake, half man. In primitive times he was probably the snake of the Athenian citadel itself. As a buried god he was, like Erechtheus, a chthonic snake-deity. Above his subterranean dwelling rose the Parthenon, the temple of the virgin goddess. The flaying of the god, which we have already touched on in connection with the flaying-ceremonies of the Aztecs, is intimately bound up with the snake-like nature of the hero. It is reported of Mani, the founder of Manichaeism, that he was killed, flayed, stuffed, and hung up.¹⁷⁵ The hanging up of the god has an unmistakable symbolic value, since suspension is the symbol of unfulfilled longing or tense expectation ("suspense"). Christ, Odin, Attis, and others all hung upon trees. Jesus ben Pandira suffered such a death on the eve of the feast of the Passover, in the reign of Alexander Jannaeus (106–79 B.C.). This Jesus is supposed to have been the founder of the Essene sect,¹⁷⁶ which had certain links with the Christianity that came afterwards. The Jesus ben Stada who was identified with the earlier Jesus but was later supposed to have lived in the second century A.D., was also hanged. Both were first stoned, a punishment which was, so to speak, a bloodless one like hanging. This may not be without significance in the light of a strange ceremony reported from Uganda:



Fig. 37. Agathodaimon serpent
Antique gem

When a king of Uganda wished to live for ever, he went to a place in Busiro, where a feast was given by the chiefs. At the feast the Mamba clan¹⁷⁷ was especially held in honour, and during the festivities a member of this clan was secretly chosen by his fellows, caught by them, and beaten to death with their fists; no stick or other weapon might be used by the men appointed to do the deed. After death, the victim's body was flayed and the skin made into a special whip.... After the ceremony of the feast in Busiro, with its strange sacrifice, the king of Uganda was supposed to live for ever, but from that day he was never allowed to see his mother again.¹⁷⁸

[595] Marsyas, who seems to have been a substitute for Attis, the son-lover of Cybele, was also skinned.¹⁷⁹ Whenever a Scythian king died, his slaves and horses were slaughtered, skinned, and stuffed, and then set up again.¹⁸⁰ In Phrygia, the representatives of the father-god were killed and skinned. The same was done in Athens with an ox, which was skinned and stuffed and afterwards hitched to the plough. In this way the renewal of the earth's fertility was celebrated.¹⁸¹

[596] The god-hero, symbolized by the spring zodiac (Aries, Taurus), descends to the lowest point in winter, overcomes it, and having passed beyond the summer solstice is himself overcome as if by an unconscious longing for death. Nevertheless he is divided within himself, and his descent and approaching end therefore seem to him like evil designs of the sinister mother who secretly lays a poisonous snake in his path to undo him. The mysteries, however, hold out the consoling promise that there is no contradiction¹⁸² and no disharmony when life changes into death: "The bull is the father of the dragon and the dragon is the father of the bull."¹⁸³

[597] Nietzsche voices the same mysterious truth:

Here I sit,

Or rather,

Here I am swallowed down

By this smallest oasis.

Yawning it opened

Its lovely lips—

All hail to that whale

If he provides thus

For his guest's welfare!

Hail to his belly,

If it is

Such a lovely oasis belly!

The desert grows; woe to him who hides deserts!

Stone grinds on stone, the desert gulps and strangles.

Monstrous Death, glowing under his tan,

Stares and chews ... his life is his chewing ...

O man burnt out by lust, do not forget:

You are the stone, the desert, the death's-head! ¹⁸⁴

[598] After slaying the dragon, Siegfried meets father Wotan, who is plagued by gloomy cares because the earth-mother Erda has laid the old serpent in his path in order to enfeeble him. He says to Erda:

All-knowing one,

Care's piercing sting

By thee was planted

In Wotan's dauntless heart:

With fear of shameful

Ruin and downfall

Thy knowledge filled him;

The fearful tidings

Choked his breast!

Art thou the world's wisest woman?

Then tell me:

How may a god conquer his care?

ERDA: Thy name

Is not as thou sayest!

[599] With poisoned sting the mother has robbed her son of the joy of life and deprived him of the power which lies in the secret name. Just as Isis demanded the secret name of Ra, so Erda says: “Thy name is not as thou sayest!” But the Wanderer has found a way to conquer the fatal charm of the mother:

The gods' downfall
No more dismays me
Since I willed their doom!

To the loveliest Wälsung
I leave my heritage;
To the eternally young
Joyously yields the god!¹⁸⁵

[600] These wise words contain in fact the saving thought: it is not the mother who lays the poisonous worm in our path, but life itself, which wills itself to complete the sun's course, to mount from morn to noon, and then, crossing the meridian, to hasten towards evening, no more at odds with itself, but desiring the descent and the end.¹⁸⁶

[601] Nietzsche's Zarathustra says:

I praise my death, the free death which comes to me because I desire it.
And when shall I desire it?
He who has a goal and an heir desires death at the proper time for the goal and the heir.¹⁸⁷

[602] Nietzsche's *amor fati* is somewhat overdone, and like an ailing Superman he tries to be always one jump ahead of fate. Siegfried is more cautious: he conquers father Wotan and sets out to win Brünhilde. The first thing he sees is her horse; then he thinks he espies a man sleeping in armour. He cuts off the coat of mail, and when he sees that it is a woman he is seized with terror:

My heart doth faint and falter!
On whom shall I call for help?
Mother! Mother!
Remember me . . .
Can this be fear?
O Mother, Mother!
Thy dauntless child!
A woman lies sleeping
And she has taught him to fear!

Awake, awake!

Holiest maid!
So shall I suck life
From sweetest lips,
Even though I die in a kiss!

[603] In the duet which immediately follows the mother is invoked:

O mother, hail,
Who gave me birth.

[604] Brünhilde's avowal is particularly significant:

Didst thou but know,
O joy of the world,
How I have ever loved thee!
Thou wert my gladness,
Thou wert my care!
Thy tender life I sheltered
Before it was thine;
Before thou wert born
My shield was thy guard.¹⁸⁸

[605] Brünhilde, standing to Wotan in a daughter-anima relationship, is clearly revealed here as the symbolical or spiritual mother of Siegfried, thus confirming the psychological rule that the first carrier of the anima-image is the mother. Siegfried says:

Then death took not my mother?
Was the loved one but sleeping?

[606] The mother-imago, at first identical with the anima, represents the feminine aspect of the hero himself. Brünhilde tells him as much in the words:

Thine own self am I
In the bliss of thy love!

[607] As the anima she is the mother-sister-wife, and as the preexistent archetype she has always loved him:

O Siegfried, Siegfried!
Conquering light!
Always I have loved thee,
For I alone divined

Wotan's hidden thought-
The thought which I never
Dared to name,
Which I dared not think,
Which I only felt,
For which I fought,
Struggled and strove,
For which I defied
Him who conceived it....
Canst thou not guess?
It was naught but my love for thee!

[608] The anima-image brings with it still other aspects of the mother-*imago*, amongst others those of water and submersion:

A glorious flood
Before me rolls.
With all my senses
I only see
Its buoyant, gladdening billows....
I long to plunge
My burning heat
In the water's balm;
Just as I am
To sink in the flood.
O that its billows
Might drown me in bliss!

[609] The water represents the maternal depths and the place of rebirth; in short, the unconscious in its positive and negative aspects. But the mystery of regeneration is of an awe-inspiring nature: it is a deadly embrace. There is an allusion to the terrible mother of heroes, who teaches them fear, in the words of Brünhilde, the horse-woman who conducts the dead to the other side:

Fearest thou, Siegfried?
Fearest thou not
The wild, raging woman?

[610] The orgiastic "Occide moriturus" from the love-scene in the metamorphosis of Apuleius resounds in Brünhilde's words:

Laughing let us be lost,
Laughing go down to death!

[611] And in the cry

Light-giving love,
Laughing death!¹⁸⁹

we find the same significant contrast. These orgiastic frenzies and barbaric extremes are in the very nature of the *Mater saeva cupidinum* and determine the fate of the hero. Luck must stand unbidden and unforeseen at his side if he is not to perish of exaggerated self-confidence at the very first undertaking. But his mother-anima is blind, and his fate overtakes him sooner or later regardless of his luck—in most cases sooner. The subsequent fate of Siegfried is the fate of every archetypal hero: the spear of the one-eyed Hagen, the Dark One, strikes his vulnerable spot. In the shape of Hagen the one-eyed Wotan slays the son. The hero is the ideal masculine type: leaving the mother, the source of life, behind him, he is driven by an unconscious desire to find her again, to return to her womb. Every obstacle that rises in his path and hampers his ascent wears the shadowy features of the Terrible Mother, who saps his strength with the poison of secret doubt and retrospective longing; and in every conquest he wins back again the smiling, loving and life-giving mother. This image, taken as a kind of musical figure, a contrapuntal modulation of feeling, is extremely simple and its meaning is obvious. To the intellect, however, it presents an almost insuperable difficulty, particularly as regards logical exposition. The reason for this lies in the fact that no part of the hero-myth is single in meaning, and that, at a pinch, all the figures are interchangeable. The only certain and reliable thing is that the myth exists and shows unmistakable analogies with other myths. Myth-interpretation is a tricky business and there is some justification for looking at it askance. Hitherto the myth-interpreter has found himself in a somewhat unenviable position, because he only had exceedingly doubtful points for orientation at his disposal, such as astronomical and meteorological data. Modern psychology has the distinct advantage of having opened up a field of psychic phenomena which are themselves the matrix of all mythology—I mean dreams, visions, fantasies, and delusional ideas. Here the psychologist not only finds numerous points of correspondence with myth-motifs, but also has an invaluable opportunity to observe how such contents arise and to analyse their function in a living organism. We can in fact discover the same multiplicity of meanings and the same apparently limitless interchangeability of figures in dreams. On the other hand we are now in a position to establish certain laws, or at any rate rules, which make dream interpretation rather more certain. Thus, we know that dreams generally compensate the conscious situation, or supply what is lacking to it.¹⁹⁰ This very important principle of dream-interpretation also applies to myths. Furthermore, investigation of the products of the unconscious yields recognizable traces of archetypal structures which coincide with the myth-motifs, among them certain types which deserve the name of dominants. These are archetypes like the anima, animus, wise old man, witch, shadow, earth-mother, etc., and the organizing dominants, the self, the circle, and the quaternity, i.e., the four functions or aspects of the self (cf. pls. LVI, LX) or of consciousness. It is evident (figs. 38 and 39; pl. LIXb) that knowledge of these types makes myth interpretation considerably easier and at the same time puts it where it belongs, that is, on a psychic basis.

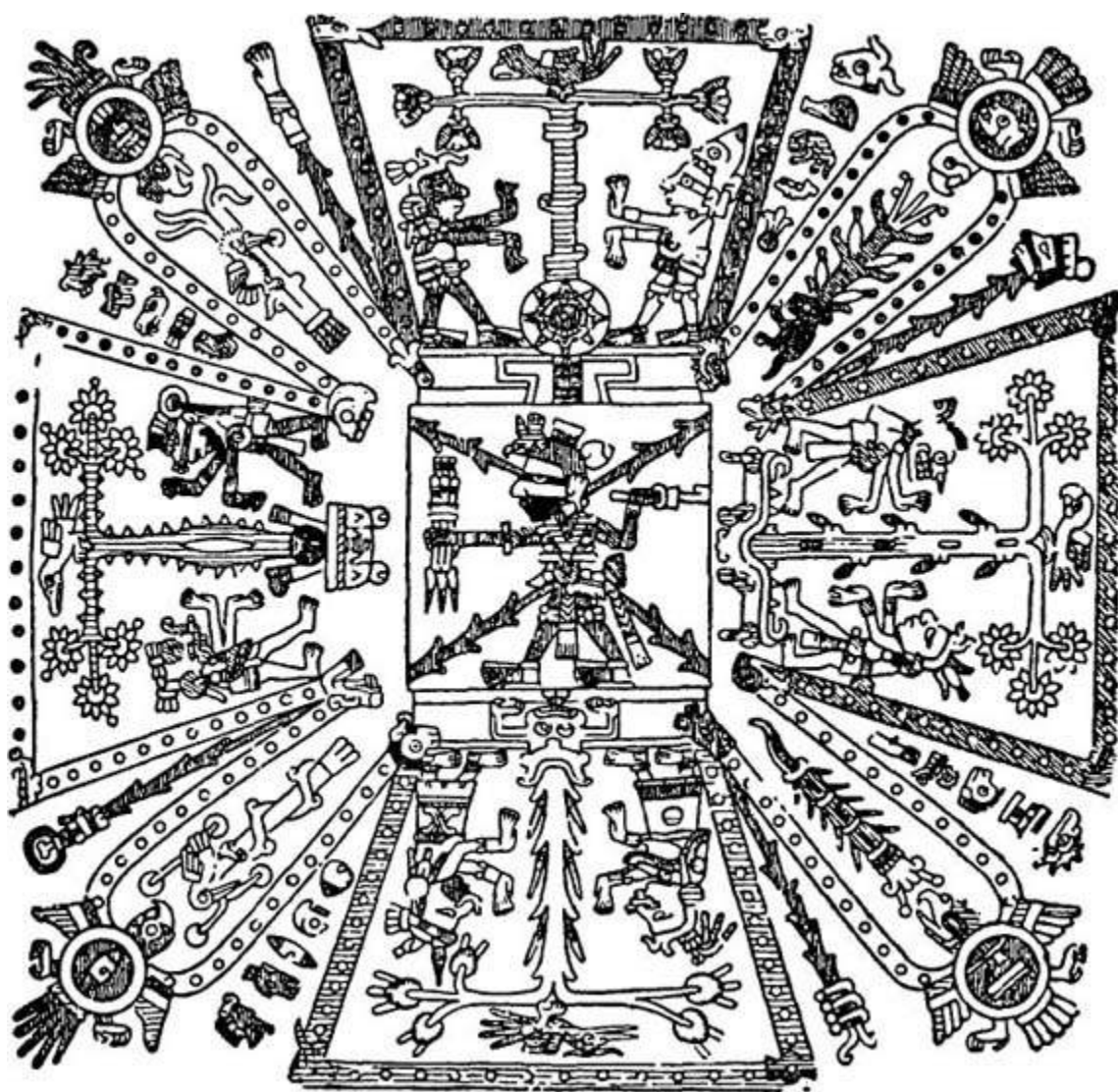

Fig. 38. World plan
From an Aztec codex

[612] Looked at in this light, the hero myth is an unconscious drama seen only in projection, like the happenings in Plato's parable of the cave. The hero himself appears as a being of more than human stature. He is distinguished from the very beginning by his godlike characteristics. Since he is psychologically an archetype of the self, his divinity only confirms that the self is numinous, a sort of god, or having some share in the divine nature. In this mythologem may lie the root of the argument in favour of "homoousia." For psychology it makes a vast difference whether the self is to be considered "of the same nature" as the Father (*ὁμοούσιος*), or merely "of a similar nature" (*ὁμοιούσιος*). The decision in favour of homoousia was of great psychological importance, for it asserted that Christ is of the same nature as God. But Christ, from the point of view of psychology and comparative religion, is a typical manifestation of the self. For psychology the self is an *imago Dei* and cannot be distinguished from it empirically. (Cf. pl. LX.) The two ideas are therefore of the same nature. The hero is the protagonist of God's transformation in man; he corresponds to what I call the "mana personality."¹⁹¹ The latter has such an immense fascination for the conscious mind that the ego all too easily succumbs to the temptation to identify

with the hero, thus bringing on a psychic inflation with all its consequences. For this reason the repugnance felt by certain ecclesiastical circles for the “inner Christ” is understandable enough, at least as a preventive measure against the danger of psychic inflation which threatens the Christian European. Although the religion and philosophy of India are largely dominated by the idea of homoousia,¹⁹² there is less danger in this direction because the Indian has an equally homoousian idea of God (Brahman), which is very definitely not the case with the Christian. The latter has far too little introspection to be able to realize what modifications in his present conception of God the homoousia of the self (Atman) would involve. I hope my reader will pardon these reflections, which may seem very remote from our theme. I add them here only to put the numinosity of the hero archetype in the right perspective.¹⁹³



Fig. 39. The four corners of the zodiac: sun and moon in centre
Coptic emblem

VIII

THE SACRIFICE ¹

[613] Let us now turn back to the Miller fantasies and watch the last act of the drama. Chiwantopel cries out with painful emotion:

“In all the world there is not a single one! I have searched among a hundred tribes. I have aged a hundred moons since I began. Will there never be anyone who will know my soul?—Yes, by almighty God, yes!—But ten thousand moons will wax and wane before her pure soul is born. And it is from another world that her parents will come to this one. She will be fair of skin and fair-haired. She will know sorrow even before her mother bears her. Suffering will be her companion; she too will seek—and will find no one who understands her. Many a suitor will wish to pay court to her, but not one of them will know how to understand her. Temptation will often assail her soul, but she will not yield.... In her dreams I shall come to her, and *she will understand*. I have kept my body inviolate. I have come ten thousand moons before her time, and she will come ten thousand moons too late. *But she will understand!* It is but once in ten thousand moons that a soul like hers is born!”

(A lacuna.)—A green viper darts out of the bushes, glides towards him, and stings him in the arm; then it attacks his horse, which is the first to succumb. Then Chi-wan-to-pel says to his horse: “Farewell, faithful brother! Enter into your rest! I have loved you and you have served me well. Farewell, I shall rejoin you soon!” Then to the serpent: “Thanks, little sister, you have put an end to my wanderings!” Now he shrieks with pain and calls out in prayer, “Almighty God, take me soon! I have sought to know thee and to keep thy law. Oh, suffer not my body to fall into corruption and decay, and become carrion for the eagles!” A smoking volcano appears in the distance, the rumbling of an earthquake is heard, followed by a landslide. Chi-wan-to-pel cries out in an extremity of anguish as the earth closes over his body: “Ah, she will understand! Ja-ni-wa-ma, Ja-ni-wa-ma, thou that understandest me.”

[614] Chiwantopel’s prophecy is an echo from Longfellow’s *Hiawatha*, where, at the end of the hero’s career, the poet could not resist the sentimentality of dragging in the white man’s Saviour in the guise of the supreme representative of Christianity and Christian morals. (One thinks ruefully of the work of salvation accomplished by the Spaniards in Mexico and Peru, and of the Indian wars in North America.) With this prophecy the personality of our author is again brought into closest relationship with the hero as the real object of Chiwantopel’s longing. The hero would undoubtedly have married her had she only lived in his time, but unfortunately she comes too late—ten thousand moons too late. This very considerable time-gap points to a gap in another sense: Miss Miller’s ego is separated by a gulf from the figure of Chiwantopel. He is wholly “on the other side.” She will seek him in vain, just as he seeks her; in other words, there will never be any possibility of a meeting or union of conscious and unconscious, the one thing needful to compensate the conscious

attitude and create wholeness. She or he will be able at most to dream of such a meeting, and only so will their souls be able to understand one another, to love and embrace. But this love will never become a conscious fact. In this respect the situation holds no favourable prognosis for Miss Miller; for every real love-relationship consists ultimately in the girl finding her hero, and the hero his soul, not in dreams, but in palpable reality.

[615] The next passage runs: "I have kept my body inviolate." This proud sentence, which naturally only a woman could utter, since a man is not given to boasting about such matters, confirms yet again that all enterprises have remained but dreams. The hero's assertion that he is inviolate refers back to the abortive attempt on his life in the preceding chapter and explains what exactly it meant. He tells us in the words: "Temptation will often assail her soul—but she will not yield." This statement expresses the "touch me not" attitude of our author, which is as it were dictated by her "ghostly lover."² At all events the awakening of this hero-figure—the animus—usually has some such consequences for the conscious mind. It is as if a new instinct were aroused, and the soul were seized by a hitherto unknown longing: the image of earthly love pales before that of the heavenly, which turns the heart and mind away from their "natural" destination. I use the word "natural" here in the sense given it by the Age of Enlightenment. In reality of course the world-spurning passion of the "spirit" is just as natural as the marriage-flight of insects. Love for the "heavenly bridegroom" or for Sophia is a phenomenon that is by no means confined to the sphere of Christianity. It is in fact that "other," equally natural instinct to cleave to the realities of the soul. These are not makeshift inventions, as certain theories would have us believe, but facts and figures which can fill a man with passion and enchantment, and turn his head as easily as the creatures of this world. "You are conscious only of the single urge,"³ says Faust to Wagner. But Miss Miller seems to be on the point of forgetting this urge for the sake of the other. By so doing she does not escape the danger of one-sidedness, but only changes its sign. Whoever loves the earth and its glory, and forgets the "dark realm," or confuses the two (which is mostly what happens), has spirit for his enemy; and whoever flees from the earth and falls into the "eternal arms" has life for an enemy. This is what happens to the hero Chiwantopel, who personifies Miss Miller's otherworldliness: he falls foul of the green snake.⁴ Green is the colour of the vegetation numen ("green is life's golden tree"), and the snake is the representative of the world of instinct, especially of those vital processes which are psychologically the least accessible of all. Snake dreams always indicate a discrepancy between the attitude of the conscious mind and instinct, the snake being a personification of the threatening aspect of that conflict. The appearance of the green viper therefore means: "Look out! Danger ahead!"

[616] We know from the rest of the story that Chiwantopel is eliminated very thoroughly indeed: first he is fatally bitten by the snake, then the snake kills his horse, his animal vitality, and finally he is engulfed in a volcanic eruption. This solution of the problem represents an attempt on the part of the unconscious to compensate and help the dangerous situation of the conscious mind. So far this situation has only been hinted at. But if it requires so drastic an annihilation of the hero, in contradiction to his usual mythological role, we may justifiably conclude that the human personality of the author is threatened in the highest degree by an invasion from the unconscious (euphemistically conceived as a “creative fantasy”). If only the fascinating Chi-wantopel could be got out of the way, then there would at least be some hope of her interest turning again to the earth and its greenness, the other way being barred by the death of her lover. An invasion from the unconscious is very dangerous for the conscious mind when the latter is not in a position to understand and integrate the contents that have irrupted into it. One certainly does not have the feeling that Miss Miller is the “one who understands,” though it is perfectly plain that “she who will understand” is meant for her. Since she has in fact not the slightest idea of what is happening, her situation is critical, because in these circumstances there is a very good chance of the conscious being overwhelmed by the unconscious, as indeed actually happened a little later, with fatal results.⁵

[617] When such an invasion happens, we are often faced with a situation in which the unconscious overtakes or “takes over” the conscious mind. The latter has somehow got stuck, with the result that the unconscious takes over the forward-striving function, the process of transformation in time, and breaks the deadlock. The contents then pouring into consciousness are archetypal representations of what the conscious mind should have experienced if deadlock was to be avoided. The tendency to stand still can easily be seen from the special emphasis laid on the inviolateness of the body, as well as from the wish to preserve it from corruption in the grave. She wants to stop the turning wheel that rolls the years along with it—wants to hang on to childhood and eternal youth rather than die and rot in the earth. But although we can forget, in the long-cherished feelings of youth, in the dreamy recollection of memories stubbornly hung on to, that the wheel rolls onward, yet the greying hair, the lax skin, the lined face are pitiless reminders that whether or not we expose ourselves to the destructive forces of life, the poison of the stealthily creeping serpent of time consumes our bodies nonetheless. Flight from life does not exempt us from the law of age and death. The neurotic who tries to wriggle out of the necessity of living wins nothing and only burdens himself with a constant foretaste of aging and dying, which must appear especially cruel on account of the total emptiness and meaninglessness of his life. If it is not possible for the libido to strive forwards, to lead a life that willingly accepts all dangers and ultimate decay, then it strikes back

along the other road and sinks into its own depths, working down to the old intimation of the immortality of all that lives, to the old longing for rebirth.

[618] Hölderlin follows this path in his poetry and in his life. I will let the poet speak for himself:

To a Rose

In the mother-womb eternal,
Sweetest queen of every lea,
Still the living and supernal
Nature carries thee and me.

Little rose, the tempest dire
Strips our petals, ages us;
Yet the deathless seeds aspire
To new blooms, miraculous.⁶

[619] The following comments may be made on the imagery of this poem. The rose is a symbol of the beloved.⁷ So when the poet dreams that he and the rose are in the womb of nature, it means psychologically that he is still in the mother. There he finds eternal germination and renewal, a potential life that has everything before it, containing in itself all possibilities of realization without his having to submit to the labour of giving them shape. Plutarch records the same motif in the naïve myth of Osiris and Isis mating in their mother's womb. Hölderlin likewise feels that it is the enviable prerogative of the gods to enjoy everlasting infancy. He says in "Hyperion's Song of Fate":

Fateless, like the sleeping
Infant, breathe the heavenly ones,
Chastely guarded
In modest bud;
Their spirits
Blossom eternally,
And the quiet eyes
Gaze out in placid
Eternal serenity.⁸

[620] This quotation shows what he means by heavenly bliss. Hölderlin was never able to forget this first and greatest happiness whose haunting presence estranged him

from real life. The motif of the twins in the mother's womb is found in the African legend, recorded by Frobenius,⁹ of the Big Snake, which grew out of a little snake in a hollow tree ("stretching forth of the serpent"), and which devoured all human beings (devouring mother = death) until only one pregnant woman remained. She dug a ditch, covered it with a stone, and there gave birth to twins who afterwards became dragon-killers. The mating in the mother also occurs in the following West African legend: "In the beginning, Obatala the Sky and Odudua the Earth, his wife, lay pressed close together in a calabash."¹⁰ Being "guarded in modest bud" is an image that is found in Plutarch, where it is said that the sun is born at dawn from a flower bud. Brahma, too, comes out of a bud (cf. pl. XLVIA), and in Assam a bud gave birth to the first human pair.

Man

Scarcely had the ancient mountain tops
Sprouted from the waters, O earth,
And the first green islands, redolent
With young saplings, breathed delight
Through the May air over the ocean,
And the joyful eye of the sun-god
Looked down on his firstlings, the trees and flowers,
Laughing children of his youth, your offspring:
When, on the fairest of those islands,
Born after a warm night, in the dawn-light long ago,
Earth's most beautiful child

Lay under clustering grapes. And the boy
Looked up to Father Helios, who knew him,
And tasting the sweet berries, he chose
The sacred vine for his nurse.
And soon he is grown; the beasts
Fear him, for he is other than they,
A Man. He is not like you and not
Like the father, for boldly the high
Soul of the father in him is united
With your joys and your sadness for always,
O earth. Rather would he resemble
Eternal nature, mother of gods, the terrible.

Therefore, O earth, his presumption
Drives him away from your breast, and your tender
Gifts are in vain; ever and ever too high
Does the proud heart beat!

Leaving the sweet meadow of his shores
Man must go out into flowerless waters,
And though his orchards shine like the starry night
With golden fruit, yet he digs

Caves for himself in the mountains and grubs in the pit
Far from the sacred ray of his father,
Faithless also to the sun-god, who
Loves not toilers and mocks at cares.

Ah! the birds of the wood breathe freer, and though
The breast of man more wildly and proudly heaves,
His arrogance turns to fear, and the delicate
Flowers of tranquillity bloom not for long.¹¹

[621] This poem contains the first hint of discord between the poet and nature; he begins to feel estranged from reality. Note that the little child chooses the “vine for his nurse.” This Dionysian allusion reminds us of Judah in Jacob’s blessing (Genesis 49:11): “binding his foal unto the vine, and his ass’s colt unto the choice vine.”

[622] There is a Gnostic gem showing a she-ass suckling her foal, surmounted by the sign of Cancer and the inscription “D.N.-IHV.XPS.”: *Dominus noster Jesus Christus*, to which is added, “*Dei filius.*”¹² As Justin Martyr indignantly observes, the connections between the Christian legend and that of Dionysus are unmistakable (e.g., the miracle of the wine). In the Dionysus legend the ass plays an important part as the steed of Silenus. The ass pertains to the “second sun,” Saturn, who was the star of Israel and is therefore to some extent identical with Yahweh. The mock crucifixion on the Palatine, with an ass’s head (cf. pl. XLIII), is an allusion to the tale that an ass’s head was worshipped in the temple at Jerusalem.¹³ The difference between Christians and Jews was at that time not very clear to an outsider.

[623] Hölderlin is mainly concerned with the Dionysian nature of man: the vine is his nurse, and his ambition is to “resemble eternal Nature, mother of gods, the terrible.” The “terrible Mother” is the *mater saeva cupidinum*, unbridled and unbroken Nature, represented by the most paradoxical god of the Greek pantheon, Dionysus, who significantly enough was also Nietzsche’s god, although actually Nietzsche’s original

experience suggests rather the sinister huntsman, Wotan. Wagner was more explicit on this point.

[624] “Presumption” drives man away from the mother and from the earth, and estranges him from the “sacred ray of his father,” until his defiance changes into fear. As a child of nature he falls into discord with her, precisely because he tries to resemble the “mother of gods.” No reason guides him, only the Dionysian *libido effrenata*:

To Nature

While about thy veil I lingered, playing,

And, like any bud, upon thee hung,¹⁴

Still I felt thy heart in every straying

Sound about my heart that shook and clung.

While I groped with faith and painful yearning

To your picture, glowing and unfurled,

Still I found a place for all my burning

Tears, and for my love I found a world!

To the sun my heart before all others

Turned as though he heard my every cry,

And it called the stars its little brothers,¹⁵

As it called the spring God’s melody;

And each breeze in groves or woodlands fruity

Held thy spirit, and that same sweet joy

Moved the well-springs of my heart with beauty—

Those were golden days without alloy.

Where the spring is cool in every valley,¹⁶

And the youngest bush and twig is green,

And about the rocks the grasses rally,

And the branches show the sky between,

There I lay, imbibing every flower

In a rapt, intoxicated glee,

And, surrounded by a golden shower,

From their heights the clouds sank down to me.¹⁷

Often, as a weary, wandering river

Longs to join the ocean's placid mirth,
I have wept and lost myself forever
In the fulness of thy love, O earth!
Then, with every other joyful being,
Forth I rushed from Time's captivity,
Like a pilgrim home from travel, fleeing
To the arms of rapt Eternity.

Blest be childhood's golden dreams, their power
Hid from me life's dismal poverty;
All the heart's good seeds ye brought to flower,
Things I could not reach, ye gave to me!
In thy beauty and thy light, O Nature,
Of all effort and compulsion free,¹⁸
Fruitful love attained a kingly stature,
Rich as harvests reaped in Arcady.

That which brought me up is dead and riven,
Dead the youthful world which was my shield,
And this breast, which used to harbour heaven,
Dead and dry as any stubble field.
Though the songs of springtime sound as ever,
Bringing friendly comfort to my smart,
Yet the morning of my life is over
And the spring has faded from my heart.

Shadows are the things that once we cherished,
Love itself must fade and cannot bide;
Since the golden dreams of youth have perished
Even friendly Nature's self has died.
Heart, poor heart, those days could never show it—
How far-off thy home, and where it lies;
Now, alas, thou nevermore wilt know it
If a dream of it does not suffice.¹⁹

Palinode

What gathers about me, Earth, in your dusky, friendly green?

What do you waft me, airs, what do you bring me again?

There is a rustling in all the tree-tops ...

Why do you wake my soul? why stir up

The past in me, ye kindly ones?

Spare me and let them rest, do not mock

The ashes of my joy. Pass on,

Ye fateless gods, let your youthfulness

Flower upon those grown old.

If you would deign to come down to mortals,

Young girls will blossom for you,

Young heroes, and sweeter than ever

Morning will play round the cheeks of the happy,

And ravishing sound

The songs of those without care ...

Ah, once the fountain of song

So easily rushed from my bosom, when heavenly

Joy still shone from my eyes ...²⁰

[625] The separation from youth has even taken away the golden glamour of Nature, and the future appears hopeless and empty. But what robs Nature of its glamour, and life of its joy, is the habit of looking back for something that used to be outside, instead of looking inside, into the depths of the depressive state. This looking back leads to regression and is the first step along that path. Regression is also an involuntary introversion in so far as the past is an object of memory and therefore a psychic content, an endopsychic factor. It is a relapse into the past caused by a depression in the present. Depression should therefore be regarded as an unconscious compensation whose content must be made conscious if it is to be fully effective. This can only be done by consciously regressing along with the depressive tendency and integrating the memories so activated into the conscious mind—which was what the depression was aiming at in the first place.

Empedocles

You seek life, and a godly fire

Gushes and gleams for you out of the deeps of earth,

As, with shuddering longing, you

Hurl yourself down to the flames of Etna.

So by a queen's wanton whim

Pearls were dissolved in wine—heed her not!

What folly, O poet, to cast your riches

Into that bright and bubbling cup!

Yet still you are holy to me, as the might of earth

That bore you away, audaciously perishing!

And I would follow the hero into the depths

Did not love hold me.²¹

[626] This poem reveals the poet's secret longing for the maternal depths and for the regenerating womb. (Cf. fig. 40.) He would like to be melted like pearls in wine, to be sacrificed in the chalice, the "krater" of rebirth. He longs to imitate Empedocles, of whom Horace says: "Empedocles, eager to be thought a god immortal, coolly leapt into burning Aetna."²²

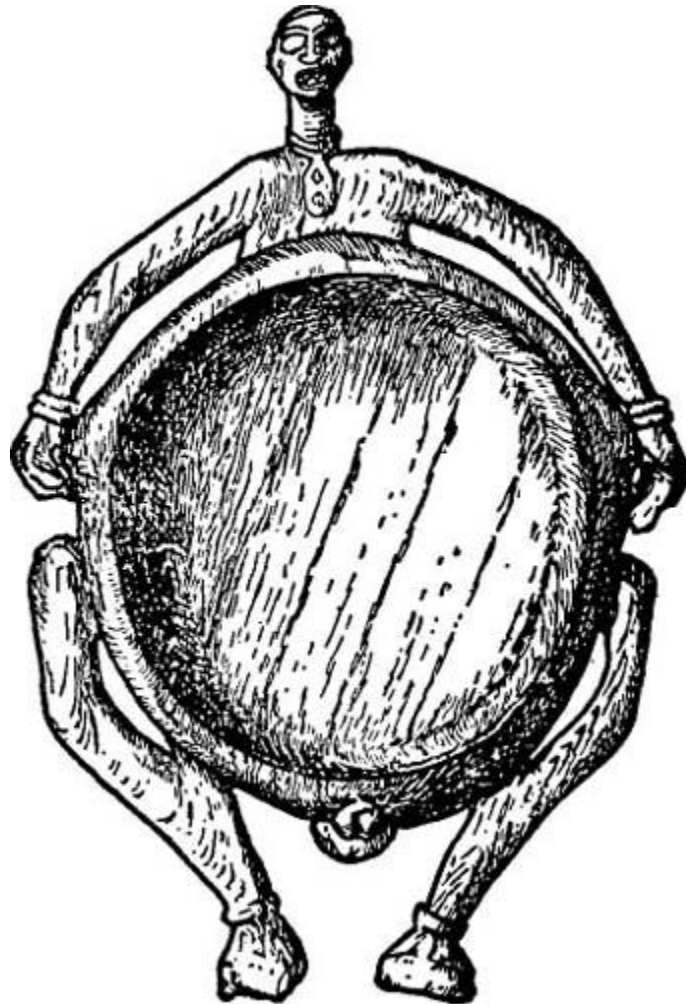

Fig. 40. The womb of the World Mother
Wooden bowl, Congo

[627] He wants to go the way of the hero, the ideal figure that floats before him, and to share his fate. Yet love still holds him back in the light of day. The libido still has an object which makes life worth living. If this object were abandoned, then the libido would sink down to the subterranean mother for rebirth:

In Memoriam

Daily I go a different path, sometimes
Into the green wood, sometimes to bathe in the spring,
Or to the rock where the roses bloom.
From the top of the hill I look over the land,

Yet nowhere, O lovely one, nowhere in the light do I find you,
And in the breezes my words die away,
The sacred words we once had ...

Aye, you are far removed, holy countenance!
And the melody of your life is kept from me,
No longer overheard. And where are
The magical songs that once

Soothed my heart with the peace of the heavenly ones?
How long it is, how long! the youth is
Grown old, the earth itself, which then
Smiled upon me, has grown different.

Farewell! each day the soul departs,
Turns back to you, and over you weeps
The eye that with brighter shining
Gazes across again, there where you tarry.²³

[628] This distinctly suggests a renunciation, an envy of one's own youth, of that time of "effortlessness" which one would so gladly cling on to. But the final stanza portends disaster: a gazing towards the other land, the distant coast of sunrise or sunset. Love no longer holds the poet fast, the bonds with the world are broken, and loudly he calls for help to the mother:

Achilles

Lordly son of the gods! Because you had lost your beloved,
You went to the rocky coast and cried aloud to the flood,
Till the depths of the holy abyss heard you and echoed your grief
In the stillness, where far from the clamour of ships,
Deep under the waves, in a peaceful cave, the beautiful
Thetis dwells, your protectress, goddess and nymph of the sea.

Mother she was to the youth, for the powerful goddess
 Had once, on the rocky shore of his island, lovingly
 Nursed the boy at her breast, had made him a hero
 With the might of her strengthening bath and the powerful song of the waves.
 And the mother, lamenting, heard the cry of her child,
 And rose like a cloud from the gloomy bed of the sea,
 Quieted with tender embraces the pains of her darling.
 And he listened while she, caressing him, promised to help him.
 Son of the gods! O were I like you, I could trustingly
 Pour out my secret grief to one of the Heavenly Ones.
 This I shall never see, but must bear the disgrace, as though I
 No more belonged to her who still thinks of me, even with tears.
 Beneficent gods, who disdain not men's prayers, then hear me!
 How raptly and fervently have I not loved you, holy light,
 Since I have lived, the earth and your fountains and woodlands,
 Father Aether—this heart has felt you about me too ardent and pure.
 O soften, ye kind ones, my sorrows, that my soul be not silenced too early,
 That I may live and thank you, heavenly powers in the highest,
 With joyful song till the last, hurrying day,
 Thank you for gifts gone by, for the joys of lost youth,
 Then take me out of my loneliness up to yourselves.²⁴

[629] These songs describe more vividly than one could hope to do in plain language the poet's steady withdrawal and increasing estrangement from life, his gradual submersion in the abyss of memory. After these nostalgic longings the apocalyptic vision of Patmos bursts upon us like a mysterious visitor from another world, a vision swirled round by mists from the abyss, by the gathering clouds of insanity bred by the mother. Mythological ideas again flash forth, symbolic intimations of death and the resurrection of life.

[630] I give here some significant fragments from "Patmos":

Near is God
 And hard to apprehend.
 But where danger is, there
 Arises salvation also.²⁵

[631] These words show that the libido has now sunk to a depth where "the danger is great" (*Faust*, "The Mothers"). There God is near, there man would find the maternal

vessel of rebirth, the seeding-place where he could renew his life. For life goes on despite loss of youth; indeed it can be lived with the greatest intensity if looking back to what is already moribund does not hamper your step. Looking back would be perfectly all right if only it did not stop at externals, which cannot be brought back again in any case; instead, it ought to consider where the fascination of the past really springs from. The golden haze of childhood memories arises not so much from the objective facts as from the admixture of magical images which are more intuited than actually conscious. The parable of Jonah who was swallowed by the whale reproduces the situation exactly. A person sinks into his childhood memories and vanishes from the existing world. He finds himself apparently in deepest darkness, but then has unexpected visions of a world beyond. The “mystery” he beholds represents the stock of primordial images which everybody brings with him as his human birthright, the sum total of inborn forms peculiar to the instincts. I have called this “potential” psyche the collective unconscious. If this layer is activated by the regressive libido, there is a possibility of life being renewed, and also of its being destroyed. Regression carried to its logical conclusion means a linking back with the world of natural instincts, which in its formal or ideal aspect is a kind of *prima materia*. If this *prima materia* can be assimilated by the conscious mind it will bring about a reactivation and reorganization of its contents. But if the conscious mind proves incapable of assimilating the new contents pouring in from the unconscious, then a dangerous situation arises in which they keep their original, chaotic, and archaic form and consequently disrupt the unity of consciousness. The resultant mental disturbance is therefore advisedly called schizophrenia, since it is a madness due to the splitting of the mind.

[632] In his poem, Hölderlin describes the experience of entering into that wonderland of primordial images:

In darkness dwell
The eagles, and fearless across the abyss
Go the sons of the Alps
On lightly built bridges.

[633] With these words the dark fantastic poem sweeps on. The eagle, the sun-bird, dwells in darkness—the libido has hidden itself, but high overhead pass the dwellers in the mountains, probably the gods (“Ye wander above in the light”), symbols of the sun travelling across the sky like an eagle flying over the depths.

Therefore, since all round are upheaped
The summits of time,
And those that dwell nearest in love

Must languish on uttermost mountains,
Give us then innocent water,
O pinions give us, to pass
Over with constant minds and again return.

[634] The first image is a sombre one of mountains and time, probably called up by the sun wandering over the mountains; the next image, visualizing the simultaneous nearness and separation of the lovers, seems to hint at life in the underworld,²⁶ where one is united with everything that was dear to one and yet cannot enjoy the happiness of reunion because it is all shadowy, unreal and devoid of life. There the descending soul drinks the “innocent” water, the drink of rejuvenation,²⁷ that he may grow wings and soar up again into life, like the winged sun-disc (cf. pls. VII, IXa) which rises swan-like from the water.

So I spoke, when swifter
Than I had fancied, and far
Whither I never had thought to come,
A Genius bore me away
From my house. In the twilight
The shadowy woods darkened as I went
And the yearning brooks of my home;
No more did I know these lands.

[635] After the dark and enigmatic prelude, which is like a premonition of what is to come, the poet begins the journey to the East, towards the sunrise, towards the mystery of eternity and rebirth, of which Nietzsche also dreams:

O how should I not burn for eternity and for the nuptial ring of rings—the ring of return! Never yet did I find the woman from whom I desired children, unless it be this woman whom I love: for I love thee, O Eternity.²⁸

[636] Hölderlin puts this same longing into a magnificent image, whose main features we know already:

Yet soon in fresh radiance,
Mysterious
In the golden smoke,
Swiftly sprung up
With the tread of the sun,

Asia bloomed out before me,
Fragrant with a thousand peaks, and dazzled
I sought one that I knew, for I was

A stranger to the broad streets
Where the gold-flecked Pactolus
Rushes down from Tmolus,
And Taurus stands and Messogis,
And full of flowers the garden,
A quiet fire. But high in the light
Blossoms the silver snow,
And, witness to life everlasting,
On attainless walls
The immemorial ivy²⁹ grows, and upborne
Upon living columns of cedars and laurels
Are the solemn,
The divinely built palaces.

[637] The vision is apocalyptic: the mother-city in the land of eternal youth, surrounded by the flowery verdure of imperishable spring.³⁰ (Cf. pl. xxii*a*.) The poet identifies himself here with John, who lived on Patmos and consorted with the “Son of the Highest” and saw him face to face:

As at the mystery of the vine
They sat together at the hour of the banquet,
And quietly prescient in his great soul
The Lord spake death and the last love ...

Thereon he died. Of that
There were much to be said. And the friends saw
How he gazed forth victorious,
The most joyful of all, at the last ...

Therefore he sent them
The Spirit, and the house
Solemnly trembled,
And the storm of God
Rolled far-thundering over their visionary heads,
Where brooding
The heroes of death were assembled,
As he now, in departure,
Once more appeared before them.
For now was put out

The day of the sun, the kingly one,
And himself, divinely suffering,
Shattered the straight-rayed sceptre,
For it shall come again
At the proper time ...

[638] The underlying images are the sacrificial death and resurrection of Christ, conceived as the self-sacrifice of the sun, which voluntarily breaks its rayed sceptre in the certain hope of resurrection. Concerning the substance of the rayed sceptre the following may be noted: Spielrein's patient said that "God pierces the earth with his ray." For her the earth was a woman; she also regarded the sunbeam in mythological fashion as something solid: "Jesus Christ has shown me his love by tapping at the window with a sunbeam." I have come across the same idea of the solid substance of the sunbeam in other insane patients. Thor's hammer, which split the earth and penetrated deep into it, may be compared with Kaineus' foot. Inside the earth the hammer comports itself like the treasure, for in the fulness of time it comes to the surface again, i.e., is born again from the earth. At the place where Samson threw away the jawbone of the ass the Lord caused a fountain to gush forth.³¹ Springs also come from hoof-marks, footprints, horse's hooves. Magic wands and sceptres in general come into this category of meanings. Gr. *σκῆπτρον* is related to *σκᾶλος*, *σκηπᾶνιον*, *σκήπων* = 'staff'; *σκηπτὸς* = 'storm-wind'; Lat. *scapus*, 'shaft, stalk'; OHG. *scaft*, 'spear, lance.'³² (Cf. pl. XLV.) So once again we meet in this context the connections already known to us as libido-symbols. The breaking of the sceptre therefore signifies the sacrifice of power as previously exercised, i.e., of the libido which had been organized in a certain direction.

[639] That Hölderlin's poem should pass from Asia to Patmos and thence to the Christian mystery may seem like a superficial association of ideas, but actually it is a highly significant train of thought: it is the entry into death and the land beyond, seen as the self-sacrifice of the hero for the attainment of immortality. At this time, when the sun has set and life seems extinguished, man awaits in secret expectancy the renewal of all life:

And it was joy
From now on
To dwell in loving night and maintain
Steadfast in simple eyes
Abysses of wisdom.

[640] Wisdom dwells in the depths, the wisdom of the mother; being one with her means being granted a vision of deeper things, of the primordial images and primitive

forces which underlie all life and are its nourishing, sustaining, creative matrix. Hölderlin, in his pathological ecstasy, senses the grandeur of the things seen, but unlike Faust he does not care to bring into the light of day all that he has found in the depths:

And no evil it is if something
Is lost and the living sound
Fades from our speech,
For heavenly labour is like to our own.
The Highest would not have
All at one time.
So long as the pit bears iron
And Etna fiery resin,
So I have riches
To fashion an image and see
The Spirit ³³ as ever it was.

[641] What the poet beholds in his Vulcan's pit is in truth the "Spirit" as ever it was, namely the totality of primary forms from which the archetypal images come. In this world of the collective unconscious spirit appears as an archetype which is endowed with supreme significance and is expressed through the figure of the divine hero, whose counterpart in the West is Christ.

He wakens the dead,
Who are not yet bound
By the grossness of death ...

And if the heavenly ones,
As I believe, so love me....

Quiet is his ³⁴ sign
In the thunderous sky. And One stands beneath it
His life long. For Christ lives yet.

[642] But, as once Gilgamesh, bringing back the magic herb from the Western Land (cf. pl. XIX), was robbed of his treasure by the demon-serpent, so Hölderlin's poem dies away in a painful lament, which tells us that his descent to the shadows will be followed by no resurrection in this world:

... shamefully
A mighty force wrenches the heart from us,

[643] This recognition, that one must give up the retrospective longing which only wants to resuscitate the torpid bliss and effortlessness of childhood, *before* the “heavenly ones” wrench the sacrifice from us (and with it the entire man), came too late to the poet.

[644] I therefore take it as a wise counsel which the unconscious gives our author, to let her hero die, for he was really not much more than the personification of a regressive and infantile reverie, having neither the will nor the power to make good his aversion from this world by fishing up another from the primeval ocean of the unconscious, which would truly have been an heroic act. Such a sacrifice can only be accomplished through whole-hearted dedication to life. All the libido that was tied up in family bonds must be withdrawn from the narrower circle into the larger one, because the psychic health of the adult individual, who in childhood was a mere particle revolving in a rotary system, demands that he should himself become the centre of a new system. That such a step includes the solution, or at least some consideration, of the sexual problem is obvious enough, for unless this is done the unemployed libido will inevitably remain fixed in the unconscious endogamous relationship to the parents and will seriously hamper the individual’s freedom. We must remember that Christ’s teaching means ruthlessly separating a man from his family, and we saw in the Nicodemus dialogue how he took especial pains to give regression a symbolic meaning. Both tendencies serve the same goal, namely that of freeing man from his family fixations, from his weakness and uncontrolled infantile feelings. For if he allows his libido to get stuck in a childish milieu, and does not free it for higher purposes, he falls under the spell of unconscious compulsion. Wherever he may be, the unconscious will then recreate the infantile milieu by projecting his complexes, thus reproducing all over again, and in defiance of his vital interests, the same dependence and lack of freedom which formerly characterized his relations with his parents. His destiny no longer lies in his own hands: his Τύχαι καὶ Μοίραι (fortunes and fates) fall from the stars. The Stoics called this condition Heimarmene, compulsion by the stars, to which every “unredeemed” soul is subject. When the libido thus remains fixed in its most primitive form it keeps men on a correspondingly low level where they have no control over themselves and are at the mercy of their affects. That was the psychological situation of late antiquity, and the saviour and physician of that time was he who sought to free humanity from bondage to Heimarmene.³⁵

[645] Miss Miller’s vision seems at first sight to treat the problem of sacrifice as a purely individual problem, but if we examine the way it is worked out we shall see that it is something that must be a problem for humanity in general. For the symbols

employed—the snake that kills the horse, and the hero who sacrifices himself of his own free will—are mythological figures born of the unconscious.

[646] To the extent that the world and everything in it is a product of thought, the sacrifice of the libido that strives back to the past necessarily results in the creation of the world. For him who looks backwards the whole world, even the starry sky, becomes the mother who bends over him and enfolds him on all sides, and from the renunciation of this image, and of the longing for it, arises the picture of the world as we know it today. This simple thought is what constitutes the meaning of the cosmic sacrifice, a good example being the slaying of Tiamat (fig. 41), the Babylonian mother-dragon, from whose body heaven and earth were made.³⁶ But perhaps the fullest expression of this idea is to be found in Indian philosophy of the oldest date, in the Vedic hymns. The Rig-Veda asks:

What was the wood, what was the tree,
From which heaven and earth were hewn?
Let the sages inquire within their minds.³⁷



Fig. 41. Marduk fighting Tiamat
Assyrian cylinder seal

[647] Vishvakarman, the All-Creator, who made the world from the unknown tree, did so as follows:

Sacrificing as a wise sacrificer,
Our Father entered into all these beings;
Striving for blessings through prayer,
Hiding his origin, he went into the lower world.
Yet what and who has served him
As a resting-place and a support?

[648] The Rig-Veda proceeds to answer these questions: Purusha (Man, Anthropos) was the primal being who

Encompassed the earth on all sides
And ruled over the ten-finger place

[649] Purusha is evidently a sort of Platonic world-soul who surrounds the earth from outside:

Being born he overtopped the world

Before, behind, and in all places.

[650] As the all-encompassing world-soul Purusha has a maternal character, for he represents the original “dawn state” of the psyche: he is the encompasser and the encompassed, mother and unborn child, an undifferentiated, unconscious state of primal being. As such a condition must be terminated, and as it is at the same time an object of regressive longing, it must be sacrificed in order that discriminated entities—i.e., conscious contents—may come into being:

Him, Purusha, born at the beginning, they besprinkled on the straw; the gods sacrificed with him, and the saints and the sages.

[651] The passage is very remarkable. If one attempted to put this mythologem on the Procrustean bed of logic sore violence would be done to it. How on earth ordinary “sages” come to be sacrificing the primal being side by side with the gods is an utterly fantastic conception, quite apart from the fact that in the beginning (i.e., before the sacrifice) nothing existed except the primal being! But if this primal being means the great mystery of the original psychic state, then everything becomes clear:

From that sacrifice when it was fully offered the speckled (clotted) butter was collected; it constituted the birds and the wild and domestic animals.

From that sacrifice when it was fully offered the hymns were born, and the chants; the metres were born from it, and from it the prose formula was born....

The moon was born from his mind; from his eye was born the sun; from his mouth Indra and Agni; from his breath Vayu was born.

From his navel grew the atmosphere; from his head the sky; from his feet the earth; from his ear the directions. Thus the worlds are made.

[652] It is evident that by this is meant not a physical, but a psychological cosmogony. The world comes into being when man discovers it. But he only discovers it when he sacrifices his containment in the primal mother, the original state of unconsciousness. What drives him towards this discovery is conceived by Freud as the “incest barrier.” The incest prohibition blocks the infantile longing for the mother and forces the libido along the path of life’s biological aim. The libido, driven back from the mother by the incest prohibition, seeks a sexual object in place of the forbidden mother. Here the terms “incest prohibition,” “mother,” etc. are used metaphorically, and it is in this sense that we have to interpret Freud’s paradoxical dictum: “To begin with we knew

only sexual objects.”³⁹ This statement is not much more than a sexual allegory, as when one speaks of male and female electrical connections, screws, etc. All it does is to read the partial truths of the adult into infantile conditions which are totally different. Freud’s view is incorrect if we take it literally, for it would be truer to say that at a still earlier stage we knew nothing but nourishing breasts. The fact that the infant finds pleasure in sucking does not prove that it is a sexual pleasure, for pleasure can have many different sources. Presumably the caterpillar finds quite as much pleasure in eating, even though caterpillars possess no sexual function whatever and the food instinct is something quite different from the sex instinct, quite unconcerned about what a later sexual stage may make of these earlier activities. Kissing, for instance, derives far more from the act of nutrition than from sexuality. Moreover the so-called “incest barrier” is an exceedingly doubtful hypothesis (admirable as it is for describing certain neurotic conditions), because it is a product of culture which nobody invented and which grew up naturally on the basis of complex biological necessities connected with the development of “marriage classes.” The main purpose of these is not to prevent incest but to meet the social danger of endogamy by instituting the “cross-cousin marriage.” The typical marriage with the daughter of the maternal uncle is actually implemented by the same libido which could equally well possess the mother or the sister. So it is not a question of avoiding incest, for which incidentally there are plenty of opportunities in the frequent fits of promiscuity to which primitives are prone, but of the social necessity of spreading the family organization throughout the whole tribe.⁴⁰

[653] Therefore it cannot have been the incest-taboo that forced mankind out of the original psychic state of non-differentiation. On the contrary, it was the evolutionary instinct peculiar to man, which distinguishes him so radically from all other animals and forced upon him countless taboos, among them the incest-taboo. Against this “other urge” the animal in us fights with all his instinctive conservatism and misoneism—hatred of novelty—which are the two outstanding features of the primitive and feebly conscious individual. Our mania for progress represents the inevitable morbid compensation.

[54] Freud’s incest theory describes certain fantasies that accompany the regression of libido and are especially characteristic of the personal unconscious as found in hysterical patients. Up to a point they are infantile-sexual fantasies which show very clearly just where the hysterical attitude is defective and why it is so incongruous. They reveal the shadow. Obviously the language used by this compensation will be dramatic and exaggerated. The theory derived from it exactly matches the hysterical attitude that causes the patient to be neurotic. One should not, therefore, take this mode of expression quite as seriously as Freud himself took it. It is just as unconvincing as the ostensibly sexual traumata of hysterics. The neurotic sexual

theory is further discomfited by the fact that the last act of the drama consists in a return to the mother's body. This is usually effected not through the natural channels but through the mouth, through being devoured and swallowed (pl. LXII), thereby giving rise to an even more infantile theory which has been elaborated by Otto Rank. All these allegories are mere makeshifts. The real point is that the regression goes back to the deeper layer of the nutritive function, which is anterior to sexuality, and there clothes itself in the experiences of infancy. In other words, the sexual language of regression changes, on retreating still further back, into metaphors derived from the nutritive and digestive functions, and which cannot be taken as anything more than a *façon de parler*. The so-called Oedipus complex with its famous incest tendency changes at this level into a "Jonah-and-the-Whale" complex, which has any number of variants, for instance the witch who eats children, the wolf, the ogre, the dragon, and so on. Fear of incest turns into fear of being devoured by the mother. The regressing libido apparently desexualizes itself by retreating back step by step to the presexual stage of earliest infancy. Even there it does not make a halt, but in a manner of speaking continues right back to the intra-uterine, pre-natal condition and, leaving the sphere of personal psychology altogether, irrupts into the collective psyche where Jonah saw the "mysteries" ("représentations collectives") in the whale's belly. The libido thus reaches a kind of inchoate condition in which, like Theseus and Peirithous on their journey to the underworld, it may easily stick fast. But it can also tear itself loose from the maternal embrace and return to the surface with new possibilities of life.

[655] What actually happens in these incest and womb fantasies is that the libido immerses itself in the unconscious, thereby provoking infantile reactions, affects, opinions and attitudes from the personal sphere, but at the same time activating collective images (archetypes) which have a compensatory and curative meaning such as has always pertained to the myth. Freud makes his theory of neurosis—so admirably suited to the nature of neurotics—much too dependent on the neurotic ideas from which precisely the patients suffer. This leads to the pretence (which suits the neurotic down to the ground) that the *causa efficiens* of his neurosis lies in the remote past. In reality the neurosis is manufactured anew every day, with the help of a false attitude that consists in the neurotic's thinking and feeling as he does and justifying it by his theory of neurosis.

[656] After this digression, let us turn back to our Vedic hymn. Rig-Veda X, 90 closes with a significant verse which is also of the greatest importance as regards the Christian mystery:

With the sacrifice the gods sacrificed to the sacrifice; these were the first ordinances. These powers (arising from the sacrifice) reach the sky where are the saints and the gods.⁴¹

[657] Sacrifice brings with it a plenitude of power that is equal to the power of the gods. Even as the world is created by sacrifice, by renouncing the personal tie to childhood, so, according to the teaching of the Upanishads, will be created the new state of man, which can be described as immortal. This new state beyond the human one is again attained through a sacrifice, the horse-sacrifice, which has cosmic significance. What the sacrificed horse means we learn from the Brihadaranyaka Upanishad:

Om!

1. Verily, dawn is the head of the sacrificial horse, the sun his eye, the wind his breath, universal fire his open mouth. The year is the body of the sacrificial horse, the sky his back, the atmosphere his belly, the earth the underpart of his belly, the quarters his flanks, the intermediate quarters his ribs, the seasons his limbs, the months and half-months his joints, days and nights his feet, the stars his bones, the clouds his flesh. Sand is the food in his stomach, rivers are his entrails. His liver and lungs are the mountains, plants and trees his hair. The rising sun is his forepart, the setting sun his hindpart. When he shows his teeth, that is lightning. When he shakes himself, then it thunders. When he urinates, then it rains. His voice is speech.

2. Verily, day was created for the horse as the sacrificial dish which stands before him; its place is the world-ocean towards the east. Night was created for the sacrificial horse as the sacrificial dish which stands behind him; its place is the world-ocean towards the west.

Verily, these two surround the horse on both sides as the two sacrificial vessels.

As a steed he carried the gods, as a charger the Gandharvas, as a racer the demons, as a horse men. The ocean is his kinsman, the sea his cradle.⁴²

[658] As Deussen remarks, the horse-sacrifice signifies a renunciation of the world. When the horse is sacrificed the world is sacrificed and destroyed—a train of thought that also suggested itself to Schopenhauer. The horse stands between two sacrificial vessels, passing from one to the other, just as the sun passes from morning to evening. (Cf. fig. 3.) Since the horse is man's steed and works for him, and energy is even measured in terms of "horse power," the horse signifies a quantum of energy that stands at man's disposal. It therefore represents the libido which has passed into the world. We saw earlier on that the "mother-libido" must be sacrificed in order to create the world; here the world is destroyed by renewed sacrifice of the same libido, which once belonged to the mother and then passed into the world. The horse, therefore, may reasonably be substituted as a symbol for this libido because, as we saw, it has numerous connections with the mother.⁴³ The sacrifice of the horse can only produce another phase of introversion similar to that which prevailed before the creation of the world. The position of the horse between the two vessels, which represent the birth-giving and the devouring mother, hints at the idea of life enclosed in the ovum; consequently the vessels are destined to "surround" the horse. That this

is in fact so can be seen from the Brihadaranyaka Upanishad 3, 3 (“Where the offerers of the horse sacrifice go”):

“What has become of the Parikshitas? I ask you, Yajñavalkya, what has become of the Parikshitas?”

Yajñavalkya said: “... Doubtless they have gone whither the offerers of the horse sacrifice go.”

“And where, pray, do the offerers of the horse sacrifice go?”

“This inhabited world is as broad as thirty-two days’ journeys of the sun-god’s chariot. The earth, which is twice as broad, surrounds it on all sides. The ocean, which is twice as broad, surrounds the earth on all sides. There ⁴⁴ is a gap as broad as the edge of a razor or the wing of a mosquito. Indra, taking the form of a falcon, delivered the Parikshitas to the wind, and the wind took them and bore them to the place where the offerers of the horse sacrifice were ...

“Therefore the wind is the most individual thing (*vyashti*) and the most universal (*samashti*). He who knows this wards off repeated death.”⁴⁵

[659] As the text says, the offerers of the horse-sacrifice go to that narrowest of gaps between the shells of the world-egg, the point where they are at once united and divided. Indra, who in the form of a falcon has stolen the soma (the treasure hard to attain), is the psychopomp who delivers the souls to the wind, to the generating pneuma, the individual and universal *prana* (life-breath),⁴⁶ to save them from “repeated death.” This line of thought summarizes the meaning of innumerable myths and is at the same time an excellent example of how far Indian philosophy is, in a certain sense, nothing more than refined and sublimated mythology.⁴⁷ In the Miller drama the first to die is the horse, the animal brother of the hero (corresponding to the early death of the half-bestial Enkidu, friend and brother of Gilgamesh). His sacrificial death brings to mind the whole category of animal-sacrifices in mythology. The animal-sacrifice, where it has lost its original meaning as an offered gift and has taken on a higher religious significance, has an inner relationship to the hero or god. The animal represents the god himself; thus the bull represents Dionysus Zagreus and Mithras, the lamb Christ, etc.⁴⁸ The sacrifice of the animal means, therefore, the sacrifice of the animal nature, the instinctual libido. This is expressed most clearly in the cult legend of Attis. Attis was the son-lover of Agdistis-Cybele, the mother of the gods. Driven mad by his mother’s insane love for him, he castrated himself under a pine-tree. The pine-tree played an important part in his cult (fig. 42); every year a pine-tree was decked with garlands, an effigy of Attis was hung upon it and then it was cut down. Cybele then took the pine-tree into her cave and lamented over it. The tree obviously signifies the son—according to one version Attis was actually changed into a pine-tree—whom the mother takes back into her “cave,” i.e., the maternal womb. At the same time, the tree also has a maternal significance, since the hanging of the son or his effigy on the tree represents the union of mother and son. Common speech employs the same image: a person is said to “hang on his mother.” Again, the

felling of the pine-tree parallels the castration and is a direct reminder of it. In that case the tree would have more of a phallic meaning. But since the tree is primarily significant of the mother, its felling has the significance of a mother-sacrifice. These intricate overlappings of meaning can only be disentangled if we reduce them to a common denominator. This denominator is the libido: the son personifies the longing for the mother which exists in the psyche of every individual who finds himself in a similar situation. The mother personifies the (incestuous) love for the son. The tree personifies the mother on the one hand and the phallus of the son on the other. The phallus in its turn stands for the son's libido. The felling of the pine, i.e., castration, denotes the sacrifice of this libido, which seeks something that is as incongruous as it is impossible. The myth therefore depicts, through the arrangement and nature of the protagonists, the typical fate of a libido regression that is played out mainly in the unconscious. At the same time the dramatis personae appear in consciousness as in a dream, but in essence they are only envisagings of the currents and tendencies of the libido. The actuating principle of all the figures is the libido, which by its own unity binds its products so closely together that certain attributes or activities may easily pass from one figure to the next—a fact which presents no difficulties to intuitive understanding, but vastly complicates the task of logical exposition.



Fig. 42. The sacred tree of Attis
Relief from an altar to Cybele

[660] The impulse to sacrifice proceeds in the above instance from the *mater saeva cupidinum*, who drives the son to madness and self-mutilation. As a primal being the mother represents the unconscious; hence the myths tell us that the impulse to sacrifice comes from the unconscious. This is to be understood in the sense that

regression is inimical to life and disrupts the instinctual foundations of the personality, and is consequently followed by a compensatory reaction taking the form of violent suppression and elimination of the incompatible tendency. It is a natural, unconscious process, a collision between instinctive tendencies, which the conscious ego experiences in most cases passively because it is not normally aware of these libido movements and does not consciously participate in them.

[661] Ovid, by the way, says of the pine-tree that it is “pleasing to the mother of the gods, because Cybelean Attis here put off his human form and stiffened into a tree-trunk.”⁴⁹

[662] Transformation into the pine-tree amounts to burial in the mother, just as Osiris was overgrown by the cedar. (Cf. fig. 23.) On the Coblenz bas-relief,⁵⁰ Attis is shown growing out of a tree. This is interpreted by Mannhardt as the indwelling vegetation numen, but it is probably simply a tree-birth, as with Mithras. (Cf. the Hedderheim Relief, pl. XL.) As Firmicus Maternus notes, tree and effigy played an important part in the Isis and Osiris cult and also in that of Kore-Persephone.⁵¹ Dionysus bore the name of Dendrites, and in Boeotia he was supposed to have been called ἔνδενδρος, ‘he in the tree.’⁵² In the legend of Pentheus, which is bound up with the Dionysus myth, there is a striking counterpart to the death of Attis and the subsequent lamentation: Pentheus,⁵³ curious to see the orgies of the Maenads, climbed up into a pine-tree but was spotted by his mother; the Maenads cut down the tree, and Pentheus, taken for a wild animal, was torn to pieces by them in their frenzy,⁵⁴ his own mother being the first to hurl herself upon him.⁵⁵ In this legend the phallic meaning of the tree (felling = castration), its maternal nature (the tree “bears” Pentheus), and its identity with the son (felling = slaying of Pentheus), are all present; at the same time we have here the counterpart and complement of the Pietà, namely the Terrible Mother. The feast of Attis was celebrated first as a lamentation and then as a festival of joy in the spring. (Good Friday and Easter.) The priests of the Attis-Cybele cult were eunuchs, and were called Galloi.⁵⁶ The *archigallos* was called Atys.⁵⁷ Instead of the annual castration the priests merely scratched their arms till they bled. (Arm as substitute for phallus; twisting out the arms.⁵⁸) There is a similar instinct-sacrificing symbolism in the Mithraic religion, where the essential portions of the mystery consisted in the catching and subduing of the bull. A parallel figure to Mithras is the Original Man, Gayomart. He was created together with his ox, and the two lived in a state of bliss for six thousand years. But when the world entered the aeon of Libra (the seventh zodiacal sign), the evil principle broke loose. In astrology, Libra is known as the “Positive House” of Venus, so the evil principle came under the dominion of the goddess of love, who personifies the erotic aspect of the mother. Since this aspect, as we have seen, is psychologically extremely dangerous, the classical catastrophe threatened to overtake the son. As a result of this constellation,

Gayomart and his ox died only thirty years later. (The trials of Zarathustra also lasted for thirty years.) Fifty-five species of grain and twelve kinds of healing plants came from the dead ox. His seed entered into the moon for purification, but the seed of Gayomart entered into the sun. This seems to suggest that the bull has a hidden feminine significance. Gosh or Drvashpa was the bull's soul and it was worshipped as a female divinity. At first she was so faint-hearted that she refused to become the goddess of cattle until, as a consolation, the coming of Zarathustra was announced to her. This has its parallel in the Purana where the earth received the promise of Krishna's coming.⁵⁹ Like Ardivisura, the goddess of love, Gosh rides in a chariot. So the bull-anima appears to be decidedly feminine. In astrology Taurus, too, is a House of Venus. The myth of Gayomart repeats in modified form the primitive "closed circle" of a self-reproducing masculine and feminine divinity.

[663] Like the sacrificial bull, fire—whose sacrifice we have already discussed in Chapter III—has a feminine nature in Chinese philosophy, according to one of the commentators⁶⁰ on the Chuang-tzu (350 B.C.): "The hearth spirit is called Chi. He is dressed in bright red, resembling fire, and in appearance is like a lovely, attractive maiden." The Book of Rites says: "Wood is burnt in the flames for the Au spirit. This sacrifice to Au is a sacrifice to the old women who are dead." These hearth and fire spirits are the souls of departed cooks and are therefore referred to as "old women." The god of kitchens grew out of this pre-Buddhistic tradition and later, as a man, became the ruler of the family and the link between it and heaven. In this way the original female fire-spirit became a sort of Logos and mediator.

[664] From the seed of the bull sprang the first progenitors of cattle, as well as 272 kinds of useful animals.⁶¹ According to the Mainyo-i-Khard,⁶² Gayomart destroyed Dev Azur, the demon of evil desires. Azhi, another evil demon, remained the longest on earth despite the activities of Zarathustra, but was finally destroyed at the Resurrection (like Satan in the Apocalypse). Another version says that Angramainyu and the serpent were left until the last so as to be destroyed by Ahura-Mazda himself.⁶³ Kern suggests that Zarathustra may mean "Golden Star" and may be identical with Mithras.⁶⁴ The name Mithras is related to Modern Persian *mihr*, meaning 'love' and 'sun.'

[665] In the case of Zagreus, we saw that the bull is identical with the god and that the bull-sacrifice is a divine sacrifice. But the animal is, as it were, only a part of the hero; he sacrifices only his animal attribute, and thus symbolically gives up his instinctuality. His inner participation in the sacrificial act⁶⁵ is perfectly expressed in the anguished and ecstatic countenance of the bull-slaying Mithras. He slays it willingly and unwillingly at once,⁶⁶ hence the rather pathetic expression on certain

monuments, which is not unlike the somewhat mawkish face of Christ in Guido Reni's *Crucifixion*. Benndorf says of Mithras:

The features, which ... especially in the upper portion have an absolutely ideal character, wear an extremely sickly expression.⁶⁷

[666] Cumont likewise stresses the facial expression of the Tauroctonos:

The face, which can be seen in the best reproductions, is that of a young man of almost feminine beauty; a mass of curly hair rising up from the forehead surrounds it as with an aureole; the head is slightly tilted backwards, so that his glance is directed towards the heavens, and the contraction of the brows and lips gives a strange expression of sorrow to the face.⁶⁸

[667] The head from Ostia (cf. frontispiece), supposed by Cumont to be that of Mithras Tauroctonos,⁶⁹ certainly wears an expression which we know all too well from our patients as one of sentimental resignation. It is a fact worth noting that the spiritual transformation that took place in the first centuries of Christianity was accompanied by an extraordinary release of feeling, which expressed itself not only in the lofty form of charity and love of God, but in sentimentality and infantilism. The lamb allegories of early Christian art fall in this category.

[668] Since sentimentality is sister to brutality, and the two are never very far apart, they must be somehow typical of the period between the first and third centuries of our era. The morbid facial expression points to the disunity and split-mindedness of the sacrificer: he wants to, and yet doesn't want to. This conflict tells us that the hero is both the sacrificer and the sacrificed. Nevertheless, it is only his animal nature that Mithras sacrifices, his instinctuality,⁷⁰ always in close analogy to the course of the sun.

[669] We have learned in the course of this investigation that the libido which builds up religious structures regresses in the last analysis to the mother, and thus represents the real bond through which we are connected with our origins. When the Church Fathers derive the word *religio* from *religare* (to reconnect, link back), they could at least have appealed to this psychological fact in support of their view.⁷¹ As we have seen, this regressive libido conceals itself in countless symbols of the most heterogeneous nature, some masculine and some feminine—differences of sex are at bottom secondary and not nearly so important psychologically as would appear at first sight. The essence and motive force of the sacrificial drama consist in an unconscious transformation of energy, of which the ego becomes aware in much the same way as sailors are made aware of a volcanic upheaval under the sea. Of course, when we consider the beauty and sublimity of the whole conception of sacrifice and its solemn ritual, it must be admitted that a psychological formulation has a shockingly sobering effect. The dramatic concreteness of the sacrificial act is reduced

to a barren abstraction, and the flourishing life of the figures is flattened into two-dimensionality. Scientific understanding is bound, unfortunately, to have regrettable effects—on one side; on the other side abstraction makes for a deepened understanding of the phenomena in question. Thus we come to realize that the figures in the mythical drama possess qualities that are interchangeable, because they do not have the same “existential” meaning as the concrete figures of the physical world. The latter suffer tragedy, perhaps, in the real sense, whereas the others merely enact it against the subjective backcloth of introspective consciousness. The boldest speculations of the human mind concerning the nature of the phenomenal world, namely that the wheeling stars and the whole course of human history are but the phantasmagoria of a divine dream, become, when applied to the inner drama, a scientific probability. The essential thing in the mythical drama is not the concreteness of the figures, nor is it important what sort of an animal is sacrificed or what sort of god it represents; what alone is important is that an act of sacrifice takes place, that a process of transformation is going on in the unconscious whose dynamism, whose contents and whose subject are themselves unknown but become visible indirectly to the conscious mind by stimulating the imaginative material at its disposal, clothing themselves in it like the dancers who clothe themselves in the skins of animals or the priests in the skins of their human victims.

[670] The great advantage of scientific abstraction is that it gives us a key to the mysterious processes enacted behind the scenes, where, leaving the colourful world of the theatre behind us, we enter into the ultimate reality of psychic dynamism and psychic meaningfulness. This knowledge strips the unconscious processes of all epiphenomenality and allows them to appear as what our whole experience tells us that they are—autonomous quantities. Consequently, every attempt to derive the unconscious from the conscious sphere is so much empty talk, a sterile, intellectual parlour-game. One suspects this wherever writers cheerfully talk of the “subconscious,” without apparently realizing what an arrogant prejudice they are presuming to express. How do they know, forsooth, that the unconscious is “lower” and not “higher” than the conscious? The only certain thing about this terminology is that consciousness deems itself higher—higher than the gods themselves. One day, let us hope, its “god-almightiness will make it quiver and quake”!

[671] The annual sacrifice of a maiden to the dragon is perhaps the ideal sacrifice on a mythological level. In order to mollify the wrath of the Terrible Mother the most beautiful girl was sacrificed as a symbol of man’s concupiscence. Milder forms were the sacrifice of the first-born and of various domestic animals. The alternative ideal is self-castration, of which a milder form is circumcision. Here at least only a modicum is sacrificed, which amounts to replacing the sacrifice by a symbolical act.⁷² By sacrificing these valued objects of desire and possession, the instinctive desire, or

libido, is given up in order that it may be regained in new form. Through sacrifice man ransoms himself from the fear of death and is reconciled to the demands of Hades. In the late cults the hero, who in olden times conquered evil and death through his labours, has become the divine protagonist, the priestly self-sacrificer and renewer of life. Since he is now a divine figure and his sacrifice is a transcendental mystery whose meaning far exceeds the value of an ordinary sacrificial gift, this deepening of the sacrificial symbolism is a reversion to the old idea of human sacrifice, because a stronger and more total expression is needed to portray the idea of *self*-sacrifice. The relation of Mithras to his bull comes very close to this idea. In Christianity it is the hero himself who dies of his own free will. On the Mithraic monuments we often come across a strange symbol: a krater ⁷³ (mixing-bowl) with a snake coiled round it, and a lion facing the snake like an antagonist.⁷⁴ (Pl. LXIIIb.) It looks as if they were fighting for the krater. The krater symbolizes the maternal vessel of rebirth, the snake fear and resistance, and the lion raging desire.⁷⁵ The snake almost always assists at the bull-sacrifice by gliding towards the blood flowing from the wound. It seems to follow from this that the bull's life—its blood—is offered to the snake, that it is a sacrificial offering to the powers of the underworld, like the blood drunk by the shades in the nekylia of Odysseus. We have already pointed out the reciprocal relationship between bull and snake, and we saw that the bull symbolizes the living hero, whereas the snake symbolizes the dead, buried, chthonic hero. But as the hero, when dead, is back in the mother, the snake also stands for the devouring mother. The combination of the bull's blood and the snake therefore looks like a union of opposites, and the lion and snake fighting for the krater may mean the same thing. This is probably the cause of the miraculous fertility that results from the sacrifice of the bull. Even on the primitive level, among the Australian blackfellows, we meet with the idea that the life-force wears out, turns "bad" or gets lost, and must therefore be renewed at regular intervals. Whenever such an *abaissement* occurs the rites of renewal must be performed. There is an infinite number of these rites, but even on a much higher level they retain their original meaning. Thus the Mithraic killing of the bull is a sacrifice to the Terrible Mother, to the unconscious, which spontaneously attracts energy from the conscious mind because it has strayed too far from its roots, forgetting the power of the gods, without whom all life withers or ends catastrophically in a welter of perversity. In the act of sacrifice the consciousness gives up its power and possessions in the interests of the unconscious. This makes possible a union of opposites resulting in a release of energy. At the same time the act of sacrifice is a fertilization of the mother: the chthonic serpent-demon drinks the blood, i.e., the soul, of the hero. In this way life becomes immortal, for, like the sun, the hero regenerates himself by his self-sacrifice and re-entry into the mother. After all this we should have no difficulty in recognizing the son's sacrifice to the mother in the Christian mystery. Just as Attis unmans himself for the sake of his mother, and

his effigy was hung on the pine-tree in memory of this deed, so Christ hangs ⁷⁶ on the tree of life, on the wood of martyrdom, the 'Εκάτη and mother (cf. pl. xxxvi), and ransoms creation from death. By entering again into the womb of the mother, he pays in death ⁷⁷ for the sin which the Protanthropos Adam committed in life, and by that deed he regenerates on a spiritual level the life which was corrupted by original sin. St. Augustine, as we have already remarked, actually interprets Christ's death as a *hieros gamos* with the mother, similar to the feast of Adonis, where Venus and Adonis were laid upon the bridal couch:

Like a bridegroom Christ went forth from his chamber, he went out with a presage of his nuptials into the field of the world.... He came to the marriage-bed of the cross, and there, in mounting it, he consummated his marriage. And when he perceived the sighs of the creature, he lovingly gave himself up to the torment in place of his bride, and he joined himself to the woman [*matrona*] for ever.⁷⁸

[672] *Matrona* in the language of St. Augustine means the Church, the bride of the Lamb. The feeling-tone of the classical *hieros gamos* has here changed into its opposite: torment instead of lust, and the martyr's stake instead of the mother and mistress. What was once felt as pleasurable—i.e., the union of the masculine consciousness with the feminine unconscious—is now felt as painful; the symbol of the *hieros gamos* is no longer experienced concretely on the bodily level, but on a higher, psychic one as the union of God with his congregation (the *corpus mysticum*). To put it in modern psychological language, this projection of the *hieros gamos* signifies the conjunction of conscious and unconscious, the transcendent function characteristic of the individuation process. Integration of the unconscious invariably has a healing effect.⁷⁹

[673] Comparison between the Mithraic and the Christian sacrifice should show just where the superiority of the Christian symbol lies: it lies in the frank admission that not only has man's animal instinctuality (symbolized by the bull) to be sacrificed, but the entire natural man, who is more than can be expressed by his theriomorphic symbol. Whereas the latter represents animal instinctuality and utter subjection to the law of the species, the natural man means something more than that, something specifically human, namely the ability to deviate from the law, or what in theological language is known as the capacity for "sin." It is only because this variability in his nature has continually kept other ways open that spiritual development has been possible for *Homo sapiens* at all. The disadvantage, however, is that the absolute and apparently reliable guidance furnished by the instincts is displaced by an abnormal learning capacity which we also find in the anthropoid apes. Instead of instinctive certainty there is uncertainty and consequently the need for a discerning, evaluating, selecting, discriminating consciousness. If the latter succeeds in compensating the instinctive certainty, it will increasingly substitute reliable rules and modes of

behaviour for instinctive action and intuition. There then arises the opposite danger of consciousness being separated from its instinctual foundations and of setting up the conscious will in the place of natural impulse.

[674] Through the sacrifice of the natural man an attempt is made to reach this goal, for only then will the dominating ideal of consciousness be in a position to assert itself completely and mould human nature as it wishes. The loftiness of this ideal is incontestable and should indeed not be contested. Yet it is precisely on this lofty height that one is beset by a doubt whether human nature is capable of being moulded in this way, and whether our dominating idea is such that it can shape the natural material without damaging it. Only experience will show. Meanwhile, the attempt must be made to climb these heights, for without such an undertaking it could never be proved that this bold and violent experiment in self-transformation is possible at all. Nor could we ever estimate or understand the powers that favour the attempt or make it utterly impossible. Only then shall we be in a position to see whether the self-sacrifice of the natural man, as the Christian understands it, is a final solution or a view capable of further modification. Whereas the Mithraic sacrifice was still symbolized by the archaic slaughter of an animal and aimed only at domesticating and disciplining the instinctual man,⁸⁰ the Christian idea of sacrifice is symbolized by the death of a human being and demands a surrender of the whole man—not merely a taming of his animal instincts, but a total renunciation of them and a disciplining of his specifically human, spiritual functions for the sake of a spiritual goal beyond this world. This ideal is a hard schooling which cannot help alienating man from his own nature and, to a large degree, from nature in general. The attempt, as history has shown, was entirely possible and led in the course of a few centuries to a development of consciousness which would have been quite out of the question but for this training. Developments of this kind are not arbitrary inventions or mere intellectual fantasies; they have their own inner logic and necessity. The barrage of materialistic criticism that has been directed against the physical impossibility of dogma ever since the age of enlightenment is completely beside the point. Dogma *must* be a physical impossibility, for it has nothing whatever to say about the physical world but is a symbol of “transcendental” or unconscious processes which, so far as psychology can understand them at all, seem to be bound up with the unavoidable development of consciousness. Belief in dogma is an equally unavoidable stop-gap which must sooner or later be replaced by adequate understanding and knowledge if our civilization is to continue.

[675] In Miss Miller’s fantasy, too, there is an inner necessity that compels it to go on from the horse-sacrifice to the sacrifice of the hero. Whereas the former symbolizes the renunciation of biological drives, the latter has the deeper and ethically more valuable meaning of a human self-sacrifice, a renunciation of egohood. In her case,

of course, this is true only in a metaphorical sense, since it is not the author of the story but its hero, Chiwantopel, who offers himself and is voluntarily sacrificed. The morally significant act is delegated to the hero, while Miss Miller only looks on admiringly and applaudingly, without, it seems, realizing that her animus-figure is constrained to do what she herself so signally fails to do. The advance from the animal sacrifice to the human sacrifice is therefore only an idea, and when Miss Miller plays the part of a pious spectator of this imaginary sacrificial act, her participation is without ethical significance. As is usual in such cases, she is totally unconscious of what it means when the hero, the vehicle of the vitally important magical action, perishes. When that happens, the projection falls away and the threatening sacrificial act recoils upon the subject herself, that is, upon the personal ego of the dreamer. In what form the drama will then run to an end it is impossible to predict. Nor, in the case of Miss Miller, owing to the lack of material and my ignorance of her personality, did I foresee, or venture to assume, that it would be a psychosis which would form the companion piece to Chiwantopel's sacrifice. It was, in fact, a *κατοχή*—a total surrender, not to the positive possibilities of life, but to the nocturnal world of the unconscious, a *débâcle* similar to the one that overtook her hero.

[676] Chiwantopel is killed by a snake. We have already found abundant evidence for the snake as an instrument of sacrifice (the legend of St. Sylvester, the virginity test, wounding of Ra and Philoctetes, lance and arrow symbolism). It is the knife that kills, but also the phallus as symbol of the regenerative power of the grain, which, buried in the earth like a corpse, is at the same time the inseminator of the earth. (P1. LXIIIa.) The snake symbolizes the numen of the transformative act as well as the transformative substance itself, as is particularly clear in alchemy. As the chthonic dweller in the cave she lives in the womb of mother earth, like the Kundalini serpent who lies coiled in the abdominal cavity, at the base of the spine. Alchemy has the legend of Gabricus and Beya, the royal brother-sister pair. During the *hieros gamos*, Gabricus gets right inside the body of his sister and disappears completely; he is buried in her womb, where, dissolved into atoms, he changes into the soul-snake, the *serpens mercurialis*.⁸¹ (Cf. fig. 6.) Such fantasies are not uncommon among patients. Thus one patient of mine had the fantasy that she was a snake which wound itself round her mother and finally crawled right into her.

[677] The snake that killed the hero is *green*. So was the snake of another patient,⁸² who said: "Then a little green snake came up to my mouth, it had the finest, loveliest feeling—as if it had human reason and wanted to tell me something—just as if it wanted to kiss me." Spielrein's patient said of her snake: "It is God's animal, it has such wonderful colours: green, blue, and white. The rattlesnake is green; it is very dangerous.... The snake can have a human mind, it can have divine judgment; it is a

friend of children. It would save the children who are needed to preserve human life.”⁸³ The significance of the snake as an instrument of regeneration is unmistakable. (Cf. fig. 37.)

[678] As the horse is the brother, so the snake is the sister of Chiwantopel (“my little sister”). Rider and horse form a centaur-like unit,⁸⁴ like man and his shadow, i.e., the higher and lower man, ego-consciousness and shadow, Gilgamesh and Enkidu. In the same way the feminine belongs to man as his own unconscious femininity, which I have called the anima. She is often found in patients in the form of a snake. Green, the life-colour, suits her very well; it is also the colour of the Creator Spiritus. I have defined the anima as the *archetype of life itself*.⁸⁵ Here, because of the snake symbolism, she must also be thought of as having the attribute of “spirit.” This apparent contradiction is due to the fact that the anima personifies the total unconscious so long as she is not differentiated as a figure from the other archetypes. With further differentiations the figure of the (wise) old man becomes detached from the anima and appears as an archetype of the “spirit.” He stands to her in the relationship of a “spiritual” father, like Wotan to The OHG. Brünhilde or Bythos to Sophia. Classic examples are to be found in the novels of Rider Haggard.

[679] When Chiwantopel calls the snake his “little sister,” this is not without significance for Miss Miller, because the hero is in fact her brother-beloved, her “ghostly lover,” the animus. She herself is his life-snake which brings death to him. When the hero and his horse die, the green snake remains, and the snake is nothing other than the unconscious psyche of the author herself who now, as we have seen, will suffer the same fate as Chiwantopel, that is, she will be overpowered by her unconscious.

[680] The conflict between horse and snake or bull and snake represents a conflict within the libido itself, a striving forwards and backwards at one and the same time.⁸⁶ It is as if the libido were not only a ceaseless forward movement, an unending will for life, evolution, creation, such as Schopenhauer envisaged in his cosmic Will, where death is a mishap or fatality coming from outside; like the sun, the libido also wills its own descent, its own involution. During the first half of life it strives for growth; during the second half, softly at first and then ever more perceptibly, it points towards an altered goal. And just as in youth the urge for limitless expansion often lies hidden under veiling layers of resistance to life, so that “other urge” often hides behind an obstinate and purposeless cleaving to life in its old form. This apparent contradiction in the nature of the libido is illustrated by a statue of Priapus in the archaeological museum at Verona: Priapus, with a sidelong smile, points with his finger to a snake biting his phallus (pl. LXIb).

[681] A similar motif can be found in a Rubens' *Last Judgment* (pl. LXIV), where, in the foreground, a man is being castrated by a serpent. This motif illustrates the meaning of the end of the world.⁸⁷ The fantasy of world conflagration, of the cataclysmic end of the world in general, is the projected primordial image of the great transformation, the enantiodromia of life into death, which Rubens represents as emasculation by the serpent. The image of the consuming change that dissolves the phenomenal world of individual psychic existence originates in the unconscious and appears before the conscious mind in dreams and shadowy premonitions. And the more unwilling the latter is to heed this intimation, the more frightening become the symbols by which it makes itself known. The snake plays an important role in dreams as a fear-symbol. Because of its poisonousness, its appearance is often an early symptom of physical disease. As a rule, however, it expresses an abnormally active or "constellated" unconscious and the physiological symptoms—mainly abdominal—associated therewith. Interpretation in any given case depends as always on individual circumstances and must be modified accordingly. In youth it denotes fear of life; in age, fear of death. In the case of Miss Miller the fatal significance of the green snake is obvious enough in the light of subsequent events. But it is not so easy to say what was the real cause of the unconscious gaining the upper hand. The necessary biographical material is lacking. I can only say that I have very often noticed in such cases a singularly narrow consciousness, an apprehensive stiffness of attitude, and a spiritual and emotional horizon bounded by childish naïveté or pedantic prejudice. To judge from the little we know of Miss Miller, it seems to be more a case of emotional naïveté: she underestimated the possibilities in her and leapt too lightly into dangerously deep waters where some knowledge of the shadow would have been in place. Such people should be given as much psychological knowledge as possible. Even if it doesn't protect them from the outbreak of psychosis, it nevertheless makes the prognosis look more hopeful, as I have often observed. In border-line cases such as this a real psychological understanding is often a matter of life and death.

[682] As at the beginning of our investigation the name of the hero obliged us to speak of the symbolism of Popocatapetl as the "creative" part of the body, so now at the end of the Miller drama we again have an opportunity to see how the volcano assists at the death of the hero and, by means of an earthquake, causes him to disappear into the bowels of the earth. Just as the volcano gave birth and name to the hero, so at the end it swallows him back again.⁸⁸ We learn from his last words that the longed-for beloved who alone understands him is called "Ja-ni-wa-ma." In this name we find those sweet lispings already known to us from the babyhood of Hiawatha: *wawa*, *wama*, *mama*. The only one who really understands us is the mother. For *ver-*, in *verstehen*, 'to understand' (OHG. *firstân*), may be derived from a primitive Germanic prefix *fri-*, which is identical with *περί*, 'round,' 'about.' The OHG. *antfristôn*, 'to

interpret,' is considered to be identical with *firstân*. Hence the fundamental meaning of *verstehen* would be to 'stand round about something.'⁸⁹ *Comprehendere* and *κατασυλλαμβάνειν* both express an image similar to the German *erfassen*, 'to grasp, comprehend.' The factor common to all these terms is the idea of surrounding, embracing. And there is no doubt at all that nothing in the world ever embraces us so completely as the mother. When the neurotic complains that the world does not understand him, he is telling us in a word that he wants his mother. Paul Verlaine has given beautiful expression to this thought in his poem "Mon Rêve familier":

Je fais souvent ce rêve étrange et pénétrant
D'une femme inconnue, et que j'aime, et qui m'aime,
Et qui n'est, chaque fois, ni tout à fait la même
Ni tout à fait une autre, et m'aime et me comprend.
Car elle me comprend, et mon cœur, transparent
Pour elle seule, hélas! cesse d'être un problème
Pour elle seule, et les moiteurs de mon front blême.
Elle seule les sait rafraîchir, en pleurant.
Est-elle brune, blonde ou rousse?—Je l'ignore.
Son nom? Je me souviens qu'il est doux et sonore
Comme ceux des aimés que la Vie exila.
Son regard est pareil au regard des statues,
Et, pour sa voix, lointaine, et calme, et grave, elle a
L'inflexion des voix chères qui se sont tues.⁹⁰

IX

EPILOGUE

[683] So end the Miller fantasies. Their melancholy outcome is due largely to the fact that they break off at the critical moment when the threat of invasion by the unconscious is plainly apparent. It is hardly to be supposed that Miss Miller, who evidently had not the faintest clue as to the real meaning of her visions—which even Théodore Flournoy, despite his fine feeling for values, could do nothing to explain—would be able to meet the next phase of the process, namely the assimilation of the hero to her conscious personality, with the right attitude. In order to do so she would have had to recognize what fate demanded of her, and what was the meaning of the bizarre images that had broken in upon her consciousness. That there was already some degree of dissociation is obvious, since the unconscious went ahead independently and kept on churning out images which she had not consciously produced herself and which she felt as strange and portentous. To the objective observer it is perfectly clear that the fantasies were products of a psychic energy not under the control of the conscious mind. They were longings, impulses, and symbolic happenings which it was quite unable to cope with either positively or negatively. The instinctual impulse that was trying to rouse the dreamer from the sleep of childhood was opposed by a personal pride that was distinctly out of place, and also, one must suppose, by a correspondingly narrow moral horizon, so that there was nothing to help her understand the spiritual content of the symbols. Our civilization has long since forgotten how to think symbolically, and even the theologian has no further use for the hermeneutics of the Church Fathers. The cure of souls in Protestantism is in an even more parlous condition. Who ever would go to the trouble, nowadays, of patching together the basic ideas of Christianity from a “welter of pathological fantasies”? For patients in this situation it is a positive life-saver when the doctor takes such products seriously and gives the patient access to the meanings they suggest. In this way he makes it possible for the patient to assimilate at least part of the unconscious and to repair the menacing dissociation by just that amount. At the same time the assimilation guards against the dangerous isolation which everyone feels when confronted by an incomprehensible and irrational aspect of his personality. Isolation leads to panic, and that is only too often the beginning of a psychosis. The wider the gap between conscious and unconscious, the nearer creeps the fatal splitting of the personality, which in neurotically disposed individuals leads

to neurosis, and, in those with a psychotic constitution, to schizophrenia and fragmentation of personality. The aim of psychotherapy is therefore to narrow down and eventually abolish the dissociation by integrating the tendencies of the unconscious into the conscious mind. Normally these promptings are realized unconsciously or, as we say, “instinctively,” and though their spiritual content remains unnoticed, it nevertheless insinuates itself into the conscious spiritual life of the patient, mostly in disguised form, without his being aware of it. All this passes off smoothly and without difficulty provided that his consciousness contains certain ideas of a symbolic nature—“for those who have the symbol the passage is easy,” say the alchemists. If, on the other hand, there is already a tendency to dissociation, perhaps dating back to youth, then every advance of the unconscious only increases the gap between it and consciousness. As a rule outside help is needed to bridge the gap. Had I treated Miss Miller I would have had to tell her some of the things of which I have written in this book, in order to build up her conscious mind to the point where it could have understood the contents of the collective unconscious. Without the help of these “représentations collectives,” which have psychotherapeutic value even for primitives, it is not possible to understand the archetypal associations of the products of the unconscious. It is in no sense sufficient to try to do so with nothing but a personalistically oriented psychology. Anyone who wants to treat serious dissociations must know something of the anatomy and evolutionary history of the mind he is setting out to cure. The physician who treats physical diseases is required to have some knowledge of anatomy, physiology, embryology, and comparative evolution. Neurotic dissociations can, up to a point, be remedied with the help of purely personalistic psychology, but not the problem of transference, which crops up in the majority of cases and always hides collective contents.

[684] The Miller case is a classic example of the unconscious manifestations which precede a serious psychic disorder. Their presence does not by any means prove that a disorder of this kind is bound to occur. That, as I have already said, depends among other things on whether the conscious attitude towards them is positive or negative. The Miller case suited my book very well because I had nothing to do with it personally and could thus refute the oft-repeated charge that I had “influenced” the patient. Had the case come up for treatment at the very first sign of spontaneous fantasy creations, the later episode of Chiwantopel, for instance, might have taken a very different turn, and the end, so we will hope, would have been less calamitous.

[685] With these remarks we come to the end of our programme. We set ourselves the task of examining an individual fantasy system in relation to its sources, and in the course of our inquiry have stumbled upon problems of such enormous proportions that our attempts to understand their full scope and complexity cannot of necessity amount to much more than a superficial survey. I do not take kindly to the argument

that because certain working hypotheses may not possess eternal validity or may possibly be erroneous, they must be withheld from the public. Certainly I have done my best to guard against error, which can be particularly pernicious on such treacherous ground, by keeping myself fully conscious of the dangers that beset an investigation of this kind. We doctors are not so happily placed as research workers in other fields. We cannot choose our assignment or mark off the territory to be investigated, for the sick man who comes to us for treatment confronts us with unforeseeable problems and expects us to fulfil a therapeutic task for which we cannot but feel inadequate. The strongest incentive to unceasing research has always come to me from my practice, and it consisted in the simple question which no man can ignore: "How can you treat something that you do not understand?" Dreams, visions, fantasies, and delusions are expressive of a situation. If I do not understand the dreams, neither do I understand the situation of the patient, and of what use is my treatment then? It was never my intention to justify my theories by my patients; it seemed to me far more important to understand their situation in all its aspects, which naturally include the compensatory activity of the unconscious. Such was the case with Miss Miller. I have tried to understand her situation to the best of my ability and have set down the results of my efforts as an example of the nature and extent of the problems about which any doctor who wants to practise psychotherapy should have scientific knowledge. He needs a science of the psyche, not a theory about it. I do not regard the pursuit of science as a bickering about who is right, but as an endeavour to augment and deepen human knowledge. The present work is addressed to those who think and feel about science in the same way.



Fig. 43. Antique cameo

APPENDIX:

THE MILLER FANTASIES

[Translated from “Quelques Faits d’imagination créatrice subconsciente,” in *Archives de psychologie* (Geneva), V (1906), 36–51. The article contains an introduction of five pages signed by Théodore Flournoy, which is not translated here. In it, Flournoy speaks of the Miller material as a “traduction”; it is therefore evident that Miss Miller wrote her memoir in English and it was translated (by Flournoy?) into French. Flournoy describes her as “a young American who studied for a semester at our [Geneva] university and who today pursues a distinguished career as a journalist and lecturer in the United States.” The original of the Miller memoir has never come to light, and accordingly a double translation has been necessary both in the present edition and in the Hinkle translation of 1916 (where, however, the full Miller text was not given, as here). Professor Jung based his study on the French version, and therefore certain words and phrases that he considered of special point are here given in French, in brackets. Likewise, indication is given of words and passages that the Flournoy publication left in English.

—EDITORS.]

[Note: The original English text of the article was published as “Some Instances of Subconscious Creative Imagination,” in *The Journal of the American Society for Psychical Research* (New York), 1:6 (June 1907). There is no evidence that Jung was acquainted with this version, and the present translated version is retained.

—EDITORS (1974).]

SOME INSTANCES OF SUBCONSCIOUS CREATIVE IMAGINATION

by Miss Frank Miller of New York

I. PHENOMENA OF TRANSITORY SUGGESTION OR OF INSTANTANEOUS AUTOSUGGESTION

What I mean by this, in default of a better term, is a curious phenomenon that I have observed in myself and that occurs in different forms. It consists in this, that at certain moments and for a few seconds only, the impressions or feelings of another person are so strongly suggested to me that they seem to be *mine*, although, as soon as the suggestion is over, I am perfectly sure that this was not the case. Here are some examples:

1. I am passionately fond of caviar, the odour and taste of which are, on the contrary, very repellent to certain members of my family. But if one of them, just as I am about to eat it, begins to express her disgust, this disgust is at once suggested to me so clearly that, for a few moments, I feel complete repugnance for the smell and the taste of

caviar. It takes, however, only a minute's effort for me to dispel this impression and to find the caviar as delectable as ever.

2. Here, on the other hand, is an example of the transmission of a pleasing impression. There are certain perfumes and essences that affect me disagreeably because they smell too strong, so much so as to give me nausea and make me almost ill. Yet if a lady begins to smell her eau-de-Cologne, recommending it to me for its strength and exquisite perfume, her pleasure for an instant becomes mine—probably not for more than three to five seconds—after which it disappears and gives place to my usual aversion to strong odours. It is much easier for me, it seems, to dismiss the agreeable suggestion and return to my real feeling of distaste than to do the reverse.

3. When I am following a story with great interest, either reading or listening, I often have the illusion, which may last up to a minute, of really taking part in the action, instead of merely reading or hearing it. This is especially marked at fine theatrical productions (for example, performances by Sarah Bernhardt, Duse, or Irving). The illusion becomes so complete in certain very moving scenes that in *Cyrano*, for instance, when Christian is killed and Sarah Bernhardt throws herself upon him to stanch the bleeding of his wound, I have felt a real, piercing pain in my own breast, just where Christian is supposed to have received the blow. This kind of suggestion may last a minute, or a second.

4. Such momentary suggestions sometimes take on very curious aspects, in which the part played by imagination is accentuated. For example, I have enjoyed my sea voyages enormously, and I retain a particularly vivid memory of crossing the Atlantic. Now, someone lately showed me a beautiful photograph of a steamship in mid ocean; and instantly—the illusion was of an arresting power and beauty—I felt the throb of the engines, the heave of the waves, the roll of the ship. It can hardly have lasted for more than a second, but during that barely appreciable instant it was as though I were once more at sea. The same phenomenon recurred, though less clearly, on seeing the same photograph again some days later.

5. Here is an example proceeding evidently from creative fantasy. One day when I was taking a bath and was preparing to use the shower, I was in the act of winding a towel round my head to protect my hair from the water. The towel, of a thick material, had taken a conical shape, and I was standing in front of a mirror to pin it firmly in place. This conical form was, no doubt, a striking reminder of the pointed head-dress of the ancient Egyptians; be that as it may, it seemed to me, for one moment and with an almost breath-taking clarity, that I was on a pedestal, a veritable Egyptian statue with all its details; stiff-limbed, one foot forward, holding insignia in my hand, etc. This indeed was superb, and it was with regret that I felt the impression fading away like a rainbow; like a rainbow, too, it returned again faintly before it disappeared altogether.

6. Yet another phenomenon. An artist of some reputation very much wished to illustrate some of my publications. But in this matter I have my own ideas and am difficult to please. However, I succeeded in making him draw landscapes, such as those of Lake Geneva, where he had never been, and he used to pretend that I could make him depict things that he had never seen and give him the sense of a surrounding atmosphere that he had never felt; in short, that I was using him as he himself used his pencil; that is, simply as an instrument.

I do not attach much importance to the various things I have just described—they are so fugitive and nebulous!—and I think that all persons with a nervous temperament and imagination, who react with a lively sympathy towards external impressions, experience analogous phenomena. They do not seem to me to be of much consequence in themselves, unless they can help us to understand other things, less elementary. I believe that this sympathetic or sympathizing (sympathetic ¹) temperament, in people whose health is quite normal, plays a large part in the creation or the possibility of such “suggested” images and impressions. Now, may it not be that, under certain favourable conditions, something quite new, different from anything that one knows, may come over the mental horizon, something as dazzling and splendid as a rainbow and yet as natural in its origin and cause? For, surely, these queer little experiences (I mean the last of those above) differ as much from the ordinary, everyday course of life as a rainbow differs from blue sky.

The aim of the few preceding observations is to serve as an introduction to two or three further, more important ones which, in their turn, seem to me of a nature that throws some light on the even more complex and mystifying phenomena experienced by other persons, who are carried away by them because they are unable—or unwilling—to analyse the abnormal, subliminal, or subconscious working of their minds.

II. “GLORY TO GOD”: A DREAM POEM

1. One could imagine nothing more delightful than the voyage from Odessa to Genoa in winter, with brief but entrancing landings at Constantinople, Smyrna, Athens, at the ports of Sicily and the west coast of Italy.... One must be a philistine indeed, devoid of any aesthetic feeling, not to be carried away with admiration by the glory of the Bosphorus, or not to respond with all one’s soul to the remembrance of the past in Athens.... That was the voyage on which I was privileged to go at the age of twenty, with my family, in 1898.

After the long and rough voyage from New York to Stockholm, then to St. Petersburg and Odessa, it was a real pleasure [*une véritable volupté*] to leave the world of cities, of roaring streets, of business—in short, of the earth—and enter the world of waves, sky, and silence.... I spent hours on end on the deck of the ship, dreaming, stretched out in a deck chair. All the histories, legends, and myths of the different countries I saw in the distance came back to me confusedly, dissolved in a kind of luminous mist in which real things seemed to lose their being, while dreams and ideas

took on the aspect of the only true reality. At first I even avoided all company and kept to myself, lost in my reveries, where everything I had ever known that was truly great, beautiful, and good came back to mind with renewspiritualism or the contra-natural ed life and vigour. I also spent a good part of my days writing to absent friends, reading, or scribbling little bits of poetry in remembrance of the various places we visited. Some of these poems were of a rather serious character. But as the voyage drew near its end, the ship's officers outdid themselves in kindness and amiability [*se montrèrent tout ce qu'il y a de plus empressés et aimables*], and I passed many an amusing hour teaching them English.

Off the coast of Sicily, in the port of Catania, I wrote a sea-chanty, which, however, was little more than an adaptation of a well-known song about the sea, wine, and love ("Brine, wine and damsels fine"²). The Italians are all good singers, as a rule; and one of the officers, singing at night as he stood watch on deck, had made a great impression on me and had given me the idea of writing some words that could be fitted to his melody.

Soon afterwards, I nearly did as the old proverb says, "See Naples and die," for in the port of Naples I began by being very ill (though not dangerously so); then I recovered sufficiently to go ashore and visit the principal sights of the city in a carriage. This outing tired me extremely; and as we were intending to visit Pisa the next day, I soon returned on board and went to bed early, without thinking of anything more serious than the good looks of the officers and the ugliness of Italian beggars.

2. From Naples to Leghorn is one night by boat, during which I slept moderately well—my sleep is rarely deep or dreamless—and it seemed to me that my mother's voice woke me up just at the end of the following dream, which must, therefore, have taken place immediately before waking.

First, I was vaguely conscious of the words "when the morning stars sang together,"³ which served as the prelude, if I may so put it, to an involved idea of creation and to mighty chorales reverberating through the universe. But, with the confusion and strange contradiction characteristic of dreams, all this was mixed up with choruses from oratorios given by one of the leading musical societies of New York, and with indistinct memories of Milton's *Paradise Lost*. Then, slowly, out of this medley, words appeared, and a little later they arranged themselves in three stanzas, in my handwriting, on a sheet of ordinary blue-lined writing-paper, in a page of my old poetry album that I always carry about with me: in short, they appeared to me exactly as they did in reality, a few minutes later, in my book.

That was the moment when my mother called to me: "Now then, wake up! You can't sleep all day and see Pisa too!" This made me jump down from my bunk, crying out, "Don't speak to me! Not a word! I've just had the most beautiful dream in my life, a real poem! I have seen and heard the words, the verses, even the refrain. Where is my

notebook? I must write it down at once before I forget any of it.”—My mother, quite accustomed to see me writing at all hours, took my whim in good part and even admired my dream, which I told her as quickly as I could put it into sentences. It took me some minutes to find my notebook and a pencil and slip on a garment; but, short though it was, this delay was enough for my immediate recollection of the dream to have begun to fade a little; so that, when I was ready to write, the words had lost something of their clearness. However, the first verse came easily enough; the second was harder to recollect, and it cost me a great effort to re-memorize the last, distracted as I was by the feeling that I cut a rather ridiculous figure, perched on the upper bunk of the cabin, and scribbling away, half-dressed, while my mother made fun of me. Thus, the first version left something to be desired. My duties as a guide absorbed me after this, until the end of our long voyage; and it was not until some months later, when I was installed at Lausanne for my studies, that the thought of this dream came back to haunt me in the calm of loneliness. Then I produced a second version of my poem, more exact than the first, I mean much closer to the original dream. I give it here in both forms.

FIRST VERSION ⁴

When God had first made Sound,
A myriad ears sprang into being
And throughout all the Universe
Rolled a mighty echo:
“Glory to the God of Sound!”
When beauty (light) first was given by God,
A myriad eyes sprang out to see
And hearing ears and seeing eyes
Again gave forth that mighty song:
“Glory to the God of Beauty (Light)!”
When God has first given Love,
A myriad hearts leapt up;
And ears full of music, eyes all full of Beauty,
Hearts all full of love sang:
“Glory to the God of Love!”

SECOND VERSION (more exact)⁴

When the Eternal first made Sound
A myriad ears sprang out to hear,
And throughout all the Universe
There rolled an echo deep and clear:
“All glory to the God of Sound!”
When the Eternal first made Light,
A myriad eyes sprang out to look,
And hearing ears and seeing eyes,
Once more a mighty choral took:
“All glory to the God of Light!”
When the Eternal first gave Love,
A myriad hearts sprang into life;
Ears filled with music, eyes with light,
Pealed forth with hearts with love all rife:
“All glory to the God of Love!”

3. Never having been an adept in spiritualism or the contranatural (which I distinguish from the supernatural), I set to work, some months afterwards, trying to find out the probable causes and the necessary conditions for such a dream.

What struck me most, and still seems to me like an unexplained fantasy, is that, contrary to the Mosaic account, in which I had always believed, my poem put the creation of light in the second place instead of the first. It may be of interest to recall that Anaxagoras, too, makes the cosmos arise out of chaos the previous poem by means of a whirlwind—which does not normally occur without producing a noise. But at that time I had not yet made a study of philosophy and I knew nothing either of Anaxagoras or of his theories about the *νοῦς* which I found I had been unconsciously following. I was in equally complete ignorance of the name of Leibniz and consequently of his doctrine “*dum Deus calculat fit mundus.*” But let us come to what I have discovered concerning the probable sources of my dream.

In the first place, there is Milton’s *Paradise Lost*, of which we had a fine edition at home, illustrated by Gustave Doré, and which I have known well since childhood. Then the Book of Job, which has been read aloud to me ever since I can remember. Now, if you compare my first line with the first words of *Paradise Lost*, you find it is in the same metre (u—/u—/u—/u—):

Of man’s first disobedience ...

When the Eternal first made sound.

Moreover, the general idea of my poem is slightly reminiscent of various passages in Job, and also of one or two places in Handel’s oratorio *The Creation* ⁵ (which appeared in the confusion at the beginning of the dream).

I remember that, at the age of fifteen, I was very much excited by an article my mother had read to me, about “the Idea spontaneously creating its own object,” and I passed almost the whole night without sleep, wondering what it could all mean.—From the age of nine to sixteen, I used to go on Sundays to a Presbyterian church, where the pastor was a highly cultivated man, now president of a well-known college. And in one of the earliest memories I have of him, I see myself, still quite a little girl, sitting in our large pew in church and struggling to keep myself awake, without being able to understand what in the world he meant when he spoke to us of “Chaos,” “Cosmos,” and “the Gift of Love.”

With regard to dreams, I recollect that once, at the age of fifteen, while I was preparing for an examination in geometry, and had gone to bed without being able to solve a problem, I awoke in the middle of the night, sat up in bed, repeated to myself a formula that I had just discovered in a dream, and then went to sleep again, and in the morning everything had become clear in my mind.—Something very similar happened to me with a Latin word I was trying to remember.—I have also dreamed, many times, that friends far away have written to me, and this just before the actual arrival of letters from them; the explanation of which is, very simply, that while I was asleep I calculated approximately the time they would be likely to write to me, and that the idea of the letter’s actual arrival was substituted, in the dream, for the expectation of its probable

arrival. I draw this conclusion from the fact that I have several times had dreams of receiving letters that were not followed by their arrival.

To sum up, when I reflect upon the foregoing, and upon the fact that I had just composed a number of poems at the time of this dream, the dream does not seem to me so extraordinary as it did at first. It seems to me to result from a mixture in my mind of *Paradise Lost*, *Job*, and *The Creation*, with notions like the “Idea spontaneously creating its own object,” the “Gift of Love,” “Chaos,” and “Cosmos.” Just as the little bits of coloured glass in a kaleidoscope form marvellous and rare patterns, so, in my opinion, the fragments of philosophy, aesthetics, and religion in my mind were blended together—under the stimulation of the voyage and of countries fleetingly seen, coupled with the vast silence and impalpable charm of the sea—to produce this beautiful dream. There was only this and nothing more. [*Ce ne fut que cela et rien de plus.*] “Only this and nothing more!”⁶

III. “THE MOTH AND THE SUN”: A HYPNAGOGIC POEM

The day before I left Geneva for Paris had been extremely exhausting. I had made an excursion up the Salève, and on my return I found a telegram that obliged me to pack my bags, settle my affairs, and depart within the space of two hours. My fatigue on the train was such that I hardly slept an hour. It was horribly hot in the ladies’ compartment. Towards four o’clock I lifted my head from the bag that had served me for a pillow, sat up, and stretched my swollen limbs. A tiny butterfly, or moth, was fluttering towards the light that shone through the glass panel behind a curtain that was swinging with the motion of the train. I lay down and tried to sleep again, and almost succeeded; that is to say, I found myself as nearly asleep as possible without completely losing self-consciousness. It was then that the following piece of poetry suddenly came into my mind. It was impossible to drive it away in spite of my repeated efforts. I took a pencil and wrote it down straight away.

*The Moth to the Sun*⁷

I longed for thee when first I crawled to consciousness.
My dreams were all of thee when in the chrysalis I lay.
Oft myriads of my kind beat out their lives
Against some feeble spark once caught from thee.
And one hour more—and my poor life is gone;
Yet my last effort, as my first desire, shall be
But to approach thy glory: then, having gained
One raptured glance, I’ll die content,
For I, the source of beauty, warmth and life
Have in his perfect splendor once beheld!

This little poem made a profound impression on me. I could not at first find a sufficiently clear and direct explanation of it. But a few days afterwards, having again

taken up a philosophical article that I had read in Berlin the previous winter, which had delighted me extremely, and reading it aloud to a friend, I came upon these words: “The same passionate longing of the moth for the star, of man for God....” I had completely forgotten them, but it seemed to me quite obvious that these were the words that had reappeared in my hypnagogic poem. Moreover, a play entitled *The Moth and the Flame*,⁸ which I saw a few years ago, also came back to me as another possible source of my poem. You see how often the word *Moth* has been impressed upon me!—I would add that, in the spring, I had been reading a selection of Byron’s poems that pleased me greatly and that I often dipped into. Moreover, there is a great similarity of rhythm between my two last lines, “For I, the source, etc.” and these two of Byron’s:

Now let me die as I have lived in faith

Nor tremble tho’ the Universe should quake!

It is possible that my having so often read this book had an influence on me, and contributed towards my inspiration, as much from the point of view of meaning as of rhythmical form.

Comparing this poem, which came to me in a half-waking dream-state, with, on the one hand, those written when wide awake and, on the other hand, the previous poem [Sec. II, above] that came when I was fast asleep, it seems to me that these three categories form a perfectly natural series. The intermediate state establishes a simple and easy transition between the two extremes, and thus dispels any suspicion of an intervention of the “occult” that one might have had about the poem I produced while asleep.

IV. “CHI WANTOPEL”: A HYPNAGOGIC DRAMA

Borderland phenomena—or, if you prefer it, the productions of the brain in the half-dreaming state—are of particular interest to me, and I believe that a detailed and intelligent examination of them would do much to clear up the mystery of so-called “spirits” and dispel superstition concerning them. It is with this idea in mind that I am sending you an observation which, in the hands of someone less careful of the exact truth, or less scrupulous about indulging in embroideries or amplifications, might very well give rise to some fantastic romance that would outdo the fictitious ramblings of your mediums. I have rewritten the following observation as faithfully as possible from the notes I made immediately after the half-dream in question, and have limited myself to the insertion between brackets [] of one or two remarks and of letters referring to the explanatory notes that follow.

Observation of 17 March, 1902. Half an hour after midnight.

1st Phase.—After an evening of trouble and anxiety, I had gone to bed at half past eleven. I felt restless; unable to sleep although very tired. I had the impression of being in a receptive mood. There was no light in the room. I closed my eyes, and had the

feeling of waiting for something that was about to happen. Then I felt a great relaxation come over me, and I remained as completely passive as possible. Lines, sparks, and spirals of fire passed before my eyes, symptoms of nervousness and ocular fatigue, followed by a kaleidoscopic and fragmentary review of recent trivial events. Then an impression that something was on the point of being communicated to me. It seemed as if these words were repeating themselves in me—"Speak, Lord, for thy servant heareth—Open thou mine ears." The head of a sphinx suddenly appeared in the field of vision, in an Egyptian setting: then it faded away. At that moment my parents called to me, and I immediately answered them in a perfectly coherent way, a proof that I was not asleep.

2nd Phase.—Suddenly, the apparition of an Aztec, complete in every detail: hand open, with large fingers, head in profile, armoured, with a head-dress resembling the plumed crests of the American Indians, etc. The whole is somewhat suggestive of the carvings on Mexican monuments [note A].^{8a}—The name "Chi-wan-to-pel" forms itself bit by bit, and it seems to belong to the previous personage, son of an Inca of Peru [note B].—Then a swarm of people. Horses, a battle, the view of a *dream-city* [note C].—A strange conifer with knotty branches, lateen sails in a bay of purple water, a perpendicular cliff. A confusion of sounds resembling Wa-ma, Wa-ma, etc.

(A lacuna.)—The scene changes to a wood. Trees, undergrowth, bushes, etc. The figure of Chi-wan-to-pel comes up from the south, on horseback, wrapped in a blanket of bright colours, red, blue, and white. An Indian, dressed in buckskin, beaded and ornamented with feathers [note D], creeps forward stealthily, making ready to shoot an arrow at Chi-wan-to-pel, who bares his breast to him in an attitude of defiance [note E]; and the Indian, fascinated by this sight, slinks away and disappears into the forest. Chi-wan-to-pel sinks down upon a mound, leaves his horse to graze on the tether, and delivers himself of the following soliloquy, all in English: ⁹ "From the tip of the backbone of these continents [probably an allusion to the Andes and the Rocky Mountains], from the farthest lowlands, I have wandered for a hundred moons since quitting my father's palace [note F], forever pursued by my mad desire to find 'her who will understand.' With jewels I tempted many beautiful women; with kisses tried I to draw out the secrets of their hearts, with deeds of daring I won their admiration. [He reviews one after another the women he has known.] Chi-ta, the princess of my own race ... she was a fool, vain as a peacock, without a thought in her head except trinkets and perfumes. Ta-nan, the peasant girl ... bah! a perfect sow, nothing but a bust and a belly, thinking of nothing but pleasure. And then Ki-ma, the priestess, a mere parrot, repeating the empty phrases learnt from the priests, all for show, without real understanding or sincerity, mistrustful, affected, hypocritical!... Alas! Not one who understands me, not one who resembles me or has a soul that is sister to mine [note G]. There is not one among them all who has known my soul, not one who could read my

thoughts—far from it; not one capable of seeking the shining summits with me, or of spelling out with me the superhuman word Love!”

(A lacuna.)—He cries mournfully: “In all the world there is not a single one! I have searched among a hundred tribes. I have aged a hundred moons since I began. Will there never be anyone who will know my soul?—Yes, by almighty God, yes!—But ten thousand moons will wax and wane before her pure soul is born. And it is from another world that her parents will come to this one. She will be fair of skin and fair-haired. She will know sorrow even before her mother bears her. Suffering will be her companion; she too will seek—and will find no one who understands her. Many a suitor will wish to pay court to her, but not one of them will know how to understand her. Temptation will often assail her soul, but she will not yield.... In her dreams I shall come to her, and *she will understand* [note H]. I have kept my body inviolate [note I]. I have come ten thousand moons before her time, and she will come ten thousand moons too late. *But she will understand!* It is but once in ten thousand moons that a soul like hers is born!”

(A lacuna.)—A green viper darts out of the bushes, glides towards him, and stings him in the arm; then it attacks his horse, which is the first to succumb. Then Chi-wan-to-pel says to his horse: “Farewell, faithful brother! Enter into your rest! I have loved you and you have served me well. Farewell, I shall rejoin you soon!” Then to the serpent: “Thanks, little sister, you have put an end to my wanderings!” Now he shrieks with pain and calls out in prayer, “Almighty God, take me soon! I have sought to know thee and to keep thy law. Oh, suffer not my body to fall into corruption and decay, and become carrion for the eagles!” A smoking volcano appears in the distance [note K], the rumbling of an earthquake is heard, followed by a landslide. Chi-wan-to-pel cries out in an extremity of anguish as the earth closes over his body: “Ah, she will understand! Ja-ni-wa-ma, Ja-ni-wa-ma, thou that understandest me!”

Remarks and Explanatory Notes

You will agree, I think, that as a work of imagination, this hypnagogic fantasy is well worth a little attention. It is certainly not wanting in complexity and strangeness of form, and one may even claim a certain originality for its combination of themes. One might even be able to make it into a kind of melodrama in one act. If I were personally inclined to exaggerate the purport of compositions of this kind, and were not able to recognize many familiar elements in this phantasmagoria, I might let myself go so far as to regard Chi-wan-to-pel as my “control,” my spirit-guide, after the manner of so many mediums. I need hardly tell you that I do no such thing. So let us look for the probable sources of this little account.

First, as to the name Chi-wan-to-pel: one day, when I was fully awake, there suddenly came into my mind the word A-ha-ma-ra-ma, surrounded by an Assyrian decoration, and I had only to compare it with other names I already knew, such as Ahasuerus, Asurabama (who made cuneiform bricks), to detect its origin. Similarly

here; compare Chi-wan-to-pel with Po-po-cat-a-pel,¹⁰ the name of a volcano in Central America as we have been taught to pronounce it: the similarity of construction is striking.

I note also that, on the previous day, I had received a letter from Naples, on the envelope of which there was a view of Vesuvius smoking in the distance [K].—In my childhood I was particularly interested in Aztec remains and in the history of Peru and the Incas. [A and B].—I had recently visited a fascinating exhibition of Indians, with their costumes, etc., which have found a quite appropriate place in the dream [D].—The well-known passage in Shakespeare¹¹ where Cassius bares his breast to Brutus furnishes me with an easy explanation of scene [E]; and scene [F] recalls to me the story of Buddha leaving his father's home, or equally, the story of Rasselas, prince of Abyssinia, by Samuel Johnson.—There are many details, too, which make one think of the Song of Hiawatha, Longfellow's Indian epic, whose rhythm has been unconsciously followed in several passages of Chi-wan-to-pel's soliloquy. And his burning need for someone who resembles himself [G] presents the greatest analogy with Siegfried's feelings for Brunhild, so marvellously expressed by Wagner.—Finally [I] I had recently heard a lecture by Felix Adler, on the Inviolable Personality (The inviolate Personality¹²).

In the feverish life one leads in New York, a thousand different elements are often mixed in the total impression of a single day. Concerts, lectures, books, reviews, theatrical performances, etc., there is enough to put your brain in quite a whirl. It is said that nothing of what enters into your mind is ever completely lost; that some association of ideas, or a certain conjunction of circumstances, may be enough to re-animate even the slightest impression. It seems that this may apply in many cases. For example here, the details of the *dream-city* [C] reproduced almost exactly those on the cover of one of the reviews I had lately been reading. So it is possible, after all, that this whole affair may be nothing more than a mosaic of the following elements:

- A.—Aztec remains and history of the Incas of Peru.
- B.—Pizarro in Peru.
- C.—Engravings and illustrations, recently seen in various magazines.
- D.—Exhibition of Indians with their costumes, etc.
- E.—Recollection of a passage from Shakespeare's *Julius Caesar*.
- F.—Departure of Buddha and of Rasselas.
- G. and H.—Siegfried sighing after Brunhild.
- I.—Memory of a lecture on the Inviolable Personality.
- K.—View of Vesuvius on the envelope of a letter.

And now, if I add that, for days before, I had been in quest of “an original idea,” not much effort is required to see that this mosaic may have formed itself out of the

multitude of impressions that are necessarily encountered in a very busy life, and may have taken on this fantastic, oneiric form. This was about midnight, and it may be that my fatigue and torment of mind had to some degree disturbed or deformed the current of my thoughts.

P.S.—I fear that my concern for exactitude may have induced me to give my observations rather too personal a turn. But I hope—and this is my excuse—that they may help others to free their minds from things of the same kind that are worrying them and do something to clear up the more complex phenomena that are often presented by mediums.

BIBLIOGRAPHY

BIBLIOGRAPHY

- ABEGHIAN, MANUK. *Der armenische Volksglaube*. Leipzig, 1899.
- ABRAHAM, KARL. *Dreams and Myths*. Translated by William Alanson White. (Nervous and Mental Disease Monograph Series, 15.) New York, 1913.
- Acts of Thomas*. In: *Apocryphal Gospels, Acts, and Revelations*. Translated by Alexander Walker. (Ante-Nicene Christian Library, 16.) Edinburgh, 1870. (Pp. 389–422.)
- ADLER, GERHARD. *Studies in Analytical Psychology*. London and New York, 1948.
- AESCHYLUS. *Prometheus*. In: *Aeschylus. [Plays]*. With an English translation by Herbert Weir Smyth. 2 vols. (Loeb Classical Library.) London and New York, 1922–26.
- AGRIPPA, HEINRICH CORNELIUS, of Nettesheim. *De occulta philosophia Libri tres*. Cologne, 1533.
- AIGREMONT, DR., pseud. (Siegmar Baron von Schultze-Galléra). *Fuss-und Schuhsymbolik und -Erotik*. Leipzig, 1909.
- _____. *Volkserotik und Pflanzenwelt*. 2 vols. Halle, 1908–9.
- ALCIATI, ANDREA. *Emblemata cum Commentariis*. Padua, 1621.
- APULEIUS, LUCIUS. *The Golden Ass, being the Metamorphoses of Lucius Apuleius*. With an English translation by William Adlington (1566) revised by Stephen Gaselee. (Loeb Classical Library.) London and New York, 1915.
- _____. *Les Metamorphoses ou l'Asne Dor de L. Apulée, Philosophe Platonique*. Paris, 1648.
- _____. *The Transformations of Lucius, known as the Golden Ass*. Translated by Robert Graves. (Penguin Classics.) London, 1950.
- Archäologische Zeitung*. (Gerhards Denkmäler, Forschungen und Berichte.) Berlin.
- ARCHAEOLOGISCHES INSTITUT DES DEUTSCHEN REICHES (Rome). *Annali*.
- ARNOBIUS. *Disputationum adversus Gentes libri septem*. See Migne, *P.L.*, vol. 5, cols. 713–1290.
- _____. *The Seven Books of Arnobius Adversus Gentes*. Translated by A. H. Bryce and H. Campbell. (Ante-Nicene Christian Library, 19.) Edinburgh, 1871.
- ARNOLD, SIR EDWIN. *The Light of Asia, or The Great Renunciation*. London, 1906 (1st edn., 1879).
- _____. See also Bhagavad Gita.
- ASTERIUS, BISHOP OF AMASEA. *Homilia X in sanctos martyres*. See Migne, *P.G.*, vol. 40, cols. 323–24.
- AUGUSTINE, SAINT. *Confessiones*. See Migne, *P.L.*, vol. 32. For translation, see:
- [_____] *The Confessions of St. Augustine*. Translated by Francis Joseph Sheed. New York and London, 1943.
- _____. *De Civitate Dei*. See Migne, *P.L.*, vol. 41.
- _____. *Sermo Suppositus* 120. (In *Natali Domini* IV, 8.) See Migne, *P.L.*, vol. 39, cols. 1984–87.
- _____. *Tractatus in Johannis Evangelium*. See Migne, *P.L.*, vol. 35.
- BACHOFEN, J. J. *Versuch über die Gräbersymbolik der Alten*. Basel. 1859.

- BAILLET, LOUIS. "Les Miniatures du Scivias de Ste Hildegarde," *Monuments et Mémoires publiés par l'Académie des Inscriptions et Belles-Lettres* (Paris), XIX (1911), 49–149.
- BALDWIN, JAMES MARK. *Thought and Things: A Study of the Development and Meaning of Thought, or Genetic Logic*. (Library of Philosophy.) London, 1906–11. 3 vols.
- BANCROFT, HUBERT HOWE. *The Native Races of the Pacific States of North America*. New York and London. 1875–76. 5 vols.
- BARCHUSEN, JOHANN KONRAD. *Elementa chemiae*. Lugdunum Batavorum [Leiden], 1718.
- BARLACH, ERNST. *Der tote Tag*. Berlin, 1912; 2nd edn., 1918.
- BELLOWS, HENRY ADAMS (trans.). *The Poetic Edda*. New York, 1923.
- BENNDORF, OTTO, and SCHÖNE, RICHARD. *Die antiken Bildwerke des Lateranischen Museums*. Leipzig, 1867.
- BERNARDINO DE SAHAGÚN. *General History of the Things of New Spain (Florentine Codex)*. Book 3: *The Origin of the Gods*. Translated by Arthur J. O. Anderson and Charles E. Dibble. (Monographs of the School of American Research, 14, Part IV.) Santa Fe, 1952.
- BERNOULLI, CARL ALBRECHT. *Franz Overbeck und Friedrich Nietzsche: Eine Freundschaft*. Jena, 1908. 2 vols.
- BERNOULLI, JOHANN JACOB. *Die erhaltenen Darstellungen Alexanders des Grossen*. Munich, 1905.
- BERTHELOT, MARCELLIN. *Collection des anciens alchimistes grecs*. Paris, 1887–88. 3 vols.: Introduction, Textes, Traductions.
- BERTSCHINGER, H. "Illustrierte Halluzinationen," *Jahrbuch für psychoanalytische und psychopathologische Forschungen* (Leipzig and Vienna), III (1912), 69–100.
- [Bhagavad Gita.] *The Song Celestial, or Bhagavad-Gita*. Translated by Sir Edwin Arnold. London, 1930.
- Bible. The following versions are cited textually:
- [AV] Authorized ("King James") Version (cited unless otherwise indicated).
- [DV] Douay-Reims Version.
- [RSV] Revised Standard Version (1952).
- [ZB] Zürcher Bibel (first trans. 16th cent.; cited in English trans. from a 1932 edn. published by the Consistory of Canton Zurich on the order of the Zurich Church Synod, being the German version generally used by the author).
- [____.] *Bybel printen ...* [by] Matthaëus Merian. Amsterdam, [1650?].
- BLAKE, WILLIAM. *Europe*. London, 1794.
- . *Jerusalem*. London, 1804.
- BLEULER, EUGEN. "Zur Theorie des schizophrener Negativismus." *Psychiatrisch-neurologische Wochenschrift* (Halle), XII (1910), nos. 18–21.
- [BÖHME, JAKOB.] *Auslese aus den mystisch-religiösen Schriften Jakob Böhmes*. Newly edited, after the original Amsterdam edn. of 1700, by A. von den Linden. (Geheime Wissenschaften, 16.) Berlin, 1918.
- BOTHO, CONRAD. *Sachsisch Chronicon ... continuirt bis vff den Monat Maium ... 1596 ... durch Mattheum Dresserum*. Magdeburg, 1596.

- BOUSSET, WILHELM. *The Antichrist Legend*. Translated by A. H. Keane. London, 1896.
- BROWN, W. NORMAN. "The Sources and Nature of pūruṣa in the Pūruṣasukta (Rigveda 10.91)," *Journal of the American Oriental Society* (New Haven), LI (1931), 108–18.
- BRUGSCH, HEINRICH. *Die Adonisklage und das Linoslied*. Berlin, 1852.
- _____. *Dictionnaire hiéroglyphique (Hieroglyphisch-demotisches Wörterbuch)*. Leipzig, 1867–82 (lithographed). 7 vols.
- _____. *Religion und Mythologie der alten Ägypter*. Leipzig, 1885–88. 2 parts.
- BUBER, MARTIN (ed.). *Ekstatische Konfessionen*. Jena, 1909.
- BÜCHER, KARL. *Arbeit und Rhythmus*. Leipzig, 1899; 3rd edn., 1902.
- _____. *Die Aufstände der unfreien Arbeiter 143 bis 129 vor Christus*. Frankfurt, 1874.
- BUDGE, SIR ERNEST ALFRED THOMPSON WALLIS. *Coptic Apocrypha in the Dialect of Upper Egypt*. London, 1913.
- _____. *The Gods of the Egyptians*. London, 1904. 2 vols.
- _____. *Osiris and the Egyptian Resurrection*. London, 1911. 2 vols.
- Bundahish. In: E. W. WEST (tr.). *Pahlavi Texts*. (Sacred Books of the East, 5.) Oxford, 1880.
- BUNSEN, CHRISTIAN CARL JOSIAS, BARON VON. *Versuch eines allgemeinen Gesang- und Gebetbuchs*. Hamburg, 1833.
- BURCKHARDT, JACOB. *The Civilization of the Renaissance [in Italy]*. London and New York (Phaidon Press), 1944.
- [_____] *The Letters of Jacob Burckhardt*. Selected, edited, and translated by Alexander Dru. London and New York, 1955.
- BYRON, GEORGE GORDON, LORD. *Poetical Works*. Oxford, 1945.
- CAESAR, CAIUS JULIUS. *The Gallic War*. With an English translation by H. J. Edwards. (Loeb Classical Library.) London and New York, 1917.
- CAETANI-LOVATELLI, ERSILIA, COUNTESS. *Antichi monumenti illustrati*. Rome, 1889.
- CANNEGIETER, HENDRIK. *Epistola ad comitem Ottonem de Lynden, de ara ad Noviomagum Gelriae reperta, aliisque inscriptionibus nuper effossis*. Arnheim, 1766.
- CARLYLE, THOMAS. "On Heroes and Hero-Worship" [1841]. In: *Sartor Resartus; On Heroes, Hero-Worship, and the Heroic in History*. (Everyman's Library.) London and New York, 1948.
- CHAMBERLAIN, HOUSTON STEWART. *The Foundations of the 19th Century*. Translated by John Lees. London and New York, 1911 [1910]. 2 vols.
- CHANTEPIE DE LA SAUSSAYE, PIERRE DANIEL. *Lehrbuch der Religionsgeschichte*. Tübingen, 1905. 2 vols.
- CHAPOUTHIER, FERNAND. *Les Dioscures au service d'une déesse*. (Bibliothèque des Écoles françaises d'Athènes et de Rome, fasc. 137.) Paris, 1935.
- CICERO, MARCUS TULLIUS. *De inventione, etc.* With an English translation by H. M. Hubbell. (Loeb Classical Library.) London and New York, 1949.

- _____. [De natura deorum.] In: *Academica*. With an English translation by H. Rackham. (Loeb Classical Library.) London and New York, 1933.
- _____. *Pro Quintio, etc.* With an English translation by J. H. Freese. (Loeb Classical Library.) London and New York, 1930.
- _____. *The Tusculan Disputations*. With an English translation by J. E. King. (Loeb Classical Library.) London and New York, 1927.
- CLAPARÈDE, ÉDOUARD. “Quelques mots sur la définition de l’hystérie,” *Archives de psychologie* (Geneva), VII (1908), 169–93.
- CLEMEN, PAUL. *Die romanischen Wandmalereien des Rheinlands*. (Publikationen der Gesellschaft für rheinische Geschichtskunde, 25.) Düsseldorf, 1905.
- CLEMENT OF ALEXANDRIA. *Protrepticus*. In: *The Writings of Clement of Alexandria*. Translated by the Rev. William Wilson. (Ante-Nicene Christian Library, 4, 12.) Edinburgh, 1877–79.
- CLEMENT OF ROME, SAINT. *Homilies*. See Migne, P.G., vol. 2. Translation: *The Clementine Homilies*. Translated by the Rev. Alexander Roberts and James Donaldson. (Ante-Nicene Christian Library, 17.) Edinburgh, 1870.
- COHN, WILLIAM. *Buddha in der Kunst des Ostens*. Leipzig, 1925.
- COLERIDGE, SAMUEL TAYLOR. *The Poems*. Edited by E. H. Coleridge. London, 1935.
- COLONNA, FRANCESCO. *Hypnerotomachia Poliphili*.... Venice, 1499. See also FIERZ-DAVID.
- CONYBEARE, F. C. C. “Die Jungfräuliche Kirche und die jungfräuliche Mutter,” *Archiv für Religionswissenschaft* (Freiburg i. B.), IX (1906), 73–86.
- CORNFORD, W. F. (trans.). *Plato’s Cosmology; The Timaeus of Plato*. New York and London, 1937.
- CREUZER, [GEORG] FRIEDRICH. *Symbolik und Mythologie der alten Völker*. Leipzig and Darmstadt, 1810–23. 6 vols.
- [CRÈVECOEUR, MICHEL GUILLAUME JEAN DE.] *Voyage dans la Haute Pensylvanie*. Paris, 1801. 3 vols.
- CUMONT, FRANZ. *The Mysteries of Mithra*. Translated from the 2nd revised French edn. by Thomas J. McCormack. London, 1903.
- _____. *Textes et monuments figurés relatifs aux mystères de Mithra*. Brussels, 1896–99. 2 vols.
- CYPRIAN, SAINT, pseud. *De Pascha Computus*. In: Migne, P.L., vol. 4, cols. 939–68.
- DANZEL, THEODOR WILHELM. “Altmexikanische Symbolik.” *Eranos-Jahrbuch 1937* (Zurich, 1938).
- _____. *Mexiko I*. (Kulturen der Erde, 11.) Hagen i. W. and Darmstadt, 1922.
- _____. *Symbole, Dämonen und heilige Türme*. Hamburg, 1930.
- DARESSY, GEORGES. “Statues de divinités,” *Catalogue générale des antiquités égyptiennes du Musée du Caire*, nos. 38001–39384 (1905–6).
- DE GUBERNATIS, ANGELO. *Zoological Mythology*. London, 1872. 2 vols.
- DE JONG, KAREL HENDRIK EDUARD. *Das antike Mysterienwesen*. Leiden, 1909.
- DEUBNER, LUDWIG. *Attische Feste*. Berlin, 1932.
- DEUSSEN, PAUL. *Allgemeine Geschichte der Philosophie*. Leipzig, 1894–1917. 2 vols.

_____. *Sechzig Upanishad's des Veda*. Leipzig, 1897; 3rd edn., 1938.

DIETERICH, ALBRECHT. *Abraxas: Studien zur Religionsgeschichte des späteren Altertums*. Leipzig, 1891.

_____. *Eine Mithrasliturgie*. Leipzig, 1903; 2nd edn., 1910.

_____. *Mutter Erde*. Leipzig, 1905; 2nd edn., 1913.

DIEZ, FRIEDRICH CHRISTIAN. *Etymologisches Wörterbuch der romanischen Sprachen*. 5th edn., Bonn, 1887.

DIO CHRYSOSTOM. [Works.] With an English translation by J. W. Cohoon and H. Lamar Crosby. (Loeb Classical Library.) London and New York, 1932–51. 5 vols.

DIODORUS. [Works.] Edited with an English translation by C. H. Oldfather and Russel M. Geer. (Loeb Classical Library.) London and New York, 1935– . 12 vols. (vols. 1–4 and 9 published).

DIOSCORIDES. *Pedanii Dioscuridis de materia medica libri quinque*. Edited by Max Wellmann. Berlin, 1907–14. 3 vols.

DREWS, ARTHUR. *The Christ Myth*. Translated [from the 3rd edn.] by C. Delisle Burns. London and Leipzig, [1910].

_____. *Plotin und der Untergang der antiken Weltanschauung*. Jena, 1907.

DREXEL, FRIEDRICH. “Das Kastell Stockstadt,” *Der obergermanisch-raetische Limes des Römerreiches* [pub. at Heidelberg by the Reichs-Limeskommission], XXXIII (1910), 1–136.

DUCHESNE, LOUIS. *Le Liber Pontificalis*. Texte, Introduction et Commentaire. (Bibliothèque des Écoles françaises d'Athènes et de Rome, 2nd series, III.) Paris, 1886–92, 2 vols.

EBBINGHAUS, HERMANN. “Psychologie.” In: WILHELM DILTHEY and others. *Die Kultur der Gegenwart*. Berlin and Leipzig, 1907.

EBERSCHWEILER, A. “Untersuchungen über die sprachliche Komponente der Assoziation.” In: *Allgemeine Zeitschrift für Psychiatrie* (Berlin), LXV (1908), 240–71.

EHRENSTEIN, THEODOR. *Das Alte Testament im Bilde*. Vienna, 1923.

ELIEZER, BEN HYRCANUS, pseud. *Pirkê de Rabbi Elieser*. Translated and annotated ... by Gerald Friedlander. London, 1916.

EMERSON, RALPH WALDO. *The Conduct of Life*. In: *The Complete Works of Ralph Waldo Emerson*. Edited by Edward Waldo Emerson. (Centenary Edition.) Boston, 1903–4. 16 vols. (Vol. VI.)

EPIPHANIUS, SAINT. *Adversus octoginta haereses, vel Panarium*. See Migne, P.G., vol. 41, col. 173, to vol. 42, col. 832.

ERMAN, ADOLF. *Life in Ancient Egypt*. Translated by H. M. Tirard. London and New York, 1894.

_____. *Literature of the Ancient Egyptians*. Translated by A. M. Blackman. London, 1927.

_____. *Die Religion der Ägypter*. Berlin and Leipzig, 1934.

EVELYN-WHITE, H. G. (trans.). *Hesiod, the Homeric Hymns and Homeric*. (Loeb Classical Library.) London and New York, 1920.

FERENCZI, SANDOR. “Introjection and Transference.” In: *First Contributions to Psycho-Analysis*. Translated by Ernest Jones. London, 1952.

- FERRERO, GUGLIELMO. *Les Lois psychologiques du symbolisme*. Paris, 1895. (Original: *I Simboli in rapporto alla storia e filosofia del diritto*. Turin, 1893.)
- FICHTE, IMMANUEL HERMANN VON. *Psychologie*. Leipzig, 1864–73. 2 vols.
- FICK, FRIEDRICH CHRISTIAN AUGUST. *Vergleichendes Wörterbuch der indogermanischen Grundsprache*. 4th edn., Göttingen, 1890–1909. 3 vols. See also STOKES.
- [FIERZ-DAVID, LINDA.] *The Dream of Poliphilo*. Related and interpreted by Linda Fierz-David. Translated by Mary Hottinger. (Bollingen Series XXV.) New York, 1950. See also COLONNA.
- FIRMICUS MATERNUS, JULIUS. *De errore profanarum religionum*. Edited by Konrad Ziegler. Leipzig, 1907.
- _____. *Matheseos libri octo*. Edited by W. Kroll, F. Skutsch, and K. Ziegler. Leipzig, 1897–1913. 2 vols.
- FLOURNOY, THÉODORE. *From India to the Planet Mars*. Translated by D. B. Vermilye. New York and London, 1900.
- _____. See also MILLER.
- FRANCE, ANATOLE. *Le Jardin d'Épicure*. 4th edn., Paris, 1895.
- FRAZER, SIR JAMES GEORGE. *The Golden Bough*. Part III: "The Dying God"; Part IV: "Adonis, Attis, Osiris." London, resp. 1911 and 1907 (2nd edn.).
- FREUD, SIGMUND. "Analysis of a Phobia in a Five-year-old Boy." In: Standard Edition,* X. London, 1955. (Pp. 3–149.)
- _____. "Creative Writers and Day-Dreaming." In: Standard Edition, IX. London, 1959. (Pp. 143–153.)
- _____. "The Dynamics of the Transference." In: Standard Edition, XII. London, 1958. (Pp. 99–108.)
- _____. "The Future of an Illusion." In: Standard Edition, XXI. London, 1961. (Pp. 5–56.)
- _____. *The Interpretation of Dreams*. In: Standard Edition, IV and V. London, 1953.
- _____. "Leonardo da Vinci and a Memory of His Childhood." In: Standard Edition, XI. London, 1957. (Pp. 63–137.)
- _____. "Psycho-Analytic Notes on an Autobiographical Account of a Case of Paranoia (Dementia Paranoides)." In: Standard Edition,* XII. London, 1958. (Pp. 9–82.)
- _____. "Three Essays on the Theory of Sexuality." In: Standard Edition, VII. London, 1953. (Pp. 123–243.)
- FRIEDLÄNDER, S. " 'Veni Creator!' Zehn Jahre nach dem Tode Friedrich Nietzsche's," *Jugend* (Munich), II (1910):35, 823.
- FROBENIUS, LEO. *Das Zeitalter des Sonnengottes*. Vol. I (no more published). Berlin, 1904.
- FUHRMANN, ERNST. *Reich der Inka*. (Kulturen der Erde, 1 and 2.) Hagen i. W., 1922. 2 vols.
- GATTI, ATTILIO. *South of the Sahara*. London, 1946.
- GIVRY, G. DE. *Le Musée des Sorciers*. Paris, 1929.
- [GOETHE.] *Goethe's Faust, Parts I and II*. An abridged version translated by Louis MacNeice. London and New York, 1951.
- _____. *Faust, Part One and Part Two*. Translated by Philip Wayne. (Penguin Classics.) Harmondsworth, 1949, 1959.

- GOODENOUGH, ERWIN R. "The Crown of Victory in Judaism," *Art Bulletin* (New York), XXVIII (Sept., 1946), 139–59.
- GÖRRES, JOHANN JOSEPH VON. *Die Christliche Mystik*. Regensburg and Landshut, 1836–42. 4 vols.
- GRAF, MAX. *Richard Wagner im Fliegenden Holländer*. (Schriften zur angewandten Seelenkunde, 9.) Leipzig and Vienna, 1911.
- GRAY, LOUIS HERBERT, and MACCULLOCH, JOHN ARNOTT (eds.). *The Mythology of All Races*. Boston, 1916–28. 13 vols.
- GRESSMANN, HUGO. *Altorientalische Texte und Bilder zum alten Testamente*. Tübingen, 1909. 2 vols.
 _____. *Die orientalischen Religionen im hellenistisch-römischen Zeitalter*. Berlin and Leipzig, 1930.
- GRIMM, JAKOB LUDWIG KARL. *Teutonic Mythology*. Translated from the 4th edn. by James Steven Stallybrass. London, 1883–88. 4 vols.
- GUÉNON, RENÉ. *Man and His Becoming according to the Vedānta*. London, 1945.
- GUIRAND, FÉLIX (ed.). *Mythologie générale*. Paris, 1935.
- GUNKEL, JOHANN FRIEDRICH HERMANN. *Schöpfung und Chaos in Urzeit und Endzeit*. Göttingen, 1895.
- GURLITT, W. "Vorbericht über Ausgrabungen in Pettau," *Jahreshefte des österreichischen archäologischen Institutes in Wien*, II (1899), col. 101.
- HAHN, EÜDARD. *Demeter und Baubo*. Lübeck, [1896].
- HAMANN, JOHANN GEORG. *Schriften*. Edited by Friederich Roth. Berlin, 1821–43. 8 vols.
- HARDING, MARY ESTHER. *The Way of All Women*. London and New York, 1933.
- HARRER, HEINRICH. *Seven Years in Tibet*. London, 1954.
- HARTLAUB, GUSTAV FRIEDRICH. *Giorgiones Geheimnis*. Munich, 1925.
- HARTMANN, KARL ROBERT EDUARD VON. *Die Weltanschauung der modernen Physik*. Leipzig, 1902.
- HAUPTMANN, GERHART. *Hannele*. Translated by Charles Henry Meltzer. London and New York, 1908.
 _____. *The Sunken Bell*. Translated by Charles Henry Meltzer. London and New York, 1900.
- HEIDEL, ALEXANDER. *The Gilgamesh Epic and Old Testament Parallels*. Chicago, 1946.
- [HEINE, HEINRICH.] *Heine's Book of Songs*. Translated by John Todhunter. Oxford, 1907.
- [_____] *Heinrich Heine, Paradox and Poet: The Poems*. Translated by Louis Untermeyer. New York, 1937.
- HERODOTUS. *The Histories*. Translated by Aubrey de Selincourt. (Penguin Classics.) Harmondsworth, 1953.
- HERRMANN, PAUL. *Nordische Mythologie in gemeinverständlicher Darstellung*. Leipzig, 1903.
- HERZOG, RUDOLF. "Aus dem Asklepieion von Kos," *Archiv für Religionswissenschaft* (Freiburg i. B.), X (1907), 201–28.
- HESIOD. See EVELYN-WHITE.
- HIPPOCRATES. In: *Hippocrates and the Fragments of Heracleitus*. Translated by W. H. S. Jones and E. T. Withington. (Loeb Classical Library.) London and New York, 1923–31. 4 vols.
- HIPPOLYTUS. *Elenchos*. In: *Hippolytus' Werke*. Edited by Paul Wendland. Vol. III. Leipzig, 1916.

- HIRT, HERMANN. *Etymologie der neuhochdeutschen Sprache*. Munich, 1909.
- HOFFMANN, ERNEST THEODOR WILHELM. *The Devil's Elixir*. Edinburgh, 1824. 2 vols.
- HÖLDERLIN, JOHANN CHRISTIAN FRIEDRICH. *Gedichte*. Edited by Franz Zinkernagel. Leipzig, 1922.
- [____.] *Hölderlin: His Poems*. Translated by Michael Hamburger. 2nd edn., London and New York, 1952.
- _____. *Selected Poems*. Translated by J. B. Leishman. London, 1944.
- HOMER. *The Iliad*. Translated by E. V. Rieu. (Penguin Classics.) Harmondsworth, 1950.
- _____. *The Odyssey*. Translated by E. V. Rieu. (Penguin Classics.) Harmondsworth, 1946.
- Homeric Hymns*. See EVELYN-WHITE.
- HORACE. *Ars poetica*. In: *Horace: Satires, Epistles, and Ars poetica*. With an English translation by H. Rushton Fairclough. (Loeb Classical Library.) London and New York, 1926.
- _____. *Odes and Epodes*. Translated by C. E. Bennett (Loeb Classical Library.) London and New York, 1914.
- HUGH OF ST. VICTOR. *De laude caritatis*. In Migne, *P.L.*, vol. 176, cols. 969–76.
- HUMBOLDT, FRIEDRICH HEINRICH ALEXANDER, BARON VON. *Cosmos*. Translated by E. C. Otté, B. H. Paul, and W. S. Dallas. (Bohn's Scientific Library.) London, 1849–58. 5 vols.
- HUME, ROBERT ERNEST (trans.). *The Thirteen Principal Upanishads*. Oxford, 1921.
- I Ching*. The German translation by Richard Wilhelm rendered into English by Cary F. Baynes. New York (Bollingen Series XIX) and London, 1950. 2 vols.
- INTERNATIONAL CHALCOGRAPHICAL SOCIETY. *Publications*. [*Veröffentlichungen der Internationalen chalkographischen Gesellschaft*.] 1888.
- [IRENAEUS.] *The Writings of Irenaeus*. Translated by Alexander Roberts and W. H. Rambaut. (Ante-Nicene Christian Library, 5, 9.) Edinburgh, 1868. 2 vols.
- JAFFÉ, ANIELA. "Bilder und Symbole aus E. T. A. Hoffmanns Märchen 'Der goldne Topf.'" In: C. G. JUNG. *Gestaltungen des Unbewussten*. Zurich, 1950.
- JÄHNS, MAX. *Ross und Reiter in Leben und Sprache, Glauben und Geschichte der Deutschen*. Leipzig, 1872. 2 vols.
- JAMES, M. R. (trans.). *The Apocryphal New Testament*. Oxford, 1924.
- JAMES, WILLIAM. *Principles of Psychology*. London, 1907. 2 vols.
- JANET, PIERRE. *Les Névroses*. Paris, 1909.
- JEFFERS, ROBINSON. *Roan Stallion, Tamar, and Other Poems*. New York, 1925.
- JENSEN, PETER. *Das Gilgamesch-Epos in der Weltliteratur*. Strasbourg, 1906– (in progress).
- JEREMIAS, ALFRED. *Das Alte Testament im Lichte des alten Orients*. 4th edn., Leipzig, 1930.
- JEROME, SAINT. *Adversus Jovinianum*. In Migne, *P.L.*, vol. 23, cols. 211–338.
- _____. *Epistola 58 ad Paulinum*. In Migne, *P.L.*, vol. 22, col. 581.
- JODL, FRIEDRICH. *Lehrbuch der Psychologie*. 5th and 6th edn., Stuttgart and Berlin, 1924. 2 vols.
- JOËL, KARL. *Seele und Welt*. Jena, 1912.
- JOHN CHRYSOSTOM, SAINT, pseud. *De solstitiis et aequinoctiis*. In Cumont, *Textes* (q.v.), p. 355.

- JOHNSON, SAMUEL. *The History of Rasselas, Prince of Abissinia*. London, 1759.
- JONES, ERNEST. "On the Nightmare." In: *American Journal of Insanity* (Baltimore), LXVI (1910), 383–417. (As a book, augmented: International Psycho-Analytical Library, 20. London, 1931.)
- JONES, H. STUART (ed.). *A Catalogue of the Ancient Sculptures Preserved in the Municipal Collections of Rome: The Sculptures of the Palazzo dei Conservatori*. (British School at Rome.) Oxford, 1926.
- JOSEPHUS, FLAVIUS. *Against Apion*. In: *Josephus*. Translated by H. Thackeray and Ralph Marcus. (Loeb Classical Library.) London and New York, 1926–43. 9 vols. (Vol. 1.)
- JUBINAL, MICHEL LOUIS ACHILLE. *Mystères inédits du XV. siècle*. Paris, 1837. 2 vols.
- [JULIAN.] *The Works of the Emperor Julian*. Translated by Wilbur Cave Wright. (Loeb Classical Library.) London and New York, 1913–23. 3 vols.
- JUNG, C. G. *Aion: Researches into the Phenomenology of the Self. Collected Works,** Vol. 9, part ii. 1959; 2nd edn., 1968.
- _____. "Answer to Job." In: *Collected Works*, Vol. 11. 1958; 2nd edn., 1969.
- _____. "The Archetypes of the Collective Unconscious." In: *Collected Works*, Vol. 9, part i. 1959; 2nd edn., 1968.
- _____. Commentary on "The Secret of the Golden Flower." In: *Collected Works*, Vol. 13. 1967.
- _____. "The Concept of the Collective Unconscious." In: *Collected Works*, Vol. 9, part i. 1959; 2nd edn., 1968.
- _____. "Concerning Rebirth." In: *Collected Works*, Vol. 9, part i. 1959.
- _____. "The Content of the Psychoses." In: *Collected Works*, Vol. 3. 1960.
- _____. "Cryptomnesia." In: *Collected Works*, Vol. 1. 1957; 2nd edn., 1970.
- _____. "General Aspects of Dream Psychology." In: *Collected Works*, Vol. 8. 1960; 2nd edn., 1969.
- _____. *Gestaltungen des Unbewussten*. Zurich, 1950.
- _____. *Mysterium Coniunctionis. Collected Works*, Vol. 14. 1963; 2nd edn., 1970.
- _____. "On the Nature of Dreams." In: *Collected Works*, Vol. 8. 1960; 2nd edn., 1969.
- _____. "On the Nature of the Psyche." In: *Collected Works*, Vol. 8. 1960; 2nd edn., 1969.
- _____. "On the Psychology and Pathology of So-called Occult Phenomena." In: *Collected Works*, Vol. 1. 1957; 2nd edn., 1970.
- _____. "On the Psychology of the Unconscious." In: *Collected Works*, Vol. 7. 1953; 2nd edn., 1966.
- _____. "Paracelsus as a Spiritual Phenomenon." In: *Collected Works*, Vol. 13. 1967.
- _____. "The Phenomenology of the Spirit in Fairytales." In: *Collected Works*, Vol. 9, part i. 1959; 2nd edn. 1968.
- _____. "Psychic Conflicts in a Child." In: *Collected Works*, Vol. 17. 1954; 2nd edn., 1964.
- _____. "A Psychological Approach to the Dogma of the Trinity." In: *Collected Works*, Vol. 11. 1958; 2nd edn., 1969.
- _____. "The Psychological Aspects of the Kore." In: *Collected Works*, Vol. 9, part i. 1959; 2nd edn., 1968.
- _____. *Psychological Types. Collected Works*, Vol. 6. 1970.
- _____. *Psychology and Alchemy. Collected Works*, Vol. 12. 1953; 2nd edn., 1968.
- _____. "Psychology and Religion." In: *Collected Works*, Vol. 11. 1958; 2nd edn., 1969.
- _____. "The Psychology of the Child Archetype." In: *Collected Works*, Vol. 9, part i. 1959; 2nd edn., 1968.

- _____. "The Psychology of Dementia Praecox." In: *Collected Works*, Vol. 3. 1960.
- _____. "The Psychology of Eastern Meditation." In: *Collected Works*, Vol. 11. 1958; 2nd edn., 1969.
- _____. "The Psychology of the Transference." In: *Collected Works*, Vol. 16. 1954; 2nd edn., 1966.
- _____. "The Relations between the Ego and the Unconscious." In: *Collected Works*, Vol. 7. 1953; 2nd edn., 1966.
- _____. "A Review of the Complex Theory." In: *Collected Works*, Vol. 8. 1960; 2nd edn., 1969.
- _____. "Studies in Word Association." In: *Collected Works*, Vol. 2. (Alternative source: *Studies in Word-Association* ... under the direction of C. G. Jung, translated by M. D. Eder, London, 1918, New York, 1919.)
- _____. "A Study in the Process of Individuation." In: *Collected Works*, Vol. 9, part i. 1959; 2nd edn., 1968.
- _____. "Transformation Symbolism in the Mass." In: *Collected Works*, Vol. 11. 1958; 2nd edn., 1969.
- _____. *Two Essays on Analytical Psychology*. *Collected Works*, Vol. 7. 1953; 2nd edn., 1966.
- _____. "The Visions of Zosimos." In: *Collected Works*, Vol. 13. 1967.
- _____. "Wotan." In: *Collected Works*, Vol. 10. 1964.
- _____. and KERÉNYI, C. *Essays on a Science of Mythology*. Translated by R. F. C. Hull. (Bollingen Series XXII.) New York, 1949; reissued 1969. (Also pub. as *Introduction to a Science of Mythology*, London 1950.)
- JUNG, EMMA. "Ein Beitrag zum Problem des Animus." In: C. G. JUNG. *Wirklichkeit der Seele*, Zurich, 1934.
- JUNG, ERICH, *Germanische Götter und Helden in Christlicher Zeit*. Munich and Berlin, 1939.
- KALTHOFF, ALBERT. *The Rise of Christianity*. Translated by Joseph McCabe. London, 1907.
- KENYON, SIR FREDERIC GEORGE. *Greek Papyri in the British Museum*. London, 1893–1917. 5 vols.
- KERÉNYI, KARL (C.). *Die Geburt der Helena*. (Albae Vigiliae, new series, 3.) Zurich, 1945.
- _____. "Die Göttin Natur," *Eranos-Jahrbuch* (Zurich), XIV (1946), 39–86.
- _____. "The Mysteries of the Kabeiroi." In: *The Mysteries*, q.v.
- _____. *Prometheus: Archetypal Image of Human Existence*. Translated by Ralph Manheim. New York (Bollingen Series LXV:1) and London, 1963.
- KERNER, JUSTINUS. *The Seeress of Prevorst*. Translated by Mrs. [Catherine] Crowe. New York, 1859. (Original: *Die Seherin von Prevorst*. Stuttgart and Tübingen, 1829. 2 vols.)
- KIRCHER, ATHANASIVS. *Oedipus Aegyptiacus*. Rome, 1652–54. 3 parts in 4 vols.
- KLEINPAUL, RUDOLF. *Das Leben der Sprache und ihre Weltstellung*. Leipzig, 1893. 3 vols.
- KLUGE, FRIEDRICH. *Etymologisches Wörterbuch der deutschen Sprache*. 2nd edn., Strassburg, 1883.
- KOCH-GRÜNBERG, THEODOR. *Südamerikanische Felszeichnungen*. Berlin, 1907.
- Koran*. Translated by J. M. Rodwell. (Everyman's Library.) London, 1909.
- [_____] *The Meaning of the Glorious Koran*. Translated by Marmaduke Pickthall. London, 1930.
- KUELPE, OSWALD. *Outlines of Psychology*. Translated by Edward Bradford Titchener. London, 1895.
- KUHN, FRANZ FELIX ADALBERT. *Mythologische Studien*, Vol. I: *Die Herabkunft des Feuers und des Göttertranks*. Gütersloh, 1886.

- _____. "Die Sprachvergleichung und die Urgeschichte der indogermanischen Völker," *Zeitschrift für vergleichende Sprachforschung* (Berlin), IV (1854), 81–124.
- _____. "Über die durch Nasale erweiterten Verbalstämme," *ibid.*, II (1853). 392–98.
- LABRUNIE DE NERVAL, GÉRARD. *Aurelia*, etc. Translated by Richard Aldington. [London], 1932. (Original: 1855.)
- LACTANTIUS, FIRMIANUS. *Divinae Institutiones*. In: *The Works of Lactantius*. Translated by William Fletcher. (Ante-Nicene Christian Library, 21, 22.) Edinburgh, 1871. 2 vols.
- LAISTNER, LUDWIG. *Das Rätsel der Sphinx*. Berlin, 1889. 2 vols.
- LAJARD, JEAN BAPTISTE FÉLIX. *Mémoire sur une représentation figurée de la Vénus orientale androgyne*. (Nouvelles annales de l'Institut Archéologique.) Rome, 1873.
- LANZONE, RIDOLFO V. *Dizionario di Mitologia Egizia*. Turin, 1881–85. 2 vols.
- [LA ROCHEFOUCAULD, FRANCOIS, Duc DE.] *The Moral Maxims and Reflections of the Duke de La Rochefoucauld*. With an introduction and notes by George N. Powell. London, 1903.
- LAYARD, JOHN WILLOUGHBY. "The Incest Taboo and the Virgin Archetype," *Eranos-Jahrbuch* (Zurich), XII (1945), 254–307.
- LE BLANT, EDMOND. *Les Sarcophages chrétiens de la Gaule*. Paris, 1886.
- LE COQ, ALBERT VON. *Die Buddhistische Spätantike in Mittelasien*. Berlin, 1922–33. 7 vols.
- LIEPMANN, HUGO. *Über Ideenflucht: Begriffsbestimmung und psychologische Analyse*. Halle, 1904.
- LOMBROSO, CESARE. *Genio e Follia*. Turin, 1882.
- LONGFELLOW, HENRY WADSWORTH. *The Song of Hiawatha*. Boston, 1855.
- LOTZE, RUDOLF HERMANN. *Logik*. (System der Philosophie, 1.) Leipzig, 1874.
- LÖWIS OF MENAR, A. VON. "Nordkaukasische Steingeburtsagen," *Archiv für Religionswissenschaft* (Freiburg i. B.), XIII (1910), 509–524.
- LUCIAN. *Menippus*. In: *Lucian*. With an English translation by A. M. Harman. (Loeb Classical Library.) London, 1913ff. 8 vols.
- LUCRETIUS. *De rerum natura*. With an English translation by W. H. D. Rouse. (Loeb Classical Library.) London and New York, 1924.
- LYDUS, JOHANNES. *De mensibus*. Edited by Richard Wünsch. Leipzig, 1898.
- MACARIUS, JOANNES. *Abraxas*. Antwerp, 1657.
- MACDONELL, ARTHUR ANTHONY. *A Practical Sanskrit Dictionary*. New edn., London, 1924.
- MACROBIUS, AMBROSIUS THEODOSIUS. *Saturnaliorum Libri VII*. In: *Opera quae supersunt*. Edited by Ludovicus Janus. Quedlinburg and Leipzig, 1848–52. 2 vols.
- MAEDER, A. "Die Symbolik in den Legenden, Märchen, Gebräuchen und Träumen," *Psychiatrisch-Neurologische Wochenschrift* (Halle), X (1908).
- MAEHLY, JACOB A. *Die Schlange in Mythos und Kultus der klassischen Völker*. Basel, 1867.
- MAETERLINCK, MAURICE. *The Blue Bird*. Translated by Alexander Teixeira de Mattos. London, 1924.

- _____. *Wisdom and Destiny*. Translated by Alfred Sutro. London, 1898.
- [Mainyo-i-Khard.] *Book of the Mainyo-i-Khard*. Translated by E. W. West. London, 1871.
- MANNHARDT, WILHELM. *Antike Wald- und Feldkulte*. Berlin, 1875—77. 2 vols.
- Manuscripts.
- Leiden. Rijksuniversiteit Bibliotheek. Codex Vossianus Chymicus 29. Thomas Aquinas, pseud. “De Alchimia.” c. 1520.
- Paris. Bibliothèque nationale. MS. Lat. 11534. Bible of Manerius.
- _____. Library of the Palais Bourbon. Codex Borbonicus. 16th cent.
- St. Gall. Bibliothek. Alchemical MS. 17th cent.
- Tübingen. Universitätsbibliothek. MS. Theol. Lat. fol. 561. Beatus Commentary. Mid 12th cent.
- Wiesbaden. Nassauische Landesbibliothek. St. Hildegarde of Bingen, “Scivias.” 12th cent.
- MAUDSLAY, A. P. *Biologia Centrali-Americana: Archaeology*. (Biologia Centrali-Americana, ed. by F. D. Godman and Osbert Salvin, 55–59.) London, 1896–99. 4 vols.
- MAURICE, THOMAS. *Indian Antiquities*. London, 1796. 7 vols.
- MAUTHNER, FRIEDRICH. *Sprache und Psychologie*. (Beiträge zur Kritik der Sprache.) Stuttgart, 1901.
- MAX MÜLLER, FRIEDRICH. *Introduction to the Science of Religion*. London, 1882.
- . *Lectures on the Origin and Growth of Religion*. London, 1891.
- (trans.). *The Upanishads*. Parts I and II. (Sacred Books of the East, 1 and 15.) Oxford, 1879 and 1884.
- MAYN, GEORG. *Über Byrons “Heaven and Earth.”* Breslau (dissertation), 1887.
- MEAD, GEORGE ROBERT STOW. *A Mithraic Ritual*. (Echoes of the Gnosis Series.) London, 1907.
- MECHTHILD OF MAGDEBURG, SAINT. *Das fliessende Licht der Gottheit*. Translated into modern German and explained by Mela Escherich. Berlin, 1909.
- . *The Revelations*. Translated by Lucy Menzies. London and New York, 1953.
- MELITO OF SARDIS. *Fragmentum ex catena in Genesim*. In Migne, P.G., vol. 5, cols. 1215–18. Also in Pitra, *Spicilegium solesmense* (q.v.), II, p. lxiii.
- MEREZHKOVSKY, DMITRY SERGYEEVICH. *Peter and Alexis*. London, 1905. (Original: 1905.)
- . *The Romance of Leonardo da Vinci*. Translated by Bernard Guilbert Guerney. London and New York, 1938. (Original: 1901.)
- MERIAN, MATTHAEUS. See Bible.
- MERINGER, R. “Wörter und Sachen.” *Indogermanische Forschungen* (Strassburg), XVI (1904), 101–96.
- MEYER, ELARD HUGO. *Indogermanische Mythen*. Berlin, 1883–87. 2 vols.
- MIGNE, JACQUES PAUL (ed.). *Patrologiae cursus completus*.
- [P.L.] Latin Series. Paris, 1844–64. 221 vols.
- [P.G.] Greek Series. Paris, 1857–66. 166 vols.
- (These works are cited as “Migne, P.L.” and “Migne, P.G.” respectively. References are to columns, not to pages;)

- MILLER, MISS FRANK, pseud. "Quelques faits de l'imagination créatrice subconsciente." [Translated?] with an introduction by Théodore Flournoy. *Archives de psychologie* (Geneva), V (1906), 36–51.
- [MONTELIUS, OSCAR.] *Opuscula archaeologica Oscari Montelio septuagenario dicata*. Stockholm, 1913.
- MÖRIKE, EDUARD. *Werke*. Edited by Harry Maync. Leipzig and Vienna, 1914. 3 vols.
- MORRIS, RICHARD. *Legends of the Holy Rood*. (Early English Text-Society Series, 46.) London, 1871.
- MÜLLER, JOHANN GEORGE. *Geschichte der amerikanischen Urreligionen*. 2nd edn., Basel, 1867.
- MÜLLER, JOHANNES. *Über die phantastischen Gesichterscheinungen*. Coblenz, 1826.
- MÜLLER, NIKLAS. *Glauben, Wissen und Kunst der alten Hindus....* Mainz, 1822.
- Musaeum Hermeticum reformatum et amplificatum ... continens tractatus chimicos XXI*. Frankfurt a. M., 1678.
- MUTHER, RICHARD. *Geschichte der Malerei*. 3rd edn., Berlin, 1920. 3 vols.
- The Mysteries*. Translated by Ralph Manheim and R. F. C. Hull. (Papers from the Eranos Yearbooks, 2.) New York (Bollingen Series XXX), 1955; London, 1956.
- NAGEL, A. "Der chinesische Küchengott (Tsau-kyun)," *Archiv für Religionswissenschaft* (Freiburg i. B.), XI (1907–8), 23–43.
- NAZARI, ORESTE. "Spizzico di etimologie latine e greche," *Rivista di Filologia* (Turin), XXXVI (1908), 567–78.
- NEGELEIN, JULIUS VON. "Das Pferd im Seelenglauben und Totenkult," *Zeitschrift des Vereins für Volkskunde* (Berlin), XI (1901), 406–20; XII (1902), 14–25, 377–90.
- . *Der Traumschlüssel des Jagaddeva*. (Religionsgeschichtliche Versuche und Vorarbeiten, 11, part 4, edited by A. Dieterich and R. Wünsch.) Giessen, 1912.
- NERVAL, GÉRARD DE. See LABRUNIE DE NERVAL.
- NEUMANN, ERICH. *The Great Mother*. Translated by Ralph Manheim. New York (Bollingen Series XLVII) and London, 1955.
- . *The Origins and History of Consciousness*. Translated by R. F. C. Hull. New York (Bollingen Series XLII) and London, 1954.
- . *Umkreisung der Mitte*. Zurich, 1953–54. 3 vols. (Vol. 3 translated in: *Art and the Creative Unconscious*. New York (Bollingen Series LXI) and London, 1959.)
- NIETZSCHE, FRIEDRICH WILHELM. *Ecce Homo and Poems*. Translated by Anthony M. Ludovici, poetry by Paul V. Cohn and others. (Complete Works, 17.) Edinburgh, London and New York, 1911.
- . *Human, All-too-Human*. Translated by Helen Zimmern and Paul V. Cohn. (Complete Works, 6, 7.) London and New York, 1909, 1911. 2 vols.
- . *Thus Spake Zarathustra*. Translated by Thomas Common. (Complete Works, 11.) London and New York, 1909.
- . *Werke*. Leipzig, 1899–1913. 19 vols.
- NORDEN, EDUARD. *Die Geburt des Kindes*. (Studien der Bibliothek Warburg, 3.) Leipzig and Berlin, 1924.
- Orientalistische Literaturzeitung*. Leipzig, 1898–
- [Orphic Hymns.] *The Mystical Hymns of Orpheus*. Translated from the Greek by Thomas Taylor. London, 1896.

- OVID (PUBLIUS OVIDIUS NASO). *Metamorphoses*. With an English translation by Frank Justus Miller. (Loeb Classical Library.) London and New York, 1916. 2 vols.
- PARACELUSUS. *Liber Azoth*. In: SUDHOFF, KARL (ed.). *Theophrast von Hohenheim genannt Paracelsus Sämtliche Werke*. First Section: Medizinische Schriften (in 14 vols.), 14. Munich and Berlin, 1933. (Pp. 547–95.)
- PAUL, HERMANN. *Grundriss der germanischen Philologie*. Strassburg, 1889–93. 2 vols.
- . *Prinzipien der Sprachgeschichte*. 4th edn., Halle, 1909.
- PAUSANIAS. *Description of Greece*. With an English translation by W. H. S. Jones. (Loeb Classical Library.) London and New York, 1918–35. 5 vols.
- PETRONIUS ARBITER, TITUS. *Satyricon*. With an English translation by Michael Heseltine. (Loeb Classical Library.) London and New York, 1913.
- PFISTER, OSKAR. *Die Frömmigkeit des Grafen Ludwig von Zinzendorf*. (Schriften zur angewandten Seelenkunde, 8.) Leipzig and Vienna, 1910.
- PHILO JUDAEUS. *De somniis*. In: [Works.] Translated by F. H. Colson and G. H. Whitaker. (Loeb Classical Library.) New York and London, 1929–. 10 vols. (Vol. 5, pp. 285ff.)
- . *Quaestiones et solutiones in Genesim*. In: *Philonis Judaei Opera omnia*. (Editio Stereotypa.) Leipzig, 1893. (Translated from Armenian into Latin by J. B. Aucher.)
- [PINDAR.] *The Odes of Pindar*. With an English translation by Sir John Sandys. (Loeb Classical Library.) London and New York, 1915
- Pistis Sophia*. Translated by G. R. S. Mead. [London], 1921.
- PITRA, JEAN BAPTISTE, CARDINAL (ed.). *Analecta sacra spicilegio Solesmense parata*. Paris, 1876–91. 8 vols.
- . *Spicilegium solesmense*.... Paris, 1852–58. 4 vols.

[PLATO.] *Plato's Cosmology; the Timaeus of Plato*. Translated by F. M. Cornford. New York and London, 1937.

- . *The Symposium*. Translated by W. Hamilton. (Penguin Classics.) Harmondsworth, 1951.
- [PLINY.] *The Natural History of Pliny*. Translated by John Bostock and H. Riley. (Bohn's Classical Library.) London, 1855–56. 6 vols.
- PLOTINUS. [Enneads.] *Complete Works*. Translated by Kenneth Sylvan Guthrie. Alpine, New Jersey, [1918]. 4 vols.
- PLUTARCH. *De Iside et Osiride*. In: *Plutarch's Moralia*. With an English translation by Frank Cole Babbitt. (Loeb Classical Library.) London and New York, 1927 ff. 14 vols. (Vol. 5, pp. 6–191.)
- . *Quaestiones Graecae*. In: *Ibid.* (Vol. 4, pp. 173–249.)
- POE, EDGAR ALLAN. *The Raven and Other Poems*. New York, 1845.
- PÖHLMANN, ROBERT VON. *Geschichte des antiken Kommunismus und Sozialismus*. Munich, 1893, 1901. 2 vols.
- PORPHYRY. *De antro nympharum*. In: *Select Works of Porphyry*. Translated by Thomas Taylor. London, 1823.
- PRAMPOLINI, GIACOMO. *La Mitologia nella vita dei popoli*. Milan, 1937–38. 2 vols.

- PRELLER, LUDWIG. *Griechische Mythologie*. Leipzig, 1854. 2 vols.
- PRELLWITZ, WALTHER. *Etymologisches Wörterbuch der griechischen Sprache*. 2nd edn., Göttingen, 1905.
- PREUSS, K. T. "Der Ursprung der Religion und Kunst." *Globus* (Brunswick), LXXXVI (1904), 355–63.
- PRITCHARD, JAMES B. (ed.). *Ancient Near Eastern Texts Relating to the Old Testament*. Princeton, 1950.
- PUROHIT SWAMI, SHREE, and YEATS, WILLIAM BUTLER (trans.). *The Ten Principal Upanishads*. New York and London, 1937.
- RANK, OTTO. *Der Künstler: Ansätze zu einer Sexualpsychologie*. (Imago-Bücher, 1.) 4th edn., Leipzig, Vienna, Zurich, 1925.
- . *Die Lohengrinsage*. (Schriften zur angewandten Seelenkunde, 13.) Leipzig and Vienna, 1911.
- . *The Myth of the Birth of the Hero*. Translated by William Alanson White. (Nervous and Mental Disease Monograph Series, 18.) New York, 1914.
- . "Ein Traum, der sich selbst deutet," *Jahrbuch für psychoanalytische und psychopathologische Forschungen* (Leipzig and Vienna), II (1910), 465–540.
- REITZENSTEIN, RICHARD. *Die hellenistischen Mysterienreligionen*. Leipzig and Berlin, 1910.
- RENAN, JOSEPH ERNEST. *Dialogues et fragments philosophiques*. Paris, 1876.
- Revue archéologique*. Paris.
- [Rig-Veda.] *The Hymns of the Rigveda*. Translated with a popular commentary by Ralph T. H. Griffith. Benares, 1889–92. 4 vols. See also BROWN, W. NORMAN; DEUSSEN, PAUL.
- RIKLIN, FRANZ. *Wishfulfilment and Symbolism in Fairy Tales*. Translated by William Alanson White. (Nervous and Mental Disease Monograph Series, 21.) New York, 1915.
- ROBERT, CARL. *Die antiken Sarkophag-Reliefs*. Berlin, 1897.
- ROBERTSON, JOHN MACKINNON. *Christ and Krishna*. London, 1889.
- . *Christianity and Mythology*. London, 1900.
- ROHDE, ERWIN. *Psyche*. Translated from the 4th German edn. by W. B. Hillis. London, 1925.
- . "Σκίρα ἐπὶ Σκίρω ἑεροποιῖα," *Hermes* (Berlin), XXI (1886), 124.
- [Rome. Archaeological Commission.] *Bullettino della Commissione Archeologica Comunale di Roma*.
- ROSCHER, WILHELM HEINRICH. *Ausführliches Lexikon der griechischen und römischen Mythologie*. Leipzig, 1884–1937. 6 vols.
- ROSSELLINI, NICCOLA FRANCESCO IPPOLITO BALDASSARE. *I Monumenti dell' Egitto e della Nubia*. Pisa, 1842–44. 3 vols.
- ROSTAND, EDMOND. *Cyrano de Bergerac*. Translated by Gladys Thomas and Mary F. Guillemard. New York and London, 1898.
- RUSKA, JULIUS FERDINAND. *Tabula Smaragdina: ein Beitrag zur Geschichte der hermetischen Literatur*. Heidelberg, 1926.

- SAINT-EXUPÉRY, ANTOINE JEAN BAPTISTE MARIE ROGER DE. *The Little Prince*. Translated by Katherine Woods. New York and London, 1944.
- SALLUST. [*Works.*] With an English translation by J. C. Rolfe. (Loeb Classical Library.) London and New York, 1920.
- SANDERS, DANIEL HENDEL. *Das Volksleben der Neugriechen*. Mannheim, 1844.
- SCHAEFER, HEINRICH. *Von ägyptischer Kunst*. 3rd edn., Leipzig, 1930.
- SCHÄRF, RIWKAH. “Die Gestalt des Satans im Alten Testament.” In: C. G. JUNG. *Symbolik des Geistes*. Zurich, 1948.
- SHELLING, FRIEDRICH WILHELM JOSEPH VON. *Philosophie der Mythologie*. Part II, vol. 2 of: *Sämmtliche Werke*. Stuttgart and Augsburg, 1856–61.
- SCHILLER, FRIEDRICH. *Die Piccolomini*. In: *Sämmtliche Werke*. Stuttgart and Tübingen, 1840.
- SCHLAUCH, MARGARET (trans.). *The Saga of the Volsungs*. (Scandinavian Classics, 35.) New York and London, 1930.
- SCHMID, HANS. “Zur Psychologie der Brandstifter.” In: C. G. JUNG (ed.). *Psychologische Abhandlungen*, I. Zurich, 1914.
- SCHOPENHAUER, ARTHUR. *The World as Will and Idea*. Translated by R. B. Haldane and J. Kemp. (English and Foreign Philosophical Library, 22–24.) London, 1883–86. 3 vols.
- SCHOTT, ALBERT. *Das Gilgamesch-Epos*. Leipzig, [1934].
- SCHREBER, DANIEL PAUL. *Memoirs of My Nervous Illness*. Translated by Ida Macalpine and Richard A. Hunter. (Psychiatric Monograph Series, 1.) London, 1955. (Original: *Denkwürdigkeiten eines Nervenkranken*. Leipzig, 1903.)
- SCHULTZ, WOLFGANG. *Dokumente der Gnosis*. Jena, 1910.
- SCHULTZE, FRITZ. *Psychologie der Naturvölker*. Leipzig, 1900.
- SCHULTZE, VIKTOR. *Die Katakomben*. Leipzig, 1882.
- SCHWARTZ, W. *Indogermanischer Volksglaube*. Berlin, 1885.
- SCHWEITZER, ALBERT. *The Quest of the Historical Jesus*. Translated by W. Montgomery. London, 1910.
- SCOTT, WALTER (ed.). *Hermetica*. Oxford, 1924–36. 4 vols.
- SENECA. *Ad Lucilium epistulae morales*. With an English translation by Richard M. Gummere. (Loeb Classical Library.) London and New York, 1917–25. 3 vols.
- SEPP, JOHANN NEPOMUK. *Das Heidentum und dessen Bedeutung für das Christentum*. Regensburg, 1853. 3 vols.
- Septem tractatus seu capitula Hermetis Trismegisti aurei* [“Tractatus aureus”]. In: *Ars chemica....* Argentorati [Strasbourg], 1566. (Pp. 7–31.)
- SHAKESPEARE, WILLIAM. *Julius Caesar*. In: *The Complete Works of William Shakespeare*. Edited by W. J. Craig. Oxford, 1947.
- SHARPE, SAMUEL. *Egyptian Mythology and Egyptian Christianity*. London, 1863.

- SIECKE, ERNST. "Der Gott Rudra im Rigveda," *Archiv für Religionswissenschaft* (Freiburg i. B.), I (1898), 209–59.
- SILBERER, HERBERT. "Phantasie und Mythos," *Jahrbuch für psychoanalytische und Forschungen* (Leipzig and Vienna), II (1910), 541–622.
- . "Über die Symbolbildung," *ibid.*, III (1912), 661–723.
- SOPHOCLES. *Philoctetes*. In: [Works.] Translated by F. Storr. (Loeb Classical Library.) London and New York, 1912–13. 2 vols. (Vol. 2.)
- SPIEGEL, FRIEDRICH. *Eränische Altertumskunde*. Leipzig, 1871–78. 3 vols.
- . *Grammatik der Parsisprache nebst Sprachproben*. Leipzig, 1851.
- SPIELREIN, S. "Über den psychologischen Inhalt eines Falls von Schizophrenie," *Jahrbuch für psychoanalytische und psychopathologische Forschungen* (Leipzig and Vienna), III (1912), 329–400.
- SPIESS, KARL VON. *Marksteine der Volkskunst*. (Jahrbuch für historische Volkskunde, 5–6, 8–9.) Berlin, 1937–42. 2 vols.
- Spirit and Nature*. Translated by Ralph Manheim and R. F. C. Hull. (Papers from the Eranos Yearbooks, 1.) New York (Bollingen Series XXX), 1954; London, 1955.
- SPITTELER, CARL. *Imago*. Jena, 1919.
- . *Prometheus and Epimetheus*. Translated by James Fullarton Muirhead. London, 1931.
- Standard Dictionary of Folklore, Mythology and Legend*. Edited by Maria Leach. New York, 1949–50. 2 vols.
- STEINTHAL, H. "Die Sage von Simson." *Zeitschrift für Völkerpsychologie und Sprachwissenschaft* (Berlin), II (1861), 129–78.
- . "Die ursprüngliche Form der Sage von Prometheus," *ibid.*, II, 1–29.
- STEKEL, WILHELM. Note on "Aus Gerhart Hauptmanns Diarium," *Zentralblatt für Psychoanalyse* (Wiesbaden), II (1912), 365–66.
- . *Die Sprache des Traumes*. Wiesbaden, 1911.
- STEPHENS, JOHN LLOYD. *Incidents of Travel in Central America etc.* London, 1841. 2 vols.
- STOKES, WHITLEY. *Urkeltischer Sprachschatz*. Göttingen, 1894. Vol. II of FICK, *Vergleichendes Wörterbuch*, q.v.)
- STOLL, OTTO. *Das Geschlechtsleben in der Völkerpsychologie*. Leipzig, 1908.
- SUETONIUS. [Opera.] With an English translation by J. C. Rolfe. (Loeb Classical Library.) London and New York, 1914. 2 vols.
- Sutta-Nipata*. Translated by Victor Fausböll. (Sacred Books of the East, 10, part 2.) Oxford, 1881.
- SWANTON, JOHN R. *Contributions to the Ethnology of the Haida*. (American Museum of Natural History Memoir.) Leiden, 1905–9.
- Tabula smaragdina*. See RUSKA.
- TACITUS, CORNELIUS. *The Histories*, etc. Translated by Clifford H. Moore. (Loeb Classical Library.) London and New York, 1925–37. 4 vols.
- TA'RIKH AL-HIND AL-GHARBI. ["History of the West Indies," in Arabic.] Constantinople, 1730.

- TERTULLIAN (Quintus Septimus Tertullianus). [*Apologia.*] *Apologeticus adversus gentes pro Christianis*. See Migne, *P.L.*, vol. I, cols. 257–536. For translation, see: *The Writings of Quintus Septimus Tertullianus*. Vol. I. Translated by S. Thelwall. (Ante-Nicene Christian Library, 11.) Edinburgh, 1869. (Pp. 53–140.)
- Theatrum chemicum*. Strasbourg, 1602–61. 6 vols. (*Platonis liber quartorum* in V, pp. 114–208.)
- THEOCRITUS. In: *The Greek Bucolic Poets*. With an English translation by J. M. Edmonds. (Loeb Classical Library.) London and New York, 1912.
- THIBOUT, GABRIELLE. *La Cathédrale de Strasbourg*. With photographs by Marc Foucault. Paris. 1939.
- THIELE, GEORG. *Antike Himmelsbilder*. Berlin, 1898.
- THOMPSON, REGINALD CAMPBELL (trans.). *The Epic of Gilgamish*. London, 1928.
- TISCHNER, HERBERT. *Oceanic Art*. With photographs by Friedrich Hewicker. London and New York, 1954.
- UNTERNÄHRER, ANTON. *Geheimes Reskript der bernischen Regierung an die Pfarr- und Statthalterämter*, n.p., 1821.
- Upanishads. See GUENON; HUME; MAX MÜLLER; PUROHIT SWAMI.
- USENER, HERMANN. *Das Weihnachtsfest*. (Religionsgeschichtliche Untersuchungen, Part I.) 2nd edn., Bonn, 1911.
- [Vendidad.] *The Zend-Avesta*. Part I: *The Vendidad*. Translated by James Darmesteter. (Sacred Books of the East, 4.) Oxford, 1880.
- VERLAINE, PAUL. *Poèmes saturniens*. Paris, 1866.
- VIRGIL (PUBLIUS VERGILIUS MARO). [*Works.*] With an English translation by H. Rushton Fairclough. (Loeb Classical Library.) London and New York, 1929. 2 vols.
- VITRUVIUS POLLIO, MARCUS. *De architectura*. Edited by Fra G. Giocondo. Venice, 1511.
- VOLLERS, KARL. “Chidher,” *Archiv für Religionswissenschaft* (Freiburg i. B.), XII (1909), 234–84.
- WACHLMAYR, ALOIS. *Das Christgeburtbild der frühen Sakralkunst*. Munich, 1939.
- WAGNER, WILHELM RICHARD. *Gesammelte Schriften*. Ed. Julius Kapp. Leipzig, n.d. 14 vols. (*Siegfried*: IV, pp. 141–222. *Walküre*: IV, pp. 71–140.)
- WAITZ, THEODOR. *Anthropologie der Naturvölker*. Leipzig, 1859–72. 6 vols.
- WALDE, ALOIS. *Lateinisches etymologisches Wörterbuch*. 2nd edn., Heidelberg, 1910.
- WEBER, ALBRECHT. *Indische Studien*. Berlin, 1850–63. 8 vols.
- WEGENER, THOMAS A VILLANOVA. *Das wunderbare innere und äussere Leben der Dienerin Gottes Anna Catherina Emmerich*. Dülmen, 1891.
- WIEDEMANN, ALFRED. “Die Toten und ihre Reiche im Glauben der alten Ägypter,” *Der Alte Orient* (Leipzig), II (1900), 33–68.
- [WILHELM, RICHARD.] *The Secret of the Golden Flower; a Chinese Book of Life*. Translated and explained by Richard Wilhelm, with a foreword and commentary by C. G. Jung. Translated from the German by Cary F. Baynes. Revised edn., London and New York, 1962.
- WIRTH, ALBRECHT (ed.). *Aus orientalischen Chroniken*. Frankfurt a. M., 1894.

WIRTH, HERMANN FELIX. *Der Aufgang der Menschheit*. Vol. I (no more pub.). Jena, 1928.

WOLFF, CHRISTIAN. *Psychologia empirica methodo scientifica pertractata*. Frankfurt a. M. and Leipzig, 1732.

WOLTERS, PAUL H. A., and BRUNS, GERDA (eds.). *Das Kabirenheiligtum bei Theben*, Vol. I. (Archaeologisches Institut des Deutschen Reiches.) Berlin, 1940.

WORRINGER, WILHELM. *Die altdeutsche Buchillustration*. Munich, 1919 (3rd edn., 1921).

WUNDT, WILHELM. *Grundriss der Psychologie*. 6th edn., Leipzig, 1904.

———. *Philosophische Studien*. Vol. XIII. Leipzig, 1898.

YEATS, WILLIAM BUTLER. See PUROHIT SWAMI.

Zeitschrift des Vereins für Volkskunde. Berlin.

ZÖCKLER, OTTO. *The Cross of Christ*. Translated by Maurice J. Evans. London, 1877.

ZOSIMOS. "Sur l'art." In Berthelot, *Alchimistes grecs* (q.v.), III, 1, 2.

LINGUISTIC ABBREVIATIONS

Armen.	Armenian	Lith.	Lithuanian
Att.	Attic	MHG.	Middle High German
Celt.	Celtic	OBulg.	Old Bulgarian
Church		OE.	Old English (Anglo-Saxon)
Slav.	Church Slavonic	OHG.	Old High German
E., Eng.	English	OIcel.	Old Icelandic
F.	French	OInd.	Old Indic
G.	German	OIr.	Old Irish
Goth.	Gothic	OIran.	Old Iranian
Gr.	Greek	ON.	Old Norse
Icel.	Icelandic	Skr.	Sanskrit
IEur.	Indo-European	Slav.	Slavonic
Lat.	Latin	Ved.	Vedic

* indicates a hypothetical form

INDEX

INDEX

A page reference with asterisk indicates a text figure. For sources of both plates and text figures, see the lists of these in the front part of the book.

A

abaissement du niveau mental (“fatigue”) 25, 432

Abegg, Emil, 150*n*

Abeghian, Manuk, 109*n*, 317*n*

Abelard, Peter, 13, 20

abnegation, self-, 380

Abraham, 333, 429*n*

Abraham, Karl, 5, 23*n*, 145*n*, 218*n*

 on boring and fire-making, 145

 on “Mama,” 23*n*

 on myths, 24

abstraction: scientific, 429*f*

 spiritual, 121

“Acherusian lake,” 365

action, fictional, autosuggestive participation in, 448

Acts of Thomas, 217*n*, 359*f*

Adah, 192

Adam: cross on grave of, pl. xxxvii

 and Lilith, 248

membrum virile as tree, 221

 “mountain of,” 196*n*

 Protanthropos, 433

 sin of, 247*f*, 262*f*, 270, 271, 433

Adam Secundus, Christ as, 262

adaptation: essence of conscious process, 177

 failure of, and regression, 140, 230

 loss of, through deviation into sex, 156

new, and introversion and regression, 293
to parents, 284
prevented by maternal ties, 307
psychological, 134, 176f
to reality, 297f
and regression, 235f, 329

adder, 425n

Adler, Alfred, xxiv

Adler, Félix, 461

Adler, Gerhard, 181n, 437n

adolescent fantasies, 26
contents of, 49

Adonis, 216n, 219, 223n, 258f, 333, 343n, 433; *see also* Attis

adult: effect of infantile attachment to mother, 213
psychic danger of incest, 213
sacrifice of family to become centre of new system, 414f

Aegina, 265

Aeschylus, 311n, 433n

Aesculapius, 239, 298n, 373

Aetna, 405

“affective deterioration,” 191

affects: control by, 415
and fantasy-thinking, 17n
source of, in conflict situations, 8

affluxes, libidinal, 132

Africa: head-dress, pl. xvii

Nandi, 345

MYTHS: Big Snake, 399

birth (Litaolane) in stable, 199n, 374n

cosmogony in calabash, 399

death, 348

hero and seaweed, 243

of Namaqua, 342n

of Natal, 296n

of Nigeria, [257n](#)
opening of rock, [246n](#)
Uganda king, [383f](#)
Zulu, of birth, [203n](#)
Agathodaimon, serpent, [269](#), [374](#), [382](#), [383*](#)
aging process: and altered goal of libido, [438](#)
 and forcible change of personality, [300](#)
 regression in, [301](#)
 renunciation of youth, [404](#), [406](#)
 resistance to, [356f](#), [397f](#)
Agni, god of fire, [146](#), [147f](#), [150n](#), [165f](#), [167f](#), [185](#), [275](#), [333](#)
 on the ram, pl. [xiiib](#)
Agrippa, Heinrich Cornelius, of Nettesheim, [265*](#)
Ahamarama, [192f](#)
Ahasuerus, [193](#), [195](#), [200](#), [460](#)
Aholah, [192](#)
Aholibamah, [111](#), [113f](#), [192](#)
Ahriman, [246n](#), [275n](#), [281](#), [341](#)
Ahura(-Mazda), [209n](#), [260](#), [275](#), [359](#), [427](#)
Aidoneus, [365](#)
Aigremont, Dr., pseud. (Siegmar Baron von Schultze-Galléra), [239n](#), [258n](#), [278n](#), [315n](#)
Aion/*Deus leontocephalus*, [108n](#), [279n](#), [280](#), [369n](#)
 with signs of zodiac, pl. [XLIV](#)
Alaska: Tlingit Indians, pls. [xxiib](#), [xxxviiiib](#)
al-Bukhari, [193](#)
alchemy, [76n](#)
 athanor, [167](#)
 coniunctio, [223](#)
 Gabricus and Beya, [436](#)
 mercurial serpent, [100*](#)
 peregrinatio, [93n](#)
 prima materia, [189](#)
 role of crown in, [184n](#)
 sacrifice of the dragon, [415n](#)

sun-eating lion, pl. [xxxii**b**](#)
symbols in, [164n](#)
Alciati, Andrea, [179n](#)
Alcmene, [295n](#)
alcohol, mythological analogue, [140](#)
alembic, as symbol, [167](#)
Alexander Jannaeus, [383](#)
Alexander the Great, [196f](#)
 as the “two-horned,” [194n](#), pl. [xxa](#)
Ali Illahija, [376n](#)
Allendorf, J. L. K., [184](#)
alma Venus, [75](#)
almus, [335n](#), pl. [xiva](#)
al-Tabari, [193](#), [195](#)
“ambitendency,” [173f](#), [438n](#)
ambition, corruptive effect of, [113](#)
“ambivalence,” [109](#), [438n](#)
Ambrose, St., [106](#)
Amenophis IV, [97ff](#), [98*](#)
American Indians: head-dress of ceremonial dancer, pl. [xxi**b**](#)
 myths in *Hiawatha*, [313ff](#)
 name for meteor, [315](#)
 on origin of human beings, [141n](#)
Americans: mother complex in, [186](#)
 representations of inferior side of personality, [183](#)
 restlessness, [326n](#)
Ammon, Jupiter, [194n](#)
Amon, of Thebes, [97](#)
 -Ra, [240](#)
Ampycus, [289](#)
amrita, [168](#)
amulets, shaman’s, pls. [xxii**b**](#), [xxxviii](#)
Anah, [111](#), [113](#), [192](#)
Anahita/Anaitis: Ardivisura-, [218](#)

orgiastic cult, 376n
anal: birth theory, 190f
fantasy, 189
region, veneration of, 189
analogy, 134
comparison by, 96f
-making, process of, 141
of the sexual act, 159
analysis, importance of patient's dreams at beginning of, 43
analytical psychology, dream images as basic principle of, 7
anamnesis: of fire-making, 169f
in the Miller fantasies, 34–38
Ananke (Necessity), 67n, 281n
anatomy, comparative, 23
Anaxagoras, 45, 49, 453
anchorites, 81n
ancient man, concept of nature, 22f
ancient world, Christianity as escape from unconsciousness of, 230; *see also* antiquity
angel(s), 111, 113
apparition of, 115f
bird-symbol, 348
“daemon lover,” 186
helpful, 248
Angkor Wat (Cambodia): lingam with yoni, pl. xxv
Angramainyu, 275, 427
anima, 391
and animus, 53n, 351
archetype of the feminine, 266n
and hero, 388
identity with, 283n
-image, *see following*
man's unconscious femininity, 437
mother as first incarnation of, 330
personification of collective unconscious, 324f

role of, 388
search for, 341
tendency to autonomy, 361
and wise old man, 333

anima-image, 283n, 316
and mother imago, 388
Wagner's Brünhilde as, 361

animal(s): as foster-mother, 321, pls. II, La
and the Great Mother, 327, pl. LI
"helpful," 181, 352
magic, killing of, 327
psyche, 176
as religious symbols, 57n
representative of the unconscious, 327
skins hung on tree, 263n
symbolic, 276
symbolism of, in erotic dreams, 8
as symbols of parental attributes, 181; *see also* bird(s); snake(s); *and names of specific animals*

animal forces, and religion, 269n

animal instinct: conservatism and misoneism, 419
moral subjugation of, 70f
overcoming of, 261
repressed, in theriomorphic representations of the libido, 179
symbols of, 275; *see also* sexuality

animal nature: of the divine power, 338
freedom from prohibitions, 235
sacrifice of, 423

animal sacrifice: advance from, to human sacrifice, 435f
inner relationship to hero or god, 423

anima mundi, 354

animus, 183, 391
opinions, substitute for reason, 300
possession, 186

animus-figure, [304](#), [307f](#), [396](#), [435](#)
 mythological, [362n](#)
 typical, [304](#)
 pl. [xvii](#)

ankh/ankhi, [269](#)

Antaeus, [178](#)

anthropoid psyche, [328f](#)

anthropomorphic vision, [105n](#)

anthropomorphism: in antiquity, [21](#)
 love as extreme example of, [64](#)
 tree, [351](#)

Anthropos, [77](#), [314n](#), [416](#)

Anti-Christ, [361](#), [368](#)

Antioch, crypt to Hecate, [369](#)

antiquity: psychological situation of, [415](#)
 reality of fantasies in, [26](#)
 reason for lack of technology, [16](#)

Anubis, jackal-headed, [237ff](#), [372](#)
 pl. [xxxiii](#)

anus, [161](#), [189](#), [190f](#)

anxiety: and dreams, [457f](#)
 and fairytales, [249](#)
 and fantasy-making, [171ff](#)
 and lust, [8f](#)

Apaosha (horse), [259](#)

apathy, [191](#)

Aphrodite, [219n](#), [370](#)
 and Ares, [244n](#)
 crown, [146n](#)
 of Cyprus, [221n](#)
 heavenly and earthly, [138](#)

Apis bull, [98n](#), [235](#), [374n](#)

Apollo, [164](#), [260](#), [288n](#), [370](#)
 and Python, [216n](#)

Apophis-serpent, 280
apostles, the twelve, zodiacal symbols of, 107
apotropaism, 368
apperception, anticipatory, 11n
appetite: feature of impulses and automatisms, 129
 as psychic energy, 137
Apsu, 252
Apuleius, 87n, 99n, 415n
 bow-and-arrow symbolism in, 288n
 initiation of, pl. vi
aqua permanens, 409n
Aquinas, Thomas, St., 20, pl. xviii
Arabian legend of Abraham, 333
archaic: features of schizophrenia, 143
 psyche, 176
 substitute, in loss of reality, 140f
archer, death as, pl. XLV
archetypal: contents, autonomy of, 178
 figures, 304
 —, endowed with personality, 255
 images, part animal, part human, 181
 incest problem, 204n
 parallels of *pramantha*, 146f
 symbolism, 292
archetype(s): anima as, 388
 a priori existence of, 328n
 collective, 56n
 of the collective unconscious, 158
 compensatory and curative meaning, 420
 and the conscious mind, 65, 232, 294
 definition of, 44n, 102
 dominant, 391
 of drawing up from the depths, 234
 energy of, 86

enrichment through introversion, 293
God-image, 323
maternal, purpose of, 301
numinosity of, 158, 294, 308
patterns of behaviour, 313
projection of, 53n
quasi-personal, 256
role of, 236, 397
of the self, 368
unconscious psychic image, 56n
universal and inherited patterns, 228
wise old man, 332
archigallos, 426
archons, and dropping of young, 319
Ardhanari, pl. xxiii
Ardvisura, 209n, 426
-Anahita, 218
Ares: and Aphrodite, 244n
battle of clubs at festival of, 256f
Argos: Linus festival, 216n
Ariantes, Scythian king, 288
Arjuna, 174n
Armenians, cave worship by, 341
arms: encircling belly, stoup with, pl. xxvii
mutilated, 239n
outstretched, and cross, 264f
Arnobius, on Eleusinian mysteries, 343
Arnold, Sir Edwin, 243, 320
arrow(s): death by, 285f, 286, pl. xlv
masculine significance, 288
self-inflicted, 291f
-shot, 264, 274, 304, 353. 379n
-symbol, 286–90
arrowsmith, 332

art, ecclesiastical, [107](#), [224n](#)
Artemidorus, dream-book of, [7](#)
Artemis, [370](#)
 and bear, [57n](#), [322n](#)
 Orthia, [244](#)
 on Persian coin, [203](#)
Artio, [322n](#)
 with bear, pl. [Lb](#)
artisan, as hero's father, [333](#)
artist(s): Miller and, [449](#)
 pathological fantasy of, [190](#)
 role of, [324n](#)
arts, the, sexuality and sensuality as basis of, [224n](#)
Arueris, [234](#)
ascension: in fiery chariot, [195f](#)
 of hero, [105n](#)
ascent, and descent, [357](#)
asceticism, [81n](#), [229](#)
Aschanes, birth of, [243n](#), [247](#)
Asclepieia, [372](#)
ash-tree, [246](#)
 legend of knights' combat over, [260n](#)
 mother of lances, [288](#)
 mother of men, [246](#); *see also* world-ash
ass: in Apuleius, [67n](#)
 and foal, [276n](#)
 jawbone of, [412](#)
 mock crucifixion, [276](#), pl. [XLIII](#)
 as symbol, [400f](#)
 worship of image of, [276](#)
assault, motif, [8](#)
assimilation: psychic, [12](#)
 of unconscious products by conscious, [442](#)
association(s): chain of, [45](#), [85](#), [110](#)

in derivation of hero's name, [192f](#)
endopsychic work of, [21](#)
in fantasy, [310](#)
of ideas, re-animation of impressions, [461](#)
linguistic components of, [15n](#)
Miller's, [45](#), [51](#), [58](#)
association experiment: complex-toned reaction-words in, [155](#)
 intrapsychic, in [16n](#)
Assurbanipal, [192](#), [252](#)
Assyria, representation of God in, [265](#)
Astarte, [219n](#), [236n](#)
Asterius, bishop of Amasea, [341](#)
astrology, derivation of symbolic animals, [276n](#)
Asurabama, [192f](#), [460](#)
aswatha, *see* peepul tree
athanor, alchemical, [167](#)
Athenaeus, [219](#)
Athene, [250](#)
 of Lindus, [219](#)
Athens: chasm on the Areopagus, [365](#)
 classical, [27](#)
 Little Metropolis, [303n](#)
 sacred precinct, [364](#)
 sacred tree, [257n](#)
atman, [160](#), [354](#)
 hermaphroditic nature, [160n](#)
 personal and trans-personal, [202n](#), [384n](#)
attention, directed, and thinking, [11f](#)
Attic: bas-relief, [203](#)
 wall-relief, pl. [xxia](#)
Attis, [127](#), [219](#), [223n](#), [258](#)
 -Adonis, [109](#)
 cult legend, [423–25](#)
 and Men, [204](#)

and Mithras, [109n](#)
mystery of, [344f](#)
and sacred pine-tree, [233](#), [423*](#)
self-castration of, [259](#), [378](#)
transformed into tree-trunk, [425](#)

Attis-Cybele cult, [384](#)
priests of, [426](#)
ritual castration in, [204](#)

Atum, [97](#), [267](#)

Augean stables, [374n](#)

Augustine, St., [429n](#)
on carnal vs. spiritual, [70n](#)
on cross as marriage bed, [269](#)
definition of libido, [130](#)
description of fate of Alypius, [68f](#)
interpretation of Christ's death, [433](#)
on love of God, [74](#)
on man and nature, [73](#)

Australian primitives, renewal rites, [432](#); *see also* Wachandi

Austria, legendary sign of rain in, [278](#)

autism, in schizophrenia, [28](#)

autoeroticism, infantile, [28](#)

automatisms, psychic, sexual theory of, [129](#)

autonomism, "God" as, [56n](#)

autonomy: of archetype, [309](#)
of naïve intellect, [60](#)

autosuggestibility, [38](#)

autosuggestion, instantaneous, [447](#)—[49](#)

autumn: equinox, [268](#), [428n](#)
first day, [267](#)

Avesta, [166](#)

Azazel, [111](#), [113](#)

Aztecs, [290](#)
eucharist of Huitzilopochtli, [336](#), [433n](#)

flaying ceremonies of, 383
human sacrifices of, 327
rite of the cross, 263f; *see also* Chiwantopel

B

Baal: of Edessa, 201
and Shemesh, 303n
Babel, tower of, 113
baby, *see* infancy: infant
 Babylon (city), 208, 214
 whore of, 215*
Babylonian: gem, picture on, 202f
 myth, 199, 201
 underworld, 215n
Bacchus, 181
 consecrations to, 345
Bachofen, J. J., 444*
Bakairi myths, 203n, 220n
Balaam, 276
Baldur: death of, 257–59
 and Loki, 30
 puer aeternus, 258
Baldwin, J. M., 14ff
Bali: circle of gods, pl. LIXb
 fire-god Tjintya, 146n, pl. XIIIa
 witch Rangda, pl. XLVIII
Bancroft, H. H., 264n
Bapp, K., 146n
baptism: of Christ, 234
 —, mythological parallels, 196
 by fire, 200
 as rebirth, 321
 water symbolism, 219
Barchusen, Johann K., 100*

Barlach, Ernst, [362n](#), [363n](#)
basket(s), [209](#), [342](#)
 Eleusinian symbolism, [342f](#)
 of Isis, with snake, pl. [LIII](#)
 winnowing, [345](#)
Basuto myths, [199n](#), [374n](#)
bathing, in fountain, [244](#)
battle of the gods, [252–54](#)
“bay,” etymology, [272](#)
bear: constellation, [103f](#)
 goddess Artemis with, [57n](#)
 goddess Artio with, pl. [Lb](#)
 mystic identity of, [316](#)
 as symbol of the mother, [322](#)
bees and dead lion, riddle *re*, [339](#)
behaviour: consciousness and rules for, [434](#)
 pattern of, and archetypes [313](#)
 —, and primordial image, [309](#)
Behemoth, [55ff](#)
beloved, symbol of, [398](#)
belt, magic, [316](#), [353](#)
ben and *bel*, [163](#)
Beneke, F., [132n](#)
Benndorf, Otto, [428](#)
Bernardino de Sahagún, [336](#)
Bernhardt, Sarah, [35](#)
Bernoulli, C. A., on Nietzsche’s dream, [34n](#), [378n](#)
Bernoulli, J. J., pl. [xxa](#)
Berthelot, Marcellin, [140n](#), [332n](#), [356n](#)
Bertschinger, H., [179](#)
Bes, [123*](#), [362n](#)
Bethlehem, birth-cave at, [109n](#)
betrayal of the hero, motif of, [30](#)
betrothal ring, meaning of, [432n](#)

Bhagavad Gita, [166](#), [174n](#)

Bhrigu, [146](#)

Bible: association of hero's name with parallels in, [192](#)

cities as women, [213](#)

longing for the mother, [212f](#)

of Manerius, pl. [LVI](#)

of Merian, pl. [XXIIa](#)

mouth, fire, and speech symbolism, [162f](#); *see also* New Testament:

Old Testament

Biblia pauperum, [167](#)

bier, name for, [281](#)

Big Snake, African legend of, [399](#)

Bi-neb-did, [240](#)

biological phenomena, changes in original sexual character of, [136](#)

bird(s): with golden wings, [289](#)

helpful, [248n](#), [347f](#), [352f](#)

language of, [402n](#)

as soul-images, [215](#)

symbol of wishful thinking, [246n](#)

birth: anal, [191](#)

dual, of the hero, motif of, [321ff](#)

extraordinary, of the hero, [318](#)

goddess of, [370](#)

mythological conjunction of rock, tree, and water, [243](#)

myths, ethical basis of, [225](#)

pangs of, [287n](#)

in a stable, [199n](#), [374n](#)

theories, of children, [353](#)

of water and spirit, [225](#)

birth-giving primary substance, [241](#)

bisexuality: of gods and goddesses, [221](#)

in libido myth, [289](#); *see also* hermaphrodite

Bithynia: Attis-Cybele cult, [426n](#)

Blackfoot, *see* Melampus

blacksmith, [358](#)

Bleuler, Eugen, [40n](#)

on “ambitendency,” [173f](#)

on “ambivalence,” [109](#), [173f](#), [438n](#)

on schizophrenic group, [18n](#)

bliss: in childhood memories, [334](#)

divine, [266](#), [402n](#)

blood: of dragon, [364](#)

Eucharistic, [168](#)

sacrificial offering, [431](#)

vestments dipped in, [104](#)

boa constrictor, [296n](#)

Bodhisattva, [321](#)

body: exploration of, in child’s rhythmic activity, [144](#)

inviolable, [395ff](#), [459](#)

motif of dismemberment and reassembly, [237f](#), [239](#)

mutilation of parts of, [239](#), [245n](#)

“pneumatic,” or subtle, [332](#)

protruding parts and cavities, [147n](#)

secretions as libido equivalents, [300](#); *see also* deformity

Boedromion, month of, [340](#)

Boeotia, sacrifice to snake deity in, pl. [LVII](#)

Bogda Gesser Khan, [353n](#)

Böhme, Jakob, [91*](#)

Bologna: Holy Sepulchre of San Stefano, [346](#)

Bombay, [237](#)

Book of the Dead (Egyptian), [280](#)

self-creation of the gods in, [256](#)

tree-image in, [246](#)

Book of Rites, [427](#)

borderland phenomena, [457](#)

“bore/born,” etymology, [147–48n](#)

Boreas, [216n](#)

boring: associated with fire and procreation, [153](#)

etymology, [147n](#)
finger gesture, [142ff](#)
and fire-making, [145ff](#)
masturbatory, [160](#)
Botho, Conrad, [96*](#)
Bousset, Wilhelm, [368n](#)
bow-and-arrow symbolism, [287n](#); *see also* arrow
Brahma, [122f](#), [351](#)
 emergence from Vishnu, [293](#), [399](#), pl. [XLVIA](#)
Brahman, [393](#), [422n](#)
Brahmanaspati, [358f](#)
Brahman ideas of fire and sacrifice, [165f](#)
brain, inherited structure and functioning, [29](#)
Brazil: Bakairi Indians, [203n](#), [220n](#)
breast: as “mama,” [23n](#), [251](#)
 drink of immortality from, [376n](#)
 exposed to arrow-shot, [282ff](#)
breast-beating, [256](#)
Brenner, Albert, [32n](#)
“bridal bed” in the field, [151n](#)
“Bride of Corinth,” [370](#)
“bright, shining,” etymology, [163](#), [220](#)
Brimo, [370](#)
brother(s): mortal and immortal, [384n](#)
 -sister incest, [358](#)
 -sister marriages, [234](#), [436](#)
 unequal, motif of, [240](#)
brotherhood of man, [70ff](#)
Brown, W. Norman, [416n](#), [420n](#)
Brugsch, Heinrich, [163n](#), [216n](#), [240n](#), [241n](#), [246n](#), [256n](#), [268n](#), [269n](#)
Brünhilde: and Siegfried, [358–64](#)
 and Wotan, [359–61](#)
Bruno, Giordano, [21](#)
Bruns, Gerda, *see* Wolters

brutality: age-old problem of, 230
and sentimentality, 428

Brutus, and Cassius, 282f, 461

Buber, Martin, 91n, 92n, 94n

Bücher, Karl, 71n, 154n

bud, 399, 401n

Buddha: birth of, 243, 320
Maya's dream of his conception, pl. XLIXb
separation from family ties, 310f
teachings of, as sun-wheel, pl. va
on unfulfilled desires, 287

Buddhism: tree of the dead, pl. XXXV
tree of enlightenment, pl. LV

budding tree, symbol, 248n

Budge, Sir E. A. T. Wallis, 98*, 237*, 241*, 268*, 315n, pl. XLlb

bull: and Dionysian orgies, 278
and dragon, 384
father-symbol, 261
fertility symbol, 103
fiery god, 220
god as, 340
hidden feminine significance, 426
seed of, 427
and snake, symbols of hero, 431f; *see also* Apis

bull-sacrifice, 121n, 238, 276, 421, pl. XL
conquest of instinctuality, 262
and fertility, 432
fruitfulness through, pl. XXXIII
function of dog in, 238
meaning of, 261f, 432
messenger of the gods, 248n
points of resemblance to Christian sacrifice, 200f

Bundahish, 282
bull-sacrifice in, 421n

Bunsen, C. C., [184n](#)
Burckhardt, Jacob, on *Faust* myth, [32](#)
 on Petrarch, [19n](#)
 quotation from St. Augustine, [73](#)
burden-carrying, [301ff](#)
burial: in consecrated ground, [372](#)
 customs, and tree symbolism, [233](#)
 —, Etruscan, [388n](#)
“burst, swell,” etymology, [163](#)
Busiris, festival of Isis, [256](#)
butterfly, and psyche, [250](#)
Byblos, [236](#)
Byron, George Gordon, Lord, [110](#), [111ff](#), [192](#), [456](#)

C

Cabir(i): attributes of, [126](#)
 banquet of, [129*](#)
 phallic aspect, [124](#)
Cacodaimon, [382](#)
Cadmus, [208](#)
Caetani-Lovatelli, E., [342n](#)
Cagliostro, Alessandro di, [193n](#)
Callistus, catacomb of, [107n](#)
Cambodia: goddess in the lingam, pl. [xxix](#)
 lingam with yoni, pl. [xxv](#)
Canaanites, [192f](#)
Canada: Nootka Indians, pl. [xlii](#)
candlesticks, seven, Son of Man between, pl. [vb](#)
Canicula, [238](#)
Cannegieter, Hendrik, [249](#)
cap, magic, [364](#); *see also* pileus
Capricorn, zodiacal symbol, [198](#)
caritas, [86n](#)
Carlyle, Thomas, [92n](#)

Carnival, in Rome, [104n](#)
carpenter, as hero's father, [333](#)
carrus navalis, [150n](#)
carrying: burden, [301ff](#)
 the cross, [302](#), [339](#)
 transitus, [338f](#)
Carus, Karl Gustav, [176](#)
Cassius, and Brutus, [282f](#), [461](#)
castigation, self-, [380f](#)
castration: motif of, [257n](#)
 ritual, and incest problem, [204](#)
 by snake, motif of, [438](#)
 substitution for, in Attis-Cybele cult, [426](#)
 tree-felling as, [424](#)
castration, self-, [343n](#), [423f](#)
 Attis, [259](#), [378](#)
 ideal sacrifice, [430](#)
 as sacrifice of instinctuality, [204f](#)
cat, Tum as tom-cat, [280](#)
catacombs, [372](#)
 sun symbolism of pictures in, [107n](#)
catatonic depression, Jung's case, [142ff](#)
cathexis(-es): egoistic, [133](#)
 libidinal, [133](#)
Catholic Church: and earthly and heavenly love, [224n](#)
 fire-lighting at Easter, [168](#)
 institutionalization of archetype in, [66](#)
 and universal need for visible hero, [177](#)
cattle: fire-making rite vs. epidemics, [149](#)
 goddess of, [426](#)
 origin of, [427](#)
caul, [198n](#), [364](#)
causalism, reductive, in Freud, XXIII
causality, psychic: law of, [46](#)

and symbol-formation, 223
Cautes and Cautopates, 200ff, pl. *xxb*
Cautopates, attributes, 203
cave/cavern: of death and rebirth, 369
 and grace, 338ff
 as maternal womb, 423
 meaning of, 296n
 seven sleepers in, 193f
 worship in, 341f, 346
caviar, suggestibility *re*, 447
Cecrops, myth of, 382f
cedar-tree, 219, 236f
celestial harmony, 164
Celts, their conception of the Fates, 250
centaurs, 279
 origin, 303n
Central America, 263
Cerberus, 182, 369, 371
Ceres, of Pharos, 219; *see also* Demeter
Chaldaeia, 208
 dream-interpreters of, 7
chalice: image, 405
 as mother-symbol, 295n
Chamberlain, Houston Stewart, 81n
chaos, and cosmos, 48, 453
Chapouthier, Fernand, 318*
chariot: fiery, 105n, 195f
 and horses, 279
Charon, obolus given to, 372
chasm, and underworld, 365
Cherokee Indian legend, 337
chest, 209, 234
child(ren): birth theories of, 353
 born with caul, 198n

creation of, 49
hindrance to natural development of, 307
individual disposition of, and parental imagos, 328
interest in defecation, 190ff
myth-making, 24
myth of persecution of, by Lamia, 248
parental imago as helpful or frightening animal, 181
relationship with mother, 213
role of inborn instincts, 180
speech of, 15
stolen by witch, pl. XLVIII
torn from womb, motif of, 216n
treading movement, 250
unborn, fish symbol of, 198
unconscious identity with mother, 235

childbirth, goddess of, 278

childhood: archaic thinking, 27f
bliss of, longing for, 414
effortless state of, 403n
impressions, and choice of wife, 326
—, effect of, 334
memories of, 89
—, and dreams, 22, 29
—, and magical images, 408
reveries, role of, 332

“childlikeness of faith,” 232

Chimera, 182

chin, 147n

China: Buddhist tree of the dead, pl. xxxv
emperor of, 209

Chinese philosophy: fire-sacrifice, 427
I Ching, 170, 279n

Chiwantopel: animus figure, 304
animus-hero, 307

apparition of, [183](#), [458](#)
Biblical parallels of name, [192f](#)
death threat to, [274](#)
horse and snake symbolism of, [437](#)
meaning of role of, [185f](#), [309](#)
Miller *re*, [457–62](#)
name, [187](#), [458](#), [460](#)
as personification of regressive reverie, [414](#)
prophecy of, [394f](#)
significance of birth from Popocatepetl, [191](#)

Christ, [109](#), [258](#)
and Anti-Christ, [368](#)
archetype of the self, [368](#), pl. [LX](#)
archetype of Spirit, [413](#)
archetypal hero, [368n](#)
baptism of, [200](#), [234](#)
biography of, [227](#)
birth of, [320](#)
birth-place of, [342](#)
blood of, [167f](#)
“branch” or “rod,” [248n](#)
and conflict with Jewish law, [262](#)
and the cross, [247](#), [269](#), [302](#), [339](#), *see also* Cross
crucified, with two thieves, [201](#)
crucifixion, [247](#), [262](#), [290](#), pl. [XXXVI](#)
—, mock, [276](#), [401](#), pl. [XLIII](#)
death of, [433](#)
divine and human, [31n](#), [177](#)
as divinity who is eaten, [339](#)
equation with Elias, [195f](#)
-figure, union of opposites, [368](#)
and fire symbolism, [167](#)
hanging on the tree, [432](#)
as Helios, [108n](#)

historical human being, [31n](#)
identification with serpent, [367](#)
-image, [345](#)
and his *ka*, [217n](#)
knowledge of, [230](#)
lost and found, [343f](#)
as manifestation of the self, [392](#)
and Mithras, and water-symbol, [218](#)
as Moses-serpent, [382](#), pl. [ixb](#)
mystic union with, [287](#)
and Nicodemus, [225f](#), [331](#)
open-armed before cross, [264](#)
personal, [177](#)
and Peter, [197](#)
pre-existence of, [322f](#)
proof of divine sonship of, [87](#)
psychological signification of, [368](#)
sacrificial death and resurrection of, [412](#)
scholasticism and, [19](#)
Second Coming of, [196](#)
self-sacrifice of, [30n](#), [431](#)
separation from family, [311](#), [414](#)
and snake, [374](#), [382](#)
as *Sol novus*, [106](#)
as Son of Man between the candlesticks, pl. [vb](#)
surrounded by the evangelists, pl. [LX](#)
and the sword, [359](#), pl. [vb](#)
temptations of, [337n](#)
Transfiguration of, [195](#)
on the Tree of Life, pl. [xxxvi](#)
in the Virgin's womb, pl. [iii](#)

Christian(s): children of the Higher City, [213](#)
conflict with powers of seduction, [81f](#)
sun-worship among, [107](#)

Christian: art, [107](#)

—, lamb allegories in, [428](#)

love, [396](#)

mystery, of sacrifice, [420](#)

myth, [166](#), [308](#)

philosophy, and homoousian idea, [392](#)

sacrifice, points of resemblance to Mithraic sacrifice, [200f](#)

symbols and symbolism, [217](#), [229](#), [290](#), [320f](#), [367n](#)

Christianity: ascetic tendency of, [257n](#)

aversion from the world in, [74](#)

vs. brutality, [71](#)

conflict with Jewish law in, [262](#)

effect of educational training in, [72](#)

fire symbolism in, [167](#)

and *hieros gamos*, [269](#)

and Mithraism, [67](#), [70](#), [200f](#)

moral degeneracy of first centuries of, [67](#)

oneness with God in, [87](#)

and pathological fantasies, [441f](#)

polytheistic tendency in, [99](#)

primitive, [229](#)

reason for original acceptance of, [230](#)

and spiritual transformation, [428](#)

subjugation of animal instincts in, [70f](#)

values of, [229f](#)

Christmas, and mistletoe, [258n](#)

Chronicles of Lanercost, [149](#)

Chronos, [280](#)

Chryse, [294f](#)

Chrysopoea, [126n](#)

Chthonia, temple of, [365](#)

Chuang-tzu, [427](#)

Church: baptismal water symbolism, [219](#)

as bride of Christ, [269](#)

connection with the mother, [217n](#)
as hero's grave, [345](#)
as mother, [213](#), [217n](#), [236](#), [270n](#), pl. [xxxxa](#)
as mother archetype, [236](#)
as mother-wife of Christ, [217n](#); *see also* Catholic Church
Church Fathers, as father-god, [49](#)
churning-stick, [146n](#), pl. [xv](#)
Ciba Archives, [152*](#), pls. [xiii](#), [xxxiii](#), [lix](#), [lxia](#)
Cicero, [129f](#)
Cinderella, [352n](#)
Cinyras, [333](#)
Circe: with Odysseus, [128*](#)
 and Picus, [352](#)
circle, [391](#)
 “closed,” [426](#)
 of gods, pl. [lix](#)
circumcision, as sacrifice, [430f](#)
cista, [342](#)
 and serpent, pl. [lviii](#)
city: maternal symbol, [207f](#)
 -mother, [213–17](#)
 and tree symbolism, [233ff](#)
 vision of, [233](#)
Claparède, Edouard, [23n](#)
classical spirit: and mythology, [20](#)
 understanding of, [4](#)
cleft, mother-symbol, [371](#)
Clemen, Paul, pl. [xiva](#)
Clement of Alexandria, on Eleusinian baskets, [342](#)
Clement of Rome, [107n](#)
Cleopatra, [8](#)
clubs, battle with, [256f](#)
Coblentz bas-relief, [425](#)
cock, [203](#)

attribute of, [280f](#)
Men on, pl. [xxia](#)
Peter's attribute, [197](#)
as solar symbol, [197](#)
as symbol of time, [280f](#)
coffin: and horse-symbol, [281](#)
Osirisin, [237*](#)
as tree-symbol, [233](#)
cohabitation: continuous, [209](#), [217n](#)
with god, [287](#)
Cohn, William, [24n](#), pl. [lv](#)
coincidentia oppositorum, [368](#)
coins, sexual symbols on, [203](#)
coitus: ritual, [151](#)
upward displacement of movements, [142n](#)
“collective representations,” [156f](#), [420](#), [442](#)
collective unconscious, *see* unconscious, collective
Colonna, Francesco, [75*](#)
“colour hearing,” [165](#)
colours, bright, [458](#)
comet, [314](#), [315](#)
communication: impression of, [458](#)
role of speech in, [13f](#)
Communion, blasphemer on, [376](#)
“communion of saints,” [226](#)
community, archetypal, [66](#)
comparative procedure: as used by Jung, [xxvi](#), [xxviii](#), [5](#), [367f](#)
in Schreber case, [128n](#), [301n](#), [382](#), *see also* Schreber
comparison(s): by analogy, [96f](#)
causative, [97](#)
choice of, [39n](#)
functional, [97](#)
in libido-symbolizing, [97ff](#)
compensation: between conscious and unconscious, [65](#), [379f](#), [390n](#)

and creation of wholeness, 395
dream expression of, 10
through fantasy, 26
between man's animal and evolutionary instincts, 418f
unconscious and, 397f

“complex,” term, 44n

complexes, 328
and extraversion and introversion, 178
feeling-toned, 141
functional autonomy of, 61
projection of, 414f
racial and national, in myth, 32
solution of, through identification, 35
stability of, 80n, 83
transformation into art, 141
unconscious fantasy-systems, 29; *see also* mother s.v.; Oedipus

“comprehend,” etymology, 440

“comprehension,” etymology, 306f

compulsion: of fear, 111
feature of impulses and automatisms, 129
by stars, 67, 415
unconscious, 414f

“concept,” etymology, 141

conception: by breath or wind, 319
supernatural, psychological explanation of, 323

concupiscentia: and natural instincts, 157
effrenata, 280

conflict(s): between good and evil, without solution, 117
conscious transference to God-image, 60f
fundamental human, 4
inner, over external object, 175
and repression, 58ff

coniunctio, 223

conscious (mind): animus and, 396

archetype vs., 308
archetypes perceptible to, 293
assimilation of contents from unconscious, 408
attitude of, and archetypal images, 181
and collective unconscious, 442*f*, *see also* unconscious, collective
and compensation, 10, 434
conflict with instinct, 396
content, use of, in dreams, 180
—, creation through sacrifice of primal being, 417
deadlock of forward-striving function, 397
development of, 435
energy attracted by unconscious from, 432
and fantasy products, 29, 310, 441
individual differences in content, 176
invasion from unconscious, 370, 397
and “mana personality,” 392
and moulding of human nature, 434
and primordial image, 438
process, adaptation as essence of, 177
rejection of the unconscious, 294*f*, 304
transferral of activity to primordial image through invocation, 178
unconscious as check to forward striving of, 299
and unconscious, projection of the *hieros gamos* and, 433
—, union of, 395, 433; *see also* unconscious, relation to conscious

consciousness: birth of, 325
of conflict, 60*f*
confrontation of subject and object, 402*n*
consolidation of, 356*f*
dawning and extinction of, 280
development of, and separation from childhood ties, 235
individual content of, 177
and instincts, 227
introspective, 430
libido tendencies and, 424

longing for nature, 205
masculine, union with feminine unconscious, 433
rebirth from darkness, 359
son as, 259
and splitting of primary instinct, 158
and transformation, 236
Constantine, Arch of, in dream, 9f
constellation(s): theriomorphic, 95
of unconscious contents, 59
containment, motif of, 234ff
contrasexual tendencies, assimilation of, 301
Conybeare, F. C. C., 217n
cooking, symbolism of, 140
Coptic myth of the Father-Creator, 315
corn: ear of, 343, pl. ivb
mortar, 203n
corn-god, 336f
Adonis, 343n
battle with, 337ff
motif of lost and found, 344
of Peru, pl. LII
coronation rite, 88n, 106
in mystery cults, 87n
corpse, devouring of, 237
corpus mysticum, 433
Cos, temple at, 372f
cosmogonic principle, 137f
cosmogony: Orphic, 370
psychological, 417
cosmos, 48
cow: divine, 242*
heavenly, 235, 242, 268, 279n, 297
as mother, 181, pl. La
as mother-symbol, 240, 359

wooden, burial in, [439n](#)
crab, dream of, [245](#)
craftsman, as hero's father, [333](#)
creation: ideal as substitute for real, [50](#)
 and repression, [60](#)
 and sacrifice, [415f](#)
 through thought, [48ff](#)
 of universe, [45f](#), [53](#)
Creation, Epic, Babylonian, [252–54](#)
creative: fantasy, [397](#), [448](#)
 force, formulations *re*, [137](#)
 —, symbols of, [124](#)
 imagination, subconscious, [446–62](#)
 powers, and the unconscious, [337](#)
 process, unconscious, [45](#)
 spiritual activity, [380](#)
 thought, and introversion, [293](#)
 word, [45](#)
creator: and creation, [60](#), [380](#)
 -God, and father-*imago*, [44](#)
 of the nations, image of, [314f](#)
Creuzer, (Georg) Friedrich, [238](#)
Crèvecoeur, M. G. J. de, [326n](#)
criticism, materialistic, [435](#)
Cronos, [244](#)
Cross/cross: on Adam's grave, [247](#), pl. [xxxvii](#)
 -carrying, [302f](#), [339](#)
 human, [265*](#)
 as marriage-bed, [433](#)
 Mary's lament to, [270](#)
 meaning of, [264](#)
 Palenque, [263](#), pl. [xlii](#)
 point of intersection, [267](#)
 with secret reliquary, [236n](#)

sign of, 264
symbolism, 233, 263–67, 269, 303, 370
tree of death, 233, 246, 247, 281, 321, pl. xxxvii
tree of life, 247, pl. xxxvi

cross-cousin marriage, 152f, 271n, 418
crossing the water, 327n
Crotopus, 216n, 260
crown: in alchemy, 184n
 of eternal life, 262
 of Helios, 196f
hermaphrodite with, pl. xviii
identification with rays of sun, 183
mural, 208, pl. xxivb
of rays, 196
symbol, 432n

Crucifix, dream of, in form of excrement, 189
crucifixion: mock, 276, 401, pl. xlIII
 and serpent, pl. ixb
 symbol, 367f

Crusaders, 189
crux ansata, 264n, 267, 268*
 meaning of forms of, 269

cryptomnesia, 313, 439n
cucurbita, 167

cults: ancient, sexual content of, 228f
 basis in relationship of son to mother, 222n

cultural: activities, Jung's early views of, as based on sexual libido, 155
 development, and psychic energy, 16

culture: anthropoid psyche vs. traditional pattern, 328f
 and development of the cult of the hero, 177
 -heroes, 31

Cumaean Sybil, 82
Cumont, Franz, 67n, 99n, 105*, 106n, 107n, 109n, 196n, 197 n, 201n, 218n, 279n,
 280n, 289n, 342n, 366n, 367n, 369n

on dadophors, [200](#)
on facial expression of the Tauroctonos, [428](#)
on nature in Mithraism, [73](#)
pls. [xxxiii](#), [xl](#), [lxiii](#)
Cupid, [288](#)
 and wheel of phalli, [203](#)
Curtius, sacrificial death of, [365](#)
cutting off of heart, [210](#)
cutting open fish's belly, [210f](#)
Cybele, [208](#), [423](#)
 and Attis, [204*](#)
cypress, [221n](#)
Cyprus, [216n](#)
Cyrano de Bergerac (Rostand), [34–37](#), [47f](#), [282f](#)
 closing scene, [111](#)
 identification with, [448](#)
Cyril of Jerusalem, [368n](#)

D

dactyls: birth of, [191](#)
 called thumbings, [127n](#)
 Idaeon, [126f](#)
 phallic aspect, [124](#)
dadophors, [200ff](#), [238](#)
 with torches, pl. [xxb](#)
daemon: transformation of, [353](#); *see also* demon
dagger-symbol, [369](#)
dancer, American Indian, headdress, pl. [xxib](#)
dance-step, [315](#)
Dancing Dervishes, [315](#)
Dante Alighieri, [82n](#)
Danzel, T. W., [125*](#), [299*](#), [318*](#), [391*](#), [405*](#)
Daressy, Georges, pl. [xxx](#)
darkness: descent into, [341](#), [357](#), [409](#), [414](#)

substitute for upper world, 292
symbolism, 124
world, of primordial images, 408ff

daughter-anima relationship, 388
daughter-wife, 322
day-dreams, fantasy products, 29
day-star, fish as, 199f

dead, the: cult of, 372
disposal of, 237f
souls of, 281, 373

death: in African Negro myth, 348
as archer, pl. XLV
dragon of, 259
emblem of, 221n
fantasies, and renunciation of desire, 110
fear of, ransom from, 431
fruitfulness from, 338
gesture of self-exposure to, 282ff, 304, 307
-instinct, 328n
as life, 344
longing for, 284f, 356, 384
as maternal womb, 218
mother as source of, 365
as omen, 354f
origin of, 271, 348
presentiments of, 285
and rebirth, 238, 244, 382, 412, 415n
ship and tree of, 246
snake as symbol of, 373
symbolic intimations of, 407ff
symbolism of, for summit of life, 285
tree of, 233, 246, 281, 321, pls. xxxv, xxxvii
and resurrection, *see* god, dying and resurgent; as re-entry into mother, 439n
voluntary, 386f, *see also* sacrifice *and* suicide

waters of, [350f](#), [353](#)
and zenith of the sun, [238](#); *see also* life and death
decision-making, and conscious mind, [304f](#)
“decoy mechanisms,” [154](#)
defecation: boy’s fantasy of, [188](#)
and propagation, [190ff](#); *see also* excrement
deformity, motif in Cabiric cult, [128](#); *see also* dwarf(s)
De Gubernatis, Angelo, [189n](#), [295n](#)
Deianira, [26](#)
deification of the believer, [86ff](#)
De Jong, K. H. E., [341n](#), [343n](#)
Delilah and Samson, [300](#)
Delphi, crevice and Castalian spring, [371](#)
Delphic: gorge, [250n](#)
oracle, [295n](#)
Deluge, the, flight from, [110](#)
delusions, in Freud’s Schreber case, [128n](#)
dementia praecox, *see* schizophrenia
Demeter, [237n](#), [239](#), [275n](#), [341](#)
Homeric hymn to, [344](#)
and Persephone, [339ff](#)
demiurge, [108n](#), [427n](#)
demon: eating the sun, pl. [xxxiv](#)
expulsion of, pl. [ia](#)
-lover, [111](#)
possession by, [337](#), *see also* daemon
-woman, myth, [300](#)
Demosthenes, [26](#)
depressive: psychosis, and symbol of all-devouring mother, [328](#)
state, an unconscious compensation, [404](#)
“De promissionibus,” [366f](#)
Desert Fathers, [81n](#)
desexualization, of libido, [419](#)
desire(s): for the good, [129f](#)

object and quality of, [84f](#)
renunciation of, and death-fantasies, [110](#)
unconscious, and torment of soul, [289](#)
—, for the mother, [306f](#)
unfulfilled, and repression, [286f](#)
violent, and anxiety, [109f](#)
desirelessness: and divine bliss, [266](#)
and sleep, [326](#)
Deubner, Ludwig, pl. [LXIIIa](#)
Deucalion and Pyrrha, [191](#)
Deussen, Paul, [382n](#), [416n](#)
on creator and creation, [380](#)
on horse-sacrifice, [421](#)
Dev Azur, [427](#)
devil: and Christ, [337n](#)
communion of, [376](#)
and divinity, [376n](#)
and horse, [277](#)
as other side of God, [56](#)
snake symbol for, [374](#)
and witch, [276*](#)
devilfish, [366n](#)
devouring, [210](#), [419](#), pl. [LXII](#)
and assimilation of magic power, [339n](#)
of hero, [347n](#)
monster, [248f](#)
motif of, [245](#), [325f](#), [351](#), pls. [XXXIIb](#), [XXXIV](#), [LXII](#)
and swallowing, [419](#)
Dhulqarnein, [194f](#)
Diana, [208](#)
of Aricia, [170](#)
of Caria, [219](#)
of Ephesus, with mural crown, pl. [XXIVb](#)

Dieterich, Albrecht, [45n](#), [66n](#), [87n](#), [90n](#), [94n](#), [100n](#), [103n](#), [150n](#), [151*](#), [202n](#), [339n](#),
[342n](#), [343n](#), [345n](#), [376n](#), [384n](#), [427n](#)
on Apollo and Python, [216n](#)
on cista, [342](#)
magic papyrus, [87](#), [89](#)
on primitive forces and religion, [269n](#)
on solar phallus, [157f](#)

Dietrich of Bern, [194n](#), [379n](#)

Diez, F. C., [272n](#)

Dio Chrysostom, mystic quadriga, [279](#)

Diodorus, [238n](#)

Dionysia, [104n](#)

Dionysian orgies, and bull, [278](#)

Dionysus, [127f](#), [205n](#), [223n](#), [401](#)
and Agni, [168n](#)
cult, [128](#), [425n](#)
dismembered, [237n](#)
double figure of, [127f](#)
and fig-tree, [221n](#)
head of, [187n](#)
legend, ass in, [401](#)
and tree, [425](#)

Dionysus Lysius, [137](#)

Dionysus-Zagreus, [423](#)
rebirth of, [340](#)
sacrifice of, [339n](#)

Dioscorides, [147n](#)

Dioscuri, [127](#), [200](#), [201](#), [384n](#)

dismemberment, motif of, [237f](#), [253](#), [358](#)

dissociation, [40](#), [441f](#)
treatment of, [442f](#)

divine, the, concept of, [311n](#)

divine nature, assimilation of, [338f](#)

divinity, theriomorphic elements, [57](#)

doctor, *see* psychotherapist

“doctor animal,” 327

dog(s): frustrated by closed door, 153

guardians of the treasure, 372

and jackals, 237

sacrifices of, 371

significance of, 369

dogma: materialistic criticism of, 435

religious, 229f

symbolic expression of an idea, 77

dog-star, 238

dolphin, and womb, 248n

Domaldi, Swedish king, 209

domestication, and incest-taboo, 271

dominants, organizing, among archetypes, 391

Dominic, St., 342n

donum amoris, 66

donum gratiae, 66

dove, 245n

symbol of Holy Ghost, 138

dragon(s), 374f, pl. xxxiv

assault by, 375*

blood, effect of drinking, 364

and bull, 384

and cave, legends of, 362n, 365–67

conqueror of, 374, pl. xviii

as evil mother symbol, 259

legend, and myth of Anti-Christ, 368

negative symbol of unconscious, 374

and St. Sylvester, 365f

self-consuming, pl. LIXa

seven heads, 214

and water, 326n

-whale myth, 210, 338n

woman and, 215, 366n

drama, unconscious, [308ff](#)
drawings, of children and artists, phallic symbolism in, [126](#)
drawing water, as individual experience and archetype, [234](#)
dream(s), [18](#)
 collective, myth as, [24](#)
 and the conscious mind, [310](#)
 contradiction characteristic of, [451](#)
 dreamer's interpretation of, [10](#)
 erotic impressions in, [43](#)
 fish symbolism, [198ff](#)
 individual foundations of, [8](#)
 interchangeability of figures in, [390](#)
 interpretation, [7](#), [390f](#)
 as modified memory, [22](#)
 primordial element in, [23](#)
 prophetic, [51n](#), [454](#)
 as reality, [39](#), [450](#)
 repetitive, [10](#)
 rule *re* dreamer, [196n](#)
 solution of problems in, [454](#)
 symbolism, analysis of, [10f](#)
 symbols of mother-*imago* in, [363f](#)
 theriomorphic representations in, [179](#), [328](#)
 unconscious bases of, [28f](#)
 water as obstacle in, [327n](#)
INSTANCES OF DREAMS: being filled with a snake, [378](#)
 crab clutching foot, [245](#)
 crucifix in form of excrement, [189](#)
 male patient having questionable relations with women, [179](#)
 Miller's, and creation of poem, [451ff](#)
 of St. Sylvester, [366](#)
 schizophrenic's, of sun and moon, [368f](#)
 snake, [436f](#), [438f](#)
 snake-bite in genital region, [378](#)

tree and poisonous fruit, 221
of young woman, illustrating sexual symbolism, 9f
woman patient's, of wild horse, 277
dream-: city, vision of, 458, 461
images, 7, 8f
language, 10
state, half-waking, 455, 457
thinking, regression in, 21
dream-book: of Artemidorus, 7
of Jagaddeva, 351
dreamer, splitting into several figures, 196n
Drews, Arthur, 31n, 333n
Drexel, Friedrich, pl. XLIXa
drink: immortality-giving, 433n
symbolism of, 167f; *see also* soma
Drosselbart, 276
Druids: and cross, 264
sacred oak and mistletoe, 258
dual mother, *see* mother s.v.
dual nature, of man, 291
Duchesne, Louis, 366n
“dum Deus calculat fit mundus,” 46
Duns Scotus, Johannes, 20
dwarf(s): animus-figure, 362ff
creative, 124
crippled, as foster-parent, 361ff
motif, figure of the divine boy, 127
dynamism, unconscious, 338

E

Ea, 252–54
eagle, 164n
symbol, 409
ear(s), 211n

piercing of, [351](#)

earth: burial in, [436](#)

—, and rebirth from, [412](#)

crevice in, as mother, [373](#)

descent into, [341f](#)

fertilization ceremonies, [365](#)

snake as symbol of, [102f](#)

splitting of, [288](#), [412](#)

—, with foot, [315](#)

Earth Mother, [159](#), [182](#), [336](#), [391](#), pl. [xiva](#)

earthquake, [460](#)

and landslide, [394f](#)

East, [210](#)

night sea journey to, [358](#)

Ebbinghaus, Hermann, [11n](#)

Eberschweiler, A., [15n](#), [155n](#)

ecclesiastical art, [107](#), [224n](#)

Echidna, [215](#)

mother of the Sphinx, [182](#)

Echion, [425n](#)

Edda: example of direct projection, [112n](#)

Hovamol, [263](#)

Eden, Garden of, [429n](#)

Egeria, [298n](#)

egg: basilisk (Nietzsche), [382](#)

of Khnum, [269](#)

Phanes in, pl. [xii](#)

self-begotten, [380](#)

and self-creation of the gods, [256](#), [352n](#)

shaped on the potter's wheel, [256](#), [269](#), pl. [xlib](#)

symbol of mother, [354](#)

world enclosed in, [354](#)

ego: and archetype, [66](#)

conscious, and collision between instinctive tendencies, [424f](#)

renunciation, [435](#)

and self, [384n](#)

and unconscious, [301](#)

ego-consciousness: and battle with the monster, [348](#)

deliverance from threat of unconscious, [353](#)

and shadow, [437](#)

egoism, and mass psychology, [71](#)

egoistic instinct, [133](#)

Egypt, [106n](#), [216n](#)

crux ansata, [267](#)

dream-interpreters of, [7](#)

fantasy of rejuvenated mother, [322](#)

polytheism in, [97ff](#)

hymns, [235](#), [268f](#), [295ff](#)

myth of Apis bull, [374n](#)

Ptah shaping the world-egg, pl. [xli](#)

statue, Miller's fantasy of, [37](#), [179](#), [448](#)
symbol of the "living sun-disc," [96](#)
text on becoming a god, [87f](#)
vessel with tree of life, pl. [xxxI](#)
water, feet, and fertility, Coptic ideas of, [315](#)
Ehrenstein, Theodor, [212*](#)
Eileithyia, [239](#), [370](#)
 darts of, [287n](#)
elephant, theriomorphic symbol, [321](#)
Eleusinian mysteries, [339](#), pl. [ivb](#)
 eating the god in, [339–40](#)
 serpent in, [378](#)
Elias/Elijah, [195f](#)
 ascension, [105n](#)
El-Khidr, *see* Khidr, El-
embracing, motif, [440](#)
Emerson, Ralph Waldo, [67n](#)
Emmerich, Anna Catherina, [286–88](#)
emotion(s), *see* affects feeling(s)
Empusa, [369f](#)
enantiodromia, [375](#)
 of life into death, [438](#)
encircling motif, [325](#)
endogamy: and exogamy, [271n](#)
 and incest-taboo, [152f](#), [335](#)
 social danger of, [418](#)
endopsychic perceptions, [129n](#)
energy: of archetype, [232](#)
 difficulties of transformation of, [158f](#)
 "horse power," [421](#)
 and its medium, [86](#)
 in physics, [131](#)
 Plotinus on, [138](#)
 release of, by conscious mind, [432](#)

solar, [122](#)
unconscious transformation of, [429](#); *see also* psychic energy
English language, fire-making symbolism, [149](#)
enlightenment, tree of, pl. [LV](#)
Entkrist, *see* Anti-Christ
entwining: and devouring, [245](#), [280](#)
 etymology of, [245](#)
 motif of, [242f](#), [351](#)
 and motif of clashing rocks, [245n](#)
environment: and creation of the God-image, [86](#)
 importance of rapport with, [207](#)
 and neurosis, [139](#)
 suggestive power of, [157](#)
Ephedra vulgaris, [410n](#)
Ephesus, Diana of, pl. [xxivb](#)
Epirus, love song of, [52n](#)
Erdmann, B., [14](#)
Erechtheus, [382](#)
Erinyes, [372](#)
Erman, Adolf, [88n](#), [97n](#), [235n](#), [242*](#), [296n](#)
Eros, [137](#)
 Diotima's description of, [166](#)
 of woman, [300](#)
Erotes, [200](#)
erotic conflict, resolution of, through religious poetry, [57f](#)
erotic impression: chain of associations, [85](#)
 transformed into religious exaltation, [59](#)
 underestimation of, [43f](#), [53](#)
eroticism, *see* sexuality
erotomania, [47n](#)
Erythia, [197](#)
Eskimo myth of woman and whale, [338n](#)
Esne, [240](#)
Essene sect, [383](#)

eternity, longing for, [410](#)

Etruscan: burial custom, [388n](#)

Pietà, pl. [LIV](#)

eucharist, [336](#)

prayer to Holy Ghost, [360](#)

Eucharistic Blood, [168](#)

eunuchs, [134](#)

Euripides, [339n](#)

Europa, [26](#)

Europe, ceremonial fire-making in, [149](#)

Eurystheus, [295n](#)

Eusebius of Alexandria, [107](#)

evangelists, surrounding Christ, pl. [LX](#)

Eve, tempting of, [103*](#)

evil: desires, demon of, [427](#)

principle, [426](#)

result of destruction of, [112f](#)

spirit of, [354](#)

strives for perfection through rebirth, [234f](#)

evolutionary instinct, [418f](#)

excitement, tendency to rhythmic expression of, [155](#)

excrement: and gold, [189](#)

as monument or souvenir, [192](#)

patient who smeared herself with, [191](#)

prima materia, [352n](#)

expectations, unconscious, unaffected by conscious attitude, [187](#)

extensity, factor of, [159n](#)

external object and subjective world, and dichotomy of the will, [173](#)

extraversion, role in complexes, [178](#)

eye(s): of fiery colour, [367](#)

of God, [91*](#)

of Horus, [123*](#)

myriad, of Rudra, [122](#)

symbolism of, [268](#)

F

facial expression, of sacrificer and sacrificed, [427f](#)

“factor of extensity,” [159n](#)

fairy, in toilet wall, child’s fantasy of, [190](#)

fairytale: and anal fantasy, [189](#)

of Crusaders, [189](#)

dream mechanism in, [24](#)

evil mother in, [248](#)

foster-parents in, [26](#)

hero’s father in, [333](#)

interpretation of, [249](#)

faith: basis in experience and tradition, [232](#)

blind, danger of, [229](#)

a charisma, [231](#)

and symbolical truth, [227](#)

falcon, Indra as, [422](#)

family: effect of prolonged dependence on, [304](#)

rebellion against ties, [311f](#)

separation from, [311](#), [414](#)

fantasy(-ies): accompanying libido regression, [419](#)

anal, [189](#)

bases of, [28f](#)

conscious, interpretation of, [31f](#)

as escape from life, [307](#)

incest and womb, [420](#)

indication for early treatment, [443](#)

insane, *re* “rays of God,” [128n](#)

intellectual, [435](#)

involuntary product, [284n](#)

mechanism of, [31](#)

Miller’s, *xxviii*f, [304](#)

—, mythological foundations of, [313](#)

mythical nature, 49
nature and source of, 25f
patient's translation of, 18n
schizophrenic, 139f
of snake, 436f
symbolical, 53
-thinking, *see following*
unconscious, adolescent, 49
—&, and decision-making, 304
unconscious activity of, 310
water-symbol of the unconscious, 219
of world conflagration, 438

fantasy-thinking: ancient basis in reality, 26
in conscious and unconscious sphere, 29
nature of, 18n
patient's difficulty in expressing, 18n
unconscious associations in, 45

Farnese stucco-relief, 345

fasting, 334

fate: fear of, 109f
personifications, 250
power of, 67n
Stoic conception, 279
symbol of, 281

father: in adolescent fantasy of creation, 49
archetypal role, 261
cause of fear, 260
-figure, magician as, 351
—, negative, 353
of hero, 332f
-imago, *see following* influence on daughter, 186
as obstacle to regression, 331
primitive side, 183
representations of, 327

and son, 127, 288, 331f, *see also* son s.v.
as vengeful pursuer, 359
father-*imago*: divine attributes of, 56f
 numinosity of, and suppression of instincts, 157
 reactivation of, 44, 59, 89
father-in-law, transference of father's attributes to, 333
father-son symbolism, 233f, 239
fatigue: and directed thinking, 12
 and dreams, 455, 462
 and fantasy-thinking, 25
 ocular, 458
Faust (Goethe), 54, 124f
 Burckhardt on, 32
 conflict in, 54, 81f
 development of sun-symbolism in, 105n
 "Doctor Marianus," 223
 fiery tripod in, 167
 life and rebirth in, 218f
 longings in, 80ff, 205f
 mission as saviour and destroyer, 82
 "The Mothers," 124ff, 182
 primordial image in, 32n
 significance of, 83
 yearning for rebirth in, 272
fear: "animal," 342
 deadly, compulsion of, 111
 dominant over sexuality in primitive group, 153
 instinct-inhibiting, 156
 and regression, 297f
 snake symbol of, 259, 431, 438f
 source of energy to check instincts, 152
 spirit of evil, 354, pl. LXII
 of struggle for existence, 156
feather, symbol of power, 88n

feather-dress, [248n](#)
feeling(s): infantile attitude toward demands of, [284](#)
 release of, in sentimentality and infantilism, [428](#)
 -tone, [85](#), [141](#), *see also* affects
Fejérváry Manuscript, [263](#)
felling of tree: as castration, [425](#)
 and sacrifice of libido, [424](#)
female symbols, [209f](#)
feminine, archetype of, [332](#)
femininity, and anima, [437](#)
Fenris-Wolf, [438n](#)
 Vidarr's fight with, [349*](#)
Ferenczi, Sandor, use of word "introjection," [136n](#)
Ferrero, Guglielmo, [2](#)
 on changes in human psychology, [27](#)
fertility: bull-sacrifice and, [432](#)
 cross as emblem of, [264](#)
 Frey, god of, pl. [XI](#)
 magic, [150f](#), [224](#), [266](#), [267](#)
 rites of the Wachandi, [150](#)
fertilization, spiritual or symbolic, [264n](#)
Fichte, Immanuel Hermann von, [29n](#)
Fick, Friedrich C. A., [245n](#), [373&n](#)
Fiechter, E., [265n](#)
field, "bridal bed" in, [151n](#)
fiery furnace, [167](#)
Fierz-David, Linda, [75*](#)
fig-tree, [221n](#)
figwood, [219](#)
finger-joint, [220](#); *see also* dactyls
fire: baptism by, [200](#)
 curtain of, and treasure hard to attain, [362](#)
 discovery of, and regression to presexual stage, [159](#)
 —, and the mouth, [161](#)

—, as a robbery, 168, 170
and divine hero, 187n
and light, horse-symbol, 279
—, in symbolism of Christian saints, 107
-making, *see following*; and speech, 161ff, 169
spirits, 427
as subject and object of sacrifice, 165f
symbolism of, 165f

fire-: boring, analogy of the sexual act, 159
—, and thinking, precaution, and foresight, 147
bringer, Hindu, 374
god, Balinese, 146n, pl. XIIIa
lighting, 210, 347
sacrifice, 427
Stick, 145, 147, 148n, 151, 266, pl. XIIIb
symbol, 279

fire-making: apotropaic significance, 168f
and boring, 145ff
as conversion of libido, 160
etymological analogies in terms for, 145ff
Nodfyr, 149
numinosity of, 169
in Occidental religious mystery, 168
as regressive reawakening of rhythm, 154
ritual, 154, 168f, 170
sexual connotation of, 147, 149f

Firminus Maternus, 318n, 384n
on Attis mystery, 344
on bridegroom, 187n
on tree and effigy, 425

fir-tree, 244n; *see also* cedar-tree; pine-tree

fish: as day-star, 199f
journey in belly of, 210f
-king, battle with sun-hero, 346f

loss of, on Moses' journey, 194, 198
symbolism of, 198ff
Vishnu as, 293, pl. XLVII
voracious, Terrible Mother as, 248
fishing for sea-monster, motif of, 255
fists, beating to death by, 384
Fitch, Clyde, 456n
flame: as libido image, 99f
-image (Carlyle), 92n
sacrificial, 167; *see also* fire
flaying, motif of, 383, 384
flood, the: called "Ogygian," 208
significance of, 364f
Flournoy, Théodore, xxviii, 29, 441, 446
and Miller fantasies, 33f, 455n
fonction du réel (Janet), 134f
fondling or kissing "fear-animal," 342
fons amoris, 218
food: Instinct, 418
mystical, 339
foot/feet: in dreams, 239
fertility significance of, 315
magical generative power of, 126
prints, 412
splitting the earth with, 288f
wounded by arrow, 295
force, physical concept of, 137
ford, wrestling at, 326n, 338
forest, maternal significance of, 274
form, an image and a mode of manifestation, 86
forward-striving: and libido, 398, 438
paralysis of, 300
taken over by unconscious, 397
Fossor Diogenes, 107n

foster-parent(s): chthonic god as, [361ff](#)
and hero, [321ff](#)
motif of, [26](#)

Fouillée, A., [132n](#)

foundlings, [26](#)

fountain(s), [402n](#)
and horse, [278](#)
of Kanathos, [244](#)
of life, pl. [xxvi](#)
of Mimir, [250n](#), [362n](#)
mother-imago as, [362n](#)
origin of, [412](#)

France, Anatole: story of Abbé Oegger, [30ff](#)
on language and thought, [12f](#)

Francis of Assisi, St., [87](#), [105n](#)

Frazer, Sir James G., [337n](#), [415n](#)

Freud, Sigmund, [29](#)
aetiological myth of the primal horde, [260](#)
attitude toward theories of instinct, [139](#)
“biological” orientation of school, [329](#)
devaluation of regression, [329](#)
“incest barrier,” [417f](#)
on incest problem, [174](#)
incest theory of, [419](#)
influence on Jung, [155](#)
interpretation of symbol-formation, [223](#)
involuntary and purposive ideas, [17n](#)
and Jung, loss of friendship, [xxvi](#)
on libido, [128f](#), [128f](#)
on myths, [24](#)
on paradox of sexual objects, [418](#)
personalism in the views of, [xxiv](#)
psychology, narrow outlook of, [xxiii](#)
on regression, in dreams, [22](#)

—, of libido to parents, 174
theory of neurosis, 420
on unconscious motives, 28
on waking vs. dream thought, 21
WORKS: “Analysis of a Phobia in a Five-year-old Boy,” 23n, 49n, 190n, 249n
“Creative Writers and Day-Dreaming,” 24n
“The Dynamics of the Transference,” 418n
The Future of an Illusion, xxiii
The Interpretation of Dreams, 3, 21n, 22n, 148n, 207n, 218n
“Little Hans,” 190
“Psycho-analytic Notes on an Autobiographical Account of a Case [Schreber’s] of
Paranoia,” 128n, 133f, 300n
Three Essays on the Theory of Sexuality, 132
Frey, 276, pl. xib
Friedländer, S., 92n
friend of man, 336
 hero as, 314
Frigg, 278
Frobenius, Leo, 168n, 198n, 199n, 203n, 220n, 236n, 243n, 257n, 261n, 318n, 341n,
 348n, 366n, 426n, 438n
 on “clashing rocks,” 245n
 diagram of mythological journeys, 210
 on missing limbs, 239n
 on sea and sun, 209f
 on whale-dragon motif, 248, 347n
fruitfulness: concept of, in Mithraic sacrifice, 238, pl. xxxiii
 spiritual, 50
Fuhrmann, Ernst, pl. LI
functional; disturbances, and instincts other than sex, 135
 phenomenon, gesture of Egyptian statue as, 179
 relationships, archetypes and, 255f
 significance of symbol, 231n
functions, derived from reproductive instinct, 136
furnace, fiery, 167

furrow, [199n](#), [209](#), [341](#)
symbol of woman, [340](#)
future, presentiment of, [50f](#)

G

Gabricus and Beya, [436](#)
Gaia, [182](#), [370](#)
Galileo Galilei, [137](#)
Gamelion, wedding month, [243](#)
garden of the gods, [244](#)
Gargantua, [211n](#)
Gatti, Attilio, [296n](#)
Gayatrimetrum, [148](#)
Gayomart, [421n](#), [426f](#)
“Geist,” [413n](#)
genital region, snake-bite in, [378](#)
genitals, female: eye as symbol of, [268](#)
lozenge as symbol of, [202f](#)
symbolic equivalent, [343](#)
genius, man of, craving for understanding, [13](#)
Gering, H., [112n](#)
German, colloquial, primitive fire-making symbolism in, [148f](#)
Germanic religious rite, [263](#)
Germany, [229](#)
fire-making as superstitious custom in, [149](#)
folklore, devil in, [277](#)
legend, of hero and snake, [382](#)
—, of birth of saviour, [248n](#)
sacred trees in, [247n](#)
Geryon, [170](#), [182](#), [197](#)
“Gift of Love,” [48](#), [454](#)
creation through, [49](#)
Gilgamesh Epic, [171n](#), [205n](#), [215n](#), [294](#), [298](#), [332](#), [355](#), [413f](#), [437](#)
Eabani/Enkidu in, [196](#), [329](#), [423](#)
giant who guards treasure in, [261](#)

herb of immortality in, pl. [XIX](#)
heroic journey in, [200](#)
Humbaba in, [327](#)
regression in, [329](#)
sun-hero in, [171n](#)
girl(s): death-wish, [285](#)
defence of innocence, [47n](#)
and father-imago, [44](#)
sacrificed to dragon, [367](#)
unconscious fantasies of 15-year-old, [49](#)
virginity test, [365f](#)
Givry, G. de, [276*](#)
“Glory to God: A Dream Poem” (Miller), [39–78](#)
analysis of, [71ff](#)
Miller on composition, [450–54](#)
Gnostic(s): gem showing she-ass and foal, [400f](#)
legend of origin of man, [318f](#)
view of snake, [374](#)
goal, spiritual, [435](#)
“Goat-Fish,” [198](#)
goblins, goddess of, pl. [XVI](#)
God: astromythological character as the sun, [108](#), [121](#)
attributes and nature of, [55ff](#)
idea of, [53f](#), [85](#)
energy of the archetype, [89](#)
eye of, [91*](#)
father-creator, [59](#)
image of, and man, [377](#), *see also* God-image
jealous, [260](#)
Lamb of, [30n](#)
laughter of, [45](#)
as light and fire, [89f](#), [166](#), [338](#)
longing for, [84](#)
loss to, through destruction of evil, [112f](#)

as love, [63f](#), [86](#)
in man, [123](#)
man's inner compulsion *re*, [25](#)
the Many and the One, [279](#)
metaphysical entity, [61](#)
mystic's love of, [90](#)
power of, menaced by the seductions of passion, [112](#)
as primordial image, [178](#)
and punishment for unconscious desires, [289f](#)
St. Augustine on man's love for, [74](#)
scientific approach to, [62](#)
Seneca on man's relation to, [78n](#)
sun, and fire, mythologically synonymous, [89](#)
union with, [66n](#), [229](#), [433](#)
unknown servant of, [194f](#); *see also* Yahweh

god(s): androgynous, [204*](#)
and animus-figure, [361](#)
battle of, in Babylonian creation epic, [252–54](#)
chthonic, [127](#)
circle of, pl. [LIXb](#)
cohabitation with, [287](#)
creative, and father-*imago*, [44](#)
dying and resurgent, motif of, [109](#), [117](#), [322](#), [338ff](#), [344f](#)
eaten, [336](#), [338n](#)
and goddesses, bisexuality of, [240f](#)
—, libido-symbols, [219ff](#)
-hero, as spring zodiac, [384](#)
man's immortal element, [202](#)
masculine and feminine aspects, [426](#)
mother of, [252](#)
pagan, contradictory nature of, [386n](#)
representatives of the unconscious, [298](#)
and sacrifice, [420](#)
sacrifice of primal being, [417](#)

self-transformation, 256
skinning and stuffing, 383f
theriomorphic representations, 27, 94
transformation through man, 337f, 392
triadic, 201
true, made by man, 367
worship of, 75f

goddess(es): changed into mares, 275n
of dogs, 369
drink of immortality from breast of, 376n
in the lingam, pl. xxix
phallic symbols, 221
Western, 92*; *see also* god(s)

God-image, complex of archetypal ideas, 56f
derivation of, 86
dialectical relation to, 60
incarnation of, 323
and prayer, 176, 178
transformation of, 262
and the unconscious, 65
universal phenomenon, 60

god-parents, 348

Goethe, J. W. von, 126n, 194n., 234n, 245n
on the core of nature, 382
“Prologue in Heaven,” 164; *see also* *Faust*

gold, and excrement, 189
golden plover, 289
good: and evil, 54, 112ff
present and future, 129f

Goodenough, E. R., 184n

Gorgon, 182, 372, pl. xivb

Görres, J. J. von, 107n

Gosh/Drvashpa, bull’s soul, 426

gossip, role of, 287

“Grace of Heaven,” 99n

Graeae, *see* Gorgon

Graf, Max, 205n

Grail king, 295n

grain, regenerative power symbolized by, 436

Gray, Louis H., and MacCulloch, John A., 275*, 349*

Great Mother, 191, 257n

and animals, 327, pl. LI

Greek folksongs, 52n, 112n

Greek mythology, 20f

sun-wheel in, 303n; *see also* Apollo; Aphrodite; Demeter; *etc.*

Greek philosophy, 77

green: colour, 436f

snake, 436f, 459

vegetation numen, 396

Gressmann, Hugo, 423*

Grimm, J. L. K., 26, 149n, 242n, 246n, 247n, 248n, 249n, 260n, 361n, 362n, 376n, 379n, 382n

on eating lentils, 189n

on “Stempe,” 250n

grumus merdae, 192

Guénon, René, 124n

Guirand, Félix, pl. va

“gulf,” etymology, 272

Gunkel, Johann F. H., 254

Gurlitt, W., 302n

H

Hades, entrances to, 365; *see also* hell; underworld

Hagen, 389

Haggard, H. Rider, 437

Hahn, E., 150n

hair and heat, 245

Halirrhothios, 250, 257n

hallucination, schizophrenic, of phallus on the sun, 101, 157

halo: at finger-ends, [185](#)
 meaning of, [88n](#)
 as symbol, [107](#)

Haloa festival, regenerative symbol, pl. [LXIIIa](#)

Hamann, Johann Georg, [12n](#)
on metaphysics and speech, [13n](#)

hand(s): as auxiliary organ in rhythmic activity, [144](#)
 baby's gesture with, involving mouth, [161](#)
 phallic meaning, [185](#)
 of sun, [101*](#)
 symbolism of, [185](#)

hanging: of the god, symbolic value, [383](#)
 hook for, pl. [XXXVIII](#)
 on a tree, [223](#), [262f](#), [423](#)

Hansel and Gretel, [248](#)

Hanuman, [211](#)

haoma, [209n](#), [246n](#), [410n](#)

Harding, M. Esther, [309n](#), [395n](#)

Harpocrates, [239](#), [362](#)

Harrer, Heinrich, [237n](#)

Hartlaub, G. F., [76n](#), [398n](#)

Hartmann, K. R. E. von, [159n](#), [176](#)

Harz Mountains, discovery of mineral wealth in, [278](#)

hat, pointed (pileus), [127](#)

Hathor, [264n](#)
 cow, suckling Queen Hatshepsut, pl. [La](#)
 Isis, [240](#), pl. [xxx**b**](#)

Hatmehit, [240](#)

Hatshepsut, suckled by the Hathor Cow, pl. [La](#)

Hauptmann, Gerhart, [292](#), [303](#), [411n](#)

Hawaii: goddess of goblins and lizards, pl. [xvi](#)

head: crown of, [353](#)
 -dress, feathered, [183](#), pls. [xvii](#), [xxi**b**](#)
 rhythmic banging of, [142](#)

healing, money-offerings for, 365

heart: cutting off of, 210

- eating of, 364
- pierced by arrows, 286

hearth spirit, 427

heat: creative, 380, 381*n*

- hair and, 245

“Heaven and Earth” (Byron), 110, 111*ff*, 192

heavenly bodies: ecstatic relationship to, 87

- as libido-symbols, 94*ff*; *see also* moon; sun; *etc.*

heavenly: bridegroom, 396

- city, 411*n*
- journey, 93*n*
- wanderings, of the soul, 93*n*

Hecate, pl. LVIII

- Aphrodisias, 369
- dog-headed, 238*f*
- as dual mother, 369*f*
- and horses, 369
- mysteries, 369*ff*
- of Samothrace, 370*

Hector, horses of, 279

Heddernheim Relief, 238, 246*f*, 261, 425

- pls. XXXIII, XL, LXIII*b*

Heidel, Alexander, 200*n*

Heimarmene, 67, 415

Heine, Heinrich, 164*n*, 319

Hel, goddess of death, 282

Helen, 126

Helios, 87, 102*f*

- ascension, 195
- in Mithraic liturgy, 103*f*
- and Mithras, pl. XXIV*a*
- scarlet mantle, 104*n*

hell, journey to, motif of, [251f](#), [316](#); *see also* Hades underworld

Hephaestus, [244n](#), [333](#)

Hera, [181](#)

of Argos, [244](#)

and Heracles, [348](#)

as lamia, [295n](#)

of Samos, [243](#)

vengeful, [301](#)

Heracles, [182](#), [205n](#), [260](#), [293n](#), [376n](#), [386n](#)

and Cerberus, [365](#)

cross of, [303n](#)

labors, [172*](#)

legend of, [295n](#)

and Mithras, [197](#)

pillars of, [302n](#)

and the sun, [197](#)

two mothers of, [295n](#)

herb, magic, [170](#), [200](#), [298](#), [332](#), [413](#)

Gilgamesh with, pl. [xix](#)

Hercules, [127](#); *see also* Heracles

hermaphrodite: atman as, [160n](#), [354](#)

crowned, [184](#), pl. [xviii](#)

and tree-symbol, [221](#)

Hermes, [50n](#), [333](#)

prayer to, [187n](#), [343n](#)

Hermetic: text, on maternal ties, [307](#)

vessel, [125f](#)

hero(es): animal brother of, [423](#)

and animus, [304](#)

assimilation of dragon's qualities, [367](#)

battle with magician, [351](#)

betrayal of, as historical and mythological motif, [31](#)

birth of, [112n](#), [318](#), [320f](#)

bull and snake symbols of, [431f](#)

burdened, [302f](#)
burial in earth, [460](#)
challenge of fear to, [354](#)
conquest of mother by, [261](#), [301](#), [353](#)
danger to, from both parents, [331](#)
death of, [112n](#)
deeds of, [347ff](#)
deliverance by, [249](#), [254](#)
descent to the underworld by, [365](#)
divine, as Spirit, [413](#)
and dragon, [374](#)
fate of, [389f](#)
-figure, attribution of fantasies to, [307](#)
goal of, [332n](#)
hanging to a tree, [263](#)
and helpful birds, [347f](#)
and horse, symbolism of, [275](#)
horse and snake, [459f](#)
identification with, [392](#)
identified with the sun, [194n](#)
incest and canalization of regressive libido into, [256](#)
isolation of soul of, [306](#)
journeys of, as motif, [93n](#), [205](#)
killing of the magic animal by, [327](#)
as libido-image, [187n](#)
longing for forbidden goal, [362](#)
loved object vs. longing for rebirth in, [405f](#)
maimed, [239](#)
as mediumistic control, [189](#)
mother as source of powers of, [336f](#)
and mother-imago, [388](#)
-myth, interchangeability of figures in, [390](#)
name of, [187f](#)
and “one who understands,” [358](#), [394f](#), [439f](#), [458f](#)

origin of, 171–206
positive symbol of unconscious, 374
possessed by daemon, 345
projection of traits upon, 284
rapid growth of, 199n
re-entry into mother, 432, *see also* mother s.v.
rejuvenation through the mother, 255
religious, 177f
sacrifice of, 35, 412, 435
self-exposure to death, 274, 285, 394, 458
and snake, 382f
struggles of, 331, 337, 348ff, 355f
as sum total of archetypes, 333
as superhuman symbol, 178, 391f
superior and inferior role of, 196
teleological significance of, 314
threatened by regression, 254
transformation through sacrifice of instinctuality, 262f
as unconscious self of man, 333
weaponless, 386n
as world-creating power, 382

Herod, 216n

Herodotus, 216n, 257n, 288n, 439n
on Apis bull, 374n
on festival of Isis, 256f

herring, 245n

Herrmann, Paul, 246n, 250n

Herz and Schmerz, 286

Herzog, Rudolf, 372n, 373n

Hesiod, 137, 369

Hesperides, apples of, 170

Hesychius, gloss of, 145f

Hiawatha: antecedents, 316ff
battle with corn-god, 336ff

battle with father, 327ff
battle with magician, 351
birth, 319ff
childhood, 323ff
deeds, 326ff, 346ff
father-in-law, 332f
grandmother, 317
historical, 312n
loss of friends, 354f
and Minnehaha, 332, 334
mother, 318
retreat into forest, 334ff
Hiawatha, Song of (Longfellow), 312–57, 395. 461
 mythological motifs, 313ff
 origin of, 312n
Hibis, hymn of, 240
Hierapolis, temple, 372
hieros gamos, 151, 155, 159, 343
 of Gabricus and Beya, 436
 with the mother, 269, 433
 projection of, 433
 and rebirth myth, 244
 and rejuvenation magic, 244
 Samian festival of, 243
 and Sleep in a fir-tree motif, 244n
 transformation into psychic symbol, 433
 in underground, 341
Hildegard of Bingen, 90f
 mystic perception of light, 91, pl. xxxa
hills, 192f
Hinduism. *Ardhanari*, pl. xxiii
 Brahma, 122f, 293, 351, 399, pl. xlvi
 churning of the milky ocean, pl. xv
 fire-making in, 145, 168

god in the lotus, 266, 293
Indra and Urvara, 209
Kama, 137f, 382n
Krishna, 166, 174n, 426
purification rite, 268n
Rama, 209
Shiva, 209, pl. xxiii
solar energy, 122
Vishnu, 293, 351, pls. iva, xlvia, xlvii
Yama, 277; *see also* Bhagavad Gita; Ramayana Rig-Veda; Upanishads; Vedas

Hippocrates, 146n
Hippolytus (god), 298n
Hippolytus (of Rome), 45n
 on deification of the believer, 87
Hirt, Hermann, 149n
historical material, comparative study of, 5
history, continuity of, 3
“hoard,” etymology, 364, 373f; *see also* treasure
Hoffmann, E. T. A., 259, 396n
Hölderlin, J. C. Friedrich: “Achilles,” 406f
 “Empedocles,” 404f, 439n
 “Hyperion’s Song of Fate,” 398f, 402n
 “Man,” 399f
 “In Memoriam,” 406
 “Palinode,” 403f
 “Patmos,” 407–14
 “Sunset,” 164
 “To a Rose,” 398
 “To Nature,” 401–3
hole in the earth: analogy of, 158
 offerings tossed into, 364f
 sacramental mating with spear, 150
Holy Ghost, 138, 162
 appearance of, 99n

depiction by medieval German artist, [101](#)
feminine aspect of, [359ff](#)
maternal significance of, [138](#)
symbol of, [138](#)

Holy Sepulchre, worship of, [345f](#)

Homer, *see* Iliad; Odysseus

Homeric hymns, [362n](#), [409n](#)
to Demeter, [344](#)

homoousia, [392](#)

Honegger, J.: paranoid patient illustrating loss of reality, [140](#)

honey-cakes, to pacify Cerberus, [371f](#)

hoof and hoofmarks, [277](#), [278](#), [412](#)

hook, for hanging, pl. [xxviii](#)

Horace, on Empedocles, [405](#)

horns: two-horned, [194n](#), [198n](#), pl. [xxa](#)

Horpi-chrud, [240](#)

horse: connection with devil, [277](#)
fear-significance, [249](#)
goddess of, [369](#)
as guardian of the treasure, [259f](#)
and hero's animal vitality, [396](#)
hooves of, phallic meaning, [277](#), [412](#)
human-footed, [276](#), [277](#)
legendary properties of, and man's unconscious, [277](#)
magic signs on coat of, [279](#)
as mother-libido, [421](#)
and rider, [249](#), [274f](#), [437](#)
-sacrifice, [420ff](#), [435](#)
-shoe, [278](#)
-symbol, [207](#), [274–82](#)
three-legged, [282f](#)
white, [278](#), [288n](#); *see also* Apaosha; Sleipnir; Tishtriyā

Horus: Bes with eyes of, [123*](#)
of the East, [97](#)

of Edfu, [97](#)
fight of the sun-hero with whale-dragon, [251](#)
and Isis, [261](#), [311](#)
and Osiris, [240](#)
and Set, [251](#);
-sun, [87n](#)
Hottentots, idea of sun, [318](#)
Hrungnir, [379n](#)
Hubur, [252](#)
Huch, Ricarda, [93n](#)
Hugh of St. Victor, [63](#)
Huitzilopochtli, [336](#), [433n](#)
human figure, as symbol of the libido, [171](#)
humanism, and syncretism of gods, [99n](#)
human nature: devilishness of, [72](#)
 moulded by consciousness, [434](#)
Humboldt, Friedrich H. A., Baron von, [315](#)
Hume, R. E., [122n](#)
humour, popular, *re* excrement, [192](#)
hunger: afflux, case of, [132n](#)
 man's repressive instinctuality, [339n](#)
 as phenomenon of energy, [137](#)
 twofold sense of, [335f](#)
Hvareno, [99n](#)
hybrids and monsters, [179](#)
Hydra, [372](#)
Hygeia, [373](#)
hypnagogic: drama, [457–62](#)
 poem, [455–57](#)
 vision, [175](#), [185](#)
hysteria: chronic, degeneration in, [40n](#)
 personal unconscious of patients, [419](#)
 sexual traumata, [419](#)
 substitution of physical for psychic pain, [286](#)

hysterical: behaviour, and infantile disposition, [282f](#)

dream-state, of catatonic patient, [142](#)

hysterogenic mechanism, [23n](#)

I

Iacchus, [340ff](#)

Iasion, [341n](#)

I Ching, [170](#), [279n](#)

idea(s): ascent to (Augustine), [70n](#)

association of, [412](#)

of becoming a god, [87ff](#)

formation of, [313](#)

inherited, [102](#)

involuntary vs. purposive, [17n](#)

mythological, [407ff](#)

neurotic, [420](#)

ruling, and thought, [11](#), [17](#)

sovereignty of, [76](#)

“spontaneously creating its own object,” [49](#), [453](#)

symbolic, and consciousness, [442](#)

ideal: man’s chief virtue, [300](#)

projection of, [284](#)

identification: with actors in a play, [35](#)

of divine hero and celebrant, [187n](#)

with fictional characters, [448](#)

of Hecate and others, [370](#)

with hero, [392](#)

with Logos, [69f](#)

with mother, [283f](#)

unconscious, of child with mother, [235](#)

with sun, [183f](#)

Ignatius Loyola, St., vision, [122n](#)

Ila, [148n](#)

Iliad, on Zeus’s conjugal couch, [244](#)

illumination of initiate, [356n](#); *see also* light

illusion(s): of conscious mind, 62
enjoyment of, 284
of participation in story or play, 448

image(s): affinity of motifs with mythologems, 313
anthropomorphic, 95
collective, role of, 420
creation of, 357
of Hera, lost and found, 243
magical, of childhood, 408
parallel, 158
of sacrificial death and resurrection, 412
“suggested,” 448
trains of, in associative thinking, 17
unconscious, uniformity of, 176; *see also* father-*imago*; God-image; mother-*imago*

imagination, role of, in autosuggestion, 448*f*

“*imago*,” term, as used by Jung, 44*n*; *see also* father-*imago*; mother-*imago*; etc.

imago Dei, 392, pl. LX

Immaculate Mother, 50

immortal, banished, 200

immortality: and conquest of mother, 295*n*
drink of, 168, 362*n*, 376*n*
goal of the hero, 332*n*
herb of, *see* herb, magic; and magical incest, 259
and self-sacrifice, 412

impression(s): pleasing, transmission of, 447*f*
re-animation of, 461

Incas, 185, 460*f*

incendiarism, 185*n*
psychology of, 169

incest, 329
“barrier,” 417*f*
definition of, 235*n*, 271
fantasy of, 3, 45*n*, 420
fear of, and devouring mother, 419

Freud on, [174](#), [417f](#), [419](#)
of the gods, [257](#)
and inertia, [174f](#)
magical, [259](#)
matriarchal, in Oedipus legend, [181f](#)
motif of prevention by fear, [260](#)
and natural love of father, [49](#)
problem, and reactivation of mother-*imago*, [213](#)
and ritual castration, [204](#)
prohibition, *see following* sin of, [358](#)
symbolical meaning of projection of, [361](#)
symbolic conquest of, [342](#)
symbolism of, [204f](#), [213](#); -taboo, *see following*
tendency: of the mother or the *anima*, [294](#)
—, libido freed from, through symbolical truths, [226](#)

incest prohibition, [417f](#)
and canalization of libido, [224](#)
and creation of self-consciousness, [271](#)
by danger of regression, [225](#)
as impulse to domestication, [271](#)
motif of father and, [261](#)
origin of, [223](#)
re son and mother, [255](#)

incest-taboo, [319](#)
effect of, [152](#)
and infantile regression, [235](#)
vs. libido, [213](#)
in marriage class system, [271n](#)
and Wachandi rite, [158](#)

incestuous: desire, basis of, [223f](#)
energy, desexualization of, [158](#)

inconscient supérieur, [50](#)

incubation: in the temple, [365](#)
self-, [380f](#); *see also* egg

incubus, [370](#)

independence: adult, [304](#)

 battle for, [310f](#)

 and development of consciousness, [235](#)

 and freedom from parental ties, [284](#)

India: Bombay, [237](#)

 Jains, [264f](#)

 “mountain of Adam,” [196n](#)

 Parsis, [237](#)

 philosophy, [380](#), [381f](#), [392f](#), [416](#), [422](#)

 sacred tree in, [351](#); *see also* Hinduism

Indian corn, *see* maize

Indians: North American: ceremonial head-dress of, pl. [xxib](#)

 Nootka, pl. [XLII](#)

 on origin of man, [141n](#), [213](#)

 taboo against deviation into sex, [155](#)

 South American: Bakairi, [203n](#)

 Incas, [185](#), [460f](#)

 Muyscas, [267](#)

 rock-paintings of, [153](#)

individual: as twig from the mother, [202](#)

 reversion to past, [89](#)

individuality, [176](#)

individuation process, [301](#), [402n](#), [433](#)

 and regression, [308](#)

 in Theseus myth, [293n](#)

 transcendent function, [433](#)

Indra, [209](#), [268](#)

 as psychopomp, [422](#)

 as Shyena, [295n](#)

inertia: of libido, [292](#)

 La Rochefoucauld on, [174](#)

 and regression, [232](#), [349](#)

infancy: anal interest of, [189](#)

everlasting, [398f](#)
paradise of, and introversion, [292f](#)
regression to experiences of, [419](#)
zones of libidinal activity, [143ff](#)

infant: gesture of hands before mouth, [161](#)
lamia and, [248](#), pl. [xxxviii](#)
threatened by snakes, [260](#)

infantile: attitude, prolonged, [298](#)
disposition, [283f](#)
sexual fantasies, [419](#)
sexuality, [329](#)
thinking, [23](#)

infantilism, regressive, [191](#)

infantium dii, [352](#)

influence, parental, [180f](#), [186](#)

In hoc signo vinces, [10](#)

initiation: ceremonies, [343](#)
into the degree of Miles, [197](#)
mysteries, symbolism of, [415n](#)

inner man, fear of, [298](#)

inner world, libido stuck in, [293](#)

innocence, personal, defence of, [47](#)

insanity: idea of solid sunbeam in, [412](#)
invasion of conscious by unconscious, [397](#); *see also* paranoia; schizophrenia

instinct(s): and adaptation, [236](#)
and archaic thought-forms, [28f](#)
bundle of, hypothesis *re*, [132](#)
checking of, [152f](#)
conflicting, [260](#), [291](#), [424f](#)
and the conscious mind, [227](#), [380](#)
depotentiations of, [138f](#)
effect of archetype on, [158](#)
endogamous/exogamous tendencies, [158](#)
and experience of divinity, [338](#)

forces of the unconscious, 305
functional disturbances and, 135
lack of knowledge of, 137
laws governing all life, 180
and learning capacity, 434
natural, and spiritual love, 396
natural power of, 57
neurotic perversion of, 139
phenomenon of energy, 137
and *prima materia*, 408
and primordial images, 408
resistance of, and symbol, 228
snake-symbol of, 396
theory of, 133
theriomorphic representations of, 179
will to suppress or repress, 157

instinctual: impulse, 72, 441
processes, 129, 138f

instinctuality: father as spirit opposed to, 261
and imagos, 328
and psychic systems, 227
renunciation of, 262
repressive, and hunger, 339n
symbolical sacrifice of, 203f, 427
theriomorphic symbol, 434

integration, of unconscious tendencies in conscious mind, 442

intellect: as Logos, 138
speech and, 13
symbolized as pointed instrument, 180

intentionality, 137

intercourse: continuous, 209, 217n
with god, 287

interest: Freud on libido as, 133
objective, and libidinal condition, 134

shifting of, from inner to outer world, 77

interpretation: of fear-symbols, 439

“monotony” of, 10

intoxicating drink, libido-symbol, 216; *see also* drink soma
introitus solis, 323

introjection, defined, 136f

introspection, in aging process, 357

introversion, 18n

- archaic features, 30
- and birth of creative thought, 293
- consequences of, 88f
- danger of, 292
- extreme, and loss of reality, 335
- and hypnagogic vision, 175
- involuntary vs. voluntary, 404
- of libido, 172f, 204, 292f, 334f, 374
- mechanism of, 294
- neurosis and, 18n
- prayer as expression of, 178
- and rebirth, 334f
- as regression to father-imago, 44
- relation to self-incubation and self-castigation, 380f
- as retreat from reality, 39f
- role of, 178, 379–82
- of sexual libido, 135
- and the unconscious, 374
- and wounding by one’s own arrow, 292

invisibility, by veil, 345

invocation, *see* prayer

involution, 245

Iran, *see* Persia

Irenaeus, 333n

Ishtar legend, 261, 294, 369n

Isis, 67n, 296f

basket, pl. [LIII](#)
cow-headed, [251](#), pl. [xxx**b**](#), *see also* Hathor
and Echidna, [182n](#)
as evil mother, [251](#)
festival of, [256f](#)
legend of, [300](#), *see also* Osiris
as mother-imago, [271](#)
mysteries of, [87](#), pl. [VI](#)
and Ra, [187](#)
Islamic legend, Khidr in, [193ff](#)
isolation, feeling of, in psychosis, [442](#)
ivy, [410](#)
Ixion, [102](#), [303n](#), pl. [XLV**b**](#)
Izanagi legend, [341n](#)

J

Jacob and the angel, [338](#)
Jaffé, Aniela, [396n](#)
Jagaddeva, dream-book of, [351](#)
Jagatimetrum, [148](#)
Jähns, Max, [276n](#), [278](#)
Jains, tree of knowledge of, [264f](#)
James, William, [11n](#), [17](#)
Janet, Pierre, [22n](#)
and *jonction du réel*, [134f](#)
Janus, [318n](#), [369n](#)
Japanese Orpheus, [341n](#)
Japhet, [113n](#)
Jatavedas, [148](#)
Java: demon eating the sun, pl. [XXXIV](#)
idols in trees, [246n](#)
Jeffers, Robinson, [278n](#)
jelly-fish, [326](#)
Jensen, Peter, [171n](#), [261n](#), [369n](#)

re banished immortal, 200

Jeremias, Alfred, 199*, 416*

Jerome, St., 101n, 109n, 429n

Jerusalem, 213, 276

- the new, mother or mother-imago, 217, pl. xxiii
- temple, 372

Jesus, *see* Christ

Jesus ben Pandira, 383

Jesus ben Stada, 383

Jew, Eternal/wandering, *see* Ahasuerus

Jewish tradition: Adam, 248

- Behemoth, 55ff
- Elias/Elijah, 105n, 195f
- Job, 46, 54, 55ff, 289
- Joshua, 194, 198, 431n
- Leviathan, 55ff, 116, 254f
- Moses, 26, 194, 198, 343f
- tree of Paradise, 247; *see also* Old Testament

Job, 46, 453

- on attributes and nature of God, 55ff
- conflict of, 54, 262n
- sorrows of, 48
- tormented by unconscious desires, 289; *see also* Old Testament s.v.

Jocasta, 4, 181

Jodl, Friedrich, 14

Joël, Karl, 324n, 325

John, St.: father-imago, 89

- in Patmos, 411; *see also* New Testament s.v.

John Chrysostom, 106f

Johnson, Samuel, 310n, 461

John the Baptist, 196

- baptism of Jesus, 200
- and Oannes, 199f

Jonah and the whale, 330

analogy of, 408
complex, 419

Jones, Ernest, 5, 249n

Jones, H. Stuart, pl. LVIII

Joseph, St., 7, 333

Josephus, 401n

Joshua, 431n
cast out to sea, 198
journey with Moses, 194, 198
reintroduced circumcision, 431n

Joshua, Palestinian god, 223n

journey: abroad, as symbolic separation from family ties, 304
to the East, 410
to Hades/hell/underworld, 251f, 293, 316, 365f, 420, 439n
to the Western Land, 355; *see also* night sea journey

Jubinal, 247n

Judas, 31f

judgment, personal and social, 14f

Julian the Apostate, 81n, 341

Julius Caesar, 277
and Brutus, 30
on the mothers, 250

Julius Caesar (Shakespeare), 282ff

Jung, C. G.: attitude toward religious ideas, 229
early views of sexual libido, 155
and Freud, loss of friendship, xxvi
metanoia of, xxvi
patient's incest fantasy, 45n
researches on mentally deranged Negroes, 102

CASES IN SUMMARY (*in order of presentation, numbered for reference*):

[1] Young woman whose dream illustrates sexual symbolism. — 9f

[2] Schizophrenic with hallucination of the sun phallus. — 101, 157

[3] Woman illustrating the hunger afflux. — 132n

[4] Female catatonic exhibiting gesture of boring in masturbatory analogue. — 142

- [5] Catatonic patient with upward displacement of coitus movements. — 142n
- [6] Young girl, catatonic, who associated kiss and food. — 144f
- [7] Young girl with delusion of electricity causing sexual feeling allied with food. — 145
- [8] Baby making peculiar gesture with hands before mouth. — 161
- [9] Dream of man with questionable relations with women. — 179
- [10] Man with hypnagogic vision of mother with fingers surrounded by halos, etc. — 185
- [11] Boy's anal fantasy. — 188
- [12] Female patient exhibiting anal fantasy. — 189
- [13] Religious patient who dreamed of the Crucifix in the form of excrement. — 189
- [14] Female patient with fantasy of fairy in the toilet. — 190
- [15] Child (Anna) and her anal fantasy. — 190
- [16] Insane woman with affective deterioration who smeared herself with faeces. — 191
- [17] Young woman with sexual marital difficulty who dreams of being poisoned by fruit of a tree. — 221
- [18] Six-year-old girl who dreamed of red worm encircling leg. — 245
- [19] Schizophrenic woman illustrating motif of animal with symbols on or under its coat. — 279n
- [20] Mother who became symbol of the all-devouring mother in her depressive psychosis. — 328
- [21] Schizophrenic whose dream illustrates weakening of parent archetypes by apotropaic means. — 368f
- [22] Male patient who dreamed of snake-bite when beginning to free himself from the mother. — 378
- [23] Female patient who dreamed of snake after relapse into neurosis. — 378
- [24] Patient who complained of a snake stuck in her throat. — 378
- [25] Male schizophrenic whose first symptom was feeling of relation to the stars. — 402n
- [26] Patient who understood the language of birds. — 402n
- [27] Female patient who had fantasy of snake crawling into her mother. — 436
- [28] Female patient who said that snake crawled into her mouth. — 436f

WORKS: *Aion*, 393n

“Answer to Job,” 54n, 262n

“Archetypes of the Collective Unconscious,” 437n

“The Concept of the Collective Unconscious,” 158n
“Concerning Rebirth,” 193n, 199n, 314n, 336n
“The Content of the Psychoses,” 134n
“Cryptomnesia,” 439n
“General Aspects of Dream Psychology,” 51n
Mysterium Coniunctionis, 223n
“On the Nature of Dreams,” 58n
“On Psychic Energy,” 131n, 231n
“On the Nature of the Psyche,” 29n, 102n, 122n, 158n, 309n
“On the Psychology and Pathology of So-called Occult Phenomena,” 29n, 49n, 439n
“On the Psychology of the Unconscious,” 117n, 183n, 245n, 327n
“Paracelsus as a Spiritual Phenomenon,” 76n
“The Phenomenology of the Spirit in Fairytales,” 248n, 282n, 333n
“Psychic Conflicts in a Child,” 18n, 23n, 49n, 190, 249n
“A Psychological Approach to the Dogma of the Trinity,” 201n, 267n
“Psychological Aspects of the Kore,” 53n, 322n
Psychological Types, 219n, 266n, 364n, 393n
Psychology and Alchemy, 53n, 126n, 167n, 221n, 262n, 282n, 295n, 303n, 307n, 309, 321n, 336n, 364n, 398n, 409n, 436n
The Psychology of Dementia Praecox, 29n, 44n, 85n, 134, 135, 279n, 343n, 436n
“Psychology and Religion,” 102n, 354n
“The Psychology of the Child Archetype,” 102n
“The Psychology of Eastern Meditation,” 368n
“The Psychology of the Transference,” 50n, 126n, 153n, 184n, 204n, 223n, 271n, 418n
“The Relations between the Ego and the Unconscious,” 44n, 53n, 259n, 267n, 362n, 392n
“A Review of the Complex Theory,” 29n, 85n
“The Stages of Life,” 300
“Studies in Word Association,” 11n, 80n
“A Study in the Process of Individuation,” 301n
Symbolik des Geistes, 55n
“Transformation Symbolism in the Mass,” 104n, 336n, 339n, 384n
“The Visions of Zosimos,” 140n, 332n, 356n

“Wotan,” 230n
and Wilhelm, *The Secret of the Golden Flower*, 303n, 364n, 398n
Jung, Emma, 183n
Jung, Erich, 101*
Juno, 219; *see also* Hera
Jupiter: Ammon, 194n
and Demeter, 343n
self-castration, 343n; *see also* Zeus
Jusas (Nebit-Hotpet), 267
Justice, 82n
Justin Martyr, 401

K

Kaineus, 253n, 288f, 412
Kainis, 289
Kalevala, 312n
Kalthoff, Albert, 31n, 77
Kama, 137f, 382n
Kanathos, fountain of, 244
Kant, Immanuel, 13n
Kar-mahi, 246n
katabasis, motif of, 365
Kenyon, Sir Frederic G., 187n, 343n
Kepler, Johannes, 21
Kerényi, Karl (C.), 26n, 57n, 76n, 126n, 127n, 128n, 147n
Kern, O., 427
Kerner, Justinus, 99n
key: creative force, 124
in *Faust*, 206
as symbol, 124f, 369
Khidr, E1-, 336n
and Elias, 195
identification and equation with others, 195f
Islamic legend, 193ff“
“two-horned,” 198n

Khnum: of Elephantine, 97
maker of his own egg, 256, 269, pl. *XL1b*
-Ra, 240

kicking, 250
associated with mother, 315
motif, 347

Kihe Wahine, Hawaiian goddess, pl. *xvi*

king: birth of, and *crux ansata*, 264n
marriage with land, 209
sacrifices to the sun-god, pl. *xia*
winged sun-disc above, pl. *vii*
wounded and ailing, 295n

Kircher, Athanasius, 50n, 392*

kissing, derivation of, 418: *see also* fondling

kitchens, god of, 427

Klagenfurt monument, 196f, pl. *xxiva*

Kleinpaul, Rudolf, 12n

Kluge, Friedrich, 373

Kneph, 264n

knights, combat of, 260n

knowledge, objective, 4

Koch-Grünberg, Theodor, 153

Koran, and origin of the Khidr myth, 194

Kore: in *Acts of Thomas*, 360;
-Persephone, 425

Kraepelin, Emil, 40n

krater, *see* mixing bowl

Krishna, 166, 174n
coming of, 426

Kronos, 275n

Kuelpe, Oswald, 11n, 17

Kuhn, F. F. A., 147n
on etymology of fire-making, 145
on *manth*, 146n

on *manthāmi*, 168

on Nodfyr, 149

Kundalini serpent, 436

Kurds, religious orgies of, 376*n*

Kuyunjik, 192

Kyffhäuser legend, 196*n*

L

Lactantius, 429*n*

Laistner, Ludwig, 249

Lajard, J. B. F., 202*f*, 204*

Lamb/lamb: and Christ, 423, 429*n*

Christian sacrifice of, 200

of God, 30*n*

marriage of, 216*f*, 223

Lamia/lamia, 248, 249, 370, pl. xxxviii*a*

Hera as, 295*n*

mother-imago as, 298, pls. xxxviii*a*, XLVIII

myth of, 248*f*

lance, 412, pl. XLV

piercing by, 290
significance of, 288; *see also* spear

land, fertile, woman-symbol, 209
land beyond, *see* other world
landing on shore, 210
language, 11*f*
 development of, 15
 exaggerated, in hysteria, 419
 personal and social meaning, 14*f*
 relationship of opposites, 375*f*
 and speech, 13*f*
 symbolic, in dreams, 7
 and thinking, 11

Lanzone, R. V., 123*

Laodonia, cattle of, 149
lap: entrance of the god through, 343
 procreative symbol, 377

La Rochefoucauld, François, Duc de, on idleness, 174
Last Judgment (Rubens), pl. LXIV

Latona, at Delos, 219
laughter: and death, 389
 of God, 45
 inhuman, 379

Laurentius Laurentii, 184
law of the species, 434
Layard, J. W., 323*n*, 418*n*
Le Blant, Edmond, 107*n*
Le Coq, Albert von, pl. XLIX*b*
Lehmann, J. E., 260*n*
Leibniz, G. W., 453
 “dum Deus calculat fit mundus,” 46

Leiden Papyrus, 45
Lenclos, Ninon de, 4
lentils, magical practice *re*, 189*n*

Leo, zodiacal sign, [121](#); *see also* lion

Leonardo da Vinci, Freud's study of, [5](#)

Leto, [216n](#), [260](#)

 night sea journey of, [371](#)

Leviathan, [55ff](#), [116](#), [254f](#)

Lévy-Bruhl, Lucien, on *participation mystique*, [141](#), [327](#)

Liber, Italian god of procreation, [131n](#)

“libidine,” (Italian) word, [130n](#)

libido: adult, bound to sexuality, [204](#)

 affluxes, [132](#)

 as appetite, [135ff](#)

 attracted to hero, [314](#)

 attributes, [125](#)

 bodily secretions as equivalents, [300](#)

 canalization of, *see following*; cathexes, projection of, [128n](#)

 characterization of, [97](#)

 of child, regression of, [307](#)

 classical authors on, [129f](#)

 and collective unconscious, [335](#)

 compared with sun and fire, [96](#)

 compulsion of, [67ff](#)

 concept of, [132–41](#)

 conflict within, [260](#), [438](#)

 conversion and transformation of, [152](#), [232](#)

 and creation of world, [253f](#), [382](#), [415](#)

 creative power of man's soul, [121](#)

 and cult of rationalism and realism, [226](#)

 daemonic nature of, [112](#)

 death and renewal of, [280f](#)

 displacement onto a symbolical object, [54](#)

 effect of blocking of, [169](#)

 effect of immersion in unconscious, [420](#)

effrenata, [401](#)

 vs. ego, [64f](#)

as an energy-value, 137
erotic, and mystic union with Christ, 287
etymological context, 131
first manifestation of, in infants, 143
fixation in childhood milieu, 414f
and forward-striving, 398, 438
freed from instinctuality by psychic systems, 227
Freud's theory of, 128f
fructifying and destructive, 282
God as projection of, 56f
gradient of, 227
heat of, 101, 381n
human figure as symbol of, 171;
-images, 99, 115n
and light, 115n, 220
and incest prohibition, 417f
and incest-taboo, 294
instinctual, sacrifice of, 423–25
intensification of impressions, 38
and internal object as substitute for external object, 175
introversion of, 88f, 172f, 204, 292f, 334f, 374
as intuitive faculty, 125
love-object of, 405f
manifestations of, and personality, 328
meaning of, 165
menacing activity of, 285
myth, typical elements of, 289
progression of, 301
psychic object, 85
psychology *re*, 131
and rapport with environment, 207
regressive, *see following*; and release from underworld, 293
religious structures of, and regression, 429
reversion to presexual stage, 159

sacrifice of, 412, 415, 431
search for sexual object, 417f
and sexuality, 134, 224n
speech and fire-making as applications of, 169
spiritualization of, 224, 263
split-off parts of, 255
symbol(s) and symbolism, *see following*; theriomorphic representations of, 21, 99, 179f, pl. *iva*
transference to mother, 297
transformation of, 142–70, 229, 231, 281
tree of, 221
unity of, 424
as urge to propagation, narrowness of view of, 136
withdrawal from family bonds, 414f
withdrawn from mother, 254, 312

libido, canalization of: and analogy-building, 141
cultivating and fructifying the earth, 151n
eroticism and, 287n
inability for love and, 173
and mother-analogies, 213, 224
and symbolical truth, 226
symbols for religious figures, 177
through rhythmic activity, 154; *see also* psychic energy

libido, regressive, 408
and activation of collective unconscious, 408
and archetypes, 308
canalization into the god, 256
and dormant possibilities of the individual, 153
in dreams, 327n
fantasies in, 419
heterogeneous symbols of, 429
and infantile kicking, 315
and introversion, 374, *see also* introversion
and mother-*imago*, 295n

and prenatal condition, [419f](#)
reactivation in earlier phases of, [145](#)
reactivation of parental imago, [213](#)
and rhythmic activities of infancy, [154f](#)
snake as symbol of, [342](#)
typical fate of, [424](#)

libido-symbol(s) and symbolism, [97](#), [220](#), [222](#), [412](#)

- absolute, heroes as, [194n](#)
- arrow, [291f](#)
- fate and time, [279](#)
- fire-maker, [316](#)
- gods and goddesses, [221](#)
- horse and wind, [278](#)
- intoxicating drink, [216](#)
- mother and horse, [275](#)
- personifications of libido, [255](#)
- “self-perceptions,” [175f](#)
- sexual, [203f](#)
- for sperma, [315](#)
- sun and stars, [94ff](#)
- sun-heroes, [202](#)
- worm, and name, [297](#)

Libitina, goddess of the dead, [131n](#)

Libra, aeon of, [426](#)

Libya, [302n](#)

Liepmann, Hugo, [11n](#)

life: anima as archetype of, [437](#)

- and death, [272](#), [371](#), [396](#), [438](#)
- after death, [344](#)
- fear of, [297f](#)
- flight from, [398](#), [407](#)
- fountain of, pl. [xxvi](#)
- physiological, sun as source of energy, [122](#)
- second half of, [xxvi](#), [300ff](#)

situations, typical patterns of, [294](#)
“spiritual” or “symbolic,” [330f](#)
summit of, and symbolism of death, [285](#)
-urge, continuous, [136](#)

life-force: magical, and tree-symbol, [258f](#)
psychic, aspects of, [220](#)
—, sun-symbol of, [202](#)
renewal rites, [432](#)

light: creation of, [453](#)
and divine hero, [187n](#)
god of, theriomorphic nature, [116](#)
and sound, etymological connections, [163](#)
substances, [114n](#), [115n](#)
symbolism, [105](#), [125n](#), [220](#)
symbols, [85](#), [279](#), [315](#)

lightning, theriomorphic symbolism, [277](#)

“like,” word, [141](#)

Lilith, [248](#)

limb, missing, [239n](#)

lime-tree, [248n](#)

linden-tree, as mother-symbol, [351f](#)

linen, [104](#)

lingam, [209](#), [219](#)
goddess in, pl. [xxix](#)
with yoni, pl. [xxv](#)

Linus legend, [216n](#)

lion: Nemean, [182](#), [296n](#)
Samson and, [121](#), [339](#)
slain by heroes, [386n](#)
and snake, [280](#), pl. [LXIIIb](#)
sun-eating, pl. [xxxiiib](#)
as symbol, [338](#), [386n](#), [431](#)
zodiacal sign, [121](#), [280](#), [431n](#)

Litaolane myth, [199n](#)

lizards, goddess of, pl. [xvi](#)

Logos, [65](#), [67](#), [70n](#), [186](#)

ancients on, [20](#)

and fire-spirit, [427](#)

image of, in the sun, [106](#)

modern spirit and, [76](#)

principle, [300](#)

as projected idea, [67](#)

in scholasticism, [20](#)

and Thoth, [264n](#)

transformation into mother, [359](#)

and the world-soul, [138](#)

Lombroso, Cesare, [190](#)

Longfellow, H. W., [312–57](#), [395](#), [461](#)

longing: for infantile security, [235](#)

of moth for star, [456](#)

regressive, sacrifice of, [417](#)

to return to mother, [236](#)

spiritual, [396](#)

unfulfilled, hanging as symbol of, [383](#)

wandering as symbol of, [205](#)

Longinus, [433n](#)

looking back, [408](#)

and regression, [404](#)

world as mother, [415](#)

Lord's supper, [339](#)

lost and found, motif of, [343f](#)

lotus, and Brahma, [266](#), [293](#), pl. [xlvi](#)

Lotze, R. H., [11n](#)

Lovatelli urn, [342](#)

love: Christian exhortations *re*, [63ff](#)

in Christian mysticism, [90](#)

and death, [285](#)

definition of word, [86n](#), [306](#), [308](#)

divine and human, 59, 65f, 224n
God as, 86
and the God-image, 86
human problem of, 308
inability to accept, 173, 285
psychological connotation, 64
-relationship, 395
-song, 52n
spiritual, 65f, 396
lover(s): ghostly, 309, 395
 nearness and separation of, 409
Löwis of Menar, A. von, 247n
lozenge, female symbol, 202f
Lubentina/Lubentia, 131n
Lucian, 341
Lucifer, revolt of, 113
Lucilius, 41st letter from Seneca, 69, 78n
Lucius, 415n
 prayer to Queen of Heaven, 99
Lucretius, 74n
 on *alma Venus*, 74ff
lunacy, cause of, 370
Lunus, *see* Men
Lupercalia, 104n
Lusitania, 100n
lust, kinds of, 130f
lutum, 191
Lydus, 318n
Lygodesma, 244
lygos-tree, and image of Hera, 243
Lysimachus, coin of, pl. *xxa*

M

Macarius, Joannes, 383*

MacCulloch, John A., *see* Gray

Macdonell, A. A., [165n](#)

Macedonia, phalanx of, [220](#)

Macrobius, Ambrosius, [281](#)

madness, sent by spirit-mother, [370](#)

Maeder, A., [5](#)

Maehly, J. A., [365n](#), [374n](#)

Maeterlinck, Maurice, [50](#), [153](#)

Magi, and Ahriman, [341](#)

magic: animal, [327](#)

 apotropaic, [348](#), [351](#)

 belt, [316](#), [353](#)

 cap, [364](#)

 herb, [170](#), [200](#), [298](#), [332](#), [413](#), pl. [xix](#)

 net, of Hephaestus, [244n](#)

 oil, [350](#)

 primitive ideas of, and modern ideologies, [156](#)

 wand, [412](#)

 word, and opening of rocks or caves, [246n](#)

magician, [350](#)

 personification of water of death, [353](#)

 significance of, [351](#)

Mahadeva, [209](#)

Maheswar, [351](#)

maiden(s): sacrificed to dragon, [430](#)

 as snake or dragon, [362n](#); *see also* girl(s)

Mainyo-i-Khard, [246n](#), [427](#)

maize: god who is eaten, [336](#)

 myth of origin of, [337](#); *see also* corn-god

maladjustment, pathological, and patient's attitude toward instinct, [139](#)

Malta, caves of, [346](#)

ma-ma, child's cry, [251](#), [273](#)

Mamba clan, in Africa, [383f](#)

man: alliance with world and nature, [76](#)

archaic heritage of, 178
archetypal dimensions attainable by, 66
biological vs. cultural view of, 177
civilized, 71, 156, 169, 324, 441
consciousness of himself as a personality, 255f
and control of his own fate, 414
created in God's image, 377
dangers of success to, 298
Dionysian nature of, 401
domestication of, 69
and dragon, as brothers, 367
effect on, of the divine, 69ff
as ego and self, 384n
enmity of mother-*imago* as spur to achievement, 301
Fall of, 46
feminine component of, 300f, 316
fire as the divine element in, 202n
first, 213
first sin of, 428n
gestures of frustration of, 153
as god, 88f
hero as symbol of unconscious self of, 333
immortality in life of the psyche, 202
immortal state of, 420
individual differences in, 176f
influence of, on his society, 67ff
and Logos principle, 300
love of fellow man, 63, 65
myths of origin of, 141n, 191, 219, 246, 288, 318f
natural, sacrifice of, 434f
and nature, 401ff
old, rejuvenation legend, 353
and passion, 113
psychic conflict in, 289–91

ransom through sacrifice, 431
rebirth as spiritual being, 226
and religious myths, 231
renunciation of animal unconsciousness by, 271
sacrificer and sacrificed, 56
spiritual vocation of, 65
unconscious self of, 333
unity of mankind, 226
wholeness of, 303

mana-concept, in Rudra, 220
mana personality, 392
mandala symbol, 208n, 303n, 398n
mani/Manichaeism, 333, 383
 and fire-substance, 99n
 and sun worship, 108

Mannhardt, Wilhelm, 151n, 425
manthāmi or *mathnāmi*, etymology, 168
mantle: scarlet, 104n
 symbol of invisibility, 198, 345

Manu, 148n, 198n
Maori myth, of hero Maui, 257n, 348n
Mar, etymology, 249ff
Mara, 249ff, 258
Marcus Aurelius, 106
Marduk: fighting Tiamat, 416*
 god of spring, 253f

mare(s): etymological connection with nightmare, 249ff
 of Lusitania, 100n; *see also* horse

marriage: brother-sister, 234, 300, 436
 classes, 223, 418
 consanguineous, 234
 cross-cousin, 152f, 271n, 418
 customs, modern, 27
 daughter-father, 322

son-mother, [240](#)
Mars, [201](#)
Marsyas, [233](#), [384](#)
martyrdom, [290](#)
Maruts, winds, [122n](#)
Mary, Virgin: Christ in womb of, pl. [III](#)
 and divine pneuma, [49](#)
 fructification, [101](#), pl. [VIII](#)
 lament to the cross, [270](#)
 Mclk hymn to, [371n](#)
 pierced heart of, [286n](#)
 rose- symbol of, [398n](#)
 water-symbol of, [251](#)
masculine ideal, [186](#)
Mashya and Mashyoi, [246](#)
mass psychology, [71](#)
masturbation: boring gesture as analogy of, [142ff](#), [160](#)
 infantile, [143f](#),
 and rhythmic activity in childhood, [144](#)
matador, as hero, [276n](#)
Matarisvan, [145](#), [146](#), [374](#)
Mater Ecclesia, pl. [xxxα](#)
mathnāmi, see *manthāmi*
mating: in the mother, [399](#)
 sacramental, between spear and hole in the earth, [150](#)
Matuta, statue of, [346](#), pl. [LIV](#)
Maudslay, A. P., pl. [xLIα](#)
Maui, myth of, [257n](#), [348n](#)
Maurice, Thomas, [264](#)
Mauthner, Friedrich, [12n](#), [16](#)
Mautmes, [264n](#)
Max Müller, F., [45n](#), [122n](#), [165n](#), [166n](#)
Maya, [251](#), [320n](#)
 dream of Buddha's conception, pl. [xLIXb](#)

Mayn, Georg, [192](#)
Mead, G. R. S., [101](#)
“meadow,” etymology, [150n](#)
meat, sacrificial, [339n](#)
Mechthild of Magdeburg, [90](#), [115n](#)
Medea: miracle of, [358](#)
 patron goddess of, [370](#)
medical psychology, [xxiii](#)*f*
medicine woman, [296n](#)
medieval: art, representation of the Cross, [247](#)
 mind, subjects of thought, [19](#)
medium: spiritualistic, [460](#), [462](#)
 hero as, [189](#)
megalomania, [342n](#)
 stage of, in paranoid case, [102n](#)
Mehnit, [267f](#)
Melampus (Blackfoot), [126](#)
Melicertes, [248n](#)
Melito of Sardis, [106](#), [429n](#)
Melkarth, [248n](#)
melting-pot, symbolism of, [167](#)
membrum virile, as a tree, [221](#)
memory(-ies): accessible to the unconscious, [51n](#)
 childhood, [89](#), [454](#)
 and dreams, [21f](#)
 integration of, and depression, [404](#)
 submersion in, [407](#)
 world of, [292](#)
Men (Phrygian god), [203f](#)
 birth of, [260](#)
 and Caesar, [277](#)
 on the cock, pl. [xxia](#)
Mendes, [240](#)
Men-kau-Re (Mykerinos), [439n](#)

mentula, 146*n*

Mercurius, 307*n*

Mercury, 201

Merezhkovsky, D. S., 368, 376*n*

Merian, Matthaeus, Bible of, pl. *xxiia*

Meringer, R., 150*n*

metanoia, xxvi

metaphor(s), 134

erotic, 8

metaphysics, and language, 13*n*

meteor, 188

Indian name for, 315

Mexico: Cross of Palenque, 263, pl. *xliia*

hieroglyphic, 263

rite of Teoqualo, 339*n*

sacrificial rite, 264*n*; *see also* Aztecs

Meyer, E. H., 279*n*, 289*n*

Middle East, Cybele cults of, 426*n*; *see also* Cybele

Midgard Serpent, 438*n*

Miles, degree of, 197

milky ocean, churning of, pl. *xv*

Miller, Miss Frank, 32

associations of hero's name, 192*f*

capacity of identification, 34*ff*, 48, 54

"Chiwantopel, hypnagogic drama," 171*ff*, 394*ff*, 457*ff*

dependence on family ties, 304

fantasies, 32*f*

—, anamnesis in, 34*ff*

—, inner necessity in, 435

—, material of, xxviii*f*

—, symbols of sacrifice in, 415

first publication by Flourney, XXVIII

"Glory to God," 39*ff*, 450*ff*

ideal figure, 284*f*

lack of understanding of symbols, 441f
“The Moth and (to) the Sun,” 79ff, 109, 113, 455–57
as object of hero’s longing, 395
participation in hero’s sacrificial act, 436
personal influence over artist, 37
“Phenomena of Transitory Suggestion or of Instantaneous Autosuggestion,” 34, 447–50
significance of sphinx symbol, 182
and ship’s officer, 52, 84f, 111, 186, 450f
spirituality personified as Aztec, 186
Milton, John, 42, 46f, 451, 453
Mime, chthonic god, 361ff
Mimir’s fountain, 250n, 362n
mind: instinctive, archaic basis, 29
 latent archetypal symbolization, 357
 modern, relegation of religion to the unconscious, 72
 modes of functioning, 313; *see also* conscious (mind)
mint, meanings of, in antiquity, 146–47n
mitos, meaning of, 127
miscegenation, and asceticism, 81n
mistletoe, 258f
Mithraic liturgy, 67n, 100
 attributes of the sun, 102f
 on breath of the spirit, 317n
 fire in, 202n
 libido-symbols in, 94
 phallic vision of tube in, 100
Mithraism: and Christianity, 67, 70, 200f
 Dioscuri motif, 384n
 doctrine of wind and soul in, 316n
 feeling for nature in, 73
 initiates of, 435n
 instinct-sacrificing symbolism in, 426
 legend, 261, pls. xxiv*a*, xl, xlix*a*

mysteries, [90](#), [102ff](#), [108n](#), [196f](#), [280](#), [338](#)
sacrifice in, [238](#), pl. [xxxiii](#), *see also* bull sacrifice
sexuality in, [67](#)
subjugation of animal instincts in, [70](#)
symbolism, [57n](#), [102ff](#), [280](#), [289n](#), [431](#)
Mithras, [109](#), [127](#), [205n](#), [223n](#), [246f](#), [260](#), [276](#), [425](#), pl. [xl](#)
attributes of, [103ff](#)
birth of, [101n](#), [246f](#), [260](#), [381n](#)
and the bull, [302](#), [427f](#), pl. [xlIXa](#), *see also* bull sacrifice
and Christ, [218](#)
and dadophors, [201n](#)
eyes of, [122n](#)
Grotto of, [372](#)
and Helios, [103ff](#), [196f](#), pl. [xxIVa](#)
as Logos, [70n](#)
meaning of name, [427](#)
Ostian head of, *frontispiece*; representations of, [196f](#)
self-sacrifice, [428](#), [431](#)
and Sol, [384n](#)
sword and torch of, [104n](#), [105*](#)
Tauroctonos, [428](#)
and trees, [233](#)
triadic character of, [201](#)
mixing bowl (krater), [431](#)
with lion and snake, pl. [LXIIIb](#)
Möbius, P. J., [132n](#)
modern spirit, [76](#)
Mondamin, [336ff](#)
money-offerings, [365](#)
monotheism, polytheistic tendency in, [99](#)
monster, [179](#), [248f](#)
devouring, pl. [LXII](#); *see also* dragon; serpent; whale-dragon
Montelius, Oscar, pl. [XIb](#)
mood(s): receptivity of, and libido, [171f](#)

as smoke-screen, 300
moon: as abode of souls, 318*
course of, 108n
equated with uterus, 203
orbit, serpent as, 108*
as parental archetype, 369
prayer to, as Queen of Heaven, 99
primitive idea of, 318
significance of, 317f
as vessel (uterus), 203
woman in, 318*
moonsickness, 370
moral law, represented by the father, 260f
Mörike, Eduard, 9, 320
“morning stars,” 41, 451
Morris, Richard, 270n
mortal and immortal, 201f
motif of the Dioscuri, 200, 201
Moses, 26, 343f
journey with Joshua, 194, 198, 344
Moses of Chorene, 341
moth: as symbol, 84, 250
and sun, 109
“Moth, Song of the” (Miller), 79–117
mother: accusation of, in legend of Osiris, 235
of all living, 75*
as anima-image, 283n
appeal for help to, 387f, 406f
archetype, 236
assault on, 319
battle for deliverance from, 274–305
birth-giving and devouring, 353, 422
burial and resurrection in, 372, *see also* rebirth s.v.
as child’s “horse,” 251

clinging to, 293n
as collective unconscious, 259
conquest of, 251–54, 295n, 386
danger of erotic aspect, 426
deadly, 353, 369, 389
of death and life, 271, 369
divine significance of, 250, 336f
dual, 236, 306–93
Earth, *see* Earth Mother; and earth and water, 140, pls. *xiva*, *xxvi*
echo of voice and speech in nature, 363
entry into, 238, 289, 301f, 353n
in *Faust*, 205f, 251, 310, 315, 330, 355
fertilization of, in act of sacrifice, 432
gateway to the unconscious, 330
helpful, nourishing, 335, 336, 338n, 342n, 352, 358, pl. *xiva*
identification with, 283
immaculate, 50
incest and, 224, 294, 417f
kicking associated with, 315
Mater Ecclesia, pl. *xxxa*
mater saeva cupidinum, 312, 327, 389, 401, 424
mating in, 399
matres and *matronae*, 250
matrona, 433
“mother’s son,” 258
as murderess, motif of, 248
Nature, 324ff, *see also* Great Mother
object of unconscious desire, 306
oneness with, 325, 413
as primordial image, 251
pursuing, 348ff
racial, 49
real, and symbolical, 322f
reentry into, 419, 432f, 439n, *see also* rebirth s.v.

regeneration in body of, pl. XLII
search for, 306f
separation and differentiation from, 271, 303f, 312, 402n
serpent as symbol of numen of, 296
sky as, 268f
snake and water attributes, 350
and son, 186, 259, 294, 363f, 386, *see also* hero s.v.
splitting of, 253
spiritual, 388
surrounding, embracing, 440
symbolic substitutes for, 213, pls. xxIIa, xxxa
Terrible, *see* s.v.; two, 295n, 317ff
union with, in death, 263
union with son in tree-symbol, 424
“of wisdom,” 360
word, archaic substitutes for, 140
world created from, 253, 421

mother-: bride, 217
city, 411
complex, 186, 258n, 363n, 378
consort, 223n
dragon, slaying of, 253f, 415
-goddess, *see below*; image, 185, 266, 415f
-imago, *see below*,
libido, sacrifice of, to create world, 421
sacrifice, 424
sister-wife, 388
symbol(s) *see following*

mother-goddess(es), 208, 223n
boar-headed, pl. IV
cow-headed, 235, pl. xxxb
myths of, 223n
son-lover of, 308

mother-imago, 57, 60, 358

as danger to hero, [359f](#)
as feminine aspect of hero, [388](#)
fountain as, [362n](#)
human and animal as, [182](#)
and ideal figure, [309f](#)
and image of the soul, [266f](#)
negative, dragon-symbol of, [259](#)
the new Jerusalem, [217](#)
projection upon water, [219](#)
regression of libido to, [295n](#), [330](#)
regressive reactivation of, [89](#)
sphinx as theriomorphic representation of, [179](#)
symbols of libido attachment to, [222](#)
transformed into lamia, [298](#)
and “treasure hard to attain,” [363f](#)
and the unconscious, [298](#)

mother-symbol(s), [207–73](#)
earth, wood, and water, [247](#)
egg, [353f](#)
entwining, [245](#)
fiery furnace/tripod, [167](#)
horses, [207](#), [275](#)
in individuation process, [301](#)
sea, water, [251](#)
tree, [233ff](#), [260](#), [351f](#), [424](#)
motifs: archetypal structures, [390f](#)
dream, [8f](#)
and mythologems, [313](#)
mythological, [31](#)
unconscious elaboration of, [5](#), [28](#)

motives, unconscious, [28](#)

mountains, image of, [409](#)

mouth: etymological connections with fire and speech, [163](#)
significance of, in infancy and early childhood, [161](#)

re-entry into mother through, 419
snake in, 378f, 436f

Müller, J. G., 263n, 264

Müller, Joh., 175n

Müller, Niklas, 381*

murder instruments, in dreams, 8

Musaeum hermeticum, pl. LIXa

music, 136, 164

Muther, Richard, 224n

Mutianus Rufus, 99n

mutilation, motif of, 239n, 245n

Muyscas Indians, use of cross symbol, 267

Mykerinos, see Men-kau-Re

myrtle, 219

mysteries: Christian, 420

- Eleusinian, 339–44, 378
- harmony of life and death, 384
- hero and celebrant, 187n
- idea of oneness with the gods, 87
- initiates, 67n, pl. vi
- Isis, 87
- Mithraic, 90, 102ff, 108n, 280, 338
- neophytes veiled, 198n, pl. ivb
- Ophite, 377f
- orgies, 376n
- purpose of, 415n
- serpent, pl. LXIa
- sun-coronation, 106

“Mysteries of St. John and the Holy Virgin,” 315

mystic/mysticism: classical, 50

- and introversion, 381
- sun as life-force of, 122
- vision of the Divine, 90

myth(s): archetypal structures, 390f

betrayal of hero, [31f](#)
dream-like structures, [24](#)
-interpretation, [390f](#)
necessity and meaning of, [xxivf](#)
Nordic, *re* creation, [246](#)
rebirth, [242](#), [251n](#)
religious, [231f](#)
significance of, [308](#)
solar, [121ff](#), [242](#)
subjective contents, [XXV](#)
summary of meaning of many, [422](#)
themes of, [26](#)
typical parts of, [212](#)

mythologem(s): basis in early infantile gesture, [161](#)
of divine nature of self, [392](#)
and psychotic images, [313](#)
of Purusha, [417](#)
of sacrificial death, [433n](#)

mythology: animal-sacrifices in, [423](#)
birth in, [225](#)
embodiments of the creative force in, [137f](#)
equation of heroes in, [194ff](#)
examples of anal birth in, [191](#)
fire-making in, [145ff](#), [168](#)
Greek, [20](#)
of horse and mare, [275n](#)
ideal sacrifice in, [430](#)
interchangeability of figures in, [429f](#)
man's view of consciousness and unconsciousness in, [260](#)
maternal significance of water in, [218](#)
matrix of, [390](#)
opposite versions in, [376](#)
parallels in, [193ff](#)
phallic characteristics of wonder-workers in, [126](#)

and products of the unconscious, [30](#)
role of serpent in, [438n](#)
solar, [121ff](#)
source of incestuous relationships in, [174](#)
statements of, as numinous experiences, [157](#)
steeds of, [276](#)
symbols of, attitude toward, [222](#)
thinking of children and primitives, [25](#)
tree symbolism in, [233ff](#)

N

Nagaga-uer, [256](#)
Nagel, A., [427n](#)
nailing to the cross, [263f](#)
name: magical power of, [141](#), [187](#)
 secret, [386](#)
 true, libido-symbol, [297](#)
naming, act of, [187](#)
Nandi, [345](#)
Naples, [41](#), [451](#)
Natal: medicine woman, [296n](#)
natural phenomena, source of names for, [188](#)
natural philosophy, [76](#)
nature: ambivalent forces of, [109](#)
 classical feeling for, [73](#)
 hero's closeness to, [324ff](#)
 language of, [332](#)
 maternal significance, [363](#), [401n](#)
 reflection of contents of unconscious, [112n](#)
 religious attitudes toward, [73ff](#)
 Mother Nature, [324ff](#)
 spiritual vs. physical, [71](#)
 symbolism of, in antiquity, [21](#)
 transference of libido to, [334f](#)
 unchained power of, [55ff](#)

womb of, as maternal womb, [398](#)
worship of, [73f](#), [81](#)
Naunet, [241](#)
navel: point of cleavage, [292f](#)
of Vishnu, [293](#), [399](#), pl. [XLVIA](#)
Nazari, Oreste, [131n](#)
Near East: Cybele cults, [426n](#)
sun-worship in, [109](#); *see also* Cybele
Nebit-Hotpet, *see* Jusas
Nebuchadnezzar, [7](#)
nectar, [138](#)
Negelein, Julius von, [275n](#), [277n](#), [278n](#), [282n](#), [351n](#)
“neglego,” [429n](#)
Negroes, Jung’s research on mental derangement among, [102](#)
Neith/Nit, [240f](#)
nekyia, [431](#); *see also* night sea journey
Nemean lion, [182](#), [296n](#)
neophyte: in mystery cults, [87](#)
prayer of, [89f](#)
Nephele, [303n](#)
Nephtys, [234](#), [264](#)
Nero, man and society in age of, [69f](#)
Nerval, Gérard de, [53n](#)
nervous temperament, and phenomena of autosuggestion, [449](#)
Neumann, Erich, [6](#)
neurosis(-es): and attitude to instinct, [139](#)
autoeroticism and, [28](#)
causes of, [XXIII](#), [XXVII](#)
created by projection, [329](#)
falsification of reality in, [140](#)
Freudian theory, [420](#)
introversion of libido in, [135](#)
through loss of adaptation, [156](#)
motive forces of, [139](#)

and patient's dream of snake, 378
psychoanalytical theory of, 133
prophetic dream at onset of illness, 51
and regression, 304
source of religious figures, 62n
splitting of personality in, 442
symptoms of, 22n

neurotic(s): conflict, 172
defence of innocence, 47
disburdening of secrets during treatment, 207
false thinking, 420
fear of separation from mother, 271
flight from life, 109f, 398
lack of selfunderstanding, 230
reasoning about cause of ills, 155

neurotic: attitude, repression as symptom of, 180
system, Freudian theory of motive forces of, 132
wish for mother, 440

New Guinea: hook for hanging, pl. xxviii

New Testament: rebirth symbolism, 224f

BOOKS: *Apocalypse*, see *Revelation*; *Acts of the Apostles*, 162
Colossians, 61n
Ephesians, 61n
Galatians, 212, 217, 383n
Hebrews, 61n, 63n, 338n
James, Epistle, 61, 63, 162
John, First Epistle, 61n, 63, 64, 86
John, Gospel, 65n, 87, 196, 225, 322, 367
Luke, 286n
Matthew, 195, 200
Peter, 60n, 61n
Revelation, 104f, 162, 214, 223, 338n
Romans, 57, 65n

New Year's Day, 189n

Nicodemus, 225f, 331

Niedfyr, 149n

Nietzsche, Friedrich, 13, 337n

arrows of God, 290

art of, 303

“basilisk egg,” 382

dream of toad, 34n

on growth to maturity, 311f

image of torment of soul, 290

images, 343n

isolation within oneself, 312

on life and death, 385

longing for eternity, 410

on medieval mind, 20

parable of, 377n

on primordial element in dreams, 23

on psychic conflict of man, 291

“sacrilegious backward grasp,” 174

on serpent’s poison, 301f

and snakes, 378n

on thinking, 11n

vision of shepherd and snake, 378ff

WORKS: *The Beacon*, 95

“Glory and Eternity,” 94

“Voluntary Death,” 386f

Nigeria, 257n

nightmare(s): and the devil, 277

etymological connection with mare, 249ff

Hecate and, 369

lamia as, 248f

night sea imprisonment, 252, 331, pl. xxii**b**

night sea journey, 210, 212, 316, 350, 358, 371, pl. xxii**b**

death as, 218

entwining by serpent, 243

with incest, [233f](#); *see also* nekylia
nigredo, [53n](#)
nimbus, *see* halo
Nit/Neith, [240f](#)
Noah, [113n](#)
 in the ark, [212*](#)
 journey over the Flood, [211](#)
Nodfyr, [149](#)
non-existence, yearning for, [356](#)
Norden, Eduard, [82n](#)
Nordic mythology, Odin, [433n](#)
normal people, need for symbol, [230f](#)
Norns, [250](#)
Norwegian riddle, tree and lake, [221](#)
nose-picking, [153](#)
nourishing earth-mother, pl. *xiva*
Nous, [77](#)
Numa Pompilius, [298n](#)
numen: of archetype, [232](#), [294](#), [308f](#)
 and snake, [436](#)
 vegetation, [396](#)
numinosity: of archetypes, [158](#), [294](#), [308f](#)
 of fire-making, [169](#)
 of primordial images, [157](#)
 of self, [391f](#)
 of sun, [86](#)
Nun, [194](#), [240](#), [256](#)
nun, meaning of, [241](#)
nuptiae chymicae, [223](#)
Nut, sky-goddess, [242](#)
 giving birth to the sun, [241*](#)

O

oak-tree, [353](#)

hollow, [353](#)
and mistletoe, [258](#)
Oannes-Ea, [199](#)
object: incorporation into psychic system, [141](#)
light-symbols for, [85](#)
symbolical, displacement of libido on, [54](#)
objective level, of unconscious products, [117n](#)
obolus, sacrifice of, [371](#)
obstetric methods, barbaric, [319](#)
ocean, milky, churning of, pl. [xv](#); *see also* sea
Oceanus, [105n](#)
Odin, [290](#)
hanging of, [233](#), [263](#), [433n](#)
Odysseus: as Cabiric dwarf, [128*](#)
journey to Hades, [409n](#)
Oedipus complex, [419](#)
Oedipus legend: Freud and, [3f](#)
myth of the Greeks, [32](#)
sphinx in, [181f](#)
studies relating to, [5](#)
“Swell-foot,” [239](#)
offerings, propitiatory, [364f](#), [372](#)
Ogyges myth, mother symbolism in, [208](#)
oil, magic, [350](#)
Oka, [220n](#)
Olaus Magnus, [276*](#)
Old Testament: cities as women, [208](#)
dream-interpreters, [7](#)
mouth and fire, [162](#)
parallels of Creation Epic, [254](#)
Rahab, [254](#)
Utrecht Psalter, [280](#)
BOOKS: *Daniel*, [7](#), [167](#)
Deuteronomy, [162](#)

Ecclesiasticus, 287n
Ezekiel, 162, 192
Genesis, 45, 111, 192, 338, 377n, 400
Isaiah, 61n, 187n, 208, 218n, 247n, 255
Jeremiah, 162, 208
Job, 51, 54f, 254
Judges, 339n, 412n
Numbers, 367
Psalms, 87, 162, 254, 288
I and II *Samuel*, 162, 178
Oleg (sun-hero), 295n
olive-tree, 250
Om (sacred syllable), 45n
“Om mani padme hum,” 243n
One, the, 137f
“Only this, and nothing more,” 52f
onomatopoeia, 12, 188, 317
ontogenesis, and phylogenesis, 23
opening of rock, 246n
Ophite(s), Christian, 360f
 mysteries, role of snakes, 377f
 snake as saviour, 382
 view of Holy Ghost, 360
opposites: great and small, 128
 harmony of, 173f
 inner tension of, 303, 375
 union of, 271, 368, 369ff, 374, 432
 young and old, 127
organs, development of, and libido, 143ff
orgies, in degeneration of religious rites, 376n
orifice, birth-giving, 125*
Origen, 338n
 self-castration, 257n
Oromazdes, 281; *see also* Ahura-Mazda

Oropos, Amphiarion, 365
Orpheus: frescoes of, 107n
 Japanese, 341n
Orphic: cosmogony, Hecate in, 370
 hymn (52nd), 343
 legend of Iacchus, 340
Orthrus, 182
Ortygia, 216n
Osiris, 109, 223n
 in coffin, 237*
 crippled shadow of, 362
 death of, 219, 234, 242, 257f
 effigy from Philae, 264
 enters Mehnit's left eye, 267f
 fate of, 242
 and Horus, 239f, 362
 and Isis, 233–40, 398, 425
ossuary, Etruscan, 346
Osterburken monument, 197
Ostia, head from, 428, *frontispiece*
other world, 407
 entry into, 412; *see also* Hades; underworld
Ovid, 289, 340, 425
ox: dead, fruitfulness of, 426
 Mithras and, 426
 skinned, 384
 oyster, in Scheffel poem, 245n

P

Palatine, mock crucifixion on, 276, 401, pl. XLIII
Palenque Cross, 263, pl. XLIIa
Pallas, Attic, 219
Pamyles of Thebes, phallic daimon, 234
Pan, 203

Papremis, battle ceremony, [256f](#)

Paracelsus, [330](#)

Paradise: serpent in, [102](#)

tree of, [247f](#)

Paradise Lost (Milton), [42](#), [46ff](#), [53f](#), [453](#)

parallels, mythological, [193ff](#)

paranoia: Freud's Schreber case, [128n](#)

Honegger's case, [140](#)

loss of reality in, [134](#), [140](#)

megalomaniac stage in, [102n](#)

parasite, *puer aeternus*, [259](#)

paredroi, [201](#)

parental imago: animal forms of, [181n](#)

and individual disposition of child, [328](#)

predominance of, and infantile behaviour, [284](#)

reactivation, of, [140](#), [204](#); *see also* father-imago; mother-imago

parents: attachment to, [284](#)

influence on children, [180](#)

role of, in neuroses, [139](#)

Paris, and Helen, [126](#), [167](#)

Parsis, [237](#)

Parthenon, [382f](#)

participation, by autosuggestion, [448](#)

participation mystique (Lévy-Bruhl), [141](#), [327](#)

parties anciennes (Janet), [23n](#)

Parvati, [209](#)

united with Shiva, pl. [xxiii](#)

passion: destructive power of, [112ff](#)

and regenerative force, [116](#)

“passionate longing,” [84](#)

past, fascination of, [408](#)

pastries, phallus-shaped, [342](#)

“pasture,” etymology, [150n](#)

paternalism, attribute of God, [57](#)

patient(s): attitude to instinct, 139
and doctor, 43f
information from, 313
need for psychological understanding by, 442
“Patmos” (Hölderlin), 407–14
Paul, Hermann, 13n
Pausanias, on Argive Hera, 244
on image of Artemis Orthia, 244
on Oropian well, 365
on temenos of Athens, 364
pearl, as symbol, 330
peepul tree, 351
Pegasus, 278
Peirithous, 293n, 310, 356, 420, 432n
Pelasgians, 126
Penelope, 4
Pentheus, and pine-tree, 425
Pepnos, 127n
peregrinatio, 93n
perfume, autosuggestion and, 447
Perga, coin from, 203
“perpendicular cliff,” 273
persecution, motif of, 359
Persephone/Proserpina, 26, 99, 340, 370
Kore-, 425; *see also* Demeter
Persia (Iran): disposal of dead, 237
Hvareno, 99n
myth, 264n
ram, 428n
personality: conscious, and archetype, 309
—, emancipation from infantile ties, 305
— vs. unconscious, 300
effect of hindrance to growth of, 298
forcible change of, 300

inferior component of, 183
inner or “real,” 329
instinctual foundations of, 424
inviolable, 461
and name, 187
primitive, 230f
splitting of, 169, 359f, 442
tendencies, in mythological material, 31f
total, 364
unconscious, 193
unconscious creation of, 193
personification: conscious attitude, 187
of the libido, 255
of shadow brother, 259
Peru: corn-god, pl. LII
Incas, 185
Muyscas Indians, 267
Peter, St., 369n
and Christ, 197
and St. Sylvester’s dream, 366
petitio principii, 227
Petrarch, ascent of Mt. Ventoux, 19n
Petronius, 239
Pfister, O., 5, 376n
Phaedra and Hippolytus, 298n
phalanx, 220
phallagogies, Dionysian, 27
phallic symbolism, 219f, 436
columns in temples of Astarte, 236n
in Eleusinian mysteries, 342
foot and treading, 315
horses’ hooves, 277
and libido, 202, 222
tree, 424

Phallophoria, [234](#)

phallus: creative force, [124](#)

as fire-stick, [147](#)

hand as symbol of, [185](#)

and horse-shoe, [278](#)

and lingam symbol, [209](#)

regenerative symbol, [436](#), pl. [LXIIIa](#)

solar, [101](#), [157](#)

source of life and libido, [97](#)

symbol of creative divinity, [126](#)

Phanes, [137](#)

in the egg, pl. [XII](#)

Pharaoh(s), [7](#), [87n](#), [257](#), [339n](#)

Philae, effigy of Osiris at, [264](#)

Philemon, [60n](#)

Philo Judaeus, [106](#), [281](#), [374](#)

Philoctetes, [294f](#)

philosophers' stone, [415n](#)

Philyra, [275n](#)

Phlegians, [146](#)

Phoenicia, [216n](#)

phoenix, [109](#), [164n](#), [348](#)

Phrygian cap, *see* pileus

Phrygians, [127](#)

phylogenesis, and ontogenesis, [23](#)

Picumnus, and Pilumnus, [352](#)

Picus, and Circe, [352](#)

piercing, [263](#), [292](#), [433n](#)

Pietà: Etruscan, pl. [LIV](#)

and Terrible Mother, [425](#)

piety, and sexual impulse, [224n](#)

pileus, [109n](#), [127](#), [203f](#)

Pillars of Hercules, [302n](#)

Pindar, [288](#)

pine-cones, [203](#), [219n](#)
pine-tree, [219](#), [233](#), [351](#), [423f](#), [425](#)
Pirkê de Rabbi Elieser, [330](#)
Pitra, J. B., [106n](#)
placenta, primitive idea of, [240](#)
Plataean cult of Hera Teleia, [244](#)
Plato: on demiurge, [266](#), [358](#)
 on Eros, [166](#)
 on heavenly journey, [93n](#)
 parable of the cave, [391](#)
pleasure, sources of, [418](#)
Pliny, Idaean dactyls, [127n](#)
Plotinus, [138](#)
plough, [148n](#), [340](#)
 etymology, [150n](#)
 phallic, [151*](#)
 symbolism of, [148n](#)
ploughed furrow, [199n](#), [209](#), [341](#)
Plutarch, [398](#)
 on Dionysian orgies, [278](#)
 on Horus, [261](#)
 image of bud, [399](#)
 on Isis, [311n](#)
 on Magi, [341](#)
 on Osiris myth, [233f](#)
 on Zeus and Hera, [243](#)
Pluto, [365](#)
pneuma, [48](#), [49](#), [99n](#), [316](#)
Poe, Edgar Allan, [52f](#)
Pöhlmann, R. von, [71n](#)
Poine, [216n](#), [260](#)
pointed instrument, [180](#)
pole, phallic symbol, [219](#)
Polynesian myths: Kombili, [211](#)

Maui, [257n](#)
sea-monster, [347n](#)
polytheism, simplification of, by synthesis of gods, [97ff](#)
Pope, *solis inviciti* comes, [198](#)
Popocatepetl, [187f](#), [439](#), [460](#)
Porphyry, [316n](#), [427n](#), [431n](#)
Poseidon, [216n](#), [275n](#), [289](#), [298n](#)
power: of God, [57](#)
 magic, assimilation of, [339n](#)
 and sex instincts, [66](#)
 symbol of sacrifice of, [412](#)
 words, [141](#)
Prajapati, [380](#)
 with world-egg, [381*](#)
pramantha, [145](#); see also fire-stick
Prampolini, Giacomo, pl. [XLVIII](#)
prana, [422](#)
Prasiae, [127n](#)
prayer: concentration of libido on the God-image, [176](#)
 as expression of introversion, [178](#)
 purpose of, [178](#)
 -word, [359](#)
“preconscious,” Schelling on, [29n](#)
Preiswerk, Samuel, [344](#)
Preller, Ludwig, [278n](#), [425n](#)
Prellwitz, Walther, [220n](#), [373](#), [412n](#)
“pre-natal stage,” and regression, [329f](#), [419](#)
preservation of the species, [136](#)
presexual stage, [144](#)
 applications of analogy to, by the libido, [159](#)
Preuss, K. T., [150n](#)
priapic animals, [278](#)
priapus, [137](#), [342n](#)
 Roman statues, [219](#)

statue with snake, at Verona, [438](#), pl. [LXIB](#)
use of image vs. cattle pest, [149](#)
priest(s): of Attis-Cybele cult, [426](#)
with fish-mask, [199*](#)
primal: being, [416f](#)
experience, [325n](#)
horde, Freud's myth, [260](#)
mother, sacrifice of containment in, [417](#)
will (Schopenhauer), [136](#), [137](#), [382](#), [438](#)
prima materia, [189](#), [352n](#), [408](#)
primitive(s): anthropomorphic and theriomorphic conceptions, [21](#)
beliefs about sun and moon, [318](#)
and blocking of the libido, [170](#)
danger of endogamous tendency to, [152f](#)
family organization of, [418](#)
fear of "inner" reality, [156](#)
initiation mysteries of, [415n](#)
link with modern man, [4f](#)
and religion, [269n](#)
significance of speech and fire-making, [169](#)
tribe vs. city as symbol, [213](#)
primordial: being, [160n](#)
creative principle, [138](#)
image(s), *see following*; waters, Amon as, [240](#)
word, and poetry, [303](#)
primordial image(s), [293](#)
autochthonous revival of, [147](#)
of children torn from the mother's womb, [216n](#)
and collective unconscious, [408](#)
course of the sun, [355](#)
of life into death, [438](#)
of the mother, [251](#)
numinosity of, [157](#)
role of, [309](#)

superhuman potency of, 177f
wonderland of, 408f; *see also* archetype(s)

Pritchard, J. B., 200n, 252n

procreation, of reborn, 323

procreative urge, analogy of, 54ff

progress: hallmark of waking thought, 21
mania for, and compensation, 419; *see also* forward-striving

progression, of waking thought (Freud), 21

prohibitions, and archetypal father, 260; *see also* incest-prohibition

projection: of an archetype, 53n
by artist into paintings, 290
of complexes, 414f
of conflict caused by repression, 59
destruction of passion in, 112
direct, 112n
in dreams, 180
on external circumstances, 297f
of hero-myth, 391
of *hieros gamos*, 433
of incest tendency, 294
and interpretation of fact, 286
upon masculine figure, 304
of menace to the power of God, 112
of mother-imago upon water, 219
of rebirth symbol, 322
of self, 368
in solar mythology, 201
and unconscious, 329

Prometheus: “one who thinks ahead,” 146n
and *pramantha*, 145ff
sacrificial death of, 432n
theft of fire by, 170

propagation: change in principles of, 136
and defecation, in mind of child, 190ff

prophets, role of, [324n](#)
Proserpina, *see* Persephone
Protestantism: and cure of souls, [441f](#)
 theology, and the historical Jesus, [177](#)
Psamathe, [216n](#)
Pseudo-Cyprian, [106](#)
psyche: ancestry, XXIV
 anthropoid, [328f](#)
 archaic, [176](#)
 attitude toward products of, [310](#)
 and butterfly, [250](#)
 collective, regressive libido and, [419f](#)
 conscious activity, [10](#)
 “dawn state,” [417](#)
 individual, and archetype, [64](#)
 —, infinite variety of, [3](#)
 life of, [202](#)
 as light substance, [114n](#)
 nature of, [228](#)
 problem of understanding, XXIVff
 purposeful and directed, [58](#)
 science of, [444](#)
 semi-animal, [329](#)
 sex as component, [151f](#)
 structure of, [313](#)
 unconscious, clue to historical problems, [5](#)
psychiatry, prognoses from therapeutic helplessness, [40n](#)
psychic: apparatus, regression as function of, [22](#)
 disturbances, causes of, [4](#)
 dynamism, [430](#)
 energy, *see following*; epidemics, [156](#)
 existent, [61f](#)
 inflation, [392f](#)
 phenomena, and mythology, [390](#)

reality, 156
state, original, and primal being, 417
symbolical significance of, 50
totality, 364
transformation, 100*

psychic energy: and conscious mind, 441
and cultural development, 16
the dynamic of the gods, 202
Jung's use of term, 135
and libido-symbols, 255
manifested as libido, 85f
phallus as symbol of, 124
phenomenon of, as God-image, 86; *see also* libido

psychologem: hero as, 374
of self-fertilization, 292

psychological: extreme, 375
formulation of sacrifice, 429f

psychology: concern with symbolism, 226f
and the humane sciences, XXVII
modern, and ancient world, 4
—, attitude toward the human soul, 77
personalistically oriented, XXIV, 443

psychoneuroses, Freud on basis of, 132–33n; *see also* neurosis(es)

psychopomp: horse as, 281
Indra as, 422
Virgil as, 82n

“psychosexuality,” term, 135

psychosis(es), 18n, 22n
border-line cases, 439
dissociation in, 441
and feeling of isolation, 442
ideas and images in, 313
latent, 40n
Miller's, 436

mother as symbol of all-devouring mother, [328](#)

and separation from mother, [402n](#)

unconscious manifestations preceding, [443](#)

psychotherapist: knowledge of unconscious contents, [176](#)

patient and, [43f](#)

and psychological understanding by patient, [442](#)

and religious experiences, [229](#)

and religious symbolism, [232f](#)

and research, [25f](#); [443f](#)

treatment of conflict, 61
treatment of dissociation, 442f
value to, of historical material, 5f

Ptah, 98n

shaping the world-egg, pl. XL**ib**

Ptolemaïs, temple of Aesculapius and Hygeia, 373

Pueblo Indians, 315

puer aeternus, 127, 258f, 340

Punchinello, 104n, 147n

pupilla, as child, 268

Purohit Swami, Shri, 124n

purpose, in psychic processes, 58

Pururavas, 147, 148, 151

purusha, 123, 160n, 161

dwarf-god, 126

primal being, 416f

size of a thumb, 124n

Pyramid Texts, 257

Pyrrha, 191

Python, 216n, 260

chthonic, 371f

Q

quadriga, mystic, 279

quaternity, 256n

-symbol, 354, 391

Quetzalcoatl, 299*

R

Ra, 199n, 239, 268n

death of, 295ff

gods identified with, 97

ship of, 246

true name of, 187; *see also* Amon-Ra; Khnum-Ra

Rabelais, François, [211n](#)
racial heredity, [102](#)
Rahab, meaning of name, [254](#)
rain, fertilizing, motif of, [260](#)
 -lake, splitting of, [288n](#)
 —, and the tree of life, [209n](#)
 —, *see also* Vouru-Kasha, sign of, [278](#)
ram, [240](#)
 Agni on, pl. [xiii**b**](#)
 as Christian sacrifice, [200](#)
 and man's first sin, [428n](#)
 zodiacal sign of, [194n](#)
Rama, [209](#)
Ramayana, [209](#), [211](#)
Rangda, Balinese witch, pl. [XLVIII](#)
Rank, Otto, [5](#), [26n](#), [209n](#), [224n](#)
 on hero, [321](#)
 on myth, [24](#)
 theory of sexual neurosis, [419](#)
rape, theme of mythology, [26f](#)
Raphael, archangel, [111](#), [113](#)
rationalism: *re* archetypal figures, [255](#)
 vs. "inner" reality, [156](#)
 modern, [77](#)
 and religious ideas, [229](#)
 view of gods as "artificial," [368](#)
"Raven, The" (Poe), [52f](#)
raven, significance in alchemy, [53n](#)
"rays of God," in Freud's Schreber case, [128n](#)
reaction-words, complex-toned, [155](#)
realism: and symbol, [231](#)
 vs. symbolical truth, [226f](#)
reality: adaptation to, [297](#)
 alienation from, in early Christian era, [72](#)

blocking of, and fantasy-substitutes, 175
desire to transcend, 225
dissociation from, 40
escape from, in fantasies, 307
and extraversion and introversion, 178
in dreams, 180
function, disturbed, and archaic substitutes, 139f
“inner,” vs. outer, 156
loss of, 134, 139f, 400
spiritual, and symbolical truth, 227
subjective, of the world, 232
-thinking, 11
withdrawal from, 298, 335, 407

re-association, compensating desire for, 40

rebirth: to become child again, 235

- burial and, 233
- cause for symbolic expression of, 226
- as deadly embrace, 389
- through deliverance by the hero, 249
- and incest, 224
- longing for, 272, 398, 405
- as mode of transformation of evil, 234
- in the mother, 211f, 233, 268, pl. XLII
- myth, mother-analogies in, 224
- in *novam in-fantiam*, 72n
- spiritual, 224ff, 321, 372, 433
- symbols, 322, 348, 407ff
- from the unconscious, 374
- water and, 218
- from water and spirit, 331
- from wind and water, 317

recollection, *see* anamnesis

“redeemed,” term, 254

redemption, *see* salvation

Red Riding Hood, [438n](#)

regeneration: in the mother's body, pl. [XLII](#)

snake-symbol of, [436f](#)

symbol of Haloa Festival, pl. [LXIIIa](#)

regenerative function, of world-ash, [246](#)

regression: archaic features of, [30](#)

to archetypes, [308](#)

of child's libido, [307](#)

and compensation, [379f](#)

cultural, [232](#)

deviation into sex, [155](#)

in dream-thinking, [21](#)

and fear, [297](#), [354](#)

goal of, [330](#)

and incest, [213](#), [224](#)

to infantilism, [191](#), [232](#)

and inhibition of sexuality, [158](#)

and introversion, [404](#)

of libido, and reactivation of parental imagos, [204](#), [213](#), *see also* libido, regressive

metaphorical language of, [419](#)

and need for new adaptation, [293](#)

to nutritive function, [419](#)

opposition of psychotherapeutic systems, [356](#)

to preconscious, prenatal phase, [181](#)

to presexual stage, [144f](#)

prevention of, [254](#)

purposive, [335](#)

and rebirth of consciousness, [359](#)

religious, use of parental imago, [90](#)

road of, [329](#)

role of therapy in, [329f](#)

of sexual libido, [135](#)

and suppression, [424](#)

to world of natural instincts, [408](#)

Reitzenstein, Richard, [66n](#)

rejuvenation, [255](#)

drink of, [409](#)

magic, [244](#)

motif of, [364](#)

religio, derivation, [429](#)

religion(s): and canalization of libido, [177](#)

degeneration of rites, [376ff](#)

founders of, as typical mythological motifs, [31](#)

and myth, [25](#)

and nature, [73ff](#)

need for, and neuroses, [71](#)

opposition to regression, [356](#)

religious experience, [62f](#), [66](#)

role of regressive parental imagos in, [89](#)

and science, [226f](#)

and the solution of conflicts, [83](#)

and symbol-formation, [224f](#)

and symbolic truth, [226f](#)

tree symbolism, [233ff](#)

religious: cults, symbolism of blood, [104n](#)

figure, as individual psychic factor, [62](#)

—, psychology of, [367f](#)

myth, value of, [231](#)

structures, of libido, [429](#)

symbol(s), [229f](#), [247](#)

Remus, *see* Romulus

Renaissance, feeling for nature, [76](#)

Renan, J. E.: cult of the sun, [90n](#)

rational image of God, [121](#)

renewal: and cross-symbol, [266](#)

and rebirth, [198](#)

Reni, Guido: *Crucifixion*, [428](#)

représentations collectives, [156f](#), [420](#), [442](#)

repression: to avoid conflict, [58ff](#)
of instincts, [180](#)
sexual, and dreams, [180](#)
and unfulfilled desires, [286f](#)

reproductive instinct, [136](#), [155](#)

research, psychological, [5f](#)

resistance: of conscious mind, [32](#)
to detachment from mother-imago, [222](#)
of instinct, and symbol, [228](#)
and regression, [173f](#), [175](#)
to self-knowledge, [4](#)
to the unconscious, [380](#)

reverie, regressive, [414](#)

Rhea, [208](#), [233f](#), [370](#)

rhythm: of dance, [315](#)
in riding fantasies, [249](#)

rhythmic activity: and discovery of fire, [159f](#)
and emotional processes, [155](#)
in infancy and childhood, [143f](#)
libidinal regression to, [154](#)
and sexuality, [154f](#)
transferral to “decoy mechanisms,” [154](#)

Ribot, T., [132n](#)

riddles: bees from dead lion, [339](#)
German, horse and rider, [276f](#)
Norwegian, [221](#)
and sphinx, [179](#), [182](#)

rider and horse, in dreams, [249](#)

Rig-Veda: creator of all things in, [380](#)
fire-making ritual in, [148](#)
invocations to Rudra in, [220](#)
on introversion, [381f](#)
on origin of world, [333](#)
on sacrifice, [416](#), [420](#)

on sun, [317n](#)
world creator in, [358f](#)
Riklin, Franz, [5](#), [24](#)
 case of a paranoid woman in megalomaniac phase, [102n](#)
ring: iron, as symbol, [432n](#); *see also* circle
ritual: actions, and mechanism of introversion, [294](#)
 bloody, in ancient religious cults, [104n](#)
Rivas, tree, [246](#)
road(s): in Hecate myth, [370f](#)
 sacrifice at junction of, [371](#)
roaring, [94f](#)
robbery, as mythological motif, [170](#)
Robert, Carl, [172*](#)
Robertson, John M., [276n](#), [374n](#), [383n](#), [401n](#), [425n](#), [429n](#)
 on Christ's relationship to the two Marys, [222n](#)
 on corn-god, [343n](#)
 on crown of Prometheus, [432n](#)
 on Mexican sacrificial priest, [264n](#)
 on symbol of carrying the cross, [302n](#)
rock(s): -birth, [246f](#)
 as chthonic mother, [432n](#)
 clashing and opening of, [245n](#)
 and snake, [260](#)
rock-paintings, South American, [153](#)
roebuck, [326f](#)
Rohde, Erwin, [342](#), [365n](#), [372n](#), [373n](#)
Roman: empire, social conditions of, [70](#), [71f](#)
 inscription at Verona, [203](#)
Rome: Biblical allusion to, [214](#)
 carnival, [104](#)
 Lacus Curtius, [365](#)
 Imperial Cadet School, pl. [XLIII](#)
Romulus and Remus, [26](#), pl. [II](#)

Roscher, W. H., 108*, 126n, 127n, 128n, 137n, 187n, 197n, 203n, 204*, 244n, 288n,
289, 295n, 340n, 343n, 369n, 425n, 426n

rose, 398

Rossellini, N. F. I. B., 264n

Rostand, Edmond, 35ff; see also *Cyrano de Bergerac*

rubbing and fire-making, 145, 148, 168

Rubens, Peter Paul, 438, pl. LXIV

Rückert, Friedrich, 193

Rudra, 122, 220

Rumpelstiltskin, 187

Russia: orgiastic cults, 376n

S

Sabazius mysteries, 343

Sabine women, 26

Sacer, G. W., 185

sacrifice, 394–440

animal, 423, 435f

of childhood dependence, 356

Christian and Mithraic compared, 433f

essence and motive force of, 429

fire as subject and object of, 165f

fruitfulness from, 238, 338, pl. XXXIII

by hanging, 233, see also hanging on a tree

human, 327, 431

impulse to, 424

inner participation in, 427

libido nature of the sacrificed, 428n

meanings of, 303, 371, 415, 432

power of, 420

of primal being, 417

problem for mankind, 415

release of energy by conscious mind, 432

self-, 431f

to snake deity, pl. [LVIIb](#)
spiritualization of libido, [263](#)
split-mindedness of sacrificer, [428](#)
by symbolical act, [431](#)
voluntary, value of, [357](#)
Saint-Exupéry, Antoine de, [258n](#)
Saint-Germain, Comte de, [193](#)
sainthood, and temptation, [286](#)
saints, fire- and light-symbols, [107](#)
Sallust, [130](#)
salvation (redemption), [61](#), [63](#), [70](#)
 through defeat of animal nature, [263](#)
 man's hope of, [81f](#)
 by the "well-beloved," [117](#)
Samaria, [192](#)
Samiasa, [111](#), [113](#)
Samos, *hieros gamos* in, [243](#)
Samothracian cult, and Hermes, [126](#)
Samson, [121](#), [302n](#), [386n](#)
 and Delilah, [300](#)
 and the jawbone, [412](#)
 and the lion, [121](#), [339](#)
Samuel, God's call to, [176](#), [178](#); *see also* Old Testament, s.v.
Sanders, D. H., [112n](#)
Sanskrit, meanings of *tejas* in, [165](#)
Saqqara, cow-headed Hathor from, pl. [xxx**b**](#)
Sarah, conception by, [374n](#)
Satan, and Yahweh, [368](#); *see also* devil
Saturnalia, [104n](#)
saviour: birth of, in German legend, [248n](#)
vs. Heimarmene, [415](#)
-hero, [345](#); *see also* Christ
Saxony, Lower: legend of ash-tree and knights, [260n](#)
scarab, [240](#)

sceptre: breaking of, [412](#)
etymology, [412](#)

Schaefer, Heinrich, [92*](#)

Schärf, Riwkah, [55n](#), [192](#)

Scheffel, J. V. von, [245n](#)

Schelling, Friedrich von, [29n](#)

Schiller, Friedrich, [67n](#)

schizophrenia: apotropaic means of weakening archetype, [368f](#)
autism in, [28](#)
case with delusion of solar phallus, [157](#)
discovery by psychiatrists, [40n](#)
dissociation in, [135](#)
emergence of archaic psychology in, [143](#)
and feeling for nature, [402n](#)
and fragmentation of personality, [442](#)
loss of nonsexual instinctive forces in, [135](#)
loss of reality in, [134](#), [139f](#)
paranoid, Freud's case of, [133f](#)
patient, *re* horses' coats, [279n](#)
—, hallucination of sun phallus, [101](#)
prodromal stages, XXV
regression to presexual stage, [144f](#)
Schreber's case, [95](#)
splitting of the mind, [408](#)

Schmid, Hans, [169](#)

scholasticism, [19f](#)

Schöne, Richard, [428n](#)

Schoolcraft, Henry Rowe, [312n](#)

Schopenhauer, Arthur, [13](#), [136](#), [137](#), [176](#), [194n](#), [382](#), [438](#)

Schott, Albert, [200n](#)

Schreber, Daniel P., case of, [29n](#), [44n](#), [95](#), [134n](#), [300f](#), [382](#)

Schultz, Wolfgang, [45n](#)

Schultze, Fritz, [150n](#), [269n](#)

Schultze, Viktor, [372n](#)

Schwartz, W., [276n](#), [277n](#)
Schweitzer, Albert, [31n](#)
science: approach of, to religion, [61f](#)
 and directed thinking, [19](#)
scientific: attitude toward symbol-formation, [228](#)
 method, [20](#)
Scorpio, [201](#)
Scott, Walter, [45n](#)
Scylla, [182](#)
Scythian king, death rites, [384](#)
sea: and horse, [281](#)
 monster, hero inside, [347](#)
 mother-symbol, [251](#)
 personified by Leviathan, [254f](#)
 and serpent, [438n](#)
 and sun, [209f](#)
 -symbol, [218](#), [271f](#)
 weed, [243](#)
sea journey: fragment of sun-myth, [198](#)
 and sun-heroes, [209f](#); *see also* night sea journey; nekylia
sea voyage: autosuggestion *re*, [448](#)
 memories associated with, [37](#)
 reveries induced by, [450](#)
Sebastian, St., [290](#)
seizing and holding, [307](#)
self, the, [303](#)
 as archetype, [323](#), [391](#)
 archetype of, [368](#), pl. [LX](#)
 aspects of, [391f](#), pls. [LVI](#), [LIXb](#), [LX](#)
 Christ as, [368](#)
 contradictory forces at work in, [386n](#)
 and ego, [384n](#), *see also* ego
 light and darkness, [368](#), pl. [LVI](#)
 numinosity of, [86](#), [391f](#)

quaternity-symbol of, [354](#)
symbol of, [364](#)
unconscious, [333](#)

self-: containment, symbol of desirelessness, [266](#)
fertilization, arrow-symbol, [291f](#)
preservation, instinct for, [136](#)
reproduction, [322ff](#)

Sem, god-name, [303n](#)

semen, [146n](#), [148](#)
and soma, [168n](#)

Semiramis, [26](#)

Semitic gods, and *paredroi*, [201](#)

Seneca, [86](#)
41st letter to Lucilius, [69](#), [78n](#)
on religious oneness with nature, [73f](#)

sentimentality, and brutality, [428](#)

Sepp, J. N., [333n](#)

serpent: Agathodaimon, [269](#), [383*](#)
Apophis, [280](#)
and cista, pl. [LVIIIa](#)
and Crucifixion, pl. [IXb](#)
death symbol, [312](#)
entwining by, [243](#)
fiery, plague of, [367](#)
mercurial, [100*](#), [436](#)
mystery, pl. [LXIa](#)
as orbit of moon, [108*](#)
as sex symbol, [8](#)
Uraeus, [96](#); *see also* snake

Set (Typhon), [234](#), [239](#), [251](#), [257n](#)

Seth, [247](#)

seven sleepers, cave of, [193](#)

sex: deviation into, [155](#)
frustration, belief in, as basis of all problems, [155f](#)

instincts, and power instincts, constellation of, 66
as instinct, 138, 180, 418
symbolism in dreams, 8, *see also* dream(s)

sexual: act, as linguistic analogy, 159, *see also* intercourse
contents, as metaphors and analogies, 134
difficulties in marriage, symbolic dream of, 221
disturbances, and blocking of libido, 169
energy, deviation of, 158
images, creative aspect of, 124
libido, recession of, and paranoid alteration, 134
object, 418
obsession, transformation of, 360
problem, and freedom from family bonds, 414
theory, Jung vs. Freud, 135
traumata, of hysterics, 419
zone, and rhythmic activity, 144

sexuality: achievement as substitute form of, 155
as appetite, 131
and horse-symbol, 277
and libido, 132f
libido-symbols, 203f
presexual stage, 144
primitive instinctuality of, 224n
recession of, 135
in religious cults, 66f
sacrifice of, in incest problem, 205

shadow, 362, 391
brother, 259
in infantile-sexual fantasies, 419
inferior side of the personality, 183

Shakespeare, William, 282f

Shakti, 266

Shaktideva, legend, 217n

shaman's amulets, pls. xxii**b**, xxxviii**b**

Sharpe, Samuel, [264n](#)
shepherd, and snake, [378ff](#)
shield, symbol, [388](#)
ship of death, [246](#)
Shiva, [209](#), pl. [xxiii](#)
Siecke, Ernst, [220n](#)
Siegfried legend, [30](#), [279](#), [358–64](#), [385–90](#)
sign(s), [12](#)
 equinoctial, [201](#)
 and symbol, [124](#)
 Silberer, Herbert, [5](#), [172n](#), [207](#), [422n](#)
Silenus, [345](#)
Simon, cross-carrier, [302n](#)
Simon/Sem, [303n](#)
Simon Magus, [45](#)
sin: Adam's, [247f](#), [262f](#), [270](#), [271](#), [433](#)
 capacity for, [434](#)
 confession of and redemption from, [61ff](#)
 consciousness of, [71f](#)
 mutual confession of, [63](#); pl. [x](#)
sister-wife, [264](#)
 -mother, [300](#)
Sita, [209](#)
skin, casting of, [364](#), [374](#)
sky, as mother, [268f](#)
slavery, [71n](#)
sleep: enchanted, [362](#)
 image, [325f](#)
 longing for, [326](#), [327n](#)
Sleeping Beauty, [242](#)
Sleipnir, [275*](#), [279](#)
slipping out, of fish's belly, [210f](#)
Smith, George, [252](#)
snake(s): African legend, [399](#)

and basket of Isis, pl. [LIII](#)
death-symbol, [373](#)
deity, sacrifice to, pl. [LVIIb](#)
dreams, meaning of, [396](#)
entwining, [115n](#), pl. [x](#)
fear-symbol, [259ff](#), [438f](#)
guardians of the treasure, [372](#)
and hero, [350](#), [384f](#), [396](#), [425n](#), [431f](#)
instrument of sacrifice and regeneration, [436f](#)
-kiss, [376](#), [378](#)
and lion, [280](#), [431](#), pl. [LXIIIb](#)
Loyola's vision of, [122n](#)
mother attribute, [350](#)
-pit, as alms box, [373](#)
poisonous, [235](#), [251](#), [350](#), [384f](#)
with Priapus, pl. [LXIb](#)
representative of instinct, [396](#)
sacred, [372f](#)
and shepherd, [378ff](#)
and sun-disc, [96f](#), [99f](#); *see also* serpent
snake-bite: analogous to demands of unconscious, [298](#)
motif, [295–97](#), [354](#), [394](#), [459](#)
in genital region, dream of, [378](#)
and rebirth, [382](#)
snake-symbol, [102ff](#), [296](#), [301f](#)
of course of the sun, [108n](#)
in Eleusinian mysteries, [342f](#)
of good and evil, [374](#)
meaning of, [269](#)
of opposites, [377f](#)
Sobk, water-god, [97n](#), [98n](#)
society: effect on the individual, [67ff](#)
primitive connection between rhythm and work, [154](#), *see also* primitive(s)
soil, as woman, [209](#)

Sol, 238, 262, pl. xxiv*a*

invictus, 197

mysticus, 323

novus, 106

solar mythology, 201*ff*

solis invicti comes, 198

Solomon, Wisdom of, 183*f*

soma, 138, 422

-fire-sun, 216

drink, 140, 295*n*, 339, 410*n*

as seminal fluid, 168

symbolism of, 167*f*

Somadeva Bhatta, 217*n*

somnambulism, intentional, and receptivity of mood, 172

son, relationship with father: conquest of, 252

father-attributes, 333

identical in rebirth, 323

neurotic fear of, 261

psychic factor, 261; *see also* hero; father

son, relationship with mother: betrayal and conquest of, 251–54*f*

as consciousness of, 259

and her erotic aspect, 426

-husband, 240, *see also* son-lover

libido of, possessed by, 363*f*

and mother-*imago*, 222

sacrifice to, 432

separation from, 271, 297*f*, 312

unconscious passion for, 4

union with, in tree-symbol, 424; *see also* hero; mother

son-gods, 258

son-lover, 343*n*, 384

Attis, 423

Demeter myth, 341*n*

of mother-goddess, 308

Song of Tishriya, 260

Sophia, 333n, 396

Sophocles, 295n

soul(s), 231f

abode of, 318*

and atman, 202n

and body, 266

and crown, 184f

cure of, in Protestantism, 441f

discord resolved through the sun, 121

“fallen in the water,” 409n

fructified by the intellect, 138

heavenly wanderings of, 93n

hero as symbol, 178

hymns of, 184f

-images, birds as, 215, 352

and light or fire-substance, 99

and mother-*imago*, 266f

murder of, 301n

and name, 187

and nature, 325

as object of scientific study, 77

realities of, 396

saved, 409n

stagnation of, 357

and sun and moon, 318n

“unredeemed,” 415

and wind, 316n, 422

woman as, 338n; *see also* world-soul

sound: creation of, 44f; *see also* light and sound

South Africa: myth, 246n

Namaquas, 342n

South America, *see* Indians s.v.

“Speak, Lord,” symbolism of, 175ff, 458

spear: and hole in the earth, 150

piercing with, 263

wound, 433n

speech: association with mouth and fire, 161ff, pl. XIIIb

function of, 15

and language of nature, 324

primordial figures of, 326

Speiser, E. A., 252n

spelaeum, *see* cave

Spencer, Herbert, 132n

sperma, libido-symbol for, 315; *see also* semen

Sphingidae, 250

Sphinx/sphinx: apparition of, 178f, 458

genealogy of, 182

masculine and feminine, 182

mother-*imago* as fear animal, 181f

of Oedipus, 179

pleasure emblem, 179n

as symbol, 182, 186, 346

as Terrible Mother, 179

of Thebes, 182

Spiegel, Friedrich, 165n, 209n, 246n, 281n, 376n, 410n, 426n, 427n, 429n

Spielrein, Sabina: on archaic definitions of words, in paranoia, 140

on death-instinct, 328n

on symbols, 141

CASE, 139n, 281n, 437n

allusions to dismemberment, 237n

“arrows from God,” 353n

association of boring with fire and procreation, 153

communion, 409n

God’s ray, 412

images, 302n

sickness, 301n

snake, 437

splitting the earth, [288n](#)
wine and water, [376n](#)
Spiess, Karl von, pl. [VIII](#)
spirit(s): and archetypal images, [413](#)
 as archetype, [228](#)
 attribute of anima, [437](#)
 autonomous reality, [228](#)
 being born of, [225](#)
 bird-symbol, [348](#)
 invisibility, [198n](#)
 the Lord as, [377](#);
 -mother, [358](#), [370](#)
 return of, after death, [354](#)
 spermatic, [321](#), pl. [VIII](#)
 symbol for, [321](#)
 world-spurning passion of, [396](#)
spiritus rector, [351](#)
Spitteler, Carl, [44n](#), [243](#)
spittle, magical significance, [300](#)
splitting, motif of, [288n](#), [315](#)
spring(s), [402n](#)
 Castalian, [371](#)
 as mother-symbol, [213](#), [218](#)
 origin of, [412](#)
 water of life, [218](#)
spring zodiac, [384](#)
stable, [199n](#), [374n](#)
stammerer, [25f](#)
stamping, [250](#), [315](#), [347](#)
star(s): as brothers, [402](#)
 compulsion by, [67](#), [415](#)
 falling, [317](#), [319](#)
 five-pointed, [89](#), [94f](#), [98n](#)
 as image, [164](#)

morning, [41](#), [113n](#)
mystic identification with, [402n](#)
steeds, of mythology, [275ff](#)
Steinthal, H., [121n](#), [145n](#), [280n](#), [386n](#)
Stekel, Wilhelm, [303n](#), [438n](#)
“Stempe,” [250](#)
Stephens, J. L., [263n](#)
Sterculus, [352n](#)
stick, twirling, [152*](#)
stigmatization, [287](#)
Stoicism: creative heat, [381n](#)
 ultimate cause, [67n](#)
Stoll, Otto, [376n](#)
stoning, punishment by, [383](#)
storm-centres, names of, [278f](#)
stoup, with arms encircling belly, pl. [xxvii](#)
stream of life, [195f](#)
struggle: hopeless, [48](#)
 for existence, [153](#), [173](#)
Stuck, Franz, [8](#), [115n](#), pl. [x](#)
stuffing, of skin, [383f](#)
Styx, [218](#), [350](#)
“subconscious,” term, [430](#)
subject and object, differentiation between, [325n](#)
subjective: intensity, and libido, [165](#)
 level, of unconscious products, [117n](#)
 reactions, and the creation of values, [85](#)
substitution: of images, [59](#)
 of physical for psychic pain; [286](#)
 of symbols for the mother, [213](#)
success, danger of, [298](#)
sucking, [143f](#)
Suetonius, [276n](#)
Sufism, [193](#)

suggestibility, 34, 38
suggestion, phenomena of, 447–49
suicide, as sacrifice, 30n
sun: aging of, 296
 attributes in Mithraic liturgy, 102ff
 arrow-symbolism, 288
 autumn, 296
 beam, solid substance of, 412
 -bird, 409
 -bull, 194n
 course of, 108n, 171, 201, 209, 355f
 crowning as identification with, 88n
 devouring myths, 315
 disc, 21, 94, 97ff, 106n, 409, pls. *ib*, *vii*, *ix a*
 -eating, *see following*;
 father-god, 121
 and foot, 317n
 -god, *see following*
 with hands, 101*
 -hero(es), *see following*
 identification with, 183f
 -idol, Germanic, 96*
 life-giving, 98*
 midday, 356n
 -moon disc, winged, and tree of life, pl. *ix a*
 and moth, 79ff
 -myth, *see following*
 nature of, 121
 as parental archetype, 369
 phallic symbolism of, 100, 203
 in primitive belief, 318
 rays of, 183, pl. *xxi b*
 religious symbolism of, 90ff
 rising, 107n, 198f, 201

and sea, [198](#), [209](#), [244](#)
self-sacrifice, [412](#)
setting, [198f](#), [201](#), [244](#), [350](#)
-ship, [246n](#)
-symbol, *see following*;
-tube, [317n](#)
voyage of, [93*](#)
wandering, [92n](#), [93n](#), [114n](#), [205](#)
-wheel, [102](#), [247](#), [303n](#), pls. [va](#), [xlvi](#)
-woman, [342n](#)
worship of, [89](#), [106](#), [107](#), [247](#), pl. [vi](#)

sun-eating: demon, pl. [xxxiv](#)
lion, pl. [xxxii](#)*b*

sun-god, pl. [ib](#)
birth of, [358](#)
daughter-wife, [322](#)
Eskimo, pl. [ib](#)
Khnum, [269](#), *see also* Helios
king sacrifices to, pl. [xia](#)
and nature, [399f](#)
slays himself, [386n](#)

sun-hero (-es), [105](#), [197](#)
arrow-shots, [353n](#)
attributes of, [109](#)
battle with fish-king, [346f](#)
fight with the whale dragon, [251](#)
longing for, [110](#)
libido-symbols of, [202](#)
Marduk, [253](#)
missing limb, [239n](#)
wandering, [193n](#)

sun-myth: devouring, embracing, and entwining, [242](#), [245](#)
fate of hero in, [211f](#)
idea of becoming a child again, [223f](#)

sun-symbol: bird and water, 348

emotional component of the psyche, 92

of God, 85ff

in pictures in catacombs, 107n

and the libido, 202

snake and scarab, 269

superbia, 157

superior and inferior role, of equated heroes, 196

superstition(s): paranoid patients as victims of, 140

primitive, 156

symbols of the unknown, 140f

suppression, compensatory reaction in regression, 424

surrounding, motif of, 440

swan: -maiden, 224n, 257n

song, 164n

-symbol, 348

Swanton, J. R., 317n

“swarm of people,” 207, 458

swastika, 107n, 247

sword: broken and restored, 358

piercing with, 366n

as sacrificial instrument, 104n

significance of, 359

Sylvanus, 238, 352

Sylvester, St., 365f

symbol(s): autonomy of, 386n

belief in, and understanding of, 231

-formation, *see following*

functional significance of, 231n

heterogeneous, and regressive libido, 429

as images of unconscious contents, 77

inner truth of, 231

interchangeability of, 429f

need for, 230

overlapping, 424
religious, canalization of libido to, 177
role of, 330f
as “self-perceptions” of the libido, 175ff
and signs, 124, 222
Spielrein on, 141
subjectivity of, 12n
theriomorphic, 180, 320f, 328
as transformers, 232
transition, from sun to man, 171
use of, in assimilating unconscious contents, 310
symbol-formation: causal interpretation of Freud, 223
and instinctual processes, 228
mother-substitutes in, 213
a natural process, 228
unconscious archetype and conscious ideas, 232
symbolism: analogy between historical and personal, 5
archetypal and collective, 292
Christian, 104n
dream, 7ff, *see* dream-image
and energy content of potent object, 165
of everything psychic, 50
importance of, 226f
mythological, 422n
purpose of, 415n
of Roman inscription, 203
sacrificial, 431
sexual, 8ff
triadic, 201
value of, 226f
Symeon, “the New Theologian,” mystic experience of light, 91f
symptoms, physiological, and abnormally active unconscious, 439
syncretism: of ancient gods, 98f
symbolism, in 11th cent. ms., 108

synthesis, subliminal, 50

T

taboos, and evolutionary instinct, 418*f*; *see also* incest-taboo

Tacitus, 401*n*

Tages, Etruscan, 199*n*, 340

Tahmurath, 275*n*

Tammuz, 109, 216*n*, 258

Tantric texts, 345

tapas, 380

Ta'rikh al-Hind ai-Gharbi, pl. xxxix

Tartarus, 182

“tau,” 264*n*

Taurophoria, 302

Taurus, 201, 426

tearing to pieces, 216*n*

technology, in ancient world, 16

tejas (Sanskrit term), 165

temenos, 364, 371

temple, over crevice or abyss, 372*f*

temptation(s): of Eve, 103*

 loss through, 47

 symbolic form, in consciousness, 286

tension, of opposites, 303, 375

Terah, 333

Terrible Mother, 175, 179, 181*f*, 236, 248, 261, 316, pls. xvi, xxxviii*a*

 animus of, 351

 Babylon as, 216

 bull-sacrifice to, 432

 as death-symbol, 328

 man and woman devoured by, pl. xxiii*b*

 masculine representative of, 362*f*

 and Pietà, 425

 power from the unconscious, 370

sacrifices to, 430
and Sphinx, 181
as unbridled Nature, 401
whale-dragon symbol, 251
tertium comparationis, 222, 278
Tertullian, 25, 219
testis, meaning, 377n
Teutons, conception of the Fates, 250
theatre, public solution of private complexes, 35
Thebes, 181, 208, 240n
 jackal-headed Anubis, pl. xxxiii*a*
 vase painting, 126n, 127
Themis, 82n
Theocritus, 287n
theology, rationalistic, and cult of the hero, 177f
Theophrastus, 216n
theriomorphism, 57, 95
 devices for attracting deity, 94f
 representations, 21, 179ff
 symbol, 320f, 328
 —, unconscious manifestations of libido, 180
Theseus and Peirithous, 293n, 310, 420, 432n
Thesmophorion, 342
Thibout, Gabrielle, pl. xxxvii
Thiele, Georg, 303n
thinking: archaic, 23n
 “associative,” 17
 conscious, and symbolism, 11
 directed, 7–33
 in dreams, 21
 logical, development of, 24
 non-directed, 7–33
 type of, independent of external factors, 76; *see also* fantasy-thinking; thought
Thmuis, 240

Thomas, and Jesus, [217n](#)

Thomas Aquinas, *see* Aquinas, St. Thomas

Thor, [315](#), [379n](#)

thorn, magic, [362](#)

Thoth, [264n](#)

thought: abstract, development of, [14](#)

 creation through, [46](#)

 limitations on, and language, [15](#)

 -process, limitations of, [13](#)

 train of, [11](#)

“three days,” stereotype of, [331ff](#)

365 steps, motif, [366](#), [369](#)

throat, snake stuck in, [378](#)

throwing upward, [317ff](#)

thumb, [123](#), [354](#)

thunder-horse, [277](#)

Tiamat, [252–54](#)

 and Marduk, [416*](#)

 slaying of, [415](#)

Tibet, [237](#)

 legend of hero and arrow-shots, [353n](#)

time: in mythology, [280ff](#)

 -symbol, [279](#), [280](#)

Tir, [289n](#)

Tischner, Herbert, pl. [xvi](#)

Tishtriya legend, [260](#), [288n](#)

Tjintya, fire-god, pl. [xiii*a*](#)

Tlingit Indians: shaman’s amulets, pls. [xxi*b*](#), [xxxviii*b*](#)

toad, Nietzsche’s dream of, [34n](#)

toilet, as place of dreams, [190](#)

Tom Thumb, phallic aspect of, [124](#)

tongue: as fire, [162*f*](#)

 whistling and clicking, [94](#)

torch(es): dadophors with, pl. [xx*b*](#)

-symbol, 200, 369
totality, images of, 402n; *see also* wholeness
Totembaum, 233
tradition, and faith, 232
transcendental processes, dogma as symbol of, 435
transference: problem of, 443
 tendency, 18n
transformation: and Christianity, 231
 of city, mother symbol, 216f
 and conscious mind, 236
 of daemon, 353
 of erotic impression, 59
 and forward-striving, 397
 of the god, through man, 337f
 of God-image, 262n
 of God in man, 392
 of instinctual drives, 58
 by introversion, 380
 of libido withdrawn from mother, 312
 of life into death, 438
 of Logos into mother, 359
 of mother-*imago*, 224, 298, 363
 into pine-tree, 425
 of self, 434f
 snake-symbol and, 436
 spiritual, 428
 unconscious, of energy, 429
 in the unconscious, and sacrifice, 430
 of values, 357
transition, between sleeping and waking, 457
transitus, 338f
“transvaluation of values,” 357
treading, 250, 315
treasure hard to attain, 259, 316, 330f, 350, 363f, 422

guardians of, 372
life as, 374; *see also* hoard
tree(s): birth from, 246f, 248, 425
as birth-giving mother, 246, pl. xxxix
bisexual character, 221
budding, 248n
of death, 233, 246, 247, 281, 321, pls. xxxv, xxxvi, xxxvii
dream of being poisoned by fruit of, 221
enclosure in, 242f
of enlightenment, pl. lv
felling of, 424, 425
feminine quality, 221, pl. xxxi
hanging on, 383
with human fruit, pls. xxxix, xlv
of knowledge, 264f
of life, 209n, 218, 219, 233ff, 247, 263, 432f, pls. ixa, xxxi, xxxvi
mother-and-son significance, 401, 423f
membrum virile as, 221
phallic meaning of, 425
Rivas, 246
sacred, 219, 247n, 351, 370, pl. lv
—, of Attis, 423*
and snake, 259ff
-symbol, 233ff, 246, 258f, 423–25
world hewn from, 333
triad, 201, 351
tribe, organization of, and incest taboo, 223; *see also* primitive(s)
Trinity, Christian, 138
tripod, fiery (*Faiust*), 206
Hermetic vessel, 125
Trishtubhmetrum, 148
trol or “treader,” 250
truth: empirical and symbolical, 225f
psychological vs. metaphysical, 231

symbolic, 229
tube: as origin of the wind, 100ff
solar, 100, 317n
Tum/Atum: attributes of, 267f
of On-Heliopolis, 267
of Pithum-Heroopolis, 269
as tom-cat, 280
Tut-Ankh-Amon, and winged sun-disc, pl. VII
Tvashtri, 333
twins: Jesus and Thomas, 217n
in mother's womb, 399
"two-horned," meaning of, 194n
Typhon, 372; *see also* Set
Tyre, 208

U

Uganda, ceremony, 383f
unconscious: and anima, 266–67n
apotropaic weakening of power of, 369
archetypal products, 442
and archetypal structures, 228, 390f
archetypal symbolization, 357
autonomous archetypes, 308f
barriers against rising flood of, 356
chaotic life of, 309f
in conflict with itself, 260
collective, *see following*;
"constellated," 439
contents, *see following*
creative power of, 126, 222
darkness of, and fire-making, 348
devouring nature of, 363, pls. xxxiib, xxxiv
directing of libido into, 176
effect of demands of, 298f

energy from conscious, 432
evil aspect of, 363
feminine aspect of, 433
general and secondary, 180
as helpful mother, 352
and historical experience, 49
and horse, 277
integration of, 301, 433
and introversion of the libido, 172f
lack of illusion in, 62
longing for consciousness, 205
maternal significance of, 327, 345
matrix of the future, 301
merging of subject and object, 325
as an objective and collective psyche, xxiv
origin of symbols of, 179
original state of, 417f
personal, 183n, 259
positive and negative aspects, 374, 389
primitive man's victory over, 169
and primordial image, 438
processes, 430, 435
products, interpretation of, 117n
psyche and, 202
relation to conscious, *see following*;
rejection of, 294f
snake-symbol of, 374
as source of conscious pain, 287
as source of all creativity, 337
subjective contents of, xxv
supra-individual universality of, 177
surrender to, 436f
"swarm of people" as symbol of, 207
symbolic fight with, 296n

transformation in, and sacrifice, 430
water-symbol and, 219
working out solution of conflict, 79f

unconscious, collective, 408, 292
and anima, 324
contents, xxv, 178
Jung's first use of term, 177n
mother as, 259
parallel images as archetypes of, 158
and the self, 368
spirit in, 413

unconscious, contents: assimilation by the conscious, 310, 408
autonomous, 198n
constellation of, 293f
drawing from, 234
infantile material in, 189
projection of, 59
reading as source of, 186
reflected in nature, 112n
subliminal, 50n
uniformity of, 176; *see also* archetypes

unconscious, relation to conscious: ascendancy over, 439
assault on, 300f
compensatory, 65, 379f, 390n
vs. moral values of, 368
counterbalance of, 43
gap between, 442
invasion of, 370, 397, 441
necessity for connection with, 298
strengthening of, 305

“understand,” etymology, 440
understanding, craving for, 13
underworld: Egyptian, 362
journey to, 293, 365f, 420

life in, [409](#)
and upper world, [292f](#); *see also* darkness
Hades undifferentiated unconscious state, [417f](#)
unicorn, [321](#)
unio mystica, [287](#)
union: idea of, and cross-symbol, [266](#)
with mother, [263](#), [324](#), [413](#)
mystic, with Christ, [287](#)
universe: creation of, [45f](#), [53](#)
fantasies of antiquity *re*, [21f](#)
Unternährer, Anton, [376f](#)
Upanishads, [160n](#)
on new state of man, [420](#)
paradox of great and small in, [128](#)
Aitareya, [161](#)
Brihadaranyaka, [160](#), [161f](#)
on horse-sacrifice, [280](#), [420ff](#)
Katha, [124](#)
Shvetashvatara, [122f](#), [126](#), [202n](#), [384n](#)
Uraeus/uraeus, [96](#), [100](#)
Uranos (the One), [138](#)
urine, of three-legged ass, [282](#)
urn, cinerary, [388n](#)
Urvara, [209](#)
Urvasi, [151](#)
Usener, Hermann, [106n](#)
uterine fantasy, [329](#)
uterus, *see* womb
Utnapishtim (Noah), [200](#), [332](#)
Utrecht Psalter, [280](#)

V

Valkyries, [281](#)
value(s): created by subjective reactions, [85](#)
-judgments, emotional, [4](#)

transformation of, [357](#)
Vanen, [150n](#)
Varro, [127n](#)
Vatican Codex, [108n](#)
Vedas, [160n](#), [166](#), [168](#), [218](#), [293](#); *see also* Rig-Veda
veil, [198](#), [257n](#), [345](#)
Venus, [150n](#)
 and Adonis, [433](#)
 erotic aspect of mother, [426](#)
 House of, [426](#); *see also* Aphrodite
Verlaine, Paul, [440](#)
Verona: Roman inscription, [203](#)
 Priapus statue, [438](#), pl. [LXIb](#)
vessel: stoup with arms encircling belly, pl. [XXVII](#)
 symbol of uterus, [203](#)
Vidarr, fight with Fenris-Wolf, [349*](#)
vine, [400f](#)
Virgil, [82](#)
virgin anima, [323](#)
virgin conception, [323](#)
virginity test, [365](#)
Virgin Mary, *see* Mary, Virgin
Vishnu, [293](#), [351](#)
 boar-headed, shakti of, pl. [IVa](#)
 as fish, pl. [XLVII](#)
 lotus growing out of navel, pl. [XLVIa](#)
Vishvakarman, All-Creator, [416](#)
vision(s): apocalyptic, [407](#), [411](#)
 of Ezekiel, pl. [LVI](#)
 functional, [207](#)
 images, symbolism of, [105](#)
 of Loyola, [122n](#)
 of Zosimos, [316](#), [332n](#), [356n](#)
Vitruvius Pollio, Marcus, [375*](#)

voice, correspondence with the sun, 45
volcano, erupting, 394, 396, 439, 460
Vollers, Karl, 195n, 196n
Völuspa, 438n
Vouru-Kasha, rain-lake, 209n, 246n, 282
vulture(s), 240
 Egyptian, 100n, 225
 as mother-symbol, 237
vulva, as wood bored by fire-stick, 147; *see also* yoni(s)

W

Wachandi of Australia, fertility rites, 150, 155, 158f
Wachlmayr, Alois, pl. III
wading, 327n
Wagner, Richard, 358–64, 385–89, 461
Waitz, Theodor, 318n
wak-wak tree, pl. XXXIX
Walde, Alois, 131n
wampum belt, 316, 353
wand: broken, 370
 magic, etymology, 412
wandering, symbolism of, 205; *see also* journey
Wandering Jew, *see* Ahasuerus
water(s): archetype, 228
 baptismal, 219, pl. XXVII
 and birth, 225, 234
 chaotic, 241
 of death, 200, 218
 “innocent,” 409
 of life, 217, 218, 356f
 maternal significance of, 218, 251, 267, 326, 350, pl. XXVI
 -monster, 210
 and mother-imago, 219, 388f
 primeval, egg which came from, 256

primordial, 240
and tree symbolism, 222, 233ff

water-symbol, 323, 365
bathing in fountain, 244
of Father-Creator, 315
of the unconscious, in fantasies, 219; *see also* stream of life

Weber, Albrecht, 147f

Wegener, Thomas a Villanova, 286n, 288n

well, Oropian, 365

Wesendonck, Mathilde von, 93n

West, 210
Wind as pneuma, 316

West Africa: head-dress symbolizing kingly power, pl. xvii

Western Land, 240, 244, 351, 413

whale-dragon, 210, 248ff, 338n

wheel: fiery, 146n
four-spoked, 303n
Ixion on, pl. xlvi**b**
phallic meaning of spokes, 202f; *see also* sun s.v.

whip-symbol, 369

whirlwind, 45, 49, 453

White, William Alanson, 102n

wholeness: of man, 303
self as symbol of, 368
son as germ of, 330
in union of conscious and unconscious, 395

Wiedemann, Alfred, 339n, 376n

Wieland the Smith, 333

Wilhelm, Richard, *see* Jung, WORKS s.v.

will: creation of, 353
dichotomy of, 173f
vs. instincts, 157
replacing natural impulse, 434
Schopenhauer on, 136f, 382, 438

Stoics on, [129f](#)
William of Ockham, [20](#)
willow, [244](#)
wind: -breath, [240n](#)
 fertilizing, [100ff](#), [225](#), [253](#), [316f](#), [319](#)
 generating pneuma, [422](#)
 -god, [122n](#)
 horse symbol, [278](#)
 -nature, [332](#)
 origin of, [157](#)
 as weapon, [253](#)
winter solstice, [236](#)
Wirth, A., [108n](#), [218n](#)
Wirth, H. F., pl. [1b](#)
wisdom, [252n](#), [413](#)
wise old man, [391](#)
 and anima, [437](#)
 archetype, [332](#)
“wish,” meaning, in Middle High German, [246n](#)
wish: fulfillment, defecation as child’s means of, [190](#)
 sexual, [155](#)
wish-fantasies, Freud on, [24](#)
wishful thinking, symbol of, [246n](#)
witch(es), [391](#)
 and devil, [276*](#)
 and horses, [275n](#), *see also* lamia
witchcraft, mother of, [370](#)
Witches’ Sabbath, [277](#)
wolf, [438n](#)
 with Romulus and Remus, pl. [II](#)
Wolff, Christian, [11n](#)
Wolters, Paul H. A., and Bruns, Gerda, [128*](#), [129*](#)
woman(en): American, [186](#)
 city symbolism of, [208](#)

and dragon, 215, 366n
Eros of, 300
erotic dreams of, 8
father as danger to, 182
furrow symbol of, 340
infantile, and animus-hero, 307
instrument of fate, 361
lower and upper half, 214–17
masculine element in, 183, 300f, 304, 351, pl. xvii
meaning of mother-imago, 309f
in moon, 318*
older, homosexual transference to, 245
pregnant, 248, 278, 318f
secret enslavement of man, 300; *see also* girl(s)

womb: Church as, 345
descent into earth, 341
entry into, 280, *see also* mother s.v.
fantasies, 420
and incest, 234
motif of mating in, 398f
re-entry into, 268, 315, *see also* mother s.v.
regenerating, longing for, 405
as symbol of creative aspect of the unconscious, 125
symbols of, 167, 209f
of the World Mother, 405*

wood: bored by fire-stick, 147
etymology, 150n, 219f
as mother-symbol, 148n
in myth, 246
symbolism of, 219ff

woodpecker, 352f

word(s): absolute meaning, 20
archaic fusion of meanings, 163
association, and thinking, 11

fetishism of, [12n](#)
power, [141](#)
prayer, [359](#)
primitive, [14](#)
primordial, and poetry, [303](#)
reaction-, [155](#)
in scholasticism, [20](#)
significance of choice of, [39n](#)
socialization of meanings, [14f](#)
spermatic, [321](#), [359](#)
thinking in, *see* thinking, directed
symbol for, [321](#)
work, rhythmic activity and, [154](#)
world: conflagration and deluge, symbols of, [279](#)
 conflict over renunciation or acceptance of, [83](#)
 creation of, [160n](#), [253](#), [358f](#), [381](#), [420f](#)
 end of, [279](#), [438](#)
 flight from, [81n](#)
 and identification with parents, [284](#)
 joining of parts of, [358f](#)
 -mother, [354](#)
 —, womb of, [405*](#)
 Parents, [240n](#)
 phenomenal, speculations *re* nature of, [430](#)
 plan of, [391*](#)
 renunciation of, [421](#)
world-ash (Yggdrasill), [233](#), [246](#), [249](#), [250](#), [281](#)
world-egg, [422](#), pl. [XLib](#)
 Prajapati with, [381*](#)
world-soul, [267n](#), [416f](#)
 as energy of the intellect, [138](#)
 Hecate as, [370](#)
 mother as, [281](#)
 Plato on, [266](#)

and world-body, 266
worm: poisonous, 295f, 362
 red, dream of, 245
Worringer, Wilhelm, 103*, 215*
 Wotan: and Brünhilde, 359–62
 as Drosselbart, 276
 and Sleipnir, 275
 and wind-bride, 278
writing, Hiawatha's invention, 353f
Wundt, Wilhelm, 14, 19n, 29n, 132n

X

Xanthos, acropolis, pl. xxxviii^a

Y

Yahweh, 254, 260, 262n, 359, 431n
Yama, 277
Yang-Yin, 375n
yearning, *see* desire; longing
Yeats, W. B., 124n
Yezidis, 376n
Yggdrasill, *see* world-ash
Ynglinga Saga, 209
yoni(s), 147n, 160, 268
 with ling-am, pl. xxv
Yoruba myth, 257n
young, the: attraction and protection of, 155
 effect of regression, 308
 eternal, 411, *see also puer aeternus*
 independence from family ties, 356
Yucatán, Mexico: Cross of Palenque, pl. xli^a

Z

Zagreus, 339n, 340, 423, 427; *see also* Dionysus
Zarathustra, 234, 386f, 426f, 439n

Zeus, [82n](#), [138](#), [243](#), [244](#), [303n](#), [359](#)

Zipporah, [431n](#)

Zöckler, Otto, [247](#), [263n](#), [264n](#), [265n](#), [267n](#)

Zodiac, [108n](#)

Aion and, pl. [XLIV](#)

four corners of, [392*](#)

signs of, [201](#), [279f](#)

symbolism of, [107](#)

zones: mixture of elements from, [144f](#)

and rhythmic activity, [143f](#)

and transferral of energy, [144](#)

Zoroaster, [281n](#)

Zosimos, visions of, [140](#), [316](#), [332n](#), [356n](#)

Zrwan akarana, [281](#)

THE COLLECTED WORKS OF

C. G. JUNG

THE PUBLICATION of the first complete edition, in English, of the works of C. G. Jung was undertaken by Routledge and Kegan Paul, Ltd., in England and by Bollingen Foundation in the United States. The American edition is number XX in Bollingen Series, which since 1967 has been published by Princeton University Press. The edition contains revised versions of works previously published, such as *Psychology of the Unconscious*, which is now entitled *Symbols of Transformation*; works originally written in English, such as *Psychology and Religion*; works not previously translated, such as *Aion*; and, in general, new translations of virtually all of Professor Jung's writings. Prior to his death, in 1961, the author supervised the textual revision, which in some cases is extensive. Sir Herbert Read (d. 1968), Dr. Michael Fordham, and Dr. Gerhard Adler compose the Editorial Committee; the translator is R. F. C. Hull (except for Volume 2) and William McGuire is executive editor.

The price of the volumes varies according to size; they are sold separately, and may also be obtained on standing order. Several of the volumes are extensively illustrated. Each volume contains an index and in most a bibliography; the final volume will contain a complete bibliography of Professor Jung's writings and a general index to the entire edition.

In the following list, dates of original publication are given in parentheses (of original composition, in brackets). Multiple dates indicate revisions.

*1. PSYCHIATRIC STUDIES

On the Psychology and Pathology of So-Called Occult Phenomena (1902)

On Hysterical Misreading (1904)

Cryptomnesia (1905)

On Manic Mood Disorder (1903)

A Case of Hysterical Stupor in a Prisoner in Detention (1902)

On Simulated Insanity (1903)

A Medical Opinion on a Case of Simulated Insanity (1904)

A Third and Final Opinion on Two Contradictory Psychiatric Diagnoses (1906)

On the Psychological Diagnosis of Facts (1905)

†2. EXPERIMENTAL RESEARCHES

Translated by Leopold Stein in collaboration with Diana Riviere

STUDIES IN WORD ASSOCIATION (1904–7, 1910)

The Associations of Normal Subjects (by Jung and F. Riklin)

An Analysis of the Associations of an Epileptic

The Reaction-Time Ratio in the Association Experiment

Experimental Observations on the Faculty of Memory

Psychoanalysis and Association Experiments

The Psychological Diagnosis of Evidence

Association, Dream, and Hysterical Symptom

The Psychopathological Significance of the Association Experiment

Disturbances in Reproduction in the Association Experiment

The Association Method

The Family Constellation

PSYCHOPHYSICAL RESEARCHES (1907–8)

On the Psychophysical Relations of the Association Experiment

Psychophysical Investigations with the Galvanometer and Pneumograph in Normal and Insane Individuals (by F. Peterson and Jung)

Further Investigations on the Galvanic Phenomenon and Respiration in Normal and Insane Individuals (by C. Ricksher and Jung)

Appendix: Statistical Details of Enlistment (1906); New Aspects of Criminal Psychology (1908); The Psychological Methods of Investigation Used in the Psychiatric Clinic of the University of Zurich (1910); On the Doctrine of Complexes ([1911] 1913); On the Psychological Diagnosis of Evidence (1937)

*3. THE PSYCHOGENESIS OF MENTAL DISEASE

The Psychology of Dementia Praecox (1907)

The Content of the Psychoses (1908/1914)

On Psychological Understanding (1914)

A Criticism of Bleuler's Theory of Schizophrenic Negativism (1911)

On the Importance of the Unconscious in Psychopathology (1914)

On the Problem of Psychogenesis in Mental Disease (1919)

Mental Disease and the Psyche (1928)

On the Psychogenesis of Schizophrenia (1939)

Recent Thoughts on Schizophrenia (1957)

Schizophrenia (1958)

†4. FREUD AND PSYCHOANALYSIS

Freud's Theory of Hysteria: A Reply to Aschaffenburg (1906)

The Freudian Theory of Hysteria (1908)

The Analysis of Dreams (1909)

A Contribution to the Psychology of Rumour (1910–11)

On the Significance of Number Dreams (1910–11)

Morton Prince, “The Mechanism and Interpretation of Dreams”: A Critical Review (1911)

On the Criticism of Psychoanalysis (1910)

Concerning Psychoanalysis (1912)

The Theory of Psychoanalysis (1913)

General Aspects of Psychoanalysis (1913)

Psychoanalysis and Neurosis (1916)

Some Crucial Points in Psychoanalysis: A Correspondence between Dr. Jung and Dr. Loÿ (1914)

Prefaces to “Collected Papers on Analytical Psychology” (1916, 1917)

The Significance of the Father in the Destiny of the Individual (1909/1949)

Introduction to Kranefeldt’s “Secret Ways of the Mind” (1930)

Freud and Jung: Contrasts (1929)

‡5. SYMBOLS OF TRANSFORMATION (1911–12/1952)

PART I

Introduction

Two Kinds of Thinking

The Miller Fantasies: Anamnesis

The Hymn of Creation

The Song of the Moth

PART II

Introduction

The Concept of Libido

The Transformation of Libido

The Origin of the Hero

Symbols of the Mother and of Rebirth

The Battle for Deliverance from the Mother

The Dual Mother

The Sacrifice

Epilogue

Appendix: The Miller Fantasies

*6. PSYCHOLOGICAL TYPES (1921)

Introduction

The Problem of Types in the History of Classical and Medieval Thought

Schiller's Ideas on the Type Problem

The Apollinian and the Dionysian

The Type Problem in Human Character

The Type Problem in Poetry

The Type Problem in Psychopathology

The Type Problem in Aesthetics

The Type Problem in Modern Philosophy

The Type Problem in Biography

General Description of the Types

Definitions

Epilogue

Four Papers on Psychological Typology (1913, 1925, 1931, 1936)

†7. TWO ESSAYS ON ANALYTICAL PSYCHOLOGY

On the Psychology of the Unconscious (1917/1926/1943)

The Relations between the Ego and the Unconscious (1928)

Appendix: New Paths in Psychology (1912); The Structure of the Unconscious (1916) (new versions, with variants, 1966)

‡8. THE STRUCTURE AND DYNAMICS OF THE PSYCHE

On Psychic Energy (1928)

The Transcendent Function ([1916]/1957)

A Review of the Complex Theory (1934)

The Significance of Constitution and Heredity in Psychology (1929)

Psychological Factors Determining Human Behavior (1937)

Instinct and the Unconscious (1919)

The Structure of the Psyche (1927/1931)

On the Nature of the Psyche (1947/1954)

General Aspects of Dream Psychology (1916/1948)

On the Nature of Dreams (1945/1948)

The Psychological Foundations of Belief in Spirits (1920/1948)

Spirit and Life (1926)

Basic Postulates of Analytical Psychology (1931)

Analytical Psychology and *Weltanschauung* (1928/1931)

The Real and the Surreal (1933)
The Stages of Life (1930–1931)
The Soul and Death (1934)
Synchronicity: An Acausal Connecting Principle (1952)
Appendix: On Synchronicity (1951)

*9. PART I. THE ARCHETYPES AND THE COLLECTIVE UNCONSCIOUS

Archetypes of the Collective Unconscious (1934/1954)
The Concept of the Collective Unconscious (1936)
Concerning the Archetypes, with Special Reference to the Anima Concept (1936/1954)
Psychological Aspects of the Mother Archetype (1938/1954)
Concerning Rebirth (1940/1950)
The Psychology of the Child Archetype (1940)
The Psychological Aspects of the Kore (1941)
The Phenomenology of the Spirit in Fairytales (1945/1948)
On the Psychology of the Trickster-Figure (1954)
Conscious, Unconscious, and Individuation (1939)
A Study in the Process of Individuation (1934/1950)
Concerning Mandala Symbolism (1950)
Appendix: Mandalas (1955)

*9. PART II. AION (1951)

RESEARCHES INTO THE PHENOMENOLOGY OF THE SELF

The Ego
The Shadow
The Syzygy: Anima and Animus
The Self
Christ, a Symbol of the Self
The Sign of the Fishes
The Prophecies of Nostradamus
The Historical Significance of the Fish
The Ambivalence of the Fish Symbol
The Fish in Alchemy
The Alchemical Interpretation of the Fish
Background to the Psychology of Christian Alchemical Symbolism
Gnostic Symbols of the Self

*10. CIVILIZATION IN TRANSITION

The Role of the Unconscious (1918)

Mind and Earth (1927/1931)

Archaic Man (1931)

The Spiritual Problem of Modern Man (1928/1931)

The Love Problem of a Student (1928)

Woman in Europe (1927)

The Meaning of Psychology for Modern Man (1933/1934)

The State of Psychotherapy Today (1934)

Preface and Epilogue to “Essays on Contemporary Events” (1946)

Wotan (1936)

After the Catastrophe (1945)

The Fight with the Shadow (1946)

The Undiscovered Self (Present and Future) (1957)

Flying Saucers: A Modern Myth (1958)

A Psychological View of Conscience (1958)

Good and Evil in Analytical Psychology (1959)

Introduction to Wolff’s “Studies in Jungian Psychology” (1959)

The Swiss Line in the European Spectrum (1928)

Reviews of Keyserling’s “America Set Free” (1930) and “La Révolution Mondiale” (1934)

The Complications of American Psychology (1930)

The Dreamlike World of India (1939)

What India Can Teach Us (1939)

Appendix: Documents (1933–1938)

†11. PSYCHOLOGY AND RELIGION: WEST AND EAST

WESTERN RELIGION

Psychology and Religion (The Terry Lectures) (1938/1940)

A Psychological Approach to the Dogma of the Trinity (1942/1948)

Transformation Symbolism in the Mass (1942/1954)

Forewords to White’s “God and the Unconscious” and Werblowsky’s “Lucifer and Prometheus” (1952)

Brother Klaus (1933)

Psychotherapists or the Clergy (1932)

Psychoanalysis and the Cure of Souls (1928)

Answer to Job (1952)

EASTERN RELIGION

Psychological Commentaries on “The Tibetan Book of the Great Liberation” (1939/1954) and “The Tibetan Book of the Dead” (1935/1953)

Yoga and the West (1936)

Foreword to Suzuki’s “Introduction to Zen Buddhism” (1939)

The Psychology of Eastern Meditation (1943)

The Holy Men of India: Introduction to Zimmer’s “Der Weg zum Selbst” (1944)

Foreword to the “I Ching” (1950)

*12. PSYCHOLOGY AND ALCHEMY (1944)

Prefatory note to the English Edition ([1951?] added 1967)

Introduction to the Religious and Psychological Problems of Alchemy

Individual Dream Symbolism in Relation to Alchemy (1936)

Religious Ideas in Alchemy (1937)

Epilogue

†13. ALCHEMICAL STUDIES

Commentary on “The Secret of the Golden Flower” (1929)

The Visions of Zosimos (1938/1954)

Paracelsus as a Spiritual Phenomenon (1942)

The Spirit Mercurius (1943/1948)

The Philosophical Tree (1945/1954)

‡14. MYSTERIUM CONIUNCTIONIS (1955–56)

AN INQUIRY INTO THE SEPARATION AND

SYNTHESIS OF PSYCHIC OPPOSITES IN ALCHEMY

The Components of the Coniunctio

The Paradoxa

The Personification of the Opposites

Rex and Regina

Adam and Eve

The Conjunction

*15. THE SPIRIT IN MAN, ART, AND LITERATURE

Paracelsus (1929)

Paracelsus the Physician (1941)

Sigmund Freud in His Historical Setting (1932)

In Memory of Sigmund Freud (1939)

Richard Wilhelm: In Memoriam (1930)

On the Relation of Analytical Psychology to Poetry (1922)

Psychology and Literature (1930/1950)

“Ulysses”: A Monologue (1932)

Picasso (1932)

†16. THE PRACTICE OF PSYCHOTHERAPY

GENERAL PROBLEMS OF PSYCHOTHERAPY

Principles of Practical Psychotherapy (1935)

What Is Psychotherapy? (1935)

Some Aspects of Modern Psychotherapy (1930)

The Aims of Psychotherapy (1931)

Problems of Modern Psychotherapy (1929)

Psychotherapy and a Philosophy of Life (1943)

Medicine and Psychotherapy (1945)

Psychotherapy Today (1945)

Fundamental Questions of Psychotherapy (1951)

SPECIFIC PROBLEMS OF PSYCHOTHERAPY

The Therapeutic Value of Abreaction (1921/1928)

The Practical Use of Dream-Analysis (1934)

The Psychology of the Transference (1946)

Appendix: The Realities of Practical Psychotherapy ([1937] added, 1966)

‡17. THE DEVELOPMENT OF PERSONALITY

Psychic Conflicts in a Child (1910/1946)

Introduction to Wickes’s “Analyses der Kinderseele” (1927/1931)

Child Development and Education (1928)

Analytical Psychology and Education: Three Lectures (1926/1946)

The Gifted Child (1943)

The Significance of the Unconscious in Individual Education (1923)

The Development of Personality (1934)

Marriage as a Psychological Relationship (1925)

18. THE SYMBOLIC LIFE

Miscellaneous Writings

19. BIBLIOGRAPHY OF C. G. JUNG'S WRITINGS

20. GENERAL INDEX TO THE COLLECTED WORKS

See also:

C. G. JUNG: LETTERS

Selected and edited by Gerhard Adler, in collaboration with Aniela Jaffé. Translations from the German by R.F.C. Hull.

VOL. 1: 1906–1950

VOL. 2: 1951–1961

THE FREUD / JUNG LETTERS

The Correspondence between Sigmund Freud and C. G. Jung

Translated by Ralph Manheim and R.F.C. Hull

Edited by William McGuire

* First published in two parts in the *Jahrbuch für psychoanalytische und psychopathologische Forschungen* (Leipzig), III–IV (1911–12), and republished the same year as a book by Deuticke Verlag, Leipzig and Vienna. An English translation, by Dr. Beatrice M. Hinkle, entitled *Psychology of the Unconscious*, was published in 1916 by Moffatt Yard and Co., New York, and in 1917 by Kegan Paul, London. Translations have also appeared in Dutch, French, and Italian.

¹ [The edition here translated.—EDITORS.]

¹ *The Interpretation of Dreams*, pp. 260–61.

² He is supposed to have killed himself when he heard that his adored Ninon was really his mother.

³ *Wishfulfilment and Symbolism in Fairy Tales*.

⁴ *Dreams and Myths*.

⁵ *The Myth of the Birth of the Hero*.

⁶ “Die Symbolik in den Legenden.”

⁷ *On the Nightmare*.

⁸ *Die Frömmigkeit des Grafen Ludwig von Zinzendorf*.

⁹ Also Rank, “Ein Traum, der sich selbst deutet.”

¹⁰ [I.e., after 1912, the date of the original publication of the present work.—EDITORS.]

¹¹ His subsequent publications, *Umkreisung der Mitte* and *The Great Mother*, may also be included in this category.

[Three of the essays in the former work were translated in *Art and the Creative Unconscious*.—EDITORS.]

¹ Mörike, *Werke*, I, p. 33.

^{1a} Cf. Liepmann, *Über Ideenflucht*; also my “Studies in Word Association” (1918/-19 edn., p. 124). For thinking as subordination to a ruling idea, cf. Ebbinghaus, in *Kultur der Gegenwart*, pp. 221ff. Kuelpe (*Outlines of Psychology*, p. 447) expresses himself in a similar manner: in thinking “we find an anticipatory apperception, which covers a more or less extensive circle of individual reproductions, and differs from a group of accidental incentives to reproduction only in the consistency with which all ideas outside the circle are checked or suppressed.”

² In his *Psychologia empirica*, ch. II, § 23, p. 16, Christian Wolff says simply and precisely: “Cogitatio est actus animae quo sibi sui rerumque aliarum extra se conscia est” (Thinking is an act of the soul whereby it becomes conscious of itself and of other things outside itself).

³ The element of adaptation is particularly stressed by William James in his definition of logical thinking (*Principles of Psychology*, II, p. 330): “Let us make this ability to deal with *novel* data the technical differentia of reasoning. This will sufficiently mark it out from common associative thinking.”

⁴ “Thoughts are shadows of our feelings, always darker, emptier, and simpler than these,” says Nietzsche. Lotze (*Logik*, p. 552) remarks in this connection: “Thinking, if left to the logical laws of its own movement, coincides once more at the end of its correct trajectory with the behaviour of objectively real things.”

⁵ Cf. Baldwin’s remarks quoted below. The eccentric philosopher Johann Georg Hamann (1730–88) actually equates reason with language. (See Hamann’s writings, pub. 1821–43.) With Nietzsche reason fares even worse as “linguistic metaphysics.” Friedrich Mauthner goes the furthest in this direction (*Sprache und Psychologie*); for him there is absolutely no thought without speech, and only speaking is thinking. His idea of the “word fetishism” that dominates science is worth noting.

⁶ Cf. Kleinpaul, *Das Leben der Sprache*.

⁷ My small son gave me an explicit example of the subjectivity of such symbols, which originally seem to belong entirely to the subject: He described everything he wanted to take or eat with an energetic “stô lôl” (Swiss-German for “leave it!”).

⁸ *Le Jardin d’Epicure*, p. 80.

⁹ It is difficult to estimate how great is the seductive influence of primitive word meanings on our thinking. “Everything that has ever been in consciousness remains as an active element in the unconscious,” says Hermann Paul (*Prinzipien der Sprachgeschichte*, p. 25). The old word-meanings continue to have an effect which is imperceptible at first and proceeds “from that dark chamber of the unconscious in the soul” (*ibid.*). Hamann states emphatically (*Schriften*, VII, p. 8): “Metaphysics misuses all the verbal signs and figures of speech based on empirical knowledge and reduces them to empty hieroglyphs and types of ideal relationships.” Kant is supposed to have learnt a thing or two from Hamann.

¹⁰ *Grundriss der Psychologie*, pp. 363–64.

¹¹ *Lehrbuch der Psychologie*, II, ch. 10, par. 26, p. 260.

¹² Baldwin, *Thought and Things*, II, pp. 145ff.

¹³ In this connection I would mention the experimental “investigations into the linguistic components of association” (1908) made by Eberschweiler [q.v., Bibliography] at my request, which disclose the remarkable fact that during an association experiment the intrapsychic association is influenced by phonetic considerations.

¹⁴ See n. 5, above.

¹⁵ There was as a matter of fact no external compulsion which would have made technical thinking necessary. The labour question was solved by an endless supply of cheap slaves, so that efforts to save labour were superfluous. We must also remember that the interest of the man of antiquity was turned in quite another direction: he revered the divine cosmos, a quality which is entirely lacking in our technological age.

¹⁶ So at least it appears to the conscious mind. Freud (*The Interpretation of Dreams*, II, p. 528) says in this connection: “For it is demonstrably untrue that we are being carried along a purposeless stream of ideas when, in the process of interpreting a dream, we abandon reflection and allow involuntary ideas to emerge. It can be shown that all we can ever get rid of are purposive ideas that are *known* to us; as soon as we have done this, *unknown*—or, as we inaccurately say, ‘unconscious’—purposive ideas take charge and thereafter determine the course of the involuntary ideas. No influence that we can bring to bear upon our mental processes can ever enable us to think without purposive ideas; nor am I aware of any states of psychical confusion which can do so.”

¹⁷ *Outlines*, p. 448.

¹⁸ *Principles*, II, p. 325.

¹⁹ This statement is based primarily on experiences derived from the field of normal psychology. Indefinite thinking is very far removed from “reflection,” particularly where readiness of speech is concerned. In psychological experiments I have frequently found that subjects—I am speaking only of cultivated and intelligent people—whom I allowed to indulge in reveries, as though unintentionally and without previous instruction, exhibited affects which could be registered experimentally, but that with the best will in the world they could express the underlying thought only very imperfectly or not at all. More instructive are experiences of a pathological nature, not so much those arising in the field of hysteria and the various neuroses, which are characterized by an overwhelming transference tendency, as experiences connected with introversion neurosis or psychosis, which must be regarded as constituting by far the greater number of mental disturbances, at any rate the whole of Bleuler’s schizophrenic group. As already indicated by the term “introversion” (which I cursorily introduced in 1910, in my “Psychic Conflicts in a Child,” pp. 13 and 16 [*Coll. Works*, Vol. 17]), this type of neurosis leads to an isolated inner life. And here we meet with that “supralinguistic” or pure “fantasy thinking” which moves in “inexpressible” images and feelings. You get some idea of this when you try to find out the meaning of the pitiful and muddled expressions used by these people. As I have often observed, it costs these patients endless trouble and effort to put their fantasies into ordinary human speech. A highly intelligent patient, who “translated” such a fantasy system for me piecemeal, used to say to me: “I know quite well what it’s all about, I can see and feel everything, but it is quite impossible for me to find the right words for it.”

²⁰ Similarly James, *Principles*, II, pp. 325–26. Reasoning is productive, whereas “empirical” (merely associative) thinking is only reproductive. This opinion, however, is not altogether satisfying. It is no doubt true that fantasy-thinking is not immediately productive, i.e., is unadapted and therefore useless for all practical purposes. But in the long run the play of fantasy uncovers creative forces and contents, just as dreams do. Such contents cannot as a rule be realized except through passive, associative, and fantasy-thinking.

²¹ Cf. the impressive description of Petrarch’s ascent of Mt. Ventoux, in Burckhardt, *The Civilization of the Renaissance in Italy*, pp. 180–81: “A description of the view from the summit would be looked for in vain, not because the poet was insensible to it, but, on the contrary, because the impression was too overwhelming. His whole past life, with all its follies, rose before his mind; he remembered that ten years ago that day he had quitted Bologna a

young man, and turned a longing gaze towards his native country; he opened a book which was then his constant companion, the 'Confessions of St. Augustine,' and his eye fell on the passage in the tenth chapter: 'and men go forth, and admire lofty mountains and broad seas, and roaring torrents, and the ocean, and the course of the stars, and turn away from themselves while doing so.' His brother, to whom he read these words, could not understand why he closed the book and said no more."

²² Wundt gives a short account of the scholastic method in his *Philosophische Studien* (XIII, p. 345). The method consisted "firstly, in regarding as the chief aim of scientific investigation the discovery of a firmly established conceptual scheme capable of being applied in a uniform manner to the most varied problems; secondly, in laying an inordinate value upon certain general concepts, and consequently upon the verbal symbols designating these concepts, as a result of which an analysis of the meanings of words or, in extreme cases, a vapid intellectual subtlety and splitting of hairs comes to replace an investigation of the real facts from which the concepts are abstracted."

²³ *The Interpretation of Dreams*, II, p. 543.

²⁴ *Ibid.*, p. 546.

²⁵ *Ibid.*, p. 567.

²⁶ The passage in *The Interpretation of Dreams* that follows immediately afterwards has since been confirmed through investigation of the psychoses. "These methods of working on the part of the psychical apparatus, which are normally suppressed in waking hours, become current once more in psychosis and then reveal their incapacity for satisfying our needs in relation to the external world" (*ibid.*, p. 567). The importance of this sentence is borne out by the views of Pierre Janet, which were developed independently of Freud and deserve mention here because they confirm it from an entirely different angle, namely the biological side. Janet distinguishes in the function a firmly organized "inferior" part and a "superior" part that is in a state of continuous transformation: "It is precisely on this 'superior' part of the functions, on their adaptation to existing circumstances, that the neuroses depend.... Neuroses are disturbances or checks in the evolution of the functions.... Neuroses are maladies dependent on the various functions of the organism and are characterized by an alteration in the superior parts of these functions, which are checked in their evolution, in their adaptation to the present moment and the existing state of the external world and of the individual, while there is no deterioration in the older parts of these same functions.... In place of these superior operations some degree of physical and mental disturbance develops—above all, emotionality. This is nothing but the tendency to replace the superior operations by an exaggeration of certain inferior operations, and particularly by gross visceral disturbances." (*Les Névroses*, pp. 386ff.) The "older parts" are the same as the "inferior parts" of the functions, and they replace the abortive attempts at adaptation. Similar views concerning the nature of neurotic symptoms are expressed by Claparède (p. 169). He regards the hysterogenic mechanism as a "tendance à la reversion," a kind of atavistic reaction.

²⁷ I am indebted to Dr. Abraham for the following story: "A small girl of three and a half had been presented with a baby brother, who soon became the object of well-known childish jealousy. One day she said to her mother: 'You are two Mamas. You are my Mama, and your breast is little brother's Mama.' " She had just been observing with great interest the act of suckling. It is characteristic of the archaic thinking of the child to call the breast "Mama" [so in the original—EDITORS]. *Mamma* is Latin for 'breast.'

²⁸ Cf. particularly Freud's "Analysis of a Phobia in a Five-year-old Boy" and my "Psychic Conflicts in a Child."

²⁹ *Human, All-Too Human*, trans. by Zimmern and Cohn, I, pp. 24–27, modified.

- ³⁰ “Creative Writers and Day “Dreaming,” p. 152, mod.
- ³¹ *Der Künstler*, p. 36.
- ³² Cf. also Rank, *The Birth of the Hero*.
- ³³ *Wishfulfilment and Symbolism in Fairy Tales*.
- ³⁴ Abraham, *Dreams and Myths*, pp. 36 and 72, modified.
- ³⁵ Rank, *The Birth of the Hero*; also Kerényi, “The Primordial Child,” in Jung and Kerényi, *Science of Mythology*, pp. 38f. (1963 edn., pp. 27ff.).
- ³⁶ For the mythological rape of the bride, cf. id., “Kore,” pp. 170ff. (122ff.).
- ³⁷ Ferrero, *Les Lois psychologiques*, p. vii.
- ³⁸ See my paper “On the Nature of the Psyche,” pars. 398ff.
- ³⁹ Except for the fact that the contents entering consciousness are already in a high state of complexity, as Wundt has pointed out.
- ⁴⁰ Schelling (*Philosophie der Mythologie*, II) regards the “preconscious” as the creative source, just as Fichte (*Psychologie*, I, pp. 508ff.) regards the “preconscious region” as the birthplace of important dream contents.
- ⁴¹ Cf. Flournoy, *From India to the Planet Mars*. Also my “On the Psychology and Pathology of So-called Occult Phenomena,” “The Psychology of Dementia Praecox,” and “A Review of the Complex Theory.” Excellent examples are to be found in Schreber, *Memoirs of My Nervous Illness*.
- ⁴² Le Jardin d’Épicure.
- ⁴³ The Judas-figure assumes great psychological significance as the sacrificer of the Lamb of God, who by this act sacrifices himself at the same time (suicide). See Part II.
- ⁴⁴ Cf. Drews’ remarks in *The Christ Myth*. Intelligent theologians, like Kalthoff (*The Rise of Christianity*), are of the same opinion as Drews. Thus Kalthoff says: “The documents that give us our information about the origin of Christianity are of such a nature that in the present state of historical science no student would venture to use them for the purpose of compiling a biography of an historical Jesus” (ibid., p. 10). “To look behind these evangelical narratives for the life of a natural historical human being would not occur to any thoughtful men today if it were not for the influence of the earlier rationalistic theologians” (p. 13). “In Christ the divine is always most intimately one with the human. From the God-man of the Church there is a straight line back, through the Epistles and Gospels of the New Testament, to the apocalypse of Daniel, in which the ecclesiastical conception of Christ makes its first appearance. But at every single point in this line Christ has superhuman features; he is never what critical theology would make him—a mere natural man, an historical individual” (p. 11). Cf. also Schweitzer, *The Quest of the Historical Jesus*.
- ⁴⁵ Cf. Burckhardt’s letter (1855) to his student Albert Brenner (trans. by Dru, p. 116, modified): “I have no special explanation of *Faust* ready prepared and filed away. And in any case you are well provided with commentaries of every kind. Listen: take all those second-hand wares back to the library from which they originally came! (Perhaps in the meanwhile you have already done so.) What you are destined to discover in *Faust*, you will have to discover intuitively (*N.B.* I am only speaking of the first part). *Faust* is a genuine myth, i.e., a great primordial image, in which every man has to discover *his* own being and destiny in his own way. Let me make a comparison: whatever would the Greeks have said if a commentator had planted himself between them and the Oedipus saga? There was an

Oedipus chord in every Greek that longed to be directly touched and to vibrate after its own fashion. The same is true of *Faust* and the German nation.”

⁴⁶ [See the Appendix for the full Miller account, translated into English.—EDITORS.]

¹ There is an example of this in C. A. Bernoulli, *Franz Overbeck und Friedrich Nietzsche*, I, p.72. Bernoulli describes Nietzsche's behaviour at a party in Basel: "Once at a dinner he said to the young lady seated next to him, 'I dreamed a short while ago that my hand, lying before me on the table, suddenly had a skin like glass, shiny and transparent; in it I saw distinctly the bones, the tissues, the play of the muscles. All at once I saw a fat toad sitting on my hand and I felt at the same time an irresistible compulsion to swallow the creature. I overcame my terrible loathing and gulped it down.' The young lady laughed. 'Is that a thing to laugh at?' Nietzsche asked, dreadfully serious, his deep eyes fixed on his companion, half questioning, half sorrowful. She then knew intuitively, even though she did not quite understand it, that an oracle had spoken to her in a parable, and that Nietzsche had allowed her to glimpse, as through a narrow crack, into the dark abyss of his inner self." Bernoulli makes (p. 166) the following observation: "One can perhaps see that behind the faultless exactitude of his dress there lay not so much a harmless pleasure in his appearance, as a fear of defilement born of some secret, tormenting disgust."

Nietzsche came to Basel very young; he was just at the age when other young people are contemplating marriage. Sitting beside a young woman, he tells her that something terrible and disgusting has happened to his transparent hand, something he must take completely into his body. We know what disease caused the premature ending of Nietzsche's life. It was precisely this that he had to tell his young lady, and her laughter was indeed out of tune.

² Rostand, *Cyrano de Bergerac*, trans. by Thomas and Guillemard, p. 282.

³ *Ibid.*, p. 293.

¹ The choice of words and comparisons is always significant. [The words “a real pleasure,” however, may not be precisely those which Miss Miller originally wrote in English and which Flournoy rendered as “une véritable volupté,” the phrase being remarked on here.—EDITORS.]

² This illness had until recently the not altogether suitable name given it by Kraepelin: dementia praecox. Bleuler later called it schizophrenia. It is the particular misfortune of this illness that it was discovered by the psychiatrists, for its apparently bad prognosis is due to this fact, dementia praecox being synonymous with therapeutic hopelessness. How would hysteria appear if judged from the standpoint of psychiatry! The psychiatrist naturally sees only the worst cases in his asylum, and because of his therapeutic helplessness he is bound to be a pessimist. Tuberculosis would indeed be in a deplorable situation if it were described solely on the basis of experiences acquired in a Home for Incurables. The chronic cases of hysteria who slowly degenerate into idiots in lunatic asylums are no more characteristic of real hysteria than schizophrenia is characteristic of the early forms of the disease, so frequently met with in practice, that hardly ever come under the supervision of the institutional psychiatrist. “Latent psychosis” is an idea that the psychotherapist knows and fears only too well.

³ The reader must remember that these lines were written before the first World War. Much has changed since then.

⁴ Here I purposely give preference to the term “imago” rather than to “complex,” in order to make clear, by this choice of a technical term, that the psychological factor which I sum up under “imago” has a living independence in the psychic hierarchy, i.e., possesses that *autonomy* which wide experience has shown to be the essential feature of feeling-toned complexes. This is brought out by the term “imago.” (Cf. my “Psychology of Dementia Praecox,” chs. 2 and 3.) My critics have seen in this view a return to medieval psychology and have therefore repudiated it. This “return” was made consciously and deliberately on my part, because the psychology of ancient and modern superstition furnishes abundant evidence for my point of view. Valuable insight and confirmation is also given us by the insane Schreber in his autobiography. My use of “imago” has close parallels in Spitteler’s novel of the same name, and also in the ancient religious idea of the “imagines et lares.” In my later writings, I use the term “archetype” instead, in order to bring out the fact that we are dealing with impersonal, collective forces.

⁵ The idea that the masculine deity is derived from the father-imago need be taken literally only within the limits of a personalistic psychology. Closer investigation of the father-imago has shown that certain collective components are contained in it from the beginning and cannot be reduced to personal experiences. Cf. my essay, “The Relations between the Ego and the Unconscious,” pars. 211ff.

⁶ “But the voice and the name [are] sun and moon.” Hippolytus, *Elenchos*, VI, 13.—Max Müller, in his foreword to the *Sacred Books of the East*, I, p. xxv, says of the sacred syllable *Om*: “He therefore who meditates on *Om*, meditates on the spirit in man as identical with the spirit ... in the sun.”

⁷ Schultz *Gnosis*, p. 62. Text in Scott, *Hermetica*, I, p. 115: Lib. I, 4.

⁸ Pap. J 395, in Dieterich, *Abraxas*, p. 17: “And God laughed seven times Cha Cha Cha Cha Cha Cha Cha, and as God laughed, there arose seven gods.”

⁹ In Anaxagoras, the living primal power of *νοῦς* imparts movement to inert matter. There is, of course, no mention of noise. Also, Miss Miller stresses the wind nature of *νοῦς* more than is warranted by ancient tradition. On the other hand, this *νοῦς* is related to the *πνεῦμα* of late antiquity and to the *λόγος σπερματικός* of the Stoics. In the

incest fantasy of one of my patients, her father covered her face with his hands and blew into her open mouth—an allusion to *inspiration*.

¹⁰ Probably Haydn's *Creation* is meant.

¹¹ See Job 16:1–11.

¹² I remember the case of a crazy young girl of 20, who continually imagined that her innocence was suspected despite all my efforts to talk her out of it. Gradually her indignant defence developed into a correspondingly aggressive erotomania.

¹³ Job 16: 1 1ff.

¹⁴ The case is published in my “On the Psychology and Pathology of So-called Occult Phenomena.”

¹⁵ Cf. Freud, “Analysis of a Phobia in a Five-year-old Boy”, and my “Psychic Conflicts in a *Child*,” pars. 46ff.

¹⁶

οὐρανὸς ἄνω, οὐρανὸς κάτω, ἄστρα ἄνω, ἄστρα κάτω, πᾶν τοῦτο ἄνω, πᾶν τοῦτο κάτω, τοῦτο λαβὲ καὶ εὐτύχει—An old paraphrase of the *Tabula smaragdina* of Hermes, and of the text mentioned by Athanasius Kircher (*Oedipus Aegyptiacus*, Part 2, p. 414). I have quoted the latter text in my “Psychology of the Transference,” par. 384.

¹⁷ *Wisdom and Destiny*.

¹⁸ This time I shall hardly escape the charge of mysticism. But perhaps the facts should be considered further: there is no doubt that the unconscious contains psychological combinations which do not reach the threshold of consciousness. Analysis dissolves these combinations back into their historical determinants. It works backwards, like the science of history. Just as a large part of the past is so remote as to be beyond the reach of historical knowledge, so too the greater part of these unconscious determinants is unreachable. History, however, knows nothing either of that which is hidden in the past or of that which is hidden in the future. Both might be reached with some degree of probability, the first as a postulate, the second as a political prognosis. Thus, in so far as tomorrow is already contained in today, and all the threads of the future are already laid down, a deeper knowledge of the present might render possible a moderately far-sighted prognosis of the future. If we apply this reasoning to the realm of the psychic we necessarily come to the same result. Just as memories that have long since fallen below the threshold are still accessible to the unconscious, so also are certain very fine subliminal combinations that point forward, and these are of the greatest significance for future events in so far as the latter are conditioned by our psychology. But no more than the science of history bothers itself with future combinations of events, which are rather the object of political science, can the forward-pointing psychological combinations be the object of analysis; they would be much more the object of a refined psychological syntheticism that knew how to follow the natural currents of libido. This we cannot do, or only badly; but it happens easily enough in the unconscious, and it seems as if from time to time, under certain conditions, important fragments of this work come to light, at least in dreams, thus accounting for the prophetic significance of dreams long claimed by superstition. Dreams are very often anticipations of future alterations of consciousness. [Cf. Jung, “General Aspects of Dream Psychology,” pars. 492ff—EDITORS.]

¹⁹ Dreams seem to remain spontaneously in the memory for just so long as they correctly sum up the psychological situation of the individual.

²⁰ How collective the elements in such an experience are can be seen from the following love-song. Of its many variants, I quote a modern Greek version from Epirus (*Zeitschrift des Vereins für Volkskunde*, XII, 1902, p. 159):

O maiden, when we kissed, it was night. Who saw us?—
A bright star saw us, and the moon saw us,
And it leaned down to the sea and whispered the tidings,
And the sea told the rudder, and the rudder told the sailor,
The sailor made a song, then the neighbours heard it,
Then the priest heard it too and told it to my mother,
From her my father heard it and was livid with anger.
They nagged me and scolded me and now have forbidden me
Ever to go to the door or look out of the window,
And yet I will go to the window as if to my flowers.
And never will I rest until my beloved is mine.

²¹ The atmosphere of the poem is very reminiscent of Gérard de Nerval's *Aurelia*, a book that anticipates the same fate that befell Miss Miller: spiritual benightedness. Cf. the significance of the raven in alchemy, where it is a synonym for the *nigredo* (*Psychology and Alchemy*, pars. 333ff.).

²² This again is decidedly reminiscent of Gérard de Nerval's attitude towards Aurelia, whose significance he refuses to admit. He would not believe that a "femme ordinaire de ce monde" could have the glamour his unconscious endowed her with. Today we know that a powerful impression of this kind is due to the projection of an archetype, i.e., that of the anima or animus. See "The Relations between the Ego and the Unconscious," pars. 296ff., and my "Psychological Aspects of the Kore," pars. 356ff.

²³ Trans. by MacNeice, p. 15, modified.

²⁴ Job 1:11. [Cf. these pars, with Jung, "Answer to Job."—EDITORS.]

²⁵ Job 40: 15–19; 41:1–4.

²⁶ Cf. Schärf, "Die Gestalt des Satans im Alten Testament," in Jung, *Symbolik des Geistes*, pp. 288ff.

²⁷ Job 41:19–29:

Out of his mouth go burning lamps, and sparks of fire leap out.
Out of his nostrils goeth smoke, as out of a seething pot or cauldron.
His breath kindleth coals, and a flame goeth out of his mouth.
In his neck remaineth strength, and sorrow is turned into joy before him
The flakes of his flesh are joined together: they are firm in themselves; they cannot be moved.
His heart is as firm as a stone; yea, as hard as a piece of the nether millstone.
When he raiseth up himself, the mighty are afraid: by reason of breakings they purify themselves.
The sword of him that layeth at him cannot hold: the spear, the dart, nor the habergeon.
He esteemeth iron as straw, and brass as rotten wood.
The arrow cannot make him flee: slingstones are turned with him into stubble.

Darts are counted as stubble: he laugheth at the shaking of a spear.

²⁸ These expressions are all anthropomorphisms whose source is primarily psychological.

²⁹ This proposition has caused much offence, because people have failed to see that it is a *psychological* view and not a metaphysical statement. The psychic fact “God” is a typical autonomism, a *collective archetype*, as I later called it. It is therefore characteristic not only of all higher forms of religion, but appears spontaneously in the dreams of individuals. The archetype is, as such, an unconscious psychic image, but it has a reality independent of the attitude of the conscious mind. It is a psychic existent which should not in itself be confused with the idea of a metaphysical God. The existence of the archetype neither postulates a God, nor does it deny that he exists.

³⁰ Theriomorphic elements are lacking in Christianity, except for remnants like the dove, the fish, and the lamb, and the beasts representing the Evangelists. The raven and the lion symbolized definite degrees of initiation in the Mithraic mysteries. Since Dionysus was represented, among other things, as a bull, his female worshippers wore horns, as though they were cows. (I owe this information to Professor Kerényi. The female worshippers of the bear goddess Artemis were called ἄρκτοι, ‘bears.’ Cf. pl. *Lb.*)

³¹ See my “On the Nature of Dreams,” pars. 542ff.

³² Cf. I Peter 4:7; and Philemon, vv. 4 and 6.

³³ Cf. I John 1: 8; “If we say we have no sin, we deceive ourselves, and the truth is not in us” (RSV; also nn. 34–36).

³⁴ Ephesians 1:7 and Colossians 1: 14. Isaiah 53:4: “Surely he has borne our griefs and carried our sorrows.”

³⁵ I Peter 2:22.

³⁶ I Peter 2: 24.

³⁷ Hebrews 9: 28 (ZB).

³⁸ As I have shown above, it is not always an illusion, for the subject himself can be the main source of these figures, as is particularly the case in neuroses and psychoses.

³⁹ James 5:16, And Galatians 6:2: “Bear one another’s burdens.” (RSV; and nn. 40–44.)

⁴⁰ Galatians 5: 13.

⁴¹ Hebrews 13: 1.

⁴² Hebrews 10:24f.

⁴³ I John 2:10f.

⁴⁴ 1 John 4:12.

⁴⁵ “Magnam ergo vim habes, caritas, tu sola Deum trahere potuisti de caelo ad terras. O quam forte est vinculum tuum, quo et Deus ligari potuit.... Adduxisti illum vinculis tuis alligatum, adduxisti illum sagittis tuis vulneratum.... Vulnerasti impassibilem, ligasti insuperabilem, traxisti incommutabilem, aeternum fecisti mortalem.... O caritas quanta est victoria tua!”— *De laude caritatis*, cols. 974f.

⁴⁶ I John 4: 16: “God is love, and he who abides in love abides in God, and God abides in him” (RSV).

⁴⁷ One cannot of one’s own free will choose and desire something that one does not know. Hence a spiritual goal cannot consciously be striven for if it does not yet exist.

⁴⁸ John 4:24 (RSV).

⁴⁹ Romans 15:7 (RSV).

⁵⁰ Cf. Reitzenstein, *Die hellenistischen Mysterienreligionen*, p. 20: “To the various forms in which primitive peoples have envisaged the supreme religious sacrament, union with God, there necessarily belongs that of sexual union, through which man takes into himself the innermost essence and power of a god, his semen. What is at first a wholly sensual idea becomes, independently in different parts of the world, a sacred act, where the god is represented by a human deputy or by his symbol the phallus.” Further material in Dieterich, *Eine Mithrasliturgie*, pp. 121ff.

⁵¹ Cf. the prayers in the so-called Mithras liturgy (published in 1910 by Dieterich, *ibid.*). There we find such characteristic passages as: τῆς ἀνθρωπίνης μου ψυχικῆς δυνάμεως ἦν ἐγὼ ἀάλιν μεταπαράλημφομαι μετὰ τὴν ἐνεστῶσαν καὶ κατεπεὶ γουσαν με πικρὰν ἀνάγκην ἀνάγκην ἀχρεοκόπητον (my human soul-force, which I shall recover again undiminished after the present bitter necessity that presses upon me), and ἔνεια τῆς κατ' ἐπιγούσης καὶ πικρὰς ἀπαρατήτου ἀνάγκης (because of the bitter inexorable necessity that oppresses me). The speech of the high priest of Isis (Apuleius, *The Golden Ass*, XI, 15) reveals a similar train of thought. The young philosopher Lucius was changed into an ass, that ever-rutting animal hateful to Isis. Later he was released from the spell and initiated into the mysteries. (Cf. pl. vi.) During his disenchantment, the priest says: “On the slippery path of your lusty youth you fell a prey to servile pleasures, and won a sinister reward for your ill-fated curiosity.... But hostile fortune has no power over those who have devoted their lives to serve the honour and majesty of our goddess.... Now, you are safe, and under the protection of that fortune which is not blind, but can see.” In his prayer to Isis, Queen of Heaven, Lucius says (XI, 25): “... thy saving hand, wherewith thou unweavest even the inextricably tangled web of fate, and assuageth the tempests of fortune, and restrainest the baleful orbits of the stars.” Altogether, the purpose of the mysteries (pl. ivb) was to break the “compulsion of the stars” by magic power.

The power of fate makes itself felt unpleasantly only when everything goes against our will, that is to say, when we are no longer in harmony with ourselves. The ancients, accordingly, brought *εἰμαρμένη* into relation with the “primal light” or “primal fire,” the Stoic conception of the ultimate cause, or all-pervading warmth which produced everything and is therefore fate. (Cf. Cumont, *The Mysteries of Mithra*, p. 114.) This warmth, as will be shown later, is a libido-image (cf. fig. 4). Another conception of Ananke (Necessity), according to Zoroaster’s book *Περὶ Φύσεως* (“On Nature”), is air, which in the form of wind is again connected with the fertilizing agent.

⁵² Schiller says in *Piccolomini*, II, 6: “The stars of thine own fate lie in thy breast.” “A man’s fortunes are the fruits of his character,” says Emerson, in his essay “Fate,” in *The Conduct of Life* (*Works*, VI, p. 41).

⁵³ *The Confessions of St. Augustine*, VI, 7–8, trans. by Sheed, pp. 88–91, slightly modified.

⁵⁴ Seneca, *Ad Lucilium epistulae morales*, trans. by Gummere, I, pp. 278f., 274f.

⁵⁵ The ascent to the “idea” is described in Augustine, *Confessions*, Book X, ch. 6ff. The beginning of ch. 8 reads: “I shall mount beyond this power of my nature, still rising by degrees towards Him who made me. And so I come to the fields and vast palaces of memory.” (Trans. by Sheed, p. 172.)

⁵⁶ The followers of Mithras also called themselves brothers. In philosophical language, Mithras was the Logos emanated by God (Cumont, *Mysteries*, p. 140).

⁵⁷ Augustine, who was close to that period of transition not only in time but intellectually too, writes in his *Confessions* (Book VI, ch. 16; Sheed trans., pp. 99–100): “And I put the question, supposing we were immortals and could live in perpetual enjoyment of the body without any fear of loss, why should we not then be happy, or what else should we seek? I did not realize that it belonged to the very heart of my wretchedness to be so drowned and blinded in it that I could not conceive the light of honour, and of beauty loved for its own sake, which the eye of the

flesh does not see but only the innermost soul. I was so blind that I never came to ask myself what was the source of the pleasure I found in discussing these ideas (worthless as they were) with friends, and of my inability to be happy without friends, even in the sense of happiness which I then held, no matter how great the abundance of carnal pleasure. For truly I loved my friends for their own sake, and I knew that I was in turn loved by them. O tortuous ways! Woe to my soul with its rash hope of finding something better if it forsook Thee! My soul turned and turned again, on back and sides and belly, and the bed was always hard. For thou alone art her rest.”

⁵⁸ Both religions teach a distinctly ascetic morality and a morality of action. The latter is particularly true of Mithraism. Cumont (p. 147) says that Mithraism owed its success to the value of its morality, “which above all things favoured action.” The followers of Mithras formed a “sacred army” in the fight against evil (p. 148), and among them were *virgines*, ‘nuns’, and *continentes*, ‘ascetics’ (p. 165).

⁵⁹ I have intentionally let these sentences stand from the earlier editions, as they typify the false *fin de siècle* sense of security. Since then we have experienced abominations of desolation of which Rome never dreamed. As regards the social conditions in the Roman Empire I would refer the reader to Pöhlmann (*Geschichte des antiken Kommunismus und Sozialismus*) and Bücher (*Die Aufstände der unfreien Arbeiter 143–129 B.C.*). The fact that an incredibly large proportion of the people languished in the black misery of slavery is no doubt one of the main causes of the singular melancholy that reigned all through the time of the Caesars. It was not in the long run possible for those who wallowed in pleasure not to be infected, through the mysterious working of the unconscious, by the deep sadness and still deeper wretchedness of their brothers. As a result, the former were driven to orgiastic frenzy, while the latter, the better of them, fell into the strange *Weltschmerz* and world-weariness typical of the intellectuals of that age.

⁶⁰ Unfortunately Freud, too, has made himself guilty of this error.

⁶¹ A theologian, who accuses me of being anti-Christian, has completely overlooked the fact that Christ never said “Unless ye *remain* as little children,” but, most emphatically, “Unless ye *become* as little children.” His accusation is proof of a remarkable dulness of religious sensibility. One cannot, after all, ignore the whole drama of rebirth *in novam infantiam!*

⁶² *Confessions*, X, 8, cited in Burckhardt, *The Renaissance in Italy*, p. 181.

⁶³ Cumont, *The Mysteries of Mithra*, p. 149, modified.

⁶⁴ [Cf. Gummere trans., pp. 272–75.]

⁶⁵ *Confessions*, X, 6, trans. based on Sheed, p. 170.

⁶⁶ Trans. by Sheed, p. 171.

⁶⁷ Lucretius, *De rerum natura*, I, 21–24 [cf. Rouse trans., pp. 4–5]:

“Quae quoniam rerum naturam sola gubernas,
Nec sine te quicquam dias in luminis oras
Exoritur, neque fit laetum neque amabile quicquam.”

⁶⁸ Cf. Kerényi, “Die Göttin Natur,” pp. 50ff.

⁶⁹ Cf. Hartlaub, *Giorgiones Geheimnis*.

⁷⁰ Particularly in alchemy. See my “Paracelsus as a Spiritual Phenomenon,” pars. 184, 198f., 228f.

⁷¹ Kalthoff, *The Rise of Christianity*, p. 200 (trans. modified).

⁷² See my “Relations between the Ego and the Unconscious,” pars. 353ff.

⁷³ When I wrote this book, these things were still completely dark to me, and I knew no other counsel but to quote to myself the following passage from the 41st letter of Seneca to Lucilius (Gummere trans., pp. 272–73): “You are doing an excellent thing, one which will be wholesome for you, if ... you persist in your effort to attain sound understanding; it is foolish to pray for this when you can acquire it from yourself. We do not need to uplift our hands towards heaven, or to beg the keeper of a temple to let us approach his idol’s ear, as if in this way our prayers were more likely to be heard. God is near you, he is with you, he is within you. This is what I mean, Lucilius; a holy spirit indwells within us, one who works our good and bad deeds, and is our guardian. As we treat this spirit, so we are treated by it. Indeed, no man can be good without the help of God. Can one rise superior to fortune unless God helps him to rise? He it is that gives noble and upright counsel. In each good man ‘a god doth dwell, but what god we know not.’”

¹ Complexes are usually of great stability even though their outward manifestations change kaleidoscopically. Experimental researches have entirely convinced me of this fact. See my “Studies in Word Association.”

² Part I, trans. by Wayne, pp. 66–67.

³ *Ibid.*, p. 54, modified.

⁴ As the reader will be aware, the last notoriously unsuccessful attempt to conquer Christianity with a nature religion was made by Julian the Apostate.

⁵ This solution of the problem had its parallel in the flight from the world during the first few centuries after Christ (cities of the anchorites in the desert). The Desert Fathers mortified themselves through spirituality in order to escape the extreme brutality of the decadent Roman civilization. Asceticism occurs whenever the animal instincts are so strong that they need to be violently exterminated. Chamberlain (*Foundations of the Nineteenth Century*) saw asceticism as a biological suicide caused by the enormous amount of racial interbreeding among the Mediterranean peoples at that time. I believe that miscegenation makes rather for a coarsened *joie de vivre*. To all appearances the ascetics were ethical people who, disgusted with the melancholy of the age which was merely an expression of the disruption of the individual, put an end to their lives in order to mortify an attitude that was itself obsolete.

⁶ Δίκη, Justice, daughter of Zeus and Themis, who after the Golden Age forsook the degenerate earth.

⁷ *Bucolica*, Eclogue IV. Trans. based on Fairclough, I, pp. 28–31. (Cf. Norden, *Die Geburt des Kindes*.) Thanks to this eclogue, Virgil was later honoured as a quasi-Christian poet. To this position he also owes his function as psychopomp in Dante.

⁸ “Below the hills a marshy plain
Is poisoning all that we have won;
This pestilential swamp to drain
Would crown the work I have begun,
Give many millions room to live.” [Cf. MacNeice trans., p. 287.]

⁹ Part I, trans. by Wayne, pp. 64–5, modified.

¹⁰ “FAUST: I long to join his quest
On tireless wings uplifted from the ground.
Then should I see, in deathless evening light,
The world in cradled stillness at my feet...
Yet stirs my heart with new-awakened might,
The streams of quenchless light I long to drink...”

(Part I, trans. by Wayne, p. 66.)

¹¹ [For a note on this play, see Appendix, pp. 456f.—EDITORS.]

¹² Cf. my “Psychology of Dementia Praecox,” pars. 77ff., and my “Review of the Complex Theory,” pars. 200ff.

¹³ I John 4: 8 and 12 (RSV). “Caritas” in the Vulgate corresponds to *ἀγάπη*. This New Testament word derives, like *ἀγάπησις* (love, affection), from *ἀγαπάν*, ‘to love, esteem, praise, approve, etc’ ‘Ἀγάπη is, therefore, an unmistakably psychic function.

¹⁴ Apuleius, *The Golden Ass*, XI: “In my right hand I carried a torch blazing with flames; my head was garlanded with a fair crown of white palm, with the leaves standing out like rays. Thus I was adorned like the sun and set up as an image.”

¹⁵ Dieterich, *Mithrasliturgie*, pp. 8–9. (Εγώ εἰμι σύμπλανος ὑμῖν ἀστῆρ καὶ ἐκ τοῦθους ἀναλάμπων.)

¹⁶ In the same way, the Sassanid kings styled themselves “brothers of the sun and moon.” In ancient Egypt the soul of every Pharaoh was a split-off from the Horus-sun.

¹⁷ *Elenchos*, X, 34, 4. (Γέγονας γὰρ θεὸς ἔαη δὲ ὀμιλήτης θεοῦ καὶ συγκληρονόμος Χριστοῦ. / Τοῦτ' ἔστι τὸ γνῶθι σεαυτόν.)

¹⁸ Cf. the coronation rite mentioned above. Feathers symbolize power. The feather crown = crown of sun rays, halo. Crowning is in itself an identification with the sun. For instance the spiked crown appeared on Roman coins from the time when the Caesars were identified with the *Sol invictus*. *Solis invicti comes*: ‘companion of the unconquerable sun.’ The halo means the same thing; it is an image of the sun, as is the tonsure. The priests of Isis had smooth-shaven heads that shone like stars (Apuleius).

¹⁹ “The Coming Forth by Day from the Underworld,” in Erman, *Life in Ancient Egypt*, p. 343 (trans. modified).

²⁰ The text of the Mithraic liturgy reads: Εγώ εἰμι σύμπλανος ὑμῖν ἀστῆρ καὶ ἐκ τοῦ βάθους ἀναλάμπων... τοῦτά σον εἰπόντος εὐθέως ὁ δίσκος ἀπλωήσεται (I am a Star wandering with you and shining up from the depths... When you have said this, the disc of the sun will immediately unfold). Through his prayer, the celebrant has the divine power to make the sun come out.

²¹ Cf. the sayings in John: “I and the Father are one” (10: 30). “He who has seen me has seen the Father” (14: 9). “Believe me that I am in the Father and the Father in me” (14: 11). “I came from the Father and have come into the world; again, I am leaving the world and going to the Father” (16: 28). “I am ascending to my Father and your Father, to my God and your God” (20:17). (All RSV.)

²² Επάκουσόν μου κύριε ὁ συνδήσας πνεύματι τὰ πύρινα κλεῖθρα τοῦ οὐρανοῦ δισώματος, πορίπολε, φωτὸς κτίστα... πνίπνοε, πυρίθυμε, πνευματὸ φως, πνιχαρῆ καλλί φως, φωτοκράτωρ, πυρισώματε, φωτοδότα, πνισπόρε, πυρικλόνε, φωτόβιε, πυριδῖνα φωτοκινῆτα, κεραυνοκλόνε, φωτός. ἀυξισί φως, ἐνπυρισχησί φως, ἀστοδάμα, κτλ

²³ *The Revelations of Mechthild of Magdeburg*, trans. by Menzies, p. 14.

²⁴ Renan, *Dialogues*, p. 168, says: “Avant que la religion fût arrivée à proclamer que Dieu doit être mis dans l’absolu et l’ideal, c’est-à-dire hors du monde, un seul culte fût raisonnable et scientifique, ce fût le culte du soleil.”

²⁵ Dieterich, p. 6: Ἡδὲ πορεία τῶν ὑρωμένων βεῶν διὰ τοῦ δίσκου, πατρός μου, θεοῦ φανήσεται.

²⁶ In Pitra, *Analecta sacra*, VIII, p. 333. Cited from Buber, pp. 51f.

²⁷ “Love-songs to God,” in Buber, p. 40. There is a related symbolism in Carlyle (“Heroes and Hero Worship,” p. 280): “The great fact of Existence is great to him. Fly as he will, he cannot get out of the awful presence of this Reality. His mind is so made; he is great by that, first of all. Fearful and wonderful, real as Life, real as Death, is this Universe to him. Though all men should forget its truth, and walk in a vain show, he cannot. *At all moments the Flame-image glares in upon him.*” One could take any amount of examples from literature. For instance, S. Friedländer says, in *Jugend* (1910), p. 823: “Her longing demands only the purest from the beloved. Like the sun, she burns to ashes with the flame of her immense vitality anything that does not desire to be light. This sun-like eye of love,” etc.

²⁸ This image contains the psychological root of the “heavenly wanderings of the soul,” an idea that is very old. It is an image of the wandering sun (fig. 3), which from its rising to its setting travels over the world. This comparison has been indelibly imprinted on man’s imagination, as is clear from the poem “Grief” of Mathilde von Wesendonck (1828–1902):

The sun, every evening weeping.
Reddens its beautiful eyes for you;
When early death seizes you,
Bathing in the mirror of the sea.

Still in its old splendour
The glory rises from the dark world;
You awaken anew in the morning
Like a proud conqueror.

Ah, why then should I lament,
When my heart, so heavy, sees you?
Must the sun itself despair?
Must the sun set?

And does death alone bear life?
Do griefs alone give joys?
O, how grateful I am that
Such pains have given me nature!

There is another parallel in a poem by Ricarda Huch (1864–1947):

As the earth, separating from the sun,
Withdraws in quick flight into the stormy night,
Starring the naked body with cold snow,
Deafened, it takes away the summer joy.
And sinking deeper in the shadows of winter.
Suddenly draws close to that which it flees,
Sees itself warmly embraced with rosy light
Leaning against the lost consort.
Thus I went, suffering the punishment of exile,
Away from your countenance, into the ancient place.
Unprotected, turning to the desolate north,
Always retreating deeper into the sleep of death;
And then would I awake on your heart,

Blinded by the splendour of the dawn.

[Both poems as trans. in the Hinkle edn. (1916).]

The heavenly journey is a special instance of the journeys of the hero, a motif that was continued as the *peregrinatio* in alchemy. The earliest appearance of this motif is probably the heavenly journey of Plato (?) in the Harranite treatise “Platonis liber quartorum” (*Theatrum chemicum*, V, p. 145). See also my *Psychology and Alchemy*, par. 457.

²⁹ Buber, p. 45.

³⁰ *Werke*, VIII, p. 427.

³¹ Dieterich, pp. 8f.

³² *Ibid.*, p. 13.

³³ *Memoirs*, pp. 4, 162ff.

³⁴ From *Ecce Homo*, trans. based on A. M. Ludovici's.

³⁵ Even the water-god Sobk, who appeared as a crocodile, was identified with Ra.

³⁶ Erman, *Life in Ancient Egypt*, p. 261.

³⁷ *Ibid.*, p. 262.

³⁸ Cf. the “five-fingered stars” mentioned above.

³⁹ The Apis-bull as manifestation of Ptah.

⁴⁰ Amon.

⁴¹ Sobk of the Fayum.

⁴² The god of Dedu, in the Delta, who was worshipped as a wooden post.

⁴³ This reformation was initiated with a great deal of fanaticism but soon collapsed.

⁴⁴ Apuleius, XI, 2. (“Regina coeli, sive tu Ceres, alma frugum parens, seu tu coelestis Venus ... seu Phoebi soror ... seu nocturnis ululatus horrenda Proserpina ... ista luce feminea conlustrans cuncta moenia.”) It is worth noting that the Humanists too (I am thinking of a passage in Mutianus Rufus) developed the same syncretism and maintained that there were really only two gods in antiquity, a masculine and a feminine.

⁴⁵ The light or fire-substance was ascribed not only to divinity but also to the soul, as for instance in the system of Mani, and again with the Greeks, who thought of it as a fiery breath of air. The Holy Ghost of the New Testament appeared to the apostles in the form of flames, because the pneuma was believed to be fiery (cf. Dieterich, p. 116). The Iranian conception of Hvareno was similar: it signified the “Grace of Heaven” through which the monarch ruled. This “Grace” was understood as a sort of fire or shining glory, something very substantial (cf. Cumont, *Mysteries*, p. 94). We come across ideas of the same type in Kerner's *Seeress of Prevorst*.

⁴⁶ Dieterich, pp. 6–7: ‘Ομοίως δὲ καὶ ὁ καλούμενος αὐλὸς, ἡ ἀρχὴ τοῦ λειτουργοῦντος ἀνέμου ἢ ὄψει γὰρ ἀπὸ τοῦ δίσκου ὡς αὐλὸν κρεμάμενον.

⁴⁷ According to ancient superstition, the mares of Lusitania and the Egyptian vultures were fertilized by the wind.

⁴⁸ St. Jerome (*Adversus Jovinianum*, I, 7, in Migne, *P.L.*, vol. 23, col. 219) says of Mithras, who was born in a miraculous manner from a rock (cf. fig. 9), that his birth was caused “solo aestu libidinis”—by the sole heat of libido. (Cumont, *Textes*, I, p. 163.)

⁴⁹ Mead, *A Mithraic Ritual*, p. 22.

⁵⁰ Dieterich, p. 7.

⁵¹ I am indebted to my late colleague Dr. Franz Riklin for the following case, which presents an interesting symbolism. It concerns a paranoid woman patient who developed the stage of manifest megalomania in the following way: She suddenly saw a *strong light*, a *wind blew upon her*, she felt as if her “heart turned over,” and from that moment she knew that God had visited her and was in her.

⁵² Permission for me to do this was kindly given by Dr. William Alanson White, late superintendent of the St. Elizabeth’s Hospital, in Washington, D.C.

⁵³ Further material in my “Psychology of the Child Archetype,” pars. 260ff., and my “On the Nature of the Psyche,” pars. 388ff.

⁵⁴ See my “Psychology and Religion,” pars. 104f.

⁵⁵ Dieterich, p.11: ὄψει θεὸν νεώτερον εὐεδή πυρινότριχα ἐν χιτῶνι λευκῷ καὶ χλαμύδι κοκκίῃ, ἔχοντα πύρινον στέφανον

⁵⁶ Ibid., p. 15: ὄψει θεὸν ὑπερμεγέθη, φωτινὴν ἔχοντα τήν ὄψιν, νεώτερον, χρυσοκόμαν, ἐν χιτῶνι λευκῷ καὶ χρυσῷ στεφάνῳ καὶ ἀναξυρίσι, κατέχοντα τῆ δειᾶ χειρὶ μὸσχου ὤμόν χρύσειον, ὃς ἐστὶν ἄρκτος ἢ κινουῖσα καὶ ἀντιστρέφουσα τὸν οὐρανόν, κατὰ ὥραν ἀναπολεῦουσα καὶ καταπολεῦουσα. ἔπειτα ὄψει αὐτοῦ ἐκ τῶν ὀμμάτων ἀστραπᾶς καὶ ἐκ τοῦ ἀώματος ἀστέρας ἄλλομένους.

⁵⁷ The Great Bear consists of seven stars.

⁵⁸ Mithras is frequently represented with a short sword in one hand and a torch in the other (fig. 9). The sword as sacrificial instrument plays a considerable role in the Mithraic myth and also in Christian symbolism. See my “Transformation Symbolism in the Mass,” pars. 324, 357ff.

⁵⁹ *στέφανον χρυσοῦν*, lit. ‘golden wreath.’

⁶⁰ Cf. the scarlet mantle of Helios. An essential feature in the rites of many different cults was that the worshippers dressed themselves in the bloody pelts of the sacrificed animals, as at the Lupercalia, Dionysia, and Saturnalia. The last of these lingers on in the Carnival; in Rome the typical Carnival figure was the priapic Punchinello.

⁶¹ Cf. the linen-clad retinue of the god Helios. The bull-headed gods wore white *τεριζώματα*. (aprons?).

⁶² The development of the sun-symbolism in *Faust* (Part I, Scene 1) does not go as far as an anthropomorphic vision; it stops in the suicide scene (Wayne, p. 54) at the chariot of Helios (“As if on wings, a chariot of fire draws near me”). The fiery chariot comes to receive the dying or departing hero, as in the ascension of Elijah or Mithras (and also with St. Francis of Assisi). Faust in his flight passes over the sea, just as Mithras does; the early Christian paintings of the ascension of Elijah are based partly on the corresponding Mithraic representations, where the horses of the sun-chariot mounting up to heaven leave the solid earth behind them and gallop away over the figure of a water-god—Oceanus—lying at their feet. Cf. Cumont, *Textes*, I, p. 178.

⁶³ Title of Mithras in the Vendidad, XIX, 28, cited by Cumont, *Textes*, I, p. 37.

⁶⁴ *De somniis*, I, 85.

⁶⁵ “Ἰλιος ἀνατολῆς... μόνος ἥλιος οὐτος ἀνέτειλεν ἅττ’ οὐρανοῦ. Cf. Pitra, *Analecta sacra*, II, p. 5, cited in Cumont, *Textes*, I, p. 355.

⁶⁶ De *Pascha Computus*, in Migne, *P.L.*, 4, col. 964. Cited in Usener, *Weihnachtsfest*, p. 5.—“O quam praeclara ... providentia ut in illo die quo factus est sol, in ipso die nasceretur Christus, v. Kal. Apr. feria IV. Et ideo de ipso merito ad plebem dicebat Malachias propheta: ‘Orietur vobis sol iustitiae et curatio est in pennis ejus,’ hic est sol iustitiae cuius in pennis curatio praeostendebatur.” The passage occurs in Malachi 4:2: “But unto you that fear my name shall the Sun of righteousness arise, with healing in his wings.” This image recalls the winged sun-disc of ancient Egypt. (Pl. IXa; cf. also pl. VII)

⁶⁷ “Sed et dominus nascitur mense Decembri hiemis tempore, VIII. kal. Januarias, quando oleae maturae premuntur ut unctio, id est chrisma, nascatur—sed et Invicti natalem appellant. Quis utique tam invictus nisi Dominus noster qui mortem subactam devicit? Vel quod dicant Solis esse natalem, ipse est sol iustitiae, de quo Malachias propheta dixit.—Dominus lucis ac noctis conditor et discretor qui a propheta Sol iustitiae cognominatus est.” Cumont, *Textes*, p. 355.

⁶⁸ Οὐ αἶ τοῖζ προσκυνοῦσι τὸν ἥλιον καὶ τὴν σαλήνην καὶ τοὺς ἀστέρας. Ποιοὶς γὰρ οἶδα τοὺς προσκυνοῦντας καὶ εὐχομένους εἰς τὸν ἥλιον “Ἰδὴ γὰρ ἀνατείλαντος τοῦ ἡλίου, προσεύχονται καὶ λέγουσιν” ‘Ἐλέησον ἡμᾶς “καὶ οὐ μόνον Ἡλιογνώσται καὶ αἰρετικοὶ τοῦτο ποιοῦσιν ἀλλὰ καὶ χριστιανοὶ καὶ ἀφέντες τὴν τοῖς αἰρετικοῖς ἀναμίγνυνται.—Oratio VI: Περὶ ἀστρονόμων, cited in Cumont, p. 356.

⁶⁹ “Non est Dominus Christus sol factus, sed per quem Sol factus est.”—In *Johannis Evang.*, Tract. XXXIV, 2. [Trans. from author’s version.]

⁷⁰ The pictures in the catacombs likewise contain a good deal of sun symbolism. For instance there is a swastika (sun-wheel) on the robe of Fossor Diogenes in the cemetery of Peter and Marcellinus. The symbols of the rising sun—bull and ram—are found in the Orpheus frescoes in the cemetery of Domitilla; also the ram and peacock (a sun-symbol like the phoenix) on an epitaph in the Callistus catacomb.

⁷¹ Numerous examples in Görres, *Die Christliche Mystik*.

⁷² Le Blant, *Sarcophages de la Gaule*. In the Homilies of Clement of Rome (*Homil.* II, 23, cited in Cumont, *Textes*, I, p. 356) we read: Τῷ κυρίῳ γεγόνασιν δώδεκα ἀπόστολοι τῶν τοῦ ἡλίου δώδεκα μηνῶν φέρονες τὸν ἀριθμὸν (The Lord had twelve apostles, bearing the number of the twelve months of the sun) (trans. by Roberts and Donaldson, p. 42). This image evidently refers to the sun’s course through the zodiac. The course of the sun (like the course of the moon in Assyria; cf. fig. 10) was represented as a snake carrying the signs of the zodiac on its back (like the *Deus leontocephalus* of the Mithraic mysteries; cf. pl. XLIV). This view is supported by a passage from a Vatican Codex edited by Cumont (190, 13th cent., p. 229; in *Textes*, I, p. 35): Τότε ὁ πάνσοφος δημιουργὸς ἄκρω νεύματι ἐκίνησε τὸν μέγαν δράκοσμημένω στεφάνῳ, λέγω δὴ τὰ ἰβ’ ξώδια βαστάζοντα ἐπὶ τοῦ νότου αὐτοῦ (Then the all-wise Demiurge, by his highest command, set in motion the great dragon with the spangled crown, I mean the twelve signs of the zodiac which are borne on his back). In the Manichaean system, the symbol of the snake, and actually the snake on the tree of Paradise, was attributed to Christ. Cf. John 3: 14: “And as Moses lifted up the serpent in the wilderness, so must the Son of man be lifted up.” (Pl. IXb.)

⁷³ *Apologia* 16: “Alii humanius et verisimilius Solem credunt deum nostrum.”

⁷⁴ “Report on the Happenings in Persia,” from an 11th-cent. MS. in Munich: Wirth, ed., *Aus orientalischen Chroniken*, p. 151.

⁷⁵ “To the great God Zeus Helios, King Jesus” (p. 166, § 22).

⁷⁶ Abeghian, *Der armenische Volksglaube*, p. 43.

⁷⁷ Attis was later assimilated to Mithras, and like him was represented with the Phrygian cap (cf. fig. 9). Cumont, *Mysteries*, p. 87. According to the testimony of St. Jerome (*Ep. 58 ad Paulinum*), the birth-cave at Bethlehem was originally a sanctuary (spelaeum) of Attis-Adonis (Usener, *Weihnachtsfest*, p. 283).

⁷⁸ Cumont (pp. iv–v) says: “The two adversaries discovered with amazement, but with no inkling of their origin, the similarities which united them.”

⁷⁹ *Works*, p. 559.

⁸⁰ Trans. by Thomas and Guillemard, p. 293.

⁸¹ Genesis 6:2.

⁸² [Cf. “Kubla Khan,” *Poems*, p. 297.—EDITORS.]

⁸³ Byron, p. 556.

⁸⁴ Nature, the object par excellence, reflects all those contents of the unconscious which as such are not conscious to us. Many nuances of pleasure and pain perceived by the senses are unthinkingly attributed to the object, without our pausing to consider how far the object can be made responsible for them. An example of direct projection can be seen in the following modern Greek folksong:

“Down on the strand, down on the shore,
A maiden washed the kerchief of her lover ...
And a soft west wind came sighing over the shore,
And lifted her skirt a little with its breath.
So that a little of her ankles could be seen,
And the seashore grew bright as all the world.”

(Sanders, *Das Volksleben der Neugriechen*, p. 81, cited in the *Zeitschrift des Vereins für Volkskunde*, XII, 1902, p. 166.) Here is a Germanic variant, from the *Edda*:

“In Gyimir’s farm I saw
A lovely maid coming towards me.
With the glory of her arm glowed
The sky and all the everlasting sea.”

(Gering, p. 53, cited in the *Zeitschrift*, p. 167.) Projection also accounts for all the miraculous reports of “cosmic” events at the birth and death of heroes.

⁸⁵ Cf. the mythical heroes, who after their greatest deeds fall into spiritual confusion.

⁸⁶ The history of religion is full of such aberrations.

⁸⁷ Anah is the beloved of Japhet, the son of Noah. She deserts him for the seraph.

⁸⁸ The one invoked is actually a star. Cf. Miss Miller’s “morning stars,” par. 60 above.

⁸⁹ This is an attribute of the “wandering sun.”

⁹⁰ The light substance of her own psyche.

⁹¹ The bringing together of the two light substances shows their common origin: they are libido images. According to Mechthild of Magdeburg (*Das fließende Licht der Gottheit*), the soul is compounded of “Minne” (love).

⁹² Cf. the paintings by Stuck—“Sin,” (pl. x), “Vice,” and “Sensuality”—where a woman’s naked body is encircled by a huge snake. At bottom it portrays the fear of death.

⁹³ Byron, p. 551.

⁹⁴ Interpretation of the products of the unconscious, for instance of a person in a dream, has a double aspect: what that person means in himself (the “objective level”) and what he means as a projection (“subjective level”). Cf. “On the Psychology of the Unconscious,” *Two Essays*, par. 130.

- ¹ Samson as a sun-god. See Steintal, “Die Sage von Simson.” The killing of the lion, like the Mithraic bull-sacrifice, is an anticipation of the god’s self-sacrifice.
- ² Rudra, properly—as father of the Maruts (winds)—a wind- or storm-god, appears here as the sole creator-god, as the text shows. The role of creator and fertilizer naturally falls to him as a wind-god. Cf. my comments on Anaxagoras in pars. 67 and 76, above.
- ³ Trans. of this and the following passages (Shvet. Up. 3. 2–4; 7, 8, 11; 12–15) based on Hume, *The Thirteen Principal Upanishads*, pp. 399–401; and Max Müller, *The Upanishads*, II, pp. 244ff.
- ⁴ Similarly, the Persian sun-god Mithras is equipped with an immense number of eyes. It is possible that Loyola’s vision of the snake with multiple eyes is a variant of this motif. See my “On the Nature of the Psyche,” par. 395.
- ⁵ Whoever has God, the sun, in himself is immortal like the sun. Cf. Part I, ch. 5, above.
- ⁶ 4. 13; trans. by Purohit Swami and Yeats, p. 34. [Or, in René Guénon’s trans., *Man and His Becoming according to the Vedanta*, p. 45: “This Purusha, of the size of a thumb, is of a clear luminosity like a smokeless fire; it is the Lord of the past and of the future; it is today, and it will be tomorrow, such as it is.”—TRANS.]
- ⁷ The light symbolism in the etymology of *φάλλος* is discussed in pars. 321f., below.
- ⁸ *Faust*, Part II, trans. based on MacNeice, p. 177.
- ⁹ *Ibid.*, Part I, trans. by Wayne, p. 75, modified.
- ¹⁰ *Psychology and Alchemy*, index, s.v. “coniunctio.” For a psychological account of the problem, see my “Psychology of the Transference.”
- ¹¹ Goethe is here referring to the “miracle” of the Chrysopoea, or gold-making.
- ¹² It is also said that, out of gratitude to him for having buried the mother of the serpents, the young serpents cleaned his ears, so that he became clairaudient.
- ¹³ Cf. the vase painting from the Cabirion at Thebes (fig. 14), where the Cabiri are depicted in a noble as well as a caricatured form (Roscher, *Lexikon*, s.v. “Megaloi Theoi”). Cf. also Kerényi, “The Mysteries of the Kabeiroi.”
- ¹⁴ Justification for calling the dactyls “Thumblings” may be found in a note in Pliny (VII, 57; Bostock and Riley trans., II, p. 225), where he says that in Crete there were precious stones, iron-coloured and shaped like a thumb, which were known as Idaean dactyls.
- ¹⁵ Hence the dactylic metre in poetry.
- ¹⁶ Roscher, s.v. “Daktyloi.”
- ¹⁷ Varro identifies the *μεγάλοι θεοί* with the *penates*. He says the “*simulacra duo virilia Castoris et Pollucis*” in the harbour of Samothrace were Cabiri.
- ¹⁸ Statues only a foot high, with caps on their heads, were found at Prasiae, on the Laconian coast, and at Pephnos.
- ¹⁹ Next to him is a female figure labelled KPATEIA, orphically interpreted as “she who brings forth.”
- ²⁰ Roscher, s.v. “Megaloi Theoi.” Today an ancient Mediterranean, pre-Grecian origin is regarded as more probable. Cf. Kerényi, *Die Geburt der Helena*, p. 59.
- ²¹ “Companion and fellow-reveller of Bacchus.” Roscher, s.v. “Phales.”
- ²² Illustrated in Kerényi, “The Mysteries of the Kabeiroi,” fig. 1 (and our fig. 14).

²³ Freud, in “Notes on ... a Case of Paranoia,” pp. 78f., which appeared simultaneously with Part I of this book (1st [1912] edition), makes an observation that closely parallels my own remarks concerning the “libido theory” based on the fantasies of the insane Schreber: “Schreber’s ‘rays of God,’ which are made up of a condensation of the sun’s rays, of nerve-fibres, and of spermatozoa, are in reality nothing else than a concrete representation and projection outwards of libidinal cathexes; and they thus lend his delusions a striking conformity with our theory. His belief that the world must come to an end because his ego was attracting all the rays to itself, his anxious concern at a later period, during the process of reconstruction, lest God should sever his ray-connection with him,—these and many other details of Schreber’s delusional formation sound almost like endopsychic perceptions of the processes whose existence I have assumed in these pages as the basis of our explanation of paranoia.”

²⁴ Cicero, *Tusculan Disputations*, Book IV, vi, 12. ([volunt ex duobus opinatis] bonis [nasci] ... libidinem et laetitiam, ut sit laetitia praesentium bonorum, libido futurorum ... cum libido ad id, quod videtur bonum, illecta et inflammata rapiatur ... natura enim omnes ea quae bona videntur, sequuntur, fugiuntque contraria; quam ob rem simul obiecta species est cuiuspiam, quod bonum videatur, ad id adipiscendum impellit ipsa natura. Id cum constanter prudenterque fit, eiusmodi appetitionem Stoici βούλησιν appellant, nos appellemus voluntatem; eam illi putant in solo esse sapiente, quam sic definiunt: voluntas est quae quid cum ratione desiderat; quae autem a ratione aversa incitata est vehementius, ea libido est, vel cupiditas effrenata, quae in omnibus stultis invenitur.)

²⁵ *Pro Quinctio*, 14.

²⁶ *The War with Catiline*, VII, trans. by Rolfe, pp. 14–15.

²⁷ *Letter to Caesar*, XIII, trans. *ibid.*, pp. 488–89.

²⁸ In this sense the word *libidine* is still commonly used in Tuscany today.

²⁹ *De Civitate Dei*, XIV, xv. (Est igitur libido ulciscendi, quae ira dicitur; est libido ~~habendi~~ pecuniam, quae avaritia; est libido quomodocumque vincendi, quae pervicacia; est libido gloriandi, quae iactantia nuncupatur. Sunt multae variaequae libidines, quarum nonnullae habent etiam vocabula propria, quaedam vero non habent. Quis enim facile dixerit, quid vocetur libido dominandi, quam tamen plurimum valere in tyrannorum animis, etiam civilia bella testantur?)

³⁰ *Ibid.* (Voluptatem vero praecedat appetitus quidam, qui sentitur in carne quasi cupiditas eius, sicut fames et sitis.)

³¹ Walde, *Wörterbuch*, p. 426, s.v. “libet.” *Liberi*, ‘children,’ is grouped with *libet* by Nazari (pp. 573f.). If this is correct, then Liber, the ancient Italian god of procreation, who is most certainly connected with *liberi*, would also be related to *libet*. Libitina, the goddess of the dead, is supposed to have nothing to do with Lubentina or Lubentia (an attribute of Venus), which is related to *libet*. The name is as yet unexplained.

³² See my “On Psychic Energy,” par. 37.

¹ [Originally *Drei Abhandlungen zur Sexualtheorie*, 1905.—EDITORS.]

² “Three Essays on the Theory of Sexuality,” pp. 135ff.

³ An idea which Möbius tried to resuscitate. Fouillée, Wundt, Beneke, Spencer, and Ribot are among the more modern writers who recognize the psychological primacy of the instincts.

⁴ But the same is also true of hunger. I once had a patient whom I had freed pretty well from her symptoms. One day she suddenly turned up with what looked like a complete relapse into her earlier neurosis. I was unable to explain it at first, until I discovered that she was so engrossed in a lively fantasy that she had forgotten to eat lunch. A glass of milk and a slice of bread successfully removed the “hunger afflux.”

⁵ Freud (“Essays on the Theory of Sexuality,” p. 163) says: “I must first explain ... that all my experience shows that these psychoneuroses are based on sexual instinctual forces. By this I do not merely mean that the energy of the sexual instinct makes a contribution to the forces that maintain the pathological manifestations (the symptoms). I mean expressly to assert that that contribution is the most important and only constant source of energy of the neurosis and that in consequence the sexual life of the persons in question is expressed—whether exclusively or principally or only partly—in these symptoms.”

⁶ “Notes on a Case of Paranoia,” pp. 73ff.

⁷ *Ibid.*, p. 75.

⁸ Schreber’s case, which Freud is here discussing, is not a pure paranoia. See Schreber, *Memoirs of My Nervous Illness*.

⁹ Pp. 30ff. Also see “The Content of the Psychoses.”

¹⁰ Cf. “The Psychology of Dementia Praecox,” pars. 19, 195.

¹¹ Ferenczi’s use of the term “introjection” denotes the exact opposite: taking the external world into oneself. Cf. his “Introjection and Transference,” p. 47.

¹² *The World as Will and Idea*, trans. by Haldane and Kemp, I, p. 145, modified.

¹³ *Theogony*, 120.

¹⁴ Cf. Roscher, *Lexikon*, III, 11, 2248ff.

¹⁵ Drews, *Plotin*, p. 127.

¹⁶ *Ibid.*, p. 132.

¹⁷ *Ibid.*, p. 135.

¹⁸ Plotinus, *Enneads*, II, 5, 3.

¹⁹ *Ibid.*, IV, 8, 3.

²⁰ *Ibid.*, III, 5, 9.

²¹ Drews, p. 141,

²² Cf. Spielrein, “Über den psychologischen Inhalt eines Falles von Schizophrenie,” p. 329.

²³ It was never published. [He committed suicide in 1911.—EDITORS.]

²⁴ Spielrein, PP. 338, 353, 387. See par. 246, n. 41, below, for soma as “seminal fluid.”

²⁵ Berthelot, *Collection*, III, 1, 2ff. (Textes, pp. 107–12; Traductions, pp. 117–21). [Cf. “The Visions of Zosimos,” par. 86.—EDITORS.]

²⁶ Spielrein, p. 345.

²⁷ *Ibid.*, p. 338.

²⁸ *Ibid.*, p. 397.

²⁹ Here I might also mention those American Indians who believe that the first human beings arose from the union of a sword-hilt and a shuttle.

³⁰ Spielrein, p. 399.

¹ I have seen this pendulum movement of the head in a catatonic patient, gradually building itself up from what Freud has termed the “upward displacement” of coitus movements.

² *Dreams and Myths*.

³ *Mythologische Studien*, I: *Die Herabkunft des Feuers und des Göttertranks*. (Cf. pl. xv.) A résumé of the contents is to be found in Steinthal, “Die ursprüngliche Form der Sage von Prometheus,” and in Abraham, *Dreams and Myths*.

⁴ Also *mathnāmi* and *māthāyati*. The root is *manth* or *math*.

⁵ Kuhn, in *Zeitschrift für vergleichende Sprachforschung*, II, p. 395 and IV, p. 124.

⁶ K. Bapp, in Roscher, *Lexikon*, III, 3034.

⁷ [“The one who thinks ahead” is the meaning of Prometheus now accepted as philologically correct.—EDITORS.] An interesting parallel is the Balinese fire-god, who has his seat in man’s brain and is always represented as dancing on a fiery wheel (a sun-symbol). He is regarded as the highest and most popular god of the Balinese. (P1. XIIIa.)

⁸ *Bhrigu* = *ὀλέγυ*, an accepted phonetic equivalence. See Roscher, III, 3034, 54.

⁹ For the eagle as a fire-totem among the Indians, see Roscher, III, 3034, 60.

¹⁰ According to Kuhn the root *manth* becomes in German *mangeln* (Eng. ‘to mangle’). *Manthara* is the stick used for churning butter. (Cf. pl. xv.) When the gods produced the *amrita* (drink of immortality: ambrosia) by churning the ocean round, they used Mt. Mandara as a churning-stick (Kuhn, *Mythologische Studien*, I, pp. 16ff.). Steinthal calls attention to Lat. *mentula*, a poetic expression for the male organ, presumably derived from *ment* or *manth*. I would add that *mentula* can be taken as a diminutive of *menta* or *mentha* (*μίνθα*), ‘mint.’ In antiquity mint was called “Aphrodite’s crown” (Dioscorides, II, 154). Apuleius calls it “*mentha venerea*,” because it was held to be an aphrodisiac. Hippocrates (“On Diet,” II, 54) gives it the opposite meaning: “*Si quis earn saepe comedat, eius genitale semen ita colliquescit, ut effluat, et arrigere prohibet et corpus imbecillum reddit*” (If one eats of it often, the genital seed becomes so liquid that it flows out; it prevents erection and renders the body weak), and according to Dioscorides (III, 34) mint is a contraceptive (cf. Aigremont, *Volkserotik*, I, p. 127). But the ancients also said: “*Menta autem appellata, quod suo odore mentem feriat ... mentae ipsius odor animum excitat*” (It is called *menta* because it strikes the mind [*mentem*] with its smell ... the smell of the mint excites the mind). This leads us to the root *ment*, as in *mens* (mind), so that the development of the parallel to *pramantha* would be complete. One might also add that a strong chin was called *mento* or *mentum*. As we know, the priapic figure of Punchinello was given a powerfully developed chin, and the pointed beards (and ears) of the satyrs and other priapic demons have a similar meaning, just as in general all the protruding parts of the body can be given a masculine, and all its concavities a feminine, significance.

¹¹ Cf. Kerényi, *Prometheus*, p. 36.

¹² “What is named the gulya (pudendum) means the yoni (the birthplace) of the god; the fire that is born there is called beneficent”: *Katyayanas Karmapradipa*, I, 7 (Kuhn, *Mythol. Studien*, I, p. 67). Kuhn’s suggestion of an etymological connection between G. *bohren*, ‘to bore,’ and *geboren*, ‘born,’ is very unlikely. According to him, G. *boron* (*bohren*) is primarily related to Lat. *forare* and Gr. *φάράω*, ‘to plough.’ He conjectures an Indo-European root **bher*, meaning ‘to bear,’ Skr. *bhar-*, Gr. *ἔρ-*, Lat. *fer-*, whence OHG, *beran*, ‘to bear’; Lat. *fero*, *fertilis*, and *fordus*, ‘pregnant’; Gr. *φορός*, ‘pregnant.’ Walde, in *Lateinisches Wörterbuch* (s.v. *ferio*), however, definitely relates *forare* to the root *bher*. Cf. the plough symbolism, below, par. 214, n. 22, and fig. 15.

- ¹³ Weber, *Indische Studien*, I, p. 197, cited in Kuhn, p. 71.
- ¹⁴ Or of mankind in general. *Vispatni* is the feminine fire-stick; *vispati*, an attribute of Agni, the masculine.
- ¹⁵ Rig-Veda, III, 29, 1–3, trans. based on Griffith, II, p. 25. For wood as a mother-symbol, see Freud, *The Interpretation of Dreams*, p. 355. “The son of Ila”: Ila was the daughter of Manu, the Indian Noah, who with the help of his fish survived the deluge and then begat a new race of human beings with his daughter.
- ¹⁶ Cf. Hirt, *Etymologie*, p. 348.
- ¹⁷ The capitulary of Charlemagne in 942 expressly forbids “illos sacrilegos ignes quos niedfyr vocant” (those sacrilegious fires which are called Niedfyr). Cf. Grimm, *Teutonic Mythology*, II, p. 604, where similar fire ceremonies are described.
- ¹⁸ *Mythologische Studien*, I, p. 43. (Pro fidei divinae integritate servanda recolat lector, quod cum hoc anno in Laodonia pestis grassaretur in pecudes armenti, quam vocant usitate Lungessouth, quidam bestiales, habitu claustrales non animo, docebant idiotas patriae ignem confrictione de lignis educere et simulacrum Priapi statuere, et per haec bestiis succurrere. Quod cum unus laicus Cisterciensis apud Fentone fecisset ante atrium aulae, ac intinctis testiculis canis in aquam benedictam super animalia sparsisset.)
- ¹⁹ Preuss, “Der Ursprung der Religion und Kunst,” p. 358.
- ²⁰ Cf. Schultze, *Psychologie der Naturvölker*, pp. 161f.
- ²¹ This primitive play leads to the phallic plough symbolism of higher cultures. ‘*Αροῦν* means ‘to plough’ and possesses in addition the poetic meaning of ‘to impregnate.’ The Latin *arare* means simply ‘to plough,’ but the phrase “fundum alienum arare” is the equivalent of ‘plucking cherries in your neighbour’s garden.’ There is an excellent picture of the phallic plough on a vase in [or once in] the Museo Archeologico in Florence: it portrays a row of six naked ithyphallic men carrying a plough which is represented ithyphallically (fig. 15). (Cf. Dieterich, *Mutter Erde*, pp. 107ff.) The “carrus navalis” (Carnival) of our spring festivals during the Middle Ages was occasionally a plough. (Hahn, *Demeter und Baubo*, p. 40, cited in Dieterich, p. 109.) Prof. Emil Abegg, of Zurich, has drawn my attention to the work of Meringer, “Wörter und Sachen,” which demonstrates a far-reaching fusion of libido-symbols with external materials and external activities, and lends the strongest support to the views I have outlined above. Meringer bases his argument on two Indo-European roots, **uen* and **ueneti*. IEur. **uen*, OInd. *ván*, *vána*, = ‘wood.’ Agni is called *garbhas vanām*, ‘fruit of the womb of the woods.’ IEur. **ueneti* = ‘he ploughs’ (*er ackert*)—piercing the ground and tearing it up with a sharp piece of wood. The verb itself is not verified, because the primitive method of agriculture it denoted—a sort of hoeing—died out at a very early date. When a better method of tillage was discovered, the designation for the primitive ploughed field was transferred to pastureland and meadows; hence Goth. *vinja*, Gr. *βομή*, Olcel. *vin*, ‘pasture, meadow.’ Also perhaps the Icet. *Vanen*, gods of agriculture. Also IEur. **uenos*, ‘enjoyment of love,’ Lat. Venus. From the emotional significance of **uenos* comes OHG. *vinnan*, ‘to rage’; also Goth. *vens*, Gr. *ἐλπίς*, OHG. *wân*, ‘expectation, hope’; Skr. *van*, ‘to want, desire’; G. *Wonne*, ‘ecstasy’; Olcel. *vinr*, ‘beloved, friend.’ From the connotation *ackern* arose G. *wohnen*, ‘to dwell,’ OE. *won*, ‘dwelling,’ a transition found only in the Germanic languages. From *wohnen* comes *gewöhnen*, ‘to get accustomed, to be wont’; OIcel. *vanr*, ‘accustomed.’ From *ackern*, again, comes *sich mühen, plagen*, ‘to take trouble or pains’; OIcel. *vinna*, ‘to work,’ OHG. *winnan*, ‘to toil or drudge’; Goth. *vinnan*, Gr. *πάσχειν*, *υunns*, *πάθημα*, ‘suffering.’ On the other hand, from *ackern* comes *gewinnen, erlangen*, ‘to win, attain,’ OHG. *giwinnan*; but also *verletzen*, ‘to

wound,' Goth, *vunds*. 'Wound' in the original sense, therefore, meant the ground torn up by hoeing. From *verletzen* come *schlagen*, 'to strike,' *besiegen*; 'to conquer'; OHG. *winna*, 'strife'; Old Saxon *winnan*, 'to battle.' (Fig. 16.)

²² The old custom of the "bridal bed" in the field, to make the field fruitful, expresses the analogy in the clearest possible way: as I make this woman fruitful, so I make the earth fruitful. The symbol canalizes the libido into cultivating and fructifying the earth. (Cf. pl. *x1b*) Cf. Mannhardt, *Wald- und Feldkulte*, I, for exhaustive evidence.

²³ Cf. "The Psychology of the Transference," pars. 433ff.

²⁴ *Südamerikanische Felszeichnungen*, p. 17.

²⁵ Teixeira de Mattos trans., p. 100.

²⁶ p. 371.

²⁷ For evidence of this, see Bücher, *Arbeit und Rhythmus*.

²⁸ Eberschweiler, "Untersuchungen über die sprachlichen Komponenten der Assoziation."

²⁹ [See pp. 100ff., above.]

³⁰ Further details of this case in "The Concept of the Collective Unconscious," pars. 104ff.

³¹ [Cf. "On the Nature of the Psyche," pars. 397ff.—EDITORS.]

³² Known as the "factor of extensity" in the older physics. Cf. von Hartmann, *Die Weltanschauung der modernen Physik*, p. 5.

³³ The Upanishads expound the theology of the Vedic writings and contain the speculative, theosophical part of the teachings. The Vedic writings are mostly of very uncertain age, and since for a long time they were handed down only orally, they may date back to the very remote past.

³⁴ The primordial universal being, a concept which in psychological terms coincides with that of the libido.

³⁵ The atman is thus thought of as originally bisexual or hermaphroditic. The world was created by desire: cf. Brih. Up. 1, 4, 1–3: "In the beginning this world was Self alone in the form of a Person (*purusha*). He looked round and saw nothing but himself.... He became afraid; therefore one who is alone is afraid. He thought: 'Why should I be afraid, since there is nothing but myself?....' He had no joy; therefore one who is alone has no joy. He desired a second." Then follows the description of his division into two, quoted above. Plato's idea of the world-soul comes very close to this Indian image: "It had no need of eyes, for there was nothing outside it to be seen; nor of ears, for there was nothing outside it to be heard.... Nothing went out from or came into it anywhere, for there was nothing." (*Timaeus*, 33, trans. based on Cornford, p. 55.)

³⁶ Brih. Up. 1, 4, 3–6, trans. based on Hume, pp. 81–82.

³⁷ I, 3–4, trans. based on Hume, p. 294.

³⁸ Trans. based on Hume, p. 133.

³⁹ Cf. Brugsch, *Religion und Mythologie der alten Aegypter*, pp. 255f., and the *Dictionnaire hiéroglyphique*.

⁴⁰ The word *swan* might also be mentioned here, because the swan sings when about to die. The swan, eagle, and phoenix occur in alchemy as related symbols. They signify the sun and thus the philosophical gold. Cf. also the verse from Heine (trans. by Todhunter):

A swan on the lake sings lonely,

He oars himself to and fro,

Then faint and fainter singing,

Sinks to his grave below.

⁴¹ Trans. by Wayne, p. 39.

⁴² Trans. based on MacNeice, p. 159, and on unpubl. trans. by Philip Wayne.

⁴³ “Sunset.” [Cf. trans. by Hamburger, p. 97.]

⁴⁴ [Cf. Macdonell, *Sanskrit Dictionary*, p. 112, s.v. “tégas.”—EDITORS.]

⁴⁵ Connected with *ag-ilis*, ‘agile.’ See Max Müller, *Origin and Growth of Religion*, p. 212.

⁴⁶ Spiegel, *Erànische Altertumskunde*, II, p. 49.

⁴⁷ Max Müller, *Introduction to the Science of Religion*, pp. 164–65 n.

⁴⁸ In Book IV, trans. by Arnold, pp. 25–26.

⁴⁹ *Symposium* 202 E, 203 D – E, trans. by Hamilton, pp. 81f., modified.

⁵⁰ The alchemists, too, were interested in this story and regarded the “fourth” as the *filius philosophorum*. Cf. *Psychology and Alchemy*, par. 449.

⁵¹ This side of Agni points to Dionysus, who exhibits parallels both with Christian and with Indian mythology.

⁵² “Whatever is liquid he created from semen, and that is soma.” Brih. Up. 1, 4, 6.

⁵³ The question is whether this meaning was only a secondary development. Kuhn seems to assume this; he says (*Mythol. Studien*, I, p. 18): “But, together with the meaning which the root *manth* had already developed, there also grew up in the Vedas, as a natural development of the procedure, the idea of tearing off or plucking.”

⁵⁴ For examples see Frobenius, *Das Zeitalter des Sonnengottes*.

⁵⁵ “Zur Psychologie der Brandstifter,” p. 80.

¹ Hence the beautiful name of the sun-hero Gilgamesh, “The Man of Joy and Sorrow,” in Jensen, *Das Gilgamesch-Epos*.

² Cf. the researches of Silberer, “Phantasie und Mythos,” pp. 513ff.

³ See Bleuler, “Zur Theorie des schizophränen Negativismus.”

⁴ Cf. Krishna’s exhortation to the hesitant Arjuna in the Bhagavad Gita: “But thou, be free of the pairs of opposites!” (Trans. by Arnold, p. 13.)

⁵ La Rochefoucauld, *Moral Maxims*, No. DLX, p. 139.

⁶ Cf. the following chapters.

⁷ Cf. Müller, *Über die phantastischen Gesichterscheinungen*.

⁸ In my later works, I therefore speak of the “collective” unconscious.

⁹ “Illustrierte Halluzinationen,” pp. 69ff.

¹⁰ In the Middle Ages, the sphinx was regarded as an “emblem” of pleasure. Thus Andrea Alciati says in his *Emblemata* (p. 801) that the sphinx signifies “corporis voluptas, primo quidem aspectu blandiens, sed asperrima, tristisque, postquam gustaveris. De qua sic ... meretricius ardor egregiis iuvenes sevocat a studiis” (the pleasure of the body, attractive indeed at first sight, but very bitter and sad after you have tasted it. And ... [name corrupt] says this about it: the love of whores lures young men away from lofty studies).

¹¹ The motif of the “helpful animals” may also be connected with the parental imago.

¹² For relevant case material, see Gerhard Adler, *Studies in Analytical Psychology*.

¹³ In Hellenistic syncretism, the Echidna became a cult-symbol of mother Isis.

¹⁴ To the extent that the shadow is unconscious it corresponds to the concept of the “personal unconscious.” Cf. “On the Psychology of the Unconscious,” *Two Essays*, par. 103.

¹⁵ Cf. Emma Jung, “Ein Beitrag zum Problem des Animus,” pp. 296ff.

¹⁶ Bunsen, *Gebetbuch*, No. 912, p. 789. [As trans. in the Hinkle (1916) edn.] The crown also plays a role in alchemy, perhaps as a result of cabalistic influence. (Cf. the compilation by Goodenough, “The Crown of Victory in Judaism,” pp. 139ff.) The hermaphrodite is generally represented as crowned (pl. xviii). For the alchemical material on the crown, see “Psychology of the Transference,” par. 497, n. 14.

¹⁷ Bunsen, No. 494, p. 271.

¹⁸ *Ibid.*, No. 640, p. 348. [As trans. in the Hinkle (1916) edn.]

¹⁹ In popular German speech, incendiarism is called “putting a red cock on the roof.”

²⁰ In the mystery religions, there is no doubt about the identity of the divine hero with the celebrant. A prayer addressed to Hermes says: σὺ γὰρ ἐγὼ καὶ ἐγὼ σὺ τὸ σὸν εἶνομα ἐμὸν καὶ τὸ ἐμὸν σὸν ἐγὼ γὰρ εἶμι τὸ εἶδωλὸν σοῦ. (For you are I and I am you; your name is mine and my name is yours; for I am your image). Kenyon, *Greek Papyri in the British Museum*, p. 116, Pap. CXXII, 36–38; cited in Dieterich, *Mithrasliturgie*, p. 97. The hero as a libido-image is aptly portrayed in the head of Dionysus in Leiden (Roscher, *Lexikon*, I, 1128), where the hair is twisted up like a flame. Cf. Isaiah 10:17 (RSV): “The light of Israel will become a fire, and his Holy One a flame.” Firmicus Maternus (*De errore*, XIX) reports that the god was greeted as the “bridegroom” and the “new light.” He quotes the saying: νυμῳίε χαῖρε νυμῳίε χαῖρε νέον ὀψῳς (Hail, bridegroom, hail, new light!), and contrasts it with the

Christian: “Nullum apud te lumen est, nec est aliqui qui sponsus mereatur audire: unum lumen est, unus est sponsus. Nominum horum gratiam Christus accepit” (No light is with you, nor is there anyone who deserves the name of bridegroom: there is only one light, one bridegroom. The grace of these titles is reserved to Christ).

²¹ Hence the old custom of giving children the names of saints.

²² [The term is reported from the United States. In a popular song, “Feet Up, Pat Him on the Po-po,” copyright 1952, a baby is being playfully patted on the buttocks. The term is said to occur in American Southern dialect and appears to be unrelated to German.—EDITORS.]

²³ De Gubernatis (*Zoological Mythology*) says that dung and gold are always associated in folklore, and Freud tells us the same thing on the basis of his psychological experience. Grimm reports the following magical practice: “If you want money in the house all the year round, you must eat lentils on New Year’s Day.” This singular association is very simply explained by the indigestibility of lentils, which reappear in the form of coins. In this manner one defecates money.

²⁴ A French-speaking father, who naturally denied that his child had any such interests, nevertheless mentioned that whenever the child spoke of “cacao” (cocoa) he always added “lit” (bed), meaning “caca-au-lit.”

²⁵ “Analysis of a Phobia in a Five-year-old Boy.”

²⁶ See the etymological connections given above.

²⁷ Lombroso, *Genio e Follia*, p. 141.

²⁸ Popular belief refuses to give up its wandering sun-heroes. Cagliostro, for instance, is said to have driven out of the city of Basel from all the gates simultaneously, with four white horses!

²⁹ Cf. my paper “Concerning Rebirth,” pars. 240ff.

³⁰ [The following passages are translated from the version used by the author, the source of which is not given. The material may also be found in Pickthall’s trans., pp. 301ff., and Rodwell’s, pp. 186ff.—TRANS.]

³¹ Allah.

³² The “two-horned.” According to the commentators this refers to Alexander the Great, who in Arabian legend plays the same kind of role as Dietrich of Bern. The two-horned refers to the strength of the sun-bull. Alexander is often found on coins with the horns of Jupiter Ammon. (Pl. *xxa*.) This is one of the identifications of the legendary ruler with the spring sun in the sign of the Ram. There can be no doubt that mankind felt a great need to eliminate everything personal and human from its heroes so as to make them equal to the sun, i.e., absolute libido-symbols, through a kind of metastasis. If we think like Schopenhauer, we shall say “libido-symbol”; but if we think like Goethe, we say “sun.” We exist because the sun sees us.

³³ Vollers, “Chidher,” pp. 234–84. This is my source for the Koran commentaries.

³⁴ Also with Mithras and Christ. See par 165, above.

³⁵ On the other hand, according to Matthew 17: 13, Elias is to be understood as John the Baptist.

³⁶ Cf. the Kyffhäuser legend. [Referring to the Emperor Barbarossa, who is said to sleep inside a mountain.—EDITORS.]

³⁷ Vollers, “Chidher.”

³⁸ There is also a legend that Alexander had been on the “mountain of Adam” in India, with his “minister” Khidr.

³⁹ These mythological equations follow the dream rule that the dreamer can be split up into several figures.

⁴⁰ John 3:30: "He must increase, but I must decrease."

⁴¹ Cumont, *Textes*, I, pp. 172ff.

⁴² *Ibid.*, p. 173.

⁴³ The parallel between Heracles and Mithras can be carried even further. Like Heracles, Mithras is an excellent archer. Judging from certain of the monuments, it would seem that not only Heracles, but Mithras too, was threatened in youth by a snake. The labours of Heracles have the same meaning as the conquest and sacrifice of the bull in the Mithraic mystery. (Cf. fig. 17.)

⁴⁴ These three scenes are represented in a row on the Klagenfurt monument, so presumably there was some dramatic connection between them. Illustrated in Cumont, *Mysteries of Mithra*, fig. 24, p. 133.

⁴⁵ *Ibid.* See also Roscher, II, 3048, 42ff.

⁴⁶ Cf. Frobenius, *Zeitalter des Sonnengottes*.

⁴⁷ This interpretation is still a bit mythological; to be more accurate, the fish signifies an autonomous content of the unconscious. Manu had a fish with horns. Christ was a fish, like 'Ιχθὺς, son of the Syrophoenician Derceto. Joshua ben Nun was called "son of the fish." The "two-horned" (Dhulqarnein = Alexander) turns up in the legend of Khidr. (Cf. pl. xx*a*.)

⁴⁸ The wrapping signifies invisibility, hence to be a "spirit." That is why the neophytes were veiled in the mysteries. (Cf. pl. iv*b*.) Children born with a caul over their heads are supposed to be particularly fortunate.

⁴⁹ The Etruscan Tages, the boy who sprang from the freshly ploughed furrow, was also a teacher of wisdom. In the Litaolane myth of the Basuto (Frobenius, p. 105), we are told how a monster devoured all human beings and left only one woman alive, who gave birth to a son, the hero, in a cowshed (instead of a cave). Before she could prepare a bed of straw for the infant, he was already grown up and spoke "words of wisdom." The rapid growth of the hero, a recurrent motif, seems to indicate that the birth and apparent childhood of the hero are extraordinary because his birth is really a rebirth, for which reason he is able to adapt so quickly to his heroic role. For a more detailed interpretation of the Khidr legend, see my paper "Concerning Rebirth," pars. 240ff.

⁵⁰ Cf. Ra's fight with the night serpent.

⁵¹ *Gilgamesch-Epos*, I, p. 50. When revising this book, I left the above account, which is based mainly on Jensen, in its original form, though certain details could have been supplemented by the results of recent research. I refer the reader to Heidel, *The Gilgamesh Epic and Old Testament Parallels*; Schott, *Das Gilgamesch-Epos*; Speiser's version in Pritchard, ed., *Ancient Near Eastern Texts*; and especially to Thompson's remarkable trans., *The Epic of Gilgamesh*.

⁵² The difference between this and the Mithraic sacrifice is significant. The dadophors are harmless gods of light who take no part in the sacrifice. The Christian scene is much more dramatic. The inner relation of the dadophors to Mithras, of which I will speak later, suggests that there was a similar relation between Christ and the two thieves.

⁵³ For instance, there is the following dedication on a monument: "D[eo] I[nvicto] M[ithrae] Cautopati." One finds that "Deo Mithrae Cauti" or "Deo Mithrae Cautopati" is interchangeable with "Deo Invicto Mithrae" or "Deo Invicto," or simply "Invicto." Sometimes the dadophors are equipped with knife and bow, the attributes of Mithras.

From this we can conclude that the three figures represent three different states, as it were, of a single person. Cf. Cumont, *Textes*, I, pp. 208f.

⁵⁴ *Ibid.*, p. 208f.

⁵⁵ The triadic symbolism is discussed in my “A Psychological Approach to the Dogma of the Trinity,” pars. 172ff.

⁵⁶ *Textes*, I, p. 210.

⁵⁷ For the period from 4300 to 2150 B.C. So, although these signs had long been superseded, they were preserved in the cults until well into the Christian era.

⁵⁸ The Shvetashvatara Upanished (4, 6ff.) uses the following parable to describe the individual and the universal soul, the personal and tianspcrsonal atman:

Behold, upon the selfsame tree,
Two birds, fast-bound companions, sit.
This one enjoys the ripened fruit,
The other looks, but does not eat.

On such a tree my spirit crouched,
Deluded by its powerlessness,
Till seeing with joy how great its Lord,
It found from sorrow swift release....

Hymns, sacrifices, Vedic lore,
Past, future, all by him are taught.
The Maya-Maker thinks the world
In which by Maya we are caught.

(Trans. based on Hume, pp. 403f.)

⁵⁹ Among the elements composing man, the Mithraic liturgy lays particular stress on fire as the divine element, describing it as *τό εἰς ἐμὴν κρᾶσιν θεοδῶρητον* (the divine gift in my composition). Dieterich, *Mithrasliturgie*, p. 58.

⁶⁰ An illustration of the periodicity or rhythm expressed in sexuality.

⁶¹ Reproduced not from a photograph, but from a drawing I myself made.

⁶² In a myth of the Bakairi Indians, of Brazil, a woman appears who sprang from a corn mortar. A Zulu myth tells a woman to catch a drop of blood in a pot, then close the pot, put it aside for eight months, and open it again in the ninth month. She follows this advice, opens the pot in the ninth month, and finds a child inside it. (Frobenius, I, p. 237.)

⁶³ Roscher, *Lexikon*, II, 2733/4, s.v. “Men.”

⁶⁴ A well-known sun-animal.

⁶⁵ Like Mithras and the dadophors.

⁶⁶ This explanation is not satisfactory, because I found it impossible to go into the archetypal incest problem and all its complications here. I have dealt with it at some length in my “Psychology of the Transference.”

⁶⁷ Like Gilgamesh, Dionysus, Heracles, Mithras, etc.

⁶⁸ Cf. Graf, *Richard Wagner im Fliegenden Holländer*.

⁶⁹ Trans. based on MacNeicc, pp. 175ff. Cf. also trans. by Wayne, Part II, pp. 76ff.

¹ Freud, *The Interpretation of Dreams*, pp. 245–46, 288.

² Today we would call it a mandala symbol of the self.

³ Another form of the same motif is the Persian idea of the tree of life, which stands in the lake of rain, Vouru-Kasha. The seeds of this tree were mixed with the water and so maintained the fertility of the earth. The Vendidad, 5, 17ff. (trans. by Darmesteter, p. 54), says that the waters flow “to the sea Vouru-Kasha, towards the well-watered tree, whereon grow the seeds of my plants of every kind.... Those plants I, Ahura-Mazda, rain down upon the earth, to bring food to the faithful, and fodder to the beneficent cow.” Another tree of life is the white haoma, which grows in the spring Ardisura, the water of life. Spiegel, *Erānische Altertumskunde*, I, pp. 465ff.

⁴ Examples in Rank, *Birth of the Hero*.

⁵ Frobenius, *Das Zeitalter des Sonnengottes*, p. 30.

⁶ *Ibid.*, p. 421.

⁷ *Ibid.*, pp. 60f.

^{7a} Elsewhere in the poem we are told that he came out of the monster’s right ear (like Rabelais’ Gargantua, who was born from the ear of his mother).

⁸ This probably means simply his soul. No moral considerations are implied.

⁹ Frobenius, pp. 173f.

¹⁰ And, of course, to the father, though the relation to the mother naturally takes first place, being on a deeper level.

¹¹ In the Babylonian underworld, for instance, the souls wear feather-dresses like birds. Cf. the Gilgamesh Epic.

¹² In a 14th-century copy of the gospels, at Bruges, there is a miniature which shows the “woman,” beautiful as the mother of God, standing with the *lower* half of her body in a dragon.

¹³ The Greek text has τὸ ἀρνίον, ‘little goat, kid,’ a diminutive of the obsolete ἀρνίον, ‘ram.’ (Theophrastus uses it in the sense of “young scion” of a family.) The related word ἄρνῃς characterizes a festival held annually in Argos in honour of Linus, where the so-called Linus lament was sung. Linus, the child of Psamathe and Apollo, was exposed at birth by his mother from fear of her father Crotopus, and was torn to pieces by dogs. In revenge Apollo sent a dragon, Poine, into the land of Crotopus, and the oracle at Delphi commanded a yearly lament by the women and maidens for the dead Linus. Honour was also paid to Psamathe. The Linus lament, as Herodotus shows (II, 79), was analogous to the lamentation for Adonis and Tammuz in Phoenicia, Cyprus, and Egypt. In Egypt, Linus was called Maneros. Brugsch thinks that the name Maneros comes from the Egyptian cry of lamentation *maa-n-chru*, ‘come to the call.’ The dragon Poine had the disagreeable habit of tearing children out of their mothers’ wombs. All these motifs are to be found in Revelation 12: 1f., where the child of the sun-woman was threatened by a dragon and afterwards “caught up” to God. Herod’s massacre of the innocents is the “human” form of this primordial image. (Cf. Brugsch, *Adonisklage und Linoslied*.) Dieterich, in *Abraxas*, refers to the parallel myth of Apollo and Python, of which he gives the following version (based on Hyginus): Python, the son of the earth and a mighty dragon, had been told by an oracle that he would be slain by the son of Leto. Leto was with child by Zeus, but Hera arranged matters so that she could only give birth where the sun did not shine. When Python saw that Leto was near her time, he began to pursue her in order to compass her death; but Boreas carried her to Poseidon, who brought her to Ortygia and covered the island with waves. Python, unable to find Leto, went back to Parnassus, and Poseidon raised the island out of the sea. Here Leto brought forth. Four days later, Apollo took his revenge and killed Python.

¹⁴ Rev. 21:2: “And I John saw the holy city, new Jerusalem, coming down from God out of heaven, prepared as a bride adorned for her husband.”

¹⁵ The legend of Shaktideva, related by Somadeva Bhatta, tells how the hero, after he had escaped being devoured by a huge fish (terrible mother), finally sees the golden city and marries his beloved princess. (Frobenius, p. 175.)

¹⁶ In the apocryphal *Acts of Thomas* (2nd century), the Church is thought of as the virgin mother-wife of Christ. One of the apostle’s invocations says (trans. by Walker, p. 404): “Come, holy name of Christ, which is above every name; come, power of the Most High, and perfect compassion; come, grace most high; come, compassionate mother; come, thou that hast charge of the male child; come, thou who revealest secret mysteries....” Another invocation says: “Come, perfect compassion; come, spouse of [lit. “communion with”] man; come, woman who knowest the mystery of the chosen one; come, woman who layest bare the hidden things, and makest manifest things not to be spoken, holy dove which hath brought forth twin nestlings; come, secret mother ...” (trans. by Walker, modified). Cf. also Conybeare, “Die jungfräuliche Kirche und die jungfräuliche Mutter.” The connection of the Church with the mother is beyond all doubt (cf. pl. xxxa), also the interpretation of the mother as the spouse. The “communion with man” points to the motif of continuous cohabitation. The “twin nestlings” refers to the old legend that Jesus and Thomas were twins, which was based on the Coptic idea of Jesus and his *ka*. See the *Pistis Sophia*.

¹⁷ Cf. Freud, *The Interpretation of Dreams*, pp. 399ff., and Abraham, *Dreams and Myths*, p. 23.

¹⁸ Isaiah 48: 1: “Hear ye this, O house of Jacob, which are called by the name of Israel, and are come forth out of the waters of Judah ...”

¹⁹ Wirth, *Aus orientalischen Chroniken*.

²⁰ Cumont, *Textes*, pp. 106f.

²¹ Part I, trans. by Wayne, p. 48.

²² See my *Psychological Types*, Def. 50.

²³ Cones were sometimes used instead of columns, as in the cults of Aphrodite, Astarte, etc.

²⁴ For the symbolism of the finger-joint, see my remarks on the dactyls, pars. 180–84. Here I would like to add the following from a Bakairi myth: “Nimagakaniro swallowed two Bakairi finger-bones. There were many of these lying about the house, because Oka used them for tipping his arrows, and killed many Bakairi and ate their flesh. From these finger-bones, and not from Oka, the woman became pregnant.” (Frobenius, p. 236.)

²⁵ Further evidence in Prellwitz, *Wörterbuch*.

²⁶ [Cf. par. 180, above.]

²⁷ Respectively, in I, 114: 3 and 4; in II, 33: 5, 6, 8, and 14. Trans. from Siecke, “Der Gott Rudra im Rigveda,” pp. 237ff.

²⁸ Cf. the anima / animus theory in my later writings.

²⁹ *Psychology and Alchemy*, fig. 131.

³⁰ The fig-tree is phallic. It is worth noting that Dionysus planted a fig-tree at the entrance to Hades, in the same way that phalloi were placed on graves. The cypress, sacred to Aphrodite, the Cyprian, became an emblem of death, and used to be placed at the door of houses where people were dying.

³¹ Concerning hermaphroditism, see *Psychology and Alchemy*, index, s.v. “hermaphrodite.”

³² The relationship of the son to the mother was the psychological basis of numerous cults. Robertson (*Christianity and Mythology*, p. 322) was struck by Christ's relationship to the two Marys, and he conjectures that it probably points to an old myth "in which a Palestinian God, perhaps named Joshua, figures in the changing relations of lover and son towards a mythic Mary—a natural fluctuation in early theosophy and one which occurs with a difference in the myths of Mithras, Adonis, Attis, Osiris, and Dionysus, all of whom are connected with Mother-Goddesses and either a consort or a female double, the mother and consort being at times identified."

³³ [Cf. "The Psychology of the Transference" and *Mysterium Coniunctionis*, ch. 6.—EDITORS.]

³⁴ *Faust*, Part II, Act 5, trans. by Wayne, p. 288.

³⁵ Rank (*Die Lohengrinsage*) has found some beautiful examples of this in the myth of the swan-maiden.

³⁶ Muther (*Geschichte der Malerei*, II, p. 355) says, in his chapter on "The First Spanish Classics": "Tieck once wrote: 'Sexuality is the great mystery of our being, sensuality the first cog in our machinery. It stirs our whole being and makes it alive and joyful. All our dreams of beauty and nobility have their source here. Sensuality and sexuality constitute the essence of music, of painting, and of all the arts. All the desires of mankind revolve round this centre like moths round a flame. The sense of beauty and artistic feeling are only other dialects, other expressions. They signify nothing more than the sexual urge of mankind. I regard even piety as a diverted channel for the sexual impulse.' This clearly expresses what one should never forget when judging the old ecclesiastical art, that the struggle to efface the boundaries between earthly and heavenly love, to blend them into each other imperceptibly, has always been the guiding thought, the most powerful impulse of the Catholic Church." To this I would add that it is hardly possible to restrict this impulse to sexuality. It is primarily a question of primitive instinctuality, of insufficiently differentiated libido which prefers to take a sexual form. Sexuality is by no means the only form of the "full feeling of life." There are some passions that cannot be derived from sex.

³⁷ [Cf. Jung's "Wotan."—EDITORS.]

³⁸ For the functional significance of the symbol, see my "On Psychic Energy," sec. III (d), on symbol formation (pars. 88ff.).

³⁹ *De Iside et Osiride*, in Babbitt trans., pp. 31–33.

⁴⁰ *Faust*, Part I, trans. by Wayne, p. 75, modified.

⁴¹ Erman, *Life in Ancient Egypt*, p. 265.

⁴² Here I must again remind the reader that I give the word "incest" a different meaning from that which properly belongs to it. Incest is the urge to get back to childhood. For the child, of course, this cannot be called incest; it is only for an adult with a fully developed sexuality that this backward striving becomes incest, because he is no longer a child but possesses a sexuality which cannot be allowed a regressive outlet.

⁴³ Frobenius, *Zeitalter*.

⁴⁴ This recalls the phallic columns set up in the temples of Astarte. In fact, according to one version, the king's wife was named Astarte. This symbol is also reminiscent of the crosses which were aptly called ἔγκόλπια (pregnant), because they had a secret reliquary inside them.

⁴⁵ Spielrein (pp. 358ff.) found numerous allusions to this motif in an insane patient. Fragments of different things and materials were "cooked" or "burnt." "The ashes can turn into a man," said the patient, and she also saw "dismembered children in glass coffins."

- ⁴⁶ Demeter collected the limbs of the dismembered Dionysus and put him together again.
- ^{46a} [Cf. Harrer, *Seven Years in Tibet*, p. 61.—EDITORS.]
- ⁴⁷ Diodorus, III, 62 (cf. Oldfather and Geer trans., II, pp. 285ff.).
- ⁴⁸ *Symbolik und Mythologie der alten Völker*.
- ⁴⁹ *Satyricon*, ch. 71. [Cf. Heseltine trans., pp. 136–37.] (“Valde te rogo, ut secundum pedes statuae meae catellam pingas ... ut mihi contingat tuo beneficio post mortem vivere.”)
- ⁵⁰ Frobenius (*Zeitalter*, p. 393) observes that the fire-gods (sun-heroes) often have a limb missing. He gives the following parallel: “Just as the god wrenches out the ogre’s arm, so Odysseus puts out the eye of the noble Polyphemus, whereupon the sun creeps mysteriously into the sky. Is there a connection between the twisting of the fire-sticks and the twisting out of the arm?” The main elements here are firstly a mutilation, and secondly a twisting movement, which Frobenius rightly connects with fire-boring. The mutilation is a castration in the case of Attis, and something similar in the case of Osiris.
- ⁵¹ Cf. Aigremont, *Fuss- und Schuhsymbolik*.
- ⁵² Brugsch, *Religion und Mythologie der alten Aegypter*, p. 354.
- ⁵³ *Ibid.*, p. 310.
- ⁵⁴ *Ibid.*, p. 310.
- ⁵⁵ *Ibid.*, pp. 112ff.
- ⁵⁶ In Thebes the chief god Khnum, in his cosmogonic aspect, represented the wind-breath, from which the “spirit ($\tau\nu\epsilon\tilde{\upsilon}\mu\alpha$) of God moving over the waters” was later developed—the primitive idea of the World Parents lying pressed together until the son separates them.
- ⁵⁷ Brugsch, pp. 114f.
- ⁵⁸ *Ibid.*, pp. 128f.
- ⁵⁹ Cf. the similar motif in the Egyptian “Tale of the Two Brothers”: Erman, *Literature*, p. 156.
- ⁶⁰ Serbian folksong, mentioned in Grimm, *Teutonic Mythology*, II, p. 653.
- ⁶¹ Frobenius, *Zeitalter*.
- ⁶² *The Light of Asia*, p. 5. Cf. the birth of the Germanic king Aschanes, where there is a similar conjunction of rock, tree, and water. [Cf. par. 368, below.] Spitteler uses the same motif of the loving tree in his *Prometheus*, to describe how nature receives the “jewel” that was brought to earth. The idea is taken from Buddha’s birth-story. Cf. “Om mani padme hum” (the jewel is in the lotus).
- ⁶³ Δύγος means ‘willow,’ or indeed any pliant twig or rod. λυγόω means ‘to twist, plait, weave.’
- ⁶⁴ *Description of Greece*, II, 38, 2.
- ⁶⁵ Book XIV, 346–52, trans. by Rieu, p. 266.
- ⁶⁶ Curiously enough, near this point (XIV, 289–91) there is a description of Sleep sitting high up in a fir-tree: “There he perched, hidden by the branches with their sharp needles, in the form of a songbird of the mountains” (Rieu, p. 264, modified). It looks as if this motif belonged to the *hieros gamos*. Cf. also the magic net with which Hephaestus caught Ares and Aphrodite *in flagrante* and kept them there for the entertainment of the gods.
- ⁶⁷ See Roscher, *Lexikon*, I, 2102, 52ff.

⁶⁸ Pausanias, III, 16, 11.

⁶⁹ See “On the Psychology of the Unconscious,” pars. 123ff.

⁷⁰ Fick, *Wörterbuch*, pp. 132f.

⁷¹ Cf. Goethe’s “sonorous day-star,” above, par. 235.

⁷² This motif also includes that of the “clashing rocks” (Frobenius, p. 405). The hero often has to steer his ship between two rocks that clash together. (A similar idea is that of the biting door or the snapping tree-trunk.) In its passage the stern of the ship (or the tail of the bird) is pinched off, another reminder of the mutilation motif (twisting out the arm). The 19th-cent. German poet J. V. von Scheffel uses this image in his poem “A herring loved an oyster.” The poem ends with the oyster nipping off the herring’s head in a kiss. The doves which bring Zeus his ambrosia have to pass through the clashing rocks. Frobenius points out that these rocks are closely connected with the rocks or caves that only open at a magic word. The most striking illustration of this is a South African myth (p. 407): “You must call the rock by name and cry loudly: ‘Rock Untunjambili, open, so that I may enter.’ ” But if the rock does not want to open, it answers: “The rock will not open to children, it opens to the swallows that fly in the air.” The remarkable thing is that no human power can open the rock, only the magic word—or a bird. This formulation implies that opening the rock is an undertaking that can never be accomplished in reality, it can only be *wished*. *Wünschen* (wish) in Middle High German means the “power to do something extraordinary.” The bird is a symbol of “wishful thinking.”

⁷³ Grimm, II, p. 571.

⁷⁴ In Athens there was a family called Αίγειροτόμοι, ‘hewn from the poplar.’

⁷⁵ Herrmann, *Nordische Mythologie*, p. 589.

⁷⁶ Certain Javanese tribes set up their idols in trees that have been artificially hollowed out. In Persian myth, the white haoma is a celestial tree growing in the lake Vouru-Kasha, while the fish Kar-mahi circles round it and protects it from the frog of Ahriman. The tree gives eternal life, children to women, husbands to girls, and horses to men. In the Mainyo-i-Khard it is called the “preparer of the corpse” (Spiegel, *Erānische Altertumskunde*, II, p. 115).

⁷⁷ I.e., the sun-ship, which accompanies the sun and the soul over the sea of death towards the sunrise.

⁷⁸ Brugsch, p. 177.

⁷⁹ Cf. Isaiah 51 : 1: “... look unto the rock whence ye are hewn, and to the hole of the pit whence ye are digged.” Further evidence in Löwis of Menar, “Nordkaukasische Steingeburtssagen,” pp. 509ff.

⁸⁰ Grimm, I, p. 474. [For Aschanes, see also Grimm, II, p. 572—EDITORS.]

⁸¹ *The Cross of Christ*.

⁸² The legend of Seth is in Jubinal, *Mystères inédits du XV. siècle*, II, pp. 16ff. Cited in Zöckler, p. 225.

⁸³ The Germanic sacred trees were under an absolute taboo: no leaf might be plucked from them, and nothing picked from the ground on which their shadow fell.

⁸⁴ According to German legend (Grimm, III, p. 969), the saviour will be born when he can be rocked in a cradle made from the wood of a tree that is now but a feeble shoot sprouting from a wall. The formula runs: “A limetree shall be planted, that shall throw out two *plantschen* [boughs] above, and out of their wood is a *poie* [buoy] to be made; the first child that therein lies is doomed to be brought from life to death by the sword, and then will salvation

ensue.” It is remarkable that in the German legends the heralding of the future event is connected with a *budding tree*. Christ was sometimes called a “branch” or a “rod.”

⁸⁵ Here we may discern, perhaps, the motif of the “helpful bird”—angels are really birds. Cf. the feather-dress of the “soul-birds” in the underworld. In the Mithraic sacrifice the messenger of the gods—the “angel”—was a raven; the messenger is winged (Hermes). In Jewish tradition angels are masculine. The symbolism of the three angels is important because it signifies the upper, aerial, spiritual triad in conflict with the *one* lower, feminine power. Cf. my “Phenomenology of the Spirit in Fairytales,” pars. 419ff.

⁸⁶ Frobenius, *Zeitalter*.

⁸⁷ Λαμός, ‘gorge’ = gullet; τὰ λαμύα, ‘gorge’ = ravine.

⁸⁸ Note the close connection between δελφίς, ‘dolphin,’ and δελφ[Entity]ς, ‘womb.’ In Delphi there was the Delphic gorge and the δελφινίς, a tripod with feet in the form of dolphins. Cf. Melicertes on the dolphin and Melkarth’s sacrifice by fire.

⁸⁹ Cf. Jones, *On the Nightmare*.

⁹⁰ *Das Rätsel der Sphinx*.

⁹¹ Freud, “Phobia in a Five-year-old Boy,” and my “Psychic Conflicts in a Child.”

⁹² *Epistola de ara ad Noviomagum reperta*, p. 25. (“Abigunt eas nymphas (matres deas, moiras) hodie rustici osse capitis equini tectis injecto, cujusmodi ossa per has terras in rusticorum villis crebra est animadvertere. Nocte autem ad concubia equitare creduntur et equos fatigare ad longinqua itinera.”) Cited from Grimm, III, p. 1246.

⁹³ *Ibid.*, III, p. 1246. [From the Ynglinga Saga, 16.]

⁹⁴ *Ibid.*; also I, pp. 277–78: “Eat fast tonight I pray, that the Stempe tread you not.” [The “Stempe,” according to Grimm’s citations, was an indeterminate nightmare figure that terrified children by trampling on them.—EDITORS.]

⁹⁵ Herrmann, *Nordische Mythologie*, p. 64, and Fick, *Wörterbuch*, I, p. 716. [In more recent philology, a kinship of mors and μωρος is not assured. Not all the etymological conjectures in this passage are now considered warranted.—EDITORS.]

⁹⁶ Grimm, I, p. 417.

⁹⁷ *The Gallic War*, I, 50, trans. by Edwards, pp. 82–83, slightly modified. (“Ut matres familiae eorum sortibus et vaticinationibus declararent, utrum proelium committi ex usu esset, necne.”) Cf. the mantic significance of the Delphic gorge, Mimir’s fountain, etc.

⁹⁸ Cf. p. 206, above.

⁹⁹ Plutarch, *De Iside et Osiride*, 19, 6. [Cf. Babbitt trans., pp. 48–49.]

¹⁰⁰ Cf. the exotic myths in Frobenius, where the belly of the whale is clearly the land of death.

¹⁰¹ One of the peculiarities of the Mara is that he can only get out through the hole by which he came in. [As Mephistopheles says (Wayne trans., p. 77): “All friends and phantoms must obey a law/To use the way they entered in before.”—TRANS.] This motif evidently belongs to the rebirth myth.

¹⁰² For the abyss of wisdom, fount of wisdom, source of fantasies, see par. 640, below.

¹⁰³ Trans. of this and following passages based on Gressmann, *Altorientalische Texte*. I, pp. 4ff., and E. A. Speiser, in Pritchard, *Ancient Near Eastern Texts*, pp. 62–67.

- ¹⁰⁴ “Then the Lord approached, looking for the inside of Tiamat.”
- ¹⁰⁵ Splitting of the mother; cf. Kaineus, pars. 439f., 460, 480, 638, below.
- ¹⁰⁶ *Schöpfung und Chaos*, p. 30ff.
- ^{106a} [This and the next three passages are RSV.—TRANS.]
- ¹⁰⁷ Represented in the human sphere by the quaternity composed of father, mother, godfather, godmother, the latter two corresponding to the divine pair.
- ¹⁰⁸ I.e., the sun-god.
- ¹⁰⁹ Brugsch, *Religion und Mythologie*, pp. 161ff.
- ¹¹⁰ Ares probably means the Egyptian god Set.
- ¹¹¹ [In the German text used by the author this word (*συνμειξαι*) is translated as ‘to have intercourse with.’—TRANS.]
- ¹¹² Herodotus, Book II, 61ff., trans. by de Selincourt, pp. 126–27.
- ¹¹³ Cited in Dieterich, *Eine Mithrasliturgie*, p. 100.
- ¹¹⁴ The Polynesian myth of Maui says that the hero robbed his mother of her girdle. The theft of the veil in the myth of the swan-maiden means the same thing. In a myth of the Yoruba, of Nigeria, the hero simply ravishes his mother (Frobenius, *Zeitalter*).
- ¹¹⁵ The above-mentioned myth of Halirrhothios (par. 372), who killed himself in the attempt to cut down the sacred tree of Athens, the moria, expresses the same psychology, as also does the castration of the priests who serve the Great Mother. The ascetic tendency in Christianity (e.g., Origen’s self-castration) is a similar phenomenon.
- ¹¹⁶ Kuhn, *Mythol. Studien*, I.
- ¹¹⁷ III, p. 1246. [Cf. par. 370, above.]
- ¹¹⁸ Hence, in England, the custom of hanging mistletoe at Christmas. For mistletoe as the wand of life, see Aigremont, *Volkserotik und Pflanzenwelt*, II, p. 36.
- ¹¹⁹ There is a beautiful description of the *puer aeternus* in an exquisite little book by the airman Antoine de Saint-Exupéry, *The Little Prince*. My impression that the author had a personal mother-complex was amply confirmed from firsthand information.
- ¹²⁰ See “The Relations between the Ego and the Unconscious,” par. 103.
- ¹²¹ A variation of the same motif can be found in a legend from Lower Saxony: There was once a young ash-tree that grew unnoticed in a wood. Each New Year’s Eve a white knight riding upon a white horse comes to cut down the young shoot. At the same time a black knight arrives and engages him in combat. After a lengthy battle the white knight overcomes the black knight and cuts down the tree. But one day the white knight will be unsuccessful, then the ash will grow, and when it is big enough for a horse to be tethered under it, a mighty king will come and a tremendous battle will begin: i.e., end of the world. (Grimm, III, p. 960.)
- ¹²² J. E. Lehmann, in Chantepie de la Saussaye, *Lehrbuch der Religionsgeschichte*, II, p. 185.
- ¹²³ Other examples in Frobenius, *passim*.
- ¹²⁴ Cf. Jensen, *Gilgamesch-Epos*, etc.
- ¹²⁵ This transformation of the God-image was clearly felt and expressed even in the Middle Ages (see *Psychology and Alchemy*, pars. 522ff.). The transformation had already begun in the Book of Job: Yahweh allows himself to be

fooled by Satan, deals faithlessly with Job, misjudges the situation, and then has to admit his error. But although Job is obliged to bow to brute force he carries off the moral victory. In this conflict there lies a budding consciousness of the Johannine Christ: "I am the way, and the truth, and the life." [Cf. also Jung, "Answer to Job."—EDITORS.]

¹²⁶ Christ dies on the same tree against which Adam sinned. Zöckler, *The Cross of Christ*, p. 225.

¹²⁷ The skins of animals were hung on the sacrificial trees and afterwards spears were thrown at them.

¹²⁸ Trans. by Bellows, *The Poetic Edda*, p. 60.

¹²⁹ J. G. Müller, *Geschichte der amerikanischen Urreligionen*, p. 498. [The codex, in the Liverpool Public Museum, is pre-Aztec, c. 11th–14th cents.—EDITORS.]

¹³⁰ Stephens, *Travel in Central America*, II, p. 346.

¹³¹ Zöckler, p. 25.

¹³² Bancroft, *The Native Races of the Pacific States of North America*, II, p. 506. Cited in Robertson, *Christianity and Mythology*, p. 408.

¹³³ Rossellini, *Monumenti dell' Egitto*, III, Pl. 23, cited in Robertson, p. 411.

¹³⁴ Zöckler, pp. 6ff. In an Egyptian picture of the birth of a king, in Luxor, the bird-headed Thoth, the Logos and messenger of the gods, is shown announcing to the young queen Mautmes that she will give birth to a son. In the next scene Kneph and Hathor hold the *crux ansata* to her mouth, thus fertilizing her in a spiritual or symbolic manner. (Cf. fig. 27.) (Sharpe, *Egyptian Mythology*, pp. 18f., cited in Robertson, p. 328.)

¹³⁵ Robertson, p. 409, mentions that in Mexico the sacrificial priest clothed himself in the skin of a newly killed woman and then stood before the war-god with arms stretched out like a cross.

¹³⁶ Maurice, *Indian Antiquities*, VI, p. 68. By "tau" he means the primitive Egyptian form of the cross: T.

¹³⁷ Zöckler, p. 12.

¹³⁸ Robertson, p. 133.

¹³⁹ I am indebted for this information to Professor E. Fiechter, formerly of the Technical Institute, Stuttgart.

¹⁴⁰ *Timaeus*, 34 B. This and the following passages trans. by Cornford, pp. 58f.

¹⁴¹ *Timaeus*, 34 B–C.

¹⁴² See *Psychological Types*, "soul" and "soul image," Defs. 48 and 49. The *anima* is the archetype of the feminine and plays a very important role in a man's unconscious. See "The Relations between the Ego and the Unconscious," pars. 296ff. I have discussed the world-soul of Plato's *Timaeus* in "A Psychological Approach to the Dogma of the Trinity," pars. 186ff.

¹⁴³ See my remarks *ibid.*

¹⁴⁴ *Timaeus*, 36 B–E.

¹⁴⁵ Zöckler, p. 24.

¹⁴⁶ The "left eye" is the moon. See below, par. 487: the moon as the gathering-place of souls (cf. fig. 31).

¹⁴⁷ Brugsch, *Religion und Mythologie der alten Aegypter*, pp. 281ff.

¹⁴⁸ Cf. the retreat of Ra on the heavenly cow (par. 351). In one of the Hindu rites of purification the penitent has to crawl through an artificial cow in order to be reborn.

¹⁴⁹ Cited in Schultze, *Psychologie der Naturvölker*, p. 338.

¹⁵⁰ Brugsch, pp. 290ff.

¹⁵¹ This formula is not surprising, since it is the primitive man in us whose animal forces appear in religion. From this point of view what Dieterich says in his *Mithrasliturgie* (p. 108) is especially significant: “The old thoughts coming from below gain a new strength in the history of religion. The revolution from below creates new life in the old indestructible forms.”

¹⁵² *Sermo Suppositus* 120, 8. (“Procedit Christus quasi sponsus de thalamo suo, praesagio nuptiarum exiit ad campum saeculi; ... pervenit usque ad crucis torum et ibi firmavit ascendendo coniugium; ubi cum sentiret anhelantem in suspiriis creaturam commercio pietatis se pro coniuge dedit ad poenam; et copulavit sibi perpetuo iure matronam.”) The “woman” is the Church. (Cf. pl. xxxa.)

¹⁵³ Dispute between Mary and the Cross,” in Morris, *Legends of the Holy Rood*, pp. 134–35.

¹⁵⁴ [In modern English: “Tree unkind thou shalt be known, my son’s stepmother I call thee: Cross, thou holdest him so high in height, my fruit’s feet I may not kiss; Cross, I find thou art my foe, thou bearest my bird, beaten blue ... / Lady, to thee I owe honour, thy bright palms now I bear; thy fruit flourisheth for me in blood colour ...; that blossom bloomed up in thy bower. And not for thee alone, but to win all this world. / Thou art crowned Heaven’s queen, through the burden that thou barest. I am a Relic that shineth bright; men desire to know where I am. At the parliament [of the judgment day] shall I be, on doomsday appear suddenly; at the parliament I shall put up complaint, how a Maiden’s fruit on me began to die.”]

¹⁵⁵ In Greece the stake on which criminals were executed or punished was known as the “hecate.”

¹⁵⁶ The incest-taboo is part of a complicated whole, i.e., the marriage class system, the most elementary form of which is the cross-cousin marriage. This is a compromise between the endogamous and exogamous tendencies. See my “Psychology of the Transference,” pars. 433ff.

¹⁵⁷ Diez, *Wörterbuch der romanischen Sprachen*, p. 168.

¹⁵⁸ Part I, trans. by Wayne, p. 66.

¹⁵⁹ *Ibid.*, p. 54.

- ¹ The goddess of the underworld, Hecate, is sometimes represented with a horse's head. Demeter and Philyra, wishing to escape the attentions of Kronos or Poseidon, change themselves into mares. Witches can easily change into horses, hence the nail-marks of the horseshoe may be seen on their hands. The devil rides on the witch's horse (fig. 29), and priests' housekeepers are changed after death into horses. (Negelein, "Das Pferd im Seelenglauben und Totenkult," XI, pp. 406ff.)
- ² In the same way the legendary king Tahmurath rides on Ahriman, the devil.
- ³ The she-ass and her foal might derive from astrology, since the zodiacal sign Cancer, which rules at the summer solstice, was known in antiquity as the ass and its young. Cf. Robertson, *Christianity and Mythology*, p. 368.
- ⁴ The image is probably taken from the Roman circus. The Spanish matador still has an heroic significance. Cf. Suetonius, *Opera*, trans. by Rolfe, II, pp. 40–43: "They drive wild bulls all over the arena, leaping upon them when they are tired out and throwing them to the ground by the horns."
- ⁵ This legend is part of the astrological aspect of the Jewish god (Saturn), which I would rather not discuss here.
- ⁶ Cf. the exhaustive account of this theme in Max Jähns, *Ross und Reiter*.
- ⁷ Wotan is one-eyed. Cf. Schwartz, *Indogermanischer Volksglaube*, pp. 164ff.
- ⁸ Odin gives this riddle to King Heidhrekr (Hervarar Saga). Schwartz, p. 183.
- ⁹ Negelein, p. 412.
- ¹⁰ *Ibid.*, p. 419.
- ¹¹ Schwartz, p. 88.
- ¹² Preller, *Griechische Mythologie*, I, p. 432. [From Plutarch, *Quaestiones Graecae*, 36.]
- ¹³ For further examples see Aigremont, *Fuss- und Schuhsymbolik*.
- ¹⁴ *Ross und Reiter*, p. 27.
- ¹⁵ Aigremont, p. 17. [Cf. the erotic role of the horse in Robinson Jeffers' poem "Roan Stallion."—EDIRORS.]
- ¹⁶ Negelein, XII, p. 386f.
- ¹⁷ Schwartz, p. 113.
- ¹⁸ Evidence for the centaurs as wind-gods may be found in Meyer, *Indogermanische Mythen*, II, pp. 417ff.
- ¹⁹ Schwartz, p. 447.
- ²⁰ *Opera*, XXXVI, 6. Cited in Cumont, *Mysteries of Mithra*, p. 25.
- ²¹ This is a special motif which must have something typical about it. A schizophrenic patient ("The Psychology of Dementia Praecox," par. 290) declared that her horses had "half-moons" under their skins "like little curls." The *Ching* is supposed to have been brought to China by a horse that had the magic signs (the "river map") on his coat. The skin of the Egyptian sky-goddess, the heavenly cow, is dotted with stars. (Cf. fig. 25.) The Mithraic Aion bears the signs of the zodiac on his skin (cf. pl. XLIV).
- ²² This is the result of a world catastrophe. In mythology, too, the blossoming and withering of the tree of life denotes the turning point, the beginning of a new age.
- ²³ Br. Up., i, i, trans. by Hume, p. 73, modified.
- ²⁴ Cumont, *Textes*, I, p. 76.

²⁵ Therefore the lion was killed by Samson, who afterwards harvested honey from the carcass. Summer's end is autumn's plenty. The legend of Samson is a parallel of the Mithraic sacrifice. Cf. Steinthal, "Die Sage von Simson," pp. 129ff.

²⁶ *Saturnaliorum Libri VII*, I, 20, 15, in *Opera*, II, p. 189. ("Leonis capite monstratur praesens tempus—quia conditio ejus ... valida fervensque est.")

²⁷ In *Genesim*, I, 100, in *Opera omnia*, VI, p. 338. Cited in Cumont, *Textes*, I, p. 82.

²⁸ Spiegel, *Erānische Altertumskunde*, II, p. 193. In the treatise *Περὶ ὀύσεως*, which is ascribed to Zoroaster, Ananke, the goddess of fate, is symbolized by air. (Cumont, p. 87.)

²⁹ Spielrein's patient (p. 394) speaks of horses who eat human beings and even exhumed corpses.

³⁰ Negelein, p. 416. Cf. my remarks on the three-legged horse in "The Phenomenology of the Spirit in Fairy Tales" (1954/55 edn., p. 28).

³¹ [Cf. *Psychology and Alchemy*, par. 535—EDITORS.]

³² Act IV, scene III.

³³ A clear case of identity with the anima. The first carrier of the anima-image is the mother.

³⁴ Because her fantasy is not a creation she consciously willed and formed, out an involuntary product.

³⁵ See par. 48, above.

³⁶ The heart of the mother of God is pierced by a sword, "that the thoughts of many hearts may be revealed." Luke 2:35.

³⁷ Wegener, *Leben der Dienerin Gottes Anna Catherina Emmerich*, p. 63.

³⁸ [German 'heart' and 'pain.'—EDITORS.]

³⁹ *Sutta-Nipata*, trans. by Fausböll, p. 146.

⁴⁰ Theocritus (27, 29), calls the pangs of birth the "darts of Eileithyia," as though the pain came from outside. [Cf. Edmonds trans., p. 337.] The same comparison is used for desire in Ecclesiasticus 19:2: "As an arrow that sticketh in the flesh of the thigh, so is a word in a fool's belly." That is to say, it gives him no peace until it is out.

⁴¹ This fact, however, does not prove that the experience of the *unio mystica* is exclusively erotic in origin. The upsurge of eroticism only proves that the canalization of libido has not been entirely successful, with the result that clear traces of the original form remain behind unassimilated.

⁴² Wegener, 77ff.

⁴³ Apuleius (*The Golden Ass*, II, 31, in Graves trans., p. 59) makes drastic use of the bow-and-arrow symbolism: "Since the first of Cupid's sharp arrows lodged in my heart this morning, I have been standing to arms all day, and now my bow is strung so tight that I'm afraid something will snap if the Advance isn't sounded pretty soon."

⁴⁴ And like the plague-bringing Apollo. In OHG., 'arrow' is *strala*.

⁴⁵ Herodotus, IV, 81. [Cf. Selincourt trans., p. 269.]

⁴⁶ Cf. Roscher, *Lexikon*, III, 894ff., s.v. "Kaineus."

⁴⁷ Pindar, fr. 166f. Spielrein's patient (p. 371) also had this idea of splitting the earth: "Iron is used for boring into the earth—With iron you can make men—The earth is split, burst open, man is divided—Man is cut up and put together again—In order to put a stop to being buried alive, Jesus told his disciples to bore into the earth." The motif of

“splitting” is of world-wide significance. The Persian hero Tishtriya, taking the form of a white horse, split open the rain-lake and so made the earth fruitful. He is also called Tir, ‘arrow.’ He is sometimes represented as feminine, with bow and arrow. (Cumont, *Textes*, I, p. 136.) Mithras shoots water from the rock with his arrow in order to stop the drought. On Mithraic monuments the knife, otherwise used as the sacrificial instrument for killing the bull, is sometimes found stuck in the earth. (Ibid., pp. 115, 116, 165.)

⁴⁸ *Metamorphoses*, trans. by Miller, II, pp. 216–17, modified.

⁴⁹ In a review of Meyer’s *Indogermanische Mythen*, in *Göttingische Gelehrte Anzeigen*, I (1884), p.155.

⁵⁰ Job 16:12ff.

⁵¹ *Thus Spake Zarathustra*. (*Werke*, VI, pp. 367f.) [Cf. trans. by Common, p. 293.]

⁵² Spielrein’s patient said that she too had been shot by God three times—“then came a resurrection of the spirit.”

⁵³ “Between Birds of Prey.” (*Werke*, VIII, p. 414.) [Cf. trans. in *Ecce Homo and Poetry* by Ludovici, Cohn, et al., p. 179.]

⁵⁴ Trans. by Meltzner, p. 75.

⁵⁵ *Faust*, Part II, “The Mothers.”

⁵⁶ This is mythologically represented in the legend of Theseus and Peirithous, who wanted to abduct Persephone from the underworld. They entered a chasm in the grove of Colonus and descended into the bowels of the earth. When they got down below they wished to rest a little, but found they had grown fast to the rocks and could not rise. In other words, they remained stuck in the mother and were lost to the upper world. Later Theseus was rescued by Heracles, who appeared in the role of the death-conquering hero. The Theseus myth is therefore a representation of the individuation process.

⁵⁷ When the Greeks set out on their expedition to Troy, they wished, like the Argonauts and Heracles before them, to offer sacrifice on the altar of Chryse, a nymph who lived on an island of the same name, in order to secure a happy end to their voyage. Philoctetes was the only one among them who knew the way to her hidden shrine. But there the disaster befell him which is described above. Sophocles treats of this episode in his *Philoctetes*. We learn from a scholiast that Chryse offered the hero her love, but, on being scorned, cursed him. Philoctetes, like his forerunner Heracles, is the prototype of the wounded and ailing king, a motif that is continued in the legend of the Grail and in alchemical symbolism (cf. *Psychology and Alchemy*, pars. 491ff. and fig. 149).

⁵⁸ Roscher, *Lexikon*, 2318, 15ff., s.v. “Philoctetes.”

⁵⁹ When the Russian sun-hero Oleg approached the skull of the slain horse, a snake darted out and bit him in the foot, so that he fell sick and died. And when Indra, in the form of Shyena the falcon, stole the soma drink, Krishanu the herdsman wounded him in the foot with an arrow. De Gubernatis, *Zoological Mythology*, II, pp. 181–82.

⁶⁰ Like the Grail king who guards the chalice, symbol of the mother. The myth of Philoctetes comes from the wider context of the Heracles cycle. Heracles had two mothers, the helpful Alcmene and the vengeful Hera, from whose breast he drank the milk of immortality. Heracles conquered Hera’s serpents while yet in the cradle; that is, he freed himself from the grip of the unconscious. But from time to time Hera sent him fits of madness, in one of which he killed his own children. This is indirect proof that she was a lamia. According to one tradition, Heracles perpetrated this deed after refusing to perform the labours for his taskmaster Eurystheus. As a consequence of his hanging back, the libido that was ready for the work regressed to the unconscious mother-imago, and this resulted in madness. In

this state he identified with the lamia and killed his own children. The Delphic oracle told him that he was named Heracles because he owed his immortal fame to Hera, who through her persecutions drove him to his great deeds. It is evident that the great deed really means overcoming the mother and thus winning immortality. His characteristic weapon, the club, he cut from the maternal olive-tree. Like the sun, he possessed the arrows of Apollo. He conquered the Nemean lion in its cave, whose meaning is the “grave in the mother’s womb” (see the end of this chapter). Then follows the fight with the Hydra (cf. also fig. 17) and his other deeds, which were all wished on him by Hera. All of them symbolize the fight with the unconscious. At the end of his career, however, he became the slave of Omphale (ὄμφαλος = ‘navel’) as the oracle prophesied; that is, he had to submit after all to the unconscious.

⁶¹ This and the following passages trans. from Erman, pp. 265–67, modified.

⁶² How concretely this mythologem is taken on the primitive level can be seen from the description in Gatti, *South of the Sahara* (pp. 226ff.), of a medicine-woman in Natal who had a twenty-foot boa constrictor as her familiar.

⁶³ The myth of Hippolytus has similar ingredients: His step-mother Phaedra falls in love with him, he repulses her, she accuses him of violation before her husband, who calls upon Poseidon to punish Hippolytus. Whereupon a monster comes out of the sea; Hippolytus’ horses take fright and drag him to death. But he is restored to life by Aesculapius, and the gods convey him to the grove of the wise nymph Egeria, the counsellor of Numa Pompilius.

⁶⁴ Cf. Heracles and Omphale.

⁶⁵ The case was written up at the time by Freud in a very unsatisfactory way after I had drawn his attention to the book. See “Psycho-Analytical Notes upon an Autobiographical Account of a Case of Paranoia.”

^{65a} [Cf. especially “A Study in the Process of Individuation.”—EDITORS.]

⁶⁶ Spielrein’s patient was also sick from “snake poison” (p. 385). Schreber said he was infected by “corpse poison,” that “soul murder” had been committed on him, etc. (pp. 54ff.).

⁶⁷ “Between Birds of Prey.” (*Werke*, VIII, p. 414.) [Cf. trans. in *Ecce Homo and Poetry*, by Ludovici et al., p. 179.]

⁶⁸ Spielrein’s patient (p. 336) uses the same images; she speaks of the “rigidity of the soul on the cross,” of “stone figures” who must be “melted.”

⁶⁹ Gurlitt says: “The carrying of the bull [pl. XLIXa] is one of the difficult δθλα which Mithras performed for the redemption of mankind; it corresponds roughly—if we may compare small things with great—to Christ carrying the cross.” (“Vorbericht über Ausgrabungen in Pettau”; cited in Cumont, *Textes*, I, p. 172.)

⁷⁰ Robertson (*Christianity and Mythology*, p. 401) makes an interesting contribution to the symbol of carrying the cross: Samson carried the gate-posts of the city of Gaza, and died between the pillars of the temple of the Philistines. Heracles carried his pillars to Gades (Cadiz), where, according to the Syrian version of the legend, he died. The Pillars of Hercules mark the point in the west where the sun sinks into the sea. “In ancient art,” says Robertson, “he was actually represented carrying the two pillars in such a way under his arms that they form exactly a cross. Here, probably, we have the origin of the myth of Jesus carrying his own cross to the place of execution. Singularly enough, the three Synoptics substitute for Jesus as cross-bearer one Simon, a man of Cyrene. Cyrene is in Libya, the legendary scene, as we saw, of the pillar-carrying exploit of Heracles; and Simon (Simeon) is the nearest Greek name-form to Samson.... In Palestine, Simon, or Sem, was actually a god-name, representing the ancient sun-god Shemesh, identified with Baal, from whose mythus that of Samson unquestionably arose; and the God Simon was especially worshipped in Samaria.” I give Robertson’s words here, but must emphasize that the etymological

connection between Simon and Samson is exceedingly questionable. The cross of Heracles may well be the sun-wheel, for which the Greeks used the symbol of the cross. The sun-wheel on the bas-relief of the Little Metropolis in Athens actually contains a cross which looks very like the Maltese cross. (Cf. Thiele, *Antike Himmelsbilder*, p. 59.) Here I must refer the reader to the mandala symbolism in *Psychology and Alchemy* and in *The Secret of the Golden Flower*.

⁷¹ The legend of Ixion (pl. XLVIb), who was “crucified on the four-spoked wheel” (Pindar), says the same thing. Ixion first murdered his father-in-law but was afterwards absolved from guilt by Zeus and blessed with his favour. Ixion, with gross ingratitude, then tried to seduce Hera, but Zeus tricked him by getting the cloud-goddess Nephele to assume Hera’s shape. From this union the centaurs are said to have sprung. Ixion boasted of his deed, but as a punishment for his crimes Zeus cast him into the underworld, where he was bound on a wheel that turned forever in the wind.

⁷² Cited from the *Zentralblatt für Psychoanalyse*, II (1912), p. 365 [in a note by W. Stekel, quoting extracts from Hauptmann’s published diary.—EDITORS].

¹ [See p. 394, n. 1, concerning this chapter heading.—EDITORS.]

² Probably an allusion to the Andes and the Rocky Mountains. [Note by Flournoy.]

³ *Septem tractatus aurei* (1566), ch. IV, p. 24. (“Ego vincit ulnis et pectori meae matris et substantiae eius continere et quiescere meam substantiam facio, et invisibile ex visibili compono.”) The subject of this sentence (Mercurius or the arcane substance) can be interpreted as inner fantasy activity. The quotation naturally has a much more comprehensive, anagogic meaning in the original text, while making use of the primordial image of relationship to the mother. Cf. *Psychology and Alchemy*, par. 141.

⁴ See “On the Nature of the Psyche,” Sec. VII.

⁵ Cf. Harding, *The Way of All Women*.

⁶ Another source mentioned by Miss Miller, namely Samuel Johnson’s *History of Basselas* (1759), was not available to me at the time of writing.

⁷ Cf. Horus’s sacrilegious assault on Isis, which so horrifies Plutarch (*De Iside et Osiride*, trans. by Babbitt, V, pp. 48–49): “If they hold such opinions and relate such tales about the blessed and imperishable (in accordance with which our concept of the divine must be framed), as if such deeds and occurrences actually took place, then ‘Much need there is to spit and cleanse the mouth,’ as Aeschylus has it.”

⁸ *Human, All Too Human*, trans. by Zimmern and Cohn, II, pp. 4f., modified.

⁹ *Ibid.*, II, p. 6.

¹⁰ [Published 1855. It is based on American Indian legend, drawing its sources mainly from the work of Henry Rowe Schoolcraft, a pioneer of American Indian ethnology. Hiawatha was, historically, a 16th-century Iroquoian leader, but the terminology and legendary material of the poem are Algonquian. (Cf. *Standard Dictionary of Folklore*, s.v. “Hiawatha.”) Longfellow derived the metre from the Finnish epic Kalevala.—EDITORS.]

¹¹ On the motif of the “friend,” see my paper “Concerning Rebirth,” pars. 240ff.

¹² The figure of Gitche Manito can be regarded as a kind of Original Man (Anthropos).

¹³ Budge, *Coptic Apocrypha in the Dialect of Upper Egypt*, p. 243.

¹⁴ [Horace, *Odes*, I, xxxvii, 1–2.]

¹⁵ [Cf. MacNeice trans., p. 179.]

¹⁶ See evidence in Aigremont, *Fuss- und Schuhsymbolik*.

¹⁷ Humboldt, *Cosmos*, I, p. 99, n.

¹⁸ Porphyry (*De antro nympharum*, p. 190), says that, according to Mithraic doctrine, the ancients “very reasonably connected winds with souls proceeding into generation, and again separating themselves from it [i.e., at birth and death], because, as some think, souls attract spirit, and have a pneumatic nature.”

¹⁹ In the Mithraic liturgy, the generating breath of the spirit comes from the sun, presumably from the “sun-tube” (cf. Part I, pars. 149–54). There is a similar idea in the Rig-Veda, where the sun is called “one-footed.” Cf. the Armenian prayer that the sun may let its foot rest on the face of the worshipper. Abeghian, *Der armenische Volksglaube*, p. 43.

²⁰ [The Haida myth upon which the depiction in fig. 32 is based tells of a woman who offended the moon and was removed thence, together with her water-pail and a berry-bush she grasped in trying to save herself. Cf. Swanton, *Ethnology of the Haida*, p. 142.—EDITORS.]

²¹ Firmicus Maternus (*Matheseos libri octo*, I, 5, 9, in edn. of Kroll, etc., pp. 16–17): “Cui [animo] descensus per orbem solis tribuitur, per orbem vero lunae praeparatur ascensus” (The soul is believed to descend through the disc of the sun, but its ascent is prepared through the disc of the moon). Lydus (*De mensibus*, IV, 1, 2, in Wunsch edn., p. 66) reports the saying of the hierophant Praetextus that Janus “sends the diviner souls to the lunar throng.” Epiphanius (*Adversus octoginta haereses*, LXVI, 52): “the disc of the moon is filled with souls.” It is the same in exotic myths. Cf. Frobenius, *Zeitalter*, pp. 352ff.

²² Waitz, *Anthropologie der Naturvölker*, II, p. 342.

²³ Trans. by Untermeyer, p. 78.

²⁴ [As trans. in the Hinkle edn. (1916), pp. 254f.]

²⁵ *The Light of Asia*, Book I, p. 2. The elephant is shown penetrating Maya’s side with his trunk. According to a medieval tradition, Mary’s conception of Jesus took place through the ear.

²⁶ Cf. *Psychology and Alchemy*, pars. 518ff.

²⁷ *The Myth of the Birth of the Hero*.

²⁸ The rapid death of the mother, or separation from the mother, is an essential part of the hero-myth. The same idea is expressed in the myth of the swan-maiden, who flies away again after the birth of the child, her purpose fulfilled.

²⁹ The bear is associated with Artemis and is thus a “feminine” animal. Cf. also the Gallo-Roman Dea Artio (pl. *Lb*), and my “Psychological Aspects of the Kore,” pars. 340ff.

³⁰ Cf. Layard, “The Incest Taboo and the Virgin Archetype,” pp. 254ff.

³¹ Karl Joël (*Seele und Welt*, pp. 153f.) says: “Life is not lessened in artists and prophets, but is enhanced. They are our guides into the Lost Paradise, which only becomes Paradise through being found again. It is not the old, mindless unity that the artist strives for, but a felt reunion; not empty unity, but full unity; not the oneness of indifference, but the oneness attained through differentiation.... All life is a loss of balance and a struggling back into balance. We find this return home in religion and art.”

³² By “primal experience” is meant that first human differentiation between subject and object, that first conscious objectivation which is psychologically inconceivable without an inner division of the human animal against himself—the very means by which he separated himself from the oneness of nature.

³³ *Seele und Welt*.

³⁴ Crèvecoeur, *Voyage dans la haute Pensylvanie*, I, p. 362. I heard much the same thing from a chief of the Pueblo Indians, who told me the Americans were mad because they were so restless.

³⁵ The dragons of Greek (and Swiss) legend also live in or near springs or other waters, of which they are often the guardians. This links up with the motif of the “struggle by the ford.”

³⁶ Where one can wade through the water—cf. what we said above about the encircling and devouring motif. Water as an obstacle in dreams seems to indicate the mother, or a regression of libido. Crossing the water means overcoming the obstacle, i.e., the mother as symbol of man’s longing for the condition of sleep or death. See my “On the Psychology of the Unconscious,” pars. 132ff.

³⁷ Cf. the Attic custom of stuffing a bull in spring; also the Lupercalia, Saturnalia, etc.

³⁸ This fact led my pupil Dr. Spielrein to develop her idea of the death-instinct, which was then taken up by Freud. In my opinion it is not so much a question of a death-instinct as of that “other” instinct (Goethe) which signifies

spiritual life.

³⁹ An essential part of this disposition is the *a priori* existence of “organizing factors,” the archetypes, which are to be understood as inborn modes of functioning that constitute, in their totality, man’s nature. The chick does not learn how to come out of the egg—it possesses this knowledge *a priori*.

⁴⁰ *Liber Azoth*, ed. by Sudhoff, XIV, p. 576.

⁴¹ Trans. by Friedlander, ch. 10, p. 69.

⁴² In the Gilgamesh Epic, too, immortality is the goal of the hero.

⁴³ Cf. “The Visions of Zosimos,” par. 86: “... by compelling necessity I am sanctified as a priest and now stand in perfection as a spirit.” (Also in Berthelot, *Alch. grecs*, III, i, 2.)

⁴⁴ Cf. my “Phenomenology of the Spirit in Fairytales,” pars. 400ff.

⁴⁵ Sepp, *Das Heidentum und dessen Bedeutung für das Christentum*, III, p. 82, cited in Drews, *The Christ Myth*, p. 116, n.

⁴⁶ An excellent example of this is the love-story of Sophia, reported by Irenaeus, *Adversus Haereses*, Roberts and Rambaut trans., I, p. 7.

⁴⁷ *Almus* means ‘nourishing, refreshing, kind, bountiful.’ (Cf. pl. *xiva*.)

⁴⁸ Bernardino de Sahagún, *General History of the Things of New Spain*, Book 3, pp. 5f. [Cf. “Transformation Symbolism in the Mass,” pars. 339ff.]

⁴⁹ For the “friend,” see my discussion of Khidr in “Concerning Rebirth,” pars. 240ff. [Cf. also *Psychology and Alchemy*, pars. 155–57. The account of Khidr is in the Koran, Sura 18.—EDITORS.]

⁵⁰ Frazer, *The Golden Bough*, IV, p. 297.

⁵¹ “You sought the heaviest burden, and found yourself.”—Nietzsche. [Cf. par. 459, above.]

⁵² Christ successfully resisted the temptations of the power-devil in the wilderness. Whoever prefers power is therefore, in the Christian view, possessed by the devil. The psychologist can only agree.

⁵³ Hebrews 10:31; Origen, *In Jeremiam*, 3, 3 [see James, *Apocryphal New Testament*, p. 35]; Hebrews 12:29; Revelation 5:5; Genesis 49:9.

⁵⁴ I Peter 5: 8.

⁵⁵ It is an almost invariable feature of the dragon-whale myth that the hero begins to feel very hungry in the belly of the monster and cuts off bits of the innards for food. He is, in fact, inside the “nourishing mother.” His next act is to make a fire in order to get out of the monster. In an Eskimo myth from the Bering Strait, the hero finds a woman in the whale’s belly, who is its soul. Cf. Frobenius, *Zeitalter*.

⁵⁶ The carrying of the tree (*θαλλοφορία*), as we know from Strabo, played an important part in the cults of Dionysus and Ceres (Demeter).

⁵⁷ A Pyramid text dealing with the arrival of the dead Pharaoh in heaven describes how he overpowers the gods in order to assimilate their divine nature and become their lord. “His servants have caught the gods with lassoes, and have taken them and dragged them away, they have bound them, they have cut their throats and taken out their entrails, they have cut them up and cooked them in hot cooking-pots. And the king consumes their strength and eats their souls. He devours the great gods for breakfast, the middle gods for dinner, and the little gods for supper ... The

king devours everything that comes his way. He consumes all things in his greed, and his magic power becomes greater than all magic power. He becomes an heir of power greater than all heirs, he becomes the lord of heaven, he eats all the crowns and bracelets, he eats the wisdom of all the gods.” (Wiedemann, in *Der Alte Orient*, II (1900), p. 50; i.e., no. 2, p. 18.) This ravenous hunger (βουλμία) aptly describes man’s repressive instinctuality at the stage where the parents have a predominantly nutritive significance.

⁵⁸ The sacrifice of Dionysus-Zagreus and the eating of the sacrificial meat produced the νέος Διόνυσος, the resurrection of the god, as is apparent from the Cretan fragment of Euripides quoted by Dieterich (*Mithrasliturgie*, p. 105):

ἄΥνὸν δὲ βίον τείνων, ἕξ οὔ
Διὸς Ἰδαίου μύστης Υνόμεν
καὶ νυκτιπόλου Ζαγρέως βούτας
τοὺς ὠμοφάγους δαΐτας τελέσας.

(Leading a holy life since I have been initiated into the mysteries of Idaean Zeus, and have eaten raw the flesh of Zagreus, the night-roaming shepherd.) Through eating the raw flesh the initiates assimilated the essence of the god. Cf. the Mexican rite of Teoqualo, “god-eating,” in my “Transformation Symbolism in the Mass,” pars. 339ff.

⁵⁹ Judges 14: 14.

⁶⁰ *Metamorphoses*, IV, 18–20, trans. by Miller, I, p. 181.

⁶¹ Orphic Hymn 46, trans. by Taylor, p. 100. Cf. Roscher, *Lexikon*, s.v. “Iakchos.”

⁶² An exact parallel is the legend of Izanagi, the Japanese Orpheus, who followed his dead wife down to the underworld and begged her to return with him. She was willing to do so but besought him not to look at her. Izanagi then made a light with one of the “masculine” prongs of his comb and immediately lost his wife. (Frobenius, *Zeitalter*, p. 343.) For “wife” read “mother,” “anima,” “unconscious.” Instead of the mother, the hero brings back fire, just as Hiawatha produced the corn, Odin the runes, etc.

⁶³ Cited from De Jong, *Das antike Mysterienwesen*, p. 22. [For Asterius, bishop of Amasea, see his *Homilia X in sanctos martyres*, in Migne, *P.G.*, vol. 40, 323–24.—EDITORS.]

⁶⁴ A son-lover from the Demeter myth was Iasion, who lay with Demeter on a thrice-ploughed cornfield, and was struck with lightning by Zeus. (Ovid, *Metamorphoses*, IX.)

⁶⁵ εἰς τόπον ἀνήλιον.—*De Iside et Osiride*, 369. [Cf. Babbitt trans., V, p. 113.]

⁶⁶ εἰς χωρίον ἔρημον καὶ ὑλῶδες καὶ ἀνήλιον.—*Menippus*. [Cf. Harman trans., IV, p. 89.]

⁶⁷ κατάβασις εἰς ἄντρον.—Oratio V. [Cf. Wright trans., I, p. 463.] Here cited from Cumont, *Textes*, I, p. 56.

⁶⁸ *Protrepticus*. [Cf. the Wilson trans., I, p. 13.] Ἐνήστευσα, ἔπιον τὸν κυκεῶνα, ἔλαβον ἐκ κίστης, ἐργασάμενος ἀπεθέμην εἰς κάλαθον καὶ ἐκ καλάθου εἰς κίστην. Instead of ἐργασάμενος Lobeck suggests ἐγγευσάμενος, ‘after I have tasted.’ Dieterich (*Mithras-liturgie*, p. 125) keeps to the traditional reading.

⁶⁹ Dieterich, pp. 123ff.

⁷⁰ As, for instance, in a Campana bas-relief in Caetani-Lovatelli, *Antichi monumenti*, Pl. IV, fig. 5. [The “Lovatelli urn” is described and depicted, also, in this work.—EDITORS.] Similarly, the Verona Priapus holds a basket filled with phalli. (Cf. pl. LX1b.)

⁷¹ Wilson trans., I, p. 17.

⁷² “ΣΚΙΠΑ,” p. 124.

⁷³ The mother is the giver of nourishment. St. Dominic was nourished at the breasts of the mother of God, and so was the adept in alchemy. The sun-woman of the Namaquas, of South Africa, is made of bacon-fat. Cf. the megalomaniac ideas of my patient: “I am Germania and Helvetia made of exclusively sweet butter” (“Psychology of Dementia Praecox,” par. 201).

⁷⁴ *Protrepticus*, II, 16. Cited in Dieterich, p. 123. (ἅ διὰ κόλπου θεός, δρᾶκων δέ ἐστι καὶ οὗτος διελκόμενος τοῦ κόλπου τῶν τελουμένων.)

⁷⁵ *Adversus Gentes*, V, 21. (“aureus coluber in sinum demittitur consecratis et eximitur rursus ab inferioribus partibus atque imis.”) [Cf. Bryce and Campbell trans., p. 244.]

⁷⁶ Cf. Nietzsche’s images: “thyself pierced through,” “working in thine own pit,” etc. [pars. 446 and 459, above]. A prayer to Hermes in a papyrus says: ἐλθέ μοι, κύριε Ἑρμῆ, ὡς τὰ βρέφη εἰς τὰς κοιλίας τῶν γυναικῶν (Come to me, O Hermes, as children come into the womb of women).—Kenyon, *Greek Papyri in the British Museum*, I, p. 116: Pap. CXXII, 11. 2ff.; cited in Dieterich, p. 97.

⁷⁷ ἘΥκε Πότνια κοῦρον, Βριμῶ Βριμόν.—Brimo = Demeter. Jupiter is said to have had intercourse with his mother Deo (Demeter) in the form of a bull. This made the goddess so furious that, to pacify her, he pretended to castrate himself. Roscher, *Lexikon*, IV, s.v. “Sabazios,” 253, 5.

⁷⁸ De Jong, *Das antike Mysterienwesen*, p. 22.

⁷⁹ The corn-god of antiquity was Adonis, whose death and resurrection were celebrated annually. He was the son-lover of the mother, for the corn is the son and fructifier of the earth’s womb, as Robertson (*Christianity and Mythology*, p. 318) has already pointed out.

⁸⁰ Trans. by Evelyn-White, p. 323.

^{80a} [Jung’s maternal grandfather.]

⁸¹ [As trans. in the Hinkle edn. (1916), p. 378.]

⁸² (“Nocte quadam simulacrum in lectica supinum ponitur, et per numeros digestis fletibus plangitur; deinde cum se ficta lamentatione satiaverint, lumen infertur: tunc a sacerdote omnium qui flebant fauces unguentur, quibus perunctis sacerdos hoc lento murmure susurrat: Θαρρεῖτε μύσται τοῦ θεοῦ σεσωσμένου, ἔσται Ἦαρ ἡμῖν ἐκ πόνων σωτηρία”).—*De errore profanarum religionum*, XXII, I, p. 57.

⁸³ Dieterich, p. 167.

⁸⁴ *Ibid.*

⁸⁵ As an example, I will quote here the Polynesian myth of Rata (Frobenius, *Zeitalter*, pp. 64–66): “The boat was sailing along merrily over the ocean under a favourable wind, when one day Nganaoa called out: ‘O Rata! A fearful enemy is rising up from the sea!’ It was a giant clam, wide open. One of its shells was in front of the boat, the other behind, and the vessel lay in between. The next moment the horrible clam would have snapped shut and ground the boat and all its occupants to pulp. But Nganaoa was prepared for this possibility. Seizing his long spear, he thrust it quickly into the creature’s belly, so that instead of snapping shut it sank instantly to the bottom of the sea. After escaping from this danger they continued on their way. Yet soon the voice of the ever watchful Nganaoa was heard again: ‘O Rata! Another fearful enemy is rising up from the sea!’ This time it was a mighty octopus, whose giant

tentacles were already wrapped round the boat to destroy it. At this critical moment Nganaoa seized his spear and plunged it into the head of the octopus. The tentacles sank down limply, and the dead monster floated away on the surface of the ocean. Once more they continued on their journey, but a still greater danger awaited them. One day the valiant Nganaoa cried out: ‘O Rata! Here is a great whale!’ Its huge jaws were wide open, the lower jaw was already under the boat, the upper one was over it. Another moment and the whale would have swallowed them. Then Nganaoa, the ‘slayer of monsters,’ broke his spear in two, and just as the whale was about to crush them he stuck the two pieces in his enemy’s gullet, so that he could not close his jaws. Then Nganaoa leapt into the maw of the great whale (devouring of the hero) and peered down into his belly, and what did he see? There sat his two parents, his father Tairitokerau and his mother Vaiaroa, who had been swallowed by this monster of the deep when out fishing. The oracle had come true. The voyage had reached its goal. Great was the joy of the parents of Nganaoa when they beheld their son, for they were now persuaded that their liberation was at hand. And Nganaoa, too, was bent upon vengeance. Taking one of the two sticks from the animal’s gullet—the other was enough to prevent the whale from closing his jaws and to keep the passage clear for Nganaoa and his parents—he broke it into two pieces for use as fire-sticks. He told his father to hold one piece firmly below, while he himself manipulated the upper one until the fire began to glimmer (fire-lighting). Then, blowing it into a flame, he hastened to heat the fatty parts inside the belly (i.e., the heart) with the fire. The monster, writhing with pain, sought relief by swimming to land (sea journey). As soon as it reached the sandbank (landing), father, mother and son stepped ashore through the open gullet of the dying whale (slipping out of the hero).” See diagram on p. 210.

⁸⁶ [Cf. par. 235, above.]

⁸⁷ In the Maori myth of Maui (Frobenius, pp. 66ff.) the monster to be overcome is Grandmother Hine-nui-te-po. Maui, the hero, says to the birds who help him: “My little friends, when I creep into the jaws of the old woman, you must not laugh, but once I have been in and have come out of her mouth again, you may welcome me with shouts of laughter.” Then Maui creeps into the mouth of the old woman as she sleeps.

⁸⁸ Negelein, ed., *Der Traumschlüssel des Jaggadeva*, p. 256.

⁸⁹ Cited from Negelein, p. 256.

⁹⁰ It is the pine-tree that speaks the significant word “Minne-wawa!”

⁹¹ In the story of Cinderella, the helpful bird appears on the tree that grows out of her mother’s grave.

⁹² Roscher, *Lexikon*, s.v. “Picus,” III, 2, 2496, 30.

⁹³ The father of Picus was called Sterculus or Sterculius, a name which is obviously derived from *stercus*, ‘excrement.’ He is also said to have invented manure. The original Creator who fashioned the mother did so in the infantile manner, as we saw earlier. This supreme god laid an egg, his mother, from which he hatched himself out. Excrement in alchemy signifies the *prima materia*.

⁹⁴ Spielrein’s patient received three arrow wounds from God, through her head, breast, and eye, “then came a resurrection of the spirit” (p. 376). In the Tibetan legend of Bogda Gesser Khan, the sun-hero shoots his arrow into the forehead of the demoniacal old woman, who then eats him and spits him out again. In a legend of the Kalmucks, from Siberia, the hero shoots the arrow into the “bull’s-eye” that grows on the bull’s forehead and “emits rays.”

⁹⁵ This is synonymous with entering into the mother, becoming immersed in oneself, crawling through something, boring, picking the ear, driving in nails, swallowing snakes, etc.

⁹⁶ Cf. “Psychology and Religion,” par. 97.

⁹⁷ Cf. the *Μεσουράνισμα ήλιου*, position of the sun at midday as symbol of the initiate’s illumination, in “The Visions of Zosimos,” pars. 86 and 95.

⁹⁸ Cf. Mary’s flight into Egypt, the persecution of Leto, etc.

⁹⁹ *Die Walküre*, li. 1782–83, 1792–94.

¹⁰⁰ Rig-Veda, X, 72, trans. from the German of Deussen, *Allgemeine Geschichte der Philosophie*, I, p. 145.

¹⁰¹ Rig-Veda, X, 31, trans. from *ibid.*, p. 140.

¹⁰² *Die Walküre*, li. 900–903, 907–908.

¹⁰³ Trans. by Walker, p. 392, modified.

¹⁰⁴ *Ibid.*, p. 416, modified.

¹⁰⁵ *Die Walküre*, li. 1867–74.

¹⁰⁶ Grimm mentions the legend that Siegfried was suckled by a doe.

¹⁰⁷ Cf. Grimm, *Teutonic Mythology*, I, pp. 379ff. Mime or Mimir is a gigantic being of great wisdom, an “elder nature god” with whom the Norse gods associate. Later fables make him a forest spirit and skilful smith. Like Wotan, who goes to the wise woman for advice, Odin goes to the fountain of Mimir in which wisdom and cunning lie hidden. There he asks for a drink (the drink of immortality), but no sooner does he receive it than he sacrifices his eye to the fountain. The fountain of Mimir is an obvious allusion to the mother-imago. Mimir and his fountain are a condensation of mother and embryo (dwarf, subterranean sun, Harpocrates); but at the same time he is, as the mother, the source of wisdom and art. Just as Bes, the dwarf and teacher, is associated with the Egyptian mother goddess, so Mimir is associated with the maternal fountain. In Barlach’s play, *Der tote Tag* (1912), the demonic mother has a familiar house-spirit called “Steissbart” (Rumpbeard), who is a dwarfish figure like Bes. These are all mythological animus-figures. Concerning the animus see “The Relations between the Ego and the Unconscious,” pars. 328ff.

¹⁰⁸ The enchanted sleep also occurs in Homer’s celebration of the *hieros gamos*.

¹⁰⁹ Cf. Siegfried’s words (li. 2641–50):

Through burning fire
I sped toward you;
Neither shield nor buckler
Guarded my body:
The flames have broken
Through to my breast;
My blood races
Hot through my veins;
A raging fire
Is kindled within me.

¹¹⁰ The dragon in the cave is the Terrible Mother. In German legend the maiden in distress often appears as a snake or dragon that has to be kissed; then it changes into a beautiful woman. Certain wise women are supposed to have a

fish's or a serpent's tail. A king's daughter was immured in the Golden Mount as a snake. In Oselberg, near Dinkelsbühl, there is a snake with a woman's head and a bunch of keys round the neck. Grimm, III, p. 969.

¹¹¹ *Siegfried*, li. 1462–70.

¹¹² *Ibid.*, li. 1482–87.

¹¹³ This problem is dealt with in Barlach's *Der tote Tag*, which gives a brilliant description of the mother complex.

¹¹⁴ *Psychological Types*; Jung and Wilhelm, *The Secret of the Golden Flower; Psychology and Alchemy; Aion*.

¹¹⁵ Cf. Schlauch, trans., *The Saga of the Volsungs*, p. 101.

¹¹⁶ *Etymologisches Wörterbuch der deutschen Sprache*, s.v. "Hort."

¹¹⁷ *Etymologisches Wörterbuch der griechischen Sprache*.

¹¹⁸ *Urkeltischer Sprachschatz*, p. 89.

¹¹⁹ *Description of Greece*, I, 18, 7.

¹²⁰ *Iliad*, XIV, 246.

¹²¹ *Ibid.* I, 34, 4.

¹²² Rohde, *Psyche*, p. 162.

¹²³ *Ibid.*

¹²⁴ Maehly, *Die Schlange im Mythos und Kultus*, p. 13.

¹²⁵ "Erat draco immanissimus in monte Tarpeio, in quo est Capitolium collocatum. Ad hunc draconem per CCCLXV gradus, quasi ad infernum, magi cum virginibus sacrilegis descendebant semel in mense cum sacrificiis et lustris, ex quibus esca poterat tanto draconi inferri. Hic draco subito ex improvise ascendebat et licet non egrederetur vicinos tamen aeres flatu suo vitiabat. Ex quo mortalitas hominum et maxima luctus de morte veniebat infantum. Sanctus itaque Silvester cum haberet cum paganis pro defensione veritatis conflictum, ad hoc venit ut dicerent ei pagani: Silvester descende ad draconem et fac eum in nomine Dei tui vel uno anno ab interfectione generis humani cessare." Duchesne, *Liber Pontificalis*, I, p. cxi; cited in Cumont, *Textes*, I, p. 351.

¹²⁶ Revelation 20: 1–2.

¹²⁷ Cf. Revelation 20: 3. We find the same motif of the armed dragon who pierces the women with a sword in a myth of the Oyster Bay tribe, of Tasmania: "A devilfish lay hidden in the hollow of a rock—a huge devilfish! The devilfish was enormous and he had a very long spear. From his hole he espied the women; he saw them dive into the water, he pierced them with his spear, he killed them, he carried them away. For a time they were no longer to be seen." The monster was then killed by the two heroes. They made a fire and brought the women back to life again. Frobenius, *Zeitalter*, p. 77.

¹²⁸ The eyes of the Son of Man are like a "flame of fire." Rev. 1:14.

¹²⁹ "Apud urbem Romam specus quidam fuit in quo draco mirae magnitudinis mechanica arte formatus, gladium ore gestans, oculis rutilantibus gemmis metuendus ac terribilis apparebat. Huic annuae devotae virgines floribus exornatae, eo modo in sacrificio dabantur, quatenus inscias munera deferentes gradum scalae, quo certe ille arte diaboli draco pendebat, contingentes impetus venientis gladii perimeret, ut sanguinem funderet innocentem. Et hunc quidam monachus, bene ob meritum cognitus Stiliconi tunc patricio, eo modo subvertit; baculo, manu, singulos gradus palpandos inspiciens, statim ut illum tangens fraudem diabolicam repperit, eo transgresso descendens,

draconem scidit, misitque in partes; ostendens et hic deos non esse qui manu fiunt.”—Cited in Cumont, *Textes*, I, p. 351.

¹³⁰ Cf. “The Psychology of Eastern Meditation,” pars. 943ff.

¹³¹ Cf. Bousset, *The Antichrist Legend*.

¹³² How very much Christ is the archetypal hero can be deduced from Cyril of Jerusalem (d. 386), who was of the opinion that Christ’s body was a bait for the devil. On swallowing the bait, however, the devil found it so indigestible that he had to yield it up again, as the whale spewed forth Jonah.

¹³³ Cited in Cumont, *Textes*, I, p. 352.

¹³⁴ Cf. Roscher, *Lexikon*, I, 1885ff.

¹³⁵ *Faust*, Part II, “The Mothers.” The key belongs to Hecate as the guardian of Hades and divine psychopomp. Cf. Janus, Peter, and Aion.

¹³⁶ An attribute of the Terrible Mother. Ishtar “chastised the horse with goad and whip and tortured him to death.” Jensen, *Gilgamesch-Epos*, p. 18. [Cf. Speiser trans., in Pritchard, p. 84.]

¹³⁷ [The relation of these words to one another and to the “mother” is etymologically apparent in the German: *Scheidung*, ‘parting’ in the sense of ‘division’; *Abschied*, ‘parting’ in the sense of ‘farewell’; *Scheide*, ‘parting’ in the sense of ‘line of separation,’ as in *Wasserscheide*, ‘watershed’; hence ‘sheath, scabbard.’ *Scheide* also means ‘vagina.’—TRANS.]

¹³⁸ Cf. the symbolism in the Melk hymn to Mary (12th century):

Sancta Maria,
Closed gate
Opened at God’s command—
Sealed fountain,
Locked garden,
Gate of Paradise. (Cf. Song of Solomon 4: 12.)

There is the same symbolism in the erotic verse:

Maiden, let me enter with you
Into your rose garden
Where the red rosebuds grow,
Those delicate and tender rosebuds,
With a tree nearby
Rustling to and fro,
And the deep cool well
That lies below.

¹³⁹ *Faust*; cf. above, p. 272.

¹⁴⁰ Herzog, “Aus dem Asklepieion von Kos,” pp. 219ff.

¹⁴¹ A Mithraic sanctuary was, whenever possible, an underground grotto, and the cave was often only an imitation one. It is possible that the Christian crypts and underground churches had a similar meaning. (Cf. pl. XXXIII.)

¹⁴² Cf. Schultze, *Die Katakomben*, pp. 9ff.

¹⁴³ Rohde, *Psyche*, p. 247. Further evidence in Herzog, p. 224.

¹⁴⁴ Further evidence in *ibid.*, p. 225.

¹⁴⁵ Sacred snakes were, however, kept for display and other purposes.

¹⁴⁶ Herzog, p. 212.

¹⁴⁷ Rohde, *Psyche*, p. 163.

¹⁴⁸ *Vergleichendes Wörterbuch der indogermanischen Grundsprache*, I, p. 28.

¹⁴⁹ Also Lat. *cuturnium*, the vessel into which wine was poured for sacrifice.

¹⁵⁰ Fick, I, p. 424.

¹⁵¹ Cf. the cleaning of the Augean stables. The stable, like the cave, is a place of birth; e.g., the cave and stable in which Christ was born. (See Robertson, *Christ and Krishna*.) Birth in a stable is also found in a Basuto myth (Frobenius, *Zeitalter*). It belongs to the sphere of animal fables; hence the story of how the barren Sarah conceived is prefigured in the Egyptian fable of the Apis bull. Herodotus says: "This Apis—or Epaphus—is the calf of a cow which is never afterwards able to have another. The Egyptian belief is that a flash of light descends upon the cow from heaven, and this causes her to conceive Apis." (III, 28; trans. by Selincourt, p. 186.) Apis is the sun, and his distinguishing marks are a white patch on the forehead, on his back the figure of an eagle, and on his tongue a beetle.

¹⁵² Some authorities connect *κῆρος*, 'supreme power,' *κῆριος*, 'lord,' with Olan. *caur, cur*, 'hero,' *Skr.ś śura-*, 'strong, hero.' But the connection is regarded as doubtful or improbable.

¹⁵³ Maehly, *Die Schlange im Mythos und Kultus*, p. 7.

¹⁵⁴ A good example of this is the Yang-Yin doctrine in classical Chinese philosophy.

¹⁵⁵ [Etymologically, 'devil' and 'divinity' are both related to *Skr. deva*, 'demon.'—TRANS.]

¹⁵⁶ Cf. the account of the orgies practised by certain Russian sects in Merezhkov-sky, *Peter and Alexis*. The orgiastic cult of Anahita or Anaitis, the Asiatic goddess of love, is still practised among the Ali Illahija, the self-styled "extinguishers of the light," and the Yezidis and Dushik Kurds, who indulged nightly in religious orgies ending in a wild sexual debauch during which incestuous unions occur. (Spiegel, *Eränische Altertumskunde*, II, p. 64.) Further examples in Stoll, *Das Geschlechtsleben in der Völkerpsychologie*.

¹⁵⁷ Concerning the snake-kiss, see Grimm, *Teutonic Mythology*, III, p. 969. By this means a beautiful woman was set free. Spielrein's patient (pp. 344f.) says: "Wine is the blood of Jesus.—The water must be blessed and was blessed by him.—He who is buried alive becomes a vineyard.—That wine turns to blood.—The water is mingled with childishness because God says 'Become like children.'—There is also a spermatic water that can be steeped in blood. Maybe that is the water of Jesus." This hotch-potch of ideas is characteristic. Wiedemann ("Die Toten und ihre Reiche," p. 51, cited from Dieterich, p. 101) documents the Egyptian idea that man could drink immortality by sucking the breast of a goddess. Cf. the myth of Heracles, who became immortal after a single sip at the breast of Hera.

- ¹⁵⁸ From the *Geheimes Reskript* (1821) of Unternährer. I have to thank the Rev. O. Pfister for calling my attention to this document.
- ¹⁵⁹ Nietzsche: “And this parable I also give unto you: not a few who sought to cast out their devil, themselves entered into the swine” (*Zarathustra*).
- ¹⁶⁰ *Testis* originally had the double meaning of ‘testicle’ and ‘testimony.’ [Cf. the Biblical custom of swearing an oath by placing the hand “under the thigh”; Genesis 24: 2f and 47: 29f.—EDITORS.]
- ¹⁶¹ Cf. Nietzsche’s poem: “Why hast thou enticed thyself / Into the old serpent’s Paradise?” [Cf. par. 459, above.]
- ¹⁶² Nietzsche himself seems to have shown at times a certain predilection for loathsome animals. Cf. Bernoulli, *Franz Overbeck und Friedrich Nietzsche*, I, p. 166.
- ¹⁶³ Cf. Nietzsche’s dream, quoted at p. 34, n. 1, above.
- ¹⁶⁴ *Thus Spake Zarathustra* (in *Werke*, VI, pp. 233f.). This image is reminiscent of the myth of Dietrich of Bern: he was wounded in the forehead by an arrow, and because a piece remained lodged there, he was called the “immortal.” Similarly, half of Hrungnir’s stone club embedded itself in Thor’s skull. Grimm, I, pp. 371–72.
- ¹⁶⁵ Rig-Veda, X, 121, trans. from Deussen, *Geschichte*, I, p. 181.
- ¹⁶⁶ *Ibid.*, pp. 181f.
- ¹⁶⁷ *Sa tapo atapyata*.
- ¹⁶⁸ *Geschichte*, I, p. 182.
- ¹⁶⁹ The Stoic conception of creative heat, which we have already recognized as libido (p. 67, n. 51, above), is a kindred idea, like the birth of Mithras from a stone “through the sole heat of libido.”
- ¹⁷⁰ Kama = Eros, and = the libido.
- ¹⁷¹ Trans. from Deussen, I, p. 123.
- ¹⁷² *Memoirs of My Nervous Illness*.
- ¹⁷³ “Glory and Eternity” (“Ruhm und Ewigkeit,” in *Werke*, VIII, I, p. 425).
- ¹⁷⁴ Grimm, IV, p. 1395. Sigurd was called “Ormr î Auga” (Snake’s Eyes).
- ¹⁷⁵ Galatians 3:27 contains an allusion to this primitive idea: “For as many of you as were baptized into Christ have put on Christ” (RSV). The word used here, *ἐνδύειν* (*induere*), means literally to ‘put on, clothe oneself, insinuate oneself into.’
- ¹⁷⁶ Cf. Robertson, *Christianity and Mythology*, p. 395.
- ¹⁷⁷ The mamba is the African cobra.
- ¹⁷⁸ Frazer, *The Golden Bough*, Part IV, p. 405.
- ¹⁷⁹ *Ibid.*, p.242.
- ¹⁸⁰ *Ibid.*, p.246.
- ¹⁸¹ *Ibid.*, p. 249. Concerning the flaying motif, see my “Transformation Symbolism in the Mass,” par. 348.
- ¹⁸² Another attempt at a solution seems to be the Dioscuri motif: two brothers who resemble one another, one mortal, the other immortal. This motif is found in Indian mythology as the two Asvins, though here they are not differentiated. It appears very clearly in Shvetashvatara Upanishad (4, 6) as the companion birds who “clasp the selfsame tree,” i.e., as the personal and suprapersonal atman. In the Mithraic cult, Mithras is the father, Sol the son,

and yet both are one as δ μέγας θεὸς Ἥλιος Μίθρας: “the great god Helios Mithras.” (Cf. Dieterich, p. 68.) That is to say, man does not change at death into his immortal part, but is mortal and immortal even in life, being both ego and self.

¹⁸³ ταῦρος δράκοντος καὶ ταύρου δράκων πατήρ.—Firmicus Maternus, *De errore profanarum religionum*, XXVI, 1, p. 67.

¹⁸⁴ *Werke*, VIII, p. 413.

¹⁸⁵ Wagner, *Siegfried*, li. 2088–2101, 2117–19, 2126–27, 2248–49.

¹⁸⁶ It is a striking fact that the lion-killing heroes Samson and Heracles fight *without weapons*. (Cf. fig. 17.) The lion is a symbol of the fierce heat of midsummer; astrologically he is the *domicilium solis*. Steintal (“Die Sage von Simson,” p. 133) reasons as follows: “When, therefore, the sun-god fights the summer heat, he is fighting himself; if he kills it, he kills himself.... The Phoenicians and Assyrians and Lydians believed that their sun-god was committing suicide, for only as suicide could they comprehend how the sun’s heat could grow less. Therefore, when the sun stood at its height in summer and burnt everything with its scorching rays, they thought: thus the god burns himself, but he does not die, he only rejuvenates himself.... Heracles burns himself too, but mounts to Olympus in the flames. This is the contradiction in the pagan gods: as forces of nature they are both helpful and harmful to men. So, in order to do good and rescue mankind, they must work against themselves. The contradiction is mitigated if each of the two sides of the force of nature is personified as a separate god, or if both are conceived as a single divine person, the beneficent and injurious sides each being assigned a separate symbol. The symbol becomes more and more autonomous and in the end becomes a god itself; and whereas originally the god worked against himself and destroyed himself, now symbol fights against symbol, god against god, or the god against the symbol.” The hero has no weapons precisely because he fights himself.

¹⁸⁷ “Voluntary Death,” in *Zarathustra*. [Cf. trans. by Common, p. 125.]

¹⁸⁸ *Siegfried*, li. 2478–82, 2496–2500, 2511–16, 2542–43, 2552–59. It was an Etruscan custom to bury the cinerary urn of the dead man in the earth and cover it with a shield.

¹⁸⁹ *Siegfried*, li. 2561–62, 2565–66, 2571–90, 2738–50, 2797–99, 2818–19, 2862–63.

¹⁹⁰ Although the unconscious is, in general, complementary to consciousness, the complementing is not of a mechanical nature that can be clearly predicted, but acts in each case purposively and intelligently, so that it is better to think of it as compensation.

¹⁹¹ See “The Relations between the Ego and the Unconscious,” pars. 374ff.

¹⁹² Identity of the personal and the suprapersonal atman.

¹⁹³ Cf. *Psychological Types* (1923 edn., pp. 245ff.), and *Aion*, the chapters on the symbolism of the self.

¹ [In the Swiss edition, Ch. VII, “Das Opfer” (“The Sacrifice”), embraces all of the text composing Chs. VII and VIII of the present edition. It contains a break in the text at this point, but no heading. The present arrangement corresponds to that of the original Swiss edition and its English trans.—EDITORS.]

² Cf. Harding, *The Way of All Women*.

³ [Cf. MacNeice trans., p. 40.]

⁴ Cf. Jaffé’s study of E. T. A. Hoffmann’s “Golden Bowl.”

⁵ See my foreword to the 2nd (1925) edn. of the present work.

⁶ *Gedichte*, p. 53. [As trans. in the Hinkle (1916) edn.]

⁷ It is, indeed, the essence of the beloved and a designation for the Virgin Mary (mystical rose). Cf. Jung and Wilhelm, *The Secret of the Golden Flower* (1962 edn.), pp. 101f., and the mandala symbolism in *Psychology and Alchemy*, pars. 99 and 139; also Hartlaub, *Giorgiones Geheimnis*.

⁸ *Gedichte*, p. 315. [Based on the trans. in the Hinkle (1916) edn.]

⁹ *Zeitalter*, p. 68.

¹⁰ *Ibid.*, p. 269.

¹¹ *Gedichte*, p. 115.

¹² Robertson, *Christianity and Mythology*, p. 369.

¹³ [Cf. Tacitus, *Historiae*, V, III, 4, and Josephus, *Against Apion*, II, 4.—EDITORS.]

¹⁴ “After our discussion of Hölderlin’s last poem, it will be clear that Nature is to be understood as the mother. (Cf. fig. 1.) Here the poet imagines the mother as a tree upon which the child hangs like a bud. (Cf. pl. XXXIX.)

¹⁵ In connection with his calling the stars his “brothers,” I would remind the reader of what I said in Part I (par. 130) about the mystic identification with the stars: “I am a star wandering together with you,” etc. Separation and differentiation from the mother, “individuation,” produces that confrontation of subject and object which is the foundation of consciousness. Before this, man was one with the mother; that is to say, he was merged with the world as a whole. He did not yet know the sun was his brother; only after the separation did he begin to realize his affinity with the stars. This is a not uncommon occurrence in psychosis. For instance, in the case of a young labouring-man who developed schizophrenia, the first symptoms of his illness consisted in the feeling that he had a special relation to the sun and the stars. The stars became full of meaning for him, he thought they had something to do with him personally, and the sun gave him all sorts of strange ideas. One finds this apparently quite novel feeling for Nature very often in this disease. Another patient began to understand the language of the birds, who brought him messages from his sweetheart. (Cf. Siegfried!)

¹⁶ Springs, fountains, etc. are images of totality.

¹⁷ This image expresses the state of divine or infantile beatitude, as in Hölderlin’s “Hyperion’s Song of Fate” (trans. by Hamburger, p. 113):

“You walk above in the light
On soft floors, O blessed genii!
Shining breezes of gods
Touch you lightly.”

¹⁸ This passage is specially significant: in childhood everything came as a gift, and he is unable to attain this state again, because it is won only through “effort and compulsion”—even love costs effort. In childhood the spring runs over in bubbling fulness, but in later life it needs a lot of hard work to keep it flowing at all, because the older we get the more it tends to flow back to its source.

¹⁹ *Gedichte*, p. 57. [As trans. in the Hinkle (1916) edn., slightly modified.]

²⁰ *Ibid.*, p. 156.

²¹ *Ibid.*, p. 142. [Cf. Leishman trans., p. 55.]

²² *Ars poetica*, trans. by Fairclough, pp. 488–89.

²³ *Gedichte*, p. 157.

²⁴ *Ibid.*, p. 244.

²⁵ *Ibid.*, pp. 335ff. [For passages up to par. 642, from “Patmos,” cf. Hamburger trans., pp. 217ff.]

²⁶ Cf. the passage in Odysseus’ journey to Hades, where he meets his mother: “As my mother spoke, there came to me out of the confusion in my heart the one desire, to embrace her spirit, dead though she was. Thrice, in my eagerness to clasp her to me, I started forward with my hands outstretched. Thrice, like a shadow or a dream, she slipped through my arms and left me harrowed by an even sharper pain.” (Odyssey, XI, 204–8, trans. by Rieu, p. 181.)

²⁷ Spielrein’s patient (p. 345), in connection with the significance of the communion, speaks of “water mingled with childishness,” “spermatic water,” “blood and wine.” On p. 368 she says: “The souls fallen in the water are saved by God: they fall on deeper ground. Souls are saved by the sun-god.” Cf. also the miraculous properties of the alchemical *aqua permanens* (*Psychology and Alchemy*, pars. 94 and 336f.).

²⁸ *Thus Spake Zarathustra*: “The Seven Seals,” trans. by Common, p. 272, modified.

²⁹ The *φάρμακον ἀθανασίας*, the soma-drink, the haoma of the Persians, may have been made from *Ephedra vulgaris*. Spiegel, *Eränische Altertumskunde*, I, p. 433.

³⁰ Like the heavenly city in Hauptmann’s *Hannele* (trans. by Meltzer, pp. 91–92):

“The Realm of Righteousness is filled with light and joy,
God’s everlasting peace reigns there without alloy,
Its mansions are marble, its roofs are of gold,
Through its rivulets ripple wines ruddy and old.
In its silver-white streets blow the lily and rose.
In its steeples the chiming of joy-bells grows.
The beautiful butterflies frolic and play
On its ramparts, rich-robed in the mosses of May ...
The blessed below, in the regions of Light,
Wander on, hand in hand, and rejoice in their flight.
In the depths of the radiant, the ruby-red waves,
Swan dives after swan, as its plumage it laves.
So they wash themselves clean in the clear, deep red

Of the blood that their Lord, their dear Saviour, had shed.”

³¹ Judges 15:17f.

³² Prellwitz, *Wörterbuch der griechischen Sprache*, s.v. σκήπτω.

³³ When writing this book I used an old edition of Hölderlin. Modern editions have “Christ” for “Geist.” I have retained the old reading, because, on the internal evidence of the poem, I gathered that it meant Christ even before I saw the modern reading.

³⁴ I.e., the Father’s.

³⁵ This was the real purpose of all the mystery religions. They created symbols of death and rebirth (cf. pl. LXIa). As Frazer points out in *The Golden Bough* (Part III: “The Dying God,” pp. 214ff.), even primitive peoples have in their initiation mysteries the same symbolism of dying and being born again as Apuleius records in connection with the initiation of Lucius into the Isis mysteries (*The Golden Ass*, XI, 23, trans. by Graves, p. 286): “I approached the very gates of death and set one foot on Proserpine’s threshold, yet was permitted to return, rapt through all the elements.” The rites of initiation “approximate to a voluntary death” from which Lucius was “born again” (p. 284). (Cf. pl. VI.)

³⁶ From the sacrifice of the dragon in alchemy comes the microcosm of the philosophers’ stone (*Psychology and Alchemy*, par. 404).

³⁷ Rig-Veda, X, 81, 4. This passage, and those in pars. 647 and 649, trans. from Deussen, *Geschichte*, pp. 136 and 156.

³⁸ Rig-Veda, X, 90. This passage, and those in pars. 650, 651, 656, trans. by W. Norman Brown, in the *Journal of the American Oriental Society*, LI (1931).

³⁹ “The Dynamics of the Transference,” p. 105.

⁴⁰ Cf. my “Psychology of the Transference,” pars. 433ff. and Layard, “The Incest Taboo and the Virgin Archetype,” pp. 254ff.

⁴¹ Trans. by W. Norman Brown.

⁴² Trans. by Hume, *The Thirteen Principal Upanishads*, pp. 73—74, modified.

⁴³ The Bundahish (XV, 37) says that the bull Sarsaok will be sacrificed at the end of the world. Sarsaok helped to distribute the human race: he carried nine of the fifteen races on his back through the sea to the most distant parts of the earth. The primordial bull of Gayomart has, as we saw earlier, a maternal significance on account of his fertility.

⁴⁴ Deussen says (*Sechzig Upanishads*, III, p. 434): “‘There,’ on the horizon where the sky and the sea meet, between the two shells of the world egg, is a narrow crack through which one can get out onto ‘the back of the sky,’ where ... union with Brahman takes place.”

⁴⁵ Trans. by Hume, p. 111, modified.

⁴⁶ Symbol of Brahman (Deussen).

⁴⁷ If mythological symbolism is for Silberer (“Über die Symbolbildung.” III. pp. 664ff.) a cognitional process on the mythological level, then there is complete agreement between his view and mine.

⁴⁸ The following interesting Sumerian-Assyrian fragment (Gressmann, *Altorientalische Texte*, I, p. 101) comes from the library of Assurbanipal: “To the wise man he said: A lamb is a substitute for a man. He gives the lamb for his life, he gives the head of a lamb for the head of a man.”

“Grata deum matri, siquidem Cybeleius Attys

Exuit hac hominem, truncoque induruit illo.”

Metamorphoses, X, 104. [Cf. Miller trans., II, pp. 70—71.]

⁵⁰ Roscher, *Lexikon*, s.v. “Attis,” I, 722, 10.

⁵¹ Firmicus Maternus, *De errore profanarum religionum*, XXVII, p. 69: “Per annos singulos arbor pinea caeditur, et in media arbore simulacrum iuvenis subligatur” (Each year a pine-tree is felled, and an effigy of a youth is tied to the middle of the tree).

⁵² Preller, *Griechische Mythologie*, I, p. 555. Cited in Robertson, *Christianity and Mythology*, p. 407.

⁵³ Another hero with a serpent nature; his father was Echion, the adder.

⁵⁴ The typical sacrificial death in the Dionysus cult.

⁵⁵ Roscher, *Lexikon*, s.v. “Dionysus,” I, 1054, 56ff.

⁵⁶ For the festal processions they wore women’s clothes.

⁵⁷ In Bithynia, Attis was called πάπας (papa, pope) and Cybele, Mā. The Cybele cults of the Near and Middle East worshipped at the fish, and fish-eating was taboo for the priests of the mother-goddess. It is also worth knowing that the son of Atargatis, who is identical with Astarte, Cybele, etc., was called ‘χθύς. Roscher, s.v. “Ichthys.”

⁵⁸ Cf. Frobenius, *Zeitalter*, *passim*.

⁵⁹ Spiegel, *Erānische Altertumskunde*, II, p. 76.

⁶⁰ Nagel, “Der chinesische Küchengott (Tsau-kyun),” pp. 23ff.

⁶¹ Spiegel, I, p. 510.

⁶² Spiegel, *Grammatik der Parsisprache*, pp. 135, 166. [Cf. West trans., *Mainyo-i-Khard*, xxvii, 15 (p. 157).]

⁶³ Spiegel, *Altertumskunde*, II, p. 164. [Cf. West trans., VIII, 15 (p. 142).]

⁶⁴ *Ibid.*, I, p. 708.

⁶⁵ Porphyry (*De antro nympharum*, 24, in Taylor trans., p. 190) says: “For Mithras, as well as the bull, is the demiurge and lord of generation.” (Cited in Dieterich, *Mithrasliturgie*, p. 72.)

⁶⁶ The death of the bull, too, is voluntary and involuntary. As Mithras stabs the bull a scorpion nips it in the testicles (cf. pl. XL). (Autumn equinox of the Taurus aeon.)

⁶⁷ Benndorf and Schöne, *Bildwerke des Lateranischen Museums*, No. 547.

⁶⁸ *Textes*, I, p. 182. In another passage (p. 183) Cumont speaks of the “sorrowful and almost morbid grace of the hero’s features.”

⁶⁹ [It has also been identified as Attis.—EDITORS.]

⁷⁰ The libido nature of the sacrificed is indubitable. In Persia it was a ram that induced the first man to commit the first sin (cohabitation); it is also the first animal they sacrifice (Spiegel, I, p. 511). The ram is therefore equivalent to the serpent in the Garden of Eden, which, according to the Manichaean view, was Christ. Melito of Sardis (2nd cent.) taught that Christ the Lamb was comparable to the ram caught in the thicket that Abraham sacrificed in place of his son, and that the thicket represented the Cross. (Fr. V, cited in Robertson, p. 412.)

⁷¹ The original derivation from *religere* (to go through again, think over, recollect) is the more probable. (Cicero, *De inventione*, 2, 53, and *De natura deorum*, 1, 42.) Lactantius (*Divinae Institutiones*, 4, 28; in Fletcher trans., I, p. 282, modified) derives it from *religare*: “Hoc vinculo pietatis obstricti Deo et religati sumus” (We are bound and tied to God by this link of piety). Similarly St. Jerome and St. Augustine. See Walde, *Lateinisches Wörterbuch*, p. 233, “diligō.” The crucial contrast is between *religo* and *neglego*.

⁷² Cf. Zipporah’s words to her son after she had circumcised him (Exodus 4 : 25): “Surely a bloody husband art thou to me.” [AV; RSV has “bridegroom of blood.”—TRANS.] Joshua 5 : 2ff. says that Joshua reintroduced circumcision for the benefit of the children born in the wilderness. “In this way he replaced the child sacrifices, which it had been customary to offer to Yahweh in early days, by the offering of the foreskin of the male” (Drews, *The Christ Myth*, p. 83).

⁷³ We learn from Porphyry (*De antr. nymph.*) that “instead of a fountain a mixing-bowl [κρατήρ] is placed near Mithras.” (Cited in Cumont, *Textes*, I, p. 101.) This is of some importance in interpreting the krater. Cf. also the krater of Zosimos (Berthelot, *Alchimistes grecs*, III, p. 235).

⁷⁴ Cumont, I, p. 100.

⁷⁵ As the zodiacal sign for the sun’s greatest heat.

⁷⁶ The end of Prometheus is a similar sacrificial death: he was chained to the rocks. In another version his chains were drawn through a pillar. He suffered as a punishment the fate that Christ took upon himself willingly. The fate of Prometheus is therefore reminiscent of the misfortune that befell Theseus and Peirithous, who grew fast to the rocks, the chthonic mother. According to Athenaeus, Jupiter, on setting Prometheus free again, commanded him to wear a willow crown and an iron ring, thus symbolizing his captivity and bondage. Robertson (p. 397) compares the crown of Prometheus to Christ’s crown of thorns. The devout wear crowns in honour of Prometheus, in order to represent his bondage. In this connection, therefore, the crown has the same meaning as *the* betrothal ring: the worshippers are *κάτοχοι τοῦ θεοῦ*, ‘captives of the god.’

⁷⁷ The spear wound given by Longinus takes the place of the dagger thrust in the Mithraic bull-sacrifice. Aeschylus says that the “jagged tooth of the brazen wedge” was driven through the breast of the enchained Prometheus (*Prometheus*, trans. by Smyth, I, pp. 220–21). Odin and Huitzilopochtli were pierced by the spear, Adonis was killed by the boar’s tusk.

⁷⁸ Sermo Suppositus 120, 8. [Cf. par. 411, above.]

⁷⁹ The same idea is found in Nordic mythology: through hanging on the tree of life Odin obtained knowledge of the runes and of the inspiring drink that gave him immortality. People are inclined to trace this mythologem back to Christian influence. But what about Huitzilopochtli?

⁸⁰ Mithraism was the religion of the Roman legionaries and admitted only men as initiates.

⁸¹ Cf. *Psychology and Alchemy*, par. 436: “Visio Arislei.”

⁸² “The Psychology of Dementia Praecox,” par. 284.

⁸³ Spielrein, p. 366.

⁸⁴ For case material, cf. Gerhard Adler, *Studies*, Ch. V, “Consciousness and Cure.”

⁸⁵ See my “Archetypes of the Collective Unconscious,” par. 66.

⁸⁶ Bleuler called this “ambivalence” or “ambitendency,” and Stekel “the bipolarity of all psychic phenomena” (*Die Sprache des Traumes*, pp. 535f.).

⁸⁷ The role played by the serpent in mythology is analogous to the end of the world. It is said in the *Völuspá* that the deluge would begin when the Midgard Serpent rises up for universal destruction. The name of the Serpent is Jormungandr, which means literally ‘monstrous dragon’ [Paul, *Grundriss der germanischen Philologie*—EDITORS]. The world-destroying Fenris-Wolf likewise has connections with the sea. *Fen* is found in Fensalir (Meersäle), the dwelling-place of Frigga; originally it meant ‘sea’ (Frobenius, *Zeitalter*, p. 179). In the story of Red Riding Hood, the serpent or fish is replaced by a wolf, because he is the typical destroyer.

⁸⁸ Cf. Hölderlin’s longing in his poem “Empedocles,” also Zarathustra’s journey to Hades through the mouth of a volcano. I have shown elsewhere (“On the Psychology of Occult Phenomena,” pars. 140ff.; “Cryptomnesia,” 181ff.) that this passage in Nietzsche is a cryptomnesia. Death is a re-entry into the mother. Hence the Egyptian king Menkau-Re (Mykerinos) had his daughter buried in a gilded wooden cow, as a guarantee of rebirth. The cow was placed in a gorgeous apartment and offerings were made to it. In an adjoining apartment were the images of the king’s concubines. Herodotus, II, 129, in Selincourt trans., p. 153.

⁸⁹ Kluge, *Wörterbuch*.

⁹⁰ *Poèmes saturniens* (1866).

¹ [In English in Flourney's publication.]

² [In English.]

³ [In English.]

⁴ [Both versions in English.]

⁵ [Probably Haydn's *Creation* is meant.—G.G.J.]

⁶ [Quoted in English, preceded by the French.]

⁷ [Title and poem in English.] Miss Miller has shown me her original draft, in pencil, written very irregularly on account of the movement of the train. It shows one or two crossings-out, or corrections of detail, in the same kind of scrawl as all the rest, which she had made immediately upon re-reading the piece as soon as it was completed. The only one that is noteworthy concerns the first line, which was first written as "I longed for thee when consciousness first woke": the last three words are crossed out with a big stroke leading right down to the bottom of the page, where the variant is written—"first I crawled to consciousness."—T.F.

⁸ [A comedy, in three acts, by the American playwright Clyde Fitch, produced in New York on Apr. 11, 1898. The following synopsis of its plot (from a review in the *New York Dramatic Mirror*, Apr. 16, 1898), is given here *in extenso* because of the interesting pertinence of its heroine's character and problems.

"*The Moth and the Flame* begins at a children's party given by Mr. and Mrs. Wolton at their New York home. Their daughter, Marion, has rejected the love of Douglas Rhodes to become betrothed to Ned Fletcher, a man of somewhat shady record, whom she expects to reform. The children's party is at its merriest moment when a thud above and a clattering chandelier announce the suicide of the host in his room. Wolton, knowing Fletcher to be a swindler and dreading the disgrace that must befall by Marion's marriage to Fletcher, has killed himself. Yet the guests know not, and the fun goes on. Marion falters into the room after discovering the horrible thing, and falls into her mother's arms, sobbing out the awful truth while a dozen unsuspecting revelers dance and sing about the stricken woman. The family are threatened with terrible distress, and Fletcher, as Marion's affianced lover, announces his purpose to stand by the Woltons.

"The next act presents St. Hubert's Chapel, wherein is to occur the wedding of Fletcher and Marion, to which society has been invited by Mrs. Wolton. The ceremony is rudely interrupted by a woman who demands that Fletcher shall marry her and give his name to her child. Fletcher repudiates the woman's story, and Marion believes him. But the interloper persists and steps between the bridal couple. Then Fletcher fells her with a cruel blow. Marion, horrified, cries 'Coward!' and, flinging the wedding bouquet at his feet, rushes from the chapel.

"In the last act, Fletcher seeks to frighten Marion into marrying him, telling her that her father had owed his respected position to the fact that his (Fletcher's) money had preserved the honor of the Wolton name in the world's eyes. But she rejects his advances and espouses the still faithful Rhodes. Fletcher, in contrition, vows to marry the woman he had scorned, and so ends the play."—EDITORS.]

^{8a} [See p. 461.]

⁹ [But given by Flourney here in French.]

¹⁰ [*Sic.* Regularly Popocatepetl; it is actually in central Mexico.]

¹¹ Julius Caesar, Act IV, scene 3.

¹² [*Sic.* in English.]

- * Complete title: *The Standard Edition of the Complete Psychological Works of Sigmund Freud*, translated from the German under the general editorship of James Strachey in collaboration with Anna Freud, assisted by Alix Strachey and Alan Tyson.
- * Complete title: *The Standard Edition of the Complete Psychological Works of Sigmund Freud*, translated from the German under the general editorship of James Strachey in collaboration with Anna Freud, assisted by Alix Strachey and Alan Tyson.
- * For details of the *Collected Works of C. G. Jung*, see the list at the end of this volume.

- * Published 1957; 2nd edn., 1970.
- † Published 1973.
- * Published 1960.
- † Published 1961.
- ‡ Published 1956; 2nd edn., 1967. (65 plates, 43 text figures.)
- * Published 1971.
- † Published 1953; 2nd edn., 1966.
- ‡ Published 1960; 2nd edn., 1969.
- * Published 1959; 2nd edn., 1968. (Part I: 79 plates, with 29 in colour.)
- * Published 1964; 2nd edn., 1970. (8 plates.)
- † Published 1958; 2nd edn., 1969.
- * Published 1953; 2nd edn., completely revised, 1968. (270 illustrations.)
- † Published 1968. (50 plates, 4 text figures.)
- ‡ Published 1963; 2nd edn., 1970. (10 plates.)
- * Published 1966.
- † Published 1954; 2nd edn., revised and augmented, 1966. (13 illustrations.)
- ‡ Published 1954.

BOLLINGEN SERIES XX

THE COLLECTED WORKS

OF

C. G. JUNG

VOLUME 6

EDITORS

† SIR HERBERT READ

MICHAEL FORDHAM, M.D., M.R.C.P.

GERHARD ADLER, PH.D.

WILLIAM MCGUIRE, *executive editor*

PSYCHOLOGICAL TYPES

C. G. JUNG

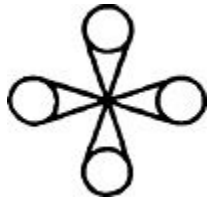

A REVISION BY R. F. C. HULL

OF THE TRANSLATION BY H. G. BAYNES

BOLLINGEN SERIES XX

PRINCETON UNIVERSITY PRESS

COPYRIGHT © 1971 BY PRINCETON UNIVERSITY PRESS, PRINCETON, N.J.

Second printing, 1974

First PRINCETON/BOLLINGEN PAPERBACK printing, with corrections, 1976

THIS EDITION IS BEING PUBLISHED IN THE UNITED STATES OF AMERICA BY PRINCETON UNIVERSITY PRESS AND IN ENGLAND BY ROUTLEDGE & KEGAN PAUL, LTD. IN THE AMERICAN EDITION, ALL THE VOLUMES COMPRISING THE COLLECTED WORKS CONSTITUTE NUMBER XX IN BOLLINGEN SERIES. THE PRESENT VOLUME IS NUMBER 6 OF THE COLLECTED WORKS AND WAS THE SIXTEENTH TO APPEAR.

Except for the appendix, originally published in German as *Psychologische Typen*, Rascher Verlag, Zurich, 1921. Including appendix, published as volume 6 in the *Gesammelte Werke*, Rascher Verlag, Zurich, 1960; 2nd edition, 1967. The H. G. Baynes translation of *Psychological Types* was published in 1923 by Kegan Paul, London, and Harcourt, Brace and Co., New York.

ISBN 0-691-01813-8 (paperback edn.)

ISBN 0-691-09770-4 (hardcover edn.)

LIBRARY OF CONGRESS CATALOGUE CARD NUMBER: 75-156

MANUFACTURED IN THE U. S. A.

EDITORIAL NOTE

Jung was engaged in the preparatory work for *Psychological Types* during his so-called “fallow period,” from 1913 to 1917 or 1918, a time of intense preoccupation with the images of his own unconscious, which he describes in the sixth and seventh chapters of *Memories, Dreams, Reflections*. As he wrote: “This work sprang originally from my need to define the ways in which my outlook differed from Freud’s and Adler’s. In attempting to answer this question, I came across the problem of types; for it is one’s psychological type which from the outset determines and limits a person’s judgment. My book, therefore, was an effort to deal with the relationship of the individual to the world, to people and things. It discussed the various aspects of consciousness, the various attitudes the conscious mind might take toward the world, and thus constitutes a psychology of consciousness regarded from what might be called a clinical angle.”

Psychologische Typen was published by Rascher Verlag, of Zurich, in 1921. It was translated into English by H. G. Baynes (1882–1943), who during 1919–22 was Jung’s assistant in Zurich and subsequently became one of the most prominent British analytical psychologists. His translation, subtitled “The Psychology of Individuation,” was published in 1923 by Kegan Paul in London and Harcourt, Brace in New York. Some 22,000 copies of the Baynes version were sold. Translations have also appeared in Dutch, French, Greek, Italian, Japanese, Portuguese, Russian, Spanish,* and Swedish.

By 1950, the Swiss edition had gone through seven reprintings (some 15,000 copies), with little revision. The work was published as Band 6 in the *Gesammelte Werke* in 1960; for that edition the text was slightly revised, partly with the help of the author, quotations and references were checked and corrected, and a definition of the “self,” formulated by Professor Jung for the edition, was added. In the original the “self” had figured under the concept of the ego. In accordance with the previously announced plan of the *Collected Works* in English, an appendix was added containing an important preliminary study for the present book, a lecture delivered at the Psychoanalytical Congress in Munich, 1913, entitled “A Contribution to the Study of Psychological Types,” and three other short works on typology (1925, 1928, 1936). A corrected edition of Band 6 appeared in 1967.

The present volume is one of the last to appear in the *Collected Works*. Owing to the continued availability of the Baynes translation in Great Britain and the United States, and the fact that Jung never subjected this work to revision (other than in minor details), the Editors have given precedence to issuing other volumes of which translations were lacking or inadequate.

The *Gesammelte Werke* version, in its second, corrected edition, is the basis of the present translation. The paragraph numbering of the Swiss and English editions differs, chiefly because it is the policy of the *Collected Works* to print quotations in smaller type and not number them as paragraphs. Furthermore, some of the very long paragraphs in the Swiss text have been broken up. For the convenience of readers who wish to compare passages in the two editions, a table of comparative paragraph numbers is given in the back of this volume.

The numbers of the Definitions fail to correspond among the various editions, owing to the vagaries of alphabetical order.

When quoted translations contain modifications, the indication "Cf." is given in the pertinent footnote. Grateful acknowledgment is made for permission to quote as follows: to Pantheon Books, a Division of Random House, Inc., for Lawrence Grant White's translation of the *Divine Comedy*; to Penguin Books Ltd., for Philip Wayne's translation of Goethe's *Faust*; to Oxford University Press, New York, and Faber and Faber, Ltd., for Louis MacNeice's translation of *Faust*.

The Editors wish to acknowledge their gratitude to the late A.S.B. Glover, who contributed research assistance, various translations of Latin quotations, and wide-ranging advice, to this as all the other volumes in the edition.

VOLUME 6 PSYCHOLOGICAL TYPES

TABLE OF CONTENTS

EDITORIAL NOTE

FOREWORD TO THE FIRST SWISS EDITION

FOREWORDS TO THE SEVENTH AND EIGHTH SWISS EDITIONS

FOREWORD TO THE ARGENTINE EDITION

Introduction

I. The Problem of Types in the History of Classical and Medieval Thought

1. PSYCHOLOGY IN THE CLASSICAL AGE: THE GNOSTICS, TERTULLIAN, ORIGEN

2. THE THEOLOGICAL DISPUTES OF THE ANCIENT CHURCH

3. THE PROBLEM OF TRANSUBSTANTIATION

4. NOMINALISM AND REALISM

a. *The Problem of Universals in Antiquity*

b. *The Problem of Universals in Scholasticism*

c. *Abelard's Attempt at Conciliation*

5. THE HOLY COMMUNION CONTROVERSY BETWEEN LUTHER AND ZWINGLI

II. Schiller's Ideas on the Type Problem

1. LETTERS ON THE AESTHETIC EDUCATION OF MAN

a. *The Superior and the Inferior Functions*

b. *Concerning the Basic Instincts*

2. A DISCUSSION ON NAÏVE AND SENTIMENTAL POETRY

a. *The Naïve Attitude*

b. *The Sentimental Attitude*

c. *The Idealist and the Realist*

III. The Apollinian and the Dionysian

IV. The Type Problem in Human Character

1. GENERAL REMARKS ON JORDAN'S TYPES
2. SPECIAL DESCRIPTION AND CRITICISM OF JORDAN'S TYPES
 - a. *The Introverted Woman*
 - b. *The Extraverted Woman*
 - c. *The Extraverted Man*
 - d. *The Introverted Man*

V. The Type Problem in Poetry

Carl Spitteler: *Prometheus and Epimetheus*

1. INTRODUCTORY REMARKS ON SPITTELER'S TYPOLOGY
2. A COMPARISON OF SPITTELER'S WITH GOETHE'S PROMETHEUS
3. THE SIGNIFICANCE OF THE UNITING SYMBOL
 - a. *The Brahmanic Conception of the Problem of Opposites*
 - b. *The Brahmanic Conception of the Uniting Symbol*
 - c. *The Uniting Symbol as the Principle of Dynamic Regulation*
 - d. *The Uniting Symbol in Chinese Philosophy*
4. THE RELATIVITY OF THE SYMBOL
 - a. *The Worship of Woman and the Worship of the Soul*
 - b. *The Relativity of the God-concept in Meister Eckhart*
5. THE NATURE OF THE UNITING SYMBOL IN SPITTELER

VI. The Type Problem in Psychopathology

VII. The Type Problem in Aesthetics

VIII. The Type Problem in Modern Philosophy

1. WILLIAM JAMES' TYPES
2. THE CHARACTERISTIC PAIRS OF OPPOSITES IN JAMES' TYPES
 - a. *Rationalism versus Empiricism*
 - b. *Intellectualism versus Sensationalism*
 - c. *Idealism versus Materialism*
 - d. *Optimism versus Pessimism*
 - e. *Religiousness versus Irreligiousness*

f. *Indeterminism versus Determinism*

g. *Monism versus Pluralism*

h. *Dogmatism versus Scepticism*

3. GENERAL CRITICISM OF JAMES' TYPOLOGY

IX. The Type Problem in Biography

X. General Description of the Types

1. INTRODUCTION

2. THE EXTRAVERTED TYPE

a. *The General Attitude of Consciousness*

b. *The Attitude of the Unconscious*

c. *The Peculiarities of the Basic Psychological Functions in the Extraverted Attitude*

Thinking

The Extraverted Thinking Type

Feeling

The Extraverted Feeling Type

Summary of the Extraverted Rational Types

Sensation

The Extraverted Sensation Type

Intuition

The Extraverted Intuitive Type

Summary of the Extraverted Irrational Types

3. THE INTROVERTED TYPE

a. *The General Attitude of Consciousness*

b. *The Attitude of the Unconscious*

c. *The Peculiarities of the Basic Psychological Functions in the Introverted Attitude*

Thinking

The Introverted Thinking Type

Feeling

The Introverted Feeling Type

Summary of the Introverted Rational Types

Sensation

The Introverted Sensation Type
Intuition
The Introverted Intuitive Type
Summary of the Introverted Irrational Types
d. The Principal and Auxiliary Functions

XI. Definitions

Epilogue

APPENDIX: FOUR PAPERS ON PSYCHOLOGICAL TYPOLOGY

1. A Contribution to the Study of Psychological Types (1913)
2. Psychological Types (1923)
3. A Psychological Theory of Types (1931)
4. Psychological Typology (1936)

TABLE: CORRELATION OF PARAGRAPH NUMBERS

BIBLIOGRAPHY

INDEX

FOREWORD TO THE FIRST SWISS EDITION

This book is the fruit of nearly twenty years' work in the domain of practical psychology. It grew gradually in my thoughts, taking shape from the countless impressions and experiences of a psychiatrist in the treatment of nervous illnesses, from intercourse with men and women of all social levels, from my personal dealings with friend and foe alike, and, finally, from a critique of my own psychological peculiarity.

It is not my intention to burden the reader with case material; my concern is rather to show how the ideas I have abstracted from my practical work can be linked up, both historically and terminologically, with an existing body of knowledge. I have done this not so much from a need for historical justification as from a desire to bring the experiences of a medical specialist out of their narrow professional setting into a more general context, a context which will enable the educated layman to derive some profit from them. I would never have embarked upon this amplification, which might easily be misunderstood as an encroachment upon other spheres, were I not convinced that the psychological views presented in this book are of wide significance and application, and are therefore better treated in a general frame of reference than left in the form of a specialized scientific hypothesis.

With this aim in view I have confined myself to examining the ideas of comparatively few workers in this field, and have refrained from mentioning all that has already been said concerning our problem in general. Apart from the fact that even an approximately complete catalogue of the relevant material and opinions would far exceed my powers, such a compilation would not make any fundamental contribution to the discussion and development of the problem. Without regret, therefore, I have omitted much that I have collected in the course of the years, and confined myself as far as possible to essentials. A valuable document that was of very great help to me has also had to be sacrificed. This is a bulky correspondence which I exchanged with my friend Dr. Hans Schmid¹, of Basel, on the question of types. I owe a great deal of clarification to this interchange of ideas, and much of it, though of course in altered and greatly revised form, has gone into my book. The correspondence belongs essentially to the preparatory stage of the work, and its inclusion would create more confusion than clarity. Nevertheless, I owe it to the labours of my friend to express my thanks to him here.

C. G. JUNG

Küsnacht/Zurich

Spring, 1920

FOREWORD TO THE SEVENTH SWISS EDITION

This new edition appears unaltered, which is not to say that the book is not in need of further additions, improvements, and supplementary material. In particular, the somewhat terse descriptions of the types could have been expanded. Also, a consideration of works on typology by psychologists since this book first appeared would have been desirable. But the present scope of the book is already so great that it ought not to be augmented unless urgently necessary. Moreover, there is little practical purpose in making the problems of typology still more complicated when not even the elements have been properly understood. Critics commonly fall into the error of assuming that the types were, so to speak, fancy free and were forcibly imposed on the empirical material. In face of this assumption I must emphasize that my typology is the result of many years of practical experience—experience that remains completely closed to the academic psychologist. I am first and foremost a doctor and practising psychotherapist, and all my psychological formulations are based on the experiences gained in the hard course of my daily professional work. What I have to say in this book, therefore, has, sentence by sentence, been tested a hundredfold in the practical treatment of the sick and originated with them in the first place. Naturally, these medical experiences are accessible and intelligible only to one who is professionally concerned with the treatment of psychic complications. It is therefore not the fault of the layman if certain of my statements strike him as strange, or if he thinks my typology is the product of idyllically undisturbed hours in the study. I doubt, however, whether this kind of ingenuousness is a qualification for competent criticism.

September 1937

C. G. JUNG

FOREWORD TO THE EIGHTH SWISS EDITION

The new edition again appears unaltered in essentials, but this time many small, long-necessary corrections have been made in the details. Also a new index has been compiled. I am especially indebted to Mrs. Lena Hurwitz-Eisner for this irksome work.

June 1949

C. G. JUNG

FOREWORD TO THE ARGENTINE EDITION¹

No book that makes an essentially new contribution to knowledge enjoys the privilege of being thoroughly understood. Perhaps it is most difficult of all for new psychological insights to make any headway. A psychology that is grounded on experience always touches upon personal and intimate matters and thus arouses everything that is contradictory and unclarified in the human psyche. If one is plunged, as I am for professional reasons, into the chaos of psychological opinions, prejudices, and susceptibilities, one gets a profound and indelible impression of the diversity of individual psychic dispositions, tendencies, and convictions, while on the other hand one increasingly feels the need for some kind of order among the chaotic multiplicity of points of view. This need calls for a critical orientation and for general principles and criteria, not too specific in their formulation, which may serve as *points de repère* in sorting out the empirical material. What I have attempted in this book is essentially a critical psychology.

This fundamental tendency in my work has often been overlooked, and far too many readers have succumbed to the error of thinking that [Chapter X](#) (“General Description of the Types”) represents the essential content and purpose of the book, in the sense that it provides a system of classification and a practical guide to a good judgment of human character. Indeed, even in medical circles the opinion has got about that my method of treatment consists in fitting patients into this system and giving them corresponding “advice.” This regrettable misunderstanding completely ignores the fact that this kind of classification is nothing but a childish parlour game, every bit as futile as the division of mankind into brachycephalics and dolichocephalics. My typology is far rather a critical apparatus serving to sort out and organize the welter of empirical material, but not in any sense to stick labels on people at first sight. It is not a physiognomy and not an anthropological system, but a critical psychology dealing with the organization and delimitation of psychic processes that can be shown to be typical. For this reason I have placed the general typology and the Definitions at the end of the book, after having described, in [chapters I to IX](#), the processes in question with the help of various examples. I would therefore recommend the reader who really wants to understand my book to immerse himself first of all in [chapters II and V](#). He will gain more from them than from any typological terminology superficially picked up, since this serves no other purpose than a totally useless desire to stick on labels.

It is now my pleasant duty to express my sincerest thanks to Madame Victoria Ocampo for her great help in securing the publication of this book, and to Señor Ramón de la Serna for his work of translation.

Küsnacht/Zurich

October 1934

C. G. JUNG

PSYCHOLOGICAL TYPES

Plato and Aristotle! These are not merely two systems, they are types of two distinct human natures, which from time immemorial, under every sort of disguise, stand more or less inimically opposed. The whole medieval world in particular was riven by this conflict, which persists down to the present day, and which forms the most essential content of the history of the Christian Church. Although under other names, it is always of Plato and Aristotle that we speak. Visionary, mystical, Platonic natures disclose Christian ideas and the corresponding symbols from the fathomless depths of their souls. Practical, orderly, Aristotelian natures build out of these ideas and symbols a fixed system, a dogma and a cult. Finally the Church embraces both natures, one of them entrenched in the clergy and the other in monasticism, but both keeping up a constant feud.

—Heine, *Deutschland*, I

INTRODUCTION

- [1] In my practical medical work with nervous patients I have long been struck by the fact that besides the many individual differences in human psychology there are also typical differences. Two types especially become clear to me; I have termed them the introverted and the extraverted types.
- [2] When we consider the course of human life, we see how the fate of one individual is determined more by the objects of his interest, while in another it is determined more by his own inner self, by the subject. Since we all swerve rather more towards one side or the other, we naturally tend to understand everything in terms of our own type.
- [3] I mention this circumstance at once in order to avoid possible misunderstandings. It will be apparent that it is one which considerably aggravates the difficulty of a general description of types. I must presume unduly upon the goodwill of the reader if I may hope to be rightly understood. It would be relatively simple if every reader knew to which category he belonged. But it is often very difficult to find out whether a person belongs to one type or the other, especially in regard to oneself. In respect of one's own personality one's judgment is as a rule extraordinarily clouded. This subjective clouding of judgment is particularly common because *in* every pronounced type there is a special tendency to compensate the one-sidedness of that type, a tendency which is biologically purposive since it strives constantly to maintain the psychic equilibrium. The compensation gives rise to secondary characteristics, or secondary types, which present a picture that is extremely difficult to interpret, so difficult that one is inclined to deny the existence of types altogether and to believe only in individual differences.
- [4] I must emphasize this difficulty in order to justify certain peculiarities in my presentation. It might seem as if the simplest way would be to describe two concrete cases and to dissect them side by side. But everyone possesses both mechanisms, extraversion as well as introversion, and only the relative predominance of one or the other determines the type. Hence, in order to throw the picture into the necessary relief, one would have to retouch it rather vigorously, and this would amount to a more or less pious fraud. Moreover, the psychological reactions of a human being are so complicated that my powers of description would hardly suffice to draw an absolutely correct picture. From sheer necessity, therefore, I must confine myself to a presentation of principles which I have abstracted from a wealth of facts observed in many different individuals. In this there is no question of a *deductio a priori*, as it

might appear; it is rather a deductive presentation of empirically gained insights. These insights will, I hope, help to clarify a dilemma which, not only in analytical psychology but in other branches of science as well, and especially in the personal relations of human beings with one another, has led and still continues to lead to misunderstanding and discord. For they explain how the existence of two distinct types is actually a fact that has long been known: a fact that in one form or another has struck the observer of human nature or dawned upon the brooding reflection of the thinker, presenting itself to Goethe's intuition, for instance, as the all-embracing principle of systole and diastole. The names and concepts by which the mechanisms of extraversion and introversion have been grasped are extremely varied, and each of them is adapted to the standpoint of the observer in question. But despite the diversity of the formulations the fundamental idea common to them all constantly shines through: in one case an outward movement of interest towards the object, and in the other a movement of interest away from the object to the subject and his own psychological processes. In the first case the object works like a magnet upon the tendencies of the subject; it determines the subject to a large extent and even alienates him from himself. His qualities may become so transformed by assimilation to the object that one might think it possessed some higher and decisive significance for him. It might almost seem as if it were an absolute determinant, a special purpose of life or fate that he should abandon himself wholly to the object. But in the second case the subject is and remains the centre of every interest. It looks, one might say, as though all the life-energy were ultimately seeking the subject, and thus continually prevented the object from exercising any overpowering influence. It is as though the energy were flowing away from the object, and the subject were a magnet drawing the object to itself.

- [5] It is not easy to give a clear and intelligible description of this two-way relationship to the object without running the risk of paradoxical formulations which would create more confusion than clarity. But in general one could say that the introverted standpoint is one which sets the ego and the subjective psychological process above the object and the objective process, or at any rate seeks to hold its ground against the object. This attitude, therefore, gives the subject a higher value than the object, and the object accordingly has a lower value. It is of secondary importance; indeed, sometimes the object represents no more than an outward token of a subjective content, the embodiment of an idea, the idea being the essential thing. If it is the embodiment of a feeling, then again the feeling is the main thing and not the object in its own right. The extraverted standpoint, on the contrary, subordinates the subject to the object, so that the object has the higher value. In this case the subject is of secondary importance, the subjective process appearing at times as no more than a disturbing or superfluous appendage of objective events. It is clear that

the psychology resulting from these contrary standpoints must be classed as two totally different orientations. The one sees everything in terms of his own situation, the other in terms of the objective event.

[6] These contrary attitudes are in themselves no more than correlative mechanisms: a diastolic *going* out and seizing of the object, and a systolic concentration and detachment of energy from the object seized. Every human being possesses both mechanisms as an expression of his natural life-rhythm, a rhythm which Goethe, surely not by chance, described physiologically in terms of the heart's activity. A rhythmical alternation of both forms of psychic activity would perhaps correspond to the normal course of life. But the complicated outer conditions under which we live and the even more complicated conditions of our individual psychic make-up seldom permit a completely undisturbed flow of psychic energy. Outer circumstances and inner disposition frequently favour one mechanism and restrict or hinder the other. One mechanism will naturally predominate, and if this condition becomes in any way chronic a *type* will be produced; that is, an habitual attitude in which one mechanism predominates permanently, although the other can never be completely suppressed since it is an integral part of the psychic economy. Hence there can never be a pure type in the sense that it possesses only one mechanism with the complete atrophy of the other. A typical attitude always means merely the relative predominance of one mechanism.

[7] The hypothesis of introversion and extraversion allows us, first of all, to distinguish two large groups of psychological individuals. Yet this grouping is of such a superficial and general nature that it permits no more than this very general distinction. Closer investigation of the individual psychologies that fall into one group or the other will at once show great differences between individuals who nevertheless belong to the same group. If, therefore, we wish to determine wherein lie the differences between individuals belonging to a definite group, we must take a further step. Experience has taught me that in general individuals can be distinguished not only according to the broad distinction between introversion and extraversion, but also according to their basic psychological functions. For in the same measure as outer circumstances and inner disposition cause either introversion or extraversion to predominate, they also favour the predominance of one definite basic function in the individual. I have found from experience that the basic psychological functions, that is, functions which are genuinely as well as essentially different from other functions, prove to be *thinking, feeling, sensation, and intuition*. If one of these functions habitually predominates, a corresponding type results. I therefore distinguish a thinking, a feeling, a sensation, and an intuitive type. *Each of these types may moreover be either introverted or extraverted*, depending on its relation to the object as we have described above. In my preliminary work on

psychological types¹ I did not carry out this differentiation, but identified the thinking type with the introvert and the feeling type with the extravert. A deeper study of the problem has shown this equation to be untenable. In order to avoid misunderstandings, I would ask the reader to bear in mind the differentiation I have developed here. For the sake of clarity, which is essential in such complicated matters, I have devoted the last chapter of this book to the definition of my psychological concepts.

THE PROBLEM OF TYPES IN THE HISTORY OF CLASSICAL AND MEDIEVAL THOUGHT

1. PSYCHOLOGY IN THE CLASSICAL AGE: THE Gnostics, Tertullian, Origen

[8] So long as the historical world has existed there has always been psychology, but an objective psychology is only of recent growth. We could say of the science of former times that in proportion to the lack of objective psychology there is an increase in the rate of subjectivity. Hence, though the works of the ancients are full of psychology, only little of it can be described as objective psychology. This may be due in no small measure to the peculiar character of human relationships in classical and medieval times. The ancients had, so to speak, an almost entirely biological valuation of their fellow-men; this is everywhere apparent in their habits of life and in the legislation of antiquity. The medieval man, in so far as his value judgments found any expression at all, had on the contrary a metaphysical valuation of his fellows, and this had its source in the idea of the imperishable value of the human soul. This metaphysical valuation, which may be regarded as compensatory to the standpoint of antiquity, is just as unfavourable as the biological one so far as a *personal* valuation is concerned, which alone can form the basis of an objective psychology.

[9] Although not a few people think that a psychology can be written *ex cathedra*, nowadays most of us are convinced that an objective psychology must be founded above all on observation and experience. This foundation would be ideal if only it were possible. The ideal and aim of science do not consist in giving the most exact possible description of the facts—science cannot compete as a recording instrument with the camera and the gramophone—but in establishing certain laws, which are merely abbreviated expressions for many diverse processes that are yet conceived to be somehow correlated. This aim goes beyond the purely empirical by means of the *concept*, which, though it may have general and proved validity, will always be a product of the subjective psychological constellation of the investigator. In the making of scientific theories and concepts many personal and accidental factors are involved. There is also a personal equation that is psychological and not merely psychophysical. We see colours but not wave-lengths. This well-known fact must nowhere be taken to heart more seriously than in psychology. The effect of the personal equation begins already in the act of observation. *One sees what one can*

best see oneself. Thus, first and foremost, one sees the mote in one's brother's eye. No doubt the mote is there, but the beam sits in one's own eye—and may considerably hamper the act of seeing. I mistrust the principle of “pure observation” in so-called objective psychology unless one confines oneself to the eye-pieces of chronoscopes and tachistoscopes and suchlike “psychological” apparatus. With such methods one also guards against too embarrassing a yield of empirical psychological facts.

- [10] But the personal equation asserts itself even more in the presentation and communication of one's own observations, to say nothing of the interpretation and abstract exposition of the empirical material. Nowhere is the basic requirement so indispensable as in psychology that the observer should be adequate to his object, in the sense of being able to see not only subjectively but also objectively. The demand that he should see *only* objectively is quite out of the question, for it is impossible. We must be satisfied if he does not see *too* subjectively. That the subjective observation and interpretation accord with the objective facts proves the truth of the interpretation only in so far as the latter makes no pretence to be generally valid, but valid only for that area of the object which is being considered. To this extent it is just the beam in one's own eye that enables one to detect the mote in one's brother's eye. The beam in one's own eye, as we have said, does not prove that one's brother has no mote in his. But the impairment of one's own vision might easily give rise to a general theory that all motes are beams.
- [11] The recognition and taking to heart of the subjective determination of knowledge in general, and of psychological knowledge in particular, are basic conditions for the scientific and impartial evaluation of a psyche different from that of the observing subject. These conditions are fulfilled only when the observer is sufficiently informed about the nature and scope of his own personality. He can, however, be sufficiently informed only when he has in large measure freed himself from the levelling influence of collective opinions and thereby arrived at a clear conception of his own individuality.
- [12] The further we go back into history, the more we see personality disappearing beneath the wrappings of collectivity. And if we go right back to primitive psychology, we find absolutely no trace of the concept of an individual. Instead of individuality we find only collective relationship or what Lévy-Bruhl calls *participation mystique*. The collective attitude hinders the recognition and evaluation of a psychology different from the subject's, because the mind that is collectively oriented is quite incapable of thinking and feeling in any other way than by projection. What we understand by the concept “individual” is a relatively recent acquisition in the history of the human mind and human culture. It is no wonder,

therefore, that the earlier all-powerful collective attitude prevented almost completely an objective psychological evaluation of individual differences, or any scientific objectification of individual psychological processes. It was owing to this very lack of psychological thinking that knowledge became “psychologized,” i.e., filled with projected psychology. We find striking examples of this in man’s first attempts at a philosophical explanation of the cosmos. The development of individuality, with the consequent psychological differentiation of man, goes hand in hand with the de-psychologizing work of objective science.

- [13] These reflections may explain why objective psychology has such a meagre source in the material handed down to us from antiquity. The differentiation of the four temperaments, which we took over from the ancients, hardly rates as a psychological typology since the temperaments are scarcely more than psychophysical colourings. But this lack of information does not mean that we can find no trace in classical literature of the effects of the psychological pairs of opposites we are discussing.
- [14] Gnostic philosophy established three types, corresponding perhaps to three of the basic psychological functions: thinking, feeling, and sensation. The *pneumatikoi* could be correlated with thinking, the *psychikoi* with feeling, and the *hylikoi* with sensation. The inferior rating of the *psychikoi* was in accord with the spirit of Gnosticism, which, unlike Christianity, insisted on the value of knowledge. The Christian principles of love and faith kept knowledge at a distance. In the Christian sphere the *pneumatikoi* would accordingly get the lower rating, since they were distinguished merely by the possession of Gnosis, i.e., knowledge.
- [15] Type differences should also be borne in mind when we consider the long and perilous struggle which the Church from its earliest beginnings waged against Gnosticism. Owing to the predominantly practical trend of early Christianity the intellectual hardly came into his own, except when he followed his fighting instincts by indulging in polemical apologetics. The rule of faith was too strict and allowed no freedom of movement. Moreover, it was poor in positive intellectual content. It boasted of few ideas, and though these were of immense practical value they were a definite obstacle to thought. The intellectual was much worse hit by the *sacrificium intellectus* than the feeling type. It is therefore understandable that the vastly superior intellectual content of Gnosis, which in the light of our present mental development has not lost but has considerably gained in value, must have made the greatest possible appeal to the intellectual within the Church. For him it held out in very truth all the temptations of this world. Docetism in particular caused grave trouble to the Church with its contention that Christ possessed only an apparent body and that his

whole earthly existence and passion had been merely a semblance. In this contention the purely intellectual element predominates at the expense of human feeling.

[16] Perhaps the struggle with Gnosis is most vividly presented to us in two figures who were of the utmost significance not only as Church Fathers but as personalities. These are Tertullian and Origen, who lived towards the end of the second century. Schultz says of them:

One organism is able to take in nourishment and assimilate it almost completely into its own nature; another with equal persistence eliminates it with every sign of passionate resistance. Thus Origen on one side, and Tertullian on the other, reacted in diametrically opposite ways to Gnosis. Their reaction is not only characteristic of the two personalities and their philosophical outlook; it is of fundamental significance with regard to the position of Gnosis in the spiritual life and religious currents of that age.¹

[17] Tertullian was born in Carthage somewhere about A.D. 160. He was a pagan, and he abandoned himself to the lascivious life of his city until about his thirty-fifth year, when he became a Christian. He was the author of numerous writings wherein his character, which is our especial interest, is unmistakably displayed. Most clearly of all we see his unparalleled noble-hearted zeal, his fire, his passionate temperament, and the profundity of his religious understanding. He was a fanatic, brilliantly one-sided in his defence of a recognized truth, possessed of a matchless fighting spirit, a merciless opponent who saw victory only in the total annihilation of his adversary, his language a flashing blade wielded with ferocious mastery. He was the creator of the Church Latin that lasted for more than a thousand years. It was he who coined the terminology of the early Church. "Once he had seized upon a point of view, he had to follow it through to its ultimate conclusion as though lashed by the legions of hell, even when right had long since ceased to be on his side and all reasonable order lay in shreds before him."² His impassioned thinking was so inexorable that again and again he alienated himself from the very thing for which he had given his heart's blood. Accordingly his ethical code was bitterly severe. Martyrdom he commanded to be sought and not shunned; he permitted no second marriage, and required the permanent veiling of persons of the female sex. Gnosis, which in reality is a passion for thinking and knowing, he attacked with unrelenting fanaticism, together with philosophy and science which differed from it so little. To him is ascribed the sublime confession: *Credo quia absurdum est* (I believe because it is absurd). This does not altogether accord with historical fact, for he merely said: "And the Son of God died, which is immediately credible because it is absurd. And buried he rose again, which is certain because it is impossible."³

[18] Thanks to the acuteness of his mind, he saw through the poverty of philosophical and Gnostic knowledge, and contemptuously rejected it. He invoked against it the testimony of his own inner world, his own inner realities, which were one with his faith. In shaping and developing these realities he became the creator of those abstract conceptions which still underlie the Catholic system of today. The irrational inner reality had for him an essentially dynamic nature; it was his principle, his foundation in face of the world and of all collectively valid and rational science and philosophy. I quote his own words:

I summon a new witness, or rather a witness more known than any written monument, more debated than any system of life, more published abroad than any promulgation, greater than the whole of man, yea that which constitutes the whole of man. Approach then, O my soul, whether you be something divine and eternal, as many philosophers believe—the less then will you lie—or not wholly divine, because mortal, as Epicurus alone contends—the less then ought you to lie—whether you come from heaven or are born of earth, whether compounded of numbers or of atoms, whether you have your beginning with the body or are later joined to it; what matter indeed whence you come and how you make man to be what he is, a reasonable being, capable of perception and of knowledge. But I summon you not, O soul, as proclaiming wisdom, trained in the schools, conversant with libraries, fed and nourished in the academies and pillared halls of Athens. No, I would speak with you, O soul, as wondrous simple and unlearned, awkward and inexperienced, such as you are for those who possess nothing else but you, even as you come from the alleys, from the street-corners, and from the workshops. It is just your unknowingness that I need.⁴

[19] The self-mutilation performed by Tertullian in the *sacrificium intellectus* led him to an unqualified recognition of the irrational inner reality, the true rock of his faith. The necessity of the religious process which he sensed in himself he crystallized in the incomparable formula *anima naturaliter christiana* (the soul is by nature Christian). With the *sacrificium intellectus* philosophy and science, and hence also Gnosis, fell to the ground. In the further course of his life the qualities I have described became exacerbated. When the Church was driven to compromise more and more with the masses, he revolted against it and became a follower of the Phrygian prophet Montanus, an ecstatic, who stood for the principle of absolute denial of the world and complete spiritualization. In violent pamphlets he now began to assail the policy of Pope Calixtus I, and this together with his Montanism put him more or less outside the pale of the Church. According to a report of Augustine, he even quarrelled with Montanism later and founded a sect of his own.

[20] Tertullian is a classic example of introverted thinking. His very considerable and keenly developed intellect was flanked by an unmistakable sensuality. The psychological process of development which we call specifically Christian led him to the sacrifice, the amputation, of the most valuable function—a mythical idea that is also found in the great and exemplary symbol of the sacrifice of the Son of God. His most valuable organ was the intellect and the clarity of knowledge it made possible. Through the *sacrificium intellectus* the way of purely intellectual development was closed to him; it forced him to recognize the irrational dynamism of his soul as the foundation of his being. The intellectuality of Gnosis, the specifically rational stamp it gave to the dynamic phenomena of the soul, must have been odious to him, for that was just the way he had to forsake in order to acknowledge the principle of feeling.

[21] In Origen we may recognize the absolute opposite of Tertullian. He was born in Alexandria about A.D. 185. His father was a Christian martyr. He himself grew up in that quite unique mental atmosphere where the ideas of East and West mingled. With an intense yearning for knowledge he eagerly absorbed all that was worth knowing, and accepted everything, whether Christian, Jewish, Hellenistic, or Egyptian, that the teeming intellectual world of Alexandria offered him. The pagan philosopher Porphyry, a pupil of Plotinus, said of him: “His outward life was that of a Christian and against the law; but in his opinions about material things and the Deity he thought like a Greek, and introduced Greek ideas into foreign fables.”⁵

[22] His self-castration had taken place sometime before A.D. 211; his inner motives for this may be guessed, but historically they are not known to us. Personally he was of great influence, and had a winning speech. He was constantly surrounded by pupils and a whole host of amanuenses who gathered up the precious words that fell from the revered master’s lips. As an author he was extraordinarily prolific and he developed into a great teacher. In Antioch he even delivered lectures on theology to the Emperor’s mother Mammaea. In Caesarea he was the head of a school. His teaching activities were frequently interrupted by his extensive journeyings. He possessed an extraordinary erudition and had an astounding capacity for careful investigation. He hunted up old biblical manuscripts and earned special merit for his textual criticism. “He was a great scholar, indeed the only true scholar the early Church possessed,” says Harnack. In complete contrast to Tertullian, Origen did not cut himself off from the influence of Gnosticism; on the contrary, he even channelled it, in attenuated form, into the bosom of the Church, or such at least was his aim. Indeed, judging by his thought and fundamental views, he was himself almost a Christian Gnostic. His position in regard to *faith* and *knowledge* is described by Harnack in the following psychologically significant words:

The Bible is equally needful to both: the believers receive from it the facts and commandments they need, while the Gnostics decipher thoughts in it and gather from it the powers which guide them to the contemplation and love of God—whereby all material things, through spiritual interpretation (allegorical exegesis, hermeneutics), seem to be melted into a cosmos of ideas, until at last everything is surmounted and left behind as a stepping-stone, while only this remains: the blessed and abiding relationship of the God-created creaturely soul to God (*amor et visio*).⁶

[23] His theology as distinguished from Tertullian's was essentially philosophical; it fitted neatly into the framework of Neoplatonic philosophy. In Origen the two worlds of Greek philosophy and Gnosis on the one hand, and Christian ideas on the other, interpenetrate in a peaceful and harmonious whole. But this daring, perspicacious tolerance and fair-mindedness led Origen, too, to the fate of condemnation by the Church. Actually the final condemnation took place only posthumously, after Origen as an old man had been tortured in the persecution of the Christians under Decius and had subsequently died from the effects of the torture. Pope Anastasius I pronounced the condemnation in 399, and in 543 his heretical teachings were anathematized at a synod convoked by Justinian, which judgment was upheld by later councils.

[24] Origen is a classic example of the extraverted type. His basic orientation was towards the object; this showed itself in his scrupulous regard for objective facts and their conditions, as well as in the formulation of that supreme principle: *amor et visio Dei*. The Christian process of development encountered in Origen a type whose ultimate foundation was the relation to the object—a relation that has always symbolically expressed itself in sexuality and accounts for the fact that there are certain theories today which reduce all the essential psychic functions to sexuality too. Castration was therefore an adequate expression of the sacrifice of the most valuable function. It is entirely characteristic that Tertullian should perform the *sacrificium intellectus*, whereas Origen was led to the *sacrificium phalli*, because the Christian process demands a complete abolition of the sensual tie to the object; in other words, it demands the sacrifice of the hitherto most valued function, the dearest possession, the strongest instinct. Considered biologically, the sacrifice serves the interests of domestication, but psychologically it opens a door for new possibilities of spiritual development through the dissolution of old ties.

[25] Tertullian sacrificed the intellect because it bound him most strongly to worldliness. He fought against Gnosis because for him it represented a deviation into intellectuality, which at the same time involved sensuality. In keeping with this fact we find that in reality Gnosticism also was divided into two schools: one school striving after a spirituality that exceeded all bounds, the other losing itself in an ethical anarchism, an absolute libertinism that shrank from no lewdness and no

depravity however atrocious and perverse. A definite distinction was made between the Encratites, who practised continence, and the Antitactae or Antinomians, who were opposed to law and order, and who in obedience to certain doctrines sinned on principle and purposely gave themselves up to unbridled debauchery. To the latter school belong the Nicolaitans, Archontics, etc., and the aptly named Borborians. How closely the seeming contraries lay side by side is shown by the example of the Archontics, for this same sect was divided into an Encratite and an Antinomian school, both of which pursued their aims logically and consistently. If anyone wants to know what are the ethical consequences of intellectualism pushed to the limit and carried out on a grand scale, let him study the history of Gnostic morals. He will then fully understand the *sacrificium intellectus*. These people were also consistent in practice and carried their crazy ideas to absurd lengths in their actual lives.

[26] Origen, by mutilating himself, sacrificed his sensual tie to the world. For him, evidently, the specific danger was not the intellect but feeling and sensation, which bound him to the object. Through castration he freed himself from the sensuality that was coupled with Gnosticism; he could then surrender without fear to the treasures of Gnostic thought, whereas Tertullian through his sacrifice of the intellect turned away from Gnosis but also reached a depth of religious feeling that we miss in Origen. "In one way he was superior to Origen," says Schultz, "because in his deepest soul he lived every one of his words; it was not reason that carried him away, like the other, but the heart. Yet in another respect Tertullian stands far behind him, inasmuch as he, the most passionate of all thinkers, was on the verge of rejecting knowledge altogether, for his battle against Gnosis was tantamount to a complete denial of human thought."⁷

[27] We see here how, in the Christian process, the original type has actually become reversed: Tertullian, the acute thinker, becomes the man of feeling, while Origen becomes the scholar and loses himself in intellectuality. Logically, of course, it is quite easy to put it the other way round and say that Tertullian had always been the man of feeling and Origen the intellectual. Apart from the fact that the difference of type is not thereby done away with but exists as before, the reversal does not explain how it comes that Tertullian saw his most dangerous enemy in the intellect, and Origen in sexuality. One could say they were both deceived, adducing as evidence the fatal outcome of both lives by way of argument. If that were the case, one would have to assume that they both sacrificed the less important thing, and that both of them made a crooked bargain with fate. That is certainly a point of view whose validity should be recognized in principle. Are there not just such slyboots among primitives who approach their fetish with a black hen under the arm, saying; "See, here is thy sacrifice, a beautiful black pig." I am, however, of the opinion that the depreciatory method of explanation, notwithstanding the unmistakable relief which

the ordinary mortal feels in dragging down something great, is not under all circumstances the correct one, even though it may appear to be very “biological.” From what we can personally know of these two great figures in the realm of the spirit, we must say that their whole nature was so sincere that their conversion to Christianity was neither an underhand trick nor a fraud, but had both reality and truthfulness.

[28] We shall not be digressing if we take this opportunity to try to grasp the psychological meaning of this rupture of the natural course of instinct, which is what the Christian process of sacrifice appears to be. From what has been said it follows that conversion signifies at the same time a transition to another attitude. This also makes it clear from what source the impelling motive for conversion comes, and how far Tertullian was right in conceiving the soul as *naturaliter Christiana*. The natural course of instinct, like everything in nature, follows the line of least resistance. One man is rather more gifted here, another there; or again, adaptation to the early environment of childhood may demand relatively more reserve and reflection or relatively more empathy and participation, according to the nature of the parents and the circumstances. In this way a certain preferential attitude is built up automatically, resulting in different types. Since every man, as a relatively stable being, possesses all the basic psychological functions, it would be a psychological necessity with a view to perfect adaptation that he should also employ them in equal measure. For there must be a reason why there are different modes of psychological adaptation: evidently one alone is not enough, since the object seems to be only partially comprehended when, for example, it is something that is merely thought or merely felt. A one-sided (“typical”) attitude leaves a deficiency in the adaptive performance which accumulates during the course of life, and sooner or later this will produce a disturbance of adaptation that drives the subject toward some kind of compensation. But the compensation can be obtained only by means of an amputation (sacrifice) of the hitherto one-sided attitude. This results in a temporary accumulation of energy and an overflow into channels not used consciously before though lying ready unconsciously. The adaptive deficiency, which is the *causa efficiens* of the process of conversion, is subjectively felt as a vague sense of dissatisfaction. Such an atmosphere prevailed at the turning-point of our era. A quite astonishing need of redemption came over mankind, and brought about that unparalleled efflorescence of every sort of possible and impossible cult in ancient Rome. Nor was there any lack of advocates of “living life to the full,” who operated with arguments based on the science of that day instead of with biological ones. They, too, could never be done with speculations as to why mankind was in such a bad way. Only, the causalism of that epoch, as compared with our science, was considerably less restricted; they could hark back far beyond childhood to cosmogony, and numerous systems were devised

proving that what had happened in the remote abyss of time was the source of insufferable consequences for mankind.

[29] The sacrifice that Tertullian and Origen carried out was drastic—too drastic for our taste—but it was in keeping with the spirit of the age, which was thoroughly concretistic. Because of this spirit the Gnostics took their visions as absolutely real, or at least as relating directly to reality, and for Tertullian the reality of his feeling was objectively valid. The Gnostics projected their subjective inner perception of the change of attitude into a cosmogonic system and believed in the reality of its psychological figures.

[30] In my book *Wandlungen und Symbole der Libido*⁸ I left the whole question open as to the origin of the peculiar course the libido took in the Christian process of development. I spoke of a splitting of libido into two halves, each directed against the other. The explanation of this is to be found in a one-sided psychological attitude so extreme that compensations from the unconscious became an urgent necessity. It is precisely the Gnostic movement in the early centuries of our era that most clearly demonstrates the breakthrough of unconscious contents at the moment of compensation. Christianity itself signified the collapse and sacrifice of the cultural values of antiquity, that is, of the classical attitude. At the present time it is hardly necessary to remark that it is a matter of indifference whether we speak of today or of that age two thousand years ago.

2. THE THEOLOGICAL DISPUTES OF THE ANCIENT CHURCH

[31] It is more than probable that the contrast of types will also be found in the history of the schisms and heresies that were so frequent in the disputes of the early Church. The Ebionites or Jewish Christians, who were probably identical with the primitive Christians generally, believed in the exclusive humanity of Christ and held him to be the son of Mary and Joseph, only subsequently receiving his consecration through the Holy Ghost. On this point the Ebionites were diametrically opposed to the Docetists. The effects of this opposition endured long after. The conflict came to light again in an altered form—which, though doctrinally attenuated, had an even graver effect on Church politics—about the year 320 in the Arian heresy. Arius denied the formula propounded by the orthodox Church: *τῷ Πατρὶ ὁμοούσιος* (of one substance with the Father), in favour of *τῷ Πατρὶ ὁμοιούσιος* (of like substance with the Father). When we examine more clearly the history of the great Arian controversy concerning *homoousia* and *homoiousia* (the complete identity as against the similarity of Christ's substance with God), it seems to us that *homoiousia* definitely puts the accent on the sensuous and humanly perceptible, in contrast to the purely conceptual and abstract

standpoint of *homoousia*. In the same way it would appear to us that the revolt of the Monophysites (who upheld the absolute unity of Christ's nature) against the Dyophysite formula of the Council of Chalcedon (which upheld the inseparable duality of Christ, his human and divine nature coexisting in one body) once more asserted the standpoint of the abstract and inconceivable as against the sensuous and naturalistic formula of the Dyophysites.

[32] At the same time it becomes overwhelmingly clear to us that, in the Arian movement as in the Monophysite dispute, although the subtle dogmatic question was the main issue for the minds that originally conceived it, this was not so for the great mass of people who took part in the controversy. Even in those early days so subtle a question had no motivating force with the masses, who were stirred rather by the problems and claims of political power that had nothing to do with differences of theological opinion. If type differences had any significance at all here, it was merely because they provided catchwords that gave a flattering label to the crude instincts of the mass. But this should in no way blind us to the fact that, for those who kindled the quarrel, *homoousia* and *homoiousia* were a very serious matter. For concealed within it, both historically and psychologically, lay the Ebionite creed of a purely human Christ with only relative ("apparent") divinity, and the Docetist creed of a purely divine Christ with only apparent corporeality. And beneath this level in turn lies the great psychological schism. The one position attaches supreme value and importance to the sensuously perceptible, whose subject, though it may not always be human and personal, is nevertheless always a projected human sensation; the other maintains that the chief value lies with the abstract and extra-human, whose subject is the function; in other words, with the objective process of nature, that runs its course determined by impersonal law, beyond human sensation, of which it is the actual foundation. The former standpoint overlooks the function in favour of the function-complex, if man may be so regarded; the latter overlooks man as the indispensable subject in favour of the function. Each standpoint denies the principal value of the other. The more resolutely the adherents of either standpoint identify themselves with it, the more they strive, with the best intentions perhaps, to force it on the other, and thereby violate the other's supreme value.

[33] Another aspect of the type conflict appears in the Pelagian controversy at the beginning of the fifth century. The experience so profoundly felt by Tertullian, that man cannot avoid sin even after baptism, grew with Augustine—who in many ways was not unlike Tertullian—into that thoroughly characteristic, pessimistic doctrine of original sin, whose essence consists in the concupiscence⁹ inherited from Adam. Over against the fact of original sin there stood, according to Augustine, the redeeming grace of God, with the institution of the Church ordained by his grace to administer the means of salvation. In this scheme of things the value of man stands

very low. He is really nothing but a miserable rejected creature, who is delivered over to the devil under all circumstances, unless through the medium of the Church, the sole means of salvation, he is made a participator of the divine grace. Not only man's value, but his moral freedom and his self-determination crumbled away accordingly, with the result that the value and significance of the Church as an *idea* were so much the more enhanced, as was altogether in keeping with Augustine's explicit programme in the *Civitas Dei*.

[34] Against such a stifling conception there rises ever anew the feeling of man's freedom and moral value—a feeling that will not long endure suppression whether by insight however searching, or logic however keen. The rightness of the feeling of human value found its defenders in Pelagius, a British monk, and Celestius, his pupil. Their teaching was founded on the moral freedom of man as a given fact. It is characteristic of the psychological kinship existing between the Pelagian standpoint and the Dyophysite view that the persecuted Pelagians found an advocate in Nestorius, the Metropolitan of Constantinople. Nestorius stressed the separation of the two natures of Christ in contrast to the Cyrillian doctrine of the φυσικὴ ἕνωσις, physical oneness of Christ as the God-man. Also, Nestorius definitely did not want Mary to be understood as the Θεοτόκος (God-bearer), but merely as the Χριστοτόκος (Christ-bearer). With some justification he even called the idea that Mary was the mother of God heathenish. From him originated the Nestorian controversy, which finally ended with the secession of the Nestorian Church.

3. THE PROBLEM OF TRANSUBSTANTIATION

[35] With the immense political upheavals of that age, the collapse of the Roman Empire, and the decay of ancient civilization, these controversies likewise passed into oblivion. But when, after several centuries, a state of stability was again reached, the psychological differences also reappeared in their characteristic ways, tentatively at first but becoming ever more intense with advancing civilization. No longer was it the problems that had thrown the early Church into an uproar; new forms had been devised, but underneath them the same psychology was concealed.

[36] About the middle of the ninth century the Abbot Paschasius Radbertus appeared on the scene with a treatise on the Communion, in which he propounded the doctrine of the transubstantiation, i.e., the assertion that the wine and holy wafer become transformed into the actual blood and body of Christ. As is well known, this view became a dogma, according to which the transformation is accomplished *vere*, *realiter*, *substantialiter* (in truth, in reality, in substance). Although the “accidentals,” the bread and wine, preserve their outward aspect, they are substantially the flesh and

blood of Christ. Against this extreme concretization of a symbol Ratramnus, a monk of the same monastery where Radbertus was abbot, ventured to raise some opposition. However, Radbertus found a more resolute opponent in Scotus Erigena, one of the great philosophers and daring thinkers of the early Middle Ages, who, as Hase says in his *History of the Christian Church*, towered so high and solitary above his time that his doctrines were not sufficiently understood to be condemned by the Church until the thirteenth century. As abbot of Malmesbury, he was butchered by his own monks about the year 889. Scotus Erigena, for whom true philosophy was also true religion, was no blind follower of authority and the “once accepted” because, unlike the majority of his age, he himself could think. He set reason above authority, very unseasonably perhaps but in a way that assured him the acclaim of later centuries. Even the Church Fathers, who were considered to be above discussion, he held as authorities only in so far as the treasures of human reason were contained in their writings. Thus he also held that the Communion was nothing more than a commemoration of that last supper which Jesus celebrated with his disciples, a view in which all reasonable men in every age will concur. Scotus Erigena, clear and humanistic as he was in his thinking, and however little disposed to detract from the significance and value of the sacred ceremony, was not attuned to the spirit of his age and the desires of the world around him, a fact that might, indeed, be inferred from his assassination by his own comrades of the cloister. Because he could think rationally and logically success did not come to him; instead, it fell to Radbertus, who assuredly could not think, but who “transubstantiated” the symbolic and meaningful and made it coarse and sensual, attuned as he obviously was to the spirit of his age, which was all for the concretization of religious experiences.

[37] Again in this controversy we can easily recognize the basic elements we have already met in the disputes discussed earlier: the abstract standpoint that abhors any contamination with the concrete object, and the concretistic that is turned towards the object.

[38] Far be it from us to pronounce, from the intellectual standpoint, a one-sided, depreciatory judgment on Radbertus and his achievement. Although to the modern mind this dogma must appear simply absurd, we should not be misled on that account into declaring it historically worthless. Certainly it is a showpiece for every collection of human aberrations, but that does not establish its worthlessness *eo ipso*. Before passing judgment, we must carefully examine what this dogma accomplished in the religious life of that epoch, and what our age still owes indirectly to its effect. It must not be overlooked, for instance, that it is precisely the belief in the reality of this miracle that demands a detachment of the psychic process from the purely sensual, and this cannot remain without influence on the psychic process itself. Directed thinking becomes absolutely impossible when the sensual has too high a

threshold value. Because its value is too high it constantly intrudes into the psyche, where it disrupts and destroys the function of directed thinking which is based on the exclusion of everything incompatible with thought. From this elementary consideration follows the practical importance of rites and dogmas that prove their value not only from this point of view but from a purely opportunistic and biological one, not to speak of the immediate, specifically religious effects accruing to individuals from a belief in this dogma. Highly as we esteem Scotus Erigena, the less is it permitted to despise the achievement of Radbertus. But what we may learn from this example is that the thinking of the introvert is incommensurable with the thinking of the extravert, since the two forms of thinking, as regards their determinants, are wholly and fundamentally different. We might perhaps say that the thinking of the introvert is *rational*, while that of the extravert is *programmatically*.

[39] These arguments, I wish particularly to emphasize, do not pretend to have said anything decisive about the individual psychology of our two protagonists. What we know of Scotus Erigena personally—it is little enough—is not sufficient for us to make a sure diagnosis of his type. What we do know speaks in favour of the introverted type. Of Radbertus we know next to nothing. We know only that he said something that contradicted ordinary human thinking, but with surer logic of feeling surmised what his age was prepared to accept as suitable. This would speak in favour of the extraverted type. For insufficient knowledge we must suspend judgment on both personalities, since, particularly in the case of Radbertus, the matter might well be decided quite differently. He might equally well have been an introvert, but with limited reasoning powers that in no way rose above the conceptions of his milieu, and with a logic so lacking in originality that it was just sufficient to draw the obvious conclusion from the premises already laid down in the writings of the Church Fathers. Conversely, Scotus Erigena might as well have been an extravert, if it could be shown that he lived in a milieu that was distinguished in any case by common sense and that considered a corresponding assertion suitable and desirable. But this has in no sense been demonstrated. On the other hand, we do know how great was the yearning of that age for the reality of religious miracles. To an age so constituted, the views of Scotus Erigena must have seemed cold and deadening, whereas the assertion of Radbertus must have been felt as life-promoting, since it concretized what everyone desired.

4. NOMINALISM AND REALISM

[40] The Communion controversy of the ninth century was merely the signal for a much greater controversy that divided the minds of men for centuries and had incalculable consequences. This was the conflict between nominalism and realism.

By nominalism is meant that school which asserted that the so-called universals, namely generic or universal concepts such as beauty, goodness, animal, man, etc., are nothing but *nomina*, names, or words, derisively called *flatus vocis*. Anatole France says: “What is thinking? And how does one think? We think with words; that in itself is sensual and brings us back to nature. Think of it! A metaphysician has nothing with which to construct his world system except the perfected cries of monkeys and dogs.”¹⁰ This is extreme nominalism, as it is when Nietzsche says that reason is “speech metaphysics.”

[41] Realism, on the contrary, affirms the existence of universals *ante rem*, and holds that general concepts exist in themselves after the manner of Platonic ideas. In spite of its ecclesiastical associations, nominalism is a sceptical tendency that denies the separate existence characteristic of abstractions. It is a kind of scientific scepticism coupled with the most rigid dogmatism. Its concept of reality necessarily coincides with the sensuous reality of things; their individuality represents the real as opposed to the abstract idea. Strict realism, on the contrary, transfers the accent on reality to the abstract, the idea, the universal, which it posits before the thing (*ante rem*).

a. The Problem of Universals in Antiquity

[42] As our reference to the doctrine of Platonic ideas shows, we are dealing with a conflict that reaches very far back in time. Certain envenomed remarks in Plato concerning “grey-bearded schoolboys” and the “mentally poverty-stricken” are innuendos aimed at the adherents of two allied schools of philosophy that were at odds with the Platonic spirit, these being the Cynics and the Megarians. Antisthenes, the leader of the former school, although by no means a stranger to the Socratic ambiance and even a friend of Xenophon, was nevertheless avowedly inimical to Plato’s beautiful world of ideas. He even wrote a pamphlet against Plato, in which he scurrilously changed Plato’s name to Σάθων. Σάθων means ‘boy’ or ‘man,’ but under his sexual aspect, since σάθων comes from σάθη, ‘penis,’ ‘cock’; whereby Antisthenes, through the time-honoured method of projection, delicately suggests what cause he is defending against Plato. For Origen, as we saw, this was also a prime cause, the very devil whom he sought to lay low by means of self-castration, in order to pass without hindrance into the richly furnished world of ideas. Antisthenes, however, was a pre-Christian pagan, and for him what the phallus has stood for from time immemorial as the acknowledged symbol was of heartfelt interest, namely the delights of the senses—not that he was alone in this, for as we know it affected the whole Cynic school, whose cry was “Back to Nature!” There were plenty of reasons that might have thrust his concrete feeling and sensation into the foreground; he was before everything a proletarian, who made a virtue of his envy. He was no *ἰθαγενής*, no thoroughbred Greek. He was an outsider, and he taught outside too, before the

gates of Athens, where he flaunted his proletarian behaviour, a model of Cynic philosophy. Moreover, the whole school was composed of proletarians, or at least of people on the fringe, all of whom indulged in corrosive criticism of the traditional values.

[43] After Antisthenes one of the most prominent members of the school was Diogenes, who conferred on himself the title of Κύύν, ‘dog,’ and whose tomb was adorned by a dog in Parian marble. Despite his warm love of man, for his whole nature was suffused with human understanding, he nonetheless pitilessly satirized everything that the men of his time held sacred. He ridiculed the horror that gripped the spectator in the theatre at the sight of Thyestes’ repast,¹¹ or the incestuous tragedy of Oedipus; anthropophagy was not so bad, since human flesh can claim no exceptional position among meats, and furthermore the mishap of an incestuous affair is not such a disaster after all, as the instructive example of our domestic animals makes plain to us. In many respects the Megarian school was akin to the Cynics. Was not Megara the unsuccessful rival of Athens? After a most promising start, when Megara rose to prominence through the founding of Byzantium and Hyblaeic Megara in Sicily, internal squabbles broke out, after which Megara sickened and wasted away, and was in every respect outstripped by Athens. Loutish peasant wit was known in Athens as “Megarian jesting.” This envy, which in the defeated is imbibed with the mother’s milk, might explain not a little that is characteristic of Megarian philosophy. Like that of the Cynics, it was thoroughly nominalistic and utterly opposed to the realism of Plato’s ideology.

[44] Another leading figure in this school was Stilpon of Megara, about whom the following characteristic anecdote is related. One day Stilpon came to Athens and saw on the Acropolis the wondrous statue of Pallas Athene made by Phidias. A true Megarian, he remarked that it was not the daughter of Zeus but of Phidias. This jest catches the whole spirit of Megarian thinking, for Stilpon taught that generic concepts are without reality and objective validity. Anyone, therefore, who speaks of “man” speaks of nobody, because he is designating τόνδε οὔτε τόνδε (neither this nor that). Plutarch ascribes to him the statement *ἕτερον ἑτέρου μὴ κατηγορεῖσθαι* (one thing can affirm nothing concerning [the nature of] another).¹² The teaching of Antisthenes was very similar. The oldest exponent of this type of propositional thinking seems to have been Antiphon of Rhamnos, a sophist and contemporary of Socrates. One of his propositions runs: “A man who perceives long objects neither sees the length with his eyes nor can perceive it with his mind.”¹³ The denial of the substantiality of generic concepts follows directly from this proposition. Naturally the whole position of Platonic ideas is undermined by this type of thinking, for with Plato it is just the ideas that have eternal and immutable validity, while the “real” and the “many” are merely their fugitive reflections. From the realist standpoint, the

Cynic-Megarian critique breaks down generic concepts into purely sophisticated and descriptive nomina lacking any substantiality, and lays the accent on the individual thing.

[45] This manifest and fundamental opposition was clearly conceived by Gomperz¹⁴ as the problem of *inherence* and *predication*. When, for instance, we speak of “warm” and “cold,” we speak of warm and cold things, to which “warm” and “cold” belong as attributes, predicates, or assertions. The assertion refers to something perceived and actually existing, namely to a warm or a cold body. From a plurality of similar cases we abstract the concepts of “warmth” and “coldness,” which again we immediately connect in our thoughts with something concrete, thing-like. Thus “warmth” and “coldness” are thing-like for us because of the reverberation of sense-perception in the abstraction. It is extremely difficult for us to strip the abstraction of its “thingness,” for there naturally clings to every abstraction the thing it is abstracted from. In this sense the thingness of the predicate is actually an *a priori*. If we now pass to the next higher generic concept, “temperature,” we still have no difficulty in perceiving its thingness, which, though it has lost its definiteness for the senses, nevertheless retains the quality of representability that adheres to every sense-perception. If we then ascend to a very much higher generic concept, such as “energy,” its thing-like character quite disappears, and with it, to a certain extent, goes the quality of representability. At this point the conflict arises about the “nature” of energy: whether energy is purely conceptual and abstract, or whether it is something “real.” The learned nominalist of our day is quite convinced that energy is nothing but a name, a mere counter in our mental calculus; but in spite of this, in our everyday speech we treat energy as though it were thing-like, thus sowing in our heads the greatest confusion from the standpoint of the theory of knowledge.

[46] The thing-likeness of the purely conceptual, which creeps so naturally into the process of abstraction and brings about the “reality” of the predicate or the abstract idea, is no artificial product, no arbitrary hypostatizing of a concept, but a natural necessity. It is not that the abstract idea is arbitrarily hypostatized and transplanted into a transcendental world of equally artificial origin; the actual historical process is quite the reverse. Among primitives, for instance, the imago, the psychic reverberation of the sense-perception, is so strong and so sensuously coloured that when it is reproduced as a spontaneous memory-image it sometimes even has the quality of an hallucination. Thus when the memory-image of his dead mother suddenly reappears to a primitive, it is as if it were her ghost that he sees and hears. We only “think” of the dead, but the primitive actually perceives them because of the extraordinary sensuousness of his mental images. This explains the primitive’s belief in ghosts and spirits; they are what we quite simply call “thoughts.” When the primitive “thinks,” he literally has visions, whose reality is so great that he constantly

mistakes the psychic for the real. Powell says: “The confusion of confusions is that universal habit of savagery—the confusion of the objective with the subjective.”¹⁵ Spencer and Gillen observe: “What a savage experiences during a dream is just as real to him as what he sees when he is awake.”¹⁶ What I myself have seen of the psychology of the Negro completely endorses these findings. From this basic fact of the psychic realism and autonomy of the image vis-à-vis the autonomy of the sense-perception springs the belief in spirits, and not from any need of explanation on the part of the primitive, which is merely imputed to him by Europeans. For the primitive, thought is visionary and auditory, hence it also has the character of revelation. Thus the sorcerer, the visionary, is always the thinker of the tribe, who brings about the manifestation of the spirits or gods. This also explains the magical effect of thought; it is as good as the deed, just because it is real. In the same way the word, the outer covering of thought, has a “real” effect because it calls up “real” memory-images. Primitive superstition surprises us only because we have largely succeeded in de-sensualizing the psychic image; we have learnt to think abstractly—always, of course, with the above-mentioned limitations. Nevertheless, as anybody who is engaged in the practice of analytical psychology knows, even “educated” European patients constantly need reminding that thinking is not doing—one patient because he believes that to think something is enough, another because he feels he must not think something or he would immediately have to go and do it.

[47] How easily the primitive reality of the psychic image reappears is shown by the dreams of normal people and the hallucinations that accompany mental derangement. The mystics even endeavour to recapture the primitive reality of the imago by means of an artificial introversion, in order to counterbalance extraversion. There is an excellent example of this in the initiation of the Mohammedan mystic Tewekkul-Beg, by Molla-Shah. Tewekkul-Beg relates:

After these words he called me to seat myself opposite to him, while still my senses were as though bemused, and commanded me to create his own image in my inner self; and after he had bound my eyes, he bade me gather all the forces of the soul into my heart. I obeyed, and in the twinkling of an eye, by divine favour and with the spiritual succour of the Sheik, my heart was opened. I beheld there in my innermost self something resembling an overturned bowl; when this vessel was righted, a feeling of boundless joy flooded through my whole being. I said to the Master: “From this cell, in which I am seated before you, I behold within me a true vision, and it is as though another Tewekkul-Beg were seated before another Molla-Shah.”¹⁷ The Master explained this to him as the first phenomenon of his initiation. Other visions soon followed, once the way to the primitive image of the real had been opened.

[48] The reality of the predicate is given *a priori* since it has always existed in the human mind. Only by subsequent criticism is the abstraction deprived of the quality of reality. Even in Plato's time the belief in the magical reality of verbal concepts was so great that it was worth the philosopher's while to devise traps or fallacies by which he was able, through the absolute significance of words, to elicit an absurd reply. A simple example is the Enkekalymmenos (veiled man) fallacy devised by the Megarian philosopher Eubulides: "Can you recognize your father? — Yes. Can you recognize this veiled man? — No. You contradict yourself; this veiled man is your father. Thus you can recognize your father and at the same time not recognize him." The fallacy merely lies in this, that the person questioned naïvely assumes the word "recognize" refers in all cases to the same objective fact, whereas in reality its validity is restricted to certain definite cases. The Keratines (horned man) fallacy is based on the same principle: "What you have not lost, you still have. You have not lost horns, therefore you have horns." Here too the fallacy lies in the naïveté of the subject, who assumes in the premise a specific fact. With the help of this method it could be convincingly shown that the absolute significance of words was an illusion. As a result, the reality of the generic concept, which in the form of the Platonic idea had a metaphysical existence and exclusive validity, was put in jeopardy. Gomperz says:

Men were not as yet possessed of that distrust of language which animates us moderns and frequently causes us to see in words a far from adequate expression of the facts. On the contrary, there was a simple and unsuspecting faith that the range of an idea and the range of the word roughly corresponding to it must in every case exactly coincide.¹⁸

[49] In view of this magical, absolute significance of words, which presupposes that words also imply the objective behaviour of things, the Sophist critique was very much in place. It offered a striking proof of the impotence of language. In so far as ideas are merely names—a supposition that remains to be proved—the attack upon Plato was justified. But generic concepts cease to be mere names when they designate the similarities or conformities of things. The question then arises whether these conformities are objective realities or not. These conformities actually exist, hence the generic concept also corresponds with some kind of reality. It contains as much reality as does the exact description of a thing. The generic concept differs from the description only in that it describes or designates the conformities of things. The weakness, therefore, lies neither in the generic concept nor in the Platonic idea, but in its verbal expression, which obviously under no circumstances adequately reproduces either the thing or the conformity. The nominalist attack on the doctrine of ideas was thus in principle an unwarrantable encroachment, and Plato's exasperated counterstroke was fully justified.

[50] According to Antisthenes, the principle of inherence consists in this, that not only can no kind of predicate be asserted of a subject which differs from it, but no predicate at all. Antisthenes granted as valid only those predicates that were identical with the subject. Apart from the fact that such statements of identity (“sweet is sweet”) affirm nothing at all and are, therefore, meaningless, the weakness of the principle of inherence is that a statement of identity has also nothing to do with the thing: the word “grass” has no connection with the thing “grass.” The principle of inherence suffers just as much from the old word-fetishism, which naïvely supposes that the word coincides with the thing. So when the nominalist tells the realist: “You are dreaming—you think you are dealing with things, but all the time you are fighting verbal chimeras!” the realist can answer the nominalist in precisely the same words; for neither is the nominalist dealing with things in themselves but with the words he has put in the place of things. Even when he uses a separate word for each individual thing, they are always only words and not the things themselves.

[51] Now though the idea of energy is admittedly a mere verbal concept, it is nevertheless so extraordinarily real that your Electricity Company pays dividends out of it. The board of directors would certainly allow no metaphysical argument to convince them of the unreality of energy. “Energy” designates simply the conformity of the phenomena of force—a conformity that cannot be denied and that daily gives striking proof of its existence. So far as a thing is real, and a word conventionally designates that thing, the word also acquires reality-significance. And so far as the conformity of things is real, the generic concept designating that conformity likewise acquires reality-significance, a significance that is neither greater nor less than that of the word designating the individual thing. The shifting of the accent of value from one side to the other is a matter of individual attitude and the psychology of the time. Gomperz was also aware of these underlying psychological factors in Antisthenes, and brings out the following points:

Sound common sense, a resistance to all dreamy enthusiasm, perhaps also the strength of individual feeling that endows the personality and hence, probably, the individual’s whole character with the stamp of complete reality—these may well have been among the forces that swelled the tide of reaction.¹⁹

To this we might add the envy of a man without full rights of citizenship, a proletarian, a man upon whom fate had bestowed but little beauty, and who at best could only climb to the heights by demolishing the values of others. This was especially characteristic of the Cynic, who must forever be carping at others, and to whom nothing was sacred if it happened to belong to somebody else; he even had no compunction about destroying the peace of the home if he might seize an occasion to parade his invaluable advice.

[52] To this essentially critical attitude of mind Plato's world of ideas with their eternal reality stands diametrically opposed. It is evident that the psychology of the man who fashioned that world had an orientation altogether foreign to the carping, corrosive judgments described above. From the world of multiplicity Plato's thinking abstracted and created synthetic constructive concepts, which designate and express the general conformities of things as that which truly exists. Their invisible and suprahuman quality is the direct opposite of the concretism of the principle of inherence, which would reduce the stuff of thought to the unique, the individual, the objective. This attempt is just as impossible as the exclusive acceptance of the principle of predication, which would exalt what has been affirmed of many isolated things to an eternally existing substance above all decay. Both forms of judgment are justifiable, as both are naturally present in every man. This is best seen, in my view, from the fact that the very founder of the Megarian school, Eucleides of Megara, established an "All-oneness" that was immeasurably far above the individual and particular. For he linked together the Eleatic principle of "being" with "good," so that for him "being" and "good" were identical. As opposed to this there was only "non-existing evil." This optimistic All-oneness was, of course, nothing but a generic concept of the highest order, one that simply included "being" but at the same time contradicted all evidence, far more so even than the Platonic ideas. With this concept Eucleides produced a compensation for the negatively critical dissolution of constructive judgments into mere verbalities. His All-oneness was so remote and so vague that it utterly failed to express the conformity of things; it was no type at all, but rather the product of a desire for a unity that would embrace the disordered multitude of individual things. This desire forces itself on all those who pay homage to extreme nominalism, in so far as they make any attempt to escape from their negatively critical attitude. Hence it is not uncommon to find in people of this sort an idea of fundamental uniformity that is superlatively improbable and arbitrary. It is manifestly impossible to base oneself entirely on the principle of inherence. Gomperz pertinently observes:

Attempts of this nature are foredoomed to failure in every age. Their success was completely out of the question in an age that was destitute of historical understanding, and in which there was next to no insight into the deeper problems of psychology. It was not a mere risk, it was an absolute certainty that the more patent and palpable, but on the whole less important, values would thrust into the background others of greater moment, though less easily discerned. In taking the brute and the savage for a model in their efforts to lop off the excrescences of civilization, men laid a destroying hand upon much that was the fruit of an ascending process of development which must be measured in myriads of years.²⁰

[53] Constructive judgment—which, unlike inherence, is based on the conformity of things—has created general ideas that must be counted among the highest values of civilization. Even if these ideas relate only to the dead, we are nevertheless still bound to them by threads which, as Gomperz says, have gained an almost unbreakable strength. He continues:

Thus it is with the body bereft of life; but things which never possessed life may also have a claim on our forbearance, our reverence, even our self-sacrificing devotion; for example, statues, graves, the soldier's flag. And if we do violence to our nature, if we succeed in breaking by main force the bonds of association, we lapse into savagery, we suffer injury in our own souls by the loss of all those feelings which, so to speak, clothe the hard bedrock of naked reality with a garniture of verdant life. On the maintenance of these overgrowths of sentiment, on the due treasuring of acquired values, depend all the refinement, the beauty, and the grace of life, all ennobling of the animal instincts, together with all enjoyment and the pursuit of art—all, in short, that the Cynics set themselves to root up without scruple and without pity. There is, no doubt, a limit—so much we may readily concede to them and their not inconsiderable imitators of the present day—beyond which we cannot allow ourselves to be ruled by the principle of association without incurring the charge of that same folly and superstition which quite certainly grew out of the unlimited sway of that principle.²¹

[54] We have gone so thoroughly into the problem of inherence and predication not only because this problem was revived in the nominalism and realism of the Scholastics but because it has never yet been finally set at rest and presumably never will be. For here again the question at issue is the typical opposition between the abstract standpoint, where the decisive value lies with the mental process itself, and the personal thinking and feeling which, consciously or unconsciously, underlie orientation by the objects of sense. In the latter case the mental process is simply a means for accentuating the personality. It is small wonder that it was precisely the proletarian philosophy that adopted the principle of inherence. Wherever sufficient reasons exist for laying the emphasis on personal feeling, thinking and feeling necessarily become negatively critical through lack of positive creative energy, which is all diverted to personal ends; they become a mere analytical organ that reduces everything to the concrete and particular. The resultant accumulation of disordered particulars is at best subordinated to a vague feeling of All-oneness, the wishful character of which is plain to see. But when the accent lies on the mental process, the product of the mind's activity is exalted above the disordered multiplicity as an *idea*. The idea is depersonalized as much as possible, while personal feeling passes over almost entirely into the mental process, which it hypostatizes.

[55] Before proceeding further we might inquire whether the psychology of the Platonic doctrine of ideas justifies us in the supposition that Plato may personally have belonged to the introverted type, and whether the psychology of the Cynics and Megarians allows us to count such figures as Antisthenes, Diogenes, and Stilpon among the extraverts. Put in this form, the question is absolutely impossible to answer. An extremely careful examination of Plato's authentic writings considered as *documents humains* might perhaps enable one to conclude to which type he belonged, but I for my part would not venture to pronounce any positive judgment. If someone were to furnish evidence that Plato belonged to the extraverted type, it would not surprise me. What has been handed down concerning the others is so very fragmentary that in my opinion a decision is out of the question. Since the two types of thinking we have been discussing depend on a displacement of the accent of value, it is of course equally possible that in the case of the introvert personal feeling may, for various reasons, be pushed into the foreground and will subordinate thinking, so that his thinking becomes negatively critical. For the extravert, the accent of value lies on his relation to the object as such, and not necessarily on his personal relation to it. When the relation to the object occupies the foreground, the mental process is already subordinate; but, if it concerns itself exclusively with the nature of the object and avoids the admixture of personal feeling, it does not possess a destructive character. We have, therefore, to class the particular conflict between the principles of inherence and predication as a special case, which in the further course of our investigation will be examined more thoroughly. The special nature of this case lies in the positive and negative parts played by personal feeling. When the type (generic concept) reduces the individual thing to a shadow, the type has acquired the reality of a collective idea. But when the value of the individual thing abolishes the type (generic concept), anarchic disintegration is at work. Both positions are extreme and unfair, but they form a contrasting picture whose clear outlines, by their very exaggeration, throw into relief features which, in a milder and more covert form, are also inherent in the nature of the introverted and extraverted types, even in the case of individuals in whom personal feeling is not pushed into the foreground. For instance, it makes a considerable difference whether the mental function is master or servant. The master thinks and feels differently from the servant. Even the most far-reaching abstraction of the personal in favour of the general value can never quite eliminate the personal admixtures. And in so far as these exist, thinking and feeling will contain destructive tendencies that come from the self-assertion of the person in the face of unfavourable social conditions. But it would surely be a great mistake if, for the sake of personal tendencies, we were to reduce the traditional universal values to personal undercurrents. That would be pseudo-psychology, but it nevertheless exists.

b. The Problem of Universals in Scholasticism

[56] The problem of the two forms of judgment remained unsolved because—*tertium non datur*. Porphyry handed down the problem to the Middle Ages thus: “As regards universal and generic concepts, the real question is whether they are substantial or merely intellectual, whether corporeal or incorporeal, whether separate from sensible things or in and around them.”²² The Scholastics took up the problem in this form. They started with the Platonic view, the *universalia ante rem*, the universal idea as the pattern or exemplar above all individual things and altogether detached from them, existing *ἐν οὐρανίῳ τόπῳ*, ‘in a heavenly place.’ As the wise Diotima says to Socrates in the dialogue on beauty:

Nor again will this beauty appear to him like the beauty of a face or hands or anything else corporeal, or like the beauty of a thought or a science, or like beauty which has its seat in something other than itself, be it a living thing or the earth or the sky or anything else whatever; he will see it as absolute, existing alone with itself, unique, eternal, and all other beautiful things as partaking of it, yet in such manner that, while they come into being and pass away, it neither undergoes any increase or diminution nor suffers any change.²³

[57] Opposed to the Platonic form, as we saw, was the critical assumption that generic concepts are mere words. Here the real is *prius*, the ideal *posterius*. This view was designated *universalia post rem*. Between the two conceptions stood the moderate, realistic view of Aristotle which we might call *universalia in re*, that form (*εἶδος*) and matter coexist. The Aristotelian standpoint is a concretistic attempt at mediation fully in accord with Aristotle’s nature. As against the transcendentalism of his teacher Plato, whose school afterwards relapsed into Pythagorean mysticism, Aristotle was entirely a man of reality—of classical reality, one should add, which contained much in concrete form that later ages abstracted and added to the inventory of the human mind. His solution reflected the concretism of classical common sense.

[58] These three forms also reveal the structure of medieval opinion in the great controversy about universals, which was the quintessence of Scholasticism. It cannot be my task—even if I were competent—to probe more deeply into the details of this controversy. I must content myself with hints for the purpose of general orientation. The dispute began with the views of Johannes Roscellinus towards the end of the eleventh century. Universals were for him nothing but *nomina rerum*, names of things, or, as tradition says, *flatus vocis*. For him there were only individual things. He was, as Taylor aptly observes, “strongly held by the reality of individuals.”²⁴ To think of God, too, as only individual was the next obvious conclusion, though actually it dissolved the Trinity into three separate persons, so that Roscellinus arrived at tritheism. This was intolerable to the prevailing realism of the times, and in 1092 his views were condemned by a synod at Soissons. The opposing side was

represented by William of Champeaux, the teacher of Abelard, an extreme realist but of Aristotelian complexion. According to Abelard, he taught that one and the same thing existed in its totality and at the same time in separate individual things. There were no essential differences between individual things, but merely a multitude of “accidentals.” By this concept the actual differences between things were explained as fortuitous, just as in the dogma of transubstantiation the bread and wine, as such, were only “accidentals.”

[59] On the realist side there was also Anselm of Canterbury, the father of Scholasticism. A true Platonist, the universals resided for him in the divine Logos. It is in this spirit that we must understand the psychologically important proof of God advanced by Anselm, which is known as the ontological proof. This proof demonstrates the existence of God from the idea of God. Fichte formulates it trenchantly as follows: “The existence of the idea of an Absolute in our consciousness proves the real existence of this Absolute.”²⁵ Anselm held that the concept of a Supreme Being present in the intellect also implied the quality of existence (*non potest esse in intellectu solo*). He continued: “So, then, there truly is a being than which a greater cannot be thought—so truly that it cannot even be thought of as not existing. And thou art this being, O Lord our God.”²⁶ The logical weakness of the ontological argument is so obvious that it even requires a psychological explanation to show how a mind like Anselm’s could advance such an argument. The immediate cause is to be sought in psychological disposition of realism in general, namely in the fact that there was not only a certain class of men but, in keeping with the current of the age, also certain groups of men for whom the accent of value lay on the idea, so that the idea represented for them a higher reality or value for life than the reality of individual things. Hence it seemed simply impossible to suppose that what to them was most valuable and significant should not *really* exist. Indeed, they had the most striking proof of its efficacy in their own hands, since their whole lives, their thinking and feeling, were entirely oriented by this point of view. The invisibility of an idea mattered little in comparison with its extraordinary efficacy, which was indeed a reality. They had an ideal, and not a sensual, concept of the real.

[60] A contemporary opponent of Anselm’s, Gaunilo, raised the objection that the oft-recurring idea of the Islands of the Blessed (based on Homer’s land of the Phaeacians, *Odyssey*, VIII) does not necessarily prove their actual existence. This objection is palpably reasonable. Similar objections were raised in the course of the centuries, though they did nothing to prevent the ontological argument surviving even down to quite recent times, it being espoused in the nineteenth century by Hegel, Fichte, and Lotze. Such contradictory statements cannot be ascribed to some peculiar defect in the logic of these thinkers or to an even greater delusion on one side or the other. That would be absurd. Rather is it a matter of deep-seated

psychological differences which must be acknowledged and clearly stated. The assumption that only *one* psychology exists or only *one* fundamental psychological principle is an intolerable tyranny, a pseudo-scientific prejudice of the common man. People always speak of man and his “psychology” as though there were “nothing but” that psychology. In the same way one always talks of “reality” as though it were the only one. Reality is simply what works in a human soul and not what is assumed by certain people to work there, and about which prejudiced generalizations are wont to be made. Even when this is done in a scientific spirit, it should not be forgotten that science is not the *summa* of life, that it is actually only one of the psychological attitudes, only one of the forms of human thought.

[61] The ontological argument is neither argument nor proof, but merely the psychological demonstration of the fact that there is a class of men for whom a definite idea has efficacy and reality—a reality that even rivals the world of perception. The sensualist brags about the undeniable certainty of his reality, and the idealist insists on his. Psychology has to resign itself to the existence of these two (or more) types, and must at all costs avoid thinking of one as a misconception of the other; and it should never seriously try to reduce one type to the other, as though everything “other” were merely a function of the one. This does not mean that the scientific axiom known as Occam’s razor—“explanatory principles should not be multiplied beyond the necessary”—should be abrogated. But the need for a plurality of psychological explanatory principles still remains. Aside from the arguments already adduced in favour of this, our eyes ought to have been opened by the remarkable fact that, notwithstanding the apparently final overthrow of the ontological proof by Kant, there are still not a few post-Kantian philosophers who have taken it up again. And we are today just as far or perhaps even further from an understanding of the pairs of opposites—idealism / realism, spiritualism / materialism, and all the subsidiary questions they raise—than were the men of the early Middle Ages, who at least had a common philosophy of life.

[62] There can surely be no logical argument that appeals to the modern intellect in favour of the ontological proof. The ontological argument in itself has really nothing to do with logic; in the form in which Anselm bequeathed it to history it is a subsequently intellectualized or rationalized *psychological fact*, and naturally this could never have come about without begging the question and sundry other sophistries. But it is just here that the unassailable validity of the argument shows itself—in the fact that it exists, and that the *consensus gentium* proves it to be a fact of universal occurrence. It is the fact that has to be reckoned with, not the sophistry of its proof. The mistake of the ontological argument consists simply and solely in its trying to argue logically, when in reality it is very much more than a merely logical proof. The real point is that it is a psychological fact whose existence and efficacy are

so overwhelmingly clear that no sort of argumentation is needed to prove it. The *consensus gentium* proves that, in the statement “God is, because he is thought,” Anselm was right. It is an obvious truth, indeed nothing but a statement of identity. The “logical” argumentation about it is quite superfluous, and false to boot, inasmuch as Anselm wanted to establish his idea of God as a concrete reality. He says: “Without doubt, therefore, there exists, both in the understanding and in reality [*in intellectu et in re*], something than which a greater cannot be thought.”²⁷ For the Scholastics, the concept *res* was something that existed on the same level as thought. Thus Dionysius the Areopagite, whose writings exercised a considerable influence on early medieval philosophy, distinguished the categories *entia rationalia*, *intellectualia*, *sensibilia*, *simpliciter existentia*. For Thomas Aquinas, *res* was *quod est in anima* (what is in the soul) as well as *quod est extra animam* (what is outside the soul).²⁸ This remarkable equation allows us to discern the primitive “thing-likeness” (*res* = “reality”) of thought in the conceptions of that time. It is a state of mind that makes the psychology of the ontological proof readily understandable. The hypostatizing of the idea was not at all an essential step, but was implicit as a reverberation of the primitive sensuousness of thought. Gaunilo’s counter-argument was psychologically unsatisfactory, for although, as the *consensus gentium* proves, the idea of the Islands of the Blessed frequently occurs, it is unquestionably less effective than the idea of God, which consequently acquires a higher reality-value.

[63] Later writers who took up the ontological argument again all fell, at least in principle, into Anselm’s error. Kant’s reasoning should be final. We will therefore briefly outline it. He says:

The concept of an absolutely necessary being is a concept of pure reason, that is, a mere idea the objective reality of which is very far from being proved by the fact that reason requires it. ... But the unconditioned necessity of judgments is not the same as an absolute necessity of things. The absolute necessity of the judgment is only a conditioned necessity of the thing, or of the predicate in the judgment.²⁹

[64] Immediately prior to this Kant shows, as an example of a necessary judgment, that a triangle must have three angles. He is referring to this proposition when he continues:

The above proposition does not declare that three angles are absolutely necessary, but that, under the condition that there is a triangle (that is, that a triangle is given), three angles will necessarily be found in it. So great, indeed, is the power of illusion exercised by this logical necessity that, by the simple device of forming an *a priori* concept of a thing in such a manner as to include existence within the scope of its meaning, we have supposed ourselves to have justified the conclusion that because existence necessarily belongs to the object of this concept—always under the

condition that we posit the thing as given (as existing)—we are also of necessity, in accordance with the law of identity, required to posit the existence of its object, and that this being is therefore itself absolutely necessary—and this, to repeat, for the reason that the existence of this being has already been thought in a concept which is assumed arbitrarily and on condition that we posit its object.³⁰

[65] The “power of illusion” referred to here is nothing else than the primitive, *magical power of the word*, which likewise mysteriously inhabits the concept. It needed a long process of development before man recognized once and for all that the word, the *flatus vocis*, does not always signify a reality or bring it into being. The fact that certain men have realized this has not by any means been able to uproot in every mind the power of superstition that dwells in formulated concepts. There is evidently something in this “instinctive” superstition that refuses to be exterminated, because it has some sort of justification which till now has not been sufficiently appreciated. In like manner the false conclusion creeps into the ontological argument, through an illusion which Kant now proceeds to elucidate. He begins with the assertion of “absolutely necessary subjects,” the conception of which is inherent in the concept of existence, and which therefore cannot be dismissed without inner contradiction. This conception would be that of the “supremely real being”:

It is declared that it possesses all reality, and that we are justified in assuming that such a being is possible. ... Now the “all reality” includes existence; existence is therefore contained in the concept of a thing that is possible. If, then, this thing is rejected, the internal possibility of the thing is rejected—which is self-contradictory ... in that case either the thought, which is in us, is the thing itself, or we have presupposed an existence as belonging to the realm of the possible, and have then, on that pretext, inferred its existence from its internal possibility—which is nothing but a miserable tautology.³¹

Being is evidently not a real predicate; that is, it is not a concept of something which could be added to the concept of a thing. It is merely the positing of a thing, or of certain of its determinants. In logical usage, it is merely the copula of a judgment. The proposition “God is omnipotent” contains two concepts, each of which has its object—God and omnipotence. The little word “is” adds no new predicate, but only serves to posit the predicate *in its relation* to the subject. If, now, we take the subject (God) with all its predicates (among which is omnipotence) and say “God is” or “There is a God,” we attach no new predicate to the concept of God, but only posit the subject in itself with all its predicates, and indeed posit it as being an *object* that stands in relation to my *concept*. The content of both must be one and the same; nothing can have been added to the concept, which expresses merely what is possible, by my thinking its object (through the expression “it is”) as given absolutely. Otherwise stated, the real contains no more than the merely possible. A

hundred real thalers do not contain a cent more than a hundred possible thalers. ... My financial position is, however, affected very differently by a hundred real thalers than it is by the mere concept of them (that is, of their possibility).³²

Whatever, therefore, and however much, our concept of an object may contain, we must go outside it, if we are to ascribe existence to the object. In the case of objects of the senses, this takes place through their connection with some one of our perceptions, in accordance with empirical laws. But in dealing with objects of pure thought, we have no means whatsoever of knowing their existence, since it would have to be known in a completely *a priori* manner. Our consciousness of all existence (whether immediately through perception, or mediately through inferences which connect something with perception) belongs exclusively to the unity of experience; any [alleged] existence outside this field, while not indeed such as we can declare to be absolutely impossible, is of the nature of an assumption which we can never be in a position to justify.³³

[66] This detailed reminder of Kant's fundamental exposition seems to me necessary, because it is precisely here that we find the clearest division between *esse in intellectu* and *esse in re*. Hegel cast the reproach at Kant that one could not compare the concept of God with an imaginary hundred thalers. But, as Kant rightly pointed out, logic strips away all content, for it would no longer be logic if a content were to prevail. From the standpoint of logic, there is, as always, no *tertium* between the logical either-or. But between *intellectus* and *res* there is still *anima*, and this *esse in anima* makes the whole ontological argument superfluous. Kant himself, in his *Critique of Practical Reason*, made an attempt on a grand scale to evaluate the *esse in anima* in philosophical terms. There he introduces God as a postulate of practical reason resulting from the *a priori* recognition of "respect for moral law necessarily directed towards the highest good, and the consequent supposition of its objective reality."³⁴

[67] The *esse in anima*, then, is a psychological fact, and the only thing that needs ascertaining is whether it occurs but once, often, or universally in human psychology. The datum which is called "God" and is formulated as the "highest good" signifies, as the term itself shows, the supreme psychic value. In other words it is a concept upon which is conferred, or is actually endowed with, the highest and most general significance in determining our thoughts and actions. In the language of analytical psychology, the God-concept coincides with the particular ideational complex which, in accordance with the foregoing definition, concentrates in itself the maximum amount of libido, or psychic energy. Accordingly, the actual God-concept is, psychologically, completely different in different people, as experience testifies. Even as an idea God is not a single, constant being, and still less so in reality. For, as we know, the highest value operative in a human soul is variously located. There are men

“whose God is the belly” (Phil. 3 : 19), and others for whom God is money, science, power, sex, etc. The whole psychology of the individual, at least in its essential aspects, varies according to the localization of the highest good, so that a psychological theory based exclusively on one fundamental instinct, such as power or sex, can explain no more than secondary features when applied to an individual with a different orientation.

c. Abelard's Attempt at Conciliation

[68] It is not without interest to inquire how the Scholastics themselves attempted to settle the dispute about universals and to create a balance between the typical opposites that were divided by the *tertium non datur*. This attempt was the work of Abelard, that unhappy man who burned with love for Héloïse and who paid for his passion with the loss of his manhood. Anyone acquainted with the life of Abelard will know how intensely his own soul harboured those separated opposites whose philosophical reconciliation was for him such a vital issue. De Rémusat in his book³⁵ characterizes him as an eclectic, who criticized and rejected every accepted theory of universals but freely borrowed from them what was true and tenable. Abelard's writings, so far as they relate to the universals controversy, are difficult and confusing, because the author was constantly engaged in weighing every argument and aspect of the case. It is precisely because he considered none of the accepted standpoints right, but always sought to comprehend and conciliate the contrary view, that he was never properly understood even by his own pupils. Some understood him as a nominalist, others as a realist. This misunderstanding is characteristic: it is much easier to think in terms of one definite type, because in it one can remain logical and consistent, than it is to think in terms of both types, since the intermediate position is lacking. Realism as well as nominalism if pursued consistently lead to precision, clarity, uniformity. But the weighing and balancing of opposites lead to confusion and, so far as the types are concerned, to an unsatisfactory conclusion, since the solution is completely satisfying neither to the one nor to the other. De Rémusat has collected from Abelard's writings a whole series of almost contradictory assertions on the subject, and exclaims: “Must we suppose that one man's head contained so vast and incoherent a collection of teachings? Is Abelard's philosophy a chaos?”³⁶

[69] From nominalism Abelard took over the truth that universals are words, in the sense that they are intellectual conventions expressed by language, and also the truth that a thing in reality is never a universal but always an individual fact. From realism he took over the truth that genera and species are combinations of individual facts and things by reason of their unquestionable similarities. For him the intermediate position was *conceptualism*. This is to be understood as a function which apprehends the individual objects perceived, classifies them into genera and species by reason of

their similarities, and thus reduces their absolute multiplicity to a relative unity. However indisputable the multiplicity and diversity of individual things may be, the existence of similarities, which makes their combination possible in a concept, is equally beyond dispute. For anyone who is psychologically so constituted as to perceive chiefly the similarity of things, the inclusive concept is, as it were, given from the start; it forcibly obtrudes itself with the undeniable actuality of a sense-perception. But for one who is psychologically so constituted as to perceive chiefly the diversity of things, their similarity is not clearly given; what he sees is their difference, which forces itself upon him with as much actuality as similarity does upon the other.

- [70] It seems as if *empathy into* the object were the psychological process which brings the distinctiveness of the object into more than usually clear focus, and as if *abstraction from* the object were the psychological process most calculated to blind one's eyes to the distinctiveness of individual things in favour of their general similarity, which is the actual foundation of the idea. Empathy and abstraction combined produce the function that underlies the concept of conceptualism. It is grounded, therefore, on the only psychological function that has any real possibility of bringing nominalism and realism together on the middle way.
- [71] Although the Scholastics knew how to wax grandiloquent on the subject of the soul, there was as yet no psychology, which is one of the youngest of the sciences. If a psychology had existed at that time, Abelard would surely have made *esse in anima* his mediatory formula. De Rémusat clearly discerned this when he said:
- In pure logic, universals are only the terms of a conventional language. In physics, which for him is transcendent rather than experimental, and is his real ontology, genera and species are based on the way in which beings are really produced and formed. Finally, between his pure logic and his physics there is a kind of mediatory or half-way science—we may call it psychology—in which Abelard examines how our concepts come into being, and retraces the whole intellectual genealogy of beings, a picture or symbol of their hierarchy and their real existence.³⁷
- [72] The *universalia ante rem* and *post rem* remained a matter of controversy for every century that followed, even though they cast aside their scholastic gown and appeared under a new guise. Fundamentally it was the same old problem. Sometimes the attempted solution veered towards realism, sometimes towards nominalism. The scientism of the nineteenth century gave the problem a push once more towards the nominalist side after the early philosophy of that century had done full justice to realism. The opposites are no longer so far apart as they were in Abelard's day. We have a psychology, a mediatory science, and this alone is capable of uniting the idea and the thing without doing violence to either. This capacity inheres in the very

nature of psychology, though no one would contend that psychology so far has accomplished this task. One has to agree with De Rémusat:

Abelard, then, has triumphed; for in spite of the serious limitations which a discerning critique discovers in the nominalism or conceptualism imputed to him, his view is really the modern view in its first form. He heralds it, foretells it, he is its promise. The light that silvers the horizon at dawn is that of the star, as yet invisible, which is about to give light to the world.³⁸

[73] If one disregards the existence of psychological types, and also the fact that the truth of the one is the error of the other, then Abelard's labours will mean nothing but one scholastic sophistry the more. But if we acknowledge the existence of the two types, Abelard's efforts must appear to us of the greatest importance. He sought the mediatory position in the *sermo*, by which he meant not so much a "discourse" as a formal proposition joined to a definite meaning—in fact, a definition requiring several words for its meaning to be established. He did not speak of *verbum*, for in the nominalist sense this was nothing more than a *vox*, a *flatus vocis*. Indeed, it is the great psychological achievement of both classical and medieval nominalism that it completely abolished the primitive, magical, mystical identity of the word with the thing—too completely for the type of man who has his foothold not in things but in the abstraction of the idea from things. Abelard's horizon was too wide for him to have overlooked the value of nominalism in this sense. For him the word was indeed a *vox*, but the *sermo*, as he understood it, was something more; it carried with it a fixed meaning, it described the common factor, the idea—what in fact has been thought and perceptively discerned about things. In the *sermo* the universal lived, and there alone. It is readily understandable, therefore, that Abelard was counted among the nominalists, though this was incorrect because the universal was for him a greater reality than a *vox*.

[74] The expression of his conceptualism must have been difficult enough for Abelard, as he had necessarily to construct it out of contradictions. An epitaph in an Oxford manuscript gives us, I think, a profound glimpse into the paradoxical nature of his teaching:

He taught what words signify in relation to things,
And that words denote things by signification;
He corrected the errors about genera and species,
And taught that genera and species were matters of words alone,
And made it clear that genera and species were sermones.

...

Thus he proved that both "living thing" and "no living thing" are each a genus,

And “man” and “no man” both rightly called species.³⁹

- [75] The opposites can hardly be expressed otherwise than in paradoxes, in so far as an expression is striven for that is based in principle on one standpoint, in Abelard’s case the intellectual. We must not forget that the radical difference between nominalism and realism is not purely logical and intellectual, but a psychological one, which in the last resort amounts to a typical difference of psychological attitude to the object as well as to the idea. The man who is oriented to the idea apprehends and reacts from the standpoint of the idea. But the man who is oriented to the object apprehends and reacts from the standpoint of sensation. For him the abstract is of secondary importance, since what must be thought about things seems to him relatively inessential, while for the former it is just the reverse. The man who is oriented to the object is by nature a nominalist—“name is sound and smoke” (*Faust*)—in so far as he has not yet learnt to compensate his object-oriented attitude. Should this happen, he will become, if he has the necessary equipment, a hair-splitting logician, unequalled for meticulousness, methodicalness, and dullness. The idea-oriented man is by nature logical; that is why, when all is said and done, he can neither understand nor appreciate textbook logic. Compensation of his type makes him, as we saw from Tertullian, a man of passionate feeling, though his feelings still remain under the spell of his ideas. Conversely, the man who is a logician by compensation remains, along with his ideas, under the spell of the object.
- [76] These reflections bring us to the shadow-side of Abelard’s thought. His attempted solution was one-sided. If the conflict between nominalism and realism had been merely a matter of logical-intellectual argumentation, it would be incomprehensible why nothing except a paradoxical end-formulation was possible. But since it was essentially a psychological conflict, a one-sided logical-intellectual formulation had to end in paradox: “Thus both man and no man are rightly called species.” Logical-intellectual expression is simply incapable, even in the form of the *sermo*, of providing the mediatory formula that will be fair to the real nature of the two opposing psychological attitudes, for it derives exclusively from the abstract side and lacks all recognition of concrete reality.
- [77] Every logical-intellectual formulation, however perfect it may be, strips the objective impression of its vitality and immediacy. It must do this in order to arrive at any formulation whatever. But then just that is lost which seems to the extravert the most important of all—the relation to the object. There is no possibility, therefore, of finding any satisfactory, reconciling formula by pursuing the one or the other attitude. And yet, even if his mind could, man cannot remain thus divided, for the split is not a mere matter of some off-beat philosophy, but the daily repeated problem of his relation to himself and to the world. And because this is basically the problem at

issue, the division cannot be resolved by a discussion of the nominalist and realist arguments. For its solution a third, mediating standpoint is needed. *Esse in intellectu* lacks tangible reality, *esse in re* lacks mind. Idea and thing come together, however, in the human psyche, which holds the balance between them. What would the idea amount to if the psyche did not provide its living value? What would the thing be worth if the psyche withheld from it the determining force of the sense-impression? What indeed is reality if it is not a reality in ourselves, an *esse in anima*? Living reality is the product neither of the actual, objective behaviour of things nor of the formulated idea exclusively, but rather of the combination of both in the living psychological process, through *esse in anima*. Only through the specific vital activity of the psyche does the sense-impression attain that intensity, and the idea that effective force, which are the two indispensable constituents of living reality.

[78] This autonomous activity of the psyche, which can be explained neither as a reflex action to sensory stimuli nor as the executive organ of eternal ideas, is, like every vital process, a continually creative act. The psyche creates reality every day. The only expression I can use for this activity is *fantasy*. Fantasy is just as much feeling as thinking; as much intuition as sensation. There is no psychic function that, through fantasy, is not inextricably bound up with the other psychic functions. Sometimes it appears in primordial form, sometimes it is the ultimate and boldest product of all our faculties combined. Fantasy, therefore, seems to me the clearest expression of the specific activity of the psyche. It is, pre-eminently, the creative activity from which the answers to all answerable questions come; it is the mother of all possibilities, where, like all psychological opposites, the inner and outer worlds are joined together in living union. Fantasy it was and ever is which fashions the bridge between the irreconcilable claims of subject and object, introversion and extraversion. In fantasy alone both mechanisms are united.

[79] Had Abelard probed deeply enough to discern the psychological difference between the two standpoints, he would logically have had to enlist the aid of fantasy in developing his mediating formula. But in the world of science, fantasy is just as much taboo as feeling. Once, however, we recognize the underlying opposition as a psychological one, psychology will be obliged to acknowledge not only the standpoint of feeling but the mediating standpoint of fantasy as well. But here comes the great difficulty: fantasy is for the most part a product of the unconscious. Though it undoubtedly includes conscious elements, it is none the less an especial characteristic of fantasy that it is essentially involuntary and, by reason of its strangeness, directly opposed to the conscious contents. It has these qualities in common with the dream, though the latter of course is involuntary and strange in a much higher degree.

[80] The relation of the individual to his fantasy is very largely conditioned by his relation to the unconscious in general, and this in turn is conditioned in particular by the spirit of the age. According to the degree of rationalism that prevails, the individual will be more disposed or less to have dealings with the unconscious and its products. Christianity, like every closed system of religion, has an undoubted tendency to suppress the unconscious in the individual as much as possible, thus paralyzing his fantasy activity. Instead, religion offers stereotyped symbolic concepts that are meant to take the place of his unconscious once and for all. The symbolic concepts of all religions are recreations of unconscious processes in a typical, universally binding form. Religious teaching supplies, as it were, the final information about the “last things” and the world beyond human consciousness. Wherever we can observe a religion being born, we see how the doctrinal figures flow into the founder himself as revelations, in other words as concretizations of his unconscious fantasy. The forms welling up from his unconscious are declared to be universally valid and thus replace the individual fantasies of others. The evangelist Matthew has preserved for us a fragment of this process from the life of Christ: in the story of the temptation we see how the idea of kingship rises out of the founder’s unconscious in the visionary form of the devil, who offers him power over all the kingdoms of the earth. Had Christ misunderstood the fantasy and taken it concretely, there would have been one madman the more in the world. But he rejected the concretism of his fantasy and entered the world as a king to whom the kingdoms of *heaven* are subject. He was therefore no paranoiac, as the result also proved. The views advanced from time to time from the psychiatric side concerning the morbidity of Christ’s psychology are nothing but ludicrous rationalistic twaddle, with no comprehension whatever of the meaning of such processes in the history of mankind.

[81] The form in which Christ presented the content of his unconscious to the world became accepted and was declared valid for all. Thereafter all individual fantasies became otiose and worthless, and were persecuted as heretical, as the fate of the Gnostic movement and of all later heresies testifies. The prophet Jeremiah is speaking just in this vein when he warns (ch. 23):

16. Thus saith the Lord of hosts, Hearken not unto the words of the prophets that prophesy unto you: they make you vain: they speak a vision of their own heart, and not out of the mouth of the Lord.

25. I have heard what the prophets said that prophesy lies in my name, saying, I have dreamed, I have dreamed.

26. How long shall this be in the heart of the prophets that prophesy lies? yea, they are prophets of the deceit of their own heart;

27. Which think to cause my people to forget my name by their dreams which they tell every man to his neighbour, as their fathers have forgotten my name for Baal.

28. The prophet that hath a dream, let him tell a dream; and he that hath my word, let him speak my word faithfully. What is the chaff to the wheat? saith the Lord.

[82] Similarly, we see in early Christianity how the bishops zealously strove to stamp out the activity of the individual unconscious among the monks. The archbishop Athanasius of Alexandria in his biography of St. Anthony gives us particularly valuable insights in this respect. By way of instruction to his monks, he describes the apparitions and visions, the perils of the soul, which befall those that pray and fast in solitude. He warns them how cleverly the devil disguises himself in order to bring saintly men to their downfall. The devil is, of course, the voice of the anchorite's own unconscious, in revolt against the forcible suppression of his nature. I give a number of excerpts from this rather inaccessible book.⁴⁰ They show very clearly how the unconscious was systematically suppressed and devalued.

There is a time when we see no man and yet the sound of the working of the devils is heard by us, and it is like the singing of a song in a loud voice; and there are times when the words of the Scriptures are heard by us, just as if a living man were repeating them, and they are exactly like the words which we should hear if a man were reading the Book. And it also happens that they [the devils] rouse us up to the night prayer, and incite us to stand up; and they make apparent unto us also the similitudes of monks and the forms of those who mourn; and they draw nigh unto us as if they had come from a long way off, and they begin to utter words like unto these, that they may make lax the understanding of those who are little of soul:—"It is now a law unto all creation that we love desolation, but we were unable, by reason of God, to enter into our houses when we came unto them, and to do fair things." And when they are unable to work their will by means of a scheme of this kind, they depart from this kind of deceit unto another, and say: "How now is it possible for thee to live? For thou hast sinned and committed iniquity in many things. Thinkest thou, that the Spirit hath not revealed unto me what hath been done by thee, or that I know not that thou hast done such and such a thing?" If therefore a simple brother hear these things, and feel within himself that he has done even as the Evil One has said, and he be not acquainted with his craftiness, his mind shall be troubled straightway, and he shall fall into despair and turn backwards.

It is then, O my beloved, unnecessary for us to be terrified at these things, and we have need to fear only when the devils multiply the speaking of the things *which are true* and then we must rebuke them severely. ... Let us then take heed that we incline not our hearing to their words, even though they be words of truth which they utter; for it would be a disgrace unto us that those who have rebelled against God should

become our teachers. And let us, O my brethren, arm ourselves with the armour of righteousness, and let us put on the helmet of redemption, and in the time of contending let us shoot out from a believing mind spiritual arrows as from a bow which is stretched. For they [the devils] are nothing at all, and even if they were, their strength has in it nothing which would enable it to resist the might of the Cross.⁴¹

And again on another occasion

there appeared unto me a devil of an exceedingly haughty and insolent appearance, and he stood up before me with the tumultuous noise of many people, and he dared to say unto me: “I, even I, am the power of God,” and “I, even I, am the Lord of the worlds.” And he said unto me: “What dost thou wish me to give thee? Ask, and thou shalt receive.” Then I blew a puff of wind at him, and I rebuked him in the name of Christ. ...

And on another occasion, when I was fasting, the crafty one appeared to me in the form of a brother monk carrying bread, and he began to speak unto me words of counsel, saying, “Rise up, and stay thy heart with bread and water, and rest a little from thine excessive labours, for thou art a man, and howsoever greatly thou mayest be exalted thou art clothed with a mortal body and thou shouldest fear sickness and tribulations.” Then I regarded his words, and I held my peace and refrained from giving an answer. And I bowed myself down in quietness, and I began to make supplications in prayer, and I said: “O Lord, make Thou an end of him, even as Thou hast been wont to do him away at all times.” And as I concluded my words he came to an end and vanished like dust, and went forth from the door like smoke.

Now on one occasion Satan approached the house one night and knocked at the door, and I went out to see who was knocking, and I lifted up mine eyes and saw the form of an exceedingly tall and strong man; and, having asked him “Who art thou?,” he answered and said unto me: “I am Satan.” And after this I said unto him: “What seekest thou?” and he answered unto me: “Why do the monks and the anchorites, and the other Christians revile me, and why do they at all times heap curses upon me?” And having clasped my head firmly in wonder at his mad folly, I said unto him: “Wherefore dost thou give them trouble?” Then he answered and said unto me: “It is not I who trouble them, but it is they who trouble themselves. For there happened to me on a certain occasion that which did happen to me, and had I not cried out to them that I was the Enemy, his slaughters would have come to an end for ever. I have therefore no place to dwell in and not one glittering sword, and not even people who are really subject unto me, for those who are in service to me hold me wholly in contempt; and moreover, I have to keep them in fetters, for they do not cleave to me because they esteem it right to do so, and they are ever ready to escape from me in every place. The Christians have filled the whole world, and behold, even the desert

is filled full with their monasteries and habitations. Let them then take good heed to themselves when they heap abuse upon me.”

Then, wondering at the grace of our Lord I said unto him: “How doth it happen that whilst thou hast been a liar on every other occasion, at this present the truth is spoken by thee? And how is it that thou speakest the truth now when thou art wont to utter lies? It is indeed true that when Christ came into this world, thou wast brought down to the lowest depths, and that the root of thine error was plucked up from the earth.” And when Satan heard the name of Christ his form vanished and his words came to an end.⁴²

[83] These quotations show how, with the help of the general belief, the unconscious of the individual was rejected despite the fact that it transparently spoke the truth. There are in the history of the mind especial reasons for this rejection, but it is not incumbent on us to discuss them here. We must be content with the fact that the unconscious was suppressed. Psychologically, the suppression consists in a withdrawal of libido. The libido thus gained promotes the growth and development of the conscious attitude, with the result that a new picture of the world is gradually built up. The undoubted advantages accruing from this process naturally consolidate the new attitude. It is, therefore, not surprising that the psychology of our time is characterized by a predominantly unfavourable attitude towards the unconscious.

[84] It is easy to understand why all sciences have excluded the standpoints of both feeling and fantasy, and indeed it was absolutely necessary for them to do so. They are sciences for that very reason. How is it then with psychology? If it is to be regarded as a science, it must do the same. But will it then do justice to its material? Every science ultimately seeks to formulate and express its material in abstractions; thus psychology could, and actually does, grasp the processes of feeling, sensation, and fantasy in abstract intellectual form. This treatment certainly establishes the rights of the abstract intellectual standpoint, but not the claims of other quite possible psychological points of view. These others can receive only a bare mention in a scientific psychology; they cannot emerge as independent scientific principles. Science is under all circumstances an affair of the intellect, and the other psychological functions are subordinated to it as objects. The intellect is the sovereign of the scientific realm. But it is another matter when science steps over into the realm of its practical application. The intellect, which was formerly king, is now merely a minister—a scientifically refined instrument it is true, but still only a tool; no longer an end in itself, but merely a precondition. The intellect, and along with it science, is now placed at the service of a creative power and purpose. Yet this is still “psychology” although no longer science; it is psychology in the wider meaning of the word, a psychological activity of a creative nature, in which creative fantasy is given prior place. Instead of using the term “creative fantasy,” it would be just as true

to say that in practical psychology of this kind the leading role is given to *life* itself; for while it is undoubtedly fantasy, procreative and productive, which uses science as a tool, it is the manifold demands of external reality which in turn stimulate the activity of creative fantasy. Science as an end in itself is assuredly a high ideal, yet its consistent fulfilment brings about as many “ends in themselves” as there are sciences and arts. Naturally this leads to a high differentiation and specialization of the particular functions concerned, but also to their detachment from the world and from life, as well as to a multiplication of specialized fields which gradually lose all connection with one another. The result is an impoverishment and desiccation not merely in the specialized fields but also in the psyche of every man who has differentiated himself up or sunk down to the specialist level. Science must prove her value for life; it is not enough that she be mistress, she must also be the maid. By so serving she in no way dishonours herself.

[85] Although science has granted us insight into the irregularities and disturbances of the psyche, thus meriting our profound respect for her intrinsic intellectual gifts, it would nevertheless be a grave mistake to impute to her an absolute aim which would incapacitate her from being simply an instrument. For when we approach the actual business of living from the side of the intellect and science, we immediately come up against barriers that shut us out from other, equally real provinces of life. We are therefore compelled to acknowledge that the universality of our ideal is a limitation, and to look round for a *Spiritus rector* which, bearing in mind the claims of a fuller life, can offer us a greater guarantee of psychological universality than the intellect alone can compass. When Faust exclaims “feeling is all,” he is expressing merely the antithesis of the intellect, and so only goes to the other extreme; he does not achieve that totality of life and of his own psyche in which feeling and thinking are united in a third and higher principle. This higher third, as I have already indicated, can be understood either as a practical goal or as the creative fantasy that creates the goal. The goal of totality can be reached neither by science, which is an end in itself, nor by feeling, which lacks the visionary power of thought. The one must lend itself as an auxiliary to the other, yet the opposition between them is so great that a bridge is needed. This bridge is already given us in creative fantasy. It is not born of either, for it is the mother of both—nay more, it is pregnant with the child, that final goal which unites the opposites.

[86] If psychology remains for us only a science, we do not penetrate into life—we merely serve the absolute aim of science. It leads us, certainly, to a knowledge of the objective situation, but it always opposes every other aim but its own. The intellect remains imprisoned in itself just so long as it does not willingly sacrifice its supremacy by recognizing the value of other aims. It shrinks from the step which takes it out of itself and which denies its universal validity, since from the standpoint

of the intellect everything else is *nothing but fantasy*. But what great thing ever came into existence that was not first fantasy? Inasmuch as the intellect rigidly adheres to the absolute aim of science it cuts itself off from the springs of life. For it fantasy is nothing but a wish dream, and herein is expressed all that depreciation of fantasy which for science is so welcome and so necessary. Science as an end in itself is inevitable so long as the development of science is the sole question at issue. But this at once becomes an evil when it is a question of life itself demanding development. Thus it was an historical necessity in the Christian process of culture that unbridled fantasy should be suppressed, just as it was also necessary, though for different reasons, that fantasy should be suppressed in our age of natural science. It must not be forgotten that creative fantasy, if not restrained within just bounds, can degenerate into the rankest of growths. But these bounds are never artificial limitations imposed by the intellect or by rational feeling; they are boundaries set by necessity and irrefutable reality.

[87] The tasks of every age differ, and it is only in retrospect that we can discern with certainty what had to be and what should not have been. In the momentary present the conflict of opinions will always rage, for “war is the father of all.”⁴³ History alone decides the issue. Truth is not eternal, it is a programme to be fulfilled. The more “eternal” a truth is, the more lifeless it is and worthless; it says nothing more to us because it is self-evident.

[88] How fantasy is assessed by psychology, so long as this remains merely science, is illustrated by the well-known views of Freud and Adler. The Freudian interpretation reduces fantasy to causal, elementary, instinctive processes. Adler’s conception reduces it to the elementary, final aims of the ego. Freud’s is a psychology of instinct, Adler’s an ego-psychology. Instinct is an impersonal biological phenomenon. A psychology founded on instinct must by its very nature neglect the ego, since the ego owes its existence to the *principium individuationis*, i.e., to individual differentiation, whose isolated character removes it from the realm of general biological phenomena. Although biological instinctive processes also contribute to the formation of the personality, individuality is nevertheless essentially different from collective instincts; indeed, it stands in the most direct opposition to them, just as the individual as a personality is always distinct from the collective. His essence consists precisely in this distinction. Every ego-psychology must necessarily exclude and ignore just the collective element that is bound to a psychology of instinct, since it describes that very process by which the ego becomes differentiated from collective drives. The characteristic animosity between the adherents of the two standpoints arises from the fact that either standpoint necessarily involves a devaluation and disparagement of the other. So long as the radical difference between ego-psychology and the psychology of instinct is not recognized, either side must naturally hold its respective

theory to be universally valid. This is not to say that a psychology of instinct could not devise a theory of the ego-process. It can very well do so, but in a way which to the ego-psychologist looks too much like a negation of his theory. Hence we find that with Freud the “ego-instincts” do occasionally emerge, but for the most part they eke out a very modest existence. With Adler, on the other hand, it would seem as though sexuality were the merest vehicle, which in one way or another serves the elementary aims of power. The Adlerian principle is the safeguarding of personal power which is superimposed on the collective instincts. With Freud it is instinct that makes the ego serve its purposes, so that the ego appears as a mere function of instinct.

[89] The scientific tendency in both is to reduce everything to their own principle, from which their deductions in turn proceed. In the case of fantasies this operation is particularly easy to accomplish because, unlike the functions of consciousness, they are not adapted to reality and therefore do not have an objectively oriented character, but express purely instinctive as well as pure ego-tendencies. Anyone who adopts the standpoint of instinct will have no difficulty in discovering in them the “wish-fulfillment,” the “infantile wish,” the “repressed sexuality.” And the man who adopts the standpoint of the ego can just as easily discover those elementary aims concerned with the security and differentiation of the ego, since fantasies are mediating products between the ego and the instincts. Accordingly they contain elements of both sides. Interpretation from either side is always somewhat forced and arbitrary, because one side is always suppressed. Nevertheless, a demonstrable truth does on the whole emerge; but it is only a partial truth that can lay no claim to general validity. Its validity extends only so far as the range of its principle. But in the domain of the other principle it is invalid.

[90] Freudian psychology is characterized by one central idea, the repression of incompatible wish-tendencies. Man appears as a bundle of wishes which are only partially adaptable to the object. His neurotic difficulties are due to the fact that environmental influences, education, and objective conditions put a considerable check on the free expression of instinct. Other influences, productive of moral conflicts or infantile fixations that compromise later life, emanate from the father and mother. The original instinctive disposition is a fundamental datum which undergoes disturbing modifications mainly through objective influences; hence the most untrammelled expression of instinct in respect of suitably chosen objects would appear to be the needful remedy. Adler’s psychology, on the other hand, is characterized by the central concept of ego-superiority. Man appears primarily as an ego-point which must not under any circumstances be subordinated to the object. While the craving for the object, the fixation on the object, and the impossible nature of certain desires for the object play a paramount role with Freud, with Adler everything is directed to the superiority of the subject. Freud’s repression of instinct

in respect of the object corresponds to the security of the subject in Adler. For Adler the remedy is the removal of the security that isolates the subject; for Freud it is the removal of the repression that makes the object inaccessible.

[91] The basic formula with Freud is therefore sexuality, which expresses the strongest relation between subject and object; with Adler it is the power of the subject, which secures him most effectively against the object and guarantees him an impregnable isolation that abolishes all relationships. Freud would like to ensure the undisturbed flow of instinct towards its object; Adler would like to break the baleful spell of the object in order to save the ego from suffocating in its own defensive armour. Freud's view is essentially extraverted, Adler's introverted. The extraverted theory holds good for the extraverted type, the introverted theory for the introverted type. Since a pure type is a product of a wholly one-sided development it is also necessarily unbalanced. Overaccentuation of the one function is synonymous with repression of the other.

[92] Psychoanalysis fails to remove this repression just in so far as the method it employs is oriented according to the theory of the patient's own type. Thus the extravert, in accordance with his theory, will reduce the fantasies rising out of his unconscious to their instinctual content, while the introvert will reduce them to his power aims. The gains resulting from such an analysis merely increase the already existing imbalance. This kind of analysis simply reinforces the existing type and renders any mutual understanding between the two types impossible. On the contrary the gap is widened, both without and within. An inner dissociation arises, because portions of other functions coming to the surface in unconscious fantasies, dreams, etc., are each time devalued and again repressed. On these grounds a certain critic was justified up to a point when he described Freud's as a neurotic theory, though the tinge of malice in this statement is merely intended to absolve us from the duty of seriously coming to grips with the problem. The standpoints of Freud and Adler are equally one-sided and characteristic only of one type.

[93] Both theories reject the principle of imagination since they reduce fantasies to something else and treat them merely as a semiotic⁴⁴ expression. In reality fantasies mean much more than that, for they represent at the same time the other mechanism—of repressed extraversion in the introvert, and of repressed introversion in the extravert. But the repressed function is unconscious, and hence undeveloped, embryonic, and archaic. In this condition it cannot be united with the higher level of the conscious function. The unacceptable nature of fantasy derives chiefly from this peculiarity of the unrecognized, unconscious function. For everyone whose guiding principle is adaptation to external reality, imagination is for these reasons something reprehensible and useless. And yet we know that every good idea and all creative

work are the offspring of the imagination, and have their source in what one is pleased to call infantile fantasy. Not the artist alone, but every creative individual whatsoever owes all that is greatest in his life to fantasy. The dynamic principle of fantasy is *play*, a characteristic also of the child, and as such it appears inconsistent with the principle of serious work. But without this playing with fantasy no creative work has ever yet come to birth. The debt we owe to the play of imagination is incalculable. It is therefore short-sighted to treat fantasy, on account of its risky or unacceptable nature, as a thing of little worth. It must not be forgotten that it is just in the imagination that a man's highest value may lie. I say "may" advisedly, because on the other hand fantasies are also valueless, since in the form of raw material they possess no realizable worth. In order to unearth the treasures they contain they must be developed a stage further. But this development is not achieved by a simple analysis of the fantasy material; a synthesis is also needed by means of a constructive method.⁴⁵

[94] It remains an open question whether the opposition between the two standpoints can ever be satisfactorily resolved in intellectual terms. Although in one sense Abelard's attempt must be rated very highly, in practice no consequences worth mentioning have resulted from it, for he was unable to establish any mediatory psychological principle beyond conceptualism or "sermonism," which is merely a revised edition, altogether one-sided and intellectual, of the ancient Logos conception. The Logos, as mediator, had of course this advantage over the *sermo*, that in its human manifestation it also did justice to man's non-intellectual aspirations.

[95] I cannot, however, rid myself of the impression that Abelard's brilliant mind, which so fully comprehended the great Yea and Nay of life, would never have remained satisfied with his paradoxical conceptualism, and would not have renounced a further creative effort, if the impelling force of passion had not been lost to him through his tragic fate. In confirmation of this we need only compare conceptualism with what the great Chinese philosophers Lao-tzu and Chuang-tzu, or the poet Schiller, made of this same problem.

5. THE HOLY COMMUNION CONTROVERSY BETWEEN LUTHER AND ZWINGLI

[96] Of the later dissensions that stirred men's minds, Protestantism and the Reformation movement should really receive our first attention. Only, this phenomenon is of such complexity that it would first have to be resolved into many separate psychological processes before it could become an object of analytical investigation. But this lies outside my competence. I must therefore content myself

with selecting a specific instance of that great dispute, namely the Holy Communion controversy between Luther and Zwingli. The dogma of transubstantiation, mentioned earlier, was sanctioned by the Lateran Council of 1215, and thenceforward became an established article of faith, in which tradition Luther grew up. Although the notion that a ceremony and its concrete performance have an objective redemptory significance is really quite unevangelical, since the evangelical movement was actually directed against the values of Catholic institutions, Luther was nevertheless unable to free himself from the immediately effective sensuous impression in the taking of bread and wine. He was unable to perceive in it a mere sign; the sensuous reality and the immediate experience of it were for him an indispensable religious necessity. He therefore claimed the actual presence of the body and blood of Christ in the Communion. "In and beneath" the bread and wine he received the body and blood of Christ. For him the religious significance of the immediate experience of the object was so great that his imagination was spellbound by the concretism of the material presence of the sacred body. All his attempts at explanation are under the spell of this fact: the body of Christ is present, albeit "non-spatially." According to the doctrine of so-called consubstantiation, the actual substance of the sacred body was also really present beside the bread and wine. The ubiquity of Christ's body, which this assumption postulated, proved especially discomfiting to human intelligence and was later replaced by the concept of *volipresence*, which means that God is present wherever he wills to be. But Luther, unperturbed by all these difficulties, held unswervingly to the immediate experience of the sensuous impression and preferred to thrust aside all the scruples of human reason with explanations that were either absurd or at best unsatisfying.

[97] It can hardly be supposed that it was merely the force of tradition that made Luther determined to cling to this dogma, for he of all people gave abundant proof of his ability to throw aside traditional forms of belief. Indeed, we should not go far wrong in assuming that it was rather the actual contact with the "real" and material in the Communion, and the feeling-value of this contact for Luther himself, that prevailed over the evangelical principle, which maintained that the word was the sole vehicle of grace and not the ceremony. For Luther the word certainly had redeeming power, but the partaking of the Communion was also a mediator of grace. This, I repeat, must have been only an apparent concession to the institutions of the Catholic Church; in reality it was an acknowledgement, demanded by Luther's own psychology, of the fact of feeling grounded upon the immediate sense-impression.

[98] In contrast to the Lutheran standpoint, Zwingli championed a purely symbolic conception of the Communion. What really mattered for him was a "spiritual" partaking of the body and blood of Christ. This standpoint is characterized by reason and by an ideal conception of the ceremony. It had the advantage of not violating the

evangelical principle, and at the same time it avoided all hypotheses contrary to reason. However, it did scant justice to the thing that Luther wished to preserve—the reality of the sense-impression and its particular feeling-value. Zwingli, it is true, also administered the Communion, and like Luther partook of the bread and wine, but his conception contained no formula that could adequately reproduce the unique sensory and feeling-value of the object. Luther provided a formula for this, but it was contrary to reason and to the evangelical principle. From the standpoint of sensation and feeling this matters little, and indeed rightly so, for the idea, the principle, is just as little concerned with the sensation of the object. In the last resort, both points of view are mutually exclusive.

[99] Luther's formulation favours the extraverted conception of things, while Zwingli's favours the ideal standpoint. Although Zwingli's formula does no violence to feeling and sensation, merely offering an ideal conception, it nevertheless appears to leave room for the efficacy of the object. But it seems as though the extraverted standpoint—Luther's—is not content with just leaving room for the object; it also demands a formulation in which the ideal subserves the sensory, exactly as the ideal formulation demands the subservience of feeling and sensation.

[100] At this point, with the consciousness of having done no more than pose the question, I close this chapter on the problem of types in the history of classical and medieval thought. I lack the competence to treat so difficult and far-reaching a problem in any way exhaustively. If I have succeeded in conveying to the reader some idea of the existence of typical differences of standpoint, my purpose will have been achieved. I need hardly add that I am aware that none of the material here touched upon has been dealt with conclusively. I must leave this task to those who command a wider knowledge of the subject than myself.

SCHILLER'S IDEAS ON THE TYPE PROBLEM

1. LETTERS ON THE AESTHETIC EDUCATION OF MAN

a. The Superior and the Inferior Functions

- [101] So far as I have been able to ascertain with my somewhat limited knowledge, Friedrich Schiller seems to have been the first to attempt a conscious differentiation of typical attitudes on a large scale and to give a detailed account of their peculiarities. This important endeavour to present the two mechanisms in question, and at the same time to discover a possible way of reconciling them, is to be found in his essay first published in 1795: "Über die ästhetische Erziehung des Menschen." The essay consists of a number of letters which Schiller addressed to the Duke of Holstein-Augustenburg.¹
- [102] Schiller's essay, by its profundity of thought, psychological penetration, and wide view of a possible psychological solution of the conflict, prompts me to a rather lengthy discussion and evaluation of his ideas, for it has never yet been their lot to be treated in such a context. The service rendered by Schiller from our psychological point of view, as will become clear in the course of our exposition, is by no means inconsiderable, for he offers us carefully worked out lines of approach whose value we, as psychologists, are only just beginning to appreciate. My undertaking will not be an easy one, for I may well be accused of putting a construction on Schiller's ideas which his actual words do not warrant. Although I shall try to quote his actual words at every essential point, it may not be altogether possible to introduce his ideas into the present context without putting certain interpretations and constructions upon them. This is a possibility I must not overlook, but on the other hand we must remember that Schiller himself belonged to a definite type, and was therefore compelled, even in spite of himself, as I am, to give a one-sided presentation of his ideas. The limitations of our views and our knowledge are nowhere more apparent than in psychological discussions, where it is almost impossible for us to project any other picture than the one whose main outlines are already laid down in our own psyche.
- [103] From various characteristics I have come to the conclusion that Schiller belongs to the introverted type, whereas Goethe—if we disregard his overriding intuition—inclines more to the extraverted side. We can easily discover Schiller's own image in

his description of the idealistic type. Because of this identification, an inevitable limitation is imposed on his formulations, a fact we must never lose sight of if we wish to gain a fuller understanding. It is owing to this limitation that the one function is presented by Schiller in richer outline than the other, which is still imperfectly developed in the introvert, and just because of its imperfect development it must necessarily have certain inferior characteristics attached to it. At this point the author's exposition requires our criticism and correction. It is evident, too, that this limitation of Schiller's impelled him to use a terminology which lacks general applicability. As an introvert he had a better relation to ideas than to things. The relation to ideas can be more emotional or more reflective according to whether the individual belongs more to the feeling or to the thinking type. And here I would request the reader, who may perhaps have been led by my earlier publications to identify feeling with extraversion and thinking with introversion, to bear in mind the definitions given in [Chapter XI](#) of this book. By the introverted and extraverted types I distinguish two general classes of men, which can be further subdivided into function-types, i.e., thinking, feeling, sensation, and intuitive types. Hence an introvert can be either a thinking or a feeling type, since feeling as well as thinking can come under the supremacy of the idea, just as both can be dominated by the object.

[104] If, then, I consider that Schiller, in his nature and particularly in his characteristic opposition to Goethe, corresponds to the introverted type, the question next arises as to which subdivision he belongs. This is hard to answer. Without doubt intuition plays a great role with him; we might on this account, or if we regard him exclusively as a poet, reckon him an intuitive. But in the letters on the aesthetic education of man it is unquestionably Schiller the thinker who confronts us. Not only from these, but from his own repeated admissions, we know how strong the reflective element was in Schiller. Consequently we must shift his intuitiveness very much towards the side of thinking, thus approaching him also from the angle of the psychology of the *introverted thinking* type. It will, I hope, become sufficiently clear from what follows that this hypothesis is in accord with reality, for there are not a few passages in Schiller's writings that speak distinctly in its favour. I would, therefore, beg the reader to remember that the hypothesis I have just advanced underlies my whole argument. This reminder seems to me necessary because Schiller approaches the problem from the angle of his own inner experience. In view of the fact that another psychology, i.e., another type of man, would have approached the same problem in quite another way, the very broad formulation which Schiller gives might be regarded as a subjective bias or an ill-considered generalization. But such a judgment would be incorrect, since there actually is a large class of men for whom the problem of the separated functions is exactly the same as it was for Schiller. If, therefore, in the

ensuing argument I occasionally emphasize Schiller's one-sidedness and subjectivity, I do not wish to detract from the importance and general validity of the problem he has raised, but rather to make room for other formulations. Such criticisms as I may occasionally offer have more the character of a transcription into another language which will relieve Schiller's formulation of its subjective limitations. My argument, nevertheless, follows Schiller's very closely, since it is concerned much less with the general question of introversion and extraversion—which exclusively engaged our attention in [Chapter I](#)—than with the *typical conflict of the introverted thinking type*.

[105] Schiller concerns himself at the very outset with the question of the cause and origin of the separation of the two functions. With sure instinct he hits on the differentiation of the individual as the basic motive. "It was culture itself that inflicted this wound upon modern humanity."² This one sentence shows Schiller's wide grasp of the problem. The breakdown of the harmonious cooperation of psychic forces in instinctive life is like an ever open and never healing wound, a veritable Amfortas' wound, because the differentiation of one function among several inevitably leads to the hypertrophy of the one and the neglect and atrophy of the others:

I do not fail to appreciate the advantages to which the present generation, considered as a unity and weighed in the scales of reason, may lay claim in the face of the best of antiquity, but it has to enter the contest in close order and let whole compete with whole. What individual modern will emerge to contend in single combat with the individual Athenian for the prize of humanity? Whence comes this disadvantageous relation of individuals in spite of all the advantages of the race?³

[106] Schiller places the responsibility for this decline of the modern individual on culture, that is, on the differentiation of functions. He next points out how, in art and learning, the intuitive and the speculative minds have become estranged, and how each has jealously excluded the other from its respective field of application:

By confining our activity to a single sphere we have handed ourselves over to a master who is not infrequently to end up by suppressing the rest of our capacities. While in one place a luxuriant imagination ravages the hard-earned fruits of the intellect, in another the spirit of abstraction stifles the fire at which the heart might have warmed itself and the fancy been enkindled.⁴

If the community makes the function the measure of a man, if it respects in one of its citizens only memory, in another a tabulating intellect, in a third only mechanical skill; if, indifferent to character, it here lays stress upon knowledge alone, and there pardons the profoundest darkness of the intellect so long as it co-exists with a spirit of order and a law-abiding demeanour—if at the same time it requires these special aptitudes to be exercised with an intensity proportionate to the loss of extensity

which it permits in the individuals concerned—can we then wonder that the remaining aptitudes of the mind become neglected in order to bestow every attention upon the only one which brings honour and profit?⁵

[107] There is volume indeed in these thoughts of Schiller's. It is understandable that Schiller's generation, who with their imperfect knowledge of the Greek world judged the Greeks by the grandeur of the works they left behind them, should also have overestimated them beyond all measure, since the peculiar beauty of Greek art is due not least to its contrast with the milieu from which it arose. The advantage enjoyed by the Greek was that he was less differentiated than modern man, if indeed one is disposed to regard that as an advantage—for the disadvantage of such a condition must be equally obvious. The differentiation of functions was assuredly not the result of human caprice, but, like everything else in nature, of necessity. Could one of those late admirers of the "Grecian heaven" and Arcadian bliss have visited the earth as an Attic helot, he might well have surveyed the beauties of Greece with rather different eyes. Even if it were true that the primitive conditions of the fifth century before Christ gave the individual a greater opportunity for an all-round development of his qualities and capacities, this was possible only because thousands of his fellow men were cramped and crippled by circumstances that were all the more wretched. A high level of individual culture was undoubtedly reached by certain exemplary personalities, but a collective culture was quite unknown to the ancient world. This achievement was reserved for Christianity. Hence it comes about that, as a mass, the moderns can not only measure up to the Greeks, but by every standard of collective culture easily surpass them. On the other hand, Schiller is perfectly right in his contention that our individual culture has not kept pace with our collective culture, and it has certainly not improved during the hundred and twenty years that have passed since Schiller wrote. Quite the reverse—for, if we had not strayed even further into the collective atmosphere so detrimental to individual development, the violent reactions personified by Stirner or Nietzsche would scarcely have been needed as a corrective. Schiller's words, therefore, still remain valid today.

[108] Just as the ancients, with an eye to individual development, catered to the well-being of an upper class by an almost total suppression of the great majority of the common people (helots, slaves), the Christian world reached a condition of collective culture by transferring this same process, as far as possible, to the psychological sphere *within* the individual himself—raising it, one might say, to the subjective level. As the chief value of the individual was proclaimed by Christian dogma to be an imperishable soul, it was no longer possible for the inferior majority of the people to be suppressed in actual fact for the freedom of a more valuable minority. Instead, the more valuable function within the individual was preferred above the inferior functions. In this way the chief importance was attached to the one valued function,

to the detriment of all the rest. Psychologically this meant that the external form of society in classical civilization was transferred into the subject, so that a condition was produced within the individual which in the ancient world had been external, namely a dominating, privileged function which was developed and differentiated at the expense of an inferior majority. By means of this psychological process a collective culture gradually came into existence, in which the “rights of man” were guaranteed for the individual to an immeasurably greater degree than in antiquity. But it had the disadvantage of depending on a subjective slave culture, that is to say on a transfer of the old mass enslavement into the psychological sphere, with the result that, while collective culture was enhanced, individual culture was degraded. Just as the enslavement of the masses was the open wound of the ancient world, so the enslavement of the inferior functions is an ever-bleeding wound in the psyche of modern man.

[109] “One-sidedness in the exercise of powers, it is true, inevitably leads the individual into error, but the race to truth,”⁶ says Schiller. The privileged position of the superior function is as detrimental to the individual as it is valuable to society. This detrimental effect has reached such a pitch that the mass organizations of our present-day culture actually strive for the complete extinction of the individual, since their very existence depends on a mechanized application of the privileged functions of individual human beings. It is not man who counts, but his one differentiated function. Man no longer appears as man in our collective culture: he is merely represented by a function, what is more he identifies himself completely with this function and denies the relevance of the other inferior functions. Thus modern man is debased to a mere function, because it is this that represents a collective value and alone guarantees a possible livelihood. But, as Schiller clearly sees, a differentiation of function could have come in no other way:

There was no other way of developing the manifold capacities of man than by placing them in opposition to each other. This antagonism of powers is the great instrument of culture, but it is only the instrument; for as long as it persists, we are only on the way towards culture.⁷

[110] According to this view the present state of our warring capacities would not be a state of culture, but only a stage on the way. Opinions will, of course, be divided about this, for by culture one man will understand a state of collective culture, while another will regard this state merely as *civilization*⁸ and will expect of culture the sterner demands of individual development. Schiller is, however, mistaken when he allies himself exclusively with the second standpoint and contrasts our collective culture unfavourably with that of the individual Greek, since he overlooks the defectiveness of the civilization of that time, which makes the unlimited validity of

that culture very questionable. Hence no culture is ever really complete, for it always swings towards one side or the other. Sometimes the cultural ideal is extraverted, and the chief value then lies with the object and man's relation to it: sometimes it is introverted, and the chief value lies with subject and his relation to the idea. In the former case, culture takes on a collective character, in the latter an individual one. It is therefore easy to understand how under the influence of Christianity, whose principle is Christian love (and by counter-association, also its counterpart, the violation of individuality), a collective culture came about in which the individual is liable to be swallowed up because individual values are depreciated on principle. Hence there arose in the age of the German classicists that extraordinary yearning for the ancient world which for them was a symbol of individual culture, and on that account was for the most part very much overvalued and often grossly idealized. Not a few attempts were even made to imitate or recapture the spirit of Greece, attempts which nowadays appear to us somewhat silly, but must none the less be appreciated as forerunners of an individual culture.

[111] In the hundred and twenty years that have passed since Schiller wrote his letters, conditions with respect to individual culture have gone from bad to worse, since the interest of the individual is invested to a far greater extent in collective occupations, and therefore much less leisure is left over for the development of individual culture. Hence we possess today a highly developed collective culture which in organization far exceeds anything that has gone before, but which for that very reason has become increasingly injurious to individual culture. There is a deep gulf between what a man is and what he represents, between what he is as an individual and what he is as a collective being. His function is developed at the expense of his individuality. Should he excel, he is merely identical with his collective function; but should he not, then, though he may be esteemed as a function in society, his individuality is wholly on the level of his inferior, undeveloped functions, and he is simply a barbarian, while in the former case he has happily deceived himself as to his actual barbarism. This one-sidedness has undoubtedly brought society advantages that should not be underestimated, and acquisitions that could have been gained in no other way, as Schiller finely observes:

Only by concentrating the whole energy of our spirit in one single focus, and drawing together our whole being into one single power, do we attach wings, so to say, to this individual power and lead it by artifice far beyond the bounds which nature seems to have imposed upon it.⁹

[112] But this one-sided development must inevitably lead to a reaction, since the suppressed inferior functions cannot be indefinitely excluded from participating in our life and development. The time will come when the division in the inner man

must be abolished, in order that the undeveloped may be granted an opportunity to live.

[113] I have already indicated that the process of differentiation in cultural development ultimately brings about a dissociation of the basic functions of the psyche, going far beyond the differentiation of individual capacities and even encroaching on the sphere of the psychological attitude in general, which governs the way in which those capacities are employed. At the same time, culture effects a differentiation of the function that already enjoys a better capacity for development through heredity. In one man it is the capacity for thought, in another feeling, which is particularly amenable to development, and therefore, impelled by cultural demands, he will concern himself in special degree with developing an aptitude to which he is already favourably disposed by nature. Its cultivation does not mean that the function in question has an *a priori* claim to any particular proficiency; on the contrary, one might say, it presupposes a certain delicacy, lability, pliability, on which account the highest individual value is not always to be sought or found in this function, but rather, perhaps, only the highest collective value, in so far as this function is developed for a collective end. It may well be, as I have said, that beneath the neglected functions there lie hidden far higher individual values which, though of small importance for collective life, are of the greatest value for individual life, and are therefore vital values that can endow the life of the individual with an intensity and beauty he will vainly seek in his collective function. The differentiated function procures for him the possibility of a collective existence, but not that satisfaction and *joie de vivre* which the development of individual values alone can give. Their absence is often sensed as a profound lack, and the severance from them is like an inner division which, with Schiller, one might compare with a painful wound. He goes on to say:

Thus, however much may be gained for the world as a whole by this fragmentary cultivation of human powers, it is undeniable that the individuals whom it affects suffer under the curse of this universal aim. Athletic bodies are certainly developed by means of gymnastic exercises, but only through the free and equable play of the limbs is beauty formed. In the same way the exertion of individual talents certainly produces extraordinary men, but only their even tempering makes full and happy men. And in what relation should we stand to past and future ages if the cultivation of human nature made such a sacrifice necessary? We should have been the bondslaves of humanity, we should have drudged for it for centuries on end, and branded upon our mutilated nature the shameful traces of this servitude—in order that a later generation might devote itself in blissful indolence to the care of its moral health, and develop the free growth of its humanity! But can man really be destined to neglect himself for any end whatever? Should Nature be able, by her designs, to

rob us of a completeness which Reason prescribes to us by hers? It must be false that the cultivation of individual powers necessitates the sacrifice of their totality; or however much the law of Nature did have that tendency, *we must be at liberty to restore by means of a higher Art this wholeness in our nature which Art has destroyed.*¹⁰

[114] It is evident that Schiller in his personal life had a profound sense of this conflict, and that it was just this antagonism in himself that generated a longing for the coherence or homogeneity which should bring deliverance to the suppressed functions languishing in servitude and a restoration of harmonious living. This idea is also the *leit-motif* of Wagner's *Parsifal*, and it is given symbolic expression in the restoration of the missing spear and the healing of the wound. What Wagner tried to say in artistic terms Schiller laboured to make clear in his philosophical reflections. Although it is nowhere openly stated, the implication is clear enough that his problem revolved round the resumption of a classical mode of life and view of the world; from which one is bound to conclude that he either overlooked the Christian solution or deliberately ignored it. In any case his spiritual eye was focussed more on the beauty of antiquity than on the Christian doctrine of redemption, which, nevertheless, has no other aim than what Schiller himself strove for—the deliverance from evil. The heart of man is “filled with raging battle,” says Julian the Apostate in his discourse on King Helios,¹¹ and with these words he aptly characterizes not only himself but his whole age—the inner laceration of late antiquity which found expression in an unexampled, chaotic confusion of hearts and minds, and from which the Christian doctrine promised deliverance. What Christianity offered was not, of course, a solution but a breaking free, a detachment of the one valuable function from all the other functions which, at that time, made an equally peremptory claim to government. Christianity offered one definite direction to the exclusion of all others. This may have been the essential reason why Schiller passed over in silence the possibility of salvation offered by Christianity. The pagan's close contact with nature seemed to promise just that possibility which Christianity did not offer:

Nature in her physical creation indicates to us the way we should pursue in moral creation. Not until the struggle of elementary powers in the lower organizations has been assuaged does she rise to the noble formation of the physical man. In the same way the strife of elements in the ethical man, the conflict of blind instincts, must first be allayed, and the crude antagonism within him must have ceased, before we may dare to promote his diversity. On the other hand, the independence of his character must be assured, and subjection to alien despotic forms have given place to a decent freedom, before we can submit the multiplicity in him to the unity of the ideal.¹²

[115] Thus it is not to be a detachment or redemption of the inferior function, but an acknowledgement of it, a coming to terms with it, that unites the opposites on the path of nature. But Schiller feels that the acceptance of the inferior function might lead to a “conflict of blind instincts,” just as, conversely, the unity of the ideal might re-establish the supremacy of the valuable function over the less valuable ones and thereby restore the original state of affairs. The inferior functions are opposed to the superior, not so much in their essential nature as because of their momentary form. They were originally neglected and repressed because they hindered civilized man from attaining his aims. But these consist of one-sided interests and are by no means synonymous with the perfection of human individuality. If that were the aim, these unacknowledged functions would be indispensable, and as a matter of fact they do not by nature contradict it. But so long as the cultural aim does not coincide with the ideal of perfecting the human individuality, these functions are subject to depreciation and some degree of repression. The conscious acceptance of repressed functions is equivalent to an internal civil war; the opposites, previously restrained, are unleashed and the “independence of character” is abolished forthwith. This independence can be attained only by a settlement of the conflict, which appears to be impossible without despotic jurisdiction over the opposing forces. In that way freedom is compromised, and without it the building up of a morally free personality is equally impossible. But if freedom is preserved, one is delivered over to the conflict of instincts:

Terrified of the freedom which always declares its hostility to their first attempts, men will in one place throw themselves into the arms of a comfortable servitude, and in another, driven to despair by a pedantic tutelage, they will break out into the wild libertinism of the natural state. Usurpation will plead the weakness of human nature, insurrection its dignity, until at length the great sovereign of all human affairs, blind force, steps in to decide the sham conflict of principles like a common prize-fight.¹³

[116] The contemporary revolution in France gave this statement a living, albeit bloody background: begun in the name of philosophy and reason, with a soaring idealism, it ended in blood-drenched chaos, from which arose the despotic genius of Napoleon. The Goddess of Reason proved herself powerless against the might of the unchained beast. Schiller felt the defeat of reason and truth and therefore had to postulate that truth herself should become a *power*:

If she has hitherto displayed so little of her conquering power, the fault lies not so much with the intellect that knew not how to unveil her, as with the heart that shut her out, and with the instinct that would not serve her. Whence arises this still universal sway of prejudice, this intellectual darkness, beside all the light that philosophy and experience have shed? *The age is enlightened*, that is to say

knowledge has been discovered and publicly disseminated, which would at least suffice to set right our practical principles. The spirit of free enquiry has scattered the delusions which for so long barred the approach to truth, and is undermining the foundations upon which fanaticism and fraud have raised their thrones. Reason has been purged of the illusions of the senses and of deceitful sophistry, and philosophy itself, which first caused us to forsake Nature, is calling us loudly and urgently back to her bosom—why is it that we still remain barbarians?¹⁴

[117] We feel in these words of Schiller the proximity of the French Enlightenment and the fantastic intellectualism of the Revolution. “The age is enlightened”—what an overvaluation of the intellect! “The spirit of free enquiry has scattered the delusions”—what rationalism! One is vividly reminded of the Proktophantasmist in *Faust*: “Vanish at once, you’ve been explained away!” Even though the men of that age were altogether too prone to overestimate the importance and efficacy of reason, quite forgetting that if reason really possessed such a power, she had long had the amplest opportunity to demonstrate it, the fact should not be overlooked that not all the influential minds of the age thought that way; consequently this soaring flight of rationalistic intellectualism may equally well have sprung from a particularly strong subjective development of this same propensity in Schiller himself. In him we have to reckon with a predominance of intellect, not at the expense of his poetic intuition but at the cost of feeling. To Schiller himself it seemed as though there were a perpetual conflict in him between imagination and abstraction, that is, between intuition and thinking. Thus he wrote to Goethe (August 31, 1794):

This is what gave me, especially in early years, a certain awkwardness both in the realm of speculation and in that of poetry; as a rule the poet would overtake me when I would be a philosopher, and the philosophic spirit hold me when I would be a poet. Even now it happens often enough that the power of imagination disturbs my abstraction, and cold reasoning my poetry.¹⁵

[118] His extraordinary admiration for Goethe’s mind, and his almost feminine empathy and sympathy with his friend’s intuition, to which he so often gives expression in his letters, spring from a piercing awareness of this conflict, which he must have felt doubly hard in comparison with the almost perfect synthesis of Goethe’s nature. This conflict was due to the psychological fact that the energy of feeling lent itself in equal measure to his intellect and to his creative imagination. Schiller seems to have suspected this, for in the same letter to Goethe he makes the observation that no sooner has he begun to “know and to use” his moral forces, which should set proper limits to imagination and intellect, than a physical illness threatens to undermine them. As has been pointed out already, it is characteristic of an imperfectly developed function to withdraw itself from conscious control and,

thanks to its own autonomy, to get unconsciously contaminated with other functions. It then behaves like a purely dynamic factor, incapable of differentiated choice, an impetus or surcharge that gives the conscious, differentiated function the quality of being carried away or coerced. In one case the conscious function is transported beyond the limits of its intentions and decisions, in another it is arrested before it attains its aim and is diverted into a side-track, and in a third it is brought into conflict with the other conscious functions—a conflict that remains unresolved so long as the unconscious contaminating and disturbing force is not differentiated and subjected to conscious control. We may safely conjecture that the exclamation “Why is it that we are still barbarians?” was rooted not merely in the spirit of the age but in Schiller’s subjective psychology. Like other men of his time, he sought the root of the evil in the wrong place; for barbarism never did and never does consist in reason or truth having so little effect but in expecting from them far too much, or even in ascribing such efficacy to reason out of a superstitious overvaluation of “truth.” Barbarism consists in one-sidedness, lack of moderation—bad measure in general.

[119] From the spectacular example of the French Revolution, which had just then reached the climax of terror, Schiller could see how far the sway of the Goddess of Reason extended, and how far the unreasoning beast in man was triumphant. It was doubtless these contemporary events that forced the problem on Schiller with particular urgency; for it often happens that, when a problem which is at bottom personal, and therefore apparently subjective, coincides with external events that contain the same psychological elements as the personal conflict, it is suddenly transformed into a general question embracing the whole of society. In this way the personal problem acquires a dignity it lacked hitherto, since the inner discord always has something humiliating and degrading about it, so that one sinks into an ignominious condition both within and without, like a state dishonoured by civil war. It is this that makes one shrink from displaying before the public a purely personal conflict, provided of course that one does not suffer from an overdose of self-esteem. But if the connection between the personal problem and the larger contemporary events is discerned and understood, it brings a release from the loneliness of the purely personal, and the subjective problem is magnified into a general question of our society. This is no small gain as regards the possibility of a solution. For whereas only the meagre energies of one’s conscious interest in one’s own person were at the disposal of the personal problem, there are now assembled the combined forces of collective instinct, which flow in and unite with the interests of the ego; thus a new situation is brought about which offers new possibilities of a solution. For what would never have been possible to the personal power of the will or to courage is made possible by the force of collective instinct; it carries a man over obstacles which his own personal energy could never overcome.

[120] We may therefore conjecture that it was largely the impressions of contemporary events that gave Schiller the courage to undertake this attempt to solve the conflict between the individual and the social function. The same antagonism was also deeply felt by Rousseau—indeed it was the starting-point for his work *Emile, ou l'éducation* (1762). We find there several passages that are of interest as regards our problem:

The citizen is but the numerator of a fraction, whose value depends on its denominator; his value depends on the whole, that is, on the community. Good social institutions are those best fitted to make a man unnatural, to exchange his independence for dependence, to merge the unit in the group.¹⁶

He who would preserve the supremacy of natural feelings in social life knows not what he asks. Ever at war with himself, hesitating between his wishes and his duties, he will be neither a man nor a citizen. He will be of no use to himself nor to others.¹⁷

[121] Rousseau opens his work with the famous sentence: “Everything as it leaves the hands of the Author of things is good; everything degenerates under the hands of man.”¹⁸ This statement is characteristic not only of Rousseau but of the whole epoch.

[122] Schiller likewise looks back, not of course to Rousseau’s natural man—and here lies the essential difference—but to the man who lived “under a Grecian heaven.” This retrospective orientation is common to both and is inextricably bound up with an idealization and overvaluation of the past. Schiller, marvelling at the beauties of antiquity, forgets the actual everyday Greek, and Rousseau mounts to dizzy heights with the sentence: “The natural man is wholly himself; he is an integral unity, an absolute whole,”¹⁹ quite forgetting that the natural man is thoroughly collective, i.e., just as much in others as in himself, and is anything rather than a unity. Elsewhere Rousseau says:

We grasp at everything, we clutch on to everything, times, places, men, things; all that is, all that will be, matters to each of us; we ourselves are but the least part of ourselves. We spread ourselves, so to speak, over the whole world, and become sensitive over this whole vast expanse.... Is it nature which thus bears men so far from themselves?²⁰

[123] Rousseau is deceived; he believes this state of affairs is a recent development. But it is not so; we have merely become conscious of it recently; it was always so, and the more so the further we descend into the beginnings of things. For what Rousseau describes is nothing but that primitive collective mentality which Lévy-Bruhl has aptly termed *participation mystique*. This suppression of individuality is nothing new, it is a relic of that archaic time when there was no individuality whatever. So it is not by any means a recent suppression we are dealing with, but merely a new sense and awareness of the overwhelming power of the collective. One naturally projects this power into the institutions of Church and State, as though there

were not already ways and means enough of evading even moral commands when occasion offered! In no sense do these institutions possess the omnipotence ascribed to them, on account of which they are from time to time assailed by innovators of every sort; the suppressive power lies unconsciously in ourselves, in our own barbarian collective mentality. To the collective psyche every individual development is hateful that does not directly serve the ends of collectivity. Hence although the differentiation of the one function, about which we have spoken above, is a development of an individual value, it is still so largely determined by the views of the collective that, as we have seen, it becomes injurious to the individual himself.

[124] It was their imperfect knowledge of earlier conditions of human psychology that led both our authors into false judgments about the values of the past. The result of this false judgment is a belief in the illusory picture of an earlier, more perfect type of man, who somehow fell from his high estate. Retrospective orientation is itself a relic of pagan thinking, for it is a well-known characteristic of the archaic and barbarian mentality that it imagined a paradisaal Golden Age as the forerunner of the present evil times. It was the great social and spiritual achievement of Christianity that first gave man hope for the future, and promised him some possibility of realizing of his ideals.²¹ The emphasizing of this retrospective orientation in the more recent development of the mind may be connected with the phenomenon of that widespread regression to paganism which has made itself increasingly felt ever since the Renaissance.

[125] To me it seems certain that this retrospective orientation must also have a decided influence on the choice of the methods of human education. The mind thus oriented is ever seeking support in some phantasmagoria of the past. We could make light of this were it not that the knowledge of the conflict between the types and the typical mechanisms compels us to look round for something that would establish their harmony. As we shall see from the following passages, this is also what Schiller had at heart. His fundamental thought is expressed in these words, which sum up what we have just said:

Let some beneficent deity snatch the infant betimes from his mother's breast, nourish him with the milk of a better age and suffer him to grow up to full maturity under that far-off Grecian heaven. Then when he has become a man, let him return, a stranger, to his own century; not to gladden it by his appearance, but rather, terrible like Agamemnon's son, to cleanse it.²²

[126] The predilection for the Grecian prototype could hardly be expressed more clearly. But in this stern formulation one can also glimpse a limitation which impels Schiller to a very essential broadening of perspective:

He will indeed take his material from the present age, but his form he will borrow from a nobler time—nay, from beyond all time, from the absolute unchangeable unity of his being.²³

Schiller clearly felt that he must go back still further, to some primeval heroic age where men were still half divine. He continues:

Here, from the pure aether of his daemonic nature, gushes down the well-spring of Beauty, untainted by the corruption of generations and ages which wallow in the dark eddies far below.²⁴

Here we have the beautiful illusion of a Golden Age when men were still gods and were ever refreshed by the vision of eternal beauty. But here, too, the poet has overtaken Schiller the thinker. A few pages further on the thinker gets the upper hand again:

It must indeed set us thinking when we find that in almost every epoch of history when the arts are flourishing and taste prevails, humanity is in a state of decline, and cannot produce a single example where a high degree and wide diffusion of aesthetic culture among a people has gone hand in hand with political freedom and civic virtue, fine manners with good morals, or polished behaviour with truth.²⁵

[127] In accordance with this familiar and in every way undeniable experience those heroes of olden time must have led a none too scrupulous life, and indeed not a single myth, Greek or otherwise, claims that they ever did anything else. All that beauty could revel in its existence only because there was as yet no penal code and no guardian of public morals. With the recognition of the psychological fact that living beauty spreads her golden shimmer only when soaring above a reality full of misery, pain, and squalor, Schiller cuts the ground from under his own feet; for he had undertaken to prove that what was divided would be united by the vision, enjoyment, and creation of the beautiful. Beauty was to be the mediator which should restore the primal unity of human nature. On the contrary, all experience goes to show that beauty needs her opposite as a condition of her existence.

[128] As before it was the poet, so now it is the thinker that carries Schiller away: he *mistrusts* beauty, he even holds it possible, arguing from experience, that she may exercise a deleterious influence:

Whenever we turn our gaze in the ancient world, we find taste and freedom mutually avoiding each other, and Beauty establishing her sway only on the ruins of heroic virtues.²⁶

This insight, gained by experience, can hardly sustain the claim that Schiller makes for beauty. In the further pursuit of his theme he even gets to the point where he depicts the reverse side of beauty with an all too glaring clarity:

If then we keep solely to what experience has taught us hitherto about the influence of Beauty, we cannot certainly be much encouraged in the development of feelings which are so dangerous to the true culture of mankind; and we should rather dispense with the melting power of Beauty, even at the risk of coarseness and austerity, than see ourselves, for all the advantages of refinement, consigned to her enervating influence.²⁷

[129] The quarrel between the poet and the thinker could surely be composed if the thinker took the words of the poet not literally but *symbolically*, which is how the tongue of the poet desires to be understood. Can Schiller have misunderstood himself? It would almost seem so, otherwise he could not argue thus against himself. The poet speaks of a spring of unsullied beauty which flows beneath every age and generation, and is constantly welling up in every human heart. It is not the man of Greek antiquity whom the poet has in mind, but the old pagan in ourselves, that bit of eternally unspoiled nature and pristine beauty which lies unconscious but living within us, whose reflected splendour transfigures the shapes of the past, and for whose sake we fall into the error of thinking that those heroes actually possessed the beauty we seek. It is the archaic man in ourselves, who, rejected by our collectively oriented consciousness, appears to us as hideous and unacceptable, but who is nevertheless the bearer of that beauty we vainly seek elsewhere. This is the man the poet Schiller means, but the thinker mistakes him for his Greek prototype. What the thinker cannot deduce logically from his evidential material, what he labours for in vain, the poet in symbolic language reveals as the promised land.

[130] From all this it is abundantly clear that any attempt to equalize the one-sided differentiation of the man of our times has to reckon very seriously with an acceptance of the inferior, because undifferentiated, functions. No attempt at mediation will be successful if it does not understand how to release the energies of the inferior functions and lead them towards differentiation. This process can take place only in accordance with the laws of energy, that is, a gradient must be created which offers the latent energies a chance to come into play.

[131] It would be a hopeless task—which nevertheless has often been undertaken and as often has foundered—to transform an inferior function directly into a superior one. It would be as easy to make a *perpetuum mobile*. No lower form of energy can simply be converted into a higher form unless a source of higher value simultaneously lends its support; that is, the conversion can be accomplished only at the expense of the superior function. But under no circumstances can the initial value of the higher form of energy be attained by the lower forms as well or be resumed by the superior function: an equalization at some intermediate level must inevitably result. For every individual who identifies with his one differentiated function, this

entails a descent to a condition which, though balanced, is of a definitely lower value as compared with the initial value. This conclusion is unavoidable. All education that aspires to the unity and harmony of man's nature has to reckon with this fact. In his own fashion, Schiller draws the same conclusion, but he struggles against accepting its consequences, even to the point where he has to renounce beauty. But when the thinker has uttered his harsh judgment, the poet speaks again:

But perhaps experience is not the tribunal before which such a question is to be decided, and before we allow any weight to its testimony it must first be established, beyond doubt, that it is the self-same Beauty about which we are speaking and against which those examples testify.²⁸

[132] It is evident that Schiller is here attempting to stand above experience; in other words he bestows on beauty a quality which experience does not warrant. He believes that "Beauty must be exhibited as a necessary condition of humanity,"²⁹ that is, as a necessary, compelling category; therefore he speaks also of a purely intellectual concept of beauty, and of a "transcendental way" that removes us from "the round of appearances and from the living presence of things." "Those who do not venture out beyond actuality will never capture Truth."³⁰ His subjective resistance to what experience has shown to be the ineluctable downward way impels Schiller to press the logical intellect into the service of feeling, forcing it to come up with a formula that makes the attainment of the original aim possible after all, despite the fact that its impossibility has already been sufficiently demonstrated.

[133] A similar violation is committed by Rousseau in his assumption that whereas dependence on nature does not involve depravity, dependence on man does, so that he can arrive at the following conclusion:

If the laws of nations, like the laws of nature, could never be broken by any human power, dependence on men would become dependence on things; all the advantages of a state of nature could be combined with all the advantages of social life in the commonwealth. The liberty which preserves a man from vice would be united with the morality which raises him to virtue.³¹

On the basis of these reflections he gives the following advice:

Keep the child dependent solely on things, and you will have followed the order of nature in the progress of his education.... Do not make him sit still when he wants to run about, nor run when he wants to stay quiet. If we did not spoil our children's wills by our blunders, their desires would be free from caprice.³²

[134] The misfortune is that never under any circumstances are the laws of nations in such concord with those of nature that the civilized state is at the same time the natural state. If such concord is to be *conceived* as possible at all, it can be conceived

only as a compromise in which neither state could attain its ideal but would remain far below it. Whoever wishes to attain one or the other of the ideals will have to rest content with Rousseau's own formulation: "You must choose between making a man or a citizen, you cannot make both at once."³³

[135] Both these necessities exist in us: nature and culture. We cannot only be ourselves, we must also be related to others. Hence a way must be found that is not a mere rational compromise; it must be a state or process that is wholly consonant with the living being, "a highway and a holy way," as the prophet says, "a straight way, so that fools shall not err therein."³⁴ I am therefore inclined to give the poet in Schiller his due, though in this case he has encroached somewhat violently on the thinker, for rational truths are not the last word, there are also irrational ones. In human affairs, what appears impossible by way of the intellect has often become true by way of the irrational. Indeed, all the greatest transformations that have ever befallen mankind have come not by way of intellectual calculation, but by ways which contemporary minds either ignored or rejected as absurd, and which only long afterwards were recognized because of their intrinsic necessity. More often than not they are never recognized at all, for the all-important laws of mental development are still a book with seven seals.

[136] I am, however, little inclined to concede any particular value to the philosophical gesturings of the poet, for in his hands the intellect is a deceptive instrument. What the intellect can achieve it has already achieved in this case; it has uncovered the contradiction between desire and experience. To persist, then, in demanding a solution of this contradiction from philosophical thinking is quite useless. And even if a solution could finally be thought out, the real obstacle would still confront us, for the solution does not lie in the possibility of thinking it or in the discovery of a rational truth, but in the discovery of a way which real life can accept. There has never been any lack of suggestions and wise precepts. If it were only a question of that, mankind would have had the finest opportunity of reaching the heights in every respect at the time of Pythagoras. That is why what Schiller proposes must not be taken in a literal sense but, as I have said, as a symbol, which in accordance with Schiller's philosophical proclivities appears under the guise of a philosophical concept. Similarly, the "transcendental way" which Schiller sets out to tread must not be understood as a piece of critical ratiocination based on knowledge, but symbolically as the way a man always follows when he encounters an obstacle that cannot be overcome by reason, or when he is confronted with an insoluble task. But in order to find and follow this way, he must first have lingered a long time with the opposites into which his former way forked. The obstacle dams up the river of his life. Whenever a damming up of libido occurs, the opposites, previously united in the steady flow of life, fall apart and henceforth confront one another like antagonists

eager for battle. They then exhaust themselves in a prolonged conflict the duration and upshot of which cannot be foreseen, and from the energy which is lost to them is built that third thing which is the beginning of the new way.

[137] In accordance with this law, Schiller now devotes himself to a profound examination of the nature of the opposites at work. No matter what obstacle we come up against—provided only it be a difficult one—the discord between our own purpose and the refractory object soon becomes a discord in ourselves. For, while I am striving to subordinate the object to my will, my whole being is gradually brought into relationship with it, following the strong libido investment which, as it were, draws a portion of my being across into the object. The result of this is a partial identification of certain portions of my personality with similar qualities in the object. As soon as this identification has taken place, the conflict is transferred into my own psyche. This “introjection” of the conflict with the object creates an inner discord, making me powerless against the object and also releasing affects, which are always symptomatic of inner disharmony. The affects, however, prove that I am sensing myself and am therefore in a position—if I am not blind—to apply my attention to myself and to follow up the play of opposites in my own psyche.

[138] This is the way that Schiller takes. The discord he finds is not between the State and the individual, but, at the beginning of the eleventh letter, he conceives it as the duality of “person and condition,”³⁵ that is, as the ego and its changing states of affect. For whereas the ego has a relative constancy, its relatedness, or proneness to affect, is variable. Schiller thus tries to grasp the discord at its root. And as a matter of fact the one side of it is the conscious ego-function, while the other side is the ego’s relation to the collective. Both determinants are inherent in human psychology. But the various types will each see these basic facts in a different light. For the introvert the idea of the ego is the continuous and dominant note of consciousness, and its antithesis for him is relatedness or proneness to affect. For the extravert, on the contrary, the accent lies more on the continuity of his relation to the object and less on the idea of the ego. Hence for him the problem is different. This point must be borne in mind as we follow Schiller’s further reflections. When, for instance, he says that the “person” reveals itself “in the eternally constant ego, and in this alone,”³⁶ this is viewed from the standpoint of the introvert. From the standpoint of the extravert we would have to say that the person reveals itself simply and solely in its relatedness, in the function of relationship to the object. For only with the introvert is the “person” exclusively the ego; with the extravert it lies in his affectivity and not in the affected ego. His ego is, as it were, of less importance than his affectivity, i.e., his relatedness. The extravert discovers himself in the fluctuating and changeable, the introvert in the constant. The ego is not “eternally constant,” least of all in the extravert, who pays little attention to it. For the introvert, on the other hand, it has too

much importance; he therefore shrinks from every change that is at all liable to affect his ego. Affectivity for him can be something positively painful, while for the extravert it must on no account be missed. Schiller at once reveals himself as an introvert in the following formulation:

To remain constantly himself throughout all change, to turn every perception into experience, that is, into the unity of knowledge, and to make each of his manifestations in time a law for all time, that is the rule which is prescribed for him by his rational nature.³⁷

[139] The abstracting, self-contained attitude is evident; it is even made the supreme rule of conduct. Every occurrence must at once be raised to the level of an experience, and from the sum of these experiences a law for all time must instantly emerge; though the other attitude, that no occurrence should become an experience lest it produce laws that might hamper the future, is equally human.

[140] It is altogether in keeping with Schiller's attitude that he cannot think of God as *becoming*, but only as *eternally being*; hence with unerring intuition he recognizes the "godlikeness" of the introverted ideal state:

Man conceived in his perfection would accordingly be the constant unity which amidst the tides of change remains eternally the same...,³⁸ Beyond question man carries the potentiality for divinity within himself.³⁹

[141] This conception of the nature of God ill accords with his Christian incarnation and with similar Neoplatonic views of the mother of the gods and of her son who descends as the demiurge into creation.⁴⁰ But it is clear what is the function to which Schiller attributes the highest value, divinity: it is the constancy of the idea of the ego. The ego that abstracts itself from affectivity is for him the most important thing, consequently this is the idea he has differentiated most, as is the case with every introvert. His god, his highest value, is the abstraction and conservation of the ego. For the extravert, on the contrary, the god is the experience of the object, complete immersion in reality; hence a god who became man is more sympathetic to him than an eternal, immutable lawgiver. These views, if I may anticipate a little, are valid only for the *conscious* psychology of the types. In the unconscious the relations are reversed. Schiller seems to have had an inkling of this: although with his conscious mind he believes in an immutably existing God, yet the way to divinity is revealed to him through the *senses*, through affectivity, through the living process of change. But for him this is a function of secondary importance, and to the extent that he identifies with his ego and abstracts it from change, his conscious attitude also becomes entirely abstract, while his affectivity, his relatedness to the object, necessarily lapses into the unconscious.

[142] From the abstracting attitude of consciousness, which in pursuit of its ideal makes an experience of every occurrence and from the sum of experience a law, a certain limitation and impoverishment result which are characteristic of the introvert. Schiller clearly sensed this in his relation to Goethe, for he felt Goethe's more extraverted nature as something objectively opposed to himself.⁴¹ Of himself Goethe significantly says:

As a contemplative man I am an arrant realist, so that I am capable of desiring nothing from all the things that present themselves to me, and of wishing nothing added to them. I make no sort of distinction among objects beyond whether they interest me or not.⁴²

Concerning Schiller's effect upon him, Goethe very characteristically says:

If I have served you as the representative of certain objects, you have led me from a too rigorous observation of external things and their relations back into myself. You have taught me to view the many-sidedness of the inner man with more justice.⁴³

[143] In Goethe, on the other hand, Schiller finds an often accentuated complement or fulfillment of his own nature, at the same time sensing the difference, which he indicates in the following way:

Expect of me no great material wealth of ideas, for that is what I find in you. My need and endeavour is to make much out of little, and, if ever you should realize my poverty in all that men call acquired knowledge, you will perhaps find that in some ways I may have succeeded. Because my circle of ideas is smaller, I traverse it more quickly and oftener, and for that reason can make better use of what small ready cash I own, creating through the form a diversity which is lacking in the content. You strive to simplify your great world of ideas, while I seek variety for my small possessions. You have a kingdom to rule, and I only a somewhat numerous family of ideas which I would like to expand into a little universe.⁴⁴

[144] If we subtract from this statement a certain feeling of inferiority that is characteristic of the introvert, and add to it the fact that the "great world of ideas" is not so much ruled by the extravert as he himself is subject to it, then Schiller's plaint gives a striking picture of the poverty that tends to develop as the result of an essentially abstracting attitude.

[145] A further result of the abstracting attitude of consciousness, and one whose significance will become more apparent in the course of our exposition, is that the unconscious develops a compensating attitude. For the more the relation to the object is restricted by abstraction (because too many "experiences" and "laws" are made), the more insistently does a craving for the object develop in the unconscious, and this finally expresses itself in consciousness as a compulsive sensuous tie to the object.

The sensuous relation to the object then takes the place of a feeling relation, which is lacking, or rather suppressed, because of abstraction. Characteristically, therefore, Schiller regards the *senses*, and not *feelings*, as the way to divinity. His ego makes use of thinking, but his affections, his feelings, make use of sensation. Thus for him the schism is between spirituality in the form of thinking, and sensuousness in the form of affectivity or feeling. For the extravert the situation is reversed: his relation to the object is highly developed, but his world of ideas is sensory and concrete.

[146] Sensuous feeling, or rather the feeling that is present in the sensuous state, is collective. It produces a relatedness or proneness to affect which always puts the individual in a state of *participation mystique*, a condition of partial identity with the sensed object. This identity expresses itself in a compulsive dependence on that object, and in turn, after the manner of a vicious circle, causes in the introvert an intensification of abstraction for the purpose of abolishing the burdensome dependence and the compulsion it evokes. Schiller recognized this peculiarity of sensuous feeling:

So long as he merely senses, merely desires and acts from mere appetite, man is still nothing but *world*.

But since the introvert cannot go on abstracting indefinitely in order to escape being affected, he sees himself forced in the end to give shape to externals. Schiller goes on:

Thus in order not to be merely world, he must impart form to matter; he must externalize all within, and shape everything without. Both tasks, in their highest fulfilment, lead back to the concept of divinity from which I started.⁴⁵

[147] This is an important point. Let us suppose the sensuously felt object to be a human being—will he accept this prescription? Will he permit himself to be shaped as though the person to whom he is related were his creator? Man is certainly called upon to play the god on a small scale, but ultimately even inanimate things have a divine right to their own existence, and the world ceased to be chaos long ago when the first hominids began to sharpen stones. It would indeed be a dubious undertaking if every introvert wanted to externalize his limited world of ideas and to shape the external world accordingly. Such attempts happen daily, but the individual suffers, and rightly so, under this “godlikeness.”

[148] For the extravert, Schiller’s formula should run: “Internalize all without and shape everything within.” This was the reaction that, as we saw, Schiller evoked in Goethe. Goethe supplies a telling parallel to this when he writes to Schiller:

On the other hand in every sort of activity I am, one might almost say, completely idealistic: I ask nothing at all from objects, but instead I demand that everything shall

conform to my conceptions.⁴⁶

This means that when the extravert thinks, things go just as autocratically as when the introvert acts upon the external world.⁴⁷ The formula can therefore hold good only when an almost perfect state has been reached, when in fact the introvert has attained a world of ideas so rich and flexible and capable of expression that it no longer forces the object on to a procrustean bed, and the extravert such an ample knowledge of and respect for the object that it no longer gives rise to a caricature when he operates with it in his thinking. Thus we see that Schiller bases his formula on the highest possible criterion and so makes almost prohibitive demands on the psychological development of the individual—assuming that he is thoroughly clear in his own mind what his formula means in every particular.

[149] Be that as it may, it is at least fairly clear that the formula “Externalize all within and shape everything without” is the ideal of the conscious attitude of the introvert. It is based, on the one hand, on the assumption of an ideal range of his inner conceptual world, of the formal principle, and, on the other, on the assumption of the possibility of an ideal application of the sensuous principle, which then no longer appears as affectivity, but as an active potency. So long as man is “sensuous” he is “nothing but world,” and “in order not to be merely world he must impart form to matter.” This implies a reversal of the passive, receptive, sensuous principle. Yet how can such a reversal come about? That is the whole point. It can scarcely be supposed that a man can give his world of ideas that extraordinary range which would be necessary in order to impose a congenial form on the material world, and at the same time convert his affectivity, his sensuous nature, from a passive to an active state in order to bring it up to the level of his world of ideas. Somewhere or other man must be related, must be subject to something, otherwise he would be really godlike. One is forced to conclude that Schiller would let it go so far that violence was done to the object. But that would be to concede to the archaic, inferior function an unlimited right to existence, which as we know Nietzsche, at least in theory, actually did. This conclusion is by no means applicable to Schiller, since, so far as I am aware, he nowhere consciously expressed himself to this effect. His formula has instead a thoroughly naïve and idealistic character, quite consistent with the spirit of his time, which was not yet vitiated by that deep distrust of human nature and of human truth which haunted the epoch of psychological criticism inaugurated by Nietzsche.

[150] Schiller’s formula could be carried out only by applying a ruthless power standpoint, with never a scruple about justice for the object nor any conscientious examination of its own competence. Only under such conditions, which Schiller certainly never contemplated, could the inferior function participate in life. In this way the archaic elements, naïve and unconscious and decked in the glamour of

mighty words and fair gestures, also came bursting through and helped to build our present “civilization,” concerning the nature of which humanity is at this moment in some measure of disagreement. The archaic power instinct, hitherto hidden behind the façade of civilized living, finally came to the surface in its true colours, and proved beyond question that we are “still barbarians.” For it should not be forgotten that, in the same measure as the conscious attitude may pride itself on a certain godlikeness by reason of its lofty and absolute standpoint, an unconscious attitude develops with a godlikeness oriented downwards to an archaic god whose nature is sensual and brutal. The enantiodromia of Heraclitus ensures that the time will come when this *deus absconditus* shall rise to the surface and press the God of our ideals to the wall. It is as though men at the close of the eighteenth century had not really seen what was taking place in Paris, but lingered on in an aesthetic, enthusiastic, or trifling attitude in order to delude themselves about the real meaning of that glimpse into the abysses of human nature.

In that nether world is terror,
And man shall not tempt the gods.
Let him never yearn to see
What they veil with night and horror!⁴⁸

[151] When Schiller lived, the time for dealing with that nether world had not yet come. Nietzsche at heart was much nearer to it; to him it was certain that we were approaching an epoch of unprecedented struggle. He it was, the only true pupil of Schopenhauer, who tore through the veil of naïveté and in his *Zarathustra* conjured up from the nether region ideas that were destined to be the most vital content of the coming age.

b. Concerning the Basic Instincts

[152] In this twelfth letter Schiller comes to grips with the two basic instincts, to which he devotes a detailed description. The “sensuous” instinct is concerned with “setting man within the bounds of time and turning him into matter.”⁴⁹ This instinct demands that there be change, so that time should have a content. This state of merely filled time is called *sensation*.

Man in this state is nothing but a unit of magnitude, a filled moment of time—or rather, he is not even that, for his personality is extinguished so long as sensation rules him and time whirls him along.

With unbreakable bonds this instinct chains the upward-striving spirit to the world of sense, and summons abstraction from its unfettered wanderings in the infinite back into the confines of the present.⁵⁰

[153] It is entirely characteristic of Schiller's psychology that he should conceive the expression of this instinct as *sensation*, and not as active, sensuous *desire*. This shows that for him sensuousness has the character of *reactiveness*, of affectivity, which is altogether typical of the introvert. An extravert would undoubtedly emphasize the element of desire. It is further significant that it is this instinct which demands *change*. The idea wants changelessness and eternity. Whoever lives under the supremacy of the idea strives for permanence; hence everything that pushes towards change must be opposed to the idea. In Schiller's case it is feeling and sensation, which as a rule are fused together on account of their undeveloped state. Schiller does not in fact discriminate sufficiently between feeling and sensation as the following passage proves:

Feeling can only say: this is true for this subject and at this moment; another moment another subject may come and revoke the statement of the present sensation.⁵¹

[154] This passage clearly shows that for Schiller feeling and sensation are actually interchangeable terms, and it reveals an inadequate evaluation and differentiation of feeling as distinct from sensation. Differentiated feeling can establish universal values as well as those that are merely specific and individual. But it is true that the "feeling-sensation" of the introverted thinking type, because of its passive and reactive character, is purely specific; it can never rise above the individual case, by which alone it is stimulated, to an abstract comparison of all cases, since with the introverted thinking type this duty is performed not by the feeling function but by the thinking function. Conversely, with the introverted feeling type, feeling attains an abstract and universal character and can establish universal and permanent values.

[155] From a further analysis of Schiller's description we find that "feeling-sensation" (by which term I mean the characteristic fusion of the two in the introverted thinking type) is the function with which the ego does not declare itself identical. It has the character of something inimical and foreign, that "extinguishes" the personality, whirls it away, setting the subject outside himself and alienating him from himself. Hence Schiller likens it to affect, which sets a man "beside himself" (= extraverted). When one has collected oneself he says this is called, "just as correctly, going into oneself [= introverted], that is, returning to one's ego, re-establishing the personality."⁵² From this it is quite evident that it seems to Schiller as though "feeling-sensation" does not really belong to the person, but is a rather precarious accessory "to which a firm will may triumphantly oppose its demands."⁵³ But to the extravert it is just this side of him which seems to constitute his true nature; it is as if he were actually himself only when he is being affected by the object—as we can well understand when we consider that for him the relation to the object is his superior, differentiated function, to which abstract thinking and feeling are just as

much opposed as they are indispensable to the introvert. The thinking of the extraverted feeling type is just as prejudiced by the sensuous instinct as is the feeling of the introverted thinking type. For both it means extreme restriction to the material and specific. Living through the object also has its “unfettered wanderings in the infinite,” and not abstraction alone, as Schiller thinks.

[156] By excluding sensuousness from the concept and scope of the “person” Schiller is able to assert that the “person, being an absolute and indivisible unity, can never be at variance with itself.”⁵⁴ This unity is a desideratum of the intellect, which would like to preserve the subject in its most ideal integrity; hence as the superior function it must exclude the ostensibly inferior function of sensuousness. The result is that very mutilation of human nature which is the motive and starting-point of Schiller’s quest.

[157] Since, for Schiller, feeling has the quality of “feeling-sensation” and is therefore merely specific, the supreme value, a really eternal value, is naturally assigned to formative thought, or what Schiller calls the “formal instinct”:⁵⁵

But when once thought pronounces: *that is*, it decides for ever and aye, and the validity of its pronouncement is vouched for by the personality itself, which defies all change.⁵⁶

One cannot refrain from asking: Do the meaning and value of the personality really lie only in what is permanent? May it not be that change, becoming, and development represent actually higher values than mere “defiance” of change?⁵⁷ Schiller continues:

When therefore the formal instinct holds sway, and the pure object acts within us, there is the highest expansion of being, all barriers disappear, and from a unit of magnitude to which the needy senses confined him, man has risen to a unity of idea embracing the whole realm of phenomena. By this operation we are no more in time, but time, with its complete and infinite succession, is in us. We are no longer individuals, but species; the judgment of all minds is pronounced by our own, the choice of all hearts is represented by our deed.⁵⁸

[158] There can be no doubt that the thinking of the introvert aspires to this Hyperion; it is only a pity that the “unity of idea” is the ideal of such a very limited class of men. Thinking is merely a function which, when fully developed and exclusively obeying its own laws, naturally sets up a claim to universal validity. Only one part of the world, therefore, can be grasped by thinking, another part only by feeling, a third only through sensation, and so on. That is probably why there are different psychic functions; for, biologically, the psychic system can be understood only as a system of adaptation, just as eyes exist presumably because there is light. Thinking can claim only a third or a fourth part of the total significance, although in its own sphere it

possesses exclusive validity—just as sight is the exclusively valid function for the perception of light waves, and hearing for that of sound waves. Consequently a man who puts the unity of idea on a pinnacle, and for whom “feeling-sensation” is something antipathetic to his personality, can be compared to a man who has good eyes but is totally deaf and suffers from anaesthesia.

[159] “We are no longer individuals, but species”: certainly, if we identify ourselves exclusively with thinking, or with any one function whatsoever; for then we are collective beings with universal validity although quite estranged from ourselves. Outside this quarter-psyche, the three other quarters languish in the darkness of repression and inferiority. “Is it nature which thus bears men so far from themselves?” we might ask with Rousseau—nature, or is it not rather our own psychology, which so barbarously overvalues the one function and allows itself to be swept away by it? This impetus is of course a piece of nature too, that untamed instinctive energy before which the differentiated type recoils if ever it should “accidentally” manifest itself in an inferior function instead of in the ideal function, where it is prized and honoured as a divine afflatus. As Schiller truly says:

But your individuality and your present need will be swept away by change, and what you now ardently desire will one day become the object of your abhorrence.⁵⁹

[160] Whether the untamed, extravagant, disproportionate energy shows itself in sensuality—in *abjectissimo loco*—or in an overestimation and deification of the most highly developed function, it is at bottom the same: barbarism. But naturally one has no insight into this so long as one is still hypnotized by the *object* of the deed and ignores *how* it is done.

[161] Identification with the one differentiated function means that one is in a collective state—not, of course, identical with the collective, as is the primitive, but collectively adapted so far as “the judgment of all minds is pronounced by our own” and our thought and speech exactly conform to the general expectations of those whose thinking is differentiated and adapted to the same degree. Furthermore, “the choice of all hearts is represented by our deed” so far as we think and do as all desire it to be thought and done. And in fact everyone thinks and believes that it is the best and most desirable thing when there is the maximum of identity with the one differentiated function, for that brings the most obvious social advantages, but at the same time the greatest disadvantages to those lesser developed sides of our human nature, which sometimes constitute a large part of our individuality. Schiller goes on: Once we assert the primary, and therefore necessary, antagonism of the two instincts, there is really no other means of preserving the unity in man except by the absolute subordination of the sensuous instinct to the rational. But the only result of that is mere uniformity, not harmony, and man still remains for ever divided.⁶⁰

Because it is difficult to remain true to our principles amidst all the ardour of the feelings, we adopt the more comfortable expedient of making the character more secure by blunting them; for it is infinitely easier to keep calm in the face of an unarmed adversary than to master a spirited and active foe. In this operation, then, consists for the most part what we call the forming of a human being; and that in the best sense of the term, as signifying the cultivation of the inner, not merely the outward, man. A man so formed will indeed be secured against being crude Nature, and from appearing as such; but he will at the same time be armed by his principles against every sensation of Nature, so that humanity can reach him as little from without as from within.⁶¹

[162] Schiller was also aware that the two functions, thinking and affectivity (feeling-sensation), can take one another's place, which happens, as we saw, when one function is privileged:

He can assign to the passive function [feeling-sensation] the intensity which the active function requires, forestall the formal by means of the material instinct, and make the receptive faculty the determining one. Or he can assign to the active function [positive thinking] the extensity which is proper to the passive, forestall the material instinct by means of the formal, and substitute the determining for the receptive faculty. In the first case he will never be himself, in the second he will never be anything else. Consequently, in both cases he is neither the one nor the other, and is therefore a nonentity.⁶²

[163] In this very remarkable passage much is contained that we have already discussed. When the energy of positive thinking is supplied to feeling-sensation, which would amount to a reversal of the introverted thinking type, the qualities of undifferentiated, archaic feeling-sensation become paramount: the individual relapses into an extreme relatedness, or identity with the sensed object. This state is one of *inferior extraversion*, an extraversion which, as it were, detaches the individual entirely from his ego and dissolves him into archaic collective ties and identifications. He is then no longer "himself," but sheer relatedness, identical with the object and therefore without a standpoint. The introvert instinctively feels the greatest resistance to this condition, which is no guarantee that he will not unconsciously fall into it. It should on no account be confused with the extraversion of the extraverted type, inclined as the introvert is to make this mistake and to display for this extraversion the same contempt which, at bottom, he always feels for his own.⁶³ Schiller's second instance, on the other hand, is the purest illustration of the introverted thinking type, who by amputating his inferior feeling-sensations condemns himself to sterility, to a state in which "humanity can reach him as little from without as from within."

[164] Here again it is obvious that Schiller is writing, as always, only from the standpoint of the introvert. The extravert, whose ego resides not in thinking but in the feeling relation to the object, actually finds himself through the object, whereas the introvert loses himself in it. But when the extravert proceeds to introvert, he arrives at a state of inferior relatedness to collective ideas, an identity with collective thinking of an archaic, concretistic kind, which one might call *sensation-thinking*. He loses himself in this inferior function just as much as the introvert in his inferior extraversion. Hence the extravert has the same repugnance, fear, or silent contempt for introversion as the introvert for extraversion.

[165] Schiller senses this opposition between the two mechanisms—in his case between sensation and thinking, or, as he puts it, “matter and form,” “passivity and activity”⁶⁴—as *unbridgeable*.

The distance between matter and form, between passivity and activity, between sensation and thought, is infinite, and the two cannot conceivably be reconciled. The two conditions are opposed to each other and can never be made one.⁶⁵

But both instincts want to exist, and as “energies”—Schiller’s own very modern word for them—they need and demand a “depotentialization.”⁶⁶

The material instinct and the formal are equally earnest in their demands, since in cognition the one relates to the reality, the other to the necessity, of things.⁶⁷

But this depotentialization of the sensuous instinct should never be the effect of a physical incapacity and a blunting of sensation which everywhere merits nothing but contempt; it must be an act of freedom, an activity of the person, tempering the sensual by its moral intensity.... For sense must lose only to the advantage of mind.⁶⁸

It follows, then, that mind must lose only to the advantage of sense. Schiller does not actually say this, but it is surely implied when he continues:

Just as little should the depotentialization of the formal instinct be the effect of spiritual incapacity and a feebleness of thought and will that would degrade humanity. Abundance of sensations must be its glorious source; sensuousness itself must maintain its territory with triumphant power, and resist the violence which by its usurping activity the mind would inflict upon it.⁶⁹

[166] With these words Schiller acknowledges the equal rights of sensuousness and spirituality. He concedes to sensation the right to its own existence. But at the same time we can see in this passage the outlines of a still deeper thought: the idea of a “reciprocity” between the two instincts, a community of interest, or, in modern language, a *symbiosis* in which the waste products of the one would be the food supply of the other.

We have now reached the conception of a reciprocal action between the two instincts, of such a kind that the operation of the one at the same time establishes and restricts the operation of the other, and each reaches its highest manifestation precisely through the activity of the other.⁷⁰

[167] Hence, if we follow out this idea, their opposition must not be conceived as something to be done away with, but on the contrary as something useful and life-promoting that should be preserved and strengthened. This is a direct attack on the predominance of the one differentiated and socially valuable function, since that is the prime cause of the suppression and depletion of the inferior functions. It would amount to a slave rebellion against the heroic ideal which compels us to sacrifice everything else for the sake of the one. If this principle, which, as we saw, was developed in particularly high degree by Christianity for the spiritualizing of man, and then proved equally effective in furthering his materialistic ends, were once finally broken, the inferior functions would find a natural release and would demand, rightly or wrongly, the same recognition as the differentiated function. The complete opposition between sensuousness and spirituality, or between the feeling-sensation and thinking of the introverted thinking type, would then be openly revealed. But, as Schiller says, this complete opposition also entails a reciprocal limitation, equivalent psychologically to an abolition of the power principle, i.e., to a renunciation of the claim to a universally valid standpoint on the strength of one differentiated and adapted collective function.

[168] The direct outcome of this renunciation is *individualism*,⁷¹ that is, the need for a realization of individuality, a realization of man as he *is*. But let us hear how Schiller tries to tackle the problem:

This reciprocal relation of the two instincts is purely a task of reason, which man will be able to solve fully only through the perfection of his being. It is in the truest sense of the term the idea of his humanity, and consequently something infinite to which he can approach ever nearer in the course of time, without ever reaching it.⁷²

[169] It is a pity that Schiller is so conditioned by his type, otherwise it could never have occurred to him to look upon the co-operation of the two instincts as a “task of reason,” for opposites are not to be united rationally: *tertium non datur*—that is precisely why they are called opposites. It must be that Schiller understands by reason something other than *ratio*, some higher and almost mystical faculty. In practice, opposites can be united only in the form of a compromise, or *irrationally*, some new thing arising between them which, although different from both, yet has the power to take up their energies in equal measure as an expression of both and of neither. Such an expression cannot be contrived by reason, it can only be created

through living. As a matter of fact Schiller means just this, as we can see from the following passage:

But if there were cases when [man] had this twofold experience at the same time, when he was at once conscious of his freedom and sensible of his existence, when he at once felt himself as matter and came to know himself as mind, he would in such cases, and positively in them alone, have a complete intuition of his humanity, and the object which afforded him this intuition would serve him as a symbol of his accomplished destiny.⁷³

Thus if a man were able to live both faculties or instincts at the same time, i.e., thinking by sensing and sensing by thinking, then, out of that experience (which Schiller calls the object), a *symbol* would arise which would express his accomplished destiny, i.e., his individual way on which the Yea and Nay are united.

[170] Before we take a closer look at the psychology of this idea, it would be as well for us to ascertain how Schiller *conceives* the nature and origin of the symbol:

The object of the sensuous instinct ... may be called *life* in its widest meaning; a concept that signifies all material being, and all that is directly present to the senses. The object of the formal instinct ... may be called *form*, both in the figurative and in the literal sense; a concept that includes all formal qualities of things and all their relations to the intellectual faculties.⁷⁴

[171] The object of the mediating function, therefore, according to Schiller, is “living form,” for this would be precisely a symbol in which the opposites are united; “a concept that serves to denote all aesthetic qualities of phenomena and, in a word, what we call *Beauty* in the widest sense of the term.”⁷⁵ But the symbol presupposes a function that creates symbols, and in addition a function that understands them. This latter function takes no part in the creation of the symbol, it is a function in its own right, which one could call symbolic thinking or symbolic understanding. The essence of the symbol consists in the fact that it represents in itself something that is not wholly understandable, and that it hints only intuitively at its possible meaning. The creation of a symbol is not a rational process, for a rational process could never produce an image that represents a content which is at bottom incomprehensible. To understand a symbol we need a certain amount of intuition which apprehends, if only approximately, the meaning of the symbol that has been created, and then incorporates it into consciousness. Schiller calls the symbol-creating function a third instinct, the *play* instinct; it bears no resemblance to the two opposing functions, but stands between them and does justice to both their natures—always provided (a point Schiller does not mention) that sensation and thinking are *serious* functions. But there are many people for whom neither function is altogether serious, and for them seriousness must occupy the middle place instead of play. Although elsewhere

Schiller denies the existence of a third, mediating, basic instinct,⁷⁶ we will nevertheless assume, though his conclusion is somewhat at fault, his intuition to be all the more accurate. For, as a matter of fact, something does stand between the opposites, but in the pure differentiated type it has become invisible. In the introvert it is what I have called feeling-sensation. On account of its relative repression, the inferior function is only partly attached to consciousness; its other part is attached to the unconscious. The differentiated function is the most fully adapted to external reality; it is essentially the reality-function; hence it is as much as possible shut off from any admixture of fantastic elements. These elements, therefore, become associated with the inferior functions, which are similarly repressed. For this reason the sensation of the introvert, which is usually sentimental, has a very strong tinge of unconscious fantasy. *The third element, in which the opposites merge, is fantasy activity, which is creative and receptive at once.* This is the function Schiller calls the play instinct, by which he means more than he actually says. He exclaims: “For, to declare it once and for all, man plays only when he is in the full sense of the word a man, and he is only wholly man when he is playing.” For him the object of the play instinct is beauty. “Man shall only *play* with Beauty, and only with *Beauty* shall he play.”⁷⁷

[172] Schiller was in fact aware what it might mean to give first place to the play instinct. As we have seen, the release of repression brings a collision between the opposites, causing an equalization that necessarily results in a lowering of the value that was highest. For culture, as we understand it today, it is certainly a catastrophe when the barbarian side of the European comes uppermost, for who can guarantee that such a man, when he begins to play, will make the aesthetic temper and the enjoyment of genuine beauty his goal? That would be an entirely unjustifiable anticipation. From the inevitable lowering of the cultural level a very different result is to be expected. Schiller rightly says:

The aesthetic play instinct will then be hardly recognizable in its first attempts, as the sensuous instinct is incessantly intervening with its headstrong caprice and its savage appetite. Hence we see crude taste first seizing on what is new and startling, gaudy, fantastic, and bizarre, on what is violent and wild, and avoiding nothing so much as simplicity and quietude.⁷⁸

[173] From this we must conclude that Schiller was aware of the dangers of this development. It also follows that he himself could not acquiesce in the solution found, but felt a compelling need to give man a more substantial foundation for his humanity than the somewhat insecure basis which a playful aesthetic attitude can offer him. And that must indeed be so. For the opposition between the two functions, or function groups, is so great and so inveterate that play alone would hardly suffice

to counterbalance the full gravity and seriousness of this conflict. *Similia similibus curantur*—a third factor is needed, which at least can equal the other two in seriousness. With the attitude of play all seriousness must vanish, and this opens the way for what Schiller calls an “unlimited determinability.”⁷⁹ Sometimes instinct will allow itself to be allured by sensation, sometimes by thinking; now it will play with objects, now with ideas. But in any case it will not play exclusively with beauty, for then man would be no longer a barbarian but already aesthetically educated, whereas the question at issue is: How is he to emerge from the state of barbarism? Above all else, therefore, it must definitely be established where man actually stands in his innermost being. *A priori* he is as much sensation as thinking; he is in opposition to himself, hence he must stand somewhere in between. In his deepest essence he must be a being who partakes of both instincts, yet may also differentiate himself from them in such a way that, though he must suffer them and in some cases submit to them, he can also use them. But first he must differentiate himself from them, as from natural forces to which he is subject but with which he does not declare himself identical. On this point Schiller says:

Moreover, this indwelling of the two fundamental instincts in no way contradicts the absolute unity of the mind, provided only that we distinguish it in itself from both instincts. Both certainly exist and operate within it, but the mind itself is neither matter nor form, neither sensuousness nor reason.⁸⁰

[174] Here, it seems to me, Schiller has put his finger on something very important, namely, *the possibility of separating out an individual nucleus*, which can be at one time the subject and at another the object of the opposing functions, though always remaining distinguishable from them. This separation is as much an intellectual as a moral judgment. In one case it comes about through thinking, in another through feeling. If the separation is unsuccessful, or if it is not made at all, a dissolution of the individuality into pairs of opposites inevitably follows, since it becomes identical with them. A further consequence is disunion with oneself, or an arbitrary decision in favour of one or the other side, together with a violent suppression of its opposite. This train of thought is a very ancient one, and so far as I know its most interesting formulation, psychologically speaking, may be found in Synesius, the Christian bishop of Ptolemais and pupil of Hypatia. In his book *De insomniis* he assigns to the *spiritus phantasticus* practically the same psychological role as Schiller to the play instinct and I to creative fantasy; only his mode of expression is not psychological but metaphysical, an ancient form of speech which is not suitable for our purpose. He says of this spirit: “The fantastic spirit is the medium between the eternal and the temporal, and in it we are most alive.”⁸¹ It unites the opposites in itself; hence it also participates in instinctive nature right down to the animal level, where it becomes instinct and arouses daemonic desires:

For this spirit borrows anything that is suitable to its purpose, taking it from both extremes as it were from neighbours, and so unites in one essence things that dwell far apart. For Nature has extended the reach of fantasy through her many realms, and it descends even to the animals, which do not yet possess reason.... It is itself the intelligence of the animal, and the animal understands much through this power of fantasy.... All classes of demons derive their essence from the life of fantasy. For they are in their whole being imaginary, and are images of that which happens within.

[175] Indeed, from the psychological point of view demons are nothing other than intruders from the unconscious, spontaneous irruptions of unconscious complexes into the continuity of the conscious process. Complexes are comparable to demons which fitfully harass our thoughts and actions; hence in antiquity and the Middle Ages acute neurotic disturbances were conceived as possession. Thus, when the individual consistently takes his stand on one side, the unconscious ranges itself on the other and rebels—which is naturally what struck the Neoplatonic and Christian philosophers most, since they represented the standpoint of exclusive spirituality. Particularly valuable is Synesius' reference to the imaginary nature of demons. It is, as I have already pointed out, precisely the fantastic element that becomes associated in the unconscious with the repressed functions. Hence, if the individuality (as we might call the "individual nucleus" for short) fails to differentiate itself from the opposites, it becomes identical with them and is inwardly torn asunder, so that a state of agonizing disunion arises. Synesius expresses this as follows:

Thus this animal spirit, which devout men have also called the spiritual soul, becomes both idol and god and demon of many shapes. In this also does the soul exhibit her torment.

[176] By participating in the instinctive forces the spirit becomes a "god and demon of many shapes." This strange idea becomes immediately intelligible when we remember that in themselves sensation and thinking are collective functions, into which the individuality (or mind, according to Schiller) is dissolved by non-differentiation. It becomes a collective entity, i.e., godlike, since God is a collective idea of an all-pervading essence. In this state, says Synesius, "the soul exhibits her torment." But deliverance is won through differentiation; for, he continues, when the spirit becomes "moist and gross" it sinks into the depths, i.e., gets entangled with the object, but when purged through pain it becomes "dry and hot" and rises up again, for it is just this fiery quality that differentiates it from the humid nature of its subterranean abode.

[177] Here the question naturally arises: By virtue of what power does that which is indivisible, i.e., the individual, defend himself against the divisive instincts? That he can do this by means of the play instinct even Schiller, at this point, no longer

believes; it must be something serious, some considerable power, that can effectively detach the individuality from both the opposites. From one side comes the call of the highest value, the highest ideal; from the other the allure of the strongest desire.

Schiller says:

Each of these two fundamental instincts, as soon as it is developed, strives by its nature and by necessity towards satisfaction; but just because both are necessary and both are yet striving towards opposite objectives, this twofold compulsion naturally cancels itself out, and the *will* preserves complete freedom between them both. Thus it is the will which acts as a power against both instincts, but neither of the two can of its own accord act as a power against the other.... There is in man no other power but his will, and only that which abolishes man, death and every destroyer of consciousness, can abolish this inner freedom.⁸²

[178] That the opposites must cancel each other is *logically* correct, but *practically* it is not so, for the instincts are in mutual, active opposition and cause a temporarily insoluble conflict. The will could indeed decide the issue, but only if we anticipate the very condition that must first be reached. However, the problem of how man is to emerge from barbarism is not yet solved, neither is that condition established which alone could impart to the will a direction that would be fair to both opposites and so unite them. It is truly a sign of the barbarian state that the will is determined unilaterally by one function, for the will must have some content, some aim, and how is this aim set? How else than by an antecedent psychic process which through an intellectual or an emotional judgment, or a sensuous desire, provides the will with both a content and an aim? If we allow sensuous desire to be a motive of the will, we act in accordance with one instinct against our rational judgment. Yet if we leave it to our rational judgment to settle the dispute, then even the fairest arbitration will always be based on that, and will give the formal instinct priority over the sensuous. In any event, the will is determined more from this side or from that, so long as it depends for its content on one side or the other. But, to be really able to settle the conflict, it must be grounded on an intermediate state or process, which shall give it a content that is neither too near nor too far from either side. According to Schiller, this must be a *symbolic* content, since the mediating position between the opposites can be reached only by the symbol. The reality presupposed by one instinct is different from the reality of the other. To the other it would be quite unreal or bogus, and vice versa. This dual character of real and unreal is inherent in the symbol. If it were only real, it would not be a symbol, for it would then be a real phenomenon and hence unsymbolic. Only that can be symbolic which embraces both. And if it were altogether unreal, it would be mere empty imagining, which, being related to nothing real, would not be a symbol either.

[179] The rational functions are, by their very nature, incapable of creating symbols, since they produce only rationalities whose meaning is determined unilaterally and does not at the same time embrace its opposite. The sensuous functions are equally unfitted to create symbols, because their products too are determined unilaterally by the object and contain only themselves and not their opposites. To discover, therefore, that impartial basis for the will, we must appeal to another authority, where the opposites are not yet clearly separated but still preserve their original unity. Manifestly this is not the case with consciousness, since the whole essence of consciousness is *discrimination*, distinguishing ego from non-ego, subject from object, positive from negative, and so forth. The separation into pairs of opposites is entirely due to conscious differentiation; only consciousness can recognize the suitable and distinguish it from the unsuitable and worthless. It alone can declare one function valuable and the other non-valuable, thus bestowing on one the power of the will while suppressing the claims of the other. But, where no consciousness exists, where purely unconscious instinctive life still prevails, there is no reflection, no *pro et contra*, no disunion, nothing but simple happening, self-regulating instinctivity, living proportion. (Provided, of course, that instinct does not come up against situations to which it is unadapted, in which case blockage, affects, confusion, and panic arise.)

[180] It would, therefore, be pointless to call upon consciousness to decide the conflict between the instincts. A conscious decision would be quite arbitrary, and could never supply the will with a symbolic content that alone can produce an irrational solution of a logical antithesis. For this we must go deeper; we must descend into the foundations of consciousness which have still preserved their primordial instinctivity—that is, into the unconscious, where all psychic functions are indistinguishably merged in the original and fundamental activity of the psyche. The lack of differentiation in the unconscious arises in the first place from the almost direct association of all the brain centres with each other, and in the second from the relatively weak energetic value of the unconscious elements.⁸³ That they possess relatively little energy is clear from the fact that an unconscious element at once ceases to be subliminal as soon as it acquires a stronger accent of value; it then rises above the threshold of consciousness, and it can do this only by virtue of the energy accruing to it. It becomes a “lucky idea” or “hunch,” or, as Herbart calls it, a “spontaneously arising presentation.” The strong energetic value of the conscious contents has the effect of intense illumination, whereby their differences become clearly perceptible and any confusion between them is ruled out. In the unconscious, on the contrary, the most heterogeneous elements possessing only a vague analogy can be substituted for one another, just because of their low luminosity and weak energetic value. Even heterogeneous sense-impressions coalesce, as we see in

“photisms” (Bleuler) or in colour hearing. Language, too, contains plenty of these unconscious contaminations, as I have shown in the case of sound, light, and emotional states.⁸⁴

[181] The unconscious, then, might well be the authority we have to appeal to, since it is a neutral region of the psyche where everything that is divided and antagonistic in consciousness flows together into groupings and configurations. These, when raised to the light of consciousness, reveal a nature that exhibits the constituents of one side as much as the other; they nevertheless belong to neither but occupy an independent middle position. It is this position that constitutes both their value and their non-value for consciousness. They are worthless in so far as nothing clearly distinguishable can be perceived from their configuration, thus leaving consciousness embarrassed and perplexed; but valuable in so far as it is just their undifferentiated state that gives them that symbolic character which is essential to the content of the mediating will.

[182] Thus, besides the will, which is entirely dependent on its content, man has a further auxiliary in the unconscious, that maternal womb of creative fantasy, which is able at any time to fashion symbols in the natural process of elementary psychic activity, symbols that can serve to determine the mediating will. I say “can” advisedly, because the symbol does not of its own accord step into the breach, but remains in the unconscious just so long as the energetic value of the conscious contents exceeds that of the unconscious symbol. Under normal conditions this is always the case; but under abnormal conditions a reversal of value sets in, whereby the unconscious acquires a higher value than the conscious. The symbol then rises to the surface without, however, being taken up by the will and the executive conscious functions, since these, on account of the reversal of value, have now become *subliminal*. The unconscious, on the other hand, has become *supraliminal*, and an abnormal state, a psychic disturbance, has supervened.

[183] Under normal conditions, therefore, energy must be artificially supplied to the unconscious symbol in order to increase its value and bring it to consciousness. This comes about (and here we return again to the idea of differentiation provoked by Schiller) through a differentiation of the self⁸⁵ from the opposites. This differentiation amounts to a detachment of libido from both sides, in so far as the libido is disposable. For the libido invested in the instincts is only in part freely disposable, just so far in fact as the power of the will extends. This is represented by the amount of energy which is at the “free” disposal of the ego. The will then has the self as a possible aim, and it becomes the more possible the more any further development is arrested by the conflict. In this case, the will does not decide between the opposites, but purely for the self, that is, the disposable energy is withdrawn into the self—in other words, it is *introverted*. The introversion simply means that the libido is

retained by the self and is prevented from taking part in the conflict of opposites. Since the way outward is barred to it, it naturally turns towards thought, where again it is in danger of getting entangled in the conflict. The act of differentiation and introversion involves the detachment of disposable libido not merely from the outer object but also from the inner object, the thought. The libido becomes wholly objectless, it is no longer related to anything that could be a content of consciousness, and it therefore sinks into the unconscious, where it automatically takes possession of the waiting fantasy material, which it thereupon activates and forces to the surface.

[184] Schiller's term for the symbol, "living form," is happily chosen, because the constellated fantasy material contains images of the psychological development of the individuality in its successive states—a sort of preliminary sketch or representation of the onward way between the opposites. Although it may frequently happen that the discriminating activity of consciousness does not find much in these images that can be immediately understood, these intuitions nevertheless contain a living power which can have a determining effect on the will. But the determining of the will has repercussions on both sides, so that after a while the opposites recover their strength. The renewed conflict again demands the same treatment, and each time a further step along the way is made possible. This function of mediation between the opposites I have termed the *transcendent function*, by which I mean nothing mysterious, but merely a combined function of conscious and unconscious elements, or, as in mathematics, a common function of real and imaginary quantities.⁸⁶

[185] Besides the will—whose importance should not on that account be denied—we also have creative fantasy, an irrational, instinctive function which alone has the power to supply the will with a content of such a nature that it can unite the opposites. This is the function that Schiller intuitively apprehended as the source of symbols; but he called it the "play instinct" and could therefore make no further use of it for the motivation of the will. In order to obtain a content for the will he reverted to the intellect and thus allied himself to one side only. But he comes surprisingly close to our problem when he says:

The sway of sensation must therefore be destroyed before the law [i.e., of the rational will] can be set up in its place. So it is not enough for something to begin which previously did not exist; something must first cease which previously did exist. Man cannot pass directly from sensation to thinking; he must take a step backwards, since only by the removal of one determinant can its opposite appear. In order, therefore, to exchange passivity for self-dependence, an inactive determinant for an active one, he must be momentarily free from all determinacy and pass through a state of pure determinability. Consequently, he must somehow return to that negative state of sheer

indeterminacy in which he existed before anything at all made an impression on his senses. But that state was completely empty of content, and it is now a question of uniting an equal indeterminacy with an equally unlimited determinability possessing the greatest possible fulness of content, since something positive is to result directly from this condition. The determinacy which he received by means of sensation must therefore be preserved, because he must not lose hold of reality; but at the same time it must, in so far as it is a limitation, be removed, because an unlimited determinability is to make its appearance.⁸⁷

[186] With the help of what has been said above, this difficult passage can be understood easily enough if we bear in mind that Schiller constantly tends to seek a solution in the rational will. Making allowance for this fact, what he says is perfectly clear. The “step backwards” is the differentiation from the contending instincts, the detachment and withdrawal of libido from all inner and outer objects. Here, of course, Schiller has the sensuous object primarily in mind, since, as we have said, his constant aim is to get across to the side of rational thinking, which seems to him an indispensable factor in determining the will. Nevertheless, he is still driven by the necessity of abolishing all determinacy, and this also implies detachment from the inner object, the thought—otherwise it would be impossible to achieve that complete indeterminacy and emptiness of content which is the original state of unconsciousness, with no discrimination of subject and object. It is obvious that Schiller means a process which might be formulated as an *introversion into the unconscious*.

[187] “Unlimited determinability” clearly means something very like the unconscious, a state in which everything acts on everything else without distinction. This empty state of consciousness must be united with the “greatest possible fulness of content.” This fulness, the counterpart of the emptiness of consciousness, can only be the content of the unconscious, since no other content is given. Schiller is thus expressing the union of conscious and unconscious, and from this state “something positive is to result.” This “positive” something is for us a symbolic determinant of the will. For Schiller it is a “mediatory condition,” by which the union of sensation and thinking is brought about. He also calls it a “mediatory disposition” where sensuousness and reason are simultaneously active; but just because of that each cancels the determining power of the other and their opposition ends in negation. This cancelling of the opposites produces a void, which we call the unconscious. Because it is not determined by the opposites, this condition is susceptible to every determinant. Schiller calls it the “aesthetic condition.”⁸⁸ It is remarkable that he overlooks the fact that sensuousness and reason cannot both be “active” in this condition, since, as he himself says, they are already cancelled by mutual negation.

But, since something must be active and Schiller has no other function at his disposal, the pairs of opposites must, according to him, become active again. Their activity is there all right, but since consciousness is “empty,” it must necessarily be in the unconscious.⁸⁹ But this concept was unknown to Schiller—hence he contradicts himself at this point. His mediating aesthetic function would thus be the equivalent of our symbol-forming activity (creative fantasy). Schiller defines the “aesthetic character” of a thing as its relation to “the totality of our various faculties, without being a specific object for any single one of them.”⁹⁰ Instead of this vague definition, he would perhaps have done better to return to his earlier concept of the symbol; for the symbol has the quality of being related to all psychic functions without being a specific object for any single one. Having now reached this “mediatory disposition,” Schiller perceives that “it is henceforth possible for man, by the way of nature, to make of himself what he will—the freedom to be what he ought to be is completely restored to him.”⁹¹

[188] Because by preference Schiller proceeds rationally and intellectually, he falls a victim to his own conclusion. This is already demonstrated in his choice of the word “aesthetic.” Had he been acquainted with Indian literature, he would have seen that the *primordial image* which floated before his mind’s eye had a very different character from an “aesthetic” one. His intuition seized on the unconscious model which from time immemorial has lain dormant in our mind. Yet he interpreted it as “aesthetic,” although he himself had previously emphasized its symbolic character. The primordial image I am thinking of is that particular configuration of Eastern ideas which is condensed in the *brahman-atman* teaching of India and whose philosophical spokesman in China is Lao-tzu.

[189] The Indian conception teaches liberation from the opposites, by which are to be understood every sort of affective state and emotional tie to the object. Liberation follows the withdrawal of libido from all contents, resulting in a state of complete introversion. This psychological process is, very characteristically, known as *tapas*, a term which can best be rendered as “self-brooding.” This expression clearly pictures the state of meditation without content, in which the libido is supplied to one’s own self somewhat in the manner of incubating heat. As a result of the complete detachment of all affective ties to the object, there is necessarily formed in the inner self an equivalent of objective reality, or a complete identity of inside and outside, which is technically described as *tat tvam asi* (that art thou). The fusion of the self with its relations to the object produces the identity of the self (*atman*) with the essence of the world (i.e., with the relations of subject to object), so that the identity of the inner with the outer *atman* is cognized. The concept of *brahman* differs only slightly from that of *atman*, for in *brahman* the idea of the self is not explicitly given; it is, as it were, a general indefinable state of identity between inside and outside.

[190] Parallel in some ways with *tapas* is the concept of yoga, understood not so much as a state of meditation as a conscious technique for attaining the *tapas* state. Yoga is a method by which the libido is systematically “introverted” and liberated from the bondage of opposites. The aim of *tapas* and yoga alike is to establish a mediatory condition from which the creative and redemptive element will emerge. For the individual, the psychological result is the attainment of *brahman*, the “supreme light,” or *ananda* (bliss). This is the whole purpose of the redemptory exercises. At the same time, the process can also be thought of as a cosmogonic one, since *brahman-atman* is the universal Ground from which all creation proceeds. The existence of this myth proves, therefore, that creative processes take place in the unconscious of the yogi which can be interpreted as new adaptations to the object. Schiller says:

As soon as it is light in man, it is no longer night without. As soon as it is hushed within him, the storm in the universe is stilled, and the contending forces of nature find rest between lasting bounds. No wonder, then, that age-old poetry speaks of this great event in the inner man as though it were a revolution in the world outside him.⁹²

[191] Yoga introverts the relations to the object. Deprived of energetic value, they sink into the unconscious, where, as we have shown, they enter into new relations with other unconscious contents, and then reassociate themselves with the object in new form after the completion of the *tapas* exercise. The transformation of the relation to the object has given the object a new face. It is as though newly created; hence the cosmogonic myth is an apt symbol for the outcome of the *tapas* exercise. The trend of Indian religious practice being almost exclusively introverted, the new adaptation to the object has of course little significance; but it still persists in the form of an unconsciously projected, doctrinal cosmogonic myth, though without leading to any practical innovations. In this respect the Indian religious attitude is the diametrical opposite of the Christian, since the Christian principle of love is extraverted and positively demands an object. The Indian principle makes for riches of knowledge, the Christian for fulness of works.

[192] The *brahman* concept also contains the concept of *rta*, right order, the orderly course of the world. In *brahman*, the creative universal essence and universal Ground, all things come upon the right way, for in it they are eternally dissolved and recreated; all development in an orderly way proceeds from *brahman*. The concept of *rta* is a stepping-stone to the concept of *tao* in Lao-tzu. *Tao* is the right way, the reign of law, the middle road between the opposites, freed from them and yet uniting them in itself. The purpose of life is to travel this middle road and never to deviate towards the opposites. The ecstatic element is entirely absent in Lao-tzu; its place is taken by sublime philosophic lucidity, an intellectual and intuitive wisdom obscured by no

mystical haze—a wisdom that represents what is probably the highest attainable degree of spiritual superiority, as far removed from chaos as the stars from the disorder of the actual world. It tames all that is wild, without denaturing it and turning it into something higher.

[193] It could easily be objected that the analogy between Schiller's train of thought and these apparently remote ideas is very far-fetched. But it must not be forgotten that not so long after Schiller's time these same ideas found a powerful spokesman through the genius of Schopenhauer and became intimately wedded to Germanic mind, never again to depart from it. In my view it is of little importance that whereas the Latin translation of the Upanishads by Anquetil du Perron (published 1801–2) was available to Schopenhauer, Schiller took at least no conscious note of the very meagre information that was available in his time.⁹³ I have seen enough in my own practical experience to know that no direct communication is needed in the formation of affinities of this kind. We see something very similar in the fundamental ideas of Meister Eckhart and also, in some respects, of Kant, which display a quite astonishing affinity with those of the Upanishads, though there is not the faintest trace of any influence either direct or indirect. It is the same as with myths and symbols, which can arise autochthonously in every corner of the earth and yet are identical, because they are fashioned out of the same worldwide human unconscious, whose contents are infinitely less variable than are races and individuals.

[194] I also feel it necessary to draw a parallel between Schiller's ideas and those of the East because in this way Schiller's might be freed from the all too constricting mantle of aestheticism.⁹⁴ Aestheticism is not fitted to solve the exceedingly serious and difficult task of educating man, for it always presupposes the very thing it should create—the capacity to love beauty. It actually hinders a deeper investigation of the problem, because it always averts its face from anything evil, ugly, and difficult, and aims at pleasure, even though it be of an edifying kind. Aestheticism therefore lacks all moral force, because *au fond* it is still only a refined hedonism. Certainly Schiller is at pains to introduce an absolute moral motive, but with no convincing success since, just because of his aesthetic attitude, it is impossible for him to see the consequences which a recognition of the other side of human nature would entail. The conflict thus engendered involves such confusion and suffering for the individual that, although the spectacle of beauty may with luck enable him to repress its opposite again, he still does not escape from it, so that, even at best, the old condition is re-established. In order to help him out of this conflict, another attitude than the aesthetic is needed. This is shown nowhere more clearly than in the parallel with Oriental ideas. The religious philosophy of India grasped this problem in all its profundity and showed the kind of remedy needed to solve the conflict. What is

needed is a supreme moral effort, the greatest self-denial and sacrifice, the most intense religious austerity and true saintliness.

[195] Schopenhauer, despite his regard for the aesthetic, most emphatically pointed out just this side of the problem. But we must not delude ourselves that the words “aesthetic,” “beauty,” etc. had the same associations for Schiller as they have for us. I am not, I think, putting it too strongly when I say that for him “beauty” was a *religious ideal*. Beauty was his religion. His “aesthetic mood” might equally well be called “devoutness.” Without definitely expressing anything of that kind, and without explicitly characterizing his central problem as a religious one, Schiller’s intuition none the less arrived at the religious problem. It was, however, the religious problem of the primitive, which he even discussed at some length in his letters, though without following out this line of thought to the end.

[196] It is worth noting that in the further course of his argument the question of the play instinct retires into the background in favour of the aesthetic mood, which seems to have acquired an almost mystical value. This, I believe, is no accident, but has a quite definite cause. Often it is the best and most profound ideas in a man’s work which most obstinately resist a clear formulation, even though they are hinted at in various places and should therefore really be ripe enough for a lucid synthesis to be possible. It seems to me that we are faced with some such difficulty here. To the concept of an aesthetic mood as a mediating creative state Schiller himself brings thoughts which at once reveal its depth and seriousness. And yet, quite as clearly, he picks on the play instinct as the long-sought mediating activity. Now it cannot be denied that these two concepts are in some sort opposed, since play and seriousness are scarcely compatible. Seriousness comes from a profound inner necessity, but play is its outward expression, the face it turns to consciousness. It is not, of course, a matter of *wanting* to play, but of *having* to play; a playful manifestation of fantasy from inner necessity, without the compulsion of circumstance, without even the compulsion of the will.⁹⁵ *It is serious play*. And yet it is certainly play in its outward aspect, as seen from the standpoint of consciousness and collective opinion. That is the ambiguous quality which clings to everything creative.

[197] If play expires in itself without creating anything durable and vital, it is only play, but in the other case it is called creative work. Out of a playful movement of elements whose interrelations are not immediately apparent, patterns arise which an observant and critical intellect can only evaluate afterwards. The creation of something new is not accomplished by the intellect, but by the play instinct acting from inner necessity. The creative mind plays with the object it loves.

[198] Hence it is easy to regard every creative activity whose potentialities remain hidden from the multitude as play. There are, indeed, very few artists who have not

been accused of playing. With the man of genius, which Schiller certainly was, one is inclined to let this label stick. But he himself wanted to go beyond the exceptional man and his nature, and to reach the common man, that he too might share the help and deliverance which the creative artist, acting from inner necessity, cannot escape anyway. But the possibility of extending such a viewpoint to the education of the common man is not guaranteed in advance, or at least it would seem not to be.

[199] To resolve this question we must appeal, as in all such cases, to the testimony of the history of human thought. But first we must once more be clear in our own minds from what angle we are approaching the question. We have seen how Schiller demands a detachment from the opposites even to the point of a complete emptying of consciousness, in which neither sensations, nor feelings, nor thoughts, nor intentions play any sort of role. The condition striven for is one of undifferentiated consciousness, a consciousness in which, by the depotentiation of energetic values, all contents have lost their distinctiveness. But real consciousness is possible only when values facilitate a discrimination of contents. Where discrimination is lacking, no real consciousness can exist. Accordingly such a state might be called “unconscious,” although the possibility of consciousness is present all the time. It is a question of an *abaissement du niveau mental* (Janet), which bears some resemblance to the yogic and trance states of hysterical *engourdissement*.

[200] So far as I know, Schiller never expressed any views concerning the actual technique—if one may use such a word—for inducing the “aesthetic mood.” The example of the Juno Ludovici that he mentions incidentally in his letters⁹⁶ testifies to a state of “aesthetic devotion” consisting in a complete surrender to, and empathy for, the object of contemplation. But such a state of devotion lacks the essential characteristics of being without any content or determinant. Nevertheless, in conjunction with other passages, this example shows that the idea of devotion or devoutness was constantly present in Schiller’s mind.⁹⁷ This brings us back to the religious problem, but at the same time it gives us a glimpse of the actual possibility of extending Schiller’s viewpoint to the common man. *For religious devotion is a collective phenomenon that does not depend on individual endowment.*

[201] There are, however, yet other possibilities. We have seen that the empty state of consciousness, the unconscious condition, is brought about by the libido sinking into the unconscious. In the unconscious feeling-toned contents lie dormant memory-complexes from the individual’s past, above all the parental complex, which is identical with the childhood complex in general. Devotion, or the sinking of libido into the unconscious, reactivates the childhood complex so that the childhood reminiscences, and especially the relations with the parents, become suffused with life. The fantasies produced by this reactivation give rise to the birth of father and

mother divinities, as well as awakening the childhood relations with God and the corresponding childlike feelings. Characteristically, it is *symbols* of the parents that become activated and by no means always the images of the real parents, a fact which Freud explains as repression of the parental imago through resistance to incest. I agree with this interpretation, yet I believe it is not exhaustive, since it overlooks the extraordinary significance of this *symbolic substitution*. Symbolization in the shape of the God-image is an immense step beyond the concretism, the sensuousness, of memory, since, through acceptance of the “symbol” as a real symbol, the regression to the parents is instantly transformed into a progression, whereas it would remain a regression if the symbol were to be interpreted merely as a *sign* for the actual parents and thus robbed of its independent character.⁹⁸

[202] Humanity came to its gods by accepting the reality of the symbol, that is, it came to the *reality of thought*, which has made man lord of the earth. Devotion, as Schiller correctly conceived it, is a regressive movement of libido towards the primordial, a diving down into the source of the first beginnings. Out of this there rises, as an image of the incipient progressive movement, the symbol, which is a condensation of all the operative unconscious factors—“living form,” as Schiller says, and a God-image, as history proves. It is therefore no accident that he should seize on a divine image, the Juno Ludovici, as a paradigm. Goethe makes the divine images of Paris and Helen float up from the tripod of the Mothers⁹⁹—on the one hand the rejuvenated pair, on the other the symbol of a process of inner union, which is precisely what Faust passionately craves for himself as the supreme inner atonement. This is clearly shown in the ensuing scene as also from the further course of the drama. As we can see from the example of Faust, the vision of the symbol is a pointer to the onward course of life, beckoning the libido towards a still distant goal—but a goal that henceforth will burn unquenchably within him, so that his life, kindled as by a flame, moves steadily towards the far-off beacon. This is the specific life-promoting significance of the symbol, and such, too, is the meaning and value of religious symbols. I am speaking, of course, not of symbols that are dead and stiffened by dogma, but of living symbols that rise up from the creative unconscious of the living man.

[203] The immense significance of such symbols can be denied only by those for whom the history of the world begins with the present day. It ought to be superfluous to speak of the significance of symbols, but unfortunately this is not so, for the spirit of our time thinks itself superior to its own psychology. The moralistic and hygienic temper of our day must always know whether such and such a thing is harmful or useful, right or wrong. A real psychology cannot concern itself with such queries; to recognize how things are in themselves is enough.

[204] The symbol-formation resulting from “devotion” is another of those collective religious phenomena that do not depend on individual endowment. So in this respect too we may assume the possibility of extending Schiller’s viewpoint to the common man. I think that at least its theoretical possibility for human psychology in general has now been sufficiently demonstrated. For the sake of completeness and clarity I should add that the question of the relation of the symbol to consciousness and the conscious conduct of life has long occupied my mind. I have come to the conclusion that, in view of its great significance as an exponent of the unconscious, too light a value should not be set on the symbol. We know from daily experience in the treatment of neurotic patients what an eminently practical importance the interventions from the unconscious possess. The greater the dissociation, i.e., the more the conscious attitude becomes alienated from the individual and collective contents of the unconscious, the more harmfully the unconscious inhibits or intensifies the conscious contents. For quite practical reasons, therefore, the symbol must be credited with a not inconsiderable value. But if we grant it a value, whether great or small, the symbol acquires a conscious motive force—that is, it is *perceived*, and its unconscious libido-charge is thereby given an opportunity to make itself felt in the conscious conduct of life. Thus, in my view, a practical advantage of no small consequence is gained, namely, the *collaboration of the unconscious*, its participation in the conscious psychic performance, and hence the elimination of disturbing influences from the unconscious.

[205] This common function, the relation to the symbol, I have termed the *transcendent function*. I cannot at this point submit this question to a thorough investigation, as it would be absolutely necessary to bring together all the material that comes up as a result of the activity of the unconscious. The fantasies hitherto described in the specialist literature give no conception of the symbolic creations we are concerned with. There are, however, not a few examples of such fantasies in *belles-lettres*; but these, of course, are not observed and reported in their “pure” state—they have undergone an intensive “aesthetic” elaboration. From all these examples I would single out two works of Meyrink for special attention: *The Golem* and *Das grüne Gesicht*. I must reserve the treatment of this aspect of the problem for a later investigation.

[206] Although these observations concerning the mediatory state were prompted by Schiller, we have already gone far beyond his conceptions. In spite of his having discerned the opposites in human nature with such keen insight, he remained stuck at an early stage in his attempt at a solution. For this failure, it seems to me, the term “aesthetic mood” is not without blame. Schiller makes the “aesthetic mood” practically identical with “beauty,” which of its own accord precipitates our sentiments into this mood.¹⁰⁰ Not only does he blend cause with effect, he also, in the

teeth of his own definition, gives the state of “indeterminacy” an unequivocally determined character by equating it with beauty. From the very outset, therefore, the edge is taken off the mediating function, since beauty immediately prevails over ugliness, whereas it is equally a question of ugliness. We have seen that Schiller defines a thing’s “aesthetic character” as its relation to “the totality of our various faculties.”¹⁰¹ Consequently “beautiful” cannot coincide with “aesthetic,” since our various faculties also vary aesthetically: some are beautiful, some ugly, and only an incorrigible idealist and optimist could conceive the “totality” of human nature as simply beautiful. To be quite accurate, human nature is simply what it is; it has its dark and its light sides. The sum of all colours is grey—light on a dark background or dark on light.

[207] This conceptual flaw also accounts for the fact that it remains far from clear *how* this mediatory condition is to be brought about. There are numerous passages which state unequivocally that it is called into being by “the enjoyment of pure beauty.” Thus Schiller says:

Whatever flatters our senses in immediate sensation opens our soft and sensitive nature to every impression, but it also makes us in the same measure less capable of exertion. What braces our intellectual powers and invites us to abstract concepts strengthens our mind for every kind of resistance, but also hardens it proportionately, and deprives us of sensibility just as much as it helps us towards a greater spontaneity. For that very reason the one no less than the other must in the end necessarily lead to exhaustion.... On the other hand, when we have abandoned ourselves to the enjoyment of pure beauty, we are at such a moment masters in equal degree of our passive and active powers, and shall turn with equal facility to seriousness or to play, to rest or to movement, to compliance or to resistance, to abstract thought or to contemplation.¹⁰²

[208] This statement is in direct contradiction to the earlier definitions of the “aesthetic condition,” where man was to be “empty,” a “cipher,” “undetermined,” whereas here he is in the highest degree determined by beauty (“abandoned” to it). But it is not worth while pursuing this question further with Schiller. Here he comes up against a barrier common both to himself and his time which it was impossible for him to overstep, for everywhere he encountered the invisible “Ugliest Man,” whose discovery was reserved for our age by Nietzsche.

[209] Schiller was intent on making the sensuous man into a rational being “by first making him aesthetic.”¹⁰³ He himself says that “we must first alter his nature,”¹⁰⁴ “we must subject man to form even in his purely physical life,”¹⁰⁵ “he must carry out his physical determination ... according to the laws of Beauty,”¹⁰⁶ “on the neutral plane of physical life man must start his moral life,”¹⁰⁷ “though still within his sensuous

limits he must begin his rational freedom,”¹⁰⁸ “he must already be imposing the law of his will upon his inclinations,”¹⁰⁹ “he must learn to desire more *nobly*.”¹¹⁰

[210] That “must” of which our author speaks is the familiar “ought” which is always invoked when one can see no other way. Here again we come up against the inevitable barriers. It would be unfair to expect one individual mind, were it never so great, to master this gigantic problem which times and nations alone can solve, and even then by no conscious purpose, but only as fate would have it.

[211] The greatness of Schiller’s thought lies in his psychological observation and in his intuitive grasp of the things observed. There is yet another of his trains of thought I would like to mention, as it deserves special emphasis. We have seen that the mediatory condition is characterized as producing “something positive,” namely the symbol. The symbol unites antithetical elements within its nature; hence it also unites the antithesis between real and unreal, because on the one hand it is a psychic reality (on account of its efficacy), while on the other it corresponds to no physical reality. It is *reality* and *appearance* at once. Schiller clearly emphasizes this in order to append an apologia for appearance, which is in every respect significant:

Extreme stupidity and extreme intelligence have a certain affinity with each other, in that both seek only the *real* and are wholly insensible to mere *appearance*. Only through the immediate presence of an object in the senses is stupidity shaken from its repose, and intelligence is granted its repose only through relating its concepts to the data of experience; in a word, stupidity cannot rise above reality and intelligence cannot remain below truth. In so far, then, as the need for reality and attachment to the real are merely the results of deficiency, it follows that indifference to reality and interest in appearance are a true enlargement of humanity and a decisive step towards culture.¹¹¹

[212] When speaking earlier of an assignment of value to the symbol, I showed the practical advantages of an appreciation of the unconscious. We exclude an unconscious disturbance of the conscious functions when we take the unconscious into our calculations from the start by paying attention to the symbol. It is well known that the unconscious, when not realized, is ever at work casting a false glamour over everything, a false appearance: *it appears to us always on objects*, because everything unconscious is projected. Hence, when we can apprehend the unconscious as such, we strip away the false appearance from objects, and this can only promote truth. Schiller says:

Man exercises this human right to sovereignty in the *art of appearance*, and the more strictly he here distinguishes between *mine* and *thine*, the more carefully he separates form from being, and the more independence he learns to give to this form, the more he will not merely extend the realm of Beauty but even secure the boundaries of

Truth; for he cannot cleanse appearance from reality without at the same time liberating reality from appearance.¹¹²

To strive after absolute appearance demands greater capacity for abstraction, more freedom of heart, more vigour of will than man needs if he confines himself to reality, and he must already have put this behind him if he wishes to arrive at appearance.¹¹³

2. A DISCUSSION ON NAÏVE AND SENTIMENTAL POETRY

[213] For a long time it seemed to me as though Schiller's division of poets into *naïve* and *sentimental*¹¹⁴, were a classification that accorded with the type psychology here expounded. After mature reflection, however, I have come to the conclusion that this is not so. Schiller's definition is very simple: "The naïve poet *is* Nature, the sentimental poet *seeks* her." This simple formula is beguiling, since it postulates two different kinds of relation to the object. It is therefore tempting to say: He who seeks or desires Nature as an object does not possess her, and such a man would be an introvert; while conversely, he who already is Nature, and therefore stands in the most intimate relation with the object, would be an extravert. But a rather forced interpretation such as this would have little in common with Schiller's point of view. His division into naïve and sentimental is one which, in contrast to our type division, is not in the least concerned with the individual mentality of the poet, but rather with the character of his creative activity, or of its product. The same poet can be sentimental in one poem, naïve in another. Homer is certainly naïve throughout, but how many of the moderns are not, for the most part, sentimental? Evidently Schiller felt this difficulty, and therefore asserted that the poet was conditioned by his time, not as an individual but as a poet. He says:

All real poets will belong either to the naïve or sentimental, depending on whether the conditions of the age in which they flourish, or accidental circumstances, exert an influence on their general make-up and on their passing emotional mood.¹¹⁵

[214] Consequently it is not a question of fundamental types for Schiller, but of certain characteristics or qualities of the individual product. Hence it is at once obvious that an introverted poet can, on occasion, be just as naïve as he is sentimental. It therefore follows that to identify naïve and sentimental respectively with extravert and introvert would be quite beside the point so far as the question of *types* is concerned. Not so, however, so far as it is a question of *typical mechanisms*.

a. The Naïve Attitude

[215] I will first present the definitions which Schiller gives of this attitude. As has already been said, the naïve poet is “Nature.” He “simply follows Nature and sensation and confines himself to the mere copying of reality.”¹¹⁶ “With naïve poetry we delight in the living presence of objects in our imagination.”¹¹⁷ “Naïve poetry is a boon of Nature. It is a lucky throw, needing no improvement when it succeeds, but fit for nothing when it fails.”¹¹⁸ “The naïve genius has to do everything through his nature; he can do little through his freedom, and he will accomplish his idea only when Nature works in him from inner necessity.”¹¹⁹ Naïve poetry is “the child of life and unto life it returns.”¹²⁰ The naïve genius is wholly dependent on “experience,” on the world, with which he is in “direct touch.” He “needs succour from without.”¹²¹ For the naïve poet the “common nature” of his surroundings can “become dangerous,” because “sensibility is always more or less dependent on the external impression, and only a constant activity of the productive faculty, which is not to be expected of human nature, would be able to prevent mere matter from exercising at times a blind power over his sensibility. But whenever this happens, the poetic feeling will be commonplace.”¹²² “The naïve genius allows Nature unlimited sway in him.”¹²³

[216] From these definitions the dependence of the naïve poet on the object is especially clear. His relation to the object has a compelling character, because he introjects the object—that is, he unconsciously identifies with it or has, as it were, an *a priori* identity with it. Lévy-Bruhl describes this relation to the object as *participation mystique*. This identity always derives from an analogy between the object and an unconscious content. One could also say that the identity comes about through the projection of an unconscious association by analogy with the object. An identity of this kind has a compelling character too, because it expresses a certain quantity of libido which, like all libido operating from the unconscious, is not at the disposal of consciousness and thus exercises a compulsion on its contents. The attitude of the naïve poet is, therefore, in a high degree conditioned by the object; the object operates independently in him, as it were; it fulfils itself in him because he himself is identical with it. He lends his expressive function to the object and represents it in a certain way, not in the least actively or intentionally, but because it represents itself that way in him. He is himself Nature: Nature creates in him the product. He “allows Nature unlimited sway in him.” Supremacy is given to the object. To this extent the naïve attitude is extraverted.

b. The Sentimental Attitude

[217] The sentimental poet *seeks* Nature. He “reflects on the impression objects make on him, and on that reflection alone depends the emotion with which he is exalted, and which likewise exalts us. Here the object is related to an idea, and on this relation

alone depends his poetic power.”¹²⁴ He “is always involved with two opposing ideas and sensations, with reality as finite, and with the idea as infinite: the mixed feeling he arouses always bears witness to this dual origin.”¹²⁵ “The sentimental mood is the result of an effort to reproduce the naïve sensation, the content of it, even under conditions of reflection.”¹²⁶ “Sentimental poetry is the product of abstraction.”¹²⁷ “As a result of his effort to remove every limitation from human nature, the sentimental genius is exposed to the danger of abolishing human nature altogether; not merely mounting, as he must and should, above every fixed and limited reality to absolute possibility: which is to *idealize*, but even transcending possibility itself: which is to *fantasize*.... The sentimental genius abandons reality in order to soar into the world of ideas and rule his material with absolute freedom.”¹²⁸

[218] It is easy to see that the sentimental poet, contrasted with the naïve, is characterized by a reflective and abstract attitude to the object. *He reflects on the object by abstracting himself from it.* He is, as it were, separated from the object *a priori* as soon as his work begins; it is not the object that operates in him, he himself is the operator. He does not, however, work in towards himself, but out beyond the object. He is distinct from the object, not identical with it; he seeks to establish *his* relation to it, to “rule his material.” From his distinction from the object comes that sense of duality which Schiller refers to; for the sentimental poet draws his creativity from two sources: from the object and/or his perception of it, and from himself. For him the external impression of the object is not something absolute, but material which he handles as directed by his own contents. He thus stands above the object and yet has a relation to it—not a relation of mere impressionability or receptivity, but one in which by his own free choice he bestows value or quality on the object. His is therefore an introverted attitude.

[219] By characterizing these two attitudes as extraverted and introverted we have not, however, exhausted Schiller’s conception. Our two mechanisms are merely basic phenomena of a rather general nature, which only vaguely indicate what is specific about those attitudes. To understand the naïve and sentimental types we must enlist the help of two further functions, *sensation* and *intuition*. I shall discuss these in greater detail at a later stage of our investigation. I only wish to say at this point that the naïve is characterized by a preponderance of sensation, and the sentimental by a preponderance of intuition. Sensation creates ties to the object, it even pulls the subject into the object; hence the “danger” for the naïve type consists in his vanishing in it altogether. Intuition, being a perception of one’s own unconscious processes, withdraws one from the object; it mounts above it, ever seeking to rule its material, to shape it, even violently, in accordance with one’s own subjective viewpoint, though without being aware of doing so. The danger for the sentimental type, therefore, is a

complete severance from reality and a vanishing in the fluid fantasy world of the unconscious.

c. The Idealist and the Realist

[220] In the same essay Schiller's reflections lead him to postulate two fundamental psychological types. He says:

This brings me to a very remarkable psychological antagonism among men in an age of progressive culture, an antagonism which, because it is radical and grounded in the innate emotional constitution, is the cause of a sharper division among men than the random conflict of interests could ever bring about; which robs the poet and artist of all hope of making a universal appeal and giving pleasure to every one—although this is his task; which makes it impossible for the philosopher, in spite of every effort, to be universally convincing—although this is implied in the very idea of philosophy; and which, finally, will never permit a man in practical life to see his mode of behaviour universally applauded: in short, an antagonism which is to blame for the fact that no work of the mind and no deed of the heart can have a decisive success with one class of men without incurring the condemnation of the other. This antagonism is, without doubt, as old as the beginning of culture, and to the end it can hardly be otherwise, save in rare individual cases, such as have always existed and, it is to be hoped, will always exist. But although it lies in the very nature of its operations that it frustrates every attempt at a settlement, because no party can be brought to admit either a deficiency on his own side or a reality on the other's, yet there is always profit enough in following up such an important antagonism to its final source, thus at least reducing the actual point at issue to a simpler formulation.¹²⁹

[221] It follows conclusively from this passage that by observing the antagonistic mechanisms Schiller arrived at a conception of two psychological types which claim the same significance in his scheme of things as I ascribe to the introverted and extraverted in mine. With regard to the reciprocal relation of the two types postulated by me I can endorse almost word for word what Schiller says of his. In agreement with what I said earlier, Schiller proceeds from the mechanism to the type, by "isolating from the naïve and the sentimental character alike the poetic quality common to both."¹³⁰ If we perform this operation too, subtracting the creative genius from both, then what is left to the naïve is his attachment to the object and its autonomy in the subject, and to the sentimental his superiority over the object, which expresses itself in his more or less arbitrary judgment or treatment of it. Schiller continues:

After this nothing remains of the [naïve], on the theoretical side, but a sober spirit of observation and a fixed dependence on the uniform testimony of the senses; and, on the practical, a resigned submission to the exigencies of Nature.... Of the sentimental character nothing remains, on the theoretical side, but a restless spirit of speculation that insists on the absolute in every act of cognition, and, on the practical, a moral rigorism that insists on the absolute in every act of the will. Whoever counts himself among the former can be called a *realist*, and, among the latter, an *idealist*.¹³¹

[222] Schiller's further observations on his two types relate almost exclusively to the familiar phenomena of the realist and idealist attitudes and are therefore without interest for our investigation.

III

THE APOLLINIAN AND THE DIONYSIAN

[223] The problem discerned and partially worked out by Schiller was taken up again in a new and original way by Nietzsche in his book *The Birth of Tragedy* (1871). This early work is more nearly related to Schopenhauer and Goethe than to Schiller. But it at least appears to share Schiller's aestheticism and Hellenism, while having pessimism and the motif of deliverance in common with Schopenhauer and unlimited points of contact with Goethe's *Faust*. Among these connections, those with Schiller are naturally the most significant for our purpose. Yet we cannot pass over Schopenhauer without paying tribute to the way in which he gave reality to those dawning rays of Oriental wisdom which appear in Schiller only as insubstantial wraiths. If we disregard his pessimism which springs from the contrast with the Christian's enjoyment of faith and certainty of redemption, Schopenhauer's doctrine of deliverance is seen to be essentially Buddhist. He was captivated by the East. This was undoubtedly a reaction against our Occidental atmosphere. It is, as we know, a reaction that still persists today in various movements more or less completely oriented towards India. For Nietzsche this pull towards the East stopped in Greece. Also, he felt Greece to be the midpoint between East and West. To this extent he maintains contact with Schiller—but how utterly different is his conception of the Greek character! He sees the dark foil upon which the serene and golden world of Olympus is painted:

In order to make life possible, the Greeks had to create those gods from sheer necessity. ... They knew and felt the terror and frightfulness of existence; to be able to live at all, the Greeks had to interpose the shining, dream-born Olympian world between themselves and that dread. That tremendous mistrust of the titanic powers of Nature, Moira pitilessly enthroned above all knowledge, the vulture of Prometheus the great friend of man, the awful fate of the wise Oedipus, the family curse of the Atrides that drove Orestes to matricide ... all this dread was ever being conquered anew by the Greeks with the help of that visionary, intermediate world of the Olympians, or was at least veiled and withdrawn from sight.¹

That Greek "serenity," that smiling heaven of Hellas seen as a shimmering illusion hiding a sombre background—this insight was reserved for the moderns, and is a weighty argument against moral aestheticism.

[224] Here Nietzsche takes up a standpoint differing significantly from Schiller's. What one might have guessed with Schiller, that his letters on aesthetic education were also an attempt to deal with his own problems, becomes a complete certainty in this work of Nietzsche's: it is a "profoundly personal" book. Whereas Schiller begins to paint light and shade almost timorously and in pallid hues, apprehending the conflict in his own psyche as "naïve" versus "sentimental," and excluding everything that belongs to the background and abysmal depths of human nature, Nietzsche has a profounder grasp and spans an opposition which, in one aspect, is no whit inferior to the dazzling beauty of Schiller's vision, while its other aspect reveals infinitely darker tones that certainly enhance the effect of the light but allow still blacker depths to be divined.

[225] Nietzsche calls his fundamental pair of opposites the *Apollinian* and the *Dionysian*. We must first try to picture to ourselves the nature of this pair. For this purpose I shall select a number of quotations which will enable the reader, even though unacquainted with Nietzsche's work, to form his own judgment and at the same time to criticize mine.

We shall have gained much for the science of aesthetics when once we have perceived not only by logical inference, but by the immediate certainty of intuition, that the continuous development of art is bound up with the duality of the Apollinian and the Dionysian, in much the same way as generation depends on the duality of the sexes, involving perpetual conflicts with only periodic reconciliations.²

From the two deities of the arts, Apollo and Dionysus, we derive our knowledge that a tremendous opposition existed in the Greek world, both as to their origin and their aim, between the Apollinian art of the shaper and the non-figurative Dionysian art of music. These two very different impulses run side by side, for the most part openly at variance, each continually rousing the other to new and mightier births, in order to perpetuate in them the warring antagonism that is only seemingly bridged by the common term "Art"; until finally, by a metaphysical miracle of the Hellenic "will," they appear paired one with the other, and from this mating the equally Apollinian and Dionysian creation of Attic tragedy is at last brought to birth.³

[226] In order to characterize these two "impulses" more closely, Nietzsche compares the peculiar psychological states they give rise to with those of *dreaming* and *intoxication*. The Apollinian impulse produces the state comparable to dreaming, the Dionysian the state comparable to intoxication. By "dreaming" Nietzsche means, as he himself says, essentially an "inward vision," the "lovely semblance of dream-worlds."⁴ Apollo "rules over the beautiful illusion of the inner world of fantasy," he is "the god of all shape-shifting powers."⁵ He signifies measure, number, limitation, and

subjugation of everything wild and untamed. “One might even describe Apollo himself as the glorious divine image of the *principium individuationis*.”⁶

[227] The Dionysian impulse, on the other hand, means the liberation of unbounded instinct, the breaking loose of the unbridled dynamism of animal and divine nature; hence in the Dionysian rout man appears as a satyr, god above and goat below.⁷ The Dionysian is the horror of the annihilation of the *principium individuationis* and at the same time “rapturous delight” in its destruction. It is therefore comparable to intoxication, which dissolves the individual into his collective instincts and components—an explosion of the isolated ego through the world. Hence, in the Dionysian orgy, man finds man: “alienated Nature, hostile or enslaved, celebrates once more her feast of reconciliation with her prodigal son—Man.”⁸ Each feels himself “not only united, reconciled, merged with his neighbour, but one with him.”⁹ His individuality is entirely obliterated. “Man is no longer the artist, he has become the work of art.”¹⁰ “All the artistry of Nature is revealed in the ecstasies of intoxication.”¹¹ Which means that the creative dynamism, libido in instinctive form, takes possession of the individual as though he were an object and uses him as a tool or as an expression of itself. If it is permissible to conceive the natural creature as a “work of art,” then of course man in the Dionysian state has become a natural work of art too; but in so far as the natural creature is decidedly not a work of art in the ordinary sense of the word, he is nothing but sheer Nature, unbridled, a raging torrent, not even an animal that is restricted to itself and the laws of its being. I must emphasize this point for the sake of clarity in the ensuing discussion, since for some reason Nietzsche has omitted to make it clear, and has consequently shed a deceptive aesthetic veil over the problem, which at times he himself has involuntarily to draw aside. Thus, in connection with the Dionysian orgies, he says:

Practically everywhere the central point of these festivals lay in exuberant sexual licence, which swamped all family life and its venerable traditions; the most savage bestialities of nature were unleashed, including that atrocious amalgam of lust and cruelty which has always seemed to me the true witch’s broth.¹²

[228] Nietzsche considers the reconciliation of the Delphic Apollo with Dionysus a symbol of the reconciliation of these opposites in the breast of the civilized Greek. But here he forgets his own compensatory formula, according to which the gods of Olympus owe their splendour to the darkness of the Greek psyche. By this token, the reconciliation of Apollo and Dionysus would be a “beautiful illusion,” a desideratum evoked by the need of the civilized Greek in his struggle with his own barbarian side, the very element that broke out unchecked in the Dionysian rout.

[229] Between the religion of a people and its actual mode of life there is always a compensatory relation, otherwise religion would have no practical significance at all. Beginning with the highly moral religion of the Persians and the notorious dubiousness, even in antiquity, of Persian habits of life, right down to our own “Christian” era, when the religion of love assisted at the greatest blood-bath in the world’s history—wherever we turn this rule holds true. We may therefore infer from the symbol of the Delphic reconciliation an especially violent split in the Greek character. This would also explain the longing for deliverance which gave the mysteries their immense significance for the social life of Greece, and which was completely overlooked by the early admirers of the Greek world. They were content with naïvely attributing to the Greeks everything they themselves lacked.

[230] Thus in the Dionysian state the Greek was anything but a “work of art”; on the contrary, he was gripped by his own barbarian nature, robbed of his individuality, dissolved into his collective components, made one with the collective unconscious (through the surrender of his individual aims), and one with “the genius of the race, even with Nature herself.”¹³ To the Apollinian side which had already achieved a certain amount of domestication, this intoxicated state that made man forget both himself and his humanity and turned him into a mere creature of instinct must have been altogether despicable, and for this reason a violent conflict between the two impulses was bound to break out. Supposing the instincts of civilized man were let loose! The culture-enthusiasts imagine that only sheer beauty would stream forth. This error is due to a profound lack of psychological knowledge. The dammed-up instinctual forces in civilized man are immensely destructive and far more dangerous than the instincts of the primitive, who in a modest degree is constantly living out his negative instinct. Consequently no war of the historical past can rival in grandiose horror the wars of civilized nations. It will have been the same with the Greeks. It was just their living sense of horror that gradually brought about a reconciliation of the Apollinian with the Dionysian—“through a metaphysical miracle,” as Nietzsche says. This statement, as well as the other where he says that the antagonism between them is “only seemingly bridged by the common term ‘Art,’” must constantly be borne in mind, because Nietzsche, like Schiller, had a pronounced tendency to credit art with a mediating and redeeming role. The problem then remains stuck in aesthetics—the ugly is also “beautiful,” even beastliness and evil shine forth enticingly in the false glamour of aesthetic beauty. The artistic nature in both Schiller and Nietzsche claims a redemptive significance for itself and its specific capacity for creation and expression.

[231] Because of this, Nietzsche quite forgets that in the struggle between Apollo and Dionysus and in their ultimate reconciliation the problem for the Greeks was never an aesthetic one, but was essentially religious. The Dionysian satyr festival, to judge

by all the analogies, was a kind of totem feast involving a regressive identification with the mythical ancestors or directly with the totem animal. The cult of Dionysus had in many places a mystical and speculative streak, and in any case exercised a very strong religious influence. The fact that Greek tragedy arose out of an originally religious ceremony is at least as significant as the connection of our modern theatre with the medieval Passion play, which was exclusively religious in origin; we are not permitted, therefore, to judge the problem under its purely aesthetic aspect.

Aestheticism is a modern bias that shows the psychological mysteries of the Dionysus cult in a light in which they were assuredly never seen or experienced by the ancients. With Nietzsche as with Schiller the religious viewpoint is entirely overlooked and is replaced by the aesthetic. These things obviously have their aesthetic side and it should not be neglected.¹⁴ Nevertheless, if medieval Christianity is understood only aesthetically its true character is falsified and trivialized, just as much as if it were viewed exclusively from the historical standpoint. A true understanding is possible only on a common ground—no one would wish to maintain that the nature of a railway bridge is adequately understood from a purely aesthetic angle. In adopting the view that the antagonism between Apollo and Dionysus is purely a question of conflicting artistic impulses, the problem is shifted to the aesthetic sphere in a way that is both historically and materially unjustified, and is subjected to a partial approach which can never do justice to its real content.

[232] This shifting of the problem must doubtless have its psychological cause and purpose. The advantages of such a procedure are not far to seek: the aesthetic approach immediately converts the problem into a picture which the spectator can contemplate at his ease, admiring both its beauty and its ugliness, merely re-experiencing its passions at a safe distance, with no danger of becoming involved in them. The aesthetic attitude guards against any real participation, prevents one from being personally implicated, which is what a religious understanding of the problem would mean. The same advantage is ensured by the historical approach—an approach which Nietzsche himself criticized in a series of very valuable essays.¹⁵ The possibility of taking such a tremendous problem—“a problem with horns,” as he calls it—merely aesthetically is of course very tempting, for its religious understanding, which in this case is the only adequate one, presupposes some actual experience of it which modern man can rarely boast of. Dionysus, however, seems to have taken his revenge on Nietzsche, as we can see from “An Attempt at Self-Criticism,” which dates from 1886 and was added as a preface to the reissue that year of *The Birth of Tragedy*:

What is a Dionysian? In this book may be found an answer: a “knowing one” speaks here, the votary and disciple of his god.¹⁶

But that was not the Nietzsche who wrote *The Birth of Tragedy*; at that time he was a votary of aestheticism, and he became a Dionysian only at the time of writing *Zarathustra* and that memorable passage with which he concludes “An Attempt at Self-Criticism”:

Lift up your hearts, my brethren, high, higher! And forget not the legs! Lift up your legs also, you good dancers, and better still if also you stand on your heads!¹⁷

[233] Nietzsche’s profound grasp of the problem in spite of his aesthetic defences was already so close to the real thing that his later Dionysian experience seems an almost inevitable consequence. His attack on Socrates in *The Birth of Tragedy* is aimed at the rationalist, who proves himself impervious to Dionysian orgiastics. This outburst is in line with the analogous error into which the aesthete always falls: he holds himself aloof from the problem. But even at that time, in spite of his aestheticism, Nietzsche had an inkling of the real solution when he said that the antagonism was not bridged by art but by “a metaphysical miracle of the Hellenic ‘will.’” He puts “will” in inverted commas, which, considering how strongly he was at that time influenced by Schopenhauer, we might well interpret as a reference to concept of the metaphysical Will. “Metaphysical” has for us the psychological connotation “unconscious.” If, then, we replace “metaphysical” in Nietzsche’s formula by “unconscious,” the desired key to the problem would be an unconscious “miracle.” A “miracle” is irrational, hence the act is an unconscious irrational happening, shaping itself without the assistance of reason and conscious purpose. It happens of itself, it just grows, like a phenomenon of creative Nature, and not from any clever trick of human wit; it is the fruit of yearning expectation, of faith and hope.

[234] At this point I must leave the problem for the time being, as we shall have occasion to discuss it more fully later. Let us turn instead to a closer examination of the Apollinian and Dionysian for their psychological qualities. First we will consider the Dionysian. From Nietzsche’s description it is immediately apparent that an unfolding is meant, a streaming outwards and upwards, a diastole, as Goethe called it; a motion embracing the whole world, as Schiller also describes it in his “Ode to Joy”:

Approach, ye millions, and embrace!

To the whole world my kiss shall swell!

...

All the world may draughts of joy

From the breasts of Nature take;

Good and ill alike employ

Pains to trace joy's rosy wake.
Kisses gave she and the grape,
And the faithful, lifelong friend;
Even the worm its joy can shape,
Heavenwards the cherubs wend.¹⁸

This is Dionysian expansion. It is a flood of overpowering universal feeling which bursts forth irresistibly, intoxicating the senses like the strongest wine. It is intoxication in the highest sense of the word.

[235] In this state the psychological function of sensation, whether it be sensory or affective, participates to the highest degree. It is an extraversion of all those feelings which are inextricably bound up with sensation, for which reason we call it feeling-sensation. What breaks out in this state has more the character of pure affect, something instinctive and blindly compelling, that finds specific expression in an affection of the bodily sphere.

[236] In contrast to this, the Apollinian is a perception of inner images of beauty, of measure, of controlled and proportioned feelings. The comparison with dreaming clearly indicates the character of the Apollinian state: it is a state of introspection, of contemplation turned inwards to the dream world of eternal ideas, and hence a state of introversion.

[237] So far the analogy with our mechanisms is unarguable. But if we were to be content with the analogy, it would be a limitation of outlook that does violence to Nietzsche's concepts by putting them on a Procrustean bed.

[238] We shall see in the course of our investigation that the state of introversion, if habitual, always entails a differentiation of the relation to the world of ideas, while habitual extraversion involves a similar differentiation of the relation to the object. We see nothing of this differentiation in Nietzsche's two concepts. Dionysian feeling has the thoroughly archaic character of affective sensation. It is therefore not pure feeling, abstracted and differentiated from instinct and becoming a mobile element, which, in the extraverted type, is obedient to the dictates of reason and lends itself to them as their willing instrument. Similarly, Nietzsche's conception of introversion is not that pure, differentiated relation to ideas which has freed itself from the perception of inner images whether sensuously determined or creatively produced, and has become a contemplation of pure and abstract forms. The Apollinian mode is an inner perception, and intuition of the world of ideas. The parallel with dreaming clearly shows that Nietzsche thinks of this state as on the one hand merely perceptive and on the other merely eidetic.

[239] These characteristics are individual peculiarities which we must not import into our conception of the introverted or extraverted attitude. In a man whose attitude is predominantly reflective, the Apollinian perception of inner images produces an elaboration of the perceived material in accordance with the nature of intellectual thinking. In other words, it produces ideas. In a man whose attitude is predominated by feeling a similar process results: a “feeling through” of the images and the production of a feeling-toned idea, which may coincide in essentials with an idea produced by thinking. Ideas, therefore, are just as much feelings as thoughts, examples being the idea of the fatherland, freedom, God, immortality, etc. In both elaborations the principle is a rational and logical one. But there is also a quite different standpoint, from which the rational and logical elaboration is not valid. This is the *aesthetic* standpoint. In introversion it dwells on the *perception* of ideas, it develops intuition, the inner vision; in extraversion it dwells on sensation and develops the senses, instinct, affectivity. From this standpoint, thinking is not the principle of an inner perception of ideas, and feeling just as little; instead, thinking and feeling are mere derivatives of inner perception and outer sensation.

[240] Nietzsche’s concepts thus lead us to the principles of a third and a fourth psychological type, which one might call “aesthetic” types as opposed to the rational types (thinking and feeling). These are the intuitive and sensation types. Both of them have the mechanisms of introversion and extraversion in common with the rational types, but they do not—like the thinking type—differentiate the perception and contemplation of inner images into thought, nor—like the feeling type—differentiate the affective experience of instinct and sensation into feeling. On the contrary, the intuitive raises unconscious perception to the level of a differentiated function, by which he also achieves his adaptation to the world. He adapts by means of unconscious directives, which he receives through an especially sensitive and sharpened perception and interpretation of dimly conscious stimuli. To describe such a function is naturally very difficult on account of its irrational and quasi-unconscious character. In a sense one might compare it to the daemon of Socrates—with the qualification, however, that the strongly rationalistic attitude of Socrates repressed the intuitive function as far as possible, so that it had to make itself felt in the form of concrete hallucinations since it had no direct access to consciousness. But this is not the case with the intuitive type.

[241] The sensation type is in every respect the converse of the intuitive. He relies almost exclusively on his sense impressions, and his whole psychology is oriented by instinct and sensation. He is therefore entirely dependent on external stimuli.

[242] The fact that it is just the psychological functions of intuition on the one hand and sensation and instinct on the other that Nietzsche emphasizes must be characteristic

of his own personal psychology. He must surely be reckoned an intuitive with leanings towards introversion. As evidence of the former we have his pre-eminently intuitive-artistic manner of production, of which *The Birth of Tragedy* is very characteristic, while his masterpiece *Thus Spake Zarathustra* is even more so. His aphoristic writings express his introverted intellectual side. These, in spite of a strong admixture of feeling, display a pronounced critical intellectualism in the manner of the intellectuals of the eighteenth century. His lack of rational moderation and conciseness argues for the intuitive type in general. Under these circumstances it is not surprising that in his early work he unwittingly sets the facts of his personal psychology in the foreground. This is quite in accord with the intuitive attitude, which perceives the outer primarily through the medium of the inner, sometimes even at the expense of reality. By means of this attitude he also gained deep insight into the Dionysian qualities of his unconscious, the crude forms of which, so far as we know, reached the surface of his consciousness only after the outbreak of his illness, although they had previously revealed their presence in various erotic allusions. It is extremely regrettable, therefore, from the standpoint of psychology, that the fragmentary writings—so significant in this respect—which were found in Turin after the onset of his malady should have met with destruction in deference to moral and aesthetic scruples.

IV

THE TYPE PROBLEM IN HUMAN CHARACTER

1. GENERAL REMARKS ON JORDAN'S TYPES

[243] Continuing my chronological survey of previous contributions to this interesting problem of psychological types, I now come to a small and rather odd work, my acquaintance with which I owe to my esteemed colleague Dr. Constance Long, of London: *Character as Seen in Body and Parentage*, by Furneaux Jordan, F.R.C.S.

[244] In this little book of one hundred and twenty-six pages, Jordan describes in the main two characterological types, the definition of which is of interest to us in more than one respect. Although—to anticipate slightly—the author is really concerned with only one half of our types, thinking and feeling, he nevertheless introduces the standpoint of the other half, the intuitive and sensation types, and blends the two together. I will first let the author speak for himself in his introductory definition:

There are two generic fundamental biases in character ... two conspicuous types of character (with a third, an intermediate one) ... one in which the tendency to action is extreme and the tendency to reflection slight, and another in which the proneness to reflection greatly predominates and the impulse for action is feebler. Between the two extremes are innumerable gradations; it is sufficient to point only to a third type ... in which the powers of reflection and action tend to meet in more or less equal degree. ... In an intermediate class may also be placed the characters which tend to eccentricity, or in which other possibly abnormal tendencies predominate over the emotional and non-emotional.¹

[245] It is clear from this definition that Jordan contrasts reflection, or thinking, with action. It is readily understandable that an observer of men, not probing too deeply, would first be struck by the contrast between reflective and active natures, and would therefore tend to define the observed antithesis in those terms. The simple reflection, however, that activity is not necessarily the product of mere impulse, but can also proceed from thinking, would make it seem necessary to carry the definition a stage further. Jordan himself reaches this conclusion, for on page 6 he introduces a further element which for us has a particular value, the element of feeling. He states here that the active type is less passionate, while the reflective temperament is distinguished by its passionate feelings. Hence he calls his types the “less impassioned” and the “more impassioned.” Thus the element he overlooked in his introductory definition

subsequently acquires the status of a fixed term. But what mainly distinguishes his conception from ours is that he makes the “less impassioned” type active and the “more impassioned” inactive.

[247] This combination seems to me unfortunate, since highly passionate and profound natures exist which at the same time are very energetic and active, and conversely, there are less passionate and superficial natures which are in no way distinguished by activity, not even by the low form of activity that consists in being busy. In my view, his otherwise valuable conception would have gained much in clarity if he had left the factors of activity and inactivity altogether out of account, as belonging to a quite different point of view, although in themselves they are important characterological determinants.

[246] It will be seen from the arguments which follow that the “less impassioned and more active” type describes the extravert, and the “more impassioned and less active” type the introvert. Either can be active or inactive without changing his type, and for this reason the factor of activity should, in my opinion, be ruled out as a main characteristic. As a determinant of secondary importance, however, it still plays a role, since the whole nature of the extravert appears more mobile, more full of life and activity than that of the introvert. But this quality entirely depends on the phase in which the individual momentarily finds himself vis-à-vis the external world. An introvert in an extraverted phase appears active, while an extravert in an introverted phase appears passive. Activity itself, as a fundamental trait of character, can sometimes be introverted; it is then all directed inwards, developing a lively activity of thought or feeling behind an outward mask of profound repose. Or else it can be extraverted, showing itself a vigorous action while behind the scenes there stands a firm unmoved thought or untroubled feeling.

[248] Before we examine Jordan’s arguments more closely, I must, for greater clarity, stress yet another point which, if not borne in mind, may give rise to confusion. I remarked at the beginning of this book that in my earlier publications I identified the introvert with the thinking and the extravert with the feeling type. As I have said before, it became clear to me only later that introversion and extraversion are to be distinguished as general basic attitudes from the function-types. These two attitudes may be recognized with the greatest ease, while it requires considerable experience to distinguish the function-type. At times it is uncommonly difficult to find out which function holds prior place. The fact that the introvert, because of his abstracting attitude, naturally has a reflective and contemplative air is misleading. One is inclined to assume that in him the primacy falls to thinking. The extravert, on the contrary, naturally displays many immediate reactions, which easily lead one to conjecture a predominance of feeling. These suppositions are deceptive, since the

extravert may well be a thinking, and the introvert a feeling type. Jordan describes in general merely the introvert and the extravert. But, when he goes into details, his description becomes misleading, because traits of different function-types are blended together which a more thorough examination of the material would have kept apart. In its general outline, however, the picture of the introverted and extraverted attitudes is unmistakable, so that the nature of the two basic attitudes can plainly be discerned.

[249] The characterization of types in terms of affectivity seems to me the really important aspect of Jordan's work. We have already seen that the reflective, contemplative nature of the introvert is compensated by a condition in which instinct and sensation are unconscious and archaic. We might even say this is just why he is introverted: he has to rise above his archaic, impulsive nature to the safe heights of abstraction in order to dominate from there his unruly and turbulent affects. This point of view is not at all wide of the mark in many cases. We might also say, conversely, that the affective life of the extravert, being less deeply rooted, lends itself more readily to differentiation and domestication than his unconscious, archaic thinking and feeling, and that this fantasy life of his can have a dangerous influence on his personality. Hence he is always the one who seeks life and experience as busily and abundantly as possible in order not to have to come to himself and face his evil thoughts and feelings. These observations, which can easily be verified, help to explain an otherwise paradoxical passage in Jordan, where he says (p. 6) that in the "less impassioned" (= extraverted) temperament the intellect predominates and has an unusually large share in the regulation of life, whereas in the "reflective" (= introverted) temperament it is affects that claim the greater importance.

[250] At first glance, this view would seem to fly in the face of my assertion that the "less impassioned" type corresponds to the extravert. But closer scrutiny proves that this is not so, since the reflective character, the introvert, though certainly *trying* to deal with his unruly affects, is in reality more influenced by his passions than the man whose life is consciously guided by desires oriented to objects. The latter, the extravert, tries to get away with this all the time, but is forced to experience how his subjective thoughts and feelings constantly stand in his way. He is far more influenced by his psychic inner world than he suspects. He cannot see it himself, but the people around him, if observant, will always detect the personal purpose in his striving. Hence his golden rule should always be to ask himself: "What am I really after? What is my secret intention?" The other, the introvert, with his conscious thought-out intentions, always overlooks what the people around him see only too clearly, that his intentions are really subservient to powerful impulses, lacking both aim and object, and are in a high degree influenced by them. The observer and critic of the extravert is liable to take the parade of thinking and feeling as a thin covering

that only imperfectly conceals a cold and calculated personal aim. Whereas the man who tries to understand the introvert will readily conclude that vehement passions are only with difficulty held in check by apparent sophistries.

[251] Either judgment is both true and false. It is *false* when the conscious standpoint, or consciousness itself, is strong enough to offer resistance to the unconscious; but it is *true* when a weaker conscious standpoint encounters a strong unconscious and eventually has to give way to it. Then the motive that was kept in the background breaks through: in one case the egoistic aim, in the other the unsubdued passion, the elemental affect, that throws every consideration to the winds.

[252] These reflections enable us to discern Jordan's mode of observation: he is evidently preoccupied with the affectivity of the observed type, hence his nomenclature: "less impassioned," "more impassioned." When, therefore, from the standpoint of affect, he conceives the introvert as the more impassioned, and the extravert as the less impassioned and even as the intellectual type, he displays a peculiar kind of discernment which one must describe as *intuitive*. I have already pointed out that Jordan blends the standpoint of the rational types with that of the "aesthetic" types.² So when he characterizes the introvert as passionate and the extravert as intellectual he is obviously seeing the two types from the unconscious side, that is, he *perceives them through the medium of his own unconscious*. He observes and cognizes intuitively, and this must always be the case, more or less, with a practical observer of men.

[253] But however true and profound such an apprehension may sometimes be, it suffers from one very important limitation: it overlooks the living reality of the person observed, since it always judges him by his unconscious mirror-image instead of by his actual appearance. This error is inseparable from all intuition, and reason has always been at loggerheads with it on that account, only grudgingly admitting its right to exist despite the fact that in many cases the objective rightness of the intuition cannot be denied. Thus Jordan's formulations accord on the whole with reality, though not with reality as it is understood by the rational types, but with the reality which for them is unconscious. Naturally these conditions are calculated to confuse all judgment of the observed and to make agreement about it all the more difficult. One should therefore not quarrel over the nomenclature but should stick exclusively to the observable differences. Although I, in accordance with my nature, express myself quite differently from Jordan, we are—allowing for certain divergences—nevertheless at one in our classification of the observed material.

[254] Before going on to discuss Jordan's typology, I should like to return for a moment to the third or "intermediate" type which he postulates. Under this heading he includes on the one hand characters that are entirely balanced, and on the other

those that are unbalanced or “eccentric.” It will not be superfluous to recall at this point the classification of the Valentinian school, according to which the *hylic* man is inferior to the psychic and the pneumatic man. The hylic man corresponds by definition to the sensation type, whose ruling determinants are supplied by the senses. The sensation type possesses neither differentiated thinking nor differentiated feeling, but his sensuousness is well developed. This, as we know, is also the case with the primitive. The instinctive sensuousness of the primitive has its counterpart in the spontaneity of his psychic processes: his mental products, his thoughts, just appear to him, as it were. It is not he who makes them or thinks them—he is not capable of that—they make themselves, they happen to him, they even confront him as hallucinations. Such a mentality must be termed intuitive, for intuition is the instinctive perception of an emergent psychic content. Although the principal psychological function of the primitive is as a rule sensation, the less conspicuous compensatory function is intuition. On the higher levels of civilization, where one man has thinking more more or less differentiated and another feeling, there are also quite a number who have developed intuition to a high degree and can employ it as the essentially determining function. From these we get the intuitive type. It is my belief, therefore, that Jordan’s intermediate group can be resolved into the sensation and intuitive types.

2. SPECIAL DESCRIPTION AND CRITICISM OF JORDAN’S TYPES

[255] As regards the general characterization of the two types, Jordan emphasizes (p. 17) that the more impassioned type includes far fewer prominent and striking personalities than the less impassioned. This assertion derives from the fact that Jordan identifies the active type with the less impassioned, which in my opinion is inadmissible. But if we discount this error, it is certainly true that the behaviour of the less impassioned or extraverted type makes him more conspicuous than the more impassioned or introverted type.

a. The Introverted Woman (“The More Impassioned Woman”)

[256] We will first summarize the chief points in Jordan’s discussion of the introverted woman:

She has quiet manners, and a character not easy to read: she is occasionally critical, even sarcastic, but though bad temper is sometimes noticeable, she is not habitually fitful, or restless, or captious, or censorious, nor is she a “nagging” woman. She diffuses an atmosphere of repose, and unconsciously she consoles and heals, but under the surface emotions and passions lie dormant. Her emotional nature matures

slowly. As she grows older the charm of her character increases. She is “sympathetic,” i.e., she brings insight and experience to bear on the problems of others. Yet the very worst characters are found among the more impassioned women. They are the cruellest stepmothers. They make most affectionate wives and mothers, but their passions and emotions are so strong that these frequently hold reason in subjection or carry it away with them. They love too much, but they also hate too much. Jealousy can make wild beasts of them. Stepchildren, if hated by them, may even be done to death. If evil is not in the ascendant, morality itself is associated with deep feeling, and may take a profoundly reasoned and independent course which will not always fit itself to conventional standards. It will not be an imitation or a submission; not a bid for a reward here or hereafter. It is only in intimate relations that the excellences and drawbacks of the impassioned woman are seen. Here she unfolds herself; here are her joys and sorrows, here her faults and weaknesses are seen, perhaps slowness to forgive, implacability, sullenness, anger, jealousy, or degraded uncontrolled passions. She is charmed with the moment, and less apt to think of the comfort and welfare of the absent. She is disposed to forget others and forget time. If she is affected, her affectation is less an imitation than a pronounced change of manners and speech with changing shades of thought and especially of feeling. In social life she tends to be the same in all circles. In both domestic and social life she is as a rule not difficult to please, she spontaneously appreciates, congratulates, and praises. She can soothe the mentally bruised and encourage the unsuccessful. She rises to the high and stoops to the low, she is the sister and playmate of all nature. Her judgment is mild and lenient. When she reads she tries to grasp the inmost thought and deepest feeling of the book; she reads and rereads the book, marks it freely, and turns down its corners.³

[257] From this description it is not difficult to recognize the introverted character. But it is, in a certain sense, one-sided, because the chief stress is laid on feeling, without considering the one characteristic to which I attach special value—the *conscious inner life*. Jordan mentions in passing that the introverted woman is “contemplative” (p. 18), but he does not pursue the matter further. His description, however, seems to me a confirmation of my comments on his mode of observation. It is chiefly the outward behaviour constellated by feeling, and the expressions of passion that strike him; he does not probe into the conscious life of this type. He never mentions that the inner life plays an altogether decisive role in the introvert’s conscious psychology. Why, for example, does the introverted woman read so attentively? Because above everything else she loves to understand and grasp ideas. Why is she restful and soothing? Because she usually keeps her feelings to herself, expressing them in her thoughts instead of unloading them on others. Her unconventional morality is backed by deep reflection and convincing inner feelings. The charm of her quiet and

intelligent character depends not merely on a peaceful attitude, but on the fact that one can talk with her reasonably and coherently, and that she is able to appreciate the value of her partner's argument. She does not interrupt him with impulsive exclamations, but accompanies his meaning with her thoughts and feelings, which none the less remain steadfast, never yielding to the opposing argument.

[258] This compact and well-developed ordering of the conscious psychic contents is a stout defence against a chaotic and passionate emotional life of which the introvert is very often aware, at least in its personal aspect: she fears it because she knows it too well. She meditates about herself, and is therefore outwardly calm and can acknowledge and accept others without overwhelming them with praise or blame. But because her emotional life would devastate these good qualities, she rejects as far as possible her instincts and affects, though without mastering them. In contrast, therefore, to her logical and well-knit consciousness, her affective life is elemental, confused, and ungovernable. It lacks the true human note, it is out of proportion, irrational, a *phenomenon of nature* that breaks through the human order. It lacks any kind of palpable afterthought or purpose, so at times it is purely destructive, a raging torrent that neither intends destruction nor avoids it, ruthless and necessary, obedient only to its own laws, a process that is its own fulfillment. Her good qualities depend on her thinking, which by its tolerant or benevolent outlook has succeeded in influencing or restraining one part of her instinctive life, though without being able to embrace and transform the whole. The introverted woman is far less conscious of the full range of her affectivity than she is of her rational thoughts and feelings. Her affectivity is much less mobile than her intellectual content; it is, as it were, viscous and curiously inert, therefore hard to change; it is persevering, hence her unconscious steadiness and equability, but also her self-will and her occasional unreasonable inflexibility in things that touch her emotions.

[259] These reflections may explain why any judgment on the introverted woman in terms of affectivity alone is incomplete and unfair in good and bad alike. If Jordan finds the vilest characters among introverted women, this, in my opinion, is due to the fact that he lays too great a stress on affectivity, as if passion alone were the mother of all evil. We can torture children to death in other ways than the merely physical. And, conversely, that wondrous wealth of love in the introverted woman is not by any means always her own possession; she is more often possessed by it and cannot choose but love, until one day a favourable opportunity occurs, when suddenly, to the amazement of her partner, she displays an inexplicable coldness. The emotional life of the introverted woman is generally her weak side, it is not absolutely trustworthy. She deceives herself about it; others also are deceived and disappointed in her if they rely too much on her emotionality. Her mind is more to be relied on, because more adapted. Her affect is too close to sheer untamed nature.

b. The Extraverted Woman ("The Less Impassioned Woman")

[260] Let us now turn to Jordan's description of the "less impassioned" woman. Here too I must reject everything the author has confused by the introduction of activity, since this admixture is only calculated to make the typical character less recognizable. Thus when he speaks of a certain "quickness" of the extravert, this does not mean vivacity or activity, but merely the mobility of active psychological processes.

[261] Of the extraverted woman Jordan says:

She is marked by activity, vivacity, quickness, and opportuneness rather than by persistence or consistency. Her life is almost wholly occupied with little things. She goes even further than Lord Beaconsfield in the belief that unimportant things are not very unimportant, and important things not very important. She likes to dwell on the way her grandmother did things, and how her grandchildren will do them, and on the universal degeneracy of human beings and affairs. Her daily wonder is how things would go on if she were not there to look after them. She is frequently invaluable in social movements. She expends her energies in household cleanliness, which is the end and aim of existence to not a few women. Frequently she is "idea-less, emotionless, restless and spotless." Her emotional development is usually precocious, and at eighteen she is little less wise than at twenty-eight or forty-eight. Her mental outlook usually lacks range and depth, but it is clear from the first. When intelligent, she is capable of taking a leading position. In society she is kindly, generous and hospitable. She judges her neighbours and friends, forgetful that she is herself being judged, but she is active in helping them in misfortune. Deep passion is absent in her, love is simply preference, hatred merely dislike, and jealousy only injured pride. Her enthusiasm is not sustained, and she is more alive to the beauty of poetry than she is to its passion and pathos. Her beliefs and disbeliefs are complete rather than strong. She has no convictions, but she has no misgivings. She does not believe, she adopts, she does not disbelieve, she ignores. She never enquires and she never doubts. In large affairs she defers to authority; in small affairs she jumps to conclusions. In the detail of her own little world, whatever is, is wrong; in the larger world outside, whatever is, is right. She instinctively rebels against carrying the conclusions of reason into practice.

At home she shows quite a different character from the one seen in society. With her, marriage is much influenced by ambition, or a love of change, or obedience to well-recognized custom and a desire to be "settled in life," or from a sincere wish to enter a greater sphere of usefulness. If her husband belongs to the impassioned type, he will love children more than she does.

In the domestic circle, her least pleasing characteristics are evident. Here she indulges in disconnected, disapproving comment, and none can foresee when there will be a gleam of sunshine through the cloud. The unemotional woman has little or no self-analysis. If she is plainly accused of habitual disapproval she is surprised and offended, and intimates that she only desires the general good, "but some people do not know what is good for them." She has one way of doing good to her family, and quite another way where society is concerned. The household must always be ready for social inspection. Society must be encouraged and propitiated. Its upper section must be impressed and its lower section kept in order. Home is her winter, society her summer. If the door but opens and a visitor is announced, the transformation is instant.

The less emotional woman is by no means given to asceticism; respectability and orthodoxy do not demand it of her. She is fond of movement, recreation, change. Her busy day may open with a religious service, and close with a comic opera. She delights, above all, to entertain her friends and to be entertained by them. In society she finds not only her work and her happiness, but her rewards and her consolations. She believes in society, and society believes in her. Her feelings are little influenced by prejudice, and as a rule she is "reasonable." She is very imitative and usually selects good models, but is only dimly conscious of her imitations. The books she reads must deal with life and action.⁴

[262] This familiar type of woman is extraverted beyond a doubt. Her whole demeanour indicates a character that by its very nature must be called extraverted. The continual criticizing, which is never based on real reflection, is an extraversion of a fleeting impression that has nothing to do with real thinking. I remember a witty aphorism I once read somewhere: "Thinking is difficult, therefore let the herd pass judgment!" Reflection demands time above everything: hence the man who reflects has no opportunity for continual criticism. Incoherent and inconsequential criticism, dependent on tradition and authority, reveals the absence of any independent reflection; similarly the lack of self-criticism and the dearth of independent ideas betray a defect in the function of judgment. The absence of inner mental life in this type comes out much more clearly than its presence in the introverted type described earlier. From this sketch one might easily conclude that there is just as great or even greater a lack of affectivity, for it is obviously superficial, shallow, almost spurious, because the ulterior motive always bound up with it or discernible behind it makes the affective output practically worthless. I am, however, inclined to assume that our author is undervaluing here, just as much as he overvalued in the former case. In spite of an occasional admission of good qualities, the type on the whole comes out of it very badly. I believe this is due to a bias on the part of the author. It is usually enough to have had bitter experiences with one or more representatives of the same

type for one's taste to be spoiled for all of them. One must not forget that, just as the good sense of the introverted woman depends on a careful accommodation of her mental contents to the general thinking, the affectivity of the extraverted woman possesses a certain lability and shallowness because it is adapted to the ordinary life of human society. It is thus a socially differentiated affectivity with an incontestable general value, which compares very favourably with the heavy, sultry, passionate affect of the introvert. This differentiated affectivity has sloughed off everything chaotic and pathetic and become a disposable function of adaptation, even though it be at the expense of the inner mental life, which is conspicuous by its absence. It none the less exists in the unconscious, and moreover in a form corresponding to the passion of the introvert, i.e., it is in an undeveloped, archaic, infantile state. Working from the unconscious, the undeveloped mentality supplies the affective output with contents and hidden motives that cannot fail to make a bad impression on the critical observer, although they may be unperceived by the uncritical eye. The disagreeable impression that the constant perception of thinly veiled egoistic motives has on the observer makes him only too prone to forget the actual reality and adapted usefulness of the affective output displayed. All that is easy-going, unforced, temperate, harmless, and superficial in life would disappear if there were no differentiated affects. One would either be stifled in perpetual pathos or engulfed in the yawning abyss of repressed passion. If the social function of the introvert concentrates mainly on individuals, it is usually true that the extravert promotes the life of the community, which also has a right to exist. For this extraversion is needed, because it is first and foremost the bridge to one's neighbour.

[263] As we all know, the expression of affect works by suggestion, whereas the mind can operate only indirectly, after arduous translation into another medium. The affects required by the social function need not be at all deep, otherwise they beget passion in others, and passion upsets the life and wellbeing of society. Similarly, the adapted, differentiated mentality of the introvert has extensity rather than intensity; hence it is not disturbing and provocative but reasonable and calming. But, just as the introvert causes trouble by the violence of his passions, the extravert irritates by his half-unconscious thoughts and feelings, incoherently and abruptly applied in the form of tactless and unsparing judgments on his fellow men. If we were to make a collection of such judgments and tried to construct a psychology out of them, they would build up into an utterly brutal outlook, which in chilling savagery, crudity, and stupidity rivals the murderous affectivity of the introvert. Hence I cannot subscribe to Jordan's view that the very worst characters are to be found among passionate introverted natures. Among extraverts there is just as much inveterate wickedness. But whereas introverted passion expresses itself in brutal actions, the vulgarity of the extravert's unconscious thoughts and feelings commits crimes against the soul of the

victim. I do not know which is worse. The drawback in the former case is that the deed is visible, while the latter's vulgarity of mind is concealed behind the veil of acceptable behaviour. I would like, however, to stress the social thoughtfulness of this type, his active concern for the general welfare, as well as a decided tendency to give pleasure to others. The introvert as a rule has these qualities only in his fantasies.

[264] Differentiated affects have the further advantage of charm and elegance. They spread about them an air that is aesthetic and beneficial. A surprising number of extraverts practise an art—chiefly music—not so much because they are specially qualified for it as from a desire to make their contribution to social life. Nor is their fault-finding always unpleasant or altogether worthless. Very often it is no more than a well-adapted educative tendency which does a great deal of good. Equally, their dependence on the judgment of others is not necessarily a bad thing, as it often conduces to the suppression of extravagances and pernicious excesses which in no way further the life and welfare of society. It would be altogether unjustifiable to maintain that one type is in any respect more valuable than the other. The types are mutually complementary, and their differences generate the tension that both the individual and society need for the maintenance of life.

c. The Extraverted Man ("The Less Impassioned Man")

[265] Of the extraverted man Jordan says:

He is fitful and uncertain in temper and behaviour, given to petulance, fuss, discontent and censoriousness. He makes depreciatory judgments on all and sundry, but is ever well satisfied with himself. His judgment is often at fault and his projects often fail, but he never ceases to place unbounded confidence in both. Sidney Smith, speaking of a conspicuous statesman of his time, said he was ready at any moment to command the Channel Fleet or amputate a limb. He has an incisive formula for everything that is put before him—either the thing is not true, or everybody knows it already. In his sky there is not room for two suns. If other suns insist on shining, he has a curious sense of martyrdom.

He matures early. He is fond of administration, and is often an admirable public servant. At the committee of his charity he is as much interested in the selection of its washer-woman as in the selection of its chairman. In company he is usually alert, to the point, witty, and apt at retort. He resolutely, confidently, and constantly shows himself. Experience helps him and he insists on getting experience. He would rather be the *known* chairman of a committee of three than the *unknown* benefactor of a nation. When he is less gifted he is probably not less self-important. Is he busy? He

believes himself to be energetic. Is he loquacious? He believes himself to be eloquent.

He rarely puts forth new ideas, or opens new paths, but he is quick to follow, to seize, to apply, to carry out. His natural tendency is to ancient, or at least accepted, forms of belief and policy. Special circumstances may sometimes lead him to contemplate with admiration the audacity of his own heresy. Not rarely the less emotional intellect is so lofty and commanding that no disturbing influence can hinder the formation of broad and just views in all the provinces of life. His life is usually characterized by morality, truthfulness, and high principle; sometimes his desire to produce an immediate effect however leads to later trouble.

If, in public assembly, adverse fates have given him nothing to do,—nothing to propose, or second, or support, or amend, or oppose—he will rise and ask for some window to be closed to keep out a draught, or, which is more likely, that one be opened to let in more air; for, physiologically, he commonly needs much air as well as much notice. He is especially prone to do what he is not asked to do—what, perhaps, he is not best fitted to do; nevertheless he constantly believes that the public sees him as he wishes it to see him, as he sees himself—a sleepless seeker of the public good. He puts others in his debt, and he cannot go unrewarded. He may, by well-chosen language, move his audience although he is not moved himself. He is probably quick to understand his time or at least his party; he warns it of impending evil, organizes its forces, deals smartly with its opponents. He is full of projects and prophecies and bustle. Society must be pleased if possible; if it will not be pleased it must be astonished; if it will neither be pleased nor astonished it must be pestered and shocked. He is a saviour by profession and as an acknowledged saviour is not ill pleased with himself. We can of ourselves do nothing right—but we can believe in him, dream of him, thank God for him, and ask him to address us.

He is unhappy in repose, and rests nowhere long. After a busy day he must have a pungent evening. He is found in the theatre, or concert, or church, or the bazaar, at the dinner, or *conversazione* or club, or all these, turn and turn about. If he misses a meeting, a telegram announces a more ostentatious call.⁵

[266] From this description, too, the type can easily be recognized. But, perhaps even more than in the description of the extraverted woman, there emerges, in spite of occasional appreciative touches, an element of depreciation that amounts to caricature. It is due partly to the fact that this method of description cannot hope to be fair to the extraverted nature in general, because it is virtually impossible for the intellectual approach to put the specific value of the extravert in the right light. This is much more possible with the introvert, because his essential reasonableness and his conscious motivation can be expressed in intellectual terms as readily as his passions

can and the actions resulting from them. With the extravert, on the other hand, the specific value lies in his relation to the object. It seems to me that only life itself can grant the extravert the just dues that intellectual criticism cannot give him. Life alone reveals his values and appreciates them. We can, of course, establish that the extravert is socially useful, that he has made great contributions to the progress of human society, and so on. But any analysis of his resources and motives will always yield a negative result, because his specific value lies in the reciprocal relation to the object and not in himself. The relation to the object is one of those imponderables that an intellectual formulation can never grasp.

[267] Intellectual criticism cannot help proceeding analytically and bringing the observed type to full clarity by pinning down its motives and aims. But this, as we have said, results in a picture that amounts to a caricature of the psychology of the extravert, and anyone who believes he has found the right attitude to an extravert on the basis of such a description would be astonished to see how the actual personality turns the description into a mockery. Such a one-sided view of things makes any adaptation to the extravert impossible. In order to do him justice, *thinking* about him must be altogether excluded, while for his part the extravert can properly adapt to the introvert only when he is prepared to accept his mental contents in themselves regardless of their practical utility. Intellectual analysis cannot help attributing to the extravert every conceivable design, stratagem, ulterior motive, and so forth, though they have no actual existence but at most are shadowy effects leaking in from the unconscious background.

[268] It is certainly true that the extravert, if he has nothing else to say, will at least demand that a window be open or shut. But who notices, who is struck by it? Only the man who is trying to account for all the possible reasons and intentions behind such an action, who reflects, dissects, puts constructions on it, while for everyone else this little stir vanishes in the general bustle of life without their seeing in it anything sinister or remarkable. But this is just the way the psychology of the extravert manifests itself: it is part and parcel of the happenings of daily human life, and it signifies nothing more than that, neither better nor worse. But the man who reflects sees further and—so far as actual life is concerned—sees crooked, though his vision is sound enough as regards the unconscious background of the extravert's thought. He does not see the positive man, but only his *shadow*. And the shadow proves the judgment right at the expense of the conscious, positive man. For the sake of understanding, it is, I think, a good thing to detach the man from his shadow, the unconscious, otherwise the discussion is threatened with an unparalleled confusion of ideas. One sees much in another man that does not belong to his conscious psychology, but is a gleam from his unconscious, and one is deluded into attributing the observed quality to his conscious ego. Life and fate may do this, but the

psychologist, to whom knowledge of the structure of the psyche and the possibility of a better understanding of man are of the deepest concern, must not. A clear differentiation of the conscious man from his unconscious is imperative, since only by the assimilation of conscious standpoints will clarity and understanding be gained, but never by a process of reduction to the unconscious backgrounds, sidelights, quarter-tones.

d. The Introverted Man ("The More Impassioned Man")

[269] Of the introverted man Jordan says:

He may spend his evenings in pleasure from a genuine love of it; but his pleasures do not change every hour, and he not driven to them from mere restlessness. If he takes part in public work he is probably invited to do so from some special fitness; or it may be that he has at heart some movement—beneficent or mischievous—which he wishes to promote. When his work is done he willingly retires. He is able to see what others can do better than he; and he would rather that his cause should prosper in other hands than fail in his own. He has a hearty word of praise for his fellow-workers. Probably he errs in estimating too generously the merits of those around him. He is never, and indeed cannot be, an habitual scold. ... Men of profound feeling and illimitable pondering tend to suspense or even hesitation; they are never the founders of religions; never leaders of religious movements; they neither receive nor deliver divine messages. They are moreover never so supremely confident as to what is error that they burn their neighbours for it; never so confident that they possess infallible truth that, although not wanting in courage, they are prepared to be burnt in its behalf.⁶

[270] To me it seems significant that in his chapter on the introverted man Jordan says no more in effect than what is given in the above excerpts. What we miss most of all is a description of the passion on account of which the introvert is called "impassioned" in the first place. One must, of course, be cautious in making diagnostic conjectures, but this case seems to invite the supposition that the introverted man has received such niggardly treatment for subjective reasons. After the elaborately unfair description of the extraverted type, one might have expected an equal thoroughness in the description of the introvert. Why is it not forthcoming?

[271] Let us suppose that Jordan himself is on the side of the introverts. It would then be intelligible that a description like the one he gives of his opposite number with such pitiless severity would hardly have suited his book. I would not say from lack of objectivity, but rather from lack of knowledge of his own shadow. The introvert cannot possibly know or imagine how he appears to his opposite type unless he allows the extravert to tell him to his face, at the risk of having to challenge him to a

duel. For as little as the extravert is disposed to accept Jordan's description as an amiable and apposite picture of his character is the introvert inclined to let his picture be painted by an extraverted observer and critic. The one would be as depreciatory as the other. Just as the introvert who tries to get hold of the nature of the extravert invariably goes wide of the mark, so the extravert who tries to understand the other's inner life from the standpoint of externality is equally at sea. The introvert makes the mistake of always wanting to derive the other's actions from the subjective psychology of the extravert, while the extravert can conceive the other's inner life only as a consequence of external circumstances. For the extravert an abstract train of thought must be a fantasy, a sort of cerebral mist, when no relation to an object is in evidence. And as a matter of fact the introvert's brain-weavings are often nothing more. At all events a lot more could be said of the introverted man, and one could draw a shadow portrait of him no less complete and no less unfavourable than the one Jordan drew of the extravert.

[272] His observation that the introvert's love of pleasure is "genuine" seems to me important. This appears to be a peculiarity of introverted feeling in general: it is genuine because it is there of itself, rooted in the man's deeper nature; it wells up out of itself, having itself as its own aim; it will serve no other ends, lending itself to none, and is content to be an end in itself. This hangs together with the spontaneity of any archaic and natural phenomenon that has never yet bowed to the ends and aims of civilization. Rightly or wrongly, or at any rate without regard to right or wrong, suitability or unsuitability, the affective state bursts out, forcing itself on the subject even against his will and expectation. There is nothing about it that suggests a calculated motivation.

[273] I do not wish to discuss the remaining chapters of Jordan's book. He cites historical personalities as examples, presenting numerous distorted points of view which all derive from the fallacy already referred to, of introducing the criterion of active and passive and mixing it up with the other criteria. This leads to the frequent conclusion that an active personality must be reckoned a passionless type and, conversely, that a passionate nature must be passive. I seek to avoid this error by excluding the factor of activity as a criterion altogether.

[274] To Jordan, however, belongs the credit for having been the first, so far as I know, to give a relatively appropriate character sketch of the emotional types.

V

THE TYPE PROBLEM IN POETRY

Carl Spitteler: *Prometheus and Epimetheus*

1. INTRODUCTORY REMARKS ON SPITTELER'S TYPOLOGY

[275] If, besides the themes offered to the poet by the complications of emotional life, the type problem did not also play a significant role, it would almost amount to a proof that the problem did not exist. But we have already seen how in Schiller this problem stirred the poet in him as deeply as the thinker. In this chapter we shall turn our attention to a poetic work based almost exclusively on the type problem: Carl Spitteler's *Prometheus and Epimetheus*, published in 1881.

[276] I have no wish to declare at the outset that Prometheus, the "forethinker," stands for the introvert, and Epimetheus, the man of action and "afterthinker," for the extravert. The conflict between these two figures is essentially a struggle between the introverted and extraverted lines of development in one and the same individual, though the poet has embodied it in two independent figures and their typical destinies.

[277] There can be no mistaking the fact that Prometheus exhibits introverted character traits. He presents the picture of a man introverted to his inner world, true to his "soul." He expresses his nature perfectly in the reply he gives to the angel:

But it does not lie with me to judge of the face of my soul, for lo, she is my Lady and Mistress, and she is my God in joy and sorrow, and all that I am, I owe to her alone. And so I will share my honour with her, and, if needs must, I am ready to forego it altogether.¹

[278] Prometheus surrenders himself, come honour or dishonour, to his soul, that is, to the function of relation to the inner world. That is why the soul has a mysterious, metaphysical character, precisely on account of her relation to the unconscious. Prometheus concedes her an absolute significance, as mistress and guide, in the same unconditional manner in which Epimetheus surrenders himself to the world. He sacrifices his individual ego to the soul, to the relation with the unconscious as the matrix of eternal images and meanings, and becomes de-individualized, because he has lost the counterweight of the persona,² the function of relation to the external

object. With this surrender to his soul Prometheus loses all connection with the surrounding world, and hence also the very necessary corrective offered by external reality. But this loss cannot be reconciled with the nature of the real world. Therefore an angel appears to Prometheus, evidently a representative of the powers-that-be; in psychological terms, he is the projected image of a tendency aiming at adaptation to reality. The angel accordingly says to Prometheus:

It shall come to pass, if you do not prevail and free yourself from your froward soul, that you shall lose the great reward of many years, and the joy of your heart, and all the fruits of your richly endowed mind.³

And again:

You shall be cast out on the day of your glory on account of your soul, for she knows no god and obeys no law, and nothing is sacred to her pride, either in heaven or on earth.⁴

[279] Because Prometheus has a one-sided orientation to his soul, all tendencies to adapt to the external world are repressed and sink into the unconscious. Consequently, if perceived at all, they appear as not belonging to his own personality but as projections. There would seem to be a contradiction in the fact that the soul, whose cause Prometheus has espoused and whom he has, as it were, fully assimilated into consciousness, appears at the same time as a projection. But since the soul, like the persona, is a function of relationship, it must consist in a certain sense of two parts—one part belonging to the individual, and the other adhering to the object of relationship, in this case the unconscious. Unless one frankly subscribes to von Hartmann's philosophy, one is generally inclined to grant the unconscious only a conditional existence as a psychological factor. On epistemological grounds, we are at present quite unable to make any valid statement about the objective reality of the complex psychological phenomenon we call the unconscious, just as we are in no position to say anything valid about the essential nature of real things, for this lies beyond our psychological ken. On the grounds of practical experience, however, I must point out that, in relation to the activity of consciousness, the contents of the unconscious lay the same claim to reality on account of their obstinate persistence as do the real things of the external world, even though this claim must appear very improbable to a mind that is "outer-directed." It must not be forgotten that there have always been many people for whom the contents of the unconscious possessed a greater reality than the things of the outside world. The history of human thought bears witness to both realities. A more searching investigation of the human psyche shows beyond question that there is in general an equally strong influence from both sides on the activity of consciousness, so that, psychologically, we have a right on

purely empirical grounds to treat the contents of the unconscious as just as *real* as the things of the outside world, even though these two realities are mutually contradictory and appear to be entirely different in their natures. But to subordinate one reality to the other would be an altogether unjustifiable presumption. Theosophy and spiritualism are just as violent in their encroachments on other spheres as materialism. We have to accommodate ourselves to our psychological capacities, and be content with that.

[280] The peculiar reality of unconscious contents, therefore, gives us the same right to describe them as *objects* as the things of the outside world. Now just as the persona, being a function of relationship, is always conditioned by the external object and is anchored as much in it as in the subject, so the soul, as a function of relationship to the inner object, is represented by that object; hence she is always distinct from the subject in one sense and is actually perceived as something different. Consequently, she appears to Prometheus as something quite separate from his individual ego. In the same way as a man who surrenders entirely to the outside world still has the world as an object distinct from himself, the unconscious world of images behaves as an object distinct from the subject even when a man surrenders to it completely. And, just as the unconscious world of mythological images speaks indirectly, through the experience of external things, to the man who surrenders wholly to the outside world, so the real world and its demands find their way indirectly to the man who has surrendered wholly to the soul; for no man can escape both realities. If he is intent only on the outer reality, he must live his myth; if he is turned only towards the inner reality, he must dream his outer, so-called real life. Accordingly the soul says to Prometheus:

I told you I was a wayward goddess, who would lead you astray on untrodden paths. But you would not listen to me, and now it has come to pass according to my words: for my sake they have robbed you of the glory of your name and stolen from you your life's happiness.⁵

[281] Prometheus refuses the kingdom the angel offers him, which means that he refuses to adapt to things as they are because his soul is demanded from him in exchange. The subject, Prometheus, is essentially human, but his soul is of a quite different character. She is daemonic, because the inner object, the suprapersonal, collective unconscious with which she is connected as the function of relationship, gleams through her. The unconscious, considered as the historical background of the human psyche, contains in concentrated form the entire succession of engrams (imprints) which from time immemorial have determined the psychic structure as it now exists. These engrams are nothing other than function-traces that typify, on average, the most frequently and intensively used functions of the human psyche.

They present themselves in the form of mythological motifs and images, appearing often in identical form and always with striking similarity among all races; they can also be easily verified in the unconscious material of modern man. It is therefore understandable that decidedly animal traits or elements should appear among the unconscious contents side by side with those sublime figures which from ancient times have been man's companions on the road of life. The unconscious is a whole world of images whose range is as boundless as that of the world of "real" things. Just as the man who has surrendered entirely to the outside world encounters it in the form of some intimate and beloved being through whom, should his destiny lie in extreme devotion to a personal object, he will experience the whole ambivalence of the world and of his own nature, so the other, who has surrendered to the soul, will encounter her as a daemonic personification of the unconscious, embodying the totality, the utter polarity and ambivalence of the world of images. These are borderline phenomena that overstep the norm; hence the normal, middle-of-the-road man knows nothing of these cruel enigmas. They do not exist for him. It is always only a few who reach the rim of the world, where its mirror-image begins. For the man who always stands in the middle the soul has a human and not a dubious, daemonic character, neither does his neighbour appear to him in the least problematical. Only complete surrender to one world or the other evokes their ambivalence. Spitteler's intuition caught a soul-image which would have appeared to a less profound nature at most in a dream:

And while he thus bore himself in the frenzy of his ardour, a strange quiver played about her lips and face, and her eyelids flickered, opening and closing quickly. And behind the soft and delicate fringe of her eyelashes something menacing lurked and prowled, like the fire that steals through a house maliciously and stealthily, or like the tiger that winds through the jungle, showing amid the dark leaves glimpses of its striped and yellow body.⁶

[282] The life-line that Prometheus chooses is unmistakably introverted. He sacrifices all connection with the present in order to create by forethought a distant future. It is very different with Epimetheus: he realizes that his aim is the world and what the world values. Therefore he says to the angel:

But now my desire is for truth and my soul lies in my hand, and if it please you, pray give me a conscience that I may mind my "p's" and "q's" and everything that is just.⁷ Epimetheus cannot resist the temptation to fulfil his own destiny and submit to the "soulless" point of view. This alliance with the world is immediately rewarded:

And it came to pass that as Epimetheus stood upon his feet, he felt his stature was increased and his courage firmer, and all his being was at one with itself, and all his feeling was sound and mightily at ease. And thus he strode with bold steps through the valley, following the straight path as one who fears no man, with free and open bearing, like a man inspired by the contemplation of his own right-doing.⁸

[283] He has, as Prometheus says, bartered his soul for the “p’s” and “q’s”.⁹ He has lost his soul—to his brother’s gain. He has followed his extraversion, and, because this orients him to the external object, he is caught up in the desires and expectations of the world, seemingly at first to his great advantage. He has become an extravert, after having lived many solitary years under the influence of his brother as an *extravert falsified by imitating the introvert*. This kind of involuntary “simulation dans le caractère” (Paulhan) is not uncommon. His conversion to true extraversion is therefore a step towards “truth” and brings him a just reward.

[284] Whereas Prometheus, through the tyrannical claims of his soul, is hampered in every relation to the external object and has to make the cruellest sacrifices in the service of the soul, Epimetheus is armed with an effective shield against the danger that most threatens the extravert—the danger of complete surrender to the external object. This protection consists in a conscience that is backed by the traditional “right ideas,” that is, by the not-to-be-despised treasures of worldly wisdom, which are employed by public opinion in much the same way as the judge uses the penal code. This provides Epimetheus with a protective barrier that restrains him from surrendering to the object as boundlessly as Prometheus does to his soul. This is forbidden him by his conscience, which deputizes for his soul. When Prometheus turns his back on the world of men and their codified conscience, he plays into the hands of his cruel soul-mistress and her caprices, and only after endless suffering does he atone for his neglect of the world.

[285] The prudent restraint of a blameless conscience puts such a bandage over Epimetheus’ eyes that he must blindly live his myth, but ever with the sense of doing right, because he always does what is expected of him, and with success ever at his side, because he fulfils the wishes of all. That is how men desire to see their king, and thus Epimetheus plays his part to the inglorious end, never forsaken by the spine-stiffening approval of the public. His self-assurance and self-righteousness, his unshakable confidence in his own worth, his indubitable “right-doing” and good conscience, present an easily recognizable portrait of the extraverted character as depicted by Jordan. Let us hear how Epimetheus visits the sick Prometheus, desiring to heal his sufferings:

When all was set in order, King Epimetheus stepped forward supported by a friend on either side, greeted Prometheus, and spoke to him these well-meant words: “I am heartily sorry for you, Prometheus, my dear brother! But nonetheless take courage, for look, I have a salve here which is a sure remedy for every ill and works wondrously well in heat and in frost, and moreover can be used alike for solace as for punishment.”

So saying, he took his staff and tied the box of ointment to it, and reached it carefully and with all due solemnity towards his brother. But as soon as he saw and smelt the ointment, Prometheus turned away his head in disgust. At that the King changed his tone, and shouted and began to read his brother a lesson with great zest: “Of a truth it seems you have need of yet greater punishment, since your present fate does not suffice to teach you.”

And as he spoke, he drew a mirror from the folds of his robe, and made everything clear to him from the beginning, and waxed very eloquent and knew all his faults.¹⁰

[286] This scene is a perfect illustration of Jordan’s words: “Society must be pleased if possible; if it will not be pleased, it must be astonished; if it will neither be pleased nor astonished, it must be pestered and shocked.”¹¹ In the East a rich man proclaims his rank by never showing himself in public unless supported by two slaves. Epimetheus affects this pose in order to make an impression. Well-doing must at the same time be combined with admonition and moral instruction. And, as that does not produce an effect, the other must at least be horrified by the picture of his own baseness. Everything is aimed at creating an impression. There is an American saying that runs: “In America two kinds of men make good—the man who can *do*, and the man who can *bluff*.” Which means that pretence is sometimes just as successful as actual performance. An extravert of this kind prefers to work by *appearance*. The introvert tries to do it by *force* and *misuses* his work to that end.

[287] If we fuse Prometheus and Epimetheus into one personality, we should have a man outwardly Epimethean and inwardly Promethean—an individual constantly torn by both tendencies, each seeking to get the ego finally on its side.

2. A COMPARISON OF SPITTELER’S WITH GOETHE’S PROMETHEUS

[288] It is of considerable interest to compare this conception of Prometheus with Goethe’s. I believe I am justified in the conjecture that Goethe belongs more to the extraverted than to the introverted type, while Spitteler would seem to belong to the latter. Only an exhaustive examination and analysis of Goethe’s biography would be able to establish the rightness of this supposition. My conjecture is based on a variety

of impressions, which I refrain from mentioning here for lack of sufficient evidence to support them.

[289] The introverted attitude need not necessarily coincide with the figure of Prometheus, by which I mean that the traditional Prometheus can be interpreted quite differently. This other version is found, for instance, in Plato's *Protagoras*, where the bestower of vital powers on the creatures the gods have created out of fire and water is not Prometheus but Epimetheus. Here, as in the myth, Prometheus (conforming to classical taste) is the crafty and inventive genius. There are two versions of Prometheus in Goethe's works. In the "Prometheus Fragment" of 1773 Prometheus is the defiant, self-sufficient, godlike, god-disdaining creator and artist. His soul is Minerva, daughter of Zeus. The relation of Prometheus to Minerva is very like the relation of Spitteler's Prometheus to his soul:

From the beginning thy words have been celestial light to me!
Always as though my soul spoke to herself
Did she reveal herself to me,
And in her of their own accord
Sister harmonies rang out.
And when I deemed it was myself,
A goddess spoke,
And when I deemed a goddess was speaking,
It was myself.
So it was between thee and me,
So fervently one.
Eternal is my love for thee!¹²

And again:

As the twilight glory of the departed sun
Hovers over the gloomy Caucasus
And encompasses my soul with holy peace,
Parting, yet ever present with me,
So have my powers waxed strong
With every breath drawn from thy celestial air.¹³

[290] So Goethe's Prometheus, too, is dependent on his soul. The resemblance between this relationship and that of Spitteler's Prometheus to his soul is very striking. The latter says to his soul:

And though I be stripped of all, yet am I rich beyond all measure so long as you alone remain with me, and name me “my friend” with your sweet mouth, and the light of your proud and gracious countenance go not from me.¹⁴

[291] But for all the similarity of the two figures and their relations with the soul, one essential difference remains. Goethe’s Prometheus is a creator and artist, and Minerva inspires his clay images with life. Spitteler’s Prometheus is suffering rather than creative; only his soul is creative, but her work is secret and mysterious. She says to him in farewell:

And now I depart from you, for a great work awaits me, a work of immense labour, and I must hasten to accomplish it.¹⁵

[292] It would seem that, with Spitteler, the Promethean creativity falls to the soul, while Prometheus himself merely suffers the pangs of the creative soul within him. But Goethe’s Prometheus is self-activating, he is essentially and exclusively creative, defying the gods out of the strength of his own creative power:

Who helped me
Against the pride of the Titans?
Who saved me from death?
And slavery?
Did you not do it all alone,
O ardent, holy heart?¹⁶

[293] Epimetheus in this fragment is only sparingly sketched, he is thoroughly inferior to Prometheus, an advocate of collective feeling who can only understand the service of the soul as “obstinacy.” He says to Prometheus:

You stand alone!
You in your obstinacy know not that bliss
When the gods, you, and all that you have,
Your world, your heaven,
Are enfolded in one embracing unity.¹⁷

[294] Such indications as are to be found in the Prometheus fragments are too sparse to enable us to discern the character of Epimetheus. But Goethe’s delineation of Prometheus shows a typical difference from the Prometheus of Spitteler. Goethe’s Prometheus creates and works outwards into the world, he peoples space with the figures he has fashioned and his soul has animated, he fills the earth with the offspring of his creativeness, he is at once the master and teacher of man. But with the Prometheus of Spitteler everything goes inwards and vanishes in the darkness of

the soul's depths, just as he himself disappears from the world of men, even wandering from the narrow confines of his homeland as though to make himself the more invisible. In accordance with the principle of compensation in analytical psychology, the soul, the personification of the unconscious, must then be especially active, preparing a work that is not yet visible. Besides the passage already quoted, there is in Spitteler a full description of this expected compensatory process. We find it in the Pandora interlude.

[295] Pandora, that enigmatical figure in the Prometheus myth, is in Spitteler's version the divine maiden who lacks every relation with Prometheus but the very deepest. This conception is based on a version of the myth in which the woman who enters into relation with Prometheus is either Pandora or Athene. The Prometheus of mythology has his soul-relation with Pandora or Athene, as in Goethe. But, in Spitteler, a noteworthy departure is introduced, though it is already indicated in the historical myth, where Prometheus and Pandora are contaminated with Hephaestus and Athene. In Goethe, the Prometheus-Athene version is given preference. In Spitteler, Prometheus is removed from the divine sphere and granted a soul of his own. But his divinity and his original relation with Pandora in the myth are preserved as a cosmic counterplot, enacted independently in the celestial sphere. The happenings in the other world are what takes place on the further side of consciousness, that is in the unconscious. The Pandora interlude, therefore, is an account of what goes on in the unconscious during the sufferings of Prometheus. When Prometheus vanishes from the world, destroying every link that binds him to mankind, he sinks into his own depths, and the only thing around him, his only object, is himself. He has become "godlike," for God is by definition a Being who everywhere reposes in himself and by virtue of his omnipresence has himself always and everywhere for an object. Naturally Prometheus does not feel in the least godlike—he is supremely wretched. After Epimetheus has come to spit upon his misery, the interlude in the other world begins, and that naturally is just at the moment when all Prometheus' relations to the world are suppressed to the point of extinction. Experience shows that at such moments the contents of the unconscious have the best opportunity to assert their independence and vitality, so much so that they may even overwhelm consciousness.¹⁸ Prometheus' condition in the unconscious is reflected in the following scene:

And on the dark morning of that very day, in a still and solitary meadow above all the worlds, wandered God, the creator of all life, pursuing the accursed round in obedience to the strange nature of his mysterious and grievous sickness.

For because of this sickness, he could never make an end of the weariness of his walk, might never find rest on the path of his feet, but ever with measured tread, day

after day, year after year, must make the round of the still meadow, with plodding steps, bowed head, furrowed brow, and distorted countenance, his beclouded gaze turned always towards the midpoint of the circle.

And when today as on all other days he made the inevitable round and his head sank deeper for sorrow and his steps dragged the more for weariness and the wellspring of his life seemed spent by the sore vigils of the night, there came to him through night and early dawn Pandora, his youngest daughter, who with uncertain step demurely approached the hallowed spot, and stood there humbly at his side, greeting him with modest glance, and questioning him with lips that held a reverential silence.¹⁹

[296] It is evident at a glance that God has caught the sickness of Prometheus. For just as Prometheus makes all his passion, his whole libido flow inwards to the soul, to his innermost depths, dedicating himself entirely to his soul's service, so God pursues his course round and round the pivot of the world and exhausts himself exactly like Prometheus, who is near to self-extinction. All his libido has gone into the unconscious, where an equivalent must be prepared; for libido is energy, and energy cannot disappear without a trace, but must always produce an equivalent. This equivalent is Pandora and the gift she brings to her father: a precious jewel which she wants to give to mankind to ease their sufferings.

[297] If we translate this process into the human sphere of Prometheus, it would mean that while Prometheus lies suffering in his state of "godlikeness," his soul is preparing a work destined to alleviate the sufferings of mankind. His soul wants to get to men. Yet the work which his soul actually plans and carries out is not identical with the work of Pandora. Pandora's jewel is an unconscious mirror-image that *symbolizes* the real work of the soul of Prometheus. The text shows unmistakably what the jewel signifies: it is a *God-redeemer*, a renewal of the sun.²⁰ The sickness of God expresses his longing for rebirth, and to this end his whole life-force flows back into the centre of the self, into the depths of the unconscious, out of which life is born anew. That is why the appearance of the jewel in the world is described in a way that reflects the imagery of the birth of the Buddha in the *Lalita-Vistara*.²¹ Pandora lays the jewel beneath a walnut-tree, just as Maya bears her child under a fig-tree:

In the midnight shade beneath the tree it glows and sparkles and flames evermore, and, like the morning star in the dark sky, its diamond lightning flashes afar.

And the bees also, and the butterflies, which danced over the flowery mead, hurried up, and played and rocked around the wonder-child ... and the larks dropped down sheer from the upper air, all eager to pay homage to the new and lovelier sun-

countenance, and as they drew near and beheld the dazzling radiance, their hearts swooned ...

And, enthroned over all, fatherly and benign, the chosen tree with his giant crown and heavy mantle of green, held his kingly hands protectingly over the faces of his children. And his many branches bent lovingly down and bowed themselves towards the earth as though they wished to screen and ward off alien glances, jealous that they alone might enjoy the unearned grace of the gift; while all the myriads of gently moving leaves fluttered and trembled with rapture, murmuring in joyous exultation a soft, clear-voice chorus in rustling accord: “Who could know what lies hidden beneath this lowly roof, or guess the treasure reposing in our midst!”²²

[298] So Maya, when her hour was come, bore her child beneath the *plaksa* tree, which bowed its crown shelteringly to earth. From the incarnate Bodhisattva an immeasurable radiance spread through the world; gods and all nature took part in the birth. At his feet there grew up an immense lotus, and standing in the lotus he scanned the world. Hence the Tibetan prayer: *Om mani padme hum* (Om! Behold the jewel in the lotus). And the moment of rebirth found the Bodhisattva beneath the chosen *bodhi* tree, where he became the Buddha, the Enlightened One. This rebirth or renewal was attended by the same light-phenomena, the same prodigies of nature and apparitions of gods, as the birth.

[299] In Spitteler’s version, the inestimable treasure gets lost in the kingdom of Epimetheus, where only conscience reigns and not the soul. Raging over the stupidity of Epimetheus, the angel upbraids him: “And had you no soul, that like the dumb and unreasoning beasts you hid from the wondrous divinity?”²³

[300] It is clear that Pandora’s jewel symbolizes a renewal of God, a new God, but this takes place in the divine sphere, i.e., in the unconscious. The intimations of the process that filter through into consciousness are not understood by the Epimethean principle, which governs the relation to the world. This is elaborated by Spitteler in the ensuing sections,²⁴ where we see how the world of consciousness with its rational attitude and orientation to objects is incapable of appreciating the true value and significance of the jewel. Because of this, it is irretrievably lost.

[301] The renewed God signifies a regenerated attitude, a renewed possibility of life, a recovery of vitality, because, psychologically speaking, God always denotes the highest value, the maximum sum of libido, the fullest intensity of life, the optimum of psychological vitality. But in Spitteler the Promethean attitude proves to be just as inadequate as the Epimethean. The two tendencies get dissociated: the Epimethean attitude is adapted to the world as it actually is, but the Promethean is not, and for that reason it has to work for a renewal of life. It also produces a new attitude to the world (symbolized by the jewel given to mankind), though this does not find favour

with Epimetheus. Nevertheless, we recognize in Pandora's gift a symbolic attempt to solve the problem discussed in the chapter on Schiller's *Letters*—the problem of uniting the differentiated with the undifferentiated function.

[302] Before proceeding further with this problem, we must turn back to Goethe's Prometheus. As we have seen, there are unmistakable differences between the creative Prometheus of Goethe and the suffering figure presented by Spitteler. Another and more important difference is the relation to Pandora. In Spitteler, Pandora is a duplicate of the soul of Prometheus belonging to the other world, the sphere of the gods; in Goethe she is entirely the creature and daughter of the Titan, and thus absolutely dependent on him. The relation of Goethe's Prometheus with Minerva puts him in the place of Vulcan, and the fact that Pandora is wholly his creature, and does not figure as a being of divine origin, makes him a creator-god and removes him altogether from the human sphere. Hence Prometheus says:

And when I deemed it was myself,
A goddess spoke,
And when I deemed a goddess was speaking,
It was myself.

[303] With Spitteler, on the other hand, Prometheus is stripped of divinity, even his soul is only an unofficial daemon; his divinity is hypostatized, quite detached from everything human. Goethe's version is classical to this extent: it emphasizes the divinity of the Titan. Accordingly Epimetheus too must diminish in stature, whilst in Spitteler he emerges as a much more positive character. Now in Goethe's "Pandora" we are fortunate in possessing a work which conveys a far more complete portrait of Epimetheus than the fragment we have been discussing. Epimetheus introduces himself as follows:

For me day and night are not clearly divided,
Always I carry the old evil of my name:
My progenitors named me Epimetheus.
Brooding on the past with its hasty actions,
Glancing back, troubled in thought,
To the melancholy realm of fugitive forms
Interfluent with the opportunities of past days.
Such bitter toil was laid on my youth
That turning impatiently towards life
I seized heedlessly the present moment
And won tormenting burdens of fresh care.²⁵

[304] With these words Epimetheus reveals his nature: he broods over the past, and can never free himself from Pandora, whom (according to the classical myth) he has taken to wife. He cannot rid himself of her memory-image, although she herself has long since deserted him, leaving him her daughter Epimeleia (Care), but taking with her Elpore (Hope). Epimetheus is portrayed so clearly that we are at once able to recognize what psychological function he represents. While Prometheus is still the same creator and modeller, who daily rises early from his couch with the same inexhaustible urge to create and to set his stamp on the world, Epimetheus is entirely given up to fantasies, dreams, and memories, full of anxious misgivings and troubled deliberations. Pandora appears as the creature of Hephaestus, rejected by Prometheus but chosen by Epimetheus for a wife. He says of her: "Even the pains which such a treasure brings are pleasure." Pandora is to him a precious jewel, the supreme value:

And forever she is mine, the glorious one!
From her I have received supreme delight.
I possessed Beauty, and Beauty enfolded me,
Splendidly she came in the wake of the spring.
I knew her, I caught her, and then it was done.
Clouding thoughts vanished like mist,
She raised me from earth and up to heaven.
You seek for words worthy to praise her,
You would extol her, she wanders already on high.
Set your best beside her, you'll see it is bad.
Her words bewilder, yet she is right.
Struggle against her, she'll win the fight.
Faltering to serve her, you're still her slave.
Kindness and love she loves to fling back.
What avails high esteem? She will strike it down.
She sets her goal and wings on her way.
If she blocks your path, she at once holds you up.
Make her an offer and she'll raise your bid,
You'll give riches and wisdom and all in the bargain.
She comes down to earth in a thousand forms,
Hovering the waters, striding the meadows.
Divinely proportioned she dazzles and thrills,
Her form ennobling the content within,
Lending it and herself the mightiest power.

- [305] For Epimetheus, as these verses clearly show, Pandora has the value of a soul-image—she stands for his soul; hence her divine power, her unshakable supremacy. Whenever such attributes are conferred upon a personality, we may conclude with certainty that such a personality is a *symbol-carrier*, or an image of projected unconscious contents. For it is the contents of the unconscious that have the supreme power Goethe has described, incomparably characterized in the line: “Make her an offer and she’ll raise your bid.” In this line the peculiar emotional reinforcement of conscious contents by association with analogous contents of the unconscious is caught to perfection. This reinforcement has in it something daemonic and compelling, and thus has a “divine” or “devilish” effect.
- [306] We have already described Goethe’s Prometheus as extraverted. It is still the same in his “Pandora,” although here the relation of Prometheus with the soul, the unconscious feminine principle, is missing. To make up for this, Epimetheus emerges as the introvert turned to the inner world. He broods, he calls back memories from the grave of the past, he “reflects.” He differs absolutely from Spitteler’s Epimetheus. We could therefore say that in Goethe’s “Pandora” the situation suggested in his earlier fragment has actually come about. Prometheus represents the extraverted man of action, and Epimetheus the brooding introvert. This Prometheus is, in extraverted form, what Spitteler’s is in introverted form. In Goethe’s “Pandora” he is purely creative for collective ends—he sets up a regular factory in his mountain, where articles of use for the whole world are produced. He is cut off from his inner world, which relation devolves this time on Epimetheus, i.e., on the secondary and purely reactive thinking and feeling of the extravert which possess all the characteristics of the undifferentiated function. Thus it comes about that Epimetheus is wholly at the mercy of Pandora, because she is in every respect superior to him. This means, psychologically, that the unconscious Epimethean function of the extravert, namely that fantastic, brooding, ruminative fancy, is intensified by the intervention of the soul. If the soul is coupled with the less differentiated function, one must conclude that the superior, differentiated function is too collective; it is the servant of the collective conscience (Spitteler’s “p’s” and “q’s”) and not the servant of freedom. Whenever this is so—and it happens very frequently—the less differentiated function or the “other side” is reinforced by a pathological egocentricity. The extravert then fills up his spare time with melancholic or hypochondriacal brooding and may even have hysterical fantasies and other symptoms,²⁷ while the introvert grapples with compulsive feelings of inferiority²⁸ which take him unawares and put him in a no less dismal plight.

- [307] The resemblance between the Prometheus of “Pandora” and the Prometheus of Spitteler ends here. He is merely a collective itch for action, so one-sided that it amounts to a repression of eroticism. His son Phileros (‘lover of Eros’) is simply erotic passion; for, as the son of his father, he must, as is often the case with children, re-enact under unconscious compulsion the un-lived lives of his parents.
- [308] The daughter of Pandora and Epimetheus, the man who always broods afterwards on his unthinking actions, is fittingly named Epimeleia, Care. Phileros loves Epimeleia, and thus the guilt of Prometheus in rejecting Pandora is expiated. At the same time, Prometheus and Epimetheus become reconciled when the industriousness of Prometheus is shown to be nothing but unadmitted eroticism, and Epimetheus’ constant broodings on the past to be rational misgivings which might have checked the unremitting productivity of Prometheus and kept it within reasonable bounds.
- [309] This attempt of Goethe’s to find a solution, which appears to have evolved from his extraverted psychology, brings us back to Spitteler’s attempt, which we left for the time being in order to discuss Goethe’s Prometheus.
- [310] Spitteler’s Prometheus, like his God, turns away from the world, from the periphery, and gazes inwards to the centre, the “narrow passage”²⁹ of rebirth. This concentration or introversion pipes the libido into the unconscious. The activity of the unconscious is increased—the psyche begins to “work” and creates a product that wants to get out of the unconscious into consciousness. But consciousness has two attitudes: the Promethean, which withdraws the libido from the world, introverting without giving out, and the Epimethean, constantly giving out and responding in a soulless fashion, fascinated by the claims of external objects. When Pandora makes her gift to the world it means, psychologically, that an unconscious product of great value is on the point of reaching the extraverted consciousness, i.e., it is seeking a relation to the real world. Although the Promethean side, or in human terms the artist, intuitively apprehends the great value of the product, his personal relations to the world are so subordinated to the tyranny of tradition that it is appreciated merely as a work of art and not taken for what it actually is, a symbol that promises a renewal of life. In order to transform it from a purely aesthetic interest into a living reality, it must be assimilated into life and actually lived. But when a man’s attitude is mainly introverted and given to abstraction, the function of extraversion is inferior, in the grip of collective restraints. These restraints prevent the symbol created by the psyche from living. The jewel gets lost, but one cannot really live if “God,” the supreme vital value that is expressed in the symbol, cannot become a living fact. Hence the loss of the jewel signifies at the same time the beginning of Epimetheus’ downfall.

[311] And now the enantiodromia begins. Instead of taking for granted, as every rationalist and optimist is inclined to do, that a good state will be followed by a better, because everything tends towards an “ascending development,” Epimetheus, the man of blameless conscience and universally acknowledged moral principles, makes a pact with Behemoth and his evil host, and even the divine children entrusted to his care are bartered to the devil.³⁰ Psychologically, this means that the collective, undifferentiated attitude to the world stifles a man’s highest values and becomes a destructive force, whose influence increases until the Promethean side, the ideal and abstract attitude, places itself at the service of the soul’s jewel and, like a true Prometheus, kindles for the world a new fire. Spitteler’s Prometheus has to come out of his solitude and tell men, even at the risk of his life, that they are in error, and where they err. He must acknowledge the pitilessness of truth, just as Goethe’s Prometheus has to experience in Phileros the pitilessness of love.

[312] That the destructive element in the Epimethean attitude is actually this traditional and collective restraint is shown in Epimetheus’ raging fury against the “little lamb,” an obvious caricature of traditional Christianity. In this outburst of affect something breaks through that is familiar to us from the Ass Festival in *Zarathustra*. It is the expression of a contemporary tendency.

[313] Man is constantly inclined to forget that what was once good does not remain good eternally. He follows the old ways that once were good long after they have become bad, and only with the greatest sacrifices and untold suffering can he rid himself of this delusion and see that what was once good is now perhaps grown old and is good no longer. This is so in great things as in small. The ways and customs of childhood, once so sublimely good, can hardly be laid aside even when their harmfulness has long since been proved. The same, only on a gigantic scale, is true of historical changes of attitude. A collective attitude is equivalent to a religion, and changes of religion constitute one of the most painful chapters in the world’s history. In this respect our age is afflicted with a blindness that has no parallel. We think we have only to declare an accepted article of faith incorrect and invalid, and we shall be psychologically rid of all the traditional effects of Christianity or Judaism. We believe in enlightenment, as if an intellectual change of front somehow had a profounder influence on the emotional processes or even on the unconscious. We entirely forget that the religion of the last two thousand years is a psychological attitude, a definite form and manner of adaptation to the world without and within, that lays down a definite cultural pattern and creates an atmosphere which remains wholly uninfluenced by any intellectual denials. The change of front is, of course, symptomatically important as an indication of possibilities to come, but on the deeper levels the psyche continues to work for a long time in the old attitude, in accordance with the laws of psychic inertia. Because of this, the unconscious was able to keep

paganism alive. The ease with which the spirit of antiquity springs to life again can be observed in the Renaissance, and the readiness of the vastly older primitive mentality to rise up from the past can be seen in our own day, perhaps better than at any other epoch known to history.

[314] The more deeply rooted the attitude, the more violent will be the attempts to shake it off. “Écrasez l’infâme,” the cry of the Age of Enlightenment, heralded the religious upheaval started off by the French Revolution, and this religious upheaval was nothing but a basic readjustment of attitude, though it lacked universality. The problem of a general change of attitude has never slept since that time; it cropped up again in many prominent minds of the nineteenth century. We have seen how Schiller sought to master it, and in Goethe’s treatment of Prometheus and Epimetheus we see yet another attempt to effect some sort of union between the more highly differentiated function, which corresponds to the Christian ideal of favouring the good, and the less differentiated function, whose repression corresponds to the Christian ideal of rejecting the evil.³¹ In the symbols of Prometheus and Epimetheus, the difficulty that Schiller sought to master philosophically and aesthetically is clothed in the garment of a classical myth. Consequently, something happens which, as I pointed out earlier, is a typical and regular occurrence: when a man meets a difficult task which he cannot master with the means at his disposal, a retrograde movement of libido automatically sets in, i.e., a regression. The libido draws away from the problem of the moment, becomes introverted, and reactivates in the unconscious a more or less primitive analogue of the conscious situation. This law determined Goethe’s choice of a symbol: Prometheus was the saviour who brought light and fire to mankind languishing *in* darkness. Goethe’s deep scholarship could easily have picked on another saviour, so that the symbol he chose is not sufficient as an explanation. It must lie rather in the classical spirit, which at the turn of the eighteenth century was felt to contain a compensatory value and was given expression in every possible way—in aesthetics, philosophy, morals, even politics (Philhellenism). It was the paganism of antiquity, glorified as “freedom,” “naïveté,” “beauty,” and so on, that met the yearnings of that age. These yearnings, as Schiller shows so clearly, sprang from a feeling of imperfection, of spiritual barbarism, of moral servitude, of drabness. This feeling in its turn arose from a one-sided evaluation of everything Greek, and from the consequent fact that the psychological dissociation between the differentiated and the undifferentiated functions became painfully evident. The Christian division of man into two halves, one valuable and one depraved, was unbearable to the superior sensibilities of that age. Sinfulness stumbled on the idea of an everlasting natural beauty, in the contemplation of which the age reached back to an earlier time when the idea of sinfulness had not yet disrupted man’s wholeness, when the heights and depths of human nature could still

dwell together in complete naïveté without offending moral or aesthetic susceptibilities.

[315] But the attempt at a regressive Renaissance shared the fate of the “Prometheus Fragment” and “Pandora”: it was stillborn. The classical solution would no longer work, because the intervening centuries of Christianity with their profound spiritual upheavals could not be undone. So the penchant for the antique gradually petered out in medievalism. This process sets in with Goethe’s *Faust*, where the problem is seized by both horns. The divine wager between good and evil is accepted. Faust, the medieval Prometheus, enters the lists with Mephistopheles, the medieval Epimetheus, and makes a pact with him. And here the problem becomes so sharply focussed that one can see that Faust and Mephisto are the same person. The Epimethean principle, which always thinks backwards and reduces everything to the primal chaos of “interfluent forms” (par. 303), condenses into the devil whose evil power threatens everything living with the “devil’s cold fist” and would force back the light into the maternal darkness whence it was born. The devil everywhere displays a true Epimethean thinking, a thinking in terms of “nothing but” which reduces All to Nothing. The naïve passion of Epimetheus for Pandora becomes the diabolical plot of Mephistopheles for the soul of Faust. And the cunning foresight of Prometheus in turning down the divine Pandora is expiated in the tragedy of Gretchen and the yearning for Helen, with its belated fulfillment, and in the endless ascent to the Heavenly Mothers (“The Eternal Feminine / Leads us upward and on”).

[316] The Promethean defiance of the accepted gods is personified in the figure of the medieval magician. The magician has preserved in himself a trace of primitive paganism;³² he possesses a nature that is still unaffected by the Christian dichotomy and is in touch with the still pagan unconscious, where the opposites lie side by side in their original naïve state, beyond the reach of “sinfulness” but liable, if assimilated into conscious life, to beget evil as well as good with the same daemonic energy (“Part of that power which would / Ever work evil yet engenders good”). He is a destroyer but also a saviour, and such a figure is pre-eminently suited to become the symbolic bearer of an attempt to resolve the conflict. Moreover the medieval magician has laid aside the classical naïveté which was no longer possible, and become thoroughly steeped *in* the Christian atmosphere. The old pagan element must at first drive him into a complete Christian denial and mortification of self, because his longing for redemption is so strong that every avenue has to be explored. But in the end the Christian attempt at a solution fails too, and it then transpires that the possibility of redemption lies precisely in the obstinate persistence of the old pagan element, because the anti-Christian symbol opens the way for an acceptance of evil. Goethe’s intuition thus grasped the problem in all its acuteness. It is certainly significant that the more superficial attempts at a solution—the “Prometheus

Fragment,” “Pandora,” and the Rosicrucian compromise, a blend of Dionysian joyousness and Christian self-sacrifice—remained uncompleted.

[317] Faust’s redemption began at his death. The divine, Promethean character he had preserved all his life fell away from him only at death, with his rebirth. Psychologically, this means that the Faustian attitude must be abandoned before the individual can become an integrated whole. The figure that first appeared as Gretchen and then on a higher level as Helen, and was finally exalted as the Mater Gloriosa, is a symbol whose many meanings cannot be discussed here. Suffice to say that it is the same primordial image that lies at the heart of Gnosticism, the image of the divine harlot—Eve, Helen, Mary, Sophia-Achamoth.

3. THE SIGNIFICANCE OF THE UNITING SYMBOL

[318] If, from the vantage point we have now gained, we glance once more at Spitteler’s presentation of the problem, we are immediately struck by the fact that the pact with evil³³ came about by no design of Prometheus but because of the thoughtlessness of Epimetheus, who possesses a merely collective conscience but has no power of discrimination with regard to the things of the inner world. As is invariably the case with a standpoint oriented to the object, it allows itself to be determined exclusively by collective values and consequently overlooks what is new and unique. Current collective values can certainly be measured by an objective criterion, but only a free and individual assessment—a matter of living feeling—can give the true measure of something newly created. It also needs a man who has a “soul” and not merely relations to objects.

[319] The downfall of Epimetheus begins with the loss of the new-born God-image. His morally unassailable thinking, feeling, and acting in no way prevent the evil and destructive element from creeping in and gaining the upper hand. The invasion of evil signifies that something previously good has turned into something harmful. Spitteler is here expressing the idea that the ruling moral principle, although excellent to begin with, in time loses its essential connection with life, since it no longer embraces life’s variety and abundance. What is rationally correct is too narrow a concept to grasp life in its totality and give it permanent expression. The divine birth is an event altogether outside the bounds of rationality. Psychologically, it proclaims the fact that a new symbol, a new expression of life at its most intense, is being created. Every Epimethean man, and everything Epimethean in man, prove incapable of comprehending this event. Yet, from that moment, the highest intensity of life is to be found only in this new direction. Every other direction gradually drops away, dissolved in oblivion.

[320] The new life-giving symbol springs from Prometheus' love for his soul-mistress, a daemonic figure indeed. One can therefore be certain that, interwoven with the new symbol and its living beauty, there will also be the element of evil, for otherwise it would lack the glow of life as well as beauty, since life and beauty are by nature morally neutral. That is why the Epimethean, collective mentality finds nothing estimable in it. It is completely blinded by its one-sided moral standpoint, which is identical with the "little lamb." The raging of Epimetheus when he turns against the "little lamb" is merely "Écrasez l'infâme" in new form, a revolt against established Christianity, which was incapable of understanding the new symbol and so giving life a new direction.

[321] This bare statement of the case might leave us entirely cold were there no poets who could fathom and read the collective unconscious. They are always the first to divine the darkly moving mysterious currents and to express them, as best they can, in symbols that speak to us. They make known, like true prophets, the stirrings of the collective unconscious or, in the language of the Old Testament, "the will of God," which in the course of time must inevitably come to the surface as a collective phenomenon. The redemptive significance of the deed of Prometheus, the downfall of Epimetheus, his reconciliation with his soul-serving brother, and the vengeance Epimetheus wreaks on the "little lamb"—recalling in its cruelty the scene between Ugolino and Archbishop Ruggieri³⁴—prepare a solution of the conflict that entails a sanguinary revolt against traditional collective morality.

[322] In a poet of modest capacity we may assume that the pinnacle of his work does not transcend his personal joys, sorrows, and aspirations. But Spitteler's work entirely transcends his personal destiny. For this reason his solution of the problem is not an isolated one. From here to Zarathustra, the breaker of the tables, is only a step. Stirner had also joined the company in the wake of Schopenhauer, who was the first to conceive the theory of "world negation." Psychologically, "world" means how I see the world, my attitude to the world; thus the world can be conceived as "my will" and "my idea."³⁵ In itself the world is indifferent. It is my Yes and No that create the differences. Negation, therefore, is itself an attitude to the world, a particularly Schopenhauerian attitude that on the one hand is purely intellectual and rational, and on the other a profound feeling of mystical identity with the world. This attitude is introverted; it suffers therefore from its typological antithesis. But Schopenhauer's work by far transcends his personality. It voices what was obscurely thought and felt by many thousands. Similarly with Nietzsche: his *Zarathustra*, in particular, brings to light the contents of the collective unconscious of our time, and in him we find the same distinguishing features: iconoclastic revolt against the conventional moral atmosphere, and acceptance of the "Ugliest Man," which leads to the shattering unconscious tragedy presented in *Zarathustra*. But what creative minds bring up out

of the collective unconscious also actually exists, and sooner or later must make its appearance in collective psychology. Anarchism, regicide, the constant increase and splitting off of a nihilistic element on the extreme Left, with a programme absolutely hostile to culture—these are phenomena of mass psychology, which were long ago adumbrated by poets and creative thinkers.

[323] We cannot, therefore, afford to be indifferent to the poets, since in their principal works and deepest inspirations they create from the very depths of the collective unconscious, voicing aloud what others only dream. But though they proclaim it aloud, they fashion only a symbol in which they take aesthetic pleasure, without any consciousness of its true meaning. I would be the last to dispute that poets and thinkers have an educative influence on their own and succeeding generations, but it seems to me that their influence consists essentially in the fact that they voice rather more clearly and resoundingly what all men know, and only to the extent that they express this universal unconscious “knowledge” have they an educative or seductive effect. The poet who has the greatest and most immediately suggestive effect is the one who knows how to express the most superficial levels of the unconscious in a suitable form. But the more deeply the vision of the creative mind penetrates, the stranger it becomes to mankind in the mass, and the greater is the resistance to the man who in any way stands out from the mass. The mass does not understand him although unconsciously living what he expresses; not because the poet proclaims it, but because the mass draws its life from the collective unconscious into which he has peered. The more thoughtful of the nation certainly comprehend something of his message, but, because his utterance coincides with processes already going on in the mass, and also because he anticipates their own aspirations, they hate the creator of such thoughts, not out of malice, but merely from the instinct of self-preservation. When his insight into the collective unconscious reaches a depth where its content can no longer be grasped in any conscious form of expression, it is difficult to decide whether it is a morbid product or whether it is incomprehensible because of its extraordinary profundity. An imperfectly understood yet deeply significant content usually has something morbid about it. And morbid products are as a rule significant. But in both cases the approach to it is difficult. The fame of these creators, if it ever arrives at all, is posthumous and often delayed for several centuries. Ostwald’s assertion that a genius today is misunderstood at most for a decade is confined, one must hope, to the realm of technological discoveries, otherwise such an assertion would be ludicrous in the extreme.

[324] There is another point of particular importance to which I feel I ought to draw attention. The solution of the problem in *Faust*, in Wagner’s *Parsifal*, in Schopenhauer, and even in Nietzsche’s *Zarathustra*, is *religious*. It is therefore not surprising that Spitteler too is drawn towards a religious setting. When a problem is

grasped as a religious one, it means, psychologically, that it is seen as something very important, of particular value, something that concerns the whole man, and hence also the unconscious (the realm of the gods, the other world, etc.). With Spitteler the religious background is of such luxuriance that the specifically religious problem loses in depth, though gaining in mythological richness and archaism. The lush mythological texture makes the work difficult to approach, as it shrouds the problem from clear comprehension and obscures its solution. The abstruse, grotesque, somewhat tasteless quality that always attaches to this kind of mythological embroidery checks the flow of empathy, alienates one from the meaning of the work, and gives the whole a rather disagreeable flavour of a certain kind of originality that manages to escape being psychically abnormal only by its meticulous attention to detail. Nevertheless, this mythological profusion, however tiresome and unpalatable it may be, has the advantage of allowing the symbol plenty of room to unfold, though in such an unconscious fashion that the conscious wit of the poet is quite at a loss to point up its meaning, but devotes itself exclusively to mythological proliferation and its embellishment. In this respect Spitteler's poem differs from both *Faust* and *Zarathustra*: in these works there is a greater conscious participation by the authors in the meaning of the symbol, with the result that the mythological profusion of *Faust* and the intellectual profusion of *Zarathustra* are pruned back in the interests of the desired solution. Both *Faust* and *Zarathustra* are, for this reason, far more satisfying *aesthetically* than Spitteler's Prometheus, though the latter, as a more or less faithful reflection of actual processes of the collective unconscious, has a deeper *truth*.

[325] *Faust* and *Zarathustra* are of very great assistance in the individual mastery of the problem, while Spitteler's *Prometheus and Epimetheus*, thanks to the wealth of mythological material, affords a more general insight into it and the way it appears in collective life. What, first and foremost, is revealed in Spitteler's portrayal of unconscious religious contents is the *symbol of God's renewal*, which was subsequently treated at greater length in his *Olympian Spring*. This symbol appears to be intimately connected with the opposition between the psychological types and functions, and is obviously an attempt to find a solution in the form of a renewal of the general attitude, which in the language of the unconscious is expressed as a renewal of God. This is a well-known primordial image that is practically universal; I need only mention the whole mythological complex of the dying and resurgent god and its primitive precursors all the way down to the re-charging of fetishes and churingas with magical force. It expresses a transformation of attitude by means of which a new potential, a new manifestation of life, a new fruitfulness, is created. This latter analogy explains the well-attested connection between the renewal of the god and seasonal and vegetational phenomena. One is naturally inclined to assume that

seasonal, vegetational, lunar, and solar myths underlie these analogies. But that is to forget that a myth, like everything psychic, cannot be solely conditioned by external events. Anything psychic brings its own internal conditions with it, so that one might assert with equal right that the myth is purely psychological and uses meteorological or astronomical events merely as a means of expression. The whimsicality and absurdity of many primitive myths often makes the latter explanation seem far more appropriate than any other.

[326] The psychological point of departure for the god-renewal is an increasing split in the deployment of psychic energy, or libido. One half of the libido is deployed in a Promethean direction, the other half in the Epimethean. Naturally this split is a hindrance not only in society but also in the individual. As a result, the vital optimum withdraws more and more from the opposing extremes and seeks a middle way, which must naturally be irrational and unconscious, just because the opposites are rational and conscious. Since the middle position, as a function of mediation between the opposites, possesses an irrational character and is still unconscious, it appears projected in the form of a mediating god, a Messiah. In our more primitive, Western forms of religion—primitive because lacking insight—the new bearer of life appears as a God or Saviour who, in his fatherly love and solicitude or from his own inner resolve, puts an end to the division as and when it suits him and for reasons we are not fitted to understand. The childishness of this conception needs no stressing. The East has for thousands of years been familiar with this process and has founded on it a psychological doctrine of salvation which brings the way of deliverance within man's ken and capacity. Thus the religions of India and China, and particularly Buddhism which combines the spheres of both, possess the idea of a redemptive middle way of magical efficacy which is attainable by means of a conscious attitude. The Vedic conception is a conscious attempt to find release from the pairs of opposites in order to reach the path of redemption.

a. The Brahmanic Conception of the Problem of Opposites

[327] The Sanskrit term for pairs of opposites in the psychological sense is *dvandva*. It also means pair (particularly man and woman), strife, quarrel, combat, doubt. The pairs of opposites were ordained by the world-creator. The *Laws of Manu* says:³⁶

Moreover, in order to distinguish actions, he separated merit from demerit, and he caused the creatures to be affected by the pairs of opposites, such as pain and pleasure.

As further pairs of opposites, the commentator Kulluka names desire and anger, love and hate, hunger and thirst, care and folly, honour and disgrace. The *Ramayana* says: "This world must suffer under the pairs of opposites for ever."³⁷ Not to allow oneself

to be influenced by the pairs of opposites, but to be *nirdvandva* (free, untouched by the opposites), to raise oneself above them, is an essentially ethical task, because deliverance from the opposites leads to redemption.

[328] In the following passages I give a series of examples:

When by the disposition [of his heart] he becomes indifferent to all objects, he obtains eternal happiness both in this world and after death. He who has in this manner gradually given up all attachments and is freed from all pairs of opposites reposes in Brahman alone.³⁸

The Vedas speak of the three *gunas*; but do you, O Arjuna, be indifferent to the three *gunas*, indifferent to the opposites, ever steadfast in courage.³⁹

Then [in deepest meditation, *samadhi*] comes the state of being untroubled by the opposites.⁴⁰

There he shakes off his good deeds and his evil deeds. His dear relatives succeed to the good deeds; those not so dear, to the evil deeds. Then, just as one driving a chariot looks down upon the two chariot wheels, so he looks down upon day and night, so upon good deeds and evil deeds, and upon all the pairs of opposites. Being freed from good and from evil, the knower of Brahman enters into Brahman.⁴¹

One entering into meditation must be a master over anger, attachment to the world, and the desires of the senses, free from the pairs of opposites, void of self-seeking, empty of expectation.⁴²

Clothed with dust, housed under the open sky, I will make my lodging at the root of a tree, surrendering all things loved as well as unloved, tasting neither grief nor pleasure, forfeiting blame and praise alike, neither cherishing hope, nor offering respect, free from the opposites, with neither fortune nor belongings.⁴³

He who remains the same in living as in dying, in fortune as in misfortune, whether gaining or losing, loving or hating, will be liberated. He who covets nothing and despises nothing, who is free from the opposites, whose soul knows no passion, is in every way liberated. ... He who does neither right nor wrong, renouncing the merit and demerit acquired in former lives, whose soul is tranquil when the bodily elements vanish away, he will be liberated.⁴⁴

A thousand years I have enjoyed the things of sense, while still the craving for them springs up unceasingly. These I will therefore renounce, and direct my mind upon Brahman; indifferent to the opposites and free from self-seeking, I will roam with the wild.⁴⁵

Through forbearance towards all creatures, through the ascetic life, through self-discipline and freedom from desire, through the vow and the blameless life, through

equanimity and endurance of the opposites, man will partake of the bliss of Brahman, which is without qualities.⁴⁶

Free from pride and delusion, with the evils of attachment conquered, faithful always to the highest Atman, with desires extinguished, untouched by the opposites of pain and pleasure, they go, undeluded, towards that imperishable place.⁴⁷

[329] As is clear from these quotations, it is external opposites, such as heat and cold, that must first be denied participation in the psyche, and then extreme fluctuations of emotion, such as love and hate. Fluctuations of emotion are, of course, the constant concomitants of all psychic opposites, and hence of all conflicts of ideas, whether moral or otherwise. We know from experience that the emotions thus aroused increase in proportion as the exciting factor affects the individual as a whole. The Indian purpose is therefore clear: it wants to free the individual altogether from the opposites inherent in human nature, so that he can attain a new life in Brahman, which is the state of redemption and at the same time God. It is an irrational union of opposites, their final overcoming. Although Brahman, the world-ground and world-creator, created the opposites, they must nevertheless be cancelled out in it again, for otherwise it would not amount to a state of redemption. Let me give another series of examples:

Brahman is *sat* and *asat*, being and non-being, *satyam* and *asatyam*, reality and irreality.⁴⁸

There are two forms of Brahman: the formed and the formless, the mortal and the immortal, the stationary and the moving, the actual and the transcendental.⁴⁹

That Person, the maker of all things, the great Self, seated forever in the heart of man, is perceived by the heart, by the thought, by the mind; they who know that become immortal. When there is no darkness [of ignorance] there is neither day nor night, neither being nor not-being.⁵⁰

In the imperishable, infinite, highest Brahman, two things are hidden: knowing and not-knowing. Not-knowing perishes, knowing is immortal; but he who controls both knowing and not-knowing is another.⁵¹

That Self, smaller than small, greater than great, is hidden in the heart of this creature here. Man becomes free from desire and free from sorrow when by the grace of the Creator he beholds the glory of the Self. Sitting still he walks afar; lying down he goes every where. Who but I can know the God who rejoices and rejoices not?⁵²

Unmoving, the One is swifter than the mind.

Speeding ahead, it outruns the gods of the senses.

Past others running, it goes standing.

...

It moves. It moves not.

Far, yet near.

Within all,

Outside all.⁵³

Just as a falcon or an eagle, after flying to and fro in space, wearies, and folds its wings, and drops down to its eyrie, so this Person (*purusha*) hastens to that state where, asleep, he desires no desires and sees no dream.

This, verily, is that form of his which is beyond desire, free from evil, without fear. As a man in the embrace of a beloved woman knows nothing of a without and within, so this Person, in the embrace of the knowing Self, knows nothing of a without and within. This, verily, is that form of his in which all desire is satisfied, Self his sole desire, which is no desire, without sorrow.

An ocean of seeing, one without a second, he becomes whose world is Brahman. ... This is man's highest achievement, his greatest wealth, his final goal, his utmost joy.⁵⁴

That which moves, that which flies and yet stands still,

That which breathes yet draws no breath,

that which closes the eyes,

That, many-formed, sustains the whole earth,

That, uniting, becomes One only.⁵⁵

[330] These quotations show that Brahman is the union and dissolution of all opposites, and at the same time stands outside them as an irrational factor. It is therefore wholly beyond cognition and comprehension. It is a divine entity, at once the self (though to a lesser degree than the analogous Atman concept) and a definite psychological state characterized by isolation from the flux of affects. Since suffering is an affect, release from affects means deliverance. Deliverance from the flux of affects, from the tension of opposites, is synonymous with the way of redemption that gradually leads to Brahman. Brahman is thus not only a state but also a process, a *durée créatrice*. It is therefore not surprising that it is expressed in the Upanishads by means of the symbols I have termed libido symbols.⁵⁶ In the following section I give some examples of these.

b. The Brahmanic Conception of the Uniting Symbol

[331] When it is said that Brahman was first born in the East, it means that each day Brahman is born in the East like yonder sun.⁵⁷

Yonder man in the sun is Parameshtin, Brahman, Atman.⁵⁸

Brahman is a light like the sun.⁵⁹

As to that Brahman, it is yonder burning disk.⁶⁰

First was Brahman born in the East.

From the horizon the Gracious One appears in splendour;

He illumines the forms of this world, the deepest, the highest,

He is the cradle of what is and is not.

Father of the luminaries, *begetter* of the treasure,

He entered many-formed into the spaces of the air.

They glorify him with hymns of praise,

*Making the youth that is Brahman increase by Brahman.*⁶¹

Brahman brought forth the gods, Brahman created the world.⁶²

[332] In this last passage, I have italicized certain characteristic points which make it clear that Brahman is not only the producer but the produced, the ever-becoming. The epithet “Gracious One” (*vena*), here bestowed on the sun, is elsewhere applied to the seer who is endowed with the divine light, for, like the Brahman-sun, the mind of the seer traverses “earth and heaven contemplating Brahman.”⁶³ The intimate connection, indeed identity, between the divine being and the self (Atman) of man is generally known. I give an example from the *Atharva Veda*:

The disciple of Brahman gives life to both worlds.

In him all the gods are of one mind.

He contains and sustains earth and heaven,

His *tapas* is food even for his teacher.

To the disciple of Brahman there come, to visit him,

Fathers and gods, singly and in multitudes,

And he nourishes all the gods with his *tapas*.⁶⁴

[333] The disciple of Brahman is himself an incarnation of Brahman, whence it follows that the essence of Brahman is identical with a definite psychological state.

The sun, set in motion by the gods, shines unsurpassed yonder.

From it came the Brahma-power, the supreme Brahman,

And all the gods, and what makes them immortal.

The disciple of Brahman upholds the splendour of Brahman,

Interwoven in him are the hosts of the gods.⁶⁵

[334] Brahman is also *prana*, the breath of life and the cosmic principle; it is *vayu*, wind, which is described in the *Brihadaranyaka Upanishad* (3, 7) as “the thread by which this world and the other world and all things are tied together, the Self, the inner controller, the immortal.”

He who dwells in man, he who dwells in the sun, are the same.⁶⁶

Prayer of the dying:

The face of the Real
Is covered with a golden disk.
Open it, O sun,
That we may see the nature of the Real.
...
Spread thy rays, and gather them in!
The light which is thy fairest form,
I see it.
That Person who dwells yonder, in the sun, is myself.
May my breath go to the immortal wind
When my body is consumed to ash.⁶⁷

And this light which shines above this heaven, higher than all, on top of everything, in the highest world, beyond which there are no other worlds, this same is the light which is in man. And of this we have tangible proof, when we perceive by touch the heat here in the body.⁶⁸

As a grain of rice, or a grain of barley, or a grain of millet, or the kernel of a grain of millet, is this golden Person in the heart, like a flame without smoke, greater than the earth, greater than the sky, greater than space, greater than all these worlds. That is the soul of all creatures, that is myself. Into that I shall enter on departing hence.⁶⁹

[335] Brahman is conceived in the *Atharva Veda* as the vitalistic-principle, the life force, which fashions all the organs and their respective instincts:

Who planted the seed within him, that he might spin the thread of generation? Who assembled within him the powers of the mind, gave him voice and the play of features?⁷⁰

[336] Even man’s strength comes from Brahman. It is clear from these examples, which could be multiplied indefinitely, that the Brahman concept, by virtue of all its attributes and symbols, coincides with that of a dynamic or creative principle which I have termed libido. The word Brahman means prayer, incantation, sacred speech,

sacred knowledge (*veda*), holy life, the sacred caste (the Brahmans), the Absolute. Deussen stresses the prayer connotation as being especially characteristic.⁷¹ The word derives from *barh* (cf. L. *farcire*), ‘to swell,’⁷² whence “prayer” is conceived as “the upward-striving will of man towards the holy, the divine.” This derivation indicates a particular psychological state, a specific concentration of libido, which through overflowing innervations produces a general state of tension associated with the feeling of swelling. Hence, in common speech, one frequently uses images like “overflowing with emotion,” “unable to restrain oneself,” “bursting” when referring to such a state. (“What filleth the heart, goeth out by the mouth.”) The yogi seeks to induce this concentration or accumulation of libido by systematically withdrawing attention (libido) both from external objects and from interior psychic states, in a word, from the opposites. The elimination of sense-perception and the blotting out of conscious contents enforce a lowering of consciousness (as in hypnosis) and an activation of the contents of the unconscious, i.e., the primordial images, which, because of their universality and immense antiquity, possess a cosmic and suprahuman character. This accounts for all those sun, fire, flame, wind, breath similes that from time immemorial have been symbols of the procreative and creative power that moves the world. As I have made a special study of these libido symbols in my book *Symbols of Transformation*, I need not expand on this theme here.

[337] The idea of a creative world-principle is a projected perception of the living essence in man himself. In order to avoid all vitalistic misunderstandings, one would do well to regard this essence in the abstract, as simply *energy*. On the other hand, the hypostatizing of the energy concept after the fashion of modern physicists must be rigorously rejected. The concept of energy implies that of polarity, since a current of energy necessarily presupposes two different states, or poles, without which there can be no current. Every energetic phenomenon (and there is no phenomenon that is not energetic) consists of pairs of opposites: beginning and end, above and below, hot and cold, earlier and later, cause and effect, etc. The inseparability of the energy concept from that of polarity also applies to the concept of libido. Hence libido symbols, whether mythological or speculative in origin, either present themselves directly as opposites or can be broken down into opposites. I have already referred in my earlier work to this inner splitting of libido, thereby provoking considerable resistance, unjustifiably, it seems to me, because the direct connection between a libido symbol and the concept of polarity is sufficient justification in itself. We find this connection also in the concept or symbol of Brahman. Brahman as a combination of prayer and primordial creative power, the latter resolving itself into the opposition of the sexes, occurs in a remarkable hymn of the *Rig Veda* (10.31.6):

And this prayer of the singer, spreading afar,

Became the bull which existed before the world was.
The gods are nurslings of the same brood,
Dwelling together in Asura's mansion.
What was the wood, what was the tree,
Out of which heaven and earth were fashioned?
These two stand fast and never grow old,
They have sung praises to many a dawn and morning.
There is no other thing greater than he,
The bull, supporter of earth and heaven.
He makes his skin a filter purifying the rays,
When as Surya his bay horses bear him along.
As the arrow of the sun he illumines the broad earth,
As the wind scatters the mist he storms through the world.
With Mitra and Varuna he comes anointed with ghee,
As Agni in the firesticks he shoots out splendour.
Driven to him, the cow once barren brought forth,
The moveless thing she created moved, pasturing freely.
She bore the son who was older than the parents.⁷³

[338] The polarity of the creative world principle is represented in another form in the *Shatapatha Brahmana* (2.2.4):

In the beginning, Prajapati⁷⁴ was this world alone. He meditated: How can I propagate myself? He travailed, he practised *tapas*; then he begat Agni (fire) out of his mouth,⁷⁵ and because he begat him out of his mouth, Agni is a devourer of food.

Prajapati meditated: As a devourer of food I have begotten this Agni out of myself, but there is nothing else beside myself that he may devour. For the earth at that time was quite barren, there were no herbs and no trees, and this thought was heavy upon him.

Then Agni turned upon him with gaping maw. His own greatness spoke to him: Sacrifice! Then Prajapati knew: My own greatness has spoken to me. And he sacrificed.

Thereupon that rose up which shines yonder (the sun); thereupon that rose up which purifies all things here (the wind). Thus Prajapati, by offering sacrifice, propagated himself, and at the same time saved himself from death, who as Agni would have devoured him.

[339] Sacrifice always means the renunciation of a valuable part of oneself, and through it the sacrificer escapes being devoured. In other words, there is no transformation into the opposite, but rather equilibration and union, from which arises a new form of libido: sun and wind. Elsewhere the *Shatapatha Brahmana* says that one half of Prajapati is mortal, the other immortal.⁷⁶

[340] In the same way as he divides himself into bull and cow, Prajapati also divides himself into the two principles *manas* (mind) and *vac* (speech):

This world was Prajapati alone, *vac* was his self, and *vac* his second self. He meditated: This *vac* I will send forth, and she shall go hence and pervade all things. Then he sent forth *vac*, and she went and filled the universe.⁷⁷

This passage is of especial interest in that speech is conceived as a creative, extraverted movement of libido, a diastole in Goethe's sense. There is a further parallel in the following passage:

In truth Prajapati was this world, and with him was *vac* his second self. He copulated with her; she conceived; she went forth out of him, and made these creatures, and once again entered into Prajapati.⁷⁸

[341] In *Shatapatha Brahmana* 8.1.2, 9 the role attributed to *vac* is a prodigious one: "Truly *vac* is the wise Vishvakarman, for by *vac* was this whole world made." But at 1.4.5, 8–11 the question of primacy between *manas* and *vac* is decided differently:

Now it happened that Mind and Speech strove for priority one with the other. Mind said: I am better than you, for you speak nothing that I have not first discerned. Then Speech said: I am better than you, for I announce what you have discerned and make it known.

They went to Prajapati for judgment. Prajapati decided in favour of Mind, saying to Speech: Truly Mind is better than you, for you copy what Mind does and run in his tracks; moreover it is the inferior who is wont to imitate his betters.

[342] These passages show that the principles into which the world-creator divides himself are themselves divided. They were at first contained in Prajapati, as is clear from the following:

Prajapati desired: I wish to be many, I will multiply myself. Then he meditated silently in his Mind, and what was in his Mind became *brihat* (song). He bethought himself: This embryo of me is hidden in my body, through Speech I will bring it forth. Then he created Speech.⁷⁹

[343] This passage shows the two principles as psychological functions: *manas* an introversion of libido begetting an inner product, *vac* a function of exteriorization or extraversion. This brings us to another passage relating to Brahman:

When Brahman had entered into that other world, he bethought himself: How can I extend myself through these worlds? And he extended himself twofold through these worlds, by Form and Name.

These two are the two monsters of Brahman; whoever knows these two monsters of Brahman, becomes a mighty monster himself. These are the two mighty manifestations of Brahman.⁸⁰

[344] A little later, Form is defined as *manas* (“*manas* is form, for through *manas* one knows it is this form”) and Name as *vac* (“for through *vac* one grasps the name”). Thus the two “mighty monsters” of Brahman turn out to be mind and speech, two psychic functions by which Brahman can “extend himself” through both worlds, clearly signifying the function of “relationship.” The forms of things are “apprehended” or “taken in” by introverting through *manas*; names are given to things by extraverting through *vac*. Both involve relationship and adaptation to objects as well as their assimilation. The two “monsters” are evidently thought of as personifications; this is indicated by their other name, *yaksha* (‘manifestation’) for *yaksha* means much the same as a daemon or superhuman being. Psychologically, personification always denotes the relative autonomy of the content personified, i.e., its splitting off from the psychic hierarchy. Such contents cannot be voluntarily reproduced; they reproduce themselves spontaneously, or else withdraw themselves from consciousness in the same way.⁸¹ A dissociation of this kind occurs, for instance, when an incompatibility exists between the ego and a particular complex. As we know, it is observed most frequently when the latter is a sexual complex, but other complexes can get split off too, for instance the power-complex, the sum of all those strivings and ideas aiming at the acquisition of personal power. There is, however, another form of dissociation, and that is the splitting off of the conscious ego, together with a selected function, from the other components of the personality. This form of dissociation can be defined as an identification of the ego with a particular function or group of functions. It is very common in people who are too deeply immersed in one of their psychic functions and have differentiated it into their sole conscious means of adaptation.

[345] A good literary example of such a man is Faust at the beginning of the tragedy. The other components of his personality approach him in the shape of the poodle, and later as Mephistopheles. Although Mephistopheles, as is perfectly clear from many of his associations, also represents the sexual complex, it would in my view be a mistake to explain him as a split-off complex and declare that he is nothing but repressed sexuality. This explanation is too narrow, because Mephistopheles is far more than sexuality—he is also power; in fact, he is practically the whole life of Faust, barring that part of it which is taken up with thinking and research. The result of the pact with the devil makes this very evident. What undreamt-of possibilities of power unfold themselves before the rejuvenated Faust! The correct explanation, therefore, would seem to be that Faust identified with one function and got split off as Mephistopheles from his personality as a whole. Subsequently, Wagner the thinker also gets split off from Faust.

[346] A *conscious* capacity for one-sidedness is a sign of the highest culture, but *involuntary* one-sidedness, i.e., the inability to be anything but one-sided, is a sign of barbarism. Hence the most one-sided differentiations are found among semi-barbarous people—for instance, certain aspects of Christian asceticism that are an affront to good taste, and parallel phenomena among the yogis and Tibetan Buddhists. For the barbarian, this tendency to fall a victim to one-sidedness in one way or another, thus losing sight of his total personality, is a great and constant danger. The Gilgamesh epic, for example, begins with this conflict. The one-sidedness of the barbarian takes the form of daemonic compulsion; it has something of the character of going berserk or running amok. In all cases it presupposes an atrophy of instinct that is not found in the true primitive, for which reason he is in general still free from the one-sidedness of the cultural barbarian.

[347] Identification with one particular function at once produces a tension of opposites. The more compulsive the one-sidedness, and the more untamed the libido which streams off to one side, the more daemonic it becomes. When a man is carried away by his uncontrolled, undomesticated libido, he speaks of daemonic possession or of magical influences. In this sense *manas* and *vac* are indeed mighty demons, since they work mightily upon men. All things that produced powerful effects were once regarded as gods or demons. Thus, among the Gnostics, the mind was personified as the serpent-like *Nous*, and speech as *Logos*. *Vac* bears the same relation to Prajapati as *Logos* to God. The sort of demons that introversion and extraversion may become is a daily experience for us psychotherapists. We see in our patients and can feel in ourselves with what irresistible force the libido streams inwards or outwards, with what unshakable tenacity an introverted or extraverted attitude can take root. The description of *manas* and *vac* as “mighty monsters of Brahman” is in complete accord with the psychological fact that at the instant of its appearance the libido divides into two streams, which as a rule alternate periodically but at times may appear simultaneously in the form of a conflict, as an outward stream opposing an inward stream. The daemonic quality of the two movements lies in their ungovernable nature and overwhelming power. This quality, however, makes itself felt only when the instinct of the primitive is already so stunted as to prevent a natural and purposive counter-movement to one-sidedness, and culture not sufficiently advanced for man to tame his libido to the point where he can follow its introverting or extraverting movement of his own free will and intention.

c. The Uniting Symbol as the Principle of Dynamic Regulation

[348] In the foregoing passages from Indian sources we have followed the development of a redemptive principle from the pairs of opposites and have traced their origin to the same creative principle, thereby gaining an insight into a regular psychological occurrence which was found to be compatible with the concepts of modern psychology. The impression that this occurrence is a regular one is confirmed by the Indian sources themselves, since they identify Brahman with *rta*. What is *rta*? *Rta* means established order, regulation, destiny, sacred custom, statute, divine law, right, truth. According to the etymological evidence its root meaning is: ordinance, (right) way, direction, course (to be followed). That which is ordained by *rta* fills the whole world, but the particular manifestations of *rta* are in those processes of nature which always remain constant and arouse the idea of regular recurrence: "By the ordinance of *rta* the heaven-born dawn was lighted." "In obedience to *rta*" the Ancient Ones who order the world "made the sun to mount into the heavens," who himself is "the burning countenance of *rta*." Around the heavens circles the year, the twelve-spoked wheel of *rta* that never ages. Agni is called the offspring of *rta*. In the doings of man, *rta* operates as moral law, which ordains truth and the straight way. "Whoso follows *rta*, finds a fair and thornless path to walk in."

[349] In so far as they represent a magical repetition or re-enactment of cosmic events, *rta* also figures in religious rites. As the rivers flow in obedience to *rta* and the crimson dawn is set ablaze, so "under the harness⁸² of *rta*" is the sacrifice kindled; on the path of *rta*, Agni offers sacrifice to the gods. "Free from magic, I invoke the gods; with *rta* I do my work, and shape my thought," says the sacrificer. Although *rta* does not appear personified in the Vedas, according to Bergaigne⁸³ a suggestion of concrete existence undoubtedly attaches to it. Since *rta* expresses the direction of events, there are "paths of *rta*," "charioteers⁸⁴ of *rta*," "ships of *rta*," and on occasion the gods appear as parallels. For instance, the same is said of *rta* as of Varuna, the sky-god. Mitra also, the ancient sun-god, is brought into relation with *rta*. Of Agni it is said: "Thou shalt become Varuna, if thou strivest after *rta*."⁸⁵ The gods are the guardians of *rta*.⁸⁶ Here are some of the most important associations:

Rta is Mitra, for Mitra is Brahman and *rta* is Brahman.⁸⁷

By giving the cow to the Brahmans, one gains all the worlds, for in her is contained *rta*, Brahman, and *tapas* also.⁸⁸

Prajapati is named the first-born of *rta*.⁸⁹

The gods followed the laws of *rta*.⁹⁰

He who has seen the hidden one (Agni), draws nigh to the streams of *rta*.⁹¹

O wise one of *rta*, know *rta*! Bore for *rta*'s many streams.⁹²

[350] The “boring” refers to the worship of Agni, to whom this hymn is dedicated. (Agni is here called “the red bull of *rta*.”) In the worship of Agni, the fire obtained by boring is used as a magic symbol of the regeneration of life. Boring for the streams of *rta* obviously has the same significance; the streams of life rise to the surface again, libido is freed from its bonds.⁹³ The effect produced by the ritual fire-boring, or by the recital of hymns, is naturally regarded by believers as the magical effect of the object; in reality it is an “enchantment” of the subject, an intensification of vital feeling, an increase and release of life force, a restoration of psychic potential:

Though he [Agni] slinks away, the prayer goes straight to him. They [the prayers] have led forth the flowing streams of *rta*.⁹⁴

[351] The revival of vital feeling, of this sense of streaming energy, is in general compared to a spring gushing from its source, to the melting of the iron-bound ice of winter in springtime, or to the breaking of a long drought by rain.⁹⁵ The following passage takes up this theme:

The lowing milch-cows of *rta* were overflowing, their udders full. The streams, imploring from afar the favour of the gods, have broken through the midst of the rock with their floods.⁹⁶

The imagery clearly suggests a state of energetic tension, a damming up of libido and its release. *Rta* appears here as the bestower of blessing in the form of “lowing milch cows” and as the ultimate source of the released energy.

[352] The aforementioned image of rain as a release of libido is borne out in the following passage:

The mists fly, the clouds thunder. When he who is swollen with the milk of *rta* is led on the straight path of *rta*, Aryaman, Mitra, and Varuna who wanders over the earth, fill the leathern sack (= cloud) in the womb of the lower (world?).⁹⁷

It is Agni, swollen with the milk of *rta*, who is likened to the lightning that bursts forth from the massed clouds heavy with rain. Here again *rta* appears as the actual source of energy, whence Agni also is born, as expressly mentioned in the *Vedic Hymns*.⁹⁸

They have greeted with shouts the streams of *rta*, which were hidden at the birthplace of the god, at his seat. There did he drink when he dwelt dispersed in the womb of the waters.⁹⁹

[353] This confirms what we have said about *rta* as the source of libido where the god dwells and whence he is brought forth in the sacred ceremonies. Agni is the positive manifestation of the latent libido; he is accomplisher or fulfiller of *rta*, its “charioteer”; he harnesses the two long-maned red mares of *rta*.¹⁰⁰ He even holds *rta* like a horse, by the bridle.¹⁰¹ He brings the gods to mankind, their power and blessing; they represent definite psychological

states in which the vital feelings and energies flow with greater freedom and joy. Nietzsche has captured this state in his verses:

You with your fiery lances
Shatter the ice-bound soul of me,
Till with high hope it advances
Rushing and roaring into the sea.¹⁰²

[354] The following invocation echoes this theme:

May the divine gates, the increasers of *rta*, open themselves ... that the gods may come forth. May Night and Dawn ... the young mothers of *rta*, sit down together on the sacrificial grass.¹⁰³

The analogy with the sunrise is unmistakable. *Rta* appears as the sun, since it is from night and dawn that the young sun is born.

[355] There is no need, I think, of further examples to show that the concept of *rta* is a libido-symbol like sun, wind, etc. Only, *rta* is less concretistic and contains the abstract element of fixed direction and regularity, the idea of a predetermined, ordered path or process. It is, therefore, a kind of philosophical libido symbol that can be directly compared with the Stoic concept of *heimarmene*. For the Stoics *heimarmene* had the significance of creative, primal heat, and at the same time it was a predetermined, regular process (hence its other meaning: “compulsion of the stars”).¹⁰⁴ Libido as psychic energy naturally has these attributes too; the concept of energy necessarily includes the idea of a regulated process, since a process always flows from a higher potential to a lower. It is the same with the libido concept, which signifies nothing more than the energy of the life process. Its laws are the laws of vital energy. Libido as an energy concept is a quantitative formula for the phenomena of life, which are naturally of varying intensity. Like physical energy, libido passes through every conceivable transformation; we find ample evidence of this in the fantasies of the unconscious and in myths. These fantasies are primarily self-representations of energetic transformation processes, which follow their specific laws and keep to a definite “path.” This path is the line or curve representing the optimal discharge of energy and the corresponding result in work. Hence it is simply the expression of flowing and self-manifesting energy. The path is *rta*, the right way, the flow of vital energy or libido, the predetermined course along which a constantly self-renewing current is directed. This path is also fate, in so far as a man’s fate depends on his psychology. It is the path of our destiny and of the law of our being.

[356] It would be quite wrong to assert that such a direction or tendency is nothing more than naturalism, meaning a complete surrender to one’s instincts. This presupposes that the instincts have a constant “downward” tendency, and that naturalism amounts to an unethical sliding down an inclined plane. I have nothing against such an interpretation of naturalism, but I am bound to observe that the man who is left to his own devices, and has therefore every opportunity for sliding downwards, as for instance the primitive, not only has a moral

code but one which in the severity of its demands is often considerably more exacting than our civilized morality. It makes no difference if good and evil mean one thing for the primitive and another for us; his naturalism leads to law-giving—that is the chief point. Morality is not a misconception invented by some vaunting Moses on Sinai, but something inherent in the laws of life and fashioned like a house or a ship or any other cultural instrument. The natural flow of libido, this same middle path, means complete obedience to the fundamental laws of human nature, and there can positively be no higher moral principle than harmony with natural laws that guide the libido in the direction of life's optimum. The vital optimum is not to be found in crude egoism, for fundamentally man is so constituted that the pleasure he gives to his neighbour is something essential to him. Nor can the optimum be reached by an unbridled craving for individualistic supremacy, because the collective element in man is so powerful that his longing for fellowship would destroy all pleasure in naked egoism. The optimum can be reached only through obedience to the tidal laws of the libido, by which systole alternates with diastole—laws which bring pleasure and the necessary limitations of pleasure, and also set us those individual life tasks without whose accomplishment the vital optimum can never be attained.

[357] If the attainment of the middle path consisted in a mere surrender to instinct, as the bewailers of “naturalism” suppose, the profoundest philosophical speculation that the human mind has ever known would have no *raison d'être*. But, as we study the philosophy of the Upanishads, the impression grows on us that the attainment of this path is not exactly the simplest of tasks. Our Western superciliousness in the face of these Indian insights is a mark of our barbarian nature, which has not the remotest inkling of their extraordinary depth and astonishing psychological accuracy. We are still so uneducated that we actually need laws from without, and a task-master or Father above, to show us what is good and the right thing to do. And because we are still such barbarians, any trust in the laws of human nature seems to us a dangerous and unethical naturalism. Why is this? Because under the barbarian's thin veneer of culture the wild beast lurks in readiness, amply justifying his fear. But the beast is not tamed by locking it up in a cage. *There is no morality without freedom.* When the barbarian lets loose the beast within him, that is not freedom but bondage. Barbarism must first be vanquished before freedom can be won. This happens, in principle, when the basic root and driving force of morality are felt by the individual as constituents of his own nature and not as external restrictions. How else is man to attain this realization but through the conflict of opposites?

d. The Uniting Symbol in Chinese Philosophy

[358] The idea of a middle way between the opposites is to be found also in China, in the form of *tao*. The concept of *tao* is usually associated with the name of the philosopher Lao-tzu, born 604 B.C. But this concept is older than the philosophy of Lao-tzu. It is bound up with the ancient folk religion of Taoism, the “way of Heaven,” a concept corresponding to the Vedic *rta*. The meanings of *tao* are as follows: way, method, principle, natural force or life force, the regulated processes of nature, the idea of the world, the prime cause of all phenomena, the right, the good, the moral order. Some translators even translate it as God,

not without some justification, it seems to me, since *tao*, like *rta*, has a tinge of substantiality.

[359] I will first give a number of passages from the *Tao Te Ching*, Lao-tzu's classic:

Was Tao the child of something else? We cannot tell.

But as a substanceless image it existed before the Ancestor.¹⁰⁵

There was something formless yet complete,

That existed before heaven and earth;

Without sound, without substance,

Dependent on nothing, unchanging,

All pervading, unfailing,

One may think of it as the mother of all things under heaven.

Its true name we do not know;

"Way" is the name that we give it.¹⁰⁶

[360] In order to characterize its essential quality, Lao-tzu likens it to water:

The highest good is like that of water. The goodness of water is that it benefits the ten thousand creatures; yet itself does not scramble, but is content with the [low] places that all men disdain. It is this that makes water so near to the Way.¹⁰⁷

The idea of a "potential" could not be better expressed.

He that is without desire sees its essence,

He that clings to desire sees only its outward form.¹⁰⁸

[361] The affinity with the fundamental Brahmanic ideas is unmistakable, though this does not necessarily imply direct contact. Lao-tzu was an entirely original thinker, and the primordial image underlying *rta-brahman-atman* and *tao* is as universal as man, appearing in every age and among all peoples as a primitive conception of energy, or "soul force," or however else it may be called.

He who knows the Always-so has room in him for everything;

He who has room in him for everything is without prejudice.

To be without prejudice is to be kingly;

To be kingly is to be of heaven;

To be of heaven is to be in Tao.

Tao is forever, and he that possesses it,

Though his body ceases, is not destroyed.¹⁰⁹

[362] Knowledge of *tao* therefore has the same redeeming and uplifting effect as the knowledge of *brahman*. Man becomes one with *tao*, with the unending *durée créatrice* (if we may compare this concept of Bergson's with its older congener), for *tao* is also the stream of time. It is irrational, inconceivable:

Tao is a thing impalpable, incommensurable.¹¹⁰

For though all creatures under heaven are the products of [Tao as] Being,
Being itself is the product of [Tao as] Not-Being.¹¹¹

Tao is hidden and nameless.¹¹²

It is obviously an irrational union of opposites, a symbol of what is and is not.

The Valley Spirit never dies;

It is named the mysterious Female.

And the door of the mysterious Female

Is the base from which heaven and earth sprang.¹¹³

[363] *Tao* is the creative process, begetting as the father and bringing forth as the mother. It is the beginning and end of all creatures.

He whose actions are in harmony with *Tao* becomes one with *Tao*.¹¹⁴

Therefore the perfected sage liberates himself from the opposites, having seen through their connection with one another and their alternation. Therefore it is said:

When your work is done, then withdraw.

Such is heaven's way.¹¹⁵

He [the perfected sage] cannot either be drawn into friendship or repelled,

Cannot be benefited, cannot be harmed,

Cannot be either raised or humbled.¹¹⁶

[364] Being one with *tao* resembles the state of infancy:

Can you keep the unquiet physical soul from straying, hold fast to the Unity, and never quit it?

Can you, when concentrating your breath, make it soft like that of a little child?¹¹⁷

He who knows the male, yet cleaves to what is female,

Becomes like a ravine, receiving all things under heaven;

And being such a ravine,

He knows all the time a power that he never calls upon in vain.

This is returning to the state of infancy.¹¹⁸

The impunity of that which is fraught with this power

May be likened to that of an infant.¹¹⁹

[365] This psychological attitude is, as we know, an essential condition for obtaining the kingdom of heaven, and this in its turn—all rational interpretations notwithstanding—is the central, irrational symbol whence the redeeming effect comes. The Christian symbol merely has a more social character than the related conceptions of the East. These are directly

connected with age-old dynamistic ideas of a magical power emanating from people and things or—at a higher level of development—from gods or a divine principle.

[366] According to the central concepts of Taoism, *tao* is divided into a fundamental pair of opposites, *yang* and *yin*. *Yang* signifies warmth, light, maleness; *yin* is cold, darkness, femaleness. *Yang* is also heaven, *yin* earth. From the *yang* force arises *shen*, the celestial portion of the human soul, and from the *yin* force comes *kwei*, the earthly part. As a microcosm, man is a reconciler of the opposites. Heaven, man, and earth form the three chief elements of the world, the *san-tsai*.

[367] The picture thus presented is an altogether primitive idea which we find in similar forms elsewhere, as for instance in the West African myth where Obatala and Odudua, the first parents (heaven and earth), lie together in a calabash until a son, man, arises between them. Hence man as a microcosm uniting the world opposites is the equivalent of an irrational symbol that unites the psychological opposites. This primordial image of man is in keeping with Schiller's definition of the symbol as "living form."

[368] The division of the psyche into a *shen* (or *hwan*) soul and a *kwei* (or *p'o*) soul is a great psychological truth. This Chinese conception is echoed in the well-known passage from *Faust*:

Two souls, alas, are housed within my breast,
And each will wrestle for the mastery there.
The one has passion's craving crude for love,
And hugs a world where sweet the senses rage;
The other longs for pastures fair above,
Leaving the murk for lofty heritage.¹²⁰

[369] The existence of two mutually antagonistic tendencies, both striving to drag man into extreme attitudes and entangle him in the world, whether on the material or spiritual level, sets him at variance with himself and accordingly demands the existence of a counterweight. This is the "irrational third," *tao*. Hence the sage's anxious endeavour to live in harmony with *tao*, lest he fall into the conflict of opposites. Since *tao* is irrational, it is not something that can be got by the will, as Lao-tzu repeatedly emphasizes. This lends particular significance to another specifically Chinese concept, *wu-wei*. *Wu-wei* means "not-doing" (which is not to be confused with "doing nothing"). Our rationalistic "doing," which is the greatness as well as the evil of our time, does not lead to *tao*.

[370] The aim of Taoist ethics, then, is to find deliverance from the cosmic tension of opposites by a return to *tao*. In this connection we must also remember the "sage of Omi," Nakae Toju,¹²¹ an outstanding Japanese philosopher of the seventeenth century. Basing himself on the teaching of the Chu-hi school, which had migrated from China, he established two principles, *ri* and *ki*. *Ri* is the world soul, *ki* is the world stuff. *Ri* and *ki* are, however, the same because they are both attributes of God and therefore exist only in him and through him. God is their union. Equally, the soul embraces both *ri* and *ki*. Toju says of

God: “As the essence of the world, God embraces the world, but at the same time he is in our midst and even in our bodies.” For him God is a universal self, while the individual self is the “heaven” within us, something supra-sensible and divine called *ryochi*. *Ryochi* is “God within us” and dwells in every individual. It is the true self. Toju distinguishes a true from a false self. The false self is an acquired personality compounded of perverted beliefs. We might define this false self as the *persona*, that general idea of ourselves which we have built up from experiencing our effect upon the world around us and its effect upon us. The *persona* is, in Schopenhauer’s words, how one *appears* to oneself and the world, but not what one *is*. What one is, is one’s individual self, Toju’s “true self” or *ryochi*. *Ryochi* is also called “being alone” or “knowing alone,” clearly because it is a condition related to the essence of the self, beyond all personal judgments conditioned by external experience. Toju conceives *ryochi* as the summum bonum, as “bliss” (*brahman* is bliss, *ananda*). It is the light which pervades the world—a further parallel with *brahman*, according to Inouye. It is love for mankind, immortal, all-knowing, good. Evil comes from the will (shades of Schopenhauer!). *Ryochi* is the self-regulating function, the mediator and uniter of the opposites, *ri* and *ki*; it is in fullest accord with the Indian idea of the “wise old man who dwells in the heart.” Or as Wang Yang-ming, the Chinese father of Japanese philosophy, says: “In every heart there dwells a *sejin* (sage). Only, we do not believe it firmly enough, and therefore the whole has remained buried.”¹²²

* * *

[371] From¹²³ this point of view it is not so difficult to see what the primordial image was that helped to solve the problem in Wagner’s *Parsifal*. Here the suffering is caused by the tension of opposites represented by the Grail and the power of Klingsor, who has taken possession of the holy spear. Under the spell of Klingsor is Kundry, symbolizing the instinctive life-force or libido that Amfortas lacks. Parsifal rescues the libido from the state of restless, compulsive instinctuality, in the first place because he does not succumb to Kundry, and in the second because he does not possess the Grail. Amfortas has the Grail and suffers for it, because he lacks libido. Parsifal has nothing of either, he is *nirvanda*, free from the opposites, and is therefore the redeemer, the bestower of healing and renewed vitality, who unites the bright, heavenly, feminine symbol of the Grail with the dark, earthly, masculine symbol of the spear. The death of Kundry may be taken as the liberation of libido from its naturalistic, undomesticated form (cf. the “bull’s shape,” par. 350, n. 93), which falls away as a lifeless husk, while the energy bursts forth as a new stream of life in the glowing of the Grail.

[372] By his renunciation of the opposites (unwilling though this was, at least in part), Parsifal caused a blockage of libido that created a new potential and thus made a new manifestation of energy possible. The undeniable sexual symbolism might easily lead to the one-sided interpretation that the union of spear and Grail merely signifies a release of sexuality. The fate of Amfortas shows, however, that sexuality is not the point. On the contrary, it was his relapse into a nature-bound, brutish attitude that was the cause of his suffering and brought about the loss of his power. His seduction by Kundry was a symbolic act, showing that it

was not sexuality that dealt him his wound so much as an attitude of nature-bound compulsion, a supine submission to the biological urge. This attitude expresses the supremacy of the animal part of our psyche. The sacrificial wound that is destined for the beast strikes the man who is overcome by the beast—for the sake of man's further development. The fundamental problem, as I have pointed out in *Symbols of Transformation*, is not sexuality *per se*, but the domestication of libido, which concerns sexuality only so far as it is one of the most important and most dangerous forms of libidinal expression.

[373] If, in the case of Amfortas and the union of spear and Grail, only the sexual problem is discerned, we get entangled in an insoluble contradiction, since the thing that harms is also the thing that heals. Such a paradox is true and permissible only when one sees the opposites as united on a higher plane, when one understands that it is not a question of sexuality, either in this form or in that, but purely a question of the attitude by which every activity, including the sexual, is regulated. Once again I must emphasize that the practical problem in analytical psychology lies deeper than sexuality and its repression. The latter point of view is no doubt very valuable in explaining the infantile and therefore morbid part of the psyche, but as an explanatory principle for the whole of the psyche it is quite inadequate. What lies behind sexuality or the power instinct is the *attitude* to sexuality or to power. In so far as an attitude is not merely an intuitive (i.e., unconscious and spontaneous) phenomenon but also a conscious function, it is, in the main, a *view of life*. Our conception of all problematical things is enormously influenced, sometimes consciously but more often unconsciously, by certain collective ideas that condition our mentality. These collective ideas are intimately bound up with the view of life and the world of the past centuries or epochs. Whether or not we are conscious of this dependence has nothing to do with it, since we are influenced by these ideas through the very air we breathe. Collective ideas always have a religious character, and a philosophical idea becomes collective only when it expresses a primordial image. Their religious character derives from the fact that they express the realities of the collective unconscious and are thus able to release its latent energies. The great problems of life, including of course sex, are always related to the primordial images of the collective unconscious. These images are balancing or compensating factors that correspond to the problems which life confronts us with in reality.

[374] This is no matter for astonishment, since these images are deposits of thousands of years of experience of the struggle for existence and for adaptation. Every great experience in life, every profound conflict, evokes the accumulated treasure of these images and brings about their inner constellation. But they become accessible to consciousness only when the individual possesses so much self-awareness and power of understanding that he also reflects on what he experiences instead of just living it blindly. In the latter event he actually lives the myth and the symbol without knowing it.

4. THE RELATIVITY OF THE SYMBOL

a. *The Worship of Woman and the Worship of the Soul*

[375] The Christian principle which unites the opposites is the *worship of God*, in Buddhism it is the *worship of the self* (self-development), while in Spitteler and Goethe it is the *worship of the soul* symbolized by the *worship of woman*. Implicit in this categorization is the modern individualistic principle on the one hand, and on the other a primitive poly-daemonism which assigns to every race, every tribe, every family, every individual its specific religious principle.

[376] The medieval background of *Faust* has a quite special significance because there actually was a medieval element that presided over the birth of modern individualism. It began, it seems to me, with the worship of woman, which strengthened the man's soul very considerably as a psychological factor, since the worship of woman meant worship of the soul. This is nowhere more beautifully and perfectly expressed than in Dante's *Divine Comedy*.

[377] Dante is the spiritual knight of his lady; for her sake he embarks on the adventure of the lower and upper worlds. In this heroic endeavour her image is exalted into the heavenly, mystical figure of the Mother of God—a figure that has detached itself from the object and become the personification of a purely psychological factor, or rather, of those unconscious contents whose personification I have termed the *anima*. Canto XXXIII of the *Paradiso* expresses this culminating point of Dante's psychic development in the prayer of St. Bernard:

O Virgin Mother, daughter of thy Son,
Humbler and more exalted than all others,
Predestined object of the eternal will!
Thou gavest such nobility to man
That He who made mankind did not disdain
To make Himself a creature of His making.

Verses 22–27, 29–33, 37–39 also allude to this development:

This man, who from the nethermost abyss
Of all the universe, as far as here,
Has seen the spiritual existences,
Now asks thy grace, so thou wilt grant him strength
That he may with his eyes uplift himself
Still higher toward the ultimate salvation.
...
I... proffer to thee
All my prayers—and pray they may suffice—
That thou wilt scatter from him every cloud

Of his mortality, with thine own prayers,
So that the bliss supreme may be revealed.

...

May thy protection quell his human passions!

Lo, Beatrice and many a blessed soul

Entreat thee, with clasped hands, to grant my wish!¹²⁴

[378] The very fact that Dante speaks here through the mouth of St. Bernard is an indication of the transformation and exaltation of his own being. The same transformation also happens to Faust, who ascends from Gretchen to Helen and from Helen to the Mother of God; his nature is altered by repeated figurative deaths (Boy Charioteer, homunculus, Euphorion), until finally he attains the highest goal as Doctor Marianus. In that form Faust utters his prayer to the Virgin Mother:

Pavilioned in the heaven's blue,
Queen on high of all the world,
For the holy sight I sue,
Of the mystery unfurled.
Sanction what in man may move
Feelings tender and austere,
And with glow of sacred love
Lifts him to thy presence near.
Souls unconquerable rise
If, sublime, thou will it;
Sinks that storm in peaceful wise
If thy pity still it.
Virgin, pure in heavenly sheen,
Mother, throned supernal,
Highest birth, our chosen Queen,
Godhead's peer eternal.

...

O contrite hearts, seek with your eyes
The visage of salvation;
Blissful in that gaze, arise,
Through glad regeneration.
Now may every pulse of good
Seek to serve before thy face,
Virgin, Queen of Motherhood,
Keep us, Goddess, in thy grace.¹²⁵

[379] We might also mention in this connection the symbolic attributes of the Virgin in the Litany of Loreto:

Mater amabilis	Lovable Mother
Mater admirabilis	Wonderful Mother
Mater boni consilii	Mother of good counsel
Speculum justitiae	Mirror of justice
Sedes sapientiae	Seat of wisdom
Causa nostrae laetitiae	Cause of our gladness
Vas spirituale	Vessel of the spirit
Vas honorabile	Vessel of honour
Vas insigne devotionis	Noble vessel of devotion
Rosa mystica	Mystical rose
Turris Davidica	Tower of David
Turris eburnea	Tower of ivory
Domus aurea	House of gold
Foederis arca	Ark of the covenant
Janua coeli	Gate of heaven
Stella matutina	Morning star ¹²⁶

[380] These attributes reveal the functional significance of the Virgin Mother image: they show how the soul-image (anima) affects the conscious attitude. She appears as a vessel of devotion, a source of wisdom and renewal.

[381] We find this characteristic transition from the worship of woman to the worship of the soul in an early Christian document, the *Shepherd* of Hermas, who flourished about A.D. 140. This book, written in Greek, consists of a number of visions and revelations describing the consolidation of the new faith. The book, long regarded as canonical, was nevertheless rejected by the Muratori Canon. It begins as follows:

The man who reared me sold me to a certain Rhoda in Rome. After many years, I made her acquaintance again and began to love her as a sister. One day I saw her bathing in the Tiber, and gave her my hand and helped her out of the water. When I saw her beauty I thought in my heart: "How happy I would be if I had a wife of such beauty and distinction." This was my only thought, and no other, no, not one.¹²⁷

[382] This experience was the starting-point for the visionary episode that followed. Hermas had apparently served Rhoda as a slave; then, as often happened, he obtained his freedom, and met her again later, when, probably as much from gratitude as from delight, a feeling of love stirred in his heart, though so far as he was aware it had merely the character of brotherly love. Hermas was a Christian, and moreover, as the text subsequently reveals, he was at that time already the father of a family, circumstances which would readily explain the repression of the erotic element. Yet the peculiar situation, doubtless provocative of many problems, was all the more likely to bring the erotic wish to consciousness. It is, in fact, expressed quite clearly in the thought that he would have liked Rhoda for a wife, though, as Hermas is at pains to emphasize, it is confined to this simple statement since

anything more explicit and more direct instantly fell under a moral ban and was repressed. It is abundantly clear from what follows that this repressed libido wrought a powerful transformation in his unconscious, for it imbued the soul-image with life and brought about a spontaneous manifestation:¹²⁸

After a certain time, as I journeyed unto Cumae, praising God's creation in its immensity, beauty, and power, I grew heavy with sleep. And a spirit caught me up, and led me away through a pathless region where a man may not go. For it was a place full of crevices and torn by water-courses. I made my passage over the river and came upon even ground, where I threw myself upon my knees, and prayed to God, confessing my sins. While I thus prayed, the heavens opened and I beheld that lady for whom I yearned, who greeted me from heaven and said: "Hail to thee, Hermas!" While my eyes dwelt upon her, I spake, saying: "Mistress, what doest thou there?" And she answered: "I was taken up, in order to charge thee with thy sins before the Lord." I said unto her: "Dost thou now accuse me?" "No," said she, "yet hearken now unto the words I shall speak unto thee. For God, who dwelleth in heaven, and hath created the existing out of the non-existing, and hath magnified it and brought it to increase for the sake of His Holy Church, is wroth with thee, because thou has sinned against me." I answered and spake unto her: "How have I sinned against thee? When and where spake I ever an evil word unto thee? Have I not looked upon thee as a goddess? Have I not ever treated thee like a sister? Wherefore, O lady, dost thou falsely charge me with such evil and unclean things?" She smiled and said unto me: "The desire of sin arose in thy heart. Or is it not indeed a sin in thine eyes for a just man to cherish a sinful desire in his heart? Verily is it a sin," said she, "and a great one. For the just man striveth after what is just."

[383] Solitary wanderings are, as we know, conducive to daydreaming and reverie.

Presumably Hermas, on his way to Cumae, was thinking of his mistress; while thus engaged, the repressed erotic fantasy gradually pulled his libido down into the unconscious. Sleep overcame him, as a result of this lowering of the intensity of consciousness, and he fell into a somnambulant or ecstatic state, which itself was nothing but a particularly intense fantasy that completely captivated his conscious mind. It is significant that what then came to him was not an erotic fantasy; instead he is transported as it were to another land, represented in fantasy as the crossing of a river and a journey through a pathless country. The unconscious appears to him as an upper world in which events take place and men move about exactly as in the real world. His mistress appears before him not in an erotic fantasy but in "divine" form, seeming to him like a goddess in heaven. The repressed erotic impression has activated the latent primordial image of the goddess, i.e., the archetypal soul-image. The erotic impression has evidently become united in the collective unconscious with archaic residues which have preserved from time immemorial the imprint of vivid impressions of the nature of woman—woman as mother and woman as desirable maid. Such impressions have immense power, as they release forces, both in the child and in the adult man, which fully merit the attribute "divine" i.e., something irresistible and absolutely compelling. The recognition of these forces as daemonic powers can hardly be

due to moral repression, but rather to a self-regulation of the psychic organism which seeks by this change of front to guard against loss of equilibrium. For if, in face of the overwhelming might of passion, which puts one human being wholly at the mercy of another, the psyche succeeds in building up a counterposition so that, at the height of passion, the boundlessly desired object is unveiled as an idol and man is forced to his knees before the divine image, then the psyche has delivered him from the curse of the object's spell. He is restored to himself again and, flung back on himself, finds himself once more between gods and men, following his own path and subject to his own laws. The awful fear that haunts the primitive, his terror of everything impressive, which he at once senses as magic, as though it were charged with magical power, protects him in a purposive way against that most dreaded of all possibilities, loss of soul, with its inevitable sequel of sickness and death.

[384] Loss of soul amounts to a tearing loose of part of one's nature; it is the disappearance and emancipation of a complex, which thereupon becomes a tyrannical usurper of consciousness, oppressing the whole man. It throws him off course and drives him to actions whose blind one-sidedness inevitably leads to self-destruction. Primitives are notoriously subject to such phenomena as running amok, going berserk, possession, and the like. The recognition of the daemonic character of passion is an effective safeguard, for it at once deprives the object of its strongest spell, relegating its source to the world of demons, i.e., to the unconscious, whence the force of passion actually springs. Exorcistic rites, whose aim is to bring back the soul and release it from enchantment, are similarly effective in causing the libido to flow back into the unconscious.

[385] This mechanism obviously worked in the case of Hermas. The transformation of Rhoda into a divine mistress deprived the actual object of her provocative and destructive power and brought Hermas under the law of his own soul and its collective determinants. Thanks to his abilities and connections, Hermas no doubt had a considerable share in the spiritual movements of his age. At that very time his brother Pius occupied the episcopal see at Rome. Hermas, therefore, was probably qualified to collaborate in the great task of his time to a greater degree than he, as a former slave, may have consciously realized. No able mind could for long have withstood the contemporary task of spreading Christianity, unless of course the barriers and peculiarities of race assigned him a different function in the great process of spiritual transformation. Just as the external conditions of life force a man to perform a social function, so the collective determinants of the psyche impel him to socialize ideas and convictions. By transforming a possible social *faux pas* into the service of his soul after having been wounded by the dart of passion, Hermas was led to accomplish a social task of a spiritual nature, which for that time was surely of no small importance.

[386] In order to fit him for this task, it was clearly necessary that his soul should destroy the last possibility of an erotic attachment to the object, as this would have meant dishonesty towards himself. By consciously denying any erotic wish, Hermas merely demonstrated that it would be more agreeable for him if the erotic wish did not exist, but it by no means proved that he actually had no erotic intentions and fantasies. Therefore his sovereign lady,

the soul, mercilessly revealed to him the existence of his sin, thus releasing him from his secret bondage to the object. As a “vessel of devotion” she took over the passion that was on the point of being fruitlessly lavished upon her. The last vestige of this passion had to be eradicated if the contemporary task was to be accomplished, and this consisted in delivering man from sensual bondage, from the state of primitive *participation mystique*. For the man of that age this bondage had become intolerable. The spiritual function had to be differentiated in order to restore the psychic equilibrium. All philosophical attempts to do this by achieving “equanimity,” most of which concentrated on the Stoic doctrine, came to grief because of their rationalism. Reason can give a man equilibrium only if his reason is already an equilibrating organ. But for how many individuals and at what periods of history has it been that? As a rule, a man needs the opposite of his actual condition to force him to find his place in the middle. For the sake of mere reason he can never forgo the sensuous appeal of the immediate situation. Against the power and delight of the temporal he must set the joy of the eternal, and against the passion of the sensual the ecstasy of the spiritual. The undeniable reality of the one must be matched by the compelling power of the other.

[387] Through insight into the actual existence of his erotic desire, Hermas was able to acknowledge this metaphysical reality. The sensual libido that had previously clung to the concrete object now passed to his soul-image and invested it with the reality which the object had claimed exclusively for itself. Consequently his soul could speak to good effect and successfully enforce her demands.

[388] After his conversation with Rhoda, her image vanishes and the heavens close. In her stead there now appears an “old woman in shining garments,” who informs Hermas that his erotic desire is a sinful and foolish defiance of a venerable spirit, but that God is angry with him not so much on that account as because he tolerates the sins of his family. In this adroit fashion the libido is drawn away entirely from the erotic desire and in a flash is directed to the social task. An especial refinement is that the soul has discarded the image of Rhoda and taken on the appearance of an old woman, thus allowing the erotic element to recede into the background. It is later revealed to Hermas that this old woman is the Church; the concrete and personal has resolved itself into an abstraction, and the idea acquires a reality it had never before possessed. The old woman then reads to him from a mysterious book attacking heathens and apostates, but whose exact meaning he is unable to grasp. Subsequently we learn that the book sets forth a mission. Thus his sovereign lady presents him with his task, which as her knight he is pledged to accomplish. Nor is the trial of virtue lacking. For, not long after, Hermas has a vision in which the old woman reappears, promising to return about the fifth hour in order to explain the revelation. Whereupon Hermas betook himself into the country to the appointed place, where he found a couch of ivory, set with a pillow and a cover of fine linen.

As I beheld these things lying there, I was sore amazed, and a quaking fell upon me and my hair stood on end, and a dreadful fear befell me, because I was alone in that place. But when I came once more to myself, I remembered the glory of God and took new courage; I knelt down and again confessed my sins unto God, as I had done before. Then she drew near with

six young men, the which also I had seen before, and stood beside me and listened while I prayed and confessed my sins unto God. And she touched me and said: “Hermas, have done with all thy prayers and the reciting of thy sins. Pray also for righteousness, whereby thou mayest bear some of it with thee to thy house.” And she raised me up by the hand and led me to the couch, and said unto the young men: “Go and build!” And when the youths were gone and we were alone, she said unto me: “Sit thee here!” I said unto her: “Mistress, let the aged first be seated.” She said: “Do as I said unto thee and be thou seated.” But, when I made as though to seat myself upon her right hand, she motioned me with a gesture of the hand to be seated upon her left.

As I wondered thereat, and was troubled, that I might not sit upon the right side, she said unto me: “Why art thou grieved, Hermas? The seat upon the right is for those who are already well-pleasing to God and have suffered for the Name. But to thee there lacketh much before thou canst sit with them. Yet remain as heretofore in thy simplicity, and thou shalt surely sit with them, and thus shall it be for all who shall have accomplished the work which those wrought, and endured what they suffered.”¹²⁹

[389] In this situation, it would have been very easy for Hermas to give way to an erotic misunderstanding. The rendezvous has about it the feeling of a trysting-place in a “beautiful and sequestered spot,” as he puts it. The rich couch waiting there is a fatal reminder of Eros, so that the terror which overcame Hermas at the sight of it is quite understandable. Clearly he must fight vigorously against these erotic associations lest he fall into a mood far from holy. He does not appear to have recognized the temptation for what it was, unless perhaps it is tacitly admitted in the description of his terror, a touch of honesty that came more easily to the man of that time than to the man of today. For in that age man was more closely in touch with his own nature than we are, and was therefore in a position to perceive his natural reactions directly and to recognize what they were. In the case of Hermas, the confession of his sins may very well have been prompted by unholy sensations. At all events, the ensuing question as to whether he shall sit on the right hand or the left leads to a moral reprimand from his mistress. For although signs coming from the left were regarded as favourable in the Roman auguries, the left side, for both the Greeks and the Romans, was on the whole inauspicious, as the double meaning of the word “sinister” shows. But the question raised here of left and right has nothing to do with popular superstitions and is clearly of Biblical origin, referring to Matthew 25:33: “And he shall set the sheep on his right hand, but the goats on the left.” Because of their guileless and gentle nature, sheep are an allegory of the good, while the unruly and lascivious nature of goats makes them an image of evil. By assigning him a seat on the left, his mistress tactfully reveals to him her understanding of his psychology.

[390] When Hermas has taken his seat on her left, rather sadly, as he records, his mistress shows him a visionary scene which unrolls itself before his eyes. He beholds how the youths, assisted by ten thousand other men, build a mighty tower whose stones fit together without seams. This seamless tower, of indestructible solidity, signifies the Church, so Hermas is given to understand. *His mistress is the Church, and so is the tower.* We have

seen already in the Litany of Loreto that the Virgin is named “tower of David” and “tower of ivory.” The same or a similar association seems to be made here. The tower undoubtedly has the meaning of something solid and secure, as in Psalm 61:4: “For thou hast been a shelter for me, and a strong tower from the enemy.” Any resemblance to the tower of Babel would involve an intense inner contradiction and must be excluded, but there may nevertheless be echoes of it, since Hermas, in company with every other thoughtful mind of that epoch, must have suffered much from the depressing spectacle of the ceaseless schisms and heretical disputes of the early Church. Such an impression may even have been his main reason for writing these confessions, an inference supported by the fact that the mysterious book that was revealed to him inveighed against heathens and apostates. The same confusion of tongues that frustrated the building of the tower of Babel almost completely dominated the Church in the early centuries, demanding desperate efforts on the part of the faithful to overcome the chaos. Since Christendom at that time was far from being one flock under one shepherd, it was only natural that Hermas should long for the “shepherd,” the *poimen*, as well as for some solid and stable structure, the “tower,” that would unite in one inviolable whole the elements gathered from the four winds, the mountains and seas.

[391] Earth-bound desire, sensuality in all its forms, attachment to the lures of this world, and the incessant dissipation of psychic energy in the world’s prodigal variety, are the main obstacle to the development of a coherent and purposive attitude. Hence the elimination of this obstacle must have been one of the most important tasks of the time. It is therefore not surprising that, in the *Shepherd* of Hermas, it is the mastering of this task that is unfolded before our eyes. We have already seen how the original erotic stimulus and the energy it released were canalized into the personification of the unconscious complex, becoming the figure of Ecclesia, the old woman, whose visionary appearance demonstrates the spontaneity of the underlying complex. We learn, moreover, that the old woman now turns into a tower, since the tower is also the Church. This transformation is unexpected, because the connection between the tower and the old woman is not immediately apparent. But the attributes of the Virgin in the Litany of Loreto will put us on the right track, for there we find, as already mentioned, the tower associated with the Virgin Mother. This attribute has its source in the Song of Songs 4:4: “Thy neck is like the tower of David builded for an armoury,” and 7:4: “Thy neck is a tower of ivory.” Similarly 8:10: “I am a wall, and my breasts like towers.”

[392] The Song of Songs, as we know, was originally a love poem, perhaps a wedding song, which was denied canonical recognition even by Jewish scholars until very late. Mystical interpretation, however, has always loved to conceive the bride as Israel and the bridegroom as Jehovah, impelled by a sound instinct to turn even erotic feelings into a relationship between God and the chosen people. Christianity appropriated the Song of Songs for the same reason, interpreting the bridegroom as Christ and the bride as the Church. To the psychology of the Middle Ages this analogy had an extraordinary appeal, and it inspired the quite unabashed Christ-eroticism of the Christian mystics, some of the best examples of which are supplied by Mechtild of Magdeburg. The Litany of Loreto was conceived in this

spirit. It derived certain attributes of the Virgin directly from the Song of Songs, as in the case of the tower symbol. The rose, too, was used as one of her attributes even at the time of the Greek Fathers, together with the lily, which likewise appear in the Song of Songs (2:1): “I am the rose of Sharon, and the lily of the valleys.” Images much used in the medieval hymns are the “enclosed garden” and the “sealed fountain” (Song of Songs 4:12: “A garden inclosed is my sister, my spouse; a spring shut up, a fountain sealed”). The unmistakably erotic nature of these images was explicitly accepted as such by the Fathers. Thus St. Ambrose interprets the “enclosed garden” as virginity.¹³⁰ In the same way, he¹³¹ compares Mary with the ark of bulrushes in which Moses was found:

By the ark of bulrushes is meant the Blessed Virgin. Therefore his mother prepared the ark of bulrushes wherein Moses was placed, because the wisdom of God, which is the Son of God, chose blessed Mary the virgin and formed in her womb a man to whom he might become joined in unity of person.¹³²

[393] St. Augustine employs the simile (frequently used by later writers) of the *thalamus*, bridal chamber, for Mary, again in an expressly anatomical sense: “He chose for himself a chaste bridal chamber, where the bridegroom was joined to the bride,”¹³³ and: “He issued forth from the bridal chamber, that is from the virginal womb.”¹³⁴

[394] The interpretation of *vas* as the womb may therefore be taken as certain when St. Ambrose says in confirmation of St. Augustine: “Not of earth but of heaven did he choose for himself this vessel, through which he should descend to sanctify the temple of shame.”¹³⁵ The designation *σκεῦος* (vessel) is not uncommon with the Greek Fathers. Here again there is probably an allusion to the Song of Songs, for although the designation *vas* does not appear in the Vulgate text, we find instead the image of the goblet and of drinking (7:2): “Thy navel is like a round goblet, which wanteth not liquor; thy belly is like a heap of wheat set about with lilies.” The meaning of the first sentence has a parallel in the *Meisterlieder der Kolmarer Handschrift*, where Mary is compared with the widow’s cruse of oil (I Kings:17: 9ff.): “... Zarephath in the land of Zidon, whither Elijah was sent to a widow who should feed him; my body is fitly compared with hers, for God sent the prophet unto me, to change for us our time of famine.”¹³⁶ With regard to the second, St. Ambrose says: “In the womb of the virgin grace increased like a heap of wheat and the flowers of the lily, even as it generated the grain of wheat and the lily.”¹³⁷ In Catholic sources¹³⁸ very far-fetched passages are drawn into this vessel symbolism, as for instance Song of Songs 1:1 (DV): “Let him kiss me with the kiss of his mouth: for thy *breasts* are better than wine,” and even Exodus 16:33: “Take a *pot*, and put an omer full of manna therein, and lay it up before the Lord, to be kept for your generations.”

[395] These associations are so contrived that they argue against rather than for the Biblical origin of the vessel symbolism. In favour of an extra-Biblical source is the fact that the medieval hymns to Mary brazenly borrowed their imagery from everywhere, so that everything that was in any way precious became associated with her. The fact that the vessel symbol is very old—it stems from the third to fourth century—is no argument against

its secular origin, since even the Fathers had a weakness for non-Biblical, pagan imagery; for instance Tertullian,¹³⁹ Augustine,¹⁴⁰ and others compared the Virgin with the undefiled earth and the unploughed field, not without a sidelong glance at the Kore of the mysteries.¹⁴¹ Such comparisons were based on pagan models, as Cumont has shown to be the case with the ascension of Elijah in the early medieval illustrated manuscripts, which keep closely to the Mithraic prototype. In many of its rites the Church followed the pagan model, not least in making the birth of Christ coincide with the birth of the *sol invictus*, the invincible sun. St. Jerome compares the Virgin with the sun as the mother of the light.

[396] These non-Biblical allegories can have their source only in pagan conceptions still current at that time. It is therefore only just, when considering the vessel symbol, to call to mind the well-known and widespread Gnostic symbolism of the vessel. A great many incised gems have been preserved from that time which bear the symbol of a pitcher with remarkable winged bands, at once recalling the uterus with the *ligamenta lata*. This vessel is called the “vase of sins,”¹⁴² in contrast with the hymns to Mary in which she is extolled as the “vessel of virtue.” King¹⁴³ contests the former interpretation as arbitrary and agrees with Köhler¹⁴⁴ that the cameo-image (principally Egyptian) refers to the pots on the water-wheels that drew up water from the Nile to irrigate the fields; this would also explain the peculiar bands which clearly served for fastening the pot to the water-wheel. The fertilizing function of the pot was, as King notes, expressed as the “fecundation of Isis by the seed of Osiris.” Often there is on the vessel a winnowing basket, probably with reference to the “mystical winnowing basket of Iakchos,” or *λίκνον*, the figurative birthplace of the grain of wheat, symbolizing fertility.¹⁴⁵ There used to be a Greek marriage ceremony in which a winnowing basket filled with fruit was placed on the head of the bride, an obvious fertility charm.

[397] This interpretation of the vessel is supported by the ancient Egyptian view that everything originated from the primal water, Nu or Nut, who was also identified with the Nile or the ocean. Nu is written with three pots, three water signs, and the sign for heaven. A hymn to Ptah-Tenen says: “Maker of grain, which cometh forth from him in his name Nu the Aged, who maketh fertile the watery mass of heaven, and maketh to come forth the water on the mountains to give life to men and women.”¹⁴⁶ Wallis Budge drew my attention to the fact that the uterus symbolism exists today in the southern hinterland of Egypt in the form of rain and fertility charms. Occasionally it still happens that the natives in the bush kill a woman and take out her uterus for use in magical rites.¹⁴⁷

[398] When one considers how strongly the Church Fathers were influenced by Gnostic ideas in spite of their resistance to these heresies,¹⁴⁸ it is not inconceivable that we have in the symbolism of the vessel a pagan relic that proved adaptable to Christianity, and this is all the more likely as the worship of Mary was itself a vestige of paganism which secured for the Christian Church the heritage of the Magna Mater, Isis, and other mother goddesses. The image of the *vas Sapientiae*, vessel of wisdom, likewise recalls its Gnostic prototype, Sophia.

[399] Official Christianity, therefore, absorbed certain Gnostic elements that manifested themselves in the worship of woman and found a place for them in an intensified worship of

Mary. I have selected the Litany of Loreto as an example of this process of assimilation from a wealth of equally interesting material. The assimilation of these elements to the Christian symbol nipped in the bud the psychic culture of the man; for his soul, previously reflected in the image of the chosen mistress, lost its individual form of expression through this absorption. Consequently, any possibility of an individual differentiation of the soul was lost when it became repressed in the collective worship. Such losses generally have unfortunate consequences, and in this case they soon made themselves felt. Since the psychic relation to woman was expressed in the collective worship of Mary, the image of woman lost a value to which human beings had a natural right. This value could find its natural expression only through individual choice, and it sank into the unconscious when the individual form of expression was replaced by a collective one. In the unconscious the image of woman received an energy charge that activated the archaic and infantile dominants. And since all unconscious contents, when activated by dissociated libido, are projected upon external objects, the devaluation of the real woman was compensated by daemonic traits. She no longer appeared as an object of love, but as a persecutor or witch. The consequence of increasing Mariolatry was the witch hunt, that indelible blot on the later Middle Ages.

[400] But this was not the only consequence. The splitting off and repression of a valuable progressive tendency resulted in a quite general activation of the unconscious. This activation could find no satisfying expression in collective Christian symbols, for an adequate expression always takes an individual form. Thus the way was paved for heresies and schisms, against which the only defence available to the Christian consciousness was fanaticism. The frenzied horror of the Inquisition was the product of over-compensated doubt, which came surging up from the unconscious and finally gave rise to one of the greatest schisms of the Church—the Reformation.

[401] If I have dwelt rather longer on the symbolism of the vessel than my readers might have expected, I have done so for a definite reason, because I wanted to elucidate the psychological relations between the worship of woman and the legend of the Grail, which was so essentially characteristic of the early Middle Ages. The central religious idea in this legend, of which there are numerous variants, is the holy vessel, which, it must be obvious to everyone, is a thoroughly non-Christian image, whose origin is to be sought in extra-canonical sources.¹⁴⁹ From the material I have cited, it seems to me a genuine relic of Gnosticism, which either survived the extermination of heresies because of a secret tradition, or owed its revival to an unconscious reaction against the domination of official Christianity. The survival or unconscious revivification of the vessel symbol is indicative of a strengthening of the feminine principle in the masculine psychology of that time. Its symbolization in an enigmatic image must be interpreted as a spiritualization of the eroticism aroused by the worship of woman. But spiritualization always means the retention of a certain amount of libido, which would otherwise be immediately squandered in sexuality. Experience shows that when the libido is retained, one part of it flows into the spiritualized expression, while the remainder sinks into the unconscious and activates images that correspond to it, in this case the vessel symbol. The symbol lives through the

restraint imposed upon certain forms of libido, and in turn serves to restrain these forms. The dissolution of the symbol means a streaming off of libido along the direct path, or at any rate an almost irresistible urge for its direct application. But the living symbol exorcises this danger. A symbol loses its magical or, if you prefer, its redeeming power as soon as its liability to dissolve is recognized. To be effective, a symbol must be by its very nature unassailable. It must be the best possible expression of the prevailing world-view, an unsurpassed container of meaning; it must also be sufficiently remote from comprehension to resist all attempts of the critical intellect to break it down; and finally, its aesthetic form must appeal so convincingly to our feelings that no argument can be raised against it on that score. For a certain time the Grail symbol clearly fulfilled these requirements, and to this fact it owed its vitality, which, as the example of Wagner shows, is still not exhausted today, even though our age and our psychology strive unceasingly for its dissolution.¹⁵⁰

[402] Let us now recapitulate this rather lengthy discussion and see what insights have been gained. We began with the vision of Hermas, in which he saw a tower being built. The old woman, who at first had declared herself to be the Church, now explains that the tower is a symbol of the Church. Her significance is thus transferred to the tower, and it is with this that the whole remaining part of the text is concerned. For Hermas it is only the tower that matters, and no longer the old woman, let alone Rhoda. The detachment of libido from the real object, its concentration on the symbol and canalization into a symbolic function, is complete. The idea of a universal and undivided Church, expressed in the symbol of a seamless and impregnable tower, has become an unshakable reality in the mind of Hermas. The detachment of libido from the object transfers it into the subject, where it activates the images lying dormant in the unconscious. These images are archaic forms of expression which become symbols, and these appear in their turn as equivalents of the devalued objects. This process is as old as mankind, for symbols may be found among the relics of prehistoric man as well as among the most primitive human types living today. Symbol-formation, therefore, must obviously be an extremely important biological function. As the symbol can come alive only through the devaluation of the object, it is evident that the purpose it serves is to deprive the object of its value. If the object had an absolute value, it would be an absolute determining factor for the subject and would abolish his freedom of action absolutely, since even a relative freedom could not coexist with absolute determination by the object. Absolute relation to the object is equivalent to a complete exteriorization of the conscious processes; it amounts to an identity of subject and object which would render all cognition impossible. In a milder form this state still exists today among primitives. The projections we so often encounter in practical analysis are only residues of this original identity of subject and object.

[403] The elimination of cognition and conscious experience resulting from such a state means a considerable impairment of the capacity for adaptation, and this weights the scales heavily against man, who is already handicapped by his natural defencelessness and the helplessness of his young. But it also produces a dangerous inferiority in the realm of affect, because an identity of feeling with the object means, firstly, that any object whatsoever can affect the subject to any degree, and secondly, any affect on the part of the subject

immediately includes and violates the object. An incident in the life of a bushman may illustrate what I mean. A bushman had a little son whom he loved with the tender monkey-love characteristic of primitives. Psychologically, this love is completely autoerotic—that is to say, the subject loves himself in the object. The object serves as a sort of erotic mirror. One day the bushman came home in a rage; he had been fishing, and had caught nothing. As usual the little fellow came running to meet him, but his father seized hold of him and wrung his neck on the spot. Afterwards, of course, he mourned for the dead child with the same unthinking abandon that had brought about his death.

[404] This is a good example of the object's identity with a passing affect. Obviously this kind of mentality is inimical to any protective tribal organization and to the propagation of the species, and must therefore be repressed and transformed. This is the purpose the symbol serves, and to this end it came into being. It draws libido away from the object, devalues it, and bestows the surplus libido on the subject. This surplus exerts its effect upon the unconscious, so that the subject finds himself placed between an inner and an outer determinant, whence arises the possibility of choice and relative subjective freedom.

[405] Symbols always derive from archaic residues, from racial engrams (imprints), about whose age and origin one can speculate much although nothing definite can be determined. It would be quite wrong to try to derive symbols from personal sources, for instance from repressed sexuality. Such a repression can at most supply the amount of libido required to activate the archaic engram. The engram, however, corresponds to an inherited mode of functioning which owes its existence not to centuries of sexual repression but to the differentiation of instinct in general. The differentiation of instinct was and still is a biological necessity; it is not peculiar to the human species but manifests itself equally in the sexual atrophy of the worker-bee.

[406] I have used the vessel symbolism as an illustration of the way symbols are derived from archaic conceptions. Just as we found the primitive notion of the uterus at the root of this symbol, we may conjecture a similar derivation in the case of the tower. The tower belongs in all probability to the category of phallic symbols in which the history of symbolism abounds. The fact that the tower, presumably symbolizing erection, appears at the very moment when Hermas has to repress his erotic fantasies at the sight of the alluring couch is not surprising. We have seen that other symbolic attributes of the Virgin and the Church are unquestionably erotic in origin, as already attested by their derivation from the Song of Songs, and that they were expressly so interpreted by the Church Fathers. The tower symbol in the Litany of Loreto has the same source and may therefore have a similar underlying meaning. The attribute "ivory" is undoubtedly erotic in origin, since it is an allusion to the tint and texture of the skin (Song of Songs 5:14: "His belly is as bright ivory"). But the tower itself is also found in an unmistakably erotic context in 8:10: "I am a wall, and my breasts like towers," which obviously refers to the jutting-out breasts with their full and elastic consistency. "His legs are as pillars of marble" (5:15), "thy neck is as a tower of ivory" (7:4), "thy nose is as the tower of Lebanon" (7:4), are equally obvious allusions to something slender and projecting. These attributes originate in tactile sensations which are

transferred from the organ to the object. Just as a gloomy mood seems grey, and a joyous one bright and colourful, so also the sense of touch is influenced by subjective sexual sensations (in this case the sensation of erection) whose qualities are transferred to the object. The erotic psychology of the Song of Songs uses the images aroused in the subject for the purpose of enhancing the object's value. Ecclesiastical psychology employs these same images in order to guide the libido towards a figurative object, while the psychology of Hermas exalts the unconsciously activated image into an end in itself, using it to embody ideas that were of supreme importance for the minds of that time, namely, the consolidation and organization of the newly won Christian attitude and view of the world.

b. The Relativity of the God-concept in Meister Eckhart

[407] The process of transformation which Hermas experienced represents on a small scale what took place on a large scale in the early medieval psychology: a new revelation of woman and the development of the feminine symbol of the Grail. Hermas saw Rhoda in a new light, and the libido thus set free transformed itself under his hands into the fulfilment of his social task.

[408] It is, I think, characteristic of our psychology that we find on the threshold of the new age two figures who were destined to exert an immense influence on the hearts and minds of the younger generation: Wagner, the prophet of love, whose music runs the whole gamut of feeling from Tristan down to incestuous passion, then up again from Tristan to the sublime spirituality of Parsifal; and Nietzsche, the prophet of power and of the triumphant will for individuality. Wagner, in his last and loftiest utterance, harked back to the Grail legend, as Goethe did to Dante, but Nietzsche seized on the idea of a master caste and a master morality, an idea embodied in many a fair-haired hero and knight of the Middle Ages. Wagner broke the bonds that fettered love, Nietzsche shattered the "tables of values" that cramp individuality. Both strove after similar goals while at the same time creating irremediable discord; for where love is, power cannot prevail, and where power prevails, love cannot reign.

[409] The fact that three of the greatest minds of Germany should fasten on early medieval psychology in their most important works is proof, it seems to me, that that age has left behind a question which still remains to be answered. It may be well, therefore, to examine this question a little more closely. I have the impression that the mysterious something that inspired the knightly orders (the Templars, for instance), and that seems to have found expression in the Grail legend, may possibly have been the germ of a new orientation to life, in other words, a nascent symbol. The non-Christian or Gnostic character of the Grail symbol takes us back to the early Christian heresies, those germinating points in which a whole world of audacious and brilliant ideas lay hidden. In Gnosticism we see man's unconscious psychology in full flower, almost perverse in its luxuriance; it contained the very thing that most strongly resisted the *regula fidei*, that Promethean and creative spirit which will bow only to the individual soul and to no collective ruling. Although in crude form, we find in Gnosticism what was lacking in the centuries that followed: a belief in the efficacy of individual revelation and individual knowledge. This belief was rooted in the

proud feeling of man's affinity with the gods, subject to no human law, and so overmastering that it may even subdue the gods by the sheer power of Gnosis. In Gnosis are to be found the beginnings of the path that led to the intuitions of German mysticism, so important psychologically, which came to flower at the time of which we are speaking.

[410] The question now before us focuses our attention on the greatest thinker of that age, Meister Eckhart. Just as signs of a new orientation are apparent in chivalry, so, in Eckhart, we are confronted with new ideas, ideas having the same *psychic* orientation that impelled Dante to follow the image of Beatrice into the underworld of the unconscious and that inspired the singers who sang the lore of the Grail.

[411] Nothing is known, unfortunately, of Eckhart's personal life that would explain how he was led to his knowledge of the soul. But the meditative air with which he says in his discourse on repentance, "And still today one seldom finds that people come to great things without they first *go* somewhat astray,"¹⁵¹ permits the inference that he wrote from personal experience. Strangely appealing is Eckhart's sense of an inner affinity with God, when contrasted with the Christian sense of sin. We feel ourselves transported back into the spacious atmosphere of the Upanishads. Eckhart must have experienced a quite extraordinary enhancement of the value of the soul, i.e., of his own inner being, that enabled him to rise to a purely psychological and relativistic conception of God and of his relation to man. This discovery and painstaking exposition of the relativity of God to man and the soul seem to me one of the most important landmarks on the way to a psychological understanding of religious phenomena, serving at the same time to liberate the religious function from the cramping limitations of intellectual criticism, though this criticism, of course, must not be denied its dues.

[412] We now come to the main theme of this chapter—the relativity of the symbol. The "relativity of God," as I understand it, denotes a point of view that does not conceive of God as "absolute," i.e., wholly "cut off" from man and existing outside and beyond all human conditions, but as in a certain sense dependent on him; it also implies a reciprocal and essential relation between man and God, whereby man can be understood as a function of God, and God as a psychological function of man. From the empirical standpoint of analytical psychology, the God-image is the symbolic expression of a particular psychic state, or function, which is characterized by its absolute ascendancy over the will of the subject, and can therefore bring about or enforce actions and achievements that could never be done by conscious effort. This overpowering impetus to action (so far as the God-function manifests itself in acts), or this inspiration that transcends conscious understanding, has its source in an accumulation of energy in the unconscious. The accumulated libido activates images lying dormant in the collective unconscious, among them the God-image, that engram or imprint which from the beginning of time has been the collective expression of the most overwhelmingly powerful influences exerted on the conscious mind by unconscious concentrations of libido.

[413] Hence, for our psychology, which as a science must confine itself to empirical data within the limits set by cognition, God is not even relative, but a function of the

unconscious—the manifestation of a dissociated quantum of libido that has activated the God-image. From the metaphysical point of view God is, of course, absolute, existing in himself. This implies his complete detachment from the unconscious, which means, psychologically, a complete unawareness of the fact that God's action springs from one's own inner being. The relativity of God, on the other hand, means that a not inconsiderable portion of the unconscious processes is registered, at least indirectly, as a psychological content. Naturally this insight is possible only when more attention than usual is paid to the psyche, with the consequence that the contents of the unconscious are withdrawn from projection into objects and become endowed with a conscious quality that makes them appear as belonging to the subject and as subjectively conditioned.

[414] This was what happened with the mystics, though it was not the first time that the idea of God's relativity had appeared. It is found in principle and in the very nature of things among primitives. Almost everywhere on the lower human levels the idea of God has a purely dynamic character; God is a divine force, a power related to health, to the soul, to medicine, to riches, to the chief, a power that can be captured by certain procedures and employed for the making of things needful for the life and well-being of man, and also to produce magical or baneful effects. The primitive feels this power as much within him as outside him; it is as much his own life force as it is the "medicine" in his amulet, or the mana emanating from his chief. Here we have the first demonstrable conception of an all-pervading spiritual force. Psychologically, the efficacy of the fetish, or the prestige of the medicine-man, is an unconscious subjective evaluation of those objects. Their power resides in the libido which is present in the subject's unconscious, and it is perceived in the object because whenever unconscious contents are activated they appear in projection.

[415] The relativity of God in medieval mysticism is, therefore, a regression to a primitive condition. In contrast, the related Eastern conceptions of the individual and supra-individual *atman* are not so much a regression to the primitive as a continuous development out of the primitive in a typically Eastern way that still manages to preserve the efficacy of the primitive principle. The regression to the primitive is not surprising, in view of the fact that every vital form of religion organizes one or the other primitive tendency in its ceremonials or its ethics, thereby securing for itself those secret instinctive forces that conduce to the perfecting of human nature in the religious process. This reversion to the primitive, or, as in India, the uninterrupted connection with it, keeps man in touch with Mother Earth, the prime source of all power. Seen from the heights of a differentiated point of view, whether rational or ethical, these instinctive forces are "impure." But life itself flows from springs both clear and muddy. Hence all excessive "purity" lacks vitality. A constant striving for clarity and differentiation means a proportionate loss of vital intensity, precisely because the muddy elements are excluded. Every renewal of life needs the muddy as well as the clear. This was evidently perceived by the great relativist Meister Eckhart when he said:

For this reason God is willing to bear the brunt of sins and often winks at them, mostly sending them to those whom he has destined for great things. Behold! Who was dearer and nearer to our Lord than the apostles? Not one of them but fell into mortal sin; all were

mortal sinners. In the Old Testament and in the New he has shown this to be true of those who afterwards were far the dearest to him; and still today one seldom finds that people come to great things without they first go somewhat astray.¹⁵²

[416] Both on account of his psychological perspicacity and his deep religious feeling and thought, Meister Eckhart was the most brilliant exponent of that critical movement within the Church which began towards the end of the thirteenth century. I would like to quote a few of his sayings to illustrate his relativistic conception of God:

For man is truly God, and God is truly man.¹⁵³

Whereas he who has not God as such an inner possession, but with every means must fetch him from without, in this thing or in that, where he is then sought for in vain, in all manner of works, people, or places; verily such a man has him not, and easily something comes to trouble him. And it is not only evil company that troubles him, but also the good, not only the street, but also the church, not only vile words and deeds, but the good as well. For the hindrance lies within himself, because in him God has not yet become the world. Were God that to him, then all would be well and good with him in every place and with all people, always possessing God.¹⁵⁴

[417] This passage is of particular psychological interest, as it exemplifies something of the primitive idea of God outlined above. "Fetching God from without" is the equivalent of the primitive view that *tondi*¹⁵⁵ can be got from outside. With Eckhart, it may be merely a figure of speech, but the original meaning nevertheless glimmers through. At any rate it is clear that Eckhart understands God as a psychological value. This is proved by the words "and easily something comes to trouble him." For, when God is outside, he is necessarily projected into objects, with the result that all objects acquire a surplus value. But whenever this happens, the object exerts an overpowering influence over the subject, holding him in slavish dependence. Eckhart is evidently referring to this subjection to the object, which makes the world appear in the role of God, i.e., as an absolutely determining factor. Hence he says that for such a person "God has not yet become the world," since for him the world has taken the place of God. The subject has not succeeded in detaching and introverting the surplus value from the object, thus turning it into an inner possession. Were he to possess it in himself, he would have God (this same value) continually as an object, so that God would have become the world. In the same passage Eckhart says:

He that is right in his feeling is right in any place and in any company, but if he is wrong he finds nothing right wherever or with whom he may be. For a man of right feeling has God with him.¹⁵⁶

A man who has this value in himself is everywhere at ease; he is not dependent on objects—not for ever needing and hoping to get from the object what he lacks himself.

[418] From all this it should be sufficiently clear that, for Eckhart, God is a psychological or, to be more accurate, a *psycho-dynamic* state.

... by this kingdom of God we understand the soul, for the soul is of like nature with the Godhead. Hence all that has been said here of the kingdom of God, how God is himself the kingdom, may be said with equal truth of the soul. St. John says, "All things were made by him." This is to be understood of the soul, for the soul is all things. The soul is all things because she is an image of God, and as such she is also the kingdom of God. ... So much, says one Master, is God in the soul, that his whole divine nature depends upon her. It is a higher state for God to be in the soul than for the soul to be in God. The soul is not blissful because she is in God, she is blissful because God is in her. Rely upon it, God himself is blissful in the soul.¹⁵⁷

[419] Looked at historically, the soul, that many-faceted and much-interpreted concept, refers to a psychological content that must possess a certain measure of autonomy within the limits of consciousness. If this were not so, man would never have hit on the idea of attributing an independent existence to the soul, as though it were some objectively perceptible thing. It must be a content in which spontaneity is inherent, and hence also partial unconsciousness, as with every autonomous complex. The primitive, as we know, usually has several souls—several autonomous complexes with a high degree of spontaneity, so that they appear as having a separate existence (as in certain mental disorders). On a higher level the number of souls decreases, until at the highest level of culture the soul resolves itself into the subject's general awareness of his psychic activities and exists only as a term for the totality of psychic processes. This absorption of the soul into consciousness is just as much a characteristic of Eastern as it is of Western culture. In Buddhism everything is dissolved into consciousness; even the *samskaras*, the unconscious formative forces, must be transformed through religious self-development.

[420] As against this historical evolution of the idea of the soul, analytical psychology opposes the view that the soul does not coincide with the totality of the psychic functions. We define the soul on the one hand as the relation to the unconscious, and on the other as a personification of unconscious contents. From the civilized standpoint it may seem deplorable that personifications of unconscious contents still exist, just as a man with a differentiated consciousness might well lament the existence of contents that are still unconscious. But since analytical psychology is concerned with man as he is and not with man as he would like to be, we have to admit that those same phenomena which impel the primitive to speak of "souls" still go on happening, just as there are still countless people among civilized nations who believe in ghosts. We may believe as much as we please in the doctrine of the "unity of the ego," according to which there can be no such things as autonomous complexes, but Nature herself does not bother in the least about our abstract theories.

[421] If the "soul" is a personification of unconscious contents, then, according to our previous definition, God too is an unconscious content, a personification in so far as he is thought of as personal, and an image or expression of something in so far as he is thought of as dynamic. God and the soul are essentially the same when regarded as personifications of an unconscious content. Meister Eckhart's view, therefore, is purely psychological. So long

as the soul, he says, is only in God, she is not blissful. If by “blissful” one understands a state of intense vitality, it follows from the passage quoted earlier that this state does not exist so long as the dynamic principle “God,” the libido, is projected upon objects. For, so long as God, the highest value, is not in the soul, it is somewhere outside. God must be withdrawn from objects and brought into the soul, and this is a “higher state” in which God himself is “blissful.” Psychologically, this means that when the libido invested in God, i.e., the surplus value that has been projected, is recognized as a projection,¹⁵⁸ the object loses its overpowering significance, and the surplus value consequently accrues to the individual, giving rise to a feeling of intense vitality, a new potential. God, life at its most intense, then resides in the soul, in the unconscious. But this does not mean that God has become completely unconscious in the sense that all idea of him vanishes from consciousness. It is as though the supreme value were shifted elsewhere, so that it is now found inside and not outside. Objects are no longer autonomous factors, but God has become an autonomous psychic complex. An autonomous complex, however, is always only partially conscious, since it is associated with the ego only in limited degree, and never to such an extent that the ego could wholly comprehend it, in which case it would no longer be autonomous. Henceforth the determining factor is no longer the overvalued object, but the unconscious. The determining influences are now felt as coming from within oneself, and this feeling produces a oneness of being, a relation between conscious and unconscious, in which of course the unconscious predominates.

[422] We must now ask ourselves, whence comes this “blissful” feeling, this ecstasy of love?¹⁵⁹ In this Brahman-like state of *ananda*, with the supreme value lying in the unconscious, there is a drop in the conscious potential, the unconscious becomes the determining factor, and the ego almost entirely disappears. It is a state strongly reminiscent of that of the child on the one hand, and of the primitive on the other, who is likewise influenced in the highest degree by the unconscious. We can safely say that the restoration of the earlier paradisaic state is the cause of this blissfulness. But we have still to find out why this original state is so peculiarly blissful. The feeling of bliss accompanies all those moments when one feels borne along by the current of life, when what was dammed up can flow off without restraint, when there is no need to do this thing or that thing with a conscious effort in order to find a way out or to achieve a result. We have all known situations or moods when “things go of themselves,” when we no longer need to manufacture all sorts of wearisome conditions for our joy or pleasure. The time of childhood is the unforgettable emblem of this joy, which, unperturbed by things without, pours in a warm flood from within. “Childlikeness” is therefore a symbol of that unique inner condition on which “blissfulness” depends. To be like a child means to possess a treasury of accumulated libido which can constantly stream forth. The libido of the child flows into things; in this way he gains the world, then by degrees loses himself in the world (to use the language of religion) through a gradual over-valuation of things. The growing dependence on things entails the necessity of sacrifice, i.e., the withdrawal of libido, the severance of ties. The intuitive teachings of religion seek by this means to gather the energy together again; indeed, religion portrays this process of re-collection in its symbols. Actually, the over-valuation of the object as

compared with the low value of the subject produces a retrograde current that would bring the libido quite naturally back to the subject were it not for the obstructing power of consciousness. Everywhere among primitives we find religious practice harmonizing with nature, because the primitive is able to follow his instinct without difficulty, now in one direction and now in another. His religious practices enable him to recreate the magical power he needs, or to recover the soul that was lost to him during the night.

[423] The aim of the great religions is expressed in the injunction “not of this world,” and this implies the inward movement of libido into the unconscious. Its withdrawal and introversion create in the unconscious a concentration of libido which is symbolized as the “treasure,” as in the parables of the “pearl of great price” and the “treasure in the field.” Eckhart interprets the latter as follows:

Christ says, “The kingdom of heaven is like a treasure hid in a field.” This field is the soul, wherein lies hidden the treasure of the divine kingdom. In the soul, therefore, are God and all creatures blessed.¹⁶⁰

[424] This interpretation agrees with our psychological argument: the soul is a personification of the unconscious, where lies the treasure, the libido which is immersed in introversion and is allegorized as God’s kingdom. This amounts to a permanent union with God, a living in his kingdom, in that state where a preponderance of libido lies in the unconscious and determines conscious life. The libido concentrated in the unconscious was formerly invested in objects, and this made the world seem all-powerful. God was then “outside,” but now he works from within, as the hidden treasure conceived as God’s kingdom. If, then, Eckhart reaches the conclusion that the soul is itself God’s kingdom, it is conceived as a function of relation to God, and God would be the power working within the soul and perceived by it. Eckhart even calls the soul the *image of God*.

[425] It is evident from the ethnological and historical material that the soul is a content that belongs partly to the subject and partly to the world of spirits, i.e., the unconscious. Hence the soul always has an earthly as well as a rather ghostly quality. It is the same with magical power, the divine force of primitives, whereas on the higher levels of culture God is entirely separate from man and is exalted to the heights of pure ideality. But the soul never loses its intermediate position. It must therefore be regarded as a function of relation between the subject and the inaccessible depths of the unconscious. The determining force (God) operating from these depths is reflected by the soul, that is, it creates symbols and images, and is itself only an image. By means of these images the soul conveys the forces of the unconscious to consciousness; it is both receiver and transmitter, an organ for perceiving unconscious contents. What it perceives are symbols. But symbols are shaped energies, determining ideas whose affective power is just as great as their spiritual value. When, says Eckhart, the soul is in God it is not “blissful,” for when this organ of perception is overwhelmed by the divine *dynamis* it is by no means a happy state. But when God is in the soul, i.e., when the soul becomes a vessel for the unconscious and makes itself an image or

symbol of it, this is a truly happy state. The happy state is a *creative* state, as we see from the following noble words:

If any should ask me, Wherefore do we pray, wherefore do we fast, wherefore do we do all manner of good works, wherefore are we baptized, wherefore did God become man, I would answer, So that God may be born in the soul and the soul again in God. Therefore were the Holy Scriptures written. Therefore did God create the whole world, that God might be born in the soul and the soul again in God. The innermost nature of all grain is wheat, and of all metal, gold, and of all birth, Man!¹⁶¹

[426] Here Eckhart states bluntly that God is dependent on the soul, and at the same time, that the soul is the birthplace of God. This latter sentence can readily be understood in the light of our previous reflections. The organ of perception, the soul, apprehends the contents of the unconscious, and, as the creative function, gives birth to its *dynamis* in the form of a symbol.¹⁶² The soul gives birth to images that from the rational standpoint of consciousness are assumed to be worthless. And so they are, in the sense that they cannot immediately be turned to account in the objective world. The first possibility of making use of them is *artistic*, if one is in any way gifted in that direction;¹⁶³ a second is *philosophical speculation*,¹⁶⁴ a third is *quasi-religious*, leading to heresy and the founding of sects; and a fourth way of employing the *dynamis* of these images is to squander it in every form of licentiousness. As we noted at the beginning (par. 25), the latter two modes of application were especially apparent in the Encratic (ascetic) and Antitactic (anarchic) schools of Gnosticism.

[427] The conscious realization of these images is, however, of indirect value from the point of view of adaptation to reality, in that one's relation to the surrounding world is thereby freed from admixtures of fantasy. Nevertheless, their main value lies in promoting the subject's happiness and well-being, irrespective of external circumstances. To be adapted is certainly an ideal, but adaptation is not always possible. There are situations in which the only adaptation is patient endurance. This form of passive adaptation is made easier by an elaboration of the fantasy-images. I say "elaboration" because at first the fantasies are merely raw material of doubtful value. They have to be worked on and put in a form best calculated to yield the maximum benefit. This is a matter of technique, which it would not be appropriate to discuss here. I will only say, for clarity's sake, that there are two methods of treatment: 1. the reductive, and 2. the synthetic. The former traces everything back to primitive instincts, the latter develops the material into a process for differentiating the personality. The two methods are complementary, for reduction to instinct leads back to reality, indeed to an over-valuation of reality and hence to the necessity of sacrifice. The synthetic method elaborates the symbolic fantasies resulting from the introversion of libido through sacrifice. This produces a new attitude to the world, whose very difference offers a new potential. I have termed this transition to a new attitude the transcendent function.¹⁶⁵ In the regenerated attitude the libido that was formerly sunk in the unconscious emerges in the form of some positive achievement. It is equivalent to a renewal of life, which Eckhart symbolizes by God's birth. Conversely, when the libido is withdrawn from external objects

and sinks into the unconscious, the soul is born again in God. This state, as he rightly observes, is not a blissful one,¹⁶⁶ because it is a negative act, a turning away from life and a descent to the *deus absconditus*, who possesses qualities very different from those of the God who shines by day.

[428] Eckhart speaks of God's birth as a continual process. As a matter of fact, the process in question is a psychological one that unconsciously repeats itself almost continually, though we are conscious of it only when it swings towards the extreme. Goethe's idea of a systole and diastole seems to have hit the mark intuitively. It may well be a question of a vital rhythm, of fluctuations of vital forces, which as a rule go on unconsciously. This may also explain why the existing terminology for such a process is in the main either religious or mythological, since these formulas refer primarily to unconscious psychological facts and not, as the scientific interpreters of myths often assert, to the phases of the moon or other meteorological phenomena. And because it is pre-eminently a question of unconscious processes, we have the greatest difficulty, as scientists, in extricating ourselves at least so far from the language of metaphor as to reach the level of metaphor used by other sciences. Reverence for the great mysteries of Nature, which the language of religion seeks to express in symbols hallowed by their antiquity, profound significance, and beauty, will not suffer from the extension of psychology to this domain, to which science has hitherto found no access. We only shift the symbols back a little, shedding a little light on their darker reaches, but without succumbing to the erroneous notion that we have created anything more than merely a new symbol for the same enigma that perplexed all ages before us. Our science is a language of metaphor too, but in practice it works better than the old mythological hypothesis, which used concretisms as a means of expression, and not, as we do, concepts.

By being created, the soul created God, for he did not exist until the soul was made. A little while since and I declared, I am the cause that God is God! God is gotten of the soul, his Godhead he has of himself.¹⁶⁷

God comes into being and passes away.¹⁶⁸

Because all creatures declare him, God comes into being. While yet I abode in the ground and the depths of Godhead, in its flood and source, none asked me whither I went or what I did; none was there who could have questioned me. But when I flowed forth, all creatures declared God. ... And why did they not declare the Godhead? All that is in Godhead is one, and of that there is nothing to declare. Only God does; Godhead does nothing, there is nothing it can do, and never has it looked for anything to do. God and Godhead are as different as doing and non-doing. When I come home again in God, I do nothing more in myself, so this my breaking through is much more excellent than my first going out. For truly it is I who bring all creatures out of their own into my mind and make them one in me. When I come back into the ground and the depths of Godhead, into its flood and source, none asks me whence I came or whither I went. None missed me. God passes away.¹⁶⁹

[429] We see from these passages that Eckhart distinguishes between God and Godhead. Godhead is All, neither knowing nor possessing itself, whereas God is a function of the soul, just as the soul is a function of Godhead. Godhead is obviously all-pervading creative power or, in psychological terms, self-generating creative instinct, that neither knows nor possesses itself, comparable to Schopenhauer's universal Will. But God appears as issuing forth from Godhead and the soul. Like every creature, the soul "declares" him: he exists in so far as the soul distinguishes itself from the unconscious and perceives its *dynamis*, and he ceases to exist as soon as the soul is immersed in the "flood and source" of unconscious *dynamis*. Thus Eckhart says:

When I flowed out from God, all things declared, "God is!" Now this cannot make me blessed, for thereby I acknowledge myself a creature. But in my breaking through I stand empty in the will of God, and empty also of God's will, and of all his works, even of God himself—then I am more than all creatures, then I am neither God nor creature: I am what I was, and that I shall remain, now and ever more! Then I receive a thrust which carries me above all angels. By this thrust I become so rich that God cannot suffice me, despite all that he is as God and all his godly works; for in this breakthrough I receive what God and I have in common. I am what I was, I neither increase nor diminish, for I am the unmoved mover that moves all things. Here God can find no more place in man, for man by his emptiness has won back that which he eternally was and ever shall remain.¹⁷⁰

[430] The "flowing out" means a realization of the unconscious content and the unconscious *dynamis* in the form of an *idea* born of the soul. This is an act of conscious differentiation from the unconscious *dynamis*, a separation of the ego as subject from God (= *dynamis*) as object. By this act God "becomes." But when the "breakthrough" abolishes this separation by cutting the ego off from the world, and the ego again becomes identical with the unconscious *dynamis*, God disappears as an object and dwindles into a subject which is no longer distinguishable from the ego. In other words the ego, as a late product of differentiation, is reunited with the dynamic All-oneness (the *participation mystique* of primitives). This is the immersion in the "flood and source." The numerous analogies with Eastern ideas are immediately apparent, and they have been elaborated by writers more qualified than myself. In the absence of direct transmission this parallelism proves that Eckhart was thinking from the depths of the collective psyche which is common to East and West. This universal foundation, for which no common historical background can be made answerable, underlies the primitive mentality with its energetic conception of God.

[431] The return to primeval nature and mystic regression to the psychic conditions of prehistory are common to all religions in which the impelling *dynamis* has not yet petrified into an abstract idea but is still a living experience, no matter whether this be expressed in ceremonies of identification with the totem among the Australian aborigines¹⁷¹ or in the ecstasies of the Christian mystics. As a result of this retrograde process the original state of identity with God is re-established and a new potential is produced. However improbable such a state may be, it is a profoundly impressive experience which, by revivifying the individual's relation to God as an object, creates the world anew.

[432] In speaking of the relativity of the God-symbol, we would be failing in our duty if we omitted to mention that solitary poet whose tragic fate it was to find no relation either to his own times or to his own inner vision: Angelus Silesius.¹⁷² What Eckhart laboured to express with a great effort of thought, and often in barely intelligible language, Angelus Silesius sings in touchingly intimate verses, which portray the relativity of God with naïve simplicity. His verses speak for themselves:

I know that without me
God can no moment live;
Were I to die, then He
No longer could survive.

God cannot without me
A single worm create;
Did I not share with Him
Destruction were its fate.

I am as great as God,
And He is small like me;
He cannot be above,
Nor I below Him be.

In me is God a fire
And I in Him its glow;
In common is our life,
Apart we cannot grow.

God loves me more than Self
My love doth give His weight,
Whate'er He gives to me
I must reciprocate.

He's God and man to me,
To Him I'm both indeed;
His thirst I satisfy,
He helps me in my need.

This God, who feels for us,
Is to us what we will;
And woe to us, if we
Our part do not fulfil.

God is whate'er He is,
I am what I must be;

If you know one, in sooth,
You know both Him and me.

I am not outside God,
Nor leave I Him afar;
I am His grace and light,
And He my guiding star.

I am the vine, which He
Doth plant and cherish most;
The fruit which grows from me
Is God, the Holy Ghost.

I am God's child, His son,
And He too is my child;
We are the two in one,
Both son and father mild.

To illuminate my God
The sunshine I must be;
My beams must radiate
His calm and boundless sea.¹⁷³

[433] It would be absurd to suppose that such audacious ideas as these and Meister Eckhart's are nothing but figments of conscious speculation. Such thoughts are always profoundly significant historical phenomena, borne along on the unconscious currents of the collective psyche. Below the threshold of consciousness, thousands of other nameless ones are ranged behind them with similar thoughts and feelings, ready to open the gates of a new age. In these bold ideas we hear the voice of the collective psyche, which with imperturbable assurance and the finality of a natural law brings about spiritual transformation and renewal. The unconscious currents reached the surface at the time of the Reformation. The Reformation largely did away with the Church as the dispenser of salvation and established once more the personal relation to God. The culminating point in the objectification of the God-concept had now been passed, and from then on it became more and more subjective. The logical consequence of this subjectifying process is a splitting up into sects, and its most extreme outcome is individualism, representing a new form of detachment from the world, the immediate danger of which is re-submersion in the unconscious *dynamis*. The cult of the "blond beast" stems from this development, besides much else that distinguishes our age from others. But whenever this submersion in instinct occurs, it is compensated by a growing resistance to the chaos of sheer dynamism, by a need for form and order. Diving down into the maelstrom, the soul must create the symbol that captures and expresses this dynamism. It is this process in the collective psyche that is felt or intuited by poets and artists whose main source of creativity is their perception of unconscious contents, and

whose intellectual horizon is wide enough to discern the crucial problems of the age, or at least their outward aspects.

5. THE NATURE OF THE UNITING SYMBOL IN SPITTELER

[434] Spitteler's *Prometheus* marks a psychological turning point: it illustrates the splitting apart of pairs of opposites that were once united. Prometheus, the artist, the servant of the soul, disappears from the world of men; while society itself, in obedience to a soulless moral routine, is delivered over to Behemoth, symbolizing the inimical, the destructive effect of an obsolete ideal. At the right moment Pandora, the soul, creates the saving jewel in the unconscious, but it does not benefit mankind because men fail to appreciate it. The change for the better comes about only through the intervention of Prometheus, who through insight and understanding brings first a few, and then many, individuals to their senses. It can hardly be doubted that this work of Spitteler's has its roots in the intimate life of its creator. But if it consisted only in a poetic elaboration of purely personal experiences, it would lack general validity and permanent value. It achieves both because it is not merely personal but is concerned with Spitteler's own experience of the collective problems of our time. On its first appearance it was bound to meet with the apathetic indifference of the public, for in any age the vast majority of men are called upon to preserve and praise the *status quo*, thus helping to bring about the disastrous consequences which the creative spirit had sought to avert.

[435] One important question still remains to be discussed, and that is the nature of this jewel, or symbol of renewed life, which the poet senses will bring joy and deliverance. We have already documented the "divine" nature of the jewel, and this clearly means that it contains possibilities for a new release of energy, for freeing the libido bound in the unconscious. The symbol always says: in some such form as this a new manifestation of life will become possible, a release from bondage and world-weariness. The libido that is freed from the unconscious by means of the symbol appears as a rejuvenated god, or actually as a new god; in Christianity, for instance, Jehovah is transformed into a loving Father with a higher and more spiritual morality. The motif of the god's renewal is universal and may be assumed to be familiar to most readers. Speaking of the redeeming power of the jewel, Pandora says: "I have heard of a race of men, full of sorrow and deserving of pity, and I have thought of a gift with which, if you graciously approve, I may assuage or solace their many sufferings."¹⁷⁴ The leaves of the tree that shelters the "wonder-child" sing: "For here is the presence, and here is bliss, and here is grace."¹⁷⁵

[436] The message of the wonder-child is love and joy, a paradisaical state just as it was at the birth of Christ; while the greeting by the sun-goddess¹⁷⁶ and the miracle that all men, however far away, became "good" and were blessed at the moment of this birth¹⁷⁷ are attributes to the birth of the Buddha. From the "divine blessing" I will excerpt only this one significant passage: "May every man meet again those images he once beheld as a child in the shimmering dream of the future."¹⁷⁸ This is an affirmation that childhood fantasies strive

for fulfilment; the images are not lost, but come again in ripe manhood and should be fulfilled. As Old Kule says in Barlach's *Der tote Tag*:

When I lie here at night, and the pillows of darkness weigh me down, at times there presses about me a light that resounds, visible to my eyes and audible to my ears; and there about my bed stand the lovely forms of a better future. Stiff they are as yet, but of a radiant beauty, still sleeping; but he who shall awaken them would make for the world a fairer face. He would be a hero who could do that. ... They stand not in the sun and nowhere are they lit by the sun. But sometime they shall and must come forth from the night. What a master-work that would be, to raise them up to the sun! There they would live.¹⁷⁹

[437] Epimetheus, too, as we shall see, longs for the image, the jewel; in his discourse on the statue of Herakles (the hero!) he says: "This is the meaning of the statue ... that a jewel shall ripen over our heads, a jewel we must win."¹⁸⁰ But when the jewel is rejected by Epimetheus and is brought to the priests, they sing in just the same strain as Epimetheus did when he longed for it: "O come, O God, with thy grace," only to repudiate and revile in the very next instant the heavenly jewel that is offered them. The verses of the hymn sung by the priests can easily be recognized as the Protestant hymn:

Living Spirit, once again
Come, Thou true eternal God!
Nor thy power descend in vain,
Make us ever Thine abode;
So shall Spirit, joy and light
Dwell in us, where all was night.
...
Spirit Thou of strength and power,
Thou new Spirit God hath given,
Aid us in temptation's hour,
Make us perfect Thou for heaven.
Arm us in the battle field,
Leave us never there to yield.¹⁸¹

[438] This hymn bears out our earlier argument. It is wholly in keeping with the rationalistic nature of Epimethean creatures that the same priests who sing this hymn should reject the new spirit of life, the new symbol. Reason must always seek the solution in some rational, consistent, logical way, which is certainly justifiable enough in all normal situations but is entirely inadequate when it comes to the really great and decisive questions. It is incapable of creating the symbol, because the symbol is irrational. When the rational way proves to be a *cul de sac*—as it always does after a time—the solution comes from the side it was least expected. ("Can there any good thing come out of Nazareth?"¹⁸²) Such is the psychological law underlying the Messianic prophecies, for instance. The prophecies themselves are projections of events foreshadowed in the unconscious. Because the solution is irrational,

the coming of the Saviour is associated with an irrational and impossible condition: the pregnancy of a virgin (Isaiah 7:14). This prophecy, like many another, can be taken in two ways, as in *Macbeth* (IV, 1):

Macbeth shall never vanquished be until
Great Birnam wood to high Dunsinane hill
Shall come against him.

[439] The birth of the Saviour, the redeeming symbol, occurs just when one is least expecting it, and in the most improbable of places. Thus Isaiah says (53: 1–3):

Who hath believed our report? and to whom is the arm of the Lord revealed?

For he shall grow up before him as a tender plant, and as a root out of a dry ground: he hath no form nor comeliness; and when we shall see him, there is no beauty that we should desire him.

He is despised and rejected of men; a man of sorrows, and acquainted with grief; and we hid as it were our faces from him; he was despised, and we esteemed him not.

[440] Not only does the redeeming power come from the place where nothing is expected, it also appears in a form that has nothing to recommend it from the Epimethean point of view. Spitteler can hardly have borrowed consciously from the Bible when describing the rejection of the symbol, or we would note it in his words. It is more likely that he drew on the same depths from which prophets and creative artists call up the redeeming symbol.

[441] The coming of the Saviour signifies a union of opposites:

The wolf also shall dwell with the lamb, and the leopard shall lie down with the kid; and the calf and the young lion and the fatling together; and a little child shall lead them.

And the cow and the bear shall feed; their young ones shall lie down together: and the lion shall eat straw like the ox.

And the sucking child shall play on the hole of the asp, and the weaned child shall put his hand on the cockatrice' den.¹⁸³

[442] The nature of the redeeming symbol is that of a child¹⁸⁴ (the “wonder-child” of Spitteler) —childlikeness or lack of prior assumptions is of the very essence of the symbol and its function. This childlike attitude necessarily brings with it another guiding principle in place of self-will and rational intentions, as overwhelmingly powerful in effect as it is divine. Since it is of an irrational nature, the new guiding principle appears in miraculous form:

For unto us a child is born, unto us a son is given; and the government shall be on his shoulder; and his name shall be called Wonderful, Counsellor, The mighty God, The everlasting Father, the Prince of Peace.¹⁸⁵

[443] These honorific titles reproduce the essential qualities of the redeeming symbol. Its “divine” effect comes from the irresistible *dynamis* of the unconscious. The saviour is always a figure endowed with magical power who makes the impossible possible. The symbol is the middle way along which the opposites flow together in a new movement, like a watercourse bringing fertility after a long drought. The tension that precedes solution is likened in Isaiah to pregnancy:

Like as a woman with child, that draweth near the time of her delivery, is in pain, and crieth out in her pangs, so we have been in thy sight, O Lord.

We have been with child, we have been in pain, we have as it were brought forth wind; we have not wrought any deliverance in the earth; neither have the inhabitants of the world fallen.

Thy dead men shall live, together with my dead body shall they arise.¹⁸⁶

[444] Through the act of deliverance what was inert and dead comes to life; in psychological terms, the functions that have lain fallow and unfertile, and were unused, repressed, undervalued, despised, etc., suddenly burst forth and begin to live. It is precisely the least valued function that enables life, which was threatened with extinction by the differentiated function, to continue.¹⁸⁷ This motif recurs in the New Testament idea of the *αποκατάστασις πάντων*, restitution of all things (Acts 3:21), which is a more highly developed form of that worldwide version of the hero myth where the hero, on his exit from the belly of the whale, brings with him not only his parents but the whole company of those previously swallowed by the monster—what Frobenius calls the “universal slipping out.”¹⁸⁸ The connection with the hero myth is preserved in Isaiah three verses later:

In that day the Lord with his sore and great and strong sword shall punish leviathan the piercing serpent, even leviathan that crooked serpent; and he shall slay the dragon that is in the sea.¹⁸⁹

[445] With the birth of the symbol, the regression of libido into the unconscious ceases. Regression is converted into progression, the blockage starts to flow again, and the lure of the maternal abyss is broken. When Old Kule in Barlach’s *Der tote Tag* says that he who awakened the sleeping images would be a hero, the mother replies: “He must first bury his mother.”¹⁹⁰ I have fully documented the motif of the “mother dragon” in my earlier work,¹⁹¹ so I may spare myself a repetition of it here. The blossoming of new life and fruitfulness where all was arid before is described in Isaiah 35:5ff.:

Then the eyes of the blind shall be opened, and the ears of the deaf shall be unstopped.

Then shall the lame man leap up as an hart, and the tongue of the dumb sing: for in the wilderness shall waters break out, and streams in the desert.

And the parched ground shall become a pool, and the thirsty land springs of water: in the habitations of dragons, where each lay, shall be grass with reeds and rushes.

And an highway shall be there, and a way, and it shall be called the way of holiness; the unclean shall not pass over it. And this shall be unto you a straight way, so that fools shall not err therein.

The redeeming symbol is a highway, a way upon which life can move forward without torment and compulsion.

[446] Hölderlin says in “Patmos”:

Near is God
And hard to apprehend.
But where danger is, there
Arises salvation also.

That sounds as though the nearness of God were a danger, i.e., as though the concentration of libido in the unconscious were a danger to conscious life. And indeed this is so, for the more the libido is invested—or, to be more accurate, invests itself—in the unconscious, the greater becomes its influence or potency: all the rejected, disused, outlived functional possibilities that have been lost for generations come to life again and begin to exert an ever-increasing influence on the conscious mind, despite its desperate struggles to gain insight into what is happening. The saving factor is the symbol, which embraces both conscious and unconscious and unites them. For while the consciously disposable libido gets gradually used up in the differentiated function and is replenished more and more slowly and with increasing difficulty, the symptoms of inner disunity multiply and there is a growing danger of inundation and destruction by the unconscious contents, but all the time the symbol is developing that is destined to resolve the conflict. The symbol, however, is so intimately bound up with the dangerous and menacing aspect of the unconscious that it is easily mistaken for it, or its appearance may actually call forth evil and destructive tendencies. At all events the appearance of the redeeming symbol is closely connected with destruction and devastation. If the old were not ripe for death, nothing new would appear; and if the old were not injuriously blocking the way for the new, it could not and need not be rooted out.

[447] This natural combination of psychological opposites is found in Isaiah, where we are told that a virgin shall conceive and bear a son, who shall be called Immanuel (7:14). Significantly, Immanuel (the redeeming symbol) means “God with us,” i.e., union with the latent *dynamis* of the unconscious. The verses which immediately follow show what this union portends:

For before the child shall know to refuse the evil and choose the good, the land that thou abhorrest shall be forsaken of both her kings.

And the Lord said to me, Take thee a great book, and write in it with a man’s pen: *Hasten to take the spoils, quickly take the prey.*¹⁹²... And I went to the prophetess, and she conceived, and bore a son. And the Lord said to me: Call his name, *Hasten to take the*

spoils, quickly take the prey. For before the child know how to cry, My father, My mother, the riches of Damascus and the spoil of Samaria shall be taken away before the king of Assyria.

Forasmuch as this people refuseth the waters of Shiloah that go softly ... behold the Lord will bring upon them the waters of the river, strong and many, even the king of Assyria, and all his glory; and he shall come up over all his channels, and go over all his banks, and he shall pass through Judah; he shall overflow and go over, and he shall reach even to the neck; and the stretching out of his wings shall fill the breadth of thy land, O Immanuel.¹⁹³

[448] I have shown in my earlier work¹⁹⁴ that the birth of the god is threatened by the dragon, by the danger of inundation, and infanticide. Psychologically, this means that the latent *dynamis* of the unconscious may burst forth and overwhelm consciousness. For Isaiah the danger is the foreign king, who rules over a powerful and hostile country. The problem for him is not, of course, psychological, but concrete because of its complete projection. With Spitteler, on the contrary, the problem is a psychological one from the start, and hence detached from the object, but it is none the less expressed in a form that closely resembles Isaiah's, even though it may not have been consciously borrowed.

[449] The birth of the saviour is equivalent to a great catastrophe, because a new and powerful life springs up just where there had seemed to be no life and no power and no possibility of further development. It comes streaming out of the unconscious, from that unknown part of the psyche which is treated as nothing by all rationalists. From this discredited and rejected region comes the new afflux of energy, the renewal of life. But what is this discredited and rejected source of vitality? It consists of all those psychic contents that were repressed because of their incompatibility with conscious values—everything hateful, immoral, wrong, unsuitable, useless, etc., which means everything that at one time or another appeared so to the individual concerned. The danger now is that when these things reappear in a new and wonderful guise, they may make such an impact on him that he will forget or repudiate all his former values. What he once despised now becomes the supreme principle, and what was once truth now becomes error. This reversal of values is similar to the devastation of a country by floods.

[450] Thus, in Spitteler, Pandora's heavenly gift brings evil to the country and its inhabitants, just as in the classical myth diseases streamed forth to ravage the land when Pandora opened her box. To understand why this should be so we must examine the nature of the symbol. The first to find the jewel were the peasants, as the shepherds were the first to greet the Saviour. They turned it about in their hands, "until in the end they were utterly dumbfounded by its bizarre, immoral, illicit appearance."¹⁹⁵ When they brought it to Epimetheus to examine, his conscience (which he kept in a wardrobe) sprang to the floor and hid itself under the bed in great alarm, "with impossible suspicions."

Like a crab goggling wickedly and malevolently brandishing its crooked claws, Conscience peered out from under the bed, and the nearer Epimetheus pushed the image, the further Conscience shrank back with gesticulations of disgust. And so it sulked there silently,

uttering not a word or syllable, in spite of all the king's entreaties and petitions and inducements.¹⁹⁶

[451] Conscience, evidently, found the new symbol acutely distasteful. The king, therefore, bade the peasants bear the jewel to the priests.

But hardly had Hiphil-Hophal [the high priest] glanced at the face of the image than he shuddered with disgust, and crossing his arms over his forehead as though to ward off a blow, he shouted: "Away with this mockery! For it is opposed to God and carnal is its heart and insolence flashes from its eyes."¹⁹⁷

[452] The peasants then brought the jewel to the academy, but the professors found it lacked "feeling and soul, and moreover it wanted in gravity, and above all had no guiding thought."¹⁹⁸ In the end the goldsmith found the jewel to be spurious and of common stuff. On the marketplace, where the peasants tried to get rid of it, the police descended on the image and cried out:

Is there no heart in your body and no conscience in your soul? How dare you expose before the eyes of all this stark, shameless, wanton piece of nakedness? ... And now, away with you at once! And woe betide you if the sight of it has polluted our innocent children and lily-white wives!¹⁹⁹

[453] The symbol is described by the poet as bizarre, immoral, illicit, outraging our moral feelings and our ideas of the spiritual and divine; it appeals to sensuality, is wanton, and liable to endanger public morals by provoking sexual fantasies. These attributes define something that is blatantly opposed to our moral values and aesthetic judgment because it lacks the higher feeling-values, and the absence of a "guiding thought" suggests the irrationality of its intellectual content. The verdict "opposed to God" might equally well be "anti-Christian," since this episode is set neither in antiquity nor in the East. By reason of its attributes, the symbol stands for the inferior functions, for psychic contents that are not acknowledged. Although it is nowhere stated, it is obvious that the "image" is of a naked human body—a "living form." It expresses the complete freedom to be what one is, and also the duty to be what one is. It is a symbol of man as he might be, the perfection of moral and aesthetic beauty, moulded by nature and not by some artificial ideal. To hold such an image before the eyes of present-day man can have no other effect than to release everything in him that lies captive and un-lived. If only half of him is civilized and the other half barbarian, all his barbarism will be aroused, for a man's hatred is always concentrated on the thing that makes him conscious of his bad qualities. Hence the fate of the jewel was sealed the moment it appeared in the world. The dumb shepherd lad who first found it was half cudgelled to death by the enraged peasants, who in the end "hurled" the jewel into the street. Thus the redeeming symbol runs its brief but typical course. The parallel with the Passion is unmistakable, and the jewel's saviour-nature is further borne out by the fact that it appears only once every thousand years. The appearance of a saviour, a Saoshyant, or a Buddha is a rare phenomenon.

[454] The end of the jewel is mysterious: it falls into the hands of a wandering Jew. “It was not a Jew of this world, and his clothes seemed to us exceedingly strange.”²⁰⁰ This peculiar Jew can only be *Ahasuerus*, who did not accept the actual Redeemer, and now, as it were, steals his image. The story of *Ahasuerus* is a late Christian legend, which cannot be traced back earlier than the thirteenth century.²⁰¹ Psychologically, it sprang from a component of the personality or a charge of libido that could find no outlet in the Christian attitude to life and the world and was therefore repressed. The Jews were always a symbol for this, hence the persecution mania against the Jews in the Middle Ages. The idea of ritual murder is a projection, in acute form, of the rejection of the Redeemer, for one always sees the mote in one’s own eye as the beam in one’s brother’s. The ritual murder idea also plays a part in Spitteler’s story—the Jew steals the wonder-child from heaven. It is a mythologized projection of a dim realization that the workings of the Redeemer are constantly being frustrated by the presence of an unredeemed element in the unconscious. This unredeemed, untamed, barbarian element, which can only be held on a chain and cannot be allowed to run free, is projected upon those who have never accepted Christianity. There is an unconscious awareness of this intractable element whose existence we don’t like to admit—hence the projection. In reality it is a part of ourselves that has contrived to escape the Christian process of domestication. The restlessness of the wandering Jew is a concretization of this unredeemed state.

[455] The unredeemed element at once attracts to itself the new light, the energy of the new symbol. This is another way of expressing what we said earlier (pars. 449ff.) about the effect the symbol has on the psyche as a whole. It arouses all the repressed and unacknowledged contents, just as it provoked the “guardians of the marketplace” in Spitteler; and it has the same effect on Hiphil-Hophal, who, because of his unconscious resistance to his own religion, immediately emphasizes the ungodliness and carnality of the new symbol. The affect displayed in the rejection of the jewel equals the amount of repressed libido. With the moral degradation of the pure gift of heaven and its conversion into the lurid fantasies of the priests and police the ritual murder is complete. The appearance of the symbol has, nevertheless, not been entirely valueless. Although not accepted in its pure form, it is devoured by the archaic and undifferentiated forces of the unconscious (symbolized by Behemoth), assiduously supported by conscious morality and ideas of beauty. Thereupon the enantiodromia begins, the transformation of the hitherto valued into the worthless, and of the former good into the bad.

[456] The kingdom of the good, ruled over by Epimetheus, had long been at enmity with the kingdom of Behemoth.²⁰² Behemoth and Leviathan are the two famous monsters of Jehovah from the Book of Job, symbolizing his mighty strength. As crude animal symbols they represent similar psychological forces in human nature.²⁰³ Jehovah declaims (Job 40:10ff., DV):

Behold Behemoth whom I made with thee. He eateth grass like an ox.

His strength is in his loins, and his force in the navel of his belly.

He setteth up his tail like a cedar: the sinews of his testicles are wrapped together.²⁰⁴

His bones are like pipes of brass, his gristle like plates of iron.

He is the beginning of the ways of God ...

[457] One should read these words attentively. This sheer *dynamis* is “the beginning of the ways of God,” that is, of Jehovah, who in the New Testament sloughs off this form and ceases to be a nature-god. This means, psychologically, that the animal side of the libido stored up in the unconscious is permanently held in check by the Christian attitude; one half of God is repressed, or written down to man’s debit account, and is ultimately consigned to the domain of the devil. Hence, when the unconscious *dynamis* starts welling up and “the ways of God” begin, God appears in the form of Behemoth.²⁰⁵ One might even say that God presents himself in the devil’s shape. These moral evaluations are optical illusions, however: the life force is beyond moral judgment. Meister Eckhart says:

So if I say God is good, it is not true: *I* am good, God is not good. I go further: I am better than God! For only what is good can become better, and only what is better can become the best. God is not good, therefore he cannot become better; and since he cannot become better he cannot become the best. These three: good, better, best, are infinitely remote from God, who is above all.²⁰⁶

[458] The immediate effect of the redeeming symbol is the union of opposites: the ideal realm of Epimetheus becomes one with the kingdom of Behemoth. That is to say, moral consciousness enters into a dangerous alliance with the unconscious contents and the libido associated with them. The “divine children,” the highest values of humanity without which man would be an animal, are now entrusted to the care of Epimetheus. But the union with his unconscious opposite brings with it the danger of devastation and inundation—the values of consciousness are liable to be swamped by the unconscious *dynamis*. Had the jewel, the symbol of natural morality and beauty, been accepted at its face value instead of serving merely to stir up all the filthiness in the background of our “moral” culture, the divine children would not have been imperilled despite the alliance with Behemoth, for Epimetheus would always have been able to discriminate between the valuable and the worthless. But because the symbol appeared unacceptable to his onesided, rationalistic, warped mentality, every standard of value fails. When the union of opposites nevertheless takes place on a higher plane, the danger of inundation and destruction necessarily follows because, characteristically, the antagonistic tendencies get smuggled in under the cover of “correct ideas.” Even the evil and pernicious can be rationalized and made to look aesthetic. Thus the conscious values are exchanged for sheer instinctuality and stupidity—one after another, the divine children are handed over to Behemoth. They are devoured by savage, barbarian tendencies that were formerly unconscious; hence Behemoth and Leviathan set up an *invisible whale* as a symbol of their power, while the corresponding symbol of the Epimethean realm is the *bird*. The whale, a denizen of the deep, is a well-known symbol of the devouring unconscious;²⁰⁷ the bird, an inhabitant of the bright realm of the air, is a symbol of conscious thought,²⁰⁸ of the (winged) ideal, and of the Holy Ghost (dove).

[459] The final extinction of the good is prevented by the intervention of Prometheus. He delivers Messias, the last of the divine children, from the power of his enemy. Messias becomes heir to the divine kingdom, while Prometheus and Epimetheus, the personifications of the divided opposites, now united, withdraw to the seclusion of their “native valley.” Both are relieved of sovereignty—Epimetheus because he was forced to renounce it, Prometheus because he never strove for it. In psychological terms, introversion and extraversion cease to dominate as exclusive principles, and consequently the psychic dissociation also ceases. In their stead a new function appears, symbolized by the divine child Messias, who had long lain sleeping. Messias is the mediator, the symbol of a new attitude in which the opposites are united. He is a child, a boy, the *puer aeternus* of the ancient prototype, heralding the rebirth and restitution (apocatastasis) of all that is lost. What Pandora brought to earth in the form of an image, and, being rejected of men, became the cause of their undoing, is fulfilled in him. This combination of symbols is frequently met with in analytical practice: a symbol emerging in dreams is rejected for the very reasons we have described, and even provokes an antagonistic reaction corresponding to the invasion of Behemoth. As a result of this conflict, the personality is levelled down to the basic characteristics that have been present since birth, and that keep the mature personality in touch with the childhood sources of energy. But as Spitteler shows, the great danger is that instead of the symbol being accepted, the archaic instincts it arouses will be rationalized and put at the disposal of the traditional ways of thinking.

[460] The English mystic William Blake says: “These two classes of men are always upon earth ... the Prolific and the Devouring. ... Religion is an endeavour to reconcile the two.”²⁰⁹ With these words of Blake, which summarize so simply the fundamental ideas of Spitteler and the whole of our previous discussion, I would like to close this chapter. If I have unduly expanded it, it was because I wanted to do full justice to the profusion of stimulating ideas that Spitteler offers us in *Prometheus and Epimetheus*, just as Schiller did in his *Letters*. I have, so far as possible, confined myself to essentials; indeed, I have had to pass over a large number of problems which would have to be considered in a comprehensive exposition of the material.

VI

THE TYPE PROBLEM IN PSYCHOPATHOLOGY

- [461] We now come to the work of a psychiatrist who made an attempt to single out two types from among the bewildering variety of mental disturbances that are generally grouped under the heading “psychopathic inferiority.” This very extensive group includes all psychopathic borderline states that cannot be reckoned among the psychoses proper; that is, all the neuroses and all degenerative states such as intellectual, moral, affective, and other psychic inferiorities.
- [462] This attempt was made by Otto Gross, who in 1902 published a theoretical study entitled *Die zerebrale Sekundärfunktion*. It was the basic hypothesis of this work that led him to the conception of two psychological types.¹ Although the empirical material discussed by him is taken from the domain of psychopathic inferiority, there is no reason why the insights gained should not be carried over into the wider field of normal psychology. The unbalanced psychic state gives the investigator an almost exaggeratedly clear view of certain psychic phenomena which, very often, can only be dimly perceived within the limits of the normal. The abnormal state sometimes acts like a magnifying glass. Gross himself, in his final chapter, also extends his conclusions to a wider domain, as we shall see.
- [463] By the “secondary function” Gross understands a cerebral cell-process that comes into action after the “primary function” has taken place. The primary function would correspond to the actual performance of the cell, namely, the production of a positive psychic process, for example an idea. This performance is an energetic process, presumably a discharge of chemical tension; in other words, it is a process of chemical decomposition. After this acute discharge, which Gross calls the primary function, the secondary function comes into action. It is a process of recovery, a rebuilding through assimilation. This function will require for its operation a longer or shorter period depending on the intensity of the preceding discharge of energy. During this time the condition of the cell has altered; it is now in a state of stimulation, and this cannot remain without influence on the subsequent psychic processes. Processes that are especially highly-toned and charged with affect require an especially intense discharge of energy, and hence an especially prolonged period of recovery governed by the secondary function. The effect of the secondary function on the psychic process in general consists, according to Gross, in its specific and demonstrable influence on the subsequent course of association, in the sense that it

restricts the choice of associations to the “theme” or “leading idea” represented by the primary function. And indeed, in my own experimental work (which was corroborated by several of my pupils), I was able to demonstrate statistically that *perseveration* followed in the train of ideas with a high feeling-tone.² My pupil Eberschweiler, in an investigation of language components,³ has demonstrated this same phenomenon in assonances and agglutinations. Further, we know from experiences in pathology how frequently perseverations occur in the case of severe cerebral lesions, apoplexies, tumours, atrophic and other degenerative states. Such perseverations may well be ascribed to this retarded process of recovery. Gross’ hypothesis thus has much to recommend it.

[464] It is therefore only natural to ask whether there may not be individuals, or even types, in whom the period of recovery, the secondary function, lasts longer than in others, and if so, whether certain characteristic psychologies may not be traceable to this. A short secondary function, clearly, will influence far fewer consecutive associations in a given period of time than a long one. Hence the primary function can operate much more frequently. The psychological picture in such a case would show a constant and rapidly renewed readiness for action and reaction, a kind of *distractibility*, a tendency to superficial associations and a lack of deeper, more concise ones, and a certain incoherence so far as an association is expected to be significant. On the other hand many new themes will crowd up in a given unit of time, though not at all intense or clearly focussed, so that heterogeneous ideas of varying value appear on the same niveau, thus giving the impression of a “levelling of ideas” (Wernicke). This rapid succession of primary functions necessarily precludes any real experience of the affective value of the ideas *per se*, with the result that the affectivity cannot be anything other than superficial. But, at the same time, this makes rapid adaptations and changes of attitude possible. The actual thought-process, or process of abstraction, naturally suffers when the secondary function is curtailed in this way, since abstraction requires a sustained contemplation of several initial ideas and their after-effects, and therefore a longer secondary function. Without this, there can be no intensification and abstraction of an idea or group of ideas.

[465] The rapid recovery of the primary function produces a higher reactivity, extensive rather than intensive, leading to a prompt grasp of the immediate present in its superficial aspects, though not of its deeper meanings. A person of this type gives the impression of having an uncritical or unprejudiced attitude; we are struck by his readiness to oblige and by his understanding, or again we may find in him an unaccountable lack of consideration, tactlessness, and even brutality. That too facile gliding over the deeper meanings evokes the impression of blindness to everything not lying immediately on the surface. His quick reactivity has the appearance of

presence of mind, of audacity to the point of foolhardiness, which from lack of criticism actually turns out to be an inability to realize danger. His rapidity of action looks like decisiveness; more often than not it is just blind impulse. Interference in other people's affairs is taken as a matter of course, and this comes all the more easily because of his ignorance of the emotional value of an idea or action and its effect on his fellow men. The ever renewed readiness for action has an adverse effect on the assimilation of perceptions and experiences; as a rule, memory is considerably impaired, because, in general, the associations that can be most readily reproduced are those that have become massively interlinked with others. Those that are relatively isolated become quickly submerged; for this reason it is infinitely more difficult to remember a series of meaningless, disconnected words than a poem. Excitability and an enthusiasm that soon fades are further characteristics of this type, also a certain lack of taste due to the rapid succession of heterogeneous contents and a failure to appreciate their differing emotional values. His thinking has more the character of a representation and orderly arrangement of contents than that of abstraction and synthesis.

[466] In describing this type with a short secondary function I have followed Gross in all essentials, here and there transcribing it in terms of normal psychology. Gross calls this type "inferiority with shallow consciousness." If the excessively crass features are toned down to the normal, we get an overall picture in which the reader will easily recognize Jordan's "less emotional" type, i.e., the extravert. Gross deserves full credit for being the first to set up a simple and consistent hypothesis to account for this type.

[467] Gross calls the opposite type "inferiority with contracted consciousness." In this type the secondary function is particularly intense and prolonged. It therefore influences the consecutive associations to a higher degree than in the other type. We may also suppose an intensified primary function, and hence a more extensive and complete cell-performance than with the extravert. A prolonged and intensified secondary function would be the natural consequence of this. As a result of this prolongation, the after-effect of the initial idea persists for a longer period. From this we get what Gross calls a "contractive effect": the choice of associations follows the path of the initial idea, resulting in a fuller realization or *approfondissement* of the "theme." The idea has a lasting influence, the impression goes deep. One disadvantage of this is that the associations are restricted to a narrow range, so that thinking loses much of its variety and richness. Nevertheless, the contractive effect aids synthesis, since the elements that have to be combined remain constellated long enough to make their abstraction possible. This restriction to one theme enriches the associations that cluster round it and consolidates one particular complex of ideas, but at the same time the complex is shut off from everything extraneous and finds

itself in isolation, a phenomenon which Gross (borrowing from Wernicke) calls “sejunction.” One result of the sejunction of the complex is a multiplication of groups of ideas (or complexes) that have no connection with one another or only quite a loose one. Outwardly such a condition shows itself as a disharmonious or, as Gross calls it, a “sejunctive” personality. The isolated complexes exist side by side without any reciprocal influence; they do not interact, mutually balancing and correcting each other. Though firmly knit in themselves, with a logical structure, they are deprived of the correcting influence of complexes with a different orientation. Hence it may easily happen that a particularly strong and therefore particularly isolated and uninfluenceable complex becomes an “over-valued idea,”⁴ a dominant that defies all criticism and enjoys complete autonomy, until it finally becomes an all-controlling factor manifesting itself as “spleen.” In pathological cases it turns into an obsessive or paranoid idea, absolutely unshakable, that rules the individual’s entire life. His whole mentality is subverted, becoming “deranged.” This conception of the growth of a paranoid idea may also explain why, during the early stages, it can sometimes be corrected by suitable psychotherapeutic procedures which bring it into connection with other complexes that have a broadening and balancing influence.⁵ Paranoiacs are very wary of associating disconnected complexes. They feel things have to remain neatly separated, the bridges between the complexes are broken down as much as possible by an over-precise and rigid formulation of the content of the complex. Gross calls this tendency “fear of association.”⁶

[468] The rigid inner cohesion of such a complex hampers all attempts to influence it from outside. The attempt is successful only when it is able to bind the complex to another complex as firmly and logically as it is bound in itself. The multiplication of insufficiently connected complexes naturally results in rigid seclusion from the outside world and a corresponding accumulation of libido within. Hence we regularly find an extraordinary concentration on inner processes, either on physical sensations or on intellectual processes, depending on whether the subject belongs to the sensation or to the thinking type. The personality seems inhibited, absorbed or distracted, “sunk in thought,” intellectually lopsided, or hypochondriacal. In every case there is only a meagre participation in external life and a distinct tendency to solitude and fear of other people, often compensated by a special love of animals or plants. To make up for this, the inner processes are particularly active, because from time to time complexes which hitherto had little or no connection with one another suddenly “collide,” thereby stimulating the primary function to intense activity which, in its turn, releases a prolonged secondary function that amalgamates the two complexes. One might think that all complexes would at some time or other collide in this way, thus producing a general uniformity and cohesion of psychic contents. Naturally, this wholesome result could only come about if in the meantime all change

in external life were arrested. But since this is not possible, fresh stimuli continually arrive and initiate secondary functions, which intersect and confuse the inner lines. Accordingly this type has a decided tendency to fight shy of external stimuli, to keep out of the way of change, to stop the steady flow of life until all is amalgamated within. Pathological cases show this tendency too; they hold aloof from everything and try to lead the life of a recluse. But only in mild cases will the remedy be found in this way. In all severe ones, the only remedy is to reduce the intensity of the primary function, but this is a chapter in itself, and one which we have already touched on in our discussion of Schiller's *Letters*.

[469] It is clear that this type is distinguished by quite peculiar phenomena in the realm of affect. We have seen how the subject realizes the associations set in motion by the initial idea. He carries out a full and coherent association of the material relevant to the theme, i.e., he associates all material that is not already linked to other complexes. When a stimulus hits on a complex, the result is either a violent explosion of affect, or, if the isolation of the complex is complete, it is entirely negative. But should realization take place, all the affective values are unleashed; there is a strong emotional reaction with a prolonged after-effect. Very often this cannot be seen from outside, but it bores in all the deeper. The emotional reverberations prey on the subject's mind and make him incapable of responding to new stimuli until the emotion has faded away. An accumulation of stimuli becomes unbearable, so he wards them off with violent defence reactions. Whenever there is a marked accumulation of complexes, a chronic attitude of defence usually develops, deepening into mistrust and in pathological cases into persecution mania.

[470] The sudden explosions, alternating with defensiveness and periods of taciturnity, can give the personality such a bizarre appearance that such people become an enigma to everyone in their vicinity. Their absorption in themselves leaves them at a loss when presence of mind or swift action is demanded. Embarrassing situations often arise from which there seems no way out—one reason the more for shunning society. Moreover the occasional outbursts of affect play havoc with their relations to others, and, because of their embarrassment and helplessness, they feel incapable of retrieving the situation. This awkwardness in adapting leads to all sorts of unfortunate experiences which inevitably produce a feeling of inferiority or bitterness, and even of hatred that is readily directed at those who were the actual or supposed authors of their misfortunes. Their affective inner life is very intense, and the manifold emotional reverberations linger on as an extremely fine gradation and perception of feeling-tones. They have a peculiar emotional sensitivity, revealing itself to the outside world as a marked timidity and uneasiness in the face of emotional stimuli, and in all situations that might evoke them. This touchiness is directed primarily against the emotional conditions in their environment. All brusque

expressions of opinion, emotional declarations, playing on the feelings, etc., are avoided from the start, prompted by the subject's fear of his own emotion, which in turn might start off a reverberating impression he might not be able to master. This sensitivity may easily develop over the years into melancholy, due to the feeling of being cut off from life. In fact, Gross considers melancholy to be especially characteristic of this type.⁷ He also emphasizes that the realization of affective values easily leads to emotional judgments, to "taking things too seriously." The prominence given in this picture to inner processes and the emotional life at once reveals the introvert. Gross's description is much fuller than Jordan's sketch of the "impassioned type," though the latter, in its main features, must be identical with the type described by Gross.

[471] In [chapter V](#) of his book Gross observes that, within the limits of the normal, both types of inferiority represent *physiological differences of individuality*. The shallow extensive or the narrow intensive consciousness is therefore a difference of character.⁸ According to Gross, the type with a shallow consciousness is essentially practical, because of his rapid adaptation to circumstances. His inner life does not predominate, having no part to play in the formation of the "great ideational complexes." "They are energetic propagandists for their own personality, and, on a higher level, they also work for the great ideas handed down from the past."⁹ Gross asserts that the emotional life of this type is primitive, though at a higher level it becomes organized through "the taking over of ready-made ideals from outside." In this way, Gross says, his activity can become "heroic," but "it is always banal." "Heroic" and "banal" scarcely seem compatible with one another. But Gross shows us at once what he means: in this type the connection between the erotic complex and the other complexes of ideas, whether aesthetic, ethical, philosophical, or religious, which make up the contents of consciousness, is not sufficiently developed. Freud would say that the erotic complex has been repressed. For Gross the marked presence of this connection is the "authentic sign of a superior nature" (p. 61). It requires for its development a prolonged secondary function, because a synthesis of the contents can be achieved only through *approfondissement* and their prolonged retention in consciousness. The taking over of conventional ideals may force sexuality into socially useful paths, but it "never rises above the level of triviality." This somewhat harsh judgment becomes explicable in the light of the extraverted character: the extravert orients himself exclusively by external data, so that his psychic activity consists mainly in his preoccupation with such things. Hence little or nothing is left over for the ordering of his inner life. It has to submit as a matter of course to determinants accepted from without. Under these circumstances, no connection between the more highly and the less developed functions can take place, for this demands a great expense of time and trouble; it is a lengthy and difficult labour of

self-education which cannot possibly be achieved without introversion. But the extravert lacks both time and inclination for this; moreover he is hampered by the same unconcealed distrust of his inner world which the introvert feels for the outer world.

[472] One should not imagine, however, that the introvert, thanks to his greater synthetizing capacity and ability to realize affective values, is thereby equipped to complete the synthesis of his own individuality without further ado—in other words, to establish once and for all a harmonious connection between the higher and lower functions. I prefer this formulation to Gross's, which maintains that it is solely a question of sexuality, for it seems to me that other instincts besides sex are involved. Sexuality is of course a very frequent form of expression for crude and untamed instincts, but so too is the striving for power in all its manifold aspects. Gross coined the term "sejunctive personality" for the introvert in order to emphasize the peculiar difficulty this type has in integrating his complexes. His synthetizing capacity merely serves in the first place to build up complexes that, so far as possible, are isolated from each other. But such complexes positively hinder the development of a higher unity. Thus the sexual complex, or the egoistic striving for power, or the search for pleasure, remains just as isolated and unconnected with other complexes in the introvert as in the extravert. I remember the case of an introverted, highly intellectual neurotic who spent his time alternating between the loftiest flights of transcendental idealism and the most squalid suburban brothels, without any conscious admission of a moral or aesthetic conflict. The two things were utterly distinct as though belonging to different spheres. The result, naturally, was an acute compulsion neurosis.

[473] We must bear this criticism in mind when following Gross's account of the type with intensive consciousness. Intensive consciousness is, as Gross says, "the foundation of the introspective individuality." Because of the strong contractive effect, external stimuli are always regarded from the standpoint of some idea. Instead of the impulse towards practical life there is a "drive for inwardness." "Things are conceived not as individual phenomena but as partial ideas or components of the great ideational complexes." This view accords with what we said earlier in our discussion of the nominalist and realist standpoints and the Platonic, Megarian, and Cynic schools in antiquity. It is easy to see from Gross's argument what the difference is between the two standpoints: the [extraverted] man with the short secondary function has many loosely connected primary functions operating in a given space of time, so that he is struck more particularly by the individual phenomenon. For him universals are only names lacking reality. But for the [introverted] man with the prolonged secondary function, the inner facts, abstractions, ideas, or universals always occupy the foreground; for him they are the only true realities, to which he *must* relate all individual phenomena. He is therefore

by nature a realist (in the Scholastic sense). Since, for the introvert, the way he thinks about things always takes precedence over the perception of externals, he is inclined to be a relativist.¹⁰ Harmony in his surroundings gives him especial pleasure;¹¹ it reflects his own inner urge to harmonize his isolated complexes. He avoids all “uninhibited behaviour” because it might easily lead to disturbing stimuli (explosions of affect must of course be excepted). His social *savoir faire* is poor because of his absorption in his inner life. The predominance of his own ideas prevents him from taking over the ideas or ideals of others. The intense inner elaboration of the complexes gives them a pronounced individual character. “The emotional life is frequently of no use socially, but is always individual.”¹²

[474] We must subject this statement to a thorough criticism, for it contains a problem which, in my experience, always gives rise to the greatest misunderstandings between the types. The introverted intellectual, whom Gross obviously has in mind here, outwardly shows as little feeling as possible, he entertains logically correct views and tries to do the right things in the first place because he has a natural distaste for any display of feeling and in the second because he is fearful lest by incorrect behaviour he should arouse disturbing stimuli, the affects of his fellow men. He is afraid of disagreeable affects in others because he credits others with his own sensitiveness; furthermore, he is always distressed by the quickness and volatility of the extravert. He bottles up his feeling inside him, so that it sometimes swells into a passion of which he is only too painfully aware. His tormenting emotions are well known to him. He compares them with the feelings displayed by others, principally, of course, with those of the extraverted feeling type, and finds that his “feelings” are quite different from those of other men. Hence he gets round to thinking that his feelings (or, more correctly, emotions) are unique or, as Gross says, “individual.” It is natural that they should differ from the feelings of the extraverted feeling type, because the latter are a differentiated instrument of adaptation and therefore lack the “genuine passion” which characterizes the deeper feelings of the introverted thinking type. But passion, as an elemental instinctive force, possesses little that is individual—it is something common to all men. Only what is differentiated can be individual. In the case of intense emotions, type differences are instantly obliterated in the “human-all-too-human.” In my view, the extraverted feeling type has really the chief claim to individualized feeling, because his feelings are differentiated; but he falls into the same delusion in regard to his thinking. He has thoughts that torment him. He compares them with the thoughts expressed by the other people around him, chiefly those of the introverted thinking type. He discovers that his thoughts have little in common with them; he may therefore regard them as individual and himself, perhaps, as an original thinker, or he may repress his thoughts altogether, since no one else thinks the same. In reality they are thoughts which everybody has but are

seldom uttered. In my view, therefore, Gross's statement springs from a subjective delusion, though one that is the general rule.

[475] "The heightened contractive power enables one to get absorbed in things to which no immediate vital interest is attached."¹³ Here Gross hits on an essential feature of the introverted mentality: the introvert delights in elaborating his thoughts for their own sake, regardless of external reality. This is both an advantage and a danger. It is a great advantage to be able to develop a thought into an abstraction, freed from the confines of the senses. The danger is that it will be removed altogether from the sphere of practical applicability and lose its vital value. The introvert is always in danger of getting too far away from life and of viewing things too much under their symbolic aspect. This is also stressed by Gross. The extravert is in no better plight, though for him matters are different. He has the capacity to curtail the secondary function to such an extent that he experiences practically nothing but a succession of positive primary functions: he is nowhere attached to anything, but soars above reality in a kind of intoxication; things are no longer seen as they are but are used merely as stimulants. This capacity is an advantage in that it enables him to manoeuvre himself out of many difficult situations ("he who hesitates is lost"), but, since it so often leads to inextricable chaos, it finally ends in catastrophe.

[476] From the extraverted type Gross derives what he calls the "civilizing genius," and from the introverted type the "cultural genius." The former he equates with "practical achievement," the latter with "abstract invention." In the end Gross expresses his conviction that our age stands in especial need of the contracted, intensive consciousness, in contrast to former ages when consciousness was shallower and more extensive. "We delight in the ideal, the profound, the symbolic. Through simplicity to harmony—that is the art of the highest culture."¹⁴

[477] Gross wrote these words in 1902. And now? If one were to express an opinion at all, one would have to say that we obviously need both civilization *and* culture,¹⁵ a shortening of the secondary function for the one, and its prolongation for the other. We cannot create one without the other, and we must admit, unfortunately, that modern humanity lacks both. Where there is too much of the one there is too little of the other, if we want to put it more cautiously. The continual harping on progress has by now become rather suspect.

[478] In conclusion I would like to remark that Gross's views coincide substantially with my own. Even my terms "extraversion" and "introversion" are justified in the light of his conceptions. It only remains for us to make a critical examination of Gross's basic hypothesis, the concept of the secondary function.

[479] It is always a risky business to frame physiological or "organic" hypotheses with respect to psychological processes. There was a regular mania for this at the time of

the great successes in brain research, and the hypothesis that the pseudopodia of the brain-cells withdrew during sleep is by no means the most absurd of those that were taken seriously and deemed worthy of “scientific” discussion. People were quite justified in speaking of a veritable “brain mythology.” I have no desire to treat Gross’s hypothesis as another “brain myth”—its empirical value is too great for that. It is an excellent working hypothesis, and one that has received due recognition in other quarters as well. The concept of the secondary function is as simple as it is ingenious. It enables one to reduce a very large number of complex psychic phenomena to a satisfying formula—phenomena whose diversity would have resisted simple reduction and classification under any other hypothesis. It is indeed such a happy one that, as always, one is tempted to overestimate its range of application. This, unfortunately, is rather limited. We will entirely disregard the fact that the hypothesis in itself is only a postulate, since no one has ever seen a secondary function of the brain cells, and no one could demonstrate how and why it has in principle the same contractive effect on subsequent associations as the primary function, which is by definition essentially different from the secondary function. There is a further fact which in my opinion carries even greater weight: the psychological attitude in one and the same individual can change its habits in a very short space of time. But if the duration of the secondary function has a physiological or organic character, it must surely be regarded as more or less constant. It could not then be subject to sudden change, for such changes are never observed in a physiological or organic character, pathological changes excepted. But, as I have pointed out more than once, introversion and extraversion are not traits of *character* at all but *mechanisms*, which can, as it were, be switched on or off at will. Only from their habitual predominance do the corresponding characters develop. The predilection one way or the other no doubt depends on the inborn disposition, but this is not always the decisive factor. I have frequently found environmental influences to be just as important. In one case in my experience, it even happened that a man with markedly extravert behaviour, while living in close proximity to an introvert, changed his attitude and became quite introverted when he later came into contact with a pronounced extraverted personality. I have repeatedly observed how quickly personal influences can alter the duration of the secondary function even in a well-defined type, and how the previous condition re-establishes itself as soon as the alien influence is removed.

[480] With such experiences in mind, we should, I think, direct our attention more to the nature of the primary function. Gross himself lays stress on the special prolongation of the secondary function in the wake of strongly feeling-toned ideas,¹⁶ thus showing its dependence on the primary function. There is, in fact, no plausible reason why one should base a theory of types on the duration of the secondary

function; it could be based just as well on the *intensity of the primary function*, since the duration of the secondary function is obviously dependent on the intensity of the cell-performance and on the expenditure of energy. It might be objected that the duration of the secondary function depends on the rapidity of cell recovery, and that there are individuals with especially prompt cerebral assimilation as opposed to others who are less favoured. In that case the brain of the extravert must possess a greater capacity for cell recovery than that of the introvert. But such a very improbable assumption lacks all proof. What is known to us of the actual causes of the prolonged secondary function is limited to the fact that, leaving pathological conditions aside, the special intensity of the primary function results, quite logically, in a prolongation of the secondary function. That being so, the real problem would lie with the primary function and might be resolved into the question: how comes it that in one person the primary function is intense, while in another it is weak? By shifting the problem to the primary function, we have to account for its varying intensity, which does indeed alter very rapidly. It is my belief that this is an energetic phenomenon, dependent on a general *attitude*.

[481] The intensity of the primary function seems to me directly dependent on the degree of tension in the propensity to act. If the psychic tension is high, the primary function will be particularly intense and will produce corresponding results. When with increasing fatigue the tension slackens, distractibility and superficiality of association appear, and finally "flight of ideas," a condition characterized by a weak primary and a short secondary function. The general psychic tension (if we discount physiological causes, such as relaxation, etc.) is dependent on extremely complex factors, such as mood, attention, expectancy, etc., that is to say, on value judgments which in their turn are the resultants of all the antecedent psychic processes. By these judgments I mean not only logical judgments but also judgments of feeling. Technically, the general tension could be expressed in the energetic sense as *libido*, but in its psychological relation to consciousness we must express it in terms of *value*. An intense primary function is a manifestation of libido, i.e., it is a highly charged energetic process. But it is also a psychological value; hence we term the trains of association resulting from it valuable in contrast to those which are the result of a weak contractive effect, and these are valueless because of their superficiality.

[482] A tense attitude is in general characteristic of the introvert, while a relaxed, easy attitude distinguishes the extravert.¹⁷ Exceptions, however, are frequent, even in one and the same individual. Give an introvert a thoroughly congenial, harmonious milieu, and he relaxes into complete extraversion, so that one begins to wonder whether one may not be dealing with an extravert. But put an extravert in a dark and silent room, where all his repressed complexes can gnaw at him, and he will get into such a state of tension that he will jump at the slightest stimulus. The changing

situations of life can have the same effect of momentarily reversing the type, but the basic attitude is not as a rule permanently altered. In spite of occasional extraversion the introvert remains what he was before, and the extravert likewise.

[483] To sum up: the primary function is in my view more important than the secondary. The intensity of the primary function is the decisive factor. It depends on the general psychic tension, i.e., on the amount of accumulated, disposable libido. The factors determining this accumulation are the complex resultants of all the antecedent psychic states—mood, attention, affect, expectancy, etc. Introversión is characterized by general tension, an intense primary function and a correspondingly long secondary function; extraversion by general relaxation, a weak primary function and a correspondingly short secondary function.

VII

THE TYPE PROBLEM IN AESTHETICS

[484] It stands to reason that every province of the human mind directly or indirectly concerned with psychology will have its contribution to make to the problem under discussion. Now that we have listened to the philosopher, the poet, the observer of men and the physician, let us hear what the aesthetician has to say.

[485] Aesthetics by its very nature is applied psychology and has to do not only with the aesthetic qualities of things but also—and perhaps even more—with the psychological question of the aesthetic attitude. A fundamental problem like the contrast between introversion and extraversion could not long escape the attention of the aesthetician, because the way in which art and beauty are sensed by different individuals differs so widely that one could not fail to be struck by it. Aside from the numerous individual peculiarities of attitude, some of them more or less unique, there are two basic antithetical forms which Worringer has described as *abstraction* and *empathy* (*Einfühlung*).¹ His definition of empathy derives principally from Lipps. For Lipps, empathy is “the objectification of myself in an object distinct from myself, no matter whether the thing objectified merits the name ‘feeling’ or not.” “By apperceiving an object, I experience, as though issuing from it or inherent in it as something apperceived, an impulse towards a particular mode of inner behaviour. This has the appearance of being communicated to me by the object.”² Jodl interprets it as follows:

The sensuous image produced by the artist not only serves to bring to our minds kindred experiences by the laws of association. Since it is subject to the general law of externalization³ and appears as something outside ourselves, we simultaneously project into it the inner processes it evokes in us, thereby endowing it with aesthetic animation [*Beseelung*]⁴—a term that may be preferred to *Einfühlung* because, in this introjection of one’s own inner state into the image, it is not feeling alone that is involved, but inner processes of all kinds.⁴

[486] Wundt reckons empathy among the elementary processes of assimilation.⁵ It is therefore a kind of perceptive process, characterized by the fact that, through feeling, some essential psychic content is projected into the object, so that the object is assimilated to the subject and coalesces with him to such an extent that he feels himself, as it were, in the object. This happens when the projected content is associated to a higher degree with the subject than with the object. He does not,

however, feel himself projected into the object; rather, the “empathized” object appears animated to him, as though it were speaking to him of its own accord. It should be noted that in itself projection is usually an unconscious process not under conscious control. On the other hand it is possible to imitate the projection consciously by means of a conditional sentence—for instance, “if you were my father”—thus bringing about the situation of empathy. As a rule, the projection transfers unconscious contents into the object, for which reason empathy is also termed “transference” (Freud) in analytical psychology. Empathy, therefore, is a form of extraversion.

[487] Worringer defines the aesthetic experience of empathy as follows: “Aesthetic enjoyment is objectified self-enjoyment.”⁶ Consequently, only a form one can empathize with is beautiful. Lipps says: “Only so far as this empathy extends are forms beautiful. Their beauty is simply my ideal having free play in them.”⁷ According to this, any form one cannot empathize with would be ugly. But here the theory of empathy reaches its limitations, for, as Worringer points out, there are art-forms to which the empathetic attitude cannot be applied. Specifically, one might mention the oriental and exotic art-forms as examples. In the West, long tradition has established “natural beauty and verisimilitude” as the criterion of beauty in art, since this is the criterion and essential character of Graeco-Roman and occidental art in general (with the exception of certain stylized medieval forms).

[488] Since antiquity, our general attitude to art has always been empathetic, and for this reason we designate as beautiful only those things we can empathize with. If the art-form is opposed to life, if it is inorganic or abstract, we cannot feel our own life in it. “What I feel myself into is life in general,” says Lipps. We can empathize only with organic form—form that is true to nature and has the will to live. And yet another art-principle undoubtedly exists, a style that is opposed to life, that denies the will to live, but nevertheless lays a claim to beauty. When art produces life-denying, inorganic, abstract forms, there can no longer be any question of the will to create arising out of the need for empathy; it is rather a need that is directly opposed to empathy—in other words, a tendency to suppress life. Worringer says: “This counter-pole to the need for empathy appears to us to be the urge to abstraction.”⁸ As to the psychology of this urge to abstraction, Worringer continues:

Now, what are the psychic preconditions for the urge to abstraction? Among those peoples where it exists we must look for them in their feeling about the world, in their psychic attitude towards the cosmos. Whereas the precondition for the urge to empathy is a happy pantheistic relationship of confidence between man and the phenomena of the external world, the urge to abstraction is the outcome of a great inner uneasiness inspired in man by these phenomena, and its religious counterpart is

the strongly transcendental colouring of all ideas. We might describe this state as an immense spiritual dread of space. When Tibullus says, *primum in mundo fecit deus timorem* [the first thing God made in the world was fear],⁹ this same feeling of fear may also be assumed to be the root of artistic creation.¹⁰

[489] It is indeed true that empathy presupposes a subjective attitude of confidence, or trustfulness towards the object. It is a readiness to meet the object halfway, a subjective assimilation that brings about a good understanding between subject and object, or at least simulates it. A passive object allows itself to be assimilated subjectively, but its real qualities are in no way altered in the process; they are merely veiled, and may even be violated, because of the transference. Empathy can create similarities and seemingly common qualities which have no real existence in themselves. It is understandable, therefore, that the possibility of another kind of aesthetic relation to the object must also exist, an attitude that does not go to meet the object halfway, but rather withdraws from it and seeks to secure itself against the influence of the object by creating in the subject a psychic activity whose function it is to neutralize the effect of the object.

[490] Empathy presupposes that the object is, as it were, empty, and seeks to imbue it with life. Abstraction, on the other hand, presupposes that the object is alive and active, and seeks to withdraw from its influence. The abstracting attitude is centripetal, i.e., introverting. Worringer's conception of abstraction therefore corresponds to the introverted attitude. It is significant that Worringer describes the influence of the object as fear or dread. The abstracting attitude endows the object with a threatening or injurious quality against which it has to defend itself. This seemingly *a priori* quality is doubtless a projection, but a negative one. We must therefore suppose that abstraction is preceded by an unconscious act of projection which transfers negative contents to the object.

[491] Since empathy, like abstraction, is a conscious act, and since the latter is preceded by an unconscious projection, we may reasonably ask whether an unconscious act may not also precede empathy. As the essence of empathy is the projection of subjective contents, it follows that the preceding unconscious act must be the opposite—a neutralizing of the object that renders it inoperative. In this way the object is emptied, so to speak, robbed of its spontaneous activity, and thus made a suitable receptacle for subjective contents. The empathizing subject wants to feel his own life in the object; hence the independence of the object and the difference between it and the subject must not be too great. As a result of the unconscious act that precedes empathy, the sovereignty of the object is depotentiated, or rather it is overcompensated, because the subject immediately gains ascendancy over the object. This can only happen unconsciously, through an unconscious fantasy that either

devalues and depotentiates the object or enhances the value and importance of the subject. Only in this way can that difference of potential arise which empathy needs in order to convey subjective contents into the object.

[492] The man with the abstracting attitude finds himself in a frighteningly animated world that seeks to overpower and smother him. He therefore withdraws into himself, in order to think up a saving formula calculated to enhance his subjective value at least to the point where he can hold his own against the influence of the object. The man with the empathetic attitude finds himself, on the contrary, in a world that needs his subjective feeling to give it life and soul. He animates it with himself, full of trust; but the other retreats mistrustfully before the daemonism of objects, and builds up a protective anti-world composed of abstractions.

[493] If we recall what was said in the preceding chapter, it is easy to see that empathy corresponds to the mechanism of extraversion, and abstraction to that of introversion. “The great inner uneasiness inspired in man by the phenomena of the external world” is nothing other than the introvert’s fear of all stimuli and change, occasioned by his deeper sensitivity and powers of realization. His abstractions serve the avowed purpose of confining the irregular and changeable within fixed limits. It goes without saying that this essentially magical procedure is found in full flower in the art of primitives, whose geometrical patterns have a magical rather than an aesthetic value. Worringer rightly says of Oriental art:

Tormented by the confusion and flux of the phenomenal world, these people were dominated by an immense need for repose. The enjoyment they sought in art consisted not so much in immersing themselves in the things of the outside world and finding pleasure there, as in raising the individual object out of its arbitrary and seemingly fortuitous existence, immortalizing it by approximation to abstract forms, and so finding a point of repose amid the ceaseless flux of appearances.¹¹

These abstract, regular forms are not merely the highest, they are the only forms in which man may find repose in face of the monstrous confusion of the world.¹²

[494] As Worringer says, it is precisely the Oriental art-forms and religions that display this abstracting attitude to the world. To the Oriental, therefore, the world must appear very different from what it does to the Occidental, who animates it with his empathy. For the Oriental, the object is imbued with life from the start and has ascendancy over him; therefore he withdraws into a world of abstraction. For an illuminating insight into the Oriental attitude, we may turn to the “Fire Sermon” of the Buddha:

All is on fire. The eye and all the senses are on fire, with the fire of passion, the fire of hate, the fire of delusion; the fire is kindled by birth, old age, and death, by pain and lamentation, by sorrow, suffering, and despair. ... The whole world is in flames,

the whole world is wrapped in smoke, the whole world is consumed by fire, the whole world trembles.¹³

[495] It is this fearful and sorrowful vision of the world that forces the Buddhist into his abstracting attitude, just as, according to legend, a similar impression started the Buddha on his life's quest. The dynamic animation of the object as the impelling cause of abstraction is strikingly expressed in the Buddha's symbolic language. This animation does not come from empathy, but from an unconscious projection that actually exists *a priori*. The term "projection" hardly conveys the real meaning of this phenomenon. Projection is really an act that happens, and not a condition existing *a priori*, which is what we are obviously dealing with here. It seems to me that Lévy-Bruhl's *participation mystique* is more descriptive of this condition, since it aptly formulates the primordial relation of the primitive to the object. His objects have a dynamic animation, they are charged with soul-stuff or soul-force (and not always possessed of souls, as the animist theory supposes), so that they have a direct psychic effect upon him, producing what is practically a dynamic identification with the object. In certain primitive languages articles of personal use have a gender denoting "alive" (the suffix of animation). With the abstracting attitude it is much the same, for here too the object is alive and autonomous from the beginning and in no need of empathy; on the contrary, it has such a powerful effect that the subject is forced into introversion. Its strong libido investment comes from its *participation mystique* with the subject's own unconscious. This is clearly expressed in the words of the Buddha: the universal fire is identical with the fire of libido, with the subject's burning passion, which appears to him as an object because it is not differentiated into a disposable function.

[496] Abstraction thus seems to be a function that is at war with the original state of *participation mystique*. Its purpose is to break the object's hold on the subject. It leads on the one hand to the creation of art-forms, and on the other to knowledge of the object. Empathy too is as much an organ of artistic creation as of cognition. But it functions on a quite different level from abstraction. Just as the latter is based on the magical significance and power of the object, the basis of empathy is the magical significance of the subject, who gains power over the object by means of *mystical identification*. The primitive is in a similar position: he is magically influenced by the power of the fetish, yet at the same time he is the magician and accumulator of magical power who charges the fetish with potency. An example of this is the *churinga* rite of the Australian aborigines.¹⁴

[497] The unconscious depotentiation that precedes the act of empathy gives the object a permanently lower value, as in the case of abstraction. Since the unconscious contents of the empathetic type are identical with the object and make it appear

inanimate,¹⁵ empathy is needed in order to cognize the nature of the object. One might speak in this case of a continual unconscious abstraction which “depsychizes” the object. All abstraction has this effect: it kills the independent activity of the object in so far as this is magically related to the psyche of the subject. The abstracting type does it quite consciously, as a defence against the magical influence of the object. The inertness of objects also explains the trustful relationship of the empathetic type to the world; there is nothing that could exert a hostile influence or oppress him, since he alone gives the object life and soul, though to his conscious mind the converse would seem to be true. For the abstracting type, on the other hand, the world is filled with potent and dangerous objects that inspire him with fear and a consciousness of his own impotence; he withdraws from any too intimate contact with the world, in order to weave those thoughts and formulas with which he hopes to gain the upper hand. His psychology, therefore, is that of the under-dog, whereas the empathetic type faces the world with confidence—its inert objects hold no terrors for him. Naturally this sketch is schematic and makes no pretence to be a complete picture of the introverted or extraverted attitude; it merely emphasizes certain nuances which, nevertheless, are not without significance.

[498] Just as the empathetic type is really taking an unconscious delight in himself through the object, so, without knowing it, the abstracting type is really reflecting himself when he reflects on the impressions which objects make upon him. For what the one projects into the object is himself, his own unconscious contents, and what the other thinks about his impression of the object is really his thoughts about his own feelings, which appear to him projected upon the object. It is evident, therefore, that both empathy and abstraction are needed for any real appreciation of the object as well as for artistic creation. Both are always present in every individual, though in most cases they are unequally differentiated.

[499] In Worringer’s view the common root of these two basic forms of aesthetic experience is “self-alienation”—the need to get outside oneself. Through abstraction and “in the contemplation of something immutable and necessary, we seek deliverance from the hazards of being human, from the seeming arbitrariness of ordinary organic existence.”¹⁶ Faced with the bewildering profusion of animate objects, we create an abstraction, an abstract universal image which conjures the welter of impressions into a fixed form. This image has the magical significance of a defence against the chaotic flux of experience. The abstracting type becomes so lost and submerged in this image that finally its abstract truth is set above the reality of life; and because life might disturb the enjoyment of abstract beauty, it gets completely suppressed. He turns himself into an abstraction, he identifies with the eternal validity of the image and petrifies in it, because for him it has become a

redeeming formula. He divests himself of his real self and puts his whole life into his abstraction, in which he is, so to speak, crystallized.

[500] The empathetic type suffers a similar fate. Since his activity, his life is empathized into the object, he himself gets into the object because the empathized content is an essential part of himself. He becomes the object. He identifies himself with it and in this way gets outside himself. By turning himself into an object he desubjectivizes himself. Worringer says:

In empathizing this will to activity into another object, we *are* in the other object. We are delivered from our individual being as long as our inner urge for experience absorbs us into an external object, a form outside ourselves. We feel our individuality flowing into fixed bounds that contrast with the boundless diversity of individual consciousness. In this self-objectivation lies a self-alienation. This affirmation of our individual need for activity represents, at the same time, a restriction of its unlimited possibilities, a negation of its irreconcilable diversities. For all our inner urge to activity, we have to rest within the limits of this objectivation.¹⁷

[501] Just as for the abstracting type the abstract image is a bulwark against the destructive effects of the unconsciously animated object,¹⁸ so for the empathetic type the transference to the object is a defence against the disintegration caused by inner subjective factors, which for him consist in limitless fantasies and corresponding impulses to action. The extraverted neurotic clings as tenaciously to the object of his transference as, according to Adler, the introverted neurotic clings to his “guiding fiction.” The introvert abstracts his “guiding fiction” from his good and bad experiences of objects, and relies on his formula to protect him from the limitless possibilities life offers.

[502] Abstraction and empathy, introversion and extraversion, are mechanisms of adaptation and defence. In so far as they make for adaptation, they protect a man from external dangers. In so far as they are directed functions,¹⁹ they liberate him from fortuitous impulses; indeed they are an actual defence against them since they make self-alienation possible. As our daily psychological experience shows, there are very many people who are completely identified with their directed (or “valuable”) function, among them the very types we are discussing. Identification with the directed function has an undeniable advantage in that a man can best adapt to collective demands and expectations; moreover, it also enables him to keep out of the way of his inferior, undifferentiated, undirected functions by self-alienation. In addition, “selflessness” is always considered a particular virtue from the standpoint of social morality. On the other hand, we also have to bear in mind the great disadvantage which identification with the directed function entails, namely, the degeneration of the individual. No doubt man can be mechanized to a very

considerable extent, but not to the point of giving himself up completely, or only at the cost of the gravest injury. For the more he identifies with one function, the more he invests it with libido, and the more he withdraws libido from the other functions. They can tolerate being deprived of libido for even quite long periods, but in the end they will react. Being drained of libido, they gradually sink below the threshold of consciousness, lose their associative connection with it, and finally lapse into the unconscious. This is a regressive development, a reversion to the infantile and finally to the archaic level. Since man has spent only a few thousand years in a cultivated state, as opposed to several hundred thousand years in a state of savagery, the archaic modes of functioning are still extraordinarily vigorous and easily reactivated. Hence, when certain functions disintegrate by being deprived of libido, their archaic foundations in the unconscious become operative again.

[503] This state brings about a dissociation of the personality, since the archaic modes of functioning have no direct connection with consciousness and no negotiable bridges exist between it and the unconscious. Consequently, the further the process of self-alienation goes, the further the unconscious functions sink down to the archaic level. The influence of the unconscious increases proportionately. It begins to provoke symptomatic disturbances of the directed function, thus producing that vicious circle characteristic of so many neuroses: the patient tries to compensate the disturbing influences by special feats on the part of the directed function, and the competition between them is often carried to the point of nervous collapse.

[504] The possibility of self-alienation by identification with the directed function does not depend solely on a rigid restriction to the one function, but also on the fact that the directed function is itself a principle that makes self-alienation necessary. Thus every directed function demands the strict exclusion of everything not suited to its nature: thinking excludes all disturbing feelings, just as feeling excludes all disturbing thoughts. Without the repression of everything alien to itself, the directed function could never operate at all. On the other hand, since the self-regulation of the living organism requires by its very nature the harmonizing of the whole human being, consideration of the less favoured functions forces itself upon us as a vital necessity and an unavoidable task in the education of the human race.

VIII

THE TYPE PROBLEM IN MODERN PHILOSOPHY

1. WILLIAM JAMES' TYPES

[505] The existence of two types has also been discovered in modern pragmatic philosophy, particularly in the philosophy of William James.¹ He says:

The history of philosophy is, to a great extent, that of a certain clash of human temperaments. ... Of whatever temperament a professional philosopher is, he tries, when philosophizing, to sink the fact of his temperament. ... Yet his temperament really gives him a stronger bias than any of his more strictly objective premises. It loads the evidence for him one way or the other, making for a more sentimental or a more hard-hearted view of the universe, just as this fact or that principle would. He trusts his temperament. Wanting a universe that suits it, he believes in any representation of the universe that does suit it. He feels men of opposite temper to be out of key with the world's character, and in his heart considers them incompetent and "not in it," in the philosophic business, even though they may far excel him in dialectical ability.

Yet in the forum he can make no claim, on the bare ground of his temperament, to superior discernment or authority. There arises thus a certain insincerity in our philosophic discussions; the potentest of all our premises is never mentioned.²

[506] Whereupon James proceeds to the characterization of the two temperaments. Just as in the domain of manners and customs we distinguish conventional and easy-going persons, in politics authoritarians and anarchists, in literature purists and realists, in art classicists and romantics, so in philosophy, according to James, we find two types, the "rationalist" and the "empiricist." The rationalist is "your devotee of abstract and eternal principles." The empiricist is the "lover of facts in all their crude variety" (p. 9). Although no man can dispense either with facts or with principles, they nevertheless give rise to entirely different points of view according to whether the accent falls on one side or on the other.

[507] James makes "rationalism" synonymous with "intellectualism," and "empiricism" with "sensationalism." Although in my opinion this equation is not tenable, we will follow James' line of thought for the time being, reserving our criticism until later. In his view, intellectualism is associated with an idealistic and optimistic tendency, whereas empiricism inclines to materialism and a very qualified and uncertain optimism. Intellectualism is always *monistic*. It begins with the whole, with the universal, and unites things; empiricism begins with the part and makes the whole into an *assemblage*. It could therefore be described as *pluralistic*. The rationalist is a man of feeling, but the empiricist is a hard-headed creature. The former is naturally disposed to a belief in free will, the latter to fatalism. The rationalist is inclined to be dogmatic, the empiricist sceptical (pp. 10ff.).

James calls the rationalist *tender-minded*, the empiricist *tough-minded*. It is obvious that he is trying to put his finger on the characteristic mental qualities of the two types. Later, we shall examine this characterization rather more closely. It is interesting to hear what James has to say about the prejudices each type cherishes about the other (pp. 12f.):

They have a low opinion of each other. Their antagonism, whenever as individuals their temperaments have been intense, has formed in all ages a part of the philosophic atmosphere of the time. It forms a part of the atmosphere today. The tough think of the tender as sentimentalists and soft-heads. The tender feel the tough to be unrefined, callous, or brutal. ... Each type believes the other to be inferior to itself.

James tabulates the qualities of the two types as follows:

<i>Tender-minded</i>	<i>Tough-minded</i>
Rationalistic (going by "principles")	Empiricist (going by "facts")
Intellectualistic	Sensationalistic
Idealistic	Materialistic
Optimistic	Pessimistic
Religious	Irreligious
Free-willist	Fatalistic
Monistic	Pluralistic
Dogmatical	Sceptical

[508] This list touches on a number of problems we have met with in the chapter on realism and nominalism. The tender-minded have certain features in common with the realists, and the tough-minded with the nominalists. As I have pointed out, realism corresponds to introversion, and nominalism to extraversion. The controversy about universals undoubtedly forms part of that "clash of temperaments" in philosophy to which James alludes. These associations tempt one to think of the tender-minded as introverted and the tough-minded as extraverted, but it remains to be seen whether this equation is valid or not.

[509] With my somewhat limited knowledge of James' writings, I have not been able to discover any more detailed definitions or descriptions of the two types, although he frequently refers to these two kinds of thinking, and incidentally describes them as "thin" and "thick." Flournoy³ interprets "thin" as "mince, ténu, maigre, chétif," and "thick" as "épais, solide, massif, cossu." On one occasion, as we have seen, James calls the tender-minded "soft-heads." Both "soft" and "tender" suggest something delicate, mild, gentle, hence weak, subdued, and rather powerless, in contrast to "thick" and "tough," which are resistant qualities, solid and hard to change, suggesting the nature of matter. Flournoy accordingly elucidates the two kinds of thinking as follows:

It is the contrast between the abstract way of thinking—that is, the purely logical and dialectical way so dear to philosophers, but which failed to inspire James with any confidence and appeared to him fragile, hollow, and thin because too remote from particular objects—and the concrete way of thinking, which nourishes itself on the facts of experience and never leaves the solid earthy region of tortoise-shells or other positive data.⁴

[510] We should not, however, conclude from this comment that James has a bias in favour of concrete thinking. He appreciates both standpoints: “Facts are good, of course ... give us lots of facts. Principles are good ... give us plenty of principles.” A fact never exists only as it is in itself, but also as we see it. When, therefore, James describes concrete thinking as “thick” and “tough,” he is saying that for him this kind of thinking has something about it that is substantial and resistant, while abstract thinking appears to him weak, thin, and colourless, perhaps even (if we go along with Flournoy) sickly and decrepit. Naturally such a view is possible only for a person who has made an *a priori* connection between substantiality and concrete thinking—and that, as we have said, is just where the question of temperament comes in. When the empiricist attributes a resistant substantiality to his concrete thinking, from the abstract point of view he is deceiving himself, because substantiality or hardness is a property of external facts and not of empirical thinking. Indeed, the latter proves to be singularly feeble and ineffective; far from holding its own in the face of external facts, it is always running after them and depending on them, and, in consequence, hardly rises above the level of a purely classifying or descriptive activity. *Qua* thinking, therefore, is very weak and unself-reliant, because it has no stability in itself but only in objects, which gain ascendancy over it as determining values. It is a thinking characterized by a succession of sense-bound representations, which are set in motion less by the inner activity of thought than by the changing stream of sense-impressions. A series of concrete representations conditioned by sensuous perceptions is not exactly what the abstract thinker would call thinking, but at best only passive apperception.

[511] The temperament that favours concrete thinking and endows it with substantiality is thus distinguished by a preponderance of sensuously conditioned representations as contrasted with active apperception, which springs from a subjective act of the will and seeks to organize such representations in accordance with the intentions of a given *idea*. In a word, what counts for this temperament is the *object*: the object is empathized, it leads a quasi-independent existence in the ideational world of the subject, and comprehension follows as a kind of after-thought. It is therefore an extraverting temperament, for the thinking of the extravert is concretistic. Its stability lies outside in the empathized object, which is why James calls it “tough.” For anyone who espouses concrete thinking, i.e., the representation of facts, abstract thinking must appear feeble and ineffective, because he measures it by the stability of concrete, sense-bound objects. For the man who is on the side of abstraction, it is not the sensuously determined representation but the abstract idea that is the decisive factor.

[512] Currently, an idea is held to be nothing more than the abstraction of a sum of experiences. One likes to think of the human mind as, originally, a *tabula rasa* that gradually gets covered with perceptions and experiences of life and the world. From this standpoint, which is the standpoint of empirical science in general, an idea cannot be anything else but an epiphenomenal, *a posteriori* abstraction from experiences, and consequently even feebler and more colourless than they are. We know, however, that the mind cannot be a *tabula rasa*, for epistemological criticism shows us that certain categories of thinking are given *a priori*; they are antecedent to all experience and appear with the first

act of thought, of which they are its preformed determinants. What Kant demonstrated in respect of logical thinking is true of the whole range of the psyche. The psyche is no more a *tabula rasa* to begin with than is the mind proper (the thinking area). Naturally the concrete contents are lacking, but the potential contents are given *a priori* by the inherited and preformed functional disposition. This is simply the product of the brain's functioning throughout the whole ancestral line, a deposit of phylogenetic experiences and attempts at adaptation. Hence the new-born brain is an immensely old instrument fitted out for quite specific purposes, which does not only apperceive passively but actively arranges the experiences of its own accord and enforces certain conclusions and judgments. These patterns of experience are by no means accidental or arbitrary; they follow strictly preformed conditions which are not transmitted by experience as contents of apprehension but are the preconditions of all apprehension. They are ideas *ante rem*, determinants of form, a kind of pre-existent ground-plan that gives the stuff of experience a specific configuration, so that we may think of them, as Plato did, as *images*, as schemata, or as inherited functional possibilities which, nevertheless, exclude other possibilities or at any rate limit them to a very great extent. This explains why even fantasy, the freest activity of the mind, can never roam into the infinite (although it seems that way to the poet) but remains anchored to these preformed patterns, these primordial images. The fairytales of the most widely separated races show, by the similarity of their motifs, the same tie. Even the images that underlie certain scientific theories—ether, energy, its transformations and constancy, the atomic theory, affinity, and so on—are proof of this restriction.

[513] Just as concrete thinking is dominated and guided by sensuously conditioned representations, abstract thinking is dominated by “irrepresentable” primordial images lacking specific content. They remain relatively inactive so long as the object is empathized and thus made a determinant of thought. But if the object is not empathized, and loses its dominance over the thinking process, the energy denied to it accumulates in the subject. It is now the subject who is unconsciously empathized; the primordial images are awakened from their slumber and emerge as operative factors in the thinking process, but in irrepresentable form, rather like invisible stage managers behind the scenes. They are irrepresentable because they lack content, being nothing but activated functional possibilities, and accordingly they seek something to fill them out. They draw the stuff of experience into their empty forms, representing themselves *in* facts rather than representing facts. They clothe themselves with facts, as it were. Hence they are not, in themselves, a known *point d'appui*, as is the empirical fact in concrete thinking, but become experienceable only through the unconscious shaping of the stuff of experience. The empiricist, too, can organize this material and give it shape, but he models it as far as possible on a concrete idea he has built up on the basis of past experience.

[514] The abstract thinker, on the other hand, uses an unconscious model, and only afterwards, from the finished product, does he experience the idea to which he has given shape. The empiricist is always inclined to assume that the abstract thinker shapes the stuff of experience in a quite arbitrary fashion from some colourless, flimsy, inadequate premise, judging the latter's mental processes by his own. But the actual premise, the idea or

primordial image, is just as unknown to the abstract thinker as is the theory which the empiricist will in due course evolve from experience after so and so many experiments. As I have shown in the first chapter,⁵ the one type (in this case the empiricist) sees only the individual object and interests himself in its behaviour, while the other, the abstract thinker, sees mainly the similarities between objects, and disregards their singularity because he finds security in reducing the multiplicity of the world to something uniform and coherent. The empiricist finds similarities frankly tiresome and disturbing, something that actually hinders him from recognizing the object's singularity. The more the individual object is empathized, the more easily he discerns its singularity, and the more he loses sight of its similarities with other objects. If only he knew how to empathize other objects as well, he would be far more capable of sensing and recognizing their similarities than the abstract thinker, who sees them only from outside.

[515] It is because he empathizes first one object and then another—always a time-consuming procedure—that the concrete thinker is very slow to recognize the similarities between them, and for this reason his thinking appears sluggish and viscid. But his empathy is fluid. The abstract thinker seizes on similarities quickly, puts general characteristics in the place of individual objects, and shapes the stuff of experience by his own mental activity, though this is just as powerfully influenced by the shadowy primordial image as the concrete thinker is by the object. The greater the influence the object has on thinking, the more it stamps its characteristics on the conceptual image. But the less the object works on the mind, the more the primordial idea will set its seal on experience.

[516] The excessive importance attached to objects gives rise in science to a certain kind of theory favoured by specialists, which for instance cropped up in psychiatry in the form of the “brain mythology” mentioned in [Chapter VI](#) (par. 479). In all such theories an attempt is made to elucidate a very wide range of experience in terms of principles which, though applicable over a small area, are wholly inappropriate for other fields. Conversely, abstract thinking, by taking cognizance of individual facts only because of their similarities with others, formulates a general hypothesis which, while presenting the leading idea in more or less pure form, has as little to do with the nature of concrete facts as a myth. When carried to extremes, therefore, both types of thinking create a mythology, the one expressed concretely in terms of cells, atoms, vibrations, etc., the other abstractly in terms of “eternal” ideas. At least extreme empiricism has the advantage of presenting the facts as purely as possible, just as extreme idealism reflects the primordial images as in a mirror. The theoretical results of the one are limited by its empirical material, just as the practical results of the other are confined to a presentation of the psychological idea. Because the contemporary scientific attitude is exclusively concretistic and empirical, it has no appreciation of the value of ideas, for facts rank higher than knowledge of the primordial forms in which the human mind conceives them. This swing towards concretism is a comparatively recent development, a relict of the Enlightenment. The results are indeed astonishing, but they have led to an accumulation of empirical material whose very immensity is productive of more confusion than clarity. The inevitable outcome is scientific separatism and specialist mythology, which spells death to universality. The predominance

of empiricism not only means the suppression of active thinking; it also imperils the building of theories in any branch of science. The dearth of general viewpoints, however, caters to the construction of mythical theories, just as much as does the absence of empirical criteria.

[517] I am therefore of the opinion that James' "tough-minded" and "tender-minded," as descriptive terms, are onesided and at bottom conceal a certain prejudice. Nevertheless, it should at least be clear from this discussion that his characterization deals with the same types which I have termed introverted and extraverted.

2. THE CHARACTERISTIC PAIRS OF OPPOSITES IN JAMES' TYPES

a. *Rationalism versus Empiricism*

[518] I have already discussed this pair of opposites in the preceding section, conceiving it as the opposition between idealism and empiricism. I avoided the term "rationalism" because concrete empirical thinking is just as "rational" as active ideological thinking. Both forms are governed by reason. Moreover, there is not only a logical rationalism but a rationalism of feeling, for rationalism as such is a general psychological attitude to the rationality of feeling as well as thought. Conceiving rationalism in this way, I find myself at odds with the historical and philosophical view which uses "rationalistic" in the sense of "ideological" and sees in rationalism the supremacy of the idea. Certainly modern philosophers have stripped reason of its purely ideal character and are fond of describing it as a faculty, a drive, an intention, even a feeling or, indeed, a method. At any rate, psychologically considered, it is a certain attitude governed, as Lipps says, by the "sense of objectivity." Baldwin regards it as the "constitutive, regulative principle of mind."⁶ Herbart conceives reason as "the capacity for reflection."⁷ Schopenhauer says it has only one function, the forming of concepts, and from this one function "all the above-mentioned manifestations of reason which distinguish the life of man from that of the brutes may easily be explained. The application or non-application of this function is all that is meant by what men have everywhere and always called rational or irrational."⁸ The "above-mentioned manifestations" refer to certain expressions of reason listed by Schopenhauer; they include "the control of the emotions and passions, the capacity for drawing conclusions and formulating general principles ... the united action of several individuals ... civilization, the state, also science, the storing up of experience," etc.⁹ If, as Schopenhauer asserts, it is the function of reason to form concepts, it must possess the character of a particular psychic attitude whose function it is to form concepts through the activity of thought. It is entirely in this sense of an attitude that Jerusalem¹⁰ conceives reason, as a disposition of the will which enables us to make use of reason in our decisions and to control our passions.

[519] Reason, therefore, is the capacity to be reasonable, a definite attitude that enables us to think, feel, and act in accordance with objective values. From the empirical standpoint these objective values are the product of experience, but from the ideological standpoint they are the result of a positive act of rational evaluation, which in the Kantian sense would be the

“capacity to judge and act in accordance with fundamental principles.” For Kant, reason is the source of the idea, which he defines as a “rational concept whose object is not to be found in experience,” and which contains the “archetype [*Urbild*] of all practical employment of reason ... a regulative principle for the sake of thorough consistency in our empirical use of the rational faculty.”¹¹ This is a genuinely introverted view, and it may be contrasted with the empirical view of Wundt, who declares that reason belongs to a group of complex intellectual functions which, with their “antecedent phases that give them an indispensable sensuous substrate,” are lumped together “in one general expression.”

It is self-evident that this concept “intellectual” is a survival from the old faculty psychology, and suffers, if possible, even more than such old concepts as memory, reason, fantasy, etc., from *confusion with logical points of view which have nothing to do with psychology*, so that the more various the psychic contents it embraces, the more indefinite and arbitrary it becomes. ... If, from the standpoint of scientific psychology, there is no such thing as memory, reason, or fantasy, but only *elementary psychic processes and their connections with one another*, which from lack of discrimination one lumps together under those names, still less can there be “intelligence” or “intellectual functions” in the sense of a homogeneous concept corresponding to some strictly delimited datum. Nevertheless there remain cases where it is useful to avail oneself of these concepts borrowed from the inventory of faculty psychology, even though using them in a sense modified by the psychological approach. Such cases arise when we encounter complex phenomena of very heterogeneous composition, phenomena that demand consideration on account of the regularity of their combination and above all on practical grounds; or when the individual consciousness presents certain definite trends in its disposition and structure; or when the regularity of the combination necessitates an analysis of such complex psychic dispositions. *But in all these cases it is naturally incumbent on psychological research not to remain rigidly dependent on the general concepts thus formed, but to reduce them whenever possible to their simple factors.*¹²

[520] Here speaks the extravert: I have italicized the passages that are specially characteristic. Whereas for the introvert “general concepts” like memory, reason, intelligence, etc. are “faculties,” i.e., simple basic functions that comprise the multitude of psychic processes governed by them, for the extraverted empiricist they are nothing but secondary, derivative concepts, elaborations of elementary processes which for him are far more important. No doubt from this standpoint such concepts are not to be circumvented, but in principle one should “reduce them whenever possible to their simple factors.” It is self-evident that for the empiricist anything except reductive thinking is simply out of the question, since for him general concepts are mere derivatives from experience. He recognizes no “rational concepts,” no *a priori* ideas, because his passive, apperceptive thinking is oriented by sense impressions. As a result of this attitude, the object is always emphasized; *it* is the agent prompting him to insights and complicated ratiocinations, and these require the existence of general concepts which merely serve to comprise certain groups of phenomena under a collective name. Thus the general concept naturally becomes a secondary factor, having no real existence apart from language.

[521] Science, therefore, can concede to reason, fantasy, etc. no right to independent existence as long as it maintains that the only things that really exist are elementary facts perceived by the senses. But when, as with the introvert, thinking is oriented by active apperception, reason, fantasy, and the rest acquire the value of basic functions, of faculties or activities operating from within, because for him the accent of value lies on the concept and not on the elementary processes covered and comprised by the concept. This type of thinking is synthetic from the start. It organizes the stuff of experience along the lines of the concept and uses it as a “filling” for ideas. Here the concept is the agent by virtue of its own inner potency, which seizes and shapes the experienced material. The extravert supposes that the source of this power is merely arbitrary choice, or else a premature generalizing of experiences which in themselves are limited. The introvert who is unconscious of the psychology of his own thought-processes, and who may even have adopted the vogue for empiricism as his guiding principle, is defenceless in the face of this reproach. But the reproach is nothing but a projection of the extravert’s psychology. For the active thinking type draws the energy for his thought-processes neither from arbitrary choice nor from experience, but from the idea, from the innate functional form which his introverted attitude has activated. He is not conscious of this source, since by reason of its *a priori* lack of content he can recognize the idea only after he has given shape to it, that is, from the form his thinking imposes on the data of experience. For the extravert, however, the object and the elementary process are important and indispensable because he unconsciously projects the idea into the object, and can reach the idea only through the accumulation and comparison of the empirical material. The two types are opposed in a remarkable way: the one shapes the material out of his own unconscious idea and thus comes to experience; the other lets himself be guided by the material which contains his unconscious projection and thus comes to the idea. There is something intrinsically irritating about this conflict of attitude, and, at bottom, it is the cause of the most heated and futile scientific discussions.

[522] I trust that the foregoing sufficiently illustrates my view that rationalism, i.e., the elevation of reason into a principle, is as much a characteristic of empiricism as of ideologism. Instead of ideologism, we might have used the term “idealism,” but the antithesis of this would be “materialism,” and we could hardly say that the opposite of the materialist is the ideologist. The history of philosophy shows that the materialist can just as often be ideological in his thinking, that is, when he does not think empirically, but starts with the general idea of matter.

b. *Intellectualism versus Sensationalism*

[523] Sensationalism connotes extreme empiricism. It postulates sense-experience as the sole and exclusive source of knowledge. The sensationalistic attitude is wholly oriented by objects of sense. James evidently means an intellectual rather than an aesthetic sensationalism, and for this reason “intellectualism” is not exactly an appropriate term for its opposite number. Psychologically speaking, intellectualism is an attitude that gives the main determining value to the intellect, to cognition on the conceptual level. But with such an attitude I can also be a sensationalist, for instance when my thinking is occupied with

concrete concepts all derived from sense-experience. For the same reason, the empiricist may be intellectualistic. Intellectualism and rationalism are employed promiscuously in philosophy, so in this case too one would have to use ideologism as the antithesis of sensationalism, in so far as the latter is, in essence, only an extreme empiricism.

c. *Idealism versus Materialism*

[524] One may have already begun to wonder whether by “sensationalism” James merely meant an extreme empiricism, i.e., an intellectual sensationalism as surmised above, or whether by “sensationalistic” he really meant “sensuous”—the quality pertaining to sensation as a function quite apart from the intellect. By “pertaining to sensation” I mean true sensuousness, not in the vulgar sense of *voluptas*, but a psychological attitude in which the orienting and determining factor is not so much the empathized object as the mere fact of sensory excitation. This attitude might also be described as reflexive, since the whole mentality depends on and culminates in sense-impressions. The object is neither cognized abstractly nor empathized, but exerts an effect by its very nature and existence, the subject being oriented exclusively by sense-impressions excited by the object. This attitude would correspond to a primitive mentality. Its antithesis and corollary is the intuitive attitude, which is distinguished by an immediate sensing or apprehension that depends neither on thinking nor on feeling but is an inseparable combination of both. Just as the object of sense *appears* before the perceiving subject, so the psychic content appears before the intuitive, as a quasi-hallucination.

[525] That James should describe the tough-minded as both “sensationalistic” and “materialistic” (and “irreligious” to boot) makes it even more doubtful whether he had in mind the same type antithesis that I have. Materialism, as commonly understood, is an attitude oriented by “material” values—in other words, a kind of moral sensationalism. Hence James’ characterization would present a very unfavourable picture if we were to impute to these terms their common meaning. This is certainly not what James intended, and his own words about the types should suffice to remove any such misunderstanding. We are probably not wrong in assuming that what he had in mind was chiefly the philosophical meaning of those terms. In this sense materialism is certainly an attitude oriented by material values, but these values are factual rather than sensuous, referring to objective and concrete reality. Its antithesis is idealism, in the philosophical sense of a supreme valuation of the idea. It cannot be a moral idealism that is meant here, for then we would have to assume, contrary to James’ intention, that by materialism he meant moral sensationalism. But if by materialism he meant an attitude oriented by factual values, we are once again in a position to find in this attitude the quality of extraversion, so that our doubts are dispelled. We have already seen that philosophical idealism corresponds to introverted ideologism. But moral idealism would not be especially characteristic of the introvert, for the materialist can be a moral idealist too.

d. *Optimism versus Pessimism*

[526] I doubt very much whether this well-known antithesis of human temperaments can be applied to James' types. Is the empirical thinking of Darwin also pessimistic, for instance? Certainly Darwin is a pessimist for one who has an idealistic view of the world and sees the other type through the lens of his unconsciously projected feelings. But this does not mean that the empiricist himself takes a pessimistic view of the world. Or again, to follow the Jamesian typology, can it be said that the thinker Schopenhauer, whose view of the world is purely idealistic (like the pure idealism of the Upanishads), is by any chance an optimist? Kant himself, an extremely pure introverted type, is as remote from either optimism or pessimism as any of the great empiricists.

[527] It seems to me, therefore, that this antithesis has nothing to do with James' types. There are optimistic introverts as well as optimistic extraverts, and both can be pessimists. But it is quite possible that James slipped into this error as a result of an unconscious projection. From the idealist standpoint, a materialistic or empirical or positivist view of the world seems utterly cheerless and is bound to be felt as pessimistic. But the same view of the world seems optimistic to the man who has put his faith in the god "Matter." For the idealist the materialistic view severs the vital nerve, because his main source of strength—active apperception and realization of the primordial images—is sapped. Such a view of the world must appear completely pessimistic to him, as it robs him of all hope of ever again seeing the eternal idea embodied in reality. A world composed only of facts means exile and everlasting homelessness. So when James equates the materialistic with the pessimistic point of view, we may infer that he personally is on the side of idealism—an inference that might easily be corroborated by numerous other traits from the life of this philosopher. This might also explain why the tough-minded are saddled with the three somewhat dubious epithets "sensationalistic," "materialistic," "irreligious." The inference is further corroborated by that passage in *Pragmatism* where James likens the mutual aversion of the two types to a meeting between Bostonian tourists and the inhabitants of Cripple Creek.¹³ It is a comparison hardly flattering to the other type, and it allows one to infer an emotional dislike which even a strong sense of justice could not entirely suppress. This little foible seems to me an amusing proof of the mutually irritating differences between the two types. It may seem rather petty to make such a point of these incompatibilities of feeling, but numerous experiences have convinced me that it is just such feelings as these, lurking in the background, that bias even the nicest reasoning and obstruct understanding. It is easy to imagine that the inhabitants of Cripple Creek might also view the Bostonian tourists with a jaundiced eye.

e. *Religiousness versus Irreligiousness*

[528] The validity of this antithesis naturally depends on the definition of religiousness. If James conceives it entirely from the idealist standpoint, as an attitude in which religious ideas (as opposed to feelings) play the dominant role, then he is certainly right to characterize the tough-minded as irreligious. But James' thought is so wide and so human that he can hardly have failed to see that a religious attitude can equally well be determined

by feeling. He himself says: “But our esteem for facts has not neutralized in us all religiousness. It is itself almost religious. Our scientific temper is devout.”¹⁴

[529] Instead of reverence for “eternal” ideas, the empiricist has an almost religious belief in facts. It makes no difference, psychologically, whether a man is oriented by the idea of God or by the idea of matter, or whether facts are exalted into the determinants of his attitude. Only when this orientation becomes absolute does it deserve the name “religious.” From such an exalted standpoint, facts are just as worthy of being absolutes as the idea, the primordial image, which is the imprint left on man’s psyche by his collision for millions of years with the hard facts of reality. At any rate, absolute surrender to facts can never be described as irreligious from the psychological point of view. The tough-minded indeed have their empiricistic religion, just as the tender-minded have an idealistic one. It is also a phenomenon of our present cultural epoch that science is dominated by the object and religion by the subject, i.e., by the subjective idea—for the idea had to take refuge somewhere after having been ousted from its place in science by the object. If religion is understood as a phenomenon of our culture in this sense, then James is right in describing the empiricist as irreligious, but only in this sense. For since philosophers are not a separate class of men, their types will also extend beyond the philosopher to all civilized humanity. On these general grounds it is surely not permissible to class half of civilized humanity as irreligious. We also know from the psychology of primitives that the religious function is an essential component of the psyche and is found always and everywhere, however undifferentiated it may be.

[530] In the absence of some such limitation of James’ concept of “religion,” we must once again assume that he was thrown off the rails by his emotions, as can happen all too easily.

f. *Indeterminism versus Determinism*

[531] This antithesis is very interesting psychologically. It stands to reason that the empiricist thinks causally, the necessary connection between cause and effect being taken as axiomatic. The empiricist is oriented by the empathized object; he is, as it were, “actuated” by the external fact and impressed with a sense of the necessity of effect following cause. It is psychologically quite natural that the impression of the inevitability of the causal connection should force itself on such an attitude. The identification of the inner psychic processes with external facts is implied from the start, because in the act of empathy a considerable sum of the subject’s activity, of his own life, is unconsciously invested in the object. The empathetic type is thereby assimilated to the object, although it feels as if the object were assimilated to him. But whenever the value of the object is emphasized, it at once assumes an importance which in its turn influences the subject, forcing him to a “dissimilation” from himself.¹⁵ Human psychology is chameleon-like, as the practising psychologist knows from daily experience. So whenever the object predominates, an assimilation to the object takes place. Identification with the love-object plays no small role in analytical psychology, and the psychology of primitives swarms with examples of dissimilation in favour of the totem animal or ancestral spirit. The stigmatization of saints in

medieval and even in recent times is a similar phenomenon. In the *imitatio Christi* dissimilation is exalted into a principle.

[532] In view of this undoubted capacity of the human psyche for dissimilation, the carrying over of objective causal connections into the subject can readily be understood. The psyche then labours under the impression of the exclusive validity of the causal principle, and the whole armoury of the theory of knowledge is needed to combat the overmastering power of this impression. This is further aggravated by the fact that the very nature of the empirical attitude prevents one from believing in inner freedom, since any proof, indeed any possibility of proof, is lacking. What use is that vague, indefinable feeling of freedom in face of the overwhelming mass of objective proofs to the contrary? The determinism of the empiricist, therefore, is a foregone conclusion, provided that he carries his thinking that far and does not prefer, as often happens, to live in two compartments—one for science, and the other for the religion he has taken over from his parents or from his surroundings.

[533] As we have seen, idealism consists essentially in an unconscious activation of the idea. This activation may be due to an aversion for empathy acquired later in life, or it may be present at birth as an *a priori* attitude fashioned and favoured by nature (in my practical experience I have seen many such cases). In this latter case the idea is active from the beginning, though, because of its lack of content and its irrepresentability, it does not appear in consciousness. Yet, as an invisible inner dominant, it gains ascendancy over all external facts and communicates a sense of its own autonomy and freedom to the subject, who, in consequence of his inner assimilation to the idea, feels independent and free in relation to the object. When the idea is the principal orienting factor, it assimilates the subject just as completely as the subject tries to assimilate the idea by shaping the stuff of experience. Thus, as in the case of his attitude to the object, the subject is dissimilated from himself, but this time in the reverse sense and in favour of the idea.

[534] The inherited primordial image outlives all time and change, preceding and superseding all individual experience. It must thus be charged with immense power. When it is activated, it communicates a distinct feeling of power to the subject by assimilating him to itself through his unconscious inner empathy. This would account for his feeling of independence, of freedom, and of living forever (cf. Kant's threefold postulate: God, freedom, and immortality). When the subject feels within him the sway of the idea over the reality of facts, the idea of freedom naturally forces itself upon him. If his idealism is unalloyed, he is bound to believe in free will.

[535] The antithesis here discussed is highly characteristic of our types. The extravert is distinguished by his craving for the object, by his empathy and identification with the object, his voluntary dependence on the object. He is influenced by the object in the same degree as he strives to assimilate it. The introvert is distinguished by his self-assertion vis-à-vis the object. He struggles against any dependence on the object, he repels all its influences, and even fears it. So much the more is he dependent on the idea, which shields him from external reality and gives him the feeling of inner freedom—though he pays for this with a very noticeable power psychology.

g. *Monism versus Pluralism*

[536] It follows from what we have already said that the idea-oriented attitude must tend towards monism. The idea always possesses an hierarchical character, no matter whether it is derived from a process of abstraction or exists *a priori* as an unconscious form. In the first case it is the apex of an edifice, so to speak, the terminal point that sums up everything that lies below it; in the second case it is the unconscious law-giver, regulating the possibilities and logical necessities of thought. In both cases the idea has a sovereign quality. Although a plurality of ideas may be present, one of them always succeeds in gaining the upper hand for a time and constellates the other psychic elements in a monarchic pattern. It is equally clear that the object-oriented attitude always tends towards a plurality of principles, because the multiplicity of objective qualities necessitates a plurality of concepts without which the nature of the object cannot be properly interpreted. The monistic tendency is a characteristic of introversion, the pluralistic of extraversion.

h. *Dogmatism versus Scepticism*

[537] It is easy to see in this case too that dogmatism is the attitude *par excellence* that clings to the idea, although an unconscious realization of the idea is not necessarily dogmatic. It is none the less true that the forceful way in which an unconscious idea realizes itself gives outsiders the impression that the idea-oriented thinker starts out with a dogma that squeezes experience into a rigid ideological mould. It is equally clear that the object-oriented thinker will be sceptical about all ideas from the start, since his primary concern is to let every object and every experience speak for itself, undisturbed by general concepts. In this sense scepticism is a necessary condition of all empiricism. Here we have another pair of opposites that confirms the essential similarity between James' types and my own.

3. GENERAL CRITICISM OF JAMES' TYPOLOGY

[538] In criticizing James' typology, I must first stress that it is almost exclusively concerned with the thinking qualities of the types. In a philosophical work one could hardly expect anything else. But the bias resulting from this philosophical setting easily leads to confusion. It would not be difficult to show that such and such a quality is equally characteristic of the opposite type, or even several of them. There are, for instance, empiricists who are dogmatic, religious, idealistic, intellectualistic, rationalistic, etc., just as there are ideologists who are materialistic, pessimistic, deterministic, irreligious, and so on. It is true, of course, that these terms cover extremely complex facts and that all sorts of subtle nuances have to be taken into account, but this still does not get rid of the possibility of confusion.

[539] Taken individually, the Jamesian terms are too *broad* and give an approximate picture of the type antithesis only when taken as a whole. Though they do not reduce it to a simple formula, they form a valuable supplement to the picture of the types we have gained from other sources. James deserves credit for being the first to draw attention to the extraordinary

importance of temperament in colouring philosophical thought. The whole purpose of his pragmatic approach is to reconcile the philosophical antagonisms resulting from temperamental differences.

[540] Pragmatism is a widely ramifying philosophical movement, deriving from English philosophy,¹⁶ which restricts the value of “truth” to its practical efficacy and usefulness, regardless of whether or not it may be contested from some other standpoint. It is characteristic of James to begin his exposition of pragmatism with this type antithesis, as if to demonstrate and justify the need for a pragmatic approach. Thus the drama already acted out in the Middle Ages is repeated. The antithesis at that time took the form of nominalism versus realism, and it was Abelard who attempted to reconcile the two in his “sermonism” or conceptualism. But since the psychological standpoint was completely lacking, his attempted solution was marred by its logical and intellectualistic bias. James dug deeper and grasped the conflict at its psychological root, coming up with a pragmatic solution. One should not, however, cherish any illusions about its value: pragmatism is but a makeshift, and it can claim validity only so long as no sources are discovered, other than intellectual capacities coloured by temperament, which might reveal new elements in the formation of philosophical concepts. Bergson, it is true, has drawn attention to the role of intuition and to the possibility of an “intuitive method,” but it remains a mere pointer. Any proof of the method is lacking and will not be easy to furnish, notwithstanding Bergson’s claim that his “*élan vital*” and “*durée créatrice*” are products of intuition. Aside from these intuitive concepts, which derive their psychological justification from the fact that they were current even in antiquity, particularly in Neoplatonism, Bergson’s method is not intuitive but intellectual. Nietzsche made far greater use of the intuitive source and in so doing freed himself from the bonds of the intellect in shaping his philosophical ideas—so much so that his intuition carried him outside the bounds of a purely philosophical system and led to the creation of a work of art which is largely inaccessible to philosophical criticism. I am speaking, of course, of *Zarathustra* and not of the collection of philosophical aphorisms, which are accessible to philosophical criticism because of their predominantly intellectual method. If one may speak of an intuitive method at all, *Zarathustra* is in my view the best example of it, and at the same time a vivid illustration of how the problem can be grasped in a non-intellectual and yet philosophical way. As forerunners of Nietzsche’s intuitive approach I would mention Schopenhauer and Hegel, the former because his intuitive feelings had such a decisive influence on his thinking, the latter because of the intuitive ideas that underlie his whole system. In both cases, however, intuition was subordinated to intellect, but with Nietzsche it ranked above it.

[541] The conflict between the two “truths” requires a pragmatic attitude if any sort of justice is to be done to the other standpoint. Yet, though it cannot be dispensed with, pragmatism presupposes too great a resignation and almost unavoidably leads to a drying up of creativeness. The solution of the conflict of opposites can come neither from the intellectual compromise of conceptualism nor from a pragmatic assessment of the practical value of logically irreconcilable views, but only from a positive act of creation which assimilates the opposites as necessary elements of co-ordination, in the same way as a co-ordinated

muscular movement depends on the innervation of opposing muscle groups. Pragmatism can be no more than a transitional attitude preparing the way for the creative act by removing prejudices. James and Bergson are signposts along the road which German philosophy—not of the academic sort—has already trodden. But it was really Nietzsche who, with a violence peculiarly his own, struck out on the path to the future. His creative act goes beyond the unsatisfying pragmatic solution just as fundamentally as pragmatism itself, in acknowledging the living value of a truth, transcended the barren one-sidedness and unconscious conceptualism of post-Abelardian philosophy—and still there are heights to be climbed.

IX

THE TYPE PROBLEM IN BIOGRAPHY

[542] As one might expect, biography too has its contribution to make to the problem of psychological types. For this we are indebted mainly to Wilhelm Ostwald, who, by comparing the biographies of a number of outstanding scientists, was able to establish a typical psychological pair of opposites which he termed the classic and romantic types.¹

Whereas the former is characterized by the all-round perfection of each of his works, and at the same time by a rather retiring disposition and a personality that has but little influence on his immediate surroundings, the romantic stands out by reason of just the opposite qualities. His peculiarity lies not so much in the perfection of each individual work as in the variety and striking originality of numerous works following one another in rapid succession, and in the direct and powerful influence he has upon his contemporaries.

It should also be emphasized that the speed of mental reaction is a decisive criterion for determining to which type a scientist belongs. Discoverers with rapid reactivity are romantics, those with slower reactions are classics.²

[543] The classic type is slow to produce, usually bringing forth the ripest fruit of his mind relatively late in life (p. 89). A never-failing characteristic of the classic type, according to Ostwald, is “the absolute need to stand unblemished in the public eye” (p. 94). As a compensation for his “lack of personal influence, the classic type is assured an all the more potent effect through his writings” (p. 100).

[544] There seem, however, to be limitations to this effect, as the following episode from the biography of Helmholtz testifies. *A propos* Helmholtz’s mathematical researches concerning the effects of induction shocks, his colleague Du Bois-Reymond wrote to the scientist: “You must—please don’t take this amiss—devote yourself much more carefully to the problem of abstracting yourself from your own scientific standpoint, and put yourself in the position of those who know nothing of what it is all about, or what it is you want to discuss.” To which Helmholtz replied: “This time I really did take pains with my paper, and I thought that at last I might be satisfied with it.” Ostwald comments: “He does not consider the reader’s point of view at all, because, true to his classic type, he is writing for himself, so that the presentation seems irreproachable to him, while to others it is not.” What Du Bois-Reymond says in the same letter to Helmholtz is entirely characteristic: “I read your

treatise and the summary several times without understanding what you have actually done, or the way you did it. ... Finally I discovered your method myself, and now I am gradually beginning to understand your paper.”³

[545] This is a thoroughly typical event in the life of the classic type who seldom or never succeeds in “setting like minds on fire with his own” (p. 100). It shows that the influence ascribed to him through his writings is as a rule posthumous, i.e., it appears after he has been disinterred from his works, as happened in the case of Robert Mayer. Moreover, his writings often seem unconvincing, uninspiring, lacking any direct personal appeal, because the way a man writes is, after all, just as much an expression of himself as the way he talks or lectures. Hence any influence the classic type exerts depends much less on the outwardly stimulating qualities of his writings than on the fact that these are all that finally remain of him, and that only from them can his achievement be reconstructed. It is also evident from Ostwald’s description that the classic type seldom communicates what he is doing and the way he does it, but only the final result, regardless of the fact that his public has no notion how he arrived at it. Evidently the way and the method of working are of little importance to him just because they are most intimately linked with his personality, which is something he always keeps in the background.

[546] Ostwald compares his two types with the four classical temperaments,⁴ with special reference to the speed of reaction, which in his view is fundamental. Slow reactions are correlated with phlegmatic and melancholic temperaments, quick reactions with the sanguine and the choleric. He regards the sanguine and the phlegmatic as the average types, whereas the choleric and the melancholic seem to him morbid exaggerations of the basic character.

[547] If one glances through the biographies of Humphry Davy and Liebig on the one hand, and Robert Mayer and Faraday on the other, it is easy to see that the former are distinctly romantic, sanguine, and choleric, while the latter are just as clearly classic, phlegmatic, and melancholic. This observation of Ostwald’s seems to me entirely convincing, since the doctrine of the four temperaments was in all probability based on the same empirical principles as Ostwald’s classic and romantic types. The four temperaments are obviously differentiations in terms of affectivity, that is, they are correlated with manifest affective reactions. But this is a superficial classification from the psychological point of view; it judges only by appearances. According to it, the man who is outwardly calm and inconspicuous in his behaviour has a phlegmatic temperament. He looks phlegmatic and is therefore classed as phlegmatic. In reality he may be anything but phlegmatic; he may have a profoundly sensitive, even passionate nature, his intense, introverted emotionality expressing itself through the greatest outward calm. Jordan, in his typology, takes this fact into account. He judges

not merely from the surface impression, but from a deeper observation of human nature. Ostwald's criteria of distinction are based on appearances, like the old division into temperaments. His romantic type is characterized by a quick outward reaction; the classic type may react just as quickly, but within.

[548] As one reads Ostwald's biographies, one can see at a glance that the romantic type corresponds to the extravert, and the classic type to the introvert. Humphry Davy and Liebig are perfect examples of the one, and Mayer and Faraday of the other. The outward reaction characterizes the extravert, just as the inward reaction is the mark of the introvert. The extravert has no especial difficulty in expressing himself; he makes his presence felt almost involuntarily, because his whole nature goes outwards to the object. He gives himself easily to the world in a form that is pleasing and acceptable, and it is always understandable even when it is unpleasing. Because of his quick reactivity and discharge of emotion, valuable and worthless psychic contents will be projected together into the object; he will react with winsome manners as well as with dour thoughts and affects. For the same reason these contents will have undergone little elaboration and are therefore easily understood; the quick succession of immediate reactions produces a series of images that show the public the path he has followed and the means by which he has attained his result.

[549] The introvert, on the other hand, who reacts almost entirely within, cannot as a rule discharge his reactions except in explosions of affect. He suppresses them, though they may be just as quick as those of the extravert. They do not appear on the surface, hence the introvert may easily give the impression of slowness. Since immediate reactions are always strongly personal, the extravert cannot help asserting his personality. But the introvert hides his personality by suppressing all his immediate reactions. Empathy is not his aim, nor the transference of contents to the object, but rather abstraction from the object. Instead of immediately discharging his reactions he prefers to elaborate them inwardly for a long time before finally coming out with the finished product. His constant endeavour is to strip the product of everything personal and to present it divested of all personal relationships. The matured fruit of prolonged inner labour, it emerges into the world in a highly abstract and depersonalized form. It is therefore difficult to understand, because the public lacks all knowledge of the preliminary stages and the way he attained his result. A personal relation to his public is also lacking, because the introvert in suppressing himself shrouds his personality from the public eye. But often enough it is just the personal relationship which brings about an understanding where mere intellectual apprehension fails. This must constantly be borne in mind when passing judgment on the introvert's development. As a rule one is badly informed about the introvert because his real self is not visible. His incapacity for immediate outward reaction

keeps his personality hidden. His life therefore affords ample scope for fantastic interpretations and projections should his achievements ever make him an object of general interest.

[550] So when Ostwald says that “early mental maturity” is characteristic of the romantic type, we must add that, though this is quite true, the classic type is just as capable of early maturity, but hides his products within himself, not intentionally of course, but from an incapacity for immediate expression. As a result of deficient differentiation of feeling, a certain awkwardness lingers on in the introvert, a real infantilism in his personal relations with other people. His outward personality is so uncertain and indefinite, and he himself is so sensitive in this respect, that he dares to appear before the public only with what in his own eyes is a perfect product. He prefers to let his work speak for him, instead of taking up the cudgels on its behalf. The natural result of such an attitude is a considerably delayed appearance on the world’s stage, so that it is easy to accuse him of late maturity. But this superficial judgment overlooks the fact that the infantilism of the apparently early matured and outwardly differentiated extravert is all internal, in his relation to his inner world. It only reveals itself later in life, in some moral immaturity or, as is often the case, in an astonishing infantilism of thought. As Ostwald observes, conditions for development and growth are more favourable for the romantic than for the classic type. His convincing appearance before the public and his outward reactions allow his personal importance to be immediately recognized. In this way many valuable relations are quickly built up which enrich his work and give it *breadth* (p. 374), whereas the other remains hidden and his lack of personal relations limits any extension of his field of work, though his activity gains in *depth* and his work has a lasting value.

[551] Both types are capable of *enthusiasm*. What fills the extravert’s heart flows out of his mouth, but the enthusiasm of the introvert is the very thing that seals his lips. He kindles no flame in others, and so he lacks colleagues of equal calibre. Even if he had any desire to impart his knowledge, his laconic manner of expression and the mystified incomprehension it produces are enough to deter him from further efforts at communication, and it frequently happens that no one believes he has anything out of the ordinary to say. His manner of expression, his “personality,” appear commonplace on a superficial view, whereas the romantic looks intrinsically “interesting” and understands the art of pandering to this impression by fair means or foul. His very glibness provides a suitable background for brilliant ideas and helps the public over the gaps in his thinking. The emphasis Ostwald lays on the successful academic careers of the romantics is therefore very much to the point. The romantic empathizes his students and knows the right word at the right moment. But the classic type is sunk in his own thoughts and problems and completely overlooks the difficulties his students have in understanding him. Ostwald says of Helmholtz:⁵

In spite of his prodigious learning, wide experience, and richly creative mind, he was never a good teacher. He never reacted on the instant, but only after a long time. Confronted by a student's question in the laboratory, he would promise to think it over, and only after several days would he bring the answer. This turned out to be so remote from the predicament of the student that only in the rarest cases could the latter see any connection between the difficulty he had experienced and the nicely rounded theory of a general problem subsequently expounded to him. Not only was the immediate help lacking on which every beginner largely relies, but also any guidance adapted to the student's own personality, that would have helped him to outgrow the natural dependence of the beginner and win to complete mastery of his subject. All these deficiencies are directly due to the teacher's inability to react instantaneously to the student's needs, so that, when the desired reaction does come, its effect is entirely lost.

[552] Ostwald's explanation in terms of the introvert's slowness to react does not seem to me sufficient. This is no sort of proof that Helmholtz possessed a slow reactivity. He merely reacted inwardly rather than outwardly. He had not empathized his student and so did not understand what he needed. His attitude was entirely directed to his own thoughts; consequently, he reacted not to the personal need of the student but to the thoughts which the student's question had aroused in himself, and he reacted so rapidly and thoroughly that he immediately perceived a further connection which, at that moment, he was incapable of evaluating and handing back in fully developed, abstract form. This was not because his thinking was too slow, but because it was impossible for him to grasp, all in a moment, the full extent of the problem he had divined. Not observing that the student had no inkling of any such problem, he naturally thought that this was what had to be dealt with, and not some extremely simple and trivial piece of advice which could have been given on the spot if only he had been able to see what the student needed in order to get on with his work. But, being an introvert, he had not empathized the other's psychology; his empathy had gone inwards to his own theoretical problems, and simply went on spinning the threads taken over from the student's problem while entirely ignoring his needs. From the academic standpoint, naturally, this peculiar attitude is highly unsuitable quite apart from the unfavourable impression it makes. The introverted teacher is to all appearances slow, somewhat eccentric, even thick-headed; because of this he is underestimated not only by the wider public but also by his own colleagues, until one day his thoughts are taken up and elaborated by other investigators.

[553] The mathematician Gauss had such a distaste for teaching that he used to inform each of his students that his course of lectures would probably not take place at all, hoping in this way to disembarass himself of the necessity of giving them. Teaching was repugnant to him because it meant having to "pronounce scientific results in his

lectures without first having checked and polished every word of the text. To be obliged to communicate his findings to others without such verification must have felt to him as though he were exhibiting himself before strangers in his nightshirt” (p. 380). Here Ostwald puts his finger on a very essential point we have already mentioned—the introvert’s dislike of anything other than entirely impersonal communications.

[554] Ostwald points out that the romantic is usually compelled to terminate his career comparatively early because of increasing exhaustion. This fact, also, Ostwald attributes to the greater speed of reaction. Since in my opinion the speed of mental reaction is still far from having been explained scientifically, and there is as yet no proof that outward reactions are quicker than inward ones, it seems to me that the earlier exhaustion of the extraverted discoverer must be essentially connected not so much with the speed of reaction as with the outward reactions peculiar to his type. He begins to publish very early, quickly makes a name for himself, and soon develops an intensive activity, both academically and as a writer; he cultivates personal relationships among a wide circle of friends and acquaintances and, in addition to all this, takes an unusual interest in the development of his pupils. The introverted pioneer begins to publish later; his works succeed one another at longer intervals, and are usually sparing in expression; repetitions of a theme are avoided unless something entirely new can be introduced into them. The pithy and laconic style of his scientific communications, frequently omitting all indications about the way he arrived at his results, prevents any general understanding or acceptance of his work, and so he remains unknown. His distaste for teaching does not bring him pupils; his lack of renown precludes relations with a large circle of acquaintances; as a rule he lives a retired life, not merely from necessity but also from choice. Thus he avoids the danger of expending himself too lavishly. His inward reactions draw him constantly back to the narrow path of his researches; these in themselves are very exacting, proving as time goes on to be so exhausting as to permit of no incidental expenditures on behalf of others. The situation is complicated by the fact that the public success of the romantic has an invigorating effect, but this is often denied to the classic type, who is therefore forced to seek his sole satisfaction in perfecting his research work. In the light of these considerations, the relatively premature exhaustion of the romantic genius, if demonstrable at all, seems to me to depend more on the outward reaction than on a quicker reactivity.

[555] Ostwald does not pretend that his type division is absolute in the sense that every investigator can be shown at once to belong to one type or the other. He is, however, of the opinion that the “really great men” can definitely be classed in one or the other category with respect to speed of reaction, while “average people” much more frequently occupy the middle range (pp. 372f.). In conclusion I would like to observe

that Ostwald's biographies contain material that has in part a very valuable bearing on the psychology of types, and strikingly exhibit the coincidence of the romantic with the extravert and the classic with the introvert.

X

GENERAL DESCRIPTION OF THE TYPES

1. INTRODUCTION

[556] In the following pages I shall attempt a general description of the psychology of the types, starting with the two basic types I have termed introverted and extraverted. This will be followed by a description of those more special types whose peculiarities are due to the fact that the individual adapts and orients himself chiefly by means of his most differentiated function. The former I would call *attitude-types*, distinguished by the direction of their interest, or of the movement of libido; the latter I would call *function-types*.

[557] The attitude-types, as I have repeatedly emphasized in the preceding chapters, are distinguished by their attitude to the object. The introvert's attitude is an abstracting one; at bottom, he is always intent on withdrawing libido from the object, as though he had to prevent the object from gaining power over him. The extravert, on the contrary, has a positive relation to the object. He affirms its importance to such an extent that his subjective attitude is constantly related to and oriented by the object. The object can never have enough value for him, and its importance must always be increased. The two types are so different and present such a striking contrast that their existence becomes quite obvious even to the layman once it has been pointed out. Everyone knows those reserved, inscrutable, rather shy people who form the strongest possible contrast to the open, sociable, jovial, or at least friendly and approachable characters who are on good terms with everybody, or quarrel with everybody, but always relate to them in some way and in turn are affected by them.

[558] One is naturally inclined, at first, to regard such differences as mere idiosyncrasies of character peculiar to individuals. But anyone with a thorough knowledge of human nature will soon discover that the contrast is by no means a matter of isolated individual instances but of typical attitudes which are far more common than one with limited psychological experience would assume. Indeed, as the preceding chapters may have shown, it is a fundamental contrast, sometimes quite clear, sometimes obscured, but always apparent when one is dealing with individuals whose personality is in any way pronounced. Such people are found not merely among the educated, but in all ranks of society, so that our types can be discovered among labourers and peasants no less than among the most highly differentiated members of a community. Sex makes no difference either; one finds the same

contrast among women of all classes. Such a widespread distribution could hardly have come about if it were merely a question of a conscious and deliberate choice of attitude. In that case, one would surely find one particular attitude in one particular class of people linked together by a common education and background and localized accordingly. But that is not so at all; on the contrary, the types seem to be distributed quite at random. In the same family one child is introverted, the other extraverted. Since the facts show that the attitude-type is a general phenomenon having an apparently random distribution, it cannot be a matter of conscious judgment or conscious intention, but must be due to some unconscious, instinctive cause. As a general psychological phenomenon, therefore, the type antithesis must have some kind of biological foundation.

[559] The relation between subject and object, biologically considered, is always one of adaptation, since every relation between subject and object presupposes the modification of one by the other through reciprocal influence. Adaptation consists in these constant modifications. The typical attitudes to the object, therefore, are processes of adaptation. There are in nature two fundamentally different modes of adaptation which ensure the continued existence of the living organism. The one consists in a high rate of fertility, with low powers of defence and short duration of life for the single individual; the other consists in equipping the individual with numerous means of self-preservation plus a low fertility rate. This biological difference, it seems to me, is not merely analogous to, but the actual foundation of, our two psychological modes of adaptation. I must content myself with this broad hint. It is sufficient to note that the peculiar nature of the extravert constantly urges him to expend and propagate himself in every way, while the tendency of the introvert is to defend himself against all demands from outside, to conserve his energy by withdrawing it from objects, thereby consolidating his own position. Blake's intuition did not err when he described the two classes of men as "prolific" and "devouring."¹ Just as, biologically, the two modes of adaptation work equally well and are successful in their own way, so too with the typical attitudes. The one achieves its end by a multiplicity of relationships, the other by monopoly.

[560] The fact that children often exhibit a typical attitude quite unmistakably even in their earliest years forces us to assume that it cannot be the struggle for existence in the ordinary sense that determines a particular attitude. It might be objected, cogently enough, that even the infant at the breast has to perform an unconscious act of psychological adaptation, in that the mother's influence leads to specific reactions in the child. This argument, while supported by incontestable evidence, becomes rather flimsy in face of the equally incontestable fact that two children of the same mother may exhibit contrary attitudes at an early age, though no change in the mother's attitude can be demonstrated. Although nothing would induce me to underrate the

incalculable importance of parental influence, this familiar experience compels me to conclude that the decisive factor must be looked for in the disposition of the child. Ultimately, it must be the individual disposition which decides whether the child will belong to this or that type despite the constancy of external conditions. Naturally I am thinking only of normal cases. Under abnormal conditions, i.e., when the mother's own attitude is extreme, a similar attitude can be forced on the children too, thus violating their individual disposition, which might have opted for another type if no abnormal external influences had intervened. As a rule, whenever such a falsification of type takes place as a result of parental influence, the individual becomes neurotic later, and can be cured only by developing the attitude consonant with his nature.

[561] As to the individual disposition, I have nothing to say except that there are obviously individuals who have a greater capacity, or to whom it is more congenial, to adapt in one way and not in another. It may well be that physiological causes of which we have no knowledge play a part in this. I do not think it improbable, in view of one's experience that a reversal of type often proves exceedingly harmful to the physiological well-being of the organism, usually causing acute exhaustion.

2. THE EXTRAVERTED TYPE

[562] In our description of this and the following types it is necessary, for the sake of clarity, to distinguish between the psychology of consciousness and the psychology of the unconscious. We shall first describe the phenomena of consciousness.

a. The General Attitude of Consciousness

[563] Although it is true that everyone orients himself in accordance with the data supplied by the outside world, we see every day that the data in themselves are only relatively decisive. The fact that it is cold outside prompts one man to put on his overcoat, while another, who wants to get hardened, finds this superfluous. One man admires the latest tenor because everybody else does, another refuses to do so, not because he dislikes him, but because in his view the subject of universal admiration is far from having been proved admirable. One man resigns himself to circumstances because experience has shown him that nothing else is possible, another is convinced that though things have gone the same way a thousand times before, the thousand and first time will be different. The one allows himself to be oriented by the given facts, the other holds in reserve a view which interposes itself between him and the objective data. Now, when orientation by the object predominates in such a way that decisions and actions are determined not by subjective views but by objective conditions, we speak of an extraverted attitude. When this is habitual, we speak of an

extraverted type. If a man thinks, feels, acts, and actually lives in a way that is *directly* correlated with the objective conditions and their demands, he is extraverted. His life makes it perfectly clear that it is the object and not this subjective view that plays the determining role in his consciousness. Naturally he has subjective views too, but their determining value is less than that of the objective conditions. Consequently, he never expects to find any absolute factors in his own inner life, since the only ones he knows are outside himself. Like Epimetheus, his inner life is subordinated to external necessity, though not without a struggle; but it is always the objective determinant that wins in the end. His whole consciousness looks outward, because the essential and decisive determination always comes from outside. But it comes from outside only because that is where he expects it to come from. All the peculiarities of his psychology, except those that depend on the primacy of one particular psychological function or on idiosyncrasies of character, follow from this basic attitude. His interest and attention are directed to objective happenings, particularly those in his immediate environment. Not only people but things seize and rivet his attention. Accordingly, they also determine his actions, which are fully explicable on those grounds. The actions of the extravert are recognizably related to external conditions. In so far as they are not merely reactive to environmental stimuli, they have a character that is always adapted to the actual circumstances, and they find sufficient play within the limits of the objective situation. No serious effort is made to transcend these bounds. It is the same with his interest: objective happenings have an almost inexhaustible fascination for him, so that ordinarily he never looks for anything else.

[564] The moral laws governing his actions coincide with the demands of society, that is, with the prevailing moral standpoint. If this were to change, the extravert's subjective moral guidelines would change accordingly, without this altering his general psychological habits in any way. This strict determination by objective factors does not mean, as one might suppose, a complete let alone ideal adaptation to the general conditions of life. In the eyes of the extravert, of course, an *adjustment* of this kind to the objective situation must seem like complete adaptation, since for him no other criterion exists. But from a higher point of view it by no means follows that the objective situation is in all circumstances a normal one. It can quite well be temporarily or locally abnormal. An individual who adjusts himself to it is admittedly conforming to the style of his environment, but together with his whole surroundings he is in an abnormal situation with respect to the universally valid laws of life. He may indeed thrive in such surroundings, but only up to the point where he and his milieu meet with disaster for transgressing these laws. He will share the general collapse to exactly the same extent as he was adjusted to the previous situation. Adjustment is not adaptation; adaptation requires far more than merely going along

smoothly with the conditions of the moment. (Once again I would remind the reader of Spitteler's Epimetheus.) It requires observance of laws more universal than the immediate conditions of time and place. The very adjustment of the normal extraverted type is his limitation. He owes his normality on the one hand to his ability to fit into existing conditions with comparative ease. His requirements are limited to the objectively possible, for instance to the career that holds out good prospects at this particular moment; he does what is needed of him, or what is expected of him, and refrains from all innovations that are not entirely self-evident or that in any way exceed the expectations of those around him. On the other hand, his normality must also depend essentially on whether he takes account of his subjective needs and requirements, and this is just his weak point, for the tendency of his type is so out-directed that even the most obvious of all subjective facts, the condition of his own body, receives scant attention. The body is not sufficiently objective or "outside," so that the satisfaction of elementary needs which are indispensable to physical well-being is no longer given its due. The body accordingly suffers, to say nothing of the psyche. The extravert is usually unaware of this latter fact, but it is all the more apparent to his household. He feels his loss of equilibrium only when it announces itself in abnormal body sensations. These he cannot ignore. It is quite natural that he should regard them as concrete and "objective," since with his type of mentality they cannot be anything else—for him. In others he at once sees "imagination" at work. A too extraverted attitude can also become so oblivious of the subject that the latter is sacrificed completely to so-called objective demands—to the demands, for instance, of a continually expanding business, because orders are piling up and profitable opportunities have to be exploited.

[565] This is the extravert's danger: he gets sucked into objects and completely loses himself in them. The resultant functional disorders, nervous or physical, have a compensatory value, as they force him into an involuntary self-restraint. Should the symptoms be functional, their peculiar character may express his psychological situation in symbolic form; for instance, a singer whose fame has risen to dangerous heights that tempt him to expend too much energy suddenly finds he cannot sing high notes because of some nervous inhibition. Or a man of modest beginnings who rapidly reaches a social position of great influence with wide prospects is suddenly afflicted with all the symptoms of a mountain sickness.² Again, a man about to marry a woman of doubtful character whom he adores and vastly overestimates is seized with a nervous spasm of the oesophagus and has to restrict himself to two cups of milk a day, each of which takes him three hours to consume. All visits to the adored are effectively stopped, and he has no choice but to devote himself to the nourishment of his body. Or a man who can no longer carry the weight of the huge

business he has built up is afflicted with nervous attacks of thirst and speedily falls a victim to hysterical alcoholism.

[566] Hysteria is, in my view, by far the most frequent neurosis of the extraverted type. The hallmark of classic hysteria is an exaggerated rapport with persons in the immediate environment and an adjustment to surrounding conditions that amounts to imitation. A constant tendency to make himself interesting and to produce an impression is a basic feature of the hysteric. The corollary of this is his proverbial suggestibility, his proneness to another person's influence. Another unmistakable sign of the extraverted hysteric is his effusiveness, which occasionally carries him into the realm of fantasy, so that he is accused of the "hysterical lie." The hysterical character begins as an exaggeration of the normal attitude; it is then complicated by compensatory reactions from the unconscious, which counteract the exaggerated extraversion by means of physical symptoms that force the libido to introvert. The reaction of the unconscious produces another class of symptoms having a more introverted character, one of the most typical being a morbid intensification of fantasy activity.

[567] After this general outline of the extraverted attitude we shall now turn to a description of the modifications which the basic psychological functions undergo as a result of this attitude.

b. The Attitude of the Unconscious

[568] It may perhaps seem odd that I should speak of an "attitude of the unconscious." As I have repeatedly indicated, I regard the attitude of the unconscious as compensatory to consciousness. According to this view, the unconscious has as good a claim to an "attitude" as the latter.

[569] In the preceding section I emphasized the tendency to one-sidedness in the extraverted attitude, due to the ascendancy of the object over the course of psychic events. The extraverted type is constantly tempted to expend himself for the apparent benefit of the object, to assimilate subject to object. I have discussed in some detail the harmful consequences of an exaggeration of the extraverted attitude, namely, the suppression of the subjective factor. It is only to be expected, therefore, that the psychic compensation of the conscious extraverted attitude will lay special weight on the subjective factor, and that we shall find a markedly egocentric tendency in the unconscious. Practical experience proves this to be the case. I do not wish to cite case material at this point, so must refer my readers to the ensuing sections, where I try to present the characteristic attitude of the unconscious in each function-type. In this section we are concerned simply with the compensation of the extraverted attitude in

general, so I shall confine myself to describing the attitude of the unconscious in equally general terms.

[570] The attitude of the unconscious as an effective complement to the conscious extraverted attitude has a definitely introverting character. It concentrates the libido on the subjective factor, that is, on all those needs and demands that are stifled or repressed by the conscious attitude. As may be gathered from what was said in the previous section, a purely objective orientation does violence to a multitude of subjective impulses, intentions, needs, and desires and deprives them of the libido that is their natural right. Man is not a machine that can be remodelled for quite other purposes as occasion demands, in the hope that it will go on functioning as regularly as before but in a quite different way. He carries his whole history with him; in his very structure is written the history of mankind. This historical element in man represents a vital need to which a wise psychic economy must respond. Somehow the past must come alive and participate in the present. Total assimilation to the object will always arouse the protest of the suppressed minority of those elements that belong to the past and have existed from the very beginning.

[571] From these general considerations it is easy to see why the unconscious demands of the extravert have an essentially primitive, infantile, egocentric character. When Freud says that the unconscious “can do nothing but wish” this is very largely true of the unconscious of the extravert. His adjustment to the objective situation and his assimilation to the object prevent low-powered subjective impulses from reaching consciousness. These impulses (thoughts, wishes, affects, needs, feelings, etc.) take on a regressive character according to the degree of repression; the less they are acknowledged, the more infantile and archaic they become. The conscious attitude robs them of all energy that is readily disposable, only leaving them the energy of which it cannot deprive them. This residue, which still possesses a potency not to be underestimated, can be described only as primordial instinct. Instinct can never be eradicated in an individual by arbitrary measures; it requires the slow, organic transformation of many generations to effect a radical change, for instinct is the energetic expression of the organism’s make-up.

[572] Thus with every repressed impulse a considerable amount of energy ultimately remains, of an instinctive character, and preserves its potency despite the deprivation that made it unconscious. The more complete the conscious attitude of extraversion is, the more infantile and archaic the unconscious attitude will be. The egoism which characterizes the extravert’s unconscious attitude goes far beyond mere childish selfishness; it verges on the ruthless and the brutal. Here we find in full flower the incest-wish described by Freud. It goes without saying that these things are entirely unconscious and remain hidden from the layman so long as the extraversion of the

conscious attitude is not extreme. But whenever it is exaggerated, the unconscious comes to light in symptomatic form; its egoism, infantilism, and archaism lose their original compensatory character and appear in more or less open opposition to the conscious attitude. This begins as an absurd exaggeration of conscious standpoint, aiming at a further repression of the unconscious, but usually it ends in a *reductio ad absurdum* of the conscious attitude and hence in catastrophe. The catastrophe may take an objective form, since the objective aims gradually become falsified by the subjective. I remember the case of a printer who, starting as a mere employee, worked his way up after years of hard struggle till at last he became the owner of a flourishing business. The more it expanded, the more it tightened its hold on him, until finally it swallowed up all his other interests. This proved his ruin. As an unconscious compensation of his exclusive interest in the business, certain memories of his childhood came to life. As a child he had taken great delight in painting and drawing. But instead of renewing this capacity for its own sake as a compensating hobby, he channelled it into his business and began wondering how he might embellish his products in an “artistic” way. Unfortunately his fantasies materialized: he actually turned out stuff that suited his own primitive and infantile taste, with the result that after a very few years his business went to pieces. He acted in accordance with one of our “cultural ideals,” which says that any enterprising person has to concentrate everything on the one aim in view. But he went too far, and merely fell a victim to the power of his infantile demands.

[573] The catastrophe can, however, also be subjective and take the form of a nervous breakdown. This invariably happens when the influence of the unconscious finally paralyzes all conscious action. The demands of the unconscious then force themselves imperiously on consciousness and bring about a disastrous split which shows itself in one of two ways: either the subject no longer knows what he really wants and nothing interests him, or he wants too much at once and has too many interests, but in impossible things. The suppression of infantile and primitive demands for cultural reasons easily leads to a neurosis or to the abuse of narcotics such as alcohol, morphine, cocaine, etc. In more extreme cases the split ends in suicide.

[574] It is an outstanding peculiarity of unconscious impulses that, when deprived of energy by lack of conscious recognition, they take on a destructive character, and this happens as soon as they cease to be compensatory. Their compensatory function ceases as soon as they reach a depth corresponding to a cultural level absolutely incompatible with our own. From this moment the unconscious impulses form a block in every way opposed to the conscious attitude, and its very existence leads to open conflict.

[575] Generally speaking, the compensating attitude of the unconscious finds expression in the maintenance of the psychic equilibrium. A normal extraverted attitude does not, of course, mean that the individual invariably behaves in accordance with the extraverted schema. Even in the same individual many psychological processes may be observed that involve the mechanism of introversion. We call a mode of behaviour extraverted only when the mechanism of extraversion predominates. In these cases the most differentiated function is always employed in an extraverted way, whereas the inferior functions are introverted; in other words, the superior function is the most conscious one and completely under conscious control, whereas the less differentiated functions are in part unconscious and far less under the control of consciousness. The superior function is always an expression of the conscious personality, of its aims, will, and general performance, whereas the less differentiated functions fall into the category of things that simply “happen” to one. These things need not be mere slips of the tongue or pen and other such oversights, they can equally well be half or three-quarters intended, for the less differentiated functions also possess a slight degree of consciousness. A classic example of this is the extraverted feeling type, who enjoys an excellent feeling rapport with the people around him, yet occasionally “happens” to express opinions of unsurpassable tactlessness. These opinions spring from his inferior and half-conscious thinking, which, being only partly under his control and insufficiently related to the object, can be quite ruthless in its effects.

[576] The less differentiated functions of the extravert always show a highly subjective colouring with pronounced egocentricity and personal bias, thus revealing their close connection with the unconscious. The unconscious is continually coming to light through them. It should not be imagined that the unconscious lies permanently buried under so many overlying strata that it can only be uncovered, so to speak, by a laborious process of excavation. On the contrary, there is a constant influx of unconscious contents into the conscious psychological process, to such a degree that at times it is hard for the observer to decide which character traits belong to the conscious and which to the unconscious personality. This difficulty is met with mainly in people who are given to express themselves more profusely than others. Naturally it also depends very largely on the attitude of the observer whether he seizes hold of the conscious or the unconscious character of the personality. Generally speaking, a judging observer will tend to seize on the conscious character, while a perceptive observer will be more influenced by the unconscious character, since judgment is chiefly concerned with the conscious motivation of the psychic process, while perception registers the process itself. But in so far as we apply judgment and perception in equal measure, it may easily happen that a personality appears to us as both introverted and extraverted, so that we cannot decide at first to

which attitude the superior function belongs. In such cases only a thorough analysis of the qualities of each function can help us to form a valid judgment. We must observe which function is completely under conscious control, and which functions have a haphazard and spontaneous character. The former is always more highly differentiated than the latter, which also possess infantile and primitive traits. Occasionally the superior function gives the impression of normality, while the others have something abnormal or pathological about them.

c. The Peculiarities of the Basic Psychological Functions in the Extraverted Attitude

Thinking

[577] As a consequence of the general attitude of extraversion, thinking is oriented by the object and objective data. This gives rise to a noticeable peculiarity. Thinking in general is fed on the one hand from subjective and in the last resort unconscious sources, and on the other hand from objective data transmitted by sense-perception. Extraverted thinking is conditioned in a larger measure by the latter than by the former. Judgment always presupposes a criterion; for the extraverted judgment, the criterion supplied by external conditions is the valid and determining one, no matter whether it be represented directly by an objective, perceptible fact or by an objective idea; for an objective idea is equally determined by external data or borrowed from outside even when it is subjectively sanctioned. Extraverted thinking, therefore, need not necessarily be purely concretistic thinking; it can just as well be purely ideal thinking, if for instance it can be shown that the ideas it operates with are largely borrowed from outside, i.e., have been transmitted by tradition and education. So in judging whether a particular thinking is extraverted or not we must first ask: by what criterion does it judge—does it come from outside, or is its origin subjective? A further criterion is the direction the thinking takes in drawing conclusions—whether it is principally directed outwards or not. It is no proof of its extraverted nature that it is preoccupied with concrete objects, since my thinking may be preoccupied with a concrete object either because I am abstracting my thought from it or because I am concretizing my thought through it. Even when my thinking is preoccupied with concrete things and could be described as extraverted to that extent, the direction it will take still remains an essential characteristic and an open question—namely, whether or not in its further course it leads back again to objective data, external facts, or generally accepted ideas. So far as the practical thinking of the business man, the technician, or the scientific investigator is concerned, its outer-directedness is obvious enough. But in the case of the philosopher it remains open to doubt when his thinking is directed to ideas. We then have to inquire whether these ideas are simply abstractions from objective experience, in which case they would represent

higher collective concepts comprising a sum of objective facts, or whether (if they are clearly not abstractions from immediate experience) they may not be derived from tradition or borrowed from the intellectual atmosphere of the time. In the latter case, they fall into the category of objective data, and accordingly this thinking should be called extraverted.

[578] Although I do not propose to discuss the nature of introverted thinking at this point, reserving it for a later section (pars. 628–31), it is essential that I should say a few words about it before proceeding further. For if one reflects on what I have just said about extraverted thinking, one might easily conclude that this covers everything that is ordinarily understood as thinking. A thinking that is directed neither to objective facts nor to general ideas, one might argue, scarcely deserves the name “thinking” at all. I am fully aware that our age and its most eminent representatives know and acknowledge only the extraverted type of thinking. This is largely because all the thinking that appears visibly on the surface in the form of science or philosophy or even art either derives directly from objects or else flows into general ideas. For both these reasons it appears essentially understandable, even though it may not always be self-evident, and it is therefore regarded as valid. In this sense it might be said that the extraverted intellect oriented by objective data is actually the only one that is recognized. But—and now I come to the question of the introverted intellect—there also exists an entirely different kind of thinking, to which the term “thinking” can hardly be denied: it is a kind that is oriented neither by immediate experience of objects nor by traditional ideas. I reach this other kind of thinking in the following manner: when my thoughts are preoccupied with a concrete object or a general idea, in such a way that the course of my thinking eventually leads me back to my starting-point, this intellectual process is not the only psychic process that is going on in me. I will disregard all those sensations and feelings which become noticeable as a more or less disturbing accompaniment to my train of thought, and will merely point out that this very thinking process which starts from the object and returns to the object also stands in a constant relation to the subject. This relation is a *sine qua non*, without which no thinking process whatsoever could take place. Even though my thinking process is directed, as far as possible, to objective data, it is still *my* subjective process, and it can neither avoid nor dispense with this admixture of subjectivity. Struggle as I may to give an objective orientation to my train of thought, I cannot shut out the parallel subjective process and its running accompaniment without extinguishing the very spark of life from my thought. This parallel process has a natural and hardly avoidable tendency to subjectify the objective data and assimilate them to the subject.

[579] Now when the main accent lies on the subjective process, that other kind of thinking arises which is opposed to extraverted thinking, namely, that purely

subjective orientation which I call introverted. This thinking is neither determined by objective data nor directed to them; it is a thinking that starts from the subject and is directed to subjective ideas or subjective facts. I do not wish to enter more fully into this kind of thinking here; I have merely established its existence as the necessary complement of extraverted thinking and brought it into clearer focus.

[580] Extraverted thinking, then, comes into existence only when the objective orientation predominates. This fact does nothing to alter the logic of thinking; it merely constitutes that difference between thinkers which James considered a matter of temperament. Orientation to the object, as already explained, makes no essential change in the thinking function; only its appearance is altered. It has the appearance of being captivated by the object, as though without the external orientation it simply could not exist. It almost seems as though it were a mere sequela of external facts, or as though it could reach its highest point only when flowing into some general idea. It seems to be constantly affected by the objective data and to draw conclusions only with their consent. Hence it gives one the impression of a certain lack of freedom, of occasional short-sightedness, in spite of all its adroitness within the area circumscribed by the object. What I am describing is simply the impression this sort of thinking makes on the observer, who must himself have a different standpoint, otherwise it would be impossible for him to observe the phenomenon of extraverted thinking at all. But because of his different standpoint he sees only its outward aspect, not its essence, whereas the thinker himself can apprehend its essence but not its outward aspect. Judging by appearances can never do justice to the essence of the thing, hence the verdict is in most cases depreciatory.

[581] In its essence this thinking is no less fruitful and creative than introverted thinking, it merely serves other ends. This difference becomes quite palpable when extraverted thinking appropriates material that is the special province of introverted thinking; when, for instance, a subjective conviction is explained analytically in terms of objective data or as being derived from objective ideas. For our scientific consciousness, however, the difference becomes even more obvious when introverted thinking attempts to bring objective data into connections not warranted by the object—in other words, to subordinate them to a subjective idea. Each type of thinking senses the other as an encroachment on its own province, and hence a sort of shadow effect is produced, each revealing to the other its least favourable aspect. Introverted thinking then appears as something quite arbitrary, while extraverted thinking seems dull and banal. Thus the two orientations are incessantly at war.

[582] One might think it easy enough to put an end to this conflict by making a clear distinction between objective and subjective data. Unfortunately, this is impossible, though not a few have attempted it. And even if it were possible it would be a

disastrous proceeding, since in themselves both orientations are one-sided and of limited validity, so that each needs the influence of the other. When objective data predominate over thinking to any great extent, thinking is sterilized, becoming a mere appendage of the object and no longer capable of abstracting itself into an independent concept. It is then reduced to a kind of “after-thought,” by which I do not mean “reflection” but a purely imitative thinking which affirms nothing beyond what was visibly and immediately present in the objective data in the first place. This thinking naturally leads directly back to the object, but never beyond it, not even to a linking of experience with an objective idea. Conversely, when it has an idea for an object, it is quite unable to experience its practical, individual value, but remains stuck in a more or less tautological position. The materialistic mentality is an instructive example of this.

[583] When extraverted thinking is subordinated to objective data as a result of over-determination by the object, it engrosses itself entirely in the individual experience and accumulates a mass of undigested empirical material. The oppressive weight of individual experiences having little or no connection with one another produces a dissociation of thought which usually requires psychological compensation. This must consist in some simple, general idea that gives coherence to the disordered whole, or at least affords the possibility of such. Ideas like “matter” or “energy” serve this purpose. But when the thinking depends primarily not on objective data but on some second-hand idea, the very poverty of this thinking is compensated by an all the more impressive accumulation of facts congregating round a narrow and sterile point of view, with the result that many valuable and meaningful aspects are completely lost sight of. Many of the allegedly scientific outpourings of our own day owe their existence to this wrong orientation.

The Extraverted Thinking Type

[584] It is a fact of experience that the basic psychological functions seldom or never all have the same strength or degree of development in the same individual. As a rule, one or the other function predominates, in both strength and development. When thinking holds prior place among the psychological functions, i.e., when the life of an individual is mainly governed by reflective thinking so that every important action proceeds, or is intended to proceed, from intellectually considered motives, we may fairly call this a thinking type. Such a type may be either introverted or extraverted. We will first discuss the extraverted thinking type.

[585] This type will, by definition, be a man whose constant endeavour—in so far, of course, as he is a pure type—is to make all his activities dependent on intellectual conclusions, which in the last resort are always oriented by objective data, whether these be external facts or generally accepted ideas. This type of man elevates

objective reality, or an objectively oriented intellectual formula, into the ruling principle not only for himself but for his whole environment. By this formula good and evil are measured, and beauty and ugliness determined. Everything that agrees with this formula is right, everything that contradicts it is wrong, and anything that passes by it indifferently is merely incidental. Because this formula seems to embody the entire meaning of life, it is made into a universal law which must be put into effect everywhere all the time, both individually and collectively. Just as the extraverted thinking type subordinates himself to his formula, so, for their own good, everybody round him must obey it too, for whoever refuses to obey it is wrong—he is resisting the universal law, and is therefore unreasonable, immoral, and without a conscience. His moral code forbids him to tolerate exceptions; his ideal must under all circumstances be realized, for in his eyes it is the purest conceivable formulation of objective reality, and therefore must also be a universally valid truth, quite indispensable for the salvation of mankind. This is not from any great love for his neighbour, but from the higher standpoint of justice and truth. Anything in his own nature that appears to invalidate this formula is a mere imperfection, an accidental failure, something to be eliminated on the next occasion, or, in the event of further failure, clearly pathological. If tolerance for the sick, the suffering, or the abnormal should chance to be an ingredient of the formula, special provisions will be made for humane societies, hospitals, prisons, missions, etc., or at least extensive plans will be drawn up. Generally the motive of justice and truth is not sufficient to ensure the actual execution of such projects; for this, real Christian charity is needed, and this has more to do with feeling than with any intellectual formula. “Oughts” and “musts” bulk large in this programme. If the formula is broad enough, this type may play a very useful role in social life as a reformer or public prosecutor or purifier of conscience, or as the propagator of important innovations. But the more rigid the formula, the more he develops into a martinet, a quibbler, and a prig, who would like to force himself and others into one mould. Here we have the two extremes between which the majority of these types move.

[586] In accordance with the nature of the extraverted attitude, the influence and activities of these personalities are the more favourable and beneficial the further from the centre their radius extends. Their best aspect is to be found at the periphery of their sphere of influence. The deeper we penetrate into their own power province, the more we feel the unfavourable effects of their tyranny. A quite different life pulses at the periphery, where the truth of the formula can be felt as a valuable adjunct to the rest. But the closer we come to centre of power where the formula operates, the more life withers away from everything that does not conform to its dictates. Usually it is the nearest relatives who have to taste the unpleasant consequences of the extraverted formula, since they are the first to receive its

relentless benefits. But in the end it is the subject himself who suffers most—and this brings us to the reverse side of the psychology of this type.

[587] The fact that an intellectual formula never has been and never will be devised which could embrace and express the manifold possibilities of life must lead to the inhibition or exclusion of other activities and ways of living that are just as important. In the first place, all those activities that are dependent on feeling will become repressed in such a type—for instance, aesthetic activities, taste, artistic sense, cultivation of friends, etc. Irrational phenomena such as religious experiences, passions, and suchlike are often repressed to the point of complete unconsciousness. Doubtless there are exceptional people who are able to sacrifice their entire life to a particular formula, but for most of us such exclusiveness is impossible in the long run. Sooner or later, depending on outer circumstances or inner disposition, the potentialities repressed by the intellectual attitude will make themselves indirectly felt by disturbing the conscious conduct of life. When the disturbance reaches a definite pitch, we speak of a neurosis. In most cases it does not go so far, because the individual instinctively allows himself extenuating modifications of his formula in a suitably rationalistic guise, thus creating a safety valve.

[588] The relative or total unconsciousness of the tendencies and functions excluded by the conscious attitude keeps them in an undeveloped state. In comparison with the conscious function they are inferior. To the extent that they are unconscious, they become merged with the rest of the unconscious contents and acquire a bizarre character. To the extent that they are conscious, they play only a secondary role, though one of considerable importance for the over-all psychological picture. The first function to be affected by the conscious inhibition is feeling, since it is the most opposed to the rigid intellectual formula and is therefore repressed the most intensely. No function can be entirely eliminated—it can only be greatly distorted. In so far as feeling is compliant and lets itself be subordinated, it has to support the conscious attitude and adapt to its aims. But this is possible only up to a point; part of it remains refractory and has to be repressed. If the repression is successful, the subliminal feeling then functions in a way that is opposed to the conscious aims, even producing effects whose cause is a complete enigma to the individual. For example, the conscious altruism of this type, which is often quite extraordinary, may be thwarted by a secret self-seeking which gives a selfish twist to actions that in themselves are disinterested. Purely ethical intentions may lead him into critical situations which sometimes have more than a semblance of being the outcome of motives far from ethical. There are guardians of public morals who suddenly find themselves in compromising situations, or rescue workers who are themselves in dire need of rescue. Their desire to save others leads them to employ means which are calculated to bring about the very thing they wished to avoid. There are extraverted idealists so

consumed by their desire for the salvation of mankind that they will not shrink from any lie or trickery in pursuit of their ideal. In science there are not a few painful examples of highly respected investigators who are so convinced of the truth and general validity of their formula that they have not scrupled to falsify evidence in its favour. Their sanction is: the end justifies the means. Only an inferior feeling function, operating unconsciously and in secret, could seduce otherwise reputable men into such aberrations.

[589] The inferiority of feeling in this type also manifests itself in other ways. In keeping with the objective formula, the conscious attitude becomes more or less impersonal, often to such a degree that personal interests suffer. If the attitude is extreme, all personal considerations are lost sight of, even those affecting the subject's own person. His health is neglected, his social position deteriorates, the most vital interests of his family—health, finances, morals—are violated for the sake of the ideal. Personal sympathy with others must in any case suffer unless they too happen to espouse the same ideal. Often the closest members of his family, his own children, know such a father only as a cruel tyrant, while the outside world resounds with the fame of his humanity. Because of the highly impersonal character of the conscious attitude, the unconscious feelings are extremely personal and oversensitive, giving rise to secret prejudices—a readiness, for instance, to misconstrue any opposition to his formula as personal ill-will, or a constant tendency to make negative assumptions about other people in order to invalidate their arguments in advance—in defence, naturally, of his own touchiness. His unconscious sensitivity makes him sharp in tone, acrimonious, aggressive. Insinuations multiply. His feelings have a sultry and resentful character—always a mark of the inferior function. Magnanimous as he may be in sacrificing himself to his intellectual goal, his feelings are petty, mistrustful, crotchety, and conservative. Anything new that is not already contained in his formula is seen through a veil of unconscious hatred and condemned accordingly. As late as the middle of the last century a certain doctor, famed for his humanitarianism, threatened to dismiss an assistant for daring to use a thermometer, because the formula decreed that temperature must be taken by the pulse.

[590] The more the feelings are repressed, the more deleterious is their secret influence on thinking that is otherwise beyond reproach. The intellectual formula, which because of its intrinsic value might justifiably claim general recognition, undergoes a characteristic alteration as a result of this unconscious personal sensitiveness: it becomes rigidly dogmatic. The self-assertion of the personality is transferred to the formula. Truth is no longer allowed to speak for itself; it is identified with the subject and treated like a sensitive darling whom an evil-minded critic has wronged. The critic is demolished, if possible with personal invective, and no argument is too gross

to be used against him. The truth must be trotted out, until finally it begins to dawn on the public that it is not so much a question of truth as of its personal begetter.

[591] The dogmatism of the intellectual formula sometimes undergoes further characteristic alterations, due not so much to the unconscious admixture of repressed personal feelings as to a contamination with other unconscious factors which have become fused with them. Although reason itself tells us that every intellectual formula can never be anything more than a partial truth and can never claim general validity, in practice the formula gains such an ascendancy that all other possible standpoints are thrust into the background. It usurps the place of all more general, less definite, more modest and therefore more truthful views of life. It even supplants that general view of life we call religion. Thus the formula becomes a religion, although in essentials it has not the slightest connection with anything religious. At the same time, it assumes the essentially religious quality of absoluteness. It becomes an intellectual superstition. But now all the psychological tendencies it has repressed build up a counter-position in the unconscious and give rise to paroxysms of doubt. The more it tries to fend off the doubt, the more fanatical the conscious attitude becomes, for fanaticism is nothing but over-compensated doubt. This development ultimately leads to an exaggerated defence of the conscious position and to the formation of a counter-position in the unconscious absolutely opposed to it; for instance, conscious rationalism is opposed by an extreme irrationality, and a scientific attitude by one that is archaic and superstitious. This explains those bigoted and ridiculous views well-known in the history of science which have proved stumbling-blocks to many an eminent investigator. Frequently the unconscious counter-position is embodied in a woman. In my experience this type is found chiefly among men, since, in general, thinking tends more often to be a dominant function in men than in women. When thinking dominates in a woman it is usually associated with a predominantly *intuitive* cast of mind.

[592] The thinking of the extraverted type is *positive*, i.e., productive. It leads to the discovery of new facts or to general conceptions based on disparate empirical material. It is usually synthetic too. Even when it analyses it constructs, because it is always advancing beyond the analysis to a new combination, to a further conception which reunites the analysed material in a different way or adds something to it. One could call this kind of judgment *predicative*. A characteristic feature, at any rate, is that it is never absolutely depreciative or destructive, since it always substitutes a fresh value for the one destroyed. This is because the thinking of this type is the main channel into which his vital energy flows. The steady flow of life manifests itself in his thinking, so that his thought has a progressive, creative quality. It is not stagnant or regressive. But it can become so if it fails to retain prior place in his consciousness. In that case it loses the quality of a positive, vital activity. It follows in

the wake of other functions and becomes Epimethean, plagued by afterthoughts, contenting itself with constant broodings on things past and gone, chewing them over in an effort to analyse and digest them. Since the creative element is now lodged in another function, thinking no longer progresses: it stagnates. Judgment takes on a distinct quality of *inherence*: it confines itself entirely to the range of the given material, nowhere overstepping it. It is satisfied with more or less abstract statements which do not impart any value to the material that is not already inherent in it. Such judgments are always oriented to the object, and they affirm nothing more about an experience than its objective and intrinsic meaning. We may easily observe this type of thinking in people who cannot refrain from tacking on to an impression or experience some rational and doubtless very valid remark which in no way ventures beyond the charmed circle of the objective datum. At bottom such a remark merely says: "I have understood it because afterwards I can think it." And there the matter ends. At best such a judgment amounts to no more than putting the experience in an objective setting, where it quite obviously belonged in the first place.

[593] But whenever a function other than thinking predominates in consciousness to any marked degree, thinking, so far as it is conscious at all and not directly dependent on the dominant function, assumes a negative character. If it is subordinated to the dominant function it may actually wear a positive aspect, but closer scrutiny will show that it simply mimics the dominant function, supporting it with arguments that clearly contradict the laws of logic proper to thinking. This kind of thinking is of no interest for our present discussion. Our concern is rather with the nature of a thinking which cannot subordinate itself to another function but remains true to its own principle. To observe and investigate this thinking is not easy, because it is more or less constantly repressed by the conscious attitude. Hence, in the majority of cases, it must first be retrieved from the background of consciousness, unless it should come to the surface accidentally in some unguarded moment. As a rule it has to be enticed with some such question as "Now what do you *really* think?" or "What is your private view of the matter?" Or perhaps one may have to use a little cunning, framing the question something like this: "What do you imagine, then, that *I* really think about it?" One should adopt this device when the real thinking is unconscious and therefore projected. The thinking that is enticed to the surface in this way has characteristic qualities, and it was these I had in mind when I described it as negative. Its habitual mode is best expressed by the two words "nothing but." Goethe personified this thinking in the figure of Mephistopheles. Above all it shows a distinct tendency to trace the object of its judgment back to some banality or other, thus stripping it of any significance in its own right. The trick is to make it appear dependent on something quite commonplace. Whenever a conflict arises between two men over something apparently objective and impersonal, negative thinking

mutters “Cherchez la femme.” Whenever somebody defends or advocates a cause, negative thinking never asks about its importance but simply: “What does *he* get out of it?” The dictum ascribed to Moleschott, “Der Mensch ist, was er isst” (man is what he eats, or, rendered more freely, what you eat you are), likewise comes under this heading, as do many other aphorisms I need not quote here.

[594] The destructive quality of this thinking, as well as its limited usefulness on occasion, does not need stressing. But there is still another form of negative thinking, which at first glance might not be recognized as such, and that is *theosophical* thinking, which today is rapidly spreading in all parts of the world, presumably in reaction to the materialism of the recent past. Theosophical thinking has an air that is not in the least reductive, since it exalts everything to a transcendental and world-embracing idea. A dream, for instance, is no longer just a dream, but an experience “on another plane.” The hitherto inexplicable fact of telepathy is very simply explained as “vibrations” passing from one person to another. An ordinary nervous complaint is explained by the fact that something has collided with the “astral body.” Certain ethnological peculiarities of the dwellers on the Atlantic seaboard are easily accounted for by the submergence of Atlantis, and so on. We have only to open a theosophical book to be overwhelmed by the realization that everything is already explained, and that “spiritual science” has left no enigmas unsolved. But, at bottom, this kind of thinking is just as negative as materialistic thinking. When the latter regards psychology as chemical changes in the ganglia or as the extrusion and retraction of cell-pseudopodia or as an internal secretion, this is just as much a superstition as theosophy. The only difference is that materialism reduces everything to physiology, whereas theosophy reduces everything to Indian metaphysics. When a dream is traced back to an overloaded stomach, this is no explanation of the dream, and when we explain telepathy as vibrations we have said just as little. For what are “vibrations”? Not only are both methods of explanation futile, they are actually destructive, because by diverting interest away from the main issue, in one case to the stomach and in the other to imaginary vibrations, they hamper any serious investigation of the problem by a bogus explanation. Either kind of thinking is sterile and sterilizing. Its negative quality is due to the fact that it is so indescribably cheap, impoverished, and lacking in creative energy. It is a thinking taken in tow by other functions.

Feeling

[595] Feeling in the extraverted attitude is likewise oriented by objective data, the object being the indispensable determinant of the quality of feeling. The extravert’s feeling is always in harmony with objective values. For anyone who has known feeling only as something subjective, the nature of extraverted feeling will be

difficult to grasp, because it has detached itself as much as possible from the subjective factor and subordinated itself entirely to the influence of the object. Even when it appears not to be qualified by a concrete object, it is none the less still under the spell of traditional or generally accepted values of some kind. I may feel moved, for instance, to say that something is “beautiful” or “good,” not because I find it “beautiful” or “good” from my own subjective feeling about it, but because it is fitting and politic to call it so, since a contrary judgment would upset the general feeling situation. A feeling judgment of this kind is not by any means a pretence or a lie, it is simply an act of adjustment. A painting, for instance, is called “beautiful” because a painting hung in a drawing room and bearing a well-known signature is generally assumed to be beautiful, or because to call it “hideous” would presumably offend the family of its fortunate possessor, or because the visitor wants to create a pleasant feeling atmosphere, for which purpose everything must be felt as agreeable. These feelings are governed by an objective criterion. As such they are genuine, and represent the feeling function as a whole.

[596] In precisely the same way as extraverted thinking strives to rid itself of subjective influences, extraverted feeling has to undergo a process of differentiation before it is finally denuded of every subjective trimming. The valuations resulting from the act of feeling either correspond directly with objective values or accord with traditional and generally accepted standards. This kind of feeling is very largely responsible for the fact that so many people flock to the theatre or to concerts, or go to church, and do so moreover with their feelings correctly adjusted. Fashions, too, owe their whole existence to it, and, what is far more valuable, the positive support of social, philanthropic, and other such cultural institutions. In these matters extraverted feeling proves itself a creative factor. Without it, a harmonious social life would be impossible. To that extent extraverted feeling is just as beneficial and sweetly reasonable in its effects as extraverted thinking. But these salutary effects are lost as soon as the object gains ascendancy. The force of extraverted feeling then pulls the personality into the object, the object assimilates him, whereupon the personal quality of the feeling, which constitutes its chief charm, disappears. It becomes cold, “unfeeling,” untrustworthy. It has ulterior motives, or at least makes an impartial observer suspect them. It no longer makes that agreeable and refreshing impression which invariably accompanies genuine feeling; instead, one suspects a pose, or that the person is acting, even though he may be quite unconscious of any egocentric motives. Over-extraverted feeling may satisfy aesthetic expectations, but it does not speak to the heart; it appeals merely to the senses or—worse still—only to reason. It can provide the aesthetic padding for a situation, but there it stops, and beyond that its effect is nil. It has become sterile. If this process goes any further, a curiously contradictory dissociation of feeling results: everything becomes an object of feeling

valuations, and innumerable relationships are entered into which are all at variance with each other. As this situation would become quite impossible if the subject received anything like due emphasis, even the last vestiges of a real personal standpoint are suppressed. The subject becomes so enmeshed in the network of individual feeling processes that to the observer it seems as though there were merely a feeling process and no longer a subject of feeling. Feeling in this state has lost all human warmth; it gives the impression of being put on, fickle, unreliable, and in the worst cases hysterical.

The Extraverted Feeling Type

[597] As feeling is undeniably a more obvious characteristic of feminine psychology than thinking, the most pronounced feeling types are to be found among women. When extraverted feeling predominates we speak of an extraverted feeling type. Examples of this type that I can call to mind are, almost without exception, women. The woman of this type follows her feeling as a guide throughout life. As a result of upbringing her feeling has developed into an adjusted function subject to conscious control. Except in extreme cases, her feeling has a personal quality, even though she may have repressed the subjective factor to a large extent. Her personality appears adjusted in relation to external conditions. Her feelings harmonize with objective situations and general values. This is seen nowhere more clearly than in her love choice: the “suitable” man is loved, and no one else; he is suitable not because he appeals to her hidden subjective nature—about which she usually knows nothing—but because he comes up to all reasonable expectations in the matter of age, position, income, size and respectability of his family, etc. One could easily reject such a picture as ironical or cynical, but I am fully convinced that the love feeling of this type of woman is in perfect accord with her choice. It is genuine and not just shrewd. There are countless “reasonable” marriages of this kind and they are by no means the worst. These women are good companions and excellent mothers so long as the husbands and children are blessed with the conventional psychic constitution.

[598] But one can feel “correctly” only when feeling is not disturbed by anything else. Nothing disturbs feeling so much as thinking. It is therefore understandable that in this type thinking will be kept in abeyance as much as possible. This does not mean that the woman does not think at all; on the contrary, she may think a great deal and very cleverly, but her thinking is never *sui generis*—it is an Epimethean appendage to her feeling. What she cannot feel, she cannot consciously think. “But I can’t think what I don’t feel,” such a type said to me once in indignant tones. So far as her feeling allows, she can think very well, but every conclusion, however logical, that might lead to a disturbance of feeling is rejected at the outset. It is simply not

thought. Thus everything that fits in with objective values is good, and is loved, and everything else seems to her to exist in a world apart.

[599] But a change comes over the picture when the importance of the object reaches a still higher level. As already explained, the subject then becomes so assimilated to the object that the subject of feeling is completely engulfed. Feeling loses its personal quality, and becomes feeling for its own sake; the personality seems wholly dissolved in the feeling of the moment. But since actual life is a constant succession of situations that evoke different and even contradictory feelings, the personality gets split up into as many different feeling states. At one moment one is this, at another something quite different—to all appearances, for in reality such a multiple personality is impossible. The basis of the ego always remains the same and consequently finds itself at odds with the changing feeling states. To the observer, therefore, the display of feeling no longer appears as a personal expression of the subject but as an alteration of the ego—a mood, in other words. Depending on the degree of dissociation between the ego and the momentary state of feeling, signs of self-disunity will become clearly apparent, because the originally compensatory attitude of the unconscious has turned into open opposition. This shows itself first of all in extravagant displays of feeling, gushing talk, loud expostulations, etc., which ring hollow: “The lady doth protest too much.” It is at once apparent that some kind of resistance is being over-compensated, and one begins to wonder whether these demonstrations might not turn out quite different. And a little later they do. Only a very slight alteration in the situation is needed to call forth at once just the opposite pronouncement on the selfsame object. As a result of these experiences the observer is unable to take either pronouncement seriously. He begins to reserve judgment. But since, for this type, it is of the highest importance to establish an intense feeling of rapport with the environment, redoubled efforts are now required to overcome this reserve. Thus, in the manner of a vicious circle, the situation goes from bad to worse. The stronger the feeling relation to the object, the more the unconscious opposition comes to the surface.

[600] We have already seen that the extraverted feeling type suppresses thinking most of all because this is the function most liable to disturb feeling. For the same reason, thinking totally shuts out feeling if ever it wants to reach any kind of pure results, for nothing is more liable to prejudice and falsify thinking than feeling values. But, as I have said, though the thinking of the extraverted feeling type is repressed as an independent function, the repression is not complete; it is repressed only so far as its inexorable logic drives it to conclusions that are incompatible with feeling. It is suffered to exist as a servant of feeling, or rather as its slave. Its backbone is broken; it may not operate on its own account, in accordance with its own laws. But since logic nevertheless exists and enforces its inexorable conclusions, this must take place

somewhere, and it takes place outside consciousness, namely in the unconscious. Accordingly the unconscious of this type contains first and foremost a peculiar kind of thinking, a thinking that is infantile, archaic, negative. So long as the conscious feeling preserves its personal quality, or, to put it another way, so long as the personality is not swallowed up in successive states of feeling, this unconscious thinking remains compensatory. But as soon as the personality is dissociated and dissolves into a succession of contradictory feeling states, the identity of the ego is lost and the subject lapses into the unconscious. When this happens, it gets associated with the unconscious thinking processes and occasionally helps them to the surface. The stronger the conscious feeling is and the more ego-less it becomes, the stronger grows the unconscious opposition. The unconscious thoughts gravitate round just the most valued objects and mercilessly strip them of their value. The “nothing but” type of thinking comes into its own here, since it effectively depotentiates all feelings that are bound to the object. The unconscious thinking reaches the surface in the form of obsessive ideas which are invariably of a negative and depreciatory character. Women of this type have moments when the most hideous thoughts fasten on the very objects most valued by their feelings. This negative thinking utilizes every infantile prejudice or comparison for the deliberate purpose of casting aspersions on the feeling value, and musters every primitive instinct in the attempt to come out with “nothing but” interpretations. It need hardly be remarked that this procedure also mobilizes the collective unconscious and activates its store of primordial images, thus bringing with it the possibility of a regeneration of attitude on a different basis. Hysteria, with the characteristic infantile sexuality of its unconscious world of ideas, is the principal form of neurosis in this type.

Summary of the Extraverted Rational Types

[601] I call the two preceding types rational or judging types because they are characterized by the supremacy of the reasoning and judging functions. It is a general distinguishing mark of both types that their life is, to a great extent, subordinated to rational judgment. But we have to consider whether by “rational” we are speaking from the standpoint of the individual’s subjective psychology or from that of the observer, who perceives and judges from without. This observer could easily arrive at a contrary judgment, especially if he intuitively apprehended merely the outward behaviour of the person observed and judged accordingly. On the whole, the life of this type is never dependent on rational judgment alone; it is influenced in almost equal degree by unconscious irrationality. If observation is restricted to outward behaviour, without any concern for the internal economy of the individual’s consciousness, one may get an even stronger impression of the irrational and fortuitous nature of certain unconscious manifestations than of the reasonableness of his conscious intentions and motivations. I therefore base my judgment on what the

individual feels to be his conscious psychology. But I am willing to grant that one could equally well conceive and present such a psychology from precisely the opposite angle. I am also convinced that, had I myself chanced to possess a different psychology, I would have described the rational types in the reverse way, from the standpoint of the unconscious—as irrational, therefore. This aggravates the difficulty of a lucid presentation of psychological matters and immeasurably increases the possibility of misunderstandings. The arguments provoked by these misunderstandings are, as a rule, quite hopeless because each side is speaking at cross purposes. This experience is one reason the more for basing my presentation on the conscious psychology of the individual, since there at least we have a definite objective footing, which completely drops away the moment we try to base our psychological rationale on the unconscious. For in that case the observed object would have no voice in the matter at all, because there is nothing about which he is more uninformed than his own unconscious. The judgment is then left entirely to the subjective observer—a sure guarantee that it will be based on his own individual psychology, which would be forcibly imposed on the observed. To my mind, this is the case with the psychologies of both Freud and Adler. The individual is completely at the mercy of the judging observer, which can never be the case when the conscious psychology of the observed is accepted as a basis. He after all is the only competent judge, since he alone knows his conscious motives.

[602] The rationality that characterizes the conscious conduct of life in both these types involves a deliberate exclusion of everything irrational and accidental. Rational judgment, in such a psychology, is a force that coerces the untidiness and fortuitousness of life into a definite pattern, or at least tries to do so. A definite choice is made from among all the possibilities it offers, only the rational ones being accepted; but on the other hand the independence and influence of the psychic functions which aid the perception of life's happenings are consequently restricted. Naturally this restriction of sensation and intuition is not absolute. These functions exist as before, but their products are subject to the choice made by rational judgment. It is not the intensity of a sensation as such that decides action, for instance, but judgment. Thus, in a sense, the functions of perception share the same fate as feeling in the case of the first type, or thinking in that of the second. They are relatively repressed, and therefore in an inferior state of differentiation. This gives a peculiar stamp to the unconscious of both our types: what they consciously and intentionally do accords with reason (*their* reason, of course), but what happens to them accords with the nature of infantile, primitive sensations and intuitions. At all events, what happens to these types is irrational (from their standpoint). But since there are vast numbers of people whose lives consist more of what happens to them than of actions governed by rational intentions, such a person, after observing them

closely, might easily describe both our types as irrational. And one has to admit that only too often a man's unconscious makes a far stronger impression on an observer than his consciousness does, and that his actions are of considerably more importance than his rational intentions.

[603] The rationality of both types is object-oriented and dependent on objective data. It accords with what is collectively considered to be rational. For them, nothing is rational save what is generally considered as such. Reason, however, is in large part subjective and individual. In our types this part is repressed, and increasingly so as the object gains in importance. Both the subject and his subjective reason, therefore, are in constant danger of repression, and when they succumb to it they fall under the tyranny of the unconscious, which in this case possesses very unpleasant qualities. Of its peculiar thinking we have already spoken. But, besides that, there are primitive sensations that express themselves compulsively, for instance in the form of compulsive pleasure-seeking in every conceivable form; there are also primitive intuitions that can become a positive torture to the person concerned and to everybody in his vicinity. Everything that is unpleasant and painful, everything that is disgusting, hateful, and evil, is sniffed out or suspected, and in most cases it is a half-truth calculated to provoke misunderstandings of the most poisonous kind. The antagonistic unconscious elements are so strong that they frequently disrupt the conscious rule of reason; the individual becomes the victim of chance happenings, which exercise a compulsive influence over him either because they pander to his sensations or because he intuits their unconscious significance.

Sensation

[604] Sensation, in the extraverted attitude, is pre-eminently conditioned by the object. As sense perception, sensation is naturally dependent on objects. But, just as naturally, it is also dependent on the subject, for which reason there is subjective sensation of a kind entirely different from objective sensation. In the extraverted attitude the subjective component of sensation, so far as its conscious application is concerned, is either inhibited or repressed. Similarly, as an irrational function, sensation is largely repressed when thinking or feeling holds prior place; that is to say, it is a conscious function only to the extent that the rational attitude of consciousness permits accidental perceptions to become conscious contents—in a word, registers them. The sensory function is, of course, absolute in the stricter sense; everything is seen or heard, for instance, to the physiological limit, but not everything attains the threshold value a perception must have in order to be apperceived. It is different when sensation itself is paramount instead of merely seconding another function. In this case no element of objective sensation is excluded and nothing is repressed (except the subjective component already mentioned).

[605] As sensation is chiefly conditioned by the object, those objects that excite the strongest sensations will be decisive for the individual's psychology. The result is a strong sensuous tie to the object. Sensation is therefore a vital function equipped with the strongest vital instinct. Objects are valued in so far as they excite sensations, and, so far as lies within the power of sensation, they are fully accepted into consciousness whether they are compatible with rational judgments or not. The sole criterion of their value is the intensity of the sensation produced by their objective qualities. Accordingly, all objective processes which excite any sensations at all make their appearance in consciousness. However, it is only concrete, sensuously perceived objects or processes that excite sensations for the extravert; those, exclusively, which everyone everywhere would sense as concrete. Hence the orientation of such an individual accords with purely sensuous reality. The judging, rational functions are subordinated to the concrete facts of sensation, and thus have all the qualities of the less differentiated functions, exhibiting negative, infantile, and archaic traits. The function most repressed is naturally the opposite of sensation—intuition, the function of unconscious perception.

The Extraverted Sensation Type

[606] No other human type can equal the extraverted sensation type in realism. His sense for objective facts is extraordinarily developed. His life is an accumulation of actual experiences of concrete objects, and the more pronounced his type, the less use does he make of his experience. In certain cases the events in his life hardly deserve the name "experience" at all. What he experiences serves at most as a guide to fresh sensations; anything new that comes within his range of interest is acquired by way of sensation and has to serve its ends. Since one is inclined to regard a highly developed reality-sense as a sign of rationality, such people will be esteemed as very rational. But in actual fact this is not the case, since they are just as much at the mercy of their sensations in the face of irrational, chance happenings as they are in the face of rational ones. This type—the majority appear to be men—naturally does not think he is at the "mercy" of sensation. He would ridicule this view as quite beside the point, because sensation for him is a concrete expression of life—it is simply real life lived to the full. His whole aim is concrete enjoyment, and his morality is oriented accordingly. Indeed, true enjoyment has its own special morality, its own moderation and lawfulness, its own unselfishness and willingness to make sacrifices. It by no means follows that he is just sensual or gross, for he may differentiate his sensation to the finest pitch of aesthetic purity without ever deviating from his principle of concrete sensation however abstract his sensations may be. Wulfen's *Der Genussmensch: ein Cicerone im rücksichtslosen Lebensgenuss*³ is the unvarnished confession of a type of this sort, and the book seems to me worth reading on that account alone.

[607] On the lower levels, this type is the lover of tangible reality, with little inclination for reflection and no desire to dominate. To feel the object, to have sensations and if possible enjoy them—that is his constant aim. He is by no means unlovable; on the contrary, his lively capacity for enjoyment makes him very good company; he is usually a jolly fellow, and sometimes a refined aesthete. In the former case the great problems of life hang on a good or indifferent dinner; in the latter, it's all a question of good taste. Once an object has given him a sensation, nothing more remains to be said or done about it. It cannot be anything except concrete and real; conjectures that go beyond the concrete are admitted only on condition that they enhance sensation. The intensification does not necessarily have to be pleasurable, for this type need not be a common voluptuary; he is merely desirous of the strongest sensations, and these, by his very nature, he can receive only from outside. What comes from inside seems to him morbid and suspect. He always reduces his thoughts and feelings to objective causes, to influences emanating from objects, quite unperturbed by the most glaring violations of logic. Once he can get back to tangible reality in any form he can breathe again. In this respect he is surprisingly credulous. He will unhesitatingly connect a psychogenic symptom with a drop in the barometer, while on the other hand the existence of a psychic conflict seems to him morbid imagination. His love is unquestionably rooted in the physical attractions of its object. If normal, he is conspicuously well adjusted to reality. That is his ideal, and it even makes him considerate of others. As he has no ideals connected with ideas, he has no reason to act in any way contrary to the reality of things as they are. This manifests itself in all the externals of his life. He dresses well, as befits the occasion; he keeps a good table with plenty of drink for his friends, making them feel very grand, or at least giving them to understand that his refined taste entitles him to make a few demands of them. He may even convince them that certain sacrifices are decidedly worth while for the sake of style.

[608] The more sensation predominates, however, so that the subject disappears behind the sensation, the less agreeable does this type become. He develops into a crude pleasure-seeker, or else degenerates into an unscrupulous, effete aesthete. Although the object has become quite indispensable to him, yet, as something existing in its own right, it is none the less devalued. It is ruthlessly exploited and squeezed dry, since now its sole use is to stimulate sensation. The bondage to the object is carried to the extreme limit. In consequence, the unconscious is forced out of its compensatory role into open opposition. Above all, the repressed intuitions begin to assert themselves in the form of projections. The wildest suspicions arise; if the object is a sexual one, jealous fantasies and anxiety states gain the upper hand. More acute cases develop every sort of phobia, and, in particular, compulsion symptoms. The pathological contents have a markedly unreal character, with a frequent moral or

religious streak. A pettifogging captiousness follows, or a grotesquely punctilious morality combined with primitive, “magical” superstitions that fall back on abstruse rites. All these things have their source in the repressed inferior functions which have been driven into harsh opposition to the conscious attitude, and they appear in a guise that is all the more striking because they rest on the most absurd assumptions, in complete contrast to the conscious sense of reality. The whole structure of thought and feeling seems, in this second personality, to be twisted into a pathological parody: reason turns into hair-splitting pedantry, morality into dreary moralizing and blatant Pharisaism, religion into ridiculous superstition, and intuition, the noblest gift of man, into meddlesome officiousness, poking into every corner; instead of gazing into the far distance, it descends to the lowest level of human meanness.

[609] The specifically compulsive character of the neurotic symptoms is the unconscious counterpart of the easy-going attitude of the pure sensation type, who, from the standpoint of rational judgment, accepts indiscriminately everything that happens. Although this does not by any means imply an absolute lawlessness and lack of restraint, it nevertheless deprives him of the essential restraining power of judgment. But rational judgment is a conscious coercion which the rational type appears to impose on himself of his own free will. This coercion overtakes the sensation type from the unconscious, in the form of compulsion. Moreover, the very existence of a judgment means that the rational type’s relation to the object will never become an absolute tie, as it is in the case of the sensation type. When his attitude attains an abnormal degree of one-sidedness, therefore, he is in danger of being overpowered by the unconscious in the same measure as he is consciously in the grip of the object. If he should become neurotic, it is much harder to treat him by rational means because the functions which the analyst must turn to are in a relatively undifferentiated state, and little or no reliance can be placed on them. Special techniques for bringing emotional pressure to bear are often needed in order to make him at all conscious.

Intuition

[610] In the extraverted attitude, intuition as the function of unconscious perception is wholly directed to external objects. Because intuition is in the main an unconscious process, its nature is very difficult to grasp. The intuitive function is represented in consciousness by an attitude of expectancy, by vision and penetration; but only from the subsequent result can it be established how much of what was “seen” was actually in the object, and how much was “read into” it. Just as sensation, when it is the dominant function, is not a mere reactive process of no further significance for the object, but an activity that seizes and shapes its object, so intuition is not mere perception, or vision, but an active, creative process that puts into the object just as

much as it takes out. Since it does this unconsciously, it also has an unconscious effect on the object.

[611] The primary function of intuition, however, is simply to transmit images, or perceptions of relations between things, which could not be transmitted by the other functions or only in a very roundabout way. These images have the value of specific insights which have a decisive influence on action whenever intuition is given priority. In this case, psychic adaptation will be grounded almost entirely on intuitions. Thinking, feeling, and sensation are then largely repressed, sensation being the one most affected, because, as the conscious sense function, it offers the greatest obstacle to intuition. Sensation is a hindrance to clear, unbiased, naïve perception; its intrusive sensory stimuli direct attention to the physical surface, to the very things round and beyond which intuition tries to peer. But since extraverted intuition is directed predominantly to objects, it actually comes very close to sensation; indeed, the expectant attitude to external objects is just as likely to make use of sensation. Hence, if intuition is to function properly, sensation must to a large extent be suppressed. By sensation I mean in this instance the simple and immediate sense-impression understood as a clearly defined physiological and psychic datum. This must be expressly established beforehand because, if I ask an intuitive how he orients himself, he will speak of things that are almost indistinguishable from sense-impressions. Very often he will even use the word “sensation.” He does have sensations, of course, but he is not guided by them as such; he uses them merely as starting-points for his perceptions. He selects them by unconscious predilection. It is not the strongest sensation, in the physiological sense, that is accorded the chief value, but any sensation whatsoever whose value is enhanced by the intuitive’s unconscious attitude. In this way it may eventually come to acquire the chief value, and to his conscious mind it appears to be pure sensation. But actually it is not so.

[612] Just as extraverted sensation strives to reach the highest pitch of actuality, because this alone can give the appearance of a full life, so intuition tries to apprehend the widest range of *possibilities*, since only through envisioning possibilities is intuition fully satisfied. It seeks to discover what possibilities the objective situation holds in store; hence, as a subordinate function (i.e., when not in the position of priority), it is the auxiliary that automatically comes into play when no other function can find a way out of a hopelessly blocked situation. When it is the dominant function, every ordinary situation in life seems like a locked room which intuition has to open. It is constantly seeking fresh outlets and new possibilities in external life. In a very short time every existing situation becomes a prison for the intuitive, a chain that has to be broken. For a time objects appear to have an exaggerated value, if they should serve to bring about a solution, a deliverance, or lead to the discovery of a new possibility. Yet no sooner have they served their

purpose as stepping-stones or bridges than they lose their value altogether and are discarded as burdensome appendages. Facts are acknowledged only if they open new possibilities of advancing beyond them and delivering the individual from their power. Nascent possibilities are compelling motives from which intuition cannot escape and to which all else must be sacrificed.

The Extraverted Intuitive Type

[613] Whenever intuition predominates, a peculiar and unmistakable psychology results. Because extraverted intuition is oriented by the object, there is a marked dependence on external situations, but it is altogether different from the dependence of the sensation type. The intuitive is never to be found in the world of accepted reality-values, but he has a keen nose for anything new and in the making. Because he is always seeking out new possibilities, stable conditions suffocate him. He seizes on new objects or situations with great intensity, sometimes with extraordinary enthusiasm, only to abandon them cold-bloodedly, without any compunction and apparently without remembering them, as soon as their range is known and no further developments can be divined. So long as a new possibility is in the offing, the intuitive is bound to it with the shackles of fate. It is as though his whole life vanished in the new situation. One gets the impression, which he himself shares, that he has always just reached a final turning-point, and that from now on he can think and feel nothing else. No matter how reasonable and suitable it may be, and although every conceivable argument speaks for its stability, a day will come when nothing will deter him from regarding as a prison the very situation that seemed to promise him freedom and deliverance, and from acting accordingly. Neither reason nor feeling can restrain him or frighten him away from a new possibility, even though it goes against all his previous convictions. Thinking and feeling, the indispensable components of conviction, are his inferior functions, carrying no weight and hence incapable of effectively withstanding the power of intuition. And yet these functions are the only ones that could compensate its supremacy by supplying the *judgment* which the intuitive type totally lacks. The intuitive's morality is governed neither by thinking nor by feeling; he has his own characteristic morality, which consists in a loyalty to his vision and in voluntary submission to its authority. Consideration for the welfare of others is weak. Their psychic well-being counts as little with him as does his own. He has equally little regard for their convictions and way of life, and on this account he is often put down as an immoral and unscrupulous adventurer. Since his intuition is concerned with externals and with ferreting out their possibilities, he readily turns to professions in which he can exploit these capacities to the full. Many business tycoons, entrepreneurs, speculators, stockbrokers, politicians, etc., belong to this type. It would seem to be more common among women, however, than among men. In women the intuitive capacity shows itself not

so much in the professional as in the social sphere. Such women understand the art of exploiting every social occasion, they make the right social connections, they seek out men with prospects only to abandon everything again for the sake of a new possibility.

[614] It goes without saying that such a type is uncommonly important both economically and culturally. If his intentions are good, i.e., if his attitude is not too egocentric, he can render exceptional service as the initiator or promoter of new enterprises. He is the natural champion of all minorities with a future. Because he is able, when oriented more to people than things, to make an intuitive diagnosis of their abilities and potentialities, he can also “make” men. His capacity to inspire courage or to kindle enthusiasm for anything new is unrivalled, although he may already have dropped it by the morrow. The stronger his intuition, the more his ego becomes fused with all the possibilities he envisions. He brings his vision to life, he presents it convincingly and with dramatic fire, he embodies it, so to speak. But this is not play-acting, it is a kind of fate.

[615] Naturally this attitude holds great dangers, for all too easily the intuitive may fritter away his life on things and people, spreading about him an abundance of life which others live and not he himself. If only he could stay put, he would reap the fruits of his labours; but always he must be running after a new possibility, quitting his newly planted fields while others gather in the harvest. In the end he goes away empty. But when the intuitive lets things come to such a pass, he also has his own unconscious against him. The unconscious of the intuitive bears some resemblance to that of the sensation type. Thinking and feeling, being largely repressed, come up with infantile, archaic thoughts and feelings similar to those of the countertype. They take the form of intense projections which are just as absurd as his, though they seem to lack the “magical” character of the latter and are chiefly concerned with quasi-realities such as sexual suspicions, financial hazards, forebodings of illness, etc. The difference seems to be due to the repression of real sensations. These make themselves felt when, for instance, the intuitive suddenly finds himself entangled with a highly unsuitable woman—or, in the case of a woman, with an unsuitable man—because these persons have stirred up the archaic sensations. This leads to an unconscious, compulsive tie which bodes nobody any good. Cases of this kind are themselves symptomatic of compulsion, to which the intuitive is as prone as the sensation type. He claims a similar freedom and exemption from restraint, submitting his decisions to no rational judgment and relying entirely on his nose for the possibilities that chance throws in his way. He exempts himself from the restrictions of reason only to fall victim to neurotic compulsions in the form of over-subtle ratiocinations, hairsplitting dialectics, and a compulsive tie to the sensation aroused by the object. His conscious attitude towards both sensation and object is one of

ruthless superiority. Not that he means to be ruthless or superior—he simply does not see the object that everyone else sees and rides roughshod over it, just as the sensation type has no eyes for its soul. But sooner or later the object takes revenge in the form of compulsive hypochondriacal ideas, phobias, and every imaginable kind of absurd bodily sensation.

Summary of the Extraverted Irrational Types

[616] I call the two preceding types irrational for the reasons previously discussed, namely that whatever they do or do not do is based not on rational judgment but on the sheer intensity of perception. Their perception is directed simply and solely to events as they happen, no selection being made by judgment. In this respect they have a decided advantage over the two judging types. Objective events both conform to law and are accidental. In so far as they conform to law, they are accessible to reason; in so far as they are accidental, they are not. Conversely, we might also say that an event conforms to law when it presents an aspect accessible to reason, and that when it presents an aspect for which we can find no law we call it accidental. The postulate of universal lawfulness is a postulate of reason alone, but in no sense is it a postulate of our perceptive functions. Since these are in no way based on the principle of reason and its postulates, they are by their very nature irrational. That is why I call the perception types “irrational” by nature. But merely because they subordinate judgment to perception, it would be quite wrong to regard them as “unreasonable.” It would be truer to say that they are in the highest degree *empirical*. They base themselves exclusively on experience—so exclusively that, as a rule, their judgment cannot keep pace with their experience. But the judging functions are none the less present, although they eke out a largely unconscious existence. Since the unconscious, in spite of its separation from the conscious subject, is always appearing on the scene, we notice in the actual life of the irrational types striking judgments and acts of choice, but they take the form of apparent sophistries, cold-hearted criticisms, and a seemingly calculating choice of persons and situations. These traits have a rather infantile and even primitive character; both types can on occasion be astonishingly naïve, as well as ruthless, brusque, and violent. To the rational types the real character of these people might well appear rationalistic and calculating in the worst sense. But this judgment would be valid only for their unconscious, and therefore quite incorrect for their conscious psychology, which is entirely oriented by perception, and because of its irrational nature is quite unintelligible to any rational judgment. To the rational mind it might even seem that such a hodge-podge of accidentals hardly deserves the name “psychology” at all. The irrational type ripostes with an equally contemptuous opinion of his opposite number: he sees him as something only half alive, whose sole aim is to fasten the fetters of reason on

everything living and strangle it with judgments. These are crass extremes, but they nevertheless occur.

[617] From the standpoint of the rational type, the other might easily be represented as an inferior kind of rationalist—when, that is to say, he is judged by what happens to him. For what happens to him is not accidental—here he is the master—instead, the accidents that befall him take the form of rational judgments and rational intentions, and these are the things he stumbles over. To the rational mind this is something almost unthinkable, but its unthinkableness merely equals the astonishment of the irrational type when he comes up against someone who puts rational ideas above actual and living happenings. Such a thing seems to him scarcely credible. As a rule it is quite hopeless to discuss these things with him as questions of principle, for all rational communication is just as alien and repellent to him as it would be unthinkable for the rationalist to enter into a contract without mutual consultation and obligation.

[618] This brings me to the problem of the psychic relationship between the two types. Following the terminology of the French school of hypnotists, psychic relationship is known in modern psychiatry as “rapport.” Rapport consists essentially in a feeling of agreement in spite of acknowledged differences. Indeed, the recognition of existing differences, if it be mutual, is itself a rapport, a feeling of agreement. If in a given case we make this feeling conscious to a higher degree than usual, we discover that it is not just a feeling whose nature cannot be analysed further, but at the same time an insight or a content of cognition which presents the point of agreement in conceptual form. This rational presentation is valid only for the rational types, but not for the irrational, whose rapport is based not on judgment but on the parallelism of living events. His feeling of agreement comes from the common perception of a sensation or intuition. The rational type would say that rapport with the irrational depends purely on chance. If, by some accident, the objective situations are exactly in tune, something like a human relationship takes place, but nobody can tell how valid it is or how long it will last. To the rational type it is often a painful thought that the relationship will last just as long as external circumstances and chance provide a common interest. This does not seem to him particularly human, whereas it is precisely in this that the irrational type sees a human situation of particular beauty. The result is that each regards the other as a man destitute of relationships, who cannot be relied upon, and with whom one can never get on decent terms. This unhappy outcome, however, is reached only when one makes a conscious effort to assess the nature of one’s relationships with others. But since this kind of psychological conscientiousness is not very common, it frequently happens that despite an absolute difference of standpoint a rapport nevertheless comes about, and in the following way: one party, by unspoken projection, assumes that the other is, in

all essentials, of the same opinion as himself, while the other divines or senses an objective community of interest, of which, however, the former has no conscious inkling and whose existence he would at once dispute, just as it would never occur to the other that his relationship should be based on a common point of view. A rapport of this kind is by far the most frequent; it rests on mutual projection, which later becomes the source of many misunderstandings.

[619] Psychic relationship, in the extraverted attitude, is always governed by objective factors and external determinants. What a man is within himself is never of any decisive significance. For our present-day culture the extraverted attitude to the problem of human relationships is the principle that counts; naturally the introverted principle occurs too, but it is still the exception and has to appeal to the tolerance of the age.

3. THE INTROVERTED TYPE

a. The General Attitude of Consciousness

[620] As I have already explained in the previous section, the introvert is distinguished from the extravert by the fact that he does not, like the latter, orient himself by the object and by objective data, but by subjective factors. I also mentioned⁴ that the introvert interposes a subjective view between the perception of the object and his own action, which prevents the action from assuming a character that fits the objective situation. Naturally this is a special instance, mentioned by way of example and intended to serve only as a simple illustration. We must now attempt a formulation on a broader basis.

[621] Although the introverted consciousness is naturally aware of external conditions, it selects the subjective determinants as the decisive ones. It is therefore oriented by the factor in perception and cognition which responds to the sense stimulus in accordance with the individual's subjective disposition. For example, two people see the same object, but they never see it in such a way that the images they receive are absolutely identical. Quite apart from the variable acuteness of the sense organs and the personal equation, there often exists a radical difference, both in kind and in degree, in the psychic assimilation of the perceptual image. Whereas the extravert continually appeals to what comes to him from the object, the introvert relies principally on what the sense impression constellates in the subject. The difference in the case of a single apperception may, of course, be very delicate, but in the total psychic economy it makes itself felt in the highest degree, particularly in the effect it has on the ego. If I may anticipate, I consider the viewpoint which inclines, with Weininger, to describe the introverted attitude as philautic, autoerotic, egocentric,

subjectivistic, egotistic, etc., to be misleading in principle and thoroughly depreciatory. It reflects the normal bias of the extraverted attitude in regard to the nature of the introvert. We must not forget—although the extravert is only too prone to do so—that perception and cognition are not purely objective, but are also subjectively conditioned. The world exists not merely in itself, but also as it appears to me. Indeed, at bottom, we have absolutely no criterion that could help us to form a judgment of a world which was unassimilable by the subject. If we were to ignore the subjective factor, it would be a complete denial of the great doubt as to the possibility of absolute cognition. And this would mean a relapse into the stale and hollow positivism that marred the turn of the century—an attitude of intellectual arrogance accompanied by crudeness of feeling, a violation of life as stupid as it is presumptuous. By overvaluing our capacity for objective cognition we repress the importance of the subjective factor, which simply means a denial of the subject. But what is the subject? The subject is man himself—we are the subject. Only a sick mind could forget that cognition must have a subject, and that there is no knowledge whatever and therefore no world at all unless “I know” has been said, though with this statement one has already expressed the subjective limitation of all knowledge.

[622] This applies to all the psychic functions: they have a subject which is just as indispensable as the object. It is characteristic of our present extraverted sense of values that the word “subjective” usually sounds like a reproof; at all events the epithet “merely subjective” is brandished like a weapon over the head of anyone who is not boundlessly convinced of the absolute superiority of the object. We must therefore be quite clear as to what “subjective” means in this inquiry. By the subjective factor I understand that psychological action or reaction which merges with the effect produced by the object and so gives rise to a new psychic datum. In so far as the subjective factor has, from the earliest times and among all peoples, remained in large measure constant, elementary perceptions and cognitions being almost universally the same, it is a reality that is just as firmly established as the external object. If this were not so, any sort of permanent and essentially unchanging reality would be simply inconceivable, and any understanding of the past would be impossible. In this sense, therefore, the subjective factor is as ineluctable a datum as the extent of the sea and the radius of the earth. By the same token, the subjective factor has all the value of a co-determinant of the world we live in, a factor that can on no account be left out of our calculations. It is another universal law, and whoever bases himself on it has a foundation as secure, as permanent, and as valid as the man who relies on the object. But just as the object and objective data do not remain permanently the same, being perishable and subject to chance, so too the subjective factor is subject to variation and individual hazards. For this reason its value is also merely relative. That is to say, the excessive development of the introverted

standpoint does not lead to a better and sounder use of the subjective factor, but rather to an artificial subjectivizing of consciousness which can hardly escape the reproach “merely subjective.” This is then counterbalanced by a de-subjectivization which takes the form of an exaggerated extraverted attitude, an attitude aptly described by Weininger as “misautic.” But since the introverted attitude is based on the ever-present, extremely real, and absolutely indispensable fact of psychic adaptation, expressions like “philautic,” “egocentric,” and so on are out of place and objectionable because they arouse the prejudice that it is always a question of the beloved ego. Nothing could be more mistaken than such an assumption. Yet one is continually meeting it in the judgments of the extravert on the introvert. Not, of course, that I wish to ascribe this error to individual extraverts; it is rather to be put down to the generally accepted extraverted view which is by no means restricted to the extraverted type, for it has just as many representatives among introverts, very much to their own detriment. The reproach of being untrue to their own nature can justly be levelled at the latter, whereas this at least cannot be held against the former.

[623] The introverted attitude is normally oriented by the psychic structure, which is in principle hereditary and is inborn in the subject. This must not be assumed, however, to be simply identical with the subject’s ego, as is implied by the above designations of Weininger; it is rather the psychic structure of the subject prior to any ego-development. The really fundamental subject, the self, is far more comprehensive than the ego, since the former includes the unconscious whereas the latter is essentially the focal point of consciousness. Were the ego identical with the self, it would be inconceivable how we could sometimes see ourselves in dreams in quite different forms and with entirely different meanings. But it is a characteristic peculiarity of the introvert, which is as much in keeping with his own inclination as with the general bias, to confuse his ego with the self, and to exalt it as the subject of the psychic process, thus bringing about the aforementioned subjectivization of consciousness which alienates him from the object.

[624] The psychic structure is the same as what Semon calls “mneme”⁵ and what I call the “collective unconscious.” The individual self is a portion or segment or representative of something present in all living creatures, an exponent of the specific mode of psychological behaviour, which varies from species to species and is inborn in each of its members. The inborn mode of *acting* has long been known as *instinct*, and for the inborn mode of psychic apprehension I have proposed the term *archetype*.⁶ I may assume that what is understood by instinct is familiar to everyone. It is another matter with the archetype. What I understand by it is identical with the “primordial image,” a term borrowed from Jacob Burckhardt,⁷ and I describe it as such in the Definitions that conclude this book. I must here refer the reader to the definition “Image.”⁸

[625] The archetype is a symbolic formula which always begins to function when there are no conscious ideas present, or when conscious ideas are inhibited for internal or external reasons. The contents of the collective unconscious are represented in consciousness in the form of pronounced preferences and definite ways of looking at things. These subjective tendencies and views are generally regarded by the individual as being determined by the object—incorrectly, since they have their source in the unconscious structure of the psyche and are merely released by the effect of the object. They are stronger than the object's influence, their psychic value is higher, so that they superimpose themselves on all impressions. Thus, just as it seems incomprehensible to the introvert that the object should always be the decisive factor, it remains an enigma to the extravert how a subjective standpoint can be superior to the objective situation. He inevitably comes to the conclusion that the introvert is either a conceited egoist or crack-brained bigot. Today he would be suspected of harbouring an unconscious power-complex. The introvert certainly lays himself open to these suspicions, for his positive, highly generalizing manner of expression, which appears to rule out every other opinion from the start, lends countenance to all the extravert's prejudices. Moreover the inflexibility of his subjective judgment, setting itself above all objective data, is sufficient in itself to create the impression of marked egocentricity. Faced with this prejudice the introvert is usually at a loss for the right argument, for he is quite unaware of the unconscious but generally quite valid assumptions on which his subjective judgment and his subjective perceptions are based. In the fashion of the times he looks outside for an answer, instead of seeking it behind his own consciousness. Should he become neurotic, it is the sign of an almost complete identity of the ego with the self; the importance of the self is reduced to nil, while the ego is inflated beyond measure. The whole world-creating force of the subjective factor becomes concentrated in the ego, producing a boundless power-complex and a fatuous egocentricity. Every psychology which reduces the essence of man to the unconscious power drive springs from this kind of disposition. Many of Nietzsche's lapses in taste, for example, are due to this subjectivization of consciousness.

b. The Attitude of the Unconscious

[626] The predominance of the subjective factor in consciousness naturally involves a devaluation of the object. The object is not given the importance that belongs to it by right. Just as it plays too great a role in the extraverted attitude, it has too little meaning for the introvert. To the extent that his consciousness is subjectivized and excessive importance attached to the ego, the object is put in a position which in the end becomes untenable. The object is a factor whose power cannot be denied, whereas the ego is a very limited and fragile thing. It would be a very different matter if the self opposed the object. Self and world are commensurable factors; hence a

normal introverted attitude is as justifiable and valid as a normal extraverted attitude. But if the ego has usurped the claims of the subject, this naturally produces, by way of compensation, an unconscious reinforcement of the influence of the object. In spite of positively convulsive efforts to ensure the superiority of the ego, the object comes to exert an overwhelming influence, which is all the more invincible because it seizes on the individual unawares and forcibly obtrudes itself on his consciousness. As a result of the ego's unadapted relation to the object—for a desire to dominate it is not adaptation—a compensatory relation arises in the unconscious which makes itself felt as an absolute and irrepressible tie to the object. The more the ego struggles to preserve its independence, freedom from obligation, and superiority, the more it becomes enslaved to the objective data. The individual's freedom of mind is fettered by the ignominy of his financial dependence, his freedom of action trembles in the face of public opinion, his moral superiority collapses in a morass of inferior relationships, and his desire to dominate ends in a pitiful craving to be loved. It is now the unconscious that takes care of the relation to the object, and it does so in a way that is calculated to bring the illusion of power and the fantasy of superiority to utter ruin. The object assumes terrifying proportions in spite of the conscious attempt to degrade it. In consequence, the ego's efforts to detach itself from the object and get it under control become all the more violent. In the end it surrounds itself with a regular system of defences (aptly described by Adler) for the purpose of preserving at least the illusion of superiority. The introvert's alienation from the object is now complete; he wears himself out with defence measures on the one hand, while on the other he makes fruitless attempts to impose his will on the object and assert himself. These efforts are constantly being frustrated by the overwhelming impressions received from the object. It continually imposes itself on him against his will, it arouses in him the most disagreeable and intractable affects and persecutes him at every step. A tremendous inner struggle is needed all the time in order to "keep going." The typical form his neurosis takes is psychasthenia, a malady characterized on the one hand by extreme sensitivity and on the other by great proneness to exhaustion and chronic fatigue.

[627] An analysis of the personal unconscious reveals a mass of power fantasies coupled with fear of objects which he himself has forcibly activated, and of which he is often enough the victim. His fear of objects develops into a peculiar kind of cowardliness; he shrinks from making himself or his opinions felt, fearing that this will only increase the object's power. He is terrified of strong affects in others, and is hardly ever free from the dread of falling under hostile influences. Objects possess puissant and terrifying qualities for him—qualities he cannot consciously discern in them, but which he imagines he sees through his unconscious perception. As his relation to the object is very largely repressed, it takes place via the unconscious,

where it becomes charged with the latter's qualities. These qualities are mostly infantile and archaic, so that the relation to the object becomes primitive too, and the object seems endowed with magical powers. Anything strange and new arouses fear and mistrust, as though concealing unknown perils; heirlooms and suchlike are attached to his soul as by invisible threads; any change is upsetting, if not positively dangerous, as it seems to denote a magical animation of the object. His ideal is a lonely island where nothing moves except what he permits to move. Vischer's novel, *Auch Einer*, affords deep insight into this side of the introvert's psychology, and also into the underlying symbolism of the collective unconscious. But this latter question I must leave to one side, since it is not specific to a description of types but is a general phenomenon.

c. The Peculiarities of the Basic Psychological Functions in the Introverted Attitude

Thinking

[628] In the section on extraverted thinking I gave a brief description of introverted thinking (pars. 578–79) and must refer to it again here. Introverted thinking is primarily oriented by the subjective factor. At the very least the subjective factor expresses itself as a feeling of guidance which ultimately determines judgment. Sometimes it appears as a more or less complete image which serves as a criterion. But whether introverted thinking is concerned with concrete or with abstract objects, always at the decisive points it is oriented by subjective data. It does not lead from concrete experience back again to the object, but always to the subjective content. External facts are not the aim and origin of this thinking, though the introvert would often like to make his thinking appear so. It begins with the subject and leads back to the subject, far though it may range into the realm of actual reality. With regard to the establishment of new facts it is only indirectly of value, since new views rather than knowledge of new facts are its main concern. It formulates questions and creates theories, it opens up new prospects and insights, but with regard to facts its attitude is one of reserve. They are all very well as illustrative examples, but they must not be allowed to predominate. Facts are collected as evidence for a theory, never for their own sake. If ever this happens, it is merely a concession to the extraverted style. Facts are of secondary importance for this kind of thinking; what seems to it of paramount importance is the development and presentation of the subjective idea, of the initial symbolic image hovering darkly before the mind's eye. Its aim is never an intellectual reconstruction of the concrete fact, but a shaping of that dark image into a luminous idea. It wants to reach reality, to see how the external fact will fit into and fill the framework of the idea, and the creative power of this thinking shows itself when it actually creates an idea which, though not inherent in the concrete fact, is yet

the most suitable abstract expression of it. Its task is completed when the idea it has fashioned seems to emerge so inevitably from the external facts that they actually prove its validity.

[629] But no more than extraverted thinking can wrest a sound empirical concept from concrete facts or create new ones can introverted thinking translate the initial image into an idea adequately adapted to the facts. For, as in the former case the purely empirical accumulation of facts paralyzes thought and smothers their meaning, so in the latter case introverted thinking shows a dangerous tendency to force the facts into the shape of its image, or to ignore them altogether in order to give fantasy free play. In that event it will be impossible for the finished product—the idea—to repudiate its derivation from the dim archaic image. It will have a mythological streak which one is apt to interpret as “originality” or, in more pronounced cases, as mere whimsicality, since its archaic character is not immediately apparent to specialists unfamiliar with mythological motifs. The subjective power of conviction exerted by an idea of this kind is usually very great, and it is all the greater the less it comes into contact with external facts. Although it may seem to the originator of the idea that his meagre store of facts is the actual source of its truth and validity, in reality this is not so, for the idea derives its convincing power from the unconscious archetype, which, as such, is eternally valid and true. But this truth is so universal and so symbolic that it must first be assimilated to the recognized and recognizable knowledge of the time before it can become a practical truth of any value for life. What would causality be, for instance, if it could nowhere be recognized in practical causes and practical effects?

[630] This kind of thinking easily gets lost in the immense truth of the subjective factor. It creates theories for their own sake, apparently with an eye to real or at least possible facts, but always with a distinct tendency to slip over from the world of ideas into mere imagery. Accordingly, visions of numerous possibilities appear on the scene, but none of them ever becomes a reality, until finally images are produced which no longer express anything externally real, being mere symbols of the ineffable and unknowable. It is now merely a mystical thinking and quite as unfruitful as thinking that remains bound to objective data. Whereas the latter sinks to the level of a mere representation of facts, the former evaporates into a representation of the irrepresentable, far beyond anything that could be expressed in an image. The representation of facts has an incontestable truth because the subjective factor is excluded and the facts speak for themselves. Similarly, the representation of the irrepresentable has an immediate, subjective power of conviction because it demonstrates its own existence. The one says “Est, ergo est”; the other says “Cogito, ergo cogito.” Introverted thinking carried to extremes arrives at the evidence of its own subjective existence, and extraverted thinking at the

evidence of its complete identity with the objective fact. Just as the latter abnegates itself by evaporating into the object, the former empties itself of each and every content and has to be satisfied with merely existing. In both cases the further development of life is crowded out of the thinking function into the domain of the other psychic functions, which till then had existed in a state of relative unconsciousness. The extraordinary impoverishment of introverted thinking is compensated by a wealth of unconscious facts. The more consciousness is impelled by the thinking function to confine itself within the smallest and emptiest circle—which seems, however, to contain all the riches of the gods—the more the unconscious fantasies will be enriched by a multitude of archaic contents, a veritable “pandaemonium” of irrational and magical figures, whose physiognomy will accord with the nature of the function that will supersede the thinking function as the vehicle of life. If it should be the intuitive function, then the “other side” will be viewed through the eyes of a Kubin or a Meyrink.⁹ If it is the feeling function, then quite unheard-of and fantastic feeling relationships will be formed, coupled with contradictory and unintelligible value judgments. If it is the sensation function, the senses will nose up something new, and never experienced before, in and outside the body. Closer examination of these permutations will easily demonstrate a recrudescence of primitive psychology with all its characteristic features. Naturally, such experiences are not merely primitive, they are also symbolic; in fact, the more primordial and aboriginal they are, the more they represent a future truth. For everything old in the unconscious hints at something coming.

[631] Under ordinary circumstances, not even the attempt to get to the “other side” will be successful—and still less the redeeming journey through the unconscious. The passage across is usually blocked by conscious resistance to any subjection of the ego to the realities of the unconscious and their determining power. It is a state of dissociation, in other words a neurosis characterized by inner debility and increasing cerebral exhaustion—the symptoms of psychasthenia.

The Introverted Thinking Type

[632] Just as we might take Darwin as an example of the normal extraverted thinking type, the normal introverted thinking type could be represented by Kant. The one speaks with facts, the other relies on the subjective factor. Darwin ranges over the wide field of objective reality. Kant restricts himself to a critique of knowledge. Cuvier and Nietzsche would form an even sharper contrast.

[633] The introverted thinking type is characterized by the primacy of the kind of thinking I have just described. Like his extraverted counterpart, he is strongly influenced by ideas, though his ideas have their origin not in objective data but in his subjective foundation. He will follow his ideas like the extravert, but in the reverse

direction: inwards and not outwards. Intensity is his aim, not extensity. In these fundamental respects he differs quite unmistakably from his extraverted counterpart. What distinguishes the other, namely his intense relation to objects, is almost completely lacking in him as in every introverted type. If the object is a person, this person has a distinct feeling that he matters only in a negative way; in milder cases he is merely conscious of being *de trop*, but with a more extreme type he feels himself warded off as something definitely disturbing. This negative relation to the object, ranging from indifference to aversion, characterizes every introvert and makes a description of the type exceedingly difficult. Everything about him tends to disappear and get concealed. His judgment appears cold, inflexible, arbitrary, and ruthless, because it relates far less to the object than to the subject. One can feel nothing in it that might possibly confer a higher value on the object; it always bypasses the object and leaves one with a feeling of the subject's superiority. He may be polite, amiable, and kind, but one is constantly aware of a certain uneasiness betraying an ulterior motive—the disarming of an opponent, who must at all costs be pacified and placated lest he prove himself a nuisance. In no sense, of course, is he an opponent, but if he is at all sensitive he will feel himself repulsed, and even belittled.

[634] Invariably the object has to submit to a certain amount of neglect, and in pathological cases it is even surrounded with quite unnecessary precautionary measures. Thus this type tends to vanish behind a cloud of misunderstanding, which gets all the thicker the more he attempts to assume, by way of compensation and with the help of his inferior functions, an air of urbanity which contrasts glaringly with his real nature. Although he will shrink from no danger in building up his world of ideas, and never shrinks from thinking a thought because it might prove to be dangerous, subversive, heretical, or wounding to other people's feelings, he is none the less beset by the greatest anxiety if ever he has to make it an objective reality. That goes against the grain. And when he does put his ideas into the world, he never introduces them like a mother solicitous for her children, but simply dumps them there and gets extremely annoyed if they fail to thrive on their own account. His amazing unpracticalness and horror of publicity in any form have a hand in this. If in his eyes his product appears correct and true, then it must be so in practice, and others have got to bow to its truth. Hardly ever will he go out of his way to win anyone's appreciation of it, especially anyone of influence. And if ever he brings himself to do so, he generally sets about it so clumsily that it has just the opposite of the effect intended. He usually has bad experiences with rivals in his own field because he never understands how to curry their favour; as a rule he only succeeds in showing them how entirely superfluous they are to him. In the pursuit of his ideas he is generally stubborn, headstrong, and quite unamenable to influence. His suggestibility to personal influences is in strange contrast to this. He has only to be convinced of a

person's seeming innocuousness to lay himself open to the most undesirable elements. They seize hold of him from the unconscious. He lets himself be brutalized and exploited in the most ignominious way if only he can be left in peace to pursue his ideas. He simply does not see when he is being plundered behind his back and wronged in practice, for to him the relation to people and things is secondary and the objective evaluation of his product is something he remains unconscious of. Because he thinks out his problems to the limit, he complicates them and constantly gets entangled in his own scruples and misgivings. However clear to him the inner structure of his thoughts may be, he is not in the least clear where or how they link up with the world of reality. Only with the greatest difficulty will he bring himself to admit that what is clear to him may not be equally clear to everyone. His style is cluttered with all sorts of adjuncts, accessories, qualifications, retractions, saving clauses, doubts, etc., which all come from his scrupulosity. His work goes slowly and with difficulty.

[635] In his personal relations he is taciturn or else throws himself on people who cannot understand him, and for him this is one more proof of the abysmal stupidity of man. If for once he is understood, he easily succumbs to credulous overestimation of his prowess. Ambitious women have only to know how to take advantage of his cluelessness in practical matters to make an easy prey of him; or he may develop into a misanthropic bachelor with a childlike heart. Often he is gauche in his behaviour, painfully anxious to escape notice, or else remarkably unconcerned and childishly naïve. In his own special field of work he provokes the most violent opposition, which he has no notion how to deal with, unless he happens to be seduced by his primitive affects into acrimonious and fruitless polemics. Casual acquaintances think him inconsiderate and domineering. But the better one knows him, the more favourable one's judgment becomes, and his closest friends value his intimacy very highly. To outsiders he seems prickly, unapproachable, and arrogant, and sometimes soured as a result of his anti-social prejudices. As a personal teacher he has little influence, since the mentality of his students is strange to him. Besides, teaching has, at bottom, no interest for him unless it happens to provide him with a theoretical problem. He is a poor teacher, because all the time he is teaching his thought is occupied with the material itself and not with its presentation.

[636] With the intensification of his type, his convictions become all the more rigid and unbending. Outside influences are shut off; as a person, too, he becomes more unsympathetic to his wider circle of acquaintances, and therefore more dependent on his intimates. His tone becomes personal and surly, and though his ideas may gain in profundity they can no longer be adequately expressed in the material at hand. To compensate for this, he falls back on emotionality and touchiness. The outside influences he has brusquely fended off attack him from within, from the unconscious,

and in his efforts to defend himself he attacks things that to outsiders seem utterly unimportant. Because of the subjectivization of consciousness resulting from his lack of relationship to the object, what secretly concerns his own person now seems to him of extreme importance. He begins to confuse his subjective truth with his own personality. Although he will not try to press his convictions on anyone personally, he will burst out with vicious, personal retorts against every criticism, however just. Thus his isolation gradually increases. His originally fertilizing ideas become destructive, poisoned by the sediment of bitterness. His struggle against the influences emanating from the unconscious increases with his external isolation, until finally they begin to cripple him. He thinks his withdrawal into ever-increasing solitude will protect him from the unconscious influences, but as a rule it only plunges him deeper into the conflict that is destroying him from within.

[637] The thinking of the introverted type is positive and synthetic in developing ideas which approximate more and more to the eternal validity of the primordial images. But as their connection with objective experience becomes more and more tenuous, they take on a mythological colouring and no longer hold true for the contemporary situation. Hence his thinking is of value for his contemporaries only so long as it is manifestly and intelligibly related to the known facts of the time. Once it has become mythological, it ceases to be relevant and runs on in itself. The counterbalancing functions of feeling, intuition, and sensation are comparatively unconscious and inferior, and therefore have a primitive extraverted character that accounts for all the troublesome influences from outside to which the introverted thinker is prone. The various protective devices and psychological minefields which such people surround themselves with are known to everyone, and I can spare myself a description of them. They all serve as a defence against “magical” influences—and among them is a vague fear of the feminine sex.

Feeling

[638] Introverted feeling is determined principally by the subjective factor. It differs quite as essentially from extraverted feeling as introverted from extraverted thinking. It is extremely difficult to give an intellectual account of the introverted feeling process, or even an approximate description of it, although the peculiar nature of this kind of feeling is very noticeable once one has become aware of it. Since it is conditioned subjectively and is only secondarily concerned with the object, it seldom appears on the surface and is generally misunderstood. It is a feeling which seems to devalue the object, and it therefore manifests itself for the most part negatively. The existence of positive feeling can be inferred only indirectly. Its aim is not to adjust itself to the object, but to subordinate it in an unconscious effort to realize the underlying images. It is continually seeking an image which has no existence in

reality, but which it has seen in a kind of vision. It glides unheedingly over all objects that do not fit in with its aim. It strives after inner intensity, for which the objects serve at most as a stimulus. The depth of this feeling can only be guessed—it can never be clearly grasped. It makes people silent and difficult of access; it shrinks back like a violet from the brute nature of the object in order to fill the depths of the subject. It comes out with negative judgments or assumes an air of profound indifference as a means of defence.

[639] The primordial images are, of course, just as much ideas as feelings.

Fundamental ideas, ideas like God, freedom, and immortality, are just as much feeling-values as they are significant ideas. Everything, therefore, that we have said about introverted thinking is equally true of introverted feeling, only here everything is felt while there it was thought. But the very fact that thoughts can generally be expressed more intelligibly than feelings demands a more than ordinary descriptive or artistic ability before the real wealth of this feeling can be even approximately presented or communicated to the world. If subjective thinking can be understood only with difficulty because of its unrelatedness, this is true in even higher degree of subjective feeling. In order to communicate with others, it has to find an external form not only acceptable to itself, but capable also of arousing a parallel feeling in them. Thanks to the relatively great inner (as well as outer) uniformity of human beings, it is actually possible to do this, though the form acceptable to feeling is extraordinarily difficult to find so long as it is still mainly oriented to the fathomless store of primordial images. If, however, feeling is falsified by an egocentric attitude, it at once becomes unsympathetic, because it is then concerned mainly with the ego. It inevitably creates the impression of sentimental self-love, of trying to make itself interesting, and even of morbid self-admiration. Just as the subjectivized consciousness of the introverted thinker, striving after abstraction to the *n*th degree, only succeeds in intensifying a thought-process that is in itself empty, the intensification of egocentric feeling only leads to inane transports of feeling for their own sake. This is the mystical, ecstatic stage which opens the way for the extraverted functions that feeling has repressed. Just as introverted thinking is counterbalanced by a primitive feeling, to which objects attach themselves with magical force, introverted feeling is counterbalanced by a primitive thinking, whose concretism and slavery to facts surpass all bounds. Feeling progressively emancipates itself from the object and creates for itself a freedom of action and conscience that is purely subjective, and may even renounce all traditional values. But so much the more does unconscious thinking fall a victim to the power of objective reality.

The Introverted Feeling Type

[640] It is principally among women that I have found the predominance of introverted feeling. "Still waters run deep" is very true of such women. They are mostly silent, inaccessible, hard to understand; often they hide behind a childish or banal mask, and their temperament is inclined to melancholy. They neither shine nor reveal themselves. As they are mainly guided by their subjective feelings, their true motives generally remain hidden. Their outward demeanour is harmonious, inconspicuous, giving an impression of pleasing repose, or of sympathetic response, with no desire to affect others, to impress, influence, or change them in any way. If this outward aspect is more pronounced, it arouses a suspicion of indifference and coldness, which may actually turn into a disregard for the comfort and well-being of others. One is distinctly aware then of the movement of feeling away from the object. With the normal type, however, this happens only when the influence of the object is too strong. The feeling of harmony, therefore, lasts only so long as the object goes its own moderate way and makes no attempt to cross the other's path. There is little effort to respond to the real emotions of the other person; they are more often damped down and rebuffed, or cooled off by a negative value judgment. Although there is a constant readiness for peaceful and harmonious co-existence, strangers are shown no touch of amiability, no gleam of responsive warmth, but are met with apparent indifference or a repelling coldness. Often they are made to feel entirely superfluous. Faced with anything that might carry her away or arouse enthusiasm, this type observes a benevolent though critical neutrality, coupled with a faint trace of superiority that soon takes the wind out of the sails of a sensitive person. Any stormy emotion, however, will be struck down with murderous coldness, unless it happens to catch the woman on her unconscious side—that is, unless it hits her feelings by arousing a primordial image. In that case she simply feels paralysed for the moment, and this in due course invariably produces an even more obstinate resistance which will hit the other person in his most vulnerable spot. As far as possible, the feeling relationship is kept to the safe middle path, all intemperate passions being resolutely tabooed. Expressions of feeling therefore remain niggardly, and the other person has a permanent sense of being undervalued once he becomes conscious of it. But this need not always be so, because very often he remains unconscious of the lack of feeling shown to him, in which case the unconscious demands of feeling will produce symptoms designed to compel attention.

[641] Since this type appears rather cold and reserved, it might seem on a superficial view that such women have no feelings at all. But this would be quite wrong; the truth is, their feelings are intensive rather than extensive. They develop in depth. While an extensive feeling of sympathy can express itself in appropriate words and deeds, and thus quickly gets back to normal again, an intensive sympathy, being shut off from every means of expression, acquires a passionate depth that comprises a

whole world of misery and simply gets benumbed. It may perhaps break out in some extravagant form and lead to an astounding act of an almost heroic character, quite unrelated either to the subject herself or to the object that provoked the outburst. To the outside world, or to the blind eyes of the extravert, this intensive sympathy looks like coldness, because usually it does nothing visible, and an extraverted consciousness is unable to believe in invisible forces. Such a misunderstanding is a common occurrence in the life of this type, and is used as a weighty argument against the possibility of any deeper feeling relation with the object. But the real object of this feeling is only dimly divined by the normal type herself. It may express itself in a secret religiosity anxiously guarded from profane eyes, or in intimate poetic forms that are kept equally well hidden, not without the secret ambition of displaying some kind of superiority over the other person by this means. Women often express a good deal of their feelings through their children, letting their passion flow secretly into them.

[642] Although this tendency to overpower or coerce the other person with her secret feelings rarely plays a disturbing role in the normal type, and never leads to a serious attempt of this kind, some trace of it nevertheless seeps through into the personal effect they have on him, in the form of a domineering influence often difficult to define. It is sensed as a sort of stifling or oppressive feeling which holds everybody around her under a spell. It gives a woman of this type a mysterious power that may prove terribly fascinating to the extraverted man, for it touches his unconscious. This power comes from the deeply felt, unconscious images, but consciously she is apt to relate it to the ego, whereupon her influence becomes debased into a personal tyranny. Whenever the unconscious subject is identified with the ego, the mysterious power of intensive feeling turns into a banal and overweening desire to dominate, into vanity and despotic bossiness. This produces a type of woman notorious for her unscrupulous ambition and mischievous cruelty. It is a change, however, that leads to neurosis.

[643] So long as the ego feels subordinate to the unconscious subject, and feeling is aware of something higher and mightier than the ego, the type is normal. Although the unconscious thinking is archaic, its reductive tendencies help to compensate the occasional fits of trying to exalt the ego into the subject. If this should nevertheless happen as a result of complete suppression of the counterbalancing subliminal processes, the unconscious thinking goes over into open opposition and gets projected. The egocentrized subject now comes to feel the power and importance of the devalued object. She begins consciously to feel “what other people think.” Naturally, other people are thinking all sorts of mean things, scheming evil, contriving plots, secret intrigues, etc. In order to forestall them, she herself is obliged to start counter-intrigues, to suspect others and sound them out, and weave

counterplots. Beset by rumours, she must make frantic efforts to get her own back and be top dog. Endless clandestine rivalries spring up, and in these embittered struggles she will shrink from no baseness or meanness, and will even prostitute her virtues in order to play the trump card. Such a state of affairs must end in exhaustion. The form of neurosis is neurasthenic rather than hysterical, often with severe physical complications, such as anaemia and its sequelae.

Summary of the Introverted Rational Types

[644] Both the foregoing types may be termed rational, since they are grounded on the functions of rational judgment. Rational judgment is based not merely on objective but also on subjective data. The predominance of one or the other factor, however, as a result of a psychic disposition often existing from early youth, will give the judgment a corresponding bias. A judgment that is truly rational will appeal to the objective and the subjective factor equally and do justice to both. But that would be an ideal case and would presuppose an equal development of both extraversion and introversion. In practice, however, either movement excludes the other, and, so long as this dilemma remains, they cannot exist side by side but at best successively. Under ordinary conditions, therefore, an ideal rationality is impossible. The rationality of a rational type always has a typical bias. Thus, the judgment of the introverted rational types is undoubtedly rational, only it is oriented more by the subjective factor. This does not necessarily imply any logical bias, since the bias lies in the premise. The premise consists in the predominance of the subjective factor prior to all conclusions and judgments. The superior value of the subjective as compared with the objective factor appears self-evident from the beginning. It is not a question of *assigning* this value, but, as we have said, of a natural disposition existing before all rational valuation. Hence, to the introvert, rational judgment has many nuances which differentiate it from that of the extravert. To mention only the most general instance, the chain of reasoning that leads to the subjective factor seems to the introvert somewhat more rational than the one that leads to the object. This difference, though slight and practically unnoticeable in individual cases, builds up in the end to unbridgeable discrepancies which are the more irritating the less one is aware of the minimal shift of standpoint occasioned by the psychological premise. A capital error regularly creeps in here, for instead of recognizing the difference in the premise one tries to demonstrate a fallacy in the conclusion. This recognition is a difficult matter for every rational type, since it undermines the apparently absolute validity of his own principle and delivers him over to its antithesis, which for him amounts to a catastrophe.

[645] The introvert is far more subject to misunderstanding than the extravert, not so much because the extravert is a more merciless or critical adversary than he himself

might be, but because the style of the times which he himself imitates works against him. He finds himself in the minority, not in numerical relation to the extravert, but in relation to the general Western view of the world as judged by his feeling. In so far as he is a convinced participator in the general style, he undermines his own foundations; for the general style, acknowledging as it does only the visible and tangible values, is opposed to his specific principle. Because of its invisibility, he is obliged to depreciate the subjective factor, and must force himself to join in the extraverted overvaluation of the object. He himself sets the subjective factor at too low a value, and his feelings of inferiority are his chastisement for this sin. Little wonder, therefore, that it is precisely in the present epoch, and particularly in those movements which are somewhat ahead of the time, that the subjective factor reveals itself in exaggerated, tasteless forms of expression bordering on caricature. I refer to the art of the present day.

[646] The undervaluation of his own principle makes the introvert egotistical and forces on him the psychology of the underdog. The more egotistical he becomes, the more it seems to him that the others, who are apparently able, without qualms, to conform to the general style, are the oppressors against whom he must defend himself. He generally does not see that his chief error lies in not depending on the subjective factor with the same trust and devotion with which the extravert relies on the object. His undervaluation of his own principle makes his leanings towards egotism unavoidable, and because of this he fully deserves the censure of the extravert. If he remained true to his own principle, the charge of egotism would be altogether false, for his attitude would be justified by its effects in general, and the misunderstanding would be dissipated.

Sensation

[647] Sensation, which by its very nature is dependent on the object and on objective stimuli, undergoes considerable modification in the introverted attitude. It, too, has a subjective factor, for besides the sensed object there is a sensing subject who adds his subjective disposition to the objective stimulus. In the introverted attitude sensation is based predominantly on the subjective component of perception. What I mean by this is best illustrated by works of art which reproduce external objects. If, for instance, several painters were to paint the same landscape, each trying to reproduce it faithfully, each painting will be different from the others, not merely because of differences in ability, but chiefly because of different ways of seeing; indeed, in some of the paintings there will be a distinct psychic difference in mood and the treatment of colour and form. These qualities betray the influence of the subjective factor. The subjective factor in sensation is essentially the same as in the other functions we have discussed. It is an unconscious disposition which alters the sense-perception at its

source, thus depriving it of the character of a purely objective influence. In this case, sensation is related primarily to the subject and only secondarily to the object. How extraordinarily strong the subjective factor can be is shown most clearly in art. Its predominance sometimes amounts to a complete suppression of the object's influence, and yet the sensation remains sensation even though it has become a perception of the subjective factor and the object has sunk to the level of a mere stimulus. Introverted sensation is oriented accordingly. True sense-perception certainly exists, but it always looks as though the object did not penetrate into the subject in its own right, but as though the subject were seeing it quite differently, or saw quite other things than other people see. Actually, he perceives the same things as everybody else, only he does not stop at the purely objective influence, but concerns himself with the subjective perception excited by the objective stimulus.

[648] Subjective perception is markedly different from the objective. What is perceived is either not found at all in the object, or is, at most, merely suggested by it. That is, although the perception can be similar to that of other men, it is not immediately derived from the objective behaviour of things. It does not impress one as a mere product of consciousness—it is too genuine for that. But it makes a definite psychic impression because elements of a higher psychic order are discernible in it. This order, however, does not coincide with the contents of consciousness. It has to do with presuppositions or dispositions of the collective unconscious, with mythological images, with primordial possibilities of ideas. Subjective perception is characterized by the meaning that clings to it. It means more than the mere image of the object, though naturally only to one for whom the subjective factor means anything at all. To another, the reproduced subjective impression seems to suffer from the defect of not being sufficiently like the object and therefore to have failed in its purpose.

[649] Introverted sensation apprehends the background of the physical world rather than its surface. The decisive thing is not the reality of the object, but the reality of the subjective factor, of the primordial images which, in their totality, constitute a psychic mirror-world. It is a mirror with the peculiar faculty of reflecting the existing contents of consciousness not in their known and customary form but, as it were, *sub specie aeternitatis*, somewhat as a million-year-old consciousness might see them. Such a consciousness would see the becoming and passing away of things simultaneously with their momentary existence in the present, and not only that, it would also see what was before their becoming and will be after their passing hence. Naturally this is only a figure of speech, but one that I needed in order to illustrate in some way the peculiar nature of introverted sensation. We could say that introverted sensation transmits an image which does not so much reproduce the object as spread over it the patina of age-old subjective experience and the shimmer of events still unborn. The bare sense impression develops in depth, reaching into the past and

future, while extraverted sensation seizes on the momentary existence of things open to the light of day.

The Introverted Sensation Type

[650] The predominance of introverted sensation produces a definite type, which is characterized by certain peculiarities. It is an irrational type, because it is oriented amid the flux of events not by rational judgment but simply by what happens. Whereas the extraverted sensation type is guided by the intensity of objective influences, the introverted type is guided by the intensity of the subjective sensation excited by the objective stimulus. Obviously therefore, no proportional relation exists between object and sensation, but one that is apparently quite unpredictable and arbitrary. What will make an impression and what will not can never be seen in advance, and from outside. Did there exist an aptitude for expression in any way proportional to the intensity of his sensations, the irrationality of this type would be extraordinarily striking. This is the case, for instance, when an individual is a creative artist. But since this is the exception, the introvert's characteristic difficulty in expressing himself also conceals his irrationality. On the contrary, he may be conspicuous for his calmness and passivity, or for his rational self-control. This peculiarity, which often leads a superficial judgment astray, is really due to his unrelatedness to objects. Normally the object is not consciously devalued in the least, but its stimulus is removed from it and immediately replaced by a subjective reaction no longer related to the reality of the object. This naturally has the same effect as devaluation. Such a type can easily make one question why one should exist at all, or why objects in general should have any justification for their existence since everything essential still goes on happening without them. This doubt may be justified in extreme cases, but not in the normal, since the objective stimulus is absolutely necessary to sensation and merely produces something different from what the external situation might lead one to expect.

[651] Seen from the outside, it looks as though the effect of the object did not penetrate into the subject at all. This impression is correct inasmuch as a subjective content does, in fact, intervene from the unconscious and intercept the effect of the object. The intervention may be so abrupt that the individual appears to be shielding himself directly from all objective influences. In more serious cases, such a protective defence actually does exist. Even with only a slight increase in the power of the unconscious, the subjective component of sensation becomes so alive that it almost completely obscures the influence of the object. If the object is a person, he feels completely devalued, while the subject has an illusory conception of reality, which in pathological cases goes so far that he is no longer able to distinguish between the real object and the subjective perception. Although so vital a distinction reaches the

vanishing point only in near-psychotic states, yet long before that the subjective perception can influence thought, feeling, and action to an excessive degree despite the fact that the object is clearly seen in all its reality. When its influence does succeed in penetrating into the subject—because of its special intensity or because of its complete analogy with the unconscious image—even the normal type will be compelled to *act* in accordance with the unconscious model. Such action has an illusory character unrelated to objective reality and is extremely disconcerting. It instantly reveals the reality-alienating subjectivity of this type. But when the influence of the object does not break through completely, it is met with well-intentioned neutrality, disclosing little sympathy yet constantly striving to soothe and adjust. The too low is raised a little, the too high is lowered, enthusiasm is damped down, extravagance restrained, and anything out of the ordinary reduced to the right formula—all this in order to keep the influence of the object within the necessary bounds. In this way the type becomes a menace to his environment because his total innocuousness is not altogether above suspicion. In that case he easily becomes a victim of the aggressiveness and domineeringness of others. Such men allow themselves to be abused and then take their revenge on the most unsuitable occasions with redoubled obtuseness and stubbornness.

[652] If no capacity for artistic expression is present, all impressions sink into the depths and hold consciousness under a spell, so that it becomes impossible to master their fascination by giving them conscious expression. In general, this type can organize his impressions only in archaic ways, because thinking and feeling are relatively unconscious and, if conscious at all, have at their disposal only the most necessary, banal, everyday means of expression. As conscious functions, they are wholly incapable of adequately reproducing his subjective perceptions. This type, therefore, is uncommonly inaccessible to objective understanding, and he usually fares no better in understanding himself.

[653] Above all, his development alienates him from the reality of the object, leaving him at the mercy of his subjective perceptions, which orient his consciousness to an archaic reality, although his lack of comparative judgment keeps him wholly unconscious of this fact. Actually he lives in a mythological world, where men, animals, locomotives, houses, rivers, and mountains appear either as benevolent deities or as malevolent demons. That they appear thus to him never enters his head, though that is just the effect they have on his judgments and actions. He judges and acts as though he had such powers to deal with; but this begins to strike him only when he discovers that his sensations are totally different from reality. If he has any aptitude for objective reason, he will sense this difference as morbid; but if he remains faithful to his irrationality, and is ready to grant his sensations reality value, the objective world will appear a mere make-believe and a comedy. Only in extreme

cases, however, is this dilemma reached. As a rule he resigns himself to his isolation and the banality of the world, which he has unconsciously made archaic.

[654] His unconscious is distinguished chiefly by the repression of intuition, which consequently acquires an extraverted and archaic character. Whereas true extraverted intuition is possessed of a singular resourcefulness, a “good nose” for objectively real possibilities, this archaicized intuition has an amazing flair for all the ambiguous, shadowy, sordid, dangerous possibilities lurking in the background. The real and conscious intentions of the object mean nothing to it; instead, it sniffs out every conceivable archaic motive underlying such an intention. It therefore has a dangerous and destructive quality that contrasts glaringly with the well-meaning innocuousness of the conscious attitude. So long as the individual does not hold too aloof from the object, his unconscious intuition has a salutary compensating effect on the rather fantastic and overcredulous attitude of consciousness. But as soon as the unconscious becomes antagonistic, the archaic intuitions come to the surface and exert their pernicious influence, forcing themselves on the individual and producing compulsive ideas of the most perverse kind. The result is usually a compulsion neurosis, in which the hysterical features are masked by symptoms of exhaustion.

Intuition

[655] Introverted intuition is directed to the inner object, a term that might justly be applied to the contents of the unconscious. The relation of inner objects to consciousness is entirely analogous to that of outer objects, though their reality is not physical but psychic. They appear to intuitive perception as subjective images of things which, though not to be met with in the outside world, constitute the contents of the unconscious, and of the collective unconscious in particular. These contents *per se* are naturally not accessible to experience, a quality they have in common with external objects. For just as external objects correspond only relatively to our perception of them, so the phenomenal forms of the inner objects are also relative—products of their (to us) inaccessible essence and of the peculiar nature of the intuitive function.

[656] Like sensation, intuition has its subjective factor, which is suppressed as much as possible in the extraverted attitude but is the decisive factor in the intuition of the introvert. Although his intuition may be stimulated by external objects, it does not concern itself with external possibilities but with what the external object has released within him. Whereas introverted sensation is mainly restricted to the perception, via the unconscious, of the phenomena of innervation and is arrested there, introverted intuition suppresses this side of the subjective factor and perceives the image that caused the innervation. Supposing, for instance, a man is overtaken by an attack of psychogenic vertigo. Sensation is arrested by the peculiar nature of this

disturbance of innervation, perceiving all its qualities, its intensity, its course, how it arose and how it passed, but not advancing beyond that to its content, to the thing that caused the disturbance. Intuition, on the other hand, receives from sensation only the impetus to its own immediate activity; it peers behind the scenes, quickly perceiving the inner image that gave rise to this particular form of expression—the attack of vertigo. It sees the image of a tottering man pierced through the heart by an arrow. This image fascinates the intuitive activity; it is arrested by it, and seeks to explore every detail of it. It holds fast to the vision, observing with the liveliest interest how the picture changes, unfolds, and finally fades.

[657] In this way introverted intuition perceives all the background processes of consciousness with almost the same distinctness as extraverted sensation registers external objects. For intuition, therefore, unconscious images acquire the dignity of things. But, because intuition excludes the co-operation of sensation, it obtains little or no knowledge of the disturbances of innervation or of the physical effects produced by the unconscious images. The images appear as though detached from the subject, as though existing in themselves without any relation to him. Consequently, in the above-mentioned example, the introverted intuitive, if attacked by vertigo, would never imagine that the image he perceived might in some way refer to himself. To a judging type this naturally seems almost inconceivable, but it is none the less a fact which I have often come across in my dealings with intuitives.

[658] The remarkable indifference of the extraverted intuitive to external objects is shared by the introverted intuitive in relation to inner objects. Just as the extraverted intuitive is continually scenting out new possibilities, which he pursues with equal unconcern for his own welfare and for that of others, pressing on quite heedless of human considerations and tearing down what has just been built in his everlasting search for change, so the introverted intuitive moves from image to image, chasing after every possibility in the teeming womb of the unconscious, without establishing any connection between them and himself. Just as the world of appearances can never become a moral problem for the man who merely senses it, the world of inner images is never a moral problem for the intuitive. For both of them it is an aesthetic problem, a matter of perception, a “sensation.” Because of this, the introverted intuitive has little consciousness of his own bodily existence or of its effect on others. The extravert would say: “Reality does not exist for him, he gives himself up to fruitless fantasies.” The perception of the images of the unconscious, produced in such inexhaustible abundance by the creative energy of life, is of course fruitless from the standpoint of immediate utility. But since these images represent possible views of the world which may give life a new potential, this function, which to the outside world is the strangest of all, is as indispensable to the total psychic economy

as is the corresponding human type to the psychic life of a people. Had this type not existed, there would have been no prophets in Israel.

[659] Introverted intuition apprehends the images arising from the *a priori* inherited foundations of the unconscious. These archetypes, whose innermost nature is inaccessible to experience, are the precipitate of the psychic functioning of the whole ancestral line; the accumulated experiences of organic life in general, a million times repeated, and condensed into types. In these archetypes, therefore, all experiences are represented which have happened on this planet since primeval times. The more frequent and the more intense they were, the more clearly focussed they become in the archetype. The archetype would thus be, to borrow from Kant, the noumenon of the image which intuition perceives and, in perceiving, creates.

[660] Since the unconscious is not just something that lies there like a psychic *caput mortuum*, but coexists with us and is constantly undergoing transformations which are inwardly connected with the general run of events, introverted intuition, through its perception of these inner processes, can supply certain data which may be of the utmost importance for understanding what is going on in the world. It can even foresee new possibilities in more or less clear outline, as well as events which later actually do happen. Its prophetic foresight is explained by its relation to the archetypes, which represent the laws governing the course of all experienceable things.

The Introverted Intuitive Type

[661] The peculiar nature of introverted intuition, if it gains the ascendancy, produces a peculiar type of man: the mystical dreamer and seer on the one hand, the artist and the crank on the other. The artist might be regarded as the normal representative of this type, which tends to confine itself to the perceptive character of intuition. As a rule, the intuitive stops at perception; perception is his main problem, and—in the case of a creative artist—the shaping of his perception. But the crank is content with a visionary idea by which he himself is shaped and determined. Naturally the intensification of intuition often results in an extraordinary aloofness of the individual from tangible reality; he may even become a complete enigma to his immediate circle. If he is an artist, he reveals strange, far-off things in his art, shimmering in all colours, at once portentous and banal, beautiful and grotesque, sublime and whimsical. If not an artist, he is frequently a misunderstood genius, a great man “gone wrong,” a sort of wise simpleton, a figure for “psychological” novels.

[662] Although the intuitive type has little inclination to make a moral problem of perception, since a strengthening of the judging functions is required for this, only a slight differentiation of judgment is sufficient to shift intuitive perception from the

purely aesthetic into the moral sphere. A variety of this type is thus produced which differs essentially from the aesthetic, although it is none the less characteristic of the introverted intuitive. The moral problem arises when the intuitive tries to relate himself to his vision, when he is no longer satisfied with mere perception and its aesthetic configuration and evaluation, when he confronts the questions: What does this mean for me or the world? What emerges from this vision in the way of a duty or a task, for me or the world? The pure intuitive who represses his judgment, or whose judgment is held in thrall by his perceptive faculties, never faces this question squarely, since his only problem is the “know-how” of perception. He finds the moral problem unintelligible or even absurd, and as far as possible forbids his thoughts to dwell on the disconcerting vision. It is different with the morally oriented intuitive. He reflects on the meaning of his vision, and is less concerned with developing its aesthetic possibilities than with the moral effects which emerge from its intrinsic significance. His judgment allows him to discern, though often only darkly, that he, as a man and a whole human being, is somehow involved in his vision, that it is not just an object to be perceived, but wants to participate in the life of the subject. Through this realization he feels bound to transform his vision into his own life. But since he tends to rely most predominantly on his vision, his moral efforts become one-sided; he makes himself and his life symbolic—adapted, it is true, to the inner and eternal meaning of events, but unadapted to present-day reality. He thus deprives himself of any influence upon it because he remains uncomprehended. His language is not the one currently spoken—it has become too subjective. His arguments lack the convincing power of reason. He can only profess or proclaim. His is “the voice of one crying in the wilderness.”

[663] What the introverted intuitive represses most of all is the sensation of the object, and this colours his whole unconscious. It gives rise to a compensatory extraverted sensation function of an archaic character. The unconscious personality can best be described as an extraverted sensation type of a rather low and primitive order. Instinctuality and intemperance are the hallmarks of this sensation, combined with an extraordinary dependence on sense-impressions. This compensates the rarefied air of the intuitive’s conscious attitude, giving it a certain weight, so that complete “sublimation” is prevented. But if, through a forced exaggeration of the conscious attitude, there should be a complete subordination to inner perceptions, the unconscious goes over to the opposition, giving rise to compulsive sensations whose excessive dependence on the object directly contradicts the conscious attitude. The form of neurosis is a compulsion neurosis with hypochondriacal symptoms, hypersensitivity of the sense organs, and compulsive ties to particular persons or objects.

[664] The two types just described are almost inaccessible to judgment from outside. Being introverted, and having in consequence little capacity or desire for expression, they offer but a frail handle in this respect. As their main activity is directed inwards, nothing is outwardly visible but reserve, secretiveness, lack of sympathy, uncertainty, and an apparently groundless embarrassment. When anything does come to the surface, it is generally an indirect manifestation of the inferior and relatively unconscious functions. Such manifestations naturally arouse all the current prejudices against this type. Accordingly they are mostly underestimated, or at least misunderstood. To the extent that they do not understand themselves—because they very largely lack judgment—they are also powerless to understand why they are so constantly underestimated by the public. They cannot see that their efforts to be forthcoming are, as a matter of fact, of an inferior character. Their vision is enthralled by the richness of subjective events. What is going on inside them is so captivating, and of such inexhaustible charm, that they simply do not notice that the little they do manage to communicate contains hardly anything of what they themselves have experienced. The fragmentary and episodic character of their communications makes too great a demand on the understanding and good will of those around them; also, their communications are without the personal warmth that alone carries the power of conviction. On the contrary, these types have very often a harsh, repelling manner, though of this they are quite unaware and did not intend it. We shall form a fairer judgment of such people, and show them greater forbearance, when we begin to realize how hard it is to translate into intelligible language what is perceived within. Yet this forbearance must not go so far as to exempt them altogether from the need to communicate. This would only do them the greatest harm. Fate itself prepares for them, perhaps even more than for other men, overwhelming external difficulties which have a very sobering effect on those intoxicated by the inner vision. Often it is only an intense personal need that can wring from them a human confession.

[665] From an extraverted and rationalistic standpoint, these types are indeed the most useless of men. But, viewed from a higher standpoint, they are living evidence that this rich and varied world with its overflowing and intoxicating life is not purely external, but also exists within. These types are admittedly one-sided specimens of nature, but they are an object-lesson for the man who refuses to be blinded by the intellectual fashion of the day. In their own way, they are educators and promoters of culture. Their life teaches more than their words. From their lives, and not least from their greatest fault—their inability to communicate—we may understand one of the greatest errors of our civilization, that is, the superstitious belief in verbal statements, the boundless overestimation of instruction by means of words and methods. A child certainly allows himself to be impressed by the grand talk of his parents, but do they really imagine he is educated by it? Actually it is the parents' lives that educate the

child—what they add by word and gesture at best serves only to confuse him. The same holds good for the teacher. But we have such a belief in method that, if only the method be good, the practice of it seems to sanctify the teacher. An inferior man is never a good teacher. But he can conceal his pernicious inferiority, which secretly poisons the pupil, behind an excellent method or an equally brilliant gift of gab. Naturally the pupil of riper years desires nothing better than the knowledge of useful methods, because he is already defeated by the general attitude, which believes in the all-conquering method. He has learned that the emptiest head, correctly parroting a method, is the best pupil. His whole environment is an optical demonstration that all success and all happiness are outside, and that only the right method is needed to attain the haven of one's desires. Or does, perchance, the life of his religious instructor demonstrate the happiness which radiates from the treasure of the inner vision? The irrational introverted types are certainly no teachers of a more perfect humanity; they lack reason and the ethics of reason. But their lives teach the other possibility, the interior life which is so painfully wanting in our civilization.

d. The Principal and Auxiliary Functions

[666] In the foregoing descriptions I have no desire to give my readers the impression that these types occur at all frequently in such pure form in actual life. They are, as it were, only Galtonesque family portraits, which single out the common and therefore typical features, stressing them disproportionately, while the individual features are just as disproportionately effaced. Closer investigation shows with great regularity that, besides the most differentiated function, another, less differentiated function of secondary importance is invariably present in consciousness and exerts a co-determining influence.

[667] To recapitulate for the sake of clarity: the products of all functions can be conscious, but we speak of the "consciousness" of a function only when its use is under the control of the will and, at the same time, its governing principle is the decisive one for the orientation of consciousness. This is true when, for instance, thinking is not a mere afterthought, or rumination, and when its conclusions possess an absolute validity, so that the logical result holds good both as a motive and as a guarantee of practical action without the backing of any further evidence. This absolute sovereignty always belongs, empirically, to one function alone, and *can* belong only to one function, because the equally independent intervention of another function would necessarily produce a different orientation which, partially at least, would contradict the first. But since it is a vital condition for the conscious process of adaptation always to have clear and unambiguous aims, the presence of a second function of equal power is naturally ruled out. This other function, therefore, can have only a secondary importance, as has been found to be the case in practice. Its

secondary importance is due to the fact that it is not, like the primary function, valid in its own right as an absolutely reliable and decisive factor, but comes into play more as an auxiliary or complementary function. Naturally only those functions can appear as auxiliary whose nature is not opposed to the dominant function. For instance, feeling can never act as the second function alongside thinking, because it is by its very nature too strongly opposed to thinking. Thinking, if it is to be real thinking and true to its own principle, must rigorously exclude feeling. This, of course, does not do away with the fact that there are individuals whose thinking and feeling are on the same level, both being of equal motive power for consciousness. But in these cases there is also no question of a differentiated type, but merely of relatively undeveloped thinking and feeling. The uniformly conscious or uniformly unconscious state of the functions is, therefore, the mark of a primitive mentality.

[668] Experience shows that the secondary function is always one whose nature is different from, though not antagonistic to, the primary function. Thus, thinking as the primary function can readily pair with intuition as the auxiliary, or indeed equally well with sensation, but, as already observed, never with feeling. Neither intuition nor sensation is antagonistic to thinking; they need not be absolutely excluded, for they are not of a nature equal and opposite to thinking, as feeling is—which, as a judging function, successfully competes with thinking—but are functions of perception, affording welcome assistance to thought. But as soon as they reached the same level of differentiation as thinking, they would bring about a change of attitude which would contradict the whole trend of thinking. They would change the judging attitude into a perceiving one; whereupon the principle of rationality indispensable to thought would be suppressed in favour of the irrationality of perception. Hence the auxiliary function is possible and useful only in so far as it *serves* the dominant function, without making any claim to the autonomy of its own principle.

[669] For all the types met with in practice, the rule holds good that besides the conscious, primary function there is a relatively unconscious, auxiliary function which is in every respect different from the nature of the primary function. The resulting combinations present the familiar picture of, for instance, practical thinking allied with sensation, speculative thinking forging ahead with intuition, artistic intuition selecting and presenting its images with the help of feeling-values, philosophical intuition systematizing its vision into comprehensible thought by means of a powerful intellect, and so on.

[670] The unconscious functions likewise group themselves in patterns correlated with the conscious ones. Thus, the correlative of conscious, practical thinking may be an unconscious, intuitive-feeling attitude, with feeling under a stronger inhibition than intuition. These peculiarities are of interest only for one who is concerned with the

practical treatment of such cases, but it is important that he should know about them. I have frequently observed how an analyst, confronted with a terrific thinking type, for instance, will do his utmost to develop the feeling function directly out of the unconscious. Such an attempt is foredoomed to failure, because it involves too great a violation of the conscious standpoint. Should the violation nevertheless be successful, a really compulsive dependence of the patient on the analyst ensues, a transference that can only be brutally terminated, because, having been left without a standpoint, the patient has made his standpoint the analyst. But the approach to the unconscious and to the most repressed function is disclosed, as it were, of its own accord, and with adequate protection of the conscious standpoint, when the way of development proceeds via the auxiliary function—in the case of a rational type via one of the irrational functions. This gives the patient a broader view of what is happening, and of what is possible, so that his consciousness is sufficiently protected against the inroads of the unconscious. Conversely, in order to cushion the impact of the unconscious, an irrational type needs a stronger development of the rational auxiliary function present in consciousness.

[671] The unconscious functions exist in an archaic, animal state. Hence their symbolic appearance in dreams and fantasies is usually represented as the battle or encounter between two animals or monsters.

XI

DEFINITIONS

[672] It may perhaps seem superfluous that I should add to my text a chapter dealing solely with definitions. But ample experience has taught me that, in psychological works particularly, one cannot proceed too cautiously in regard to the concepts and terms one uses: for nowhere do such wide divergences of meaning occur as in the domain of psychology, creating only too frequently the most obstinate misunderstandings. This drawback is due not only to the fact that the science of psychology is still in its infancy; there is the further difficulty that the empirical material, the object of scientific investigation, cannot be displayed in concrete form, as it were, before the eyes of the reader. The psychological investigator is always finding himself obliged to make extensive use of an indirect method of description in order to present the reality he has observed. Only in so far as elementary facts are communicated which are amenable to quantitative measurement can there be any question of a direct presentation. But how much of the actual psychology of man can be experienced and observed as quantitatively measurable facts? Such facts do exist, and I believe I have shown in my association studies¹ that extremely complicated psychological facts are accessible to quantitative measurement. But anyone who has probed more deeply into the nature of psychology, demanding something more of it as a science than that it should confine itself within the narrow limits of the scientific method, will also have realized that an experimental method will never succeed in doing justice to the nature of the human psyche, nor will it ever project anything like a true picture of the more complex psychic phenomena.

[673] But once we leave the domain of measurable facts we are dependent on *concepts*, which have now to take over the role of measure and number. The precision which measure and number lend to the observed fact can be replaced only by the *precision of the concept*. Unfortunately, as every investigator and worker in this field knows only too well, current psychological concepts are so imprecise and so ambiguous that mutual understanding is practically impossible. One has only to take the concept "feeling," for instance, and try to visualize everything this concept comprises, to get some sort of notion of the variability and ambiguity of psychological concepts in general. And yet the concept of feeling does express something characteristic that, though not susceptible of quantitative measurement, nevertheless palpably exists. One simply cannot resign oneself, as Wundt does in his physiological psychology, to a mere denial of such essential and fundamental phenomena, and seek to replace

them by elementary facts or to resolve them into such. In this way an essential part of psychology is thrown overboard.

[674] In order to escape the ill consequences of this overvaluation of the scientific method, one is obliged to have recourse to well-defined concepts. But in order to arrive at such concepts, the collaboration of many workers would be needed, a sort of *consensus gentium*. Since this is not within the bounds of possibility at present, the individual investigator must at least try to give his concepts some fixity and precision, and this can best be done by discussing the meaning of the concepts he employs so that everyone is in a position to see what in fact he means by them.

[675] To meet this need I now propose to discuss my principal psychological concepts in alphabetical order, and I would like the reader to refer to these explanations in case of doubt. It goes without saying that these definitions and explanations are merely intended to establish the sense in which I myself use the concepts; far be it from me to affirm that this use is in all circumstances the only possible one or the absolutely right one.

[676] 1. ABSTRACTION, as the word itself indicates, is the drawing out or singling out of a content (a meaning, a general characteristic, etc.) from a context made up of other elements whose combination into a whole is something unique or individual and therefore cannot be compared with anything else. Singularity, uniqueness, and incomparability are obstacles to cognition; hence the other elements associated with a content that is felt to be the essential one are bound to appear irrelevant.

[677] Abstraction, therefore, is a form of mental activity that frees this content from its association with the irrelevant elements by distinguishing it from them or, in other words, *differentiating* it (v. *Differentiation*). In its wider sense, everything is *abstract* that is separated from its association with elements that are felt to have no relevance to its meaning.

[678] Abstraction is an activity pertaining to the psychological *functions* (q.v.) in general. There is an abstract *thinking*, just as there is abstract *feeling*, *sensation*, and *intuition* (qq. v.). Abstract thinking singles out the rational, logical qualities of a given content from its intellectually irrelevant components. Abstract feeling does the same with a content characterized by its feeling-values; similarly with sensation and intuition. Hence, not only are there abstract thoughts but also abstract feelings, the latter being defined by Sully as intellectual, aesthetic, and moral.² To these Nahlowsky adds all religious feelings.³ Abstract feelings would, in my view, correspond to the “higher” or “ideal” feelings of Nahlowsky. I put abstract feelings on the same level as abstract thoughts. Abstract sensation would be aesthetic as

opposed to sensuous *sensation* (q.v.), and abstract intuition would be symbolic as opposed to fantastic *intuition* (v. *Fantasy and Intuition*).

[679] In this work I also associate abstraction with the awareness of the psycho-energetic process it involves. When I take an abstract attitude to an object, I do not allow the object to affect me in its totality; I focus my attention on one part of it by excluding all the irrelevant parts. My aim is to disembarass myself of the object as a singular and unique whole and to abstract only a portion of this whole. No doubt I am aware of the whole, but I do not immerse myself in this awareness; my interest does not flow into the whole, but draws back from it, pulling the abstracted portion into myself, into my conceptual world, which is already prepared or constellated for the purpose of abstracting a part of the object. (It is only because of a subjective constellation of concepts that I am able to abstract from the object.) “Interest” I conceive as the energy or *libido* (q.v.) which I bestow on the object as a value, or which the object draws from me, maybe even against my will or unknown to myself. I visualize the process of abstraction as a withdrawal of libido from the object, as a backflow of value from the object into a subjective, abstract content. For me, therefore, abstraction amounts to an energetic *devaluation of the object*. In other words, abstraction is an introverting movement of libido (v. *Introversion*).

[680] I call an *attitude* (q.v.) *abstractive* when it is both introverting and at the same time *assimilates* (q.v.) a portion of the object, felt to be essential, to abstract contents already constellated in the subject. The more abstract a content is, the more it is *irrepresentable*. I subscribe to Kant’s view that a concept gets more abstract “the more the differences of things are left out of it,”⁴ in the sense that abstraction at its highest level detaches itself absolutely from the object, thereby attaining the extreme limit of irrepresentability. It is this pure “abstract” which I term an *idea* (q.v.). Conversely, an abstract that still possesses some degree of representability or plasticity is a *concrete* concept (v. *Concretism*).

[681] 2. AFFECT. By the term affect I mean a state of feeling characterized by marked physical innervation on the one hand and a peculiar disturbance of the ideational process on the other.⁵ I use *emotion* as synonymous with affect. I distinguish—in contrast to Bleuler (v. *Affectivity*)—*feeling* (q.v.) from affect, in spite of the fact that the dividing line is fluid, since every feeling, after attaining a certain strength, releases physical innervations, thus becoming an affect. For practical reasons, however, it is advisable to distinguish affect from feeling, since feeling can be a voluntarily disposable function, whereas affect is usually not. Similarly, affect is clearly distinguished from feeling by quite perceptible physical innervations, while feeling for the most part lacks them, or else their intensity is so slight that they can be demonstrated only by the most delicate instruments, as in the case of psychogalvanic

phenomena.⁶ Affect becomes cumulative through the sensation of the physical innervations released by it. This observation gave rise to the James-Lange theory of affect, which derives affect causally from physical innervations. As against this extreme view, I regard affect on the one hand as a psychic feeling-state and on the other as a physiological innervation-state, each of which has a cumulative, reciprocal effect on the other. That is to say, a component of sensation allies itself with the intensified feeling, so that the affect is approximated more to *sensation* (q.v.) and essentially differentiated from the feeling-state. Pronounced affects, i.e., affects accompanied by violent physical innervations, I do not assign to the province of feeling but to that of the sensation function.

[682] 3. AFFECTIVITY is a term coined by Bleuler. It designates and comprises “not only the affects proper, but also the slight feelings or feeling-tones of pain and pleasure.”⁷ Bleuler distinguishes affectivity from the sense-perceptions and physical sensations as well as from “feelings” that may be regarded as inner perception processes (e.g., the “feeling” of certainty, of probability, etc.) or vague thoughts or discernments.⁸

4. ANIMA / ANIMUS, V. SOUL; SOUL-IMAGE.

[683] 5. APPERCEPTION is a psychic process by which a new content is articulated with similar, already existing contents in such a way that it becomes understood, apprehended, or “clear.”⁹ We distinguish *active* from *passive* apperception. The first is a process by which the subject, of his own accord and from his own motives, consciously apprehends a new content with attention and assimilates it to other contents already constellated; the second is a process by which a new content forces itself upon consciousness either from without (through the senses) or from within (from the unconscious) and, as it were, compels attention and enforces apprehension. In the first case the activity lies with the *ego* (q.v.); in the second, with the self-enforcing new content.

[684] 6. ARCHAISM is a term by which I designate the “oldness” of psychic contents or *functions* (q.v.). By this I do not mean qualities that are “archaistic” in the sense of being pseudo-antique or copied, as in later Roman sculpture or nineteenth-century Gothic, but qualities that have the character of *relics*. We may describe as archaic all psychological traits that exhibit the qualities of the primitive mentality. It is clear that archaism attaches primarily to the *fantasies* (q.v.) of the unconscious, i.e., to the products of unconscious fantasy activity which reach consciousness. An *image* (q.v.) has an archaic quality when it possesses unmistakable mythological parallels.¹⁰ Archaic, too, are the associations-by-analogy of unconscious fantasy, and so is their symbolism (v. *Symbol*). The relation of *identity* (q.v.) with an object, or *participation mystique* (q.v.), is likewise archaic. *Concretism* (q.v.) of thought and feeling is

archaic; also compulsion and inability to control oneself (ecstatic or trance states, possession, etc.). Fusion of the psychological functions (v. *Differentiation*), of thinking with feeling, feeling with sensation, feeling with intuition, and so on, is archaic, as is also the fusion of part of a function with its counterpart, e.g., positive with negative feeling, or what Bleuler calls ambitendency and ambivalence, and such phenomena as *colour hearing*.

6a. ARCHETYPE,¹¹ v. IMAGE, primordial: also IDEA.

[685] 7. ASSIMILATION is the approximation of a new content of consciousness to already constellated subjective material,¹² the similarity of the new content to this material being especially accentuated in the process, often to the detriment of its independent qualities.¹³ Fundamentally, assimilation is a process of *apperception* (q.v.), but is distinguished from apperception by this element of approximation to the subjective material. It is in this sense that Wundt says:¹⁴

This way of building up ideas [i.e., by assimilation] is most conspicuous when the assimilating elements arise through reproduction, and the assimilated ones through an immediate sense impression. For then the elements of memory-images are projected, as it were, into the external object, so that, particularly when the object and the reproduced elements differ substantially from one another, the finished sense impression appears as an illusion, deceiving us as to the real nature of things.

[686] I use the term assimilation in a somewhat broader sense, as the approximation of object to subject in general, and with it I contrast *dissimilation*, as the approximation of subject to object, and a consequent alienation of the subject from himself in favour of the object, whether it be an external object or a “psychological” object, for instance an idea.

[687] 8. ATTITUDE. This concept is a relatively recent addition to psychology. It originated with Müller and Schumann.¹⁵ Whereas Külpe¹⁶ defines attitude as a predisposition of the sensory or motor centres to react to a particular stimulus or constant impulse, Ebbinghaus¹⁷ conceives it in a wider sense as an effect of training which introduces the factor of habit into individual acts that deviate from the habitual. Our use of the concept derives from Ebbinghaus's. For us, attitude is a readiness of the psyche to act or react in a certain way. The concept is of particular importance for the psychology of complex psychic processes because it expresses the peculiar fact that certain stimuli have too strong an effect on some occasions, and little or no effect on others. To have an attitude means to be ready for something definite, even though this something is unconscious; for having an attitude is synonymous with an *a priori* orientation to a definite thing, no matter whether this be represented in consciousness or not. The state of readiness, which I conceive attitude

to be, consists in the presence of a certain subjective constellation, a definite combination of psychic factors or contents, which will either determine action in this or that definite direction, or react to an external stimulus in a definite way. Active *apperception* (q.v.) is impossible without an attitude. An attitude always has a point of reference; this can be either conscious or unconscious, for in the act of apperceiving a new content an already constellated combination of contents will inevitably accentuate those qualities or elements that appear to belong to the subjective content. Hence a selection or judgment takes place which excludes anything irrelevant. As to what is or is not relevant, this is decided by the already constellated combination of contents. Whether the point of reference is conscious or unconscious does not affect the selectivity of the attitude, since the selection is implicit in the attitude and takes place automatically. It is useful, however, to distinguish between the two, because the presence of two attitudes is extremely frequent, one conscious and the other unconscious. This means that consciousness has a constellation of contents different from that of the unconscious, a duality particularly evident in neurosis.

[688] The concept of attitude has some affinity with Wundt's concept of *apperception*, with the difference that apperception includes the process of relating the already constellated contents to the new content to be apperceived, whereas attitude relates exclusively to the subjectively constellated content. Apperception is, as it were, the bridge which connects the already existing, constellated contents with the new one, whereas attitude would be the support or abutment of the bridge on the one bank, and the new content the abutment on the other bank. Attitude signifies *expectation*, and expectation always operates selectively and with a sense of direction. The presence of a strongly feeling-toned content in the conscious field of vision forms (maybe with other contents) a particular constellation that is equivalent to a definite attitude, because such a content promotes the perception and apperception of everything similar to itself and blacks out the dissimilar. It creates an attitude that corresponds to it. This automatic phenomenon is an essential cause of the one-sidedness of conscious *orientation* (q.v.). It would lead to a complete loss of equilibrium if there were no self-regulating, compensatory (v. *Compensation*) function in the psyche to correct the conscious attitude. In this sense, therefore, the duality of attitude is a normal phenomenon, and it plays a disturbing role only when the one-sidedness is excessive.

[689] Attitude in the sense of ordinary *attention* can be a relatively unimportant subsidiary phenomenon, but it can also be a general principle governing the whole psyche. Depending on environmental influences and on the individual's education, general experience of life, and personal convictions, a subjective constellation of contents may be habitually present, continually moulding a certain attitude that may

affect the minutest details of his life. Every man who is particularly aware of the seamy side of existence, for instance, will naturally have an attitude that is constantly on the look-out for something unpleasant. This conscious imbalance is compensated by an unconscious expectation of pleasure. Again, an oppressed person has a conscious attitude that always anticipates oppression; he selects this factor from the general run of experience and scents it out everywhere. His unconscious attitude, therefore, aims at power and superiority.

[690] The whole psychology of an individual even in its most fundamental features is oriented in accordance with his habitual attitude. Although the general psychological laws operate in every individual, they cannot be said to be characteristic of a particular individual, since the way they operate varies in accordance with his habitual attitude. The habitual attitude is always a resultant of all the factors that exert a decisive influence on the psyche, such as innate disposition, environmental influences, experience of life, insights and convictions gained through *differentiation* (q.v.), *collective* (q.v.) views, etc. Were it not for the absolutely fundamental importance of attitude, the existence of an individual psychology would be out of the question. But the habitual attitude brings about such great displacements of energy, and so modifies the relations between the individual *functions* (q.v.), that effects are produced which often cast doubt on the validity of general psychological laws. In spite of the fact, for instance, that some measure of sexual activity is held to be indispensable on physiological and psychological grounds, there are individuals who, without loss to themselves, i.e., without pathological effects or any demonstrable restriction of their powers, can, to a very great extent, dispense with it, while in other cases quite insignificant disturbances in this area can have far-reaching consequences. How enormous the individual differences are can be seen most clearly, perhaps, in the question of likes and dislikes. Here practically all rules go by the board. What is there, in the last resort, that has not at some time given man pleasure, and what is there that has not caused him pain? Every instinct, every function can be subordinated to another. The ego instinct or power instinct can make sexuality its servant, or sexuality can exploit the ego. Thinking may overrun everything else, or feeling swallow up thinking and sensation, all depending on the attitude.

[691] At bottom, attitude is an individual phenomenon that eludes scientific investigation. In actual experience, however, certain typical attitudes can be distinguished in so far as certain psychic functions can be distinguished. When a function habitually predominates, a typical attitude is produced. According to the nature of the differentiated function, there will be constellations of contents that create a corresponding attitude. There is thus a typical thinking, feeling, sensation, and intuitive attitude. Besides these purely psychological attitudes, whose number might very well be increased, there are also social attitudes, namely, those on which a

collective idea has set its stamp. They are characterized by the various “-isms.” These collective attitudes are very important, in some cases even outweighing the importance of the individual attitude.

[692] 9. COLLECTIVE. I term *collective* all psychic contents that belong not to one individual but to many, i.e., to a society, a people, or to mankind in general. Such contents are what Lévy-Bruhl¹⁸ calls the *représentations collectives* of primitives, as well as general concepts of justice, the state, religion, science, etc., current among civilized man. It is not only concepts and ways of looking at things, however, that must be termed collective, but also *feelings*. Among primitives, the *représentations collectives* are at the same time collective feelings, as Lévy-Bruhl has shown. Because of this collective feeling-value he calls the *représentations collectives* “mystical,” since they are not merely intellectual but emotional.¹⁹ Among civilized peoples, too, certain collective ideas—God, justice, fatherland, etc.—are bound up with collective feelings. This collective quality adheres not only to particular psychic elements or contents but to whole *functions* (q.v.). Thus the thinking function as a whole can have a collective quality, when it possesses general validity and accords with the laws of logic. Similarly, the feeling function as a whole can be collective, when it is identical with the general feeling and accords with general expectations, the general moral consciousness, etc. In the same way, sensation and intuition are collective when they are at the same time characteristic of a large group of men. The antithesis of collective is *individual* (q.v.).

[693] 10. COMPENSATION means *balancing, adjusting, supplementing*. The concept was introduced into the psychology of the neuroses by Adler.²⁰ He understands by it the functional balancing of the feeling of inferiority by a compensatory psychological system, comparable to the compensatory development of organs in organ inferiority.²¹ He says:

With the breaking away from the maternal organism the struggle with the outer world begins for these inferior organs and organ systems, a struggle which must necessarily break out and declare itself with greater violence than in a normally developed apparatus. ... Nevertheless, the foetal character supplies at the same time the heightened possibility of compensation and overcompensation, increases the capacity for adaptation to usual and unusual resistance, and ensures the development of new and higher forms, of new and higher achievements.²²

The neurotic's feeling of inferiority, which according to Adler corresponds aetiologically to an organ inferiority, gives rise to an “auxiliary device,”²³ that is, a compensation, which consists in the setting up of a “guiding fiction” to balance the inferiority. The “guiding fiction” is a psychological system that endeavours to turn an

inferiority into a superiority. The significant thing about this conception is the undeniable and empirically demonstrable existence of a compensating function in the sphere of psychological processes. It corresponds to a similar function in the physiological sphere, namely, the self-regulation of the living organism.

[694] Whereas Adler restricts his concept of compensation to the balancing of inferiority feelings, I conceive it as functional adjustment in general, an inherent self-regulation of the psychic apparatus.²⁴ In this sense, I regard the activity of the *unconscious* (q.v.) as a balancing of the one-sidedness of the general *attitude* (q.v.) produced by the function of *consciousness* (q.v.). Psychologists often compare consciousness to the eye: we speak of a visual field and a focal point of consciousness. The nature of consciousness is aptly characterized by this simile: only a limited number of contents can be held in the conscious field at the same time, and of these only a few can attain the highest grade of consciousness. The activity of consciousness is *selective*. Selection demands *direction*. But direction requires the *exclusion of everything irrelevant*. This is bound to make the conscious *orientation* (q.v.) one-sided. The contents that are excluded and inhibited by the chosen direction sink into the unconscious, where they form a counterweight to the conscious orientation. The strengthening of this counterposition keeps pace with the increase of conscious one-sidedness until finally a noticeable tension is produced. This tension inhibits the activity of consciousness to a certain extent, and though at first the inhibition can be broken down by increased conscious effort, in the end the tension becomes so acute that the repressed unconscious contents break through in the form of dreams and spontaneous *images* (q.v.). The more one-sided the conscious attitude, the more antagonistic are the contents arising from the unconscious, so that we may speak of a real opposition between the two. In this case the compensation appears in the form of a counter-function, but this case is extreme. As a rule, the unconscious compensation does not run counter to consciousness, but is rather a balancing or supplementing of the conscious orientation. In dreams, for instance, the unconscious supplies all those contents that are constellated by the conscious situation but are inhibited by conscious selection, although a knowledge of them would be indispensable for complete adaptation.

[695] Normally, compensation is an unconscious process, i.e., an unconscious regulation of conscious activity. In neurosis the unconscious appears in such stark contrast to the conscious state that compensation is disturbed. The aim of analytical therapy, therefore, is a realization of unconscious contents in order that compensation may be re-established.

[696] 11. CONCRETISM. By this I mean a peculiarity of thinking and feeling which is the antithesis of *abstraction* (q.v.). The actual meaning of *concrete* is “grown together.”

A concretely thought concept is one that has grown together or coalesced with other concepts. Such a concept is not abstract, not segregated, not thought “in itself,” but is always alloyed and related to something else. It is not a differentiated concept, but is still embedded in the material transmitted by sense-perception. Concretistic *thinking* (q.v.) operates exclusively with concrete concepts and percepts, and is constantly related to *sensation* (q.v.). Similarly, concretistic *feeling* (q.v.) is never segregated from its sensuous context.

[697] Primitive thinking and feeling are entirely concretistic; they are always related to sensation. The thought of the primitive has no detached independence but clings to material phenomena. It rises at most to the level of *analogy*. Primitive feeling is equally bound to material phenomena. Both of them depend on sensation and are only slightly differentiated from it. Concretism, therefore, is an *archaism* (q.v.). The magical influence of the fetish is not experienced as a subjective state of feeling, but sensed as a magical effect. That is concretistic feeling. The primitive does not experience the idea of divinity as a subjective content; for him the sacred tree is the abode of the god, or even the god himself. That is concretistic thinking. In civilized man, concretistic thinking consists in the inability to conceive of anything except immediately obvious facts transmitted by the senses, or in the inability to discriminate between subjective feeling and the sensed object.

[698] Concretism is a concept which falls under the more general concept of *participation mystique* (q.v.). Just as the latter represents a fusion of the individual with external objects, concretism represents a fusion of thinking and feeling with sensation, so that the object of one is at the same time the object of the other. This fusion prevents any differentiation of thinking and feeling and keeps them both within the sphere of sensation; they remain its servants and can never be developed into pure functions. The result is a predominance of the sensation factor in psychological *orientation* (q.v.). (Concerning the importance of this factor, v. *Sensation*.)

[699] The disadvantage of concretism is the subjection of the functions to sensation. Because sensation is the perception of physiological stimuli, concretism either rivets the function to the sensory sphere or constantly leads back to it. This results in a bondage of the psychological functions to the senses, favouring the influence of sensuous facts at the expense of the psychic independence of the individual. So far as the recognition of facts is concerned this orientation is naturally of value, but not as regards the *interpretation* of facts and their relation to the individual. Concretism sets too high a value on the importance of facts and suppresses the freedom of the individual for the sake of objective data. But since the individual is conditioned not merely by physiological stimuli but by factors which may even be opposed to

external realities, concretism results in a *projection* (q.v.) of these inner factors into the objective data and produces an almost superstitious veneration of mere facts, as is precisely the case with the primitive. A good example of concretistic feeling is seen in the excessive importance which Nietzsche attached to diet, and in the materialism of Moleschott (“Man is what he eats”). An example of the superstitious overvaluation of facts would be the hypostatizing of the concept of energy in Ostwald’s monism.

[700] 12. CONSCIOUSNESS. By consciousness I understand the relation of psychic contents to the *ego* (q.v.), in so far as this relation is perceived as such by the ego.²⁵ Relations to the ego that are not perceived as such are *unconscious* (q.v.). Consciousness is the function or activity²⁶ which maintains the relation of psychic contents to the ego. Consciousness is not identical with the *psyche* (v. *Soul*), because the psyche represents the totality of all psychic contents, and these are not necessarily all directly connected with the ego, i.e., related to it in such a way that they take on the quality of consciousness. A great many psychic complexes exist which are not all necessarily connected with the ego.²⁷

[701] 13. CONSTRUCTIVE. This concept is used by me in an equivalent sense to *synthetic*, almost in fact as an illustration of it. Constructive means “building up.” I use *constructive* and *synthetic* to designate a method that is the antithesis of the *reductive* (q.v.).²⁸ The constructive method is concerned with the elaboration of the products of the unconscious (dreams, fantasies, etc.; v. *Fantasy*). It takes the unconscious product as a symbolic expression (v. *Symbol*) which anticipates a coming phase of psychological development.²⁹ Maeder actually speaks of a *prospective function* of the *unconscious* (q.v.), which half playfully anticipates future developments.³⁰ Adler, too, recognizes an anticipatory function of the unconscious.³¹ It is certain that the product of the unconscious cannot be regarded as a finished thing, as a sort of end-product, for that would be to deny it any purposive significance. Freud himself allows the dream a teleological role at least as the “guardian of sleep,”³² though for him its prospective function is essentially restricted to “wishing.” The purposive character of unconscious tendencies cannot be contested *a priori* if we are to accept their analogy with other psychological or physiological functions. We conceive the product of the unconscious, therefore, as an expression oriented to a goal or purpose, but characterizing its objective in symbolic language.³³

[702] In accordance with this conception, the constructive method of interpretation is not so much concerned with the primary sources of the unconscious product, with its raw materials, so to speak, as with bringing its symbolism to a general and comprehensible expression. The “free associations” of the subject are considered with respect to their aim and not with respect to their derivation. They are viewed from the angle of future action or inaction; at the same time, their relation to the

conscious situation is carefully taken into account, for, according to the *compensation* (q.v.) theory, the activity of the unconscious has an essentially complementary significance for the conscious situation. Since it is a question of an anticipatory *orientation* (q.v.), the actual relation to the object does not loom so large as in the reductive procedure, which is concerned with actual relations to the object in the past. It is more a question of the subjective *attitude* (q.v.), the object being little more than a signpost pointing to the tendencies of the subject. The aim of the constructive method, therefore, is to elicit from the unconscious product a meaning that relates to the subject's future attitude. Since, as a rule, the unconscious can create only symbolic expressions, the constructive method seeks to elucidate the symbolically expressed meaning in such a way as to indicate how the conscious orientation may be corrected, and how the subject may act in harmony with the unconscious.

[703] Thus, just as no psychological method of interpretation relies exclusively on the associative material supplied by the analysand, the constructive method also makes use of comparative material. And just as reductive interpretation employs parallels drawn from biology, physiology, folklore, literature, and other sources, the constructive treatment of an intellectual problem will make use of philosophical parallels, while the treatment of an intuitive problem will depend more on parallels from mythology and the history of religion.

[704] The constructive method is necessarily *individualistic*, since a future collective attitude can develop only through the individual. The reductive method, on the contrary, is *collective* (q.v.), since it leads back from the individual to basic collective attitudes or facts. The constructive method can also be directly applied by the subject to his own material, in which case it is an *intuitive* method, employed to elucidate the general meaning of an unconscious product. This elucidation is the result of an *associative* (as distinct from actively *apperceptive*, q.v.) addition of further material, which so enriches the, symbolic product (e.g., a dream) that it eventually attains a degree of clarity sufficient for conscious comprehension. It becomes interwoven with more general associations and is thereby assimilated.

[705] 14. DIFFERENTIATION means the development of differences, the separation of parts from a whole. In this work I employ the concept of differentiation chiefly with respect to the psychological *functions* (q.v.). So long as a function is still so fused with one or more other functions—thinking with feeling, feeling with sensation, etc.—that it is unable to operate on its own, it is in an *archaic* (q.v.) condition, i.e., not differentiated, not separated from the whole as a special part and existing by itself. Undifferentiated thinking is incapable of thinking apart from other functions; it is continually mixed up with sensations, feelings, intuitions, just as undifferentiated feeling is mixed up with sensations and fantasies, as for instance in the sexualization

(Freud) of feeling and thinking in neurosis. As a rule, the undifferentiated function is also characterized by ambivalence and ambivalence,³⁴ i.e., every position entails its own negation, and this leads to characteristic inhibitions in the use of the undifferentiated function. Another feature is the fusing together of its separate components; thus, undifferentiated sensation is vitiated by the coalescence of different sensory spheres (colour-hearing), and undifferentiated feeling by confounding hate with love. To the extent that a function is largely or wholly unconscious, it is also undifferentiated; it is not only fused together in its parts but also merged with other functions. Differentiation consists in the separation of the function from other functions, and in the separation of its individual parts from each other. Without differentiation direction is impossible, since the direction of a function towards a goal depends on the elimination of anything irrelevant. Fusion with the irrelevant precludes direction; only a differentiated function is *capable* of being directed.

15. DISSIMILATION, V. ASSIMILATION.

[706] 16. EGO. By ego I understand a complex of ideas which constitutes the centre of my field of consciousness and appears to possess a high degree of continuity and identity. Hence I also speak of an *ego-complex*.³⁵ The ego-complex is as much a content as a condition of *consciousness* (q.v.), for a psychic element is conscious to me only in so far as it is related to my ego-complex. But inasmuch as the ego is only the centre of my field of consciousness, it is not identical with the totality of my psyche, being merely one complex among other complexes. I therefore distinguish between the ego and the *self* (q.v.), since the ego is only the subject of my consciousness, while the self is the subject of my total psyche, which also includes the unconscious. In this sense the self would be an ideal entity which embraces the ego. In unconscious *fantasies* (q.v.) the self often appears as supraordinate or ideal personality, having somewhat the relationship of Faust to Goethe or Zarathustra to Nietzsche. For the sake of idealization the archaic features of the self are represented as being separate from the “higher” self, as for instance Mephistopheles in Goethe, Epimetheus in Spitteler, and in Christian psychology the devil or Antichrist. In Nietzsche, Zarathustra discovered his shadow in the “Ugliest Man.”

16a. EMOTION, V. AFFECT.

[707] 17. EMPATHY³⁶ is an *introjection* (q.v.) of the object. For a fuller description of the concept of empathy, see [Chapter VII](#); also *projection*.

[708] 18. ENANTIODROMIA means a “running counter to.” In the philosophy of Heraclitus³⁷ it is used to designate the play of opposites in the course of events—the

view that everything that exists turns into its opposite. “From the living comes death and from the dead life, from the young old age and from the old youth; from waking, sleep, and from sleep, waking; the stream of generation and decay never stands still.”³⁸ “Construction and destruction, destruction and construction—this is the principle which governs all the cycles of natural life, from the smallest to the greatest. Just as the cosmos itself arose from the primal fire, so must it return once more into the same—a dual process running its measured course through vast periods of time, a drama eternally re-enacted.”³⁹ Such is the enantiodromia of Heraclitus in the words of qualified interpreters. He himself says:

It is the opposite which is good for us.

Men do not know how what is at variance agrees with itself. It is an attunement of opposite tensions, like that of the bow and the lyre.

The bow (*βίος*) is called life (*βίος*), but its work is death.

Mortals are immortals and immortals are mortals, the one living the others’ death and dying the others’ life.

For souls it is death to become water, for water death to become earth. But from earth comes water, and from water, soul.

All things are an exchange for fire, and fire for all things, like goods for gold and gold for goods.

The way up and the way down are the same.⁴⁰

[709] I use the term enantiodromia for the emergence of the unconscious opposite in the course of time. This characteristic phenomenon practically always occurs when an extreme, onesided tendency dominates conscious life; in time an equally powerful counterposition is built up, which first inhibits the conscious performance and subsequently breaks through the conscious control. Good examples of enantiodromia are: the conversion of St. Paul and of Raymund Lully,⁴¹ the self-identification of the sick Nietzsche with Christ, and his deification and subsequent hatred of Wagner, the transformation of Swedenborg from an erudite scholar into a seer, and so on.

[710] 19. EXTRAVERSION is an outward-turning of *libido* (q.v.). I use this concept to denote a manifest relation of subject to object, a positive movement of subjective interest towards the object. Everyone in the extraverted state thinks, feels, and acts in relation to the object, and moreover in a direct and clearly observable fashion, so that no doubt can remain about his positive dependence on the object. In a sense, therefore, extraversion is a transfer of interest from subject to object. If it is an extraversion of thinking, the subject thinks himself into the object; if an extraversion of feeling, he feels himself into it. In extraversion there is a strong, if not exclusive, determination by the object. Extraversion is *active* when it is intentional, and *passive*

when the object compels it, i.e., when the object attracts the subject's interest of its own accord, even against his will. When extraversion is habitual, we speak of the extraverted *type* (q.v.).

[711] 20. FANTASY.⁴² By fantasy I understand two different things: 1. a *fantasm*, and 2. *imaginative activity*. In the present work the context always shows which of these meanings is intended. By fantasy in the sense of *fantasm* I mean a complex of ideas that is distinguished from other such complexes by the fact that it has no objective referent. Although it may originally be based on memory-images of actual experiences, its content refers to no external reality; it is merely the output of creative psychic activity, a manifestation or product of a combination of energized psychic elements. In so far as psychic energy can be voluntarily directed, a fantasy can be consciously and intentionally produced, either as a whole or at least in part. In the former case it is nothing but a combination of *conscious* elements, an artificial experiment of purely theoretical interest. In actual everyday psychological experience, fantasy is either set in motion by an intuitive attitude of expectation, or it is an irruption of *unconscious* contents into consciousness.

[712] We can distinguish between *active* and *passive* fantasy. *Active* fantasies are the product of *intuition* (q.v.), i.e., they are evoked by an *attitude* (q.v.) directed to the perception of unconscious contents, as a result of which the *libido* (q.v.) immediately invests all the elements emerging from the unconscious and, by association with parallel material, brings them into clear focus in visual form. *Passive* fantasies appear in visual form at the outset, neither preceded nor accompanied by intuitive expectation, the attitude of the subject being wholly passive. Such fantasies belong to the category of psychic *automatisms* (Janet). Naturally, they can appear only as a result of a relative dissociation of the psyche, since they presuppose a withdrawal of energy from conscious control and a corresponding activation of unconscious material. Thus the vision of St. Paul⁴³ presupposes that unconsciously he was already a Christian, though this fact had escaped his conscious insight.

[713] It is probable that passive fantasies always have their origin in an unconscious process that is antithetical to consciousness, but invested with approximately the same amount of energy as the conscious attitude, and therefore capable of breaking through the latter's resistance. Active fantasies, on the other hand, owe their existence not so much to this unconscious process as to a conscious propensity to assimilate hints or fragments of lightly-toned unconscious complexes and, by associating them with parallel elements, to elaborate them in clearly visual form. It is not necessarily a question of a dissociated psychic state, but rather of a positive participation of consciousness.

[714] Whereas passive fantasy not infrequently bears a morbid stamp or at least shows some trace of abnormality, active fantasy is one of the highest forms of psychic activity. For here the conscious and the unconscious personality of the subject flow together into a common product in which both are united. Such a fantasy can be the highest expression of the unity of a man's *individuality* (q.v.), and it may even create that individuality by giving perfect expression to its unity. As a general rule, passive fantasy is never the expression of a unified individuality since, as already observed, it presupposes a considerable degree of dissociation based in turn on a marked conscious/unconscious opposition. Hence the fantasy that irrupts into consciousness from such a state can never be the perfect expression of a unified individuality, but will represent mainly the standpoint of the unconscious personality. The life of St. Paul affords a good example of this: his conversion to Christianity signified an acceptance of the hitherto unconscious standpoint and a repression of the hitherto anti-Christian one, which then made itself felt in his hysterical attacks. Passive fantasy, therefore, is always in need of conscious *criticism*, lest it merely reinforce the standpoint of the unconscious opposite. Whereas active fantasy, as the product of a conscious attitude *not* opposed to the unconscious, and of unconscious processes not opposed but merely compensatory to consciousness, does not require criticism so much as *understanding*.

[715] In fantasies as in dreams (which are nothing but passive fantasies), a *manifest* and a *latent* meaning must be distinguished. The manifest meaning is found in the actual "look" of the fantasy image, in the direct statement made by the underlying complex of ideas. Frequently, however, the manifest meaning hardly deserves its name, although it is always far more developed in fantasies than in dreams, probably because the dream-fantasy usually requires very little energy to overcome the feeble resistance of the sleeping consciousness, with the result that tendencies which are only slightly antagonistic and slightly compensatory can also reach the threshold of perception. Waking fantasy, on the other hand, must muster considerable energy to overcome the inhibition imposed by the conscious attitude. For this to take place, the unconscious opposite must be a very important one in order to break through into consciousness. If it consisted merely of vague, elusive hints it would never be able to direct attention (conscious libido) to itself so effectively as to interrupt the continuity of the conscious contents. The unconscious opposite, therefore, has to depend on a very strong inner cohesion, and this expresses itself in an emphatic manifest meaning.

[716] The manifest meaning always has the character of a visual and concrete process which, because of its objective unreality, can never satisfy the conscious demand for understanding. Hence another meaning of the fantasy, in other words its interpretation or latent meaning, has to be sought. Although the existence of a latent

meaning is by no means certain, and although the very possibility of it may be contested, the demand for understanding is a sufficient motive for a thorough-going investigation. This investigation of the latent meaning may be purely causal, inquiring into the psychological origins of the fantasy. It leads on the one hand to the remoter causes of the fantasy in the distant past, and on the other to ferreting out the instinctual forces which, from the energetic standpoint, must be responsible for the fantasy activity. As we know, Freud has made intensive use of this method. It is a method of interpretation which I call *reductive* (q.v.). The justification of a reductive view is immediately apparent, and it is equally obvious that this method of interpreting psychological facts suffices for people of a certain temperament, so that no demand for a deeper understanding is made. If somebody shouts for help, this is sufficiently and satisfactorily explained when it is shown that the man is in immediate danger of his life. If a man dreams of a sumptuous feast, and it is shown that he went to bed hungry, this is a sufficient explanation of his dream. Or if a man who represses his sexuality has sexual fantasies like a medieval hermit, this is satisfactorily explained by a reduction to sexual repression.

[717] But if we were to explain Peter's vision⁴⁴ by reducing it to the fact that, being "very hungry," he had received an invitation from the unconscious to eat animals that were "unclean," or that the eating of unclean beasts merely signified the fulfilment of a forbidden wish, such an explanation would send us away empty. It would be equally unsatisfactory to reduce Paul's vision to his repressed envy of the role Christ played among his fellow countrymen, which prompted him to identify himself with Christ. Both explanations may contain some glimmering of truth, but they are in no way related to the real psychology of the two apostles, conditioned as this was by the times they lived in. The explanation is too facile. One cannot discuss historical events as though they were problems of physiology or a purely personal *chronique scandaleuse*. That would be altogether too limited a point of view. We are therefore compelled to broaden very considerably our conception of the latent meaning of fantasy, first of all in its causal aspect. The psychology of an individual can never be exhaustively explained from himself alone: a clear recognition is needed of the way it is also conditioned by historical and environmental circumstances. His individual psychology is not merely a physiological, biological, or moral problem, it is also a contemporary problem. Again, no psychological fact can ever be exhaustively explained in terms of causality alone; as a living phenomenon, it is always indissolubly bound up with the continuity of the vital process, so that it is not only something evolved but also continually evolving and creative.

[718] Anything psychic is Janus-faced—it looks both backwards and forwards. Because it is evolving, it is also preparing the future. Were this not so, intentions, aims, plans, calculations, predictions and premonitions would be psychological

impossibilities. If, when a man expresses an opinion, we simply relate it to an opinion previously expressed by someone else, this explanation is quite futile, for we wish to know not merely what prompted him to do so, but what he means by it, what his aims and intentions are, and what he hopes to achieve. And when we know that, we are usually satisfied. In everyday life we instinctively, without thinking, introduce a final standpoint into an explanation; indeed, very often we take the final standpoint as the decisive one and completely disregard the strictly causal factor, instinctively recognizing the creative element in everything psychic. If we do this in everyday life, then a scientific psychology must take this fact into account, and not rely exclusively on the strictly causal standpoint originally taken over from natural science, for it has also to consider the purposive nature of the psyche.

[719] If, then, everyday experience establishes beyond doubt the final orientation of conscious contents, we have absolutely no grounds for assuming, in the absence of experience to the contrary, that this is not the case with the contents of the unconscious. My experience gives me no reason at all to dispute this; on the contrary, cases where the introduction of the final standpoint alone provides a satisfactory explanation are in the majority. If we now look at Paul's vision again, but this time from the angle of his future mission, and come to the conclusion that Paul, though consciously a persecutor of Christians, had unconsciously adopted the Christian standpoint, and that he was finally brought to avow it by an irruption of the unconscious, because his unconscious personality was constantly striving toward this goal—this seems to me a more adequate explanation of the real significance of the event than a reduction to personal motives, even though these doubtless played their part in some form or other, since the “all-too-human” is never lacking. Similarly, the clear indication given in Acts 10:28 of a purposive interpretation of Peter's vision is far more satisfying than a merely physiological and personal conjecture.

[720] To sum up, we might say that a fantasy needs to be understood both causally and purposively. Causally interpreted, it seems like a *symptom* of a physiological or personal state, the outcome of antecedent events. Purposively interpreted, it seems like a *symbol*, seeking to characterize a definite goal with the help of the material at hand, or trace out a line of future psychological development. Because active fantasy is the chief mark of the artistic mentality, the artist is not just a *reproducer* of appearances but a creator and educator, for his works have the value of symbols that adumbrate lines of future development. Whether the symbols will have a limited or a general social validity depends on the viability of the creative individual. The more abnormal, i.e., the less viable he is, the more limited will be the social validity of the symbols he produces, though their value may be absolute for the individual himself.

[721] One can dispute the existence of the latent meaning of fantasy only if one is of the opinion that natural processes in general are devoid of meaning. Science, however, has extracted the meaning of natural processes in the form of natural laws. These, admittedly, are human hypotheses advanced in explanation of such processes. But, in so far as we have ascertained that the proposed law actually coincides with the objective process, we are also justified in speaking of the meaning of natural occurrences. We are equally justified in speaking of the meaning of fantasies when it can be shown that they conform to law. But the meaning we discover is satisfying, or to put it another way, the demonstrated law deserves its name, only when it adequately reflects the nature of fantasy. Natural processes both conform to law and demonstrate that law. It is a law that one dreams when one sleeps, but that is not a law which demonstrates anything about the nature of the dream; it is a mere condition of the dream. The demonstration of a physiological source of fantasy is likewise a mere condition of its existence, not a law of its nature. The law of fantasy as a psychological phenomenon can only be a psychological law.

[722] This brings us to the second connotation of fantasy, namely *imaginative activity*. Imagination is the reproductive or creative activity of the mind in general. It is not a special faculty, since it can come into play in all the basic forms of psychic activity, whether *thinking, feeling, sensation, or intuition* (qq.v.). Fantasy as imaginative activity is, in my view, simply the direct expression of psychic life,⁴⁵ of psychic energy which cannot appear in consciousness except in the form of images or contents, just as physical energy cannot manifest itself except as a definite physical state stimulating the sense organs in physical ways. For as every physical state, from the energetic standpoint, is a dynamic system, so from the same standpoint a psychic content is a dynamic system manifesting itself in consciousness. We could therefore say that fantasy in the sense of a *fantasm* is a definite sum of libido that cannot appear in consciousness in any other way than in the form of an image. A *fantasm* is an *idée-force*. Fantasy as imaginative activity is identical with the flow of psychic energy.

[723] 21. FEELING.⁴⁶ I count feeling among the four basic psychological *functions* (q.v.). I am unable to support the psychological school that considers feeling a secondary phenomenon dependent on “representations” or sensations, but in company with Höffding, Wundt, Lehmann, Külpe, Baldwin, and others, I regard it as an independent function *sui generis*.⁴⁷

[724] Feeling is primarily a process that takes place between the *ego* (q.v.) and a given content, a process, moreover, that imparts to the content a definite *value* in the sense of acceptance or rejection (“like” or “dislike”). The process can also appear isolated, as it were, in the form of a “mood,” regardless of the momentary contents of

consciousness or momentary sensations. The mood may be causally related to earlier conscious contents, though not necessarily so, since, as psychopathology amply proves, it may equally well arise from unconscious contents. But even a mood, whether it be a general or only a partial feeling, implies a valuation; not of one definite, individual conscious content, but of the whole conscious situation at the moment, and, once again, with special reference to the question of acceptance or rejection.

[725] Feeling, therefore, is an entirely *subjective* process, which may be in every respect independent of external stimuli, though it allies itself with every sensation.⁴⁸ Even an “indifferent” sensation possesses a feeling-tone, namely that of indifference, which again expresses some sort of valuation. Hence feeling is a kind of *judgment*, differing from intellectual judgment in that its aim is not to establish conceptual relations but to set up a subjective criterion of acceptance or rejection. Valuation by feeling extends to *every* content of consciousness, of whatever kind it may be. When the intensity of feeling increases, it turns into an *affect* (q.v.), i.e., a feeling-state accompanied by marked physical innervations. Feeling is distinguished from affect by the fact that it produces no perceptible physical innervations, i.e., neither more nor less than an ordinary thinking process.

[726] Ordinary, “simple” feeling is *concrete* (q.v.), that is, it is mixed up with other functional elements, more particularly with sensations. In this case we can call it *affective* or, as I have done in this book, *feeling-sensation*, by which I mean an almost inseparable amalgam of feeling and sensation elements. This characteristic amalgamation is found wherever feeling is still an undifferentiated function, and is most evident in the psyche of a neurotic with differentiated thinking. Although feeling is, in itself, an independent function, it can easily become dependent on another function—thinking, for instance; it is then a mere concomitant of thinking, and is not repressed only in so far as it accommodates itself to the thinking processes.

[727] It is important to distinguish *abstract* feeling from ordinary concrete feeling. Just as the abstract concept (v. *Thinking*) abolishes the differences between things it apprehends, abstract feeling rises above the differences of the individual contents it evaluates, and produces a “mood” or feeling-state which embraces the different individual valuations and thereby abolishes them. In the same way that thinking organizes the contents of consciousness under concepts, feeling arranges them according to their value. The more concrete it is, the more subjective and personal is the value conferred upon them; but the more abstract it is, the more universal and objective the value will be. Just as a completely abstract concept no longer coincides with the singularity and discreteness of things, but only with their universality and non-differentiation, so completely abstract feeling no longer coincides with a

particular content and its feeling-value, but with the undifferentiated totality of all contents. Feeling, like thinking, is a *rational* (q.v.) function, since values in general are assigned according to the laws of reason, just as concepts in general are formed according to these laws.

[728] Naturally the above definitions do not give the essence of feeling—they only describe it from outside. The intellect proves incapable of formulating the real nature of feeling in conceptual terms, since thinking belongs to a category incommensurable with feeling; in fact, no basic psychological function can ever be completely expressed by another. That being so, it is impossible for an intellectual definition to reproduce the specific character of feeling at all adequately. The mere classification of feelings adds nothing to an understanding of their nature, because even the most exact classification will be able to indicate only the content of feeling which the intellect can apprehend, without grasping its specific nature. Only as many classes of feelings can be discriminated as there are classes of contents that can be intellectually apprehended, but feeling *per se* can never be exhaustively classified because, beyond every possible class of contents accessible to the intellect, there still exist feelings which resist intellectual classification. The very notion of classification is intellectual and therefore incompatible with the nature of feeling. We must therefore be content to indicate the limits of the concept.

[729] The nature of valuation by feeling may be compared with intellectual *apperception* (q.v.) as an *apperception of value*. We can distinguish *active* and *passive* apperception by feeling. Passive feeling allows itself to be attracted or excited by a particular content, which then forces the feelings of the subject to participate. Active feeling is a transfer of value from the subject; it is an intentional valuation of the content in accordance with feeling and not in accordance with the intellect. Hence active feeling is a *directed* function, an act of the *will* (q.v.), as for instance loving as opposed to being in love. The latter would be *undirected*, passive feeling, as these expressions themselves show: the one is an activity, the other a passive state. Undirected feeling is *feeling-intuition*. Strictly speaking, therefore, only active, directed feeling should be termed *rational*, whereas passive feeling is *irrational* (q.v.) in so far as it confers values without the participation or even against the intentions of the subject. When the subject's attitude as a whole is oriented by the feeling function, we speak of a *feeling type* (v. *Type*).

[730] 21a. FEELING, A (OR FEELINGS). A feeling is the specific content or material of the feeling function, discriminated by *empathy* (q.v.).

[731] 22. FUNCTION (v. also INFERIOR FUNCTION). By a psychological function I mean a particular form of psychic activity that remains the same in principle under varying

conditions. From the energetic standpoint a function is a manifestation of *libido* (q.v.), which likewise remains constant in principle, in much the same way as a physical force can be considered a specific form or manifestation of physical energy. I distinguish four basic functions in all, two rational and two irrational (qq.v.): *thinking* and *feeling*, *sensation* and *intuition* (qq.v.). I can give no *a priori* reason for selecting these four as basic functions, and can only point out that this conception has shaped itself out of many years' experience. I distinguish these functions from one another because they cannot be related or reduced to one another. The principle of thinking, for instance, is absolutely different from the principle of feeling, and so forth. I make a cardinal distinction between these functions and *fantasies* (q.v.), because fantasy is a characteristic form of activity that can manifest itself in all four functions. Volition or *will* (q.v.) seems to me an entirely secondary phenomenon, and so does *attention*.

[732] 23. IDEA. In this work the concept "idea" is sometimes used to designate a certain psychological element which is closely connected with what I term *image* (q.v.). The image may be either *personal* or *impersonal* in origin. In the latter case it is *collective* (q.v.) and is also distinguished by mythological qualities. I then term it a *primordial image*. When, on the other hand, it has no mythological character, i.e., is lacking in visual qualities and merely collective, I speak of an *idea*. Accordingly, I use the term idea to express the *meaning* of a primordial image, a meaning that has been abstracted from the *concretism* (q.v.) of the image. In so far as an idea is an *abstraction* (q.v.), it has the appearance of something derived, or developed, from elementary factors, a product of thought. This is the sense in which it is conceived by Wundt⁴⁹ and many others.

[733] In so far, however, as an idea is the formulated meaning of a primordial image by which it was represented *symbolically* (v. *Symbol*), its essence is not just something derived or developed, but, psychologically speaking, exists *a priori*, as a given possibility for thought-combinations in general. Hence, in accordance with its essence (but not with its formulation), the idea is a psychological determinant having an *a priori* existence. In this sense Plato sees the idea as a prototype of things, while Kant defines it as the "archetype [*Urbild*] of all practical employment of reason," a transcendental concept which as such exceeds the bounds of the experienceable,⁵⁰ "a rational concept whose object is not to be found in experience."⁵¹ He says:

Although we must say of the transcendental concepts of reason that *they are only ideas*, this is not by any means to be taken as signifying that they are superfluous and void. For even if they cannot determine any object, they may yet, in a fundamental and unobserved fashion, be of service to the understanding as a canon for its extended and consistent employment. The understanding does not thereby obtain more knowledge of any object than it would have by means of its own concepts, but

for the acquiring of such knowledge it receives better and more extensive guidance. Further—what we need here no more than mention—concepts of reason may perhaps make a possible transition from the concepts of nature to the practical concepts, and in that way may give support to the moral ideas themselves.⁵²

[734] Schopenhauer says:

By Idea, then, I understand every definite and well-established stage in the objectivation of the Will, so far as the Will is a thing-in-itself and therefore without multiplicity, which stages are related to individual things as their eternal forms or prototypes.⁵³

For Schopenhauer the idea is a visual thing, for he conceives it entirely in the way I conceive the primordial image. Nevertheless, it remains uncognizable by the individual, revealing itself only to the “pure subject of cognition,” which “is beyond all willing and all individuality.”⁵⁴

[735] Hegel hypostatizes the idea completely and attributes to it alone real being. It is the “concept, the reality of the concept, and the union of both.”⁵⁵ It is “eternal generation.”⁵⁶ Lasswitz regards the idea as the “law showing the direction in which our experience should develop.” It is the “most certain and supreme reality.”⁵⁷ For Cohen, it is the “concept’s awareness of itself,” the “foundation” of being.⁵⁸

[736] I do not want to pile up evidence for the primary nature of the idea. These quotations should suffice to show that it can be conceived as a fundamental, *a priori* factor. It derives this quality from its precursor—the primordial, symbolic image. Its secondary nature as something abstract and derived is a result of the rational elaboration to which the primordial image is subjected to fit it for rational use. The primordial image is an autochthonous psychological factor constantly repeating itself at all times and places, and the same might be said of the idea, although, on account of its rational nature, it is much more subject to modification by rational elaboration and formulations corresponding to local conditions and the spirit of the time. Since it is derived from the primordial image, a few philosophers ascribe a transcendent quality to it; this does not really belong to the idea as I conceive it, but rather to the primordial image, about which a timeless quality clings, being an integral component of the human mind everywhere from time immemorial. Its autonomous character is also derived from the primordial image, which is never “made” but is continually present, appearing in perception so spontaneously that it seems to strive for its own realization, being sensed by the mind as an active determinant. Such a view, however, is not general, and is presumably a question of *attitude* (q.v., also [Ch. VII](#)).

[737] The idea is a psychological factor that not only determines thinking but, as a practical idea, also conditions feeling. As a general rule, I use the term *idea* only when speaking of the determination of thought in a thinking type, or of feeling in a

feeling type. On the other hand, it would be terminologically correct to speak of an *a priori* determination by the primordial image in the case of an undifferentiated function. The dual nature of the idea as something both primary and derived is responsible for the fact that I sometimes use it promiscuously with primordial image. For the introverted attitude the idea is the prime mover; for the extraverted, a product.

[738] 24. IDENTIFICATION. By this I mean a psychological process in which the personality is partially or totally *dissimilated* (v. *Assimilation*). Identification is an alienation of the subject from himself for the sake of the object, in which he is, so to speak, disguised. For example, identification with the father means, in practice, adopting all the father's ways of behaving, as though the son were the same as the father and not a separate individuality. Identification differs from *imitation* in that it is an *unconscious* imitation, whereas imitation is a conscious copying. Imitation is an indispensable aid in developing the youthful personality. It is beneficial so long as it does not serve as a mere convenience and hinder the development of ways and means suited to the individual. Similarly, identification can be beneficial so long as the individual cannot go his own way. But when a better possibility presents itself, identification shows its morbid character by becoming just as great a hindrance as it was an unconscious help and support before. It now has a dissociative effect, splitting the individual into two mutually estranged personalities.

[739] Identification does not always apply to persons but also to things (e.g., a movement of some kind, a business, etc.) and to psychological functions. The latter kind is, in fact, particularly important.⁵⁹ Identification then leads to the formation of a secondary character, the individual identifying with his best developed function to such an extent that he alienates himself very largely or even entirely from his original character, with the result that his true *individuality* (q.v.) falls into the unconscious. This is nearly always the rule with people who have one highly differentiated function. It is, in fact, a necessary transitional stage on the way to *individuation* (q.v.).

[740] Identification with parents or the closest members of the family is a normal phenomenon in so far as it coincides with the *a priori family identity*. In this case it is better not to speak of *identification* but of *identity* (q.v.), a term that expresses the actual situation. Identification with members of the family differs from identity in that it is not an *a priori* but a secondary phenomenon arising in the following way. As the individual emerges from the original family identity, the process of adaptation and development brings him up against obstacles that cannot easily be mastered. A damming up of *libido* (q.v.) ensues, which seeks a regressive outlet. The regression reactivates the earlier states, among them the state of family identity. Identification with members of the family corresponds to this regressive revival of an identity that

had almost been overcome. All identifications with persons come about in this way. Identification always has a purpose, namely, to obtain an advantage, to push aside an obstacle, or to solve a task in the way another individual would.

[741] 25. IDENTITY. I use the term *identity* to denote a psychological conformity. It is always an unconscious phenomenon since a conscious conformity would necessarily involve a consciousness of two dissimilar things, and, consequently, a separation of subject and object, in which case the identity would already have been abolished. Psychological identity presupposes that it is unconscious. It is a characteristic of the primitive mentality and the real foundation of *participation mystique* (q.v.), which is nothing but a relic of the original non-differentiation of subject and object, and hence of the primordial unconscious state. It is also a characteristic of the mental state of early infancy, and, finally, of the unconscious of the civilized adult, which, in so far as it has not become a content of consciousness, remains in a permanent state of identity with objects. Identity with the parents provides the basis for subsequent *identification* (q.v.) with them; on it also depends the possibility of *projection* (q.v.) and *introjection* (q.v.).

[742] Identity is primarily an unconscious conformity with objects. It is not an *equation*, but an *a priori likeness* which was never the object of consciousness. Identity is responsible for the naïve assumption that the psychology of one man is like that of another, that the same motives occur everywhere, that what is agreeable to me must obviously be pleasurable for others, that what I find immoral must also be immoral for them, and so on. It is also responsible for the almost universal desire to correct in others what most needs correcting in oneself. Identity, too, forms the basis of suggestion and psychic infection. Identity is particularly evident in pathological cases, for instance in paranoid ideas of reference, where one's own subjective contents are taken for granted in others. But identity also makes possible a consciously *collective* (q.v.), social *attitude* (q.v.), which found its highest expression in the Christian ideal of brotherly love.

[743] 26. IMAGE. When I speak of "image" in this book, I do not mean the psychic reflection of an external object, but a concept derived from poetic usage, namely, a figure of fancy or *fantasy-image*, which is related only indirectly to the perception of an external object. This image depends much more on unconscious fantasy activity, and as the product of such activity it appears more or less abruptly in consciousness, somewhat in the manner of a vision or hallucination, but without possessing the morbid traits that are found in a clinical picture. The image has the psychological character of a fantasy idea and never the quasi-real character of an hallucination, i.e., it never takes the place of reality, and can always be distinguished from sensuous reality by the fact that it is an "inner" image. As a rule, it is not a projection in space,

although in exceptional cases it can appear in exteriorized form. This mode of manifestation must be termed *archaic* (q.v.) when it is not primarily pathological, though that would not by any means do away with its archaic character. On the primitive level, however, the inner image can easily be projected in space as a vision or an auditory hallucination without being a pathological phenomenon.

[744] Although, as a rule, no reality-value attaches to the image, this can at times actually increase its importance for psychic life, since it then has a greater *psychological* value, representing an inner reality which often far outweighs the importance of external reality. In this case the *orientation* (q.v.) of the individual is concerned less with adaptation to reality than with adaptation to inner demands.

[745] The inner image is a complex structure made up of the most varied material from the most varied sources. It is no conglomerate, however, but a homogeneous product with a meaning of its own. The image is a *condensed expression of the psychic situation as a whole*, and not merely, nor even predominately, of unconscious contents pure and simple. It undoubtedly does express unconscious contents, but not the whole of them, only those that are momentarily constellated. This constellation is the result of the spontaneous activity of the unconscious on the one hand and of the momentary conscious situation on the other, which always stimulates the activity of relevant subliminal material and at the same time inhibits the irrelevant. Accordingly the image is an expression of the unconscious as well as the conscious situation of the moment. The interpretation of its meaning, therefore, can start neither from the conscious alone nor from the unconscious alone, but only from their reciprocal relationship.

[746] I call the image *primordial* when it possesses an *archaic* (q.v.) character.⁶⁰ I speak of its archaic character when the image is in striking accord with familiar mythological motifs. It then expresses material primarily derived from the *collective unconscious* (q.v.), and indicates at the same time that the factors influencing the conscious situation of the moment are *collective* (q.v.) rather than personal. A *personal* image has neither an archaic character nor a collective significance, but expresses contents of the *personal unconscious* (q.v.) and a personally conditioned conscious situation.

[747] The primordial image, elsewhere also termed *archetype*,⁶¹ is always collective, i.e., it is at least common to entire peoples or epochs. In all probability the most important mythological motifs are common to all times and races; I have, in fact, been able to demonstrate a whole series of motifs from Greek mythology in the dreams and fantasies of pure-bred Negroes suffering from mental disorders.⁶²

[748] From⁶³ the scientific, causal standpoint the primordial image can be conceived as a mnemonic deposit, an imprint or *engram* (Semon), which has arisen through the

condensation of countless processes of a similar kind. In this respect it is a precipitate and, therefore, a typical basic form, of certain ever-recurring psychic experiences. As a mythological motif, it is a continually effective and recurrent expression that reawakens certain psychic experiences or else formulates them in an appropriate way. From this standpoint it is a psychic expression of the physiological and anatomical disposition. If one holds the view that a particular anatomical structure is a product of environmental conditions, working on living matter, then the primordial image, in its constant and universal distribution, would be the product of equally constant and universal influences from without, which must, therefore, act like a natural law. One could in this way relate myths to nature, as for instance solar myths to the daily rising and setting of the sun, or to the equally obvious change of the seasons, and this has in fact been done by many mythologists, and still is. But that leaves the question unanswered why the sun and its apparent motions do not appear direct and undisguised as a content of the myths. The fact that the sun or the moon or the meteorological processes appear, at the very least, in allegorized form points to an independent collaboration of the psyche, which in that case cannot be merely a product or stereotype of environmental conditions. For whence would it draw the capacity to adopt a standpoint outside sense perception? How, for that matter, could it be at all capable of any performance more or other than the mere corroboration of the evidence of the senses? In view of such questions Semon's naturalistic and causalistic engram theory no longer suffices. We are forced to assume that the given structure of the brain does not owe its peculiar nature merely to the influence of surrounding conditions, but also and just as much to the peculiar and autonomous quality of living matter, i.e., to a law inherent in life itself. The given constitution of the organism, therefore, is on the one hand a product of external conditions, while on the other it is determined by the intrinsic nature of living matter. Accordingly, the primordial image is related just as much to certain palpable, self-perpetuating, and continually operative natural processes as it is to certain inner determinants of psychic life and of life in general. The organism confronts light with a new structure, the eye, and the psyche confronts the natural process with a symbolic image, which apprehends it in the same way as the eye catches the light. And just as the eye bears witness to the peculiar and spontaneous creative activity of living matter, the primordial image expresses the unique and unconditioned creative power of the psyche.

[749] The primordial image is thus a condensation of the living process. It gives a coordinating and coherent meaning both to sensuous and to inner perceptions, which at first appear without order or connection, and in this way frees psychic energy from its bondage to sheer uncomprehended perception. At the same time, it links the energies released by the perception of stimuli to a definite meaning, which then guides action along paths corresponding to this meaning. It releases unavailable, dammed-up

energy by leading the mind back to nature and canalizing sheer instinct into mental forms.

[750] The primordial image is the precursor of the *idea* (q.v.), and its matrix. By detaching it from the *concretism* (q.v.) peculiar and necessary to the primordial image, reason develops it into a concept—i.e., an idea which differs from all other concepts in that it is not a datum of experience but is actually the underlying principle of all experience. The idea derives this quality from the primordial image, which, as an expression of the specific structure of the brain, gives every experience a definite form.

[751] The degree of psychological efficacy of the primordial image is determined by the *attitude* (q.v.) of the individual. If the attitude is introverted, the natural consequence of the withdrawal of *libido* (q.v.) from the external object is the heightened significance of the internal object, i.e., thought. This leads to a particularly intense development of thought along the lines unconsciously laid down by the primordial image. In this way the primordial image comes to the surface indirectly. The further development of thought leads to the idea, which is nothing other than the primordial image intellectually formulated. Only the development of the counter-function can take the idea further—that is to say, once the idea has been grasped intellectually, it strives to become effective in life. It therefore calls upon *feeling* (q.v.), which in this case is much less differentiated and more concretistic than thinking. Feeling is impure and, because undifferentiated, still fused with the *unconscious*. Hence the individual is unable to unite the contaminated feeling with the idea. At this juncture the primordial image appears in the inner field of vision as a *symbol* (q.v.), and, by virtue of its concrete nature, embraces the undifferentiated, concretized feeling, but also, by virtue of its intrinsic significance, embraces the idea, of which it is indeed the matrix, and so unites the two. In this way the primordial image acts as a mediator, once again proving its redeeming power, a power it has always possessed in the various religions. What Schopenhauer says of the idea, therefore, I would apply rather to the primordial image, since, as I have already explained, the idea is not something absolutely *a priori*, but must also be regarded as secondary and derived (v. *Idea*).

[752] In the following passage from Schopenhauer, I would ask the reader to replace the word “idea” by “primordial image,” and he will then be able to understand my meaning.

It [the idea] is never cognized by the individual as such, but only by him who has raised himself beyond all willing and all individuality to the pure subject of cognition. Thus it is attainable only by the genius, or by the man who, inspired by works of genius, has succeeded in elevating his powers of pure cognition into a

temper akin to genius. It is, therefore, not absolutely but only conditionally communicable, since the idea conceived and reproduced in a work of art, for instance, appeals to each man only according to the measure of his own intellectual worth.

The idea is the unity that falls into multiplicity on account of the temporal and spatial form of our intuitive apprehension.

The concept is like an inert receptacle, in which the things one puts into it lie side by side, but from which no more can be taken out than was put in. The idea, on the other hand, develops, in him who has comprehended it, notions which are new in relation to the concept of the same name: it is like a living, self-developing organism endowed with generative power, constantly bringing forth something that was not put into it.⁶⁴

[753] Schopenhauer clearly discerned that the “idea,” or the primordial image as I define it, cannot be produced in the same way that a concept or an “idea” in the ordinary sense can (Kant defines an “idea” as a concept “formed from notions”).⁶⁵ There clings to it an element beyond rational formulation, rather like Schopenhauer’s “temper akin to genius,” which simply means a state of feeling. One can get to the primordial image from the idea only because the path that led to the idea passes over the summit into the counterfunction, feeling.

[754] The primordial image has one great advantage over the clarity of the idea, and that is its vitality. It is a self-activating organism, “endowed with generative power.” The primordial image is an inherited organization of psychic energy, an ingrained system, which not only gives expression to the energetic process but facilitates its operation. It shows how the energetic process has run its unvarying course from time immemorial, while simultaneously allowing a perpetual repetition of it by means of an apprehension or psychic grasp of situations so that life can continue into the future. It is thus the necessary counterpart of *instinct* (q.v.), which is a purposive mode of action presupposing an equally purposive and meaningful grasp of the momentary situation. This apprehension is guaranteed by the pre-existent primordial image. It represents the practical formula without which the apprehension of a new situation would be impossible.

26a. IMAGO V. SUBJECTIVE LEVEL.

[755] 27. INDIVIDUAL. The psychological individual is characterized by a peculiar and in some respects unique psychology. The peculiar nature of the individual psyche appears less in its elements than in its complex formations. The psychological individual, or his *individuality* (q.v.), has an *a priori* unconscious existence, but exists consciously only so far as a consciousness of his peculiar nature is present, i.e., so far

as there exists a conscious distinction from other individuals. The psychic individuality is given *a priori* as a correlate of the physical individuality, although, as observed, it is at first unconscious. A conscious process of *differentiation* (q.v.), or *individuation* (q.v.), is needed to bring the individuality to consciousness, i.e., to raise it out of the state of *identity* (q.v.) with the object. The identity of the individuality with the object is synonymous with its unconsciousness. If the individuality is unconscious, there is no psychological individual but merely a collective psychology of consciousness. The unconscious individuality is then projected on the object, and the object, in consequence, possesses too great a value and acts as too powerful a determinant.

[756] 28. INDIVIDUALITY. By individuality I mean the peculiarity and singularity of the individual in every psychological respect. Everything that is not *collective* (q.v.) is individual, everything in fact that pertains only to one individual and not to a larger group of individuals. Individuality can hardly be said to pertain to the psychic elements themselves, but only to their peculiar and unique grouping and combination (v. *Individual*).

[757] 29. INDIVIDUATION. The concept of individuation plays a large role in our psychology. In general, it is the process by which individual beings are formed and differentiated; in particular, it is the development of the psychological *individual* (q.v.) as a being distinct from the general, collective psychology. Individuation, therefore, is a process of *differentiation* (q.v.), having for its goal the development of the individual personality.

[758] Individuation is a natural necessity inasmuch as its prevention by a levelling down to collective standards is injurious to the vital activity of the individual. Since *individuality* (q.v.) is a prior psychological and physiological datum, it also expresses itself in psychological ways. Any serious check to individuality, therefore, is an artificial stunting. It is obvious that a social group consisting of stunted individuals cannot be a healthy and viable institution; only a society that can preserve its internal cohesion and collective values, while at the same time granting the individual the greatest possible freedom, has any prospect of enduring vitality. As the individual is not just a single, separate being, but by his very existence presupposes a collective relationship, it follows that the process of individuation must lead to more intense and broader collective relationships and not to isolation.

[759] Individuation is closely connected with the *transcendent function* (v. *Symbol*, par. 828), since this function creates individual lines of development which could never be reached by keeping to the path prescribed by collective norms.

[760] Under no circumstances can individuation be the sole aim of psychological education. Before it can be taken as a goal, the educational aim of adaptation to the necessary minimum of collective norms must first be attained. If a plant is to unfold its specific nature to the full, it must first be able to grow in the soil in which it is planted.

[761] Individuation is always to some extent opposed to collective norms, since it means separation and differentiation from the general and a building up of the particular—not a particularity that is *sought out*, but one that is already ingrained in the psychic constitution. The opposition to the collective norm, however, is only apparent, since closer examination shows that the individual standpoint is not *antagonistic* to it, but only *differently oriented*. The individual way can never be directly opposed to the collective norm, because the opposite of the collective norm could only be another, but contrary, norm. But the individual way can, by definition, never be a norm. A norm is the product of the totality of individual ways, and its justification and beneficial effect are contingent upon the existence of individual ways that need from time to time to orient to a norm. A norm serves no purpose when it possesses absolute validity. A real conflict with the collective norm arises only when an individual way is raised to a norm, which is the actual aim of extreme individualism. Naturally this aim is pathological and inimical to life. It has, accordingly, nothing to do with individuation, which, though it may strike out on an individual bypath, precisely on that account needs the norm for its *orientation* (q.v.) to society and for the vitally necessary relationship of the individual to society. Individuation, therefore, leads to a natural esteem for the collective norm, but if the orientation is exclusively collective the norm becomes increasingly superfluous and morality goes to pieces. The more a man's life is shaped by the collective norm, the greater is his individual immorality.

[762] Individuation is practically the same as the development of consciousness out of the original state of *identity* (q.v.). It is thus an extension of the sphere of consciousness, an enriching of conscious psychological life.

[763] 30. INFERIOR function. This term is used to denote the function that lags behind in the process of *differentiation* (q.v.). Experience shows that it is practically impossible, owing to adverse circumstances in general, for anyone to develop all his psychological functions simultaneously. The demands of society compel a man to apply himself first and foremost to the differentiation of the function with which he is best equipped by nature, or which will secure him the greatest social success. Very frequently, indeed as a general rule, a man identifies more or less completely with the most favoured and hence the most developed function. It is this that gives rise to the various psychological *types* (q.v.). As a consequence of this one-sided development,

one or more functions are necessarily retarded. These functions may properly be called *inferior* in a psychological but not psychopathological sense, since they are in no way morbid but merely backward as compared with the favoured function.

[764] Although the inferior function may be conscious as a phenomenon, its true significance nevertheless remains unrecognized. It behaves like many repressed or insufficiently appreciated contents, which are partly conscious and partly unconscious, just as, very often, one knows a certain person from his outward appearance but does not know him as he really is. Thus in normal cases the inferior function remains conscious, at least in its effects; but in a neurosis it sinks wholly or in part into the unconscious. For, to the degree that the greater share of *libido* (q.v.) is taken up by the favoured function, the inferior function undergoes a regressive development; it reverts to the *archaic* (q.v.) stage and becomes incompatible with the conscious, favoured function. When a function that should normally be conscious lapses into the unconscious, its specific energy passes into the unconscious too. A function such as feeling possesses the energy with which it is endowed by nature; it is a well-organized living system that cannot under any circumstances be wholly deprived of its energy. So with the inferior function: the energy left to it passes into the unconscious and activates it in an unnatural way, giving rise to *fantasies* (q.v.) on a level with the archaicized function. In order to extricate the inferior function from the unconscious by analysis, the unconscious fantasy formations that have now been activated must be brought to the surface. The conscious realization of these fantasies brings the inferior function to consciousness and makes further development possible.

[765] 31. INSTINCT. When I speak of instinct in this work or elsewhere, I mean what is commonly understood by this word, namely, an *impulsion* towards certain activities. The impulsion can come from an inner or outer stimulus which triggers off the mechanism of instinct psychically, or from organic sources which lie outside the sphere of psychic causality. Every psychic phenomenon is instinctive that does not arise from voluntary causation but from dynamic impulsion, irrespective of whether this impulsion comes directly from organic, extra-psychic sources, or from energies that are merely released by voluntary intention—in the latter case with the qualification that the end-result exceeds the effect voluntarily intended. In my view, all psychic processes whose energies are not under conscious control are instinctive. Thus *affects* (q.v.) are as much instinctive processes as they are *feeling* (q.v.) processes. Psychic processes which under ordinary circumstances are functions of the *will* (q.v.), and thus entirely under conscious control, can, in abnormal circumstances, become instinctive processes when supplied with unconscious energy. This phenomenon occurs whenever the sphere of consciousness is restricted by the

repression of incompatible contents, or when, as a result of fatigue, intoxication, or morbid cerebral conditions in general, an *abaissement du niveau mental* (Janet) ensues—when, in a word, the most strongly feeling-toned processes are no longer, or not yet, under conscious control. Processes that were once conscious but in time have become *automatized* I would reckon among the automatic processes rather than the instinctive. Nor do they normally behave like instincts, since in normal circumstances they never appear as impulsions. They do so only when supplied with an energy which is foreign to them.

[766] 32. INTELLECT. I call *directed thinking* (q.v.) intellect.

[767] 33. INTROJECTION. This term was introduced by Avenarius⁶⁶ to correspond with *projection* (q.v.). The expulsion of a subjective content into an object, which is what Avenarius meant, is expressed equally well by the term projection, and it would therefore be better to reserve the term projection for this process. Ferenczi has now defined introjection as the opposite of projection, namely as an indrawing of the object into the subjective sphere of interest, while projection is an expulsion of subjective contents into the object. “Whereas the paranoiac expels from his ego emotions which have become disagreeable, the neurotic helps himself to as large a portion of the outer world as his ego can ingest, and makes this an object of unconscious fantasies.”⁶⁷ The first mechanism is projection, the second introjection. Introjection is a sort of “diluting process,” an “expansion of the circle of interest.” According to Ferenczi, the process is a normal one.

[768] Psychologically speaking, introjection is a process of *assimilation* (q.v.), while projection is a process of *dissimilation*. Introjection is an assimilation of object to subject, projection a dissimilation of object from subject through the expulsion of a subjective content into the object (v. *Projection, active*). Introjection is a process of *extraversion* (q.v.), since assimilation to the object requires *empathy* (q.v.) and an investment of the object with *libido* (q.v.). A *passive* and an *active* introjection may be distinguished: transference phenomena in the treatment of the neuroses belong to the former category, and, in general, all cases where the object exercises a compelling influence on the subject, while empathy as a process of adaptation belongs to the latter category.

[769] 34. INTROVERSION means an inward-turning of *libido* (q.v.), in the sense of a negative relation of subject to object. Interest does not move towards the object but withdraws from it into the subject. Everyone whose attitude is introverted thinks, feels, and acts in a way that clearly demonstrates that the subject is the prime motivating factor and that the object is of secondary importance. Introversion may be intellectual or emotional, just as it can be characterized by *sensation* or *intuition*

(qq.v.). It is *active* when the subject *voluntarily* shuts himself off from the object, *passive* when he is unable to restore to the object the libido streaming back from it. When introversion is habitual, we speak of an *introverted type* (q.v.).

[770] 35. INTUITION (L. *intueri*, ‘to look at or into’). I regard intuition as a basic psychological *function* (q.v.). It is the function that mediates perceptions in an *unconscious way*. Everything, whether outer or inner objects or their relationships, can be the focus of this perception. The peculiarity of intuition is that it is neither sense perception, nor feeling, nor intellectual inference, although it may also appear in these forms. In intuition a content presents itself whole and complete, without our being able to explain or discover how this content came into existence. Intuition is a kind of instinctive apprehension, no matter of what contents. Like *sensation* (q.v.), it is an *irrational* (q.v.) function of perception. As with sensation, its contents have the character of being “given,” in contrast to the “derived” or “produced” character of *thinking* and *feeling* (qq.v.) contents. Intuitive knowledge possesses an intrinsic certainty and conviction, which enabled Spinoza (and Bergson) to uphold the *scientia intuitiva* as the highest form of knowledge. Intuition shares this quality with *sensation* (q.v.), whose certainty rests on its physical foundation. The certainty of intuition rests equally on a definite state of psychic “alertness” of whose origin the subject is unconscious.

[771] Intuition may be *subjective* or *objective*: the first is a perception of unconscious psychic data originating in the subject, the second is a perception of data dependent on subliminal perceptions of the object and on the feelings and thoughts they evoke. We may also distinguish *concrete* and *abstract* forms of intuition, according to the degree of participation on the part of sensation. Concrete intuition mediates perceptions concerned with the actuality of things, abstract intuition mediates perceptions of ideational connections. Concrete intuition is a reactive process, since it responds directly to the given facts; abstract intuition, like abstract sensation, needs a certain element of direction, an act of the will, or an aim.

[772] Like sensation, intuition is a characteristic of infantile and primitive psychology. It counterbalances the powerful sense impressions of the child and the primitive by mediating perceptions of mythological images, the precursors of *ideas* (q.v.). It stands in a compensatory relationship to sensation and, like it, is the matrix out of which thinking and feeling develop as rational functions. Although intuition is an irrational function, many intuitions can afterwards be broken down into their component elements and their origin thus brought into harmony with the laws of reason.

[773] Everyone whose general *attitude* (q.v.) is oriented by intuition belongs to the *intuitive type* (q.v.).⁶⁸ Introverted and extraverted intuitives may be distinguished

according to whether intuition is directed inwards, to the inner vision, or outwards, to action and achievement. In abnormal cases intuition is in large measure fused together with the contents of the *collective unconscious* (q.v.) and determined by them, and this may make the intuitive type appear extremely irrational and beyond comprehension.

[774] 36. IRRATIONAL. I use this term not as denoting something *contrary* to reason, but something *beyond* reason, something, therefore, not grounded on reason. Elementary facts come into this category; the fact, for example, that the earth has a moon, that chlorine is an element, that water reaches its greatest density at four degrees centigrade, etc. Another irrational fact is *chance*, even though it may be possible to demonstrate a rational causation after the event.⁶⁹

[775] The irrational is an existential factor which, though it may be pushed further and further out of sight by an increasingly elaborate rational explanation, finally makes the explanation so complicated that it passes our powers of comprehension, the limits of rational thought being reached long before the whole of the world could be encompassed by the laws of reason. A completely rational explanation of an object that actually exists (not one that is merely posited) is a Utopian ideal. Only an object that is posited can be completely explained on rational grounds, since it does not contain anything beyond what has been posited by rational thinking. Empirical science, too, posits objects that are confined within rational bounds, because by deliberately excluding the accidental it does not consider the actual object as a whole, but only that part of it which has been singled out for rational observation.

[776] In this sense *thinking* is a *directed function*, and so is *feeling* (qq.v.). When these functions are concerned not with a rational choice of objects, or with the qualities and interrelations of objects, but with the perception of accidentals which the actual object never lacks, they at once lose the attribute of directedness and, with it, something of their rational character, because they then accept the accidental. They begin to be irrational. The kind of thinking or feeling that is directed to the perception of accidentals, and is therefore irrational, is either *intuitive* or *sensational*. Both *intuition* and *sensation* (qq.v.) are functions that find fulfilment in the *absolute perception* of the flux of events. Hence, by their very nature, they will react to every possible occurrence and be attuned to the absolutely contingent, and must therefore lack all rational direction. For this reason I call them irrational functions, as opposed to thinking and feeling, which find fulfilment only when they are in complete harmony with the laws of reason.

[777] Although the irrational as such can never become the object of science, it is of the greatest importance for a practical psychology that the irrational factor should be correctly appraised. Practical psychology stirs up many problems that are not

susceptible of a rational solution, but can only be settled irrationally, in a way not in accord with the laws of reason. The expectation or exclusive conviction that there must be a rational way of settling every conflict can be an insurmountable obstacle to finding a solution of an irrational nature.

[778] 37. LIBIDO. By libido I mean *psychic energy*.⁷⁰ Psychic energy is the *intensity* of a psychic process, its *psychological value*. This does not imply an assignment of value, whether moral, aesthetic, or intellectual; the psychological value is already implicit in its *determining* power, which expresses itself in definite psychic effects. Neither do I understand libido as a psychic *force*, a misconception that has led many critics astray. I do not hypostatize the concept of energy, but use it to denote intensities or values. The question as to whether or not a specific psychic force exists has nothing to do with the concept of libido. I often use “libido” promiscuously with “energy.” The justification for calling psychic energy libido is fully gone into in the works cited in the footnote.

[779] 38. OBJECTIVE LEVEL. When I speak of interpreting a dream or fantasy on the objective level, I mean that the persons or situations appearing in it are referred to objectively real persons or situations, in contrast to interpretation on the *subjective level* (q.v.), where the persons or situations refer exclusively to subjective factors. Freud’s interpretation of dreams is almost entirely on the objective level, since the dream wishes refer to real objects, or to sexual processes which fall within the physiological, extra-psychological sphere.

[780] 39. ORIENTATION. I use this term to denote the general principle governing an *attitude* (q.v.). Every attitude is oriented by a certain viewpoint, no matter whether this viewpoint is conscious or not. A power attitude (v. *Power-complex*) is oriented by the power of the *ego* (q.v.) to hold its own against unfavourable influences and conditions. A thinking attitude is oriented by the principle of logic as its supreme law; a sensation attitude is oriented by the sensuous perception of given facts.

[781] 40. PARTICIPATION MYSTIQUE is a term derived from Lévy-Bruhl.⁷¹ It denotes a peculiar kind of psychological connection with objects, and consists in the fact that the subject cannot clearly distinguish himself from the object but is bound to it by a direct relationship which amounts to partial *identity* (q.v.). This identity results from an *a priori* oneness of subject and object. *Participation mystique* is a vestige of this primitive condition. It does not apply to the whole subject-object relationship but only to certain cases where this peculiar tie occurs. It is a phenomenon that is best observed among primitives, though it is found very frequently among civilized peoples, if not with the same incidence and intensity. Among civilized peoples it

usually occurs between persons, seldom between a person and a thing. In the first case it is a transference relationship, in which the object (as a rule) obtains a sort of magical—i.e. absolute—influence over the subject. In the second case there is a similar influence on the part of the thing, or else an *identification* (q.v.) with a thing or the idea of a thing.

41. PERSONA, V. SOUL.

[782] 42. POWER-COMPLEX. I occasionally use this term to denote the whole complex of ideas and strivings which seek to subordinate all other influences to the *ego* (q.v.), no matter whether these influences have their source in people and objective conditions or in the subject's own impulses, thoughts, and feelings.

[783] 43. PROJECTION means the expulsion of a subjective content into an object; it is the opposite of *introjection* (q.v.). Accordingly it is a process of *dissimilation* (v. *Assimilation*), by which a subjective content becomes alienated from the subject and is, so to speak, embodied in the object. The subject gets rid of painful, incompatible contents by projecting them, as also of positive values which, for one reason or another—self-depreciation, for instance—are inaccessible to him. Projection results from the archaic *identity* (q.v.) of subject and object, but is properly so called only when the need to dissolve the identity with the object has already arisen. This need arises when the identity becomes a disturbing factor, i.e., when the absence of the projected content is a hindrance to adaptation and its withdrawal into the subject has become desirable. From this moment the previous partial identity acquires the character of projection. The term projection therefore signifies a state of identity that has become noticeable, an object of criticism, whether it be the self-criticism of the subject or the objective criticism of another.

[784] We may distinguish *passive* and *active* projection. The passive form is the customary form of all pathological and many normal projections; they are not intentional and are purely automatic occurrences. The active form is an essential component of the act of *empathy* (q.v.). Taken as a whole, empathy is a process of introjection, since it brings the object into intimate relation with the subject. In order to establish this relationship, the subject detaches a content—a feeling, for instance—from himself, lodges it in the object, thereby animating it, and in this way draws the object into the sphere of the subject. The active form of projection is, however, also an act of judgment, the aim of which is to separate the subject from the object. Here a subjective judgment is detached from the subject as a valid statement and lodged in the object; by this act the subject distinguishes himself from the object. Projection, accordingly, is a process of *introversion* (q.v.) since, unlike introjection, it does not lead to ingestion and assimilation but to differentiation and separation of subject from

object. Hence it plays a prominent role in paranoia, which usually ends in the total isolation of the subject.

43a. PSYCHE, V. SOUL.

[785] 44. RATIONAL. The rational is the reasonable, that which accords with reason. I conceive reason as an *attitude* (q.v.) whose principle it is to conform thought, feeling, and action to objective values. Objective values are established by the everyday experience of external facts on the one hand, and of inner, psychological facts on the other. Such experiences, however, could not represent objective “values” if they were “valued” as such by the subject, for that would already amount to an act of reason. The rational attitude which permits us to declare objective values as valid at all is not the work of the individual subject, but the product of human history.

[786] Most objective values—and reason itself—are firmly established complexes of ideas handed down through the ages. Countless generations have laboured at their organization with the same necessity with which the living organism reacts to the average, constantly recurring environmental conditions, confronting them with corresponding functional complexes, as the eye, for instance, perfectly corresponds to the nature of light. One might, therefore, speak of a pre-existent, metaphysical, universal “Reason” were it not that the adapted reaction of the living organism to average environmental influences is the necessary condition of its existence—a thought already expressed by Schopenhauer. Human reason, accordingly, is nothing other than the expression of man’s adaptability to average occurrences, which have gradually become deposited in firmly established complexes of ideas that constitute our objective values. Thus the laws of reason are the laws that designate and govern the average, “correct,” adapted *attitude* (q.v.). Everything is “rational” that accords with these laws, everything that contravenes them is “irrational” (q.v.).

[787] *Thinking* and *feeling* (qq.v.) are rational functions in so far as they are decisively influenced by *reflection*. They function most perfectly when they are in the fullest possible accord with the laws of reason. The irrational functions, *sensation* and *intuition* (qq.v.), are those whose aim is pure *perception*; for, as far as possible, they are forced to dispense with the rational (which presupposes the exclusion of everything that is outside reason) in order to attain the most complete perception of the general flux of events.

[788] 45. REDUCTIVE means “leading back.” I use this term to denote a method of psychological interpretation which regards the unconscious product not as a *symbol* (q.v.) but *semiotically*, as a *sign* or *symptom* of an underlying process. Accordingly, the reductive method traces the unconscious product back to its elements, no matter whether these be reminiscences of events that actually took place, or elementary

psychic processes. The reductive method is oriented backwards, in contrast to the *constructive* (q.v.) method, whether in the purely historical sense or in the figurative sense of tracing complex, differentiated factors back to something more general and more elementary. The interpretive methods of both Freud and Adler are reductive, since in both cases there is a reduction to the elementary processes of wishing or striving, which in the last resort are of an infantile or physiological nature. Hence the unconscious product necessarily acquires the character of an inauthentic expression to which the term “symbol” is not properly applicable. Reduction has a disintegrative effect on the real significance of the unconscious product, since this is either traced back to its historical antecedents and thereby annihilated, or integrated once again with the same elementary process from which it arose.

[789] 46. SELF.⁷² As an empirical concept, the self designates the whole range of psychic phenomena in man. It expresses the unity of the personality as a whole. But in so far as the total personality, on account of its unconscious component, can be only in part conscious, the concept of the self is, in part, only *potentially* empirical and is to that extent a *postulate*. In other words, it encompasses both the experienceable and the inexperienceable (or the not yet experienced). It has these qualities in common with very many scientific concepts that are more names than ideas. In so far as psychic totality, consisting of both conscious and unconscious contents, is a postulate, it is a *transcendental* concept, for it presupposes the existence of unconscious factors on empirical grounds and thus characterizes an entity that can be described only in part but, for the other part, remains at present unknowable and illimitable.

[790] Just as conscious as well as unconscious phenomena are to be met with in practice, the self as psychic totality also has a conscious as well as an unconscious aspect. Empirically, the self appears in dreams, myths, and fairytales in the figure of the “supraordinate personality” (v. EGO), such as a king, hero, prophet, saviour, etc., or in the form of a totality symbol, such as the circle, square, *quadratura circuli*, cross, etc. When it represents a *complexio oppositorum*, a union of opposites, it can also appear as a united duality, in the form, for instance, of *tao* as the interplay of *yang* and *yin*, or of the hostile brothers, or of the hero and his adversary (arch-enemy, dragon), Faust and Mephistopheles, etc. Empirically, therefore, the self appears as a play of light and shadow, although conceived as a totality and unity in which the opposites are united. Since such a concept is irrepresentable—*tertium non datur*—it is transcendental on this account also. It would, logically considered, be a vain speculation were it not for the fact that it designates symbols of unity that are found to occur empirically.

[791] The self is not a philosophical idea, since it does not predicate its own existence, i.e., does not hypostatize itself. From the intellectual point of view it is only a working hypothesis. Its empirical symbols, on the other hand, very often possess a distinct *numinosity*, i.e., an *a priori* emotional value, as in the case of the mandala,⁷³ “Deus est circulus . . .,”⁷⁴ the Pythagorean tetraktys,⁷⁵ the quaternity,⁷⁶ etc. It thus proves to be an *archetypal idea* (v. *Idea; Image*), which differs from other ideas of the kind in that it occupies a central position befitting the significance of its content and its numinosity.

[792] 47. SENSATION. I regard sensation as one of the basic psychological *functions* (q.v.). Wundt likewise reckons it among the elementary psychic phenomena.⁷⁷ Sensation is the psychological function that mediates the perception of a physical stimulus. It is, therefore, identical with perception. Sensation must be strictly distinguished from *feeling* (q.v.), since the latter is an entirely different process, although it may associate itself with sensation as “feeling-tone.” Sensation is related not only to external stimuli but to inner ones, i.e., to changes in the internal organic processes.

[793] Primarily, therefore, sensation is *sense perception*—perception mediated by the sense organs and “body-senses” (kinaesthetic, vasomotor sensation, etc.). It is, on the one hand, an element of ideation, since it conveys to the mind the perceptual image of the external object; and on the other hand, it is an element of feeling, since through the perception of bodily changes it gives feeling the character of an *affect* (q.v.). Because sensation conveys bodily changes to consciousness, it is also a representative of physiological impulses. It is not identical with them, being merely a perceptive function.

[794] A distinction must be made between sensuous or *concrete* (q.v.) sensation and *abstract* (q.v.) sensation. The first includes all the above-mentioned forms of sensation, whereas the second is a sensation that is abstracted or separated from the other psychic elements. Concrete sensation never appears in “pure” form, but is always mixed up with ideas, feelings, thoughts. Abstract sensation is a differentiated kind of perception, which might be termed “aesthetic” in so far as, obeying its own principle, it detaches itself from all contamination with the different elements in the perceived object and from all admixtures of thought and feeling, and thus attains a degree of purity beyond the reach of concrete sensation. The concrete sensation of a flower, on the other hand, conveys a perception not only of the flower as such, but also of the stem, leaves, habitat, and so on. It is also instantly mingled with feelings of pleasure or dislike which the sight of the flower evokes, or with simultaneous olfactory perceptions, or with thoughts about its botanical classification, etc. But abstract sensation immediately picks out the most salient sensuous attribute of the

flower, its brilliant redness, for instance, and makes this the sole or at least the principal content of consciousness, entirely detached from all other admixtures. Abstract sensation is found chiefly among artists. Like every abstraction, it is a product of functional *differentiation* (q.v.), and there is nothing primitive about it. The primitive form of a function is always concrete, i.e., contaminated (v. *Archaism; Concretism*). Concrete sensation is a reactive phenomenon, while abstract sensation, like every abstraction, is always associated with the *will* (q.v.), i.e., with a sense of direction. The will that is directed to abstract sensation is an expression and application of the *aesthetic sensation attitude*.

[795] Sensation is strongly developed in children and primitives, since in both cases it predominates over thinking and feeling, though not necessarily over *intuition* (q.v.). I regard sensation as conscious, and intuition as unconscious, perception. For me sensation and intuition represent a pair of opposites, or two mutually compensating functions, like thinking and feeling. Thinking and feeling as independent functions are developed, both ontogenetically and phylogenetically, from sensation (and equally, of course, from intuition as the necessary counterpart of sensation). A person whose-whole *attitude* (q.v.) is oriented by sensation belongs to the *sensation type* (q.v.).

[796] Since sensation is an elementary phenomenon, it is given *a priori*, and, unlike thinking and feeling, is not subject to rational laws. I therefore call it an *irrational* (q.v.) function, although reason contrives to assimilate a great many sensations into a rational context. Normal sensations are proportionate, i.e., they correspond approximately to the intensity of the physical stimulus. Pathological sensations are disproportionate, i.e., either abnormally weak or abnormally strong. In the former case they are inhibited, in the latter exaggerated. The inhibition is due to the predominance of another function; the exaggeration is the result of an abnormal fusion with another function, for instance with undifferentiated thinking or feeling. It ceases as soon as the function with which sensation is fused is differentiated in its own right. The psychology of the neuroses affords instructive examples of this, since we often find a strong *sexualization* (Freud) of other functions, i.e., their fusion with sexual sensations.

[797] 48. SOUL. [Psyche, personality, persona, anima.] I have been compelled, in my investigations into the structure of the unconscious, to make a conceptual distinction between *soul* and *psyche*. By *psyche* I understand the totality of all psychic processes, conscious as well as unconscious. By *soul*, on the other hand, I understand a clearly demarcated functional complex that can best be described as a "personality." In order to make clear what I mean by this, I must introduce some further points of view. It is, in particular, the phenomena of somnambulism, double

consciousness, split personality, etc., whose investigation we owe primarily to the French school,⁷⁸ that have enabled us to accept the possibility of a plurality of personalities in one and the same individual.

[*Soul as a functional complex or “personality”*]

[798] It is at once evident that such a plurality of personalities can never appear in a normal individual. But, as the above-mentioned phenomena show, the possibility of a dissociation of personality must exist, at least in the germ, within the range of the normal. And, as a matter of fact, any moderately acute psychological observer will be able to demonstrate, without much difficulty, traces of character-splitting in normal individuals. One has only to observe a man rather closely, under varying conditions, to see that a change from one milieu to another brings about a striking alteration of personality, and on each occasion a clearly defined character emerges that is noticeably different from the previous one. “Angel abroad, devil at home” is a formulation of the phenomenon of character-splitting derived from everyday experience. A particular milieu necessitates a particular *attitude* (q.v.). The longer this attitude lasts, and the more often it is required, the more habitual it becomes. Very many people from the educated classes have to move in two totally different milieus—the domestic circle and the world of affairs. These two totally different environments demand two totally different attitudes, which, depending on the degree of the ego’s *identification* (q.v.) with the attitude of the moment, produce a duplication of character. In accordance with social conditions and requirements, the social character is oriented on the one hand by the expectations and demands of society, and on the other by the social aims and aspirations of the individual. The domestic character is, as a rule, moulded by emotional demands and an easy-going acquiescence for the sake of comfort and convenience; whence it frequently happens that men who in public life are extremely energetic, spirited, obstinate, wilful and ruthless appear good-natured, mild, compliant, even weak, when at home and in the bosom of the family. Which is the true character, the real personality? This question is often impossible to answer.

[799] These reflections show that even in normal individuals character-splitting is by no means an impossibility. We are, therefore, fully justified in treating personality dissociation as a problem of normal psychology. In my view the answer to the above question should be that such a man has no real character at all: he is not *individual* (q.v.) but *collective* (q.v.), the plaything of circumstance and general expectations. Were he individual, he would have the same character despite the variation of attitude. He would not be identical with the attitude of the moment, and he neither would nor could prevent his *individuality* (q.v.) from expressing itself just as clearly in one state as in another. Naturally he is individual, like every living being, but

unconsciously so. Because of his more or less complete identification with the attitude of the moment, he deceives others, and often himself, as to his real character. He puts on a *mask*, which he knows is in keeping with his conscious intentions, while it also meets the requirements and fits the opinions of society, first one motive and then the other gaining the upper hand.

[*Soul as persona*]

[800] This mask, i.e., the *ad hoc* adopted attitude, I have called the *persona*,⁷⁹ which was the name for the masks worn by actors in antiquity. The man who identifies with this mask I would call “personal” as opposed to “individual.”

[801] The two above-mentioned attitudes represent two collective personalities, which may be summed up quite simply under the name “*personae*.” I have already suggested that the real individuality is different from both. The *persona* is thus a functional complex that comes into existence for reasons of adaptation or personal convenience, but is by no means identical with the individuality. The *persona* is exclusively concerned with the relation to objects. The relation of the individual to the object must be sharply distinguished from the relation to the subject. By the “subject” I mean first of all those vague, dim stirrings, feelings, thoughts, and sensations which flow in on us not from any demonstrable continuity of conscious experience of the object, but well up like a disturbing, inhibiting, or at times helpful, influence from the dark inner depths, from the background and underground vaults of consciousness, and constitute, in their totality, our perception of the life of the unconscious. The subject, conceived as the “inner object,” is the unconscious. Just as there is a relation to the outer object, an outer attitude, there is a relation to the inner object, an inner attitude. It is readily understandable that this inner attitude, by reason of its extremely intimate and inaccessible nature, is far more difficult to discern than the outer attitude, which is immediately perceived by everyone. Nevertheless, it does not seem to me impossible to formulate it as a concept. All those allegedly accidental inhibitions, fancies, moods, vague feelings, and scraps of fantasy that hinder concentration and disturb the peace of mind even of the most normal man, and that are rationalized away as being due to bodily causes and suchlike, usually have their origin, not in the reasons consciously ascribed to them, but in perceptions of unconscious processes. Dreams naturally belong to this class of phenomena, and, as we all know, are often traced back to such external and superficial causes as indigestion, sleeping on one’s back, and so forth, in spite of the fact that these explanations can never stand up to searching criticism. The attitude of the individual in these matters is extremely varied. One man will not allow himself to be disturbed in the slightest by his inner processes—he can ignore them completely; another man is just as completely at their mercy—as soon as he wakes up some fantasy or other,

or a disagreeable feeling, spoils his mood for the whole day; a vaguely unpleasant sensation puts the idea into his head that he is suffering from a secret disease, a dream fills him with gloomy forebodings, although ordinarily he is not superstitious. Others, again, have only periodic access to these unconscious stirrings, or only to a certain category of them. For one man they may never have reached consciousness at all as anything worth thinking about, for another they are a worrying problem he broods on daily. One man takes them as physiological, another attributes them to the behaviour of his neighbours, another finds in them a religious revelation.

[802] These entirely different ways of dealing with the stirrings of the unconscious are just as habitual as the attitudes to the outer object. The inner attitude, therefore, is correlated with just as definite a functional complex as the outer attitude. People who, it would seem, entirely overlook their inner psychic processes no more lack a typical inner attitude than the people who constantly overlook the outer object and the reality of facts lack a typical outer one. In all the latter cases, which are by no means uncommon, the persona is characterized by a lack of relatedness, at times even a blind inconsiderateness, that yields only to the harshest blows of fate. Not infrequently, it is just these people with a rigid persona who possess an attitude to the unconscious processes which is extremely susceptible and open to influence. Inwardly they are as weak, malleable, and “soft-centered” as they are inflexible and unapproachable outwardly. Their inner attitude, therefore, corresponds to a personality that is diametrically opposed to the outer personality. I know a man, for instance, who blindly and pitilessly destroyed the happiness of those nearest to him, and yet would interrupt important business journeys just to enjoy the beauty of a forest scene glimpsed from the carriage window. Cases of this kind are doubtless familiar to everyone, so I need not give further examples.

[*Soul as anima*]

[803] We can, therefore, speak of an inner personality with as much justification as, on the grounds of daily experience, we speak of an outer personality. The inner personality is the way one behaves in relation to one’s inner psychic processes; it is the inner attitude, the characteristic face, that is turned towards the unconscious. I call the outer attitude, the outward face, the *persona*; the inner attitude, the inward face, I call the *anima*.⁸⁰ To the degree that an attitude is habitual, it is a well-knit functional complex with which the ego can identify itself more or less. Common speech expresses this very graphically: when a man has an habitual attitude to certain situations, an habitual way of doing things, we say he is quite *another man* when doing this or that. This is a practical demonstration of the autonomy of the functional complex represented by the habitual attitude: it is as though another personality had taken possession of the individual, as though “another spirit had got into him.” The

same autonomy that very often characterizes the outer attitude is also claimed by the inner attitude, the *anima*. It is one of the most difficult educational feats to change the *persona*, the outer attitude, and it is just as difficult to change the *anima*, since its structure is usually quite as well-knit as the *persona*'s. Just as the *persona* is an entity that often seems to constitute the whole character of a man, and may even accompany him unaltered throughout his entire life, the *anima* is a clearly defined entity with a character that, very often, is autonomous and immutable. It therefore lends itself very readily to characterization and description.

[804] As to the character of the *anima*, my experience confirms the rule that it is, by and large, *complementary* to the character of the *persona*. The *anima* usually contains all those common human qualities which the conscious attitude lacks. The tyrant tormented by bad dreams, gloomy forebodings, and inner fears is a typical figure. Outwardly ruthless, harsh, and unapproachable, he jumps inwardly at every shadow, is at the mercy of every mood, as though he were the feeblest and most impressionable of men. Thus his *anima* contains all those fallible human qualities his *persona* lacks. If the *persona* is intellectual, the *anima* will quite certainly be sentimental. The complementary character of the *anima* also affects the sexual character, as I have proved to myself beyond a doubt. A very feminine woman has a masculine soul, and a very masculine man has a feminine soul. This contrast is due to the fact that a man is not in all things wholly masculine, but also has certain feminine traits. The more masculine his outer attitude is, the more his feminine traits are obliterated: instead, they appear in his unconscious. This explains why it is just those very virile men who are most subject to characteristic weaknesses; their attitude to the unconscious has a womanish weakness and impressionability. Conversely, it is often just the most feminine women who, in their inner lives, display an intractability, an obstinacy, and a wilfulness that are to be found with comparable intensity only in a man's outer attitude. These are masculine traits which, excluded from the womanly outer attitude, have become qualities of her soul.

[805] If, therefore, we speak of the *anima* of a man, we must logically speak of the *animus* of a woman, if we are to give the soul of a woman its right name. Whereas logic and objectivity are usually the predominant features of a man's outer attitude, or are at least regarded as ideals, in the case of a woman it is feeling. But in the soul it is the other way round: inwardly it is the man who feels, and the woman who reflects. Hence a man's greater liability to total despair, while a woman can always find comfort and hope; accordingly a man is more likely to put an end to himself than a woman. However much a victim of social circumstances a woman may be, as a prostitute for instance, a man is no less a victim of impulses from the unconscious, taking the form of alcoholism and other vices.

[806] As to its common human qualities, the character of the anima can be deduced from that of the persona. Everything that should normally be in the outer attitude, but is conspicuously absent, will invariably be found in the inner attitude. This is a fundamental rule which my experience has borne out over and over again. But as regards its individual qualities, nothing can be deduced about them in this way. We can only be certain that when a man is identical with his persona, his individual qualities will be associated with the anima. This association frequently gives rise in dreams to the symbol of psychic pregnancy, a symbol that goes back to the *primordial image* (q.v.) of the hero's birth. The child that is to be born signifies the individuality, which, though present, is not yet conscious. For in the same way as the persona, the instrument of adaptation to the environment, is strongly influenced by environmental conditions, the anima is shaped by the unconscious and its qualities. In a primitive milieu the persona necessarily takes on primitive features, and the anima similarly takes over the *archaic* (q.v.) features of the unconscious as well as its symbolic, prescient character. Hence the "pregnant," "creative" qualities of the inner attitude.

[807] *Identity* (q.v.) with the persona automatically leads to an unconscious identity with the anima because, when the ego is not differentiated from the persona, it can have no conscious relation to the unconscious processes. Consequently, it is these processes, it is identical with them. Anyone who is himself his outward role will infallibly succumb to the inner processes; he will either frustrate his outward role by absolute inner necessity or else reduce it to absurdity, by a process of *enantiodromia* (q.v.). He can no longer keep to his individual way, and his life runs into one deadlock after another. Moreover, the anima is inevitably projected upon a real object, with which he gets into a relation of almost total dependence. Every reaction displayed by this object has an immediate, inwardly enervating effect on the subject. Tragic ties are often formed in this way (v. *Soul-image*).

[808] 49. SOUL-IMAGE [Anima / Animus].⁸¹ The soul-image is a specific *image* (q.v.) among those produced by the unconscious. Just as the *persona* (v. *Soul*), or outer attitude, is represented in dreams by images of definite persons who possess the outstanding qualities of the persona in especially marked form, so in a man the soul, i.e., anima, or inner attitude, is represented in the unconscious by definite persons with the corresponding qualities. Such an image is called a "soul-image." Sometimes these images are of quite unknown or mythological figures. With men the anima is usually personified by the unconscious as a woman; with women the animus is personified as a man. In every case where the *individuality* (q.v.) is unconscious, and therefore associated with the soul, the soul-image has the character of the same sex. In all cases where there is an *identity* (q.v.) with the persona, and the soul accordingly

is unconscious, the soul-image is transferred to a real person. This person is the object of intense love or equally intense hate (or fear). The influence of such a person is immediate and absolutely compelling, because it always provokes an affective response. The *affect* (q.v.) is due to the fact that a real, conscious adaptation to the person representing the soul-image is impossible. Because an objective relationship is non-existent and out of the question, the *libido* (q.v.) gets dammed up and explodes in an outburst of affect. Affects always occur where there is a failure of adaptation. Conscious adaptation to the person representing the soul-image is impossible precisely because the subject is unconscious of the soul. Were he conscious of it, it could be distinguished from the object, whose immediate effects might then be mitigated, since the potency of the object depends on the *projection* (q.v.) of the soul-image.

[809] For a man, a woman is best fitted to be the real bearer of his soul-image, because of the feminine quality of his soul; for a woman it will be a man. Wherever an impassioned, almost magical, relationship exists between the sexes, it is invariably a question of a projected soul-image. Since these relationships are very common, the soul must be unconscious just as frequently—that is, vast numbers of people must be quite unaware of the way they are related to their inner psychic processes. Because this unconsciousness is always coupled with complete identification with the persona, it follows that this identification must be very frequent too. And in actual fact very many people are wholly identified with their outer attitude and therefore have no conscious relation to their inner processes. Conversely, it may also happen that the soul-image is not projected but remains with the subject, and this results in an identification with the soul because the subject is then convinced that the way he relates to his inner processes is his real character. In that event the persona, being unconscious, will be projected on a person of the same sex, thus providing a foundation for many cases of open or latent homosexuality, and of father-transferences in men or mother-transferences in women. In such cases there is always a defective adaptation to external reality and a lack of relatedness, because identification with the soul produces an attitude predominantly oriented to the perception of inner processes, and the object is deprived of its determining power.

[810] If the soul-image is projected, the result is an absolute affective tie to the object. If it is not projected, a relatively unadapted state develops, which Freud has described as *narcissism*. The projection of the soul-image offers a release from preoccupation with one's inner processes so long as the behaviour of the object is in harmony with the soul-image. The subject is then in a position to live out his persona and develop it further. The object, however, will scarcely be able to meet the demands of the soul-image indefinitely, although there are many women who, by completely disregarding their own lives, succeed in representing their husband's soul-image for a very long

time. The biological feminine instinct assists them in this. A man may unconsciously do the same for his wife, though this will prompt him to deeds which finally exceed his capacities whether for good or evil. Here again the biological masculine instinct is a help.

[811] If the soul-image is not projected, a thoroughly morbid relation to the unconscious gradually develops. The subject is increasingly overwhelmed by unconscious contents, which his inadequate relation to the object makes him powerless to assimilate or put to any kind of use, so that the whole subject-object relation only deteriorates further. Naturally these two attitudes represent the two extremes between which the more normal attitudes lie. In a normal man the soul-image is not distinguished by any particular clarity, purity, or depth, but is apt to be rather blurred. In men with a good-natured and unaggressive persona, the soul-image has a rather malevolent character. A good literary example of this is the daemonic woman who is the companion of Zeus in Spitteler's *Olympian Spring*. For an idealistic woman, a depraved man is often the bearer of the soul-image; hence the "saviour fantasy" so frequent in such cases. The same thing happens with men, when the prostitute is surrounded with the halo of a soul crying for succour.

[812] 50. SUBJECTIVE LEVEL. When I speak of interpreting a dream or fantasy on the subjective level, I mean that the persons or situations appearing in it refer to subjective factors entirely belonging to the subject's own psyche. As we know, the psychic image of an object is never exactly like the object—at most there is a near resemblance. It is the product of sense perception and *apperception* (q.v.), and these are processes that are inherent in the psyche and are merely stimulated by the object. Although the evidence of our senses is found to coincide very largely with the qualities of the object, our apperception is conditioned by unpredictable subjective influences which render a correct knowledge of the object extraordinarily difficult. Moreover, such a complex psychic factor as a man's character offers only a few *points d'appui* for pure sense perception. Knowledge of human character requires *empathy* (q.v.), reflection, *intuition* (q.v.). As a result of these complications, our final judgment is always of very doubtful value, so that the image we form of a human object is, to a very large extent, subjectively conditioned. In practical psychology, therefore, we would do well to make a rigorous distinction between the image or *imago* of a man and his real existence. Because of its extremely subjective origin, the *imago* is frequently more an image of a subjective functional complex than of the object itself. In the analytical treatment of unconscious products it is essential that the *imago* should not be assumed to be identical with the object; it is better to regard it as an image of the subjective relation to the object. That is what is meant by interpretation on the subjective level.

[813] Interpretation of an unconscious product on the subjective level reveals the presence of subjective judgments and tendencies of which the object is made the vehicle. When, therefore, an object-*imago* appears in an unconscious product, it is not on that account the image of a real object; it is far more likely that we are dealing with a subjective functional complex (v. *Soul*, pars. 798ff.). Interpretation on the subjective level allows us to take a broader psychological view not only of dreams but also of literary works, in which the individual figures then appear as representatives of relatively autonomous functional complexes in the psyche of the author.

[814] 51. SYMBOL. The concept of a *symbol* should in my view be strictly distinguished from that of a *sign*. Symbolic and *semiotic* meanings are entirely different things. In his book on symbolism, Ferrero⁸² does not speak of symbols in the strict sense, but of signs. For instance, the old custom of handing over a piece of turf at the sale of a plot of land might be described as “symbolic” in the vulgar sense of the word, but actually it is purely semiotic in character. The piece of turf is a sign, or token, standing for the whole estate. The winged wheel worn by railway officials is not a *symbol* of the railway, but a *sign* that distinguishes the personnel of the railway system. A symbol always presupposes that the chosen expression is the best possible description or formulation of a relatively unknown fact, which is none the less known to exist or is postulated as existing. Thus, when the badge of a railway official is explained as a symbol, it amounts to saying that this man has something to do with an unknown system that cannot be differently or better expressed than by a winged wheel.

[815] Every view which interprets the symbolic expression as an analogue or an abbreviated designation for a *known* thing is *semiotic*. A view which interprets the symbolic expression as the best possible formulation of a relatively *unknown* thing, which for that reason cannot be more clearly or characteristically represented, is *symbolic*. A view which interprets the symbolic expression as an intentional paraphrase or transmogrification of a known thing is *allegoric*. The interpretation of the cross as a symbol of divine love is *semiotic*, because “divine love” describes the fact to be expressed better and more aptly than a cross, which can have many other meanings. On the other hand, an interpretation of the cross is *symbolic* when it puts the cross beyond all conceivable explanations, regarding it as expressing an as yet unknown and incomprehensible fact of a mystical or transcendent, i.e., psychological, nature, which simply finds itself most appropriately represented in the cross.

[816] So long as a symbol is a living thing, it is an expression for something that cannot be characterized in any other or better way. The symbol is alive only so long as it is pregnant with meaning. But once its meaning has been born out of it, once that

expression is found which formulates the thing sought, expected, or divined even better than the hitherto accepted symbol, then the symbol is *dead*, i.e., it possesses only an historical significance. We may still go on speaking of it as a symbol, on the tacit assumption that we are speaking of it as it was before the better expression was born out of it. The way in which St. Paul and the earlier speculative mystics speak of the cross shows that for them it was still a living symbol which expressed the inexpressible in unsurpassable form. For every esoteric interpretation the symbol is dead, because esotericism has already given it (at least ostensibly) a better expression, whereupon it becomes merely a conventional sign for associations that are more completely and better known elsewhere. Only from the exoteric standpoint is the symbol a living thing.

[817] An expression that stands for a known thing remains a mere sign and is never a symbol. It is, therefore, quite impossible to create a living symbol, i.e., one that is pregnant with meaning, from known associations. For what is thus produced never contains more than was put into it. Every psychic product, if it is the best possible expression at the moment for a fact as yet unknown or only relatively known, may be regarded as a symbol, provided that we accept the expression as standing for something that is only divined and not yet clearly conscious. Since every scientific theory contains an hypothesis, and is therefore an anticipatory description of something still essentially unknown, it is a symbol. Furthermore, every psychological expression is a symbol if we assume that it states or signifies something more and other than itself which eludes our present knowledge. This assumption is absolutely tenable wherever a consciousness exists which is attuned to the deeper meaning of things. It is untenable only when this same consciousness has itself devised an expression which states exactly what it is intended to state—a mathematical term, for instance. But for another consciousness this limitation does not exist. It can take the mathematical term as a symbol for an unknown psychic fact which the term was not intended to express but is concealed within it—a fact which is demonstrably not known to the man who devised the semiotic expression and which therefore could not have been the object of any conscious use.

[818] Whether a thing is a symbol or not depends chiefly on the *attitude* (q.v.) of the observing consciousness; for instance, on whether it regards a given fact not merely as such but also as an expression for something unknown. Hence it is quite possible for a man to establish a fact which does not appear in the least symbolic to himself, but is profoundly so to another consciousness. The converse is also true. There are undoubtedly products whose symbolic character does not depend merely on the attitude of the observing consciousness, but manifests itself spontaneously in the symbolic effect they have on the observer. Such products are so constituted that they would lack any kind of meaning were not a symbolic one conceded to them. Taken as

a bare fact, a triangle with an eye enclosed in it is so meaningless that it is impossible for the observer to regard it as a merely accidental piece of foolery. Such a figure immediately conjures up a symbolic interpretation. This effect is reinforced by the widespread incidence of the same figure in identical form, or by the particular care that went into its production, which is an expression of the special value placed upon it.

[819] Symbols that do not work in this way on the observer are either extinct, i.e., have been superseded by a better formulation, or are products whose symbolic nature depends entirely on the attitude of the observing consciousness. The attitude that takes a given phenomenon as symbolic may be called, for short, the *symbolic attitude*. It is only partially justified by the actual behaviour of things; for the rest, it is the outcome of a definite view of the world which *assigns meaning* to events, whether great or small, and attaches to this meaning a greater value than to bare facts. This view of things stands opposed to another view which lays the accent on sheer facts and subordinates meaning to them. For the latter attitude there can be no symbols whatever when the symbolism depends exclusively on the mode of observation. But even for such an attitude symbols do exist—those, namely, that prompt the observer to conjecture a hidden meaning. A bull-headed god can certainly be explained as a man's body with a bull's head on it. But this explanation can hardly hold its own against the symbolic explanation, because the symbolism is too arresting to be overlooked. A symbol that forcibly obtrudes its symbolic nature on us need not be a *living* symbol. It may have a merely historical or philosophical significance, and simply arouses intellectual or aesthetic interest. A symbol really lives only when it is the best and highest expression for something divined but not yet known to the observer. It then compels his unconscious participation and has a life-giving and life-enhancing effect. As Faust says: "How differently this new sign works upon me!"⁸³

[820] The living symbol formulates an essential unconscious factor, and the more widespread this factor is, the more general is the effect of the symbol, for it touches a corresponding chord in every psyche. Since, for a given epoch, it is the best possible expression for what is still unknown, it must be the product of the most complex and differentiated minds of that age. But in order to have such an effect at all, it must embrace what is common to a large group of men. This can never be what is most differentiated, the highest attainable, for only a very few attain to that or understand it. The common factor must be something that is still so primitive that its ubiquity cannot be doubted. Only when the symbol embraces that and expresses it in the highest possible form is it of general efficacy. Herein lies the potency of the living, social symbol and its redeeming power.

[821] All that I have said about the social symbol applies equally to the individual symbol. There are individual psychic products whose symbolic character is so obvious that they at once compel a symbolic interpretation. For the individual they have the same functional significance that the social symbol has for a larger human group. These products never have an exclusively conscious or an exclusively unconscious source, but arise from the equal collaboration of both. Purely unconscious products are no more convincingly symbolic *per se* than purely conscious ones; it is the symbolic attitude of the observing consciousness that endows them both with the character of a symbol. But they can be conceived equally well as causally determined facts, in much the same way as one might regard the red exanthema of scarlet fever as a “symbol” of the disease. In that case it is perfectly correct to speak of a “symptom” and not of a “symbol.” In my view Freud is quite justified when, from his standpoint, he speaks of *symptomatic*⁸⁴ rather than symbolic actions, since for him these phenomena are not symbolic in the sense here defined, but are symptomatic signs of a definite and generally known underlying process. There are, of course, neurotics who regard their unconscious products, which are mostly morbid symptoms, as symbols of supreme importance. Generally, however, this is not what happens. On the contrary, the neurotic of today is only too prone to regard a product that may actually be full of significance as a mere “symptom.”

[822] The fact that there are two distinct and mutually contradictory views eagerly advocated on either side concerning the meaning or meaninglessness of things shows that processes obviously exist which express no particular meaning, being in fact mere consequences, or symptoms; and that there are other processes which bear within them a hidden meaning, processes which are not merely derived from something but which seek to become something, and are therefore symbols. It is left to our discretion and our critical judgment to decide whether the thing we are dealing with is a symptom or a symbol.

[823] The symbol is always a product of an extremely complex nature, since data from every psychic function have gone into its making. It is, therefore, neither *rational* nor *irrational* (qq.v.). It certainly has a side that accords with reason, but it has another side that does not; for it is composed not only of rational but also of irrational data supplied by pure inner and outer perception. The profundity and pregnant significance of the symbol appeal just as strongly to *thinking* as to *feeling* (qq.v.), while its peculiar plastic imagery, when shaped into sensuous form, stimulates *sensation* as much as *intuition* (qq.v.). The living symbol cannot come to birth in a dull or poorly developed mind, for such a mind will be content with the already existing symbols offered by established tradition. Only the passionate yearning of a highly developed mind, for which the traditional symbol is no longer the unified

expression of the rational and the irrational, of the highest and the lowest, can create a new symbol.

[824] But precisely because the new symbol is born of man's highest spiritual aspirations and must at the same time spring from the deepest roots of his being, it cannot be a onesided product of the most highly differentiated mental functions but must derive equally from the lowest and most primitive levels of the psyche. For this collaboration of opposing states to be possible at all, they must first face one another in the fullest conscious opposition. This necessarily entails a violent disunion with oneself, to the point where thesis and antithesis negate one another, while the ego is forced to acknowledge its absolute participation in both. If there is a subordination of one part, the symbol will be predominantly the product of the other part, and, to that extent, less a symbol than a symptom—a symptom of the suppressed antithesis. To the extent, however, that a symbol is merely a symptom, it also lacks a redeeming effect, since it fails to express the full right of all parts of the psyche to exist, being a constant reminder of the suppressed antithesis even though consciousness may not take this fact into account. But when there is full parity of the opposites, attested by the ego's absolute participation in both, this necessarily leads to a suspension of the *will* (q.v.), for the will can no longer operate when every motive has an equally strong countermotive. Since life cannot tolerate a standstill, a damming up of vital energy results, and this would lead to an insupportable condition did not the tension of opposites produce a new, uniting function that transcends them. This function arises quite naturally from the regression of *libido* (q.v.) caused by the blockage. All progress having been rendered temporarily impossible by the total division of the will, the libido streams backwards, as it were, to its source. In other words, the neutralization and inactivity of consciousness bring about an activity of the unconscious, where all the differentiated functions have their common, archaic root, and where all contents exist in a state of promiscuity of which the primitive mentality still shows numerous vestiges.

[825] From the activity of the unconscious there now emerges a new content, constellated by thesis and antithesis in equal measure and standing in a *compensatory* (q.v.) relation to both. It thus forms the middle ground on which the opposites can be united. If, for instance, we conceive the opposition to be sensuality versus spirituality, then the mediatory content born out of the unconscious provides a welcome means of expression for the spiritual thesis, because of its rich spiritual associations, and also for the sensual antithesis, because of its sensuous imagery. The ego, however, torn between thesis and antithesis, finds in the middle ground its own counterpart, its sole and unique means of expression, and it eagerly seizes on this in order to be delivered from its division. The energy created by the tension of opposites therefore flows into the mediatory product and protects it from the conflict which immediately breaks out

again, for both the opposites are striving to get the new product on their side. Spirituality wants to make something spiritual out of it, and sensuality something sensual; the one wants to turn it into science or art, the other into sensual experience. The appropriation or dissolution of the mediatory product by either side is successful only if the ego is not completely divided but inclines more to one side or the other. But if one side succeeds in winning over and dissolving the mediatory product, the ego goes along with it, whereupon an identification of the ego with the most favoured function (v. *Inferior Function*) ensues. Consequently, the process of division will be repeated later on a higher plane.

[826] If, however, as a result of the stability of the ego, neither side succeeds in dissolving the mediatory product, this is sufficient demonstration that it is superior to both. The stability of the ego and the superiority of the mediatory product to both thesis and antithesis are to my mind correlates, each conditioning the other. Sometimes it seems as though the stability of the inborn *individuality* (q.v.) were the decisive factor, sometimes as though the mediatory product possessed a superior power that determines the ego's absolute stability. In reality it may be that the stability of the one and the superior power of the other are two sides of the same coin.

[827] If the mediatory product remains intact, it forms the raw material for a process not of dissolution but of construction, in which thesis and antithesis both play their part. In this way it becomes a new content that governs the whole attitude, putting an end to the division and forcing the energy of the opposites into a common channel. The standstill is overcome and life can flow on with renewed power towards new goals.

[828] I have called this process in its totality the *transcendent function*, "function" being here understood not as a basic function but as a complex function made up of other functions, and "transcendent" not as denoting a metaphysical quality but merely the fact that this function facilitates a transition from one attitude to another. The raw material shaped by thesis and antithesis, and in the shaping of which the opposites are united, is the living symbol. Its profundity of meaning is inherent in the raw material itself, the very stuff of the psyche, transcending time and dissolution; and its configuration by the opposites ensures its sovereign power over all the psychic functions.

[829] Indications of the process of symbol-formation are to be found in the scanty records of the conflicts experienced by the founders of religion during their initiation period, e.g., the struggle between Jesus and Satan, Buddha and Mara, Luther and the devil, Zwingli and his previous worldly life; or the regeneration of Faust through the pact with the devil. In *Zarathustra* we find an excellent example of the suppressed antithesis in the "Ugliest Man."

- [830] 53. THINKING. This I regard as one of the four basic psychological *functions* (q.v.). Thinking is the psychological function which, following its own laws, brings the contents of ideation into conceptual connection with one another. It is an *apperceptive* (q.v.) activity, and as such may be divided into *active* and *passive* thinking. Active thinking is an act of the *will* (q.v.), passive thinking is a mere occurrence. In the former case, I submit the contents of ideation to a voluntary act of judgment; in the latter, conceptual connections establish themselves of their own accord, and judgments are formed that may even contradict my intention. They are not consonant with my aim and therefore, for me, lack any sense of direction, although I may afterwards recognize their directedness through an act of active apperception. Active thinking, accordingly, would correspond to my concept of *directed thinking*.⁸⁵ Passive thinking was inadequately described in my previous work as “fantasy thinking.”⁸⁶ Today I would call it *intuitive* thinking.
- [831] To my mind, a mere stringing together of ideas, such as is described by certain psychologists as *associative thinking*,⁸⁷ is not thinking at all, but mere ideation. The term “thinking” should, in my view, be confined to the linking up of ideas by means of a concept, in other words, to an act of judgment, no matter whether this act is intentional or not.
- [832] The capacity for directed thinking I call *intellect*; the capacity for passive or undirected thinking I call *intellectual intuition*. Further, I call directed thinking a *rational* (q.v.) function, because it arranges the contents of ideation under concepts in accordance with a rational norm of which I am conscious. Undirected thinking is in my view an *irrational* (q.v.) function, because it arranges and judges the contents of ideation by norms of which I am not conscious and therefore cannot recognize as being in accord with reason. Subsequently I may be able to recognize that the intuitive act of judgment accorded with reason, although it came about in a way that appears to me irrational.
- [833] Thinking that is governed by *feeling* (q.v.) I do not regard as intuitive thinking, but as a thinking dependent on feeling; it does not follow its own logical principle but is subordinated to the principle of feeling. In such thinking the laws of logic are only ostensibly present; in reality they are suspended in favour of the aims of feeling.
- [834] 53a. THOUGHT. Thought is the specific content or material of the thinking function, discriminated by *thinking* (q.v.).

[835] 55. TYPE. A type is a specimen or example which reproduces in a characteristic way the character of a species or class. In the narrower sense used in this particular work, a type is a characteristic specimen of a general *attitude* (q.v.) occurring in many individual forms. From a great number of existing or possible attitudes I have singled out four; those, namely, that are primarily oriented by the four basic psychological *functions* (q.v.): *thinking, feeling, sensation, intuition* (qq.v.). When any of these attitudes is *habitual*, thus setting a definite stamp on the character of an *individual* (q.v.), I speak of a psychological type. These *function-types*, which one can call the thinking, feeling, sensation, and intuitive types, may be divided into two classes according to the quality of the basic function, i.e., into the *rational* and the *irrational* (qq.v.). The thinking and feeling types belong to the former class, the sensation and intuitive types to the latter. A further division into two classes is permitted by the predominant trend of the movement of *libido* (q.v.), namely *introversion* and *extraversion* (qq.v.). All the basic types can belong equally well to one or the other of these classes, according to the predominance of the introverted or extraverted attitude.⁸⁸ A thinking type may belong either to the introverted or to the extraverted class, and the same holds good for the other types. The distinction between rational and irrational types is simply another point of view and has nothing to do with introversion and extraversion.

[836] In my previous contributions to typology⁸⁹ I did not differentiate the thinking and feeling types from the introverted and extraverted types, but identified the thinking type with the introverted, and the feeling type with the extraverted. But a more thorough investigation of the material has shown me that we must treat the introverted and extraverted types as categories over and above the function-types. This differentiation, moreover, fully accords with experience, since, for example, there are undoubtedly two kinds of feeling types, the attitude of the one being oriented more by his feeling-experience [= introverted feeling type], the other more by the object [= extraverted feeling type].

[837] 56. UNCONSCIOUS. The concept of the *unconscious* is for me an *exclusively psychological* concept, and not a philosophical concept of a metaphysical nature. In my view the unconscious is a psychological borderline concept, which covers all psychic contents or processes that are not conscious, i.e., not related to the *ego* (q.v.) in any perceptible way. My justification for speaking of the existence of unconscious processes at all is derived simply and solely from experience, and in particular from psychopathological experience, where we have undoubted proof that, in a case of hysterical amnesia, for example, the ego knows nothing of the existence of numerous psychic complexes, and the next moment a simple hypnotic procedure is sufficient to bring the lost contents back to memory.

[838] Thousands of such experiences justify us in speaking of the existence of unconscious psychic contents. As to the actual state an unconscious content is in when not attached to consciousness, this is something that eludes all possibility of cognition. It is therefore quite pointless to hazard conjectures about it. Conjectures linking up the unconscious state with cerebration and physiological processes belong equally to the realm of fantasy. It is also impossible to specify the range of the unconscious, i.e., what contents it embraces. Only experience can decide such questions.

[839] We know from experience that conscious contents can become unconscious through loss of their energetic value. This is the normal process of “forgetting.” That these contents do not simply get lost below the threshold of consciousness we know from the experience that occasionally, under suitable conditions, they can emerge from their submersion decades later, for instance in dreams, or under hypnosis, or in the form of cryptomnesia,⁹⁰ or through the revival of associations with the forgotten content. We also know that conscious contents can fall below the threshold of consciousness through “intentional forgetting,” or what Freud calls the *repression* of a painful content, with no appreciable loss of value. A similar effect is produced by a dissociation of the personality, i.e., the disintegration of consciousness as the result of a violent *affect* (q.v.) or nervous shock, or through the collapse of the personality in schizophrenia (Bleuler).

[840] We know from experience, too, that sense perceptions which, either because of their slight intensity or because of the deflection of attention, do not reach conscious *apperception* (q.v.), none the less become psychic contents through unconscious apperception, which again may be demonstrated by hypnosis, for example. The same thing may happen with certain judgments or other associations which remain unconscious because of their low energy charge or because of the deflection of attention. Finally, experience also teaches that there are unconscious psychic associations—mythological *images* (q.v.), for instance—which have never been the object of consciousness and must therefore be wholly the product of unconscious activity.

[841] To this extent, then, experience furnishes *points d'appui* for the assumption of unconscious contents. But it can tell us nothing about what might *possibly* be an unconscious content. It is idle to speculate about this, because the range of what *could* be an unconscious content is simply illimitable. What is the lowest limit of subliminal sense perception? Is there any way of measuring the scope and subtlety of unconscious associations? When is a forgotten content totally obliterated? To these questions there is no answer.

[842] Our experience so far of the nature of unconscious contents permits us, however, to make one general classification. We can distinguish a *personal unconscious*, comprising all the acquisitions of personal life, everything forgotten, repressed, subliminally perceived, thought, felt. But, in addition to these personal unconscious contents, there are other contents which do not originate in personal acquisitions but in the inherited possibility of psychic functioning in general, i.e., in the inherited structure of the brain. These are the mythological associations, the motifs and images that can spring up anew anytime anywhere, independently of historical tradition or migration. I call these contents the *collective unconscious*. Just as conscious contents are engaged in a definite activity, so too are the unconscious contents, as experience confirms. And just as conscious psychic activity creates certain products, so unconscious psychic activity produces dreams, *fantasies* (q.v.), etc. It is idle to speculate on how great a share consciousness has in dreams. A dream presents itself to us: we do not consciously create it. Conscious reproduction, or even the perception of it, certainly alters the dream in many ways, without, however, doing away with the basic fact of the unconscious source of creative activity.

[843] The functional relation of the unconscious processes to consciousness may be described as *compensatory* (q.v.), since experience shows that they bring to the surface the subliminal material that is constellated by the conscious situation, i.e., all those contents which could not be missing from the picture if everything were conscious. The compensatory function of the unconscious becomes more obvious the more one-sided the conscious *attitude* (q.v.) is; pathology furnishes numerous examples of this.

[844] 57. WILL. I regard the will as the amount of psychic energy at the disposal of consciousness. Volition would, accordingly, be an energetic process that is released by conscious motivation. A psychic process, therefore, that is conditioned by unconscious motivation I would not include under the concept of the will. The will is a psychological phenomenon that owes its existence to culture and moral education, but is largely lacking in the primitive mentality.

EPILOGUE

[845] In our age, which has seen the fruits of the French Revolution—“Liberté, Egalité, Fraternité”—growing into a broad social movement whose aim is not merely to raise or lower political rights to the same general level, but, more hopefully, to abolish unhappiness altogether by means of external regulations and egalitarian reforms—in such an age it is indeed a thankless task to speak of the complete inequality of the elements composing a nation. Although it is certainly a fine thing that every man should stand equal before the law, that every man should have his political vote, and that no man, through hereditary social position and privilege, should have unjust advantage over his brother, it is distinctly less fine when the idea of equality is extended to other walks of life. A man must have a very clouded vision, or view human society from a very misty distance, to cherish the notion that the uniform regulation of life would automatically ensure a uniform distribution of happiness. He must be pretty far gone in delusion if he imagines that equality of income, or equal opportunities for all, would have approximately the same value for everyone. But, if he were a legislator, what would he do about all those people whose greatest opportunities lie not without, but within? If he were just, he would have to give at least twice as much money to the one man as to the other, since to the one it means much, to the other little. No social legislation will ever be able to overcome the psychological differences between men, this most necessary factor for generating the vital energy of a human society. It may serve a useful purpose, therefore, to speak of the heterogeneity of men. These differences involve such different requirements for happiness that no legislation, however perfect, could afford them even approximate satisfaction. No outward form of life could be devised, however equitable and just it might appear, that would not involve injustice for one or the other human type. That, in spite of this, every kind of enthusiast—political, social, philosophical, or religious—is busily endeavouring to find those uniform external conditions which would bring with them greater opportunities for the happiness of all seems to me connected with a general attitude to life too exclusively oriented by the outer world.

[846] It is not possible to do more than touch on this far-reaching question here, since such considerations lie outside the scope of this book. We are here concerned only with the psychological problem, and the existence of different typical attitudes is a problem of the first order, not only for psychology but for all departments of science and life in which man’s psychology plays a decisive role. It is, for instance, obvious to anyone of ordinary intelligence that every philosophy that is not just a history of philosophy depends on a personal psychological premise. This premise may be of a

purely individual nature, and indeed is generally regarded as such if any psychological criticism is made at all. The matter is then considered settled. But this is to overlook the fact that what one regards as an individual prejudice is by no means so under all circumstances, since the standpoint of a particular philosopher often has a considerable following. It is acceptable to his followers not because they echo him without thinking, but because it is something they can fully understand and appreciate. Such an understanding would be impossible if the philosopher's standpoint were determined only individually, for it is quite certain in that case that he would be neither fully understood nor even tolerated. The peculiarity of the standpoint which is understood and acknowledged by his followers must therefore correspond to a *typical* personal attitude, which in the same or a similar form has many representatives in a society. As a rule, the partisans of either side attack each other purely externally, always seeking out the chinks in their opponent's armour. Squabbles of this kind are usually fruitless. It would be of considerably greater value if the dispute were transferred to the psychological realm, from which it arose in the first place. The shift of position would soon show a diversity of psychological attitudes, each with its own right to existence, and each contributing to the setting up of incompatible theories. So long as one tries to settle the dispute by external compromises, one merely satisfies the modest demands of shallow minds that have never yet been enkindled by the passion of a principle. A real understanding can, in my view, be reached only when the diversity of psychological premises is accepted.

[847] It is a fact, which is constantly and overwhelmingly apparent in my practical work, that people are virtually incapable of understanding and accepting any point of view other than their own. In small things a general superficiality of outlook, combined with a none too common forbearance and tolerance and an equally rare goodwill, may help to build a bridge over the chasm which lack of understanding opens between man and man. But in more important matters, and especially those concerned with ideals, an understanding seems, as a rule, to be beyond the bounds of possibility. Certainly strife and misunderstanding will always be among the props of the tragicomedy of human existence, but it is none the less undeniable that the advance of civilization has led from the law of the jungle to the establishment of courts of justice and standards of right and wrong which are above the contending parties. It is my conviction that a basis for the settlement of conflicting views would be found in the recognition of different types of attitude—a recognition not only of the existence of such types, but also of the fact that every man is so imprisoned in his type that he is simply incapable of fully understanding another standpoint. Failing a recognition of this exacting demand, a violation of the other standpoint is practically inevitable. But just as the contending parties in a court of law refrain from direct violence and submit their claims to the justice of the law and the impartiality of the

judge, so each type, conscious of his own partiality, should refrain from heaping abuse, suspicion, and indignity upon his opponent.

[848] In considering the problem of typical attitudes, and in presenting them in outline, I have endeavoured to direct the eye of my readers to this picture of the many possible ways of viewing life, in the hope that I may have contributed my small share to the knowledge of the almost infinite variations and gradations of individual psychology. No one, I trust, will draw the conclusion from my description of types that I believe the four or eight types here presented to be the only ones that exist. This would be a serious misconception, for I have no doubt whatever that these attitudes could also be considered and classified from other points of view. Indeed, there are indications of such possibilities in this book, as for instance Jordan's classification in terms of activity. But whatever the criterion for a classification of types may be, a comparison of the various forms of habitual attitudes will result in an equal number of psychological types.

[849] However easy it may be to regard the existing attitudes from other viewpoints than the one here adopted, it would be difficult to adduce evidence against the existence of psychological types. I have no doubt at all that my opponents will be at some pains to strike the question of types off the scientific agenda, since the type problem must, to say the least of it, be a very unwelcome obstacle for every theory of complex psychic processes that lays claim to general validity. Every theory of complex psychic processes presupposes a uniform human psychology, just as scientific theories in general presuppose that nature is fundamentally one and the same. But in the case of psychology there is the peculiar condition that, in the making of its theories, the psychic process is not merely an object but at the same time the subject. Now if one assumes that the subject is the same in all individual cases, it can also be assumed that the subjective process of theory-making, too, is the same everywhere. That this is not so, however, is demonstrated most impressively by the existence of the most diverse theories about the nature of complex psychic processes. Naturally, every new theory is ready to assume that all other theories were wrong, usually for the sole reason that its author has a different subjective view from his predecessors. He does not realize that the psychology he sees is *his* psychology, and on top of that is the psychology of his type. He therefore supposes that there can be only one true explanation of the psychic process he is investigating, namely the one that agrees with his type. All other views—I might almost say all seven other views—which, in their way, are just as true as his, are for him mere aberrations. In the interests of the validity of his own theory, therefore, he will feel a lively but very understandable distaste for any view that establishes the existence of different types of human psychology, since his own view would then lose, shall we say, seven-eighths of its truth. For, besides his own theory, he would have to regard seven other

theories of the same process as equally true, or, if that is saying too much, at least grant a second theory a value equal to his own.

[850] I am quite convinced that a natural process which is very largely independent of human psychology, and can therefore be viewed only as an object, can have but one true explanation. But I am equally convinced that the explanation of a complex psychic process which cannot be objectively registered by any apparatus must necessarily be only the one which that subjective process itself produces. In other words, the author of the concept can produce only just such a concept as corresponds to the psychic process he is endeavouring to explain; but it will correspond only when the process to be explained coincides with the process occurring in the author himself. If neither the process to be explained, nor any analogy of it, were to be found in the author, he would be confronted with a complete enigma, whose explanation he would have to leave to the man who himself experienced the process. If I have a vision, for instance, no objectively registering apparatus will enable me to discover how it originated; I can explain its origin only as I myself understand it. But in this "as I myself understand it" lies the partiality, for at best my explanation will start from the way the visionary process presents itself to me. By what right do I assume that the visionary process presents itself in the same or a similar way to everyone?

[851] With some show of reason, one will adduce the uniformity of human psychology at all times and places as an argument in favour of this generalization of a subjective judgment. I myself am so profoundly convinced of the uniformity of the psyche that I have even summed it up in the concept of the collective unconscious, as a universal and homogeneous substratum whose uniformity is such that one finds the same myth and fairytale motifs in all corners of the earth, with the result that an uneducated American Negro dreams of motifs from Greek mythology¹ and a Swiss clerk re-experiences in his psychosis the vision of an Egyptian Gnostic.² But this fundamental homogeneity is offset by an equally great heterogeneity of the conscious psyche. What immeasurable distances lie between the consciousness of a primitive, a Periclean Athenian, and a modern European! What a difference even between the consciousness of a learned professor and that of his spouse! What, in any case, would our world be like if there existed a uniformity of minds? No, the notion of a uniformity of the conscious psyche is an academic chimera, doubtless simplifying the task of a university lecturer when facing his pupils, but collapsing into nothing in the face of reality. Quite apart from the differences among individuals whose innermost natures are separated by stellar distances, the types, as classes of individuals, are themselves to a very large extent different from one another, and it is to the existence of these types that we must ascribe the differences of views in general.

[852] In order to discover the uniformity of the human psyche, I have to descend into the very foundations of consciousness. Only there do I find that in which all are alike. If I build my theory on what is common to all, I explain the psyche in terms of its foundation and origin. But that does nothing to explain its historical and individual differentiation. With such a theory I ignore the peculiarities of the conscious psyche. I actually deny the whole other side of the psyche, its differentiation from the original germinal state. I reduce man to his phylogenetic prototype, or I dissolve him into his elementary processes; and when I try to reconstruct him again, in the former case an ape will emerge, and in the latter a welter of elementary processes engaged in aimless and meaningless reciprocal activity.

[853] No doubt an explanation of the psyche on the basis of its uniformity is not only possible but fully justified. But if I want to project a picture of the psyche in its totality, I must bear in mind the diversity of psyches, since the conscious individual psyche belongs just as much to a general picture of psychology as does its unconscious foundation. In my construction of theories, therefore, I can, with as much right, proceed from the fact of differentiated psyches, and consider the same process from the standpoint of differentiation which I considered before from the standpoint of uniformity. This naturally leads me to a view diametrically opposed to the former one. Everything which in that view was left out of the picture as an individual variant now becomes important as a starting-point for further differentiations; and everything which previously had a special value on account of its uniformity now appears valueless, because merely collective. From this angle I shall always be intent on where a thing is going to, not where it comes from; whereas from the former angle I never bothered about the goal but only about the origin. I can, therefore, explain the same psychic process with two contradictory and mutually exclusive theories, neither of which I can declare to be wrong, since the rightness of one is proved by the uniformity of the psyche, and the rightness of the other by its diversity.

[854] This brings us to the great difficulty which the reading of my earlier book³ only aggravated, both for the scientific public and for the layman, with the result that many otherwise competent heads were thrown into confusion. There I made an attempt to present both views with the help of case material. But since reality neither consists of theories nor follows them, the two views, which we are bound to think of as divided, are united within it. Each is a product of the past and carries a future meaning, and of neither can it be said with certainty whether it is an end or a beginning. Everything that is alive in the psyche shimmers in rainbow hues. For anyone who thinks there is only one true explanation of a psychic process, this vitality of psychic contents, which necessitates two contradictory theories, is a matter

for despair, especially if he is enamoured of simple and uncomplicated truths, incapable maybe of thinking both at the same time.

[855] On the other hand, I am not convinced that, with these two ways of looking at the psyche—the reductive and constructive as I have called them⁴—the possibilities of explanation are exhausted. I believe that other equally “true” explanations of the psychic process can still be put forward, just as many in fact as there are types. Moreover, these explanations will agree as well or as ill with one another as the types themselves in their personal relations. Should, therefore, the existence of typical differences of human psyches be granted—and I confess I see no reason why it should not be granted—the scientific theorist is confronted with the disagreeable dilemma of either allowing several contradictory theories of the same process to exist side by side, or of making an attempt, foredoomed at the outset, to found a sect which claims for itself the only correct method and the only true theory. Not only does the former possibility encounter the extraordinary difficulty of an inwardly contradictory “double-think” operation, it also contravenes one of the first principles of intellectual morality: *principia explicandi non sunt multiplicanda praeter necessitatem*.⁵ But in the case of psychological theories the necessity of a plurality of explanations is given from the start, since, in contrast to any other scientific theory, the object of psychological explanation is consubstantial with the subject: one psychological process has to explain another. This serious difficulty has already driven thoughtful persons to remarkable subterfuges, such as the assumption of an “objective intellect” standing outside the psychic process and capable of contemplating the subordinate psyche objectively, or the similar assumption that the intellect is a faculty which can stand outside itself and contemplate itself. All these expedients are supposed to create a sort of extra-terrestrial Archimedean point by means of which the intellect can lift itself off its own hinges. I understand very well the profound human need for convenient solutions, but I do not see why truth should bow to this need. I can also understand that, aesthetically, it would be far more satisfactory if, instead of the paradox of mutually contradictory explanations, we could reduce the psychic process to the simplest possible instinctive foundation and leave it at that, or if we could credit it with a metaphysical goal of redemption and find peace in that hope.

[856] Whatever we strive to fathom with our intellect will end in paradox and relativity, if it be honest work and not *a petitio principii* in the interests of convenience. That an intellectual understanding of the psychic process must end in paradox and relativity is simply unavoidable, if only for the reason that the intellect is but one of many psychic functions which is intended by nature to serve man in constructing of his images of the objective world. We should not pretend to understand the world only by the intellect; we apprehend it just as much by feeling. Therefore the judgment of

the intellect is, at best, only a half-truth, and must, if it is honest, also admit its inadequacy.

[857] To deny the existence of types is of little avail in the face of the facts. In view of their existence, therefore, every theory of psychic processes has to submit to being evaluated in its turn as itself a psychic process, as the expression of a specific type of human psychology with its own justification. Only from these typical self-representations of the psyche can the materials be collected which will co-operate to form a higher synthesis.

APPENDIX

FOUR PAPERS ON PSYCHOLOGICAL TYPOLOGY

A CONTRIBUTION TO THE STUDY OF PSYCHOLOGICAL TYPES¹

[858] It is well known that in their general aspects hysteria and schizophrenia present a striking contrast, which is particularly evident in the attitude of the patients to the external world. In their relations to the object, the hysteric displays as a rule an intensity of feeling that surpasses the normal, while in the schizophrenic the normal level is not reached at all. The clinical picture is exaggerated emotivity in the one, and extreme apathy in the other, with regard to the environment. In their personal relations this difference is marked by the fact that we can remain in affective rapport with our hysterical patients, which is not the case in schizophrenia. The contrast between the two types of illness is also observable in the rest of their symptomatology. So far as the intellectual symptoms of hysteria are concerned, they are fantasy products which may be accounted for in a natural and human way by the antecedents and individual history of the patient; in schizophrenia, on the contrary, the fantasy products are more nearly related to dreams than to the psychology of the waking state. They have, moreover, a distinctly archaic character, the mythological creations of the primitive imagination being far more in evidence than the personal memories of the patient. Finally, the physical symptoms so common in hysteria, which simulate well-known and impressive organic illnesses, are not to be found in the clinical picture of schizophrenia.

[859] All this clearly indicates that hysteria is characterized by a centrifugal movement of libido, while in schizophrenia the movement is more centripetal. The reverse obtains, however, when the illness has fully established its compensatory effects. In the hysteric the libido is then hampered in its movement of expansion and is forced to regress upon itself; the patients cease to partake in the common life, are wrapped up in their daydreams, keep to their beds, remain shut up in their sickrooms, etc. During the incubation of his illness the schizophrenic likewise turns away from the outer world in order to withdraw into himself, but when the period of morbid compensation arrives, he seems constrained to draw attention to himself, to force himself upon the notice of those around him, by his extravagant, insupportable, or directly aggressive behaviour.

[860] I propose to use the terms *extraversion* and *introversion* to describe these two opposite movements of libido, further qualifying them as *regressive* in pathological cases where delusional ideas, fictions, or fantastic interpretations, all inspired by emotivity, falsify the judgment of the patient about things or about himself. We speak

of extraversion when he gives his whole interest to the outer world, to the object, and attributes an extraordinary importance and value to it. When, on the contrary, the objective world sinks into the shadow, at it were, or undergoes a devaluation, while the individual occupies the centre of his own interest and becomes in his own eyes the only person worthy of consideration, it is a case of introversion. I call *regressive extraversion* the phenomenon which Freud calls *transference*, when the hysteric projects upon the object his own illusions and subjective valuations. In the same way, I call *regressive introversion* the opposite phenomenon which we find in schizophrenia, when these fantastic ideas refer to the subject himself.

[861] It is obvious that these two contrary movements of libido, as simple psychic mechanisms, may operate alternately in the same individual, since after all they serve the same purpose by different methods—namely, to minister to his well-being. Freud has taught us that in the mechanism of hysterical extraversion the personality seeks to get rid of disagreeable memories and impressions, and to free itself from its complexes, by a process of *repression*. The individual clings to the object in order to forget these painful contents and leave them behind him. Conversely, in the mechanism of introversion, the libido concentrates itself wholly on the complexes, and seeks to detach and isolate the personality from external reality. This psychological process is associated with a phenomenon which is not properly speaking “repression,” but would be better rendered by the term “devaluation” of the objective world.

[862] To this extent, extraversion and introversion are two modes of psychic reaction which can be observed in the same individual. The fact, however, that two such contrary disturbances as hysteria and schizophrenia are characterized by the predominance of the mechanism of extraversion or of introversion suggests that there may also be normal human types who are distinguished by the predominance of one or other of the two mechanisms. And indeed, psychiatrists know very well that long before the illness is fully established, the hysterical patient as well as the schizophrenic is marked by the predominance of his specific type, which reaches back into the earliest years of childhood.

[863] As Binet has pointed out so aptly,^{1a} a neurosis simply emphasizes and throws into excessive relief the characteristic traits of a personality. It has long been known that the so-called hysterical character is not simply the product of the manifest neurosis, but predated it to a certain extent. And Hoch has shown the same thing by his researches into the histories of schizophrenic patients; he speaks of a “shut-in” personality² which was present before the onset of the illness. If this is so, we may certainly expect to find the two types outside the sphere of pathology. There are moreover numerous witnesses in literature to the existence of the two types of

mentality. Without pretending to exhaust the subject, I will give a few striking examples.

[864] So far as my limited knowledge goes, we have to thank William James for the best observations in this respect. He lays down the principle: "Of whatever temperament a professional philosopher is, he tries, when philosophizing, to sink the fact of his temperament."³ And starting from this idea, which is altogether in accord with the spirit of psychoanalysis, he divides philosophers into two classes: the "tender-minded" and the "tough-minded," or, as we might also call them, the "spiritually-minded" and the "materially-minded." The very terms clearly reveal the opposite movements of the libido. The first class direct their libido to the world of thought, and are predominantly introverted; the second direct it to material things and objective reality, and are extraverted.

[865] James characterizes the "tender-minded" first of all as *rationalistic*, "going by principles."⁴ They are the men of principles and systems; they aspire to dominate experience and to transcend it by abstract reasoning, by their logical deductions and purely rational concepts. They care little for facts, and the multiplicity of empirical phenomena hardly bothers or disconcerts them at all; they forcibly fit the data into their ideal constructions, and reduce everything to their *a priori* premises. This was the method of Hegel in settling beforehand the number of the planets. In the domain of pathology we again meet this kind of philosopher in paranoiacs, who, unperturbed by all factual evidence to the contrary, impose their delirious conceptions on the universe, and find a means of interpreting everything, and according to Adler "arranging" everything, in conformity with their preconceived system.

[866] The other characteristics of this type which James enumerates follow logically from these premises. The "tender-minded" man is "intellectualistic, idealistic, optimistic, religious, free-willist, monistic, dogmatical."⁵ All these qualities betray the almost exclusive concentration of libido upon his intellectual life. This concentration on the inner world of thought is nothing else than introversion. In so far as experience plays any role with these philosophers, it serves only as a fillip to abstraction, to the imperative need to fit the multiplicity and chaos of events into an order which, in the last resort, is the creation of purely subjective thinking.

[867] The "tough-minded" man, on the other hand, is empirical, "going by facts." Experience is his master, facts are his guide and they colour all his thinking. It is only tangible phenomena in the outside world that count. Thought is merely a reaction to external experience. For him principles are always of less value than facts; if he has any, they merely reflect and describe the flux of events, and are incapable of forming a system. Hence his theories are liable to inner contradiction and get overlaid by the accumulation of empirical material. Psychic reality limits itself for him to

observation and to the experience of pleasure and pain; he does not go beyond that, nor does he recognize the rights of philosophical thought. Remaining on the ever-changing surface of the phenomenal world, he himself partakes of its instability; he sees all its aspects, all its theoretical and practical possibilities, but he never arrives at the unity of a settled system, which alone could satisfy the tender-minded. The tough-minded man is reductive. As James so excellently says: “What is higher is explained by what is lower and treated for ever as a case of ‘nothing but’—nothing but something else of a quite inferior sort.”⁶

[868] From these general characteristics, the others which James points out logically follow. The tough-minded man is “sensationalistic,” giving more value to the senses than to reflection. He is “materialistic and pessimistic,” for he knows only too well the uncertainty and hopeless chaos of the course of things. He is “irreligious,” being incapable of asserting the realities of his inner world against the pressure of external facts; a fatalist, because resigned; a pluralist, incapable of all synthesis; and finally a sceptic, as a last and inevitable consequence of all the rest.⁷

[869] The expressions, therefore, used by James show clearly that the difference between the types is the result of a different localization of the libido, this “magical power” in the depth of our being, which, depending on the individual, is directed sometimes to our inner life, sometimes to the objective world. Contrasting the religious subjectivism of the solipsist with the contemporary empirical attitude, James says: “But our esteem for facts has not neutralized in us all religiousness. It is itself almost religious. Our scientific temper is devout.”⁸

[870] A second parallel is furnished by Wilhelm Ostwald,⁹ who divides men of genius into “classics” and “romantics.” The romantics are distinguished by their rapid reactions, their abundant production of ideas, some of which are badly digested and of doubtful value. They are brilliant teachers, of a compelling ardour, and collect round them a large and enthusiastic circle of students, on whom they exert great personal influence. This type is obviously identical with our extraverted type. The classics, on the contrary, are slow to react; they produce with much difficulty, paralyzed by their own severe self-criticism; they have no love for teaching, and are in fact mostly bad teachers, lacking enthusiasm; living apart and absorbed in themselves, they exercise little direct personal influence, making scarcely any disciples, but producing works of finished perfection which often bring them only posthumous fame. This type is an unmistakable introvert.

[871] We find a third, very valuable parallel in the aesthetic theory of Wilhelm Worringer.¹⁰ Borrowing A. Riegl’s expression “absolute artistic volition”¹¹ to designate the internal force which inspires the artist, he distinguishes two forms: abstraction and empathy. He speaks of the urge to abstraction and the urge to

empathy, thereby making clear the libidinal nature of these two forms, the stirring of the *élan vital*. “In the same way,” says Worringer, “as the urge to empathy finds its gratification in organic beauty, so the urge to abstraction discovers beauty in the inorganic, the negation of all life, in crystalline forms or, generally speaking, wherever the severity of abstract law reigns.”¹² Empathy is a movement of libido towards the object in order to assimilate it and imbue it with emotional values; abstraction withdraws libido from the object, despoils it of all that could recall life; leaching out, as it were, its intellectual content, and crystallizing from the lye the typical elements that conform to law, which are either superimposed on the object or are its very antithesis. Bergson also makes use of these images of crystallization and rigidity to illustrate the nature of intellectual abstraction and clarification.

[872] Worringer’s “abstraction” represents that process which we have already encountered as a consequence of introversion—the exaltation of the intellect to offset the devaluation of external reality. “Empathy” corresponds to extraversion, as Theodor Lipps had already pointed out. “What I feel myself into is life in general, and life is power, inner work, effort, and accomplishment. To live, in a word, is to act, and to act is to experience the expenditure of my forces. This activity is by its very nature an activity of the will.”¹³ “Aesthetic enjoyment,” says Worringer, “is objectified self-enjoyment,”¹⁴ a formula that accords very well with our definition of extraversion. But Worringer’s conception of aesthetics is not vitiated by any “tough-mindedness,” and so he is fully capable of appreciating the value of psychological realities. Hence Worringer says: “The crucial factor is thus not so much the tone of the feeling as the feeling itself, the inner movement, the inner life, the subject’s inner activity.”¹⁵ And again: “The value of a line or of a form consists in the vital value which it holds for us. It acquires its beauty only through the vital feeling which we unconsciously project into it.”¹⁶ These statements correspond exactly to my own view of the theory of libido, which seeks to maintain the balance between the two psychological opposites of extraversion and introversion.

[873] The counterpole of empathy is abstraction. According to Worringer, “the urge to abstraction is the outcome of a great inner uneasiness inspired in man by the phenomena of the external world, and its religious counterpart is the strongly transcendental colouring of all ideas. We might describe this state as an immense spiritual dread of space.... This same feeling of fear may also be assumed to be the root of artistic creation.”¹⁷ We recognize in this definition the primary tendency towards introversion. To the introverted type the universe does not appear beautiful and desirable, but disquieting and even dangerous; he entrenches himself in his inner fastness, securing himself by the invention of regular geometrical figures full of repose, whose primitive, magical power assures him of domination over the surrounding world.

[874] “The urge to abstraction is the origin of all art,” says Worringer.¹⁸ This idea finds weighty confirmation in the fact that schizophrenics produce forms and figures showing the closest analogy with those of primitive humanity, not only in their thoughts but also in their drawings.

[875] In this connection it would be unjust not to recall that Schiller attempted a similar formulation in his *naïve* and *sentimental* types.¹⁹ The naïve poet “is Nature, the sentimental seeks her,” he says. The naïve poet expresses primarily *himself*, while the sentimental is primarily influenced by the object. For Schiller, a perfect example of the naïve poet is Homer. “The naïve poet follows simple Nature and sensation and confines himself to a mere copying of reality.”²⁰ “The sentimental poet,” on the contrary “reflects on the impression objects make on him, and on that reflection alone depends the emotion with which he is exalted, and which likewise exalts us. Here the object is related to an idea, and on this relation alone depends his poetic power.”²¹ But Schiller also saw that these two types result from the predominance of psychological mechanisms which might be present in the same individual. “It is not only in the same poet,” he says, “but even in the same work that these two categories are frequently found united.”²² These quotations show what types Schiller had in mind, and one recognizes their basic identity with those we have been discussing.

[876] We find another parallel in Nietzsche’s contrast between the *Apollinian* and the *Dionysian*.²³ The example which Nietzsche uses to illustrate this contrast is instructive—namely, that between dream and intoxication. In a dream the individual is shut up in himself, it is the most intimate of all psychic experiences; in intoxication he is liberated from himself, and, utterly self-forgetful, plunges into the multiplicity of the objective world. In his picture of Apollo, Nietzsche borrows the words of Schopenhauer: “As upon a tumultuous sea, unbounded in every direction, the mariner sits full of confidence in his frail barque, rising and falling amid the raging mountains of waves, so the individual man, in a world of troubles, sits passive and serene, trusting to the *principium individuationis*.”²⁴ “Yes,” continues Nietzsche, “one might say that the unshakable confidence in this principle, and the calm security of those whom it has inspired, have found in Apollo their most sublime expression, and one might describe Apollo himself as the glorious divine image of the principle of individuation.”²⁵

[877] The Apollinian state, therefore, as Nietzsche conceives it, is a withdrawal into oneself, or introversion. Conversely the Dionysian state is the unleashing of a torrent of libido into things. “Not only,” says Nietzsche, “is the bond between man and man reconfirmed in the Dionysian enchantment, but alienated Nature, hostile or enslaved, celebrates once more her feast of reconciliation with her prodigal son—Man. Liberally the earth proffers her gifts, and the wild beasts from rock and desert draw

near peacefully. The car of Dionysos is heaped with flowers and garlands; panthers and tigers stride beneath his yoke. Transform Beethoven's Ode to Joy into a painting, and give free rein to your imagination as the awestruck millions prostrate themselves in the dust: thus you approach the Dionysian intoxication. Now is the slave free, now all the rigid, hostile barriers which necessity, caprice, or shameless fashion have set up between man and man are broken down. Now, with this gospel of universal harmony, each feels himself not only united, reconciled, merged with his neighbour, but one with him, as though the veil of Maya had been torn away, and nothing remained of it but a few shreds floating before the mystery of the Primal Unity."²⁶ Any commentary on this passage would be superfluous.

[878] In concluding this series of examples drawn from outside my own special field of study, I would still like to mention a parallel from the sphere of linguistics, which likewise illustrates our two types. This is Franz Finck's hypothesis concerning the structure of language.²⁷ According to Finck, there are two main types of linguistic structure. The one is represented in general by the transitive verbs: I see him, I kill him, etc. The other is represented by the intransitive verbs: He appears before me, he dies at my feet. The first type clearly shows a centrifugal movement of libido going out from the subject; the second, a centripetal movement of libido coming in from the object. The latter, introverting type of structure is found particularly among the primitive languages of the Eskimos.

[879] Finally, in the domain of psychiatry our two types have been described by Otto Gross.²⁸ He distinguishes two forms of inferiority: a type with a diffuse and shallow consciousness, and another with a contracted and deep consciousness. The first is characterized by the weakness, the second by the intense activity, of the "secondary function." Gross recognized that the secondary function is closely connected with affectivity, from which it is not difficult to see that once again our two types are meant. The relation he established between manic-depressive insanity and the type with a shallow consciousness shows that we are dealing with extraversion, while the relation between the psychology of the paranoiac and the type with a contracted consciousness indicates the identity with introversion.

[880] After the foregoing considerations it will come as a surprise to nobody to learn that in the domain of psychoanalysis we also have to reckon with the existence of these two psychological types. On the one side we have a theory which is essentially reductive, pluralistic, causal, and sensualistic. This is the theory of Freud, which is strictly limited to empirical facts, and traces back complexes to their antecedents and to more simple elements. It regards psychological life as consisting in large measure of reactions, and accords the greatest role to sensation. On the other side we have the diametrically opposed theory of Adler,²⁹ which is thoroughly intellectualistic,

monistic, and finalistic. Here psychological phenomena are not reduced to antecedent and more simple elements, but are conceived as “arrangements,” as the outcome of intentions and aims of a complex nature. Instead of the *causa efficiens* we have the *causa finalis*. The previous history of the patient and the concrete influences of the environment are of much less importance than his dominating principles, his “guiding fictions.” It is not his striving for the object and his subjective pleasure in it that are the determining factors, but the securing of the individual’s power in the face of the hostile environmental influences.

[881] While the dominant note in Freudian psychology is a centrifugal tendency, a striving for pleasure in the object, in Adler’s it is a centripetal striving for the supremacy of the subject, who wants to be “on top,” to safeguard his power, to defend himself against the overwhelming forces of existence. The expedient to which the type described by Freud resorts is the infantile transference of subjective fantasies into the object, as a compensatory reaction to the difficulties of life. The characteristic recourse of the type described by Adler is, on the contrary, “security,” “masculine protest,” and the stubborn reinforcement of the “guiding fiction.”

[882] The difficult task of creating a psychology which will be equally fair to both types must be reserved for the future.

PSYCHOLOGICAL TYPES¹

[883] From ancient times there have been numerous attempts to reduce the manifold differences between human individuals to definite categories, and on the other hand to break down the apparent uniformity of mankind by a sharper characterization of certain typical differences. Without wishing to go too deeply into the history of these attempts, I would like to call attention to the fact that the oldest categories known to us originated with physicians. Of these perhaps the most important was Claudius Galen, the Greek physician who lived in the second century A.D. He distinguished four basic temperaments: the sanguine, the phlegmatic, the choleric, and the melancholic. The underlying idea goes back to the fifth century B.C., to the teachings of Hippocrates, that the human body was composed of the four elements, air, water, fire, and earth. Corresponding to these elements, four substances were to be found in the living body, blood, phlegm, yellow bile, and black bile; and it was Galen's idea that, by the varying admixture of these four substances, men could be divided into four classes. Those in whom there was a preponderance of blood belonged to the sanguine type; a preponderance of phlegm produced the phlegmatic; yellow bile produced the choleric, and black bile the melancholic. As our language shows, these differences of temperament have passed into history, though they have, of course, long since been superseded as a physiological theory.

[884] To Galen undoubtedly belongs the credit for having created a psychological classification of human beings which has endured for two thousand years, a classification based on perceptible differences of *emotionality* or *affectivity*. It is interesting to note that the first attempt at a typology was concerned with the emotional behaviour of man—obviously because affectivity is the commonest and most striking feature of behaviour in general.

[885] Affects, however, are by no means the only distinguishing mark of the human psyche. Characteristic data can be expected from other psychological phenomena as well, the only requirement being that we perceive and observe other functions as clearly as we do affects. In earlier centuries, when the concept "psychology" as we know it today was entirely lacking, all psychic functions other than affects were veiled in darkness, just as they still seem to be scarcely discernible subtleties for the great majority of people today. Affects can be seen on the surface, and that is enough for the unpsychological man—the man for whom the psyche of his neighbour presents no problem. He is satisfied with seeing other people's affects; if he sees

none, then the other person is psychologically invisible to him because, apart from affects, he can perceive nothing in the other's consciousness.

[886] The reason why we are able to discover other functions besides affects in the psyche of our fellow men is that we ourselves have passed from an "unproblematical" state of consciousness to a problematical one. If we judge others only by affects, we show that our chief, and perhaps only, criterion is affect. This means that the same criterion is also applicable to our own psychology, which amounts to saying that our psychological judgment is neither objective nor independent but is enslaved to affect. This truth holds good for the majority of men, and on it rests the psychological possibility of murderous wars and the constant threat of their recurrence. This must always be so as long as we judge the people "on the other side" by our own affects. I call such a state of consciousness "unproblematical" because it has obviously never become a problem to itself. It becomes a problem only when a doubt arises as to whether affects—including our own affects—offer a satisfactory basis for psychological judgments. We are always inclined to justify ourselves before anyone who holds us responsible for an emotional action by saying that we acted only on an outburst of affect and are not usually in that condition. When it concerns ourselves we are glad to explain the affect as an exceptional condition of diminished responsibility but are loath to make the same allowance for others. Even if this is a not very edifying attempt to exculpate our beloved ego, there is still something positive in the feeling of justification such an excuse affords: it is an attempt to distinguish oneself from one's own affect, and hence one's fellow man from *his* affect. Even if my excuse is only a subterfuge, it is nevertheless an attempt to cast doubt on the validity of affect as the sole index of personality, and to appeal to other psychic functions that are just as characteristic of it as the affect, if not more so. When a man judges us by our affects, we readily accuse him of lack of understanding, or even injustice. But this puts us under an obligation not to judge others by their affects either.

[887] For this purpose the primitive, unpsychological man, who regards affects in himself and others as the only essential criterion, must develop a problematical state of consciousness in which other factors besides affects are recognized as valid. In this problematical state a paradoxical judgment can be formed: "I am this affect" and "this affect is not me." This antithesis expresses a splitting of the ego, or rather, a splitting of the psychic material that constitutes the ego. By recognizing myself as much in my affect as in something else that is not my affect, I differentiate an affective factor from other psychic factors, and in so doing I bring the affect down from its original heights of unlimited power into its proper place in the hierarchy of psychic functions. Only when a man has performed this operation on himself, and has distinguished between the various psychic factors in himself, is he in a position to

look around for other criteria in his psychological judgment of others, instead of merely falling back on affect. Only in this way is a really objective psychological judgment possible.

[888] What we call “psychology” today is a science that can be pursued only on the basis of certain historical and moral premises laid down by Christian education during the last two thousand years. A saying like “Judge not, that ye be not judged,” inculcated by religion, has created the possibility of a will which strives, in the last resort, for simple objectivity of judgment. This objectivity, implying no mere indifference to others but based on the principle of excusing others as we do ourselves, is the prerequisite for a just judgment of our fellow men. You wonder perhaps why I dwell so insistently on this question of objectivity, but you would cease to wonder if ever you should try to classify people in practice. A man of pronounced sanguine temperament will tell you that at bottom he is deeply melancholic; a choleric, that his only fault consists in his having always been too phlegmatic. But a classification in the validity of which I alone believe is about as helpful as a universal church of which I am the sole member. We have, therefore, to find criteria which can be accepted as binding not only by the judging subject but also by the judged object.

[889] In complete contrast to the old system of classification by temperaments, the new typology begins with the explicit agreement neither to allow oneself to be judged by affect nor to judge others by it, since no one can declare himself finally identical with his affect. This creates a problem, because it follows that, where affects are concerned, the general agreement which science demands can never be reached. We must, therefore, look around for other factors as a criterion—factors to which we appeal when we excuse ourselves for an emotional action. We say perhaps: “Admittedly I said this or that in a state of affect, but of course I was exaggerating and no harm was meant.” A very naughty child who has caused his mother a lot of trouble might say: “I didn’t mean to, I didn’t want to hurt you, I love you too much.”

[890] Such explanations appeal to the existence of a different kind of personality from the one that appeared in the affect. In both cases the affective personality appears as something inferior that seized hold of the real ego and obscured it. But often the personality revealed in the affect is a higher and better one, so much so that, regrettably, one cannot remain on such a pinnacle of perfection. We all know those sudden fits of generosity, altruism, self-sacrifice, and similar “beautiful gestures” for which, as an ironical observer might remark, one does not care to be held responsible—perhaps a reason why so many people do so little good.

[891] But whether the affective personality be high or low, the affect is considered an exceptional state whose qualities are represented either as a falsification of the “real”

personality or as not belonging to it as an authentic attribute. What then is this “real” personality? Obviously, it is partly that which everyone distinguishes in himself as separate from affect, and partly that in everyone which is dismissed as inauthentic in the judgment of others. Since it is impossible to deny the pertinence of the affective state to the ego, it follows that the ego is the same ego whether in the affective state or in the so-called “authentic” state, even though it displays a differential attitude to these psychological happenings. In the affective state it is unfree, driven, coerced. By contrast, the normal state is a state of free will, with all one’s powers at one’s disposal. In other words, *the affective state is unproblematical, while the normal state is problematical: it comprises both the problem and possibility of free choice*. In this latter state an understanding becomes possible, because in it alone can one discern one’s motives and gain self-knowledge. Discrimination is the *sine qua non* of cognition. But discrimination means splitting up the contents of consciousness into discrete functions. Therefore, if we wish to define the psychological peculiarity of a man in terms that will satisfy not only our own subjective judgment but also the object judged, we must take as our criterion that state or attitude which is felt by the object to be the conscious, normal condition. Accordingly, we shall make his conscious motives our first concern, while eliminating as far as possible our own arbitrary interpretations.

[892] Proceeding thus we shall discover, after a time, that in spite of the great variety of conscious motives and tendencies, certain groups of individuals can be distinguished who are characterized by a striking conformity of motivation. For example, we shall come upon individuals who in all their judgments, perceptions, feelings, affects, and actions feel external factors to be the predominant motivating force, or who at least give weight to them no matter whether causal or final motives are in question. I will give some examples of what I mean. St. Augustine: “I would not believe the Gospel if the authority of the Catholic Church did not compel it.”² A dutiful daughter: “I could not allow myself to think anything that would be displeasing to my father.” One man finds a piece of modern music beautiful because everybody else pretends it is beautiful. Another marries in order to please his parents but very much against his own interests. There are people who contrive to make themselves ridiculous in order to amuse others; they even prefer to make butts of themselves rather than remain unnoticed. There are not a few who in everything they do or don’t do have but one motive in mind: what will others think of them? “One need not be ashamed of a thing if nobody knows about it.” There are some who can find happiness only when it excites the envy of others; some who make trouble for themselves in order to enjoy the sympathy of their friends.

[893] Such examples could be multiplied indefinitely. They point to a psychological peculiarity that can be sharply distinguished from another attitude which, by contrast,

is motivated chiefly by internal or subjective factors. A person of this type might say: "I know I could give my father the greatest pleasure if I did so and so, but I don't happen to think that way." Or: "I see that the weather has turned out bad, but in spite of it I shall carry out my plan." This type does not travel for pleasure but to execute a preconceived idea. Or: "My book is probably incomprehensible, but it is perfectly clear to me." Or, going to the other extreme: "Everybody thinks I could do something, but I know perfectly well I can do nothing." Such a man can be so ashamed of himself that he literally dares not meet people. There are some who feel happy only when they are quite sure nobody knows about it, and to them a thing is disagreeable just because it is pleasing to everyone else. They seek the good where no one would think of finding it. At every step the sanction of the subject must be obtained, and without it nothing can be undertaken or carried out. Such a person would have replied to St. Augustine: "I would believe the Gospel if the authority of the Catholic Church did *not* compel it." Always he has to prove that everything he does rests on his own decisions and convictions, and never because he is influenced by anyone, or desires to please or conciliate some person or opinion.

[894] This attitude characterizes a group of individuals whose motivations are derived chiefly from the subject, from inner necessity. There is, finally, a third group, and here it is hard to say whether the motivation comes chiefly from within or without. This group is the most numerous and includes the less differentiated normal man, who is considered normal either because he allows himself no excesses or because he has no need of them. The normal man is, by definition, influenced as much from within as from without. He constitutes the extensive middle group, on one side of which are those whose motivations are determined mainly by the external object, and, on the other, those whose motivations are determined from within. I call the first group *extraverted*, and the second group *introverted*. The terms scarcely require elucidation as they explain themselves from what has already been said.

[895] Although there are doubtless individuals whose type can be recognized at first glance, this is by no means always the case. As a rule, only careful observation and weighing of the evidence permit a sure classification. However simple and clear the fundamental principle of the two opposing attitudes may be, in actual reality they are complicated and hard to make out, because every individual is an exception to the rule. Hence one can never give a description of a type, no matter how complete, that would apply to more than one individual, despite the fact that in some ways it aptly characterizes thousands of others. Conformity is one side of a man, uniqueness is the other. Classification does not explain the individual psyche. Nevertheless, an understanding of psychological types opens the way to a better understanding of human psychology in general.

[896] Type differentiation often begins very early, so early that in some cases one must speak of it as innate. The earliest sign of extraversion in a child is his quick adaptation to the environment, and the extraordinary attention he gives to objects and especially to the effect he has on them. Fear of objects is minimal; he lives and moves among them with confidence. His apprehension is quick but imprecise. He appears to develop more rapidly than the introverted child, since he is less reflective and usually without fear. He feels no barrier between himself and objects, and can therefore play with them freely and learn through them. He likes to carry his enterprises to the extreme and exposes himself to risks. Everything unknown is alluring.

[897] To reverse the picture, one of the earliest signs of introversion in a child is a reflective, thoughtful manner, marked shyness and even fear of unknown objects. Very early there appears a tendency to assert himself over familiar objects, and attempts are made to master them. Everything unknown is regarded with mistrust; outside influences are usually met with violent resistance. The child wants his own way, and under no circumstances will he submit to an alien rule he cannot understand. When he asks questions, it is not from curiosity or a desire to create a sensation, but because he wants names, meanings, explanations to give him subjective protection against the object. I have seen an introverted child who made his first attempts to walk only after he had learned the names of all the objects in the room he might touch. Thus very early in an introverted child the characteristic defensive attitude can be noted which the adult introvert displays towards the object; just as in an extraverted child one can very early observe a marked assurance and initiative, a happy trustfulness in his dealings with objects. This is indeed the basic feature of the extraverted attitude: psychic life is, as it were, enacted outside the individual in objects and objective relationships. In extreme cases there is even a sort of blindness for his own individuality. The introvert, on the contrary, always acts as though the object possessed a superior power over him against which he has to defend himself. His real world is the inner one.

[898] Sad though it is, the two types are inclined to speak very badly of one another. This fact will immediately strike anyone who investigates the problem. And the reason is that the psychic values have a diametrically opposite localization for the two types. The introvert sees everything that is in any way valuable for him in the subject; the extravert sees it in the object. This dependence on the object seems to the introvert a mark of the greatest inferiority, while to the extravert the preoccupation with the subject seems nothing but infantile auto-eroticism. So it is not surprising that the two types often come into conflict. This does not, however, prevent most men from marrying women of the opposite type. Such marriages are very valuable as psychological symbioses so long as the partners do not attempt a mutual

“psychological” understanding. But this phase of understanding belongs to the normal development of every marriage provided the partners have the necessary leisure or the necessary urge to development—though even if both these are present real courage is needed to risk a rupture of the marital peace. In favourable circumstances this phase enters automatically into the lives of both types, for the reason that each type is an example of one-sided development. The one develops only external relations and neglects the inner; the other develops inwardly but remains outwardly at a standstill. In time the need arises for the individual to develop what has been neglected. The development takes the form of a differentiation of certain functions, to which I must now turn in view of their importance for the type problem.

[899] The conscious psyche is an apparatus for adaptation and orientation, and consists of a number of different psychic functions. Among these we can distinguish four basic ones: *sensation, thinking, feeling, intuition*. Under sensation I include all perceptions by means of the sense organs; by thinking I mean the function of intellectual cognition and the forming of logical conclusions; feeling is a function of subjective valuation; intuition I take as perception by way of the unconscious, or perception of unconscious contents.

[900] So far as my experience goes, these four basic functions seem to me sufficient to express and represent the various modes of conscious orientation. For complete orientation all four functions should contribute equally: thinking should facilitate cognition and judgment, feeling should tell us how and to what extent a thing is important or unimportant for us, sensation should convey concrete reality to us through seeing, hearing, tasting, etc., and intuition should enable us to divine the hidden possibilities in the background, since these too belong to the complete picture of a given situation.

[901] In reality, however, these basic functions are seldom or never uniformly differentiated and equally at our disposal. As a rule one or the other function occupies the foreground, while the rest remain undifferentiated in the background. Thus there are many people who restrict themselves to the simple perception of concrete reality, without thinking about it or taking feeling values into account. They bother just as little about the possibilities hidden in a situation. I describe such people as *sensation types*. Others are exclusively oriented by what they think, and simply cannot adapt to a situation which they are unable to understand intellectually. I call such people *thinking types*. Others, again, are guided in everything entirely by feeling. They merely ask themselves whether a thing is pleasant or unpleasant, and orient themselves by their feeling impressions. These are the *feeling types*. Finally, the *intuitives* concern themselves neither with ideas nor with feeling reactions, nor yet

with the reality of things, but surrender themselves wholly to the lure of possibilities, and abandon every situation in which no further possibilities can be scented.

[902] Each of these types represents a different kind of one-sidedness, but one which is linked up with and complicated in a peculiar way by the introverted or extraverted attitude. It was because of this complication that I had to mention these function-types, and this brings us back to the question of the one-sidedness of the introverted and extraverted attitudes. This one-sidedness would lead to a complete loss of psychic balance if it were not compensated by an unconscious counterposition. Investigation of the unconscious has shown, for example, that alongside or behind the introvert's conscious attitude there is an unconscious extraverted attitude which automatically compensates his conscious one-sidedness.

[903] Though one can, in practice, intuit the existence of a general introverted or extraverted attitude, an exact scientific investigator cannot rest content with an intuition but must concern himself with the actual material presented. We then discover that no individual is simply introverted or extraverted, but that he is so in one of his functions. Take a thinking type, for example: most of the conscious material he presents for observation consists of thoughts, conclusions, reflections, as well as actions, affects, valuations, and perceptions of an intellectual nature, or at least the material is directly dependent on intellectual premises. We must interpret the nature of his general attitude from the peculiarity of this material. The material presented by a feeling type will be of a different kind, that is, feelings and emotional contents of all sorts, thoughts, reflections, and perceptions dependent on emotional premises. Only from the peculiar nature of his feelings shall we be able to tell to which of the attitude-types he belongs. That is why I mention these function-types here, because in individual cases the introverted and extraverted attitudes can never be demonstrated *per se*; they appear only as the peculiarity of the predominating conscious function. Similarly, there is no general attitude of the unconscious, but only typically modified forms of unconscious functions, and only through the investigation of the unconscious functions and their peculiarities can the unconscious attitude be scientifically established.

[904] It is hardly possible to speak of typical unconscious functions, although in the economy of the psyche one has to attribute *some* function to the unconscious. It is best, I think, to express oneself rather cautiously in this respect, and I would not go beyond the statement that the unconscious, so far as we can see at present, has a compensatory function to consciousness. What the unconscious is in itself is an idle speculation. By its very nature it is beyond all cognition. We merely postulate its existence from its products, such as dreams and fantasies. But it is a well-established fact of scientific experience that dreams, for example, practically always have a

content that could correct the conscious attitude, and this justifies us in speaking of a compensatory function of the unconscious.

[905] Besides this general function, the unconscious also possesses functions that can become conscious under other conditions. The thinking type, for instance, must necessarily repress and exclude feeling as far as possible, since nothing disturbs thinking so much as feeling, and the feeling type represses thinking, since nothing is more injurious to feeling than thinking. Repressed functions lapse into the unconscious. Just as only one of the four sons of Horus had a human head,³ so as a rule only one of the four basic functions is fully conscious and differentiated enough to be freely manipulable by the will, the others remaining partially or wholly unconscious. This “unconsciousness” does not mean that a thinking type, for instance, is not conscious of his feelings. He knows his feelings very well, in so far as he is capable of introspection, but he denies them any validity and declares they have no influence over him. They therefore come upon him against his will, and being spontaneous and autonomous, they finally appropriate to themselves the validity which his consciousness denies them. They are activated by unconscious stimulation, and form indeed a sort of counterpersonality whose existence can be established only by analysing the products of the unconscious.

[906] When a function is not at one’s disposal, when it is felt as something that disturbs the differentiated function, suddenly appearing and then vanishing again fitfully, when it has an obsessive character, or remains obstinately in hiding when most needed—it then has all the qualities of a quasi-unconscious function. Other peculiarities may be noted: there is always something inauthentic about it, as it contains elements that do not properly belong to it. Thus the unconscious feelings of the thinking type are of a singularly fantastic nature, often in grotesque contrast to the excessively rationalistic intellectualism of his conscious attitude. His conscious thinking is purposive and controlled, but his feeling is impulsive, uncontrolled, moody, irrational, primitive, and just as archaic as the feelings of a savage.

[907] The same is true of every function that is repressed into the unconscious. It remains undeveloped, fused together with elements not properly belonging to it, in an archaic condition—for the unconscious is the residue of unconquered nature in us, just as it is also the matrix of our unborn future. The undeveloped functions are always the seminal ones, so it is no wonder that sometime in the course of life the need will be felt to supplement and alter the conscious attitude.

[908] Apart from the qualities I have mentioned, the undeveloped functions possess the further peculiarity that, when the conscious attitude is introverted, they are extraverted and vice versa. One could therefore expect to find extraverted feelings in an introverted intellectual, and this was aptly expressed by just such a type when he

said: "Before dinner I am a Kantian, but after dinner a Nietzschean." In his habitual attitude, that is to say, he is an intellectual, but under the stimulating influence of a good dinner a Dionysian wave breaks through his conscious attitude.

[909] It is just here that we meet with a great difficulty in diagnosing the types. The observer sees both the manifestations of the conscious attitude and the autonomous phenomena of the unconscious, and he will be at a loss as to what he should ascribe to the conscious and what to the unconscious. A differential diagnosis can be based only on a careful study of the qualities of the observed material. We must try to discover which phenomena result from consciously chosen motives and which are spontaneous; and it must also be established which of them are adapted, and which of them have an unadapted, archaic character.

[910] It will now be sufficiently clear that the qualities of the main conscious function, i.e., of the conscious attitude as a whole, are in strict contrast to those of the unconscious attitude. In other words, we can say that between the conscious and the unconscious there is normally an opposition. This opposition, however, is not perceived as a conflict so long as the conscious attitude is not too one-sided and not too remote from that of the unconscious. But if the contrary should be the case, then the Kantian will be disagreeably surprised by his Dionysian counterpart, which will begin to develop highly unsuitable impulses. His consciousness will then feel obliged to suppress these autonomous manifestations, and thus the conflict situation is created. Once the unconscious gets into active opposition to consciousness, it simply refuses to be suppressed. It is true that certain manifestations which consciousness has marked down are not particularly difficult to suppress, but then the unconscious impulses simply seek other outlets that are less easy to recognize. And once these false safety valves are opened, one is already on the way to neurosis. The indirect outlets can, of course, each be made accessible to understanding by analysis and subjected again to conscious suppression. But that does not extinguish their instinctual dynamism; it is merely pushed still further into the background, unless an understanding of the indirect route taken by the unconscious impulses brings with it an understanding of the one-sidedness of the conscious attitude. The one should alter the other, for it was just this one-sidedness that activated the unconscious opposition in the first place, and insight into the unconscious impulses is useful only when it effectively compensates that one-sidedness.

[911] The alteration of the conscious attitude is no light matter, because any habitual attitude is essentially a more or less conscious ideal, sanctified by custom and historical tradition, and founded on the bedrock of one's innate temperament. The conscious attitude is always in the nature of a *Weltanschauung*, if it is not explicitly a religion. It is this that makes the type problem so important. The opposition between

the types is not merely an external conflict between men, it is the source of endless inner conflicts; the cause not only of external disputes and dislikes, but of nervous ills and psychic suffering. It is this fact, too, that obliges us physicians constantly to widen our medical horizon and to include within it not only general psychological standpoints but also questions concerning one's views of life and the world.

[912] Within the space of a lecture I cannot, of course, give you any idea of the depth and scope of these problems. I must content myself with a general survey of the main facts and their implications. For a fuller elaboration of the whole problem I must refer you to my book *Psychological Types*.

[913] Recapitulating, I would like to stress that each of the two general attitudes, introversion and extraversion, manifests itself in a special way in an individual through the predominance of one of the four basic functions. Strictly speaking, there are no introverts and extraverts pure and simple, but only introverted and extraverted function-types, such as thinking types, sensation types, etc. There are thus at least eight clearly distinguishable types. Obviously one could increase this number at will if each of the functions were split into three subgroups, which would not be impossible empirically. One could, for example, easily divide thinking into its three well-known forms: intuitive and speculative, logical and mathematical, empirical and positivist, the last being mainly dependent on sense perception. Similar subgroups could be made of the other functions, as in the case of intuition, which has an intellectual as well as an emotional and sensory aspect. In this way a large number of types could be established, each new division becoming increasingly subtle.

[914] For the sake of completeness, I must add that I do not regard the classification of types according to introversion and extraversion and the four basic functions as the only possible one. Any other psychological criterion could serve just as well as a classifier, although, in my view, no other possesses so great a practical significance.

A PSYCHOLOGICAL THEORY OF TYPES¹

- [915] Character is the fixed individual form of a human being. Since this form is compounded of body and mind, a general characterology must teach the significance of both physical and psychic features. The enigmatic oneness of the living organism has as its corollary the fact that bodily traits are not merely physical, nor mental traits merely psychic. The continuity of nature knows nothing of those antithetical distinctions which the human intellect is forced to set up as aids to understanding.
- [916] The distinction between mind and body is an artificial dichotomy, an act of discrimination based far more on the peculiarity of intellectual cognition than on the nature of things. In fact, so intimate is the intermingling of bodily and psychic traits that not only can we draw far-reaching inferences as to the constitution of the psyche from the constitution of the body, but we can also infer from psychic peculiarities the corresponding bodily characteristics. It is true that the latter process is far more difficult, not because the body is less influenced by the psyche than the psyche by the body, but for quite another reason. In taking the psyche as our starting-point, we work from the relatively unknown to the known; while in the opposite case we have the advantage of starting from something known, that is, from the visible body. Despite all the psychology we think we possess today, the psyche is still infinitely more obscure to us than the visible surface of the body. The psyche is still a foreign, barely explored country of which we have only indirect knowledge, mediated by conscious functions that are open to almost endless possibilities of deception.
- [917] This being so, it seems safer to proceed from outside inwards, from the known to the unknown, from the body to the psyche. Thus all attempts at characterology have started from the outside world; astrology, in ancient times, even started from interstellar space in order to arrive at those lines of fate whose beginnings lie in the human heart. To the same class of interpretations from outward signs belong palmistry, Gall's phrenology, Lavater's physiognomy, and—more recently—graphology, Kretschmer's physiological types, and Rorschach's klexographic method. As we can see, there are any number of paths leading from outside inwards, from the physical to the psychic, and it is necessary that research should follow this direction until the elementary psychic facts are established with sufficient certainty. But once having established these facts, we can reverse the procedure. We can then put the question: What are the bodily correlatives of a given psychic condition? Unfortunately we are not yet far enough advanced to give even an approximate

answer. The first requirement is to establish the primary facts of psychic life, and this is far from having been accomplished. Indeed, we have only just begun the work of compiling an inventory of the psyche, not always with great success.

[918] Merely to establish the fact that certain people have this or that physical appearance is of no significance if it does not allow us to infer a psychic correlative. We have learned something only when we have determined what psychic attributes go with a given bodily constitution. The body means as little to us without the psyche as the latter without the body. But when we try to infer a psychic correlative from a physical characteristic, we are proceeding—as already stated—from the known to the unknown.

[919] I must, unfortunately, stress this point, since psychology is the youngest of the sciences and therefore the one that suffers most from preconceived opinions. The fact that we have only recently discovered psychology tells us plainly enough that it has taken us all this time to make a clear distinction between ourselves and the content of our minds. Until this could be done, it was impossible to study the psyche objectively. Psychology, as a science, is actually our most recent acquisition; up to now it has been just as fantastic and arbitrary as was natural science in the Middle Ages. It was believed that psychology could be created as it were by decree—a prejudice under which we are still labouring. Psychic life is, after all, what is most immediate to us, and apparently what we know most about. Indeed, it is more than familiar, we yawn over it. We are irritated by the banality of its everlasting commonplaces; they bore us to extinction and we do everything in our power to avoid thinking about them. The psyche being immediacy itself, and we ourselves being the psyche, we are almost forced to assume that we know it through and through in a way that cannot be doubted or questioned. That is why each of us has his own private opinion about psychology and is even convinced that he knows more about it than anyone else. Psychiatrists, because they must struggle with their patients' relatives and guardians whose "understanding" is proverbial, are perhaps the first to become aware as a professional group of that blind prejudice which encourages every man to take himself as his own best authority in psychological matters. But this of course does not prevent the psychiatrist also from becoming a "know-all." One of them even went so far as to confess: "There are only two normal people in this city—Professor B. is the other."

[920] Since this is how matters stand in psychology today, we must bring ourselves to admit that what is closest to us, the psyche, is the very thing we know least about, although it seems to be what we know best of all, and furthermore that everyone else probably understands it better than we do ourselves. At any rate that, for a start, would be a most useful heuristic principle. As I have said, it is just because the

psyche is so close to us that psychology has been discovered so late. And because it is still in its initial stages as a science, we lack the concepts and definitions with which to grasp the facts. If concepts are lacking, facts are not; on the contrary, we are surrounded—almost buried—by facts. This is in striking contrast to the state of affairs in other sciences, where the facts have first to be unearthed. Here the classification of primary data results in the formation of descriptive concepts covering certain natural orders, as, for example, the grouping of the elements in chemistry and of plant families in botany. But it is quite different in the case of the psyche. Here an empirical and descriptive method merely plunges us into the ceaseless stream of subjective psychic happenings, so that whenever any sort of generalizing concept emerges from this welter of impressions it is usually nothing more than a symptom. Because we ourselves are psyches, it is almost impossible to us to give free rein to psychic happenings without being dissolved in them and thus robbed of our ability to recognize distinctions and make comparisons.

[921] This is one difficulty. The other is that the more we turn from spatial phenomena to the non-spatiality of the psyche, the more impossible it becomes to determine anything by exact measurement. It becomes difficult even to establish the facts. If, for example, I want to emphasize the unreality of something, I say that I merely “thought” it. I say: “I would never even have had this thought unless such and such had happened; and besides, I never think things like that.” Remarks of this kind are quite usual, and they show how nebulous psychic facts are, or rather, how vague they appear subjectively—for in reality they are just as objective and just as definite as any other events. The truth is that I actually did think such and such a thing, regardless of the conditions and provisos I attach to this process. Many people have to wrestle with themselves in order to make this perfectly obvious admission, and it often costs them a great moral effort. These, then, are the difficulties we encounter when we draw inferences about the state of affairs in the psyche from the known things we observe outside.

[922] My more limited field of work is not the clinical study of external characteristics, but the investigation and classification of the psychic data which may be inferred from them. The first result of this work is a phenomenology of the psyche, which enables us to formulate a corresponding theory about its structure. From the empirical application of this structural theory there is finally developed a psychological typology.

[923] Clinical studies are based on the description of symptoms, and the step from this to a phenomenology of the psyche is comparable to the step from a purely symptomatic pathology to the pathology of cellular and metabolic processes. That is to say, the phenomenology of the psyche brings into view those psychic processes in

the background which underlie the clinical symptoms. As is generally known, this knowledge is obtained by the application of analytical methods. We have today a working knowledge of the psychic processes that produce psychogenic symptoms, and have thus laid the foundations for a theory of complexes. Whatever else may be taking place in the obscure recesses of the psyche—and there are notoriously many opinions about this—one thing is certain: it is the complexes (emotionally-toned contents having a certain amount of autonomy) which play the most important part here. The term “autonomous complex” has often met with opposition, unjustifiably, it seems to me, because the active contents of the unconscious do behave in a way I cannot describe better than by the word “autonomous.” The term is meant to indicate the capacity of the complexes to resist conscious intentions, and to come and go as they please. Judging by all we know about them, they are psychic entities which are outside the control of the conscious mind. They have been split off from consciousness and lead a separate existence in the dark realm of the unconscious, being at all times ready to hinder or reinforce the conscious functioning.

[924] A deeper study of the complexes leads logically to the problem of their origin, and as to this a number of different theories are current. Theories apart, experience shows that complexes always contain something like a conflict, or at least are either the cause or the effect of a conflict. At any rate the characteristics of conflict—shock, upheaval, mental agony, inner strife—are peculiar to the complexes. They are the “sore spots,” the *bêtes noires*, the “skeletons in the cupboard” which we do not like to remember and still less to be reminded of by others, but which frequently come back to mind unbidden and in the most unwelcome fashion. They always contain memories, wishes, fears, duties, needs, or insights which somehow we can never really grapple with, and for this reason they constantly interfere with our conscious life in a disturbing and usually a harmful way.

[925] Complexes obviously represent a kind of inferiority in the broadest sense—a statement I must at once qualify by saying that to have complexes does not necessarily indicate inferiority. It only means that something discordant, unassimilated, and antagonistic exists, perhaps as an obstacle, but also as an incentive to greater effort, and so, perhaps, to new possibilities of achievement. In this sense, therefore, complexes are focal or nodal points of psychic life which we would not wish to do without; indeed, they should not be missing, for otherwise psychic activity would come to a fatal standstill. They point to the unresolved problems in the individual, the places where he has suffered a defeat, at least for the time being, and where there is something he cannot evade or overcome—his weak spots in every sense of the word.

- [926] These characteristics of the complex throw a significant light on its origin. It obviously arises from the clash between a demand of adaptation and the individual's constitutional inability to meet the challenge. Seen in this light, the complex is a valuable symptom which helps us to diagnose an individual disposition.
- [927] Experience shows us that complexes are infinitely varied, yet careful comparison reveals a relatively small number of typical primary forms, which are all built upon the first experiences of childhood. This must necessarily be so, because the individual disposition is already a factor in infancy; it is innate, and not acquired in the course of life. The parental complex is therefore nothing but the first manifestation of a clash between reality and the individual's constitutional inability to meet the demands it makes upon him. The primary form of the complex cannot be other than a parental complex, because the parents are the first reality with which the child comes into conflict.
- [928] The existence of a parental complex therefore tells us little or nothing about the peculiar constitution of the individual. Practical experience soon teaches us that the crux of the matter does not lie in the presence of a parental complex, but rather in the special way in which the complex works itself out in the individual's life. And here we observe the most striking variations, though only a very small number can be attributed to the special nature of the parental influence. There are often several children who are exposed to the same influence, and yet each of them reacts to it in a totally different way.
- [929] I therefore turned my attention to these differences, telling myself that it is through them that the peculiarities of the individual dispositions may be discerned. Why, in a neurotic family, does one child react with hysteria, another with a compulsion neurosis, the third with a psychosis, and the fourth apparently not at all? This problem of the "choice of neurosis," which Freud was also faced with, robs the parental complex as such of its aetiological significance, and shifts the inquiry to the reacting individual and his special disposition.
- [930] Although Freud's attempts to solve this problem leave me entirely dissatisfied, I am myself unable to answer the question. Indeed, I think it premature to raise the question of the choice of neurosis at all. Before we tackle this extremely difficult problem we need to know a great deal more about the way the individual reacts. The question is: How does a person react to an obstacle? For instance, we come to a brook over which there is no bridge. It is too broad to step across, so we must jump. For this purpose we have at our disposal a complicated functional system, namely, the psychomotor system. It is fully developed and needs only to be triggered off. But before this happens, something of a purely psychic nature takes place: a decision is made about what is to be done. This is followed by those crucial events which settle

the matter in some way and vary with each individual. But, significantly enough, we rarely if ever recognize these events as characteristic, for as a rule we do not see ourselves at all or only as a last resort. That is to say, just as the psychomotor apparatus is habitually at our disposal for jumping, there is an exclusively psychic apparatus ready for use in making decisions, which functions by habit and therefore unconsciously.

[931] Opinions differ widely as to what this apparatus is like. It is certain only that every individual has his accustomed way of making decisions and dealing with difficulties. One person will say he jumped the brook for fun; another, that there was no alternative; a third, that every obstacle he meets challenges him to overcome it. A fourth did not jump the brook because he dislikes useless effort, and a fifth refrained because he saw no urgent necessity to get to the other side.

[932] I have purposely chosen this commonplace example in order to demonstrate how irrelevant such motivations seem. They appear so futile that we are inclined to brush them aside and to substitute our own explanation. And yet it is just these variations that give us valuable insights into the individual psychic systems of adaptation. If we observe, in other situations of life, the person who jumped the brook for fun, we shall probably find that for the most part everything he does or omits to do can be explained in terms of the pleasure it gives him. We shall observe that the one who jumped because he saw no alternative goes through life cautiously and apprehensively, always deciding *faute de mieux*. And so on. In all these cases special psychic systems are in readiness to execute the decisions. We can easily imagine that the number of these attitudes is legion. The individual attitudes are certainly as inexhaustible as the variations of crystals, which may nevertheless be recognized as belonging to one or another system. But just as crystals show basic uniformities which are relatively simple, these attitudes show certain fundamental peculiarities which allow us to assign them to definite groups.

[933] From earliest times attempts have been made to classify individuals according to types, and so to bring order into the chaos. The oldest attempts known to us were made by oriental astrologers who devised the so-called trigons of the four elements—air, water, earth, and fire. The air trigon in the horoscope consists of the three aerial signs of the zodiac, Aquarius, Gemini, Libra; the fire trigon is made up of Aries, Leo, Sagittarius. According to this age-old view, whoever is born in these trigons shares in their aerial or fiery nature and will have a corresponding temperament and fate. Closely connected with this ancient cosmological scheme is the physiological typology of antiquity, the division into four temperaments corresponding to the four humours. What was first represented by the signs of the zodiac was later expressed in the physiological language of Greek medicine, giving us the classification into the

phlegmatic, sanguine, choleric, and melancholic. These are simply designations for the secretions of the body. As is well known, this typology lasted at least seventeen hundred years. As for the astrological type theory, to the astonishment of the enlightened it still remains intact today, and is even enjoying a new vogue.

[934] This historical retrospect may serve to assure us that our modern attempts to formulate a theory of types are by no means new and unprecedented, even though our scientific conscience does not permit us to revert to these old, intuitive ways of thinking. We must find our own answer to this problem, an answer which satisfies the need of science. And here we meet the chief difficulty of the problem of types—that is, the question of standards or criteria. The astrological criterion was simple and objective: it was given by the constellations at birth. As to the way characterological qualities could be correlated with the zodiacal signs and the planets, this is a question which reaches back into the grey mists of prehistory and remains unanswerable. The Greek classification according to the four physiological temperaments took as its criteria the appearance and behaviour of the individual, exactly as we do today in the case of physiological typology. But where shall we seek our criterion for a psychological theory of types?

[935] Let us return to the example of the four people who had to cross a brook. How and from what standpoints are we to classify their habitual motivations? One person does it for fun, another does it because not to do it is more troublesome, a third doesn't do it because he has second thoughts, and so on. The list of possibilities seems both endless and useless for purposes of classification.

[936] I do not know how other people would set about this task. I can only tell you how I myself have tackled it, and I must bow to the charge that my way of solving the problem is the outcome of my personal prejudice. This objection is so entirely true that I would not know how to defend myself. I can only point happily to old Columbus, who, following his subjective assumptions, a false hypothesis, and a route abandoned by modern navigation, nevertheless discovered America. Whatever we look at, and however we look at it, we see only through our own eyes. For this reason science is never made by one man, but many. The individual merely offers his own contribution, and it is only in this sense that I dare to speak of *my* way of seeing things.

[937] My profession has always obliged me to take account of the peculiarities of individuals, and the special circumstance that in the course of I don't know how many years I have had to treat innumerable married couples and have been faced with the task of making husband and wife plausible to each other has emphasized the need to establish certain average truths. How many times, for instance, have I not had to say: "Look here, your wife has a very active nature, and it cannot be expected that

her whole life should centre on housekeeping.” That is a sort of statistical truth, and it holds the beginnings of a type theory: there are active natures and passive natures. But this time-worn truth did not satisfy me. My next attempt was to say that some persons are reflective and others are unreflective, because I had observed that many apparently passive natures are in reality not so much passive as given to forethought. They first consider a situation and then act, and because they do this habitually they miss opportunities where immediate action without reflection is called for, thus coming to be prejudged as passive. The persons who did not reflect always seemed to me to jump headfirst into a situation without any forethought, only to reflect afterwards that they had perhaps landed themselves in a swamp. Thus they could be considered “unreflective,” and this seemed a more appropriate word than “active.” Forethought is in certain cases a very important form of activity, a responsible course of action as compared with the unthinking, short-lived zeal of the mere busybody. But I soon discovered that the hesitation of the one was by no means always forethought, and that the quick action of the other was not necessarily want of reflection. The hesitation equally often arises from a habitual timidity, or at least from a customary shrinking back as if faced with too great a task; while immediate action is frequently made possible by a predominating self-confidence in relation to the object. This observation caused me to formulate these typical differences in the following way: there is a whole class of men who, at the moment of reaction to a given situation, at first draw back a little as if with an unvoiced “No,” and only after that are able to react; and there is another class who, in the same situation, come out with an immediate reaction, apparently quite confident that their behaviour is self-evidently right. The former class would therefore be characterized by a negative relation to the object, and the latter by a positive one.

[938] The former class corresponds to the *introverted* and the second to the *extraverted* attitude. But these two terms in themselves signify as little as the discovery of Molière’s *bourgeois gentilhomme* that he ordinarily spoke in prose. They acquire meaning and value only when we know all the other characteristics that go with the type.

[939] One cannot be introverted or extraverted without being so in every respect. For example, to be “introverted” means that everything in the psyche happens as it must happen according to the law of the introvert’s nature. Were that not so, the statement that a certain individual is “introverted” would be as irrelevant as the statement that he is six feet tall, or that he has brown hair, or is brachycephalic. These statements contain no more than the facts they express. The term “introverted” is incomparably more exacting. It means that the consciousness as well as the unconscious of the introvert must have certain definite qualities, that his general behaviour, his relation to people, and even the course of his life show certain typical characteristics.

- [940] Introversion or extraversion, as a typical attitude, means an essential bias which conditions the whole psychic process, establishes the habitual mode of reaction, and thus determines not only the style of behaviour but also the quality of subjective experience. Not only that, it determines the kind of compensation the unconscious will produce.
- [941] Once we have established the habitual mode of reaction it is bound to hit the mark to a certain extent, because habit is, so to speak, the central switchboard from which outward behaviour is regulated and by which specific experiences are shaped. A certain kind of behaviour brings corresponding results, and the subjective understanding of these results gives rise to experiences which in turn influence our behaviour, in accordance with the saying "Every man is the maker of his own fate."
- [942] While there can be little doubt that the habitual mode of reaction brings us to the central point, the delicate question remains as to whether or not we have satisfactorily characterized it by the term "introverted" or "extraverted." There can be a honest difference of opinion about this even among those with an intimate knowledge of this special field. In my book on types I have put together everything I could find in support of my views, though I expressly stated that I do not imagine mine to be the only true or possible typology.
- [943] The contrast between introversion and extraversion is simple enough, but simple formulations are unfortunately the most open to doubt. They all too easily cover up the actual complexities and so deceive us. I speak here from my own experience, for scarcely had I published the first formulation of my criteria² when I discovered to my dismay that somehow or other I had been taken in by them. Something was amiss. I had tried to explain too much in too simple a way, as often happens in the first joy of discovery.
- [944] What struck me now was the undeniable fact while people may be classed as introverts or extraverts, this does not account for the tremendous differences between individuals in either class. So great, indeed, are these differences that I was forced to doubt whether I had observed correctly in the first place. It took nearly ten years of observation and comparison to clear up this doubt.
- [945] The question as to where the tremendous differences among individuals of the same type came from entangled me in unforeseen difficulties which for a long time I was unable to master. To observe and recognize the differences gave me comparatively little trouble, the root of my difficulties being now, as before, the problem of criteria. How was I to find suitable terms for the characteristic differences? Here I realized for the first time how young psychology really is. It is still little more than a chaos of arbitrary opinions and dogmas, produced for the most part in the study or consulting room by spontaneous generation from the isolated and

Jove-like brains of learned professors, with complete lack of agreement. Without wishing to be irreverent, I cannot refrain from confronting the professor of psychology with, say, the psychology of women, of the Chinese, or of the Australian aborigines. Our psychology must get down to brass tacks, otherwise we simply remain stuck in the Middle Ages.

[946] I realized that no sound criteria were to be found in the chaos of contemporary psychology, that they had first to be created, not out of thin air, but on the basis of the invaluable preparatory work done by many men whose names no history of psychology will pass over in silence.

[947] Within the limits of a lecture I cannot possibly mention all the separate observations that led me to pick out certain *psychic functions* as criteria for the differences under discussion. I will only state very broadly what the essential differences are, so far as I have been able to ascertain them. An introvert, for example, does not simply draw back and hesitate before the object, but he does so in a quite definite way. Moreover he does not behave just like every other introvert, but again in a way peculiar to himself. Just as the lion strikes down his enemy or his prey with his fore-paw, in which his specific strength resides, and not with his tail like the crocodile, so our habitual mode of reaction is normally characterized by the use of our most reliable and efficient function, which is an expression of our particular strength. However, this does not prevent us from reacting occasionally in a way that reveals our specific weakness. According to which function predominates, we shall seek out certain situations while avoiding others, and shall thus have experiences specific to ourselves and different from those of other people. An intelligent man will adapt to the world through his intelligence, and not like a sixth-rate pugilist, even though now and then, in a fit of rage, he may make use of his fists. In the struggle for existence and adaptation everyone instinctively uses his most developed function, which thus becomes the criterion of his habitual mode of reaction.

[948] How are we to sum up these functions under general concepts, so that they can be distinguished from the welter of merely individual events? A rough typization of this kind has long since existed in social life, in the figures of the peasant, the worker, the artist, the scholar, the fighter, and so forth, or in the various professions. But this sort of typization has little or nothing to do with psychology, for, as a well-known savant once maliciously remarked, there are certain scholars who are no more than “intellectual porters.”

[949] A type theory must be more subtle. It is not enough, for example, to speak of intelligence, for this is too general and too vague a concept. Almost any kind of behaviour can be called intelligent if it works smoothly, quickly, effectively and to a purpose. Intelligence, like stupidity, is not a function but a modality; the word tells us

no more than *how* a function is working, not *what* is functioning. The same holds true of moral and aesthetic criteria. We must be able to designate what it is that functions outstandingly in the individual's habitual way of reacting. We are thus forced to revert to something that at first glance looks alarmingly like the old faculty psychology of the eighteenth century. In reality, however, we are only returning to ideas current in daily speech, perfectly accessible and comprehensible to everyone. When, for instance, I speak of "thinking," it is only the philosopher who does not know what it means; no layman will find it incomprehensible. He uses the word every day, and always in the same general sense, though it is true he would be at a loss if suddenly called upon to give an unequivocal definition of thinking. The same is true of "memory" or "feeling." However difficult it is to define these purely psychological concepts scientifically, they are easily intelligible in current speech. Language is a storehouse of concrete images; hence concepts which are too abstract and nebulous do not easily take root in it, or quickly die out again for lack of contact with reality. But thinking and feeling are such insistent realities that every language above the primitive level has absolutely unmistakable expressions for them. We can therefore be sure that these expressions coincide with quite definite psychic facts, no matter what the scientific definition of these complex facts may be. Everyone knows, for example, what consciousness means, and nobody can doubt that it coincides with a definite psychic condition, however far science may be from defining it satisfactorily.

[950] And so it came about that I simply took the concepts expressed in current speech as designations for the corresponding psychic functions, and used them as my criteria in judging the differences between persons of the same attitude-type. For instance, I took thinking, as it is generally understood, because I was struck by the fact that many people habitually do more thinking than others, and accordingly give more weight to thought when making important decisions. They also use their thinking in order to understand the world and adapt to it, and whatever happens to them is subjected to consideration and reflection or at least subordinated to some principle sanctioned by thought. Other people conspicuously neglect thinking in favour of emotional factors, that is, of feeling. They invariably follow a policy dictated by feeling, and it takes an extraordinary situation to make them reflect. They form an unmistakable contrast to the other type, and the difference is most striking when the two are business partners or are married to each other. It should be noted that a person may give preference to thinking whether he be extraverted or introverted, but he will use it only in the way that is characteristic of his attitude-type, and the same is true of feeling.

[951] The predominance of one or the other of these functions does not explain all the differences that occur. What I call the thinking and feeling types comprise two groups

of persons who again have something in common which I cannot designate except by the word *rationality*. No one will dispute that thinking is essentially rational, but when we come to feeling, weighty objections may be raised which I would not like to brush aside. On the contrary, I freely admit that this problem of feeling has been one that has caused me much brain-racking. However, as I do not want to overload my lecture with the various existing definitions of this concept, I shall confine myself briefly to my own view. The chief difficulty is that the word “feeling” can be used in all sorts of different ways. This is especially true in German, but is noticeable to some extent in English and French as well. First of all, then, we must make a careful distinction between feeling and *sensation*, which is a sensory function. And in the second place we must recognize that a feeling of regret is something quite different from a “feeling” that the weather will change or that the price of our aluminum shares will go up. I have therefore proposed using *feeling* as a proper term in the first example, and dropping it—so far as its psychological usage is concerned—in the second. Here we should speak of *sensation* when sense impressions are involved, and of *intuition* if we are dealing with a kind of perception which cannot be traced back directly to conscious sensory experience. Hence I define sensation as perception via conscious sensory functions, and intuition as perception via the unconscious.

[952] Obviously we could argue until Doomsday about the fitness of these definitions, but ultimately it is only a question of terminology. It is as if we were debating whether to call a certain animal a leopard or a panther, when all we need to know is what name we are giving to what. Psychology is virgin territory, and its terminology has still to be fixed. As we know, temperature can be measured according to Réaumur, Celsius, or Fahrenheit, but we must indicate which system we are using.

[953] It is evident, then, that I take feeling as a function *per se* and distinguish it from sensation and intuition. Whoever confuses these last two functions with feeling in the strict sense is obviously not in a position to acknowledge the rationality of feeling. But once they are distinguished from feeling, it becomes quite clear that feeling values and feeling judgments—indeed, feelings in general—are not only rational but can also be as logical, consistent and discriminating as thinking. This may seem strange to the thinking type, but it is easily explained when we realize that in a person with a differentiated thinking function the feeling function is always less developed, more primitive, and therefore contaminated with other functions, these being precisely the functions which are not rational, not logical, and not discriminating or evaluating, namely, sensation and intuition. These two are by their very nature opposed to the rational functions. When we think, it is in order to judge or to reach a conclusion, and when we feel it is in order to attach a proper value to something. Sensation and intuition, on the other hand, are perceptive functions—they make us aware of what is happening, but do not interpret or evaluate it. They do not proceed

selectively, according to principles, but are simply receptive to what happens. But “what happens” is essentially irrational. There is no inferential method by which it could ever be proved that there must be so and so many planets, or so and so many species of warm-blooded animals. Irrationality is a vice where thinking and feeling are called for, rationality is a vice where sensation and intuition should be trusted.

[954] Now there are many people whose habitual reactions are irrational because they are based either on sensation or on intuition. They cannot be based on both at once, because sensation is just as antagonistic to intuition as thinking is to feeling. When I try to assure myself with my eyes and ears of what is actually happening, I cannot at the same time give way to dreams and fantasies about what lies around the corner. As this is just what the intuitive type must do in order to give the necessary free play to his unconscious or to the object, it is easy to see that the sensation type is at the opposite pole to the intuitive. Unfortunately, time does not allow me to go into the interesting variations which the extraverted or introverted attitude produces in the irrational types.

[955] Instead, I would like to add a word about the effects regularly produced on the other functions when preference is given to one function. We know that a man can never be everything at once, never quite complete. He always develops certain qualities at the expense of others, and wholeness is never attained. But what happens to those functions which are not consciously brought into daily use and are not developed by exercise? They remain in a more or less primitive and infantile state, often only half conscious, or even quite unconscious. These relatively undeveloped functions constitute a specific inferiority which is characteristic of each type and is an integral part of his total character. The one-sided emphasis on thinking is always accompanied by an inferiority of feeling, and differentiated sensation is injurious to intuition and vice versa.

[956] Whether a function is differentiated or not can easily be recognized from its strength, stability, consistency, reliability, and adaptedness. But inferiority in a function is often not so easy to recognize or to describe. An essential criterion is its lack of self-sufficiency and consequent dependence on people and circumstances, its disposing us to moods and crotchiness, its unreliable use, its suggestible and labile character. The inferior function always puts us at a disadvantage because we cannot direct it, but are rather its victims.

[957] Since I must restrict myself here to a mere sketch of the ideas underlying a psychological theory of types, I must forgo a detailed description of each type. The total result of my work in this field up to the present is the establishing of two general attitude-types, extraversion and introversion, and four function-types, thinking,

feeling, sensation, and intuition. Each of these function-types varies according to the general attitude and thus eight variants are produced.

[958] I have often been asked, almost accusingly, why I speak of four functions and not of more or fewer. That there are exactly four was a result I arrived at on purely empirical grounds. But as the following consideration will show, these four together produce a kind of totality. Sensation establishes what is actually present, thinking enables us to recognize its meaning, feeling tells us its value, and intuition points to possibilities as to whence it came and whither it is going in a given situation. In this way we can orient ourselves with respect to the immediate world as completely as when we locate a place geographically by latitude and longitude. The four functions are somewhat like the four points of the compass; they are just as arbitrary and just as indispensable. Nothing prevents our shifting the cardinal points as many degrees as we like in one direction or the other, or giving them different names. It is merely a question of convention and intelligibility.

[959] But one thing I must confess: I would not for anything dispense with this compass on my psychological voyages of discovery. This is not merely for the obvious, all-too-human reason that everyone is in love with his own ideas. I value the type theory for the objective reason that it provides a system of comparison and orientation which makes possible something that has long been lacking, a critical psychology.

PSYCHOLOGICAL TYPOLOGY¹

[960] Ever since the early days of science, it has been a notable endeavour of the reflective intellect to interpose gradations between the two poles of the absolute similarity and dissimilarity of human beings. This resulted in a number of types, or “temperaments” as they were then called, which classified similarities and dissimilarities into regular categories. The Greek philosopher Empedocles attempted to impose order on the chaos of natural phenomena by dividing them into the four elements: earth, water, air, and fire. It was above all the physicians of ancient times who applied this principle of order, in conjunction with the related doctrine of the four qualities, dry, moist, cold, warm, to human beings, and thus tried to reduce the bewildering diversity of mankind to orderly groups. Of these physicians one of the most important was Galen, whose use of these teachings influenced medical science and the treatment of the sick for nearly seventeen hundred years. The very names of the Galenic temperaments betray their origin in the pathology of the four “humours.” *Melancholic* denotes a preponderance of black bile, *phlegmatic* a preponderance of phlegm or mucus (the Greek word *phlegma* means fire, and phlegm was regarded as the end-product of inflammation), *sanguine* a preponderance of blood, and *choleric* a preponderance of choler, or yellow bile.

[961] Our modern conception of “temperament” has certainly become much more psychological, since in the course of man’s development over the last two thousand years the “soul” has freed itself from any conceivable connection with cold agues and fevers, or secretions of mucus and bile. Not even the doctors of today would equate a temperament, that is, a certain kind of emotional state or excitability, directly with the constitution of the blood or lymph, although their profession and their exclusive approach to human beings from the side of physical illness tempt them, more often than the layman, to regard the psyche as an end-product dependent on the physiology of the glands. The “humours” of present-day medicine are no longer the old body-secretions, but the more subtle hormones, which influence “temperament” to an outstanding degree, if we define this as the sum-total of emotional reactions. The whole make-up of the body, its constitution in the broadest sense, has in fact a very great deal to do with the psychological temperament, so much that we cannot blame the doctors if they regard psychic phenomena as largely dependent on the body. Somewhere the psyche is living body, and the living body is animated matter; somehow and somewhere there is an undiscoverable unity of psyche and body which

would need investigating psychically as well as physically; in other words, this unity must be as dependent on the body as it is on the psyche so far as the investigator is concerned. The materialism of the nineteenth century gave the body first place and relegated the psyche to the rank of something secondary and derived, allowing it no more substantiality than that of a so-called “epiphenomenon.” What proved to be a good working hypothesis, namely, that psychic phenomena are conditioned by physical processes, became a philosophical presumption with the advent of materialism. Any serious science of the living organism will reject this presumption; for on the one hand it will constantly bear in mind that living matter is an as yet unsolved mystery, and on the other hand it will be objective enough to recognize that for us there is a completely unbridgeable gulf between physical and psychic phenomena, so that the psychic realm is no less mysterious than the physical.

[962] The materialistic presumption became possible only in recent times, after man’s conception of the psyche had, in the course of many centuries, emancipated itself from the old view and developed in an increasingly abstract direction. The ancients could still see body and psyche together, as an undivided unity, because they were closer to that primitive world where no moral rift yet ran through the personality, and the pagan could still feel himself indivisibly one, childishly innocent and unburdened by responsibility. The ancient Egyptians could still enjoy the naïve luxury of a negative confession of sin: “I have not let any man go hungry. I have not made anyone weep. I have not committed murder,” and so on. The Homeric heroes wept, laughed, raged, outwitted and killed each other in a world where these things were taken as natural and self-evident by men and gods alike, and the Olympians amused themselves by passing their days in a state of amaranthine irresponsibility.

[963] It was on this archaic level that pre-philosophical man lived and experienced the world. He was entirely in the grip of his emotions. All passions that made his blood boil and his heart pound, that accelerated his breathing or took his breath away, that “turned his bowels to water”—all this was a manifestation of the “soul.” Therefore he localized the soul in the region of the diaphragm (in Greek *phren*, which also means mind)² and the heart. It was only with the first philosophers that the seat of reason began to be assigned to the head. There are still Negroes today whose “thoughts” are localized principally in the belly, and the Pueblo Indians “think” with their hearts —“only madmen think with their heads,” they say.³ On this level consciousness is essentially passion and the experience of oneness. Yet, serene and tragic at once, it was just this archaic man who, having started to think, invented that dichotomy which Nietzsche laid at the door of Zarathustra: the discovery of pairs of opposites, the division into odd and even, above and below, good and evil. It was the work of the old Pythagoreans, and it was their doctrine of moral responsibility and the grave metaphysical consequences of sin that gradually, in the course of the centuries,

percolated through to all strata of the population, chiefly owing to the spread of the Orphic and Pythagorean mysteries. Plato even used the parable of the white and black horses⁴ to illustrate the intractability and polarity of the human psyche, and, still earlier, the mysteries proclaimed the doctrine of the good rewarded in the Hereafter and of the wicked punished in hell. These teachings cannot be dismissed as the mystical humbug of “backwoods” philosophers, as Nietzsche claimed, or as so much sectarian cant, for already in the sixth century B.C. Pythagoreanism was something like a state religion throughout Graecia Magna. Also, the ideas underlying its mysteries never died out, but underwent a philosophical renaissance in the second century B.C., when they exercised the strongest influence on the Alexandrian world of thought. Their collision with Old Testament prophecy then led to what one can call the beginnings of Christianity as a world religion.

[964] From Hellenistic syncretism there now arose a classification of man into types which was entirely alien to the “humoral” psychology of Greek medicine. In the philosophical sense, it established gradations between the Parmenidean poles of light and darkness, of above and below. It classified men into *hylikoi*, *psychikoi*, and *pneumatikoi*—material, psychic, and spiritual beings. This classification is not, of course, a scientific formulation of similarities and dissimilarities; it is a critical system of values based not on the behaviour and outward appearance of man as a phenotype, but on definitions of an ethical, mystical, and philosophic kind. Although it is not exactly a “Christian” conception it nevertheless forms an integral part of early Christianity at the time of St. Paul. Its very existence is incontrovertible proof of the split that had occurred in the original unity of man as a being entirely in the grip of his emotions. Before this, he was merely alive and there, the plaything of experience, incapable of any reflective analysis concerning his origins and his destination. Now, suddenly, he found himself confronted by three fateful factors and endowed with body, soul, and spirit, to each of which he had moral obligations. Presumably it was already decided at birth whether he would pass his life in the hylic or the pneumatic state, or in the indeterminate centre between the two. The ingrained dichotomy of the Greek mind had now become acute, with the result that the accent shifted significantly to the psychic and spiritual, which was unavoidably split off from the hylic realm of the body. All the highest and ultimate goals lay in man’s moral destination, in a spiritual, supramundane end-state, and the separation of the hylic realm broadened into a cleavage between world and spirit. Thus the original, suave wisdom expressed in the Pythagorean pairs of opposites became a passionate moral conflict. Nothing, however, is so apt to challenge our self-awareness and alertness as being at war with oneself. One can hardly think of any other or more effective means of waking humanity out of the irresponsible and innocent half-sleep of the primitive mentality and bringing it to a state of conscious responsibility.

[965] This process is called cultural development. It is, at any rate, a development of man's powers of discrimination and capacity for judgment, and of consciousness in general. With the increase of knowledge and enhanced critical faculties the foundations were laid for the whole subsequent development of the human mind in terms of intellectual achievement. The particular mental product that far surpassed all the achievements of the ancient world was science. It closed the rift between man and nature in the sense that, although he was separated from nature, science enabled him to find his rightful place again in the natural order. His special metaphysical position, however, had to be jettisoned—so far as it was not secured by belief in the traditional religion—whence arose the notorious conflict between “faith and knowledge.” At all events, science brought about a splendid rehabilitation of matter, and in this respect materialism may even be regarded as an act of historical justice.

[966] But one absolutely essential field of experience, the human psyche itself, remained for a very long time the preserve of metaphysics, although increasingly serious attempts were made after the Enlightenment to open it up to scientific investigation. They began, tentatively, with the sense perceptions, and gradually ventured into the domain of associations. This line of research paved the way for experimental psychology, and it culminated in the “physiological psychology” of Wundt. A more descriptive kind of psychology, with which the medical men soon made contact, developed in France. Its chief exponents were Taine, Ribot, and Janet. It was characteristic of this scientific approach that it broke down the psyche into particular mechanisms or processes. In face of these attempts, there were some who advocated what we today would call a “holistic” approach—the systematic observation of the psyche as a whole. It seems as if this trend originated in a certain type of biography, more particularly the kind that an earlier age, which also had its good points, used to describe as “curious lives.” In this connection I think of Justinus Kerner and his *Seeress of Prevorst*, and the case of the elder Blumhardt and his medium Gottliebin Dittus.⁵ To be historically fair, however, I should not forget the medieval *Acta Sanctorum*.⁶

[967] This line of research has been continued in more recent investigations associated with the names of William James, Freud, and Theodore Flournoy. James and his friend Flournoy, a Swiss psychologist, made an attempt to describe the whole phenomenology of the psyche and also to view it as a totality. Freud, too, as a doctor, took as his point of departure the wholeness and indivisibility of the human personality, though, in keeping with the spirit of the age, he restricted himself to the investigation of instinctive mechanisms and individual processes. He also narrowed the picture of man to the wholeness of an essentially “bourgeois” collective person, and this necessarily led to philosophically onesided interpretations. Freud, unfortunately, succumbed to the medical man's temptation to trace everything

psychic to the body, in the manner of the old “humoral” psychologists, not without rebellious gestures at those metaphysical preserves of which he had a holy dread.

[968] Unlike Freud, who after a proper psychological start reverted to the *ancient* assumption of the sovereignty of the physical constitution, trying to turn everything back in theory into instinctual processes conditioned by the body, I start with the assumption of the sovereignty of the psyche. Since body and psyche somewhere form a unity, although in their manifest natures they are so utterly different, we cannot but attribute to the one as to the other a substantiality of its own. So long as we have no way of knowing that unity, there is no alternative but to investigate them separately and, for the present, treat them as though they were independent of each other, at least in their structure. That they are not so, we can see for ourselves every day. But if we were to stop at that, we would never be in a position to make out anything about the psyche at all.

[969] Now if we assume the sovereignty of the psyche, we exempt ourselves from the—at present—insoluble task of reducing everything psychic to something definitely physical. We can then take the manifestations of the psyche as expressions of its intrinsic being, and try to establish certain conformities or types. So when I speak of a psychological typology, I mean by this the formulation of the structural elements of the psyche and not a description of the psychic emanations of a particular type of constitution. This is covered by, for instance, Kretschmer’s researches into body-structure and character.

[970] I have given a detailed description of a purely psychological typology in my book *Psychological Types*. My investigation was based on twenty years of work as a doctor, which brought me into contact with people of all classes from all the great nations. When one begins as a young doctor, one’s head is still full of clinical pictures and diagnoses. In the course of the years, impressions of quite another kind accumulate. One is struck by the enormous diversity of human individuals, by the chaotic profusion of individual cases, the special circumstances of whose lives and whose special characters produce clinical pictures that, even supposing one still felt any desire to do so, can be squeezed into the straitjacket of a diagnosis only by force. The fact that the disturbance can be given such and such a name appears completely irrelevant beside the overwhelming impression one has that all clinical pictures are so many mimetic or histrionic demonstrations of certain definite character traits. The pathological problem upon which everything turns has virtually nothing to do with the clinical picture, but is essentially an expression of character. Even the complexes, the “nuclear elements” of a neurosis, are beside the point, being mere concomitants of a certain characterological disposition. This can be seen most easily in the relation of the patient to his parental family. He is, let us say, one of four siblings, is neither

the eldest nor the youngest, has had the same education and conditioning as the others. Yet he is sick and they are sound. The anamnesis shows that a whole series of influences to which the others were exposed as well as he, and from which indeed they all suffered, had a pathological effect on him alone—at least to all appearances. In reality these influences were not aetiological factors in his case either, but prove to be false explanations. The real cause of the neurosis lies in the peculiar way he responded to and assimilated the influences emanating from the environment.

[971] By comparing many such cases it gradually became clear to me that there must be two fundamentally different general attitudes which would divide human beings into two groups—provided the whole of humanity consisted of highly differentiated individuals. Since this is obviously not the case, one can only say that this difference of attitude becomes plainly observable only when we are confronted with a comparatively well-differentiated personality; in other words, it becomes of practical importance only after a certain degree of differentiation has been reached. Pathological cases of this kind are almost always people who deviate from the familial type and, in consequence, no longer find sufficient security in their inherited instinctual foundation. Weak instincts are one of the prime causes of the development of an habitual one-sided attitude, though in the last resort it is conditioned or reinforced by heredity.

[972] I have called these two fundamentally different attitudes *extraversion* and *introversion*. Extraversion is characterized by interest in the external object, responsiveness, and a ready acceptance of external happenings, a desire to influence and be influenced by events, a need to join in and get “with it,” the capacity to endure bustle and noise of every kind, and actually find them enjoyable, constant attention to the surrounding world, the cultivation of friends and acquaintances, none too carefully selected, and finally by the great importance attached to the figure one cuts, and hence by a strong tendency to make a show of oneself. Accordingly, the extravert’s philosophy of life and his ethics are as a rule of a highly collective nature with a strong streak of altruism, and his conscience is in large measure dependent on public opinion. Moral misgivings arise mainly when “other people know.” His religious convictions are determined, so to speak, by majority vote.

[973] The actual subject, the extravert as a subjective entity, is, so far as possible, shrouded in darkness. He hides it from himself under veils of unconsciousness. The disinclination to submit his own motives to critical examination is very pronounced. He has no secrets he has not long since shared with others. Should something unmentionable nevertheless befall him, he prefers to forget it. Anything that might tarnish the parade of optimism and positivism is avoided. Whatever he thinks, intends, and does is displayed with conviction and warmth.

[974] The psychic life of this type of person is enacted, as it were, outside himself, in the environment. He lives in and through others; all self-communings give him the creeps. Dangers lurk there which are better drowned out by noise. If he should ever have a “complex,” he finds refuge in the social whirl and allows himself to be assured several times a day that everything is in order. Provided he is not too much of a busybody, too pushing, and too superficial, he can be a distinctly useful member of the community.

[975] In this short essay I have to content myself with an allusive sketch. It is intended merely to give the reader some idea of what extraversion is like, something he can bring into relationship with his own knowledge of human nature. I have purposely started with a description of extraversion because this attitude is familiar to everyone; the extravert not only lives in this attitude, but parades it before his fellows on principle. Moreover it accords with certain popular ideals and moral requirements.

[976] *Introversion*, on the other hand, being directed not to the object but to the subject, and not being oriented by the object, is not so easy to put into perspective. The introvert is not forthcoming, he is as though in continual retreat before the object. He holds aloof from external happenings, does not join in, has a distinct dislike of society as soon as he finds himself among too many people. In a large gathering he feels lonely and lost. The more crowded it is, the greater becomes his resistance. He is not in the least “with it,” and has no love of enthusiastic get-togethers. He is not a good mixer. What he does, he does in his own way, barricading himself against influences from outside. He is apt to appear awkward, often seeming inhibited, and it frequently happens that, by a certain brusqueness of manner, or by his glum unapproachability, or some kind of malapropism, he causes unwitting offence to people. His better qualities he keeps to himself, and generally does everything he can to dissemble them. He is easily mistrustful, self-willed, often suffers from inferiority feelings and for this reason is also envious. His apprehensiveness of the object is not due to fear, but to the fact that it seems to him negative, demanding, overpowering or even menacing. He therefore suspects all kinds of bad motives, has an everlasting fear of making a fool of himself, is usually very touchy and surrounds himself with a barbed wire entanglement so dense and impenetrable that finally he himself would rather do anything than sit behind it. He confronts the world with an elaborate defensive system compounded of scrupulosity, pedantry, frugality, cautiousness, painful conscientiousness, stiff-lipped rectitude, politeness, and open-eyed distrust. His picture of the world lacks rosy hues, as he is over-critical and finds a hair in every soup. Under normal conditions he is pessimistic and worried, because the world and human beings are not in the least good but crush him, so he never feels accepted and taken to their bosom. Yet he himself does not accept the world either, at any rate not outright, for everything has first to be judged by his own critical

standards. Finally only those things are accepted which, for various subjective reasons, he can turn to his own account.

[977] For him self-communications are a pleasure. His own world is a safe harbour, a carefully tended and walled-in garden, closed to the public and hidden from prying eyes. His own company is the best. He feels at home in his world, where the only changes are made by himself. His best work is done with his own resources, on his own initiative, and in his own way. If ever he succeeds, after long and often wearisome struggles, in assimilating something alien to himself, he is capable of turning it to excellent account. Crowds, majority views, public opinion, popular enthusiasm never convince him of anything, but merely make him creep still deeper into his shell.

[978] His relations with other people become warm only when safety is guaranteed, and when he can lay aside his defensive distrust. All too often he cannot, and consequently the number of friends and acquaintances is very restricted. Thus the psychic life of this type is played out wholly within. Should any difficulties and conflicts arise in this inner world, all doors and windows are shut tight. The introvert shuts himself up with his complexes until he ends in complete isolation.

[979] In spite of these peculiarities the introvert is by no means a social loss. His retreat into himself is not a final renunciation of the world, but a search for quietude, where alone it is possible for him to make his contribution to the life of the community. This type of person is the victim of numerous misunderstandings—not unjustly, for he actually invites them. Nor can he be acquitted of the charge of taking a secret delight in mystification, and that being misunderstood gives him a certain satisfaction, since it reaffirms his pessimistic outlook. That being so, it is easy to see why he is accused of being cold, proud, obstinate, selfish, conceited, cranky, and what not, and why he is constantly admonished that devotion to the goals of society, clubbability, imperturbable urbanity, and selfless trust in the powers-that-be are true virtues and the marks of a sound and vigorous life.

[980] The introvert is well enough aware that such virtues exist, and that somewhere, perhaps—only not in his circle of acquaintances—there are divinely inspired people who enjoy undiluted possession of these ideal qualities. But his self-criticism and his awareness of his own motives have long since disabused him of the illusion that he himself would be capable of such virtues; and his mistrustful gaze, sharpened by anxiety, constantly enables him to detect on his fellow men the ass's ear sticking up from under the lion's mane. The world and men are for him a disturbance and a danger, affording no valid standard by which he could ultimately orient himself. What alone is valid for him is his subjective world, which he sometimes believes, in moments of delusion, to be the objective one. We could easily charge these people

with the worst kind of subjectivism, indeed with morbid individualism, if it were certain beyond a doubt that only one objective world existed. But this truth, if such it be, is not axiomatic; it is merely a half truth, the other half of which is the fact that the world *also* is as it is seen by human beings, and in the last resort by the individual. There is simply no world at all without the knowing subject. This, be it never so small and inconspicuous, is always the other pier supporting the bridge of the phenomenal world. The appeal to the subject therefore has the same validity as the appeal to the so-called objective world, for it is grounded on psychic reality itself. But this is a reality with its own peculiar laws which are not of a secondary nature.

[981] The two attitudes, extraversion and introversion, are opposing modes that make themselves felt not least in the history of human thought. The problems to which they give rise were very largely anticipated by Friedrich Schiller, and they underlie his *Letters on the Aesthetic Education of Man*.⁷ But since the concept of the unconscious was still unknown to him, he was unable to reach a satisfactory solution. Moreover philosophers, who would be the best equipped to go more closely into this question, do not like having to submit their thinking function to a thorough psychological criticism, and therefore hold aloof from such discussions. It should, however, be obvious that the intrinsic polarity of such an attitude exerts a very great influence on the philosopher's own point of view.

[982] For the extravert the object is interesting and attractive *a priori*, as is the subject, or psychic reality, for the introvert. We could therefore use the expression "numinal accent" for this fact, by which I mean that for the extravert the quality of positive significance and value attaches primarily to the object, so that it plays the predominant, determining, and decisive role in all psychic processes from the start, just as the subject does for the introvert.

[983] But the numinal accent does not decide only between subject and object; it also selects the conscious function of which the individual makes the principal use. I distinguish four functions: *thinking, feeling, sensation, and intuition*. The essential function of sensation is to establish that something exists, thinking tells us what it means, feeling what its value is, and intuition surmises whence it comes and whither it goes. Sensation and intuition I call irrational functions, because they are both concerned simply with what happens and with actual or potential realities. Thinking and feeling, being discriminative functions, are rational. Sensation, the *fonction du réel*, rules out any simultaneous intuitive activity, since the latter is not concerned with the present but is rather a sixth sense for hidden possibilities, and therefore should not allow itself to be unduly influenced by existing reality. In the same way, thinking is opposed to feeling, because thinking should not be influenced or deflected from its purpose by feeling values, just as feeling is usually vitiated by too much

reflection. The four functions therefore form, when arranged diagrammatically, a cross with a rational axis at right angles to an irrational axis.

[984] The four orienting functions naturally do not contain everything that is in the conscious psyche. Will and memory, for instance, are not included. The reason for this is that the differentiation of the four orienting functions is, essentially, an empirical consequence of typical differences in the functional attitude. There are people for whom the numinal accent falls on sensation, on the perception of actualities, and elevates it into the sole determining and all-overriding principle. These are the fact-minded men, in whom intellectual judgment, feeling, and intuition are driven into the background by the paramount importance of actual facts. When the accent falls on thinking, judgment is reserved as to what significance should be attached to the facts in question. And on this significance will depend the way in which the individual deals with the facts. If feeling is numinal, then his adaptation will depend entirely on the feeling value he attributes to them. Finally, if the numinal accent falls on intuition, actual reality counts only in so far as it seems to harbour possibilities which then become the supreme motivating force, regardless of the way things actually are in the present.

[985] The localization of the numinal accent thus gives rise to four function-types, which I encountered first of all in my relations with people and formulated systematically only very much later. In practice these four types are always combined with the attitude-type, that is, with extraversion or introversion, so that the functions appear in an extraverted or introverted variation. This produces a set of eight demonstrable function-types. It is naturally impossible to present the specific psychology of these types within the confines of an essay, and to go into its conscious and unconscious manifestations. I must therefore refer the interested reader to the aforementioned study.

[986] It is not the purpose of a psychological typology to classify human beings into categories—this in itself would be pretty pointless. Its purpose is rather to provide a critical psychology which will make a methodical investigation and presentation of the empirical material possible. First and foremost, it is a critical tool for the research worker, who needs definite points of view and guidelines if he is to reduce the chaotic profusion of individual experiences to any kind of order. In this respect we could compare typology to a trigonometric net or, better still, to a crystallographic axial system. Secondly, a typology is a great help in understanding the wide variations that occur among individuals, and it also furnishes a clue to the fundamental differences in the psychological theories now current. Last but not least, it is an essential means for determining the “personal equation” of the practising

psychologist, who, armed with an exact knowledge of his differentiated and inferior functions, can avoid many serious blunders in dealing with his patients.

[987] The typological system I have proposed is an attempt, grounded on practical experience, to provide an explanatory basis and theoretical framework for the boundless diversity that has hitherto prevailed in the formation of psychological concepts. In a science as young as psychology, limiting definitions will sooner or later become an unavoidable necessity. Some day psychologists will have to agree upon certain basic principles secure from arbitrary interpretation if psychology is not to remain an unscientific and fortuitous conglomeration of individual opinions.

CORRELATION OF PARAGRAPH NUMBERS

CORRELATION OF PARAGRAPH NUMBERS

As the *Gesammelte Werke* edition of *Psychologische Typen* (1960; 2nd edn., 1967) follows a different system of paragraph numbering from the *Collected Works* edition, the following table gives the equivalents between the two. Paragraphs 1–7 are numbered alike in both.

Collected Works	Gesammelte Werke	Collected Works	Gesammelte Werke	Collected Works	Gesammelte Werke
CHAPTER I		47	39	84	81/82
1	1	48/49	40	85	82
.....	50	41	86/87	83
8–11	8	51	42	88	84
12/13	9	52	43	89/90	85
14	10	53	44	91/92	86
15/16	11	54	45	93*	87/88
17	12	55	46/47	94	89
18	13/14	56	48/49	95	90
19	15/16	57	50/51	96	91
20	17	58	52	97	92
21/22	18	59	53	98	93
23	19	60	54	99	94
24–26	20	61	55	100	95
27	21	62	56	CHAPTER II	
28	22	63	57/58	101	96
29	23	64	59	102	97/98
30	24	65	59–62	103	98
31	25	66	63	104	99
32	26	67	64	105	100/101
33	27	68	65	106	102/103
34	28	69/70	66	107	104
35	29	71	67	108	105
36	30	72	68	109	106
37/38	31	73	69	110	107/108
39	32	74	70	111	108
40	33	75	71	112	109
41	34	76	72	113	109/110
42/43	35	77/78	73	114	111/112
44	36	79	74	115	113/114
45	37	80/81	75	116	115
46	38/39	82	76–79		
		83	80		

* Last sentence from 1950 Swiss edn., p. 85.

Collected Works	Gesammelte Werke	Collected Works	Gesammelte Werke	Collected Works	Gesammelte Werke
117	116	176	167	236	219
118	117	177	168	237	220
119	118	178	169	238	221
120	119/120	179	170	239	222
121/122	121	180	171	240	223
123/124	122	181/182	172	241	224
125/126	123	183	173	242	225
127	124	184	174		
128	125/126	185	175	CHAPTER I V	
129	127	186	176		
130	128	187	177/178		
131	128/129	188	178	243	226
132	129	189	179	244	227
133	129/130	190/191	180	245-247	228
134	131	192	181	248	229
135	132	193	182	249	230
136	133	194	183	250	231
137	134	195	184	251-253	232
138-140	135	196-198	185	254	233
141	136	199/200	186	255	234
142/143	137	201	187	256	235/236
144	138	202/203	188	257	237
145	139	204/205	189	258	238
146	140	206	190	259	239
147/148	141	207	191	260	240
149	142	208	192	261	241-243
150	143	209	193	262	244/245
151	144	210	194	263	246
152	145	211	195-196	264	247
153	146	212	197	265	248-252
154	147	213/214	198	266	253
155	148	215/216	199	267/268	254
156	149	217	200	269	255
157	150/151	218	201	270	256
158	152	219	202	271	257
159	153	220	203	272	258
160	154	221	204	273	259
161	155	222	205	274	260
162	156				
163	157	CHAPTER III		CHAPTER V	
164	158	223/224	206	275	261
165	159	225	207-209	276	262
166/167	160	226/227	210	277	263/264
168	161	228/229	211	278	265/266
169	161/162	230	212	279	267
170	162	231	213	280	267-269
171	162/163	232	214	281	270/271
172/173	164	233	215	282	272-274
174	165	234	216/217	283	275
175	166	235	218	284	276
				285	276-280

Collected Works	Gesammelte Werke	Collected Works	Gesammelte Werke	Collected Works	Gesammelte Werke
286/287	281	343	373	397/398	445
288	282	344	374/375	399/400	447
289	283	345	375	401	446
290-292	284	346	376	402	448/449
293	285	347	377	403	449
294	286	348	378	404	450
295	287-289	349	379-385	405/406	451
296	290	350	386/387	407	452
297	291-294	351	388/390	408	453
298	295	352	391-393	409	454/455
299	296	353	394	410/411	455
300	297	354	395/397	412/413	456
301	298	355	398	414/415	457
302	299	356	399	416	458-460
303	300	357	400	417	461
304	301/302	358	401	418	461/462
305	303/304	359	402-404	419/420	463
306	305/306	360	405	421	464/465
307-309	307	361	406/407	422	465
310	308	362	408-411	423/424	466
311	309	363	412-414	425	466/467
312	310	364*	415	426	468
313	311	365	416	427	469
314	312	366/367	417	428	470-473
315	313	368	418	429	474
316/317	314	369	419	430/431	475
318/319	315	370	420	432	476/477
320	316	371/372	421	433	478
321	317	373	421-423	434	479
322	318	374	423	435	480/481
323	318/319	375	424	436/437	482
324	320/321	376	425	438	483
325	322	377	425/426	439	484-486
326	323	378	427	440	487
327	324/325	379	428	441	488-490
328	326-336	380	429	442	491
329	337-347	381	430/431	443	492-495
330	348	382	431/432	444	496
331	349-354	383/384	433	445	497-501
332	355	385	434	446	502
333	356/357	386	435	447	502-510
334	358-362	387	436	448/449	511
335	363/364	388	436/437	450	512
336	365-367	389	438	451	513/514
337	367/368	390	439	452	515-517
338	369	391	440/441	453	518/519
339	370	392/393	442	454/455	520
340/341	371	394/395	443	456	521/522
342	372	396	444/445	457	523

* Quotations referred to in G. W. 6, p. 121, n. 120 added.

Collected Works	Gesammelte Werke	Collected Works	Gesammelte Werke	Collected Works	Gesammelte Werke
458	524	508	574	561	626
459	525	509	575	562	627
460	526	510	575/576	563	628/629
		511	577	564	629/632
		512	578	565	633
CHAPTER VI		513	579	566/567	634
461/462	527	514	580/581	568	635
463	528/529	515	581	569	636
464	529	516	581/582	570/571	637
465	529-531	517	583	572	638
466	532	518	584	573/574	639
467	533/534	519	585	575	640
468	534-536	520	586	576	641
469	537	521	586/587	577	642-644
470	538	522	588	578	645/646
471	539	523	589	579	646
472	540	524	590	580	647/648
473	541	525	591	581	648
474	542	526/527	592	582	649
475	543	528/529	593	583	650
476	544	530	594	584	651
477	545	531	595	585	652
478	546	532	596	586	653
479	547/548	533/534	597	587	654
480	549	535	598	588	655
481	549/550	536	599/600	589	656
482	551	537	601/602	590	657
483	552	538/539	603	591	658/659
		540	603-605	592	660
CHAPTER VII		541	606	593	661
484/485	553			594	662
486	554	CHAPTER IX		595	663
487	554/555	542-544	607	596	663/664
488	555/556	545	608	597/598	665
489/490	557	546/547	609	599	666
491	558/559	548	610	600	667-669
492	559	549	611	601	670
493	560-562	550	612/613	602	671/672
494	563	551	614/615	603	673
495	564	552	616	604/605	674
496/497	565	553	617	606	675
498/499	566	554	618	607	676
500/501	567	555	619/620	608	677
502	568/569			609	678
503/504	570	CHAPTER X		610/611	679
		556	621	612	680
CHAPTER VIII		557	622	613	681/682
505	571	558	622/623	614	683
506	572	559	624	615	684/685
507	572/573	560	625	616	686/687
				617	688

Collected Works	Gesammelte Werke	Collected Works	Gesammelte Werke	Collected Works	Gesammelte Werke
618/619	689	CHAPTER XI		719	866
620	691	672	741	720	867
621	692	673	742	721	868
622	692-694	674	743	722	869
623	695	675	744	723-725	801
624/625	696	676	745	726	802
626	697/698	677	746	727	803
627	699	678	747	728	804
628	700	679	748	729	805/806
629	701	680	749	730	809
630	702	681	750	731	807
631	703	682	751	732	811
632	704	752	733	812
633	705	683	753	734	813
634	705/706	684	754	735	814-816
635	706	755	736	817
636	707	685	756	737	818
637	708	686	757	738	819
638	709	687	781	739/740	820
639	710/711	688/689	782	741	821
640	712	690	783	742	822
641	713	691	784	823
642	714	692	838	743	759
643	715	693	839	744	760
644	716	694	840	745	761
645/646	717	695	841	746	762/763
647	718/719	696	842	747	764
648/649	720	697	843	748	765
650	721	698	844	749	766
651	722	699	845	750	767
652	723	700	758	751	768
653	724	701	846	752	768-771
654	725	702	847	753	772
655	726	703	848	754	773
656	726	704	849	755	829
657	727	705	778	756	824
658	728	779	757/758	825
659/660	729	706	810	759	826
661	730	707	780	760	827
662	731	708	793-797	761/762	828
663	732	709	798	763	852
664	733	710	799	764	852/853
665	734	711	858	765	911/912
666	735	712	859	766	830
667	736	713	859/860	767	831
668	737	714	861	768	832
669	738	715	862	769	833
670	739	716	863	770/771	834
671	740	717	864	772/773	835
		718	865	774-776	836
				777	837

Collected Works	Gesammelte Werke	Collected Works	Gesammelte Werke	Collected Works	Gesammelte Werke
778	850	830	774	APPENDIX 2	
779	854	831	775	883	951
780	855	832	776	884	952
781	856	833	777	885	953
.....	857	834	808	886-888	954
782	851	835	913	889	955
783	870	836	914	890	956
784	871	837/838	915	891	957/958
.....	872	839	915/916	892/893	958
785	873	840	917	894	959
786	874	841	918	895	960
787	875	842	919	896	961
788	876	843	920	897	962
789-791	891	844	921	898	962/963
792	786/787			899	964
793	787			900	965
794/795	788	EPILOGUE		901	966
796	790-792	845/846	922	902	967
797	877	847/848	923	903	968
798	878	849	924	904	969
799/800*	879	850	925	905/906	970
801	880/881	851-853	926	907	971
802	882	854	927	908	972
803	883	855	928	909	973
804/805	884	856	929	910	974
806	885	857	930	911	975
807	886			912	976
808	887			913	977
809	888	APPENDIX 1		914	978
810	889				
811	890	858/859	931	APPENDIX 3	
812	892	860	932		
813	893	861/862	933	915/916	979
814	894	863	934	917	980/981
815	895	864/865	935	918	982
816	896	866	936	919	983
817	897	867/868	937	920	984
818	898	869	938	921	985/986
819	899/900	870	939	922	987
820	901	871	940	923	988
821/822	902	872	941/942	924	989
823	903	873	943/944	925	990
824	903/904	874	944	926	991
825	905	875	945	927	992
826	906	876/877	946	928	993
827	907	878	947	929	994
828/829	908	879	948	930	995
.....	909	880/881	949	931	996
.....	910	882	950	932	997/998

* Last sentence from 1950 Swiss edn., p. 631.

Collected Works	Gesammelte Werke	Collected Works	Gesammelte Werke	Collected Works	Gesammelte Werke
933	999	953	1022	971	1040
934	1000/1001	954	1023	972	1041
935	1002	955	1024	973	1042
936	1003	956	1025	974	1043/1044
937	1004	957	1026/1027	975	1045
938	1005/1006	958	1028/1029	976	1046
939	1007	959	1030	977	1047
940	1008			978	1048
941	1009			979	1049/1050
942	1010	APPENDIX 4		980	1051
943	1011			981	1052
944	1012	960/961	1031	982	1053
945	1013	962	1032	983	1054
946	1014	963	1033	984	1055
947	1015	964	1034	985	1056
948	1016/1017	965	1035	986	1057
949	1018	966/967	1036	987	1058
950	1019	968	1037		
951	1020	969	1038		
952	1021	970	1039		

BIBLIOGRAPHY

- ADLER, ALFRED. *The Neurotic Constitution*. Translated by Bernard Glueck and John E. Lind. New York, 1916. (Original: *Über den nervösen Charakter*. Wiesbaden, 1912.)
- _____. *Study of Organ Inferiority and Its Physical Compensation*. Translated by Smith Ely Jelliffe. (Nervous and Mental Disease Monographs, 24.) New York, 1917. (Original: *Studie über Minderwertigkeit von Organen*. Vienna, 1907.)
- AMBROSE, SAINT, Bishop of Milan. *De institutione Virginis*. In MIGNE, P.L., vol. 16, cols. 305–334.
- AMBROSE, SAINT (pseudo-). *Expositio beati Ambrosii Episcopi super Apocalypsin*. Paris, 1554.
- ANGELUS, SILESIUS. See SCHEFFLER, JOHANN.
- ANQUETIL DU PERRON, A. H. *Oupnek'hat (id est, Secretum legendum) ... in Latinum conversum*. Strasbourg, 1801–2. 2 vols.
- ANSELM, SAINT, Archbishop of Canterbury. *An Address (Proslogion)*. In: EUGENE R. FAIRWEATHER (ed. and trans.). *A Scholastic Miscellany: Anselm to Ockham*. (Library of Christian Classics, 10.) Philadelphia and London, 1956.
- ATHANASIUS, SAINT, Bishop of Alexandria. *Life of Saint Antony*. In: E. A. WALLIS BUDGE. *The Book of Paradise*. (Lady Meux MS., no. 6.) London, 1904. 2 vols. (Vol. I, pp. 3–76.)
- Atharva Veda*. See: *Atharva-Veda Samhita*. Translated by William Dwight Whitney and Charles Rockwell Lanman. (Harvard Oriental Series, 7, 8.) Cambridge, Mass., 1905. 2 vols.
- AUGUSTINE, SAINT, Bishop of Hippo. *Contra epistolam Manichaei*. In MIGNE, P.L., vol. 42, cols. 173–206.
- _____. *Sermones*. In MIGNE, P.L., vol. 38.
- AVENARIUS, RICHARD. *Der menschliche Weltbegriff*. Leipzig, 1891.
- AZAM, C. M. ÉTIENNE EUGÈNE. *Hypnotisme, double conscience, et altérations de la personnalité*. Paris, 1887.
- BALDWIN, JAMES MARK. *Handbook of Psychology: Senses and Intellect*. London and New York, 1890.
- BARLACH, ERNST. *Der tote Tag*. Berlin, 1912; 2nd edn., 1918.

- BARTSCH, KARL (ed.). *Meisterlieder der Kolmarer Handschrift*. (Bibliothek des Literarischen Vereins in Stuttgart, 68.) Stuttgart, 1862.
- BERGAIGNE, ABEL. *La Religion védique d'après les hymnes du Rig-Veda*. Vol. III. (Bibl. de l'École des hautes études, 54.) Paris, 1883.
- Bhagavad Gita*. See: *The Song of God: Bhagavad-Gita*. Translated by Swami Prabhavananda and Christopher Isherwood. London, 1947.
- Bhagavata Purana*. Translated by Manmatha Nath Dutt. Calcutta, 1895–96. 5 parts.
- BINSWANGER, LUDWIG. "On the Psychogalvanic Phenomena in Association Experiments." In: C. G. JUNG (ed.). *Studies in Word-Association*. Translated by M. D. Eder. London, 1918; New York, 1919.
- BJERRE, PAUL. "Zur Radikalbehandlung der chronischen Paranoia," *Jahrbuch für psychoanalytische und psychopathologische Forschungen* (Vienna), III (1911), 795–847.
- BLAKE, WILLIAM. *The Complete Writings of William Blake*. Edited by Geoffrey Keynes. London, 1966.
- BLEULER, EUGEN. "Die negative Suggestibilität, ein psychologisches Prototyp des Negativismus," *Psychiatrisch-neurologische Wochenschrift* (Halle), VI (1904), 249–69.
- _____. "Affectivity, Suggestibility, Paranoia" (translated by Charles Ricksher), *New York State Hospitals Bulletin* (Utica, N.Y.), V (1912), pp. 481ff. (Original: *Affektivität, Suggestibilität, Paranoia*. Halle, 1906.)
- _____. *Textbook of Psychiatry*. Translated by A. A. Brill. New York and London, 1924. (Original: *Lehrbuch der Psychiatrie*. Berlin, 1916.)
- _____. *The Theory of Schizophrenic Negativism*. Translated by William A. White. (Nervous and Mental Disease Monograph Series, 11.) New York, 1912. (Original: "Zur Theorie des schizophrenen Negativismus," *Psychiatrisch-neurologische Wochenschrift* (Halle), XII (1910–11), 171, 189, 195.)
- BORGES, JORGE LUIS. "Pascal's Sphere." In: *Other Inquisitions*. Translated by Ruth L. C. Simms. Austin, Tex., 1964. (Original: "La esfera de Pascal," in *Otras Inquisiciones*. (Obras Completas, 8.) Buenos Aires, 1960.)
- Brihadaranyaka Upanishad*. See HUME.
- BUBER, MARTIN. *Ekstatische Konfessionen*. Jena, 1909.
- BUDGE, E. A. WALLIS. *The Gods of the Egyptians*. London, 1904. 2 vols.
- _____. See also ATHANASIUS, SAINT.
- BURNET, JOHN. *Early Greek Philosophy*. 4th edn., London, 1930.

Chhandogya Upanishad. See HUME.

COHEN, HERMANN. *Logik der reinen Erkenntnis*. Berlin, 1902.

Colmar Manuscript. See BARTSCH, KARL.

DANTE ALIGHIERI. *The Divine Comedy. The Inferno, Purgatorio, and Paradiso*.
Translated by Lawrence Grant White. New York, 1948.

DESSOIR, MAX. *Geschichte der neueren deutschen Psychologie*. Vol. I: *Von Leibniz bis Kant*. Berlin, 1894; 2nd edn., 1902.

DEUSSEN, PAUL. *Allgemeine Geschichte der Philosophie*. Leipzig, 1894–1917. 2 vols, in 6 parts.

DIONYSIUS THE AREOPAGITE (pseudo-). *On the Divine Names and The Mystical Theology*. Translated by C. E. Rolt. London and New York, 1920.

EBBINGHAUS, HERMANN. *Grundzüge der Psychologie*. 2nd edn., Leipzig, 1905–13. 2 vols.

EBERSCHWEILER, ADOLF. “Untersuchungen über die sprachliche Komponente der Assoziation,” *Allgemeine Zeitschrift für Psychiatrie* (Berlin), LXV (1908), 240–71.

ECKHART, MEISTER. [Works.] Translated by C. de B. Evans. London, 1924–31. 2 vols.

EUSEBIUS, Bishop of Caesarea. *The Ecclesiastical History and the Martyrs of Palestine*. Translated by H. J. Lawlor and J. E. L. Oulton. London, 1927–28. 2 vols.

FÉRÉ, CHARLES. “Note sur des modifications de la résistance électrique sous l’influence des excitations sensorielles et des émotions,” *Comptes-rendus hebdomadaires des séances et memoires de la Société de Biologie* (Paris), ser. 8, V (1888), 217–19.

FERENCZI, SANDOR. “Introjection and Transference.” In: *First Contributions to Psycho-Analysis*. Translated by Ernest Jones. London, 1952. (Pp. 35–93.) (Original: “Introjektion und Übertragung,” *Jahrbuch für psychoanalytische und psychopathologische Forschungen* (Vienna), II (1910).)

FERRERO, GUGLIELMO. *I simboli in rapporto alla storia e filosofia del diritto*. Turin, 1893. (French translation: *Les Lois psychologiques du symbolisme*. Paris, 1895.)

FICHTE, IMMANUEL HERMANN VON. *Psychologie*. Leipzig, 1864–73. 2 vols.

FINCK, FRANZ NIKOLAUS. *Der deutsche Sprachbau als Ausdruck deutscher Weltanschauung*. Marburg, 1899.

FLOURNOY, THÉODORE. *From India to the Planet Mars*. Translated by D. B. Vermilye. New York, 1900. (Original: *Des Indes à la planète Mars*. 3rd edn., Paris, 1900.)

_____. “Une Mystique moderne,” *Archives de psychologie* (Geneva), XV (1915), 1–224.

- _____. "Nouvelles observations sur un cas de somnambulisme avec glossolalie," *Archives de psychologie* (Geneva), I (1901), 101–255.
- _____. *The Philosophy of William James*. Translated by Edwin B. Holt and William James, Jr. London, 1917.
- FRANCE, ANATOLE. *Le Jardin d'Epicure*. 4th edn., Paris, 1895.
- FREUD, SIGMUND. *The Interpretation of Dreams*. (Complete Psychological Works, 4 and 5.) Translated by James Strachey. London, 1953. 2 vols. (Original: *Die Traumdeutung*. 1900.)
- _____. *The Psychopathology of Everyday Life*. (Complete Psychological Works, 6.) Translated by Alan Tyson. London, 1960. (Original: *Zur Psychopathologie des Alltagsleben*. 1901.)
- FROBENIUS, LEO. *Das Zeitalter des Sonnengottes*. (Only vol. I published.) Berlin, 1904.
- Garuda-Purana*. Translated by E. Wood and S. V. Subrahmanyam. (Sacred Books of the Hindus, 26 and 27.) Allahabad, 1911. 2 vols.
- GOETHE, JOHANN WOLFGANG. *Werke*. (Gedenkausgabe.) Edited by Ernst Beutler. Zurich, 1948–54. 24 vols. (For *Die Geheimnisse*, see vol. 3, pp. 273–83; *Pandora*, vol. 6, pp. 406–443; *Prometheus*, vol. 1, pp. 320–21, and vol. 4, pp. 185–98; Correspondence with Schiller, vol. 20.)
- _____. *Faust, Part One and Part Two*. Translated by Philip Wayne. Harmondsworth and Baltimore, 1956, 1959.
- _____. *Goethe's Faust*. Parts I and II. An abridged version translated by Louis MacNeice. London and New York, 1952.
- GOMPERZ, THEODOR. *Greek Thinkers*. Translated by Laurie Magnus and G. G. Berry. London, 1901–12. 4 vols. (Original: *Griechische Denker*. 3rd edn., Leipzig, 1911–12.)
- GÖRRES, JOHAN JOSEPH VON. *Die christliche Mystik*. Regensburg and Landshut, 1836–42. 4 vols.
- GROSS, OTTO. *Die zerebrale Sekundärfunktion*. Leipzig, 1902. (See also an unsigned review of the book in *Archives de psychologie* (Geneva), III (1903), 397–99.)
- _____. *Über psychopathische Minderwertigkeit*. Vienna, 1909.
- HARNACK, ADOLF VON. *History of Dogma*. Translated from the 3rd German edition. (Theological Translation Library, 2, 7–12.) London, 1896–1905. 7 vols. (Original: *Lehrbuch der Dogmengeschichte*. 1888–94.)
- HARTMANN, EDUARD VON. *Die moderne Psychologie*. (Ausgewählte Werke, 13.) Leipzig, 1901.

- HASE, CARL AUGUST VON. *A History of the Christian Church*. Translated by Charles E. Blumenthal and Conway P. Wing. New York, 1855. (Original: *Kirchengeschichte*. 10th edn., Leipzig, 1877.)
- HEGEL, GEORG WILHELM FRIEDRICH. *The Logic of Hegel*. Translated by William Wallace. 2nd edn., Oxford, 1892.
- _____. *Einleitung in die Aesthetik*. (Sämtliche Werke, Jubiläumsausgabe, edited by Hermann Glockner, 12.) Stuttgart, 1927.
- HEINE, HEINRICH. *Deutschland*. (Original: 1834.) Cf.: *Germany*. (Works, translated by Charles Godfrey Leland, 5.) New York, 1892. (P. 81.)
- HERBART, JOHANN FRIEDRICH. *Psychologie als Wissenschaft, neu gegründet auf Erfahrung, Metaphysik und Mathematik*. (Sämtliche Werke, edited by G. Hartenstein, 6, pt. 2.) Leipzig, 1850. (Cf.: *A Text-book in Psychology*. Translated by Margaret K. Smith. New York, 1894.)
- HERMAS. *The Shepherd*. In: *The Apostolic Fathers*. With an English translation by Kirsopp Lake. (Loeb Classical Library.) London and New York, 1917. 2 vols. (Vol. 2, pp. 6–305.)
- HOCH, AUGUST. “Constitutional Factors in the Dementia Praecox Group,” *Review of Neurology and Psychiatry* (Edinburgh), VIII:8 (Aug., 1910).
- HÖLDERLIN, JOHANN CHRISTIAN FRIEDRICH. See: *Hölderlin: His Poems*. Translated by Michael Hamburger. 2nd edn., London and New York, 1952.
- HUME, ROBERT ERNEST (trans.). *The Thirteen Principal Upanishads*. 2nd edn., revised, London and New York, 1934.
- INOUE, TETSUJIRO. “Die japanische Philosophie,” in *Allgemeine Geschichte der Philosophie*, by W. Wundt and others. (Die Kultur der Gegenwart, edited by Paul Hinneberg, Part I, sec. V.) Berlin and Leipzig, 2nd edn., 1923.
- Isha Upanishad*. See HUME.
- JACOBI, JOLANDE. *Complex/Archetype/Symbol in the Psychology of C. G. Jung*. Translated by Ralph Manheim. New York (Bollingen Series) and London, 1959.
- JAMES, WILLIAM. *Pragmatism: A New Name for Some Old Ways of Thinking*. London and New York, 1911.
- _____. *The Principles of Psychology*. New York, 1890. 2 vols.
- JERUSALEM, WILHELM. *Lehrbuch der Psychologie*. 5th edn., Vienna and Leipzig, 1912.
- JODL, FRIEDRICH. *Lehrbuch der Psychologie*. 3rd edn., Stuttgart and Berlin, 1908. 2 vols.
- JORDAN FURNEAUX. *Character as Seen in Body and Parentage*. 3rd edn., London, 1896.

- JULIAN, "the Apostate." Works. Translated by Wilmer Cave Wright. (Loeb Classical Library.) Vol. I. London and New York, 1913. ("Hymn to King Helios," pp. 353–435; "Hymn to the Mother of the Gods," pp. 443–503.)
- JUNG, CARL GUSTAV.* "The Aims of Psychotherapy." In *Collected works*, 9, ii.
- _____. *Aion: Researches into the Phenomenology of the Self*. *Collected Works*, 9, ii.
- _____. *Collected Papers on Analytical Psychology*. Edited by Constance E. Long. London and New York, 1916; 2nd edn., 1917.
- _____ "Commentary on *The Secret of the Golden Flower*," in *Collected Works*, 13.
- JUNG, CARL GUSTAV. "The Concept of the Collective Unconscious." In *Collected Works*, 9, i.
- _____. "Concerning Mandala Symbolism." In *Collected Works*, 9, i.
- _____. "The Content of the Psychoses." In *Collected Works*, 3.
- _____. "Cryptomnesia." In *Collected Works*, 1.
- _____. "Flying Saucers: A Modern Myth of Things Seen in the Sky." In *Collected Works*, 10.
- _____. "Instinct and the Unconscious." In *Collected Works*, 8.
- _____. *Letters*. Selected and edited by Gerhard Adler, in collaboration with Aniela Jaffé. Translated by R.F.C. Hull. Princeton (Bollingen Series) and London, 1973, 1975. 2 vols.
- _____. *Memories, Dreams, Reflections*. Recorded and edited by Aniela Jaffé. Translated by Richard and Clara Winston. New York and London, 1963. (Edns. separately paginated.)
- _____. *Mysterium Coniunctionis*. *Collected Works*, 14.
- _____. "On the Importance of the Unconscious in Psychopathology." In *Collected Works*, 3.
- _____. "On the Nature of the Psyche." In *Collected Works*, 8.
- _____. "On Psychic Energy." In *Collected Works*, 8.
- _____. "On Psychological Understanding." In *Collected Works*, 3.
- _____. "On the Psychology and Pathology of So-called Occult Phenomena." In *Collected Works*, 1.
- _____. "On Psychophysical Relations of the Association Experiment." In *Collected Works*, 2.
- _____. *The Practice of Psychotherapy*. *Collected Works*, 16.
- _____. *Psychiatric Studies*. *Collected Works*, 1.

- _____. "A Psychological Approach to the Dogma of the Trinity." In *Collected Works*, 11.
- _____. "The Psychological Aspects of the Kore." In *Collected Works*, 9, i.
- _____. "Psychological Aspects of the Mother Archetype." In *Collected Works*, 9, i.
- _____. *Psychology and Alchemy*. *Collected Works*, 12.
- _____. *Psychology and Religion: West and East*. *Collected Works*, 11.
- _____. "The Psychology of the Child Archetype." In *Collected Works*, 9, i.
- JUNG, CARL GUSTAV. "The Psychology of Dementia Praecox." In *Collected Works*, 3.
- _____. *Psychology of the Unconscious: A Study of the Transformations and Symbolisms of the Libido*. Translated by Beatrice M. Hinkle. New York, 1916; London, 1917. (Original: *Wandlungen und Symbole der Libido*. Vienna, 1912.) Revised as *Symbols of Transformation*, q.v.
- _____. "The Psychology of the Unconscious Processes." In *Collected Papers on Analytical Psychology*, q.v.
- _____. "A Review of the Complex Theory." In *Collected Works*, 8.
- _____. "The Structure of the Psyche." In *Collected Works*, 8.
- _____. "The Structure of the Unconscious." In *Collected Works*, 7. (Revised version in the 2nd edn., 1966.)
- _____. *Studies in Word-Association*. Under the direction of C. G. Jung. Translated by M. D. Eder. London, 1918; New York, 1919. (Jung's contributions, retranslated, in *Collected Works*, 2.)
- _____. "A Study in the Process of Individuation." In *Collected Works*, 9, i.
- _____. *Symbols of Transformation*. *Collected Works*, 5. Cf. JUNG, *Psychology of the Unconscious*.
- _____. "Synchronicity: An Acausal Connecting Principle." In *Collected Works*, 8.
- _____. "The Tavistock Lectures (On the Theory and Practice of Analytical Psychology)." In *Collected Works*, 18.
- _____. "The Theory of Psychoanalysis." In *Collected Works*, 4.
- _____. "The Transcendent Function." In *Collected Works*, 8.
- _____. "Transformation Symbolism in the Mass." In *Collected Works*, 11.
- _____. *Two Essays on Analytical Psychology*. *Collected Works*, 7.
- _____ and FREUD, SIGMUND. *The Freud / Jung Letters*. Edited by William McGuire. Translated by Ralph Manheim and R.F.C. Hull. Princeton (Bollingen Series) and London, 1974.

- KANT, IMMANUEL. *Critique of Practical Reason and Other Writings in Moral Philosophy*. Translated and edited by Lewis White Beck. Chicago, 1949.
- _____. *Immanuel Kant's Critique of Pure Reason*. Translated by Norman Kemp Smith. London and New York, 1929.
- _____. *Logik*. In: *Werke*. Edited by Ernst Cassirer. Berlin, 1912–22. 11 vols. (Vol. 8, pages 325–452.)
- Katha Upanishad*. See HUME.
- Kaushitaki Upanishad*. See HUME.
- KERNER, JUSTINUS. *The Seeress of Prevorst*. Translated by Mrs. Catherine Crowe. New York, 1859.
- KING, CHARLES WILLIAM. *The Gnostics and Their Remains, Ancient and Medieval*. London, 1864; 2nd edn., 1887.
- KÖHLER, HEINRICH KARL ERNST VON. "Einleitung über die Gemmen mit dem Namen der Künstler, vom wirklichen Staatsrath von Köhler in Skt. Petersburg," in: K. A. BÖTTIGER (ed.). *Archaeologie und Kunst*. Breslau, 1828.
- KÖNIG, [FRIEDRICH] EDUARD. *Ahasver, "der Ewige Jude."* Gütersloh, 1907.
- KUBIN, ALFRED. *The Other Side*. Translated by Denver Lindley. New York, 1967. (Original: *Die andere Seite*. Munich, 1909.)
- KÜLPE, OSWALD. *Grundriss der Psychologie*. Leipzig, 1893.
- Lalita-Vistara, The; or Memoirs of the Early Life of Shakya Sinha*. Translated from the Sanskrit by Rajendralala Mitra. (Bibliotheca Indica, Asiatic Society of Bengal, n.s., 455, 473, 575.) Calcutta, 1881–86. 3 vols.
- LANDMANN, S. *Die Mehrheit geistiger Persönlichkeiten in einem Individuum*. Stuttgart, 1894.
- LASSWITZ, KURD. *Wirklichkeiten. Beiträge zur Weltverständnis*. Leipzig, 1900.
- Laws of Manu, The*. Translated by Georg Bühler. (Sacred Books of the East, 25.) Oxford, 1886.
- LEHMANN, ALFRED GEORG LUDWIG. *Die Hauptgesetze des menschlichen Gefühlslebens*. 2nd edn., Leipzig, 1914.
- LÉVY-BRUHL, LUCIEN. *How Natives Think*. Translated by Lilian A. Clare. London, 1926. (Original: *Les Fonctions mentales dans les sociétés inférieures*. Paris, 1912.)
- LIPPS, THEODOR. *Aesthetik: Psychologie des Schönen und der Kunst*. Hamburg, 1903–6. 2 vols.
- _____. *Leitfaden der Psychologie*. 3rd edn., Leipzig, 1909.

Lyra Germanica: Second Series. Translated from the German by Catherine Winkworth. London, 1858. (Pp. 53f.)

MAEDER, A. *The Dream Problem*. Translated by Frank Mead Hallock and Smith Ely Jelliffe. (Nervous and Mental Disease Monograph Series, 22.) New York, 1916. (Original: "Über das Traumproblem," *Jahrbuch für psychoanalytische und psychopathologische Forschungen* (Vienna), V (1913), 647–86.)

Mahabharata. Translated by Manmatha Nath Dutt. Calcutta, 1895–1905. 17 vols.

Manuscripts. Oxford, Bodleian Library, Digby MS. 65. By Godfrey, Prior of St. Swithin's, Winchester. 13th century.

_____. See also BARTSCH.

MATTER, JACQUES. *Histoire critique du gnosticisme*. Paris, 1828. 2 vols.

MEYRINK, GUSTAV. *The Golem*. Translated by Madge Pemberton. London, 1928. (Original: *Der Golem*. Leipzig, 1915.)

_____. *Das grüne Gesicht; eine Roman*. Leipzig, 1916.

MIGNE, JACQUES PAUL (ed.). *Patrologiae cursus completus*. [P.L.] Latin Series. Paris, 1844–64. 221 vols. [P.G.] Greek Series. Paris, 1857–66. 166 vols.

MÜLLER, G. E., and SCHUMANN, F. "Über die psychologischen Grundlagen der Vergleichung gehobener Gewichte." In: *Archiv für die gesamte Physiologie*, ed. E.F.W. Pflüger ("Pflüger's Archiv," Bonn), XLV (1889), 37–112.

NAHLOWSKY, JOSEPH WILHELM. *Das Gefühlsleben in seinen wesentlichsten Erscheinungen und Beziehungen*. 3rd edn., Leipzig, 1907.

NATORP, PAUL. *Einleitung in die Psychologie nach kritischer Methode*. Freiburg im Breisgau, 1888.

NEUMANN, ERICH. *The Origins and History of Consciousness*. Translated by R.F.C. Hull. New York (Bollingen Series) and London, 1954.

NIETZSCHE, FRIEDRICH. *The Birth of Tragedy*. Translated by William A. Haussmann. (Complete Works, 1.) Edinburgh and London, 1909.

_____. *The Joyful Wisdom*. Translated by Thomas Common, with poetry rendered by Paul V. Cohn and Maude D. Petre. (Complete Works, 10.) Edinburgh and London, 1910.

_____. *Thus Spake Zarathustra*. Translated by Thomas Common and revised by Oscar Levy and John L. Beevers. London, 1931.

_____. "The Use and Abuse of History," in *Thoughts Out of Season*, part II. Translated by Adrian Collins. (Complete Works, 5.) Edinburgh and London, 1915.

- NUNBERG, HERMANN. "On the Physical Accompaniments of Association Processes." In: C. G. JUNG (ed.). *Studies in Word-Association*. Translated by M. D. Eder. London, 1918; New York, 1919. (Pp. 531–60.)
- OLDENBERG, HERMANN. *Die Religion des Veda*. Berlin, 1894; 2nd edn., 1917.
- _____. "Zur Religion und Mythologie des Veda." In: *Nachrichten von der königlichen Gesellschaft der Wissenschaften zu Göttingen*, Philologisch-historische Klasse. Berlin, 1916. (Pp. 167–225.)
- ONIANS, RICHARD BROXTON. *The Origins of European Thought*. 2nd edn., Cambridge, 1954.
- OSTWALD, FRIEDRICH WILHELM. *Grosse Männer*. 3/4th edn., Leipzig, 1919.
- Pañcavimsha Brahmana*. Translated by W. Caland. (Bibliotheca Indica, 252.) Calcutta, 1931.
- PLATO. *The Symposium*. Translated by W. Hamilton. (Penguin Classics.) Harmondsworth, 1956.
- PLUTARCH. *Adversus Colotem*. See: Plutarch's *Moralia*, vol. XIV. (Loeb Classical Library.) London and Cambridge, Mass., 1967.
- PORPHYRY. See: *The Organon, or Logical Treatises, of Aristotle, with the Introduction of Porphyry*. Translated by Octavius Freire Owen. London, 1853. 2 vols.
- POWELL, JOHN WESLEY. "Sketch of the Mythology of the North American Indians." In: *First Annual Report of the Bureau of Ethnology to the Secretary of the Smithsonian Institution, 1897–80*. Washington, 1881. (Pp. 19–56.)
- PRINCE, MORTON. *The Dissociation of a Personality: A Biographical Study in Abnormal Psychology*. New York, 1906.
- Ramayana*. Translated by Manmatha Nath Dutt. Calcutta, 1892–94. 7 vols.
- RÉMUSAT, CHARLES F. M. DE. *Abélard*. Paris, 1845. 2 vols.
- RIBOT, THÉODULE ARMAND. *Die Persönlichkeit. Pathologisch-psychologische Studien*. Berlin, 1894.
- RIBOT, THÉODULE ARMAND. *The Psychology of the Emotions*. London, 1897. (Original: *Psychologie der Gefühle*. Altenburg, 1903.)
- RIEGL, ALOIS. *Spättrömische Kunstindustrie*. Vienna, 1901.
- _____. *Stilfragen*. Berlin, 1893.
- RIEHL, ALOIS. *Zur Einführung in die Philosophie der Gegenwart*. 4th edn., Leipzig and Berlin, 1913.

- Rig Veda*. See: *The Hymns of the Rigveda*. Translated by Ralph H. T. Griffith. Benares, 2nd edn., 1896–97. 2 vols. Also: *Vedic Hymns*. Translated by F. Max Müller and Hermann Oldenberg. (Sacred Books of the East, 32, 46.) Oxford, 1891–97.
- ROUSSEAU, JEAN-JACQUES. *Emile; or, Education*. Translated by Barbara Foxley. (Everyman's Library.) London and New York, 1911.
- SALZER, ANSELM. *Die Sinnbilder und Beiworte Mariens in der deutschen Literatur und lateinischen Hymnenpoesie des Mittelalters*. Linz, 1886.
- SCHÄRF KLUGER, RIVKAH. *Satan in the Old Testament*. Translated by Hildegard Nagel. Evanston, 1967.
- SCHEFFLER, JOHANN (Angelus Silesius). "Cherubinischer Wandersmann." In: *Johann Schefflers Sämmtliche Poetische Werke*. Edited by David August Rosenthal. Regensburg, 1862. 2 vols.
- SCHILLER, F.C.S. *Humanism; Philosophical Essays*. 2nd edn., London, 1912.
- SCHILLER, JOHANN CHRISTOPH FRIEDRICH VON. *Letters to Goethe*. See GOETHE, *Werke*, Gedenkausgabe, of which the Schiller-Goethe correspondence forms vol. 20.
- _____. *On the Aesthetic Education of Man, in a Series of Letters*. Translated by Reginald Snell. New Haven and London, 1954. (Original: "Über die ästhetische Erziehung des Menschen." In: *Sämmtliche Werke*, q.v., vol. 18, pp. 1–164.)
- _____. "The Diver." Cf. *Poems*. Translated by E. P. Arnold-Forster. London, 1901.
- _____. *Sämmtliche Werke*. Cottasche Ausgabe. Stuttgart and Tübingen, 1826.
- _____. "Über naive und sentimentalische Dichtung." In: *Sämmtliche Werke*, q.v., vol. 18, pp. 205–348.
- _____. "Über die notwendigen Grenzen beim Gebrauch schöner Formen." In: *Sämmtliche Werke*, q.v., vol. 18, pp. 165–204.
- SCHOPENHAUER, ARTHUR. *The World as Will and Idea*. Translated by R. B. Haldane and J. Kemp. London, 1883. 3 vols. (Original: *Die Welt als Wille und Vorstellung*. (Sämmtliche Werke, ed. by Eduard Grisebach, 6.) Leipzig, 1891.)
- SCHULTZ, WOLFGANG. *Dokumente der Cnosis*. Jena, 1910.
- SEMON, RICHARD. *The Mneme*. Translated by L. Simon. London, 1921. (Original: *Die Mneme als erhaltendes Prinzip im Wechsel des organischen Geschehens*. Leipzig, 1904.)
- Shatapatha Brahmana*. Translated by Julius Eggeling. (Sacred Books of the East, 12, 26, 41, 43, 44.) Oxford, 1882–1900. 5 vols.
- Shvetashvatara Upanishad*. See HUME.

- SILBERER, HERBERT. *Problems of Mysticism and Its Symbolism*. Translated by Smith Ely Jelliffe. New York, 1917. (Original: *Probleme der Mystik und ihrer Symbolik*. Vienna and Leipzig, 1904.)
- Song of Tishtriya, The*. See *Tir Yasht*.
- SPENCER, SIR WALTER R., and GILLEN, FRANCIS JAMES. *The Northern Tribes of Central Australia*. London, 1904.
- SPITTELER, CARL. *Prometheus and Epimetheus: a Prose Epic*. Translated by James Fullarton Muirhead. London, 1931. (Original: 1880–81.)
- STATIUS. *Thebaid*. See: *Works*. With a translation by J. H. Mozley. (Loeb Classical Library.) London and New York, 1928. 2 vols. (Vol. I.)
- STOBAEUS, JOHANNES. *Eclogarum physicarum et ethicorum Libri duo*. Edited by Thomas Gaisford. Oxford, 1850. 2 vols.
- SULLY, JAMES. *The Human Mind; a Text-book of Psychology*. London, 1892. 2 vols.
- SYNESIUS. *De Insomniis*. In: *Iamblichus De Mysteriis Aegyptiorum ... etc*. Translated by Marsilio Ficino. Venice, 1497. See also: “Concerning Dreams” (“De Insomniis”). In: *The Essays and Hymns of Synesius of Cyrene*. Translated by Augustine FitzGerald. London, 1930. 3 vols. (II, pp. 326ff.)
- Taittiriya Aranyaka*. With Sayana’s commentary. Edited by Baba Shastri Phadke. (Anandashrama Sanskrit Series, 36.) Poona, 1897–98. 2 vols.
- Taittiriya Brahmana*. With the commentary of Vedarthaprakasa of Sayana. Edited by Narayana Balakrishna Godbole. (Anandashrama Sanskrit Series, 37.) Poona, 1898. 3 vols.
- Taittiriya Samhita*. See: ARTHUR BERRIEDALE KEITH (trans.). *The Veda of the Black Yajus School, entitled Taittiriya Sanhita*. (Harvard Oriental Series, 18, 19.) Cambridge, Mass., 1914. 2 vols.
- Taittiriya Upanishad*. See HUME.
- TALBOT, P. AMAURY. *In the Shadow of the Bush*. London, 1912.
- Tao Te King*. See WALEY.
- TAYLOR, HENRY OSBORN. *The Medieval Mind*. London, 1911. 2 vols.
- Tejobindu (Teyovindu) Upanishad*. See: *Minor Upanishads*. With text, introduction, English rendering, and commentary. Mayavati (Advaita Ashrama), 1928. (Pp. 35–42.)
- TERTULLIAN. *De came Christi*. See: *Tertullian’s Treatise on the Incarnation*. The text with translation by Ernest Evans. London, 1956.

- _____. *De testimonio animae*. See: *The Writings of Tertullian*. Vol. I: *Apologetic and Practical Treatises*. Translated by C. Dodgson. (Library of the Fathers of the Holy Catholic Church.) Oxford, 1842.
- _____. *Liber adversus Judaeos*. In MIGNE, P.L., vol. 2, cols. 595–642. For translation, see: S. THELWALL. *The Writings of Tertullianus*. (Ante-Nicene Christian Library, 11, 15, 18.) Edinburgh, 1869–70. 3 vols. (III, pp. 201–88.)
- THOMAS AQUINAS. *Scriptum supra libros Sententiarum magistri Petri Lombardi*. Edited by P. F. Mandonnet. Paris, 1929–47. 5 vols.
- Tir Yasht*. In: *The Zend-Avesta*, Part II. Translated by James Darmesteter. (Sacred Books of the East, 23.) Oxford, 1883. (Pp. 92ff.)
- Vajasanayi Samhita*. See: *The Texts of the White Yajurveda*. Translated by P.T.H. Griffith. Benares, 1899.
- VERAGUTH, OTTO. “Das psycho-galvanische Reflex-Phänomen,” *Monatsschrift für Psychologie und Neurologie* (Berlin), XXI (1907), 387–425.
- VILLA, GUIDO. *Contemporary Psychology*. Translated by H. Manacorda. London, 1903. (Original: *Einleitung in die Psychologie der Gegenwart*. Leipzig, 1902.)
- VISCHER, FRIEDRICH THEODOR VON. *Auch Einer*, 9th edn., Leipzig, 1902.
- WALEY, ARTHUR (trans.). *The Way and Its Power; A Study of the Tao Tê Ching*. London, 1934.
- WANG YING-MING. *Instructions for Practical Living and Other Neo-Confucian Writings*. Translated by Wing-tsit Chan. (Records of Civilization: Sources and Studies, Columbia University, 68.) New York and London, 1963.
- WARNECK, JOHANNES GUSTAV. *Die Religion der Batak*. (Religions-Urkunden der Völker, ed. Julius Böhmer, Part IV, Vol. I.) Leipzig, 1909.
- WARREN, HENRY CLARKE. *Buddhism in Translations*. (Harvard Oriental Series, 3.) Cambridge, Mass., 1900.
- WEBER, ALBRECHT. *Indische Studien*. Vol. 9. Leipzig, 1865.
- WERNICKE, CARL. *Grundriss der Psychiatrie in klinischen Vorlesungen*. Leipzig, 1894–1900. 3 vols.
- WORRINGER, WILHELM ROBERT. *Abstraction and Empathy*. Translated by Michael Bullock. London, 1953. (Original: *Abstraktion und Einfühlung*. 3rd edn., Munich, 1911.)
- WULFEN WILLEM, VAN (pseud. of Willem van Vloten) *Der Genussmensch : Ein Cicerone im rücksichtslosen Lebensgenuss*. 3rd edn., Munich, 1911.

WUNDT, WILHELM. *Grundzüge der physiologischen Psychologie*. 5th edn., Leipzig, 1902/3. 3 vols. For translation, see: *Principles of Physiological Psychology*. Translated from the 5th German edn. by Edward Bradford Titchener. London and New York, 1904. (Vol. I only published.)

_____. *Logik*. 3rd edn. Stuttgart, 1906–8. 3 vols.

_____. *Outlines of Psychology*. Translated by Charles Hubbard Judd. 2nd revised English edn. Leipzig, London, and New York, 1902. (Original: *Grundriss der Psychologie*. 5th edn., Leipzig, 1902.)

_____. “Was soll uns Kant nicht sein?” In: *Philosophische Studien*. Edited by W. Wundt. Leipzig, 1883–1903. 20 vols. (VII, pp. 1ff.)

ZELLER, EDUARD. *A History of Greek Philosophy from the Earliest Period to the Time of Socrates*. Translated by S. F. Alleyne. London, 1881. 2 vols. (Original: *Die Philosophie der Griechen in ihrer geschichtlichen Entwicklung dargestellt*. Tübingen, 1856–68. 5 vols.)

ZÜNDEL, FRIEDRICH *Pfarrer J. C. Blumhardt: Ein Lebensbild*. Zurich and Heilbronn, 1880.

INDEX

A

abaissement du niveau mental, 123, 451

Abegg, Emil, 209n

Abelard, Peter, 39, 46–52, 63–64, 320

abstract, as idea, 411

abstracting: attitude of consciousness, and introvert, 91–93, 149, 184, 292–93

—, Buddhist, 294

type, 295–97

abstraction, 29, 409–11 (Def.)

from object in introvert, 48, 149, 292–95, 297, 325, 330

Worringer's concept, 289, 291–94, 504–6

Acta Sanctorum, 547

activity, and character, 148–49

Adam, 22

adaptation, 18, 158–59, 279, 285, 378, 420

and adjustment, 334f

as aim, 449

collective, 100, 298

by differentiated function, 106, 206, 330, 518, 536, 540

of extravert, 334–35

failure of, 471

individual systems of, 531

to inner world, 185, 442

by intuition, 145, 366

passive, 252

phylogenetic attempts at, 304

rapid, 275, 280

to reality/object, 63, 119, 145, 167, 185, 206, 252, 442

religion as, 185

adjustment, 334f

Adler, Alfred, 360, 379, 418–19, 422, 459, 502, 508–9

“guiding fiction” concept, 297, 418

theory contrasted with Freud's, 60–62

aesthetic: attitude, *see* attitude s.v.; condition, 137&n, 128
mood, 122–23, 127
types, 145, 151&n

aestheticism, 121&n, 141&n, 142–43

aesthetics, 140, 289–99, 505
and empathy, 289–92

affect (s), 239, 269, 274, 411–12 (Def.), 513–14
control of, 149
deliverance from, 199
differentiated, 159
and feeling, 462
inferiority of, 239, 273, 573
as instinctive process, 112, 144, 451
origin of, 471
Schiller on, 98, 101
symptom of disharmony, 89

affectivity, 101, 275, 412 (Def.), 508, 511
ego and, 90–91
extravert and, 90, 145, 158
of introvert, 149–50, 155, 159, 165
sensuousness and, 95, 97
and types, 149, 151; *see also* feeling-sensation

Africa, West, creation myth of, 217

Agni (fire), 203–4, 208–9&n, 210–11

aggressiveness, 397, 500

Ahasuerus legend, 268

alcoholism, 336, 340, 469

Alexandria, 14

All-oneness, 34, 36

altruism, 349, 549

ambitendency/ambivalence, 413, 424

Ambrose, St., 232–33

Ambrose, pseudo-, 232n

Amfortas, 70, 219–20

amnesia, 483

anaemia, 391

analysis, 62, 420, 473, 522, 528

ananda, 119, 218, 249

anarchism, 191

Anastasius I, Pope, 16

ancestral spirits, 141, 316

Angelus Silesius (Johann Scheffler), 256&n, 257&n

anima, 221, 223, 463, 467n, 467–72 (Def.); *see also* soul-image

anima naturaliter christiana, 13–14, 18

animals: battle of, in dreams, 407

and conscience, 179n

distinguished from man, 270, 308

love of, as compensation, 278

part of man's psyche, 213, 219, 270

symbol of crude strength, 269

as totem, 141, 316

without soul, 179

as union of opposites, 262

SPECIFIC ANIMALS: bird, 271

bull, 204, 209

cow, 204, 210

crocodile, 536

dragon, 263, 265, 460

goat, 230

horse, 208n, 211, 544

lamb, 185, 190

lion, 536

pig, 18

sheep, 230

whale, 263, 271

animus, 467n–468n, 470–72

Anquetil du Perron, A. H., 120

Anselm of Canterbury, 39–40, 42–43

Anthony, St., 54–56

anthropophagy, 28

Antinomians, 17

Antiphon of Rhamnos, 28

antiquity, 320, 542–43

chaos of, 76

Christianity and, *see* Christianity; and neurotic disturbances, 109
overvalued, 73, 82
paganism of, 186
psychology and, 8, 10
and Renaissance, 185
Schiller and, *see* Schiller s.v.

Antisthenes, 27–28, 33, 36

Antitactae, 17, 252

Anton, Gabriel, 418*n*

apocatastasis, 263, 271

Apollinian impulse, 137–46, 507
and dreaming, 138, 144, 506
reconciliation with Dionysian, 140–41

Apollo, 138–39, 141, 506–7

apperception, 412–13 (Def.)

approfondissement, 276, 280

a priori: foundations of unconscious, 400; *see also* idea(s) s.v.

Aquinas, St. Thomas, 42

archaic man in ourselves, 86

archaism, 413 (Def.)

archetype(s), 376–77, 381, 400–401, 413&*n*, 443 (Def.), 461 (*Urbild*)
Kant's term, 309, 438; *see also* engram(s); primordial image

Archontics, 17

Aristotle, 39

Arius/Arian heresy, 20–21

art: Apollinian/Dionysian, 137
mediating role of, 140
Oriental, 293–94
of present day, 393
of primitives, 293
and subjective factor, 393–94
western, 291

artist: as introverted intuitive type, 401
and abstract sensation, 462

asceticism, Christian, 207

Ass Festival (*Zarathustra*), 185

assimilation, 413–14 (Def.)

of object, empathy and, [290](#), [292](#); *see also* extraverted type s.v.

association(s), [274–78](#), [287](#), [546](#)

free, [423](#)

assonances, [274](#)

Astarte, [269n](#)

astrology, [525](#), [531–32](#)

Athanasius, St., Bishop of Alexandria, [54](#)

Atharva Veda, *see* Vedas

Athene, [176](#)

Phidias' statue of, [28](#)

Athens, [27–28](#)

Atlantis, [354](#)

atman/Atman, [118](#), [198–200](#), [215](#), [244](#)

Atreus, [27n](#)

Atrides, [137](#)

attitude(s) [414–17](#) (Def.)

abstracting, of consciousness, *see* abstracting; aesthetic, [107](#), [121](#), [142](#), [289](#)

collective, [10](#), [184–85](#)

—, undifferentiated, [184](#)

Epimethean, [179](#), [183–84](#)

negation as, [191](#)

Promethean ideal and abstract, [179](#), [183–84](#)

religion as, [185](#)

renewal of, [193](#)

-types, [330–31](#), [483n](#), [519](#), [540](#), [549](#), [554](#) (*see also* extraverted type; introverted type)

of unconscious, [337ff](#), [378ff](#), [520](#)

Augustine, St., [14](#), [22](#), [232–34](#), [514–15](#)

Australian aborigines, [30n](#), [255](#), [295](#)

autoerotism, [239](#), [374](#), [517](#)

Avenarius, Richard, [452](#)

Azam, C.M.É.E., [464n](#)

B

Baldwin, James Mark, [308](#), [434](#)

barbarism/barbarian side of man, [80](#), [96](#), [107–8](#), [111](#), [207](#), [213](#), [267–68](#)

untamed energy as, [100](#)

Barlach, Ernst: *Der tote Tag*, [252n](#), [259–60&n](#), [263](#)

Bartsch, Karl, [233n](#)

Bataks, [245n](#)

beauty: and its opposite, [84–87](#), [121](#)

and play instinct, [106–8](#)

(Schiller's concept) and aesthetic mood, [127–28](#)

as religious ideal, [121](#)

in western art, [291](#)

Behemoth, [184](#), [189n](#), [258](#), [263n](#), [269–71](#)

Bergaigne, Abel, [209](#)

Bergson, Henri, [215](#), [320–21](#), [453](#), [504](#)

Bhagavad Gita, [195n](#)

Bhagavata Purana, [196n](#)

Bible: O.T., [190](#)

Elijah, [234](#)

Exodus, [233](#)

Isaiah, [88n](#), [261–62&n](#), [263&n](#), [265&n](#)

Jeremiah, [54](#)

Job, [269](#)

Kings, [233](#)

Psalms, [230](#)

Song of Songs, [231–33](#), [240](#)

N.T.: Acts, [263](#), [430n](#), [432](#)

John, [261n](#)

Matthew, [230](#)

Philippians, [46](#)

Binet, Alfred, [501](#)

Binswanger, Ludwig, [412n](#)

biography, type problem in, [322–29](#)

birth: Buddha's, [178](#), [259](#)

Christ's, [234&n](#), [259](#)

divine, [189](#)

God's, [253](#)

of god, [265](#)

of hero, [469](#)

of saviour, [261–62](#), [265](#), [268](#)

of symbol, [263](#)

Bjerre, Paul, [277n](#)

Blake, William, [249n](#), [272](#), [332](#)
Bleuler, Eugen, [113](#), [411–12](#), [424n](#), [484](#)
bliss/ananda, see *ananda*
“blond beast” cult, [258](#)
Blumhardt, J. C., [547](#)
Bodhisattva, [178](#)
Boller-Schmid, Marie-Jeanne, [xii](#)
Bonaventure, St., [461n](#)
Borborians, [17](#)
Borges, Jorge Luis, [461n](#)
Bostonians, [314&n](#)
brahman/Brahman, [118–20](#)
 meanings of, [199n](#), [201](#), [203](#)
 and opposites, [195–99](#)
 and *rta*, [208](#), [215](#)
 and uniting symbol, [199](#)
Brahmanas: *Pañcavimsha*, [204n](#), [205n](#)
 Shatapatha, [199n](#), [201n](#), [203](#), [204](#), [205n](#), [209n](#)
 Taittiriya, [199n](#)
Brihadaranyaka Upanishad, see *Upanishads*
Buber, Martin, [31n](#)
Buddha, [268](#), [294–95](#), [481](#)
 birth of, see birth; “Fire Sermon,” [294](#)
Buddhism (-ists), [221](#), [247](#)
 and redemptive middle way, [194](#)
 Schopenhauer and, [136](#)
 Tibetan, [207](#)
Budge, E. A. Wallis, [235](#)
Burckhardt, Jakob, [377](#)
Burnet, John, [59n](#), [426n](#)
bushman, [239](#)

C

Calixtus I, Pope, [14](#)
Capuchins, [188n](#)
castration, Origen’s, see Origen
Celestius, [22](#)

Celtic mythology, [236n–237n](#)
Chalcedon, Council of, [21](#)
Chhandogya Upanishad, *see* Upanishads
child/children, [249](#)
 attitude of, and parental influence, [332](#)
 customs, [185](#)
 divine, [184](#), [270–71](#)
 extraversion in, [516–17](#)
 fantasies, [259](#)
 introversion in, [517](#)
 and parental complex, [124](#), [529–30](#)
 and parents' unlived lives, [183](#)
 wonder-, [259](#), [262](#), [268](#)
childlikeness, [262](#)
Chinese philosophy, [214–18](#)
choleric temperament, [324](#), [510](#), [531](#), [542](#)
Christ/Jesus
 birth of, *see* birth; as bridegroom, [232](#)
 and Dionysus, [186n](#), [188](#)
 duality of, [20–22](#)
 psychology of, [53](#)
 and Satan, [481](#)
Christian: education, [512](#)
 sacrifice, [16](#), [18](#)
Christianity, [545](#)
 and antiquity, [20](#)
 and collective culture, [71–73](#)
 as compensatory, [139](#)
 and conflict of functions, [76–77](#), [104](#), [186–88](#)
 and conversion, [17](#), [18](#)
 as extraverted, [120](#)
 and fantasy, [59](#)
 and individuality, [73](#)
 and knowledge, [11](#)
 medieval, [141](#)
 as psychological attitude, [185](#)
 and suppression of unconscious, [53–54](#)

and worship of woman, 235–37

Chu-hi school, 218

Chuang-tzu, 64

Church: Augustine on, 22
in Hermas' visions, 228, 230–31, 238
and Origen, 16
Tertullian and, 12, 14

churingas, 193, 295

circle, 460

civilization: archaic elements in, 96
and culture, 73&n, 284
errors of our, 404–5

classic type (Ostwald), 322–24, 327–29, 504

Cohen, Hermann, 439

collective, 417–18 (Def.)
element in man, 213
feeling, Epimetheus and, 175
idea(s), 220
—, God is, 110
mentality, primitive, 82 (see also *participation mystique*)
religious phenomena/worship, 125, 235–36
sensuous feeling is, 93
state, and identification with differentiated function, 100
thinking, 102; see also attitude; conscience; culture; ego; function; instinct;
unconscious collectivity, 10, 82

colour hearing, 113, 413

Columbus, Christopher, 532

Communion controversy: in ninth century, 23, 26
of Luther and Zwingli, 64–66

compensation, 418–20 (Def.)
and one-sided attitude, 19, 20
principle of, 175

complex(es), 226, 528–29
autonomous, 247–48, 528
collision of, 278
conflict, 277
erotic, 280

“over-valued,” 277n
parental, 124, 529–30
power, *see* power; sejunction of, 277
sexual, 206
unconscious, 109

compulsion(s), 93, 183, 407, 413
in extraverted intuitive type, 370
in extraverted sensation type, 365–66
neurosis, 281, 365, 370, 398, 403
one-sidedness of, 207
“of the stars,” 211–12

concepts, generic, 28–29, 32–34, 37–38

conceptualism, 47–49, 64, 321

concretism, 19, 24, 34, 39, 307, 420–21 (Def.)
in Communion, 65
of memory, 124

conscience: collective, 182, 189
of Epimetheus, 171–72, 179n, 184, 189, 266

consciousness, 421–22 (Def.)
abstracting attitude of, *see* abstracting s.v.; and assimilation of unconscious material, 115n
as discrimination, 112
emptying/empty state of, 117, 123–24
extravert’s attitude of, 333–34
introvert’s attitude of, 373–78
narrow intensive (Gross), *see* introverted type (Gross) s.v.; and Pandora’s jewel, 179
problematical state of, 511–12
shallow extensive (Gross), *see* extraverted type (Gross)
subjectivization of, 375–76, 378, 386, 388 (*see also* subjective factor); symbol and, 126
two attitudes of (Promethean and Epimethean), 183
and unconscious, *see* unconscious s.v.; undifferentiated, 123

constructive, 422–24 (Def.), 493; *see also* synthetic technique

consubstantiation, doctrine of, 65

cosmogony, 19

creation myth, 216f

creativity, Promethean, 174–75

Cripple Creek, [314&n](#)
cross, [186n](#), [460](#), [474](#)
cryptomnesia, [484](#)
culture: collective, [71–73](#)
 modern, [70–74](#), [107](#)
 —, and extraverted attitude, [373](#); *see also* civilization s.v.
Cumont, Franz, [234](#)
Cuvier, Georges, [383](#)
Cynics, [27–29](#), [34](#), [36](#), [282](#)
 proletarians among, [27](#), [36](#)
Cyrillian doctrine, [22](#)

D

Dante, [242](#)
 Inferno, [190n](#)
 Paradiso, [221–22](#)
Darwin, Charles, [313](#), [383](#)
Davy, Humphry, [324](#)
Decius, [16](#)
defensiveness, in neurosis, [279](#)
deliverance: and Greek mysteries, [140](#)
 Schopenhauer's doctrine of, [136](#)
demiurge, [91n](#)
demons/daemons, [109](#), [207](#), [226](#)
dependence, [93](#), [368](#), [378](#)
 on collective ideas, [220](#)
 on man, [87](#)
 on things, [249](#)
Dessoir, Max, [461n](#)
determinism, and James' typology, [316–17](#)
deus absconditus, [96](#), [253](#)
Deussen, Paul, [196n](#), [197n](#), [201&n](#), [203n](#), [209n](#)
devil, [270](#), [425](#)
 Epimetheus and, [184](#), [187](#)
devotion, [124–25](#)
“devouring” type (Blake), [272](#), [332](#)
diastole, [4–5](#), [143](#), [204](#), [213](#), [253](#)

differentiated type, 100
differentiation, 244, 424–25
 conscious, 112
 and deliverance, 110
 of functions, *see* function; of instinct, 239
 one-sided, 207
 —, of modern man, 86
 individual/psychological, of man/soul, 10, 60, 69, 71, 235
 of typical attitudes, 67
Diogenes, 27, 36
Dionysian impulse, 136–46, 507, 521–22
 as expansion, 143–44
 as intoxication, 138, 140, 144, 506
Dionysius the Areopagite, 42
Dionysus, 138–39, 141&n, 142, 186n, 188
Dioscuri motif, 204n
Diotima, 38
dissimilation, 316, 414 (Def.)
dissociation, 206, 383
 of basic functions, 74
 of conscious from unconscious, 126
 of differentiated and undifferentiated functions, 187
 inner, 62
 of personality, 298
distractibility, 274, 287
Docetism/ists, 11, 20–21
dogmatism, 318
dragon, *see* animals s.v.
dream(s)/dreaming, 31, 53, 419, 422, 429
 and Apollinian impulse, 138, 144, 506
 and unconscious functions, 407
Du Bois-Reymond, E., 322–23
durée créatrice (Bergson), 199, 215, 320
dvandva, 195
dynamis, 252, 254–55, 258, 262, 265, 269–70
Dyophysites, 21–22

E

earth, virgin as, [234](#)

mother, [244](#)

Ebbinghaus, Hermann, [414](#)

Eberschweiler, Adolf, [274](#)

Ebionites, [20–21](#)

Ecclesia, *see* old woman; *see also* Church

Eckhart, Meister, [120](#), [242](#), [245–48](#), [250–53](#), [254–57](#), [270](#)

“Écrasez l’infâme,” [185](#), [190](#)

education, [83](#), [86](#), [123](#), [404](#), [449](#)

ego, [425](#) (Def.)

abstraction and conservation of, [91](#)

and collective, [90](#)

detachment from, [102](#)

explosion of, [138](#)

-function, conscious, [90](#)

introvert and, *see* introverted type; -psychology, Adler’s, [60](#)

and self, [114n](#), [376–77](#)

and unconscious subject, [391](#)

egocentric feeling, [388](#)

egocentricity, [182](#), [378](#)

egocentrism of unconscious in extravert, [337–39](#), [341](#)

egotism, [213](#), [393](#)

Egypt, [234–35](#)

negative confession in, [544](#)

“élan vital,” [320](#), [504](#)

Eleatic principle of “being,” [34](#)

Elijah, [234](#)

emotion, fluctuations of, [197](#)

empathetic type, [295–97](#)

empathy, [289–94](#), [425](#) (Def.), [504–5](#)

as extraversion, [290](#), [293](#)

introvert’s lack of, [327–28](#)

into individual object, [48](#), [289–90](#), [292–93](#), [295](#), [297](#), [303](#), [305–6](#), [316–17](#)

Empedocles, [542](#)

empiricism, [307](#), [311](#)

empiricist type (James), 300, 306, 310, 315–17
enantiodromia, 96, 184, 269, 425–26 (Def.), 470
Encratites, 17, 252
energetic tension, 210
energetic value(s): of conscious contents, 112–13
 depotentiation of, 123
 of relations to object, 119
energy, 33
 accumulation of, 19, 243
 daemonic, 188
 discharge of, 273–74
 laws of, 86
 nature of, 29
 and pairs of opposites, 202
 and primordial instinct, 338
 psychic, *see* libido; release of, 210, 219, 231, 259
 Schiller on, 103
 of unconscious elements, 112, 114
 untamed, 100
engourdissement, hysterical, 123
engram(s), 169, 239, 243, 444; *see also* archetype(s); primordial image
Enkekalymmenos (veiled man) fallacy, 31
enlightenment, 185
 Age of, 79, 186, 307, 546
envy among Megarians, 28
Epicurus, 13
Epimeleia (Care), 180, 183
Epimethean attitude, 179, 183–84
 function, 352
 mentality, 189–90
 principle, 187
 thinking, 357
Epimetheus, 269–70, 334, 335
 conscience of, *see* conscience; as extraverted type, in Spitteler, 166, 170–73
 Goethe on, 175, 180–83, 184–85, 186–87
 as introverted type, in Goethe, 182
 and jewel symbol, 260

erection, [240](#)
Eros, [229](#)
eroticism: and Christianity, [232](#), [237](#)
 and Prometheus legend, [183](#)
Eskimos, [508](#)
Eubulides, [31](#)
Euclides of Megara, [34](#)
Eusebius, [15n](#)
evangelical principle, [65–66](#)
Evans, C. de B. (trans.): *Meister Eckhart*, [242n](#), [245n](#), [246n](#), [250n](#), [251n](#), [253n](#), [254n](#),
 [255n](#), [270n](#)
Eve, [188](#)
evil, [218](#), [264](#), [271](#)
 Christian rejection of, [186](#)
 goats as image of, [230](#)
 “non-existing,” [34](#)
 pact with, [184](#), [189](#)
externalization (Jodl), [290&n](#)
extraversion, [271](#), [285](#), [427](#) (Def.), [534–35](#), [549–50](#)
 and aesthetic standpoint, [145](#)
 in children, [516–17](#)
 empathy and, *see* empathy s.v.; of feelings, [144](#)
 and Freudian theory, [62](#)
 hysterical, [501](#)
 inferior, [102](#)
 introjection of, [452](#)
 and introversion, [4](#), [6](#), [52](#)
 and Luther’s doctrine, [66](#)
 among mystics, [31](#)
 and object, [4](#)
 —, differentiation of relation to, [144](#)
 and pluralism, [318](#)
 regressive, [500](#)
 vac and, [205](#)
extraverted attitude, [333](#)
 and suppression of subjective factor, [335](#), [337](#)
extraverted feeling type, *see* feeling s.v.

extraverted irrational types, 370–73
extraverted rational types, 359–62
extraverted thinking type, *see* thinking type s.v.
extraverted type: adjustment of, 334–36
 Cynics and Megarians as, 36
 Epimetheus as, in Spitteler, 166, 171, 173
 ethics of, 549
 fantasy life of, 150
 Goethe as, 68, 92, 94&n, 173, 183
 hysterical fantasies of, 183
 and introvert, 164
 —, complementary, 160
 and Jordan's typology, 148–151, 152–53, 156–63, 172, 276, 280n
 of man, 160–63
 and object, 4–5, 51, 93, 102, 150, 162, 330, 517, 533, 553
 —, assimilation to, 4, 316–17, 337–38, 355, 357 (*see also* assimilation s.v.)
 —, in consciousness, 333–34
 —, danger of surrender to, 4, 171, 336
 —, empathy with, *see* empathy s.v.
 —, in feeling function, 354–55
 —, identification with, 297, 317
 —, projection of contents into, 296, 324–25 (*see also* empathy)
 —, projection of idea into, 311
 —, relation to, as superior differentiated function, 98
 —, in thinking function, 344–45, 382
Origen as, 16
poet as, 130, 131
programmatically thinking of, 25
Prometheus as, in Goethe, 182–83
psychoanalysis and, 62
 and reason/rational concepts, 310
 and romantic type, 324–25, 328–29
social usefulness of, 157–59, 161
of woman, 156–60; *see also* affectivity; feeling; functions; sensation; thinking with
 short secondary function/shallow extensive consciousness (Gross), 275–76, 280,
 282, 284, 288, 508

F

fairytales, [305](#), [460](#)

fantasy (-ies), [52–53](#), [427–33](#) (Def.)

creative, [57–59](#), [107](#), [109](#), [115](#), [117](#)

infantile, [63](#)

as mediating products, [52](#), [61](#)

unconscious, [106](#), [115](#), [212](#)

Faraday, Michael, [324](#)

father divinities, [124](#)

Faust, [58](#), [187–88](#), [206–7](#), [481](#); *see also* Goethe: *Faust*

fear, [292](#), [296](#)

“first brought gods into world,” [291](#)&*n*

lack of, in extravert child, [516](#)

of people, [278](#)

of women, [387](#)

feeling, [433–36](#) (Def.)

and extraverted attitude, [354–56](#)

function, [6](#), [518](#), [553–54](#)

—, inferior, of extraverted intuitive type, [368](#)

—, inferior, of extraverted thinking type, [348–50](#)

and introverted attitude, [387–88](#)

personal, [36–38](#)

in Schiller, [79](#), [97](#)

-sensation, [97–102](#), [106](#), [144](#), [435](#) (*see also* affectivity); specific content of feeling function, [436](#) (Def.)

and thought, as opposites, [58–59](#)

-toned idea, [145](#)

feeling type, [6–7](#), [11](#), [68](#), [145](#), [519](#), [537–38](#)

and Christianity, [11](#)

extraverted, [98](#), [283](#), [340](#), [356–62](#)

—, intuitive, [94](#)*n*

introverted, [98](#), [149](#), [388–91](#)

Jordan on, [147](#)

Féré, Charles S., [412](#)*n*

Ferenczi, Sandor, [452](#)

Ferrero, Guglielmo, [473](#)

fertility symbols, [234–35](#)

fetishes, [193](#), [244](#), [295](#), [420](#)

Fichte, I. H. von, [40–41](#)

Ficino, Marsilio, [109n](#)

field: virgin as, [234](#)

treasure in, [250](#)

Finck, F. N., [507](#)

fire, [203&n](#)

Buddha's sermon, [294–95](#)

of Prometheus, [184](#), [186](#)

-boring, [209–10](#)

flatus vocis, [26](#), [39](#), [44](#), [49](#)

Flournoy, Théodore, [270n](#), [302](#), [464n](#), [484n](#), [547](#)

formal instinct (Schiller), [99&n](#)

four(th): elements, [542](#)

functions, *see s.v.*; temperaments, [10](#), [542](#); *see also* quaternity

France, Anatole, [26](#)

freedom: man's moral, [22](#)

of personality, [77](#)

French Revolution, [78–80](#), [186](#), [487](#)

Freud, Sigmund, [60–62](#), [63n](#), [280](#), [290](#), [339](#), [360](#), [422](#), [424](#), [430](#), [459](#), [463](#), [472](#), [477](#),
[484](#), [499n](#), [500–1](#), [508–9](#), [530](#), [547](#)

on incest, [124](#)

letter to, [443n](#)

The Interpretation of Dreams, [422n](#)

The Psychopathology of Everyday Life, [477n](#)

Frobenius, Leo, [263](#)

function(s), [436–37](#) (Def.)

auxiliary/secondary, [405–7](#)

collective, [75](#), [182](#)

—, sensation and thinking as, [110](#)

differentiated/primary, [58](#), [106](#), [264](#), [405](#), [518](#), [520](#)

—, of extravert, [340](#)

—, identification with, [72](#), [100–101](#), [206–7](#), [298–99](#), [440](#)

—, and suppression of inferior functions, [63](#), [69–70](#), [72](#), [74](#), [104](#)

—, in harmony/unity with undifferentiated, [86](#), [179](#), [186](#), [281](#)

differentiation of, and culture, [70–73](#), [75](#), [83](#)

directed/valuable, [298–99](#)

four basic psychological/orienting, [6](#), [11](#), [19](#), [518](#), [553–54](#)
—, and extravert, [337](#), [342](#), [523](#)
—, and introvert, [523](#)
God as, *see* God; inferior/repressed/undifferentiated/archaic, [95–96](#), [109](#), [450–51](#),
[520–21](#), [540](#)
—, of extravert, [102](#), [340–41](#)
—, of extraverted thinking type, [348–49](#)
—, need to develop/accept, [74–77](#), [86](#), [263](#), [299](#)
—, and symbol, [267](#)
—, and the unconscious, [106](#), [298–99](#) (*see also* feeling s.v.; thinking s.v.); mediating,
[105–6](#)
opposition between, [106–8](#), [193](#)
primary and secondary (Gross), [273–76](#), [278](#), [280–88](#), [508](#)
religious, *see* religious s.v.; self-regulating, [218](#)
-types, [68](#), [149](#), [330](#), [482](#), [540](#) (*see also* feeling type; intuitive type; sensation type;
thinking type)
—, and extravert, [68](#), [149](#)

G

Galen, [510–11](#), [542](#)
Gall, F. J., [525](#)
Garuda Purana, [197n](#)
Gaunilo, [40](#), [43](#)
Gauss, V. F., [328](#)
Generic concept, *see* concepts
genius, [192](#)
German classicists, [73](#)
Gesangbuch der evangelisch-reformierten Kirchen ..., [260n](#)
ghosts, primitive's belief in, [30](#)
Gilgamesh epic, [207](#)
Glover, A.S.B., [223n](#), [232n](#)
Gnosis, [11–14](#), [16–17](#)
Gnostic(s)/-ism, [16–17](#), [207](#), [235](#), [241–42](#)
and Christianity, [11](#), [20](#), [54](#)
and divine harlot, [188](#)
schools of, [17](#), [252](#)
vessel symbolism, [234](#), [236–37](#)

God: childhood relations with, 124

-concept, 46

as function, 243

and Godhead, 254

-image, 189, 243

—, symbolization and, 124–25

only individual, 39

ontological proof of, 40

Prometheus and, 177, 179

-redeemer, 177

relativity of, to man, 242–45, 256

renewal, 193–94

Schiller's view of, 91

and soul, 249–50, 253–54

and symbol, 184

as value, 246, 248

within us, 218

god(s), 192–93, 259

belief in, 30

Celtic, 236n, 237n

goddess(es), 226, 235

sun-, 259

Godfrey, Prior of St. Swithin's, 50n

godlikeness, 94

of conscious and unconscious attitudes, 96

of Prometheus, 176–77

Goethe, Johann Wolfgang von, 136, 221, 252n, 353, 425

as extraverted (feeling) type, 68, 92, 94&n, 173, 183

principle of systole and diastole, 4–5, 143

and problem of redemption, 188

and Schiller, 68, 79, 92

Briefwechsel mit Schiller, 79n, 92n, 93n, 94n

Faust, 50, 79, 125&n, 136, 187, 192–94, 221, 476n

Faust, Part One (trans. Wayne), 217&n

—(trans. McNeice), 476n

Faust, Part Two (trans. Wayne), 222–23&n

“Geheimnisse,” 186n

“Pandora,” [180&n](#), [181n](#), [182–83](#), [187–88](#)
“Prometheus Fragment,” [173–74&n](#), [175n](#), [187–88](#)
Golden Age, [83–84](#)
Gomperz, Theodor, [29](#), [32](#), [33](#), [35](#)
 Greek Thinkers, [28n](#), [29n](#), [32n](#), [34n](#), [35n](#), [36n](#), [426n](#)
Görres, Johan Joseph von, [547n](#)
“Gracious One” (*vena*), [199](#)
Grail, [219&n](#), [220](#), [236](#), [237&n](#), [241](#)
graphology, [525](#)
Greek(s): character, dichotomy of, [545](#)
 —, Nietzsche on, [136–37](#), [139–40](#)
 mysteries, [83n](#) (*see also* Orphic mysteries; Pythagorean mysteries)
 philosophy, [15–16](#) (*see also* Cynics; Megarians; Platonic ideas; Sophism); and
 moderns, contrasted, [71](#), [73](#)
 tragedy, [141](#)
Gretchen, [187–88](#), [222](#)
Griffith, Ralph, H. T., [203n](#)
Gross, Otto, [273–77](#), [279–86](#), [418n](#), [508](#)
 Über psychopathische Minderwertigkeit, [273n](#), [277n](#), [286n](#)
 Die zerebrale Sekundärfunktion, [273](#), [280n](#), [282n](#), [283n](#), [286n](#), [508n](#), gypsies, [188n](#)

H

hallucination(s), [30–31](#)
 among primitives, [30](#), [152](#)
 Socrates and, [146](#)
harlot, divine, [188](#)
Harnack, Adolf von, [15](#)
Hartmann, Eduard von, [168](#), [461n](#)
Hase, Carl August von, [23](#)
Hegel, G.W.F., [41](#), [45](#), [320](#), [438](#), [502](#)
heimarmene, [22n](#), [211](#)
Heine, Heinrich, [2](#)
Helen, [125](#), [187–88](#), [222](#)
Helios, King, [76](#)
Helmholtz, H. von, [322–23](#), [327](#)
Héloïse, [46](#)
Hephaestus, [176](#), [181](#)

Heraclitus, [59n](#), [96](#), [425–26](#)
Herakles, [260](#)
Herbart, Johann Friedrich, [113](#), [308](#)
heresies, [20–21](#), [54](#), [236–37](#), [241](#), [252](#)
Hermas: *Shepherd*, [224&n](#), [225](#), [227–31](#), [229n](#), [231](#), [238](#)
hermeneutics, [15](#)
hero: birth of, [469](#)
 myth, [260](#), [263](#)
Hippocrates, [510](#)
historical approach, [141–42](#)
Hoch, August, [501](#)
Höffding, H., [434](#)
Hoffmann, E.T.A., [252n](#)
Hölderlin, J.C.F., [264](#)
Holstein-Augustenburg, Duke of, [67](#)
Holy Ghost, [271](#)
Homer, [130](#), [506](#), [544n](#)
 Odyssey, [40](#)
homoousia and *homoiousia*, [20–22](#)
homosexuality, [471](#)
Horus, sons of, [520](#)
Hume, R. E. (trans.): *The Thirteen Principal Upanishads*, [196n](#), [197n](#), [198n](#), [200n](#),
 [201n](#)
hylikoi/hylic man, [11](#), [152](#), [545](#)
Hypatia, [108](#)
hypertrophy of function, [70](#)
hypnosis, [202](#), [372](#), [483](#)
hysteria, [336](#), [359](#), [499–501](#)
hysterical: *engourdissement*, [123](#)
 fantasies, [183](#)

I

idea(s), [437–39](#) (Def.)
 a priori/ante rem existence of, [304](#), [310–11](#), [317](#), [318](#), [437](#), [446](#)
 and changelessness, [97](#)
 depersonalized, [36](#)
 feeling-toned, [145](#)

flight of, 287
as higher reality, 40
hypostatizing of, 43
introvert's relation to, 68, 381, 383–85
over-valued, 277&n
and thing united, 49, 51
unconscious activation of, and idealism, 313–14, 317
unity of, 99–100

ideal: cultural, 73
heroic, 104
Zwingli's doctrine and, 66

idealism, and James' typology, 312–14, 317

idealistic type, 41
Schiller on, 68, 133–35

identification, 440–41 (Def.)
with differentiated function, *see* function; mystical, 295

identity, 441–42 (Def.)

ideologism, 307, 311–12

image(s), 442–47 (Def.)
mythological, 169–70
Plato on, 304
primordial, *see* primordial image; psychic realism of, 30
soul-, *see* soul s.v.

imagination, principle of, 62–63

imago, 473 (Def.)
parental, *see* parental imago; primitive, 29
primitive reality of, 31

imitatio Christi, 316

Immanuel, 265

imprints, *see* engrams

incest: repression and, 124
-wish (Freud), 339

India, religious philosophy of, 119–21

individual, 447–48 (Def.)
nucleus, 108, 109, 114n (*see also* individuality); and social function in conflict, 81

individualism, 104&n, 221, 258

individuality, 448 (Def.)

dissolution/obliteration of, 138–39
—, into collective function, 110
—, into pairs of opposites, 108–9
and functions, 74
of observer, 10
psychological development of, 115
and self, 114*n*
suppression of, 82
synthesis of, 281
violated in Christianity, 73

individuation, 104*n*, 448–50 (Def.), 507

inertia, psychic, 185

infantile fixations, 61

infantilism, 326

inferior function, 450–51 (Def.); *see also* function(s) *s.v.*

inferiority: introvert's feeling, 93, 183
 psychopathic (Gross), 273, 508

inherence, principle of, 29, 33, 34–38

initiation of Mohammedan mystic, 31

Inouye, Tetsujiro, 218

Inquisition, 236

instinct(s), 376, 451 (Def.)
 collective, 81, 138
 conflict of, 78
 differentiation of, 239
 formal (Schiller), 99&*n*
 Freud's psychology of, 60–61
 primordial, 338
 sensuous (Schiller), 96–97

intellect, 452 (Def.)
 in Schiller, 87–88, 116
 and science, 57–59; *see also* thinking, directed

intellectualism, 146
 in James' theory, 301, 311

intoxication and Dionysian impulse, 138, 140, 144, 506

introjection, 452 (Def.)
 of conflict with the object, 89

introversion, 271, 285, 452–53 (Def.), 505, 534–35, 550–52

and Adler's psychology, 62

and aesthetic standpoint, 145

Apollinian, 144

artificial, 31

in children, 517

of energy, 114

of libido, 119, 183

manas and, 205

and monism, 318

regressive, 500

and relation to ideas, 144

and subject, 4–5

and *tapas*, 118

into unconscious, 117

introverted attitude: and feeling, *see* feeling s.v.

and intuition, *see* intuition s.v.; negation as, 190–91

introverted feeling type, *see* feeling type s.v.

introverted ideal state, “godlikeness” of, 91

introverted intuitive type, *see* intuitive type s.v.

introverted irrational types, 403–5

introverted rational types, 391–93

introverted sensation type, *see* sensation type s.v.

introverted thinking, *see* thinking s.v.

introverted thinking type, *see* thinking type s.v.

introverted type: abstracting attitude of consciousness in, *see* abstracting s.v.; and

classic type (Ostwald), 322–24, 327–29

and ego, 90–91

and functions, 281

and function-types, 68, 149

with prolonged secondary function/narrow intensive contracted consciousness
(Gross), 276, 278, 281–84, 288, 508

ideal of, 95

impoverishment of, 92–93

inferiority feelings in, 93, 183

and Jordan's typology, 148–56, 162–65, 280

Kant as, 313, 383

and object, 93, 317, 378–79, 396–97, 517 (*see also* abstraction s.v.)
—, identity with sensed, 102
—, negative relation to, 383–84, 533
Plato as, 36
poet as, 130, 133
Prometheus as, in Spitteler, 166, 170, 173
psychoanalysis and, 62
rational thinking of, 25
Schiller as, 68
Scotus as, 25
Spitteler as, 173
and unconscious fantasy, 106
 woman, 153–56; *see also* affectivity s.v.
intuition, 320–21, 453–54 (Def.), 538–39

as basic psychological function, 6, 518, 553
in extraverted attitude, 366–68
in introverted attitude, 398–401
Nietzsche and, 146
and object, 133
in Schiller, 69, 79
intuitive type, 6, 68, 145–46, 151n, 519
 extraverted, 368–70
 extraverted feeling, 94n
 introverted, 401–3
 introverted thinking, 94n, Jordan on, 147, 152
 Nietzsche as, 146
irrational, 454–55 (Def.), 539
 types: extraverted, 370–73
 introverted, 403–5
Isha Upanishad, see *Upanishads*
Isis and Osiris, 234–35
Islands of the Blessed, 40, 43

J

Jacobi, Jolande, 413n
James, William, 300–21, 344, 501–3, 547
 Pragmatism, 300n, 314&n, 315n, 502n, 503n
 Principles of Psychology, 481n
James-Lange theory of affect, 412
Janet, Pierre, 123, 428, 451, 546
Jehovah, 231, 259, 269
Jerome, St., 234
Jerusalem, Wilhelm, 308
jewel, motif/symbol, 177&n, 178–79, 181, 184, 189n, 258–60, 266–70
Jews, persecution of, 268
Jodl, Friedrich, 289–90&n
Jordan, Furneaux, 147–65 *passim*, 172, 276, 280, 324, 490
 Character as Seen in Body and Parentage, 147, 153–72 *passim*
Judaism, 185
judging types, see rational types
Julian, “the Apostate,” 76, 91n

Jung, C. G.:

CASES: Negro psychotics with classical dream-motifs, 443&n, 491

printer, whose business was ruined, 339

Swiss clerk, with vision of solar phallus, 491&n

WORKS CITED: "The Aims of Psychotherapy," 433n

Aion, 235n

Analytical Psychology: Its Theory and Practice, 433n

Collected Papers on Analytical Psychology, 6n–7n, 483n, 499n

"Commentary on *The Secret of the Golden Flower*," 461n

"The Concept of the Collective Unconscious," 491n

"Concerning Mandala Symbolism," 461n

"The Content of the Psychoses," 176n

"A Contribution to the Study of Psychological Types," 6n, 483n, 499&n

"Cryptomnesia," 484n

"Flying Saucers," 38n

"Instinct and the Unconscious," 376n, 443n

letters, xiin, 443n

Memories, Dreams, Reflections, 544n

Mysterium Coniunctionis, 433n, 461n

"On the Importance of the Unconscious in Psychotherapy," 419n

"On the Nature of the Psyche," 433n

"On Psychic Energy," 245n, 455n

"On Psychological Understanding," 63n, 493n

"On the Psychology and Pathology of So-called Occult Phenomena," 422n, 464n,
484n

"On the Psychophysical Relations of the Association Experiment," 412n

The Practice of Psychotherapy, 73n

Psychiatric Studies, 425n

"A Psychological Approach to the Dogma of the Trinity," 461n

"The Psychological Aspects of the Kore," 234n

"Psychological Aspects of the Mother Archetype," 38n

Psychology and Alchemy, 271n, 461n, 468n, 520n

"The Psychology of the Child Archetype," 262n

"The Psychology of Dementia Praecox," 422n, 425n, 426n

Psychology and Religion: West and East, 461n

Psychology of the Unconscious, 20n

"The Psychology of the Unconscious Processes," 6n, 115n, 483n

“A Review of the Complex Theory,” 206n, 422n
“The Structure of the Psyche,” 38n, 491n
“The Structure of the Unconscious,” 7n, 114n, 115n, 483n
Studies in Word-Association, 112n, 274n, 408n
“A Study in the Process of Individuation,” 461n
Symbols of Transformation, 20n, 113n, 124n, 177n, 183n, 199n, 200n, 202, 203n,
204n, 210n, 212n, 220, 234n, 263n, 265n, 268n, 269n, 271n, 298n, 377n, 413n,
443n, 455n, 481n, 491n, 493n
“Synchronicity: An Acausal Connecting Principle,” 454n
“The Tavistock Lectures,” 336n, 433n, 443n
“The Theory of Psycho-analysis,” 454n
“The Transcendent Function,” 115n, 252n, 433n
“Transformation Symbolism in the Mass,” 38n
Two Essays on Analytical Psychology, 6n–7n, 63n, 104n, 114n, 115n, 167n, 176n,
422n, 433n, 465n, 468, 483n, 493n
Wandlungen und Symbole der Libido, 20, 443n
Juno Ludovici, 123, 125
Justinian, 16

K

Kant, Immanuel, 41, 43–45, 120, 304, 309, 313, 317, 383, 401, 411, 438, 446
Critique of Practical Reason, 45&n
Critique of Pure Reason, 43n, 44n, 45n, 438n, 477n
Logik, 309n, 411n, 438n
Katha Upanishad, see Upanishads
Kaushitaki Upanishad, see Upanishads
Keratines (horned man) fallacy, 32
Kerner, Justinus, 547
King, Charles William, 234
Klingsor, 219
knowledge: Gnosticism and, 11, 13
“psychologized,” 10
Köhler, H.K.E. von, 234
König, Friedrich Eduard, 268n
Kore, 234
Kretschmer, Ernst, 525, 548
Krishna, 195n

Kubin, Alfred, [382](#)
Kulluka, [195](#)
Külpe, Oswald, [414](#), [434](#)
Kundry, [219](#)

L

Lalita-Vistara, [178&n](#)
Landmann, S., [464n](#)
language: structure, [507–8](#)
 unconscious contaminations in, [112](#)
Lao-tzu, [64](#), [118](#), [120](#), [214–15](#), [217](#)
Lasswitz, Kurd, [438](#)
Lateran Council (1215), [64](#)
Lavater, J. K., [525](#)
Laws of Manu, [195&n](#)
Left extremism, [191](#)
Lehmann, Alfred, [434](#)
Leviathan, [263&n](#), [269](#), [271](#)
Lévy-Bruhl, Lucien, [10](#), [82](#), [131](#)
 How Natives Think, [417n](#), [418n](#), [456n](#)
libido/psychic energy, [5–6](#), [46](#), [177](#), [194](#), [207](#), [212–13](#), [455–56 \(Def.\)](#), [503](#)
 accumulation of, [288](#)
 and Brahman concept, [201–3&n](#), [204–5](#)
 and Christianity, [20](#), [237](#)
 as creative dynamism, [139](#)
 damming up of, [89](#)
 detachment of, from object, [114–16](#), [118](#), [238–39](#), [250](#), [253](#)
 and energy, [287](#)
 freed from unconscious by symbol, [259](#), [263](#)
 God and, [179](#)
 as *heimarmene*, [22n](#), introversion of, [119](#), [186](#), [250](#)
 invested in unconscious, [264](#)
 and meditation, [118](#)
 operating from the unconscious, [131](#)
 in Parsifal, [219–20](#)
 and primordial, [125](#)
 of Prometheus, [177](#)

release of, [210&n](#)
sinks into the unconscious, [115](#), [124](#), [237](#), [253](#)
split in, [194](#)
symbols, *see* symbols; withdrawal of, from unconscious, [57](#)
Liebig, Justus von, [324](#)
linguistics, [507](#)
Lipps, Theodor, [289–91](#), [308](#), [413n](#)
Litany of Loreto, [223](#), [230](#), [232](#), [235](#), [240](#)
Logos, [207](#)
 as mediator, [64](#)
 universals and, [39](#)
Long, Constance, [147](#)
Lotze, Rudolf Hermann, [41](#)
Lully, Raymund, [426&n](#)
Luther, Martin, [64–66](#), [481](#)
Lyra Germanica, [260n](#)

M

Maeder, Alfons, [422](#)
magic/magician, [31](#), [187–88](#), [226](#), [295](#), [365](#), [380](#), [387](#)
 cauldron, [236n](#)
Magna Mater, [235](#)
Mahabharata, [196n](#)
Mammaea, [15](#)
man: in opposition to himself, [108](#)
 two halves of, [187](#)
 as work of art, [139](#)
manas (mind), [204–5](#), [207](#)
manic-depressive insanity, [508](#)
Manuscript: Bodleian Library, Ms Digby (65), [50n](#)
marriage, [517–18](#)
Mary, [188](#), [232–36](#)
 as Christ-bearer, [22–23](#); *see also* Mother of God; Virgin
Mater Gloriosa, [188](#)
materialism, [353–54](#), [543](#), [546](#)
 and James' typology, [312–13](#)
 and spiritualism, [41–42](#), [168](#)

materialistic mentality, 346
Matter, Jacques, 234n
Matthew, St., 53
Maya, 178
Mayer, Robert, 323–24
Mechtild of Magdeburg, 232
mediatory condition, 127–28
medicine-man, 244
medievalism, 8, 187
meditation, 118
Megara, 28
Megarian school of philosophy, 27–29, 31, 34, 36, 282
Meisterlieder der Kolmarer Handschrift, 233&n
melancholic temperament, 324, 510, 531, 542
melancholy, 279
memory-complexes, 124
memory-image of primitives, 30
Mephistopheles, 187, 206–7, 353
Messiah, 194
Messianic prophecies, 261
Messias (Spitteler), 271
Meyrink, Gustav, 252n, 382
 The Golem, 126
 Das grüne Gesicht, 126, 382n
microcosm, man as, 217
Middle Ages, 109, 232
middle path/way, 194, 212–14
Migne, J.-P.: *Patrologia Latina*, 232n, 235n, 234n
Minerva, 173, 174, 180
“misautic” attitude (Weininger), 375
Mitra (sun-god), 209
mneme (Semon), 376
Moleschott, Jacob, 353, 421
Molla-Shah, 31
Moltzer, Mary, 454n
monism, 301, 318, 421
Monophysites, 21

Montanus/Montanism, 14
morality, 212–13
 of intuitive type, 368
Moses, 232
mother/Mother(s): divinities, 124
 dragon, 263
 of God, 221–22 (*see also* Mary; Virgin); of the gods, 91&n
 Heavenly, 187
motif(s): Dioscuri, 204n
 of god's renewal, 259
 of "mother dragon," 263
 of rebirth, *see* rebirth
Müller, G. E., and Schumann, F., 414
Muratori Canon, 224
mysteries: Greek/Dionysian, 83n, 141
 Orphic, 544
mystics/mysticism, 31, 255
 German, 242, 244
 Pythagorean, 39, 544–45
myth(s)/mythology, 120–21, 212, 253, 307
 "brain," 285, 306
 Celtic, 236n, 237n, classical, 186
 seasonal and vegetational, 194, 444
 West African, 217; *see also* hero
mythological motifs, 169, 381

N

Nahlowky, Joseph Wilhelm, 410, 434n
naïve poet (Schiller), 130–34, 137, 506
Napoleon Bonaparte, 78
narcotics, abuse of, 340
Natorp, Paul, 421n
naturalism, 212–13
nature: and culture, 87–88
 poet and, 130–32
negation, 190–91
Negro(es), 443&n, 491, 544

psychology of, 30
Neoplatonic philosophy, 15–16, 91, 109, 320
Nepalese, magical powers of, 188n
Nestorius/Nestorian Church, 22–23
Neumann, Erich, 263n
neurosis/nervous breakdown, 415, 420, 549
 choice of, 530
 of extraverted type, 336, 339–40, 348
 of introverted type, 391; *see also* compulsion; hysteria; psychasthenia;
 psychopathology
neurotic patients, 126
Nicolaitans, 17
Nicoll, Maurice, 237n
Nietzsche, Friedrich, 26, 71, 95–96, 128, 136–46, 211, 241, 252n, 320–21, 378, 383,
 421, 425, 427, 506–7, 545
 and introversion, 144, 146
 “An Attempt at Self-Criticism,” 142
 The Birth of Tragedy, 136, 137n, 138n, 139n, 142, 146, 507n
 The Joyful Wisdom, 211n
 Thus Spake Zarathustra, 96, 142, 146, 185, 190–93, 320, 481, 544
 “The Use and Abuse of History,” 142n
nirdvandva, 195, 219
nominalism: classical, 26, 28, 32–33, 35–36, 49
 medieval, 47–51
 and realism, 26, 33, 36, 39–40, 47–48, 50, 282, 320
 and tough-minded, 302
“nothing but” type of thinking, 187, 353, 359, 503
Nous, 207
number, Apollo and, 138
numinal accent, 533–54
Nunberg, Hermann, 112n
Nutt, Alfred, 237n

O

Obatala and Odudua, 217
object: and collective values, 189
 conflict with, 89

dynamic animation of, [294](#), [297](#)&*n*, extraverted cultural ideal and, [73](#)
Freudian psychology and, [61](#)–[62](#)
Luther-Zwingli controversy and, [66](#)
naïve or sentimental poets and, [130](#)–[34](#)
nominalism and, [50](#)
spell/magical power of, [226](#)–[27](#), [295](#), [365](#), [379](#)–[80](#)
and subject, identity of, [238](#)–[39](#)
subjection to, [246](#)
yoga and, [119](#); *see also* abstraction; empathy; extraverted type; introverted type, *ss.*
 vv.

objective: level, [456](#) (Def.)
 psychology, [8](#)–[10](#)
 and subjective, confused, [30](#)

obsessive ideas, [359](#)

Ocampo, Victoria, [xv](#)

Occam's razor, [41](#), [494](#)*n*

Oedipus, [28](#)

Old Kule (Barlach), [259](#), [263](#)

old woman/Ecclesia, [228](#)–[29](#), [231](#), [238](#)

Oldenberg, Hermann, [209](#)*n*

Om mani padme hum, [178](#)

one-sidedness, [74](#), [80](#), [207](#)–[8](#), [226](#), [337](#), [415](#)–[16](#), [519](#), [522](#)

Onians, Richard Broxton, [544](#)*n*

ontological argument, [40](#)–[45](#)

opposite(s), pairs of: beauty and, [84](#), [121](#)
 Brahmanic view of, [195](#)–[99](#)
 cancellation of, [117](#)
 conflict of, [213](#), [217](#)
 detachment from, [123](#)
 dissolution of individuality into, [108](#)–[9](#)
 energy and, [202](#)
 liberation/deliverance/release from, [118](#), [194](#)–[95](#), [199](#), [216](#)
 mediation between, [115](#), [218](#)
 —, and symbol, [111](#)–[12](#), [479](#) (*see also* transcendent function); and middle way, [194](#)
 natural combination of, [265](#)
 in pagan unconscious, [188](#)
 play of, [89](#)

Pythagorean, 544, 546
and redemption, *see* redemption; release of repression and, 107
renunciation of, 219
Schiller on, *see* Schiller s.v.; self and, 114&n, 460
separation/splitting apart of, 46, 89, 258
solution of conflict of, by creative act, 321
tao and, 120, 216–17
tension of, 199, 207, 217, 219
union/reconciliation of, 77, 105–6, 109, 111–12, 139, 197, 215, 217, 220–21, 262,
270–71
—, Brahman is, 198–99
—, and will, 115
yogi and, 202
optimism, 313–14
orientation, 456 (Def.), 518
Origen, 11–12, 14–19, 27
self-castration, 15–17, 27
Orphic mysteries, 544
Ostwald, F. W., 192, 322–24, 326–29, 421, 504
Grosse Männer, 322n, 323n, 327n, 504n
“other side,” 382–83

P

paganism, 185–86
palmistry, 525
Pañcavimsha Brahmana, *see* Brahmanas
Pandora, 175–84, 187, 258–59, 266, 271
paranoia, 277, 502, 508
parental: complex, 124, 529–30
imago, 201
influence, and child’s attitude, 332
Paris and Helen, 125
participation mystique, 10, 82, 93, 131, 227, 255, 294–95, 420, 456–57 (Def.)
Passion play, medieval, 141
Patanjali, 196n
Paul, St., 426, 428–32, 475
Paulhan, Frédéric, 171

Peirce, C. S., [319n](#)
Pelagius/Pelagianism, [22](#)
Pelops, [27n](#)
perception, [393–94](#), [401](#)
persecution mania, [279](#)
perseveration, [274](#)
Persian religion, [139](#)
persona, [167–68](#), [218](#), [463](#), [465–67](#) (Def.)
personification, [206](#)
pessimism, [313–14](#)
phallus: solar, [443n](#), [491n](#)
 as symbol, [27](#)
 symbols of, [240](#)
phantasy, *see* [fantasy](#)
Phidias, [28](#)
Phileros, [183–84](#)
Philhellenism, [186](#)
phlegmatic temperament, [324](#), [510](#), [531](#), [542](#)
photisms, [113](#)
Pius, brother of Hermas, [227](#)
plants, love of, as compensation, [278](#)
Plato, [26–28](#), [31–32](#), [34](#), [36–38&n](#), [438](#), [544](#)
 on ideas, [26–39](#) *passim*
 on images, [304](#)
 Phaedrus, [38n](#), [544n](#)
 Protagoras, [173](#)
 Symposium, [38n](#)
Platonic school of philosophy, [39](#), [282](#)
play: creative activity as, [123](#)
 fantasy and, [63](#)
 instinct, [106–10](#), [115](#), [122–23](#)
Plotinus, [14](#)
pluralism, [318](#)
Plutarch, [28](#)
pneumatikoi/pneumatic man, [11](#), [152](#), [545](#)
poet and collective unconscious, [190–92](#)
poetry, Schiller on, *see* [Schiller s.v.](#)

Porphyry, 14, 38
positivism, 374
Powell, John Wesley, 30
power: complex/instinct, 96, 206, 220, 377–78, 457
 fantasies, 379
 psychology, 318
pragmatism, 319n, 320–21
Prajapati, 203&n, 204–5, 207
prayer, 201, 203
predication, principle of, 29, 34, 36–37
primitive(s), 18, 207–8, 212, 226, 238–39, 244, 247, 249–50, 255, 315, 420, 543
 art of, 293
 consciousness, 512
 imago among, 30
 mentality, 185, 406
 negative instincts of, 140
 psychology, 10, 383
 relation to object, 294–95
 sensation and intuition of, 152
primordial image, 202, 219, 305–7, 315, 443–47 (Def.)
 activation of, 317, 359
 as archetype, 377, 443 (*see also* archetype); and *brahman-atman*, 118, 215
 and collective unconscious, 220–21, 443
 divine harlot as, 188
 God-renewal as, 193
 of goddess, 226
 of hero's birth, 469
 and idea, 437–39
 idealism and, 307, 314
 introverted type and, 386–89, 395
 “irrepresentable,” 305
 of man as microcosm, 217
Prince, Morton, 464n
principium individuationis, 60, 138
projection(s), 248&n, 290, 292, 294, 457–58 (Def.)
 in analysis, 238
 and collective attitude, 10

soul as, [167–68](#)
Proktophantasmist (Goethe), [79](#)
proletarians, *see* Cynics s.v.
“prolific” type (Blake), [272](#), [332](#)
Promethean attitude, *see* attitude s.v.
Prometheus, [271](#)
 in Goethe, [173–76](#), [179–80](#), [182–84](#), [186](#)
 in Plato’s *Protagoras*, [173](#)
 and soul, *see* soul
 in Spitteler, [166–93](#), *see also* extraverted type s.v.; introverted type s.v.
Protestantism, [64](#)
psychasthenia, [379](#), [383](#)
psyche: creates reality, [51–52](#)
 idea and thing in, [51](#)
 and soul, [463](#) (Def.)
psychikoi/psychic man, [11](#), [152](#), [545](#)
psychoanalysis, and two types, [62](#); *see also* analysis
psychology: mass/collective, [191](#)
 of our time, [57](#), [125](#)
 practical, [58](#)
 as science, [57–60](#)
 unites idea and thing, [49](#)
psychopathic states, [273](#)
psychopathology, [273](#); *see also* schizophrenia
Pueblo Indians, [544](#)
puer aeternus, [271](#)
pupils, [404](#)
Pythagoras, [89](#)
Pythagorean mysticism, [39](#), [544–45](#)

Q

quaternity, [461](#)&*n*

R

Radbertus, Paschasius, [23–25](#)
Ramayana, [195](#)&*n*
rapport, [372–73](#)

rational, 458–59 (Def.)
rational/judging types, 145, 151, 538
 extraverted, 359–62
 introverted, 391–93
rationalism, 228
 of feeling, 308
 and James' typology, 301, 307, 311, 502
 and unconscious, 53
Ratramnus, 23
realism: nominalism and, *see* nominalism s.v.; Plato's, 28
 and tender-minded, 302
realist and idealist, Schiller on, 133–35
reality, 40–41
 inner, 13, 52
Reason, Goddess of, 78, 80
rebirth: Faust's, 188
 motif, 177&n, 271
 “narrow passage” of, 183
redeemer/Saviour, 178, 188, 261
 birth of, *see* birth s.v.
redemption, 19, 76, 140, 188, 194–95, 197, 199, 208; *see also* symbol, redeeming
reductive, 252, 459–60 (Def.), 493, 508
Reformation, 64–65, 236, 257
regicide, 191
regression to parents, 124
religion(s), 194, 249–50
 changes of, 185
 and life, compensatory relation, 139
 and symbolic concepts, 53
religious: devotion, 124
 function, 141n, 242, 315
 problem, *see* Schiller s.v.; Spitteler s.v.
 rites, *see* sacrifice; symbols, 125
religiousness and James' typology, 314–15
Remusat, Charles F. M. de, 46–49
Renaissance, 185
représentations collectives, 417

repression, 183n, 501
of eroticism, 183
in Freudian psychology, 61–62
of functions, 63, 77, 109
of inferior function, 106
of parental imago, 124
release of, 107
retrospective orientation, 83
Rhoda (in *Shepherd of Hermas*), 224, 227–28, 241
ri and *vi*, 218
Ribot, Théodule Armand, 434n, 464n, 546
Riegl, Alois, 504
Riehl, Alois, 421n
Rig Veda, see *Vedas*
rites, 234
exorcistic, 226
magical, 235
practical importance of, 25; see also sacrifice
ritual murder, 268
Rituale Romanum, 223n, 224n
romantic type (Ostwald), 322, 324–29, 504
Rorschach, Hermann, 525
Roscellinus, Johannes, 39
Rosicrucianism, 186n, 188
Rousseau, Jean-Jacques, 81–82, 87, 100
Émile, ou l'Éducation, 81&n, 82n, 87n, 88n
rta, 120, 208&n, 210–12, 214
Ruggieri, Archbishop, 190
ryochi, 218

S

sacrifice, 204, 208–9
Christian, 16, 18–19
sacrificium intellectus, 11, 13–14, 16–17
sacrificium phalli, 16
salvation, psychological doctrine of, 194
Salzer, Anselm, 233n

samskaras, 247

sanguine temperament, 324, 510, 531, 542

Saoshyant, 268

satyr: festival, Dionysian, 141

man as, 138

saviour, birth of, *see* birth

scepticism, 318

Schärf Kluger, Rivkah, 269*n*

Scheffler, Johann, *see* Angelus Silesius

Schiller, Friedrich, 64, 67–137, 166, 179

and aesthetic mood, 121–22

on beauty, *see* beauty; and Christianity, 77

on feeling and sensation, 97–98

and Greek antiquity, 71, 73–74, 82–85, 186

on idealist and realist types, 68, 133–35

as introverted type, 68–69, 102

on naïve and sentimental poetry, 130–34, 506

Nietzsche and, 136–37, 140–41

on opposites, 117, 123, 127

on rational will, 116

and religious problem, 121–22, 124, 186–87

on symbol, 105–6, 111, 115, 117, 125, 217

on two basic instincts, 96–118 (*see also* affectivity; thinking); “The Diver,” 96*n*

“Ode to Joy,” 143

“Über die ästhetische Erziehung des Menschen” (trans. Snell: *On the Aesthetic Education of Man*), 67&*n*, 70*n*–129*n passim*, 553

“Über naive und sentimentalische Dichtung,” 130*n*–135*n*, 506*n*

“Über die notwendigen Grenzen beim Gebrauch schöner Formen,” 122*n*

Schiller, F.C.S., 319*n*

schizophrenia, 499–501, 506

Schmid-Guisan, H., xii&*n*

Scholastics(-ism), 36, 38–39, 42, 46, 48

Schopenhauer, Arthur, 96, 120–22, 143, 190, 191–92, 218, 308, 313, 320, 438, 446–47, 459, 506

concept of will, *see* will; and doctrine of deliverance, 136

The World as Will and Idea, 191*n*, 308*n*, 438*n*, 446*n*, 507*n*

Schultz, Wolfgang, 11, 17

Schumann, F., *see* Müller

science, 41

and fantasy, 57–59

and myth, 253

and primordial images, 305

scientific: attitude, contemporary, 307, 315

method, 409

scientism, 48–49

Scotus Erigena, 23–26

Sejin (sage), 218

“sejunctive personality” (Gross), 277, 281

self, 460–61 (Def.)

Brahman is, 198

-determination, 22

differentiation of, 114

ego and, *see* ego s.v.; true and false, 218

-alienation (Worringer), 296, 298–99

semiotic, vs. symbolic, 63&n, 459, 473

Semon, Richard, 376, 444

sensation, 461–63 (Def.), 538–39

as basic psychological function, 6, 518, 553–54

and extraverted attitude, 362–63

feeling-, *see* feeling-sensation; and introverted attitude, 393–95

and object, 133

and thinking, 108, 117

sensation type, 6, 11, 68, 145–46, 151n, 278, 519

extraverted, 363–66

and hylic man, 152

introverted, 395–98

Jordan on, 147,

sensationalism, in James’ typology, 301, 311–12

sense-impression of Communion, 65–66

sense-perception, 29–30

sensualist type, 41

sensuous instinct (Schiller), 96, 101, 103, 105

sensuousness/sensuous feeling, 93, 98, 103

sentimental poet (Schiller), 130–35, 137, 506

sermo/sermonism in Abelard, 49, 51, 64, 320
Serna, Ramón de la, *xivn*, *xv*
sexuality, 16, 46, 219–20, 237, 280, 281
 with Adler, 60
 complex, 206
 and ego, 417
 with Freud, 62
 repressed, 220, 239, 430
shadow: of introverted man, 165
 man's (is unconscious), 163
 -side of Abelard's thought, 51
Shakespeare: *Macbeth*, 261
Shatapatha Brahmana, see Brahmanas
sign, as opposed to symbol, 63&n, 459, 473
Shvetashvatava Upanishad, see Upanishads
Silberer, Herbert, 422n
“simulation dans le caractère” (Paulhan), 171
sin, original, 22
slave culture, subjective, 72
Socrates, 38, 142, 145
Soissons, synod of, 39
Song of Tishtriya, 210n
Sophia, 235
 -Achamoth, 188
Sophism, 32
sorcerer, 30
soul, 189, 463–70 (Def.)
 God and, see God; -image, 223–24, 226, 228, 470–72 (Def.)
 —, Pandora as, 181 (see also anima); loss of, 226
 -mistress, 190
 as personification of unconscious contents, 247–48, 250
 Prometheus and, 166–67, 169, 171, 173–75, 177, 180, 182
 worship of, 221, 224, 227
spear symbol, 219–20
speech, 203n, 204; see also *vac*
Spencer, W. R., and Gillen, F. J., 30&n, 255n, 295n
Spinoza, Baruch, 453

spirits, primitive belief in, 30
spiritualism, and materialism, 41–42, 168
spiritus: phantasticus, 109
 rector, 58
Spitteler, Carl, 166ff, 221, 252n, 265–66, 425
 as introverted type, 173
 and religious problem, 192
 Olympian Spring, 193, 472
 Prometheus and Epimetheus, 166–179 *passim*, 193, 258–60, 267–69, 272
Square, 460
Statius, 291n
stigmatization of saints, 316
Stilpon, 28, 36
Stirner, Max, 71, 190
Stobaeus, Johannes, 425n
Stoics/Stoic doctrine, 211, 228
subject: introversion and, 4–5
 power of, in Adler’s psychology, 62
subjective factor: extravert’s suppression of, 335, 337
 importance of, 374–75
 introvert and, 378, 380–82, 387, 392–95, 399
subjective: level, 472–73 (Def.)
 view, interposed between introvert and object, 333, 373
subjectivity, in Schiller, 69
suicide, 340
Sully, James, 410
summum bonum, 218
sun: Brahman and, 199
 -goddess, 259
 invincible, 234
 libido and, 204, 211
 renewal of, 177
 symbol, 234; *see also* Mitra
superstition, 30, 36, 351, 354, 365
 in words/facts, 44, 404, 421
Supreme Being, 40
Swedenborg, Emanuel, 427

symbiosis of two instincts, 103
symbol(s), 63n, 120, 125–26, 184, 191, 251, 473–81 (Def.)
 animal, 269
 -carriers, 182
 combination of, 271
 dissolution of, 237
 fertility, 234–35
 -formation, 238–40
 of God’s renewal, 193
 of libido, 199, 202–3, 211
 as mediator between opposites, 111, 128, 479
 of parents, 124
 phallic, 240
 Prometheus and Epimetheus as, 186
 of psychic pregnancy, 469
 reality of, 125, 129
 redeeming, 216, 259–62, 264–65, 268, 270
 relativity of, 221, 243
 religious, 125, 253
 Schiller on, *see* Schiller s.v.; totality, 460
 unconscious, 113–14, 126
 uniting, 189, 199, 208, 214
 of uterus, 234–35, 240
 value of, 125–26, 129; *see also* animals s.v. bird, horse, whale; fire; Grail; jewel;
 phallus; spear; tower; treasure; *vas*
syncretism, Hellenistic, 545
Synesius, 108–10
synthesis of fantasy material, 63
synthetic, 252, 422 (Def.)
systole, 4–5, 213, 253; *see also* diastole

T

Taine, Hippolyte, 546
Taittiriya: Aranyaka, 199n
 Brahmana, *see* s.v.; *Samhita*, 203n
 Upanishad, *see* s.v.
Talbot, P. Amaury, 235n

tao, 120, 214&n, 215–17, 460

Taoism, 214, 216–17

tapas, 118–20, 200&n

tat tvam asi, 118

Taylor, Henry Osborn, 39

Tejobindu Upanishad, see Upanishads

telepathy, 354

temperaments, four basic, 10, 323–24, 510, 531–32, 542

tender-minded (James), 301, 307, 502–3

tertium non datur, 45, 46, 105, 460

Tertullian, 11–14, 16–19, 22, 51, 233

Tewekkul-Beg, 31

theosophy, 168, 353–54

thinking, 481–82 (Def.)

abstract, 303–6

associative, 481

concrete, 302–3, 305–6, 308

directed, 24–25, 298*n*

of extravert, 25, 303, 342–46

and feeling, united, 58

function, 6, 99–100, 101, 518, 553–54

as inferior/repressed function of extraverted intuitive type, 368

—, of extraverted feeling type, 357–58

introverted, 25, 343–45, 380–83

—, in Schiller, 69

—, in Tertullian, 14

negative, 352–54, 359 (*see also* “nothing but”); synthetic, of extravert, 351

—, of introvert, 310

theosophical, 353–54

thinking type, 6–7, 11, 68, 145, 278, 519–21, 537–38

extraverted, 149, 346–54

introverted, 97–98, 102, 104, 283, 383–87

—, intuitive, 94*n*

—, Schiller as, 69

Jordan on, 147

thought(s), 482

libido and, 115

of primitives, 30
reality of, 125
“thing-likeness” of, 42
three/third, 11, 58, 107, 217; see also *tertium non datur*; triangle
Thyestes, 27&n
Tibullus, 291&n
Tir Yasht, see *Song of Tishtriya*
Titan, 179–80
Toju, Nakae, 217–18
tondi, 245&n
totality, goal of, 58
totem ceremonies, 141, 255
tough-minded (James), 301, 307, 312, 314–15, 502–3
tower symbol, 230–32, 238, 240
transcendent function, 115&n, 126, 252&n, 480 (Def.)
transcendentalism, Plato’s, 39
transference, 290, 407, 452, 457, 500
transubstantiation, 23–24, 39, 64
treasure symbol, 250
tree: and birth motif, 178
 sacred, 420
triangle, in Vant, 43
Trinity, 39
tripod of Mothers, 125&n
tritheism, 39
type(s), 482–83 (Def.)
 and balancing of opposites, 47
 conflict/opposition, 83, 193, 523
 —, biological foundation of, 331–32
 —, and Pelagian controversy, 22
 contrast of, in early Church, 20–21
 reversal of/falsification, 332–33
 three, in Gnostic philosophy, 11
 two (Gross’s theory), 273, 276

U

“Ugliest Man,” 128, 191, 425, 481

Ugolino, 190

unconscious, the, 112–15, 483–86 (Def.)

compensatory function of, 340, 520

and conscious, differentiation of, 163

and consciousness, opposition of, 522

—, union of, 117

differentiation and, 112

of extravert, egocentric infantile tendency in, 337–39, 341, 361

of extraverted intuitive type, 369–70

fantasy and, 52–53

and inferior function, *see* function(s) s.v.; introversion into, 117, 183

libido and, *see* libido s.v.; projected onto objects, 129

and Prometheus-Pandora myth, 175–77

soul's relation to, 167–70

suppression of, 54–57

and symbol, 125–26

worldwide human, 121

unconscious, collective, 190, 220, 226, 243, 376, 485, 491

contents of, 377, 398

Dionysian state and, 140

poets and, *see* poets; soul and, 170

Spitteler and, 192–93

Zarathustra and, 191

unconscious contents, 170, 270

breakthrough, in Gnosticism, 20

and dissociation, 126, 236

of empathetic type, 295&n

feeling-toned, 124

object and, 131

personification of, 247

power of, 182

and projection, 243–44

reality of, 168

religious, 193

universals, 26, 38, 39, 46–48, 302

Upanishads, 120, 213, 242, 313

Brihadaranyaka, 196n, 197n, 198n, 200

Chhandogya, 201n
Isha, 198n
Katha, 198n
Kaushitaki, 196n
Shvetashvatara, 197n
Taittiriya, 200n
Tejobindu, 196n
uterus symbolism, 234–35, 240

V

vac (speech), 204–7
Vajasanayi Samhita, 199n
Valentinian school, 152
value(s): psychological, 287
 reversal of, 266
 of woman, 236
Varuna (sky-god), 209
vas/vessel symbol, 219n, 233–36&n, 240
 Sapientiae, 235
Vedas, 209
 and opposites, 194
 Atharva, 198n, 199n, 200&n, 201&n, 209n
 Rig, 203&n, 209n, 210n, 211n
Vedic Hymns, 209n, 210n, 211&n
Veraguth, Otto, 412n
vertigo, psychogenic, 399
vessel, *see vas*
Villa, Guido, 434n, 461n
Virgin, 221–22, 231–32, 234, 240, 261, 265
Vischer, Friedrich Theodor von, 380
vision(s): of Egyptian Gnostic and Swiss clerk, 491
 of Hermas, 225, 227–31, 238
 of Paul, 428, 430–32
 of Peter, 430, 432
 among primitives, 30
 of Tewekkul-Beg, 31
volipresence, 65

Vulcan, [180](#)

W

Wagner, Richard, [237](#), [241](#), [252n](#)

Parsifal, [76](#), [192](#), [219](#)

Wagner (in Faust legend), [207](#)

Waley, Arthur, [214n](#), [215n](#)

Wandering Jew, legend of, [268](#)

Wang Yang-ming, [218&n](#)

Warneck, Johannes Gustav, [245n](#)

Warren, Henry Clarke, [294n](#)

Weber, Albrecht, [204n](#)

Weininger, Otto, [374–76](#)

Wernicke, Carl, [275](#), [277](#)

White, William Alanson, [443n](#)

will, [486](#) (Def.)

Nietzsche on, [143](#)

and opposites, [111–16](#)

Schopenhauer's concept of, [143](#), [218](#), [254](#)

William of Champeaux, [39](#)

wish-fulfillment, [61](#)

witch hunt, [236](#)

woman/women: extraverted, [156–60](#)

as extraverted feeling type, [356](#)

as extraverted intuitive type, [369](#)

introverted, [153–56](#)

as introverted feeling type, [388–90](#)

thinking function in, [351](#)

worship of, [221](#), [224](#), [226](#), [236–37](#)

wonder-child, *see* child

word(s): -fetishism, [33](#)

magical reality of, [31–32](#), [44](#), [49](#)

universals “world negation” (Schopenhauer), [190–91](#)

Worringer, Wilhelm Robert, [289–91&n](#), [292–94](#), [296–97](#), [504](#)

Abstraction and Empathy, [289–97 passim](#), [504–6](#)

Wulfen, Willem van, [363](#)

Wundt, Wilhelm, [290](#), [309](#), [409](#), [411n](#), [412n](#), [414&n](#), [415](#), [434](#), [437](#), [461](#), [546](#)

wu-wei, [217](#)

X

Xenophon, [27](#)

Y

yang and *yin*, [216–17](#), [460](#)

yoga, [119](#), [123](#), [202](#), [207](#)

Yogasutra (Patanjali), [196n](#)

Z

Zarathustra, *see* Nietzsche

Zeller, Eduard, [426n](#)

Zündel, Friedrich, [547n](#)

Zwingli, Ulrich, [64](#), [65–66](#), [481](#)

THE COLLECTED WORKS OF

C. G. JUNG

THE PUBLICATION of the first complete edition, in English, of the works of C. G. Jung was undertaken by Routledge and Kegan Paul, Ltd., in England and by Bollingen Foundation in the United States. The American edition is number XX in Bollingen Series, which since 1967 has been published by Princeton University Press. The edition contains revised versions of works previously published, such as *Psychology of the Unconscious*, which is now entitled *Symbols of Transformation*; works originally written in English, such as *Psychology and Religion*; works not previously translated, such as *Aion*; and, in general, new translations of virtually all of Professor Jung's writings. Prior to his death, in 1961, the author supervised the textual revision, which in some cases is extensive. Sir Herbert Read (d. 1968), Dr. Michael Fordham, and Dr. Gerhard Adler compose the Editorial Committee; the translator is R. F. C. Hull (except for Volume 2) and William McGuire is executive editor.

The price of the volumes varies according to size; they are sold separately, and may also be obtained on standing order. Several of the volumes are extensively illustrated. Each volume contains an index and in most a bibliography; the final volumes will contain a complete bibliography of Professor Jung's writings and a general index to the entire edition.

In the following list, dates of original publication are given in parentheses (of original composition, in brackets). Multiple dates indicate revisions.

* 1. PSYCHIATRIC STUDIES

On the Psychology and Pathology of So-Called Occult Phenomena (1902)

On Hysterical Misreading (1904)

Cryptomnesia (1905)

On Manic Mood Disorder (1903)

A Case of Hysterical Stupor in a Prisoner in Detention (1902)

On Simulated Insanity (1903)

A Medical Opinion on a Case of Simulated Insanity (1904)

A Third and Final Opinion on Two Contradictory Psychiatric Diagnoses (1906)

On the Psychological Diagnosis of Facts (1905)

[†]2. EXPERIMENTAL RESEARCHES

Translated by Leopold Stein in collaboration with Diana Riviere

STUDIES IN WORD ASSOCIATION (1904–7, 1910)

The Associations of Normal Subjects (by Jung and F. Riklin)

An Analysis of the Associations of an Epileptic

The Reaction-Time Ratio in the Association Experiment

Experimental Observations on the Faculty of Memory

Psychoanalysis and Association Experiments

The Psychological Diagnosis of Evidence

Association, Dream, and Hysterical Symptom

The Psychopathological Significance of the Association Experiment

Disturbances in Reproduction in the Association Experiment

The Association Method

The Family Constellation

PSYCHOPHYSICAL RESEARCHES (1907–8)

On the Psychophysical Relations of the Association Experiment

Psychophysical Investigations with the Galvanometer and Pneumograph in Normal and Insane Individuals (by F. Peterson and Jung)

Further Investigations on the Galvanic Phenomenon and Respiration in Normal and Insane Individuals (by C. Ricksher and Jung)

Appendix: Statistical Details of Enlistment (1906); New Aspects of Criminal Psychology (1908); The Psychological Methods of Investigation Used in the Psychiatric Clinic of the University of Zurich (1910); On the Doctrine of Complexes ([1911] 1913); On the Psychological Diagnosis of Evidence (1937)

^{*}3. THE PSYCHOGENESIS OF MENTAL DISEASE

The Psychology of Dementia Praecox (1907)

The Content of the Psychoses (1908/1914)

On Psychological Understanding (1914)

A Criticism of Bleuler's Theory of Schizophrenic Negativism (1911)

On the Importance of the Unconscious in Psychopathology (1914)

On the Problem of Psychogenesis in Mental Disease (1919)

Mental Disease and the Psyche (1928)

On the Psychogenesis of Schizophrenia (1939)

Recent Thoughts on Schizophrenia (1957)

Schizophrenia (1958)

†4. FREUD AND PSYCHOANALYSIS

Freud's Theory of Hysteria: A Reply to Aschaffenburg (1906)

The Freudian Theory of Hysteria (1908)

The Analysis of Dreams (1909)

A Contribution to the Psychology of Rumour (1910–11)

On the Significance of Number Dreams (1910–11)

Morton Prince, "The Mechanism and Interpretation of Dreams": A Critical Review (1911)

On the Criticism of Psychoanalysis (1910)

Concerning Psychoanalysis (1912)

The Theory of Psychoanalysis (1913)

General Aspects of Psychoanalysis (1913)

Psychoanalysis and Neurosis (1916)

Some Crucial Points in Psychoanalysis: A Correspondence between Dr. Jung and Dr. Loÿ (1914)

Prefaces to "Collected Papers on Analytical Psychology" (1916, 1917)

The Significance of the Father in the Destiny of the Individual (1909/1949)

Introduction to Kranefeldt's "Secret Ways of the Mind" (1930)

Freud and Jung: Contrasts (1929)

‡5. SYMBOLS OF TRANSFORMATION (1911–12/1952)

PART I

Introduction

Two Kinds of Thinking

The Miller Fantasies: Anamnesis

The Hymn of Creation

The Song of the Moth

PART II

Introduction

The Concept of Libido

The Transformation of Libido

The Origin of the Hero
Symbols of the Mother and of Rebirth
The Battle for Deliverance from the Mother
The Dual Mother
The Sacrifice
Epilogue
Appendix: The Miller Fantasies

***6. PSYCHOLOGICAL TYPES (1921)**

Introduction
The Problem of Types in the History of Classical and Medieval Thought
Schiller's Ideas on the Type Problem
The Apollinian and the Dionysian
The Type Problem in Human Character
The Type Problem in Poetry
The Type Problem in Psychopathology
The Type Problem in Aesthetics
The Type Problem in Modern Philosophy
The Type Problem in Biography
General Description of the Types
Definitions
Epilogue
Four Papers on Psychological Typology (1913, 1925, 1931, 1936)

†7. TWO ESSAYS ON ANALYTICAL PSYCHOLOGY

On the Psychology of the Unconscious (1917/1926/1943)
The Relations between the Ego and the Unconscious (1928)
Appendix: New Paths in Psychology (1912); The Structure of the Unconscious
(1916) (new versions, with variants, 1966)

‡8. THE STRUCTURE AND DYNAMICS OF THE PSYCHE

On Psychic Energy (1928)
The Transcendent Function ([1916]/1957)
A Review of the Complex Theory (1934)
The Significance of Constitution and Heredity in Psychology (1929)
Psychological Factors Determining Human Behavior (1937)

Instinct and the Unconscious (1919)
The Structure of the Psyche (1927/1931)
On the Nature of the Psyche (1947/1954)
General Aspects of Dream Psychology (1916/1948)
On the Nature of Dreams (1945/1948)
The Psychological Foundations of Belief in Spirits (1920/1948)
Spirit and Life (1926)
Basic Postulates of Analytical Psychology (1931)
Analytical Psychology and *Weltanschauung* (1928/1931)
The Real and the Surreal (1933)
The Stages of Life (1930–1931)
The Soul and Death (1934)
Synchronicity: An Acausal Connecting Principle (1952)
Appendix: On Synchronicity (1951)

9. PART I. THE ARCHETYPES AND THE COLLECTIVE UNCONSCIOUS

Archetypes of the Collective Unconscious (1934/1954)
The Concept of the Collective Unconscious (1936)
Concerning the Archetypes, with Special Reference to the Anima Concept
(1936/1954)
Psychological Aspects of the Mother Archetype (1938/1954)
Concerning Rebirth (1940/1950)
The Psychology of the Child Archetype (1940)
The Psychological Aspects of the Kore (1941)
The Phenomenology of the Spirit in Fairytales (1945/1948)
On the Psychology of the Trickster-Figure (1954)
Conscious, Unconscious, and Individuation (1939)
A Study in the Process of Individuation (1934/1950)
Concerning Mandala Symbolism (1950)
Appendix: Mandalas (1955)

9. PART II. AION (1951)

RESEARCHES INTO THE PHENOMENOLOGY OF THE SELF

The Ego
The Shadow

The Syzygy: Anima and Animus

The Self

Christ, a Symbol of the Self

The Sign of the Fishes

The Prophecies of Nostradamus

The Historical Significance of the Fish

The Ambivalence of the Fish Symbol

The Fish in Alchemy

The Alchemical Interpretation of the Fish

Background to the Psychology of Christian Alchemical Symbolism

Gnostic Symbols of the Self

The Structure and Dynamics of the Self

Conclusion

***10. CIVILIZATION IN TRANSITION**

The Role of the Unconscious (1918)

Mind and Earth (1927/1931)

Archaic Man (1931)

The Spiritual Problem of Modern Man (1928/1931)

The Love Problem of a Student (1928)

Woman in Europe (1927)

The Meaning of Psychology for Modern Man (1933/1934)

The State of Psychotherapy Today (1934)

Preface and Epilogue to “Essays on Contemporary Events” (1946)

Wotan (1936)

After the Catastrophe (1945)

The Fight with the Shadow (1946)

The Undiscovered Self (Present and Future) (1957)

Flying Saucers: A Modern Myth (1958)

A Psychological View of Conscience (1958)

Good and Evil in Analytical Psychology (1959)

Introduction to Wolff’s “Studies in Jungian Psychology” (1959)

The Swiss Line in the European Spectrum (1928)

Reviews of Keyserling’s “America Set Free” (1930) and “La Révolution Mondiale” (1934)

The Complications of American Psychology (1930)

The Dreamlike World of India (1939)

What India Can Teach Us (1939)

Appendix: Documents (1933–1938)

†11. PSYCHOLOGY AND RELIGION: WEST AND EAST

WESTERN RELIGION

Psychology and Religion (The Terry Lectures) (1938/1940)

A Psychological Approach to the Dogma of the Trinity (1942/1948)

Transformation Symbolism in the Mass (1942/1954)

Forewords to White's "God and the Unconscious" and Werblowsky's "Lucifer and Prometheus" (1952)

Brother Klaus (1933)

Psychotherapists or the Clergy (1932)

Psychoanalysis and the Cure of Souls (1928)

Answer to Job (1952)

EASTERN RELIGION

Psychological Commentaries on "The Tibetan Book of the Great Liberation" (1939/1954) and "The Tibetan Book of the Dead" (1935/1953)

Yoga and the West (1936)

Foreword to Suzuki's "Introduction to Zen Buddhism" (1939)

The Psychology of Eastern Meditation (1943)

The Holy Men of India: Introduction to Zimmer's "Der Weg zum Selbst" (1944)

Foreword to the "I Ching" (1950)

***12. PSYCHOLOGY AND ALCHEMY (1944)**

Prefatory note to the English Edition ([1951?] added 1967)

Introduction to the Religious and Psychological Problems of Alchemy

Individual Dream Symbolism in Relation to Alchemy (1936)

Religious Ideas in Alchemy (1937)

Epilogue

†13. ALCHEMICAL STUDIES

Commentary on "The Secret of the Golden Flower" (1929)

The Visions of Zosimos (1938/1954)

Paracelsus as a Spiritual Phenomenon (1942)

The Spirit Mercurius (1943/1948)

The Philosophical Tree (1945/1954)

‡14. MYSTERIUM CONIUNCTIONIS (1955–56)

AN INQUIRY INTO THE SEPARATION AND SYNTHESIS OF PSYCHIC OPPOSITES IN ALCHEMY

The Components of the Coniunctio

The Paradoxa

The Personification of the Opposites

Rex and Regina

Adam and Eve

The Conjunction

***15. THE SPIRIT IN MAN, ART, AND LITERATURE**

Paracelsus (1929)

Paracelsus the Physician (1941)

Sigmund Freud in His Historical Setting (1932)

In Memory of Sigmund Freud (1939)

Richard Wilhelm: In Memoriam (1930)

On the Relation of Analytical Psychology to Poetry (1922)

Psychology and Literature (1930/1950)

“Ulysses”: A Monologue (1932)

Picasso (1932)

†16. THE PRACTICE OF PSYCHOTHERAPY

GENERAL PROBLEMS OF PSYCHOTHERAPY

Principles of Practical Psychotherapy (1935)

What Is Psychotherapy? (1935)

Some Aspects of Modern Psychotherapy (1930)

The Aims of Psychotherapy (1931)

Problems of Modern Psychotherapy (1929)

Psychotherapy and a Philosophy of Life (1943)

Medicine and Psychotherapy (1945)

Psychotherapy Today (1945)

Fundamental Questions of Psychotherapy (1951)

SPECIFIC PROBLEMS OF PSYCHOTHERAPY

The Therapeutic Value of Abreaction (1921/1928)
The Practical Use of Dream-Analysis (1934)
The Psychology of the Transference (1946)
Appendix: The Realities of Practical Psychotherapy ([1937] added, 1966)

***17. THE DEVELOPMENT OF PERSONALITY**

Psychic Conflicts in a Child (1910/1946)
Introduction to Wickes's "Analyses der Kinderseele" (1927/1931)
Child Development and Education (1928)
Analytical Psychology and Education: Three Lectures (1926/1946)
The Gifted Child (1943)
The Significance of the Unconscious in Individual Education (1928)
The Development of Personality (1934)
Marriage as a Psychological Relationship (1925)

18. THE SYMBOLIC LIFE

Miscellaneous Writings

19. BIBLIOGRAPHY OF C. G. JUNG'S WRITINGS

20. GENERAL INDEX TO THE COLLECTED WORKS

See also:

C. G. JUNG: LETTERS

Selected and edited by Gerhard Adler, in collaboration with Aniela Jaffé.
Translations from the German by R.F.C. Hull.

VOL. 1: 1906–1950

VOL. 2: 1951–1961

THE FREUD/JUNG LETTERS

Edited by William McGuire, translated by
Ralph Manheim and R.F.C. Hull

* See infra, Foreword to the Argentine Edition.

¹ [Swiss psychotherapist and former pupil of Jung's; died 1932. The correspondence (1915–16) was brought to light in 1966 by Schmid's daughter, Marie-Jeanne Boller-Schmid, who had been Jung's secretary from 1932 to 1952. The correspondence was discontinued early in 1916 at Jung's request. After careful consideration we concur with his view that its inclusion (e.g., in an Appendix to this volume) "would create more confusion than clarity"; nor, on account of its prolixity, is it included in *Coll. Works*, vol. 18. A remarkable personal codicil to a letter to Schmid, written on November 6, 1915, too valuable and moving to pass into oblivion, is, however, included in *C. G. Jung: Letters*, vol. 1. Cf. also Jung's obituary for Schmid, *Coll. Works*, vol. 18, pars. 1713ff.—EDITORS.]

¹ [*Tipos psicológicos*, translated by Ramón de la Serna (Buenos Aires, 1936).]

¹ “A Contribution to the Study of Psychological Types” (1913), *infra*, Appendix, pars. 858ff., and “The Psychology of the Unconscious Processes,” *Collected Papers on Analytical Psychology* (2nd edn., 1917), pp. 391ff. [The latter section, on types, was subsequently revised and appears as ch. IV (“The Problem of the Attitude-Type”) of the first of the *Two Essays on Analytical Psychology*. Cf. also “The Structure of the Unconscious” (1916), in *ibid.*, pars. 462, n. 8, and 482.—EDITORS.]

¹ *Dokumente der Gnosis*, p. xxix.

² *Ibid.*, p. xxv.

³ “Et mortuus est dei filius, prorsus credibile est, quia ineptum est. Et sepultus resurrexit; certum est, quia impossibile est” (*De carne Christi*, 5). Cf. *Treatise on the Incarnation*, p. 19.

⁴ *De Testimonio animae*, 1. Cf. *The Writings of Tertullian*, I, p. 132.

⁵ [Cf. Harnack, *A History of Dogma*, I, p. 357; Eusebius, *The Ecclesiastical History and the Martyrs of Palestine*, I, p. 192.]

⁶ [Reference cannot be traced.—EDITORS.]

⁷ *Dokumente der Gnosis*, p. xxvii.

⁸ [1911–12; first translated as *Psychology of the Unconscious* (1916); revised edition (1952) retitled *Symbols of Transformation*.]

⁹ We would rather say untamed libido, which, in the form of *heimarmene* (compulsion of the stars, or fate), leads man into wrongdoing and corruption.

¹⁰ *Le Jardin d’Epicure*, p. 80.

¹¹ [Thyestes, son of Pelops, in the course of a struggle for the kingdom with his brother Atreus, was given, unknown to himself, the flesh of his own children to eat.—EDITORS.]

¹² Plutarch, *Adversus Colotem*, 22.

¹³ [Cf. Gomperz, *Greek Thinkers*, I, p. 434.]

¹⁴ *Ibid.*, II, pp. 175ff.

¹⁵ “Sketch of the Mythology of the North American Indians,” p. 20.

¹⁶ *The Northern Tribes of Central Australia*, p. 451.

¹⁷ Buber, *Ekstatische Konfessionen*, pp. 31f.

¹⁸ Cf. *Greek Thinkers*, II, p. 193.

¹⁹ Cf. *ibid.*, pp. 181f.

²⁰ Cf. *ibid.*, pp. 167f.

²¹ Cf. *ibid.*, p. 168.

²² Cf. *The Organon, or Logical Treatises of Aristotle, with the Introduction of Porphyry*, II, pp. 609f.

²³ *Symposium*, 211B (trans. Hamilton), pp. 93f. [In similar contexts, Jung cited from Plato the phrase “a supra-celestial place” or “a place beyond the skies,” which is from *Phaedrus* 247C. See “The Structure of the Psyche,” par. 336; “Psychological Aspects of the Mother Archetype,” par. 149; “Transformation Symbolism in the Mass,” par. 430; “Flying Saucers,” par. 621.—EDITORS.]

²⁴ *The Mediaeval Mind*, II, p. 340.

²⁵ *Psychologie*, II, p. 120.

²⁶ “Sic ergo vere est aliquid, quo majus cogitari non potest, ut nec cogitari possit non esse, et hoc es tu, Domine Deus Noster” (*Proslogion*, trans. Fairweather, p. 74).

²⁷ *Ibid.*

²⁸ *Scriptum supra libros Sententiarum magistri Petri Lombardi*, I, dist. 25, qu. 1, art. 4 (ed. Mandonnet, I, p. 612).

²⁹ *Critique of Pure Reason* (trans. Kemp Smith), pp. 500f.

³⁰ *Ibid.*, pp. 510f.

³¹ *Ibid.*, p. 503.

³² *Ibid.*, pp. 504f.

³³ *Ibid.*, p. 506.

³⁴ Cf. *Critique of Practical Reason*, pp. 226f.

³⁵ *Abelard*.

³⁶ *Ibid.*, II, p. 119.

³⁷ *Ibid.*, p. 112.

³⁸ *Ibid.*, p. 140.

³⁹ “Hic docuit voces cum rebus significare,

Et docuit voces res significando notare;

Errores generum correxit, ita specierum.

Hic genus et species in sola voce locavit,

Et genus et species sermones esse notavit.

...

Sic animal nullumque animal genus esse probatur.

Sic et homo et nullus homo species vocitatur.”

Ms. by Godfrey, Prior of St. Swithin’s, Winchester. Bodleian Library, Ms. Digby 65 (13th cent.), fol. 7.

⁴⁰ “Life of St. Anthony,” in *The Paradise or Garden of the Holy Fathers*, compiled by Athanasius, Archbishop of Alexandria, and others (trans. E. A. W. Budge), I, pp. 3–76.

⁴¹ *Ibid.*, pp. 24f.

⁴² *Ibid.*, pp. 33ff.

⁴³ Heraclitus, fr. 44, in Burnet, *Early Greek Philosophy*, p. 136.

⁴⁴ I say “semiotic” in contradistinction to “symbolic.” What Freud terms symbols are no more than *signs* for elementary instinctive processes. But a *symbol* is the best possible expression for something that cannot be expressed otherwise than by a more or less close analogy.

⁴⁵ Jung, “On Psychological Understanding,” pars. 391ff., and *Two Essays on Analytical Psychology*, pars. 121ff.

¹ All quotations are from the translation by Snell, *On the Aesthetic Education of Man*.

² Ibid., p. 39.

³ Ibid.

⁴ Ibid.

⁵ Ibid., pp. 40f.

⁶ Cf. p. 44.

⁷ Ibid., p. 43.

⁸ [For the Germanic distinction between culture and civilization, see *The Practice of Psychotherapy*, par. 227, n. 10.—TRANS.]

⁹ Cf. Snell, p. 44.

¹⁰ Ibid., pp. 44f. My italics.

¹¹ Oratio IV, *In regem solem*. Cf. Julian, *Works* (L.C.L.), I, p. 389.

¹² Snell, p. 46.

¹³ Ibid., p. 47.

¹⁴ Cf. *ibid.*, pp. 48f.

¹⁵ Goethe, *Briefwechsel mit Schiller in den Jahren 1794–1805*, in *Werke* (ed. Beutler), XX, p. 20.

¹⁶ *Emile* (trans. Foxley), p. 7.

¹⁷ Ibid., p. 8.

¹⁸ Cf. *ibid.*, p. 5.

¹⁹ Cf. *ibid.*, p. 7.

²⁰ Cf. *ibid.*, p. 46.

²¹ Indications of this are already to be found in the Greek mysteries.

²² Cf. Snell, p. 51.

²³ Cf. *ibid.*, pp. 51f.

²⁴ Cf. *ibid.*, p. 52.

²⁵ Cf. *ibid.*, p. 58.

²⁶ Ibid., p. 59.

²⁷ Ibid., p. 59

²⁸ Ibid.

²⁹ Ibid., p. 60.

³⁰ Cf. *ibid.*

³¹ *Emile* (trans. Foxley), p. 49.

³² Cf. *ibid.*, p. 50.

³³ Cf. *ibid.*, p. 7.

³⁴ Isaiah 35:8.

³⁵ Snell, p. 60.

³⁶ Cf. *ibid.*, p. 61.

³⁷ *Ibid.*, p. 62.

³⁸ *Ibid.*

³⁹ *Ibid.*, p. 63.

⁴⁰ Cf. the discourse of Julian the Apostate on the mother of the gods, *Works*, I, pp. 462ff.

⁴¹ Letter to Goethe, January 5, 1798 (Beutler, XX, p. 485).

⁴² Letter to Schiller, April 27, 1798 (p. 564).

⁴³ Letter to Schiller, January 6, 1798 (pp. 486f.).

⁴⁴ Letter to Goethe, August 31, 1794 (p. 19).

⁴⁵ Cf. Snell, p. 63.

⁴⁶ Letter to Schiller, April 27, 1798 (p. 564).

⁴⁷ I would like to emphasize that everything I say in this chapter about the extravert and introvert applies only to the types we are discussing: the intuitive, extraverted feeling type represented by Goethe, and the intuitive, introverted thinking type represented by Schiller.

⁴⁸ Schiller, *The Diver*.

⁴⁹ Snell, p. 64.

⁵⁰ Cf. *ibid.*, p. 64f.

⁵¹ Cf. *ibid.*, p. 66.

⁵² *Ibid.*, p. 65n.

⁵³ P. 65.

⁵⁴ P. 66.

⁵⁵ The “formal instinct” is equivalent to the “power of thought” for Schiller.

⁵⁶ P. 66.

⁵⁷ Later on Schiller himself criticizes this point.

⁵⁸ Cf. p. 67.

⁵⁹ P. 66.

⁶⁰ Cf. p. 68n.

⁶¹ Cf. p. 71n.

⁶² Cf. p. 70.

⁶³ To avoid misunderstandings, I should like to observe that this contempt does not apply to the object, at least not as a rule, but to the relation to it.

⁶⁴ That is, between affectivity and *active* thinking, in contrast to the *reactive* thinking previously referred to.

⁶⁵ Cf. Snell, p. 88.

⁶⁶ Cf. p. 72.

⁶⁷ Cf. p. 78.

⁶⁸ Cf. p. 72.

⁶⁹ Cf. *ibid.*

⁷⁰ Cf. p. 73.

⁷¹ Individualism. [The positive definition of individualism, given here, which is similar to the definition of individuation (cf. par. 757), is in marked contrast to the negative aspect stressed in par. 433 and especially par. 761: “A real conflict with the collective norm arises only when an individual way is raised to a norm, which is the actual aim of extreme individualism. Naturally this aim is pathological and inimical to life. It has, accordingly, nothing to do with individuation.” This fundamental distinction between individualism and individuation is expanded upon in *Two Essays*, pars. 267–8.—EDITORS.]

⁷² Cf. p. 73.

⁷³ Cf. pp. 73f.

⁷⁴ Cf. p. 76.

⁷⁵ *Ibid.*

⁷⁶ P. 67.

⁷⁷ Cf. p. 80.

⁷⁸ Cf. p. 135.

⁷⁹ Cf. *infra*, pars. 185f.

⁸⁰ Cf. p. 94.

⁸¹ [No page references are given in the German text for these quotations. Jung used a Latin translation by Ficino, cited in the Bibliography. For the longer passage, as translated from the original Greek, cf. *The Essays and Hymns of Synesius* (trans. FitzGerald), II, pp. 334f.—EDITORS.]

⁸² Cf. Snell, p. 94.

⁸³ Cf. Nunberg, “On the Physical Accompaniments of Association Processes,” in Jung (ed.), *Studies in Word-Association*, pp. 531ff.

⁸⁴ Cf. *Symbols of Transformation*, pars. 233ff.

⁸⁵ [A preliminary formulation of the “self” first occurs in “The Structure of the Unconscious” (1916), *Two Essays* (1966 edn.), par. 512: “The unconscious personal contents constitute the *self*, the *unconscious* or *subconscious* ego.” Thereafter the self does not appear to have been mentioned in Jung’s writings until the publication of *Psychological Types*, and even as late as the 1950 Swiss edition it is at one point (p. 123) used interchangeably with the ego. This has been corrected in *Ges. Werke* (p. 95), where “Selbst” (self) is deleted. (In the Baynes version confusion is made worse confounded because throughout this whole passage “Ich”=ego is more often than not translated as “self,” which Jung used only at that one point. Cf. Baynes, pp. 115–17, with pars. 138–41 of the present edition.) Thus, in par. 183, the “self” appears for the first time as an entity distinct from the ego, though it is evident from the context that the term also has an affinity with the “individual nucleus” which can be differentiated from the opposing functions or opposites (par. 174). In par. 175, however, the “individual nucleus” is abbreviated into the “individuality.” The relation between the self and individuality is developed later, in *Two Essays*. Cf. par. 266: “... in so far as ‘individuality’ embraces our innermost, last, and incomparable uniqueness, it also implies becoming one’s

own self.” Par. 404: “The self is our life’s goal, for it is the completest expression of that fateful combination we call individuality.”—EDITORS.]

⁸⁶ I must emphasize that I am here presenting this function only in principle. Further contributions to this very complex problem, concerning in particular the fundamental importance of the way in which the unconscious material is assimilated into consciousness, will be found in “The Structure of the Unconscious” and “The Psychology of the Unconscious Processes.” [These were subsequently expanded into *Two Essays on Analytical Psychology*. Cf. also “The Transcendent Function.”—EDITORS.]

⁸⁷ Cf. Snell, p. 98.

⁸⁸ Ibid., p. 99.

⁸⁹ As Schiller says, “man in the aesthetic condition is a cipher” (p. 101).

⁹⁰ Cf. p. 99n.

⁹¹ Cf. p. 101.

⁹² Cf. p. 120.

⁹³ Schiller died in 1805.

⁹⁴ I use “aestheticism” as an abbreviated expression for an “aesthetic view of world.” I do not mean aestheticism in the pejorative sense of a sentimental pose or fashionable fad, which might perhaps be connoted by that word.

⁹⁵ Cf. “Über die notwendigen Grenzen beim Gebrauch schöner Formen” (Cottasche Ausgabe, XVIII), p. 195: “For since, in the man of aesthetic refinement, the imagination, even in its free play, is governed by law, and the senses permit themselves enjoyment only with the consent of reason, the reciprocal favour is required that in the seriousness of its law-making reason shall be governed in the interests of the imagination, and not command the will without the consent of the sensuous instincts.”

⁹⁶ Snell, p. 81.

⁹⁷ Ibid.: “While the womanly god demands our veneration, the godlike woman kindles our love.”

⁹⁸ *Symbols of Transformation*, esp. pars. 180, 329ff.

⁹⁹ *Faust, Part Two* (trans. Wayne) Act 1, “Baronial Hall,” pp. 83ff. [For the tripod see also p. 79.]

¹⁰⁰ Cf. Snell, p. 99n.

¹⁰¹ Cf. *ibid.*

¹⁰² Cf. pp. 103f.

¹⁰³ P. 109.

¹⁰⁴ P. 110.

¹⁰⁵ *Ibid.*

¹⁰⁶ Cf. *ibid.*

¹⁰⁷ Cf. p. 112.

¹⁰⁸ Cf. *ibid.*

¹⁰⁹ *Ibid.*

¹¹⁰ *Ibid.*

- ¹¹¹ Cf. p. 125.
- ¹¹² Cf. p. 127.
- ¹¹³ P. 131.
- ¹¹⁴ “Über naive und sentimentalische Dichtung” (Cottasche Ausgabe, XVIII), pp. 205ff.
- ¹¹⁵ P. 236.
- ¹¹⁶ Ibid., p. 248.
- ¹¹⁷ P. 250n.
- ¹¹⁸ P. 303.
- ¹¹⁹ P. 304.
- ¹²⁰ P. 303.
- ¹²¹ P. 305.
- ¹²² Pp. 307f.
- ¹²³ P. 314.
- ¹²⁴ P. 249.
- ¹²⁵ P. 250.
- ¹²⁶ P. 301 n.
- ¹²⁷ P. 303.
- ¹²⁸ P. 314.
- ¹²⁹ Pp. 329f.
- ¹³⁰ P. 331.
- ¹³¹ Ibid.

¹ Cf. *The Birth of Tragedy* (trans. Hausmann), pp. 31ff. [The extracts appear here in modified form.—TRANS.]

² Ibid., p. 21.

³ Ibid., pp. 21f.

⁴ P. 23.

⁵ P. 24.

⁶ P. 25.

⁷ Pp. 63ff.

⁸ P. 26.

⁹ P. 27. Cf. *infra*, par. 230.

¹⁰ P. 27.

¹¹ Ibid.

¹² P. 30.

¹³ P. 32.

¹⁴ Aestheticism can, of course, take the place of the religious function. But how many things are there that could not do the same? What have we not come across at one time or another as a substitute for the absence of religion? Even though aestheticism may be a very noble substitute, it is nevertheless only a compensation for the real thing that is lacking. Moreover, Nietzsche's later "conversion" to Dionysus best shows that the aesthetic substitute did not stand the test of time.

¹⁵ *Thoughts Out of Season*, Part 2: "The Use and Abuse of History."

¹⁶ *Complete Works*, I, p. 6.

¹⁷ Ibid., p. 15.

¹⁸ Cf. *Poems* (trans. Arnold-Forster), p. 61.

¹ P. 5.

² [Cf. supra, par. 240, where the intuitive and sensation types are called the “aesthetic” types.—EDITORS.]

³ Pp. 17ff. [Although printed as quoted matter, this and the following two extracts (pars. 261, 265) are a mixture of Jung’s own summary and direct quotation. It would not be possible to quote Jordan verbatim without adding a great deal of irrelevant material. For the sake of easier reading, suspension points have been omitted. Only the extract in par. 269 is a direct quotation.—EDITORS.]

⁴ Pp. 9ff.

⁵ Pp. 26ff.

⁶ Pp. 35f., 40f.

- ¹ *Prometheus and Epimetheus* (trans. Muirhead), pp. 22f.
- ² Jung, *Two Essays on Analytical Psychology*, pars. 243ff., 254ff., 305ff.
- ³ Cf. Muirhead, p. 23.
- ⁴ Cf. *ibid.*, p. 22.
- ⁵ Cf. p. 38.
- ⁶ Cf. p. 38.
- ⁷ Cf. p. 24.
- ⁸ Cf. *ibid.*
- ⁹ [Literally, *-heit* and *-keit*.—TRANS.]
- ¹⁰ Cf. pp. 108f.
- ¹¹ *Character as Seen in Body and Parentage*, p. 31. [Cf. *supra*, par. 265.]
- ¹² *Werke* (ed. Beutler), IV, pp. 188f.
- ¹³ *Ibid.*, p. 189.
- ¹⁴ Cf. Muirhead, p. 38.
- ¹⁵ Cf. *ibid.*, p. 41.
- ¹⁶ From another Prometheus fragment, *Werke*, I, p. 321.
- ¹⁷ *Werke*, IV, p. 188.
- ¹⁸ “The Content of the Psychoses” and *Two Essays on Analytical Psychology*, pars. 221ff., 250ff.
- ¹⁹ Cf. Muirhead, p. 113.
- ²⁰ For the motifs of the jewel and rebirth, see *Symbols of Transformation*, Part II, chs. IV and V.
- ²¹ [Trans. Rajendralala Mitra, ch. VI, esp. p. 94.]
- ²² Cf. Muirhead, pp. 130f.
- ²³ Cf. p. 161. Spitteler depicts the famous “conscience” of Epimetheus as a little animal. It corresponds to the animal’s opportunist instinct.
- ²⁴ Muirhead, pp. 135ff.
- ²⁵ “Pandora,” *Werke*, VI, p. 407.
- ²⁶ *Ibid.*, pp. 429f.
- ²⁷ This may be compensated by an outburst of sociability or by an intensive social round in the eager pursuit of which forgetfulness is sought.
- ²⁸ Sometimes compensated by a morbid and feverish activity which likewise serves the purpose of repression.
- ²⁹ Cf. *Symbols of Transformation*, par. 417, end of quotation.
- ³⁰ Cf. *infra*, pars. 456ff.
- ³¹ Cf. Goethe’s “Geheimnisse,” *Werke*, III, pp. 273-83. Here the Rosicrucian solution is attempted: the union of Dionysus and Christ, rose and cross. The poem leaves one cold. One cannot pour new wine into old bottles.
- ³² Very often it is the older folk-elements that possess magical powers. In India it is the Nepalese, in Europe the gypsies, and in Protestant areas the Capuchins.

³³ [The pact with Behemoth (supra, par. 311), described in section 5 (infra, pars. 456ff.). The reader may find it helpful to read the whole of section 5 at this point, as it also describes (pars. 450ff.) the fate of the redeeming symbol, the jewel whose loss was mentioned earlier (pars. 300, 310).—EDITORS.]

³⁴ Dante, *Inferno*, XXXII.

³⁵ [A reference to Schopenhauer's *Die Welt als Wille und Vorstellung*.—EDITORS.]

³⁶ *Sacred Books of the East*, XXV, p. 13. [Since the existing English translations of the Sanskrit texts quoted in sections *a*, *b*, and *c* often differ widely from one another, and also from the German sources used by the author, both in meaning and in readability, the quotations given here are for the most part composites of the English and German versions, and in general lean towards the latter. For the purpose of comparison, standard translations are cited in the footnotes; full details are given in the bibliography.—TRANS.]

³⁷ [Source in the *Ramayana* untraceable.—EDITORS.]

³⁸ Cf. *The Laws of Manu*, SBE, XXV, p. 212.

³⁹ The famous exhortation of Krishna, *Bhagavad Gita* 2.45. [The three *gunas* are the qualities or constituents of organic matter: *tamas* (darkness, inertia), *rajas* (passion, impurity, activity), *sattva* (purity, clarity, harmony).—TRANSLATOR.]

⁴⁰ *Yogasutra* of Patanjali. Deussen, *Allgemeine Geschichte der Philosophie*, I, Part 3, p. 511.

⁴¹ *Kaushitaki Upanishad* 1.4. Cf. Hume, *The Thirteen Principal Upanishads*, pp. 304f.

⁴² *Tejobindu Upan.* 3. Cf. *Minor Upanishads*, p. 17.

⁴³ *Mahabharata* 1.119.8f. Cf. Dutt trans., 1, p. 168.

⁴⁴ *Ibid.* 14.19.4f. Cf. Dutt, XIV, p. 22.

⁴⁵ *Bhagavata Purana* 9.19.18f. Cf. *Brihadaranyaka Upan.* 3.5, in Hume, p. 112: "When he has become disgusted both with the non-ascetic state and with the ascetic state, then he becomes a Brahman."

⁴⁶ *Bhagavata Purana* 4.22.24.

⁴⁷ *Garuda Purana* 16.110. Cf. *Sacred Books of the Hindus*, XXVI, p. 167.

⁴⁸ Deussen, *Geschichte der Philosophie*, I, Part 2, p. 117.

⁴⁹ *Brihadaranyaka Upan.*, 2.3.1. Cf. Hume, p. 97.

⁵⁰ *Shvetashvatara Upan.* 4.17–8. Cf. Hume, p. 405.

⁵¹ *Shvet. Upan.* 5.1. Cf. Hume, p. 406.

⁵² *Katha Upan.* 2.20–1. Cf. Hume, pp. 349ff.

⁵³ *Isha Upan.* 4–5. Cf. Hume, pp. 362f. [Last two lines perhaps: "immanent, transcendent."—TRANSLATOR.]

⁵⁴ *Brihad. Upan.* 4.3.19, 21, 32. Cf. Hume, pp. 136ff.

⁵⁵ *Atharva Veda* 10.8.11. Cf. Whitney/Lanman trans., VIII, p. 597.

⁵⁶ *Symbols of Transformation*, pars. 204ff.

⁵⁷ *Shatapatha Brahmana* 14.1.3, 3. Cf. SBE, XLIV, pp. 459f.

⁵⁸ *Taittiriya Aranyaka* 10.63.15.

⁵⁹ *Vajasanayi Samhita* 23.48. Cf. Griffith trans., p. 215.

- ⁶⁰ *Shatapatha Brahmana* 8.5.3, 7. Cf. *SBE*, XLIII, p. 94.
- ⁶¹ [One meaning of Brahman is prayer, hymn, sacred knowledge, magic formula. Cf. par. 336.—TRANSLATOR.]
- ⁶² *Taittiriya Brahmana* 2.8.8, 8ff.
- ⁶³ *Atharva Veda* 10.5.1.
- ⁶⁴ *Ibid.* [For *tapas* (self-incubation) see *Symbols of Transformation*, pars. 588ff.]
- ⁶⁵ *Atharva Veda* 11.5.23f. Cf. Whitney/Lanman trans., VIII, pp. 639f.
- ⁶⁶ *Taittiriya Upan.* 2.8. Cf. Hume, p. 289.
- ⁶⁷ *Brihad. Upan.* 5.15. Cf. Hume, p. 157.
- ⁶⁸ *Chhandogya Upan.* 3.13.7. Cf. Hume, p. 209.
- ⁶⁹ *Shatapatha Brahmana* 10.6.3. Cf. *SBE*, XLIII, p. 400. [Cf. *Chhandogya Upan.* 3.14.3–4; Hume, p. 209.—TRANSLATOR.]
- ⁷⁰ *Atharva Veda* 10.2.17. Cf. Whitney/Lanman trans., VIII, p. 569.
- ⁷¹ Deussen, I, Part 1, pp. 240ff.
- ⁷² Also confirmed by the reference to Brahman, or breath (*prana*), as *mata-risvan*, ‘he who swells in the mother,’ in *Atharva Veda* 11.4.15. Cf. Whitney/Lanman trans., VIII, p. 63.
- ⁷³ [The above rendering is a composite of the Deussen version (Jung, *Gesammelte Werke*, 6, p. 217) translated by Baynes in the 1923 edn. (p. 251) of the present volume, and the Griffith version in *The Hymns of the Rigveda*, II, p. 426. The interested reader would do well to compare all four versions.—TRANSLATOR.]
- ⁷⁴ Prajapati is the cosmic creative principle = libido. *Taittiriya Samhita* 5.5.2, 1: “After he had created them, Prajapati instilled love into all his creatures.” Cf. Keith trans., II, p. 441.
- ⁷⁵ The begetting of fire in the mouth has remarkable connections with speech. Cf. *Symbols of Transformation*, pars. 208ff.
- ⁷⁶ Cf. the Dioscuri motif in *Symbols of Transformation*, par. 294.
- ⁷⁷ *Pañcavimsha Brahmana* 20.14.12. Cf. *Bibliotheca Indica*, vol. 252, pp. 145f.
- ⁷⁸ Weber, *Indische Studien*, IX, p. 477, as in Deussen, I, Part 1, p. 206.
- ⁷⁹ *Pañcavimsha Brahmana* 7.6.
- ⁸⁰ *Shatapatha Brahmana* 11.2.3. Cf. *SBE*, XXVI, pp. 27f.
- ⁸¹ [Jung, “A Review of the Complex Theory.”—EDITORS.]
- ⁸² Allusion to the horse, indicating the dynamic nature of *rta*.
- ⁸³ [Cf. *La Religion védique*, III, index I, s.v. *rita*.—EDITORS.]
- ⁸⁴ Agni is called the charioteer of *rta*. Cf. *Vedic Hymns*, *SBE*, XLVI, p. 158, 7 (*Rig Veda* 1.143.7), p. 160, 3 (*Rig Veda* 1.144.3), p. 229, 8 (*Rig Veda* 3.2.8).
- ⁸⁵ Oldenberg, “Zur Religion und Mythologie des Veda,” pp. 167ff., and *Die Religion des Veda*, pp. 194ff. For this reference I am indebted to Prof. E. Abegg, Zurich.
- ⁸⁶ Deussen, *Geschichte der Philosophie*, I, Part 1, p. 92.
- ⁸⁷ *Shatapatha Brahmana* 4.1.4, 10. Cf. *SBE*, XXVI, p. 272.

⁸⁸ *Atharva Veda* 10.10.33. Cf. Whitney/Lanman trans., II, p. 608.

⁸⁹ *Ibid.*, 12.1.61. Cf. Whitney/Lanman trans., II, p. 671.

⁹⁰ *Rig Veda* 1.65.3. (*Vedic Hymns*, SBE, XLVI, p. 54.)

⁹¹ 1.67.7. (Cf. p. 61.)

⁹² 4.12.2. (Cf. p. 393.)

⁹³ Release of libido is obtained through ritual work. The release puts the libido at the disposal of consciousness, where it becomes domesticated. From an instinctive, undomesticated state it is converted into a state of disposability. The following passage is an illustration of this: “The rulers, the bountiful lords, brought him (Agni) forth by their power out of the depths, out of the bull’s shape.” *Rig Veda* 1.141.3. (Cf. *Vedic Hymns*, p. 147.)

⁹⁴ *Rig Veda* 1.141.1. (Cf. *ibid.*)

⁹⁵ Cf. *The Song of Tishtriya (Tir Yasht)*, in *Symbols of Transformation*, pars. 395 and 439, n. 47.

⁹⁶ *Rig Veda* 1.73.6. (Cf. *Vedic Hymns*, p. 88.)

⁹⁷ 1.79.2–3. (Cf. p. 103.)

⁹⁸ *Ibid.*, p. 161, 7.

⁹⁹ 1.144.2. (Cf. p. 160, 2.)

¹⁰⁰ 3.6 (p. 244, 6) and 4.2 (p. 316, 3).

¹⁰¹ *Ibid.*, p. 382.

¹⁰² Cf. *The Joyful Wisdom*, p. 211.

¹⁰³ *Rig Veda* 1.142.6. (Cf. *Vedic Hymns*, p. 153, 8.)

¹⁰⁴ [Cf. *Symbols of Transformation*, pars. 102, 644.—TRANSLATOR.]

¹⁰⁵ Waley, trans., *The Way and Its Power*, p. 146. [This and the next quotation, unfortunately, contradict Jung’s statement that *tao* has a tinge of substantiality.—TRANSLATOR.]

¹⁰⁶ *Ibid.*, p. 174.

¹⁰⁷ P. 151.

¹⁰⁸ [Trans. from author’s German. Cf. Waley, p. 141.]

¹⁰⁹ P. 162.

¹¹⁰ P. 170.

¹¹¹ P. 192.

¹¹² P. 193.

¹¹³ P. 149.

¹¹⁴ [Trans. from author’s German. Cf. Waley, p. 172.]

¹¹⁵ P. 153.

¹¹⁶ P. 210.

¹¹⁷ P. 153.

¹¹⁸ P. 178.

¹¹⁹ P. 209.

- ¹²⁰ *Faust, Part One* (trans. Wayne), p. 67.
- ¹²¹ Inouye, “Die japanische Philosophie” in *Allg. Geschichte der Phil.*, pp. 84f.
- ¹²² *Ibid.*, p. 85. [Cf. Wang Yang-ming, *Instructions for Practical Living*, trans. Chan, sec. 207, pp. 193f.]
- ¹²³ [The following four paragraphs, though coming abruptly after the excursus on Chinese symbolism, may be taken as a bridge-passage to the Western solution of the problem of opposites discussed in section 4. This passage is of direct relevance to the interpretation and derivation of the *vas/Grail* symbol in pars. 394–401.—EDITORS.]
- ¹²⁴ *The Divine Comedy* (trans. L. G. White), p. 187.
- ¹²⁵ *Faust, Part Two* (trans. Wayne), pp. 284f., 288.
- ¹²⁶ [From the *Rituale Romanum*, trans. here by A. S. B. Glover.]
- ¹²⁷ [This and the following extracts were translated by an unknown hand (possibly by Baynes) from the German source used by the author. For an alternative version see *The Shepherd of Hermas* (trans. Kirsopp Lake), in *The Apostolic Fathers*, vol. 2.—TRANSLATOR.] Cf. *ibid.*, p. 7.
- ¹²⁸ Cf. *ibid.*, pp. 7–9.
- ¹²⁹ Cf. *ibid.*, pp. 27ff.
- ¹³⁰ *De institutione virginis*, cap. 9 (Migne, *P.L.*, vol. 16, col. 321).
- ¹³¹ [A. S. B. Glover, who made the following translation, points out that this *Sermo* is by *pseudo-Ambrose*. See bibliography s.v. *Ambrose*.—EDITORS.]
- ¹³² *Expositio beati Ambrosii Episcopi super Apocalypsin*, Visio 111, cap. 6, p. 38.
- ¹³³ [A. S. B. Glover was unable to locate this quotation.—EDITORS.]
- ¹³⁴ *Sermo* 192 (Migne, *P.L.*, vol. 38, col. 1013).
- ¹³⁵ *De institutione virginis*, cap. 5 (Migne, *P.L.*, vol. 16, col. 313).
- ¹³⁶ Ed. Bartsch, p. 216.
- ¹³⁷ *De institutione virginis*, cap. 14 (Migne, *P.L.*, vol. 16, col. 327).
- ¹³⁸ E.g., Salzer, *Sinnbilder und Beiworte Mariens*.
- ¹³⁹ *Adversus Judaeos*, XIII (Migne, *P.L.*, vol. 2, col. 635): “That virgin earth, not yet watered by the rains nor fecundated by showers.”
- ¹⁴⁰ *Sermones*, 189, II (Migne, *P.L.*, vol. 38, col. 1006): “Truth is arisen from the earth, because Christ is born of a virgin.”
- ¹⁴¹ Cf. Jung, “The Psychological Aspects of the Kore.”
- ¹⁴² Jacques Matter, *Histoire critique du gnosticisme*. [As cited by King, *The Gnostics and Their Remains*, p. 111.]
- ¹⁴³ King, *ibid.*
- ¹⁴⁴ [Possibly H.K.E. von Köhler, “Einleitung über die Gemmen mit dem Namen der Künstler.”—EDITORS.]
- ¹⁴⁵ *Symbols of Transformation*, pars. 528ff.
- ¹⁴⁶ Budge, *The Gods of the Egyptians*, I, p. 511.
- ¹⁴⁷ Talbot, *In the Shadow of the Bush*, pp. 67, 74ff.
- ¹⁴⁸ [Jung, *Aion*, chs. V and XIII.—EDITORS.]

¹⁴⁹ Further evidence of the pagan root of the vessel symbolism is the “magic cauldron” of Celtic mythology. Dagda, one of the benevolent gods of ancient Ireland, possesses such a cauldron, which supplies everybody with food according to his needs or merits. The Celtic god Bran likewise possesses a cauldron of renewal. It has even been suggested that the name Brons, one of the figures in the Grail legend, is derived from Bran. Alfred Nutt considers that Bran, lord of the cauldron, and Brons are steps in the transformation of the Celtic Peredur Saga into the quest of the Holy Grail. It would seem, therefore, that Grail motifs already existed in Celtic mythology. I am indebted to Dr. Maurice Nicoll, of London, for this information.

¹⁵⁰ [Pars. 399–400 = *Ges. Werke* 6, par. 447, which there follows our par. 401.—EDITORS.]

¹⁵¹ Cf. Evans, *Meister Eckhart*, II, p. 19.

¹⁵² Cf. Evans, pp. 18f.

¹⁵³ *Ibid.*, I, p. 188.

¹⁵⁴ Cf. *ibid.*, II, p. 8.

¹⁵⁵ The libido concept of the Bataks. Cf. Warneck, *Die Religion der Batak. Tondi* is the magic force round which every thing turns. [Cf. “On Psychic Energy.” par. 125.—EDITORS.]

¹⁵⁶ Cf. Evans, II, p. 7.

¹⁵⁷ Cf. *ibid.*, I, p. 270. [The last sentence contains an untranslatable play on words: “Gott ist selig (blissful) in der Seele (soul).”—TRANSLATOR.]

¹⁵⁸ The recognition of something as a projection should never be understood as a purely intellectual process. Intellectual insight dissolves a projection only when it is ripe for dissolution. But when it is not, it is impossible to withdraw libido from it by an intellectual judgment or by an act of the will.

¹⁵⁹ “Energy is eternal delight”: Blake, “The Marriage of Heaven and Hell,” *The Complete Writings* (ed. Keynes), p. 149.

¹⁶⁰ Cf. Evans, I, p. 271.

¹⁶¹ Cf. *ibid.*, p. 81.

¹⁶² According to Eckhart, the soul is as much the comprehender as the comprehended. Evans, I, p. 389.

¹⁶³ Literary examples are E. T. A. Hoffmann, Meyrink, Barlach (*Der tote Tag*), and, on a higher level, Spitteler, Goethe, Wagner.

¹⁶⁴ E.g., Nietzsche’s *Zarathustra*.

¹⁶⁵ See *infra*, par. 828. Cf. also “The Transcendent Function.”

¹⁶⁶ Eckhart says: “Therefore do I turn back once more to myself, there do I find the deepest places, deeper than hell itself; for even from there does my wretchedness drive me. Nowhere can I escape myself! Here I will set me down and here I will remain.” Cf. Evans, I, p. 389.

¹⁶⁷ Cf. *ibid.*, p. 410.

¹⁶⁸ Cf. *ibid.*, p. 143.

¹⁶⁹ Cf. *ibid.*

¹⁷⁰ Cf. p. 221.

¹⁷¹ Spencer and Gillen, *The Northern Tribes of Central Australia*.

- ¹⁷² [Johann Scheffer, mystic and doctor, 1624–1677.—EDITORS.]
- ¹⁷³ From the “Cherubinischer Wandersmann” in Scheffler’s *Sämmtliche Poetische Werke* (ed. Rosenthal), I, pp. 5ff. [The twelve stanzas do not constitute one continuous poem, but are respectively aphorisms Nos. I,8; I,96; I,10; I,11; I,18; I,224; III,140; I,212; I,106; II,122; I,256; I,115.—EDITORS.]
- ¹⁷⁴ Cf. *Prometheus and Epimetheus* (trans. Muirhead), p. 114.
- ¹⁷⁵ *Ibid.*, p. 131.
- ¹⁷⁶ *Ibid.*, pp. 135f.
- ¹⁷⁷ P. 132.
- ¹⁷⁸ Cf. *ibid.*
- ¹⁷⁹ Pp. 30f.
- ¹⁸⁰ Cf. *Prometheus and Epimetheus*, pp. 140f.
- ¹⁸¹ *Lyra Germanica: Second Series*. Trans. from the *Gesangbuch der evangelisch-reformierten Kirchen der deutschsprachigen Schweiz* by Catherine Winkworth, pp. 53f.
- ¹⁸² John 1:46.
- ¹⁸³ Isaiah 11:6ff.
- ¹⁸⁴ Jung, “The Psychology of the Child Archetype.”
- ¹⁸⁵ Isaiah 9:6.
- ¹⁸⁶ Isaiah 26:17–19.
- ¹⁸⁷ *Supra*, pars. 111ff.
- ¹⁸⁸ *Das Zeitalter des Sonnengottes*. Cf. *Symbols of Transformation*, par. 309.
- ¹⁸⁹ Isaiah 27:1.
- ¹⁹⁰ P. 30. [Cf. Neumann, *The Origins and History of Consciousness*, pp. 165ff., 174, 186.—EDITORS.]
- ¹⁹¹ *Symbols of Transformation*, Part II, chs. V and VII, esp. pars. 394, 379ff., 580. In Spitteler, the parallel of the slaying of Leviathan is the overpowering of Behemoth.
- ¹⁹² 8:1 and 3 (AV): Maher-shalal-hash-baz.
- ¹⁹³ Isaiah 7:16; 8:1, 3, 4; 8:6–8 (AV and DV, mod.).
- ¹⁹⁴ *Symbols of Transformation*, Part II, chs. V–VII.
- ¹⁹⁵ Cf. *Prometheus and Epimetheus*, p. 136.
- ¹⁹⁶ Cf. *ibid.*, p. 142.
- ¹⁹⁷ Cf. p. 144.
- ¹⁹⁸ Cf. p. 146.
- ¹⁹⁹ Cf. p. 149.
- ²⁰⁰ *Ibid.*, p. 164.
- ²⁰¹ König, *Ahasver*. [Cf. *Symbols of Transformation*, par. 282.—EDITORS.]
- ²⁰² Spitteler, p. 179.
- ²⁰³ Cf. *Symbols of Transformation*, pars. 87ff. Also Schärf, *Satan in the Old Testament*, pp. 51, 127.

²⁰⁴ Spitteler—significantly enough—makes Astarte the daughter of Behemoth.

²⁰⁵ Cf. Flourney, “Une Mystique moderne.”

²⁰⁶ Cf. Evans, I, p. 246.

²⁰⁷ For further documentation see *Symbols of Transformation*, pars. 309ff., 375ff., 538n.

²⁰⁸ [Cf. *Psychology and Alchemy*, par. 305.—EDITORS.]

²⁰⁹ “The Marriage of Heaven and Hell,” *The Complete Writings of William Blake* (ed. Keynes), p. 155.

¹ Gross gives a revised though essentially unaltered account of his types in his book *Über psychopathische Minderwertigkeiten*, pp. 27ff.

² *Studies in Word-Association*.

³ “Untersuchungen über die sprachliche Komponente der Assoziation.”

⁴ Elsewhere (*Psychopath. Minderw.*, p. 41) Gross draws a distinction, rightly, in my opinion, between the “over-valued idea” and what he calls the “over-valued complex.” The latter is characteristic not only of this type, as Gross thinks, but also of the other. The “conflict complex” always has considerable value because of its high feeling-tone, no matter in which type it may appear.

⁵ Bjerre, “Zur Radikalbehandlung der chronischen Paranoia,” pp. 795ff.

⁶ *Psychopath. Minderw.*, p. 40.

⁷ *Ibid.*, p. 37.

⁸ *Die zerebrale Sekundärfunktion*, pp. 58f.

⁹ Cf. *supra*, par. 265, Jordan’s remarks on the Extraverted Man.

¹⁰ *Die zerebrale Sekundärfunktion*, p. 63.

¹¹ *Ibid.*, p. 64.

¹² *Ibid.*, p. 65.

¹³ *Ibid.*

¹⁴ *Ibid.*, pp. 68f.

¹⁵ [Cf. *supra*, par. 110, n. 8.—TRANSLATOR.]

¹⁶ *Ibid.*, p. 12. See also *Psychopath. Minderw.*, pp. 30, 37.

¹⁷ This tension or relaxation can sometimes be perceived even in the muscle tone. Usually one can see it in the facial expression.

¹ *Abstraction and Empathy* (trans. Bullock).

² *Leitfaden der Psychologie*, pp. 193f.

³ By externalization Jodl means the localizing of sense-perception in space. We neither hear sounds in the ear nor see colours in the eye, but in the spatially localized object. Jodl, *Lehrbuch der Psychologie*, II, p. 223.

⁴ *Ibid.*, p. 396.

⁵ *Grundzüge der physiologischen Psychologie*, III, p. 191.

⁶ *Abstraction and Empathy*, p. 5.

⁷ *Aesthetik*, p. 247.

⁸ *Abstraction and Empathy*, p. 14.

⁹ [Worringer was mistaken about both the author and the quotation. The above words cannot be traced in Tibullus. But the following may be found in Statius (*Thebaid*, Book 3, line 661): “Primus in orbe deos fecit timor” (fear was what first brought gods into the world). This, obviously, expresses the sense of Worringer’s argument.—EDITORS.]

¹⁰ Cf. *Abstraction and Empathy*, p. 15.

¹¹ Cf. *ibid.*, p. 16.

¹² Cf. *ibid.*, p. 19.

¹³ Condensed from Warren, *Buddhism in Translations*, p. 352.

¹⁴ Cf. Spencer and Gillen, *The Northern Tribes of Central Australia*.

¹⁵ Because the unconscious contents of the empathetic type are themselves relatively unactivated.

¹⁶ *Abstraction and Empathy*, p. 24.

¹⁷ Cf. *ibid.*

¹⁸ Friedrich Theodor Vischer, in his novel *Auch Einer*, gives an excellent description of “animated” objects.

¹⁹ On directed thinking, see *Symbols of Transformation*, Part I, ch. II.

¹ *Pragmatism: A New Name for Some Old Ways of Thinking.*

² *Ibid.*, pp. 7f.

³ *The Philosophy of William James.*

⁴ *Ibid.*, pp. 24f.

⁵ *Supra*, par. 69.

⁶ *Handbook of Psychology: Sense and Intellect*, p. 312.

⁷ *Psychologie als Wissenschaft*, sec. 117.

⁸ *The World as Will and Idea* (trans. Haldane and Kemp), I, p. 50.

⁹ *Ibid.*, p. 48.

¹⁰ *Lehrbuch der Psychologie*, p. 195.

¹¹ *Logik*, I, sec. 1, par. 3, n. 2 (*Werke*, ed. Cassirer, VIII, p. 400).

¹² *Grundzüge der physiologischen Psychologie*, III, pp. 582f.

¹³ *Pragmatism*, p. 13. The Bostonians are noted for their high-brow aestheticism. Cripple Creek is a mining district in Colorado. "Each type believes the other to be inferior to itself; but disdain in the one case is mingled with amusement, in the other it has a dash of fear" (*ibid.*).

¹⁴ *Ibid.*, p. 15.

¹⁵ See *infra*, Def. 7.

¹⁶ F.C.S. Schiller, *Humanism*. [Schiller says (2nd edn., 1912, p. 5): "James first unequivocally advanced the pragmatist doctrine in connexion with what he called the 'Will to believe.' He had, however, laid the foundation of his doctrine long before in an article in *Mind* (1879)." James appears to have used the word first in an article in 1898 (see *Oxf. Eng. Dict.*), in which he wrote "... pragmatism, as he [C. S. Peirce] called it, when I first heard him enunciate it at Cambridge [Mass.] in the early '70's."—EDITORS.]

¹ *Grosse Männer*.

² *Ibid.*, pp. 44f.

³ *Ibid.*, p. 280.

⁴ P. 372. [Cf. *infra*, Appendix, pars. 883, 960.—EDITORS.]

⁵ *Grosse Männer*, p. 377.

¹ Supra, par. 460.

² [For a detailed discussion of this case, see “The Tavistock Lectures,” *Coll. Works*, vol. 18, pars. 161ff.—EDITORS.]

³ [“The Sybarite: A Guide to the Ruthless Enjoyment of Life.”—TRANS.]

⁴ Supra, par. 563.

⁵ *Die Mneme als erhaltendes Prinzip im Wechsel des organischen Geschehens* (trans. by L. Simon: *The Mneme*).

⁶ “Instinct and the Unconscious,” pars. 270ff.

⁷ [Cf. *Symbols of Transformation*, par. 45, n. 45.—EDITORS.]

⁸ [Especially pars. 746ff.—EDITORS.]

⁹ Kubin, *The Other Side*, and Meyrink, *Das grüne Gesicht*.

- ¹ *Studies in Word-Association*.
- ² Sully, *The Human Mind*, II, ch. 16.
- ³ Nahlowsky, *Das Gefühlsleben*, p. 48.
- ⁴ Kant, *Logik*, I, par. 6. (*Werke*, ed. Cassirer, VIII, p. 403.)
- ⁵ Wundt, *Grundzüge der physiologischen Psychologie*, pp. 209ff.
- ⁶ Féré, “Note sur des modifications de la résistance électrique,” pp. 217ff.; Veraguth, “Das psychogalvanische Reflexphänomen,” pp. 387ff.; Binswanger “On the Psychogalvanic Phenomenon in Association Experiments,” in *Studies in Word-Association*, pp. 446ff.; Jung, “On the Psychophysical Relations of the Association Experiment.”
- ⁷ Bleuler, *Affektivität, Suggestibilität, Paranoia*, p. 6.
- ⁸ *Ibid.*, pp. 13f.
- ⁹ Wundt, *Grundzüge der physiologischen Psychologie*, I, p. 322.
- ¹⁰ Jung, *Symbols of Transformation*.
- ¹¹ [Note by Editors of the *Gesammelte Werke*: “The structure of the archetype was always central to Jung’s investigations, but the formulation of the concept took place only in the course of the years.”] [For a helpful survey of the development of the concept, see Jacobi, *Complex/Archetype/Symbol*.—EDITORS.]
- ¹² Wundt, *Logik*, I, p. 23.
- ¹³ Lipps, *Leitfaden der Psychologie*, p. 104.
- ¹⁴ Wundt, *Grundzüge*, III, p. 529.
- ¹⁵ “Ueber die psychologischen Grundlagen der Vergleichung gehobener Gewichte,” pp. 37ff.
- ¹⁶ *Grundriss der Psychologie*, p. 44.
- ¹⁷ *Grundzüge der Psychologie*, I, pp. 681f.
- ¹⁸ *How Natives Think*, pp. 35ff.
- ¹⁹ *Ibid.*, pp. 36f.
- ²⁰ *The Neurotic Constitution*. References to the theory of compensation, originally inspired by G. Anton, are also to be found in Gross.
- ²¹ *Study of Organ Inferiority and Its Psychological Compensation*, p. 73.
- ²² Cf. *The Neurotic Constitution*, p. 7.
- ²³ Cf. *ibid.*, p. 14. [*Hilfskonstruktion*; see also p. xii.—TRANS.]
- ²⁴ Jung, “On the Importance of the Unconscious in Psychopathology,” pars. 409ff.
- ²⁵ Natorp, *Einleitung in die Psychologie nach kritischer Methode*, p. 11. Cf. also Lipps, *Leitfaden der Psychologie*, p. 3.
- ²⁶ Riehl, *Zur Einführung in die Philosophie der Gegenwart*, p. 161. Riehl considers consciousness an “activity” or “process.”
- ²⁷ Jung, “The Psychology of Dementia Praecox.” [See also “A Review of the Complex Theory.”—EDITORS.]
- ²⁸ Jung, *Two Essays on Analytical Psychology*, pars. 121ff.

²⁹ For a detailed example of this see my “On the Psychology and Pathology of So-called Occult Phenomena,” esp. par. 136.

³⁰ *The Dream Problem*, p. 30.

³¹ *The Neurotic Constitution*.

³² *The Interpretation of Dreams* (Standard Edition, vol. 4), p. 233.

³³ Silberer (*Problems of Mysticism and Its Symbolism*, pp. 241ff.) expresses himself in a similar way in his formulation of *anagogic* significance.

³⁴ Bleuler, “Die negative Suggestibilität,” *Psychiatrisch-neurologische Wochenschrift*, vol. 6, pp. 249ff.; *The Theory of Schizophrenic Negativism* (orig. in *ibid.*, vol. 12, pp. 171, 189, 195); *Textbook of Psychiatry*, pp. 130, 382. [See also *supra*, par. 684.—EDITORS.]

³⁵ “The Psychology of Dementia Praecox,” *Psychiatric Studies*, index, s.v., “ego-complex.”

³⁶ [This appeared as Def. 21, FEELING-INTO, in the Baynes translation.—EDITORS.]

³⁷ Stobaeus, *Eclogae physicae*, 1, 60: *εἰμαρμένην δὲ λόγον ἐκ τῆς ἐναντιοδρομίας δημιουργὸν τῶν ὄντων*. (“Fate is the logical product of enantiodromia, creator of all things.”)

³⁸ Zeller, *A History of Greek Philosophy*, II, p. 17.

³⁹ Cf. Gomperz, *Greek Thinkers*, I, p. 64.

⁴⁰ Cf. Burnet, *Early Greek Philosophy*, pp. 133ff., Fragments 46, 45, 66, 67, 68, 22, 69.

⁴¹ [Ramon Llull, 1234–1315. Cf. “The Psychology of Dementia Praecox,” par. 89.—EDITORS.]

⁴² [This appeared as Def. 41, PHANTASY, in the Baynes translation.—EDITORS.]

⁴³ Acts 9:3ff.

⁴⁴ Acts 10:10ff. and 11:4ff.

⁴⁵ [Imaginative activity is therefore not to be confused with “active imagination,” a psychotherapeutic method developed by Jung himself. Active imagination corresponds to the definitions of *active fantasy* in pars. 712–14. The method of active imagination (though not called by that name) may be found in “The Aims of Psychotherapy,” pars. 101–6, “The Transcendent Function,” pars. 166ff., “On the Nature of the Psyche,” pars. 400–2, and *Two Essays on Analytical Psychology*, pars. 343ff., 366. The term “active imagination” was used for the first time in “The Tavistock Lectures” (delivered in London, 1935), first published as *Analytical Psychology: Its Theory and Practice* (1968), now in *Coll. Works*, vol. 18. The method is described there in pars. 391ff. Further descriptions occur in *Mysterium Coniunctionis*, esp. pars. 706, 749–54.—EDITORS.]

⁴⁶ [This appeared as Def. 20 in the Baynes translation.—EDITORS.]

⁴⁷ For the history both of the theory and concept of feeling, see Wundt, *Outlines of Psychology*, pp. 33ff.; Nahlowsky, *Das Gefühlsleben in seinen wesentlichen Erscheinungen*; Ribot, *The Psychology of the Emotions*; Lehmann, *Die Hauptgesetze des menschlichen Gefühlslebens*; Villa, *Contemporary Psychology*, pp. 182ff.

⁴⁸ For the distinction between feeling and sensation, see Wundt, *Grundzüge der physiologischen Psychologie*, I, pp. 350ff.

⁴⁹ “Was soll uns Kant nicht sein?,” *Philosophische Studien*, VII, p. 13.

⁵⁰ Cf. Kant, *Critique of Pure Reason* (trans. Kemp Smith), p. 319.

⁵¹ *Logik*, I, sec. 1, par. 3 (*Werke*, ed. Cassirer, VIII, p. 400). [Cf. supra, par. 519, n. 11.]

⁵² *Critique of Pure Reason*, pp. 319ff.

⁵³ Cf. *The World as Will and Idea*, I, p. 168.

⁵⁴ *Ibid.*, p. 302. See also infra, par. 752.

⁵⁵ *Einleitung in die Aesthetik (Sämtliche Werke, XII)*, Part I, ch. 1, i.

⁵⁶ *The Logic of Hegel* (trans. Wallace), p. 356.

⁵⁷ *Wirklichkeiten: Beiträge zur Weltverständnis*, pp. 152, 154.

⁵⁸ *Logik der reinen Erkenntnis*, pp. 14, 18.

⁵⁹ Supra, pars. 108f., 158ff.

⁶⁰ A striking example of an archaic image is that of the solar phallus, *Symbols of Transformation*, pars. 151ff.

⁶¹ Jung, “Instinct and the Unconscious,” pars. 270ff. See also supra, par. 624.

⁶² [In a letter to Freud, Nov. 11, 1912, reporting on a recent visit to the United States, Jung wrote: “I analyzed fifteen Negroes in Washington, with demonstrations.” He did this at St. Elizabeths Hospital (a government facility) through the cooperation of its director, Dr. William Alanson White; see *Symbols of Transformation*, par. 154 and n. 52. In late 1912 Jung had already written and partially published *Wandlungen und Symbole der Libido*, and he mentioned the research on Negroes only in its revision. *Symbols of Transformation* (orig. 1952). Cf. also “The Tavistock Lectures,” par. 79.—EDITORS.]

⁶³ [This paragraph has been somewhat revised in *Gesammelte Werke*, vol. 6, and the translation reproduces the revisions.—EDITORS.]

⁶⁴ Cf. *The World as Will and Idea*, I, pp. 302f.

⁶⁵ *Critique of Pure Reason*, p. 314.

⁶⁶ *Der menschliche Weltbegriff*, pp. 25ff.

⁶⁷ “Introjection and Transference,” *First Contributions to Psychoanalysis*, pp. 47f.

⁶⁸ The credit for having discovered the existence of this type belongs to Miss M. Moltzer. [Mary Moltzer, daughter of a Netherlands distiller, took up nursing as a personal gesture against alcoholic abuse and moved to Zurich. She studied under Jung, became an analytical psychologist, and was joint translator of his *The Theory of Psychoanalysis* (see vol. 4, p. 83 and par. 458). She attended the international congress of psychoanalysts at Weimar, 1911.—EDITORS.]

⁶⁹ Jung, “Synchronicity: An Acausal Connecting Principle.”

⁷⁰ *Symbols of Transformation*, Part II, chs. II and III, and “On Psychic Energy,” pars. 7ff.

⁷¹ *How Natives Think*.

⁷² [This definition was written for the *Gesammelte Werke* edition. It may be of interest to note that the definition here given of the self as “the whole range of psychic phenomena in man” is almost identical with the definition of the psyche as “the totality of all psychic processes, conscious as well as unconscious” (par. 797). The inference would seem to be that every individual, by virtue of having, or being, a psyche, is potentially the self. It is only a question of “realizing” it. But the realization, if ever achieved, is the work of a lifetime.—EDITORS.]

⁷³ [Jung, “A Study in the Process of Individuation” and “Concerning Mandala Symbolism.”—EDITORS.]

⁷⁴ [The full quotation is “Deus est circulus cuius centrum est ubique, circumferentia vero nusquam” (God is a circle whose centre is everywhere and the circumference nowhere); see “A Psychological Approach to the Dogma of the Trinity,” par. 229, n. 6. In this form the saying is a variant of one attributed to St. Bonaventure (*Itinerarium mentis in Deum*, 5): “Deus est figura intellectualis cuius centrum ...” (God is an intelligible sphere whose centre ...); see *Mysterium Coniunctionis*, par. 41, n. 42. For more documentation see Borges, “Pascal’s Sphere.”—EDITORS.]

⁷⁵ [Concerning the *tetraktys* see *Psychology and Alchemy*, par. 189; “Commentary on The Secret of the Golden Flower,” par. 31; *Psychology and Religion: West and East*, pars. 61, 90, 246.—EDITORS.]

⁷⁶ [The quaternity figures so largely in Jung’s later writings that the reader who is interested in its numerous significations, including that of a symbol of the self, should consult the indexes (s.v. “quaternity,” “self”) of *Coll. Works*, vols. 9, Parts I and II, 11, 12, 13, 14.—EDITORS.]

⁷⁷ For the history of the concept of sensation see Wundt, *Grundzüge der physiologischen Psychologie*, I, pp. 350ff.; Dessoir, *Geschichte der neueren Psychologie*; Villa, *Contemporary Psychology*; Hartmann, *Die moderne Psychologie*.

⁷⁸ Azam, *Hypnotisme, double conscience, et altérations de la personnalité*; Prince, *The Dissociation of a Personality*; Landmann, *Die Mehrheit geistiger Persönlichkeiten in einem Individuum*; Ribot, *Die Persönlichkeit*; Flournoy, *From India to the Planet Mars*; Jung, “On the Psychology and Pathology of So-called Occult Phenomena.”

⁷⁹ *Two Essays on Analytical Psychology*, pars. 243ff.

⁸⁰ [In the German text the word *Anima* is used only twice: here and at the beginning of par. 805. Everywhere else the word used is *Seele* (soul). In this translation *anima* is substituted for “soul” when it refers specifically to the feminine component in a man, just as in Def. 49 (SOUL-IMAGE) *animus* is substituted for “soul” when it refers specifically to the masculine component in a woman. “Soul” is retained only when it refers to the psychic factor common to both sexes. The distinction is not always easy to make, and the reader may prefer to translate *anima/animus* back into “soul” on occasions when this would help to clarify Jung’s argument. For a discussion of this question and the problems involved in translating *Seele* see *Psychology and Alchemy*, par. 9 n. 8. See also *Two Essays on Analytical Psychology*, pars. 296ff., for the relations between *anima/animus* and *persona*.—EDITORS.]

⁸¹ [See n. 80.—EDITORS.]

⁸² *I simboli in rapporto alla storia e filosofia del dicetto*.

⁸³ [*Goethe’s Faust* (trans. MacNeice), p. 22.]

⁸⁴ *The Psychopathology of Everyday Life*.

⁸⁵ *Symbols of Transformation*, pars. 11 ff.

⁸⁶ *Ibid.*, par. 20.

⁸⁷ [Cf. *ibid.*, par. 18, citing James, *The Principles of Psychology*, II, p. 325.]

⁸⁸ [Hence the types belonging to the introverted or extraverted class are called *attitude-types*. Cf. *supra*, par. 556, and *Two Essays on Analytical Psychology*, Part I, ch. IV.—EDITORS.]

⁸⁹ “A Contribution to the Study of Psychological Types,” *infra*, [Appendix 1](#); “The Psychology of the Unconscious Processes,” *Collected Papers on Analytical Psychology*, pp. 391 ff., 401 ff.; “The Structure of the Unconscious,” *Two Essays on Analytical Psychology*, pars. 462, n. 8, and 482.

⁹⁰ Flournoy, *From India to the Planet Mars*; Jung, “On the Psychology and Pathology of So-called Occult Phenomena,” pars. 139ff., and “Cryptomnesia.”

¹ [*Symbols of Transformation*, par. 154, and supra, par. 747 and n. 62.—EDITORS.]

² [Vision of the solar phallus. *Symbols of Transformation*, pars. 151ff.; “The Structure of the Psyche,” pars. 31ff.; “The Concept of the Collective Unconscious,” pars. 104ff.]

³ *Symbols of Transformation*.

⁴ “On Psychological Understanding,” pars. 391ff. [Also *Two Essays on Analytical Psychology*, pars. 121ff.]

⁵ [“Explanatory principles are not to be multiplied beyond the necessary”: Occam’s Razor.—TRANSLATOR.]

¹ [A lecture delivered at the Psychoanalytical Congress in Munich during September 1913 (the last time Jung and Freud met), but not published in German until 1960, as “Zur Frage der psychologischen Typen,” in *Gesammelte Werke*, 6, Appendix, pp. 541ff. A French translation, incorporating the author’s revisions, appeared in the *Archives de psychologie* (Geneva), XIII:52 (Dec. 1913), 289–99, and was translated into English by C. E. Long, as “A Contribution to the Study of Psychological Types,” in *Collected Papers on Analytical Psychology* (London and New York, 1916), pp. 287ff. The present version is based on a comparison of the German original with the previous French and English translations.—EDITORS.]

^{1a} [Reference cannot be traced.]

² [“Constitutional Factors in the Dementia Praecox Group” (1910).—EDITORS.]

³ *Pragmatism*, p. 7. Cf. also supra, pars. 505ff.

⁴ *Ibid.*, p. 12.

⁵ *Ibid.*

⁶ *Ibid.*, p. 16.

⁷ *Ibid.*, p. 12.

⁸ *Ibid.*, p. 15.

⁹ *Grosse Männer*. Cf. supra, pars. 542ff.

¹⁰ *Abstraction and Empathy*. Cf. supra, pars. 484ff.

¹¹ *Ibid.*, pp. 9f. [Worringer refers to Riegl, *Stilfragen* and *Spätromische Kunstindustrie*.]

¹² Cf. *ibid.*, p. 4.

¹³ Cited in *ibid.*, p. 5.

¹⁴ *Ibid.*

¹⁵ Cf. *ibid.*

¹⁶ Cf. *ibid.*, p. 14.

¹⁷ Cf. *ibid.*, p. 15. [See supra, par. 488.]

¹⁸ Cf. *ibid.*

¹⁹ “Über naive und sentimentalische Dichtung” (Cottasche Ausgabe, XVIII), pp. 205ff.

²⁰ *Ibid.*, p. 248.

²¹ *Ibid.*, p. 249.

²² *Ibid.*, p. 244.

²³ Cf. supra, pars. 223ff.

²⁴ Cf. *The World as Will and Idea*, p. 455.

²⁵ Cf. *The Birth of Tragedy*, p. 125.

²⁶ Cf. *ibid.*, pp. 26f.

²⁷ *Der deutsche Sprachbau als Ausdruck deutscher Weltanschauung*.

²⁸ *Die zerebrale Sekundärfunktion*. Cf. supra, pars. 461ff.

²⁹ *The Neurotic Constitution*.

¹ [A lecture delivered at the International Congress of Education, Territet, Switzerland, 1923, and published as “Psychologische Typen,” in the *Zeitschrift für Menschenkunde* (Kampen a. Sylt), I:1 (May 1925), 45–65. First translated into English in *Problems of Personality, Studies presented to Dr. Morton Prince* (London and New York, 1925), pp. 289–302; retranslated by H. G. and C. F. Baynes in *Contributions to Analytical Psychology* (London and New York, 1928), pp. 295ff. The present translation is made from the republication in *Gesammelte Werke*, 6, Appendix, pp. 552ff., in consultation with the Baynes version.—EDITORS.]

² *Contra epistolam Manichaei*, V, 6 (Migne, *P.L.*, vol. 42, col. 176).

³ [Cf. *Psychology and Alchemy*, par. 314, n. 143, and fig. 102.]

¹ [A lecture delivered at the Congress of Swiss Psychiatrists, Zurich, 1928, and published as “Psychologische Typologie” in *Seelenprobleme der Gegenwart* (Zurich, 1931), pp. 101ff., reprinted in *Gesammelte Werke*, 6, Appendix, pp. 568ff. Translated into English by W. S. Dell and Cary F. Baynes as “A Psychological Theory of Types,” in *Modern Man in Search of a Soul* (London and New York, 1933), pp. 85ff., which version is reproduced here with minor modifications.—EDITORS.]

² *Supra*, pars. 858ff.

¹ [First published as “Psychologische Typologie” in *Süddeutsche Monatshefte*, XXXIII: 5 (Feb. 1936), 264–72. Reprinted in *Gesammelte Werke*, 6, Appendix, pp. 587ff., from which the present version is newly translated.—EDITORS.]

² [As Onians (*The Origins of European Thought*, pp. 26ff.) has shown, *phrenes* in Homer were the lungs.—EDITORS.]

³ [Jung, *Memories, Dreams, Reflections*, p. 248.]

⁴ [*Phaedrus* 246, 253–54.]

⁵ [Zündel, *Pfarrer J. C. Blumhardt: Ein Lebensbild*.]

⁶ [Görres, *Die christliche Mystik*.]

⁷ *Supra*, pars. 101 ff.

* For details of *The Collected Works of C. G. Jung*, see list at the end of this volume.

- * Published 1957; 2nd edn., 1970.
- † Published 1973.
- Published 1960.
- † Published 1961.
- ‡ Published 1956; 2nd edn., 1967. (65 plates, 43 text figures.)
- Published 1971.
- † Published 1953; 2nd edn., 1966.
- ‡ Published 1960; 2nd edn., 1969.
- Published 1959; 2nd edn., 1968. (Part I: 79 plates, with 29 in colour.)
- Published 1964; 2nd edn., 1970. (8 plates.)
- † Published 1958; 2nd edn., 1969.
- * Published 1953; 2nd edn., completely revised, 1968. (270 illustrations.)
- † Published 1968. (50 plates, 4 text figures.)
- ‡ Published 1963; 2nd edn., 1970. (10 plates.)
- * Published 1966.
- † Published 1954; 2nd edn., revised and augmented, 1966. (13 illustrations.)
- ‡ Published 1954.

BOLLINGEN SERIES XX

THE COLLECTED WORKS

OF

C. G. JUNG

VOLUME 7

EDITORS

†SIR HERBERT READ

MICHAEL FORDHAM, M.D., M.R.C.P.

GERHARD ADLER, PH.D.

WILLIAM MCGUIRE, *executive editor*

**TWO ESSAYS IN
ANALYTICAL
PSYCHOLOGY**

C. G. JUNG

SECOND EDITION

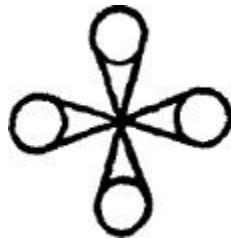

TRANSLATED BY R. F. C. HULL

BOLLINGEN SERIES XX

PRINCETON UNIVERSITY PRESS

COPYRIGHT 1953 BY BOLLINGEN FOUNDATION INC., NEW YORK, N.Y. NEW MATERIAL COPYRIGHT
© 1966 BY BOLLINGEN FOUNDATION PUBLISHED BY PRINCETON UNIVERSITY PRESS, PRINCETON,
N.J. ALL RIGHTS RESERVED

Second edition, revised and augmented, 1966

First Princeton / Bollingen Paperback Printing, 1972

THE HARDCOVER EDITION IS PUBLISHED IN THE UNITED
STATES OF AMERICA BY PRINCETON UNIVERSITY PRESS
AND IN ENGLAND BY ROUTLEDGE AND KEGAN PAUL, LTD.

IN THE AMERICAN EDITION, ALL THE VOLUMES
COMPRISING THE COLLECTED WORKS CONSTITUTE
NUMBER XX IN BOLLINGEN SERIES. THE PRESENT VOLUME
IS NUMBER 7 OF THE COLLECTED WORKS AND WAS THE
SECOND TO APPEAR.

The two principal works in this volume are
translated from *Über die Psychologie des
Unbewussten* (1943) and *Die Beziehungen zwischen
dem Ich und dem Unbewussten* (1928; 2nd edn.,
1935), published by Rascher Verlag, Zurich.

The first edition was published in a Meridian Books paperback edition (New
York, 1956)

LIBRARY OF CONGRESS CATALOGUE CARD NUMBER: 75-156

ISBN 0-691-01782-4 (paperback edn.)

ISBN 0-691-09776-3 (hardcover edn.)

MANUFACTURED IN THE U.S.A.

EDITORIAL NOTE TO THE FIRST EDITION

“The Structure of the Unconscious” and “New Paths in Psychology” together marked a turning point in the history of analytical psychology, for they revealed the foundations upon which the greater part of Professor Jung’s later work was built.

Both these essays were considerably revised and expanded for the successive editions mentioned in the Prefaces to the present volume. These Prefaces indicate the extent of the changes which were made on each occasion. As C. F. and H. G. Baynes say in the introduction to their English translation of an intermediate version, where the title *Two Essays in Analytical Psychology* was used for the first time: “Of the first essay only the framework of its earlier form can be recognized, and so much new material has been added to the second essay that both works start afresh, so to speak, full of the amazing vitality of Jung’s mind.” The essays are indeed remarkable for the number of revisions to which they have been subjected, each reflecting a new development of thought based upon increasingly fruitful researches into the unconscious.

However interesting the intermediate versions may be in themselves, the original drafts of these essays are undoubtedly far more significant to the student of analytical psychology. They contain the first tentative formulations of Jung’s concept of archetypes and the collective unconscious, as well as his germinating theory of types. This theory was put forward, partially at least, as an attempt to explain the conflicts within the psychoanalytic school, of which he had been so prominent a member and from which he had so recently seceded.

With these considerations in mind the Editors decided to include the original drafts of these two essays in separate Appendices. It was felt that their historical interest fully justified the duplication of reading matter which comparison of the texts would involve.

Acknowledgment is gratefully made of the kindness of Faber and Faber, Ltd., London, and the Oxford University Press, New York, in permitting quotation from the Louis MacNeice translation of Goethe’s *Faust*.

EDITORIAL NOTE TO THE SECOND EDITION

When the stock of the first edition of this volume was exhausted, twelve years after its first publication, the publishers undertook a complete resetting of type rather than a corrected reprint, as the result of research among Professor Jung's posthumous papers.

The text of Appendix 1, "New Paths in Psychology," was found to be an incomplete version of what the author published in 1912, and it was decided to publish the complete version, with the earliest deletions indicated. For Appendix 2, "The Structure of the Unconscious," it had been necessary in the first edition to retranslate a French translation in the absence of the original German. Subsequently the author's holograph manuscript was discovered in his archives, and this furthermore contained several unpublished passages and variants of historical interest.

Both appendices have accordingly been re-edited and largely retranslated to take the new findings into account. (For details, see the editorial note at the beginning of each appendix.) Similar though not identical presentations were published in Volume 7 of the *Gesammelte Werke*, i.e., the Swiss edition, in 1964. Also on the model of the Swiss edition, the complete texts of the various forewords have been added. The title of the first essay has been modified to "On the Psychology of the Unconscious."

The texts of the two main essays have also been revised, for consistency, the reference apparatus has been brought up to date, a bibliography has been added, and a new index has been supplied.

**VOLUME 7
TWO ESSAYS IN ANALYTICAL PSYCHOLOGY**

TABLE OF CONTENTS

EDITORIAL NOTE TO THE FIRST EDITION

EDITORIAL NOTE TO THE SECOND EDITION

I

ON THE PSYCHOLOGY OF THE UNCONSCIOUS

PREFACE TO THE FIRST EDITION

PREFACE TO THE SECOND EDITION

PREFACE TO THE THIRD EDITION

PREFACE TO THE FOURTH EDITION

PREFACE TO THE FIFTH EDITION

I. Psychoanalysis

II. The Eros Theory

III. The Other Point of View: The Will to Power

IV. The Problem of the Attitude-Type

V. The Personal and the Collective (or Transpersonal) Unconscious

VI. The Synthetic or Constructive Method

VII. The Archetypes of the Collective Unconscious

VIII. General Remarks on the Therapeutic Approach to the Unconscious

Conclusion

II

THE RELATIONS BETWEEN THE EGO AND THE UNCONSCIOUS

PREFACE TO THE SECOND EDITION

PREFACE TO THE THIRD EDITION

Part One

**THE EFFECTS OF THE UNCONSCIOUS
UPON CONSCIOUSNESS**

- I. The Personal and the Collective Unconscious
- II. Phenomena Resulting from the Assimilation of the Unconscious
- III. The Persona as a Segment of the Collective Psyche
- IV. Negative Attempts to Free the Individuality from the Collective Psyche
 - a. *Regressive Restoration of the Persona*
 - b. *Identification with the Collective Psyche*

Part Two
INDIVIDUATION

- I. The Function of the Unconscious
- II. Anima and Animus
- III. The Technique of Differentiation between the Ego and the Figures of the Unconscious
- IV. The Mana-Personality

APPENDICES

- I. New Paths in Psychology
- II. The Structure of the Unconscious
 - 1. THE DISTINCTION BETWEEN THE PERSONAL AND THE IMPERSONAL UNCONSCIOUS
 - 2. PHENOMENA RESULTING FROM THE ASSIMILATION OF THE UNCONSCIOUS
 - 3. THE PERSONA AS A SEGMENT OF THE COLLECTIVE PSYCHE
 - 4. ATTEMPTS TO FREE THE INDIVIDUALITY FROM THE COLLECTIVE PSYCHE
 - a. *The Regressive Restoration of the Persona*
 - b. *Identification with the Collective Psyche*
 - 5. FUNDAMENTAL PRINCIPLES IN THE TREATMENT OF COLLECTIVE IDENTITY
[Addendum]
 - 6. SUMMARY
 - [First Version]
 - [Second Version]

BIBLIOGRAPHY

INDEX

I

ON THE PSYCHOLOGY OF THE UNCONSCIOUS

PREFACE TO THE FIRST EDITION (1917)

This essay* is the result of my attempt to revise, at the publisher's request, the paper which appeared in the Rascher Yearbook for 1912 under the title "Neue Bahnen der Psychologie."† The present work thus reproduces that earlier essay, though in altered and enlarged form. In my earlier paper I confined myself to the exposition of one essential aspect of the psychological views inaugurated by Freud. The manifold and important changes which recent years have brought in the psychology of the unconscious have compelled me to broaden considerably the framework of my earlier paper. On the one hand a number of passages on Freud were shortened, while on the other hand, Adler's psychology was taken into account; and, so far as was possible within the limits of this essay, a general survey of my own views was given.

I must warn the reader at the outset that he will be dealing with a study which, on account of its rather complicated subject-matter, will make considerable demands on his patience and attention. Nor can I associate this work with the idea that it is in any sense conclusive or adequately convincing. This requirement could be met only by comprehensive scientific treatises on each separate problem touched upon in the essay. The reader who wishes to probe more deeply into the questions at issue must therefore be referred to the specialist literature. My intention is simply to give a broad survey of the most recent views on the nature and psychology of the unconscious. I regard the problem of the unconscious as so important and so topical that it would, in my opinion, be a great loss if this question, which touches each one of us so closely, were to disappear from the orbit of the educated lay public by being banished to some inaccessible technical journal, there to lead a shadowy paper-existence on the shelves of libraries.

The psychological concomitants of the present war—above all the incredible brutalization of public opinion, the mutual slanderings, the unprecedented fury of destruction, the monstrous flood of lies, and man's incapacity to call a halt to the bloody demon—are uniquely fitted to force upon the attention of every thinking person the problem of the chaotic unconscious which slumbers uneasily beneath the ordered world of consciousness. This war has pitilessly revealed to civilized man that he is still a barbarian, and has at the same time shown what an iron scourge lies in store for him if ever again he should be tempted to make his neighbour responsible for his own evil qualities. The psychology of the individual is reflected in the psychology of the nation. What the nation does is done also by each individual, and so long as the individual continues to do it, the nation will do likewise. Only a change in the attitude of the

individual can initiate a change in the psychology of the nation. The great problems of humanity were never yet solved by general laws, but only through regeneration of the attitudes of individuals. If ever there was a time when self-reflection was the absolutely necessary and only right thing, it is now, in our present catastrophic epoch. Yet whoever reflects upon himself is bound to strike upon the frontiers of the unconscious, which contains what above all else he needs to know.

Küsnacht, Zurich, December 1916

G. JUNG

C.

PREFACE TO THE SECOND EDITION (1918)

I am glad that it has been the lot of this little book to pass into a second edition in so short a time, despite the difficulties it must have presented to many readers. I am letting the second edition appear unaltered except for a few minor modifications and improvements, although I am aware that the last chapters in particular, owing to the extraordinary difficulty and the novelty of the material, really needed discussion on a much broader basis in order to be generally understood. But a more detailed treatment of the fundamental principles there outlined would far exceed the bounds of a more or less popular presentation, so that I preferred to treat these questions with due circumstantiality in a separate work which is now in preparation.*

From the many communications I received after the publication of the first edition I have discovered that, even among the wider public, interest in the problems of the human psyche is very much keener than I expected. This interest may be due in no small measure to the profound shock which our consciousness sustained through the World War. The spectacle of this catastrophe threw man back upon himself by making him feel his complete impotence; it turned his gaze inwards, and, with everything rocking about him, he must needs seek something that guarantees him a hold. Too many still look outwards, some believing in the illusion of victory and of victorious power, others in treaties and laws, and others again in the overthrow of the existing order. But still too few look inwards, to their own selves, and still fewer ask themselves whether the ends of human society might not best be served if each man tried to abolish the old order in himself, and to practise in his own person and in his own inward state those precepts, those victories which he preaches at every street-corner, instead of always expecting these things of his fellow men. Every individual needs revolution, inner division, overthrow of the existing order, and renewal, but not by forcing them upon his neighbours under the hypocritical cloak of Christian love or the sense of social responsibility or any of the other beautiful euphemisms for unconscious urges to personal power. Individual self-reflection, return of the individual to the ground of human nature, to his own deepest being with its individual and social destiny—here is the beginning of a cure for that blindness which reigns at the present hour.

Interest in the problem of the human psyche is a symptom of this instinctive return to oneself. It is to serve this interest that the present book was written.

PREFACE TO THE THIRD EDITION* (1926)

This book was written during the World War, and it owes its existence primarily to the psychological repercussions of that great event. Now that the war is over, the waves are beginning to subside again. But the great psychological problems that the war threw up still occupy the mind and heart of every thinking and feeling person. It is probably thanks to this that my little book has survived the postwar period and now appears in a third edition.

In view of the fact that seven years have elapsed since the publication of the first edition, I have deemed it necessary to undertake fairly extensive alterations and improvements, particularly in the chapters on types and on the unconscious. The chapter on “The Development of Types in the Analytical Process”† I have omitted entirely, as this question has since received comprehensive treatment in my book *Psychological Types*, to which I must refer the interested reader.

Anyone who has tried to popularize highly complicated material that is still in the process of scientific development will agree with me that this is no easy task. It is even more difficult when many of the psychological processes and problems I have to discuss here are quite unknown to most people. Much of what I say may arouse their prejudices or may appear arbitrary; but they should bear in mind that the purpose of such a book can be, at most, to give them a rough idea of its subject and to provoke thought, but not to enter into all the details of the argument. I shall be quite satisfied if my book fulfils this purpose.

Küsnacht, Zurich, April 1925

C. G. J.

PREFACE TO THE FOURTH EDITION (1936)

Aside from a few improvements the fourth edition appears unchanged. From numerous reactions of the public I have seen that the idea of the collective unconscious, to which I have devoted one chapter in this book, has aroused particular interest. I cannot therefore omit calling the attention of my readers to the latest issues of the *Eranos-Jahrbuch*,* which contain important works by various authors on this subject. The present book makes no attempt to give a comprehensive account of the full range of analytical psychology; consequently, much is merely hinted at and some things are not mentioned at all. I hope, however, that it will continue to fulfil its modest purpose.

Küsnacht, Zurich, April 1936

C. G. J.

PREFACE TO THE FIFTH EDITION† (1943)

Since the last, unchanged edition, six years have gone by; hence it seemed to me advisable to submit the present, new edition of the book to a thorough revision. On this occasion a number of inadequacies could be eliminated or improved, and superfluous material deleted. A difficult and complicated matter like the psychology of the unconscious gives rise not only to many new insights but to errors as well. It is still a boundless expanse of virgin territory into which we make experimental incursions, and only by going the long way round do we strike the direct road. Although I have tried to introduce as many new viewpoints as possible into the text, my reader should not expect anything like a complete survey of the fundamentals of our contemporary psychological knowledge in this domain. In this popular account I am presenting only a few of the most essential aspects of medical psychology and also of my own researches, and this only by way of an introduction. A solid knowledge cannot be acquired except through the study of the literature on the one hand and through practical experience on the other. In particular I would like to recommend to those readers who are desirous of gaining detailed knowledge of these matters that they should not only study the basic works of medical psychology and psychopathology, but also thoroughly digest the psychological text-books. So doing, they will acquire the requisite knowledge of the position and general significance of medical psychology in the most direct way.

From such a comparative study the reader will be able to judge how far Freud's complaint about the "unpopularity" of his psychoanalysis, and my own feeling that I occupy an isolated outpost, are justified. Although there have been a few notable exceptions, I do not think I exaggerate when I say that the views of modern medical psychology have still not penetrated far enough into the strongholds of academic science. New ideas, if they are not just a flash in the pan, generally require at least a generation to take root. Psychological innovations probably take much longer, since in this field more than in any other practically everybody sets himself up as an authority.

Küsnacht, Zurich, April 1942

C. G. J.

PSYCHOANALYSIS

- [1] If he wants to help his patient, the doctor and above all the “specialist for nervous diseases” must have psychological knowledge; for nervous disorders and all that is embraced by the terms “nervousness,” hysteria, etc. are of psychic origin and therefore logically require psychic treatment. Cold water, light, fresh air, electricity, and so forth have at best a transitory effect and sometimes none at all. The patient is sick in mind, in the highest and most complex of the mind’s functions, and these can hardly be said to belong any more to the province of medicine. Here the doctor must also be a psychologist, which means that he must have knowledge of the human psyche.
- [2] In the past, that is to say up to fifty years ago, the doctor’s psychological training was still very bad. His psychiatric textbooks were wholly confined to clinical descriptions and the systematization of mental diseases, and the psychology taught in the universities was either philosophy or the so-called “experimental psychology” inaugurated by Wundt.¹ The first moves towards a psychotherapy of the neuroses came from the Charcot school, at the Salpêtrière in Paris; Pierre Janet² began his epoch-making researches into the psychology of neurotic states, and Bernheim³ in Nancy took up with great success Liébeault’s⁴ old and forgotten idea of treating the neuroses by suggestion. Sigmund Freud translated Bernheim’s book and also derived valuable inspiration from it. At that time there was still no psychology of the neuroses and psychoses. To Freud belongs the undying merit of having laid the foundations of a psychology of the neuroses. His teachings sprang from his experience in the practical treatment of the neuroses, that is, from the application of a method which he called *psychoanalysis*.
- [3] Before we enter upon a closer presentation of our subject, something must be said about its relation to science as known hitherto. Here we encounter a curious spectacle which proves yet again the truth of Anatole France’s remark: “Les savants ne sont pas curieux.” The first work of any magnitude⁵ in this field awakened only the faintest echo, in spite of the fact that it introduced an entirely new conception of the neuroses. A few writers spoke of it appreciatively and then, on the next page, proceeded to explain their hysterical cases in the same old way. They behaved very much like a man who, having eulogized the idea or fact that the earth was a sphere, calmly continues to represent it as flat. Freud’s next publications remained absolutely unnoticed, although they put forward observations which were of incalculable importance for psychiatry. When, in the year 1900, Freud wrote the first real psychology of dreams⁶ (a proper Stygian darkness had hitherto reigned over this

field), people began to laugh, and when he actually started to throw light on the psychology of sexuality in 1905,⁷ laughter turned to insult. And this storm of learned indignation was not behindhand in giving Freudian psychology an unwanted publicity, a notoriety that extended far beyond the confines of scientific interest.

[4] Accordingly we must look more closely into this new psychology. Already in Charcot's time it was known that the neurotic symptom is "psychogenic," i.e., originates in the psyche. It was also known, thanks mainly to the work of the Nancy school, that all hysterical symptoms can be produced through suggestion. Equally, something was known, thanks to the researches of Janet, about the psychological mechanisms that produce such hysterical phenomena as anaesthesia, paresia, paralysis, and amnesia. But it was not known *how* an hysterical symptom originates in the psyche; the psychic causal connections were completely unknown. In the early eighties Dr. Breuer, an old Viennese practitioner, made a discovery which became the real starting-point for the new psychology. He had a young, very intelligent woman patient suffering from hysteria, who manifested the following symptoms among others: she had a spastic (rigid) paralysis of the right arm, and occasional fits of absentmindedness or twilight states; she had also lost the power of speech inasmuch as she could no longer command her mother tongue but could only express herself in English (systematic aphasia). They tried at that time to account for these disorders with anatomical theories, although the cortical centre for the arm function was as little disturbed here as with a normal person. The symptomatology of hysteria is full of anatomical impossibilities. One lady, who had completely lost her hearing because of an hysterical affection, often used to sing. Once, when she was singing, her doctor seated himself unobserved at the piano and softly accompanied her. In passing from one stanza to the next he made a sudden change of key, whereupon the patient, without noticing it, went on singing in the changed key. Thus she hears—and does not hear. The various forms of systematic blindness offer similar phenomena: a man suffering from total hysterical blindness recovered his power of sight in the course of treatment, but it was only partial at first and remained so for a long time. He could see everything with the exception of people's heads. He saw all the people round him without heads. Thus he sees—and does not see. From a large number of like experiences it had been concluded that only the conscious mind of the patient does not see and hear, but that the sense function is otherwise in working order. This state of affairs directly contradicts the nature of an organic disorder, which always affects the actual function as well.

[5] After this digression, let us come back to the Breuer case. There were no organic causes for the disorder, so it had to be regarded as hysterical, i.e., psychogenic. Breuer had observed that if, during her twilight states (whether spontaneous or artificially induced), he got the patient to tell him of the reminiscences and fantasies

that thronged in upon her, her condition was eased for several hours afterwards. He made systematic use of this discovery for further treatment. The patient devised the name “talking cure” for it or, jokingly, “chimney-sweeping.”

[6] The patient had become ill when nursing her father in his fatal illness. Naturally her fantasies were chiefly concerned with these disturbing days. Reminiscences of this period came to the surface during her twilight states with photographic fidelity; so vivid were they, down to the last detail, that we can hardly assume the waking memory to have been capable of such plastic and exact reproduction. (The name “hypermnesia” has been given to this intensification of the powers of memory which not infrequently occurs in restricted states of consciousness.) Remarkable things now came to light. One of the many stories told ran somewhat as follows:

One night, watching by the sick man, who had a high fever, she was tense with anxiety because a surgeon was expected from Vienna to perform an operation. Her mother had left the room for a while, and Anna, the patient, sat by the sick-bed with her right arm hanging over the back of the chair. She fell into a sort of waking dream in which she saw a black snake coming, apparently out of the wall, towards the sick man as though to bite him. (It is quite likely that there really were snakes in the meadow at the back of the house, which had already given the girl a fright and which now provided the material for the hallucination.) She wanted to drive the creature away, but felt paralysed; her right arm, hanging over the back of the chair, had “gone to sleep”: it had become anaesthetic and paretic, and, as she looked at it, the fingers changed into little serpents with death’s-heads. Probably she made efforts to drive away the snake with her paralysed right hand, so that the anaesthesia and paralysis became associated with the snake hallucination. When the snake had disappeared, she was so frightened that she wanted to pray; but all speech failed her, she could not utter a word until finally she remembered an English nursery rhyme, and then she was able to go on thinking and praying in English.⁸

[7] Such was the scene in which the paralysis and the speech disturbance originated, and with the narration of this scene the disturbance itself was removed. In this manner the case is said to have been finally cured.

[8] I must content myself with this one example. In the book I have mentioned by Breuer and Freud there is a wealth of similar examples. It can readily be understood that scenes of this kind make a powerful impression, and people are therefore inclined to impute causal significance to them in the genesis of the symptom. The view of hysteria then current, which derived from the English theory of the “nervous shock” energetically championed by Charcot, was well qualified to explain Breuer’s discovery. Hence there arose the so-called trauma theory, which says that the hysterical symptom, and, in so far as the symptoms constitute the illness, hysteria in

general, derive from psychic injuries or traumata whose imprint persists unconsciously for years. Freud, now collaborating with Breuer, was able to furnish abundant confirmation of this discovery. It turned out that none of the hundreds of hysterical symptoms arose by chance—they were always caused by psychic occurrences. So far the new conception opened up an extensive field for empirical work. But Freud's inquiring mind could not remain long on this superficial level, for already deeper and more difficult problems were beginning to emerge. It is obvious enough that moments of extreme anxiety such as Breuer's patient experienced may leave an abiding impression. But how did she come to experience them at all, since they already clearly bear a morbid stamp? Could the strain of nursing bring this about? If so, there ought to be many more occurrences of the kind, for there are unfortunately very many exhausting cases to nurse, and the nervous health of the nurse is not always of the best. To this problem medicine gives an excellent answer: "The x in the calculation is predisposition." One is just "predisposed" that way. But for Freud the problem was: what constitutes the predisposition? This question leads logically to an examination of the previous history of the psychic trauma. It is a matter of common observation that exciting scenes have quite different effects on the various persons involved, or that things which are indifferent or even agreeable to one person arouse the greatest horror in others—witness frogs, snakes, mice, cats, etc. There are cases of women who will assist at bloody operations without turning a hair, while they tremble all over with fear and loathing at the touch of a cat. I remember a young woman who suffered from acute hysteria following a sudden fright.⁹ She had been to an evening party and was on her way home about midnight in the company of several acquaintances, when a cab came up behind them at full trot. The others got out of the way, but she, as though spellbound with terror, kept to the middle of the road and ran along in front of the horses. The cabman cracked his whip and swore; it was no good, she ran down the whole length of the road, which led across a bridge. There her strength deserted her, and to avoid being trampled on by the horses she would in her desperation have leapt into the river had not the passers-by prevented her. Now, this same lady had happened to be in St. Petersburg on the bloody twenty-second of January [1905], in the very street which was cleared by the volleys of the soldiers. All round her people were falling to the ground dead or wounded; she, however, quite calm and clear-headed, espied a gate leading into a yard through which she made her escape into another street. These dreadful moments caused her no further agitation. She felt perfectly well afterwards—indeed, rather better than usual.

[9] This failure to react to an apparent shock can frequently be observed. Hence it necessarily follows that the intensity of a trauma has very little pathogenic significance in itself, but it must have a special significance for the patient. That is to

say, it is not the shock as such that has a pathogenic effect under all circumstances, but, in order to have an effect, it must impinge on a special psychic disposition, which may, in certain circumstances, consist in the patient's unconsciously attributing a specific significance to the shock. Here we have a possible key to the "predisposition." We have therefore to ask ourselves: what are the particular circumstances of the scene with the cab? The patient's fear began with the sound of the trotting horses; for an instant it seemed to her that this portended some terrible doom—her death, or something as dreadful; the next moment she lost all sense of what she was doing.

[10] The real shock evidently came from the horses. The patient's predisposition to react in so unaccountable a way to this unremarkable incident might therefore consist in the fact that horses have some special significance for her. We might conjecture, for instance, that she once had a dangerous accident with horses. This was actually found to be the case. As a child of about seven she was out for a drive with her coachman, when suddenly the horses took fright and at a wild gallop made for the precipitous bank of a deep river-gorge. The coachman *jumped* down and shouted to her to do likewise, but she was in such deadly fear that she could hardly make up her mind. Nevertheless she jumped in the nick of time, while the horses crashed with the carriage into the depths below. That such an event would leave a very deep impression scarcely needs proof. Yet it does not explain why at a later date such an insensate reaction should follow the perfectly harmless hint of a similar situation. So far we know only that the later symptom had a prelude in childhood, but the pathological aspect of it still remains in the dark. In order to penetrate this mystery, further knowledge is needed. For it had become clear with increasing experience that in all the cases analysed so far, there existed, apart from the traumatic experiences, another, special class of disturbances which lie in the province of love. Admittedly "love" is an elastic concept that stretches from heaven to hell and combines in itself good and evil, high and low. With this discovery Freud's views underwent a considerable change. If, more or less under the spell of Breuer's trauma theory, he had formerly sought the cause of neurosis in traumatic experiences, now the centre of gravity of the problem shifted to an entirely different point. This is best illustrated by our case: we can understand well enough why horses should play a special part in the life of the patient, but we do not understand the later reaction, so exaggerated and uncalled for. The pathological peculiarity of this story lies in the fact that she is frightened of quite harmless horses. Remembering the discovery that besides the traumatic experience there is often a disturbance in the province of love, we might inquire whether perhaps there is something peculiar in this connection.

[11] The lady knows a young man to whom she thinks of becoming engaged; she loves him and hopes to be happy with him. At first nothing more is discoverable. But it would never do to be deterred from investigation by the negative results of the preliminary questioning. There are indirect ways of reaching the goal when the direct way fails. We therefore return to that singular moment when the lady ran headlong in front of the horses. We inquire about her companions and what sort of festive occasion it was in which she had just taken part. It had been a farewell party for her best friend, who was going abroad to a health resort on account of her nerves. This friend is married and, we are told, happily; she is also the mother of a child. We may take leave to doubt the statement that she is happy; for, were she really so, she would presumably have no reason to be "nervous" and in need of a cure. Shifting my angle of approach, I learned that after her friends had rescued her they brought the patient back to the

house of her host—her best friend’s husband—as this was the nearest shelter at that late hour of night. There she was hospitably received in her exhausted state. At this point the patient broke off her narrative, became embarrassed, fidgeted, and tried to change the subject. Evidently some disagreeable reminiscence had suddenly bobbed up. After the most obstinate resistance had been overcome, it appeared that yet another very remarkable incident had occurred that night: the amiable host had made her a fiery declaration of love, thus precipitating a situation which, in the absence of the lady of the house, might well be considered both difficult and distressing. Ostensibly this declaration of love came to her like a bolt from the blue, but these things usually have their history. It was now the task of the next few weeks to dig out bit by bit a long love story, until at last a complete picture emerged which I attempt to outline somewhat as follows:

As a child the patient had been a regular tomboy, caring only for wild boys’ games, scorning her own sex, and avoiding all feminine ways and occupations. After puberty, when the erotic problem might have come too close, she began to shun all society, hated and despised everything that even remotely reminded her of the biological destiny of woman, and lived in a world of fantasies which had nothing in common with rude reality. Thus, until about her twenty-fourth year, she evaded all those little adventures, hopes, and expectations which ordinarily move a girl’s heart at this age. Then she got to know two men who were destined to break through the thorny hedge that had grown up around her. Mr. A was her best friend’s husband, and Mr. B was his bachelor friend. She liked them both. Nevertheless it soon began to look as though she liked Mr. B a vast deal better. An intimacy quickly sprang up between them and before long there was talk of a possible engagement. Through her relations with Mr. B and through her friend she often came into contact with Mr. A, whose presence sometimes disturbed her in the most unaccountable way and made her nervous. About this time the patient went to a large party. Her friends were also there. She became lost in thought and was dreamily playing with her ring when it suddenly slipped off her finger and rolled under the table. Both gentlemen looked for it and Mr. B succeeded in finding it. He placed the ring on her finger with an arch smile and said, “You know what that means!” Overcome by a strange and irresistible feeling, she tore the ring from her finger and flung it through the open window. A painful moment ensued, as may be imagined, and soon she left the party in deep dejection. Not long after this, so-called chance brought it about that she should spend her summer holidays at a health resort where Mr. and Mrs. A were also staying. Mrs. A then began to grow visibly nervous, and frequently stayed indoors because she felt out of sorts. The patient was thus in a position to go out for walks alone with Mr. A. On one occasion they went boating. So boisterous was she in her merriment that she suddenly fell overboard. She could not swim, and it was only with great difficulty that Mr. A pulled her half-unconscious into the boat. And then it was that he kissed her. With this romantic episode the bonds were tied fast. But the patient would not allow the depths of this passion to come to consciousness,

evidently because she had long habituated herself to pass over such things or, better, to run away from them. To excuse herself in her own eyes she pursued her engagement to Mr. B all the more energetically, telling herself every day that it was Mr. B whom she loved. Naturally this curious little game had not escaped the keen glances of wifely jealousy. Mrs. A, her friend, had guessed the secret and fretted accordingly, so that her nerves only got worse. Hence it became necessary for Mrs. A to go abroad for a cure. At the farewell party the evil spirit stepped up to our patient and whispered in her ear, "Tonight he is alone. Something must happen to you so that you can go to his house." And so indeed it happened: through her own strange behaviour she came back to his house, and thus she attained her desire.

[12] After this explanation everyone will probably be inclined to assume that only a devilish subtlety could devise such a chain of circumstances and set it to work. There is no doubt about the subtlety, but its moral evaluation remains a doubtful matter, because I must emphasize that the motives leading to this dramatic dénouement were in no sense conscious. To the patient, the whole story seemed to happen of itself, without her being conscious of any motive. But the previous history makes it perfectly clear that everything was unconsciously directed to this end, while the conscious mind was struggling to bring about the engagement to Mr. B. The unconscious drive in the other direction was stronger.

[13] So once more we return to our original question, namely, whence comes the pathological (i.e., peculiar or exaggerated) nature of the reaction to the trauma? On the basis of a conclusion drawn from analogous experiences, we conjectured that in this case too there must be, in addition to the trauma, a disturbance in the erotic sphere. This conjecture has been entirely confirmed, and we have learnt that the trauma, the ostensible cause of the illness, is no more than an occasion for something previously not conscious to manifest itself, i.e., an important erotic conflict. Accordingly the trauma loses its exclusive significance, and is replaced by a much deeper and more comprehensive conception which sees the pathogenic agent as an erotic conflict.

[14] One often hears the question: why should the erotic conflict be the cause of the neurosis rather than any other conflict? To this we can only answer: no one asserts that it must be so, but in point of fact it frequently is so. In spite of all indignant protestations to the contrary, the fact remains that love,¹⁰ its problems and its conflicts, is of fundamental importance in human life and, as careful inquiry consistently shows, is of far greater significance than the individual suspects.

[15] The trauma theory has therefore been abandoned as antiquated; for with the discovery that not the trauma but a hidden erotic conflict is the root of the neurosis, the trauma loses its causal significance.¹¹

THE EROS THEORY

[16] In the light of this discovery, the question of the trauma was answered in a most unexpected manner; but in its place the investigator was faced with the problem of the erotic conflict, which, as our example shows, contains a wealth of abnormal elements and cannot at first sight be compared with an ordinary erotic conflict. What is peculiarly striking and almost incredible is that only the pretence should be conscious, while the patient's real passion remained hidden from her. In this case certainly, it is beyond dispute that the real relationship was shrouded in darkness, while the pretended one dominated the field of consciousness. If we formulate these facts theoretically, we arrive at the following result: there are in a neurosis two tendencies standing in strict opposition to one another, one of which is unconscious. This proposition is formulated in very general terms on purpose, because I want to stress that although the pathogenic conflict is a personal matter it is also a broadly human conflict manifesting itself in the individual, for disunity with oneself is the hall-mark of civilized man. The neurotic is only a special instance of the disunited man who ought to harmonize nature and culture within himself.

[17] The growth of culture consists, as we know, in a progressive subjugation of the animal in man. It is a process of domestication which cannot be accomplished without rebellion on the part of the animal nature that thirsts for freedom. From time to time there passes as it were a wave of frenzy through the ranks of men too long constrained within the limitations of their culture. Antiquity experienced it in the Dionysian orgies that surged over from the East and became an essential and characteristic ingredient of classical culture. The spirit of these orgies contributed not a little towards the development of the stoic ideal of asceticism in the innumerable sects and philosophical schools of the last century before Christ, which produced from the polytheistic chaos of that epoch the twin ascetic religions of Mithraism and Christianity. A second wave of Dionysian licentiousness swept over the West at the Renaissance. It is difficult to gauge the spirit of one's own time; but in the succession of revolutionary questions to which the last half century gave birth, there was the "sexual question," and this has fathered a whole new species of literature. In this "movement" are rooted the beginnings of psychoanalysis, on whose theories it exerted a very one-sided influence. After all, nobody can be completely independent of the currents of his age. Since then the "sexual question" has largely been thrust into the background by political and spiritual problems. That, however, does nothing to alter the fundamental fact that man's instinctual nature is always coming up against the checks imposed by civilization. The names alter, but the facts remain the same. We also know today that it is by no means the animal nature alone that is at odds with civilized constraints; very often it is new ideas which are thrusting upwards from the unconscious and are just as much out of harmony with the dominating culture as the instincts. For instance, we could easily construct a political theory of neurosis, in so far as the man of today is chiefly excited by political passions to which the "sexual question" was only an insignificant prelude. It may turn out that politics are but the forerunner of a far deeper religious convulsion. Without being aware of it, the neurotic participates in the dominant currents of his age and reflects them in his own conflict.

[18] Neurosis is intimately bound up with the problem of our time and really represents an unsuccessful attempt on the part of the individual to solve the general problem in his own person. Neurosis is self-division. In most people the cause of the division is that the conscious mind wants to hang on to its moral ideal, while the unconscious strives after its—in the contemporary sense—immoral ideal which the conscious mind tries to deny. Men of this type want to be more respectable than they really are. But the conflict can easily be the other way about: there are men who are to all appearances very disreputable and do not put the least restraint upon themselves. This is at bottom only a pose of wickedness, for in the background they have their moral side which has fallen into the unconscious just as surely as the immoral side in the case of the moral man. (Extremes should therefore be avoided as far as possible, because they always arouse suspicion of their opposite.)

[19] This general discussion was necessary in order to clarify the idea of an “erotic conflict.” Thence we can proceed to discuss firstly the technique of psychoanalysis and secondly the question of therapy.

[20] Obviously the great question for this technique is: How are we to arrive by the shortest and best path at a knowledge of what is happening in the unconscious of the patient? The original method was hypnotism: either interrogation in a state of hypnotic concentration or else the spontaneous production of fantasies by the patient while in this state. This method is still occasionally employed, but compared with the present technique it is primitive and often unsatisfactory. A second method was evolved by the Psychiatric Clinic, in Zurich, the so-called association method.¹ It demonstrates very accurately the presence of conflicts in the form of “complexes” of feeling-toned ideas, as they are called, which betray themselves through characteristic disturbances in the course of the experiment.² But the most important method of getting at the pathogenic conflicts is, as Freud was the first to show, through the analysis of dreams.

[21] Of the dream it can indeed be said that “the stone which the builders rejected, the same is become the the head of the corner.” It is only in modern times that the dream, this fleeting and insignificant-looking product of the psyche, has met with such profound contempt. Formerly it was esteemed as a harbinger of fate, a portent and comforter, a messenger of the gods. Now we see it as the emissary of the unconscious, whose task it is to reveal the secrets that are hidden from the conscious mind, and this it does with astounding completeness. The “manifest” dream, i.e., the dream as we remember it, is in Freud’s view only a façade which gives us no idea of the interior of the house, but, on the contrary, carefully conceals it with the help of the “dream censor.” If, however, while observing certain technical rules, we induce the dreamer to talk about the details of his dream, it soon becomes evident that his associations tend in a particular direction and group themselves round particular topics. These are of personal significance and yield a meaning which could never have been conjectured to lie behind the dream, but which, as careful comparison has shown, stands in an extremely delicate and meticulously exact relationship to the dream façade. This particular complex of ideas wherein are united all the threads of the dream is the conflict we are looking for, or rather a variation of it conditioned by circumstances. According to Freud, the painful and incompatible elements in the conflict are in this way so covered up or obliterated that we we may speak of a “wish-fulfilment.” However, it is only very seldom that dreams fulfil obvious wishes, as for instance in the so-called body-stimulus dreams, e.g., the sensation of hunger during sleep, when the desire for food is satisfied by dreaming about delicious meals. Likewise the pressing idea that one ought to get up, conflicting with the desire to go on sleeping, leads to the wish-fulfilling dream-idea that one has already got up, etc. In Freud’s view there are also unconscious wishes whose nature is incompatible with the ideas of the waking mind, painful wishes which

one prefers not to admit, and these are precisely the wishes that Freud regards as the real architects of the dream. For instance, a daughter loves her mother tenderly, but dreams to her great distress that her mother is dead. Freud argues that there exists in this daughter, unbeknown to herself, the exceedingly painful wish to see her mother removed from this world with all speed, because she has secret resistances to her. Even in the most blameless daughter such moods may occur, but they would be met with the most violent denial if one tried to saddle her with them. To all appearances the manifest dream contains no trace of wish-fulfilment, rather of apprehension or alarm, consequently the direct opposite of the supposed unconscious impulse. But we know well enough that *exaggerated* alarm can often and rightly be suspected of the contrary. (Here the critical reader may justifiably ask: When is the alarm in a dream exaggerated?) Such dreams, in which there is apparently no trace of wish-fulfilment, are innumerable: the conflict worked out in the dream is unconscious, and so is the attempted solution. Actually, there does exist in our dreamer the tendency to be rid of her mother; expressed in the language of the unconscious, she wants her mother to die. But the dreamer should certainly not be saddled with this tendency because, strictly speaking, it was not she who fabricated the dream, but the unconscious. The unconscious has this tendency, most unexpected from the dreamer's point of view, to get rid of the mother. The very fact that she can dream such a thing proves that she does not consciously think it. She has no notion why her mother should be got rid of. Now we know that a certain layer of the unconscious contains everything that has passed beyond the recall of memory, including all those infantile instinctual impulses which could find no outlet in adult life. We can say that the bulk of what comes out of the unconscious has an infantile character at first, as for instance this wish, which is simplicity itself: "When Mummy dies you will marry me, won't you, Daddy?" This expression of an infantile wish is the substitute for a recent desire to marry, a desire in this case painful to the dreamer, for reasons still to be discovered. The idea of marriage, or rather the seriousness of the corresponding impulse, is, as they say, "repressed into the unconscious" and from there must necessarily express itself in an infantile fashion, because the material at the disposal of the unconscious consists largely of infantile reminiscences.

[22] Our dream is apparently concerned with a twinge of infantile jealousy. The dreamer is more or less in love with her father, and for that reason she wants to get rid of her mother. But her real conflict lies in the fact that on the one hand she wants to marry, and on the other hand is unable to make up her mind: for one never knows what it will be like, whether he will make a suitable husband, etc. Again, it is so nice at home, and what will happen when she has to part from darling Mummy and be all independent and grown up? She fails to notice that the marriage question is now a serious matter for her and has her in its grip, so that she can no longer creep home to father and mother without bringing the fateful question into the bosom of the family. She is no longer the child she once was; she is the woman who wants to get married. As such she comes back, complete with her wish for a husband. But in the family the father is the husband and, without her being aware of it, it is on him that the daughter's desire for a husband falls. But that is *incest!* In this way there arises a secondary incest-intrigue. Freud assumes that the tendency to incest is primary and the real reason why the dreamer cannot make up her mind to marry. Compared with that, the other reasons we have cited count for little. With regard to this view I have long adopted the standpoint that the occasional occurrence of incest is no proof of a universal tendency to incest, any more than the fact of murder proves the existence of a universal homicidal mania productive of conflict. I would not go so far as to say that the germs of every kind of criminality are not present in each of us. But there is a world

of difference between the presence of such a germ and an actual conflict with its resulting cleavage of the personality, such as exists in a neurosis.

[23] If we follow the history of a neurosis with attention, we regularly find a critical moment when some problem emerged that was evaded. This evasion is just as natural and just as common a reaction as the laziness, slackness, cowardice, anxiety, ignorance, and unconsciousness which are at the back of it. Whenever things are unpleasant, difficult, and dangerous, we mostly hesitate and if possible give them a wide berth. I regard these reasons as entirely sufficient. The symptomatology of incest, which is undoubtedly there and which Freud rightly saw, is to my mind a secondary phenomenon, already pathological.

[24] The dream is often occupied with apparently very silly details, thus producing an impression of absurdity, or else it is on the surface so unintelligible as to leave us thoroughly bewildered. Hence we always have to overcome a certain resistance before we can seriously set about disentangling the intricate web through patient work. But when at last we penetrate to its real meaning, we find ourselves deep in the dreamer's secrets and discover with astonishment that an apparently quite senseless dream is in the highest degree significant, and that in reality it speaks only of important and serious matters. This discovery compels rather more respect for the so-called superstition that dreams have a meaning, to which the rationalistic temper of our age has hitherto given short shrift.

[25] As Freud says, dream-analysis is the *via regia* to the unconscious. It leads straight to the deepest personal secrets, and is, therefore, an invaluable instrument in the hand of the physician and educator of the soul.

[26] The analytical method in general, and not only the specifically Freudian psychoanalysis, consists in the main of numerous dream-analyses. In the course of treatment, the dreams successively throw up the contents of the unconscious in order to expose them to the disinfecting power of daylight, and in this way much that is valuable and believed lost is found again. It is only to be expected that for many people who have false ideas about themselves the treatment is a veritable torture. For, in accordance with the old mystical saying, "Give up what thou hast, then shalt thou receive!" they are called upon to abandon all their cherished illusions in order that something deeper, fairer, and more embracing may arise within them. It is a genuine old wisdom that comes to light again in the treatment, and it is especially curious that this kind of psychic education should prove necessary in the heyday of our culture. In more than one respect it may be compared with the Socratic method, though it must be said that analysis penetrates to far greater depths.

[27] The Freudian mode of investigation sought to prove that an overwhelming importance attaches to the erotic or sexual factor as regards the origin of the pathogenic conflict. According to this theory there is a collision between the trend of the conscious mind and the unmoral, incompatible, unconscious wish. The unconscious wish is infantile, i.e., it is a wish from the childish past that will no longer fit the present, and is therefore repressed on moral grounds. The neurotic has the soul of a child who bears ill with arbitrary restrictions whose meaning he does not see; he tries to make this morality his own, but falls into disunity with himself: one side of him wants to suppress, the other longs to be free—and this struggle goes by the name of neurosis. Were the conflict clearly conscious in all its parts, presumably it would never give rise to neurotic symptoms; these occur only when we cannot see the other side of our nature and the urgency of its problems. Only under these conditions does the symptom appear, and it helps to give expression to the unrecognized side of the psyche. The symptom is therefore, in Freud's view, the fulfilment of unrecognized desires which, when conscious, come into violent conflict with our

moral convictions. As already observed, this shadow-side of the psyche, being withdrawn from conscious scrutiny, cannot be dealt with by the patient. He cannot correct it, cannot come to terms with it, nor yet disregard it; for in reality he does not “possess” the unconscious impulses at all. Thrust out from the hierarchy of the conscious psyche, they have become autonomous complexes which it is the task of analysis, not without great resistances, to bring under control again. There are patients who boast that for them the shadow-side does not exist; they assure us that they have no conflict, but they do not see that other things of unknown origin cumber their path—hysterical moods, underhand tricks which they play on themselves and their neighbours, a nervous catarrh of the stomach, pains in various places, irritability for no reason, and a whole host of nervous symptoms.

[28] Freudian psychoanalysis has been accused of liberating man’s (fortunately) repressed animal instincts and thus causing incalculable harm. This apprehension shows how little trust we place in the efficacy of our moral principles. People pretend that only the morality preached from the pulpit holds men back from unbridled licence; but a much more effective regulator is necessity, which sets bounds far more real and persuasive than any moral precepts. It is true that psychoanalysis makes the animal instincts conscious, though not, as many would have it, with a view to giving them boundless freedom, but rather to incorporating them in a purposeful whole. It is under all circumstances an advantage to be in full possession of one’s personality, otherwise the repressed elements will only crop up as a hindrance elsewhere, not just at some unimportant point, but at the very spot where we are most sensitive. If people can be educated to see the shadow-side of their nature clearly, it may be hoped that they will also learn to understand and love their fellow men better. A little less hypocrisy and a little more self-knowledge can only have good results in respect for our neighbour; for we are all too prone to transfer to our fellows the injustice and violence we inflict upon our own natures.

[29] The Freudian theory of repression certainly does seem to say that there are, as it were, only hypermoral people who repress their unmoral, instinctive natures. Accordingly the unmoral man, who lives a life of unrestrained instinct, should be immune to neurosis. This is obviously not the case, as experience shows. Such a man can be just as neurotic as any other. If we analyse him, we simply find that his morality is repressed. The neurotic immoralist presents, in Nietzsche’s striking phrase, the picture of the “pale felon” who does not live up to his acts.

[30] We can of course take the view that the repressed remnants of decency are in this case only a traditional hang-over from infancy, which imposes an unnecessary check on instinctual nature and should therefore be eradicated. The principle of *écrasez l’infâme* would end in a theory of absolute libertinism. Naturally, that would be quite fantastic and nonsensical. It should never be forgotten—and of this the Freudian school must be reminded—that morality was not brought down on tables of stone from Sinai and imposed on the people, but is a function of the human soul, as old as humanity itself. Morality is not imposed from outside; we have it in ourselves from the start—not the law, but our moral nature without which the collective life of human society would be impossible. That is why morality is found at all levels of society. It is the instinctive regulator of action which also governs the collective life of the herd. But moral laws are valid only within a compact human group. Beyond that, they cease. There the old truth runs: *Homo homini lupus*. With the growth of civilization we have succeeded in subjecting ever larger human groups to the rule of the same morality, without, however, having yet brought the moral code to prevail beyond the social frontiers, that is, in the free space between mutually independent societies. There, as of old, reign lawlessness and licence and mad immorality—though of course it is only the enemy who dares to say it out loud.

[31] The Freudian school is so convinced of the fundamental, indeed exclusive, importance of sexuality in neurosis that it has drawn the logical conclusion and valiantly attacked the sexual morality of our day. This was beyond a doubt useful and necessary, for in this field there prevailed and still prevail ideas which in view of the extremely complicated state of affairs are too undifferentiated. Just as in the early Middle Ages finance was held in contempt because there was as yet no differentiated financial morality to suit each case, but only a mass morality, so today there is only a mass sexual morality. A girl who has an illegitimate baby is condemned and nobody asks whether she is a decent human being or not. Any form of love not sanctioned by law is considered immoral, whether between worth-while people or bounders. We are still so hypnotized by *what* happens that we forget *how* and *to whom* it happens, just as for the Middle Ages finance was nothing but glittering gold, fiercely coveted and therefore the devil.

[32] Yet things are not quite so simple as that. Eros is a questionable fellow and will always remain so, whatever the legislation of the future may have to say about it. He belongs on one side to man's primordial animal nature which will endure as long as man has an animal body. On the other side he is related to the highest forms of the spirit. But he thrives only when spirit and instinct are in right harmony. If one or the other aspect is lacking to him, the result is injury or at least a lopsidedness that may easily veer towards the pathological. Too much of the animal distorts the civilized man, too much civilization makes sick animals. This dilemma reveals the vast uncertainty that Eros holds for man. For, at bottom, Eros is a superhuman power which, like nature herself, allows itself to be conquered and exploited as though it were impotent. But triumph over nature is dearly paid for. Nature requires no explanations of principle, but asks only for tolerance and wise measure.

[33] "Eros is a mighty daemon," as the wise Diotima said to Socrates. We shall never get the better of him, or only to our own hurt. He is not the whole of our inward nature, though he is at least one of its essential aspects. Thus Freud's sexual theory of neurosis is grounded on a true and factual principle. But it makes the mistake of being one-sided and exclusive; also it commits the imprudence of trying to lay hold of unconfined Eros with the crude terminology of sex. In this respect Freud is a typical representative of the materialistic epoch,³ whose hope it was to solve the world riddle in a test-tube. Freud himself, with advancing years, admitted this lack of balance in his theory, and he opposed to Eros, whom he called libido, the destructive or death instinct.⁴ In his posthumous writings he says:

After long hesitations and vacillations we have decided to assume the the existence of only two basic instincts, *Eros* and *the destructive instinct*.... The aim of the first of these basic instincts is to establish ever greater unities and to preserve them thus—in short, to bind together; the aim of the second is, on the contrary, to undo connections and so to destroy things.... For this reason we also call it the *death instinct*.⁵

[34] I must content myself with this passing reference, without entering more closely into the questionable nature of the conception. It is sufficiently obvious that life, like any other process, has a beginning and an end and that every beginning is also the beginning of the end. What Freud probably means is the essential fact that every process is a phenomenon of energy, and that all energy can proceed only from the tension of opposites.



THE OTHER POINT OF VIEW: THE WILL TO POWER

[35] So far we have considered the problem of this new psychology essentially from the Freudian point of view. Undoubtedly it has shown us a very real truth to which our pride, our civilized consciousness, may say no, though something else in us says yes. Many people find this fact extremely irritating; it arouses their hostility or even their fear, and consequently they are unwilling to recognize the conflict. And indeed it is a frightening thought that man also has a shadow-side to him, consisting not just of little weaknesses and foibles, but of a positively demonic dynamism. The individual seldom knows anything of this; to him, as an individual, it is incredible that he should ever in any circumstances go beyond himself. But let these harmless creatures form a mass, and there emerges a raging monster; and each individual is only one tiny cell in the monster's body, so that for better or worse he must accompany it on its bloody rampages and even assist it to the utmost. Having a dark suspicion of these grim possibilities, man turns a blind eye to the shadow-side of human nature. Blindly he strives against the salutary dogma of original sin, which is yet so prodigiously true. Yes, he even hesitates to admit the conflict of which he is so painfully aware. It can readily be understood that a school of psychology—even if it be biased and exaggerated in this or that respect—which insists on the seamy side, is unwelcome, not to say frightening, because it forces us to gaze into the bottomless abyss of this problem. A dim premonition tells us that we cannot be whole without this negative side, that we have a body which, like all bodies, casts a shadow, and that if we deny this body we cease to be three-dimensional and become flat and without substance. Yet this body is a beast with a beast's soul, an organism that gives unquestioning obedience to instinct. To unite oneself with this shadow is to say yes to instinct, to that formidable dynamism lurking in the background. From this the ascetic morality of Christianity wishes to free us, but at the risk of disorganizing man's animal nature at the deepest level.

[36] Has anyone made clear to himself what that means—a yea-saying to instinct? That was what Nietzsche desired and taught, and he was in deadly earnest. With a rare passion he sacrificed himself, his whole life, to the idea of the Superman—to the idea of the man who through obedience to instinct transcends himself. And what was the course of that life? It was as Nietzsche himself prophesied in *Zarathustra*, in that foreboding vision of the fatal fall of the rope-dancer, the man who would not be “surpassed.” To the dying rope-dancer Zarathustra says: “Thy soul will sooner be dead than thy body!” and later the dwarf says to Zarathustra, “O Zarathustra, stone of wisdom! High thou flingest thyself, but every stone that is flung must fall! Condemned to thyself and to thine own stoning: O Zarathustra, far indeed thou flingest the stone—but upon thyself will it fall.” And when he cried his “Ecce Homo” over himself, again it was too late, as once before when this saying was uttered, and the crucifixion of the soul began before the body was dead.

[37] We must look very critically at the life of one who taught such a yea-saying, in order to examine the effects of this teaching on the teacher's own life. When we scrutinize his life with this aim in view we are bound to admit that Nietzsche lived beyond instinct, in the lofty heights of heroic sublimity—heights that he could maintain only with the help of the most meticulous diet, a carefully selected climate, and many aids to sleep—until the tension

shattered his brain. He talked of yea-saying and lived the nay. His loathing for man, for the human animal that lived by instinct, was too great. Despite everything, he could not swallow the toad he so often dreamed of and which he feared had to be swallowed. The roaring of the Zarathustrian lion drove back into the cavern of the unconscious all the “higher” men who were clamouring to live. Hence his life does not convince us of his teaching. For the “higher” man wants to be able to sleep without chloral, to live in Naumburg and Basel despite “fogs and shadows.” He desires wife and offspring, standing and esteem among the herd, innumerable commonplace realities, and not least those of the Philistine. Nietzsche failed to live this instinct, the animal urge to life. For all his greatness and importance, Nietzsche’s was a pathological personality.

[38] But what was it that he lived, if not the life of instinct? Can Nietzsche really be accused of having denied his instincts in practice? He would scarcely have agreed to that. He could even show without much difficulty that he lived his instinctual life in the highest sense. But how is it possible, we may ask in astonishment, for man’s instinctual nature to drive him into separation from his kind, into absolute isolation from humanity, into an aloofness from the herd upheld by loathing? We think of instinct as uniting man, causing him to mate, to beget, to seek pleasure and good living, the satisfaction of all sensuous desires. We forget that this is only one of the possible directions of instinct. There exists not only the instinct for the preservation of the species, but also the instinct of self-preservation.

[39] It is of this last instinct, the *will to power*, that Nietzsche obviously speaks. Whatever else is instinctual only follows, for him, in the train of the will to power. From the standpoint of Freud’s sexual psychology, this is an error of the most glaring kind, a misconception of biology, the bungling of a decadent neurotic. For it is a very simple matter for any adherent of sexual psychology to prove that everything lofty and heroic in Nietzsche’s view of life and the world is nothing but a consequence of the repression and misunderstanding of that other instinct which *this* psychology regards as fundamental.

[40] The case of Nietzsche shows, on the one hand, the consequences of neurotic one-sidedness, and, on the other hand, the dangers that lurk in this leap beyond Christianity. Nietzsche undoubtedly felt the Christian denial of animal nature very deeply indeed, and therefore he sought a higher human wholeness beyond good and evil. But he who seriously criticizes the basic attitudes of Christianity also forfeits the protection which these bestow upon him. He delivers himself up unresistingly to the animal psyche. That is the moment of Dionysian frenzy, the overwhelming manifestation of the “blond beast,”¹ which seizes the unsuspecting soul with nameless shudderings. The seizure transforms him into a hero or into a godlike being, a superhuman entity. He rightly feels himself “six thousand feet beyond good and evil.”

[41] The psychological observer knows this state as “identification with the shadow,” a phenomenon which occurs with great regularity at such moments of collision with the unconscious. The only thing that helps here is cautious self-criticism. Firstly and before all else, it is exceedingly unlikely that one has just discovered a world-shattering truth, for such things happen extremely seldom in the world’s history. Secondly, one must carefully inquire whether something similar might not have happened elsewhere—for instance Nietzsche, as a philologist, could have adduced a few obvious classical parallels which would certainly have calmed his mind. Thirdly, one must reflect that a Dionysian experience may well be nothing more than a relapse into a pagan form of religion, so that in reality nothing new is discovered and the same story only repeats itself from the beginning. Fourthly, one cannot

avoid foreseeing that this joyful intensification of mood to heroic and godlike heights is dead certain to be followed by an equally deep plunge into the abyss. These considerations would put one in a position of advantage: the whole extravaganza could then be reduced to the proportions of a somewhat exhausting mountaineering expedition, to which succeed the eternal commonplaces of day. Just as every stream seeks the valley and the broad river that hastens towards the flatlands, so life not only flows along in commonplaces, but makes everything else commonplace. The uncommon, if it is not to end in catastrophe, may steal in alongside the commonplace, but not often. If heroism becomes chronic, it ends in a cramp, and the cramp leads to catastrophe or to neurosis or both. Nietzsche got stuck in a state of high tension. But with this ecstasy he could just as well have borne up under Christianity. Not that this answers the question of the animal psyche in the least—for an ecstatic animal is a monstrosity. An animal fulfils the law of its own life, neither more nor less. We can call it obedient and “good.” But the ecstatic by-passes the law of his own life and behaves, from the point of view of nature, improperly. This impropriety is the exclusive prerogative of man, whose consciousness and free will can occasionally loose themselves *contra naturam* from their roots in animal nature. It is the indispensable foundation of all culture, but also of spiritual sickness if exaggerated. Man can suffer only a certain amount of culture without injury. The endless dilemma of culture and nature is always a question of too much or too little, never of either-or.

[42] The case of Nietzsche faces us with the question: What did the collision with the shadow, namely the will to power, reveal to him? Is it to be regarded as something bogus, a symptom of repression? Is the will to power genuine or merely secondary? If the conflict with the shadow had let loose a flood of sexual fantasies, the matter would be perfectly clear; but it happened otherwise. The “Kern des Pudels” was not Eros but the power of the ego. From this we would have to conclude that what was repressed was not Eros but the will to power. There is in my opinion no ground for the assumption that Eros is genuine and the will to power bogus. The will to power is surely just as mighty a daemon as Eros, and just as old and original.

[43] A life like Nietzsche’s, lived to its fatal end with rare consistency in accordance with the underlying instinct for power, cannot simply be explained away as bogus. Otherwise one would make oneself guilty of the same unfair judgment that Nietzsche passed on his polar opposite, Wagner: “Everything about him is false. What is genuine is hidden or decorated. He is an actor, in every good and bad sense of the word.” Why this prejudice? Because Wagner embodies that other elemental urge which Nietzsche overlooked, and upon which Freud’s psychology is built. If we inquire whether Freud knew of that other instinct, the urge to power, we find that he conceived it under the name of “ego-instinct.” But these “ego-instincts” occupy a rather pokey little corner in his psychology compared with the broad, all too broad, development of the sexual factor. In reality human nature bears the burden of a terrible and unending conflict between the principle of the ego and the principle of instinct: the ego all barriers and restraint, instinct limitless, and both principles of equal might. In a certain sense man may count himself happy that he is “conscious only of the single urge,” and therefore it is only prudent to guard against ever knowing the other. But if he does learn to know the other, it is all up with him: he then enters upon the Faustian conflict. In the first part of *Faust* Goethe has shown us what it means to accept instinct and in the second part what it means to accept the ego and its weird unconscious world. All that is insignificant, paltry, and cowardly in us cowers and shrinks from this acceptance—and there is an excellent pretext for this: we discover that the “other” in us is indeed “another,” a real man, who actually thinks, does, feels, and desires all the things that are despicable and odious. In this way we can seize hold of the bogey and declare war on him to our satisfaction. Hence those chronic

idiosyncrasies of which the history of morals has preserved some fine examples. A particularly transparent example is that already cited—"Nietzsche *contra* Wagner, *contra* Paul," etc. But daily life abounds in such cases. By this ingenious device a man may save himself from the Faustian catastrophe, before which his courage and his strength might well fail him. A whole man, however, knows that his bitterest foe, or indeed a host of enemies, does not equal that one worst adversary, the "other self" who dwells in his bosom. Nietzsche had Wagner *in himself*, and that is why he envied him *Parsifal*; but, what was worse, he, Saul, also had Paul in him. Therefore Nietzsche became one stigmatized by the spirit; like Saul he had to experience Christification, when the "other" whispered the "Ecce Homo" in his ear. Which of them "broke down before the cross"—Wagner or Nietzsche?

[44] Fate willed it that one of Freud's earliest disciples, Alfred Adler, should formulate a view of neurosis² based exclusively on the power principle. It is of no little interest, indeed singularly fascinating, to see how utterly different the same things look when viewed in a contrary light. To take the main contrast first: with Freud everything follows from antecedent circumstances according to a rigorous causality, with Adler everything is a teleological "arrangement." Here is a simple example: A young woman begins to have attacks of anxiety. At night she wakes up from a nightmare with a blood-curdling cry, is scarcely able to calm herself, clings to her husband and implores him not to leave her, demanding assurance that he really loves her, etc. Gradually a nervous asthma develops, the attacks also coming on during the day.

[45] The Freudian method at once begins burrowing into the inner causality of the sickness and its symptoms. What were the first anxiety dreams about? Ferocious bulls, lions, tigers, and evil men were attacking her. What are the patient's associations? A story of something that happened to her before she was married. She was staying at a health resort in the mountains. She played a good deal of tennis and the usual acquaintances were made. There was a young Italian who played particularly well and also knew how to handle a guitar in the evening. An innocent flirtation developed, leading once to a moonlight stroll. On this occasion the Italian temperament "unexpectedly" broke loose, much to the alarm of the unsuspecting girl. He gave her "such a look" that she could never forget it. This look follows her even in her dreams: the wild animals that pursue her look at her just like that. But does this look in fact come only from the Italian? Another reminiscence is instructive. The patient had lost her father through an accident when she was about fourteen years old. Her father was a man of the world and travelled a good deal. Not long before his death he took her with him to Paris, where they visited, among other places, the Folies Bergères. There something happened that made an indelible impression on her. On leaving the theatre, a painted hussy jostled her father in an incredibly brazen way. Looking in alarm to see what he would do, she saw this same look, this animal glare, in his eyes. This inexplicable something followed her day and night. From then on her relations with her father changed. Sometimes she was irritable and subject to venomous moods, sometimes she loved him extravagantly. Then came sudden fits of weeping for no reason, and for a time, whenever her father was at home, she suffered at table from a horrible gulping accompanied by what looked like choking-fits, generally followed by loss of voice for one or two days. When the news of the sudden death of her father reached her, she was seized by uncontrollable grief, which gave way to fits of hysterical laughter. However, she soon calmed down; her condition quickly improved, and the neurotic symptoms practically vanished. A veil of forgetfulness was drawn over the past. Only the episode with the Italian stirred something in her of which she was afraid. She then abruptly broke off all connection with the young man. A few years later she married. The first appearance of her

present neurosis was after the birth of her second child, just when she made the discovery that her husband had a certain tender interest in another woman.

[46] This history gives rise to many questions: for example, what about the mother? Concerning the mother the relevant facts are that she was very nervous and spent her time trying every kind of sanatorium and method of cure. She too suffered from nervous asthma and anxiety symptoms. The marriage had been of a very distant kind as far back as the patient could remember. Her mother did not understand the father properly; the patient always had the feeling that she understood him much better. She was her father's confessed darling and was correspondingly cool at heart towards her mother.

[47] These hints may suffice to give us an over-all picture of the illness. Behind the present symptoms lie fantasies which are immediately related to the experience with the Italian, but which clearly point back to the father, whose unhappy marriage gave the little daughter an early opportunity to secure for herself the place that should properly have been filled by the mother. Behind this conquest there lies, of course, the fantasy of being the really suitable wife for the father. The first attack of neurosis broke out at a moment when this fantasy received a severe shock, probably the same shock that the mother had also received, though this would be unknown to the child. The symptoms are easily understandable as an expression of disappointed and slighted love. The choking is due to that feeling of constriction in the throat, a well-known concomitant of violent affects which cannot be quite "swallowed down." (The metaphors of common speech, as we know, frequently relate to such physiological phenomena.) When the father died, her conscious mind was grieved to death, but her shadow laughed, after the manner of Till Eulenspiegel, who was doleful when things went downhill, but full of merry pranks on the weary way up, always on the look-out for what lay ahead. When her father was at home, she was dejected and ill; when he was away, she always felt much better, like the innumerable husbands and wives who hide from each other the sweet secret that neither is altogether indispensable to the other.

[48] That the unconscious had at this juncture some justification for laughing is shown by the supervening period of good health. She succeeded in letting her whole past sink into oblivion. Only the episode with the Italian threatened to resurrect the underworld. But with a quick gesture she flung the door to and remained healthy until the dragon of neurosis came creeping back, just when she imagined herself safely over the mountain, in the perfect state, so to speak, of wife and mother.

[49] Sexual psychology says: the cause of the neurosis lies in the patient's fundamental inability to free herself from her father. That is why that experience came up again when she discovered in the Italian the mysterious "something" which had previously made such an overwhelming impression on her in connection with her father. These memories were naturally revived by the analogous experience with her husband, the immediate cause of the neurosis. We could therefore say that the content of and reason for the neurosis was the conflict between the infantile-erotic relation to her father and her love for her husband.

[50] If, however, we look at the same clinical picture from the point of view of the "other" instinct, the will to power, it assumes quite a different aspect. Her parents' unhappy marriage afforded an excellent opportunity for the childish urge to power. The power-instinct wants the ego to be "on top" under all circumstances, by fair means or foul. The "integrity of the personality" must be preserved at all costs. Every attempt, be it only an apparent attempt, of the environment to obtain the slightest ascendancy over the subject is met, to use Adler's expression,

by the “masculine protest.” The disillusionment of the mother and her withdrawal into neurosis created the desired opportunity for a display of power and for gaining the ascendancy. Love and good behaviour are, from the standpoint of the power-instinct, known to be a choice means to this end. Virtuousness often serves to *compel* recognition from others. Already as a child the patient knew how to secure a privileged position with her father through especially ingratiating and affectionate behaviour, and to get the better of her mother—not out of love for her father, but because love was a good method of gaining the upper hand. The laughing-fit at the time of her father’s death is striking proof of this. We are inclined to regard such an explanation as a horrible depreciation of love, not to say a malicious insinuation, until we reflect for a moment and look at the world as it is. Have we not seen countless people who love and believe in their love, and then, when their purpose is accomplished, turn away as though they had never loved? And finally, is not this the way of nature herself? Is “disinterested” love at all possible? If so, it belongs to the highest virtues, which in point of fact are exceedingly rare. Perhaps there is in general a tendency to think as little as possible about the purpose of love; otherwise we might make discoveries which would show the worth of our love in a less favourable light.

[51] The patient, then, had a laughing-fit at the death of her father—she had finally arrived on top. It was an hysterical laughter, a psychogenic symptom, something that sprang from unconscious motives and not from those of the conscious ego. That is a difference not to be made light of, and one that also tells us whence and how certain human virtues arise. Their opposites went down to hell—or, in modern parlance, into the unconscious—where the counterparts of our conscious virtues have long been accumulating. Hence for very virtue we wish to know nothing of the unconscious; indeed it is the acme of virtuous sagacity to declare that there is no such thing as the unconscious. But alas! it fares with us all as with Brother Medardus in Hoffmann’s tale *The Devil’s Elixir*: somewhere we have a sinister and frightful brother, our own flesh-and-blood counterpart, who holds and maliciously hoards everything that we would so willingly hide under the table.

[52] The first outbreak of neurosis in our patient occurred the moment she realized that there was something in her father which she could not dominate. And then a great light dawned: she now knew what was the purpose of her mother’s neurosis, namely that when you encounter an obstacle which cannot be overcome by rational methods and charm, there is still another method, hitherto unknown to her, which her mother had already discovered beforehand, i.e., neurosis. So from now on she imitates her mother’s neurosis. But what, we may ask in astonishment, is the good of a neurosis? What can it do? Anyone who has in his neighbourhood a definite case of neurosis knows well enough what it can “do.” There is no better method of tyrannizing over the entire household. Heart-attacks, choking-fits, spasms of all kinds, produce an enormous effect that can hardly be surpassed. Oceans of sympathy are let loose, there is the anguish of worried parents, the running to and fro of servants, telephone bells, hurrying doctors, difficult diagnoses, elaborate examinations, lengthy treatments, heavy expenses, and there in the midst of all the hubbub lies the innocent sufferer, with everybody overflowing with gratitude when at last she recovers from her “spasms.”

[53] This unsurpassable “arrangement”—to use Adler’s expression—was discovered by the little one and applied with success whenever her father was there. It became superfluous when the father died, for now she was finally on top. The Italian was dropped overboard when he laid too much emphasis on her femininity by an appropriate reminder of his virility. But when a suitable chance of marriage presented itself, she loved, and resigned herself without a murmur to the fate of wife and mother. So long as her revered superiority was maintained, everything

went swimmingly. But once her husband had a little bit of interest outside, she had recourse as before to that exceedingly effective “arrangement” for the indirect exercise of her power, because she had again encountered the obstacle—this time in her husband—which previously in her father’s case had escaped her mastery.

[54] This is how things look from the point of view of power psychology. I fear the reader must feel like the *cadi* who, having heard the counsel for the one party, said, “Thou hast well spoken. I perceive that thou art right.” Then came the other party, and when he had finished, the *cadi* scratched himself behind the ear and said, “Thou hast well spoken. I perceive that thou also art right.” It is unquestionable that the urge to power plays an extraordinarily important part. It is correct that neurotic symptoms and complexes are also elaborate “arrangements” which inexorably pursue their aims, with incredible obstinacy and cunning. Neurosis is teleologically oriented. In establishing this Adler has won for himself no small credit.

[55] Which of the two points of view is right? That is a question that might lead to much brain-racking. One simply cannot lay the two explanations side by side, for they contradict each other absolutely. In the one, the chief and decisive fact is Eros and its destiny; in the other, it is the power of the ego. In the first case, the ego is merely a sort of appendage to Eros; in the second, love is just a means to the end, which is ascendancy. Those who have the power of the ego most at heart will revolt against the first conception, but those who care most for love will never be reconciled to the second.

IV

THE PROBLEM OF THE ATTITUDE-TYPE

1

[56] The incompatibility of the two theories discussed in the preceding chapters requires a standpoint superordinate to both, in which they could come together in unison. We are certainly not entitled to discard one in favour of the other, however convenient this expedient might be. For, if we examine the two theories without prejudice, we cannot deny that both contain significant truths, and, contradictory as these are, they should not be regarded as mutually exclusive. The Freudian theory is attractively simple, so much so that it almost pains one if anybody drives in the wedge of a contrary assertion. But the same is true of Adler's theory. It too is of illuminating simplicity and explains just as much as the Freudian theory. No wonder, then, that the adherents of both schools obstinately cling to their one-sided truths. For humanly understandable reasons they are unwilling to give up a beautiful, rounded theory in exchange for a paradox, or, worse still, lose themselves in the confusion of contradictory points of view.

[57] Now, since both theories are in a large measure correct—that is to say, since they both appear to explain their material—it follows that a neurosis must have two opposite aspects, one of which is grasped by the Freudian, the other by the Adlerian theory. But how comes it that each investigator sees only one side, and why does each maintain that he has the only valid view? It must come from the fact that, owing to his psychological peculiarity, each investigator most readily sees that factor in the neurosis which corresponds to his peculiarity. It cannot be assumed that the cases of neurosis seen by Adler are totally different from those seen by Freud. Both are obviously working with the same material; but because of personal peculiarities they each see things from a different angle, and thus they evolve fundamentally different views and theories. Adler sees how a subject who feels suppressed and inferior tries to secure an illusory superiority by means of “protests,” “arrangements,” and other appropriate devices directed equally against parents, teachers, regulations, authorities, situations, institutions, and such. Even sexuality may figure among these devices. This view lays undue emphasis upon the subject, before which the idiosyncrasy and significance of objects entirely vanish. Objects are regarded at best as vehicles of suppressive tendencies. I shall probably not be wrong in assuming that the love relation and other desires directed upon objects exist equally in Adler as essential factors; yet in his theory of neurosis they do not play the principal role assigned to them by Freud.

[58] Freud sees his patient in perpetual dependence on, and in relation to, significant objects. Father and mother play a large part here; whatever other significant influences or conditions enter into the life of the patient go back in a direct line of causality to these prime factors. The *pièce de résistance* of his theory is the concept of transference, i.e., the patient's relation to the doctor. Always a specifically qualified object is either desired or met with resistance, and this reaction always follows the pattern established in earliest childhood through the relation to father and mother. What comes from the subject is essentially a blind striving after pleasure; but this striving

always acquires its quality from specific objects. With Freud objects are of the greatest significance and possess almost exclusively the determining power, while the subject remains remarkably insignificant and is really nothing more than the source of desire for pleasure and a “seat of anxiety.” As already pointed out, Freud recognizes ego-instincts, but this term alone is enough to show that his conception of the subject differs *toto coelo* from Adler’s, where the subject figures as the determining factor.

[59] Certainly both investigators see the subject in relation to the object; but how differently this relation is seen! With Adler the emphasis is placed on a subject who, no matter what the object, seeks his own security and supremacy: with Freud the emphasis is placed wholly upon objects, which, according to their specific character, either promote or hinder the subject’s desire for pleasure.

[60] This difference can hardly be anything else but a difference of temperament, a contrast between two types of human mentality, one of which finds the determining agency pre-eminently in the subject, the other in the object. A middle view, it may be that of common sense, would suppose that human behaviour is conditioned as much by the subject as by the object. The two investigators would probably assert, on the other hand, that their theory does not envisage a psychological explanation of the normal man, but is a theory of neurosis. But in that case Freud would have to explain and treat some of his patients along Adlerian lines, and Adler condescend to give earnest consideration in certain instances to his former teacher’s point of view—which has occurred neither on the one side nor on the other.

[61] The spectacle of this dilemma made me ponder the question: are there at least two different human types, one of them more interested in the object, the other more interested in himself? And does that explain why the one sees only the one and the other only the other, and thus each arrives at totally different conclusions? As we have said, it was hardly to be supposed that fate selected the patients so meticulously that a definite group invariably reached a definite doctor. For some time it had struck me, in connection both with myself and with my colleagues, that there are some cases which make a distinct appeal, while others somehow refuse to “click.” It is of crucial importance for the treatment whether a good relationship between doctor and patient is possible or not. If some measure of natural confidence does not develop within a short period, then the patient will do better to choose another doctor. I myself have never shrunk from recommending to a colleague a patient whose peculiarities were not in my line or were unsympathetic to me, and indeed this is in the patient’s own interests. I am positive that in such a case I would not do good work. Everyone has his personal limitations, and the psychotherapist in particular is well advised never to disregard them. Excessive personal differences and incompatibilities cause resistances that are disproportionate and out of place, though they are not altogether unjustified. The Freud-Adler controversy is simply a paradigm and one single instance among many possible attitude-types.

[62] I have long busied myself with this question and have finally, on the basis of numerous observations and experiences, come to postulate two fundamental attitudes, namely *introversion* and *extraversion*. The first attitude is normally characterized by a hesitant, reflective, retiring nature that keeps itself to itself, shrinks from objects, is always slightly on the defensive and prefers to hide behind mistrustful scrutiny. The second is normally characterized by an outgoing, candid, and accommodating nature that adapts easily to a given situation, quickly forms attachments, and, setting aside any possible misgivings, will often venture forth with careless confidence into unknown situations. In the first case obviously the subject, and in the second the object, is all-important.

[63] Naturally these remarks sketch the two types only in the roughest outlines.¹ As a matter of empirical fact the two attitudes, to which I shall come back shortly, can seldom be observed in their pure state. They are infinitely varied and compensated, so that often the type is not at all easy to establish. The reason for variation—apart from individual fluctuations—is the predominance of one of the conscious functions, such as thinking or feeling, which then gives the basic attitude a special character. The numerous compensations of the basic type are generally due to experiences which teach a man, perhaps in a very painful way, that he cannot give free rein to his nature. In other cases, for instance with neurotics, one frequently does not know whether one is dealing with a conscious or an unconscious attitude because, owing to the dissociation of the personality, sometimes one half of it and sometimes the other half occupies the foreground and confuses one's judgment. This is what makes it so excessively trying to live with neurotic persons.

[64] The actual existence of far-reaching type-differences,² of which I have described eight groups² in the above-mentioned book, has enabled me to conceive the two controversial theories of neurosis as manifestations of a type-antagonism.

[65] This discovery brought with it the need to rise above the opposition and to create a theory which should do justice not merely to one or the other side, but to both equally. For this purpose a critique of both the aforementioned theories is essential. Both are painfully inclined to reduce high-flown ideals, heroic attitudes, nobility of feeling, deep convictions, to some banal reality, if applied to such things as these. On no account should they be so applied, for both theories are properly therapeutic instruments from the armoury of the doctor, whose knife must be sharp and pitiless for excising what is diseased and injurious. This was what Nietzsche wanted with his destructive criticism of ideals, which he held to be morbid overgrowths in the soul of humanity (as indeed they sometimes are). In the hand of a good doctor, of one who really knows the human soul—who, to use Nietzsche's phrase, has a "finger for nuances"—both theories, when applied to the really sick part of a soul, are wholesome caustics, of great help in dosages measured to the individual case, but harmful and dangerous in the hand that knows not how to measure and weigh. They are critical methods, having, like all criticism, the power to do good when there is something that must be destroyed, dissolved, or reduced, but capable only of harm when there is something to be built.

[66] Both theories may therefore be allowed to pass with no ill consequences provided that, like medical poisons, they are entrusted to the sure hand of the physician, for it requires an uncommon knowledge of the human psyche to apply these caustics with advantage. One must be capable of distinguishing the pathological and the useless from what is valuable and worth preserving, and that is one of the most difficult things. Anyone who wishes to get a vivid impression of how irresponsibly a psychologizing doctor can falsify his subject through narrow, pseudo-scientific prejudice, should turn to the writings of Möbius on Nietzsche, or, better still, to the various "psychiatric" writings on the "case" of Christ. He will not hesitate to cry a "threefold lamentation" over the patient who meets with such "understanding."

[67] The two theories of neurosis are not universal theories: they are caustic remedies to be applied, as it were, locally. They are destructive and reductive. They say to everything, "You are nothing but..." They explain to the sufferer that his symptoms come from here and from there and are nothing but this or that. It would be unjust to assert that this reduction is wrong in a given case; but, exalted to the status of a general explanation of the healthy

psyche as well as the sick, a reductive theory by itself is impossible. For the human psyche, be it sick or healthy, cannot be explained *solely* by reduction. Eros is certainly always and everywhere present, the urge to power certainly pervades the heights and depths of the psyche, but the psyche is not *just* the one or the other, nor for that matter both together. It is *also* what it has made and will make out of them. A man is only half understood when we know how everything in him came into being. If that were all, he could just as well have been dead years ago. As a living being he is not understood, for life does not have only a yesterday, nor is it explained by reducing today to yesterday. Life has also a tomorrow, and today is understood only when we can add to our knowledge of what was yesterday the beginnings of tomorrow. This is true of all life's psychological expressions, even of pathological symptoms. The symptoms of a neurosis are not simply the effects of long-past causes, whether "infantile sexuality" or the infantile urge to power; they are also attempts at a new synthesis of life—unsuccessful attempts, let it be added in the same breath, yet attempts nevertheless, with a core of value and meaning. They are seeds that fail to sprout owing to the inclement conditions of inner and outer nature.

[68] The reader will doubtless ask: What in the world is the value and meaning of a neurosis, this most useless and pestilent curse of humanity? To be neurotic—what good can that do? As much good, possibly, as flies and other pests, which the good Lord created so that man might exercise the useful virtue of patience. However stupid this thought is from the point of view of natural science, it may yet be sensible enough from the point of view of psychology, if we put "nervous symptoms" instead of "pests." Even Nietzsche, a rare one for scorning stupid and banal thoughts, more than once acknowledged how much he owed to his malady. I myself have known more than one person who owed his entire usefulness and reason for existence to a neurosis, which prevented all the worst follies in his life and *forced* him to a mode of living that developed his valuable potentialities. These might have been stifled had not the neurosis, with iron grip, held him to the place where he belonged. There are actually people who have the whole meaning of their life, their true significance, in the unconscious, while in the conscious mind is nothing but inveiglement and error. With others the case is reversed, and here neurosis has a different meaning. In these cases, but not in the former, a thoroughgoing reduction is indicated.

[69] At this point the reader may be inclined to grant the possibility that the neurosis has such a meaning in certain cases, while denying it so far-reaching a purposiveness in ordinary everyday cases. What, for instance, could be the value of a neurosis in the above-mentioned case of asthma with its hysterical anxiety-states? I admit that the value is not so obvious here, especially when the case is considered from the theoretical reductive standpoint, that is, from the shadow-side of individual development.

[70] The two theories we have been discussing evidently have this much in common: they pitilessly unveil everything that belongs to man's shadow-side. They are theories or, more correctly, hypotheses which explain in what the pathogenic factor consists. They are accordingly concerned not with a man's positive values, but with his negative values which make themselves so disturbingly conspicuous.

[71] A "value" is a possibility for the display of energy. But in so far as a negative value is likewise a possibility for the display of energy—which can be seen most clearly in the notable manifestations of neurotic energy—it too is properly a "value," but one that brings about useless and harmful manifestations of energy. Energy in itself is neither good nor bad, neither useful nor harmful, but neutral, since everything depends on the *form* into which energy passes. Form gives energy its quality. On the other hand, mere form without energy is equally neutral. For

the creation of a real value, therefore, both energy and valuable form are needed. In neurosis psychic energy³ is present, but undoubtedly it is there in an inferior and unserviceable form. The two reductive theories act as solvents of this inferior form. They are approved caustic remedies, by means of which we obtain free but neutral energy. Now, it has hitherto been supposed that this newly disengaged energy is at the conscious disposal of the patient, so that he can apply it at his pleasure. Since it was thought that the energy is nothing but the instinctual power of sex, people talked of a “sublimated” application of it, on the assumption that the patient could, with the help of analysis, canalize the sexual energy into a “sublimation,” in other words, could apply it non-sexually, in the practice of an art, perhaps, or in some other good or useful activity. According to this view, it is possible for the patient, from free choice or inclination, to achieve the sublimation of his instinctual forces.

[72] We may allow that this view has a certain justification in so far as man is at all capable of marking out a definite line along which his life has to go. But we know that there is no human foresight or wisdom that can prescribe direction to our life, except for small stretches of the way. This is of course true only of the “ordinary” type of life, not of the “heroic” type. The latter kind also exists, though it is much rarer. Here we are certainly not entitled to say that no marked direction can be given to life, or only for short distances. The heroic style of life is absolute—that is, it is oriented by fateful decisions, and the decision to go in a certain direction holds, sometimes, to the bitter end. Admittedly the doctor has to do, in the main, only with human beings, seldom with voluntary heroes, and then they are mostly of a type whose surface heroism is an infantile defiance of a fate greater than they, or else a pomposity meant to cover up some touchy inferiority. In this overpoweringly humdrum existence, alas, there is little out of the ordinary that is healthy, and not much room for conspicuous heroism. Not that heroic demands are never put to us: on the contrary—and this is just what is so irritating and irksome—the banal everyday makes banal demands upon our patience, our devotion, perseverance, self-sacrifice; and for us to fulfil these demands (as we must) humbly and without courting applause through heroic gestures, a heroism is needed that cannot be seen from the outside. It does not glitter, is not belauded, and it always seeks concealment in everyday attire. These are the demands which, if not fulfilled, are the cause of neurosis. In order to evade them, many a man has dared the *great* decision of his life and carried it through, even if in the common human estimation it was a great error. Before a fate such as this one can only bow one’s head. But, as I say, such cases are rare; the others are in the vast majority. For them the direction of their life is not a simple, straight line; fate confronts them like an intricate labyrinth, all too rich in possibilities, and yet of these many possibilities only one is their own right way. Who would presume—even though armed with the completest knowledge of his own character—to designate in advance that single possibility? Much indeed can be attained by the will, but, in view of the fate of certain markedly strong-willed personalities, it is a fundamental error to try to subject our own fate at all costs to our will. Our will is a function regulated by reflection; hence it is dependent on the quality of that reflection. This, if it really is reflection, is supposed to be rational, i.e., in accord with reason. But has it ever been shown, or will it ever be, that life and fate are in accord with reason, that they too are rational? We have on the contrary good grounds for supposing that they are irrational, or rather that in the last resort they are grounded beyond human reason. The irrationality of events is shown in what we call chance, which we are obviously compelled to deny because we cannot in principle think of any process that is not causal and necessary, whence it follows that it cannot happen by chance.⁴ In practice, however, chance reigns everywhere, and so obtrusively that we might as well put our causal philosophy in our pocket. The plenitude of life is governed by law and yet not

governed by law, rational and yet irrational. Hence reason and the will that is grounded in reason are valid only up to a point. The further we go in the direction selected by reason, the surer we may be that we are excluding the irrational possibilities of life which have just as much right to be lived. It was indeed highly expedient for man to become somewhat more capable of directing his life. It may justly be maintained that the acquisition of reason is the greatest achievement of humanity; but that is not to say that things must or will always continue in that direction. The frightful catastrophe of the first World War drew a very thick line through the calculations of even the most optimistic rationalizers of culture. In 1913, Wilhelm Ostwald wrote:

The whole world is agreed that the present state of armed peace is untenable and is gradually becoming impossible. It demands tremendous sacrifices from each single nation, far exceeding the expenditure for cultural purposes, yet without securing any positive values. If mankind could discover ways and means for doing away with these preparations for wars *which never take place*, together with the immobilization of a large part of the nation's manhood, at the age of maximum strength and efficiency, for the furtherance of warlike aims, and all the other innumerable evils which the present state of affairs creates, such an immense economy of energy would be effected that from this moment onwards we could look forward to a blossoming of culture hitherto undreamed of. For war, like personal combat, although the oldest of all possible means of settling contests of will, is on that very account the most inept, and entails the most grievous waste of energy. Hence the complete abolition of warfare, potential no less than actual, is the categorical imperative of efficiency and one of the supremely important cultural tasks of our day.⁵

[73] The irrationality of fate, however, did not concur with the rationality of well-meaning thinkers; it ordained not only the destruction of the accumulated arms and armies, but, far beyond that, a mad and monstrous devastation, a mass murder without parallel—from which humanity may possibly draw the conclusion that only one side of fate can be mastered with rational intentions.

[74] What is true of humanity in general is also true of each individual, for humanity consists only of individuals. And as is the psychology of humanity so also is the psychology of the individual. The World War brought a terrible reckoning with the rational intentions of civilization. What is called "will" in the individual is called "imperialism" in nations; for all will is a demonstration of power over fate, i.e., the exclusion of chance. Civilization is the rational, "purposeful" sublimation of free energies, brought about by will and intention. It is the same with the individual; and just as the idea of a world civilization received a fearful correction at the hands of war, so the individual must often learn in his life that so-called "disposable" energies are not his to dispose.

[75] Once, in America, I was consulted by a business man of about forty-five, whose case is a good illustration of what has been said. He was a typical American self-made man who had worked his way up from the bottom. He had been very successful and had founded an immense business. He had also succeeded in organizing it in such a way that he was able to think of retiring. Two years before I saw him he had in fact taken his farewell. Until then he had lived entirely for his business and concentrated all his energies on it with the incredible intensity and one-

sidedness peculiar to successful American business men. He had purchased a splendid estate where he thought of “living,” by which he meant horses, automobiles, golf, tennis, parties and what not. But he had reckoned without his host. The energy which should have been at his disposal would not enter into these alluring prospects, but went capering off in quite another direction. A few weeks after the initiation of the longed-for life of bliss, he began brooding over peculiar, vague sensations in his body, and a few weeks more sufficed to plunge him into a state of extreme hypochondria. He had a complete nervous collapse. From a healthy man, of uncommon physical strength and abounding energy, he became a peevish child. That was the end of all his glories. He fell from one state of anxiety to the next and worried himself almost to death with hypochondriacal mopings. He then consulted a famous specialist, who recognized at once that there was nothing wrong with the man but lack of work. The patient saw the sense of this, and returned to his former position. But, to his immense disappointment, no interest in the business could be aroused. Neither patience nor resolution was of any use. His energy could not by any means be forced back into the business. His condition naturally became worse than before. All that had formerly been living, creative energy in him now turned against him with terrible destroying force. His creative genius rose up, as it were, in revolt against him; and just as before he had built up great organizations in the world, so now his daemon spun equally subtle systems of hypochondriacal delusion that completely annihilated him. When I saw him he was already a hopeless moral ruin. Nevertheless I tried to make clear to him that though such colossal energy might be withdrawn from the business, the question remained, where should it go? The finest horses, the fastest cars, and the most amusing parties may very likely fail to allure the energy, although it would be rational enough to think that a man who had devoted his whole life to serious work had a sort of natural right to enjoy himself. Yes, if fate behaved in a humanly rational way, it would certainly be so: first work, then well-earned rest. But fate behaves irrationally, and the energy of life inconveniently demands a gradient agreeable to itself; otherwise it simply gets dammed up and turns destructive. It regresses to former situations—in the case of this man, to the memory of a syphilitic infection contracted twenty-five years before. Yet even this was only a stage on the way to the resuscitation of infantile reminiscences which had all but vanished in the meantime. It was the original relation to his mother that mapped the course of his symptoms: they were an “arrangement” whose purpose it was to compel the attention and interest of his long-dead mother. Nor was this stage the last; for the ultimate goal was to drive him back, as it were, into his own body, after he had lived since his youth only in his head. He had differentiated one side of his being; the other side remained in an inert physical state. He would have needed this other side in order to “live.” The hypochondriacal “depression” pushed him down into the body he had always overlooked. Had he been able to follow the direction indicated by his depression and hypochondriacal illusion, and make himself conscious of the fantasies which proceed from such a condition, that would have been the road to salvation. My arguments naturally met with no response, as was to be expected. A case so far advanced can only be cared for until death; it can hardly be cured.

[76] This example clearly shows that it does not lie in our power to transfer “disposable” energy at will to a rationally chosen object. The same is true in general of the apparently disposable energy which is disengaged when we have destroyed its unserviceable forms through the corrosive of reductive analysis. This energy, as we have said, can at best be applied voluntarily for only a short time. But in most cases it refuses to seize hold, for any length of time, of the possibilities rationally presented to it. Psychic energy is a very fastidious thing which insists

on fulfilment of its own conditions. However much energy may be present, we cannot make it serviceable until we have succeeded in finding the right gradient.

[77] This question of the gradient is an eminently practical problem which crops up in most analyses. For instance, when in a favourable case the disposable energy, the so-called libido,⁶ does seize hold of a rational object, we think we have brought about the transformation through conscious exertion of the will. But in that we are deluded, because even the most strenuous exertions would not have sufficed had there not been present at the same time a gradient in that direction. How important the gradient is can be seen in cases when, despite the most desperate exertions, and despite the fact that the object chosen or the form desired impresses everybody with its reasonableness, the transformation still refuses to take place, and all that happens is a new repression.

[78] It has become abundantly clear to me that life can flow forward only along the path of the gradient. But there is no energy unless there is a tension of opposites; hence it is necessary to discover the opposite to the attitude of the conscious mind. It is interesting to see how this compensation by opposites also plays its part in the historical theories of neurosis: Freud's theory espoused Eros, Adler's the will to power. Logically, the opposite of love is hate, and of Eros, Phobos (fear); but psychologically it is the will to power. Where love reigns, there is no will to power; and where the will to power is paramount, love is lacking. The one is but the shadow of the other: the man who adopts the standpoint of Eros finds his compensatory opposite in the will to power, and that of the man who puts the accent on power is Eros. Seen from the one-sided point of view of the conscious attitude, the shadow is an inferior component of the personality and is consequently repressed through intensive resistance. But the repressed content must be made conscious so as to produce a tension of opposites, without which no forward movement is possible. The conscious mind is on top, the shadow underneath, and just as high always longs for low and hot for cold, so all consciousness, perhaps without being aware of it, seeks its unconscious opposite, lacking which it is doomed to stagnation, congestion, and ossification. Life is born only of the spark of opposites.

[79] It was a concession to intellectual logic on the one hand and to psychological prejudice on the other that impelled Freud to name the opposite of Eros the destructive or death instinct. For in the first place, Eros is not equivalent to life; but for anyone who thinks it is, the opposite of Eros will naturally appear to be death. And in the second place, we all feel that the opposite of our own highest principle must be purely destructive, deadly, and evil. We refuse to endow it with any positive life-force; hence we avoid and fear it.

[80] As I have already indicated, there are many highest principles both of life and of philosophy, and accordingly there are just as many different forms of compensation by opposites. Earlier on I singled out the two—as it seems to me—main opposite types, which I have called introverted and extraverted. William James⁷ had already been struck by the existence of both these types among thinkers. He distinguished them as “tender-minded” and “tough-minded.” Similarly Ostwald⁸ found an analogous division into “classic” and “romantic” types among men of learning. So I am not alone in my idea of types, to mention only these two well-known names among many others. Inquiries into history have shown me that not a few of the great spiritual controversies rest upon the opposition of the two types. The most significant case of this kind was the opposition between nominalism and realism which, beginning with the difference between the Platonic and Megarian schools, became the heritage of scholastic philosophy, and it was Abelard's great merit to have hazarded at least the attempt to unite the two opposed standpoints in his “conceptualism.”⁹ This controversy has continued right into our own day, as is shown in the

opposition between idealism and materialism. And again, not only the human mind in general, but each individual has a share in this opposition of types. It has come to light on closer investigation that either type has a predilection to marry its opposite, each being unconsciously complementary to the other. The reflective nature of the introvert causes him always to think and consider before acting. This naturally makes him slow to act. His shyness and distrust of things induce hesitation, and so he always has difficulty in adapting to the external world. Conversely the extravert has a positive relation to things. He is, so to speak, attracted to them. New, unknown situations fascinate him. In order to make closer acquaintance with the unknown he will jump into it with both feet. As a rule he acts first and thinks afterwards. Thus his action is swift, subject to no misgivings and hesitations. The two types therefore seem created for a symbiosis. The one takes care of reflection and the other sees to the initiative and practical action. When the two types marry they may effect an ideal union. So long as they are fully occupied with their adaptation to the manifold external needs of life they fit together admirably. But when the man has made enough money, or if a fine legacy should drop from the skies and external necessity no longer presses, then they have time to occupy themselves with one another. Hitherto they stood back to back and defended themselves against necessity. But now they turn face to face and look for understanding—only to discover that they have never understood one another. Each speaks a different language. Then the conflict between the two types begins. This struggle is envenomed, brutal, full of mutual depreciation, even when conducted quietly and in the greatest intimacy. For the value of the one is the negation of value for the other. It might reasonably be supposed that each, conscious of his own value, could peaceably recognize the other's value, and that in this way any conflict would be superfluous. I have seen a good number of cases where this line of argument was adopted, without, however, arriving at a satisfactory goal. Where it is a question of normal people, such critical periods of transition will be overcome fairly smoothly. By "normal" I mean a person who can somehow exist under all circumstances which afford him the minimum needs of life. But many people cannot do this; therefore not so very many people are normal. What we commonly mean by a "normal person" is actually an ideal person whose happy blend of character is a rare occurrence. By far the greater number of more or less differentiated persons demand conditions of life which offer considerably more than the certainty of food and sleep. For these the ending of a symbiotic relationship comes as a severe shock.

[81] It is not easy to understand why this should be so. Yet if we consider that no man is simply introverted or simply extraverted, but has both attitudes potentially in him—although he has developed only one of them as a function of adaptation—we shall immediately conjecture that with the introvert extraversion lies dormant and undeveloped somewhere in the background, and that introversion leads a similar shadowy existence in the extravert. And this is indeed the case. The introvert does possess an extraverted attitude, but it is unconscious, because his conscious gaze is always turned to the subject. He sees the object, of course, but has false or inhibiting ideas about it, so that he keeps his distance as much as possible, as though the object were something formidable and dangerous. I will make my meaning clear by a simple illustration:

Let us suppose two youths rambling in the country. They come to a fine castle; both want to see inside it. The introvert says, "I'd like to know what it's like inside." The extravert answers, "Right, let's go in," and makes for the gateway. The introvert draws back—"Perhaps we aren't allowed in," says he, with visions of policemen, fines, and fierce dogs in the background. Whereupon the extravert answers, "Well,

we can ask. They'll let us in all right"—with visions of kindly old watchmen, hospitable seigneurs, and the possibility of romantic adventures. On the strength of extraverted optimism they at length find themselves in the castle. But now comes the dénouement. The castle has been rebuilt inside, and contains nothing but a couple of rooms with a collection of old manuscripts. As it happens, old manuscripts are the chief joy of the introverted youth. Hardly has he caught sight of them than he becomes as one transformed. He loses himself in contemplation of the treasures, uttering cries of enthusiasm. He engages the caretaker in conversation so as to extract from him as much information as possible, and when the result is disappointing he asks to see the curator in order to propound his questions to him. His shyness has vanished, objects have taken on a seductive glamour, and the world wears a new face. But meanwhile the spirits of the extraverted youth are ebbing lower and lower. His face grows longer and he begins to yawn. No kindly watchmen are forthcoming here, no knightly hospitality, not a trace of romantic adventure—only a castle made over into a museum. There are manuscripts enough to be seen at home. While the enthusiasm of the one rises, the spirits of the other fall, the castle bores him, the manuscripts remind him of a library, library is associated with university, university with studies and menacing examinations. Gradually a veil of gloom descends over the once so interesting and enticing castle. The object becomes negative. “Isn't it marvellous,” cries the introvert, “to have stumbled on this wonderful collection?” “The place bores me to extinction,” replies the other with undisguised ill humour. This annoys the introvert, who secretly vows never again to go rambling with an extravert. The latter is annoyed with the other's annoyance, and he thinks to himself that he always knew the fellow was an inconsiderate egotist who would, in his own selfish interest, waste all the lovely spring day that could be enjoyed so much better out of doors.

[82] What has happened? Both were wandering together in happy symbiosis until they discovered the fatal castle. Then the forethinking, or Promethean, introvert said it might be seen from the inside, and the after-thinking, or Epimethean, extravert opened the door.¹⁰ At this point the types invert themselves: the introvert, who at first resisted the idea of going in, cannot now be induced to go out, and the extravert curses the moment when he set foot inside the castle. The former is now fascinated by the object, the latter by his negative thoughts. When the introvert spotted the manuscripts, it was all up with him. His shyness vanished, the object took possession of him, and he yielded himself willingly. The extravert, however, felt a growing resistance to the object and was eventually made the prisoner of his own ill-humoured subjectivity. The introvert became extraverted, the extravert introverted. But the extraversion of the introvert is different from the extraversion of the extravert, and vice versa. So long as both were wandering along in joyous harmony, neither fell foul of the other, because each was in his natural character. Each was positive to the other, because their attitudes were complementary. They were complementary, however, only because the attitude of the one included the other. We can see this from the short conversation at the gateway. Both wanted to enter the castle. The doubt of the introvert as to whether an entry were

possible also held good for the other. The initiative of the extravert likewise held good for the other. Thus the attitude of the one includes the other, and this is always in some degree true if a person happens to be in the attitude natural to him, for this attitude has some degree of collective adaptation. The same is true of the introvert's attitude, although this always starts from the subject. It simply goes from subject to object, while the extravert's attitude goes from object to subject.

[83] But the moment when, in the case of the introvert, the object overpowers and attracts the subject, his attitude loses its social character. He forgets the presence of his friend, he no longer includes him, he becomes absorbed into the object and does not see how very bored his friend is. In the same way the extravert loses all consideration for the other as soon as his expectations are disappointed and he withdraws into subjectivity and moodiness.

[84] We can therefore formulate the occurrence as follows: in the introvert the influence of the object produces an inferior extraversion, while in the extravert an inferior introversion takes the place of his social attitude. And so we come back to the proposition from which we started: "The value of the one is the negation of value for the other."

[85] Positive as well as negative occurrences can constellate the inferior counter-function. When this happens, sensitiveness appears. Sensitiveness is a sure sign of the presence of inferiority. This provides the psychological basis for discord and misunderstanding, not only as between two people, but also in ourselves. The essence of the inferior function¹¹ is autonomy: it is independent, it attacks, it fascinates and so spins us about that we are no longer masters of ourselves and can no longer rightly distinguish between ourselves and others.

[86] And yet it is necessary for the development of character that we should allow the other side, the inferior function, to find expression. We cannot in the long run allow one part of our personality to be cared for symbiotically by another; for the moment when we might have need of the other function may come at any time and find us unprepared, as the above example shows. And the consequences may be bad: the extravert loses his indispensable relation to the object, and the introvert loses his to the subject. Conversely, it is equally indispensable for the introvert to arrive at some form of action not constantly bedevilled by doubts and hesitations, and for the extravert to reflect upon himself, yet without endangering his relationships.

[87] In extraversion and introversion it is clearly a matter of two antithetical, natural attitudes or trends, which Goethe once referred to as diastole and systole. They ought, in their harmonious alternation, to give life a rhythm, but it seems to require a high degree of art to achieve such a rhythm. Either one must do it quite unconsciously, so that the natural law is not disturbed by any conscious act, or one must be conscious in a much higher sense, to be capable of willing and carrying out the antithetical movements. Since we cannot develop backwards into animal unconsciousness, there remains only the more strenuous way forwards into higher consciousness. Certainly that consciousness, which would enable us to live the great Yea and Nay of our own free will and purpose, is an altogether superhuman ideal. Still, it is a goal. Perhaps our present mentality only allows us consciously to will the Yea and to bear with the Nay. When that is the case, much is already achieved.

[88] The problem of opposites, as an inherent principle of human nature, forms a further stage in our process of realization. As a rule it is one of the problems of maturity. The practical treatment of a patient will hardly ever begin with this problem, especially not in the case of young people. The neuroses of the young generally come from a collision between the forces of reality and an inadequate, infantile attitude, which from the causal point of view is characterized by an abnormal dependence on the real or imaginary parents, and from the teleological point

of view by unrealizable fictions, plans, and aspirations. Here the reductive methods of Freud and Adler are entirely in place. But there are many neuroses which either appear only at maturity or else deteriorate to such a degree that the patients become incapable of work. Naturally one can point out in these cases that an unusual dependence on the parents existed even in youth, and that all kinds of infantile illusions were present; but all that did not prevent them from taking up a profession, from practising it successfully, from keeping up a marriage of sorts until that moment in riper years when the previous attitude suddenly failed. In such cases it is of little help to make them conscious of their childhood fantasies, dependence on the parents, etc., although this is a necessary part of the procedure and often has a not unfavourable result. But the real therapy only begins when the patient sees that it is no longer father and mother who are standing in his way, but himself—i.e., an unconscious part of his personality which carries on the role of father and mother. Even this realization, helpful as it is, is still negative; it simply says, “I realize that it is not father and mother who are against me, but I myself.” But *who* is it in him that is against him? What is this mysterious part of his personality that hides under the father-and mother-imagos, making him believe for years that the cause of his trouble must somehow have got into him from outside? This part is the counterpart of his conscious attitude, and it will leave him no peace and will continue to plague him until it has been accepted. For young people a liberation from the past may be enough: a beckoning future lies ahead, rich in possibilities. It is sufficient to break a few bonds; the life-urge will do the rest. But we are faced with another task in the case of people who have left a large part of their life behind them, for whom the future no longer beckons with marvellous possibilities, and nothing is to be expected but the endless round of familiar duties and the doubtful pleasures of old age.

[89] If ever we succeed in liberating young people from the past, we see that they always transfer the imagos of their parents to more suitable substitute figures. For instance, the feeling that clung to the mother now passes to the wife, and the father’s authority passes to respected teachers and superiors or to institutions. Although this is not a fundamental solution, it is yet a practical road which the normal man treads unconsciously and therefore with no notable inhibitions and resistances.

[90] The problem for the adult is very different. He has put this part of the road behind him with or without difficulty. He has cut loose from his parents, long since dead perhaps, and has sought and found the mother in the wife, or, in the case of a woman, the father in the husband. He has duly honoured his fathers and their institutions, has himself become a father, and, with all this in the past, has possibly come to realize that what originally meant advancement and satisfaction has now become a boring mistake, part of the illusion of youth, upon which he looks back with mingled regret and envy, because nothing now awaits him but old age and the end of all illusions. Here there are no more fathers and mothers; all the illusions he projected upon the world and upon things gradually come home to him, jaded and way-worn. The energy streaming back from these manifold relationships falls into the unconscious and activates all the things he had neglected to develop.

[91] In a young man, the instinctual forces tied up in the neurosis give him, when released, buoyancy and hope and the chance to extend the scope of his life. To the man in the second half of life the development of the function of opposites lying dormant in the unconscious means a renewal; but this development no longer proceeds via the dissolution of infantile ties, the destruction of infantile illusions and the transference of old imagos to new figures: it proceeds via the problem of opposites.

[92] The principle of opposition is, of course, fundamental even in adolescence, and a psychological theory of the adolescent psyche is bound to recognize this fact. Hence the Freudian and Adlerian viewpoints contradict each other only when they claim to be generally applicable theories. But so long as they are content to be technical, auxiliary concepts, they do not contradict or exclude one another. A psychological theory, if it is to be more than a technical makeshift, must base itself on the principle of opposition; for without this it could only re-establish a neurotically unbalanced psyche. There is no balance, no system of self-regulation, without opposition. The psyche is just such a self-regulating system.

2

[93] If at this point we take up the thread we let fall earlier, we shall now see clearly why it is that the values which the individual lacks are to be found in the neurosis itself. At this point, too, we can return to the case of the young woman and apply the insight we have gained. Let us suppose that this patient is “analysed,” i.e., she has, through the treatment, come to understand the nature of the unconscious thoughts lurking behind her symptoms, and has thus regained possession of the unconscious energy which constituted the strength of those symptoms. The question then arises: what to do with the so-called disposable energy? In accordance with the psychological type of the patient, it would be rational to transfer this energy to an object—to philanthropic work, for example, or some useful activity. With exceptionally energetic natures that are not afraid of wearing themselves to the bone, if need be, or with people who delight in the toil and moil of such activities, this way is possible, but mostly it is impossible. For—do not forget—the libido, as this psychic energy is technically called, already possesses its object unconsciously, in the form of the young Italian or some equally real human substitute. In these circumstances a sublimation is as impossible as it is desirable, because the real object generally offers the energy a much better gradient than do the most admirable ethical activities. Unfortunately far too many of us talk about a man only as it would be desirable for him to be, never about the man as he really is. But the doctor has always to do with the real man, who remains obstinately himself until all sides of his reality are recognized. True education can only start from naked reality, not from a delusive ideal.

[94] It is unhappily the case that no man can direct the so-called disposable energy at will. It follows its own gradient. Indeed, it had already found that gradient even before we set the energy free from the unserviceable form to which it was linked. For we discover that the patient’s fantasies, previously occupied with the young Italian, have now transferred themselves to the doctor.¹² The doctor has himself become the object of the unconscious libido. If the patient altogether refuses to recognize the fact of the transference,¹³ or if the doctor fails to understand it, or interprets it falsely, vigorous resistances supervene, directed towards making the relation with the doctor completely impossible. Then the patient goes away and looks for another doctor, or for someone who understands; or, if he gives up the search, he gets stuck in his problem.

[95] If, however, the transference to the doctor takes place, and is accepted, a natural form is found which supplants the earlier one and at the same time provides the energy with an outlet relatively free from conflict. Hence if the libido is allowed to run its natural course, it will find its own way to the destined object. Where this does not happen, it is always a question of wilful defiance of the laws of nature, or of some disturbing influence.

[96] In the transference all kinds of infantile fantasies are projected. They must be cauterized, i.e., resolved by reductive analysis, and this is generally known as “resolving the transference.” Thereby the energy is again released from an unserviceable form, and again we are faced with the problem of its disposability. Once more we shall put our trust in nature, hoping that, even before it is sought, an object will have been chosen which will provide a favourable gradient.

V

THE PERSONAL AND THE COLLECTIVE (OR TRANSPERSONAL) UNCONSCIOUS

[97] At this point a new stage in our process of realization begins. We carried the analysis of infantile transference fantasies to the point where it became sufficiently clear, even to the patient, that he was making the doctor his father, mother, uncle, guardian, and teacher, and all the rest of the parental authorities. But, as experience has repeatedly shown, still other fantasies appear which represent the doctor as a saviour or godlike being—naturally in complete contradiction to healthy conscious reasoning. Moreover it transpires that these godlike attributes go far beyond the framework of Christianity in which we have grown up; they take on a pagan glamour and indeed very often appear in animal form.

[98] The transference is in itself no more than a projection of unconscious contents. At first the so-called superficial contents of the unconscious are projected, as can be seen from symptoms, dreams, and fantasies. In this state the doctor is interesting as a possible lover (rather like the young Italian in the case we were discussing). Then he appears more in the role of the father: either the good, kind father or the “thunderer,” depending on the qualities which the real father had for the patient. Sometimes the doctor has a maternal significance, a fact that seems somewhat peculiar, but is still within the bounds of possibility. All these fantasy projections are founded on personal memories.

[99] Finally there appear forms of fantasy that possess an extravagant character. The doctor is then endowed with uncanny powers: he is a magician or a wicked demon, or else the corresponding personification of goodness, a saviour. Again, he may appear as a mixture of both. Of course it is to be understood that he need not necessarily appear like this to the patient’s conscious mind; it is only the fantasies coming to the surface which picture him in this guise. Such patients often cannot get it into their heads that their fantasies really come from themselves and have little or nothing to do with the character of the doctor. This delusion rests on the fact that there are no personal grounds in the memory for this kind of projection. It can sometimes be shown that similar fantasies had, at a certain period in childhood, attached themselves to the father or mother, although neither father nor mother provided any real occasion for them.

[100] Freud has shown in a little essay¹ how Leonardo da Vinci was influenced in his later life by the fact that he had two mothers. The fact of the two mothers, or of a double descent, was real enough in Leonardo’s case, but it plays a role in the lives of other artists as well. Benvenuto Cellini had this fantasy of a double descent. Generally speaking it is a mythological motif. Many heroes in legend have two mothers. The fantasy does not arise from the actual fact that the heroes have two mothers; it is a widespread “primordial” image belonging not to the domain of personal memory but to the secrets of the mental history of mankind.

[101] There are present in every individual, besides his personal memories, the great “primordial” images, as Jacob Burckhardt once aptly called them, the inherited possibilities of human imagination as it was from time immemorial. The fact of this inheritance explains the truly amazing phenomenon that certain motifs from myths and legends repeat themselves the world over in identical forms. It also explains why it is that our mental patients can reproduce exactly the same images and associations that are known to us from the old texts. I give some examples of this in my book *Symbols of Transformation*.² In so doing I do not by any means assert the inheritance of ideas, but only of the possibility of such ideas, which is something very different.

[102] In this further stage of treatment, then, when fantasies are produced which no longer rest on personal memories, we have to do with the manifestations of a deeper layer of the unconscious where the primordial images common to humanity lie sleeping. I have called these images or motifs “archetypes,” also “dominants” of the unconscious. For a further elucidation of the idea I must refer the reader to the relevant literature.³

[103] This discovery means another step forward in our understanding: the recognition, that is, of two layers in the unconscious. We have to distinguish between a personal unconscious and an *impersonal* or *transpersonal unconscious*. We speak of the latter also as the *collective unconscious*,⁴ because it is detached from anything personal and is common to all men, since its contents can be found everywhere, which is naturally not the case with the personal contents. The personal unconscious contains lost memories, painful ideas that are repressed (i.e., forgotten on purpose), subliminal perceptions, by which are meant sense-perceptions that were not strong enough to reach consciousness, and finally, contents that are not yet ripe for consciousness. It corresponds to the figure of the shadow so frequently met with in dreams.⁵

[104] The primordial images are the most ancient and the most universal “thought-forms” of humanity. They are as much feelings as thoughts; indeed, they lead their own independent life rather in the manner of part-souls,⁶ as can easily be seen in those philosophical or Gnostic systems which rely on perception of the unconscious as the source of knowledge. The idea of angels, archangels, “principalities and powers” in St. Paul, the archons of the Gnostics, the heavenly hierarchy of Dionysius the Areopagite, all come from the perception of the relative autonomy of the archetypes.

[105] We have now found the object which the libido chooses when it is freed from the personal, infantile form of transference. It follows its own gradient down into the depths of the unconscious, and there activates what has lain slumbering from the beginning. It has discovered the hidden treasure upon which mankind ever and anon has drawn, and from which it has raised up its gods and demons, and all those potent and mighty thoughts without which man ceases to be man.

[106] Let us take as an example one of the greatest thoughts which the nineteenth century brought to birth: the idea of the conservation of energy. Robert Mayer, the real creator of this idea, was a physician, and not a physicist or natural philosopher, for whom the making of such an idea would have been more appropriate. But it is very important to realize that the idea was not, strictly speaking, “made” by Mayer. Nor did it come into being through the fusion of ideas or scientific hypotheses then extant, but grew in its creator like a plant. Mayer wrote about it in the following way to Griesinger, in 1844:

I am far from having hatched out the theory at my writing desk. [He then reports certain physiological observations he had made in 1840 and 1841 as ship’s doctor.] Now, if one wants to be clear on matters of physiology, some knowledge of physical processes is essential, unless one prefers to work at things from the metaphysical side, which I find infinitely disgusting. I therefore held fast to physics and stuck to the subject with such fondness that, although many may laugh at me for this, I paid but little attention to that remote quarter of the globe in which we were, preferring to remain on board where I could work without intermission, and where I passed many an hour as though *inspired*, the like of which I cannot remember either before or since. Some flashes of thought that passed through me while in the roads of Surabaya were at once assiduously followed up, and in their turn led to fresh subjects. Those times have passed, but the quiet examination of that which then came to the surface in me has taught me that it is a truth, which can not only be subjectively felt, but objectively proved. It remains to be seen whether this can be accomplished by a man so little versed in physics as I am.⁷

[107] In his book on energetics,⁸ Helm expresses the view that “Robert Mayer’s new idea did not detach itself gradually from the traditional concepts of energy by deeper reflection on them, but belongs to those intuitively apprehended ideas which, arising in other realms of a spiritual nature, as it were take possession of the mind and compel it to reshape the traditional conceptions in their likeness.”

[108] The question now arises: Whence came this new idea that thrust itself upon consciousness with such elemental force? And whence did it derive the power that could so seize upon consciousness that it completely eclipsed the multitudinous impressions of a first voyage to the tropics? These questions are not so easy to answer. But if we apply our theory here, the explanation can only be this: the idea of energy and its conservation must be a primordial image that was dormant in the collective unconscious. Such a conclusion naturally obliges us to prove that a primordial image of this kind really did exist in the mental history of mankind and was operative through the ages. As a matter of fact, this proof can be produced without much difficulty: the most primitive religions in the most widely separated parts of the earth are founded upon this image. These are the so-called dynamistic religions whose sole and determining thought is that there exists a universal magical power⁹ about which everything revolves. Tylor, the well-known English investigator, and Frazer likewise, misunderstood this idea as animism. In reality primitives do not

mean, by their power-concept, souls or spirits at all, but something which the American investigator Lovejoy has appropriately termed “primitive energetics.”¹⁰ This concept is equivalent to the idea of soul, spirit, God, health, bodily strength, fertility, magic, influence, power, prestige, medicine, as well as certain states of feeling which are characterized by the release of affects. Among certain Polynesians *mulungu*—this same primitive power-concept—means spirit, soul, daemonism, magic, prestige; and when anything astonishing happens, the people cry out “Mulungu!” This power-concept is also the earliest form of a concept of God among primitives, and is an image which has undergone countless variations in the course of history. In the Old Testament the magic power glows in the burning bush and in the countenance of Moses; in the Gospels it descends with the Holy Ghost in the form of fiery tongues from heaven. In Heraclitus it appears as world energy, as “ever-living fire”; among the Persians it is the fiery glow of *haoma*, divine grace; among the Stoics it is the original heat, the power of fate. Again, in medieval legend it appears as the aura or halo, and it flares up like a flame from the roof of the hut in which the saint lies in ecstasy. In their visions the saints behold the sun of this power, the plenitude of its light. According to the old view, the soul itself is this power; in the idea of the soul’s immortality there is implicit its conservation, and in the Buddhist and primitive notion of metempsychosis—transmigration of souls—is implicit its unlimited changeability together with its constant duration.

[109] So this idea has been stamped on the human brain for aeons. That is why it lies ready to hand in the unconscious of every man. Only, certain conditions are needed to cause it to appear. These conditions were evidently fulfilled in the case of Robert Mayer. The greatest and best thoughts of man shape themselves upon these primordial images as upon a blueprint. I have often been asked where the archetypes or primordial images come from. It seems to me that their origin can only be explained by assuming them to be deposits of the constantly repeated experiences of humanity. One of the commonest and at the same time most impressive experiences is the apparent movement of the sun every day. We certainly cannot discover anything of the kind in the unconscious, so far as the known physical process is concerned. What we do find, on the other hand, is the myth of the sun-hero in all its countless variations. It is this myth, and not the physical process, that forms the sun archetype. The same can be said of the phases of the moon. The archetype is a kind of readiness to produce over and over again the same or similar mythical ideas. Hence it seems as though what is impressed upon the unconscious were exclusively the subjective fantasy-ideas aroused by the physical process. We may therefore assume that the archetypes are recurrent impressions made by subjective reactions.¹¹ Naturally this assumption only pushes the problem further back without solving it. There is nothing to prevent us from assuming that certain archetypes exist even in

animals, that they are grounded in the peculiarities of the living organism itself and are therefore direct expressions of life whose nature cannot be further explained. Not only are the archetypes, apparently, impressions of ever-repeated typical experiences, but, at the same time, they behave empirically like agents that tend towards the repetition of these same experiences. For when an archetype appears in a dream, in a fantasy, or in life, it always brings with it a certain influence or power by virtue of which it either exercises a numinous or a fascinating effect, or impels to action.

[110] Having shown, in this example, how new ideas arise out of the treasure-house of primordial images, we will proceed to the further discussion of the transference process. We saw that the libido had, for its new object, seized upon those seemingly absurd and singular fantasies, the contents of the collective unconscious. As I have already said, the projection of primordial images upon the doctor is a danger not to be underrated at this stage of the treatment. The images contain not only all the fine and good things that humanity has ever thought and felt, but the worst infamies and devilries of which men have been capable. Owing to their specific energy—for they behave like highly charged autonomous centres of power—they exert a fascinating and possessive influence upon the conscious mind and can thus produce extensive alterations in the subject. One can see this in religious conversions, in cases of influence by suggestion, and particularly at the onset of certain forms of schizophrenia.¹² Now, if the patient is unable to distinguish the personality of the doctor from these projections, all hope of an understanding is finally lost and a human relationship becomes impossible. But if the patient avoids this Charybdis, he is wrecked on the Scylla of *introjecting* these images—in other words, he ascribes their peculiarities not to the doctor but to himself. This is just as disastrous. In projection, he vacillates between an extravagant and pathological deification of the doctor, and a contempt bristling with hatred. In introjection, he gets involved in a ridiculous self-deification, or else in a moral self-laceration. The mistake he makes in both cases comes from attributing to a *person* the contents of the collective unconscious. In this way he makes himself or his partner either god or devil. Here we see the characteristic effect of the archetype: it seizes hold of the psyche with a kind of primeval force and compels it to transgress the bounds of humanity. It causes exaggeration, a puffed-up attitude (inflation), loss of free will, delusion, and enthusiasm in good and evil alike. This is the reason why men have always needed demons and cannot live without gods, except for a few particularly clever specimens of *homo occidentalis* who lived yesterday or the day before, supermen for whom “God is dead” because they themselves have become gods—but tin-gods with thick skulls and cold hearts. The idea of God is an absolutely necessary psychological function of an irrational nature, which has nothing whatever to do with the question of God’s existence. The human intellect can never answer this question, still less give

any proof of God. Moreover such proof is superfluous, for the idea of an all-powerful divine Being is present everywhere, unconsciously if not consciously, because it is an archetype. There is in the psyche some superior power, and if it is not consciously a god, it is the “belly” at least, in St. Paul’s words. I therefore consider it wiser to acknowledge the idea of God consciously; for, if we do not, something else is made God, usually *something quite* inappropriate and stupid such as only an “enlightened” intellect could hatch forth. Our intellect has long known that we can form no proper idea of God, much less picture to ourselves in what manner he really exists, if at all. The existence of God is once and for all an unanswerable question. The *consensus gentium* has been talking of gods for aeons and will still be talking of them aeons hence. No matter how beautiful and perfect man may believe his reason to be, he can always be certain that it is only one of the possible mental functions, and covers only that one side of the phenomenal world which corresponds to it. But the irrational, that which is not agreeable to reason, rings it about on all sides. And the irrational is likewise a psychological function—in a word, it is the collective unconscious; whereas the rational is essentially tied to the conscious mind. The conscious mind must have reason, firstly to discover some order in the chaos of disorderly individual events occurring in the world, and secondly to create order, at least in human affairs. We are moved by the laudable and useful ambition to extirpate the chaos of the irrational both within and without to the best of our ability. Apparently the process has gone pretty far. As a mental patient once told me: “Doctor, last night I disinfected the whole heavens with bichloride of mercury, but I found no God.” Something of the sort has happened to us as well.

[111] Old Heraclitus, who was indeed a very great sage, discovered the most marvellous of all psychological laws: the regulative function of opposites. He called it *enantiodromia*, a running contrariwise, by which he meant that sooner or later everything runs into its opposite. (Here I would remind you of the case above of the American business man, a beautiful example of *enantiodromia*.) Thus the rational attitude of culture necessarily runs into its opposite, namely the irrational devastation of culture.¹³ We should never identify ourselves with reason, for man is not and never will be a creature of reason alone, a fact to be noted by all pedantic culture-mongers. The irrational cannot be and must not be extirpated. The gods cannot and must not die. I said just now that there seems to be something, a kind of superior power, in the human psyche, and that if this is not the idea of God, then it is the “belly.” I wanted to express the fact that one or other basic instinct, or complex of ideas, will invariably concentrate upon itself the greatest sum of psychic energy and thus force the ego into its service. As a rule the ego is drawn into this focus of energy so powerfully that it identifies with it and thinks it desires and needs nothing further. In this way a craze develops, a monomania or possession, an acute one-sidedness which

most seriously imperils the psychic equilibrium. Without doubt the capacity for such one-sidedness is the secret of success—of a sort, for which reason our civilization assiduously strives to foster it. The passion, the piling up of energy in these monomanias, is what the ancients called a “god,” and in common speech we still do the same. Do we not say, “He makes a god of this or that”? A man thinks that he wills and chooses, and does not notice that he is already possessed, that his interest has become the master, arrogating all power to itself. Such interests are indeed gods of a kind which, once recognized by the many, gradually form a “church” and gather a herd of believers about them. This we then call an “organization.” It is followed by a disorganizing reaction which aims to drive out the devil with Beelzebub. The enantiodromia that always threatens when a movement attains to undisputed power offers no solution of the problem, for it is just as blind in its disorganization as it was in its organization.

[112] The only person who escapes the grim law of enantiodromia is the man who knows how to separate himself from the unconscious, not by repressing it—for then it simply attacks him from the rear—but by putting it clearly before him as *that which he is not*.

[113] This prepares the way for the solution of the Scylla and Charybdis problem described above. The patient must learn to differentiate what is ego and what is non-ego, i.e., collective psyche. In this way he finds the material to which he will henceforth have to accommodate himself. His energy, until now laid up in unserviceable and pathological forms, has come into its proper sphere. It is essential, in differentiating the ego from the non-ego, that a man should be firmly rooted in his ego-function; that is, he must fulfil his duty to life, so as to be in every respect a viable member of the community. All that he neglects in this respect falls into the unconscious and reinforces its position, so that he is in danger of being swallowed up by it. But the penalties for this are heavy. As Synesius opined of old, it is just the “inspired soul” (*πνευματική ψυχή*) that becomes god and demon, and as such suffers the divine punishment of being torn asunder like Zagreus. This was what Nietzsche experienced at the onset of his malady. Enantiodromia means being torn asunder into pairs of opposites, which are the attributes of “the god” and hence also of the godlike man, who owes his godlikeness to overcoming his gods. As soon as we speak of the collective unconscious we find ourselves in a sphere, and concerned with a problem, which is altogether precluded in the practical analysis of young people or of those who have remained infantile too long. Wherever the father and mother imagos have still to be overcome, wherever there is a little bit of life still to be conquered, which is the natural possession of the average man, then we had better make no mention of the collective unconscious and the problem of opposites. But once the parental transferences and the youthful illusions have been mastered, or are at least ripe for

mastery, then we must speak of these things. We are here outside the range of Freudian and Adlerian reductions; we are no longer concerned with how to remove the obstacles to a man's profession, or to his marriage, or to anything that means a widening of his life, but are confronted with the task of finding a meaning that will enable him to continue living at all—a meaning more than blank resignation and mournful retrospect.

[114] Our life is like the course of the sun. In the morning it gains continually in strength until it reaches the zenith-heat of high noon. Then comes the enantiodromia: the steady forward movement no longer denotes an increase, but a decrease, in strength. Thus our task in handling a young person is different from the task of handling an older person. In the former case, it is enough to clear away all the obstacles that hinder expansion and ascent; in the latter, we must nurture everything that assists the descent. An inexperienced youth thinks one can let the old people go, because not much more can happen to them anyway: they have their lives behind them and are no better than petrified pillars of the past. But it is a great mistake to suppose that the meaning of life is exhausted with the period of youth and expansion; that, for example, a woman who has passed the menopause is “finished.” The afternoon of life is just as full of meaning as the morning; only, its meaning and purpose are different.¹⁴ Man has two aims: the first is the natural aim, the begetting of children and the business of protecting the brood; to this belongs the acquisition of money and social position. When this aim has been reached a new phase begins: the cultural aim. For the attainment of the former we have the help of nature and, on top of that, education; for the attainment of the latter, little or nothing helps. Often, indeed, a false ambition survives, in that an old man wants to be a youth again, or at least feels he must behave like one, although in his heart he can no longer make believe. This is what makes the transition from the natural to the cultural phase so terribly difficult and bitter for many people; they cling to the illusion of youth or to their children, hoping to salvage in this way a last little scrap of youth. One sees it especially in mothers, who find their sole meaning in their children and imagine they will sink into a bottomless void when they have to give them up. No wonder that many bad neuroses appear at the onset of life's afternoon. It is a sort of second puberty, another “storm and stress” period, not infrequently accompanied by tempests of passion—the “dangerous age.” But the problems that crop up at this age are no longer to be solved by the old recipes: the hand of this clock cannot be put back. What youth found and must find outside, the man of life's afternoon must find within himself. Here we face new problems which often cause the doctor no light headache.

[115] The transition from morning to afternoon means a revaluation of the earlier values. There comes the urgent need to appreciate the value of the opposite of our former ideals, to perceive the error in our former convictions, to recognize the

untruth in our former truth, and to feel how much antagonism and even hatred lay in what, until now, had passed for love. Not a few of those who are drawn into the conflict of opposites jettison everything that had previously seemed to them good and worth striving for; they try to live in complete opposition to their former ego. Changes of profession, divorces, religious convulsions, apostasies of every description, are the symptoms of this swing over to the opposite. The snag about a radical conversion into one's opposite is that one's former life suffers repression and thus produces just as unbalanced a state as existed before, when the counterparts of the conscious virtues and values were still repressed and unconscious. Just as before, perhaps, neurotic disorders arose because the opposing fantasies were unconscious, so now other disorders arise through the repression of former idols. It is of course a fundamental mistake to imagine that when we see the non-value in a value or the untruth in a truth, the value or the truth ceases to exist. It has only become *relative*. Everything human is relative, because everything rests on an inner polarity; for everything is a phenomenon of energy. Energy necessarily depends on a pre-existing polarity, without which there could be no energy. There must always be high and low, hot and cold, etc., so that the equilibrating process—which is energy—can take place. Therefore the tendency to deny all previous values in favour of their opposites is just as much of an exaggeration as the earlier one-sidedness. And in so far as it is a question of rejecting universally accepted and indubitable values, the result is a fatal loss. One who acts in this way empties himself out with his values, as Nietzsche has already said.

[116] The point is not conversion into the opposite but conservation of previous values together with recognition of their opposites. Naturally this means conflict and self-division. It is understandable enough that one should shrink from it, philosophically as well as morally; hence the alternative sought, more often than conversion into the opposite, is a convulsive stiffening of the previous attitude. It must be admitted that, in the case of elderly men, this is a phenomenon of no little merit, however disagreeable it may be: at least they do not become renegades, they remain upright, they do not fall into muddle-headedness nor yet into the mud; they are no defaulters, but are merely dead wood or, to put it more politely, pillars of the past. But the accompanying symptoms, the rigidity, the narrow-mindedness, the stand-offishness of these *laudatores temporis acti* are unpleasant, not to say harmful; for their method of espousing a truth or any other value is so inflexible and violent that their unmannerliness repels more than the truth attracts, so that the result is the opposite of the intended good. The fundamental cause of their rigidity is fear of the problem of opposites: they have a foreboding and secret dread of the “sinister brother of Medardus.” Therefore there must be only one truth and one guiding principle of action, and that must be absolute; otherwise it affords no protection against the

impending disaster, which is sensed everywhere save in themselves. But actually the most dangerous revolutionary is within ourselves, and all must realize this who wish to pass over safely into the second half of life. Certainly this means exchanging the apparent security we have so far enjoyed for a condition of insecurity, of internal division, of contradictory convictions. The worst feature of all is that there appears to be no way out of this condition. *Tertium non datur*, says logic—there is no middle way.

[117] The practical necessities of treatment have therefore forced us to look for ways and means that might lead out of this intolerable situation. Whenever a man is confronted by an apparently insurmountable obstacle, he draws back: he makes what is technically called a regression. He goes back to the times when he found himself in similar situations, and he tries to apply again the means that helped him then. But what helped in youth is of no use in age. What good did it do that American business man to return to his former position? It simply wouldn't work. So the regression continues right back into childhood (hence the childishness of many elderly neurotics) and ends up in the time before childhood. That may sound strange, but in point of fact it is not only logical but altogether possible.

[118] We mentioned earlier that the unconscious contains, as it were, two layers: the personal and the collective. The personal layer ends at the earliest memories of infancy, but the collective layer comprises the pre-infantile period, that is, the residues of ancestral life. Whereas the memory-images of the personal unconscious are, as it were, filled out, because they are images personally experienced by the individual, the archetypes of the collective unconscious are not filled out because they are forms not personally experienced. When, on the other hand, psychic energy regresses, going beyond even the period of early infancy, and breaks into the legacy of ancestral life, the mythological images are awakened: these are the archetypes.¹⁵ An interior spiritual world whose existence we never suspected opens out and displays contents which seem to stand in sharpest contrast to all our former ideas. These images are so intense that it is quite understandable why millions of cultivated persons should be taken in by theosophy and anthroposophy. This happens simply because such modern gnostic systems meet the need for expressing and formulating the wordless occurrences going on within ourselves *better* than any of the existing forms of Christianity, not excepting Catholicism. The latter is certainly able to express, far more comprehensively than Protestantism, the facts in question through its dogma and ritual symbolism. But neither in the past nor in the present has even Catholicism attained anything like the richness of the old pagan symbolism, which is why this symbolism persisted far into Christianity and then gradually went underground, forming currents that, from the early Middle Ages to modern times, have never quite lost their vitality. To a large extent they vanished from the surface;

but, changing their form, they come back again to compensate the one-sidedness of our conscious mind with its modern orientation.¹⁶ Our consciousness is so saturated with Christianity, so utterly moulded by it, that the unconscious counter-position can discover no foothold there, for the simple reason that it seems too much the antithesis of our ruling ideas. The more one-sidedly, rigidly, and absolutely the one position is held, the more aggressive, hostile, and incompatible will the other become, so that at first sight there would seem to be little prospect of reconciling the two. But once the conscious mind admits at least the *relative* validity of all human opinion, then the opposition loses something of its irreconcilable character. In the meantime the conflict casts round for appropriate expression in, for instance, the oriental religions—Buddhism, Hinduism, Taoism. The syncretism of theosophy goes a long way towards meeting this need, and that explains its numerous successes.

[119] The work involved in analytical treatment gives rise to experiences of an archetypal nature which require to be expressed and shaped. Obviously this is not the only occasion for experiences of such a kind; often they occur quite spontaneously, and by no means only in the case of “psychological-minded” people. I have heard the most curious dreams and visions from the lips of people whose mental sanity not even the professional psychologist could doubt. The experience of the archetype is frequently guarded as the closest personal secret, because it is felt to strike into the very core of one’s being. It is like a primordial experience of the non-ego, of an interior opponent who throws down a challenge to the understanding. Naturally enough we then look round for helpful parallels, and it happens all too easily that the original occurrence is interpreted in terms of derivative ideas. A typical instance of this kind is the Trinity vision of Brother Nicholas of Flüe,¹⁷ or again, St. Ignatius’ vision of the snake with multiple eyes, which he interpreted first as a divine apparition and then as a visitation from the devil. Through these periphrastic interpretations the authentic experience is replaced by images and words borrowed from a foreign source, and by views, ideas, and forms that have not grown on our soil and have no ties with our hearts, but only with our heads. Indeed, not even our thought can clearly grasp them, because it never invented them. It is a case of stolen goods that bring no prosperity. Such substitutes make men shadowy and unreal; they put empty words in the place of living realities, and slip out of the painful tension of opposites into a wan, two-dimensional, phantasmal world where everything vital and creative withers and dies.

[120] The wordless occurrences which are called forth by regression to the pre-infantile period need no substitutes; they demand to be individually shaped in and by each man’s life and work. They are images sprung from the life, the joys and sorrows, of our ancestors; and to life they seek to return, not in experience only, but in deed. Because of their opposition to the conscious mind they cannot be translated straight

into our world; hence a way must be found that can mediate between conscious and unconscious reality.

VI

THE SYNTHETIC OR CONSTRUCTIVE METHOD

[121] The process of coming to terms with the unconscious is a true labour, a work which involves both action and suffering. It has been named the “transcendent function”¹ because it represents a function based on real and “imaginary,” or rational and irrational, data, thus bridging the yawning gulf between conscious and unconscious. It is a natural process, a manifestation of the energy that springs from the tension of opposites, and it consists in a series of fantasy-occurrences which appear spontaneously in dreams and visions.² The same process can also be observed in the initial stages of certain forms of schizophrenia. A classical account of such a proceeding is to be found, for example, in Gérard de Nerval’s autobiographical fragment, *Aurelia*. But the most important literary example is Part II of *Faust*. The natural process by which the opposites are united came to serve me as the model and basis for a method consisting essentially in this: everything that happens at the behest of nature, unconsciously and spontaneously, is deliberately summoned forth and integrated into the conscious mind and its outlook. Failure in many cases is due precisely to the fact that they lack the mental and spiritual equipment to master the events taking place in them. Here medical help must intervene in the form of a special method of treatment.

[122] As we have seen, the theories discussed at the beginning of this book rest on an exclusively causal and reductive procedure which resolves the dream (or fantasy) into its memory components and the underlying instinctual processes. I have indicated above the justification as well as the limitation of this procedure. It breaks down at the point where the dream symbols can no longer be reduced to personal reminiscences or aspirations, that is, when the images of the collective unconscious begin to appear. It would be quite senseless to try to reduce these collective ideas to anything personal—not only senseless but positively harmful, as painful experience has taught me. Only with much difficulty, after long hesitation and disabuse by many failures, was I able to decide to abandon the purely personalistic attitude of medical psychology in the sense indicated. I had first to come to the fundamental realization that analysis, in so far as it is reduction and nothing more, must necessarily be followed by synthesis, and that certain kinds of psychic material mean next to nothing if simply broken down, but display a wealth of meaning if, instead of being broken down, that meaning is reinforced and extended by all the conscious means at our disposal—by the so-called method of amplification.³ The images or symbols of

the collective unconscious yield their distinctive values only when subjected to a synthetic mode of treatment. Just as analysis breaks down the symbolical fantasy-material into its components, so the synthetic procedure integrates it into a general and intelligible statement. The procedure is not exactly simple, so I will give an example which will help to explain the whole process.

[123] A woman patient, who had just reached the critical borderline between the analysis of the personal unconscious and the emergence of contents from the collective unconscious, had the following dream: *She is about to cross a wide river. There is no bridge, but she finds a ford where she can cross. She is on the point of doing so, when a large crab that lay hidden in the water seizes her by the foot and will not let her go.* She wakes up in terror.

Associations:

[124] *River*: “Forms a boundary that is difficult to get across—I have to overcome an obstacle—probably to do with the fact that I’m progressing so slowly—I ought to reach the other side.”

[125] *Ford*: “An opportunity to cross in safety—a possible way, otherwise the river would be too broad—in the treatment lies the possibility of surmounting the obstacle.”

[126] *Crab*: “The crab was quite hidden in the water, I did not see it before—cancer [German *Krebs*= crab] is a terrible disease, incurable [reference to Mrs. X, who died of carcinoma]—I am afraid of this disease—the crab is an animal that walks backwards—and obviously wants to drag me into the river—it caught hold of me in a horrible way and I was terribly frightened—what keeps stopping me from getting across? Oh yes, I had another row with my friend [a woman].”

[127] There is something peculiar about her relations with this friend. It is a sentimental attachment, bordering on the homosexual, that has lasted for years. The friend is like the patient in many ways, and equally nervy. They have marked artistic interests in common. The patient is the stronger personality of the two. Because their mutual relationship is too intimate and excludes too many of the other possibilities of life, both are nervy and, despite their ideal friendship, have violent scenes due to mutual irritability. The unconscious is trying in this way to put a distance between them, but they refuse to listen. The quarrel usually begins because one of them finds that she is still not sufficiently understood, and urges that they should speak more plainly to one another; whereupon both make enthusiastic efforts to unbosom themselves. Naturally a misunderstanding comes about in next to no time, and a worse scene than ever ensues. *Faute de mieux*, this quarrelling had long been for both of them a pleasure substitute which they were unwilling to relinquish. My patient in particular could not

do without the sweet pain of being misunderstood by her best friend, although every scene “tired her to death.” She had long since realized that this friendship had become moribund, and that only false ambition led her to believe that something ideal could still be made of it. She had formerly had an exaggerated, fantastic relation to her mother and after her mother’s death had transferred her feelings to her friend.

*Analytical (causal-reductive) interpretation:*⁴

[128] This interpretation can be summed up in one sentence: “I see well enough that I ought to cross the river (that is, give up relations with my friend), but I would much rather that my friend did not let me out of her clutches (i.e., embraces)—which, as an infantile wish, means that I want Mother to draw me to her in the exuberant embrace I know so well.” The incompatibility of the wish lies in the strong undercurrent of homosexuality, abundantly proved by the facts. The crab seizes her by the foot. The patient has large “masculine” feet, she plays the masculine role with her friend and has corresponding sexual fantasies. The foot has a notoriously phallic significance.⁵ Thus the over-all interpretation would be: The reason why she does not want to leave her friend is because she has repressed sexual desires for her. As these desires are morally and aesthetically incompatible with the tendency of the conscious personality, they are repressed and therefore more or less unconscious. Her anxiety corresponds to her repressed desire.

[129] This interpretation is a severe depreciation of the patient’s exalted ideal of friendship. To be sure, at this point in the analysis she would no longer have taken exception to such an interpretation. Some time earlier certain facts had amply convinced her of her homosexual tendency, so that she could freely admit this inclination, although it was by no means agreeable to her. If, then, I had given her this interpretation at the present stage of treatment, I would have not encountered any resistance. She had already overcome the painfulness of this unwelcome tendency by understanding it. But she would have said to me, “Why are we still analysing this dream? It only reiterates what I have known for a long time.” The interpretation, in fact, tells the patient nothing new; it is therefore uninteresting and ineffective. Such an interpretation would have been impossible at the beginning of the treatment, because the unusual prudery of the patient would not under any circumstances have admitted anything of that kind. The “poison” of understanding had to be injected with extreme care, and in very small doses, until she gradually became more reasonable. Now, when the analytical or causal-reductive interpretation ceases to bring to light anything new, but only the same thing in different variations, the moment has come to look out for possible archetypal motifs. If such a motif comes clearly to the forefront, it is high time to change the interpretative procedure. The causal-reductive procedure has in this particular case certain disadvantages. Firstly, it does not take

accurate account of the patient's associations, e.g., the association of "crab" with "cancer." Secondly, the peculiar choice of the symbol remains unexplained. Why should the mother-friend appear as a crab? A prettier and more graphic representation would have been a water-nymph. ("Half drew she him, half sank he under," etc.) An octopus, a dragon, a snake, or a fish would have served as well. Thirdly, the causal-reductive procedure forgets that the dream is a subjective phenomenon, and that consequently an exhaustive interpretation can never refer the crab to the friend or the mother alone, but must refer it also to the subject, the dreamer herself. The dreamer is the whole dream; she is the river, the ford, and the crab, or rather these details express conditions and tendencies in the unconscious of the subject.

[130] I have therefore introduced the following terminology: I call every interpretation which equates the dream images with real objects an *interpretation on the objective level*. In contrast to this is the interpretation which refers every part of the dream and all the actors in it back to the dreamer himself. This I call *interpretation on the subjective level*. Interpretation on the objective level is analytic, because it breaks down the dream content into memory-complexes that refer to external situations. Interpretation on the subjective level is synthetic, because it detaches the underlying memory-complexes from their external causes, regards them as tendencies or components of the subject, and reunites them with that subject. (In any experience I experience not merely the object but first and foremost myself, provided of course that I render myself an account of the experience.) In this case, therefore, all the contents of the dream are treated as symbols for subjective contents.

[131] Thus the synthetic or constructive process of interpretation⁶ is interpretation on the subjective level.

The synthetic (constructive) interpretation:

[132] The patient is unconscious of the fact that the obstacle to be overcome lies in herself: namely, a boundary-line that is difficult to cross and hinders further progress. Nevertheless it is possible to pass the barrier. But a special and unexpected danger looms up just at this moment—something "animal" (non-human or subhuman), which moves backwards and downwards, threatening to drag with it the whole personality of the dreamer. This danger is like a deadly disease that begins in some secret place and is incurable (overpowering). The patient imagines that her friend is hindering her and trying to drag her down. So long as she believes this, she must go on trying to "uplift" her friend, educate and improve her; she has to make futile and senselessly idealistic efforts to stop herself from being dragged down. Naturally her friend makes similar efforts too, for she is in the same pass as the patient. So the two keep jumping at each other like fighting cocks, each trying to get the upper hand. And the higher the pitch the one screws herself up to, the fiercer become the self-

torments of the other. Why? Because each thinks the fault lies in the other, in the object. Interpretation on the subjective level brings release from this folly; for the dream shows the patient that she has something in herself which prevents her from crossing the boundary, i.e., from getting out of one situation or attitude into another. The interpretation of a change of place as a change of attitude is corroborated by forms of speech in certain primitive languages, where, for example, "I am thinking of going" is expressed as "I am at the place of (on the point of) going." To make the language of dreams intelligible we need numerous parallels from the psychology of primitive and historical symbolism, because dreams spring essentially from the unconscious, which contains remnants of the functional possibilities of all preceding epochs of evolution. A classical example of this is the "Crossing of the Great Water" in the oracles of the *I Ching*.

[133] Obviously, everything now depends on what is meant by the crab. We know in the first place that it is something connected with the friend (since the patient associates it with her friend), and also something connected with her mother. Whether mother and friend really have this quality is irrelevant so far as the patient is concerned. The situation can be changed only by the patient changing herself. Nothing can be changed in the mother, for she is dead. And the friend cannot be nagged into changing. If she wants to change, that is her own affair. The fact that the quality in question is connected with the mother points to something infantile. What, then, is there in common in the patient's relation to her mother and to her friend? The common factor is a violent, sentimental demand for love, so impassioned that she feels herself overwhelmed. This demand has the character of an overpowering infantile craving which, as we know, is blind. So we are dealing with an undisciplined, undifferentiated, and not yet humanized part of the libido which still possesses the compulsive character of an instinct, a part still untamed by domestication. For such a part some kind of *animal* is an entirely appropriate symbol. But why should the animal be a crab? The patient associates it with cancer, of which disease Mrs. X died at about the same age as that now reached by the patient herself. So there may be a hint of identification with Mrs. X. We must therefore follow this up. The patient relates the following facts about her: Mrs. X was widowed early; she was very merry and full of life; she had a series of adventures with men, and one in particular with an extremely gifted artist whom the patient knew personally and who always impressed her as remarkably fascinating and strange.

[134] An identification can occur only on the basis of some unrealized, i.e., unconscious, similarity. Now in what way is our patient similar to Mrs. X? Here I was able to remind the patient of a series of earlier fantasies and dreams which had plainly shown that she too had a frivolous streak in her, and one which she always anxiously repressed, because she feared this dimly apprehended tendency in herself

might betray her into leading an immoral life. With this we have made a further important contribution towards understanding the “animal” element; for once more we come upon the same untamed, instinctual craving, but this time directed towards men. And we have also discovered another reason why she cannot let go of her friend: she must cling to her so as not to fall victim to this other tendency, which seems to her much more dangerous. Accordingly she remains at the infantile, homosexual level, because it serves her as a defence. (Experience shows that this is one of the most potent motives for clinging to unsuitable infantile relationships.) In this animal element, however, also lies her health, the germ of a future sound personality which will not shrink from the hazards of life.

[135] But the patient had drawn quite a different conclusion from the fate of Mrs. X. She had taken the latter’s sudden grave illness and early death as the punishment of fate for the gay life which, without admitting it, the patient had always envied. When Mrs. X died, the patient made a very long moral face which concealed an all-too-human malicious satisfaction. To punish herself for this, she continually used the example of Mrs. X to scare herself away from life and all further development, and burdened herself with the misery of an unsatisfying friendship. Naturally this whole sequence of events had never been clear to her, otherwise she would never have acted as she did. The rightness of this surmise was easily verified from the material.

[136] The story of this identification by no means ends here. The patient subsequently emphasized that Mrs. X possessed a not inconsiderable artistic capacity which developed only after her husband’s death and then led to her friendship with the artist. This fact seems to be one of the essential reasons for the identification, if we remember that the patient had remarked what a strong and peculiarly fascinating impression the artist had made upon her. A fascination of this kind is never exercised exclusively by one person upon another; it is always a phenomenon of relationship, which requires two people in so far as the person fascinated necessarily has a corresponding disposition. But the disposition must be unconscious, or no fascination will take place. Fascination is a compulsive phenomenon in the sense that it lacks a conscious motive; it is not a voluntary process, but something that rises up from the unconscious and forcibly obtrudes itself upon the conscious mind.

[137] It must therefore be assumed that the patient has an unconscious disposition similar to that of the artist. Accordingly she is also identified with a man.⁷ We recall the analysis of the dream, where we met an allusion to the “masculine” foot. And in fact the patient does play a masculine role with her friend; she is the active one who always sets the tone, who bosses her friend and sometimes actually forces her to do something she alone wants. Her friend is distinctly feminine, even in external appearance, while the patient is clearly of a somewhat masculine type. Her voice too

is strong and deeper than her friend's. Mrs. X is described as a very feminine woman, comparable to her friend, so the patient thinks, in gentleness and affectionateness. This gives us another clue: in relation to her friend, the patient obviously plays the same role that the artist played with Mrs. X. Thus she unconsciously completes her identification with Mrs. X and her lover, and thus, in spite of all, she gives expression to the frivolous streak in her which she had so anxiously repressed. But she is not living it consciously, she is rather the plaything of this unconscious tendency; in other words, she is possessed by it, and has become the unconscious exponent of her complex.

[138] We now know very much more about the crab: it contains the inner psychology of this untamed bit of libido. The unconscious identifications keep drawing her down further and further. They have this power because, being unconscious, they are not open to insight or correction. The crab is therefore the symbol for the unconscious contents. These contents are always trying to draw the patient back into her relations with her friend. (The crab walks backwards.) But the connection with her friend is synonymous with disease, for through it she became neurotic.

[139] Strictly speaking, all this really belongs to the analysis on the objective level. But we must not forget that we came into possession of this knowledge only by making use of the subjective level, which thus proves to be an important heuristic principle. For practical purposes we might rest content with the results so far reached; but we have to satisfy the demands of theory: not all the associations have yet been evaluated, nor has the significance of the choice of symbol yet been sufficiently explained.

[140] We shall now take up the patient's remark that the crab lay hidden in the water and that she did not see it at first. Nor did she see, at first, the unconscious relations which we have just discussed; they too lay hidden in the water. The river is the obstacle that prevents her from crossing to the other side. It is precisely these unconscious relations, binding her to her friend, that prevented her. The unconscious was the obstacle. Thus the water signifies the unconscious, or rather, the state of unconsciousness, of concealment; for the crab too is something unconscious, in fact it is the dynamic content that lies concealed in its depths.

VII

THE ARCHETYPES OF THE COLLECTIVE UNCONSCIOUS

[141] We are now faced with the task of raising to the subjective level the phenomena which have so far been understood on the objective level. For this purpose we must detach them from the object and take them as symbolical exponents of the patient's subjective complexes. If we try to interpret the figure of Mrs. X on the subjective level, we must regard it as the personification of a part-soul, or rather of a certain aspect of the dreamer. Mrs. X then becomes an image of what the patient would like to be, and yet fears to be. She represents, as it were, a partial picture of the patient's future character. The fascinating artist cannot so easily be raised to the subjective level, because the unconscious artistic capacity lying dormant in the patient is already taken up by Mrs. X. It would, however, be correct to say that the artist is the image of the patient's masculinity which is not consciously realized and therefore lies in the unconscious.¹ This is true in the sense that the patient does in fact delude herself in this matter. In her own eyes she is quite remarkably fragile, sensitive, and feminine, and not in the least masculine. She was therefore indignantly amazed when I pointed out her masculine traits. But the strange, fascinating element is out of keeping with these traits. It seems to be entirely lacking to them. Yet it must be hiding somewhere, since she produced this feeling out of herself.

[142] Whenever such an element is not to be found in the dreamer himself, experience tells us that it is always projected. But upon whom? Is it still attached to the artist? He has long since disappeared from the patient's purview and cannot very well have taken the projection with him, since it lies anchored in the unconscious of the patient, and moreover she had no personal relation with this man despite his fascination. For her he was more a figure of fantasy. No, a projection of this kind is always topical, that is, somewhere there must be somebody upon whom this content is projected, otherwise she would be palpably aware of it in herself.

[143] At this point we come back to the objective level, for without it we cannot locate the projection. The patient does not know any man who means anything special to her, apart from myself; and as her doctor I mean a good deal. Presumably therefore this content is projected on to me, though I had certainly noticed nothing of the sort. But these subtler contents never appear on the surface; they always come to light outside the consulting hour. I therefore asked her cautiously, "Tell me, how do I seem to you when you are not with me? Am I just the same?" She said, "When I am with you, you are quite pleasant, but when I am by myself, or have not seen you for some

time, the picture I have of you changes in a remarkable way. Sometimes you seem quite idealized, and then again different.” Here she hesitated, and I prompted her: “In what way different?” Then she said, “Sometimes you seem rather dangerous, sinister, like an evil magician or a demon. I don’t know how I ever get such ideas—you are not a bit like that.”

[144] So the content was fixed on me as part of the transference, and that is why it was missing from her psychic inventory. Here we recognize another important fact: I was contaminated (identified) with the artist, so in her unconscious fantasy she naturally plays the role of Mrs. X with me. I could easily prove this to her with the help of the material—sexual fantasies—previously brought to light. But I myself am then the obstacle, the crab that prevents her from getting across. If, in this particular case, we were to confine ourselves to the objective level, the position would be very tricky. What would be the good of my explaining, “But I am not this artist in any sense, I am not in the least sinister, nor am I an evil magician!” That would leave the patient quite cold, for she knows that just as well as I do. The projection continues as before, and I really am the obstacle to her further progress.

[145] It is at this point that many a treatment comes to a standstill. There is no way of getting out of the toils of the unconscious, except for the doctor to raise himself to the subjective level and to acknowledge himself as an image. But an image of what? Here lies the greatest difficulty of all. “Well now,” the doctor will say, “an image of something in the unconscious of the patient.” Whereupon she will say, “What, so I am a man, and a sinister, fascinating man at that, a wicked magician or demon? Not on your life! I cannot accept that, it’s all nonsense. I’d sooner believe this of you!” She is right: it is preposterous to transfer such things to her. She cannot accept being turned into a demon any more than the doctor can. Her eyes flash, an evil expression creeps into her face, the gleam of an unknown resistance never seen before. I am suddenly faced by the possibility of a painful misunderstanding. What is it? Disappointed love? Does she feel offended, depreciated? In her glance there lurks something of the beast of prey, something really demoniacal. Is she a demon after all? Or am I the beast of prey, the demon, and is this a terrified victim sitting before me, trying to defend herself with the brute strength of despair against my wicked spells? All this must surely be nonsense—fantastic delusion. What have I touched? What new chord is vibrating? Yet it is only a passing moment. The expression on the patient’s face clears, and she says, as though relieved, “It is queer, but just now I had a feeling you had touched the point I could never get over in relation to my friend. It’s a horrible feeling, something inhuman, evil, cruel. I simply cannot describe how queer this feeling is. It makes me hate and despise my friend when it comes, although I struggle against it with all my might.”

[146] This remark throws an explanatory light on what has happened: I have taken the place of the friend. The friend has been overcome. The ice of the repression is broken and the patient has entered a new phase of life without knowing it. Now I know that all that was painful and bad in her relation with her friend will devolve upon me, as well as all the good, but it will be in violent conflict with the mysterious *x* which the patient has never been able to master. A new phase of the transference has started, although it does not as yet clearly reveal the nature of the *x* that has been projected upon me.

[147] One thing is certain: if the patient gets stuck in this form of transference, the most troublesome misunderstandings lie ahead, for she will be bound to treat me as she treated her friend—in other words, the *x* will be continually in the air giving rise to misunderstandings. It will inevitably turn out that she will see the demon in me, since she cannot accept it in herself. All insoluble conflicts come about in this fashion. And an insoluble conflict means bringing life to a standstill.

[148] Or another possibility: the patient could use her old defence mechanism against this new difficulty and could simply ignore the point of obscurity. That is to say, she could begin repressing again, instead of keeping things conscious, which is the necessary and obvious demand of the whole method. But nothing would be gained by this; on the contrary, the *x* now threatens from the unconscious, and that is far more unpleasant.

[149] Whenever such an unacceptable content appears, we must consider carefully whether it is a personal quality at all. “Magician” and “demon” may well represent qualities whose very names make it instantly clear that these are not human and personal qualities but mythological ones. Magician and demon are mythological figures which express the unknown, “inhuman” feeling that swept over the patient. They are attributes not in any sense applicable to a human personality, although, as intuitive judgments not subjected to closer criticism, they are constantly being projected upon our fellow men, to the very great detriment of human relations.

[150] These attributes always indicate that contents of the transpersonal or collective unconscious are being projected. Personal memories cannot account for “demons,” or for “wicked magicians,” although everyone has, of course, at one time or another heard or read of these things. We have all heard of rattlesnakes, but we do not call a lizard or a blindworm a rattlesnake and display the corresponding emotions merely because we have been startled by the rustling of a lizard or a blindworm. Similarly, we do not call one of our fellows a demon unless there really is something demonic in his effect upon us. But if this effect were truly a part of his personal character, it would show itself everywhere, and then the man would be a demon indeed, a sort of werewolf. But that is mythology, i.e., collective psyche, and not individual psyche. In

so far as through our unconscious we have a share in the historical collective psyche, we live naturally and unconsciously in a world of werewolves, demons, magicians, etc., for these are things which all previous ages have invested with tremendous affectivity. Equally we have a share in gods and devils, saviours and criminals; but it would be absurd to attribute these potentialities of the unconscious to ourselves personally. It is therefore absolutely essential to make the sharpest possible demarcation between the personal and the impersonal attributes of the psyche. This is not to deny the sometimes very formidable existence of the contents of the collective unconscious, but only to stress that, as contents of the collective psyche, they are opposed to and different from the individual psyche. Simple-minded folk have never, of course, separated these things from their individual consciousness, because the gods and demons were not regarded as psychic projections and hence as contents of the unconscious, but as self-evident realities. Only in the age of enlightenment did people discover that the gods did not really exist, but were simply projections. Thus the gods were disposed of. But the corresponding psychological function was by no means disposed of; it lapsed into the unconscious, and men were thereupon poisoned by the surplus of libido that had once been laid up in the cult of divine images. The devaluation and repression of so powerful a function as the religious function naturally have serious consequences for the psychology of the individual. The unconscious is prodigiously strengthened by this reflux of libido, and, through its archaic collective contents, begins to exercise a powerful influence on the conscious mind. The period of the Enlightenment closed, as we know, with the horrors of the French Revolution. And at the present time, too, we are once more experiencing this uprising of the unconscious destructive forces of the collective psyche. The result has been mass-murder on an unparalleled scale.² This is precisely what the unconscious was after. Its position had been immeasurably strengthened beforehand by the rationalism of modern life, which, by depreciating everything irrational, precipitated the function of the irrational into the unconscious. But once this function finds itself in the unconscious, it works unceasing havoc, like an incurable disease whose focus cannot be eradicated because it is invisible. Individual and nation alike are then compelled to live the irrational in their own lives, even devoting their loftiest ideals and their best wits to expressing its madness in the most perfect form. We see the same thing in miniature in our patient, who fled from a course of life that seemed to her irrational—Mrs. X—only to act it out in pathological form, and with the greatest sacrifices, in her relations with her friend.

[151] There is nothing for it but to recognize the irrational as a necessary, because ever-present, psychological function, and to take its contents not as concrete realities—that would be a regression!—but as psychic realities, real because they *work*. The collective unconscious, being the repository of man's experience and at the same

time the prior condition of this experience, is an image of the world which has taken aeons to form. In this image certain features, the archetypes or dominants, have crystallized out in the course of time. They are the ruling powers, the gods, images of the dominant laws and principles, and of typical, regularly occurring events in the soul's cycle of experience.³ In so far as these images are more or less faithful replicas of psychic events, their archetypes, that is, their general characteristics which have been emphasized through the accumulation of similar experiences, also correspond to certain general characteristics of the physical world. Archetypal images can therefore be taken metaphorically, as intuitive concepts for physical phenomena. For instance, *aether*, the primordial breath or soul-substance, is a concept found all over the world, and *energy*, or magical power, is an intuitive idea that is equally widespread.

[152] On account of their affinity with physical phenomena,⁴ the archetypes usually appear in projection; and, because projections are unconscious, they appear on persons in the immediate environment, mostly in the form of abnormal over- or undervaluations which provoke misunderstandings, quarrels, fanaticisms, and follies of every description. Thus we say, "He makes a god of so-and-so," or, "So-and-so is Mr. X's *bête noire*." In this way, too, there grow up modern myth-formations, i.e., fantastic rumours, suspicions, prejudices. The archetypes are therefore exceedingly important things with a powerful effect, meriting our closest attention. They must not be suppressed out of hand, but must be very carefully weighed and considered, if only because of the danger of psychic infection they carry with them. Since they usually occur as projections, and since these only attach themselves where there is a suitable hook, their evaluation and assessment is no light matter. Thus, when somebody projects the devil upon his neighbour, he does so because this person has something about him which makes the attachment of such an image possible. But this is not to say that the man is on that account a devil; on the contrary, he may be a particularly good fellow, but antipathetic to the maker of the projection, so that a "devilish" (i.e., *dividing*) effect arises between them. Nor need the projector necessarily be a devil, although he has to recognize that he has something just as devilish in himself, and has only stumbled upon it by projecting it. But that does not make him a devil; indeed he may be just as decent as the other man. The appearance of the devil in such a case simply means that the two people are at present incompatible: for which reason the unconscious forces them apart and keeps them away from each other. The devil is a variant of the "shadow" archetype, i.e., of the dangerous aspect of the unrecognized dark half of the personality.

[153] One of the archetypes that is almost invariably met with in the projection of unconscious collective contents is the "magic demon" with mysterious powers. A good example of this is Gustav Meyrink's *Golem*, also the Tibetan wizard in the same author's *Fledermäuse*, who unleashes world war by magic. Naturally Meyrink

learned nothing of this from me; he brought it independently out of his unconscious by clothing in words and imagery a feeling not unlike the one which my patient had projected upon me. The magician type also figures in *Zarathustra*, while in *Faust* he is the actual hero.

[154] The image of this demon forms one of the lowest and most ancient stages in the conception of God. It is the type of primitive tribal sorcerer or medicine-man, a peculiarly gifted personality endowed with magical power.⁵ This figure often appears as dark-skinned and of mongoloid type, and then it represents a negative and possibly dangerous aspect. Sometimes it can hardly be distinguished, if at all, from the shadow; but the more the magical note predominates, the easier it is to make the distinction, and this is not without relevance in so far as the demon can also have a very positive aspect as the “wise old man.”⁶

[155] The recognition of the archetypes takes us a long step forwards. The magical or daemonic effect emanating from our neighbour disappears when the mysterious feeling is traced back to a definite entity in the collective unconscious. But now we have an entirely new task before us: the question of how the ego is to come to terms with this psychological non-ego. Can we rest content with establishing the real existence of the archetypes, and simply let things take care of themselves?

[156] That would be to create a permanent state of dissociation, a split between the individual and the collective psyche. On the one side we should have the differentiated modern ego, and on the other a sort of negroid culture, a very primitive state of affairs. We should have, in fact, what actually exists—a veneer of civilization over a dark-skinned brute; and the cleavage would be clearly demonstrated before our eyes. But such a dissociation requires immediate synthesis and the development of what has remained undeveloped. There must be a union of the two parts; for, failing that, there is no doubt how the matter would be decided: the primitive man would inevitably lapse back into repression. But that union is possible only where a still valid and therefore living religion exists, which allows the primitive man adequate means of expression through a richly developed symbolism. In other words, in its dogmas and rites, this religion must possess a mode of thinking and acting that harks back to the most primitive level. Such is the case in Catholicism, and this is its special advantage as well as its greatest danger.

[157] Before we go into this new question of a possible union, let us return to the dream from which we started. This whole discussion has given us a wider understanding of the dream, and particularly of one essential part of it—the feeling of fear. This fear is a primitive dread of the contents of the collective unconscious. As we have seen, the patient identifies herself with Mrs. X, thereby showing that she also has some relation to the mysterious artist. It proved that the doctor was identified

with the artist, and further we saw that on the subjective level I became an image for the figure of the magician in the collective unconscious.

[158] All this is covered in the dream by the symbol of the crab, which walks backwards. The crab is the living content of the unconscious, and it cannot be exhausted or made ineffective by analysis on the objective level. We can, however, separate the mythological or collective psychic contents from the objects of consciousness, and consolidate them as psychological realities outside the individual psyche. Through the act of cognition we “posit” the reality of the archetypes, or, more precisely, we postulate the psychic existence of such contents on a cognitive basis. It must emphatically be stated that it is not just a question of cognitive contents, but of transsubjective, largely autonomous psychic systems which on that account are only very conditionally under the control of the conscious mind and for the most part escape it altogether.

[159] So long as the collective unconscious and the individual psyche are coupled together without being differentiated, no progress can be made; or, to speak in terms of the dream, the boundary cannot be crossed. If, despite that, the dreamer makes ready to cross the border-line, the unconscious becomes activated, seizes her, and holds her fast. The dream and its material characterize the collective unconscious partly as a lower animal that lives hidden in the depths of the water, and partly as a dangerous disease that can be cured only by a timely operation. To what extent this characterization is apt has already been seen. As we have said, the animal symbol points specifically to the extra-human, the transpersonal; for the contents of the collective unconscious are not only the residues of archaic, specifically human modes of functioning, but also the residues of functions from man’s animal ancestry, whose duration in time was infinitely greater than the relatively brief epoch of specifically human existence. These residues, or “engrams,” as Semon calls them,⁷ are extremely liable, when activated, not only to retard the pace of development, but actually to force it into regression until the store of energy that activated the unconscious has been used up. But the energy becomes serviceable again by being brought into play through man’s conscious attitude towards the collective unconscious. The religions have established this cycle of energy in a concrete way by means of ritual communion with the gods. This method, however, is too much at variance with our intellectual morality, and has moreover been too radically supplanted by Christianity, for us to accept it as an ideal, or even possible, solution of the problem. If on the other hand we take the figures of the unconscious as collective psychic phenomena or functions, this hypothesis in no way violates our intellectual conscience. It offers a rationally acceptable solution, and at the same time a possible method of effecting a settlement with the activated residues of our racial history. This settlement makes the crossing of previous boundaries altogether feasible and is therefore appropriately

called the *transcendent function*. It is synonymous with progressive development towards a new attitude.

[160] The parallel with the hero-myth is very striking. More often than not the typical struggle of the hero with the monster (the unconscious content) takes place beside the water, perhaps at a ford. This is the case particularly in the Redskin myths with which Longfellow's *Hiawatha* has made us familiar. In the decisive battle the hero is, like Jonah, invariably swallowed by the monster, as Frobenius has shown⁸ with a wealth of detail. But, once inside the monster, the hero begins to settle accounts with the creature in his own way, while it swims eastwards with him towards the rising sun. He cuts off a portion of the viscera, the heart for instance, or some essential organ by virtue of which the monster lives (i.e., the valuable energy that activates the unconscious). Thus he kills the monster, which then drifts to land, where the hero, new-born through the transcendent function (the "night sea journey," as Frobenius calls it), steps forth, sometimes in the company of all those whom the monster has previously devoured. In this manner the normal state of things is restored, since the unconscious, robbed of its energy, no longer occupies the dominant position. Thus the myth graphically describes the problem which also engages our patient.⁹

[161] I must now emphasize the not unimportant fact, which must also have struck the reader, that in the dream the collective unconscious appears under a very negative aspect, as something dangerous and harmful. This is because the patient has a richly developed, indeed positively luxuriant, fantasy life, possibly due to her literary gift. Her powers of fantasy are a symptom of illness in that she revels in them far too much and allows real life to slip by. Any more mythology would be exceedingly dangerous for her, because a great chunk of external life stands before her, still un-lived. She has too little hold upon life to risk all at once a complete reversal of standpoint. The collective unconscious has fallen upon her and threatens to bear her away from a reality whose demands have not been adequately met. Accordingly, as the dream indicates, the collective unconscious had to be presented to her as something dangerous, otherwise she would have been only too ready to make it a refuge from the demands of life.

[162] In judging a dream we must observe very carefully *how* the figures are introduced. For example, the crab that personifies the unconscious is negative in that it "walks backwards" and, in addition, holds back the dreamer at the critical moment. Misled by the so-called dream mechanisms of Freudian manufacture, such as displacement, inversion, etc., people have imagined they could make themselves independent of the "façade" of the dream by supposing that the true dream-thoughts lay hidden behind it. As against this I have long maintained that we have no right to accuse the dream of, so to speak, a deliberate manoeuvre calculated to deceive.

Nature is often obscure or impenetrable, but she is not, like man, deceitful. We must therefore take it that the dream is just what it pretends to be, neither more nor less.¹⁰ If it shows something in a negative light, there is no reason for assuming that it is meant positively. The archetypal “danger at the ford” is so patent that one is almost tempted to take the dream as a warning. But I must discountenance all such anthropomorphic interpretations. The dream itself wants nothing; it is a self-evident content, a plain natural fact like the sugar in the blood of a diabetic or the fever in a patient with typhus. It is only we who, if we are clever and can unriddle the signs of nature, turn it into a warning.

[163] But—a warning of what? Of the obvious danger that the unconscious might overpower the dreamer at the moment of crossing. And what would being overpowered mean? An invasion by the unconscious may very easily occur at moments of critical change and decision. The bank from which she approaches the river is her situation as known to us so far. This situation has precipitated her into a neurotic deadlock, as though she had come up against an impassable obstacle. The obstacle is represented by the dream as a perfectly passable river. So things do not seem to be very serious. But in the river, most unexpectedly, the crab is hiding, and this represents the real danger on account of which the river is, or appears to be, impassable. For had she only known beforehand that the dangerous crab was lurking at this particular spot, she might perhaps have ventured to cross somewhere else, or have taken other precautions. In the dreamer’s present situation it is eminently desirable that a crossing should be made. The crossing means in the first place a carrying over—a transference—of the earlier situation to the doctor. That is the new feature. Were it not for the unpredictable unconscious, this would not involve such a great risk. But we saw that through the transference the activity of archetypal figures is liable to be let loose, a fact we had not banked on. We have reckoned without our host, for we “forgot the gods.”

[164] Our dreamer is not a religious person, she is “modern.” She has forgotten the religion she was once taught, she knows nothing of those moments when the gods intervene, or rather she does not know that there are age-old situations whose nature it is to stir us to the depths. One such situation is love, its passion and its danger. Love may summon forth unsuspected powers in the soul for which we had better be prepared. “Religio” in the sense of a “careful consideration” of unknown dangers and agencies—that is what is in question here. From a simple projection love may come upon her with all its fatal power, some dazzling illusion that might throw her life off its natural course. Is it a good thing or a bad, God or devil, that will befall the dreamer? Without knowing which, she feels that she is already in its clutches. And who can say whether she will be able to cope with this complication! Until now she had managed to circumvent such an eventuality, but now it threatens to seize hold of

her. That is a risk we should avoid, or, if we must take the plunge, we need a good deal of “trust in God” or “faith” in a successful issue. Thus, unsought and unexpected, the question creeps in of one’s religious attitude to fate.

[165] The dream as it stands leaves the dreamer no alternative at present but to withdraw her foot carefully; for to go on would be fatal. She cannot yet leave the neurotic situation, because the dream gives her no positive indication of any help from the unconscious. The unconscious powers are still inauspicious and obviously expect more work and a deeper insight from the dreamer before she can really venture across.

[166] I certainly do not wish, by this negative example, to convey the impression that the unconscious plays a negative role in all cases. I will therefore add two further dreams, this time of a young man, which illuminate another and more favourable side of the unconscious. I do this the more readily since the solution of the problem of opposites can be reached only irrationally, by way of contributions from the unconscious, i.e., from dreams.

[167] First I must acquaint the reader in some measure with the personality of the dreamer, for without this acquaintance he will hardly be able to transport himself into the peculiar atmosphere of the dreams. There are dreams that are pure poems and can therefore only be understood through the mood they convey as a whole. The dreamer is a youth of a little over twenty, still entirely boyish in appearance. There is even a touch of girlishness in his looks and manner of expression. The latter betrays a very good education and upbringing. He is intelligent, with pronounced intellectual and aesthetic interests. His aestheticism is very much in evidence: we are made instantly aware of his good taste and his fine appreciation of all forms of art. His feelings are tender and soft, given to the enthusiasms typical of puberty, but somewhat effeminate. There is no trace of adolescent callowness. Undoubtedly he is too young for his age, a clear case of retarded development. It is quite in keeping with this that he should have come to me on account of his homosexuality. The night preceding his first visit he had the following dream: *“I am in a lofty cathedral filled with mysterious twilight. They tell me that it is the cathedral at Lourdes. In the centre there is a deep dark well, into which I have to descend.”*

[168] The dream is clearly a coherent expression of mood. The dreamer’s comments are as follows: “Lourdes is the mystic fount of healing. Naturally I remembered yesterday that I was going to you for treatment and was in search of a cure. There is said to be a well like this at Lourdes. It would be rather unpleasant to go down into this water. The well in the church was ever so deep.”

[169] Now what does dream tell us? On the surface it seems clear enough, and we might be content to take it as a kind of poetic formulation of the mood of the day

before. But we should never stop there, for experience shows that dreams are much deeper and more significant. One might almost suppose that the dreamer came to the doctor in a highly poetic mood and was entering upon the treatment as though it were a sacred religious act to be performed in the mystical half-light of some awe-inspiring sanctuary. But this does not fit the facts at all. The patient merely came to the doctor to be treated for that unpleasant matter, his homosexuality, which is anything but poetic. At any rate we cannot see from the mood of the preceding day why he should dream so poetically, if we were to accept so direct a causation for the origin of the dream. But we might conjecture, perhaps, that the dream was stimulated precisely by the dreamer's impressions of that highly unpoetical affair which impelled him to come to me for treatment. We might even suppose that he dreamed in such an intensely poetical manner just because of the unpoeticalness of his mood on the day before, much as a man who has fasted by day dreams of delicious meals at night. It cannot be denied that the thought of treatment, of the cure and its unpleasant procedure, recurs in the dream, but poetically transfigured, in a guise which meets most effectively the lively aesthetic and emotional needs of the dreamer. He will be drawn on irresistibly by this inviting picture, despite the fact that the well is dark, deep, and cold. Something of the dream-mood will persist after sleep and will even linger on into the morning of the day on which he has to submit to the unpleasant and unpoetical duty of visiting me. Perhaps the drab reality will be touched by the bright, golden after-glow of the dream feeling.

[170] Is this, perhaps, the purpose of the dream? That would not be impossible, for in my experience the vast majority of dreams are compensatory.¹¹ They always stress the other side in order to maintain the psychic equilibrium. But the compensation of mood is not the only purpose of the dream picture. The dream also provides a *mental corrective*. The patient had of course nothing like an adequate understanding of the treatment to which he was about to submit himself. But the dream gives him a picture which describes in poetic metaphors the nature of the treatment before him. This becomes immediately apparent if we follow up his associations and comments on the image of the cathedral: "Cathedral," he says, "makes me think of Cologne Cathedral. Even as a child I was fascinated by it. I remember my mother telling me of it for the first time, and I also remember how, whenever I saw a village church, I used to ask if that were Cologne Cathedral. I wanted to be a priest in a cathedral like that."

[171] In these associations the patient is describing a very important experience of his childhood. As in nearly all cases of this kind, he had a particularly close tie with his mother. By this we are not to understand a particularly good or intense *conscious* relationship, but something in the nature of a secret, subterranean tie which expresses itself consciously, perhaps, only in the retarded development of character, i.e., in a relative infantilism. The developing personality naturally veers away from such an

unconscious infantile bond; for nothing is more obstructive to development than persistence in an unconscious—we could also say, a psychically embryonic—state. For this reason instinct seizes on the first opportunity to replace the mother by another object. If it is to be a real mother-substitute, this object must be, in some sense, an analogy of her. This is entirely the case with our patient. The intensity with which his childish fantasy seized upon the symbol of Cologne Cathedral corresponds to the strength of his unconscious need to find a substitute for the mother. The unconscious need is heightened still further in a case where the infantile bond could become harmful. Hence the enthusiasm with which his childish imagination took up the idea of the Church; for the Church is, in the fullest sense, a mother. We speak not only of Mother Church, but even of the Church's womb. In the ceremony known as the *benedictio fontis*, the baptismal font is apostrophized as “immaculatus divini fontis uterus”—the immaculate womb of the divine font. We naturally think that a man must have known this meaning consciously before it could get to work in his fantasy, and that an unknowing child could not possibly be affected by these significations. Such analogies certainly do not work by way of the conscious mind, but in quite another manner.

[172] The Church represents a higher spiritual substitute for the purely natural, or “carnal,” tie to the parents. Consequently it frees the individual from an unconscious natural relationship which, strictly speaking, is not a relationship at all but simply a condition of inchoate, unconscious identity. This, just because it is unconscious, possesses a tremendous inertia and offers the utmost resistance to any kind of spiritual development. It would be hard to say what the essential difference is between this state and the soul of an animal. Now, it is by no means the special prerogative of the Christian Church to try to make it possible for the individual to detach himself from his original, animal-like condition; the Church is simply the latest, and specifically Western, form of an instinctive striving that is probably as old as mankind itself. It is a striving that can be found in the most varied forms among all primitive peoples who are in any way developed and have not yet become degenerate: I mean the institution or rite of initiation into manhood. When he has reached puberty the young man is conducted to the “men's house,” or some other place of consecration, where he is systematically alienated from his family. At the same time he is initiated into the religious mysteries, and in this way is ushered not only into a wholly new set of relationships, but, as a renewed and changed personality, into a new world, like one reborn (*quasimodo genitus*). The initiation is often attended by all kinds of tortures, sometimes including such things as circumcision and the like. These practices are undoubtedly very old. They have almost become instinctive mechanisms, with the result that they continue to repeat themselves without external compulsion, as in the “baptisms” of German students or

the even more wildly extravagant initiations in American students' fraternities. They are engraved on the unconscious as a primordial image.

[173] When his mother told him as a little boy about Cologne Cathedral, this primordial image was stirred and awakened to life. But there was no priestly instructor to develop it further, so the child remained in his mother's hands. Yet the longing for a man's leadership continued to grow in the boy, taking the form of homosexual leanings—a faulty development that might never have come about had a man been there to educate his childish fantasies. The deviation towards homosexuality has, to be sure, numerous historical precedents. In ancient Greece, as also in certain primitive communities, homosexuality and education were practically synonymous. Viewed in this light, the homosexuality of adolescence is only a misunderstanding of the otherwise very appropriate need for masculine guidance. One might also say that the fear of incest which is based on the mother-complex extends to women in general; but in my opinion an immature man is quite right to be afraid of women, because his relations with women are generally disastrous.

[174] According to the dream, then, what the initiation of the treatment signifies for the patient is the fulfilment of the true meaning of his homosexuality, i.e., his entry into the world of the adult man. All that we have been forced to discuss here in such tedious and long-winded detail, in order to understand it properly, the dream has condensed into a few vivid metaphors, thus creating a picture which works far more effectively on the imagination, feeling, and understanding of the dreamer than any learned discourse. Consequently the patient was better and more intelligently prepared for the treatment than if he had been overwhelmed with medical and pedagogical maxims. (For this reason I regard dreams not only as a valuable source of information but as an extraordinarily effective instrument of education.)

[175] We come now to the second dream. I must explain in advance that in the first consultation I did not refer in any way to the dream we have just been discussing. It was not even mentioned. Nor was there a word said that was even remotely connected with the foregoing. This is the second dream: *“I am in a great Gothic cathedral. At the altar stands a priest. I stand before him with my friend, holding in my hand a little Japanese ivory figure, with the feeling that it is going to be baptized. Suddenly an elderly woman appears, takes the fraternity ring from my friend's finger, and puts it on her own. My friend is afraid that this may bind him in some way. But at the same moment there is a sound of wonderful organ music.”*

[176] Here I will only bring out briefly those points which continue and supplement the dream of the preceding day. The second dream is unmistakably connected with the first: once more the dreamer is in church, that is, in the state of initiation into manhood. But a new figure has been added: the priest, whose absence in the previous

situation we have already noted. The dream therefore confirms that the unconscious meaning of his homosexuality has been fulfilled and that a further development can be started. The actual initiation ceremony, namely the baptism, may now begin. The dream symbolism corroborates what I said before, namely that it is not the prerogative of the Christian Church to bring about such transitions and psychic transformations, but that behind the Church there is a living primordial image which in certain conditions is capable of enforcing them.

[177] What, according to the dream, is to be baptized is a little Japanese ivory figure. The patient says of this: "It was a tiny, grotesque little manikin that reminded me of the male organ. It was certainly odd that this member was to be baptized. But after all, with the Jews circumcision is a sort of baptism. That must be a reference to my homosexuality, because the friend standing with me before the altar is the one with whom I have sexual relations. We belong to the same fraternity. The fraternity ring obviously stands for our relationship."

[178] We know that in common usage the ring is the token of a bond or relationship, as for example the wedding ring. We can therefore safely take the fraternity ring in this case as symbolizing the homosexual relationship, and the fact that the dreamer appears together with his friend points in the same direction.

[179] The complaint to be remedied is homosexuality. The dreamer is to be led out of this relatively childish condition and initiated into the adult state by means of a kind of circumcision ceremony under the supervision of a priest. These ideas correspond exactly to my analysis of the previous dream. Thus far the development has proceeded logically and consistently with the aid of archetypal images. But now a disturbing factor comes on the scene. An elderly woman suddenly takes possession of the fraternity ring; in other words, she draws to herself what has hitherto been a homosexual relationship, thus causing the dreamer to fear that he is getting involved in a new relationship with obligations of its own. Since the ring is now on the hand of a woman, a marriage of sorts has been contracted, i.e., the homosexual relationship seems to have passed over into a heterosexual one, but a heterosexual relationship of a peculiar kind since it concerns an elderly woman. "She is a friend of my mother's," says the patient. "I am very fond of her, in fact she is like a mother to me."

[180] From this remark we can see what has happened in the dream: as a result of the initiation the homosexual tie has been cut and a heterosexual relationship substituted for it, a platonic friendship with a motherly type of woman. In spite of her resemblance to his mother, this woman is not his mother any longer, so the relationship with her signifies a step beyond the mother towards masculinity, and hence a partial conquest of his adolescent homosexuality.

[181] The fear of the new tie can easily be understood, firstly as fear which the woman's resemblance to his mother might naturally arouse—it might be that the dissolution of the homosexual tie has led to a complete regression to the mother—and secondly as fear of the new and unknown factors in the adult heterosexual state with its possible obligations, such as marriage, etc. That we are in fact concerned here not with a regression but with a progression seems to be confirmed by the music that now peals forth. The patient is musical and especially susceptible to solemn organ music. Therefore music signifies for him a very positive feeling, so in this case it forms a harmonious conclusion to the dream, which in its turn is well qualified to leave behind a beautiful, holy feeling for the following morning.

[182] If you consider the fact that up to now the patient had seen me for only one consultation, in which little more was discussed than a general anamnesis, you will doubtless agree with me when I say that both dreams make astonishing anticipations. They show the patient's situation in a highly remarkable light, and one that is very strange to the conscious mind, while at the same time lending to the banal medical situation an aspect that is uniquely attuned to the mental peculiarities of the dreamer, and thus capable of stringing his aesthetic, intellectual, and religious interests to concert pitch. No better conditions for treatment could possibly be imagined. One is almost persuaded, from the meaning of these dreams, that the patient entered upon the treatment with the utmost readiness and hopefulness, quite prepared to cast aside his boyishness and become a man. In reality, however, this was not the case at all. Consciously he was full of hesitation and resistance; moreover, as the treatment progressed, he constantly showed himself antagonistic and difficult, ever ready to slip back into his previous infantilism. Consequently the dreams stand in strict contrast to his conscious behaviour. They move along a progressive line and take the part of the educator. They clearly reveal their special function. This function I have called compensation. The unconscious progressiveness and the conscious regressiveness together form a pair of opposites which, as it were, keeps the scales balanced. The influence of the educator tilts the balance in favour of progression.

[183] In the case of this young man the images of the collective unconscious play an entirely positive role, which comes from the fact that he has no really dangerous tendency to fall back on a fantasy-substitute for reality and to entrench himself behind it against life. The effect of these unconscious images has something fateful about it. Perhaps—who knows?—these eternal images are what men mean by fate.

[184] The archetypes are of course always at work everywhere. But practical treatment, especially in the case of young people, does not always require the patient to come to close quarters with them. At the climacteric, on the other hand, it is necessary to give special attention to the images of the collective unconscious, because they are the

source from which hints may be drawn for the solution of the problem of opposites. From the conscious elaboration of this material the transcendent function reveals itself as a mode of apprehension mediated by the archetypes and capable of uniting the opposites. By “apprehension” I do not mean simply intellectual understanding, but understanding through experience. An archetype, as we have said, is a dynamic image, a fragment of the objective psyche, which can be truly understood only if experienced as an autonomous entity.

[185] A general account of this process, which may extend over a long period of time, would be pointless—even if such a description were possible—because it takes the greatest imaginable variety of forms in different individuals. The only common factor is the emergence of certain definite archetypes. I would mention in particular the shadow, the animal, the wise old man, the anima, the animus, the mother, the child, besides an indefinite number of archetypes representative of situations. A special position must be accorded to those archetypes which stand for the goal of the developmental process. The reader will find the necessary information on this point in my *Psychology and Alchemy*, as well as in “Psychology and Religion” and the volume written in collaboration with Richard Wilhelm, *The Secret of the Golden Flower*.

[186] The transcendent function does not proceed without aim and purpose, but leads to the revelation of the essential man. It is in the first place a purely natural process, which may in some cases pursue its course without the knowledge or assistance of the individual, and can sometimes forcibly accomplish itself in the face of opposition. The meaning and purpose of the process is the realization, in all its aspects, of the personality originally hidden away in the embryonic germ-plasm; the production and unfolding of the original, potential wholeness. The symbols used by the unconscious to this end are the same as those which mankind has always used to express wholeness, completeness, and perfection: symbols, as a rule, of the quaternity and the circle. For these reasons I have termed this the *individuation process*.

[187] This natural process of individuation served me both as a model and guiding principle for my method of treatment. The unconscious compensation of a neurotic conscious attitude contains all the elements that could effectively and healthily correct the one-sidedness of the conscious mind if these elements were made conscious, i.e., were understood and integrated into it as realities. It is only very seldom that a dream achieves such intensity that the shock is enough to throw the conscious mind out of the saddle. As a rule dreams are too feeble and too unintelligible to exercise a radical influence on consciousness. In consequence, the compensation runs underground in the unconscious and has no immediate effect. But it has some effect all the same; only, it is indirect in so far as the unconscious

opposition will, if consistently ignored, arrange symptoms and situations which irresistibly thwart our conscious intentions. The aim of the treatment is therefore to understand and to appreciate, so far as practicable, dreams and all other manifestations of the unconscious, firstly in order to prevent the formation of an unconscious opposition which becomes more dangerous as time goes on, and secondly in order to make the fullest possible use of the healing factor of compensation.

[188] These proceedings naturally rest on the assumption that a man is capable of attaining wholeness, in other words, that he has it in him to be healthy. I mention this assumption because there are without doubt individuals who are not at bottom altogether viable and who rapidly perish if, for any reason, they come face to face with their wholeness. Even if this does not happen, they merely lead a miserable existence for the rest of their days as fragments or partial personalities, shored up by social or psychic parasitism. Such people are, very much to the misfortune of others, more often than not inveterate humbugs who cover up their deadly emptiness under a fine outward show. It would be a hopeless undertaking to try to treat them with the method here discussed. The only thing that “helps” here is to keep up the show, for the truth would be unendurable or useless.

[189] When a case is treated in the manner indicated, the initiative lies with the unconscious, but all criticism, choice, and decision lie with the conscious mind. If the decision is right, it will be confirmed by dreams indicative of progress; in the other event correction will follow from the side of the unconscious. The course of treatment is thus rather like a running conversation with the unconscious. That the correct interpretation of dreams is of paramount importance should be sufficiently clear from what has been said. But when, you may rightly ask, is one sure of the interpretation? Is there anything approaching a reliable criterion for the correctness of an interpretation? This question, happily, can be answered in the affirmative. If we have made a wrong interpretation, or if it is somehow incomplete, we may be able to see it from the next dream. Thus, for example, the earlier motif will be repeated in clearer form, or our interpretation may be deflated by some ironic paraphrase, or it may meet with straightforward violent opposition. Now supposing that these interpretations also go astray, the general inconclusiveness and futility of our procedure will make itself felt soon enough in the bleakness, sterility, and pointlessness of the undertaking, so that doctor and patient alike will be suffocated either by boredom or by doubt. Just as the reward of a correct interpretation is an uprush of life, so an incorrect one dooms them to deadlock, resistance, doubt, and mutual desiccation. Stoppages can of course also arise from the resistance of the patient, as for instance from an obstinate clinging to outworn illusions or to infantile demands. Sometimes, too, the doctor lacks the necessary understanding, as once

happened to me in the case of a very intelligent patient, a woman who, for various reasons, looked to me rather a rum customer. After a satisfactory beginning I had the feeling more and more that somehow my interpretation of her dreams was not quite hitting the mark. As I was unable to lay my finger on the source of error, I tried to talk myself out of my doubts. But during the consulting hours I became aware of the growing dullness of our conversation, with a steadily mounting sense of excruciating futility. Finally I resolved to speak about it at the next opportunity to my patient, who, it seemed to me, had not failed to notice this fact. The next night I had the following dream: *I was walking along a country road through a valley lit by the evening sun. To my right, standing on a steep hill, was a castle, and on the topmost tower, on a kind of balustrade, sat a woman. In order to see her properly I had to bend my head back so far that I got a crick in the neck. Even in my dream I recognized the woman as my patient.*¹²

[190] From this I concluded that if I had to look up so much in the dream, I must obviously have looked down on my patient in reality. When I told her the dream together with the interpretation, a complete change came over the situation at once and the treatment shot ahead beyond all expectation. Experiences of this kind, although paid for very dearly, lead to an unshakable confidence in the reliability of dream compensations.

[191] To the manifold problems involved in this method of treatment all my labours and researches have been devoted for the last ten years. But since, in this present account of analytical psychology, I am concerned only to provide a general survey, a more detailed exposition of the widely ramified scientific, philosophical, and religious implications must remain in abeyance. For this I shall have to refer my reader to the literature I have mentioned.

VIII

GENERAL REMARKS ON THE THERAPEUTIC APPROACH TO THE UNCONSCIOUS

[192] We are greatly mistaken if we think that the unconscious is something harmless that could be made into an object of entertainment, a parlour game. Certainly the unconscious is not always and in all circumstances dangerous, but as soon as a neurosis is present it is a sign of a special heaping up of energy in the unconscious, like a charge that may explode. Here caution is indicated. One never knows what one may be releasing when one begins to analyse dreams. Something deeply buried and invisible may thereby be set in motion, very probably something that would have come to light sooner or later anyway—but again, it might not. It is as if one were digging an artesian well and ran the risk of stumbling on a volcano. When neurotic symptoms are present one must proceed very carefully. But the neurotic cases are not by a long way the most dangerous. There are cases of people, apparently quite normal, showing no especial neurotic symptoms—they may themselves be doctors and educators—priding themselves on their normality, models of good upbringing, with exceptionally normal views and habits of life, yet whose normality is an artificial compensation for a latent psychosis. They themselves suspect nothing of their condition. Their suspicions may perhaps find only an indirect expression in the fact that they are particularly interested in psychology and psychiatry, and are attracted to these things as a moth to the light. But since the analytical technique activates the unconscious and brings it to the fore, in these cases the healthful compensation is destroyed, the unconscious breaks forth in the form of uncontrollable fantasies and overwrought states which may, in certain circumstances, lead to mental disorder and possibly even to suicide. Unfortunately these latent psychoses are not so very uncommon.

[193] The danger of stumbling on cases like these threatens everybody who concerns himself with the analysis of the unconscious, even if he be equipped with a large measure of experience and skill. Through clumsiness, mistaken ideas, arbitrary interpretations, and so forth, he may even wreck cases that need not necessarily have turned out badly. This is by no means peculiar to the analysis of the unconscious, but is the penalty of all medical intervention that miscarries. The assertion that analysis drives people mad is obviously just as stupid as the vulgar notion that the psychiatrist is bound to go mad because he deals with lunatics.

[194] Apart from the risks of treatment, the unconscious may also turn dangerous on its own account. One of the commonest forms of danger is the instigating of accidents. A very large number of accidents of every description, more than people would ever guess, are of psychic causation, ranging from trivial mishaps like stumbling, banging oneself, burning one's fingers, etc., to car smashes and catastrophes in the mountains: all these may be psychically caused and may sometimes have been preparing for weeks or even months. I have examined many cases of this kind, and often I could point to dreams which showed signs of a tendency to self-injury weeks beforehand. All those accidents that happen from so-called carelessness should be examined for such determinants. We know of course that when for one reason or another we feel out of sorts, we are liable to commit not only the minor follies, but something really dangerous which, given the right psychological moment, may well put an end to our lives. The popular saying, "Old so-and-so chose the right time to die," comes from a sure sense of the secret psychological cause in question. In the same way, bodily ills can be brought into being or protracted. A wrong functioning of the psyche can do much to injure the body, just as conversely a bodily illness can affect the psyche; for psyche and body are not separate entities but one and the same life. Thus there is seldom a bodily ailment that does not show psychic complications, even if it is not psychically caused.

[195] It would be wrong, however, to dwell only on the unfavourable side of the unconscious. In all ordinary cases the unconscious is unfavourable or dangerous only because we are not at one with it and therefore in opposition to it. A negative attitude to the unconscious, or its splitting off, is detrimental in so far as the dynamics of the unconscious are identical with instinctual energy.¹ Disalliance with the unconscious is synonymous with loss of instinct and rootlessness.

[196] If we can successfully develop that function which I have called transcendent, the disharmony ceases and we can then enjoy the favourable side of the unconscious. The unconscious then gives us all the encouragement and help that a bountiful nature can shower upon man. It holds possibilities which are locked away from the conscious mind, for it has at its disposal all subliminal psychic contents, all those things which have been forgotten or overlooked, as well as the wisdom and experience of uncounted centuries which are laid down in its archetypal organs.

[197] The unconscious is continually active, combining its material in ways which serve the future. It produces, no less than the conscious mind, subliminal combinations that are prospective; only, they are markedly superior to the conscious combinations both in refinement and in scope. For these reasons the unconscious could serve man as a unique guide, provided that he can resist the lure of being misguided.

[198] In practice the treatment is adjusted according to the therapeutic results obtained. Results may appear at almost any stage of the treatment, quite irrespective of the severity or duration of the illness. And conversely, the treatment of a severe case may last a very long time without reaching, or needing to reach, the higher stages of development. There are a fair number who, even after therapeutic results have been obtained, go through further stages of transformation for the sake of their own development. So it is not true that one must be a serious case in order to go through the whole process. At all events only those individuals can attain to a higher degree of consciousness who are destined to it and called to it from the beginning, i.e., who have a capacity and an urge for higher differentiation. In this matter men differ extremely, as also do the animal species, among whom there are conservatives and progressives. Nature is aristocratic, but not in the sense of having reserved the possibility of differentiation exclusively for species high in the scale. So too with the possibility of psychic development: it is not reserved for specially gifted individuals. In other words, in order to undergo a far-reaching psychological development, neither outstanding intelligence nor any other talent is necessary, since in this development moral qualities can make up for intellectual shortcomings. It must not on any account be imagined that the treatment consists in grafting upon people's minds general formulas and complicated doctrines. There is no question of that. Each can take what he needs, in his own way and in his own language. What I have presented here is an intellectual formulation; it is not the sort of thing discussed in the general run of practical work. The little snippets of case histories I have woven into my theme give a rough idea of what happens in practice.

[199] If, after all that has been related in the foregoing chapters, the reader should still not feel capable of forming a clear picture of the theory and practice of modern medical psychology, that would not surprise me so very much. I would, on the contrary, be inclined to blame my faulty gift of exposition, since I can hardly hope to give a concrete picture of that wide field of thought and experience which is the domain of medical psychology. On paper the interpretation of a dream may look arbitrary, muddled, and spurious; but the same thing in reality can be a little drama of unsurpassed realism. To *experience* a dream and its interpretation is very different from having a tepid rehash set before you on paper. Everything about this psychology is, in the deepest sense, experience; the entire theory, even where it puts on the most abstract airs, is the direct outcome of something experienced. If I accuse the Freudian sexual theory of one-sidedness, that does not mean that it rests on rootless speculation; it too is a faithful picture of real facts which force themselves upon our practical observation. And if the inferences made from them proliferate into a one-sided theory, that only goes to show with what powers of persuasion, both objective and subjective, the facts in question themselves bring to bear. The individual

investigator can hardly be asked to rise superior to his own deepest impressions and their abstract formulation; for the acquisition of such impressions as well as their conceptual mastery is in itself the labour of a lifetime. For my part, I had the great advantage over both Freud and Adler of not having grown up within the narrow confines of a psychology of the neuroses; rather, I approach them from the side of psychiatry, prepared for modern psychology by Nietzsche, and apart from Freud's views I also had before my eyes the growth of the views of Adler. In this way I found myself in the thick of the conflict from the very beginning, and was forced to regard not only the existing opinions, but my own as well, as relative, or rather as expressions of a certain psychological type. Just as the Breuer case we have discussed was decisive for Freud, so a decisive experience underlies my own views. Towards the end of my medical training I observed for a long period a case of somnambulism in a young girl. It became the theme of my doctor's dissertation.² For one acquainted with my scientific writings it may not be without interest to compare this forty-year-old study with my later ideas.

[200] Work in this field is pioneer work. I have often made mistakes and had many times to forget what I had learned. But I know and am content to know that as surely as light comes out of darkness, truth is born of error. I have let Guglielmo Ferrero's *mot* about the "misérable vanité du savant"³ serve me for a warning, and have therefore neither feared my mistakes nor seriously regretted them. For me, scientific research work was never a milch-cow or a means of prestige, but a struggle, often a bitter one, forced upon me by daily psychological experience of the sick. Hence not everything I bring forth is written out of my head, but much of it comes from the heart also, a fact I would beg the gracious reader not to overlook if, following up the intellectual line of thought, he comes upon certain lacunae that have not been properly filled in. A harmonious flow of exposition can be expected only when one is writing about things which one already knows. But when, urged on by the need to help and to heal, one acts as a path-finder, one must speak also of realities as yet unknown.

CONCLUSION

[201] In conclusion I must ask the reader to forgive me for having ventured to say in these few pages so much that is new and perhaps hard to understand. I expose myself to his critical judgment because I feel it is the duty of one who goes his own way to inform society of what he finds on his voyage of discovery, be it cooling water for the thirsty or the sandy wastes of unfruitful error. The one helps, the other warns. Not the criticism of individual contemporaries will decide the truth or falsity of his discoveries, but future generations. There are things that are not yet true today, perhaps we dare not find them true, but tomorrow they may be. So every man whose fate it is to go his individual way must proceed with hopefulness and watchfulness, ever conscious of his loneliness and its dangers. The peculiarity of the way here described is largely due to the fact that in psychology, which springs from and acts upon real life, we can no longer appeal to the narrowly intellectual, scientific standpoint, but are driven to take account of the standpoint of feeling, and consequently of everything that the psyche actually contains. In practical psychology we are dealing not with any generalized human psyche, but with individual human beings and the multitudinous problems that oppress them. A psychology that satisfies the intellect alone can never be practical, for the totality of the psyche can never be grasped by intellect alone. Whether we will or no, philosophy keeps breaking through, because the psyche seeks an expression that will embrace its total nature.



THE RELATIONS BETWEEN THE EGO AND THE UNCONSCIOUS

PREFACE TO THE SECOND EDITION (1935)

This little book is the outcome of a lecture which was originally published in 1916 under the title “La Structure de l’inconscient.”¹ This same lecture later appeared in English under the title “The Conception of the Unconscious” in my *Collected Papers on Analytical Psychology*.² I mention these facts because I wish to place it on record that the present essay is not making its first appearance, but is rather the expression of a long-standing endeavour to grasp and—at least in its essential features—to depict the strange character and course of that *drame intérieur*, the transformation process of the unconscious psyche. This idea of the independence of the unconscious, which distinguishes my views so radically from those of Freud, came to me as far back as 1902, when I was engaged in studying the psychic history of a young girl somnambulist.³ In a lecture given in Zurich [1908] on “The Content of the Psychoses,” I approached this idea from another side. In 1912, I illustrated some of the main points of the process in an individual case and at the same time I indicated the historical and ethnological parallels to these seemingly universal psychic events.⁴ In the above-mentioned essay, “La Structure de l’inconscient,” I attempted for the first time to give a comprehensive account of the whole process. It was a mere attempt, of whose inadequacy I was painfully aware. The difficulties presented by the material were so great that I could not hope to do them anything like justice in a single essay. I therefore let it rest at the stage of an “interim report,” with the firm intention of returning to this theme at a later opportunity. Twelve years of further experience enabled me, in 1928, to undertake a thorough revision of my formulations of 1916, and the result of these labours was the little book *Die Beziehungen zwischen dem Ich and dem Unbewussten*.⁵ This time I tried to describe chiefly the relation of the ego-consciousness to the unconscious process. Following this intention, I concerned myself more particularly with those phenomena which are to be regarded as the reactive symptoms of the conscious personality to the influences of the unconscious. In this way I tried to effect an indirect approach to the unconscious process itself. These investigations have not yet come to a satisfactory conclusion, for the answer to the crucial problem of the nature and essence of the unconscious process has still to be found. I would not venture upon this exceedingly difficult task without the fullest possible experience. Its solution is reserved for the future.

I trust the reader of this book will bear with me if I beg him to regard it—should he persevere—as an earnest attempt on my part to form an intellectual conception of a new and hitherto unexplored field of experience. It is not concerned with a clever system of

thought, but with the formulation of complex psychic experiences which have never yet been the subject of scientific study. Since the psyche is an irrational datum and cannot, in accordance with the old picture, be equated with a more or less divine Reason, it should not surprise us if in the course of psychological experience we come across, with extreme frequency, processes and happenings which run counter to our rational expectations and are therefore rejected by the rationalistic attitude of our conscious mind. Such an attitude is naturally not very skilled at psychological observation because it is in the highest degree unscientific. We must not attempt to tell nature what to do if we want to observe her operations undisturbed.

It is twenty-eight years of psychological and psychiatric experience that I am trying to sum up here, so perhaps my little book may lay some claim to serious consideration. Naturally I could not say everything in this single exposition. The reader will find a development of the last chapter, [with reference to the concept of the self], in my commentary to *The Secret of the Golden Flower*, the book I brought out in collaboration with my friend Richard Wilhelm. I did not wish to omit reference to this publication, because Oriental philosophy has been concerned with these interior psychic processes for many hundreds of years and is therefore, in view of the great need for comparative material, of inestimable value in psychological research.

October 1934

C. G. JUNG

PREFACE TO THE THIRD EDITION (1938)

The new edition is published without changes. Since this work first appeared no new points of view have emerged which might have made revisions desirable. I would like to preserve the character of this little book—an unpretentious introduction to the psychological problems of the process of individuation—and not burden it with copious details that might limit its readability.

April 1938

C. G. JUNG

PART ONE

THE EFFECTS OF THE UNCONSCIOUS UPON CONSCIOUSNESS

THE PERSONAL AND THE COLLECTIVE UNCONSCIOUS

[202] In Freud's view, as most people know, the contents of the unconscious are reducible to infantile tendencies which are repressed because of their incompatible character. Repression is a process that begins in early childhood under the moral influence of the environment and continues throughout life. By means of analysis the repressions are removed and the repressed wishes made conscious.

[203] According to this theory, the unconscious contains only those parts of the personality which could just as well be conscious, and have been suppressed only through the process of education. Although from one point of view the infantile tendencies of the unconscious are the most conspicuous, it would nonetheless be a mistake to define or evaluate the unconscious entirely in these terms. The unconscious has still another side to it: it includes not only repressed contents, but all psychic material that lies below the threshold of consciousness. It is impossible to explain the subliminal nature of all this material on the principle of repression, for in that case the removal of repression ought to endow a person with a prodigious memory which would thenceforth forget nothing.

[204] We therefore emphatically affirm that in addition to the repressed material the unconscious contains all those psychic components that have fallen below the threshold, as well as subliminal sense-perceptions. Moreover we know, from abundant experience as well as for theoretical reasons, that the unconscious also contains all the material that has *not yet* reached the threshold of consciousness. These are the seeds of future conscious contents. Equally we have reason to suppose that the unconscious is never quiescent in the sense of being inactive, but is ceaselessly engaged in grouping and regrouping its contents. This activity should be thought of as completely autonomous only in pathological cases; normally it is coordinated with the conscious mind in a compensatory relationship.

[205] It is to be assumed that all these contents are of a personal nature in so far as they are acquired during the individual's life. Since this life is limited, the number of acquired contents in the unconscious must also be limited. This being so, it might be thought possible to empty the unconscious either by analysis or by making a complete inventory of the unconscious contents, on the ground that the unconscious cannot produce anything more than what is already known and assimilated into consciousness. We should also have to suppose, as already said, that if one could arrest the descent of conscious contents into the unconscious by doing away with

repression, unconscious productivity would be paralysed. This is possible only to a very limited extent, as we know from experience. We urge our patients to hold fast to repressed contents that have been re-associated with consciousness, and to assimilate them into their plan of life. But this procedure, as we may daily convince ourselves, makes no impression on the unconscious, since it calmly goes on producing dreams and fantasies which, according to Freud's original theory, must arise from personal repressions. If in such cases we pursue our observations systematically and without prejudice, we shall find material which, although similar in form to the previous personal contents, yet seems to contain allusions that go far beyond the personal sphere.

[206] Casting about in my mind for an example to illustrate what I have just said, I have a particularly vivid memory of a woman patient with a mild hysterical neurosis which, as we expressed it in those days [about 1910], had its principal cause in a "father-complex." By this we wanted to denote the fact that the patient's peculiar relationship to her father stood in her way. She had been on very good terms with her father, who had since died. It was a relationship chiefly of feeling. In such cases it is usually the intellectual function that is developed, and this later becomes the bridge to the world. Accordingly our patient became a student of philosophy. Her energetic pursuit of knowledge was motivated by her need to extricate herself from the emotional entanglement with her father. This operation may succeed if her feelings can find an outlet on the new intellectual level, perhaps in the formation of an emotional tie with a suitable man, equivalent to the former tie. In this particular case, however, the transition refused to take place, because the patient's feelings remained suspended, oscillating between her father and a man who was not altogether suitable. The progress of her life was thus held up, and that inner disunity so characteristic of a neurosis promptly made its appearance. The so-called normal person would probably be able to break the emotional bond in one or the other direction by a powerful act of will, or else—and this is perhaps the more usual thing—he would come through the difficulty unconsciously, on the smooth path of instinct, without ever being aware of the sort of conflict that lay behind his headaches or other physical discomforts. But any weakness of instinct (which may have many causes) is enough to hinder a smooth unconscious transition. Then all progress is delayed by conflict, and the resulting stasis of life is equivalent to a neurosis. In consequence of the standstill, psychic energy flows off in every conceivable direction, apparently quite uselessly. For instance, there are excessive innervations of the sympathetic system, which lead to nervous disorders of the stomach and intestines; or the vagus (and consequently the heart) is stimulated; or fantasies and memories, uninteresting enough in themselves, become overvalued and prey on the conscious mind (mountains out of molehills). In this state a new motive is needed to put an end to the morbid

suspension. Nature herself paves the way for this, unconsciously and indirectly, through the phenomenon of the transference (Freud). In the course of treatment the patient transfers the father-*imago* to the doctor, thus making him, in a sense, the father, and in the sense that he is *not* the father, also making him a substitute for the man she cannot reach. The doctor therefore becomes both a father and a kind of lover—in other words, an object of conflict. In him the opposites are united, and for this reason he stands for a quasi-ideal solution of the conflict. Without in the least wishing it, he draws upon himself an over-valuation that is almost incredible to the outsider, for to the patient he seems like a saviour or a god. This way of speaking is not altogether so laughable as it sounds. It is indeed a bit much to be a father and lover at once. Nobody could possibly stand up to it in the long run, precisely because it is too much of a good thing. One would have to be a demigod at least to sustain such a role without a break, for all the time one would have to be the giver. To the patient in the state of transference, this provisional solution naturally seems ideal, but only at first; in the end she comes to a standstill that is just as bad as the neurotic conflict was. Fundamentally, nothing has yet happened that might lead to a real solution. The conflict has merely been transferred. Nevertheless a successful transference can—at least temporarily—cause the whole neurosis to disappear, and for this reason it has been very rightly recognized by Freud as a healing factor of first-rate importance, but, at the same time, as a provisional state only, for although it holds out the possibility of a cure, it is far from being the cure itself.

[207] This somewhat lengthy discussion seemed to me essential if my example was to be understood, for my patient had arrived at the state of transference and had already reached the upper limit where the standstill begins to make itself disagreeable. The question now arose: what next? I had of course become the complete saviour, and the thought of having to give me up was not only exceedingly distasteful to the patient, but positively terrifying. In such a situation “sound common sense” generally comes out with a whole repertory of admonitions: “you simply must,” “you really ought,” “you just cannot,” etc. So far as sound common sense is, happily, not too rare and not entirely without effect (pessimists, I know, exist), a rational motive can, in the exuberant feeling of buoyancy you get from the transference, release so much enthusiasm that a painful sacrifice can be risked with a mighty effort of will. If successful—and these things sometimes are—the sacrifice bears blessed fruit, and the erstwhile patient leaps at one bound into the state of being practically cured. The doctor is generally so delighted that he fails to tackle the theoretical difficulties connected with this little miracle.

[208] If the leap does not succeed—and it did not succeed with my patient—one is then faced with the problem of resolving the transference. Here “psychoanalytic” theory shrouds itself in a thick darkness. Apparently we are to fall back on some nebulous

trust in fate: somehow or other the matter will settle itself. “The transference stops automatically when the patient runs out of money,” as a slightly cynical colleague once remarked to me. Or the ineluctable demands of life make it impossible for the patient to linger on in the transference—demands which compel the involuntary sacrifice, sometimes with a more or less complete relapse as a result. (One may look in vain for accounts of such cases in the books that sing the praises of psychoanalysis!)

[209] To be sure, there are hopeless cases where nothing helps; but there are also cases that do not get stuck and do not inevitably leave the transference situation with bitter hearts and sore heads. I told myself, at this juncture with my patient, that there must be a clear and respectable way out of the impasse. My patient had long since run out of money—if indeed she ever possessed any—but I was curious to know what means nature would devise for a satisfactory way out of the transference deadlock. Since I never imagined that I was blessed with that “sound common sense” which always knows exactly what to do in every quandary, and since my patient knew as little as I, I suggested to her that we could at least keep an eye open for any movements coming from a sphere of the psyche uncontaminated by our superior wisdom and our conscious plannings. That meant first and foremost her dreams.

[210] Dreams contain images and thought-associations which we do not create with conscious intent. They arise spontaneously without our assistance and are representatives of a psychic activity withdrawn from our arbitrary will. Therefore the dream is, properly speaking, a highly objective, natural product of the psyche, from which we might expect indications, or at least hints, about certain basic trends in the psychic process. Now, since the psychic process, like any other life-process, is not just a causal sequence, but is also a process with a teleological orientation, we might expect dreams to give us certain *indicia* about the objective causality as well as about the objective tendencies, precisely because dreams are nothing less than self-representations of the psychic life-process.

[211] On the basis of these reflections, then, we subjected the dreams to a careful examination. It would lead too far to quote word for word all the dreams that now followed. Let it suffice to sketch their main character: the majority referred to the person of the doctor, that is to say, the actors were unmistakably the dreamer herself and her doctor. The latter, however, seldom appeared in his natural shape, but was generally distorted in a remarkable way. Sometimes his figure was of supernatural size, sometimes he seemed to be extremely aged, then again he resembled her father, but was at the same time curiously woven into nature, as in the following dream: *Her father (who in reality was of small stature) was standing with her on a hill that was covered with wheat-fields. She was quite tiny beside him, and he seemed to her like a*

giant. He lifted her up from the ground and held her in his arms like a little child. The wind swept over the wheat-fields, and as the wheat swayed in the wind, he rocked her in his arms.

[212] From this dream and from others like it I could discern various things. Above all I got the impression that her unconscious was holding unshakably to the idea of my being the father-lover, so that the fatal tie we were trying to undo appeared to be doubly strengthened. Moreover one could hardly avoid seeing that the unconscious placed a special emphasis on the supernatural, almost “divine” nature of the father-lover, thus accentuating still further the over-valuation occasioned by the transference. I therefore asked myself whether the patient had still not understood the wholly fantastic character of her transference, or whether perhaps the unconscious could never be reached by understanding at all, but must blindly and idiotically pursue some nonsensical chimera. Freud’s idea that the unconscious can “do nothing but wish,” Schopenhauer’s blind and aimless Will, the gnostic demiurge who in his vanity deems himself perfect and then in the blindness of his limitation creates something lamentably imperfect—all these pessimistic suspicions of an essentially negative background to the world and the soul came threateningly near. And there would indeed be nothing to set against this except a well-meaning “you ought,” reinforced by a stroke of the axe that would cut down the whole phantasmagoria for good and all.

[213] But, as I turned the dreams over and over in my mind, there dawned on me another possibility. I said to myself: it cannot be denied that the dreams continue to speak in the same old metaphors with which our conversations have made the patient as well as myself sickeningly familiar. But the patient has an undoubted understanding of her transference fantasy. She knows that I appear to her as a semi-divine father-lover, and she can, at least intellectually, distinguish this from my factual reality. Therefore the dreams are obviously reiterating the conscious standpoint minus the conscious criticism, which they completely ignore. They reiterate the conscious contents, not *in toto*, but insist on the fantastic standpoint as opposed to “sound common sense.”

[214] I naturally asked myself what was the source of this obstinacy and what was its purpose? That it must have some purposive meaning I was convinced, for there is no truly living thing that does not have a final meaning, that can in other words be explained as a mere left-over from antecedent facts. But the energy of the transference is so strong that it gives one the impression of a vital instinct. That being so, what is the purpose of such fantasies? A careful examination and analysis of the dreams, especially of the one just quoted, revealed a very marked tendency—in contrast to conscious criticism, which always seeks to reduce things to human

proportions—to endow the person of the doctor with superhuman attributes. He had to be gigantic, primordial, huger than the father, like the wind that sweeps over the earth—was he then to be made into a god? Or, I said to myself, was it rather the case that the unconscious was trying to *create* a god out of the person of the doctor, as it were to free a vision of God from the veils of the personal, so that the transference to the person of the doctor was no more than a misunderstanding on the part of the conscious mind, a stupid trick played by “sound common sense”? Was the urge of the unconscious perhaps only apparently reaching out towards the person, but in a deeper sense towards a god? Could the longing for a god be a *passion* welling up from our darkest, instinctual nature, a passion unswayed by any outside influences, deeper and stronger perhaps than the love for a human person? Or was it perhaps the highest and truest meaning of that inappropriate love we call “transference,” a little bit of real *Gottesminne*, that has been lost to consciousness ever since the fifteenth century?

[215] No one will doubt the reality of a passionate longing for a human person; but that a fragment of religious psychology, an historical anachronism, indeed something of a medieval curiosity—we are reminded of Mechtild of Magdeburg—should come to light as an immediate living reality in the middle of the consulting-room, and be expressed in the prosaic figure of the doctor, seems almost too fantastic to be taken seriously.

[216] A genuinely scientific attitude must be unprejudiced. The sole criterion for the validity of an hypothesis is whether or not it possesses an heuristic—i.e., explanatory—value. The question now is, can we regard the possibilities set forth above as a valid hypothesis? There is no *a priori* reason why it should not be just as possible that the unconscious tendencies have a goal beyond the human person, as that the unconscious can “do nothing but wish.” Experience alone can decide which is the more suitable hypothesis. This new hypothesis was not entirely plausible to my very critical patient. The earlier view that I was the father-lover, and as such presented an ideal solution of the conflict, was incomparably more attractive to her way of feeling. Nevertheless her intellect was sufficiently keen to appreciate the theoretical possibility of the new hypothesis. Meanwhile the dreams continued to disintegrate the person of the doctor and swell him to ever vaster proportions. Concurrently with this there now occurred something which at first I alone perceived, and with the utmost astonishment, namely a kind of subterranean undermining of the transference. Her relations with a certain friend deepened perceptibly, notwithstanding the fact that consciously she still clung to the transference. So that when the time came for leaving me, it was no catastrophe, but a perfectly reasonable parting. I had the privilege of being the only witness during the process of severance. I saw how the transpersonal control-point developed—I cannot call it anything else—a *guiding function* and step by step gathered to itself all the former personal over-valuations;

how, with this afflux of energy, it gained influence over the resisting conscious mind without the patient's consciously noticing what was happening. From this I realized that the dreams were not just fantasies, but self-representations of unconscious developments which allowed the psyche of the patient gradually to grow out of the pointless personal tie.¹

[217] This change took place, as I showed, through the unconscious development of a transpersonal control-point; a virtual goal, as it were, that expressed itself symbolically in a form which can only be described as a vision of God. The dreams swelled the human person of the doctor to superhuman proportions, making him a gigantic primordial father who is at the same time the wind, and in whose protecting arms the dreamer rests like an infant. If we try to make the patient's conscious, and traditionally Christian, idea of God responsible for the divine image in the dreams, we would still have to lay stress on the distortion. In religious matters the patient had a critical and agnostic attitude, and her idea of a possible deity had long since passed into the realm of the inconceivable, i.e., had dwindled into a complete abstraction. In contrast to this, the god-image of the dreams corresponded to the archaic conception of a nature daemon, something like Wotan. *Θεὸς τὸ πνεῦμα*, 'God is spirit,' is here translated back into its original form where *πνεῦμα* means 'wind': God is the wind, stronger and mightier than man, an invisible breath-spirit. As in Hebrew *ruah*, so in Arabic *ruh* means breath and spirit.² Out of the purely personal form the dreams develop an archaic god-image that is infinitely far from the conscious idea of God. It might be objected that this is simply an infantile image, a childhood memory. I would have no quarrel with this assumption if we were dealing with an old man sitting on a golden throne in heaven. But there is no trace of any sentimentality of that kind; instead, we have a primordial idea that can correspond only to an archaic mentality.

[218] These primordial ideas, of which I have given a great many examples in my *Symbols of Transformation*, oblige one to make, in regard to unconscious material, a distinction of quite a different character from that between "preconscious" and "unconscious" or "subconscious" and "unconscious." The justification for these distinctions need not be discussed here. They have their specific value and are worth elaborating further as points of view. The fundamental distinction which experience has forced upon me claims to be no more than that. It should be evident from the foregoing that we have to distinguish in the unconscious a layer which we may call the *personal unconscious*. The materials contained in this layer are of a personal nature in so far as they have the character partly of acquisitions derived from the individual's life and partly of psychological factors which could just as well be conscious. It can readily be understood that incompatible psychological elements are liable to repression and therefore become unconscious. But on the other hand this implies the possibility of making and keeping the repressed contents conscious once

they have been recognized. We recognize them as personal contents because their effects, or their partial manifestation, or their source can be discovered in our personal past. They are the integral components of the personality, they belong to its inventory, and their loss to consciousness produces an inferiority in one respect or another—an inferiority, moreover, that has the psychological character not so much of an organic lesion or an inborn defect as of a lack which gives rise to a feeling of moral resentment. The sense of moral inferiority always indicates that the missing element is something which, to judge by this feeling about it, really ought not be missing, or which could be made conscious if only one took sufficient trouble. The moral inferiority does not come from a collision with the generally accepted and, in a sense, arbitrary moral law, but from the conflict with one's own self which, for reasons of psychic equilibrium, demands that the deficit be redressed. Whenever a sense of moral inferiority appears, it indicates not only a need to assimilate an unconscious component, but also the possibility of such assimilation. In the last resort it is a man's moral qualities which force him, either through direct recognition of the need or indirectly through a painful neurosis, to assimilate his unconscious self and to keep himself fully conscious. Whoever progresses along this road of self-realization must inevitably bring into consciousness the contents of the personal unconscious, thus enlarging the scope of his personality. I should add at once that this enlargement has to do primarily with one's moral consciousness, one's knowledge of oneself, for the unconscious contents that are released and brought into consciousness by analysis are usually unpleasant—which is precisely why these wishes, memories, tendencies, plans, etc. were repressed. These are the contents that are brought to light in much the same way by a thorough confession, though to a much more limited extent. The rest comes out as a rule in dream analysis. It is often very interesting to watch how the dreams fetch up the essential points, bit by bit and with the nicest choice. The total material that is added to consciousness causes a considerable widening of the horizon, a deepened self-knowledge which, more than anything else, one would think, is calculated to humanize a man and make him modest. But even self-knowledge, assumed by all wise men to be the best and most efficacious, has different effects on different characters. We make very remarkable discoveries in this respect in practical analysis, but I shall deal with this question in the next chapter.

[219] As my example of the archaic idea of God shows, the unconscious seems to contain other things besides personal acquisitions and belongings. My patient was quite unconscious of the derivation of "spirit" from "wind," or of the parallelism between the two. This content was not the product of her thinking, nor had she ever been taught it. The critical passage in the New Testament was inaccessible to her—*τὸ πνεῦμα πνεῖ ὅπου θέλει*—since she knew no Greek. If we must take it as a wholly personal acquisition, it might be a case of so-called cryptomnesia,³ the unconscious

recollection of a thought which the dreamer had once read somewhere. I have nothing against such a possibility in this particular case; but I have seen a sufficient number of other cases—many of them are to be found in the book mentioned above—where cryptomnesia can be excluded with certainty. Even if it were a case of cryptomnesia, which seems to me very improbable, we should still have to explain what the predisposition was that caused just this image to be retained and later, as Semon puts it, “ecphorated” (*ἐκφορεῖν*, Latin *efferre*, ‘to produce’). In any case, cryptomnesia or no cryptomnesia, we are dealing with a genuine and thoroughly primitive god-image that grew up in the unconscious of a civilized person and produced a living effect—an effect which might well give the psychologist of religion food for reflection. There is nothing about this image that could be called personal: it is a wholly collective image, the ethnic origin of which has long been known to us. Here is an historical image of world-wide distribution that has come into existence again through a natural psychic function. This is not so very surprising, since my patient was born into the world with a human brain which presumably still functions today much as it did of old. We are dealing with a reactivated *archetype*, as I have elsewhere called these primordial images.⁴ These ancient images are restored to life by the primitive, analogical mode of thinking peculiar to dreams. It is not a question of inherited ideas, but of inherited thought-patterns.⁵

[220] In view of these facts we must assume that the unconscious contains not only personal, but also impersonal collective components in the form of inherited categories⁶ or archetypes. I have therefore advanced the hypothesis that at its deeper levels the unconscious possesses collective contents in a relatively active state. That is why I speak of a collective unconscious.

II

PHENOMENA RESULTING FROM THE ASSIMILATION OF THE UNCONSCIOUS

[221] The process of assimilating the unconscious leads to some very remarkable phenomena. It produces in some patients an unmistakable and often unpleasant increase of self-confidence and conceit: they are full of themselves, they know everything, they imagine themselves to be fully informed of everything concerning their unconscious, and are persuaded that they understand perfectly everything that comes out of it. At every interview with the doctor they get more and more above themselves. Others on the contrary feel themselves more and more crushed under the contents of the unconscious, they lose their self-confidence and abandon themselves with dull resignation to all the extraordinary things that the unconscious produces. The former, overflowing with feelings of their own importance, assume a responsibility for the unconscious that goes much too far, beyond all reasonable bounds; the others finally give up all sense of responsibility, overcome by a sense of the powerlessness of the ego against the fate working through the unconscious.

[222] If we analyse these two modes of reaction more deeply, we find that the optimistic self-confidence of the first conceals a profound sense of impotence, for which their conscious optimism acts as an unsuccessful compensation; while the pessimistic resignation of the others masks a defiant will to power, far surpassing in cocksureness the conscious optimism of the first type.

[223] With these two modes of reaction I have sketched only two crude extremes. A finer shading would have been truer to reality. As I have said elsewhere, every analysand starts by unconsciously misusing his newly won knowledge in the interests of his abnormal, neurotic attitude, unless he is sufficiently freed from his symptoms in the early stages to be able to dispense with further treatment altogether. A very important contributory factor is that in the early stages everything is still understood on the objective level, i.e., without distinction between imago and object, so that everything is referred directly to the object. Hence the man for whom "other people" are the objects of prime importance will conclude from any self-knowledge he may have imbibed at this stage of the analysis: "Aha! so that is what other people are like!" He will therefore feel it his duty, according to his nature, tolerant or otherwise, to enlighten the world. But the other man, who feels himself to be more the object of his fellows than their subject, will be weighed down by this self-knowledge and become correspondingly depressed. (I am naturally leaving out of account those

numerous and more superficial natures who experience these problems only by the way.) In both cases the relation to the object is reinforced—in the first case in an active, in the second case in a reactive sense. The collective element is markedly accentuated. The one extends the sphere of his action, the other the sphere of his suffering.

[224] Adler has employed the term “godlikeness” to characterize certain basic features of neurotic power psychology. If I likewise borrow the same term from *Faust*, I use it here more in the sense of that well-known passage where Mephisto writes “Eritis sicut Deus, scientes bonum et malum” in the student’s album, and makes the following aside:

Just follow the old advice
And my cousin the snake.
There’ll come a time when your godlikeness
Will make you quiver and quake.¹

The godlikeness evidently refers to knowledge, the knowledge of good and evil. The analysis and conscious realization of unconscious contents engender a certain superior tolerance, thanks to which even relatively indigestible portions of one’s unconscious characterology can be accepted. This tolerance may look very wise and superior, but often it is no more than a grand gesture that brings all sorts of consequences in its train. Two spheres have been brought together which before were kept anxiously apart. After considerable resistances have been overcome, the union of opposites is successfully achieved, at least to all appearances. The deeper understanding thus gained, the juxtaposition of what was before separated, and hence the apparent overcoming of the moral conflict, give rise to a feeling of superiority that may well be expressed by the term “godlikeness.” But this same juxtaposition of good and evil can have a very different effect on a different kind of temperament. Not everyone will feel himself a superman, holding in his hands the scales of good and evil. It may also seem as though he were a helpless object caught between hammer and anvil; not in the least a Hercules at the parting of the ways, but rather a rudderless ship buffeted between Scylla and Charybdis. For without knowing it, he is caught up in perhaps the greatest and most ancient of human conflicts, experiencing the throes of eternal principles in collision. Well might he feel himself like a Prometheus chained to the Caucasus, or as one crucified. This would be a “godlikeness” in suffering. Godlikeness is certainly not a scientific concept, although it aptly characterizes the psychological state in question. Nor do I imagine that every reader will immediately grasp the peculiar state of mind implied by “godlikeness.” The term belongs too exclusively to the sphere of *belles-lettres*. So I should probably be better advised to give a more circumspect description of this state. The insight and understanding, then, gained by the analysis and usually reveal much to him that was before unconscious. He naturally applies this knowledge to his environment; in consequence he sees, or thinks he sees, many things that before were invisible. Since his knowledge was helpful to him, he readily assumes that it would be useful also to others. In this way he is liable to become arrogant; it may be well meant, but it is nonetheless annoying to other people. He feels as though he possesses a key that opens many, perhaps even all, doors. Psychoanalysis itself has this same bland unconsciousness of its limitations, as can clearly be seen from the way it meddles with works of art.

[225] Since human nature is not compounded wholly of light, but also abounds in shadows, the insight gained in practical analysis is often somewhat painful, the more so if, as is generally the case, one has previously neglected the other side. Hence there are people who take their newly won insight very much to heart, far too much in fact, quite forgetting that they are not unique in having a shadow-side. They allow themselves to get unduly depressed and are then inclined to doubt everything, finding nothing right anywhere. That is why many excellent analysts with very good ideas can never bring themselves to publish them, because the psychic problem, as they see it, is so overwhelmingly vast that it seems to them almost impossible to tackle it scientifically. One man's optimism makes him overweening, while another's pessimism makes him over-anxious and despondent. Such are the forms which the great conflict takes when reduced to a smaller scale. But even in these lesser proportions the essence of the conflict is easily recognized: the arrogance of the one and the despondency of the other share a common uncertainty as to their boundaries. The one is excessively expanded, the other excessively contracted. Their individual boundaries are in some way obliterated. If we now consider the fact that, as a result of psychic compensation, great humility stands very close to pride, and that "pride goeth before a fall," we can easily discover behind the haughtiness certain traits of an anxious sense of inferiority. In fact we shall see clearly how his uncertainty forces the enthusiast to puff up his truths, of which he feels none too sure, and to win proselytes to his side in order that his followers may prove to himself the value and trustworthiness of his own convictions. Nor is he altogether so happy in his fund of knowledge as to be able to hold out alone; at bottom he feels isolated by it, and the secret fear of being left alone with it induces him to trot out his opinions and interpretations in and out of season, because only when convincing someone else does he feel safe from gnawing doubts.

[226] It is just the reverse with our despondent friend. The more he withdraws and hides himself, the greater becomes his secret need to be understood and recognized. Although he speaks of his inferiority he does not really believe it. There arises within him a defiant conviction of his unrecognized merits, and in consequence he is sensitive to the slightest disapprobation, always wearing the stricken air of one who is misunderstood and deprived of his rightful due. In this way he nurses a morbid pride and an insolent discontent—which is the very last thing he wants and for which his environment has to pay all the more dearly.

[227] Both are at once too small and too big; their individual mean, never very secure, now becomes shakier than ever. It sounds almost grotesque to describe such a state as "godlike." But since each in his way steps beyond his human proportions, both of them are a little "superhuman" and therefore, figuratively speaking, godlike. If we wish to avoid the use of this metaphor, I would suggest that we speak instead of

“psychic inflation.” The term seems to me appropriate in so far as the state we are discussing involves an extension of the personality beyond individual limits, in other words, a state of being puffed up. In such a state a man fills a space which normally he cannot fill. He can only fill it by appropriating to himself contents and qualities which properly exist for themselves alone and should therefore remain outside our bounds. What lies outside ourselves belongs either to someone else, or to everyone, or to no one. Since psychic inflation is by no means a phenomenon induced exclusively by analysis, but occurs just as often in ordinary life, we can investigate it equally well in other cases. A very common instance is the humourless way in which many men identify themselves with their business or their titles. The office I hold is certainly my special activity; but it is also a collective factor that has come into existence historically through the cooperation of many people and whose dignity rests solely on collective approval. When, therefore, I identify myself with my office or title, I behave as though I myself were the whole complex of social factors of which that office consists, or as though I were not only the bearer of the office, but also and at the same time the approval of society. I have made an extraordinary extension of myself and have usurped qualities which are not in me but outside me. *L'état c'est moi* is the motto for such people.

[228] In the case of inflation through knowledge we are dealing with something similar in principle, though psychologically more subtle. Here it is not the dignity of an office that causes the inflation, but very significant fantasies. I will explain what I mean by a practical example, choosing a mental case whom I happened to know personally and who is also mentioned in a publication by Maeder.² The case is characterized by a high degree of inflation. (In mental cases we can observe all the phenomena that are present only fleetingly in normal people, in a cruder and enlarged form.)³ The patient suffered from paranoid dementia with megalomania. He was in telephonic communication with the Mother of God and other great ones. In human reality he was a wretched locksmith's apprentice who at the age of nineteen had become incurably insane. He had never been blessed with intelligence, but he had, among other things, hit upon the magnificent idea that the world was his picture-book, the pages of which he could turn at will. The proof was quite simple: he had only to turn round, and there was a new page for him to see.

[229] This is Schopenhauer's "world as will and idea" in unadorned, primitive concreteness of vision. A shattering idea indeed, born of extreme alienation and seclusion from the world, but so naïvely and simply expressed that at first one can only smile at the grotesqueness of it. And yet this primitive way of looking lies at the very heart of Schopenhauer's brilliant vision of the world. Only a genius or a madman could so disentangle himself from the bonds of reality as to see the world as his picture-book. Did the patient actually work out or build up such a vision, or did it

just befall him? Or did he perhaps fall into it? His pathological disintegration and inflation point rather to the latter. It is no longer *he* that thinks and speaks, but *it* thinks and speaks within him: he hears voices. So the difference between him and Schopenhauer is that, in him, the vision remained at the stage of a mere spontaneous growth, while Schopenhauer abstracted it and expressed it in language of universal validity. In so doing he raised it out of its subterranean beginnings into the clear light of collective consciousness. But it would be quite wrong to suppose that the patient's vision had a purely personal character or value, as though it were something that belonged to him. If that were so, he would be a philosopher. A man is a philosopher of genius only when he succeeds in transmuting the primitive and merely natural vision into an abstract idea belonging to the common stock of consciousness. This achievement, and this alone, constitutes his personal value, for which he may take credit without necessarily succumbing to inflation. But the sick man's vision is an impersonal value, a natural growth against which he is powerless to defend himself, by which he is actually swallowed up and "wafted" clean out of the world. Far from *his* mastering the idea and expanding *it* into a philosophical view of the world, it is truer to say that the undoubted grandeur of his vision blew *him* up to pathological proportions. The personal value lies entirely in the philosophical achievement, not in the primary vision. To the philosopher as well this vision comes as so much increment, and is simply a part of the common property of mankind, in which, in principle, everyone has a share. The golden apples drop from the same tree, whether they be gathered by an imbecile locksmith's apprentice or by a Schopenhauer.

[230] There is, however, yet another thing to be learnt from this example, namely that these transpersonal contents are not just inert or dead matter that can be annexed at will. Rather they are living entities which exert an attractive force upon the conscious mind. Identification with one's office or one's title is very attractive indeed, which is precisely why so many men are nothing more than the decorum accorded to them by society. In vain would one look for a personality behind the husk. Underneath all the padding one would find a very pitiable little creature. That is why the office—or whatever this outer husk may be—is so attractive: it offers easy compensation for personal deficiencies.

[231] Outer attractions, such as offices, titles, and other social regalia are not the only things that cause inflation. These are simply impersonal quantities that lie outside in society, in the collective consciousness. But just as there is a society outside the individual, so there is a collective psyche outside the personal psyche, namely the collective unconscious, concealing, as the above example shows, elements that are no whit less attractive. And just as a man may suddenly step into the world on his professional dignity ("Messieurs, à présent je suis Roy"), so another may disappear out of it equally suddenly when it is his lot to behold one of those mighty images that

put a new face upon the world. These are the magical *représentations collectives* which underlie the slogan, the catchword, and, on a higher level, the language of the poet and mystic. I am reminded of another mental case who was neither a poet nor anything very outstanding, just a naturally quiet and rather sentimental youth. He had fallen in love with a girl and, as so often happens, had failed to ascertain whether his love was requited. His primitive *participation mystique* took it for granted that his agitations were plainly the agitations of the other, which on the lower levels of human psychology is naturally very often the case. Thus he built up a sentimental love-fantasy which precipitately collapsed when he discovered that the girl would have none of him. He was so desperate that he went straight to the river to drown himself. It was late at night, and the stars gleamed up at him from the dark water. It seemed to him that the stars were swimming two by two down the river, and a wonderful feeling came over him. He forgot his suicidal intentions and gazed fascinated at the strange, sweet drama. And gradually he became aware that every star was a face, and that all these pairs were lovers, who were carried along locked in a dreaming embrace. An entirely new understanding came to him: all had changed—his fate, his disappointment, even his love, receded and fell away. The memory of the girl grew distant, blurred; but instead, he felt with complete certainty that untold riches were promised him. He knew that an immense treasure lay hidden for him in the neighbouring observatory. The result was that he was arrested by the police at four o'clock in the morning, attempting to break into the observatory.

[232] What had happened? His poor head had glimpsed a Dantesque vision, whose loveliness he could never have grasped had he read it in a poem. But he saw it, and it transformed him. What had hurt him most was now far away; a new and undreamed-of world of stars, tracing their silent courses far beyond this grievous earth, had opened out to him the moment he crossed “Proserpine’s threshold.” The intuition of untold wealth—and could any fail to be touched by this thought?—came to him like a revelation. For his poor turnip-head it was too much. He did not drown in the river, but in an eternal image, and its beauty perished with him.

[233] Just as one man may disappear in his social role, so another may be engulfed in an inner vision and be lost to his surroundings. Many fathomless transformations of personality, like sudden conversions and other far-reaching changes of mind, originate in the attractive power of a collective image,⁴ which, as the present example shows, can cause such a high degree of inflation that the entire personality is disintegrated. This disintegration is a mental disease, of a transitory or a permanent nature, a “splitting of the mind” or “schizophrenia,” in Bleuler’s term.⁵ The pathological inflation naturally depends on some innate weakness of the personality against the autonomy of collective unconscious contents.

[234] We shall probably get nearest to the truth if we think of the conscious and personal psyche as resting upon the broad basis of an inherited and universal psychic disposition which is as such unconscious, and that our personal psyche bears the same relation to the collective psyche as the individual to society.

[235] But equally, just as the individual is not merely a unique and separate being, but is also a social being, so the human psyche is not a self-contained and wholly individual phenomenon, but also a collective one. And just as certain social functions or instincts are opposed to the interests of single individuals, so the human psyche exhibits certain functions or tendencies which, on account of their collective nature, are opposed to individual needs. The reason for this is that every man is born with a highly differentiated brain and is thus assured of a wide range of mental functioning which is neither developed ontogenetically nor acquired. But, to the degree that human brains are uniformly differentiated, the mental functioning thereby made possible is also collective and universal. This explains, for example, the interesting fact that the unconscious processes of the most widely separated peoples and races show a quite remarkable correspondence, which displays itself, among other things, in the extraordinary but well-authenticated analogies between the forms and motifs of autochthonous myths. The universal similarity of human brains leads to the universal possibility of a uniform mental functioning. This functioning is the *collective psyche*. Inasmuch as there are differentiations corresponding to race, tribe, and even family, there is also a collective psyche limited to race, tribe, and family over and above the “universal” collective psyche. To borrow an expression from Pierre Janet,⁶ the collective psyche comprises the *parties inférieures* of the psychic functions, that is to say those deep-rooted, well-nigh automatic portions of the individual psyche which are inherited and are to be found everywhere, and are thus impersonal or suprapersonal. Consciousness plus the personal unconscious constitutes the *parties supérieures* of the psychic functions, those portions, therefore, that are developed ontogenetically and acquired. Consequently, the individual who annexes the unconscious heritage of the collective psyche to what has accrued to him in the course of his ontogenetic development, as though it were part of the latter, enlarges the scope of his personality in an illegitimate way and suffers the consequences. In so far as the collective psyche comprises the *parties inférieures* of the psychic functions and thus forms the basis of every personality, it has the effect of crushing and devaluing the personality. This shows itself either in the aforementioned stifling of self-confidence or else in an unconscious heightening of the ego’s importance to the point of a pathological will to power.

[236] By raising the personal unconscious to consciousness, the analysis makes the subject aware of things which he is generally aware of in others, but never in himself. This discovery makes him therefore less individually unique, and more collective.

His collectivization is not always a step to the bad; it may sometimes be a step to the good. There are people who repress their good qualities and consciously give free rein to their infantile desires. The lifting of personal repressions at first brings purely personal contents into consciousness; but attached to them are the collective elements of the unconscious, the ever-present instincts, qualities, and ideas (images) as well as all those “statistical” quotas of average virtue and average vice which we recognize when we say, “Everyone has in him something of the criminal, the genius, and the saint.” Thus a living picture emerges, containing pretty well everything that moves upon the checkerboard of the world, the good and the bad, the fair and the foul. A sense of solidarity with the world is gradually built up, which is felt by many natures as something very positive and in certain cases actually is the deciding factor in the treatment of neurosis. I have myself seen cases who, in this condition, managed for the first time in their lives to arouse love, and even to experience it themselves; or, by daring to leap into the unknown, they get involved in the very fate for which they were suited. I have seen not a few who, taking this condition as final, remained for years in a state of enterprising euphoria. I have often heard such cases referred to as shining examples of analytical therapy. But I must point out that cases of this euphoric and enterprising type are so utterly lacking in differentiation from the world that nobody could pass them as fundamentally cured. To my way of thinking they are as much cured as not cured. I have had occasion to follow up the lives of such patients, and it must be owned that many of them showed symptoms of maladjustment, which, if persisted in, gradually leads to the sterility and monotony so characteristic of those who have divested themselves of their egos. Here too I am speaking of the border-line cases, and not of the less valuable, normal, average folk for whom the question of adaptation is more technical than problematical. If I were more of a therapist than an investigator, I would naturally be unable to check a certain optimism of judgment, because my eyes would then be glued to the number of cures. But my conscience as an investigator is concerned not with quantity but with quality. Nature is aristocratic, and one person of value outweighs ten lesser ones. My eye followed the valuable people, and from them I learned the dubiousness of the results of a purely personal analysis, and also to understand the reasons for this dubiousness.

[237] If, through assimilation of the unconscious, we make the mistake of including the collective psyche in the inventory of personal psychic functions, a dissolution of the personality into its paired opposites inevitably follows. Besides the pair of opposites already discussed, megalomania and the sense of inferiority, which are so painfully evident in neurosis, there are many others, from which I will single out only the specifically moral pair of opposites, namely good and evil. The specific virtues and vices of humanity are contained in the collective psyche like everything else. One

man arrogates collective virtue to himself as his personal merit, another takes collective vice as his personal guilt. Both are as illusory as the megalomania and the inferiority, because the imaginary virtues and the imaginary wickednesses are simply the moral pair of opposites contained in the collective psyche, which have become perceptible or have been rendered conscious artificially. How much these paired opposites are contained in the collective psyche is exemplified by primitives: one observer will extol the greatest virtues in them, while another will record the very worst impressions of the selfsame tribe. For the primitive, whose personal differentiation is, as we know, only just beginning, both judgments are true, because his psyche is essentially collective and therefore for the most part unconscious. He is still more or less identical with the collective psyche, and for that reason shares equally in the collective virtues and vices, without any personal attribution and without inner contradiction. The contradiction arises only when the personal development of the psyche begins, and when reason discovers the irreconcilable nature of the opposites. The consequence of this discovery is the conflict of repression. We want to be good, and therefore must repress evil; and with that the paradise of the collective psyche comes to an end. Repression of the collective psyche was absolutely necessary for the development of personality. In primitives, development of personality, or more accurately, development of the person, is a question of magical prestige. The figure of the medicine-man or chief leads the way: both make themselves conspicuous by the singularity of their ornaments and their mode of life, expressive of their social roles. The singularity of his outward tokens marks the individual off from the rest, and the segregation is still further enhanced by the possession of special ritual secrets. By these and similar means the primitive creates around him a shell, which might be called a persona (mask). Masks, as we know, are actually used among primitives in totem ceremonies—for instance, as a means of enhancing or changing the personality. In this way the outstanding individual is apparently removed from the sphere of the collective psyche, and to the degree that he succeeds in identifying himself with his persona, he actually is removed. This removal means magical prestige. One could easily assert that the impelling motive in this development is the will to power. But that would be to forget that the building up of prestige is always a product of collective compromise: not only must there be one who wants prestige, there must also be a public seeking somebody on whom to confer prestige. That being so, it would be incorrect to say that a man creates prestige for himself out of his individual will to power; it is on the contrary an entirely collective affair. Since society as a whole needs the magically effective figure, it uses this need of the will to power in the individual, and the will to submit in the mass, as a vehicle, and thus brings about the creation of personal prestige. The latter is a phenomenon which, as the history of political institutions shows, is of the utmost importance for the comity of nations.

[238] The importance of personal prestige can hardly be overestimated, because the possibility of regressive dissolution in the collective psyche is a very real danger, not only for the outstanding individual but also for his followers. This possibility is most likely to occur when the goal of prestige—universal recognition—has been reached. The person then becomes a collective truth, and that is always the beginning of the end. To gain prestige is a positive achievement not only for the outstanding individual but also for the clan. The individual distinguishes himself by his deeds, the many by their renunciation of power. So long as this attitude needs to be fought for and defended against hostile influences, the achievement remains positive; but as soon as there are no more obstacles and universal recognition has been attained, prestige loses its positive value and usually becomes a dead letter. A schismatic movement then sets in, and the whole process begins again from the beginning.

[239] Because personality is of such paramount importance for the life of the community, everything likely to disturb its development is sensed as a danger. But the greatest danger of all is the premature dissolution of prestige by an invasion of the collective psyche. Absolute secrecy is one of the best known primitive means of exorcising this danger. Collective thinking and feeling and collective effort are far less of a strain than individual functioning and effort; hence there is always a great temptation to allow collective functioning to take the place of individual differentiation of the personality. Once the personality has been differentiated and safeguarded by magical prestige, its levelling down and eventual dissolution in the collective psyche (e.g., Peter's denial) occasion a "loss of soul" in the individual, because an important personal achievement has been either neglected or allowed to slip into regression. For this reason taboo infringements are followed by Draconian punishments altogether in keeping with the seriousness of the situation. So long as we regard these things from the causal point of view, as mere historical survivals and metastases of the incest taboo,⁷ it is impossible to understand what all these measures are for. If, however, we approach the problem from the teleological point of view, much that was quite inexplicable becomes clear.

[240] For the development of personality, then, strict differentiation from the collective psyche is absolutely necessary, since partial or blurred differentiation leads to an immediate melting away of the individual in the collective. There is now a danger that in the analysis of the unconscious the collective and the personal psyche may be fused together, with, as I have intimated, highly unfortunate results. These results are injurious both to the patient's life-feeling and to his fellow men, if he has any influence at all on his environment. Through his identification with the collective psyche he will infallibly try to force the demands of his unconscious upon others, for identity with the collective psyche always brings with it a feeling of universal validity—"godlikeness"—which completely ignores all differences in the personal

psyche of his fellows. (The feeling of universal validity comes, of course, from the universality of the collective psyche.) A collective attitude naturally presupposes this same collective psyche in others. But that means a ruthless disregard not only of individual differences but also of differences of a more general kind within the collective psyche itself, as for example differences of race.⁸ This disregard for individuality obviously means the suffocation of the single individual, as a consequence of which the element of differentiation is obliterated from the community. The element of differentiation is the individual. All the highest achievements of virtue, as well as the blackest villainies, are individual. The larger a community is, and the more the sum total of collective factors peculiar to every large community rests on conservative prejudices detrimental to individuality, the more will the individual be morally and spiritually crushed, and, as a result, the one source of moral and spiritual progress for society is choked up. Naturally the only thing that can thrive in such an atmosphere is sociality and whatever is collective in the individual. Everything individual in him goes under, i.e., is doomed to repression. The individual elements lapse into the unconscious, where, by the law of necessity, they are transformed into something essentially baleful, destructive, and anarchical. Socially, this evil principle shows itself in the spectacular crimes—regicide and the like—perpetrated by certain prophetically-inclined individuals; but in the great mass of the community it remains in the background, and only manifests itself indirectly in the inexorable moral degeneration of society. It is a notorious fact that the morality of society as a whole is in inverse ratio to its size; for the greater the aggregation of individuals, the more the individual factors are blotted out, and with them morality, which rests entirely on the moral sense of the individual and the freedom necessary for this. Hence every man is, in a certain sense, unconsciously a worse man when he is in society than when acting alone; for he is carried by society and to that extent relieved of his individual responsibility. Any large company composed of wholly admirable persons has the morality and intelligence of an unwieldy, stupid, and violent animal. The bigger the organization, the more unavoidable is its immorality and blind stupidity (*Senatus bestia, senatores boni viri*). Society, by automatically stressing all the collective qualities in its individual representatives, puts a premium on mediocrity, on everything that settles down to vegetate in an easy, irresponsible way. Individuality will inevitably be driven to the wall. This process begins in school, continues at the university, and rules all departments in which the State has a hand. In a small social body, the individuality of its members is better safeguarded, and the greater is their relative freedom and the possibility of conscious responsibility. Without freedom there can be no morality. Our admiration for great organizations dwindles when once we become aware of the other side of the wonder: the tremendous piling up and accentuation of all that is primitive in man, and the unavoidable destruction of his individuality in the interests of the monstrosity that

every great organization in fact is. The man of today, who resembles more or less the collective ideal, has made his heart into a den of murderers, as can easily be proved by the analysis of his unconscious, even though he himself is not in the least disturbed by it. And in so far as he is normally “adapted”⁹ to his environment, it is true that the greatest infamy on the part of his group will not disturb him, so long as the majority of his fellows steadfastly believe in the exalted morality of their social organization. Now, all that I have said here about the influence of society upon the individual is identically true of the influence of the collective unconscious upon the individual psyche. But, as is apparent from my examples, the latter influence is as invisible as the former is visible. Hence it is not surprising that its inner effects are not understood, and that those to whom such things happen are called pathological freaks and treated as crazy. If one of them happened to be a real genius, the fact would not be noted until the next generation or the one after. So obvious does it seem to us that a man should drown in his own dignity, so utterly incomprehensible that he should seek anything other than what the mob wants, and that he should vanish permanently from view in this other. One could wish both of them a sense of humour, that—according to Schopenhauer—truly “divine” attribute of man which alone befits him to maintain his soul in freedom.

[241] The collective instincts and fundamental forms of thinking and feeling whose activity is revealed by the analysis of the unconscious constitute, for the conscious personality, an acquisition which it cannot assimilate without considerable disturbance. It is therefore of the utmost importance in practical treatment to keep the integrity of the personality constantly in mind. For, if the collective psyche is taken to be the personal possession of the individual, it will result in a distortion or an overloading of the personality which is very difficult to deal with. Hence it is imperative to make a clear distinction between personal contents and those of the collective psyche. This distinction is far from easy, because the personal grows out of the collective psyche and is intimately bound up with it. So it is difficult to say exactly what contents are to be called personal and what collective. There is no doubt, for instance, that archaic symbolisms such as we frequently find in fantasies and dreams are collective factors. All basic instincts and basic forms of thinking and feeling are collective. Everything that all men agree in regarding as universal is collective, likewise everything that is universally understood, universally found, universally said and done. On closer examination one is always astonished to see how much of our so-called individual psychology is really collective. So much, indeed, that the individual traits are completely overshadowed by it. Since, however, individuation¹⁰ is an ineluctable psychological necessity, we can see from the ascendancy of the collective what very special attention must be paid to this delicate plant “individuality” if it is not to be completely smothered.

[242] Human beings have one faculty which, though it is of the greatest utility for collective purposes, is most pernicious for individuation, and that is the faculty of imitation. Collective psychology cannot dispense with imitation, for without it all mass organizations, the State and the social order, are impossible. Society is organized, indeed, less by law than by the propensity to imitation, implying equally suggestibility, suggestion, and mental contagion. But we see every day how people use, or rather abuse, the mechanism of imitation for the purpose of personal differentiation: they are content to ape some eminent personality, some striking characteristic or mode of behaviour, thereby achieving an outward distinction from the circle in which they move. We could almost say that as a punishment for this the uniformity of their minds with those of their neighbours, already real enough, is intensified into an unconscious, compulsive bondage to the environment. As a rule these specious attempts at individual differentiation stiffen into a pose, and the imitator remains at the same level as he always was, only several degrees more sterile than before. To find out what is truly individual in ourselves, profound reflection is needed; and suddenly we realize how uncommonly difficult the discovery of individuality is.

III

THE PERSONA AS A SEGMENT OF THE COLLECTIVE PSYCHE

[243] In this chapter we come to a problem which, if overlooked, is liable to cause the greatest confusion. It will be remembered that in the analysis of the personal unconscious the first things to be added to consciousness are the personal contents, and I suggested that these contents, which have been repressed but are capable of becoming conscious, should be called the *personal unconscious*. I also showed that to annex the deeper layers of the unconscious, which I have called the *collective unconscious*, produces an enlargement of the personality leading to the state of inflation. This state is reached by simply continuing the analytical work, as in the case of the young woman discussed above. By continuing the analysis we add to the personal consciousness certain fundamental, general, and impersonal characteristics of humanity, thereby bringing about the inflation¹ I have just described, which might be regarded as one of the unpleasant consequences of becoming fully conscious.

[244] From this point of view the conscious personality is a more or less arbitrary segment of the collective psyche. It consists in a sum of psychic facts that are felt to be personal. The attribute “personal” means: pertaining exclusively to this particular person. A consciousness that is purely personal stresses its proprietary and original right to its contents with a certain anxiety, and in this way seeks to create a whole. But all those contents that refuse to fit into this whole are either overlooked and forgotten or repressed and denied. This is one way of educating oneself, but it is too arbitrary and too much of a violation. Far too much of our common humanity has to be sacrificed in the interests of an ideal image into which one tries to mould oneself. Hence these purely “personal” people are always very sensitive, for something may easily happen that will bring into consciousness an unwelcome portion of their real (“individual”) character.

[245] This arbitrary segment of collective psyche—often fashioned with considerable pains—I have called the *persona*. The term *persona* is really a very appropriate expression for this, for originally it meant the mask once worn by actors to indicate the role they played. If we endeavour to draw a precise distinction between what psychic material should be considered personal, and what impersonal, we soon find ourselves in the greatest dilemma, for by definition we have to say of the persona’s contents what we have said of the impersonal unconscious, namely, that it is collective. It is only because the persona represents a more or less arbitrary and fortuitous segment of the collective psyche that we can make the mistake of

regarding it *in toto* as something individual. It is, as its name implies, only a mask of the collective psyche, a mask that *feigns individuality*, making others and oneself believe that one is individual, whereas one is simply acting a role through which the collective psyche speaks.

[246] When we analyse the persona we strip off the mask, and discover that what seemed to be individual is at bottom collective; in other words, that the persona was only a mask of the collective psyche. Fundamentally the persona is nothing real: it is a compromise between individual and society as to what a man should appear to be. He takes a name, earns a title, exercises a function, he is this or that. In a certain sense all this is real, yet in relation to the essential individuality of the person concerned it is only a secondary reality, a compromise formation, in making which others often have a greater share than he. The persona is a semblance, a two-dimensional reality, to give it a nickname.

[247] It would be wrong to leave the matter as it stands without at the same time recognizing that there is, after all, something individual in the peculiar choice and delineation of the persona, and that despite the exclusive identity of the ego-consciousness with the persona the unconscious self, one's real individuality, is always present and makes itself felt indirectly if not directly. Although the ego-consciousness is at first identical with the persona—that compromise role in which we parade before the community—yet the unconscious self can never be repressed to the point of extinction. Its influence is chiefly manifest in the special nature of the contrasting and compensating contents of the unconscious. The purely personal attitude of the conscious mind evokes reactions on the part of the unconscious, and these, together with personal repressions, contain the seeds of individual development in the guise of collective fantasies. Through the analysis of the personal unconscious, the conscious mind becomes suffused with collective material which brings with it the elements of individuality. I am well aware that this conclusion must be almost unintelligible to anyone not familiar with my views and technique, and particularly so to those who habitually regard the unconscious from the standpoint of Freudian theory. But if the reader will recall my example of the philosophy student, he can form a rough idea of what I mean. At the beginning of the treatment the patient was quite unconscious of the fact that her relation to her father was a fixation, and that she was therefore seeking a man like her father, whom she could then meet with her intellect. This in itself would not have been a mistake if her intellect had not had that peculiarly protesting character such as is unfortunately often encountered in intellectual women. Such an intellect is always trying to point out mistakes in others; it is pre-eminently critical, with a disagreeably personal undertone, yet it always wants to be considered objective. This invariably makes a man bad-tempered, particularly if, as so often happens, the criticism touches on some weak spot which,

in the interests of fruitful discussion, were better avoided. But far from wishing the discussion to be fruitful, it is the unfortunate peculiarity of this feminine intellect to seek out a man's weak spots, fasten on them, and exasperate him. This is not usually a conscious aim, but rather has the unconscious purpose of forcing a man into a superior position and thus making him an object of admiration. The man does not as a rule notice that he is having the role of the hero thrust upon him; he merely finds her taunts so odious that in future he will go a long way to avoid meeting the lady. In the end the only man who can stand her is the one who gives in at the start, and therefore has nothing wonderful about him.

[248] My patient naturally found much to reflect upon in all this, for she had no notion of the game she was playing. Moreover she still had to gain insight into the regular romance that had been enacted between her and her father ever since childhood. It would lead us too far to describe in detail how, from her earliest years, with unconscious sympathy, she had played upon the shadow-side of her father which her mother never saw, and how, far in advance of her years, she became her mother's rival. All this came to light in the analysis of the personal unconscious. Since, if only for professional reasons, I could not allow myself to be irritated, I inevitably became the hero and father-lover. The transference too consisted at first of contents from the personal unconscious. My role as a hero was just a sham, and so, as it turned me into the merest phantom, she was able to play her traditional role of the supremely wise, very grown-up, all-understanding mother-daughter-beloved—an empty role, a persona behind which her real and authentic being, her individual self, lay hidden. Indeed, to the extent that she at first completely identified herself with her role, she was altogether unconscious of her real self. She was still in her nebulous infantile world and had not yet discovered the real world at all. But as, through progressive analysis, she became conscious of the nature of her transference, the dreams I spoke of in Chapter I began to materialize. They brought up bits of the collective unconscious, and that was the end of her infantile world and of all the heroics. She came to herself and to her own real potentialities. This is roughly the way things go in most cases, if the analysis is carried far enough. That the consciousness of her individuality should coincide exactly with the reactivation of an archaic god-image is not just an isolated coincidence, but a very frequent occurrence which, in my view, corresponds to an unconscious law.

[249] After this digression, let us turn back to our earlier reflections.

[250] Once the personal repressions are lifted, the individuality and the collective psyche begin to emerge in a coalescent state, thus releasing the hitherto repressed personal fantasies. The fantasies and dreams which now appear assume a somewhat different aspect. An infallible sign of collective images seems to be the appearance of

the “cosmic” element, i.e., the images in the dream or fantasy are connected with cosmic qualities, such as temporal and spatial infinity, enormous speed and extension of movement, “astrological” associations, telluric, lunar, and solar analogies, changes in the proportions of the body, etc. The obvious occurrence of mythological and religious motifs in a dream also points to the activity of the collective unconscious. The collective element is very often announced by peculiar symptoms,² as for example by dreams where the dreamer is flying through space like a comet, or feels that he is the earth, or the sun, or a star; or else is of immense size, or dwarfishly small; or that he is dead, is in a strange place, is a stranger to himself, confused, mad, etc. Similarly, feelings of disorientation, of dizziness and the like, may appear along with symptoms of inflation.

[251] The forces that burst out of the collective psyche have a confusing and blinding effect. One result of the dissolution of the persona is a release of involuntary fantasy, which is apparently nothing else than the specific activity of the collective psyche. This activity throws up contents whose existence one had never suspected before. But as the influence of the collective unconscious increases, so the conscious mind loses its power of leadership. Imperceptibly it becomes the led, while an unconscious and impersonal process gradually takes control. Thus, without noticing it, the conscious personality is pushed about like a figure on a chess-board by an invisible player. It is this player who decides the game of fate, not the conscious mind and its plans. This is how the resolution of the transference, apparently so impossible to the conscious mind, was brought about in my earlier example.

[252] The plunge into this process becomes unavoidable whenever the necessity arises of overcoming an apparently insuperable difficulty. It goes without saying that this necessity does not occur in every case of neurosis, since perhaps in the majority the prime consideration is only the removal of temporary difficulties of adaptation. Certainly severe cases cannot be cured without a far-reaching change of character or of attitude. In by far the greater number, adaptation to external reality demands so much work that inner adaptation to the collective unconscious cannot be considered for a very long time. But when this inner adaptation becomes a problem, a strange, irresistible attraction proceeds from the unconscious and exerts a powerful influence on the conscious direction of life. The predominance of unconscious influences, together with the associated disintegration of the persona and the deposition of the conscious mind from power, constitute a state of psychic disequilibrium which, in analytical treatment, is artificially induced for the therapeutic purpose of resolving a difficulty that might block further development. There are of course innumerable obstacles that can be overcome with good advice and a little moral support, aided by goodwill and understanding on the part of the patient. Excellent curative results can be obtained in this way. Cases are not uncommon where there is no need to breathe a

word about the unconscious. But again, there are difficulties for which one can foresee no satisfactory solution. If in these cases the psychic equilibrium is not already disturbed before treatment begins, it will certainly be upset during the analysis, and sometimes without any interference by the doctor. It often seems as though these patients had only been waiting to find a trustworthy person in order to give up and collapse. Such a loss of balance is similar in principle to a psychotic disturbance; that is, it differs from the initial stages of mental illness only by the fact that it leads in the end to greater health, while the latter leads to yet greater destruction. It is a condition of panic, a letting go in face of apparently hopeless complications. Mostly it was preceded by desperate efforts to master the difficulty by force of will; then came the collapse, and the once guiding will crumbles completely. The energy thus freed disappears from consciousness and falls into the unconscious. As a matter of fact, it is at these moments that the first signs of unconscious activity appear. (I am thinking of the example of that young man who was weak in the head.) Obviously the energy that fell away from consciousness has activated the unconscious. The immediate result is a change of attitude. One can easily imagine that a stronger head would have taken that vision of the stars as a healing apparition, and would have looked upon human suffering *sub specie aeternitatis*, in which case his senses would have been restored.³

[253] Had this happened, an apparently insurmountable obstacle would have been removed. Hence I regard the loss of balance as purposive, since it replaces a defective consciousness by the automatic and instinctive activity of the unconscious, which is aiming all the time at the creation of a new balance and will moreover achieve this aim, provided that the conscious mind is capable of assimilating the contents produced by the unconscious, i.e., of understanding and digesting them. If the unconscious simply rides roughshod over the conscious mind, a psychotic condition develops. If it can neither completely prevail nor yet be understood, the result is a conflict that cripples all further advance. But with this question, namely the understanding of the collective unconscious, we come to a formidable difficulty which I have made the theme of my next chapter.

IV

NEGATIVE ATTEMPTS TO FREE THE INDIVIDUALITY FROM THE COLLECTIVE PSYCHE

a. *Regressive Restoration of the Persona*

[254] A collapse of the conscious attitude is no small matter. It always feels like the end of the world, as though everything had tumbled back into original chaos. One feels delivered up, disoriented, like a rudderless ship that is abandoned to the moods of the elements. So at least it seems. In reality, however, one has fallen back upon the collective unconscious, which now takes over the leadership. We could multiply examples of cases where, at the critical moment, a “saving” thought, a vision, an “inner voice,” came with an irresistible power of conviction and gave life a new direction. Probably we could mention just as many cases where the collapse meant a catastrophe that destroyed life, for at such moments morbid ideas are also liable to take root, or ideals wither away, which is no less disastrous. In the one case some psychic oddity develops, or a psychosis; in the other, a state of disorientation and demoralization. But once the unconscious contents break through into consciousness, filling it with their uncanny power of conviction, the question arises of how the individual will react. Will he be overpowered by these contents? Will he credulously accept them? Or will he reject them? (I am disregarding the ideal reaction, namely critical understanding.) The first case signifies paranoia or schizophrenia; the second may either become an eccentric with a taste for prophecy, or he may revert to an infantile attitude and be cut off from human society; the third signifies the *regressive restoration of the persona*. This formulation sounds very technical, and the reader may justifiably suppose that it has something to do with a complicated psychic reaction such as can be observed in the course of analytical treatment. It would, however, be a mistake to think that cases of this kind make their appearance only in analytical treatment. The process can be observed just as well, and often better, in other situations of life, namely in all those careers where there has been some violent and destructive intervention of fate. Every one, presumably, has suffered adverse turns of fortune, but mostly they are wounds that heal and leave no crippling mark. But here we are concerned with experiences that are destructive, that can smash a man completely or at least cripple him for good. Let us take as an example a businessman who takes too great a risk and consequently becomes bankrupt. If he does not allow himself to be discouraged by this depressing experience, but, undismayed, keeps his former daring, perhaps with a little salutary caution added, his

wound will be healed without permanent injury. But if, on the other hand, he goes to pieces, abjures all further risks, and laboriously tries to patch up his social reputation within the confines of a much more limited personality, doing inferior work with the mentality of a scared child, in a post far below him, then, technically speaking, he will have restored his persona in a regressive way. He will as a result of his fright have slipped back to an earlier phase of his personality; he will have demeaned himself, pretending that he is as he was *before* the crucial experience, though utterly unable even to think of repeating such a risk. Formerly perhaps he wanted more than he could accomplish; now he does not even dare to attempt what he has it in him to do.

[255] Such experiences occur in every walk of life and in every possible form, hence in psychological treatment also. Here again it is a question of widening the personality, of taking a risk on one's circumstances or on one's nature. What the critical experience is in actual treatment can be seen from the case of our philosophy student: it is the transference. As I have already indicated, it is possible for the patient to slip over the reef of the transference unconsciously, in which case it does not become an experience and nothing fundamental happens. The doctor, for the sake of mere convenience, might well wish for such patients. But if they are intelligent, the patients soon discover the existence of this problem for themselves. If then the doctor, as in the above case, is exalted into the father-lover and consequently has a flood of demands let loose against him, he must perforce think out ways and means of parrying the onslaught, without himself getting drawn into the maelstrom and without injury to the patient. A violent rupture of the transference may bring on a complete relapse, or worse; so the problem must be handled with great tact and foresight. Another possibility is the pious hope that "in time" the "nonsense" will stop of its own accord. Certainly everything stops in time, but it may be an unconscionably long time, and the difficulties may be so unbearable for both sides that one might as well give up the idea of time as a healing factor at once.

[256] A far better instrument for "combatting" the transference would seem to be offered by the Freudian theory of neurosis. The dependence of the patient is explained as an infantile sexual demand that takes the place of a rational application of sexuality. Similar advantages are offered by the Adlerian theory,¹ which explains the transference as an infantile power-aim, and as a "security measure." Both theories fit the neurotic mentality so neatly that every case of neurosis can be explained by both theories at once.² This highly remarkable fact, which any unprejudiced observer is bound to corroborate, can only rest on the circumstance that Freud's "infantile eroticism" and Adler's "power drive" are one and the same thing, regardless of the clash of opinions between the two schools. It is simply a fragment of uncontrolled, and at first uncontrollable, primordial instinct that comes to light in the phenomenon

of transference. The archaic fantasy-forms that gradually reach the surface of consciousness are only a further proof of this.

[257] We can try both theories to make the patient see how infantile, impossible, and absurd his demands are, and perhaps in the end he will actually come to his senses again. My patient, however, was not the only one who did not do this. True enough, the doctor can always save his face with these theories and extricate himself from a painful situation more or less humanely. There are indeed patients with whom it is, or seems to be, unrewarding to go to greater lengths; but there are also cases where these procedures cause senseless psychic injury. In the case of my student I dimly felt something of the sort, and I therefore abandoned my rationalistic attempts in order—with ill-concealed mistrust—to give nature a chance to correct what seemed to me to be her own foolishness. As already mentioned, this taught me something extraordinarily important, namely the existence of an unconscious self-regulation. Not only can the unconscious “wish,” it can also cancel its own wishes. This realization, of such immense importance for the integrity of the personality, must remain sealed to anyone who cannot get over the idea that it is simply a question of infantilism. He will turn round on the threshold of this realization and tell himself: “It was all nonsense of course. I am a crazy visionary! The best thing to do would be to bury the unconscious or throw it overboard with all its works.” The meaning and purpose he so eagerly desired he will see only as infantile maunderings. He will understand that his longing was absurd; he learns to be tolerant with himself, resigned. What can he do? Rather than face the conflict he will turn back and, as best he can, regressively restore his shattered persona, discounting all those hopes and expectations that had blossomed under the transference. He will become smaller, more limited, more rationalistic than he was before. One could not say that this result would be an unqualified misfortune in all cases, for there are all too many who, on account of their notorious ineptitude, thrive better in a rationalistic system than in freedom. Freedom is one of the more difficult things. Those who can stomach this way out can say with Faust:

This earthly circle I know well enough.

Towards the Beyond the view has been cut off;

Fool—who directs that way his dazzled eye,

Contrives himself a double in the sky!

Let him look round him here, not stray beyond;

To a sound man this world must needs respond.

To roam into eternity is vain!

What he perceives, he can attain.

Thus let him walk along his earthlong day;

[258] Such a solution would be perfect if a man were really able to shake off the unconscious, drain it of its energy and render it inactive. But experience shows that the unconscious can be deprived of its energy only in part: it remains continually active, for it not only contains but is itself the source of the libido from which the psychic elements flow. It is therefore a delusion to think that by some kind of magical theory or method the unconscious can be finally emptied of libido and thus, as it were, eliminated. One may for a while play with this delusion, but the day comes when one is forced to say with Faust:

But now such spectredom so throngs the air
That none knows how to dodge it, none knows where.
Though one day greet us with a rational gleam,
The night entangles us in webs of dream.
We come back happy from the fields of spring—
And a bird croaks. Croaks what? Some evil thing.
Enmeshed in superstition night and morn,
It forms and shows itself and comes to warn.
And we, so scared, stand without friend or kin,
And the door creaks—and nobody comes in.⁴

Nobody, of his own free will, can strip the unconscious of its effective power. At best, one can merely deceive oneself on this point. For, as Goethe says:

Unheard by the outward ear
In the heart I whisper fear;
Changing shape from hour to hour
I employ my savage power.⁵

Only one thing is effective against the unconscious, and that is hard outer necessity. (Those with rather more knowledge of the unconscious will see behind the outer necessity the same face which once gazed at them from within.) An inner necessity can change into an outer one, and so long as the outer necessity is real, and not just faked, psychic problems remain more or less ineffective. This is why Mephisto offers Faust, who is sick of the “madness of magic,” the following advice:

Right. There is one way that needs
No money, no physician, and no witch.
Pack up your things and get back to the land
And there begin to dig and ditch;

Keep to the narrow round, confine your mind,
And live on fodder of the simplest kind,
A beast among the beasts; and don't forget
To use your own dung on the crops you set!⁶

It is a well-known fact that the "simple life" cannot be faked, and therefore the unproblematical existence of a poor man, who really is delivered over to fate, cannot be bought by such cheap imitations. Only the man who lives such a life not as a mere possibility, but is actually driven to it by the necessity of his own nature, will blindly pass over the problem of his soul, since he lacks the capacity to grasp it. But once he has seen the Faustian problem, the escape into the "simple life" is closed for ever. There is of course nothing to stop him from taking a two-room cottage in the country, or from pottering about in a garden and eating raw turnips. But his soul laughs at the deception. Only what is really oneself has the power to heal.

[259] The regressive restoration of the persona is a possible course only for the man who owes the critical failure of his life to his own inflatedness. With diminished personality, he turns back to the measure he can fill. But in every other case resignation and self-belittlement are an evasion, which in the long run can be kept up only at the cost of neurotic sickliness. From the conscious point of view of the person concerned, his condition does not look like an evasion at all, but seems to be due to the impossibility of coping with the problem. Usually he is a lonely figure, with little or nothing to help him in our present-day culture. Even psychology has only purely reductive interpretations to offer, since it inevitably underlines the archaic and infantile character of these transitional states and makes them unacceptable to him. The fact that a medical theory may also serve the purpose of enabling the doctor to pull his own head more or less elegantly out of the noose does not occur to him. That is precisely why these reductive theories fit the essence of neurosis so beautifully—because they are of such great service to the doctor.

b. Identification with the Collective Psyche

[260] The second way leads to identification with the collective psyche. This would amount to an acceptance of inflation, but now exalted into a system. That is to say, one would be the fortunate possessor of *the* great truth which was only waiting to be discovered, of the eschatological knowledge which spells the healing of the nations. This attitude is not necessarily megalomania in direct form, but in the milder and more familiar form of prophetic inspiration and desire for martyrdom. For weak-minded persons, who as often as not possess more than their fair share of ambition, vanity, and misplaced naïveté, the danger of yielding to this temptation is very great. Access to the collective psyche means a renewal of life for the individual, no matter whether this renewal is felt as pleasant or unpleasant. Everybody would like to hold fast to this renewal: one man because it enhances his life-feeling, another because it

promises a rich harvest of knowledge, a third because he has discovered the key that will transform his whole life. Therefore all those who do not wish to deprive themselves of the great treasures that lie buried in the collective psyche will strive by every means possible to maintain their newly won connection with the primal source of life.⁷ Identification would seem to be the shortest road to this, for the dissolution of the persona in the collective psyche positively invites one to wed oneself with the abyss and blot out all memory in its embrace. This piece of mysticism is innate in all better men as the “longing for the mother,” the nostalgia for the source from which we came.

[261] As I have shown in my book on libido, there lie at the root of the regressive longing, which Freud conceives as “infantile fixation” or the “incest wish,” a specific value and a specific need which are made explicit in myths. It is precisely the strongest and best among men, the heroes, who give way to their regressive longing and purposely expose themselves to the danger of being devoured by the monster of the maternal abyss. But if a man is a hero, he is a hero because, in the final reckoning, he did not let the monster devour him, but subdued it, not once but many times. Victory over the collective psyche alone yields the true value—the capture of the hoard, the invincible weapon, the magic talisman, or whatever it be that the myth deems most desirable. Anyone who identifies with the collective psyche—or, in mythological terms, lets himself be devoured by the monster—and vanishes in it, attains the treasure that the dragon guards, but he does so in spite of himself and to his own greatest harm.

[262] Probably no one who was conscious of the absurdity of this identification would have the courage to make a principle of it. But the danger is that very many people lack the necessary humour, or else it fails them at this particular juncture; they are seized by a sort of pathos, everything seems pregnant with meaning, and all effective self-criticism is checked. I would not deny in general the existence of genuine prophets, but in the name of caution I would begin by doubting each individual case; for it is far too serious a matter for us lightly to accept a man as a genuine prophet. Every respectable prophet strives manfully against the unconscious pretensions of his role. When therefore a prophet appears at a moment’s notice, we would be better advised to contemplate a possible psychic disequilibrium.

[263] But besides the possibility of becoming a prophet, there is another alluring joy, subtler and apparently more legitimate: the joy of becoming a prophet’s disciple. This, for the vast majority of people, is an altogether ideal technique. Its advantages are: the *odium dignitatis*, the superhuman responsibility of the prophet, turns into the so much sweeter *otium indignitatis*. The disciple is unworthy; modestly he sits at the Master’s feet and guards against having ideas of his own. Mental laziness becomes a

virtue; one can at least bask in the sun of a semidivine being. He can enjoy the archaism and infantilism of his unconscious fantasies without loss to himself, for all responsibility is laid at the Master's door. Through his deification of the Master, the disciple, apparently without noticing it, waxes in stature; moreover, does he not possess the great truth—not his own discovery, of course, but received straight from the Master's hands? Naturally the disciples always stick together, not out of love, but for the very understandable purpose of effortlessly confirming their own convictions by engendering an air of collective agreement.

[264] Now this is an identification with the collective psyche that seems altogether more commendable: somebody else has the honour of being a prophet, but also the dangerous responsibility. For one's own part, one is a mere disciple, but nonetheless a joint guardian of the great treasure which the Master has found. One feels the full dignity and burden of such a position, deeming it a solemn duty and a moral necessity to revile others not of a like mind, to enrol proselytes and to hold up a light to the Gentiles, exactly as though one were the prophet oneself. And these people, who creep about behind an apparently modest persona, are the very ones who, when inflated by identification with the collective psyche, suddenly burst upon the world scene. For, just as the prophet is a primordial image from the collective psyche, so also is the disciple of the prophet.

[265] In both cases inflation is brought about by the collective unconscious, and the independence of the individuality suffers injury. But since by no means all individualities have the strength to be independent, the disciple-fantasy is perhaps the best they can accomplish. The gratifications of the accompanying inflation at least do something to make up for the loss of spiritual freedom. Nor should we underestimate the fact that the life of a real or imagined prophet is full of sorrows, disappointments, and privations, so that the hosanna-shouting band of disciples has the value of a compensation. All this is so humanly understandable that it would be a matter for astonishment if it led to any further destination whatever.

PART TWO

INDIVIDUATION

THE FUNCTION OF THE UNCONSCIOUS

[266] There is a destination, a possible goal, beyond the alternative stages dealt with in our last chapter. That is the way of individuation. Individuation means becoming an “in-dividual,” and, in so far as “individuality” embraces our innermost, last, and incomparable uniqueness, it also implies becoming one’s own self. We could therefore translate individuation as “coming to selfhood” or “self-realization.”

[267] The possibilities of development discussed in the preceding chapters were, at bottom, alienations of the self, ways of divesting the self of its reality in favour of an external role or in favour of an imagined meaning. In the former case the self retires into the background and gives place to social recognition; in the latter, to the auto-suggestive meaning of a primordial image. In both cases the collective has the upper hand. Self-alienation in favour of the collective corresponds to a social ideal; it even passes for social duty and virtue, although it can also be misused for egotistical purposes. Egoists are called “selfish,” but this, naturally, has nothing to do with the concept of “self” as I am using it here. On the other hand, self-realization seems to stand in opposition to self-alienation. This misunderstanding is quite general, because we do not sufficiently distinguish between individualism and individuation. Individualism means deliberately stressing and giving prominence to some supposed peculiarity rather than to collective considerations and obligations. But individuation means precisely the better and more complete fulfilment of the collective qualities of the human being, since adequate consideration of the peculiarity of the individual is more conducive to a better social performance than when the peculiarity is neglected or suppressed. The idiosyncrasy of an individual is not to be understood as any strangeness in his substance or in his components, but rather as a unique combination, or gradual differentiation, of functions and faculties which in themselves are universal. Every human face has a nose, two eyes, etc., but these universal factors are variable, and it is this variability which makes individual peculiarities possible. Individuation, therefore, can only mean a process of psychological development that fulfils the individual qualities given; in other words, it is a process by which a man becomes the definite, unique being he in fact is. In so doing he does not become “selfish” in the ordinary sense of the word, but is merely fulfilling the peculiarity of his nature, and this, as we have said, is vastly different from egotism or individualism.

[268] Now in so far as the human individual, as a living unit, is composed of purely universal factors, he is wholly collective and therefore in no sense opposed to collectivity. Hence the individualistic emphasis on one's own peculiarity is a contradiction of this basic fact of the living being. Individuation, on the other hand, aims at a living co-operation of all factors. But since the universal factors always appear only in individual form, a full consideration of them will also produce an individual effect, and one which cannot be surpassed by anything else, least of all by individualism.

[269] The aim of individuation is nothing less than to divest the self of the false wrappings of the persona on the one hand, and of the suggestive power of primordial images on the other. From what has been said in the previous chapters it should be sufficiently clear what the persona means psychologically. But when we turn to the other side, namely to the influence of the collective unconscious, we find we are moving in a dark interior world that is vastly more difficult to understand than the psychology of the persona, which is accessible to everyone. Everyone knows what is meant by "putting on official airs" or "playing a social role." Through the persona a man tries to appear as this or that, or he hides behind a mask, or he may even build up a definite persona as a barricade. So the problem of the persona should present no great intellectual difficulties.

[270] It is, however, another thing to describe, in a way that can be generally understood, those subtle inner processes which invade the conscious mind with such suggestive force. Perhaps we can best portray these influences with the help of examples of mental illness, creative inspiration, and religious conversion. A most excellent account—taken from life, so to speak—of such an inner transformation is to be found in H. G. Wells' *Christina Alberta's Father*.^a Changes of a similar kind are described in Léon Daudet's eminently readable *L'Hérédo*. A wide range of material is contained in William James' *Varieties of Religious Experience*. Although in many cases of this kind there are certain external factors which either directly condition the change, or at least provide the occasion for it, yet it is not always the case that the external factor offers a sufficient explanation of these changes of personality. We must recognize the fact that they can also arise from subjective inner causes, opinions, convictions, where external stimuli play no part at all, or a very insignificant one. In pathological changes of personality this can even be said to be the rule. The cases of psychosis that present a clear and simple reaction to some overwhelming outside event belong to the exceptions. Hence, for psychiatry, the essential aetiological factor is the inherited or acquired pathological disposition. The same is probably true of most creative intuitions, for we are hardly likely to suppose a purely causal connection between the falling apple and Newton's theory of gravitation. Similarly all religious conversions that cannot be traced back directly to

suggestion and contagious example rest upon independent interior processes culminating in a change of personality. As a rule these processes have the peculiarity of being subliminal, i.e., unconscious, in the first place and of reaching consciousness only gradually. The moment of irruption can, however, be very sudden, so that consciousness is instantaneously flooded with extremely strange and apparently quite unsuspected contents. That is how it looks to the layman and even to the person concerned, but the experienced observer knows that psychological events are never sudden. In reality the irruption has been preparing for many years, often for half a lifetime, and already in childhood all sorts of remarkable signs could have been detected which, in more or less symbolic fashion, hinted at abnormal future developments. I am reminded, for instance, of a mental case who refused all nourishment and created quite extraordinary difficulties in connection with nasal feeding. In fact an anaesthetic was necessary before the tube could be inserted. The patient was able in some remarkable way to swallow his tongue by pressing it back into the throat, a fact that was quite new and unknown to me at the time. In a lucid interval I obtained the following history from the man. As a boy he had often revolved in his mind the idea of how he could take his life, even if every conceivable measure were employed to prevent him. He first tried to do it by holding his breath, until he found that by the time he was in a semiconscious state he had already begun to breathe again. So he gave up these attempts and thought: perhaps it would work if he refused food. This fantasy satisfied him until he discovered that food could be poured into him through the nasal cavity. He therefore considered how this entrance might be closed, and thus it was that he hit upon the idea of pressing his tongue backwards. At first he was unsuccessful, and so he began a regular training, until at last he succeeded in swallowing his tongue in much the same way as sometimes happens accidentally during anaesthesia, evidently in his case by artificially relaxing the muscles at the root of the tongue.

[271] In this strange manner the boy paved the way for his future psychosis. After the second attack he became incurably insane. This is only one example among many others, but it suffices to show how the subsequent, apparently sudden irruption of alien contents is really not sudden at all, but is rather the result of an unconscious development that has been going on for years.

[272] The great question now is: in what do these unconscious processes consist? And how are they constituted? Naturally, so long as they are unconscious, nothing can be said about them. But sometimes they manifest themselves, partly through symptoms, partly through actions, opinions, affects, fantasies, and dreams. Aided by such observational material we can draw indirect conclusions as to the momentary state and constitution of the unconscious processes and their development. We should not, however, labour under the illusion that we have now discovered the real nature of the

unconscious processes. We never succeed in getting further than the hypothetical “as if.”

[273] “No mortal mind can plumb the depths of nature”—nor even the depths of the unconscious. We do know, however, that the unconscious never rests. It seems to be always at work, for even when asleep we dream. There are many people who declare that they never dream, but the probability is that they simply do not remember their dreams. It is significant that people who talk in their sleep mostly have no recollection either of the dream which started them talking, or even of the fact that they dreamed at all. Not a day passes but we make some slip of the tongue, or something slips our memory which at other times we know perfectly well, or we are seized by a mood whose cause we cannot trace, etc. These things are all symptoms of some consistent unconscious activity which becomes directly visible at night in dreams, but only occasionally breaks through the inhibitions imposed by our daytime consciousness.

[274] So far as our present experience goes, we can lay it down that the unconscious processes stand in a compensatory relation to the conscious mind. I expressly use the word “compensatory” and not the word “contrary” because conscious and unconscious are not necessarily in opposition to one another, but complement one another to form a totality, which is the *self*. According to this definition the self is a quantity that is supraordinate to the conscious ego. It embraces not only the conscious but also the unconscious psyche, and is therefore, so to speak, a personality which we *also* are. It is easy enough to think of ourselves as possessing part-souls. Thus we can, for instance, see ourselves as a persona without too much difficulty. But it transcends our powers of imagination to form a clear picture of what we are as a self, for in this operation the part would have to comprehend the whole. There is little hope of our ever being able to reach even approximate consciousness of the self, since however much we may make conscious there will always exist an indeterminate and indeterminable amount of unconscious material which belongs to the totality of the self. Hence the self will always remain a supraordinate quantity.

[275] The unconscious processes that compensate the conscious ego contain all those elements that are necessary for the self regulation of the psyche as a whole. On the personal level, these are the not consciously recognized personal motives which appear in dreams, or the meanings of daily situations which we have overlooked, or conclusions we have failed to draw, or affects we have not permitted, or criticisms we have spared ourselves. But the more we become conscious of ourselves through self-knowledge, and act accordingly, the more the layer of the personal unconscious that is superimposed on the collective unconscious will be diminished. In this way there arises a consciousness which is no longer imprisoned in the petty, oversensitive,

personal world of the ego, but participates freely in the wider world of objective interests. This widened consciousness is no longer that touchy, egotistical bundle of personal wishes, fears, hopes, and ambitions which always has to be compensated or corrected by unconscious counter-tendencies; instead, it is a function of relationship to the world of objects, bringing the individual into absolute, binding, and indissoluble communion with the world at large. The complications arising at this stage are no longer egotistic wish-conflicts, but difficulties that concern others as much as oneself. At this stage it is fundamentally a question of collective problems, which have activated the collective unconscious because they require collective rather than personal compensation. We can now see that the unconscious produces contents which are valid not only for the person concerned, but for others as well, in fact for a great many people and possibly for all.

[276] The Elgonyi, natives of the Elgon forests, of central Africa, explained to me that there are two kinds of dreams: the ordinary dream of the little man, and the “big vision” that only the great man has, e.g., the medicine-man or chief. Little dreams are of no account, but if a man has a “big dream” he summons the whole tribe in order to tell it to everybody.

[277] How is a man to know whether his dream is a “big” or a “little” one? He knows it by an instinctive feeling of significance. He feels so overwhelmed by the impression it makes that he would never think of keeping the dream to himself. He *has* to tell it, on the psychologically correct assumption that it is of general significance. Even with us the collective dream has a feeling of importance about it that impels communication. It springs from a conflict of relationship and must therefore be built into our conscious relations, because it compensates these and not just some inner personal quirk.

[278] The processes of the collective unconscious are concerned not only with the more or less personal relations of an individual to his family or to a wider social group, but with his relations to society and to the human community in general. The more general and impersonal the condition that releases the unconscious reaction, the more significant, bizarre, and overwhelming will be the compensatory manifestation. It impels not just private communication, but drives people to revelations and confessions, and even to a dramatic representation of their fantasies.

[279] I will explain by an example how the unconscious manages to compensate relationships. A somewhat arrogant gentleman once came to me for treatment. He ran a business in partnership with his younger brother. Relations between the two brothers were very strained, and this was one of the essential causes of my patient’s neurosis. From the information he gave me, the real reason for the tension was not altogether clear. He had all kinds of criticisms to make of his brother, whose gifts he

certainly did not show in a very favourable light. The brother frequently came into his dreams, always in the role of a Bismarck, Napoleon, or Julius Caesar. His house looked like the Vatican or Yildiz Kiosk. My patient's unconscious evidently had the need to exalt the rank of the younger brother. From this I concluded that he was setting himself too high and his brother too low. The further course of analysis entirely justified this inference.

[280] Another patient, a young woman who clung to her mother in an extremely sentimental way, always had very sinister dreams about her. She appeared in the dreams as a witch, as a ghost, as a pursuing demon. The mother had spoilt her beyond all reason and had so blinded her by tenderness that the daughter had no conscious idea of her mother's harmful influence. Hence the compensatory criticism exercised by the unconscious.

[281] I myself once happened to put too low a value on a patient, both intellectually and morally. In a dream I saw a castle perched on a high cliff, and on the topmost tower was a balcony, and there sat my patient. I did not hesitate to tell her this dream at once, naturally with the best results.

[282] We all know how apt we are to make fools of ourselves in front of the very people we have unjustly underrated. Naturally the case can also be reversed, as once happened to a friend of mine. While still a callow student he had written to Virchow, the pathologist, craving an audience with "His Excellency." When, quaking with fear, he presented himself and tried to give his name, he blurted out, "My name is Virchow." Whereupon His Excellency, smiling mischievously, said, "Ah! So your name is Virchow too?" The feeling of his own nullity was evidently too much for the unconscious of my friend, and in consequence it instantly prompted him to present himself as equal to Virchow in grandeur.

[283] In these more personal relations there is of course no need for any very collective compensations. On the other hand, the figures employed by the unconscious in our first case are of a definitely collective nature: they are universally recognized heroes. Here there are two possible interpretations: either my patient's younger brother is a man of acknowledged and far-reaching collective importance, or my patient is overestimating his own importance not merely in relation to his brother but in relation to everybody else as well. For the first assumption there was no support at all, while for the second there was the evidence of one's own eyes. Since the man's extreme arrogance affected not only himself, but a far wider social group, the compensation availed itself of a collective image.

[284] The same is true of the second case. The "witch" is a collective image; hence we must conclude that the blind dependence of the young woman applied as much to the wider social group as it did to her mother personally. This was indeed the case, in so

far as she was still living in an exclusively infantile world, where the world was identical with her parents. These examples deal with relations within the personal orbit. There are, however, impersonal relations which occasionally need unconscious compensation. In such cases collective images appear with a more or less mythological character. Moral, philosophical, and religious problems are, on account of their universal validity, the most likely to call for mythological compensation. In the aforementioned novel by H. G. Wells we find a classical type of compensation: Mr. Preemby, a midget personality, discovers that he is really a reincarnation of Sargon, King of Kings. Happily, the genius of the author rescues poor old Sargon from pathological absurdity, and even gives the reader a chance to appreciate the tragic and eternal meaning in this lamentable affray. Mr. Preemby, a complete nonentity, recognizes himself as the point of intersection of all ages past and future. This knowledge is not too dearly bought at the cost of a little madness, provided that Preemby is not in the end devoured by that monster of a primordial image—which is in fact what nearly happens to him.

[285] The universal problem of evil and sin is another aspect of our impersonal relations to the world. Almost more than any other, therefore, this problem produces collective compensations. One of my patients, aged sixteen, had as the initial symptom of a severe compulsion neurosis the following dream: *He is walking along an unfamiliar street. It is dark, and he hears steps coming behind him. With a feeling of fear he quickens his pace. The footsteps come nearer, and his fear increases. He begins to run. But the footsteps seem to be overtaking him. Finally he turns round, and there he sees the devil. In deathly terror he leaps into the air and hangs there suspended.* This dream was repeated twice, a sign of its special urgency.

[286] It is a notorious fact that the compulsion neuroses, by reason of their meticulousness and ceremonial punctilio, not only have the surface appearance of a moral problem but are indeed brimfull of inhuman beastliness and ruthless evil, against the integration of which the very delicately organized personality puts up a desperate struggle. This explains why so many things have to be performed in ceremonially “correct” style, as though to counteract the evil hovering in the background. After this dream the neurosis started, and its essential feature was that the patient had, as he put it, to keep himself in a “provisional” or “uncontaminated” state of purity. For this purpose he either severed or made “invalid” all contact with the world and with everything that reminded him of the transitoriness of human existence, by means of lunatic formalities, scrupulous cleansing ceremonies, and the anxious observance of innumerable rules and regulations of an unbelievable complexity. Even before the patient had any suspicion of the hellish existence that lay before him, the dream showed him that if he wanted to come down to earth again there would have to be a pact with evil.

[287] Elsewhere I have described a dream that illustrates the compensation of a religious problem in a young theological student.¹ He was involved in all sorts of difficulties of belief, a not uncommon occurrence in the man of today. In his dream he was the pupil of the “white magician,” who, however, was dressed in black. After having instructed him up to a certain point, the white magician told him that they now needed the “black magician.” The black magician appeared, but clad in a white robe. He declared that he had found the keys of paradise, but needed the wisdom of the white magician in order to understand how to use them. This dream obviously contains the problem of opposites which, as we know, has found in Taoist philosophy a solution very different from the views prevailing in the West. The figures employed by the dream are impersonal collective images corresponding to the nature of the impersonal religious problem. In contrast to the Christian view, the dream stresses the relativity of good and evil in a way that immediately calls to mind the Taoist symbol of Yin and Yang.

[288] We should certainly not conclude from these compensations that, as the conscious mind becomes more deeply engrossed in universal problems, the unconscious will bring forth correspondingly far-reaching compensations. There is what one might call a legitimate and an illegitimate interest in impersonal problems. Excursions of this kind are legitimate only when they arise from the deepest and truest needs of the individual; illegitimate when they are either mere intellectual curiosity or a flight from unpleasant reality. In the latter case the unconscious produces all too human and purely personal compensations, whose manifest aim is to bring the conscious mind back to ordinary reality. People who go illegitimately mooning after the infinite often have absurdly banal dreams which endeavour to damp down their ebullience. Thus, from the nature of the compensation, we can at once draw conclusions as to the seriousness and rightness of the conscious strivings.

[289] There are certainly not a few people who are afraid to admit that the unconscious could ever have “big” ideas. They will object, “But do you really believe that the unconscious is capable of offering anything like a constructive criticism of our Western mentality?” Of course, if we take the problem intellectually and impute rational intentions to the unconscious, the thing becomes absurd. But it would never do to foist our conscious psychology upon the unconscious. Its mentality is an instinctive one; it has no differentiated functions, and it does not “think” as we understand “thinking.” It simply creates an image that answers to the conscious situation. This image contains as much thought as feeling, and is anything rather than a product of rationalistic reflection. Such an image would be better described as an artist’s vision. We tend to forget that a problem like the one which underlies the dream last mentioned cannot, even to the conscious mind of the dreamer, be an intellectual problem, but is profoundly emotional. For a moral man the ethical

problem is a passionate question which has its roots in the deepest instinctual processes as well as in his most idealistic aspirations. The problem for him is devastatingly real. It is not surprising, therefore, that the answer likewise springs from the depths of his nature. The fact that everyone thinks his psychology is the measure of all things, and, if he also happens to be a fool, will inevitably think that such a problem is beneath his notice, should not trouble the psychologist in the least, for he has to take things objectively, as he finds them, without twisting them to fit his subjective suppositions. The richer and more capacious natures may legitimately be gripped by an impersonal problem, and to the extent that this is so, their unconscious can answer in the same style. And just as the conscious mind can put the question, "Why is there this frightful conflict between good and evil?," so the unconscious can reply, "Look closer! Each needs the other. The best, just because it is the best, holds the seed of evil, and there is nothing so bad but good can come of it."

[290] It might then dawn on the dreamer that the apparently insoluble conflict is, perhaps, a prejudice, a frame of mind conditioned by time and place. The seemingly complex dream-image might easily reveal itself as plain, instinctive common sense, as the tiny germ of a rational idea, which a maturer mind could just as well have thought consciously. At all events Chinese philosophy thought of it ages ago. The singularly apt, plastic configuration of thought is the prerogative of that primitive, natural spirit which is alive in all of us and is only obscured by a one-sided conscious development. If we consider the unconscious compensations from this angle, we might justifiably be accused of judging the unconscious too much from the conscious standpoint. And indeed, in pursuing these reflections, I have always started from the view that the unconscious simply reacts to the conscious contents, albeit in a very significant way, but that it lacks initiative. It is, however, far from my intention to give the impression that the unconscious is merely reactive in all cases. On the contrary, there is a host of experiences which seem to prove that the unconscious is not only spontaneous but can actually take the lead. There are innumerable cases of people who lingered on in a pettifogging unconsciousness, only to become neurotic in the end. Thanks to the neurosis contrived by the unconscious, they are shaken out of their apathy, and this in spite of their own laziness and often desperate resistance.

[291] Yet it would, in my view, be wrong to suppose that in such cases the unconscious is working to a deliberate and concerted plan and is striving to realize certain definite ends. I have found nothing to support this assumption. The driving force, so far as it is possible for us to grasp it, seems to be in essence only an urge towards self-realization. If it were a matter of some general teleological plan, then all individuals who enjoy a surplus of unconsciousness would necessarily be driven towards higher consciousness by an irresistible urge. That is plainly not the case. There are vast masses of the population who, despite their notorious unconsciousness, never get

anywhere near a neurosis. The few who are smitten by such a fate are really persons of the “higher” type who, for one reason or another, have remained too long on a primitive level. Their nature does not in the long run tolerate persistence in what is for them an unnatural torpor. As a result of their narrow conscious outlook and their cramped existence they save energy; bit by bit it accumulates in the unconscious and finally explodes in the form of a more or less acute neurosis. This simple mechanism does not necessarily conceal a “plan.” A perfectly understandable urge towards self-realization would provide a quite satisfactory explanation. We could also speak of a retarded maturation of the personality.

[292] Since it is highly probable that we are still a long way from the summit of absolute consciousness, presumably everyone is capable of wider consciousness, and we may assume accordingly that the unconscious processes are constantly supplying us with contents which, if consciously recognized, would extend the range of consciousness. Looked at in this way, the unconscious appears as a field of experience of unlimited extent. If it were merely reactive to the conscious mind, we might aptly call it a psychic mirror-world. In that case, the real source of all contents and activities would lie in the conscious mind, and there would be absolutely nothing in the unconscious except the distorted reflections of conscious contents. The creative process would be shut up in the conscious mind, and anything new would be nothing but conscious invention or cleverness. The empirical facts give the lie to this. Every creative man knows that spontaneity is the very essence of creative thought. Because the unconscious is not just a reactive mirror-reflection, but an independent, productive activity, its realm of experience is a self-contained world, having its own reality, of which we can only say that it affects us as we affect it—precisely what we say about our experience of the outer world. And just as material objects are the constituent elements of this world, so psychic factors constitute the objects of that other world.

[293] The idea of psychic objectivity is by no means a new discovery. It is in fact one of the earliest and most universal acquisitions of humanity: it is nothing less than the conviction as to the concrete existence of a spirit-world. The spirit-world was certainly never an invention in the sense that fire-boring was an invention; it was far rather the experience, the conscious acceptance of a reality in no way inferior to that of the material world. I doubt whether primitives exist anywhere who are not acquainted with magical influence or a magical substance. (“Magical” is simply another word for “psychic”) It would also appear that practically all primitives are aware of the existence of spirits.² “Spirit” is a psychic fact. Just as we distinguish our own bodiliness from bodies that are strange to us, so primitives—if they have any notion of “souls” at all—distinguish between their own souls and the spirits, which are felt as strange and as “not belonging.” They are objects of outward perception,

whereas their own soul (or one of several souls where a plurality is assumed), though believed to be essentially akin to the spirits, is not usually an object of so-called sensible perception. After death the soul (or one of the plurality of souls) becomes a spirit which survives the dead man, and often it shows a marked deterioration of character that partly contradicts the notion of personal immortality. The Bataks,³ of Sumatra, go so far as to assert that the people who were good in this life turn into malign and dangerous spirits. Nearly everything that the primitives say about the tricks which the spirits play on the living, and the general picture they give of the *revenants*, corresponds down to the last detail with the phenomena established by spiritualistic experience. And just as the communications from the “Beyond” can be seen to be the activities of broken-off bits of the psyche, so these primitive spirits are manifestations of unconscious complexes.⁴ The importance that modern psychology attaches to the “parental complex” is a direct continuation of primitive man’s experience of the dangerous power of the ancestral spirits. Even the error of judgment which leads him unthinkingly to assume that the spirits are realities of the external world is carried on in our assumption (which is only partially correct) that the real parents are responsible for the parental complex. In the old trauma theory of Freudian psychoanalysis, and in other quarters as well, this assumption even passed for a scientific explanation. (It was in order to avoid this confusion that I advocated the term “parental imago.”⁵)

[294] The simple soul is of course quite unaware of the fact that his nearest relations, who exercise immediate influence over him, create in him an image which is only partly a replica of themselves, while its other part is compounded of elements derived from himself. The imago is built up of parental influences plus the specific reactions of the child; it is therefore an image that reflects the object with very considerable qualifications. Naturally, the simple soul believes that his parents are as he sees them. The image is unconsciously projected, and when the parents die, the projected image goes on working as though it were a spirit existing on its own. The primitive then speaks of parental spirits who return by night (*revenants*), while the modern man calls it a father or mother complex.

[295] The more limited a man’s field of consciousness is, the more numerous the psychic contents (imagos) which meet him as quasi-external apparitions, either in the form of spirits, or as magical potencies projected upon living people (magicians, witches, etc.). At a rather higher stage of development, where the idea of the soul already exists, not all the imagos continue to be projected (where this happens, even trees and stones talk), but one or the other complex has come near enough to consciousness to be felt as no longer strange, but as somehow “belonging.” Nevertheless, the feeling that it “belongs” is not at first sufficiently strong for the complex to be sensed as a subjective content of consciousness. It remains in a sort of

no man's land between conscious and unconscious, in the half-shadow, in part belonging or akin to the conscious subject, in part an autonomous being, and meeting consciousness as such. At all events it is not necessarily obedient to the subject's intentions, it may even be of a higher order, more often than not a source of inspiration or warning, or of "supernatural" information. Psychologically such a content could be explained as a partly autonomous complex that is not yet fully integrated. The archaic souls, the *ba* and *ka* of the Egyptians, are complexes of this kind. At a still higher level, and particularly among the civilized peoples of the West, this complex is invariably of the feminine gender—*anima* and *ψυχή*—a fact for which deeper and cogent reasons are not lacking.

ANIMA AND ANIMUS

[296] Among all possible spirits the spirits of the parents are in practice the most important; hence the universal incidence of the ancestor cult. In its original form it served to conciliate the *revenants*, but on a higher level of culture it became an essentially moral and educational institution, as in China. For the child, the parents are his closest and most influential relations. But as he grows older this influence is split off; consequently the parental imagos become increasingly shut away from consciousness, and on account of the restrictive influence they sometimes continue to exert, they easily acquire a negative aspect. In this way the parental imagos remain as alien elements somewhere “outside” the psyche. In place of the parents, woman now takes up her position as the most immediate environmental influence in the life of the adult man. She becomes his companion, she belongs to him in so far as she shares his life and is more or less of the same age. She is not of a superior order, either by virtue of age, authority, or physical strength. She is, however, a very influential factor and, like the parents, she produces an imago of a relatively autonomous nature—not an imago to be split off like that of the parents, but one that has to be kept associated with consciousness. Woman, with her very dissimilar psychology, is and always has been a source of information about things for which a man has no eyes. She can be his inspiration; her intuitive capacity, often superior to man’s, can give him timely warning, and her feeling, always directed towards the personal, can show him ways which his own less personally accented feeling would never have discovered. What Tacitus says about the Germanic women is exactly to the point in this respect.¹

[297] Here, without a doubt, is one of the main sources for the feminine quality of the soul. But it does not seem to be the only source. No man is so entirely masculine that he has nothing feminine in him. The fact is, rather, that very masculine men have—carefully guarded and hidden—a very soft emotional life, often incorrectly described as “feminine.” A man counts it a virtue to repress his feminine traits as much as possible, just as a woman, at least until recently, considered it unbecoming to be “mannish.” The repression of feminine traits and inclinations naturally causes these contrasexual demands to accumulate in the unconscious. No less naturally, the imago of woman (the soul-image) becomes a receptacle for these demands, which is why a man, in his love-choice, is strongly tempted to win the woman who best corresponds to his own unconscious femininity—a woman, in short, who can unhesitatingly receive the projection of his soul. Although such a choice is often regarded and felt as

altogether ideal, it may turn out that the man has manifestly married his own worst weakness. This would explain some highly remarkable conjunctions.

[298] It seems to me, therefore, that apart from the influence of woman there is also the man's own femininity to explain the feminine nature of the soul-complex. There is no question here of any linguistic "accident," of the kind that makes the sun feminine in German and masculine in other languages. We have, in this matter, the testimony of art from all ages, and besides that the famous question: *habet mulier animam*? Most men, probably, who have any psychological insight at all will know what Rider Haggard means by "She-who-must-be-obeyed," and will also recognize the chord that is struck when they read Benoît's description of Antinéa.² Moreover they know at once the kind of woman who most readily embodies this mysterious factor, of which they have so vivid a premonition.

[299] The wide recognition accorded to such books shows that there must be some supra-individual quality in this image of the anima,³ something that does not owe a fleeting existence simply to its individual uniqueness, but is far more typical, with roots that go deeper than the obvious surface attachments I have pointed out. Both Rider Haggard and Benoît give unmistakable utterance to this supposition in the *historical* aspect of their anima figures.

[300] As we know, there is no human experience, nor would experience be possible at all, without the intervention of a subjective aptitude. What is this subjective aptitude? Ultimately it consists in an innate psychic structure which allows man to have experiences of this kind. Thus the whole nature of man presupposes woman, both physically and spiritually. His system is tuned in to woman from the start, just as it is prepared for a quite definite world where there is water, light, air, salt, carbohydrates, etc. The form of the world into which he is born is already inborn in him as a virtual image. Likewise parents, wife, children, birth, and death are inborn in him as virtual images, as psychic aptitudes. These *a priori* categories have by nature a collective character; they are images of parents, wife, and children in general, and are not individual predestinations. We must therefore think of these images as lacking in solid content, hence as unconscious. They only acquire solidity, influence, and eventual consciousness in the encounter with empirical facts, which touch the unconscious aptitude and quicken it to life. They are in a sense the deposits of all our ancestral experiences, but they are not the experiences themselves. So at least it seems to us, in the present limited state of our knowledge. (I must confess that I have never yet found infallible evidence for the inheritance of memory images, but I do not regard it as positively precluded that in addition to these collective deposits which contain nothing specifically individual, there may also be inherited memories that are individually determined.)

[301] An inherited collective image of woman exists in a man's unconscious, with the help of which he apprehends the nature of woman. This inherited image is the third important source for the femininity of the soul.

[302] As the reader will have grasped, we are not concerned here with a philosophical, much less a religious, concept of the soul, but with the psychological recognition of the existence of a semiconscious psychic complex, having partial autonomy of function. Clearly, this recognition has as much or as little to do with philosophical or religious conceptions of the soul, as psychology has as much or as little to do with philosophy or religion. I have no wish to embark here on a "battle of the faculties," nor do I seek to demonstrate either to the philosopher or to the theologian what exactly he means by "soul." I must, however, restrain both of them from prescribing what the psychologist *ought* to mean by "soul." The quality of personal immortality so fondly attributed to the soul by religion is, for science, no more than a psychological *indicium* which is already included in the idea of autonomy. The quality of personal immortality is by no means a constant attribute of the soul as the primitive sees it, nor even immortality as such. But setting this view aside as altogether inaccessible to science, the immediate meaning of "immortality" is simply a psychic activity that transcends the limits of consciousness. "Beyond the grave" or "on the other side of death" means, psychologically, "beyond consciousness." There is positively nothing else it could mean, since statements about immortality can only be made by the living, who, as such, are not exactly in a position to pontificate about conditions "beyond the grave."

[303] The autonomy of the soul-complex naturally lends support to the notion of an invisible, personal entity that apparently lives in a world very different from ours. Consequently, once the activity of the soul is felt to be that of an autonomous entity having no ties with our mortal substance, it is but a step to imagining that this entity must lead an entirely independent existence, perhaps in a world of invisible things. Yet it is not immediately clear why the *invisibility* of this independent entity should simultaneously imply its *immortality*. The quality of immortality might easily derive from another fact to which I have already alluded, namely the characteristically historical aspect of the soul. Rider Haggard has given one of the best descriptions of this in *She*. When the Buddhists say that progressive perfection through meditation awakens memories of former incarnations, they are no doubt referring to the same psychological reality, the only difference being that they ascribe the historical factor not to the soul but to the Self (*atman*). It is altogether in keeping with the thoroughly extraverted attitude of the Western mind so far, that immortality should be ascribed, both by feeling and by tradition, to a soul which we distinguish more or less from our ego, and which also differs from the ego on account of its feminine qualities. It would be entirely logical if, by deepening that neglected, introverted side of our spiritual

culture, there were to take place in us a transformation more akin to the Eastern frame of mind, where the quality of immortality would transfer itself from the ambiguous figure of the soul (*anima*) to the self. For it is essentially the overvaluation of the material object without that constellates a spiritual and immortal figure within (obviously for the purpose of compensation and self-regulation). Fundamentally, the historical factor does not attach only to the archetype of the feminine, but to all archetypes whatsoever, i.e., to every inherited unit, mental as well as physical. Our life is indeed the same as it ever was. At all events, in our sense of the word it is not transitory; for the same physiological and psychological processes that have been man's for hundreds of thousands of years still endure, instilling into our inmost hearts this profound intuition of the "eternal" continuity of the living. But the self, as an inclusive term that embraces our whole living organism, not only contains the deposit and totality of all past life, but is also a point of departure, the fertile soil from which all future life will spring. This premonition of futurity is as clearly impressed upon our innermost feelings as is the historical aspect. The idea of immortality follows legitimately from these psychological premises.

[304] In the Eastern view the concept of the *anima*, as we have stated it here, is lacking, and so, logically, is the concept of a *persona*. This is certainly no accident, for, as I have already indicated, a compensatory relationship exists between *persona* and *anima*.

[305] The *persona* is a complicated system of relations between the individual consciousness and society, fittingly enough a kind of mask, designed on the one hand to make a definite impression upon others, and, on the other, to conceal the true nature of the individual. That the latter function is superfluous could be maintained only by one who is so identified with his *persona* that he no longer knows himself; and that the former is unnecessary could only occur to one who is quite unconscious of the true nature of his fellows. Society expects, and indeed must expect, every individual to play the part assigned to him as perfectly as possible, so that a man who is a parson must not only carry out his official functions objectively, but must at all times and in all circumstances play the role of parson in a flawless manner. Society demands this as a kind of surety; each must stand at his post, here a cobbler, there a poet. No man is expected to be both. Nor is it advisable to be both, for that would be "odd." Such a man would be "different" from other people, not quite reliable. In the academic world he would be a dilettante, in politics an "unpredictable" quantity, in religion a free-thinker—in short, he would always be suspected of unreliability and incompetence, because society is persuaded that only the cobbler who is not a poet can supply workmanlike shoes. To present an unequivocal face to the world is a matter of practical importance: the average man—the only kind society knows anything about—must keep his nose to one thing in order to achieve anything worth

while, two would be too much. Our society is undoubtedly set on such an ideal. It is therefore not surprising that everyone who wants to get on must take these expectations into account. Obviously no one could completely submerge his individuality in these expectations; hence the construction of an artificial personality becomes an unavoidable necessity. The demands of propriety and good manners are an added inducement to assume a becoming mask. What goes on behind the mask is then called “private life.” This painfully familiar division of consciousness into two figures, often preposterously different, is an incisive psychological operation that is bound to have repercussions on the unconscious.

[306] The construction of a collectively suitable persona means a formidable concession to the external world, a genuine self-sacrifice which drives the ego straight into identification with the persona, so that people really do exist who believe they are what they pretend to be. The “soullessness” of such an attitude is, however, only apparent, for under no circumstances will the unconscious tolerate this shifting of the centre of gravity. When we examine such cases critically, we find that the excellence of the mask is compensated by the “private life” going on behind it. The pious Drummond once lamented that “bad temper is the vice of the virtuous.” Whoever builds up too good a persona for himself naturally has to pay for it with irritability. Bismarck had hysterical weeping fits, Wagner indulged in correspondence about the belts of silk dressing-gowns, Nietzsche wrote letters to his “dear lama,” Goethe held conversations with Eckermann, etc. But there are subtler things than the banal lapses of heroes. I once made the acquaintance of a very venerable personage—in fact, one might easily call him a saint. I stalked round him for three whole days, but never a mortal failing did I find in him. My feeling of inferiority grew ominous, and I was beginning to think seriously of how I might better myself. Then, on the fourth day, his wife came to consult me. ... Well, nothing of the sort has ever happened to me since. But this I did learn: that any man who becomes one with his persona can cheerfully let all disturbances manifest themselves through his wife without her noticing it. though she pays for her self-sacrifice with a bad neurosis.

[307] These identifications with a social role are a very fruitful source of neuroses. A man cannot get rid of himself in favour of an artificial personality without punishment. Even the attempt to do so brings on, in all ordinary cases, unconscious reactions in the form of bad moods, affects, phobias, obsessive ideas, backslidings, vices, etc. The social “strong man” is in his private life often a mere child where his own states of feeling are concerned; his discipline in public (which he demands quite particularly of others) goes miserably to pieces in private. His “happiness in his work” assumes a woeful countenance at home; his “spotless” public morality looks strange indeed behind the mask—we will not mention deeds, but only fantasies, and

the wives of such men would have a pretty tale to tell. As to his selfless altruism, his children have decided views about that.

[308] To the degree that the world invites the individual to identify with the mask, he is delivered over to influences from within. "High rests on low," says Lao-tzu. An opposite forces its way up from inside; it is exactly as though the unconscious suppressed the ego with the very same power which drew the ego into the persona. The absence of resistance outwardly against the lure of the persona means a similar weakness inwardly against the influence of the unconscious. Outwardly an effective and powerful role is played, while inwardly an effeminate weakness develops in face of every influence coming from the unconscious. Moods, vagaries, timidity, even a limp sexuality (culminating in impotence) gradually gain the upper hand.

[309] The persona, the ideal picture of a man as he should be, is inwardly compensated by feminine weakness, and as the individual outwardly plays the strong man, so he becomes inwardly a woman, i.e., the anima, for it is the anima that reacts to the persona. But because the inner world is dark and invisible to the extraverted consciousness, and because a man is all the less capable of conceiving his weaknesses the more he is identified with the persona, the persona's counterpart, the anima, remains completely in the dark and is at once projected, so that our hero comes under the heel of his wife's slipper. If this results in a considerable increase of her power, she will acquit herself none too well. She becomes inferior, thus providing her husband with the welcome proof that it is not he, the hero, who is inferior in private, but his wife. In return the wife can cherish the illusion, so attractive to many, that at least she has married a hero, unperturbed by her own uselessness. This little game of illusion is often taken to be the whole meaning of life.

[310] Just as, for the purpose of individuation, or self-realization, it is essential for a man to distinguish between what he is and how he appears to himself and to others, so it is also necessary for the same purpose that he should become conscious of his invisible system of relations to the unconscious, and especially of the anima, so as to be able to distinguish himself from her. One cannot of course distinguish oneself from something unconscious. In the matter of the persona it is easy enough to make it clear to a man that he and his office are two different things. But it is very difficult for a man to distinguish himself from his anima, the more so because she is invisible. Indeed, he has first to contend with the prejudice that everything coming from inside him springs from the truest depths of his being. The "strong man" will perhaps concede that in private life he is singularly undisciplined, but that, he says, is just his "weakness" with which, as it were, he proclaims his solidarity. Now there is in this tendency a cultural legacy that is not to be despised; for when a man recognizes that his ideal persona is responsible for his anything but ideal anima, his ideals are

shattered, the world becomes ambiguous, he becomes ambiguous even to himself. He is seized by doubts about goodness, and what is worse, he doubts his own good intentions. When one considers how much our private idea of good intentions is bound up with vast historical assumptions, it will readily be understood that it is pleasanter and more in keeping with our present view of the world to deplore a personal weakness than to shatter ideals.

[311] But since the unconscious factors act as determinants no less than the factors that regulate the life of society, and are no less collective, I might just as well learn to distinguish between what *I* want and what the unconscious thrusts upon me, as to see what my office demands of me and what I myself desire. At first the only thing that is at all clear is the incompatibility of the demands coming from without and from within, with the ego standing between them, as between hammer and anvil. But over against this ego, tossed like a shuttlecock between the outer and inner demands, there stands some scarcely definable arbiter, which I would on no account label with the deceptive name “conscience,” although, taken in its best sense, the word fits that arbiter very aptly indeed. What we have made of this “conscience” Spitteler has described with unsurpassable humour.⁴ Hence we should strenuously avoid this particular signification. We should do far better to realize that the tragic counterplay between inside and outside (depicted in Job and *Faust* as the wager with God) represents, at bottom, the energetics of the life process, the polar tension that is necessary for self-regulation. However different, to all intents and purposes, these opposing forces may be, their fundamental meaning and desire is the life of the individual: they always fluctuate round this centre of balance. Just because they are inseparably related through opposition, they also unite in a mediatory meaning, which, willingly or unwillingly, is born out of the individual and is therefore divined by him. He has a strong feeling of what should be and what could be. To depart from this divination means error, aberration, illness.

[312] It is probably no accident that our modern notions of “personal” and “personality” derive from the word *persona*. I can assert that my ego is personal or a personality, and in exactly the same sense I can say that my persona is a personality with which I identify myself more or less. The fact that I then possess two personalities is not so remarkable, since every autonomous or even relatively autonomous complex has the peculiarity of appearing as a personality, i.e., of being personified. This can be observed most readily in the so-called spiritualistic manifestations of automatic writing and the like. The sentences produced are always personal statements and are propounded in the first person singular, as though behind every utterance there stood an actual personality. A naïve intelligence at once thinks of spirits. The same sort of thing is also observable in the hallucinations of the insane, although these, more clearly than the first, can often be recognized as mere

thoughts or fragments of thoughts whose connection with the conscious personality is immediately apparent to everyone.

[313] The tendency of the relatively autonomous complex to direct personification also explains why the persona exercises such a “personal” effect that the ego is all too easily deceived as to which is the “true” personality.

[314] Now, everything that is true of the persona and of all autonomous complexes in general also holds true of the anima. She likewise is a personality, and this is why she is so easily projected upon a woman. So long as the anima is unconscious she is always projected, for everything unconscious is projected. The first bearer of the soul-image is always the mother; later it is borne by those women who arouse the man’s feelings, whether in a positive or a negative sense. Because the mother is the first bearer of the soul-image, separation from her is a delicate and important matter of the greatest educational significance. Accordingly among primitives we find a large number of rites designed to organize this separation. The mere fact of becoming adult, and of outward separation, is not enough; impressive initiations into the “men’s house” and ceremonies of rebirth are still needed in order to make the separation from the mother (and hence from childhood) entirely effective.

[315] Just as the father acts as a protection against the dangers of the external world and thus serves his son as a model persona, so the mother protects him against the dangers that threaten from the darkness of his psyche. In the puberty rites, therefore, the initiate receives instruction about these things of “the other side,” so that he is put in a position to dispense with his mother’s protection.

[316] The modern civilized man has to forgo this primitive but nonetheless admirable system of education. The consequence is that the anima, in the form of the mother-imago, is transferred to the wife; and the man, as soon as he marries, becomes childish, sentimental, dependent, and subservient, or else truculent, tyrannical, hypersensitive, always thinking about the prestige of his superior masculinity. The last is of course merely the reverse of the first. The safeguard against the unconscious, which is what his mother meant to him, is not replaced by anything in the modern man’s education; unconsciously, therefore, his ideal of marriage is so arranged that his wife has to take over the magical role of the mother. Under the cloak of the ideally exclusive marriage he is really seeking his mother’s protection, and thus he plays into the hands of his wife’s possessive instincts. His fear of the dark incalculable power of the unconscious gives his wife an illegitimate authority over him, and forges such a dangerously close union that the marriage is permanently on the brink of explosion from internal tension—or else, out of protest, he flies to the other extreme, with the same results.

[317] I am of the opinion that it is absolutely essential for a certain type of modern man to recognize his distinction not only from the persona, but from the anima as well. For the most part our consciousness, in true Western style, looks outwards, and the inner world remains in darkness. But this difficulty can be overcome easily enough, if only we will make the effort to apply the same concentration and criticism to the psychic material which manifests itself, not outside, but in our private lives. So accustomed are we to keep a shamefaced silence about this other side—we even tremble before our wives, lest they betray us!—and, if found out, to make rueful confessions of “weakness,” that there would seem to be only one method of education, namely, to crush or repress the weaknesses as much as possible or at least hide them from the public. But that gets us nowhere.

[318] Perhaps I can best explain what has to be done if I use the persona as an example. Here everything is plain and straightforward, whereas with the anima all is dark, to Western eyes anyway. When the anima continually thwarts the good intentions of the conscious mind, by contriving a private life that stands in sorry contrast to the dazzling persona, it is exactly the same as when a naïve individual, who has not the ghost of a persona, encounters the most painful difficulties in his passage through the world. There are indeed people who lack a developed persona—“Canadians who know not Europe’s sham politeness”—blundering from one social solecism to the next, perfectly harmless and innocent, soulful bores or appealing children, or, if they are women, spectral Cassandras dreaded for their tactlessness, eternally misunderstood, never knowing what they are about, always taking forgiveness for granted, blind to the world, hopeless dreamers. From them we can see how a neglected persona works, and what one must do to remedy the evil. Such people can avoid disappointments and an infinity of sufferings, scenes, and social catastrophes only by learning to see how men behave in the world. They must learn to understand what society expects of them; they must realize that there are factors and persons in the world far above them; they must know that what they do has a meaning for others, and so forth. Naturally all this is child’s play for one who has a properly developed persona. But if we reverse the picture and confront the man who possesses a brilliant persona with the anima, and, for the sake of comparison, set him beside the man with no persona, then we shall see that the latter is just as well informed about the anima and her affairs as the former is about the world. The use which either makes of his knowledge can just as easily be abused, in fact it is more than likely that it will be.

[319] The man with the persona is blind to the existence of inner realities, just as the other is blind to the reality of the world, which for him has merely the value of an amusing or fantastic playground. But the fact of inner realities and their unqualified recognition is obviously the *sine qua non* for a serious consideration of the anima

problem. If the external world is, for me, simply a phantasm, how should I take the trouble to establish a complicated system of relationship and adaptation to it? Equally, the “nothing but fantasy” attitude will never persuade me to regard my anima manifestations as anything more than fatuous weakness. If, however, I take the line that the world is outside *and* inside, that reality falls to the share of both, I must logically accept the upsets and annoyances that come to me from inside as symptoms of faulty adaptation to the conditions of that inner world. No more than the blows rained on the innocent abroad can be healed by moral repression will it help him resignedly to catalogue his “weaknesses.” Here are reasons, intentions, consequences, which can be tackled by will and understanding. Take, for example, the “spotless” man of honour and public benefactor, whose tantrums and explosive moodiness terrify his wife and children. What is the anima doing here?

[320] We can see it at once if we just allow things to take their natural course. Wife and children will become estranged; a vacuum will form about him. At first he will bewail the hard-heartedness of his family, and will behave if possible even more vilely than before. That will make the estrangement absolute. If the good spirits have not utterly forsaken him, he will after a time notice his isolation, and in his loneliness he will begin to understand how he caused the estrangement. Perhaps, aghast at himself, he will ask, “What sort of devil has got into me?”—without of course seeing the meaning of this metaphor. Then follow remorse, reconciliation, oblivion, repression, and, in next to no time, a new explosion. Clearly, the anima is trying to enforce a separation. This tendency is in nobody’s interest. The anima comes between them like a jealous mistress who tries to alienate the man from his family. An official post or any other advantageous social position can do the same thing, but there we can understand the force of the attraction. Whence does the anima obtain the power to wield such enchantment? On the analogy with the persona there must be values or some other important and influential factors lying in the background like seductive promises. In such matters we must guard against rationalizations. Our first thought is that the man of honour is on the lookout for another woman. That might be—it might even be arranged by the anima as the most effective means to the desired end. Such an arrangement should not be misconstrued as an end in itself, for the blameless gentleman who is correctly married according to the law can be just as correctly divorced according to the law, which does not alter his fundamental attitude one iota. The old picture has merely received a new frame.

[321] As a matter of fact, this arrangement is a very common method of implementing a separation—and of hampering a final solution. Therefore it is more reasonable not to assume that such an obvious possibility is the end-purpose of the separation. We would be better advised to investigate what is behind the tendencies of the anima. The first step is what I would call the objectivation of the anima, that is, the strict

refusal to regard the trend towards separation as a weakness of one's own. Only when this has been done can one face the anima with the question, "Why do you want this separation?" To put the question in this personal way has the great advantage of recognizing the anima as a personality, and of making a relationship possible. The more personally she is taken the better.

[322] To anyone accustomed to proceed purely intellectually and rationally, this may seem altogether too ridiculous. It would indeed be the height of absurdity if a man tried to have a conversation with his persona, which he recognized merely as a psychological means of relationship. But it is absurd only for the man who *has* a persona. If he has none, he is in this point no different from the primitive who, as we know, has only one foot in what we commonly call reality. With the other foot he stands in a world of spirits, which is quite real to him. Our model case behaves, in the world, like a modern European; but in the world of spirits he is the child of a troglodyte. He must therefore submit to living in a kind of prehistoric kindergarten until he has got the right idea of the powers and factors which rule that other world. Hence he is quite right to treat the anima as an autonomous personality and to address personal questions to her.

[323] I mean this as an actual technique. We know that practically every one has not only the peculiarity, but also the faculty, of holding a conversation with himself. Whenever we are in a predicament we ask ourselves (or whom else?), "What shall I do?" either aloud or beneath our breath, and we (or who else?) supply the answer. Since it is our intention to learn what we can about the foundations of our being, this little matter of living in a metaphor should not bother us. We have to accept it as a symbol of our primitive backwardness (or of such naturalness as is still, mercifully, left to us) that we can, like the Negro, discourse personally with our "snake." The psyche not being a unity but a contradictory multiplicity of complexes, the dissociation required for our dialectics with the anima is not so terribly difficult. The art of it consists only in allowing our invisible partner to make herself heard, in putting the mechanism of expression momentarily at her disposal, without being overcome by the distaste one naturally feels at playing such an apparently ludicrous game with oneself, or by doubts as to the genuineness of the voice of one's interlocutor. This latter point is technically very important: we are so in the habit of identifying ourselves with the thoughts that come to us that we invariably assume we have made them. Curiously enough, it is precisely the most impossible thoughts for which we feel the greatest subjective responsibility. If we were more conscious of the inflexible universal laws that govern even the wildest and most wanton fantasy, we might perhaps be in a better position to see these thoughts above all others as objective occurrences, just as we see dreams, which nobody supposes to be deliberate or arbitrary inventions. It certainly requires the greatest objectivity and absence of

prejudice to give the “other side” the opportunity for perceptible psychic activity. As a result of the repressive attitude of the conscious mind, the other side is driven into indirect and purely symptomatic manifestations, mostly of an emotional kind, and only in moments of overwhelming affectivity can fragments of the unconscious come to the surface in the form of thoughts or images. The inevitable accompanying symptom is that the ego momentarily identifies with these utterances, only to revoke them in the same breath. And, indeed, the things one says when in the grip of an affect sometimes seem very strange and daring. But they are easily forgotten, or wholly denied. This mechanism of deprecation and denial naturally has to be reckoned with if one wants to adopt an objective attitude. The habit of rushing in to correct and criticize is already strong enough in our tradition, and it is as a rule further reinforced by fear—a fear that can be confessed neither to oneself nor to others, a fear of insidious truths, of dangerous knowledge, of disagreeable verifications, in a word, fear of all those things that cause so many of us to flee from being alone with ourselves as from the plague. We say that it is egoistic or “morbid” to be preoccupied with oneself; one’s own company is the worst, “it makes you melancholy”—such are the glowing testimonials accorded to our human make-up. They are evidently deeply ingrained in our Western minds. Whoever thinks in this way has obviously never asked himself what possible pleasure other people could find in the company of such a miserable coward. Starting from the fact that in a state of affect one often surrenders involuntarily to the truths of the other side, would it not be far better to make use of an affect so as to give the other side an opportunity to speak? It could therefore be said just as truly that one should cultivate the art of conversing with oneself in the setting provided by an affect, as though the affect itself were speaking without regard to our rational criticism. So long as the affect is speaking, criticism must be withheld. But once it has presented its case, we should begin criticizing as conscientiously as though a real person closely connected with us were our interlocutor. Nor should the matter rest there, but statement and answer must follow one another until a satisfactory end to the discussion is reached. Whether the result is satisfactory or not, only subjective feeling can decide. Any humbug is of course quite useless. Scrupulous honesty with oneself and no rash anticipation of what the other side might conceivably say are the indispensable conditions of this technique for educating the anima.

[324] There is, however, something to be said for this characteristically Western fear of the other side. It is not entirely without justification, quite apart from the fact that it is real. We can understand at once the fear that the child and the primitive have of the great unknown. We have the same childish fear of our inner side, where we likewise touch upon a great unknown world. All we have is the affect, the fear, without knowing that this is a world-fear—for the world of affects is invisible. We have either

purely theoretical prejudices against it, or superstitious ideas. One cannot even talk about the unconscious before many educated people without being accused of mysticism. The fear is legitimate in so far as our rational *Weltanschauung* with its scientific and moral certitudes—so hotly believed in because so deeply questionable—is shattered by the facts of the other side. If only one could avoid them, then the emphatic advice of the Philistine to “let sleeping dogs lie” would be the only truth worth advocating. And here I would expressly point out that I am not recommending the above technique as either necessary or even useful to any person not driven to it by necessity. The stages, as I said, are many, and there are greybeards who die as innocent as babes in arms, and in this year of grace troglodytes are still being born. There are truths which belong to the future, truths which belong to the past, and truths which belong to no time.

[325] I can imagine someone using this technique out of a kind of holy inquisitiveness, some youth, perhaps, who would like to set wings to his feet, not because of lameness, but because he yearns for the sun. But a grown man, with too many illusions dissipated, will submit to this inner humiliation and surrender only if forced, for why should he let the terrors of childhood again have their way with him? It is no light matter to stand between a day-world of exploded ideals and discredited values, and a night-world of apparently senseless fantasy. The weirdness of this standpoint is in fact so great that there is probably nobody who does not reach out for security, even though it be a reaching back to the mother who shielded his childhood from the terrors of night. Whoever is afraid must needs be dependent; a weak thing needs support. That is why the primitive mind, from deep psychological necessity, begot religious instruction and embodied it in magician and priest. *Extra ecclesiam nulla salus* is still a valid truth today—for those who can go back to it. For the few who cannot, there is only dependence upon a human being, a humbler and a prouder dependence, a weaker and a stronger support, so it seems to me, than any other. What can one say of the Protestant? He has neither church nor priest, but only God—and even God becomes doubtful.

[326] The reader may ask in some consternation, “But what on earth does the anima do, that such double insurances are needed before one can come to terms with her?” I would recommend my reader to study the comparative history of religion so intently as to fill these dead chronicles with the emotional life of those who lived these religions. Then he will get some idea of what lives on the other side. The old religions with their sublime and ridiculous, their friendly and fiendish symbols did not drop from the blue, but were born of this human soul that dwells within us at this moment. All those things, their primal forms, live on in us and may at any time burst in upon us with annihilating force, in the guise of mass-suggestions against which the individual is defenceless. Our fearsome gods have only changed their names: they

now rhyme with *ism*. Or has anyone the nerve to claim that the World War or Bolshevism was an ingenious invention? Just as outwardly we live in a world where a whole continent may be submerged at any moment, or a pole be shifted, or a new pestilence break out, so inwardly we live in a world where at any moment something similar may occur, albeit in the form of an idea, but no less dangerous and untrustworthy for that. Failure to adapt to this inner world is a negligence entailing just as serious consequences as ignorance and ineptitude in the outer world. It is after all only a tiny fraction of humanity, living mainly on that thickly populated peninsula of Asia which juts out into the Atlantic Ocean, and calling themselves “cultured,” who, because they lack all contact with nature, have hit upon the idea that religion is a peculiar kind of mental disturbance of undiscoverable purport. Viewed from a safe distance, say from central Africa or Tibet, it would certainly look as if this fraction had projected its own unconscious mental derangements upon nations still possessed of healthy instincts.

[327] Because the things of the inner world influence us all the more powerfully for being unconscious, it is essential for anyone who intends to make progress in self-culture (and does not all culture begin with the individual?) to objectivate the effects of the anima and then try to understand what contents underlie those effects. In this way he adapts to, and is protected against, the invisible. No adaptation can result without concessions to both worlds. From a consideration of the claims of the inner and outer worlds, or rather, from the conflict between them, the possible and the necessary follows. Unfortunately our Western mind, lacking all culture in this respect, has never yet devised a concept, nor even a name, for the *union of opposites through the middle path*, that most fundamental item of inward experience, which could respectably be set against the Chinese concept of Tao. It is at once the most individual fact and the most universal, the most legitimate fulfilment of the meaning of the individual’s life.

[328] In the course of my exposition so far, I have kept exclusively to *masculine* psychology. The anima, being of feminine gender, is exclusively a figure that compensates the masculine consciousness. In woman the compensating figure is of a masculine character, and can therefore appropriately be termed the *animus*. If it was no easy task to describe what is meant by the anima, the difficulties become almost insuperable when we set out to describe the psychology of the animus.

[329] The fact that a man naïvely ascribes his anima reactions to himself, without seeing that he really cannot identify himself with an autonomous complex, is repeated in feminine psychology, though if possible in even more marked form. This identification with an autonomous complex is the essential reason why it is so difficult to understand and describe the problem, quite apart from its inherent

obscurity and strangeness. We always start with the naïve assumption that we are masters in our own house. Hence we must first accustom ourselves to the thought that, in our most intimate psychic life as well, we live in a kind of house which has doors and windows to the world, but that, although the objects or contents of this world act upon us, they do not belong to us. For many people this hypothesis is by no means easy to conceive, just as they do not find it at all easy to understand and to accept the fact that their neighbour's psychology is not necessarily identical with their own. My reader may think that the last remark is something of an exaggeration, since in general one is aware of individual differences. But it must be remembered that our individual conscious psychology develops out of an original state of unconsciousness and therefore of non-differentiation (termed by Lévy-Bruhl *participation mystique*). Consequently, consciousness of differentiation is a relatively late achievement of mankind, and presumably but a relatively small sector of the indefinitely large field of original identity. Differentiation is the essence, the *sine qua non* of consciousness. Everything unconscious is undifferentiated, and everything that happens unconsciously proceeds on the basis of non-differentiation—that is to say, there is no determining whether it belongs or does not belong to oneself. It cannot be established *a priori* whether it concerns me, or another, or both. Nor does feeling give us any sure clues in this respect.

[330] An inferior consciousness cannot *eo ipso* be ascribed to women; it is merely different from masculine consciousness. But, just as a woman is often clearly conscious of things which a man is still groping for in the dark, so there are naturally fields of experience in a man which, for woman, are still wrapped in the shadows of non-differentiation, chiefly things in which she has little interest. Personal relations are as a rule more important and interesting to her than objective facts and their interconnections. The wide fields of commerce, politics, technology, and science, the whole realm of the applied masculine mind, she relegates to the penumbra of consciousness; while, on the other hand, she develops a minute consciousness of personal relationships, the infinite nuances of which usually escape the man entirely.

[331] We must therefore expect the unconscious of woman to show aspects essentially different from those found in man. If I were to attempt to put in a nutshell the difference between man and woman in this respect, i.e., what it is that characterizes the animus as opposed to the anima, I could only say this: as the anima produces *moods*, so the animus produces *opinions*; and as the moods of a man issue from a shadowy background, so the opinions of a woman rest on equally unconscious prior assumptions. Animus opinions very often have the character of solid convictions that are not lightly shaken, or of principles whose validity is seemingly unassailable. If we analyse these opinions, we immediately come upon unconscious assumptions whose existence must first be inferred; that is to say, the opinions are apparently

conceived *as though* such assumptions existed. But in reality the opinions are not thought out at all; they exist ready made, and they are held so positively and with so much conviction that the woman never has the shadow of a doubt about them.

[332] One would be inclined to suppose that the animus, like the anima, personifies itself in a single figure. But this, as experience shows, is true only up to a point, because another factor unexpectedly makes its appearance, which brings about an essentially different situation from that existing in a man. The animus does not appear as one person, but as a plurality of persons. In H. G. Wells' novel *Christina Alberta's Father*, the heroine, in all that she does or does not do, is constantly under the surveillance of a supreme moral authority, which tells her with remorseless precision and dry matter-of-factness what she is doing and for what motives. Wells calls this authority a "Court of Conscience." This collection of condemnatory judges, a sort of College of Preceptors, corresponds to a personification of the animus. The animus is rather like an assembly of fathers or dignitaries of some kind who lay down incontestable, "rational," *ex cathedra* judgments. On closer examination these exacting judgments turn out to be largely sayings and opinions scraped together more or less unconsciously from childhood on, and compressed into a canon of average truth, justice, and reasonableness, a compendium of preconceptions which, whenever a conscious and competent judgment is lacking (as not infrequently happens), instantly obliges with an opinion. Sometimes these opinions take the form of so-called sound common sense, sometimes they appear as principles which are like a travesty of education: "People have always done it like this," or "Everybody says it is like that."

[333] It goes without saying that the animus is just as often projected as the anima. The men who are particularly suited to these projections are either walking replicas of God himself, who know all about everything, or else they are misunderstood word-addicts with a vast and windy vocabulary at their command, who translate common or garden reality into the terminology of the sublime. It would be insufficient to characterize the animus merely as a conservative, collective conscience; he is also a neologist who, in flagrant contradiction to his correct opinions, has an extraordinary weakness for difficult and unfamiliar words which act as a pleasant substitute for the odious task of reflection.

[334] Like the anima, the animus is a jealous lover. He is an adept at putting, in place of the real man, an opinion about him, the exceedingly disputable grounds for which are never submitted to criticism. Animus opinions are invariably collective, and they override individuals and individual judgments in exactly the same way as the anima thrusts her emotional anticipations and projections between man and wife. If the woman happens to be pretty, these animus opinions have for the man something

rather touching and childlike about them, which makes him adopt a benevolent, fatherly, professorial manner. But if the woman does not stir his sentimental side, and competence is expected of her rather than appealing helplessness and stupidity, then her animus opinions irritate the man to death, chiefly because they are based on nothing but opinion for opinion's sake, and "everybody has a right to his own opinions." Men can be pretty venomous here, for it is an inescapable fact that the animus always plays up the anima—and *vice versa*, of course—so that all further discussion becomes pointless.

[335] In intellectual women the animus encourages a critical disputatiousness and would-be highbrowism, which, however, consists essentially in harping on some irrelevant weak point and nonsensically making it the main one. Or a perfectly lucid discussion gets tangled up in the most maddening way through the introduction of a quite different and if possible perverse point of view. Without knowing it, such women are solely intent upon exasperating the man and are, in consequence, the more completely at the mercy of the animus. "Unfortunately I am always right," one of these creatures once confessed to me.

[336] However, all these traits, as familiar as they are unsavoury, are simply and solely due to the extraversion of the animus. The animus does not belong to the function of conscious relationship; his function is rather to facilitate relations with the unconscious. Instead of the woman merely associating opinions with external situations—situations which she ought to think about consciously—the animus, as an associative function, should be directed inwards, where it could associate the contents of the unconscious. The technique of coming to terms with the animus is the same in principle as in the case of the anima; only here the woman must learn to criticize and hold her opinions at a distance; not in order to repress them, but, by investigating their origins, to penetrate more deeply into the background, where she will then discover the primordial images, just as the man does in his dealings with the anima. The animus is the deposit, as it were, of all woman's ancestral experiences of man—and not only that, he is also a creative and procreative being, not in the sense of masculine creativity, but in the sense that he brings forth something we might call the *λόγος σπερματικός*, the spermatic word. Just as a man brings forth his work as a complete creation out of his inner feminine nature, so the inner masculine side of a woman brings forth creative seeds which have the power to fertilize the feminine side of the man. This would be the *femme inspiratrice* who, if falsely cultivated, can turn into the worst kind of dogmatist and high-handed pedagogue—a regular "animus hound," as one of my women patients aptly expressed it.

[337] A woman possessed by the animus is always in danger of losing her femininity, her adapted feminine persona, just as a man in like circumstances runs the risk of

effeminacy. These psychic changes of sex are due entirely to the fact that a function which belongs inside has been turned outside. The reason for this perversion is clearly the failure to give adequate recognition to an inner world which stands autonomously opposed to the outer world, and makes just as serious demands on our capacity for adaptation.

[338] With regard to the plurality of the animus as distinguished from what we might call the “uni-personality” of the anima, this remarkable fact seems to me to be a correlate of the conscious attitude. The conscious attitude of woman is in general far more exclusively personal than that of man. Her world is made up of fathers and mothers, brothers and sisters, husbands and children. The rest of the world consists likewise of families, who nod to each other but are, in the main, interested essentially in themselves. The man’s world is the nation, the state, business concerns, etc. His family is simply a means to an end, one of the foundations of the state, and his wife is not necessarily *the* woman for him (at any rate not as the woman means it when she says “my man”). The general means more to him than the personal; his world consists of a multitude of co-ordinated factors, whereas her world, outside her husband, terminates in a sort of cosmic mist. A passionate exclusiveness therefore attaches to the man’s anima, and an indefinite variety to the woman’s animus. Whereas the man has, floating before him, in clear outlines, the alluring form of a Circe or a Calypso, the animus is better expressed as a bevy of Flying Dutchmen or unknown wanderers from over the sea, never quite clearly grasped, protean, given to persistent and violent motion. These personifications appear especially in dreams, though in concrete reality they can be famous tenors, boxing champions, or great men in far-away, unknown cities.

[339] These two crepuscular figures from the dark hinterland of the psyche—truly the semi-grotesque “guardians of the threshold,” to use the pompous jargon of theosophy—can assume an almost inexhaustible number of shapes, enough to fill whole volumes. Their complicated transformations are as rich and strange as the world itself, as manifold as the limitless variety of their conscious correlate, the persona. They inhabit the twilight sphere, and we can just make out that the autonomous complex of anima and animus is essentially a psychological function that has usurped, or rather retained, a “personality” only because this function is itself autonomous and undeveloped. But already we can see how it is possible to break up the personifications, since by making them conscious we convert them into bridges to the unconscious. It is because we are not using them purposefully as functions that they remain personified complexes. So long as they are in this state they must be accepted as relatively independent personalities. They cannot be integrated into consciousness while their contents remain unknown. The purpose of the dialectical process is to bring these contents into the light; and only when this task has been

completed, and the conscious mind has become sufficiently familiar with the unconscious processes reflected in the anima, will the anima be felt simply as a function.

[340] I do not expect every reader to grasp right away what is meant by animus and anima. But I hope he will at least have gained the impression that it is not a question of anything “metaphysical,” but far rather of empirical facts which could equally well be expressed in rational and abstract language. I have purposely avoided too abstract a terminology because, in matters of this kind, which hitherto have been so inaccessible to our experience, it is useless to present the reader with an intellectual formulation. It is far more to the point to give him some conception of what the actual possibilities of experience are. Nobody can really understand these things unless he has experienced them himself. I am therefore much more interested in pointing out the possible ways to such experience than in devising intellectual formulae which, for lack of experience, must necessarily remain an empty web of words. Unfortunately there are all too many who learn the words by heart and add the experiences in their heads, thereafter abandoning themselves, according to temperament, either to credulity or to criticism. We are concerned here with a new questioning, a new—and yet age-old—field of psychological experience. We shall be able to establish relatively valid theories about it only when the corresponding psychological facts are known to a sufficient number of people. The first things to be discovered are always facts, not theories. Theory-building is the outcome of discussion among many.

III

THE TECHNIQUE OF DIFFERENTIATION BETWEEN THE EGO AND THE FIGURES OF THE UNCONSCIOUS

[341] I owe it to the reader to give him a detailed example of the specific activity of animus and anima. Unfortunately this material is so enormous and demands so much explanation of symbols that I cannot include such an account within the compass of this essay. I have, however, published some of these products with all their symbolical associations in a separate work,¹ and to this I must refer the reader. In that book I said nothing about the animus, because at that time this function was still unknown to me. Nevertheless, if I advise a woman patient to associate her unconscious contents, she will always produce the same kind of fantasy. The masculine hero figure who almost unfailingly appears is the animus, and the succession of fantasy-experiences demonstrates the gradual transformation and dissolution of the autonomous complex.

[342] This transformation is the aim of the analysis of the unconscious. If there is no transformation, it means that the determining influence of the unconscious is unabated, and that it will in some cases persist in maintaining neurotic symptoms in spite of all our analysis and all our understanding. Alternatively, a compulsive transference will take hold, which is just as bad as a neurosis. Obviously in such cases no amount of suggestion, good will, and purely reductive understanding has helped to break the power of the unconscious. This is not to say—once again I would like to emphasize this point very clearly—that all psychotherapeutic methods are, by and large, useless. I merely want to stress the fact that there are not a few cases where the doctor has to make up his mind to deal fundamentally with the unconscious, to come to a real settlement with it. This is of course something very different from interpretation. In the latter case it is taken for granted that the doctor *knows* beforehand, so as to be able to interpret. But in the case of a real settlement it is not a question of interpretation: it is a question of releasing unconscious processes and letting them come into the conscious mind in the form of fantasies. We can try our hand at interpreting these fantasies if we like. In many cases it may be quite important for the patient to have some idea of the meaning of the fantasies produced. But it is of vital importance that he should experience them to the full and, in so far as intellectual understanding belongs to the totality of experience, also understand them. Yet I would not give priority to understanding. Naturally the doctor must be able to assist the patient in his understanding, but, since he will not and indeed cannot

understand everything, the doctor should assiduously guard against clever feats of interpretation. For the important thing is not to interpret and understand the fantasies, but primarily to experience them. Alfred Kubin has given a very good description of the unconscious in his book *Die andere Seite*; that is, he has described what he, as an artist, experienced of the unconscious. It is an artistic experience which, in the deeper meaning of human experience, is incomplete. I would like to recommend an attentive reading of this book to everybody who is interested in these questions. He will then discover the incompleteness I speak of: the vision is experienced artistically, but not humanly. By "human" experience I mean that the person of the author should not just be included passively in the vision, but that he should face the figures of the vision actively and reactively, with full consciousness. I would level the same criticism at the authoress of the fantasies dealt with in the book mentioned above; she, too, merely stands opposite the fantasies forming themselves out of the unconscious, perceiving them, or at best passively enduring them. But a real settlement with the unconscious demands a firmly opposed conscious standpoint.

[343] I will try to explain what I mean by an example. One of my patients had the following fantasy: *He sees his fiancée running down the road towards the river. It is winter, and the river is frozen. She runs out on the ice, and he follows her. She goes right out, and then the ice breaks, a dark fissure appears, and he is afraid she is going to jump in. And that is what happens: she jumps into the crack, and he watches her sadly.*

[344] This fragment, although torn out of its context, clearly shows the attitude of the conscious mind: it perceives and passively endures, the fantasy-image is merely seen and felt, it is two-dimensional, as it were, because the patient is not sufficiently involved. Therefore the fantasy remains a flat image, concrete and agitating perhaps, but unreal, like a dream. This unreality comes from the fact that he himself is not playing an active part. If the fantasy happened in reality, he would not be at a loss for some means to prevent his fiancée from committing suicide. He could, for instance, easily overtake her and restrain her bodily from jumping into the crack. Were he to act in reality as he acted in the fantasy, he would obviously be paralysed, either with horror, or because of the unconscious thought that he really has no objection to her committing suicide. The fact that he remains passive in the fantasy merely expresses his attitude to the activity of the unconscious in general: he is fascinated and stupefied by it. In reality he suffers from all sorts of depressive ideas and convictions; he thinks he is no good, that he has some hopeless hereditary taint, that his brain is degenerating, etc. These negative feelings are so many auto-suggestions which he accepts without argument. Intellectually, he can understand them perfectly and recognize them as untrue, but nevertheless the feelings persist. They cannot be attacked by the intellect because they have no intellectual or rational basis; they are

rooted in an unconscious, irrational fantasy-life which is not amenable to conscious criticism. In these cases the unconscious must be given an opportunity to produce its fantasies, and the above fragment is just such a product of unconscious fantasy activity. Since the case was one of psychogenic depression, the depression itself was due to fantasies of whose existence the patient was totally unconscious. In genuine melancholia, extreme exhaustion, poisoning, etc., the situation would be reversed: the patient has such fantasies because he is in a depressed condition. But in a case of psychogenic depression he is depressed because he has such fantasies. My patient was a very clever young man who had been intellectually enlightened as to the cause of his neurosis by a lengthy analysis. However, intellectual understanding made no difference to his depression. In cases of this sort the doctor should spare himself the useless trouble of delving still further into the causality; for, when a more or less exhaustive understanding is of no avail, the discovery of yet another little bit of causality will be of no avail either. The unconscious has simply gained an unassailable ascendancy; it wields an attractive force that can invalidate all conscious contents—in other words, it can withdraw libido from the conscious world and thereby produce a “depression,” an *abaissement du niveau mental* (Janet). But as a result of this we must, according to the law of energy, expect an accumulation of value—i.e., libido—in the unconscious.

[345] Libido can never be apprehended except in a definite form; that is to say, it is identical with fantasy-images. And we can only release it from the grip of the unconscious by bringing up the corresponding fantasy-images. That is why, in a case like this, we give the unconscious a chance to bring its fantasies to the surface. This is how the foregoing fragment was produced. It is a single episode from a long and very intricate series of fantasy-images, corresponding to the quota of energy that was lost to the conscious mind and its contents. The patient’s conscious world has become cold, empty, and grey; but his unconscious is activated, powerful, and rich. It is characteristic of the nature of the unconscious psyche that it is sufficient unto itself and knows no human considerations. Once a thing has fallen into the unconscious it is retained there, regardless of whether the conscious mind suffers or not. The latter can hunger and freeze, while everything in the unconscious becomes verdant and blossoms.

[346] So at least it appears at first. But when we look deeper, we find that this unconcern of the unconscious has a meaning, indeed a purpose and a goal. There are psychic goals that lie beyond the conscious goals; in fact, they may even be inimical to them. But we find that the unconscious has an inimical or ruthless bearing towards the conscious only when the latter adopts a false or pretentious attitude.

[347] The conscious attitude of my patient is so one-sidedly intellectual and rational that nature herself rises up against him and annihilates his whole world of conscious values. But he cannot de-intellectualize himself and make himself dependent on another function, e.g., feeling, for the very simple reason that he has not got it. The unconscious has it. Therefore we have no alternative but to hand over the leadership to the unconscious and give it the opportunity of becoming a conscious content in the form of fantasies. If, formerly, my patient clung to his intellectual world and defended himself with rationalizations against what he regarded as his illness, he must now yield himself up to it entirely, and when a fit of depression comes upon him, he must no longer force himself to some kind of work in order to forget, but must accept his depression and give it a hearing.

[348] Now this is the direct opposite of succumbing to a mood, which is so typical of neurosis. It is no weakness, no spineless surrender, but a hard achievement, the essence of which consists in keeping your objectivity despite the temptations of the mood, and in making the mood your object, instead of allowing it to become in you the dominating subject. So the patient must try to get his mood to speak to him; his mood must tell him all about itself and show him through what kind of fantastic analogies it is expressing itself.

[349] The foregoing fragment is a bit of visualized mood. If he had not succeeded in keeping his objectivity in relation to his mood, he would have had, in place of the fantasy-image, only a crippling sense that everything was going to the devil, that he was incurable, etc. But because he gave his mood a chance to express itself in an image, he succeeded in converting at least a small sum of libido, of unconscious creative energy in eidetic form, into a conscious content and thus withdrawing it from the sphere of the unconscious.

[350] But this effort is not enough, for the fantasy, to be completely experienced, demands not just perception and passivity, but active participation. The patient would comply with this demand if he conducted himself in the fantasy as he would doubtless conduct himself in reality. He would never remain an idle spectator while his fiancée tried to drown herself; he would leap up and stop her. This should also happen in the fantasy. If he succeeds in behaving in the fantasy as he would behave in a similar situation in reality, he would prove that he was taking the fantasy seriously, i.e., assigning absolute reality value to the unconscious. In this way he would have won a victory over his one-sided intellectualism and, indirectly, would have asserted the validity of the irrational standpoint of the unconscious.

[351] That would be the complete experience of the unconscious demanded of him. But one must not underestimate what that actually means: your whole world is menaced by fantastic irreality. It is almost insuperably difficult to forget, even for a moment,

that all this is only fantasy, a figment of the imagination that must strike one as altogether arbitrary and artificial. How can one assert that anything of this kind is “real” and take it seriously?

[352] We can hardly be expected to believe in a sort of double life, in which we conduct ourselves on one plane as modest average citizens, while on another we have unbelievable adventures and perform heroic deeds. In other words, we must not concretize our fantasies. But there is in man a strange propensity to do just this, and all his aversion to fantasy and his critical depreciation of the unconscious come solely from the deep-rooted fear of this tendency. Concretization and the fear of it are both primitive superstitions, but they still survive in the liveliest form among so-called enlightened people. In his civic life a man may follow the trade of a shoemaker, but as the member of a sect he puts on the dignity of an archangel. To all appearances he is a small tradesman, but among the freemasons he is a mysterious grandee. Another sits all day in his office; at evening, in his circle, he is a reincarnation of Julius Caesar, fallible as a man, but in his official capacity infallible. These are all unintentional concretizations.

[353] As against this, the scientific credo of our time has developed a superstitious phobia about fantasy. But the real is what works. And the fantasies of the unconscious work, there can be no doubt about that. Even the cleverest philosopher can be the victim of a thoroughly idiotic agoraphobia. Our famous scientific reality does not afford us the slightest protection against the so-called irreality of the unconscious. Something works behind the veil of fantastic images, whether we give this something a good name or a bad. It is something real, and for this reason its manifestations must be taken seriously. But first the tendency to concretization must be overcome; in other words, we must not take the fantasies literally when we approach the question of interpreting them. While we are in the grip of the actual experience, the fantasies cannot be taken literally enough. But when it comes to understanding them, we must on no account mistake the semblance, the fantasy-image as such, for the operative process underlying it. The semblance is not the thing itself, but only its expression.

[354] Thus my patient is not experiencing the suicide scene “on another plane” (though in every other respect it is just as concrete as a real suicide); he experiences something real which looks like a suicide. The two opposing “realities,” the world of the conscious and the world of the unconscious, do not quarrel for supremacy, but each makes the other relative. That the reality of the unconscious is very relative indeed will presumably arouse no violent contradiction; but that the reality of the conscious world could be doubted will be accepted with less alacrity. And yet both

“realities” are psychic experience, psychic semblances painted on an inscrutably dark back-cloth. To the critical intelligence, nothing is left of *absolute* reality.

[355] Of the essence of things, of absolute being, we know nothing. But we experience various effects: from “outside” by way of the senses, from “inside” by way of fantasy. We would never think of asserting that the colour “green” had an independent existence; similarly we ought never to imagine that a fantasy-experience exists in and for itself, and is therefore to be taken quite literally. It is an expression, an appearance standing for something unknown but real. The fantasy-fragment I have mentioned coincides in time with a wave of depression and desperation, and this event finds expression in the fantasy. The patient really does have a fiancée; for him she represents the one emotional link with the world. Snap that link, and it would be the end of his relation to the world. This would be an altogether hopeless aspect. But his fiancée is also a symbol for his anima, that is, for his relation to the unconscious. Hence the fantasy simultaneously expresses the fact that, without any hindrance on his part, his anima is disappearing again into the unconscious. This aspect shows that once again his mood is stronger than he is. It throws everything to the winds, while he looks on without lifting a hand. But he could easily step in and arrest the anima.

[356] I give preference to this latter aspect, because the patient is an introvert whose life-relationship is ruled by inner facts. Were he an extravert, I would have to give preference to the first aspect, because for the extravert life is governed primarily by his relation to human beings. He might in the trough of a mood do away with his fiancée and himself too, whereas the introvert harms himself most when he casts off his relation to the anima, i.e., to the object within.

[357] So my patient’s fantasy clearly reveals the negative movement of the unconscious, a tendency to recoil from the conscious world so energetically that it sucks away the libido from consciousness and leaves the latter empty. But, by making the fantasy conscious, we stop this process from happening unconsciously. If the patient were himself to participate actively in the way described above, he would possess himself of the libido invested in the fantasy, and would thus gain added influence over the unconscious.

[358] Continual conscious realization of unconscious fantasies, together with active participation in the fantastic events, has, as I have witnessed in a very large number of cases, the effect firstly of extending the conscious horizon by the inclusion of numerous unconscious contents; secondly of gradually diminishing the dominant influence of the unconscious; and thirdly of bringing about a change of personality.

[359] This change of personality is naturally not an alteration of the original hereditary disposition, but rather a transformation of the general attitude. Those sharp cleavages and antagonisms between conscious and unconscious, such as we see so clearly in the

endless conflicts of neurotic natures, nearly always rest on a noticeable one-sidedness of the conscious attitude, which gives absolute precedence to one or two functions, while the others are unjustly thrust into the background. Conscious realization and experience of fantasies assimilates the unconscious inferior functions to the conscious mind—a process which is naturally not without far-reaching effects on the conscious attitude.

[360] For the moment I will refrain from discussing the nature of this change of personality, since I only want to emphasize the fact that an important change does take place. I have called this change, which is the aim of our analysis of the unconscious, the transcendent function. This remarkable capacity of the human psyche for change, expressed in the transcendent function, is the principal object of late medieval alchemical philosophy, where it was expressed in terms of alchemical symbolism. Herbert Silberer, in his very able book *Problems of Mysticism and Its Symbolism*, has already pointed out the psychological content of alchemy. It would be an unpardonable error to accept the current view and reduce these “alchymical” strivings to a mere matter of alembics and melting-pots. This side certainly existed; it represented the tentative beginnings of exact chemistry. But alchemy also had a spiritual side which must not be underestimated and whose psychological value has not yet been sufficiently appreciated: there was an “alchymical” philosophy, the groping precursor of the most modern psychology. The secret of alchemy was in fact the transcendent function, the transformation of personality through the blending and fusion of the noble with the base components, of the differentiated with the inferior functions, of the conscious with the unconscious.

[361] But, just as the beginnings of scientific chemistry were hopelessly distorted and confused by fantastic conceits and whimsicalities, so alchemical philosophy, hampered by the inevitable concretizations of the still crude and undifferentiated intellect, never advanced to any clear psychological formulation, despite the fact that the liveliest intuition of profound truths kept the medieval thinker passionately attached to the problems of alchemy. No one who has undergone the process of assimilating the unconscious will deny that it gripped his very vitals and changed him.

[362] I would not blame my reader at all if he shakes his head dubiously at this point, being quite unable to imagine how such a *quantité négligeable* as the footling fantasy given above could ever have the slightest influence on anybody. I admit at once that in considering the transcendent function and the extraordinary influence attributed to it, the fragment we have quoted is anything but illuminating. But it is—and here I must appeal to the benevolent understanding of my reader—exceedingly difficult to give any examples, because every example has the unfortunate characteristic of being

impressive and significant only to the individual concerned. Therefore I always advise my patients not to cherish the naïve belief that what is of the greatest significance to them personally also has objective significance.

[363] The vast majority of people are quite incapable of putting themselves individually into the mind of another. This is indeed a singularly rare art, and, truth to tell, it does not take us very far. Even the man whom we think we know best and who assures us himself that we understand him through and through is at bottom a stranger to us. He is *different*. The most we can do, and the best, is to have at least some inkling of his otherness, to respect it, and to guard against the outrageous stupidity of wishing to interpret it.

[364] I can, therefore, produce nothing convincing, nothing that would convince the reader as it convinces the man whose deepest experience it is. We must simply believe it by reason of its analogy with our own experience. Ultimately, when all else fails, the end-result is plain beyond a doubt: the perceptible change of personality. With these reservations in mind, I would like to present the reader with another fantasy-fragment, this time from a woman. The difference from the previous example leaps to the eye: here the experience is total, the observer takes an active part and thus makes the process her own. The material in this case is very extensive, culminating in a profound transformation of personality. The fragment comes from a late phase of personal development and is an organic part of a long and continuous series of transformations which have as their goal the attainment of the mid-point of the personality.

[365] It may not be immediately apparent what is meant by a “mid-point of the personality.” I will therefore try to outline this problem in a few words. If we picture the conscious mind, with the ego as its centre, as being opposed to the unconscious, and if we now add to our mental picture the process of assimilating the unconscious, we can think of this assimilation as a kind of approximation of conscious and unconscious, where the centre of the total personality no longer coincides with the ego, but with a point midway between the conscious and the unconscious. This would be the point of new equilibrium, a new centering of the total personality, a virtual centre which, on account of its focal position between conscious and unconscious, ensures for the personality a new and more solid foundation. I freely admit that visualizations of this kind are no more than the clumsy attempts of the unskilled mind to give expression to inexpressible, and well-nigh indescribable, psychological facts. I could say the same thing in the words of St. Paul: “Yet not I live, but Christ liveth in me.” Or I might invoke Lao-tzu and appropriate his concept of Tao, the Middle Way and creative centre of all things. In all these the same thing is meant. Speaking as a psychologist with a scientific conscience, I must say at once

that these things are psychic factors of undeniable power; they are not the inventions of an idle mind, but definite psychic events obeying definite laws and having their legitimate causes and effects, which can be found among the most widely differing peoples and races today, as thousands of years ago. I have no theory as to what constitutes the nature of these processes. One would first have to know what constitutes the nature of the psyche. I am content simply to state the facts.

[366] Coming now to our example: it concerns a fantasy of intensely visual character, something which in the language of the ancients would be called a “vision.” Not a “vision seen in a dream,” but a vision perceived by intense concentration on the background of consciousness, a technique that is perfected only after long practice.² Told in her own words, this is what the patient saw:

“I climbed the mountain and came to a place where I saw seven red stones in front of me, seven on either side, and seven behind me. I stood in the middle of this quadrangle. The stones were flat like steps. I tried to lift the four stones nearest me. In doing so I discovered that these stones were the pedestals of four statues of gods buried upside down in the earth. I dug them up and arranged them about me so that I was standing in the middle of them. Suddenly they leaned towards one another until their heads touched, forming something like a tent over me. I myself fell to the ground and said, ‘Fall upon me if you must! I am tired.’ Then I saw that beyond, encircling the four gods, a ring of flame had formed. After a time I got up from the ground and overthrew the statues of the gods. Where they fell, four trees shot up. At that blue flames leapt up from the ring of fire and began to burn the foliage of the trees. Seeing this I said, ‘This must stop. I must go into the fire myself so that the leaves shall not be burned.’ Then I stepped into the fire. The trees vanished and the fiery ring drew together to one immense blue flame that carried me up from the earth.”

[367] Here the vision ended. Unfortunately I cannot see how I can make conclusively clear to the reader the extraordinarily interesting meaning of this vision. The fragment is an excerpt from a long sequence, and one would have to explain everything that happened before and afterwards, in order to grasp the significance of the picture. At all events the unprejudiced reader will recognize at once the idea of a “mid-point” that is reached by a kind of climb (mountaineering, effort, struggle, etc.). He will also recognize without difficulty the famous medieval conundrum of the squaring of the circle, which belongs to the field of alchemy. Here it takes its rightful place as a symbol of individuation. The total personality is indicated by the four cardinal points, the four gods, i.e., the four functions which give bearings in psychic space, and also by the circle enclosing the whole. Overcoming the four gods who threaten to smother the individual signifies liberation from identification with the

four functions, a fourfold *nirdvandva* (“free from opposites”) followed by an approximation to the circle, to undivided wholeness. This in its turn leads to further exaltation.

[368] I must content myself with these hints. Anyone who takes the trouble to reflect upon the matter will be able to form a rough idea of how the transformation of personality proceeds. Through her active participation the patient merges herself in the unconscious processes, and she gains possession of them by allowing them to possess her. In this way she joins the conscious to the unconscious. The result is ascension in the flame, transmutation in the alchemical heat, the genesis of the “subtle spirit.” That is the transcendent function born of the union of opposites.

[369] I must recall at this point a serious misunderstanding to which my readers often succumb, and doctors most commonly. They invariably assume, for reasons unknown, that I never write about anything except my method of treatment. This is far from being the case. I write about *psychology*. I must therefore expressly emphasize that my method of treatment does not consist in causing my patients to indulge in strange fantasies for the purpose of changing their personality, and other nonsense of that kind. I merely put it on record that there are certain cases where such a development occurs, not because I force anyone to it, but because it springs from inner necessity. For many of my patients these things are and must remain double Dutch. Indeed, even if it were possible for them to tread this path, it would be a disastrously wrong turning, and I would be the first to hold them back. The way of the transcendent function is an individual destiny. But on no account should one imagine that this way is equivalent to the life of a psychic anchorite, to alienation from the world. Quite the contrary, for such a way is possible and profitable only when the specific worldly tasks which these individuals set themselves are carried out in reality. Fantasies are no substitute for living; they are fruits of the spirit which fall to him who pays his tribute to life. The shirker experiences nothing but his own morbid fear, and it yields him no meaning. Nor will this way ever be known to the man who has found his way back to Mother Church. There is no doubt that the *mysterium magnum* is hidden in her forms, and in these he can live his life sensibly. Finally, the normal man will never be burdened, either, with this knowledge, for he is everlastingly content with the little that lies within his reach. Wherefore I entreat my reader to understand that I write about things which actually happen, and am not propounding methods of treatment.

[370] These two examples of fantasy represent the positive activity of anima and animus. To the degree that the patient takes an active part, the personified figure of anima or animus will disappear. It becomes the function of relationship between conscious and unconscious. But when the unconscious contents—these same

fantasies—are not “realized,” they give rise to a negative activity and personification, i.e., to the autonomy of animus and anima. Psychic abnormalities then develop, states of possession ranging in degree from ordinary moods and “ideas” to psychoses. All these states are characterized by one and the same fact that an unknown “something” has taken possession of a smaller or greater portion of the psyche and asserts its hateful and harmful existence undeterred by all our insight, reason, and energy, thereby proclaiming the power of the unconscious over the conscious mind, the sovereign power of possession. In this state the possessed part of the psyche generally develops an animus or anima psychology. The woman’s incubus consists of a host of masculine demons; the man’s succubus is a vampire.

[371] This particular concept of a soul which, according to the conscious attitude, either exists by itself or disappears in a function, has, as anyone can see, not the remotest connection with the Christian concept of the soul.

[372] The second fantasy is a typical example of the kind of content produced by the collective unconscious. Although the form is entirely subjective and individual, the substance is none the less collective, being composed of universal images and ideas common to the generality of men, components, therefore, by which the individual is assimilated to the rest of mankind. If these contents remain unconscious, the individual is, in them, unconsciously commingled with other individuals—in other words, he is not differentiated, not individuated.

[373] Here one may ask, perhaps, why it is so desirable that a man should be individuated. Not only is it desirable, it is absolutely indispensable because, through his contamination with others, he falls into situations and commits actions which bring him into disharmony with himself. From all states of unconscious contamination and non-differentiation there is begotten a compulsion to be and to act in a way contrary to one’s own nature. Accordingly a man can neither be at one with himself nor accept responsibility for himself. He feels himself to be in a degrading, unfree, unethical condition. But the disharmony with himself is precisely the neurotic and intolerable condition from which he seeks to be delivered, and deliverance from this condition will come only when he can be and act as he feels is conformable with his true self. People have a feeling for these things, dim and uncertain at first, but growing ever stronger and clearer with progressive development. When a man can say of his states and actions, “As I am, so I act,” he can be at one with himself, even though it be difficult, and he can accept responsibility for himself even though he struggles against it. We must recognize that nothing is more difficult to bear with than oneself. (“You sought the heaviest burden, and found yourself,” says Nietzsche.) Yet even this most difficult of achievements becomes possible if we can distinguish ourselves from the unconscious contents. The introvert discovers these contents in

himself, the extravert finds them projected upon human objects. In both cases the unconscious contents are the cause of blinding illusions which falsify ourselves and our relations to our fellow men, making both unreal. For these reasons individuation is indispensable for certain people, not only as a therapeutic necessity, but as a high ideal, an idea of the best we can do. Nor should I omit to remark that it is at the same time the primitive Christian ideal of the Kingdom of Heaven which "is within you." The idea at the bottom of this ideal is that right action comes from right thinking, and that there is no cure and no improving of the world that does not begin with the individual himself. To put the matter drastically: the man who is pauper or parasite will never solve the social question.

IV

THE MANA-PERSONALITY

[374] My initial material for the discussion that now follows is taken from cases where the condition that was presented in the previous chapter as the immediate goal has been achieved, namely the conquest of the anima as an autonomous complex, and her transformation into a function of relationship between the conscious and the unconscious. With the attainment of this goal it becomes possible to disengage the ego from all its entanglements with collectivity and the collective unconscious. Through this process the anima forfeits the daemonic power of an autonomous complex; she can no longer exercise the power of possession, since she is depotentiated. She is no longer the guardian of treasures unknown; no longer Kundry, daemonic Messenger of the Grail, half divine and half animal; no longer is the soul to be called “Mistress,” but a psychological function of an intuitive nature, akin to what the primitives mean when they say, “He has gone into the forest to talk with the spirits” or “My snake spoke with me” or, in the mythological language of infancy, “A little bird told me.”

[375] Those of my readers who know Rider Haggard’s description of “She-who-must-be-obeyed” will surely recall the magical power of this personality. “She” is a mana-personality, a being full of some occult and bewitching quality (*mana*), endowed with magical knowledge and power. All these attributes naturally have their source in the naïve projection of an unconscious self-knowledge which, expressed in less poetic terms, would run somewhat as follows: “I recognize that there is some psychic factor active in me which eludes my conscious will in the most incredible manner. It can put extraordinary ideas into my head, induce in me unwanted and unwelcome moods and emotions, lead me to astonishing actions for which I can accept no responsibility, upset my relations with other people in a very irritating way, etc. I feel powerless against this fact and, what is worse, I am in love with it, so that all I can do is marvel.” (Poets often call this the “artistic temperament,” unpoetical folk excuse themselves in other ways.)

[376] Now when the anima loses her mana, what becomes of it? Clearly the man who has mastered the anima acquires her mana, in accordance with the primitive belief that when a man kills the mana-person he assimilates his mana into his own body.

[377] Well then: who is it that has integrated the anima? Obviously the conscious ego, and therefore the ego has taken over the mana. Thus the ego becomes a mana-

personality. But the mana-personality is a dominant of the collective unconscious, the well-known archetype of the mighty man in the form of hero, chief, magician, medicine-man, saint, the ruler of men and spirits, the friend of God.

[378] This masculine collective figure who now rises out of the dark background and takes possession of the conscious personality entails a psychic danger of a subtle nature, for by inflating the conscious mind it can destroy everything that was gained by coming to terms with the anima. It is therefore of no little practical importance to know that in the hierarchy of the unconscious the anima occupies the lowest rank, only one of many possible figures, and that her subjection constellates another collective figure which now takes over her mana. Actually it is the figure of the magician, as I will call it for short, who attracts the mana to himself, i.e., the autonomous valency of the anima. Only in so far as I unconsciously identify with his figure can I imagine that I myself possess the anima's mana. But I will infallibly do so under these circumstances.

[379] The figure of the magician has a no less dangerous equivalent in women: a sublime, matriarchal figure, the Great Mother, the All-Merciful, who understands everything, forgives everything, who always acts for the best, living only for others, and never seeking her own interests, the discoverer of the great love, just as the magician is the mouthpiece of the ultimate truth. And just as the great love is never appreciated, so the great wisdom is never understood. Neither, of course, can stand the sight of the other.

[380] Here is cause for serious misunderstanding, for without a doubt it is a question of inflation. The ego has appropriated something that does not belong to it. But how has it appropriated the mana? If it was really the ego that conquered the anima, then the mana does indeed belong to it, and it would be correct to conclude that one has become important. But why does not this importance, the mana, work upon others? That would surely be an essential criterion! It does not work because one has not in fact become important, but has merely become adulterated with an archetype, another unconscious figure. Hence we must conclude that the ego never conquered the anima at all and therefore has not acquired the mana. All that has happened is a new adulteration, this time with a figure of the same sex corresponding to the father-imago, and possessed of even greater power.

From the power that binds all creatures none is free

Except the man who wins self-mastery!¹

Thus he becomes a superman, superior to all powers, a demigod at the very least. "I and the Father are one"—this mighty avowal in all its awful ambiguity is born of just such a psychological moment.

[381] In the face of this, our pitifully limited ego, if it has but a spark of self-knowledge, can only draw back and rapidly drop all pretence of power and importance. It was a delusion: the conscious mind has not become master of the unconscious, and the anima has forfeited her tyrannical power only to the extent that the ego was able to come to terms with the unconscious. This accommodation, however, was not a victory of the conscious over the unconscious, but the establishment of a balance of power between the two worlds.

[382] Hence the “magician” could take possession of the ego only because the ego dreamed of victory over the anima. That dream was an encroachment, and every encroachment of the ego is followed by an encroachment from the unconscious:

Changing shape from hour to hour

I employ my savage power.²

Consequently, if the ego drops its claim to victory, possession by the magician ceases automatically. But what happens to the mana? Who or what becomes mana when even the magician can no longer work magic? So far we only know that neither the conscious nor the unconscious has mana, for it is certain that when the ego makes no claim to power there is no possession, that is to say, the unconscious too loses its ascendancy. In this situation the mana must have fallen to something that is both conscious and unconscious, or else neither. This something is the desired “mid-point” of the personality, that ineffable something betwixt the opposites, or else that which unites them, or the result of conflict, or the product of energetic tension: the coming to birth of personality, a profoundly individual step forward, the next stage.

[383] I do not expect the reader to have followed this rapid survey of the whole problem in all its parts. He may regard it as a kind of preliminary statement leading up to the more closely reasoned analysis which now follows.

[384] The starting-point of our problem is the condition which results when the unconscious contents that are the efficient cause of the animus and anima phenomenon have become sufficiently assimilated to the conscious mind. This can best be represented in the following way: the unconscious contents are, in the first instance, things belonging to the personal sphere, similar perhaps to the fantasy of the male patient quoted above. Subsequently, fantasies from the impersonal unconscious develop, containing essentially collective symbols more or less similar to the vision of my woman patient. These fantasies are not so wild and unregulated as a naïve intelligence might think; they pursue definite, unconscious lines of direction which converge upon a definite goal. We could therefore most fittingly describe these later series of fantasies as processes of initiation, since these form the closest analogy. All

primitive groups and tribes that are in any way organized have their rites of initiation, often very highly developed, which play an extraordinarily important part in their social and religious life.³ Through these ceremonies boys are made men, and girls women. The Kavirondos stigmatize those who do not submit to circumcision and excision as “animals.” This shows that the initiation ceremonies are a magical means of leading man from the animal state to the human state. They are clearly transformation mysteries of the greatest spiritual significance. Very often the initiands are subjected to excruciating treatment, and at the same time the tribal mysteries are imparted to them, the laws and hierarchy of the tribe on the one hand, and on the other the cosmogonic and mythical doctrines. Initiations have survived among all cultures. In Greece the ancient Eleusinian mysteries were preserved, it seems, right into the seventh century of our era. Rome was flooded with mystery religions. Of these Christianity was one, and even in its present form it still preserves the old initiation ceremonies, somewhat faded and degenerated, in the rites of baptism, confirmation, and communion. Hence nobody is in a position to deny the enormous historical importance of initiations.

[385] Modern men have absolutely nothing to compare with this (consider the testimonies of the ancients in regard to the Eleusinian mysteries). Freemasonry, *l'Église gnostique de la France*, legendary Rosicrucians, theosophy, and so forth are all feeble substitutes for something that were better marked up in red letters on the historical casualty list. The fact is that the whole symbolism of initiation rises up, clear and unmistakable, in the unconscious contents. The objection that this is antiquated superstition and altogether unscientific is about as intelligent as remarking, in the presence of a cholera epidemic, that it is merely an infectious disease and exceedingly unhygienic. The point is not—I cannot be too emphatic about this—whether the initiation symbols are objective truths, but whether these unconscious contents are or are not the equivalents of initiation practices, and whether they do or do not influence the human psyche. Nor is it a question of whether they are desirable or not. It is enough that they exist and that they work.

[386] Since it is not possible in this connection to put before the reader in detail these sometimes very lengthy sequences of images, I trust he will be content with the few examples already given and, for the rest, accept my statement that they are logically constructed, purposive sequences. I must own that I use the word “purposive” with some hesitation. This word needs to be used cautiously and with reserve. For in mental cases we come across dream-sequences, and in neurotics fantasy sequences, which run on in themselves with no apparent aim or purpose. The young man whose suicide fantasy I gave above was in a fair way to produce a string of aimless fantasies, unless he could learn to take an active part and to intervene consciously. Only thus could there be orientation to a goal. From one point of view the

unconscious is a purely natural process without design, but from another it has that potential directedness which is characteristic of all energy processes. When the conscious mind participates actively and experiences each stage of the process, or at least understands it intuitively, then the next image always starts off on the higher level that has been won, and purposiveness develops.

[387] The immediate goal of the analysis of the unconscious, therefore, is to reach a state where the unconscious contents no longer remain unconscious and no longer express themselves indirectly as animus and anima phenomena; that is to say, a state in which animus and anima become functions of relationship to the unconscious. So long as they are not this, they are autonomous complexes, disturbing factors that break through the conscious control and act like true “disturbers of the peace.” Because this is such a well-known fact my term “complex,” as used in this sense, has passed into common speech. The more “complexes” a man has, the more he is possessed; and when we try to form a picture of the personality which expresses itself through his complexes we must admit that it resembles nothing so much as an hysterical woman—i.e., the anima! But if such a man makes himself conscious of his unconscious contents, as they appear firstly in the factual contents of his personal unconscious, and then in the fantasies of the collective unconscious, he will get to the roots of his complexes, and in this way rid himself of his possession. With that the anima phenomenon comes to a stop.

[388] That superior power, however, which caused the possession—for what I cannot shake off must in some sense be superior to me—should, logically, disappear with the anima. One should then be “complex-free,” psychologically house-trained, so to speak. Nothing more should happen that is not sanctioned by the ego, and when the ego wants something, nothing should be capable of interfering. The ego would thus be assured of an impregnable position, the steadfastness of a superman or the sublimity of a perfect sage. Both figures are ideal images: Napoleon on the one hand, Lao-tzu on the other. Both are consistent with the idea of “the extraordinarily potent,” which is the term that Lehmann, in his celebrated monograph,⁴ uses for his definition of mana. I therefore call such a personality simply the *mana-personality*. It corresponds to a dominant of the collective unconscious, to an archetype which has taken shape in the human psyche through untold ages of just that kind of experience. Primitive man does not analyse and does not work out why another is superior to him. If another is cleverer and stronger than he, then he has mana, he is possessed of a stronger power; and by the same token he can lose this power, perhaps because someone has walked over him in his sleep, or stepped on his shadow.

[389] Historically, the mana-personality evolves into the hero and the godlike being,⁵ whose earthly form is the priest. How very much the doctor is still mana is the whole

plaint of the analyst! But in so far as the ego apparently draws to itself the power belonging to the anima, the ego does become a mana-personality. This development is an almost regular phenomenon. I have never yet seen a fairly advanced development of this kind where at least a temporary identification with the archetype of the mana-personality did not take place. It is the most natural thing in the world that this should happen, for not only does one expect it oneself, but everybody else expects it too. One can scarcely help admiring oneself a little for having seen more deeply into things than others, and the others have such an urge to find a tangible hero somewhere, or a superior wise man, a leader and father, some undisputed authority, that they build temples to little tin gods with the greatest promptitude and burn incense upon the altars. This is not just the lamentable stupidity of idolaters incapable of judging for themselves, but a natural psychological law which says that what has once been will always be in the future. And so it will be, unless consciousness puts an end to the naïve concretization of primordial images. I do not know whether it is desirable that consciousness should alter the eternal laws; I only know that occasionally it does alter them, and that this measure is a vital necessity for some people—which, however, does not always prevent these same people from setting themselves up on the father's throne and making the old rule come true. It is indeed hard to see how one can escape the sovereign power of the primordial images.

[390] Actually I do not believe it can be escaped. One can only alter one's attitude and thus save oneself from naively falling into an archetype and being forced to act a part at the expense of one's humanity. Possession by an archetype turns a man into a flat collective figure, a mask behind which he can no longer develop as a human being, but becomes increasingly stunted. One must therefore beware of the danger of falling victim to the dominant of the mana-personality. The danger lies not only in oneself becoming a father-mask, but in being overpowered by this mask when worn by another. Master and pupil are in the same boat in this respect.

[391] The dissolution of the anima means that we have gained insight into the driving forces of the unconscious, but not that we have made these forces ineffective. They can attack us at any time in new form. And they will infallibly do so if the conscious attitude has a flaw in it. It's a question of might against might. If the ego presumes to wield power over the unconscious, the unconscious reacts with a subtle attack, deploying the dominant of the mana-personality, whose enormous prestige casts a spell over the ego. Against this the only defence is full confession of one's weakness in face of the powers of the unconscious. By opposing no force to the unconscious we do not provoke it to attack.

[392] It may sound rather comical to the reader if I speak of the unconscious in this personal way. I hope I shall not arouse the prejudice that I regard the unconscious as

something personal. The unconscious consists of natural processes that lie outside the sphere of the human personality. Only our conscious mind is “personal.” Therefore when I speak of “provoking” the unconscious I do not mean that it is offended and—like the gods of old—rises up to smite the offender in jealous anger or revenge. What I mean is more like an error in psychic diet which upsets the equilibrium of my digestion. The unconscious reacts automatically like my stomach which, in a manner of speaking, wreaks its revenge upon me. When I presume to have power over the unconscious, that is like a dietary solecism, an unseemly attitude which in the interests of one’s own well-being were better avoided. My unpoetical comparison is, if anything, far too mild in view of the far-reaching and devastating moral effects of a disordered unconscious. In this regard it would be more fitting to speak of the wrath of offended gods.

[393] In differentiating the ego from the archetype of the mana-personality one is now forced, exactly as in the case of the anima, to make conscious those contents which are specific of the mana-personality. Historically, the mana-personality is always in possession of the secret name, or of some esoteric knowledge, or has the prerogative of a special way of acting—*quod licet Jovi, non licet bovi*—in a word, it has an individual distinction. Conscious realization of the contents composing it means, for the man, the second and real liberation from the father, and, for the woman, liberation from the mother, and with it comes the first genuine sense of his or her true individuality. This part of the process corresponds exactly to the aim of the concretistic primitive initiations up to and including baptism, namely, severance from the “carnal” (or animal) parents, and rebirth *in novam infantiam*, into a condition of immortality and spiritual childhood, as formulated by certain mystery religions of the ancient world, among them Christianity.

[394] It is now quite possible that, instead of identifying with the mana-personality, one will concretize it as an extramundane “Father in Heaven,” complete with the attribute of absoluteness—something that many people seem very prone to do. This would be tantamount to giving the unconscious a supremacy that was just as absolute (if one’s faith could be pushed that far!), so that all value would flow over to that side.⁶ The logical result is that the only thing left behind here is a miserable, inferior, worthless, and sinful little heap of humanity. This solution, as we know, has become an historical world view. As I am moving here on psychological ground only, and feel no inclination whatever to dictate my eternal truths to the world at large, I must observe, by way of criticizing this solution, that if I shift all the highest values over to the side of the unconscious, thus converting it into a *summum bonum*, I am then placed in the unfortunate position of having to discover a devil of equal weight and dimensions who could act as the psychological counterbalance to my *summum bonum*. Under no circumstances, however, will my modesty allow me to identify

myself with the devil. That would be altogether too presumptuous and would, moreover, bring me into unbearable conflict with my highest values. Nor, with my moral deficit, can I possibly afford it.

[395] On psychological grounds, therefore, I would recommend that no God be constructed out of the archetype of the mana-personality. In other words, he must not be concretized, for only thus can I avoid projecting my values and non-values into God and Devil, and only thus can I preserve my human dignity, my specific gravity, which I need so much if I am not to become the unresisting shuttlecock of unconscious forces. In his dealings with the visible world, a man must certainly be mad to suppose that he is master of this world. Here we follow, quite naturally, the principle of non-resistance to all superior forces, up to a certain individual limit, beyond which the most peaceful citizen becomes a bloody revolutionary. Our bowing down before law and order is a commendable example of what our general attitude to the collective unconscious should be. (“Render unto Caesar...”) Thus far our obeisance would not be too difficult. But there are other factors in the world to which our conscience does not give unqualified assent—and yet we bow to them. Why? Because in practice it is more expedient than the reverse. Similarly there are factors in the unconscious with regard to which we must be worldly-wise (“Resist not evil.” “Make to yourselves friends of the mammon of unrighteousness.” “The children of this world are in their generation wiser than the children of light.” *Ergo*: “Be ye therefore wise as serpents and harmless as doves.”)

[396] The mana-personality is on one side a being of superior wisdom, on the other a being of superior will. By making conscious the contents that underlie this personality, we find ourselves obliged to face the fact that we have learnt more and want more than other people. This uncomfortable kinship with the gods, as we know, struck so deep into poor Angelus Silesius’ bones that it sent him flying out of his super-Protestantism, past the precarious halfway house of the Lutherans, back to the nethermost womb of the dark Mother—unfortunately very much to the detriment of his lyrical gifts and the health of his nerves.

[397] And yet Christ, and Paul after him, wrestled with these same problems, as a number of clues still make evident. Meister Eckhart, Goethe in his *Faust*, Nietzsche in his *Zarathustra*, have again brought this problem somewhat closer to us. Goethe and Nietzsche try to solve it by the idea of mastery, the former through the figure of the magician and ruthless man of will who makes a pact with the devil, the latter through the masterman and supreme sage who knows neither God nor devil. With Nietzsche man stands alone, as he himself did, neurotic, financially dependent, godless, and worldless. This is no ideal for a real man who has a family to support and taxes to pay. Nothing can argue the reality of the world out of existence, there is

no miraculous way round it. Similarly, nothing can argue the effects of the unconscious out of existence. Or can the neurotic philosopher prove to us that he has no neurosis? He cannot prove it even to himself. Therefore we stand with our soul suspended between formidable influences from within and from without, and somehow we must be fair to both. This we can do only after the measure of our individual capacities. Hence we must bethink ourselves not so much of what we “ought” to do as of what we *can* and *must* do.

[398] Thus the dissolution of the mana-personality through conscious assimilation of its contents leads us, by a natural route, back to ourselves as an actual, living something, poised between two world-pictures and their darkly discerned potencies. This “something” is strange to us and yet so near, wholly ourselves and yet unknowable, a virtual centre of so mysterious a constitution that it can claim anything—kinship with beasts and gods, with crystals and with stars—without moving us to wonder, without even exciting our disapprobation. This “something” claims all that and more, and having nothing in our hands that could fairly be opposed to these claims, it is surely wiser to listen to this voice.

[399] I have called this centre the *self*. Intellectually the self is no more than a psychological concept, a construct that serves to express an unknowable essence which we cannot grasp as such, since by definition it transcends our powers of comprehension. It might equally well be called the “God within us.” The beginnings of our whole psychic life seem to be inextricably rooted in this point, and all our highest and ultimate purposes seem to be striving towards it. This paradox is unavoidable, as always, when we try to define something that lies beyond the bourn of our understanding.

[400] I hope it has become sufficiently clear to the attentive reader that the self has as much to do with the ego as the sun with the earth. They are not interchangeable. Nor does it imply a deification of man or a dethronement of God. What is beyond our understanding is in any case beyond its reach. When, therefore, we make use of the concept of a God we are simply formulating a definite psychological fact, namely the independence and sovereignty of certain psychic contents which express themselves by their power to thwart our will, to obsess our consciousness and to influence our moods and actions. We may be outraged at the idea of an inexplicable mood, a nervous disorder, or an uncontrollable vice being, so to speak, a manifestation of God. But it would be an irreparable loss for religious experience if such things, perhaps even evil things, were artificially segregated from the sum of autonomous psychic contents. It is an apotropaic euphemism⁷ to dispose of these things with a “nothing but” explanation. In that way they are merely repressed, and as a rule only an apparent advantage is gained, a new twist given to illusion. The personality is not

enriched by it, only impoverished and smothered. What seems evil, or at least meaningless and valueless to contemporary experience and knowledge, might on a higher level of experience and knowledge appear as the source of the best—everything depending, naturally, on the use one makes of one's seven devils. To explain them as meaningless robs the personality of its proper shadow, and with this it loses its form. The living form needs deep shadow if it is to appear plastic. Without shadow it remains a two-dimensional phantom, a more or less well brought-up child.

[401] Here I am alluding to a problem that is far more significant than these few simple words would seem to suggest: mankind is, in essentials, psychologically still in a state of childhood—a stage that cannot be skipped. The vast majority needs authority, guidance, law. This fact cannot be overlooked. The Pauline overcoming of the law falls only to the man who knows how to put his soul in the place of conscience. Very few are capable of this (“Many are called, but few are chosen”). And these few tread this path only from inner necessity, not to say suffering, for it is sharp as the edge of a razor.

[402] The conception of God as an autonomous psychic content makes God into a moral problem—and that, admittedly, is very uncomfortable. But if this problem does not exist, God is not real, for nowhere can he touch our lives. He is then either an historical and intellectual bogey or a philosophical sentimentality.

[403] If we leave the idea of “divinity” quite out of account and speak only of “autonomous contents,” we maintain a position that is intellectually and empirically correct, but we silence a note which, psychologically, should not be missing. By using the concept of a divine being we give apt expression to the peculiar way in which we experience the workings of these autonomous contents. We could also use the term “daemonic,” provided that this does not imply that we are still holding up our sleeves some concretized God who conforms exactly to our wishes and ideas. Our intellectual conjuring tricks do not help us to make a reality of the God we desire, any more than the world accommodates itself to our expectations. Therefore, by affixing the attribute “divine” to the workings of autonomous contents, we are admitting their relatively superior force. And it is this superior force which has at all times constrained men to ponder the inconceivable, and even to impose the greatest sufferings upon themselves in order to give these workings their due. It is a force as real as hunger and the fear of death.

[404] The self could be characterized as a kind of compensation of the conflict between inside and outside. This formulation would not be unfitting, since the self has somewhat the character of a result, of a goal attained, something that has come to pass very gradually and is experienced with much travail. So too the self is our life's goal, for it is the completest expression of that fateful combination we call

individuality, the full flowering not only of the single individual, but of the group, in which each adds his portion to the whole.

[405] Sensing the self as something irrational, as an indefinable existent, to which the ego is neither opposed nor subjected, but merely attached, and about which it revolves very much as the earth revolves round the sun—thus we come to the goal of individuation. I use the word “sensing” in order to indicate the apperceptive character of the relation between ego and self. In this relation nothing is knowable, because we can say nothing about the contents of the self. The ego is the only content of the self that we do know. The individuated ego senses itself as the object of an unknown and supraordinate subject. It seems to me that our psychological inquiry must come to a stop here, for the idea of a self is itself a transcendental postulate which, although justifiable psychologically, does not allow of scientific proof. This step beyond science is an unconditional requirement of the psychological development I have sought to depict, because without this postulate I could give no adequate formulation of the psychic processes that occur empirically. At the very least, therefore, the self can claim the value of an hypothesis analogous to that of the structure of the atom. And even though we should once again be enmeshed in an image, it is none the less powerfully alive, and its interpretation quite exceeds my powers. I have no doubt at all that it is an image, but one in which we are contained.

[406] I am deeply conscious that in this essay I have made no ordinary demands on the understanding of my reader. Though I have done my utmost to smooth the path of understanding, there is one great difficulty which I could not eliminate, namely the fact that the experiences which form the basis of my discussion are unknown to most people and are bound to seem strange. Consequently I cannot expect my readers to follow all my conclusions. Although every author naturally prefers to be understood by his public, yet the interpretation of my observations is of less moment to me than the disclosure of a wide field of experience, at present hardly explored, which it is the aim of this book to bring within reach of many. In this field, hitherto so dark, it seems to me that there lie the answers to many riddles which the psychology of consciousness has never even approached. I would not pretend to have formulated these answers with any degree of finality. I shall, therefore, be well satisfied if my essay may be counted as a tentative attempt at an answer.

APPENDICES

NEW PATHS IN PSYCHOLOGY¹

[407] Like all sciences, psychology has gone through its epoch of scholasticism, and something of this spirit has lasted on into the present. Against this kind of philosophical psychology it must be objected that it decides *ex cathedra* how the psyche shall be constituted, and what qualities must belong to it in this world and in the next. The spirit of modern scientific investigation has to a large extent disposed of these fantasies and put in their place an exact empirical method. From this there arose the experimental psychology of today, or what the French call “psychophysiology.” The father of this movement was the dual minded Fechner, who, in his *Elemente der Psychophysik*, dared to introduce the physical point of view into the conception of psychic phenomena. This idea [, and not least the brilliant errors in this work,] was a fertilizing force. Fechner’s younger contemporary and, we might say, the perfecter of his work, was Wundt, whose great erudition, industry, and genius for devising new methods of experimental research have created the dominant trend in modern psychology.

[408] Until quite recently experimental psychology was essentially academic. The first notable attempt to enlist at least some of its numerous experimental methods in the service of practical psychology came from the psychiatrists of the former Heidelberg school (Kraepelin, Aschaffenburg, and others); for, as may easily be imagined, the psychiatrist was the first to feel the pressing need for exact knowledge of the psychic processes. Next came pedagogy, making its own demands on psychology. From this there has recently grown up an “experimental pedagogy,” in which field Meumann in Germany and Binet in France have rendered signal service.

[409] If he wants to help his patient, the doctor, and above all the “specialist for nervous diseases,” must have psychological knowledge; for nervous disorders and all that is embraced by the terms “nervousness,” hysteria, etc. are of psychic origin and therefore logically require psychic treatment. Cold water, light, fresh air, electricity, and so forth have at best a transitory effect and sometimes none at all. Often they are disreputable artifices, calculated to work upon suggestibility. But the patient is sick in mind, in the highest and most complex of the mind’s functions, and these can hardly be said to belong any more to the province of medicine. Here the doctor must also be a psychologist, which means that he must have knowledge of the human psyche. The doctor cannot evade this demand. So he naturally turns for help to psychology, since

his psychiatry text-books have nothing to offer him. The experimental psychology of today, however, does not even begin to give him any coherent insight into what are, practically, the most important psychic processes. That is not its aim: it tries to isolate the very simplest and most elementary processes which border on physiology, and studies them in isolation. It is ill-disposed towards the infinite variety and mobility of individual psychic life, and for this reason its findings and its facts are so many details lacking organic cohesion. Therefore anyone who wants to know the human psyche will learn next to nothing from experimental psychology. He would be better advised to [abandon exact science] put away his scholar's gown, bid farewell to his study, and wander with human heart through the world. There, in the horrors of prisons, lunatic asylums and hospitals, in drab suburban pubs, in brothels and gambling-hells, in the salons of the elegant, the Stock Exchanges, Socialist meetings, churches, revivalist gatherings and ecstatic sects, through love and hate, through the experience of passion in every form in his own body, he would reap richer stores of knowledge than text-books a foot thick could give him, and he will know how to doctor the sick with real knowledge of the human soul. He may be pardoned if his respect for the so-called cornerstones of experimental psychology is no longer excessive. For between what science calls psychology and what the practical needs of daily life demand from psychology there is a great gulf fixed.

[410] This deficiency became the starting-point for a new psychology, whose inception we owe first and foremost to Sigmund Freud of Vienna, the brilliant physician and investigator of functional nervous disorders. One could describe the psychology inaugurated by him as "analytical psychology." Bleuler has suggested the name "depth psychology,"² in order to indicate that Freudian psychology was concerned with the deeper regions or hinterland of the psyche, also called the unconscious. Freud himself was content just to name his method of investigation: he called it psychoanalysis. And such is the name by which this movement is generally known.

[411] Before we enter upon a closer presentation of our subject, something must be said about its relation to science as known hitherto. Here we encounter a curious spectacle which proves yet again the truth of Anatole France's remark, "Les savants ne sont pas curieux." The first work of any magnitude³ in this field awakened only the faintest echo, in spite of the fact that it introduced an entirely new and fundamental conception of the neuroses. A few writers spoke of it appreciatively and then, on the next page, proceeded to explain their hysterical cases in the same old way. They behaved very much like a man who, having eulogized the idea or fact that the earth was a sphere, calmly continues to represent it as flat. Freud's next publications⁴ remained absolutely unnoticed, although they put forward observations which were of incalculable importance for psychiatry. When, in the year 1899, Freud wrote the first real psychology of dreams⁵ (a Stygian darkness had hitherto reigned over this

field), people began to laugh, and when about the middle of the last decade he started to throw light on the psychology of sexuality itself,⁶ [and at the same time the Zurich school decided to range itself on his side,] laughter turned to insult, sometimes of the nastiest kind, and this has lasted until very recently. [Even a layman like Förster insinuated himself among the denigrators. (I hope the ugliness and impertinence of his tone came from his ignorance of the actual facts.) At the last South-West German Congress of Alienists the adherents of the new psychology also had the pleasure of hearing Hoche, University Professor of Psychiatry at Freiburg im Breisgau, describe the movement in a long and loudly applauded address as an epidemic of insanity among doctors. The old adage “*Medicus medicum non decimat*” was here quite put to shame.] How carefully the works had been studied is shown by the naïve remark of one of the most eminent neurologists of Paris at an International Congress in 1907, which I heard with my own ears: “I have not read Freud’s works” (he knew no German) “but as for his theories, they are nothing but a *mauvaise plaisanterie*.” [Freud, the dignified old master, once said to me: “I first became clearly conscious of what I had discovered when it was met everywhere with resistance and indignation, and since that time I have learnt to judge the value of my work by the degree of resistance it provoked. It is the sexual theory that raises the greatest outcry, so it would seem that therein lies my best work. Perhaps after all the real benefactors of mankind are its false teachers, for opposition to the false teachings pushes men willy-nilly into truth. Your truth-teller is a pernicious fellow, he drives men into error.”]

[412] [The reader must now calmly accept the idea that in this psychology he is dealing with something quite unique, if not indeed some altogether irrational, sectarian, or occult wisdom; for what else could possibly provoke all the scientific authorities to pooh-pooh it from the start?]

[413] Accordingly we must look more closely into this new psychology. Already in Charcot’s time it was known that the neurotic symptom is “psychogenic,” i.e., originates in the psyche. It was also known, thanks mainly to the work of the Nancy school, that all hysterical symptoms can be produced in exactly the same way by suggestion. But it was not known *how* an hysterical symptom originates in the psyche; the psychic causal factors were completely unknown. In the early eighties Dr. Breuer, an old Viennese practitioner, made a discovery which became the real starting-point of the new psychology. He had a young, very intelligent woman patient suffering from hysteria, who manifested the following symptoms among others: she had a spastic (rigid) paralysis of the right arm, and occasional fits of absent-mindedness or twilight states; she had also lost the power of speech inasmuch as she could no longer command her mother tongue but could only express herself in English (systematic aphasia). They tried at that time, and still try, to account for these disorders with anatomical theories, although the cortical centre for the arm function

is as little disturbed here as in the corresponding centre of a normal person [who gives somebody a box on the ears]. The symptomatology of hysteria is full of anatomical impossibilities. One lady, who had completely lost her hearing because of an hysterical affection, often used to sing. Once, when she was singing, her doctor seated himself unobserved at the piano and softly accompanied her. In passing from one stanza to the next he made a sudden change of key, whereupon the patient, without noticing it, went on singing in the changed key. Thus she hears—and does not hear. The various forms of systematic blindness offer similar phenomena: a man suffering from total hysterical blindness recovered his sight in the course of treatment, but it was only partial at first and remained so for a long time. He could see everything with the exception of people's heads. He saw all the people round him without heads. Thus he sees—and does not see. From a large number of like experiences it has long been concluded that only the conscious mind of the patient does not see and hear, but that the sense-function is otherwise in working order. This state of affairs directly contradicts the nature of an organic disorder, which always affects the function in some way.

[414] After this digression, let us come back to the Breuer case. There were no organic causes for the disorder, so it had to be regarded as hysterical, i.e., psychogenic. Breuer had observed that if, during her twilight states (whether spontaneous or artificially induced), he got the patient to tell him of the reminiscences and fantasies that thronged in upon her, her condition was eased for several hours afterwards. He made systematic use of this discovery for further treatment. The patient devised the appropriate name “talking cure” for it, or, jokingly, “chimney-sweeping.”

[415] The patient had become ill when nursing her father in his fatal illness. Naturally her fantasies were chiefly concerned with these disturbing days. Reminiscences of this period came to the surface during her twilight states with photographic fidelity; so vivid were they, down to the last detail, that we can hardly assume the waking memory to have been capable of such plastic and exact reproduction. (The name “hypermnesia” has been given to this intensification of the powers of memory which may easily occur in restricted states of consciousness.) Remarkable things now came to light. One of the many stories told ran somewhat as follows:

One night, watching by the sick man, who had a high fever, she was tense with anxiety because a surgeon was expected from Vienna to perform an operation. Her mother had left the room for a while, and Anna, the patient, sat by the sick-bed with her right arm hanging over the back of the chair. She fell into a sort of waking dream and saw a black snake coming, apparently out of the wall, towards the sick man as though to bite him. (It is quite likely that there really were snakes in the meadow at the back of the house, which had already given the girl a fright and which now

provided the material for the hallucination.) She wanted to drive the creature away, but felt paralysed; her right arm, hanging over the back of the chair, had “gone to sleep”: it had become anaesthetic and paretic, and as she looked at it, the fingers changed into little serpents with death’s-heads [the fingernails]. Probably she made efforts to drive away the snake with her paralysed right hand, so that the anaesthesia and paralysis became associated with the snake hallucination. When the snake had disappeared, she was so frightened that she wanted to pray; but all speech failed her, she could not utter a word until finally she remembered an English nursery rhyme, and then she was able to go on thinking and praying in English.

[416] Such was the scene in which the paralysis and the speech disturbance originated, and with the narration of this scene the disturbance itself was removed. In this manner the case was finally cured.

[417] I must content myself with this one example. In the book I have mentioned by Breuer and Freud there is a wealth of similar examples. It can readily be understood that scenes of this kind make a powerful impression, and people are therefore inclined to impute causal significance to them in the genesis of the symptom. The view of hysteria then current, which derived from the English theory of the “nervous shock” energetically championed by Charcot, was well qualified to explain Breuer’s discovery. Hence there arose the so-called trauma theory, which says that the hysterical symptom, and, in so far as the symptoms constitute the illness, hysteria in general, derive from psychic injuries or traumata whose imprint persists unconsciously for years. Freud, now collaborating with Breuer, was able to furnish abundant confirmation of this discovery. It turned out that none of the hundreds of hysterical symptoms arose by chance—they were always caused by psychic occurrences. So far the new conception opened up an extensive field for empirical work. But Freud’s inquiring mind could not remain long on this superficial level, for already deeper and more difficult problems were beginning to emerge. It is obvious enough that moments of extreme anxiety such as Breuer’s patient experienced may leave an abiding impression. But how did she come to experience them at all, since they already clearly bear a morbid stamp? Could the strain of nursing bring this about? If so, there ought to be many more occurrences of the kind, for there are unfortunately very many exhausting cases to nurse, and the nervous health of the nurse is not always of the best. To this problem medicine gives an excellent answer; “The x in the calculation is predisposition.” One is just “predisposed” that way. But for Freud the problem was: what constitutes the predisposition? This question leads logically to an examination of the previous history of the psychic trauma. It is a matter of common observation that exciting scenes have quite different effects on the various persons involved, or that things which are indifferent or even agreeable to one person arouse the greatest horror in others—witness frogs, snakes, mice, cats,

etc. There are cases of women who will assist at bloody operations without turning a hair, while they tremble all over with fear and loathing at the touch of a cat. I remember a young woman who suffered from acute hysteria following a sudden fright. She had been to an evening party and was on her way home about midnight in the company of several acquaintances, when a cab came up behind them at full trot. The others got out of the way, but she, as though spellbound with terror, kept to the middle of the road and ran along in front of the horses. The cabman cracked his whip and swore; it was no good, she ran down the whole length of the road, which led across a bridge. There her strength deserted her, and to avoid being trampled on by the horses she would in her desperation have leapt into the river had not the passers-by prevented her. Now, this same lady had happened to be in St. Petersburg on the bloody twenty-second of January [1905], in the very street which was cleared by the volleys of the soldiers. All round her people were falling to the ground dead or wounded; she, however, quite calm and clear-headed, espied a gate leading into a yard through which she made her escape into another street. These dreadful moments caused her no further agitation. She felt perfectly well afterwards—indeed, rather better than usual.

[418] This failure to react to an apparent shock can frequently be observed. Hence it necessarily follows that the intensity of a trauma has very little pathogenic significance in itself; everything depends on the particular circumstances. Here we have the key to the predisposition [, or at least to one of its anterooms]. We have therefore to ask ourselves: what are the particular circumstances of the scene with the cab? The patient's fear began with the sound of the trotting horses; for an instant it seemed to her that this portended some terrible doom—her death, or something as dreadful; the next moment she lost all sense of what she was doing.

[419] The real shock evidently came from the horses. The patient's predisposition to react in so unaccountable a way to this unremarkable incident might therefore consist in the fact that horses have some special significance for her. We might conjecture, for instance, that she once had a dangerous accident with horses. This was actually found to be the case. As a child of about seven she was out for a drive with the coachman, when suddenly the horses took fright and at a wild gallop made for the precipitous bank of a deep river-gorge. The coachman jumped down and shouted to her to do likewise, but she was in such deadly fear that she could hardly make up her mind. Nevertheless she jumped in the nick of time, while the horses crashed with the carriage into the depths below. That such an event would leave a very deep impression scarcely needs proof. Yet it does not explain why at a later date such an insensate reaction should follow a perfectly harmless stimulus. So far we know only that the later symptom had a prelude in childhood, but the pathological aspect of it still remains in the dark. In order to penetrate this mystery, further knowledge is

needed. For it had become clear with increasing experience that in all the cases analysed so far, there existed, apart from the traumatic experiences, another, special class of disturbance which can only be described as a disturbance in the province of love. Admittedly “love” is an elastic concept that stretches from heaven to hell and combines in itself good and evil, high and low.⁷ With this discovery Freud’s views underwent a considerable change. If, more or less under the spell of Breuer’s trauma theory, he had formerly sought the cause of the neurosis in traumatic experiences, now the centre of gravity of the problem shifted to an entirely different point. This may be best illustrated by our case: we can understand well enough why horses should play a special part in the life of the patient, but we do not understand the later reaction, so exaggerated and uncalled for. The pathological peculiarity of this story does not lie in the fact that she is frightened of horses. Remembering the empirical discovery mentioned above, that besides the traumatic experiences there is [invariably] a disturbance in the province of love, we might inquire whether perhaps there is something not quite in order in this connection.

[420] The lady knows a young man to whom she thinks of becoming engaged; she loves him and hopes to be happy with him. At first nothing more is discoverable. But it would never do to be deterred from investigation by the negative results of the preliminary questioning. There are indirect ways of reaching the goal when the direct way fails. We therefore return to that singular moment when the lady ran headlong in front of the horses. We inquire about her companions and what sort of festive occasion it was in which she had just taken part. It had been a farewell party for her best friend, who was going abroad to a health resort on account of her nerves. This friend is married and, we are told, happily; she is also the mother of a child. We may take leave to doubt the statement that she is happy; for, were she really so, she would presumably have no reason to be “nervous” and in need of a cure. Shifting my angle of approach, I learned that after her friends had rescued her they brought the patient back to the house of her host, as this was the nearest shelter. There she was hospitably received in her exhausted state. At this point the patient broke off her narrative, became embarrassed, fidgeted, and tried to change the subject. Evidently some disagreeable reminiscence had suddenly bobbed up. After the most obstinate resistance had been overcome, it appeared that yet another very remarkable incident had occurred that night: the amiable host had made her a fiery declaration of love, thus precipitating a situation which, in the absence of the lady of the house, might well be considered both difficult and distressing. Ostensibly this declaration of love came to her like a bolt from the blue. [A small dose of criticism teaches us that these things never do drop from the sky but always have their previous history.] It was now the task of the next few weeks to dig out bit by bit a long love story, until at last a complete picture emerged which I attempt to outline somewhat as follows:

As a child the patient had been a regular tomboy, caring only for wild boys' games, scorning her own sex and avoiding all feminine ways and occupations. After puberty, when the erotic problem might have come too close, she began to shun all society, hated and despised everything that even remotely reminded her of the biological destiny of woman, and lived in a world of fantasies which had nothing in common with rude reality. Thus, until about her twenty-fourth year, she evaded all those little adventures, hopes, and expectations which ordinarily move a girl's heart at this age. (In these matters women are often amazingly insincere with themselves and with the doctor.) Then she got to know two men who were destined to break through the thorny hedge that had grown up around her. Mr. A was her best friend's husband, and Mr. B was his bachelor friend. She liked them both. Nevertheless it soon began to look as though she liked Mr. B a vast deal better. An intimacy quickly sprang up between them and before long there was talk of a possible engagement. Through her relations with Mr. B and through her friend she often came into contact with Mr. A, whose presence sometimes disturbed her in the most unaccountable way and made her nervous. About this time the patient went to a large party. Her friends were also there. She became lost in thought and was dreamily playing with her ring when it suddenly slipped off her finger and rolled under the table. Both gentlemen looked for it and Mr. B succeeded in finding it. He placed the ring on her finger with an arch smile and said, "You know what that means!" Overcome by a strange and irresistible feeling, she tore the ring from her finger and flung it through the open window. A painful moment ensued, as may be imagined, and soon she left the party in deep dejection. Not long after this, so-called chance brought it about that she should spend her summer holidays at a health resort where Mr. and Mrs. A were also staying. Mrs. A then began to grow visibly nervous, and frequently stayed indoors because she felt out of sorts. The patient was thus in a position to go out for walks alone with Mr. A. On one occasion they went boating. So boisterous was she in her merriment that she suddenly fell overboard. She could not swim, and it was only with great difficulty that Mr. A pulled her half-unconscious into the boat. And then it was that he kissed her. With this romantic episode the bonds were tied fast. To excuse herself in her own eyes she pursued her engagement to Mr. B all the more energetically, telling herself every day that it was Mr. B whom she loved. Naturally this curious little game had not escaped the keen glances of wifely jealousy. Mrs. A, her friend, had guessed the secret and fretted accordingly, so that her nerves only got worse. Hence it became necessary for Mrs. A to go abroad for a cure. At the farewell party the evil spirit stepped up to our patient and whispered in her ear, "Tonight he is alone. Something must happen to you so that you can go to his house." And so indeed it happened: through her own strange behaviour she came back to his house, and thus she attained her desire.

[421] After this explanation everyone will probably be inclined to assume that only a devilish subtlety could devise such a chain of circumstances and set it to work. There is no doubt about the subtlety, but its moral evaluation remains a doubtful matter, because I must emphasize that the motives leading to this dramatic dénouement were in no sense conscious. To the patient, the whole story seemed to happen of itself, without her being conscious of any motive. But the previous history makes it perfectly clear that everything was [most ingeniously] directed to this end, while the conscious mind was struggling to bring about the engagement to Mr. B. The unconscious drive in the other direction was stronger.

[422] So once more we return to our original question, namely, whence comes the pathological (i.e., peculiar or exaggerated) nature of the reaction to the trauma? On the basis of a conclusion drawn from analogous experiences we conjectured that in this case too there must be, in addition to the trauma, a disturbance in the erotic sphere. This conjecture has been entirely confirmed, and we have learned that the trauma, the ostensible cause of the illness, is no more than an occasion for something previously not conscious to manifest itself, i.e., an important erotic conflict. Accordingly the trauma loses its pathogenic significance and is replaced by a much deeper and more comprehensive conception which sees the pathogenic agent as an erotic conflict. [This conception might be called the *sexual theory of neurosis*.]

[423] I often hear the question: why should the erotic conflict be the cause of the neurosis rather than any other conflict? To this we can only answer: no one asserts that it must be so, but in point of fact it [always] is so [, notwithstanding all the cousins and aunts, parents, godparents, and teachers who rage against it]. In spite of all indignant protestations to the contrary, the fact remains that love,⁸ its problems and its conflicts, is of fundamental importance in human life, and, as careful inquiry consistently shows, is of far greater significance than the individual suspects.

[424] The trauma theory has therefore been abandoned as antiquated; for with the discovery that not the trauma but a hidden erotic conflict is the [true] root of the neurosis, the trauma completely loses its pathogenic significance.

[425] [The theory was thus shifted onto an entirely different plane.] The question of the trauma was solved and disposed of; but in its place the investigator was faced with the problem of the erotic conflict, which, as our example shows, contains a wealth of abnormal elements and cannot at first sight be compared with an ordinary erotic conflict. What is peculiarly striking and almost incredible is that only the pose should be conscious, while the patient's real passion remained hidden from her. In this case certainly, it is beyond dispute that the real erotic relationship was shrouded in darkness, while the pose largely dominated the field of consciousness. If we formulate these facts theoretically, we arrive at the following result: there are in a

neurosis two [erotic] tendencies standing in strict opposition to one another, one of which at least is unconscious. [Against this formula it might be objected that it obviously fits only this particular case and therefore lacks general validity. The objection will be urged the more readily because no one is willing to admit that the erotic conflict is of universal prevalence. On the contrary, it is assumed that the erotic conflict belongs more properly to the sphere of novels, since it is generally understood as something in the nature of such extra-marital adventures as are described in the novels of Karin Michaelis, or by Forel in *The Sexual Question*. But this is not so at all, for we know that the wildest and most moving dramas are played not in the theatre but in the hearts of ordinary men and women who pass by without exciting attention, and who betray to the world nothing of the conflicts that rage within them except possibly by a nervous breakdown. What is so difficult for the layman to grasp is the fact that in most cases the patients themselves have no suspicion whatever of the internecine war raging in their unconscious. If we remember that there are many people who understand nothing at all about themselves, we shall be less surprised at the realization that there are also people who are utterly unaware of their actual conflicts.]

[426] [Now even if the reader is ready to admit the possible existence of pathogenic, and perhaps even of unconscious conflicts, he will still protest that they are not *erotic* conflicts. If this kind reader should happen himself to be somewhat nervous, the mere suggestion will arouse his indignation; for we are all accustomed, through our education at school and at home, to cross ourselves three times when we meet words like “erotic” and “sexual”—and so we are conveniently able to think that nothing of the sort exists, or at least very seldom, and at a great distance from ourselves. But it is just this attitude that brings about neurotic conflicts in the first place.]

[427] The growth of culture consists, as we know, in a progressive subjugation of the animal in man. It is a process of domestication which cannot be accomplished without rebellion on the part of the animal nature that thirsts for freedom. From time to time there passes as it were a wave of frenzy through the ranks of men too long constrained within the limitations of their culture. Antiquity experienced it in the Dionysian orgies that surged over from the East and became an essential and characteristic ingredient of classical culture. The spirit of these orgies contributed not a little towards the development of the stoic ideal of asceticism in the innumerable sects and philosophical schools of the last century before Christ, which produced from the polytheistic chaos of that epoch the twin ascetic religions of Mithraism and Christianity. A second wave of Dionysian licentiousness swept over the West at the Renaissance. It is difficult to gauge the spirit of one’s own time; but, if we observe the trend of art, of style, and of public taste, and see what people read and write, what sort of societies they found, what “questions” are the order of the day, what the

Philistines fight against, we shall find that in the long catalogue of our present social questions by no means the last is the so-called "sexual question." This is discussed by men and women who challenge the existing sexual morality and who seek to throw off the burden of moral guilt which past centuries have heaped upon Eros. One cannot simply deny the existence of these endeavours nor condemn them as indefensible; they exist, and probably have adequate grounds for their existence. It is more interesting and more useful to examine carefully the underlying causes of these contemporary movements than to join in the lamentations of the professional mourners of morality who [with hysterical unctiousness] prophesy the moral downfall of humanity. It is the way of moralists not to put the slightest trust in God, as if they thought that the good tree of humanity flourished only by dint of being pruned, tied back, and trained on a trellis; whereas in fact Father Sun and Mother Earth have allowed it to grow for their delight in accordance with deep, wise laws.

[428] Serious-minded people know that there is something of a sexual problem today. They know that the rapid development of the towns, with the specialization of work brought about by the extraordinary division of labour, the increasing industrialization of the countryside, and the growing sense of insecurity, deprive men of many opportunities for giving vent to their affective energies. The peasant's alternating rhythm of work secures him unconscious satisfactions through its symbolical content—satisfactions which the factory workers and office employees do not know and can never enjoy. What do these know of his life with nature, of those grand moments when, as lord and fructifier of the earth, he drives his plough through the soil, and with a kingly gesture scatters the seed for the future harvest; of his rightful fear of the destructive power of the elements, of his joy in the fruitfulness of his wife who bears him the daughters and sons who mean increased working-power and prosperity? [Alas!] From all this we city-dwellers, we modern machine-minders, are far removed. Is not the fairest and most natural of all satisfactions beginning to fail us, when we can no longer regard with unmixed joy the harvest of our own sowing, the "blessing" of children? [Marriages where no artifices are resorted to are rare. Is not this an all-important departure from the joys which Mother Nature gave her first-born son?] Can such a state of affairs bring satisfaction? See how men slink to work, only observe the faces in trains at 7:30 in the morning! One man makes his little wheels go round, another writes things that interest him not at all. What wonder that nearly every man belongs to as many clubs as there are days in the week, or that there are flourishing little societies for women where they can pour out, on the hero of the latest cult, those inarticulate longings which the man drowns at the pub in big talk and small beer? To these sources of discontent there is added a further and graver difficulty. Nature has armed defenceless and weaponless man with a vast store of energy, to enable him not only passively to endure the rigours of existence but also to overcome them. She has

equipped her son for tremendous hardships [and has placed a costly premium on the overcoming of them, as Schopenhauer well understood when he said that happiness is merely the cessation of unhappiness]. As a rule we are protected from the most pressing necessities, and for that reason we are daily tempted to excess; for the animal in man always becomes rampant unless hard necessity presses. But if we are high-spirited, in what orgiastic feasts and revels can we let off our surplus of energy? Our moral views forbid this outlet.

[429] [Let us reckon up the many sources of discontent: the denial of continual procreation and giving birth, for which purpose nature has endowed us with vast quantities of energy; the monotony of our highly differentiated methods of labour, which exclude any interest in the work itself; our effortless security against war, lawlessness, robbery, plague, child and female mortality—all this gives a sum of surplus energy which needs must find an outlet. But how? Relatively few create quasi-natural dangers for themselves in reckless sport; many more, seeking for some equivalent of the hard life in order to siphon off dangerous accumulations of energy that might burst out even more crazily, are driven to alcoholic excess, or expend themselves in the rush of money-making, or in the frenzied performance of duties, or in perpetual overwork. It is for such reasons that we have today a sexual question. The pent-up energy would like to get out here, as it has done since time immemorial in periods of security and abundance. Under such circumstances it is not only rabbits that multiply; men and women, too, are made the sport of these whims of nature—the sport, because their moral views have shut them up in a narrow cage, the excessive narrowness of which was not felt so long as harsh necessity pressed with even greater constraint. But now it is too tight even for the city-dweller. Temptation surrounds him on all sides, and like an invisible procurer there slinks through society the knowledge of the preventive methods that make everything unhappened.]

[430] Why then the moral restriction? Out of religious consideration for a wrathful God? Irrespective of the widespread unbelief, even the believer might quietly ask himself whether, if he were God, he would punish every Jack-and-Jill escapade with everlasting damnation. Such ideas are no longer compatible with our comfortable conception of God. Our God is far too tolerant to make a great fuss about it. [Mean-mindedness and hypocrisy are a thousand times worse.] Thus the ascetically inspired and markedly hypocritical⁹ sexual morality of our time is robbed of any effective background. Or can we say that we are protected from excess by our superior wisdom and our insight into the nullity of human behaviour? Unfortunately we are very far from that. [The hypnotic power of tradition still holds us in thrall, and out of cowardice and thoughtlessness the herd goes trudging along the same old path.] But man possesses in the unconscious a fine flair for the spirit of his time; he divines his possibilities and feels in his heart the instability of present-day morality, no longer

supported by living religious conviction. Here is the source of most of our [erotic] conflicts. The urge to freedom beats upon the weakening barriers of morality: we are in a state of temptation, we want and do not want. And because we want and yet cannot think out what it is we really want, the [erotic] conflict is largely unconscious, and thence comes neurosis. Neurosis, therefore, is intimately bound up with the problem of our time and really represents an unsuccessful attempt on the part of the individual to solve the general problem in his own person. Neurosis is self-division. In most people the cause of the division is that the conscious mind wants to hang on to its moral ideal, while the unconscious strives after its—in the contemporary sense—unmoral ideal which the conscious mind [steadfastly] tries to deny. Men of this type want to be more respectable than they really are. But the conflict can easily be the other way about: there are men who to all appearances are very disreputable and do not put the least restraint upon [their sexuality], but at bottom this is only a pose of wickedness [assumed for heaven knows what reasons], for in the background they have [a highly respectable soul] which has fallen into the unconscious just as surely as the immoral side in the case of the moral man. (Extremes should therefore be avoided as far as possible, because they always arouse suspicion of their opposite.)

[431] This general discussion was necessary in order to clarify the idea of an “erotic conflict” [in analytical psychology, for it is the key to the whole conception of neurosis]. Thence we can proceed to discuss firstly the technique of psychoanalysis and secondly the question of therapy. [Obviously the latter question would involve us in details and complicated case material which far exceed the scope of this short introduction. We must therefore be content to cast a glance at the technique of psychoanalysis.]

[432] Obviously the great question for this technique is: How are we to arrive by the shortest and best path at a knowledge of what is happening in the unconscious of the patient? The original method was hypnotism: either interrogation in a state of hypnotic concentration or else the spontaneous production of fantasies by the patient while in this state. This method is still occasionally employed, but compared with the present technique it is too primitive and therefore unsatisfactory. A second method was evolved by the Psychiatric Clinic, in Zurich, the so-called association method,¹⁰ the value of which is primarily theoretical and experimental. Its results give one a comprehensive though superficial grasp of the unconscious conflict or “complex.”¹¹ The more penetrating method is that of dream-analysis, discovered by [the genius of Sigmund] Freud.

[433] Of the dream it can indeed be said that “the stone which the builders rejected has become the head of the corner.” It is only in modern times that the dream, this fleeting and insignificant-looking product of the psyche, has met with such profound

contempt. Formerly it was esteemed as a harbinger of fate, a portent and comforter, a messenger of the gods. Now we see it as an emissary of the unconscious, whose task it is to reveal the secrets [which our unconscious jealously hides] from the conscious mind, and this it does with astounding completeness.

[434] From the analytical study of the dream it was found that the dream, as it appears to us, is only a façade which conceals the interior of the house. If, however, while observing certain technical rules, we induce the dreamer to talk about the details of his dream, it soon becomes evident that his associations tend in a particular direction and group themselves round particular topics. These appear to be of personal significance and yield a meaning which could never have been conjectured to lie behind the dream, but which, as careful comparison has shown, stands in an extremely delicate and meticulously exact [symbolic] relation to the dream façade.¹² This particular complex of ideas, wherein are united all the threads of the dream, is the conflict we are looking for, or rather a variation of it conditioned by circumstances. The painful and incompatible elements in the conflict are in this way so covered up or obliterated that one may speak of a “wish-fulfilment”; though we must immediately add that the wishes fulfilled in the dream do not seem to be ours, but are of a kind that often runs directly counter to them. Thus, for instance, a daughter loves her mother tenderly, but dreams to her great distress that her mother is dead. Such dreams, in which there is apparently no trace of wish-fulfilment, are innumerable, and are a constant stumbling-block to our learned critics, for [—incredible to relate—] they still cannot grasp the elementary distinction between the manifest and the latent content of the dream. We must guard against this error: the conflict worked out in the dream is unconscious, and so is the resultant wish for a solution. Our dreamer does in fact have the wish to be rid of her mother; expressed in the language of the unconscious, she wants her mother to die. Now we know that a certain compartment of the unconscious contains everything that has passed beyond the recall of memory, including all those infantile instinctual impulses which could find no outlet in adult life, that is, a succession of ruthless childish desires. We can say that the bulk of what comes out of the unconscious has an infantile character, as for instance this wish, which is simplicity itself: “When Mummy dies you will marry me, won’t you, Daddy?” This expression of an infantile wish is the substitute for a recent desire to marry, a desire in this case painful to the dreamer, for reasons still to be discovered. The idea of marriage, or rather the seriousness of the corresponding impulse, is, as they say, “repressed into the unconscious” and from there must necessarily express itself in an infantile fashion, because the material at the disposal of the unconscious consists largely of infantile reminiscences. [As the latest researches of the Zurich school have shown,¹³ besides the infantile reminiscences there are also “race memories” extending far beyond the limits of the individual.]

[435] [This is not the place to elucidate the extraordinarily complicated field of dream analysis. We must content ourselves with the results of research: dreams are a symbolic substitute for a personally important wish which was not sufficiently appreciated during the day and was “repressed.” In consequence of the predominant moral tendencies, the insufficiently appreciated wishes that strive to realize themselves symbolically in dreams are, as a rule, erotic ones. It is therefore inadvisable to tell one’s dreams to a knowledgeable person, for the symbolism is often quite transparent to one who knows the rules. The clearest in this respect are anxiety dreams, which are so common, and which invariably symbolize a strong erotic wish.]

[436] The dream is often occupied with apparently very silly details, thus producing an impression of absurdity, or else it is on the surface so unintelligible as to leave us thoroughly bewildered. Hence we always have to overcome a certain resistance before we can seriously set about disentangling the [symbolic] web through patient work. But when at last we penetrate to its real meaning, we find ourselves deep in the dreamer’s secrets and discover with astonishment that an apparently quite senseless dream is in the highest degree significant, and that in reality it speaks only of extraordinarily important and serious things of the soul. This discovery compels rather more respect for the old superstition that dreams have a meaning, to which the rationalistic temper of our age has hitherto given short shrift.

[437] As Freud says, dream-analysis is the *via regia* to the unconscious. It leads straight to the deepest personal secrets, and is, therefore, an invaluable instrument in the hand of the physician and educator of the soul. The attacks of the opposition against this method are, as might be expected, based upon arguments which—setting aside the undercurrents of personal feeling—derive chiefly from the very strong scholastic streak that still exists in the learned thought of our day. Dream-analysis above all else mercilessly uncovers the lying morality and hypocritical pretences of man, showing him, for once, the other side of his character in the most vivid light; can we wonder if many feel that their toes have been heavily trodden upon? In this connection I am always reminded of the striking statue of Carnal Pleasure outside Basel Cathedral, the front exhibiting the sweet archaic smile, the rear covered with toads and serpents. Dream-analysis reverses the picture and shows the other side. The ethical value of this reality-corrective can hardly be denied. It is a painful but extremely useful operation which makes great demands on both doctor and patient. Psychoanalysis, considered as a therapeutic technique, consists in the main of numerous dream-analyses. In the course of treatment the dreams successively throw up the dregs of the unconscious in order to expose them to the disinfecting power of daylight, and in this way much that is valuable and believed lost is found again. It is a catharsis of a special kind, something like the maieutics of Socrates, the “art of the midwife.” It is

only to be expected that for many people who have adopted a certain pose towards themselves, in which they violently believe, psychoanalysis is a veritable torture. For, in accordance with the old mystical saying, "Give up what thou hast, then shalt thou receive!" they are called upon to abandon all their cherished illusions in order that something deeper, fairer, and more embracing may arise within them. Only through the mystery of self-sacrifice can a man find himself anew. It is a genuine old wisdom that comes to light again in psychoanalytical treatment, and it is especially curious that this kind of psychic education should prove necessary in the heyday of our culture. In more than one respect it may be compared with the Socratic method, though it must be said that psychoanalysis penetrates to far greater depths.

[438] We always find in the patient a conflict which at a certain point is connected with the great problems of society. Hence, when the analysis is pushed to this point, the apparently individual conflict of the patient is revealed as a universal conflict of his environment and epoch. Neurosis is thus nothing less than an individual attempt, however unsuccessful, to solve a universal problem; indeed it cannot be otherwise, for a general problem, a "question," is not an *ens per se*, but exists only in the hearts of individuals. ["The question" that troubles the patient is—whether you like it or not—the "sexual" question, or more precisely, the problem of present-day sexual morality. His increased demand for life and the joy of life, for glowing reality, can stand the necessary limitations that reality itself imposes, but not the arbitrary, ill-supported prohibitions of present-day morality, which would curb too much the creative spirit rising up from the depths of the animal darkness.] The neurotic has the soul of a child who bears ill with arbitrary restrictions whose meaning he does not see; he tries to make this morality his own, but falls into profound division and disunity with himself: one side of him wants to suppress, the other longs to be free—and this struggle goes by the name of neurosis. Were the conflict clearly conscious in all its parts, it would never give rise to neurotic symptoms; these occur only when we cannot see the other side of our nature and the urgency of its problems. Only under these conditions does the symptom appear, and it helps to give expression to the unrecognized side of the psyche. The symptom is therefore an indirect expression of unrecognized desires which, when conscious, come into violent conflict with our moral convictions. As already observed, this shadow-side of the psyche, being withdrawn from conscious scrutiny, cannot be dealt with by the patient. He cannot correct it, cannot come to terms with it, nor yet disregard it; for in reality he does not "possess" the unconscious impulses at all. Thrust out from the hierarchy of the conscious psyche, they have become *autonomous complexes* which can be brought under control again through the analysis of the unconscious, though not without great resistances. There are very many patients who boast that for them the erotic conflict does not exist; they assure us that the sexual question is all nonsense, for they say

they possess no sexuality whatever. These people do not see that other things of unknown origin cumber their path—hysterical moods, underhand tricks which they play on themselves and their neighbours, a nervous catarrh of the stomach, pains in various places, irritability for no reason, and a whole host of nervous symptoms. [That is where the trouble lies. Only a few especially favoured by fate escape the great conflict of modern man; the majority are caught in it from sheer necessity.]

[439] Psychoanalysis has been accused of liberating man's (fortunately) repressed animal instincts and thus causing incalculable harm. This [childish] apprehension shows how little trust we place in the efficacy of our moral principles. People pretend that *only* morality holds men back from unbridled licence; but a much more effective regulator is necessity, which sets bounds far more real and persuasive than any moral precepts. It is true that analysis liberates the animal instincts, though not, as many would have it, with a view to giving them unbridled power, but rather to put them to higher uses, so far as this is possible for the individual concerned and so far as he requires such "sublimation." It is under all circumstances an advantage to be in full possession of one's personality, otherwise the repressed portions of the personality will only crop up as a hindrance elsewhere, not just at some unimportant point, but at the very spot where we are most sensitive: this worm always rots the core. [Instead of waging war on himself it is surely better for a man to learn to tolerate himself, and to convert his inner difficulties into real experiences instead of expending them in useless fantasies. Then at least he lives, and does not waste his life in fruitless struggles.] If people can be educated to see the lowly side of their own natures, it may be hoped that they will also learn to understand and to love their fellow men better. A little less hypocrisy and a little more tolerance towards oneself can only have good results in respect for our neighbour; for we are all too prone to transfer to our fellows the injustice and violence we inflict upon our own natures.

[440] [This funnelling of the individual conflict into the general moral problem puts psychoanalysis far outside the confines of a merely medical therapy. It gives the patient a working philosophy of life based on empirical insights, which, besides affording him a knowledge of his own nature, also make it possible for him to fit himself into this scheme of things. Wherein these very varied insights consist cannot be discussed here. It is also not at all easy to form an adequate picture of an actual analysis from the existing literature, since by no means everything has been published that relates to the technique of a deep analysis. Very great problems still remain to be solved in this field. Unfortunately the number of scientific works on this subject is still rather small, because too many prejudices still prevent most of the specialists from collaborating in this important endeavour. Many, especially in Germany, are also held back by the fear of ruining their careers if they venture to set foot on this territory.]

[441] [All these weird and wonderful phenomena that congregate round psychoanalysis allow us to conjecture—in accordance with psychoanalytic principles—that something extremely significant is going on here, which the learned public will (as usual) first combat by displays of the liveliest affect. But: *magna est vis veritatis et praevalebit.*]

II

THE STRUCTURE OF THE UNCONSCIOUS¹

1. *The Distinction between the Personal and the Impersonal Unconscious*

[442] Since we parted company with the Viennese school on the question of the interpretive principle in psychoanalysis, namely, whether it be *sexuality* or simply *energy*, our concepts have undergone considerable development. Once the prejudice regarding the explanatory cause had been removed by accepting a purely abstract one, the nature of which was not postulated in advance, our interest was directed to the concept of the unconscious.

[202] 443 In Freud's view, as most people know, the contents of the unconscious are reducible to infantile tendencies which are repressed because of their incompatible character. Repression is a process that begins in early childhood under the moral influence of the environment and continues throughout life. By means of analysis the repressions are removed and the repressed wishes are made conscious again. Theoretically the unconscious would thus find itself emptied and, so to speak, done away with; but in reality the production of infantile-sexual wish-fantasies continues right into old age.

[203] 444 According to this theory, the unconscious would contain only those elements of the personality which could just as well be conscious, and have in fact been suppressed only through the process of education. It follows that the essential content of the unconscious would be of a personal character. Although from one point of view the infantile tendencies of the unconscious are the most conspicuous, it would none the less be a mistake to define or evaluate the unconscious entirely in these terms. The unconscious has still another side to it: it includes not only repressed contents, but also all psychic material that lies below the threshold of consciousness. It is impossible to explain the subliminal nature of all this material on the principle of repression, for in that case the removal of repression ought to endow a person with a prodigious memory which would thenceforth forget nothing. No doubt repression plays a part, but it is not the only factor. If what we call a bad memory were always only the result of repression, those who enjoy an excellent memory ought never to suffer from repression, nor in consequence be neurotic. But experience shows that this is not the case at all. There are certainly cases of abnormally bad memory where it is obvious that the lion's share must be attributed to repression, but these are relatively rare.

We therefore affirm that in addition to the repressed material the unconscious contains all those psychic components that have fallen below the threshold, as well as subliminal sense-perceptions. Moreover, we know, from abundant experience as well as for theoretical reasons, that besides this the unconscious contains all the material that has *not yet* reached the threshold of consciousness. These are the seeds of future conscious contents. Equally we have every reason to suppose that the unconscious is never quiescent in the sense of being inactive, but presumably is ceaselessly engaged in the grouping and regrouping of so-called unconscious fantasies. This activity should be thought of as relatively autonomous only in pathological cases; normally it is co-ordinated with consciousness in a compensatory relationship.

It is to be assumed that all these contents are of a personal nature in so far as they are acquired during the individual's life. Since this life is limited, the number of acquired contents in the unconscious must also be limited. This being so, it might be thought possible to empty the unconscious either by analysis or by making a complete inventory of the unconscious contents, on the ground that the unconscious cannot produce anything more than what is already known and assimilated into consciousness. We should also have to suppose, as we have said, that if one could arrest the descent of conscious contents into the unconscious by doing away with repression, unconscious productivity would be paralysed. This is possible only to a very limited extent, as we know from experience. We urge our patients to hold fast to repressed contents that have been re-associated with consciousness, and to assimilate them into their plan of life. But this procedure, as we may daily convince ourselves, makes no impression on the unconscious, since it calmly goes on producing apparently the same infantile-sexual fantasies which, according to the earlier theory, should be the effects of personal repressions. If in such cases the analysis be continued systematically, one uncovers little by little a medley of incompatible wish-fantasies of a most surprising composition. Besides all the sexual perversions one finds every conceivable kind of criminality, as well as the noblest deeds and the loftiest ideas imaginable, the existence of which one would never have suspected in the subject under analysis.

By way of example I would like to recall the case of a schizophrenic patient of Maeder's, who used to declare that the world was his picture-book.² He was a wretched locksmith's apprentice who fell ill at an early age and had never been blessed with much intelligence. This notion of his, that the world was his picture-book, the leaves of which he was turning over as he looked around him, is exactly the same as Schopenhauer's "world as will and idea," but expressed in primitive picture language. His vision is just as sublime as Schopenhauer's, the only difference being that with the patient it remained at an embryonic stage, whereas in Schopenhauer the

same idea is transformed from a vision into an abstraction and expressed in a language that is universally valid.

[229] 448 It would be quite wrong to suppose that the patient's vision had a personal character and value, for that would be to endow the patient with the dignity of a philosopher. But, as I have indicated, he alone is a philosopher who can transmute a vision born of nature into an abstract idea, thereby translating it into a universally valid language. Schopenhauer's philosophical conception represents a personal value, but the vision of the patient is an impersonal value, a merely natural growth, the proprietary right to which can be acquired only by him who abstracts it into an idea and expresses it in universal terms. It would, however, be wrong to attribute to the philosopher, by exaggerating the value of his achievement, the additional merit of having actually created or invented the vision itself. It is a primordial idea that grows up quite as naturally in the philosopher and is simply a part of the common property of mankind, in which, in principle, everyone has a share. The golden apples drop from the same tree, whether they be gathered by a locksmith's apprentice or by a Schopenhauer.

[218] 449 These primordial ideas, of which I have given a great many examples in my work on libido,³ oblige one to make, in regard to unconscious material, a distinction of quite a different character from that between "preconscious" and "unconscious" or "subconscious" and "unconscious." The justification for these distinctions need not be discussed here. They have their specific value and are well worth elaborating further as points of view. The fundamental distinction which experience has forced upon me claims to be no more than that. It should be evident from the foregoing that we have to distinguish in the unconscious a layer which we may call the *personal unconscious*. The contents of this layer are of a personal nature in so far as they have the character partly of acquisitions derived from the individual's life and partly of psychological factors⁴ which could just as well be conscious.

[218] 450 It can readily be understood that incompatible psychological elements are liable to repression and therefore become unconscious. But this implies the possibility, on the other hand, of making and keeping the repressed contents conscious once they have been recognized. We recognize them as personal contents because their effects, or their partial manifestation, or their source can be discovered in our personal past. They are integral components of the personality, they belong to its inventory, and their loss to consciousness produces an inferiority in one respect or another. This inferiority has the psychological character not so much of an organic lesion or an inborn defect as of a lack which gives rise to a feeling of moral resentment. The sense of moral inferiority always indicates that the missing element is something which, to judge by this feeling about it, really ought not to be missing,

or which could be made conscious if only one took sufficient trouble. The moral inferiority does not come from a collision with the generally accepted and, in a sense, arbitrary moral law, but from the conflict with one's own self, which for reasons of psychic equilibrium demands that the deficit be redressed. Whenever a sense of moral inferiority appears, it indicates not only a need to assimilate an unconscious component, but also the possibility of such assimilation. In the last resort it is a man's moral qualities which force him, either through direct recognition of the need or indirectly through a painful neurosis, to assimilate his unconscious self and keep himself fully conscious. Whoever progresses along this path of self-realization must inevitably bring into consciousness the contents of his personal unconscious, thus enlarging considerably the scope of his personality.

2. *Phenomena Resulting from the Assimilation of the Unconscious*

[221] 451 The process of assimilating the unconscious gives rise to some very remarkable phenomena. It produces in some patients an unmistakable and often unpleasant increase of self-confidence and conceit: they are full of themselves, they know everything, they imagine themselves to be fully informed of everything concerning their unconscious, and are persuaded that they understand perfectly everything that comes out of it. At every interview with the doctor they get more and more above themselves. Others on the contrary feel themselves more and more crushed under the contents of the unconscious, they lose their self-confidence and abandon themselves with dull resignation to all the extraordinary things that the unconscious produces. The former, overflowing with feelings of their own importance, assume a responsibility for the unconscious that goes much too far, beyond all reasonable bounds; the others finally give up all sense of responsibility, overcome by a sense of the powerlessness of the ego against the fate working through the unconscious.

[222] 452 If we analyse these two modes of reaction more deeply, we find that the optimistic self-confidence of the first conceals a profound sense of impotence, for which their conscious optimism acts as an unsuccessful compensation; while the pessimistic resignation of the others masks a defiant will to power, far surpassing in cocksureness the conscious optimism of the first type.

[224] 453 Adler has employed the term "godlikeness" to characterize certain basic features of neurotic power psychology. If I likewise borrow the same term from *Faust*, I use it here more in the sense of that well known passage where Mephisto writes "Eritis sicut Deus, scientes bonum et malum" in the student's album, and makes the following aside:

Of my cousin the snake.

There'll come a time when your godlikeness

Will make you quiver and quake.⁵

[454] Godlikeness is certainly not a scientific concept, although it aptly characterizes the psychological state in question. It has yet to be seen whence this attitude arises and why it deserves the name of godlikeness. As the term indicates, the abnormality of the patient's condition consists in his attributing to himself qualities or values which obviously do not belong to him, for to be "godlike" is to be like a spirit superior to the spirit of man.

[235] 455 If, with a psychological aim in view, we dissect this notion of godlikeness, we find that the term comprises not only the dynamic phenomenon I have discussed in my book on libido, but also a certain psychic function having a collective character supraordinate to the individual mentality. Just as the individual is not merely a unique and separate being, but is also a social being, so the human mind is not a self-contained and wholly individual phenomenon, but also a collective one. And just as certain social functions or instincts are opposed to the egocentric interests of the individual, so certain functions or tendencies of the human mind are opposed, by their collective nature, to the personal mental functions.⁶ The reason for this is that every man is born with a brain that is highly differentiated. This makes him capable of a wide range of mental functioning which is neither developed ontogenetically nor acquired. But, inasmuch as human brains are uniformly differentiated, the mental functioning thereby made possible is collective and universal. This explains, for example, the interesting fact that the unconscious processes of the most widely separated peoples and races show a quite remarkable correspondence, which displays itself, among other things, in the extraordinary but well-authenticated analogies between the forms and motifs of autochthonous myths.

[235] 456 The universal similarity of human brains leads to the universal possibility of a uniform mental functioning. This functioning is the *collective psyche*. This can be subdivided into the *collective mind* and the *collective soul*.⁷ Inasmuch as there are differentiations corresponding to race, tribe, and even family, there is also a collective psyche limited to race, tribe, and family over and above the "universal" collective psyche. To borrow an expression from Pierre Janet, the collective psyche comprises the *parties inférieures* of the mental functions, that is to say those deep-rooted, well-nigh automatic portions of the individual psyche which are inherited and are to be found everywhere, and are thus impersonal or suprapersonal. Consciousness plus the personal unconscious constitutes the *parties supérieures* of the mental functions, those portions, therefore, that are developed ontogenetically and acquired as a result of personal differentiation.

[235] 457 Consequently, the individual who annexes the unconscious heritage of the collective psyche to what has accrued to him in the course of his ontogenetic development enlarges the scope of his personality in an illegitimate way and suffers the consequences. In so far as the collective psyche comprises the *parties inférieures* of the mental functions and thus forms the basis of every personality, it has the effect of crushing and devaluing the latter. This shows itself in the aforementioned stifling of self-confidence and in an unconscious heightening of the ego's importance to the point of a pathological will to power. On the other hand, in so far as the collective psyche is supraordinate to the personality, being the matrix of all personal differentiations and the mental function common to all individuals, it will have the effect, if annexed to the personality, of producing a hypertrophy of self-confidence, which in turn is compensated by an extraordinary sense of inferiority in the unconscious.

[237] 458 If, through assimilation of the unconscious, we make the mistake of including the collective psyche in the inventory of personal mental functions, a dissolution of the personality into its paired opposites inevitably follows. Besides the pair of opposites already discussed, megalomania and the sense of inferiority, which are so painfully evident in neurosis, there are many others, from which I will single out only the specifically moral pair of opposites, namely good and evil (*scientes bonum et malum!*). The formation of this pair goes hand in hand with the increase and diminution of self-confidence. The specific virtues and vices of humanity are contained in the collective psyche like everything else. One man arrogates collective virtue to himself as his personal merit, another takes collective vice as his personal guilt. Both are as illusory as the megalomania and the inferiority, because the imaginary virtues and the imaginary wickedness are simply the moral pair of opposites contained in the collective psyche, which have become perceptible or have been rendered conscious artificially. How much these paired opposites are contained in the collective psyche is exemplified by primitives: one observer will extol the greatest virtues in them, while another will record the very worst impressions of the selfsame tribe. For the primitive, whose personal differentiation is, as we know, only just beginning, both judgments are true, because his mentality is essentially collective. He is still more or less identical with the collective psyche, and for that reason shares equally in the collective virtues and vices without any personal attribution and without inner contradiction. The contradiction arises only when the personal development of the mind begins, and when reason discovers the irreconcilable nature of the opposites. The consequence of this discovery is the conflict of repression. We want to be good, and therefore must repress evil; and with that the paradise of the collective psyche comes to an end.

[237] 459 Repression of the collective psyche was absolutely necessary for the development of the personality, since collective psychology and personal psychology exclude one another up to a point. History teaches us that whenever a psychological attitude acquires a collective value, schisms begin to break out. Nowhere is this more evident than in the history of religion. A collective attitude is always a threat to the individual, even when it is a necessity. It is dangerous because it is very apt to check and smother all personal differentiation. It derives this characteristic from the collective psyche, which is itself a product of the psychological differentiation of the powerful gregarious instinct in man. Collective thinking and feeling and collective effort are relatively easy in comparison with individual functioning and performance; and from this may arise, all too easily, a dangerous threat to the development of personality through enfeeblement of the personal function. The damage done to the personality is compensated—for everything is compensated in psychology—by a compulsive union and unconscious identity with the collective psyche.

[240] 460 There is now a danger that in the analysis of the unconscious the collective and the personal psyche may be fused together, with, as I have intimated, highly unfortunate results. These results are injurious both to the patient's life-feeling and to his fellow men, if he has any power at all over his environment. Through his identification with the collective psyche he will infallibly try to force the demands of his unconscious upon others, for identity with the collective psyche always brings with it a feeling of universal validity—"godlikeness"—which completely ignores all differences in the psychology of his fellows.

[461] The worst abuses of this kind can be avoided by a clear understanding and appreciation of the fact that there are differently oriented psychological types whose psychology cannot be forced into the mould of one's own type. It is hard enough for one type completely to understand another type, but perfect understanding of another individuality is totally impossible. Due regard for the individuality of another is not only advisable but absolutely essential in analysis if the development of the patient's personality is not to be stifled. Here it is to be observed that, for one type of individual, to show respect for another's freedom is to grant him freedom of action, while for another it is to grant him freedom of thought. In analysis both must be safeguarded so far as the analyst's own self-preservation permits him to do so. An excessive desire to understand and enlighten is just as useless and injurious as a lack of understanding.

[241] 462 The collective instincts and fundamental forms of thinking and feeling brought to light by analysis of the unconscious constitute, for the conscious personality, an acquisition which it cannot assimilate completely without injury to itself.⁸ It is therefore of the utmost importance in practical treatment to keep the goal

of the individual's development constantly in view. For, if the collective psyche is taken to be the personal possession of the individual or as a personal burden, it will result in a distortion or an overloading of the personality which is very difficult to deal with. Hence it is imperative to make a clear distinction between the personal unconscious and the contents of the collective psyche. This distinction is far from easy, because the personal grows out of the collective psyche and is intimately bound up with it. So it is difficult to say exactly what contents are to be called personal and what collective. There is no doubt, for instance, that archaic symbolisms such as we frequently find in fantasies and dreams are collective factors. All basic instincts and basic forms of thinking and feeling are collective. Everything that all men agree in regarding as universal is collective, likewise everything that is universally understood, universally found, universally said and done. On closer examination one is always astonished to see how much of our so-called individual psychology is really collective. So much, indeed, that the individual traits are completely overshadowed by it. Since, however, individuation is an ineluctable psychological necessity, we can see from the ascendancy of the collective what very special attention must be paid to this delicate plant "individuality" if it is not to be completely smothered.

[242] 463 Human beings have one faculty which, though it is of the greatest utility for collective purposes, is most pernicious for individuation, and that is the faculty of imitation. Collective psychology cannot dispense with imitation, for without it all mass organizations, the State and the social order, are simply impossible. Society is organized, indeed, less by law than by the propensity to imitation, implying equally suggestibility, suggestion, and mental contagion. But we see every day how people use, or rather abuse, the mechanism of imitation for the purpose of personal differentiation: they are content to ape some eminent personality, some striking characteristic or mode of behaviour, thereby achieving an outward distinction from the circle in which they move. We could almost say that as a punishment for this the uniformity of their minds with those of their neighbours, already real enough, is still further increased until it becomes an unconscious enslavement to their surroundings. As a rule these specious attempts at differentiation stiffen into a pose, and the imitator remains at the same level as he always was, only several degrees more sterile than before. To find out what is truly individual in ourselves, profound reflection is needed; and suddenly we realize how uncommonly difficult the discovery of individuality is.

3. *The Persona as a Segment of the Collective Psyche*

[243] 464 Here we come to a problem which, if overlooked, is liable to cause the greatest confusion. It will be remembered that in the analysis of the personal unconscious the first things to be added to consciousness are the personal contents,

and I suggested that these contents, which have been repressed but are capable of being made conscious again, should be called the *personal unconscious*. I also showed that to annex the deeper layers of the unconscious, which I have called the *impersonal unconscious*, produces an enlargement of the personality leading to the state of “godlikeness.” This state is reached by simply continuing the analytical work which has restored to consciousness the repressed portions of the personality. By continuing the analysis we add to the personal consciousness certain fundamental, general, and impersonal characteristics of humanity, thereby bringing about the condition I have described, which might be regarded as one of the disagreeable consequences of analysis.⁹

[245] 465 From this point of view the conscious personality looks to us like a more or less arbitrary segment of the collective psyche. It owes its existence simply to the fact that it is from the outset unconscious of these fundamental and universal characteristics of humanity, and in addition has repressed, more or less arbitrarily, psychic or characterological elements of which it could just as well be conscious, in order to build up that segment of the collective psyche which we call the *persona*. The term *persona* is a very appropriate expression for this, for originally it meant the mask once worn by actors to indicate the role they played. If we endeavour to draw a precise distinction between what psychic material should be considered personal, and what impersonal, we soon find ourselves in the greatest dilemma, for by definition we have to say of the *persona*'s contents what we have said of the impersonal unconscious, namely, that they are collective. It is only because the *persona* represents a more or less arbitrary and fortuitous segment of the collective psyche that we can make the mistake of regarding it *in toto* as something individual. It is, as its name implies, only the mask worn by the collective psyche, a mask that *feigns individuality*, making others and oneself believe that one is individual, whereas one is simply acting a role through which the collective psyche speaks.

[246] 466 When we analyse the *persona* we strip off the mask, and discover that what seemed to be individual is at bottom collective. We thus trace the “petty god of this world” back to his origin in the universal god who is a personification of the collective psyche. Whether we reduce the personality to the fundamental instinct of sexuality, like Freud, or to the ego's elementary will to power, like Adler, or to the general principle of the collective psyche which embraces both the Freudian and the Adlerian principles, we arrive at the same result: the dissolution of the personality in the collective. That is why, in any analysis that is pushed far enough, there comes a moment when the subject experiences that feeling of “godlikeness” of which we have spoken.

[250] 467 This condition frequently announces itself by very peculiar symptoms, as for example dreams in which the dreamer is flying through space like a comet, or feels that he is the earth, the sun, or a star, or that he is of immense size, or dwarfishly small, or that he is dead, is in a strange place, is a stranger to himself, confused, mad, etc. He may also experience body-sensations, such as being too large for his skin, or too fat; or hypnagogic sensations of falling or rising endlessly, of the body growing larger or of vertigo. Psychologically this state is marked by a peculiar disorientation in regard to one's own personality; one no longer knows who one is, or one is absolutely certain that one actually is what one seems to have become. Intolerance, dogmatism, self-conceit, self-depreciation, and contempt for "people who have not been analysed," and for their views and activities, are common symptoms. Often enough I have observed an increase in the liability to physical illness, but only when the patients relish their condition and dwell on it too long.

[251] 468 The forces that burst out of the collective psyche are confusing and blinding. One result of the dissolution of the persona is the release of fantasy, which is apparently nothing less than the specific activity of the collective psyche. This outburst of fantasy throws up into consciousness materials and impulses whose existence one had never before suspected. All the treasures of mythological thinking and feeling are unlocked. It is not always easy to hold one's own against such an overwhelming impression. This phase must be reckoned one of the real dangers of analysis a danger that ought not to be minimized.

[469] It will readily be understood that this condition is so insupportable that one would like to put an end to it as speedily as possible, since the analogy with mental derangement is too close. As we know, the commonest form of insanity, dementia praecox or schizophrenia, consists essentially in the fact that the unconscious in large measure ousts and supplants the function of the conscious mind. The unconscious usurps the reality function and substitutes its own reality. Unconscious thoughts become audible as voices, or are perceived as visions or body-hallucinations, or they manifest themselves in senseless, unshakable judgments upheld in the face of reality.

[470] In a similar but not quite identical manner the unconscious is pushed into consciousness when the persona is dissolved in the collective psyche. The one difference between this state and that of mental alienation is that here the unconscious is brought to the surface with the help of conscious analysis—at least, this is how things go at the beginning of an analysis, when powerful cultural resistances to the unconscious have still to be overcome. Later, when the barriers built up by the years have been broken down, the unconscious intrudes spontaneously, and sometimes irrupts into the conscious mind like a torrent. In this phase the analogy with mental derangement is very close. [In the same way, the

moments of inspiration in a genius often bear a decided resemblance to pathological states.] But it would be real insanity only if the contents of the unconscious became a reality that took the place of conscious reality; in other words, if they were believed in without reserve. [Actually, one can believe in the contents of the unconscious without this amounting to insanity in the proper sense, even though actions of an unadapted nature may be performed on the basis of such convictions. Paranoid delusions, for instance, do not depend on belief—they appear to be true *a priori* and have no need of belief in order to lead an effective and valid existence. In the cases we are discussing the question is still open whether belief or criticism will triumph. This alternative is not found in genuine insanity.]

4. *Attempts to Free the Individuality from the Collective Psyche*

a. THE REGRESSIVE RESTORATION OF THE PERSONA

[471] The unbearable state of identity with the collective psyche drives the patient, as we have said, to some radical solution. Two ways are open to him for getting out of the condition of “godlikeness.” The first possibility is to try to re-establish regressively the previous persona by attempting to control the unconscious through the application of a reductive theory—by declaring, for instance, that it is “nothing but” repressed and long overdue infantile sexuality which would really be best replaced by the normal sexual function. This explanation is based on the undeniably sexual symbolism of the language of the unconscious and on its concretistic interpretation. Alternatively the power theory may be invoked and, relying on the equally undeniable power tendencies of the unconscious, one may interpret the feeling of “godlikeness” as “masculine protest,” as the infantile desire for domination and security. Or one may explain the unconscious in terms of the archaic psychology of primitives, an explanation that would not only cover both the sexual symbolism and the “godlike” power strivings that come to light in the unconscious material but would also seem to do justice to its religious, philosophical, and mythological aspects.

[472] In each case the conclusion will be the same, for what it amounts to is a repudiation of the unconscious as something everybody knows to be useless, infantile, devoid of sense, and altogether impossible and obsolete. After this devaluation, there is nothing to be done but shrug one’s shoulders resignedly. To the patient there seems to be no alternative, if he is to go on living rationally, but to reconstitute, as best he can, that segment of the collective psyche which we have called the persona, and quietly give up analysis, trying to forget if possible that he possesses an unconscious. He will take Faust’s words to heart:

[257] This earthly circle I know well enough.

Towards the Beyond the view has been cut off;

Fool—who directs that way his dazzled eye,

Contrives himself a double in the sky!

Let him look round him here, not stray beyond;

To a sound man this world must needs respond.

To roam into eternity is vain!

What he perceives, he can attain.

Thus let him walk along his earthlong day;

Though phantoms haunt him, let him go his way,

And, moving on, to weal and woe assent—

He at each moment ever discontent.¹⁰

[258] 473 Such a solution would be perfect if a man were really able to shake off the unconscious, drain it of libido and render it inactive. But experience shows that it is not possible to drain the energy from the unconscious: it remains active, for it not only contains but is itself the source of libido from which all the psychic elements flow into us—the thought-feelings or feeling-thoughts, the still undifferentiated germs of formal thinking and feeling. It is therefore a delusion to think that by some kind of magical theory or method the unconscious can be finally emptied of libido and thus, as it were, eliminated. One may for a while play with this delusion, but the day comes when one is forced to say with Faust:

But now such spectredom so throngs the air

That none knows how to dodge it, none knows where.

Though one day greet us with a rational gleam,

The night entangles us in webs of dream.

We come back happy from the fields of spring—

And a bird croaks. Croaks what? Some evil thing.

Enmeshed in superstition night and morn,

It forms and shows itself and comes to warn.

And we, so scared, stand without friend or kin,

And the door creaks—and nobody comes in.

Anyone here?

CARE: The answer should be clear.

FAUST: And you, who are you then?

CARE: I am just here.

FAUST: Take yourself off!

CARE: This is where I belong.

FAUST: Take care, Faust, speak no magic spell, be strong.

CARE: Unheard by the outward ear

In the heart I whisper fear;

Changing shape from hour to hour

I employ my savage power.¹¹

[258] 474 The unconscious cannot be analysed to a finish and brought to a standstill. Nothing can deprive it of its power for any length of time. To attempt to do so by the method described is to deceive ourselves, and is nothing but ordinary repression in a new guise.

[258] 475 Mephistopheles leaves an avenue open which should not be overlooked, since it is a real possibility for some people. He tells Faust, who is sick of the “madness of magic” and would gladly escape from the witch’s kitchen:

Right. There is one way that needs

No money, no physician, and no witch.

Pack up your things and get back to the land

And there begin to dig and ditch;

Keep to the narrow round, confine your mind,

And live on fodder of the simplest kind,

A beast among the beasts; and don’t forget

To use your own dung on the crops you set.¹²

[Anyone who finds it possible to live this kind of life will never be in danger of coming to grief in either of the two ways we are discussing, for his nature does not compel him to tackle a problem that is beyond his powers. But if ever the great problem should be thrust upon him, this way out will be closed.]

b. IDENTIFICATION WITH THE COLLECTIVE PSYCHE

[260] 476 The second way leads to identification with the collective psyche. This amounts to an acceptance of “godlikeness,” but now exalted into a system. That is to say, one is the fortunate possessor of *the* great truth which was only waiting to be discovered, of the eschatological knowledge which spells the healing of the nations. This attitude is not necessarily megalomania in direct form, but in the milder and more familiar form of prophetic inspiration and desire for martyrdom. For weak-minded persons, who as often as not possess more than their fair share of ambition,

vanity, and misplaced naïveté, the danger of yielding to this temptation is very great. Access to the collective psyche means a renewal of life for the individual, no matter whether this renewal is felt as pleasant or unpleasant. Everybody would like to hold fast to this renewal: one man because it enhances his life-feeling, another because it promises a rich harvest of knowledge. Therefore both of them, not wishing to deprive themselves of the great treasures that lie buried in the collective psyche, will strive by every means possible to maintain their newly won connection with the primal source of life.¹³ Identification would seem to be the shortest road to this, for the dissolution of the persona in the collective psyche positively invites one to plunge into that “ocean of divinity” and blot out all memory in its embrace. This piece of mysticism is innate in all better men as the “longing for the mother,” the nostalgia for the source from which we came.

[261] 477 As I have shown in my book on libido, there lie at the root of the regressive longing, which Freud conceives as “infantile fixation” or the “incest wish,” a specific value and a specific need which are made explicit in myths. It is precisely the strongest and best among men, the heroes, who give way to their regressive longing and purposely expose themselves to the danger of being devoured by the monster of the maternal abyss. But if a man is a hero, he is a hero because, in the final reckoning, he did not let the monster devour him, but subdued it, not once but many times. Victory over the collective psyche alone yields the true value—the capture of the hoard, the invincible weapon, the magic talisman, or whatever it be that the myth deems most desirable. Anyone who identifies with the collective psyche—or, in mythological terms, lets himself be devoured by the monster—and vanishes in it, attains the treasure that the dragon guards, but he does so in spite of himself and to his own greatest harm.

[478] [The danger, therefore, of falling victim to the collective psyche by identification is not to be minimized. Identification is a retrograde step, one more stupidity has been committed, and on top of that the principle of individuation is denied and repressed under the cloak of the individual deed and in the nebulous conceit that one has discovered what is truly one’s own. In reality one has not discovered one’s own at all, but rather the eternal truths and errors of the collective psyche. In the collective psyche one’s true individuality is lost.]

[479] Identification with the collective psyche is thus a mistake that, in another form, ends as disastrously as the first way, which led to the separation of the persona from the collective psyche.

5. Fundamental Principles in the Treatment of Collective Identity

[480] In order to solve the problem presented by the assimilation of the collective psyche, and to find a practical method of treatment, we have first of all to take account of the error of the two procedures we have just described. We have seen that neither the one nor the other can lead to good results.

[481] The first, by abandoning the vital values in the collective psyche, simply leads back to the point of departure. The second penetrates directly into the collective psyche, but at the price of losing that separate human existence which alone can render life supportable and satisfying. Yet each of these ways proffers absolute values that should not be lost to the individual.

[482] The mischief, then, lies neither with the collective psyche nor with the individual psyche, but in allowing the one to exclude the other. The disposition to do this is encouraged by the *monistic tendency*, which always and everywhere looks for a *unique* principle. Monism, as a general psychological tendency, is a characteristic of all civilized thinking and feeling, and it proceeds from the desire to set up one function or the other as the supreme psychological principle. The introverted type knows only the principle of *thinking*, the extraverted type only that of *feeling*.¹⁴ This psychological monism, or rather monotheism, has the advantage of simplicity but the defect of one-sidedness. It implies on the one hand exclusion of the diversity and rich reality of life and the world, and on the other the practicality of realizing the ideals of the present and the immediate past, but it holds out no real possibility of human development.

[483] The disposition to exclusiveness is encouraged no less by *rationalism*. The essence of this consists in the flat denial of whatever is opposed to one's own way of seeing things either from the logic of the intellect or from the logic of feeling. It is equally monistic and tyrannical in regard to reason itself. We ought to be particularly grateful to Bergson for having broken a lance in defence of the irrational. Although it may not be at all to the taste of the scientific mind, psychology will nonetheless have to recognize a plurality of principles and accommodate itself to them. It is the only way to prevent psychology from getting stranded. In this matter we owe a great deal to the pioneer work of William James.

[484] With regard to individual psychology, however, science must waive its claims. To speak of a science of individual psychology is already a contradiction in terms. It is only the collective element in the psychology of an individual that constitutes an object for science; for the individual is by definition something unique that cannot be compared with anything else. A psychologist who professes a "scientific" individual psychology is simply denying individual psychology. He exposes his individual psychology to the legitimate suspicion of being merely his own psychology. The

psychology of every individual would need its own manual, for the general manual can deal only with collective psychology.

[485] These remarks are intended as a prelude to what I have to say about the handling of the aforesaid problem. The fundamental error of both procedures consists in identifying the subject with one side or the other of his psychology. His psychology is as much individual as collective, but not in the sense that the individual ought to merge himself in the collective, nor the collective in the individual. We must rigorously separate the concept of the individual from that of the persona, for the persona *can* be entirely dissolved in the collective. But the individual is precisely that which can never be merged with the collective and is never identical with it. That is why identification with the collective and voluntary segregation from it are alike synonymous with disease.

[486] It is simply impossible to effect a clear division of the individual from the collective, and even if it were possible it would be quite pointless and valueless for our purpose. It is sufficient to know that the human psyche is both individual and collective, and that its well-being depends on the natural co-operation of these two apparently contradictory sides. Their union is essentially an irrational life process that can, at most, be described in individual cases, but can neither be brought about, nor understood, nor explained rationally.¹⁵

[487] If I may be forgiven a humorous illustration of the starting-point for the solution of our problem, I would cite Buridan's ass between the two bundles of hay. Obviously his question was wrongly put. The important thing was not whether the bundle on the right or the one on the left was the better, or which one he ought to start eating, but what he wanted in the depths of his being—which did he feel pushed towards? The ass wanted the object to make up his mind for him.

[488] What is it, at this moment and in this individual, that represents the natural urge of life? That is the question.

[489] That question neither science, nor worldly wisdom, nor religion, nor the best of advice can resolve for him. The resolution can come solely from absolutely impartial observation of those psychological germs of life which are born of the natural collaboration of the conscious and the unconscious on the one hand and of the individual and the collective on the other. Where do we find these germs of life? One man seeks them in the conscious, another in the unconscious. But the conscious is only one side, and the unconscious is only its reverse. We should never forget that dreams are the compensators of consciousness. If it were not so, we would have to regard them as a source of knowledge superior to consciousness: we should then be degraded to the mental level of fortune tellers and would be obliged to accept all the

futility of superstition, or else, following vulgar opinion, deny any value at all to dreams.

[490] It is in *creative fantasies* that we find the unifying function we seek. All the functions that are active in the psyche converge in fantasy. Fantasy has, it is true, a poor reputation among psychologists, and up to the present psychoanalytic theories have treated it accordingly. For Freud as for Adler it is nothing but a “symbolic” disguise for the basic drives and intentions presupposed by these two investigators. As against these opinions it must be emphasized—not on theoretical grounds but essentially for practical reasons—that although fantasy can be causally explained and devalued in this way, it nevertheless remains the creative matrix of everything that has made progress possible for humanity. Fantasy has its own irreducible value, for it is a psychic function that has its roots in the conscious and the unconscious alike, in the individual as much as in the collective.

[491] Whence has fantasy acquired its bad reputation? Above all from the circumstance that it cannot be taken literally. *Concretely* understood, it is worthless. If it is understood *semiotically*, as Freud understands it, it is interesting from the scientific point of view; but if it is understood *hermeneutically*, as an authentic symbol, it acts as a signpost, providing the clues we need in order to carry on our lives in harmony with ourselves.

[492] The symbol is not a sign that disguises something generally known.¹⁶ Its meaning resides in the fact that it is an attempt to elucidate, by a more or less apt analogy, something that is still entirely unknown or still in the process of formation.¹⁷ If we reduce this by analysis to something that is generally known, we destroy the true value of the symbol; but to attribute hermeneutic significance to it is consistent with its value and meaning.

[493] The essence of hermeneutics, an art widely practised in former times, consists in adding further analogies to the one already supplied by the symbol: in the first place subjective analogies produced at random by the patient, then objective analogies provided by the analyst out of his general knowledge. This procedure widens and enriches the initial symbol, and the final outcome is an infinitely complex and variegated picture the elements of which can be reduced to their respective *tertia comparationis*. Certain lines of psychological development then stand out that are at once individual and collective. There is no science on earth by which these lines could be proved “right”; on the contrary, rationalism could very easily prove that they are wrong. Their validity is proved by their intense value for life. And that is what matters in practical treatment: that human beings should get a hold on their own lives, not that the principles by which they live should be proved rationally to be “right.”

[494] [This view will seem the only acceptable one to the man of our time who thinks and feels scientifically, but not to the extraordinarily large number of so-called educated people for whom science is not a principle of intellectual ethics superior to their own minds, but rather a means of corroborating their inner experiences and giving them general validity. No one who is concerned with psychology should blind himself to the fact that besides the relatively small number of those who pay homage to scientific principles and techniques, humanity fairly swarms with adherents of quite another principle. It is entirely in keeping with the spirit of our present-day culture that one can read in an encyclopaedia, in an article on astrology, the following remark: "One of its last adherents was I. W. Pfaff, whose *Astrologie* (Bamberg, 1816) and *Der Stern der Drei Weisen* (1821) must be called strange anachronisms. Even today, however, astrology is still highly regarded in the East, particularly in Persia, India, and China." One must be smitten with blindness to write such a thing nowadays. The truth is that astrology flourishes as never before. There is a regular library of astrological books and magazines that sell for far better than the best scientific works. The Europeans and Americans who have horoscopes cast for them may be counted not by the hundred thousand but by the million. Astrology is a flourishing industry. Yet the encyclopaedia can say: "The poet Dryden (d. 1701) still had horoscopes cast for his children." Christian Science, too, has swamped Europe and America. Hundreds and thousands of people on both sides of the Atlantic swear by theosophy and anthroposophy, and anyone who believes that the Rosicrucians are a legend of the dim bygone has only to open his eyes to see them as much alive today as they ever were. Folk magic and secret lore have by no means died out. Nor should it be imagined that only the dregs of the populace fall for such superstitions. We have, as we know, to climb very high on the social scale to find the champions of this other principle.]

[495] [Anyone who is interested in the real psychology of man must bear such facts in mind. For if such a large percentage of the population has an insatiable need for this counterpole to the scientific spirit, we can be sure that the collective psyche in every individual—be he never so scientific—has this psychological requirement in equally high degree. A certain kind of "scientific" scepticism and criticism in our time is nothing but a misplaced compensation of the powerful and deep-rooted superstitious impulses of the collective psyche. We have seen from experience that extremely critical minds have succumbed completely to this demand of the collective psyche, either directly, or indirectly by making a fetish of their particular scientific theory.]¹⁸

[496] Faithful to the spirit of scientific superstition, someone may now begin to talk about *suggestion*. But we ought to have realized long ago that a suggestion is not accepted unless it is agreeable to the person concerned. Unless it is acceptable, all suggestion is futile; otherwise the treatment of neurosis would be an extremely

simple affair: one would merely have to suggest the state of health. This pseudo-scientific talk about suggestion is based on the unconscious superstition that suggestion is possessed of some self-generated magical power. No one succumbs to suggestion unless from the very bottom of his heart he is willing to comply with it.

[497] By means of the hermeneutic treatment of fantasies we arrive, in theory, at a synthesis of the individual with the collective psyche; but in practice one indispensable condition remains to be fulfilled. It belongs essentially to the regressive nature of the neurotic—and this is something he has also learnt in the course of his illness—never to take himself or the world seriously, but always to rely first on one doctor and then on another, by this or that method, and in such and such circumstances, to cure him, without any serious cooperation on his part. Now, no dog can be washed without getting wet. Without the complete willingness and absolute seriousness of the patient, no recovery is possible. There are no magical cures for neurosis. The moment we begin to map out the lines of advance that are symbolically indicated, the patient himself must proceed along them. If he shirks this by his own deceit, he automatically precludes any cure. He must in very truth take the way of the individual lifeline he has recognized as his own, and continue along it until such time as an unmistakable reaction from the unconscious tells him that he is on the wrong track.

[498] He who does not possess this moral function, this loyalty to himself, will never get rid of his neurosis. But he who has this capacity will certainly find the way to cure himself.

[499] Neither the doctor nor the patient, therefore, should let himself slip into the belief that analysis by itself is sufficient to remove a neurosis. That would be a delusion and a deception. Infallibly, in the last resort, it is the moral factor that decides between health and sickness.

[500] The construction of “life-lines” reveals to consciousness the ever-changing direction of the currents of libido. These life-lines are not to be confused with the “guiding fictions” discovered by Adler, for the latter are nothing but arbitrary attempts to cut off the persona from the collective psyche and lend it an independent existence. One might rather say that the guiding fiction is an unsuccessful attempt to construct a life-line. Moreover—and this shows the uselessness of the fiction—such a line as it does produce persists far too long; it has the tenacity of a cramp.

[501] The life-line constructed by the hermeneutic method is, on the contrary, temporary, for life does not follow straight lines whose course can be predicted far in advance. “All truth is crooked,” says Nietzsche. These life-lines, therefore, are never general principles or universally accepted ideals, but points of view and attitudes that have a provisional value. A decline in vital intensity, a noticeable loss of libido, or,

on the contrary, an upsurge of feeling indicate the moment when one line has been quitted and a new line begins, or rather ought to begin. Sometimes it is enough to leave the unconscious to discover the new line, but this attitude is not to be recommended to the neurotic under all circumstances, although there are indeed cases where this is just what the patient needs to learn—how to put his trust in so-called chance. However, it is not advisable to let oneself drift for any length of time; a watchful eye should at least be kept on the reactions of the unconscious, that is, on dreams, which indicate like a barometer the one-sidedness of our attitude.¹⁹ Unlike other psychologists, I therefore consider it necessary for the patient to remain in contact with his unconscious, even after analysis, if he wishes to avoid a relapse.²⁰ I am persuaded that the true end of analysis is reached when the patient has gained an adequate knowledge of the methods by which he can maintain contact with the unconscious, and has acquired a psychological understanding sufficient for him to discern the direction of his life-line at the moment. Without this his conscious mind will not be able to follow the currents of libido and consciously sustain the individuality he has achieved. A patient who has had any serious neurosis needs to be equipped in this way if he is to persevere in his cure.

[502] Analysis, thus understood, is by no means a therapeutic method of which the medical profession holds a monopoly. It is an art, a technique, a science of psychological life, which the patient, when cured, should continue to practise for his own good and for the good of those amongst whom he lives. If he understands it in this way, he will not set himself up as a prophet, nor as a world reformer; but, with a sound sense of the general good, he will profit by the knowledge he has acquired during treatment, and his influence will make itself felt more by the example of his own life than by any high discourse or missionary propaganda.

[ADDENDUM]²¹

[503] [I am well aware that this discussion has landed me on perilous ground. It is virgin territory which psychology has still to conquer, and I am obliged to do pioneer work. I am painfully conscious of the inadequacy of many of my formulations, though unfortunately this knowledge is of little avail when it comes to improving on them. I must therefore beg the reader not to be put off by the shortcomings of my presentation, but to try to feel his way into what I am endeavouring to describe. I would like to say a few words more about the concept of individuality in relation to the personal and the collective in order to clarify this central problem.

[504] As I have already pointed out, individuality reveals itself primarily in the particular selection of those elements of the collective psyche which constitute the persona. These components, as we have seen, are not individual but collective. It is only their combination, or the selection of a group already combined in a pattern, that

is individual. Thus we have an individual nucleus which is covered by the personal mask. It is in the particular differentiation of the persona that the individuality exhibits its resistance to the collective psyche. By analysing the persona we confer a greater value on the individuality and thus accentuate its conflict with the collectivity. This conflict consists, of course, in a psychological opposition within the subject. The dissolution of the compromise between the two halves of a pair of opposites renders their activity more intense. In purely unconscious, natural life this conflict does not exist, despite the fact that purely physiological life has to satisfy individual and collective requirements equally. The natural and unconscious attitude is harmonious. The body, its faculties, and its needs furnish of their own nature the rules and limitations that prevent any excess or disproportion. But because of its one-sidedness, which is fostered by conscious and rational intention, a differentiated psychological function always tends to disproportion. The body also forms the basis of what we might call the mental individuality, which is, as it were, an expression of corporeal individuality and can never come into being unless the rights of the body are acknowledged. Conversely, the body cannot thrive unless the mental individuality is accepted. At the same time, it is in the body that the individual is in the highest degree similar to other individuals, although each individual body is distinguishable from all other bodies. Equally, every mental or moral individuality differs from all the others, and yet is so constituted as to render every man equal to all other men. Every living being that is able to develop itself individually, without constraint, will best realize, by the very perfection of its individuality, the ideal type of its species, and by the same token will achieve a collective value.

[505] The persona is always identical with a *typical* attitude dominated by a single psychological function, for example, by thinking, feeling, or intuition. This one-sidedness necessarily results in the relative repression of the other functions. In consequence, the persona is an obstacle to the individual's development. The dissolution of the persona is therefore an indispensable condition for individuation. It is, however, impossible to achieve individuation by conscious intention, because conscious intention invariably leads to a typical attitude that excludes whatever does not fit in with it. The assimilation of unconscious contents leads, on the contrary, to a condition in which conscious intention is excluded and is supplanted by a process of development that seems to us irrational. This process alone signifies individuation, and its product is individuality as we have just defined it: particular and universal at once. So long as the persona persists, individuality is repressed, and hardly betrays its existence except in the choice of its personal accessories—by its actor's wardrobe, one might say. Only when the unconscious is assimilated does the individuality emerge more clearly, together with the psychological phenomenon which links the

ego with the non-ego and is designated by the word *attitude*. But this time it is no longer a typical attitude but an individual one.

[506] The paradox in this formulation arises from the same root as the ancient dispute about universals. The proposition: *animal nullumque animal genus est* makes the fundamental paradox clear and intelligible. The *realia*—these are the particular, the individual; the *universalia* exist psychologically, but are based on a real resemblance between particulars. Thus the individual is that particular thing which possesses in greater or lesser degree the qualities upon which we base the general conception of “collectivity”; and the more individual it is, the more it develops those qualities which are fundamental to the collective conception of humanity.

[507] In the hope of unravelling these tangled problems, I would like to emphasize the architectonics of the factors to be considered. We have to do with the following fundamental concepts:

1. *The world of consciousness and reality*. By this is meant those contents of consciousness which consist of perceived images of the world, and of our conscious thoughts and feelings about it.

2. *The collective unconscious*. By this is meant that part of the unconscious which consists on the one hand of unconscious perceptions of external reality and, on the other, of all the residues of the phylogenetic perceptive and adaptive functions. A reconstruction of the unconscious view of the world would yield a picture showing how external reality has been perceived from time immemorial. The collective unconscious contains, or is, an historical mirror-image of the world. It too is a world, but a world of images.

3. Since the world of consciousness, like the world of the unconscious, is to a large extent collective, these two spheres together form the *collective psyche* in the individual.

4. The collective psyche must be contrasted with a fourth concept, namely, the concept of *individuality*. The individual stands, as it were, between the conscious part of the collective psyche and the unconscious part. He is the reflecting surface in which the world of consciousness can perceive its own unconscious, historical image, even as Schopenhauer says that the intellect holds up a mirror to the universal Will. Accordingly, the individual would be a point of intersection or a dividing line, neither conscious nor unconscious, but a bit of both.

5. The paradoxical nature of the psychological individual must be contrasted with that of the *persona*. The persona is conscious all round, so to speak, or is at least capable of becoming so. It represents a compromise formation between external reality and the individual. In essence, therefore, it is a function for adapting the

individual to the real world. The persona thus occupies a place midway between the real world and individuality.

6. Beyond individuality, which appears to be the innermost core of ego-consciousness and of the unconscious alike, we find the collective unconscious. The place between the individual and the collective unconscious, corresponding to the persona's position between the individual and external reality, appears to be empty. Experience has taught me, however, that here too a kind of persona exists, but a persona of a compensatory nature which (in a man) could be called the *anima*. The anima would thus be a compromise formation between the individual and the unconscious world, that is, the world of historical images, or "primordial images." We frequently meet the anima in dreams, where it appears as a feminine being in a man, and as a man (*animus*) in a woman. A good description of the anima figure can be found in Spitteler's *Imago*. In his *Prometheus and Epimetheus* she appears as the soul of Prometheus, and in his *Olympian Spring* as the soul of Zeus.

[508] To the degree that the ego identifies with the persona, the anima, like everything unconscious, is projected into the real objects of our environment. She is regularly to be found, therefore, in the woman we are in love with. This can be seen easily enough from the expressions we use when in love. The poets, too, have supplied a good deal of evidence in this respect. The more normal a person is, the less will the daemonic qualities of the anima appear in the objects of his immediate environment. They are projected upon more distant objects, from which no immediate disturbance is to be feared. But the more sensitive a person is, the closer these daemonic projections will come, until in the end they break through the family taboo and produce the typical neurotic complications of a family romance.

[509] If the ego identifies with the persona, the subject's centre of gravity lies in the unconscious. It is then practically identical with the collective unconscious, because the whole personality is collective. In these cases there is a strong pull towards the unconscious and, at the same time, violent resistance to it on the part of consciousness because the destruction of conscious ideals is feared.

[510] In certain cases, found chiefly among artists or highly emotional people, the ego is localized not in the persona (the function of relationship to the real world) but in the anima (the function of relationship to the collective unconscious). Here individual and persona are alike unconscious. The collective unconscious then intrudes into the conscious world, and a large part of the real world becomes an unconscious content. Such persons have the same daemonic fear of reality as ordinary people have of the unconscious.]

6. Summary

[511] A. We have to divide psychological material into *conscious* and *unconscious* contents.

1. The *conscious* contents are in part *personal* inasmuch as their general validity is not recognized, and in part *impersonal*, that is, *collective*, inasmuch as their general validity is recognized.

2. The *unconscious* contents are in part *personal* inasmuch as they consist of personal material that was once conscious but was then repressed, and whose general validity is therefore not recognized when it becomes conscious again. They are *impersonal* inasmuch as the material is recognized as having general validity, and of which it is impossible to prove any anterior or even relative consciousness.

[512] B. *The Composition of the Persona.*

1. The conscious personal contents constitute the conscious personality, the *conscious ego*.

2. The unconscious personal contents constitute the *self*, the *unconscious or subconscious ego*.

3. The conscious and unconscious contents of a personal nature constitute the *persona*.

[513] C. *The Composition of the Collective Psyche.*

1. The conscious and unconscious contents of an *impersonal* or *collective* nature constitute the psychological *non-ego*, the *object-imago*. These contents may appear in analysis as projections of feelings or judgments, but they are *a priori* collective and are identical with the object-imago; that is, they appear to be qualities of the object, and it is only *a posteriori* that they are recognized as subjective psychological qualities.

2. The persona is a grouping of conscious and unconscious contents which is opposed as ego to the non-ego. A general comparison of the personal contents belonging to different individuals shows the surprising resemblance between them, which may even amount to identity, and largely cancels out the *individual* nature of the personal contents as well as of the persona. To this extent the persona must be considered a segment and also a constituent of the collective psyche.

3. The collective psyche is thus composed of the object-imago and the persona.

[514] D. *Individuality.*

1. Individuality manifests itself partly as the principle which selects and sets limits to contents that are recognized as personal.
2. Individuality is the principle which makes possible, and if need be compels, a progressive differentiation from the collective psyche.
3. Individuality manifests itself partly as an obstacle to collective functioning, and partly as resistance to collective thinking and feeling.
4. Individuality is that which is peculiar and unique in a given combination of collective psychological elements.
5. Individuality corresponds to the systole, and collective psychology to the diastole, of the movement of libido.

[515] *E.* The conscious and unconscious contents are subdivided into those that are *individual* and those that are *collective*.

1. A content whose developmental tendency is towards differentiation from the collective is individual.
2. A content whose developmental tendency is towards a general value is collective.
3. There are insufficient criteria by which to determine whether a given content is purely individual or purely collective, for individuality is very difficult to determine, although always and everywhere present.
4. The life-line of an individual is the resultant of the individual and collective tendencies of the psychological process at a given moment.

[SECOND VERSION]

[516] *A.* We have to divide psychological material into *conscious* and *unconscious* contents.

1. The *conscious* contents are in part *personal* inasmuch as their general validity is not recognized, and in part *impersonal*, that is, *collective*, inasmuch as their general validity is recognized.
2. The *unconscious* contents are in part *personal* inasmuch as they consist of personal material that was once conscious but was then repressed, and whose general validity is therefore not recognized when it becomes conscious again. They are *impersonal* inasmuch as the material is recognized as having general validity, and of which it is impossible to prove any anterior or even relative consciousness.

[517] *B. The Composition of the Persona.*

1. The conscious personal contents constitute the conscious persona[lity], the *conscious ego*.

2. The unconscious personal contents are combined with the germs of the still undeveloped individuality and with the collective unconscious. All these elements appear in combination with the repressed personal contents (i.e., the personal unconscious), and, when assimilated by consciousness, dissolve the persona into the collective material.

[518] C. *The Composition of the Collective Psyche*.

1. The conscious and unconscious contents of an *impersonal* or *collective* nature constitute the psychological *non-ego*, the *object-imago*. These materials, in so far as they are unconscious, are *a priori* identical with the object-imago; that is, they appear to be qualities of the object, and it is only *a posteriori* that they are recognized as subjective psychological qualities.

2. The persona is a *subject-imago*, which, like the object-imago, largely consists of collective material inasmuch as the persona represents a compromise with society, the ego identifying more with the persona than with individuality. The more the ego identifies with the persona, the more the subject becomes what he appears to be, and is de-individualized.

3. The collective psyche is thus composed of the object-imago and the persona. When the ego is completely identical with the persona, individuality is wholly repressed, and the entire conscious psyche becomes collective. This represents the maximum adaptation to society and the minimum adaptation to one's own individuality.

[519] D. *Individuality*.

1. Individuality is that which is unique in the combination of collective elements of the persona and its manifestations.

2. Individuality is the principle of resistance to collective functioning. It makes possible, and if need be compels, differentiation from the collective psyche.

3. Individuality is a developmental tendency constantly aiming at differentiation and separation from the collective.

4. A distinction must be made between *individuality* and the *individual*. The individual is determined on the one hand by the principle of uniqueness and distinctiveness, and on the other by the society to which he belongs. He is an indispensable link in the social structure.

5. Development of individuality is simultaneously a development of society. Suppression of individuality through the predominance of collective ideals and

organizations is a moral defeat for society.

6. The development of individuality can never take place through personal relationships alone, but requires a *psychic* relationship to the collective unconscious.

[520] *E. The Collective Unconscious.*

1. The collective unconscious is the unconscious portion of the collective psyche. It is the unconscious object-*imago*.

2. The collective unconscious is composed of:

- a. Subliminal perceptions, thoughts and feelings that were not repressed because of their incompatibility with personal values, but were subliminal from the start because of their low stimulus value or low libido investment.
- b. Subliminal vestiges of archaic functions that exist *a priori* and can be brought back into function at any time through an accumulation of libido. These vestiges are not merely formal but have the dynamic nature of instincts. They represent the primitive and the animal in civilized man.
- c. Subliminal combinations in symbolic form, not yet capable of becoming conscious.

3. An actual content of the collective unconscious always consists of an amalgamation of the elements enumerated in *a–c*, and its expression varies accordingly.

4. The collective unconscious always appears projected on a conscious [external] object.

5. The collective unconscious in individual A bears a greater resemblance to the collective unconscious in individual B than the conscious ideas in the minds of A and B do to one another.

6. The most important contents of the collective unconscious appear to be “primordial images,” that is, unconscious collective ideas (mythical thinking) and vital instincts.

7. So long as the ego is identical with the persona, individuality forms an essential content of the collective unconscious. In the dreams and fantasies of men it begins by appearing as a masculine figure, and in those of women as a feminine figure. Later it shows hermaphroditic traits which characterize its intermediate position. (Good examples in Meyrink’s *Golem* and in the *Walpurgisnacht*.)

[521] *F. The Anima.*

1. The anima is an unconscious subject-*imago* analogous to the persona. Just as the persona is the image of himself which the subject presents to the world, and

which is seen by the world, so the anima is the image of the subject in his relation to the collective unconscious, or an expression of unconscious collective contents unconsciously constellated by him. One could also say: the anima is the face of the subject as seen by the collective unconscious.

2. If the ego adopts the standpoint of the anima, adaptation to reality is severely compromised. The subject is fully adapted to the collective unconscious but has no adaptation to reality. In this case too he is de-individualized.

BIBLIOGRAPHY

BIBLIOGRAPHY

- ADLER, ALFRED. *The Neurotic Constitution*. Translated by B. Glueck and J. E. Lind. London, 1921. (Original: *Über den nervösen Charakter*. Wiesbaden, 1912.)
- AIGREMONT, DR., pseud. (Siegmar Baron von Schultze-Galléra). *Fussund Schuhsymbolik und -Erotik*. Leipzig, 1909.
- BENNET, E. A. *What Jung Really Said*. London, 1966.
- BENOÎT, PIERRE. *Atlantida*. Translated by Mary C. Tongue and Mary Ross. New York, 1920. (Original: *L'Atlantide*. Paris, 1920.)
- BERNHEIM, HIPPOLYTE. *De la suggestion et de ses applications à la thérapeutique*. Paris, 1886. (Translated by Sigmund Freud as *Die Suggestion und ihre Heilwirkung*, 1888.)
- BLEULER, EUGEN. "Dementia praecox oder die Gruppe der Schizophrenien," in *Handbuch der Psychiatrie*, ed. G. Aschaffenburg (Leipzig, 1911). (Translated by J. Zinkin as *Dementia Praecox or the Group of Schizophrenias*, New York, 1950.)
- . "Die Psychoanalyse Freuds," *Jahrbuch für psychoanalytische und psychopathologische Forschungen* (Leipzig and Vienna), II (1910), 623–730.
- BREUER, JOSEF, and FREUD, SIGMUND. *Studies on Hysteria*. Translated by James and Alix Strachey. *Standard Edition of the Complete Psychological Works of Sigmund Freud*, vol. 2. London, 1955.
- DAUDET, LÉON. *L'Hérédo*. Paris, 1916.
- FECHNER, G. T. *Elemente der Psychophysik*. Leipzig, 1860.
- FERRERO, GUGLIELMO. *Les Lois psychologiques du symbolisme*. Paris, 1895. (Original: *I simboli in rapporto alla storia e filosofia del diritto alla psicologia e alla sociologia*. Turin, 1893.)
- FLOURNOY, THÉODORE. "Automatisme téléologique antisuicide: un cas de suicide empêché par une hallucination," *Archives de psychologie* (Geneva), VII (1907), 113–37.
- . *Des Indes à la planète Mars: Étude sur un cas de somnambulisme avec glossolalie*. Paris and Geneva, 1900. (Translation: *From India to the Planet Mars*. Trans. by D. B. Vermilye. New York, 1900.)
- FOREL, AUGUST. *The Sexual Question*. Translated from the second German edition by C. F. Marshall. New York, 1925. (Original: *Die sexuelle Frage*. Munich, 1905; 2nd

- edn., 1906.)
- FREUD, SIGMUND. "Beyond the Pleasure Principle." Translated by James Strachey. *Standard Edition*, vol. 18 (1955), pp. 3–64.
- . *The Interpretation of Dreams*. Translated by James Strachey. *Standard Edition*, vols. 4 and 5 (1953).
- . "Leonardo da Vinci and a Memory of His Childhood." Translated by Alan Tyson. *Standard Edition*, vol. 11 (1957), pp. 63–137
- . "An Outline of Psycho-Analysis." Translated by James Strachey. *Standard Edition*, vol. 23 (1946), pp. 141–207.
- . *The Standard Edition of the Complete Psychological Works*. Translated from the German under the general editorship of James Strachey, in collaboration with Anna Freud, assisted by Alix Strachey and Alan Tyson. London, 1953–. 24 vols.
- . *Early Psycho-Analytic Publications*. Translated by James Strachey and others. *Standard Edition*, vol. 3 (1962).
- . "Three Essays on the Theory of Sexuality." Translated by James Strachey. *Standard Edition*, vol. 7 (1953), pp. 125–243.
- . *Totem and Taboo*. Translated by James Strachey. *Standard Edition*, vol. 13 (1955), pp. 1–161.
- . See also BREUER.
- FROBENIUS, LEO. *Das Zeitalter des Sonnengottes*. Vol. I (no more published). Berlin, 1904.
- GANZ, HANS. *Das Unbewusste bei Leibniz in Beziehung zu modernen Theorien*. Zurich, 1917.
- [GOETHE, JOHANN WOLFGANG VON.] *Goethe's Faust, Parts I and II*. An abridged version translated by Louis MacNeice. London and New York, 1951.
- . "Die Geheimnisse." In *Werke* (Gedenkausgabe), edited by Ernst Beutler. Zurich, 1948–54. 24 vols. (Vol. III, pp. 273–83.)
- HAGGARD, SIR HENRY RIDER. *She*. London, 1887.
- HELM, GEORG. *Die Energetik nach ihrer geschichtlichen Entwicklung*. Leipzig, 1898.
- HOFFMANN, ERNST THEODORE WILHELM (Amadeus). *The Devil's Elixir*. (Trans. anon.) Edinburgh, 1824. 2 vols.
- HUBERT, HENRI, and MAUSS, MARCEL. *Mélanges d'histoire des religions*. Paris, 1909.
- I Ching, or the Book of Changes*. The German translation by Richard Wilhelm rendered into English by Cary F. Baynes. New York (Bollingen Series XIX) and London, 1950. 2 vols. (1 vol. edn., 1961.) 3rd edn. in 1 vol., 1967.

- JAMES, WILLIAM. *Pragmatism*. London and Cambridge, Mass., 1907.
- . *The Varieties of Religious Experience*. London and Cambridge, Mass., 1902.
- JANET, PIERRE. *L'Automatisme psychologique*. Paris, 1889.
- . *Névroses et idées fixes*. Paris, 1898. 2 vols.
- . *Les Névroses*. (Bibliothèque de philosophie scientifique.) Paris, 1909.
- JUNG, CARL GUSTAV. *The Archetypes and the Collective Unconscious*. In: *Collected Works,** vol. 9, i.
- . “The Archetypes of the Collective Unconscious.” In: *Collected Works,** vol. 9, i.
- . “Brother Klaus.” In: *Collected Works,** vol. II.
- . *Collected Papers on Analytical Psychology*. Edited by Constance E. Long; translated by various persons. London and New York, 1916; 2nd edn., 1917.
- . Commentary on *The Secret of the Golden Flower*. In: *Collected Works,** vol. 13. (Alternative source: Wilhelm and Jung, *The Secret of the Golden Flower*, q.v.)
- . “The Concept of the Collective Unconscious.” In: *Collected Works,** vol. 9, i.
- . “Concerning the Archetypes, with Special Reference to the Anima Concept.” In: *Collected Works,** vol. 9, i.
- . “The Content of the Psychoses.” In: *Collected Works,** vol. 3.
- . *Freud and Psychoanalysis*. *Collected Works*, vol. 4.
- . “General Aspects of Dream Psychology.” In: *Collected Works,** vol. 8.
- . “Instinct and the Unconscious.” In: *Collected Works,** vol. 8.
- . *Mysterium Coniunctionis*. *Collected Works,** vol. 14.
- . “On Psychic Energy.” In: *Collected Works,** vol. 8.
- . “On the Psychology and Pathology of So-Called Occult Phenomena.” In: *Collected Works,** vol. 1.
- . “Paracelsus as a Spiritual Phenomenon.” In: *Collected Works,** vol. 13.
- . *The Practice of Psychotherapy*. *Collected Works,** vol. 16. (2nd edn., 1966.)
- . “Preface to the Second Edition of *Collected Papers on Analytical Psychology*.” In: *Collected Works,** vol. 4.
- . “The Psychological Aspects of the Kore.” In: *Collected Works,** vol. 9, i.
- . “The Psychological Foundations of Belief in Spirits.” In: *Collected Works,** vol. 8.
- . *Psychological Types*. *Collected Works,** vol. 6. (Alternative source: Translation by H. Godwin Baynes. London and New York, 1923.)

- . *Psychology and Alchemy. Collected Works,** vol. 12.
- . “The Psychology of Dementia Praecox” In: *Collected Works,** vol. 3.
- . “On Psychological Understanding.” In: *Collected Works,** vol. 3.
- . “Psychology and Religion.” In: *Collected Works,** vol. 11.
- . “The Realities of Practical Psychotherapy.” In: *Collected Works,** vol. 16, 2nd edn.
- . “A Review of the Complex Theory.” In: *Collected Works,** vol. 8.
- . “The Role of the Unconscious.” In: *Collected Works,** vol. 10.
- . “Sigmund Freud in His Historical Setting.” In: *Collected Works,** vol. 15.
- . “The Stages of Life.” In: *Collected Works,** vol. 8.
- . “The Structure of the Psyche.” In: *Collected Works,** vol. 8.
- . *Studies in Word Association. Collected Works,** vol. 2. (Alternative source: Translation by M. D. Eder, London, 1918; New York, 1919.)
- . “A Study in the Process of Individuation.” In: *Collected Works,** vol. 9, i.
- . *Symbols of Transformation. Collected Works,** vol. 5.
- . “The Theory of Psychoanalysis.” In: *Collected Works,** vol. 4.
- . “The Transcendent Function.” In: *Collected Works,** vol. 8.
- . *Wandlungen und Symbole der Libido. Ein Beitrag zur Entwicklungsgeschichte des Denkens.* Leipzig and Vienna, 1912. For translation, see: *Psychology of the Unconscious.* Translated by Beatrice M. Hinkle. New York, 1916; London, 1917. (Subsequently replaced by *Symbols of Transformation*, q.v.)
- JUNG, EMMA. “On the Nature of the Animus.” Translated by Cary F. Baynes, in: *Animus and Anima.* New York (Analytical Psychology Club), 1957.
- KANT, IMMANUEL. *Vorlesungen über Psychologie.* Leipzig, 1889.
- KUBIN, ALFRED. *Die andere Seite.* Munich, 1908.
- LEHMANN, FRIEDRICH RUDOLF. *Mana.* Leipzig, 1922.
- LIÉBEAULT, AMBROISE AUGUSTE. *Du sommeil et des états analogues considérés au point de vue de l’action du moral sur le physique.* Paris, 1866.
- LONGFELLOW, HENRY WADSWORTH. *The Song of Hiawatha.* Boston, 1855.
- LOVEJOY, ARTHUR O. “The Fundamental Concept of the Primitive Philosophy.” *The Monist* (Chicago), XVI (1906), 357–82.
- MAEDER, ALFRED. “La Langue d’un aliéné.” *Archives de psychologie* (Geneva), IX (1910), 208–216.

- . “Psychologische Untersuchungen an Dementia-Praecox-Kranken,” *Jahrbuch für psychoanalytische und psychopathologische Forschungen* (Leipzig and Vienna), II (1910), 185–245.
- MAYER, ROBERT. *Kleinere Schriften and Briefe*. Stuttgart, 1893.
- MEYRINK, GUSTAV. *Der Golem*. Leipzig, 1915. For translation, see: *The Golem*. Translated by Madge Pemberton. London, 1928.
- . *Fledermäuse: 7 Geschichten*. Leipzig, 1916.
- NELKEN, JAN. “Analytische Beobachtungen über Phantasien eines Schizophrenen,” *Jahrbuch für psychoanalytische und psychopathologische Forschungen* (Leipzig and Vienna), IV (1912), 504–62.
- NERVAL, GÉRARD DE (LABRUNIE DE). “Aurélia.” In: *Le Rêve et la vie*. Paris, 1855. (Pp.1–129.) For translation, see: *Aurelia*. Translated by Richard Aldington. London, 1932.
- OSTWALD, WILHELM. *Grosse Männer*. Leipzig, 1910.
- . *Die Philosophie der Werte*. Leipzig, 1913.
- PFAFF, JOHANN WILHELM ANDREAS. *Astrologie*. Nurnberg, 1816.
- . *Der Stern der Drei Weisen*. 1821.
- ROUSSEAU, JEAN-JACQUES. *Emile, ou L’Education*. Amsterdam and The Hague, 1762. 4 vols. For translation, see: *Emile*. Translated by Barbara Foxley. London and New York (Everyman’s Library), 1911.
- SEMON, RICHARD WOLFGANG. *Die Mneme als erhaltendes Prinzip im Wechsel des organischen Geschehens*. Leipzig, 1904. For translation, see: *The Mneme*. Translated by Louis Simon. London and New York, 1921.
- SILBERER, HERBERT. *Problems of Mysticism and Its Symbolism*. Translated by Smith Ely Jelliffe. New York, 1917.
- SÖDERBLOM, NATHAN. *Das Werden des Gottesglaubens*. Leipzig, 1916. (Original: *Gudstrons uppkomst*. Stockholm, 1914.)
- SPIELREIN, SABINA. “Die Destruktion als Ursache des Werdens,” *Jahrbuch für psychoanalytische und psychopathologische Forschungen* (Leipzig and Vienna), IV (1912), 465–503.
- . *Spiritual Disciplines*. Translated by Ralph Manheim and R. F. C. Hull. (Papers from the Eranos Yearbooks, 4.) New York (Bollingen Series XXX:4) and London, 1960.
- SPITTELER, CARL. *Imago*. Jena, 1919.
- . *Olympischer Frühling: Epos*. Leipzig, 1900–1905. 4 parts.

- . *Prometheus und Epimetheus*. Jena, 1920. For translation, see: *Prometheus and Epimetheus*. Translated by James Fullarton Muirhead. London, 1931.
- TACITUS, PUBLIUS CORNELIUS. *Dialogus: Agricola: Germania*. Translated by Sir William Peterson and Maurice Hutton. (Loeb Classical Library.) London and New York, 1920.
- WARNECKE, JOHANNES. *Die Religion der Batak*. (Religions-Urkunden der Völker, ed. Julius Boehmer, Part IV, vol. 1.) Leipzig, 1909.
- WEBSTER, HUTTON. *Primitive Secret Societies*. New York, 1908.
- WELLS, HERBERT GEORGE. *Christina Alberta's Father*. London and New York, 1925.
- WILHELM, RICHARD, and JUNG, CARL GUSTAV. *The Secret of the Golden Flower*. Translated by Cary F. Baynes. New edition, London and New York, 1962.
- WOLFF, TONI. "Einführung in die Grundlagen der komplexen Psychologie." In: *Die kulturelle Bedeutung der komplexen Psychologie*. Berlin, 1935.
- WUNDT, WILHELM. *Grundzüge der physiologischen Psychologie*. Leipzig, 1893. 2 vols. For translation (from 5th German edn., 1902) see: *Principles of Physiological Psychology*. Translated by E. B. Titchener. London, 1904.

INDEX

INDEX

Page numbers in the appendices are printed in italic numerals. To facilitate comparison, identical or similar references in the appendices and in the main Two Essays are printed as follows: “absentmindedness, 11/249.” A numbered list of Jung’s cases is given under his name.

A

- abaissement du niveau mental*, 215
- Abelard, Peter, 54
- absentmindedness, 11/249
- “absolute,” meaning of, 235*n*
- absoluteness, 235
- abyss, maternal, 170/287
- accidents, 115
- Achomawi (Californian tribe), 96*n*
- activity of unconscious: autonomous, 128/271
 - instinctive, 162
 - mythological, 100*n*
- adaptation, 55, 56, 149, 154*n*, 204*f*, 209, 278*n*, 279*n*
 - collective, 58
 - to collective unconscious, 161
 - difficulties of, 161
 - faulty, 199
 - maximum, to society, 303
 - minimum, to individuality, 303
 - to reality, 304
- adjustment, 154*n*
- Adler, Alfred, 3, 117*f*
 - Adlerian theory, 165
 - “arrangement,” *see* arrangement(s)

and “godlikeness,” 140/274
and “guiding fictions,” 294
“masculine protest,” see masculine/masculinity
“power drive,” 165
and power principle, 35, 38, 40, 53, 140/274, 281
reductive method, 59
theory of compensation, 104n
theory of fantasy, 290
theory of neurosis contrasted with Freud’s, 35, 40ff, 61, 281
and transference, 165
The Neurotic Constitution, 35n, 165n
adolescence, 107ff; see also young people
adulthood: entry into, 106
 special problems of, 60
aestheticism, 102
aether, 95
affect, 176, 178, 194
 release of, 68
 state of, 202
 world of, 203
affectivity, 94, 202
Africa, 205; see also Elgon; Kavirondos
age, and youth, 76; see also life, afternoon of; young people; youth
agoraphobia, 217
Aigremont, Dr. (Baron Siegmund von Schultze-Galléra), *Fuss-und Schuh-symbolik und -
 Erotik*, 83n
aim: cultural, 74
 final, 295n
 natural, of man, 74
alchemy, 219f, 223
 secret of, 220
alienation from the world, 224
All-Merciful, the, 228
Also sprach Zarathustra, see Nietzsche, Friedrich

altar, 106

America, 292

American: businessman, Jung's case [3], 50f, 72, 76

students, 106

American Indians, myths of, 98; *see also* Achomawi

amnesia, 10

amplification, 81

anaesthesia, 10, 12/250f, 176

analogies, 147/275

fantastic, 216

lunar, 160

objective, 291

solar, 160

subjective, 291

telluric, 160; *see also* thinking, analogical mode of

analysis, 78, 136, 141, 156f/280f, 278

aim of, 212, 219, 295 (*see also* goals)

dangers of, 114ff, 152/277, 282

effect of, 140, 148, 281ff, 294

Freud's theory of, 127/270

of infantile transference fantasies, 64

of Jung's case [4], 83

objective, *see* interpretations, objective; personal, 149

subjective, *see* interpretations, subjective; sublimation through, 47f, 267

technique, 24f

of unconscious, 128/271, 232; *see also* dreams; psychoanalysis; reduction

analytical psychology, v, 7, 112, 186n, 247, 261

Zurich school, *see* Zurich

anamnesis, 108

ancestor cult, 188

ancestral: experiences, 190, 209

life, 77, 79

soul, 147n

spirits, 186; *see also* archetype(s)

angels, 66

Angelus Silesius (Johannes Scheffler), 237

anima, 90*n*, 110, 187, 212, 228*ff*, 233, 235, 296*n*, 299, 304

and animus, 206

anything but ideal, 195

as autonomous personality, 201, 224, 227

autonomous valency of, 228

compensates masculine consciousness, 205

compensatory relationship with persona, 192

concept of, 197

as counterpart of persona, 195

daemonic qualities of, 299

dark, 198

definition of, 304

dialectics with, 201

differentiation from persona, 198

differentiation of oneself from, 195

dissolution of, 234

education of, 203

no Eastern concept of, 192

as feminine weakness of strong man, 194

figure, 299

figures, historical aspect of, 190

as function, 210

as function of relationship, 227, 299

as inner persona, 299

as invisible partner, 201

jealous mistress, 200

in Jung's case [15], 218*f*

as mother-*imago*, 197

objectivation of, 200

and persona, 304

as a personality, 197, 200

positive activity of, 224

- problem, 199
- produces moods, 206
- projected to wife/woman, 195, 197
- reactions, 205
- supra-individual, 189
- tyrannical power of, 229
- and unconscious, 232
- as unconscious subject-*imago*, 304
- uni-personality of, 209; *see also* animus

animal(s): and anima, 227

- and archetypes, 69, 98, 110
- and civilization, 28
- conservative and progressive, 116
- degrees of differentiation, 116*f*
- as doctor, 96*n*
- in Jung's case [2], 35*f*
- soul of, 105
- as symbol, 35*f*, 64, 85*f*
- unconsciousness, 59; *see also* list under symbol(s)

animal ancestry, man's, 98

animal elements/instincts/nature, man's, 19/258, 20, 28, 31*ff*, 86, 231, 260, 304

- repressed, 26/266*f*

animism, 68*f*

animus, 90*n*, 110, 205*ff*, 212, 230, 296*n*, 299

- as associative function, 209
- deposit of woman's ancestral experiences of man, 209
- extraversion of, 208
- function of, 208
- "hound," 209
- a jealous lover, 208
- a neologist, 208
- opinions, 206–8
- personification of, 207
- plays up anima, 208

plurality of, 207, 209
positive activity of, 224
possession, 209
projected, 207
psychology of, 205
technique of coming to terms with, 209
and unconscious, 232; *see also* anima; hero(es); lover

Anna, *see* Breuer's case of hysteria

anthroposophy, 77, 292

Antinéa, 189

anti-Semitism, 152n

anxiety, 13/251, 24, 83
dreams, 264
Jung's case [2], 35ff, 47
Jung's case [3], 51
"seat of," 42
-states, hysterical, 47

aphasia, systematic, 11/249; *see also* voice, loss of

apostasies, 75

apotropaic euphemism, 238

apparitions, 187; *see also* hallucinations; vision (s)

apprehension, 109

aptitude(s): psychic, 190
subjective, 190
unconscious, 190

archaic: collective contents, 94
functions, 303f
god-image, 135
idea of God, 137
mentality, 135
modes of functioning, 98
psychology, 284
smile, 265

archaism of unconscious fantasies, 170

archangels, 66

archetype(s), v, 65ff, 77ff, 84, 95ff, 108ff, 116, 138

in animals, 69

as autonomous entity, 109

and historical factor, 192

karma and, 77n

mana-personality as, 228f, 233ff

parental, 186n

possession by, 234

reality of, 98

of situations, 110

sun, 69

and transference, 101

transjective, 98; *see also* symbol(s) *where list is given*

archons, *see* Gnosticism

arrangement(s): Adler's term, 40, 42

in Jung's case [3], 52

teleological, 35

arrogance, 141f, 180

art, 189

analysis as, 295

psychoanalysis and, 141

sublimation and, 48

artist(s), 299

and experience of unconscious, 213

vision of, 183

artistic: capacity, unconscious, in Jung's case [4], 87, 89

temperament, 228

ascent, 74

asceticism: and Christianity, 31f

Stoic ideal of, 19/258

Aschaffenburg, Gustav, 246

Asia, 204

assimilation: of anima and animus, 230

of collective psyche, 288
of contents of mana-personality, 237
of the unconscious, 136/273, 139/273, 149/276, 220f, 297

association(s), 35, 65
“astrological,” 160
in Jung’s case [4], 84, 88
in Jung’s case [5], 104
method, 21/262
symbolical, 212
thought-, 131

assumptions: historical, 195
unconscious, of animus, 207 (*see also* animus)

asthma, nervous, 35ff, 47

astrology, 292; *see also* association(s), “astrological”

Atlantic Ocean, 204

atman, 191

atom, 240

attitude(s): antithetical, 59
change of, 161f
collective, 152, 277
complementary, 57f
conscious, 44, 53, 60, 99, 215, 219, 224, 234
of extraversion and introversion, 56
general, to collective unconscious, 236
infantile, 59, 163
natural and unconscious, 296
negative, 115
neurotic, 139
objective, 202
personal, 158
personalistic, of medical psychology, 81
psychological, 277
puffed-up, 71
rationalistic, of conscious mind, 124

scientific, 134
social, 58
stiffening of, 76
typical, and persona, 297
to unconscious activity, 214
attitude-types, 41, 43
author, and public, 240
authority(-ies), 233
 parental, 64
“autofécondation intérieure,” 147n
automatic writing, 196
autonomous: activity, 128/271
 complex, *see* complex(es); entity, archetypes as, 109
 personality, anima as, 201, 224, 227
 valency of anima, 228
autonomy, 58, 191
 of anima and animus, 224
 of collective unconscious contents, 147
auto-suggestion, 173, 214

B

ba, 187
balance: centre of, 196
 loss of, 161f
 of power, 229
baptism(s), 105ff, 231, 235
Basel, 31
 Cathedral, 265
Bataks (of Sumatra), 186; *see also* Warnecke
“battle of the faculties,” 190f
Baynes, H. G. and C. F., v, 6n, 124n
Beelzebub, 73
“belly,” 71f

benedictio fontis, 105

Benoît, Pierre, 189f

L'Atlantide, 189n

Bergson, Henri, 288

Bernheim, Hippolyte: *De la suggestion et de ses applications à la thérapeutique*, 9n

“Beyond,” the, 166/284, 186

Bible, *see* New Testament; Old Testament

Binet, Alfred, 246

bird, “little,” 227

birth, 190; *see also* rebirth

Bismarck, Prince Otto von, 179, 193

Bleuler, Eugen: and “depth psychology,” 247

Dementia Praecox or the Group of Schizophrenias, 147n

blindness: hysterical, 11/249

systematic, 11/249

blindworm, 93

“blond beast,” Nietzsche’s, 32

body, 30f, 52, 247

-hallucinations, 282f

illness of, 115

in Jung’s case [3], 51f

proportions, 160

and psyche, 115

rights of, 296

sensations, 282

-stimulus, 22

Bolshevism, 204

boundary(-ies), 81, 85, 98f

individual, 142; *see also* river

brain, 69, 138, 147/275, 214

breath, 95, 135

Breuer, Joseph, 11/249, 12/251, 250

his case of hysteria (Anna), 11f/249f, 118

trauma theory, [15/253](#)

Studies on Hysteria (with Freud), [10/247](#)

bridge, [14/252](#), [81](#)

intellectual function as, [129](#)

British Museum, [235n](#)

brother, [179f](#); sinister, *see* Medardus

Buddhism, [69](#), [78](#), [191](#)

bulls, as dream symbol, [35](#)

Burckhardt, Jacob, [65](#)

Buridan's ass, [290](#)

bush, burning, [68](#)

C

Caesar: Julius, [179](#), [217](#)

“render unto,” [236](#)

Calypso, [210](#)

“Canadians who know not ...,” [198](#)

cancer, [82](#), [84](#), [86](#), [98](#)

carcinoma, *see* cancer

cardinal points, four, [223](#)

Carnal Pleasure, statue of, [265](#)

castle, [112](#), [179](#)

cat(s), [13/251f](#)

category(-ies): *a priori*, [190](#)

inherited, [138](#) (*see also* archetypes)

catharsis, [265](#)

cathedral, [103ff](#)

Gothic, [106](#); *see also* Basel; Cologne; Lourdes

Catholicism, [77](#), [97](#)

Caucasus, [141](#), [157n](#)

causal: point of view, [59](#)

-reductive interpretations, [83f](#)

causality: Freud and, [35](#), [42](#)

limits of, 215
objective, 131
and physics, 49n
in psychology, 295n
Cellini, Benvenuto, 65
censor, Freud's theory of, 21
centre, 238
 creative, 221
 of gravity, 299
 virtual, 237; *see also* mid-point
ceremonies, cleansing, 181; *see also* initiation; rites
chance, 13/251, 17/255, 49, 294
chaos: feeling of, 163
 polytheistic, 20/258
characterology, unconscious, 140
Charcot, Jean Martin, 10/249, 13/251
chemistry and alchemy, 220
child(ren): as archetype, 110
 fear of unknown, 203
 "of light," 236
 neurotic has soul of, 25
 and parental imago, 186, 188
childhood, 127/270, 239, 278n
 fantasies, 60, 65
 in Jung's case [5], 104
 memory, 135
 psychotic elements in, 175f
 separation from, 197
 spiritual, 235
 terrors of, 203f
"chimney-sweeping," 11/250
China, 188, 292; *see also* philosophy; Tao(ism)
choking-fits in Jung's case [2], 36f, 39

cholera, 231

Christ, 20/258, 221, 233n, 237

- “case of,” 45

Christian: ideal, 226

- love, 5
- Science, 292

Christianity, 33, 64, 77f, 99, 231, 235

- and asceticism, 31f
- and Mithraism, 20/258

Christification, 35

church, 72, 105, 107

- a magical instrument, 235n
- as mother, 105
- Mother Church, 224
- womb of, 105; *see also* priest

Circe, 210

circle, 110, 223

circumcision, 105, 107, 230

civilization, 72, 97

- and animal nature, 28
- conflict with instincts, 20
- and morality, 27
- and neurosis, 19
- and war, 50; *see also* culture

clan, 151

classical, 54; *see also* culture

climacteric, 109; *see also* menopause

code, moral, 27

cognition, 98

collaboration of conscious and unconscious, 290

collective, 173

- attitude, 152, 277
- and collectivistic, 278n

compensation, 180f
compromise, 150
consciousness, 144f
dreams, 160n, 178
element, 140
—, in psychology, 289
factors, 143, 153, 155/279, 196
figure, 234
—, masculine, 228
identity, 288
images, 190
and individual, 290, 296
melting of individual in, 152
mentality, 277
opinions, 208 (*see also* animus);/p>
psyche, *see* psyche, collective
and self-alienation, 173
truth, 151
unconscious, *see* unconscious, collective; *see also* feeling; functioning; thinking

collectivity, 174, 227, 296, 298
collectivization, 148
collision: with the shadow, 34
 with the unconscious, 33
Cologne Cathedral, 104, 106
combinations, 116
common sense, 130, 131, 133, 183, 207
communion: Christian, 231
 ritual, 99
community, 73, 151ff, 158, 179
 primitive, 106
compensation, 171, 292
 Adler and, 104n
 animus as, 205
 of basic type, 44

between conscious and unconscious, 177
collective, 180f
in dreams, 102, 104, 109ff, 112, 290, 294n
humility and pride, 142
for latent psychoses, 114
mythological, 180
of neurotic conscious attitude, 110
office as, 145
optimism as unsuccessful, 139/274
persona and anima, 192
persona and feminine weakness, 194
personal, 178, 182
of relationships, 179 (*see also* relationships, compensatory)
of religious problem, 181
self as, 239
of self-confidence by inferiority, 276
unconscious, 180

completeness, 110

complex(es), 21ff, 88ff, 262ff
anima as autonomous, 227
and association method, 21/262
autonomous, 25/266, 187, 196, 232
—, of anima and animus, 210, 232
—, identification with, 205
—, tendency to personification, 197
—, transformation and dissolution of, 212
father-, 186 (*see also* Jung's case [8])
Jung's theory of, 262n
memory-, 84
mother-, 106, 186 (*see also* mother)
neurotic, 40
personified, 210
soul as psyche, 190f
subjective, 90

unconscious, 186f

compromise, 158

 collective, 150

compulsion, 225

 neurosis, in Jung's case [13], 181; *see also* neurosis

conceptualism, 54

concretization(s): of God, 236, 239

 of images, 233

 of intellect, 220

 as primitive superstition, 217

confession, 136, 179

 of weakness, 234

confirmation, 231

conflict, 19ff/262ff, 25/266, 38, 63, 76, 136/273, 162, 166, 219, 230

 with collectivity, 296

 of conscious and unconscious, 20, 25

 in dreams, 22ff

 of ego and instinct, 34

 erotic, *see* erotic conflict

 Faustian, 34

 of good and evil, 183

 with highest values, 236

 ideal solution of, 130, 134

 individual, 267

 of inner and outer world, 205, 239

 insoluble, 93f, 183

 moral, 141f

 neurotic, 130, 258

 pathogenic, 19, 21, 25, 129ff; 257

 of relationship, 178f

 of repression, 150/277

 of types, 55f

 unconscious, 257, 262

conscience, 196, 207f, 239

“Court of,” 207
intellectual, 99
scientific, 222

conscious psyche, *see* psyche

consciousness, 33, 148/276, 156f/280f, 175, 222, 233, 290, 294, 298
absolute, 184
beyond, 191
collective, 144f
and complexes, 187
daytime, 177
defective, 162
division of, 193
ego-, *see* ego
empty, 219
enlargement/extension of/widened, 156n, 157n, 178, 184
extraverted, 195
flooded, 175
four orienting functions of, 44n
higher degree, 59, 116, 184
individual, 94
masculine, compensated by anima, 205
moral, 136
penumbra of, 206
restricted states of, 12/250
seeks unconscious opposite, 54
threshold of, 127/270
Western, 198
woman’s different from man’s, 206

consensus gentium, 71

conservatives, 116

contamination, 91, 225

contents: autonomous, 238, 239
psychic, division of, 300, 302
of unconscious, *see* unconscious

contrasexual demands, 189

conversing with oneself, art of, 202

controversies, spiritual, 54

conversion: into opposite, 75*f*
 religious, 70, 175
 sudden, 147

convulsions, religious, 75

co-operation: of individual and collective, 289
 in individuation, 174

Corinthians, 156*n*

correspondence of unconscious processes, 147/275

cosmic element, 160

counter-function, inferior, 58

“Court of Conscience,” 207

coyotes, “doctor,” 96*n*

crab, 81–89, 91, 98, 100*f*

craving, infantile, 86

creative thought-process, 185

crimes, 153

criminal(s), 94, 148

criminality, 24, 271

cross, 35

crossing, 81*f*, 85, 89, 91, 99, 101*f*
 “Crossing of the Great Water,” 85

crucifixion, 141
 of soul, 31

cryptomnesia, 137

crystals, 237

cultural aim, 74*f*

culture: classical, 19/258
 growth of, 19/258
 introverted side of spiritual, 191
 irrational devastation of, 72

and nature, 19, 34
negroid, 97
present-day, 25/265, 168, 292
self-culture, 205
and war, 49f, 72
cure, 149, 295
magical, 293
“talking cure,” 11/250
curiosity, intellectual, 182

D

daemon(ism), 28, 68, 72n, 239
danger: “at the ford,” *see* ford
psychic, 228
“dangerous age,” 75
Daudet, Léon: *L’Hérédo*, 147n, 175
day-world of exploded ideals, 203
deadlock: neurotic, 101
in transference, 131
deafness, hysterical, 11/249
death, 185f, 190, 191
instinct, Freud’s theory of, 28f, 54; *see also* immortality; instinct, destructive
death’s-heads, 12/250
deceit, 293
defence: homosexuality as, 87
mechanism, 91
deification: of doctor, 70, 133
of man, 238
of master by disciple, 170
self, 70
delusion(s), 71, 229
paranoid, 283
demand(s): contrasexual, 189

infantile sexual, 165
outer and inner, 196
dementia: paranoid, 144 (Maeder's case); praecox, *see* schizophrenia
demigod, 130, 229; *see also* superman
demiurge: Gnostic, 132
demon(s), 67, 91f, 94
 doctor as, 64
 magic, 96
 man's need of, 71
 masculine, 224
 mother as pursuing, 179; *see also* devil(s)
demoralization, 163
denial, mechanism of, 202
dependence, infantile, on parents, 59f, 105
deprecation, mechanism of, 202
depression, 215, 218
 in Jung's case [3], 52
 psychogenic, 214 *see also* Jung's case [15]
"depth psychology," 247
derangement, mental, *see* mental derangement
descent, 74
destiny, individual, 224
destructive instinct, 53n *see also* death instinct
devaluation of religious function, 94
development, 173
 abnormal, 176
 conscious, 183
 human, 288
 ontogenetic, 148/276
 pace of, 99
 of person, 150
 personal, 155n, 158, 221, 278f, 297
 of personality, 150/277, 151f, 155n, 278

progressive, 225
psychic, 116
psychological, 116f, 174, 240
retarded, in Jung's case [5], 102
spiritual, 105
unconscious, 134f

devil(s), 27, 70, 73, 78, 94, 96, 102, 181, 200
pact with, 237
as psychological counterbalance, 236
seven, 236; *The Devil's Elixir*, see Hoffmann; see also demon (s)

diabetic: sugar in blood of, 101

dialectical process, 210

diastole, 59, 301

difference(s): individual, 152, 206
of race, 152

differentiation, 56, 149, 225, 296
from collective psyche, 152, 301, 303
of ego and non-ego, 73
of ego and unconscious, 212ff
of functions, 174, 220
higher, 116
of human brain, 147/275
non-, 206
of persona, see persona
personal, 150/277, 155/280, 276
of personality, 151
process of, 155n
racial, 152n

Dionysian licentiousness 19f/258, 32f; see also orgies, Dionysian; Zagreus

Dionysius the Areopagite, 66

Dionysus, see Dionysian

Diotima, 28

disciple, 170f
-fantasy, 171

discontent, sources of, [259](#), [260](#)
disequilibrium, psychic, [161](#), [170](#)
disharmony with oneself, [225](#)
disintegration, pathological, [144](#)
 of persona, [161](#), [169](#)
 of personality, [147](#)
disorientation, [160/282](#), [163](#)
displacement, [100](#)
disposition: hereditary, [219](#)
 inherited or acquired pathological, [175](#)
 inherited and universal psychic, [147](#)
 psychic, [14](#)
 unconscious, [87f](#)
disproportion, [296](#)
dissociation, [97](#)
 of personality, [44](#)
dissolution: of compromise, [296](#)
 of infantile ties, [61](#)
 of mana-personality, [237](#)
 of persona, [160/282](#), [169/287](#), [297](#)
 of personality, [281f](#)
 —, in collective psyche, [151](#)
 —, into paired opposites, [149/276](#)
 of prestige, [151](#)
 regressive, [151](#)
disturbance: in erotic sphere, [18/256](#)
 psychotic, [161](#)
disunity, inner, [19](#), [25/266](#), [129](#)
divinity: idea of, [239](#)
 “ocean of,” [287](#)
divorce, [75](#), [200](#)
doctor, [223](#), [294](#)
 and correct interpretations, [112f](#)

as demon, 64
“doctors” among animals, 96
as father/lover, 129
and Freud’s theory, 248
as God, 70, 130, 133, 135
as image, 92
as mana-personality, 233
has maternal significance, 64
as object of conflict, 129
patient’s behaviour to, 139/274
person of, 132ff
personality of, 70
personification of goodness, 64
psychological training of, 9/246, 45
and reductive theories, 168
relation to patient, 42f, 62f, 70f, 91ff, 129ff, 164f (*see also* transference)
as saviour, 64
technique of, 215
transference of fantasies to, 62, 64
—of father-*imago* to, 129
and treatment of unconscious, 212f

dog, 293

dogma, 77, 97

dogmatism, 282

dominant(s): of mana-personality, 234
of unconscious, *see* archetype (s)

domination, infantile desire for, 284

doves, 236

dragon, 37, 84, 170/287

dreams, 64, 78, 86, 110ff, 131f, 138, 160/282, 214, 294
analysis of, 21/262ff, 133, 263n
anima and animus personifications, 210, 299, 304
archetypes in, 70
banal, 182

“big,” 178

collective, 178

—, elements in, 160*n*

compensatory function of, 290, 294*n* (see also compensation)

façade, 22/263, 100

of flying, 160/282

as harbinger of fate, 21/262

-image, 183

as instrument of education, 106

interpretation of, 10/248, 114, 117, 136

language of, 85

manifest and latent contents, 21*f*/263

mechanism, 100

moral function of, 294*n*

as natural product of psyche, 131

and personal unconscious, 66, 128, 176*ff*

psychology of, 10/248

purpose of, 102

revealing accident-proneness, 115

as self-representations of unconscious developments, 134

-sequences, 231

and shadow, 66

symbols, 81, 155/279

teleological function of, 294*n*

-thoughts, 100

two kinds of, 178

waking, 12/250

whole, and dreamer, 84

INSTANCES OF DREAMS (*in order of occurrence in text; numbers in brackets refer to Jung's cases*):

black snake comes to bite father [Breuer's case (Anna)], 12/250

mother is dead [hypothetical case], 22*f*

wild animals and evil men attack [2], 35*ff*

crab hidden at river ford [4], 81*ff*, 97–102

Lourdes Cathedral and dark well [5], [103–6](#), [108f](#)
baptism scene in Gothic cathedral [5], [106–9](#)
woman in castle tower [Jung’s in relation to [6]], [112f](#), [179](#)
father-giant in wheat fields [8], [132f](#), [160](#)
mother as witch [12], [179](#)
devil is pursuing [13], [181f](#)
white magician and black magician [14], [182](#)
fiancée jumps into frozen river [15], [213–9](#), [230](#), [232](#)
vision of four gods [16], [221f](#), [230](#)

Drummond, Henry, [193](#)

Dryden, John, [292](#)

duty: to life, [73](#)

 social, [173](#)

dynamism, [68f](#)

E

earth, [222](#), [238](#), [240](#), [259](#)

 flat, [10/247](#)

 Mother, [258f](#)

Eastern mind, [192](#)

“Ecce Homo,” [31](#), [35](#)

eccentric, [163](#)

Eckermann, *see* Goethe

Eckhart, Meister, [237](#)

ecphoration, [137](#)

ecstasy/ecstatic, [33](#), [69](#)

Eder, M.D., [21n/262n](#)

education, [74](#), [257](#)

 and homosexuality, [106](#)

 primitive system of, [197](#)

 psychic, [25/265](#)

 and repression, [127/270](#)

 travesty of, [207](#)

effect, numinous, 70

effeminacy, 209

Eglise gnostique de la France, 231

ego, 34, 40, 72ff, 148/276, 196, 202, 227, 232f, 238, 281

and archetypes, 97f

conscious, 39, 177, 221, 300, 302

-consciousness, 124, 158, 299

-consciousness, identical with the persona, 158

divestment of, 149

former, 75

-function, 73

identification with anima, 299

identification with persona, 193, 299, 302, 304

individuated, 240

and instinct, 34

integrity of, 279n

and mana-personality, 228ff, 233ff

and non-ego, 73, 297, 300

and persona, 194

personal world of, 178

and personality, 196f

power of, 34

and power-instinct, 38

powerlessness of, 139/274

and self, 240

and soul, 191

subconscious, 300

unconscious, 300

ego-instinct: Adler's theory of, 42

Freud's theory of, 34, 42

egotism, 174

Egyptians, concept of souls among, 187

electricity, 9/246

element(s): cosmic, 160

psychic, [167/285](#)

Eleusis, mysteries of, [231](#)

Elgon, Mount, [185n](#)

Elgonyi, [178](#)

enantiodromia, [72f](#)

energetics, [67](#)

of life-process, [196](#)

energy, [29](#), [47f](#), [50ff](#), [61f](#), [72](#), [75](#), [80](#), [98](#), [134](#), [162](#), [166](#), [259](#), [269](#)

conservation, [67ff](#)

contained in neurosis, [114](#), [215](#)

creative, [51](#), [216](#)

cycle of, [99](#)

disposable, [50](#), [52](#), [62](#)

gradient, [52f](#), [62f](#)

instinctual, [116](#)

law of, [215](#)

as magical power, [95](#)

in old age, [61](#)

psychic, [47](#), [52](#), [53n](#), [72](#), [77](#), [129](#), [162](#)

release by analysis, [61](#)

surplus, [260](#)

of transference, [133](#)

unconscious, [167/285](#), [184](#)

world, [68](#)

engrams, [98](#)

enlightenment, age of, [94](#)

environment, [141](#), [299](#)

adaptation to, [154](#)

bondage to, [155](#)

moral influence of, [127/270](#)

patient's influence on, [152/278](#)

epilepsy, [233n](#)

Epimethean extravert, [57](#)

equilibrium, psychic, [72](#), [104](#), [136/273](#), [161](#), [221](#)

Eranos-Jahrbuch, [7](#)

Eros, [28f](#), [34](#), [40](#), [46](#), [53f](#), [258](#)
erotic: conflict, [16/254](#), [18/256](#), [19f/257f](#), [25/266](#), [261](#)
 sphere, disturbance in, [18/256](#)
 wishes, [264](#); *see also* sexuality
ethical problem, [183](#)
ethnology, [123](#), [137](#)
euphemism, apotropaic, [238](#)
euphoria, [148](#)
Europe, [292](#); *see also* Western
evasion, [168](#)
evil, [236](#), [238](#)
 pact with, [181](#)
 principle, [153](#)
 qualities, [4](#); *see also* good and evil
exaltation, [223](#)
exclusiveness, [288](#)
exhaustion, [214](#)
experience(s), [117](#), [211](#), [221](#)
 destructive, [164](#)
 of fantasy, [213](#), [216](#), [219](#)
 psychic, [218](#)
 of unconscious, [184f](#)
experimental psychology, [9](#), [245ff](#)
extension of personality, [143](#)
extra-human, [98](#)
extraversion/extravert, [44](#), [54ff](#), [218](#), [225](#), [279n](#)
 of animus, [208](#)
 Epimethean, [57](#)
 inferior, [58](#)
 introversion of, [57f](#)
 and object, [58f](#)
 Western, [191](#)

F

façade, of dream, [22/263](#), [100](#)

factor(s): aetiological, [175](#)

collective, *see* collective

historical, [191](#)

individual, [153](#)

karmic, [77n](#)

social, [143](#)

universal, [174](#)

family, [147f/275](#), [179](#), [200](#), [209f](#), [299](#)

fantasy(-ies), [52](#), [75](#), [86](#), [128f](#), [143f](#), [155/279](#), [176](#), [179](#), [213](#), [218](#), [223f](#), [220](#), [290f](#)

archaic, [165](#)

archaism of unconscious, [170](#)

childhood, [60](#), [65](#)

childish, [104](#)

collective, [158](#)

of collective unconscious, [232](#)

creative, unifying function of, [290](#)

disciple-, [171](#)

experience of, [213](#), [219](#)

figure of, [91](#)

hermeneutic treatment of, [293](#)

in hysteria, [11/250](#)

-image, [214ff](#)

infantile, [63](#), [170](#), [271](#)

infantilism of unconscious, [170](#)

interpretation of, [213](#)

in Jung's case [1], [16](#)

laws governing, [201](#)

life, [100](#)

-material, symbolical, [81](#)

and myth, [69f](#)

night-world of, [203](#)

-occurrences, [80f](#)

phobia of, 217
powers of, 100
in psychoanalysis, 21/262, 114
relation to symptom, 37
repressed personal, 160
-sequences, 231f
sexual, 34, 83, 91
as specific activity of collective psyche, 160f/282
spontaneous, 21
of “strong man,” 194
and transference to doctor, 62ff, 133
unconscious, 271
understanding of, 213, 217
useless, 267
wish-, 271
world of, 16/254

fascination, 87f, 91
of unconscious, 214

fate, 21/262, 35, 43, 48ff, 131, 139/274, 149, 164, 168, 266
eternal images as, 109
power of, 69
religious attitude to, 102

father, 23, 233f
in Breuer’s case (Anna), 11f/250f
child’s relation to, 42, 60
complex, 128, 186, *see also* Jung’s case [8] below
doctor as, 64, 129, 133
-fixation, 158
in Jung’s case [2], 36ff
in Jung’s case [8], 128ff, 158f
liberation from, 235
-lover, 129, 130, 132, 134, 159, 164
—, semi-divine, 133
-mask, 234

as model persona, 197
primordial, 135; *see also* imago, father-
“Father in Heaven,” 235; *see also* God/god(s)
Father Sun, 258
Faust (Goethe), v, 34, 35, 80, 96, 140/274, 166ff/284f, 196, 229, 237
Faustian problem, 168
fear, 202, 224, 167/285
of collective unconscious, 97
of concretization, 217
of inner side, 203
in Jung’s case [13], 181
of new relationship, 108
of reality, 300
of unconscious, 198
of unknown, 203
world-, 203; *see also* anxiety
Fechner, Gustav Theodor: *Elemente der Psychophysik*, 245f
feeling(s), 119, 129f, 134, 183, 194, 215, 279n, 285, 288, 294, 297, 298
civilized, 288
collective, 151, 154f/278f, 277, 301
logic of, 288
of moral resentment, 136/273
mythological, 282
negative, 214
projection of, 300
subjective, 203
subliminal, 303
-thoughts, 285
in woman, 188
feminine, 189, 191f, 194
nature, man’s, 209
psychology, 205
traits in man, 189; *see also* anima; woman
femininity, unconscious, 189

femme inspiratrice, 209

Ferrero, Guglielmo: *Les Lois psychologiques du symbolisme*, 118

fertility, 68

fiancée, 213ff, 218

“fictions, guiding,” Adler’s theory of, 294

finality, 295n

finance, morality of, 27f

fire, 221ff

- boring, 185
- ever-living, 68f

fish, 84

fixation, 295n

- father-, 158
- infantile, 169; *see also* complex

flame: blue, 222f

- ring of, 222

Fledermäuse (Meyrink), 96

Flournoy, Théodore: “Automatisme téléologique antisuicide: un cas de suicide empêché par une hallucination,” 162n

- From India to the Planet Mars*, 137n

flying, dreams of, 160/282

“Flying Dutchman,” 210

Folies Bergères, 36

font, baptismal, 105; *see also* baptism(s)

foot, 81, 83, 88, 102

- phallic symbolism of, 83

ford, 81, 82, 84, 99f

- “danger at the,” 100

Forel, Auguste Henri: *The Sexual Question*, 257

Förster, Friedrich Wilhelm, 248

fortune tellers, 290

four, *see* functions; quaternity

France, Anatole, 10/247

fraternity(-ies): ring, 107

student, 105

Frazer, J. G., 68

freedom, 278

and morality, 153, 261

and nationalism, 166

spiritual, 171

Freemasonry, 231

free will, 33, 59, 71, 167

French Revolution, 94

Freud, Sigmund, 3, 8ff/247f, 123, 127f/270f

and death-instinct, 28f, 54

and dream analysis, 21ff/262ff, 100

and ego-instincts, 34, 42

and fantasy, 290f

and incest, 23f

and Jung's case of anxiety [2], 35ff

and libido, 28, 52n, 53n

and morality, 26ff

and neurotic symptoms, 25

origins of psychoanalysis, 13/251, 15/253

as product of materialism, 28

and reductive method, 59 (*see also* reduction)

on repression, 26

sexual theory of, 10/248, 27f, 32, 38, 117f, 165, 269

theory of neurosis contrasted with Adler's, 35, 61, 281

and transference, 42, 62n, 129f, 165

and trauma theory, 13/251, 15/253, 186

and unconscious, 132, 158

and wish-fulfilment, 22; *see also* infantile/infantilism

WORKS: "Beyond the Pleasure Principle," 28n

The Interpretation of Dreams, 10n/248n

"Leonardo da Vinci and a Memory of His Childhood," 65n

"An Outline of Psycho-Analysis," 29n

Early Psycho-Analytic Publications, 247n

(with Breuer) *Studies on Hysteria*, 10n/247n, 12f/251

“Three Essays on the Theory of Sexuality,” 10n/248n, 53n

Totem and Taboo, 152n

Freudian school, *see* psychoanalysis

friendship, platonic, 108

fright, sudden, 13/252

Frobenius, Leo: *Das Zeitalter des Sonnengottes*, 99n

frogs, 13/251

function(s), 225, 277, 297

adaptive, 298

of anima and animus, 208ff, 224, 227 (*see also* of relationship *below*)

archaic, 303f

associative, of animus, 209

collective psychological, 275n

conscious, 44

differentiated, 220

four, identification with, 223

four orienting, 44n

guiding, 134

inferior, 58f, 219f

inside and outside, 209

intellectual, 129

of the irrational, 94f

mental, 71, 276

moral, 293, 294n

official, 192

perceptive, 298

personal, mental, 275f

—, psychic, 137, 147f, 149

psychological, 71

reality, 282

of relationship, anima and animus as, 232

religious, 94

sexual, 284
social, 147
subliminal, 303
thinking, 44
transcendent, *see* transcendent function
and unconscious, 99
unifying, of fantasy, 290
universal, 174; *see also* feeling; intuition; sensation; thinking
functioning: collective, 151, 278n, 301, 303
individual, 151
mental, 147/275
futurity, premonition of, 192

G

Ganz, Hans: *Das Unbewusste bei Leibniz in Beziehung zu modernen Theorien*, 98n
Genesis, 156n
genius, 148, 154, 283
Gentiles, 171
Germanic women, Tacitus on, 188
Germany, 267
ghost, mother as, 179
giant, 132
Gnosticism, 66, 77, 132
archons, 66
l'Eglise gnostique de la France, 231
goal(s): of analysis, 232
conquest of anima as, 227
conscious, 215
of developmental process, 110
of dreams, 294n
of fantasies, 230
higher consciousness as, 59
of individual's development, 279
of individuation, 155n, 240

midpoint of personality as, 221
psychic, 215
self as life's, 239f
of unconscious, 134

God/god(s), 21/262, 67ff, 70, 94ff, 101f, 135, 137, 156n, 157n, 228, 236, 258, 281
as absolute, 235n
as autonomous psychic content, 239
becomes doubtful, 204
Christian idea of, 235n
concept of, 238
concretized, 239
and demon, 73
dethronement of, 238
doctor as, 130, 133, 135
existence of, 71
as Father in Heaven, 235n
four, 223
idea of, 135
-image, 135
—, primitive, 137
—, reactivation of archaic, 160
in Jung's case [16], 222f
kinship with, 237
moral problem, 239
projection and, 207
proof of, 71
psychological, 235n
as psychological function of an irrational nature, 71
relativity of, 235n
rhyme with *-ism*, 204
ritual communion with, 99
is spirit, 135
statues of, 222
tin, 233

vision of, 135
wager with, 196
is wind, 135
wrathful, 260
godlikeness, 73, 140f/274f, 152/278, 169/286, 233, 280, 281n, 282ff; *see also* inflation;
man, godlike
Goethe, J. W. von, 34, 59, 237
and Eckermann, 193
“Die Geheimnisse: Ein Fragment,” 229n
Faust, *see s.v.*
Golem, The (Meyrink), 94, 304
good and bad/evil, 15/253, 32f, 71, 102, 140f, 148, 149f/276f
conflict between, 183
relativity of, 182
goodness, doctor as personification of, 64
Gospels, 68
Gottesminne, 133
grace, divine, 69
gradient, 52ff
of libido, 62n, 66f *see also* energy
Greece: homosexuality in, 106
mysteries in, 231
Griesinger, Wilhelm, 67
“guardians of the threshold,” 210
“guiding fictions,” Adler’s theory of, 294
guilt, 149
moral, 258
Promethean, 156n

H

Haggard, H. Rider, 189, 227
She, 189n, 191
hallucinations, 12/250, 197

body-hallucinations, [282f](#)
halo, [69](#)
haoma, [69](#)
happiness, [260](#)
hate/hatred, [75](#), [247](#)
headache(s), [129](#)
health, [68](#)
hearing, hysterical loss of, [11/249](#)
heat: alchemical, [223](#)
 original, [69](#)
Hecht, Dora, [3n](#)
Heidelberg school, [246](#)
Helm, G. F., [67f](#)
 Die Energetik nach ihrer geschichtlichen Entwicklung, [67n](#)
Heraclitus, [68](#), [72](#)
Hercules, [141](#)
herd, [27](#), [31](#), [32](#), [261](#)
 “soul” in individual, [278n](#)
hermeneutic(s), [291](#)
 method, [85](#), [293](#), [294](#)
hero(es), [65](#), [99f](#), [159](#), [169f/287](#), [180](#), [195](#), [228](#), [233](#), [259](#)
 figure, masculine, [212](#)
 lapses of, [193](#)
 struggle with monster, [99](#), [170/287](#)
 sun-, [69](#)
heroism, [33](#), [48](#)
 heroic type, [48](#)
heuristic: principle, [88](#)
 value, [134](#)
Hiawatha (Longfellow), [99](#)
Hinduism, [78](#)
Hinkle, Beatrice M., [123n](#)
history, racial, [99](#)

hoard, capture of, [170/287](#)

Hoche, Alfred Erich, [248](#)

Hoffmann, E. T. W.: *The Devil's Elixir*, [39](#)

Holy Ghost, [68](#)

homosexuality, [82f](#), [87](#)

- of adolescence, [106](#), [108](#)
- and education, [106](#)
- unconscious meaning of, [107](#) *see also* Jung's cases [4], [5]

honesty, [203](#)

horoscopes, [292](#)

horses, [14f/252f](#), [51](#)

Hubert, Henry: *Mélanges d'histoire des religions*, [138n](#)

human: brain, *see* brain

- nature, [30](#), [141](#) *see also* animal, man's nature; nature

humanity: and archetypes, [69](#)

- collective conception of, [298](#)
- consists of individuals, [50](#)
- general characteristics of, [156/280](#), [157/281](#)

humility, [142](#)

humour, [170](#)

- sense of, [154](#)

husband, as father substitute, [60](#)

hypermnesia, [12/250](#)

hypnagogic sensations, [282](#)

- cf. [160/282](#)

hypnotism, [21/262](#)

hypochondria, [51f](#)

hypocrisy, [260f](#), [264](#)

- and self-knowledge, [26/267](#)
- in various disguises, [5](#)

hysteria, [11-17/249](#)

- Breuer's case, [11f/249f](#)
- and "nervous shock," [13/251](#)

psychic origin of, [9f/246f](#), [249](#)
symptomatology of, [10/247](#)
trauma theory, [13/251](#), [18](#); see also *asthma*
Jung's cases [2],[8], laughter

I

ice, [213f](#)

I Ching, [85](#)

idea(s), [69](#), [148](#), [204](#), [224](#)

abstract, [144/272](#)

“big,” [182](#)

collective, [81](#), [304](#)

conscious, [304](#)

depressive, [214](#)

feeling-toned, [21](#)

inheritance of, [65](#)

inherited, [138](#)

intuitively apprehended, [67f](#), [95](#)

of mastery, [237](#)

morbid, [163](#)

mythical, [69](#)

obsessive, [194](#)

primordial, [135/272](#)

universal, [225](#)

ideal(ism), [45](#), [54](#), [94](#), [163](#), [278n](#), [288](#)

collective, [154](#), [303](#)

delusive, [62](#)

destruction of, [299](#)

exploded, [203](#)

of individuation, [226](#)

moral, [20/261](#)

opposite of former, [75](#)

primitive Christian, [226](#)

shattering of, [195](#)

social, 173
superhuman, 59
type, 297

identification, 86ff, 91, 145, 169ff/286f, 194, 289
with: archetype, 233
the collective, 289
collective psyche, 152/278, 287
mana-personality, 235
office or title, 143, 145
persona, *see* persona
the shadow, 33

identity, 301
collective, 288
with collective psyche, 283
original, 206
unconscious, 105

idiosyncrasy, 174

idol(s), repression of, 75

Ignatius Loyola, St., 78

illness, mental, *see* mental derangement

illusion(s), 25/265, 60f, 112, 203, 225, 238
hypochondriacal, 52
infantile, 59, 61
of youth, 60f, 73f

image(s), 77f, 92f, 95f, 98, 145, 148, 183, 190, 202, 232, 240, 298
archetypal, 95
at climacteric, 109
collective, 137, 147, 160, 180, 182
of collective unconscious, 109
divine, 94, 135 (*see also* God-image)
dream-, 183
in dreams, 131
eternal, 109, 146
fantasy-, 214ff

ideal, 157, 232
infantile, 135
primordial, 65*f*, 68*ff*, 106*f*, 138, 171, 173*f*, 181, 209, 234, 299, 304
—, concretization of, 233
—, of parent, 186*n*
—, self-representations of libido, 169*n*/287*n*
projected, 186
repetition of, 65
universal, 225
virtual, 190
imagination: active, 222*n*
 inherited possibilities of, 65
 powers of, 177
imago, 60*f*, 187*f*
 father-imago, 60, 73, 129*f*, 229
 mother-imago, 60, 73, 197
 object-, 300*ff*
 and object, 140
 parent(al), 186, 188
 subject, 302, 304
 of woman, 188*f*
imitation, 155/279*f*, 168
 in Jung's case [2], 39
immorality, 153
immortality, 69, 191*f*, 235
 personal, 186
imperialism, 50
impersonal unconscious, *see* unconscious, impersonal
impotence, 194
 sense of, 139/274
incarnations, former, 191
incest, 23*f*
 fear of, 106
 taboo, 152

wish, [169/287](#)

incubus, [224](#)

independence of unconscious, [123](#)

India, [292](#); *see also* psychology, Indian

individual(s), [147f/275f](#), [152](#), [155/279f](#), [240](#), [278](#), [289](#), [299](#)

- and collective, [151](#), [289f](#), [301](#)
- differences, [152](#), [206](#)
- differentiation from persona, [289](#)
- and disposable energies, [50](#)
- egocentric interests of, [275](#)
- factors, [153](#)
- functioning, [151](#)
- idiosyncrasy of, [174](#)
- and individuation, [173](#)
- life of, [196](#)
- and mass, [30](#)
- and nation, [4](#), [94](#)
- needs of, [182](#)
- outstanding, [150f](#)
- and persona, [157f/281](#)
- psychology of, [4](#)
- and society, [147/275](#), [158](#)
- specially gifted, [117](#)

individualism, [173](#)

- and individuation, [173](#)

individuality, [158](#), [160](#), [173](#), [193](#), [295](#), [297](#)

- concept of, [296](#), [298](#)
- corporeal, [296](#)
- definition of, [301](#), [303](#)
- destruction of, [154](#)
- disregard for, [152](#)
- feigned, [157/281](#)
- independence of, [171](#)
- and individual, [303](#)

as masculine, feminine and hermaphroditic figure, [304](#)
mental, [296](#), [297](#)
moral, [297](#)
perfection of, [297](#)
and society, [303](#)
true, [235](#), [287](#)
undeveloped, [302](#)

individuation, [125](#), [155/279](#), [195](#), [223](#), [225](#), [297](#)
goal of, [173f](#), [240](#)
and individualism, [173](#)
natural process of, [110](#)
principle of, [287](#)

Indonesians, *see* [Bataks](#)

industrialization, [259](#)

inertia, of unconscious identity, [105](#)

infancy/infant, [77](#) *see also* [child](#), [childhood](#)

infantile/infantilism: attitude, [59](#), [163](#)
bond, unconscious, [104](#)
craving, [86](#)
demands, [112](#)
—, sexual, [165](#)
desires, [148](#)
dissolution of infantile ties, [61](#)
fantasies, [63](#), [170](#), [271](#)
fixation, [169](#)
in Freud's theory, [127/270](#), [169f/287](#)
illusions, [59](#), [61](#)
image, [135](#)
instinctual impulses, [23/263f](#), [25](#)
in Jung's case [4], [86](#), [5], [104f](#), [109](#), [8], [159f](#), [12], [180](#)
in neurosis, [59ff](#)
relationship, [87](#)
reminiscences, [23/264](#), [52](#)
sexuality, [38](#), [46](#), [284](#)

transference, 66, 165f
wish, 23/263, 83
world, 180

infection, psychic, 96

inferior function, 58, 219, 220

inferiority, 48, 58, 136/273
 Jung's feeling of, 194
 moral, 136/273
 sense of, 142, 149/276

infinite/infinity, 160, 182

inflation, 71, 156, 160, 168, 169, 171, 228
 psychic, 143ff, 147; *see also* godlikeness

information, "supernatural," 187

inheritance, of ideas, 65

inhibition, 60, 177

initiation, 230f, 235
 into manhood, 105, 107
 rites, 105ff, 197, 230f
 symbolism, 231

initiative, lacking in unconscious, 184

injury, psychic, 165

inquisitiveness, holy, 203

insanity, 283; *see also* mental derangement/illness

inside and outside, 196

insight(s), 102, 141, 159, 224, 234, 267

inspiration, 67, 283
 creative, 175
 prophetic, 169/286

instinct(s), 86, 104, 129, 133, 148, 304
 basic, 155/279
 and body, 30f
 collective, 154/278f
 conflict with civilization, 20

destructive, [53n](#) (*see also* death instinct)
ego-instinct, [34](#)
feeble, [152n](#)
gregarious, [277](#)
loss of, [116](#)
and neurosis, [26](#), [61](#)
for preservation of species, [32](#)
primordial, [165](#)
psychoanalysis and, [26](#)
self-preservation, [32](#)
social, [147/275](#)
and spirit, [28](#)
vital, [304](#)
weakness of, [129](#); *see also* animal instincts, man's
instinctual; impulses, and sublimation, [47f](#)
impulses, in the unconscious, [23](#)
processes, [81](#)
integrity of personality, [38](#), [154](#), [166](#)
intellect, [214](#), [288](#), [298](#)
cannot grasp psyche, [119](#)
concretizations of, [220](#)
in women, [158f](#)
intellectualism, [216](#)
intelligence, [117](#)
intensities, psychic, [53n](#)
intention, conscious, [111](#), [297](#)
interpretation(s): anthropomorphic, [101](#)
at beginning of treatment, [83](#)
causal-reductive, [83f](#)
of dreams, *see* dream(s)
hermeneutic, [291](#)
objective, [84](#), [88](#), [90](#), [98](#)
semiotic, [291](#)
and settlement with the unconscious, [213](#)

subjective, [84f](#), [88](#), [90](#)
synthetic (constructive), [85](#)
of transference, [63](#)
interpretive principle, [269](#)
introjection, [70](#)
introversion, [44](#), [54ff](#)
 anima in, [218f](#)
 in extravert, [56f](#)
 inferior, [58](#)
 neglected, of Western culture, [191](#)
 rhythm of, [59](#)
introvert: characteristics, [55](#)
 extraversion of, [57f](#)
 illustration of, [56f](#)
 and integrity of ego, [278n](#)
 meaning of persona for, [278n](#)
 Promethean, [57](#)
 subject and object in, [56ff](#)
 and thinking, [278n](#), [288](#)
 unconscious contents in, [225](#)
intuition, [44n](#), [297](#)
 creative, [175](#)
 in woman, [188](#)
inversion, [100](#)
 of types, [57](#)
irrational, the, [71f](#), [94f](#), [288f](#) *see also* rational
irrationality, [49f](#)
irreality, [217](#)
isolation, [200](#)
ivory figure, Japanese, [107](#)

J

James, William, [289](#)
 Pragmatism, [54](#)

Janet, Pierre, 9f, 148/276, 215

L'Automatisme psychologique, 9n

Les Névroses, 148

Névroses et idées fixes, 9n

jealousy, infantile, 23

Jew(s), 107 *see also* circumcision; psychology

Job, 196

Jonah, 99

judgment(s): of animus, 207

intuitive, 93

projections of, 300

senseless, 283

Jung, Carl Gustav:

CASES IN SUMMARY (in *order of presentation*, numbered for reference):

- [1] Young woman, whose hysterical neurosis arose following a trauma. Case leads to problem of predisposition as a cause of the neurosis.—13–18/252f
- [2] Young married woman with anxiety attacks and hysterical asthma, and background of father fixation; case used to illustrate Adlerian system.—35–40
- [3] American business man, aged 45, who became hypochondriacal upon retiring from business; case illustrates factors of disposable energy in relation to energy gradients.—50f, 72, 76
- [4] Woman, with homosexual attachment, whose dream of crossing a ford and encountering crab is analysed to show critical nature of transition from the personal to the collective unconscious.—81–88, 97–102
- [5] Homosexual youth; religious dreams compensate the negative view of his condition.—102–109
- [6] Woman, treatment of whom does not succeed until doctor's dream of her.—112f
- [7] Young girl, a somnambulistic medium; here only referred to (Jung's first published case).—118, 123
- [8] Young woman philosophy student with father fixation, in which the father image deepened into the image of God, through it the transference being resolved.—128–35, 156, 158ff, 164ff

- [9] Youth with sentimental love-fantasy, who intends suicide, has hallucination of stars, commits crime.—146, 162
- [10] Insane patient, in whom refusal of food indicated a suicidal attempt; illustrates importance of previous history.—176f
- [11] Business man, in conflict with his brother, his dreams illustrating the compensatory function of the unconscious.—179, 180
- [12] Young woman, with mother fixation, whose dreams illustrate the compensatory function of the unconscious.—179, 180
- [13] Youth, aged 16, with severe compulsion neurosis, who dreams of seeing devil behind him.—181
- [14] Young theological student, with religious problem, who dreams of black and white magicians.—181ff
- [15] Young man, with a psychogenic depression; a dream demonstrates the limits of intellectual insight and the need for inaugurating the fantasy method.—213–9, 230, 232
- [16] Woman, whose “vision” leads to her merging in unconscious processes.—221ff, 230

WORKS: *The Archetypes and the Collective Unconscious*, 7n, 66n, 97n, 100n, 181n

Die Beziehungen zwischen dem Ich and dem Unbewussten, 123f, 269n

“Brother Klaus,” 78n

Collected Papers on Analytical Psychology, 3n, 6n, 49n, 123, 245n, 269n

Commentary on *The Secret of the Golden Flower* 66n

“The Concept of the Collective Unconscious,” 65n

“The Conception of the Unconscious,” 123, 269n

“Concerning the Archetypes, with Special Reference to the Anima Concept,” 189n

“The Content of the Psychoses,” 123, 291n

“Dream Symbols of the Individuation Process,” 7n

Freud and Psychoanalysis, 49n

“*General Aspects of Dreams Psychology*,” 100n

“Instinct and the Unconscious,” 116n

Mysterium Coniunctionis, 100n, 222n

“*Neue Bahnen der Psychologie*,” 3 (see also “New Paths in Psychology”):

“New Paths in Psychology,” v, vii, 3n

“On Psychic Energy,” 47n, 53n

“On the Psychology and Pathology of So-called Occult Phenomena,” 118n, 123, 137n

“Paracelsus as a Spiritual Phenomenon,” 78n
The Practice of Psychotherapy, 112n
“The Psychological Aspects of the Kore,” 189n
“The Psychological Foundations of Belief in Spirits,” 186n
Psychological Types, 5n, 6, 44n, 54n, 57n, 58n, 100n, 134n, 138, 147n, 154n, 155n, 189n, 196n, 279n
Die Psychologie der unbewussten Prozesse, 3n, 245n (see also “The Psychology of the Unconscious Processes”)
Ueber die Psychologie des Unbewussten, 7n
Psychology and Alchemy, 78n, 80n, 110
“The Psychology of Dementia Praecox,” 162n, 262n
“On Psychological Understanding,” 85n
“Psychology and Religion,” 110
Psychology of the Unconscious, 123n, 169/275, 272n, 287, 291n
“The Psychology of the Unconscious Processes,” 3n, 245n
“The Realities of Practical Psychotherapy,” 112n
“A Review of the Complex Theory,” 21n
“The Role of the Unconscious,” 32n
The Secret of the Golden Flower 110, 124
“Sigmund Freud in His Historical Setting,” 28n
“The Stages of Life,” 74n
“La Structure de l’inconscient,” 123, 269n
“The Structure of the Psyche,” 69n, 95n
“The Structure of the Unconscious,” v, vii, 123n
“Studies in Word Association,” 21n/262n
“A Study in the Process of Individuation,” 7n
Symbole der Wandlung, 123n
Symbols of Transformation, 53n, 65, 66n, 70n, 100n, 123n, 135, 212n
“The Theory of Psychoanalysis,” 13n, 81n
“The Transcendent Function,” 80n, 222n
Das Unbewusste im normalen und kranken Seelenleben, 6n
“The Unconscious in the Normal and Pathological Mind,” 6n
Wandlungen und Symbole der Libido, 123n, 264n
Jung, Emma: “On the Nature of the Animus,” 90n

K

ka, 187

Kant, Immanuel: *Vorlesungen über Psychologie*, 169n/286n

karma, 77n

Kavirondos (of E. Africa), 228, 230

Kingdom of Heaven, 226

knowledge: dangerous, 202

enthusiast's fund of, 142

eschatological, 169/286

esoteric, 235

of good and evil, 140

inflation through, 143

magical, 227

new, 156n, 157n

theory of, 295n

and transcendent function, 224

tree of, 156n *see also* self-knowledge

Kraepelin, Emil, 246

Kubin, Alfred: *Die andere Seite*, 213

Kundry, 227

L

language: of dreams, 85

mythological, of infancy, 227

picture, 272

of unconscious, 22/263

of universal validity, 144/272

Lao-tzu, 194, 221, 233

laughter/laughing, in Jung's case[2], 36–39

law(s), 5, 155/280, 200, 231, 236, 259

dominant, archetypes as images of, 95

eternal, 233

general 4

governing structure of dreams, [263n](#)
moral, [136/273](#)
moral validity of, [27](#)
natural, [59](#)
Pauline overcoming of, [239](#)
plenitude of life governed by, [49](#)
psychic, [222](#)
psychological, [72](#), [233](#)
social, [275n](#)
unconscious, [160](#)

laziness, [170](#)

Lehmann, F: *Mana*, [233n](#)

Leibniz, Gottfried Wilhelm, [98n](#)

Leonardo da Vinci, [65](#)

“let sleeping dogs lie,” [203](#)

level: objective, [90f](#), [98](#), [140](#)
subjective, [90](#), [92](#), [97](#); *see also* interpretations

Lévy-Bruhl, Lucien, [206](#)

libido, [52f](#), [62f](#), [86](#), [88](#), [167/285](#), [169f/287](#), [272](#), [275](#), [284](#)
accumulation of, [215f](#), [304](#)
conversion of, [216](#)
currents of, [294f](#)
definition, [52n](#)
and Eros, [28](#)
and fantasy-images, [215](#), [219](#)
gradient of, [62n](#)
Jung’s book on, *see Psychology of the Unconscious*
movement of, [301](#)
object of, [66](#), [70](#)
and religion, [94](#): *see also* love

Liébault, A. A.: *Du Sommeil et des états analogues considérés au point de vue de l’action du moral sur le physique*, [9n](#)

life: afternoon of, [74f](#) (*see also* second half of *below*)
demands of, [100](#), [131](#)

double, [217](#)
duty to, [73](#):
fantasy, *see* [fantasy](#)
-feeling, [152/277](#), [169/286](#)
-force, [54](#)
-line, [293f](#)
—, of individual, [301](#)
meaning of, [74](#), [205](#)
natural, [296](#)
opposite types in, [48](#), [54](#)
“ordinary” and “heroic,” [48](#)
physiological, [296](#)
plan of, [128/271](#)
private, [193ff](#), [198](#)
-process, [131](#), [196](#), [289](#)

psychic, 238
-relationship, 218
renewal of, 169/286
second half of, 61
“simple,” 168
stasis of, 129
not transitory, 192
-urge, 60, 290
widening of, 74

lion(s): as dream symbol, 35
 Nietzsche’s Zarathustrian, 31

lizard, 93

locksmith, apprentice, *see* Maeder’s case

λόγος σπερματικός 209

loneliness, 157n, 168, 200

Longfellow, H. W.: *The Song of Hiawatha*, 99

longing, regressive: “for the mother,” 169f/287

loss: of soul, 151
 of voice, in Jung’s case [2], 36, *see also* aphasia

Lourdes Cathedral, 103ff

love, 23, 27, 101f, 149, 228, 299
 Christian, 5
 -choice, 189
 demand for, 86
 depreciation of, 38
 “disinterested,” 38f
 as factor in neurosis, 15f/253f, 18/256, 247
 -fantasy, 146
 and hatred, 75
 in Jung’s case [9], 146
 means to power, 38f, 40
 relation to object, 42
 slighted, 37
 as transference, 133

and will to power, [53](#); *see also* erotic conflict
Lovejoy, Arthur O.: “The Fundamental Concept of the Primitive Philosophy,” [68n](#)
lover, [146](#)
 anima and animus as, [208](#)
 doctor as, [64](#), [130f](#)
 father-, *see* father
loyalty to oneself, [293](#)
Lutheranism, [237](#)

M

MacNeice, Louis: translation of *Faust*, [v](#), [166n/284n](#), [229n](#)
madness “of magic,” [167/285](#)
Maeder, A: Maeder’s case of megalomania, [143ff/271ff](#), [162](#)
 “La Langue d’un aliéné,” [271n](#)
 “Psychologische Untersuchungen an Dementia Praecox-Kranken,” [143n](#)
magic, [96f](#), [145](#), [150f](#), [185](#), [230f](#), [292](#)
 “madness of,” [167/285](#)
 power, images of, [68f](#) (*see also* power)
 talisman, [170/287](#) *see also* medicine-man
magical: cure, [293](#)
 influence, [185](#)
 role of mother, [198](#)
 substance, [185](#)
magician, [92f](#), [98](#), [187](#), [204](#), [228ff](#)
 black and white, in Jung’s case[14], [182](#)
 hero in *Faust*, [96](#), [237](#)
 in Jung’s case [4], [91](#)
 in transference, [64f](#)
maieutics, [265](#); *see also* Socrates
Mairet, Philip, [269n](#)
maladjustment, [149](#)
male organ, [107](#)
mammon of unrighteousness, [236](#)

man: average, 193
 compared and contrasted with woman, 206ff
 femininity of, 189, 209
 godlike, 73
 of honour, 199f
 and mana-personality, 235
 presupposes woman, 190
 relations to woman, 188ff
 strong, *see* “strong man”
 wise old, 97, 110 *see also* anima; manhood; “men’s house”

mana, 68n, 227ff
 definition of, 233

mana-personality, 227ff, 233ff
 dissolution of, 237
 identification with, 235

manhood, initiation into, *see* initiation

manikin, 107

marriage, 23/263, 60, 74, 108, 259
 game of illusion, 195
 ideal of, 198
 in Jung’s case [2], 37
 types in, 55

Marsen, M., 269n

martyrdom, desire for, 169/286

masculine/masculinity: consciousness, 206
 foot, 83, 88
 mind, 206
 prestige of, 197
 protest, 38, 42, 284
 psychology, 205
 role, 83, 88
 step towards, 108
 traits in woman, 90, 189, 209, *see also* animus
 type, 88

mask(s), [150](#), [157/281](#), [192ff](#), [234](#), [296](#) *see also* persona

mass, [151ff](#)

-murder, [94](#)

organizations, [280](#)

-suggestion, [204](#)

material, subliminal, [127/270](#)

materialism, [54](#)

and Freud, [28](#)

mathematics, [80n](#)

maturation, retarded, [184](#)

maturity, [59ff](#)

Mauss, Marcel: *Mélanges d'histoire des religions*, [138n](#)

Mayer, Robert, [67ff](#)

Kleinere Schriften and Briefe, [67n](#)

meaning, mediatory, [196](#)

mechanism: defence, [91](#)

dream, [100](#)

instinctive, [105](#)

psychological, [10](#)

Mechtild of Magdeburg, [134](#)

Medardus: Brother, [39](#)

brother of, [76](#)

medical psychology, [8](#), [117](#)

and personalistic attitude, [81](#)

medicine-man, [96f](#), [150](#), [178](#), [228](#)

mediocrity, [153](#)

meditation, [191](#)

megalomania, [144](#), [149/276](#), [169/286](#)

Maeder's case of, *see* Maeder

Megarian school of philosophy, [54](#)

melancholia, [214](#)

memory(-ies), [23/263](#), [64f](#), [80](#), [136](#)

blotting out of, [169/287](#)

childhood, 135
-complexes, 84
of former incarnations, 191
images, 77
—, inheritance of, 190
of infancy, 77
intensification of powers of, 12/250
in Jung's case [2], 38
lost, 66
overvalued, 129
personal, 65, 93
race, 264, *see also* archetypes
and repression, 127/270
slip of, 177
waking, 12/250

menopause, 74; *see also* climacteric
“men's house,” 105

mental: contagion, 155/280
corrective, 104
functioning, 147/275

mental disease, 9, 162, 175*f*, 282*f*; *see also* neurosis; psychosis

mentality: Aryan, 152*n*;
collective, 277 (*see also* psyche, collective)
Hamitic, 152*n*
Mongolian, 152*n*
neurotic, 165
Semitic, 152*n*

Mephistopheles, 140/274, 167/255, 253*n*

Messenger of the Grail, 227

metempsychosis, 69

Meumann, Ernst, 246

Meyrink, Gustav, 96
Fledermäuse, 96
The Golem, 96, 304

mice, [13/251](#)

Michaelis, Karin, [257](#)

Middle Ages, [27f](#), [69](#), [77f](#), [134f](#)

middle way, [76](#), [221](#)

mid-point of personality, [221](#), [223](#), [230](#); *see also* personality

mind: collective, [275](#)

- conscious, [25](#), [71](#), [111](#)
- , attitude of, [214](#)
- , repressive attitude of, [202](#)
- , whims of, [156n](#)

Eastern, [192](#)

human, [275](#)

masculine, [206](#)

personal development of, [277](#)

scientific, [288](#)

“splitting of,” [147](#) (*see also* schizophrenia),

Western, [191](#), [202](#), [205](#)

mirror: -image of world, [298](#)

- world, psychic, [185](#)

Mithraism, [20/258](#)

mneme, phylogenetic, [98n](#)

Möbius, Paul Julius, [45](#)

money and psychoanalysis, [131](#)

monism, psychological, [288](#)

monomania, [72](#)

monotheism, psychological, [288](#)

monster, [99](#)

- mass as, [30](#)
- of maternal abyss, [170/287](#)

mood(s), [177](#), [194](#), [218f](#), [224](#), [227](#)

- anima and, [206](#)
- dream as expression of, [103](#)
- hysterical, [26](#), [266](#)

of man, 207
succumbing to, 216
venomous, in Jung's case [2], 36

moon, 69

moral(s): authority, 207
conflict, 141f
consciousness, 136
factor, 294
function, 293, 294n
guilt, 258
history of, 35
ideal, 20/261
law, 27, 136/273
opposites, 149f
principles, 26/266
problem as compensation, 180f
progress, 153
qualities, 117, 136/273
resentment, 136/273
views, 260

morality: ascetic, 31
and freedom, 153
intellectual, 99
mass, 27
and neurosis, 20/261, 25ff/266f, 136
public, 194
and repression, 127/270, 264
sexual, 27, 258, 261, 265
of social organization, 154
of society, 153; *see also* ascetism; Christianity

morals, history of, 35

mortality, child and female, 260

Moses, 68

mother, 204

as archetype, 110
in Breuer's case (Anna), 12/250
child's relation to, 42, 52, 60
clings to child, 74f
-complex, 106, 186
dark, 237
-daughter-beloved, 159
daughter's relation to, 22f/263
first bearer of soul-image, 197
-friend, 84
in Jung's cases [2], 37f, [4], 82ff, [5], 104ff, 108, [8], 159, [12], 179f
liberation from, 235 (*see also* separation *below*)
longing for, 169f/287
magical role of, taken over by wife, 198
separation from, 197
substitute, 104f
tie with, 104
in transference, 64f; *see also* abyss, maternal; imago, mother

Mother: Church, 105 (*see also* church)

Earth, 258f
of God, 144
Great, 228
Nature, 259

motif(s): archetypal, 84
mythological, 65, 160
religious, 160; *see also* archetype(s); symbol(s)

motive(s): conscious, 178
unconscious, 39, 62n, 17/256

mountain, 222

mulungu, 68f

music, organ, 107f

mysteries, 231
Eleusinian, 231
religious, 105

transformation, 231
mysterium magnum, 224
mystic(-ism): 138n, 146, 169/287, 203
 participation, 146, 206, *see also* Lévy-Bruhl
myth(s), 65, 99, 169f/287, 157n
 autochthonous, 147/275
 formations, 95
 incest wish in, 169f/287
 mythical ideas, 69
mythology, 93, 98, 100, 180
 in dream, 160

N

name, secret, 235
Nancy school, 9, 10/249; *see also* Bernheirn
Napoleon I, 179, 232
nasal feeding, 176
nation(s), comity of, 151
 and individual, 4, 94
 as man's world, 210
 psychology of, 4
nature, 28, 38, 63, 74, 100, 124, 129, 131f, 166, 177, 259f
 aristocratic, 116, 149
 and conscious values, 215
 and culture, 19, 34
 -daemon, 135
 and differentiation, 116
 human, 30, 141
 man's instinctual, 27, 133 (*see also* animal nature, man's)
 Mother, 259
 other side of our, 25/266
 signs of, 101
Naumburg, 31
necessity, 26/267, 55, 153, 155/279, 167f, 260, 266

inner, 223, 239

therapeutic, 226

needs, aesthetic and emotional, 103

negative: aspect of parental imagos, 188

attitude, 115

side, necessity of, 30 (*see also* shadow (-side))

values, 47, 49, 50

Negro, 201

Nelken, Jan: "Analytische Beobachtungen über Phantasien eines Schizophrenen," 70n

Nerval, Gerard de: *Aurelia*, 80

nervous: breakdown, 257

diseases, 9

shock, theory of, 13/251

nervousness, psychic origin of, 9/246, 16/254, 129; *see also* symptoms; shock

neurosis, 20/261, 33, 46f, 114, 117f, 129ff, 136/273, 165, 216, 237, 262, 265, 294f

Adler's theory of, 35ff, 45, 61, 281

causes of, 15/253, 18f/256f, 24f, 48 (*see also* source of, *below*)

compulsion, in Jung's case [13], 181

contrived by the unconscious, 184

Freudian theory of, 10/247, 45, 61, 165, 281

history of, 24

hysterical, *see* Jung's case [8]

and inner disunity, 129

in Jung's case [2], 36ff [11], 179

love and, 18n

in maturity, 59f, 75

and politics, 20

psychology of, 9f/247f, 161

as self-division, 20/261

sexual theory of, 28, 256

source of, 194

teleologically oriented, 40

treatment of, 148, 293

value and meaning of, 46f, 61

in young people, [59f](#)
neurotic, [19](#), [20](#), [25/266](#), [44](#), [231f](#), [237](#), [281](#), [294](#)
attitude, [139](#)
conflict, [130](#), [258](#)
condition, [225](#)
deadlock, [101](#)
elderly, [77](#)
energy, [47](#)
mentality, [165](#)
regressive nature of, [293](#)
sickliness, [168](#)
symptoms, *see* symptom(s)
New Testament, [137](#)
 Corinthians, [156n](#)
 Gospels, [68](#); *see also* St. Paul; Peter
Newton, Sir Isaac: theory of gravitation, [175](#)
Nicholas of Flüe, [78](#)
Nietzsche, Friedrich, [26](#), [35](#), [45f](#), [73](#), [75](#), [118](#), [193](#), [225](#), [237](#), [294](#)
 Also Sprach Zarathustra, [31](#), [96](#), [237](#)
 and instinct, [31ff](#)
 pathological personality, [32](#)
night, terrors of, [204](#)
nightmare, in Jung's case [2], [35](#)
"night sea journey," [99](#)
night-world of fantasy, [203](#)
nirdvandva, [223](#)
nominalism, [54](#)
non-differentiation, [206](#), [225](#); *see also* mystic participation
non-ego, [73](#), [78](#), [97](#), [297](#), [301](#)
 psychological, [300](#), [302](#)
non-resistance, [236](#)
non-values, [236](#)
normal(-ity), [149](#), [224](#), [281n](#)

definition of, [55f](#)
and latent psychosis, [114](#)
man, [60](#)
person/people, [129](#), [143](#), [299](#)
“nothing but,” [45](#), [238](#), [283](#)
numbers, real and imaginary, [80n](#)
nursing, [13/251](#)

O

object(s), [42ff](#), [62f](#), [84](#), [90](#), [104](#), [216](#), [300](#), [302](#), [304](#)
in extravert and introvert, [56f](#)
-imago, [300ff](#)
and imago, [140](#)
overvaluation of, [192](#)
rational, [53](#)
relation to, [140](#)
of (unconscious) libido, [62](#), [66](#), [70](#)
world of, [178](#)
objective: causality, [131](#)
interpretations, [84](#), [88](#), [90](#), [98](#)
level, [90f](#), [98](#), [140](#)
—, of analysis, *see* interpretations *above*
psyche, [66n](#), [109](#)
tendencies, [131](#)
objectivity, [202](#), [216](#)
psychic, [185](#)
observatory, [146](#)
obstacle, [81f](#), [89](#), [91](#), [101](#), [161](#), [162](#)
and neurosis, [39](#)
“ocean of divinity,” [287](#)
occult wisdom, [248](#)
octopus, [84](#)
office, in society, [143](#), [145](#), [195f](#)
old(er): age, [60f](#)

person, 74; *see also* maturity

Old Testament, 68

 Genesis, 156*n*

 Job, 196

 Jonah, 99

one-sided truths, 41

one-sidedness, 72, 75, 288, 294, 297

 of conscious mind, 78, 110

 of differentiated psychological function, 296

 of Freudian sexual theory, 117

 neurotic, 32

ontogenesis, 148

ontogenetic development, 147/275

opinions, 206

 animus, 207*ff*

opposite(s), 53*ff*, 61, 72*ff*, 102, 149*f*/276*f*, 296

 compensation by, 53*f*

 conflict of, 75

 conversion into, 75*f*

 free from, 223

 irreconcilable, 150/277

 in old age, 61, 109

 pairs of, 73, 109, 150/277

 —, moral, 149/276*f*

 problem of, 61, 76, 100*n*, 102, 182

 regulative function of, 72

 tension of, 29, 53*f*, 79*f*

 union of, 109, 129*f*, 140*f*, 223, 230

 —, through the middle path, 205

EXAMPLES: analysis/synthesis, 81

 ascent/descent, 74

 chaos/order, 72

 classic/romantic, 54

 conscious/unconscious, 19/53*f*

culture/nature, 33f
diastole/systole, 59
ego/non-ego, 97 (*see also* ego)
Eros/death instinct, 28
Eros/Phobos, 53
good/evil, *see* good and evil; heaven/hell, 15
high/low, 15/253, 54, 75, 194
homosexual/heterosexual, 108
hot/cold, 54, 75
idealism/materialism, 54
inside/outside, 196
introvert/extravert, 54ff, 57
love/hate, 53, 75
love/will to power, 53
megalomania/inferiority, 149/276
moral/immoral, 21/261
nominalism/realism, 54
organization/disorganization, 73
Promethean/Epimethean, 57
rational/irrational, 49, 51, 71, 80
real/imaginary, 80
reflection/action, 55
subject/object, 42ff, 58f
truth/untruth, 75
unconscious progressiveness/conscious regressiveness, 109
value/non-value, 75
virtue/vice, 149/276
youth/age, 74, 76

opposition, 196
 principle of, 61
 of two types, 54f
 unconscious, 110

optimism, 139/274, 142
 extraverted, 56

of judgment, 149
organic disorder, 11/249
organization(s), 153ff, 155/280, 303
orgies, Dionysian, 19/258
Ostwald, Wilhelm, 49f, 54
 Die Philosophie der Werte, 50n
 Grosse Männer, 54n
other: principle, 292
 “self,” 35
 “side,” see shadow (-side); side
outside and inside, 196
over-valuation, 134

P

paganism, 64, 77
 relapse into, 33
panic, 162
paradise, 150/277
 keys of, 182
paralysis, spastic, 10ff/249ff
paranoia, 163; see also delusions; dementia, paranoid
parasite(-ism), 226
 psychic, 111
parent(s), 42, 190
 animal, 235
 “carnal,” 235
 -complex, 186
 -imagos, 60, 186, 188
 infantile dependence on, 59f, 105
 in Jung’s case [12], 180
 spirits, 188
 tie to, 105; see also father; mother
parental: authorities, 64

transference, 73

paresia, 10f/250f

Paris, 36, 248

Parsifal (Wagner), 35

participation: active, 223

- active, in fantasy, 216, 219
- participation mystique*, 146, 206

parties: inférieures, 148/276

- supérieures*, 148/276

part-soul(s), 66, 90, 177

pathogenic: agent, 18/256

- conflict, *see* conflict
- factor, 47
- significance, 14/252

Paul, St., 35, 66, 71, 156n, 221, 237, 239

peasant, 259

pedagogy, experimental, 246

penis, *see* male organ

perceptions: sense-, 66, 128/270

- subliminal, *see* subliminal

perfection, 110, 191, 278n

Persia, 292

- Persian, 69

person: becomes collective truth, 151

- and collective unconscious, 70
- development of, 150
- of doctor, 132–5
- meaning for introvert and extravert, 278n, 279n

persona, 157f/281, 160f/282f, 174f, 177, 201, 289

- analysis of, 158/281
- and anima, 195
- as barricade, 175
- and collective psyche, 294, 296f

compensatory relationship with anima, 192
composition of, 300, 302
as compromise with society, 302
contents of, 157/281
dazzling, 198
definition of, 192
developed, 198, 199
differentiation from anima, 198
differentiation of, 296
of disciple, 171
disintegration of, 161, 169
dissolution of, *see* dissolution;
no Eastern concept of, 192
and ego, 194
effect on ego, 197
ego's identification with, 193, 195
feminine, 209
function of, 298f
ideal, 195
identical with typical attitude, 297
identification with, 150, 192
in Jung's case [8], 159
as mask of collective psyche, 158
neglected, 199
obstacle to individual development, 297
and personality, 196f
psychology of, 174
regressive restoration of, 163, 166, 168, 283f
as segment of collective psyche, 287
as subject-*imago*, 302
variety of, 210
personal, 196, 234
attitude, 158
and collective, 296 (*see also* individual *and* collective)

definition of, 157
tie, 134
unconscious, *see* unconscious, personal

personality(-ies), 26/267, 58, 110, 151, 232, 238f
anima as, 197, 210
animus as, 210
artificial, 193f (*see also* persona)
birth of, 230
change of, 175f, 219, 221 (*see also* transformation *below*)
—, pathological, 175
cleavage of, 24
collective, 299
components of, 136/273
and compulsion neurosis, 181
conscious, 83, 124, 154/278, 161, 228, 300, 302
—, a segment of collective psyche, 157/281
dark half of, 96
developing, 104
development, *see* development
differentiation, 151
diminished, 168
disintegration, 147
dissociation of, 44
dissolution, *see* dissolution
distortion of, 154/279
enlargement/extension/widening, 136/273, 143, 148/276, 156/280, 164
in Freud's theory, 127/270
integrity of, 38, 154, 166
and internal parent-imagos, 60
limited, 164
mana-, *see* mana
mid-point of, 221, 230
modern notion of, 196f
negative side of, 66n

partial, 111
pathological, 32
and personal unconscious, 136/273
renewed, 105
retarded maturation of, 184
and shadow, 53
total, 221, 223
transformations, 146f, 220, 223
“true,” 197
weakness of, 147

personification: of anima and animus, 207, 210, 224
of autonomous complex, 196
of part-soul, 90
negative, 224

perversion, 209
sexual, 271

pessimism(-ist), 130, 139/274, 142

Peter, St., denial, 151

Pfaff, I. W.: *Astrologie*, 292
Der Stern der Drei Weisen, 292

phallic symbolism: of figurine, 107
of foot, 83, 87

philosopher, 144f/272
neurotic, 237

philosophy, 54, 129, 145, 190, 267
causal, 49
Chinese, 183
Gnostic, 66
Indian, 77n, 152n
medieval alchemical, 219f
Oriental, 124f
Platonic, 54
in psychoanalysis, 119
student, case of, *see Jung's case* [8]

Taoist, [78](#), [182](#); *see also* Stoics

phobias, [194](#)

Phobos, [53](#)

physics, [67](#)

- and causality, [49n](#)

physiology, [67](#), [246](#)

picture-book, world as, [144/271f](#)

platonic friendship, [108](#)

Platonic school of philosophy, [54](#)

pleasure: Carnal, statue of, [265](#)

- principle, [42](#)

plurality: of animus, [209](#)

- of persons, [207](#)
- of principles, [289](#)

πνεῦμα, [135](#), [137](#)

πνευματικὴ ψυχὴ, [73](#)

poet(s), [166](#), [193](#), [228](#), [299](#)

point of view: causal, [59](#)

- teleological, [59](#), [152](#)

“poison” of understanding, [84](#)

poisoning, [214](#)

polarity: inner, [75](#)

- pre-existing, [75](#)

political institutions, [151](#)

politics, [193](#), [206](#)

- and neurosis, [20](#)

Polynesians, [68](#)

polytheism, [20/258](#)

positive values, [47](#), [49](#), [50](#)

possession, [72](#), [230](#), [232](#)

- by archetype, [234](#)
- power of, [227](#)
- states of, [224](#)

power, 68, 72f, 151, 227

-aim, infantile, 165 (*see also* Adler, “power drive”)

balance of, 229

concept, of primitives, 68

of ego, 34

of fantasy, 100

-instinct, 32, 34, 38

—, in Jung’s case [2], 38

magical universal, 68, 95, 96 (*see also* magic)

of mana, 233

personal, 5

principle, 35, 284

psychology, neurotic, 40, 140/274

of unconscious, 167/285

over unconscious, 234; *see also* will to power

pre-conscious and unconscious, 135/272

predestination, individual, 190

predisposition, 13f/251f, 137

Preemby, *see* H. G. Wells: *Christina Alberta’s Father*

pre-infantile period, 77, 79

prejudice, 153

prestige, 68, 118, 234

dissolution of, 151

magical, 150, 151

personal, 151

pride, 142

priest, 104, 106, 107, 204, 233

primitive(s), 68f, 96f, 150/277, 153, 185f, 197, 201, 204, 227, 230, 235

in civilized man, 304

communities, 106

energetics, 68

fear of unknown, 203

and immortality, 191

and initiation rites, *see* initiation

language, 85
and mana-personality, 233
mode of thinking, 138
psychology, 284
symbolism, 85
vision, 144

primordial: idea, 135/272
image, *see* image

“principalities and powers,” 66

principles: of animus, 207
moral, 26/266

“probability, statistical,” 49*n*

processes: instinctual, 81
subliminal, 175

productivity of unconscious, *see* unconscious

progression and regression, 108

progressiveness: and differentiation, 116
unconscious, 109

projection, 90*ff*, 189, 225, 227, 300
of anima, 197
of anima and animus, 207*f*
—, daemonic, 299
archetypes in, 94*f*
fantasy, 64*f*
in transference, 62*n*, 70*f*

Prometheus (Promethean), 141, 299
guilt, 156*n*
introvert, 57

prophecy/prophet(s), 163, 169*ff*/286, 295

“Proserpine’s threshold,” 146

prostitution, 261*n*

Protestant(-ism), 77, 204, 237 *u*

ⲡⲏ, 187

psyche, [25/266](#), [45f](#), [131](#), [134](#), [224](#), [288](#), [295n](#)

animal, [32f](#)

and body, [115](#)

broken-off bits of, [186](#)

collective, *see* psyche, collective, *below*

conscious, [25/266](#), [147](#), [177](#)

as god and demon, [71ff](#)

hinterland of, [210](#)

impersonal, [148/276](#) (*see also* psyche, collective, *below*)

individual, [148/276](#)

inherited, [148/276](#)

irrationality of, [124](#)

multiplicity of complexes, [201](#)

objective, [66n](#), [109](#)

personal, [93f](#), [97f](#), [145](#), [147](#), [152/277](#)

—, and collective contents of, [154/279](#)

—, development of, [150](#)

as self-regulating system, [61](#), [178](#)

shadow-side of, *see* shadow (-side)

subjective, [66n](#)

suprapersonal, [148/276](#)

total nature of, [119](#)

transformation of, [123](#)

unconscious, [215](#)

not a unity, [201](#)

psyche, collective, [93f](#), [97](#), [147ff/275ff](#), [157/281](#), [160f/282](#), [169ff/286ff](#), [283](#), [288](#), [294](#),
[296](#), [298](#), [302](#)

composition of, [300](#), [302](#)

contents of, [154/279](#)

historical, [93](#)

outside the personal psyche, [145](#) (*see also* unconscious, collective)

repression of, [150/277](#)

segment of, [284](#)

superstitious impulses of, [292](#)

unconscious heritage of, [148/276](#)
unconscious identity with, [277](#)
universality of, [152](#)

psychiatry: and aetiology of psychosis, [175](#)
and latent psychosis, [114](#)
and psychoanalysis, [10](#), [117f](#)
and psychology, [246](#)

psychic: contents, division of, [300](#), [302](#)
disposition, universal, [147](#)
energy, *see* energy
equilibrium, *see* equilibrium
function, *see* function
infection, [96](#)
inflation, [143ff](#), [147](#)
intensities, [53n](#)
systems, [98](#)
transformations, [107](#)

psychoanalysis, [24ff/265ff](#), [131](#)
differing theories in, [v](#), [269](#), [290](#)
Freudian, [186](#)
origin of, [10/247](#), [20](#)
technique of, [21/262](#)
unconscious of its limitations, [141](#)
unpopularity of, [8](#); *see also* dreams, interpretation of

psychogenic: disorder, [11/250](#)
symptoms, [10/249](#)

psychology, [114](#), [119](#), [146](#), [168](#), [288f](#), [292](#)
Adlerian, *see* Adler
and alchemy, [220](#)
and analysis, [295f](#)
analytical, *see* analytical psychology
anima and animus, [224](#)
archaic/primitive, [284](#)
Chinese, [152n](#)

collective, [155/279f](#), [301](#)
collectivistic, [278n](#)
conscious, [206](#)
of consciousness, [241](#)
depth, [247](#)
of dreams, [10/248](#)
experimental, [9](#), [245ff](#)
feminine, [205](#) (*see also* anima; woman)
Freudian, *see* Freud *and* psychoanalysis
Indian, [152n](#)
individual, [4](#), [289](#)
—, and collective, [155/279](#), [277](#)
Jewish, [152n](#)
Jung's theory of types, [v](#), [44n](#), [278n](#), [279n](#)
masculine, [205](#)
medical, [8](#), [117](#)
—, and personalistic attitude, [81](#)
national, [4](#)
of neurosis, *see* neurosis
philosophical, [245](#)
power, [40](#), [140/274](#)
of psychosis, [9](#)
religious, [133](#)
of sexuality, *see* sexuality
of unconscious, [3](#) (*see also* unconscious)
of woman, [188](#)
psychopathology, [8](#)
psychophysiology, [245](#)
psychosis, [175f](#), [224](#)
 development of, [162f](#)
 latent, [114](#)
 psychology of, [9](#), *see also* psychotic disturbance
psychotherapy, origins, [9](#)
psychotic disturbance, [161](#)

puberty, [16/254](#), [75](#), [102](#), [105](#), [197](#); *see also* initiation rites

punishment, [155/280](#), [194](#)

divine, [73](#)

Draconian, [151](#)

self-, [87](#)

purity, [181](#)

purposiveness, [232](#)

of neurosis, [47](#)

in psychic loss of balance, [162](#)

Q

quadrangle, [222](#)

quaternity, [110](#)

also cf. [222f](#)

R

race, [147f/275](#)

differences of, [152](#)

memories, [264](#), *see also* archetypes

racial history, activated residues of, [99](#)

“railway spine,” [18n](#)

Rascher Yearbook, [3](#), [245](#)

rational: and irrational, [80](#)

tied to conscious mind, [71](#)

rationalism, [24/264](#), [94](#), [166](#), [288](#), [291](#)

rationality, [49f](#), [124](#)

rationalization(s), 200, 216
rattlesnake, 93
realia, 297
realism, 54, 117
reality(-ies), 110, 201, 298*f*
 absolute, 218
 adaptation to, 161, 278*n*, 304
 of archetypes, 98
 conscious and unconscious, 79, 218, 283
 and fantasy, 216
 fantasy-substitute for, 109
 flight from, 182
 function, 282
 inner and outer, 199
 and persona, 158
 opposing, 218
 psychic, 95, 98
 scientific, 217
 of the self, 173
 of unconscious, 185, 218, 282*f*
 of the world, 237, 295*n*
realization, 140
 conscious, 235
 of personality, 110
 process of, 59, 64
 self-, *see* self-realization
 of unconscious fantasy, 219, 281*n*
reason, 71*f*, 124, 150, 224, 288; *see also* rationality
rebirth, 105, 235
 ceremonies of, 197
reduction, 45*ff*, 80*f*
 Freud's and Adler's methods, 45*f*, 59, 74
 and transference, 63, 168, 212; *see also* analysis
reflection, 155/280

and introversion, 55
and will, 49
regression, 76, 95, 99, 151
 into childhood, 77
 to pre-infantile period, 79
 and progression, 108
 to the mother, 108
regressive: dissolution, 151
 longing, 169/287
 restoration of persona, *see* persona
regressiveness, conscious, 109
relapse, 131, 295
relation(s)/relationships: compensated, 179
 compensatory, 128/271, 177
 conflict of, 178
 conscious and unconscious, 208f
 functions of, 232
 heterosexual, 108
 homosexual, *see* homosexuality
 impersonal, 180f
 infantile, 87
 to object, 140
 personal, 206, 225
 psychic, 303
relativity of God, 235n
“religio,” 101
religion(s), 97ff, 101, 137, 190f; 193
 comparative history of, 204
 in dreams, 160
 history of, 277
 mystery, 231, 235
 oriental, 78
 primitive, 68f, 105f
 relapse into pagan form of, 33, *see also* Christianity

religious: aspects of unconscious, 284
convulsions, 75
experience, 238
function, repression of, 94,
problem as compensation, 180ff
psychology, 133

reminiscence(s), 11f/250
infantile, 23/264, 52
in Jung's case [1], 16/254, [2], 36, [3], 52
personal, 81

Renaissance, and licentiousness, 20/258

renewal in second half of life, 61

représentations collectives, 145

repression, 23/263f, 53, 92f, 97, 136/273, 153, 200, 285
of collective psyche, 150/277
conflict of, 150/277
of former idols, 75
Freudian theory of, 26, 127f/270f
of functions, 297
of instinct, 26, 32
lifting of personal, 148
moral, 199
personal, 128/271, 158, 160
of religious function, 94
removal of, 127/270
will to power and, 34

resentment, moral, 136/273

resistance, 60, 83, 140, 184, 299
to analysis of unconscious, 25/266, 283
to dream analysis, 24f/264
to Freud's work, 248
in Jung's case [5], 109
to object, 42, 57
in psychotherapy, 43

secret, 22
and shadow-side, 53f
and transference, 63, 92f
to wrong interpretations, 112; *see also* unconscious opposition

responsibility, 139/274, 153, 225, 227
of prophet, 170
social, 5
subjective, 201
for unconscious, 139/274

restoration of persona, *see* persona

results of treatment, 116

revenants, 186, 188

rigidity in old age, 76

ring, 16f/255
of flame, 222
fraternity, 107
wedding, 107

risk, 164

rites/ritual, 97, 150, 197
initiation, *see* initiation

river, 14/252, 81–84, 89, 101, 146, 213

role(s), 157/281, 170
external, 173
identification with, in Jung's case [8], 159
masculine, 83, 88
social, 146, 150, 174, 194

romantic, 54

Rome, 231

rope-dancer, in *Zarathustra*, 31

Rosicrucianism, 231, 292

Rousseau, Jean-Jacques: *Emile*, 275n

ruah/ruh, 135

S

sacrifice, [130f](#)

 involuntary, [131](#)

saint(s), [69](#), [148](#), [194](#), [228](#)

St. Petersburg, [14/252](#)

Salpetrière, [9](#)

Sargon, [180](#)

Saul of Tarsus, [35](#)

see also Paul,

 St. saviour(s), [94](#)

 doctor as, [64](#), [130](#)

scepticism, “scientific,” [292](#)

schisms, [277](#)

schizophrenia, [70](#), [80](#), [147](#), [163](#), [271](#), [282](#)

scholasticism, [54](#), [245](#)

Schopenhauer, Arthur, [132](#), [144f/272](#), [154](#), [259f](#), [298](#)

Schultze-Galléra, Siegmars, Baron von: *see* Aigremont, Dr.

science, [10/247n](#) [190](#), [206](#), [240](#), [289](#), [291f](#), [295](#)

 Christian Science, [292](#)

scientific: attitude, [134](#)

 investigation, [245](#)

 mind, [288](#)

 superstition, [293](#)

Scylla and Charybdis, [70](#), [73](#), [141](#)

secrecy, [151](#)

secret love, [292](#)

secrets, ritual, [150](#)

sects, ecstatic, [247](#); *see also* ecstasy

security, [204](#), [284](#)

 “security measure,” [165](#)

Self (*atman*), [191](#)

self, [192](#), [300](#)

 -alienation, [173](#)

-belittlement/depreciation, 168, 282
-conceit, 156, 282
-confidence, 139/274, 148/276
-criticism, 33, 170
-culture, 205
-definition of, 177, 238ff:
-deification, 70
-divesting of, 173f
-division, 20/261, 76
individual, 159
as individuality, 240
-injury, 115
-knowledge, 26, 136f, 140, 178, 229
—, projection of unconscious, 227
-laceration, moral, 70
-as life's goal, 240
-mastery, 229
-one's own, 136/273
—, becoming, 173
-“other,” 35
-preservation, of analyst, 278
—, instinct of, 32
-realization, 136/273, 173, 184, 195 (see also individuation)
-reflection, 4f
-regulation, 61, 178, 192, 196
—, unconscious, 166
-sacrifice, 48, 193, 265
and selfish, 173
is totality, 177
a transcendental postulate, 240
true, 225
unconscious, 136/273, 158, see also subject
selfhood, 173
selfish, 174

and self, 173

Semon, R. W., 98, 137

The Mneme, 98n

sensation, 44n

sense-perceptions, subliminal, 66, 128/270

sensitiveness, 58

separation, 200

 from mother, 197

serpents, 236, 265

 with death's-heads, 12/250; *see also* snake(s)

sex: psychic change of, 209

 terminology of, 28

sexual: desires, repressed, 83

 factor, 34

 fantasies, 34, 83, 91

 function, 284

 infantile, demands, 165

 morality, 27, 258, 261, 265

 perversion, 271

 problem, 259

 question, 20/258, 260, 265, 266

 symbolism, 284

 theory of neurosis, 248, 256ff

sexuality, 42

 and energy, 47f

 Freud's psychology of, 10/248, 27f, 32, 38, 117f, 165, 269, 281

 infantile, 38, 46, 284

 limp, 194

 and love, 18n, 256n

 and morality, 27, 261; *see also* erotic conflict

shadow (-side), 25f/266, 30f, 33f, 47, 66n, 142, 233, 238f

 archetype, 96, 110

 dangerous aspect of, 97

 of father in Jung's case [8], 159

in Jung's case [2], [37](#)
and opposites, [53](#), [56](#)
and personal unconscious, [66n](#)
of psyche, [25/266](#)

She, see Haggard, H. Rider
 "She-who-must-be-obeyed," [189](#), [227](#)

shell-shock, [18n](#)

shock, [14/252](#), [56](#), [110](#)
 English theory of nervous, [13/251](#)
 in Jung's case [2], [37](#)
 neuroses, [18n](#)

side: negative, necessity of, [30](#)
 other, [81](#), [89](#), [104](#), [141](#), [197f](#); [202](#), [204](#)
 —, truths of, [202](#)
 —, Western fear of, [203](#); see also nature, other side of our; one-sidedness; shadow (-side)

sign, definition of, [291](#)
 significance, [178f](#)
 pathogenic, [14/252](#)

Silberer, Herbert: *Problems of Mysticism and Its Symbolism*, [83n](#), [219f](#), [291n](#)

Simon, L., [98n](#)

sin, [156n](#), [181](#)
 original, [30](#)

slip: of memory, [177](#)
 of the tongue, [177](#)

snake(s), [13/251](#), [84](#), [227](#)
 black, in Breuer's case, [12/250](#)
 in *Faust*, [140/274](#)
 Negro's, [201](#)
 in St. Ignatius' vision, [78](#)

social: factors, [143](#)
 order, [155/280](#)

sociality, [153](#)

society, 4, 27, 119, 143, 144n, 145, 147, 151, 163, 179, 193, 196, 199, 260, 265, 278n,

303

and imitation, 155/250

influence on individual, 154

moral degeneration of, 153

outside the individual, 145

and persona, 158, 192, 302 *see also* office; organization(s)

Socrates, 28, 265

Socratic method, 25/265

Söderblom, Nathan: *Das Werden des Gottesglaubens*, 68n

somnambulism, in Jung's case [7], 118, 123

sorcerer, tribal, 96

Song of Hiawatha, The (Longfellow), 99

soul, 24/264, 27, 31, 45, 68f, 95, 132, 168, 190ff, 237, 239, 266

ancestral, 147n

as autonomous complex, 190

beast's, 30

Christian concept of, 225

collective, 275

complex, 189

—, autonomy of, 191

concept of, 224

crucifixion of, 31

after death, 185

feminine quality of, 188, 190

“herd soul” in individual, 278n

historical aspect of, 191

idea of, 187

-image, 189, 197

immortality of, 191

“inspired,” 73

loss of, 151

as “mistress,” 227

philosophical concept of, 190

plurality of, 185
projection of man's, 189
religious concept of, 190
respectable, 261
and spirit, 185
-substance, 95 *see also* part-souls
spastic paralysis, 10ff/249ff
species: ideal type, 297
 instinct for preservation of, 32
speech disturbance, 12/251 *see also* aphasia
Spielrein, Sabina: "Die Destruktion als Ursache des Werdens," 28n
spirit(s), 68, 96n, 135, 137, 185, 224, 227f
 ancestral, 186
 dangerous, 186
 and instinct, 28
 natural, 183
 parental, 186, 188
 as personality, 197
 "subtle," 223
 -world, 185, 201
spiritual: development, 105
 substitute, 105
Spiritual Disciplines, 7n
spiritualism, 196
 spiritualistic experience, 186
Spitteler, Carl, 196
 Imago, 299
 Olympian Spring, 299
 Prometheus and Epimetheus, 57n, 299
"splitting of the mind," 147 *see also* schizophrenia
spontaneity, 185
standstill, 129
star(s), 146, 160/282, 162, 237
stasis, 129

State, [153](#), [155/280](#), [210](#)
“statistical probability,” [49n](#)
sterility, mental, [149](#), [155](#)
Stock Exchange, [247](#)
Stoics, [19/258](#), [69](#)
stomach and intestines, nervous disorders of, [129](#)
“storm and stress,” [75](#)
“strong man”: private life of, [194](#)
 weakness of, [195](#)
structure, psychic, [190](#)
student(s): fraternities, [105](#)
 initiation of, [105f](#)
 of philosophy, *see* Jung’s case [8]
 theological, [181–182](#), *see also* Jung’s case [14]
subconscious and unconscious, [135/272](#)
subject, [84](#), [140](#), [216](#), [289](#), [296](#); [302](#)
 de-individualized, [303](#), [304](#)
 -*imago*, [302](#), [304](#)
 and introversion, [56](#), [58](#)
 in relation to object, [42ff](#)
 supraordinate, [240](#)
subjective: complexes, [90](#)
 interpretations, [84f](#), [88](#), [90](#)
 level, [90](#), [92](#), [97](#)
 —, of analysis, *see* interpretations *above*
 psyche, [66n](#)
subjectivity, [57f](#)
sublimation: through analysis, [47f](#), [267](#)
 and civilization, [50](#)
 obstacles to, [62](#)
subliminal: combinations, [304](#)
 elements, [127/270](#), [294](#)
 material, [127/270](#)

perceptions, 66f, 127f/270, 303
processes, 175
psychic contents, 116
substitute: for father, 129f
 figures, 60
 for mother, 104f
 spiritual, 105
succubus, 224
suffering, 141, 162
suggestibility, 155/280, 246
suggestion, 10/249, 70, 155/280, 175, 293
 as treatment method, 9
suicide, 114, 146, 214, 218, 232
Sumatra, 186
Summum bonum, 236
sun, 69, 74, 99, 112, 160/282, 189, 203, 238
 archetype, 69
 Father, 258
 -hero, 69
superhuman, 59
superiority, 42, 141
 in Jung's case [2], 40
superman, 31, 71, 141, 229, 232
supernatural, 132, 187
superstition, 167/285, 217, 290, 292
 scientific, 293
Surabaya, 67
symbiosis of types, 55ff
symbol(s), 201
 animal, 98
 arrangement of, 111
 choice of, 84, 88
 collective, 230

of Cologne Cathedral, [104](#)

definition of, [291](#)

dream, [81](#)

explanation of, [212](#)

religious, [204](#)

and subjective contents, [84](#)

Taoist, [182](#)

of wholeness, [110](#); *see also* altar; animal(s); archetype(s); baptism(s); bridge; bull; cathedral; child; circle; crab; dragon; earth; fire; fish; flame; foot; ford; giant; God/god(s); hoard; horses; ivory figure; lion; magician; mountain; music; octopus; priest; quadrangle; quaternity; ring; river; snake; talisman; tiger; toad; tower; treasure; trees; water; water-nymph; weapon; wheatfields; wind; woman

symbolism: alchemical, [219f](#)

archaic, [155/279](#)

Catholic, [77](#)

in dreams, [107/263n](#), [264](#) (*see also* dreams)

of initiation, [231](#)

pagan, [77f](#)

phallic, of foot, [83](#)

psychology of primitive and historical, [85](#)

in religion, [97](#)

ritual, [77f](#)

sexual, [284](#) *see also* fantasy

sympathetic system, innervations of, [129](#)

symptom(s), [25](#), [64](#), [139](#), [176f](#), [202](#)

and collective unconscious, [160/282](#)

genesis of, [12f/251](#), [111](#)

in Jung's case [2], [35f](#), [3], [52](#)

nervous, [26/266](#), [46](#)

neurotic, [10/249](#), [25/266](#), [40](#), [46](#), [114](#), [212](#)

of old age, [76](#)

pathological, [46](#)

psychogenic, [10/249](#), [39](#)

and unconscious energy, [61f](#); *see also under specific symptoms, e.g., amnesia;*
hysteria
symptomatic manifestations, [202](#)
syncretism, [78](#)
Synesius, [73](#)
synthesis, [97](#)
 in analysis, [81](#)
 of individual and collective psyche, [293](#)
 and subjective interpretations, [84f](#)
 symptoms and, [46](#)
synthetic: interpretations, [85](#)
 procedure, [81](#)
syphilis, [261n](#)
system(s), [169/286](#)
 of man, [190](#)
 psychic, [98](#)
 rationalistic, [166](#)
systole, [59](#), [301](#)

T

taboo: incest, [152](#)
 infringement, [151](#), [156n](#)
Tacitus: *Germania*, [188](#)
talisman, magic, [170/287](#)
“talking cure,” [11/250](#)
Tao(-ism), [78](#), [182](#), [205](#), [221](#)
technique: analysis as, [295](#)
 of concentration, [222](#)
 of educating anima, [203](#)
 of psychoanalysis, [21/262](#)
teleology(-ical), [152](#), [294f](#)
 and neurosis, [40](#)
 plan, [184](#)
 point of view, [59](#), [152](#)

and psychic process, 131

temperament: artistic, 228

 differences of, 43, 141

tendencies, opposing, in neurosis, 19

tender-minded, 54

tension of opposites, *see* opposites

terminology, Jung's choice of, 211

tertium non datur, 76

theological student, Jung's case [14]:

 religious problem of, 181f

theory(-ies): building of, 211

 of complexes, Jung's, 262n

theosophy, 77, 78, 210, 231, 292

therapist, *see* doctor

therapy, 21/262

 analytical, 149 (*see also* analysis; psychoanalysis; treatment)

 real beginning of, 60

thinker, medieval, 220

thinking, 97, 183, 226, 285, 288, 297

 analogical mode of, 138

 civilized, 288

 collective, 151, 154f/278f, 275n, 277f, 301

 mythical, 304

 mythological, 282

thought(s), 298

 -associations, 131

 creative, 185

 dream-, 100

 -feelings, 285

 -forms, universal, 66

 identification with, 201

 as objective occurrences, 202

 -patterns, 138

“saving,” 163
subliminal, 303
Tibet, 205
tie, personal, 134
tigers, as dream symbol, 35
Till Eulenspiegel, 37
toad(s), 31, 265
tolerance, 140
tongue(s): fiery, 68
 slip of, 177
 swallowing of, 176
tortures, 105
totem ceremonies, 150
tough-minded, 54
tower, 112, 179
tradition, 261
transcendent function, 80, 99, 109ff, 116, 134n, 219f, 223f
transference, 70f, 91ff, 164, 166
 compulsive, 212
 definition of, 62n
 and doctor, 64f, 101, 133 (*see also* doctor)
 of fantasies to doctor, 62f
 of father-*imago* to doctor, 129
 Freud’s theory of, 42, 62n, 129f, 165
 as healing factor, 130
 in Jung’s case [8], 159f
 of old *imagos*, 61
 over-valuation occasioned by, 132
 parental, 73
 personal, 66
 resolution of, 63, 131, 161
 rupture of, 165
 undermining of, 134

transformation, [53](#), [192](#)

- of anima and animus, [210](#), [212](#)
- of attitude, [219](#)
- of autonomous complex, [212](#)
- inner, [175](#)
- mysteries, [231](#)
- of personality, [164f](#), [220](#), [223](#)
- psychic, [107](#)
- stages of, [116](#)
- of unconscious psyche, [123](#)

transmigration, of souls, [69](#)

transpersonal, [98](#)

- control-point, [134f](#)
- contents, [93](#), [145](#)
- unconscious, *see* unconscious, collective

trauma, [18](#)

- theory of, as origin of neurosis, [13f/251ff](#), [18/256](#), [186](#) *see also* Breuer

treasure, [146](#), [169n/286n](#), [170/287](#), [171](#), [227](#)

- hidden, [67](#)

treatment, [164](#)

- aim of, [110ff](#), [117](#)
- dreams in, [25](#)
- individuation and, [110](#)
- Jung's method, [223](#), [288](#)
- as mystical fount of healing, [103](#)
- practical necessities of, [76](#)
- and problem of opposites, [59](#)
- results of, [116](#)
- risks of, [115](#), [154/279](#)
- of young people, [109](#) *see also* analysis; “talking cure”; therapy; transference

trees, [187](#), [222](#)

tribe, [147f/275](#)

Trinity vision, [78](#)

truth, [33](#), [75](#), [76](#), [169f/286](#), [204](#), [220](#), [228](#), [294](#)

collective, 151
eternal, 236
insidious, 202
objective, 231
one-sided, 41
of other side, 202
temporal relativity of, 203
twilight states, 11f/249f
Tylor, E. B., 68
type(s), 42ff, 48, 54ff:
 attitude-, 41, 43
 “classic” and “romantic,” 54
 different psychological, 43f, 278
 heroic, 48
 ideal, 297
 inversion of, 57
 Jung’s type-psychology, 44n (*see also* psychology)
 masculine, 88
 opposition between, 54f
 psychological, 115
 —, of patient, 62
 symbiosis of, 56
 “tender-minded” and “tough-minded,” 54, *see also* extraversion, introversion
typhus, 101

U

unconscious, *passim*
 analysis of, 114ff, 212, 283
 artistic experience of, 213
 assimilation of, 139f, 221
 autonomous activity of, 128/271
 as barrier, 89
 borderline with collective unconscious, 81
 cannot be emptied, 128/271, 167/285

compensatory, criticism, 179
—, relationship to conscious, 128/271
conflict, *see* conflict(s)
counter-position, 78
depreciation of, 217
directness of, 232
disordered, 235
dreams and, 21ff/262ff (*see also* dreams)
dynamics of, 116
fantasies, 214 (*see also* fantasy)
favourable side, 102, 116
and future conscious contents, 128/270
given leadership, 215
hierarchy of, 228
impersonal, 66, 138, 157/281, 230, 280 (*see also* unconscious, collective, *below*)
influence of, 124, 212
instinctive activity of, 162
invasion by, 101
irrational standpoint of, 216
irreality of, 217
layers of, 77
loses ascendancy, 230
and mana-personality, 234
mythological activity of, 100n
nature of, 3, 124, 127ff/270ff, 182ff
negative: attitude to, 115
—, movement of, 219
—, role of, 102
opposition, 110f
and persona, 194
personal, 66, 135ff/272ff, 148/276, 156/280, 178, 232, 302
—, analysis of, 158f
processes, 176f, 184, 213, 223
productivity of, 128/270f

prospective role of subliminal combinations, 116
and repression, 127/270
—, removal of, 127/270
repudiation of, 284
settlement with, 213
splitting off of, 116
subliminal material in, 127/270
tendencies, 88, 134
therapeutic approach to, 114ff
transpersonal, 66
unconcern of, 215
unfavorable side, 115
urges to power, 5
view of the world, 298
and wish, 132, 134
of woman, 206

unconscious, collective, v, 7n, 66n, 73, 81, 95ff, 138, 145f, 156, 163, 178, 227, 236, 298f, 302, 304
adaptation to, 161
and ancestral life, 77
composition of, 303
dominants of, 228, 233
fantasies of, 232
historical mirror-image of world, 298
images of, play positive role, 109
influence on individual psyche, 154, 174f
in Jung's case [8], 160, [16], 225
and mana-personality, 228, 233
understanding of, 162 *see also* unconscious, impersonal, *above*

unconscious, contents of, 300ff
acquired, 128/271
assimilation of, 128/271
autonomy of collective, 147
collective, 96f, 138, 147, 232

- impersonal, 128
- infantile, 23, 25, 127/270
- personal, 66f, 77f, 128/271, 230, 232
- projected in transference, 62n
- repressed wishes, 127/270
- unconsciousness, 24, 184
 - original state of, 206
- understanding, 109, 240, 278
 - born of, 238
 - of collective unconscious, 162
 - of fantasies, 213, 217
 - intellectual, 213, 214
 - “poison” of, 84
 - psychological, 295
 - reductive, 212
- unifying function, of fantasy, 290
- union, 97
 - of opposites, *see* opposites
- universalia*, 297
- universality, of collective psyche, 152
- universals, 155/279, 297
- urge to power, 46 *see also* will to power

V

- vagus, 129
- validity: general, of psyche contents, 300, 302
 - of hypothesis, 134
 - relative, 78
 - universal, 144/272, 152/278
- valuation(s): abnormal, 130, 132, 134
 - personal over-, 134
- values, 55, 58, 75f, 200, 235
 - absolute, 288
 - accumulation of, 215 (*see also* libido)

collective, [277](#), [297](#)
conscious, [215](#)
discredited, [203](#)
and display of energy, [47](#)
of fantasy, [290](#)
general, [301](#)
heuristic, of hypothesis, [134](#)
highest, [236](#)
in neurosis, [61](#)
personal, [303](#)
—, and impersonal, [144/272](#)
positive and negative, [47](#), [49f](#)
reality, [216](#)
real personal, [62n](#)
relativity of, [75](#)
reevaluation of, [75](#)
true, [170/287](#)

vampire, [224](#)

variability, [174](#)

Vatican, [179](#)

Vermilye, D. B., [137n](#)

vertigo, [282](#)

via regia, dream as, to the unconscious, [24/264](#)

vice, [148](#), [149f/276f](#), [194](#), [238](#)
 collective, [149/276f](#), [150](#)
 “of the virtuous,” [193](#)

Vienna, [12/250](#), [247](#)

Viennese school, [269](#); *see also* Freud

view: causal point of, [59](#)
 teleological point of, [59](#), [152](#)

Virchow, Rudolf, [180](#)

virtue(s), [39f](#), [75](#), [148](#), [149f/276f](#), [173](#)
 collective, [149f/276f](#)

virtuousness, [38](#)

vision(s), 78, 80, 135, 144f/272, 146, 163, 222, 282

artists', 183, 213

“big,” 178

in Jung's case [16], 222f, 230

primary, 145

primitive, 144

of rope-dancer, 31

of saints, 69

of stars, 162

Trinity, 78

visualizations, 221

voice(s), 282

“inner,” 163

loss of, in Jung's case [2], 36, *see also* aphasia

W

Wagner, Richard, 34f, 193

Walpurgisnacht, 304 *see also* *Faust*

war, 260

World War I, 4, 5, 6, 49f, 72n, 94, 204

World War II, 72n, 94n

Warnecke, J.: *Die Religion der Batak*, 186n

water, 82, 89, 98f, 103, 146, 190

signifies the unconscious, 89

water-nymph, 84

weapon, invincible, 170/287

Webster, Hutton: *Primitive Secret Societies*, 230n

weeping fits, hysterical, 193

well, 103f

Wells, H. G.: *Christina Alberta's Father*, 175, 180ff, 207

Weltanschauung, rational, 203

werewolf, 93f

Western: mind, 205, 202

—, extraverted attitude of, 191
fear of other side, 203
wheat-fields, 132
wholeness, 110*f*, 223
wife: man's relation with, 190, 195, 199, 208, 210
 as mother-substitute, 60, 197*f*
 neurosis of, 194
Wilhelm, Richard: *The Secret of the Golden Flower*, 110, 124
will, 129–32, 162, 199, 238
 contests of, 50
 conscious exertion of, 53
 free, 167
 good, 212
 limitations of, 49
 man of, 237
 of mana-personality, 237
 superior, 237
 universal, 298
 world as, and idea, 144/272
will to power, 32*ff*, 38, 40*f*, 46, 53, 139/274, 150*f*
 of ego, 281
 pathological, 148/276 *see also* instinct
wind, 132, 133, 135, 137
wisdom, 228
 occult, 248
wise old man, 97, 110
wish(es), 22/263, 23/263, 136, 264
 erotic, 264
 -fantasies, 271
 infantile, 23/263, 83
 personal, 178
 repressed, 127/270, 273
 unconscious, 22, 25
 and unconscious, 132, 134, 166

wish-fulfilment, [22/263](#)
wish-conflicts, egoistic, [178](#)
witch, [179](#), [180](#), [187](#)
wizard, Tibetan, [96](#)
Wolff, Toni: "Einführung in die Grundlagen der komplexen Psychologie," [66n](#)
woman (women), [188ff](#), [194](#), [206](#), [228](#)
 and animus, [208f](#) (*see also* animus)
 biological destiny of, [16/254](#)
 conscious attitude of, [209](#)
 dissimilar psychology of, [188](#)
 feminine persona of, [209](#)
 Germanic, Tacitus on, [188](#)
 hysterical, [232](#)
 imago of, [188](#), [189](#)
 inherited collective image of, [190](#)
 inner masculine side of, [209](#)
 inspiration of man, [188](#)
 intellectual, [159](#), [208](#)
 intuitive capacity of, [188](#)
 and mana-personality, [235](#)
 masculinity of, [189](#) *see also* wife
womb, of Church, [105](#)
word(s): addicts, [208](#)
 and experience, [211](#)
 spermatic, [209](#)
work, symbolical content of, [259](#)
world, [148](#), [190](#), [199](#), [226](#), [236](#)
 of adult man, [106](#)
 of conscious, [218](#)
 day- and night-, [203](#)
 end of, [163](#)
 external/outer, [193f](#), [197](#), [204f](#), [209](#) (*see also* society)
 of fantasy, [16/254](#), [203](#)
 -fear, [203](#)

of historical images, [299](#)

infantile, [180](#)

inner, [198](#), [203ff](#), [209](#)

intellectual, [216](#)

mirror-image of, [298](#)

of objects, [178](#)

as picture-book, [144/271f](#)

-pictures, two, [237](#)

psychic mirror-, [185](#)

reality of, [237](#), [295n](#)

reformer, [295](#)

of spirits, [185](#), [201](#)

of unconscious, [218](#), [298](#)

as will and idea, [144/272](#)

World War, *see* war

Wotan, [135](#)

Wundt, Wilhelm: *Principles of Physiological Psychology*, [9/246](#)

Y

Yildiz Kiosk, [179](#)

Yin and Yang, [182](#)

young people, [59ff](#)

analysis of, [73](#), [109](#)

homosexuality in, [106f](#)

opposites in, [61](#)

treatment of, [109](#)

youth: and age, [76](#)

illusions in, [60f](#), [73f](#)

Z

Zagreus, [73](#) *see also* Dionysian

Zarathustra (Nietzsche), [31](#), [96](#), [237](#)

Zeus, [299](#)

Zurich, [123](#), [144n](#)

school of analytical psychology, [21/262](#), [264](#), [269n](#)

THE COLLECTED WORKS OF

C. G. JUNG

THE PUBLICATION of the first complete edition, in English, of the works of C. G. Jung was undertaken by Routledge and Kegan Paul, Ltd., in England and by Bollingen Foundation in the United States. The American edition is number XX in Bollingen Series, which since 1967 has been published by Princeton University Press. The edition contains revised versions of works previously published, such as *Psychology of the Unconscious*, which is now entitled *Symbols of Transformation*; works originally written in English, such as *Psychology and Religion*; works not previously translated, such as *Aion*; and, in general, new translations of virtually all of Professor Jung's writings. Prior to his death, in 1961, the author supervised the textual revision, which in some cases is extensive. Sir Herbert Read (d. 1968), Dr. Michael Fordham, and Dr. Gerhard Adler compose the Editorial Committee; the translator is R. F. C. Hull (except for Volume 2) and William McGuire is executive editor.

The price of the volumes varies according to size; they are sold separately, and may also be obtained on standing order. Several of the volumes are extensively illustrated. Each volume contains an index and in most a bibliography; the final volume will contain a complete bibliography of Professor Jung's writings and a general index to the entire edition.

In the following list, dates of original publication are given in parentheses (of original composition, in brackets). Multiple dates indicate revisions.

*1. PSYCHIATRIC STUDIES

On the Psychology and Pathology of So-Called Occult Phenomena (1902)

On Hysterical Misreading (1904)

Cryptomnesia (1905)

On Manic Mood Disorder (1903)

A Case of Hysterical Stupor in a Prisoner in Detention (1902)

On Simulated Insanity (1903)

A Medical Opinion on a Case of Simulated Insanity (1904)

A Third and Final Opinion on Two Contradictory Psychiatric Diagnoses
(1906)

On the Psychological Diagnosis of Facts (1905)

2. EXPERIMENTAL RESEARCHES

Translated by Leopold Stein in collaboration with Diana Riviere

STUDIES IN WORD ASSOCIATION (1904–7, 1910)

The Associations of Normal Subjects (by Jung and F. Riklin)

An Analysis of the Associations of an Epileptic

The Reaction-Time Ratio in the Association Experiment

Experimental Observations on the Faculty of Memory

Psychoanalysis and Association Experiments

The Psychological Diagnosis of Evidence

Association, Dream, and Hysterical Symptom

The Psychopathological Significance of the Association Experiment

Disturbances in Reproduction in the Association Experiment

The Association Method

The Family Constellation

PSYCHOPHYSICAL RESEARCHES (1907–8)

On the Psychophysical Relations of the Association Experiment

Psychophysical Investigations with the Galvanometer and Pneumograph in Normal
and Insane Individuals (by F. Peterson and Jung)

Further Investigations on the Galvanic Phenomenon and Respiration in Normal and
Insane Individuals (by C. Ricksher and Jung)

Appendix: Statistical Details of Enlistment (1906); New Aspects of Criminal
Psychology (1908); The Psychological Methods of Investigation Used in the
Psychiatric Clinic of the University of Zurich (1910); On the Doctrine of
Complexes ([1911] 1913); On the Psychological Diagnosis of Evidence (1937)

*3. THE PSYCHOGENESIS OF MENTAL DISEASE

The Psychology of Dementia Praecox (1907)

The Content of the Psychoses (1908/1914)

On Psychological Understanding (1914)

A Criticism of Bleuler's Theory of Schizophrenic Negativism (1911)

On the Importance of the Unconscious in Psychopathology (1914)

On the Problem of Psychogenesis in Mental Disease (1919)

Mental Disease and the Psyche (1928)
On the Psychogenesis of Schizophrenia (1939)
Recent Thoughts on Schizophrenia (1957)
Schizophrenia (1958)

†4. FREUD AND PSYCHOANALYSIS

Freud's Theory of Hysteria: A Reply to Aschaffenburg (1906)
The Freudian Theory of Hysteria (1908)
The Analysis of Dreams (1909)
A Contribution to the Psychology of Rumour (1910–11)
On the Significance of Number Dreams (1910–11)
Morton Prince, "The Mechanism and Interpretation of Dreams": A Critical Review (1911)
On the Criticism of Psychoanalysis (1910)
Concerning Psychoanalysis (1912)
The Theory of Psychoanalysis (1913)
General Aspects of Psychoanalysis (1913)
Psychoanalysis and Neurosis (1916)
Some Crucial Points in Psychoanalysis: A Correspondence between Dr. Jung and Dr. Loÿ (1914)
Prefaces to "Collected Papers on Analytical Psychology" (1916, 1917)
The Significance of the Father in the Destiny of the Individual (1909/1949)
Introduction to Kranefeldt's "Secret Ways of the Mind" (1930)
Freud and Jung: Contrasts (1929)

‡5. SYMBOLS OF TRANSFORMATION (1911–12/1952)

PART I

Introduction
Two Kinds of Thinking
The Miller Fantasies: Anamnesis
The Hymn of Creation
The Song of the Moth

PART II

Introduction
The Concept of Libido

The Transformation of Libido

The Origin of the Hero

Symbols of the Mother and of Rebirth

The Battle for Deliverance from the Mother

The Dual Mother

The Sacrifice

Epilogue

Appendix: The Miller Fantasies

*6. PSYCHOLOGICAL TYPES (1921)

Introduction

The Problem of Types in the History of Classical and Medieval Thought

Schiller's Ideas on the Type Problem

The Apollinian and the Dionysian

The Type Problem in Human Character

The Type Problem in Poetry

The Type Problem in Psychopathology

The Type Problem in Aesthetics

The Type Problem in Modern Philosophy

The Type Problem in Biography

General Description of the Types

Definitions

Epilogue

Four Papers on Psychological Typology (1913, 1925, 1931, 1936)

†7. Two Essays in Analytical Psychology

On the Psychology of the Unconscious (1917/1926/1943)

The Relations between the Ego and the Unconscious (1928)

Appendix: New Paths in Psychology (1912); The Structure of the Unconscious (1916) (new versions, with variants, 1966)

‡8. THE STRUCTURE AND DYNAMICS OF THE PSYCHE

On Psychic Energy (1928)

The Transcendent Function ([1916]/1957)

A Review of the Complex Theory (1934)

The Significance of Constitution and Heredity in Psychology (1929)

Psychological Factors Determining Human Behavior (1937)

Instinct and the Unconscious (1919)

The Structure of the Psyche (1927/1931)

On the Nature of the Psyche (1947/1954)

General Aspects of Dream Psychology (1916/1948)

On the Nature of Dreams (1945/1948)

The Psychological Foundations of Belief in Spirits (1920/1948)

Spirit and Life (1926)

Basic Postulates of Analytical Psychology (1931)

Analytical Psychology and *Weltanschauung* (1928/1931)

The Real and the Surreal (1933)

The Stages of Life (1930–1931)

The Soul and Death (1934)

Synchronicity: An Acausal Connecting Principle (1952)

Appendix: On Synchronicity (1951)

*9. PART I. THE ARCHETYPES AND THE COLLECTIVE UNCONSCIOUS

Archetypes of the Collective Unconscious (1934/1954)

The Concept of the Collective Unconscious (1936)

Concerning the Archetypes, with Special Reference to the Anima Concept
(1936/1954)

Psychological Aspects of the Mother Archetype (1938/1954)

Concerning Rebirth (1940/1950)

The Psychology of the Child Archetype (1940)

The Psychological Aspects of the Kore (1941)

The Phenomenology of the Spirit in Fairytales (1945/1948)

On the Psychology of the Trickster-Figure (1954)

Conscious, Unconscious, and Individuation (1939)

A Study in the Process of Individuation (1934/1950)

Concerning Mandala Symbolism (1950)

Appendix: Mandalas (1955)

*9. PART II. AION (1951)

RESEARCHES INTO THE PHENOMENOLOGY OF THE SELF

The Ego

The Shadow

The Syzygy: Anima and Animus

The Self

Christ, a Symbol of the Self

The Sign of the Fishes

The Prophecies of Nostradamus

The Historical Significance of the Fish

The Ambivalence of the Fish Symbol

The Fish in Alchemy

The Alchemical Interpretation of the Fish

Background to the Psychology of Christian Alchemical Symbolism

Gnostic Symbols of the Self

The Structure and Dynamics of the Self

Conclusion

*10. CIVILIZATION IN TRANSITION

The Role of the Unconscious (1918)

Mind and Earth (1927/1931)

Archaic Man (1931)

The Spiritual Problem of Modern Man (1928/1931)

The Love Problem of a Student (1928)

Woman in Europe (1927)

The Meaning of Psychology for Modern Man (1933/1934)

The State of Psychotherapy Today (1934)

Preface and Epilogue to "Essays on Contemporary Events" (1946)

Wotan (1936)

After the Catastrophe (1945)

The Fight with the Shadow (1946)

The Undiscovered Self (Present and Future) (1957)

Flying Saucers: A Modern Myth (1958)

A Psychological View of Conscience (1958)

Good and Evil in Analytical Psychology (1959)

Introduction to Wolff's "Studies in Jungian Psychology" (1959)

The Swiss Line in the European Spectrum (1928)

Reviews of Keyserling's "America Set Free" (1930) and "La Révolution Mondiale" (1934)

The Complications of American Psychology (1930)

The Dreamlike World of India (1939)

What India Can Teach Us (1939)

Appendix: Documents (1933–1938)

†11. PSYCHOLOGY AND RELIGION: WEST AND EAST

WESTERN RELIGION

Psychology and Religion (The Terry Lectures) (1938/1940)

A Psychological Approach to the Dogma of the Trinity (1942/1948)

Transformation Symbolism in the Mass (1942/1954)

Forewords to White's "God and the Unconscious" and Werblowsky's "Lucifer and Prometheus" (1952)

Brother Klaus (1933)

Psychotherapists or the Clergy (1932)

Psychoanalysis and the Cure of Souls (1928)

Answer to Job (1952)

EASTERN RELIGION

Psychological Commentaries on "The Tibetan Book of the Great Liberation" (1939/1954) and "The Tibetan Book of the Dead" (1935/1953)

Yoga and the West (1936)

Foreword to Suzuki's "Introduction to Zen Buddhism" (1939)

The Psychology of Eastern Meditation (1943)

The Holy Men of India: Introduction to Zimmer's "Der Weg zum Selbst" (1944)

Foreword to the "I Ching" (1950)

*12. PSYCHOLOGY AND ALCHEMY (1944)

Prefatory note to the English Edition ([1951?] added 1967)

Introduction to the Religious and Psychological Problems of Alchemy

Individual Dream Symbolism in Relation to Alchemy (1936)

Religious Ideas in Alchemy (1937)

Epilogue

†13. ALCHEMICAL STUDIES

Commentary on “The Secret of the Golden Flower” (1929)

The Visions of Zosimos (1938/1954)

Paracelsus as a Spiritual Phenomenon (1942)

The Spirit Mercurius (1943/1948)

The Philosophical Tree (1945/1954)

‡14. MYSTERIUM CONIUNCTIONIS (1955–56)

AN INQUIRY INTO THE SEPARATION AND
SYNTHESIS OF PSYCHIC OPPOSITES IN ALCHEMY

The Components of the Coniunctio

The Paradoxa

The Personification of the Opposites

Rex and Regina

Adam and Eve

The Conjunction

*15. THE SPIRIT IN MAN, ART, AND LITERATURE

Paracelsus (1929)

Paracelsus the Physician (1941)

Sigmund Freud in His Historical Setting (1932)

In Memory of Sigmund Freud (1939)

Richard Wilhelm: In Memoriam (1930)

On the Relation of Analytical Psychology to Poetry (1922)

Psychology and Literature (1930/1950)

“Ulysses”; A Monologue (1932)

Picasso (1932)

†16. THE PRACTICE OF PSYCHOTHERAPY

GENERAL PROBLEMS OF PSYCHOTHERAPY

Principles of Practical Psychotherapy (1935)

What Is Psychotherapy? (1935)

Some Aspects of Modern Psychotherapy (1930)

The Aims of Psychotherapy (1931)

Problems of Modern Psychotherapy (1929)

Psychotherapy and a Philosophy of Life (1943)

Medicine and Psychotherapy (1945)

Psychotherapy Today (1945)

Fundamental Questions of Psychotherapy (1951)

SPECIFIC PROBLEMS OF PSYCHOTHERAPY

The Therapeutic Value of Abreaction (1921/1928)

The Practical Use of Dream-Analysis (1934)

The Psychology of the Transference (1946)

Appendix: The Realities of Practical Psychotherapy ([1937] added, 1966)

‡17. THE DEVELOPMENT OF PERSONALITY

Psychic Conflicts in a Child (1910/1946)

Introduction to Wickes's "Analyses der Kinderseele" (1927/1931)

Child Development and Education (1928)

Analytical Psychology and Education: Three Lectures (1926/1946)

The Gifted Child (1943)

The Significance of the Unconscious in Individual Education (1928)

The Development of Personality (1934)

Marriage as a Psychological Relationship (1925)

18. MISCELLANY

Posthumous and Other Miscellaneous Works

19. BIBLIOGRAPHY AND INDEX

Complete Bibliography of C. G. Jung's Writings

General Index to the Collected Works

Also available in Princeton/Bollingen Paperbacks:

ON THE NATURE OF THE PSYCHE by C. G. Jung, translated by R.F.C. Hull, Extracted from *The Structure and Dynamics of the Psyche*, Vol. 8, Collected Works (P/B Paperback #157)

THE PSYCHOLOGY OF THE TRANSFERENCE by C. G. Jung, translated by R.F.C. Hull, Extracted from *The Practice of Psychotherapy*, Vol. 16, Collected Works (P/B Paperback #158)

PSYCHOLOGY AND EDUCATION by C. G. Jung, translated by R.F.C. Hull, Extracted from *The Development of Personality*, Vol. 17, Collected Works (P/B Paperback # 159)

ESSAYS ON A SCIENCE OF MYTHOLOGY by C. G. Jung and C. Kerényi, translated by R.F.C. Hull (P/B Paperback #180)

THE ORIGINS AND HISTORY OF CONSCIOUSNESS by Erich Neumann, translated by R.F.C. Hull (P/B Paperback #204)

AMOR AND PSYCHE: THE PSYCHIC DEVELOPMENT OF THE FEMININE by Erich Neumann, translated by Ralph Manheim (P/B Paperback #239)

ART AND THE CREATIVE UNCONSCIOUS by Erich Neumann, translated by R.F.C. Hull (P/B Paperback #240)

COMPLEX/ARCHETYPE/SYMBOL IN THE PSYCHOLOGY OF C. G. JUNG by Jolande Jacobi, translated by Ralph Manheim (P/B Paperback #241)

THE SPIRIT IN MAN, ART, AND LITERATURE by C. G. Jung, translated by R.F.C Hull, Vol. 15, Collected Works (P/B Paperback #252)

* [*Die Psychologie der unbewussten Prozesse* (Zurich, 1917). Trans. by Dora Hecht as “The Psychology of the Unconscious Processes” in *Collected Papers on Analytical Psychology* (2nd edn., London and New York, 1917).—EDITORS.]

† [Cf. below, pars. 407ff.: “New Paths in Psychology.”]

* *Psychological Types.*

* [Zurich, 1926; title changed to *Das Unbewusste im normalen und kranken Seelenleben*. Trans. by H. G. and C. F. Baynes as “The Unconscious in the Normal and Pathological Mind” in *Two Essays in Analytical Psychology* (London and New York, 1928).]

† [*Collected Papers on Analytical Psychology* (2nd edn.), pp. 437–41.]

* [For translations of several papers from the first three issues of the *Eranos-Jahrbuch* (1933–35), see *Spiritual Disciplines* (Papers from the Eranos Yearbooks, 4). Those issues also first published Jung’s “A Study in the Process of Individuation,” “Archetypes of the Collective Unconscious,” and “Dream Symbols of the Individuation Process.”]

† [Zurich, 1943; title changed to *Ueber die Psychologie des Unbewussten*. It is this edition which is translated in the present volume.]

- 1 *Principles of Physiological Psychology* (orig. 1893).
- 2 *L'Automatisme psychologique* (1889); *Névroses et idées fixes* (1898).
- 3 *De la suggestion et de ses applications à la thérapeutique* (1886); trans. by S. Freud as *Die Suggestion und ihre Heilwirkung*.
- 4 Liébeault, *Du sommeil et des états analogues considérés au point de vue de l'action du moral sur le physique* (1866).
- 5 Breuer and Freud, *Studies on Hysteria* (orig. 1895).
- 6 *The Interpretation of Dreams*.
- 7 "Three Essays on the Theory of Sexuality."
- 8 [Cf. Breuer and Freud, pp. 38f.]
- 9 [For another presentation of this case, see "The Theory of Psychoanalysis," pars. 218ff., 297ff., and 355ff.—EDITORS.]
- 10 Using the word in the wider sense which belongs to it by right and embraces more than sexuality. This is not to say that love and its disturbances are the *only* source of neurosis. Such disturbances may be of secondary nature and conditioned by deeper-lying causes. There are other ways of becoming neurotic.
- 11 Genuine shock-neuroses like shell-shock, "railway spine," etc. form an exception.

1 Jung and others, *Studies in Word Association*, trans. by M. D. Eder. [In the *Coll. Works*, Vol. 2.]

2 Jung, “A Review of the Complex Theory.”

3 Cf. Jung, “Sigmund Freud in His Historical Setting.”

4 This idea came originally from my pupil S. Spielrein: cf. “Die Destruktion als Ursache des Werdens” (1912). This work is mentioned by Freud, who introduces the destructive instinct in “Beyond the Pleasure Principle” (orig. 1920), Ch. V. [More fully in Ch. VI, which contains the Spielrein reference: Standard Edn., XVIII, p. 55.—EDITORS.]

5 [“An Outline of Psycho-Analysis” (orig. 1940), Standard Edn., XXIII, p. 148.]

1 [Cf. Jung, "The Role of the Unconscious," par. 17.—EDITORS.]

2 *The Neurotic Constitution.*

1 A complete study of the type problem is to be found in my *Psychological Types*.

2 Naturally this does not include all the existing types. Further points of difference are age, sex, activity, emotionality, and level of development. My type-psychology is based on the four orienting functions of consciousness: thinking, feeling, sensation, and intuition. See *ibid.*, pars. 577ff.

3 Cf. my essay “On Psychic Energy.”

4 Modern physics has put an end to this strict causality. Now there is only “statistical probability.” As far back as 1916, I had pointed out the limitations of the causal view in psychology, for which I was heavily censured at the time. See my preface to the second edition of *Collected Papers on Analytical Psychology*, in *Freud and Psychoanalysis*, pp. 293ff.

5 Ostwald, *Die Philosophie der Werte*, pp. 312f.

6 From the foregoing it will have become clear to the reader that the term “libido,” coined by Freud and very suitable for practical usage, is used by me in a much wider sense. Libido for me means psychic energy, which is equivalent to the intensity with which psychic contents are charged. Freud, in accordance with his theoretical assumptions, identifies libido with Eros and tries to distinguish it from psychic energy in general. Thus he says (“Three Essays on the Theory of Sexuality” [orig. 1908], p. 217): “We have defined the concept of libido as a quantitatively variable force which could serve as a measure of processes and transformations occurring in the field of sexual excitation. We distinguish this libido in respect of its special origin from the energy which must be supposed to underlie mental processes in general.” Elsewhere Freud remarks that in respect of the destructive instinct he lacks “a term analogous to libido.” Since the so-called destructive instinct is also a phenomenon of energy, it seems to me simpler to define libido as an inclusive term for psychic intensities, and consequently as sheer psychic energy. Cf. my *Symbols of Transformation*, pars. 190ff.; also “On Psychic Energy,” pars. 4ff.

7 *Pragmatism*.

8 *Grosse Männer*.

9 *Psychological Types*, pars. 68ff.

10 Cf. my discussion of Carl Spitteler’s *Prometheus und Epimetheus* in *Psychological Types*, pars. 275ff.

11 *Psychological Types*, Def. 30.

12 Freud introduced the concept of transference as a designation for the projection of unconscious contents.

13 Contrary to certain views I am not of the opinion that the “transference to the doctor” is a regular phenomenon indispensable to the success of the treatment. Transference is projection, and projection is either there or not there. But it is not *necessary*. In no sense can it be “made,” for by definition it springs from unconscious motivations. The doctor may be a suitable object for the projection, or he may not. There is absolutely no saying that he will in all circumstances correspond to the natural gradient of the patient’s libido; for it is quite on the cards that the libido is envisaging a much more important object for its projections. The absence of projections to the doctor may in fact considerably facilitate the treatment, because the real personal values can then come more clearly to the forefront.

1 “Leonardo da Vinci and a Memory of His Childhood” (orig. 1910).

2 Cf. also “The Concept of the Collective Unconscious.”

3 *Symbols of Transformation; Psychological Types*, Def. 26; *The Archetypes and the Collective Unconscious*; Commentary on *The Secret of the Golden Flower*.

4 The collective unconscious stands for the objective psyche, the personal unconscious for the subjective psyche.

5 By shadow I mean the “negative” side of the personality, the sum of all those unpleasant qualities we like to hide, together with the insufficiently developed functions and the contents of the personal unconscious. A comprehensive account is to be found in T. Wolff, “Einführung in die Grundlagen der komplexen Psychologie,” pp. 107ff.

6 Cf. “A Review of the Complex Theory.”

7 Mayer, *Kleinere Schriften und Briefe*, p. 213 (letter to Wilhelm Griesinger, June 16, 1844).

8 Helm, *Die Energetik nach ihrer geschichtlichen Entwicklung*, p. 20.

9 Generally called *mana*. Cf. Söderblom, *Das Werden des Gottesglaubens* (trans. from the Swedish *Gudstrons uppkomst*).

10 Lovejoy, “The Fundamental Concept of the Primitive Philosophy,” p. 361.

11 Cf. “The Structure of the Psyche,” pp. 152ff.

12 One such case is analysed in detail in *Symbols of Transformation*. Cf. also Nelken, “Analytische Beobachtungen über Phantasien eines Schizophrenen” (1912), p. 504.

13 This sentence was written during the first World War. I have let it stand in its original form because it contains a truth which has been confirmed more than once in the course of history. (Written in 1925.) As present events show, the confirmation did not have to wait very long. Who wants this blind destruction? But we all help the daemon to our last gasp. *O sancta simplicitas!* (Written in 1942.)

14 Cf. “The Stages of Life.”

15 The reader will note the admixture here of a new element in the idea of the archetypes, not previously mentioned. This admixture is not a piece of unintentional obscurantism, but a deliberate extension of the archetype by means of the *karmic* factor, which is so very important in Indian philosophy. The *karma* aspect is essential to a deeper understanding of the nature of an archetype. Without entering here into a closer description of this factor, I would like at least to mention its existence. I have been severely attacked by critics for my idea of archetypes. I admit at once that it is a controversial idea and more than a little perplexing. But I have always wondered what sort of idea my critics would have used to characterize the empirical material in question.

16 Cf. “Paracelsus as a Spiritual Phenomenon” and *Psychology and Alchemy*.

17 Cf. “Brother Klaus.”

1 I discovered only subsequently that the idea of the transcendent function also occurs in the higher mathematics, and is actually the name of the function of real and imaginary numbers. See also my essay “The Transcendent Function.”

2 For an analysis of one such dream-series see *Psychology and Alchemy*.

3 [For an account of amplification see “The Theory of Psychoanalysis,” pars. 326ff.—EDITORS.]

4 A parallel view of the two kinds of interpretation is to be found in Herbert Silberer’s commendable book, *Problems of Mysticism and Its Symbolism*.

5 Aigremont (pseud. of Siegmund Baron von Schultze-Galléra), *Fuss- und Schuh-symbolik und -Erotik*[1909].

6 Cf. “On Psychological Understanding.” Elsewhere I have called this procedure the “hermeneutic” method; cf. *infra*, pars. 493ff.

7 I am not overlooking the fact that the deeper reason for her identification with the artist lies in a certain creative aptitude on the part of the patient.

1 I have called this masculine element in woman the animus and the corresponding feminine element in man the anima. See *infra*, pars. 296–340; also Emma Jung, “On the Nature of the Animus.”

2 Written in 1916; superfluous to remark that it is still true today [1943].

3 As indicated earlier (par. 109), the archetypes may be regarded as the effect and deposit of experiences that have already taken place, but equally they appear as the factors which cause such experiences.

4 Cf. “The Structure of the Psyche,” pars. 325ff.

5 The idea of the medicine-man who communes with spirits and wields magical powers is so deeply ingrained in many primitives that they even believe “doctors” are to be found among animals. Thus the Achomawi of northern California speak of ordinary coyotes and of “doctor” coyotes.

6 Cf. “Archetypes of the Collective Unconscious,” pars. 74ff.

7 In his philosophical dissertation on Leibniz’s theory of the unconscious (*Das Unbewusste bei Leibniz in Beziehung zu modernen Theorien*), Ganz has used the engram theory of R. W. Semon to explain the collective unconscious. The concept of the collective unconscious advanced by me coincides only at certain points with Semon’s concept of the phylogenetic *mneme*. Cf. Semon, *Die Mneme als erhaltendes Prinzip im Wechsel des organischen Geschehens* (1904); trans. by L. Simon as *The Mneme*.

8 Frobenius, *Das Zeitalter des Sonnengottes*.

9 Those of my readers who have a deeper interest in the problem of opposites and its solution, as well as in the mythological activity of the unconscious, are referred to *Symbols of Transformation, Psychological Types, and The Archetypes and the Collective Unconscious*. [Cf. also *Mysterium Coniunctionis*.—EDITORS.]

10 Cf. “General Aspects of Dream Psychology.”

11 The idea of compensation has already been extensively used by Alfred Adler.

12 [Further details in “The Realities of Practical Psychotherapy,” in the 2nd edn. of *The Practice of Psychotherapy*, pars. 540ff. Cf. *infra*, par. 281.—EDITORS.]

1 Cf. “Instinct and the Unconscious.”

2 “On the Psychology and Pathology of So-called Occult Phenomena.”

3 “C’est donc un devoir moral de l’homme de science de s’exposer à commettre des erreurs et à subir des critiques, pour que la science avance toujours.... Ceux qui sont doués d’un esprit assez sérieux et froid pour ne pas croire que tout ce qu’ils écrivent est l’expression de la vérité absolue et éternelle, approuvent cette théorie qui place les raisons de la science au-dessus de la misérable vanité et du mesquin amour propre du savant.”— *Les Lois psychologiques du symbolisme*, p. viii; trans. of *I simboli in rapporto alla storia e filosofia del diritto alla psicologia e alla sociologia* (1893).

1 Cf. below, pars. 442ff.: “The Structure of the Unconscious.”

2 2nd edn., London, 1917; New York, 1920.

3 “On the Psychology and Pathology of So-called Occult Phenomena.”

4 *Wandlungen und Symbole der Libido* (Leipzig and Vienna, 1912); trans. by Beatrice M. Hinkle as *Psychology of the Unconscious* (New York, 1916; London, 1917). [Rewritten as *Symbole der Wandlung* (Zurich, 1952), trans. in *Coll. Works*, Vol. 5: *Symbols of Transformation*.—EDITORS.]

5 [Trans. by H. G. and C. F. Baynes as “The Relations Between the Ego and the Unconscious” in *Two Essays in Analytical Psychology* (London and New York, 1928).]

- 1 Cf. the “transcendent function” in *Psychological Types*, Def. 51, “Symbol.”
- 2 For a fuller elaboration of this theme see *Symbols of Transformation*, index, s.v. “wind.”
- 3 Cf. Flournoy, *Des Indes à la planète Mars: Étude sur un cas de somnambulisme avec glossolalie* (trans. by D. B. Vermilye as *From India to the Planet Mars*), and Jung, “Psychology and Pathology of So-called Occult Phenomena,” pars. 138ff.
- 4 Cf. *Psychological Types*, Def. 26.
- 5 Consequently, the accusation of “fanciful mysticism” levelled at my ideas is lacking in foundation.
- 6 Hubert and Mauss, *Mélanges d’histoire des religions*, p. xxix.

1 *Faust*, Part I, 3rd scene in Faust's study.

2 Maeder, "Psychologische Untersuchungen an Dementia-Praecox-Kranken" (1910), pp. 209ff.

3 When I was still a doctor at the psychiatric clinic in Zurich, I once took an intelligent layman through the sick-wards. He had never seen a lunatic asylum from the inside before. When we had finished our round, he exclaimed, "I tell you, it's just like Zurich in miniature! A quintessence of the population. It is as though all the types one meets every day on the streets had been assembled here in their classical purity. Nothing but oddities and picked specimens from top to bottom of society!" I had never looked at it from this angle before, but my friend was not far wrong.

4 Cf. *Psychological Types*, Def. 26, "Image." Léon Daudet, in *L'Hérédo*, calls this process "autofécondation intérieure," by which he means the reawakening of an ancestral soul.

5 Bleuler, *Dementia Praecox or the Group of Schizophrenias* (orig. 1911).

6 *Les Névroses* (1898).

7 Freud, *Totem and Taboo*.

8 Thus it is a quite unpardonable mistake to accept the conclusions of a Jewish psychology as generally valid. Nobody would dream of taking Chinese or Indian psychology as binding upon ourselves. The cheap accusation of anti-Semitism that has been levelled at me on the ground of this criticism is about as intelligent as accusing me of an anti-Chinese prejudice. No doubt, on an earlier and deeper level of psychic development, where it is still impossible to distinguish between an Aryan, Semitic, Hamitic, or Mongolian mentality, all human races have a common collective psyche. But with the beginning of racial differentiation essential differences are developed in the collective psyche as well. For this reason we cannot transplant the spirit of a foreign race *in globo* into our own mentality without sensible injury to the latter, a fact which does not, however, deter sundry natures of feeble instinct from affecting Indian philosophy and the like.

9 Cf. "adjustment" and "adaptation" in *Psychological Types*, par. 564.

10 *Ibid.*, Def. 29: "Individuation is a process of differentiation, having for its goal the development of the individual personality."—"As the individual is not just a single, separate being, but by his very existence presupposes a collective relationship, it follows that the process of individuation must lead to more intense and broader collective relationships and not to isolation."

1 This phenomenon, which results from the extension of consciousness, is in no sense specific to analytical treatment. It occurs whenever people are overpowered by knowledge or by some new realization. “Knowledge puffeth up,” Paul writes to the Corinthians, for the new knowledge had turned the heads of many, as indeed constantly happens. The inflation has nothing to do with the *kind* of knowledge, but simply and solely with the fact that any new knowledge can so seize hold of a weak head that he no longer sees and hears anything else. He is hypnotized by it, and instantly believes he has solved the riddle of the universe. But that is equivalent to almighty self-conceit. This process is such a general reaction that, in Genesis 2:17, eating of the tree of knowledge is represented as a deadly sin. It may not be immediately apparent why greater consciousness followed by self-conceit should be such a dangerous thing. Genesis represents the act of becoming conscious as a taboo infringement, as though knowledge meant that a sacrosanct barrier had been impiously overstepped. I think that Genesis is right in so far as every step towards greater consciousness is a kind of Promethean guilt: through knowledge, the gods are as it were robbed of their fire, that is, something that was the property of the unconscious powers is torn out of its natural context and subordinated to the whims of the conscious mind. The man who has usurped the new knowledge suffers, however, a transformation or enlargement of consciousness, which no longer resembles that of his fellow men. He has raised himself above the human level of his age (“ye shall become like unto God”), but in so doing has alienated himself from humanity. The pain of this loneliness is the vengeance of the gods, for never again can he return to mankind. He is, as the myth says, chained to the lonely cliffs of the Caucasus, forsaken of God and man.

2 It may not be superfluous to note that collective elements in dreams are not restricted to this stage of the analytical treatment. There are many psychological situations in which the activity of the collective unconscious can come to the surface. But this is not the place to enlarge upon these conditions.

3 Cf. Flournoy, “Automatisme téléologique antisuicide: un cas de suicide empêché par une hallucination” (1907), 113–37; and Jung, “The Psychology of Dementia Praecox,” pars. 304ff.

1 Adler, *The Neurotic Constitution* (orig. 1912).

2 Cf. supra, pars. 44ff., for an example of such a case.

3 *Faust*, trans. by Louis MacNeice, p. 283 (Part II, Act V).

4 *Ibid.*, p. 281 (Part II, Act V).

5 *Ibid.*, p. 282 (Part II, Act V), modified.

6 *Ibid.*, p. 67 (Part I, Witch's Kitchen scene), modified.

7 I would like to call attention here to an interesting remark of Kant's. In his lectures on psychology (*Vorlesungen über Psychologie*, Leipzig, 1889) he speaks of the "treasure lying within the field of dim representations, that deep abyss of human knowledge forever beyond our reach." This treasure, as I have demonstrated in my *Symbols of Transformation*, is the aggregate of all those primordial images in which the libido is invested, or rather, which are self-representations of the libido.

a [Concerning the origin of this novel in a conversation between Wells and Jung, cf. Bennet, *What Jung Really Said*, p. 93.—EDITORS.]

1 “Archetypes of the Collective Unconscious,” par. 71.

2 In cases of reports to the contrary, it must always be borne in mind that the fear of spirits is sometimes so great that people will actually deny that there are any spirits to fear. I have come across this myself among the dwellers on Mount Elgon.

3 Warnecke, *Die Religion der Batak* (1909).

4 Cf. “The Psychological Foundations of Belief in Spirits.”

5 [This term was taken up by psychoanalysis, but in analytical psychology it has been largely replaced by “primordial image of the parent” or “parental archetype.”—EDITORS.]

1 *Germania* (Loeb edn.), pars. 18, 19.

2 Cf. Rider Haggard, *She*; Benoît, *L'Atlantide*.

3 Cf. *Psychological Types*, Def. 48, "Soul." [Also "Concerning the Archetypes, with Special Reference to the Anima Concept" and "The Psychological Aspects of the Kore."—EDITORS.]

4 *Psychological Types*, pars. 282ff.

1 *Symbols of Transformation*.

2 [This technique is elsewhere called “active imagination.” Cf. “The Transcendent Function,” pars. 166ff., and *Mysterium Coniunctionis*, pars. 706 and 749ff.—EDITORS.]

1 Goethe, "Die Geheimnisse: Ein Fragment," lines 191–92.

2 *Faust*, trans. by Louis MacNeice, p. 282 (Part II, Act V), modified.

3 Cf. Webster, *Primitive Secret Societies* (1908).

4 Lehmann, *Mana* (1922).

5 According to popular belief, the Most Christian King could cure epilepsy with his mana by the laying on of hands.

6 "Absolute" means "cut off," "detached." To assert that God is absolute amounts to placing him outside all connection with mankind. Man cannot affect him, or he man. Such a God would be of no consequence at all. We can in fairness only speak of a God who is relative to man, as man is to God. The Christian idea of God as a "Father in Heaven" puts God's relativity in exquisite form. Quite apart from the fact that a man can know even less about God than an ant can know of the contents of the British Museum, this urge to regard God as "absolute" derives solely from the fear that God might become "psychological." This would naturally be dangerous. An absolute God, on the other hand, does not concern us in the least, whereas a "psychological" God would be *real*. This kind of God could reach man. The Church seems to be a magical instrument for protecting man against this eventuality, since it is written: "It is a fearful thing to fall into the hands of the living God."

7 Giving a bad thing a good name in order to avert its disfavour.

1 [First published as “Neue Bahnen der Psychologie” in *Raschers Jahrbuch für Schweizer Art and Kunst* (Zurich, 1912); trans. as “New Paths in Psychology,” *Collected Papers on Analytical Psychology* (1st edn., London, 1916). Subsequently revised and expanded (more than threefold) and published under the title *Die Psychologie der unbewussten Prozesse* (Zurich, 1917); trans. as “The Psychology of the Unconscious Processes,” *Collected Papers on Analytical Psychology* (2nd edn., London, 1917; New York, 1920). This work, after further revision and expansion (see Prefaces, *supra*, pp. 3–7), finally appeared as *Ueber die Psychologie des Unbewussten* (Zurich, 1943), a translation of which forms Part I of the present volume.

[In reworking “Neue Bahnen der Psychologie” for the first (1917) edition of *Die Psychologie der unbewussten Prozesse*, the author deleted or modified a number of passages, and these passages were similarly treated in the text of “New Paths in Psychology” as it appeared in the first edition of the present volume. (It should be noted that, except for pars. 440 and 441 and a few other brief passages, they were not deleted in the equivalent opening section of “The Psychology of the Unconscious Processes” in the 1917 edition of *Collected Papers on Analytical Psychology*.) In this revised edition of *Collected Works*, vol. 7, the deleted passages have been restored and are indicated by square brackets. They are similarly but not identically treated in Vol. 7 of the *Gesammelte Werke* (Zurich, 1964).—EDITORS.]

2 [“Die Psychoanalyse Freuds” (1910).]

3 Breuer and Freud, *Studies on Hysteria* (orig. 1895).

4 *Early Psycho-Analytic Publications* (orig. 1906), Standard Edition, vol. 3.

5 *The Interpretation of Dreams* (orig. 1900).

6 “Three Essays on the Theory of Sexuality” (orig. 1905).

7 We may apply to love the old mystic saying: “Heaven above, heaven below, sky above, sky below, all above, all below, accept this and rejoice.” [Mephistopheles expresses the same idea when he speaks of the “power that produces good whilst ever scheming evil.”]

8 Using the word in the wider sense which belongs to it by right and embraces more than sexuality.

9 [The abolition of houses of prostitution is also one of the hypocritical pests of our famous sexual morality. Prostitution exists anyway; the less it is organized and looked after, the more scandalous and dangerous it becomes. Since this evil nevertheless exists and always will, we should be more tolerant and make the thing as hygienic as possible. If people had not worn moral blinkers, syphilis would have been put down long ago.] [Note omitted in both editions of *Collected Papers*.—EDITORS.]

10 Jung and others, *Studies in Word Association*, trans. by M. D. Eder.

11 The theory of complexes is set out in Jung, “The Psychology of Dementia Praecox.”

12 [The rules of dream analysis, the laws governing the structure of the dream, and its symbolism together form almost a science, or at any rate one of the most important chapters of the psychology of the unconscious and one requiring particularly arduous study.]

13 [Jung, *Wandlungen and Symbole der Libido*.]

1 [First delivered as a lecture to the Zurich School for Analytical Psychology, 1916, and published the same year, in a French translation by M. Marsen, in the *Archives de Psychologie* (XVI, pp. 152–79) under the title “La Structure de l’inconscient.” The lecture appeared in English with the title “The Conception of the Unconscious” in *Collected Papers on Analytical Psychology* (2nd edn., 1917), and had evidently been translated from a German MS, which subsequently disappeared. For the first edition of the present volume a translation was made by Philip Mairet from the French version. The German MS, titled “Über das Unbewusste and seine Inhalte,” came to light again only after Jung’s death in 1961. It contained a stratum of revisions and additions, in a later hand of the author’s, most of which were incorporated in the revised and expanded version, titled *Die Beziehungen zwischen dem Ich and dem Unbewussten* (1928), a translation of which forms Part II of the present volume. The MS did not, however, contain all the new material that was added in the 1928 version. In particular, section 5 (infra, pars. 480–521) was replaced by Part Two of that essay.

[The text that now follows is a new translation from the newly discovered German MS. Additions that found their way into the 1928 version have not been included; additions that are not represented in that version are given in square brackets. To facilitate comparison between the 1916 and the final versions, the corresponding paragraph numbers of the latter are likewise given in square brackets. A similar but not identical presentation of the rediscovered MS is given in Vol. 7 of the Swiss edition.—EDITORS.]

2 Maeder, “La Langue d’un aliéné,” *Archives de Psychologie*, IX, 212.

3 *Psychology of the Unconscious*.

4 For instance, repressed wishes or tendencies that are incompatible with the moral or aesthetic sentiments of the subject.

5 *Faust*, Part I, 3rd scene in Faust’s study.

6 This conflict arises, for instance, when it is a question of subordinating personal desires or opinions to social laws. Cf. Rousseau, *Emile*, Book I: “What can one do ... when, instead of educating a man for himself, people want to educate him for others? Harmony is then impossible. Obligated to fight either against nature or against the social institutions, one has to choose between making a man or a citizen; for one cannot make the one and the other at the same time.”

7 By the collective mind I mean collective thinking; by the collective soul collective feeling; and by the collective psyche the collective psychological functions as a whole.

8 Here I would pause to remark that I intentionally abstain from discussing the question of how this problem presents itself from the point of view of the psychology of types. A special and somewhat complicated study would be required to formulate this in the language of type psychology. I must content myself here with indicating the difficulties that such a task would involve. The word “person,” for instance, signifies one thing to the introvert and another to the extravert. During childhood the conscious function of adaptation to reality is archaic and collective, but it soon acquires a personal character which it may maintain henceforth if the individual feels no particular need to develop his type towards the ideal. If such an eventuality arises, the function of adaptation to reality may attain a perfection which pretends to universal validity, and therefore bears a *collectivistic* character as contrasted with its primitive *collective* character. To pursue this terminology, the *collective psyche* would be identical with the “herd soul” in the individual, whereas a *collectivistic* psychology would represent a highly differentiated attitude to society.

Now in the introvert the conscious function of adaptation to reality is *thinking*, which in the early stages of development is personal, but which tends to acquire a general character of a collectivistic nature, while his *feeling* remains markedly personal in so far as it is conscious, and collective-archaic in so far as it is unconscious or is repressed. In the extravert, precisely the reverse happens. Besides this important difference there is another, and one which is much more profound, between the role and meaning of the “person” for the extravert and for the introvert. The whole endeavour of the introvert is directed towards preserving the integrity of his ego, which makes him assume an attitude towards his own person entirely different from that of the extravert, whose adaptation is made through feeling, even at the cost of his own person. These observations show what extraordinary difficulties we should have to surmount if we wished to consider our problem from the angle of type psychology, and justify us in abstaining from the attempt.

[This theme was greatly developed in *Psychological Types*, where the identification of thinking with introversion and feeling with extraversion was given up.—EDITORS.]

9 In a certain sense this feeling of “godlikeness” exists *a priori*, even before analysis, not only in the neurotic but also in the normal person, the only difference being that the normal individual is effectively shielded from any perception of his unconscious, while the neurotic is less and less so. On account of his quite peculiar sensibility, the latter participates to a greater extent in the life of the unconscious than does the normal person. Consequently, “godlikeness” manifests itself more clearly in the neurotic and it is heightened still further by the realization of unconscious contents through analysis.

10 *Faust*, trans. by MacNeice, Part II, Act V, p. 283.

11 *Ibid.*, pp. 281f. (modified).

12 *Ibid.*, Part I, p. 67 (modified).

13 I would like to call attention here to an interesting remark of Kant’s. In his lectures on psychology (*Vorlesungen über Psychologie*) he speaks of the “treasure lying within the field of dim representations, that deep abyss of human knowledge forever beyond our reach.” This treasure, as I have demonstrated in my *Psychology of the Unconscious*, is the aggregate of all those primordial images in which the libido is invested, or rather, which are self-representations of the libido.

14 [A view abandoned later. Cf. n. 8 supra.—EDITORS.]

15 [This paragraph, though included in the earliest draft of the German MS, was omitted from the earlier French and English translations.—EDITORS.]

16 A disguise, that is, for the basic drive or elementary intention.

17 Cf. Silberer, *Problems of Mysticism and Its Symbolism*; also my *Symbols of Transformation* and “The Content of the Psychoses.”

18 [In *Gesammelte Werke*, vol. 7, these additions (pars. 494–95) follow par. 477. There is, however, no indication in the holograph MS that they belong there—or indeed anywhere else, since they were written on a separate slip of paper. We have therefore placed them where they seem to have a greater relevance to the context.—EDITORS.]

19 One should not look for any moral function in this signification of dreams, and I am not suggesting that there is one. Nor is the function of the dream “teleological” in the philosophic sense of the word—that is, of having a final

end, still less of projecting a goal. I have often pointed out that the function of dreams is above all compensatory, in that they represent the subliminal elements constellated by the actual situation of the conscious mind. There is no moral intention in that, nor anything teleological whatsoever; it is simply a phenomenon that ought, in the first place, to be understood causally. However, it would be doing violence to the psyche to consider it from the causal angle alone. One not only can, but one *must* envisage it from the standpoint of finality—causality is itself a point of view—in order to discover to what purpose just these given elements are grouped together. This is not to say that the final meaning, in the sense of an end given *a priori*, pre-existed in the preliminary stages of the phenomenon we are discussing. According to the theory of knowledge it is evidently not possible, from the indubitably final meaning of biological mechanisms, to deduce the pre-existent fixation of a final end. But while thus legitimately abandoning a teleological conclusion it would be weak-minded to sacrifice also the point of view of finality. All one can say is that things happen as if there were a fixed final aim. In psychology one ought to be as wary of believing absolutely in causality as of an absolute belief in teleology.

20 This is not to say that he should adapt himself simply to the unconscious and not to the world of reality.

21 [In the German *Urtext*, pars. 504–506 followed par. 485, and appeared in that position in the earlier French and English translations. At the time of the first revision, however, they were incorporated in this addendum, which was not included in the 1928 version. Pars. 507 (sec. 6), 508, and 521 are of particular interest as they contain what appears to be the first formulation of the anima and animus in Jung's writings. For purposes of comparison, the first and second versions of the concluding summary are given in full.—EDITORS.]

* For details of the *Collected Works* of C. G. Jung, see list at end of this volume.

- * Published 1957; 2nd edn., 1970.
- * Published 1960.
- † Published 1961.
- ‡ Published 1956; 2nd edn., 1967. (65 plates, 43 text figures.)
- * Published 1971.
- † Published 1953; 2nd edn., 1966.
- ‡ Published 1960; 2nd edn., 1969.
- * Published 1959; 2nd edn., 1968. (Part I: 79 plates, with 29 in colour.)
- * Published 1964; 2nd edn., 1970. (8 plates.)
- † Published 1958; 2nd edn., 1969.
- * Published 1953; 2nd edn., completely revised, 1968. (270 illustrations.)
- † Published 1968. (50 plates, 4 text figures.)
- ‡ Published 1963; 2nd edn., 1970. (10 plates.)
- * Published 1966.
- † Published 1954; and 2nd edn., revised and augmented, 1966. (13 illustrations.)
- ‡ Published 1954.

B O L L I N G E N S E R I E S X X

THE COLLECTED WORKS

OF

C. G. JUNG

VOLUME 8

EDITORS

† SIR HERBERT READ

MICHAEL FORDHAM, M.D., M.R.C.P.

GERHARD ADLER, PH.D.

WILLIAM MCGUIRE, *executive editor*



The Dream of Nebuchadnezzar From the “*Speculum humanae salvationis*,” Codex Palatinus Latinus 413, Vatican, 15th cent. (see pars. 163, 484f., 559)

THE STRUCTURE AND DYNAMICS OF THE PSYCHE

C. G. JUNG

SECOND EDITION

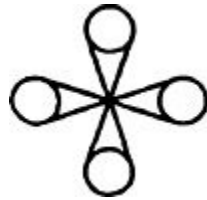

TRANSLATED BY R. F. C. HULL

BOLLINGEN SERIES XX

PRINCETON UNIVERSITY PRESS

COPYRIGHT © 1960 BY BOLLINGEN FOUNDATION, NEW YORK, N. Y. SECOND EDITION COPYRIGHT
© 1969 BY PRINCETON UNIVERSITY PRESS PUBLISHED BY PRINCETON UNIVERSITY PRESS,
PRINCETON, N. J.

Third printing, with corrections, 1975

THIS EDITION IS BEING PUBLISHED IN THE UNITED STATES OF AMERICA FOR THE BOLLINGEN FOUNDATION BY PRINCETON UNIVERSITY PRESS, AND IN ENGLAND BY ROUTLEDGE AND KEGAN PAUL, LTD. IN THE AMERICAN EDITION, ALL THE VOLUMES COMPRISING THE COLLECTED WORKS CONSTITUTE NUMBER XX IN BOLLINGEN SERIES. THE PRESENT VOLUME IS NUMBER 8 OF THE COLLECTED WORKS, AND WAS THE NINTH TO APPEAR.

LIBRARY OF CONGRESS CATALOG CARD NUMBER: 75-156

ISBN 0-691-09774-7

MANUFACTURED IN THE UNITED STATES OF AMERICA
BY PRINCETON UNIVERSITY PRESS, PRINCETON, N. J.

EDITORIAL NOTE

This volume of the Collected Works contains essays which reveal the main dynamic models Jung has used and developed over a period that began when he broke away from psychoanalysis and formulated his own concepts as distinct from those of Freud.

The first work, “On Psychic Energy,” was written by Jung in answer to criticisms of his libido theory as it had been expounded in *Wandlungen und Symbole der Libido* (trans. as *Psychology of the Unconscious*) and *The Theory of Psychoanalysis*. Originally entitled “The Theory of Libido,” it was begun *circa* 1912 but not completed till many years later (1928). Its importance lies in the clarity of its argument and the comprehensiveness of its subject-matter.

Another and longer essay, “On the Nature of the Psyche” (first version, 1946), presents an extensive review of Jung’s theoretical position many years later and covers almost the whole field of his endeavour. In it the author thoroughly examines the concepts of consciousness and the unconscious against their historical background, particularly in relation to instinct, and elaborates his theory of archetypes, a subject first broached more than twenty-five years earlier in “Instinct and the Unconscious” (1919).

Of the first importance for understanding Jung’s thinking is “Synchronicity: An Acausal Connecting Principle” (1952). Here he advocates the inclusion of “meaningful coincidence” as a dimension of understanding over and above causality. This more specialized essay is truly revolutionary in nature, and Jung hesitated for many years before writing it; the subject was first broached in 1930, and eventually he published the developed work in a volume to which Professor Pauli also contributed. It contains hints for linking physics with psychology, as indeed the two aforementioned essays do also.

Round these three works the remaining papers are grouped thematically. From among them two may be singled out: “The Stages of Life,” because of the influence of the ideas it contains on individuation as a phenomenon of the second half of life, and “The Transcendent Function,” written in 1916 but not brought to light for forty years. The latter develops Jung’s earliest researches into the prospective character of unconscious processes and contains the first and, indeed, one of the most comprehensive accounts of “active imagination,” though his later writings refer to and exemplify this technique again and again.

The papers in Section V may also be of particular interest, as showing how the entities “soul,” “mind,” “spirit,” and “life” are reduced to an empirical basis and

replaced by the phenomenological concept of “psychic reality” as the subject of psychological investigation.

TRANSLATOR'S NOTE

As indicated in the editorial footnotes appended to these papers, previous translations have been consulted whenever possible in the preparation of this volume. Grateful acknowledgment is here made, in particular, to Mr. A. R. Pope, for help derived from his version of "The Transcendent Function," issued by the Students Association of the C. G. Jung Institute, Zurich; to Dr. Robert A. Clark, for reference to his translation of "General Aspects of Dream Psychology," privately published by the Analytical Psychology Club of New York, in *Spring*, 1956; to Miss Ethel Kirkham, for reference to her translation of "On the Nature of Dreams," *Spring*, 1948; and to Dr. Eugene H. Henley, whose translation of "The Soul and Death" in *Spring*, 1945, forms the basis of the present version.

EDITORIAL NOTE TO THE SECOND EDITION

For this edition, bibliographical citations and entries have been revised in the light of subsequent publications in the *Collected Works*, and essential corrections have been made. The German language equivalent of the present volume was published in the *Gesammelte Werke* in 1967, under the title *Die Dynamik des Unbewussten* (Zurich: Rascher). The English and German versions of Volume 8 contain the same works, with corresponding paragraph numbers up to par. 871, after which there are variations as explained in the editorial note on [page 417](#) infra. A third revised edition of *Über psychische Energetik und das Wesen der Träume*, source of five works in the present volume, appeared in 1965 (Zurich: Rascher), its revisions being chiefly bibliographical. Both of the aforementioned Swiss editions yielded revisions for the present English edition.

VOLUME 8
STRUCTURE & DYNAMICS OF THE PSYCHE

TABLE OF CONTENTS

EDITORIAL NOTE

TRANSLATOR'S NOTE

EDITORIAL NOTE TO THE SECOND EDITION

On Psychic Energy

Translated from "Über die Energetik der Seele," in *Über psychische Energetik und das Wesen der Träume* (Zurich: Rascher, 1948).

I. General Remarks on the Energetic Point of View in Psychology

a. Introduction

b. The Possibility of Quantitative Measurement in Psychology

II. Application of the Energetic Standpoint

a. The Psychological Concept of Energy

b. The Conservation of Energy

c. Entropy

d. Energism and Dynamism

III. Fundamental Concepts of the Libido Theory

a. Progression and Regression

b. Extraversion and Introversion

c. The Canalization of Libido

d. Symbol Formation

IV. The Primitive Conception of Libido

The Transcendent Function

Translated from an unpublished ms., "Die Transzendente Funktion," written in 1916, later published in *Geist und Werk* (Zurich: Rhein-Verlag, 1958).

A Review of the Complex Theory

Translated from “Allgemeines zur Komplextheorie,” *Über psychische Energetik und das Wesen der Träume* (Zurich: Rascher, 1948).

II

The Significance of Constitution and Heredity in Psychology

Translated from “Die Bedeutung von Konstitution und Vererbung für die Psychologie,” *Die medizinische Welt* (Berlin), III (1929).

Psychological Factors Determining Human Behaviour

Originally published in English in *Factors Determining Human Behavior* (Harvard Tercentenary Conference of Arts and Sciences, 1936; Cambridge: Harvard University Press, 1937).

III

Instinct and the Unconscious

Translated from “Instinkt und Unbewusstes,” *Über psychische Energetik und das Wesen der Träume* (Zurich: Rascher, 1948).

The Structure of the Psyche

Translated from “Die Struktur der Seele,” *Seelenprobleme der Gegenwart* (Zurich: Rascher, 1931).

On the Nature of the Psyche

Translated from “Theoretische Überlegungen zum Wesen des Psychischen,” *Von den Wurzeln des Bewusstseins* (Zurich: Rascher, 1954).

1. The Unconscious in Historical Perspective
2. The Significance of the Unconscious in Psychology
3. The Dissociability of the Psyche
4. Instinct and Will
5. Conscious and Unconscious
6. The Unconscious as a Multiple Consciousness
7. Patterns of Behaviour and Archetypes
8. General Considerations and Prospects

Supplement

IV

General Aspects of Dream Psychology

Translated from “Allgemeine Gesichtspunkte zur Psychologie des Traumes,” in *Über psychische Energetik und das Wesen der Träume* (Zurich: Rascher, 1948).

On the Nature of Dreams

Translated from “Vom Wesen der Träume,” *Über psychische Energetik und das Wesen der Träume* (Zurich, Rascher, 1948).

V

The Psychological Foundations of Belief in Spirits

Translated from “Die psychologischen Grundlagen des Geisterglaubens,” *Über psychische Energetik und das Wesen der Träume* (Zurich: Rascher, 1948).

Spirit and Life

Translated from “Geist und Leben,” *Form und Sinn* (Augsburg), II (1926).

Basic Postulates of Analytical Psychology

Translated from “Das Grundproblem der gegenwärtigen Psychologie,” *Wirklichkeit der Seele* (Zurich: Rascher, 1934).

Analytical Psychology and *Weltanschauung*

Translated from “Analytische Psychologie und Weltanschauung,” *Seelenprobleme der Gegenwart* (Zurich: Rascher, 1931).

The Real and the Surreal

Translated from “Wirklichkeit und Überwirklichkeit,” *Querschnitt* (Berlin), XII (1933).

VI

The Stages of Life

Translated from “Die Lebenswende,” *Seelenprobleme der Gegenwart* (Zurich: Rascher, 1931).

The Soul and Death

Translated from “Seele und Tod,” *Wirklichkeit der Seele* (Zurich: Rascher, 1934).

Synchronicity: An Acausal Connecting Principle

Translated from “Synchronizität als ein Prinzip akausaler Zusammenhänge,” *Naturerklärung und Psyche* (Studien aus dem C. G. Jung-Institut, IV; Zurich: Rascher, 1952).

FOREWORD

1. EXPOSITION

2. AN ASTROLOGICAL EXPERIMENT

3. FORERUNNERS OF THE IDEA OF SYNCHRONICITY

4. CONCLUSION

APPENDIX: On Synchronicity

Translated from “Über Synchronizität,” *Eranos-Jahrbuch 1951* (Zurich: Rhein-Verlag, 1952).

BIBLIOGRAPHY

INDEX

I

ON PSYCHIC ENERGY

—

THE TRANSCENDENT FUNCTION

—

A REVIEW OF THE COMPLEX THEORY

ON PSYCHIC ENERGY¹

I. GENERAL REMARKS ON THE ENERGIIC POINT OF VIEW IN PSYCHOLOGY

a. Introduction

- [1] The concept of libido which I have advanced² has met with many misunderstandings and, in some quarters, complete repudiation; it may therefore not be amiss if I examine once more the bases of this concept.
- [2] It is a generally recognized truth that physical events can be looked at in two ways: from the mechanistic and from the energetic standpoint.³ The mechanistic view is purely causal; it conceives an event as the effect of a cause, in the sense that unchanging substances change their relations to one another according to fixed laws.
- [3] The energetic point of view on the other hand is in essence final;⁴ the event is traced back from effect to cause on the assumption that some kind of energy underlies the changes in phenomena, that it maintains itself as a constant throughout these changes and finally leads to entropy, a condition of general equilibrium. The flow of energy has a definite direction (goal) in that it follows the gradient of potential in a way that cannot be reversed. The idea of energy is not that of a substance moved in space; it is a concept abstracted from relations of movement. The concept, therefore, is founded not on the substances themselves but on their relations, whereas the moving substance itself is the basis of the mechanistic view.
- [4] Both points of view are indispensable for understanding physical events and consequently enjoy general recognition. Meanwhile, their continued existence side by side has gradually given rise to a third conception which is mechanistic as well as energetic—although, logically speaking, the advance from cause to effect, the progressive action of the cause, cannot at the same time be the retrogressive selection of a means to an end.⁵ It is not possible to conceive that one and the same combination of events could be simultaneously causal and final, for the one determination excludes the other. There are in fact two different points of view, the one reversing the other; for the principle of finality is the logical reverse of the principle of causality. Finality is not only logically possible, it is also an indispensable explanatory principle, since no explanation of nature can be mechanistic only. If indeed our concepts were exclusively those of moving bodies in space, there would be only causal explanation; but we have also to deal conceptually

with relations of movement, which require the energetic standpoint.⁶ If this were not so, there would have been no need to invent the concept of energy.

[5] The predominance of one or the other point of view depends less upon the objective behaviour of things than upon the psychological attitude of the investigator and thinker. Empathy leads to the mechanistic view, abstraction to the energetic view. Both these types are liable to commit the error of hypostatizing their principles because of the so-called objective facts of experience. They make the mistake of assuming that the subjective concept is identical with the behaviour of the thing itself; that, for example, causality as we experience it is also to be found objectively in the behaviour of things. This error is very common and leads to incessant conflicts with the opposing principle; for, as was said, it is impossible to think of the determining factor being both causal and final at the same time. But this intolerable contradiction only comes about through the illegitimate and thoughtless projection into the object of what is a mere point of view. Our points of view remain without contradiction only when they are restricted to the sphere of the psychological and are projected merely as hypotheses into the objective behaviour of things. The causality principle can suffer without contradiction its logical reversal, but the facts cannot; hence causality and finality must preclude one another in the object. On the well-known principle of minimizing differences, it is customary to effect a theoretically inadmissible compromise by regarding a process as partly causal, partly final⁷—a compromise which gives rise to all sorts of theoretical hybrids but which yields, it cannot be denied, a relatively faithful picture of reality.⁸ We must always bear in mind that despite the most beautiful agreement between the facts and our ideas, explanatory principles are only points of view, that is, manifestations of the psychological attitude and of the *a priori* conditions under which all thinking takes place.

b. The Possibility of Quantitative Measurement in Psychology

[6] From what has been said it should be sufficiently clear that every event requires the mechanistic-causal as well as the energetic-final point of view. Expediency, that is to say, the possibility of obtaining results, alone decides whether the one or the other view is to be preferred. If, for example, the qualitative side of the event comes into question, then the energetic point of view takes second place, because it has nothing to do with the things themselves but only with their quantitative relations of movement.

[7] It has been much disputed whether or not mental and psychic events can be subjected to an energetic view. *A priori* there is no reason why this should not be possible, since there are no grounds for excluding psychic events from the field of objective experience. The psyche itself can very well be an object of experience. Yet,

as Wundt's example shows,⁹ one can question in good faith whether the energetic point of view is applicable to psychic phenomena at all, and if it is applicable, whether the psyche can be looked upon as a relatively closed system.

- [8] As to the first point, I am in entire agreement with von Grot—one of the first to propose the concept of psychic energy—when he says: “The concept of psychic energy is as much justified in science as that of physical energy, and psychic energy has just as many quantitative measurements and different forms as has physical energy.”¹⁰
- [9] As to the second point, I differ from previous investigators in that I am not concerned in the least in fitting psychic energy processes into the physical system. I am not interested in such a classification because we have at best only the vaguest conjectures to go on and no real point of departure. Although it seems certain to me that psychic energy is in some way or other closely connected with physical processes, yet, in order to speak with any authority about this connection, we would need quite different experiences and insights. As to the philosophical side of the question, I entirely endorse the views of Busse.¹¹ I must also support Külpe when he says: “It would thus make no difference whether a quantum of mental energy inserts itself into the course of the material process or not: the law of the conservation of energy as formulated hitherto would not be impaired.”¹²
- [10] In my view the psychophysical relation is a problem in itself, which perhaps will be solved some day. In the meantime, however, the psychologist need not be held up by this difficulty, but can regard the psyche as a *relatively* closed system. In that case we must certainly break with what seems to me the untenable “psychophysical” hypothesis, since its epiphenomenalist point of view is simply a legacy from the old-fashioned scientific materialism. Thus, as Lasswitz, von Grot, and others think, the phenomena of consciousness have no functional connections with one another, for they are *only* (!) “phenomena, expressions, symptoms of certain deeper functional relationships.” The causal connections existing between psychic facts, which we can observe at any time, contradict the epiphenomenon theory, which has a fatal similarity to the materialistic belief that the psyche is secreted by the brain as the gall is by the liver. A psychology that treats the psyche as an epiphenomenon would better call itself brain-psychology, and remain satisfied with the meagre results that such a psycho-physiology can yield. The psyche deserves to be taken as a phenomenon in its own right; there are no grounds at all for regarding it as a mere epiphenomenon, dependent though it may be on the functioning of the brain. One would be as little justified in regarding life as an epiphenomenon of the chemistry of carbon compounds.

[11] The immediate experience of quantitative psychic relations on the one hand, and the unfathomable nature of a psychophysical connection on the other, justify at least a provisional view of the psyche as a relatively closed system. Here I find myself in direct opposition to von Grot's psychophysical energetics. In my view he is moving here on very uncertain ground, so that his further remarks have little plausibility. Nevertheless, I would like to put von Grot's formulations before the reader in his own words, as they represent the opinions of a pioneer in this difficult field:

(1) Psychic energies possess quantity and mass, just like physical energies.

(2) As different forms of psychic work and psychic potentiality, they can be transformed into one another.

(3) They can be converted into physical energies and vice versa, by means of physiological processes.¹³

[12] I need scarcely add that statement three seems to require a significant question mark. In the last analysis it is only expediency that can decide, not whether the energetic view is possible in itself, but whether it promises results in practice.¹⁴

[13] The possibility of exact quantitative measurement of physical energy has *proved* that the energetic standpoint does yield results when applied to physical events. But it would still be possible to consider physical events as forms of energy even if there were no exact quantitative measurement but merely the possibility of *estimating quantities*.¹⁵ If, however, even that proved to be impossible, then the energetic point of view would have to be abandoned, since if there is not at least a possibility of a quantitative estimate the energetic standpoint is quite superfluous.

(i) THE SUBJECTIVE SYSTEM OF VALUES

[14] The applicability of the energetic standpoint to psychology rests, then, exclusively on the question whether a quantitative estimate of psychic energy is possible or not. This question can be met with an unconditional affirmative, since our psyche actually possesses an extraordinarily well-developed evaluating system, namely the *system of psychological values*. Values are quantitative estimates of energy. Here it should be remarked that in our collective moral and aesthetic values we have at our disposal not merely an objective system of value but an objective system of measurement. This system of measurement is not, however, directly available for our purpose, since it is a general scale of values which takes account only indirectly of subjective, that is to say individual, psychological conditions.

[15] What we must first of all consider, therefore, is the *subjective value system*, the subjective estimates of the single individual. We can, as a matter of fact, estimate the subjective values of our psychic contents up to a certain point, even though it is at times extraordinarily difficult to measure them with objective accuracy against the

generally established values. However, this comparison is superfluous for our purpose, as already said. We can weigh our subjective evaluations against one another and determine their *relative* strength. Their measurement is nevertheless relative to the value of other contents and therefore not absolute and objective, but it is sufficient for our purpose inasmuch as different intensities of value in relation to similar qualities can be recognized with certainty, while equal values under the same conditions plainly maintain themselves in equilibrium.

[16] The difficulty begins only when we have to compare the value intensities of different qualities, say the value of a scientific idea compared with a feeling impression. Here the subjective estimate becomes uncertain and therefore unreliable. In the same way, the subjective estimate is restricted to the contents of consciousness; hence it is useless with respect to unconscious influences, where we are concerned with valuations that go beyond the boundaries of consciousness.

[17] In view of the compensatory relationship known to exist between the conscious and the unconscious,¹⁶ however, it is of great importance to find a way of determining the value of unconscious products. If we want to carry through the energetic approach to psychic events, we must bear in mind the exceedingly important fact that conscious values can apparently disappear without showing themselves again in an equivalent conscious achievement. In this case we should theoretically expect their appearance in the unconscious. But since the unconscious is not directly accessible either in ourselves or in others, the evaluation can only be an indirect one, so we must have recourse to auxiliary methods in order to arrive at our estimates of value. In the case of subjective evaluation, feeling and insight come to our aid immediately, because these are functions which have been developing over long periods of time and have become very finely differentiated. Even the child practises very early the differentiation of his scale of values; he weighs up whether he likes his father or mother better, who comes in the second and third place, who is most hated, etc. This conscious evaluation not only breaks down in regard to the manifestations of the unconscious but is actually twisted into the most obvious false estimates, also described as “repressions” or the “displacement of affect.” Subjective evaluation is therefore completely out of the question in estimating unconscious value intensities. Consequently we need an objective point of departure that will make an indirect but objective estimate possible.

(ii) OBJECTIVE ESTIMATE OF QUANTITY

[18] In my studies of the phenomena of association¹⁷ I have shown that there are certain constellations of psychic elements grouped round feeling-toned¹⁸ contents, which I have called “complexes.” The feeling-toned content, the complex, consists of a nuclear element and a large number of secondarily constellated associations. The

nuclear element consists of two components: first, a factor determined by experience and causally related to the environment; second, a factor innate in the individual's character and determined by his disposition.

[19] The nuclear element is characterized by its feeling-tone, the emphasis resulting from the intensity of affect. This emphasis, expressed in terms of energy, is a value quantity. In so far as the nuclear element is conscious, the quantity can be subjectively estimated, at least relatively. But if, as frequently happens, the nuclear element is unconscious,¹⁹ at any rate in its psychological significance, then a subjective estimate becomes impossible, and one must substitute the indirect method of evaluation. This is based, in principle, on the following fact: that the nuclear element automatically creates a complex to the degree that it is affectively toned and possesses energetic value, as I have shown in detail in the second and third chapters of my "Psychology of Dementia Praecox." The nuclear element has a constellating power corresponding to its energetic value. It produces a specific constellation of psychic contents, thus giving rise to the complex, which is a constellation of psychic contents dynamically conditioned by the energetic value. The resultant constellation, however, is not just an irradiation of the psychic stimulus, but a selection of the stimulated psychic contents which is conditioned by the *quality* of the nuclear element. This selection cannot, of course, be explained in terms of energy, because the energetic explanation is quantitative and not qualitative. For a qualitative explanation we must have recourse to the causal view.²⁰ The proposition upon which the objective estimate of psychological value intensities is based therefore runs as follows: *the constellating power of the nuclear element corresponds to its value intensity, i.e., to its energy.*

[20] But what means have we of estimating the energetic value of the constellating power which enriches the complex with associations? We can estimate this quantum of energy in various ways: (1) from the relative number of constellations effected by the nuclear element; (2) from the relative frequency and intensity of the reactions indicating a disturbance or complex; (3) from the intensity of the accompanying affects.

[21] 1. The data required to determine the relative number of constellations may be obtained partly by direct observation and partly by analytical deduction. That is to say, the more frequent the constellations conditioned by one and the same complex, the greater must be its psychological valency.

[22] 2. The reactions indicating a disturbance or complex do not include only the symptoms that appear in the course of the association experiment. These are really nothing but the effects of the complex, and their form is determined by the particular type of experiment. We are more concerned here with those phenomena that are

peculiar to psychological processes outside experimental conditions. Freud has described the greater part of them under the head of lapses of speech, mistakes in writing, slips of memory, misunderstandings, and other symptomatic actions. To these we must add the automatisms described by me, "thought-deprivation," "interdiction," "irrelevant talk,"²¹ etc. As I have shown in my association experiments, the intensity of these phenomena can be directly determined by a time record, and the same thing is possible also in the case of an unrestricted psychological procedure, when, watch in hand, we can easily determine the value intensity from the time taken by the patient to speak about certain things. It might be objected that patients very often waste the better part of their time talking about irrelevancies in order to evade the main issue, but that only shows how much more important these so-called irrelevancies are to them. The observer must guard against arbitrary judgments that explain the real interests of the patient as irrelevant, in accordance with some subjective, theoretical assumption of the analyst's. In determining values, he must hold strictly to objective criteria. Thus, if a patient wastes hours complaining about her servants instead of coming to the main conflict, which may have been gauged quite correctly by the analyst, this only means that the servant-complex has in fact a higher energetic value than the still unconscious conflict, which will perhaps reveal itself as the nuclear element only during the further course of treatment, or that the inhibition exercised by the highly valued conscious position keeps the nuclear element in the unconscious through overcompensation.

[23] 3. In order to determine the intensity of affective phenomena we have objective methods which, while not measuring the quantity of affect, nevertheless permit an estimate. Experimental psychology has furnished us with a number of such methods. Apart from time measurements, which determine the inhibition of the association process rather than the actual affects, we have the following devices in particular:

- (a) the pulse curve;²²
- (b) the respiration curve;²³
- (c) the psycho-galvanic phenomenon.²⁴

[24] The easily recognizable changes in these curves permit inferential estimates to be made concerning the intensity of the disturbing cause. It is also possible, as experience has shown to our satisfaction, deliberately to induce affective phenomena in the subject by means of psychological stimuli which one knows to be especially charged with affect for this particular individual in relation to the experimenter.²⁵

[25] Besides these experimental methods we have a highly differentiated subjective system for recognizing and evaluating affective phenomena in others. There is present in each of us a direct instinct for registering this, which animals also possess in high degree, with respect not only to their own species but also to other animals

and human beings. We can perceive the slightest emotional fluctuations in others and have a very fine feeling for the quality and quantity of affects in our fellow-men.

II. APPLICATION OF THE ENERGETIC STANDPOINT

a. The Psychological Concept of Energy

[26] The term “psychic energy” has long been in use. We find it, for example, as early as Schiller,²⁶ and the energetic point of view was also used by von Grot²⁷ and Theodor Lipps.²⁸ Lipps distinguishes psychic energy from physical energy, while Stern²⁹ leaves the question of their connection open. We have to thank Lipps for the distinction between *psychic energy* and *psychic force*. For Lipps, psychic force is the possibility of processes arising in the psyche at all and of attaining a certain degree of efficiency. Psychic energy, on the other hand, is defined by Lipps as the “inherent capacity of these processes to actualize this force in themselves.”³⁰ Elsewhere Lipps speaks of “psychic quantities.” The distinction between force and energy is a conceptual necessity, for energy is really a concept and, as such, does not exist objectively in the phenomena themselves but only in the specific data of experience. In other words, energy is always experienced specifically as motion and force when actual, and as a state or condition when potential. Psychic energy appears, when actual, in the specific, dynamic phenomena of the psyche, such as instinct, wishing, willing, affect, attention, capacity for work, etc., which make up the psychic forces. When potential, energy shows itself in specific achievements, possibilities, aptitudes, attitudes, etc., which are its various states.

[27] The differentiation of specific energies, such as pleasure energy, sensation energy, contrary energy, etc., proposed by Lipps, seems to me theoretically inadmissible as the specific forms of energy are the above-mentioned forces and states. Energy is a quantitative concept which includes them all. It is only these forces and states that are determined qualitatively, for they are concepts that express qualities brought into action through energy. The concept of quantity should never be qualitative at the same time, otherwise it would never enable us to expound the relations between forces, which is after all its real function.

[28] Since, unfortunately, we cannot prove scientifically that a relation of equivalence exists between physical and psychic energy,³¹ we have no alternative except either to drop the energetic viewpoint altogether, or else to postulate a special psychic energy—which would be entirely possible as a hypothetical operation. Psychology as much as physics may avail itself of the right to build its own concepts, as Lipps has already remarked, but only in so far as the energetic view proves its value and is not just a

summing-up under a vague general concept—an objection justly enough raised by Wundt. We are of the opinion, however, that the energetic view of psychic phenomena is a valuable one because it enables us to recognize just those quantitative relations whose existence in the psyche cannot possibly be denied but which are easily overlooked from a purely qualitative standpoint.

[29] Now if the psyche consisted, as the psychologists of the conscious mind maintain, of conscious processes alone (admittedly somewhat “dark” now and then), we might rest content with the postulate of a “special psychic energy.” But since we are persuaded that the unconscious processes also belong to psychology, and not merely to the physiology of the brain (as substratum processes), we are obliged to put our concept of energy on a rather broader basis. We fully agree with Wundt that there are things of which we are dimly conscious. We accept, as he does, a scale of clarity for conscious contents, but for us the psyche does not stop where the blackness begins but is continued right into the unconscious. We also leave brain-psychology its share, since we assume that the unconscious functions ultimately go over into substratum processes to which no psychic quality can be assigned, except by way of the philosophical hypothesis of pan-psychism.

[30] In delimiting a concept of psychic energy we are thus faced with certain difficulties, because we have absolutely no means of dividing what is psychic from the biological process as such. Biology as much as psychology can be approached from the energetic standpoint, in so far as the biologist feels it to be useful and valuable. Like the psyche, the life-process in general does not stand in any exactly demonstrable relationship of equivalence to physical energy.

[31] If we take our stand on the basis of scientific common sense and avoid philosophical considerations which would carry us too far, we would probably do best to regard the psychic process simply as a life-process. In this way we enlarge the narrower concept of psychic energy to a broader one of life-energy, which includes “psychic energy” as a specific part. We thus gain the advantage of being able to follow quantitative relations beyond the narrow confines of the psychic into the sphere of biological functions in general, and so can do justice, if need be, to the long discussed and ever-present problem of “mind and body.”

[32] The concept of life-energy has nothing to do with a so-called life-force, for this, *qua* force, would be nothing more than a specific form of universal energy. To regard life-energy thus, and so bridge over the still yawning gulf between physical processes and life-processes, would be to do away with the special claims of bio-energetics as opposed to physical energetics. I have therefore suggested that, in view of the psychological use we intend to make of it, we call our hypothetical life-energy “libido.” To this extent I have differentiated it from a concept of universal energy, so

maintaining the right of biology and psychology to form their own concepts. In adopting this usage I do not in any way wish to forestall workers in the field of bioenergetics, but freely admit that I have adopted the term libido with the intention of using it for *our* purposes: for theirs, some such term as “bio-energy” or “vital energy” may be preferred.

[33] I must at this point guard against a possible misunderstanding. I have not the smallest intention, in the present paper, of letting myself in for a discussion of the controversial question of psychophysical parallelism and reciprocal action. These theories are speculations concerning the possibility of mind and body functioning together or side by side, and they touch on the very point I am purposely leaving out of account here, namely whether the psychic energy process exists independently of, or is included in, the physical process. In my view we know practically nothing about this. Like Busse,³² I consider the idea of reciprocal action tenable, and can see no reason to prejudice its credibility with the hypothesis of psychophysical parallelism. To the psychotherapist, whose special field lies just in this crucial sphere of the interaction of mind and body, it seems highly probable that the psychic and the physical are not two independent parallel processes, but are essentially connected through reciprocal action, although the actual nature of this relationship is still completely outside our experience. Exhaustive discussions of this question may be all very well for philosophers, but empirical psychology should confine itself to empirically accessible facts. Even though we have not yet succeeded in proving that the processes of psychic energy are included in the physical process, the opponents of such a possibility have been equally unsuccessful in separating the psychic from the physical with any certainty.

b. The Conservation of Energy

[34] If we undertake to view the psychic life-process from the energetic standpoint, we must not rest content with the mere concept, but must accept the obligation to test its applicability to empirical material. An energetic standpoint is otiose if its main principle, the conservation of energy, proves to be inapplicable. Here we must follow Busse's suggestion and distinguish between the principle of equivalence and the principle of constancy.³³ The principle of equivalence states that “for a given quantity of energy expended or consumed in bringing about a certain condition, an equal quantity of the same or another form of energy will appear elsewhere”; while the principle of constancy states that “the sum total of energy remains constant, and is susceptible neither of increase nor of decrease.” Hence the principle of constancy is a logically necessary but generalized conclusion from the principle of equivalence and is not so important in practice, since our experience is always concerned with partial systems only.

[35] For our purpose, the principle of equivalence is the only one of immediate concern. In my book *Symbols of Transformation*,³⁴ I have demonstrated the possibility of considering certain developmental processes and other transformations of the kind under the principle of equivalence. I will not repeat *in extenso* what I have said there, but will only emphasize once again that Freud's investigation of sexuality has made many valuable contributions to our problem. Nowhere can we see more clearly than in the relation of sexuality to the total psyche how the disappearance of a given quantum of libido is followed by the appearance of an equivalent value in another form. Unfortunately Freud's very understandable over-valuation of sexuality led him to reduce transformations of other specific psychic forces co-ordinated with sexuality to sexuality pure and simple, thus bringing upon himself the not unjustified charge of pan-sexualism. The defect of the Freudian view lies in the one-sidedness to which the mechanistic-causal standpoint always inclines, that is to say in the all-simplifying *reductio ad causam*, which, the truer, the simpler, the more inclusive it is, does the less justice to the product thus analysed and reduced. Anyone who reads Freud's works with attention will see what an important role the equivalence principle plays in the structure of his theories. This can be seen particularly clearly in his investigations of case material, where he gives an account of repressions and their substitute formations.³⁵ Anyone who has had practical experience of this field knows that the equivalence principle is of great heuristic value in the treatment of neuroses. Even if its application is not always conscious, you nevertheless apply it instinctively or by feeling. For instance, when a conscious value, say a transference, decreases or actually disappears, you immediately look for the substitute formation, expecting to see an equivalent value spring up somewhere else. It is not difficult to find the substitute if the substitute formation is a conscious content, but there are frequent cases where a sum of libido disappears apparently without forming a substitute. In that case the substitute is unconscious, or, as usually happens, the patient is unaware that some new psychic fact is the corresponding substitute formation. But it may also happen that a considerable sum of libido disappears as though completely swallowed up by the unconscious, with no new value appearing in its stead. In such cases it is advisable to cling firmly to the principle of equivalence, for careful observation of the patient will soon reveal signs of unconscious activity, for instance an intensification of certain symptoms, or a new symptom, or peculiar dreams, or strange, fleeting fragments of fantasy, etc. If the analyst succeeds in bringing these hidden contents into consciousness, it can usually be shown that the libido which disappeared from consciousness generated a product in the unconscious which, despite all differences, has not a few features in common with the conscious contents that lost their energy. It is as if the libido dragged with it into the unconscious certain qualities which are often so distinct that one can recognize from their character the source of the libido now activating the unconscious.

[36] There are many striking and well-known examples of these transformations. For instance, when a child begins to separate himself subjectively from his parents, fantasies of substitute parents arise, and these fantasies are almost always transferred to real people. Transferences of this sort prove untenable in the long run, because the maturing personality must assimilate the parental complex and achieve authority, responsibility, and independence. He or she must become a father or mother. Another field rich in striking examples is the psychology of Christianity, where the repression of instincts (i.e., of primitive instinctuality) leads to religious substitute formations, such as the medieval *Gottesminne*, ‘love of God,’ the sexual character of which only the blind could fail to see.

[37] These reflections lead us to a further analogy with the theory of physical energy. As we know, the theory of energy recognizes not only a factor of *intensity*, but also a factor of *extensity*, the latter being a necessary addition in practice to the pure concept of energy. It combines the concept of pure intensity with the concept of quantity (e.g., the quantity of light as opposed to its strength). “The quantity, or the extensity factor, of energy is attached to one structure and cannot be transferred to another structure without carrying with it parts of the first; but the intensity factor can pass from one structure to another.”³⁶ The extensity factor, therefore, shows the dynamic measure of energy present at any time in a given phenomenon.³⁷

[38] Similarly, there is a psychological extensity factor which cannot pass into a new structure without carrying over parts or characteristics of the previous structure with which it was connected. In my earlier work, I have drawn particular attention to this peculiarity of energy transformation, and have shown that libido does not leave a structure as pure intensity and pass without trace into another, but that it takes the character of the old function over into the new.³⁸ This peculiarity is so striking that it gives rise to false conclusions—not only to wrong theories, but to self-deceptions fraught with unfortunate consequences. For instance, say a sum of libido having a certain sexual form passes over into another structure, taking with it some of the peculiarities of its previous application. It is then very tempting to think that the dynamism of the new structure will be sexual too.³⁹ Or it may be that the libido of some spiritual activity goes over into an essentially material interest, whereupon the individual erroneously believes that the new structure is equally spiritual in character. These conclusions are false in principle because they take only the relative similarities of the two structures into account while ignoring their equally essential differences.

[39] Practical experience teaches us as a general rule that a psychic activity can find a substitute only on the basis of equivalence. A pathological interest, for example, an intense attachment to a symptom, can be replaced only by an equally intense

attachment to another interest, which is why a release of libido from the symptom never takes place without this substitute. If the substitute is of less energetic value, we know at once that a part of the energy is to be sought elsewhere—if not in the conscious mind, then in unconscious fantasy formations or in a disturbance of the “parties supérieures” of the psychological functions (to borrow an apt expression of Janet’s).

[40] Apart from these practical experiences which have long been at our disposal, the energetic point of view also enables us to build up another side of our theory. According to the causal standpoint of Freud, there exists only this same immutable substance, the sexual component, to whose activity every interpretation is led back with monotonous regularity, a fact which Freud himself once pointed out. It is obvious that the spirit of the *reductio ad causam* or *reductio in primam figuram* can never do justice to the idea of final development, of such paramount importance in psychology, because each change in the conditions is seen as nothing but a “sublimation” of the basic substance and therefore as a masked expression of the same old thing.

[41] The idea of development is possible only if the concept of an immutable substance is not hypostatized by appeals to a so-called “objective reality”—that is to say, if causality is not assumed to be identical with the behaviour of things. The idea of development requires the possibility of change in substances, which, from the energetic standpoint, appear as systems of energy capable of theoretically unlimited interchangeability and modulation under the principle of equivalence, and on the obvious assumption of a difference in potential. Here again, just as in examining the relations between causality and finality, we come upon an insoluble antinomy resulting from an illegitimate projection of the energetic hypothesis, for an immutable substance cannot at the same time be a system of energy.⁴⁰ According to the mechanistic view, energy is attached to substance, so that Wundt can speak of an “energy of the psychic” which has increased in the course of time and therefore does not permit the application of the principles of energy. From the energetic standpoint, on the other hand, substance is nothing more than the expression or sign of an energetic system. This antinomy is insoluble only so long as it is forgotten that points of view correspond to fundamental psychological attitudes, which obviously coincide to some extent with the conditions and behaviour of objects—a coincidence that renders the points of view applicable in practice. It is therefore quite understandable that causalists and finalists alike should fight desperately for the objective validity of their principles, since the principle each is defending is also that of his personal attitude to life and the world, and no one will allow without protest that his attitude may have only a conditional validity. This unwelcome admission feels somewhat like a suicidal attempt to saw off the branch upon which one is sitting. But the unavoidable

antinomies to which the projection of logically justified principles gives rise force us to a fundamental examination of our own psychological attitudes, for only in this way can we avoid doing violence to the other logically valid principle. The antinomy must resolve itself in an *antinomian postulate*, however unsatisfactory this may be to our concretistic thinking, and however sorely it afflicts the spirit of natural science to admit that the essence of so-called reality is of a mysterious irrationality. This, however, necessarily follows from an acceptance of the antinomian postulate.⁴¹

[42] The theory of development cannot do without the final point of view. Even Darwin, as Wundt points out, worked with final concepts, such as adaptation. The palpable fact of differentiation and development can never be explained exhaustively by causality; it requires also the final point of view, which man produced in the course of his psychic evolution, as he also produced the causal.

[43] According to the concept of finality, causes are understood as means to an end. A simple example is the process of regression. Regarded causally, regression is determined, say, by a “mother fixation.” But from the final standpoint the libido regresses to the *imago* of the mother in order to find there the memory associations by means of which further development can take place, for instance from a sexual system into an intellectual or spiritual system.

[44] The first explanation exhausts itself in stressing the importance of the cause and completely overlooks the final significance of the regressive process. From this angle the whole edifice of civilization becomes a mere substitute for the impossibility of incest. But the second explanation allows us to foresee what will follow from the regression, and at the same time it helps us to understand the significance of the memory-images that have been reactivated by the regressive libido. To the causalist the latter interpretation naturally seems unbelievably hypothetical, while to the finalist the “mother fixation” is an arbitrary assumption. This assumption, he objects, entirely fails to take note of the aim, which alone can be made responsible for the reactivation of the mother imago. Adler, for instance, raises numerous objections of this sort against Freud’s theory. In my *Symbols of Transformation* I tried to do justice to both views, and met for my pains the accusation from both sides of holding an obscurantist and dubious position. In this I share the fate of neutrals in wartime, to whom even good faith is often denied.

[45] What to the causal view is *fact* to the final view is *symbol*, and vice versa. Everything that is real and essential to the one is unreal and inessential to the other. We are therefore forced to resort to the antinomian postulate and must view the world, too, as a psychic phenomenon. Certainly it is necessary for science to know how things are “in themselves,” but even science cannot escape the psychological conditions of knowledge, and psychology must be peculiarly alive to these

conditions. Since the psyche also possesses the final point of view, it is psychologically inadmissible to adopt the purely causal attitude to psychic phenomena, not to mention the all too familiar monotony of its one-sided interpretations.

[46] The symbolic interpretation of causes by means of the energetic standpoint is necessary for the differentiation of the psyche, since unless the facts are symbolically interpreted, the causes remain immutable substances which go on operating continuously, as in the case of Freud's old trauma theory. Cause alone does not make development possible. For the psyche the *reductio ad causam* is the very reverse of development; it binds the libido to the elementary facts. From the standpoint of rationalism this is all that can be desired, but from the standpoint of the psyche it is lifeless and comfortless boredom—though it should never be forgotten that for many people it is absolutely necessary to keep their libido close to the basic facts. But, in so far as this requirement is fulfilled, the psyche cannot always remain on this level but must go on developing, the causes transforming themselves into means to an end, into symbolical expressions for the way that lies ahead. The exclusive importance of the cause, i.e., its energetic value, thus disappears and emerges again in the symbol, whose power of attraction represents the equivalent quantum of libido. The energetic value of a cause is never abolished by positing an arbitrary and rational goal: that is always a makeshift.

[47] Psychic development cannot be accomplished by intention and will alone; it needs the attraction of the symbol, whose value quantum exceeds that of the cause. But the formation of a symbol cannot take place until the mind has dwelt long enough on the elementary facts, that is to say until the inner or outer necessities of the life-process have brought about a transformation of energy. If man lived altogether instinctively and automatically, the transformation could come about in accordance with purely biological laws. We can still see something of the sort in the psychic life of primitives, which is entirely concretistic and entirely symbolical at once. In civilized man the rationalism of consciousness, otherwise so useful to him, proves to be a most formidable obstacle to the frictionless transformation of energy. Reason, always seeking to avoid what to it is an unbearable antinomy, takes its stand exclusively on one side or the other, and convulsively seeks to hold fast to the values it has once chosen. It will continue to do this so long as human reason passes for an "immutable substance," thereby precluding any symbolical view of itself. But reason is only relative, and eventually checks itself in its own antinomies. It too is only a means to an end, a symbolical expression for a transitional stage in the path of development.

[48] The principle of equivalence is one proposition of practical importance in the theory of energy; the other proposition, necessary and complementary, is the principle of entropy. Transformations of energy are possible only as a result of differences in intensity. According to Carnot's law, heat can be converted into work only by passing from a warmer to a colder body. But mechanical work is continually being converted into heat, which on account of its reduced intensity cannot be converted back into work. In this way a closed energetic system gradually reduces its differences in intensity to an even temperature, whereby any further change is prohibited.

[49] So far as our experience goes, the principle of entropy is known to us only as a principle of partial processes which make up a relatively closed system. The psyche, too, can be regarded as such a relatively closed system, in which transformations of energy lead to an equalization of differences. According to Boltzmann's formulation,⁴² this levelling process corresponds to a transition from an improbable to a probable state, whereby the possibility of further change is increasingly limited. Psychologically, we can see this process at work in the development of a lasting and relatively unchanging attitude. After violent oscillations at the beginning the opposites equalize one another, and gradually a new attitude develops, the final stability of which is the greater in proportion to the magnitude of the initial differences. The greater the tension between the pairs of opposites, the greater will be the energy that comes from them; and the greater the energy, the stronger will be its constellating, attracting power. This increased power of attraction corresponds to a wider range of constellated psychic material, and the further this range extends, the less chance is there of subsequent disturbances which might arise from friction with material not previously constellated. For this reason an attitude that has been formed out of a far-reaching process of equalization is an especially lasting one.

[50] Daily psychological experience affords proof of this statement. The most intense conflicts, if overcome, leave behind a sense of security and calm which is not easily disturbed, or else a brokenness that can hardly be healed. Conversely, it is just these intense conflicts and their conflagration which are needed in order to produce valuable and lasting results. Since our experience is confined to relatively closed systems, we are never in a position to observe an absolute psychological entropy; but the more the psychological system is closed off, the more clearly is the phenomenon of entropy manifested.⁴³ We see this particularly well in those mental disturbances which are characterized by intense seclusion from the environment. The so-called "dulling of affect" in dementia praecox or schizophrenia may well be understood as a phenomenon of entropy. The same applies to all those so-called degenerative phenomena which develop in psychological attitudes that permanently exclude all connection with the environment. Similarly, such voluntarily directed processes as

directed thinking and directed feeling can be viewed as relatively closed psychological systems. These functions are based on the principle of the exclusion of the inappropriate, or unsuitable, which might bring about a deviation from the chosen path. The elements that “belong” are left to a process of mutual equalization, and meanwhile are protected from disturbing influences from outside. Thus after some time they reach their “probable” state, which shows its stability in, say, a “lasting” conviction or a “deeply ingrained” point of view, etc. How firmly such things are rooted can be tested by anyone who has attempted to dissolve such a structure, for instance to uproot a prejudice or change a habit of thought. In the history of nations these changes have cost rivers of blood. But in so far as absolute insulation is impossible (except, maybe, in pathological cases), the energetic process continues as development, though, because of “loss by friction,” with lessening intensity and decreased potential.

[51] This way of looking at things has long been familiar. Everyone speaks of the “storms of youth” which yield to the “tranquillity of age.” We speak, too, of a “confirmed belief” after “battling with doubts,” of “relief from inner tension,” and so on. This is the involuntary energetic standpoint shared by everyone. For the scientific psychologist, of course, it remains valueless so long as he feels no need to estimate psychological values, while for physiological psychology this problem does not arise at all. Psychiatry, as opposed to psychology, is purely descriptive, and until recently it has not concerned itself at all about psychological causality, has in fact even denied it. Analytical psychology, however, was obliged to take the energetic standpoint into account, since the causal-mechanistic standpoint of Freudian psychoanalysis was not sufficient to do justice to psychological values. Value requires for its explanation a quantitative concept, and a qualitative concept like sexuality can never serve as a substitute. A qualitative concept is always the description of a thing, a substance; whereas a quantitative concept deals with relations of intensity and never with a substance or a thing. A qualitative concept that does not designate a substance, a thing, or a fact is a more or less arbitrary exception, and as such I must count a qualitative, hypostatized concept of energy. A scientific causal explanation now and then needs assumptions of this kind, yet they must not be taken over merely for the purpose of making an energetic standpoint superfluous. The same is true of the theory of energy, which at times shows a tendency to deny substance in order to become purely teleological or finalistic. To substitute a qualitative concept for energy is inadmissible, for that would be a specification of energy, which is in fact a force. This would be in biology vitalism, in psychology sexualism (Freud), or some other “ism,” in so far as it could be shown that the investigators reduced the energy of the total psyche to one definite force or drive. But drives, as we have shown, are specific

forms of energy. Energy includes these in a higher concept of relation, and it cannot express anything else than the relations between psychological values.

d. Energism and Dynamism

[52] What has been said above refers to a *pure* concept of energy. The concept of energy, like its correlate, the concept of time, is on the one hand an immediate, *a priori*, intuitive idea,⁴⁴ and on the other a concrete, applied, or empirical concept abstracted from experience, like all scientific explanatory concepts.⁴⁵ The *applied* concept of energy always deals with the behaviour of forces, with substances in motion; for energy is accessible to experience in no other way than through the observation of moving bodies. Hence, in practice, we speak of electrical energy and the like, as if energy were a definite force. This merging of the applied or empirical concept with the intuitive idea of the event gives rise to those constant confusions of “energy” with “force.” Similarly, the psychological concept of energy is not a pure concept, but a concrete and applied concept that appears to us in the form of sexual, vital, mental, moral “energy,” and so on. In other words, it appears in the form of a drive, the unmistakably dynamic nature of which justifies us in making a conceptual parallel with physical forces.

[53] The application of the pure concept to the stuff of experience necessarily brings about a concretization or visualization of the concept, so that it looks as if a substance had been posited. This is the case, for instance, with the physicist’s concept of ether, which, although a concept, is treated exactly as if it were a substance. This confusion is unavoidable, since we are incapable of imagining a quantum unless it be a quantum of something. This something is the substance. Therefore every applied concept is unavoidably hypostatized, even against our will, though we must never forget that what we are dealing with is still a concept.

[54] I have suggested calling the energy concept used in analytical psychology by the name “libido.” The choice of this term may not be ideal in some respects, yet it seemed to me that this concept merited the name libido if only for reasons of historical justice. Freud was the first to follow out these really dynamic, psychological relationships and to present them coherently, making use of the convenient term “libido,” albeit with a specifically sexual connotation in keeping with his general starting-point, which was sexuality. Together with “libido” Freud used the expressions “drive” or “instinct” (e.g., “ego-instincts”)⁴⁶ and “psychic energy.” Since Freud confines himself almost exclusively to sexuality and its manifold ramifications in the psyche, the sexual definition of energy as a specific driving force is quite sufficient for his purpose. In a general psychological theory, however, it is impossible to use purely sexual energy, that is, one specific drive, as an

explanatory concept, since psychic energy transformation is not merely a matter of sexual dynamics. Sexual dynamics is only one particular instance in the total field of the psyche. This is not to deny its existence, but merely to put it in its proper place.

[55] Since, for our concretistic thinking, the applied concept of energy immediately hypostatizes itself as the psychic forces (drives, affects, and other dynamic processes), its concrete character is in my view aptly expressed by the term “libido.” Similar conceptions have always made use of designations of this kind, for instance Schopenhauer’s “Will,” Aristotle’s *ὄρμη*, Plato’s Eros, Empedocles’ “love and hate of the elements,” or the *élan vital* of Bergson. From these concepts I have borrowed only the concrete character of the term, not the definition of the concept. The omission of a detailed explanation of this in my earlier book is responsible for numerous misunderstandings, such as the accusation that I have built up a kind of vitalistic concept.

[56] While I do not connect any specifically sexual definition with the word “libido,”⁴⁷ this is not to deny the existence of a sexual dynamism any more than any other dynamism, for instance that of the hunger-drive, etc. As early as 1912 I pointed out that my conception of a general life instinct, named libido, takes the place of the concept of “psychic energy” which I used in “The Psychology of Dementia Praecox.” I was, however, guilty of a sin of omission in presenting the concept only in its psychological concreteness and leaving out of account its metaphysical aspect, which is the subject of the present discussion. But, by leaving the libido concept wholly in its concrete form, I treated it as though it were hypostatized. Thus far I am to blame for the misunderstandings. I therefore expressly declared, in my “Theory of Psychoanalysis,”⁴⁸ published in 1913, that “the libido with which we operate is not only not concrete or known, but is a complete X, a pure hypothesis, a model or counter, and is no more concretely conceivable than the energy known to the world of physics.” Libido, therefore, is nothing but an abbreviated expression for the “energetic standpoint.” In a concrete presentation we shall never be able to operate with pure concepts unless we succeed in expressing the phenomenon mathematically. So long as this is impossible, the applied concept will automatically become hypostatized through the data of experience.

[57] We must note yet another obscurity arising out of the concrete use of the libido-concept and of the concept of energy in general, namely the confusion, unavoidable in practical experience, of energy with the causal concept of effect, which is a dynamic and not an energetic concept at all.

[58] The causal-mechanistic view sees the sequence of facts, *a-b-c-d*, as follows: *a* causes *b*, *b* causes *c*, and so on. Here the concept of effect appears as the designation of a quality, as a “virtue” of the cause, in other words, as a dynamism. The final-

energetic view, on the other hand, sees the sequence thus: *a-b-c* are means towards the transformation of energy, which flows causelessly from *a*, the improbable state, entropically to *b-c* and so to the probable state *d*. Here a causal effect is totally disregarded, since only intensities of effect are taken into account. In so far as the intensities are the same, we could just as well put *w-x-y-z* instead of *a-b-c-d*.

[59] The datum of experience is in both cases the sequence *a-b-c-d*, with the difference that the mechanistic view infers a dynamism from the causal effect observed, while the energetic view observes the equivalence of the transformed effect rather than the effect of a cause. That is to say, both observe the sequence *a-b-c-d*, the one qualitatively, the other quantitatively. The causal mode of thought abstracts the dynamic concept from the datum of experience, while the final view applies its pure concept of energy to the field of observation and allows it, as it were, to become a dynamism. Despite their epistemological differences, which are as absolute as could be wished, the two modes of observation are unavoidably blended in the concept of force, the causal view abstracting its pure perception of the operative quality into a concept of dynamism, and the final view allowing its pure concept to become concretized through application. Thus the mechanist speaks of the “energy of *the psychic*,” while the energist speaks of “*psychic energy*.” From what has been said it should be evident that one and the same process takes on different aspects according to the different standpoints from which it is viewed.

III. FUNDAMENTAL CONCEPTS OF THE LIBIDO THEORY

a. Progression and Regression

[60] One of the most important energetic phenomena of psychic life is the progression and regression of libido. Progression could be defined as the daily advance of the process of psychological adaptation. We know that adaptation is not something that is achieved once and for all, though there is a tendency to believe the contrary. This is due to mistaking a person’s psychic attitude for actual adaptation. We can satisfy the demands of adaptation only by means of a suitably directed attitude. Consequently, the achievement of adaptation is completed in two stages: (1) attainment of attitude, (2) completion of adaptation by means of the attitude. A man’s attitude to reality is something extraordinarily persistent, but the more persistent his mental habitus is, the less permanent will be his effective achievement of adaptation. This is the necessary consequence of the continual changes in the environment and the new adaptations demanded by them.

[61] The progression of libido might therefore be said to consist in a continual satisfaction of the demands of environmental conditions. This is possible only by means of an attitude, which as such is necessarily directed and therefore characterized by a certain one-sidedness. Thus it may easily happen that an attitude can no longer satisfy the demands of adaptation because changes have occurred in the environmental conditions which require a different attitude. For example, a feeling-attitude that seeks to fulfil the demands of reality by means of empathy may easily encounter a situation that can only be solved through thinking. In this case the feeling-attitude breaks down and the progression of libido also ceases. The vital feeling that was present before disappears, and in its place the psychic value of certain conscious contents increases in an unpleasant way; subjective contents and reactions press to the fore and the situation becomes full of affect and ripe for explosions. These symptoms indicate a damming up of libido, and the stoppage is always marked by the breaking up of the pairs of opposites. During the progression of libido the pairs of opposites are united in the co-ordinated flow of psychic processes. Their working together makes possible the balanced regularity of these processes, which without this inner polarity would become one-sided and unreasonable. We are therefore justified in regarding all extravagant and exaggerated behaviour as a loss of balance, because the co-ordinating effect of the opposite impulse is obviously lacking. Hence it is essential for progression, which is the successful achievement of adaptation, that impulse and counter-impulse, positive and negative, should reach a state of regular interaction and mutual influence. This balancing and combining of pairs of opposites can be seen, for instance, in the process of reflection that precedes a difficult decision. But in the stoppage of libido that occurs when progression has become impossible, positive and negative can no longer unite in co-ordinated action, because both have attained an equal value which keeps the scales balanced. The longer the stoppage lasts, the more the value of the opposed positions increases; they become enriched with more and more associations and attach to themselves an ever-widening range of psychic material. The tension leads to conflict, the conflict leads to attempts at mutual repression, and if one of the opposing forces is successfully repressed a dissociation ensues, a splitting of the personality, or disunion with oneself. The stage is then set for a neurosis. The acts that follow from such a condition are unco-ordinated, sometimes pathological, having the appearance of symptomatic actions. Although in part normal, they are based partly on the repressed opposite which, instead of working as an equilibrating force, has an obstructive effect, thus hindering the possibility of further progress.

[62] The struggle between the opposites would persist in this fruitless way if the process of regression, the backward movement of libido, did not set in with the outbreak of the conflict. Through their collision the opposites are gradually deprived

of value and depotentiated. This loss of value steadily increases and is the only thing perceived by consciousness. It is synonymous with regression, for in proportion to the decrease in value of the conscious opposites there is an increase in the value of all those psychic processes which are not concerned with outward adaptation and therefore are seldom or never employed consciously. These psychic factors are for the most part unconscious. As the value of the subliminal elements and of the unconscious increases, it is to be expected that they will gain influence over the conscious mind. On account of the inhibiting influence which the conscious exercises over the unconscious, the unconscious values assert themselves at first only indirectly. The inhibition to which they are subjected is a result of the exclusive directedness of conscious contents. (This inhibition is identical with what Freud calls the “censor.”) The indirect manifestation of the unconscious takes the form of disturbances of conscious behaviour. In the association experiment they appear as complex-indicators, in daily life as the “symptomatic actions” first described by Freud, and in neurotic conditions they appear as symptoms.

[63] Since regression raises the value of contents that were previously excluded from the conscious process of adaptation, and hence are either totally unconscious or only “dimly conscious,” the psychic elements now being forced over the threshold are momentarily useless from the standpoint of adaptation, and for this reason are invariably kept at a distance by the directed psychic function. The nature of these contents is for all the world to read in Freudian literature. They are not only of an infantile-sexual character, but are altogether incompatible contents and tendencies, partly immoral, partly unaesthetic, partly again of an irrational, imaginary nature. The obviously inferior character of these contents as regards adaptation has given rise to that depreciatory view of the psychic background which is habitual in psychoanalytic writings.⁴⁹ What the regression brings to the surface certainly seems at first sight to be slime from the depths; but if one does not stop short at a superficial evaluation and refrains from passing judgment on the basis of a preconceived dogma, it will be found that this “slime” contains not merely incompatible and rejected remnants of everyday life, or inconvenient and objectionable animal tendencies, but also germs of new life and vital possibilities for the future.⁵⁰ This is one of the great merits of psychoanalysis, that it is not afraid to dredge up the incompatible elements, which would be a thoroughly useless and indeed reprehensible undertaking were it not for the possibilities of new life that lie in the repressed contents. That this is and must be so is not only proved by a wealth of practical experience but can also be deduced from the following considerations.

[64] The process of adaptation requires a directed conscious function characterized by inner consistency and logical coherence. Because it is directed, everything unsuitable must be excluded in order to maintain the integrity of direction. The unsuitable

elements are subjected to inhibition and thereby escape attention. Now experience shows that there is only *one* consciously directed function of adaptation. If, for example, I have a thinking orientation I cannot at the same time orient myself by feeling, because thinking and feeling are two quite different functions. In fact, I must carefully exclude feeling if I am to satisfy the logical laws of thinking, so that the thought-process will not be disturbed by feeling. In this case I withdraw as much libido as possible from the feeling process, with the result that this function becomes relatively unconscious. Experience shows, again, that the orientation is largely habitual; accordingly the other unsuitable functions, so far as they are incompatible with the prevailing attitude, are relatively unconscious, and hence unused, untrained, and undifferentiated. Moreover, on the principle of coexistence they necessarily become associated with other contents of the unconscious, the inferior and incompatible quality of which I have already pointed out. Consequently, when these functions are activated by regression and so reach consciousness, they appear in a somewhat incompatible form, disguised and covered up with the slime of the deep.

[65] If we remember that the stoppage of libido was due to the failure of the conscious attitude, we can now understand what valuable seeds lie in the unconscious contents activated by regression. They contain the elements of that other function which was excluded by the conscious attitude and which would be capable of effectively complementing or even of replacing the inadequate conscious attitude. If thinking fails as the adapted function, because it is dealing with a situation to which one can adapt only by feeling, then the unconscious material activated by regression will contain the missing feeling function, although still in embryonic form, archaic and undeveloped. Similarly, in the opposite type, regression would activate a thinking function that would effectively compensate the inadequate feeling.

[66] By activating an unconscious factor, regression confronts consciousness with the problem of the psyche as opposed to the problem of outward adaptation. It is natural that the conscious mind should fight against accepting the regressive contents, yet it is finally compelled by the impossibility of further progress to submit to the regressive values. In other words, regression leads to the necessity of adapting to the inner world of the psyche.

[67] Just as adaptation to the environment may fail because of the one-sidedness of the adapted function, so adaptation to the inner world may fail because of the one-sidedness of the function in question. For instance, if the stoppage of libido was due to the failure of the thinking attitude to cope with the demands of outward adaptation, and if the unconscious feeling function is activated by regression, there is only a feeling attitude towards the inner world. This may be sufficient at first, but in the long run it will cease to be adequate, and the thinking function will have to be

enlisted too, just as the reverse was necessary when dealing with the outer world. Thus a complete orientation towards the inner world becomes necessary until such time as inner adaptation is attained. Once the adaptation is achieved, progression can begin again.

[68] The principle of progression and regression is portrayed in the myth of the whale-dragon worked out by Frobenius,⁵¹ as I have shown in detail in my book *Symbols of Transformation* (pars. 307ff.). The hero is the symbolical exponent of the movement of libido. Entry into the dragon is the regressive direction, and the journey to the East (the “night sea journey”) with its attendant events symbolizes the effort to adapt to the conditions of the psychic inner world. The complete swallowing up and disappearance of the hero in the belly of the dragon represents the complete withdrawal of interest from the outer world. The overcoming of the monster from within is the achievement of adaptation to the conditions of the inner world, and the emergence (“slipping out”) of the hero from the monster’s belly with the help of a bird, which happens at the moment of sunrise, symbolizes the recommencement of progression.

[69] It is characteristic that the monster begins the night sea journey to the East, i.e., towards sunrise, while the hero is engulfed in its belly. This seems to me to indicate that regression is not necessarily a retrograde step in the sense of a backwards development or degeneration, but rather represents a necessary phase of development. The individual is, however, not consciously aware that he is developing; he feels himself to be in a compulsive situation that resembles an early infantile state or even an embryonic condition within the womb. It is only if he remains stuck in this condition that we can speak of involution or degeneration.

[70] Again, *progression* should not be confused with *development*, for the continuous flow or current of life is not necessarily development and differentiation. From primeval times certain plant and animal species have remained at a standstill without further differentiation, and yet have continued in existence. In the same way the psychic life of man can be progressive without evolution and regressive without involution. Evolution and involution have as a matter of fact no immediate connection with progression and regression, since the latter are mere life-movements which, notwithstanding their direction, actually have a static character. They correspond to what Goethe has aptly described as systole and diastole.⁵²

[71] Many objections have been raised against the view that myths represent psychological facts. People are very loath to give up the idea that the myth is some kind of explanatory allegory of astronomical, meteorological, or vegetative processes. The coexistence of explanatory tendencies is certainly not to be denied, since there is abundant proof that myths also have an explanatory significance, but

we are still faced with the question: why should myths explain things in this allegorical way? It is essential to understand where the primitive gets this explanatory material from, for it should not be forgotten that the primitive's need of causal explanations is not nearly so great as it is with us. He is far less interested in explaining things than in weaving fables. We can see almost daily in our patients how mythical fantasies arise: they are not thought up, but present themselves as images or chains of ideas that force their way out of the unconscious, and when they are recounted they often have the character of connected episodes resembling mythical dramas. That is how myths arise, and that is the reason why the fantasies from the unconscious have so much in common with primitive myths. But in so far as the myth is nothing but a projection from the unconscious and not a conscious invention at all, it is quite understandable that we should everywhere come upon the same myth-motifs, and that myths actually represent typical psychic phenomena.

[72] We must now consider how the processes of progression and regression are to be understood energetically. That they are essentially dynamic processes should by now be sufficiently clear. Progression might be compared to a watercourse that flows from a mountain into a valley. The damming up of libido is analogous to a specific obstruction in the direction of the flow, such as a dike, which transforms the kinetic energy of the flow into the potential energy of a reservoir. Thus dammed back, the water is forced into another channel, if as a result of the damming it reaches a level that permits it to flow off in another direction. Perhaps it will flow into a channel where the energy arising from the difference in potential is transformed into electricity by means of a turbine. This transformation might serve as a model for the new progression brought about by the damming up and regression, its changed character being indicated by the new way in which the energy now manifests itself. In this process of transformation the principle of equivalence has a special heuristic value: the intensity of progression reappears in the intensity of regression.

[73] It is not an essential postulate of the energetic standpoint that there must be progression and regression of libido, only that there must be equivalent transformations, for energetics is concerned only with quantity and makes no attempt to explain quality. Thus progression and regression are specific processes which must be conceived as dynamic, and which as such are conditioned by the qualities of matter. They cannot in any sense be derived from the essential nature of the concept of energy, though in their reciprocal relations they can only be understood energetically. Why progression and regression should exist at all can only be explained by the qualities of matter, that is by means of a mechanistic-causal hypothesis.

[74] Progression as a continuous process of adaptation to environmental conditions springs from the vital need for such adaptation. Necessity enforces complete

orientation to these conditions and the suppression of all those tendencies and possibilities which subserve individuation.

[75] Regression, on the other hand, as an adaptation to the conditions of the inner world, springs from the vital need to satisfy the demands of individuation. Man is not a machine in the sense that he can consistently maintain the same output of work. He can meet the demands of outer necessity in an ideal way only if he is also adapted to his own inner world, that is, if he is in harmony with himself. Conversely, he can only adapt to his inner world and achieve harmony with himself when he is adapted to the environmental conditions. As experience shows, the one or the other function can be neglected only for a time. If, for example, there is only one-sided adaptation to the outer world while the inner one is neglected, the value of the inner world will gradually increase, and this shows itself in the irruption of personal elements into the sphere of outer adaptation. I once saw a drastic instance of this: A manufacturer who had worked his way up to a high level of success and prosperity began to remember a certain phase of his youth when he took great pleasure in art. He felt the need to return to these pursuits, and began making artistic designs for the wares he manufactured. The result was that nobody wanted to buy these artistic products, and the man became bankrupt after a few years. His mistake lay in carrying over into the outer world what belonged to the inner, because he misunderstood the demands of individuation. So striking a failure of a function that was adequately adapted before can only be explained by this typical misunderstanding of the inner demands.

[76] Although progression and regression are causally grounded in the nature of the life-processes on the one hand and in environmental conditions on the other, yet, if we look at them energetically, we must think of them only as a means, as transitional stages in the flow of energy. Looked at from this angle, progression and the adaptation resulting therefrom are a means to regression, to a manifestation of the inner world in the outer. In this way a new means is created for a changed mode of progression, bringing better adaptation to environmental conditions.

b. Extraversion and Introversion

[77] Progression and regression can be brought into relationship with extraversion and introversion: progression, as adaptation to outer conditions, could be regarded as extraversion; regression, as adaptation to inner conditions, could be regarded as introversion. But this parallel would give rise to a great deal of conceptual confusion, since progression and regression are at best only vague analogies of extraversion and introversion. In reality the latter two concepts represent dynamisms of a different kind from progression and regression. These are dynamic forms of a specifically determined transformation of energy, whereas extraversion and introversion, as their

names suggest, are the forms taken both by progression and by regression. Progression is a forwards movement of life in the same sense that time moves forwards. This movement can occur in two different forms: either extraverted, when the progression is predominantly influenced by objects and environmental conditions, or introverted, when it has to adapt itself to the conditions of the ego (or, more accurately, of the “subjective factor”). Similarly, regression can proceed along two lines: either as a retreat from the outside world (introversion), or as a flight into extravagant experience of the outside world (extraversion). Failure in the first case drives a man into a state of dull brooding, and in the second case into leading the life of a wastrel. These two different ways of reacting, which I have called introversion and extraversion, correspond to two opposite types of attitude and are described in detail in my book *Psychological Types*.

[78] Libido moves not only forwards and backwards, but also outwards and inwards. The psychology of the latter movement is described at some length in my book on types, so I can refrain from further elaboration here.

c. The Canalization of Libido

[79] In my *Symbols of Transformation* (pars. 203f) I used the expression “canalization of libido” to characterize the process of energetic transformation or conversion. I mean by this a transfer of psychic intensities or values from one content to another, a process corresponding to the physical transformation of energy; for example, in the steam-engine the conversion of heat into the pressure of steam and then into the energy of motion. Similarly, the energy of certain psychological phenomena is converted by suitable means into other dynamisms. In the abovementioned book I have given examples of these transformation processes and need not elaborate them here.

[80] When Nature is left to herself, energy is transformed along the line of its natural “gradient.” In this way natural phenomena are produced, but not “work.” So also man when left to himself lives as a natural phenomenon, and, in the proper meaning of the word, produces no work. It is culture that provides the machine whereby the natural gradient is exploited for the performance of work. That man should ever have invented this machine must be due to something rooted deep in his nature, indeed in the nature of the living organism as such. For living matter is itself a transformer of energy, and in some way as yet unknown life participates in the transformation process. Life proceeds, as it were, by making use of natural physical and chemical conditions as a means to its own existence. The living body is a machine for converting the energies it uses into other dynamic manifestations that are their

equivalents. We cannot say that physical energy is transformed into life, only that its transformation is the expression of life.

[81] In the same way that the living body as a whole is a machine, other adaptations to physical and chemical conditions have the value of machines that make other forms of transformation possible. Thus all the means an animal employs for safeguarding and furthering its existence—apart from the direct nourishment of its body—can be regarded as machines that exploit the natural gradient for the performance of work. When the beaver fells trees and dams up a river, this is a performance conditioned by its differentiation. Its differentiation is a product of what one might call “natural culture,” which functions as a transformer of energy, as a machine. Similarly human culture, as a natural product of differentiation, is a machine; first of all a technical one that utilizes natural conditions for the transformation of physical and chemical energy, but also a psychic machine that utilizes psychic conditions for the transformation of libido.

[82] Just as man has succeeded in inventing a turbine, and, by conducting a flow of water to it, in transforming the latter’s kinetic energy into electricity capable of manifold applications, so he has succeeded, with the help of a psychic mechanism, in converting natural instincts, which would otherwise follow their gradient without performing work, into other dynamic forms that are productive of work.

[83] The transformation of instinctual energy is achieved by its canalization into an *analogue of the object of instinct*. Just as a power-station imitates a waterfall and thereby gains possession of its energy, so the psychic mechanism imitates the instinct and is thereby enabled to apply its energy for special purposes. A good example of this is the spring ceremony performed by the Wachandi, of Australia.⁵³ They dig a hole in the ground, oval in shape and set about with bushes so that it looks like a woman’s genitals. Then they dance round this hole, holding their spears in front of them in imitation of an erect penis. As they dance round, they thrust their spears into the hole, shouting: “Pulli nira, pulli nira, wataka!” (not a pit, not a pit, but a c——!). During the ceremony none of the participants is allowed to look at a woman.

[84] By means of the hole the Wachandi make an analogue of the female genitals, the object of natural instinct. By the reiterated shouting and the ecstasy of the dance they suggest to themselves that the hole is really a vulva, and in order not to have this illusion disturbed by the real object of instinct, none may look at a woman. There can be no doubt that this is a canalization of energy and its transference to an analogue of the original object by means of the dance (which is really a mating-play, as with birds and other animals) and by imitating the sexual act.⁵⁴

[85] This dance has a special significance as an earth-impregnation ceremony and therefore takes place in the spring. It is a magical act for the purpose of transferring

libido to the earth, whereby the earth acquires a special psychic value and becomes an object of expectation. The mind then busies itself with the earth, and in turn is affected by it, so that there is a possibility and even a probability that man will give it his attention, which is the psychological prerequisite for cultivation. Agriculture did in fact arise, though not exclusively, from the formation of sexual analogies. The “bridal bed in the field” is a canalization ceremony of this kind: on a spring night the farmer takes his wife into the field and has intercourse with her there, in order to make the earth fruitful. In this way a very close analogy is established, which acts like a channel that conducts water from a river to a power-station. The instinctual energy becomes closely associated with the field, so that the cultivation of it acquires the value of a sexual act. This association assures a permanent flow of interest to the field, which accordingly exerts an attraction on the cultivator. He is thus induced to occupy himself with the field in a way that is obviously beneficial to fertility.

[86] As Meringer has convincingly shown, the association of libido (also in the sexual sense) and agriculture is expressed in linguistic usage.⁵⁵ The putting of libido into the earth is achieved not by sexual analogy alone, but by the “magic touch,” as in the custom of rolling (*wälzen, walen*) in the field.⁵⁶ To primitive man the canalization of libido is so concrete a thing that he even feels fatigue from work as a state of being “sucked dry” by the daemon of the field.⁵⁷ All major undertakings and efforts, such as tilling the soil, hunting, war, etc., are entered upon with ceremonies of magical analogy or with preparatory incantations which quite obviously have the psychological aim of canalizing libido into the necessary activity. In the buffalo-dances of the Taos Pueblo Indians the dancers represent both the hunters and the game. Through the excitement and pleasure of the dance the libido is channelled into the form of hunting activity. The pleasure required for this is produced by rhythmic drumming and the stirring chants of the old men who direct the whole ceremony. It is well known that old people live in their memories and love to speak of their former deeds; this “warms” them. Warmth “kindles,” and thus the old men in a sense give the first impulse to the dance, to the mimetic ceremony whose aim is to accustom the young men and boys to the hunt and to prepare them for it psychologically. Similar *rites d’entrée* are reported of many primitive tribes.⁵⁸ A classic example of this is the *atninga* ceremony of the Aruntas, of Australia. It consists in first stirring to anger the members of a tribe who are summoned for an expedition of revenge. This is done by the leader tying the hair of the dead man to be avenged to the mouth and penis of the man who is to be made angry. Then the leader kneels on the man and embraces him as if performing the sexual act with him.⁵⁹ It is supposed that in this way “the bowels of the man will begin to burn with desire to avenge the murder.” The point of the ceremony is obviously to bring about an intimate acquaintance of each individual with the murdered man, so that each is made ready to avenge the dead.

[87] The enormous complexity of such ceremonies shows how much is needed to divert the libido from its natural river-bed of everyday habit into some unaccustomed activity. The modern mind thinks this can be done by a mere decision of the will and that it can dispense with all magical ceremonies—which explains why it was so long at a loss to understand them properly. But when we remember that primitive man is much more unconscious, much more of a “natural phenomenon” than we are, and has next to no knowledge of what we call “will,” then it is easy to understand why he needs complicated ceremonies where a simple act of will is sufficient for us. We are more conscious, that is to say more domesticated. In the course of the millennia we have succeeded not only in conquering the wild nature all round us, but in subduing our own wildness—at least temporarily and up to a point. At all events we have been acquiring “will,” i.e., disposable energy, and though it may not amount to much it is nevertheless more than the primitive possesses. We no longer need magical dances to make us “strong” for whatever we want to do, at least not in ordinary cases. But when we have to do something that exceeds our powers, something that might easily go wrong, then we solemnly lay a foundation-stone with the blessing of the Church, or we “christen” a ship as she slips from the docks; in time of war we assure ourselves of the help of a patriotic God, the sweat of fear forcing a fervent prayer from the lips of the stoutest. So it only needs slightly insecure conditions for the “magical” formalities to be resuscitated in the most natural way. Through these ceremonies the deeper emotional forces are released; conviction becomes blind auto-suggestion, and the psychic field of vision is narrowed to one fixed point on which the whole weight of the unconscious forces is concentrated. And it is, indeed, an objective fact that success attends the sure rather than the unsure.

d. Symbol Formation

[88] The psychological mechanism that transforms energy is the symbol. I mean by this a real symbol and not a sign. The Wa-chandi’s hole in the earth is not a sign for the genitals of a woman, but a symbol that stands for the idea of the earth woman who is to be made fruitful. To mistake it for a human woman would be to interpret the symbol semiotically, and this would fatally disturb the value of the ceremony. It is for this reason that none of the dancers may look at a woman. The mechanism would be destroyed by a semiotic interpretation—it would be like smashing the supply-pipe of a turbine on the ground that it was a very unnatural waterfall that owed its existence to the repression of natural conditions. I am far from suggesting that the semiotic interpretation is meaningless; it is not only a possible interpretation but also a very true one. Its usefulness is undisputed in all those cases where nature is merely thwarted without any effective work resulting from it. But the semiotic interpretation

becomes meaningless when it is applied exclusively and schematically—when, in short, it ignores the real nature of the symbol and debases it to a mere sign.

[89] The first achievement wrested by primitive man from instinctual energy, through analogy-building, is magic. A ceremony is magical so long as it does not result in effective work but preserves the state of expectancy. In that case the energy is canalized into a new object and produces a new dynamism, which in turn remains magical so long as it does not create effective work. The advantage accruing from a magical ceremony is that the newly invested object acquires a working potential in relation to the psyche. Because of its value it has a determining and stimulating effect on the imagination, so that for a long time the mind is fascinated and possessed by it. This gives rise to actions that are performed in a half-playful way on the magical object, most of them rhythmical in character. A good example is those South American rock-drawings which consist of furrows deeply engraved in the hard stone. They were made by the Indians playfully retracing the furrows again and again with stones, over hundreds of years. The content of the drawings is difficult to interpret, but the activity bound up with them is incomparably more significant.⁶⁰

[90] The influence exerted on the mind by the magically effective object has other possible consequences. Through a sustained playful interest in the object, a man may make all sorts of discoveries about it which would otherwise have escaped him. As we know, many discoveries have actually been made in this way. Not for nothing is magic called the “mother of science.” Until late in the Middle Ages what we today call science was nothing other than magic. A striking example of this is alchemy, whose symbolism shows quite unmistakably the principle of transformation of energy described above, and indeed the later alchemists were fully conscious of this fact.⁶¹ But only through the development of magic into science, that is, through the advance from the stage of mere expectation to real technical work on the object, have we acquired that mastery over the forces of nature of which the age of magic dreamed. Even the alchemist’s dream of the transmutation of the elements has been fulfilled, and magical action at a distance has been realized by the discovery of electricity. So we have every reason to value symbol-formation and to render homage to the symbol as an inestimable means of utilizing the mere instinctual flow of energy for effective work. A waterfall is certainly more beautiful than a power-station, but dire necessity teaches us to value electric light and electrified industry more highly than the superb wastefulness of a waterfall that delights us for a quarter of an hour on a holiday walk.

[91] Just as in physical nature only a very small portion of natural energy can be converted into a usable form, and by far the greater part must be left to work itself out unused in natural phenomena, so in our psychic nature only a small part of the

total energy can be diverted from its natural flow. An incomparably greater part cannot be utilized by us, but goes to sustain the regular course of life. Hence the libido is apportioned by nature to the various functional systems, from which it cannot be wholly withdrawn. The libido is invested in these functions as a specific force that cannot be transformed. Only where a symbol offers a steeper gradient than nature is it possible to canalize libido into other forms. The history of civilization has amply demonstrated that man possesses a relative surplus of energy that is capable of application apart from the natural flow. The fact that the symbol makes this deflection possible proves that not all the libido is bound up in a form that enforces the natural flow, but that a certain amount of energy remains over, which could be called excess libido. It is conceivable that this excess may be due to failure of the firmly organized functions to equalize differences in intensity. They might be compared to a system of water-pipes whose diameter is too small to draw off the water that is being steadily supplied. The water would then have to flow off in one way or another. From this excess libido certain psychic processes arise which cannot be explained—or only very inadequately—as the result of merely natural conditions. How are we to explain religious processes, for instance, whose nature is essentially symbolical? In abstract form, symbols are religious ideas; in the form of action, they are rites or ceremonies. They are the manifestation and expression of excess libido. At the same time they are stepping-stones to new activities, which must be called cultural in order to distinguish them from the instinctual functions that run their regular course according to natural law.

[92] I have called a symbol that converts energy a “libido analogue.”⁶² By this I mean an idea that can give equivalent expression to the libido and canalize it into a form different from the original one. Mythology offers numerous equivalents of this kind, ranging from sacred objects such as *churingas*, fetishes, etc., to the figures of gods. The rites with which the sacred objects are surrounded often reveal very clearly their nature as transformers of energy. Thus the primitive rubs his *churinga* rhythmically and takes the magic power of the fetish into himself, at the same time giving it a fresh “charge.”⁶³ A higher stage of the same line of thought is the idea of the totem, which is closely bound up with the beginnings of tribal life and leads straight to the idea of the palladium, the tutelary tribal deity, and to the idea of an organized human community in general. The transformation of libido through the symbol is a process that has been going on ever since the beginnings of humanity and continues still. Symbols were never devised consciously, but were always produced out of the unconscious by way of revelation or intuition.⁶⁴ In view of the close connection between mythological symbols and dream-symbols, and of the fact that the dream is “le dieu des sauvages,” it is more than probable that most of the historical symbols derive directly from dreams or are at least influenced by them.⁶⁵ We know that this is

true of the choice of totem, and there is similar evidence regarding the choice of gods. This age-old function of the symbol is still present today, despite the fact that for many centuries the trend of mental development has been towards the suppression of individual symbol-formation. One of the first steps in this direction was the setting up of an official state religion, a further step was the extermination of polytheism, first attempted in the reforms of Amenophis IV. We know the extraordinary part played by Christianity in the suppression of individual symbol-formation. But as the intensity of the Christian idea begins to fade, a recrudescence of individual symbol-formation may be expected. The prodigious increase of Christian sects since the eighteenth century, the century of "enlightenment," bears eloquent witness to this. Christian Science, theosophy, anthroposophy, and "Mazdaznan" are further steps along the same path.

[93] In practical work with our patients we come upon symbol-formations at every turn, the purpose of which is the transformation of libido. At the beginning of treatment we find the symbol-forming process at work, but in an unsuitable form that offers the libido too low a gradient. Instead of being converted into effective work, the libido flows off unconsciously along the old channels, that is, into archaic sexual fantasies and fantasy activities. Accordingly the patient remains at war with himself, in other words, neurotic. In such cases analysis in the strict sense is indicated, i.e., the reductive psychoanalytic method inaugurated by Freud, which breaks down all inappropriate symbol-formations and reduces them to their natural elements. The power-station, situated too high and unsuitably constructed, is dismantled and separated into its original components, so that the natural flow is restored. The unconscious continues to produce symbols which one could obviously go on reducing to their elements *ad infinitum*.

[94] But man can never rest content with the natural course of things, because he always has an excess of libido that can be offered a more favourable gradient than the merely natural one. For this reason he will inevitably seek it, no matter how often he may be forced back by reduction to the natural gradient. We have therefore reached the conclusion that when the unsuitable structures have been reduced and the natural course of things is restored, so that there is some possibility of the patient living a normal life, the reductive process should not be continued further. Instead, symbol-formation should be reinforced in a synthetic direction until a more favourable gradient for the excess libido is found. Reduction to the natural condition is neither an ideal state nor a panacea. If the natural state were really the ideal one, then the primitive would be leading an enviable existence. But that is by no means so, for aside from all the other sorrows and hardships of human life the primitive is tormented by superstitions, fears, and compulsions to such a degree that, if he lived in our civilization, he could not be described as other than profoundly neurotic, if not

mad. What would one say of a European who conducted himself as follows?—A Negro dreamt that he was pursued by his enemies, caught, and burned alive. The next day he got his relatives to make a fire and told them to hold his feet in it, in order, by this apotropaic ceremony, to avert the misfortune of which he had dreamed. He was so badly burned that for many months he was unable to walk.⁶⁶

[95] Mankind was freed from these fears by a continual process of symbol-formation that leads to culture. Reversion to nature must therefore be followed by a synthetic reconstruction of the symbol. Reduction leads down to the primitive natural man and his peculiar mentality. Freud directed his attention mainly to the ruthless desire for pleasure, Adler to the “psychology of prestige.” These are certainly two quite essential peculiarities of the primitive psyche, but they are far from being the only ones. For the sake of completeness we would have to mention other characteristics of the primitive, such as his playful, mystical, or “heroic” tendencies, but above all that outstanding quality of the primitive mind, which is its subjection to supra-personal “powers,” be they instincts, affects, superstitions, fantasies, magicians, witches, spirits, demons, or gods. Reduction leads back to the subjection of the primitive, which civilized man hopes he had escaped. And just as reduction makes a man aware of his subjection to these “powers” and thus confronts him with a rather dangerous problem, so the synthetic treatment of the symbol brings him to the religious question, not so much to the problem of present-day religious creeds as to the religious problem of primitive man. In the face of the very real powers that dominate him, only an equally real fact can offer help and protection. No intellectual system, but direct experience only, can counterbalance the blind power of the instincts.

[96] Over against the polymorphism of the primitive’s instinctual nature there stands the regulating principle of individuation. Multiplicity and inner division are opposed by an integrative unity whose power is as great as that of the instincts. Together they form a pair of opposites necessary for self-regulation, often spoken of as nature and spirit. These conceptions are rooted in psychic conditions between which human consciousness fluctuates like the pointer on the scales.

[97] The primitive mentality can be directly experienced by us only in the form of the infantile psyche that still lives in our memories. The peculiarities of this psyche are conceived by Freud, justly enough, as infantile sexuality, for out of this germinal state there develops the later, mature sexual being. Freud, however, derives all sorts of other mental peculiarities from this infantile germinal state, so that it begins to look as if the mind itself came from a preliminary sexual stage and were consequently nothing more than an offshoot of sexuality. Freud overlooks the fact that the infantile, polyvalent germinal state is not just a singularly perverse preliminary stage of normal and mature sexuality; it seems perverse because it is a

preliminary stage not only of adult sexuality but also of the whole mental make-up of the individual. Out of the infantile germinal state there develops the complete adult man; hence the germinal state is no more exclusively sexual than is the mind of the grown man. In it are hidden not merely the beginnings of adult life, but also the whole ancestral heritage, which is of unlimited extent. This heritage includes not only instincts from the animal stage, but all those differentiations that have left hereditary traces behind them. Thus every child is born with an immense split in his make-up: on one side he is more or less like an animal, on the other side he is the final embodiment of an age-old and endlessly complicated sum of hereditary factors. This split accounts for the tension of the germinal state and does much to explain the many puzzles of child psychology, which certainly has no lack of them.

[98] If now, by means of a reductive procedure, we uncover the infantile stages of the adult psyche, we find as its ultimate basis germs containing on the one hand the later sexual being *in statu nascendi*, and on the other all those complicated preconditions of the civilized being. This is reflected most beautifully in children's dreams. Many of them are very simple "childish" dreams and are immediately understandable, but others contain possibilities of meaning that almost make one's head spin, and things that reveal their profound significance only in the light of primitive parallels. This other side is the mind *in nuce*. Childhood, therefore, is important not only because various warpings of instinct have their origin there, but because this is the time when, terrifying or encouraging, those far-seeing dreams and images appear before the soul of the child, shaping his whole destiny, as well as those retrospective intuitions which reach back far beyond the range of childhood experience into the life of our ancestors. Thus in the child-psyche the natural condition is already opposed by a "spiritual" one. It is recognized that man living in the state of nature is in no sense merely "natural" like an animal, but sees, believes, fears, worships things whose meaning is not at all discoverable from the conditions of his natural environment. Their underlying meaning leads us in fact far away from all that is natural, obvious, and easily intelligible, and quite often contrasts most sharply with the natural instincts. We have only to think of all those gruesome rites and customs against which every natural feeling rises in revolt, or of all those beliefs and ideas which stand in insuperable contradiction to the evidence of the facts. All this drives us to the assumption that the spiritual principle (whatever that may be) asserts itself against the merely natural conditions with incredible strength. One can say that this too is "natural," and that both have their origin in one and the same "nature." I do not in the least doubt this origin, but must point out that this "natural" something consists of a conflict between two principles, to which you can give this or that name according to taste, and that this opposition is the expression, and perhaps also the basis, of the tension we call psychic energy.

[99] For theoretical reasons as well there must be some such tension of opposites in the child, otherwise no energy would be possible, for, as Heraclitus has said, “war is the father of all things.” As I have remarked, this conflict can be understood as an opposition between the profoundly primitive nature of the newborn infant and his highly differentiated inheritance. The natural man is characterized by unmitigated instinctuality, by his being completely at the mercy of his instincts. The inheritance that opposes this condition consists of mnemonic deposits accruing from all the experience of his ancestors. People are inclined to view this hypothesis with scepticism, thinking that “inherited ideas” are meant. There is naturally no question of that. It is rather a question of inherited *possibilities* of ideas, “pathways” gradually traced out through the cumulative experience of our ancestors. To deny the inheritance of these pathways would be tantamount to denying the inheritance of the brain. To be consistent, such sceptics would have to assert that the child is born with the brain of an ape. But since it is born with a human brain, this must sooner or later begin to function in a human way, and it will necessarily begin at the level of the most recent ancestors. Naturally this functioning remains profoundly unconscious to the child. At first he is conscious only of the instincts and of what opposes these instincts—namely, his parents. For this reason the child has no notion that what stands in his way may be within himself. Rightly or wrongly it is projected on to the parents. This infantile prejudice is so tenacious that we doctors often have the greatest difficulty in persuading our patients that the wicked father who forbade everything is far more inside than outside themselves. Everything that works from the unconscious appears projected on others. Not that these others are wholly without blame, for even the worst projection is at least hung on a hook, perhaps a very small one, but still a hook offered by the other person.

[100] Although our inheritance consists of physiological pathways, it was nevertheless mental processes in our ancestors that traced them. If they come to consciousness again in the individual, they can do so only in the form of other mental processes; and although these processes can become conscious only through individual experience and consequently appear as individual acquisitions, they are nevertheless pre-existent pathways which are merely “filled out” by individual experience. Probably every “impressive” experience is just such a break-through into an old, previously unconscious river-bed.

[101] These pre-existent pathways are hard facts, as indisputable as the historical fact of man having built a city out of his original cave. This development was made possible only by the formation of a community, and the latter only by the curbing of instinct. The curbing of instinct by mental and spiritual processes is carried through with the same force and the same results in the individual as in the history of mankind. It is a normative or, more accurately, a “nomothetical”⁶⁷ process, and it

derives its power from the unconscious fact of these inherited pathways. The mind, as the active principle in the inheritance, consists of the sum of the ancestral minds, the “unseen fathers”⁶⁸ whose authority is born anew with the child.

[102] The philosophical concept of mind as “spirit” has still not been able to free itself, as a term in its own right, from the overpowering bond of identity with the other connotation of spirit, namely “ghost.” Religion, on the other hand, has succeeded in getting over the linguistic association with “spirits” by calling the supreme spiritual authority “God.” In the course of the centuries this conception came to formulate a spiritual principle which is opposed to mere instinctuality. What is especially significant here is that God is conceived at the same time as the Creator of nature. He is seen as the maker of those imperfect creatures who err and sin, and at the same time he is their judge and taskmaster. Simple logic would say: if I make a creature who falls into error and sin, and is practically worthless because of his blind instinctuality, then I am manifestly a bad creator and have not even completed my apprenticeship. (As we know, this argument played an important role in Gnosticism.) But the religious point of view is not perturbed by this criticism; it asserts that the ways and intentions of God are inscrutable. Actually the Gnostic argument found little favour in history, because the unassailability of the God-concept obviously answers a vital need before which all logic pales. (It should be understood that we are speaking here not of God as a *Ding an sich*, but only of a human conception which as such is a legitimate object of science.)

[103] Although the God-concept is a spiritual principle *par excellence*, the collective metaphysical need nevertheless insists that it is at the same time a conception of the First Cause, from which proceed all those instinctual forces that are opposed to the spiritual principle. God would thus be not only the essence of spiritual light, appearing as the latest flower on the tree of evolution, not only the spiritual goal of salvation in which all creation culminates, not only the end and aim, but also the darkest, nethermost cause of Nature’s blackest deeps. This is a tremendous paradox which obviously reflects a profound psychological truth. For it asserts the essential contradictoriness of one and the same being, a being whose innermost nature is a tension of opposites. Science calls this “being” energy, for energy is like a living balance between opposites. For this reason the God-concept, in itself impossibly paradoxical, may be so satisfying to human needs that no logic however justified can stand against it. Indeed the subtlest cogitation could scarcely have found a more suitable formula for this fundamental fact of inner experience.

[104] It is not, I believe, superfluous to have discussed in considerable detail the nature of the opposites that underlie psychic energy.⁶⁹ Freudian theory consists in a causal explanation of the psychology of instinct. From this standpoint the spiritual principle

is bound to appear only as an appendage, a by-product of the instincts. Since its inhibiting and restrictive power cannot be denied, it is traced back to the influence of education, moral authorities, convention and tradition. These authorities in their turn derive their power, according to the theory, from repression in the manner of a vicious circle. The spiritual principle is not recognized as an equivalent counterpart of the instincts.

[105] The spiritual standpoint, on the other hand, is embodied in religious views which I can take as being sufficiently known. Freudian psychology appears threatening to this standpoint, but it is not more of a threat than materialism in general, whether scientific or practical. The one-sidedness of Freud's sexual theory is significant at least as a symptom. Even if it has no scientific justification, it has a moral one. It is undoubtedly true that instinctuality conflicts with our moral views most frequently and most conspicuously in the realm of sex. The conflict between infantile instinctuality and ethics can never be avoided. It is, it seems to me, the *sine qua non* of psychic energy. While we are all agreed that murder, stealing, and ruthlessness of any kind are obviously inadmissible, there is nevertheless what we call a "sexual question." We hear nothing of a murder question or a rage question; social reform is never invoked against those who wreak their bad tempers on their fellow men. Yet these things are all examples of instinctual behaviour, and the necessity for their suppression seems to us self-evident. Only in regard to sex do we feel the need of a question mark. This points to a doubt—the doubt whether our existing moral concepts and the legal institutions founded on them are really adequate and suited to their purpose. No intelligent person will deny that in this field opinion is sharply divided. Indeed, there would be no problem at all if public opinion were united about it. It is obviously a reaction against a too rigorous morality. It is not simply an outbreak of primitive instinctuality; such outbreaks, as we know, have never yet bothered themselves with moral laws and moral problems. There are, rather, serious misgivings as to whether our existing moral views have dealt fairly with the nature of sex. From this doubt there naturally arises a legitimate interest in any attempt to understand the nature of sex more truly and deeply, and this interest is answered not only by Freudian psychology but by numerous other researches of the kind. The special emphasis, therefore, that Freud has laid on sex could be taken as a more or less conscious answer to the question of the hour, and conversely, the acceptance that Freud has found with the public proves how well-timed his answer was.

[106] An attentive and critical reader of Freud's writings cannot fail to remark how wide and flexible his concept of sexuality is. In fact it covers so much that one often wonders why in certain places the author uses a sexual terminology at all. His concept of sexuality includes not only the physiological sexual processes but practically every stage, phase, and kind of feeling or desire. This enormous flexibility

makes his concept universally applicable, though not always to the advantage of the resulting explanations. By means of this inclusive concept you can explain a work of art or a religious experience in exactly the same terms as an hysterical symptom. The absolute difference between these three things then drops right out of the picture. The explanation can therefore be only an apparent one for at least two of them. Apart from these inconveniences, however, it is psychologically correct to tackle the problem first from the sexual side, for it is just there that the unprejudiced person will find something to think about.

[107] The conflict between ethics and sex today is not just a collision between instinctuality and morality, but a struggle to give an instinct its rightful place in our lives, and to recognize in this instinct a power which seeks expression and evidently may not be trifled with, and therefore cannot be made to fit in with our well-meaning moral laws. Sexuality is not mere instinctuality; it is an indisputably creative power that is not only the basic cause of our individual lives, but a very serious factor in our psychic life as well. Today we know only too well the grave consequences that sexual disturbances can bring in their train. We could call sexuality the spokesman of the instincts, which is why from the spiritual standpoint sex is the chief antagonist, not because sexual indulgence is in itself more immoral than excessive eating and drinking, avarice, tyranny, and other extravagances, but because the spirit senses in sexuality a counterpart equal and indeed akin to itself. For just as the spirit would press sexuality, like every other instinct, into its service, so sexuality has an ancient claim upon the spirit, which it once—in procreation, pregnancy, birth, and childhood—contained within itself, and whose passion the spirit can never dispense with in its creations. Where would the spirit be if it had no peer among the instincts to oppose it? It would be nothing but an empty form. A reasonable regard for the other instincts has become for us a self-evident necessity, but with sex it is different. For us sex is still problematical, which means that on this point we have not reached a degree of consciousness that would enable us to do full justice to the instinct without appreciable moral injury. Freud is not only a scientific investigator of sexuality, but also its champion; therefore, having regard to the great importance of the sexual problem, I recognize the moral justification of his concept of sexuality even though I cannot accept it scientifically.

[108] This is not the place to discuss the possible reasons for the present attitude to sex. It is sufficient to point out that sexuality seems to us the strongest and most immediate instinct,⁷⁰ standing out as *the* instinct above all others. On the other hand, I must also emphasize that the spiritual principle does not, strictly speaking, conflict with instinct as such but only with blind instinctuality, which really amounts to an unjustified preponderance of the instinctual nature over the spiritual. The spiritual appears in the psyche also as an instinct, indeed as a real passion, a “consuming fire,”

as Nietzsche once expressed it. It is not derived from any other instinct, as the psychologists of instinct would have us believe, but is a principle *sui generis*, a specific and necessary form of instinctual power. I have gone into this problem in a special study, to which I would refer the reader.⁷¹

[109] Symbol-formation follows the road offered by these two possibilities in the human mind. Reduction breaks down all inappropriate and useless symbols and leads back to the merely natural course, and this causes a damming up of libido. Most of the alleged “sublimations” are compulsory products of this situation, activities cultivated for the purpose of using up the unbearable surplus of libido. But the really primitive demands are not satisfied by this procedure. If the psychology of this dammed-up condition is studied carefully and without prejudice, it is easy to discover in it the beginnings of a primitive form of religion, a religion of an individual kind altogether different from a dogmatic, collective religion.

[110] Since the making of a religion or the formation of symbols is just as important an interest of the primitive mind as the satisfaction of instinct, the way to further development is logically given: escape from the state of reduction lies in evolving a religion of an individual character. One’s true individuality then emerges from behind the veil of the collective personality, which would be quite impossible in the state of reduction since our instinctual nature is essentially collective. The development of individuality is also impossible, or at any rate seriously impeded, if the state of reduction gives rise to forced sublimations in the shape of various cultural activities, since these are in their essence equally collective. But, as human beings are for the most part collective, these forced sublimations are therapeutic products that should not be underestimated, because they help many people to bring a certain amount of useful activity into their lives. Among these cultural activities we must include the practice of a religion within the framework of an existing collective religion. The astonishing range of Catholic symbolism, for instance, has an emotional appeal which for many natures is absolutely satisfying. The immediacy of the relationship to God in Protestantism satisfies the mystic’s passion for independence, while theosophy with its unlimited speculative possibilities meets the need for pseudo-Gnostic intuitions and caters to lazy thinking.

[111] These organizations or systems are “symbola” (*σύμβολον* = confession of faith) which enable man to set up a spiritual counterpole to his primitive instinctual nature, a cultural attitude as opposed to sheer instinctuality. This has been the function of all religions. For a long time and for the great majority of mankind the symbol of a collective religion will suffice. It is perhaps only temporarily and for relatively few individuals that the existing collective religions have become inadequate. Wherever the cultural process is moving forward, whether in single individuals or in groups, we

find a shaking off of collective beliefs. Every advance in culture is, psychologically, an extension of consciousness, a coming to consciousness that can take place only through discrimination. Therefore an advance always begins with individuation, that is to say with the individual, conscious of his isolation, cutting a new path through hitherto untrodden territory. To do this he must first return to the fundamental facts of his own being, irrespective of all authority and tradition, and allow himself to become conscious of his distinctiveness. If he succeeds in giving collective validity to his widened consciousness, he creates a tension of opposites that provides the stimulation which culture needs for its further progress.

[112] This is not to say that the development of individuality is in all circumstances necessary or even opportune. Yet one may well believe, as Goethe has said, that “the highest joy of man should be the growth of personality.” There are large numbers of people for whom the development of individuality is the prime necessity, especially in a cultural epoch like ours, which is literally flattened out by collective norms, and where the newspaper is the real monarch of the earth. In my naturally limited experience there are, among people of maturer age, very many for whom the development of individuality is an indispensable requirement. Hence I am privately of the opinion that it is just the mature person who, in our times, has the greatest need of some further education in individual culture after his youthful education in school or university has moulded him on exclusively collective lines and thoroughly imbued him with the collective mentality. I have often found that people of riper years are in this respect capable of education to a most unexpected degree, although it is just those matured and strengthened by the experience of life who resist most vigorously the purely reductive standpoint.

[113] Obviously it is in the youthful period of life that we have most to gain from a thorough recognition of the instinctual side. A timely recognition of sexuality, for instance, can prevent that neurotic suppression of it which keeps a man unduly withdrawn from life, or else forces him into a wretched and unsuitable way of living with which he is bound to come into conflict. Proper recognition and appreciation of normal instincts leads the young person into life and entangles him with fate, thus involving him in life’s necessities and the consequent sacrifices and efforts through which his character is developed and his experience matured. For the mature person, however, the continued expansion of life is obviously not the right principle, because the descent towards life’s afternoon demands simplification, limitation, and intensification—in other words, individual culture. A man in the first half of life with its biological orientation can usually, thanks to the youthfulness of his whole organism, afford to expand his life and make something of value out of it. But the man in the second half of life is oriented towards culture, the diminishing powers of his organism allowing him to subordinate his instincts to cultural goals. Not a few are

wrecked during the transition from the biological to the cultural sphere. Our collective education makes practically no provision for this transitional period. Concerned solely with the education of the young, we disregard the education of the adult, of whom it is always assumed—on what grounds who can say?—that he needs no more education. There is an almost total lack of guidance for this extraordinarily important transition from the biological to the cultural attitude, for the transformation of energy from the biological form into the cultural form. This transformation process is an individual one and cannot be enforced by general rules and maxims. It is achieved by means of the symbol. Symbol-formation is a fundamental problem that cannot be discussed here. I must refer the reader to Chapter V in my *Psychological Types*, where I have dealt with this question in detail.

IV. THE PRIMITIVE CONCEPTION OF LIBIDO

[114] How intimately the beginnings of religious symbol-formation are bound up with a concept of energy is shown by the most primitive ideas concerning a magical potency, which is regarded both as an objective force and as a subjective state of intensity.

[115] I will give some examples to illustrate this. According to the report of McGee, the Dakota Indians have the following conception of this “power.” The sun is *wakonda*, not *the wakonda*, or *a wakonda*, but simply *wakonda*. The moon is *wakonda*, and so are thunder, lightning, stars, wind, etc. Men too, especially the shaman, are *wakonda*, also the demons of the elemental forces, fetishes, and other ritual objects, as well as many animals and localities of an especially impressive character. McGee says: “The expression [*wakonda*] can perhaps be rendered by the word ‘mystery’ better than any other, but even this concept is too narrow, because *wakonda* can equally well mean power, holy, old, greatness, alive, immortal.”⁷²

[116] Similar to the use of *wakonda* by the Dakotas is that of *oki* by the Iroquois and of *manitu* by the Algonquins, with the abstract meaning of power or productive energy. *Wakonda* is the conception of a “diffused, all-pervasive, invisible, manipulable and transferable life-energy and universal force.”⁷³ The life of the primitive with all its interests is centred upon the possession of this power in sufficient amount.

[117] Especially valuable is the observation that a concept like *manitu* occurs also as an exclamation when anything astonishing happens. Hetherwick⁷⁴ reports the same thing of the Yaos of central Africa, who cry *mulungu!* when they see something astonishing or incomprehensible. *Mulungu* means: (1) the soul of a man, which is called *lisoka* in life and becomes *mulungu* after death; (2) the entire spirit world; (3) the magically effective property or power inherent in any kind of object, such as the

life and health of the body; (4) the active principle in everything magical, mysterious, inexplicable, and unexpected; and (5) the great spiritual power that has created the world and all life.

[118] Similar to this is the *wong* concept of the Gold Coast. *Wong* can be a river, a tree, an amulet, or a lake, a spring, an area of land, a termite hill, crocodiles, monkeys, snakes, birds, etc. Tylor⁷⁵ erroneously interprets the *wong* force animistically as spirit or soul. But the way in which *wong* is used shows that it is a dynamic relation between man and objects.

[119] The *churinga*⁷⁶ of the Australian aborigines is a similar energetic concept. It means: (1) the ritual object; (2) the body of an individual ancestor (from whom the life force comes); (3) the mystical property of any object.

[120] Much the same is the *zogo* concept of the Australian tribesmen of the Torres Strait, the word being used both as a noun and an adjective. The Australian *arunquiltha* is a parallel concept of similar meaning, only it is the word for bad magic and for the evil spirit who likes to swallow the sun in an eclipse.⁷⁷ Of similar character is the Malayan *badi*, which also includes evil magical relationships.

[121] The investigations of Lumholtz⁷⁸ have shown that the Mexican Huichols likewise have a fundamental conception of a power that circulates through men, ritual animals and plants (deer, mescal, corn, plumes, etc.).⁷⁹

[122] From the researches of Alice Fletcher among North American Indians it appears that the *wakan* concept is one of energetic relationship similar to those already discussed. A man may become *wakan* through fasting, prayer, or visions. The weapons of a young man are *wakan*; they may not be touched by a woman (otherwise the libido runs backwards). For this reason the weapons are prayed to before battle (in order to make them powerful by charging them with libido). *Wakan* establishes the connection between the visible and the invisible, between the living and the dead, between the part and the whole of an object.

[123] Codrington says of the Melanesian concept of *mana*: “The Melanesian mind is entirely possessed by the belief in a supernatural power or influence, called almost universally *mana*. This is what works to effect everything which is beyond the power of the ordinary man, outside the common processes of nature; it is present in the atmosphere of life, attaches itself to persons and to things, and is manifested by results which can only be ascribed to its operation. ... It is a power or influence, not physical, and in a way supernatural; but it shows itself in physical force, or in any kind of power or influence which a man possesses. This *mana* is not fixed in anything, and can be conveyed in almost anything; but spirits, whether disembodied souls or supernatural beings, have it and can impart it; and it essentially belongs to

personal beings to originate it, though it may act through the medium of water, or a stone, or a bone.”⁸⁰

[124] This description shows clearly that in the case of *mana*, as with the other concepts, we are dealing with a concept of energy which alone enables us to explain the remarkable fact of these primitive ideas. This is not to suggest that the primitive has an abstract idea of energy, but there can be no doubt that his concept is the preliminary concretistic stage of the abstract idea.

[125] We find similar views in the *tondi* concept of the Bataks,⁸¹ in the *atua* of the Maoris, in the *ani* or *han* of Ponape, the *kasinge* or *kalit* of Palau, the *anut* of Kusaie, the *yaris* of Tobi, the *ngai* of the Masai, the *andriamanitra* of the Malagasy, the *njom* of the Ekoi, etc. A complete survey is given by Söderblom in his book *Das Werden des Gottesglaubens*.

[126] Lovejoy is of the opinion—with which I am in full agreement—that these concepts “are not primarily names for the ‘supernormal’ or the astonishing and certainly not for that which evokes awe, respect and love—but rather for the efficacious, the powerful, the productive.” The concept in question really concerns the idea of “a diffused substance or energy upon the possession of which all exceptional power or ability or fecundity depends. The energy is, to be sure, terrible (under certain circumstances) and it is mysterious and incomprehensible; but it is so because it is vastly powerful, not because the things that manifest it are unusual and ‘supernatural’ or such as ‘defeat reasonable expectation.’” The pre-animistic principle is the belief in “a force which is conceived as working according to quite regular and intelligible laws, a force which can be studied and controlled.”⁸² For these concepts Lovejoy suggests the term “primitive energetics.”

[127] Much that was taken by investigators animistically as spirit, demon, or numen really belongs to the primitive concept of energy. As I have already remarked, it is, in the strict sense, incorrect to speak of a “concept.” “A concept of primitive philosophy,” as Lovejoy calls it, is an idea obviously born of our own mentality; that is to say, for us *mana* would be a psychological concept of energy, but for the primitive it is a psychic *phenomenon* that is perceived as something inseparable from the object. There are no abstract ideas to be found among primitives, not even, as a rule, simple concrete concepts, but only “representations.” All primitive languages offer abundant proof of this. Thus *mana* is not a concept but a representation based on the perception of a “phenomenal” relationship. It is the essence of Lévy-Bruhl’s *participation mystique*. In primitive speech only the fact of the relationship and the experience it evokes are indicated, as some of the above examples clearly show, not the nature or essence of that relationship, or of the principle determining it. The discovery of a suitable designation for the nature and essence of the unifying

principle was reserved for a later level of culture, which substituted symbolic expressions.

[128] In his classic study of *mana* Lehmann defines it as something “extraordinarily effective.” The psychic nature of *mana* is especially emphasized by Preuss⁸³ and Röhr.⁸⁴ We cannot escape the impression that the primitive view of *mana* is a forerunner of our concept of psychic energy and, most probably, of energy in general.⁸⁵

[129] The basic conception of *mana* crops up again on the animistic level in personified form.⁸⁶ Here it is souls, demons, gods, who produce the extraordinary effect. As Lehmann rightly points out, nothing “divine” attaches to *mana*, so that one cannot see in *mana* the original form of an idea of God. Nonetheless, it cannot be denied that *mana* is a necessary or at least a very important precondition for the development of an idea of God, even though it may not be the most primitive of all preconditions. Another essential precondition is personification, for whose explanation other psychological factors must be adduced.

[130] The almost universal incidence of the primitive concept of energy is a clear expression of the fact that even at early levels of human consciousness man felt the need to represent the sensed dynamism of psychic events in a concrete way. If, therefore, in our psychology we lay stress on the energetic point of view, this is in accord with the psychic facts which have been graven on the mind of man since primordial times.

THE TRANSCENDENT FUNCTION¹

Prefatory Note

This essay was written in 1916. Recently it was discovered by students of the C. G. Jung Institute, Zurich, and was brought out in a private edition in its first, provisional form, in an English translation. In order to prepare it for publication, I have worked over the manuscript, while preserving the main trend of thought and the unavoidable limitedness of its horizon. After forty-two years, the problem has lost nothing of its topicality, though its presentation is still in need of extensive improvement, as anyone can see who knows the material. The essay may therefore stand, with all its imperfections, as an historical document. It may give the reader some idea of the efforts of understanding which were needed for the first attempts at a synthetic view of the psychic process in analytical treatment. As its basic argument is still valid today, it may stimulate the reader to a broader and deeper understanding of the problem. This problem is identical with the universal question: How does one come to terms in practice with the unconscious?

This is the question posed by the philosophy of India, and particularly by Buddhism and Zen. Indirectly, it is the fundamental question, in practice, of all religions and all philosophies. For the unconscious is not this thing or that; it is the Unknown as it immediately affects us.

The method of “active imagination,” hereinafter described, is the most important auxiliary for the production of those contents of the unconscious which lie, as it were, immediately below the threshold of consciousness and, when intensified, are the most likely to irrupt spontaneously into the conscious mind. The method, therefore, is not without its dangers and should, if possible, not be employed except under expert supervision. One of the lesser dangers is that the procedure may not lead to any positive result, since it easily passes over into the so-called “free association” of Freud, whereupon the patient gets caught in the sterile circle of his own complexes, from which he is in any case unable to escape. A further danger, in itself harmless, is that, though authentic contents may be produced, the patient evinces an exclusively aesthetic interest in them and consequently remains stuck in an all-enveloping phantasmagoria, so that once more nothing is gained. The meaning and value of these fantasies are revealed only through their integration into the personality as a whole—that is to say, at the moment when one is confronted not only with what they mean but also with their moral demands.

Finally, a third danger—and this may in certain circumstances be a very serious matter—is that the subliminal contents already possess such a high energy charge that, when afforded an outlet by active imagination, they may overpower the conscious mind and take possession of the personality. This gives rise to a condition which—temporarily, at least—cannot easily be distinguished from schizophrenia, and may even lead to a genuine “psychotic interval.” The method of active imagination, therefore, is not a plaything for children. The prevailing undervaluation of the unconscious adds considerably to the dangers of this method. On the other hand, there can be no doubt that it is an invaluable auxiliary for the psychotherapist.

C. G. J.

Küsnacht, July 1958 / September 1959

[131] There is nothing mysterious or metaphysical about the term “transcendent function.” It means a psychological function comparable in its way to a mathematical function of the same name, which is a function of real and imaginary numbers. The psychological “transcendent function” arises from the union of conscious and unconscious contents.

[132] Experience in analytical psychology has amply shown that the conscious and the unconscious seldom agree as to their contents and their tendencies. This lack of parallelism is not just accidental or purposeless, but is due to the fact that the unconscious behaves in a compensatory or complementary manner towards the conscious. We can also put it the other way round and say that the conscious behaves in a complementary manner towards the unconscious. The reasons for this relationship are:

(1) Consciousness possesses a threshold intensity which its contents must have attained, so that all elements that are too weak remain in the unconscious.

(2) Consciousness, because of its directed functions, exercises an inhibition (which Freud calls censorship) on all incompatible material, with the result that it sinks into the unconscious.

(3) Consciousness constitutes the momentary process of adaptation, whereas the unconscious contains not only all the forgotten material of the individual’s own past, but all the inherited behaviour traces constituting the structure of the mind.

(4) The unconscious contains all the fantasy combinations which have not yet attained the threshold intensity, but which in the course of time and under suitable conditions will enter the light of consciousness.

[133] This readily explains the complementary attitude of the unconscious towards the conscious.

[134] The definiteness and directedness of the conscious mind are qualities that have been acquired relatively late in the history of the human race, and are for instance largely lacking among primitives today. These qualities are often impaired in the neurotic patient, who differs from the normal person in that his threshold of consciousness gets shifted more easily; in other words, the partition between conscious and unconscious is much more permeable. The psychotic, on the other hand, is under the direct influence of the unconscious.

[135] The definiteness and directedness of the conscious mind are extremely important acquisitions which humanity has bought at a very heavy sacrifice, and which in turn have rendered humanity the highest service. Without them science, technology, and civilization would be impossible, for they all presuppose the reliable continuity and directedness of the conscious process. For the statesman, doctor, and engineer as well as for the simplest labourer, these qualities are absolutely indispensable. We may say in general that social worthlessness increases to the degree that these qualities are impaired by the unconscious. Great artists and others distinguished by creative gifts are, of course, exceptions to this rule. The very advantage that such individuals enjoy consists precisely in the permeability of the partition separating the conscious and the unconscious. But, for those professions and social activities which require just this continuity and reliability, these exceptional human beings are as a rule of little value.

[136] It is therefore understandable, and even necessary, that in each individual the psychic process should be as stable and definite as possible, since the exigencies of life demand it. But this involves a certain disadvantage: the quality of directedness makes for the inhibition or exclusion of all those psychic elements which appear to be, or really are, incompatible with it, i.e., likely to bias the intended direction to suit their purpose and so lead to an undesired goal. But how do we know that the concurrent psychic material is "incompatible"? We know it by an act of judgment which determines the direction of the path that is chosen and desired. This judgment is partial and prejudiced, since it chooses one particular possibility at the cost of all the others. The judgment in its turn is always based on experience, i.e., on what is already known. As a rule it is never based on what is new, what is still unknown, and what under certain conditions might considerably enrich the directed process. It is evident that it cannot be, for the very reason that the unconscious contents are excluded from consciousness.

[137] Through such acts of judgment the directed process necessarily becomes one-sided, even though the rational judgment may appear many-sided and unprejudiced. The very rationality of the judgment may even be the worst prejudice, since we call reasonable what appears reasonable to us. What appears to us unreasonable is therefore doomed to be excluded because of its irrational character. It may really be

irrational, but may equally well merely appear irrational without actually being so when seen from another standpoint.

[138] One-sidedness is an unavoidable and necessary characteristic of the directed process, for direction implies one-sidedness. It is an advantage and a drawback at the same time. Even when no outwardly visible drawback seems to be present, there is always an equally pronounced counter-position in the unconscious, unless it happens to be the ideal case where all the psychic components are tending in one and the same direction. This possibility cannot be disputed in theory, but in practice it very rarely happens. The counter-position in the unconscious is not dangerous so long as it does not possess any high energy-value. But if the tension increases as a result of too great one-sidedness, the counter-tendency breaks through into consciousness, usually just at the moment when it is most important to maintain the conscious direction. Thus the speaker makes a slip of the tongue just when he particularly wishes not to say anything stupid. This moment is critical because it possesses a high energy tension which, when the unconscious is already charged, may easily “spark” and release the unconscious content.

[139] Civilized life today demands concentrated, directed conscious functioning, and this entails the risk of a considerable dissociation from the unconscious. The further we are able to remove ourselves from the unconscious through directed functioning, the more readily a powerful counter-position can build up in the unconscious, and when this breaks out it may have disagreeable consequences.

[140] Analysis has given us a profound insight into the importance of unconscious influences, and we have learnt so much from this for our practical life that we deem it unwise to expect an elimination or standstill of the unconscious after the so-called completion of the treatment. Many patients, obscurely recognizing this state of affairs, have great difficulty in deciding to give up the analysis, although both they and the analyst find the feeling of dependency irksome. Often they are afraid to risk standing on their own feet, because they know from experience that the unconscious can intervene again and again in their lives in a disturbing and apparently unpredictable manner.

[141] It was formerly assumed that patients were ready to cope with normal life as soon as they had acquired enough practical self-knowledge to understand their own dreams. Experience has shown, however, that even professional analysts, who might be expected to have mastered the art of dream interpretation, often capitulate before their own dreams and have to call in the help of a colleague. If even one who purports to be an expert in the method proves unable to interpret his own dreams satisfactorily, how much less can this be expected of the patient. Freud's hope that the

unconscious could be “exhausted” has not been fulfilled. Dream-life and intrusions from the unconscious continue—*mutails mutandis*—unimpeded.

[142] There is a widespread prejudice that analysis is something like a “cure,” to which one submits for a time and is then discharged healed. That is a layman’s error left over from the early days of psychoanalysis. Analytical treatment could be described as a readjustment of psychological attitude achieved with the help of the doctor. Naturally this newly won attitude, which is better suited to the inner and outer conditions, can last a considerable time, but there are very few cases where a single “cure” is permanently successful. It is true that medical optimism has never stinted itself of publicity and has always been able to report definitive cures. We must, however, not let ourselves be deceived by the all-too-human attitude of the practitioner, but should always remember that the life of the unconscious goes on and continually produces problematical situations. There is no need for pessimism; we have seen too many excellent results achieved with good luck and honest work for that. But this need not prevent us from recognizing that analysis is no once-and-for-all “cure”; it is no more, at first, than a more or less thorough readjustment. There is no change that is unconditionally valid over a long period of time. Life has always to be tackled anew. There are, of course, extremely durable collective attitudes which permit the solution of typical conflicts. A collective attitude enables the individual to fit into society without friction, since it acts upon him like any other condition of life. But the patient’s difficulty consists precisely in the fact that his individual problem cannot be fitted without friction into a collective norm; it requires the solution of an individual conflict if the whole of his personality is to remain viable. No rational solution can do justice to this task, and there is absolutely no collective norm that could replace an individual solution without loss.

[143] The new attitude gained in the course of analysis tends sooner or later to become inadequate in one way or another, and necessarily so, because the constant flow of life again and again demands fresh adaptation. Adaptation is never achieved once and for all. One might certainly demand of analysis that it should enable the patient to gain new orientations in later life, too, without undue difficulty. And experience shows that this is true up to a point. We often find that patients who have gone through a thorough analysis have considerably less difficulty with new adjustments later on. Nevertheless, these difficulties prove to be fairly frequent and may at times be really troublesome. That is why even patients who have had a thorough analysis often turn to their old analyst for help at some later period. In the light of medical practice in general there is nothing very unusual about this, but it does contradict a certain misplaced enthusiasm on the part of the therapist as well as the view that analysis constitutes a unique “cure.” In the last resort it is highly improbable that there could ever be a therapy that got rid of all difficulties. Man needs difficulties;

they are necessary for health. What concerns us here is only an excessive amount of them.

[144] The basic question for the therapist is not how to get rid of the momentary difficulty, but how future difficulties may be successfully countered. The question is: what kind of mental and moral attitude is it necessary to have towards the disturbing influences of the unconscious, and how can it be conveyed to the patient?

[145] The answer obviously consists in getting rid of the separation between conscious and unconscious. This cannot be done by condemning the contents of the unconscious in a one-sided way, but rather by recognizing their significance in compensating the one-sidedness of consciousness and by taking this significance into account. The tendencies of the conscious and the unconscious are the two factors that together make up the transcendent function. It is called “transcendent” because it makes the transition from one attitude to another organically possible, without loss of the unconscious. The constructive or synthetic method of treatment presupposes insights which are at least potentially present in the patient and can therefore be made conscious. If the analyst knows nothing of these potentialities he cannot help the patient to develop them either, unless analyst and patient together devote proper scientific study to this problem, which as a rule is out of the question.

[146] In actual practice, therefore, the suitably trained analyst mediates the transcendent function for the patient, i.e., helps him to bring conscious and unconscious together and so arrive at a new attitude. In this function of the analyst lies one of the many important meanings of the *transference*. The patient clings by means of the transference to the person who seems to promise him a renewal of attitude; through it he seeks this change, which is vital to him, even though he may not be conscious of doing so. For the patient, therefore, the analyst has the character of an indispensable figure absolutely necessary for life. However infantile this dependence may appear to be, it expresses an extremely important demand which, if disappointed, often turns to bitter hatred of the analyst. It is therefore important to know what this demand concealed in the transference is really aiming at; there is a tendency to understand it in the reductive sense only, as an erotic infantile fantasy. But that would mean taking this fantasy, which is usually concerned with the parents, literally, as though the patient, or rather his unconscious, still had the expectations the child once had towards the parents. Outwardly it still is the same expectation of the child for the help and protection of the parents, but in the meantime the child has become an adult, and what was normal for a child is improper in an adult. It has become a metaphorical expression of the not consciously realized need for help in a crisis. Historically it is correct to explain the erotic character of the transference in terms of the infantile *eros*. But in that way the meaning and purpose of the

transference are not understood, and its interpretation as an infantile sexual fantasy leads away from the real problem. The understanding of the transference is to be sought not in its historical antecedents but in its purpose. The one-sided, reductive explanation becomes in the end nonsensical, especially when absolutely nothing new comes out of it except the increased resistances of the patient. The sense of boredom which then appears in the analysis is simply an expression of the monotony and poverty of ideas—not of the unconscious, as is sometimes supposed, but of the analyst, who does not understand that these fantasies should not be taken merely in a concretistic-reductive sense, but rather in a constructive one. When this is realized, the standstill is often overcome at a single stroke.

[147] Constructive treatment of the unconscious, that is, the question of meaning and purpose, paves the way for the patient's insight into that process which I call the transcendent function.

[148] It may not be superfluous, at this point, to say a few words about the frequently heard objection that the constructive method is simply "suggestion." The method is based, rather, on evaluating the symbol (i.e., dream-image or fantasy) not *semiotically*, as a sign for elementary instinctual processes, but symbolically in the true sense, the word "symbol" being taken to mean the best possible expression for a complex fact not yet clearly apprehended by consciousness. Through reductive analysis of this expression nothing is gained but a clearer view of the elements originally composing it, and though I would not deny that increased insight into these elements may have its advantages, it nevertheless bypasses the question of purpose. Dissolution of the symbol at this stage of analysis is therefore a mistake. To begin with, however, the method for working out the complex meanings suggested by the symbol is the same as in reductive analysis. The associations of the patient are obtained, and as a rule they are plentiful enough to be used in the synthetic method. Here again they are evaluated not semiotically but symbolically. The question we must ask is: to what meaning do the individual associations A, B, C point, when taken in conjunction with the manifest dream-content?

[149] An unmarried woman patient dreamt that *someone gave her a wonderful, richly ornamented, antique sword dug up out of a tumulus*. [For interpretation, see p. 76.]

[150] In this case there was no need of any supplementary analogies on the part of the analyst. The patient's associations provided all that was necessary. It might be objected that this treatment of the dream involves suggestion. But this ignores the fact that a suggestion is never accepted without an inner readiness for it, or if after great insistence it is accepted, it is immediately lost again. A suggestion that is accepted for any length of time always presupposes a marked psychological readiness which is merely brought into play by the so-called suggestion. This

objection is therefore thoughtless and credits suggestion with a magical power it in no way possesses, otherwise suggestion therapy would have an enormous effect and would render analytical procedures quite superfluous. But this is far from being the case. Furthermore, the charge of suggestion does not take account of the fact that the patient's own associations point to the cultural significance of the sword.

[151] After this digression, let us return to the question of the transcendent function. We have seen that during treatment the transcendent function is, in a sense, an "artificial" product because it is largely supported by the analyst. But if the patient is to stand on his own feet he must not depend permanently on outside help. The interpretation of dreams would be an ideal method for synthesizing the conscious and unconscious data, but in practice the difficulties of analyzing one's own dreams are too great.

ASSOCIATIONS

Her *father's* dagger, which he once flashed in the sun in front of her. It made a great impression on her. Her father was in every respect an energetic, strong-willed man, with an impetuous temperament, and adventurous in love affairs. A *Celtic* bronze sword: Patient is proud of her Celtic ancestry. The Celts are full of temperament, impetuous, passionate. The ornamentation has a mysterious look about it, ancient tradition, runes, signs of ancient wisdom, ancient civilizations, heritage of mankind, brought to light again out of the grave.

ANALYTICAL INTERPRETATION

Patient has a pronounced father complex and a rich tissue of sexual fantasies about her father, whom she lost early. She always put herself in her mother's place, although with strong resistances towards her father. She has never been able to accept a man like her father and has therefore chosen weakly, neurotic men against her will. Also in the analysis violent resistance towards the physician-father. The dream digs up her wish for her father's "weapon." The rest is clear. In theory, this would immediately point to a phallic fantasy.

CONSTRUCTIVE INTERPRETATION

It is as if the patient needed such a weapon. Her father had the weapon. He was energetic, lived accordingly, and also took upon himself the difficulties inherent in his temperament. Therefore, though living a passionate, exciting life he was not neurotic. This weapon is a very ancient heritage of mankind, which lay buried in the patient and was brought to light through excavation (analysis). The weapon has to do with insight, with wisdom. It is a means of attack and defence. Her father's weapon was a passionate, unbending will, with which he made his way through life. Up till now the patient has been the opposite in every respect. She is just on the point of realizing that a person can also will something and need not merely be driven, as she had always believed. The will based on a knowledge of life and on insight is an ancient heritage of the human race, which also is in her, but till now lay buried, for in this respect, too, she is her father's daughter. But she had not

appreciated this till now, because her character had been that of a perpetually whining, pampered, spoiled child. She was extremely passive and completely given to sexual fantasies.

Interpretation of dream (see par. 149)

[152] We must now make clear what is required to produce the transcendent function. First and foremost, we need the unconscious material. The most readily accessible expression of unconscious processes is undoubtedly dreams. The dream is, so to speak, a pure product of the unconscious. The alterations which the dream undergoes in the process of reaching consciousness, although undeniable, can be considered irrelevant, since they too derive from the unconscious and are not intentional distortions. Possible modifications of the original dream-image derive from a more superficial layer of the unconscious and therefore contain valuable material too. They are further fantasy-products following the general trend of the dream. The same applies to the subsequent images and ideas which frequently occur while dozing or rise up spontaneously on waking. Since the dream originates in sleep, it bears all the characteristics of an “*abaissement du niveau mental*” (Janet), or of low energy-tension: logical discontinuity, fragmentary character, analogy formations, superficial associations of the verbal, clang, or visual type, condensations, irrational expressions, confusion, etc. With an increase of energy-tension, the dreams acquire a more ordered character; they become dramatically composed and reveal clear sense-connections, and the valency of the associations increases.

[153] Since the energy-tension in sleep is usually very low, dreams, compared with conscious material, are inferior expressions of unconscious contents and are very difficult to understand from a constructive point of view, but are usually easier to understand reductively. In general, dreams are unsuitable or difficult to make use of in developing the transcendent function, because they make too great demands on the subject.

[154] We must therefore look to other sources for the unconscious material. There are, for instance, the unconscious interferences in the waking state, ideas “out of the blue,” slips, deceptions and lapses of memory, symptomatic actions, etc. This material is generally more useful for the reductive method than for the constructive one; it is too fragmentary and lacks continuity, which is indispensable for a meaningful synthesis.

[155] Another source is spontaneous fantasies. They usually have a more composed and coherent character and often contain much that is obviously significant. Some patients are able to produce fantasies at any time, allowing them to rise up freely simply by eliminating critical attention. Such fantasies can be used, though this particular talent is none too common. The capacity to produce free fantasies can,

however, be developed with practice. The training consists first of all in systematic exercises for eliminating critical attention, thus producing a vacuum in consciousness. This encourages the emergence of any fantasies that are lying in readiness. A prerequisite, of course, is that fantasies with a high libido-charge are actually lying ready. This is naturally not always the case. Where this is not so, special measures are required.

[156] Before entering upon a discussion of these, I must yield to an uncomfortable feeling which tells me that the reader may be asking dubiously, what really is the point of all this? And why is it so absolutely necessary to bring up the unconscious contents? Is it not sufficient if from time to time they come up of their own accord and make themselves unpleasantly felt? Does one have to drag the unconscious to the surface by force? On the contrary, should it not be the job of analysis to empty the unconscious of fantasies and in this way render it ineffective?

[157] It may be as well to consider these misgivings in somewhat more detail, since the methods for bringing the unconscious to consciousness may strike the reader as novel, unusual, and perhaps even rather weird. We must therefore first discuss these natural objections, so that they shall not hold us up when we begin demonstrating the methods in question.

[158] As we have seen, we need the unconscious contents to supplement the conscious attitude. If the conscious attitude were only to a slight degree "directed," the unconscious could flow in quite of its own accord. This is what does in fact happen with all those people who have a low level of conscious tension, as for instance primitives. Among primitives, no special measures are required to bring up the unconscious. Nowhere, really, are special measures required for this, because those people who are least aware of their unconscious side are the most influenced by it. But they are unconscious of what is happening. The secret participation of the unconscious is everywhere present without our having to search for it, but as it remains unconscious we never really know what is going on or what to expect. What we are searching for is a way to make conscious those contents which are about to influence our actions, so that the secret interference of the unconscious and its unpleasant consequences can be avoided.

[159] The reader will no doubt ask: why cannot the unconscious be left to its own devices? Those who have not already had a few bad experiences in this respect will naturally see no reason to control the unconscious. But anyone with sufficiently bad experience will eagerly welcome the bare possibility of doing so. Directedness is absolutely necessary for the conscious process, but as we have seen it entails an unavoidable one-sidedness. Since the psyche is a self-regulating system, just as the body is, the regulating counteraction will always develop in the unconscious. Were it

not for the directedness of the conscious function, the counteracting influences of the unconscious could set in unhindered. It is just this directedness that excludes them. This, of course, does not inhibit the counteraction, which goes on in spite of everything. Its regulating influence, however, is eliminated by critical attention and the directed will, because the counteraction as such seems incompatible with the conscious direction. To this extent the psyche of civilized man is no longer a self-regulating system but could rather be compared to a machine whose speed-regulation is so insensitive that it can continue to function to the point of self-injury, while on the other hand it is subject to the arbitrary manipulations of a one-sided will.

[160] Now it is a peculiarity of psychic functioning that when the unconscious counteraction is suppressed it loses its regulating influence. It then begins to have an accelerating and intensifying effect on the conscious process. It is as though the counteraction had lost its regulating influence, and hence its energy, altogether, for a condition then arises in which not only no inhibiting counteraction takes place, but in which its energy seems to add itself to that of the conscious direction. To begin with, this naturally facilitates the execution of the conscious intentions, but because they are unchecked, they may easily assert themselves at the cost of the whole. For instance, when someone makes a rather bold assertion and suppresses the counteraction, namely a well-placed doubt, he will insist on it all the more, to his own detriment.

[161] The ease with which the counteraction can be eliminated is proportional to the degree of dissociability of the psyche and leads to loss of instinct. This is characteristic of, as well as very necessary for, civilized man, since instincts in their original strength can render social adaptation almost impossible. It is not a real atrophy of instinct but, in most cases, only a relatively lasting product of education, and would never have struck such deep roots had it not served the interests of the individual.

[162] Apart from the everyday cases met with in practice, a good example of the suppression of the unconscious regulating influence can be found in Nietzsche's *Zarathustra*. The discovery of the "higher" man, and also of the "ugliest" man, expresses the regulating influence, for the "higher" men want to drag Zarathustra down to the collective sphere of average humanity as it always has been, while the "ugliest" man is actually the personification of the counteraction. But the roaring lion of Zarathustra's moral conviction forces all these influences, above all the feeling of pity, back again into the cave of the unconscious. Thus the regulating influence is suppressed, but not the secret counteraction of the unconscious, which from now on becomes clearly noticeable in Nietzsche's writings. First he seeks his adversary in Wagner, whom he cannot forgive for *Parsifal*, but soon his whole wrath turns against

Christianity and in particular against St. Paul, who in some ways suffered a fate similar to Nietzsche's. As is well known, Nietzsche's psychosis first produced an identification with the "Crucified Christ" and then with the dismembered Dionysus. With this catastrophe the counteraction at last broke through to the surface.

[163] Another example is the classic case of megalomania preserved for us in the fourth chapter of the Book of Daniel. Nebuchadnezzar at the height of his power had a dream which foretold disaster if he did not humble himself. Daniel interpreted the dream quite expertly, but without getting a hearing. Subsequent events showed that his interpretation was correct, for Nebuchadnezzar, after suppressing the unconscious regulating influence, fell victim to a psychosis that contained the very counteraction he had sought to escape: he, the lord of the earth, was degraded to an animal.

[164] An acquaintance of mine once told me a dream in which *he stepped out into space from the top of a mountain*. I explained to him something of the influence of the unconscious and warned him against dangerous mountaineering expeditions, for which he had a regular passion. But he laughed at such ideas. A few months later while climbing a mountain he actually did step off into space and was killed.

[165] Anyone who has seen these things happen over and over again in every conceivable shade of dramatic intensity is bound to ponder. He becomes aware how easy it is to overlook the regulating influences, and that he should endeavour to pay attention to the unconscious regulation which is so necessary for our mental and physical health. Accordingly he will try to help himself by practising self-observation and self-criticism. But mere self-observation and intellectual self-analysis are entirely inadequate as a means to establishing contact with the unconscious. Although no human being can be spared bad experiences, everyone shrinks from risking them, especially if he sees any way by which they might be circumvented. Knowledge of the regulating influences of the unconscious offers just such a possibility and actually does render much bad experience unnecessary. We can avoid a great many detours that are distinguished by no particular attraction but only by tiresome conflicts. It is bad enough to make detours and painful mistakes in unknown and unexplored territory, but to get lost in inhabited country on broad highways is merely exasperating. What, then, are the means at our disposal of obtaining knowledge of the regulating factors?

[166] If there is no capacity to produce fantasies freely, we have to resort to artificial aid. The reason for invoking such aid is generally a depressed or disturbed state of mind for which no adequate cause can be found. Naturally the patient can give any number of rationalistic reasons—the bad weather alone suffices as a reason. But none of them is really satisfying as an explanation, for a causal explanation of these states is usually satisfying only to an outsider, and then only up to a point. The outsider is

content if his causal requirements are more or less satisfied; it is sufficient for him to know where the thing comes from; he does not feel the challenge which, for the patient, lies in the depression. The patient would like to know what it is all for and how to gain relief. *In the intensity of the emotional disturbance itself lies the value, the energy which he should have at his disposal in order to remedy the state of reduced adaptation.* Nothing is achieved by repressing this state or devaluing it rationally.

[167] In order, therefore, to gain possession of the energy that is in the wrong place, he must make the emotional state the basis or starting point of the procedure. He must make himself as conscious as possible of the mood he is in, sinking himself in it without reserve and noting down on paper all the fantasies and other associations that come up. Fantasy must be allowed the freest possible play, yet not in such a manner that it leaves the orbit of its object, namely the affect, by setting off a kind of “chain-reaction” association process. This “free association,” as Freud called it, leads away from the object to all sorts of complexes, and one can never be sure that they relate to the affect and are not displacements which have appeared in its stead. Out of this preoccupation with the object there comes a more or less complete expression of the mood, which reproduces the content of the depression in some way, either concretely or symbolically. Since the depression was not manufactured by the conscious mind but is an unwelcome intrusion from the unconscious, the elaboration of the mood is, as it were, a picture of the contents and tendencies of the unconscious that were massed together in the depression. The whole procedure is a kind of enrichment and clarification of the affect, whereby the affect and its contents are brought nearer to consciousness, becoming at the same time more impressive and more understandable. This work by itself can have a favourable and vitalizing influence. At all events, it creates a new situation, since the previously unrelated affect has become a more or less clear and articulate idea, thanks to the assistance and co-operation of the conscious mind. This is the beginning of the transcendent function, i.e., of the collaboration of conscious and unconscious data.

[168] The emotional disturbance can also be dealt with in another way, not by clarifying it intellectually but by giving it visible shape. Patients who possess some talent for drawing or painting can give expression to their mood by means of a picture. It is not important for the picture to be technically or aesthetically satisfying, but merely for the fantasy to have free play and for the whole thing to be done as well as possible. In principle this procedure agrees with the one first described. Here too a product is created which is influenced by both conscious and unconscious, embodying the striving of the unconscious for the light and the striving of the conscious for substance.

[169] Often, however, we find cases where there is no tangible mood or depression at all, but just a general, dull discontent, a feeling of resistance to everything, a sort of boredom or vague disgust, an indefinable but excruciating emptiness. In these cases no definite starting point exists—it would first have to be created. Here a special introversion of libido is necessary, supported perhaps by favourable external conditions, such as complete rest, especially at night, when the libido has in any case a tendency to introversion. (“’Tis night: now do all fountains speak louder. And my soul also is a bubbling fountain.”²)

[170] Critical attention must be eliminated. Visual types should concentrate on the expectation that an inner image will be produced. As a rule such a fantasy-picture will actually appear—perhaps hypnagogically—and should be carefully observed and noted down in writing. Audio-verbal types usually hear inner words, perhaps mere fragments of apparently meaningless sentences to begin with, which however should be carefully noted down too. Others at such times simply hear their “other” voice. There are, indeed, not a few people who are well aware that they possess a sort of inner critic or judge who immediately comments on everything they say or do. Insane people hear this voice directly as auditory hallucinations. But normal people too, if their inner life is fairly well developed, are able to reproduce this inaudible voice without difficulty, though as it is notoriously irritating and refractory it is almost always repressed. Such persons have little difficulty in procuring the unconscious material and thus laying the foundation of the transcendent function.

[171] There are others, again, who neither see nor hear anything inside themselves, but whose hands have the knack of giving expression to the contents of the unconscious. Such people can profitably work with plastic materials. Those who are able to express the unconscious by means of bodily movements are rather rare. The disadvantage that movements cannot easily be fixed in the mind must be met by making careful drawings of the movements afterwards, so that they shall not be lost to the memory. Still rarer, but equally valuable, is automatic writing, direct or with the planchette. This, too, yields useful results.

[172] We now come to the next question: what is to be done with the material obtained in one of the manners described. To this question there is no *a priori* answer; it is only when the conscious mind confronts the products of the unconscious that a provisional reaction will ensue which determines the subsequent procedure. Practical experience alone can give us a clue. So far as my experience goes, there appear to be two main tendencies. One is the way of *creative formulation*, the other the way of *understanding*.

[173] Where the principle of creative formulation predominates, the material is continually varied and increased until a kind of condensation of motifs into more or

less stereotyped symbols takes place. These stimulate the creative fantasy and serve chiefly as aesthetic motifs. This tendency leads to the aesthetic problem of artistic formulation.

[174] Where, on the other hand, the principle of understanding predominates, the aesthetic aspect is of relatively little interest and may occasionally even be felt as a hindrance. Instead, there is an intensive struggle to understand the *meaning* of the unconscious product.

[175] Whereas aesthetic formulation tends to concentrate on the formal aspect of the motif, an intuitive understanding often tries to catch the meaning from barely adequate hints in the material, without considering those elements which would come to light in a more careful formulation.

[176] Neither of these tendencies can be brought about by an arbitrary effort of will; they are far more the result of the peculiar make-up of the individual personality. Both have their typical dangers and may lead one astray. The danger of the aesthetic tendency is overvaluation of the formal or "artistic" worth of the fantasy-productions; the libido is diverted from the real goal of the transcendent function and sidetracked into purely aesthetic problems of artistic expression. The danger of wanting to understand the meaning is overvaluation of the content, which is subjected to intellectual analysis and interpretation, so that the essentially symbolic character of the product is lost. Up to a point these bypaths must be followed in order to satisfy aesthetic or intellectual requirements, whichever predominate in the individual case. But the danger of both these bypaths is worth stressing, for, after a certain point of psychic development has been reached, the products of the unconscious are greatly overvalued precisely because they were boundlessly undervalued before. This undervaluation is one of the greatest obstacles in formulating the unconscious material. It reveals the collective standards by which anything individual is judged: nothing is considered good or beautiful that does not fit into the collective schema, though it is true that contemporary art is beginning to make compensatory efforts in this respect. What is lacking is not the collective recognition of the individual product but its subjective appreciation, the understanding of its meaning and value for the *subject*. This feeling of inferiority for one's own product is of course not the rule everywhere. Sometimes we find the exact opposite: a naïve and uncritical overvaluation coupled with the demand for collective recognition once the initial feeling of inferiority has been overcome. Conversely, an initial overvaluation can easily turn into depreciatory scepticism. These erroneous judgments are due to the individual's unconsciousness and lack of self-reliance: either he is able to judge only by collective standards, or else, owing to ego-inflation, he loses his capacity for judgment altogether.

[177] *One tendency seems to be the regulating principle of the other*; both are bound together in a compensatory relationship. Experience bears out this formula. So far as it is possible at this stage to draw more general conclusions, we could say that aesthetic formulation needs understanding of the meaning, and understanding needs aesthetic formulation. The two supplement each other to form the transcendent function.

[178] The first steps along both paths follow the same principle: consciousness puts its media of expression at the disposal of the unconscious content. It must not do more than this at first, so as not to exert undue influence. In giving the content form, the lead must be left as far as possible to the chance ideas and associations thrown up by the unconscious. This is naturally something of a setback for the conscious standpoint and is often felt as painful. It is not difficult to understand this when we remember how the contents of the unconscious usually present themselves: as things which are too weak by nature to cross the threshold, or as incompatible elements that were repressed for a variety of reasons. Mostly they are unwelcome, unexpected, irrational contents, disregard or repression of which seems altogether understandable. Only a small part of them has any unusual value, either from the collective or from the subjective standpoint. But contents that are collectively valueless may be exceedingly valuable when seen from the standpoint of the individual. This fact expresses itself in their affective tone, no matter whether the subject feels it as negative or positive. Society, too, is divided in its acceptance of new and unknown ideas which obtrude their emotionality. The purpose of the initial procedure is to discover the feeling-toned contents, for in these cases we are always dealing with situations where the one-sidedness of consciousness meets with the resistance of the instinctual sphere.

[179] The two ways do not divide until the aesthetic problem becomes decisive for the one type of person and the intellectual-moral problem for the other. The ideal case would be if these two aspects could exist side by side or rhythmically succeed each other; that is, if there were an alternation of creation and understanding. It hardly seems possible for the one to exist without the other, though it sometimes does happen in practice: the creative urge seizes possession of the object at the cost of its meaning, or the urge to understand overrides the necessity of giving it form. The unconscious contents want first of all to be seen clearly, which can only be done by giving them shape, and to be judged only when everything they have to say is tangibly present. It was for this reason that Freud got the dream-contents, as it were, to express themselves in the form of “free associations” before he began interpreting them.

[180] It does not suffice in all cases to elucidate only the conceptual context of a dream-content. Often it is necessary to clarify a vague content by giving it a visible form. This can be done by drawing, painting, or modelling. Often the hands know how to solve a riddle with which the intellect has wrestled in vain. By shaping it, one goes on dreaming the dream in greater detail in the waking state, and the initially incomprehensible, isolated event is integrated into the sphere of the total personality, even though it remains at first unconscious to the subject. Aesthetic formulation leaves it at that and gives up any idea of discovering a meaning. This sometimes leads patients to fancy themselves artists—misunderstood ones, naturally. The desire to understand, if it dispenses with careful formulation, starts with the chance idea or association and therefore lacks an adequate basis. It has better prospects of success if it begins only with the formulated product. The less the initial material is shaped and developed, the greater is the danger that understanding will be governed not by the empirical facts but by theoretical and moral considerations. The kind of understanding with which we are concerned at this stage consists in a reconstruction of the meaning that seems to be immanent in the original “chance” idea.

[181] It is evident that such a procedure can legitimately take place only when there is a sufficient motive for it. Equally, the lead can be left to the unconscious only if it already contains the will to lead. This naturally happens only when the conscious mind finds itself in a critical situation. Once the unconscious content has been given form and the meaning of the formulation is understood, the question arises as to how the ego will relate to this position, and how the ego and the unconscious are to come to terms. This is the second and more important stage of the procedure, the bringing together of opposites for the production of a third: the transcendent function. At this stage it is no longer the unconscious that takes the lead, but the ego.

[182] We shall not define the individual ego here, but shall leave it in its banal reality as that continuous centre of consciousness whose presence has made itself felt since the days of childhood. It is confronted with a psychic product that owes its existence mainly to an unconscious process and is therefore in some degree opposed to the ego and its tendencies.

[183] This standpoint is essential in coming to terms with the unconscious. The position of the ego must be maintained as being of equal value to the counter-position of the unconscious, and vice versa. This amounts to a very necessary warning: for just as the conscious mind of civilized man has a restrictive effect on the unconscious, so the rediscovered unconscious often has a really dangerous effect on the ego. In the same way that the ego suppressed the unconscious before, a liberated unconscious can thrust the ego aside and overwhelm it. There is a danger of the ego losing its head, so to speak, that it will not be able to defend itself against the

pressure of affective factors—a situation often encountered at the beginning of schizophrenia. This danger would not exist, or would not be so acute, if the process of having it out with the unconscious could somehow divest the affects of their dynamism. And this is what does in fact happen when the counter-position is aestheticized or intellectualized. But the confrontation with the unconscious must be a many-sided one, for the transcendent function is not a partial process running a conditioned course; it is a total and integral event in which all aspects are, or should be, included. The affect must therefore be deployed in its full strength. Aestheticization and intellectualization are excellent weapons against dangerous affects, but they should be used only when there is a vital threat, and not for the purpose of avoiding a necessary task.

[184] Thanks to the fundamental insight of Freud, we know that emotional factors must be given full consideration in the treatment of the neuroses. The personality *as a whole* must be taken seriously into account, and this applies to both parties, the patient as well as the analyst. How far the latter may hide behind the shield of theory remains a delicate question, to be left to his discretion. At all events, the treatment of neurosis is not a kind of psychological water-cure, but a renewal of the personality, working in every direction and penetrating every sphere of life. Coming to terms with the counter-position is a serious matter on which sometimes a very great deal depends. Taking the other side seriously is an essential prerequisite of the process, for only in that way can the regulating factors exert an influence on our actions. Taking it seriously does not mean taking it literally, but it does mean giving the unconscious credit, so that it has a chance to co-operate with consciousness instead of automatically disturbing it.

[185] Thus, in coming to terms with the unconscious, not only is the standpoint of the ego justified, but the unconscious is granted the same authority. The ego takes the lead, but the unconscious must be allowed to have its say *too*—*audiatur et altera pars*.

[186] The way this can be done is best shown by those cases in which the “other” voice is more or less distinctly heard. For such people it is technically very simple to note down the “other” voice in writing and to answer its statements from the standpoint of the ego. It is exactly as if a dialogue were taking place between two human beings with equal rights, each of whom gives the other credit for a valid argument and considers it worth while to modify the conflicting standpoints by means of thorough comparison and discussion or else to distinguish them clearly from one another. Since the way to agreement seldom stands open, in most cases a long conflict will have to be borne, demanding sacrifices from both sides. Such a rapprochement could

just as well take place between patient and analyst, the role of devil's advocate easily falling to the latter.

[187] The present day shows with appalling clarity how little able people are to let the other man's argument count, although this capacity is a fundamental and indispensable condition for any human community. Everyone who proposes to come to terms with himself must reckon with this basic problem. For, to the degree that he does not admit the validity of the other person, he denies the "other" within himself the right to exist—and vice versa. The capacity for inner dialogue is a touchstone for outer objectivity.

[188] Simple as the process of coming to terms may be in the case of the inner dialogue, it is undoubtedly more complicated in other cases where only visual products are available, speaking a language which is eloquent enough for one who understands it, but which seems like deaf-and-dumb language to one who does not. Faced with such products, the ego must seize the initiative and ask: "How am I affected by this sign?"³ This Faustian question can call forth an illuminating answer. The more direct and natural the answer is, the more valuable it will be, for directness and naturalness guarantee a more or less total reaction. It is not absolutely necessary for the process of confrontation itself to become conscious in every detail. Very often a total reaction does not have at its disposal those theoretical assumptions, views, and concepts which would make clear apprehension possible. In such cases one must be content with the wordless but suggestive feelings which appear in their stead and are more valuable than clever talk.

[189] The shuttling to and fro of arguments and affects represents the transcendent function of opposites. The confrontation of the two positions generates a tension charged with energy and creates a living, third thing—not a logical stillbirth in accordance with the principle *tertium non datur* but a movement out of the suspension between opposites, a living birth that leads to a new level of being, a new situation. The transcendent function manifests itself as a quality of conjoined opposites. So long as these are kept apart—naturally for the purpose of avoiding conflict—they do not function and remain inert.

[190] In whatever form the opposites appear in the individual, at bottom it is always a matter of a consciousness lost and obstinately stuck in one-sidedness, confronted with the image of instinctive wholeness and freedom. This presents a picture of the anthropoid and archaic man with, on the one hand, his supposedly uninhibited world of instinct and, on the other, his often misunderstood world of spiritual ideas, who, compensating and correcting our one-sidedness, emerges from the darkness and shows us how and where we have deviated from the basic pattern and crippled ourselves psychically.

[191] I must content myself here with a description of the outward forms and possibilities of the transcendent function. Another task of greater importance would be the description of its *contents*. There is already a mass of material on this subject, but not all the difficulties in the way of exposition have yet been overcome. A number of preparatory studies are still needed before the conceptual foundation is laid which would enable us to give a clear and intelligible account of the contents of the transcendent function. I have unfortunately had the experience that the scientific public are not everywhere in a position to follow a purely psychological argument, since they either take it too personally or are bedevilled by philosophical or intellectual prejudices. This renders any meaningful appreciation of the psychological factors quite impossible. If people take it personally their judgment is always subjective, and they declare everything to be impossible which seems not to apply in their case or which they prefer not to acknowledge. They are quite incapable of realizing that what is valid for them may not be valid at all for another person with a different psychology. We are still very far from possessing a general valid scheme of explanation in all cases.

[192] One of the greatest obstacles to psychological understanding is the inquisitive desire to know whether the psychological factor adduced is “true” or “correct.” If the description of it is not erroneous or false, then the factor is valid in itself and proves its validity by its very existence. One might just as well ask if the duck-billed platypus is a “true” or “correct” invention of the Creator’s will. Equally childish is the prejudice against the role which mythological assumptions play in the life of the psyche. Since they are not “true,” it is argued, they have no place in a scientific explanation. But mythologems *exist*, even though their statements do not coincide with our incommensurable idea of “truth.”

[193] As the process of coming to terms with the counter-position has a total character, nothing is excluded. Everything takes part in the discussion, even if only fragments become conscious. Consciousness is continually widened through the confrontation with previously unconscious contents, or—to be more accurate—could be widened if it took the trouble to integrate them. That is naturally not always the case. Even if there is sufficient intelligence to understand the procedure, there may yet be a lack of courage and self-confidence, or one is too lazy, mentally and morally, or too cowardly, to make an effort. But where the necessary premises exist, the transcendent function not only forms a valuable addition to psychotherapeutic treatment, but gives the patient the inestimable advantage of assisting the analyst on his own resources, and of breaking a dependence which is often felt as humiliating. It is a way of attaining liberation by one’s own efforts and of finding the courage to be oneself.

A REVIEW OF THE COMPLEX THEORY¹

[194] Modern psychology has one thing in common with modern physics, that its method enjoys greater intellectual recognition than its subject. Its subject, the psyche, is so infinitely diverse in its manifestations, so indefinite and so unbounded, that the definitions given of it are difficult if not impossible to interpret, whereas the definitions based on the mode of observation and on the method derived from it are—or at least should be—known quantities. Psychological research proceeds from these empirically or arbitrarily defined factors and observes the psyche in terms of their alteration. The psyche therefore appears as the *disturbance* of a probable mode of behaviour postulated by one or other of these methods. This procedure is, *cum grano salis*, that of natural science in general.

[195] It goes without saying that in these circumstances almost everything depends on the method and its presuppositions and that they largely determine the result. The actual object of investigation does, of course, have some say in the matter, yet it does not behave as an autonomous being would behave if left undisturbed in its natural conditions. It has therefore long been recognized in experimental psychology, and above all in psychopathology, that a particular experimental procedure does not apprehend the psychic process directly, but that a certain psychic condition interpolates itself between it and the experiment, which one could call the “experimental situation.” This psychic “situation” can sometimes jeopardize the whole experiment by *assimilating* not only the experimental procedure but the purpose underlying it. By “assimilation” we mean an attitude on the part of the subject, who misinterprets the experiment because he has at first an insuperable tendency to assume that it is, shall we say, an intelligence test or an attempt to take an indiscreet look behind the scenes. Such an attitude disguises the process which the experimenter is struggling to observe.

[196] Experiences of this kind were very common in the association tests, and it was discovered on these occasions that what the method was aiming at, namely to establish the average speed of the reactions and their qualities, was a relatively subsidiary result compared with the way in which the method was *disturbed* by the autonomous behaviour of the psyche, that is, by assimilation. It was then that I discovered the feeling-toned complexes, which had always been registered before as *failures to react*.

[197] The discovery of complexes, and of the phenomena of assimilation caused by them, showed very clearly on what a weak footing the old view—dating back to Condillac—stood, that it was possible to investigate *isolated* psychic processes. There are no isolated psychic processes, just as there are no isolated life-processes; at any rate, no means have yet been found of isolating them experimentally.² Only with the help of specially trained attention and concentration can the subject isolate a process so that it appears to meet the requirements of the experiment. But this is yet another “experimental situation,” which differs from the one previously described only because this time the role of the assimilating complex is taken over by the conscious mind, whereas before this was done by more or less unconscious inferiority complexes.

[198] Now this does not mean that the *value* of the experiment is put in question in any fundamental sense, only that it is critically limited. In the realm of psychophysiological processes—for instance, sense perceptions or motor reactions, where the purpose of the experiment is obviously harmless—pure reflex mechanisms predominate, and there are few if any assimilations, so that the experiment is not appreciably disturbed. It is very different in the realm of complicated psychic processes, where the experimental procedure cannot be restricted to certain definite possibilities. Here, where the safeguards afforded by specific aims fall away, unlimited possibilities emerge, and these sometimes give rise right at the beginning to an experimental situation which we call a “constellation.” This term simply expresses the fact that the outward situation releases a psychic process in which certain contents gather together and prepare for action. When we say that a person is “constellated” we mean that he has taken up a position from which he can be expected to react in a quite definite way. But the constellation is an automatic process which happens involuntarily and which no one can stop of his own accord. The constellated contents are definite complexes possessing their own specific energy. If the experiment in question is an association test, the complexes will influence its course in high degree by provoking disturbed reactions or—more rarely—by hiding behind a definite mode of reaction which, however, can be recognized by the fact that it no longer corresponds to the meaning of the stimulus word. Educated subjects with strong wills can, through verbal-motor facility, screen off the meaning of a stimulus word by short reaction times in such a way that it does not reach them at all. But this only works when really important personal secrets have to be protected. Talleyrand’s art of using words to conceal thoughts is given only to a few. Unintelligent people, and particularly women, protect themselves with the help of *value predicates*. This often presents a very comical picture. Value predicates are attributes of feeling, such as *beautiful, good, dear, sweet, friendly*, etc. One often notices, in conversation, how certain people find everything *interesting, charming, good, lovely*, or—if they are

English—*fine, marvellous, grand, splendid*, and (a great favourite!) *fascinating*, all of which serve either to cover up their total lack of interest or to hold the object at arm's length. But the great majority of subjects cannot prevent their complexes from picking on certain stimulus words and furnishing them with various symptoms of disturbance, the chief of these being delayed reaction time. One can also combine these experiments with the electrical measurement of resistance, first used by Veraguth,³ where the so-called psychogalvanic reflex phenomenon provides further indications of reactions disturbed by complexes.

[199] The association test is of general interest in that, like no other psychological experiment of comparable simplicity, it reproduces the psychic situation of the *dialogue*, and at the same time makes fairly accurate quantitative and qualitative evaluation possible. Instead of questions in the form of definite sentences, the subject is confronted with the vague, ambiguous, and therefore disconcerting stimulus word, and instead of an answer he has to react with a *single* word. Through accurate observation of the reaction disturbances, facts are revealed and registered which are often assiduously overlooked in ordinary discussion, and this enables us to discover things that point to the unspoken background, to those states of readiness, or constellations, which I mentioned before. What happens in the association test also happens in every discussion between two people. In both cases there is an experimental situation which constellates complexes that assimilate the topic discussed or the situation as a whole, including the parties concerned. The discussion loses its objective character and its real purpose, since the constellated complexes frustrate the intentions of the speakers and may even put answers into their mouths which they can no longer remember afterwards. This fact has been put to practical use in the cross-examination of witnesses. Its place in psychology is taken by the so-called repetition experiment, which discovers and localizes the gaps in the memory. After, say, a hundred reactions, the subject is asked what answers he gave to the individual stimulus words. Gaps or falsifications of memory occur with average regularity in all spheres of association disturbed by complexes.

[200] So far, I have purposely avoided discussing the nature of complexes, on the tacit assumption that their nature is generally known. The word “complex” in its psychological sense has passed into common speech both in German and in English. Everyone knows nowadays that people “have complexes.” What is not so well known, though far more important theoretically, is that complexes can *have us*. The existence of complexes throws serious doubt on the naïve assumption of the unity of consciousness, which is equated with “psyche,” and on the supremacy of the will. Every constellation of a complex postulates a disturbed state of consciousness. The unity of consciousness is disrupted and the intentions of the will are impeded or made impossible. Even memory is often noticeably affected, as we have seen. The complex

must therefore be a psychic factor which, in terms of energy, possesses a value that sometimes exceeds that of our conscious intentions, otherwise such disruptions of the conscious order would not be possible at all. And in fact, an active complex puts us momentarily under a state of duress, of compulsive thinking and acting, for which under certain conditions the only appropriate term would be the judicial concept of diminished responsibility.

[201] What then, scientifically speaking, is a “feeling-toned complex”? It is the *image* of a certain psychic situation which is strongly accentuated emotionally and is, moreover, incompatible with the habitual attitude of consciousness. This image has a powerful inner coherence, it has its own wholeness and, in addition, a relatively high degree of autonomy, so that it is subject to the control of the conscious mind to only a limited extent, and therefore behaves like an animated foreign body in the sphere of consciousness. The complex can usually be suppressed with an effort of will, but not argued out of existence, and at the first suitable opportunity it reappears in all its original strength. Certain experimental investigations seem to indicate that its intensity or activity curve has a wavelike character, with a “wave-length” of hours, days, or weeks. This very complicated question remains as yet unclarified.

[202] We have to thank the French psychopathologists, Pierre Janet in particular, for our knowledge today of the extreme *dissociability* of consciousness. Janet and Morton Prince both succeeded in producing four to five splittings of the personality, and it turned out that each fragment of personality had its own peculiar character and its own separate memory. These fragments subsist relatively independently of one another and can take one another’s place at any time, which means that each fragment possesses a high degree of autonomy. My findings in regard to complexes corroborate this somewhat disquieting picture of the possibilities of psychic disintegration, for fundamentally there is no difference in principle between a fragmentary personality and a complex. They have all the essential features in common, until we come to the delicate question of fragmented consciousness. Personality fragments undoubtedly have their own consciousness, but whether such small psychic fragments as complexes are also capable of a consciousness of their own is a still unanswered question. I must confess that this question has often occupied my thoughts, for complexes behave like Descartes’ devils and seem to delight in playing impish tricks. They slip just the wrong word into one’s mouth, they make one forget the name of the person one is about to introduce, they cause a tickle in the throat just when the softest passage is being played on the piano at a concert, they make the tiptoeing latecomer trip over a chair with a resounding crash. They bid us congratulate the mourners at a burial instead of condoling with them, they are the instigators of all those maddening things which F. T. Vischer attributed to the “mischievousness of the object.”⁴ They are the actors in our dreams, whom we

confront so powerlessly; they are the elfin beings so aptly characterized in Danish folklore by the story of the clergyman who tried to teach the Lord's prayer to two elves. They took the greatest pains to repeat the words after him correctly, but at the very first sentence they could not avoid saying: "Our Father, who art not in heaven." As one might expect on theoretical grounds, these impish complexes are unteachable.

[203] I hope that, taking it with a very large grain of salt, no one will mind this metaphorical paraphrase of a scientific problem. But even the soberest formulation of the phenomenology of complexes cannot get round the impressive fact of their autonomy, and the deeper one penetrates into their nature—I might almost say into their biology—the more clearly do they reveal their character as *splinter psyches*. Dream psychology shows us as plainly as could be wished how complexes appear in personified form when there is no inhibiting consciousness to suppress them, exactly like the hobgoblins of folklore who go crashing round the house at night. We observe the same phenomenon in certain psychoses when the complexes get "loud" and appear as "voices" having a thoroughly personal character.

[204] Today we can take it as moderately certain that complexes are in fact "splinter psyches." The aetiology of their origin is frequently a so-called trauma, an emotional shock or some such thing, that splits off a bit of the psyche. Certainly one of the commonest causes is a moral conflict, which ultimately derives from the apparent impossibility of affirming the whole of one's nature. This impossibility presupposes a direct split, no matter whether the conscious mind is aware of it or not. As a rule there is a marked unconsciousness of any complexes, and this naturally guarantees them all the more freedom of action. In such cases their powers of assimilation become especially pronounced, since unconsciousness helps the complex to assimilate even the ego, the result being a momentary and unconscious alteration of personality known as identification with the complex. In the Middle Ages it went by another name: it was called possession. Probably no one imagines this state as being particularly harmless, and there is in fact no difference in principle between a slip of the tongue caused by a complex and the wildest blasphemies; it is only a difference of degree. The history of language provides innumerable illustrations of this. When some one is in the throes of a violent emotion we exclaim: "What's got into him today?" "He is driven by the devil," "hag-ridden," etc. In using these somewhat worn metaphors we naturally do not think of their original meaning, although it is easily recognizable and points without a doubt to the fact that naïver and more primitive people did not "psychologize" disturbing complexes as we do, but regarded them as beings in their own right, that is, as demons. Later levels of conscious development created such an intense ego-complex or ego-consciousness that the complexes were deprived of their original autonomy, at least in ordinary speech. As a rule a person says: "I have a complex," or the admonishing voice of the doctor says to the

hysterical patient: “Your pain is not real, you merely imagine it hurts you.” Fear of infection is, apparently, an arbitrary fancy of the patient’s, at any rate everybody tries to convince him that he is cooking up a delusional idea.

[205] It is not difficult to see that the ordinary modern conception of the problem treats it as though it were certain beyond all doubt that the complex was invented and “imagined” by the patient, and that it would not exist at all had the patient not gone to the trouble of deliberately bringing it to life. As against this, it has now been firmly established that complexes possess a remarkable degree of autonomy, that organically unfounded, so-called “imaginary” pains hurt just as much as legitimate ones, and that a phobia of illness has not the slightest inclination to disappear even if the patient himself, his doctor, and common speech-usage all unite in asseverating that it is nothing but “imagination.”

[206] Here we have an interesting example of “apotropaic” thinking, which is quite on a par with the euphemistic names bestowed by the ancients, a classic example of which is the πόντος εὔξεινος, the ‘hospitable sea.’ Just as the Erinyes (“Furies”) were called, cautiously and propitiatingly, the Eumenides (“Kindly Ones”), so the modern mind conceives all inner disturbances as its own activity: it simply assimilates them. This is not done, of course, with an open avowal of apotropaic euphemism, but with an equally unconscious tendency to make the autonomy of the complex *unreal* by giving it a different name. Consciousness behaves like some one who hears a suspicious noise in the attic and thereupon dashes down into the cellar, in order to assure himself that no burglar has broken in and that the noise was mere imagination. In reality he has simply not dared to go up into the attic.

[207] It is not immediately apparent that fear could be the motive which prompts consciousness to explain complexes as its own activity. Complexes appear to be such trivial things, such ridiculous “nothings,” in fact, that we are positively ashamed of them and do everything possible to conceal them. But if they were really “nothing” they could not be so painful. Painful is what causes pain—something decidedly unpleasant, therefore, which for that reason is important in itself and deserves to be taken seriously. But we are only too ready to make anything unpleasant *unreal*—so long as we possibly can. The outbreak of neurosis signalizes the moment when this can no longer be done by the primitive magical means of apotropaic gestures and euphemisms. From this moment the complex establishes itself on the conscious surface; it can no longer be circumvented and proceeds to assimilate the ego-consciousness step by step, just as, previously, the ego-consciousness tried to assimilate it. This eventually leads to a neurotic dissociation of the personality.

[208] Such a development reveals the complex in its original strength, which, as I said, sometimes exceeds even that of the ego-complex. Only then can one understand that

the ego had every reason for practising the magic of names on complexes, for it is obvious enough that what I fear is something sinister that threatens to swallow me up. There are, among people who generally pass for normal, a large number who have a “skeleton in the cupboard,” the existence of which must not be mentioned in their presence on pain of death, so great is their fear of the lurking spectre. All those people who are still in the stage of making their complexes unreal use any reference to neurosis as proving that this obviously applies only to positively morbid natures, to which category, of course, they do not belong. As though it were the privilege only of the sick person to become sick!

[209] The tendency to make complexes unreal by assimilation does not prove their nugatoriness but, on the contrary, their importance. It is a negative admission of the instinctive fear which primitive man has of invisible things that move in the dark. With primitives, this fear does in fact set in with the fall of darkness, just as, with us, complexes are swamped by day, but at night raise their voices all the more clamorously, driving away sleep or filling it with bad dreams. Complexes are objects of inner experience and are not to be met in the street and in public places. It is on them that the weal and woe of personal life depends; they are the *lares* and *penates* who await us at the fireside and whose peaceableness it is dangerous to extol; they are the “little people” whose pranks disturb our nights. Naturally, so long as the evil falls only on our neighbours, it counts for nothing; but when it attacks us—then one must be a doctor in order to appreciate what an appalling menace a complex can be. Only when you have seen whole families destroyed by them, morally and physically, and the unexampled tragedy and hopeless misery that follow in their train, do you feel the full impact of the reality of complexes. You then understand how idle and unscientific it is to think that a person can “imagine” a complex. Casting about for a medical comparison, one could best compare them with infections or with malign tumours, both of which arise without the least assistance from the conscious mind. This comparison is not altogether satisfactory because complexes are not entirely morbid by nature but are *characteristic expressions of the psyche*, irrespective of whether this psyche is differentiated or primitive. Consequently we find unmistakable traces of them in all peoples and in all epochs. The oldest literary records bear witness to them; thus the Gilgamesh Epic describes in masterly fashion the psychology of the power-complex, and the Book of Tobit in the Old Testament gives the history of an erotic complex together with its cure.

[210] The universal belief in spirits is a direct expression of the complex structure of the unconscious. Complexes are in truth the living units of the unconscious psyche, and it is only through them that we are able to deduce its existence and its constitution. The unconscious would in fact be—as it is in Wundt’s psychology—nothing but a vestige of dim or “obscure” representations, or a “fringe of

consciousness,” as William James calls it, were it not for the existence of complexes. That is why Freud became the real discoverer of the unconscious in psychology, because he examined those dark places and did not simply dismiss them, with a disparaging euphemism, as “parapraxes.” The *via regia* to the unconscious, however, is not the dream, as he thought, but the complex, which is the architect of dreams and of symptoms. Nor is this *via* so very “royal,” either, since the way pointed out by the complex is more like a rough and uncommonly devious footpath that often loses itself in the undergrowth and generally leads not into the heart of the unconscious but past it.

[211] Fear of complexes is a bad signpost, however, because it always points away from the unconscious and back into consciousness. Complexes are something so unpleasant that nobody in his right senses can be persuaded that the motive forces which maintain them could betoken anything good. The conscious mind is invariably convinced that complexes are something unseemly and should therefore be eliminated somehow or other. Despite overwhelming evidence of all kinds that complexes have always existed and are ubiquitous, people cannot bring themselves to regard them as normal phenomena of life. The fear of complexes is a rooted prejudice, for the superstitious fear of anything unfavourable has remained untouched by our vaunted enlightenment. This fear provokes violent resistance whenever complexes are examined, and considerable determination is needed to overcome it.

[212] Fear and resistance are the signposts that stand beside the *via regia* to the unconscious, and it is obvious that what they primarily signify is a preconceived opinion of the thing they are pointing at. It is only natural that from the feeling of fear one should infer something dangerous, and from the feeling of resistance something repellent. The patient does so, the public does so, and in the end the analyst does so too, which is why the first medical theory about the unconscious was, logically, the theory of repression worked out by Freud. By drawing conclusions *a posteriori* from the nature of complexes, this view naturally conceives the unconscious as consisting essentially of incompatible tendencies which are repressed on account of their immorality. Nothing could offer a more striking proof that the author of this view proceeded purely empirically, without being in the least influenced by philosophical considerations. There had been talk of the unconscious long before Freud. It was Leibniz who first introduced the idea into philosophy; Kant and Schelling expressed opinions about it, and Carus elaborated it into a system, on whose foundations Eduard von Hartmann built his portentous *Philosophy of the Unconscious*. The first medico-psychological theory of the unconscious has as little to do with these antecedents as it has with Nietzsche.

[213] Freud's theory is a faithful account of his actual experiences during the investigation of complexes. But since such an investigation is always a dialogue between two people, in building up the theory one has to consider not only the complexes of the one partner, but also those of the other. Every dialogue that pushes forward into territory hedged about by fear and resistance is aiming at something vital, and by impelling the one partner to integrate his wholeness it forces the other to take up a broader position. He too is impelled towards wholeness, for without this he would not be able to push the dialogue deeper and deeper into those fear-bound regions. No investigator, however unprejudiced and objective he is, can afford to disregard his own complexes, for they enjoy the same autonomy as those of other people. As a matter of fact, he *cannot* disregard them, because they do not disregard *him*. Complexes are very much a part of the psychic constitution, which is the most absolutely prejudiced thing in every individual. His constitution will therefore inexorably decide *what* psychological view a given observer will have. Herein lies the unavoidable limitation of psychological observation: its validity is contingent upon the personal equation of the observer.

[214] Psychological theory therefore formulates, first and foremost, a psychic situation that has come about through a dialogue between one particular observer and a number of observed persons. As the dialogue moves mainly in the sphere of resistances set up by complexes, the character of these complexes will necessarily become attached to the theory, that is to say it will be, in the most general sense of the word, offensive, because it works on the complexes of the public. That is why all the views of modern psychology are not only controversial in the objective sense, but provocative. They force the public to react violently either for or against and, in scientific discussions, give rise to emotional debates, outbursts of dogmatism, personal vituperation, and so forth.

[215] It can easily be seen from all this that modern psychology with its investigation of complexes has opened up a psychic taboo area riddled with hopes and fears. Complexes are the real focus of psychic unrest, and its repercussions are so far-reaching that psychological investigators have no immediate hope of pursuing their work in peace, for this presupposes some consensus of scientific opinion. But complex psychology is, at present, far indeed from any such agreement, much further, it seems to me, than even the pessimists suppose. For, with the discovery of incompatible tendencies, only *one* sector of the unconscious has come under review, and only *one* source of fear has been revealed.

[216] It will no doubt be remembered what a storm of indignation was unleashed on all sides when Freud's works became generally known. This violent reaction of public complexes drove Freud into an isolation which has brought the charge of dogmatism

upon him and his school. All psychological theoreticians in this field run the same risk, for they are playing with something that directly affects all that is uncontrolled in man—the *numinosum*, to use an apt expression of Rudolf Otto's. Where the realm of complexes begins the freedom of the ego comes to an end, for complexes are psychic agencies whose deepest nature is still unfathomed. Every time the researcher succeeds in advancing a little further towards the psychic *tremendum*, then, as before, reactions are let loose in the public, just as with patients who, for therapeutic reasons, are urged to take up arms against the inviolability of their complexes.

[217] To the uninitiated ear, my presentation of the complex theory may sound like a description of primitive demonology or of the psychology of taboos. This peculiar note is due simply to the fact that the existence of complexes, of split-off psychic fragments, is a quite perceptible vestige of the primitive state of mind. The primitive mind is marked by a high degree of dissociability, which expresses itself in the fact, for instance, that primitives assume the existence of several souls—in one case, even six—besides an immense number of gods and spirits, who are not just talked about, as with us, but are very often highly impressive psychic experiences.

[218] I would like to take this opportunity to remark that I use the term “primitive” in the sense of “primordial,” and that I do not imply any kind of value judgment. Also, when I speak of a “vestige” of a primitive state, I do not necessarily mean that this state will sooner or later come to an end. On the contrary, I see no reason why it should not endure as long as humanity lasts. So far, at any rate, it has not changed very much, and with the World War and its aftermath there has even been a considerable increase in its strength. I am therefore inclined to think that autonomous complexes are among the normal phenomena of life and that they make up the structure of the unconscious psyche.

[219] As can be seen, I have contented myself with describing only the essential features of the complex theory. I must refrain, however, from filling in this incomplete picture by a description of the problems arising out of the existence of autonomous complexes. Three important problems would have to be dealt with: the therapeutic, the philosophical, and the moral. All three still await discussion.



THE SIGNIFICANCE OF CONSTITUTION AND HEREDITY IN PSYCHOLOGY



PSYCHOLOGICAL FACTORS DETERMINING HUMAN BEHAVIOUR

THE SIGNIFICANCE OF CONSTITUTION AND HEREDITY IN PSYCHOLOGY¹

[220] In the opinion of scientists today, there is no doubt that the individual psyche is in large measure dependent on the physiological constitution; indeed, there are not a few who consider this dependence absolute. I would not like to go as far as that myself, but would regard it as more appropriate in the circumstances to grant the psyche a *relative* independence of the physiological constitution. It is true that there are no rigorous proofs of this, but then there is no proof of the psyche's total dependence on the constitution either. We should never forget that if the psyche is the X, constitution is its complementary Y. Both, at bottom, are unknown factors, which have only recently begun to take on clearer form. But we are still far from having anything approaching a real understanding of their nature.

[221] Although it is impossible to determine, in individual cases, the relations between constitution and psyche, such attempts have frequently been made, but the results are nothing more than unproven opinions. The only method that could lead to fairly reliable results at present is the *typological* method, applied by Kretschmer to the constitution and by me to the psychological attitude. In both cases the method is based on a large amount of empirical material, and though the individual variations cancel one another out to a large extent, certain typical basic features emerge all the more clearly and enable us to construct a number of ideal types. These ideal types, of course, never occur in reality in their pure form, but only as individual variations of the principle underlying them, just as crystals are usually individual variations of the same isometric system. Physiological typology endeavours first and foremost to ascertain the outward physical features by means of which individuals can be classified and their residual qualities examined. Kretschmer's researches have shown that the physiological peculiarities may determine the psychic conditions.

[222] Psychological typology proceeds in exactly the same way in principle, but its starting point is not, so to speak, outside, but inside. It does not try to enumerate the outward characteristics; it seeks, rather, to discover the inner principles governing typical psychological attitudes. While physiological typology is bound to employ essentially scientific methods in order to obtain results, the invisible and non-measurable nature of psychic processes compels us to employ methods derived from the humane sciences, above all an analytical critique. There is, as I have said, no difference of principle but only of the nuance given by the different point of departure. The present state of research justifies us in hoping that the results obtained on both sides will show a substantial measure of agreement with regard to certain

basic facts. I personally have the impression that some of Kretschmer's main types are not so far removed from certain of the basic psychological types I have enumerated. It is conceivable that at these points a bridge might be established between the physiological constitution and the psychological attitude. That this has not been done already may well be due to the fact that the physiological findings are still very recent, while on the other hand investigation from the psychological side is very much more difficult and therefore less easy to understand.

[223] We can readily agree that physiological characteristics are something that can be seen, touched, measured. But in psychology not even the meanings of words are fixed. There are hardly two psychologies that could agree, for instance, about the concept of "feeling." Yet the verb "to feel" and the noun "feeling" refer to psychic facts, otherwise a word for them would never have been invented. In psychology we have to do with facts which are definite enough in themselves but have not been defined scientifically. The state of our knowledge might be compared with natural philosophy in the Middle Ages—that is to say, everybody in psychology knows better than everybody else. There are only opinions about unknown facts. Hence the psychologist has an almost invincible tendency to cling to the physiological facts, because there he feels safe, in the security of things that appear to be known and defined. As science is dependent on the definiteness of verbal concepts, it is incumbent upon the psychologist to make conceptual distinctions and to attach definite names to certain groups of psychic facts, regardless of whether somebody else has a different conception of the meaning of this term or not. The only thing he has to consider is whether the name he uses agrees, in its ordinary usage, with the psychic facts designated by it. At the same time he must rid himself of the common notion that the name *explains* the psychic fact it denotes. The name should mean to him no more than a mere cipher, and his whole conceptual system should be to him no more than a trigonometrical survey of a certain geographical area, in which the fixed points of reference are indispensable in practice but irrelevant in theory.

[224] Psychology has still to invent its own specific language. When I first started giving names to the attitude-types I had discovered empirically, I found this question of language the greatest obstacle. I was driven, whether I would or no, to fix definite boundaries to my concepts and give these areas names which were taken, as far as possible, from common usage. In so doing, I inevitably exposed myself to the danger I have already mentioned—the common prejudice that the name explains the thing. Although this is an undoubted survival left over from the old belief in the magic of words, it does not prevent misunderstandings, and I have repeatedly heard the objection, "But feeling is something quite different."

[225] I mention this apparently trivial fact only because its very triviality is one of the greatest obstacles to psychological research. Psychology, being the youngest of all the sciences, is still afflicted with a medieval mentality in which no distinction is made between words and things. I must lay stress on these difficulties in order to explain to a wider scientific public unacquainted with it the apparent inadequacies as well as the peculiar nature of psychological research.

[226] The typological method sets up what it is pleased to call “natural” classifications—no classification is natural!—which are of the greatest heuristic value because they bring together individuals who have outward features in common, or common psychic attitudes, and enable us to submit them to a closer and more accurate scrutiny. Research into constitution gives the psychologist an extremely valuable criterion with which he can either eliminate the organic factor when investigating the psychic context, or take it into his calculations.

[227] This is one of the most important points at which pure psychology comes into collision with the X represented by the organic disposition. But it is not the only point where this happens. There is still another factor, of which those who are engaged in investigating the constitution take no account at present. This is the fact that the psychic process does not start from scratch with the individual consciousness, but is rather a repetition of functions which have been ages in the making and which are inherited with the brain structure. Psychic processes antedate, accompany, and outlive consciousness. Consciousness is an interval in a continuous psychic process; it is probably a climax requiring a special physiological effort, therefore it disappears again for a period each day. The psychic process underlying consciousness is, so far as we are concerned, automatic and its coming and going are unknown to us. We only know that the nervous system, and particularly its centres, condition and express the psychic function, and that these inherited structures start functioning in every new individual exactly as they have always done. Only the climaxes of this activity appear in our consciousness, which is periodically extinguished. However infinitely varied individual consciousnesses may be, the basic substrate of the unconscious psyche remains uniform. So far as it is possible to understand the nature of unconscious processes, they manifest themselves everywhere in astonishingly identical forms, although their expressions, filtered through the individual consciousness, may assume a diversity that is just as great. It is only because of this fundamental uniformity of the unconscious psyche that human beings are able to communicate with one another and to transcend the differences of individual consciousness.

[228] There is nothing strange about these observations, at least to begin with; they become perplexing only when we discover how far even the individual consciousness

is infected by this uniformity. Astounding cases of mental similarity can be found in families. Fürst published a case of a mother and daughter with a concordance of associations amounting to thirty per cent.² A large measure of psychic concordance between peoples and races separated from one another in space and time is generally regarded as flatly impossible. In actual fact, however, the most astonishing concordances can be found in the realm of so-called fantastic ideas. Every endeavour has been made to explain the concordance of myth-motifs and -symbols as due to migration and tradition; Goblet d'Almellas' *Migration of Symbols* is an excellent example of this. But this explanation, which naturally has some value, is contradicted by the fact that a mythologem can arise anywhere, at any time, without there being the slightest possibility of any such transmission. For instance, I once had under my observation an insane patient who produced, almost word for word, a long symbolic passage which can be read in a papyrus published by Dieterich a few years later.³ After I had seen a sufficient number of such cases, my original idea that such things could only happen to people belonging to the same race was shattered, and I accordingly investigated the dreams of purebred Negroes living in the southern United States. I found in these dreams, among other things, motifs from Greek mythology, and this dispelled any doubt I had that it might be a question of racial inheritance.

[229] I have frequently been accused of a superstitious belief in "inherited ideas"—quite unjustly, because I have expressly emphasized that these concordances are not produced by "ideas" but rather by the inherited disposition to react in the same way as people have always reacted. Again, the concordance has been denied on the ground that the redeemer-figure is in one case a hare, in another a bird, and in another a human being. But this is to forget something which so much impressed a pious Hindu visiting an English church that, when he got home, he told the story that the Christians worshipped animals, because he had seen so many lambs about. The names matter little; everything depends on the connection between them. Thus it does not matter if the "treasure" is in one case a golden ring, in another a crown, in a third a pearl, and in a fourth a hidden hoard. The essential thing is the idea of an exceedingly precious treasure hard to attain, no matter what it is called locally. And the essential thing, psychologically, is that in dreams, fantasies, and other exceptional states of mind the most far-fetched mythological motifs and symbols can appear autochthonously at any time, often, apparently, as the result of particular influences, traditions, and excitations working on the individual, but more often without any sign of them. These "primordial images," or "archetypes," as I have called them, belong to the basic stock of the unconscious psyche and cannot be explained as personal acquisitions. Together they make up that psychic stratum which I have called the collective unconscious.

[230] The existence of the collective unconscious means that individual consciousness is anything but a *tabula rasa* and is not immune to predetermining influences. On the contrary, it is in the highest degree influenced by inherited presuppositions, quite apart from the unavoidable influences exerted upon it by the environment. The collective unconscious comprises in itself the psychic life of our ancestors right back to the earliest beginnings. It is the matrix of all conscious psychic occurrences, and hence it exerts an influence that compromises the freedom of consciousness in the highest degree, since it is continually striving to lead all conscious processes back into the old paths. This positive danger explains the extraordinary resistance which the conscious puts up against the unconscious. It is not a question here of resistance to sexuality, but of something far more general—the instinctive fear of losing one's freedom of consciousness and of succumbing to the automatism of the unconscious psyche. For certain types of people the danger seems to lie in sex, because it is there that they are afraid of losing their freedom. For others it lies in very different regions, but it is always where a certain weakness is felt, and where, therefore, a high threshold cannot be opposed to the unconscious.

[231] The collective unconscious is another of those points at which pure psychology comes up against organic factors, where it has, in all probability, to recognize a non-psychological fact resting on a physiological foundation. Just as the most inveterate psychologist will never succeed in reducing the physiological constitution to the common denominator of individual psychic causation, so it will not be possible to dismiss the physiologically necessary postulate of the collective unconscious as an individual acquisition. The constitutional type and the collective unconscious are both factors which are outside the control of the conscious mind. The constitutional conditions and the immaterial forms in the collective unconscious are thus realities, and this, in the case of the unconscious, means nothing less than that its symbols and motifs are factors quite as real as the constitution, which can be neither dismissed nor denied. Neglect of the constitution leads to pathological disturbances, and disregard of the collective unconscious does the same. In my therapeutic work I therefore direct my attention chiefly to the patient's relation to occurrences in the collective unconscious, for ample experience has taught me that it is just as important for him to live in harmony with the unconscious as with his individual disposition.

PSYCHOLOGICAL FACTORS DETERMINING HUMAN BEHAVIOUR¹

[232] The separation of psychology from the basic assumptions of biology is purely artificial, because the human psyche lives in indissoluble union with the body. And since these biological assumptions hold good not only for man but for the whole world of living things, the scientific foundation on which they rest obtains a validity far exceeding that of a psychological judgment, which is valid only in the realm of consciousness. It is therefore no matter for surprise if the psychologist is often inclined to fall back on the security of the biological standpoint and to borrow freely from physiology and the theory of instinct. Nor is it astonishing to find a widely accepted point of view which regards psychology as merely a chapter in physiology. Although psychology rightly claims autonomy in its own special field of research, it must recognize a far-reaching correspondence between its facts and the data of biology.

[233] Among the psychological factors determining human behaviour, the instincts are the chief motivating forces of psychic events. In view of the controversy which has raged around the nature of the instincts, I should like to establish clearly what seems to me to be the relation between instincts and the psyche, and why I call instincts psychological factors. If we started with the hypothesis that the psyche is absolutely identical with the state of being alive, then we should have to accept the existence of a psychic function even in unicellular organisms. In that case, instinct would be a kind of psychic organ, and the hormone-producing activity of the glands would have a psychic causation.

[234] But if we look upon the appearance of the psyche as a relatively recent event in evolutionary history, and assume that the psychic function is a phenomenon accompanying a nervous system which in some way or other has become centralized, then it would be difficult to believe that the instincts were originally psychic in nature. And since the connection of the psyche with the brain is a more probable conjecture than the psychic nature of life in general, I regard the characteristic *compulsiveness* of instinct as an ectopsychic factor. None the less, it is psychologically important because it leads to the formation of structures or patterns which may be regarded as determinants of human behaviour. Under these circumstances the immediate determining factor is not the ectopsychic instinct but the structure resulting from the interaction of instinct and the psychic situation of the moment. The determining factor would thus be a *modified* instinct. The change undergone by the instinct is as significant as the difference between the colour we see

and the objective wave-length producing it. Instinct as an ectopsychic factor would play the role of a stimulus merely, while instinct as a psychic phenomenon would be an assimilation of this stimulus to a pre-existent psychic pattern. A name is needed for this process. I should term it *psychization*. Thus, what we call instinct offhand would be a datum already psychized, but of ectopsychic origin.

1. *General Phenomenology*

[235] The view outlined above makes it possible for us to understand the variability of instinct within the framework of its general phenomenology. The psychized instinct forfeits its uniqueness to a certain extent, at times actually losing its most essential characteristic—compulsiveness. It is no longer an ecto-psychic, unequivocal fact, but has become instead a modification conditioned by its encounter with a psychic datum. As a determining factor, instinct is variable and therefore lends itself to different applications. Whatever the nature of the psyche may be, it is endowed with an extraordinary capacity for variation and transformation.

[236] For example, no matter how unequivocal the physical state of excitation called hunger may be, the psychic consequences resulting from it can be manifold. Not only can the reactions to ordinary hunger vary widely, but the hunger itself can be “denatured,” and can even appear as something metaphorical. It is not only that we use the word hunger in different senses, but in combination with other factors hunger can assume the most varied forms. The originally simple and unequivocal determinant can appear transformed into pure greed, or into many aspects of boundless desire or insatiability, as for instance the lust for gain or inordinate ambition.

[237] *Hunger*, as a characteristic expression of the instinct of self-preservation, is without doubt one of the primary and most powerful factors influencing behaviour; in fact, the lives of primitives are more strongly affected by it than by sexuality. At this level, hunger is the alpha and omega—existence itself.

[238] The importance of the instinct for preservation of the species is obvious. However, the growth of culture having brought with it so many restrictions of a moral and a social nature, sexuality has been lent, temporarily at least, an excess value comparable to that of water in a desert. Because of the premium of intense sensuous enjoyment which nature has set upon the business of reproduction, the urge for sexual satisfaction appears in man—no longer conditioned by a mating season—almost as a separate instinct. The sexual instinct enters into combination with many different feelings, emotions, affects, with spiritual and material interests, to such a

degree that, as is well known, the attempt has even been made to trace the whole of culture to these combinations.

[239] *Sexuality*, like hunger, undergoes a radical psychization which makes it possible for the originally purely instinctive energy to be diverted from its biological application and turned into other channels. The fact that the energy can be deployed in various fields indicates the existence of still other drives strong enough to change the direction of the sexual instinct and to deflect it, at least in part, from its immediate goal.

[240] I should like, then, to differentiate as a third group of instincts the *drive to activity*. This urge starts functioning when the other urges are satisfied; indeed, it is perhaps only called into being after this has occurred. Under this heading would come the urge to travel, love of change, restlessness, and the play-instinct.

[241] There is another instinct, different from the drive to activity and so far as we know specifically human, which might be called the *reflective instinct*. Ordinarily we do not think of "reflection" as ever having been instinctive, but associate it with a conscious state of mind. *Reflexio* means 'bending back' and, used psychologically, would denote the fact that the reflex which carries the stimulus over into its instinctive discharge is interfered with by psychization. Owing to this interference, the psychic processes exert an attraction on the impulse to act excited by the stimulus. Therefore, before having discharged itself into the external world, the impulse is deflected into an endopsychic activity. *Reflexio* is a turning inwards, with the result that, instead of an instinctive action, there ensues a succession of derivative contents or states which may be termed reflection or deliberation. Thus in place of the compulsive act there appears a certain degree of freedom, and in place of predictability a relative unpredictability as to the effect of the impulse.

[242] The richness of the human psyche and its essential character are probably determined by this reflective instinct. Reflection re-enacts the process of excitation and carries the stimulus over into a series of images which, if the impetus is strong enough, are reproduced in some form of expression. This may take place directly, for instance in speech, or may appear in the form of abstract thought, dramatic representation, or ethical conduct; or again, in a scientific achievement or a work of art.

[243] Through the reflective instinct, the stimulus is more or less wholly transformed into a psychic content, that is, it becomes an experience: a natural process is transformed into a conscious content. Reflection is the cultural instinct *par excellence*, and its strength is shown in the power of culture to maintain itself in the face of untamed nature.

[244] Instincts are not creative in themselves; they have become stably organized and are therefore largely automatic. The reflective instinct is no exception to this rule, for the production of consciousness is not of itself a creative act but may under certain conditions be a merely automatic process. It is a fact of great importance that this compulsiveness of instinct, so feared by civilized man, also produces that characteristic fear of becoming conscious, best observed in neurotic persons, but not in them alone.

[245] Although, in general, instinct is a system of stably organized tracts and consequently tends towards unlimited repetition, man nevertheless has the distinctive power of creating something new in the real sense of the word, just as nature, in the course of long periods of time, succeeds in creating new forms. Though we cannot classify it with a high degree of accuracy, the *creative instinct* is something that deserves special mention. I do not know if "instinct" is the correct word. We use the term "creative instinct" because this factor behaves at least dynamically, like an instinct. Like instinct it is compulsive, but it is not common, and it is not a fixed and invariably inherited organization. Therefore I prefer to designate the creative impulse as a psychic factor similar in nature to instinct, having indeed a very close connection with the instincts, but without being identical with any one of them. Its connections with sexuality are a much discussed problem and, furthermore, it has much in common with the drive to activity and the reflective instinct. But it can also suppress them, or make them serve it to the point of the self-destruction of the individual. Creation is as much destruction as construction.

[246] To recapitulate, I would like to emphasize that from the psychological standpoint five main groups of instinctive factors can be distinguished: hunger, sexuality, activity, reflection, and creativity. In the last analysis, instincts are ectopsychic determinants.

[247] A discussion of the dynamic factors determining human behaviour is obviously incomplete without mention of the *will*. The part that will plays, however, is a matter for dispute, and the whole problem is bound up with philosophical considerations, which in turn depend on the view one takes of the world. If the will is posited as free, then it is not tied to causality and there is nothing more to be said about it. But if it is regarded as predetermined and causally dependent upon the instincts, it is an epiphenomenon of secondary importance.

[248] Different from the dynamic factors are the *modalities* of psychic functioning which influence human behaviour in other ways. Among these I would mention especially the sex, age, and hereditary disposition of the individual. These three factors are understood primarily as physiological data, but they are also psychological inasmuch as, like the instincts, they are subject to psychization.

Anatomical masculinity, for instance, is far from being proof of the psychic masculinity of the individual. Similarly, physiological age does not always correspond with the psychological age. As regards the hereditary disposition, the determining factor of race or family may be overlaid by a psychological superstructure. Much that is interpreted as heredity in the narrow sense is rather a sort of psychic contagion, which consists in an adaptation of the child psyche to the unconscious of the parents.

[249] To these three semi-physiological modalities I should like to add three that are psychological. Among these I wish to stress the conscious and the unconscious. It makes a great deal of difference to the behaviour of the individual whether his psyche is functioning mainly consciously or unconsciously. Naturally it is only a question of a greater or lesser degree of consciousness, because total consciousness is empirically impossible. An extreme state of unconsciousness is characterized by the predominance of compulsive instinctual processes, the result of which is either uncontrolled inhibition or a lack of inhibition throughout. The happenings within the psyche are then contradictory and proceed in terms of alternating, non-logical antitheses. In such a case the level of consciousness is essentially that of a dream-state. A high degree of consciousness, on the other hand, is characterized by a heightened awareness, a preponderance of will, directed, rational behaviour, and an almost total absence of instinctual determinants. The unconscious is then found to be at a definitely animal level. The first state is lacking in intellectual and ethical achievement, the second lacks naturalness.

[250] The second modality is extraversion and introversion. It determines the direction of psychic activity, that is, it decides whether the conscious contents refer to external objects or to the subject. Therefore, it also decides whether the value stressed lies outside or inside the individual. This modality operates so persistently that it builds up habitual attitudes, that is, types with recognizable outward traits.

[251] The third modality points, to use a metaphor, upward and downward, because it has to do with spirit and matter. It is true that matter is in general the subject of physics, but it is also a psychic category, as the history of religion and philosophy clearly shows. And just as matter is ultimately to be conceived of merely as a working hypothesis of physics, so also spirit, the subject of religion and philosophy, is a hypothetical category in constant need of reinterpretation. The so-called reality of matter is attested primarily by our sense-perceptions, while belief in the existence of spirit is supported by psychic experience. Psychologically, we cannot establish anything more final with respect to either matter or spirit than the presence of certain conscious contents, some of which are labelled as having a material, and others a spiritual, origin. In the consciousness of civilized peoples, it is true, there seems to

exist a sharp division between the two categories, but on the primitive level the boundaries become so blurred that matter often seems endowed with “soul” while spirit appears to be material. However, from the existence of these two categories ethical, aesthetic, intellectual, social, and religious systems of value arise which in the end determine how the dynamic factors in the psyche are to be used. Perhaps it would not be too much to say that the most crucial problems of the individual and of society turn upon the way the psyche functions in regard to spirit and matter.

2. *Special Phenomenology*

[252] Let us now turn to the special phenomenology. In the first section we distinguished five principal groups of instincts and six modalities. The concepts described, however, have only an academic value as general categories. In reality the psyche is a complicated interplay of all these factors. Moreover, in conformity with its peculiar structure, it shows endless individual variation on the one hand, and on the other an equally great capacity for change and differentiation. The variability is due to the fact that the psyche is not a homogeneous structure but apparently consists of hereditary units only loosely bound together, and therefore it shows a very marked tendency to split into parts. The tendency to change is conditioned by influences coming both from within and from without. Functionally speaking, these tendencies are closely related to one another.

[253] 1. Let us turn first to the question of the psyche’s tendency to split. Although this peculiarity is most clearly observable in psychopathology, fundamentally it is a normal phenomenon, which can be recognized with the greatest ease in the projections made by the primitive psyche. The tendency to split means that parts of the psyche detach themselves from consciousness to such an extent that they not only appear foreign but lead an autonomous life of their own. It need not be a question of hysterical multiple personality, or schizophrenic alterations of personality, but merely of so-called “complexes” that come entirely within the scope of the normal. Complexes are psychic fragments which have split off owing to traumatic influences or certain incompatible tendencies. As the association experiments prove, complexes interfere with the intentions of the will and disturb the conscious performance; they produce disturbances of memory and blockages in the flow of associations; they appear and disappear according to their own laws; they can temporarily obsess consciousness, or influence speech and action in an unconscious way. In a word, complexes behave like independent beings, a fact especially evident in abnormal states of mind. In the voices heard by the insane they even take on a personal ego-character like that of the spirits who manifest themselves through automatic writing

and similar techniques. An intensification of complexes leads to morbid states, which are extensive multiple dissociations endowed with an indomitable life of their own.

[254] The behaviour of *new* contents that have been constellated in the unconscious but are not yet assimilated to consciousness is similar to that of complexes. These contents may be based on subliminal perceptions, or they may be creative in character. Like complexes, they lead a life of their own so long as they are not made conscious and integrated with the life of the personality. In the realm of artistic and religious phenomena, these contents may likewise appear in personified form, especially as archetypal figures. Mythological research designates them as “motifs,” to Lévy-Bruhl they are *représentations collectives*, Hubert and Mauss call them “categories of the imagination.” I have employed the concept of the collective unconscious to embrace all these archetypes. They are psychic forms which, like the instincts, are common to all mankind, and their presence can be proved wherever the relevant literary records have been preserved. As factors influencing human behaviour, archetypes play no small role. The total personality can be affected by them through a process of identification. This effect is best explained by the fact that archetypes probably represent typical situations in life. Abundant proof of identification with archetypes can be found in the psychological and psychopathological case material. The psychology of Nietzsche’s *Zarathustra* also furnishes a good example. The difference between archetypes and the dissociated products of schizophrenia is that the former are entities endowed with personality and charged with meaning, whereas the latter are only fragments with vestiges of meaning—in reality, they are products of disintegration. Both, however, possess to a high degree the capacity to influence, control, and even to suppress the ego-personality, so that a temporary or lasting transformation of personality ensues.

[255] 2. As we have seen, the inherent tendency of the psyche to split means on the one hand dissociation into multiple structural units, but on the other hand the possibility of change and differentiation. It allows certain parts of the psychic structure to be singled out so that, by concentration of the will, they can be trained and brought to their maximum development. In this way certain capacities, especially those that promise to be socially useful, can be fostered to the neglect of others. This produces an unbalanced state similar to that caused by a dominant complex—a change of personality. It is true that we do not refer to this as obsession by a complex, but as one-sidedness. Still, the actual state is approximately the same, with this difference, that the one-sidedness is intended by the individual and is fostered by all the means in his power, whereas the complex is felt to be injurious and disturbing. People often fail to see that consciously willed one-sidedness is one of the most important causes of an undesirable complex, and that, conversely, certain complexes cause a one-sided differentiation of doubtful value. Some degree of one-sidedness is unavoidable, and,

in the same measure, complexes are unavoidable too. Looked at in this light, complexes might be compared to modified instincts. An instinct which has undergone too much psychization can take its revenge in the form of an autonomous complex. This is one of the chief causes of neurosis.

[256] It is well known that very many faculties in man can become differentiated. I do not wish to lose myself in the details of case histories and must limit myself to the normal faculties that are always present in consciousness. Consciousness is primarily an organ of orientation in a world of outer and inner facts. First and foremost, it establishes the fact that something is there. I call this faculty *sensation*. By this I do not mean the specific activity of any one of the senses, but perception in general. Another faculty interprets what is perceived; this I call *thinking*. By means of this function, the object perceived is assimilated and its transformation into a psychic content proceeds much further than in mere sensation. A third faculty establishes the value of the object. This function of evaluation I call *feeling*. The pain-pleasure reaction of feeling marks the highest degree of subjectivation of the object. Feeling brings subject and object into such a close relationship that the subject must choose between acceptance and rejection.

[257] These three functions would be quite sufficient for orientation if the object in question were isolated in space and time. But, in space, every object is in endless connection with a multiplicity of other objects; and, in time, the object represents merely a transition from a former state to a succeeding one. Most of the spatial relationships and temporal changes are unavoidably unconscious at the moment of orientation, and yet, in order to determine the meaning of an object, space-time relationships are necessary. It is the fourth faculty of consciousness, *intuition*, which makes possible, at least approximately, the determination of space-time relationships. This is a function of perception which includes subliminal factors, that is, the possible relationship to objects not appearing in the field of vision, and the possible changes, past and future, about which the object gives no clue. Intuition is an immediate awareness of relationships that could not be established by the other three functions at the moment of orientation.

[258] I mention the orienting functions of consciousness because they can be singled out for empirical observation and are subject to differentiation. At the very outset, nature has established marked differences in their importance for different individuals. As a rule, one of the four functions is especially developed, thus giving the mentality as a whole its characteristic stamp. The predominance of one or the other function gives rise to typical attitudes, which may be designated thinking types, feeling types, and so on. A type of this kind is a bias like a vocation with which a person has identified himself. Anything that has been elevated into a principle or a

virtue, whether from inclination or because of its usefulness, always results in one-sidedness and a compulsion to one-sidedness which excludes all other possibilities, and this applies to men of will and action just as much as to those whose object in life is the constant training of memory. Whatever we persistently exclude from conscious training and adaptation necessarily remains in an untrained, undeveloped, infantile, or archaic condition, ranging from partial to complete unconsciousness. Hence, besides the motives of consciousness and reason, unconscious influences of a primitive character are always normally present in ample measure and disturb the intentions of consciousness. For it is by no means to be assumed that all those forms of activity latent in the psyche, which are suppressed or neglected by the individual, are thereby robbed of their specific energy. For instance, if a man relied wholly on the data of vision, this would not mean that he would cease to hear. Even if he could be transplanted to a soundless world, he would in all probability soon satisfy his need to hear by indulging in auditory hallucinations.

[259] The fact that the natural functions of the psyche cannot be deprived of their specific energy gives rise to characteristic antitheses, which can best be observed wherever these four orienting functions of consciousness come into play. The chief contrasts are those between thinking and feeling on the one hand, and sensation and intuition on the other. The opposition between the first two is an old story and needs no comment. The opposition between the second pair becomes clearer when it is understood as the opposition between objective fact and mere possibility. Obviously anyone on the look-out for new possibilities does not rest content with the actual situation of the moment, but will pass beyond it as soon as ever he can. These polarities have a markedly irritating nature, and this remains true whether the conflict occurs within the individual psyche or between individuals of opposite temperament.

[260] It is my belief that the problem of opposites, here merely hinted at, should be made the basis for a critical psychology. A critique of this sort would be of the utmost value not only in the narrower field of psychology, but also in the wider field of the cultural sciences in general.

[261] In this paper I have gathered together all those factors which, from the standpoint of a purely empirical psychology, play a leading role in determining human behaviour. The multiplicity of aspects claiming attention is due to the nature of the psyche, reflecting itself in innumerable facets, and they are a measure of the difficulties confronting the investigator. The tremendous complexity of psychic phenomena is borne in upon us only after we see that all attempts to formulate a comprehensive theory are foredoomed to failure. The premises are always far too simple. The psyche is the starting-point of all human experience, and all the knowledge we have gained eventually leads back to it. The psyche is the beginning

and end of all cognition. It is not only the object of its science, but the subject also. This gives psychology a unique place among all the other sciences: on the one hand there is a constant doubt as to the possibility of its being a science at all, while on the other hand psychology acquires the right to state a theoretical problem the solution of which will be one of the most difficult tasks for a future philosophy.

[262] In my survey, far too condensed, I fear, I have left unmentioned many illustrious names. Yet there is one which I should not like to omit. It is that of William James, whose psychological vision and pragmatic philosophy have on more than one occasion been my guides. It was his far-ranging mind which made me realize that the horizons of human psychology widen into the immeasurable.



INSTINCT AND THE UNCONSCIOUS



THE STRUCTURE OF THE PSYCHE



ON THE NATURE OF THE PSYCHE

INSTINCT AND THE UNCONSCIOUS¹

[263] The theme of this symposium concerns a problem that is of great importance for biology as well as for psychology and philosophy. But if we are to discuss the relation between instinct and the unconscious, it is essential that we start out with a clear definition of our terms.

[264] With regard to the definition of instinct, I would like to stress the significance of the “all-or-none” reaction formulated by Rivers; indeed, it seems to me that this peculiarity of instinctive activity is of special importance for the psychological side of the problem. I must naturally confine myself to this aspect of the question, because I do not feel competent to treat the problem of instinct under its biological aspect. But when I attempt to give a psychological definition of instinctive activity, I find I cannot rely solely on Rivers’ criterion of the “all-or-none” reaction, and for the following reason: Rivers defines this reaction as a process that shows no gradation of intensity in respect of the circumstances which provoke it. It is a reaction that takes place with its own specific intensity under all circumstances and is not proportional to the precipitating stimulus. But when we examine the psychological processes of consciousness in order to determine whether there are any whose intensity is out of all proportion to the stimulus, we can easily find a great many of them in everybody, for instance disproportionate affects, impressions, exaggerated impulses, intentions that go too far, and others of the kind. It follows that all these processes cannot possibly be classed as instinctive processes, and we must therefore look round for another criterion.

[265] We use the word “instinct” very frequently in ordinary speech. We speak of “instinctive actions,” meaning by that a mode of behaviour of which neither the motive nor the aim is fully conscious and which is prompted only by obscure inner necessity. This peculiarity has already been stressed by an older English writer, Thomas Reid, who says: “By instinct, I mean a natural impulse to certain actions, without having any end in view, without deliberation and without any conception of what we do.”² Thus instinctive action is characterized by an *unconsciousness* of the psychological motive behind it, in contrast to the strictly conscious processes which are distinguished by the conscious continuity of their motives. Instinctive action appears to be a more or less abrupt psychic occurrence, a sort of interruption of the continuity of consciousness. On this account, it is felt as an inner necessity—which is, in fact, the definition of instinct given by Kant.³

[266] Accordingly, instinctive activity would have to be included among the specifically unconscious processes, which are accessible to consciousness only through their results. But were we to rest content with this conception of instinct, we should soon discover its insufficiency: it merely marks off instinct from the conscious processes and characterizes it as unconscious. If, on the other hand, we survey the unconscious processes as a whole, we find it impossible to class them all as instinctive, even though no differentiation is made between them in ordinary speech. If you suddenly meet a snake and get a violent fright, you can legitimately call this impulse instinctive because it is no different from the instinctive fear of snakes in monkeys. It is just the uniformity of the phenomenon and the regularity of its recurrence which are the most characteristic qualities of instinctive action. As Lloyd Morgan aptly remarks, it would be as uninteresting to bet on an instinctive reaction as on the rising of the sun tomorrow. On the other hand, it may also happen that someone is regularly seized with fright whenever he meets a perfectly harmless hen. Although the mechanism of fright in this case is just as much an unconscious impulse as the instinct, we must nevertheless distinguish between the two processes. In the former case the fear of snakes is a purposive process of general occurrence; the latter, when habitual, is a phobia and not an instinct, since it occurs only in isolation and is not a general peculiarity. There are many other unconscious compulsions of this kind—for instance, obsessive thoughts, musical obsessions, sudden ideas and moods, impulsive affects, depressions, anxiety states, etc. These phenomena are met with in normal as well as abnormal individuals. In so far as they occur only in isolation and are not repeated regularly they must be distinguished from instinctive processes, even though their psychological mechanism seems to correspond to that of an instinct. They may even be characterized by the all-or-none reaction, as can easily be observed in pathological cases. In psychopathology there are many such cases where a given stimulus is followed by a definite and relatively disproportionate reaction comparable to an instinctive reaction.

[267] All these processes must be distinguished from instinctive ones. Only those unconscious processes which are inherited, and occur uniformly and regularly, can be called instinctive. At the same time they must show the mark of compelling necessity, a reflex character of the kind pointed out by Herbert Spencer. Such a process differs from a mere sensory-motor reflex only because it is more complicated. William James therefore calls instinct, not unjustly, “a mere excitomotor impulse, due to the pre-existence of a certain ‘reflex-arc’ in the nerve-centres.”⁴ Instincts share with reflexes their uniformity and regularity as well as the unconsciousness of their motivations.

[268] The question of where instincts come from and how they were acquired is extraordinarily complicated. The fact that they are invariably inherited does nothing

to explain their origin; it merely shifts the problem back to our ancestors. The view is widely held that instincts originated in individual, and then general, acts of will that were frequently repeated. This explanation is plausible in so far as we can observe every day how certain laboriously learnt activities gradually become automatic through constant practice. But if we consider the marvellous instincts to be found in the animal world, we must admit that the element of learning is sometimes totally absent. In certain cases it is impossible to conceive how any learning and practice could ever have come about. Let us take as an example the incredibly refined instinct of propagation in the yucca moth (*Pronuba yuccasella*).⁵ The flowers of the yucca plant open for one night only. The moth takes the pollen from one of the flowers and kneads it into a little pellet. Then it visits a second flower, cuts open the pistil, lays its eggs between the ovules and then stuffs the pellet into the funnel-shaped opening of the pistil. Only once in its life does the moth carry out this complicated operation.

[269] Such cases are difficult to explain on the hypothesis of learning and practice. Hence other ways of explanation, deriving from Bergson's philosophy, have recently been put forward, laying stress on the factor of intuition. Intuition is an unconscious process in that its result is the irruption into consciousness of an unconscious content, a sudden idea or "hunch."⁶ It resembles a process of perception, but unlike the conscious activity of the senses and introspection the perception is unconscious. That is why we speak of intuition as an "instinctive" act of comprehension. It is a process analogous to instinct, with the difference that whereas instinct is a purposive impulse to carry out some highly complicated action, intuition is the unconscious, purposive apprehension of a highly complicated situation. In a sense, therefore, intuition is the reverse of instinct, neither more nor less wonderful than it. But we should never forget that what we call complicated or even wonderful is not at all wonderful for Nature, but quite ordinary. We always tend to project into things our own difficulties of understanding and to call them complicated, when in reality they are very simple and know nothing of our intellectual problems.

[270] A discussion of the problem of instinct without reference to the concept of the unconscious would be incomplete, because it is just the instinctive processes which make the supplementary concept of the unconscious necessary. I define the unconscious as the totality of all psychic phenomena that lack the quality of consciousness. These psychic contents might fittingly be called "subliminal," on the assumption that every psychic content must possess a certain energy value in order to become conscious at all. The lower the value of a conscious content falls, the more easily it disappears below the threshold. From this it follows that the unconscious is the receptacle of all lost memories and of all contents that are still too weak to become conscious. These contents are products of an unconscious associative activity which also gives rise to dreams. Besides these we must include all more or less

intentional repressions of painful thoughts and feelings. I call the sum of all these contents the “personal unconscious.” But, over and above that, we also find in the unconscious qualities that are not individually acquired but are inherited, e.g., instincts as impulses to carry out actions from necessity, without conscious motivation. In this “deeper” stratum we also find the *a priori*, inborn forms of “intuition,” namely the *archetypes*⁷ of perception and apprehension, which are the necessary *a priori* determinants of all psychic processes. Just as his instincts compel man to a specifically human mode of existence, so the archetypes force his ways of perception and apprehension into specifically human patterns. The instincts and the archetypes together form the “collective unconscious.” I call it “collective” because, unlike the personal unconscious, it is not made up of individual and more or less unique contents but of those which are universal and of regular occurrence. Instinct is an essentially collective, i.e., universal and regularly occurring phenomenon which has nothing to do with individuality. Archetypes have this quality in common with the instincts and are likewise collective phenomena.

[271] In my view the question of instinct cannot be dealt with psychologically without considering the archetypes, because at bottom they determine one another. It is, however, extremely difficult to discuss this problem, as opinions about the role of instinct in human psychology are extraordinarily divided. Thus William James is of the opinion that man is swarming with instincts, while others restrict them to a very few processes barely distinguishable from reflexes, namely to certain movements executed by the infant, to particular reactions of its arms and legs, of the larynx, the use of the right hand, and the formation of syllabized sounds. In my opinion, this restriction goes too far, though it is very characteristic of human psychology in general. Above all, we should always remember that in discussing human instincts we are speaking of ourselves and, therefore, are doubtless prejudiced.

[272] We are in a far better position to observe instincts in animals or in primitives than in ourselves. This is due to the fact that we have grown accustomed to scrutinizing our own actions and to seeking rational explanations for them. But it is by no means certain that our explanations will hold water, indeed it is highly unlikely. No superhuman intellect is needed to see through the shallowness of many of our rationalizations and to detect the real motive, the compelling instinct behind them. As a result of our artificial rationalizations it may seem to us that we were actuated not by instinct but by conscious motives. Naturally I do not mean to say that by careful training man has not succeeded in partially converting his instincts into acts of the will. Instinct has been domesticated, but the basic motive still remains instinct. There is no doubt that we have succeeded in enveloping a large number of instincts in rational explanations to the point where we can no longer recognize the original motive behind so many veils. In this way it seems as though we possessed practically

no instincts any more. But if we apply the Rivers criterion of the disproportionate all-or-none reaction to human behaviour, we find innumerable cases where exaggerated reactions occur. Exaggeration, indeed, is a universal human peculiarity, although everybody carefully tries to explain his reactions in terms of rational motives. There is never any lack of good arguments, but the fact of exaggeration remains. And why is it that a man does not do or say, give or take, just as much as is needed, or reasonable, or justifiable in a given situation, but frequently so much more or less? Precisely because an unconscious process is released in him that runs its course without the aid of reason and therefore falls short of, or exceeds, the degree of rational motivation. This phenomenon is so uniform and so regular that we can only call it instinctive, though no one in this situation likes to admit the instinctive nature of his behaviour. I am therefore inclined to believe that human behaviour is influenced by instinct to a far higher degree than is generally supposed, and that we are prone to a great many falsifications of judgment in this respect, again as a result of an instinctive exaggeration of the rationalistic standpoint.

[273] *Instincts are typical modes of action, and wherever we meet with uniform and regularly recurring modes of action and reaction we are dealing with instinct, no matter whether it is associated with a conscious motive or not.*

[274] Just as it may be asked whether man possesses many instincts or only a few, so we must also raise the still unbroached question of whether he possesses many or few primordial forms, or archetypes, of psychic reaction. Here we are faced with the same difficulty I mentioned above: we are so accustomed to operating with conventional and self-evident concepts that we are no longer conscious of the extent to which they are based on archetypal modes of perception. Like the instincts, the primordial images have been obscured by the extraordinary differentiation of our thinking. Just as certain biological views attribute only a few instincts to man, so the theory of cognition reduces the archetypes to a few, logically limited categories of understanding.

[275] In Plato, however, an extraordinarily high value is set on the archetypes as metaphysical ideas, as “paradigms” or models, while real things are held to be only the copies of these model ideas. Medieval philosophy, from the time of St. Augustine—from whom I have borrowed the idea of the archetype⁸—down to Malebranche and Bacon, still stands on a Platonic footing in this respect. But in scholasticism we find the notion that archetypes are natural images engraved on the human mind, helping it to form its judgments. Thus Herbert of Cherbury says: “Natural instincts are expressions of those faculties which are found in every normal man, through which the Common Notions touching the internal conformity of things, such as the cause,

means and purpose of things, the good, bad, beautiful, pleasing, etc. ... are brought into conformity independently of discursive thought.”⁹

[276] From Descartes and Malebranche onward, the metaphysical value of the “idea” or archetype steadily deteriorated. It became a “thought,” an internal condition of cognition, as clearly formulated by Spinoza: “By ‘idea’ I understand a conception of the mind which the mind forms by reason of its being a thinking thing.”¹⁰ Finally Kant reduced the archetypes to a limited number of categories of understanding. Schopenhauer carried the process of simplification still further, while at the same time endowing the archetypes with an almost Platonic significance.

[277] In this all-too-summary sketch we can see once again that same psychological process at work which disguises the instincts under the cloak of rational motivations and transforms the archetypes into rational concepts. It is hardly possible to recognize the archetype under this guise. And yet the way in which man inwardly pictures the world is still, despite all differences of detail, as uniform and as regular as his instinctive actions. Just as we have been compelled to postulate the concept of an instinct determining or regulating our conscious actions, so, in order to account for the uniformity and regularity of our perceptions, we must have recourse to the correlated concept of a factor determining the mode of apprehension. It is this factor which I call the archetype or primordial image. The primordial image might suitably be described as the *instinct's perception of itself*, or as the self-portrait of the instinct, in exactly the same way as consciousness is an inward perception of the objective life-process. Just as conscious apprehension gives our actions form and direction, so unconscious apprehension through the archetype determines the form and direction of instinct. If we call instinct “refined,” then the “intuition” which brings the instinct into play, in other words the apprehension by means of the archetype, must be something incredibly precise. Thus the yucca moth must carry within it an image, as it were, of the situation that “triggers off” its instinct. This image enables it to “recognize” the yucca flower and its structure.

[278] The criterion of the all-or-none reaction proposed by Rivers has helped us to discover the operation of instinct everywhere in human psychology, and it may be that the concept of the primordial image will perform a similar service with regard to acts of intuitive apprehension. Intuitional activity can be observed most easily among primitives. There we constantly meet with certain typical images and motifs which are the foundations of their mythologies. These images are autochthonous and occur with great regularity; everywhere we find the idea of a magic power or substance, of spirits and their doings, of heroes and gods and their legends. In the great religions of the world we see the perfection of those images and at the same time their progressive incrustation with rational forms. They even appear in the exact sciences,

as the foundation of certain indispensable auxiliary concepts such as energy, ether, and the atom.¹¹ In philosophy, Bergson affords an example of the revival of a primordial image with his conception of “durée créatrice,” which can be found in Proclus and, in its original form, in Heraclitus.

[279] Analytical psychology is daily concerned, in the normal and sick alike, with disturbances of conscious apprehension caused by the admixture of archetypal images. The exaggerated actions due to the interference of instinct are caused by intuitive modes of apprehension actuated by archetypes and all too likely to lead to over-intense and often distorted impressions.

[280] *Archetypes are typical modes of apprehension, and wherever we meet with uniform and regularly recurring modes of apprehension we are dealing with an archetype, no matter whether its mythological character is recognized or not.*

[281] The collective unconscious consists of the sum of the instincts and their correlates, the archetypes. Just as everybody possesses instincts, so he also possesses a stock of archetypal images. The most striking proof of this is the psychopathology of mental disturbances that are characterized by an irruption of the collective unconscious. Such is the case in schizophrenia; here we can often observe the emergence of archaic impulses in conjunction with unmistakable mythological images.

[282] In my view it is impossible to say which comes first—apprehension of the situation, or the impulse to act. It seems to me that both are aspects of the same vital activity, which we have to think of as two distinct processes simply for the purpose of better understanding.¹²

THE STRUCTURE OF THE PSYCHE¹

[283] The psyche, as a reflection of the world and man, is a thing of such infinite complexity that it can be observed and studied from a great many sides. It faces us with the same problem that the world does: because a systematic study of the world is beyond our powers, we have to content ourselves with mere rules of thumb and with aspects that particularly interest us. Everyone makes for himself his own segment of world and constructs his own private system, often with air-tight compartments, so that after a time it seems to him that he has grasped the meaning and structure of the whole. But the finite will never be able to grasp the infinite. Although the world of psychic phenomena is only a part of the world as a whole, it may seem easier to grasp precisely for that reason. But one would be forgetting that the psyche is the only phenomenon that is given to us immediately and, therefore, is the *sine qua non* of all experience.

[284] The only things we experience immediately are the contents of consciousness. In saying this I am not attempting to reduce the “world” to our “idea” of it. What I am trying to emphasize could be expressed from another point of view by saying: Life is a function of the carbon atom. This analogy reveals the limitations of the specialist point of view, to which I succumb as soon as I attempt to say anything explanatory about the world, or even a part of it.

[285] My point of view is naturally a psychological one, and moreover that of a practising psychologist whose task it is to find the quickest road through the chaotic muddle of complicated psychic states. This view must needs be very different from that of the psychologist who can study an isolated psychic process at his leisure, in the quiet of his laboratory. The difference is roughly that between a surgeon and an histologist. I also differ from the metaphysician, who feels he has to say how things are “in themselves,” and whether they are absolute or not. My subject lies wholly within the bounds of experience.

[286] My prime need is to grasp complicated conditions and be able to talk about them. I must be able to differentiate between various groups of psychic facts. The distinctions so made must not be arbitrary, since I have to reach an understanding with my patient. I therefore have to rely on simple schemata which on the one hand satisfactorily reflect the empirical facts, and on the other hand link up with what is generally known and so find acceptance.

[287] If we now set out to classify the contents of consciousness, we shall begin, according to tradition, with the proposition: *Nihil est in intellectu quod non antea fuerit in sensu.*

[288] Consciousness seems to stream into us from outside in the form of *sense-perceptions*. We see, hear, taste, and smell the world, and so are conscious of the world. Sense-perceptions tell us that something *is*. But they do not tell us *what* it is. This is told us not by the process of perception but by the process of *apperception*, and this has a highly complex structure. Not that sense-perception is anything simple; only, its complex nature is not so much psychic as physiological. The complexity of apperception, on the other hand, is psychic. We can detect in it the cooperation of a number of psychic processes. Supposing we hear a noise whose nature seems to us unknown. After a while it becomes clear to us that the peculiar noise must come from air-bubbles rising in the pipes of the central heating: we have *recognized* the noise. This recognition derives from a process which we call thinking. Thinking tells us *what* a thing is.

[289] I have just called the noise “peculiar.” When I characterize something as “peculiar,” I am referring to the special *feeling-tone* which that thing has. The feeling-tone implies an *evaluation*.

[290] The *process of recognition* can be conceived in essence as comparison and differentiation with the help of memory. When I see a fire, for instance, the light-stimulus conveys to me the idea “fire.” As there are countless memory-images of fire lying ready in my memory, these images enter into combination with the fire-image I have just received, and the process of comparing it with and differentiating it from these memory-images produces the recognition; that is to say, I finally establish in my mind the peculiarity of this particular image. In ordinary speech this process is called *thinking*.

[291] The *process of evaluation* is different. The fire I see arouses emotional reactions of a pleasant or unpleasant nature, and the memory-images thus stimulated bring with them concomitant emotional phenomena which are known as *feeling-tones*. In this way an object appears to us as pleasant, desirable, and beautiful, or as unpleasant, disgusting, ugly, and so on. In ordinary speech this process is called *feeling*.

[292] The *intuitive process* is neither one of sense-perception, nor of thinking, nor yet of feeling, although language shows a regrettable lack of discrimination in this respect. One person will exclaim: “I can see the whole house burning down already!” Another will say: “It is as certain as two and two make four that there will be a disaster if a fire breaks out here.” A third will say: “I have the feeling that this fire will lead to catastrophe.” According to their respective temperaments, the one speaks of his intuition as a distinct *seeing*, that is, he makes a sense-perception of it. The

other designates it as *thinking*: “One has only to reflect, and then it is quite clear what the consequences will be.” The third, under the stress of emotion, calls his intuition a process of *feeling*. But intuition, as I conceive it, is one of the basic functions of the psyche, namely, *perception of the possibilities inherent in a situation*. It is probably due to the insufficient development of language that “feeling,” “sensation,” and “intuition” are still confused in German, while *sentiment* and *sensation* in French, and “feeling” and “sensation” in English, are absolutely distinct, in contrast to *sentiment* and “feeling,” which are sometimes used as auxiliary words for “intuition.” Recently, however, “intuition” has begun to be commonly used in English speech.

[293] As further contents of consciousness, we can also distinguish *volitional* processes and *instinctual* processes. The former are defined as directed impulses, based on apperception, which are at the disposal of so-called free will. The latter are impulses originating in the unconscious or directly in the body and are characterized by lack of freedom and by compulsiveness.

[294] Apperceptive processes may be either *directed* or *undirected*. In the former case we speak of “attention,” in the latter case of “fantasy” or “dreaming.” The directed processes are rational, the undirected irrational. To these last-named processes we must add—as the seventh category of contents of consciousness—*dreams*. In some respects dreams are like conscious fantasies in that they have an undirected, irrational character. But they differ inasmuch as their cause, course, and aim are, at first, very obscure. I accord them the dignity of coming into the category of conscious contents because they are the most important and most obvious results of unconscious psychic processes obtruding themselves upon consciousness. These seven categories probably give a somewhat superficial survey of the contents of consciousness, but they are sufficient for our purpose.

[295] There are, as we know, certain views which would restrict everything psychic to consciousness, as being identical with it. I do not believe this is sufficient. If we assume that there is anything at all beyond our sense-perception, then we are entitled to speak of psychic elements whose existence is only indirectly accessible to us. For anybody acquainted with the psychology of hypnotism and somnambulism, it is a well-known fact that though an artificially or morbidly restricted consciousness of this kind does not contain certain ideas, it nevertheless behaves exactly as if it did. For instance, there was an hysterically deaf patient who was fond of singing. One day the doctor unobtrusively sat down at the piano and accompanied the next verse in another key, whereupon the patient went on singing in the new key. Another patient always fell into “hystero-epileptic” convulsions at the sight of a naked flame. He had a markedly restricted field of vision, that is, he suffered from peripheral blindness (having what is known as a “tubular” field of vision). If one now held a lighted match

in the blind zone, the attack followed just as if he had seen the flame. In the symptomatology of such states there are innumerable cases of this kind, where with the best will in the world one can only say that these people perceive, think, feel, remember, decide, and act unconsciously, doing unconsciously what others do consciously. These processes occur regardless of whether consciousness registers them or not.

[296] These unconscious psychic processes also include the not inconsiderable labour of composition that goes into a dream. Though sleep is a state in which consciousness is greatly restricted, the psyche by no means ceases to exist and to act. Consciousness has merely withdrawn from it and, lacking any objects to hold its attention, lapsed into a state of comparative unconsciousness. But psychic life obviously goes on, just as there is unconscious psychic activity during the waking state. Evidence for this is not difficult to find; indeed, Freud has described this particular field of experience in *The Psychopathology of Everyday Life*. He shows that our conscious intentions and actions are often frustrated by unconscious processes whose very existence is a continual surprise to us. We make slips of the tongue and slips in writing and unconsciously do things that betray our most closely guarded secrets—which are sometimes unknown even to ourselves. “Lingua lapsa verum dicit,” says an old proverb. These phenomena can also be demonstrated experimentally by the association tests, which are very useful for finding out things that people cannot or will not speak about.

[297] But the classic examples of unconscious psychic activity are to be found in pathological states. Almost the whole symptomatology of hysteria, of the compulsion neuroses, of phobias, and very largely of schizophrenia, the commonest mental illness, has its roots in unconscious psychic activity. We are therefore fully justified in speaking of an unconscious psyche. It is not directly accessible to observation—otherwise it would not be unconscious—but can only be inferred. Our inferences can never go beyond: “it is as if.”

[298] The unconscious, then, is part of the psyche. Can we now, on the analogy of the different contents of consciousness, also speak of contents of the unconscious? That would be postulating another consciousness, so to speak, in the unconscious. I will not go into this delicate question here, since I have discussed it in another connection, but will confine myself to inquiring whether we can differentiate anything in the unconscious or not. This question can only be answered empirically, that is, by the counter-question whether there are any plausible grounds for such a differentiation.

[299] To my mind there is no doubt that all the activities ordinarily taking place in consciousness can also proceed in the unconscious. There are numerous instances of an intellectual problem, unsolved in the waking state, being solved in a dream. I

know, for instance, of an expert accountant who had tried in vain for many days to clear up a fraudulent bankruptcy. One day he had worked on it till midnight, without success, and then went to bed. At three in the morning his wife heard him get up and go into his study. She followed, and saw him industriously making notes at his desk. After about a quarter of an hour he came back. In the morning he remembered nothing. He began working again and discovered, in his own handwriting, a number of notes which straightened out the whole tangle finally and completely.

[300] In my practical work I have been dealing with dreams for more than twenty years. Over and over again I have seen how thoughts that were not thought and feelings that were not felt by day afterwards appeared in dreams, and in this way reached consciousness indirectly. The dream as such is undoubtedly a content of consciousness, otherwise it could not be an object of immediate experience. But in so far as it brings up material that was unconscious before, we are forced to assume that these contents already had some kind of psychic existence in an unconscious state and appeared to the “remnant” of consciousness only in the dream. The dream belongs to the normal contents of the psyche and may be regarded as a resultant of unconscious processes obtruding on consciousness.

[301] Now if, with these experiences in mind, we are driven to assume that all the categories of conscious contents can on occasion also be unconscious, and can act on the conscious mind as unconscious processes, we find ourselves faced with the somewhat unexpected question whether the unconscious has dreams too. In other words, are there resultants of still deeper and—if that be possible—still more unconscious processes which infiltrate into the dark regions of the psyche? I should have to dismiss this paradoxical question as altogether too adventurous were there not, in fact, grounds which bring such an hypothesis within the realm of possibility.

[302] We must first see what sort of evidence is required to prove that the unconscious has dreams. If we wish to prove that dreams appear as contents of consciousness, we have simply to show that there are certain contents which, in character and meaning, are strange and not to be compared with the other contents which can be rationally explained and understood. If we are to show that the unconscious also has dreams, we must treat its contents in a similar way. It will be simplest if I give a practical example:

[303] The case is that of an officer, twenty-seven years of age. He was suffering from severe attacks of pain in the region of the heart and from a choking sensation in the throat, as though a lump were stuck there. He also had piercing pains in the left heel. There was nothing organically the matter with him. The attacks had begun about two months previously, and the patient had been exempted from military service on account of his occasional inability to walk. Various cures had availed nothing. Close

investigation into the previous history of his illness gave no clue, and he himself had no idea what the cause might be. He gave the impression of having a cheerful, rather light-hearted nature, perhaps a bit on the tough side, as though saying theatrically: “You can’t keep us down.” As the anamnesis revealed nothing, I asked about his dreams. It at once became apparent what the cause was. Just before the beginning of his neurosis the girl with whom he was in love jilted him and got engaged to another man. In talking to me he dismissed this whole story as irrelevant—“a stupid girl, if she doesn’t want me it’s easy enough to get another one. A man like me isn’t upset by a thing like that.” That was the way he treated his disappointment and his real grief. But now the affects came to the surface. The pains in his heart soon disappeared, and the lump in his throat vanished after a few bouts of weeping. “Heartache” is a poeticism, but here it became an actual fact because his pride would not allow him to suffer the pain in his soul. The “lump in the throat,” the so-called *globus hystericus*, comes, as everyone knows, from swallowed tears. His consciousness had simply withdrawn from contents that were too painful to him, and these, left to themselves, could reach consciousness only indirectly, as symptoms. All this was a rationally understandable and perfectly intelligible process, which could just as well have passed off consciously, had it not been for his masculine pride.

[304] But now for the third symptom. The pains in the heel did not disappear. They do not belong in the picture we have just sketched, for the heart is in no way connected with the heel, nor does one express sorrow through the heel. From the rational point of view, one cannot see why the other two syndromes should not have sufficed. Theoretically, it would have been entirely satisfactory if the conscious realization of the repressed psychic pain had resulted in normal grief and hence in a cure.

[305] As I could get no clue to the heel symptom from the patient’s conscious mind, I turned once more to the previous method—to the dreams. The patient now had a dream in which *he was bitten in the heel by a snake and instantly paralysed*. This dream plainly offered an interpretation of the heel symptom. His heel hurt him because he had been bitten there by a snake. This is a very strange content, and one can make nothing of it rationally. We could understand at once why his heart ached, but that his heel should ache too is beyond all rational expectation. The patient was completely mystified.

[306] Here, then, we have a content that propels itself into the unconscious zone in a singular manner, and probably derives from some deeper layer that cannot be fathomed rationally. The nearest analogy to this dream is obviously the neurosis itself. When the girl jilted him, she gave him a wound that paralyzed him and made him ill. Further analysis of the dream elicited something from his previous history that now became clear to the patient for the first time: He had been the darling of a

somewhat hysterical mother. She had pitied him, admired him, pampered him so much that he never got along properly at school because he was too girlish. Later he suddenly swung over to the masculine side and went into the army, where he was able to hide his inner weakness by a display of “toughness.” Thus, in a sense, his mother too had lamed him.

[307] We are evidently dealing here with that same old serpent who had been the special friend of Eve. “And I will put enmity between thee and the woman, and between thy seed and her seed; it shall bruise thy head, and thou shalt bruise his heel,” runs the saying in Genesis, an echo of the much more ancient Egyptian hymn that used to be recited or chanted for the cure of snake-bite:

The mouth of the god trembled with age,
His spittle fell to the earth,
And what he spat forth fell upon the ground.
Then Isis kneaded it with her hands
Together with the earth which was there;
And she made it like a spear.
She wound not the living snake about her face,
But threw it in a coil upon the path
Where the great god was wont to wander
At his pleasure through his two kingdoms.
The noble god stepped forth in splendour,
The gods serving Pharaoh bore him company,
And he went forth as was each day his wont.
Then the noble worm stung him ...
His jawbones chattered,
He trembled in all his limbs,
And the poison invaded his flesh
As the Nile invades his territory.²

[308] The patient’s conscious knowledge of the Bible was at a lamentable minimum. Probably he had once heard of the serpent biting the heel and then quickly forgotten it. But something deep in his unconscious heard it and did not forget; it remembered this story at a suitable opportunity. This part of the unconscious evidently likes to express itself mythologically, because this way of expression is in keeping with its nature.

[309] But to what kind of mentality does the symbolical or metaphorical way of expression correspond? It corresponds to the mentality of the primitive, whose

language possesses no abstractions but only natural and “unnatural” analogies. This primeval mentality is as foreign to the psyche that produced the heartache and the lump in the throat as a brontosaurus is to a racehorse. The dream of the snake reveals a fragment of psychic activity that has nothing whatever to do with the dreamer as a modern individual. It functions at a deeper level, so to speak, and only the results of this activity rise up into the upper layer where the repressed affects lie, as foreign to them as a dream is to waking consciousness. Just as some kind of analytical technique is needed to understand a dream, so a knowledge of mythology is needed in order to grasp the meaning of a content deriving from the deeper levels of the psyche.

[310] The snake-motif was certainly not an individual acquisition of the dreamer, for snake-dreams are very common even among city-dwellers who have probably never seen a real snake.

[311] It might be objected that the snake in the dream is nothing but a concretized figure of speech. We say of certain women that they are treacherous as snakes, wily as serpents; we speak of the snake of temptation, etc. This objection does not seem to me to hold good in the present instance, though it would be difficult to prove this because the snake is in fact a common figure of speech. A more certain proof would be possible only if we succeeded in finding a case where the mythological symbolism is neither a common figure of speech nor an instance of cryptomnesia—that is to say, where the dreamer had not read, seen, or heard the motif somewhere, and then forgotten it and remembered it unconsciously. This proof seems to me of great importance, since it would show that the rationally explicable unconscious, which consists of material that has been made unconscious artificially, as it were, is only a top layer, and that underneath is an absolute unconscious which has nothing to do with our personal experience. This absolute unconscious would then be a psychic activity which goes on independently of the conscious mind and is not dependent even on the upper layers of the unconscious, untouched—and perhaps untouchable—by personal experience. It would be a kind of supra-individual psychic activity, a *collective unconscious*, as I have called it, as distinct from a superficial, relative, or personal unconscious.

[312] But before we go in search of this proof, I would like, for the sake of completeness, to make a few more remarks about the snake-dream. It seems as if this hypothetical deeper layer of the unconscious—the collective unconscious, as I shall now speak of it—had translated the patient’s experiences with women into the snake-bite dream and thus turned them into a regular mythological motif. The reason—or rather, the purpose—of this is at first somewhat obscure. But if we remember the fundamental principle that the symptomatology of an illness is at the same time a

natural attempt at healing—the heartaches, for example, being an attempt to produce an emotional outburst—then we must regard the heel symptom as an attempt at healing too. As the dream shows, not only the recent disappointment in love, but all other disappointments, in school and elsewhere, are raised by this symptom to the level of a mythological event, as though this would in some way help the patient.

[313] This may strike us as flatly incredible. But the ancient Egyptian priest-physicians, who intoned the hymn to the Isis-serpent over the snake-bite, did not find this theory at all incredible; and not only they, but the whole world believed, as the primitive today still believes, in magic by analogy or “sympathetic magic.”

[314] We are concerned here, then, with the psychological phenomenon that lies at the root of magic by analogy. We should not think that this is an ancient superstition which we have long since outgrown. If you read the Latin text of the Mass carefully, you will constantly come upon the famous “sicut”; this always introduces an analogy by means of which a change is to be produced. Another striking example of analogy is the making of fire on Holy Saturday. In former times, the new fire was struck from the stone, and still earlier it was obtained by boring into a piece of wood, which was the prerogative of the Church. Therefore in the prayer of the priest it is said: “Deus, qui per Filium tuum, angularem scilicet lapidem, claritatis tuae fidelibus ignem contulisti productum ex silice, nostris profuturum usibus, novum hunc ignem sanctifica.”—“O God, who through thy Son, who is called the cornerstone, hast brought the fire of thy light to the faithful, make holy for our future use this new fire struck from the firestone.” By the analogy of Christ with the cornerstone, the firestone is raised to the level of Christ himself, who again kindles a new fire.

[315] The rationalist may laugh at this. But something deep in us is stirred, and not in us alone but in millions of Christian men and women, though we may call it only a feeling for beauty. What is stirred in us is that faraway background, those immemorial patterns of the human mind, which we have not acquired but have inherited from the dim ages of the past.

[316] If this supra-individual psyche exists, everything that is translated into its picture-language would be depersonalized, and if this became conscious would appear to us *sub specie aeternitatis*. Not as my sorrow, but as the sorrow of the world; not a personal isolating pain, but a pain without bitterness that unites all humanity. The healing effect of this needs no proof.

[317] But as to whether this supra-individual psychic activity actually exists, I have so far given no proof that satisfies all the requirements. I should now like to do this once more in the form of an example. The case is that of a man in his thirties, who was suffering from a paranoid form of schizophrenia. He became ill in his early twenties. He had always presented a strange mixture of intelligence, wrong-headedness, and

fantastic ideas. He was an ordinary clerk, employed in a consulate. Evidently as a compensation for his very modest existence he was seized with megalomania and believed himself to be the Saviour. He suffered from frequent hallucinations and was at times very much disturbed. In his quiet periods he was allowed to go unattended in the corridor. One day I came across him there, blinking through the window up at the sun, and moving his head from side to side in a curious manner. He took me by the arm and said he wanted to show me something. He said I must look at the sun with eyes half shut, and then I could see the sun's phallus. If I moved my head from side to side the sun-phallus would move too, and that was the origin of the wind.

[318] I made this observation about 1906. In the course of the year 1910, when I was engrossed in mythological studies, a book of Dieterich's came into my hands. It was part of the so-called Paris magic papyrus and was thought by Dieterich to be a liturgy of the Mithraic cult.³ It consisted of a series of instructions, invocations, and visions. One of these visions is described in the following words: "And likewise the so-called tube, the origin of the ministering wind. For you will see hanging down from the disc of the sun something that looks like a tube. And towards the regions westward it is as though there were an infinite east wind. But if the other wind should prevail towards the regions of the east, you will in like manner see the vision veering in that direction." The Greek word for 'tube,' *αὐλός*, means a wind-instrument, and the combination *αὐλὸς παχύς* in Homer means 'a thick jet of blood.' So evidently a stream of wind is blowing through the tube out of the sun.

[319] The vision of my patient in 1906, and the Greek text first edited in 1910, should be sufficiently far apart to rule out the possibility of cryptomnesia on his side and of thought-transference on mine. The obvious parallelism of the two visions cannot be disputed, though one might object that the similarity is purely fortuitous. In that case we should expect the vision to have no connections with analogous ideas, nor any inner meaning. But this expectation is not fulfilled, for in certain medieval paintings this tube is actually depicted as a sort of hose-pipe reaching down from heaven under the robe of Mary. In it the Holy Ghost flies down in the form of a dove to impregnate the Virgin. As we know from the miracle of Pentecost, the Holy Ghost was originally conceived as a mighty rushing wind, the *πνεῦμα*, "the wind that bloweth where it listeth." In a Latin text we read: "Animo descensus per orbem solis tribuitur" (They say that the spirit descends through the disc of the sun). This conception is common to the whole of late classical and medieval philosophy.

[320] I cannot, therefore, discover anything fortuitous in these visions, but simply the revival of possibilities of ideas that have always existed, that can be found again in the most diverse minds and in all epochs, and are therefore not to be mistaken for inherited ideas.

[321] I have purposely gone into the details of this case in order to give you a concrete picture of that deeper psychic activity which I call the collective unconscious. Summing up, I would like to emphasize that we must distinguish three psychic levels: (1) consciousness, (2) the personal unconscious, and (3) the collective unconscious. The personal unconscious consists firstly of all those contents that became unconscious either because they lost their intensity and were forgotten or because consciousness was withdrawn from them (repression), and secondly of contents, some of them sense-impressions, which never had sufficient intensity to reach consciousness but have somehow entered the psyche. The collective unconscious, however, as the ancestral heritage of possibilities of representation, is not individual but common to all men, and perhaps even to all animals, and is the true basis of the individual psyche.

[322] This whole psychic organism corresponds exactly to the body, which, though individually varied, is in all essential features the specifically human body which all men have. In its development and structure, it still preserves elements that connect it with the invertebrates and ultimately with the protozoa. Theoretically it should be possible to “peel” the collective unconscious, layer by layer, until we came to the psychology of the worm, and even of the amoeba.

[323] We are all agreed that it would be quite impossible to understand the living organism apart from its relation to the environment. There are countless biological facts that can only be explained as reactions to environmental conditions, e.g., the blindness of *Proteus anguinus*, the peculiarities of intestinal parasites, the anatomy of vertebrates that have reverted to aquatic life.

[324] The same is true of the psyche. Its peculiar organization must be intimately connected with environmental conditions. We should expect consciousness to react and adapt itself to the present, because it is that part of the psyche which is concerned chiefly with events of the moment. But from the collective unconscious, as a timeless and universal psyche, we should expect reactions to universal and constant conditions, whether psychological, physiological, or physical.

[325] The collective unconscious—so far as we can say anything about it at all—appears to consist of mythological motifs or primordial images, for which reason the myths of all nations are its real exponents. In fact, the whole of mythology could be taken as a sort of projection of the collective unconscious. We can see this most clearly if we look at the heavenly constellations, whose originally chaotic forms were organized through the projection of images. This explains the influence of the stars as asserted by astrologers. These influences are nothing but unconscious, introspective perceptions of the activity of the collective unconscious. Just as the constellations were projected into the heavens, similar figures were projected into legends and

fairytale or upon historical persons. We can therefore study the collective unconscious in two ways, either in mythology or in the analysis of the individual. As I cannot make the latter material available here, I must confine myself to mythology. This is such a wide field that we can select from it only a few types. Similarly, environmental conditions are endlessly varied, so here too only a few of the more typical can be discussed.

[326] Just as the living body with its special characteristics is a system of functions for adapting to environmental conditions, so the psyche must exhibit organs or functional systems that correspond to regular physical events. By this I do not mean sense-functions dependent on organs, but rather a sort of psychic parallel to regular physical occurrences. To take an example, the daily course of the sun and the regular alternation of day and night must have imprinted themselves on the psyche in the form of an image from primordial times. We cannot demonstrate the existence of this image, but we find instead more or less fantastic analogies of the physical process. Every morning a divine hero is born from the sea and mounts the chariot of the sun. In the West a Great Mother awaits him, and he is devoured by her in the evening. In the belly of a dragon he traverses the depths of the midnight sea. After a frightful combat with the serpent of night he is born again in the morning.

[327] This conglomerate myth undoubtedly contains a reflection of the physical process. Indeed this is so obvious that many investigators assume that primitives invent such myths merely to explain physical processes. There can be no doubt that science and philosophy have grown from this matrix, but that primitives think up such things merely from a need for explanation, as a sort of physical or astronomical theory, seems to me highly improbable.

[328] What we can safely say about mythical images is that the physical process imprinted itself on the psyche in this fantastic, distorted form and was preserved there, so that the unconscious still reproduces similar images today. Naturally the question now arises: why does the psyche not register the actual process, instead of mere fantasies about the physical process?

[329] If you can put yourself in the mind of the primitive, you will at once understand why this is so. He lives in such "participation mystique" with his world, as Lévy-Bruhl calls it, that there is nothing like that absolute distinction between subject and object which exists in our minds. What happens outside also happens in him, and what happens in him also happens outside. I witnessed a very fine example of this when I was with the Elgonyi, a primitive tribe living on Mount Elgon, in East Africa. At sunrise they spit on their hands and then hold the palms towards the sun as it comes over the horizon. "We are happy that the night is past," they say. Since the word for sun, *adhista*, also means God, I asked: "Is the sun God?" They said "No" to

this and laughed, as if I had said something especially stupid. As the sun was just then high in the heavens, I pointed to it and asked: "When the sun is there you say it is not God, but when it is in the east you say it is God. How is that?" There was an embarrassed silence till an old chief began to explain. "It is so," he said. "When the sun is up there it is not God, but when it rises, that is God [or: then it is God]." To the primitive mind it is immaterial which of these two versions is correct. Sunrise and his own feeling of deliverance are for him the same divine experience, just as night and his fear are the same thing. Naturally his emotions are more important to him than physics; therefore what he registers is his emotional fantasies. For him night means snakes and the cold breath of spirits, whereas morning means the birth of a beautiful god.

[330] There are mythological theories that explain everything as coming from the sun and lunar theories that do the same for the moon. This is due to the simple fact that there are countless myths about the moon, among them a whole host in which the moon is the wife of the sun. The moon is the changing experience of the night, and thus coincides with the primitive's sexual experience of woman, who for him is also the experience of the night. But the moon can equally well be the injured brother of the sun, for at night affect-laden and evil thoughts of power and revenge may disturb sleep. The moon, too, is a disturber of sleep, and is also the abode of departed souls, for at night the dead return in dreams and the phantoms of the past terrify the sleepless. Thus the moon also signifies madness ("lunacy"). It is such experiences as these that have impressed themselves on the mind, rather than the changing image of the moon.

[331] It is not storms, not thunder and lightning, not rain and cloud that remain as images in the psyche, but the fantasies caused by the affects they arouse. I once experienced a violent earthquake, and my first, immediate feeling was that I no longer stood on the solid and familiar earth, but on the skin of a gigantic animal that was heaving under my feet. It was this image that impressed itself on me, not the physical fact. Man's curses against devastating thunderstorms, his terror of the unchained elements—these affects anthropomorphize the passion of nature, and the purely physical element becomes an angry god.

[332] Like the physical conditions of his environment, the physiological conditions, glandular secretions, etc., also can arouse fantasies charged with affect. Sexuality appears as a god of fertility, as a fiercely sensual, feminine daemon, as the devil himself with Dionysian goat's legs and obscene gestures, or as a terrifying serpent that squeezes its victims to death.

[333] Hunger makes food into gods. Certain Mexican tribes even give their food-gods an annual holiday to allow them to recuperate, and during this time the staple food is

not eaten. The ancient Pharaohs were worshipped as eaters of gods. Osiris is the wheat, the son of the earth, and to this day the Host must be made of wheat-meal, i.e., a god to be eaten, as also was Iacchos, the mysterious god of the Eleusinian mysteries. The bull of Mithras is the edible fruitfulness of the earth.

[334] The psychological conditions of the environment naturally leave similar mythical traces behind them. Dangerous situations, be they dangers to the body or to the soul, arouse affect-laden fantasies, and, in so far as such situations typically repeat themselves, they give rise to *archetypes*, as I have termed myth-motifs in general.

[335] Dragons make their lairs by watercourses, preferably near a ford or some such dangerous crossing; jinn and other devils are to be found in waterless deserts or in dangerous gorges; spirits of the dead haunt the eerie thickets of the bamboo forest; treacherous nixies and sea-serpents live in the depths of the ocean and its whirlpools. Mighty ancestor-spirits or gods dwell in the man of importance; deadly fetish-power resides in anyone strange or extraordinary. Sickness and death are never due to natural causes, but are invariably caused by spirits, witches, or wizards. Even the weapon that has killed a man is *mana*, endowed with extraordinary power.

[336] How is it then, you may ask, with the most ordinary everyday events, with immediate realities like husband, wife, father, mother, child? These ordinary everyday facts, which are eternally repeated, create the mightiest archetypes of all, whose ceaseless activity is everywhere apparent even in a rationalistic age like ours. Let us take as an example the Christian dogma. The Trinity consists of Father, Son, and Holy Ghost, who is represented by the bird of Astarte, the dove, and who in early Christian times was called Sophia and thought of as feminine. The worship of Mary in the later Church is an obvious substitute for this. Here we have the archetype of the family ἐν ὑπερουρανίῳ τόπῳ ‘in a supracelestial place,’ as Plato expresses it, enthroned as a formulation of the ultimate mystery. Christ is the bridegroom, the Church is the bride, the baptismal font is the womb of the Church, as it is still called in the text of the *Benedictio fontis*. The holy water has salt put into it, with the idea of making it like the amniotic fluid, or like sea-water. A *hieros gamos* or sacred wedding is performed on Holy Saturday before Easter, which I have just mentioned, and a burning candle as a phallic symbol is plunged three times into the font, in order to fertilize it and lend it the power to bear the baptized child anew (*quasimodo genitus*). The *mana* personality, the medicine-man, is the *pontifex maximus*, the *Papa*; the Church is *mater ecclesia*, the *magna mater* of magical power, and mankind are children in need of help and grace.

[337] The deposit of mankind’s whole ancestral experience—so rich in emotional imagery—of father, mother, child, husband and wife, of the magic personality, of dangers to body and soul, has exalted this group of archetypes into the supreme

regulating principles of religious and even of political life, in unconscious recognition of their tremendous psychic power.

[338] I have found that a rational understanding of these things in no way detracts from their value; on the contrary, it helps us not only to feel but to gain insight into their immense significance. These mighty projections enable the Catholic to experience large tracts of his collective unconscious in tangible reality. He has no need to go in search of authority, superior power, revelation, or something that would link him with the eternal and the timeless. These are always present and available for him: there, in the Holy of Holies on every altar, dwells the presence of God. It is the Protestant and the Jew who have to seek, the one because he has, in a manner of speaking, destroyed the earthly body of the Deity, the other because he can never find it. For both of them the archetypes, which to the Catholic world have become a visible and living reality, lie in the unconscious. Unfortunately I cannot enter here into the remarkable differences of attitude towards the unconscious in our culture, but would only point out that this question is one of the greatest problems confronting humanity.

[339] That this is so is immediately understandable when we consider that the unconscious, as the totality of all archetypes, is the deposit of all human experience right back to its remotest beginnings. Not, indeed, a dead deposit, a sort of abandoned rubbish-heap, but a living system of reactions and aptitudes that determine the individual's life in invisible ways—all the more effective because invisible. It is not just a gigantic historical prejudice, so to speak, an *a priori* historical condition; it is also the source of the instincts, for the archetypes are simply the forms which the instincts assume. From the living fountain of instinct flows everything that is creative; hence the unconscious is not merely conditioned by history, but is the very source of the creative impulse. It is like Nature herself—prodigiously conservative, and yet transcending her own historical conditions in her acts of creation. No wonder, then, that it has always been a burning question for humanity how best to adapt to these invisible determinants. If consciousness had never split off from the unconscious—an eternally repeated event symbolized as the fall of the angels and the disobedience of the first parents—this problem would never have arisen, any more than would the question of environmental adaptation.

[340] The existence of an individual consciousness makes man aware of the difficulties of his inner as well as his outer life. Just as the world about him takes on a friendly or a hostile aspect to the eyes of primitive man, so the influences of his unconscious seem to him like an opposing power, with which he has to come to terms just as with the visible world. His countless magical practices serve this end. On higher levels of civilization, religion and philosophy fulfil the same purpose. Whenever such a

system of adaptation breaks down a general unrest begins to appear, and attempts are made to find a suitable new form of relationship to the unconscious.

[341] These things seem very remote to our modern, “enlightened” eyes. When I speak of this hinterland of the mind, the unconscious, and compare its reality with that of the visible world, I often meet with an incredulous smile. But then I must ask how many people there are in our civilized world who still believe in *mana* and spirits and suchlike theories—in other words, how many millions of Christian Scientists and spiritualists are there? I will not add to this list of questions. They are merely intended to illustrate the fact that the problem of invisible psychic determinants is as alive today as ever it was.

[342] The collective unconscious contains the whole spiritual heritage of mankind’s evolution, born anew in the brain structure of every individual. His conscious mind is an ephemeral phenomenon that accomplishes all provisional adaptations and orientations, for which reason one can best compare its function to orientation in space. The unconscious, on the other hand, is the source of the instinctual forces of the psyche and of the forms or categories that regulate them, namely the archetypes. All the most powerful ideas in history go back to archetypes. This is particularly true of religious ideas, but the central concepts of science, philosophy, and ethics are no exception to this rule. In their present form they are variants of archetypal ideas, created by consciously applying and adapting these ideas to reality. For it is the function of consciousness not only to recognize and assimilate the external world through the gateway of the senses, but to translate into visible reality the world within us.

ON THE NATURE OF THE PSYCHE¹

1. The Unconscious in Historical Perspective

[343] More clearly, perhaps, than any other science, psychology demonstrates the spiritual transition from the classical age to the modern. The history of psychology² up to the seventeenth century consists essentially in the enumeration of doctrines concerning the soul, but the soul was never able to get a word in as the object investigated. As the immediate datum of experience, it seemed so completely known to every thinker that he was convinced there could be no need of any further, let alone objective, experience. This attitude is totally alien to the modern standpoint, for today we are of the opinion that, over and above all subjective certainty, objective experience is needed to substantiate an opinion that lays claim to be scientific. Notwithstanding this it is still difficult, even today, to apply the purely empirical or phenomenological standpoint consistently in psychology, because the original naïve idea that the soul, being the immediate datum of experience, was the best known of all knowables is one of our most deeply rooted convictions. Not only does every layman presume to an opinion, but every psychologist too—and not merely with reference to the subject but, what is of greater consequence, with reference to the object. He knows, or rather he thinks he knows, what is going on in another individual, and what is good for him. This is due less to a sovereign disregard of differences than to a tacit assumption that all individuals are alike. As a result, people incline unconsciously to a belief in the universal validity of subjective opinions. I mention this fact only to show that, in spite of the growing empiricism of the last three hundred years, the original attitude has by no means disappeared. Its continued existence only goes to prove how difficult is the transition from the old philosophical view to the modern empirical one.

[344] Naturally it never occurred to the representatives of the old view that their doctrines were nothing but psychic phenomena, for it was naïvely assumed that with the help of intelligence or reason man could, as it were, climb out of his psychic condition and remove himself to one that was suprap psychic and rational. Even now, the doubt as to whether the statements of the human mind might not in the end be symptoms of certain psychic conditions is one that few people would consider seriously.³ This question would be very much to the point, but it has such far-reaching and revolutionary consequences that we can understand only too well why

both past and present have done their best to ignore it. We are still very far today from Nietzsche's view of philosophy, and indeed of theology, as an "ancilla psychologiae," for not even the psychologist is prepared to regard his statements, at least in part, as a subjectively conditioned confession. We can say that individuals are equal only in so far as they are in large measure unconscious—unconscious, that is, of their actual differences. The more unconscious a man is, the more he will conform to the general canon of psychic behaviour. But the more conscious he becomes of his individuality, the more pronounced will be his difference from other subjects and the less he will come up to common expectations. Further, his reactions are much less predictable. This is due to the fact that an individual consciousness is always more highly differentiated and more extensive. But the more extensive it becomes the more differences it will perceive and the more it will emancipate itself from the collective rules, for the empirical freedom of the will grows in proportion to the extension of consciousness.

[345] As the individual differentiation of consciousness proceeds, the objective validity of its views decreases and their subjectivity increases, at least in the eyes of the environment, if not in actual fact. For if a view is to be valid, it must have the acclaim of the greatest possible number, regardless of the arguments put forward in its favour. "True" and "valid" describe what the majority believe, for this confirms the equality of all. But a differentiated consciousness no longer takes it for granted that one's own preconceptions are applicable to others, and vice versa. This logical development had the consequence that in the seventeenth century—a century of great importance for the growth of science—psychology began to rise up by the side of philosophy, and it was Christian von Wolf (1679–1754) who was the first to speak of "empirical" or "experimental" psychology,⁴ thus acknowledging the need to put psychology on a new footing. Psychology had to forgo the philosopher's rational definition of truth, because it gradually became clear that no philosophy had sufficient general validity to be uniformly fair to the diversity of individual subjects. And since on questions of principle, too, an indefinitely large number of different subjective statements was possible, whose validity in their turn could be maintained only subjectively, it naturally became necessary to abandon philosophical argument and to replace it by experience. Psychology thereupon turned into a natural science.

[346] For the time being, however, philosophy retained its grip on the wide field of "rational" or "speculative" psychology, and only with the passage of the centuries could the latter gradually develop into a natural science. This process of change is not complete even today. Psychology, as a subject, still comes under the Philosophical Faculty in most universities and remains in the hands of professional philosophers, while "medical" psychology has still to seek refuge with the Medical Faculty. So officially the situation is still largely medieval, since even the natural sciences are

only admitted as “Phil. II,” under the cloak of Natural Philosophy.⁵ Although it has been obvious for at least two hundred years that philosophy above all is dependent on psychological premises, everything possible was done to obscure the autonomy of the empirical sciences after it became clear that the discovery of the earth’s rotation and the moons of Jupiter could no longer be suppressed. Of all the natural sciences, psychology has been the least able to win its independence.

[347] This backwardness seems to me significant. The position of psychology is comparable with that of a psychic function which is inhibited by the conscious mind: only such components of it are admitted to exist as accord with the prevailing trend of consciousness. Whatever fails to accord is actually denied existence, in defiance of the fact that there are numerous phenomena or symptoms to prove the contrary. Anyone acquainted with these psychic processes knows with what subterfuges and self-deceiving manoeuvres one sets about splitting off the inconvenience. It is precisely the same with empirical psychology: as the discipline subordinate to a general philosophical psychology, experimental psychology is admitted as a concession to the empiricism of natural science, but is cluttered up with technical philosophical terms. As for psychopathology, it stays put in the Medical Faculty as a curious appendix to psychiatry. “Medical” psychology, as might be expected, finds little or no recognition in the universities.”⁶

[348] If I express myself somewhat drastically in this matter, it is with intent to throw into relief the position of psychology at the turn of the nineteenth and the beginning of the twentieth century. Wundt’s standpoint is entirely representative of the situation as it then was—representative also because there emerged from his school a succession of notable psychologists who set the tone at the beginning of the twentieth century. In his *Outlines of Psychology*, Wundt says: “Any psychical element that has disappeared from consciousness is to be called unconscious in the sense that we assume the possibility of its renewal, that is, its reappearance in the actual interconnection of psychical processes. Our knowledge of an element that has become unconscious does not extend beyond this possibility of its renewal. ... For psychology, therefore, it has no meaning except as a disposition for the inception of future components. ... Assumptions as to the state of the ‘unconscious’ or as to ‘unconscious processes’ of any kind ... are *entirely unproductive for psychology*. There are, of course, physical concomitants of the psychical dispositions mentioned, of which some can be directly demonstrated, some inferred from various experiences.”⁷

[349] A representative of the Wundt school opines that “a psychic state cannot be described as psychic unless it has reached at least the threshold of consciousness.” This argument assumes, or rather asserts, that only the conscious is psychic and that

therefore everything psychic is conscious. The author happens to say a “psychic” state: logically he should have said a “state,” for whether such a state is psychic is precisely the point at issue. Another argument runs: the simplest psychic fact is sensation, since it cannot be analysed into simpler facts. Consequently, that which precedes or underlies a sensation is never psychic, but only physiological. *Ergo*, there is no unconscious.

[350] J. F. Herbart once said: “When a representation [idea] falls below the threshold of consciousness it goes on living in a latent way, continually striving to recross the threshold and to displace the other representations.” As it stands, the proposition is undoubtedly incorrect, for unfortunately anything genuinely forgotten has no tendency to recross the threshold. Had Herbart said “complex” in the modern sense of the word instead of “representation,” his proposition would have been absolutely right. We shall hardly be wrong in assuming that he really did mean something of the sort. In this connection, a philosophical opponent of the unconscious makes the very illuminating remark: “Once this be admitted, one finds oneself at the mercy of all manner of hypotheses concerning this unconscious life, hypotheses which cannot be controlled by any observation.”⁸ It is evident that this thinker is not out to recognize facts, but that for him the fear of running into difficulties is decisive. And how does he know that these hypotheses cannot be controlled by observation? For him this is simply an *a priori*. But with Herbart’s observation he does not deal at all.

[351] I mention this incident not because of its positive significance but only because it is so thoroughly characteristic of the antiquated philosophical attitude towards empirical psychology. Wundt himself is of the opinion that, as regards the “so-called unconscious processes, it is not a question of unconscious psychic elements, but only of *more dimly conscious* ones,” and that “for hypothetical unconscious processes we could substitute actually demonstrable or at any rate less hypothetical conscious processes.”⁹ This attitude implies a clear rejection of the unconscious as a psychological hypothesis. The cases of “double consciousness” he explains as “modifications of individual consciousness which very often occur continuously, in steady succession, and for which, by a violent misinterpretation of the facts, a plurality of individual consciousnesses is substituted.” The latter, so Wundt argues, “would have to be simultaneously present in one and the same individual.” This, he says, “is admittedly not the case.” Doubtless it is hardly possible for two consciousnesses to express themselves simultaneously in a single individual in a blatantly recognizable way. That is why these states usually alternate. Janet has shown that while the one consciousness controls the head, so to speak, the other simultaneously puts itself into communication with the observer by means of a code of expressive manual movements.¹⁰ Double consciousness may therefore very well be simultaneous.

[352] Wundt thinks that the idea of a double consciousness, and hence of a “superconsciousness” and “subconsciousness” in Fechner’s sense,¹¹ is a “survival from the psychological mysticism” of the Schelling school. He obviously boggles at an unconscious representation being one which nobody “has.”¹² In that case the word “representation” would naturally be obsolete too, since it suggests a subject to whom something is present or “presented.” That is the basic reason for Wundt’s rejection of the unconscious. But we can easily get round this difficulty by speaking, not of “representations” or “perceptions,” but of *contents*, as I usually do. Here I must anticipate a point with which I shall be dealing at some length later on, namely the fact that something very like “representedness” or consciousness does attach to unconscious contents, so that the possibility of an unconscious subject becomes a serious question. Such a subject, however, is not identical with the ego. That it was principally the “representations” which were Wundt’s *bête noire* is clear also from his emphatic rejection of “inborn ideas.” How literally he takes this can be seen from the following: “If the new-born animal really had an idea beforehand of all the actions it purposes to do, what a wealth of anticipated life-experiences would lie stored in the human and animal instincts, and how incomprehensible it would seem that not man alone, but animals too, acquire most things only through experience and practice!”¹³ There is, nevertheless, an inborn “pattern of behaviour” and just such a treasure-house, not indeed of anticipated, but of accumulated, life-experiences; only, it is not a question of “representations” but of sketches, plans, or images which, though not actually “presented” to the ego, are yet just as real as Kant’s hundred thalers, which had been sewn into the lining of a jacket and forgotten by the owner. Wundt might have remembered Christian von Wolf, whom he himself mentions, and his distinction with regard to “unconscious” states which “can be inferred only from what we find in our consciousness.”¹⁴

[353] To the category of “inborn ideas” also belong Adolf Bastian’s “elementary ideas,”¹⁵ by which we are to understand the fundamentally analogous forms of perception that are to be found everywhere, therefore more or less what we know today as “archetypes.” Wundt, of course, rejects this notion, under the delusion that he is dealing here with “representations” and not with “dispositions.” He says: “The origination of one and the same phenomenon in different places is not absolutely impossible, but, from the standpoint of empirical psychology, it is in the highest degree unlikely.”¹⁶ He denies a “common psychic heritage of humanity” in this sense and repudiates the very idea of an intelligible myth-symbolism with the characteristic pronouncement that the supposition of a “system of ideas” hiding behind the myth is impossible.¹⁷ The pedantic assumption that the unconscious is, of all things, a system of ideas would not hold water even in Wundt’s day, let alone before or afterwards.

[354] It would be incorrect to assume that the rejection of the idea of the unconscious in academic psychology at the turn of the century was anything like universal. That is by no means the case, for Fechner,¹⁸ and after him Theodor Lipps, had given the unconscious a place of decisive importance.¹⁹ Although for Lipps psychology is a “science of consciousness,” he nevertheless speaks of “unconscious” perceptions and representations, which he regards as processes. “The nature or, more accurately, the idea of a ‘psychic’ process is not so much a conscious content or conscious experience as the psychic reality which must necessarily be thought to underlie the existence of such a process.”²⁰ “Observation of conscious life persuades us that not only are unconscious perceptions and representations ... at times to be found in us, but that psychic life *proceeds in that form most of the time, and only occasionally, at special points, does the agent within us reveal its presence directly, in appropriate images.*”²¹ “Thus psychic life always goes far beyond the bounds of what is or may be present in us in the form of conscious contents or images.”

[355] Theodor Lipps’ remarks in no wise conflict with our modern views, on the contrary they form the theoretical basis for the psychology of the unconscious in general. Nevertheless resistance to the hypothesis of the unconscious persisted for a long time afterwards. For instance it is characteristic that Max Dessoir, in his history of modern German psychology,²² does not even mention C. G. Carus and Eduard von Hartmann.

2. *The Significance of the Unconscious in Psychology*

[356] The hypothesis of the unconscious puts a large question-mark after the idea of the psyche. The soul, as hitherto postulated by the philosophical intellect and equipped with all the necessary faculties, threatened to emerge from its chrysalis as something with unexpected and uninvestigated properties. It no longer represented anything immediately known, about which nothing more remained to be discovered except a few more or less satisfying definitions. Rather it now appeared in strangely double guise, as both known and unknown. In consequence, the old psychology was thoroughly unseated and as much revolutionized²³ as classical physics had been by the discovery of radioactivity. These first experimental psychologists were in the same predicament as the mythical discoverer of the numerical sequence, who strung peas together in a row and simply went on adding another unit to those already present. When he contemplated the result, it looked as if there were nothing but a hundred identical units; but the numbers he had thought of only as names unexpectedly turned out to be peculiar entities with irreducible properties. For instance, there were even, uneven, and primary numbers; positive, negative,

irrational, and imaginary numbers, etc.²⁴ So it is with psychology: if the soul is really only an idea, this idea has an alarming air of unpredictability about it—something with qualities no one would ever have imagined. One can go on asserting that the psyche is consciousness and its contents, but that does not prevent, in fact it hastens, the discovery of a background not previously suspected, a true matrix of all conscious phenomena, a preconsciousness and a postconsciousness, a superconsciousness and a subconsciousness. The moment one forms an idea of a thing and successfully catches one of its aspects, one invariably succumbs to the illusion of having caught the whole. One never considers that a total apprehension is right out of the question. Not even an idea posited as total is total, for it is still an entity on its own with unpredictable qualities. This self-deception certainly promotes peace of mind: the unknown is named, the far has been brought near, so that one can lay one's finger on it. One has taken possession of it, and it has become an inalienable piece of property, like a slain creature of the wild that can no longer run away. It is a magical procedure such as the primitive practises upon objects and the psychologist upon the psyche. He is no longer at its mercy, but he never suspects that the very fact of grasping the object conceptually gives it a golden opportunity to display all those qualities which would never have made their appearance had it not been imprisoned in a concept (remember the numbers!).

[357] The attempts that have been made, during the last three hundred years, to grasp the psyche are all part and parcel of that tremendous expansion of knowledge which has brought the universe nearer to us in a way that staggers the imagination. The thousandfold magnifications made possible by the electron-microscope vie with the five hundred million light-year distances which the telescope travels. Psychology is still a long way from a development similar to that which the other natural sciences have undergone; also, as we have seen, it has been much less able to shake off the trammels of philosophy. All the same, every science is a function of the psyche, and all knowledge is rooted in it. The psyche is the greatest of all cosmic wonders and the *sine qua non* of the world as an object. It is in the highest degree odd that Western man, with but very few—and ever fewer-exceptions, apparently pays so little regard to this fact. Swamped by the knowledge of external objects, the subject of all knowledge has been temporarily eclipsed to the point of seeming non-existence.

[358] The soul was a tacit assumption that seemed to be known in every detail. With the discovery of a possible unconscious psychic realm, man had the opportunity to embark upon a great adventure of the spirit, and one might have expected that a passionate interest would be turned in this direction. Not only was this not the case at all, but there arose on all sides an outcry against such an hypothesis. Nobody drew the conclusion that if the subject of knowledge, the psyche, were in fact a veiled form of existence not immediately accessible to consciousness, then all our knowledge

must be incomplete, and moreover to a degree that we cannot determine. The validity of conscious knowledge was questioned in an altogether different and more menacing way than it had ever been by the critical procedures of epistemology. The latter put certain bounds to human knowledge in general, from which post-Kantian German Idealism struggled to emancipate itself; but natural science and common sense accommodated themselves to it without much difficulty, if they condescended to notice it at all. Philosophy fought against it in the interests of an antiquated pretension of the human mind to be able to pull itself up by its own bootstraps and know things that were right outside the range of human understanding. The victory of Hegel over Kant dealt the gravest blow to reason and to the further development of the German and, ultimately, of the European mind, all the more dangerous as Hegel was a psychologist in disguise who projected great truths out of the subjective sphere into a cosmos he himself had created. We know how far Hegel's influence extends today. The forces compensating this calamitous development personified themselves partly in the later Schelling, partly in Schopenhauer and Carus, while on the other hand that unbridled "bacchantic God" whom Hegel had already scented in nature finally burst upon us in Nietzsche.

[359] Carus' hypothesis of the unconscious was bound to hit the then prevailing trend of German philosophy all the harder, as the latter had apparently just got the better of Kantian criticism and had restored, or rather reinstated, the well-nigh godlike sovereignty of the human spirit—Spirit with a capital S. The spirit of medieval man was, in good and bad alike, still the spirit of the God whom he served. Epistemological criticism was on the one hand an expression of the modesty of medieval man, and on the other a renunciation of, or abdication from, the spirit of God, and consequently a modern extension and reinforcement of human consciousness within the limits of reason. Wherever the spirit of God is extruded from our human calculations, an unconscious substitute takes its place. In Schopenhauer we find the unconscious Will as the new definition of God, in Carus the unconscious, and in Hegel identification and inflation, the practical equation of philosophical reason with Spirit, thus making possible that intellectual juggling with the object which achieved such a horrid brilliance in his philosophy of the State. Hegel offered a solution of the problem raised by epistemological criticism in that he gave ideas a chance to prove their unknown power of autonomy. They induced that hybris of reason which led to Nietzsche's superman and hence to the catastrophe that bears the name of Germany. Not only artists, but philosophers too, are sometimes prophets.

[360] I think it is obvious that all philosophical statements which transgress the bounds of reason are anthropomorphic and have no validity beyond that which falls to psychically conditioned statements. A philosophy like Hegel's is a self-revelation of

the psychic background and, philosophically, a presumption. Psychologically, it amounts to an invasion by the unconscious. The peculiar high-flown language Hegel uses bears out this view: it is reminiscent of the megalomaniac language of schizophrenics, who use terrific spellbinding words to reduce the transcendent to subjective form, to give banalities the charm of novelty, or pass off commonplaces as searching wisdom. So bombastic a terminology is a symptom of weakness, ineptitude, and lack of substance. But that does not prevent the latest German philosophy from using the same crackpot power-words and pretending that it is not unintentional psychology.

[361] In the face of this elemental inrush of the unconscious into the Western sphere of human reason, Schopenhauer and Carus had no solid ground under them from which to develop and apply their compensatory effect. Man's salutary submission to a benevolent Deity, and the *cordon sanitaire* between him and the demon of darkness—the great legacy of the past—remained unimpaired with Schopenhauer, at any rate in principle, while with Carus it was hardly touched at all, since he sought to tackle the problem at the root by leading it away from the over-presumptuous philosophical standpoint towards that of psychology. We have to close our eyes to his philosophical allure if we wish to give full weight to his essentially psychological hypothesis. He had at least come a step nearer to the conclusion we mentioned earlier, by trying to construct a world-picture that included the dark part of the soul. This structure still lacked something whose unprecedented importance I would like to bring home to the reader.

[362] For this purpose we must first make it quite clear to ourselves that all knowledge is the result of imposing some kind of order upon the reactions of the psychic system as they flow into our consciousness—an order which reflects the behaviour of a *meta-psychic* reality, of that which is in itself real. If, as certain modern points of view, too, would have it, the psychic system coincides and is identical with our conscious mind, then, in principle, we are in a position to know everything that is capable of being known, i.e., everything that lies within the limits of the theory of knowledge. In that case there is no cause for disquiet, beyond that felt by anatomists and physiologists when contemplating the function of the eye or the organ of hearing. But should it turn out that the psyche does *not* coincide with consciousness, and, what is more, that it functions unconsciously in a way similar to, or *different* from, the conscious portion of it, then our disquiet must rise to the point of agitation. For it is then no longer a question of general epistemological limits, but of a flimsy threshold that separates us from the unconscious contents of the psyche. The hypothesis of the threshold and of the unconscious means that the indispensable raw material of all knowledge—namely psychic reactions—and perhaps even unconscious “thoughts” and “insights” lie close beside, above, or below

consciousness, separated from us by the merest “threshold” and yet apparently unattainable. We have no knowledge of how this unconscious functions, but since it is conjectured to be a psychic system it may possibly have everything that consciousness has, including perception, apperception, memory, imagination, will, affectivity, feeling, reflection, judgment, etc., all in subliminal form.²⁵

[363] Here we are faced with Wundt’s objection that one cannot possibly speak of unconscious “perceptions,” “representations,” “feelings,” much less of “volitional actions,” seeing that none of these phenomena can be represented without an experiencing subject. Moreover, the idea of a threshold presupposes a mode of observation in terms of energy, according to which consciousness of psychic contents is essentially dependent upon their intensity, that is, their energy. Just as only a stimulus of a certain intensity is powerful enough to cross the threshold, so it may with some justice be assumed that other psychic contents too must possess a higher energy-potential if they are to get across. If they possess only a small amount of energy they remain subliminal, like the corresponding sense-perceptions.

[364] As Lipps has already pointed out, the first objection is nullified by the fact that the psychic process remains essentially the same whether it is “represented” or not. Anyone who takes the view that the phenomena of consciousness comprise the whole psyche must go a step further and say that “representations which we do not have”²⁶ can hardly be described as “representations.” He must also deny any psychic quality to what is left over. For this rigorous point of view the psyche can only have the phantasmagoric existence that pertains to the ephemeral phenomena of consciousness. This view does not square with common experience, which speaks in favour of a possible psychic activity without consciousness. Lipps’ idea of the existence of psychic processes *an sich* does more justice to the facts. I do not wish to waste time in proving this point, but will content myself with saying that never yet has any reasonable person doubted the existence of psychic processes in a dog, although no dog has, to our knowledge, ever expressed consciousness of its psychic contents.²⁷

3. *The Dissociability of the Psyche*

[365] There is no *a priori* reason for assuming that unconscious processes must inevitably have a subject, any more than there is for doubting the reality of psychic processes. Admittedly the problem becomes difficult when we suppose unconscious acts of the will. If this is not to be just a matter of “instincts” and “inclinations,” but rather of considered “choice” and “decision” which are peculiar to the will, then one cannot very well get round the need for a controlling subject to whom something is

“represented.” But that, by definition, would be to lodge a consciousness in the unconscious, though this is a conceptual operation which presents no great difficulties to the psychopathologist. He is familiar with a psychic phenomenon that seems to be quite unknown to “academic” psychology, namely the dissociation or dissociability of the psyche. This peculiarity arises from the fact that the connecting link between the psychic processes themselves is a very conditional one. Not only are unconscious processes sometimes strangely independent of the experiences of the conscious mind, but the conscious processes, too, show a distinct loosening or discreteness. We all know of the absurdities which are caused by complexes and are to be observed with the greatest accuracy in the association experiment. Just as the cases of double consciousness doubted by Wundt really do happen, so the cases where not the whole personality is split in half, but only smaller fragments are broken off, are much more probable and in fact more common. This is an age-old experience of mankind which is reflected in the universal supposition of a plurality of souls in one and the same individual. As the plurality of psychic components at the primitive level shows, the original state is one in which the psychic processes are very loosely knit and by no means form a self-contained unity. Moreover, psychiatric experience indicates that it often takes only a little to shatter the unity of consciousness so laboriously built up in the course of development and to resolve it back into its original elements.

[366] This dissociability also enables us to set aside the difficulties that flow from the logically necessary assumption of a threshold of consciousness. If it is correct to say that conscious contents become subliminal, and therefore unconscious, through loss of energy, and conversely that unconscious processes become conscious through accretion of energy, then, if unconscious acts of volition are to be possible, it follows that these must possess an energy which enables them to achieve consciousness, or at any rate to achieve a state of secondary consciousness which consists in the unconscious process being “represented” to a subliminal subject who chooses and decides. This process must necessarily possess the amount of energy required for it to achieve such a consciousness; in other words, it is bound eventually to reach its “bursting point.”²⁸ If that is so, the question arises as to why the unconscious process does not go right over the threshold and become perceptible to the ego. Since it obviously does not do this, but apparently remains suspended in the domain of a subliminal secondary subject, we must now explain why this subject, which is *ex hypothesi* charged with sufficient energy to become conscious, does not in its turn push over the threshold and articulate with the primary ego-consciousness. Psychopathology has the material needed to answer this question. This secondary consciousness represents a personality-component which has not been separated from ego-consciousness by mere accident, but which owes its separation to definite causes.

Such a dissociation has two distinct aspects: in the one case, there is an originally conscious content that became subliminal because it was repressed on account of its incompatible nature: in the other case, the secondary subject consists essentially in a process that never entered into consciousness at all because no possibilities exist there of apperceiving it. That is to say, ego-consciousness cannot accept it for lack of understanding, and in consequence it remains for the most part subliminal, although, from the energy point of view, it is quite capable of becoming conscious. It owes its existence not to repression, but to subliminal processes that were never themselves conscious. Yet because there is in both cases sufficient energy to make it potentially conscious, the secondary subject does in fact have an effect upon ego-consciousness—indirectly or, as we say, “symbolically,” though the expression is not a particularly happy one. The point is that the contents that appear in consciousness are at first *symptomatic*. In so far as we know, or think we know, what they refer to or are based on, they are *semiotic*, even though Freudian literature constantly uses the term “symbolic,” regardless of the fact that in reality symbols always express something we do *not* know. The symptomatic contents are in part truly symbolic, being the indirect representatives of unconscious states or processes whose nature can be only imperfectly inferred and realized from the contents that appear in consciousness. It is therefore possible that the unconscious harbours contents so powered with energy that under other conditions they would be bound to become perceptible to the ego. In the majority of cases they are not repressed contents, but simply contents that are *not yet conscious* and have not been subjectively realized, like the demons and gods of the primitives or the “isms” so fanatically believed in by modern man. This state is neither pathological nor in any way peculiar; it is on the contrary the original norm, whereas the psychic wholeness comprehended in the unity of consciousness is an ideal goal that has never yet been reached.

[367] Not without justice we connect consciousness, by analogy, with the sense functions, from the physiology of which the whole idea of a “threshold” is derived. The sound-frequencies perceptible to the human ear range from 20 to 20,000 vibrations per second; the wave-lengths of light visible to the eye range from 7700 to 3900 angstrom-units. This analogy makes it conceivable that there is a lower as well as an upper threshold for psychic events, and that consciousness, the perceptual system par excellence, may therefore be compared with the perceptible scale of sound or light, having like them a lower and upper limit. Maybe this comparison could be extended to the psyche in general, which would not be an impossibility if there were “psychoid” processes at both ends of the psychic scale. In accordance with the principle “*natura non facit saltus*,” such an hypothesis would not be altogether out of place.

[368] In using the term “psychoid” I am aware that it comes into collision with the concept of the same name postulated by Driesch. By “the psychoid” he understands the directing principle, the “reaction determinant,” the “prospective potency” of the germinal element. It is “the elemental agent discovered in action,”²⁹ the “entelechy of real acting.”³⁰ As Eugen Bleuler has aptly pointed out, Driesch’s concept is more philosophical than scientific. Bleuler, on the other hand, uses the expression “die Psychoide”³¹ as a collective term chiefly for the subcortical processes, so far as they are concerned with biological “adaptive functions.” Among these Bleuler lists “reflexes and the development of species.” He defines it as follows: “The *Psychoide* is the sum of all the purposive, mnemonic, and life-preserving functions of the body and central nervous system, with the exception of those cortical functions which we have always been accustomed to regard as psychic.”³² Elsewhere he says: “The body-psyche of the individual and the phylo-psyche together form a unity which, for the purposes of our present study, can most usefully be designated by the name *Psychoide*. Common to both *Psychoide* and psyche are ... conation and the utilization of previous experiences ... in order to reach the goal. This would include memory (engraphy and ecphoria) and association, hence something analogous to thinking.”³³ Although it is clear what is meant by the “Psychoide,” in practice it often gets confused with “psyche,” as the above passage shows. But it is not at all clear why the subcortical functions it is supposed to designate should then be described as “quasi-psychic.” The confusion obviously springs from the organological standpoint, still observable in Bleuler, which operates with concepts like “cortical soul” and “medullary soul” and has a distinct tendency to derive the corresponding psychic functions from these parts of the brain, although it is always the function that creates its own organ, and maintains or modifies it. The organological standpoint has the disadvantage that all the purposeful activities inherent in living matter ultimately count as “psychic,” with the result that “life” and “psyche” are equated, as in Bleuler’s use of the words “phylo-psyche” and “reflexes.” It is extremely difficult, if not impossible, to think of a psychic function as independent of its organ, although in actual fact we experience the psychic process apart from its relation to the organic substrate. For the psychologist, however, it is the totality of these experiences that constitutes the object of investigation, and for this reason he must abjure a terminology borrowed from the anatomist. If I make use of the term “psychoid”³⁴ I do so with three reservations: firstly, I use it as an adjective, not as a noun; secondly, no psychic quality in the proper sense of the word is implied, but only a “quasi-psychic” one such as the reflex-processes possess; and thirdly, it is meant to distinguish a category of events from merely vitalistic phenomena on the one hand and from specifically psychic processes on the other. The latter distinction also obliges us to define more closely the nature and extent of the psyche, and of the unconscious psyche in particular.

[369] If the unconscious can contain everything that is known to be a function of consciousness, then we are faced with the possibility that it too, like consciousness, possesses a subject, a sort of ego. This conclusion finds expression in the common and ever-recurring use of the term “subconsciousness.” The latter term is certainly open to misunderstanding, as either it means what is “below consciousness,” or it postulates a “lower” and secondary consciousness. At the same time this hypothetical “subconsciousness,” which immediately becomes associated with a “superconsciousness,”³⁵ brings out the real point of my argument: the fact, namely, that a second psychic system coexisting with consciousness—no matter what qualities we suspect it of possessing—is of absolutely revolutionary significance in that it could radically alter our view of the world. Even if no more than the perceptions taking place in such a second psychic system were carried over into ego-consciousness, we should have the possibility of enormously extending the bounds of our mental horizon.

[370] Once we give serious consideration to the hypothesis of the unconscious, it follows that our view of the world can be but a provisional one; for if we effect so radical an alteration in the subject of perception and cognition as this dual focus implies, the result must be a world view very different from any known before. This holds true only if the hypothesis of the unconscious holds true, which in turn can be verified only if unconscious contents can be changed into conscious ones—if, that is to say, the disturbances emanating from the unconscious, the effects of spontaneous manifestations, of dreams, fantasies, and complexes, can successfully be integrated into consciousness by the interpretative method.

4. Instinct and Will

[371] Whereas, in the course of the nineteenth century, the main concern was to put the unconscious on a philosophical footing,³⁶ towards the end of the century various attempts were made in different parts of Europe, more or less simultaneously and independently of one another, to understand the unconscious experimentally or empirically. The pioneers in this field were Pierre Janet³⁷ in France and Sigmund Freud³⁸ in the old Austria. Janet made himself famous for his investigation of the formal aspect, Freud for his researches into the content of psychogenic symptoms.

[372] I am not in a position here to describe in detail the transformation of unconscious contents into conscious ones, so must content myself with hints. In the first place, the structure of psychogenic symptoms was successfully explained on the hypothesis of unconscious processes. Freud, starting from the symptomatology of the neuroses, also made out a plausible case for dreams as the mediators of unconscious contents.

What he elicited as contents of the unconscious seemed, on the face of it, to consist of elements of a personal nature that were quite capable of consciousness and had therefore been conscious under other conditions. It seemed to him that they had “got repressed” on account of their morally incompatible nature. Hence, like forgotten contents, they had once been conscious and had become subliminal, and more or less irrecoverable, owing to a counter-effect exerted by the attitude of the conscious mind. By suitably concentrating the attention and letting oneself be guided by associations—that is, by the pointers still existing in consciousness—the associative recovery of lost contents went forward as in a mnemo-technical exercise. But whereas forgotten contents were irrecoverable because of their lowered threshold-value, repressed contents owed their relative irrecoverability to a check exercised by the conscious mind.

[373] This initial discovery logically led to the interpretation of the unconscious as a phenomenon of repression which could be understood in personalistic terms. Its contents were lost elements that had once been conscious. Freud later acknowledged the continued existence of archaic vestiges in the form of primitive modes of functioning, though even these were explained personalistically. On this view the unconscious psyche appears as a subliminal appendix to the conscious mind.

[374] The contents that Freud raised to consciousness are those which are the most easily recoverable because they have the capacity to become conscious and were originally conscious. The only thing they prove with respect to the unconscious psyche is that there is a psychic limbo somewhere beyond consciousness. Forgotten contents which are still recoverable prove the same. This would tell us next to nothing about the nature of the unconscious psyche did there not exist an undoubted link between these contents and the instinctual sphere. We think of the latter as physiological, as in the main a function of the glands. The modern theory of internal secretions and hormones lends the strongest support to this view. But the theory of human instincts finds itself in a rather delicate situation, because it is uncommonly difficult not only to define the instincts conceptually, but even to establish their number and their limitations.³⁹ In this matter opinions diverge. All that can be ascertained with any certainty is that the instincts have a physiological and a psychological aspect.⁴⁰ Of great use for descriptive purposes is Pierre Janet’s view of the “*partie supérieure et inférieure d’une fonction.*”⁴¹

[375] The fact that all the psychic processes accessible to our observation and experience are somehow bound to an organic substrate indicates that they are articulated with the life of the organism as a whole and therefore partake of its dynamism—in other words, they must have a share in its instincts or be in a certain sense the results of the action of those instincts. This is not to say that the psyche

derives exclusively from the instinctual sphere and hence from its organic substrate. The psyche as such cannot be explained in terms of physiological chemistry, if only because, together with “life” itself, it is the only “natural factor” capable of converting statistical organizations which are subject to natural law into “higher” or “unnatural” states, in opposition to the rule of entropy that runs throughout the inorganic realm. How life produces complex organic systems from the inorganic we do not know, though we have direct experience of how the psyche does it. Life therefore has a specific law of its own which cannot be deduced from the known physical laws of nature. Even so, the psyche is to some extent dependent upon processes in the organic substrate. At all events, it is highly probable that this is so. The instinctual base governs the *partie inférieure* of the function, while the *partie supérieure* corresponds to its predominantly “psychic” component. The *partie inférieure* proves to be the relatively unalterable, automatic part of the function, and the *partie supérieure* the voluntary and alterable part.⁴²

[376] The question now arises: when are we entitled to speak of “psychic” and how in general do we define the “psychic” as distinct from the “physiological”? Both are life-phenomena, but they differ in that the functional component characterized as the *partie inférieure* has an unmistakably physiological aspect. Its existence or nonexistence seems to be bound up with the hormones. Its functioning has a compulsive character: hence the designation “drive.” Rivers asserts that the “all-or-none reaction”⁴³ is natural to it, i.e., the function acts altogether or not at all, which is specific of compulsion. On the other hand the *partie supérieure*, which is best described as psychic and is more-over sensed as such, has lost its compulsive character, can be subjected to the will⁴⁴ and even applied in a manner contrary to the original instinct.

[377] From these reflections it appears that the psychic is an emancipation of function from its instinctual form and so from the compulsiveness which, as sole determinant of the function, causes it to harden into a mechanism. The psychic condition or quality begins where the function loses its outer and inner determinism and becomes capable of more extensive and freer application, that is, where it begins to show itself accessible to a will motivated from other sources. At the risk of anticipating my programme, I cannot refrain from pointing out that if we delimit the psyche from the physiological sphere of instinct at the bottom, so to speak, a similar delimitation imposes itself at the top. For, with increasing freedom from sheer instinct the *partie supérieure* will ultimately reach a point at which the intrinsic energy of the function ceases altogether to be oriented by instinct in the original sense, and attains a so-called “spiritual” form. This does not imply a substantial alteration of the motive power of instinct, but merely a different mode of its application. The meaning or purpose of the instinct is not unambiguous, as the instinct may easily mask a sense of

direction other than biological, which only becomes apparent in the course of development.

[378] Within the psychic sphere the function can be deflected through the action of the will and modified in a great variety of ways. This is possible because the system of instincts is not truly harmonious in composition and is exposed to numerous internal collisions. One instinct disturbs and displaces the other, and, although taken as a whole it is the instincts that make individual life possible, their blind compulsive character affords frequent occasion for mutual injury. Differentiation of function from compulsive instinctuality, and its voluntary application, are of paramount importance in the maintenance of life. But this increases the possibility of collision and produces cleavages—the very dissociations which are forever putting the unity of consciousness in jeopardy.

[379] In the psychic sphere, as we have seen, the will influences the function. It does this by virtue of the fact that it is itself a form of energy and has the power to overcome another form. In this sphere which I define as psychic, the will is in the last resort motivated by instincts—not, of course, absolutely, otherwise it would not be a will, which by definition must have a certain freedom of choice. “Will” implies a certain amount of energy freely disposable by the psyche. There must be such amounts of disposable libido (or energy), or modifications of the functions would be impossible, since the latter would then be chained to the instincts—which are in themselves extremely conservative and correspondingly unalterable—so exclusively that no variations could take place, unless it were organic variations. As we have already said, the motivation of the will must in the first place be regarded as essentially biological. But at the (permitting such an expression) upper limit of the psyche, where the function breaks free from its original goal, the instincts lose their influence as movers of the will. Through having its form altered, the function is pressed into the service of other determinants or motivations, which apparently have nothing further to do with the instincts. What I am trying to make clear is the remarkable fact that the will cannot transgress the bounds of the psychic sphere: it cannot coerce the instinct, nor has it power over the spirit, in so far as we understand by this something more than the intellect. Spirit and instinct are by nature autonomous and both limit in equal measure the applied field of the will. Later I shall show what seems to me to constitute the relation of spirit to instinct.

[380] Just as, in its lower reaches, the psyche loses itself in the organic-material substrate, so in its upper reaches it resolves itself into a “spiritual” form about which we know as little as we do about the functional basis of instinct. What I would call the psyche proper extends to all functions which can be brought under the influence of a will. Pure instinctuality allows no consciousness to be conjectured and needs

none. But because of its empirical freedom of choice, the will needs a supraordinate authority, something like a consciousness of itself, in order to modify the function. It must “know” of a goal different from the goal of the function. Otherwise it would coincide with the driving force of the function. Driesch rightly emphasizes: “There is no willing without knowing.”⁴⁵ Volition presupposes a choosing subject who envisages different possibilities. Looked at from this angle, psyche is essentially conflict between blind instinct and will (freedom of choice). Where instinct predominates, *psychoïd* processes set in which pertain to the sphere of the unconscious as elements incapable of consciousness. The psychoïd process is not the unconscious as such, for this has a far greater extension. Apart from psychoïd processes, there are in the unconscious ideas and volitional acts, hence something akin, to conscious processes;⁴⁶ but in the instinctual sphere these phenomena retire so far into the background that the term “psychoïd” is probably justified. If, however, we restrict the psyche to acts of the will, we arrive at the conclusion that psyche is more or less identical with consciousness, for we can hardly conceive of will and freedom of choice without consciousness. This apparently brings us back to where we always stood, to the axiom *psyche = consciousness*. What, then, has happened to the postulated psychic nature of the unconscious?

5. Conscious and Unconscious

[381] This question, regarding the nature of the unconscious, brings with it the extraordinary intellectual difficulties with which the psychology of the unconscious confronts us. Such difficulties must inevitably arise whenever the mind launches forth boldly into the unknown and invisible. Our philosopher sets about it very cleverly, since, by his flat denial of the unconscious, he clears all complications out of his way at one sweep. A similar quandary faced the physicist of the old school, who believed exclusively in the wave theory of light and was then led to the discovery that there are phenomena which can be explained only by the particle theory. Happily, modern physics has shown the psychologist that it can cope with an apparent *contradictio in adiecto*. Encouraged by this example, the psychologist may be emboldened to tackle this controversial problem without having the feeling that he has dropped out of the world of natural science altogether. It is not a question of his *asserting* anything, but of constructing a *model* which opens up a promising and useful field of inquiry. A model does not assert that something *is* so, it simply illustrates a particular mode of observation.

[382] Before we scrutinize our dilemma more closely, I would like to clarify one aspect of the concept of the unconscious. The unconscious is not simply the unknown, it is

rather the *unknown psychic*; and this we define on the one hand as all those things in us which, if they came to consciousness, would presumably differ in no respect from the known psychic contents, with the addition, on the other hand, of the psychoid system, of which nothing is known directly. So defined, the unconscious depicts an extremely fluid state of affairs: everything of which I know, but of which I am not at the moment thinking; everything of which I was once conscious but have now forgotten; everything perceived by my senses, but not noted by my conscious mind; everything which, involuntarily and without paying attention to it, I feel, think, remember, want, and do; all the future things that are taking shape in me and will sometime come to consciousness: all this is the content of the unconscious. These contents are all more or less capable, so to speak, of consciousness, or were once conscious and may become conscious again the next moment. Thus far the unconscious is “a fringe of consciousness,” as William James put it.⁴⁷ To this marginal phenomenon, which is born of alternating shades of light and darkness, there also belong the Freudian findings we have already noted. But, as I say, we must also include in the unconscious the psychoid functions that are not capable of consciousness and of whose existence we have only indirect knowledge.

[383] We now come to the question: in what state do psychic contents find themselves when not related to the conscious ego? (This relation constitutes all that can be called consciousness.) In accordance with “Occam’s razor,” *entia praeter necessitatem non sunt multiplicanda* (“principles are not to be multiplied beyond the necessary”), the most cautious conclusion would be that, except for the relation to the conscious ego, nothing is changed when a content becomes unconscious. For this reason I reject the view that momentarily unconscious contents are only physiological. The evidence is lacking, and apart from that the psychology of neurosis provides striking proofs to the contrary. One has only to think of the cases of double personality, *automatisme ambulatoire*, etc. Both Janet’s and Freud’s findings indicate that everything goes on functioning in the unconscious state just as though it were conscious. There is perception, thinking, feeling, volition, and intention, just as though a subject were present; indeed, there are not a few cases—e.g., the double personality above mentioned—where a second ego actually appears and vies with the first. Such findings seem to show that the unconscious is in fact a “subconscious.” But from certain experiences—some of them known already to Freud—it is clear that the state of unconscious contents is not quite the same as the conscious state. For instance, feeling-toned complexes in the unconscious do not change in the same way that they do in consciousness. Although they may be enriched by associations, they are not corrected, but are conserved in their original form, as can easily be ascertained from the continuous and uniform effect they have upon the conscious mind. Similarly, they take on the uninfluenceable and compulsive character of an automatism, of which

they can be divested only if they are made conscious. This latter procedure is rightly regarded as one of the most important therapeutic factors. In the end such complexes—presumably in proportion to their distance from consciousness—assume, by self-amplification, an archaic and mythological character and hence a certain numinosity, as is perfectly clear in schizophrenic dissociations. Numinosity, however, is wholly outside conscious volition, for it transports the subject into the state of rapture, which is a state of will-less surrender.

[384] These peculiarities of the unconscious state contrast very strongly with the way complexes behave in the conscious mind. Here they can be corrected: they lose their automatic character and can be substantially transformed. They slough off their mythological envelope, and, by entering into the adaptive process going forward in consciousness, they personalize and rationalize themselves to the point where a dialectical discussion becomes possible.⁴⁸ Evidently the unconscious state is different after all from the conscious. Although at first sight the process continues in the unconscious as though it were conscious, it seems, with increasing dissociation, to sink back to a more primitive (archaic-mythological) level, to approximate in character to the underlying instinctual pattern, and to assume the qualities which are the hallmarks of instinct: automatism, non-susceptibility to influence, all-or-none reaction, and so forth. Using the analogy of the spectrum, we could compare the lowering of unconscious contents to a displacement towards the red end of the colour band, a comparison which is especially edifying in that red, the blood colour, has always signified emotion and instinct.⁴⁹

[385] The unconscious is accordingly a different medium from the conscious. In the near-conscious areas there is not much change, because here the alternation of light and shadow is too rapid. But it is just this no man's land which is of the greatest value in supplying the answer to the burning question of whether psyche = consciousness. It shows us how relative the unconscious state is, so relative, indeed, that one feels tempted to make use of a concept like "the subconscious" in order to define the darker part of the psyche. But consciousness is equally relative, for it embraces not only consciousness as such, but a whole scale of intensities of consciousness. Between "I do this" and "I am conscious of doing this" there is a world of difference, amounting sometimes to outright contradiction. Consequently there is a consciousness in which unconsciousness predominates, as well as a consciousness in which self-consciousness predominates. This paradox becomes immediately intelligible when we realize that there is no conscious content which can with absolute certainty be said to be totally conscious,⁵⁰ for that would necessitate an unimaginable totality of consciousness, and that in turn would presuppose an equally unimaginable wholeness and perfection of the human mind. So we come to the paradoxical conclusion that there is no conscious content which is not in some other

respect unconscious. Maybe, too, there is no unconscious psychism which is not at the same time conscious.⁵¹ The latter proposition is more difficult to prove than the first, because our ego, which alone could verify such an assertion, is the point of reference for all consciousness and has no such association with unconscious contents as would enable it to say anything about their nature. So far as the ego is concerned, they are, for all practical purposes, unconscious: which is not to say that they are not conscious to it in another respect, for the ego may know these contents under one aspect but not know them under another aspect, when they cause disturbances of consciousness. Besides, there are processes with regard to which no relation to the conscious ego can be demonstrated and which yet seem to be “represented” or “quasi-conscious.” Finally, there are cases where an unconscious ego and hence a second consciousness are present, as we have already seen, though these are the exceptions.⁵²

[386] In the psychic sphere, the compulsive pattern of behaviour gives way to variations of behaviour which are conditioned by experience and by volitional acts, that is, by conscious processes. With respect to the psychoid, reflex-instinctual state, therefore, the psyche implies a loosening of bonds and a steady recession of mechanical processes in favour of “selected” modifications. This selective activity takes place partly inside consciousness and partly outside it, i.e., without reference to the conscious ego, and hence unconsciously. In the latter case the process is “quasi-conscious,” *as if* it were “represented” and conscious.

[387] As there are no sufficient grounds for assuming that a second ego exists in every individual or that everyone suffers from dissociation of personality, we have to discount the idea of a second ego-consciousness as a source of voluntary decisions. But since the existence of highly complex, quasi-conscious processes in the unconscious has been shown, by the study of psychopathology and dream psychology, to be uncommonly probable, we are for better or worse driven to the conclusion that although the state of unconscious contents is not identical with that of conscious ones, it is somehow very “like” it. In these circumstances there is nothing for it but to suppose something midway between the conscious and unconscious state, namely an approximative consciousness. As we have immediate experience only of a reflected state, which is *ipso facto* conscious and known because it consists essentially in relating ideas or other contents to an ego-complex that represents our empirical personality, it follows that any other kind of consciousness—either without an ego or without contents—is virtually unthinkable. But there is no need to frame the question so absolutely. On a somewhat more primitive human level, ego-consciousness loses much of its meaning, and consciousness is accordingly modified in a characteristic way. Above all, it ceases to be reflected. And when we observe the psychic processes in the higher vertebrates and particularly in domestic animals, we

find phenomena resembling consciousness which nevertheless do not allow us to conjecture the existence of an ego. As we know from direct experience, the light of consciousness has many degrees of brightness, and the ego-complex many gradations of emphasis. On the animal and primitive level there is a mere “luminosity,” differing hardly at all from the glancing fragments of a dissociated ego. Here, as on the infantile level, consciousness is not a unity, being as yet un-centred by a firmly-knit ego-complex, and just flickering into life here and there wherever outer or inner events, instincts, and affects happen to call it awake. At this stage it is still like a chain of islands or an archipelago. Nor is it a fully integrated whole even at the higher and highest stages; rather, it is capable of indefinite expansion. Gleaming islands, indeed whole continents, can still add themselves to our modern consciousness—a phenomenon that has become the daily experience of the psychotherapist. Therefore we would do well to think of ego-consciousness as being surrounded by a multitude of little luminosities.

6. *The Unconscious as a Multiple Consciousness*

[388] The hypothesis of multiple luminosities rests partly, as we have seen, on the quasi-conscious state of unconscious contents and partly on the incidence of certain images which must be regarded as symbolical. These are to be found in the dreams and visual fantasies of modern individuals, and can also be traced in historical records. As the reader may be aware, one of the most important sources for symbolical ideas in the past is alchemy. From this I take, first and foremost, the idea of the *scintillae*—sparks—which appear as visual illusions in the “arcane substance.”⁵³ Thus the *Aurora consurgens*, Part II, says: “Scito quod terra foetida cito recipit scintillulas albas” (Know that the foul earth quickly receives white sparks).⁵⁴ These sparks Khunrath explains as “radii atque scintillae” of the “anima catholica,” the world-soul, which is identical with the spirit of God.⁵⁵ From this interpretation it is clear that certain of the alchemists had already divined the psychic nature of these luminosities. They were seeds of light broadcast in the chaos, which Khunrath calls “mundi futuri seminarium” (the seed plot of a world to come).⁵⁶ One such spark is the human mind.⁵⁷ The arcane substance—the watery earth or earthy water (*limus*: mud) of the World Essence—is “universally animated” by the “fiery spark of the soul of the world,” in accordance with the Wisdom of Solomon 1 : 7: “For the Spirit of the Lord filleth the world.”⁵⁸ In the “Water of the Art,” in “our Water,” which is also the chaos,⁵⁹ there are to be found the “fiery sparks of the soul of the world as pure *Formae Rerum essentielles*.”⁶⁰ These *formae*⁶¹ correspond to the Platonic Ideas, from which one could equate the *scintillae* with the archetypes on the assumption that the Forms “stored up in a supracelestial place” are a philosophical version of the latter.

One would have to conclude from these alchemical visions that the archetypes have about them a certain effulgence or quasi-consciousness, and that numinosity entails luminosity. Paracelsus seems to have had an inkling of this. The following is taken from his *Philosophia sagax*: “And as little as aught can exist in man without the divine numen, so little can aught exist in man without the natural lumen. A man is made perfect by numen and lumen and these two alone. Everything springs from these two, and these two are in man, but without them man is nothing, though they can be without man.”⁶² In confirmation of this Khunrath writes: “There be ... *Scintillae Animae Mundi igneae, Luminis nimirum Naturae*, fiery sparks of the world soul, i.e., of the light of nature ... dispersed or sprinkled in and throughout the structure of the great world into all fruits of the elements everywhere.”⁶³ The sparks come from the “Ruach Elohim,” the Spirit of God.⁶⁴ Among the *scintillae* he distinguishes a “scintilla perfecta Unici Potentis ac Fortis,” which is the elixir and hence the arcane substance itself.⁶⁵ If we may compare the sparks to the archetypes, it is evident that Khunrath lays particular stress on one of them. This One is also described as the Monad and the Sun, and they both indicate the Deity. A similar image is to be found in the letter of Ignatius of Antioch to the Ephesians, where he writes of the coming of Christ: “How, then, was he manifested to the world? A star shone in heaven beyond the stars, and its light was unspeakable, and its newness caused astonishment, and all the other stars, with the sun and moon, gathered in chorus round this star. ...”⁶⁶ Psychologically, the One Scintilla or Monad is to be regarded as a symbol of the self—an aspect I mention only in passing.

[389] The sparks have a clear psychological meaning for Dorn. He says: “Thus little by little he will come to see with his mental eyes a number of sparks shining day by day and more and more and growing into such a great light that thereafter all things needful to him will be made known.”⁶⁷ This light is the *lumen naturae* which illuminates consciousness, and the *scintillae* are germinal luminosities shining forth from the darkness of the unconscious. Dorn, like Khunrath, owes much to Paracelsus, with whom he concurs when he supposes an “invisibilem solem plurimis incognitum” in man (an invisible sun unknown to many).⁶⁸ Of this natural light innate in man Dorn says: “For the life, the light of men,⁶⁹ shineth in us, albeit dimly, and as though in darkness. It is not to be extracted from us, yet it is in us and not of us, but of Him to Whom it belongs, Who deigns to make us his dwelling-place. ... He has implanted that light in us that we may see in its light the light of Him Who dwells in inaccessible light, and that we may excel His other creatures; in this wise we are made like unto Him, that He has given us a spark of His light. Thus the truth is to be sought not in ourselves, but in the image of God which is within us.”⁷⁰

[390] Thus the one archetype emphasized by Khunrath is known also to Dorn as the *sol invisibilis* or *imago Dei*. In Paracelsus the *lumen naturae* comes primarily from the

“astrum” or “sydus,” the “star” in man.⁷¹ The “firmament” (a synonym for the star) is the natural light.⁷² Hence the “corner-stone” of all truth is “Astronomia,” which is “a mother to all the other arts. ... After her beginneth the divine wisdom, after her beginneth the light of nature,”⁷³ even the “most excellent Religiones” hang upon Astronomia.⁷⁴ For the star “desireth to drive man toward great wisdom ... that he may appear wondrous in the light of nature, and the mysteria of God’s wondrous work be discovered and revealed in their grandeur.”⁷⁵ Indeed, man himself is an “Astrum”: “not by himself alone, but for ever and ever with all apostles and saints; each and every one is an astrum, the heaven a star ... therefore saith also the Scripture: ye are lights of the world.”⁷⁶ “Now as in the star lieth the whole natural light, and from it man taketh the same like food from the earth into which he is born, so too must he be born into the star.”⁷⁷ Also the animals have the natural light which is an “inborn spirit.”⁷⁸ Man at his birth is “endowed with the perfect light of nature.”⁷⁹ Paracelsus calls it “primum ac optimum thesaurum, quem naturae Monarchia in se claudit”⁸⁰ (the first and best treasure which the monarchy of nature hides within itself), in this concurring with the world-wide descriptions of the One as the pearl of great price, the hidden treasure, the “treasure hard to attain,” etc. The light is given to the “inner man” or the inner body (*corpus subtile*, breath-body), as the following passage makes clear:

A man may come forth with sublimity and wisdom from his outer body, because the same wisdom and understanding which he needeth for this are coeval with this body and are the inner man,⁸¹ thus he may live and not as an outer man. For such an inner man is eternally transfigured and true, and if in the mortal body he appeareth not perfect, yet he appeareth perfect after the separation of the same. That which we now tell of is called *lumen naturae* and is eternal. God hath given it to the inner body, that it may be ruled by the inner body and in accordance with reason ... for the light of nature alone is reason and no other thing ... the light is that which giveth faith ... to each man God hath given sufficient predestined light that he err not. ... But if we are to describe the origin of the inner man or body, mark that all inner bodies be but one body and one single thing in all men, albeit divided in accordance with the well-disposed numbers of the body, each one different. And should they all come together, it is but one light, and one reason.⁸²

[391] “Moreover, the light of nature is a light that is lit from the Holy Ghost and goeth not out, for it is well lit ... and the light is of a kind that desireth to burn,⁸³ and the longer [it burns] to shine the more, and the longer the greater ... therefore in the light of nature is a fiery longing to enkindle.”⁸⁴ It is an “invisible” light: “Now it follows that in the invisible alone hath man his wisdom, his art from the light of nature.”⁸⁵ Man is “a prophet of the natural light.”⁸⁶ He “learns” the *lumen naturae* through dreams,⁸⁷ among other things. “As the light of nature cannot speak, it buildeth shapes in sleep from the power of the word” (of God).⁸⁸

[392] I have allowed myself to divell at some length on Paracelsus and to cite a number of authentic texts, because I wanted to give the reader a rough idea of the way in which this author conceives the *lumen naturae*. It strikes me as significant, particularly in regard to our hypothesis of a multiple consciousness and its phenomena, that the characteristic alchemical vision of sparks scintillating in the blackness of the arcane substance should, for Paracelsus, change into the spectacle of the “interior firmament” and its stars. He beholds the darksome psyche as a star-strewn night sky, whose planets and fixed constellations represent the archetypes in all their luminosity and numinosity.⁸⁹ The starry vault of heaven is in truth the open book of cosmic projection, in which are reflected the mythologems, i.e., the archetypes. In this vision astrology and alchemy, the two classical functionaries of the psychology of the collective unconscious, join hands.

[393] Paracelsus was directly influenced by Agrippa von Nettesheim,⁹⁰ who supposes a “*luminositas sensus naturae*.” From this “gleams of prophecy came down to the four-footed beasts, the birds, and other living creatures,” and enabled them to foretell future things.⁹¹ He bases the *sensus naturae* on the authority of Gulielmus Parisiensis, who is none other than William of Auvergne (G. Alvernus; d. 1249), bishop of Paris from about 1228, author of many works, which influenced Albertus Magnus among others. Alvernus says that the *sensus naturae* is superior to the perceptive faculty in man, and he insists that animals also possess it.⁹² The doctrine of the *sensus naturae* is developed from the idea of the all-pervading world-soul with which another Gulielmus Parisiensis was much concerned, a predecessor of Alvernus by name of Guillaume de Conches⁹³ (1080–1154), a Platonist scholastic who taught in Paris. He identified the *anima mundi*, this same *sensus naturae*, with the Holy Ghost, just as Abelard did. The world-soul is a natural force which is responsible for all the phenomena of life and the psyche. As I have shown elsewhere, this view of the *anima mundi* ran through the whole tradition of alchemy in so far as Mercurius was interpreted now as *anima mundi* and now as the Holy Ghost.⁹⁴ In view of the importance of alchemical ideas for the psychology of the unconscious, it may be worth our while to devote a little time to a very illuminating variant of this spark symbolism.

[394] Even more common than the spark-motif is that of the fish’s eyes, which have the same significance. I said above that a Morienus passage is given by the authors as the source for the “doctrine” of the *scintillae*. This passage is, indeed, to be found in the treatise of Morienus Romanus. But it reads: “... Purus laton tamdiu decoquitur, donee veluti oculi piscium elucescat ...”⁹⁵ Here too the saying seems to be a citation from a still earlier source. In later authors these fish’s eyes are always cropping up. There is a variant in Sir George Ripley, stating that on the “desiccation of the sea” a substance is left behind which “glitters like a fish’s eye”⁹⁶—an obvious allusion to the

gold and the sun (God's eye). Hence it is not to be wondered at if an alchemist⁹⁷ of the seventeenth century uses the words of Zacharias 4 : 10 as a motto for his edition of Nicholas Flamel: "Et videbunt lapidem stanneum in manu Zorobabel. Septem isti oculi sunt Domini, qui discurrunt in universam terram" (And ... they shall see the tin plummet in the hand of Zorobabel. These are the seven eyes of the Lord that run to and fro through the whole earth).⁹⁸ These seven eyes are evidently the seven planets which, like the sun and moon, are the eyes of God, never resting, ubiquitous and all-seeing. The same motif is probably at the bottom of the many-eyed giant Argus. He is nicknamed Πανόπτης, 'the All-Seeing,' and is supposed to symbolize the starry heavens. Sometimes he is one-eyed, sometimes four-eyed, sometimes hundred-eyed, and even myriad-eyed (μυριωπόζ). Besides which he never sleeps. Hera transferred the eyes of Argus Panoptes to the peacock's tail.⁹⁹ Like the guardian Argus, the constellation of the Dragon is also given an all-surveying position in the Aratus citations of Hippolytus. He is there described as the one "who from the height of the Pole looks down upon all things and sees all things, so that nothing that happens shall be hidden from him."¹⁰⁰ This dragon is sleepless, because the Pole "never sets." Often he appears to be confused with the sun's serpentine passage through the sky: "C'est pour ce motif qu'on dispose parfois les signes du zodiaque entre les circonvolutions du reptile," says Cumont.¹⁰¹ Sometimes the serpent bears six signs of the zodiac upon his back.¹⁰² As Eisler has remarked, on account of the time symbolism the all-seeing quality of the dragon is transferred to Chronos, whom Sophocles names "ὁ πάντ' ὄρῳνχρόνος," while in the memorial tablet for those who fell at Chaeronea he is called "πανεπίσκοπος δαίμων."¹⁰³ The Uroboros has the meaning of eternity (αἰών) and cosmos in Horapollo. The identification of the All-Seeing with Time probably explains the eyes on the wheels in Ezekiel's vision (A.V., 1 : 18: "As for their rings, they were so high that they were dreadful; and their rings were full of eyes round about them four"). We mention this identification because of its special importance: it indicates the relation between the *mundus archetypus* of the unconscious and the "phenomenon" of Time—in other words, it points to the *synchronicity* of archetypal events, of which I shall have more to say towards the end of this paper.

[395] From Ignatius Loyola's autobiography, which he dictated to Loys Gonzales,¹⁰⁴ we learn that he used to see a bright light, and sometimes this apparition seemed to him to have the form of a serpent. It appeared to be full of shining eyes, which were yet no eyes. At first he was greatly comforted by the beauty of the vision, but later he recognized it to be an evil spirit.¹⁰⁵ This vision sums up all the aspects of our optic theme and presents a most impressive picture of the unconscious with its disseminated luminosities. One can easily imagine the perplexity which a medieval man would be bound to feel when confronted by such an eminently "psychological" intuition, especially as he had no dogmatic symbol and no adequate patristic allegory

to come to his rescue. But, as a matter of fact, Ignatius was not so very wide of the mark, for multiple eyes are also a characteristic of Purusha, the Hindu Cosmic Man. The Rig-Veda (10. 90) says: “Thousand-headed is Purusha, thousand-eyed, thousand-footed. He encompasses the earth on every side and rules over the ten-finger space.”¹⁰⁶ Monoïmos the Arabian, according to Hippolytus, taught that the First Man (“Ἀνθρῶπος) was a single Monad (μία μονάς), not composed (ἀσίνητος), indivisible (ἀδιαίρετος), and at the same time composed (συνθετή) and divisible (διαρετή). This Monad is the iota or dot (μία κεραία), and this tiniest of units which corresponds to Khunrath’s one *scintilla* has “many faces” (πολυπρόσωπος) and “many eyes” (πολνόμματος).¹⁰⁷ Monoïmos bases himself here mainly on the prologue to the Gospel of St. John! Like Purusha, his First Man is the universe (ἄνθρωπος εἶναι τὸ πᾶν).¹⁰⁸

[396] Such visions must be understood as introspective intuitions that somehow capture the state of the unconscious and, at the same time, as assimilations of the central Christian idea. Naturally enough, the motif has the same meaning in modern dreams and fantasies, where it appears as the star-strewn heavens, as stars reflected in dark water, as nuggets of gold or golden sand scattered in black earth,¹⁰⁹ as a regatta at night, with lanterns on the dark surface of the sea, as a solitary eye in the depths of the sea or earth, as a parapsychic vision of luminous globes, and so on. Since consciousness has always been described in terms derived from the behaviour of light, it is in my view not too much to assume that these multiple luminosities correspond to tiny conscious phenomena. If the luminosity appears in monadic form as a single star, sun, or eye, it readily assumes the shape of a mandala and must then be interpreted as the self. It has nothing whatever to do with “double consciousness,” because there is no indication of a dissociated personality. On the contrary, the symbols of the self have a “uniting” character.¹¹⁰

7. Patterns of Behaviour and Archetypes

[397] We have stated that the lower reaches of the psyche begin where the function emancipates itself from the compulsive force of instinct and becomes amenable to the will, and we have defined the will as disposable energy. But that, as said, presupposes a disposing subject, capable of judgment and endowed with consciousness. In this way we arrived at the position of proving, as it were, the very thing that we started by rejecting, namely the identification of psyche with consciousness. This dilemma resolves itself once we realize how very relative consciousness is, since its contents are conscious and unconscious at the same time, i.e., conscious under one aspect and unconscious under another. As is the way of paradoxes, this statement is not

immediately comprehensible.¹¹¹ We must, however, accustom ourselves to the thought that conscious and unconscious have no clear demarcations, the one beginning where the other leaves off. It is rather the case that the psyche is a conscious-unconscious whole. As to the no man's land which I have called the "personal unconscious," it is fairly easy to prove that its contents correspond exactly to our definition of the psychic. But—as we define "psychic"—is there a psychic unconscious that is not a "fringe of consciousness" and not personal?

[398] I have already mentioned that Freud established the existence of archaic vestiges and primitive modes of functioning in the unconscious. Subsequent investigations have confirmed this result and brought together a wealth of observational material. In view of the structure of the body, it would be astonishing if the psyche were the only biological phenomenon not to show clear traces of its evolutionary history, and it is altogether probable that these marks are closely connected with the instinctual base. Instinct and the archaic mode meet in the biological conception of the "pattern of behaviour." There are, in fact, no amorphous instincts, as every instinct bears in itself the pattern of its situation. Always it fulfils an image, and the image has fixed qualities. The instinct of the leaf-cutting ant fulfils the image of ant, tree, leaf, cutting, transport, and the little ant-garden of fungi.¹¹² If any one of these conditions is lacking, the instinct does not function, because it cannot exist without its total pattern, without its image. Such an image is an *a priori* type. It is inborn in the ant prior to any activity, for there can be no activity at all unless an instinct of corresponding pattern initiates and makes it possible. This schema holds true of all instincts and is found in identical form in all individuals of the same species. The same is true also of man: he has in him these *a priori* instinct-types which provide the occasion and the pattern for his activities, in so far as he functions instinctively. As a biological being he has no choice but to act in a specifically human way and fulfil his pattern of behaviour. This sets narrow limits to his possible range of volition, the more narrow the more primitive he is, and the more his consciousness is dependent upon the instinctual sphere. Although from one point of view it is quite correct to speak of the pattern of behaviour as a still-existing archaic vestige, as Nietzsche did in respect of the function of dreams, such an attitude does scant justice to the biological and psychological meaning of these types. They are not just relics or vestiges of earlier modes of functioning; they are the ever-present and biologically necessary regulators of the instinctual sphere, whose range of action covers the whole realm of the psyche and only loses its absoluteness when limited by the relative freedom of the will. We may say that the image represents the *meaning* of the instinct.

[399] Although the existence of an instinctual pattern in human biology is probable, it seems very difficult to prove the existence of distinct types empirically. For the organ

with which we might apprehend them—consciousness—is not only itself a transformation of the original instinctual image, but also its transformer. It is therefore not surprising that the human mind finds it impossible to specify precise types for man similar to those we know in the animal kingdom. I must confess that I can see no direct way to solve this problem. And yet I have succeeded, or so I believe, in finding at least an indirect way of approach to the instinctual image.

[400] In what follows, I would like to give a brief description of how this discovery took place. I had often observed patients whose dreams pointed to a rich store of fantasy-material. Equally, from the patients themselves, I got the impression that they were stuffed full of fantasies, without their being able to tell me just where the inner pressure lay. I therefore took up a dream-image or an association of the patient's, and, with this as a point of departure, set him the task of elaborating or developing his theme by giving free rein to his fantasy. This, according to individual taste and talent, could be done in any number of ways, dramatic, dialectic, visual, acoustic, or in the form of dancing, painting, drawing, or modelling. The result of this technique was a vast number of complicated designs whose diversity puzzled me for years, until I was able to recognize that in this method I was witnessing the spontaneous manifestation of an unconscious process which was merely assisted by the technical ability of the patient, and to which I later gave the name "individuation process." But, long before this recognition dawned upon me, I had made the discovery that this method often diminished, to a considerable degree, the frequency and intensity of the dreams, thus reducing the inexplicable pressure exerted by the unconscious. In many cases, this brought a large measure of therapeutic success, which encouraged both myself and the patient to press forward despite the baffling nature of the results.¹¹³ I felt bound to insist that they were baffling, if only to stop myself from framing, on the basis of certain theoretical assumptions, interpretations which I felt were not only inadequate but liable to prejudice the ingenuous productions of the patient. The more I suspected these configurations of harbouring a certain purposefulness, the less inclined I was to risk any theories about them. This reticence was not made easy for me. since in many cases I was dealing with patients who needed an intellectual *point d'appui* if they were not to get totally lost in the darkness. I had to try to give provisional interpretations at least, so far as I was able, interspersing them with innumerable "perhapses" and "ifs" and "buts" and never stepping beyond the bounds of the picture lying before me. I always took good care to let the interpretation of each image tail off into a question whose answer was left to the free fantasy-activity of the patient.

[401] The chaotic assortment of images that at first confronted me reduced itself in the course of the work to certain well-defined themes and formal elements, which repeated themselves in identical or analogous form with the most varied individuals.

I mention, as the most salient characteristics, chaotic multiplicity and order; duality; the opposition of light and dark, upper and lower, right and left; the union of opposites in a third; the quaternity (square, cross); rotation (circle, sphere); and finally the centring process and a radial arrangement that usually followed some quaternary system. Triadic formations, apart from the *complexio oppositorum* in a third, were relatively rare and formed notable exceptions which could be explained by special conditions.¹¹⁴ The centring process is, in my experience, the never-to-be-surpassed climax of the whole development,¹¹⁵ and is characterized as such by the fact that it brings with it the greatest possible therapeutic effect. The typical features listed above go to the limits of abstraction, yet at the same time they are the simplest expressions of the formative principles here at work. In actual reality, the patterns are infinitely more variegated and far more concrete than this would suggest. Their variety defies description. I can only say that there is probably no motif in any known mythology that does not at some time appear in these configurations. If there was any conscious knowledge of mythological motifs worth mentioning in my patients, it is left far behind by the ingenuities of creative fantasy. In general, my patients had only a minimal knowledge of mythology.

[402] These facts show in an unmistakable manner how fantasies guided by unconscious regulators coincide with the records of man's mental activity as known to us from tradition and ethnological research. All the abstract features I have mentioned are in a certain sense conscious: everyone can count up to four and knows what a circle is and a square; but, as formative principles, they are unconscious, and by the same token their psychological meaning is not conscious either. My most fundamental views and ideas derive from these experiences. First I made the observations, and only then did I hammer out my views. And so it is with the hand that guides the crayon or brush, the foot that executes the dance-step, with the eye and the ear, with the word and the thought: a dark impulse is the ultimate arbiter of the pattern, an unconscious *a priori* precipitates itself into plastic form, and one has no inkling that another person's consciousness is being guided by these same principles at the very point where one feels utterly exposed to the boundless subjective vagaries of chance. Over the whole procedure there seems to reign a dim foreknowledge not only of the pattern but of its meaning.¹¹⁶ Image and meaning are identical; and as the first takes shape, so the latter becomes clear. Actually, the pattern needs no interpretation: it portrays its own meaning. There are cases where I can let interpretation go as a therapeutic requirement. Scientific knowledge, of course, is another matter. Here we have to elicit from the sum total of our experience certain concepts of the greatest possible general validity, which are not given *a priori*. This particular work entails a translation of the timeless, ever-present operative archetype into the scientific language of the present.

[403] These experiences and reflections lead me to believe that there are certain collective unconscious conditions which act as regulators and stimulators of creative fantasy-activity and call forth corresponding formations by availing themselves of the existing conscious material. They behave exactly like the motive forces of dreams, for which reason active imagination, as I have called this method, to some extent takes the place of dreams. The existence of these unconscious regulators—I sometimes refer to them as “dominants”¹¹⁷ because of their mode of functioning—seemed to me so important that I based upon it my hypothesis of an impersonal collective unconscious. The most remarkable thing about this method, I felt, was that it did not involve a *reductio in primam figuram*, but rather a synthesis—supported by an attitude voluntarily adopted, though for the rest wholly natural—of passive conscious material and unconscious influences, hence a kind of spontaneous amplification of the archetypes. The images are not to be thought of as a reduction of conscious contents to their simplest denominator, as this would be the direct road to the primordial images which I said previously was unimaginable; they make their appearance only in the course of amplification.

[404] On this natural amplification process I also base my method of eliciting the meaning of dreams, for dreams behave in exactly the same way as active imagination; only the support of conscious contents is lacking. To the extent that the archetypes intervene in the shaping of conscious contents by regulating, modifying, and motivating them, they act like the instincts. It is therefore very natural to suppose that these factors are connected with the instincts and to inquire whether the typical situational patterns which these collective form-principles apparently represent are not in the end identical with the instinctual patterns, namely, with the patterns of behaviour. I must admit that up to the present I have not laid hold of any argument that would finally refute this possibility.

[405] Before I pursue my reflections further, I must stress one aspect of the archetypes which will be obvious to anybody who has practical experience of these matters. That is, the archetypes have, when they appear, a distinctly numinous character which can only be described as “spiritual,” if “magical” is too strong a word. Consequently this phenomenon is of the utmost significance for the psychology of religion. In its effects it is anything but unambiguous. It can be healing or destructive, but never indifferent, provided of course that it has attained a certain degree of clarity.¹¹⁸ This aspect deserves the epithet “spiritual” above all else. It not infrequently happens that the archetype appears in the form of a *spirit* in dreams or fantasy-products, or even comports itself like a ghost. There is a mystical aura about its numinosity, and it has a corresponding effect upon the emotions. It mobilizes philosophical and religious convictions in the very people who deemed themselves miles above any such fits of weakness. Often it drives with unexampled passion and remorseless logic towards its

goal and draws the subject under its spell, from which despite the most desperate resistance he is unable, and finally no longer even willing, to break free, because the experience brings with it a depth and fulness of meaning that was unthinkable before. I fully appreciate the resistance that all rooted convictions are bound to put up against psychological discoveries of this kind. With more foreboding than real knowledge, most people feel afraid of the menacing power that lies fettered in each of us, only waiting for the magic word to release it from the spell. This magic word, which always ends in “ism,” works most successfully with those who have the least access to their interior selves and have strayed the furthest from their instinctual roots into the truly chaotic world of *collective consciousness*.

[406] In spite or perhaps because of its affinity with instinct, the archetype represents the authentic element of spirit, but a spirit which is not to be identified with the human intellect, since it is the latter's *spiritus rector*. The essential content of all mythologies and all religions and all isms is archetypal. The archetype is spirit or anti-spirit: what it ultimately proves to be depends on the attitude of the human mind. Archetype and instinct are the most polar opposites imaginable, as can easily be seen when one compares a man who is ruled by his instinctual drives with a man who is seized by the spirit. But, just as between all opposites there obtains so close a bond that no position can be established or even thought of without its corresponding negation, so in this case also “les extremes se touchent.” They belong together as correspondences, which is not to say that the one is derivable from the other, but that they subsist side by side as reflections in our own minds of the opposition that underlies all psychic energy. Man finds himself simultaneously driven to act and free to reflect. This contrariety in his nature has no moral significance, for instinct is not in itself bad any more than spirit is good. Both can be both. Negative electricity is as good as positive electricity: first and foremost it is electricity. The psychological opposites, too, must be regarded from a scientific standpoint. True opposites are never incommensurables; if they were they could never unite. All contrariety notwithstanding, they do show a constant propensity to union, and Nicholas of Cusa defined God himself as a *complexio oppositorum*.

[407] Opposites are extreme qualities in any state, by virtue of which that state is perceived to be real, for they form a potential. The psyche is made up of processes whose energy springs from the equilibration of all kinds of opposites. The spirit / instinct antithesis is only one of the commonest formulations, but it has the advantage of reducing the greatest number of the most important and most complex psychic processes to a common denominator. So regarded, psychic processes seem to be balances of energy flowing between spirit and instinct, though the question of whether a process is to be described as spiritual or as instinctual remains shrouded in darkness. Such evaluation or interpretation depends entirely upon the standpoint or

state of the conscious mind. A poorly developed consciousness, for instance, which because of massed projections is inordinately impressed by concrete or apparently concrete things and states, will naturally see in the instinctual drives the source of all reality. It remains blissfully unaware of the spirituality of such a philosophical surmise, and is convinced that with this opinion it has established the essential instinctuality of all psychic processes. Conversely, a consciousness that finds itself in opposition to the instincts can, in consequence of the enormous influence then exerted by the archetypes, so subordinate instinct to spirit that the most grotesque “spiritual” complications may arise out of what are undoubtedly biological happenings. Here the instinctuality of the fanaticism needed for such an operation is ignored.

[408] Psychic processes therefore behave like a scale along which consciousness “slides.” At one moment it finds itself in the vicinity of instinct, and falls under its influence; at another, it slides along to the other end where spirit predominates and even assimilates the instinctual processes most opposed to it. These counterpositions, so fruitful of illusion, are by no means symptoms of the abnormal; on the contrary, they form the twin poles of that psychic one-sidedness which is typical of the normal man of today. Naturally this does not manifest itself only in the spirit / instinct antithesis; it assumes many other forms, as I have shown in my *Psychological Types*.

[409] This “sliding” consciousness is thoroughly characteristic of modern man. But the one-sidedness it causes can be removed by what I have called the “realization of the shadow.” A less “poetic” and more scientific-looking Greco-Latin neologism could easily have been coined for this operation. In psychology, however, one is to be dissuaded from ventures of this sort, at least when dealing with eminently practical problems. Among these is the “realization of the shadow,” the growing awareness of the inferior part of the personality, which should not be twisted into an intellectual activity, for it has far more the meaning of a suffering and a passion that implicate the whole man. The essence of that which has to be realized and assimilated has been expressed so trenchantly and so plastically in poetic language by the word “shadow” that it would be almost presumptuous not to avail oneself of this linguistic heritage. Even the term “inferior part of the personality” is inadequate and misleading, whereas “shadow” presumes nothing that would rigidly fix its content. The “man without a shadow” is statistically the commonest human type, one who imagines he actually *is* only what he cares to know about himself. Unfortunately neither the so-called religious man nor the man of scientific pretensions forms any exception to this rule.

[410] Confrontation with an archetype or instinct is an *ethical* problem of the first magnitude, the urgency of which is felt only by people who find themselves faced with the need to assimilate the unconscious and integrate their personalities. This only falls to the lot of the man who realizes that he has a neurosis or that all is not well with his psychic constitution. These are certainly not the majority. The “common man,” who is preponderantly a mass man, acts on the principle of realizing nothing, nor does he need to, because for him the only thing that commits mistakes is that vast anonymity conventionally known as “State” or “Society.” But once a man knows that he is, or should be, responsible, he feels responsible also for his psychic constitution, the more so the more clearly he sees what he would have to be in order to become healthier, more stable, and more efficient. Once he is on the way to assimilating the unconscious he can be certain that he will escape no difficulty that is an integral part of his nature. The mass man, on the other hand, has the privilege of being at all times “not guilty” of the social and political catastrophes in which the whole world is engulfed. His final calculation is thrown out accordingly; whereas the other at least has the possibility of finding a spiritual point of vantage, a kingdom that “is not of this world.”

[411] It would be an unpardonable sin of omission were one to overlook the *feeling-value* of the archetype. This is extremely important both theoretically and therapeutically. As a numinous factor, the archetype determines the nature of the configurational process and the course it will follow, with seeming foreknowledge, or as though it were already in possession of the goal to be circumscribed by the centring process.¹¹⁹ I would like to make the way in which the archetype functions clear from this simple example. While sojourning in equatorial east Africa, on the southern slopes of Mount Elgon, I found that the natives used to step out of their huts at sunrise, hold their hands before their mouths, and spit or blow into them vigorously. Then they lifted their arms and held their hands with the palms toward the sun. I asked them the meaning of what they did, but nobody could give me an explanation. They had always done it like that, they said, and had learnt it from their parents. The medicineman, he would know what it meant. So I asked the medicineman. He knew as little as the others, but assured me that his grandfather had still known. It was just what people did at every sunrise, and at the first phase of the new moon. For these people, as I was able to show, the moment when the sun or the new moon appeared was “mungu,” which corresponds to the Melanesian words “mana” or “mulungu”¹²⁰ and is translated by the missionaries as “God.” Actually the word *adhista* in Elgonyi means sun as well as God, although they deny that the sun is God. Only the moment when it rises is *mungu* or *adhista*. Spittle and breath mean soul-substance. Hence they offer their soul to God, but do not know what they are doing and never have known. They do it, motivated by the same preconscious

archetype which the ancient Egyptians, on their monuments, also ascribed to the sun-worshipping dog-headed baboon, albeit in full knowledge that this ritual gesture was in honour of God. The behaviour of the Elgonyi certainly strikes us as exceedingly primitive, but we forget that the educated Westerner behaves no differently. What the meaning of the Christmas-tree might be our forefathers knew even less than ourselves, and it is only quite recently that we have bothered to find out at all.

[412] The archetype is pure, unvitiated nature,¹²¹ and it is nature that causes man to utter words and perform actions whose meaning is unconscious to him, so unconscious that he no longer gives it a thought. A later, more conscious humanity, faced with such meaningful things whose meaning none could declare, hit upon the idea that these must be the last vestiges of a Golden Age, when there were men who knew all things and taught wisdom to the nations. In the degenerate days that followed, these teachings were forgotten and were now only repeated as mindless mechanical gestures. In view of the findings of modern psychology it cannot be doubted that there are preconscious archetypes which were never conscious and can be established only indirectly through their effects upon the conscious contents. There is in my opinion no tenable argument against the hypothesis that all the psychic functions which today seem conscious to us were once unconscious and yet worked as if they *were* conscious. We could also say that all the psychic phenomena to be found in man were already present in the natural unconscious state. To this it might be objected that it would then be far from clear why there is such a thing as consciousness at all. I would, however, remind the reader that, as we have already seen, all unconscious functioning has the automatic character of an instinct, and that the instincts are always coming into collision or, because of their compulsiveness, pursuing their courses unaltered by any influence even under conditions that may positively endanger the life of the individual. As against this, consciousness enables him to adapt in an orderly way and to check the instincts, and consequently it cannot be dispensed with. Man's capacity for consciousness alone makes him man.

[413] The achievement of a synthesis of conscious and unconscious contents, and the conscious realization of the archetype's effects upon the conscious contents, represents the climax of a concentrated spiritual and psychic effort, in so far as this is undertaken consciously and of set purpose. That is to say, the synthesis can also be prepared in advance and brought to a certain point—James's "bursting point"—unconsciously, whereupon it irrupts into consciousness of its own volition and confronts the latter with the formidable task of assimilating the contents that have burst in upon it, yet without damaging the viability of the two systems, i.e., of ego-consciousness on the one hand and the irrupted complex on the other. Classical examples of this process are Paul's conversion and the Trinity vision of Nicholas of Flüe.

[414] By means of “active imagination” we are put in a position of advantage, for we can then make the discovery of the archetype without sinking back into the instinctual sphere, which would only lead to blank unconsciousness or, worse still, to some kind of intellectual substitute for instinct. This means—to employ once more the simile of the spectrum—that the instinctual image is to be located not at the red end but at the violet end of the colour band. The dynamism of instinct is lodged as it were in the infra-red part of the spectrum, whereas the instinctual image lies in the ultra-violet part. If we remember our colour symbolism, then, as I have said, red is not such a bad match for instinct. But for spirit, as might be expected,¹²² blue would be a better match than violet. Violet is the “mystic” colour, and it certainly reflects the indubitably “mystic” or paradoxical quality of the archetype in a most satisfactory way. Violet is a compound of blue and red, although in the spectrum it is a colour in its own right. Now, it is, as it happens, rather more than just an edifying thought if we feel bound to emphasize that the archetype is more accurately characterized by violet, for, as well as being an image in its own right, it is at the same time a *dynamism* which makes itself felt in the numinosity and fascinating power of the archetypal image. The realization and assimilation of instinct never take place at the red end, i.e., by absorption into the instinctual sphere, but only through integration of the image which signifies and at the same time evokes the instinct, although in a form quite different from the one we meet on the biological level. When Faust remarks to Wagner: “You are conscious only of the single urge / O may you never learn to know the other!” this is a saying that could equally well be applied to instinct in general. It has two aspects: on the one hand it is experienced as physiological dynamism, while on the other hand its multitudinous forms enter into consciousness as images and groups of images, where they develop numinous effects which offer, or appear to offer, the strictest possible contrast to instinct physiologically regarded. For anyone acquainted with religious phenomenology it is an open secret that although physical and spiritual passion are deadly enemies, they are nevertheless brothers-in-arms, for which reason it often needs the merest touch to convert the one into the other. Both are real, and together they form a pair of opposites, which is one of the most fruitful sources of psychic energy. There is no point in deriving one from the other in order to give primacy to one of them. Even if we know only one at first, and do not notice the other until much later, that does not prove that the other was not there all the time. Hot cannot be derived from cold, nor high from low. An opposition either exists in its binary form or it does not exist at all, and a being without opposites is completely unthinkable, as it would be impossible to establish its existence.

[415] Absorption into the instinctual sphere, therefore, does not and cannot lead to conscious realization and assimilation of instinct, because consciousness struggles in a regular panic against being swallowed up in the primitivity and unconsciousness of

sheer instinctuality. This fear is the eternal burden of the hero-myth and the theme of countless taboos. The closer one comes to the instinct-world, the more violent is the urge to shy away from it and to rescue the light of consciousness from the murks of the sultry abyss. Psychologically, however, the archetype as an image of instinct is a spiritual goal toward which the whole nature of man strives; it is the sea to which all rivers wend their way, the prize which the hero wrests from the fight with the dragon.

[416] Because the archetype is a formative principle of instinctual power, its blue is contaminated with red: it appears to be violet, or again, we could interpret the simile as an apocatastasis of instinct raised to a higher frequency, just as we could easily derive instinct from a latent (i.e., transcendent) archetype that manifests itself on a longer wave-length.¹²³ Although it can admittedly be no more than an analogy, I nevertheless feel tempted to recommend this violet image to my reader as an illustrative hint of the archetype's affinity with its own opposite. The creative fantasy of the alchemists sought to express this abstruse secret of nature by means of another, no less concrete, symbol: the Uroboros, or tail-eating serpent.

[417] I do not want to work this simile to death, but, as the reader will understand, one is always delighted, when discussing difficult problems, to find support in a helpful analogy. In addition this simile helps to throw light on a question we have not yet asked ourselves, much less answered, the question regarding the *nature* of the archetype. The archetypal representations (images and ideas) mediated to us by the unconscious should not be confused with the archetype as such. They are very varied structures which all point back to one essentially "irrepresentable" basic form. The latter is characterized by certain formal elements and by certain fundamental meanings, although these can be grasped only approximately. The archetype as such is a psychoid factor that belongs, as it were, to the invisible, ultraviolet end of the psychic spectrum. It does not appear, in itself, to be capable of reaching consciousness. I venture this hypothesis because everything archetypal which is perceived by consciousness seems to represent a set of variations on a ground theme. One is most impressed by this act when one studies the endless variations of the mandala motif. This is a relatively simple ground form whose meaning can be said to be "central." But although it looks like the structure of a centre, it is still uncertain whether within that structure the centre or the periphery, division or non-division, is the more accentuated. Since other archetypes give rise to similar doubts, it seems to me probable that the real nature of the archetype is not capable of being made conscious, that it is transcendent, on which account I call it psychoid. Moreover every archetype, when represented to the mind, is already conscious and therefore differs to an indeterminable extent from that which caused the representation. As Theodor Lipps has stressed, the nature of the psychic is unconscious. Anything conscious is part of the phenomenal world which—so modern physics teaches—does

not supply explanations of the kind that objective reality requires. Objective reality requires a mathematical model, and experience shows that this is based on invisible and irrepresentable factors. Psychology cannot evade the universal validity of this fact, the less so as the observing psyche is already included in any formulation of objective reality. Nor can psychological theory be formulated mathematically, because we have no measuring rod with which to measure psychic quantities. We have to rely solely upon qualities, that is, upon perceptible phenomena. Consequently psychology is incapacitated from making any valid statement about unconscious states, or to put it another way, there is no hope that the validity of any statement about unconscious states or processes will ever be verified scientifically. Whatever we say about the archetypes, they remain visualizations or concretizations which pertain to the field of consciousness. But—we cannot speak about archetypes in any other way. We must, however, constantly bear in mind that what we mean by “archetype” is in itself irrepresentable, but has effects which make visualizations of it possible, namely, the archetypal images and ideas. We meet with a similar situation in physics: there the smallest particles are themselves irrepresentable but have effects from the nature of which we can build up a model. The archetypal image, the motif or mythologem, is a construction of this kind. When the existence of two or more irrerepresentables is assumed, there is always the possibility—which we tend to overlook—that it may not be a question of two or more factors but of one only. The identity or non-identity of two irrerepresentable quantities is something that cannot be proved. If on the basis of its observations psychology assumes the existence of certain irrerepresentable psychoid factors, it is doing the same thing in principle as physics does when the physicist constructs an atomic model. And it is not only psychology that suffers from the misfortune of having to give its object, the unconscious, a name that has often been criticized because it is merely negative; the same thing happened in physics, since it could not avoid using the ancient term “atom” (meaning “indivisible”) for the smallest particle of matter. Just as the atom is not indivisible, so, as we shall see, the unconscious is not merely unconscious. And just as physics in its psychological aspect can do no more than establish the existence of an observer without being able to assert anything about the nature of that observer, so psychology can only indicate the relation of psyche to matter without being able to make out the least thing about its nature.

[418] Since psyche and matter are contained in one and the same world, and moreover are in continuous contact with one another and ultimately rest on irrepresentable, transcendental factors, it is not only possible but fairly probable, even, that psyche and matter are two different aspects of one and the same thing. The synchronicity phenomena point, it seems to me, in this direction, for they show that the nonpsychic can behave like the psychic, and vice versa, without there being any causal

connection between them. Our present knowledge does not allow us to do much more than compare the relation of the psychic to the material world with two cones, whose apices, meeting in a point without extension—a real zero-point—touch and do not touch.

[419] In my previous writings I have always treated archetypal phenomena as psychic, because the material to be expounded or investigated was concerned solely with ideas and images. The psychoid nature of the archetype, as put forward here, does not contradict these earlier formulations; it only means a further degree of conceptual differentiation, which became inevitable as soon as I saw myself obliged to undertake a more general analysis of the nature of the psyche and to clarify the empirical concepts concerning it, and their relation to one another.

[420] Just as the “psychic infra-red,” the biological instinctual psyche, gradually passes over into the physiology of the organism and thus merges with its chemical and physical conditions, so the “psychic ultra-violet,” the archetype, describes a field which exhibits none of the peculiarities of the physiological and yet, in the last analysis, can no longer be regarded as psychic, although it manifests itself psychically. But physiological processes behave in the same way, without on that account being declared psychic. Although there is no form of existence that is not mediated to us psychically and only psychically, it would hardly do to say that everything is merely psychic. We must apply this argument logically to the archetypes as well. Since their essential being is unconscious to us, and still they are experienced as spontaneous agencies, there is probably no alternative now but to describe their nature, in accordance with their chiefest effect, as “spirit,” in the sense which I attempted to make plain in my paper “The Phenomenology of the Spirit in Fairytales.” If so, the position of the archetype would be located beyond the psychic sphere, analogous to the position of physiological instinct, which is immediately rooted in the stuff of the organism and, with its psychoid nature, forms the bridge to matter in general. In archetypal conceptions and instinctual perceptions, spirit and matter confront one another on the psychic plane. Matter and spirit both appear in the psychic realm as distinctive qualities of conscious contents. The ultimate nature of both is transcendental, that is, irrepresentable, since the psyche and its contents are the only reality which is given to us *without a medium*.

8. *General Considerations and Prospects*

[421] The problems of analytical psychology, as I have tried to outline them here, led to conclusions that astonished even me. I fancied I was working along the best scientific lines, establishing facts, observing, classifying, describing causal and functional

relations, only to discover in the end that I had involved myself in a net of reflections which extend far beyond natural science and ramify into the fields of philosophy, theology, comparative religion, and the humane sciences in general. This transgression, as inevitable as it was suspect, has caused me no little worry. Quite apart from my personal incompetence in these fields, it seemed to me that my reflections were suspect also in principle, because I am profoundly convinced that the “personal equation” has a telling effect upon the results of psychological observation. The tragic thing is that psychology has no selfconsistent mathematics at its disposal, but only a calculus of subjective prejudices. Also, it lacks the immense advantage of an Archimedean point such as physics enjoys. The latter observes the physical world from the psychic standpoint and can translate it into psychic terms. The psyche, on the other hand, observes itself and can only translate the psychic back into the psychic. Were physics in this position, it could do nothing except leave the physical process to its own devices, because in that way it would be most plainly itself. There is no medium for psychology to reflect itself in: it can only portray itself in itself, and describe itself. That, logically, is also the principle of my own method: it is, at bottom, a purely experiential process in which hit and miss, interpretation and error, theory and speculation, doctor and patient, form a *symptosis* (σύμπτωσις) or a *symptoma* (σύμπτωμα)—a coming together—and at the same time are symptoms of a certain process or run of events. What I am describing, therefore, is basically no more than an outline of psychic happenings which exhibit a certain statistical frequency. We have not, scientifically speaking, removed ourselves to a plane in any way “above” the psychic process, nor have we translated it into another medium. Physics, on the other hand, is in a position to detonate mathematical formulae—the product of pure psychic activity—and kill seventy-eight thousand persons at one blow.

[422] This literally “devastating” argument is calculated to reduce psychology to silence. But we can, in all modesty, point out that mathematical thinking is also a psychic function, thanks to which matter can be organized in such a way as to burst asunder the mighty forces that bind the atoms together—which it would never occur to them to do in the natural course of things, at least not upon this earth. The psyche is a disturber of the natural laws of the cosmos, and should we ever succeed in doing something to Mars with the aid of atomic fission, this too will have been brought to pass by the psyche.

[423] The psyche is the world’s pivot: not only is it the one great condition for the existence of a world at all, it is also an intervention in the existing natural order, and no one can say with certainty where this intervention will finally end. It is hardly necessary to stress the dignity of the psyche as an object of natural science. With all the more urgency, then, we must emphasize that the smallest alteration in the psychic factor, if it be an alteration of principle, is of the utmost significance as regards our

knowledge of the world and the picture we make of it. The integration of unconscious contents into consciousness, which is the main endeavour of analytical psychology, is just such an alteration of principle, in that it does away with the sovereignty of the subjective ego-consciousness and confronts it with unconscious collective contents. Accordingly ego-consciousness seems to be dependent on two factors: firstly, on the conditions of the collective, i.e., the social, consciousness; and secondly, on the archetypes, or dominants, of the collective unconscious. The latter fall phenomenologically into two categories: instinctual and archetypal. The first includes the natural impulses, the second the dominants that emerge into consciousness as universal ideas. Between the contents of collective consciousness, which purport to be generally accepted truths, and those of the collective unconscious there is so pronounced a contrast that the latter are rejected as totally irrational, not to say meaningless, and are most unjustifiably excluded from the scientific purview as though they did not exist. However, psychic phenomena of this kind exist with a vengeance, and if they appear nonsensical to us, that only proves that we do not understand them. Once their existence is recognized they can no longer be banished from our world-picture, even though the prevailing conscious *Weltanschauung* proves to be incapable of grasping the phenomena in question. A conscientious study of these phenomena quickly reveals their uncommon significance, and we can hardly avoid the conclusion that between collective consciousness and the collective unconscious there is an almost unbridgeable gulf over which the subject finds himself suspended.

[424] As a rule, collective consciousness wins hands down with its “reasonable” generalities that cause the average intelligence no difficulty whatever. It still believes in the necessary connection of cause and effect and has scarcely taken note of the fact that causality has become relative. The shortest distance between two points is still, for it, a straight line, although physics has to reckon with innumerable shortest distances, which strikes the educated Philistine of today as exquisitely absurd. Nevertheless the impressive explosion at Hiroshima has induced an awestruck respect for even the most abstruse alembications of modern physics. The explosion which we recently had occasion to witness in Europe, though far more terrible in its repercussions, was recognized as an unmitigated psychic disaster only by the few. Rather than do this, people prefer the most preposterous political and economic theories, which are about as useful as explaining the Hiroshima explosion as the chance hit of a large meteorite.

[425] If the subjective consciousness prefers the ideas and opinions of collective consciousness and identifies with them, then the contents of the collective unconscious are repressed. The repression has typical consequences: the energy-charge of the repressed contents adds itself, in some measure,¹²⁴ to that of the

repressing factor, whose effectiveness is increased accordingly. The higher its charge mounts, the more the repressive attitude acquires a fanatical character and the nearer it comes to conversion into its opposite, i.e., an enantiodromia. And the more highly charged the collective consciousness, the more the ego forfeits its practical importance. It is, as it were, absorbed by the opinions and tendencies of collective consciousness, and the result of that is the mass man, the ever-ready victim of some wretched “ism.” The ego keeps its integrity only if it does not identify with one of the opposites, and if it understands how to hold the balance between them. This is possible only if it remains conscious of both at once, however, the necessary insight is made exceedingly difficult not by one’s social and political leaders alone, but also by one’s religious mentors. They all want decision in favour of one thing, and therefore the utter identification of the individual with a necessarily one-sided “truth.” Even if it were a question of some great truth, identification with it would still be a catastrophe, as it arrests all further spiritual development. Instead of knowledge one then has only belief, and sometimes that is more convenient and therefore more attractive.

[426] If, on the other hand, the content of the collective unconscious is realized, if the existence and efficacy of archetypal representations are acknowledged, then a violent conflict usually breaks out between what Fechner has called the “day-time and the night-time view.” Medieval man (and modern man too, in so far as he has kept the attitude of the past) lived fully conscious of the discord between worldliness, which was subject to the *princeps huius mundi* (St. John 12 : 31 and 16 : 11¹²⁵), and the will of God. For centuries this contradiction was demonstrated before his very eyes by the struggle between imperial and papal power. On the moral plane the conflict swelled to the everlasting cosmic tug of war between good and evil in which man was implicated on account of original sin. The medieval man had not yet fallen such a helpless victim to worldliness as the contemporary mass man, for, to offset the notorious and, so to speak, tangible powers of this world, he still acknowledged the equally influential metaphysical potencies which demanded to be taken into account. Although in one respect he was politically and socially unfree and without rights—e.g., as a serf—and also found himself in the extremely disagreeable situation of being tyrannized over by black superstition, he was at least biologically nearer to that unconscious wholeness which primitive man enjoys in even larger measure, and the wild animal possesses to perfection. Looked at from the standpoint of modern consciousness, the position of medieval man seems as deplorable as it is in need of improvement. But the much needed broadening of the mind by science has only replaced medieval one-sidedness—namely, that age-old unconsciousness which once predominated and has gradually become defunctive—by a new one-sidedness, the overvaluation of “scientifically” attested views. These each and all relate to

knowledge of the external object and in a chronically one-sided way, so that nowadays the backwardness of psychic development in general and of self-knowledge in particular has become one of the most pressing contemporary problems. As a result of the prevailing one-sidedness, and in spite of the terrifying optical demonstration of an unconscious that has become alienated from the conscious, there are still vast numbers of people who are the blind and helpless victims of these conflicts, and who apply their scientific scrupulosity only to external objects, never to their own psychic condition. Yet the psychic facts are as much in need of objective scrutiny and acknowledgment. There are objective psychic factors which are every bit as important as radios and automobiles. Ultimately everything (particularly in the case of the atom-bomb) depends on the uses to which these factors are put, and that is always conditioned by one's state of mind. The current "isms" are the most serious threat in this respect, because they are nothing but dangerous identifications of the subjective with the collective consciousness. Such an identity infallibly produces a mass psyche with its irresistible urge to catastrophe. Subjective consciousness must, in order to escape this doom, avoid identification with collective consciousness by recognizing its shadow as well as the existence and the importance of the archetypes. These latter are an effective defence against the brute force of collective consciousness and the mass psyche that goes with it. In point of effectiveness, the religious outlook of medieval man corresponds roughly to the attitude induced in the ego by the integration of unconscious contents, with the difference that in the latter case susceptibility to environmental influences and unconsciousness are replaced by scientific objectivity and conscious knowledge. But so far as religion, for the contemporary consciousness, still means, if anything, a creed, and hence a collectively accepted system of religious statements neatly codified as dogmatic precepts, it has closer affinities with collective consciousness even though its symbols express the once-operative archetypes. So long as the communal consciousness presided over by the Church is objectively present, the psyche, as said, continues to enjoy a certain equilibrium. At all events, it constitutes a sufficiently effective defence against inflation of the ego. But once Mother Church and her motherly Eros fall into abeyance, the individual is at the mercy of any passing collectivism and the attendant mass psyche. He succumbs to social or national inflation, and the tragedy is that he does so with the same psychic attitude which had once bound him to a church.

[427] But if he is independent enough to recognize the bigotedness of the social "ism," he may then be threatened with subjective inflation, for usually he is not capable of seeing that religious ideas do not, in psychological reality, rest solely upon tradition and faith, but originate with the archetypes, the "careful consideration" of which—*religere!*—constitutes the essence of religion. The archetypes are continuously

present and active; as such they need no believing in, but only an intuition of their meaning and a certain sapient awe, a δεισιδαιμονία, which never loses sight of their import. A consciousness sharpened by experience knows the catastrophic consequences that disregard of this entails for the individual as well as for society. Just as the archetype is partly a spiritual factor, and partly like a hidden meaning immanent in the instincts, so the spirit, as I have shown,¹²⁶ is two-faced and paradoxical: a great help and an equally great danger.¹²⁷ It seems as if man were destined to play a decisive role in solving this uncertainty, and to solve it moreover by virtue of his consciousness, which once started up like a light in the murk of the primeval world. Nowhere do we know for sure about these matters, but least of all where “isms” flourish, for they are only a sophisticated substitute for the lost link with psychic reality. The mass psyche that infallibly results destroys the meaning of the individual and of culture generally.

[428] From this it is clear that the psyche not only disturbs the natural order but, if it loses its balance, actually destroys its own creation. Therefore the careful consideration of psychic factors is of importance in restoring not merely the individual's balance, but society's as well, otherwise the destructive tendencies easily gain the upper hand. In the same way that the atom-bomb is an unparalleled means of physical mass destruction, so the misguided development of the soul must lead to psychic mass destruction. The present situation is so sinister that one cannot suppress the suspicion that the Creator is planning another deluge that will finally exterminate the existing race of men. But if anyone imagines that a healthy belief in the existence of archetypes can be inculcated from outside, he is as simple as the people who want to outlaw war or the atom-bomb. Such measures remind one of the bishop who excommunicated the cockchafers for their unseemly proliferation. Change of consciousness begins at home; it is an age-long process that depends entirely on how far the psyche's capacity for development extends. All we know at present is that there are single individuals who are capable of developing. How great their total number is we do not know, just as we do not know what the suggestive power of an extended consciousness may be, or what influence it may have upon the world at large. Effects of this kind never depend on the reasonableness of an idea, but far more on the question (which can only be answered *ex effectu*): is the time ripe for change, or not?

*

[429] As I have said, the psychology of complex phenomena finds itself in an uncomfortable situation compared with the other natural sciences because it lacks a base outside its object. It can only translate itself back into its own language, or fashion itself in its own image. The more it extends its field of research and the more

complicated its objects become, the more it feels the lack of a point which is distinct from those objects. And once the complexity has reached that of the empirical man, his psychology inevitably merges with the psychic process itself. It can no longer be distinguished from the latter, and so turns into it. But the effect of this is that the process attains to consciousness. In this way, psychology actualizes the unconscious urge to consciousness. It is, in fact, the coming to consciousness of the psychic process, but it is not, in the deeper sense, an explanation of this process, for no explanation of the psychic can be anything other than the living process of the psyche itself. Psychology is doomed to cancel itself out as a science and therein precisely it reaches its scientific goal. Every other science has so to speak an outside; not so psychology, whose object is the inside subject of all science.

[430] Psychology therefore culminates of necessity in a developmental process which is peculiar to the psyche and consists in integrating the unconscious contents into consciousness. This means that the psychic human being becomes a whole, and becoming whole has remarkable effects on ego-consciousness which are extremely difficult to describe. I doubt my ability to give a proper account of the change that comes over the subject under the influence of the individuation process; it is a relatively rare occurrence, which is experienced only by those who have gone through the wearisome but, if the unconscious is to be integrated, indispensable business of coming to terms with the unconscious components of the personality. Once these unconscious components are made conscious, it results not only in their assimilation to the already existing ego-personality, but in a transformation of the latter. The main difficulty is to describe the manner of this transformation. Generally speaking the ego is a hard-and-fast complex which, because tied to consciousness and its continuity, cannot easily be altered, and should not be altered unless one wants to bring on pathological disturbances. The closest analogies to an alteration of the ego are to be found in the field of psychopathology, where we meet not only with neurotic dissociations but also with the schizophrenic fragmentation, or even dissolution, of the ego. In this field, too, we can observe pathological attempts at integration—if such an expression be permitted. These consist in more or less violent irruptions of unconscious contents into consciousness, the ego proving itself incapable of assimilating the intruders. But if the structure of the ego-complex is strong enough to withstand their assault without having its framework fatally dislocated, then assimilation can take place. In that event there is an alteration of the ego as well as of the unconscious contents. Although it is able to preserve its structure, the ego is ousted from its central and dominating position and thus finds itself in the role of a passive observer who lacks the power to assert his will under all circumstances, not so much because it has been weakened in any way, as because certain considerations give it pause. That is, the ego cannot help discovering that the

afflux of unconscious contents has vitalized the personality, enriched it and created a figure that somehow dwarfs the ego in scope and intensity. This experience paralyzes an over-egocentric will and convinces the ego that in spite of all difficulties it is better to be taken down a peg than to get involved in a hopeless struggle in which one is invariably handed the dirty end of the stick. In this way the will, as disposable energy, gradually subordinates itself to the stronger factor, namely to the new totality-figure I call the *self*. Naturally, in these circumstances there is the greatest temptation simply to follow the power-instinct and to identify the ego with the self outright, in order to keep up the illusion of the ego's mastery. In other cases the ego proves too weak to offer the necessary resistance to the influx of unconscious contents and is thereupon assimilated by the unconscious, which produces a blurring or darkening of ego-consciousness and its identification with a preconscious wholeness.¹²⁸ Both these developments make the realization of the self impossible, and at the same time are fatal to the maintenance of ego-consciousness. They amount, therefore, to pathological effects. The psychic phenomena recently observable in Germany fall into this category. It is abundantly clear that such an *abaissement du niveau mental*, i.e., the overpowering of the ego by unconscious contents and the consequent identification with a preconscious wholeness, possesses a prodigious psychic virulence, or power of contagion, and is capable of the most disastrous results. Developments of this kind should, therefore, be watched very carefully; they require the closest control. I would recommend anyone who feels himself threatened by such tendencies to hang a picture of St. Christopher on the wall and to meditate upon it. For the self has a functional meaning only when it can act compensatorily to ego-consciousness. If the ego is dissolved in identification with the self, it gives rise to a sort of nebulous superman with a puffed-up ego and a deflated self. Such a personage, however saviourlike or baleful his demeanour, lacks the *scintilla*, the soul-spark, the little wisp of divine light that never burns more brightly than when it has to struggle against the invading darkness. What would the rainbow be were it not limned against the lowering cloud?

[431] This simile is intended to remind the reader that pathological analogies of the individuation process are not the only ones. There are spiritual monuments of quite another kind, and they are positive illustrations of our process. Above all I would mention the *koans* of Zen Buddhism, those sublime paradoxes that light up, as with a flash of lightning, the inscrutable interrelations between ego and self. In very different language, St. John of the Cross has made the same problem more readily accessible to the Westerner in his account of the "dark night of the soul." That we find it needful to draw analogies from psychopathology and from both Eastern and Western mysticism is only to be expected: the individuation process is, psychically, a border-line phenomenon which needs special conditions in order to become

conscious. Perhaps it is the first step along a path of development to be trodden by the men of the future—a path which, for the time being, has taken a pathological turn and landed Europe in catastrophe.

[432] To one familiar with our psychology, it may seem a waste of time to keep harping on the long-established difference between becoming conscious and the coming-to-be of the self (individuation). But again and again I note that the individuation process is confused with the coming of the ego into consciousness and that the ego is in consequence identified with the self, which naturally produces a hopeless conceptual muddle. Individuation is then nothing but ego-centredness and autoeroticism. But the self comprises infinitely more than a mere ego, as the symbolism has shown from of old. It is as much one's self, and all other selves, as the ego. Individuation does not shut one out from the world, but gathers the world to oneself.

[433] With this I would like to bring my exposition to an end. I have tried to sketch out the development and basic problems of our psychology and to communicate the quintessence, the very spirit, of this science. In view of the unusual difficulties of my theme, the reader may pardon the undue demands I have made upon his good-will and attention. Fundamental discussions are among the things that mould a science into shape, but they are seldom entertaining.

Supplement

[434] As the points of view that have to be considered in elucidating the unconscious are often misunderstood, I would like, in connection with the foregoing discussions of principle, to examine at least two of the main prejudices somewhat more closely.

[435] What above all stultifies understanding is the arrant assumption that “archetype” means an inborn idea. No biologist would ever dream of assuming that each individual acquires his general mode of behaviour afresh each time. It is much more probable that the young weaver-bird builds his characteristic nest because he is a weaver-bird and not a rabbit. Similarly, it is more probable that man is born with a specifically human mode of behaviour and not with that of a hippopotamus or with none at all. Integral to his characteristic behaviour is his psychic phenomenology, which differs from that of a bird or quadruped. Archetypes are typical forms of behaviour which, once they become conscious, naturally present themselves *as ideas and images*, like everything else that becomes a content of consciousness. Because it is a question of characteristically human modes, it is hardly to be wondered at that we can find psychic forms in the individual which occur not only at the antipodes but also in other epochs with which archaeology provides the only link.

[436] Now if we wish to prove that a certain psychic form is not a unique but a typical occurrence, this can be done only if I myself testify that, having taken the necessary precautions, I have observed the same thing in different individuals. Then other observers, too, must confirm that they have made the same or similar observations. Finally we have to establish that the same or similar phenomena can be shown to occur in the folklore of other peoples and races and in the texts that have come down to us from earlier centuries and epochs. My method and whole outlook, therefore, begin with individual psychic facts which not I alone have established, but other observers as well. The material brought forward—folkloristic, mythological, or historical—serves in the first place to demonstrate the uniformity of psychic events in time and space. But, since the meaning and substance of the typical individual forms are of the utmost importance in practice, and knowledge of them plays a considerable role in each individual case, it is inevitable that the mythologem and its content will also be drawn into the limelight. This is not to say that the purpose of the investigation is to interpret the mythologem. But, precisely in this connection, a widespread prejudice reigns that the psychology of unconscious processes is a sort of *philosophy* designed to explain mythologems. This unfortunately rather common prejudice assiduously overlooks the crucial point, namely, that our psychology starts with observable facts and not with philosophical speculations. If, for instance, we study the mandala structures that are always cropping up in dreams and fantasies, ill-considered criticism might raise, and indeed has raised, the objection that we are reading Indian or Chinese philosophy into the psyche. But in reality all we have done is to compare individual psychic occurrences with obviously related collective phenomena. The introspective trend of Eastern philosophy has brought to light material which all introspective attitudes bring to light all over the world, at all times and places. The great snag so far as the critic is concerned is that he has no personal experience of the facts in question, any more than he has of the state of mind of a lama engaged in “constructing” a mandala. These two prejudices render any access to modern psychology impossible for not a few heads with scientific pretensions. There are in addition many other stumbling-blocks that cannot be overcome by reason. We shall therefore refrain from discussing them.

[437] Inability to understand, or the ignorance of the public, cannot however prevent the scientist from employing certain calculations of probability, of whose treacherous nature he is sufficiently well informed. We are fully aware that we have no more knowledge of the various states and processes of the unconscious as such than the physicist has of the process underlying physical phenomena. Of what lies beyond the phenomenal world we can have absolutely no idea, for there is no idea that could have any other source than the phenomenal world. If we are to engage in fundamental reflections about the nature of the psychic, we need an Archimedean

point which alone makes a judgment possible. This can only be the nonpsychic, for, as a living phenomenon, the psychic lies embedded in something that appears to be of a nonpsychic nature. Although we perceive the latter as a psychic datum only, there are sufficient reasons for believing in its objective reality. This reality, so far as it lies outside our body's limits, is mediated to us chiefly by particles of light impinging on the retina of the eye. The organization of these particles produces a picture of the phenomenal world which depends essentially upon the constitution of the apperceiving psyche on the one hand, and upon that of the light medium on the other. The apperceiving consciousness has proved capable of a high degree of development, and constructs instruments with the help of which our range of seeing and hearing has been extended by many octaves. Consequently the postulated reality of the phenomenal world as well as the subjective world of consciousness have undergone an unparalleled expansion. The existence of this remarkable correlation between consciousness and the phenomenal world, between subjective perception and objectively real processes, i.e., their energetic effects, requires no further proof.

[438] As the phenomenal world is an aggregate of processes of atomic magnitude, it is naturally of the greatest importance to find out whether, and if so how, the photons (shall we say) enable us to gain a definite knowledge of the reality underlying the mediative energy processes. Experience has shown that light and matter both behave like separate particles and also like waves. This paradoxical conclusion obliged us to abandon, on the plane of atomic magnitudes, a causal description of nature in the ordinary space-time system, and in its place to set up invisible fields of probability in multidimensional spaces, which do in fact represent the state of our knowledge at present. Basic to this abstract scheme of explanation is a conception of reality that takes account of the uncontrollable effects the observer has upon the system observed, the result being that reality forfeits something of its objective character and that a subjective element attaches to the physicist's picture of the world.¹²⁹

[439] The application of statistical laws to processes of atomic magnitude in physics has a noteworthy correspondence in psychology, so far as psychology investigates the bases of consciousness by pursuing the conscious processes until they lose themselves in darkness and unintelligibility, and nothing more can be seen but effects which have an *organizing* influence on the contents of consciousness.¹³⁰ Investigation of these effects yields the singular fact that they proceed from an unconscious, i.e., objective, reality which behaves at the same time like a subjective one—in other words, like a consciousness. Hence the reality underlying the unconscious effects includes the observing subject and is therefore constituted in a way that we cannot conceive. It is, at one and the same time, absolute subjectivity and universal truth, for in principle it can be shown to be present everywhere, which certainly cannot be said of conscious contents of a personalistic nature. The elusiveness, capriciousness,

haziness, and uniqueness that the lay mind always associates with the idea of the psyche applies only to consciousness, and not to the absolute unconscious. The qualitatively rather than quantitatively definable units with which the unconscious works, namely the archetypes, therefore have a nature that *cannot with certainty be designated as psychic*.

[440] Although I have been led by purely psychological considerations to doubt the exclusively psychic nature of the archetypes, psychology sees itself obliged to revise its “only psychic” assumptions in the light of the physical findings too. Physics has demonstrated, as plainly as could be wished, that in the realm of atomic magnitudes an observer is postulated in objective reality, and that only on this condition is a satisfactory scheme of explanation possible. This means that a subjective element attaches to the physicist’s world picture, and secondly that a connection necessarily exists between the psyche to be explained and the objective space-time continuum. Since the physical continuum is inconceivable it follows that we can form no picture of its psychic aspect either, which also necessarily exists. Nevertheless, the relative or partial identity of psyche and physical continuum is of the greatest importance theoretically, because it brings with it a tremendous simplification by bridging over the seeming incommensurability between the physical world and the psychic, not of course in any concrete way, but from the physical side by means of mathematical equations, and from the psychological side by means of empirically derived postulates—archetypes—whose content, if any, cannot be represented to the mind. Archetypes, so far as we can observe and experience them at all, manifest themselves only through their ability to *organize* images and ideas, and this is always an unconscious process which cannot be detected until afterwards. By assimilating ideational material whose provenance in the phenomenal world is not to be contested, they become visible and *psychic*. Therefore they are recognized at first only as psychic entities and are conceived as such, with the same right with which we base the physical phenomena of immediate perception on Euclidean space. Only when it comes to explaining psychic phenomena of a minimal degree of clarity are we driven to assume that archetypes must have a nonpsychic aspect. Grounds for such a conclusion are supplied by the phenomena of synchronicity, which are associated with the activity of unconscious operators and have hitherto been regarded, or repudiated, as “telepathy,” etc.¹³¹ Scepticism should, however, be levelled only at incorrect theories and not at facts which exist in their own right. No unbiased observer can deny them. Resistance to the recognition of such facts rests principally on the repugnance people feel for an allegedly supernatural faculty tacked on to the psyche, like “clairvoyance.” The very diverse and confusing aspects of these phenomena are, so far as I can see at present, completely explicable on the assumption of a psychically relative space-time continuum. As soon as a psychic

content crosses the threshold of consciousness, the synchronistic marginal phenomena disappear, time and space resume their accustomed sway, and consciousness is once more isolated in its subjectivity. We have here one of those instances which can best be understood in terms of the physicist's idea of "complementarity." When an unconscious content passes over into consciousness its synchronistic manifestation ceases; conversely, synchronistic phenomena can be evoked by putting the subject into an unconscious state (trance). The same relationship of complementarity can be observed just as easily in all those extremely common medical cases in which certain clinical symptoms disappear when the corresponding unconscious contents are made conscious. We also know that a number of psychosomatic phenomena which are otherwise outside the control of the will can be induced by hypnosis, that is, by this same restriction of consciousness. Professor Pauli formulates the physical side of the complementarity relationship here expressed, as follows: "It rests with the free choice of the experimenter (or observer) to decide ... which insights he will gain and which he will lose; or, to put it in popular language, whether he will measure A and ruin B or ruin A and measure B. It does *not* rest with him, however, to gain only insights and not lose any." This is particularly true of the relation between the physical standpoint and the psychological. Physics determines quantities and their relation to one another; psychology determines qualities without being able to measure quantities. Despite that, both sciences arrive at ideas which come significantly close to one another. The parallelism of psychological and physical explanations has already been pointed out by C. A. Meier in his essay "Moderne Physik—Moderne Psychologie."¹³² He says: "Both sciences have, in the course of many years of independent work, amassed observations and systems of thought to match them. Both sciences have come up against certain barriers which ... display similar basic characteristics. The object to be investigated, and the human investigator with his organs of sense and knowledge and their extensions (measuring instruments and procedures), are indissolubly bound together. That is complementarity in physics as well as in psychology." Between physics and psychology there is in fact "a genuine and authentic relationship of complementarity."

[441] Once we can rid ourselves of the highly unscientific pretence that it is merely a question of chance coincidence, we shall see that synchronistic phenomena are not unusual occurrences at all, but are relatively common. This fact is in entire agreement with Rhine's "probability-exceeding" results. The psyche is not a chaos made up of random whims and accidents, but is an objective reality to which the investigator can gain access by the methods of natural science. There are indications that psychic processes stand in some sort of energy relation to the physiological substrate. In so far as they are objective events, they can hardly be interpreted as anything but energy

processes,¹³³ or to put it another way: in spite of the nonmeasurability of psychic processes, the perceptible changes effected by the psyche cannot possibly be understood except as a phenomenon of energy. This places the psychologist in a situation which is highly repugnant to the physicist: the psychologist also talks of energy although he has nothing measurable to manipulate, besides which the concept of energy is a strictly defined mathematical quantity which cannot be applied as such to anything psychic. The formula for kinetic energy, $E = \frac{mv^2}{2}$, contains the factors m (mass) and v (velocity), and these would appear to be incommensurable with the nature of the empirical psyche. If psychology nevertheless insists on employing its own concept of energy for the purpose of expressing the activity (*ἐνέργεια*) of the psyche, it is not of course being used as a mathematical formula, but only as its analogy. But note: the analogy is itself an older intuitive idea from which the concept of physical energy originally developed. The latter rests on earlier applications of an *ἐνέργεια* not mathematically defined, which can be traced back to the primitive or archaic idea of the “extraordinarily potent.” This mana concept is not confined to Melanesia, but can also be found in Indonesia and on the east coast of Africa; and it still echoes in the Latin *numen* and, more faintly, in *genius* (e.g., *genius loci*). The use of the term *libido* in the newer medical psychology has surprising affinities with the primitive mana.¹³⁴ This archetypal idea is therefore far from being only primitive, but differs from the physicist’s conception of energy by the fact that it is essentially qualitative and not quantitative. In psychology the exact measurement of quantities is replaced by an approximate determination of intensities, for which purpose, in strictest contrast to physics, we enlist the function of *feeling* (valuation). The latter takes the place, in psychology, of concrete measurement in physics. The psychic intensities and their graduated differences point to quantitative processes which are inaccessible to direct observation and measurement. While psychological data are essentially qualitative, they also have a sort of latent physical energy, since psychic phenomena exhibit a certain quantitative aspect. Could these quantities be measured the psyche would be bound to appear as having motion in space, something to which the energy formula would be applicable. Therefore, since mass and energy are of the same nature, mass and velocity would be adequate concepts for characterizing the psyche so far as it has any observable effects in space: in other words, it must have an aspect under which it would appear as mass in motion. If one is unwilling to postulate a pre-established harmony of physical and psychic events, then they can only be in a state of interaction. But the latter hypothesis requires a psyche that touches matter at some point, and, conversely, a matter with a latent psyche, a postulate not so very far removed from certain formulations of modern physics (Eddington, Jeans, and others). In this connection I would remind the reader of the

existence of parapsychic phenomena whose reality value can only be appreciated by those who have had occasion to satisfy themselves by personal observation.

[442] If these reflections are justified, they must have weighty consequences with regard to the nature of the psyche, since as an objective fact it would then be intimately connected not only with physiological and biological phenomena but with physical events too—and, so it would appear, most intimately of all with those that pertain to the realm of atomic physics. As my remarks may have made clear, we are concerned first and foremost to establish certain analogies, and no more than that; the existence of such analogies does not entitle us to conclude that the connection is already proven. We must, in the present state of our physical and psychological knowledge, be content with the mere resemblance to one another of certain basic reflections. The existing analogies, however, are significant enough in themselves to warrant the prominence we have given them.

IV

GENERAL ASPECTS OF DREAM PSYCHOLOGY



ON THE NATURE OF DREAMS

GENERAL ASPECTS OF DREAM PSYCHOLOGY¹

[443] Dreams have a psychic structure which is unlike that of other contents of consciousness because, so far as we can judge from their form and meaning, they do not show the continuity of development typical of conscious contents. They do not appear, as a rule, to be integral components of our conscious psychic life, but seem rather to be extraneous, apparently accidental occurrences. The reason for this exceptional position of dreams lies in their peculiar mode of origin: they do not arise, like other conscious contents, from any clearly discernible, logical and emotional continuity of experience, but are remnants of a peculiar psychic activity taking place during sleep. Their mode of origin is sufficient in itself to isolate dreams from the other contents of consciousness, and this is still further increased by the content of the dreams themselves, which contrasts strikingly with our conscious thinking.

[444] An attentive observer, however, will have no difficulty in discovering that dreams are not entirely cut off from the continuity of consciousness, for in almost every dream certain details can be found which have their origin in the impressions, thoughts, and moods of the preceding day or days. To that extent a certain continuity does exist, though at first sight it points *backwards*. But anyone sufficiently interested in the dream problem cannot have failed to observe that dreams also have a continuity *forwards*—it such an expression be permitted—since dreams occasionally exert a remarkable influence on the conscious mental life even of persons who cannot be considered superstitious or particularly abnormal. These after-effects consist mostly in more or less distinct alterations of mood.

[445] It is probably in consequence of this loose connection with the other contents of consciousness that the recollected dream is so extremely unstable. Many dreams baffle all attempts at reproduction, even immediately after waking; others can be remembered only with doubtful accuracy, and comparatively few can be called really distinct and clearly reproducible. This peculiar behaviour may be explained by considering the characteristics of the various elements combined in a dream. The combination of ideas in dreams is essentially *fantastic*; they are linked together in a sequence which is as a rule quite foreign to our “reality thinking,” and in striking contrast to the logical sequence of ideas which we consider to be a special characteristic of conscious mental processes.

[446] It is to this characteristic that dreams owe the vulgar epithet “meaningless.” But before pronouncing this verdict we should remember that the dream and its context is

something that we do not understand. With such a verdict, therefore, we would merely be projecting our own lack of understanding upon the object. But that would not prevent dreams from having an inherent meaning of their own.

[447] Apart from the efforts that have been made for centuries to extract a prophetic meaning from dreams, Freud's discoveries are the first successful attempt in practice to find their real significance. His work merits the term "scientific" because he has evolved a technique which not only he but many other investigators assert achieves its object, namely the understanding of the meaning of the dream. This meaning is not identical with the fragmentary meanings suggested by the manifest dream-content.

[448] This is not the place for a critical discussion of Freud's psychology of dreams. I shall try, rather, to give a brief summary of what may be regarded as the more or less established facts of dream psychology today.

[449] The first question we must discuss is: what is our justification for attributing to dreams any other significance than the unsatisfying fragmentary meaning suggested by the manifest dream-content? One especially cogent argument in this respect is the fact that Freud discovered the hidden meaning of dreams *empirically* and *not deductively*. A further argument in favour of a possible hidden meaning is obtained by comparing dream-fantasies with other fantasies of the waking state in one and the same individual. It is not difficult to see that waking fantasies have not merely a superficial, concretistic meaning but also a deeper psychological meaning. There is a very old and widespread type of fantastic story, of which Aesop's fables are typical examples, that provides a very good illustration of what may be said about the meaning of fantasies in general. For instance, a fantastic tale is told about the doings of a lion and an ass. Taken superficially and concretely, the tale is an impossible phantasm, but the hidden moral meaning is obvious to anyone who reflects upon it. It is characteristic that children are pleased and satisfied with the exoteric meaning of the fable.

[450] But by far the best argument for the existence of a hidden meaning in dreams is obtained by conscientiously applying the technical procedure for breaking down the manifest dream-content. This brings us to our second main point, the question of analytic procedure. Here again I desire neither to defend nor to criticize Freud's views and discoveries, but shall confine myself to what seem to me to be firmly established facts. If we start from the fact that a dream is a psychic product, we have not the least reason to suppose that its constitution and function obey laws and purposes other than those applicable to any other psychic product. In accordance with the maxim "Principles are not to be multiplied beyond the necessary," we have to

treat the dream, analytically, just like any other psychic product until experience teaches us a better way.

[451] We know that every psychic structure, regarded from the causal standpoint, is the result of antecedent psychic contents. We know, furthermore, that every psychic structure, regarded from the final standpoint, has its own peculiar meaning and purpose in the actual psychic process. This criterion must also be applied to dreams. When, therefore, we seek a psychological explanation of a dream, we must first know what were the preceding experiences out of which it is composed. We must trace the antecedents of every element in the dreampicture. Let me give an example: someone dreams that *he is walking down a street—suddenly a child crosses in front of him and is run over by a car.*

[452] We reduce the dreampicture to its antecedents with the help of the dreamer's recollections. He recognizes the street as one down which he had walked on the previous day. The child he recognizes as his brother's child, whom he had seen on the previous evening when visiting his brother. The car accident reminds him of an accident that had actually occurred a few days before, but of which he had only read in a newspaper. As we know, most people are satisfied with a reduction of this kind. "Aha," they say, "that's why I had this dream."

[453] Obviously this reduction is quite unsatisfying from the scientific point of view. The dreamer had walked down many streets on the previous day; why was this particular one selected? He had read about several accidents; why did he select just this one? The discovery of a single antecedent is by no means sufficient, for a plausible determination of the dream-images results only from the competition of several causes. The collection of additional material proceeds according to the same principle of recollection, which has also been called the method of free association. The result, as can readily be understood, is an accumulation of very diverse and largely heterogeneous material, having apparently nothing in common but the fact of its evident associative connection with the dream-content, otherwise it could never have been reproduced by means of this content.

[454] How far the collection of such material should go is an important question from the technical point of view. Since the entire psychic content of a life could ultimately be disclosed from any single starting point, theoretically the whole of a person's previous life-experience might be found in every dream. But we need to collect only just so much material as is absolutely necessary in order to understand the dream's meaning. The limitation of the material is obviously an arbitrary proceeding, in accordance with Kant's principle that to "comprehend" a thing is to "cognize it to the extent necessary for our purpose."² For instance, when undertaking a survey of the causes of the French Revolution, we could, in amassing our material, include not

only the history of medieval France but also that of Rome and Greece, which certainly would not be “necessary for our purpose,” since we can understand the historical genesis of the Revolution just as well from much more limited material. So in collecting the material for a dream we go only so far as seems necessary to us in order to extract from it a valid meaning.

[455] Except for the aforesaid arbitrary limitation, the collection of material lies outside the choice of the investigator. The material collected must now be sifted and examined according to principles which are always applied to the examination of historical or any other empirical material. The method is essentially a comparative one, which obviously does not work automatically but is largely dependent on the skill and aim of the investigator.

[456] When a psychological fact has to be explained, it must be remembered that psychological data necessitate a twofold point of view, namely that of *causality* and that of *finality*. I use the word finality intentionally, in order to avoid confusion with the concept of teleology. By finality I mean merely the immanent psychological striving for a goal. Instead of “striving for a goal” one could also say “sense of purpose.” All psychological phenomena have some such sense of purpose inherent in them, even merely reactive phenomena like emotional reactions. Anger over an insult has its purpose in revenge; the purpose of ostentatious mourning is to arouse the sympathy of others, and so on.

[457] Applying the causal point of view to the material associated with the dream, we reduce the manifest dream-content to certain fundamental tendencies or ideas exhibited by the material. These, as one would expect, are of an elementary and general nature. For example, a young man dreams; “*I was standing in a strange garden and picked an apple from a tree. I looked about cautiously, to make sure that no one saw me.*”

[458] The associated dream-material is a memory of having once, when a boy, plucked a couple of pears surreptitiously from a neighbour’s garden. The feeling of bad conscience, which is a prominent feature of the dream, reminds him of a situation experienced on the previous day. He met a young lady in the street—a casual acquaintance—and exchanged a few words with her. At that moment a gentleman passed whom he knew, whereupon he was suddenly seized with a curious feeling of embarrassment, as if he were doing something wrong. He associated the apple with the scene in the Garden of Eden, and also with the fact that he had never really understood why the eating of the forbidden fruit should have had such dire consequences for our first parents. This had always made him feel angry; it seemed to him an unjust act of God, for God had made men as they were, with all their curiosity and greed.

[459] Another association was that sometimes his father had punished him for certain things in a way that seemed to him incomprehensible. The worst punishment had been bestowed on him after he was caught secretly watching girls bathing. This led up to the confession that he had recently begun a love-affair with a housemaid but had not yet carried it through to its natural conclusion. On the evening before the dream he had had a rendezvous with her.

[460] Reviewing this material, we can see that the dream contains a very transparent reference to the last-named incident. The associative material shows that the apple episode is obviously intended as an erotic scene. For various other reasons, too, it may be considered extremely probable that this experience of the previous day has gone on working in the dream. In the dream the young man plucks the apple of Paradise, which in reality he has not yet plucked. The remainder of the material associated with the dream is concerned with another experience of the previous day, namely the peculiar feeling of bad conscience which seized the dreamer when he was talking to his casual lady acquaintance. This, again, was associated with the fall of man in Paradise, and finally with an erotic misdemeanour of his childhood, for which his father had punished him severely. All these associations are linked together by the idea of *guilt*.

[461] We shall first consider this material from the causal standpoint of Freud; in other words, we shall “interpret” the dream, to use Freud’s expression. A wish has been left unfulfilled from the day before. In the dream this wish is fulfilled under the *symbol* of the apple episode. But why is this fulfilment disguised and hidden under a symbolical image instead of being expressed in a clearly sexual thought? Freud would point to the unmistakable element of guilt in this material and say that the morality inculcated into the young man from childhood is bent on repressing such wishes, and to that end brands the natural craving as something painful and incompatible. The repressed painful thought can therefore express itself only “symbolically.” As these thoughts are incompatible with the moral content of consciousness, a psychic authority postulated by Freud, called the censor, prevents this wish from passing undisguised into consciousness.

[462] Considering a dream from the standpoint of finality, which I contrast with the causal standpoint of Freud, does not—as I would expressly like to emphasize—involve a denial of the dream’s causes, but rather a different interpretation of the associative material gathered round the dream. The material facts remain the same, but the criterion by which they are judged is different. The question may be formulated simply as follows: What is the purpose of this dream? What effect is it meant to have? These questions are not arbitrary inasmuch as they can be applied to every psychic activity. Everywhere the question of the “why” and the “wherefore”

may be raised, because every organic structure consists of a complicated network of purposive functions, and each of these functions can be resolved into a series of individual facts with a purposive orientation.

[463] It is clear that the material added by the dream to the previous day's erotic experience chiefly emphasizes the element of guilt in the erotic act. The same association had already shown itself to be operative in another experience of the previous day, in that meeting with the casual lady acquaintance, when the feeling of a bad conscience was automatically and inexplicably aroused, as if in that instance too the young man was doing something wrong. This feeling also plays a part in the dream and is further intensified by the association of the additional material, the erotic experience of the day before being depicted by the story of the Fall, which was followed by such severe punishment.

[464] I maintain that there exists in the dreamer an unconscious propensity or tendency to represent his erotic experiences as guilt. It is characteristic that the dream is followed by the association with the Fall and that the young man had never really grasped why the punishment should have been so drastic. This association throws light on the reasons why he did not think simply: "What I am doing is not right." Obviously he does not know that he might condemn his conduct as morally wrong. This is actually the case. His conscious belief is that his conduct does not matter in the least morally, as all his friends were acting in the same way, besides which he was quite unable on other grounds to understand why such a fuss should be made about it.

[465] Now whether this dream should be considered meaningful or meaningless depends on a very important question, namely, whether the standpoint of morality, handed down through the ages, is itself meaningful or meaningless. I do not wish to wander off into a philosophical discussion of this question, but would merely observe that mankind must obviously have had very strong reasons for devising this morality, for otherwise it would be truly incomprehensible why such restraints should be imposed on one of man's strongest desires. If we give this fact its due, we are bound to pronounce the dream to be meaningful, because it shows the young man the necessity of looking at his erotic conduct for once from the standpoint of morality. Primitive tribes have in some respects extremely strict laws concerning sexuality. This proves that sexual morality is a not-to-be-neglected factor in the higher functions of the psyche and deserves to be taken fully into account. In the case in question we should have to say that the young man, hypnotized by his friends' example, has somewhat thoughtlessly given way to his erotic desires, unmindful of the fact that man is a morally responsible being who, voluntarily or involuntarily, submits to the morality that he himself has created.

[466] In this dream we can discern a compensating function of the unconscious whereby those thoughts, inclinations, and tendencies which in conscious life are too little valued come spontaneously into action during the sleeping state, when the conscious process is to a large extent eliminated.

[467] Here the question might certainly be asked: of what use is this to the dreamer if he does not understand the dream?

[468] To this I must remark that understanding is not an exclusively intellectual process for, as experience shows, a man may be influenced, and indeed convinced in the most effective way, by innumerable things of which he has no intellectual understanding. I need only remind my readers of the effectiveness of religious symbols.

[469] The above example might lead one to suppose that the function of dreams is a distinctly “moral” one. Such it appears to be in this case, but if we recall the formula that dreams contain the subliminal material of a given moment, we cannot speak simply of a “moral” function. For it is worth noting that the dreams of those persons whose actions are morally unassailable bring material to light that might well be described as “immoral” in the ordinary meaning of the term. Thus it is characteristic that St. Augustine was glad that God did not hold him responsible for his dreams. The unconscious is the unknown at any given moment, so it is not surprising that dreams add to the conscious psychological situation of the moment all those aspects which are essential for a totally different point of view. It is evident that this function of dreams amounts to a psychological adjustment, a compensation absolutely necessary for properly balanced action. In a conscious process of reflection it is essential that, so far as possible, we should realize all the aspects and consequences of a problem in order to find the right solution. This process is continued automatically in the more or less unconscious state of sleep, where, as experience seems to show, all those aspects occur to the dreamer (at least by way of allusion) that during the day were insufficiently appreciated or even totally ignored—in other words, were comparatively unconscious.

[470] As regards the much discussed *symbolism* of dreams, its evaluation varies according to whether it is considered from the causal or from the final standpoint. The causal approach of Freud starts from a desire or craving, that is, from the repressed dream-wish. This craving is always something comparatively simple and elementary, which can hide itself under manifold disguises. Thus the young man in question could just as well have dreamt that he had to open a door with a key, that he was flying in an aeroplane, kissing his mother, etc. From this point of view all those things could have the same meaning. Hence it is that the more rigorous adherents of the Freudian school have come to the point of interpreting—to give a gross example-

pretty well all oblong objects in dreams as phallic symbols and all round or hollow objects as feminine symbols.

[471] From the standpoint of finality the images in a dream each have an intrinsic value of their own. For instance if the young man, instead of dreaming of the apple scene, had dreamt he had to open a door with a key, this dream-image would probably have furnished associative material of an essentially different character, which would have supplemented the conscious situation in a way quite different from the material connected with the apple scene. From this standpoint, the significance lies precisely in the diversity of symbolical expressions in the dream and not in their uniformity of meaning. The causal point of view tends by its very nature towards uniformity of meaning, that is, towards a fixed significance of symbols. The final point of view, on the other hand, perceives in the altered dream-image the expression of an altered psychological situation. It recognizes no fixed meaning of symbols. From this standpoint, all the dream-images are important in themselves, each one having a special significance of its own, to which, indeed, it owes its inclusion in the dream. Keeping to our previous example, we can see that from the final standpoint the symbol in the dream has more the value of a parable: it does not conceal, it teaches. The apple scene vividly recalls the sense of guilt while at the same time disguising the deed of our first parents.

[472] It is clear that we reach very dissimilar interpretations of the meaning of dreams according to the point of view we adopt. The question now arises: which is the better or truer interpretation? After all, for us psychotherapists it is a practical and not merely a theoretical necessity that we should have *some* interpretation of the meaning of dreams. If we want to treat our patients we must for quite practical reasons endeavour to lay hold of any means that will enable us to educate them effectively. It should be obvious from the foregoing example that the material associated with the dream has touched on a question calculated to open the eyes of the young man to many things which till now he had heedlessly overlooked. But by disregarding these things he was really overlooking something in himself, for he has a moral standard and a moral need just like any other man. By trying to live without taking this fact into account his life was one-sided and incomplete, as if unco-ordinated—with the same consequences for psychic life as a one-sided and incomplete diet would have for the body. In order to educate an individuality to completeness and independence we need to bring to fruition all those functions which have hitherto attained but little conscious development or none at all. And to achieve this aim we must for therapeutic reasons enter into all the unconscious aspects of the contribution made by the dream-material. This makes it abundantly clear that the standpoint of finality is of great importance as an aid to the development of the individual.

[473] The causal point of view is obviously more sympathetic to the scientific spirit of our time with its strictly causalistic reasoning. Much may be said for Freud's view as a scientific explanation of dream psychology. But I must dispute its completeness, for the psyche cannot be conceived merely in causal terms but requires also a final view. Only a combination of points of view—which has not yet been achieved in a scientifically satisfactory manner, owing to the enormous difficulties, both practical and theoretical, that still remain to be overcome—can give us a more complete conception of the nature of dreams.

[474] I would now like to treat briefly of some further problems of dream psychology which are contingent to a general discussion of dreams. First, as to the *classification of dreams*, I would not put too high a value either on the practical or on the theoretical importance of this question. I investigate yearly some fifteen hundred to two thousand dreams, and on the basis of this experience I can assert that typical dreams do actually exist. But they are not very frequent, and from the final point of view they lose much of the importance which the causal standpoint attaches to them on account of the fixed significance of symbols. It seems to me that the *typical motifs* in dreams are of much greater importance since they permit a comparison with the motifs of mythology. Many of those mythological motifs—in collecting which Frobenius in particular has rendered such signal service—are also found in dreams, often with precisely the same significance. Though I cannot enter into this question more fully here, I would like to emphasize that the comparison of typical dream-motifs with those of mythology suggests the idea—already put forward by Nietzsche—that dream-thinking should be regarded as a phylogenetically older mode of thought. Instead of multiplying examples I can best show what I mean by reference to our specimen dream. It will be remembered that the dream introduced the apple scene as a typical way of representing erotic guilt. The thought abstracted from it would boil down to: "I am doing wrong by acting like this." It is characteristic that dreams never express themselves in this logical, abstract way but always in the language of parable or simile. This is also a characteristic of primitive languages, whose flowery turns of phrase are very striking. If we remember the monuments of ancient literature, we find that what nowadays is expressed by means of abstractions was then expressed mostly by similes. Even a philosopher like Plato did not disdain to express certain fundamental ideas in this way.

[475] Just as the body bears the traces of its phylogenetic development, so also does the human mind. Hence there is nothing surprising about the possibility that the figurative language of dreams is a survival from an archaic mode of thought.

[476] At the same time the theft of the apple is a typical dream-motif that occurs in many different variations in numerous dreams. It is also a well-known mythological

motif, which is found not only in the story of the Garden of Eden but in countless myths and fairytales from all ages and climes. It is one of those universally human symbols which can reappear autochthonously in any one, at any time. Thus dream psychology opens the way to a general comparative psychology from which we may hope to gain the same understanding of the development and structure of the human psyche as comparative anatomy has given us concerning the human body.³

[477] Dreams, then, convey to us in figurative language—that is, in sensuous, concrete imagery—thoughts, judgments, views, directives, tendencies, which were unconscious either because of repression or through mere lack of realization. Precisely because they are contents of the unconscious, and the dream is a derivative of unconscious processes, it contains a reflection of the unconscious contents. It is not a reflection of unconscious contents in general but only of certain contents, which are linked together associatively and are selected by the conscious situation of the moment. I regard this observation as a very important one in practice. If we want to interpret a dream correctly, we need a thorough knowledge of the conscious situation at that moment, because the dream contains its unconscious complement, that is, the material which the conscious situation has constellated in the unconscious. Without this knowledge it is impossible to interpret a dream correctly, except by a lucky fluke. I would like to illustrate this by an example:

[478] A man once came to me for a first consultation. He told me that he was engaged in all sorts of learned pursuits and was also interested in psychoanalysis from a literary point of view. He was in the best of health, he said, and was not to be considered in any sense a patient. He was merely pursuing his psychoanalytic interests. He was very comfortably off and had plenty of time to devote himself to his pursuits. He wanted to make my acquaintance in order to be inducted by me into the theoretical secrets of analysis. He admitted it must be very boring for me to have to do with a normal person, since I must certainly find “mad” people much more interesting. He had written to me a few days before to ask when I could see him. In the course of conversation we soon came to the question of dreams. I thereupon asked him whether he had had a dream the night before he visited me. He affirmed this and told me the following dream: *“I was in a bare room. A sort of nurse received me, and wanted me to sit at a table on which stood a bottle of fermented milk, which I was supposed to drink. I wanted to go to Dr. Jung, but the nurse told me that I was in a hospital and that Dr. Jung had no time to receive me.”*

[479] It is clear even from the manifest content of the dream that the anticipated visit to me had somehow constellated his unconscious. He gave the following associations: Bare room: “A sort of frosty reception room, as in an official building, or the waiting-room in a hospital. I was never in a hospital as a patient.” Nurse: “She looked

repulsive, she was cross-eyed. That reminds me of a fortune-teller and palmist whom I once visited to have my fortune told. Once I was sick and had a deaconess as a nurse.” Bottle of fermented milk: “Fermented milk is nauseating, I cannot drink it. My wife is always drinking it, and I make fun of her for this because she is obsessed with the idea that one must always be doing something for one’s health. I remember I was once in a sanatorium—my nerves were not so good—and there I had to drink fermented milk.”

[480] At this point I interrupted him with the indiscreet question: had his neurosis entirely disappeared since then? He tried to worm out of it, but finally had to admit that he still had his neurosis, and that actually his wife had for a long time been urging him to consult me. But he certainly didn’t feel so nervous that he had to consult me on that account, he was after all not mad, and I treated only mad people. It was merely that he was interested in learning about my psychological theories, etc.

[481] From this we can see how the patient has falsified the situation. It suits his fancy to come to me in the guise of a philosopher and psychologist and to allow the fact of his neurosis to recede into the background. But the dream reminds him of it in a very disagreeable way and forces him to tell the truth. He has to swallow this bitter drink. His recollection of the fortune-teller shows us very clearly just how he had imagined my activities. As the dream informs him, he must first submit to treatment before he can get to me.

[482] The dream rectifies the situation. It contributes the material that was lacking and thereby improves the patient’s attitude. That is the reason we need dream-analysis in our therapy.

[483] I do not wish to give the impression that all dreams are as simple as this one, or that they are all of this type. I believe it is true that all dreams are compensatory to the content of consciousness, but certainly not in all dreams is the compensatory function so clear as in this example. Though dreams contribute to the self-regulation of the psyche by automatically bringing up everything that is repressed or neglected or unknown, their compensatory significance is often not immediately apparent because we still have only a very incomplete knowledge of the nature and the needs of the human psyche. There are psychological compensations that seem to be very remote from the problem on hand. In these cases one must always remember that every man, in a sense, represents the whole of humanity and its history. What was possible in the history of mankind at large is also possible on a small scale in every individual. What mankind has needed may eventually be needed by the individual too. It is therefore not surprising that religious compensations play a great role in dreams. That this is increasingly so in our time is a natural consequence of the prevailing materialism of our outlook.

[484] Lest it be thought that the compensatory significance of dreams is a new discovery or has simply been “made up” to suit the convenience of interpretation, I shall cite a very old and well-known example which can be found in the fourth chapter of the Book of Daniel (10–16, AV). When Nebuchadnezzar was at the height of his power he had the following dream:

... I saw, and behold a tree in the midst of the earth, and the height thereof was great.

The tree grew, and was strong, and the height thereof reached unto heaven, and the sight thereof to the end of all the earth.

The leaves thereof were fair, and the fruit thereof much, and in it was meat for all: the beasts of the field had shadow under it, and the fowls of the heaven dwelt in the boughs thereof, and all flesh was fed of it.

I saw in the visions of my head upon my bed, and behold, a watcher and an holy one came down from heaven;

He cried aloud, and said thus, Hew down the tree, and cut off his branches, shake off his leaves, and scatter his fruit: let the beasts get away from under it, and the fowls from his branches.

Nevertheless leave the stump of his roots in the earth, even with a band of iron and brass in the tender grass of the field; and let it be wet with the dew of heaven, and let his portion be with the beasts in the grass of the earth:

Let his heart be changed from man's, and let a beast's heart be given unto him; and let seven times pass over him.

[485] In the second part of the dream the tree becomes personified, so that it is easy to see that the great tree is the dreaming king himself. Daniel interprets the dream in this sense. Its meaning is obviously an attempt to compensate the king's megalomania which, according to the story, developed into a real psychosis. To interpret the dream-process as compensatory is in my view entirely consistent with the nature of the biological process in general. Freud's view tends in the same direction, since he too ascribes a compensatory role to dreams in so far as they preserve sleep. There are, as Freud has demonstrated, dreams which show how certain external stimuli that would rob the dreamer of sleep are distorted in such a way that they abet the wish to sleep, or rather the desire not to be disturbed. Equally, there are innumerable dreams in which, as Freud was able to show, intrapsychic excitations, such as personal ideas that would be likely to release powerful affective reactions, are distorted in such a way as to fit in with a dream-context which disguises the painful ideas and makes any strong affective reaction impossible.

[486] As against this, we should not overlook the fact that the very dreams which disturb sleep most—and these are not uncommon—have a dramatic structure which aims logically at creating a highly affective situation, and builds it up so efficiently that the affect unquestionably wakes the dreamer. Freud explains these dreams by saying that the censor was no longer able to suppress the painful affect. It seems to me that this explanation fails to do justice to the facts. Dreams which concern

themselves in a very disagreeable manner with the painful experiences and activities of daily life and expose just the most disturbing thoughts with the most painful distinctness are known to everyone. It would, in my opinion, be unjustified to speak here of the dream's sleep-preserving, affect-disguising function. One would have to stand reality on its head to see in these dreams a confirmation of Freud's view. The same is true of those cases where repressed sexual fantasies appear undisguised in the manifest dream content.

[487] I have therefore come to the conclusion that Freud's view that dreams have an essentially wish-fulfilling and sleep-preserving function is too narrow, even though the basic thought of a compensatory biological function is certainly correct. This compensatory function is concerned only to a limited extent with the sleeping state; its chief significance is rather in relation to conscious life. Dreams, I maintain, are compensatory to the conscious situation of the moment. They preserve sleep whenever possible: that is to say, they function necessarily and automatically under the influence of the sleeping state; but they break through when their function demands it, that is, when the compensatory contents are so intense that they are able to counteract sleep. A compensatory content is especially intense when it has a vital significance for conscious orientation.

[488] As far back as 1907 I pointed out the compensatory relation between consciousness and the split-off complexes and also emphasized their purposive character. Flournoy did the same thing independently of me.⁴ From these observations the possibility of purposive unconscious impulses became evident. It should be emphasized, however, that the final orientation of the unconscious does not run parallel with our conscious intentions. As a rule, the unconscious content contrasts strikingly with the conscious material, particularly when the conscious attitude tends too exclusively in a direction that would threaten the vital needs of the individual. The more one-sided his conscious attitude is, and the further it deviates from the optimum, the greater becomes the possibility that vivid dreams with a strongly contrasting but purposive content will appear as an expression of the self-regulation of the psyche. Just as the body reacts purposively to injuries or infections or any abnormal conditions, so the psychic functions react to unnatural or dangerous disturbances with purposive defence-mechanisms. Among these purposive reactions we must include the dream, since it furnishes the unconscious material constellated in a given conscious situation and supplies it to consciousness in symbolical form. In this material are to be found all those associations which remained unconscious because of their feeble accentuation but which still possess sufficient energy to make themselves perceptible in the sleeping state. Naturally the purposive nature of the dream-content is not immediately discernible from outside without further investigation. An analysis of the manifest dream-content is required before we can

get at the really compensatory factors in the latent dream-content. Most of the physical defence-mechanisms are of this non-obvious and, so to speak, indirect nature, and their purposiveness can be recognized only after careful investigation. I need only remind you of the significance of fever or of suppuration processes in an infected wound.

[489] The processes of psychic compensation are almost always of a very individual nature, and this makes the task of proving their compensatory character considerably more difficult. Because of this peculiarity, it is often very difficult, especially for the beginner, to see how far a dream-content has a compensatory significance. On the basis of the compensation theory, one would be inclined to assume, for instance, that anyone with a too pessimistic attitude to life must have very cheerful and optimistic dreams. This expectation is true only in the case of someone whose nature allows him to be stimulated and encouraged in this way. But if he has a rather different nature, his dreams will purposively assume a much blacker character than his conscious attitude. They can then follow the principle of like curing like.

[490] It is therefore not easy to lay down any special rules for the type of dream-compensation. Its character is always closely bound up with the whole nature of the individual. The possibilities of compensation are without number and inexhaustible, though with increasing experience certain basic features gradually crystallize out.

[491] In putting forward a compensation theory I do not wish to assert that this is the only possible theory of dreams or that it completely explains *all* the phenomena of dream-life. The dream is an extraordinarily complicated phenomenon, just as complicated and unfathomable as the phenomena of consciousness. It would be inappropriate to try to understand all conscious phenomena from the standpoint of the wish-fulfilment theory or the theory of instinct, and it is as little likely that dream-phenomena are susceptible of so simple an explanation. Nor should we regard dream-phenomena as merely compensatory and secondary to the contents of consciousness, even though it is commonly supposed that conscious life is of far greater significance for the individual than the unconscious. This view, however, may yet have to be revised, for, as our experience deepens, it will be realized that the function of the unconscious in the life of the psyche has an importance of which we perhaps have still too low an estimate. It is analytical experience, above all, which has discovered to an increasing degree the influences of the unconscious on our conscious psychic life—influences whose existence and significance had till then been overlooked. In my view, which is based on many years of experience and on extensive research, the significance of the unconscious in the total performance of the psyche is probably just as great as that of consciousness. Should this view prove correct, then not only should the function of the unconscious be regarded as compensatory and relative to

the content of consciousness, but the content of consciousness would have to be regarded as relative to the momentarily constellated unconscious content. In this case active orientation towards goals and purposes would not be the privilege of consciousness alone but would also be true of the unconscious, so that it too would be just as capable of taking a finally oriented lead. The dream, accordingly, would then have the value of a positive, guiding idea or of an aim whose vital meaning would be greatly superior to that of the momentarily constellated conscious content. This possibility meets with the approval of the *consensus gentium*, since in the superstitions of all times and races the dream has been regarded as a truth-telling oracle. Making allowances for exaggeration and prejudice, there is always a grain of truth in such widely disseminated views. Maeder has laid energetic stress on the prospective-final significance of dreams as a purposive unconscious function which paves the way for the solution of real conflicts and problems and seeks to portray it with the help of gropingly chosen symbols.⁵

[492] I should like to distinguish between the *prospective* function of dreams and their *compensatory* function. The latter means that the unconscious, considered as relative to consciousness, adds to the conscious situation all those elements from the previous day which remained subliminal because of repression or because they were simply too feeble to reach consciousness. This compensation, in the sense of being a self-regulation of the psychic organism, must be called purposive.

[493] The prospective function, on the other hand, is an anticipation in the unconscious of future conscious achievements, something like a preliminary exercise or sketch, or a plan roughed out in advance. Its symbolic content sometimes outlines the solution of a conflict, excellent examples of this being given in Maeder. The occurrence of prospective dreams cannot be denied. It would be wrong to call them prophetic, because at bottom they are no more prophetic than a medical diagnosis or a weather forecast. They are merely an anticipatory combination of probabilities which may coincide with the actual behaviour of things but need not necessarily agree in every detail. Only in the latter case can we speak of "prophecy." That the prospective function of dreams is sometimes greatly superior to the combinations we can consciously foresee is not surprising, since a dream results from the fusion of subliminal elements and is thus a combination of all the perceptions, thoughts, and feelings which consciousness has not registered because of their feeble accentuation. In addition, dreams can rely on subliminal memory traces that are no longer able to influence consciousness effectively. With regard to prognosis, therefore, dreams are often in a much more favourable position than consciousness.

[494] Although the prospective function is, in my view, an essential characteristic of dreams, one would do well not to overestimate this function, for one might easily be

led to suppose that the dream is a kind of psychopomp which, because of its superior knowledge, infallibly guides life in the right direction. However much people underestimate the psychological significance of dreams, there is an equally great danger that anyone who is constantly preoccupied with dream-analysis will overestimate the significance of the unconscious for real life. But, judging from all previous experience, we do have a right to assume that the importance of the unconscious is about equal to that of consciousness. Undoubtedly there are conscious attitudes which are surpassed by the unconscious—attitudes so badly adapted to the individual as a whole that the unconscious attitude or constellation is a far better expression of his essential nature. But this is by no means always the case. Very often the dreams contribute only the merest fragments to the conscious attitude, because the latter is on the one hand sufficiently well adapted to reality and on the other satisfies fairly well the nature of the individual. A more or less exclusive regard for the dream standpoint without considering the conscious situation would be inappropriate in this case and would serve only to confuse and disrupt the conscious performance. Only if there is an obviously unsatisfactory and defective conscious attitude have we a right to allow the unconscious a higher value. The criteria necessary for such a judgment constitute, of course, a delicate problem. It goes without saying that the value of a conscious attitude can never be judged from an exclusively collective standpoint. For this a thorough investigation of the individuality in question is needed, and only from an accurate knowledge of the individual character can it be decided in what respect the conscious attitude is unsatisfactory. When I lay stress on knowledge of individual character I do not mean that the demands of the collective standpoint should be entirely neglected. As we know, the individual is not conditioned by himself alone but just as much by his collective relationships. When, therefore, the conscious attitude is more or less adequate, the meaning of the dream will be confined simply to its compensatory function. This is the general rule for the normal individual living under normal inner and outer conditions. For these reasons it seems to me that the compensation theory provides the right formula and fits the facts by giving dreams a compensatory function in the self-regulation of the psychic organism.

[495] But when the individual deviates from the norm in the sense that his conscious attitude is unadapted both objectively and subjectively, the—under normal conditions—merely compensatory function of the unconscious becomes a guiding, prospective function capable of leading the conscious attitude in a quite different direction which is much better than the previous one, as Maeder has successfully shown in the books I have mentioned. Into this category come dreams of the Nebuchadnezzar type. It is obvious that dreams of this sort are found chiefly in people who are not living on their true level. It is equally obvious that this lack of proportion is very frequent.

Hence we have frequent occasion to consider dreams from the standpoint of their prospective value.

[496] There is yet another side of dreams to be considered, and one that should certainly not be overlooked. There are many people whose conscious attitude is defective not as regards adaptation to environment but as regards expression of their own character. These are people whose conscious attitude and adaptive performance exceed their capacities as individuals; that is to say, they appear to be better and more valuable than they really are. Their outward success is naturally never paid for out of their individual resources alone, but very largely out of the dynamic reserves generated by collective suggestion. Such people climb above their natural level thanks to the influence of a collective ideal or the lure of some social advantage, or the support offered by society. They have not grown inwardly to the level of their outward eminence, for which reason the unconscious in all these cases has a *negatively compensating, or reductive*, function. It is clear that in these circumstances a reduction or devaluation is just as much a compensatory effort at self-regulation as in other cases, and also that this function may be eminently prospective (witness Nebuchadnezzar's dream). We like to associate "prospective" with the idea of construction, preparation, synthesis. But in order to understand these reductive dreams we must entirely divorce the term "prospective" from any such idea, for reductive dreams have an effect that is the very reverse of constructive, preparatory, or synthetic—it tends rather to disintegrate, to dissolve, to devalue, even to destroy and demolish. This is naturally not to say that the assimilation of a reductive content must have an altogether destructive effect on the individual as a whole; on the contrary, the effect is often very salutary, in so far as it affects merely his attitude and not the entire personality. But this secondary effect does not alter the essential character of such dreams, which bear a thoroughly reductive and retrospective stamp and for this reason cannot properly be called prospective. For purposes of exact qualification it would be better to call them reductive dreams and the corresponding function a reductive function of the unconscious although, at bottom, it is still the same compensatory function. We must accustom ourselves to the fact that the unconscious does not always present the same aspect any more than the conscious attitude does. It alters its appearance and its function just as much as the latter—which is another reason why it is so extremely difficult to form any concrete idea of the nature of the unconscious.

[497] Our knowledge of the reductive function of the unconscious we owe mainly to the researches of Freud. His dream-interpretation limits itself in essentials to the repressed personal background of the individual and its infantile-sexual aspects. Subsequent researches then established the bridge to the archaic elements, to the suprapersonal, historical, phylogenetic functional residues in the unconscious. Today

we can safely assert that the reductive function of dreams constellates material which consists in the main of repressed infantile-sexual wishes (Freud), infantile claims to power (Adler), and suprapersonal, archaic elements of thought, feeling, and instinct. The reproduction of such elements, with their thoroughly retrospective character, does more than anything else to undermine effectively a position that is too high, and to reduce the individual to his human nullity and to his dependence on physiological, historical, and phylogenetic conditions. Every appearance of false grandeur and importance melts away before the reductive imagery of the dream, which analyses his conscious attitude with pitiless criticism and brings up devastating material containing a complete inventory of all his most painful weaknesses. One is precluded at the outset from calling such a dream prospective, for everything in it, down to the last detail, is retrospective and can be traced back to a past which the dreamer imagined long since buried. This naturally does not prevent the dream-content from being compensatory to the conscious content and finally oriented, since the reductive tendency may sometimes be of the utmost importance for adaptation. Patients can often feel, quite spontaneously, how the dream-content is related to their conscious situation, and it is felt to be prospective, reductive, or compensatory in accordance with this sensed knowledge. Yet this is not always so, by a long way, and it must be emphasized that in general, particularly at the beginning of an analysis, the patient has an insuperable tendency to interpret the results of the analytical investigation of his material obstinately in terms of his pathogenic attitude.

[498] Such cases need the help of the analyst in order to interpret their dreams correctly. This makes it exceedingly important how the analyst judges the conscious psychology of his patient. For dream-analysis is not just the practical application of a method that can be learnt mechanically; it presupposes a familiarity with the whole analytical point of view, and this can only be acquired if the analyst has been analysed himself. The greatest mistake an analyst can make is to assume that his patient has a psychology similar to his own. This projection may hit the mark once, but mostly it remains a mere projection. Everything that is unconscious is projected, and for this reason the analyst should be conscious of at least the most important contents of his unconscious, lest unconscious projections cloud his judgment. Everyone who analyses the dreams of others should constantly bear in mind that there is no simple and generally known theory of psychic phenomena, neither with regard to their nature, nor to their causes, nor to their purpose. We therefore possess no general criterion of judgment. We know that there are all kinds of psychic phenomena, but we know nothing certain about their essential nature. We know only that, though the observation of the psyche from any one isolated standpoint can yield very valuable results, it can never produce a satisfactory theory from which one could make deductions. The sexual theory and the wish theory, like the power theory, are

valuable points of view without, however, doing anything like justice to the profundity and richness of the human psyche. Had we a theory that did, we could then content ourselves with learning a method mechanically. It would then be simply a matter of reading certain signs that stood for fixed contents, and for this it would only be necessary to learn a few semiotic rules by heart. Knowledge and correct assessment of the conscious situation would then be as superfluous as in the performance of a lumbar puncture. The overworked practitioner of our day has learnt to his sorrow that the psyche remains completely refractory to all methods that approach it from a single exclusive standpoint. At present the only thing we know about the contents of the unconscious, apart from the fact that they are subliminal, is that they stand in a compensatory relationship to consciousness and are therefore essentially relative. It is for this reason that knowledge of the conscious situation is necessary if we want to understand dreams.

[499] Reductive, prospective, or simply compensatory dreams do not exhaust the possibilities of interpretation. There is a type of dream which could be called simply a *reaction-dream*. One would be inclined to class in this category all those dreams which seem to be nothing more than the reproduction of an experience charged with affect, did not the analysis of such dreams disclose the deeper reason why these experiences are reproduced so faithfully. It turns out that these experiences also have a symbolical side which escaped the dreamer, and only because of this side is the experience reproduced in the dream. These dreams, however, do not belong to the reaction type, but only those in respect of which certain objective events have caused a trauma that is not merely psychic but at the same time a physical lesion of the nervous system. Such cases of severe shock were produced in abundance by the war, and here we may expect a large number of pure reaction-dreams in which the trauma is the determining factor.

[500] Although it is certainly very important for the over-all functioning of the psyche that the traumatic content gradually loses its autonomy by frequent repetition and in this way takes its place again in the psychic hierarchy, a dream of this kind, which is essentially only a reproduction of the trauma, can hardly be called compensatory. Apparently it brings back a split-off, autonomous part of the psyche, but it soon proves that conscious assimilation of the fragment reproduced by the dream does not by any means put an end to the disturbance which determined the dream. The dream calmly goes on “reproducing”: that is to say, the content of the trauma, now become autonomous, goes on working and will continue to do so until the traumatic stimulus has exhausted itself. Until that happens, conscious “realization” is useless.

[501] In practice it is not easy to decide whether a dream is essentially reactive or is merely reproducing a traumatic situation symbolically. But analysis can decide the

question, because in the latter case the reproduction of the traumatic scene ceases at once if the interpretation is correct, whereas reactive reproduction is left undisturbed by dream-analysis.

[502] We find similar reactive dreams in pathological physical conditions where, for instance, severe pain influences the course of the dream. But, in my view, it is only in exceptional cases that somatic stimuli are the determining factor. Usually they coalesce completely with the symbolical expression of the unconscious dream-content; in other words, they are used as a means of expression. Not infrequently the dreams show that there is a remarkable inner symbolical connection between an undoubted physical illness and a definite psychic problem, so that the physical disorder appears as a direct mimetic expression of the psychic situation. I mention this curious fact more for the sake of completeness than to lay any particular stress on this problematic phenomenon. It seems to me, however, that a definite connection does exist between physical and psychic disturbances and that its significance is generally underrated, though on the other hand it is boundlessly exaggerated owing to certain tendencies to regard physical disturbances merely as an expression of psychic disturbances, as is particularly the case with Christian Science. Dreams throw very interesting sidelights on the inter-functioning of body and psyche, which is why I raise this question here.

[503] Another dream-determinant that deserves mention is telepathy. The authenticity of this phenomenon can no longer be disputed today. It is, of course, very simple to deny its existence without examining the evidence, but that is an unscientific procedure which is unworthy of notice. I have found by experience that telepathy does in fact influence dreams, as has been asserted since ancient times. Certain people are particularly sensitive in this respect and often have telepathically influenced dreams. But in acknowledging the phenomenon of telepathy I am not giving unqualified assent to the popular theory of action at a distance. The phenomenon undoubtedly exists, but the theory of it does not seem to me so simple. In every case one must consider the possibilities of concordance of associations, of parallel psychic processes⁶ which have been shown to play a very great role especially in families, and which also manifest themselves in an identity or far-reaching similarity of attitude. Equally one must take into account the possibility of cryptomnesia, on which special emphasis has been laid by Flournoy.⁷ It sometimes causes the most astounding phenomena. Since any kind of subliminal material shows up in dreams, it is not at all surprising that cryptomnesia sometimes appears as a determining factor. I have had frequent occasion to analyse telepathic dreams, among them several whose telepathic significance was still unknown at the moment of analysis. The analysis yielded subjective material, like any other dream-analysis, in consequence of which the dream had a significance that bore on the situation of the

dreamer at the moment. It yielded nothing that could have shown that the dream was telepathic. So far I have found no dream in which the telepathic content lay beyond a doubt in the associative material brought up by analysis (i.e., in the latent dream-content). It invariably lay in the manifest dream-content.

[504] Usually in the literature of telepathic dreams only those are mentioned where a powerfully affective event is anticipated “telepathically” in space or time, that is to say when the human importance of the event, such as a death, would help to explain the premonition of it or its perception at a distance or at least make it more intelligible. The telepathic dreams I have observed were mostly of this type. A few of them, however, were distinguished by the remarkable fact that the manifest dream-content contained a telepathic statement about something completely unimportant, for instance the face of an unknown and quite commonplace individual, or a certain arrangement of furniture in indifferent surroundings, or the arrival of an unimportant letter, etc. Naturally when I say “unimportant” I mean only that neither by the usual questioning nor by analysis could I discover any content whose importance would have “justified” the telepathic phenomenon. In such cases one is inclined, more so than in those first mentioned, to think of “chance.” But it seems to me, unfortunately, that the hypothesis of chance is always an *asylum ignorantiae*. Certainly no one will deny that very strange chance events do occur, but the fact that one can count with some probability on their repetition excludes their chance nature. I would not, of course, assert that the law behind them is anything “supernatural,” but merely something which we cannot get at with our present knowledge. Thus even questionable telepathic contents possess a reality character that mocks all expectations of probability. Although I would not presume to a theoretical opinion on these matters, I nevertheless consider it right to recognize and emphasize their reality. This standpoint brings an enrichment to dream-analysis.⁸

[505] As against Freud’s view that the dream is essentially a wish-fulfilment, I hold with my friend and collaborator Alphonse Maeder that the dream is a *spontaneous self-portrayal, in symbolic form, of the actual situation in the unconscious*. Our view coincides at this point with the conclusions of Silberer.⁹ The agreement with Silberer is the more gratifying in that it came about as the result of mutually independent work.

[506] Now this view contradicts Freud’s formula only in so far as it declines to make a definite statement about the meaning of dreams. Our formula merely says that the dream is a symbolical representation of an unconscious content. It leaves the question open whether these contents are always wish-fulfilments. Further researches, expressly referred to by Maeder, have shown that the sexual language of dreams is not always to be interpreted in a concretistic way¹⁰—that it is, in fact, an archaic

language which naturally uses all the analogies readiest to hand without their necessarily coinciding with a real sexual content. It is therefore unjustifiable to take the sexual language of dreams literally under all circumstances, while other contents are explained as symbolical. But as soon as you take the sexual metaphors as symbols for something unknown, your conception of the nature of dreams at once deepens. Maeder has demonstrated this from a practical example given by Freud.¹¹ So long as the sexual language of dreams is understood concretistically, there can be only a direct, outward, and concrete solution, or else nothing is done at all—one resigns oneself opportunistically to one’s inveterate cowardice or laziness. There is no real conception of, and no attitude to, the problem. But that immediately becomes possible when the concretistic misconception is dropped, that is, when the patient stops taking the unconscious sexual language of the dream literally and interpreting the dream-figures as real persons.

[507] Just as we tend to assume that the world is as we see it, we naïvely suppose that people are as we imagine them to be. In this latter case, unfortunately, there is no scientific test that would prove the discrepancy between perception and reality. Although the possibility of gross deception is infinitely greater here than in our perception of the physical world, we still go on naïvely projecting our own psychology into our fellow human beings. In this way everyone creates for himself a series of more or less imaginary relationships based essentially on projection. Among neurotics there are even cases where fantasy projections provide the sole means of human relationship. A person whom I perceive mainly through my projections is an *imago* or, alternatively, a *carrier* of imagos or symbols. All the contents of our unconscious are constantly being projected into our surroundings, and it is only by recognizing certain properties of the objects as projections or imagos that we are able to distinguish them from the real properties of the objects. But if we are not aware that a property of the object is a projection, we cannot do anything else but be naïvely convinced that it really does belong to the object. All human relationships swarm with these projections; anyone who cannot see this in his personal life need only have his attention drawn to the psychology of the press in wartime. *Cum grano salis*, we always see our own unavowed mistakes in our opponent. Excellent examples of this are to be found in all personal quarrels. Unless we are possessed of an unusual degree of self-awareness we shall never see through our projections but must always succumb to them, because the mind in its natural state presupposes the existence of such projections. It is the natural and given thing for unconscious contents to be projected. In a comparatively primitive person this creates that characteristic relationship to the object which Lévy-Bruhl has fittingly called “mystic identity” or “participation mystique.”¹² Thus every normal person of our time, who is not reflective beyond the average, is bound to his environment by a whole system of

projections. So long as all goes well, he is totally unaware of the compulsive, i.e., “magical” or “mystical,” character of these relationships. But if a paranoid disturbance sets in, then these unconscious relationships turn into so many compulsive ties, decked out, as a rule, with the same unconscious material that formed the content of these projections during the normal state. So long as the libido can use these projections as agreeable and convenient bridges to the world, they will alleviate life in a positive way. But as soon as the libido wants to strike out on another path, and for this purpose begins running back along the previous bridges of projection, they will work as the greatest hindrances it is possible to imagine, for they effectively prevent any real detachment from the former object. We then witness the characteristic phenomenon of a person trying to devalue the former object as much as possible in order to detach his libido from it. But as the previous identity is due to the projection of subjective contents, complete and final detachment can only take place when the imago that mirrored itself in the object is restored, together with its meaning, to the subject. This restoration is achieved through conscious recognition of the projected content, that is, by acknowledging the “symbolic value” of the object.

[508] The frequency of such projections is as certain as the fact that they are never seen through. That being so, it is hardly surprising that the naïve person takes it as self-evident from the start that when he dreams of Mr. X this dream-image is identical with the real Mr. X. It is an assumption that is entirely in accord with his ordinary, uncritical conscious attitude, which makes no distinction between the object as such and the idea one has of it. But there is no denying that, looked at critically, the dream-image has only an outward and very limited connection with the object. In reality it is a complex of psychic factors that *has fashioned itself*—albeit under the influence of certain external stimuli—and therefore consists mainly of subjective factors that are peculiar to the subject and often have very little to do with the real object. We understand another person in the same way as we understand, or seek to understand, ourselves. What we do not understand in ourselves we do not understand in the other person either. So there is plenty to ensure that his image will be for the most part subjective. As we know, even an intimate friendship is no guarantee of objective knowledge.

[509] Now if one begins, as the Freudian school does, by taking the manifest content of the dream as “unreal” or “symbolical,” and explains that though the dream speaks of a church-spire it really means a phallus, then it is only a step to saying that the dream often speaks of sexuality but does not always mean it, and equally, that the dream often speaks of the father but really means the dreamer himself. Our imagos are constituents of our minds, and if our dreams reproduce certain ideas these ideas are primarily *our* ideas, in the structure of which our whole being is interwoven. They are subjective factors, grouping themselves as they do in the dream, and expressing

this or that meaning, not for extraneous reasons but from the most intimate promptings of our psyche. The whole dream-work is essentially subjective, and a dream is a theatre in which the dreamer is himself the scene, the player, the prompter, the producer, the author, the public, and the critic. This simple truth forms the basis for a conception of the dream's meaning which I have called *interpretation on the subjective level*. Such an interpretation, as the term implies, conceives all the figures in the dream as personified features of the dreamer's own personality.¹³

[510] This view has aroused a considerable amount of resistance. One line of argument appeals to the naive assumption we have just mentioned, concerning Mr. X. Another argument is based on the question of principle: which is the more important, the "objective level" or the "subjective level"? I can really think of no valid objection to the theoretical probability of a subjective level. But the second problem is considerably more difficult. For just as the image of an object is composed subjectively on the one side, it is conditioned objectively on the other side. When I reproduce it in myself, I am producing something that is determined as much subjectively as objectively. In order to decide which side predominates in any given case, it must first be shown whether the image is reproduced for its subjective or for its objective significance. If, therefore, I dream of a person with whom I am connected by a vital interest, the interpretation on the objective level will certainly be nearer to the truth than the other. But if I dream of a person who is not important to me in reality, then interpretation on the subjective level will be nearer the truth. It is, however, possible—and this happens very frequently in practice—that the dreamer will at once associate this unimportant person with someone with whom he is connected by a strong emotion or affect. Formerly one would have said: the unimportant figure has been thrust forward in the dream intentionally, in order to cover up the painfulness of the other figure. In that case I would follow the path of nature and say: in the dream that highly emotional reminiscence has obviously been replaced by the unimportant figure of Mr. X, hence interpretation on the subjective level would be nearer the truth. To be sure, the substitution achieved by the dream amounts to a repression of the painful reminiscence. But if this reminiscence can be thrust aside so easily it cannot be all that important. The substitution shows that this personal affect allows itself to be depersonalized. I can therefore rise above it and shall not get myself back into the personal, emotional situation again by devaluing the depersonalization achieved by the dream as a mere "repression." I think I am acting more correctly if I regard the replacement of the painful figure by an unimportant one as a depersonalization of the previously personal affect. In this way the affect, or the corresponding sum of libido, has become impersonal, freed from its personal attachment to the object, and I can now shift the previous real conflict on to the subjective plane and try to understand to what extent it is an exclusively

subjective conflict. I would like, for clarity's sake, to illustrate this by a short example:

[511] I once had a personal conflict with a Mr. A, in the course of which I gradually came to the conclusion that the fault was more on his side than on mine. About this time I had the following dream: *I consulted a lawyer on a certain matter, and to my boundless astonishment he demanded a fee of no less than five thousand francs for the consultation—which I strenuously resisted.*

[512] The lawyer was an unimportant reminiscence from my student days. But the student period was important because at that time I got into many arguments and disputes. With a surge of affect, I associated the brusque manner of the lawyer with the personality of Mr. A and also with the continuing conflict. I could now proceed on the objective level and say: Mr. A is hiding behind the lawyer, therefore Mr. A is asking too much of me. He is in the wrong. Shortly before this dream a poor student approached me for a loan of five thousand francs. Thus (by association) Mr. A is a poor student, in need of help and incompetent, because he is at the beginning of his studies. Such a person has no right to make any demands or have any opinions. That, then, would be the wish-fulfilment: my opponent would be gently devalued and pushed aside, and my peace of mind would be preserved. But in reality I woke up at this point with the liveliest affect, furious with the lawyer for his presumption. So I was not in the least calmed by the “wish-fulfilment.”

[513] Sure enough, behind the lawyer is the unpleasant affair with Mr. A. But it is significant that the dream should dig up that unimportant jurist from my student days. I associate “lawyer” with lawsuit, being in the right, self-righteousness, and hence with that memory from my student days when, right or wrong, I often defended my thesis tenaciously, obstinately, self-righteously, in order at least to win for myself the appearance of superiority by fighting for it. All this, so I feel, has played its part in the dispute with Mr. A. Then I know that he is really myself, that part of me which is unadapted to the present and demands too much, just as I used to do—in other words, squeezes too much libido out of me. I know then that the dispute with Mr. A. cannot die because the self-righteous disputant in me would still like to see it brought to a “rightful” conclusion.

[514] This interpretation led to what seemed to me a meaningful result, whereas interpretation on the objective level was unproductive, since I am not in the least interested in proving that dreams are wish-fulfilments. If a dream shows me what sort of mistake I am making, it gives me an opportunity to correct my attitude, which is always an advantage. Naturally such a result can only be achieved through interpretation on the subjective level.

[515] Enlightening as interpretation on the subjective level may be in such a case, it may be entirely worthless when a vitally important relationship is the content and cause of the conflict. Here the dream-figure must be related to the real object. The criterion can always be discovered from the conscious material, except in cases where the transference enters into the problem. The transference can easily cause falsifications of judgment, so that the analyst may sometimes appear as the absolutely indispensable *deus ex machina* or as an equally indispensable prop for reality. So far as the patient is concerned he actually is so. It must be left to the analyst to decide how far he himself is the patient's real problem. As soon as the objective level of interpretation starts getting monotonous and unproductive, it is time to regard the figure of the analyst as a symbol for projected contents that belong to the patient. If the analyst does not do that, he has only two alternatives: either he can devalue, and consequently destroy, the transference by reducing it to infantile wishes, or he can accept its reality and sacrifice himself for the patient, sometimes in the teeth of the latter's unconscious resistance. This is to the advantage of neither party, and the analyst invariably comes off worst. But if it is possible to shift the figure of the analyst on to the subjective level, all the projected contents can be restored to the patient with their original value. An example of the withdrawal of projections can be found in my *Two Essays on Analytical Psychology*.¹⁴

[516] It is clear to me that anyone who is not a practising analyst himself will see no particular point in discussing the relative merits of the "subjective level" and the "objective level." But the more deeply we penetrate into the problem of dreams, the more the technical aspects of practical treatment have to be taken into account. In this regard necessity is indeed the mother of invention, for the analyst must constantly strive to develop his techniques in such a way that they can be of help even in the most difficult cases. We owe it to the difficulties presented by the daily treatment of the sick that we were driven to formulate views which shake the foundations of our everyday beliefs. Although it is a truism to say that an imago is subjective, this statement nevertheless has a somewhat philosophical ring that sounds unpleasant to certain ears. Why this should be so is immediately apparent from what was said above, that the naïve mind at once identifies the imago with the object. Anything that disturbs this assumption has an irritating effect on this class of people. The idea of a subjective level is equally repugnant to them because it disturbs the naïve assumption that conscious contents are identical with objects. As events in wartime¹⁵ have clearly shown, our mentality is distinguished by the shameless naïveté with which we judge our enemy, and in the judgment we pronounce upon him we unwittingly reveal our own defects: we simply accuse our enemy of our own unadmitted faults. We see everything in the other, we criticize and condemn the other, we even want to improve and educate the other. There is no need for me to adduce case material to prove this

proposition; the most convincing proof can be found in every newspaper. But it is quite obvious that what happens on a large scale can also happen on a small scale in the individual. Our mentality is still so primitive that only certain functions and areas have outgrown the primary mystic identity with the object. Primitive man has a minimum of self-awareness combined with a maximum of attachment to the object; hence the object can exercise a direct magical compulsion upon him. All primitive magic and religion are based on these magical attachments, which simply consist in the projection of unconscious contents into the object. Self-awareness gradually developed out of this initial state of identity and went hand in hand with the differentiation of subject and object. This differentiation was followed by the realization that certain qualities which, formerly, were naïvely attributed to the object are in reality subjective contents. Although the men of antiquity no longer believed that they were red cockatoos or brothers to the crocodile, they were still enveloped in magical fantasies. In this respect, it was not until the Age of Enlightenment that any essential advance was made. But as everyone knows, our self-awareness is still a long way behind our actual knowledge. When we allow ourselves to be irritated out of our wits by something, let us not assume that the cause of our irritation lies simply and solely outside us, in the irritating thing or person. In that way we endow them with the power to put us into the state of irritation, and possibly even one of insomnia or indigestion. We then turn round and unhesitatingly condemn the object of offence, while all the time we are raging against an unconscious part of ourselves which is projected into the exasperating object.

[517] Such projections are legion. Some of them are favourable, serving as bridges for easing off the libido, some of them are unfavourable, but in practice these are never regarded as obstacles because the unfavourable projections usually settle outside our circle of intimate relationships. To this the neurotic is an exception: consciously or unconsciously, he has such an intensive relationship to his immediate surroundings that he cannot prevent even the unfavourable projections from flowing into the objects closest to him and arousing conflicts. He is therefore compelled—if he wants to be cured—to gain insight into his primitive projections to a far higher degree than the normal person does. It is true that the normal person makes the same projections, but they are better distributed: for the favourable ones the object is close at hand, for the unfavourable ones it is at a distance. It is the same for the primitive: anything strange is hostile and evil. This line of division serves a purpose, which is why the normal person feels under no obligation to make these projections conscious, although they are dangerously illusory. War psychology has made this abundantly clear: everything my country does is good, everything the others do is bad. The centre of all iniquity is invariably found to lie a few miles behind the enemy lines. Because the individual has this same primitive psychology, every attempt to bring

these age-old projections to consciousness is felt as irritating. Naturally one would like to have better relations with one's fellows, but only on the condition that *they* live up to *our* expectations—in other words, that they become willing carriers of our projections. Yet if we make ourselves conscious of these projections, it may easily act as an impediment to our relations with others, for there is then no bridge of illusion across which love and hate can stream off so relievingly, and no way of disposing so simply and satisfactorily of all those alleged virtues that are intended to edify and improve others. In consequence of this obstruction there is a damming up of libido, as a result of which the negative projections become increasingly conscious. The individual is then faced with the task of putting down to his own account all the iniquity, devilry, etc. which he has blandly attributed to others and about which he has been indignant all his life. The irritating thing about this procedure is the conviction, on the one hand, that if everybody acted in this way life would be so much more endurable, and a violent resistance, on the other hand, against applying this principle seriously to oneself. If everybody else did it, how much better the world would be; but to do it oneself—how intolerable!

[518] The neurotic is *forced* by his neurosis to take this step, but the normal person is not. Instead, he acts out his psychic disturbances socially and politically, in the form of mass psychoses like wars and revolutions. The real existence of an enemy upon whom one can foist off everything evil is an enormous relief to one's conscience. You can then at least say, without hesitation, who the devil is; you are quite certain that the cause of your misfortune is outside, and not in your own attitude. Once you have accepted the somewhat disagreeable consequences of interpretation on the subjective level, however, the misgiving forces itself on you that it is surely impossible that *all* the bad qualities which irritate you in others should belong to you. By that token the great moralist, the fanatical educationist and world-improver, would be the worst of all. Much could be said about the close proximity of good and evil, and even more about the direct relations between pairs of opposites, but that would lead us too far from our theme.

[519] The interpretation on the subjective level should not, of course, be carried to extremes. It is simply a question of a rather more critical examination of what is pertinent and what is not. Something that strikes me about the object may very well be a real property of that object. But the more subjective and emotional this impression is, the more likely it is that the property will be a projection. Yet here we must make a not unimportant distinction: between the quality actually present in the object, without which a projection could not take place, and the value, significance, or energy of this quality. It is not impossible for a quality to be projected upon the object of which the object shows barely any trace in reality (for instance, the primitive projection of magical qualities into inanimate objects). But it is different

with the ordinary projection of traits of character or momentary attitudes. Here it frequently happens that the object offers a hook to the projection, and even lures it out. This is generally the case when the object himself (or herself) is not conscious of the quality in question: in that way it works directly upon the unconscious of the projector. *For all projections provoke counter-projections* when the object is unconscious of the quality projected upon it by the subject, in the same way that a transference is answered by a counter-transference from the analyst when it projects a content of which he is unconscious but which nevertheless exists in him.¹⁶ The counter-transference is then just as useful and meaningful, or as much of a hindrance, as the transference of the patient, according to whether or not it seeks to establish that better rapport which is essential for the realization of certain unconscious contents. Like the transference, the counter-transference is compulsive, a forcible tie, because it creates a “mystical” or unconscious identity with the object. Against these unconscious ties there are always resistances—conscious resistances if the subject’s attitude allows him to give his libido only voluntarily, but not to have it coaxed or forced out of him; unconscious resistances if he likes nothing better than having his libido taken away from him. Thus transference and counter-transference, if their contents remain unconscious, create abnormal and untenable relationships which aim at their own destruction.

[520] But even supposing some trace of the projected quality can be found in the object, the projection still has a purely subjective significance in practice and recoils upon the subject, because it gives an exaggerated value to whatever trace of that quality was present in the object.

[521] When the projection corresponds to a quality actually present in the object, the projected content is nevertheless present in the subject too, where it forms a part of the object-*imago*. The object-*imago* itself is a psychological entity that is distinct from the actual perception of the object; it is an image existing independently of, and yet based on, all perception,¹⁷ and the relative autonomy of this image remains unconscious so long as it coincides with the actual behaviour of the object. The autonomy of the *imago* is therefore not recognized by the conscious mind and is unconsciously projected on the object—in other words, it is contaminated with the autonomy of the object. This naturally endows the object with a compelling reality in relation to the subject and gives it an exaggerated value. This value springs from the projection of the *imago* on the object, from its *a priori* identity with it, with the result that the outer object becomes at the same time an inner one. In this way the outer object can exert, via the unconscious, a direct psychic influence on the subject, since, by virtue of its identity with the *imago*, it has so to speak a direct hand in the psychic mechanism of the subject. Consequently the object can gain “magical” power over the subject. Excellent examples of this can be found among primitives, who treat

their children or any other objects with “souls” exactly as they treat their own psyches. They dare not do anything to them for fear of offending the soul of the child or object. That is why the children are given as little education as possible until the age of puberty, when suddenly a belated education is thrust upon them, often a rather gruesome one (initiation).

[522] I have just said that the autonomy of the imago remains unconscious because it is identified with that of the object. The death of the object would, accordingly, be bound to produce remarkable psychological effects, since the object does not disappear completely but goes on existing in intangible form. This is indeed the case. The unconscious imago, which no longer has an object to correspond to it, becomes a ghost and now exerts influences on the subject which cannot be distinguished in principle from psychic phenomena. The subject’s unconscious projections, which canalized unconscious contents into the imago and identified it with the object, outlive the actual loss of the object and play an important part in the life of primitives as well as of all civilized peoples past and present. These phenomena offer striking proof of the autonomous existence of the object-imagos in the unconscious. They are evidently in the unconscious because they have never been consciously differentiated from the object.

[523] Every advance, every conceptual achievement of mankind, has been connected with an advance in self-awareness: man differentiated himself from the object and faced Nature as something distinct from her. Any reorientation of psychological attitude will have to follow the same road: it is evident that the identity of the object with the subjective imago gives it a significance which does not properly belong to it but which it has possessed from time immemorial. This identity is the original state of things. For the subject, however, it is a primitive condition, which can last only so long as it does not lead to serious inconvenience. Overvaluation of the object is one of the things most liable to prejudice the development of the subject. An over-accentuated, “magical” object orients the subject’s consciousness in the direction of the object and thwarts any attempt at individual differentiation, which would obviously have to set in with the detachment of the imago from the object. The direction of his individual differentiation cannot possibly be maintained if external factors “magically” interfere with the psychic mechanism. The detachment of the imagos that give the objects their exaggerated significance restores to the subject that split-off energy which he urgently needs for his own development.

[524] To interpret the dream-imagos on the subjective level has therefore the same meaning for modern man as taking away his ancestral figures and fetishes would have for primitive man, and trying to convince him that his “medicine” is a spiritual force which dwells not in the object but in the human psyche. The primitive feels a

legitimate resistance against this heretical assumption, and in the same way modern man feels that it is disagreeable, perhaps even somehow dangerous, to dissolve the time-honoured and sacrosanct identity between imago and object. The consequences for our psychology, too, can scarcely be imagined: we would no longer have anybody to rail against, nobody whom we could make responsible, nobody to instruct, improve, and punish! On the contrary we would have to begin, in all things, with ourselves; we would have to demand of ourselves, and of no one else, all the things which we habitually demand of others. That being so, it is understandable why the interpretation of dream-imagos on the subjective level is no light step, particularly as it leads to one-sidednesses and exaggerations in one direction or the other.

[525] Apart from this purely moral difficulty there are a number of intellectual obstacles as well. It has often been objected that interpretation on the subjective level is a philosophical problem and that the application of this principle verges on a *Weltanschauung* and therefore ceases to be scientific. It does not surprise me that psychology debouches into philosophy, for the thinking that underlies philosophy is after all a psychic activity which, as such, is the proper study of psychology. I always think of psychology as encompassing the whole of the psyche, and that includes philosophy and theology and many other things besides. For underlying all philosophies and all religions are the facts of the human soul, which may ultimately be the arbiters of truth and error.

[526] It does not matter greatly to our psychology whether our problems touch on the one sphere or on the other. We have to do first and foremost with practical necessities. If the patient's view of the world becomes a psychological problem, we have to treat it regardless of whether philosophy pertains to psychology or not. Similarly, religious questions are primarily psychological questions so far as we are concerned. It is a regrettable defect that present-day medical psychology should, in general, hold aloof from these problems, and nowhere is this more apparent than in the treatment of the psychogenic neuroses, which often have a better chance of cure anywhere rather than in academic medicine. Although I am a doctor myself, and, on the principle that dog does not eat dog, would have every reason not to criticize the medical profession, I must nevertheless confess that doctors are not always the best guardians of the psychiatric art. I have often found that the medical psychologists try to practise their art in the routine manner inculcated into them by the peculiar nature of their studies. The study of medicine consists on the one hand in storing up in the mind an enormous number of facts, which are simply memorized without any real knowledge of their foundations, and on the other hand in learning practical skills, which have to be acquired on the principle "Don't think, act!" Thus it is that, of all the professionals, the medical man has the least opportunity of developing the function of *thinking*. So it is no wonder that even psychologically trained doctors

have the greatest difficulty in following my reflections, if they follow them at all. They have habituated themselves to handing out prescriptions and mechanically applying methods which they have not thought out themselves. This tendency is the most unsuitable that can be imagined for the practice of medical psychology, for it clings to the skirts of authoritarian theories and techniques and hinders the development of independent thought. I have found that even elementary distinctions, such as those between subjective level and objective level, ego and self, sign and symbol, causality and finality, etc., which are of the utmost importance in practical treatment, overtax their thinking capacities. This may explain their obstinate adherence to views that are out of date and have long been in need of revision. That this is not merely my own subjective opinion is evident from the fanatical one-sidedness and sectarian exclusiveness of certain psychoanalytical groups. Everyone knows that this attitude is a symptom of over-compensated doubt. But then, who applies psychological criteria to himself?

[527] The interpretation of dreams as infantile wish-fulfillments or as finalistic “arrangements” subserving an infantile striving for power is much too narrow and fails to do justice to the essential nature of dreams. A dream, like every element in the psychic structure, is a product of the total psyche. Hence we may expect to find in dreams everything that has ever been of significance in the life of humanity. Just as human life is not limited to this or that fundamental instinct, but builds itself up from a multiplicity of instincts, needs, desires, and physical and psychic conditions, etc., so the dream cannot be explained by this or that element in it, however beguilingly simple such an explanation may appear to be. We can be certain that it is incorrect, because no simple theory of instinct will ever be capable of grasping the human psyche, that mighty and mysterious thing, nor, consequently, its exponent, the dream. In order to do anything like justice to dreams, we need an interpretive equipment that must be laboriously fitted together from all branches of the humane sciences.

[528] Critics have sometimes accused me outright of “philosophical” or even “theological” tendencies, in the belief that I want to explain everything “philosophically” and that my psychological views are “metaphysical.”¹⁸ But I use certain philosophical, religious, and historical material for the exclusive purpose of *illustrating* the psychological facts. If, for instance, I make use of a God-concept or an equally metaphysical concept of energy, I do so because they are images which have been found in the human psyche from the beginning. I find I must emphasize over and over again that neither the moral order, nor the idea of God, nor any religion has dropped into man’s lap from outside, straight down from heaven, as it were, but that he contains all this *in nuce* within himself, and for this reason can produce it all out of himself. It is therefore idle to think that nothing but enlightenment is needed to dispel these phantoms. The ideas of the moral order and of God belong to the

ineradicable substrate of the human soul. That is why any honest psychology, which is not blinded by the garish conceits of enlightenment, must come to terms with these facts. They cannot be explained away and killed with irony. In physics we can do without a God-image, but in psychology it is a definite fact that has got to be reckoned with, just as we have to reckon with “affect,” “instinct,” “mother,” etc. It is the fault of the everlasting contamination of object and imago that people can make no conceptual distinction between “God” and “God-image,” and therefore think that when one speaks of the “God-image” one is speaking of God and offering “theological” explanations. It is not for psychology, as a science, to demand a hypostatization of the God-image. But, the facts being what they are, it does have to reckon with the existence of a God-image. In the same way it reckons with instinct but does not deem itself competent to say what “instinct” really is. The psychological factor thereby denoted is clear to everyone, just as it is far from clear what that factor is in itself. It is equally clear that the God-image corresponds to a definite complex of psychological facts, and is thus a quantity which we can operate with; but what God is in himself remains a question outside the competence of all psychology. I regret having to repeat such elementary truths.

[529] Herewith I have said pretty well all I have to say about the general aspects of dream psychology.¹⁹ I have purposely refrained from going into details; this must be reserved for studies of case material. Our discussion of the general aspects has led us to wider problems which are unavoidable in speaking of dreams. Naturally very much more could be said about the aims of dream-analysis, but since dream-analysis is instrumental to analytical treatment in general, this could only be done if I were to embark on the whole question of therapy. But a thorough-going description of the therapy would require a number of preliminary studies that tackled the problem from different sides. This question is an exceedingly complex one, despite the fact that certain authors outdo one another in simplifications and try to make us believe that the known “roots” of the illness can be extracted with the utmost simplicity. I must warn against all such frivolous undertakings. I would rather see serious minds settling down to discuss, thoroughly and conscientiously, the great problems which analysis has brought in its train. It is really high time academic psychologists came down to earth and wanted to hear about the human psyche as it really is and not merely about laboratory experiments. It is insufferable that professors should forbid their students to have anything to do with analytical psychology, that they should prohibit the use of analytical concepts and accuse our psychology of taking account, in an unscientific manner, of “everyday experiences.” I know that psychology in general could derive the greatest benefit from a serious study of the dream problem once it could rid itself of the unjustified lay prejudice that dreams are caused solely by somatic stimuli. This overrating of the somatic factor in psychiatry is one of the

basic reasons why psychopathology has made no advances unless directly fertilized by analytical procedures. The dogma that “mental diseases are diseases of the brain” is a hangover from the materialism of the 1870’s. It has become a prejudice which hinders all progress, with nothing to justify it. Even if it were true that all mental diseases are diseases of the brain, that would still be no reason for not investigating the psychic side of the disease. But the prejudice is used to discredit at the outset all attempts in this direction and to strike them dead. Yet the proof that all mental diseases are diseases of the brain has never been furnished and never can be furnished, any more than it can be proved that man thinks or acts as he does because this or that protein has broken down or formed itself in this or that cell. Such a view leads straight to the materialistic gospel; “Man is what he eats.” Those who think in this way conceive our mental life as anabolic and catabolic processes in the brain-cells. These processes are necessarily thought of merely as laboratory processes of synthesis and disintegration—for to think of them as living processes is totally impossible so long as we cannot think in terms of the life-process itself. But that is how we would have to think of the cell-processes if validity were to be claimed for the materialistic view. In that case we would already have passed beyond materialism, for life can never be thought of as a function of matter, but only as a process existing in and for itself, to which energy and matter are subordinate. Life as a function of matter postulates spontaneous generation, and for proof of that we shall have a very long time to wait. We have no more justification for understanding the psyche as a brain-process than we have for understanding life in general from a one-sided, arbitrarily materialistic point of view that can never be proved, quite apart from the fact that the very attempt to imagine such a thing is crazy in itself and has always engendered craziness whenever it was taken seriously. We have, on the contrary, to consider the psychic process as psychic and not as an organic cell-process. However indignant people may get about “metaphysical phantoms” when cell-processes are explained vitalistically, they nevertheless continue to regard the physical hypothesis as “scientific,” although it is no less fantastic. But it fits in with the materialistic prejudice, and therefore every bit of nonsense, provided only that it turns the psychic into the physical, becomes scientifically sacrosanct. Let us hope that the time is not far off when this antiquated relic of ingrained and thoughtless materialism will be eradicated from the minds of our scientists.

ON THE NATURE OF DREAMS¹

[530] Medical psychology differs from all other scientific disciplines in that it has to deal with the most complex problems without being able to rely on tested rules of procedure, on a series of verifiable experiments and logically explicable facts. On the contrary, it is confronted with a mass of shifting irrational happenings, for the psyche is perhaps the most baffling and unapproachable phenomenon with which the scientific mind has ever had to deal. Although we must assume that all psychic phenomena are somehow, in the broadest sense, causally dependent, it is advisable to remember at this point that causality is in the last analysis no more than a statistical truth. Therefore we should perhaps do well in certain cases to make allowance for absolute irrationality even if, on heuristic grounds, we approach each particular case by inquiring into its causality. Even then, it is advisable to bear in mind at least one of the classical distinctions, namely that between *causa efficiens* and *causa finalis*. In psychological matters, the question “Why does it happen?” is not necessarily more productive of results than the other question “To what purpose does it happen?”

[531] Among the many puzzles of medical psychology there is one problem-child, the dream. It would be an interesting, as well as difficult, task to examine the dream exclusively in its medical aspects, that is, with regard to the diagnosis and prognosis of pathological conditions. The dream does in fact concern itself with both health and sickness, and since, by virtue of its source in the unconscious, it draws upon a wealth of subliminal perceptions, it can sometimes produce things that are very well worth knowing. This has often proved helpful to me in cases where the differential diagnosis between organic and psychogenic symptoms presented difficulties. For prognosis, too, certain dreams are important.² In this field, however, the necessary preliminary studies, such as careful records of case histories and the like, are still lacking. Doctors with psychological training do not as yet make a practice of recording dreams systematically, so as to preserve material which would have a bearing on a subsequent outbreak of severe illness or a lethal issue—in other words, on events which could not be foreseen at the beginning of the record. The investigation of dreams in general is a life-work in itself, and their detailed study requires the co-operation of many workers. I have therefore preferred, in this short review, to deal with the fundamental aspects of dream psychology and interpretation in such a way that those who have no experience in this field can at least get some idea of the problem and the method of inquiry. Anyone who is familiar with the material will probably agree with me that a knowledge of fundamentals is more

important than an accumulation of case histories, which still cannot make up for lack of experience.

[532] The dream is a fragment of involuntary psychic activity, just conscious enough to be reproducible in the waking state. Of all psychic phenomena the dream presents perhaps the largest number of “irrational” factors. It seems to possess a minimum of that logical coherence and that hierarchy of values shown by the other contents of consciousness, and is therefore less transparent and understandable. Dreams that form logically, morally, or aesthetically satisfying wholes are exceptional. Usually a dream is a strange and disconcerting product distinguished by many “bad qualities,” such as lack of logic, questionable morality, uncouth form, and apparent absurdity or nonsense. People are therefore only too glad to dismiss it as stupid, meaningless, and worthless.

[533] Every interpretation of a dream is a psychological statement about certain of its contents. This is not without danger, as the dreamer, like most people, usually displays an astonishing sensitiveness to critical remarks, not only if they are wrong, but even more if they are right. Since it is not possible, except under very special conditions, to work out the meaning of a dream without the collaboration of the dreamer, an extraordinary amount of tact is required not to violate his self-respect unnecessarily. For instance, what is one to say when a patient tells a number of indecent dreams and then asks: “Why should *I* have such disgusting dreams?” To this sort of question it is better to give no answer, since an answer is difficult for several reasons, especially for the beginner, and one is very apt under such circumstances to say something clumsy, above all when one thinks one knows what the answer is. So difficult is it to understand a dream that for a long time I have made it a rule, when someone tells me a dream and asks for my opinion, to say first of all to myself: “I have no idea what this dream means.” After that I can begin to examine the dream.

[534] Here the reader will certainly ask: “Is it worth while in any individual case to look for the meaning of a dream—supposing that dreams have any meaning at all and that this meaning can be proved?”

[535] It is easy to prove that an animal is a vertebrate by laying bare the spine. But how does one proceed to lay bare the inner, meaningful structure of a dream? Apparently the dream follows no clearly determined laws or regular modes of behaviour, apart from the well-known “typical” dreams, such as nightmares. Anxiety dreams are not unusual but they are by no means the rule. Also, there are typical dream-motifs known to the layman, such as of flying, climbing stairs or mountains, going about with insufficient clothing, losing your teeth, crowds of people, hotels, railway stations, trains, aeroplanes, automobiles, frightening animals (snakes), etc. These

motifs are very common but by no means sufficient to confirm the existence of any system in the organization of a dream.

[536] Some people have recurrent dreams. This happens particularly in youth, but the recurrence may continue over several decades. These are often very impressive dreams which convince one that they “must surely have a meaning.” This feeling is justified in so far as one cannot, even taking the most cautious view, avoid the assumption that a definite psychic situation does arise from time to time which causes the dream. But a “psychic situation” is something that, if it can be formulated, is identical with a definite *meaning*—provided, of course, that one does not stubbornly hold to the hypothesis (certainly not proven) that all dreams can be traced back to stomach trouble or sleeping on one’s back or the like. Such dreams do indeed tempt one to conjecture some kind of cause. The same is true of so-called typical motifs which repeat themselves frequently in longer series of dreams. Here again it is hard to escape the impression that they mean something.

[537] But how do we arrive at a plausible meaning and how can we confirm the rightness of the interpretation? One method—which, however, is not scientific—would be to predict future happenings from the dreams by means of a dream-book and to verify the interpretation by subsequent events, assuming of course that the meaning of dreams lies in their anticipation of the future.

[538] Another way to get at the meaning of the dream directly might be to turn to the past and reconstruct former experiences from the occurrence of certain motifs in the dreams. While this is possible to a limited extent, it would have a decisive value only if we could discover in this way something which, though it had actually taken place, had remained unconscious to the dreamer, or at any rate something he would not like to divulge under any circumstances. If neither is the case, then we are dealing simply with memory-images whose appearance in the dream is (a) not denied by anyone, and (b) completely irrelevant so far as a meaningful dream function is concerned, since the dreamer could just as well have supplied the information consciously. This unfortunately exhausts the possible ways of proving the meaning of a dream directly.

[539] It is Freud’s great achievement to have put dream-interpretation on the right track. Above all, he recognized that no interpretation can be undertaken without the dreamer. The words composing a dream-narrative have not just *one* meaning, but many meanings. If, for instance, someone dreams of a table, we are still far from knowing what the “table” of the dreamer signifies, although the word “table” sounds unambiguous enough. For the thing we do not know is that this “table” is the very one at which his father sat when he refused the dreamer all further financial help and threw him out of the house as a good-for-nothing. The polished surface of this table stares at him as a symbol of his lamentable worthlessness in his daytime

consciousness as well as in his dreams at night. This is what our dreamer understands by “table.” Therefore we need the dreamer’s help in order to limit the multiple meanings of words to those that are essential and convincing. That the “table” stands as a mortifying landmark in the dreamer’s life may be doubted by anyone who was not present. But the dreamer does not doubt it, nor do I. Clearly, dream-interpretation is in the first place an experience which has immediate validity for only two persons.

[540] If, therefore, we establish that the “table” in the dream means just that fatal table, with all that this implies, then, although we have not explained the dream, we have at least interpreted one important motif of it; that is, we have recognized the subjective context in which the word “table” is embedded.

[541] We arrived at this conclusion by a methodical questioning of the dreamer’s own associations. The further procedures to which Freud subjects the dream-contents I have had to reject, for they are too much influenced by the preconceived opinion that dreams are the fulfilment of “repressed wishes.” Although there are such dreams, this is far from proving that all dreams are wish-fulfillments, any more than are the thoughts of our conscious psychic life. There is no ground for the assumption that the unconscious processes underlying the dream are more limited and one-sided, in form and content, than conscious processes. One would rather expect that the latter could be limited to known categories, since they usually reflect the regularity or even monotony of the conscious way of life.

[542] On the basis of these conclusions and for the purpose of ascertaining the meaning of the dream, I have developed a procedure which I call “taking up the context.” This consists in making sure that every shade of meaning which each salient feature of the dream has for the dreamer is determined by the associations of the dreamer himself. I therefore proceed in the same way as I would in deciphering a difficult text. This method does not always produce an immediately understandable result; often the only thing that emerges, at first, is a hint that looks significant. To give an example: I was working once with a young man who mentioned in his anamnesis that he was happily engaged, and to a girl of “good” family. In his dreams she frequently appeared in very unflattering guise. The context showed that the dreamer’s unconscious connected the figure of his bride with all kinds of scandalous stories from quite another source—which was incomprehensible to him and naturally also to me. But, from the constant repetition of such combinations, I had to conclude that, despite his conscious resistance, there existed in him an unconscious tendency to show his bride in this ambiguous light. He told me that if such a thing were true it would be a catastrophe. His acute neurosis had set in a short time after his engagement. Although it was something he could not bear to think about, this suspicion of his bride seemed to me a point of such capital importance that I advised

him to instigate some inquiries. These showed the suspicion to be well founded, and the shock of the unpleasant discovery did not kill the patient but, on the contrary, cured him of his neurosis and also of his bride. Thus, although the taking up of the context resulted in an “unthinkable” meaning and hence in an apparently nonsensical interpretation, it proved correct in the light of facts which were subsequently disclosed. This case is of exemplary simplicity, and it is superfluous to point out that only rarely do dreams have so simple a solution.

[543] The examination of the context is, to be sure, a simple, almost mechanical piece of work which has only a preparatory significance. But the subsequent production of a readable text, i.e., the actual interpretation of the dream, is as a rule a very exacting task. It needs psychological empathy, ability to coordinate, intuition, knowledge of the world and of men, and above all a special “canniness” which depends on wide understanding as well as on a certain “intelligence du cœur.” All these presupposed qualifications, including even the last, are valuable for the art of medical diagnosis in general. No sixth sense is needed to understand dreams. But more is required than routine recipes such as are found in vulgar little dreambooks, or which invariably develop under the influence of preconceived notions. Stereotyped interpretation of dream-motifs is to be avoided; the only justifiable interpretations are those reached through a painstaking examination of the context. Even if one has great experience in these matters, one is again and again obliged, before each dream, to admit one’s ignorance and, renouncing all preconceived ideas, to prepare for something entirely unexpected.

[544] Even though dreams refer to a definite attitude of consciousness and a definite psychic situation, their roots lie deep in the unfathomably dark recesses of the conscious mind. For want of a more descriptive term we call this unknown background the unconscious. We do not know its nature in and for itself, but we observe certain effects from whose qualities we venture certain conclusions in regard to the nature of the unconscious psyche. Because dreams are the most common and most normal expression of the unconscious psyche, they provide the bulk of the material for its investigation.

[545] Since the meaning of most dreams is *not* in accord with the tendencies of the conscious mind but shows peculiar deviations, we must assume that the unconscious, the matrix of dreams, has an independent function. This is what I call the autonomy of the unconscious. The dream not only fails to obey our will but very often stands in flagrant opposition to our conscious intentions. The opposition need not always be so marked; sometimes the dream deviates only a little from the conscious attitude and introduces only slight modifications; occasionally it may even coincide with conscious contents and tendencies. When I attempted to express this behaviour in a

formula, the concept of *compensation* seemed to me the only adequate one, for it alone is capable of summing up all the various ways in which a dream behaves. Compensation must be strictly distinguished from *complementation*. The concept of a complement is too narrow and too restricting; it does not suffice to explain the function of dreams, because it designates a relationship in which two things supplement one another more or less mechanically.³ Compensation, on the other hand, as the term implies, means balancing and comparing different data or points of view so as to produce an adjustment or a rectification.

[546] In this regard there are three possibilities. If the conscious attitude to the life situation is in large degree one-sided, then the dream takes the opposite side. If the conscious has a position fairly near the “middle,” the dream is satisfied with variations. If the conscious attitude is “correct” (adequate), then the dream coincides with and emphasizes this tendency, though without forfeiting its peculiar autonomy. As one never knows with certainty how to evaluate the conscious situation of a patient, dream-interpretation is naturally impossible without questioning the dreamer. But even if we know the conscious situation we know nothing of the attitude of the unconscious. As the unconscious is the matrix not only of dreams but also of psychogenic symptoms, the question of the attitude of the unconscious is of great practical importance. The unconscious, not caring whether I and those about me feel my attitude to be right, may—so to speak—be of “another mind.” This, especially in the case of a neurosis, is not a matter of indifference, as the unconscious is quite capable of bringing about all kinds of unwelcome disturbances “by mistake,” often with serious consequences, or of provoking neurotic symptoms. These disturbances are due to lack of harmony between conscious and unconscious. “Normally,” as we say, such harmony should be present. The fact is, however, that very frequently it is simply not there, and this is the reason for a vast number of psychogenic misfortunes ranging from severe accidents and illness to harmless slips of the tongue. We owe our knowledge of these relationships to the work of Freud.⁴

[547] Although in the great majority of cases compensation aims at establishing a normal psychological balance and thus appears as a kind of self-regulation of the psychic system, one must not forget that under certain circumstances and in certain cases (for instance, in latent psychoses) compensation may lead to a fatal outcome owing to the preponderance of destructive tendencies. The result is suicide or some other abnormal action, apparently preordained in the life-pattern of certain hereditarily tainted individuals.

[548] In the treatment of neurosis, the task before us is to reestablish an approximate harmony between conscious and unconscious. This, as we know, can be achieved in a

variety of ways: from “living a natural life,” persuasive reasoning, strengthening the will, to analysis of the unconscious.

[549] Because the simpler methods so often fail and the doctor does not know how to go on treating the patient, the compensatory function of dreams offers welcome assistance. I do not mean that the dreams of modern people indicate the appropriate method of healing, as was reported of the incubation-dreams dreamt in the temples of Aesculapius.⁵ They do, however, illuminate the patient’s situation in a way that can be exceedingly beneficial to health. They bring him memories, insights, experiences, awaken dormant qualities in the personality, and reveal the unconscious element in his relationships. So it seldom happens that anyone who has taken the trouble to work over his dreams with qualified assistance for a longer period of time remains without enrichment and a broadening of his mental horizon. Just because of their compensatory behaviour, a methodical analysis of dreams discloses new points of view and new ways of getting over the dreaded impasse.

[550] The term “compensation” naturally gives us only a very general idea of the function of dreams. But if, as happens in long and difficult treatments, the analyst observes a series of dreams often running into hundreds, there gradually forces itself upon him a phenomenon which, in an isolated dream, would remain hidden behind the compensation of the moment. This phenomenon is a kind of developmental process in the personality itself. At first it seems that each compensation is a momentary adjustment of one-sidedness or an equalization of disturbed balance. But with deeper insight and experience, these apparently separate acts of compensation arrange themselves into a kind of plan. They seem to hang together and in the deepest sense to be subordinated to a common goal, so that a long dream-series no longer appears as a senseless string of incoherent and isolated happenings, but resembles the successive steps in a planned and orderly process of development. I have called this unconscious process spontaneously expressing itself in the symbolism of a long dream-series the individuation process.

[551] Here, more than anywhere else in a discussion of dream psychology, illustrative examples would be desirable. Unfortunately, this is quite impossible for technical reasons. I must therefore refer the reader to my book *Psychology and Alchemy*, which contains an investigation into the structure of a dream-series with special reference to the individuation process.

[552] The question whether a long series of dreams recorded outside the analytical procedure would likewise reveal a development aiming at individuation is one that cannot be answered at present for lack of the necessary material. The analytical procedure, especially when it includes a systematic dream-analysis, is a “process of quickened maturation,” as Stanley Hall once aptly remarked. It is therefore possible

that the motifs accompanying the individuation process appear chiefly and predominantly in dream-series recorded under analysis, whereas in “extra-analytical” dream-series they occur only at much greater intervals of time.

[553] I have mentioned before that dream-interpretation requires, among other things, specialized knowledge. While I am quite ready to believe that an intelligent layman with some psychological knowledge and experience of life could, with practice, diagnose dream-compensation correctly, I consider it impossible for anyone without knowledge of mythology and folklore and without some understanding of the psychology of primitives and of comparative religion to grasp the essence of the individuation process, which, according to all we know, lies at the base of psychological compensation.

[554] Not all dreams are of equal importance. Even primitives distinguish between “little” and “big” dreams, or, as we might say, “insignificant” and “significant” dreams. Looked at more closely, “little” dreams are the nightly fragments of fantasy coming from the subjective and personal sphere, and their meaning is limited to the affairs of everyday. That is why such dreams are easily forgotten, just because their validity is restricted to the day-to-day fluctuations of the psychic balance. Significant dreams, on the other hand, are often remembered for a lifetime, and not infrequently prove to be the richest jewel in the treasure-house of psychic experience. How many people have I encountered who at the first meeting could not refrain from saying: “I once had a dream!” Sometimes it was the first dream they could ever remember, and one that occurred between the ages of three and five. I have examined many such dreams, and often found in them a peculiarity which distinguishes them from other dreams: they contain symbolical images which we also come across in the mental history of mankind. It is worth noting that the dreamer does not need to have any inkling of the existence of such parallels. This peculiarity is characteristic of dreams of the individuation process, where we find the mythological motifs or mythologems I have designated as archetypes. These are to be understood as specific forms and groups of images which occur not only at all times and in all places but also in individual dreams, fantasies, visions, and delusional ideas. Their frequent appearance in individual case material, as well as their universal distribution, prove that the human psyche is unique and subjective or personal only in part, and for the rest is collective and objective.”⁶

[555] Thus we speak on the one hand of a *personal* and on the other of a *collective* unconscious, which lies at a deeper level and is further removed from consciousness than the personal unconscious. The “big” or “meaningful” dreams come from this deeper level. They reveal their significance—quite apart from the subjective impression they make—by their plastic form, which often has a poetic force and

beauty. Such dreams occur mostly during the critical phases of life, in early youth, puberty, at the onset of middle age (thirty-six to forty), and within sight of death. Their interpretation often involves considerable difficulties, because the material which the dreamer is able to contribute is too meagre. For these archetypal products are no longer concerned with personal experiences but with general ideas, whose chief significance lies in their intrinsic meaning and not in any personal experience and its associations. For example, a young man dreamed of *a great snake that guarded a golden bowl in an underground vault*. To be sure, he had once seen a huge snake in a zoo, but otherwise he could suggest nothing that might have prompted such a dream, except perhaps the reminiscence of fairytales. Judging by this unsatisfactory context the dream, which actually produced a very powerful effect, would have hardly any meaning. But that would not explain its decided emotionality. In such a case we have to go back to mythology, where the combination of snake or dragon with treasure and cave represents an ordeal in the life of the hero. Then it becomes clear that we are dealing with a collective emotion, a typical situation full of affect, which is not primarily a personal experience but becomes one only secondarily. Primarily it is a universally human problem which, because it has been overlooked subjectively, forces itself objectively upon the dreamer's consciousness.⁷

[556] A man in middle life still feels young, and age and death lie far ahead of him. At about thirty-six he passes the zenith of life, without being conscious of the meaning of this fact. If he is a man whose whole make-up and nature do not tolerate excessive unconsciousness, then the import of this moment will be forced upon him, perhaps in the form of an archetypal dream. It would be in vain for him to try to understand the dream with the help of a carefully worked out context, for it expresses itself in strange mythological forms that are not familiar to him. The dream uses collective figures because it has to express an eternal human problem that repeats itself endlessly, and not just a disturbance of personal balance.

[557] All these moments in the individual's life, when the universal laws of human fate break in upon the purposes, expectations, and opinions of the personal consciousness, are stations along the road of the individuation process. This process is, in effect, the spontaneous realization of the whole man. The ego-conscious personality is only a part of the whole man, and its life does not yet represent his total life. The more he is merely "I," the more he splits himself off from the collective man, of whom he is also a part, and may even find himself in opposition to him. But since everything living strives for wholeness, the inevitable one-sidedness of our conscious life is continually being corrected and compensated by the universal human being in us, whose goal is the ultimate integration of conscious and unconscious, or better, the assimilation of the ego to a wider personality.

[558] Such reflections are unavoidable if one wants to understand the meaning of “big” dreams. They employ numerous mythological motifs that characterize the life of the hero, of that greater man who is semi-divine by nature. Here we find the dangerous adventures and ordeals such as occur in initiations. We meet dragons, helpful animals, and demons; also the Wise Old Man, the animal-man, the wishing tree, the hidden treasure, the well, the cave, the walled garden, the transformative processes and substances of alchemy, and so forth—all things which in no way touch the banalities of everyday. The reason for this is that they have to do with the realization of a part of the personality which has not yet come into existence but is still in the process of becoming.

[559] How such mythologems get “condensed” in dreams, and how they modify one another, is shown by the picture of the Dream of Nebuchadnezzar (Daniel 4 : 7ff.) [*frontispiece*]. Although purporting to be no more than a representation of that dream, it has, so to speak, been dreamed over again by the artist, as is immediately apparent if one examines the details more closely. The tree is growing (in a quite unbiblical manner) out of the king’s navel: it is therefore the genealogical tree of Christ’s ancestors, that grows from the navel of Adam, the tribal father.⁸ For this reason it bears in its branches the pelican, who nourishes its young with its blood—a well-known allegory of Christ. Apart from that the pelican, together with the four birds that take the place of the four symbols of the evangelists, form a quincunx, and this quincunx reappears lower down in the stag, another symbol of Christ,⁹ with the four animals looking expectantly upwards. These two quaternities have the closest connections with alchemical ideas: above the *volatilia*, below the *terrena*, the former traditionally represented as birds, the latter as quadrupeds. Thus not only has the Christian conception of the genealogical tree and of the evangelical quaternity insinuated itself into the picture, but also the alchemical idea of the double quaternity (“superius est sicut quod inferius”). This contamination shows in the most vivid way how individual dreams make use of archetypes. The archetypes are condensed, interwoven, and blended not only with one another (as here), but also with unique individual elements.

[560] But if dreams produce such essential compensations, why are they not understandable? I have often been asked this question. The answer must be that the dream is a natural occurrence, and that nature shows no inclination to offer her fruits gratis or according to human expectations. It is often objected that the compensation must be ineffective unless the dream is understood. This is not so certain, however, for many things can be effective without being understood. But there is no doubt that we can enhance its effect considerably by understanding the dream, and this is often necessary because the voice of the unconscious so easily goes unheard. “What nature leaves imperfect is perfected by the art,” says an alchemical dictum.

[561] Coming now to the form of dreams, we find everything from lightning impressions to endlessly spun out dream-narrative. Nevertheless there are a great many “average” dreams in which a definite structure can be perceived, not unlike that of a drama. For instance, the dream begins with a STATEMENT OF PLACE, such as, “*I was in a street, it was an avenue*” (1), or, “*I was in a large building like a hotel*” (2). Next comes a statement about the PROTAGONISTS, for instance, “*I was walking with my friend X in a city park. At a crossing we suddenly ran into Mrs. Y*” (3), or, “*I was sitting with Father and Mother in a train compartment*” (4), or, “*I was in uniform with many of my comrades*” (5). Statements of time are rarer. I call this phase of the dream the EXPOSITION. It indicates the scene of action, the people involved, and often the initial situation of the dreamer.

[562] In the second phase comes the DEVELOPMENT of the plot. For instance: “*I was in a street, it was an avenue. In the distance a car appeared, which approached rapidly. It was being driven very unsteadily, and I thought the driver must be drunk*” (1). Or: “*Mrs. Y seemed to be very excited and wanted to whisper something to me hurriedly, which my friend X was obviously not intended to hear*” (3). The situation is somehow becoming complicated, and a definite tension develops because one does not know what will happen.

[563] The third phase brings the CULMINATION or *peripeteia*. Here something decisive happens or something changes completely: “*Suddenly I was in the car and seemed to be myself this drunken driver. Only I was not drunk, but strangely insecure and as if without a steering-wheel. I could no longer control the fast moving car, and crashed into a wall*” (1). Or: “*Suddenly Mrs. Y turned deathly pale and fell to the ground*” (3).

[564] The fourth and last phase is the *lysis*, the SOLUTION or RESULT produced by the dream-work. (There are certain dreams in which the fourth phase is lacking, and this can present a special problem, not to be discussed here.) Examples: “*I saw that the front part of the car was smashed. It was a strange car that I did not know. I myself was unhurt. I thought with some uneasiness of my responsibility*” (1). “*We thought Mrs. Y was dead, but it was evidently only a faint. My friend X cried out: ‘I must fetch a doctor’*” (3). The last phase shows the final situation, which is at the same time the solution “sought” by the dreamer. In dream 1 a new reflectiveness has supervened after a kind of rudderless confusion, or rather, should supervene, since the dream is compensatory. The upshot of dream 3 is the thought that the help of a competent third person is indicated.

[565] The first dreamer was a man who had rather lost his head in difficult family circumstances and did not want to let matters go to extremes. The other dreamer wondered whether he ought to obtain the help of a psychiatrist for his neurosis.

Naturally these statements are not an interpretation of the dream, they merely outline the initial situation. This division into four phases can be applied without much difficulty to the majority of dreams met with in practice—an indication that dreams generally have a “dramatic” structure.

[566] The essential content of the dream-action, as I have shown above, is a sort of finely attuned compensation of the one-sidedness, errors, deviations, or other shortcomings of the conscious attitude. An hysterical patient of mine, an aristocratic lady who seemed to herself no end distinguished, met in her dreams a whole series of dirty fishwives and drunken prostitutes. In extreme cases the compensation becomes so menacing that the fear of it results in sleeplessness.

[567] Thus the dream may either repudiate the dreamer in a most painful way, or bolster him up morally. The first is likely to happen to people who, like the last-mentioned patient, have too good an opinion of themselves; the second to those whose self-valuation is too low. Occasionally, however, the arrogant person is not simply humiliated in the dream, but is raised to an altogether improbable and absurd eminence, while the all-too-humble individual is just as improbably degraded, in order to “rub it in,” as the English say.

[568] Many people who know something, but not enough, about dreams and their meaning, and who are impressed by their subtle and apparently intentional compensation, are liable to succumb to the prejudice that the dream actually has a moral purpose, that it warns, rebukes, comforts, foretells the future, etc. If one believes that the unconscious always knows best, one can easily be betrayed into leaving the dreams to take the necessary decisions, and is then disappointed when the dreams become more and more trivial and meaningless. Experience has shown me that a slight knowledge of dream psychology is apt to lead to an overrating of the unconscious which impairs the power of conscious decision. The unconscious functions satisfactorily only when the conscious mind fulfils its tasks to the very limit. A dream may perhaps supply what is then lacking, or it may help us forward where our best efforts have failed. If the unconscious really were superior to consciousness it would be difficult to see wherein the advantage of consciousness lay, or why it should ever have come into being as a necessary element in the scheme of evolution. If it were nothing but a *lusus naturae*, the fact of our conscious awareness of the world and of our own existence would be without meaning. The idea that consciousness is a freak of nature is somehow difficult to digest, and for psychological reasons we should avoid emphasizing it, even if it were correct—which, by the way, we shall luckily never be in a position to prove (any more than we can prove the contrary). It is a question that belongs to the realm of metaphysics, where no criterion of truth exists. However, this is in no way to underestimate the

fact that metaphysical views are of the utmost importance for the well-being of the human psyche.

[569] In the study of dream psychology we encounter far-reaching philosophical and even religious problems to the understanding of which the phenomenon of dreams has already made decisive contributions. But we cannot boast that we are, at present, in possession of a generally satisfying theory or explanation of this complicated phenomenon. We still know far too little about the nature of the unconscious psyche for that. In this field there is still an infinite amount of patient and unprejudiced work to be done, which no one will begrudge. For the purpose of research is not to imagine that one possesses the theory which alone is right, but, doubting all theories, to approach gradually nearer to the truth.

V

THE PSYCHOLOGICAL FOUNDATIONS OF BELIEF IN SPIRITS

SPIRIT AND LIFE

BASIC POSTULATES OF ANALYTICAL PSYCHOLOGY

ANALYTICAL PSYCHOLOGY AND 'WELTANSCHAUUNG'

THE REAL AND THE SURREAL

[The papers in this section present a special problem with regard to the translation of the words *Geist* and *Seele*. In “The Psychological Foundations of Belief in Spirits,” the author used *Geist*, as the translated title implies, almost exclusively to designate a spirit (ghost, apparition, etc.). In “Spirit and Life,” he used it in an equally unequivocal sense to denote *the* spirit, i.e., the spiritual principle in its various definitions. Both here and in “Basic Postulates of Analytical Psychology,” however, *Geist* has also the connotation “mind.” This makes the translation of *Seele* in this group of papers a problematical matter which may give rise to confusion. Ordinarily *Seele* means “soul,” and even in a Jungian context it can sometimes quite legitimately be translated as such. It must nevertheless be remembered that there is no consistent equivalent of *Seele* in English, just as German lacks an unambiguous word for the English “mind.” This applies particularly to the use of *Seele* in the essay “Spirit and Life,” where “soul” would give entirely the wrong meaning. It has therefore been translated here and in the other papers either as “psyche” or as “mind,” and its adjectival form as “psychic” or (less frequently) as “mental,” since a consistent use of either term would be misleading. The reader who objects to the one is free to substitute the other in his thoughts. He may then see how easily mind and psyche shade off into each other.

[Those interested in textual criticism will note, in this group of papers, an increasing tendency to replace the concept *Seele* by *Psyche*, until, in “The Real and the Surreal” (1933), *Psyche* alone occupies the field. It appears there as a principle *sui generis*, which has completely ousted the older, ambiguous philosophical concepts of mind, soul, and spirit as the “real” subject of psychology. Cf. Jung, *Psychology and Alchemy*, par. 9, n. 2.—TRANSLATOR.]

THE PSYCHOLOGICAL FOUNDATIONS OF BELIEF IN SPIRITS¹

[570] If we look back into the past history of mankind, we find, among many other religious convictions, a universal belief in the existence of phantoms or ethereal beings who dwell in the neighbourhood of men and who exercise an invisible yet powerful influence upon them. These beings are generally supposed to be the spirits or souls of the dead. This belief is to be found among highly civilized peoples as well as among Australian aborigines, who are still living in the Stone Age. Among Western peoples, however, belief in spirits has been counteracted by the rationalism and scientific enlightenment of the last one hundred and fifty years, so that among the majority of educated people today it has been suppressed along with other metaphysical beliefs.

[571] But just as these beliefs are still alive among the masses, so too is the belief in spirits. The “haunted house” has not yet become extinct even in the most enlightened and the most intellectual cities, nor has the peasant ceased to believe in the bewitching of his cattle. On the contrary, in this age of materialism—the inevitable consequence of rationalistic enlightenment—there has been a revival of the belief in spirits, but this time on a higher level. It is not a relapse into the darkness of superstition, but an intense scientific interest, a need to direct the searchlight of truth on to the chaos of dubious facts. The names of Crookes, Myers, Wallace, Zöllner, and many other eminent men symbolize this rebirth and rehabilitation of the belief in spirits. Even if the real nature of their observations be disputed, even if they can be accused of errors and self-deception, these investigators have still earned for themselves the undying moral merit of having thrown the full weight of their authority and of their great scientific name into these endeavours to shed fresh light on the darkness, regardless of all personal fears and considerations. They shrank neither from academic prejudice nor from the derision of the public, and at the very time when the thinking of educated people was more than ever spellbound by materialistic dogmas, they drew attention to phenomena of psychic provenience that seemed to be in complete contradiction to the materialism of their age.

[572] These men typify the reaction of the human mind against the materialistic view of the world. Looked at from the historical standpoint, it is not at all surprising that they used the belief in spirits as the most effective weapon against the mere truth of the senses, for belief in spirits has the same functional significance also for primitive man. His utter dependence on circumstances and environment, the manifold distresses and tribulations of his life, surrounded by hostile neighbours, dangerous

beasts of prey, and often exposed to the pitiless forces of nature; his keen senses, his cupidity, his uncontrolled emotions—all these things bind him to the physical realities, so that he is in constant danger of adopting a purely materialistic attitude and becoming degenerate. His belief in spirits, or rather, his awareness of a spiritual world, pulls him again and again out of that bondage in which his senses would hold him; it forces on him the certainty of a spiritual reality whose laws he must observe as carefully and as guardedly as the laws of his physical environment. Primitive man, therefore, really lives in two worlds. Physical reality is at the same time spiritual reality. The physical world is undeniable, and for him the world of spirits has an equally real existence, not just because he thinks so, but because of his naïve awareness of things spiritual. Wherever this naïveté is lost through contact with civilization and its disastrous “enlightenment,” he forfeits his dependence on spiritual law and accordingly degenerates. Even Christianity cannot save him from corruption, for a highly developed religion like Christianity demands a highly developed psyche if its beneficial effects are to be felt.

[573] For the primitive, the phenomenon of spirits is direct evidence for the reality of a spiritual world. If we inquire what these spirit-phenomena mean to him, and in what they consist, we find that the most frequent phenomenon is the seeing of apparitions, or ghosts. It is generally assumed that the seeing of apparitions is far commoner among primitives than among civilized people, the inference being that this is nothing but superstition, because civilized people do not have such visions unless they are ill. It is quite certain that civilized man makes much less use of the hypothesis of spirits than the primitive, but in my view it is equally certain that psychic phenomena occur no less frequently with civilized people than they do with primitives. The only difference is that where the primitive speaks of ghosts, the European speaks of dreams and fantasies and neurotic symptoms, and attributes less importance to them than the primitive does. I am convinced that if a European had to go through the same exercises and ceremonies which the medicine-man performs in order to make the spirits visible, he would have the same experiences. He would interpret them differently, of course, and devalue them, but this would not alter the facts as such. It is well known that Europeans have very curious psychic experiences if they have to live under primitive conditions for a long time, or if they find themselves in some other unusual psychological situation.

[574] One of the most important sources of the primitive belief in spirits is dreams. People very often appear as the actors in dreams, and the primitive readily believes them to be spirits or ghosts. The dream has for him an incomparably higher value than it has for civilized man. Not only does he talk a great deal about his dreams, he also attributes an extraordinary importance to them, so that it often seems as though he were unable to distinguish between them and reality. To the civilized man dreams

as a rule appear valueless, though there are some people who attach great significance to certain dreams on account of their weird and impressive character. This peculiarity lends plausibility to the view that dreams are inspirations. But inspiration implies something that inspires, a spirit or ghost, although this logical inference is not likely to appeal to the modern mind. A good instance of this is the fact that the dead sometimes appear in dreams; the primitive naïvely takes them for revenants.

[575] Another source of the belief in spirits is psychogenic diseases, nervous disorders, especially those of an hysterical character, which are not rare among primitives. Since these illnesses stem from psychic conflicts, mostly unconscious, it seems to the primitive that they are caused by certain persons, living or dead, who are in some way connected with his subjective conflict. If the person is dead, it is naturally assumed that his spirit is having an injurious influence. As pathogenic conflicts usually go back to childhood and are connected with memories of the parents, we can understand why the primitive attaches special importance to the spirits of dead relatives. This accounts for the wide incidence of ancestor-worship, which is primarily a protection against the malice of the dead. Anyone who has had experience of nervous illnesses knows how great is the importance of parental influences on patients. Many patients feel persecuted by their parents long after they are dead. The psychological after-effects of the parents are so powerful that many cultures have developed a whole system of ancestor-worship to propitiate them.²

[576] There can be no doubt that mental illnesses play a significant part in causing belief in spirits. Among primitive peoples these illnesses, so far as is known, are mostly of a delirious, hallucinatory or catatonic nature, belonging apparently to the broad domain of schizophrenia, an illness which covers the great majority of chronically insane patients. In all ages and all over the world, insane people have been regarded as possessed by evil spirits, and this belief is supported by the patient's own hallucinations. The patients are tormented less by visions than by auditory hallucinations: they hear "voices." Very often these voices are those of relatives or of persons in some way connected with the patient's conflicts. To the naive mind, the hallucinations naturally appear to be caused by spirits.

[577] It is impossible to speak of belief in spirits without at the same time considering the belief in souls. Belief in souls is a correlate of belief in spirits. Since, according to primitive belief, a spirit is usually the ghost of one dead, it must once have been the soul of a living person. This is particularly the case wherever the belief is held that people have only one soul. But this assumption does not prevail everywhere; it is frequently supposed that people have two or more souls, one of which survives death

and is immortal. In this case the spirit of the dead is only one of the several souls of the living. It is thus only a part of the total soul—a psychic fragment, so to speak.

[578] Belief in souls is therefore a necessary premise for belief in spirits, at least so far as the spirits of the dead are concerned. However, primitives do not believe only in spirits of the dead. There are also elemental demons who are supposed never to have been human souls or soul-parts. This group of spirits must therefore have a different origin.

[579] Before going into the psychological grounds for belief in souls I should like to take a quick glance back at the facts already mentioned. I have pointed out three main sources that put the belief in spirits on a solid foundation: the seeing of apparitions, dreams, and pathological disturbances of psychic life. The commonest and most normal of these phenomena is the dream, and its great significance for primitive psychology is now widely recognized. What, then, is a dream?

[580] A dream is a psychic product originating in the sleeping state without conscious motivation. In a dream, consciousness is not completely extinguished; there is always a small remnant left. In most dreams, for instance, there is still some consciousness of the ego, although it is a very limited and curiously distorted ego known as the dream-ego. It is a mere fragment or shadow of the waking ego. Consciousness exists only when psychic contents are associated with the ego, and the ego is a psychic complex of a particularly solid kind. As sleep is seldom quite dreamless, we may assume that the activity of the ego-complex seldom ceases entirely; its activity is as a rule only restricted by sleep. The psychic contents associated with it in a dream confront the ego in much the same way as do the outward circumstances in real life, so that in dreams we generally find ourselves in situations such as we could not conceive when awake, but which are very like the situations we are confronted with in reality. As in our waking state, real people and things enter our field of vision, so the dream-images enter like another kind of reality into the field of consciousness of the dream-ego. We do not feel as if we were producing the dreams, it is rather as if the dreams came to us. They are not subject to our control but obey their own laws. They are obviously autonomous psychic complexes which form themselves out of their own material. We do not know the source of their motives, and we therefore say that dreams come from the unconscious. In saying this, we assume that there are independent psychic complexes which elude our conscious control and come and go according to their own laws. In our waking life, we imagine we make our own thoughts and can have them when we want them. We also think we know where they come from, and why and to what end we have them. Whenever a thought comes to us against our will, or suddenly vanishes against our will, we feel as if something exceptional or even morbid had happened. The difference between psychic activity in

the waking and in the sleeping state seems, therefore, to be an important one. In the waking state the psyche is apparently under the control of the conscious will, but in the sleeping state it produces contents that are strange and incomprehensible, as though they came from another world.

[581] The same is true of visions. They are like dreams, only they occur in the waking state. They enter consciousness along with conscious perceptions and are nothing other than the momentary irruption of an unconscious content. The same phenomenon also happens in mental disturbances. Quite out of the blue, apparently, against the background of noises in the environment and sound-waves coming from outside, the ear, excited from within, hears psychic contents that have nothing to do with the immediate concerns of the conscious mind.³ Besides judgments formed by intellect and feeling from definite premises, opinions and convictions thrust themselves on the patient, apparently deriving from real perceptions but actually from unconscious factors within him. These are delusional ideas.

[582] Common to all three types of phenomena is the fact that the psyche is not an indivisible unity but a divisible and more or less divided whole. Although the separate parts are connected with one another, they are relatively independent, so much so that certain parts of the psyche never become associated with the ego at all, or only very rarely. I have called these psychic fragments “autonomous complexes,” and I based my theory of complexes on their existence.⁴ According to this theory the ego-complex forms the centre characteristic of our psyche. But it is only one among several complexes. The others are more often than not associated with the ego-complex and in this way become conscious, but they can also exist for some time without being associated with it. An excellent and very well known example of this is the conversion of St. Paul. Although the actual moment of conversion often seems quite sudden and unexpected, we know from experience that such a fundamental upheaval always requires a long period of incubation. It is only when this preparation is complete, that is to say when the individual is ripe for conversion, that the new insight breaks through with violent emotion. Saul, as he was then called, had unconsciously been a Christian for a long time, and this would explain his fanatical hatred of the Christians, because fanaticism is always found in those who have to stifle a secret doubt. That is why converts are always the worst fanatics. The vision of Christ on the road to Damascus merely marks the moment when the unconscious Christ-complex associated itself with Paul’s ego. The fact that Christ appeared to him objectively, in the form of a vision, is explained by the circumstance that Saul’s Christianity was an unconscious complex which appeared to him in projection, as if it did not belong to him. He could not see himself as a Christian; therefore, from sheer resistance to Christ, he became blind and could only be healed again by a Christian. We know that psychogenic blindness is always an unconscious unwillingness to see,

which in Saul's case corresponds with his fanatical resistance to Christianity. This resistance, as we know from the Epistles, was never entirely overcome, and occasionally it broke out in the form of fits which are erroneously explained as epileptic. The fits were a sudden return of the old Saul-complex which had been split off by his conversion just as the Christ-complex was before.

[583] For reasons of intellectual morality, we should not explain Paul's conversion on metaphysical grounds, otherwise we should have to explain all similar cases that occur among our patients in the same metaphysical way. This would lead to quite absurd conclusions repugnant to reason and feeling alike.

[584] Autonomous complexes appear most clearly in dreams, visions, pathological hallucinations, and delusional ideas. Because the ego is unconscious of them, they always appear first in projected form. In dreams they are represented by other people, in visions they are projected, as it were, into space, just like the voices in insanity when not ascribed to persons in the patient's environment. Ideas of persecution, as we know, are frequently associated with particular persons to whom the patient attributes the peculiarities of his own unconscious complex. He feels these persons as hostile because he is hostile to the unconscious complex, just as Saul resented the Christ-complex he could not acknowledge in himself and persecuted the Christians as its representatives. We see this constantly repeated in everyday life: people unhesitatingly project their own assumptions about others on to the persons concerned and hate or love them accordingly. Since reflection is so troublesome and difficult, they prefer to judge without restraint, not realizing that they are merely projecting and making themselves the victims of a stupid illusion. They take no account of the injustice and uncharitableness of such a procedure, and above all they never consider the serious loss of personality they suffer when, from sheer negligence, they allow themselves the luxury of foisting their own mistakes or merits onto others. It is exceedingly unwise to think that other people are as stupid and inferior as one is oneself, and one should also realize the damage one does by assigning one's own good qualities to moral highwaymen with an eye to the main chance.

[585] Spirits, therefore, viewed from the psychological angle, are unconscious autonomous complexes which appear as projections because they have no direct association with the ego.⁵

[586] I said earlier on that belief in souls is a necessary correlate of belief in spirits. Whilst spirits are felt to be strange and as not belonging to the ego, this is not true of the soul or souls. The primitive feels the proximity or the influence of a spirit as something uncanny or dangerous, and is greatly relieved when the spirit is banished. Conversely, he feels the loss of a soul as if it were a sickness; indeed, he often

attributes serious physical diseases to loss of soul. There are innumerable rites for calling the “soul-bird” back into the sick person. Children may not be struck because their souls might feel insulted and depart. Thus, for the primitive, the soul is something that seems normally to belong to him, but spirits seem to be something that normally should not be near him. He avoids places haunted by spirits, or visits them only with fear, for religious or magical purposes.

[587] The plurality of souls indicates a plurality of relatively autonomous complexes that can behave like spirits. The soul-complexes seem to belong to the ego and the loss of them appears pathological. The opposite is true of spirit-complexes: their association with the ego causes illness, and their dissociation from it brings recovery. Accordingly, primitive pathology recognizes two causes of illness: loss of soul, and possession by a spirit. The two theories keep one another more or less balanced. We therefore have to postulate the existence of unconscious complexes that normally belong to the ego, and of those that normally should not become associated with it. The former are the soul-complexes, the latter the spirit-complexes.

[588] This distinction, common to most primitive beliefs, corresponds exactly to my conception of the unconscious. According to my view, the unconscious falls into two parts which should be sharply distinguished from one another. One of them is the personal unconscious; it includes all those psychic contents which have been forgotten during the course of the individual’s life. Traces of them are still preserved in the unconscious, even if all conscious memory of them has been lost. In addition, it contains all subliminal impressions or perceptions which have too little energy to reach consciousness. To these we must add unconscious combinations of ideas that are still too feeble and too indistinct to cross over the threshold. Finally, the personal unconscious contains all psychic contents that are incompatible with the conscious attitude. This comprises a whole group of contents, chiefly those which appear morally, aesthetically, or intellectually inadmissible and are repressed on account of their incompatibility. A man cannot always think and feel the good, the true, and the beautiful, and in trying to keep up an ideal attitude everything that does not fit in with it is automatically repressed. If, as is nearly always the case in a differentiated person, one function, for instance thinking, is especially developed and dominates consciousness, then feeling is thrust into the background and largely falls into the unconscious.

[589] The other part of the unconscious is what I call the impersonal or collective unconscious. As the name indicates, its contents are not personal but collective; that is, they do not belong to one individual alone but to a whole group of individuals, and generally to a whole nation, or even to the whole of mankind. These contents are not acquired during the individual’s lifetime but are products of innate forms and

instincts. Although the child possesses no inborn ideas, it nevertheless has a highly developed brain which functions in a quite definite way. This brain is inherited from its ancestors; it is the deposit of the psychic functioning of the whole human race. The child therefore brings with it an organ ready to function in the same way as it has functioned throughout human history. In the brain the instincts are preformed, and so are the primordial images which have always been the basis of man's thinking—the whole treasure-house of mythological motifs.⁶ It is, of course, not easy to prove the existence of the collective unconscious in a normal person, but occasionally mythological ideas are represented in his dreams. These contents can be seen most clearly in cases of mental derangement, especially in schizophrenia, where mythological images often pour out in astonishing variety. Insane people frequently produce combinations of ideas and symbols that could never be accounted for by experiences in their individual lives, but only by the history of the human mind. It is an instance of primitive, mythological thinking, which reproduces its own primordial images, and is not a reproduction of conscious experiences.⁷

[590] The personal unconscious, then, contains complexes that belong to the individual and form an intrinsic part of his psychic life. When any complex which ought to be associated with the ego becomes unconscious, either by being repressed or by sinking below the threshold, the individual experiences a sense of loss. Conversely, when a lost complex is made conscious again, for instance through psychotherapeutic treatment, he experiences an increase of power.⁸ Many neuroses are cured in this way. But when, on the other hand, a complex of the collective unconscious becomes associated with the ego, i.e., becomes conscious, it is felt as strange, uncanny, and at the same time fascinating. At all events the conscious mind falls under its spell, either feeling it as something pathological, or else being alienated by it from normal life. The association of a collective content with the ego always produces a state of alienation, because something is added to the individual's consciousness which ought really to remain unconscious, that is, separated from the ego. If the content can be removed from consciousness again, the patient will feel relieved and more normal. The irruption of these alien contents is a characteristic symptom marking the onset of many mental illnesses. The patients are seized by weird and monstrous thoughts, the whole world seems changed, people have horrible, distorted faces, and so on.⁹

[591] While the contents of the personal unconscious are felt as belonging to one's own psyche, the contents of the collective unconscious seem alien, as if they came from outside. The reintegration of a personal complex has the effect of release and often of healing, whereas the invasion of a complex from the collective unconscious is a very disagreeable and even dangerous phenomenon. The parallel with the primitive belief in souls and spirits is obvious: souls correspond to the autonomous complexes of the personal unconscious, and spirits to those of the collective unconscious. We, from the

scientific standpoint, prosaically call the awful beings that dwell in the shadows of the primeval forests “psychic complexes.” Yet if we consider the extraordinary role played by the belief in souls and spirits in the history of mankind, we cannot be content with merely establishing the existence of such complexes, but must go rather more deeply into their nature.

[592] These complexes can easily be demonstrated by means of the association experiment.¹⁰ The procedure is simple. The experimenter calls out a word to the test-person, and the test-person reacts as quickly as possible with the first word that comes into his mind. The reaction time is measured by a stopwatch. One would expect all simple words to be answered with roughly the same speed, and that only “difficult” words would be followed by a prolonged reaction time. But actually this is not so. There are unexpectedly prolonged reaction times after very simple words, whereas difficult words may be answered quite quickly. Closer investigation shows that prolonged reaction times generally occur when the stimulus-word hits a content with a strong feeling-tone. Besides the prolonged reaction-time there are other characteristic disturbances that cannot be discussed in detail here. The feeling-toned contents generally have to do with things which the test-person would like to keep secret—painful things which he has repressed, some of them being unknown even to the test-person himself. When a stimulus-word hits such a complex, no answer occurs to him at all, or else so many things crowd into his mind that he does not know what answer to give, or he mechanically repeats the stimulus-word, or he gives an answer and then immediately substitutes another, and so forth. When, after completing the experiment, the test-person is asked what answers he gave to the individual words, we find that ordinary reactions are remembered quite well, while words connected with a complex are usually forgotten.

[593] These peculiarities plainly reveal the qualities of the autonomous complex. It creates a disturbance in the readiness to react, either inhibiting the answer or causing an undue delay, or it produces an unsuitable reaction, and afterwards often suppresses the memory of the answer. It interferes with the conscious will and disturbs its intentions. That is why we call it autonomous. If we subject a neurotic or insane person to this experiment, we find that the complexes which disturb the reactions are at the same time essential components of the psychic disturbance. They cause not only the disturbances of reaction but also the symptoms. I have seen cases where certain stimulus-words were followed by strange and apparently nonsensical answers, by words that came out of the test-person’s mouth quite unexpectedly, as though a strange being had spoken through him. These words belonged to the autonomous complex. When excited by an external stimulus, complexes can produce sudden confusions, or violent affects, depressions, anxiety-states, etc., or they may express

themselves in hallucinations. In short, they behave in such a way that the primitive theory of spirits strikes one as being an uncommonly apt formulation for them.

[594] We may carry this parallel further. Certain complexes arise on account of painful or distressing experiences in a person's life, experiences of an emotional nature which leave lasting psychic wounds behind them. A bad experience of this sort often crushes valuable qualities in an individual. All these produce unconscious complexes of a personal nature. A primitive would rightly speak of a loss of soul, because certain portions of the psyche have indeed disappeared. A great many autonomous complexes arise in this way. But there are others that come from quite a different source. While the first source is easily understood, since it concerns the outward life everyone can see, this other source is obscure and difficult to understand because it has to do with perceptions or impressions of the collective unconscious. Usually the individual tries to rationalize these inner perceptions in terms of external causes, but that does not get at the root of the matter. At bottom they are irrational contents of which the individual had never been conscious before, and which he therefore vainly seeks to discover somewhere outside him. The primitive expresses this very aptly when he says that some spirit is interfering with him. So far as I can judge, these experiences occur either when something so devastating happens to the individual that his whole previous attitude to life breaks down, or when for some reason the contents of the collective unconscious accumulate so much energy that they start influencing the conscious mind. In my view this happens when the life of a large social group or of a nation undergoes a profound change of a political, social, or religious nature. Such a change always involves an alteration of the psychological attitude. Incisive changes in history are generally attributed exclusively to external causes. It seems to me, however, that external circumstances often serve merely as occasions for a new attitude to life and the world, long prepared in the unconscious, to become manifest. Social, political, and religious conditions affect the collective unconscious in the sense that all those factors which are suppressed by the prevailing views or attitudes in the life of a society gradually accumulate in the collective unconscious and activate its contents. Certain individuals gifted with particularly strong intuition then become aware of the changes going on in it and translate these changes into communicable ideas. The new ideas spread rapidly because parallel changes have been taking place in the unconscious of other people. There is a general readiness to accept the new ideas, although on the other hand they often meet with violent resistance. New ideas are not just the enemies of the old; they also appear as a rule in an extremely unacceptable form.

[595] Whenever contents of the collective unconscious become activated, they have a disturbing effect on the conscious mind, and confusion ensues. If the activation is due to the collapse of the individual's hopes and expectations, there is a danger that the

collective unconscious may take the place of reality. This state would be pathological. If, on the other hand, the activation is the result of psychological processes in the unconscious of the people, the individual may feel threatened or at any rate disoriented, but the resultant state is not pathological, at least so far as the individual is concerned. Nevertheless, the mental state of the people as a whole might well be compared to a psychosis. If the translation of the unconscious into a communicable language proves successful, it has a redeeming effect. The driving forces locked up in the unconscious are canalized into consciousness and form a new source of power, which may, however, unleash a dangerous enthusiasm.¹¹

[596] Spirits are not under all circumstances dangerous and harmful. They can, when translated into ideas, also have beneficial effects. A well-known example of this transformation of a content of the collective unconscious into communicable language is the miracle of Pentecost. From the point of view of the onlookers, the apostles were in a state of ecstatic intoxication (“These men are full of new wine”: Acts 2 : 13). But it was just when they were in this state that they communicated the new teaching which gave expression to the unconscious expectations of the people and spread with astonishing rapidity through the whole Roman Empire.

[597] Spirits are complexes of the collective unconscious which appear when the individual loses his adaptation to reality, or which seek to replace the inadequate attitude of a whole people by a new one. They are therefore either pathological fantasies or new but as yet unknown ideas.

[598] The psychogenesis of the spirits of the dead seems to me to be more or less as follows. When a person dies, the feelings and emotions that bound his relatives to him lose their application to reality and sink into the unconscious, where they activate a collective content that has a deleterious effect on consciousness. The Bataks and many other primitives therefore say that when a man dies his character deteriorates, so that he is always trying to harm the living in some way. This view is obviously based on the experience that a persistent attachment to the dead makes life seem less worth living, and may even be the cause of psychic illnesses. The harmful effect shows itself in the form of loss of libido, depression, and physical debility. There are also universal reports of these post-mortem phenomena in the form of ghosts and hauntings. They are based in the main on psychic facts which cannot be dismissed out of hand. Very often the fear of superstition—which, strangely enough, is the concomitant of universal enlightenment—is responsible for the hasty suppression of extremely interesting factual reports which are thus lost to science. I have not only found many reports of this kind among my patients, but have also observed a few things myself. But my material is too slender for me to base any verifiable hypothesis on it. Nevertheless, I myself am convinced that ghosts and

suchlike have to do with psychic facts of which our academic wisdom refuses to take cognizance, although they appear clearly enough in our dreams.

*

[599] In this essay I have sketched out a psychological interpretation of the problem of spirits from the standpoint of our present knowledge of unconscious processes. I have confined myself wholly to the psychological side of the problem, and purposely avoided the question of whether spirits exist in themselves and can give evidence of their existence through material effects. I avoid this question not because I regard it as futile from the start, but because I am not in a position to adduce experiences that would prove it one way or the other. I think the reader will be as conscious as I am that it is extraordinarily difficult to find reliable evidence for the independent existence of spirits, since the usual spiritualistic communications are as a rule nothing but very ordinary products of the personal unconscious.¹² There are, nevertheless, a few exceptions worth mentioning. I would like to call attention to a remarkable case Stewart E. White has described in a number of books. Here the communications have a much profounder content than usual. For instance, a great many archetypal ideas were produced, among them the archetype of the self, so that one might almost think there had been borrowings from my writings. If we discount the possibility of conscious plagiarism, I should say that cryptomnesic reproduction is very unlikely. It appears to be a case of genuine, spontaneous production of a collective archetype. This is not in itself anything extraordinary, since the archetype of the self is met with everywhere in mythology as well as in the products of individual fantasy. The spontaneous irruption of collective contents whose existence in the unconscious has long been known to psychology is part of the general tendency of mediumistic communications to filter the contents of the unconscious through to consciousness. I have studied a wide range of spiritualistic literature precisely for these tendencies and have come to the conclusion that in spiritualism we have a spontaneous attempt of the unconscious to become conscious in a collective form. The psychotherapeutic endeavours of the so-called spirits are aimed at the living either directly, or indirectly through the deceased person, in order to make them more conscious. Spiritualism as a collective phenomenon thus pursues the same goals as medical psychology, and in so doing produces, as in this case, the same basic ideas and images—styling themselves the “teachings of the spirits”—which are characteristic of the nature of the collective unconscious. Such things, however baffling they may be, prove nothing either for or against the hypothesis of spirits. But it is a very different matter when we come to proven cases of identity. I shall not commit the fashionable stupidity of regarding everything I cannot explain as a fraud. There are probably very few proofs of this kind which could stand up to the test of cryptomnesia and, above all, of extra-sensory perception. Science cannot afford the luxury of naivete in these matters.

Nevertheless, I would recommend anyone who is interested in the psychology of the unconscious to read the books of Stewart White.¹³ The most interesting to my mind is *The Unobstructed Universe* (1940). *The Road I Know* (1942) is also remarkable in that it serves as an admirable introduction to the method of “active imagination” which I have been using for more than thirty years in the treatment of neurosis, as a means to bringing unconscious contents to consciousness.¹⁴ In all these books you still find the primitive equation: spirit-land = dreamland (the unconscious).

[600] These parapsychic phenomena seem to be connected as a rule with the presence of a medium. They are, so far as my experience goes, the exteriorized effects of unconscious complexes. I for one am certainly convinced that they are exteriorizations. I have repeatedly observed the telepathic effects of unconscious complexes, and also a number of parapsychic phenomena. But in all this I see no proof whatever of the existence of real spirits, and until such proof is forthcoming I must regard this whole territory as an appendix of psychology.¹⁵ I think science has to impose this restriction on itself. Yet one should never forget that science is simply a matter of intellect, and that the intellect is only one among several fundamental psychic functions and therefore does not suffice to give a complete picture of the world. For this another function—feeling—is needed too. Feeling often arrives at convictions that are different from those of the intellect, and we cannot always prove that the convictions of feeling are necessarily inferior. We also have subliminal perceptions of the unconscious which are not at the disposal of the intellect and are therefore missing in a purely intellectual picture of the world. So we have every reason to grant our intellect only a limited validity. But when we work with the intellect, we must proceed scientifically and adhere to empirical principles until irrefutable evidence against their validity is forthcoming.

SPIRIT AND LIFE¹

[601] The connection between spirit and life is one of those problems involving factors of such complexity that we have to be on our guard lest we ourselves get caught in the net of words in which we seek to ensnare these great enigmas. For how can we bring within the orbit of our thought those limitless complexes of facts which we call “spirit” or “life” unless we clothe them in verbal concepts, themselves mere counters of the intellect? The mistrust of verbal concepts, inconvenient as it is, nevertheless seems to me to be very much in place in speaking of fundamentals. “Spirit” and “life” are familiar enough words to us, very old acquaintances in fact, pawns that for thousands of years have been pushed back and forth on the thinker’s chessboard. The problem must have begun in the grey dawn of time, when someone made the bewildering discovery that the living breath which left the body of the dying man in the last death-rattle meant more than just air in motion. It can scarcely be an accident that onomatopoeic words like *ruach*, *ruch*, *roho* (Hebrew, Arabic, Swahili) mean “spirit” no less clearly than the Greek *πνεῦμα* and the Latin *spiritus*.

[602] Do we know then, for all our familiarity with the verbal concept, what spirit really is? Are we sure that when we use this word we all mean the same thing? Is not the word “spirit” a most perplexingly ambiguous term? The same verbal sign, spirit, is used for an inexpressible, transcendental idea of all-embracing significance; in a more commonplace sense it is synonymous with “mind”; it may connote courage, liveliness, or wit, or it may mean a ghost; it can also represent an unconscious complex that causes spiritualistic phenomena like table-turning, automatic writing, rappings, etc. In a metaphorical sense it may refer to the dominant attitude in a particular social group—the “spirit” that prevails there. Finally, it is used in a material sense, as spirits of wine, spirits of ammonia, and spirituous liquors in general. This is not just a bad joke—it is a part of the venerable heritage of our language, while on the other hand it is a paralysing encumbrance to thought, a tragic obstacle to all who hope to scale the ethereal heights of pure ideas on the ladders of words. When I utter the word “spirit,” no matter how accurately I may define the meaning I intend it to convey, the aura of its many other meanings cannot be wholly excluded.

[603] We must therefore ask ourselves the fundamental question: What is really meant by the word “spirit” when it is used in connection with the concept “life”? Under no circumstances should it be tacitly assumed that, at bottom, everybody knows just what is meant by “spirit” or “life.”

[604] Not being a philosopher, but an empiricist, I am inclined in all difficult questions to let experience decide. Where it is impossible to find any tangible basis in experience, I prefer to leave the questions unanswered. It is my aim, therefore, always to reduce abstract concepts to their empirical basis, in order to be moderately sure that I know what I am talking about. I must confess that I know as little what “spirit” may be in itself as I know what “life” is. I know “life” only in the form of a living body; what it might be in and for itself, in an abstract state, other than a mere word, I cannot even darkly guess. Thus instead of “life” I must first speak of the living body, and instead of “spirit” of psychic factors. This does not mean that I want to evade the question as originally put in order to indulge in reflections on body and mind. On the contrary, I hope the empirical approach will help us to find a real basis for spirit—and not at the expense of life.

[605] The concept of the living body brings fewer difficulties to our task of elucidation than does the general concept of life, for the body is a visible and tangible reality that does not elude our grasp. We can easily agree, then, that the body is a self-contained system of material units adapted to the purpose of living and, as such, is a phenomenon of the living being apprehended by our senses. More simply, it is a purposive arrangement of matter that makes a living being possible. To avoid confusion, I must point out that I do not include in my definition of the body proper something which I vaguely characterize as a “living being.” This separation of the two things, which I do not propose either to defend or to criticize for the moment, is meant only to indicate that the body cannot be understood as a mere heaping together of inert matter, but must be regarded as a material system ready for life and making life possible, with the proviso that for all its readiness it could not live without the addition of this “living being.” For, setting aside the possible significance of “living being,” there is lacking to the body by itself something that is necessary to its life, namely the psychic factor. We know this directly from our own experience of ourselves, and indirectly from our experience of our fellow men. We also know it through our scientific study of the higher vertebrates, and, for total lack of evidence to the contrary, we must suppose that some such factor is present in lower organisms and even in plants.

[606] Shall we now assume that this “living being” of which I spoke is equivalent to the psychic factor directly experienced by us in human consciousness, and so re-establish the ancient duality of mind and body? Or are there any reasons that would justify the separation of the “living being” from the psyche? In that case the psyche, too, would have to be understood as a purposive system, as an arrangement not merely of matter *ready for life*, but of *living matter* or, more precisely, of *living processes*. I am not at all sure that this view will meet with general acceptance, for we are so accustomed to thinking of mind and body as a living unit that it is difficult

for us to conceive of the psyche merely as an arrangement of life-processes taking place in the body.

[607] So far as our experience permits of any inferences at all about the nature of the psyche, it shows the psychic process as a phenomenon dependent on the nervous system. We know with tolerable certainty that disturbance of certain portions of the brain brings about corresponding psychic defects. The spinal cord and the brain consist essentially of interconnections between the sensory and motor tracts, the so-called reflex arcs. What is meant by this I can best show by means of an example. Suppose one touches a hot object with the finger: at once the nerve-endings are stimulated by the heat. This stimulus alters the condition of the whole path of conduction up the spinal cord and thence to the brain. In the spinal cord, the ganglion cells taking up the heat stimulus pass on the change of condition to the neighbouring motor-ganglion cells, which in their turn send out a stimulus to the arm-muscles, thereby causing a sudden contraction of the muscles and a withdrawal of the hand. All this occurs with such rapidity that the conscious perception of pain often comes when the hand has already been withdrawn. The reaction is automatic and is not registered consciously till afterwards. But what happens in the spinal cord is transmitted to the perceiving ego in the form of a record, or image, which one can furnish with names and concepts. On the basis of such a reflex arc, that is, a stimulus moving from without inward, followed by an impulse from within outward, one can form some idea of the processes that lie beneath the mind.

[608] Let us now take a less simple example. We hear an indistinct sound the initial effect of which is no more than a stimulus to listen in order to find out what it means. In this case the auditory stimulus releases a whole series of images which associate themselves with the stimulus. They will be partly acoustic images, partly visual images, and partly images of feeling. Here I use the word "image" simply in the sense of a representation. A psychic entity can be a conscious content, that is, it can be represented, only if it has the quality of an image and is thus *representable*. I therefore call all conscious contents images, since they are reflections of processes in the brain.

[609] The series of images excited by the auditory stimulus is now suddenly joined by a remembered acoustic image associated with a visual image: the rattle of a rattlesnake. This is immediately followed by an alarm signal to all the body muscles. The reflex arc is complete, but in this case it differs from the previous one in that a cerebral process, a series of mental images, interposes itself between the sensory stimulus and the motor impulse. The sudden tension of the body now reacts on the heart and bloodvessels and releases processes that are mentally recorded as terror.

[610] In this way we can form an idea of the nature of the psyche. It consists of reflected images of simple processes in the brain, and of reproductions of these images in an almost infinite series. These images have the quality of consciousness. The nature of consciousness is a riddle whose solution I do not know. It is possible to say, however, that anything psychic will take on the quality of consciousness if it comes into association with the ego. If there is no such association, it remains unconscious. Forget-fulness shows how often and how easily contents lose their connection with the ego. We could therefore compare consciousness to the beam of a searchlight. Only those objects upon which the cone of light falls enter the field of perception. An object that happens to lie in the darkness has not ceased to exist, it is merely not seen. So what is unconscious to me exists somewhere, in a state which is probably no different from what it is when seen by the ego.

[611] Consciousness can therefore be understood as a state of association with the ego. But the critical point is the ego. What do we mean by the ego? For all its appearance of unity, it is obviously a highly composite factor. It is made up of images recorded from the sense-functions that transmit stimuli both from within and from without, and furthermore of an immense accumulation of images of past processes. All these multifarious components need a powerful cohesive force to hold them together, and this we have already recognized as a property of consciousness. Consciousness therefore seems to be the necessary precondition for the ego. Yet without the ego, consciousness is unthinkable. This apparent contradiction may perhaps be resolved by regarding the ego, too, as a reflection not of one but of very many processes and their interplay—in fact, of all those processes and contents that make up ego-consciousness. Their diversity does indeed form a unity, because their relation to consciousness acts as a sort of gravitational force drawing the various parts together, towards what might be called a virtual centre. For this reason I do not speak simply of *the* ego, but of an *ego-complex*, on the proven assumption that the ego, having a fluctuating composition, is changeable and therefore cannot be simply *the* ego. (Unfortunately, I cannot discuss here the classic ego-changes that are found in mental illnesses and in dreams.)

[612] This view of the ego as a composite of psychic elements logically brings us to the question: Is the ego the central image and thus the exclusive representative of the total human being? Are all the contents and functions related to it and does it express them all?

[613] We must answer this question in the negative. The ego is a complex that does not comprise the total human being; it has forgotten infinitely more than it knows. It has heard and seen an infinite amount of which it has never become conscious. There are thoughts that spring up beyond the range of consciousness, fully formed and

complete, and it knows nothing of them. The ego has scarcely even the vaguest notion of the incredibly important regulative function of the sympathetic nervous system in relation to the internal bodily processes. What the ego comprehends is perhaps the smallest part of what a complete consciousness would have to comprehend.

[614] The ego can therefore be only a fragmentary complex. Is it perhaps that peculiar complex whose inner cohesion amounts to consciousness? But is not every cohesion of psychic parts consciousness? It is not altogether clear why the cohesion of a certain part of the sense-functions and a certain part of our memory-material should be consciousness, while the cohesion of other parts of the psyche should not. The complex of seeing, hearing, etc. has a strong and well-organized inner unity. There is no reason to suppose that this unity could not be a consciousness as well. As the case of the deaf and blind Helen Keller shows, the sense of touch and the bodily sensations are sufficient to make consciousness possible, at any rate a consciousness limited to these senses. I therefore think of ego-consciousness as a synthesis of the various "sense-consciousnesses," in which the independence of each separate consciousness is submerged in the unity of the overruling ego.

[615] Since ego-consciousness does not embrace all psychic activities and phenomena, that is, since they are not all recorded there as images, the question naturally arises whether there may not be a cohesion of all psychic activities similar to that of ego-consciousness. This might be conceived as a higher or wider consciousness in which the ego would be seen as an objective content, just as the act of seeing is an object of my consciousness, and, like it, would be fused with other activities of which I am not conscious. Our ego-consciousness might well be enclosed within a more complete consciousness like a smaller circle within a larger.

[616] Just as the activities of seeing, hearing, etc. create images of themselves which, when related to the ego, produce a consciousness of the activity in question, so the ego, as I have said, can be understood as an image or reflection of all the activities comprehended by it. We would expect that all psychic activities would produce images of themselves and that this would be their essential nature without which they could not be called "psychic." It is difficult to see why unconscious psychic activities should not have the same faculty of producing images as those that are represented in consciousness. And since man appears to be a living unity in himself, the conclusion would follow that the images of all his psychic activities are united in one total image of the whole man, which if known to him would be regarded as an ego.

[617] I could advance no conclusive argument against such an assumption, but it would remain an idle dream so long as it were not needed as an explanatory hypothesis. Yet, even if the possibility of a higher consciousness were needed to explain certain

psychic facts, it would still remain a mere hypothesis, since it would far exceed the power of reason to prove the existence of a consciousness other than the one we know. It is always possible that what lies in the darkness beyond our consciousness is totally different from anything the most daring speculation could imagine.

[618] I shall return to this question in the course of my exposition. We will put it aside for the time being and turn back to the original question of mind and body. From what has been said, it should be clear that the psyche consists essentially of images. It is a series of images in the truest sense, not an accidental juxtaposition or sequence, but a structure that is throughout full of meaning and purpose; it is a “picturing” of vital activities. And just as the material of the body that is ready for life has need of the psyche in order to be capable of life, so the psyche presupposes the living body in order that its images may live.

[619] Mind and body are presumably a pair of opposites and, as such, the expression of a single entity whose essential nature is not knowable either from its outward, material manifestation or from inner, direct perception. According to an ancient belief, man arose from the coming together of a soul and a body. It would probably be more correct to speak of an unknowable living being, concerning the ultimate nature of which nothing can be said except that it vaguely expresses the quintessence of “life.” This living being appears outwardly as the material body, but inwardly as a series of images of the vital activities taking place within it. They are two sides of the same coin, and we cannot rid ourselves of the doubt that perhaps this whole separation of mind and body may finally prove to be merely a device of reason for the purpose of conscious discrimination—an intellectually necessary separation of one and the same fact into two aspects, to which we then illegitimately attribute an independent existence.

[620] Science has never been able to grasp the riddle of life either in organic matter or in the mysterious trains of mental imagery; consequently we are still in search of the “living being” whose existence we must postulate somewhere beyond experience. Anyone who knows the abysses of physiology will become dizzy at the thought of them, just as anyone who knows the psyche will be staggered by the thought that this amazing mirror-thing should ever attain anything approaching “knowledge.”

[621] From this point of view one might easily abandon all hope of discovering anything fundamental about that elusive thing called “spirit.” One thing alone seems clear: just as the “living being” is the quintessence of life in the body, so “spirit” is the quintessence of the life of the mind; indeed, the concept “spirit” is often used interchangeably with the concept “mind.” Viewed thus, “spirit” exists in the same transliminal realm as “living being,” that is, in the same misty state of indistinguishableness. And the doubt as to whether mind and body may not

ultimately prove to be the same thing also applies to the apparent contrast between “spirit” and “living being.” They too are probably the same thing.

[622] But are these quintessential concepts necessary at all? Could we not rest content with the already sufficiently mysterious contrast between mind and body? From the scientific standpoint, we would have to stop here. But there is another standpoint, satisfying to our intellectual conscience, which not only allows but even forces us to go forward and overleap that seemingly impassable boundary. This is the *psychological* standpoint.

[623] So far I have based my reflections on the realistic standpoint of scientific thinking, without ever questioning the foundation on which I stood. But in order to explain briefly what I mean by the psychological standpoint, I must show that serious doubt can be cast on the exclusive validity of the realistic standpoint. Let us take as an example what a naïve mind would consider to be the realest thing of all, namely matter. We can make only the dimmest theoretical guesses about the nature of matter, and these guesses are nothing but images created by our minds. The wave-movements or solar emanations which meet my eye are translated by my perception into light. It is my mind, with its store of images, that gives the world colour and sound; and that supremely real and rational certainty which I call “experience” is, in its most simple form, an exceedingly complicated structure of mental images. Thus there is, in a certain sense, nothing that is directly experienced except the mind itself. Everything is mediated through the mind, translated, filtered, allegorized, twisted, even falsified by it. We are so enveloped in a cloud of changing and endlessly shifting images that we might well exclaim with a well-known sceptic: “Nothing is absolutely true—and even that is not quite true.” So thick and deceptive is this fog about us that we had to invent the exact sciences in order to catch at least a glimmer of the so-called “real” nature of things. To a naïve-minded person, of course, this almost too vivid world will not seem in the least foggy. But let him delve into the mind of a primitive and compare his picture of the world with that of civilized man. He will then have an inkling of the profound twilight in which we still live.

[624] What we know of the world, and what we are immediately aware of in ourselves, are conscious contents that flow from remote, obscure sources. I do not contest the relative validity either of the realistic standpoint, the *esse in re*, or of the idealistic standpoint, the *esse in intellectu solo*; I would only like to unite these extreme opposites by an *esse in anima*, which is the psychological standpoint. We live immediately only in the world of images.

[625] If we take this standpoint seriously, peculiar results follow. We find that the validity of psychic facts cannot be subjected either to epistemological criticism or to scientific verification. We can only put the question: Is a conscious content present or

not? If it is present, then it is valid in itself. Science can only be invoked when the content claims to be an assertion about something that can be met with in the external world; we can appeal to epistemological criticism only when an unknowable thing is posited as knowable. Let us take an example familiar to everyone. Science has never discovered any “God,” epistemological criticism proves the impossibility of knowing God, but the psyche comes forward with the assertion of the experience of God. God is a psychic fact of immediate experience, otherwise there would never have been any talk of God. The fact is valid in itself, requiring no non-psychological proof and inaccessible to any form of non-psychological criticism. It can be the most immediate and hence the most real of experiences, which can be neither ridiculed nor disproved. Only people with a poorly developed sense of fact, or who are obstinately superstitious, could deny this truth. So long as the experience of God does not claim universal validity or assert the absolute existence of God, criticism is impossible; for an irrational fact, such as, for instance, the existence of elephants, cannot be criticized. Nevertheless, the experience of God has general validity inasmuch as almost everyone knows approximately what is meant by the term “experience of God.” As a fact occurring with relative frequency it must be recognized by a scientific psychology. Nor can we simply turn our backs on what is decried as superstition. When a person asserts that he has seen ghosts or that he is bewitched, and it means more to him than just talk, then again we are dealing with a fact of experience, and one so general that everyone knows what is meant by “ghost” or by being “bewitched.” We can therefore be sure that even in these cases we are confronted with a definite complex of psychic facts which, as such, are just as “real” as the light I see. I do not know how I could prove the existence of the ghost of a dead person in empirical reality, nor can I imagine the logical method whereby I could deduce with certainty the continuance of life after death; but, none the less, I have to reckon with the fact that at all times and in all places the psyche has claimed to experience ghosts. I have to take this into consideration, just as much as the fact that many people flatly deny this subjective experience.

[626] After this more general discussion I would now like to come back to the concept of spirit, which we were unable to grasp from our former realistic standpoint. Spirit, like God, denotes an object of psychic experience which cannot be proved to exist in the external world and cannot be understood rationally. This is its meaning if we use the word “spirit” in its best sense. Once we have freed ourselves from the prejudice that we have to refer a concept either to objects of external experience or to *a priori* categories of reason, we can turn our attention and curiosity wholly to that strange and still unknown thing we call “spirit.” It is always useful in such cases to take a glance at the probable etymology of the word, because it often happens that a word’s history throws a surprising light on the nature of the psychic fact underlying it.

[627] In Old High German *Geist*, and in Anglo-Saxon *gāst*, meant a supernatural being in contradistinction to the body. According to Kluge, the fundamental meaning of the word is not quite certain, though there seem to be connections with the Old Norse *geisa*, ‘to rage’, with the Gothic *us-gaisyan*, ‘to be beside oneself’, with the Swiss-German *üf-gaistä*, ‘to fly into a passion’, and with the English *aghast*. These connections are substantiated by other figures of speech. For a person “to be seized with rage” means that something falls on him, sits on him, rides him, he is ridden by the devil, he is possessed, something has got into him, etc. At the pre-psychological stage, and also in poetic language, which owes its power to its vital primitivity, emotions and affects are often personified as daemons. To be in love is to be “struck by Cupid’s arrow,” or “Eris has thrown the apple of discord,” and so on. When we are “beside ourselves with rage” we are obviously no longer identical with ourselves, but are possessed by a daemon or spirit.

[628] The primitive atmosphere in which the word “spirit” came to birth exists in us still, though of course on a psychic level somewhere below consciousness. But as modern spiritualism shows, it needs very little to bring that bit of primitive mentality to the surface. If the etymological derivation (which in itself is quite plausible) holds good, then “spirit” in this sense would be the image of a personified affect. For instance, when a person lets himself be carried away by imprudent talk, we say his tongue has run away with him, which is equivalent to saying that his talk has become an independent being that has snatched him up and run off with him. Psychologically we would say: every affect tends to become an autonomous complex, to break away from the hierarchy of consciousness and, if possible, to drag the ego after it. No wonder, then, that the primitive mind sees in this the activity of a strange invisible being, a spirit. Spirit in this case is the reflection of an autonomous affect, which is why the ancients, very appropriately, called the spirits *imagines*, ‘images’.

[629] Let us now turn to other usages of the concept “spirit.” The phrase “he acts in the spirit of his dead father” still has a double meaning, for here the word “spirit” refers as much to the spirit of the dead as to an attitude of mind. Other idioms are “doing something in a new spirit” or “a new spirit is growing up,” meaning a renewal of mental attitude. The basic idea is again that of possession by a spirit, which has become, say, the “guiding spirit” of a group. A more sombre note is struck when we say: “An evil spirit reigns in that family.”

[630] Here we are dealing not with personifications of affects but with visualizations of a whole frame of mind or—to put it psychologically—an attitude. A bad attitude expressed as an evil spirit therefore has, if naïvely conceived, nearly the same psychological function as a personified affect. This may be surprising to many people, since “attitude” is ordinarily understood as taking an attitude towards

something, an ego-activity in short, implying purposefulness. However, an attitude or frame of mind is by no means always a product of volition; more often it owes its peculiarity to mental contagion, i.e., to example and the influence of environment. It is a well-known fact that there are people whose bad attitude poisons the atmosphere; their bad example is contagious, they make others nervous by their intolerableness. At school a single mischief-maker can spoil the spirit of a whole class; and conversely, the joyous, innocent disposition of a child can brighten and irradiate the otherwise dreary atmosphere of a family, which is naturally only possible when the attitude of each individual in it is bettered by the good example. An attitude can also take effect even against the conscious will—"bad company spoils good manners." This is particularly evident in mass-suggestion.

[631] The attitude or disposition, then, can thrust itself on consciousness from outside or from inside, like an affect, and can therefore be expressed by the same figures of speech. An attitude seems, at first glance, to be something very much more complicated than an affect. On closer inspection, however, we find that this is not so, because most attitudes are based, consciously or unconsciously, on some kind of *maxim*, which often has the character of a proverb. In some attitudes one can immediately detect the underlying maxim and even discover where it was picked up. Often the attitude is distinguished only by a single word, which as a rule stands for an ideal. Not infrequently, the quintessence of an attitude is neither a maxim nor an ideal but a personality who is revered and emulated.

[632] Educators make use of these psychological facts and try to suggest suitable attitudes by means of maxims and ideals, and some of them may indeed remain effective throughout life as permanent guiding principles. They take possession of a person like spirits. On a more primitive level it is the vision of the Master, the shepherd, the *poimen* or *poimandres*, who personifies the guiding principles and concretizes them in a symbolical figure.

[633] Here we approach a concept of "spirit" that goes far beyond the animistic frame of reference. Aphorisms and proverbs are as a rule the result of much experience and individual effort, a summing up of insights and conclusions in a few pregnant words. If you subject the Gospel saying "The first shall be last" to a thorough analysis, and try to reconstruct all the experiences that have been distilled into this quintessence of life's wisdom, you cannot but marvel at the fullness and mellowness of the experience behind it. It is an "impressive" saying, which strikes upon the receptive mind with great power, and perhaps retains possession of it for ever. Those sayings or ideals that store up the richest experience of life and the deepest reflection constitute what we call "spirit" in the best sense of the word. When a ruling principle of this kind attains absolute mastery we speak of the life lived under its guidance as "ruled

by the spirit,” or as a “spiritual life.” The more absolute and compelling the ruling idea, the more it has the nature of an autonomous complex that confronts the ego-consciousness as an unshakable fact.

[634] We must not forget, however, that such maxims and ideals, even the best of them, are not magic spells whose power is absolute, but that they gain mastery only under certain conditions, when there is something in us that responds to them, an affect that is ready to seize hold of the proffered form. Only under the stress of emotion can the idea, or whatever the ruling principle may be, become an autonomous complex; without this the idea remains a concept subservient to the arbitrary opinions of the conscious mind, a mere intellectual counter with no compelling power behind it. An idea that is nothing but an intellectual counter can have no influence on life, because in this state it is little more than an empty word. Conversely, once the idea attains the status of an autonomous complex, it works on the individual through his emotions.

[635] One should not think of these autonomous attitudes as coming about through conscious volition and conscious choice. When I say that the help of emotion is needed, I could just as well have said that besides the conscious will there must be an unconscious readiness to bring about an autonomous attitude. You cannot, so to speak, *will* to be spiritual. Those principles we can select and strive for always remain within the sphere of our judgment and under our conscious control; hence they can never turn into something that dominates the conscious will. It is far more a matter of fate what principle will rule our attitude.

[636] The question will certainly be asked whether for some people their own free will may not be the ruling principle, so that every attitude is intentionally chosen by themselves. I do not believe that anyone reaches or has ever reached this godlike state, but I know that there are many who strive after this ideal because they are possessed by the heroic idea of absolute freedom. In one way or another all men are dependent; all are in some way limited, since none are gods.

[637] The truth is that our conscious mind does not express the whole of our human nature; it is and remains only a part. In the introductory section of my lecture I mentioned the possibility that our ego-consciousness is not the only sort of consciousness in our system, but might perhaps be subordinate to a wider consciousness, just as simpler complexes are subordinate to the ego-complex.

[638] I would not know how we could ever prove that a consciousness higher or wider than the ego-consciousness exists in us; but, if it does exist, the ego-consciousness must find it acutely disturbing. A simple example will make clear what I mean. Let us imagine that our optical system had a consciousness of its own and was therefore a kind of personality, which we shall call the “eye-personality.” This “eye-personality” has, let us say, discovered a beautiful view and is lost in contemplation of it. All of a

sudden the auditory system hears the horn of an automobile. This perception remains unconscious to the optical system. From the ego there now follows, again in a way unconscious to the optical system, an order to the muscles to move the body to another position in space. Through this movement the object is suddenly taken away from the eye-consciousness. If the eyes could think, they would naturally come to the conclusion that the light-world was subject to all sorts of obscure disturbances.

[639] Something of the sort would be bound to happen if a wider consciousness exists, a consciousness which, as I suggested before, would be an image of the whole man. Are there in fact obscure disturbances of this kind, which no will can control and no purpose deflect? And is there anywhere in us something intangible that might conceivably be the source of such disturbances? To the first question we can answer yes, without more ado. In normal people, not to speak of neurotics, we can easily observe the most obvious interferences and disturbances from another sphere. A mood may suddenly change, a headache comes upon us unawares, the name of a friend we are about to introduce vanishes into thin air, a melody pursues us for a whole day, we want to do something but the energy for it has in some inexplicable way disappeared. We forget what we least wanted to forget, we resign ourselves happily to sleep and sleep is snatched away from us, or we sleep and our slumber is disturbed by fantastic, annoying dreams; spectacles resting on our nose are searched for, the new umbrella is left we know not where. As to the psychology of neurotics, we find ourselves confronted with the most paradoxical disturbances. Amazing pathological symptoms develop, yet no organ is diseased. Without the least organic disorder the patient's temperature may shoot up to over 105° F., or there may be suffocating states of anxiety without any real foundation, obsessive ideas whose senselessness is apparent even to the patient, skin-rashes that come and go regardless of all reason and all therapy. For each case an explanation can naturally be found, either good or bad, though it entirely fails to explain the next case. Yet there can be no doubt about the existence of the disturbances.

[640] Coming now to the second question, the source of the disturbances. We know that medical psychology has put forward the concept of the unconscious, and has demonstrated that these disturbances depend on unconscious processes. It is as though the "eye-personality" had discovered that there must be invisible determining factors as well as visible ones. If the facts do not deceive us, the unconscious processes are far from being unintelligent. The character of automatism and mechanism is lacking to them, even to a striking degree. They are not in the least inferior to the conscious processes in subtlety; on the contrary, they often far surpass our conscious insights.

[641] Our imaginary “eye-personality” might doubt that the sudden disturbances of its light-world came from another consciousness. Similarly, we can be sceptical about a wider consciousness, though with no more ground for scepticism than the eye-personality would have. But as we cannot attain to such a state of wider consciousness or understand it, we would do well to call that dark region, from our point of view, the “unconscious,” without jumping to the conclusion that it is necessarily unconscious of itself.

[642] I have returned at this point in the discussion to my previous hypothesis of a higher consciousness because the problem we are concerned with here, namely the life-ruling power of the spirit, is connected with processes outside ego-consciousness. A little further back I mentioned in passing that an idea which lacks emotional force can never become a life-ruling factor. I also said it was a matter of fate what kind of attitude or “spirit” would develop, in order to emphasize that the conscious mind is not in a position to create an autonomous complex at will. It is not autonomous unless it comes upon us forcibly, and visibly proves its superiority to the conscious will. It, too, is one of those disturbances that arise out of the dark regions. When I said earlier that an idea must evoke a response from the emotions, I meant an unconscious readiness which, because of its affective nature, springs from deeper levels that are quite inaccessible to consciousness. Thus, our conscious reason can never destroy the roots of nervous symptoms; for this emotional processes are needed, which even have the power to influence the sympathetic nervous system. We could equally well say that when the wider consciousness sees fit, a compelling idea is put before the ego-consciousness as an unconditional command. Anyone who is conscious of his guiding principle knows with what indisputable authority it rules his life. But generally consciousness is too preoccupied with the attainment of some beckoning goal to consider the nature of the spirit that determines its course.

[643] From the psychological point of view the phenomenon of spirit, like every autonomous complex, appears as an intention of the unconscious superior to, or at least on a par with, the intentions of the ego. If we are to do justice to the essence of the thing we call spirit, we should really speak of a “higher” consciousness rather than of the unconscious, because the concept of spirit is such that we are bound to connect it with the idea of superiority over the ego-consciousness. The superiority of the spirit is not something attributed to it by conscious reflection, but clings to it as an essential quality, as is evident from the records of all ages, from the Holy Scriptures down to Nietzsche’s *Zarathustra*. Psychologically, the spirit manifests itself as a personal being, sometimes with visionary clarity; in Christian dogma it is actually the third Person of the Trinity. These facts show that spirit is not always merely a maxim or an idea that can be formulated, but that in its strongest and most immediate manifestations it displays a peculiar life of its own which is felt as an

independent being. So long as the spirit can be named and formulated as an intelligible principle or a clear idea, it will certainly not be felt as an independent being. But when the idea or principle involved is inscrutable, when its intentions are obscure in origin and in aim and yet enforce themselves, then the spirit is necessarily felt as an independent being, as a kind of higher consciousness, and its inscrutable, superior nature can no longer be expressed in the concepts of human reason. Our powers of expression then have recourse to other means; they create a *symbol*.

[644] By a symbol I do not mean an allegory or a sign, but an image that describes in the best possible way the dimly discerned nature of the spirit. A symbol does not define or explain; it points beyond itself to a meaning that is darkly divined yet still beyond our grasp, and cannot be adequately expressed in the familiar words of our language. Spirit that can be translated into a definite concept is a psychic complex lying within the orbit of our ego-consciousness. It will not bring forth anything, nor will it achieve anything more than we have put into it. But spirit that demands a symbol for its expression is a psychic complex that contains the seeds of incalculable possibilities. The most obvious and best example of this is the effectiveness of the Christian symbols, whose power changed the face of history. If one looks without prejudice at the way the spirit of early Christianity worked on the mind of the average man of the second century, one can only be amazed. But then, no spirit was ever as creative as this. No wonder it was felt to be of godlike superiority.

[645] It is this clear feeling of superiority that gives the phenomenon of the spirit its revelatory character and absolute authority—a dangerous quality, to be sure; for what we might perhaps call “higher” consciousness is not always higher from the point of view of our conscious values and often contrasts violently with our accepted ideals. One should, strictly speaking, describe this hypothetical consciousness simply as a “wider” one, so as not to arouse the prejudice that it is necessarily higher in the intellectual or moral sense. There are many spirits, both light and dark. We should, therefore, be prepared to accept the view that spirit is not absolute, but something relative that needs completing and perfecting through life. There are all too many cases of men so possessed by a spirit that the man does not live any more but only the spirit, and in a way that does not bring him a richer and fuller life but only cripples him. I am far from implying that the death of a Christian martyr was a meaningless and purposeless act of destruction—on the contrary, such a death can also mean a fuller life than any other—rather, I refer to the spirit of certain sects which wholly deny life. Naturally the strict Montanist view was in accord with the highest moral demands of the age, but it destroyed life all the same. What is to become of the spirit when it has exterminated man? I believe, therefore, that a spirit which accords with our highest ideals will find its limits set by life. It is certainly necessary for life, since a mere ego-life, as we well know, is a most inadequate and unsatisfactory thing. Only

a life lived in a certain spirit is worth living. It is a remarkable fact that a life lived entirely from the ego is dull not only for the person himself but for all concerned. The fullness of life requires more than just an ego; it needs spirit, that is, an independent, overruling complex, for it seems that this alone is capable of giving vital expression to those psychic potentialities that lie beyond the reach of ego-consciousness.

[646] But, just as there is a passion that strives for blind unrestricted life, so there is a passion that would like to sacrifice all life to the spirit because of its superior creative power. This passion turns the spirit into a malignant growth that senselessly destroys human life.

[647] Life is a touchstone for the truth of the spirit. Spirit that drags a man away from life, seeking fulfilment only in itself, is a false spirit—though the man too is to blame, since he can choose whether he will give himself up to this spirit or not.

[648] Life and spirit are two powers or necessities between which man is placed. Spirit gives meaning to his life, and the possibility of its greatest development. But life is essential to spirit, since its truth is nothing if it cannot live.

BASIC POSTULATES OF ANALYTICAL PSYCHOLOGY¹

[649] It was universally believed in the Middle Ages as well as in the Greco-Roman world that the soul is a substance. Indeed, mankind as a whole has held this belief from its earliest beginnings, and it was left for the second half of the nineteenth century to develop a “psychology without the soul.” Under the influence of scientific materialism, everything that could not be seen with the eyes or touched with the hands was held in doubt; such things were even laughed at because of their supposed affinity with metaphysics. Nothing was considered “scientific” or admitted to be true unless it could be perceived by the senses or traced back to physical causes. This radical change of view did not begin with philosophical materialism, for the way was being prepared long before. When the spiritual catastrophe of the Reformation put an end to the Gothic Age, with its impetuous yearning for the heights, its geographical confinement, and its restricted view of the world, the vertical outlook of the European mind was henceforth cut across by the horizontal outlook of modern times. Consciousness ceased to grow upward, and grew instead in breadth of view, geographically as well as philosophically. This was the age of the great voyages, of the widening of man’s mental horizon by empirical discoveries. Belief in the substantiality of things spiritual yielded more and more to the obtrusive conviction that material things alone have substance, till at last, after nearly four hundred years, the leading European thinkers and investigators came to regard the mind as wholly dependent on matter and material causation.

[650] We are certainly not justified in saying that philosophy or natural science has brought about this complete *volte-face*. There were always a fair number of intelligent philosophers and scientists who had enough insight and depth of thought to accept this irrational reversal of standpoint only under protest; a few even resisted it, but they had no following and were powerless against the wave of unreasoning, not to say excitable, surrender to the all-importance of the physical world. Let no one suppose that so radical a change in man’s outlook could be brought about by reasoned reflection, for no chain of reasoning can prove or disprove the existence of either mind or matter. Both these concepts, as every intelligent person today can ascertain for himself, are mere symbols that stand for something unknown and unexplored, and this something is postulated or denied according to the temperament of the individual or as the spirit of the age dictates. There is nothing to prevent the speculative intellect from treating the mind as a complicated biochemical phenomenon and at bottom a mere play of electrons, or on the other hand from

regarding the unpredictable behaviour of electrons as the sign of mental life even in them.

[651] The fact that a metaphysics of the mind was supplanted in the nineteenth century by a metaphysics of matter is, intellectually considered, a mere trick, but from the psychological point of view it is an unexampled revolution in man's outlook. Otherworldliness is converted into matter-of-factness; empirical boundaries are set to every discussion of man's motivations, to his aims and purposes, and even to the assignment of "meaning." The whole invisible inner world seems to have become the visible outer world, and no value exists unless founded on a so-called fact. At least, this is how it appears to the simple mind.

[652] It is futile, indeed, to treat this irrational change of opinion as a question of philosophy. We had better not try to do so, for if we maintain that mental and psychic phenomena arise from the activity of the glands we can be sure of the respect and applause of our contemporaries, whereas if we attempted to explain the break up of atoms in the sun as an emanation of the creative *Weltgeist* we should be looked upon as intellectual cranks. And yet both views are equally logical, equally metaphysical, equally arbitrary and equally symbolic. From the standpoint of epistemology it is just as admissible to derive animals from the human species as man from the animal species. But we know how ill Dacqué² fared in his academic career because of his sin against the spirit of the age, which will not let itself be trifled with. It is a religion or, better, a creed which has absolutely no connection with reason, but whose significance lies in the unpleasant fact that it is taken as the absolute measure of all truth and is supposed always to have common sense on its side.

[653] The spirit of the age cannot be fitted into the categories of human reason. It is more a bias, an emotional tendency that works upon weaker minds, through the unconscious, with an overwhelming force of suggestion that carries them along with it. To think otherwise than as our contemporaries think is somehow illegitimate and disturbing; it is even indecent, morbid or blasphemous, and therefore socially dangerous for the individual. He is stupidly swimming against the social current. Just as formerly the assumption was unquestionable that everything that exists originates in the creative will of a God who is a spirit, so the nineteenth century discovered the equally unquestionable truth that everything arises from material causes. Today the psyche does not build itself a body, but on the contrary matter, by chemical action, produces the psyche. This reversal of outlook would be ludicrous if it were not one of the unquestioned verities of the spirit of the age. It is the popular way of thinking, and therefore it is decent, reasonable, scientific, and normal. Mind must be thought of as an epiphenomenon of matter. The same conclusion is reached even if we say not "mind" but "psyche," and instead of "matter" speak of "brain," "hormones,"

“instincts,” and “drives.” To allow the soul or psyche a substantiality of its own is repugnant to the spirit of the age, for that would be heresy.

[654] We have now discovered that it was an intellectually unjustified presumption on our forefathers' part to assume that man has a soul; that that soul has substance, is of divine nature and therefore immortal; that there is a power inherent within it which builds up the body, sustains its life, heals its ills and enables the soul to live independently of the body; that there are incorporeal spirits with which the soul associates; and that beyond our empirical present there is a spiritual world from which the soul receives knowledge of spiritual things whose origins cannot be discovered in this visible world. But people who are not above the general level of consciousness have not yet discovered that it is just as presumptuous and fantastic to assume that matter produces mind, that apes give rise to human beings, that from the harmonious interplay of the drives of hunger, love, and power Kant's *Critique of Pure Reason* should have emerged, and that all this could not possibly be other than it is.

[655] What or who, indeed, is this all-powerful matter? It is the old Creator God over again, stripped this time of his anthropomorphic features and taking the form of a universal concept whose meaning everyone presumes to understand. Consciousness today has grown enormously in breadth and extent, but unfortunately only in the spatial dimension and not in the temporal, otherwise we should have a much more living sense of history. If our consciousness were not of today only, but had historical continuity, we should be reminded of similar transformations of the gods in Greek philosophy, and this might dispose us to be more critical of our present philosophical assumptions. We are, however, effectively prevented from indulging in such reflections by the spirit of the age. History, for it, is a mere arsenal of convenient arguments that enables us, on occasion, to say: “Why, even old Aristotle knew that.” This being so, we must ask ourselves how the spirit of the age attains such uncanny power. It is without doubt a psychic phenomenon of the greatest importance—at all events, a prejudice so deeply rooted that until we give it proper consideration we cannot even approach the problem of the psyche.

[656] As I have said, the irresistible tendency to explain everything on physical grounds corresponds to the horizontal development of consciousness in the last four centuries, and this horizontal perspective is a reaction against the exclusively vertical perspective of the Gothic Age. It is an ethnopsychological phenomenon, and as such cannot be treated in terms of individual consciousness. Like primitives, we are at first wholly unconscious of our actions, and only discover long afterwards why it was that we acted in a certain way. In the meantime, we content ourselves with all sorts of rationalizations of our behaviour, all of them equally inadequate.

[657] If we were conscious of the spirit of the age, we should know why we are so inclined to account for everything on physical grounds; we should know that it is because, up till now, too much was accounted for in terms of spirit. This realization would at once make us critical of our bias. We would say: most likely we are now making exactly the same mistake on the other side. We delude ourselves with the thought that we know much more about matter than about a “metaphysical” mind or spirit, and so we overestimate material causation and believe that it alone affords us a true explanation of life. But matter is just as inscrutable as mind. As to the ultimate things we can know nothing, and only when we admit this do we return to a state of equilibrium. This is in no sense to deny the close connection of psychic happenings with the physiological structure of the brain, with the glands and the body in general. We still remain deeply convinced of the fact that the contents of consciousness are to a large extent determined by our sense-perceptions. We cannot fail to recognize that unalterable characteristics of a physical as well as a psychic nature are unconsciously ingrained in us by heredity, and we are profoundly impressed by the power of the instincts which can inhibit or reinforce or otherwise modify even the most spiritual contents. Indeed, we must admit that as to cause, purpose, and meaning the human psyche, wherever we touch it, is first and foremost a faithful reflection of everything we call material, empirical, and mundane. And finally, in face of all these admissions, we must ask ourselves if the psyche is not after all a secondary manifestation—an epiphenomenon—and completely dependent on the physical substrate. Our practical reasonableness and worldly-mindedness prompt us to say yes to this question, and it is only our doubts as to the omnipotence of matter that might lead us to examine in a critical way this verdict of science upon the human psyche.

[658] The objection has already been raised that this view reduces psychic happenings to a kind of activity of the glands; thoughts are regarded as secretions of the brain, and thus we achieve a psychology without the psyche. From this standpoint, it must be confessed, the psyche does not exist in its own right; it is nothing in itself, but is the mere expression of processes in the physical substrate. That these processes have the quality of consciousness is just an irreducible fact—were it otherwise, so the argument runs, we could not speak of psyche at all; there would be no consciousness, and so we should have nothing to say about anything. Consciousness, therefore, is taken as the *sine qua non* of psychic life, that is to say, as the psyche itself. And so it comes about that all modern “psychologies without the psyche” are psychologies of consciousness, for which an unconscious psychic life simply does not exist.

[659] For there is not *one* modern psychology—there are dozens of them. This is curious enough when we remember that there is only one science of mathematics, of geology, zoology, botany, and so forth. But there are so many psychologies that an American university was able to publish a thick volume under the title *Psychologies*

of 1930.³ I believe there are as many psychologies as philosophies, for there is also no single philosophy, but many. I mention this for the reason that philosophy and psychology are linked by indissoluble bonds which are kept in being by the interrelation of their subject-matters. Psychology takes the psyche for its subject, and philosophy—to put it briefly—takes the world. Until recently psychology was a special branch of philosophy, but now we are coming to something which Nietzsche foresaw—the rise of psychology in its own right, so much so that it is even threatening to swallow philosophy. The inner resemblance between the two disciplines consists in this, that both are systems of opinion about objects which cannot be fully experienced and therefore cannot be adequately comprehended by a purely empirical approach. Both fields of study thus encourage speculation, with the result that opinions are formed in such variety and profusion that many heavy volumes are needed to contain them all. Neither discipline can do without the other, and the one invariably furnishes the unspoken—and generally unconscious—assumptions of the other.

[660] The modern belief in the primacy of physical explanations has led, as already remarked, to a “psychology without the psyche,” that is, to the view that the psyche is nothing but a product of biochemical processes. As for a modern, scientific psychology which starts from the spirit as such, there simply is none. No one today would venture to found a scientific psychology on the postulate of a psyche independent of the body. The idea of spirit in and for itself, of a self-contained spiritual world-system, which would be the necessary postulate for the existence of autonomous individual souls, is extremely unpopular with us, to say the least. But here I must remark that, in 1914, I attended at Bedford College, London, a joint session of the Aristotelian Society, the Mind Association, and the British Psychological Society, at which a symposium was held on the question, “Are individual minds contained in God or not?” Should anyone in England dispute the scientific standing of these societies he would not receive a very cordial hearing, for their members include the cream of the British intelligentsia. And perhaps I was the only person in the audience who listened with astonishment to arguments that had the ring of the thirteenth century. This instance may serve to show that the idea of an autonomous spirit whose existence is taken for granted has not died out everywhere in Europe or become a mere fossil left over from the Middle Ages.

[661] If we keep this in mind, we can perhaps summon up courage to consider the possibility of a “psychology *with* the psyche”—that is, a theory of the psyche ultimately based on the postulate of an autonomous, spiritual principle. We need not be alarmed at the unpopularity of such an undertaking, for to postulate “spirit” is no more fantastic than to postulate “matter.” Since we have literally no idea how the psychic can arise out of the physical, and yet cannot deny the reality of psychic

events, we are free to frame our assumptions the other way about for once, and to suppose that the psyche arises from a spiritual principle which is as inaccessible to our understanding as matter. It will certainly not be a modern psychology, for to be modern is to deny such a possibility. For better or worse, therefore, we must turn back to the teachings of our forefathers, for it was they who made such assumptions.

[662] The ancient view held that the soul was essentially the life of the body, the life-breath, or a kind of life force which assumed spatial and corporeal form at the moment of conception, or during pregnancy, or at birth, and left the dying body again after the final breath. The soul in itself was a being without extension, and because it existed before taking corporeal form and afterwards as well, it was considered timeless and hence immortal. From the standpoint of modern, scientific psychology, this conception is of course pure illusion. But as it is not our intention to indulge in “metaphysics,” even of a modern variety, we will examine this time-honoured notion for once in an unprejudiced way and test its empirical justification.

[663] The names people give to their experiences are often very revealing. What is the origin of the word *Seele*? Like the English word *soul*, it comes from the Gothic *saiwala* and the old German *saiwalô*, and these can be connected etymologically with the Greek *aiolos*, ‘quick-moving, twinkling, iridescent’. The Greek word *psyche* also means ‘butterfly’. *Saiwalô* is related on the other side to the Old Slavonic *sila*, ‘strength’. These connections throw light on the original meaning of the word *soul*: it is moving force, that is, life-force.

[664] The Latin words *animus*, ‘spirit’, and *anima*, ‘soul’, are the same as the Greek *anemos*, ‘wind’. The other Greek word for ‘wind’, *pneuma*, also means ‘spirit’. In Gothic we find the same word in *us-anan*, ‘to breathe out’, and in Latin it is *anhelare*, ‘to pant’. In Old High German, *spiritus sanctus* was rendered by *atum*, ‘breath’. In Arabic, ‘wind’ is *rîh*, and *rûh* is ‘soul, spirit’. The Greek word *psyche* has similar connections; it is related to *psychein*, ‘to breathe’, *psychos*, ‘cool’, *psychros*, ‘cold, chill’, and *physa*, ‘bellows’. These connections show clearly how in Latin, Greek, and Arabic the names given to the soul are related to the notion of moving air, the “cold breath of the spirits.” And this is probably the reason why the primitive view also endows the soul with an invisible breath-body.

[665] It is quite understandable that, since breath is the sign of life, it should be taken for life, as are also movement and moving force. According to another primitive view the soul is a fire or flame, because warmth is likewise a sign of life. A very curious, but by no means rare, primitive conception identifies the soul with the name. The name of an individual is his soul, and hence arises the custom of using the ancestor’s name to reincarnate the ancestral soul in the new-born child. This means nothing less than that ego-consciousness is recognized as being an expression of the soul. Very

often the soul is also identified with the shadow, hence it is a deadly insult to tread on a person's shadow. For the same reason noonday, the ghost-hour of southern latitudes, is considered threatening; one's shadow then grows small, and this means that life is endangered. This conception of the shadow contains an idea which was indicated by the Greeks in the word *synopados*, 'he who follows behind'. They expressed in this way the feeling of an intangible, living presence—the same feeling which led to the belief that the souls of the departed were "shades."

[666] These indications may serve to show how primitive man experienced the psyche. To him the psyche appears as the source of life, the prime mover, a ghostlike presence which has objective reality. Therefore the primitive knows how to converse with his soul; it becomes vocal within him because it is not simply he himself and his consciousness. To primitive man the psyche is not, as it is to us, the epitome of all that is subjective and subject to the will; on the contrary, it is something objective, self-subsistent, and living its own life.

[667] This way of looking at the matter is empirically justified, for not only on the primitive level, but with civilized man as well, psychic happenings have an objective side. In large measure they are withdrawn from our conscious control. We are unable, for example, to suppress many of our emotions; we cannot change a bad mood into a good one, and we cannot command our dreams to come or go. The most intelligent man may be obsessed at times with thoughts which he cannot drive away even with the greatest effort of will. The mad tricks that memory plays sometimes leave us in helpless amazement, and at any time unexpected fantasies may run through our heads. We believe that we are masters in our own house only because we like to flatter ourselves. In reality we are dependent to a startling degree on the proper functioning of the unconscious psyche, and must trust that it does not fail us. If we study the psychic processes of neurotic persons, it seems perfectly ludicrous that any psychologist could take the psyche as the equivalent of consciousness. And it is well known that the psychic processes of neurotics differ hardly at all from those of so-called normal persons—for what man today is quite sure that he is not neurotic?

[668] This being so, we shall do well to admit that there is some justification for the old view of the soul as an objective reality—as something independent, and therefore capricious and dangerous. The further assumption that this being, so mysterious and frightening, is at the same time the source of life is also understandable in the light of psychology. Experience shows us that the sense of the "I"—the ego-consciousness—grows out of unconscious life. The small child has psychic life without any demonstrable ego-consciousness, for which reason the earliest years leave hardly any traces in the memory. Where do all our good and helpful flashes of intelligence come from? What is the source of our enthusiasms, inspirations, and of our heightened

feeling of vitality? The primitive senses in the depths of his soul the springs of life; he is deeply impressed by the life-giving activity of his soul, and he therefore believes in everything that affects it—in magical practices of every kind. That is why, for him, the soul is life itself. He does not imagine that he directs it, but feels himself dependent on it in every respect.

[669] However preposterous the idea of the immortality of the soul may seem to us, it is nothing extraordinary to the primitive. The soul is, after all, something out of the common. While everything else that exists takes up a certain amount of room, the soul cannot be located in space. We suppose, of course, that our thoughts are in our heads, but when it comes to our feelings we begin to be uncertain; they appear to dwell more in the region of the heart. Our sensations are distributed over the whole body. Our theory is that the seat of consciousness is in the head, but the Pueblo Indians told me that the Americans were mad because they believed their thoughts were in their heads, whereas any sensible man knows that he thinks with his heart. Certain Negro tribes locate their psychic functioning neither in the head nor in the heart, but in the belly.

[670] To this uncertainty about the localization of psychic functions another difficulty is added. Psychic contents in general are nonspatial except in the particular realm of sensation. What bulk can we ascribe to thoughts? Are they small, large, long, thin, heavy, fluid, straight, circular, or what? If we wished to form a living picture of a non-spatial, fourth-dimensional being, we could not do better than to take thought for our model.

[671] It would all be so much simpler if only we could deny the existence of the psyche. But here we are with our immediate experiences of something that *is*—something that has taken root in the midst of our measurable, ponderable, three-dimensional reality, that differs mysteriously from this in every respect and in all its parts, and yet reflects it. The psyche could be regarded as a mathematical point and at the same time as a universe of fixed stars. It is small wonder, then, if, to the unsophisticated mind, such a paradoxical being borders on the divine. If it occupies no space, it has no body. Bodies die, but can something invisible and incorporeal disappear? What is more, life and psyche existed for me before I could say “I,” and when this “I” disappears, as in sleep or unconsciousness, life and psyche still go on, as our observation of other people and our own dreams inform us. Why should the simple mind deny, in the face of such experiences, that the “soul” lives in a realm beyond the body? I must admit that I can see as little nonsense in this so-called superstition as in the findings of research regarding heredity or the instincts.

[672] We can easily understand why higher and even divine knowledge was formerly attributed to the soul if we remember that in ancient cultures, beginning with

primitive times, man always resorted to dreams and visions as a source of information. It is a fact that the unconscious contains subliminal perceptions whose scope is nothing less than astounding. In recognition of this fact, primitive societies used dreams and visions as important sources of information. Great and enduring civilizations like those of India and China were built upon this psychological foundation and developed from it a discipline of self-knowledge which they brought to a high pitch of refinement both in philosophy and in practice.

[673] A high regard for the unconscious psyche as a source of knowledge is not nearly such a delusion as our Western rationalism likes to suppose. We are inclined to assume that in the last resort all knowledge comes from without. Yet today we know for certain that the unconscious has contents which would bring an immeasurable increase of knowledge if they could only be made conscious. Modern investigation of animal instinct, for instance in insects, has brought together a rich fund of empirical material which shows that if man sometimes acted as certain insects do he would possess a higher intelligence than at present. It cannot, of course, be proved that insects possess conscious knowledge, but common sense cannot doubt that their unconscious patterns of behaviour are psychic functions. Man's unconscious likewise contains all the patterns of life and behaviour inherited from his ancestors, so that every human child is possessed of a ready-made system of adapted psychic functioning prior to all consciousness. In the conscious life of the adult as well this unconscious, instinctive functioning is continually present and active. In this activity all the functions of the conscious psyche are prefigured. The unconscious perceives, has purposes and intuitions, feels and thinks as does the conscious mind. We find sufficient evidence for this in the field of psychopathology and the investigation of dream-processes. Only in one respect is there an essential difference between the conscious and the unconscious functioning of the psyche. Though consciousness is intensive and concentrated, it is transitory and is trained upon the immediate present and the immediate field of attention; moreover, it has access only to material that represents one individual's experience stretching over a few decades. A wider range of "memory" is an artificial acquisition consisting mostly of printed paper. But matters stand very differently with the unconscious. It is not concentrated and intensive, but shades off into obscurity; it is highly extensive and can juxtapose the most heterogeneous elements in the most paradoxical way. More than this, it contains, besides an indeterminable number of subliminal perceptions, the accumulated deposits from the lives of our ancestors, who by their very existence have contributed to the differentiation of the species. If it were possible to personify the unconscious, we might think of it as a collective human being combining the characteristics of both sexes, transcending youth and age, birth and death, and, from having at its command a human experience of one or two million years, practically

immortal. If such a being existed, it would be exalted above all temporal change; the present would mean neither more nor less to it than any year in the hundredth millennium before Christ; it would be a dreamer of age-old dreams and, owing to its limitless experience, an incomparable prognosticator. It would have lived countless times over again the life of the individual, the family, the tribe, and the nation, and it would possess a living sense of the rhythm of growth, flowering, and decay.

[674] Unfortunately—or rather let us say, fortunately—this being dreams. At least it seems to us as if the collective unconscious, which appears to us in dreams, had no consciousness of its own contents, though of course we cannot be sure of this, any more than we can in the case of insects. The collective unconscious, moreover, seems to be not a person, but something like an unceasing stream or perhaps ocean of images and figures which drift into consciousness in our dreams or in abnormal states of mind.

[675] It would be positively grotesque to call this immense system of experience in the unconscious psyche an illusion, for our visible and tangible body is itself just such a system. It still carries within it evolutionary traces from primeval times, and it is certainly a whole that functions purposively—for otherwise we could not live. It would never occur to anyone to look upon comparative anatomy or physiology as nonsense, and neither can we dismiss the investigation of the collective unconscious as illusion or refuse to recognize it as a valuable source of knowledge.

[676] Looked at from the outside, the psyche appears to be essentially a reflection of external happenings—to be not only occasioned by them, but to have its origin in them. And it also seems to us, at first, that the unconscious can be explained only from the outside and from the side of consciousness. It is well known that Freud has attempted to do this—an undertaking which could succeed only if the unconscious were actually something that came into being with the existence and consciousness of the individual. But the truth is that the unconscious is always there beforehand as a system of inherited psychic functioning handed down from primeval times. Consciousness is a late-born descendant of the unconscious psyche. It would certainly show perversity if we tried to explain the lives of our ancestors in terms of their late descendants, and it is just as wrong, in my opinion, to regard the unconscious as a derivative of consciousness. We are probably nearer the truth if we put it the other way round.

[677] This was the standpoint of past ages, which, knowing the untold treasures of experience lying hidden beneath the threshold of the ephemeral individual consciousness, always held the individual soul to be dependent on a spiritual world-system. Not only did they make this hypothesis, they assumed without question that this system was a being with a will and consciousness—was even a person—and they

called this being God, the quintessence of reality. He was for them the most real of beings, the first cause, through whom alone the soul could be explained. There is some psychological justification for such an hypothesis, for it is only appropriate that an almost immortal being whose experience is almost eternal should be called, in comparison with man, “divine.”

[678] In the foregoing I have shown where the problems lie for a psychology that does not appeal to the physical world as a ground of explanation, but rather to a spiritual system whose active principle is neither matter and its qualities nor any state of energy, but God. At this juncture, we might be tempted by the modern brand of nature philosophy to call energy or the *élan vital* God, and thus to blend into one spirit and nature. So long as such an undertaking is restricted to the misty heights of speculative philosophy, no great harm is done. But if we should operate with this idea in the lower realm of practical psychology, where only practical explanations bear any fruit, we should soon find ourselves involved in the most hopeless difficulties. We do not profess a psychology with merely academic pretensions, or seek explanations that have no bearing on life. What we want is a practical psychology which yields approvable results—one which explains things in a way that must be justified by the outcome for the patient. In practical psychotherapy we strive to fit people for life, and we are not free to set up theories which do not concern our patients and may even injure them. Here we come to a question that is sometimes a matter of life and death—the question whether we base our explanations on “physis” or spirit. We must never forget that everything spiritual is illusion from the naturalistic standpoint, and that often the spirit has to deny and overcome an insistent physical fact in order to exist at all. If I recognize only naturalistic values, and explain everything in physical terms, I shall depreciate, hinder, or even destroy the spiritual development of my patients. And if I hold exclusively to a spiritual interpretation, then I shall misunderstand and do violence to the natural man in his right to exist as a physical being. More than a few suicides in the course of psychotherapeutic treatment are to be laid at the door of such mistakes. Whether energy is God or God is energy concerns me very little, for how, in any case, can I know such things? But to give appropriate psychological explanations—this I must be able to do.

[679] The modern psychologist occupies neither the one position nor the other, but finds himself between the two, dangerously committed to “this as well as that”—a situation which seductively opens the way to a shallow opportunism. This is undoubtedly the great danger of the *coincidentia oppositorum*—of intellectual freedom from the opposites. How should anything but a formless and aimless uncertainty result from giving equal value to two contradictory hypotheses? In contrast to this we can readily appreciate the advantage of an explanatory principle

that is unequivocal: it allows of a standpoint that can serve as a point of reference. Undoubtedly we are confronted here with a very difficult problem. We must be able to appeal to an explanatory principle founded on reality, and yet it is no longer possible for the modern psychologist to take his stand exclusively on the physical aspect of reality once he has given the spiritual aspect its due. Nor will he be able to put weight on the latter alone, for he cannot ignore the relative validity of the physical aspect. To what, then, can he appeal?

[680] The following reflections are my way of attempting to solve this problem. The conflict between nature and spirit is itself a reflection of the paradox of psychic life. This reveals a physical and a spiritual aspect which appear a contradiction because, ultimately, we do not understand the nature of psychic life itself. Whenever, with our human understanding, we want to make a statement about something which in the last analysis we have not grasped and cannot grasp, then we must, if we are honest, be willing to contradict ourselves, we must pull this something into its antithetical parts in order to be able to deal with it at all. The conflict between the physical and the spiritual aspects only shows that psychic life is in the last analysis an incomprehensible “something.” Without a doubt it is our only immediate experience. All that I experience is psychic. Even physical pain is a psychic image which I experience; my sense-impressions—for all that they force upon me a world of impenetrable objects occupying space—are psychic images, and these alone constitute my immediate experience, for they alone are the immediate objects of my consciousness. My own psyche even transforms and falsifies reality, and it does this to such a degree that I must resort to artificial means to determine what things are like apart from myself. Then I discover that a sound is a vibration of air of such and such a frequency, or that a colour is a wave of light of such and such a length. We are in truth so wrapped about by psychic images that we cannot penetrate at all to the essence of things external to ourselves. All our knowledge consists of the stuff of the psyche which, because it alone is immediate, is superlatively real. Here, then, is a reality to which the psychologist can appeal—namely, psychic reality.

[681] If we try to penetrate more deeply into the meaning of this concept, it seems to us that certain psychic contents or images are derived from a “material” environment to which our bodies belong, while others, which are in no way less real, seem to come from a “spiritual” source which appears to be very different from the physical environment. Whether I picture to myself the car I wish to buy or try to imagine the state in which the soul of my dead father now is—whether it is an external fact or a thought that concerns me—both happenings are psychic reality. The only difference is that one psychic happening refers to the physical world, and the other to the spiritual world. If I shift my concept of reality on to the plane of the psyche—where alone it is valid—this puts an end to the conflict between mind and matter, spirit and

nature, as contradictory explanatory principles. Each becomes a mere designation for the particular source of the psychic contents that crowd into my field of consciousness. If a fire burns me I do not question the reality of the fire, whereas if I am beset by the fear that a ghost will appear, I take refuge behind the thought that it is only an illusion. But just as the fire is the psychic image of a physical process whose nature is ultimately unknown, so my fear of the ghost is a psychic image from a spiritual source; it is just as real as the fire, for my fear is as real as the pain caused by the fire. As for the spiritual process that underlies my fear of the ghost, it is as unknown to me as the ultimate nature of matter. And just as it never occurs to me to account for the nature of fire except by the concepts of chemistry and physics, so I would never think of trying to explain my fear of ghosts except in terms of spiritual processes.

[682] The fact that all immediate experience is psychic and that immediate reality can only be psychic explains why it is that primitive man puts spirits and magical influences on the same plane as physical events. He has not yet torn his original experience into antithetical parts. In his world, spirit and matter still interpenetrate each other, and his gods still wander through forest and field. He is like a child, only half born, still enclosed in his own psyche as in a dream, in a world not yet distorted by the difficulties of understanding that beset a dawning intelligence. When this aboriginal world fell apart into spirit and nature, the West rescued nature for itself. It was prone by temperament to a belief in nature, and only became the more entangled in it with every painful effort to make itself spiritual. The East, on the other hand, took spirit for its own, and by explaining away matter as mere illusion—*Maya*—continued to dream in Asiatic filth and misery. But since there is only *one* earth and *one* mankind, East and West cannot rend humanity into two different halves. Psychic reality still exists in its original oneness, and awaits man's advance to a level of consciousness where he no longer believes in the one part and denies the other, but recognizes both as constituent elements of one psyche.

[683] We could well point to the idea of psychic reality as the most important achievement of modern psychology if it were recognized as such. It seems to me only a question of time for this idea to be generally accepted. It must be accepted in the end, for it alone enables us to understand the manifestations of the psyche in all their variety and uniqueness. Without this idea it is unavoidable that we should explain our psychic experiences in a way that does violence to a good half of them, while with it we can give its due to that side of psychic life which expresses itself in superstition and mythology, religion and philosophy. And this aspect of the psyche is not to be undervalued. Truth that appeals to the testimony of the senses may satisfy reason, but it offers nothing that stirs our feelings and expresses them by giving a meaning to human life. Yet it is most often feeling that is decisive in matters of good and evil,

and if feeling does not come to the aid of reason, the latter is usually powerless. Did reason and good intentions save us from the World War, or have they ever saved us from any other catastrophic stupidity? Have any of the great spiritual and social revolutions sprung from reason—for instance, the transformation of the Greco-Roman world into the age of feudalism, or the explosive spread of Islam?

[684] As a physician I am of course not directly concerned with these epochal questions; my duties lie with people who are ill. Medicine has until recently gone on the supposition that illness should be treated and cured by itself; yet voices are now heard which declare this view to be wrong, and demand the treatment of the sick person and not of the sickness. The same demand is forced upon us in the treatment of psychic suffering. More and more we turn our attention from the visible illness and direct it upon the man as a whole. We have come to understand that psychic suffering is not a definitely localized, sharply delimited phenomenon, but rather the symptom of a wrong attitude assumed by the total personality. We can therefore never hope for a thorough cure from a treatment restricted to the illness itself, but only from a treatment of the personality as a whole.

[685] I am reminded of a case which is very instructive in this respect. It concerns a highly intelligent young man who had worked out a detailed analysis of his own neurosis after a thorough study of the medical literature. He brought me his findings in the form of a precise and admirably written monograph, fit for publication, and asked me to read the manuscript and to tell him why he was still not cured, although he ought to have been, according to his scientific judgment. After reading his monograph I was forced to admit that, if it were only a question of insight into the causal structure of a neurosis, he should in all truth have been cured. Since he was not, I supposed this must be due to the fact that his attitude to life was somehow fundamentally wrong, though certainly his symptoms did not betray it. During his anamnesis I had been struck by his remark that he often spent his winters at St. Moritz or Nice. I therefore asked him who actually paid for these holidays, and it there-upon came out that a poor school-teacher who loved him almost starved herself to indulge this young man in his visits to pleasure-resorts. His want of conscience was the cause of his neurosis, and this also explains why all his scientific insight availed him nothing. His fundamental error lay in his moral attitude. He found my way of looking at it shockingly unscientific, for morals have nothing to do with science. He thought that he could scientifically unthink the immorality which he himself, at bottom, could not stomach. He would not even admit that any conflict existed, because his mistress gave him the money of her own free will.

[686] We can think what we like about this scientifically, but the fact remains that the great majority of civilized persons simply cannot tolerate such behaviour. The moral

attitude is a real factor with which the psychologist must reckon if he is not to commit the gravest errors. He must also remember that certain religious convictions not founded on reason are a vital necessity for many people. Again, there are psychic realities which can cause or cure diseases. How often have I heard a patient exclaim: "If only I knew that my life had some meaning and purpose, there would be no need of all this trouble with my nerves!" Whether the patient is rich or poor, has family and social position or not, alters nothing, for outer circumstances are far from giving his life a meaning. It is much more a question of his quite irrational need for what we call a spiritual life, and this he cannot obtain from universities, libraries, or even from churches. He cannot accept what these have to offer because it touches only his head but does not stir his heart. In such cases the physician's recognition of the spiritual factors in their true light is vitally important, and the patient's unconscious comes to the aid of this vital need by producing dreams whose content is essentially religious. Not to recognize the spiritual source of such contents means faulty treatment and failure.

[687] General conceptions of a spiritual nature are indispensable constituents of psychic life. We can point them out among all peoples who possess some measure of articulated consciousness. Their relative absence or their denial by a civilized people is therefore to be regarded as a sign of degeneration. Whereas, in its development up to the present, psychology has considered psychic processes mainly in the light of their physical causation, the future task of psychology will be the investigation of their spiritual determinants. But the natural history of the mind is no further advanced today than was natural science in the thirteenth century. We are only just beginning to take scientific note of our spiritual experiences.

[688] If modern psychology can boast of having removed any of the veils which hid the psyche from us, it is only that one which had concealed from the investigator the psyche's biological aspect. We may compare the present situation to the state of medicine in the sixteenth century, when people began to study anatomy but had not as yet the faintest idea of physiology. So, too, the spiritual aspect of the psyche is known to us only in a very fragmentary way. We have learnt that there are spiritual processes of transformation in the psyche which underlie, for example, the well-known initiation rites of primitive peoples and the states induced by the practice of yoga. But we have not yet succeeded in determining their particular laws. We only know that many of the neuroses arise from a disturbance of these processes. Psychological research has not drawn aside all the many veils from the human psyche; it remains as unapproachable and obscure as all the deep secrets of life. We can only speak of what we have tried to do, and what we hope to do in the future, in the way of attempting a solution of the great riddle.

ANALYTICAL PSYCHOLOGY AND 'WELTANSCHAUUNG'¹

[689] The German expression *Weltanschauung* is scarcely translatable into another language. This tells us at once that the word must have a peculiar psychological character. It expresses not only a conception of the world—this meaning could be translated without much difficulty—but also the way in which one views the world. The word “philosophy” implies something similar, but restricted to the intellectual sphere, whereas *Weltanschauung* embraces all sorts of attitudes to the world, including the philosophical. Thus there is an aesthetic, a religious, an idealistic, a realistic, a romantic, a practical *Weltanschauung*, to mention only a few possibilities. In this sense a *Weltanschauung* has much in common with an attitude. Accordingly, we could define *Weltanschauung* as an attitude that has been formulated into concepts.

[690] Now what is to be understood by attitude? Attitude is a psychological term designating a particular arrangement of psychic contents oriented towards a goal or directed by some kind of ruling principle. If we compare our psychic contents to an army, and the various forms of attitude to military dispositions, then attention, for example, would be represented by a concentrated force standing to arms, surrounded by reconnoitring parties. As soon as the strength and position of the enemy are known, the disposition changes: the army begins to move in the direction of a given objective. In precisely the same way the psychic attitude changes. During the state of attention the dominant idea is alertness; one's own thoughts are suppressed as much as possible, along with other subjective contents. But in going over to an active attitude, subjective contents appear in consciousness—purposive ideas and impulses to act. And just as an army has a commander and a general staff, so the psychic attitude has a general guiding idea which is reinforced by a wide assortment of experiences, principles, affects of all kinds, etc.

[691] That is to say, no human action is entirely simple—an isolated reaction, as it were, to a single stimulus. Each of our actions and reactions is influenced by complicated psychic factors. To use the military analogy again, we might compare these processes with the situation at general headquarters. To the man in the ranks it might seem that the army retreated simply because it was attacked, or that an attack was launched because the enemy had been located. Our conscious mind is always disposed to play the role of the common soldier and to believe in the simplicity of its actions. But, in reality, battle was given at this particular place and this particular moment because of a general plan of attack, which for days before had been

marshalling the common soldier to this point. Again, this general plan is not simply a reaction to reconnaissance reports, but results from the creative initiative of the commander. Furthermore, it is conditioned by the action of the enemy, and also perhaps by wholly unmilitary, political considerations of which the common soldier is quite unaware. These last factors are of a very complex nature and lie far outside the understanding of the common soldier, though they may be only too clear to the commander of the army. But even to him certain factors are unknown, such as his own personal psychology and its complicated assumptions. Thus the army stands under a simple and unified command, but this command is a result of the coordinated operation of infinitely complex factors.

[692] Psychic action takes place on a similarly complicated basis. However simple an impulse appears to be, every nuance of its particular character, its strength and direction, its course, its timing, its aim, all depend on special psychic conditions, in other words, on an attitude; and the attitude in turn consists of a constellation of contents so numerous that they cannot be counted. The ego is the army commander; its reflections and decisions, its reasons and doubts, its intentions and expectations are the general staff, and its dependence on outside factors is the dependence of the commander on the well-nigh incalculable influences emanating from general headquarters and from the dark machinations of politics in the background.

[693] I hope we shall not overload our analogy if we now include within it the relation of man to the world. The individual ego could be conceived as the commander of a small army in the struggle with his environment—a war not infrequently on two fronts, before him the struggle for existence, in the rear the struggle against his own rebellious instinctual nature. Even to those of us who are not pessimists our existence feels more like a struggle than anything else. The state of peace is a desideratum, and when a man has found peace with himself and the world it is indeed a noteworthy event. Hence, in order to meet the more or less chronic state of war, we need a carefully organized attitude; and should some superman achieve enduring mental peace his attitude would need a still higher degree of detailed preparation if his peace is to have even a modest duration. It is much easier for the mind to live in a state of movement, in a continuous up and down of events, than in a balanced state of permanency, for in the latter state—however lofty and perfect it may be—one is threatened with suffocation and unbearable ennui. So we are not deluding ourselves if we assume that peaceful states of mind, that is, moods without conflict, serene, deliberate, and well-balanced, so far as they are lasting, depend on specially well-developed attitudes.

[694] You may perhaps be surprised that I prefer the word “attitude” to *Weltanschauung*. In using the concept of attitude, I have simply left it an open

question whether this depends on a conscious or unconscious *Weltanschauung*. One can be one's own army commander and engage successfully in the struggle for existence both without and within, and even achieve a relatively secure condition of peace, without possessing a conscious *Weltanschauung*, but one cannot do this without an attitude. We can only speak of a *Weltanschauung* when a person has at least made a serious attempt to formulate his attitude in conceptual or concrete form, so that it becomes clear to him why and to what purpose he acts and lives as he does.

[695] But what is the use of a *Weltanschauung*, you may ask, if one can get on perfectly well without it? You might just as well ask why have consciousness if one can do without it! For what, after all, is a *Weltanschauung* but a widened or deepened consciousness? The reason why consciousness exists, and why there is an urge to widen and deepen it, is very simple: without consciousness things go less well. This is obviously the reason why Mother Nature deigned to produce consciousness, that most remarkable of all nature's curiosities. Even the well-nigh unconscious primitive can adapt and assert himself, but only in his primitive world, and that is why under other conditions he falls victim to countless dangers which we on a higher level of consciousness can avoid without effort. True, a higher consciousness is exposed to dangers undreamt of by the primitive, but the fact remains that the conscious man has conquered the earth and not the unconscious one. Whether in the last analysis, and from a superhuman point of view, this is an advantage or a calamity we are not in a position to decide.

[696] Consciousness determines *Weltanschauung*. All conscious awareness of motives and intentions is a *Weltanschauung* in the bud; every increase in experience and knowledge is a step in the development of a *Weltanschauung*. And with the picture that the thinking man fashions of the world he also changes himself. The man whose sun still moves round the earth is essentially different from the man whose earth is a satellite of the sun. Giordano Bruno's reflections on infinity were not in vain: they represent one of the most important beginnings of modern consciousness. The man whose cosmos hangs in the empyrean is different from one whose mind is illuminated by Kepler's vision. The man who is still dubious about the sum of twice two is different from the thinker for whom nothing is less doubtful than the *a priori* truths of mathematics. In short, it is not a matter of indifference what sort of *Weltanschauung* we possess, since not only do we create a picture of the world, but this picture retroactively changes us.

[697] The conception we form of the world is our picture of what we call world. And it is in accordance with this picture that we orient ourselves and adapt to reality. As I have said, this does not happen consciously. Nearly always a forceful decision is needed to tear the mind away from the pressing concerns of the moment and to direct

it to the general problem of attitude. If we do not do this, we naturally remain unconscious of our attitude, and in that case we have no *Weltanschauung*, but merely an unconscious attitude. If no account is taken of our motives and intentions they remain unconscious; that is, everything seems very simple, as though it just happened like that. But in reality complicated processes are at work in the background, using motives and intentions whose subtlety leaves nothing to be desired. For this reason there are many scientists who avoid having a *Weltanschauung* because this is supposed not to be scientific. It has obviously not dawned on these people what they are really doing. For what actually happens is this: by deliberately leaving themselves in the dark as to their guiding ideas they cling to a lower, more primitive level of consciousness than would correspond to their true capacities. Criticism and scepticism are not always a sign of intelligence—often they are just the reverse, especially when used by someone as a cloak to hide his lack of *Weltanschauung*. Very often it is a moral rather than an intellectual deficiency. For you cannot see the world without seeing yourself, and as a man sees the world, so he sees himself, and for this considerable courage is needed. Hence it is always fatal to have no *Weltanschauung*.

[698] To have a *Weltanschauung* means to create a picture of the world and of oneself, to know what the world is and who I am. Taken literally, this would be too much. No one can know what the world is, just as little as can he know himself. But, *cum grano salis*, it means the best possible knowledge—a knowledge that esteems wisdom and abhors unfounded assumptions, arbitrary assertions, and didactic opinions. Such knowledge seeks the well-founded hypothesis, without forgetting that all knowledge is limited and subject to error.

[699] If the picture we create of the world did not have a retroactive effect on us, we could be content with any sort of beautiful or diverting sham. But such self-deception recoils on us, making us unreal, foolish, and ineffectual. Because we are tilting at a false picture of the world, we are overcome by the superior power of reality. In this way we learn from experience how important it is to have a well-based and carefully constructed *Weltanschauung*.

[700] A *Weltanschauung* is a hypothesis and not an article of faith. The world changes its *face*—*tempora mutantur et nos mutamur in illis*—for we can grasp the world only as a psychic image in ourselves, and it is not always easy to decide, when the image changes, whether the world or ourselves have changed, or both. The picture of the world can change at any time, just as our conception of ourselves changes. Every new discovery, every new thought, can put a new face on the world. We must be prepared for this, else we suddenly find ourselves in an antiquated world, itself a relic of lower levels of consciousness. We shall all be as good as dead one day, but in the

interests of life we should postpone this moment as long as possible, and this we can only do by never allowing our picture of the world to become rigid. Every new thought must be tested to see whether or not it adds something to our *Weltanschauung*.

*

[701] If I now set out to discuss the relation between analytical psychology and *Weltanschauung*, I do so from the standpoint I have just elaborated, namely, “Do the findings of analytical psychology add something new to our *Weltanschauung*, or not?” In order to deal with this question effectively, we must first consider the essentials of analytical psychology. What I mean by this term is a special trend in psychology which is mainly concerned with complex psychic phenomena, in contrast to physiological or experimental psychology, which strives to reduce complex phenomena as far as possible to their elements. The term “analytical” derives from the fact that this branch of psychology developed out of the original Freudian psychoanalysis. Freud identified psychoanalysis with his theory of sex and repression, and thereby riveted it to a doctrinaire frame-work. For this reason I avoid the expression “psychoanalysis” when I am discussing other than merely technical matters.

[702] Freudian psychoanalysis consists essentially in a technique for bringing back to consciousness so-called repressed contents that have become unconscious. This technique is a therapeutic method designed to treat and to cure neuroses. In the light of this method, it seems as if the neuroses came into existence because disagreeable memories and tendencies—so-called incompatible contents—were repressed from consciousness and made unconscious by a sort of moral resentment due to educational influences. From this point of view unconscious psychic activity, or what we call the unconscious, appears chiefly as a receptacle of all those contents that are antipathetic to consciousness, as well as of all forgotten impressions. On the other hand, one cannot close one’s eyes to the fact that these same incompatible contents derive from unconscious instincts, which means that the unconscious is not just a receptacle but is the matrix of the very things that the conscious mind would like to be rid of. We can go a step further and say that the unconscious actually creates *new* contents. Everything that the human mind has ever created sprang from contents which, in the last analysis, existed once as unconscious seeds. While Freud lays special emphasis on the first aspect, I have stressed the latter, without denying the first. Although it is a not unimportant fact that man evades everything unpleasant, and therefore gladly forgets whatever does not suit him, it nevertheless seems to me far more important to find out what really constitutes the *positive* activity of the unconscious. From this point of view the unconscious appears as the totality of all

psychic contents *in statu nascendi*. This positive function of the unconscious is, in the main, merely disturbed by repressions, and this disturbance of its natural activity is perhaps the most important source of the so-called psychogenic illnesses. The unconscious is best understood if we regard it as a natural organ with its own specific creative energy. If as a result of repressions its products can find no outlet in consciousness, a sort of blockage ensues, an unnatural inhibition of a purposive function, just as if the bile, the natural product of the function of the liver, were impeded in its discharge into the bowel. As a result of the repression, wrong psychic outlets are found. Like bile seeping into the blood, the repressed content infiltrates into other psychic and physiological spheres. In hysteria it is chiefly the physiological functions that are disturbed; in other neuroses, such as phobias, obsessions, and compulsion neuroses, it is chiefly the psychic functions, including dreams. Just as the activity of the repressed contents can be demonstrated in the physical symptoms of hysteria and in the psychic symptoms of other neuroses (and also psychoses), so it can in dreams. The dream in itself is a normal function which can be disturbed by blockages like any other function. The Freudian theory of dreams considers, and even explains, the dream from this angle alone, as though it were nothing but a symptom. Other fields of activity are, as we know, treated by psychoanalysis in the same way—works of art, for instance. But here the weakness of the theory becomes painfully evident, since a work of art is clearly not a symptom but a genuine creation. A creative achievement can only be understood on its own merits. If it is taken as a pathological misunderstanding and explained in the same terms as a neurosis, the attempted explanation soon begins to assume a curiously bedraggled air.

[703] The same is true of the dream. It is a typical product of the unconscious, and is merely deformed and distorted by repression. Hence any explanation that interprets it as a mere symptom of repression will go very wide of the mark.

[704] Let us confine ourselves for the moment to the conclusions to be drawn from Freud's psychoanalysis. In Freudian theory, man appears as a creature of instinct who, in various ways, comes into conflict with the law, with moral precepts, and with his own insights, and who is consequently compelled to repress certain instincts either wholly or in part. The aim of the method is to bring these instinctual contents to consciousness and make repression unnecessary by conscious correction. The menace entailed by their liberation is countered by the explanation that they are nothing but infantile wish-fantasies, which can still be suppressed, though in a wiser way. It is also assumed that they can be "sublimated," to use the technical term, by which is meant a sort of bending of them to a suitable form of adaptation. But if anyone believes this can be done at will he is sadly mistaken—only absolute necessity can effectively inhibit a natural instinct. When there is no need and no

inexorable necessity, the “sublimation” is merely a self-deception, a new and somewhat more subtle form of repression.

[705] Does this theory and this conception of man contain anything valuable for our *Weltanschauung*? I hardly think so. It is the well-known rationalistic materialism of the late nineteenth century, which is the guiding principle of the interpretive psychology underlying Freud’s psychoanalysis. From it can come no other picture of the world, and therefore no other attitude to the world. But we must not forget that only in rare instances is an attitude influenced by theories. A far more effective influence is that of feeling. True, a dry theoretical presentation cannot reach the feelings. I could read you a detailed statistical report on prisons and you would go to sleep. But if I took you through a prison, or through a lunatic asylum, you would certainly not go to sleep. You would be profoundly impressed. Was it any theory that made the Buddha what he was? No, it was the sight of old age, sickness, and death that burned into his soul.

[706] Thus the partly one-sided, partly erroneous concepts of psychoanalysis really tell us very little. But if we look into the psychoanalysis of actual cases of neurosis and see what devastation the so-called repressions have wrought, what destruction has resulted from a disregard of elementary instinctual processes, then we receive—to put it mildly—a lasting impression. There is no form of human tragedy that does not in some measure proceed from this conflict between the ego and the unconscious. Anyone who has ever seen the horror of a prison, an insane asylum, or a hospital will surely experience, from the impression these things make upon him, a profound enrichment of his *Weltanschauung*. And he will be no less deeply impressed if he looks into the abyss of human suffering behind a neurosis. How often I have heard: “But that is terrible! Who could ever have believed such things were possible!” And there’s no gainsaying that one really does receive a tremendous impression of the power of the unconscious when one tries, with the necessary conscientiousness and thoroughness, to investigate the structure of a neurosis. It is also rewarding to show someone the slums of London, and anyone who has seen them has seen a great deal more than one who has not. But all that is nothing more than a shock, and the question “What is to be done about it?” still remains unanswered.

[707] Psychoanalysis has removed the veil from facts that were known only to a few, and has even made an effort to deal with them. But has it any new attitude to them? Has the deep impression produced lasting and fruitful results? Has it altered our picture of the world and thus added to our *Weltanschauung*? The *Weltanschauung* of psychoanalysis is a rationalistic materialism, the *Weltanschauung* of an essentially practical science—and this view we feel to be inadequate. When we trace a poem of Goethe’s to his mother-complex, when we seek to explain Napoleon as a case of

masculine protest, or St. Francis as a case of sexual repression, a sense of profound dissatisfaction comes over us. The explanation is insufficient and does not do justice to the reality and meaning of things. What becomes of beauty, greatness, and holiness? These are vital realities without which human existence would be superlatively stupid. What is the right answer to the problem of terrible sufferings and conflicts? The true answer should strike a chord that at least reminds us of the magnitude of the suffering. But the merely reasonable, practical attitude of the rationalist, however desirable it may be in other respects, ignores the real meaning of suffering. It is simply set aside and explained away as irrelevant. It was a great noise about nothing. Much may fall into this category, but not everything.

[708] The mistake, as I have said, lies in the circumstance that psychoanalysis has a scientific but purely rationalistic conception of the unconscious. When we speak of instincts we imagine that we are talking about something known, but in reality we are talking about something unknown. As a matter of fact, all we know is that effects come to us from the dark sphere of the psyche which somehow or other must be assimilated into consciousness if devastating disturbances of other functions are to be avoided. It is quite impossible to say offhand what the nature of these effects is, whether they originate in sexuality, the power instinct, or some other instinct. They have as many meanings and facets as the unconscious itself.

[709] I have already pointed out that although the unconscious is a receptacle for everything that is forgotten, past, and repressed, it is also the sphere in which all subliminal processes take place. It contains sense-perceptions that are still too weak to reach consciousness, and, furthermore, is the matrix out of which the whole psychic future grows. Thus, just as a person can repress a disquieting wish and thereby cause its energy to contaminate other functions, so he can shut out a new idea that is alien to him so that its energy flows off into other functions and disturbs them. I have seen many cases where abnormal sexual fantasies disappeared, suddenly and completely, the moment a new idea or content became conscious, or when a migraine suddenly vanished when the patient became aware of an unconscious poem. Just as sexuality can express itself inappropriately in fantasies, so creative fantasy can express itself inappropriately in sexuality. As Voltaire once remarked: “*En étymologie n’importe quoi peut désigner n’importe quoi*”—and we must say the same thing of the unconscious. At any rate we can never know beforehand what is what. With regard to the unconscious we merely have the gift of being wise after the event; it is quite impossible to know anything about the true state of things. Every conclusion in this respect is an admitted “as if.”

[710] Under these circumstances the unconscious seems like a great X, concerning which the only thing indisputably known is that important effects proceed from it. A

glance at the world religions shows us just how important these effects are historically. And a glance at the suffering of modern man shows us the same thing—we merely express ourselves somewhat differently. Three hundred years ago a woman was said to be possessed of the devil, now we say she has a hysteria. Formerly a sufferer was said to be bewitched, now the trouble is called a neurotic dyspepsia. The facts are the same; only the previous explanation, psychologically speaking, is almost exact, whereas our rationalistic description of symptoms is really without content. For if I say that someone is possessed by an evil spirit, I imply that the possessed person is not legitimately ill but suffers from some invisible psychic influence which he is quite unable to control. This invisible something is an autonomous complex, an unconscious content beyond the reach of the conscious will. When one analyses the psychology of a neurosis one discovers a complex, a content of the unconscious, that does not behave as other contents do, coming or going at our command, but obeys its own laws, in other words it is independent or, as we say, autonomous. It behaves exactly like a goblin that is always eluding our grasp. And when the complex is made conscious—which is the aim of analysis—the patient will exclaim with relief: “So that’s what the trouble was!” Apparently something has been gained: the symptoms disappear, the complex is, as we say, resolved. We can exclaim with Goethe: “Be off with you, you’ve been explained away!” but with Goethe we must go on to add: “For all our wisdom, Tegel still is haunted.”² The true state of affairs is now for the first time revealed. We become aware that this complex would never have existed at all had not our nature lent it a secret driving power. I will explain what I mean by an example:

[711] A patient suffers from nervous stomach symptoms that consist in painful contractions resembling hunger. Analysis shows an infantile longing for the mother, a so-called mother-complex. The symptoms disappear with this new-won insight, but there remains a longing which refuses to be assuaged by the explanation that it was “nothing but an infantile mother-complex.” What was before a sort of physical hunger and a physical pain now becomes psychic hunger and psychic pain. One longs for something and yet knows that it would be quite wrong to mistake it for the mother. But the ever-present, unappeasable longing remains, and the solution of this problem is considerably more difficult than the reduction of the neurosis to a mother-complex. The longing is an insistent demand, an aching inner emptiness, which can be forgotten from time to time but never overcome by strength of will. It always returns. At first one does not know where it comes from or what the patient is really longing for. A good deal can be conjectured, but all that can be said with certainty is that over and above the mother-complex something unconscious voices this demand independently of consciousness and continues to raise its voice despite all criticism. This something I have called an autonomous complex. It is the source of that driving

power which originally sustained the infantile claim on the mother and thus caused the neurosis, for an adult consciousness was bound to discountenance such a childish demand and repress it as incompatible.

[712] All infantile complexes ultimately resolve themselves into autonomous contents of the unconscious. The primitive mind has always felt these contents to be strange and incomprehensible and, personifying them as spirits, demons, and gods, has sought to fulfil their demands by sacred and magical rites. Recognizing correctly that this hunger or thirst can be stilled neither by food nor by drink nor by returning to the mother's womb, the primitive mind created images of invisible, jealous, and exacting beings, more potent and more dangerous than man, denizens of an invisible world, yet so interfused with visible reality that there are spirits who dwell even in the cooking-pots. Spirits and magic are almost the sole causes of illness among primitives. The autonomous contents are projected by the primitive upon these supernatural beings. Our world, on the other hand, is freed of demons to the last trace, but the autonomous contents and their demands have remained. They express themselves partly in religion, but the more the religion is rationalized and watered down—an almost unavoidable fate—the more intricate and mysterious become the ways by which the contents of the unconscious contrive to reach us. One of the commonest ways is neurosis, which is the last thing one would expect. A neurosis is usually considered to be something inferior, a *quantité négligeable* from the medical point of view. This is a great mistake, as we have seen. For behind the neurosis are hidden those powerful psychic influences which underlie our mental attitude and its guiding principles. Rationalistic materialism, an attitude that does not seem at all suspect, is really a psychological countermove to mysticism—that is the secret antagonist who has to be combatted. Materialism and mysticism are a psychological pair of opposites, just like atheism and theism. They are hostile brothers, two different methods of grappling with these powerful influences from the unconscious, the one by denying, the other by recognizing them.

[713] If, therefore, I had to name the most essential thing that analytical psychology can add to our *Weltanschauung*, I should say it is the recognition that there exist certain unconscious contents which make demands that cannot be denied, or send forth influences with which the conscious mind must come to terms, whether it will or no.

[714] You would no doubt find my remarks somewhat unsatisfactory if I left that “something” which I described as an autonomous content in this indefinite state and made no attempt to tell you what our psychology has discovered empirically about these contents.

[715] If, as psychoanalysis assumes, a definitive and satisfactory answer can be given, as for example that the original infantile dependence on the mother is the cause of the longing, then this recognition should also provide a solution. And in some cases the infantile dependence does in fact disappear when the patient has recognized it sufficiently. But one must not infer that this is true in all cases. In every case something remains unresolved; sometimes it is apparently so little that the case is, for all practical purposes, finished; but again, it may be so much that neither the patient nor the analyst is satisfied with the result, and it seems as though nothing had been accomplished. Moreover, I have treated many patients who were conscious of the cause of their complexes down to the last detail, without having been helped in any essential way by this insight.

[716] A causal explanation may be relatively satisfactory from a scientific point of view, but psychologically there is still something unsatisfying about it, because we still do not know anything about the purpose of that driving power at the root of the complex—the meaning of the longing, for example—nor what is to be done about it. If I already know that an epidemic of typhoid comes from infected drinking water, this is still not sufficient to stop the pollution of the water-supply. A satisfactory answer is given only when we know *what* it is that maintained the infantile dependence into adult life, and what it is aiming at.

[717] If the human mind came into the world as a complete *tabula rasa* these problems would not exist, for there would then be nothing in the mind that it had not acquired or that had not been implanted in it. But there are many things in the human psyche that were never acquired by the individual, for the human mind is not born a *tabula rasa*, nor is every man provided with a wholly new and unique brain. He is born with a brain that is the result of development in an endlessly long chain of ancestors. This brain is produced in each embryo in all its differentiated perfection, and when it starts functioning it will unfailingly produce the same results that have been produced innumerable times before in the ancestral line. The whole anatomy of man is an inherited system identical with the ancestral constitution, which will unfailingly function in the same way as before. Consequently, the possibility that anything new and essentially different will be produced becomes increasingly small. All those factors, therefore, which were essential to our near and remote ancestors will also be essential to us, since they are embedded in the inherited organic system. They are even necessities which make themselves felt as needs.

[718] Do not fear that I shall speak to you of inherited ideas. Far from it. The autonomous contents of the unconscious, or, as I have called them, dominants, are not inherited ideas but inherited possibilities, not to say compelling necessities, for reproducing the images and ideas by which these dominants have always been

expressed. Of course every region of the earth and every epoch has its own distinctive language, and this can be endlessly varied. It matters little if the mythological hero conquers now a dragon, now a fish or some other monster; the fundamental motif remains the same, and that is the common property of mankind, not the ephemeral formulations of different regions and epochs.

[719] Thus man is born with a complicated psychic disposition that is anything but a *tabula rasa*. Even the boldest fantasies have their limits determined by our psychic inheritance, and through the veil of even the wildest fantasy we can still glimpse the dominants that were inherent in the human mind from the very beginning. It seems very remarkable to us when we discover that insane people develop fantasies that can be found in almost identical form among primitives. But it would be remarkable if it were otherwise.

[720] I have called the sphere of our psychic heritage the collective unconscious. The contents of consciousness are all acquired individually. If the human psyche consisted simply and solely of consciousness, there would be nothing psychic that had not arisen in the course of the individual's life. In that case we would seek in vain for any prior conditions or influences behind a simple parental complex. With the reduction to father and mother the last word would be said, for they are the figures that first influenced the conscious psyche to the exclusion of all else. But actually the contents of consciousness did not come into existence simply through the influence of the environment; they were also influenced and arranged by our psychic inheritance, the collective unconscious. Naturally the image of the individual mother is impressive, but its peculiar impressiveness is due to the fact that it is blended with an unconscious aptitude or inborn image which is the result of the symbiotic relationship of mother and child that has existed from eternity. Where the individual mother fails in this or that respect, a loss is felt, and this amounts to a demand of the collective mother-image for fulfilment. An instinct has been balked, so to speak. This very often gives rise to neurotic disturbances, or at any rate to peculiarities of character. If the collective unconscious did not exist, everything could be achieved by education; one could reduce a human being to a psychic machine with impunity, or transform him into an ideal. But strict limits are set to any such enterprise, because the dominants of the unconscious make almost irresistible demands for fulfilment.

[721] So if, in the case of the patient with the stomach-neurosis, I were asked to name what it is in the unconscious, over and above the personal mother-complex, that keeps alive an indefinable but agonizing longing, the answer is: it is the collective image of the mother, not of the personal mother, but of the mother in her universal aspect.

[722] But why should this collective image arouse such longing? It is not very easy to answer this question. Yet if we could get a clear idea of the nature and meaning of this collective image, which I have called the archetype, then its effects could readily be understood.

[723] In order to explain this, I should use the following argument. The mother-child relationship is certainly the deepest and most poignant one we know; in fact, for some time the child is, so to speak, a part of the mother's body. Later it is part of the psychic atmosphere of the mother for several years, and in this way everything original in the child is indissolubly blended with the mother-image. This is true not only for the individual, but still more in a historical sense. It is the absolute experience of our species, an organic truth as unequivocal as the relation of the sexes to one another. Thus there is inherent in the archetype, in the collectively inherited mother-image, the same extraordinary intensity of relationship which instinctively impels the child to cling to its mother. With the passing of the years, the man grows naturally away from the mother—provided, of course, that he is no longer in a condition of almost animal-like primitivity and has attained some degree of consciousness and culture—but he does not outgrow the archetype in the same natural way. If he is merely instinctive, his life will run on without choice, since freedom of will always presupposes consciousness. It will proceed according to unconscious laws, and there will be no deviation from the archetype. But, if consciousness is at all effective, conscious contents will always be overvalued to the detriment of the unconscious, and from this comes the illusion that in separating from the mother nothing has happened except that one has ceased to be the child of this individual woman. Consciousness only recognizes contents that are individually acquired; hence it recognizes only the individual mother and does not know that she is at the same time the carrier and representative of the archetype, of the “eternal” mother. Separation from the mother is sufficient only if the archetype is included, and the same is true of separation from the father.

[724] The development of consciousness and of free will naturally brings with it the possibility of deviating from the archetype and hence from instinct. Once the deviation sets in a dissociation between conscious and unconscious ensues, and then the activity of the unconscious begins. This is usually felt as very unpleasant, for it takes the form of an inner, unconscious fixation which expresses itself only symptomatically, that is, indirectly. Situations then develop in which it seems as though one were still not freed from the mother.

[725] The primitive mind, while not understanding this dilemma, felt it all the more keenly and accordingly instituted highly important rites between childhood and adulthood, puberty-rites and initiation ceremonies, for the quite unmistakable

purpose of effecting the separation from the parents by magical means. This institution would be entirely superfluous if the relation to the parents were not felt to be equally magical. But “magical” means everything where unconscious influences are at work. The purpose of these rites, however, is not only separation from the parents, but induction into the adult state. There must be no more longing backward glances at childhood, and for this it is necessary that the claims of the injured archetype should be met. This is done by substituting for the intimate relationship with the parents another relationship, namely that with the clan or tribe. The infliction of certain marks on the body, such as circumcision and scars, is intended to serve this end, as also the mystical instruction which the young man receives during his initiation. Often these initiations have a decidedly cruel character.

[726] This is the way the primitive, for reasons unknown to him, attempts to fulfil the claims of the archetype. A simple parting from the parents is not sufficient; there must be a drastic ceremony that looks very like sacrifice to the powers which might hold the young man back. This shows us at a glance the power of the archetype: it forces the primitive to act against nature so that he shall not become her victim. This is indeed the beginning of all culture, the inevitable result of consciousness and of the possibility of deviating from unconscious law.

[727] Our world has long been estranged to these things, though this does not mean that nature has forfeited any of her power over us. We have merely learnt to undervalue that power. But we find ourselves at something of a loss when we come to the question, what should be our way of dealing with the effects of unconscious contents? For us it can no longer be a matter of primitive rites; that would be an artificial and futile regression. If you put the question to me, I too would be at a loss for an answer. I can only say this much, that for years I have observed in many of my patients the ways they instinctively select in order to meet the demands of the unconscious. It would far exceed the limits of a lecture if I were to report on these observations. I must refer you to the literature in which this question is thoroughly discussed.³

[728] If, in this lecture, I have helped you to recognize that the powers which men have always projected into space as gods, and worshipped with sacrifices, are still alive and active in our own unconscious psyche, I shall be content. This recognition should suffice to show that the manifold religious practices and beliefs which, from the earliest times, have played such an enormous role in history cannot be traced back to the whimsical fancies and opinions of individuals, but owe their existence far more to the influence of unconscious powers which we cannot neglect without disturbing the psychic balance. The example I gave of the mother-complex is naturally only one among many. The archetype of the mother is a single instance that could be

supplemented by a number of other archetypes. This multiplicity of unconscious dominants helps to explain the diversity of religious ideas.

[729] All these factors are still active in our psyche; only the expression and evaluation of them have been superseded, not their actual existence and effectiveness. The fact that we can now understand them as psychic quantities is a new formulation, a new expression, which may enable us to discover a new way of relating to the powers of the unconscious. I believe this possibility to be of immense significance, because the collective unconscious is in no sense an obscure corner of the mind, but the mighty deposit of ancestral experience accumulated over millions of years, the echo of prehistoric happenings to which each century adds an infinitesimally small amount of variation and differentiation. Because the collective unconscious is, in the last analysis, a deposit of world-processes embedded in the structure of the brain and the sympathetic nervous system, it constitutes in its totality a sort of timeless and eternal world-image which counterbalances our conscious, momentary picture of the world. It means nothing less than another world, a mirror-world if you will. But, unlike a mirror-image, the unconscious image possesses an energy peculiar to itself, independent of consciousness. By virtue of this energy it can produce powerful effects which do not appear on the surface but influence us all the more powerfully from within. These influences remain invisible to anyone who fails to subject his momentary picture of the world to adequate criticism, and who therefore remains hidden from himself. That the world has an inside as well as an outside, that it is not only outwardly visible but acts upon us in a timeless present, from the deepest and apparently most subjective recesses of the psyche—this I hold to be an insight which, even though it be ancient wisdom, deserves to be evaluated as a new factor in building a *Weltanschauung*.

*

[730] Analytical psychology is not a *Weltanschauung* but a science, and as such it provides the building-material or the implements with which a *Weltanschauung* can be built up or torn down, or else reconstructed. There are many people today who think they can smell a *Weltanschauung* in analytical psychology. I wish I were one of them, for then I should be spared the pains of investigation and doubt, and could tell you clearly and simply the way that leads to Paradise. Unfortunately we are still a long way from that. I merely conduct an experiment in *Weltanschauung* when I try to make clear to myself the meaning and scope of what is happening today. But this experimentation is, in a sense, a way, for when all is said and done, our own existence is an experiment of nature, an attempt at a new synthesis.⁴

[731] A science can never be a *Weltanschauung* but merely the tool with which to make one. Whether we take this tool in hand or not depends on the sort of *Weltanschauung*

we already have. For no one is without a *Weltanschauung* of some sort. Even in an extreme case, he will at least have the *Weltanschauung* that education and environment have forced on him. If this tells him, to quote Goethe, that “the highest joy of man should be the growth of personality,” he will unhesitatingly seize upon science and its conclusions, and with this as a tool will build himself a *Weltanschauung*—to his own edification. But if his hereditary convictions tell him that science is not a tool but an end in itself, he will follow the watchword that has become more and more prevalent during the last one hundred and fifty years and has proved to be the decisive one in practice. Here and there single individuals have desperately resisted it, for to their way of thinking the meaning of life culminates in the perfection of the human personality and not in the differentiation of techniques, which inevitably leads to an extremely one-sided development of a single instinct, for instance the instinct for knowledge. If science is an end in itself, man’s *raison d’être* lies in being a mere intellect. If art is an end in itself, then his sole value lies in the imaginative faculty, and the intellect is consigned to the lumber-room. If making money is an end in itself, both science and art can quietly shut up shop. No one can deny that our modern consciousness, in pursuing these mutually exclusive ends, has become hopelessly fragmented. The consequence is that people are trained to develop one quality only; they become tools themselves.

[732] In the last one hundred and fifty years we have witnessed a plethora of *Weltanschauungen*—a proof that the whole idea of a *Weltanschauung* has been discredited, for the more difficult an illness is to treat, the more the remedies multiply, and the more remedies there are, the more disreputable each one becomes. It seems as if a *Weltanschauung* were now an obsolete phenomenon.

[733] One can hardly imagine that this development is a mere accident, a regrettable and senseless aberration, for something that is good and valuable in itself does not usually disappear from sight in this suspicious manner. There must have been something meretricious and objectionable about it to begin with. We must therefore ask ourselves: what is wrong with all *Weltanschauungen*?

[734] It seems to me that the fatal error of every *Weltanschauung* so far has been that it claims to be an objectively valid truth, and ultimately a kind of scientific evidence of this truth. This would lead to the insufferable conclusion that, for instance, the same God must help the Germans, the French, the English, the Turks, and the heathen—in short, everybody against everybody else. Our modern consciousness, with its broader grasp of world-events, has recoiled in horror from such a monstrosity, only to put in its place various philosophical substitutes. But these in turn laid claims to being objectively valid truths. That discredited them, and so we arrive at the differentiated fragmentation of consciousness with its highly undesirable consequences.

[735] The basic error of every *Weltanschauung* is its remarkable tendency to pretend to be the truth of things themselves, whereas actually it is only a name which we give to things. Would any scientist argue whether the name of the planet Neptune befits the nature of this heavenly body and whether, therefore, it is the only “right” name? Of course not—and that is why science is superior, because it deals only in working hypotheses. In the fairytale you can blast Rumpelstiltskin to fragments if you call him by his right name. The tribal chief hides his true name and gives himself an exoteric name for daily use, so that nobody can put a spell on him. When the Egyptian Pharaohs were laid in the tomb, the true names of the gods were imparted to them in word and image, so that they could compel the gods to do their bidding. For the Cabalists the possession of the true name of God meant absolute magic power. To sum up: for the primitive mind the thing itself is posited by the name. “What he says, is” runs the old saying about Ptah.

[736] This piece of unconscious primitivity is the bane of every *Weltanschauung*. Just as astronomers have no means of knowing whether the inhabitants of Neptune have complained about the wrong naming of their planet, so we may safely assume that it is all one to the world what we think about it. But that does not mean that we need stop thinking. And indeed we do not; science lives on, as the heir to *Weltanschauungen* fallen into decay. It is only man who is impoverished by this change of status. In a *Weltanschauung* of the old style he had naively substituted his mind for things; he could regard his own face as the face of the world, see himself in the likeness of God—a glory that was not paid for too dearly even with everlasting damnation. But in science he does not think of himself, he thinks only of the world, of the object; he has put himself aside and sacrificed his personality to the objective spirit of research. That is why the spirit of science is ethically superior to a *Weltanschauung* of the old style.

[737] Nevertheless, we are beginning to feel the consequences of this atrophy of the human personality. Everywhere one hears the cry for a *Weltanschauung*; everyone asks the meaning of life and the world. There have been numerous attempts in our time to put the clock back and to indulge in a *Weltanschauung* of the old style—to wit, theosophy, or, as it is more palatably called, anthroposophy. But if we do not want to develop backwards, a new *Weltanschauung* will have to abandon the superstition of its objective validity and admit that it is only a picture which we paint to please our minds, and not a magical name with which we can conjure up real things. A *Weltanschauung* is made not for the world, but for ourselves. If we do not fashion for ourselves a picture of the world, we do not see ourselves either, who are the faithful reflections of that world. Only when mirrored in our picture of the world can we see ourselves in the round. Only in our creative acts do we step forth into the light and see ourselves whole and complete. Never shall we put any face on the world

other than our own, and we have to do this precisely in order to find ourselves. For higher than science or art as an end in itself stands man, the creator of his instruments. Nowhere are we closer to the sublime secret of all origination than in the recognition of our own selves, whom we always think we know already. Yet we know the immensities of space better than we know our own depths, where—even though we do not understand it—we can listen directly to the throb of creation itself.

[738] In this sense analytical psychology offers us new possibilities. It calls our attention to the existence of fantasy-images that spring from the dark background of the psyche and throw light on the processes going on in the unconscious. The contents of the collective unconscious are, as I have pointed out, the results of the psychic functioning of our whole ancestry; in their totality, they compose a natural world-image, the condensation of millions of years of human experience. These images are mythological and therefore symbolical, for they express the harmony of the experiencing subject with the object experienced. All mythology and all revelation come from this matrix of experience, and all our future ideas about the world and man will come from it likewise. Nevertheless, it would be a misunderstanding to suppose that the fantasy-images of the unconscious can be used directly, like a revelation. They are only the raw material, which, in order to acquire a meaning, has first to be translated into the language of the present. If this is successful, then the world as we perceive it is reunited with the primordial experience of mankind by the symbol of a *Weltanschauung*; the historical, universal man in us joins hands with the newborn, individual man. This is an experience which comes very close to that of the primitive, who symbolically unites himself with the totem-ancestor by partaking of the ritual feast.

[739] Seen in this light, analytical psychology is a reaction against the exaggerated rationalization of consciousness which, seeking to control nature, isolates itself from her and so robs man of his own natural history. He finds himself transplanted into a limited present, consisting of the short span between birth and death. The limitation creates a feeling that he is a haphazard creature without meaning, and it is this feeling that prevents him from living his life with the intensity it demands if it is to be enjoyed to the full. Life becomes stale and is no longer the exponent of the complete man. That is why so much un-lived life falls into the unconscious. People live as though they were walking in shoes too small for them. That quality of eternity which is so characteristic of the life of primitive man is entirely lacking. Hemmed round by rationalistic walls, we are cut off from the eternity of nature. Analytical psychology seeks to break through these walls by digging up again the fantasy-images of the unconscious which our rationalism has rejected. These images lie beyond the walls; they are part of the nature *in us*, which apparently lies buried in our past and against which we have barricaded ourselves behind the walls of reason. Analytical

psychology tries to resolve the resultant conflict not by going “back to Nature” with Rousseau, but by holding on to the level of reason we have successfully reached, and by enriching consciousness with a knowledge of man’s psychic foundations.

[740] Everyone who has achieved this break-through always describes it as overwhelming. But he will not be able to enjoy this impression for long, because the question immediately arises of how the new-won knowledge is to be assimilated. What lies on this side of the walls proves to be irreconcilable with what lies outside. This opens up the whole problem of translation into contemporary language, and perhaps the creation of a new language altogether. Thus we come back to the question of *Weltanschauung*—a *Weltanschauung* that will help us to get into harmony with the historical man in us, in such a way that the deeper chords in him are not drowned by the shrill strains of rationalism, and the precious light of individual consciousness is not extinguished in the infinite darkneses of the natural psyche. But no sooner do we touch this question than we have to leave the realm of science behind us, for now we need the creative resolve to entrust our life to this or that hypothesis. In other words, this is where the ethical problem begins, without which a *Weltanschauung* is inconceivable.

[741] I think I have made it clear enough in the present discussion that analytical psychology, though not in itself a *Weltanschauung*, can still make an important contribution to the building of one.

THE REAL AND THE SURREAL¹

[742] I know nothing of a “super-reality.” Reality contains everything I can know, for everything that acts upon me is real and actual. If it does not act upon me, then I notice nothing and can, therefore, know nothing about it. Hence I can make statements only about real things, but not about things that are unreal, or surreal, or subreal. Unless, of course, it should occur to someone to limit the concept of reality in such a way that the attribute “real” applied only to a particular segment of the world’s reality. This restriction to the so-called material or concrete reality of objects perceived by the senses is a product of a particular way of thinking—the thinking that underlies “sound common sense” and our ordinary use of language. It operates on the celebrated principle “Nihil est in intellectu quod non antea fuerit in sensu,” regardless of the fact that there are very many things in the mind which did not derive from the data of the senses. According to this view, everything is “real” which comes, or seems to come, directly or indirectly from the world revealed by the senses.

[743] This limited picture of the world is a reflection of the one-sidedness of Western man, which is often very unjustly laid at the door of the Greek intellect. Restriction to *material* reality carves an exceedingly large chunk out of reality as a whole, but it nevertheless remains a fragment only, and all round it is a dark penumbra which one would have to call unreal or surreal. This narrow perspective is alien to the Eastern view of the world, which therefore has no need of any philosophical conception of super-reality. Our arbitrarily delimited reality is continually menaced by the “supersensual,” the “supernatural,” the “superhuman,” and a whole lot more besides. Eastern reality includes all this as a matter of course. For us the zone of disturbance already begins with the concept of the “psychic.” In our reality the psychic cannot be anything except an effect at third hand, produced originally by physical causes; a “secretion of the brain,” or something equally savoury. At the same time, this appendage of the material world is credited with the power to pull itself up by its own bootstraps, so to speak; and not only to fathom the secrets of the physical world, but also, in the form of “mind,” to know itself. All this, without its being granted anything more than an indirect reality.

[744] Is a thought “real”? Probably—to this way of thinking—only in so far as it refers to something that can be perceived by the senses. If it does not, it is considered “unreal,” “fanciful,” “fantastic,” etc., and is thus declared nonexistent. This happens all the time in practice, despite the fact that it is a philosophical monstrosity. The thought *was* and *is*, even though it refers to no tangible reality; it even has an effect,

otherwise no one would have noticed it. But because the little word “is”—to our way of thinking—refers to something material, the “unreal” thought must be content to exist in a nebulous super-reality, which in practice means the same thing as unreality. And yet the thought may have left undeniable traces of its reality behind it; we may, perhaps, have speculated with it, and thereby made a painful hole in our bank balance.

[745] Our practical conception of reality would therefore seem to be in need of revision. So true is this that even popular literature is beginning to include all sorts of “super”-concepts in its mental horizon. I have every sympathy with this, for there is something really not quite right about the way we look at the world. Far too little in theory, and almost never in practice, do we remember that consciousness has no direct relation to any material objects. We perceive nothing but images, transmitted to us indirectly by a complicated nervous apparatus. Between the nerve-endings of the sense-organs and the image that appears in consciousness, there is interpolated an unconscious process which transforms the physical fact of light, for example, into the psychic image “light.” But for this complicated and unconscious process of transformation consciousness could not perceive anything material.

[746] The consequence of this is, that what appears to us as immediate reality consists of carefully processed images, and that, furthermore, we live immediately only in a world of images. In order to determine, even approximately, the real nature of material things we need the elaborate apparatus and complicated procedures of chemistry and physics. These disciplines are really tools which help the human intellect to cast a glance behind the deceptive veil of images into a non-psychic world.

[747] Far, therefore, from being a material world, this is a psychic world, which allows us to make only indirect and hypothetical inferences about the real nature of matter. The psychic alone has immediate reality, and this includes all forms of the psychic, even “unreal” ideas and thoughts which refer to nothing “external.” We may call them “imagination” or “delusion,” but that does not detract in any way from their effectiveness. Indeed, there is no “real” thought that cannot, at times, be thrust aside by an “unreal” one, thus proving that the latter is stronger and more effective than the former. Greater than all physical dangers are the tremendous effects of delusional ideas, which are yet denied all reality by our world-blinded consciousness. Our much vaunted reason and our boundlessly overestimated will are sometimes utterly powerless in the face of “unreal” thoughts. The world-powers that rule over all mankind, for good or ill, are unconscious psychic factors, and it is they that bring consciousness into being and hence create the *sine qua non* for the existence of any world at all. We are steeped in a world that was created by our own psyche.

[748] From this we can judge the magnitude of the error which our Western consciousness commits when it allows the psyche only a reality derived from physical causes. The East is wiser, for it finds the essence of all things grounded in the psyche. Between the unknown essences of spirit and matter stands the reality of the psychic-psychic reality, the only reality we can experience immediately.

VI

THE STAGES OF LIFE



THE SOUL AND DEATH

THE STAGES OF LIFE¹

[749] To discuss the problems connected with the stages of human development is an exacting task, for it means nothing less than unfolding a picture of psychic life in its entirety from the cradle to the grave. Within the framework of a lecture such a task can be carried out only on the broadest lines, and it must be well understood that no attempt will be made to describe the normal psychic occurrences within the various stages. We shall restrict ourselves, rather, to certain “problems,” that is, to things that are difficult, questionable, or ambiguous; in a word, to questions which allow of more than one answer—and, moreover, answers that are always open to doubt. For this reason there will be much to which we must add a question-mark in our thoughts. Worse still, there will be some things we must accept on faith, while now and then we must even indulge in speculations.

[750] If psychic life consisted only of self-evident matters of fact—which on a primitive level is still the case—we could content ourselves with a sturdy empiricism. The psychic life of civilized man, however, is full of problems; we cannot even think of it except in terms of problems. Our psychic processes are made up to a large extent of reflections, doubts, experiments, all of which are almost completely foreign to the unconscious, instinctive mind of primitive man. It is the growth of consciousness which we must thank for the existence of problems; they are the Danaän gift of civilization. It is just man’s turning away from instinct—his opposing himself to instinct—that creates consciousness. Instinct is nature and seeks to perpetuate nature, whereas consciousness can only seek culture or its denial. Even when we turn back to nature, inspired by a Rousseauesque longing, we “cultivate” nature. As long as we are still submerged in nature we are unconscious, and we live in the security of instinct which knows no problems. Everything in us that still belongs to nature shrinks away from a problem, for its name is doubt, and wherever doubt holds sway there is uncertainty and the possibility of divergent ways. And where several ways seem possible, there we have turned away from the certain guidance of instinct and are handed over to fear. For consciousness is now called upon to do that which nature has always done for her children—namely, to give a certain, unquestionable, and unequivocal decision. And here we are beset by an all-too-human fear that consciousness—our Promethean conquest—may in the end not be able to serve us as well as nature.

[751] Problems thus draw us into an orphaned and isolated state where we are abandoned by nature and are driven to consciousness. There is no other way open to

us; we are forced to resort to conscious decisions and solutions where formerly we trusted ourselves to natural happenings. Every problem, therefore, brings the possibility of a widening of consciousness, but also the necessity of saying goodbye to childlike unconsciousness and trust in nature. This necessity is a psychic fact of such importance that it constitutes one of the most essential symbolic teachings of the Christian religion. It is the sacrifice of the merely natural man, of the unconscious, ingenuous being whose tragic career began with the eating of the apple in Paradise. The biblical fall of man presents the dawn of consciousness as a curse. And as a matter of fact it is in this light that we first look upon every problem that forces us to greater consciousness and separates us even further from the paradise of unconscious childhood. Every one of us gladly turns away from his problems; if possible, they must not be mentioned, or, better still, their existence is denied. We wish to make our lives simple, certain, and smooth, and for that reason problems are taboo. We want to have certainties and no doubts—results and no experiments—without even seeing that certainties can arise only through doubt and results only through experiment. The artful denial of a problem will not produce conviction; on the contrary, a wider and higher consciousness is required to give us the certainty and clarity we need.

[752] This introduction, long as it is, seemed to me necessary in order to make clear the nature of our subject. When we must deal with problems, we instinctively resist trying the way that leads through obscurity and darkness. We wish to hear only of unequivocal results, and completely forget that these results can only be brought about when we have ventured into and emerged again from the darkness. But to penetrate the darkness we must summon all the powers of enlightenment that consciousness can offer; as I have already said, we must even indulge in speculations. For in treating the problems of psychic life we perpetually stumble upon questions of principle belonging to the private domains of the most heterogeneous branches of knowledge. We disturb and anger the theologian no less than the philosopher, the physician no less than the educator; we even grope about in the field of the biologist and of the historian. This extravagant behaviour is due not to arrogance but to the circumstance that man's psyche is a unique combination of factors which are at the same time the special subjects of far-reaching lines of research. For it is out of himself and out of his peculiar constitution that man has produced his sciences. They are *symptoms* of his psyche.

[753] If, therefore, we ask ourselves the unavoidable question, "Why does man, in obvious contrast to the animal world, have problems at all?" we run into that inextricable tangle of thoughts which many thousands of incisive minds have woven in the course of the centuries. I shall not perform the labours of a Sisyphus upon this masterpiece of confusion, but will try to present quite simply my contribution toward man's attempt to answer this basic question.

[754] There are no problems without consciousness. We must therefore put the question in another way and ask, "How does consciousness arise in the first place?" Nobody can say with certainty; but we can observe small children in the process of becoming conscious. Every parent can see it if he pays attention. And what we see is this: when the child recognizes someone or something—when he "knows" a person or a thing—then we feel that the child has consciousness. That, no doubt, is also why in Paradise it was the tree of knowledge which bore such fateful fruit.

[755] But what is recognition or "knowledge" in this sense? We speak of "knowing" something when we succeed in linking a new perception to an already existing context, in such a way that we hold in consciousness not only the perception but parts of this context as well. "Knowing" is based, therefore, upon the perceived connection between psychic contents. We can have no knowledge of a content that is not connected with anything, and we cannot even be conscious of it should our consciousness still be on this low initial level. Accordingly the first stage of consciousness which we can observe consists in the mere connection between two or more psychic contents. At this level, consciousness is merely sporadic, being limited to the perception of a few connections, and the content is not remembered later on. It is a fact that in the early years of life there is no continuous memory; at most there are islands of consciousness which are like single lamps or lighted objects in the far-flung darkness. But these islands of memory are not the same as those earliest connections which are merely perceived; they contain a new, very important series of contents belonging to the perceiving subject himself, the so-called ego. This series, like the initial series of contents, is at first merely perceived, and for this reason the child logically begins by speaking of itself objectively, in the third person. Only later, when the ego-contents—the so-called ego-complex—have acquired an energy of their own (very likely as a result of training and practice) does the feeling of subjectivity or "I-ness" arise. This may well be the moment when the child begins to speak of itself in the first person. The continuity of memory probably begins at this stage. Essentially, therefore, it would be a continuity of ego-memories.

[756] In the childish stage of consciousness there are as yet no problems; nothing depends upon the subject, for the child itself is still wholly dependent on its parents. It is as though it were not yet completely born, but were still enclosed in the psychic atmosphere of its parents. Psychic birth, and with it the conscious differentiation from the parents, normally takes place only at puberty, with the eruption of sexuality. The physiological change is attended by a psychic revolution. For the various bodily manifestations give such an emphasis to the ego that it often asserts itself without stint or moderation. This is sometimes called "the unbearable age".

[757] Until this period is reached the psychic life of the individual is governed largely by instinct, and few or no problems arise. Even when external limitations oppose his subjective impulses, these restraints do not put the individual at variance with himself. He submits to them or circumvents them, remaining quite at one with himself. He does not yet know the state of inner tension induced by a problem. This state only arises when what was an external limitation becomes an inner one; when one impulse is opposed by another. In psychological language we would say: the problematical state, the inner division with oneself, arises when, side by side with the series of ego-contents, a second series of equal intensity comes into being. This second series, because of its energy value, has a functional significance equal to that of the ego-complex; we might call it another, second ego which can on occasion even wrest the leadership from the first. This produces the division with oneself, the state that betokens a problem.

[758] To recapitulate what we have said: the first stage of consciousness, consisting in merely recognizing or “knowing,” is an anarchic or chaotic state. The second, that of the developed ego-complex, is monarchic or monistic. The third brings another step forward in consciousness, and consists in an awareness of the divided, or dualistic, state.

[759] And here we come to our real theme—the problem of the stages of life. First of all we must deal with the period of youth. It extends roughly from the years just after puberty to middle life, which itself begins between the thirty-fifth and fortieth year.

[760] I might well be asked why I begin with the second stage, as though there were no problems connected with childhood. The complex psychic life of the child is, of course, a problem of the first magnitude to parents, educators, and doctors, but when normal the child has no real problems of its own. It is only the adult human being who can have doubts about himself and be at variance with himself.

[761] We are all familiar with the sources of the problems that arise in the period of youth. For most people it is the demands of life which harshly put an end to the dream of childhood. If the individual is sufficiently well prepared, the transition to a profession or career can take place smoothly. But if he clings to illusions that are contrary to reality, then problems will surely arise. No one can take the step into life without making certain assumptions, and occasionally these assumptions are false—that is, they do not fit the conditions into which one is thrown. Often it is a question of exaggerated expectations, underestimation of difficulties, unjustified optimism, or a negative attitude. One could compile quite a list of the false assumptions that give rise to the first conscious problems.

[762] But it is not always the contradiction between subjective assumptions and external facts that gives rise to problems; it may just as often be inner, psychic

difficulties. They may exist even when things run smoothly in the outside world. Very often it is the disturbance of psychic equilibrium caused by the sexual instinct; equally often it is the feeling of inferiority which springs from an unbearable sensitivity. These inner conflicts may exist even when adaptation to the outer world has been achieved without apparent effort. It even seems as if young people who have had a hard struggle for existence are spared inner problems, while those who for some reason or other have no difficulty with adaptation run into problems of sex or conflicts arising from a sense of inferiority.

[763] People whose own temperaments offer problems are often neurotic, but it would be a serious misunderstanding to confuse the existence of problems with neurosis. There is a marked difference between the two in that the neurotic is ill because he is unconscious of his problems, while the person with a difficult temperament suffers from his conscious problems without being ill.

[764] If we try to extract the common and essential factors from the almost inexhaustible variety of individual problems found in the period of youth, we meet in all cases with one particular feature: a more or less patent clinging to the childhood level of consciousness, a resistance to the fateful forces in and around us which would involve us in the world. Something in us wishes to remain a child, to be unconscious or, at most, conscious only of the ego; to reject everything strange, or else subject it to our will; to do nothing, or else indulge our own craving for pleasure or power. In all this there is something of the inertia of matter; it is a persistence in the previous state whose range of consciousness is smaller, narrower, and more egoistic than that of the dualistic phase. For here the individual is faced with the necessity of recognizing and accepting what is different and strange as a part of his own life, as a kind of “also-I.”

[765] The essential feature of the dualistic phase is the widening of the horizon of life, and it is this that is so vigorously resisted. To be sure, this expansion—or diastole, as Goethe called it—had started long before this. It begins at birth, when the child abandons the narrow confinement of the mother’s body; and from then on it steadily increases until it reaches a climax in the problematical state, when the individual begins to struggle against it.

[766] What would happen to him if he simply changed himself into that foreign-seeming “also-I” and allowed the earlier ego to vanish into the past? We might suppose this to be a quite practical course. The very aim of religious education, from the exhortation to put off the old Adam right back to the rebirth rituals of primitive races, is to transform the human being into the new, future man, and to allow the old to die away.

[767] Psychology teaches us that, in a certain sense, there is nothing in the psyche that is old; nothing that can really, finally die away. Even Paul was left with a thorn in the flesh. Whoever protects himself against what is new and strange and regresses to the past falls into the same neurotic condition as the man who identifies himself with the new and runs away from the past. The only difference is that the one has estranged himself from the past and the other from the future. In principle both are doing the same thing: they are reinforcing their narrow range of consciousness instead of shattering it in the tension of opposites and building up a state of wider and higher consciousness.

[768] This outcome would be ideal if it could be brought about in the second stage of life—but there's the rub. For one thing, nature cares nothing whatsoever about a higher level of consciousness; quite the contrary. And then society does not value these feats of the psyche very highly; its prizes are always given for achievement and not for personality, the latter being rewarded for the most part posthumously. These facts compel us towards a particular solution: we are forced to limit ourselves to the attainable, and to differentiate particular aptitudes in which the socially effective individual discovers his true self.

[769] Achievement, usefulness and so forth are the ideals that seem to point the way out of the confusions of the problematical state. They are the lodestars that guide us in the adventure of broadening and consolidating our physical existence; they help us to strike our roots in the world, but they cannot guide us in the development of that wider consciousness to which we give the name of culture. In the period of youth, however, this course is the normal one and in all circumstances preferable to merely tossing about in a welter of problems.

[770] The dilemma is often solved, therefore, in this way: whatever is given to us by the past is adapted to the possibilities and demands of the future. We limit ourselves to the attainable, and this means renouncing all our other psychic potentialities. One man loses a valuable piece of his past, another a valuable piece of his future. Everyone can call to mind friends or schoolmates who were promising and idealistic youngsters, but who, when we meet them again years later, seem to have grown dry and cramped in a narrow mould. These are examples of the solution mentioned above.

[771] The serious problems in life, however, are never fully solved. If ever they should appear to be so it is a sure sign that something has been lost. The meaning and purpose of a problem seem to lie not in its solution but in our working at it incessantly. This alone preserves us from stultification and petrification. So also the solution of the problems of youth by restricting ourselves to the attainable is only temporarily valid and not lasting in a deeper sense. Of course, to win for oneself a

place in society and to transform one's nature so that it is more or less fitted to this kind of existence is in all cases a considerable achievement. It is a fight waged within oneself as well as outside, comparable to the struggle of the child for an ego. That struggle is for the most part unobserved because it happens in the dark; but when we see how stubbornly childish illusions and assumptions and egoistic habits are still clung to in later years we can gain some idea of the energies that were needed to form them. And so it is with the ideals, convictions, guiding ideas and attitudes which in the period of youth lead us out into life, for which we struggle, suffer, and win victories: they grow together with our own being, we apparently change into them, we seek to perpetuate them indefinitely and as a matter of course, just as the young person asserts his ego in spite of the world and often in spite of himself.

[772] The nearer we approach to the middle of life, and the better we have succeeded in entrenching ourselves in our personal attitudes and social positions, the more it appears as if we had discovered the right course and the right ideals and principles of behaviour. For this reason we suppose them to be eternally valid, and make a virtue of unchangeably clinging to them. We overlook the essential fact that the social goal is attained only at the cost of a diminution of personality. Many—far too many—aspects of life which should also have been experienced lie in the lumber-room among dusty memories; but sometimes, too, they are glowing coals under grey ashes.

[773] Statistics show a rise in the frequency of mental depressions in men about forty. In women the neurotic difficulties generally begin somewhat earlier. We see that in this phase of life—between thirty-five and forty—an important change in the human psyche is in preparation. At first it is not a conscious and striking change; it is rather a matter of indirect signs of a change which seems to take its rise in the unconscious. Often it is something like a slow change in a person's character; in another case certain traits may come to light which had disappeared since childhood; or again, one's previous inclinations and interests begin to weaken and others take their place. Conversely—and this happens very frequently—one's cherished convictions and principles, especially the moral ones, begin to harden and to grow increasingly rigid until, somewhere around the age of fifty, a period of intolerance and fanaticism is reached. It is as if the existence of these principles were endangered and it were therefore necessary to emphasize them all the more.

[774] The wine of youth does not always clear with advancing years; sometimes it grows turbid. All the phenomena mentioned above can best be seen in rather one-sided people, turning up sometimes sooner and sometimes later. Their appearance, it seems to me, is often delayed by the fact that the parents of the person in question are still alive. It is then as if the period of youth were being unduly drawn out. I have

seen this especially in the case of men whose fathers were long-lived. The death of the father then has the effect of a precipitate and almost catastrophic ripening.

[775] I know of a pious man who was a churchwarden and who, from the age of forty onward, showed a growing and finally unbearable intolerance in matters of morality and religion. At the same time his moods grew visibly worse. At last he was nothing more than a darkly lowering pillar of the Church. In this way he got along until the age of fifty-five, when suddenly, sitting up in bed in the middle of the night, he said to his wife: "Now at last I've got it! I'm just a plain rascal." Nor did this realization remain without results. He spent his declining years in riotous living and squandered a goodly part of his fortune. Obviously quite a likable fellow, capable of both extremes!

[776] The very frequent neurotic disturbances of adult years all have one thing in common: they want to carry the psychology of the youthful phase over the threshold of the so-called years of discretion. Who does not know those touching old gentlemen who must always warm up the dish of their student days, who can fan the flame of life only by reminiscences of their heroic youth, but who, for the rest, are stuck in a hopelessly wooden Philistinism? As a rule, to be sure, they have this one merit which it would be wrong to undervalue: they are not neurotic, but only boring and stereotyped. The neurotic is rather a person who can never have things as he would like them in the present, and who can therefore never enjoy the past either.

[777] As formerly the neurotic could not escape from childhood, so now he cannot part with his youth. He shrinks from the grey thoughts of approaching age, and, feeling the prospect before him unbearable, is always straining to look behind him. Just as the childish person shrinks back from the unknown in the world and in human existence, so the grown man shrinks back from the second half of life. It is as if unknown and dangerous tasks awaited him, or as if he were threatened with sacrifices and losses which he does not wish to accept, or as if his life up to now seemed to him so fair and precious that he could not relinquish it.

[778] Is it perhaps at bottom the fear of death? That does not seem to me very probable, because as a rule death is still far in the distance and therefore somewhat abstract. Experience shows us, rather, that the basic cause of all the difficulties of this transition is to be found in a deep-seated and peculiar change within the psyche. In order to characterize it I must take for comparison the daily course of the sun—but a sun that is endowed with human feeling and man's limited consciousness. In the morning it rises from the nocturnal sea of unconsciousness and looks upon the wide, bright world which lies before it in an expanse that steadily widens the higher it climbs in the firmament. In this extension of its field of action caused by its own rising, the sun will discover its significance; it will see the attainment of the greatest

possible height, and the widest possible dissemination of its blessings, as its goal. In this conviction the sun pursues its course to the unforeseen zenith—unforeseen, because its career is unique and individual, and the culminating point could not be calculated in advance. At the stroke of noon the descent begins. And the descent means the reversal of all the ideals and values that were cherished in the morning. The sun falls into contradiction with itself. It is as though it should draw in its rays instead of emitting them. Light and warmth decline and are at last extinguished.

[779] All comparisons are lame, but this simile is at least not lamer than others. A French aphorism sums it up with cynical resignation: *Si jeunesse savait, si vieillesse pouvait.*

[780] Fortunately we are not rising and setting suns, for then it would fare badly with our cultural values. But there is something sunlike within us, and to speak of the morning and spring, of the evening and autumn of life is not mere sentimental jargon. We thus give expression to psychological truths and, even more, to physiological facts, for the reversal of the sun at noon changes even bodily characteristics. Especially among southern races one can observe that older women develop deep, rough voices, incipient moustaches, rather hard features and other masculine traits. On the other hand the masculine physique is toned down by feminine features, such as adiposity and softer facial expressions.

[781] There is an interesting report in the ethnological literature about an Indian warrior chief to whom in middle life the Great Spirit appeared in a dream. The spirit announced to him that from then on he must sit among the women and children, wear women's clothes, and eat the food of women. He obeyed the dream without suffering a loss of prestige. This vision is a true expression of the psychic revolution of life's noon, of the beginning of life's decline. Man's values, and even his body, do tend to change into their opposites.

[782] We might compare masculinity and femininity and their psychic components to a definite store of substances of which, in the first half of life, unequal use is made. A man consumes his large supply of masculine substance and has left over only the smaller amount of feminine substance, which must now be put to use. Conversely, the woman allows her hitherto unused supply of masculinity to become active.

[783] This change is even more noticeable in the psychic realm than in the physical. How often it happens that a man of forty-five or fifty winds up his business, and the wife then dons the trousers and opens a little shop where he perhaps performs the duties of a handyman. There are many women who only awaken to social responsibility and to social consciousness after their fortieth year. In modern business life, especially in America, nervous breakdowns in the forties are a very common occurrence. If one examines the victims one finds that what has broken down is the

masculine style of life which held the field up to now, and that what is left over is an effeminate man. Contrariwise, one can observe women in these self-same business spheres who have developed in the second half of life an uncommonly masculine tough-mindedness which thrusts the feelings and the heart aside. Very often these changes are accompanied by all sorts of catastrophes in marriage, for it is not hard to imagine what will happen when the husband discovers his tender feelings and the wife her sharpness of mind.

[784] The worst of it all is that intelligent and cultivated people live their lives without even knowing of the possibility of such transformations. Wholly unprepared, they embark upon the second half of life. Or are there perhaps colleges for forty-year olds which prepare them for their coming life and its demands as the ordinary colleges introduce our young people to a knowledge of the world? No, thoroughly unprepared we take the step into the afternoon of life; worse still, we take this step with the false assumption that our truths and ideals will serve us as hitherto. But we cannot live the afternoon of life according to the programme of life's morning; for what was great in the morning will be little at evening, and what in the morning was true will at evening have become a lie. I have given psychological treatment to too many people of advancing years, and have looked too often into the secret chambers of their souls, not to be moved by this fundamental truth.

[785] Ageing people should know that their lives are not mounting and expanding, but that an inexorable inner process enforces the contraction of life. For a young person it is almost a sin, or at least a danger, to be too preoccupied with himself; but for the ageing person it is a duty and a necessity to devote serious attention to himself. After having lavished its light upon the world, the sun withdraws its rays in order to illuminate itself. Instead of doing likewise, many old people prefer to be hypochondriacs, niggards, pedants, applauders of the past or else eternal adolescents—all lamentable substitutes for the illumination of the self, but inevitable consequences of the delusion that the second half of life must be governed by the principles of the first.

[786] I said just now that we have no schools for forty-year-olds. That is not quite true. Our religions were always such schools in the past, but how many people regard them like that today? How many of us older ones have been brought up in such a school and really prepared for the second half of life, for old age, death and eternity?

[787] A human being would certainly not grow to be seventy or eighty years old if this longevity had no meaning for the species. The afternoon of human life must also have a significance of its own and cannot be merely a pitiful appendage to life's morning. The significance of the morning undoubtedly lies in the development of the individual, our entrenchment in the outer world, the propagation of our kind, and the

care of our children. This is the obvious purpose of nature. But when this purpose has been attained—and more than attained—shall the earning of money, the extension of conquests, and the expansion of life go steadily on beyond the bounds of all reason and sense? Whoever carries over into the afternoon the law of the morning, or the natural aim, must pay for it with damage to his soul, just as surely as a growing youth who tries to carry over his childish egoism into adult life must pay for this mistake with social failure. Money-making, social achievement, family and posterity are nothing but plain nature, not culture. Culture lies outside the purpose of nature. Could by any chance culture be the meaning and purpose of the second half of life?

[788] In primitive tribes we observe that the old people are almost always the guardians of the mysteries and the laws, and it is in these that the cultural heritage of the tribe is expressed. How does the matter stand with us? Where is the wisdom of our old people, where are their precious secrets and their visions? For the most part our old people try to compete with the young. In the United States it is almost an ideal for a father to be the brother of his sons, and for the mother to be if possible the younger sister of her daughter.

[789] I do not know how much of this confusion is a reaction against an earlier exaggeration of the dignity of age, and how much is to be charged to false ideals. These undoubtedly exist, and the goal of those who hold them lies behind, and not ahead. Therefore they are always striving to turn back. We have to grant these people that it is hard to see what other goal the second half of life can offer than the well-known aims of the first. Expansion of life, usefulness, efficiency, the cutting of a figure in society, the shrewd steering of offspring into suitable marriages and good positions—are not these purposes enough? Unfortunately not enough meaning and purpose for those who see in the approach of old age a mere diminution of life and can feel their earlier ideals only as something faded and worn out. Of course, if these persons had filled up the beaker of life earlier and emptied it to the lees, they would feel quite differently about everything now; they would have kept nothing back, everything that wanted to catch fire would have been consumed, and the quiet of old age would be very welcome to them. But we must not forget that only a very few people are artists in life; that the art of life is the most distinguished and rarest of all the arts. Who ever succeeded in draining the whole cup with grace? So for many people all too much un-lived life remains over—sometimes potentialities which they could never have lived with the best of wills, so that they approach the threshold of old age with unsatisfied demands which inevitably turn their glances backward.

[790] It is particularly fatal for such people to look back. For them a prospect and a goal in the future are absolutely necessary. That is why all great religions hold out the promise of a life beyond, of a supramundane goal which makes it possible for mortal

man to live the second half of life with as much purpose and aim as the first. For the man of today the expansion of life and its culmination are plausible goals, but the idea of life after death seems to him questionable or beyond belief. Life's cessation, that is, death, can only be accepted as a reasonable goal either when existence is so wretched that we are only too glad for it to end, or when we are convinced that the sun strives to its setting "to illuminate distant races" with the same logical consistency it showed in rising to the zenith. But to believe has become such a difficult art today that it is beyond the capacity of most people, particularly the educated part of humanity. They have become too accustomed to the thought that, with regard to immortality and such questions, there are innumerable contradictory opinions and no convincing proofs. And since "science" is the catchword that seems to carry the weight of absolute conviction in the temporary world, we ask for "scientific" proofs. But educated people who can think know very well that proof of this kind is a philosophical impossibility. We simply cannot know anything whatever about such things.

[791] May I remark that for the same reasons we cannot know, either, whether something *does* happen to a person after death? No answer of any kind is permissible, either for or against. We simply have no definite scientific knowledge about it one way or the other, and are therefore in the same position as when we ask whether the planet Mars is inhabited or not. And the inhabitants of Mars, if there are any, are certainly not concerned whether we affirm or deny their existence. They may exist or they may not. And that is how it stands with so-called immortality—with which we may shelve the problem.

[792] But here my medical conscience awakens and urges me to say a word which has an important bearing on this question. I have observed that a life directed to an aim is in general better, richer, and healthier than an aimless one, and that it is better to go forwards with the stream of time than backwards against it. To the psychotherapist an old man who cannot bid farewell to life appears as feeble and sickly as a young man who is unable to embrace it. And as a matter of fact, it is in many cases a question of the selfsame childish greediness, the same fear, the same defiance and wilfulness, in the one as in the other. As a doctor I am convinced that it is hygienic—if I may use the word—to discover in death a goal towards which one can strive, and that shrinking away from it is something unhealthy and abnormal which robs the second half of life of its purpose. I therefore consider that all religions with a supramundane goal are eminently reasonable from the point of view of psychic hygiene. When I live in a house which I know will fall about my head within the next two weeks, all my vital functions will be impaired by this thought; but if on the contrary I feel myself to be safe, I can dwell there in a normal and comfortable way. From the standpoint of

psychotherapy it would therefore be desirable to think of death as only a transition, as part of a life process whose extent and duration are beyond our knowledge.

[793] In spite of the fact that the majority of people do not know why the body needs salt, everyone demands it nonetheless because of an instinctive need. It is the same with the things of the psyche. By far the greater portion of mankind have from time immemorial felt the need of believing in a continuance of life. The demands of therapy, therefore, do not lead us into any bypaths but down the middle of the highway trodden by humanity. For this reason we are thinking correctly, and in harmony with life, even though we do not understand what we think.

[794] Do we ever understand what we think? We only understand that kind of thinking which is a mere equation, from which nothing comes out but what we have put in. That is the working of the intellect. But besides that there is a thinking in primordial images, in symbols which are older than the historical man, which are inborn in him from the earliest times, and, eternally living, outlasting all generations, still make up the groundwork of the human psyche. It is only possible to live the fullest life when we are in harmony with these symbols; wisdom is a return to them. It is a question neither of belief nor of knowledge, but of the agreement of our thinking with the primordial images of the unconscious. They are the unthinkable matrices of all our thoughts, no matter what our conscious mind may cogitate. One of these primordial thoughts is the idea of life after death. Science and these primordial images are incommensurables. They are irrational data, *a priori* conditions of the imagination which are simply there, and whose purpose and justification science can only investigate *a posteriori*, much as it investigates a function like that of the thyroid gland. Before the nineteenth century the thyroid was regarded as a meaningless organ merely because it was not understood. It would be equally shortsighted of us today to call the primordial images senseless. For me these images are something like psychic organs, and I treat them with the very greatest respect. It happens sometimes that I must say to an older patient: "Your picture of God or your idea of immortality is atrophied, consequently your psychic metabolism is out of gear." The ancient *athanasias pharmakon*, the medicine of immortality, is more profound and meaningful than we supposed.

[795] In conclusion I would like to come back for a moment to the comparison with the sun. The one hundred and eighty degrees of the arc of life are divisible into four parts. The first quarter, lying to the east, is childhood, that state in which we are a problem for others but are not yet conscious of any problems of our own. Conscious problems fill out the second and third quarters; while in the last, in extreme old age, we descend again into that condition where, regardless of our state of consciousness, we once more become something of a problem for others. Childhood and extreme old

age are, of course, utterly different, and yet they have one thing in common: submersion in unconscious psychic happenings. Since the mind of a child grows out of the unconscious its psychic processes, though not easily accessible, are not as difficult to discern as those of a very old person who is sinking again into the unconscious, and who progressively vanishes within it. Childhood and old age are the stages of life without any conscious problems, for which reason I have not taken them into consideration here.

THE SOUL AND DEATH¹

[796] I have often been asked what I believe about death, that un-problematical ending of individual existence. Death is known to us simply as the end. It is the period, often placed before the close of the sentence and followed only by memories or aftereffects in others. For the person concerned, however, the sand has run out of the glass; the rolling stone has come to rest. When death confronts us, life always seems like a downward flow or like a clock that has been wound up and whose eventual “running down” is taken for granted. We are never more convinced of this “running down” than when a human life comes to its end before our eyes, and the question of the meaning and worth of life never becomes more urgent or more agonizing than when we see the final breath leave a body which a moment before was living. How different does the meaning of life seem to us when we see a young person striving for distant goals and shaping the future, and compare this with an incurable invalid, or with an old man who is sinking reluctantly and impotently into the grave! Youth—we should like to think—has purpose, future, meaning, and value, whereas the coming to an end is only a meaningless cessation. If a young man is afraid of the world, of life and the future, then everyone finds it regrettable, senseless, neurotic; he is considered a cowardly shirker. But when an ageing person secretly shudders and is even mortally afraid at the thought that his reasonable expectation of life now amounts to only so and so many years, then we are painfully reminded of certain feelings within our own breast; we look away and turn the conversation to some other topic. The optimism with which we judge the young man fails us here. Naturally we have a stock of suitable banalities about life which we occasionally hand out to the other fellow, such as “everyone must die sometime,” “you can’t live forever,” etc. But when one is alone and it is night and so dark and still that one hears nothing and sees nothing but the thoughts which add and subtract the years, and the long row of those disagreeable facts which remorselessly indicate how far the hand of the clock has moved forward, and the slow, irresistible approach of the wall of darkness which will eventually engulf everything I love, possess, wish for, hope for, and strive for, then all our profundities about life slink off to some undiscoverable hiding-place, and fear envelops the sleepless one like a smothering blanket.

[797] Many young people have at bottom a panic fear of life (though at the same time they intensely desire it), and an even greater number of the ageing have the same fear of death. Indeed, I have known those people who most feared life when they were young to suffer later just as much from the fear of death. When they are young one

says they have infantile resistances against the normal demands of life; one should really say the same thing when they are old, for they are likewise afraid of one of life's normal demands. We are so convinced that death is simply the end of a process that it does not ordinarily occur to us to conceive of death as a goal and a fulfilment, as we do without hesitation the aims and purposes of youthful life in its ascendance.

[798] Life is an energy-process. Like every energy-process, it is in principle irreversible and is therefore directed towards a goal. That goal is a state of rest. In the long run everything that happens is, as it were, no more than the initial disturbance of a perpetual state of rest which forever attempts to re-establish itself. Life is teleology *par excellence*; it is the intrinsic striving towards a goal, and the living organism is a system of directed aims which seek to fulfil themselves. The end of every process is its goal. All energy-flow is like a runner who strives with the greatest effort and the utmost expenditure of strength to reach his goal. Youthful longing for the world and for life, for the attainment of high hopes and distant goals, is life's obvious teleological urge which at once changes into fear of life, neurotic resistances, depressions, and phobias if at some point it remains caught in the past, or shrinks from risks without which the unseen goal cannot be attained. With the attainment of maturity and at the zenith of biological existence, life's drive towards a goal in no wise halts. With the same intensity and irresistibility with which it strove upward before middle age, life now descends; for the goal no longer lies on the summit, but in the valley where the ascent began. The curve of life is like the parabola of a projectile which, disturbed from its initial state of rest, rises and then returns to a state of repose.

[799] The psychological curve of life, however, refuses to conform to this law of nature. Sometimes the lack of accord begins early in the ascent. The projectile ascends biologically, but psychologically it lags behind. We straggle behind our years, hugging our childhood as if we could not tear ourselves away. We stop the hands of the clock and imagine that time will stand still. When after some delay we finally reach the summit, there again, psychologically, we settle down to rest, and although we can see ourselves sliding down the other side, we cling, if only with longing backward glances, to the peak once attained. Just as, earlier, fear was a deterrent to life, so now it stands in the way of death. We may even admit that fear of life held us back on the upward slope, but just because of this delay we claim all the more right to hold fast to the summit we have now reached. Though it may be obvious that in spite of all our resistances (now so deeply regretted) life has reasserted itself, yet we pay no attention and keep on trying to make it stand still. Our psychology then loses its natural basis. Consciousness stays up in the air, while the curve of the parabola sinks downward with ever-increasing speed.

[800] Natural life is the nourishing soil of the soul. Anyone who fails to go along with life remains suspended, stiff and rigid in midair. That is why so many people get wooden in old age; they look back and cling to the past with a secret fear of death in their hearts. They withdraw from the life-process, at least psychologically, and consequently remain fixed like nostalgic pillars of salt, with vivid recollections of youth but no living relation to the present. From the middle of life onward, only he remains vitally alive who is ready to *die with life*. For in the secret hour of life's midday the parabola is reversed, death is born. The second half of life does not signify ascent, unfolding, increase, exuberance, but death, since the end is its goal. The negation of life's fulfilment is synonymous with the refusal to accept its ending. Both mean not wanting to live, and not wanting to live is identical with not wanting to die. Waxing and waning make one curve.

[801] Whenever possible our consciousness refuses to accommodate itself to this undeniable truth. Ordinarily we cling to our past and remain stuck in the illusion of youthfulness. Being old is highly unpopular. Nobody seems to consider that not being able to grow old is just as absurd as not being able to outgrow child's-size shoes. A still infantile man of thirty is surely to be deplored, but a youthful septuagenarian— isn't that delightful? And yet both are perverse, lacking in style, psychological monstrosities. A young man who does not fight and conquer has missed the best part of his youth, and an old man who does not know how to listen to the secrets of the brooks, as they tumble down from the peaks to the valleys, makes no sense; he is a spiritual mummy who is nothing but a rigid relic of the past. He stands apart from life, mechanically repeating himself to the last triviality.

[802] Our relative longevity, substantiated by present-day statistics, is a product of civilization. It is quite exceptional for primitive people to reach old age. For instance, when I visited the primitive tribes of East Africa, I saw very few men with white hair who might have been over sixty. But they were really old, they seemed to have always been old, so fully had they assimilated their age. They were exactly what they were in every respect. We are forever only more or less than we actually are. It is as if our consciousness had somehow slipped from its natural foundations and no longer knew how to get along on nature's timing. It seems as though we were suffering from a hybris of consciousness which fools us into believing that one's time of life is a mere illusion which can be altered according to one's desire. (One asks oneself where our consciousness gets its ability to be so contrary to nature and what such arbitrariness might signify.)

[803] Like a projectile flying to its goal, life ends in death. Even its ascent and its zenith are only steps and means to this goal. This paradoxical formula is no more than a logical deduction from the fact that life strives towards a goal and is

determined by an aim. I do not believe that I am guilty here of playing with syllogisms. We grant goal and purpose to the ascent of life, why not to the descent? The birth of a human being is pregnant with meaning, why not death? For twenty years and more the growing man is being prepared for the complete unfolding of his individual nature, why should not the older man prepare himself twenty years and more for his death? Of course, with the zenith one has obviously reached something, one is it and has it. But what is attained with death?

[804] At this point, just when it might be expected, I do not want suddenly to pull a belief out of my pocket and invite my reader to do what nobody can do—that is, believe something. I must confess that I myself could never do it either. Therefore I shall certainly not assert now that one must believe death to be a second birth leading to survival beyond the grave. But I can at least mention that the *consensus gentium* has decided views about death, unmistakably expressed in all the great religions of the world. One might even say that the majority of these religions are complicated systems of preparation for death, so much so that life, in agreement with my paradoxical formula, actually has no significance except as a preparation for the ultimate goal of death. In both the greatest living religions, Christianity and Buddhism, the meaning of existence is consummated in its end.

[805] Since the Age of Enlightenment a point of view has developed concerning the nature of religion which, although it is a typically rationalistic misconception, deserves mention because it is so widely disseminated. According to this view, all religions are something like philosophical systems, and like them are concocted out of the head. At some time someone is supposed to have invented a God and sundry dogmas and to have led humanity around by the nose with this “wish-fulfilling” fantasy. But this opinion is contradicted by the psychological fact that the head is a particularly inadequate organ when it comes to thinking up religious symbols. They do not come from the head at all, but from some other place, perhaps the heart; certainly from a deep psychic level very little resembling consciousness, which is always only the top layer. That is why religious symbols have a distinctly “revelatory” character; they are usually spontaneous products of unconscious psychic activity. They are anything rather than thought up; on the contrary, in the course of the millennia, they have developed, plant-like, as natural manifestations of the human psyche. Even today we can see in individuals the spontaneous genesis of genuine and valid religious symbols, springing from the unconscious like flowers of a strange species, while consciousness stands aside perplexed, not knowing what to make of such creations. It can be ascertained without too much difficulty that in form and content these individual symbols arise from the same unconscious mind or “spirit” (or whatever it may be called) as the great religions of mankind. At all events experience shows that religions are in no sense conscious constructions, but that they

arise from the natural life of the unconscious psyche and somehow give adequate expression to it. This explains their universal distribution and their enormous influence on humanity throughout history, which would be incomprehensible if religious symbols were not at the very least truths of man's psychological nature.

[806] I know that very many people have difficulties with the word "psychological." To put these critics at ease, I should like to add that no one knows what "psyche" is, and one knows just as little how far into nature "psyche" extends. A psychological truth is therefore just as good and respectable a thing as a physical truth, which limits itself to matter as the former does to the psyche.

[807] The *consensus gentium* that expresses itself through the religions is, as we saw, in sympathy with my paradoxical formula. Hence it would seem to be more in accord with the collective psyche of humanity to regard death as the fulfilment of life's meaning and as its goal in the truest sense, instead of a mere meaningless cessation. Anyone who cherishes a rationalistic opinion on this score has isolated himself psychologically and stands opposed to his own basic human nature.

[808] This last sentence contains a fundamental truth about all neuroses, for nervous disorders consist primarily in an alienation from one's instincts, a splitting off of consciousness from certain basic facts of the psyche. Hence rationalistic opinions come unexpectedly close to neurotic symptoms. Like these, they consist of distorted thinking, which takes the place of psychologically correct thinking. The latter kind of thinking always retains its connection with the heart, with the depths of the psyche, the tap-root. For, enlightenment or no enlightenment, consciousness or no consciousness, nature prepares itself for death. If we could observe and register the thoughts of a young person when he has time and leisure for day-dreaming, we would discover that, aside from a few memory-images, his fantasies are mainly concerned with the future. As a matter of fact, most fantasies consist of anticipations. They are for the most part preparatory acts, or even psychic exercises for dealing with certain future realities. If we could make the same experiment with an ageing person—without his knowledge, of course—we would naturally find, owing to his tendency to look backwards, a greater number of memory-images than with a younger person, but we would also find a surprisingly large number of anticipations, including those of death. Thoughts of death pile up to an astonishing degree as the years increase. Willynilly, the ageing person prepares himself for death. That is why I think that nature herself is already preparing for the end. Objectively it is a matter of indifference what the individual consciousness may think about it. But subjectively it makes an enormous difference whether consciousness keeps in step with the psyche or whether it clings to opinions of which the heart knows nothing. It is just as

neurotic in old age not to focus upon the goal of death as it is in youth to repress fantasies which have to do with the future.

[809] In my rather long psychological experience I have observed a great many people whose unconscious psychic activity I was able to follow into the immediate presence of death. As a rule the approaching end was indicated by those symbols which, in normal life also, proclaim changes of psychological condition—rebirth symbols such as changes of locality, journeys, and the like. I have frequently been able to trace back for over a year, in a dream-series, the indications of approaching death, even in cases where such thoughts were not prompted by the outward situation. Dying, therefore, has its onset long before actual death. Moreover, this often shows itself in peculiar changes of personality which may precede death by quite a long time. On the whole, I was astonished to see how little ado the unconscious psyche makes of death. It would seem as though death were something relatively unimportant, or perhaps our psyche does not bother about what happens to the individual. But it seems that the unconscious is all the more interested in *how* one dies; that is, whether the attitude of consciousness is adjusted to dying or not. For example, I once had to treat a woman of sixty-two. She was still hearty, and moderately intelligent. It was not for want of brains that she was unable to understand her dreams. It was unfortunately only too clear that she did not *want* to understand them. Her dreams were very plain, but also very disagreeable. She had got it fixed in her head that she was a faultless mother to her children, but the children did not share this view at all, and the dreams too displayed a conviction very much to the contrary. I was obliged to break off the treatment after some weeks of fruitless effort because I had to leave for military service (it was during the war). In the meantime the patient was smitten with an incurable disease, leading after a few months to a moribund condition which might bring about the end at any moment. Most of the time she was in a sort of delirious or somnambulistic state, and in this curious mental condition she spontaneously resumed the analytical work. She spoke of her dreams again and acknowledged to herself everything that she had previously denied to me with the greatest vehemence, and a lot more besides. This self-analytic work continued daily for several hours, for about six weeks. At the end of this period she had calmed herself, just like a patient during normal treatment, and then she died.

[810] From this and numerous other experiences of the kind I must conclude that our psyche is at least not indifferent to the dying of the individual. The urge, so often seen in those who are dying, to set to rights whatever is still wrong might point in the same direction.

[811] How these experiences are ultimately to be interpreted is a problem that exceeds the competence of an empirical science and goes beyond our intellectual capacities,

for in order to reach a final conclusion one must necessarily have had the actual experience of death. This event unfortunately puts the observer in a position that makes it impossible for him to give an objective account of his experiences and of the conclusions resulting therefrom.

[812] Consciousness moves within narrow confines, within the brief span of time between its beginning and its end, and shortened by about a third by periods of sleep. The life of the body lasts somewhat longer; it always begins earlier and, very often, it ceases later than consciousness. Beginning and end are unavoidable aspects of all processes. Yet on closer examination it is extremely difficult to see where one process ends and another begins, since events and processes, beginnings and endings, merge into each other and form, strictly speaking, an indivisible continuum. We divide the processes from one another for the sake of discrimination and understanding, knowing full well that at bottom every division is arbitrary and conventional. This procedure in no way infringes the continuum of the world process, for “beginning” and “end” are primarily necessities of conscious cognition. We may establish with reasonable certainty that an individual consciousness as it relates to ourselves has come to an end. But whether this means that the continuity of the psychic process is also interrupted remains doubtful, since the psyche’s attachment to the brain can be affirmed with far less certitude today than it could fifty years ago. Psychology must first digest certain parapsychological facts, which it has hardly begun to do as yet.

[813] The unconscious psyche appears to possess qualities which throw a most peculiar light on its relation to space and time. I am thinking of those spatial and temporal telepathic phenomena which, as we know, are much easier to ignore than to explain. In this regard science, with a few praiseworthy exceptions, has so far taken the easier path of ignoring them. I must confess, however, that the so-called telepathic faculties of the psyche have caused me many a headache, for the catchword “telepathy” is very far from explaining anything. The limitation of consciousness in space and time is such an overwhelming reality that every occasion when this fundamental truth is broken through must rank as an event of the highest theoretical significance, for it would prove that the space-time barrier can be annulled. The annulling factor would then be the psyche, since space-time would attach to it at most as a relative and conditioned quality. Under certain conditions it could even break through the barriers of space and time precisely because of a quality essential to it, that is, its relatively trans-spatial and trans-temporal nature. This possible transcendence of space-time, for which it seems to me there is a good deal of evidence, is of such incalculable import that it should spur the spirit of research to the greatest effort. Our present development of consciousness is, however, so backward that in general we still lack the scientific and intellectual equipment for adequately evaluating the facts of

telepathy so far as they have bearing on the nature of the psyche. I have referred to this group of phenomena merely in order to point out that the psyche's attachment to the brain, i.e., its space-time limitation, is no longer as self-evident and incontrovertible as we have hitherto been led to believe.

[814] Anyone who has the least knowledge of the parapsychological material which already exists and has been thoroughly verified will know that so-called telepathic phenomena are undeniable facts. An objective and critical survey of the available data would establish that perceptions occur as if in part there were no space, in part no time. Naturally, one cannot draw from this the metaphysical conclusion that in the world of things as they are "in themselves" there is neither space nor time, and that the space-time category is therefore a web into which the human mind has woven itself as into a nebulous illusion. Space and time are not only the most immediate certainties for us, they are also obvious empirically, since everything observable happens as though it occurred in space and time. In the face of this overwhelming certainty it is understandable that reason should have the greatest difficulty in granting validity to the peculiar nature of telepathic phenomena. But anyone who does justice to the facts cannot but admit that their apparent space-timelessness is their most essential quality. In the last analysis, our naïve perception and immediate certainty are, strictly speaking, no more than evidence of a psychological *a priori* form of perception which simply rules out any other form. The fact that we are totally unable to imagine a form of existence without space and time by no means proves that such an existence is in itself impossible. And therefore, just as we cannot draw, from an appearance of space-timelessness, any absolute conclusion about a space-timeless form of existence, so we are not entitled to conclude from the apparent space-time quality of our perception that there is no form of existence *without* space and time. It is not only permissible to doubt the absolute validity of space-time perception; it is, in view of the available facts, even imperative to do so. The hypothetical possibility that the psyche touches on a form of existence outside space and time presents a scientific question-mark that merits serious consideration for a long time to come. The ideas and doubts of theoretical physicists in our own day should prompt a cautious mood in psychologists too; for, philosophically considered, what do we mean by the "limitedness of space" if not a relativization of the space category? Something similar might easily happen to the category of time (and to that of causality as well).² Doubts about these matters are more warranted today than ever before.

[815] The nature of the psyche reaches into obscurities far beyond the scope of our understanding. It contains as many riddles as the universe with its galactic systems, before whose majestic configurations only a mind lacking in imagination can fail to admit its own insufficiency. This extreme uncertainty of human comprehension

makes the intellectualistic hubbub not only ridiculous, but also deplorably dull. If, therefore, from the needs of his own heart, or in accordance with the ancient lessons of human wisdom, or out of respect for the psychological fact that “telepathic” perceptions occur, anyone should draw the conclusion that the psyche, in its deepest reaches, participates in a form of existence beyond space and time, and thus partakes of what is inadequately and symbolically described as “eternity”—then critical reason could counter with no other argument than the “non liquet” of science. Furthermore, he would have the inestimable advantage of conforming to a bias of the human psyche which has existed from time immemorial and is universal. Anyone who does not draw this conclusion, whether from scepticism or rebellion against tradition, from lack of courage or inadequate psychological experience or thoughtless ignorance, stands very little chance, statistically, of becoming a pioneer of the mind, but has instead the indubitable certainty of coming into conflict with the truths of his blood. Now whether these are in the last resort absolute truths or not we shall never be able to determine. It suffices that they are present in us as a “bias,” and we know to our cost what it means to come into unthinking conflict with these truths. It means the same thing as the conscious denial of the instincts—uprootedness, disorientation, meaninglessness, and whatever else these symptoms of inferiority may be called. One of the most fatal of the sociological and psychological errors in which our time is so fruitful is the supposition that something can become entirely different all in a moment; for instance, that man can radically change his nature, or that some formula or truth might be found which would represent an entirely new beginning. Any essential change, or even a slight improvement, has always been a miracle. Deviation from the truths of the blood begets neurotic restlessness, and we have had about enough of that these days. Restlessness begets meaninglessness, and the lack of meaning in life is a soul-sickness whose full extent and full import our age has not as yet begun to comprehend.

VII

SYNCHRONICITY: AN ACAUSAL CONNECTING PRINCIPLE

[Translated from “Synchronizität als ein Prinzip akausaler Zusammenhänge,” which, together with a monograph by Professor W. Pauli entitled “Der Einfluss archetypischer Vorstellungen auf die Bildung naturwissenschaftlicher Theorien bei Kepler,” formed the volume *Naturerklärung und Psyche* (Studien aus dem C. G. Jung-Institut, IV; Zurich, 1952). This volume was translated as *The Interpretation of Nature and the Psyche* (New York [Bollingen Series LI] and London, 1955), with corrections and extensive revisions by Professor Jung in his [Chapter 2](#), “An Astrological Experiment.” These important alterations were not, however, incorporated in the republication of the monograph in the Swiss *Gesammelte Werke*, Volume 8: *Die Dynamik des Unbewussten* (Zurich, 1967), which preserves the original 1952 version unchanged. The monograph is here republished with additional revisions by the Editors and the translator, with the aim of further clarifying the difficult exposition while retaining the author’s substance. (The chief revisions occur in pars. 856, 880, 883, 890, 893, 895, and 901. [Figs. 2](#) and [3](#) have been redrawn.)

[The brief essay “On Synchronicity” printed in the appendix to [Part VII](#), *infra*, was an earlier (1951) and more popular version of the present work. Here it replaces a brief “Résumé” written by the author for the 1955 version of the monograph.—EDITORS.]

FOREWORD

[816] In writing this paper I have, so to speak, made good a promise which for many years I lacked the courage to fulfil. The difficulties of the problem and its presentation seemed to me too great; too great the intellectual responsibility without which such a subject cannot be tackled; too inadequate, in the long run, my scientific training. If I have now conquered my hesitation and at last come to grips with my theme, it is chiefly because my experiences of the phenomenon of synchronicity have multiplied themselves over decades, while on the other hand my researches into the history of symbols, and of the fish symbol in particular, brought the problem ever closer to me, and finally because I have been alluding to the existence of this phenomenon on and off in my writings for twenty years without discussing it any further. I would like to put a temporary end to this unsatisfactory state of affairs by trying to give a consistent account of everything I have to say on this subject. I hope it will not be construed as presumption on my part if I make uncommon demands on the open-mindedness and goodwill of the reader. Not only is he expected to plunge into regions of human experience which are dark, dubious, and hedged about with prejudice, but the intellectual difficulties are such as the treatment and elucidation of so abstract a subject must inevitably entail. As anyone can see for himself after reading a few pages, there can be no question of a complete description and explanation of these complicated phenomena, but only an attempt to broach the problem in such a way as to reveal some of its manifold aspects and connections, and to open up a very obscure field which is philosophically of the greatest importance. As a psychiatrist and psychotherapist I have often come up against the phenomena in question and could convince myself how much these inner experiences meant to my patients. In most cases they were things which people do not talk about for fear of exposing themselves to thoughtless ridicule. I was amazed to see how many people have had experiences of this kind and how carefully the secret was guarded. So my interest in this problem has a human as well as a scientific foundation.

[817] In the performance of my work I had the support of a number of friends who are mentioned in the text. Here I would like to express my particular thanks to Dr.

Liliane Frey-Rohn, for her help with the astrological material.

1. EXPOSITION

[818] The discoveries of modern physics have, as we know, brought about a significant change in our scientific picture of the world, in that they have shattered the absolute validity of natural law and made it relative. Natural laws are *statistical* truths, which means that they are completely valid only when we are dealing with macrophysical quantities. In the realm of very small quantities prediction becomes uncertain, if not impossible, because very small quantities no longer behave in accordance with the known natural laws.

[819] The philosophical principle that underlies our conception of natural law is *causality*. But if the connection between cause and effect turns out to be only statistically valid and only relatively true, then the causal principle is only of relative use for explaining natural processes and therefore presupposes the existence of one or more other factors which would be necessary for an explanation. This is as much as to say that the connection of events may in certain circumstances be other than causal, and requires another principle of explanation.¹

[820] We shall naturally look round in vain in the macrophysical world for acausal events, for the simple reason that we cannot imagine events that are connected non-causally and are capable of a non-causal explanation. But that does not mean that such events do not exist. Their existence—or at least their possibility—follows logically from the premise of statistical truth.

[821] The experimental method of inquiry aims at establishing regular events which can be repeated. Consequently, unique or rare events are ruled out of account. Moreover, the experiment imposes limiting conditions on nature, for its aim is to force her to give answers to questions devised by man. Every answer of nature is therefore more or less influenced by the kind of questions asked, and the result is always a hybrid product. The so-called “scientific view of the world” based on this can hardly be anything more than a psychologically biased partial view which misses out all those by no means unimportant aspects that cannot be grasped statistically. But, to grasp these unique or rare events at all, we seem to be dependent on equally

“unique” and individual descriptions. This would result in a chaotic collection of curiosities, rather like those old natural history cabinets where one finds, cheek by jowl with fossils and anatomical monsters in bottles, the horn of a unicorn, a mandragora manikin, and a dried mermaid. The descriptive sciences, and above all biology in the widest sense, are familiar with these “unique” specimens, and in their case only *one* example of an organism, no matter how unbelievable it may be, is needed to establish its existence. At any rate numerous observers will be able to convince themselves, on the evidence of their own eyes, that such a creature does in fact exist. But where we are dealing with ephemeral events which leave no demonstrable traces behind them except fragmentary memories in people’s minds, then a single witness no longer suffices, nor would several witnesses be enough to make a unique event appear absolutely credible. One has only to think of the notorious unreliability of eye-witness accounts. In these circumstances we are faced with the necessity of finding out whether the apparently unique event is really unique in our recorded experience, or whether the same or similar events are not to be found elsewhere. Here the *consensus omnium* plays a very important role psychologically, though empirically it is somewhat doubtful, for only in exceptional cases does the *consensus omnium* prove to be of value in establishing facts. The empiricist will not leave it out of account, but will do better not to rely on it. Absolutely unique and ephemeral events whose existence we have no means of either denying or proving can never be the object of empirical science; rare events might very well be, provided that there was a sufficient number of reliable individual observations. The so-called *possibility* of such events is of no importance whatever, for the criterion of what is possible in any age is derived from that age’s rationalistic assumptions. There are no “absolute” natural laws to whose authority one can appeal in support of one’s prejudices. The most that can fairly be demanded is that the number of individual observations shall be as high as possible. If this number, statistically considered, falls within the limits of chance expectation, then it has been statistically proved that it was a question of chance; but no *explanation* has thereby been furnished. There has merely been an exception to the rule. When, for instance, the number of symptoms indicating a complex falls below the probable number of disturbances to be expected during the association experiment, this is no justification for assuming that no complex exists. But that did not prevent the reaction disturbances from being regarded earlier as pure chance.²

[822] Although, in biology especially, we move in a sphere where causal explanations often seem very unsatisfactory—indeed, well-nigh impossible—we shall not concern ourselves here with the problems of biology, but rather with the question whether there may not be some general field where acausal events not only are possible but are found to be actual facts.

[823] Now, there is in our experience an immeasurably wide field whose extent forms, as it were, the counterbalance to the domain of causality. This is the world of chance, where a chance event seems causally unconnected with the coinciding fact. So we shall have to examine the nature and the whole idea of chance a little more closely. Chance, we say, must obviously be susceptible of some causal explanation and is only called “chance” or “coincidence” because its causality has not yet been discovered. Since we have an inveterate conviction of the absolute validity of causal law, we regard this explanation of chance as being quite adequate. But if the causal principle is only relatively valid, then it follows that even though in the vast majority of cases an apparently chance series can be causally explained, there must still remain a number of cases which do not show any causal connection. We are therefore faced with the task of sifting chance events and separating the acausal ones from those that can be causally explained. It stands to reason that the number of causally explicable events will far exceed those suspected of acausality, for which reason a superficial or prejudiced observer may easily overlook the relatively rare acausal phenomena. As soon as we come to deal with the problem of chance the need for a statistical evaluation of the events in question forces itself upon us.

[824] It is not possible to sift the empirical material without a criterion of distinction. How are we to recognize acausal combinations of events, since it is obviously impossible to examine all chance happenings for their causality? The answer to this is that acausal events may be expected most readily where, on closer reflection, a causal connection appears to be inconceivable. As an example I would cite the “duplication of cases” which is a phenomenon well known to every doctor. Occasionally there is a trebling or even more, so that Kammerer³ can speak of a “law of series,” of which he gives a number of excellent examples. In the majority of such cases there is not even the remotest probability of a causal connection between the coinciding events. When for instance I am faced with the fact that my tram ticket bears the same number as the theatre ticket which I buy immediately afterwards, and I receive that same evening a telephone call during which the same number is mentioned again as a telephone number, then a causal connection between these events seems to me improbable in the extreme, although it is obvious that each must have its own causality. I know, on the other hand, that chance happenings have a tendency to fall into aperiodic groupings—necessarily so, because otherwise there would be only a periodic or regular arrangement of events which would by definition exclude chance.

[825] Kammerer holds that though “runs”⁴ or successions of chance events are not subject to the operation of a common cause,⁵ i.e., are acausal, they are nevertheless an expression of inertia—the property of persistence.⁶ The simultaneity of a “run of the same thing side by side” he explains as “imitation.”⁷ Here he contradicts himself,

for the run of chance has not been “removed outside the realm of the explicable,”⁸ but, as we would expect, is included within it and is consequently reducible, if not to a common cause, then at least to several causes. His concepts of seriality, imitation, attraction, and inertia belong to a causally conceived view of the world and tell us no more than that the run of chance corresponds to statistical and mathematical probability.⁹ Kammerer’s factual material contains nothing but runs of chance whose only “law” is probability; in other words, there is no apparent reason why he should look behind them for anything else. But for some obscure reason he does look behind them for something more than mere probability warrants—for a *law of seriality* which he would like to introduce as a principle coexistent with causality and finality. This tendency, as I have said, is in no way justified by his material. I can only explain this obvious contradiction by supposing that he had a dim but fascinated intuition of an acausal arrangement and combination of events, probably because, like all thoughtful and sensitive natures, he could not escape the peculiar impression which runs of chance usually make on us, and therefore, in accordance with his scientific disposition, took the bold step of postulating an acausal seriality on the basis of empirical material that lay within the limits of probability. Unfortunately he did not attempt a quantitative evaluation of seriality. Such an undertaking would undoubtedly have thrown up questions that are difficult to answer. The investigation of individual cases serves well enough for the purpose of general orientation, but only quantitative evaluation or the statistical method promises results in dealing with chance.

[826] Chance groupings or series seem, at least to our present way of thinking, to be meaningless, and to fall as a general rule within the limits of probability. There are, however, incidents whose “chancefulness” seems open to doubt. To mention but one example out of many, I noted the following on April 1, 1949: Today is Friday. We have fish for lunch. Somebody happens to mention the custom of making an “April fish” of someone. That same morning I made a note of an inscription which read: “Est homo totus medius *piscis* ab imo.” In the afternoon a former patient of mine, whom I had not seen for months, showed me some extremely impressive pictures of fish which she had painted in the meantime. In the evening I was shown a piece of embroidery with fish-like sea-monsters in it. On the morning of April 2 another patient, whom I had not seen for many years, told me a dream in which she stood on the shore of a lake and saw a large fish that swam straight towards her and landed at her feet. I was at this time engaged on a study of the fish symbol in history. Only one of the persons mentioned here knew anything about it.

[827] The suspicion that this must be a case of *meaningful coincidence*; i.e., an acausal connection, is very natural. I must own that this run of events made a considerable impression on me. It seemed to me to have a certain numinous quality.¹⁰ In such circumstances we are inclined to say, “That cannot be mere chance,” without

knowing what exactly we are saying. Kammerer would no doubt have reminded me of his “seriality.” The strength of an impression, however, proves nothing against the fortuitous coincidence of all these fishes. It is, admittedly, exceedingly odd that the fish theme recurs no less than six times within twenty-four hours. But one must remember that fish on Friday is the usual thing, and on April 1 one might very easily think of the April fish. I had at that time been working on the fish symbol for several months. Fishes frequently occur as symbols of unconscious contents. So there is no possible justification for seeing in this anything but a chance grouping. Runs or series which are composed of quite ordinary occurrences must for the present be regarded as fortuitous.¹¹ However wide their range may be, they must be ruled out as acausal connections. It is, therefore, generally assumed that all coincidences are lucky hits and do not require an acausal interpretation.¹² This assumption can, and indeed must, be regarded as true so long as proof is lacking that their incidence exceeds the limits of probability. Should this proof be forthcoming, however, it would prove at the same time that there are genuinely non-causal combinations of events for whose explanation we should have to postulate a factor incommensurable with causality. We should then have to assume that events in general are related to one another on the one hand as causal chains, and on the other hand by a kind of *meaningful cross-connection*.

[828] Here I should like to draw attention to a treatise of Schopenhauer’s, “On the Apparent Design in the Fate of the Individual,”¹³ which originally stood godfather to the views I am now developing. It deals with the “simultaneity of the causally unconnected, which we call ‘chance’.”¹⁴ Schopenhauer illustrates this simultaneity by a geographical analogy, where the parallels represent the cross-connection between the meridians, which are thought of as causal chains.¹⁵

All the events in a man’s life would accordingly stand in two fundamentally different kinds of connection: firstly, in the objective, causal connection of the natural process; secondly, in a subjective connection which exists only in relation to the individual who experiences it, and which is thus as subjective as his own dreams. ... That both kinds of connection exist simultaneously, and the selfsame event, although a link in two totally different chains, nevertheless falls into place in both, so that the fate of one individual invariably fits the fate of the other, and each is the hero of his own drama while simultaneously figuring in a drama foreign to him—this is something that surpasses our powers of comprehension, and can only be conceived as possible by virtue of the most wonderful pre-established harmony.¹⁶

In his view “the subject of the great dream of life ... is but one,”¹⁷ the transcendental Will, the *prima causa*, from which all causal chains radiate like meridian lines from the poles and, because of the circular parallels, stand to one another in a meaningful

relationship of simultaneity.¹⁸ Schopenhauer believed in the absolute determinism of the natural process and furthermore in a first cause. There is nothing to warrant either assumption. The first cause is a philosophical mythologem which is only credible when it appears in the form of the old paradox “Ἐν τὸ πᾶν, as unity and multiplicity at once. The idea that the simultaneous points in the causal chains, or meridians, represent meaningful coincidences would only hold water if the first cause really were a unity. But if it were a multiplicity, which is just as likely, then Schopenhauer’s whole explanation collapses, quite apart from the fact, which we have only recently realized, that natural law possesses a merely statistical validity and thus keeps the door open to indeterminism. Neither philosophical reflection nor experience can provide any evidence for the regular occurrence of these two kinds of connection, in which the same thing is both subject and object. Schopenhauer thought and wrote at a time when causality held sovereign sway as a category *a priori* and had therefore to be dragged in to explain meaningful coincidences. But, as we have seen, it can do this with some degree of probability only if we have recourse to the other, equally arbitrary assumption of the unity of the first cause. It then follows as a *necessity* that every point on a given meridian stands in a relationship of meaningful coincidence to every other point on the same degree of latitude. This conclusion, however, goes far beyond the bounds of what is empirically possible, for it credits meaningful coincidences with occurring so regularly and systematically that their verification would be either unnecessary or the simplest thing in the world. Schopenhauer’s examples carry as much or as little conviction as all the others. Nevertheless, it is to his credit that he saw the problem and understood that there are no facile *ad hoc* explanations. Since this problem is concerned with the foundations of our epistemology, he derived it in accordance with the general trend of his philosophy from a transcendental premise, from the Will which creates life and being on all levels, and which modulates each of these levels in such a way that they are not only in harmony with their synchronous parallels but also prepare and arrange future events in the form of Fate or Providence.

[829] In contrast to Schopenhauer’s accustomed pessimism, this utterance has an almost friendly and optimistic tone which we can hardly sympathize with today. One of the most problematical and momentous centuries the world has ever known separates us from that still medievalistic age when the philosophizing mind believed it could make assertions beyond what could be empirically proved. It was an age of large views, which did not cry halt and think that the limits of nature had been reached just where the scientific road-builders had come to a temporary stop. Thus Schopenhauer, with true philosophical vision, opened up a field for reflection whose peculiar phenomenology he was not equipped to understand, though he outlined it more or less correctly. He recognized that with their *omina* and *praesagia* astrology

and the various intuitive methods of interpreting fate have a common denominator which he sought to discover by means of “transcendental speculation.” He recognized, equally rightly, that it was a problem of principle of the first order, unlike all those before and after him who operated with futile conceptions of some kind of energy transmission, or conveniently dismissed the whole thing as nonsense in order to avoid a too difficult task.¹⁹ Schopenhauer’s attempt is the more remarkable in that it was made at a time when the tremendous advance of the natural sciences had convinced everybody that causality alone could be considered the final principle of explanation. Instead of ignoring all those experiences which refuse to bow down to the sovereign rule of causality, he tried, as we have seen, to fit them into his deterministic view of the world. In so doing, he forced concepts like prefiguration, correspondence, and pre-established harmony, which as a universal order coexisting with the causal one have always underlain man’s explanations of nature, into the causal scheme, probably because he felt—and rightly—that the scientific view of the world based on natural law, though he did not doubt its validity, nevertheless lacked something which played a considerable role in the classical and medieval view (as it also does in the intuitive feelings of modern man).

[830] The mass of facts collected by Gurney, Myers, and Podmore²⁰ inspired three other investigators—Dariex,²¹ Richet,²² and Flammarion²³—to tackle the problem in terms of a probability calculus. Dariex found a probability of 1 : 4,114,545 for telepathic precognitions of death, which means that the explanation of such a warning as due to “chance” is more than four million times more improbable than explaining it as a “telepathic,” or acausal, meaningful coincidence. The astronomer Flammarion reckoned a probability of no less than 1 : 804,622,222 for a particularly well-observed instance of “phantasms of the living.”²⁴ He was also the first to link up other suspicious happenings with the general interest in phenomena connected with death. Thus he relates²⁵ that, while writing his book on the atmosphere, he was just at the chapter on wind-force when a sudden gust of wind swept all his papers off the table and blew them out of the window. He also cites, as an example of triple coincidence, the edifying story of Monsieur de Fortgibu and the plum-pudding.²⁶ The fact that he mentions these coincidences at all in connection with the problem of telepathy shows that Flammarion had a distinct intuition, albeit an unconscious one, of a far more comprehensive principle.

[831] The writer Wilhelm von Scholz²⁷ has collected a number of stories showing the strange ways in which lost or stolen objects come back to their owners. Among other things, he tells the story of a mother who took a photograph of her small son in the Black Forest. She left the film to be developed in Strassburg. But, owing to the outbreak of war, she was unable to fetch it and gave it up for lost. In 1916 she bought a film in Frankfurt in order to take a photograph of her daughter, who had been born

in the meantime. When the film was developed it was found to be doubly exposed: the picture underneath was the photograph she had taken of her son in 1914! The old film had not been developed and had somehow got into circulation again among the new films. The author comes to the understandable conclusion that everything points to the “mutual attraction of related objects,” or an “elective affinity.” He suspects that these happenings are arranged as if they were the dream of a “greater and more comprehensive consciousness, which is unknowable.”

[832] The problem of chance has been approached from the psychological angle by Herbert Silberer.²⁸ He shows that apparently meaningful coincidences are partly unconscious arrangements, and partly unconscious, arbitrary interpretations. He takes no account either of parapsychic phenomena or of synchronicity, and theoretically he does not go much beyond the causalism of Schopenhauer. Apart from its valuable psychological criticism of our methods of evaluating chance, Silberer’s study contains no reference to the occurrence of meaningful coincidences as here understood.

[833] Decisive evidence for the existence of acausal combinations of events has been furnished, with adequate scientific safeguards, only very recently, mainly through the experiments of J. B. Rhine and his fellow-workers,²⁹ who have not, however, recognized the far-reaching conclusions that must be drawn from their findings. Up to the present no critical argument that cannot be refuted has been brought against these experiments. The experiment consists, in principle, in an experimenter turning up, one after another, a series of numbered cards bearing simple geometrical patterns. At the same time the subject, separated by a screen from the experimenter, is given the task of guessing the signs as they are turned up. A pack of twenty-five cards is used, each five of which carry the same sign. Five cards are marked with a star, five with a square, five with a circle, five with wavy lines, and five with a cross. The experimenter naturally does not know the order in which the pack is arranged, nor has the subject any opportunity of seeing the cards. Many of the experiments were negative, since the result did not exceed the probability of five chance hits. In the case of certain subjects, however, some results were distinctly above probability. The first series of experiments consisted in each subject trying to guess the cards 800 times. The average result showed 6.5 hits for 25 cards, which is 1.5 more than the chance probability of 5 hits. The probability of there being a chance deviation of 1.5 from the number 5 works out at 1 : 250,000. This proportion shows that the probability of a chance deviation is not exactly high, since it is to be expected only once in 250,000 cases. The results vary according to the specific gift of the individual subject. One young man, who in numerous experiments scored an average of 10 hits for every 25 cards (double the probable number), once guessed all 25 cards correctly, which gives a probability of 1 : 298,023,223,876,953,125. The possibility of the pack

being shuffled in some arbitrary way is guarded against by an apparatus which shuffles the cards automatically, independently of the experimenter.

[834] After the first series of experiments the spatial distance between the experimenter and the subject was increased, in one case to 250 miles. The average result of numerous experiments amounted here to 10.1 hits for 25 cards. In another series of experiments, when experimenter and subject were in the same room, the score was 11.4 for 25; when the subject was in the next room, 9.7 for 25; when two rooms away, 12.0 for 25. Rhine mentions the experiments of F. L. Usher and E. L. Burt, which were conducted with positive results over a distance of 960 miles.³⁰ With the aid of synchronized watches experiments were also conducted between Durham, North Carolina, and Zagreb, Yugoslavia, about 4,000 miles, with equally positive results.³¹

[835] The fact that distance has no effect in principle shows that the thing in question cannot be a phenomenon of force or energy, for otherwise the distance to be overcome and the diffusion in space would cause a diminution of the effect, and it is more than probable that the score would fall proportionately to the square of the distance. Since this is obviously not the case, we have no alternative but to assume that distance is psychically variable, and may in certain circumstances be reduced to vanishing point by a psychic condition.

[836] Even more remarkable is the fact that *time* is not in principle a prohibiting factor either; that is to say, the scanning of a series of cards to be turned up in the future produces a score that exceeds chance probability. The results of Rhine's time experiment show a probability of 1 : 400,000, which means a considerable probability of there being some factor independent of time. They point, in other words, to a psychic relativity of time, since the experiment was concerned with perceptions of events which had not yet occurred. In these circumstances the time factor seems to have been eliminated by a psychic function or psychic condition which is also capable of abolishing the spatial factor. If, in the spatial experiments, we were obliged to admit that energy does not decrease with distance, then the time experiments make it completely impossible for us even to think of there being any energy relationship between the perception and the future event. We must give up at the outset all explanations in terms of energy, which amounts to saying that events of this kind cannot be considered from the point of view of causality, for causality presupposes the existence of space and time in so far as all observations are ultimately based upon bodies in motion.

[837] Among Rhine's experiments we must also mention the experiments with dice. The subject has the task of throwing the dice (which is done by an apparatus), and at the same time he has to wish that one number (say 3) will turn up as many times as

possible. The results of this so-called PK (psychokinetic) experiment were positive, the more so the more dice were used at one time.³² If space and time prove to be psychically relative, then the moving body must possess, or be subject to, a corresponding relativity.

[838] One consistent experience in all these experiments is the fact that the number of hits scored tends to sink after the first attempt, and the results then become negative. But if, for some inner or outer reason, there is a freshening of interest on the subject's part, the score rises again. Lack of interest and boredom are negative factors; enthusiasm, positive expectation, hope, and belief in the possibility of ESP make for good results and seem to be the real conditions which determine whether there are going to be any results at all. In this connection it is interesting to note that the well-known English medium, Mrs. Eileen J. Garrett, achieved bad results in the Rhine experiments because, as she herself admits, she was unable to summon up any feeling for the "soulless" test-cards.

[839] These few hints may suffice to give the reader at least a superficial idea of these experiments. The above-mentioned book by G. N. M. Tyrrell, late president of the Society for Psychical Research, contains an excellent summing-up of all experiences in this field. Its author himself rendered great service to ESP research. From the physicist's side the ESP experiments have been evaluated in a positive sense by Robert A. McConnell in an article entitled "ESP—Fact or Fancy?"³³

[840] As is only to be expected, every conceivable kind of attempt has been made to explain away these results, which seem to border on the miraculous and frankly impossible. But all such attempts come to grief on the facts, and the facts refuse so far to be argued out of existence. Rhine's experiments confront us with the fact that there are events which are related to one another experimentally, and in this case *meaningfully*, without there being any possibility of proving that this relation is a causal one, since the "transmission" exhibits none of the known properties of energy. There is therefore good reason to doubt whether it is a question of transmission at all. The time experiments rule out any such thing in principle, for it would be absurd to suppose that a situation which does not yet exist and will only occur in the future could transmit itself as a phenomenon of energy to a receiver in the present.³⁴ It seems more likely that scientific explanation will have to begin with a criticism of our concepts of space and time on the one hand, and with the unconscious on the other. As I have said, it is impossible, with our present resources, to explain ESP, or the fact of meaningful coincidence, as a phenomenon of energy. This makes an end of the causal explanation as well, for "effect" cannot be understood as anything except a phenomenon of energy. Therefore it cannot be a question of cause and effect, but of a falling together in time, a kind of simultaneity. Because of this quality

of simultaneity, I have picked on the term “synchronicity” to designate a hypothetical factor equal in rank to causality as a principle of explanation. In my essay “On the Nature of the Psyche,”³⁵ I considered synchronicity as a psychically conditioned relativity of space and time. Rhine’s experiments show that in relation to the psyche space and time are, so to speak, “elastic” and can apparently be reduced almost to vanishing point, as though they were dependent on psychic conditions and did not exist in themselves but were only “postulated” by the conscious mind. In man’s original view of the world, as we find it among primitives, space and time have a very precarious existence. They become “fixed” concepts only in the course of his mental development, thanks largely to the introduction of measurement. In themselves, space and time consist of *nothing*. They are hypostatized concepts born of the discriminating activity of the conscious mind, and they form the indispensable co-ordinates for describing the behaviour of bodies in motion. They are, therefore, essentially psychic in origin, which is probably the reason that impelled Kant to regard them as *a priori* categories. But if space and time are only apparently properties of bodies in motion and are created by the intellectual needs of the observer, then their relativization by psychic conditions is no longer a matter for astonishment but is brought within the bounds of possibility. This possibility presents itself when the psyche observes, not external bodies, but *itself*. That is precisely what happens in Rhine’s experiments: the subject’s answer is not the result of his observing the physical cards, it is a product of pure imagination, of “chance” ideas which reveal the structure of that which produces them, namely the unconscious. Here I will only point out that it is the decisive factors in the unconscious psyche, the archetypes, which constitute the structure of the collective unconscious. The latter represents a psyche that is identical in all individuals. It cannot be directly perceived or “represented,” in contrast to the perceptible psychic phenomena, and on account of its “irrepresentable” nature I have called it “psychoid.”

[841] The archetypes are formal factors responsible for the organization of unconscious psychic processes: they are “patterns of behaviour.” At the same time they have a “specific charge” and develop numinous effects which express themselves as *affects*. The affect produces a partial *abaissement du niveau mental*, for although it raises a particular content to a supernormal degree of luminosity, it does so by withdrawing so much energy from other possible contents of consciousness that they become darkened and eventually unconscious. Owing to the restriction of consciousness produced by the affect so long as it lasts, there is a corresponding lowering of orientation which in its turn gives the unconscious a favourable opportunity to slip into the space vacated. Thus we regularly find that unexpected or otherwise inhibited unconscious contents break through and find expression in the affect. Such contents are very often of an inferior or primitive nature and thus betray their archetypal

origin. As I shall show further on, certain phenomena of simultaneity or synchronicity seem to be bound up with the archetypes. That is the reason why I mention the archetypes here.

[842] The extraordinary spatial orientation of animals may also point to the psychic relativity of space and time. The puzzling time-orientation of the palolo worm, for instance, whose tail-segments, loaded with sexual products, always appear on the surface of the sea the day before the last quarter of the moon in October and November,³⁶ might be mentioned in this connection. One of the causes suggested is the acceleration of the earth owing to the gravitational pull of the moon at this time. But, for astronomical reasons, this explanation cannot possibly be right.³⁷ The relation which undoubtedly exists between the human menstruation period and the course of the moon is connected with the latter only numerically and does not really coincide with it. Nor has it been proved that it ever did.

*

[843] The problem of synchronicity has puzzled me for a long time, ever since the middle twenties,³⁸ when I was investigating the phenomena of the collective unconscious and kept on coming across connections which I simply could not explain as chance groupings or “runs.” What I found were “coincidences” which were connected so meaningfully that their “chance” concurrence would represent a degree of improbability that would have to be expressed by an astronomical figure. By way of example, I shall mention an incident from my own observation. A young woman I was treating had, at a critical moment, a dream in which she was given a golden scarab. While she was telling me this dream I sat with my back to the closed window. Suddenly I heard a noise behind me, like a gentle tapping. I turned round and saw a flying insect knocking against the window-pane from outside. I opened the window and caught the creature in the air as it flew in. It was the nearest analogy to a golden scarab that one finds in our latitudes, a scarabaeid beetle, the common rose-chafer (*Cetonia aurata*), which contrary to its usual habits had evidently felt an urge to get into a dark room at this particular moment. I must admit that nothing like it ever happened to me before or since, and that the dream of the patient has remained unique in my experience.^{38a}

[844] I should like to mention another case that is typical of a certain category of events. The wife of one of my patients, a man in his fifties, once told me in conversation that, at the deaths of her mother and her grandmother, a number of birds gathered outside the windows of the death-chamber. I had heard similar stories from other people. When her husband’s treatment was nearing its end, his neurosis having been cleared up, he developed some apparently quite innocuous symptoms which seemed to me, however, to be those of heart-disease. I sent him along to a specialist,

who after examining him told me in writing that he could find no cause for anxiety. On the way back from this consultation (with the medical report in his pocket) my patient collapsed in the street. As he was brought home dying, his wife was already in a great state of anxiety because, soon after her husband had gone to the doctor, a whole flock of birds alighted on their house. She naturally remembered the similar incidents that had happened at the death of her own relatives, and feared the worst.

[845] Although I was personally acquainted with the people concerned and know very well that the facts here reported are true, I do not imagine for a moment that this will induce anybody who is determined to regard such things as pure “chance” to change his mind. My sole object in relating these two incidents is simply to give some indication of how meaningful coincidences usually present themselves in practical life. The meaningful connection is obvious enough in the first case in view of the approximate identity of the chief objects (the scarab and the beetle); but in the second case the death and the flock of birds seem to be incommensurable with one another. If one considers, however, that in the Babylonian Hades the souls wore a “feather dress,” and that in ancient Egypt the *ba*, or soul, was thought of as a bird,³⁹ it is not too far-fetched to suppose that there may be some archetypal symbolism at work. Had such an incident occurred in a dream, that interpretation would be justified by the comparative psychological material. There also seems to be an archetypal foundation to the first case. It was an extraordinarily difficult case to treat, and up to the time of the dream little or no progress had been made. I should explain that the main reason for this was my patient’s animus, which was steeped in Cartesian philosophy and clung so rigidly to its own idea of reality that the efforts of three doctors—I was the third—had not been able to weaken it. Evidently something quite irrational was needed which was beyond my powers to produce. The dream alone was enough to disturb ever so slightly the rationalistic attitude of my patient. But when the “scarab” came flying in through the window in actual fact, her natural being could burst through the armour of her animus possession and the process of transformation could at last begin to move. Any essential change of attitude signifies a psychic renewal which is usually accompanied by symbols of rebirth in the patient’s dreams and fantasies. The scarab is a classic example of a rebirth symbol. The ancient Egyptian Book of What Is in the Netherworld describes how the dead sun-god changes himself at the tenth station into Khepri, the scarab, and then, at the twelfth station, mounts the barge which carries the rejuvenated sun-god into the morning sky. The only difficulty here is that with educated people cryptomnesia often cannot be ruled out with certainty (although my patient did not happen to know this symbol). But this does not alter the fact that the psychologist is continually coming up against cases where the emergence of symbolic parallels⁴⁰ cannot be explained without the hypothesis of the collective unconscious.

[846] Meaningful coincidences—which are to be distinguished from meaningless chance groupings⁴¹—therefore seem to rest on an archetypal foundation. At least all the cases in my experience—and there is a large number of them—show this characteristic. What that means I have already indicated above.⁴² Although anyone with my experience in this field can easily recognize their archetypal character, he will find it difficult to link them up with the psychic conditions in Rhine's experiments, because the latter contain no direct evidence of any constellation of the archetype. Nor is the emotional situation the same as in my examples. Nevertheless, it must be remembered that with Rhine the first series of experiments generally produced the best results, which then quickly fell off. But when it was possible to arouse a new interest in the essentially rather boring experiment, the results improved again. It follows from this that the emotional factor plays an important role. Affectivity, however, rests to a large extent on the instincts, whose formal aspect is the archetype.

[847] There is yet another psychological analogy between my two cases and the Rhine experiments, though it is not quite so obvious. These apparently quite different situations have as their common characteristic an element of "impossibility." The patient with the scarab found herself in an "impossible" situation because the treatment had got stuck and there seemed to be no way out of the impasse. In such situations, if they are serious enough, archetypal dreams are likely to occur which point out a possible line of advance one would never have thought of oneself. It is this kind of situation that constellates the archetype with the greatest regularity. In certain cases the psychotherapist therefore sees himself obliged to discover the rationally insoluble problem towards which the patient's unconscious is steering. Once this is found, the deeper layers of the unconscious, the primordial images, are activated and the transformation of the personality can get under way.

[848] In the second case there was the half-unconscious fear and the threat of a lethal end with no possibility of an adequate recognition of the situation. In Rhine's experiment it is the "impossibility" of the task that ultimately fixes the subject's attention on the processes going on inside him, and thus gives the unconscious a chance to manifest itself. The questions set by the ESP experiment have an emotional effect right from the start, since they postulate something unknowable as being potentially knowable and in that way take the possibility of a miracle seriously into account. This, regardless of the subject's scepticism, immediately appeals to his unconscious readiness to witness a miracle, and to the hope, latent in all men, that such a thing may yet be possible. Primitive superstition lies just below the surface of even the most toughminded individuals, and it is precisely those who most fight against it who are the first to succumb to its suggestive effects. When therefore a serious experiment with all the authority of science behind it touches this readiness, it

will inevitably give rise to an emotion which either accepts or rejects it with a good deal of affectivity. At all events an affective expectation is present in one form or another even though it may be denied.

[849] Here I would like to call attention to a possible misunderstanding which may be occasioned by the term “synchronicity.” I chose this term because the simultaneous occurrence of two meaningfully but not causally connected events seemed to me an essential criterion. I am therefore using the general concept of synchronicity in the special sense of a coincidence in time of two or more causally unrelated events which have the same or a similar meaning, in contrast to “synchronism,” which simply means the simultaneous occurrence of two events.

[850] Synchronicity therefore means the simultaneous occurrence of a certain psychic state with one or more external events which appear as meaningful parallels to the momentary subjective state—and, in certain cases, vice versa. My two examples illustrate this in different ways. In the case of the scarab the simultaneity is immediately obvious, but not in the second example. It is true that the flock of birds occasioned a vague fear, but that can be explained causally. The wife of my patient was certainly not conscious beforehand of any fear that could be compared with my own apprehensions, for the symptoms (pains in the throat) were not of a kind to make the layman suspect anything bad. The unconscious, however, often knows more than the conscious, and it seems to me possible that the woman’s unconscious had already got wind of the danger. If, therefore, we rule out a conscious psychic content such as the idea of deadly danger, there is an obvious simultaneity between the flock of birds, in its traditional meaning, and the death of the husband. The psychic state, if we disregard the possible but still not demonstrable excitation of the unconscious, appears to be dependent on the external event. The woman’s psyche is nevertheless involved in so far as the birds settled on her house and were observed by her. For this reason it seems to me probable that her unconscious was in fact constellated. The flock of birds has, as such, a traditional mantic significance.⁴³ This is also apparent in the woman’s own interpretation, and it therefore looks as if the birds represented an unconscious premonition of death. The physicians of the Romantic Age would probably have talked of “sympathy” or “magnetism.” But, as I have said, such phenomena cannot be explained causally unless one permits oneself the most fantastic *ad hoc* hypotheses.

[851] The interpretation of the birds as an omen is, as we have seen, based on two earlier coincidences of a similar kind. It did not yet exist at the time of the grandmother’s death. There the coincidence was represented only by the death and the gathering of the birds. Both then and at the mother’s death the coincidence was

obvious, but in the third case it could only be verified when the dying man was brought into the house.

[852] I mention these complications because they have an important bearing on the concept of synchronicity. Let us take another example: An acquaintance of mine saw and experienced in a dream the sudden death of a friend, with all the characteristic details. The dreamer was in Europe at the time and the friend in America. The death was confirmed next morning by telegram, and ten days later a letter confirmed the details. Comparison of European time with American time showed that the death occurred at least an hour before the dream. The dreamer had gone to bed late and not slept until about one o'clock. The dream occurred at approximately two in the morning. The dream experience is *not synchronous* with the death. Experiences of this kind frequently take place a little before or after the critical event. J. W. Dunne⁴⁴ mentions a particularly instructive dream he had in the spring of 1902, when serving in the Boer War. He seemed to be standing on a volcanic mountain. It was an island, which he had dreamed about before and knew was threatened by a catastrophic volcanic eruption (like Krakatoa). Terrified, he wanted to save the four thousand inhabitants. He tried to get the French officials on the neighbouring island to mobilize all available shipping for the rescue work. Here the dream began to develop the typical nightmare motifs of hurrying, chasing, and not arriving on time, and all the while there hovered before his mind the words: "Four thousand people will be killed unless——" A few days later Dunne received with his mail a copy of the *Daily Telegraph*, and his eye fell on the following headlines:

VOLCANO DISASTER
IN MARTINIQUE

Town Swept Away

AN AVALANCHE OF FLAME

Probable Loss of Over 40,000 Lives

[853] The dream did not take place at the moment of the actual catastrophe, but only when the paper was already on its way to him with the news. While reading it, he misread 40,000 as 4,000. The mistake became fixed as a paramnesia, so that whenever he told the dream he invariably said 4,000 instead of 40,000. Not until

fifteen years later, when he copied out the article, did he discover his mistake. His unconscious knowledge had made the same mistake in reading as himself.

[854] The fact that he dreamed this shortly before the news reached him is something that happens fairly frequently. We often dream about people from whom we receive a letter by the next post. I have ascertained on several occasions that at the moment when the dream occurred the letter was already lying in the post-office of the addressee. I can also confirm, from my own experience, the reading mistake. During the Christmas of 1918 I was much occupied with Orphism, and in particular with the Orphic fragment in Malalas, where the Primordial Light is described as the “trinitarian Metis, Phanes, Ericapaeus.” I consistently read Ericapaeus instead of Ericepaeus, as in the text. (Actually both readings occur.) This misreading became fixed as a paramnesia, and later I always remembered the name as Ericapaeus and only discovered thirty years afterward that Malalas’ text has Ericepaeus. Just at this time one of my patients, whom I had not seen for a month and who knew nothing of my studies, had a dream in which an unknown man handed her a piece of paper, and on it was written a “Latin” hymn to a god called *Ericipaeus*. The dreamer was able to write this hymn down upon waking. The language it was written in was a peculiar mixture of Latin, French, and Italian. The lady had an elementary knowledge of Latin, knew a bit more Italian, and spoke French fluently. The name “Ericipaeus” was completely unknown to her, which is not surprising as she had no knowledge of the classics. Our two towns were about fifty miles apart, and there had been no communication between us for a month. Oddly enough, the variant of the name affected the very same vowel which I too had misread (*a* instead of *e*), but her unconscious misread it another way (*i* instead of *e*). I can only suppose that she unconsciously “read” not my mistake but the text in which the Latin transliteration “Ericepaeus” occurs, and was evidently put off her stroke by my misreading.

[855] Synchronistic events rest on the *simultaneous occurrence of two different psychic states*. One of them is the normal, probable state (i.e., the one that is causally explicable), and the other, the critical experience, is the one that cannot be derived causally from the first. In the case of sudden death the critical experience cannot be recognized immediately as “extra-sensory perception” but can only be verified as such afterwards. Yet even in the case of the “scarab” what is immediately experienced is a psychic state or psychic image which differs from the dream image only because it can be verified immediately. In the case of the flock of birds there was in the woman an unconscious excitation or fear which was certainly conscious *to me* and caused me to send the patient to a heart specialist. In all these cases, whether it is a question of spatial or of temporal ESP, we find a simultaneity of the normal or ordinary state with another state or experience which is not causally derivable from it, and whose objective existence can only be verified afterwards. This definition

must be borne in mind particularly when it is a question of future events. They are evidently not *synchronous* but are *synchronistic*, since they are experienced as psychic images *in the present*, as though the objective event already existed. An unexpected content which is directly or indirectly connected with some objective external event coincides with the ordinary psychic state: this is what I call synchronicity, and I maintain that we are dealing with exactly the same category of events whether their objectivity appears separated from my consciousness in space or in time. This view is confirmed by Rhine's results in so far as they were not influenced by changes in space or time. Space and time, the conceptual co-ordinates of bodies in motion, are probably at bottom one and the same (which is why we speak of a long or short "space of time"), and Philo Judaeus said long ago that "the extension of heavenly motion is time."⁴⁵ Synchronicity in space can equally well be conceived as perception in time, but remarkably enough it is not so easy to understand synchronicity in time as spatial, for we cannot imagine any space in which future events are objectively present and could be experienced as such through a reduction of this spatial distance. But since experience has shown that under certain conditions space and time can be reduced almost to zero, causality disappears along with them, because causality is bound up with the existence of space and time and physical changes, and consists essentially in the succession of cause and effect. For this reason synchronistic phenomena cannot in principle be associated with any conceptions of causality. Hence the interconnection of meaningfully coincident factors must necessarily be thought of as acausal.

[856] Here, for want of a demonstrable cause, we are all too likely to fall into the temptation of positing a *transcendental* one. But a "cause" can only be a demonstrable quantity. A "transcendental cause" is a contradiction in terms, because anything transcendental cannot by definition be demonstrated. If we don't want to risk the hypothesis of acausality, then the only alternative is to explain synchronistic phenomena as mere chance, which brings us into conflict with Rhine's ESP discoveries and other well-attested facts reported in the literature of parapsychology. Or else we are driven to the kind of reflections I described above, and must subject our basic principles of explanation to the criticism that space and time are constants in any given system only when they are measured without regard to psychic conditions. That is what regularly happens in scientific experiments. But when an event is observed without experimental restrictions, the observer can easily be influenced by an emotional state which alters space and time by "contraction." Every emotional state produces an alteration of consciousness which Janet called *abaissement du niveau mental*; that is to say there is a certain narrowing of consciousness and a corresponding strengthening of the unconscious which, particularly in the case of strong affects, is noticeable even to the layman. The tone of

the unconscious is heightened, thereby creating a gradient for the unconscious to flow towards the conscious. The conscious then comes under the influence of unconscious instinctual impulses and contents. These are as a rule complexes whose ultimate basis is the archetype, the “instinctual pattern.” The unconscious also contains subliminal perceptions (as well as forgotten memory-images that cannot be reproduced at the moment, and perhaps not at all). Among the subliminal contents we must distinguish perceptions from what I would call an inexplicable “knowledge,” or an “immediacy” of psychic images. Whereas the sense-perceptions can be related to probable or possible sensory stimuli below the threshold of consciousness, this “knowledge,” or the “immediacy” of unconscious images, either has no recognizable foundation, or else we find that there are recognizable causal connections with certain already existing, and often archetypal, contents. But these images, whether rooted in an already existing basis or not, stand in an analogous or equivalent (i.e., meaningful) relationship to objective occurrences which have no recognizable or even conceivable causal relationship with them. How could an event remote in space and time produce a corresponding psychic image when the transmission of energy necessary for this is not even thinkable? However incomprehensible it may appear, we are finally compelled to assume that there is in the unconscious something like an *a priori* knowledge or an “immediacy” of events which lacks any causal basis. At any rate our conception of causality is incapable of explaining the facts.

[857] In view of this complicated situation it may be worth while to recapitulate the argument discussed above, and this can best be done with the aid of our examples. In Rhine’s experiment I made the assumption that, owing to the tense expectation or emotional state of the subject, an already existing, correct, but unconscious image of the result enables his conscious mind to score a more than chance number of hits. The scarab dream is a conscious representation arising from an unconscious, already existing image of the situation that will occur on the following day, i.e., the recounting of the dream and the appearance of the rose-chafer. The wife of the patient who died had an unconscious knowledge of the impending death. The flock of birds evoked the corresponding memory-images and consequently her fear. Similarly, the almost simultaneous dream of the violent death of the friend arose from an already existing unconscious knowledge of it.

[858] In all these cases and others like them there seems to be an *a priori*, causally inexplicable knowledge of a situation which at the time is unknowable. Synchronicity therefore consists of two factors: *a*) An unconscious image comes into consciousness either directly (i.e., literally) or indirectly (symbolized or suggested) in the form of a dream, idea, or premonition, *b*) An objective situation coincides with this content. The one is as puzzling as the other. How does the unconscious image arise, and how the coincidence? I understand only too well why people prefer to doubt the reality of

these things. Here I will only pose the question. Later in this study I will try to answer it.

[859] As regards the role which affects play in the occurrence of synchronistic events, I should perhaps mention that this is by no means a new idea but was already known to Avicenna and Albertus Magnus. On the subject of magic, Albertus Magnus writes:

I discovered an instructive account [of magic] in Avicenna's *Liber sextus naturalium*, which says that a certain power⁴⁶ to alter things indwells in the human soul and subordinates the other things to her, particularly when she is swept into a great excess of love or hate or the like.⁴⁷ When therefore the soul of a man falls into a great excess of any passion, it can be proved by experiment that it [the excess] binds things [magically] and alters them in the way it wants,⁴⁸ and for a long time I did not believe it, but after I had read the nigromantic books and others of the kind on signs and magic, I found that the emotionality⁴⁹ of the human soul is the chief cause of all these things, whether because, on account of her great emotion, she alters her bodily substance and the other things towards which she strives, or because, on account of her dignity, the other, lower things are subject to her, or because the appropriate hour or astrological situation or another power coincides with so inordinate an emotion, and we [in consequence] believe that what this power does is then done by the soul.⁵⁰ ... Whoever would learn the secret of doing and undoing these things must know that everyone can influence everything magically if he falls into a great excess ... and he must do it at that hour when the excess befalls him, and operate with the things which the soul prescribes. For the soul is then so desirous of the matter she would accomplish that of her own accord she seizes on the more significant and better astrological hour which also rules over the things suited to that matter. ... Thus it is the soul who desires a thing more intensely, who makes things more effective and more like what comes forth. ... Such is the manner of production with everything the soul intensely desires. Everything she does with that aim in view possesses motive power and efficacy for what the soul desires.⁵¹

[860] This text shows clearly that synchronistic (“magical”) happenings are regarded as being dependent on affects. Naturally Albertus Magnus, in accordance with the spirit of his age, explains this by postulating a magical faculty in the soul, without considering that the psychic process itself is just as much “arranged” as the coinciding image which anticipates the external physical process. This image originates in the unconscious and therefore belongs to those “cogitationes quae sunt a nobis independentes,” which, in the opinion of Arnold Geulincx, are prompted by God and do not spring from our own thinking.⁵² Goethe thinks of synchronistic events in the same “magical” way. Thus he says, in his conversations with Eckermann: “We all have certain electric and magnetic powers within us and ourselves exercise an attractive and repelling force, according as we come into touch with something like or unlike.”⁵³

[861] After these general considerations let us return to the problem of the empirical basis of synchronicity. The main difficulty here is to procure empirical material from which we can draw reasonably certain conclusions, and unfortunately this difficulty is not an easy one to solve. The experiences in question are not ready to hand. We

must therefore look in the obscurest corners and summon up courage to shock the prejudices of our age if we want to broaden the basis of our understanding of nature. When Galileo discovered the moons of Jupiter with his telescope he immediately came into head-on collision with the prejudices of his learned contemporaries. Nobody knew what a telescope was and what it could do. Never before had anyone talked of the moons of Jupiter. Naturally every age thinks that all ages before it were prejudiced, and today we think this more than ever and are just as wrong as all previous ages that thought so. How often have we not seen the truth condemned! It is sad but unfortunately true that man learns nothing from history. This melancholy fact will present us with the greatest difficulties as soon as we set about collecting empirical material that would throw a little light on this dark subject, for we shall be quite certain to find it where all the authorities have assured us that nothing is to be found.

[862] Reports of remarkable isolated cases, however well authenticated, are unprofitable and lead at most to their reporter being regarded as a credulous person. Even the careful recording and verification of a large number of such cases, as in the work of Gurney, Myers, and Podmore,⁵⁴ have made next to no impression on the scientific world. The great majority of “professional” psychologists and psychiatrists seem to be completely ignorant of these researches.⁵⁵

*

[863] The results of the ESP and PK experiments have provided a statistical basis for evaluating the phenomenon of synchronicity, and at the same time have pointed out the important part played by the psychic factor. This fact prompted me to ask whether it would not be possible to find a method which would on the one hand demonstrate the existence of synchronicity and, on the other hand, disclose psychic contents which would at least give us a clue to the nature of the psychic factor involved. I asked myself, in other words, whether there were not a method which would yield measurable results and at the same time give us an insight into the psychic background of synchronicity. That there are certain essential psychic conditions for synchronistic phenomena we have already seen from the ESP experiments, although the latter are in the nature of the case restricted to the fact of coincidence and only stress its psychic background without illuminating it any further. I had known for a long time that there were intuitive or “mantic” methods which start with the psychic factor and take the existence of synchronicity as self-evident. I therefore turned my attention first of all to the intuitive technique for *grasping the total situation* which is so characteristic of China, namely the *I Ching* or *Book of Changes*.⁵⁶ Unlike the Greek-trained Western mind, the Chinese mind does not aim at grasping details for their own sake, but at a view which sees the detail as part of a whole. For obvious

reasons, a cognitive operation of this kind is impossible to the unaided intellect. Judgment must therefore rely much more on the irrational functions of consciousness, that is on sensation (the “sens du réel”) and intuition (perception by means of subliminal contents). The *I Ching*, which we can well call the experimental foundation of classical Chinese philosophy, is one of the oldest known methods for grasping a situation as a whole and thus placing the details against a cosmic background—the interplay of Yin and Yang.

[864] This grasping of the whole is obviously the aim of science as well, but it is a goal that necessarily lies very far off because science, whenever possible, proceeds experimentally and in all cases statistically. Experiment, however, consists in asking a definite question which excludes as far as possible anything disturbing and irrelevant. It makes conditions, imposes them on Nature, and in this way forces her to give an answer to a question devised by man. She is prevented from answering out of the fullness of her possibilities since these possibilities are restricted as far as practicable. For this purpose there is created in the laboratory a situation which is artificially restricted to the question and which compels Nature to give an unequivocal answer. The workings of Nature in her unrestricted wholeness are completely excluded. If we want to know what these workings are, we need a method of inquiry which imposes the fewest possible conditions, or if possible no conditions at all, and then leaves Nature to answer out of her fullness.

[865] In the laboratory experiment, the known and established procedure forms the stable factor in the statistical compilation and comparison of the results. In the intuitive or “mantic” experiment-with-the-whole, on the other hand, there is no need of any question which imposes conditions and restricts the wholeness of the natural process. It is given every possible chance to express itself. In the *I Ching* the coins fall just as happens to suit them.⁵⁷ From the point of view of an observer, an unknown question is followed by a rationally unintelligible answer. Thus far the conditions for a total reaction are positively ideal. The disadvantage, however, leaps to the eye: in contrast to the scientific experiment one does not know what has happened. To overcome this drawback, two Chinese sages, King Wên and the Duke of Chou, in the twelfth century before our era, basing themselves on the hypothesis of the unity of nature, sought to explain the simultaneous occurrence of a psychic state with a physical process as *an equivalence of meaning*. In other words, they supposed that the same living reality was expressing itself in the psychic state as in the physical. But, in order to verify such an hypothesis, *some* limiting condition was needed in this apparently limitless experiment, namely a definite form of physical procedure, a method or technique which forced nature to answer in even and odd numbers. These, as representatives of Yin and Yang, are found both in the unconscious and in nature in the characteristic form of opposites, as the “mother” and “father” of everything

that happens, and they therefore form the *tertium comparationis* between the psychic inner world and the physical outer world. Thus the two sages devised a method by which an inner state could be represented as an outer one and vice versa. This naturally presupposes an intuitive knowledge of the meaning of each oracle figure. The *I Ching*, therefore, consists of a collection of sixty-four interpretations in which the meaning of each of the possible Yin-Yang combinations is worked out. These interpretations formulate the inner unconscious knowledge that corresponds to the state of consciousness at the moment, and this psychological situation coincides with the chance results of the method, that is, with the odd and even numbers resulting from the fall of the coins or the division of the yarrow stalks.⁵⁸

[866] The method, like all divinatory or intuitive techniques, is based on an acausal or synchronistic connective principle.⁵⁹ In practice, as any unprejudiced person will admit, many obvious cases of synchronicity occur during the experiment, which could be rationally and somewhat arbitrarily explained away as mere projections. But if one assumes that they really are what they appear to be, then they can only be meaningful coincidences for which, as far as we know, there is no causal explanation. The method consists either in dividing the forty-nine yarrow stalks into two heaps at random and counting off the heaps by threes and fives, or in throwing three coins six times, each line of the hexagram being determined by the value of obverse and reverse (heads 3, tails 2).⁶⁰ The experiment is based on a triadic principle (two trigrams) and contains sixty-four mutations, each corresponding to a psychic situation. These are discussed at length in the text and appended commentaries. There is also a Western method of very ancient origin⁶¹ which is based on the same general principle as the *I Ching*, the only difference being that in the West this principle is not triadic but, significantly enough, tetradic, and the result is not a hexagram built up of Yang and Yin lines but sixteen figures composed of odd and even numbers. Twelve of them are arranged, according to certain rules, in the astrological houses. The experiment is based on 4×4 lines consisting of a random number of points which the questioner marks in the sand or on paper from right to left.⁶² In true Occidental fashion the combination of all these factors goes into considerably more detail than the *I Ching*. Here too there are any amount of meaningful coincidences, but they are as a rule harder to understand and therefore less obvious than in the latter. In the Western method, which was known since the thirteenth century as the *Ars Geomantica* or the Art of Punctuation⁶³ and enjoyed a widespread vogue, there are no real commentaries, since its use was only mantic and never philosophical like that of the *I Ching*.

[867] Though the results of both procedures point in the desired direction, they do not provide any basis for a statistical evaluation. I have, therefore, looked round for another intuitive technique and have hit on astrology, which, at least in its modern

form, claims to give a more or less total picture of the individual's character. There is no lack of commentaries here; indeed, we find a bewildering profusion of them—a sure sign that interpretation is neither simple nor certain. The meaningful coincidence we are looking for is immediately apparent in astrology, since the astronomical data are said by astrologers to correspond to individual traits of character; from the remotest times the various planets, houses, zodiacal signs, and aspects have all had meanings that serve as a basis for a character study or for an interpretation of a given situation. It is always possible to object that the result does not agree with our psychological knowledge of the situation or character in question, and it is difficult to refute the assertion that knowledge of character is a highly subjective affair, because in characterology there are no infallible or even reliable signs that can be in any way measured or calculated—an objection that also applies to graphology, although in practice it enjoys widespread recognition.

[868] This criticism, together with the absence of reliable criteria for determining traits of character, makes the meaningful coincidence of horoscope structure and individual character postulated by astrology seem inapplicable for the purpose here under discussion. If, therefore, we want astrology to tell us anything about the acausal connection of events, we must discard this uncertain diagnosis of character and put in its place an absolutely certain and indubitable fact. One such fact is the marriage connection between two persons.⁶⁴

[869] Since antiquity, the main traditional astrological and alchemical correspondence to marriage has been the *coniunctio Solis ☉ et Lunae ☾*, the *coniunctio Lunae et Lunae*, and the conjunction of the moon with the ascendent.⁶⁵ There are others, but these do not come within the main traditional stream. The ascendent-descendent axis was introduced into the tradition because it has long been regarded as having a particularly important influence on the personality.⁶⁶ As I shall refer later to the conjunction and opposition of Mars (♂) and Venus (♀), I may say here that these are related to marriage only because the conjunction or opposition of these two planets points to a love relationship, and this may or may not produce a marriage. So far as my experiment is concerned, we have to investigate the coincident aspects ☉ ☾, ☾ ☾ and ☾ Asc. in the horoscopes of married pairs in relation to those of unmarried pairs. It will, further, be of interest to compare the relation of the above aspects to those of the aspects which belong only in a minor degree to the main traditional stream. No belief in astrology is needed to carry out such an investigation, only the birth-dates, an astronomical almanac, and a table of logarithms for working out the horoscope.

[870] As the above three mantic procedures show, the method best adapted to the nature of chance is the numerical method. Since the remotest times men have used numbers

to establish meaningful coincidences, that is, coincidences that can be interpreted. There is something peculiar, one might even say mysterious, about numbers. They have never been entirely robbed of their numinous aura. If, so a text-book of mathematics tells us, a group of objects is deprived of every single one of its properties or characteristics, there still remains, at the end, its *number*, which seems to indicate that number is something irreducible. (I am not concerned here with the logic of this mathematical argument, but only with its psychology!) The sequence of natural numbers turns out to be unexpectedly more than a mere stringing together of identical units: it contains the whole of mathematics and everything yet to be discovered in this field. Number, therefore, is in one sense an unpredictable entity. Although I would not care to undertake to say anything illuminating about the inner relation between two such apparently incommensurable things as number and synchronicity, I cannot refrain from pointing out that not only were they always brought into connection with one another, but that both possess numinosity and mystery as their common characteristics. Number has invariably been used to characterize some numinous object, and all numbers from 1 to 9 are “sacred,” just as 10, 12, 13, 14, 28, 32, and 40 have a special significance. The most elementary quality about an object is whether it is one or many. Number helps more than anything else to bring order into the chaos of appearances. It is the predestined instrument for creating order, or for apprehending an already existing, but still unknown, regular arrangement or “orderedness.” It may well be the most primitive element of order in the human mind, seeing that the numbers 1 to 4 occur with the greatest frequency and have the widest incidence. In other words, primitive patterns of order are mostly triads or tetrads. That numbers have an archetypal foundation is not, by the way, a conjecture of mine but of certain mathematicians, as we shall see in due course. Hence it is not such an audacious conclusion after all if we define number psychologically as an *archetype of order* which has become conscious.⁶⁷ Remarkably enough, the psychic images of wholeness which are spontaneously produced by the unconscious, the symbols of the self in mandala form, also have a mathematical structure. They are as a rule quaternities (or their multiples).⁶⁸ These structures not only express order, they also create it. That is why they generally appear in times of psychic disorientation in order to compensate a chaotic state or as formulations of numinous experiences. It must be emphasized yet again that they are not inventions of the conscious mind but are spontaneous products of the unconscious, as has been sufficiently shown by experience. Naturally the conscious mind can imitate these patterns of order, but such imitations do not prove that the originals are conscious inventions. From this it follows irrefutably that the unconscious uses number as an ordering factor.

[871] It is generally believed that numbers were *invented* or thought out by man, and are therefore nothing but concepts of quantities, containing nothing that was not previously put into them by the human intellect. But it is equally possible that numbers were *found* or discovered. In that case they are not only concepts but something more—autonomous entities which somehow contain more than just quantities. Unlike concepts, they are based not on any psychic conditions but on the quality of being themselves, on a “so-ness” that cannot be expressed by an intellectual concept. Under these conditions they might easily be endowed with qualities that have still to be discovered. I must confess that I incline to the view that numbers were as much found as invented, and that in consequence they possess a relative autonomy analogous to that of the archetypes. They would then have, in common with the latter, the quality of being pre-existent to consciousness, and hence, on occasion, of conditioning it rather than being conditioned by it. The archetypes too, as *a priori* forms of representation, are as much found as invented: they are *discovered* inasmuch as one did not know of their unconscious autonomous existence, and *invented* inasmuch as their presence was inferred from analogous representational structures. Accordingly it would seem that natural numbers have an archetypal character. If that is so, then not only would certain numbers and combinations of numbers have a relation to and an effect on certain archetypes, but the reverse would also be true. The first case is equivalent to number magic, but the second is equivalent to inquiring whether numbers, in conjunction with the combination of archetypes found in astrology, would show a tendency to behave in a special way.

2. AN ASTROLOGICAL EXPERIMENT

[872] As I have already said, we need two different facts, one of which represents the astrological constellation, and the other the married state.

[873] The material to be examined, namely a quantity of marriage horoscopes, was obtained from friendly donors in Zurich, London, Rome, and Vienna. Originally the material had been put together for purely astrological purposes, some of it many years ago, so that those who gathered the material knew of no connection between its collection and the aim of the present study, a fact which I stress because it might be objected that the material was specially selected with that aim in view. This was not so; the sample was a random one. The horoscopes, or rather the birth data, were piled up in chronological order just as the post brought them in. When the horoscopes of 180 married pairs had come in, there was a pause in the collection, during which the 360 horoscopes were worked out. This first batch was used to conduct a pilot investigation, as I wanted to test out the methods to be employed.

[874] Since the material had been collected originally in order to test the empirical foundations of this intuitive method, a few more general remarks may not be out of place concerning the considerations which prompted the collection of the material.

[875] Marriage is a well-characterized fact, though its psychological aspect shows every conceivable sort of variation. According to the astrological view, it is precisely this aspect of marriage that expresses itself most markedly in the horoscopes. The possibility that the individuals characterized by the horoscopes married one another, so to say, by accident will necessarily recede into the background; all external factors seem capable of astrological evaluation, but only inasmuch as they are represented psychologically. Owing to the very large number of characterological variations, we would hardly expect marriage to be characterized by only *one* astrological configuration; rather, if astrological assumptions are at all correct, there will be several configurations that point to a predisposition in the choice of a marriage partner. In this connection I must call the reader's attention to the well-known correspondence between the sun-spot periods and the mortality curve. The connecting

link appears to be the disturbances of the earth's magnetic field, which in their turn are due to fluctuations in the proton radiation from the sun. These fluctuations also have an influence on "radio weather" by disturbing the ionosphere that reflects the radio waves.¹ Investigation of these disturbances seems to indicate that the conjunctions, oppositions, and quartile aspects of the planets play a considerable part in increasing the proton radiation and thus causing electromagnetic storms. On the other hand, the astrologically favourable trine and sextile aspects have been reported to produce uniform radio weather.

[876] These observations give us an unexpected glimpse into a possible causal basis for astrology. At all events, this is certainly true of Kepler's weather astrology. But it is also possible that, over and above the already established physiological effects of proton radiation, psychic effects can occur which would rob astrological statements of their chance nature and bring them within range of a causal explanation. Although nobody knows what the validity of a nativity horoscope rests on, it is just conceivable that there is a causal connection between the planetary aspects and the psychophysiological disposition. One would therefore do well not to regard the results of astrological observation as synchronistic phenomena, but to take them as possibly causal in origin. For, wherever a cause is even remotely thinkable, synchronicity becomes an exceedingly doubtful proposition.

[877] For the present, at any rate, we have insufficient grounds for believing that the astrological results are more than mere chance, or that statistics involving large numbers yield a statistically significant result.² As large-scale studies are lacking, I decided to investigate the empirical basis of astrology, using a large number of horoscopes of married pairs just to see what kind of figures would turn up.

Pilot Investigation

[878] With the first batch assembled, I turned first to the conjunctions (♌) and oppositions (♌) of sun and moon,³ two aspects regarded in astrology as being about equally strong (though in opposite senses), i.e., as signifying intensive relations between the heavenly bodies. Together with the ♃, ♄, Asc, and Desc. conjunctions and oppositions, they yield fifty different aspects.⁴

from representing a significant figure. Its probability is much too great; in other words, there is no ground for assuming that our maximum frequencies are more than mere dispersions due to chance.

Analysis of First Batch

[882] First we counted all the conjunctions and oppositions between ☉ ☾ ☽ ♀ Asc. and Desc. for the 180 married and the 32,220 unmarried pairs. The results are shown in [Table I](#), where it will be observed that the aspects are arranged by frequency of their occurrence in the married and unmarried pairs.

[883] Clearly, the frequencies of occurrence shown in columns 2 and 4 of [Table I](#) for observed occurrences of the aspects in married and unmarried pairs respectively are not immediately comparable, since the first are occurrences in 180 pairs and the second in 32,220 pairs.⁵ In column 5, therefore, we show the figures in column 4 multiplied by the factor $\frac{180}{32,220}$. [Table II](#) shows the ratios between the figures in columns 2 and 5 of [Table I](#) arranged according to frequency; e.g., the ratio for moon-sun conjunction is $18 : 8.4 = 2.14$.

[884] To a statistician, these figures cannot be used to confirm anything, and so are valueless, because they are chance dispersions. But on psychological grounds I have discarded the idea that we are dealing with *mere* chance numbers. In a total picture of natural events, it is just as important to consider the exceptions to the rule as the averages. This is the fallacy of the statistical picture: it is one-sided, inasmuch as it represents only the average aspect of reality and excludes the total picture. The statistical view of the world is a mere abstraction and therefore incomplete and even fallacious, particularly so when it deals with man's psychology. Inasmuch as chance maxima and minima occur, they are *facts* whose nature I set out to explore.

TABLE I

Fem.	Aspect		Observed Occurrences for 180 Married Pairs		Observed Occurrences for 32,220 Unmarried Pairs	Calculated Frequency for 180 Unmarried Pairs	
	Masc.		Actual Occurrences	Percentage Occurrences		Actual Frequency	Frequency Percentage
Moon	♂	Sun	18	10.0%	1506	8.4	4.7
Asc.	♂	Venus	15	8.3%	1411	7.9	4.4
Moon	♂	Asc.	14	7.7%	1485	8.3	4.6
Moon	♂	Sun	13	7.2%	1438	8.0	4.4
Moon	♂	Moon	13	7.2%	1479	8.3	4.6
Venus	♂	Moon	13	7.2%	1526	8.5	4.7
Mars	♂	Moon	13	7.2%	1548	8.6	4.8
Mars	♂	Mars	13	7.2%	1711	9.6	5.3
Mars	♂	Asc.	12	6.6%	1467	8.2	4.6
Sun	♂	Mars	12	6.6%	1485	8.3	4.6
Venus	♂	Asc.	11	6.1%	1409	7.9	4.4
Sun	♂	Asc.	11	6.1%	1413	7.9	4.4
Mars	♂	Desc.	11	6.1%	1471	8.2	4.6
Desc.	♂	Venus	11	6.1%	1470	8.2	4.6
Venus	♂	Desc.	11	6.1%	1526	8.5	4.7
Moon	♂	Mars	10	5.5%	1540	8.6	4.8
Venus	♂	Venus	9	5.0%	1415	7.9	4.4
Venus	♂	Mars	9	5.0%	1498	8.4	4.7
Venus	♂	Sun	9	5.0%	1526	8.5	4.7
Moon	♂	Mars	9	5.0%	1539	8.6	4.8
Sun	♂	Desc.	9	5.0%	1556	8.7	4.8
Asc.	♂	Asc.	9	5.0%	1595	8.9	4.9
Desc.	♂	Sun	8	4.3%	1398	7.8	4.3
Venus	♂	Sun	8	4.3%	1485	8.3	4.6
Sun	♂	Moon	8	4.3%	1508	8.4	4.7
Sun	♂	Venus	8	4.3%	1502	8.4	4.7
Sun	♂	Mars	8	4.3%	1516	8.5	4.7
Mars	♂	Sun	8	4.3%	1516	8.5	4.7
Mars	♂	Venus	8	4.3%	1520	8.5	4.7
Venus	♂	Mars	8	4.3%	1531	8.6	4.8
Asc.	♂	Moon	8	4.3%	1541	8.6	4.8
Moon	♂	Moon	8	4.3%	1548	8.6	4.8
Desc.	♂	Moon	8	4.3%	1543	8.6	4.8
Asc.	♂	Mars	8	4.3%	1625	9.1	5.0
Moon	♂	Venus	7	3.8%	1481	8.3	4.6
Mars	♂	Venus	7	3.8%	1521	8.5	4.7
Moon	♂	Desc.	7	3.8%	1539	8.6	4.8
Mars	♂	Moon	7	3.8%	1540	8.6	4.8
Asc.	♂	Desc.	6	3.3%	1328	7.4	4.1
Desc.	♂	Mars	6	3.3%	1433	8.0	4.4
Venus	♂	Moon	6	3.3%	1436	8.0	4.4
Asc.	♂	Sun	6	3.3%	1587	8.9	4.9
Mars	♂	Sun	6	3.3%	1575	8.8	4.9
Moon	♂	Venus	6	3.3%	1576	8.8	4.9
Venus	♂	Venus	5	2.7%	1497	8.4	4.7
Sun	♂	Moon	5	2.7%	1530	8.6	4.8
Sun	♂	Venus	4	2.2%	1490	8.3	4.6
Mars	♂	Mars	3	1.6%	1440	8.0	4.4
Sun	♂	Sun	2	1.1%	1480	8.3	4.6
Sun	♂	Sun	2	1.1%	1482	8.3	4.6

TABLE II

Aspect		Proportion of Aspect Frequencies for Married Pairs	Aspect		Proportion of Aspect Frequencies for Married Pairs
fem.	Masc.		Fem.	Masc.	
Moon	♂ Sun	2.14	Sun	♂ Venus	0.95
Asc.	♂ Venus	1.89	Sun	♂ Mars	0.94
Moon	♂ Asc.	1.68	Mars	♂ Sun	0.94
Moon	♂ Sun	1.61	Mars	♂ Venus	0.94
Moon	♂ Moon	1.57	Venus	♂ Mars	0.94
Venus	♂ Moon	1.53	Asc.	♂ Moon	0.93
Mars	♂ Moon	1.50	Moon	♂ Moon	0.93
Mars	♂ Asc.	1.46	Desc.	♂ Moon	0.92
Sun	♂ Mars	1.44	Asc.	♂ Mars	0.88
Venus	♂ Asc.	1.39	Moon	♂ Venus	0.85
Sun	♂ Asc.	1.39	Mars	♂ Venus	0.82
Mars	♂ Mars	1.36	Moon	♂ Desc.	0.81
Mars	♂ Desc.	1.34	Asc.	♂ Desc.	0.81
Desc.	♂ Venus	1.34	Mars	♂ Moon	0.81
Venus	♂ Desc.	1.29	Desc.	♂ Mars	0.75
Moon	♂ Mars	1.16	Venus	♂ Moon	0.75
Venus	♂ Venus	1.14	Asc.	♂ Sun	0.68
Venus	♂ Mars	1.07	Mars	♂ Sun	0.68
Venus	♂ Sun	1.06	Moon	♂ Venus	0.68
Moon	♂ Mars	1.05	Venus	♂ Venus	0.60
Sun	♂ Desc.	1.04	Sun	♂ Moon	0.59
Desc.	♂ Sun	1.02	Sun	♂ Venus	0.48
Asc.	♂ Asc.	1.01	Mars	♂ Mars	0.37
Venus	♂ Sun	0.96	Sun	♂ Sun	0.24
Sun	♂ Moon	0.95	Sun	♂ Sun	0.24

[885] What strikes us in [Table II](#) is the unequal distribution of the frequency values. The top seven and bottom six aspects both show a fairly strong dispersion, while the middle values tend to cluster round the ratio 1 : 1. I shall come back to this peculiar distribution with the help of a special graph ([Fig. 2](#)).

[886] An interesting point is the confirmation of the traditional astrological and alchemical correspondence between marriage and the moon-sun aspects:

(fem.) moon ♂ (masc.) sun 2.14 : 1

(fem.) moon ♂ (masc.) sun 1.61 : 1

whereas there is no evidence of any emphasis on the Venus-Mars aspects.

[887] Of the fifty possible aspects, the result shows that for the married pairs there are fifteen such configurations whose frequency is well above the proportion 1 : 1. The highest value is found in the aforementioned moon-sun conjunction, and the two next-highest figures—1.89 : 1 and 1.68 : 1—correspond to the conjunctions between (fem.) Asc. and (masc.) Venus, or (fem.) moon and (masc.) Asc, thus apparently confirming the traditional significance of the ascendent.

[888] Of these fifteen aspects, a moon aspect occurs four times for women, whereas only six moon aspects are distributed among the thirty-five other possible values. The mean proportional value of all moon aspects amounts to 1.24 : 1. The average value of the four just cited in the table amounts to 1.74 : 1, as compared with 1.24 : 1 for all moon aspects. The moon seems to be less emphasized for men than for women.

[889] For men the corresponding role is played not by the sun but by the *Asc.-Desc.* axis. In the first fifteen aspects of [Table II](#), these aspects occur six times for men and only twice for women. In the former case they have an average value of 1.42 : 1, as compared with 1.22 : 1 for all masculine aspects between *Asc.* or *Desc.* on the one hand and one of the four heavenly bodies on the other.

[890] [Figures 2](#) and [3](#) give a graphic representation of the frequencies shown respectively in columns 2 and 5 of [Table I](#) from the point of view of the dispersion of aspects.

[891] This arrangement enables us not only to visualize the dispersion in the frequency of occurrence of the different aspects but also to make a rapid estimate of the mean number of occurrences per aspect, using the median as an estimator. Whereas, in order to get the arithmetic mean, we have to total the aspect frequencies and divide by the number of aspects, the median frequency is found by counting down the histogram to a point where half the squares are counted and half are still to count. Since there are fifty squares in the histogram, the median is seen to be 8.0, since 25 squares do not exceed this value and 25 squares do exceed it (cf. [Fig. 2](#)).

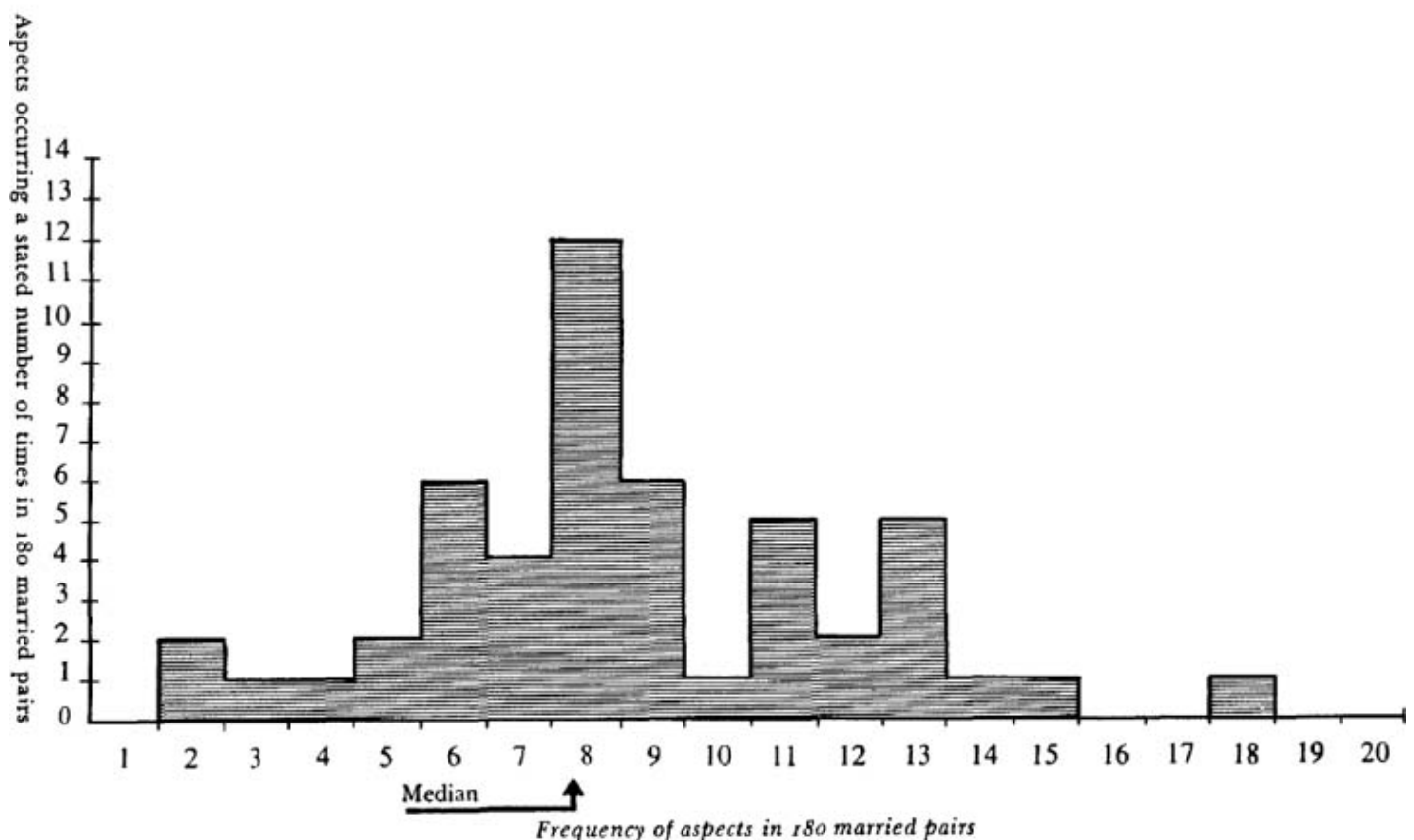

FIG. 2

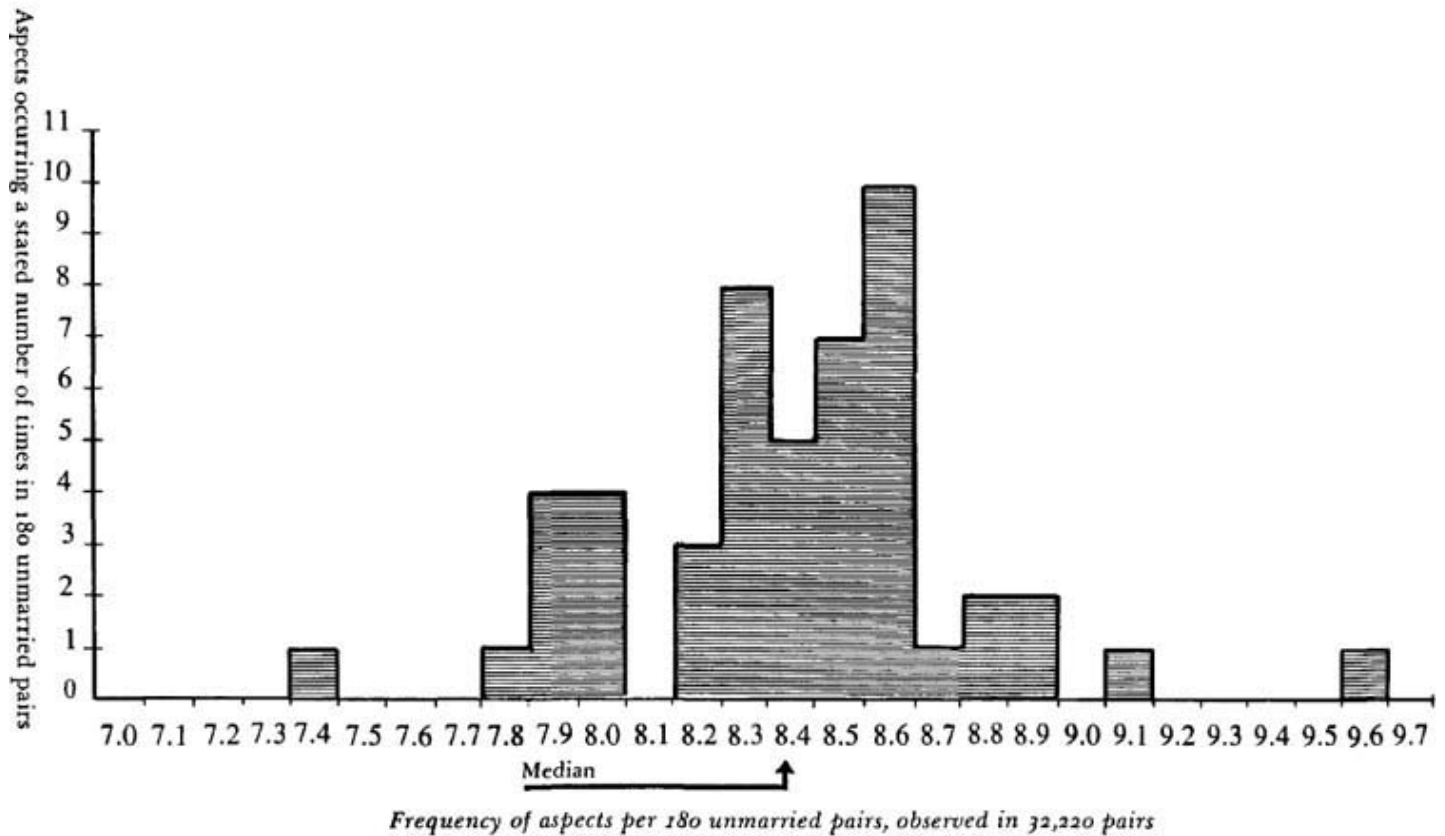

FIG. 3

[892] For the married pairs the median amounts to 8 cases, but in the combinations of unmarried pairs it is more, namely 8.4 (cf. Fig. 3). For the unmarried the median coincides with the arithmetic mean—both amount to 8.4—whereas the median for the married is lower than the corresponding mean value of 8.4, which is due to the presence of lower values for the married pairs. A glance at Figure 2 will show that there is a wide dispersion of values which contrasts strikingly with those clustered round the mean figure of 8.4 in Figure 3. Here there is not a single aspect with a frequency greater than 9.6 (cf. Fig. 3), whereas among the married one aspect reaches a frequency of nearly twice as much, namely 18 (cf. Fig. 2).

TABLE III

First Batch		Second Batch		Both Batches	
180 Married Pairs		220 Married Pairs		400 Married Pairs	
Moon ♂ Sun	10.0%	Moon ♂ Moon	10.9%	Moon ♂ Moon	9.2%
Asc. ♂ Venus	9.4%	Mars ♂ Venus	7.7%	Moon ♂ Sun	7.0%
Moon ♂ Asc.	7.7%	Venus ♂ Moon	7.2%	Moon ♂ Sun	7.0%
Moon ♂ Moon	7.2%	Moon ♂ Sun	6.8%	Mars ♂ Mars	6.2%
Moon ♂ Sun	7.2%	Moon ♂ Mars	6.8%	Desc. ♂ Venus	6.2%
Mars ♂ Moon	7.2%	Desc. ♂ Mars	6.8%	Moon ♂ Mars	6.2%
Venus ♂ Moon	7.2%	Desc. ♂ Venus	6.3%	Mars ♂ Moon	6.0%
Mars ♂ Mars	7.2%	Moon ♂ Venus	6.3%	Mars ♂ Venus	5.7%
Mars ♂ Asc.	6.6%	Venus ♂ Venus	6.3%	Moon ♂ Asc.	5.7%
Sun ♂ Mars	6.6%	Sun ♂ Mars	5.9%	Venus ♂ Desc.	5.7%
Venus ♂ Desc.	6.1%	Venus ♂ Desc.	5.4%	Venus ♂ Moon	5.5%
Venus ♂ Asc.	6.1%	Venus ♂ Mars	5.4%	Desc. ♂ Mars	5.2%
Mars ♂ Desc.	6.1%	Sun ♂ Moon	5.4%	Asc. ♂ Venus	5.2%
Sun ♂ Asc.	6.1%	Sun ♂ Sun	5.4%	Sun ♂ Mars	5.2%

Comparison of All Batches

[893] On the supposition that the dispersion apparent in [Figure 2](#) was due to chance, I investigated a larger number of marriage horoscopes by combining the first batch of 180 and the second batch of 220 married pairs, thus making 400 in all (or 800 individual horoscopes). The results are shown in [Table III](#), though I have confined myself here to the maximal figures that clearly exceed the median. Figures are given in percentages.

[894] The 180 couples in the first column represent the results of the first collection, while the 220 in the second column were collected more than a year later. The second column not only differs from the first in its aspects, but shows a marked sinking of the frequency values. The only exception is the top figure, representing the classical ☾ ♂ ☾. It takes the place of the equally classical ☾ ♂ ☉ in the first column. Of the fourteen aspects in the first column only four come up again in the second, but of these no less than three are moon aspects, and this is in accord with astrological expectations. The absence of correspondence between the aspects of the first and second columns indicates a great inequality of material, i.e., there is a wide dispersion. One can see this in the aggregate figures for the 400 married pairs: as a result of the evening out of the dispersion they all show a marked decrease. This is brought out still more clearly in [Table IV](#), where the third batch is added.

TABLE IV

Frequency in %	☾ ☽ ☽	☾ ☽ ☾	☾ ☽ ☽	Average
180 Married Pairs	10.0	7.2	7.2	8.1
220 Married Pairs	5.4	10.9	6.8	7.7
180 + 220 = 400 Married Pairs	7.0	9.2	7.0	7.7
83 Additional Married Pairs	7.2	4.8	4.8	5.6
83 + 400 = 483 Married Pairs	7.2	8.4	6.6	7.4

[895] This table shows the frequency figures for the three constellations that occur most often: two lunar conjunctions and one lunar opposition. The highest average frequency, that for the original 180 marriages, is 8.1%; for the 220 collected and worked out later the average maximum drops to 7.7%; and for the 83 marriages that were added still later the average amounts to only 5.6%. In the original batches of 180 and 220 the maxima still lie with the same aspects, ☾ ☽ ☽, ☾ ☽ ☾, but in the last batch of 83 it turned out that the maxima lay with different aspects, namely Asc. ☽ ☾, ☽ ☽ ☽, ☽ ☽ ☽, Oda, and Asc., ☽ Asc. The average maximum for these four aspects is 8.7%. This high figure exceeds our highest average of 8.1% for the first batch of 180, which only proves how fortuitous our “favourable” initial results were. Nevertheless it is worth pointing out that, amusingly enough, in the last batch the maximum of 9.6% lies, as we said earlier,⁶ with the Asc. ☽ ☾, aspect, that is, with another lunar aspect which is supposed to be particularly characteristic of marriage. A *lusus naturae*, no doubt, but a very queer one, since according to tradition the ascendent or “horoscopus,” together with sun and moon, forms the trinity that determines fate and character. Had one wanted to falsify the statistical findings so as to bring them into line with tradition one could not have done it more successfully.

[896] Table V gives the maximal frequencies for unmarried pairs.

TABLE V

Maximal Frequency in % for

1. 300 pairs combined at random	7.3
2. 325 pairs chosen by lot	6.5
3. 400 pairs chosen by lot	6.2
4. 32,220 pairs	5.3

The first result was obtained by my co-worker, Dr. Liliane Frey-Rohn, putting the men’s horoscopes on one side and the women’s on the other, and then combining each of the pairs that happened to lie on top. Care was naturally taken that a real married pair was not accidentally combined. The resultant frequency of 7.3 is pretty high in comparison with the much more probable maximal figure for the 32,220 unmarried pairs, which is only 5.3. This first result seemed to me somewhat suspicious.⁷ I therefore suggested that we should not combine the pairs ourselves, but should proceed in the following way: 325 men’s horoscopes were numbered, the numbers

were written on separate slips, thrown into a pot, and mixed up. Then a person who knew nothing of astrology and psychology and even less of these investigations was invited to draw the slips one by one out of the pot, without looking at them. The numbers were each combined with the topmost on the pile of women's horoscopes, care being again taken that married pairs did not accidentally come together. In this way 325 artificial pairs were obtained. The resultant 6.5 is rather nearer to probability. Still more probable is the result obtained for the 400 unmarried pairs. Even so, this figure (6.2) is still too high.

[897] The somewhat curious behaviour of our figures led to a further experiment whose results I mention here with all the necessary reserve, though it seems to me to throw some light on the statistical variations. It was made with three people whose psychological status was accurately known. The experiment consisted in taking 400 marriage horoscopes at random and providing 200 of them with numbers. Twenty of these were then drawn by lot by the subject. These twenty married pairs were examined statistically for our fifty marriage characteristics. The first subject was a woman patient who, at the time of the experiment, found herself in a state of intense emotional excitement. It proved that of twenty Mars aspects no less than ten were emphasized, with a frequency of 15.0; of the moon aspects nine, with a frequency of 10.0; and of the sun aspects nine, with a frequency of 14.0. The classical significance of Mars lies in his emotionality, in this case supported by the masculine sun. As compared with our general results there is a predominance of the Mars aspects, which fully agrees with the psychic state of the subject.

[898] The second subject was a woman patient whose main problem was to realize and assert her personality in the face of her self-suppressive tendencies. In this case the axial aspects (*Asc. Desc*), which are supposed to be characteristic of the personality, came up twelve times with a frequency of 20.0, and the moon aspects with a frequency of 18.0. This result, astrologically considered, was in full agreement with the subject's actual problems.

[899] The third subject was a woman with strong inner oppositions whose union and reconciliation constituted her main problem. The moon aspects came up fourteen times with a frequency of 20.0, the sun aspects twelve times with a frequency of 15.0, and the axial aspects nine times with a frequency of 14.0. The classical *coniunctio Solis et Lunae* as the symbol of the union of opposites is clearly emphasized.

[900] In all these cases the selection by lot of marriage horoscopes proves to have been influenced, and this fits in with our experience of the *I Ching* and other mantic procedures. Although all these figures lie well within the limits of probability and cannot therefore be regarded as anything more than chance, their variation, which each time corresponds surprisingly well with the psychic state of the subject, still

gives one food for thought. The psychic state was characterized as a situation in which insight and decision come up against the insurmountable barrier of an unconscious opposed to the will. This relative defeat of the powers of the conscious mind constellates the moderating archetype, which appears in the first case as Mars, the emotional *maleficus*, in the second case as the equilibrating axial system that strengthens the personality, and in the third case as the *Meros gamos* or *coniunctio* of supreme opposites.⁸ The psychic and physical event (namely, the subject's problems and choice of horoscope) correspond, it would seem, to the nature of the archetype in the background and could therefore represent a synchronistic phenomenon.

[901] Inasmuch as I am not very well up in the higher mathematics, and had therefore to rely on the help of a professional, I asked Professor Markus Fierz, of Basel, to calculate the probability of my maximal figures. This he very kindly did, and using the Poisson distribution he arrived at a probability of 1 : 10,000 for the first two maxima, and of 1 : 1300 for the third.^{8a} Later, on checking the calculation, he found an error whose correction raised the probability of the first two maxima to 1 : 1500.⁹ A further check proved the probabilities of the three maxima to be, respectively, 1 : 1000, 1 : 10,000, 1 : 50¹⁰ From this it is clear that although our best results—♁ ♃ ☉ and ♁ ♃ ♁—are fairly improbable in practice, they are theoretically so probable that there is little justification for regarding the immediate results of our statistics as anything more than chance. If for instance there is a 1 : 1000 probability of my getting the telephone connection I want, I shall probably prefer, instead of waiting on the off-chance for a telephone conversation, to write a letter. Our investigation shows that not only do the frequency values approximate to the average with the greatest number of married pairs, but that any chance pairings produce similar statistical proportions. From the scientific point of view the result of our investigation is in some respects not encouraging for astrology, as everything seems to indicate that in the case of large numbers the differences between the frequency values for the marriage aspects of married and unmarried pairs disappear altogether. Thus, from the scientific point of view, there is little hope of proving that astrological correspondence is something that conforms to law. At the same time, it is not so easy to counter the astrologer's objection that my statistical method is too arbitrary and too clumsy to evaluate correctly the numerous psychological and astrological aspects of marriage.

[902] So the essential thing that remains over from our astrological statistics is the fact that the first batch of 180 marriage horoscopes shows a distinct maximum of 18 for ♁ ♃ ☉ and the second batch of 220 a maximum of 24 for ♁ ♃ ♁. These two aspects have long been mentioned in the old literature as marriage characteristics, and they therefore represent the oldest tradition. The third batch of 83 yields a maximum of 8 for ♁ ♃ Asc. These maxima, as we have said, have probabilities of about 1 : 1000, 1 :

10,000, and 1 : 50 respectively. I should like to illustrate what has happened here by means of an example:

You take three matchboxes, put 1,000 black ants in the first, 10,000 in the second and 50 in the third, together with one white ant in each, shut the boxes, and bore a hole in each of them, small enough to allow only one ant to crawl through at a time. The first ant to come out of each of the three boxes is always the white one.

[903] The chances of this actually happening are extremely improbable. Even in the first two cases, the probability works out at $1 : 1000 \times 10,000$, which means that such a coincidence is to be expected only in one case out of 10,000,000. It is improbable that it would ever happen in anyone's experience. Yet in my statistical investigation it happened that precisely the three conjunctions stressed by astrological tradition came together in the most improbable way.

[904] For the sake of accuracy, however, it should be pointed out that it is not the *same* white ant that is the first to appear each time. That is to say, although there is always a lunar conjunction and always a "classical" one of decisive significance, they are nevertheless different conjunctions, because each time the moon is associated with a different partner. These are of course the three main components of the horoscope, namely the ascendent, or rising degree of a zodiacal sign, which characterizes the moment, the moon, which characterizes the day, and the sun, which characterizes the month of birth. Hence, if we consider only the first two batches, we must assume two white ants for each box. This correction raises the probability of the coinciding lunar conjunctions to $1 : 2,500,000$. If we take the third batch as well, the coincidence of the three classical moon aspects has a probability of $1 : 62,500,000$. The first proportion is significant even when taken by itself, for it shows that the coincidence is a very improbable one. But the coincidence with the third lunar conjunction is so remarkable that it looks like a deliberate arrangement in favour of astrology. If, therefore, the result of our experiment should be found to have a significant—i.e., more than merely chance—probability, the case for astrology would be proved in the most satisfactory way. If, on the contrary, the figures actually fall within the limits of chance expectation, they do not support the astrological claim, they merely *imitate* accidentally the ideal answer to astrological expectation. It is nothing but a chance result from the statistical point of view, yet it is *meaningful* on account of the fact that it looks as if it validated this expectation. It is just what I call a synchronistic phenomenon. The statistically significant statement only concerns regularly occurring events, and if considered as axiomatic, it simply abolishes all exceptions to the rule. It produces a merely average picture of natural events, but not a *true* picture of the world as it is. Yet the exceptions—and my results are exceptions and most improbable ones at that—are just as important as the rules. Statistics would not even make sense without the exceptions. There is no rule that is true under all circumstances, for this is

the real and not a statistical world. Because the statistical method shows only the average aspects, it creates an artificial and predominantly conceptual picture of reality. That is why we need a complementary principle for a complete description and explanation of nature.

[905] If we now consider the results of Rhine's experiments, and particularly the fact that they depend in large measure on the subject's active interest,¹¹ we can regard what happened in our case as a synchronistic phenomenon. The statistical material shows that a practically as well as theoretically improbable chance combination occurred which coincides in the most remarkable way with traditional astrological expectations. That such a coincidence should occur at all is so improbable and so incredible that nobody could have dared to predict anything like it. It really does look as if the statistical material had been manipulated and arranged so as to give the appearance of a positive result. The necessary emotional and archetypal conditions for a synchronistic phenomenon were already given, since it is obvious that both my co-worker and myself had a lively interest in the outcome of the experiment, and apart from that the question of synchronicity had been engaging my attention for many years. What seems in fact to have happened—and seems often to have happened, bearing in mind the long astrological tradition—is that we got a result which has presumably turned up many times before in history. Had the astrologers (with but few exceptions) concerned themselves more with statistics and questioned the justice of their interpretations in a scientific spirit, they would have discovered long ago that their statements rested on a precarious foundation. But I imagine that in their case too, as with me, a secret, mutual connivance existed between the material and the psychic state of the astrologer. This correspondence is simply *there* like any other agreeable or annoying accident, and it seems doubtful to me whether it can be proved scientifically to be anything more than that.¹² One may be fooled by coincidence, but one has to have a very thick skin not to be impressed by the fact that, out of fifty possibilities, three times precisely those turned up as maxima which are regarded by tradition as typical.

[906] As though to make this startling result even more impressive, we found that use had been made of unconscious deception. On first working out the statistics I was put off the trail by a number of errors which I fortunately discovered in time. After overcoming this difficulty I then forgot to mention, in the Swiss edition of this book, that the ant comparison, if applied to our experiment, only fits if respectively two or three white ants are assumed each time. This considerably reduces the improbability of our results. Then, at the eleventh hour, Professor Fierz, on checking his probability calculations yet again, found that he had been deceived by the factor 5. The improbability of our results was again reduced, though without reaching a degree which one could have described as probable. *The errors all tend to exaggerate the*

results in a way favourable to astrology, and add most suspiciously to the impression of an artificial or fraudulent arrangement of the facts, which was so mortifying to those concerned that they would probably have preferred to keep silent about it.

[907] I know, however, from long experience of these things that spontaneous synchronistic phenomena draw the observer, by hook or by crook, into what is happening and occasionally make him an accessory to the deed. That is the danger inherent in all parapsychological experiments. The dependence of ESP on an emotional factor in the experimenter and subject is a case in point. I therefore consider it a scientific duty to give as complete an account as possible of the result and to show how not only the statistical material, but the psychic processes of the interested parties, were affected by the synchronistic arrangement. Although, warned by previous experience, I was cautious enough to submit my original account (in the Swiss edition) to four competent persons, among them two mathematicians, I allowed myself to be lulled into a sense of security too soon.

[908] The corrections made here do not in any way alter the fact that the maximal frequencies lie with the three classical lunar aspects.

[909] In order to assure myself of the chance nature of the result, I undertook one more statistical experiment. I broke up the original and fortuitous chronological order and the equally fortuitous division into three batches by mixing the first 150 marriages with the last 150, taking the latter in reverse order; that is to say, I put the first marriage on top of the last, and then the second on top of the last but one, and so on. Then I divided the 300 marriages into three batches of a hundred. The result was as follows:

	1st Batch	2nd Batch	3rd Batch
Maximum	No Aspects 11%	☉ ☌ ☌ 11% ☾ ☌ ☾ 11%	☾ ☌ Asc. 12%

[910] The result of the first batch is amusing in so far as only fifteen of the 300 marriages have none of the fifty selected aspects in common. The second batch yields two maxima, of which the second again represents a classical conjunction. The third batch yields a maximum for ☾ ☌ which we already know as the third “classical” conjunction. The total result shows that another chance arrangement of the marriages can easily produce a result that deviates from the earlier total, but still does not quite prevent the classical conjunctions from turning up.

*

[911] The result of our experiment tallies with our experience of mantic procedures. One has the impression that these methods, and others like them, create favourable conditions for the occurrence of meaningful coincidences. It is quite true that the verification of synchronistic phenomena is a difficult and sometimes impossible task.

Rhine's achievement in demonstrating, with the help of unexceptionable material, the coincidence of a psychic state with a corresponding objective process must therefore be rated all the higher. Despite the fact that the statistical method is in general highly unsuited to do justice to unusual events, Rhine's experiments have nevertheless withstood the ruinous influence of statistics. Their results must therefore be taken into account in any assessment of synchronistic phenomena.

[912] In view of the levelling influence which the statistical method has on the quantitative determination of synchronicity, we must ask how it was that Rhine succeeded in obtaining positive results. I maintain that he would never have got the results he did if he had carried out his experiments with a single subject,¹³ or only a few. He needed a constant renewal of interest, an emotion with its characteristic *abaissement mental*, which tips the scales in favour of the unconscious. Only in this way can space and time be relativized to a certain extent, thereby reducing the chances of a causal process. What then happens is a kind of *creatio ex nihilo*, an act of creation that is not causally explicable. The mantic procedures owe their effectiveness to this same connection with emotionality: by touching an unconscious aptitude they stimulate interest, curiosity, expectation, hope, and fear, and consequently evoke a corresponding preponderance of the unconscious. The effective (numinous) agents in the unconscious are the archetypes. By far the greatest number of spontaneous synchronistic phenomena that I have had occasion to observe and analyse can easily be shown to have a direct connection with an archetype. This, in itself, is an irrepresentable, psychoid factor¹⁴ of the collective unconscious. The latter cannot be localized, since either it is complete in principle in every individual or is found to be the same everywhere. You can never say with certainty whether what appears to be going on in the collective unconscious of a single individual is not also happening in other individuals or organisms or things or situations. When, for instance, the vision arose in Swedenborg's mind of a fire in Stockholm, there was a real fire raging there at the same time, without there being any demonstrable or even thinkable connection between the two.¹⁵ I certainly would not like to undertake to prove the archetypal connection in this case. I would only point to the fact that in Swedenborg's biography there are certain things which throw a remarkable light on his psychic state. We must assume that there was a lowering of the threshold of consciousness which gave him access to "absolute knowledge." The fire in Stockholm was, in a sense, burning in him too. For the unconscious psyche space and time seem to be relative; that is to say, knowledge finds itself in a space-time continuum in which space is no longer space, nor time time. If, therefore, the unconscious should develop or maintain a potential in the direction of consciousness, it is then possible for parallel events to be perceived or "known."

[913] Compared with Rhine's work the great disadvantage of my astrological statistics lies in the fact that the entire experiment was carried out on only one subject, myself. I did not experiment with a variety of subjects; rather, it was the varied material that challenged *my* interest. I was thus in the position of a subject who is at first enthusiastic, but afterwards cools off on becoming habituated to the ESP experiment. The results therefore deteriorated with the growing number of experiments, which in this case corresponded to the exposition of the material in batches, so that the accumulation of larger numbers only blurred the "favourable" initial result. Equally my final experiment showed that the discarding of the original order and the division of the horoscopes into arbitrary batches produce, as might be expected, a different picture, though its significance is not altogether clear.

[914] Rhine's rules are to be recommended wherever (as in medicine) very large numbers are not involved. The interest and expectancy of the investigator might well be accompanied synchronistically by surprisingly favourable results to begin with, despite every precaution. These will be interpreted as "miracles" only by persons insufficiently acquainted with the statistical character of natural law.¹⁶

*

[915] If—and it seems plausible—the meaningful coincidence or "cross-connection" of events cannot be explained causally, then the connecting principle must lie in the *equal significance* of parallel events; in other words, their *tertium comparationis* is *meaning*. We are so accustomed to regard meaning as a psychic process or content that it never enters our heads to suppose that it could also exist outside the psyche. But we do know at least enough about the psyche not to attribute to it any magical power, and still less can we attribute any magical power to the conscious mind. If, therefore, we entertain the hypothesis that one and the same (transcendental) meaning might manifest itself simultaneously in the human psyche and in the arrangement of an external and independent event, we at once come into conflict with the conventional scientific and epistemological views. We have to remind ourselves over and over again of the merely statistical validity of natural laws and of the effect of the statistical method in eliminating all unusual occurrences, if we want to lend an ear to such an hypothesis. The great difficulty is that we have absolutely no scientific means of proving the existence of an *objective* meaning which is not just a psychic product. We are, however, driven to some such assumption if we are not to regress to a *magical causality* and ascribe to the psyche a power that far exceeds its empirical range of action. In that case we should have to suppose, if we don't want to let causality go, either that Swedenborg's unconscious staged the Stockholm fire, or conversely that the objective event activated in some quite inconceivable manner the corresponding images in Swedenborg's brain. In either case we come up against the unanswerable question of transmission discussed earlier. It is of course entirely a matter of

subjective opinion which hypothesis is felt to make more sense. Nor does tradition help us much in choosing between magical causality and transcendental meaning, because on the one hand the primitive mentality has always explained synchronicity as magical causality right down to our own day, and on the other hand philosophy assumed a secret correspondence or meaningful connection between natural events until well into the eighteenth century. I prefer the latter hypothesis because it does not, like the first, conflict with the empirical concept of causality, and can count as a principle *sui generis*. That obliges us, not indeed to correct the principles of natural explanation as hitherto understood, but at least to add to their number, an operation which only the most cogent reasons could justify. I believe, however, that the hints I have given in the foregoing constitute an argument that needs thorough consideration. Psychology, of all the sciences, cannot in the long run afford to overlook such experiences. These things are too important for an understanding of the unconscious, quite apart from their philosophical implications.

APPENDIX TO CHAPTER 2

[The following notes have been compiled by the Editors on the basis of Professor Fierz's mathematical argument, of which he kindly furnished a précis. These represent his latest thoughts on the topic. These data are presented here for the benefit of readers with a special interest in mathematics or statistics who want to know how the figures in the text were arrived at.

Since an orbit of 8° was taken as the basis of Professor Jung's calculations for the estimation of conjunctions and oppositions (cf. par. 880), it follows that, for a particular relation between two heavenly bodies to be called a conjunction (e.g., sun δ moon), one of them must lie within an arc of 16° . (Since the only concern was to test the character of the distribution, an arc of 15° was taken for convenience.)

Now, all positions on a circle of 360° are equally probable. So the probability α that the heavenly body will lie on an arc of 15° is

$$\alpha = \frac{15}{360} = \frac{1}{24} \quad (1)$$

This probability α holds for every aspect.

Let n be the number of particular aspects that will occur in N married pairs if the probability that it will occur in one married pair be α .

Applying the binomial distribution, we get:

$$W_n = \frac{N!}{n!(N-n)!} \alpha^n (1-\alpha)^{N-n} \quad (2)$$

In order to obtain a numerical evaluation of W_n , (2) can be simplified. This results in an error, which, however, is not important. The simplification can be arrived at by replacing (2) by the Poisson distribution:

$$P_n = \frac{1}{n!} x^n \cdot e^{-x}$$

This approximation is valid if α may be regarded as very small in comparison with 1, while x is finite.

Upon the basis of these considerations the following numerical results can be arrived at:

(a) The probability of $\alpha \delta \odot$, $\alpha \delta \alpha$ and $\alpha \delta \text{Asc.}$ turning up simultaneously is:

$$\alpha^3 = \left(\frac{1}{24}\right)^3 \sim \frac{1}{10,000}$$

(b) The probability P for the maximal figures in the three batches is:

1. 18 aspects in 180 married pairs, $P = 1 : 1,000$
2. 24 aspects in 220 married pairs, $P = 1 : 10,000$
3. 8 aspects in 83 married pairs, $P = 1 : 50$.

—EDITORS]

3. FORERUNNERS OF THE IDEA OF SYNCHRONICITY

[916] The causality principle asserts that the connection between cause and effect is a necessary one. The synchronicity principle asserts that the terms of a meaningful coincidence are connected by *simultaneity* and *meaning*. So if we assume that the ESP experiments and numerous other observations are established facts, we must conclude that besides the connection between cause and effect there is another factor in nature which expresses itself in the arrangement of events and appears to us as meaning. Although meaning is an anthropomorphic interpretation it nevertheless forms the indispensable criterion of synchronicity. What that factor which appears to us as “meaning” may be in itself we have no possibility of knowing. As an hypothesis, however, it is not quite so impossible as may appear at first sight. We must remember that the rationalistic attitude of the West is not the only possible one and is not all-embracing, but is in many ways a prejudice and a bias that ought perhaps to be corrected. The very much older civilization of the Chinese has always thought differently from us in this respect, and we have to go back to Heraclitus if we want to find something similar in our civilization, at least where philosophy is concerned. Only in astrology, alchemy, and the mantic procedures do we find no differences of principle between our attitude and the Chinese. That is why alchemy developed along parallel lines in East and West and why in both spheres it strove towards the same goal with more or less identical ideas.¹

[917] In Chinese philosophy one of the oldest and most central ideas is that of Tao, which the Jesuits translated as “God.” But that is correct only for the Western way of thinking. Other translations, such as “Providence” and the like, are mere makeshifts. Richard Wilhelm brilliantly interprets it as “meaning.”² The concept of Tao pervades the whole philosophical thought of China. Causality occupies this paramount position with us, but it acquired its importance only in the course of the last two centuries, thanks to the levelling influence of the statistical method on the one hand and the unparalleled success of the natural sciences on the other, which brought the metaphysical view of the world into disrepute.

[918] Lao-tzu gives the following description of Tao in his celebrated *Tao Teh Ching*:³

There is something formless yet complete

That existed before heaven and earth.

How still! how empty!

Dependent on nothing, unchanging,

All pervading, unfailing.

One may think of it as the mother of all things under heaven.

I do not know its name,

But I call it "Meaning."

If I had to give it a name, I should call it "The Great." [Ch. XXV.]

[919] Tao "covers the ten thousand things like a garment but does not claim to be master over them"(Ch. XXXIV). Lao-tzu describes it as "Nothing,"⁴ by which he means, says Wilhelm, only its "contrast with the world of reality." Lao-tzu describes its nature as follows:

We put thirty spokes together and call it a wheel;

But it is on the space where there is nothing that the utility of the wheel depends.

We turn clay to make a vessel;

But it is on the space where there is nothing that the utility of the vessel depends.

We pierce doors and windows to make a house;

And it is on these spaces where there is nothing that the utility of the house depends.

Therefore just as we take advantage of what is, we should recognize the utility of what is not. [Ch. XI.]

[920] "Nothing" is evidently "meaning" or "purpose," and it is only called Nothing because it does not appear in the world of the senses, but is only its organizer.⁵ Lao-tzu says:

Because the eye gazes but can catch no glimpse of it,

It is called elusive.

Because the ear listens but cannot hear it,

It is called the rarefied.

Because the hand feels for it but cannot find it,

It is called the infinitesimal. ...

These are called the shapeless shapes,

Forms without form,

Vague semblances.

Go towards them, and you can see no front;

Go after them, and you see no rear. [Ch. XIV.]

[921] Wilhelm describes it as “a borderline conception lying at the extreme edge of the world of appearances.” In it, the opposites “cancel out in non-discrimination,” but are still potentially present. “These seeds,” he continues, “point to something that corresponds firstly to *the visible*, i.e., something in the nature of an image; secondly to *the audible*, i.e., something in the nature of words; thirdly to *extension in space*, i.e., something with a form. But these three things are not clearly distinguished and definable, they are a non-spatial and non-temporal unity, having no above and below or front and back.” As the *Tao Teh Ching* says:

Incommensurable, impalpable,
Yet latent in it are forms;
Impalpable, incommensurable,
Yet within it are entities.
Shadowy it is and dim. [Ch. XXI.]

[922] Reality, thinks Wilhelm, is conceptually knowable because according to the Chinese view there is in all things a latent “rationality.”⁶ This is the basic idea underlying meaningful coincidence: it is possible because both sides have the same meaning. Where meaning prevails, order results:

Tao is eternal, but has no name;
The Uncarved Block, though seemingly of small account,
Is greater than anything under heaven.
If the kings and barons would but possess themselves of it,
The ten thousand creatures would flock to do them homage;
Heaven and earth would conspire
To send Sweet Dew;
Without law or compulsion men would dwell in harmony. [Ch. XXXII.]

Tao never does;
Yet through it all things are done. [Ch. XXXVII.]

Heaven’s net is wide;
Coarse are the meshes, yet nothing slips through. [Ch. LXXIII.]

[923] Chuang-tzu (a contemporary of Plato’s) says of the psychological premises on which Tao is based: “The state in which ego and non-ego are no longer opposed is called the pivot of Tao.”⁷ It sounds almost like a criticism of our scientific view of the world when he remarks that “Tao is obscured when you fix your eye on little segments of existence only,”⁸ or “Limitations are not originally grounded in the meaning of life. Originally words had no fixed meanings. Differences only arose through looking at things subjectively.”⁹ The sages of old, says Chuang-tzu, “took as

their starting-point a state when the existence of things had not yet begun. That is indeed the extreme limit beyond which you cannot go. The next assumption was that though things existed they had not yet begun to be separated. The next, that though things were separated in a sense, affirmation and negation had not yet begun. When affirmation and negation came into being, Tao faded. After Tao faded, then came one-sided attachments.”¹⁰ “Outward hearing should not penetrate further than the ear; the intellect should not seek to lead a separate existence, thus the soul can become empty and absorb the whole world. It is Tao that fills this emptiness.” If you have insight, says Chuang-tzu, “you use your inner eye, your inner ear, to pierce to the heart of things, and have no need of intellectual knowledge.”¹¹ This is obviously an allusion to the absolute knowledge of the unconscious, and to the presence in the microcosm of macrocosmic events.

[924] This Taoistic view is typical of Chinese thinking. It is, whenever possible, *a thinking in terms of the whole*, a point also brought out by Marcel Granet,¹² the eminent authority on Chinese psychology. This peculiarity can be seen in ordinary conversation with the Chinese: what seems to us a perfectly straightforward, precise question about some detail evokes from the Chinese thinker an unexpectedly elaborate answer, as though one had asked him for a blade of grass and got a whole meadow in return. With us details are important for their own sakes; for the Oriental mind they always complete a total picture. In this totality, as in primitive or in our own medieval, pre-scientific psychology (still very much alive!), are included things which seem to be connected with one another only “by chance,” by a coincidence whose meaningfulness appears altogether arbitrary. This is where the theory of *correspondentia*¹³ comes in, which was propounded by the natural philosophers of the Middle Ages, and particularly the classical idea of the *sympathy of all things*¹⁴ Hippocrates says:

There is one common flow, one common breathing, all things are in sympathy. The whole organism and each one of its parts are working in conjunction for the same purpose ... the great principle extends to the extremest part, and from the extremest part it returns to the great principle, to the one nature, being and not-being.¹⁵

The universal principle is found even in the smallest particle, which therefore corresponds to the whole.

[925] In this connection there is an interesting idea in Philo (25 B.C. – A.D. 42):

God, being minded to unite in intimate and loving fellowship the beginning and end of created things, made heaven the beginning and man the end, the one the most perfect of imperishable objects of sense, the other the noblest of things earthborn and perishable, being, in very truth, a miniature heaven. He bears about within himself, like holy images, endowments of nature that correspond to the constellations ... For since the corruptible

and the incorruptible are by nature contrary the one to the other, God assigned the fairest of each sort to the beginning and the end, heaven (as I have said) to the beginning, and man to the end.¹⁶

[926] Here the great principle¹⁷ or beginning, heaven, is infused into man the microcosm, who reflects the star-like natures and thus, as the smallest part and end of the work of Creation, contains the whole.

[927] According to Theophrastus (371–288 B.C.) the suprasensuous and the sensuous are joined by a bond of community. This bond cannot be mathematics, so must presumably be God.¹⁸ Similarly in Plotinus the individual souls born of the one World Soul are related to one another by sympathy or antipathy, regardless of distance.¹⁹ Similar views are to be found in Pico della Mirandola:

Firstly there is the unity in things whereby each thing is at one with itself, consists of itself, and coheres with itself. Secondly there is the unity whereby one creature is united with the others and all parts of the world constitute one world. The third and most important (unity) is that whereby the whole universe is one with its Creator, as an army with its commander.²⁰

By this threefold unity Pico means a simple unity which, like the Trinity, has three aspects; “a unity distinguished by a threefold character, yet in such a way as not to depart from the simplicity of unity.”²¹ For him the world is *one* being, a visible God, in which everything is naturally arranged from the very beginning like the parts of a living organism. The world appears as the *corpus mysticum* of God, just as the Church is the *corpus mysticum* of Christ, or as a well-disciplined army can be called a sword in the hand of the commander. The view that all things are arranged according to God’s will is one that leaves little room for causality. Just as in a living body the different parts work in harmony and are meaningfully adjusted to one another, so events in the world stand in a meaningful relationship which cannot be derived from any immanent causality. The reason for this is that in either case the behaviour of the parts depends on a central control which is supraordinate to them.

[928] In his treatise *De hominis dignitate* Pico says: “The Father implanted in man at birth seeds of all kinds and the germs of original life.”²² Just as God is the “copula” of the world, so, within the created world, is man. “Let us make man in our image, who is not a fourth world or anything like a new nature, but is rather the fusion and synthesis of three worlds (the supra-celestial, the celestial, and the sublunary).”²³ In body and spirit man is “the little God of the world,” the microcosm.²⁴ Like God, therefore, man is a centre of events, and all things revolve about him.²⁵ This thought, so utterly strange to the modern mind, dominated man’s picture of the world until a few generations ago, when natural science proved man’s subordination to nature and his extreme dependence on causes. The idea of a correlation between events and meaning (now assigned exclusively to man) was banished to such a remote and

benighted region that the intellect lost track of it altogether. Schopenhauer remembered it somewhat belatedly after it had formed one of the chief items in Leibniz's scientific explanations.

[929] By virtue of his microcosmic nature man is a son of the firmament or macrocosm. "I am a star travelling together with you," the initiate confesses in the Mithraic liturgy.²⁶ In alchemy the microcosmos has the same significance as the *rotundum*, a favourite symbol since the time of Zosimos of Panopolis, which was also known as the Monad.

[930] The idea that the inner and outer man together form the whole, the οὐλομελίη of Hippocrates, a microcosm or smallest part wherein the "great principle" is undividedly present, also characterizes the thought of Agrippa von Nettesheim. He says:

It is the unanimous consent of all Platonists, that as in the archetypal World, all things are in all; so also in this corporeal world, all things are in all, albeit in different ways, according to the receptive nature of each. Thus the Elements are not only in these inferiour bodies, but also in the Heavens, in Stars, in Divels, in Angels, and lastly in God, the maker, and archetype of all things.²⁷

The ancients had said: "All things are full of gods."²⁸ These gods were "divine powers which are diffused in things."²⁹ Zoroaster had called them "divine allurements,"³⁰ and Synesius "symbolic inticements."³¹ This latter interpretation comes very close indeed to the idea of archetypal projections in modern psychology, although from the time of Synesius until quite recently there was no epistemological criticism, let alone the newest form of it, namely psychological criticism. Agrippa shares with the Platonists the view that "there is in the lower beings a certain virtue through which they agree in large measure with the higher," and that as a result the animals are connected with the "divine bodies" (i.e., the stars) and exert an influence on them.³² Here he quotes Virgil: "I for my part do not believe that they [the rooks] are endowed with divine spirit or with a foreknowledge of things greater than the oracle."³³

[931] Agrippa is thus suggesting that there is an inborn "knowledge" or "perception" in living organisms, an idea which recurs in our own day in Hans Driesch.³⁴ Whether we like it or not, we find ourselves in this embarrassing position as soon as we begin seriously to reflect on the teleological processes in biology or to investigate the compensatory function of the unconscious, not to speak of trying to explain the phenomenon of synchronicity. Final causes, twist them how we will, postulate a *foreknowledge of some kind*. It is certainly not a knowledge that could be connected with the ego, and hence not a conscious knowledge as we know it, but rather a self-subsistent "unconscious" knowledge which I would prefer to call "absolute

knowledge.” It is not cognition but, as Leibniz so excellently calls it, a “perceiving” which consists—or to be more cautious, seems to consist—of images, of subjectless “simulacra.” These postulated images are presumably the same as my archetypes, which can be shown to be formal factors in spontaneous fantasy products. Expressed in modern language, the microcosm which contains “the images of all creation” would be the collective unconscious.³⁵ By the *spiritus mundi*, the *ligamentum animae et corporis*, the *quinta essentia*,^{TM36} which he shares with the alchemists, Agrippa probably means what we would call the unconscious. The spirit that “penetrates all things,” or shapes all things, is the World Soul: “The soul of the world therefore is a certain only thing, filling all things, bestowing all things, binding, and knitting together all things, that it might make one frame of the world. ...”³⁷ Those things in which this spirit is particularly powerful therefore have a tendency to “beget their like,”³⁸ in other words, to produce correspondences or meaningful coincidences.³⁹ Agrippa gives a long list of these correspondences, based on the numbers 1 to 12.⁴⁰ A similar but more alchemical table of correspondences can be found in a treatise of Aegidius de Vadis.⁴¹ Of these I would only mention the *scala unitatis*, because it is especially interesting from the point of view of the history of symbols: “Yod [the first letter of the tetragrammaton, the divine name]—anima mundi—sol—lapis philosophorum—cor—Lucifer.”⁴² I must content myself with saying that this is an attempt to set up a hierarchy of archetypes, and that tendencies in this direction can be shown to exist in the unconscious.⁴³

[932] Agrippa was an older contemporary of Theophrastus Paracelsus and is known to have had a considerable influence on him.⁴⁴ So it is not surprising if the thinking of Paracelsus proves to be steeped in the idea of correspondence. He says:

If a man will be a philosopher without going astray, he must lay the foundations of his philosophy by making heaven and earth a microcosm, and not be wrong by a hair’s breadth. Therefore he who will lay the foundations of medicine must also guard against the slightest error, and must make from the microcosm the revolution of heaven and earth, so that the philosopher does not find anything in heaven and earth which he does not also find in man, and the physician does not find anything in man which heaven and earth do not have. And these two differ only in outward form, and yet the form on both sides is understood as pertaining to one thing.⁴⁵

The *Paragranum*⁴⁶ has some pointed psychological remarks to make about physicians:

For this reason, [we assume] not four, but one arcanum, which is, however, four-square, like a tower facing the four winds. And as little as a tower may lack a corner, so little may the physician lack one of the parts. ... At the same [time he] knows how the world is symbolized [by] an egg in its shell, and how a chick with all its substance lies hidden within it. Thus everything in the world and in man must lie hidden in the physician. And just as the hens, by their brooding, transform the world prefigured in the shell into a chick, so Alchemy brings to maturity

the philosophical arcana lying in the physician. ... Herein lies the error of those who do not understand the physician aright.⁴⁷

What this means for alchemy I have shown in some detail in my *Psychology and Alchemy*.

[933] Johannes Kepler thought in much the same way. He says in his *Tertius interveniens* (1610):⁴⁸

This [viz., a geometrical principle underlying the physical world] is also, according to the doctrine of Aristotle, the strongest tie that links the lower world to the heavens and unifies it therewith so that all its forms are governed from on high; for in this lower world, that is to say the globe of the earth, there is inherent a spiritual nature, capable of *Geometria*, which *ex instinctu creatoris, sine ratio-cinatione* comes to life and stimulates itself into a use of its forces through the geometrical and harmonious combination of the heavenly rays of light. Whether all plants and animals as well as the globe of the earth have this faculty in themselves I cannot say. But it is not an unbelievable thing. ... For, in all these things [e.g., in the fact that flowers have a definite colour, form, and number of petals] there is at work the *instinctus divinus, rationis particeps*, and not at all man's own intelligence. That man, too, through his soul and its lower faculties, has a like affinity to the heavens as has the soil of the earth can be tested and proven in many ways.⁴⁹

[934] Concerning the astrological "Character," i.e., astrological synchronicity, Kepler says:

This *Character* is received, not into the body, which is much too inappropriate for this, but into the soul's own nature, which behaves like a point (for which reason it can also be transformed into the point of the *confluxus radiorum*). This [nature of the soul] not only partakes of their reason (on account of which we human beings are called reasonable above other living creatures) but also has another, innate reason [enabling it] to apprehend instantaneously, without long learning, the *Geometriam* in the *radiis* as well as in the *vocibus*, that is to say, in *Musica*.⁵⁰

Thirdly, another marvellous thing is that the nature which receives this *Characterem* also induces a certain correspondence *in constellationibus coelestibus* in its relatives. When a mother is great with child and the natural time of delivery is near, nature selects for the birth a day and hour which correspond, on account of the heavens [scil., from an astrological point of view], to the nativity of the mother's brother or father, and this *non qualitative, sed astronomice et quantitative*.⁵¹

Fourthly, so well does each nature know not only its *characterem coelestem* but also the celestial configurations and courses of every day that, whenever a planet moves *de praesenti* into its *characteris ascendentem* or *loca praecipua*, especially into the *Natalitia*,⁵² it responds to this and is affected and stimulated thereby in various ways.⁵³

[935] Kepler supposes that the secret of the marvellous correspondence is to be found in the *earth*, because the earth is animated by an *anima telluris*, for whose existence he adduces a number of proofs. Among these are: the constant temperature below the

surface of the earth; the peculiar power of the earth-soul to produce metals, minerals, and fossils, namely the *facultas formatrix*, which is similar to that of the womb and can bring forth in the bowels of the earth shapes that are otherwise found only outside—ships, fishes, kings, popes, monks, soldiers, etc.;⁵⁴ further the practice of geometry, for it produces the five geometrical bodies and the six-cornered figures in crystals. The *anima telluris* has all this from an original impulse, independent of the reflection and ratiocination of man.⁵⁵

[936] The seat of astrological synchronicity is not in the planets but in the earth;⁵⁶ not in matter, but in the *anima telluris*. Therefore every kind of natural or living power in bodies has a certain “divine similitude.”⁵⁷

*

[937] Such was the intellectual background when Gottfried Wilhelm von Leibniz (1646–1716) appeared with his idea of *pre-established harmony*, that is, an absolute synchronism of psychic and physical events. This theory finally petered out in the concept of “psychophysical parallelism.” Leibniz’s pre-established harmony and the above-mentioned idea of Schopenhauer’s, that the unity of the primal cause produces a simultaneity and interrelationship of events not in themselves causally connected, are at bottom only a repetition of the old peripatetic view, with a modern deterministic colouring in the case of Schopenhauer and a partial replacement of causality by an antecedent order in the case of Leibniz. For him God is the creator of order. He compares soul and body to two synchronized clocks⁵⁸ and uses the same simile to express the relations of the monads or entelechies with one another. Although the monads cannot influence one another directly because, as he says, they “have no windows”⁵⁹ (relative abolition of causality!), they are so constituted that they are always in accord without having knowledge of one another. He conceives each monad to be a “little world” or “active indivisible mirror.”⁶⁰ Not only is man a microcosm enclosing the whole in himself, but every entelechy or monad is in effect such a microcosm. Each “simple substance” has connections “which express all the others.” It is “a perpetual living mirror of the universe.”⁶¹ He calls the monads of living organisms “souls”: “the soul follows its own laws, and the body its own likewise, and they accord by virtue of the harmony pre-established among all substances, since they are all representations of one and the same universe.”⁶² This clearly expresses the idea that man is a microcosm. “Souls in general,” says Leibniz, “are the living mirrors or images of the universe of created things.” He distinguishes between minds on the one hand, which are “images of the Divinity ... capable of knowing the system of the universe, and of imitating something of it by architectonic patterns, each mind being as it were a little divinity in its own department,”⁶³ and bodies on the other hand, which “act according to the laws of efficient causes by

motions,” while the souls act “according to the laws of final causes by appetitions, ends, and means.”⁶⁴ In the monad or soul alterations take place whose cause is the “appetition.”⁶⁵ “The passing state, which involves and represents a plurality within the unity or simple substance, is nothing other than what is called perception,” says Leibniz.⁶⁶ Perception is the “inner state of the monad representing external things,” and it must be distinguished from conscious apperception. “For perception is unconscious.”⁶⁷ Herein lay the great mistake of the Cartesians, “that they took no account of perceptions which are not apperceived.”⁶⁸ The perceptive faculty of the monad corresponds to the *knowledge*, and its appetitive faculty to the *will*, that is in God.⁶⁹

[938] It is clear from these quotations that besides the causal connection Leibniz postulates a complete pre-established parallelism of events both inside and outside the monad. The synchronicity principle thus becomes the absolute rule in all cases where an inner event occurs simultaneously with an outside one. As against this, however, it must be borne in mind that the synchronistic phenomena which can be verified empirically, far from constituting a rule, are so exceptional that most people doubt their existence. They certainly occur much more frequently in reality than one thinks or can prove, but we still do not know whether they occur so frequently and so regularly in any field of experience that we could speak of them as conforming to law.⁷⁰ We only know that there must be an underlying principle which might possibly explain all such (related) phenomena.

[939] The primitive as well as the classical and medieval views of nature postulate the existence of some such principle alongside causality. Even in Leibniz, causality is neither the only view nor the predominant one. Then, in the course of the eighteenth century, it became the exclusive principle of natural science. With the rise of the physical sciences in the nineteenth century the correspondence theory vanished completely from the surface, and the magical world of earlier ages seemed to have disappeared once and for all until, towards the end of the century, the founders of the Society for Psychical Research indirectly opened up the whole question again through their investigation of telepathic phenomena.

[940] The medieval attitude of mind I have described above underlies all the magical and mantic procedures which have played an important part in man’s life since the remotest times. The medieval mind would regard Rhine’s laboratory-arranged experiments as magical performances, whose effect for this reason would not seem so very astonishing. It was interpreted as a “transmission of energy,” which is still commonly the case today, although, as I have said, it is not possible to form any empirically verifiable conception of the transmitting medium.

[941] I need hardly point out that for the primitive mind synchronicity is a self-evident fact; consequently at this stage there is no such thing as chance. No accident, no illness, no death is ever fortuitous or attributable to “natural” causes. Everything is somehow due to magical influence. The crocodile that catches a man while he is bathing has been sent by a magician; illness is caused by some spirit or other; the snake that was seen by the grave of somebody’s mother is obviously her soul; etc. On the primitive level, of course, synchronicity does not appear as an idea by itself, but as “magical” causality. This is an early form of our classical idea of causality, while the development of Chinese philosophy produced from the significance of the magical the “concept” of Tao, of meaningful coincidence, but no causality-based science.

[942] Synchronicity postulates a meaning which is *a priori* in relation to human consciousness and apparently exists outside man.⁷¹ Such an assumption is found above all in the philosophy of Plato, which takes for granted the existence of transcendental images or models of empirical things, the εἶδη (forms, species), whose reflections (εἰδωλα) we see in the phenomenal world. This assumption not only presented no difficulty to earlier centuries but was on the contrary perfectly self-evident. The idea of an *a priori* meaning may also be found in the older mathematics, as in the mathematician Jacobi’s paraphrase of Schiller’s poem “Archimedes and His Pupil.” He praises the calculation of the orbit of Uranus and closes with the lines:

What you behold in the cosmos is only the light of God’s glory;
In the Olympian host Number eternally reigns.

[943] The great mathematician Gauss is the putative author of the saying: “God arithmetizes.”⁷²

[944] The idea of synchronicity and of a self-subsistent meaning, which forms the basis of classical Chinese thinking and of the naïve views of the Middle Ages, seems to us an archaic assumption that ought at all costs to be avoided. Though the West has done everything possible to discard this antiquated hypothesis, it has not quite succeeded. Certain mantic procedures seem to have died out, but astrology, which in our own day has attained an eminence never known before, remains very much alive. Nor has the determinism of a scientific epoch been able to extinguish altogether the persuasive power of the synchronicity principle. For in the last resort it is not so much a question of superstition as of a truth which remained hidden for so long only because it had less to do with the physical side of events than with their psychic aspects. It was modern psychology and parapsychology which proved that causality does not explain a certain class of events and that in this case we have to consider a formal factor, namely synchronicity, as a principle of explanation.

[945] For those who are interested in psychology I should like to mention here that the peculiar idea of a self-subsistent meaning is suggested in dreams. Once when this idea was being discussed in my circle somebody remarked: "The geometrical square does not occur in nature except in crystals." A lady who had been present had the following dream that night: *In the garden there was a large sandpit in which layers of rubbish had been deposited. In one of these layers she discovered thin, slaty plates of green serpentine. One of them had black squares on it, arranged concentrically. The black was not painted on, but was ingrained in the stone, like the markings in an agate. Similar marks were found on two or three other plates, which Mr. A (a slight acquaintance) then took away from her.*⁷³ Another dream-motif of the same kind is the following: *The dreamer was in a wild mountain region where he found contiguous layers of triassic rock. He loosened the slabs and discovered to his boundless astonishment that they had human heads on them in low relief. This dream was repeated several times at long intervals.*⁷⁴ Another time the dreamer was travelling through the Siberian tundra and found an animal he had long been looking for. *It was a more than lifesize cock, made of what looked like thin, colourless glass. But it was alive and had just sprung by chance from a microscopic unicellular organism which had the power to turn into all sorts of animals (not otherwise found in the tundra) or even into objects of human use, of whatever size. The next moment each of these chance forms vanished without trace.* Here is another dream of the same type: *The dreamer was walking in a wooded mountain region. At the top of a steep slope he came to a ridge of rock honeycombed with holes, and there he found a little brown man of the same colour as the iron oxide with which the rock was coated.*⁷⁵ *The little man was busily engaged in hollowing out a cave, at the back of which a cluster of columns could be seen in the living rock. On the top of each column was a dark brown human head with large eyes, carved with great care out of some very hard stone, like lignite. The little man freed this formation from the amorphous conglomerate surrounding it. The dreamer could hardly believe his eyes at first, but then had to admit that the columns were continued far back into the living rock and must therefore have come into existence without the help of man. He reflected that the rock was at least half a million years old and that the artefact could not possibly have been made by human hands.*⁷⁶

[946] These dreams seem to point to the presence of a formal factor in nature. They describe not just a *lusus naturae*, but the meaningful coincidence of an absolutely natural product with a human idea apparently independent of it. This is what the dreams are obviously saying,⁷⁷ and what they are trying to bring nearer to consciousness through repetition.

4. CONCLUSION

[947] I do not regard these statements as in any way a final proof of my views, but simply as a conclusion from empirical premises which I would like to submit to the consideration of my reader. From the material before us I can derive no other hypothesis that would adequately explain the facts (including the ESP experiments). I am only too conscious that synchronicity is a highly abstract and “irrepresentable” quantity. It ascribes to the moving body a certain psychoid property which, like space, time, and causality, forms a criterion of its behaviour. We must completely give up the idea of the psyche’s being somehow connected with the brain, and remember instead the “meaningful” or “intelligent” behaviour of the lower organisms, which are without a brain. Here we find ourselves much closer to the formal factor which, as I have said, has nothing to do with brain activity.

[948] If that is so, then we must ask ourselves whether the relation of soul and body can be considered from this angle, that is to say whether the co-ordination of psychic and physical processes in a living organism can be understood as a synchronistic phenomenon rather than as a causal relation. Both Geulincx and Leibniz regarded the co-ordination of the psychic and the physical as an act of God, of some principle standing outside empirical nature. The assumption of a causal relation between psyche and physis leads on the other hand to conclusions which it is difficult to square with experience: either there are physical processes which cause psychic happenings, or there is a preexistent psyche which organizes matter. In the first case it is hard to see how chemical processes can ever produce psychic processes, and in the second case one wonders how an immaterial psyche could ever set matter in motion. It is not necessary to think of Leibniz’s pre-established harmony or anything of that kind, which would have to be absolute and would manifest itself in a universal correspondence and sympathy, rather like the meaningful coincidence of time-points lying on the same degree of latitude in Schopenhauer. The synchronicity principle possesses properties that may help to clear up the body-soul problem. Above all it is the fact of causeless order, or rather, of meaningful orderedness, that may throw light on psychophysical parallelism. The “absolute knowledge” which is characteristic of

synchronistic phenomena, a knowledge not mediated by the sense organs, supports the hypothesis of a self-subsistent meaning, or even expresses its existence. Such a form of existence can only be transcendental, since, as the knowledge of future or spatially distant events shows, it is contained in a psychically relative space and time, that is to say in an irrepresentable space-time continuum.

[949] It may be worth our while to examine more closely, from this point of view, certain experiences which seem to indicate the existence of psychic processes in what are commonly held to be unconscious states. Here I am thinking chiefly of the remarkable observations made during deep syncopes resulting from acute brain injuries. Contrary to all expectations, a severe head injury is not always followed by a corresponding loss of consciousness. To the observer, the wounded man seems apathetic, “in a trance,” and not conscious of anything. Subjectively, however, consciousness is by no means extinguished. Sensory communication with the outside world is in a large measure restricted, but is not always completely cut off, although the noise of battle, for instance, may suddenly give way to a “solemn” silence. In this state there is sometimes a very distinct and impressive sensation or hallucination of levitation, the wounded man seeming to rise into the air in the same position he was in at the moment he was wounded. If he was wounded standing up, he rises in a standing position, if lying down, he rises in a lying position, if sitting, he rises in a sitting position. Occasionally his surroundings seem to rise with him—for instance the whole bunker in which he finds himself at the moment. The height of the levitation may be anything from eighteen inches to several yards. All feeling of weight is lost. In a few cases the wounded think they are making swimming movements with their arms. If there is any perception of their surroundings at all, it seems to be mostly imaginary, i.e., composed of memory images. During levitation the mood is predominantly euphoric. “‘Buoyant, solemn, heavenly, serene, relaxed, blissful, expectant, exciting’ are the words used to describe it. ... There are various kinds of ‘ascension experiences.’”¹ Jantz and Beringer rightly point out that the wounded can be roused from their syncope by remarkably small stimuli, for instance if they are addressed by name or touched, whereas the most terrific bombardment has no effect.

[950] Much the same thing can be observed in deep comas resulting from other causes. I would like to give an example from my own medical experience. A woman patient, whose reliability and truthfulness I have no reason to doubt, told me that her first birth was very difficult. After thirty hours of fruitless labour the doctor considered that a forceps delivery was indicated. This was carried out under light narcosis. She was badly torn and suffered great loss of blood. When the doctor, her mother, and her husband had gone, and everything was cleared up, the nurse wanted to eat, and the patient saw her turn round at the door and ask, “Do you want anything before I go to

supper?” She tried to answer, but couldn’t. She had the feeling that she was sinking through the bed into a bottomless void. She saw the nurse hurry to the bedside and seize her hand in order to take her pulse. From the way she moved her fingers to and fro the patient thought it must be almost imperceptible. Yet she herself felt quite all right, and was slightly amused at the nurse’s alarm. She was not in the least frightened. That was the last she could remember for a long time. The next thing she was aware of was that, without feeling her body and its position, she was *looking down* from a point in the ceiling and could see everything going on in the room below her: she saw herself lying in the bed, deadly pale, with closed eyes. Beside her stood the nurse. The doctor paced up and down the room excitedly, and it seemed to her that he had lost his head and didn’t know what to do. Her relatives crowded to the door. Her mother and her husband came in and looked at her with frightened faces. She told herself it was too stupid of them to think she was going to die, for she would certainly come round again. All this time she knew that behind her was a glorious, park-like landscape shining in the brightest colours, and in particular an emerald green meadow with short grass, which sloped gently upwards beyond a wrought-iron gate leading into the park. It was spring, and little gay flowers such as she had never seen before were scattered about in the grass. The whole demesne sparkled in the sunlight, and all the colours were of an indescribable splendour. The sloping meadow was flanked on both sides by dark green trees. It gave her the impression of a clearing in the forest, never yet trodden by the foot of man. “I knew that this was the entrance to another world, and that if I turned round to gaze at the picture directly, I should feel tempted to go in at the gate, and thus step out of life.” She did not actually *see* this landscape, as her back was turned to it, but she *knew* it was there. She felt there was nothing to stop her from entering in through the gate. She only knew that she would turn back to her body and would not die. That was why she found the agitation of the doctor and the distress of her relatives stupid and out of place.

[951] The next thing that happened was that she awoke from her coma and saw the nurse bending over her in bed. She was told that she had been unconscious for about half an hour. The next day, some fifteen hours later, when she felt a little stronger, she made a remark to the nurse about the incompetent and “hysterical” behaviour of the doctor during her coma. The nurse energetically denied this criticism in the belief that the patient had been completely unconscious at the time and could therefore have known nothing of the scene. Only when she described in full detail what had happened during the coma was the nurse obliged to admit that the patient had perceived the events exactly as they happened in reality.

[952] One might conjecture that this was simply a psychogenic twilight state in which a split-off part of consciousness still continued to function. The patient, however, had

never been hysterical and had suffered a genuine heart collapse followed by syncope due to cerebral anaemia, as all the outward and evidently alarming symptoms indicated. She really was in a coma and ought to have had a complete psychic black-out and been altogether incapable of clear observation and sound judgment. The remarkable thing was that it was not an immediate perception of the situation through indirect or unconscious observation, but she saw the whole situation from *above*, as though “her eyes were in the ceiling,” as she put it.

[953] Indeed, it is not easy to explain how such unusually intense psychic processes can take place, and be remembered, in a state of severe collapse, and how the patient could observe actual events in concrete detail with closed eyes. One would expect such obvious cerebral anaemia to militate against or prevent the occurrence of highly complex psychic processes of that kind.

[954] Sir Auckland Geddes presented a very similar case before the Royal Society of Medicine on February 26, 1927, though here the ESP went very much further. During a state of collapse the patient noted the splitting off of an integral consciousness from his bodily consciousness, the latter gradually resolving itself into its organ components. The other consciousness possessed verifiable ESP.²

[955] These experiences seem to show that in swoon states, where by all human standards there is every guarantee that conscious activity and sense perception are suspended, consciousness, reproducible ideas, acts of judgment, and perceptions can still continue to exist. The accompanying feeling of levitation, alteration of the angle of vision, and extinction of hearing and of coenaesthetic perceptions indicate a shift in the localization of consciousness, a sort of separation from the body, or from the cerebral cortex or cerebrum which is conjectured to be the seat of conscious phenomena. If we are correct in this assumption, then we must ask ourselves whether there is some other nervous substrate in us, apart from the cerebrum, that can think and perceive, or whether the psychic processes that go on in us during loss of consciousness are synchronistic phenomena, i.e., events which have no causal connection with organic processes. This last possibility cannot be rejected out of hand in view of the existence of ESP, i.e., of perceptions independent of space and time which cannot be explained as processes in the biological substrate. Where sense perceptions are impossible from the start, it can hardly be a question of anything but synchronicity. But where there are spatial and temporal conditions which would make perception and apperception possible in principle, and only the activity of consciousness, or the cortical function, is extinguished, and where, as in our example, a conscious phenomenon like perception and judgment nevertheless occurs, then the question of a nervous substrate might well be considered. It is well nigh axiomatic that conscious processes are tied to the cerebrum, and that the lower centres contain

nothing but chains of reflexes which in themselves are unconscious. This is particularly true of the sympathetic system. Hence the insects, which have no cerebrospinal nervous system at all, but only a double chain of ganglia, are regarded as reflex automata.

[956] This view has recently been challenged by the researches which von Frisch, of Graz, made into the life of bees. It turns out that bees not only tell their comrades, by means of a peculiar sort of dance, that they have found a feeding-place, but that they also indicate its direction and distance, thus enabling the beginners to fly to it directly.³ This kind of message is no different in principle from information conveyed by a human being. In the latter case we would certainly regard such behaviour as a conscious and intentional act and can hardly imagine how anyone could prove in a court of law that it had taken place unconsciously. We could, at a pinch, admit on the basis of psychiatric experiences that objective information can in exceptional cases be communicated in a twilight state, but would expressly deny that communications of this kind are normally unconscious. Nevertheless it would be possible to suppose that in bees the process is unconscious. But that would not help to solve the problem, because we are still faced with the fact that the ganglionic system apparently achieves exactly the same result as our cerebral cortex. Nor is there any proof that bees are unconscious.

[957] Thus we are driven to the conclusion that a nervous substrate like the sympathetic system, which is absolutely different from the cerebrospinal system in point of origin and function, can evidently produce thoughts and perceptions just as easily as the latter. What then are we to think of the sympathetic system in vertebrates? Can it also produce or transmit specifically psychic processes? Von Frisch's observations prove the existence of transcerebral thought and perception. One must bear this possibility in mind if we want to account for the existence of some form of consciousness during an unconscious coma. During a coma the sympathetic system is not paralysed and could therefore be considered as a possible carrier of psychic functions. If that is so, then one must ask whether the normal state of unconsciousness in sleep, and the potentially conscious dreams it contains, can be regarded in the same light—whether, in other words, dreams are produced not so much by the activity of the sleeping cortex, as by the unsleeping sympathetic system, and are therefore of a transcerebral nature.

[958] Outside the realm of psychophysical parallelism, which we cannot at present pretend to understand, synchronicity is not a phenomenon whose regularity it is at all easy to demonstrate. One is as much impressed by the disharmony of things as one is surprised by their occasional harmony. In contrast to the idea of a pre-established harmony, the synchronistic factor merely stipulates the existence of an intellectually

necessary principle which could be added as a fourth to the recognized triad of space, time, and causality. These factors are necessary but not absolute—most psychic contents are non-spatial, time and causality are psychically relative—and in the same way the synchronistic factor proves to be only conditionally valid. But unlike causality, which reigns despotically over the whole picture of the macrophysical world and whose universal rule is shattered only in certain lower orders of magnitude, synchronicity is a phenomenon that seems to be primarily connected with psychic conditions, that is to say with processes in the unconscious. Synchronistic phenomena are found to occur—experimentally—with some degree of regularity and frequency in the intuitive, “magical” procedures, where they are subjectively convincing but are extremely difficult to verify objectively and cannot be statistically evaluated (at least at present).

[959] On the organic level it might be possible to regard biological morphogenesis in the light of the synchronistic factor. Professor A. M. Dalcq (of Brussels) understands form, despite its tie with matter, as a “continuity that is supraordinate to the living organism.”⁴ Sir James Jeans reckons radioactive decay among the causeless events which, as we have seen, include synchronicity. He says: “Radioactive break-up appeared to be an effect without a cause, and suggested that the ultimate laws of nature were not even causal.”⁵ This highly paradoxical formula, coming from the pen of a physicist, is typical of the intellectual dilemma with which radioactive decay confronts us. It, or rather the phenomenon of “half-life,” appears as an instance of acausal orderedness—a conception which also includes synchronicity and to which I shall revert below.

[960] Synchronicity is not a philosophical view but an empirical concept which postulates an intellectually necessary principle. This cannot be called either materialism or metaphysics. No serious investigator would assert that the nature of what is observed to exist, and of that which observes, namely the psyche, are known and recognized quantities. If the latest conclusions of science are coming nearer and nearer to a unitary idea of being, characterized by space and time on the one hand and by causality and synchronicity on the other, that has nothing to do with materialism. Rather it seems to show that there is some possibility of getting rid of the incommensurability between the observed and the observer. The result, in that case, would be a unity of being which would have to be expressed in terms of a new conceptual language—a “neutral language,” as W. Pauli once called it.

[961] Space, time, and causality, the triad of classical physics, would then be supplemented by the synchronicity factor and become a tetrad, a *quaternio* which makes possible a whole judgment:

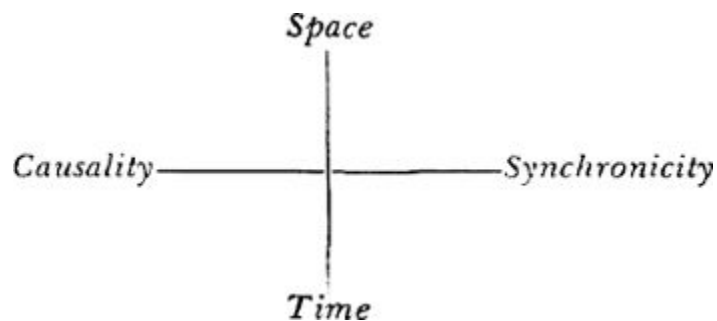

[962] Here synchronicity is to the three other principles as the one-dimensionality of time⁶ is to the three-dimensionality of space, or as the recalcitrant “Fourth” in the *Timaeus*, which, Plato says, can only be added “by force” to the other three.⁷ Just as the introduction of time as the fourth dimension in modern physics postulates an irrepresentable space-time continuum, so the idea of synchronicity with its inherent quality of meaning produces a picture of the world so irrepresentable as to be completely baffling.⁸ The advantage, however, of adding this concept is that it makes possible a view which includes the psychoid factor in our description and knowledge of nature—that is, an *a priori* meaning or “equivalence.” The problem that runs like a red thread through the speculations of alchemists for fifteen hundred years thus repeats and solves itself, the so-called axiom of Maria the Jewess (or Copt): “Out of the Third comes the One as the Fourth.”⁹ This cryptic observation confirms what I said above, that in principle new points of view are not as a rule discovered in territory that is already known, but in out-of-the-way places that may even be avoided because of their bad name. The old dream of the alchemists, the transmutation of chemical elements, this much-derided idea, has become a reality in our own day, and its symbolism, which was no less an object of ridicule, has turned out to be a veritable gold-mine for the psychology of the unconscious. Their dilemma of three and four, which began with the story that serves as a setting for the *Timaeus* and extends all the way to the Cabiri scene in *Faust, Part II*, is recognized by a sixteenth-century alchemist, Gerhard Dorn, as the decision between the Christian Trinity and the *serpens quadricornutus*, the four-horned serpent who is the Devil. As though in anticipation of things to come he anathematizes the pagan quaternity which was ordinarily so beloved of the alchemists, on the ground that it arose from the binarius (the number 2) and is thus something material, feminine, and devilish.¹⁰ Dr. von Franz has demonstrated this emergence of trinitarian thinking in the *Parable* of Bernard of Treviso, in Khunrath’s *Amphitheatrum*, in Michael Maier, and in the anonymous author of the *Aquarium sapientum*.¹¹ W. Pauli calls attention to the polemical writings of Kepler and of Robert Fludd, in which Fludd’s correspondence theory was the loser and had to make room for Kepler’s theory of three principles.¹² The decision in favour of the triad, which in certain respects ran counter to the alchemical tradition, was followed by a scientific epoch that knew nothing of correspondence and clung with passionate insistence to a triadic view of the world—

a continuation of the trinitarian type of thinking—which described and explained everything in terms of space, time, and causality.

[963] The revolution brought about by the discovery of radioactivity has considerably modified the classical views of physics. So great is the change of standpoint that we have to revise the classical schema I made use of above. As I was able, thanks to the friendly interest which Professor Pauli evinced in my work, to discuss these questions of principle with a professional physicist who could at the same time appreciate my psychological arguments, I am in a position to put forward a suggestion that takes modern physics into account. Pauli suggested replacing the opposition of space and time in the classical schema by (conservation of) energy and the space-time continuum. This suggestion led me to a closer definition of the other pair of opposites—causality and synchronicity—with a view to establishing some kind of connection between these two heterogeneous concepts. We finally agreed on the following *quaternio*:

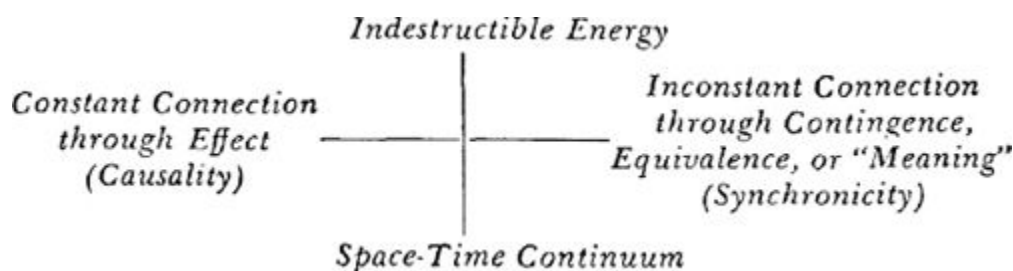

[964] This schema satisfies on the one hand the postulates of modern physics, and on the other hand those of psychology. The psychological point of view needs clarifying. A causalistic explanation of synchronicity seems out of the question for the reasons given above. It consists essentially of "chance" equivalences. Their *tertium comparationis* rests on the psychoid factors I call archetypes. These are *indefinite*, that is to say they can be known and determined only approximately. Although associated with causal processes, or "carried" by them, they continually go beyond their frame of reference, an infringement to which I would give the name "transgressivity," because the archetypes are not found exclusively in the psychic sphere, but can occur just as much in circumstances that are not psychic (equivalence of an outward physical process with a psychic one). Archetypal equivalences are *contingent* to causal determination, that is to say there exist between them and the causal processes no relations that conform to law. They seem, therefore, to represent a special instance of randomness or chance, or of that "random state" which "runs through time in a way that fully conforms to law," as Andreas Speiser says.¹³ It is an initial state which is "not governed by mechanistic law" but is the precondition of law, the chance substrate on which law is based. If we consider synchronicity or the archetypes as the contingent, then the latter takes on the specific aspect of a modality that has the functional significance of a world-constituting factor. The archetype

represents *psychic probability*, portraying ordinary instinctual events in the form of *types*. It is a special psychic instance of probability in general, which “is made up of the laws of chance and lays down rules for nature just as the laws of mechanics do.”¹⁴ We must agree with Speiser that although in the realm of pure intellect the contingent is “a formless substance,” it reveals itself to psychic introspection—so far as inward perception can grasp it at all—as an image, or rather a type which underlies not only the psychic equivalences but, remarkably enough, the psychophysical equivalences too.

[965] It is difficult to divest conceptual language of its causalistic colouring. Thus the word “underlying,” despite its causalistic connotation, does not refer to anything causal, but simply to an existing quality, an irreducible contingency which is “Just-So.” The meaningful coincidence or equivalence of a psychic and a physical state that have no causal relationship to one another means, in general terms, that it is a modality without a cause, an “acausal orderedness.” The question now arises whether our definition of synchronicity with reference to the equivalence of psychic and physical processes is capable of expansion, or rather, requires expansion. This requirement seems to force itself on us when we consider the above, wider conception of synchronicity as an “acausal orderedness.” Into this category come all “acts of creation,” *a priori* factors such as the properties of natural numbers, the discontinuities of modern physics, etc. Consequently we would have to include constant and experimentally reproducible phenomena within the scope of our expanded concept, though this does not seem to accord with the nature of the phenomena included in synchronicity narrowly understood. The latter are mostly individual cases which cannot be repeated experimentally. This is not of course altogether true, as Rhine’s experiments show and numerous other experiences with clairvoyant individuals. These facts prove that even in individual cases which have no common denominator and rank as “curiosities” there are certain regularities and therefore constant factors, from which we must conclude that our narrower conception of synchronicity is probably too narrow and really needs expanding. I incline in fact to the view that synchronicity in the narrow sense is only a particular instance of general acausal orderedness—that, namely, of the equivalence of psychic and physical processes where the observer is in the fortunate position of being able to recognize the *tertium comparationis*. But as soon as he perceives the archetypal background he is tempted to trace the mutual assimilation of independent psychic and physical processes back to a (causal) effect of the archetype, and thus to overlook the fact that they are merely contingent. This danger is avoided if one regards synchronicity as a special instance of general acausal orderedness. In this way we also avoid multiplying our principles of explanation illegitimately, for the archetype is the introspectively recognizable form of *a priori* psychic orderedness. If an

external synchronistic process now associates itself with it, it falls into the same basic pattern—in other words, it too is “ordered.” This form of orderedness differs from that of the properties of natural numbers or the discontinuities of physics in that the latter have existed from eternity and occur regularly, whereas the forms of psychic orderedness are *acts of creation in time*. That, incidentally, is precisely why I have stressed the element of time as being characteristic of these phenomena and called them *synchronistic*.

[966] The modern discovery of discontinuity (e.g., the orderedness of energy quanta, of radium decay, etc.) has put an end to the sovereign rule of causality and thus to the triad of principles. The territory lost by the latter belonged earlier to the sphere of correspondence and sympathy, concepts which reached their greatest development in Leibniz’s idea of pre-established harmony. Schopenhauer knew far too little about the empirical foundations of correspondence to realize how hopeless his causalistic attempt at explanation was. Today, thanks to the ESP experiments, we have a great deal of empirical material at our disposal. We can form some conception of its reliability when we learn from G. E. Hutchinson¹⁵ that the ESP experiments conducted by S. G. Soal and K. M. Goldney have a probability of 1 : 10³⁵, this being equivalent to the number of molecules in 250,000 tons of water. There are relatively few experiments in the field of the natural sciences whose results come anywhere near so high a degree of certainty. The exaggerated scepticism in regard to ESP is really without a shred of justification. The main reason for it is simply the ignorance which nowadays, unfortunately, seems to be the inevitable accompaniment of specialism and screens off the necessarily limited horizon of specialist studies from all higher and wider points of view in the most undesirable way. How often have we not found that the so-called “superstitions” contain a core of truth that is well worth knowing! It may well be that the originally magical significance of the word “wish,” which is still preserved in “wishing-rod” (divining rod, or magic wand) and expresses not just wishing in the sense of desire but a magical action,¹⁶ and the traditional belief in the efficacy of prayer, are both based on the experience of concomitant synchronistic phenomena.

[967] Synchronicity is no more baffling or mysterious than the discontinuities of physics. It is only the ingrained belief in the sovereign power of causality that creates intellectual difficulties and makes it appear unthinkable that causeless events exist or could ever occur. But if they do, then we must regard them as *creative acts*, as the continuous creation¹⁷ of a pattern that exists from all eternity, repeats itself sporadically, and is not derivable from any known antecedents. We must of course guard against thinking of every event whose cause is unknown as “causeless.” This, as I have already stressed, is admissible only when a cause is not even thinkable. But thinkability is itself an idea that needs the most rigorous criticism. Had the atom¹⁸

corresponded to the original philosophical conception of it, its fissionability would be unthinkable. But once it proves to be a measurable quantity, its non-fissionability becomes unthinkable. Meaningful coincidences are thinkable as pure chance. But the more they multiply and the greater and more exact the correspondence is, the more their probability sinks and their unthinkability increases, until they can no longer be regarded as pure chance but, for lack of a causal explanation, have to be thought of as meaningful arrangements. As I have already said, however, their “inexplicability” is not due to the fact that the cause is unknown, but to the fact that a cause is not even thinkable in intellectual terms. This is necessarily the case when space and time lose their meaning or have become relative, for under those circumstances a causality which presupposes space and time for its continuance can no longer be said to exist and becomes altogether unthinkable.

[968] For these reasons it seems to me necessary to introduce, alongside space, time, and causality, a category which not only enables us to understand synchronistic phenomena as a special class of natural events, but also takes the contingent partly as a universal factor existing from all eternity, and partly as the sum of countless individual acts of creation occurring in time.

APPENDIX

ON SYNCHRONICITY¹

[969] It might seem appropriate to begin my exposition by defining the concept with which it deals. But I would rather approach the subject the other way and first give you a brief description of the facts which the concept of synchronicity is intended to cover. As its etymology shows, this term has something to do with time or, to be more accurate, with a kind of simultaneity. Instead of simultaneity we could also use the concept of a *meaningful coincidence* of two or more events, where something other than the probability of chance is involved. A statistical—that is, a probable—concurrence of events, such as the “duplication of cases” found in hospitals, falls within the category of chance. Groupings of this kind can consist of any number of terms and still remain within the framework of the probable and rationally possible. Thus, for instance, someone chances to notice the number on his street-car ticket. On arriving home he receives a telephone call during which the same number is mentioned. In the evening he buys a theatre ticket that again has the same number. The three events form a chance grouping that, although not likely to occur often, nevertheless lies well within the framework of probability owing to the frequency of each of its terms. I would like to recount from my own experience the following chance grouping, made up of no fewer than six terms:

[970] On April 1, 1949, I made a note in the morning of an inscription containing a figure that was half man and half fish. There was fish for lunch. Somebody mentioned the custom of making an “April fish” of someone. In the afternoon, a former patient of mine, whom I had not seen for months, showed me some impressive pictures of fish. In the evening, I was shown a piece of embroidery with sea monsters and fishes in it. The next morning, I saw a former patient, who was visiting me for the first time in ten years. She had dreamed of a large fish the night before. A few months later, when I was using this series for a larger work and had just finished writing it down, I walked over to a spot by the lake in front of the house, where I had already been several times that morning. This time a fish a foot long lay on the sea-wall. Since no one else was present, I have no idea how the fish could have got there.

[971] When coincidences pile up in this way one cannot help being impressed by them—for the greater the number of terms in such a series, or the more unusual its

character, the more improbable it becomes. For reasons that I have mentioned elsewhere and will not discuss now, I assume that this was a chance grouping. It must be admitted, though, that it is more improbable than a mere duplication.

[972] In the abovementioned case of the street-car ticket, I said that the observer “chanced” to notice the number and retain it in his memory, which ordinarily he would never have done. This formed the basis for the series of chance events, but I do not know what caused him to notice the number. It seems to me that in judging such a series a factor of uncertainty enters in at this point and requires attention. I have observed something similar in other cases, without, however, being able to draw any reliable conclusions. But it is sometimes difficult to avoid the impression that there is a sort of foreknowledge of the coming series of events. This feeling becomes irresistible when, as so frequently happens, one thinks one is about to meet an old friend in the street, only to find to one’s disappointment that it is a stranger. On turning the next corner one then runs into him in person. Cases of this kind occur in every conceivable form and by no means infrequently, but after the first momentary astonishment they are as a rule quickly forgotten.

[973] Now, the more the foreseen details of an event pile up, the more definite is the impression of an existing foreknowledge, and the more improbable does chance become. I remember the story of a student friend whose father had promised him a trip to Spain if he passed his final examinations satisfactorily. My friend thereupon dreamed that he was walking through a Spanish city. The street led to a square, where there was a Gothic cathedral. He then turned right, around a corner, into another street. There he was met by an elegant carriage drawn by two cream-coloured horses. Then he woke up. He told us about the dream as we were sitting round a table drinking beer. Shortly afterward, having successfully passed his examinations, he went to Spain, and there, in one of the streets, he recognized the city of his dream. He found the square and the cathedral, which exactly corresponded to the dream-image. He wanted to go straight to the cathedral, but then remembered that in the dream he had turned right, at the corner, into another street. He was curious to find out whether his dream would be corroborated further. Hardly had he turned the corner when he saw in reality the carriage with the two cream-coloured horses.

[974] The *sentiment du déjà-vu* is based, as I have found in a number of cases, on a foreknowledge in dreams, but we saw that this foreknowledge can also occur in the waking state. In such cases mere chance becomes highly improbable because the coincidence is known in advance. It thus loses its chance character not only psychologically and subjectively, but objectively too, since the accumulation of details that coincide immeasurably increases the improbability of chance as a determining factor. (For correct precognitions of death, Dariex and Flammarion have

computed probabilities ranging from 1 in 4,000,000 to 1 in 8,000,000.)² So in these cases it would be incongruous to speak of “chance” happenings. It is rather a question of meaningful coincidences. Usually they are explained by precognition—in other words, foreknowledge. People also talk of clairvoyance, telepathy, etc., without, however, being able to explain what these faculties consist of or what means of transmission they use in order to render events distant in space and time accessible to our perception. All these ideas are mere names; they are not scientific concepts which could be taken as statements of principle, for no one has yet succeeded in constructing a causal bridge between the elements making up a meaningful coincidence.

[975] Great credit is due to J. B. Rhine for having established a reliable basis for work in the vast field of these phenomena by his experiments in extrasensory perception, or ESP. He used a pack of 25 cards divided into 5 groups of 5, each with its special sign (star, square, circle, cross, two wavy lines). The experiment was carried out as follows. In each series of experiments the pack is laid out 800 times, in such a way that the subject cannot see the cards. He is then asked to guess the cards as they are turned up. The probability of a correct answer is 1 in 5. The result, computed from very high figures, showed an average of 6.5 hits. The probability of a chance deviation of 1.5 amounts to only 1 in 250,000. Some individuals scored more than twice the probable number of hits. On one occasion all 25 cards were guessed correctly, which gives a probability of 1 in 298,023,223,876,953,125. The spatial distance between experimenter and subject was increased from a few yards to about 4,000 miles, with no effect on the result.

[976] A second type of experiment consisted in asking the subject to guess a series of cards that was still to be laid out in the near or more distant future. The time factor was increased from a few minutes to two weeks. The result of these experiments showed a probability of 1 in 400,000.

[977] In a third type of experiment, the subject had to try to influence the fall of mechanically thrown dice by wishing for a certain number. The results of this so-called psychokinetic (PK) experiment were the more positive the more dice were used at a time.

[978] The result of the spatial experiment proves with tolerable certainty that the psyche can, to some extent, eliminate the space factor. The time experiment proves that the time factor (at any rate, in the dimension of the future) can become psychically relative. The experiment with dice proves that moving bodies, too, can be influenced psychically—a result that could have been predicted from the psychic relativity of space and time.

[979] The energy postulate shows itself to be inapplicable to the Rhine experiments, and thus rules out all ideas about the transmission of force. Equally, the law of causality does not hold—a fact that I pointed out thirty years ago. For we cannot conceive how a future event could bring about an event in the present. Since for the time being there is no possibility whatever of a causal explanation, we must assume provisionally that improbable accidents of an acausal nature—that is, meaningful coincidences—have entered the picture.

[980] In considering these remarkable results we must take into account a fact discovered by Rhine, namely that in each series of experiments the first attempts yielded a better result than the later ones. The falling off in the number of hits scored was connected with the mood of the subject. An initial mood of faith and optimism makes for good results. Scepticism and resistance have the opposite effect, that is, they create an unfavourable disposition. As the energetic, and hence also the causal, approach to these experiments has shown itself to be inapplicable, it follows that the affective factor has the significance simply of a *condition* which makes it possible for the phenomenon to occur, though it need not. According to Rhine's results, we may nevertheless expect 6.5 hits instead of only 5. But it cannot be predicted in advance when the hit will come. Could we do so, we would be dealing with a law, and this would contradict the entire nature of the phenomenon. It has, as said, the improbable character of a "lucky hit" or accident that occurs with a more than merely probable frequency and is as a rule dependent on a certain state of affectivity.

[981] This observation has been thoroughly confirmed, and it suggests that the psychic factor which modifies or even eliminates the principles underlying the physicist's picture of the world is connected with the affective state of the subject. Although the phenomenology of the ESP and PK experiments could be considerably enriched by further experiments of the kind described above, deeper investigation of its bases will have to concern itself with the nature of the affectivity involved. I have therefore directed my attention to certain observations and experiences which, I can fairly say, have forced themselves upon me during the course of my long medical practice. They have to do with spontaneous, meaningful coincidences of so high a degree of improbability as to appear flatly unbelievable. I shall therefore describe to you only one case of this kind, simply to give an example characteristic of a whole category of phenomena. It makes no difference whether you refuse to believe this particular case or whether you dispose of it with an *ad hoc* explanation. I could tell you a great many such stories, which are in principle no more surprising or incredible than the irrefutable results arrived at by Rhine, and you would soon see that almost every case calls for its own explanation. But the causal explanation, the only possible one from the standpoint of natural science, breaks down owing to the psychic relativization of

space and time, which together form the indispensable premises for the cause-and-effect relationship.

[982] My example concerns a young woman patient who, in spite of efforts made on both sides, proved to be psychologically inaccessible. The difficulty lay in the fact that she always knew better about everything. Her excellent education had provided her with a weapon ideally suited to this purpose, namely a highly polished Cartesian rationalism with an impeccably “geometrical”³ idea of reality. After several fruitless attempts to sweeten her rationalism with a somewhat more human understanding, I had to confine myself to the hope that something unexpected and irrational would turn up, something that would burst the intellectual retort into which she had sealed herself. Well, I was sitting opposite her one day, with my back to the window, listening to her flow of rhetoric. She had had an impressive dream the night before, in which someone had given her a golden scarab—a costly piece of jewellery. While she was still telling me this dream, I heard something behind me gently tapping on the window. I turned round and saw that it was a fairly large flying insect that was knocking against the window-pane from outside in the obvious effort to get into the dark room. This seemed to me very strange. I opened the window immediately and caught the insect in the air as it flew in. It was a scarabaeid beetle, or common rose-chaffer (*Cetonia aurata*), whose gold-green colour most nearly resembles that of a golden scarab. I handed the beetle to my patient with the words, “Here is your scarab.” This experience punctured the desired hole in her rationalism and broke the ice of her intellectual resistance. The treatment could now be continued with satisfactory results.

[983] This story is meant only as a paradigm of the innumerable cases of meaningful coincidence that have been observed not only by me but by many others, and recorded in large collections. They include everything that goes by the name of clairvoyance, telepathy, etc., from Swedenborg’s well-attested vision of the great fire in Stockholm to the recent report by Air Marshal Sir Victor Goddard about the dream of an unknown officer, which predicted the subsequent accident to Goddard’s plane.⁴

[984] All the phenomena I have mentioned can be grouped under three categories:

1. The coincidence of a psychic state in the observer with a simultaneous, objective, external event that corresponds to the psychic state or content (e.g., the scarab), where there is no evidence of a causal connection between the psychic state and the external event, and where, considering the psychic relativity of space and time, such a connection is not even conceivable.

2. The coincidence of a psychic state with a corresponding (more or less simultaneous) external event taking place outside the observer’s field of perception, i.e., at a distance, and only verifiable afterward (e.g., the Stockholm fire).

3. The coincidence of a psychic state with a corresponding, not yet existent future event that is distant in time and can likewise only be verified afterward.

[985] In groups 2 and 3 the coinciding events are not yet present in the observer's field of perception, but have been anticipated in time in so far as they can only be verified afterward. For this reason I call such events *synchronistic*, which is not to be confused with *synchronous*.

[986] Our survey of this wide field of experience would be incomplete if we failed to take into account the so-called mantic methods. Manticism lays claim, if not actually to producing synchronistic events, then at least to making them serve its ends. An example of this is the oracle method of the *I Ching*, which Dr. Hellmut Wilhelm has described in detail.⁵ The *I Ching* presupposes that there is a synchronistic correspondence between the psychic state of the questioner and the answering hexagram. The hexagram is formed either by the random division of the 49 yarrow stalks or by the equally random throw of three coins. The result of this method is, incontestably, very interesting, but so far as I can see it does not provide any tool for an objective determination of the facts, that is to say a statistical evaluation, since the psychic state in question is much too indefinite and indefinable. The same holds true of the geomantic experiment, which is based on similar principles.

[987] We are in a somewhat more favourable situation when we turn to the astrological method, as it presupposes a meaningful coincidence of planetary aspects and positions with the character or the existing psychic state of the questioner. In the light of the most recent astrophysical research, astrological correspondence is probably not a matter of synchronicity but, very largely, of a causal relationship. As Professor Max Knoll has demonstrated,⁶ the solar proton radiation is influenced to such a degree by planetary conjunctions, oppositions, and quartile aspects that the appearance of magnetic storms can be predicted with a fair amount of probability. Relationships can be established between the curve of the earth's magnetic disturbances and the mortality rate that confirm the unfavourable influence of conjunctions, oppositions, and quartile aspects and the favourable influence of trine and sextile aspects. So it is probably a question here of a causal relationship, i.e., of a natural law that excludes synchronicity or restricts it. At the same time, the zodiacal qualification of the houses, which plays a large part in the horoscope, creates a complication in that the astrological zodiac, although agreeing with the calendar, does not coincide with the actual constellations themselves. These have shifted their positions by almost a whole platonic month as a result of the precession of the equinoxes since the time when the spring-point was in zero Aries, about the beginning of our era. Therefore, anyone born in Aries today (according to the calendar) is actually born in Pisces. It is simply that his birth took place at a time which, for approximately 2,000 years, has been

called "Aries." Astrology presupposes that this time has a determining quality. It is possible that this quality, like the disturbances in the earth's magnetic field, is connected with the seasonal fluctuations to which solar proton radiation is subject. It is therefore not beyond the realm of possibility that the zodiacal positions may also represent a causal factor.

[988] Although the psychological interpretation of horoscopes is still a very uncertain matter, there is nevertheless some prospect today of a causal explanation in conformity with natural law. Consequently, we are no longer justified in describing astrology as a mantic method. Astrology is in the process of becoming a science. But as there are still large areas of uncertainty, I decided some time ago to make a test and find out how far an accepted astrological tradition would stand up to statistical investigation. For this purpose it was necessary to select a definite and indisputable fact. My choice fell on marriage. Since antiquity, the traditional belief in regard to marriage has been that there is a conjunction of sun and moon in the horoscope of the marriage partners, that is, ☉ (sun) with an orbit of 8 degrees in the case of one partner, in ☌ (conjunction) with ☾ (moon) in the case of the other. A second, equally old, tradition takes (☾ ☌ ☾ as another marriage characteristic. Of like importance are the conjunctions of the ascendent (*Asc.*) with the large luminaries.

[989] Together with my co-worker, Mrs. Liliane Frey-Rohn, I first proceeded to collect 180 marriages, that is to say, 360 horoscopes,⁷ and compared the 50 most important aspects that might possibly be characteristic of marriage, namely the conjunctions and oppositions of ☉ ☾ ☌ (Mars) ♀ (Venus) *Asc.* and *Desc.* This resulted in a maximum of 10 per cent for ☉ ☌ ☾. As Professor Markus Fierz, of Basel, who kindly went to the trouble of computing the probability of my result, informed me, my figure has a probability of 1 : 10,000. The opinion of several mathematical physicists whom I consulted about the significance of this figure is divided: some find it considerable, others find it of questionable value. Our figure is inconclusive inasmuch as a total of 360 horoscopes is far too small from a statistical point of view.

[990] While the aspects of these 180 marriages were being worked out statistically, our collection was enlarged, and when we had collected 220 more marriages, this batch was subjected to separate investigation. As on the first occasion, the material was evaluated just as it came in. It was not selected from any special point of view and was drawn from the most varied sources. Evaluation of this second batch yielded a maximum figure of 10.9 per cent for ☾ ☌ ☾. The probability of this figure is also about 1 : 10,000.

[991] Finally, 83 more marriages arrived, and these in turn were investigated separately. The result was a maximum figure of 9.6 per cent for ☉ ☌ *Asc.* The probability of this figure is approximately 1 : 3,000.⁸

[992] One is immediately struck by the fact that the conjunctions are all *moon conjunctions*, which is in accord with astrological expectations. But the strange thing is that what has turned up here are the three basic positions of the horoscope, ☉ ♀ and Asc. The probability of a concurrence of ☉ ♂ ♀ and ♀ ♂ ♀ amounts to 1 : 100,000,000. The concurrence of the three moon conjunctions with ☉ ♀ Asc. has a probability of 1 : 3×10^{11} ; in other words, the improbability of its being due to mere chance is so enormous that we are forced to take into account the existence of some factor responsible for it. The three batches were so small that little or no theoretical significance can be attached to the individual probabilities of 1 : 10,000 and 1 : 3,000. Their concurrence, however, is so improbable that one cannot help assuming the existence of an impelling factor that produced this result.

[993] The possibility of there being a scientifically valid connection between astrological data and proton radiation cannot be held responsible for this, since the individual probabilities of 1 : 10,000 and 1 : 3,000 are too great for us to be able, with any degree of certainty, to view our result as other than mere chance. Besides, the maxima cancel each other out as soon as one divides up the marriages into a larger number of batches. It would require hundreds of thousands of marriage horoscopes to establish the statistical regularity of occurrences like the sun, moon, and ascendent conjunctions, and even then the result would be questionable. That anything so improbable as the turning up of the three classical moon conjunctions should occur at all, however, can only be explained either as the result of an intentional or unintentional fraud, or else as precisely such a meaningful coincidence, that is, as synchronicity.

[994] Although I was obliged to express doubt, earlier, about the mantic character of astrology, I am now forced as a result of my astrological experiment to recognize it again. The chance arrangement of the marriage horoscopes, which were simply piled on top of one another as they came in from the most diverse sources, and the equally fortuitous way they were divided into three unequal batches, suited the sanguine expectations of the research workers and produced an over-all picture that could scarcely have been improved upon from the standpoint of the astrological hypothesis. The success of the experiment is entirely in accord with Rhine's ESP results, which were also favorably affected by expectation, hope, and faith. However, there was no definite expectation of any one result. Our selection of 50 aspects is proof of this. After we got the result of the first batch, a slight expectation did exist that the ☉ ♂ ♀ would be confirmed. But we were disappointed. The second time, we made up a larger batch from the newly added horoscopes in order to increase the element of certainty. But the result was ♀ ♂ ♀. With the third batch, there was only a faint expectation that ♀ ♂ ♀ would be confirmed, but again this was not the case.

[995] What happened in this case was admittedly a curiosity, apparently a unique instance of meaningful coincidence. If one is impressed by such things, one could call it a minor miracle. Today, however, we are obliged to view the miraculous in a somewhat different light. The Rhine experiments have demonstrated that space and time, and hence causality, are factors that can be eliminated, with the result that acausal phenomena, otherwise called miracles, appear possible. All natural phenomena of this kind are unique and exceedingly curious combinations of chance, held together by the common meaning of their parts to form an unmistakable whole. Although meaningful coincidences are infinitely varied in their phenomenology, as acausal events they nevertheless form an element that is part of the scientific picture of the world. Causality is the way we explain the link between two successive events. Synchronicity designates the parallelism of time and meaning between psychic and psychophysical events, which scientific knowledge so far has been unable to reduce to a common principle. The term explains nothing, it simply formulates the occurrence of meaningful coincidences which, in themselves, are chance happenings, but are so improbable that we must assume them to be based on some kind of principle, or on some property of the empirical world. No reciprocal causal connection can be shown to obtain between parallel events, which is just what gives them their chance character. The only recognizable and demonstrable link between them is a common meaning, or equivalence. The old theory of correspondence was based on the experience of such connections—a theory that reached its culminating point and also its provisional end in Leibniz' idea of pre-established harmony, and was then replaced by causality. Synchronicity is a modern differentiation of the obsolete concept of correspondence, sympathy, and harmony. It is based not on philosophical assumptions but on empirical experience and experimentation.

[996] Synchronistic phenomena prove the simultaneous occurrence of meaningful equivalences in heterogeneous, causally unrelated processes; in other words, they prove that a content perceived by an observer can, at the same time, be represented by an outside event, without any causal connection. From this it follows either that the psyche cannot be localized in space, or that space is relative to the psyche. The same applies to the temporal determination of the psyche and the psychic relativity of time. I do not need to emphasize that the verification of these findings must have far-reaching consequences.

[997] In the short space of a lecture I cannot, unfortunately, do more than give a very cursory sketch of the vast problem of synchronicity. For those of you who would care to go into this question more deeply, I would mention that a more extensive work of mine is soon to appear under the title "Synchronicity: An Acausal Connecting Principle." It will be published together with a work by Professor W. Pauli in a book called *The Interpretation of Nature and the Psyche*.⁹

BIBLIOGRAPHY

BIBLIOGRAPHY

ABEGG, LILY. *The Mind of East Asia*. London and New York, 1952.

AEGIDIUS DE VADIS. "Dialogus inter naturam et filium philosophiae." See *Theatrum chemicum*, iv.

AGRIPPA VON NETTESHEIM, HEINRICH (HENRICUS) CORNELIUS. *De occulta philosophia libri tres*, Cologne, 1533. For translation, see: *Three Books of Occult Philosophy*. Translated by "J. F." London, 1651. Republished (Book I only) as: *The Occult Philosophy or Magic*. Edited by Willis F. Whitehead. Chicago, 1898.

ALBERTUS MAGNUS. *De mirabilibus mundi*. Incunabulum, undated, in the Zentralbibliothek, Zuzich. (There is an ed. printed at Cologne, 1485.)

ALVERDES, FRIEDRICH. "Die Wirksamkeit von Archetypen in den Instinkthandlungen der Tiere," *Zoologischer Anzeiger* (Leipzig), CXIX: 9/10 (1937), 225–36.

ANONYMOUS. *De triplici habitaculo*. See MIGNE, P.L., vol. 40, cols. 991–98.

ARTIS AURIFERAE quam chemiam vocant ... Basileae [Basel], [1593]. 2 vols.

Contents quoted in this volume:

VOLUME I

i Aurora consurgens, quae dicitur Aurea hora [pp. 185–246]

VOLUME II

ii Morienus Romanus: Sermo de transmutatione metallica [Liber de compositione Alchemiae] (pp. 7–54).

AUGUSTINE, SAINT. *Confessions*. Translated by Francis Joseph Sheed. London and New York, 1951.

_____. *Expositions on the Book of Psalms*. Translated by J. Tweed, T. Scratton, and others. (Library of the Fathers of the Holy Catholic Church.) Oxford, 1847–57. 6 vols.

"Aurora consurgens." See *Artis auriferae*, i.

BASTIAN, ADOLF. *Ethnische Elementargedanken in der Lehre vom Menschen*. Berlin, 1895. 2 parts.

BASTIAN, ADOLF. *Der Mensch in der Geschichte*. Leipzig, 1860. 3 vols.

BERGER, HANS. *Über die körperlichen Äusserungen psychischer Zustände*. Jena, 1904.

BINSWANGER, LUDWIG. "On the Psycho-galvanic Phenomenon in Association Experiments." In: JUNG, *Studies in Word-Association*, q.v. (pp. 446–530).

BLEULER, EUGEN. *Naturgeschichte der Seele und ihres Bewusstwerdens*. Berlin, 1921.

_____. *Die Psychoide als Prinzip der organischen Entwicklung*. Berlin, 1925.

BÖHME, JAKOB. *De signatura rerum*. Amsterdam, 1635. For translation, see: *The Signature of All Things*. Translated by John Ellistone, edited by Clifford Bax. (Everyman's Library.) London and New York, 1912.

BOLTZMANN, LUDWIG. *Populäre Schriften*. Leipzig, 1905.

- BROWN, G. SPENCER. "De la recherche psychique considérée comme un test de la théorie des probabilités," *Revue métapsychique* (Paris), no. 29–30 (May-Aug. 1954), 87–96.
- BUSEMANN, ADOLF. *Die Einheit der Psychologie*. Stuttgart, 1948.
- BUSSE, LUDWIG. *Geist und Körper, Seele und Leib*. Leipzig, 1903.
- BUTLER, SAMUEL. *Hudibras*. Edited by A. R. Waller. Cambridge, 1905.
- CARDAN, JEROME (Hieronymus Cardanus). *Commentaria in Ptolemaeum De astrorum judiciis*. In: *Opera omnia*. Lyons, 1663. 10 vols. (V, 93–368.)
- CARPENTER, WILLIAM B. *Principles of Mental Physiology*. London, 1874; 4th edn., 1876.
- CHAMBERLAIN, HOUSTON STEWART. *Goethe*. Munich, 1912.
- CODRINGTON, ROBERT HENRY. *The Melanesians*. Oxford, 189'.
- COOMARASWAMY, ANANDA K. "Rgveda 10.90.1 áty atisthad daśangulám," *Journal of American Oriental Society* (Boston, Mass.), LVI (1946), 145–61.
- CRAWLEY, ALFRED ERNEST. *The Idea of the Soul*. London, 1909.
- CUMONT, FRANZ. *Textes et monuments figures relatifs aux mystères de Mithra*. Brussels, 1894–99. 2 vols.
- DAHNS, FRITZ. "Das Schwärmen des Palolo," *Der Naturforscher* (Berlin), VIII (1932), 379–82.
- DALCQ, A. M. "La Morphogenèse dans la cadre de la biologie générale," *Verhandlungen der Schweizerischen naturforschenden Gesellschaft* (129th Annual Meeting at Lausanne; pub. at Aarau), 1949. 37–72.
- DARIEUX, XAVIER. "Le Hazard et la télépathie," *Annales des sciences psychiques* (Paris), I (1891), 295–304.
- DELATTE, LOUIS. *Textes latins et vieux français relatifs aux Cyranides*. (Bibliothèque de la faculté de philosophie et de lettres de l'Université de Liège, fasc. 93.) Liège and Paris, 1942.
- DESSOIR, MAX. *Geschichte der neueren deutschen Psychologie*. 2nd edn., Berlin, 1902. 2 vols.
- "De triplici habitaculo." See ANONYMOUS.
- DIETERICH, ALBRECHT. *Eine Mithrasliturgie*. Leipzig, 1903; 2nd edn., 1910.
- DILTHEY, WILHELM. *Gesammelte Schriften*. Leipzig, 1923–36. 12 vols.
- DORN, GERHARD. See *Theatrum chemicum*, i–iii.
- DREWS, A. C. H. *Plotin und der Untergang der antiken Weltanschauung*. Jena, 1907.
- DRIESCH, HANS. *Philosophie des Organischen*. Leipzig, 1909. 2 vols. 2nd edn., Leipzig, 1921. 1 vol. For translation, see: *The Science and Philosophy of the Organism*. 2nd edn., London, 1929.
- _____. *Die "Seele" als elementarer Naturfaktor*. Leipzig, 1903.
- DUNNE, JOHN WILLIAM. *An Experiment with Time*. London, 1927; 2nd edn., New York, 1938.
- ECKERMANN, J. P. *Conversations with Goethe*. Translated by R. O. Moon. London [1951].
- EISLER, ROBERT. *Weltenmantel und Himmelszelt*. Munich, 1910. 2 vols.
- ERMAN, ADOLF. *Life in Ancient Egypt*. Translated by H. M. Tirard. London, 1894.
- FECHNER, GUSTAV THEODOR. *Elemente der Psychophysik*. 2nd edn., Leipzig, 1889. 2 vols.

- FIERZ, MARKUS. "Zur physikalischen Erkenntnis," *Eranos-Jahrbuch 1948* (Zurich, 1949), 433–460.
- FLAMBART, PAUL. *Preuves et bases de l'astrologie scientifique*, Paris, 1921.
- FLAMMARION, CAMILLE. *The Unknown*. London and New York, 1900.
- FLOURNOY, THÉODORE. "Automatisme téléologique antisuicide," *Archives de psychologie de la Suisse romande* (Geneva), VII (1908), 113–37.
- _____. *From India to the Planet Mars*. Translated by D. B. Vermilye. New York and London, 1900. (Orig.: *Des Indes à la Planète Mars; Étude sur un cas de somnambulisme avec glossolalie*. Paris and Geneva, 3rd edn., 1900.)
- _____. "Nouvelles observations sur un cas de somnambulisme avec glossolalie," *Archives de psychologie de la Suisse romande* (Geneva), I (1901, pub. 1902), 102–255.
- FLUDD, ROBERT. [*De arte geomantica*.] "Animae intellectualis scientia seu De geomantia." In: *Fasciculus geomanticus, in quo varia variorum opera geomantica*. Verona, 1687.
- FRANZ, MARIE-LOUISE VON. "Die Parabel von der Fontina des Grafen von Tarvis." Unpublished.
- _____. "Die Passio Perpetuae." In: C. G. JUNG. *Aion*. Zurich, 1951.
- _____. "Der Traum des Descartes." In: *Zeitlose Dokumente der Seele*. (Studien aus dem C. G. Jung Institut, 3.) Zurich, 1952.
- FREUD, SIGMUND. *Introductory Lectures on Psycho-Analysis*. The Standard Edition of the Complete Psychological Works, 15, 16. Translated by James Strachey et al. London, 1963.
- _____. *The Psychopathology of Everyday Life*. Standard Edition, 6. London, 1960.
- _____. *Sammlung kleiner Schriften zur Neurosenlehre*. Vienna, 1906–22. 5 vols. (Mostly translated in: *Collected Papers of Sigmund Freud*, Vols. I-IV. London, 1924–25. In Standard Edition, scattered.)
- _____. "The Unconscious." *Papers on Metapsychology*. In: Standard Edition, 14. London, 1957. (Pp. 159–215.)
- FRISCH, KARL VON. *The Dancing Bees*. Translated by Dora Ilse. New York and London, 1954.
- FROBENIUS, LEO. *Das Zeitalter des Sonnengottes*. Berlin, 1904.
- FUNK, PHILIPP. *Ignatius von Loyola*. (Die Klassiker der Religion, 6.) Berlin, 1913.
- FÜRST, EMMA. "Statistical Investigations on Word-Associations and on Familial Agreement in Reaction Type among Uneducated Persons." In JUNG, *Studies in Word-Association*, q.v. (Pp. 407–45.)
- GATSCHET, ALBERT SAMUEL. "The Klamath Indians of South-Western Oregon." In: *Contributions to North American Ethnology*, Vol. II. (Miscellaneous Documents of the House of Representatives for the First Session of the 51st Congress, 1889–90; United States Department of the Interior, U.S. Geographical and Geological Survey of the Rocky Mountain Region, 44.) Washington, 1890–91. 2 vols.
- GEULINX, ARNOLD. *Opera philosophica*. Edited by J. P. N. Land. The Hague, 1891–99. 3 vols. (Vol. II: *Metaphysica vera*.)
- GOBLET D'ALMELLAS, EUGÈNE, COUNT. *The Migration of Symbols*. With an introduction by Sir G. Birdwood. Westminster, 1894.
- GOETHE, J. W. VON. *Faust, Part One*. Translated by Philip Wayne. Harmondsworth, 1949.

- GONZALES, LOYS (Ludovicus Gonsalvus). *The Testament of Ignatius Loyola, being Sundry Acts of our Father Ignatius, ... taken down from the Saint's own lips by Luis Gonzales*. Translated by E. M. Rix. London, 1900.
- GRANET, MARCEL. *La Pensée chinoise*. Paris, 1934.
- GRIMM, JACOB. *Teutonic Mythology*. Translated by J. S. Stallybrass. London, 1883–88. 4 vols.
- GROT, NICOLAS VON. “Die Begriffe der Seele und der psychischen Energie in der Psychologie,” *Archiv für systematische Philosophie* (Berlin), IV (1898), 257–335.
- GURNEY, EDMUND; MYERS, FREDERIC W. H.; and PODMORE, FRANK. *Phantasms of the Living*. London, 1886. 2 vols.
- HARDY, A. C. See: “The Scientific Evidence for Extra-Sensory Perception,” in Report of the British Association Meeting at Newcastle, 31 Aug.–7 Sept., 1949, *Discovery* (London), X (1949), 348.
- HARTMANN, CARL ROBERT EDUARD VON. *Philosophie des Unbewussten*. Leipzig, 1869. For translation, see: *Philosophy of the Unconscious*. (English and Foreign Philosophical Library, vols. 25–27.) Translated by W. C. Coupland. London, 1884. 3 vols.
- _____. *Die Weltanschauung der modernen Physik*. Leipzig, 1909.
- HERBERT OF CHERBURY, EDWARD, BARON. *De veritate* [originally published 1624]. Translated by Meyrick H. Carré. (University of Bristol Studies, 6.) Bristol, 1937.
- HETHERWICK, ALEXANDER. “Some Animistic Beliefs among the Yaos of Central Africa,” *Journal of the Royal Anthropological Institute* (London), XXXII (1902), 89–95.
- HIPPOCRATES (ascribed to). *De alimento*. In: *Hippocrates on Diet and Hygiene*. Translated by John Precope. London, 1952.
- HIPPOLYTUS. *Elenchos*. In: *Hippolytus' Werke*, Vol. III. Edited by Paul Wendland. (Griechische Christliche Schriftsteller.) Leipzig, 1916. For translation, see: *Philosophumena: or, The Refutation of All Heresies*. Translated by Francis Legge. (Translations of Christian Literature.) London and New York, 1921. 2 vols.
- HONORIUS OF AUTUN. *Speculum de Mysteriis Ecclesiae*. See MIGNE, P.L., vol. 172, cols. 313–1108.
- [HORAPOLLO NILIACUS.] *The Hieroglyphics of Horapollo*. Translated and edited by George Boas. (Bollingen Series XXIII.) New York, 1950.
- HUBERT; HENRI, and MAUSS, MARCEL. *Mélanges d'histoire des religions*. (Travaux de l'Année sociologique.) Paris, 1909.
- I Ching*. The German translation by Richard Wilhelm, rendered into English by Cary F. Baynes. New York (Bollingen Series XIX), 1950; London, 1951. 2 vols.; 2nd edn., 1 vol., 1961; 3rd edn., revised, Princeton and London, 1967.
- IGNATIUS OF ANTIOCH, SAINT. *Epistle to the Ephesians*. In: *The Apostolic Fathers*. Translated by Kirsopp Lake. (Loeb Classical Library.) London and New York, 1914. 2 vols. (Vol. I, pp. 173–97.)
- IRENAEUS, SAINT. *Contra [or Adversus] haereses libri quinque*. See MIGNE, P.G., vol. 7, cols. 433–1224. For translation, see: *The Writings of Irenaeus*. Translated by Alexander Roberts and W. H. Rambaut. Vol. I. (Ante-Nicene Christian Library, 5.) Edinburgh, 1868.

- ISIDORE OF SEVILLE, SAINT. *Liber etymologiarum*. See MIGNE, P.L., vol. 82, cols. 73–728.
- JAFFÉ, ANIELA. “Bilder und Symbole aus E. T. A. Hoffmanns Märchen 'Der Goldene Topf.'” In: C. G. JUNG. *Gestaltungen des Unbewussten*. Zurich, 1950.
- JAMES, WILLIAM. “Frederic Myers’ Service to Psychology,” *Proceedings of the Society for Psychical Research* (London), XVII (1901; pub. 1903), 13–23.
- _____. *Principles of Psychology*. New York, 1890. 2 vols.
- _____. *The Varieties of Religious Experience*. London, 1902.
- JANET, PIERRE. *L’Automatisme psychologique*. Paris, 1889.
- _____. *Les Névroses*. Paris, 1909.
- JANTZ, HUBERT, and BERINGER, KURT. “Das Syndrom des Schwebbeerlebnisses unmittelbar nach Kopfverletzungen,” *Der Nervenarzt* (Berlin), XVII (1944), 197–206.
- JEANS, JAMES. *Physics and Philosophy*. Cambridge, 1942.
- JERUSALEM, WILHELM. *Lehrbuch der Psychologie*. 3rd edn., Vienna and Leipzig, 1902.
- JORDAN, PASCUAL. “Positivistische Bemerkungen über die parapsychischen Erscheinungen,” *Zentralblatt für Psychotherapie* (Leipzig). IX (1936), 3–17.
- _____. *Verdrängung und Komplementarität*. Hamburg, 1947.
- JUNG, CARL GUSTAV. “The Aims of Psychotherapy.” In: *The Practice of Psychotherapy*. Collected Works,* 16.
- _____. *Alchemical Studies*. Collected Works, 13.
- _____. “The Association Method.” In: *Experimental Researches*, q.v.
- _____. *Collected Papers on Analytical Psychology*. Edited by Constance E. Long, translated by various hands. London and New York, 1916; 2nd edn., 1917.
- _____. Commentary on *The Secret of the Golden Flower*. In: *Alchemical Studies*, q.v.; see also WILHELM, RICHARD.
- _____. “The Concept of the Collective Unconscious.” In: *The Archetypes and the Collective Unconscious*, Collected Works, 9, i.
- JUNG, CARL GUSTAV. “Concerning Mandala Symbolism.” In: *ibid*.
- _____. *Experimental Researches*. Collected Works, 2.
- _____. *Mysterium Coniunctionis*. Collected Works, 14.
- _____. “On the Psychology of Eastern Meditation.” In: *Psychology and Religion: West and East*. Collected Works, 11.
- _____. “The Phenomenology of the Spirit in Fairy Tales.” In *The Archetypes and the Collective Unconscious*, Collected Works, 9, i.
- _____. “The Philosophical Tree.” In: *Alchemical Studies*, q.v.
- _____. “The Practical Use of Dream-Analysis.” In: *The Practice of Psychotherapy*. Collected Works, 16.
- _____. *Psychiatric Studies*. Collected Works, 1.
- _____. “A Psychological Approach to the Dogma of the Trinity.” In: *Psychology and Religion: West and East*. Collected Works, 11.

- _____. *Psychological Types*. Collected Works, 6.
- _____. *Psychology and Alchemy*. Collected Works, 12.
- _____. "The Psychology of Dementia Praecox." In: *Psychogenesis of Mental Disease*. Collected Works, 3.
- _____. "The Psychology of the Transference." In: *The Practice of Psychotherapy*. Collected Works, 16.
- _____. "Richard Wilhelm: In Memoriam." In: *The Spirit in Man, Art, and Literature*. Collected Works, 15.
- _____. "The Spirit Mercurius." In: *Alchemical Studies*, q.v.
- _____. "Studies in Word Association." Part I of *Experimental Researches*, q.v.
- _____. "A Study in the Process of Individuation." In: *The Archetypes and the Collective Unconscious*. Collected Works, 9, i.
- _____. *Symbols of Transformation*. Collected Works, 5.
- _____. "The Theory of Psychoanalysis." In: *Freud and Psychoanalysis*. Collected Works, 4.
- _____. *Two Essays on Analytical Psychology*. Collected Works, 7.
- _____. See also PETERSON; RICKSHER; WILHELM, RICHARD.
- _____ (ed.). *Studies in Word-Association ...* under the direction of C. G. Jung. Translated by M. D. Eder. London, 1918; New York, 1919. Contains works by Jung (now in *Experimental Researches*, q.v.) and others.
- _____ and KERÉNYI, C. *Essays on a Science of Mythology*. Translated by R. F. C. Hull. New York (Bollingen Series XXII), 1949; paperback edn., 1969. (British edn.: *Introduction to a Science of Mythology*. London, 1949.)

*
*
*
*
*
*

- KAMMERER, PAUL. *Das Gesetz der Serie*. Stuttgart and Berlin, 1919.
- KANT, IMMANUEL. *Werke*. Edited by Ernst Cassirer. Berlin, 1912–22. 11 vols. (*Anthropologie*, VIII, pp. 2–228; *Logik*, VIII, pp. 325–452; *Träume eines Geistersehers*, II, pp. 331–90.)
- _____. *Dreams of a Spirit-Seer, Illustrated by Dreams of Metaphysics*. Translated by Emanuel F. Goerwitz. London, 1900.
- _____. *Introduction to Logic*. Translated by Thomas Kingsmill Abbott. London, 1885.
- KATZ, DAVID. *Animals and Men*. Translated by Hannah Steinberg and Arthur Summerfield. London (Penguin Books), 1953.
- KEPLER, JOHANNES. *Gesammelte Werke*. Edited by Max Caspar and others. Munich, 1937ff. (Vol. IV: *Kleinere Schriften (1602–1611)*. Edited by Max Caspar and Franz Hammer. 1941.)
- [_____] *Joannis Kepleri astronomi Opera omnia*. Edited by C. Frisch. Frankfurt and Erlangen, 1858–71. 8 vols.
- KERNER VON MARILAUN, ANTON. *The Natural History of Plants*. Translated by F. W. Oliver and others. London, 1902. 2 vols.

- KHUNRATH, HEINRICH. *Amphitheatrum sapientiae aeternae solius verae*. Hanau, 1604.
- _____. *Von hylealischen ... Chaos*. Magdeburg, 1597.
- KLOECKLER, HERBERT VON. *Astrologie als Erfahrungswissenschaft*. Leipzig, 1927.
- KNOLL, MAX. "Transformations of Science in Our Age." In *Man and Time*, q.v.
- KOCH-GRÜNBERG, THEODOR. *Südamerikanische Felszeichnungen*. Berlin, 1907.
- KRAFFT, K. E.; BUDAI, E.; and FERRIÈRE, A. *Le Premier Traité d'astro-biologie*. Paris, 1939.
- KRÄMER, AUGUSTIN FRIEDRICH. *Über den Bau der Korallenriffe*. Kiel and Leipzig, 1897.
- KRONECKER, LEOPOLD. *Werke*. Leipzig, 1895–1930. 5 vols.
- KÜLPE, OSWALD. *Einleitung in die Philosophie*. 7th edn., Leipzig, 1915.
- _____. *Outlines of Psychology*. Translated by Edward Bradford Titchener. London and New York, 1895.
- LEHMANN, ALFRED. *Die körperlichen Äusserungen psychischer Zustände*. Translated (into German) by F. Bendixen. Leipzig, 1899–1905. 3 vols.
- LEHMANN, FRIEDRICH RUDOLF. *Mana, der Begriff des "ausserordentlich Wirkungsvollen" bei Südseevölkern*. Leipzig, 1922.
- LEIBNIZ, GOTTFRIED WILHELM. *Kleinere philosophische Schriften*. Edited by R. Habs. Leipzig, 1883. 3 vols.
- _____. *Philosophical Writings*. Selected and translated by Mary Morris. (Everyman's Library.) London and New York, 1934. (*Monadology*, pp. 3–20; *Principles of Nature and of Grace, founded on Reason*, pp. 21–31.)
- [_____] *The Philosophical Works of Leibniz; a Selection*. Translated by G. M. Duncan. New Haven, 1890.
- _____. *Theodicy*. Translated by E. M. Huggard. Edited by Austin Farrer. London, 1951 [1952].
- LÉVY-BRUHL, LUCIEN. *How Natives Think*. Translated by Lilian A. Clare. London, 1926. (Orig.: *Les Fonctions mentales dans les sociétés inférieures*. Paris, 1912.)
- LEWES, GEORGE HENRY. *Problems of Life and Mind*. London, 1874 [1873]–79. 5 vols. (Vol. II, *The Physical Basis of Mind*, 1877.)
- "Liber de compositione Alchemiae." See *Artis auriferae*, ii.
- LIPPS, THEODOR. "Der Begriff des Unbewussten." In: [*Report of*] *Third International Congress for Psychology*, Munich, 4–7 August 1896. Munich, 1897.
- _____. *Grundtatsachen des Seelenlebens*. Bonn, 1912.
- _____. *Leitfaden der Psychologie*. Leipzig, 1903; 2nd edn., 1906.
- LOVEJOY, ARTHUR O. "The Fundamental Concept of the Primitive Philosophy," *The Monist* (Chicago), XVI (1906), 357–82.
- LUMHOLTZ, CARL. *Unknown Mexico*. London, 1903.
- MCCONNELL, ROBERT A. "E.S.P.—Fact or Fancy?" *Scientific Monthly* (Lancaster, Pennsylvania), LXIX: 2 (1949), 121–25.
- MACDONELL, A. A. *A Practical Sanskrit Dictionary*. London, 1924.

MCGEE, W. J. "The Siouan Indians—A Preliminary Sketch." In: *Fifteenth Report of the U.S. Bureau of Ethnology for 1893–94*. Washington, 1897. (Pp. 153–204.)

MACNICOL, NICOL (ed.). *Hindu Scriptures*. (Everyman's Library.) London and New York, 1938.

MAEDER, ALPHONSE. *Heilung und Entwicklung im Seelenleben*. Zurich, 1918.

_____. "Régulation psychique et guérison," *Archives suisses de neurologie et de psychiatrie* (Zurich), XVI (1925), 198–224.

_____. "Sur le mouvement psychanalytique: un point de vue nouveau en psychologie," *L'Année psychologique* (Paris), XVIII (1912), 389–418.

_____. "Über die Funktion des Traumes," *Jahrbuch für psychoanalytische und psychopathologische Forschungen* (Leipzig and Vienna), IV (1912), 692–707.

_____. *The Dream Problem*. Translated by Frank Mead Hallack and Smith Ely Jelliffe. (Nervous and Mental Disease Monograph Series, 20.) New York, 1916. (Orig.: "Über das Traumproblem," *Jahrbuch für psychoanalytische und psychopathologische Forschungen* (Leipzig and Vienna), V (1913), 647–86.)

Man and Time. (Papers from the Eranos Yearbooks, 3.) Translated by Ralph Manheim and R. F. C. Hull. New York (Bollingen Series XXX) and London, 1957.

MANGET, JOANNES JACOBUS (ed.). *Bibliotheca chemica curiosa*. Geneva, 1702. 2 vols.

MANNHARDT, WILHELM. *Wald- und Feldkulte*. 2nd edn., Berlin, 1904–5. 2 vols.

MARAIS, EUGÈNE NIELEN. *The Soul of the White Ant*. Translated (from the Afrikaans) by Winifred de Kok. London, 1937.

MARSILIO FICINO. *Auctores platonici*. Venice, 1497.

MEIER, CARL ALFRED. *Ancient Incubation and Modern Psychotherapy*. Translated by Monica Curtis et al. Evanston, Ill., 1968.

_____. "Moderne Physik—Moderne Psychologie" In: *Die kulturelle Bedeutung der komplexen Psychologie*. (Festschrift zum 60. Geburtstag von C. G. Jung.) Berlin, 1935.

_____. "Spontanmanifestationen des kollektiven Unbewussten," *Zentralblatt für Psychotherapie* (Leipzig), XI (1939), 284–303.

_____. *Zeitgemässe Probleme der Traumforschung*. (Eidgenössische Technische Hochschule: Kultur- und Staatswissenschaftliche Schriften, 75.) Zurich, 1950.

MERINGER, R. "Wörter und Sachen," *Indogermanische Forschungen* (Strassburg), XVI (1904), 101–196.

MIGNE, JACQUES PAUL (ed.). *Patrologiae cursus completus*.

[P.L.] Latin series. Paris, 1844–64. 221 vols.

[P.G.] Greek series. Paris, 1857–66. 166 vols.

[These works are cited as "MIGNE, P.L." and "MIGNE, P.G." respectively. References are to columns, not to pages.]

MORGAN, CONWAY LLOYD. *Habit and Instinct*. London, 1896.

- MURCHISON, C. (ed.). *Psychologies of 1930*. (International University Series in Psychology.) Worcester, Mass., 1930.
- MYERS, FREDERIC W. H. "The Subliminal Consciousness," *Proceedings of the Society for Psychical Research* (London), VII (1892), 298–355.
- MYLIUS, JOHANN DANIEL. *Philosophia reformata*. Frankfurt, 1622.
- NELKEN, JAN. "Analytische Beobachtungen über Phantasien eines Schizophrenen," *Jahrbuch für psychoanalytische und psychopathologische Forschungen* (Leipzig), IV (1912), 504–62.
- NIETZSCHE, FRIEDRICH WILHELM. *Thus Spake Zarathustra*. Translated by Thomas Common, revised by Oscar Levy and John L. Beevers. London, 1932.
- NUNBERG, H. "On the Physical Accompaniments of Association Processes." In: *Studies in Word-Association ...* under the direction of C. G. Jung. Translated by M. D. Eder. London, 1918; New York, 1919. (Pp. 531–60.)
- ORANDUS, EIRENAEUS. *Nicholas Flammel: His Exposition of the Hieroglyphicall Figures, etc.* London, 1624.
- ORIGEN. *De principiis*. See MIGNE, P.G., vol. 11, cols. 115–414. For translation, see: *On First Principles*. Translated by G. W. Butterworth. London, 1936.
- _____. *In Jeremiam homiliae*. See MIGNE, P.G., vol. 13, cols. 255–544.
- OSTWALD, (FRIEDRICH) WILHELM. *Die Philosophie der Werte*. Leipzig, 1913.
- PARACELUS (Theophrastus Bombastes of Hohenheim). *Das Buch Paragranum*. Edited by Franz Strunz. Leipzig, 1903.
- _____. *De vita longa*. Edited by Adam von Bodenstein. Basel, 1562.
- _____. *Sämtliche Werke*. Edited by Karl Sudhoff and Wilhelm Matthiessen. Munich and Berlin, 1922–35. 15 vols.
- _____. *Erster [–Zehender] Theil der Bücher und Schrifften ... Philippi Theophrasti Bombast von Hohenheim, Paracelsi genannt*. Edited by Johannes Huser. Basel, 1589–91. 10 vols.
- PAULI, W. "The Influence of Archetypal Ideas on the Scientific Theories of Kepler." Translated by Priscilla Silz. In: *The Interpretation of Nature and the Psyche*. New York (Bollingen Series LI) and London, 1955.
- PAULUS, JEAN. *Le Problème de l'hallucination et l'évolution de la psychologie d'Esquirol à Pierre Janet*. (Bibliothèque de la Faculté de Philosophie et de Lettres de l'Université de Liège, fasc. 91.) Liège and Paris, 1941.
- PECHUËL-LOESCHE, EDUARD. *Volkskunde von Loango*. Stuttgart, 1907.
- PETERSON, FREDERICK, and JUNG, C. G. "Psychophysical Investigations with the Galvanometer and Pneumograph in Normal and Insane Individuals," *Brain* (London), XXX (1907), 153–218. Also in JUNG, *Experimental Researches*, q.v.
- PHILO JUDAEUS. *De opificio mundi*. In: [Works]. Translated by F. H. Colson and G. H. Whitaker. (Loeb Classical Library.) New York and London, 1929–. 12 vols. [I, 2–137.]
- PICAVET, FRANÇOIS. *Essais sur l'histoire générale et comparée des théologies et des philosophies médiévales*. Paris, 1913.
- PICO DELLA MIRANDOLA. *Opera omnia*. Basel, 1557.

- PITRA, JEAN BAPTISTE. *Analecta sacra et classica Spicilegio Solesmensi parata*. Paris and Rome, 1876–91. 8 vols.
- PLOTINUS. *The Enneads*. Translated by Stephen Mackenna. 2nd edn., revised by B. S. Page. London, 1956.
- PRATT, J. G.; RHINE, J. B.; STUART, C. E.; SMITH, B. M.; and GREENWOOD, J. A. *Extra-Sensory Perception after Sixty Years*. New York, 1940.
- PREUSS, K. T. “Der Ursprung der Religion und Kunst,” *Globus* (Brunswick), LXXXVI (1904), 321–92 passim; LXXXVII (1905), 333–419 passim.
- PROSPER OF AQUITAINE. *Sententiae ex Augustino delibatae*. See MIGNE, P.L., vol. 51, cols. 427–496.
- PTOLEMAEUS (Ptolemy). See CARDAN, JEROME.
- REID, THOMAS. *Essays on the Active Powers of Man*. Edinburgh, 1788.
- RHINE, J. B. *Extra-Sensory Perception*. Boston, 1934.
- _____. “An Introduction to the Work of Extra-Sensory Perception,” *Transactions of the New York Academy of Sciences* (New York), Ser. II, XII (1950), 164–68.
- _____. *New Frontiers of the Mind*. New York and London, 1937.
- _____. *The Reach of the Mind*. London, 1948. Reprinted Harmondsworth (Penguin Books), 1954.
- _____ and HUMPHREY, BETTY M. “A Transoceanic ESP Experiment,” *Journal of Parapsychology* (Durham, North Carolina), VI (1942), 52–74.
- RICHET, CHARLES. “Relations de diverses expériences sur transmission mentale, la lucidité, et autres phénomènes non explicable par les données scientifiques actuelles,” *Proceedings of the Society for Psychical Research* (London), V (1888), 18–168.
- RICKSHER, C, and JUNG, C. G. “Further Investigations on the Galvanic Phenomenon,” *Journal of Abnormal and Social Psychology* (Albany, N. Y.), II (1907), 189–217. Also in JUNG, *Experimental Researches*, q.v.
- RIPLEY, SIR GEORGE. *Opera omnia chemica*. Cassel, 1649.
- RIVERS, W. H. R. “Instinct and the Unconscious,” *British Journal of Psychology* (Cambridge), X (1919–20), 1–7.
- RÖHR, J. “Das Wesen des Mana,” *Anthropos* (Salzburg), XIV–XV (1919–20), 97–124.
- ROSENBERG, ALFONS. *Zeichen am Himmel: Das Weltbild der Astrologie*. Zurich, 1949.
- ROSENCREUTZ, CHRISTIAN. *Chymische Hochzeit*. Strasbourg, 1616.
- Saint-Graal*. Edited by Eugène Hucher. Le Mans, 1878. 3 vols.
- SCHILLER, FRIEDRICH. *On the Aesthetic Education of Man*. Translated by Reginald Snell. London, 1954.
- _____. “The Cranes of Ibycus.” In: *The Poems*. Translated by E. P. Arnold-Forster. London, 1901. (Pp. 158–63.)
- SCHMIEDLER, G. R. “Personality Correlates of ESP as Shown by Rorschach Studies,” *Journal of Parapsychology* (Durham, North Carolina), XIII (1949), 23–31.
- SCHOLZ, WILHELM VON. *Der Zufall: eine Vorform des Schicksals*. Stuttgart, 1924.
- SCHOPENHAUER, ARTHUR. *Parerga und Paralipomena*. Edited by R. von Koeber. Berlin, 1891. 2 vols.
- _____. *Transcendent Speculations on the Apparent Design in the Fate of the Individual*. Translated by David Irvine. London, 1913.

- SCHULTZE, FRITZ. *Psychologie der Naturvölker*. Leipzig, 1900; another edn., 1925.
- SELIGMANN, CHARLES GABRIEL. *The Melanesians of British New Guinea*. Cambridge, 1910.
- SIEBECK, HERMANN. *Geschichte der Psychologie*. Gotha, 1880–84. 2 parts.
- SILBERER, HERBERT. *Problems of Mysticism and Its Symbolism*. Translated by Smith Ely Jelliffe. New York, 1917.
- _____. “Über die Symbolbildung,” *Jahrbuch für psychoanalytische und psychopathologische Forschungen* (Vienna and Leipzig), III (1911), 661–723; IV (1912), 607–83.
- _____. *Der Zufall und die Koboldstreiche des Unbewussten*. (Schriften zur Seelenkunde und Erziehungskunst, 3.) Bern and Leipzig, 1921.
- SOAL, S. G. “Science and Telepathy,” *Enquiry* (London), 1:2 (1948), 5–7.
- _____. “The Scientific Evidence for Extra-Sensory Perception,” *Discovery* (London), X (1949), 373–77.
- ____ and BATEMAN, F. *Modern Experiments in Telepathy*. London, 1954.
- SÖDERBLOM, NATHAN. *Das Werden des Gottesglaubens*. Leipzig, 1926.
- SPEISER, ANDREAS. *Über die Freiheit*. (Basler Universitätsreden, 28.) Basel, 1950.
- SPENCER, BALDWIN, and GILLEN, F. J. *The Northern Tribes of Central Australia*. London, 1904.
- SPIELREIN, S. “Über den psychologischen Inhalt eines Falles von Schizophrenie,” *Jahrbuch für psychoanalytische und psychopathologische Forschungen* (Vienna and Leipzig), III (1911), 329–400.
- SPINOZA, BENEDICT. *Ethics*. Translated by Andrew Boyle. (Everyman’s Library.) London and New York, 1934.
- Spirit and Nature*. (Papers from the Eranos Yearbooks, 1.) Translated by Ralph Manheim and R. F. C. Hull. New York (Bollingen Series XXX), 1954; London, 1955.
- STEKEL, WILHELM. “Die Verpflichtung des Namens,” *Zeitschrift für Psychotherapie und medizinische Psychologie* (Stuttgart), III (1911), 110ff.
- STERN, L. WILLIAM. *Über Psychologie der individuellen Differenzen*. (Schriften der Gesellschaft für psychologische Forschung, 12.) Leipzig, 1900.
- SYNESIUS. *Opuscula*. Edited by Nicolaus Terzaghi. (Scriptores Graeci et Latini.) Rome, 1949.
- SZONDI, LIPOT. *Experimentelle Triebdiagnostik*. Bonn, 1947–49. 2 vols.
- _____. *Triebpathologie*. Bern, 1952.
- Tao Teh Ching*. See WALEY.
- THEATRUM CHEMICUM*. Ursel and Strasbourg, 1602–61. 6 vols. (Vols. 1–3, Ursel, 1602; etc.)

Contents quoted in this volume:

VOLUME I

- i Dorn: Speculativae philosophiae [pp. 255–310]
- ii Dorn: Philosophia meditativa [pp. 450–72]
- iii Dorn: De tenebris contra naturam et vita brevi [pp. 518–35]

VOLUME II

- iv Aegidius de Vadis: Dialogus inter naturam et filium philosophiae [pp. 95–123]

- THORNDIKE, LYNN. *A History of Magic and Experimental Science*. New York, 1929–41. 6 vols.
- TYLOR, EDWARD B. *Primitive Culture*. 3rd edn., London, 1891. 2 vols.
- TYRRELL, G. N. M. *The Personality of Man*. London, 1947.
- VERAGUTH, OTTO. *Das psycho-galvanische Reflexphänomen*. Berlin, 1909.
- VILLA, GUIDO. *Einleitung in die Psychologie der Gegenwart*. (Translated from Italian.) Leipzig, 1902.
- VIRGIL. [Works], Translated by H. Rushton Fairclough. (Loeb Classical Library.) London and New York, 1929. 2 vols.
- VISCHER, FRIEDRICH THEODOR. *Auch Einer*. Stuttgart and Leipzig, 1884. 2 vols.
- WALEY, ARTHUR (trans.). *The Way and Its Power*. London, 1934.
- WARNECKE, J. *Die Religion der Batak*. Leipzig, 1909.
- [WEI PO-YANG.] “An Ancient Chinese Treatise on Alchemy entitled Ts’an T’ung Ch’i” (translated by Lu-chiang Wu), *Isis* (Bruges), XVIII (1932), 210–89.
- WEYL, HERMANN. “Wissenschaft als symbolische Konstruktion des Menschen,” *Eranos-Jahrbuch 1948* (Zurich, 1949), 375–439.
- WHITE, STEWART EDWARD. *The Road I Know*. New York, 1942; London, 1951.
- _____. *The Unobstructed Universe*. New York, 1940; London, 1949.
- WILHELM, HELLMUT. “The Concept of Time in the Book of Changes.” In *Man and Time*, q.v.
- WILHELM, RICHARD. *Chinesische Lebensweisheit*. Darmstadt, 1922.
- _____. (trans.). *The Secret of the Golden Flower*. With a commentary and a memorial by C. G. Jung. London and New York, 1931; 2nd edn., revised, 1962. Jung’s commentary in his *Alchemical Studies*, q.v.
- _____. *Das wahre Buch vom südlichen Blütenland*. Jena, 1912.
- _____. See also *I Ching*.
- WOLF, CHRISTIAN VON. *Psychologia empirica*. Frankfurt and Leipzig, 1732.
- _____. *Vernünfftige Gedanken von Gott, der Welt, und der Seele des Menschen*. 1719.
- WUNDT, WILHELM. *Grundzüge der physiologischen Psychologie*. 5th edn., Leipzig, 1902–3. 3 vols.
- _____. *Outlines of Psychology*. Translated by Charles Hubbard Judd. Leipzig, 1902.
- _____. *Völkerpsychologie*. Leipzig, 1911–23. 10 vols.
- ZELLER, EDUARD. *Die Philosophie der Griechen in ihrer geschichtlichen Entwicklung dargestellt*. Tübingen, 1856. 3 vols.

INDEX

INDEX

A

abaissement du niveau mental, 77, 235, 436, 446, 480

Abegg, Lily, 489n

Abelard, Pierre, 5n, 196

abstraction, 5

acausal events, *see* events

actions: instinctive, 130

 symptomatic, 34, 77

 volitional, 172

activity: drive to, 117, 118

 psychic, waking and sleeping, 306

Acts of the Apostles, 315

Adam, 293

 old, 393

adaptation, 23, 34ff

 and direction, 35

 harmonious, 39

 need of continuous, 73

 to outer world, 392

 psychological, libido and, 32

 stages towards achievement, 32

adhista, 154, 209

Adler, Alfred, 10n, 24, 50, 258, 263n

adiposity, 398

adolescents, eternal, 399

adult state, induction into, 374

Aegidius de Vadis, 494

aeroplanes, dream-motif, 283

Aesculapius, 289

Aesop, 239

affect(s): archetypes and, 436

and attitude, 330ff

displacement of, 10

disproportionate, 130

dulling of, 26

enrichment of, 82

impulsive, 131

personified, 329f

and synchronicity, 448f

tends to become autonomous complex, 330

value-estimation of, 14

violent, 313

affectivity: and ESP experiments, 524

and the instincts, 440

in unconscious, 172

affinity, elective, 431

Africa, 233

East, 407

afternoon of life, 399f; *see also* second half of life

age: dignity of, 400

physiological and psychological, 119; *see also* old, the; old age

ageing, the: and contraction of life, 399

and preparation for death, 410; *see also* old, the; old age

“aghast,” 329

agriculture: libido and, 43

origin of, 43

Agrippa von Nettesheim, Henricus Cornelius, 195, 492f, 495

aiolos, 345

air, *moving*, and soul, 345

Albertus Magnus, 196, 448f

alchemy, 46f, 190ff, 485, 495

micro-cosmos in, 492

and three/four, 513

transformation in, 293

alertness, [359](#)
Algonquins, [61](#)
alienation, [311](#)
“all-or-none reaction,” [129f](#), [131](#), [135](#), [137](#), [181](#), [187](#)
allurements, divine, [493](#)
“also-I,” [393](#)
Alverdes, Friedrich, [138n](#)
ambition, inordinate, [116](#)
Amboina, [437n](#)
Amenophis IV, [49](#)
America; death of friend in, [443](#); *see also* United States
amoeba, [152](#)
amplification, of archetypes, [205](#)
anaemia, cerebral, [509](#)
analogy(-ies), [147](#)
 magic by, [149](#)
analysis: beginning of, [259](#)
 not a “cure,” [72](#), [73](#)
 as “quickened maturation,” [290](#)
 self-, [411](#)
 unwillingness to terminate, [71](#); *see also* statistical analysis
analyst: and dream-interpretation, [259](#)
 need of analysis in, [259](#)
 relation to patient, [74](#), [269](#)
analytical psychology, [137](#), [279](#), [363ff](#), [376f](#)
anatomy, [357](#), [371](#)
ancestors, psychic inheritance from, [349](#), [371](#)
ancestor-worship, [304](#)
andriamanitra, [64](#)
angels, fall of the, [157](#)
anger, [241](#)
angle of vision, alteration of, [509](#)
ant, [64](#)
anima/animus, etymology, [345](#)

anima catholica, 190

anima mundi, 495; *see also* world-soul

anima telluris, 496

animal(s); frightening, dream-motif, 283

helpful, 293

instincts in, 134

psychic processes in, 189

sensus naturae in, 196

spatial orientation of, 437

animal-man, 293

animus, 439, 503*n*; *see also* anima/animus

ant(s), 476, 478

leaf-cutting, 201

Anthroparion, 503*n*

Anthropos, 199

anthroposophy, 49, 379

anticipations, 410

antinomian postulate, 23

antithesis, spirit/instinct, 207*f*

anut, 64

anxiety states, 131, 313, 334

aperiodic groupings, 424

apes, 341

aphorisms, 331

Apocalypse, *see* Revelation, Book of apostles, at Pentecost, 315

apparitions, *see* ghosts

apperception, 140, 500

directed and undirected, 142

in unconscious, 172

appetition, 500

apple, 241*f*, 248, 388

apprehension: archetypes of, 133

conscious and unconscious, 137

and impulse to act, 138

total, 168

April fish, *see* fish

Aquarium sapientum, 514

Aratus, 197

arcane substance/arcanum, 190ff, 495

archetype(s), 112, 122, 133ff, 155, 158, 165f, 190ff, 294, 373ff, 436, *et passim*

and acausal orderedness, 516

discovered and invented, 457

in dreams, 291

as dynamism, 211

feeling-value of, 209

first use of term, 133n

hierarchy of, 495

not an “inborn idea,” 226

are indefinite, 515

and instinct, 133ff, 157, 206

instinct’s perception of itself, 136

instinctual and archetypal, 218

many or few, 135

as models, 135

nature of, 213

not merely negative, 312n

numinous character of, 205f, 209, 312

as organizers, 231

preconscious, 210

not certainly/exclusively/merely psychic, 215, 230, 515

and religion, 221

scintillae and, 191

as spirit, 205f, 216

spontaneous amplification of, 205

and synchronicity, 437ff, 481

typical modes of apprehension, 137; *see also* apprehension; family; mother; self;
wise old man

Argus, 197

Aries, 527f

Aristotelian Society, 344
Aristotle, 30, 341, 496
army, and psyche, compared, 359
arrangement(s), 277
 meaningful, 519
 of psychic process, 449
 unconscious, 431
Ars Geomantica, 453
art: contemporary, 85
 as end in itself, 377
 works of, 365
Artis auriferae, 190n, 196n
arunquiltha, 63
Arunta, 44
ascendent, 454, 455n, 461ff, 528
ascension experiences, 507
“as if,” 368
aspects, astrological, 454, 455n
 and marriage, 461ff
 and mortality rate, 527
 and radio weather, 460
assimilation: of complexes, 93, 98ff
 of unconscious contents, 224
association, free, 82, 86, 240
association experiments/tests, 93, 95, 121, 143, 173, 423
 method of, 312
associations: concordance of, 111, 262
 meaning of, 75
 and recovery of lost contents of consciousness, 179
assumptions, false, and problems, 392
Astarte, 156
astrology, 152, 195, 205n, 429, 453ff, 485, 502, 527f
 mantic character of, 530
 possible causal laws, 460

Astronomia, [193](#)
astrophysics, [527](#)
astrum, *see* star
Atninga ceremony, [44](#)
atom(s), [137](#), [214](#), [518](#)
 break-up of, [340](#)
atom-bomb, [218](#), [220f](#), [222](#)
atomic fission, [217](#), [518](#)
attainable, restriction to the, [394](#)
attention, [142](#), [359](#)
attitude(s): and affect, [330f](#)
 alteration of national, [314](#)
 breakdown of previous, [314](#)
 collective, [72](#)
 conscious, [259](#)
 —, badly adapted, [256](#)
 —, and dreams, [288](#)
 of consciousness, and death, [411](#)
 effects of, [330f](#)
 expressed as spirit, [330](#)
 function and, [124](#)
 ideal, and repression, [311](#)
 meaning of, [358f](#)
 moral, and neurosis, [356](#)
 negative, [392](#)
 personal, [395](#)
 post-analytic, becomes inadequate, [73](#)
 and progression of libido, [32](#)
 psychic suffering and, [355](#)
 rationalistic, of the West, [485](#)
 theories and, [366](#)
 unconscious, [362](#)
 to the world, [358](#)
 youthful, [395](#)

attraction, [425](#)
 of related objects, [431](#)
atua, [64](#)
auguries, [442n](#)
Augustine, St., [135](#), [245](#), [518n](#)
Aurora consurgens, [190](#)
Australian aborigines, [62](#), [137n](#), [301](#); see also *churinga*
autoeroticism, [226](#)
automata, reflex, insects as, [510](#)
automatism(s), [13](#), [186](#), [187](#)
automatisme ambulatoire, [186](#)
automobiles, dream-motif, [283](#)
autonomy, of images and object, [274](#)
Avicenna, [448](#)
ayik, [65n](#)
Azoth, [191n](#)

B

ba, [439](#)
baboon, dog-headed, [209](#)
Bacon, Francis, [136](#)
badi, [63](#)
bankruptcy, fraudulent, [144](#)
baptism, [156](#)
bariaua, [64n](#)
Bastian, Adolf, [165](#)
Bataks, [64](#), [315](#)
Bateman, F., [432n](#)
beaver, [42](#)
bed, bridal, in field, [43](#)
Bedford College, London, [344](#)
bees, [510](#)
beetle, scarabaeid, [438f](#), [525f](#)
behaviour: causality and, [22](#)
 and instinct, [135](#)

pattern(s) of, 201, 205, 278n, 436, 494n
—, inborn, 165

being, unitary idea of, 512

belief, 408
difficulty of, 401

belly, as seat of psyche, 347

Berger, Hans, 14n

Bergson, Henri, 30, 132, 137

Bernard of Treviso, 514

bewitchment, 368
of cattle, 302

Bible, *see names of individual books*

bile, 364

binarius, 514

Binswanger, Ludwig, 14n

biochemical processes, psyche and, 344

biology: causality in, 423
energetic standpoint and, 16
and the psyche, 114ff
and the “unique,” 422

bird(s), 293, 294
flock seen at death, 438f, 442, 445, 447
as redeemer figure, 111; *see also* weaver-bird

birth, 345
psychic, 391

Bleuler, Eugen, 176f, 188n

blindness: peripheral, 143
psychogenic, 308

blockage: dreams and, 365
of unconscious, 364

blue (colour), representing spirit, 211

body: correspondence with psychic organism, 152
living, concept of, 320f
inner/subtle/breath-, 194

and mind, duality, [321](#)
—, two aspects of single fact, [326](#)
and psyche, co-functioning, [261](#), [321](#), [342](#)
separation of consciousness from, [509](#)

body markings, [374](#)

body-soul problem, [506](#); *see also* body and mind

Boer War, [443](#)

Böhme, Jakob, [496n](#)

Bohr, Niels, [489n](#)

Boltzmann, Ludwig, [26](#)

“Book of What Is in the Netherworld,” [439](#)

boredom: in analysis, [74](#)
and telepathic experiments, [434](#)

bowl, golden, [291](#)

brain, [340](#), [505](#)
at birth, [371](#)
child’s, [53](#), [310](#)
disturbance of, and psychic defects, [322](#)
injuries to, [506](#)
mental diseases and, [279f](#)
and psyche, [115](#), [412](#)
psychic as secretion of, [383](#)
and reflex arcs, [322](#)
thought as secretion of, [343](#)

brain psychology, [8](#), [16](#)

breakdowns, nervous, in forties, [398](#)

break-up, radioactive, *see* radioactive decay

breath, [319](#), [345](#)
breath-body, [345](#)

British Psychological Society, [344](#)

brothers, hostile, [370](#)

Brown, G. Spencer, [482](#)

Bruno, Giordano, [361](#)

Buddha, [366](#)

Buddhists/Buddhism, [68f](#)
and death, [408](#); *see also* Zen
bull, of Mithras, [155](#)
Burckhardt, Jakob, [133n](#)
Burt, E. L., [433](#)
Busemann, Adolf, [177n](#)
Busse, Ludwig, [7 & n](#), [17](#), [18](#)
Butler, Samuel (1612–80), [34n](#)
Butler, Samuel (1835–1902), [494n](#)
butterfly, [345](#)

C

Cabalists, [378](#)
cabinets, natural history, [422](#)
candle, [156](#)
Cardan, Jerome, [455n](#)
cards, for ESP experiments, [432](#), [523](#)
career, transition to, [392](#)
Carnot's law, [25](#)
Carpenter, W. B., [179n](#)
Cartesians, and perception, [500](#); *see also* Descartes
Carus, C. G., [102](#), [167](#), [169](#), [170](#), [171](#)
Catholic, and collective unconscious, [156](#)
cattle, bewitching of, [302](#)
cauda pavonis, *see* peacock's tail
causa efficiens/causa finalis, [281](#)
causality, [421ff](#), [445f](#), [486](#), [491](#), [501](#), [511](#), [530](#)
and behaviour, [22](#)
and finality, [4ff](#), [22ff](#), [241](#), *see also* finality
magical, [483](#), [501](#)
and objectivity, [5](#)
psychiatry and, [27](#)
has become relative, [218](#), [414](#)
and synchronicity, compared, [485](#)
causation, material, [339](#), [342](#)

cause(s): final, 493; first, 351, 428
material, 340
mechanical and final, 4n
mechanistic and energetic views and, 4
natural, primitives and, 501
transcendental, 446; see also *causa efficiens*; causality; effect, cause and
cave, 293
and hero, 292
Plato's, 213n
censor(ship), 34, 69, 243, 251
centring process, 203
cerebrospinal system, 511
cerebrum, 509
consciousness and, 510
ceremonies: for canalizing libido, 44f
puberty and initiation, 374; see also *Atinga*; initiation(s)
certainties, 389
Cetonia aurata, 438, 526
Chaeronea, 198
Chamberlain, Houston Stewart, 37n
chance, 446, 515, 518
and explanation, 423
groupings, 440
laws of, 421n
and telepathic dreams, 263
world of, 423
chancefulness, 426
change: love of, 117
psychic, in middle life, 395, 397, 398; see also character; personality; political
changes; religious changes; social changes
chaos, 190, 191
character: astrological, 496f
change in, 395
peculiarities of, 373
traits of, and astrology, 454; see also personality

characterology, 454

chemistry, 384

chen-yen, 486n

chief, tribal, 378

child(ren): brain of, 53, 310

dependence on parents, 391

has no real problems, 392

inherited psychic functioning, 349

and mother, 373

psychic processes of, 403

rise of consciousness in, 390

small, and ego-consciousness, 347

souls of, 309

tension of opposites in, 52f; *see also* dreams; psychology, child-
childhood, 403

unconscious, 389

level of consciousness, 393

China/Chinese, 348, 450, 485, 489, 502; *see also* philosophy

Chou, Duke of, 452

Christ: ancestors of, 293

as bridegroom, 156

coming of, 192

corpus mysticum of, 491

St. Paul's vision of, 307f

symbols of, 293

Christ-complex, 308

Christians, St. Paul and, 307

Christianity: and consciousness, 388

and death, 408

demands highly developed psyche, 303

Nietzsche and, 80

St. Paul's, an unconscious complex, 308

spirit in, 335

substitute formations in, 20

and symbol-formation, 49

Christian Science, 49, 158, 261

Christmas-tree, 210

Christopher, St., 225

Chronos, 198

Chuang-tzu, 488f

Church: as bride, 156
as mother, 156, 221

churchwarden, 396

churinga, 48, 62

circle, 203

circumcision, 374

clairvoyance, 231, 523, 526
spatial, 450n

clan, 374

classification(s): of contents of consciousness, 140
“natural,” 110

climbing, dream-motif, 283

clocks, synchronized, 498

clothing, insufficient, dream-motif, 283

cock, dream-symbol, 503

Codrington, Robert Henry, 63, 64n

coenaesthetic perception, extinction of, 509

coincidence, 423, 437, 521
meaningful, 426, 435, 439f, 453, 501, 504, 516, 520, 524, 530

coincidentia oppositorum, 352; *see also* opposites

coins, 451, 452, 453, 527

colour, 353
symbolism, 211

columns, 504

coma, 507ff
consciousness during, 511

common sense, 382

communication(s): of information, in twilight state, 510

medium-istic/spiritualistic, 316f
—, irruption of collective contents in, 317
compensation, psychic, 253ff, 287; *see also* dreams; unconscious
complementarity, 229–30n, 232, 287n
complementation, 287
complex(es), 11ff, 121, 446 *et passim*
 autonomous/autonomy of, 97, 99, 307, 308, 368
 —, example of, 369
 —, why so called, 313
 characteristic expressions of psyche, 101
 compensatory function, 251
 in conscious and unconscious, 186f
 as demons, 98, 369
 effects, 100f
 —, exteriorized, 318
 fear of, 101
 feeling-toned, discovery of, 93
 —, nature of, 96
 in unconscious, 186
 identification with, 98
 infantile, 369
 loss and revival of, 311
 nature of, 95f
 nuclear element in, 11f
 of observer, 103
 and one-sidedness, 122f
 painful-ness of, 99
 soul- and spirit-, 309
 sources of, 314
 theory of, 307
 unconscious, 11n
 “wave-like” character, 96; *see also* assimilation
complex-indicators, 34
complexio oppositorum, 203

God as, 207
comprehension, 241
compulsion neuroses, 143, 364
compulsiveness, 142
conception, 345
conceptions, general, spiritual, 356
concordance, psychic, 111
Condillac, Etienne Bonnot de, 93
conflict: dream symbolizing solution of, 255
 ego/unconscious, 366
 physical/spiritual, 352
 mind/matter, 353
 psychic, and psychogenic diseases, 304
 spirit/nature, 353
confusions, 313
coniunctio/conjunction, 454, 461ff, 528
 Solis et Lunae, 474
conscience, want of, and neurosis, 356
conscious: directedness of, 69f
 fear of becoming, 118
 as psychic modality, 119
 and unconscious, complementarity, 188; *see also* unconscious
consciousness: adaptation to present, 152
 approximative, 189
 articulated, 356
 assumed unity of, 96
 categories of, seven, 141f
 characteristics of heightened, 119
 collective, 206, 218
 dawn of, 388
 and death, 407
 descendant of unconscious, 350
 dissociability of, 96
 disturbances of, 333

double, [164](#), [173](#), [199](#)
in dreams, [306](#)
essential to man, [210](#)
field of, [185n](#)
first stage of, [390](#)
fragmentation of/fragmented, [97](#), [377](#)
growth of, [341](#)
—, and problems, [388](#), [390](#)
higher/wider, [325](#), [333](#), [334](#), [335](#), [336](#), [393](#)
—, dangers of, [361](#)
horizontal development, [339](#), [342](#)
incompatible contents, [364](#)
individual differentiation of, [160f](#)
interval in continuous process, [110](#)
and light, [199](#)
loss of, [506](#)
and material objects, [383](#)
narrow limits of, [412](#)
and nature, [388](#)
nature of, [323](#)
origin of, [390](#)
perception of life-process, [136f](#)
phenomena of, [7](#)
precondition of ego, [323](#)
processes of, intensity and stimulus, [130](#)
psyche identical with, [184](#)
psychologies of, [343](#)
relation to psyche, [171](#), [200](#)
relativity of, [200](#)
return of complex to, [311](#)
secondary, [174](#)
semiotic contents, [175](#)
and sense-functions, [175f](#), [342](#)
shift in localization of, [509](#)

sine qua non of psychic life, 343
in sleep, 143
splitting off of, 410, 508
subliminal, 167n, 185n
symptomatic contents, 175
total, impossible, 119
transitoriness of, 349
unconscious as fringe of, 185
and *Weltanschauung*, 361
why it exists, 361
consensus gentium: and death, 408
and religion, 409
consensus omnium, 422
constancy, principle of, 18
constellation, 94, 95
of the archetype, 440
constellations, celestial, 152
constitution, and psyche, 107ff
contagion, mental, attitude and, 330
context, taking up, 285f
contingent, the, 515, 519
continuum, 412; *see also* space-time continuum
contraction, 446
conversion: of St. Paul, *see* Paul, St.; sudden, 307
convictions, hardening of, 395
Coomaraswamy, Ananda, 198n
co-ordinates, conceptual, 445
co-ordination, of psychic and physical processes, 505
Corpus Hermeticum, 136n
corpus mysticum, 491
correspondence(s), 430, 494, 497, 517
argument/principle/theory of, 489n, 492n, 495, 501, 514, 531
astrological, 527
correspondentia, 489

cortex, cerebral, [509](#), [510](#)
 dreams and, [511](#)
cortical function, extinction of, [510](#)
counteraction, of unconscious, [79f](#)
counter-transference, [273](#)
cranes, [442n](#)
craving, in dreams, [245](#)
Crawley, Ernest, [48n](#)
creatio ex nihilo, [480](#)
creation: acts of, [516](#), [517](#), [518](#)
 continuous, [517](#)
creative: achievements, [365](#); *see* creation, acts of
 instinct, [118](#)
 products, in unconscious, [11n](#)
creativity: and sexuality, [118](#), [368](#)
 and unconscious, [70](#), [157](#)
criticism, [362](#)
crocodile, [501](#)
Crookes, Sir William, [302](#)
cross, *see* quaternity
cross-connection, meaningful, [427](#), [482](#)
crowds, dream-motif, [283](#)
crown, [112](#)
cryptomnesia, [148](#), [151](#), [262](#), [317](#), [439](#)
crystals, [108](#), [311n](#), [503](#)
culmination, of dream, [295](#)
culture, [394](#)
 beginning of, [375](#)
 consciousness and, [388](#)
 individual, [60](#)
 natural, [42](#)
 and nature, [400](#)
 reflection and, [116ff](#); *see also* work
Cumont, Franz, [197](#)

Cupid's arrow, [329](#)

cure, analysis not a, [72](#), [73](#)

D

Dacqué, Edgar, [340](#)

dagger, [76](#)

Dahns, Fritz, [437n](#)

Dakota Indians, [61](#)

Dalcq, A. M., [512](#)

Damascus, [307](#)

damnation, everlasting, [379](#)

dance/dancing, [42f](#), [202](#)

of bees, [510](#)

buffalo-, [44](#)

dangers, [155](#)

Daniel, Book of, [80](#), [251](#)

Dariex, Xavier, [430](#), [522](#)

dark night of the soul, [225](#)

Darwin, Charles, [23](#)

day-dreaming, [410](#); *see also* fantasies dead: appearance in dreams, [304](#)

deterioration of character in the, [315](#)

effects of attachment to, [316](#)

malice of the, [304](#)

spirits of, *see* spirits

death, [404ff](#)

acceptance of, [401](#)

consensus gentium and, [408](#)

departure of spirit at, [345](#)

fear of, [397](#), [402](#), [405](#), [407](#)

as goal, [402](#), [405](#), [409](#)

precognitions of, [438](#), [522](#)

preparation for, [408](#), [410](#)

and telepathic dreams, [262](#)

debility, physical, [316](#)

decay, radioactive, [512](#), [517](#)

deer, [293n](#); *see also* stag
defence-mechanisms, [253](#)
degeneration, [37](#), [356](#)
degradation, in dream, [296](#)
déjà-vu, [522](#)
Delatte, Louis, [293n](#)
deliberation, [117](#)
delusional ideas, [307](#), [308](#), [384](#)
dementia praecox, *see* schizophrenia
Democritus, [137n](#)
demons, [293](#)
 complexes as, [98](#), [369](#)
 elemental, [305](#)
 personified affects as, [329](#)
 sexuality as, [155](#)
dependence: infantile, [370](#)
 of patient on analyst, [74](#)
depersonalization of affect, [267](#)
depression(s), [82](#), [131](#), [313](#), [316](#), [406](#)
 in men about forty, [395](#)
Descartes, René, [8n](#), [97](#), [136](#), [525n](#)
descendent, [461ff](#)
Deschamps, M., [431n](#)
Dessoir, Max, [167](#)
destruction, mass, [222](#)
details, [450](#), [489](#)
determinism: of function, [182](#)
 Schopenhauer and, [428](#)
 and synchronicity, [502](#)
De triplici habitaculo, [518n](#)
development: of dream, [294f](#)
 final, [22](#), [23](#)
 of progression, [37](#)
deviation, from archetype and instinct, [374](#)

Devil, the, [220n](#), [513](#)
 sexuality as, [155](#)

dialogue, [95](#)
 inner, [89](#)
 of observer and observed, [103](#); *see also* voice, “other”

diastole, [37](#), [393](#)

dice, in ESP experiments, [434](#), [523](#)

Dieterich, Albrecht, [111](#), [150](#), [492n](#)

differentiation, individual, [275](#)

difficulties: psychic, [392](#)
 underestimation of, [392](#)

Dionysius (pseudo-) the Areopagite, [136n](#)

Dionysus, [80](#)

Dirac, P. A. M., [513n](#)

directedness: and unconscious, [78](#)
 value of, [70](#)

discontent, [83](#)

discontinuity (-ies), of physics, [516](#), [517](#), [518](#)

discretion, years of, [396](#)

discussion, [95](#)

disease, psychic realities and, [356](#)

disintegration, psychic, [97](#)

disorientation, [415](#)

dispersions, [440n](#)

disposition, *see* attitude

dissociation(s), [33](#), [182](#)
 of conscious and unconscious, [374](#)
 multiple, [121](#), [122](#)
 of personality, neurotic, [100](#)
 of psyche, [173ff](#)
 schizophrenic, [186](#), [187n](#)

distance, and psychic condition, [433](#)

disturbances, reaction, [423](#)

divining rod, [517](#)

doctors, and psychiatry, 276
dog, psychic processes in, 173
dogmatism, 103
dominants, 204, 218, 372; *see also* archetypes
Dorn, Gerhard, 192/, 513
doubt, 388f
dove, Holy Ghost as, 151, 156
dragon(s), 36f, 155, 293
 hero's fight with, 212, 292, 372
 myth, 153
Dragon (constellation), 197
drawing, 82, 86, 202
dream(s), 133, 143, 237ff, 303, 348, 350, 365
 active fantasy and, 202
 of American Negroes, 111
 analysis of, 239
 analysts and own, 72
 anxiety, 283
 apparently accidental, 237
 archetypal/archetypes in, 291, 440
 —, in middle life, 292
 autonomy of, 306
 and belief in spirits, 303, 306ff
 “big,” 291, 293
 —, and “little,” 290
 as category of consciousness, 142
 characteristics of, 77, 142
 children's, 52
 classification, 247
 compensatory function, 245, 250, 251ff, 288ff
 complex as architect of, 101
 conscious(ness) and unconscious in, 144, 306
 continuity in, 238
 dramatic structure of, 295

fantastic/and fantasies, 238, 239
foreknowledge in, 522
form of, 294ff
Freud and, 179, 238f, 284f, 365
images in, 190
instability of, 238
interpretation, 283ff
—, on subjective level, 266
“irrational” factors in, 282
light-motif in, 199
lumen naturae and, 195
meaning of, 238ff, 283ff
medical aspects, 282
moral function/purpose, 245, 296
mythological ideas in, 311
nature of, 306
possibly transcerebral, 511
primitives and, 49n
prospective function of, 255ff
pure product of unconscious, 77
qualifications for interpretation, 286
reaction-, 260
recurrent, 283f
reflection of unconscious contents, 248
religious, 356
retrospective, 259
series, 289f
—, extra-analytical, 290
sexual language in, 263f
of snakes, 147ff
solution of problems in, 144
somatic stimuli and, 261
symbolism of, 245f
telepathic, 261f

and transcendent function, 77
typical, 283
in unconscious, 145ff
wishful thinking and, 504n
INSTANCES OF DREAMS: antique sword, 75f
car with drunken driver, 294n
child run over by car, 240
death of friend in America, 443
“Ericipaeus,” 444
fainting woman, 294f
fish in lake, 426
glass cock, 503
heads on rocks, 503
Indian chief who became effeminate, 398
lawyer’s demand for high fee, 268
little brown man, 503f
Nebuchadnezzar’s, 80, 251, 257, 258, 293
nurse who denied access to Dr. Jung, 249
picking apple, 241ff
sandpit containing serpentine, 503
scandalous, of bride, 286
snake guarding golden bowl, 291
snakebite in heel, 146
solving fraudulent bankruptcy, 144
stepping off mountain, 81
volcanic eruption, 443
woman given golden scarab, 438
dream-book, 284, 286f
dream-ego, 306
dream-image: and ego, 306
 modifications of, 77
 relation to object, 266
dreamland, 318
dream-motifs: stereotyped interpretation, 287

typical, 247, 283f
dream-series, 289ff
 and death, 411
dream-symbols, 48
Drews, A. C. H., 490n
Driesch, Hans, 176, 183, 437n, 493
drive(s), 28, 282, 340, 341
 energy as a, 29
 Freud's use of term, 29
dualistic phase, 393
duality, 203
Dunne, J. W., 443f
duplication of cases, 424, 520
durée creatrice, 137
Durham (North Carolina), 433
dying, onset of, 411
dyspepsia, neurotic, 368

E

earth: acceleration of, 437
 black, 199
 and correspondences, 496
 transference of libido to, 43
 watery, 191
earthquake, 155
earth-soul, 497; see also *anima telluris*
East, the: and psyche/spirit, 354, 384
Eastern view of world, 383
Eckermann, J. P., 449
Eddington, Sir Arthur, 234
Eden, Garden of, 242, 248
education, 373
 of the adult, 61
 religious, 393
effect: cause and, 3f, 31

and energy, [435](#)

egg, symbol of world, [495](#)

ego, [390](#)

- as army commander, [360](#)
- assimilation to wider personality, [292](#)
- association of collective content with, [311](#)
- child's struggle for an, [395](#)
- and complexes, [100](#)
- conscious, and psychic contents, [186f](#)
- and consciousness, [323](#)
- dream-, [306](#)
- highly composite, [323f](#)
- fragmentation of, [224](#)
- and images of psychic activities, [324](#)
- meaning of, [323](#)
- not easily altered, [224](#)
- not whole human being, [324](#)
- St. Paul's, and Christ complex, [308](#)
- second, [186](#), [391](#)
- and self, [224ff](#)
- soul-complexes and, [309ff](#)
- and unconscious, relation, [87f](#), [165](#)

ego-centredness, [226](#)

ego-complex, [100](#), [324](#), [390](#)

- centre characteristic of psyche, [307](#)

ego-consciousness, [178](#), [189](#), [217](#), [323](#)

- and complexes, [100](#)
- effects of wholeness on, [223](#)
- expression of soul, [346](#)
- grows out of unconscious, [347](#)
- and secondary consciousness, [174](#), [189](#)
- synthesis of sense-consciousness, [324](#)
- and wider consciousness, [333](#)

ego-memories, [390](#)

ego-personality, transformation of, [224](#)
Egypt/Egyptians, ancient, [209](#), [439](#)
Eisler, Robert, [197](#), [198n](#)
Ekoi, [64](#)
élan vital, [30](#), [351](#)
electricity, [47](#)
electrons, [339](#)
electron-microscope, [168](#)
elements, transformation/transmutation of, [47](#), [513](#)
Eleusinian mysteries, [155](#)
Elgon, Mount, [209](#)
Elgonyi, [65n](#), [154](#), [209](#), [304n](#)
elixir, [192](#)
elves, [97](#)
emotion(s), [346](#), [440](#)
 and attitude, [332](#)
 collective, [292](#)
empathy, [5](#), [32](#)
Empedocles, [30](#)
empiricism, [388](#)
enantiodromia, [219](#)
enemy, judgment of, [270](#)
energetic: and mechanistic standpoints, [3ff](#)
 —, and psychic events, [6ff](#)
 view, value of, [16](#)
energy(-ies): concept of, [4](#), [278](#)
 —, pure and applied, [28](#)
 conservation of, [18ff](#)
 of constellating power in complexes, [12](#)
 degree of, and threshold, [172](#)
 and ESP, [434f](#)
 God as, [351](#)
 indestructible, [514](#)
 kinetic, formula for, [233](#)

life as, 405f
and physical events, 4, 8
primitive concept of, 64
as primordial image, 137
psychic, *see below*; quanta of, 517
and quantity, 8f
and relation, 6n
sexual, 29
specific, of archetypes, 219n
—, differentiation of, 15
and substance, 22, 28
transformation of, 41
transmission of, 501; *see also* force; life-energy

energy, psychic: actual and potential, differentiation, 15
differentiation of libido as, 17
and “energy of the psychic,” 31
Freud’s use of term, 29
history of term, 14f
and physical processes, 7
quantitative estimation, 9
varying forms of, 29; *see also* unconscious processes

energy-tension, and dreams, 77

Enlightenment, Age of, 271, 408
superstition, concomitant of, 316
“enlightenment,” of civilization, 303

ennui, 360

entelechies, 499

enthusiasm(s), 315, 347, 434

enticements, divine, 493

entropy, 4, 25ff, 181
psychological, 26

environment: organism and, 152
psyche and, 152, 353

epilepsy, St. Paul’s, 308

epiphenomenalism, [7f](#)
epiphenomenon, mind/psyche as, [340](#), [342](#)
epistemology/epistemological criticism, [169](#), [170](#), [328](#), [340](#), [429](#), [482](#)
equilibrium, [342](#)
 disturbed psychic, [392](#)
equinoxes, precession of, [527](#)
equivalence, [513](#), [531](#)
 principle of, [18](#), [39](#)
 in Freud, [19](#)
 —, and psychic substitutes, [21](#)
 —, psychic and psychophysical, [515](#), [516](#)
Ericapeus, [444](#)
Erinyes, [99](#)
Eris, [329](#)
Erman, Adolf, [147n](#)
eros, infantile, [74](#)
eruption, [443](#)
ESP, [434](#), [441](#), [445](#), [446](#), [450](#), [479](#), [505](#), [509](#), [510](#), [517](#), [523ff](#), [530](#)
eternity, [381](#), [414](#)
ether, [29](#), [137](#)
ethics: and archetypes, [158](#)
 and sex, conflict, [57](#)
 and *Weltanschauung*, [158](#)
Eumenides, [99](#)
euphemism, [99](#)
euphoria, [507](#)
Europeans, and primitive conditions, [303](#)
Euxine, [99](#)
evaluation, [141](#)
evangelists, symbol of, [293](#)
Eve, [147](#)
events: acausal/causeless, [422ff](#), [512](#), [518](#)
 —, how recognized, [424](#)
 and mental activities, [513](#)

unique/rare, 422f
evolution, and progression, 37
exaggeration, 135, 276
exaltation, in dream, 296
existence: immediate, 446f
 meaning of, 408
 space-timeless, 414
expectation(s): affective, 441, 447
 exaggerated, 392
 positive, 434
experience, 320, 327
 critical, 445
 of God, validity of, 328
 all psychic, 353, 354
experiment(s), 422, 446
 nature of, 451
 parapsychological, danger of, 479; *see also* association experiments; repetition experiments; Rhine
exposition, of dream, 294
expression, and reflection, 117
extensity, in energy theory, 20
exteriorizations, 318
extra-sensory perception, *see* ESP; perception
extraversion: and progression, 40
 as psychic modality, 119f
eye(s): as light-symbol, 199
 serpent's, 198
 seven, 197; *see also* fish's eyes
eye-personality, 333, 334
Ezekiel, vision of, 198

F

fables, 239
faces, distorted, 312
facts: irrational, 328

psychic, validity of, 328
faculties, differentiation of, 123
fairytales, 152, 248, 291
Fall of Man, 242f, 388
family, archetype of, 156
fanaticism, 307, 395
fantasy(-ies), 142, 303, 346
 active/creative, 202ff
 and anticipations, 410
 artificial production of, 8ff
 capacity to produce, 78
 and dominants, 372
 light-motif in, 199
 origin of mythical, 38
 of sexuality, 155, 367f
 spontaneous, 78
 visual, images in, 190
 waking, and dreams, 239
fate, 429
father(s), 372
 long-lived, 396
 wicked, 53
Faust, see Goethe
fear, 388
 and complexes, 99ff
 of dark, 100
 of life, 406
 of spirits, among primitives, 309; see also death; fright; ghosts
feast, ritual, 380
“feather dress,” 439
features: feminine, in men, 398
 hardening of, 397
Fechner, Gustav Theodor, 164, 166, 172n, 219
feeling, 141, 355

and adaptation, 34
and attitude, 366
directed, 27
faculty of, 123
function, and values, 10, 234
and intellect, 318
meaning of, in psychology, 108
site of, 347
in unconscious, 172

feeling-tone, 141
 complexes and, 11, 313

femininity, 397f

fertility, god of, 155

fetishes, 48, 155, 275

feudalism, 355

fever, 253; *see also* typhoid

Ficino, Marsilio, 493n

field, libido and, 43f

Fierz, Markus, 475, 478, 483, 502n, 528, 529n

finality, 5f, 23f
 and dreams, 241ff
 importance of, 247

fire, 353f
 making of, 149
 soul as, 345

firestone, 149

firmament, 193
 interior, 195

first half of life, 60, 398

fish, 372
 April, 426, 521
 in example of synchronicity, 426, 427n, 521
 symbol, 419

fish's eyes, 196f

fits, St. Paul and, 308
fixation, 374
Flambart, Paul, 454
flame, soul as, 345
Flamel, Nicholas, 197
Flammarion, Camille, 430*f*, 522
Fletcher, Alice, 63
Flournoy, Théodore, 179, 252, 262
flowers, 496
Fludd, Robert, 453*n*, 514
flying, dream-motif, 283
folklore, 227
font, blessing of, 156
food, as god, 155
force: and energy, confusion, 29
 psychic, 15, 31
 transmission of, 524
foreknowledge, 493, 521, 522*f*
forgetfulness, 323
form, 512
formae essentiales, 191
formulation: aesthetic, and understanding, 85
 creative, 84
Fortgibu, M. de, 431
fortune-teller, 249, 250
forty, age of, 395, 398
Francis, St., 367
Franz, Marie-Louise von, 191*n*, 495*n*, 500*n* 514
freedom, absolute, 332
French Revolution, 241
Freud, Sigmund, 10*n*, 13, 24, 49, 51, 55–58, 72, 82, 86, 88, 103, 143, 179*f*, 186, 200,
 264, 288, 364
 and “censor,” 34, 69
 discoverer of unconscious, 101
 and dream-interpretation, 238*f*, 243, 247, 251*f*, 284*f*

on instinct and unconscious, [200n](#)
and libido, [29](#)
and pleasure, [50](#)
and reductive function of unconscious, [258](#)
and sexuality, [19](#), [22](#), [29](#), [51](#), [55f](#)
theory of repression, [11n](#), [102](#)
and unconscious, [350](#); *see also* psychoanalysis

Freya, [517n](#)

Frey-Rohn, Liliane, [474](#), [528](#)

fright, mechanism of, [131](#)

Frisch, Karl von, [510](#), [511](#)

Frobenius, Leo, [36](#)

function(s): and adaptation, [34](#)

antithetical, [124](#)

apportionment of libido among, [47](#)

and attitude, [124](#)

biological adaptive, [176](#)

and compensation, [35f](#)

dominating, [310](#)

four, [122f](#)

and the psychic, [181f](#)

transcendent, an artificial product, [76](#)

—, contents, [90](#)

how produced, [77](#)

meaning, [68f](#), [73](#)

Funk, Philipp, [198n](#)

Furies, [99](#)

Fürst, Emma, [111](#)

future, psychic, [367](#)

G

gain, lust for, [116](#)

Galileo, [449](#)

ganglia: in insects, [510](#)

ganglion cells, [322](#)

garden, walled, [293](#)
Garrett, Eileen J., [434](#)
Gatschet, Albert Samuel, [49](#)
Gauss, Karl Friedrich, [502](#)
Geddes, Sir Auckland, [509](#)
Geist/gāst, [300](#), [329](#)
Gelaria, [65n](#)
generation, spontaneous, [280](#)
Genesis, Book of, [147](#)
genius, [233](#)
geomantic experiment, [527](#)
geometria, [496](#)
geometry, [497](#)
Germany, [170](#), [225](#)
“getting stuck,” [440](#)
Geulincx, Arnold, [449](#), [498n](#), [505](#)
ghost(s), [303](#), [316](#), [328](#)
 fear of, [353f](#)
 unconscious imago as, [274](#)
ghost-trap, [305n](#)
Gilgamesh Epic, [101](#)
Gillen, F. J., [44n](#), [48n](#), [62n](#), [63n](#)
glands, [340](#), [342](#), [343](#)
 hormone-producing, [115](#)
 instincts and, [180](#); *see also* thyroid gland
globes, luminous, [199](#)
globus hystericus, [146](#)
Gnosticism, [54](#), [190n](#)
goal: life and, [405f](#), [408](#)
 of second half of life, [400](#)
 social, [395](#)
 supra-mundane, [401](#); *see also* death
Goblet d’Almellas, Eugène, Count, [111](#)
God: bacchantic, [170](#)

bond of sensuous and suprasensuous, 490
Cabalists, and name of, 378f
concept of, 278
contradictoriness of, 55
creator/and creation, 341, 518n
energy as, 352
experience of, 328
always Father, 518n
and God-image, 278f
idea of, and *mana*, 65
and imperfect creation, 54
individual minds and, 344
invention of, 409
knowledge and will in, 500
as psychic fact, 328
as spirit/spirit of, 54, 170, 340
and Sun, Elgonyi view, 154, 209
world as visible/world-system as, 351, 491

God-image, 278f

Goddard, Air Marshal Sir Victor, 526

gods: all things full of, 493
complexes as, 369
as libido analogues, 48f
names of, 378
transformations of, Greek, 341

Goethe, Johann Wolfgang von, 37, 60, 89, 187n, 212, 368f, 377, 393, 449, 455n, 513
mother-complex of, 367

gold, 199

Gold Coast [Ghana], 62

Golden Age, 210

Goldney, K. M., 517

Gonzales, Loys, 198

good and evil, 272

Gothic Age, 338, 342

Gottesminne, 20

Granet, Marcel, 489

graphology, 454

Great Mother, 153; *see also* mother; mother-image

Greco-Roman world, 338, 355

greed, 116

Greek intellect, and one-sidedness, 382

Greeks, and the soul, 345

Grimm, Jacob, 517*n*

Grot, Nicolas von, 7, 8, 15

Guillaume de Conches, 196

guilt, 242*ff*, 248

Gulielmus Parisiensis/Alvernus, *see* Guillaume de Conches; William of Auvergne

Gungnir, 517*n*

Gurney, E., 430*n*, 450

H

Hades, Babylonian, 439

half-life, 512

Hall, Stanley, 290

hallucination(s), 506: auditory, 83, 124, 305, 307

 complexes and, 313

 pathological, 308

hammer, Thor's, 517*n*

han, 64

hands, and unconscious, 83, 86

"Hans, Clever," 173*n*

Hardy, A. C., 494, 513*n*

hare, as redeemer figure, 111

harmony: between conscious and unconscious, 288*f*

 pre-established, 428, 430, 498*ff*, 506, 511, 517, 531

Hartmann, Eduard von, 3*n*, 6*n*, 20*n*, 102, 167, 178*n*

hauntings, 316

head(s): carved in rock, dream of, 504

 in relief, dream of, 503

as seat of consciousness, 347
healing, symptomatology and, 149
hearing, extinction of, 509
heartache, 145f
heaven(s): as light-symbol, 199
 man and, 490, 495, 496
heel, case of pains in, 145f
Hegel, G. W. F., 169, 170
Heraclitus, 53, 137, 485
Herbart, J. F., 163
Herbert of Cherbury, Lord, 136
hereditary disposition, as psychic modality, 119
heredity, 342
 psychic, 349
hero: divine, seaborne, 153
 mythological, 372; *see also* dragon
hero-myth, 212, 293
Hetherwick, Alexander, 62
hexagrams, *see I Ching*
hieros gamos 156, 475
“higher” man, Nietzsche’s, 80
hikuli, 63n
Hindu, and animal-worship, 111f
Hippocrates, 489f, 492
Hippolytus, 197, 198f
Hiroshima, 218
history, 341
 changes in, 314
hoard, hidden, 112
holidays, 355
Holy Ghost, 151, 156, 194
 world-soul and, 196
Holy Saturday, 149, 156
Homer, 151, 438n

Honorius of Autun, [293n](#)
Horapollo, [195n](#), [198](#)
hormones, [180](#), [181](#), [340](#); *see also* glands
horoscope, [454](#), [455n](#), [459ff](#), [528](#); *see also* astrology
hospital, [249](#)
Host (Eucharistic), the, [155](#)
hotels, dream-motif, [283](#)
house(s): astrological, [453](#), [455n](#), [527](#)
 haunted, [302](#)
Hubert, Henri, [28n](#), [122](#)
Hudibras, [34](#)
Huichols, [63](#)
hunch, [132](#)
hunger, [116](#), [155](#), [369](#)
Hutchinson, G. E., [517](#)
hybris, of consciousness, [408](#)
hymn, Egyptian, for cure of snakebite, [147](#), [149](#)
hypnosis/hypnotism, [142](#), [232](#)
hypochondriacs, [399](#)
hysteria/hysterical disorders, [143](#), [304](#), [364](#), [365](#), [368](#)

I

Iacchos, [155](#)
Ibycus, [442n](#)
I Ching, [205n](#), [450ff](#), [474](#), [526](#)
idea(s): archetypal, *see* images, archetypal delusional, *see* delusional ideas
 elementary, [165](#)
 in born, [165](#), [226](#), [310](#)

inherited, 111, 372
mythological, in dreams, 311
obsessive, 334
Platonic, 191, 502
ruling, 332
spirits as new, 315
spread of new, 314
unconscious combinations of, 310
universal, 218

Idealism, German, 169

identification(s): in Hegel, 170
with archetypes, 122
of subjective with collective consciousness, 221

identity: mystic, with object, 270, 273, see also *participation mystique*
of object with subjective imago, 275f

Ignatius (of Antioch), St., 192

Ignatius Loyola, St., 198

illness: primitives and causes of, 309, 370, 501
psychic, attachment to dead and, 316
soul-complexes and, 309
treatment of, 355

illusion, 354, 408

image(s): acoustic, 322
in active fantasy, 202ff
archetypal, 213, 214
of feeling, 322
memory, see memory-images; perceiving consisting of, 494
primordial, 112, 133n, 310, 402, see also archetypes
processed, 384
psyche a series of, 325
psychic, material and mental sources, 353
represents meaning of instinct, 201
sole objects of perception, 383
spirits as, 330

subjective and objective significance, 267
symbolical, 190
typical, among primitives, 137
visual, 322; *see also* dream-images

imagination: 82
active, 204, 211, 317, *see also* fantasy, active
categories of the, 122
in unconscious, 172

imago/imagines, 264, 330
autonomy of, 274
object-, 274f

imago Dei, 193

imitation, 425

immediacy, of events, 447

immortality: medicine of, 403
of soul, 347, 401
of unconscious, 349; *see also* life, future

impossibility, 440, 441

impressions, 130, 138
subliminal, 310

impulse(s): and attitude, 360
exaggerated, 130
natural, 218

incest, and civilization, 23

incubation dreams, 289

indeterminism, 181n, 428

India, 348

Indian(s): Mexican, 63
North American, 44, 61f, 63
—, chief, effeminized, 398
South American, 46

indigestion, 271

individual, and collective relationship, 257

individuality, development of, *see* individuation

individuation, 40, 51, 202, 225f, 292

change involved in, 223

dream-series and, 290

religion and, 59

Indonesia, 233

inertia, 393, 425

inferences, 384

inferiority, 392

infinity, 361

inflation: ego-/subjective, 85, 221

in Hegel, 170

social/national, 221

inheritance, child's psychic, 53

inhibition: by conscious of incompatible material, 69

of unconscious/and unconsciousness, 34, 119, 364

initiation(s), 274, 293, 357, 374f

injuries, brain, 506

insanity: complexes in, 313

fantasies in, 372

and mythological ideas/symbols, 311

and possession by evil spirits, 305

insects, 349, 350, 510

insomnia, 271

inspirations, 304, 347

instinct(s), 180ff, 340, 391, *et passim*

and affectivity, 440

in animals, 349

—, and primitives, 134

compulsiveness, 115, 118, 182

collective character of, 134

and consciousness, 388

curbing of, 54

definition of, 129, 130

—, Kant's, 130

as ectopsychic factor, 115
five main groups, 118
Freudian theory and, 55, 365
Freud's use of term, 29
imitation of, 42
and intuition, 132
William James on, 131, 134
loss of, 80
modified, 115
no amorphous, 201
origin of, 131f
physiological and psychological aspects, 180
power of, 342
preformation of, 310
relation to psyche, 115ff
repression of, 20
restricted view of, 134
source of, in unconscious, 157
theory of, 114
two aspects of, 212
typical modes of action, 135
and unconscious, 133ff
unconsciousness of, 130
are unknown, 367
variability of, 115ff; *see also* archetype sexuality; spirit

integration: pathological attempts at, 224
of unconscious contents into consciousness, 223

intellect: not self-sufficient, 318
in primordial images, 402
thinking and, 402

intelligence, flashes of, 347

intentions, 130, 362
good, 355

interdiction, 13

interest, and telepathic experiments, 431
interpretations, unconscious, 431
intolerance, 395
introversion: as psychic modality, 119*f*
 and regression, 40
 tendency to, at night, 83
intuition(s), 141*f*, 314, 451
 archetypes and, 133
 faculty of, 123*f*
 and instinct, 132
 among primitives, 137
 retrospective, 52
 use of word, 142
invertebrates, 152
involution, 37
ionosphere, 460
iota, 199
Irenaeus, 191*n*
Iroquois, 61
irritation, 271
Isaiah, Book of, 222*n*
Isidore of Seville, 453*n*
Isis, 147
Islam, 355
“isms,” 175, 206, 219, 221, 222
isolation, of psychic processes, 93

J

Jacobi, K. G. J., 502
Jaffé, Aniela, 495*n*
James, William, 101, 125, 131, 134, 167*n*, 174*n*, 185, 211
Janet, Pierre, 21, 77, 96, 164, 179, 180, 181*n*, 186, 446
Jantz, Hubert, and Beringer, Kurt, 507*n*
Japan, *see* Hiroshima; Zen Buddhists
Jeans, Sir James, 213*n*, 234, 512, 513*n*

Jerusalem, W., [180n](#)

Jesuits, [486](#)

Jew, [156](#)

jinn, [155](#)

John, Gospel of, [192n](#), [199](#), [220](#)

John of the Cross, St., [225](#)

Jordan, Pascual, [231n](#), [450n](#)

journeys, [410](#)

judgment; and directedness of conscious, [70](#)

 in unconscious, [172](#)

Jung, Carl Gustav:

 CASES IN SUMMARY (*in order of presentation, numbered for reference*):

 [1] Insane patient who uttered papyrus passage.—[111](#) (cf. case 6)

 [2] Hysterically deaf patient who heard key change.—[142](#)

 [3] Male patient, “hystero-epileptic,” with peripheral blindness.—[142f](#)

 [4] Accountant who solved problem in sleep.—[144](#)

 [5] Officer, [27](#), with psychogenic pains in heart, throat, and heel, who had snake dream.—[145ff](#)

 [6] Schizophrenic clerk, in [30](#)'s, who had hallucination of sun's phallus.—[150f](#)

 [7] Male patient, “normal,” whose dream of Dr. Jung revealed his “nervous” trouble.—[249f](#)

 [8] Young man, neurotic, who suspected fiancée.—[286](#)

 [9] Female patient, hysterical, who dreamed of prostitutes.—[295f](#)

 [10] Young man, neurotic, who wrote monograph on his neurosis.—[355f](#)

 [11] Patient with stomach trouble, who had mother-complex.—[369](#)

 [12] Woman, [62](#), who succeeded in analysing own dreams before her death.—[411](#)

 [13] Young woman, who dreamed of scarab, which then appeared during analytical session.—[438](#), [525f](#)

 [14] Male patient, in [50](#)'s, whose wife had vivid premonition of his death.—[438](#)

 [15] Woman patient, who had vision of other world in coma.—[507f](#)

 WORKS: “The Aims of Psychotherapy,” [202n](#)

Aion, [199n](#)

Alchemical Studies, [195n](#), [495n](#)

 “The Association Method,” [14n](#)

Collected Papers on Analytical Psychology, [437n](#)

“The Concept of the Collective Unconscious,” 150n
“Concerning Mandala Symbolism,” 375n, 457n
Essays on a Science of Mythology (with Kerényi), 292n
Mysterium Coniunctionis, 190n, 317n, 486n
On the Psychology of Eastern Meditation,” 456
“The Phenomenology of the Spirit in Fairytales,” 216, 222n
“The Philosophical Tree,” 293n, 486n
“The Practical Use of Dream-Analysis,” 282n
Psychiatric Studies, 11n
“A Psychological Approach to the Dogma of the Trinity,” 513n
Psychological Types, 23n, 28n 41, 55n, 61, 132n, 199n, 208
Psychology and Alchemy, 190n, 196n, 204n, 209n, 290, 293n, 375n, 486n, 496, 513n
“The Psychology of Dementia Praecox,” 10n, 12, 13n, 30, 252n
“Psychology of the Transference,” 269n, 273n
“Richard Wilhelm: In Memoriam,” 452n
“The Spirit Mercurius,” 486n
Studies in in Word Association, 10n, 14n, 262, 312n, 423n
“A Study in the Process of Individuation,” 375n, 457
Symbols of Transformation, 3n, 18, 21n, 24, 30n, 36, 41, 42n, 43n, 48n, 55n, 133n 150n, 292n, 311n
“The Theory of Psychoanalysis,” 30
Two Essays on Analytical Psychology, 28n, 65n, 133n, 137n, 202n, 204n, 209n, 269n, 291n, 317n, 375n; see also Peterson; Ricksher; Wilhelm, Richard
Jupiter, moons of, 449

K

kalit, 64
Kammerer, Paul, 424f, 426, 435n
Kant, Immanuel, 34n, 102, 136, 165, 169, 241, 341, 430n, 436, 481n
kasinge, 64
Katz, David, 173n
Keller, Helen, 324
Kenya, 65n
Kepler, Johannes, 361, 460, 496f, 504n, 514

Kerényi, C, [292n](#)
Kerner von Marilaun, Anton, [132n](#)
Khepri, [439](#)
Khunrath, Heinrich, [190ff](#), [199](#), [514](#)
Kloeckler, Herbert von, [454n](#)
Kluge, Friedrich, [329](#)
Knoll, Max, [460n](#), [527](#)
knowledge: absolute, [481](#), [489](#), [493](#), [506](#)
 acausal, in unconscious, [447](#)
 best, [326](#)
 inborn, [493](#)
 psychic system and, [171](#)
 unconscious, [493](#)
 —, as source of, [348](#)
 what it is, [390](#); *see also* epistemology
koans, [225](#)
Koch-Grünberg, Theodor, [46n](#)
Krafft, K. E., et al., [46n](#)
Krakatoa, [443](#)
Krämer, A. F., [437n](#)
Kretschmer, Ernst, [107](#), [108](#)
Kronecker, Leopold, [502n](#)
Külpe, Oswald, [7 & n](#), [180n](#)
Künkel, Fritz, [317n](#)
Kusaie, [64](#)

L

labuni, [65n](#)
lambs, [112](#)
language: conceptual, causalistic colouring of, [515](#)
 neutral, [512](#)
 of psychology, [109](#)
Lao-tzu, [486](#)
lapis philosophorum, [495](#)
Lasswitz, [7](#)

law: mechanistic, substrate of, 515

natural, 421

—, merely statistical, 428

no “absolute,” 423

lawyer, 268

learning, and instinct, 132

legends, 152

Lehmann, Alfred, 14n

Lehmann, Friedrich Rudolf, 28n, 65

Leibniz, Gottfried Wilhelm von, 102, 492, 493, 498ff, 505, 506, 517, 531

levels, psychic, three, 151

levitation, 506f, 509

Lévy-Bruhl, Lucien, 44n, 49n, 50n, 63n, 65, 122, 153, 265

Lewes, George Henry, 172n, 179n

libido, 233

apportionment among functions, 47

bases of concept, 3ff, 30f

canalization of, 41ff

damming up of, 38, 58, 272

disappearance of, and equivalence, 19f

excess, 47f, 49

Freud’s synonyms for, 29

justification of term, 29f

life-energy as, 17

loss of, 316

metaphysical aspect, 30

primitive conception, 61ff

progression and regression of, 32ff

and projections, 265

sexuality and, 30

similarities and differences, 21

stoppage of, 32f

symbols as analogues of, 48; *see also* adaptation

life: aim of, 402

art of, 400
contraction of, 399
curve of, 406
and energy, 41f
expectation of, 405
fear of, 405, 406
as function of matter, 280
future/after death, 401, 402
irreversible, 405
meaning of, 377, 404f
as preparation for death, 408
science and riddle of, 326
soul as source of, 347
and spirit, 319ff, 345
spiritual, 332, 356
stages of, *see* stages; *see also* afternoon of life; first half of life; second half of life

life-breath, 345
life-energy, 17
life-force, 17, 345
ligamentum mentis et corporis, 494
light, 327
 physical fact and psychic image, 384
 primordial, 444
 wavelengths, 175, 353
 wave and particle theories, 184, 229; *see also* lumen

Light, seeds of, 190n
limbo, psychic, 180
lions, four, 293n
Lipps, Theodor, 15, 16, 166, 172f, 214
lisoka, 62
“living being,” 321, 327
 and spirit, 327
 unknowable, 326
locality, changes of, 411

London, slums of, 366
longevity, 399
 and civilization, 407
longing, unappeasable, 369
loss, sense of, and repression of complex, 311
lost objects, return to owners, 431
Lovejoy, Arthur O., 61n, 62n, 64
lower organisms, “meaningful” behaviour of, 505
Lucifer, 495
Luke, Gospel of, 194n
lumen, 191
 naturae, 192
Lumholtz, Carl, 63
luminosity(-ies), 189ff, 199, 436
lysis, 295

M

McConnell, Robert A., 434f
Macdonell, A. A., 518n
McGee, W. J., 61n
machine, life and use of, 42
macrocosm, 492
Maeder, Alphonse, 10n, 15n, 255, 257, 263ff
magic, 46, 61ff, 270, 448, 501
 “mother of science,” 46
 number, 458
 among primitives, 137, 157, 347’ 369, 370, 374
 sympathetic, 149; *see also* ceremonies
magna mater, 156
magnetic field, earth’s, 460, 527f
magnetism, 442
magpies, 442f
Maier, Michael, 514
Malagasy, 64
Malalas, John, 444

Malaya, 63
Malebranche, Nicolas, 136
man: brown, dream of, 503f
 centre of events, 492
 civilized, psychic life of, 388
 Cosmic, *see* Purusha; effeminate, 398
 First, 199
 and heaven, affinity, 490, 495, 496
 inner, 194
 metallic, 503n
 new, 393
 synthesis of three worlds, 491
 universal and individual, 380
 wounded, 506; *see also* mass man; medieval man; microcosm
mana, 28n 63f, 65, 137n, 155, 158, 209, 233
 personality, 156
mandala, 199, 213, 227f, 457
Manichaeism, 190n
Manget, J. J., 293n
manitu, 61f
Mannhardt, Wilhelm, 43n, 44n
“mantic” methods/procedures, 450, 451, 453, 456, 474, 480, 485, 501, 502, 525f, 530
Maoris, 64
Marais, E. N., 180n
Maria the Jewess, 513
marriage: catastrophes in, 398
 connections, 454ff
 horoscopes, 459ff, 528f; *see also* aspects, astrological
martyr, Christian, 336
Mars, 401, 455, 461, 474, 528
Mary, the Virgin, 151, 156
Masai, 64
masculine protest, 367
masculinity, 119, 397f

Mass, the, [149](#)
mass, energy and, [20n](#)
mass man, [208f](#), [219](#), [220](#)
Master, [331](#)
mater ecclesia, [156](#)
materialism, [280](#), [302](#), [338](#), [365f](#), [367](#), [370](#), [512](#)
 reaction against, [302](#)
mathematics, [456](#), [490](#), [502](#)
matter: inscrutable, [342](#)
 latent psyche in, [234](#)
 mind and, [339](#)
 nature of, [327](#), [384](#)
 and psyche, relation, [215](#), [234](#)
 as psychic category, [120](#)
 and spirit, [216](#)
Matthew, Gospel of, [193n](#)
maturity, [406](#)
 need of education in, [60](#)
Mauss, Marcel, [28n](#), [122](#)
maxim, [331](#)
maya, [354](#)
Mayer, Robert, [65n](#)
Mazdaznan, [49](#)
meaning, [339](#), [482](#), [485ff](#), [487ff](#)
 criterion of synchronicity, [485](#)
 equivalence of, [452](#), [531](#)
 self-subsistent, dreams and, [503](#)
 Tao as, [486](#)
meaninglessness, [415](#)
measurement, [436](#)
 in psychology, [6ff](#)
 and values, [9](#)
mechanistic and energetic standpoints, [3ff](#)
medicine: sixteenth-century, [357](#)

study of, 277
and treatment, 355
medicine-man, 156, 209, 303, 304*n*
medieval man, 219*f*, 221
medium, spiritualistic, 318
megalomania, 80, 150
 Nebuchadnezzar's, 251
 of schizophrenia, 170
Meier, C. A., 188*n*, 232, 289*n*, 311*n*, 500*n*
Melanesia, 63, 233
melons, 190*n*
memory: artificial acquisition, 349
 continuity of, 390
 in early life, 390
 and recognition, 141
 slips/lapses of, 13, 77
 subconscious racial, 494*n*
 tricks of, 346
 in unconscious, 172
memory-images, 507
 in daydreams, 410
 in dreams, 284
 forgotten, 446
menstruation, 437
mental illness, irruption of complexes and, 312
Mercurius, 191*n*, 196, 293*n*
meridians, 427, 428, 429
Meringer, R., 43
mescal, 63
metaphors: outworn, 98
 sexual, in dreams, 264
metaphysics: 296, 338, 345, 413, 512
 of mind and of matter, 339
 and Paul's conversion, 308

Mexican/Mexico, 63, 155
microcosm, 495
 collective unconscious as, 494
 man as, 490, 492, 499
 monad as, 499
microphysics, 230n, 450n
“micropsychic,” 177n
Middle Ages, 109, 338, 344, 489, 502
 “possession” in, 98
middle life, 291, 292; *see also* change
migraine, 368
migration, of myths and symbols, 111
milk, fermented, 249
mind: as biochemical phenomenon, 339
 and body, duality, 321
 as epiphenomenon of matter, 340
 and matter, 339
 self-knowledge of, 383
 as spark, 191
 and spirit, 326
 “spirit” and “ghost,” 54, 300, 320
 as sum of ancestral minds, 54
Mind Association, 344
miracle, 441, 482, 530
misunderstandings, 13
Mithraism, 150
 Mithras, 155
 Mithraic liturgy, 492
Mjollnir, 517n
modalities, of psychic functioning, 119
modelling, 84, 86, 202
monad(s), 192, 199, 492, 499f
money, making, 377
monograph, 355

Monoimos, [198f](#)
Montanism, [336](#)
mood(s), [82](#), [346](#)
 change of, [333](#)
 dreams and alterations of, [238](#)
 and ESP experiments, [524](#)
 peaceful, [360](#)
 sudden, [131](#)
moon, [154](#), [437](#)
 in astrology, [454f](#), [528](#)
morality: meaningful or no, [244](#)
 and sex, [56f](#)
Morgan, C. Lloyd, [131](#), [201n](#)
Morienus Romanus, [190n](#), [196](#)
morphogenesis, biological, [511](#)
mortality curve/rate, [460](#), [527](#)
mother, [372f](#)
 archetype of, [375](#)
 pampering, [146](#)
 universal aspect of, [373](#)
Mother, Great, *see* Great Mother
mother-child relationship, [373](#)
mother-complex, [369](#), [373](#)
 Goethe's, [367](#)
mother-image, [372f](#)
motifs: dream, *see* dream-image; mythological, [122](#), [152](#), [247](#), [311](#)
motives, [362](#)
mountain, dream of, [81](#)
mourning, [241](#)
moustaches, [397](#)
movement(s): and energy, [5](#)
 as expressing unconscious, [84](#)
multiplicity, in fantasy, [203](#)
mulungu, [62](#), [209](#)

mungu, see *mulungu*

murder, 454n

Myers, F. W. H., 167n, 179n, 185n, 302, 430n, 450

Mylius, Johann Daniel, 190n

mysticism, 225

and materialism, 370

myth(s): and collective unconscious, 152

as explanations, 37f

migration of, 111; see also dragon; hero myth; night sea journey

mythologems, 111, 195, 227, 291

condensed in dreams, 293

and “truth,” 91

mythology, 203, 354, 380

and content of psyche, 148

Greek, in dream-motifs, 111

projection of collective unconscious, 152ff

N

name(s): compulsion of the, 427n

and facts, 109

and profession, 427n

“right” and “true,” 378f

and soul, 346

Napoleon Bonaparte, 367

natalitia, 496

nations, changes in life of, 314

“natural” and “spiritual,” 52

nature: formal factor in, 504

instinct and, 388

light of, see *lumen naturae*; and reason, 381

spirit and, 351

—, conflict, 352

terror of, 155

unity of, 452

the West and, 354

workings of, [451](#)

Nebuchadnezzar, [80](#), [251](#), [257](#), [258](#), [293](#)

necessity, inner instinct as, [130](#)

Negro, who burnt feet, [50](#)

Negroes; American, [111](#)

 and seat of psyche, [347](#)

Nelken, Jan, [311n](#)

Neptune (planet), [378f](#)

nerve-endings: and conscious image, [384](#)

 stimulation of, [322](#)

nervous system: ego's ignorance of, [324](#)

 emotional processes and, [335](#)

 and psyche, [115](#), [322](#), [376](#)

neurosis(-es), [100](#), [179](#), [250](#), [276](#), [355](#), [410](#)

 autonomous psychic contents and, [370](#)

 complex and, [368](#)

 dissociation and, [33](#)

 emotional factors and treatment of, [88](#)

 and making conscious of complex, [311](#)

 moment of outbreak, [99](#)

 moral attitude and, [356](#)

 problems and, [392](#)

 psychized instincts and, [123](#)

 psychoanalysis and, [364](#)

 psychology of, [186](#)

 treatment of, and equivalence principle, [19](#)

 —, and harmony of conscious and unconscious, [289](#)

 unconscious attitude in, [288](#); *see also* compulsion neuroses

neurotic(s), [396](#)

 and complexes, [313](#)

 conscious and unconscious in, [69](#)

 disturbances in, [333f](#), [373](#)

 fear of consciousness in, [118](#)

 and projections, [271n](#)

psychic processes of, 346f
neurotic disturbances, adult, 396
New Guinea, 65n
ngai, 64
nganga, 304n
Nicholas of Cusa, 207
Nicholas of Flüe, vision of, 211
Nietzsche, F. W., 58, 80, 83n, 102, 122, 160, 170, 201, 247, 335, 343
Night My Number Came Up, The, (film) 526n
nightmares, 283
night sea journey, 36f
nixies, 155
njom, 64
noonday, 346, 397
 psychic revolution of life's, 398
nothing, 486f
null hypothesis, 425n
number(s), 168, 456, 502n
 archetypal foundation, 456f
 coincidence of, 424, 520f
 invented or found, 457
 properties of, 516, 517
 "sacred," 456
 and synchronicity, 456
numen, 191, 233
numinosity, 186, 191, 456
 of archetype, 205f, 209, 312
 of series of chance happenings, 426n
numinosum, 104
Nunberg, H., 14n
nurse, 249

O

object: death of, 274
 -*imago*, 274

mischievousness of, 97
overvaluation of, 275
projection and, 273
and subject, primitive confusion, 154; *see also* subject and object; subjective level
observer: in physics, 215, 229
and observed, incommensurability, 512
obsessions, 131, 364; *see also* ideas, obsessive
Occam's razor, 186
Odin, 517n
oki, 61
old, the/old age: extreme, 403
"getting wooden" in, 407
and libido in dance, 44
among primitives, 400, 407
purpose of, 399ff
omen, 442
one-sidedness, 122f, 124, 207, 276, 377, 396
of conscious life/consciousness, 292
—, compensation for, 73
implied by direction, 71, 79
of science, 220
of Western man, 382
opposites: pairs of, 272
—, and libido, 32f
problem of, 125
tension of, 393
—, in child, 52f
—, in God, 55
—, and progress of culture, 59
and transcendental function, 90
union of, 203, 207, 474; *see also* *complexio oppositorum*; *conflict*
INSTANCES: atheism/theism, 370
light/dark, 203
materialism/mysticism, 370

mind/body, 326
nature/spirit, 51
physical/spiritual passion, 212
right/left, 203
spirit/instinct, 207f
upper/lower, 203
Yin/Yang, 452
opposition(s), astrological, 461ff
optimism, 526
 unjustified, 392
Orandus, Eirenaeus, 197n
order: archetype of, 456
 in fantasy, 203
 God as creator of, 498
 number and, 456
orderedness, acausal, 512, 516
organic systems, production of, 181
organological standpoint, 177
Origen, 222n, 518n
Orphism, 444
Osiris, 155
Ostwald, (Friedrich) Wilhelm, 6n, 12n
Otto, Rudolf, 104
outlooks, horizontal and vertical, 339, 342

P

pain: and dreams, 261
 perception of, 322
 a psychic image, 353
pain-pleasure reaction, 123
painting, 82, 86, 202
Palau, 64
palladium, 48
palolo worm, 437
pan-psychism, 16

Papa, 156

parable, language of, 248

Paracelsus, 191, 192, 193ff, 493n, 495

Paradise, 388, 390

parallelism: pre-established, 500

of psychic processes, 262

psychophysical, 17, 498, 506, 511; *see also* harmony

parallels, symbolic, 440

paramnesia, 444

parapraxes, 101

parapsychic phenomena, 205n, 234, 318

parapsychology, 318n, 412f, 446, 502; *see also* telepathy

parasites, intestinal, 152

parents, 396

differentiation from, 391

and pathogenic conflicts, 304

persecution by dead, 304

separation from, 373f

substitute, fantasies of, 20; *see also* father; mother

participation mystique, 65, 153, 265

“parties supérieures”/“inférieures,” 21, 180ff

passion, physical and spiritual, 212

pathology, primitive, 309

patient, *see* analyst

pattern, instinctual, 446

Paul, St.: conversion of, 211, 307n

Epistles of, 308

Nietzsche and, 80

thorn in the flesh, 393

Pauli, W., 229n, 232, 435n, 489n, 498n, 512, 514

Paulus, Jean, 179n

peace, 360

peacock's tail, 197

pearl, 112

of great price, 194
Pechuël-Loesche, Eduard, 43, 62n
pelican, 293
Pentecost, 151, 315
perception(s): archetypes of, 133
of collective unconscious, 314
extrasensory, 317, *see also* ESP
and immediate existence, 446
inborn, 493
of inherent possibilities, 141
intuition and, 132
is of images only, 383
and knowledge, 390
Leibniz on, 500
object-*imago* and, 274
outside space and time, 413
and reality, discrepancy, 264
subliminal, 310, 446
in time, and synchronicity, 445
transcerebral, 511
in unconscious, 172; *see also* sense-perceptions
peripeteia, 295
persecution, ideas of, 308
persistence, 425
person, first and third, child's use of, 390
personality: admired, and attitude, 331
changes of, 411
diminution of, 395
double, 186, *see also* consciousness, double
loss of, in projection, 309
perfection of, 377
transformation of, 122, 441; *see also* character
personification, 66
pessimism, 429

Peterson, Frederick, and Jung, C. G., [14n](#)
phantasms of the living, [430](#)
Pharaohs, [155](#), [378](#)
Philistinism, [396](#)
Philo Judaeus, [445](#), [490](#)
philosophy, [354](#)
 and archetypes, [158](#)
 Cartesian, [439](#)
 Chinese, [486](#), [501](#)
 Eastern, introspective character of, [228](#)
 German, power-words in, [170f](#)
 Greek, [341](#)
 Hegel's, [170](#)
 Indian, and superconsciousness, [178n](#)
 myths and, [153](#)
 not one but many, [343](#)
 and psychology, [276](#), [343](#)
 and the soul, [339](#)
 speculative, [351](#)
 and *Weltanschauung*, [358](#)
phobia(s), [131](#), [143](#), [364](#), [406](#)
photograph, lost, [431](#)
phylogenesis, traces in mind, [248](#)
physical illness, and psychic problems, [261](#)
physical and spiritual, conflict, [352](#)
physics, [384](#), [421](#), [514](#)
 atomic, and psyche, [234](#)
 and models, [214f](#)
 nuclear, [318n](#)
 observer in, [229f](#)
 and psychology, [216f](#), [232](#), [515](#)
 time in, [512](#); *see also* discontinuities
physiology, [357](#)
 abysses of, [326](#)

physique, changes in, 397
physis, 351
Picavet, François, 196n
Pico della Mirandola, Giovanni, 490ff
pictures, as expressing fantasy, 82f
Pisces, 528
Pitra, Jean-Baptiste, 197n
PK, *see* psychokinetic experiment
planchette, 84
planets, 454
 seven, 197
plants, 321
Plato, 30, 156, 502
 and archetypes, 135
 cave myth, 213n
 “Fourth” in *Timaeus*, 513
 parables of, 248
Platonists, 493
play-instinct, 117
pleasure, craving for, 393
 Freud and, 50
Plotinus, 490
plum-pudding, 43n
pneuma/πνεῦμα 320, 345
Podmore, F., 430n, 450
poimandres/*poimen*, 331
political changes, and psychology, 314
polytheism, extermination of, 49
Ponape, 64
pontifex maximus, 156
possession, 98
 and hysteria, 368
and insanity, 305
possibility, criterion of, 423

potentialities, psychic, loss of, [394](#)

power: craving for, [393](#)

infantile claims to, [258](#), [260](#)

instinct, [367](#)

psychotherapy and increase of, [311](#)

“powers,” suprapersonal, subjection to, [50](#)

Pratt, J. G., et al., [432n](#)

prayer, [518](#)

precognition, *see* foreknowledge

predicates, value, [94](#)

prefiguration, [430](#)

pregnancy, [345](#)

Press, the, in wartime, [264](#)

prestige, psychology of, [50](#)

Preuss, K. T., [42n](#), [65](#)

primitives, [354](#), [361](#)

and autonomous psychic contents, [369](#)

and belief in souls/spirits, [302ff](#), [305](#), [309](#)

and canalization of libido, [44f](#)

and claims of archetype, [375](#)

conceptions of libido, [61ff](#)

dissociability in, [104](#)

and dreams, [49n](#), [303](#)

and evocation of unconscious, [78](#)

hunger among, [116](#)

instincts in, [134](#)

intuition among, [137](#)

live in two worlds, [303](#)

and loss of soul, [313](#)

and magic, [46](#)

matter and spirit among, [120](#)

mental illnesses in, [305](#)

and metaphor, [147](#)

and myths, [38](#), [153](#)

- and object, [270](#), [274](#)
- old people among, [400](#)
- and the psyche, [346](#)
- psychology of, [50](#)
- quasi-neurosis of, [50](#)
- seldom reach old age, [407](#)
- and sexuality, [244](#)
- and space and time, [436](#)
- symbol and, [25](#)
- and synchronicity, [50](#)
- and unconscious, [157](#)
- world-picture of, [327](#); *see also* initiation; magic

Prince, Morton, [96](#)

principle(s): guiding, [335](#)

- hardening of, [395](#)
- triad of, [517](#)
- universal, [490](#)

probability, [228f](#), [425](#), [528f](#)

- calculus, [430](#)
- psychic, archetypes as, [515](#)

problems, [388ff](#)

- and consciousness, [390](#)
- purpose of, [394](#)

process(es): and instincts, [180](#)

- psychic, [166](#), [207](#)

Proclus, [137](#)

prognosis, dreams and, [282](#)

progression: and development, [37](#)

- energetic view, [38f](#)
- and extraversion, [40](#)
- of libido, [32ff](#)
- means to regression, [40](#)
- origin of, [39](#)

projectile, [406](#), [408](#)

projection(s), 207, 264f, 271, 308, 370, 452
of analyst's psychology, 259
archetypal, 493
in child, on to parents, 53
and counter-projections, 273
favourable and unfavourable, 271
negative, 272
in neurotics, 264
of primitive psyche, 121
withdrawal of, 269

proof, demand for, 401

prophecy, in dreams, 255

Prosper of Aquitaine, 518n

protagonists, in dream, 294

Protestant/Protestantism, 59, 156

Proteus anguinus, 152

proton radiation, 460, 527, 528

protozoa, 152

proverb, 331

Providence, 429

psyche, 300, 340 *et passim*
arrangement of life-processes, 322
biological aspect, 357
= "butterfly," 345
cannot be denied, 348
collective, genesis of, 315
conflict between instinct and will, 183
a conscious-unconscious whole, 200
dependence on physiology, 107
disappearance of portion of, 314

dissociability of, 173ff
a divisible whole, 307
energetic aspect of, 233
as epiphenomenon, 342
etymology, 345
and external happenings, 350
falsifies reality, 353
functional systems of, 153
given immediately, 139
whether identical with consciousness, 184, 187, 200
infantile, 51
and “living being,” 321
localization of, 347
as machine, 79
mass, 221, 222
and matter, relation, 215, 340
nature of, 323
—, unknown, 409
nothing old in, 393
as object of experience, 6
and the physical, relation, 7, 17f, 505f
presupposes body, 325
primitive, 50
reflection of the material, 342
relation to consciousness, 171
as relatively closed system, 7, 8, 26
self-observation of, 436
a series of images, 325
and space, 531
tendency to split, 121
transcending space and time, 413
unconscious, uniformity of, 110
upper and lower limits, 182f
variability of, 120f

in waking and sleeping state, 306
the world's pivot, 217; *see also* mind; soul; spirit

psychiatry, and causality, 27

psychic: how defined, 181
energy of the, 22, 31, *see also* energy, psychic
events, objective side of, 346
—, reality of, 344
its nature, unconscious, 214
and physical, relation, 344
and reality, 383f

Psychical Research, Society for, 501

psychization, 115

psychoanalysis, 27, 34f, 49, 363ff, 370
Weltanschauung of, 367; *see also* Freud

psycho-galvanic phenomenon, 14, 95

psychogenesis, of spirits of the dead, 315

psychogenic diseases/illness, 304
and belief in spirits, 364

“psychoid,” 176f, 183f, 436, 505, 513

psychokinetic experiment, 434, 523

“psychological,” 409

Psychologies of 1930, 343

psychology, child-, 52
Chinese, 489
experimental, 363
—, first use of term, 161
future task of, 356
has no outside, 223
medical, 281
modern, 357
—, no single, 343
physiological, 363
position in universities, 162
practical, 351

relation to biology, 114
uniqueness of, 125
“with the psyche,” 344
“within the psyche,” 343
“without the soul/psyche,” 338, 343, 344; *see also* analytical psychology; brain
psychology; consciousness; physics
psychopathology, 224f, 349
psychosis(-es), 315, 365
 latent, compensation in, 288
 mass, 272, 315
psychosomatic phenomena, 232
psychotherapy: and death, 402
 practical, 351
 and return of lost complex to consciousness, 311
psychotic, under influence of unconscious, 69
Ptah, 379
Ptolemy (the astrologer), 454n
puberty, 391
puberty-rites, 374
Pueblo Indians, 347
pulse curve, 14
punctuation, art of, 453
purpose, sense of, 241, 243
Purusha, 198, 199

Q

quanta, energy, 517
quantities(-y): factor of energy, 20
 measurement of, and energy, 8f, 15
 psychic, 15
 very small, 421
quaternio, 512, 514; *see also* tetrad
quaternity(-ies), 203, 294, 457
 double, 294
 pagan, 513

quincunx, 293
quinta essentia, 494
quintessence, 192*n*

R

radial arrangement, 203
radioactive decay, 512, 517
radioactivity, 167, 514
radio weather, 460
radium decay, *see* radioactive decay
railway stations, dream-motif, 283
randomness, 515
rappings, 320
rapture, 186
rashes, skin, 334
rationalistic opinions, and neurotic symptoms, 410
rationality, 488
rationalization(s), 134, 342
 of consciousness, 380
 of inner perceptions, 314
rattlesnake, 323
reaction(s): disturbed by complexes, 95, 313; *see also* “all-or-none” reaction
reaction-dreams, 260
reaction times, in association tests, 312
realism, relative, 5*n*
reality: adaptation to, 362
 —, lost, 315
 “geometric” idea of, 525
 God as quintessence of, 350
 not purely material, 382*f*
 psychic, 353, 354, 384
 —, oneness of, 354
 replacement by collective unconscious, 315
 and super-reality, 382
reason: and catastrophe, 355

- innate, 496
- relativity of, 25
- rebirth: rituals, 393
 - symbols, 411
- reciprocal action, body-psyche, 17f
- recognition, 141, 390
- red (colour), 187
 - representing instinct, 211
- redeemer-figure, 111
- reduction, 50, 58, 257f
 - of dream-content, 240
- reflection, 33, 308
 - as instinct, 117
 - in unconscious, 172
- reflex(es), 176
 - chains of, 510
 - and instincts, 131
- reflex arcs, 322f
- reflexio*, 117
- Reformation, 338
- regatta, as symbol of self, 199
- regression, 23
 - energetic view, 38f
 - and introversion, 40
 - of libido, 32ff
 - origin of, 39
- Reid, Thomas, 130
- relationships: human, and projections, 264
 - mother-child, 373
 - space-time, 123
- relatives, dead, primitives and, 304
- relativity, of space and time, psychic, 435, 524
- religion(s), 354
 - and archetypes, 221

autonomous psychic contents and, 370
collective, inadequacy of, 59
and collective consciousness, 221
compensatory factor in dreams, 250
and death, 408
and future life, 401
images in, 137
individual, 58f
nature of, 408f
not conscious constructions, 409
primitive, 270
problem of, 51
and psychology, 276
psychology of, and archetypes, 205
reasonableness of, 402
as schools for second half of life, 399
state, 49; *see also* education, religious
religious: changes, and psychology, 314
 ideas, diversity of, 376
reminiscence, emotional, 267
renewal, psychic, 439
repetition experiment, 95
representations, 165, 166, 172, 322
 Herbart on, 163
 inheritance of, 133n
 primitive, 65
représentations collectives, 122
repression(s), 10, 133, 151, 255, 310, 364, 365f
 of contents of collective unconscious, 219
 dreams and, 365
 Freud and, 11n, 19, 55, 102, 179
 and ideal attitude, 311
 sexual, 367
resentment, moral, 364

resistance(s): of conscious to unconscious, [112](#)
 infantile, [405](#)
 neurotic, [406](#)
 to unconscious ties, [273](#)
respiration curve, [14](#)
responsibility, diminished, [96](#)
restlessness, [177](#)
 neurotic, [415](#)
revelation, [380](#)
Revelation, Book of, [220n](#)
revenants, [304](#)
revolution(s), [355](#)
 psychic, [391](#)
Rhine, J. B., [233](#), [263n](#), [432ff](#), [440](#), [441](#), [445](#), [446](#), [447](#), [477](#), [480](#), [482](#), [501](#), [516](#), [523ff](#),
 [530](#)
Richet, Charles, [430](#)
Ricksher, C., [14n](#)
Rig-Veda, [198](#)
rīh/rūh, [345](#)
ring, gold, [112](#)
Ripley, Sir George, [196](#)
rites, *see* ceremonies; initiation; puberty
rites d'entrée, [44](#)
Rivers, W. H. R., [129](#), [137](#), [181](#)
rock-drawings, South American, [46](#)
Röhr, J., [65](#)
Romantic Age, [442](#)
rose-chafer, [438](#), [526](#)
Rosenberg, Alfons, [492n](#)
Rosencreutz, Christian, [47n](#)
rotation, [203](#)
rotundum, [492](#)
Rousseau, Jean-Jacques, [381](#), [388](#)
Royal Society of Medicine, [509](#)
ruach/ruch/roho, [319](#)

Rumpelstiltskin, 378

“runs,” of chance events, 424f, 437

S

Saint-Graal, 293n

salt, 156, 402

Saul, *see* Paul, St.

scala unitatis, 494

scarab, 438f, 440, 441, 445, 447, 525f

scars, ceremonial, 374

scepticism, 362, 524

Schelling, F. W. J. von, 102, 165, 169

Schiller, Friedrich, 14, 442n, 502

schizophrenia, 88, 122, 143, 150

 among primitives, 305

 archetypes in, 138

 blunting of affect in, 26

 mythological images in, 311

schizophrenics, megalomania of, 170

Schmiedler, G. R., 477n

scholasticism, 136

Scholz, Wilhelm von, 431

Schopenhauer, Arthur, 30, 136, 169, 170, 171, 427ff, 492, 498, 506, 517

Schultze, Fritz, 42n

science(s): and archetypes, 158, 403

 and causality, 430

 and correspondence theory, 501

 images in, 137

 limitations of, 328

 magic and, 46

 myths and, 153

 one-sidedness of, 220

 and reality, 327

 and the soul, 339, 401

 symptoms of man's psyche, 389

and *Weltanschauung*, 377, 379
and wholeness, 451
scientists, and *Weltanschauung*, 362
scintilla(e), 190ff, 199
searchlight, 323
sea-serpents, 155
second half of life, 60, 396ff; see also afternoon of life forty, age of; maturity
sects, life-denying, 336
Seele, 300, 345
self: archetype of, 316, 317
 and ego, 224ff
 subordination of will to, 224
 “uniting” symbols of, 199
self-awareness, 270f, 275
self-criticism, 81
self-observation, 81
Seligmann, Charles Gabriel, 64n
sensation, 451
 faculty of, 123
 seat of, 347
 unanalysable, 163
 use of word, 142
senses: mind and, 382
 truth and, 354
sense-functions, and consciousness, 175
sense-impressions, as psychic images, 353
sense-perceptions, 140
 unconscious, 367
sensus naturae, 195f
sentiment, 142
seriality, 425, 426
series, law of, 424f
serpens quadricornutus, 513
serpent(s): four-horned, 513

sexuality as, 155
in vision of St. Ignatius Loyola, 199
and zodiac, 197; *see also* snake(s); uroboros
serpentine, 503
sex: as psychic modality, 119
youth, and problems of, 392
sexualism, 28
sexuality, 367
eruption of, 391
fantasies of, 155
Freud and, 19, 22, 29, 51, 55*f*, 112
importance in psychic life, 57
incomplete explanation of psychic phenomena, 21*n*
infantile, 51, 258
as instinct, 116
and libido, 30
primitives and, 244
as strongest instinct, 58
young people and, 60
“sexual question,” 56
shadow: man without a, 208
realization of the, 208, 221
soul and, 346
shepherd, 331
shock, 260
“sicut,” in the Mass, 149
Siebeck, Hermann, 159*n*
significance, equal, of parallel events, 482
Silberer, Herbert, 47*n*, 263, 431
simile, 248
similitude, divine, 498
simultaneity, 427, 435, 485
of two psychic states, 444*f*
sin, original, 220

situation: experimental, 93
psychic, and dreams, 284
total, 450
“skeleton in the cupboard,” 100
sleep, 511
consciousness in, 143
dreams as preserving, 251
seldom dreamless, 306
sleeplessness, 296
snake(s): dream-motif, 146ff, 283, 291
fear of, 130f
and hero, 292 *see also* dragon; serpent; urahoros
Soal, S. G., 432n, 517
social changes, and psychology, 314
Söderblom, Nathan, 54n, 64
sol invisibilis, 193
solution of dream, 295
somnambulism/somnambulistic state, 142, 411
“so-ness,” 457
Sophia, 156
Sophocles, 198
soul(s): belief in, 305, 309
as birds, 309, 439
cortical/medullary, 177
dark part of the, 171
dependent on spiritual world-system, 351
etymology, 345
immortality of, 305, 347
in Leibniz, 499
as life, 345
loss of, 309, 313
multiple/plurality of, 104, 174, 305, 309
not located in space, 347
objective reality of, 347

primitives and, 274
psychology and the, 159f, 167
rites for recall of, 309
as a substance, 338; *see also* dark night of the soul; psyche; spirit(s)
soul-bird, 309
soul-spark(s), 137n, 225; *see also* scintilla(e)
sound, 322, 353
frequencies, 175
southern races, physique of, 397
space, 513
multi-dimensionality of, 512
psychic in origin, 436
relative, 231n, 433f, 531
synchronicity in, 445; *see also* space-time continuum
space-time barrier, 413f
space-time continuum, 318n, 481, 506, 513f
relative, 231
Spain, 522
sparks, 190ff; *see also* soul-spark
spear(s), 42
Odin's, 517n
species: development of, 176
differentiation of, 349
origin of, 340n
spectrum, 187, 211
speculation, 343, 387, 389
transcendental, 429
speech: figures of, 329
lapses of, 13, 71, 98, 143, 288
Speiser, Andreas, 486n, 515
Spencer, B., 44n, 48n, 62n, 63n
Spencer, Herbert, 131
sphere, 203
Spielrein, S., 311n

spinal cord, 322

Spinoza, B., 136

spirit(s): antithesis with instinct, 207

- archetype as, 205f, 216
- autonomous complexes, 309
- belief in, 101, 301ff
 - , among masses, 302
 - , mental illness and, 305
 - , on higher level, 302
 - , sources of, 305
- of the dead, 155, 330
- of early Christianity, 336
- the East and, 354
- etymology, 329f
- evil, 330
 - , possession by, 305
- extra-psychic existence of, 309n
- “guiding,” 330
- idea of, unpopular, 344
- and illness, 370
- independent life of, 335
- and instinct, as limiting will, 183
- intention of the unconscious, 335
- limits set by life, 337
- and “living being,” 327
- meaning of term, 54, 300, 320, 329ff
- and mind, interchangeable concepts, 326
- “new,” 330
- not absolute, 336
- not always dangerous, 315
- as personal being, 335
- among primitives, 137, 369
- projection and, 309
- as psychic category, 120

psychogenesis of, 315
and sexuality, 57
sovereignty of, 170
superiority over ego-consciousness, 335
“teachings of the,” 317
timeless and immortal, 345
two-faced, 222; *see also* mind; psyche; soul
spirit of the age, 340, 341, 342
spiritualism, 158, 317, 330
 spiritualistic communications, 316f
 —, phenomena, 320
Spiritus mundi, 494
splinter psyches, complexes as, 97, 98
splitting: of personality, 33, 96, 173f
 of psyche, 121, 122; *see also* consciousness
square: in crystals, 503; *see also* quaternity
stag, 293
stages of life, 387ff
standpoints, psychological and realistic, 327f
star(s): and astrology, 152
 in man, 193
 reflected in water, 199
State, philosophy of the, 170
state: anarchic/chaotic, 391
 divided/dualistic, 391
 monarchic/monistic, 391
statistical: analysis, 440n
 laws, 229
Stekel, Wilhelm, 427n
Stern, L. W., 15 & n
stimulus: auditory, 322
 and nervous system, 322
 and reaction, 131
stimulus-words, 312f

storms, magnetic, [460](#), [527](#)
struggle, existence as, [360](#)
style of life, masculine, breakdown of, [398](#)
subconscious(ness), [164](#), [168](#), [177f](#), [186](#), [187](#)
subcortical processes, [176](#)
subject: and psychic processes, [173](#)
 unconscious, [165](#)
subject and object: primitive confusion, [154](#)
 same thing as both, [428](#)
subjective level, dream interpretation on, [266ff](#)
subjectivity, [390](#)
sublimation(s), [22](#), [58](#), [365](#)
 forced, [59](#)
 a self-deception, [365](#)
“subliminal,” [133](#), [175](#)
 processes in unconscious, [367](#)
substance, and energy, [22](#)
substitute formations, [19](#)
suffering: behind neurosis, [366](#)
 meaning of, [367](#)
 psychic, treatment of, [355](#)
suggestion: constructive method not mere, [75](#)
 readiness needed for acceptance, [75](#)
suicide, [288](#), [454n](#)
 during therapeutic treatment, [352](#)
sun, [191](#), [192](#)
 in astrology, [454f](#), [528](#)
 comparison of life with, [403](#)
 daily course of, [397](#)
 dragon and, [197](#)
 Elgonyi and, [154](#), [209](#)
 hallucinated phallus of, [150](#)
 proton radiation from, [460](#)
sun-god, [439](#)

sun-hero, 153
sun-spot periods, 460
superconsciousness, 164, 168, 178
“super”-concepts, 383
superman, 170
super-reality, 382ff
superstition, 303, 316, 328, 354
 core of truth in, 517
 primitive, 441
suppuration, 253
Swedenborg, Emmanuel, 481, 483, 526
swoon states, 509
sword, 75f
 Freya’s, 517
sydus, see star
symbol(s): alchemical, 46
 at approaching death, 410
 cause and, 24f
 Christian, effectiveness of, 336
 dissolution of, 75
 formation of, 45ff, 61, 263n
 in Freudian literature, 175, 246
 history of, 495
 “libido analogues,” 48
 migration of, 111
 nature of, 336
 rebirth, 411
 religious, genesis of, 409
 —, heart source of, 409
 —, “revelatory” character, 409
 semiotic interpretation, 46, 75
 significance of, 246
 Spirit as, 336
 symbolic interpretation of, 75

“uniting,” 199; *see also* dream-symbols “
symbola,” 59
symbolism: Catholic, 59
 colour, 211
 of dreams, 245
sympathetic system, 510, 511; *see also* nervous system
symposium, 344
symptom(s): in neurosis/neurotic/nervous, 34, 303
 —, and reason, 335
 psychogenic, and unconscious, 179
symptoma/symptosis, 217
synchronicity, 205n, 215, 231ff, 419ff, 520ff
 of archetypal events, 198
 astrological, 496f
 body-soul, 500n
 and causality, 485
 instance of acausal orderedness, 516
 irrepresentable, 505, 513
 meaning and use of term, 441, 445
 psychic conditions for, 450
 regularity of, 511
 in space and time, 445
 two factors in, 447
 without participation of human psyche, 502n; *see also* affects
synchronism, 441
synchronistic: phenomena, frequency of, 500, 511
 —, in loss of consciousness, 509
 principle, first use of term, 452 and
syncope, 506f, 509
Synesius, 493
synopados, 346
systole, 37
Szondi, L., 180n

table, as dream-symbol, 285
table-turning, 320
taboos, 212
talk: imprudent, 330
 irrelevant, 13
Talleyrand, Charles Maurice de, 94
Tao, 486ff, 501
Tao Teh Ching, 486ff
Taos Indians, 44
technique, differentiation of, 377
teeth, losing, dream-motif, 283
teleology, 4n
 in biology, 493
 life as, 406
telepathy, 231, 412f, 431, 494n, 501, 523, 526
 and dreams, 261f
 and unconscious complexes, 318
telescope, 168, 449
temperament, difficult, 392
temperature, 334, 497
tension: bodily, 322
 problems and, 391; *see also* energy-tension; opposites
terrena, 294
terror, 323
tetrad, 456, 512
tetradic principle, in astrology, 453
tetragrammaton, 495
Theatrum chemicum, 192n, 193n, 494n, 514n
Theophrastus, 490
theosophy, 49, 59, 379
thinking: apotropaic, 99
 control of, 306
 directed, 27
 distorted, 410

dream-, 247
faculty of, 123
function, and adaptation, 34
medical man and, 277
primitive, 311
and primordial images, 402f
and recognition, 141
trinitarian type, 514
and understanding, 402
wishful, and dreams, 504n; *see also* thought

Thor, 517n

Thorndike, Lynn, 196n, 453n

thought(s): extra-conscious, 324
non-spatial, 347f
reality of, 383
seat of, 347
as secretions of brain, 343
transcerebral, 511
unreal and real, 384; *see also* thinking

thought-deprivation, 13

thought-transference, 151

three and four, dilemma of, 513

threshold, 310
lower and upper, 176
psychological, 166n, 176

throat, lump in, 145f

thyroid gland, 403

Timaeus, 513; *see also* Plato

time, 511
in association experiments, 13
and creation, 518n
as fourth dimension, 512
multi-dimensionality of, 513n
one-dimensionality of, 512

psychic in origin, 436
psychic relativity of, 433, 531
probably same as space, 445
in Rhine's experiments, 433
statements of, in dream, 294
symbolism, 197f
and synchronistic phenomena, 445, 517; *see also* space; space-time

Tobi, 64

Tobit, Book of, 101

tondi, 64

tongue, slips of, *see* speech, lapses of

Torres Strait, tribesmen of, 62

totem, 48
-ancestor, 380

touch, magic, 43

trains, dream-motif, 283

trance, 232, 506

transference, 74, 269, 273
erotic character of, 74

transformation: alchemical, 293
energetic, 41
of physical into psychic, 384
psychic, in middle life, 398
spiritual processes of, 357

transgressivity, of archetypes, 515

transmission, 435, 524

transmutation of elements, *see* elements

transpsychic reality, underlying psyche, 318n

trauma, 98, 260f

travel, urge to, 117

treasure: hard to attain, 112, 194
hero and, 292
hidden, 293

tree: as alchemical symbol, 293n

of knowledge, 390
in Nebuchadnezzar's dream, *frontisp.*, 251, 293
wishing, 293
triad, 456, 514, 517
triadic: fantasy-formations, 203
 principle, in *I Ching*, 453
 view of world, 514
tribe, 374
trigrams, 453
Trinity, 156, 335, 491, 513
 astrological, 472
 Nicholas of Flue's vision of, 211
truth(s): of the blood, 415
 identification with one-sided, 219
 psychological, 409
 statistical, 421*f*
 and *Weltanschauungen*, 378
tube, origin of wind, 150*f*
turbine, 42
twilight state, 508, 510
Tylor, E. B., 62
types: functions and, 124
 ideal, 108
 instinctual events as, 515
 in man, 201
typhoid, 371
typological method, 107*ff*
Tyrrell, G. N. M., 432, 434, 509*n*

U

“ugliest man,” 80
uncertainty, factor of, 521
unconscious, 33*f*, 287, 334, 364, *et passim*
 absolute, 148
 ancestral deposit in, 349

attitude of, [288](#)
autonomy of, [287](#)
behaviour of new contents, [121](#)
collective, *see separate entry below*
compensatory function of, [10](#), [69](#), [344](#), [493](#)
and consciousness, complementarity, [188](#)
contents of, [69](#), [144](#), [165](#), [185](#), [367](#)
—, deliberate evocation of, [78](#)
—, creates new, [364](#)
and death, [411](#)
definition, [133](#)
deposit of all experience, [157](#)
disturbances and, [334](#)
dreams and, [77](#), [145ff](#)
Fechner and Lipps on, [166](#)
Freud's view, [179](#)
fringe of conscious, [185](#)
highly extensive, [349](#)
instinct and, [133ff](#)
overrating of, [296](#)
personal, [133](#), [151f](#), [200](#), [310](#)
—, and collective, [291](#), [310](#)
—, contents of, *see separate entry below*
personified conception, [349](#)
positive activity of, [364](#)
as psychic modality, [119](#)
reasons for controlling, [79](#)
reductive function, [257f](#)
regulating factors of, [81ff](#)
relativity of, [187](#)
separation from conscious, removal of, [73](#)
significance of, [254](#), [256](#)
statements about it unverifiable, [214](#)
subject of, [177](#)

and telepathy, [412](#)
two parts of, [310](#)
units of unconscious psyche, [101](#)
as unknown psychic, [185](#)
Wundt's view, [164](#)

unconscious, collective: [112ff](#), [122](#), [133f](#), [148ff](#), [310f](#), [372](#)
basis of individual psyche, [152](#)
Catholic and, [156](#)
contents of, [152](#), [310](#)
danger of its replacing reality, [315](#)
deposit of ancestral experience, [376](#)
immortality of, [349](#)
inherited, [350](#)
irrepresentable, [436](#)
as microcosm, [494](#)
is purposive, [350](#)
spiritualism and, [317](#)
sum of instincts and archetypes, [137f](#)
unconscious of own contents, [350](#)

unconscious contents, [310](#)
essentially relative, [260](#)
integration into consciousness, [223](#)
reflected in dreams, [248](#)
“representedness” of, [165](#)

unconscious processes, and energy, [16](#)

unconscious products: nature of, [143](#)
over- and under-valuation of, [85](#)

“underlying,” [515](#)

understanding: and aesthetic formulation, [85](#)
not exclusively intellectual, [244f](#)
of unconscious product, [84ff](#)

unicellular organisms, psychic function and, [115](#)

uniformity, psychic, [111](#), [227](#)

uniqueness, [422](#)

United States of America, 400

unity, 491

universals, 5*n*

uprootedness, 415

uroboros, 198, 213

Usher, F. L., 433

V

values: change into opposites, 398

comparison of, 9*ff*

conscious, disappearance of, 10

subjective, 9*f*

unconscious, 10

Venus, 455, 461, 528

Veraguah, Otto, 14*n*, 95

verbal concepts, mistrust of, 319

vertebrates: aquatic, 152

higher, 321

sympathetic system in, 511

view, day-time and night-time, 219

Villa, Guido, 164*n*

violet (colour), representing archetype, 211, 212

Virgil, 493

Vischer, F. T., 97

vision: of sun-tube, 151

of Trinity, 211; *see also* Ezckiel; Nicholas of Flüe; Swedenborg

vitalism, 28

vitality, heightened feeling of, 347

vituperation, 103

voice(s): deepening of, in women, 397

heard by insane, 305, 308

inner, 83

“other,” 83, 88*f*

volatilia, 294

volcano, 443

volition, 142
and attitude, 332
presupposes choosing subject, 183; *see also* will
Voltaire, 368
voyages, great, 339
Vulpus, Christine, 455n

W

Wachandi, 42f, 45
Wagner, Richard, 80
wakan, 63
wakonda, 61
walen/wälzen, 43
Waley, Arthur, 486n
Wallace, A. R., 302
wand, magic, 517
war: and judgment of enemy, 270
 psychology of, 271
 and reaction-dreams, 260
 World, reason and, 355; *see also* atom-bomb; Boer War
Warnecke, J., 64n
water, in alchemy, 191
wawo, 437n
weather, radio, 460
weaver-bird, 226
wedding, sacred, *see hieros gamos*
Wei Po-yang, 486n
well, 293
Weltanschauung, 276, 358ff
 and attitude, 360f
 claims to truth, 378
 determined by consciousness, 361
 purpose of, 361
 what is wrong with?, 378
Wên, King, 452

wheat, [155](#)

West, the, and nature, [354](#)

Weyl, Hermann, [502](#)

wheels, [198](#)

White, Stewart Edward, [316](#), [317](#)

whole, grasping of the, [451](#)

wholeness, [292](#)

conscious, [225n](#)

preconscious, [225](#)

psychic, [175](#)

—, images of, [457](#)

unconscious, [211](#)

Wilhelm, Hellmut, [527](#)

Wilhelm, Richard, [452n](#), [486](#), [487](#), [488](#)

will, [181ff](#), [498–9n](#)

and attitude, [332](#)

biological motivation of, [183](#)

as factor determining behaviour, [118f](#)

free or determined, [119](#)

freedom of, and consciousness, [373](#)

and function, [182](#)

and instinct, [132](#), [134](#), [200](#)

primitives and, [45](#)

in Schopenhauer, [170](#)

subordination to self, [224](#)

supremacy of, [96](#)

transcendental, [428](#), [429](#)

in unconscious, [172](#)

unconscious acts of, [173](#), [174](#)

William of Auvergne, [196](#)

wind, sun-phallus and, [150f](#)

wind-force, [430](#)

Wisdom of Solomon, [191](#)

wise old man, [293](#)

“wish,” 517

wish-fantasies, 365

wish-fulfilment, 268, 277, 285

- religion as, 409
- theory, 254, 260, 263

wishing-rod, 517

wish-objects, 51n

witches/wizards, 155

witnesses, 422

Wolf, Christian von, 161, 165

woman, and moon, 154

women: masculinity in, 398

- neurotic difficulties in, 395
- physical change in older, 397
- psychic change in older, 398

wong, 62

words: fantasied, 83

- magic of, 109
- spellbinding, 170

work: culture and, 41

- energy and, 41f

world: created by psyche, 384

- Eastern view of, 383
- man’s relation to, 360
- material and psychic, 384
- picture of, 361ff
- as psychic image, 363
- scientific view of, 422

World Essence, 191

world-image, 376, 380

world-soul, 190, 196, 490, 494; see also *anima mundi*

wounded man, 506

wounds: head and brain, 506f

- psychic, 313; see also trauma

writing: automatic, [84](#), [121](#), [320](#)

mistakes in, [13](#)

Wundt, Wilhelm, [3n](#), [4n](#), [6 & n](#), [16](#), [22](#), [23](#), [101](#), [164ff](#), [172](#), [173](#)

Y

Yang and Yin, [451](#), [452](#)

Yaos, [62](#)

yaris, [64](#)

yarrow stalks, [451n](#), [452](#), [453](#), [527](#)

yod, [495](#)

yoga, [357](#)

youth, [405](#)

period of, [391ff](#)

unwillingness to part with, [396](#)

yucca moth, [132](#), [137](#)

Z

Zacharias, Book of, [197n](#)

Zagreb, [433](#)

Zarathustra (Nietzsche's), [80](#), [122](#), [335](#)

Zeller, Eduard, [490n](#)

Zen Buddhists/Buddhism, [68](#), [225](#)

zodiac, [197](#), [527](#)

signs of, [454](#), [455n](#)

zogo, [62](#)

Zöllner, J. K. F., [302](#)

Zoroaster, [493](#)

Zorobabel, [197](#)

Zosimos of Panopolis, [492](#)

THE COLLECTED WORKS OF

C. G. JUNG

THE PUBLICATION of the first complete edition, in English, of the works of C. G. Jung was undertaken by Routledge and Kegan Paul, Ltd., in England and by Bollingen Foundation in the United States. The American edition is number XX in Bollingen Series, which since 1967 has been published by Princeton University Press. The edition contains revised versions of works previously published, such as *Psychology of the Unconscious*, which is now entitled *Symbols of Transformation*; works originally written in English, such as *Psychology and Religion*; works not previously translated, such as *Aion*; and, in general, new translations of virtually all of Professor Jung's writings. Prior to his death, in 1961, the author supervised the textual revision, which in some cases is extensive. Sir Herbert Read (d. 1968), Dr. Michael Fordham, and Dr. Gerhard Adler compose the Editorial Committee; the translator is R. F. C. Hull (except for Volume 2) and William McGuire is executive editor.

The price of the volumes varies according to size; they are sold separately, and may also be obtained on standing order. Several of the volumes are extensively illustrated. Each volume contains an index and in most a bibliography; the final volume will contain a complete bibliography of Professor Jung's writings and a general index to the entire edition.

In the following list, dates of original publication are given in parentheses (of original composition, in brackets). Multiple dates indicate revisions.

*1. PSYCHIATRIC STUDIES

On the Psychology and Pathology of So-Called Occult Phenomena (1902)

On Hysterical Misreading (1904)

Cryptomnesia (1905)

On Manic Mood Disorder (1903)

A Case of Hysterical Stupor in a Prisoner in Detention (1902)

On Simulated Insanity (1903)

A Medical Opinion on a Case of Simulated Insanity (1904)

A Third and Final Opinion on Two Contradictory Psychiatric Diagnoses
(1906)

On the Psychological Diagnosis of Facts (1905)

+2. EXPERIMENTAL RESEARCHES

Translated by Leopold Stein in collaboration with Diana Riviere

STUDIES IN WORD ASSOCIATION (1904–7, 1910)

The Associations of Normal Subjects (by Jung and F. Riklin)

An Analysis of the Associations of an Epileptic

The Reaction-Time Ratio in the Association Experiment

Experimental Observations on the Faculty of Memory

Psychoanalysis and Association Experiments

The Psychological Diagnosis of Evidence

Association, Dream, and Hysterical Symptom

The Psychopathological Significance of the Association Experiment

Disturbances in Reproduction in the Association Experiment

The Association Method

The Family Constellation

PSYCHOPHYSICAL RESEARCHES (1907–8)

On the Psychophysical Relations of the Association Experiment

Psychophysical Investigations with the Galvanometer and Pneumograph in
Normal and Insane Individuals (by F. Peterson and Jung)

Further Investigations on the Galvanic Phenomenon and Respiration in
Normal and Insane Individuals (by C. Ricksher and Jung)

Appendix: Statistical Details of Enlistment (1906); New Aspects of Criminal
Psychology (1908); The Psychological Methods of Investigation Used in the
Psychiatric Clinic of the University of Zurich (1910); On the Doctrine of
Complexes ([1911] 1913); On the Psychological Diagnosis of Evidence
(1937)

*3. THE PSYCHOGENESIS OF MENTAL DISEASE

The Psychology of Dementia Praecox (1907)

The Content of the Psychoses (1908/1914)

On Psychological Understanding (1914)

A Criticism of Bleuler's Theory of Schizophrenic Negativism (1911)

On the Importance of the Unconscious in Psychopathology (1914)

On the Problem of Psychogenesis in Mental Disease (1919)

Mental Disease and the Psyche (1928)

On the Psychogenesis of Schizophrenia (1939)

Recent Thoughts on Schizophrenia (1957)

Schizophrenia (1958)

†4. FREUD AND PSYCHOANALYSIS

Freud's Theory of Hysteria: A Reply to Aschaffenburg (1906)
The Freudian Theory of Hysteria (1908)
The Analysis of Dreams (1909)
A Contribution to the Psychology of Rumour (1910–11)
On the Significance of Number Dreams (1910–11)
Morton Prince, "The Mechanism and Interpretation of Dreams": A Critical Review (1911)
On the Criticism of Psychoanalysis (1910)
Concerning Psychoanalysis (1912)
The Theory of Psychoanalysis (1913)
General Aspects of Psychoanalysis (1913)
Psychoanalysis and Neurosis (1916)
Some Crucial Points in Psychoanalysis: A Correspondence between Dr. Jung and Dr. Loÿ (1914)
Prefaces to "Collected Papers on Analytical Psychology" (1916, 1917)
The Significance of the Father in the Destiny of the Individual (1909–1949)
Introduction to Kranefeldt's "Secret Ways of the Mind" (1930)
Freud and Jung: Contrasts (1929)

‡5. SYMBOLS OF TRANSFORMATION (1911–12/1952)

PART I

Introduction
Two Kinds of Thinking
The Miller Fantasies: Anamnesis
The Hymn of Creation
The Song of the Moth

PART II

Introduction
The Concept of Libido
The Transformation of Libido
The Origin of the Hero
Symbols of the Mother and of Rebirth
The Battle for Deliverance from the Mother
The Dual Mother
The Sacrifice

Epilogue

Appendix: The Miller Fantasies

*6. PSYCHOLOGICAL TYPES (1921)

Introduction

The Problem of Types in the History of Classical and Medieval Thought

Schiller's Ideas on the Type Problem

The Apollinian and the Dionysian

The Type Problem in Human Character

The Type Problem in Poetry

The Type Problem in Psychopathology

The Type Problem in Aesthetics

The Type Problem in Modern Philosophy

The Type Problem in Biography

General Description of the Types

Definitions

Epilogue

Four Papers on Psychological Typology (1913, 1925, 1931, 1936)

†7. TWO ESSAYS ON ANALYTICAL PSYCHOLOGY

On the Psychology of the Unconscious (1917/1926/1943)

The Relations between the Ego and the Unconscious (1928)

Appendix: New Paths in Psychology (1912); The Structure of the Unconscious (1916) (new versions, with variants, 1966)

‡8. THE STRUCTURE AND DYNAMICS OF THE PSYCHE

On Psychic Energy (1928)

The Transcendent Function ([1916]/1957)

A Review of the Complex Theory (1934)

The Significance of Constitution and Heredity in Psychology (1929)

Psychological Factors Determining Human Behavior (1937)

Instinct and the Unconscious (1919)

The Structure of the Psyche (1927/1931)

On the Nature of the Psyche (1947/1954)

General Aspects of Dream Psychology (1916/1948)

On the Nature of Dreams (1945/1948)

The Psychological Foundations of Belief in Spirits (1920/1948)

Spirit and Life (1926)

Basic Postulates of Analytical Psychology (1931)
Analytical Psychology and *Weltanschauung* (1928/1931)
The Real and the Surreal (1933)
The Stages of Life (1930–1931)
The Soul and Death (1934)
Synchronicity: An Acausal Connecting Principle (1952)
Appendix: On Synchronicity (1951)

*9. PART I. THE ARCHETYPES AND THE COLLECTIVE UNCONSCIOUS

Archetypes of the Collective Unconscious (1934/1954)
The Concept of the Collective Unconscious (1936)
Concerning the Archetypes, with Special Reference to the Anima Concept
(1936/1954)
Psychological Aspects of the Mother Archetype (1938/1954)
Concerning Rebirth (1940/1950)
The Psychology of the Child Archetype (1940)
The Psychological Aspects of the Kore (1941)
The Phenomenology of the Spirit in Fairytales (1945/1948)
On the Psychology of the Trickster-Figure (1954)
Conscious, Unconscious, and Individuation (1939)
A Study in the Process of Individuation (1934/1950)
Concerning Mandala Symbolism (1950)
Appendix: Mandalas (1955)

*9. PART II. AION (1951)

RESEARCHES INTO THE PHENOMENOLOGY OF THE SELF

The Ego
The Shadow
The Syzygy: Anima and Animus
The Self
Christ, a Symbol of the Self
The Sign of the Fishes
The Prophecies of Nostradamus
The Historical Significance of the Fish
The Ambivalence of the Fish Symbol
The Fish in Alchemy
The Alchemical Interpretation of the Fish

Background to the Psychology of Christian Alchemical Symbolism
Gnostic Symbols of the Self
The Structure and Dynamics of the Self
Conclusion

*10. CIVILIZATION IN TRANSITION

The Role of the Unconscious (1918)
Mind and Earth (1927/1931)
Archaic Man (1931)
The Spiritual Problem of Modern Man (1928/1931)
The Love Problem of a Student (1928)
Woman in Europe (1927)
The Meaning of Psychology for Modern Man (1933/1934)
The State of Psychotherapy Today (1934)
Preface and Epilogue to “Essays on Contemporary Events” (1946)
Wotan (1936)
After the Catastrophe (1945)
The Fight with the Shadow (1946)
The Undiscovered Self (Present and Future) (1957)
Flying Saucers: A Modern Myth (1958)
A Psychological View of Conscience (1958)
Good and Evil in Analytical Psychology (1959)
Introduction to Wolff’s “Studies in Jungian Psychology” (1959)
The Swiss Line in the European Spectrum (1928)
Reviews of Keyserling’s “America Set Free” (1930) and “La Révolution
Mondiale” (1934)
The Complications of American Psychology (1930)
The Dreamlike World of India (1939)
What India Can Teach Us (1939)
Appendix: Documents (1933–1938)

†11 PSYCHOLOGY AND RELIGION: WEST AND EAST

WESTERN RELIGION

Psychology and Religion (The Terry Lectures) (1938/1940)
A Psychological Approach to the Dogma of the Trinity (1942/1948)
Transformation Symbolism in the Mass (1942/1954)

Forewords to White's "God and the Unconscious" and Werblowsky's "Lucifer and Prometheus" (1952)

Brother Klaus (1933)

Psychotherapists or the Clergy (1932)

Psychoanalysis and the Cure of Souls (1928)

Answer to Job (1952)

EASTERN RELIGION

Psychological Commentaries on "The Tibetan Book of the Great Liberation" (1939/1954) and "The Tibetan Book of the Dead" (1935/1953)

Yoga and the West (1936)

Foreword to Suzuki's "Introduction to Zen Buddhism" (1939)

The Psychology of Eastern Meditation (1943)

The Holy Men of India: Introduction to Zimmer's "Der Weg zum Selbst" (1944)

Foreword to the "I Ching" (1950)

*12. PSYCHOLOGY AND ALCHEMY (1944)

Prefatory note to the English Edition ([1951?] added 1967)

Introduction to the Religious and Psychological Problems of Alchemy

Individual Dream Symbolism in Relation to Alchemy (1936)

Religious Ideas in Alchemy (1937)

Epilogue

†13. ALCHEMICAL STUDIES

Commentary on "The Secret of the Golden Flower" (1929)

The Visions of Zosimos (1938/1954)

Paracelsus as a Spiritual Phenomenon (1942)

The Spirit Mercurius (1943/1948)

The Philosophical Tree (1945/1954)

‡14. MYSTERIUM CONIUNCTIONIS (1955–56)

AN INQUIRY INTO THE SEPARATION AND

SYNTHESIS OF PSYCHIC OPPOSITES IN ALCHEMY

The Components of the Coniunctio

The Paradoxa

The Personification of the Opposites

Rex and Regina

Adam and Eve
The Conjunction

*15. THE SPIRIT IN MAN, ART, AND LITERATURE

Paracelsus (1929)

Paracelsus the Physician (1941)

Sigmund Freud in His Historical Setting (1932)

In Memory of Sigmund Freud (1939)

Richard Wilhelm: In Memoriam (1930)

On the Relation of Analytical Psychology to Poetry (1922)

Psychology and Literature (1930/1950)

“Ulysses”: A Monologue (1932)

Picasso (1932)

†16. THE PRACTICE OF PSYCHOTHERAPY

GENERAL PROBLEMS OF PSYCHOTHERAPY

Principles of Practical Psychotherapy (1935)

What Is Psychotherapy? (1935)

Some Aspects of Modern Psychotherapy (1930)

The Aims of Psychotherapy (1931)

Problems of Modern Psychotherapy (1929)

Psychotherapy and a Philosophy of Life (1943)

Medicine and Psychotherapy (1945)

Psychotherapy Today (1945)

Fundamental Questions of Psychotherapy (1951)

SPECIFIC PROBLEMS OF PSYCHOTHERAPY

The Therapeutic Value of Abreaction (1921/1928)

The Practical Use of Dream-Analysis (1934)

The Psychology of the Transference (1946)

Appendix: The Realities of Practical Psychotherapy ([1937] added, 1966)

‡17. THE DEVELOPMENT OF PERSONALITY

Psychic Conflicts in a Child (1910/1946)

Introduction to Wickes’s “Analyses der Kinderseele” (1927/1931)

Child Development and Education (1928)

Analytical Psychology and Education: Three Lectures (1926/1946)

The Gifted Child (1943)

The Significance of the Unconscious in Individual Education (1928)

The Development of Personality (1934)

Marriage as a Psychological Relationship (1925)

18. MISCELLANY

Posthumous and Other Miscellaneous Works

19. BIBLIOGRAPHY AND INDEX

Complete Bibliography of C. G. Jung's Writings

General Index to the Collected Works

¹ [First published as “Über die Energetik der Seele” in a volume of the same title (Zurich, 1928), which version was translated by H. G. and C. F. Baynes as “On Psychological Energy” in *Contributions to Analytical Psychology* (London and New York, 1928). The translators’ foreword to the latter volume states that this paper “was framed soon after the author had finished the *Psychology of the Unconscious* [i.e., *Wandlungen und Symbole der Libido*, pub. 1912]. It was, however, pressed aside by the greater importance of the type problem . . . , and, originally entitled ‘The Theory of the Libido,’ was taken up again only last summer.” The original version was republished, under the same title, in *Über psychische Energetik und das Wesen der Träume* (Zurich, 1948). Both Swiss volumes are no. II of the *Psychologische Abhandlungen*.—EDITORS.]

² Cf. *Symbols of Transformation*, pars. 190ff.

³ Cf. Wundt, *Grundzüge der physiologischen Psychologie*, III, 692ff. For the dynamistic standpoint see von Hartmann, *Weltanschauung der modernen Physik*, pp. 202ff.

⁴ I use the word “final” rather than “teleological” in order to avoid the misunderstanding that attaches to the common conception of teleology, namely that it contains the idea of an anticipated end or goal.

⁵ “Final causes and mechanical causes are mutually exclusive, because a function having one meaning cannot at the same time be one with many meanings” (Wundt, p. 728). It seems to me inadmissible to speak of “final causes,” since this is a hybrid concept born of the mixing of the causal and final points of view. For Wundt the causal sequence has two terms and one meaning, i.e., cause M and effect E, whereas the final sequence has three terms and several meanings, i.e., the positing of a goal A, the means M', and the achievement of the goal E'. This construction I hold also to be a hybrid product, in that the positing of a goal is a causally conceived complement of the real final sequence M'-E', which likewise has two terms and one meaning. In so far as the final standpoint is only the reverse of the causal (Wundt), M'-E' is simply the causal sequence M-E seen in reverse. The principle of finality recognizes no cause posited at the beginning, for the final standpoint is not a causal one and therefore has no concept of a cause, just as the causal standpoint has no concept of a goal or of an end to be achieved.

⁶ The conflict between energism and mechanism is a parallel of the old problem of universals. Certainly it is true that the individual thing is all that is “given” in sense perception, and to that extent a universal is only a *nomen*, a word. But at the same time the similarities, the relations between things, are also given, and to that extent a universal is a reality (Abelard’s “relative realism”).

⁷ Finality and causality are two possible ways of understanding which form an antinomy. They are progressive and regressive “interpretants” (Wundt) and as such are contradictory. Naturally this statement is correct only if it is assumed that the concept of energy is an abstraction that expresses relation. (“Energy is relation”: von Hartmann, p. 196). But the statement is not correct if an hypostatized concept of energy is assumed, as in Ostwald’s *Die Philosophie der Werte*.

⁸ “The difference between the teleological and the causal view of things is not a real one dividing the contents of experience into two disparate realms. The sole difference between the two views is the formal one that a causal connection belongs as a complement to every final relationship, and conversely, every causal connection can be given, if need be, a teleological form.” Wundt, p. 737.

⁹ [Cf. n. 5.—EDITORS.]

¹⁰ “Die Begriffe der Seele und der psychischen Energie in der Psychologie,” *Archiv für systematische Philosophie*, IV,

¹¹ Busse, *Geist und Körper, Seele und Leib*.

¹² Külpe, *Einleitung in die Philosophie*, p. 150.

¹³ *Ibid.*, p. 323.

¹⁴ Von Grot goes so far as to say (p. 324): “The burden of proof falls on those who deny psychic energy, not on those who acknowledge it.”

¹⁵ This was actually the case with Descartes, who first formulated the principle of the conservation of the quantity of movement, but had not at his disposal the methods of physical measurement which were discovered only in recent times.

¹⁶ The one-sidedness of consciousness is compensated by a counterposition in the unconscious. It is chiefly the facts of psychopathology that show the compensatory attitude of the unconscious most clearly. Evidence for this may be found in the writings of Freud and Adler, also in my “Psychology of Dementia Praecox.” For a theoretical discussion see my “Instinct and the Unconscious,” pars. 263ff., *infra*. On the general significance of psychological compensation see Maeder, “Régulation psychique et guérison.”

¹⁷ [Cf. Vol. 2, *Collected Works*.—EDITORS.]

¹⁸ [Cf. *Psychiatric Studies*, par. 168, n. 2a.—EDITORS.]

¹⁹ That a complex or its essential nucleus can be unconscious is not a self-evident fact. A complex would not be a complex at all if it did not possess a certain, even a considerable, affective intensity. One would expect that this energetic value would automatically force the complex into consciousness, that the power of attraction inherent within it would compel conscious attention. (Fields of power attract one another mutually!) That this, as experience shows, is frequently not the case requires a special explanation. The readiest and simplest explanation is given by Freud’s theory of repression. This theory presupposes a counterposition in the conscious mind: the conscious attitude is, so to speak, hostile to the unconscious complex and does not allow it to reach consciousness. This theory certainly explains very many cases, but in my experience there are some cases that cannot be so explained. Actually, the repression theory takes account only of those cases in which a content, in itself perfectly capable of becoming conscious, is either quite consciously repressed and made unconscious, or has right from the beginning never reached consciousness. It does not take into account those other cases in which a content of high energetic intensity is formed out of unconscious material that is not in itself capable of becoming conscious, and so cannot be made conscious at all, or only with the greatest difficulty. In these cases the conscious attitude, far from being hostile to the unconscious content, would be most favourably disposed towards it, as in the case of creative products, which, as we know, almost always have their first beginnings in the unconscious. Just as a mother awaits her child with longing and yet brings it into the world only with effort and pain, so a new, creative content, despite the willingness of the conscious mind, can remain for a long time in the unconscious without being “repressed.” Though it has a high energetic value it still does not become conscious. Cases of this sort are not too difficult to explain. Because the content is new and therefore strange to consciousness, there are no existing associations and connecting bridges to the conscious contents. All these connections must first be laid down with considerable effort, for without them no consciousness is possible. Two main grounds must therefore be considered in explaining the unconsciousness of a complex: (1) the

repression of a content capable of becoming conscious, and (2) the strangeness of a content not yet capable of reaching consciousness.

²⁰ Or to an hypostatized concept of energy, such as Ostwald holds. But the concept of substance needed for a causal-mechanistic mode of explanation can hardly be circumvented in this fashion, since “energy” is at bottom always a concept concerned with quantity alone.

²¹ [Cf. “The Psychology of Dementia Praecox,” pars. 175ff.—EDITORS.]

²² Cf. Berger, *Über die körperlichen Äusserungen psychischer Zustände*; Lehmann, *Die körperlichen Äusserungen psychischer Zustände*, trans. (into German) by Bendixen.

²³ Peterson and Jung, “Psycho-physical Investigations with the Galvanometer and Pneumograph in Normal and Insane Individuals”; Nunberg, “On the Physical Accompaniments of Association Processes,” in Jung, *Studies in Word Association*; Ricksher and Jung, “Further Investigations on the Galvanic Phenomenon.”

²⁴ Veraguth, *Das psycho-galvanische Reflexphänomen*; Binswanger, “On the Psycho-galvanic Phenomenon in Association Experiments,” in Jung, *Studies in Word-Association*.

²⁵ Cf. *Studies in Word-Association* and “The Association Method.”

²⁶ Schiller thinks in terms of energy, so to speak. He operates with ideas like “transfer of intensity,” etc. Cf. *On the Aesthetic Education of Man*, trans. by Snell.

²⁷ “Die Begriffe der Seele und der psychischen Energie in der Psychologie.”

²⁸ *Leitfaden der Psychologie*, pp. 62, 66f.

²⁹ Stern, *Über Psychologie der individuellen Differenzen*, pp. 119ff.

³⁰ *Leitfaden der Psychologie*, p. 36 (1903 edn.).

³¹ Maeder is of the opinion that the “creative activity” of the organism, and particularly that of the psyche, “exceeds the energy consumed.” He also holds that in regard to the psyche, together with the principle of conservation and the principle of entropy, one must make use of yet a third principle, that of integration. Cf. *Heilung und Entwicklung im Seelenleben*, pp. 50 and 69f

³² *Geist und Körper, Seele und Leib*.

³³ *Ibid.*

³⁴ Cf. particularly Part II, ch. III.

³⁵ *Sammlung kleiner Schriften zur Neurosenlehre* [cf. *Collected Papers*, I–IV].

³⁶ Hartmann, *Weltanschauung der modernen Physik*, p. 6.

³⁷ Physics today equates energy with mass, but this is irrelevant for our purpose.

³⁸ *Symbols of Transformation*, par. 226.

³⁹ The reduction of a complex structure to sexuality is a valid causal explanation only if it is agreed beforehand that we are interested in explaining solely the function of the sexual components in complex structures. But if we accept the reduction to sexuality as valid, this can only be done on the tacit assumption that we are dealing with an exclusively sexual structure. To assume this, however, is to assert *a priori* that a complex psychic structure can only be a sexual structure, a manifest *petitio principii*. It cannot be asserted that sexuality is the only fundamental psychic

instinct, hence every explanation on a sexual basis can be only a partial explanation, never an all-sufficing psychological theory.

⁴⁰ This applies only to the macrophysical realm, where “absolute” laws hold good.

⁴¹ Cf. *Psychological Types*, pars. 505ff.

⁴² *Populäre Schriften*, p. 33.

⁴³ A system is absolutely closed when no energy from outside can be fed into it. Only in such a system can entropy occur.

⁴⁴ Therefore the idea of it is as old as humanity. We meet it in the fundamental ideas of primitives. Cf. Lehmann, *Mana, der Begriff des ‘ausserordentlich Wirkungsvollen’ bei Südseevölkern*, and my remarks in *Two Essays on Analytical Psychology*, par. 108. Hubert and Mauss (*Mélanges d’histoire des religions*, preface, p. xxix) also call *mana* a “category” of the understanding. I quote their words verbatim: “[The categories] constantly manifested in language, though not necessarily explicit in it, exist as a rule rather in the form of habits that govern consciousness, while themselves unconscious. The notion of *mana* is one of these principles. It is a datum of language; it is implied in a whole series of judgements and reasonings concerned with attributes which are those of *mana*. We have called *mana* a category. But it is not only a category peculiar to primitive thought, and today, by reduction, it is still the first form taken on by other categories which are always operative in our minds, those of substance and cause,” etc.

⁴⁵ [For a discussion of the formation of intuitive vs. empirical concepts, see *Psychological Types*, pars. 518ff., and Def. 22: “Function.”]

⁴⁶ [Jung here uses the terms *Trieb* and *Ichtriebe* (lit. “drive,” “ego-drives”) following Freud’s German terminology. Freud’s terms have been trans. into English as “instinct” and “ego-instincts.” Cf., e.g., Freud, *Introductory Lectures*, pp. 350ff.—EDITORS.]

⁴⁷ The Latin word *libido* has by no means an exclusively sexual connotation, but the general meaning of desire, longing, urge. Cf. *Symbols of Transformation*, pars. 185ff.

⁴⁸ *Freud and Psychoanalysis*, par. 282.

⁴⁹ Somewhat after the manner of *Hudibras*, whose opinion is quoted by Kant (*Träume eines Geisterseliens*, III): “When a hypochondriacal wind is roaring in the bowels, everything depends on the direction it takes. If it goes downwards, it turns into a fart, but if it mounts upwards, it is a vision or a divine inspiration.” [For a much bowdlerized version see *Dreams of a Spirit-Scer*, trans. by Emanuel Goerwitz, p. 84. Kant’s version is presumably based on Samuel Butler’s *Hudibras*, Part II, Canto iii, lines 773–76:

“As wind i’ th’ *Hypochondrias* pent
Is but a blast if downward sent;
But if it upwards chance to fly
Becomes new *Light* and *Prophecy*.”—TRANS.]

⁵⁰ Though professional satiety with neurotic unrealities makes the analyst sceptical, a generalized judgment from the pathological angle has the disadvantage of being always biased.

⁵¹ *Das Zeitalter des Sonnengottes*.

⁵² Diastole is an extraversion of libido spreading through the entire universe; systole is its contraction into the individual, the monad. (“Systole, the conscious, powerful contraction that brings forth the individual, and diastole,

the longing to embrace the All.” Chamberlain, *Goethe*, p. 571.) To remain in either of these attitudes means death (p. 571), hence the one type is insufficient and needs complementing by the opposite function. (“If a man holds himself exclusively in the receptive attitude, if diastole persists indefinitely, then there enters into his psychic life, as into his bodily life, crippling and finally death. Only action can animate, and its first condition is limitation, i.e., systole, which creates a firmly bounded measure. The more energetic the act, the more resolute must be the enforcing of the limitation.”—p. 581.)

⁵³ Preuss, “Der Ursprung der Religion und Kunst,” p. 388; Schultze, *Psychologie der Naturvölker*, p. 168; *Symbols of Transformation*, pars. 213f

⁵⁴ Cf. the observation in Pechuël-Loesche, *Volkskunde von Loango*, p. 38: the dancers scrape the ground with one foot and at the same time carry out specific abdominal movements.

⁵⁵ “Wörter und Sachen.” Cf. *Symbols of Transformation*, par. 214, n. 21.

⁵⁶ Mannhardt, *Wald- und Feldkulte*, I, pp. 480ff.

⁵⁷ *Ibid.*, p. 483.

⁵⁸ A comprehensive survey in Lévy-Bruhl, *How Natives Think*, trans. by Clare, pp. 228ff.

⁵⁹ See illustration in Spencer and Gillen, *The Northern Tribes of Central Australia*, p. 560.

⁶⁰ Koch-Grünberg, *Südamerikanische Felszeichnungen*.

⁶¹ Silberer, *Problems of Mysticism and Its Symbolism*; also Rosencreutz, *Chymische Hochzeit* (1616).

⁶² *Symbols of Transformation*, pars. 146, 203.

⁶³ Spencer and Gillen, p. 277.

⁶⁴ “Man, of course, has always been trying to understand and to control his environment, but in the early stages this process was unconscious. The matters which are problems for us existed latent in the primitive brain; there, undefined, lay both problem and answer; through many ages of savagery, first one and then another partial answer emerged into consciousness; at the end of the series, hardly completed today, there will be a new synthesis in which riddle and answer are one.” Crawley, *The Idea of the Soul*, p. 11.

⁶⁵ “Dreams are to the savage man what the Bible is to us—the source of divine revelation.” Gatschet, “The Klamath Indians of South-western Oregon,” cited in Lévy-Bruhl, p. 57.

⁶⁶ Lévy-Bruhl, p. 57.

⁶⁷ [“Ordained by law.”—EDITORS.]

⁶⁸ Söderblom, *Das Werden des Gottesglaubens*, pp. 88ff. and 175ff.

⁶⁹ I have treated this same problem under other aspects and in another way in *Symbols of Transformation*, pars. 253, 680; and *Psychological Types*, par. 326 and section 3 (a).

⁷⁰ This is not the case with primitives, for whom the food question plays a far greater role.

⁷¹ See “Instinct and the Unconscious,” *infra*.

⁷² “The Siouan Indians—A Preliminary Sketch,” p. 182; Lovejoy, “The Fundamental Concept of the Primitive Philosophy,” p. 363.

⁷³ Lovejoy, p. 365.

⁷⁴ “Some Animistic Beliefs among the Yaos of Central Africa.”

⁷⁵ Tylor, *Primitive Culture*, II, pp. 176, 205.

⁷⁶ Spencer and Gillen, pp. 277f., where the following is reported of the *churinga* as a ritual object: “The native has a vague and undefined but still a very strong idea that any sacred object such as a Churinga, which has been handed down from generation to generation, is not only endowed with the magic power put into it when first it was made, but has gained some kind of virtue from every individual to whom it has belonged. A man who owns such a Churinga as this snake one will constantly rub it over with his hand, singing as he does so the Alcheringa history of the snake, and gradually comes to feel that there is some special association between him and the sacred object—that a virtue of some kind passes from it to him and also from him to it.” Fetishes become charged with new power if left standing for some weeks or months near another strong fetish. Cf. Pechuël-Loesche, p. 366.

⁷⁷ Spencer and Gillen, p. 458.

⁷⁸ *Unknown Mexico*.

⁷⁹ “When the Huichols, influenced by the law of participation, affirm the identity of corn, deer, *hikuli* [= mescal], and plumes, a classification has been established between their representatives, the governing principle of which is a common presence in these entities, or rather the circulation among them of a mystic power which is of supreme importance to the tribe.” Lévy-Bruhl, p. 128.

⁸⁰ Codrington, *The Melanesians*, p. 118. Seligmann, in his book *The Melanesians of British New Guinea*, so rich in valuable observations, speaks of *bariaua* (p. 446), which likewise belongs to the *mana* concept.

⁸¹ Warnecke, *Die Religion der Batak*.

⁸² Lovejoy, pp. 380f.

⁸³ “Der Ursprung der Religion und Kunst.”

⁸⁴ “Das Wesen des Mana.”

⁸⁵ cf. my discussion of the way in which Robert Mayer discovered the concept of energy: *Two Essays on Analytical Psychology*, pars. 106ff.

⁸⁶ Seligmann (pp. 640ff.) reports observations which in my view show transitions of *mana* into animistic personifications. Such are the *labuni* of the Gelaria people of New Guinea. *Labuni* means “sending.” It has to do with dynamic (magical) effects which emanate, or can be sent out, from the ovaries (?) of women who have borne children. *Labuni* look like “shadows,” they use bridges to cross streams, change into animals, but otherwise possess no personality or definable form. Similar to this is the conception of the *ayik* which I observed among the Elgonyi, in northern Kenya.

¹ [Written in 1916 under the title “Die Transzendente Funktion,” the ms. lay in Professor Jung’s files until 1953. First published in 1957 by the Students Association, C. G. Jung Institute, Zurich, in an English translation by A. R. Pope. The German original, considerably revised by the author, was published in *Geist und werk ... turn 75. Geburlstag von Dr. Daniel Brody* (Zurich, 1958), together with a prefatory note of more general import specially written for that volume. The author has partially rewritten the note for publication here. The present translation is based on the revised German version, and Mr. Pope’s translation has been consulted.—EDITORS.]

² [Nietzsche, *Thus Spake Zarathustra*, XXXI; Common trans., p. 156.—EDITORS.]

³ [Cf. *Faust: Part I*, Wayne trans., p. 46.]

¹ Inaugural lecture delivered at the Federal Polytechnic Institute, Zurich, May 5, 1934. [Repeated later in May at the 7th Congress for Psychotherapy, Bad Nau-heim, of which Jung was president; a summary, “Über Komplextheorie,” in the *Zentralblatt für Psychotherapie* (Leipzig), VII (1934): 3. First published fully as *Allgemeines zur Komplextheorie* (Kultur- und Staatswissenschaftliche Schriften der Eidgenössischen Technischen Hochschule, 12; Aarau, 1934). Republished with slight revisions in *Über psychische Energetik und das Wesen der Träume* (Psychologische Abhandlungen, II; Zurich, 1948),—EDITORS.]

² Exceptions to this rule are the processes of growth in tissues that can be kept alive in a nutrient medium.

³ Das *psycho-galvanische Reflexphänomen*.

⁴ Cf. *Auch Einer*.

¹ [“Die Bedeutung von Konstitution und Vererbung für die Psychologie,” *Die medizinische Welt* (Berlin), III : 47 (Nov., 1929), 1677–79.—EDITORS.]

² Cf. *Studies in Word-Association* (1918 edn.), p. 435.

³ [Cf. infra, “The Structure of the Psyche,” pars. 317ff.—EDITORS.]

¹ [Originally delivered (in English) as a lecture at the Harvard (University) Tercentenary Conference of Arts and Sciences. Cambridge. Mass., 1936, and published in a symposium, *Factors Determining Human Behavior* (Cambridge, 1937). With slight alterations it was republished as “Human Behaviour” in another symposium. *Science and Man*, edited by Ruth Nanda Anshen (New York, 1942). The latter version is here published, with further slight alterations based on the original German typescript.—EDITORS.]

¹ A contribution to the symposium of the same name, presented, in an English translation prepared by H. G. Baynes, at a joint meeting of the Aristotelian Society, the Mind Association, and the British Psychological Society, at Bedford College, London University, July, 1919. [First published in the *British Journal of Psychology* (General Section) (London), X (1919) : 1, 15–26; republished in *Contributions to Analytical Psychology* (London and New York, 1928). The original ms. was subsequently published as “Instinkt und Unbewusstes” in *Über die Energetik der Seele* (Psychologische Abhandlungen, II; Zurich, 1928); republished, with a short concluding note, in *Über psychische Energetik und das Wesen der Träume* (Zurich, 1948). The Baynes version has been consulted in the preparation of the present translation.—EDITORS.]

² *Essays on the Active Powers of Man* (1788), p. 103.

³ *Anthropologie*, in *Werke*, ed. by Cassirer, VIII, p. 156.

⁴ *Principles of Psychology*, II, p. 391.

⁵ Kerner von Marilaun, *The Natural History of Plants*, II, p. 156.

⁶ Cf. *Psychological Types*, Def. 35: “Intuition.”

⁷ [This is the first occasion on which Jung uses the term “archetype” (*Archetypus*). Previously, in his publications, he had discussed the same concept under the term “primordial image” (*Urbild*), which he derived from Burckhardt (cf. *Symbols of Transformation*, par. 45, n. 45; *Two Essays*, par. 101). The primordial image, be it observed, is here and elsewhere used as the equivalent of the archetype; this has given rise to some confusion and to the belief that Jung’s theory of hereditary elements involves the inheritance of representations (ideas or images), a view against which Jung repeatedly protests. The primordial image is, however, in the present text, clearly understood as a more graphic term for the archetype, an essentially unconscious entity which, as Jung points out, is an *a priori* form—the inherited component of the representational image perceived in consciousness.—EDITORS.]

⁸ The actual term “archetype,” however, is to be found in Dionysius the Areopagite and in the *Corpus Hermeticum*.

⁹ *De veritate*, trans. by Carré, p. 122.

¹⁰ Cf. *Ethics* (Everyman edn.), p. 37.

¹¹ Like the now obsolete concept of ether, energy and the atom are primitive intuitions. A primitive form of the one is *mana*, and of the other the atom of Democritus and the “soul-sparks” of the Australian aborigines. [Cf. *Two Essays on Analytical Psychology*, pars. 108f.—EDITORS.]

¹² In the course of my life I have often reflected on the theme of this short essay, and the conclusions I have come to are set down in a paper entitled “On the Nature of the Psyche” [cf. *infra*, pars. 343ff.], where the problem of instinct and archetype in its later developments is dealt with in considerable detail. The biological side of the problem is discussed in Alverdes, “Die Wirksamkeit von Arche-typen in den Instinkthandlungen der Tiere.”

¹ [Originally published as part of “Die Erdbedingtheit der Psyche.” in the symposium *Mensch und Erde*, edited by Count Hermann Keyserling (Darmstadt, 1927). (The other part became the essay “Seele und Erde,” which is now published as “Mind and Earth” in Vol. 10 of the *Collected Works*.) The present work, constituting about the first half of the 1927 publication, was published as “Die Struktur der Seele,” *Europäische Revue* (Berlin), IV (1928), 1 and 2. It was later revised and expanded in *Seelenprobleme der Gegenwart* (Psychologische Abhandlungen, III; Zurich, 1931), and this version is translated here.—EDITORS.]

² Trans. from German, *Life in Ancient Egypt*, pp. 265–67, modified.

³ [*Eine Mithrasliturgie*, pp. 6–7. As the author subsequently learned, the 1910 edition was actually the second, there having been a first edition in 1903. The patient had, however, been committed some years before 1903. Cf. *Symbols of Transformation*, pars. 149ff. and 223, and “The Concept of the Collective Unconscious,” par. 105.—EDITORS.]

¹ [Originally published as “Der Geist der Psychologie,” *Eranos-Jahrbuch 1946* (Zurich, 1947), pp. 385–490. This essay, revised and augmented, was republished as “Theoretische Überlegungen zum Wesen des Psychischen” in *Von den Wurzeln des Bewusstseins* (“Psychologische Abhandlungen, IX; Zurich, 1954), pp. 497–608. The former version was translated by R. F. C. Hull as “The Spirit of Psychology” and published in *Spirit and Nature* (Papers from the Eranos Yearbooks, I; New York, 1954; London, 1955), pp. 371–444. That translation is now further revised to bring it into conformity with the 1954 German version.—EDITORS.]

² Hermann Siebeck, *Geschichte der Psychologie*.

³ Actually this is true only of the old psychology. In recent times there has been a considerable change of standpoint.

⁴ *Psychologia empirica* (1732).

⁵ In Anglo-Saxon countries there is the degree of “Doctor Scientiae,” and psychology too enjoys greater independence.

⁶ Recently these conditions have somewhat improved.

⁷ Trans. by C. H. Judd, pp. 227–28, from *Grundriss der Psychologie*. (My italics.)

⁸ Guido Villa, *Einleitung in die Psychologie der Gegenwart*, p. 330.

⁹ Wilhelm Wundt, *Grundzüge der physiologischen Psychologie*, III, p. 327.

¹⁰ Pierre Janet, *Automatisme psychologique*, pp. 243, 238ff.

¹¹ Gustav Theodor Fechner, *Elemente der Psychophysik*, II, p. 438: “... the idea of a psychophysical threshold ... gives a firm foundation to that of the unconscious generally. Psychology cannot abstract representations from unconscious perceptions, nor even from the effects of unconscious perceptions.”

¹² *Ibid.*, p. 439.

¹³ *Grundzüge der physiologischen Psychologie*, III, p. 328.

¹⁴ *Ibid.*, p. 326. Cited from Wolf’s *Vernünfftige Gedanken von Gott, der Welt, und der Seele des Menschen* (1719), §193.

¹⁵ *Ethnische Elementargedanken in der Lehre vom Menschen* and *Der Mensch in der Geschichte*, I, pp. 166ff., 213ff.; II, pp. 24ff.

¹⁶ *Volkerpsychologie*, V, Part II, p. 459.

¹⁷ *Ibid.*, IV, Part I, p. 41.

¹⁸ Cf. Fechner’s remark that “the idea of a psychophysical threshold is of the utmost importance because it gives a firm foundation to that of the unconscious generally.” He goes on: “Perceptions and representations in the state of unconsciousness have, of course, ceased to exist as real ones ... but something continues in us. psychophysical activity.” etc. (II, pp. 438f.). This conclusion is a little incautious, because the psychic process remains more or less the same whether conscious or not. A “representation” exists not only through its “representedness,” but—and this is the main point—it also exists in its own psychic right.

¹⁹ Cf. Lipps, “Der Begriff des Unbewussten,” pp. 146ff.; and *Grundtatsachen des Seelenlebens*, pp. 125, ff.

²⁰ *Leitfaden der Psychologie*, p. 64.

²¹ *Ibid.*, pp. 65f. (My italics.)

²² *Geschichte der neueren deutschen Psychologie*.

²³ I reproduce here what William James says about the importance of the discovery of the unconscious psyche (*Varieties of Religious Experience*, p. 233): “I cannot but think that the most important step forward that has occurred in psychology since I have been a student of that science is the discovery, first made in 1886, that ... there is not only the consciousness of the ordinary field, with its usual center and margin, but an addition thereto in the shape of a set of memories, thoughts, and feelings which are extramarginal and outside of the primary consciousness altogether, but yet must be classed as conscious facts of some sort, able to reveal their presence by unmistakable signs. I call this the most important step forward because, unlike the other advances which psychology has made, this discovery has revealed to us an entirely unsuspected peculiarity in the constitution of human nature. No other step forward which psychology has made can proffer any such claim as this.” The discovery of 1886 to which James refers is the positing of a “subliminal consciousness” by Frederic W. H. Myers. See n. 47, *infra*.

²⁴ A mathematician once remarked that everything in science was man-made except numbers, which had been created by God himself.

²⁵ G. H. Lewes in *The Physical Basis of Mind* takes all this for granted. For instance, on p. 358, he says: “Sentience has various modes and degrees, such as Perception, Ideation, Emotion, Volition, which may be conscious, subconscious, or unconscious.” On p. 363: “Consciousness and Unconsciousness are correlatives, both belonging to the sphere of Sentience. Every one of the unconscious processes is operant, changes the general state of the organism, and is capable of at once issuing in a discriminated sensation when the force which balances it is disturbed.” On p. 367: “There are many involuntary actions of which we are distinctly conscious, and many voluntary actions of which we are at times subconscious and unconscious. ... Just as the thought which at one moment passes unconsciously, at another consciously, is in itself the same thought ... so the action which at one moment is voluntary, and at another involuntary, is itself the same action.” Lewes certainly goes too far when he says (p. 373): “There is no real and essential distinction between voluntary and involuntary actions.” Occasionally there is a world of difference.

²⁶ Fechner, II, pp. 438f

²⁷ I am not counting “Clever Hans” [but cf. D. Katz, *Animals and Men*, 13ff.—EDITORS] and the dog who talked about the “primordial soul.”

²⁸ James, *Varieties of Religious Experience*, p. 232.

²⁹ Hans A. E. Driesch, *The Science and Philosophy of the Organism*, 1929, p. 221.

³⁰ *Ibid.*, p. 281.

³¹ In *Die Psychoide als Prinzip der organischen Entwicklung*, p. 11. A fem, sing, noun derived from *Psyche* (*ψυχοειδής* = ‘soul-like’).

³² *Ibid.*, p. 11.

³³ *Ibid.*, p. 33.

³⁴ I can avail myself of the word “psychoid” all the more legitimately because, although my use of the term derives from a different field of perception, it nevertheless seeks to delineate roughly the same group of phenomena that Bleuler had in mind. A. Busemann, in his book *Die Einheit der Psychologie* (p. 31), calls this non-differentiated psyche the “micropsychic.”

³⁵ Especial exception is taken to this “superconsciousness” by people who have come under the influence on Indian philosophy. They usually fail to appreciate that their objection only applies to the hypothesis of a

“subconscious,” which ambiguous term I avoid using. On the other hand my concept of the *unconscious* leaves the question of “above” or “below” completely open, as it embraces both aspects of the psyche.

³⁶ Cf. in particular Eduard von Hartmann, *Philosophie des Unbewussten* (1869).

³⁷ An appreciation of his work is to be found in Jean Paulus, *Le Problème de l'haltucination et l'évolution de la psychologie d'Esquirol à Pierre Janet*.

³⁸ In this connection we should also mention the important Swiss psychologist Théodore Flournoy and his chef d'oeuvre *Des Indes à la Planète Mars* (1900). Other pioneers were W. B. Carpenter (*Principles of Mental Physiology*, 1874) and G. H. Lewes (*Problems of Life and Mind*, 1873–79). For Frederic W. H. Myers see nn. 23 and 47.

³⁹ This indistinctness and blurring of the instincts may, as E. N. Marais has shown in his experiments with apes (*The Soul of the White Ant*, p. 429), have something to do with the superior learning-capacity prevailing over the instincts, as is obviously the case with man too. On the question of instincts see L. Szondi, *Experimentelle Triebdiagnostik* and *Triebpathologie*.

⁴⁰ “The instincts are physiological and psychic dispositions which ... cause the organism to move in a clearly defined direction” (W. Jerusalem, *Lehrbuch der Psychologie*, p. 188). From another point of view Oswald Külpe describes instinct as “a fusion of feelings and organ sensations” (*Outlines of Psychology*, p. 322, modified).

⁴¹ *Les Neuroses*, pp. 384ff.

⁴² Janet says (p. 384): “It seems that we must distinguish in every function inferior and superior parts. When a function has been in use for a long time it contains parts which are very old, work very easily, and are represented by very distinct and specialized organs ... these are the inferior parts of the function. But it is my opinion that in every function there are also superior parts which consist in the function’s adaptation to more recent and much less usual circumstances, and are represented by organs which are differentiated in a markedly lesser degree.” But the highest part of the function consists “in its adaptation to the particular circumstances of the present moment, the moment at which we have to use it.”

⁴³ W. H. R. Rivers, “Instinct and the Unconscious.”

⁴⁴ This formulation is purely psychological and has nothing to do with the philosophical problem of indeterminism.

⁴⁵ *Die “Seele” als elementarer Naturfaktor*, p. 80. “Individualized stimuli inform ... the ‘primary knower’ of the abnormal state, and now this ‘knower’ not only *wants* a remedy but *knows* what it is” (p. 82).

⁴⁶ Cf. sec. 6 below, “The Unconscious as a Multiple Consciousness.”

⁴⁷ James speaks also of a “transmarginal field” of consciousness and identifies it with the “subliminal consciousness” of F. W. H. Myers, one of the founders of the British Society for Psychical Research (cf. *Proceedings S.P.R.*, VII, 1892, pp. 298ff., and William James, “Frederic Myers’ Service to Psychology,” *ibid.*, XVII, 1901, pp. 13ff.). Concerning the “field of consciousness” James says (*Varieties of Religious Experience*, p. 232): “The important fact which this ‘field’ formula commemorates is the indetermination of the margin. Inattentively realized as is the matter which the margin contains, it is nevertheless there, and helps both to guide our behavior and to determine the next movement of our attention. It lies around us like a ‘magnetic field’ inside of which our center of energy turns like a compass needle as the present phase of consciousness alters into its successor. Our whole past store of memories floats beyond this margin, ready at a touch to come in; and the entire mass of residual powers, impulses, and

knowledges that constitute our empirical self stretches continuously beyond it. So vaguely drawn are the outlines between what is actual and what is only potential at any moment of our conscious life, that it is always hard to say of certain mental elements whether we are conscious of them or not.”

⁴⁸ In schizophrenic dissociation there is no such change in the conscious state, because the complexes are received not into a complete but into a fragmentary consciousness. That is why they so often appear in the original archaic state.

⁴⁹ Red had a *spiritual* significance for Goethe, but that was in accord with his creed of feeling. Here we may conjecture the alchemical and Rosicrucian background, e.g., the red tincture and the carbuncle. Cf. *Psychology and Alchemy*, pars. 335, 454, 552.

⁵⁰ As already pointed out by E. Bleuler: *Naturgeschichte der Seele und ihres Bewusstwerdens*, pp. 300f.

⁵¹ With the explicit exception of the psychoid unconscious, as this includes things which are not capable of consciousness and are only “quasi-psychic.”

⁵² In this connection I would mention that C. A. Meier associates observations of this kind with similar phenomena in physics. He says: “The relationship of complementarity between conscious and unconscious urges upon us yet another physical parallel, namely the need for a strict application of the ‘principle of correspondence.’ This might provide the key to the ‘strict logic’ of the unconscious (the logic of probability) which we so often experience in analytical psychology and which makes us think of an ‘extended state of consciousness.’”—“Moderne Physik—Moderne Psychologie,” p. 360.

⁵³ *Psychology and Alchemy*, pars. 352, 472. [Also *Myst. Coniunctionis*, pars. 42ff.]

⁵⁴ *Artis aurijerae* (1593), I, p. 208. Said to be a quotation from Morienus (cf. *infra*, par. 394), repeated by Mylius, *Philosophia reformata* (1622), p. 146. On p. 149 he adds “scintillas aureas.”

⁵⁵ “Variae eius radii atque scintillae, per totius ingentem materiei primae massae molem hinc inde dispersae ac dissipatae: inque mundi partibus disiunctis etiam et loco et corporis mole, necnon circumscriptione, postea separatis ... unius Animae universalis scintillae nunc etiam inhabitantes” (Its divers rays and sparks are dispersed and dissipated throughout the immense bulk of the whole mass of the *prima materia*: the sparks of the one universal soul now inhabiting those disunited parts of the world which were later separated from the place and mass of the body, and even from its circumference). Khunrath, *Amphitheatrum sapientiae aeternae solius verae* (1604), pp. 195f., 198.

⁵⁶ *Ibid.*, p. 197. Cf. the Gnostic doctrine of the Seeds of Light harvested by the Virgin of Light, and the Manichaean doctrine of the light-particles which have to be taken into one’s body as ritual food, at a sort of Eucharist when melons were eaten. The earliest mention of this idea seems to be the Καρπιστ ῆς (Irenaeus, *Contra haecreses*, I, 2, 4). Concerning the melons see M.-L. von Franz, “Der Traum des Descartes.”

⁵⁷ “Mens humani animi scintilla altior et lucidior” (The mind of the human soul is a higher and more luminous spark). *Amphitheatrum*, p. 63.

⁵⁸ Khunrath, *Von hylealischen ... Chaos* (1597), p. 63.

⁵⁹ As synonyms, Khunrath mentions (p. 216) “forma aquina, pontica, limus terrae Adamae, Azoth, Mercurius” (a form watery and sea-like, the slime of the earth of Adama, etc.). [*Adama* is Hebrew for ‘earth.’—EDITORS.]

⁶⁰ *Ibid.*, p. 216.

- ⁶¹ The “*formae scintillae Animae Mundi*” (forms or sparks of the world soul) are also called by Khunrath (p. 189) “*rationes seminariae Naturae specificae*” (the seed-ideas of Nature, the origin of species), thus reproducing an ancient idea. In the same way he calls the *scintilla* “*Entelechia*” (p. 65).
- ⁶² *Paracelsus: Sämtliche Werke*, ed. by Karl Sudhoff, XII, p. 231; *Bücher und Schriften ... Paracelsi ...*, ed. by Johannes Huser, X, p. 206.
- ⁶³ *Von hylealisclien Chaos*, p. 94.
- ⁶⁴ *Ibid.*, p. 249.
- ⁶⁵ *Ibid.*, p. 54. In this he agrees with Paracelsus, who calls the *lumen naturae* the Quintessence, extracted from the four elements by God himself. (Sudhoff, XII, pp. 36, 304.)
- ⁶⁶ Ch. XIX, 1ff. (trans. by Lake in *The Apostolic Fathers*, I, p. 193).
- ⁶⁷ “Sic paulatim scintillas aliquot magis ac magis indes perlucere suis oculis mentalibus percipiet, ac in tantam excrescere lucem, ut successivo tempore quaevis innotescant, quae sibi necessaria fuerint.” Gerhard Dorn, “*Speculativae philosophiae*,” in *Theatrum chemicum*, I (1602), p. 275.
- ⁶⁸ “Sol est invisibilis in hominibus, in terra vero visibilis, tamen ex uno et eodem sole sunt ambo” (The sun is invisible in men, but visible in the world, yet both are of one and the same sun). *Ibid.*, p. 308.
- ⁶⁹ “Et vita erat lux hominum. Et lux in tenebris lucet” (And the life was the light of men. And the light shineth in the darkness). John 1 : 4, 5.
- ⁷⁰ “Lucet in nobis licet obscure vita lux hominum tanquam in tenebris, quae non ex nobis quaerenda, tamen in et non a nobis, sed ab eo cuius est, qui etiam in nobis habitationem facere dignatur. ... Hic eam lucem plantavit in nobis, ut in eius lumine qui lucem inaccessibilem inhabitat, videremus lumen; hoc ipso quoque caeteras eius praecelleremus creaturas; illi nimirum similes hac ratione facti, quod scintillam sui luminis dederit nobis. Est igitur veritas non in nobis quaerenda, sed in imagine Dei quae in nobis est.” “*philosophia meditativa*,” *Theatrum chemicum*, I, p. 460.
- ⁷¹ Sudhoff, XII, p. 23; “That which is in the light of nature, the same is the working of the star.” (Huser, X, p. 19.)
- ⁷² *Philosophia sagax*, Huser, X, p. 1 (Sudhoff, XII, p. 3).
- ⁷³ *Ibid.*, pp. 3f. (pp. 5f.).
- ⁷⁴ The apostles are “*Astrologi*”: *ibid.*, p. 23 (p. 27).
- ⁷⁵ *Ibid.*, p. 54 (p. 62).
- ⁷⁶ *Ibid.*, p. 344 (p. 386). The last sentence refers to Matthew 5 : 14: “*Vos estis lux mundi.*”
- ⁷⁷ *Ibid.*, p. 409 (pp. 456f.).
- ⁷⁸ “... like the cocks which crow the coming weather and the peacocks the death of their master ... all this is of the inborn spirit and is the light of nature.” *Fragmenta medica*, cap. “*De morbis somnii*,” Huser, V, p. 130 (Sudhoff, IX, p. 361).
- ⁷⁹ *Liber de generatione hominis*, VIII, p. 172 (I, p. 300).
- ⁸⁰ *De vita longa*, ed. by Adam von Bodenstein (1562), Lib. V, c. ii.
- ⁸¹ *Philosophia sagax*, X, p. 341 (XII, p. 382): “Now it is clear that all the human wisdom of the earthly body lieth in the light of nature.” It is “*man’s light of eternal wisdom*”: *ibid.*, p. 395 (p. 441).
- ⁸² *Liber de generatione hominis*, VIII, pp. 171 f. (I, pp. 299f.).

- ⁸³ “I am come to send fire on the earth; and what will I, if it be already kindled?” Luke (AV) 12 : 49.
- ⁸⁴ *Fragmenta cum libro de fundamento sapientiae*, IX, p. 448 (XIII, pp. 325f).
- ⁸⁵ *Philosophia sagax*, X, p. 46 (XII, p. 53).
- ⁸⁶ *Ibid.*, p. 79 (p. 94).
- ⁸⁷ *Practica in scientiam divinationis*, X, p. 438 (XII, p. 488).
- ⁸⁸ *Liber de Caducis*. IV. p. 274 (VIII, p. 298).
- ⁸⁹ In the *Hieroglyphica* of Horapollo the starry sky signifies God as ultimate Fate, symbolized by a “5,” presumably a quincunx. [Trans. by George Boas, p. 66.—EDITORS.]
- ⁹⁰ *Alchemical Studies*, index, s.v. “Agrippa.”
- ⁹¹ Cornelius Heinrich Agrippa von Nettesheim, *De occulta philosophia* (1533), p. lxix: “Nam iuxta Platoniorum doctrinam, est rebus inferioribus vis quaedam insita, per quam magna ex parte cum superioribus conveniunt, unde etiam animalium taciti consensus cum divinis corporibus consentire videntur, atque his viribus eorum corpora et affectus affici.” (For according to the doctrine of the Platonists there is in the lower things a certain virtue through which they agree in large measure with the higher; whence it would seem that the tacit consent of animals is in agreement with divine bodies, and that their bodies and affections are touched by these virtues), etc.
- ⁹² Lynn Thorndike, *History of Magic and Experimental Science*, II, pp. 348f
- ⁹³ François Picavet, *Essais sur l’histoire générale et comparée des théologies et des philosophies médiévales*, p. 207.
- ⁹⁴ Cf. *Psychology and Alchemy*, pars. 172, 265, 506, and pars. 446, 518.
- ⁹⁵ “Liber de compositione Alchemiae.” in *Artis auriferae*, II, p. 32: “The pure lato is cooked until it has the lustre of fish’s eyes.” Thus, by the authors themselves, the *oculi piscium* are interpreted as *scintillae*.
- ⁹⁶ *Opera omnia chemica* (1649), p. 159.
- ⁹⁷ Eirenaeus Orandus, *Nicholas Flamel: His Exposition of the Hieroglyphicall Figures etc.* (1624).
- ⁹⁸ Zach. 3 : 9 is also relevant: “... upon one stone there are seven eyes.” (Both DV.)
- ⁹⁹ This mythologem is of importance in interpreting the “cauda pavonis.”
- ¹⁰⁰ “Τετάρχαι γὰρ νομίζουσι κατὰ τὸν ἀρκτικὸν πόλον τὸν Δράκοντα, τὸν ὄφλν, ἀπὸ τοῦ ὑψηλοτάτου πόλον πάντα ἐπλβλέποντα καὶ πάντα ἐφορῶντα, ἵνα μηδὲν τῶν πραττομένων αὐτὸν λάθῃ.” *Elenchos*, IV, 47, 2, 3. Cf. Legge, I, p. 109.
- ¹⁰¹ F. Cumont, *Textes et monuments figures relatifs aux mystères de Mithra*, I, p. 80.
- ¹⁰² “Προέταξε τὸν αὐτὸν δράκοντα βαστάζελν ξξ ζώδια ἐπὶ τὸν νότου αὐτὸν”—Pitra, ed., *Analecla sacra*, V, p. 300. Quoted in Robert Eisler, *Weltenmantel und Himmelszelt* (1910), II, p. 389, 5.
- ¹⁰³ Eisler, p. 388. “The All-seeing Chronos” and “the all-beholding daemon.”
- ¹⁰⁴ *The Testament of Ignatius Loyola*, trans. by E. M. Rix, p. 72.
- ¹⁰⁵ Ignatius also had the vision of a “res quaedam rotunda tanquain cx auto et magna” that floated before his eyes: a thing round, as if made of gold, and great. He interpreted it as Christ appearing to him like a *sun*. Philipp Funk, *Ignatius von Loyola*, pp. 57, 65, 74, 112.
- ¹⁰⁶ [Trans. derived from various sources. As Coomaraswamy explains in the *Journal of the American Oriental Society*, LVI (1946), 143–61, “the ten-finger space” (lit. “the ten-fingered”) refers “niacrocsmically to the distance

between sky and earth and macrocosmically to the space between the top of the head and the chin” of a man. He continues: “I therefore consider it shown that what RV 10. 90. 1 ... means is that Purusha, making the whole earth his footstool, fills the entire universe, and rules over it by means of the powers of vision, etc., that proceed from his face, and to which man’s own powers of vision, etc., are analogous; this face, whether of God or man, being ... itself an image of the whole threefold universe.”—TRANS.]

¹⁰⁷ *Edenchos*, VIII, 12, 5. [Cf. *Aion*, pars. 340ff.—EDITORS.]

¹⁰⁸ *Ibid.*, VIII, 12, 2.

¹⁰⁹ Cf. the alchemical dictum: “Seminare aurum in terram albam foliatam” (Sow the gold in white foliated earth).

¹¹⁰ Cf. my remarks on the “uniting symbol” in *Psychological Types*, ch. V, sections 3 and 5.

¹¹¹ Freud also arrived at similar paradoxical conclusions. Thus, in his article “The Unconscious” (p. 177): he says: “An instinct can never become an object of consciousness—only the idea that represents the instinct can. *Even in the unconscious, moreover, an instinct cannot be represented otherwise than by an idea.*” (My italics.) As in my above account we were left asking, “Who is the subject of the unconscious will?” so we must ask here, “Exactly *who* has the idea of the instinct in the unconscious state?” For “unconscious” ideation is a *contradictio in adjecto*.

¹¹² For details see C. Lloyd Morgan, *Habit and Instinct*.

¹¹³ Cf. “The Aims of Psychotherapy,” pars. 101ff.; and *Two Essays on Analytical Psychology*, pars. 343ff. [Also “The Transcendent Function,” pars. 166ff]

¹¹⁴ The same applies to the pentadic figures.

¹¹⁵ So far as the development can be ascertained from the objective material.

¹¹⁶ Cf. *Psychology and Alchemy*, par. 329.

¹¹⁷ Cf. *Two Essays on Analytical Psychology*, par. 151.

¹¹⁸ Occasionally it is associated with synchronistic or parapsychic effects. I mean by synchronicity, as I have explained elsewhere, the not uncommonly observed “coincidence” of subjective and objective happenings, which just cannot be explained causally, at least in the present state of our knowledge. On this premise astrology is based and the methods of the *I Ching*. These observations, like the astrological findings, are not generally accepted, though as we know this has never hurt the facts. I mention these special effects solely for the sake of completeness and solely for the benefit of those readers who have had occasion to convince themselves of the reality of parapsychic phenomena. For a detailed discussion, see the final paper in this volume.

¹¹⁹ Cf. *Psychology and Alchemy*, Part II, for evidence of this.

¹²⁰ [*Mulungu* = ‘spirit, soul, daemonism, magic, prestige’: *Two Essays*, par. 108, and the first paper in this volume, pars. 117, 123f.—EDITORS.]

¹²¹ “Nature” here means simply that which is, and always was, given.

¹²² This expectation is based on the experience that blue, the colour of air and sky, is most readily used for depicting spiritual contents, whereas red, the “warm” colour, is used for feelings and emotions.

¹²³ Sir James Jeans (*Physics and Philosophy*, p. 193) points out that the shadows on the wall of Plato’s cave are just as real as the invisible figures that cast them and whose existence can only be inferred mathematically.

¹²⁴ It is very probable that the archetypes, as instincts, possess a specific energy which cannot be taken away from them in the long run. The energy peculiar to the archetype is normally not sufficient to raise it into consciousness. For this it needs a definite quantum of energy flowing into the unconscious from consciousness, whether because consciousness is not using this energy or because the archetype attracts it to itself. The archetype can be deprived of its supplementary charge, but not of its specific energy.

¹²⁵ Although both passages hint that the devil was cast out during the life-time of Jesus, in the Apocalypse the business of rendering him harmless is deferred until Doomsday (Rev. 20 : 2ff.).

¹²⁶ Cf. "The Phenomenology of the Spirit in Fairytales."

¹²⁷ Aptly expressed in the logion cited by Origen (*Homiliae in Jeremiam*, XX, 3): "He who is near unto me is near unto the fire. He who is far from me is far from the kingdom." This "unclaimed saying of the Master" refers to Isaiah 33 : 14.

¹²⁸ Conscious wholeness consists in a successful union of ego and self, so that both preserve their intrinsic qualities. If, instead of this union, the ego is overpowered by the self, then the self too does not attain the form it ought to have, but remains fixed on a primitive level and can express itself only through archaic symbols.

¹²⁹ I owe this formulation to the kind help of Professor W. Pauli.

¹³⁰ It may interest the reader to hear the opinion of a physicist on this point. Professor Pauli, who was good enough to glance through the ms. of this supplement, writes: "As a matter of fact the physicist would expect a psychological correspondence at this point, because the epistemological situation with regard to the concepts 'conscious' and 'unconscious' seems to offer a pretty close analogy to the undermentioned "complementarity" situation in physics. On the one hand the unconscious can only be inferred indirectly from its (organizing) effects on conscious contents. On the other hand every Observation of the unconscious," i.e., every conscious realization of unconscious contents, has an uncontrollable reactive effect on these same contents (which as we know precludes in principle the possibility of 'exhausting' the unconscious by making it conscious). Thus the physicist will conclude *per analogiam* that this uncontrollable reactive effect of the observing subject on the unconscious limits the objective character of the latter's reality and lends it at the same time a certain subjectivity. Although the *position* of the 'cut' between conscious and unconscious is (at least up to a point) left to the free choice of the 'psychological experimenter,' the *existence* of this 'cut' remains an unavoidable necessity. Accordingly, from the standpoint of the psychologist, the 'observed system' would consist not of physical objects only, but would also include the unconscious, while consciousness would be assigned the role of 'observing medium.' It is undeniable that the development of 'microphysics' has brought the way in which nature is described in this science very much closer to that of the newer psychology: but whereas the former, on account of the basic 'complementarity' situation, is faced with the impossibility of eliminating the effects of the observer by determinable correctives, and has therefore to abandon in principle any objective understanding of physical phenomena, the latter can supplement the purely subjective psychology of consciousness by postulating the existence of an unconscious that possesses a large measure of objective reality."

¹³¹ The physicist Pascual Jordan ("Positivistische Bemerkungen über die para-psychischen Erscheinungen," 14ff.) has already used the idea of relative space to explain telepathic phenomena.

¹³² *Die kulturelle Bedeutung der komplexen Psychologie*, p. 362.

¹³³ By this I only mean that psychic phenomena have an energetic aspect by virtue of which they can be described as "phenomena." I do not mean that the energetic aspect embraces or explains the whole of the psyche.

134 Cf. the first paper in this volume.

¹ [First published in English: “The Psychology of Dreams,” in *Collected Papers on Analytical Psychology*, edited by Constance Long (London, 1916; 2nd edn., London, 1917, and New York, 1920). The translation was by Dora Hecht from a ms., which, in much expanded form, was published as “Allgemeine Gesichtspunkte zur Psychologie des Traumes,” in *Über die Energetik der Seele* (Psychologische Abhandlungen, II; Zurich, 1928). It was again expanded in *Über psychische Energetik und das Wesen der Träume* (Zurich, 1948), and this version is translated here.—EDITORS.]

² [Cf. *Introduction to Logic*, p. 55.—EDITORS.]

³ [The original 1916 version ends at this point.—EDITORS.]

⁴ Cf. my “The Psychology of Dementia Praecox.” Flournoy, “Automatisme téléologique antisuicide” (1908).

⁵ “Sur le mouvement psychanalytique”; “Über die Funktion des Traumes”; *The Dream Problem*.

⁶ Fürst, “Statistical Investigations ... on Familial Agreement,” pp. 407ff.

⁷ *From India to the Planet Mars* and “Nouvelles observations sur un cas de somnambulisme avec glossolalie.”

⁸ On the question of telepathy see Rhine, *New Frontiers of the Mind*.

⁹ Cf. Silberer’s works on “symbol-formation”: “Ober die Symbolbildung.”

¹⁰ At this point we meet with agreement from Adler.

¹¹ Maeder, *The Dream Problem*, pp. 31 ff.

¹² *How Natives Think*, p. 129. It is to be regretted that Lévy-Bruhl expunged this exceedingly apt term from later editions of his books. Probably he succumbed to the attacks of those stupid persons who imagine that “mystic” means their own nonsensical conception of it. [Cf. the original edn., *Les Fonctions mentales*, p. 140.—EDITORS.]

¹³ Several examples of interpretation on the subjective level have been furnished by Maeder. The two kinds of interpretation are discussed in detail in *Two Essays on Analytical Psychology*, pars. 128ff.

¹⁴ Pars. 206ff. Concerning projections in the transference, see “Psychology of the Transference,” index, s.v. “transference,” “projection.”

¹⁵ The first World War.

¹⁶ Cf. “The Psychology of the Transference,” pars. 364ff., 383f.

¹⁷ For the sake of completeness I should mention that no imago comes exclusively from outside. Its specific form is due just as much to the *a priori* psychic disposition, namely the archetype.

¹⁸ By this they mean the theory of archetypes. But is the biological concept of the “pattern of behaviour” also “metaphysical”?

¹⁹ A few additions will be found in the next paper, written very much later.

¹ [First published as “Vom Wesen der Träume,” *Ciba-Zeitschrift* (Basel), IX : 99 (July, 1945). Revised and expanded in *Über psychische Energetik und das Wesen der Träume* (Psychologische Abhandlungen, II; Zurich, 1948).—EDITORS.]

² Cf. “The Practical Use of Dream-Analysis,” pars. 343ff.

³ This is not to deny the principle of *complementarity*. “Compensation” is simply a psychological refinement of this concept.

⁴ *The Psychopathology of Everyday Life*.

⁵ [Cf. Meier, *Ancient Incubation and Modern Psychotherapy*.—EDITORS.]

⁶ Cf. *Two Essays on Analytical Psychology*, I, chs. V–VII.

⁷ Cf. my and C. Kerényi’s *Essays on (or Introduction to) a Science of Mythology*. [Also, *Symbols of Transformation*, pars. 572ff., 577ff.]

⁸ The tree is also an alchemical symbol. Cf. *Psychology and Alchemy*, index, s.v. “tree”; and “The Philosophical Tree.”

⁹ The stag is an allegory of Christ because legend attributes to it the capacity for self-renewal. Thus Honorius of Autun writes in his *Speculum de Mysteriis Ecclesiae* (Migne, *P.L.*, vol. 172, col. 847): “They say that the deer, after he has swallowed a serpent, hastens to the water, that by a draught of water he may eject the poison, and then cast his horns and his hair and so take new.” In the *Saint-Graal* (III, pp. 219 and 224), it is related that Christ sometimes appeared to the disciples as a white stag with four lions (= four evangelists). In alchemy, Mercurius is allegorized as the stag (Manget, *Bibl. chem.*, Tab. IX, fig. XIII, and elsewhere) because the stag can renew itself. “Les os du cuer du serf vault moult pour conforter le cuer humain” (Delatte, *Textes latins et vieux français relatifs aux Cyranides*, p. 346).

¹ Originally translated by H. G. Baynes from a German manuscript and published in *Proceedings of the Society for Psychological Research* (London), XXXI (1920), having been read at a general meeting of the Society on July 4, 1919. This translation was republished in *Contributions to Analytical Psychology* (London and New York, 1928). The German original was first published as “Die psychologischen Grundlagen des Geisterglaubens,” in *Über die Energetik der Seele* (Psychologische Abhandlungen, II; Zurich, 1928), and was revised and expanded in *Über psychische Energetik und das Wesen der Träume* (Zurich, 1948). The latter version is here translated, but the Baynes translation has also been consulted.—EDITORS.]

² When I was on an expedition to Mount Elgon (East Africa) in 1925–26, one of our water-bearers, a young woman who lived in a neighbouring kraal, fell ill with what looked like a septic abortion with high fever. We were unable to treat her from our meagre medical supplies, so her relatives immediately sent for a *nganga*, a medicine-man. When he arrived, the medicine-man walked round and round the hut in ever-widening circles, snuffing the air. Suddenly he came to a halt on a track that led down from the mountain, and explained that the sick girl was the only daughter of parents who had died young and were now up there in the bamboo forest. Every night they came down to make their daughter ill so that she should die and keep them company. On the instructions of the medicine-man a “ghost-trap” was then built on the mountain path, in the form of a little hut, and a clay figure of the sick girl was placed inside it together with some food. During the night the ghosts went in there, thinking to be with their daughter. To our boundless astonishment the girl recovered within two days. Was our diagnosis wrong? The puzzle remained unsolved.

³ There are even cases where the voices repeat the patient’s thoughts aloud. But these are rather rare.

⁴ Cf. *supra*, “A Review of the Complex Theory.”

⁵ This should not be misconstrued as a metaphysical statement. The question of whether spirits exist *in themselves* is far from having been settled. Psychology is not concerned with things as they are “in themselves,” but only with what people think about them.

⁶ By this I do not mean the existing form of the motif but its preconscious, invisible “ground plan.” This might be compared to the crystal lattice which is preformed in the crystalline solution. It should not be confused with the variously structured axial system of the individual crystal.

⁷ Cf. my *Symbols of Transformation*; also Spielrein, “Über den psychologischen Inhalt eines Falles von Schizophrenic”; Nelken, “Analytische Beobachtungen über Phantasien eines Schizophrenen”; C. A. Meier, “Spontanmanifestationen des kollektiven Unbewussten.”

⁸ This is not always a pleasant feeling, for the patient was quite content to lose the complex so long as he did not feel the disagreeable consequences of the loss.

⁹ Those who are familiar with this material will object that my description is one-sided, because they know that the archetype, the autonomous collective content, does not have only the negative aspect described here. I have merely restricted myself to the common symptomatology that can be found in every text-book of psychiatry, and to the equally common defensive attitude towards anything extraordinary. Naturally the archetype also has a positive numinosity which I have repeatedly mentioned elsewhere.

¹⁰ Cf. my *Studies in Word Association*.

¹¹ This account of the genesis of a collective psyche was written in the spring of 1919. Events since 1933 have amply confirmed it.

¹² [The rest of this paragraph was added in the 1948 Swiss edition.—EDITORS.]

¹³ I am indebted to Dr. Fritz Kiinkel, of Los Angeles, for drawing my attention to this author.

¹⁴ Cf. “The Transcendent Function,” supra, pars. 166ff., and *Two Essays*, pars. 343ff. [Also *Mysterium Coniunctionis*, pars. 706, 752ff.]

¹⁵ After collecting psychological experiences from many people and many countries for-fifty years, I no longer feel as certain as I did in 1919, when I wrote this sentence. To put it bluntly, I doubt whether an exclusively psychological approach can do justice to the phenomena in question. Not only the findings of parapsychology, but my own theoretical reflections, outlined in “On the Nature of the Psyche,” have led me to certain postulates which touch on the realm of nuclear physics and the conception of the space-time continuum. This opens up the whole question of the transpsychic reality immediately underlying the psyche.

¹ A lecture delivered to the literary society of Augsburg, October 29, 1926, one of a series of lectures on the theme “Nature and Spirit.” [First published as “Geist und Leben,” *Form und Sinn* (Augsburg), II : 2 (Nov. 1926), which was translated by H. G. and C. F. Baynes in *Contributions to Analytical Psychology* (London and New York, 1928). The original version was republished in *Seelen-probleme der Gegenwart* (Psychologische Abhandlungen, II; Zurich, 1931). The present translation is based on the Baynes version.—EDITORS.]

¹ [First published as “Die Entschleierung der Seele,” *Europäische Revue* (Berlin), VII: 2/7 (July 1931), which version was translated by W. S. Dell and Cary F. Baynes as “The Basic Postulates of Analytical Psychology,” *Modern Man in Search of a Soul* (London and New York, 1933). The original version was republished, with slight revisions and the title “Das Grundproblem der gegenwärtigen Psychologie,” in *Wirklichkeit der Seele* (Psychologische Abhandlungen, IV; Zurich, 1934). The present version is a slight revision of the Dell/Baynes trans.—EDITORS.]

² [Edgar Dacqué (1878–1945) was a geologist who risked (and lost) his reputation by reversing the Darwinian theory of origin of species.—EDITORS.]

³ [See Bibliography s.v. “Murchison.”—EDITORS.]

¹ [A lecture delivered in Karlsruhe, 1927. It was translated from the original ms. by H. G. and C. F. Baynes and first published under the present title in *Contributions to Analytical Psychology* (London and New York, 1928). Again a lecture, to the Philosophical Society of Zurich, March 4, 1930. The original version was subsequently revised, enlarged, and published as “Analytische Psychologie und Weltanschauung,” *Seelenprobleme der Gegenwart* (Psychologische Abhandlungen, III; Zurich, 1931). The present translation is of the latter, but the Baynes version has been consulted.—EDITORS.]

² *Faust*, Part I, trans. by Wayne, p. 178.

³ [*Two Essays on Analytical Psychology; Psychology and Alchemy*, Part II; “A Study in the Process of Individuation”; “Concerning Mandala Symbolism.”—EDITORS.]

⁴ [The remaining paragraphs were added in the 1931 Swiss edn.—EDITORS.]

¹ [Originally published as “Wirklichkeit and Oberwirklichkeit,” *Querschnitt* (Berlin), XII : 12 (Dec. 1933).—
EDITORS.]

¹ [Originally published as “Die seelischen Probleme der menschlichen Altersstufen,” *Neue Zürcher Zeitung*, March 14 and 16, 1930. Revised and largely rewritten, it was republished as “Die Lebenswende,” *Seelenprobleme der Gegenwart* (Psychologische Abhandlungen, III; Zurich, 1931), which version was translated by W. S. Dell and Cary F. Baynes as “The Stages of Life,” *Modern Man in Search of a Soul* (London and New York, 1933). The present translation is based on this.—EDITORS.]

¹ [Originally published as “Seele und Tod,” *Europäische Revue* (Berlin), X (April 1934) and republished in *Wirklichkeit der Seele* (Psychologische Abhandlungen, IV; Zurich, 1934). A shortened version appeared as “Von der Psychologie des Sterbens,” *Münchener Neueste Nachrichten*, No. 269 (Oct. 2, 1935)—The present version is a slight revision of a translation by Eugene H. Henley in *Spring* (Analytical Psychology Club, New York), 1945, to whom grateful acknowledgment is made.—EDITORS.]

² [Cf. the next paper in this volume.—EDITORS.]

¹ [Other than, or supplementary to, the laws of chance.—EDITORS.]

² [Cf. Jung, *Studies in Word Association*—EDITORS.]

³ Paul Kammerer, *Das Gesetz der Serie*.

⁴ *Ibid.*, p. 130.

⁵ Pp. 36, 93f., 102f.

⁶ “The law of series is an expression of the inertia of the objects involved in its repetitions (i.e., producing the series). The far greater inertia of a complex of objects and forces (as compared to that of a single object or force) explains the persistence of an identical constellation and the emergence, connected therewith, of repetitions over long periods of time” (p. 117).

⁷ P. 130.

⁸ P. 94.

⁹ [The term “probability” therefore refers to the probability on a chance hypothesis (Null Hypothesis). This is the sense in which the term is most often used in this paper.—EDITORS.]

¹⁰ The numinosity of a series of chance happenings grows in proportion to the number of its terms. Unconscious—probably archetypal—contents are thereby constellated, which then give rise to the impression that the series has been “caused” by these contents. Since we cannot conceive how this could be possible without recourse to positively magical categories, we generally let it go at the bare impression.

¹¹ As a pendant to what I have said above, I should like to mention that I wrote these lines sitting by the lake. Just as I had finished this sentence, I walked over to the sea-wall and there lay a dead fish, about a foot long, apparently uninjured. No fish had been there the previous evening. (Presumably it had been pulled out of the water by a bird of prey or a cat.) The fish was the seventh in the series.

¹² We find ourselves in something of a quandary when it comes to making up our minds about the phenomenon which Stekel calls the “compulsion of the name.” What he means by this is the sometimes quite grotesque coincidence between a man’s name and his peculiarities or profession. For instance Herr Gross (Mr. Grand) suffers from delusions of grandeur, Herr Kleiner (Mr. Small) has an inferiority complex. The Altmann sisters marry men twenty years older than themselves. Herr Feist (Mr. Stout) is the Food Minister, Herr Rosstauscher (Mr. Horsetrader) is a lawyer, Herr Kalberer (Mr. Calver) is an obstetrician, Herr Freud (joy) champions the pleasure-principle, Herr Adler (eagle) the will-to-power, Herr Jung (young) the idea of rebirth, and so on. Are these the whimsicalities of chance, or the suggestive effects of the name, as Stekel seems to suggest, or are they “meaningful coincidences”? (“Die Verpflichtung des Namens,” *noff.*)

¹³ *Parerga und Paralipomena*, I, ed. by von Koeber. [Cf. the trans. by David Irvine, to which reference is made for convenience, though not quoted here.]

¹⁴ *Ibid.*, p. 40. [Irvine, p. 41.]

¹⁵ P. 39. [Irvine, pp. 39f.]

¹⁶ P. 45. [Irvine, pp. 49f.]

¹⁷ P. 46. [Irvine, p. 50.]

¹⁸ Hence my term “synchronicity.”

- ¹⁹ Here I must make an exception of Kant, whose treatise *Dreams of a Spirit-Seer, Illustrated by Dreams of Metaphysics* pointed the way for Schopenhauer.
- ²⁰ Edmund Gurney, Frederic W. H. Myers, and Frank Podmore, *Phantasms of the Living*.
- ²¹ Xavier Dariex, “Le Hazard et la télépathie.”
- ²² Charles Richet, “Relations de diverses expériences sur transmission mentale, la lucidité, et autres phénomènes non explicable par les données scientifiques actuelles.”
- ²³ Camille Flammarion, *The Unknown*, pp. 191ff.
- ²⁴ *Ibid.*, p. 202.
- ²⁵ Pp. 192f.
- ²⁶ Pp. 194ff. A certain M. Deschamps, when a boy in Orléans, was once given a piece of plum-pudding by a M. de Fortgibu. Ten years later he discovered another plum-pudding in a Paris restaurant, and asked if he could have a piece. It turned out, however, that the plum-pudding was already ordered—by M. de Fortgibu. Many years afterwards M. Deschamps was invited to partake of a plum-pudding as a special rarity. While he was eating it he remarked that the only thing lacking was M. de Fortgibu. At that moment the door opened and an old, old man in the last stages of disorientation walked in: M. de Fortgibu, who had got hold of the wrong address and burst in on the party by mistake.
- ²⁷ *Der Zufall: Eine Vorjorm des Schicksals*.
- ²⁸ *Der Zufall und die Koboldstreiche des Unbewussten*.
- ²⁹ J. B. Rhine, *Extra-Sensory Perception and New Frontiers of the Mind*. J. G. Pratt, J. B. Rhine, C. E. Stuart, B. M. Smith, and J. A. Greenwood, *Extra-Sensory Perception after Sixty Years*. A general survey of the findings in Rhine, *The Reach of the Mind*, and also in the valuable book by G. N. M. Tyrrell, *The Personality of Man*. A short résumé in Rhine, “An Introduction to the Work of Extra-Sensory Perception.” S. G. Soal and F. Bateman, *Modern Experiments in Telepathy*.
- ³⁰ *The Reach of the Mind* (1954 edn.), p. 48.
- ³¹ Rhine and Betty M. Humphrey, “A Transoceanic ESP Experiment.”
- ³² *The Reach of the Mind*, pp. 75ff.
- ³³ Professor Pauli was kind enough to draw my attention to this paper, which appeared in 1949.
- ³⁴ Kammerer has dealt, not altogether convincingly, with the question of the “countereffect of the succeeding state on the preceding one” (cf. *Das Gesetz der Serie*, pp. 131f.).
- ³⁵ Cf. above, par. 440.
- ³⁶ To be more accurate, the swarming begins a little before and ends a little after this day, when the swarming is at its height. The months vary according to location. The palolo worm, or wawo, of Amboina is said to appear at full moon in March. (A. F. Krämer, *Über den Bau der Korallenriffe*.)
- ³⁷ Fritz Dahns, “Das Schwärmen des Palolo.”
- ³⁸ Even before that time certain doubts had arisen in me as to the unlimited applicability of the causal principle in psychology. In the foreword to the 1st edn. of *Collected Papers on Analytical Psychology*, I had written (p. ix): “Causality is only one principle and psychology essentially cannot be exhausted by causal methods only, because the

mind [= psyche] lives by aims as well.” Psychic finality rests on a “pre-existent” meaning which becomes problematical only when it is an unconscious arrangement. In that case we have to suppose a “knowledge” prior to all consciousness. Hans Driesch comes to the same conclusion (*Die “Seele” als elementarer Naturfaktor*, pp. 80ff.).

^{38a} [The case is discussed more fully below, par. 982.—EDITORS.]

³⁹ In Homer the souls of the dead “twitter.” [*Odyssey*, Book XI.—EDITORS.]

⁴⁰ Naturally these can only be verified when the doctor himself has the necessary knowledge of symbology.

⁴¹ [Statistical analysis is designed to separate out groupings (termed dispersions) due to random activity from significant dispersions in which causes may be looked for. On Professor Jung’s hypothesis, however, dispersions due to chance can be subdivided into meaningful and meaningless. The meaningless dispersions due to chance are made meaningful by the activation of the psychoid archetype.—EDITORS.]

⁴² Cf. par. 841; also “On the Nature of the Psyche,” par. 404f.

⁴³ A literary example is “The Cranes of Ibycus.” [A poem by Schiller (1798), inspired by the story of the Greek poet murdered by robbers who were brought to justice through the appearance of a swarm of cranes. As cranes had also flown over the scene of the crime, the murderers cried out at the sight and so betrayed themselves.—EDITORS.] Similarly, when a flock of chattering magpies settles on a house it is supposed to mean death, and so on. Cf. also the significance of auguries.

⁴⁴ *An Experiment with Time* (2nd edn.), pp. 34ff.

⁴⁵ *De opificio mundi*, 26. (“Διάστημα τῆς τοῦ οὐρανοῦ κινήσαώς ἐστι ὁ χρόνος.”)

⁴⁶ “virtus”

⁴⁷ “quando ipsa fertur in magnum amoris excessum aut odii aut alicuius talium.”

⁴⁸ “fertur in grandem excessum alicuius passionis invenitur experimento manifesto quod ipse ligat res et alterat ad idem quod desiderat”

⁴⁹ “affectio”

⁵⁰ “cum tali affectione exterminata concurrat hora conveniens aut ordo coelestis aut alia virtus, quae quodvis faciet, illud reputavimus tunc animam facere.”

⁵¹ *De mirabilibus mundi* (1485?).

⁵² *Metaphysica vera*, Part III, “Secunda scientia,” in *Opera philosophica*, ed. by Land, II, pp. 187f.

⁵³ *Eckermann’s Conversations with Goethe*, trans. by Moon, pp. 514f. (modified)

⁵⁴ See p. 430. *supra*.

⁵⁵ Recently Pascual Jordan has put up an excellent case for the scientific investigation of spatial clairvoyance (“Positivistische Bemerkungen über die parapsychischen Erscheinungen”). I would also draw attention to his *Verdrängung und Komplementarität*, concerning the relations between microphysics and the psychology of the unconscious.

⁵⁶ Trans. by Cary F. Baynes from the Richard Wilhelm translation.

⁵⁷ If the experiment is made with the traditional yarrow stalks, the division of the forty-nine stalks represents the chance factor.

⁵⁸ See also *infra*, par. 986.

⁵⁹ I first used this term in my memorial address for Richard Wilhelm (delivered May 10, 1930, in Munich). The address later appeared as an appendix to *The Secret of the Golden Flower*, where I said: “The science of the *I Ching* is not based on the causality principle, but on a principle (hitherto unnamed because not met with among us) which I have tentatively called the synchronistic principle” (p. 141). [Cf. “Richard Wilhelm: In Memoriam,” par. 81.]

⁶⁰ *I Ching*, Appendix.

⁶¹ Mentioned by Isidore of Seville in his *Liber etymologiarum*, VIII, ix, 13.

⁶² Grains of corn or dice can also be used.

⁶³ The best account is to be found in Robert Fludd (1574–1637), *De arte geomantica*. Cf. Lynn Thorndike, *A History of Magic and Experimental Science*, II, p. 110.

⁶⁴ Other obvious facts would be murder and suicide. Statistics are to be found in Herbert von Kloeckler (*Astrologie als Erfahrungswissenschaft*, pp. 232ff. and 260ff.), but unfortunately they fail to give comparisons with normal average values and cannot be used for our purpose. On the other hand, Paul Flambart (*Preuves et bases de l’astrologie scientifique*, pp. 79ff.) shows a graph of statistics on the ascendants of 123 outstandingly intelligent people. Definite accumulations occur at the corners of the airy trigon ((♈, ♎, ♊)). This result was confirmed by a further 300 cases.

⁶⁵ This view dates back to Ptolemy: “Apponit [Ptolemaeus] autem tres gradus concordiae: Primus cum Sol in viro, et Sol vel Luna in femina, aut Luna in utrisque, fuerint in locis se respicientibus trigono, vel hexagono aspectu. Secundus cum in viro Luna, in uxore Sol eodem modo disponuntur. Tertius si cum hoc alter alterum recipiat.” (Ptolemy postulates three degrees of harmony. The first is when the sun in the man’s [horoscope], and the sun or moon in the woman’s, or the moon in both, are in their respective places in a trine or sextile aspect. The second degree is when the moon in a man’s [horoscope] and the sun in a woman’s are constellated in the same way. The third degree is when the one is receptive to the other.) On the same page, Cardan quotes Ptolemy (*De iudiciis astrorum*): “Omnino vero constantes et diurni convictus permanent quando in utriusque conjugis genitura luminaria contigerit configurata esse concorditer” (Generally speaking, their life together will be long and constant when in the horoscopes of both partners the luminaries [sun and moon] are harmoniously constellated). Ptolemy regards the conjunction of a masculine moon with a feminine sun as particularly favourable for marriage.—Jerome Cardan, *Commentaria in Ptolemaeum de astrorum iudiciis*, Book IV (in his *Opera omnia*, V, p. 332).

⁶⁶ The practising astrologer can hardly suppress a smile here, because for him these correspondences are absolutely self-evident, a classic example being Goethe’s connection with Christiane Vulpius: ☉ 5° ♏ ☽ ☾ 7° ♏.

I should perhaps add a few explanatory words for those readers who do not feel at home with the ancient art and technique of astrology. Its basis is the horoscope, a circular arrangement of sun, moon, and planets according to their relative positions in the signs of the zodiac at the moment of an individual’s birth. There are three main positions, viz., those of sun (☉), moon (☾), and the so-called ascendent (Asc); the last has the greatest importance for the interpretation of a nativity: the Asc. represents the degree of the zodiacal sign rising over the eastern horizon at the moment of birth. The horoscope consists of 12 so-called “houses,” sectors of 30° each. Astrological tradition ascribes different qualities to them as it does to the various “aspects,” i.e., angular relations of the planets and the *luminaria* (sun ☉ and moon ☾), and to the zodiacal signs.

⁶⁷ Cf. “On the Psychology of Eastern Meditation,” par. 942.

⁶⁸ Cf. “A Study in the Process of Individuation” and “Concerning Mandala Symbolism.”

¹ For a comprehensive account of this, see Max Knoll, “Transformations of Science in Our Age,” in *Man and Time*.

² Cf. the statistical results in K. E. Krafft and others, *Le Premier Traité d’astrobiologie*, pp. 23ff. and passim.

³ Although the quartile, trine and sextile aspects and the relations to the Medium and Imum Coeli ought really to be considered, I have omitted them here so as not to make the exposition unduly complicated. The main point is not *what* marriage aspects are, but whether they can be detected in the horoscope.

⁴ Fig. 1 (p. 461) sets out clearly the 50 different aspects as they actually occurred in the 180 married pairs.

⁵ [In this way a rough control group is obtained. It will, however, be appreciated that it is derived from a much larger number of pairs than the married pairs: 32,220 as compared with 180. This leads to the possibility of showing the chance nature of the 180 pairs. On the hypothesis that all the figures are due to chance, we would expect a far greater accuracy in the greater number and consequently a much smaller range in the figures. This is so, for the range in the 180 married pairs is $18 - 2 = 16$, whereas in the 180 unmarried pairs we get $9.6 - 7.4 = 2.2$.—EDITORS.]

⁶ [Par. 880. $9.6\% = 8$ such aspects in 83 married pairs. See par. 902 and App., (b).—EDITORS.]

⁷ How subtle these things can be is shown by the following incident: Recently it fell to my colleague to make the table arrangement for a number of people who were invited to dinner. She did this with care and discretion. But at the last moment an esteemed guest, a man, unexpectedly turned up who had at all costs to be suitably placed. The table arrangement was all upset, and a new one had to be hastily devised. There was no time for elaborate reflection. As we sat down to table, the following astrological picture manifested itself in the immediate vicinity of the guest:

LADY ☾ in ♀	LADY ☉ in ♋	GUEST ☉ in ♌	LADY ☉ in ♋
LADY ☉ in ♀	LADY ☾ in ♋	GENTLEMAN ☾ in ♌	LADY ☾ in ♋

Four ☉ ☾ marriages had arisen. My colleague, of course, had a thorough knowledge of astrological marriage aspects, and she was also acquainted with the horoscopes of the people in question. But the speed with which the new table arrangement had to be made left her no opportunity for reflection, so that the unconscious had a free hand in secretly arranging the “marriages.”

⁸ Cf. the nuptials of sun and moon in alchemy: *Psychology and Alchemy*, index, s.v. “Sol and Luna.”

^{8a} [See infra, pars. 989–91—EDITORS.]

⁹ Professor Fierz wishes to correct this sentence as follows: “Later on he called my attention to the fact that the sequence of the 3 aspects does not matter. As there are 6 possible sequences, we have to multiply our probability by 6, which gives 1 : 1500.” To this I reply that I never suggested anything of the kind! The sequence, i.e., the way in which the 3 conjunctions follow each other, has no importance at all.

¹⁰ [See App., (b). This passage has been rewritten to include the three sets of probabilities supplied by Professor Fierz.—EDITORS.]

¹¹ Cf. G. Schmiedler, “Personality Correlates of ESP as Shown by Rorschach Studies.” The author points out that those who accept the possibility of ESP get results above expectation, whereas those who reject it get negative results.

¹² As my statistics show, the result becomes blurred with larger figures. So it is very probable that if more material were collected it would no longer produce a similar result. We have therefore to be content with this apparently unique *lusus naturae*, though its uniqueness in no way prejudices the facts.

¹³ By which I mean a subject chosen at random, and not one with specific gifts.

¹⁴ Cf. “On the Nature of the Psyche,” pars. 417f.

¹⁵ This case is well authenticated. See report in Kant’s *Dreams of a Spirit-Seer, Illustrated by Dreams of Metaphysics*.

¹⁶ Cf. the interesting reflections of G. Spencer Brown: “De la recherche psychique considérée comme un test de la théorie des probabilités.”

¹ Cf. *Psychology and Alchemy*, par. 453. and “The Spirit Mercurius,” par. 273. Also the doctrine of *chèn-yên* in Wei Po-yang [“Phil. Tree,” pars. 432ff., and *Mysterium*, pars. 490, 711n] and in Chuang-tzu.

² Jung, “Commentary on *The Secret of the Golden Flower*,” par. 28, and Wilhelm, *Chinesische Lebensweisheit*.

³ [Quotations from Arthur Waley’s *The Way and Its Power*, with occasional slight changes to fit Wilhelm’s reading. —TRANS.]

⁴ Tao is the contingent, which Andreas Speiser defines as “pure nothing” (“über die Freiheit”).

⁵ Wilhelm, *Chinesische Lebensweisheit*, p. 15: “The relation between meaning (Tao) and reality cannot be conceived under the category of cause and effect.”

⁶ *Ibid.*, p. 19.

⁷ *Dos wahre Buch vom südlichen Blütenland*, trans. by R. Wilhelm, II, 3.

⁸ *Ibid.*, II, 3.

⁹ II, 7.

¹⁰ II, 5.

¹¹ IV, 1.

¹² *La Pensée chinoise*; also Lily Abegg, *The Mind of East Asia*. The latter gives an excellent account of the synchronistic mentality of the Chinese.

¹³ Professor W. Pauli kindly calls my attention to the fact that Niels Bohr used “correspondence” as a mediating term between the representation of the dis-continuum (particle) and the continuum (wave). Originally (1913–18) he called it the “principle of correspondence,” but later (1927) it was formulated as the “argument of correspondence.”

¹⁴ “συμπάθεια τῶν ὅλων”

¹⁵ *De alimento*, a tract ascribed to Hippocrates. (Trans. by John Precoppe in *Hippocrates on Diet and Hygiene*, p. 174, modified.) Σύρροια μία, συμπινοία μία, πάντα συμπαθέα κατά μὲν οὐλομελίην πάντα κατά μέρος δέ τό ἐν ἐκάστω μέρει μερέα πρὸς τό ἔργον ... ἀρχή μεγάλη ἐς ἑαχάτον μέρος ἀφικνέεται, ἐξ ἑσχάτον μέρους εἰς ἀρχήν μεγάλην ἀφικνέεται μία Φύσις εἶναι καὶ μὴ εἶναι.”

¹⁶ *De officio mundi*, 82 (trans. by F. H. Colson and G. H. Whitaker, I, p. 67).

¹⁷ “ἀρχή μεγάλη”

¹⁸ Eduard Zeller, *Die Philosophie der Griechen*, II, part ii, p. 654.

¹⁹ *Enneads*, IV, 3, 8 and 4, 32 (in A. C. H. Dews, *Plotin und der Untergang der antiken Weltanschauung*, p. 179).

²⁰ *Heptaplus*, VI, prooem., in *Opera omnia*, pp. 40f. (“Est enim primum ea in rebus unitas, qua unumquodque sibi est unum sibi que constat atque cohaeret. Est ea secundo, per quam altera alteri creatura unitur, et per quam demum omnes mundi partes unus sunt mundus. Tertia atque omnium principalissima est, qua *totum* universum cum suo opifice quasi exercitus cum suo duce est unum.”)

²¹ “unitas ita ternario distincta, ut ab unitatis simplicitate non discedat.”

²² *Opera omnia*, p. 315. (“Nascenti homini omnifaria semina et origenae vitae germina indidit pater.”)

²³ *Heptaplus*, V, vi, in *ibid.*, p. 38. (“Faciamus hominem ad imaginem nostram, qui non tam quartus est mundus, quasi nova aliqua natura, quam triuin (mundus supercoelestis, coelestis, sublunaris) complexus et colligatio.”)

²⁴ “God ... placed man in the centre [of the world] after his image and the similitude of forms” (“Deus ... hominem in medio [mundi] statuit ad imaginem suam et similitudinem formarum”).

²⁵ Pico’s doctrine is a typical example of the medieval correspondence theory. A good account of cosmological and astrological correspondence is to be found in Alfons Rosenberg, *Zeichen am Himmel: Das Weltbild der Astrologie*.

²⁶ Albrecht Dieterich, *Eine Mithrasliturgie*, p. 9.

²⁷ Henricus Cornelius Agrippa von Nettesheim, *De occulta philosophia Libri tres*, I, viii, p. 12. Trans. by “J. F.” as *Three Books of Occult Philosophy* (1651 edn.), p. 20; republished under the editorship of W. F. Whitehead, p. 55. [Quotations from the J. F. translation have been slightly modified.—TRANS.] (“Est Platoniorum omnium unanimes sententia quemadmodum i 1 archetypo mundo omnia sunt in omnibus, ita etiam in hoc corpóreo mundo, omnia in omnibus esse, modis tamen diversis, pro natura videlicet suscipientium: sic et elementa non solum sunt in istis inferioribus, sed in coelis, in stellis, in daemonibus, in angelis, in ipso denique omnium opifice et archetypo.”)

²⁸ “Omnia plena diis esse.”

²⁹ “virtutes divinae in rebus diffusae”

³⁰ “divinae illices”

³¹ “symbolicae illecebrae.” [In J. F. original edn., p. 32; Whitehead edn., p. 69.—TRANS.] Agrippa is basing himself here on the Marsilio Ficino translation (*Auctores Platonici*, II, vo). In Synesius (*Opuscula*, ed. by Nicolaus Terzaghi, p. 148), the text of Περὶ ἐνυπνῶν III B has το θελγόμενον, from τέλγοιν “to excite, charm, enchant.”

³² *De occulta philosophia*, I, iv, p. 69. (J. F. edn., p. 117; Whitehead edn., p. 169.) Similarly in Paracelsus.

³³ “Haud equidem credo, quia sit divinius illis

Ingenium aut rerum fato prudentia maior.”

—*Georgics*, I, 415f

³⁴ *Die “Seele” als elementarer Naturfaktor*, pp. 80, 82.

³⁵ Cf. supra, “On the Nature of the Psyche,” pars. 392f.

³⁶ Agrippa says of this (*op. cit.*, I, xiv, p. 29; J. F. edn., p. 33; Whitehead edn., p. 70): “That which we call the quintessence: because it is not from the four Elements, but a certain fifth thing, having its being above, and besides them.” (“Quoddam quintum super illa [elementa] aut praeter illa subsistens.”)

³⁷ II, lvii, p. 203 (J. F. edn., p. 331): “Est itaque anima mundi, vita quaedam unica omnia replens, omnia perfundens, omnia colligens et connectens, ut unam reddat totius mundi machinam. ...”

³⁸ *Ibid.*: “... potentius perfectiusque agunt, tum etiam promptius generant sibi simile.”

³⁹ The zoologist A. C. Hardy reaches similar conclusions: “Perhaps our ideas on evolution may be altered if something akin to telepathy—unconscious no doubt—were found to be a factor in moulding the patterns of behaviour among members of a species. If there was such a non-conscious group-behaviour plan, distributed between, and linking, the individuals of the race, we might find ourselves coming back to something like those ideas of subconscious racial memory of Samuel Butler, but on a group rather than an individual basis.” “The Scientific Evidence for Extra-Sensory Perception,” in *Discovery*, X, 328, quoted by Soal, q.v.

⁴⁰ Op. cit., II, iv-xiv.

⁴¹ “Dialogus inter naturam et filium philosophiae.” *Theatrum chemicum*, II (1602), p. 123.

⁴² Cited in Agrippa, op. cit., II, iv, p. 104 (J. F. edn., p. 176).

⁴³ Cf. Aniela Jaffé, “Bilder und Symbole aus E. T. A. Hoffmann’s Märchen ‘Der goldene Topf,’” and Marie-Louise von Franz, “Die Passio Perpetuae.”

⁴⁴ Cf. *Alchemical Studies*, index, s.v. “Agrippa.”

⁴⁵ *Das Buch Paragranum*, ed. by Franz Strunz, pp. 35f. Much the same in *Labyrinthus medicorum*, in the *Sämtliche Werke*, ed. Sudhoff, XI, pp. 204ff

⁴⁶ Strunz edn., p. 34.

⁴⁷ Similar ideas in Jakob Böhme, *The Signature of All Things*, trans. by John Ellistone, p. 10: “Man has indeed the forms of all the three worlds in him, for he is a complete image of God, or of the Being of all beings. ...” (*Signatura rerum*, I, 7.)

⁴⁸ *Opera omnia*, ed. by C. Frisen, I, pp. 605ff.

⁴⁹ Ibid., No. 64.

⁵⁰ No. 65.

⁵¹ No. 67.

⁵² [“in die Natalitia” = “into those [positions presiding] at birth,” if “in die” is construed as German. The *Gesammelte Werke*, ed. by M. Caspar and F. Hammer, IV, p. 211, has “in die Natalitio” = “in the day of birth,” the words “in die” being construed as Latin.—TRANS.]

⁵³ No. 68.

⁵⁴ See the dreams mentioned below.

⁵⁵ Kepler, *Opera*, ed. by Frisch, V, p. 254; cf. also II, pp. 270f. and VI, pp. 178f “... formatrix facultas est in visceribus terrae, quae feminae praegnantis more occursantes foris res humanas veluti eas videret, in fissibilibus lapidibus exprimit, ut militum, monachorum, pontificum, regum et quidquid in ore hominum est. ...”

⁵⁶ “... quod scl. principatus causae in terra sedeat, non in planetis ipsis.” Ibid., II, p. 642.

⁵⁷ “... ut omne genus naturalium vel animalium facultatum in corporibus Dei quandam gerat similitudinem.” Ibid. I am indebted to Dr. Liliane Frey-Rohn and Dr. Marie Louise von Franz for this reference to Kepler.

⁵⁸ C. W. Leibniz, “Second Explanation of the System of the Communication between Substances” (*The Philosophical Works of Leibniz*, trans. by G. M. Duncan, pp. 90–91): “From the beginning God has made each of these two substances of such a nature that merely by following its own peculiar laws, received with its being, it

nevertheless accords with the other, just as if there were a mutual influence or as if God always put his hand thereto in addition to his general co-operation.”

As Professor Pauli has kindly pointed out, it is possible that Leibniz took his idea of the synchronized clocks from the Flemish philosopher Arnold Geulincx (1625–99). In his *Metaphysica vera*, Part III, there is a note to “Octava scientia” (p. 195), which says (p. 296): “... horologium voluntatis nostrae quadret cum horologio motus in corpore” (the clock of our will is synchronized with the clock of our physical movement). Another note (p. 297) explains: “Voluntas nostra nullum habet influxum, causalitatem, determinationem aut efficaciam quam-cunque in motum ... cum cogitationes nostras bene excutimus, nullam apud nos invenimus ideam seu notionem determinationis. ... Restat igitur Deus solus primus motor et solus motor, quia et ita motum ordinat atque disponit et ita simul voluntati nostrae licet libere moderatur, ut eodem temporis momento conspiret et voluntas nostra ad projiciendum v.g. pedes inter ambulandum, et simul ipsa ilia pedum projectio seu ambulatio.” (Our will has no influence, no causative or determinative power, and no effect of any kind on our movement. ... If we examine our thoughts carefully, we find in ourselves no idea or concept of determination. ... There remains, therefore, only God as the prime mover and only mover, because he arranges and orders movement and freely co-ordinates it with our will, so that our will wishes simultaneously to throw the feet forward into walking, and simultaneously the forward movement and the walking take place.) A note to “Nona scientia” adds (p. 298): “Mens nostra ... penitus independens est ab illo (scl. corpore) ... omnia quae de corpore scimus jam praevis quasi ante nostram cognitionem esse in corpore. Ut ilia quodam modo nos in corpore legamus, non vero inscribamiis, quod Deo proprium est.” (Our mind ... is totally independent of the body ... everything we know about the body is already in the body, before our thought. So that we can, as it were, read ourselves in our body, but not imprint ourselves on it. Only God can do that.) This idea anticipates Leibniz’ clock comparison.

⁵⁹ *Monadology*, § 7: “Monads have no windows, by which anything could come in or go out. ... Thus neither substance nor accident can enter a monad from without.”

⁶⁰ Rejoinder to the remarks in Bayle’s *Dictionary*, from the *Kleinere philosophische Schrijten*, XI, p. 105.

⁶¹ *Monadology*, § 56 (Morris edn., p. 12): “Now this connection or adaptation of all created things with each, and of each with all the rest, means that each simple substance has relations which express all the others, and that consequently it is a perpetual living mirror of the universe.”

⁶² *Ibid.*, § 78 (p. 17),

⁶³ § 83 (P. 18): cf. *Theodicy*, § 147 (trans. by E. M. Huggard. pp. 215f).

⁶⁴ *Monadology*, § 79 (Morris edn., p. 17).

⁶⁵ *Ibid.*, § 15 (p. 5).

⁶⁶ § 14 (pp. 4f)

⁶⁷ *Principles of Nature and of Grace, Founded on Reason*, § 4 (Morris edn., p. 22).

⁶⁸ *Monadology*, § 14 (p. 5). Cf. also Dr. Marie-Louise von Franz's paper on the dream of Descartes in *Zeitlose Dokumente der Seele*.

⁶⁹ *Monadology*, § 48 (p. 11); *Theodicy* § 149.

⁷⁰ I must again stress the possibility that the relation between body and soul may yet be understood as a synchronistic one. Should this conjecture ever be proved, my present view that synchronicity is a relatively rare phenomenon would have to be corrected. Cf. C. A. Meier's observations in *Zeitgemässe Probleme der Traumforschung*, p. 22.

⁷¹ In view of the possibility that synchronicity is not only a psychophysical phenomenon but might also occur without the participation of the human psyche, I should like to point out that in this case we should have to speak not of *meaning* but of equivalence or conformity.

⁷² “ὁ θεὸς ἀριθμητίζει.” But in a letter of 1830 Gauss says: “We must in all humility admit that if number is *merely* a product of our mind, space has a reality outside our mind.” (Leopold Kronecker, *über den Zahlenbegriff*, in his *Werke*, III, p. 252.) Hermann Weyl likewise takes number as a product of reason. (“Wissenschaft als symbolische Konstruktion des Menschen,” p. 375). Markus Fierz, on the other hand, inclines more to the Platonic idea. (“Zur physikalischen Erkenntnis,” p. 434.)

⁷³ According to the rules of dream interpretation this Mr. A would represent the animus, who, as a personification of the unconscious, takes back the designs because the conscious mind has no use for them and regards them only as *lusus naturae*.

⁷⁴ The recurrence of the dream expresses the persistent attempt of the unconscious to bring the dream content before the conscious mind.

⁷⁵ An Anthroparion or “metallic man.”

⁷⁶ Cf. Kepler's ideas quoted above.

⁷⁷ Those who find the dreams unintelligible will probably suspect them of harbouring quite a different meaning which is more in accord with their preconceived opinions. One can indulge in wishful thinking about dreams just as one can about anything else. For my part I prefer to keep as close to the dream statement as possible, and to try to formulate it in accordance with its manifest meaning. If it proves impossible to relate this meaning to the conscious situation of the dreamer, then I frankly admit that I do not understand the dream, but I take good care not to juggle it into line with some preconceived theory.

¹ Hubert Jantz and Kurt Beringer, “Das Syndrom des Schwebbeerlebnisses unmittelbar nach Kopfverletzungen,” 202.

² Cf. G. N. M. Tyrrell's report in *The Personality of Man*, pp. 197f. There is another case of this kind on pp. 199f.

³ Karl von Frisch, *The Dancing Bees*, trans. by Dora Ilse, pp. 112ff.

⁴ “La Morphogénèse dans la cadre de la biologie générale.” Cf. above, the similar conclusion reached by the zoologist A. C. Hardy.

⁵ *Physics and Philosophy*, p. 127; cf. also p. 151.

⁶ I am not counting P. A. M. Dirac's multi-dimensionality of time.

⁷ Cf. my “Psychological Approach to the Dogma of the Trinity,” pars. 186ff., 280, 290.

⁸ Sir James Jeans (*Physics and Philosophy*, p. 215) thinks it possible “that the springs of events in this substratum include our own mental activities, so that the future course of events may depend in part on these mental activities.”

The causalism of this argument does not seem to me altogether tenable.

⁹ “ἕκ τοῦ τρίτου τὸ ἔν τέταρτον.” Cf. *Psychology and Alchemy*, par. 26.

¹⁰ “De tenebris contra naturam,” in *Theatrum chemicum*, I (1602), pp. 518ff.

¹¹ Marie-Louise von Franz, “Die Parabel von der Fontina des Grafen von Tarvis.”

¹² See Pauli’s contribution in *The Interpretation of Nature and the Psyche*.

¹³ *Über die Freiheit*, 4f

¹⁴ *Ibid.*, p. 6.

¹⁵ S. G. Soal, “Science and Telepathy,” p. 6.

¹⁶ Jacob Grimm, *Teutonic Mythology*, trans. by J. S. Stallybrass, I, p. 137. Wish-objects are magic implements forged by dwarfs, such as Odin’s spear Gungnir, Thor’s hammer Mjollnir, and Freya’s sword (II, p. 870). Wishing is “gotes kraft” (divine power). “Got hât an sie den wunsch geleit und der wünschelruoten hort” (God has bestowed the wish on her and the treasure of [or: found by] the wishing rod). “Beschoenen mit wunsches gewalte” (to make beautiful with the power of the wish) (IV, p. 1329). “Wish” = Sanskrit *manoratha*, literally, “car of the mind” or of the psyche, i.e., wish, desire, fancy. (A. A. Macdonell, *A Practical Sanskrit Dictionary*, s.v.)

¹⁷ Continuous creation is to be thought of not only as a series of successive acts of creation, but also as the eternal presence of the *one* creative act, in the sense that God “was always the Father and always generated the Son” (Origen, *De principles*, I, 2, 3), or that he is the “eternal Creator of minds” (Augustine, *Confessions*, XI, 31, trans. F. J. Sheed, p. 232). God is contained in his own creation, “nor does he stand in need of his own works, as if he had place in them where he might abide; but endures in his own eternity, where he abides and creates whatever pleases him, both in heaven and earth” (Augustine, on Ps. 113 : 14, in *Expositions on the Book of Psalms*). What happens successively in time is simultaneous in the mind of God: “An immutable order binds mutable things into a pattern, and in this order things which are not simultaneous in time exist simultaneously outside time” (Prosper of Aquitaine, *Sententiae ex Augustino delibatae*, XLI [Migne, *PL.*, LI, col. 433]). “Temporal succession is without time in the eternal wisdom of God” (LVII [Migne, col. 455]). Before the Creation there was no time—time only began with created things: “Rather did time arise from the created than the created from time” (CCLXXX [Migne, col. 468]). “There was no time before time, but time was created together with the world” (Anon., *De triplici habitaculo*, VI [Migne, *P.L.*, XL, col. 995]).

¹⁸ [From ἀτμῶς, ‘indivisible, that cannot be cut.’—TRANS.]

¹ [Originally given as a lecture, “Über Synchronizität,” at the 1951 Eranos conference, Ascona, Switzerland, and published in the *Eranos-Jahrbuch 1951* (Zurich, 1952). The present translation was published in *Man and Time* (Papers from the Eranos Yearbooks, 3; New York and London, 1957); it is republished with minor revisions. The essay was, in the main, drawn from the preceding monograph.—EDITORS.]

² [For documentation, see *supra*, par. 830.—EDITORS.]

³ [Descartes demonstrated his propositions by the “Geometrical Method.”—EDITORS.]

⁴ [This case was the subject of an English film. *The Night My Number Came Up*—EDITORS.]

⁵ [“The Concept of Time in the Book of Changes,” originally a lecture at the 1951 Eranos conference.—EDITORS.]

⁶ [“Transformations of Science in Our Age,” *ibid.*]

⁷ This material stemmed from different sources. They were simply horoscopes of married people. There was no selection of any kind. We took at random all the marriage horoscopes we could lay hands on.

⁸ [These and the following figures were later revised by Professor Fierz and considerably reduced. See *supra*, pars. 901ff.—EDITORS.]

⁹ [See the foregoing.—EDITORS.]

* For details of the Collected works of C G. Jung, see announcement at end of this volume.

- * Published 1957; 2nd edn., 1970.
- + Published 1973.
- * Published 1960.
- + Published 1961.
- ‡ Published 1956; 2nd edn., 1967. (65 plates, 43 text figures.)
- * Published 1971.
- + Published 1953; 2nd edn., 1966.
- ‡ Published 1960 and edn., 1969.
- * Published 1959; 2nd edn., 1968. (Part I: 79 plates, with 29 in colour.)
- * Published 1964; 2nd edn., 1970. (8 plates.)
- † Published 1958; 2nd edn., 1969.
- * Published 1953; 2nd edn., completely revised, 1968. (270 illustrations.)
- † Published 1968. (50 plates, 4 text figures.)
- ‡ Published 1963; 2nd edn., 1970. (10 plates.)
- * Published 1966.
- † Published 1954; 2nd edn., revised and augmented, 1966. (13 illustrations.)
- ‡ Published 1954.

B O L L I N G E N S E R I E S X X

THE COLLECTED WORKS

OF

C. G. JUNG

VOLUME 9, PART 1

EDITORS

†SIR HERBERT READ

MICHAEL FORDHAM, F.R.C.PSYCH., HON. F.B.P.S.S.

GERHARD ADLER, PH.D.

WILLIAM MCGUIRE, *executive editor*

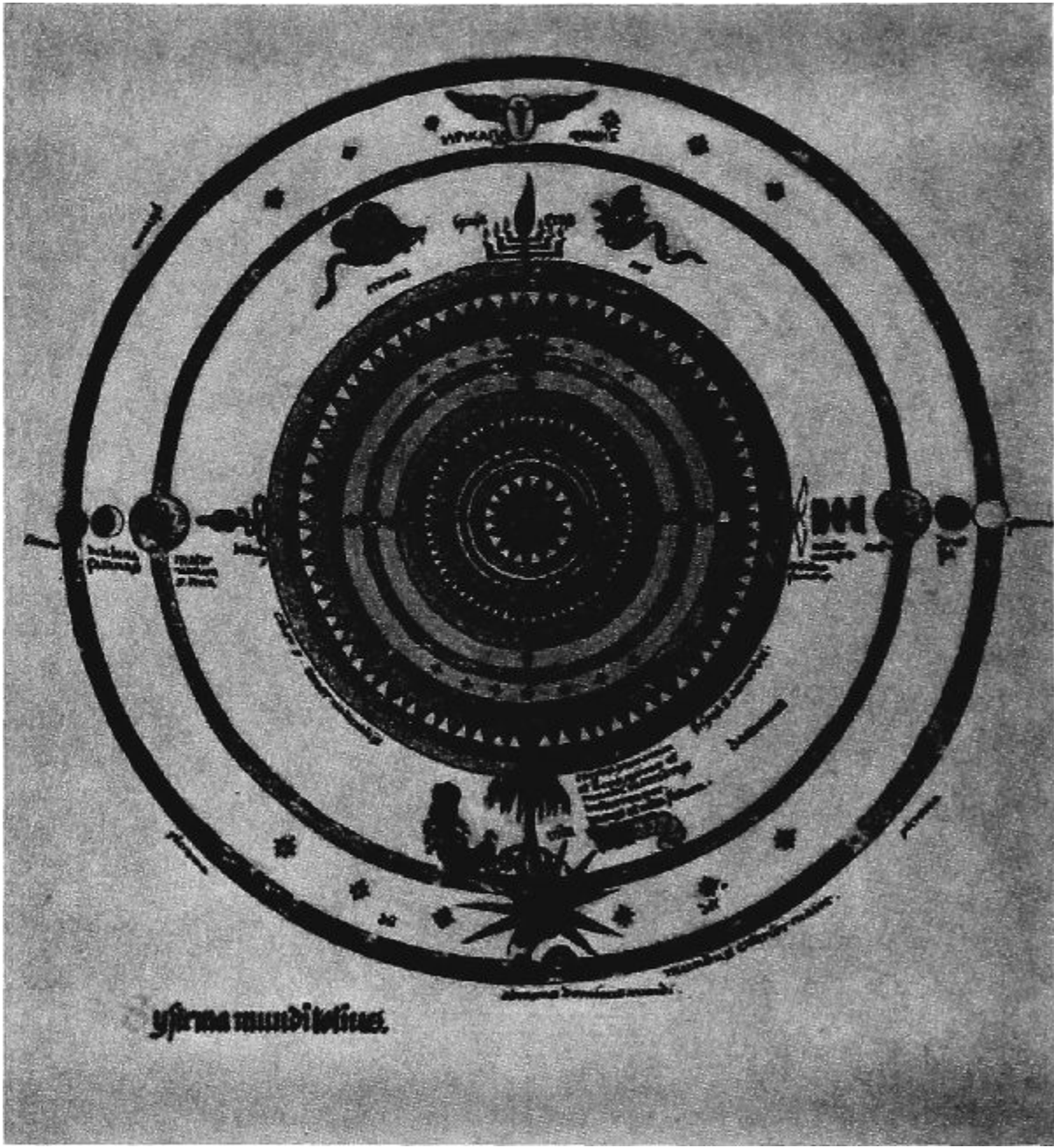

Mandala of a Modern Man

**THE ARCHETYPES
AND THE
COLLECTIVE
UNCONSCIOUS**

SECOND EDITION

C. G. JUNG

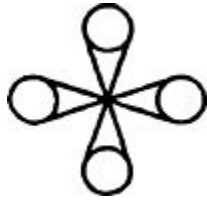

TRANSLATED BY R. F. C. HULL

BOLLINGEN SERIES XX

PRINCETON UNIVERSITY PRESS

COPYRIGHT © 1959 BY BOLLINGEN FOUNDATION INC., NEW YORK, N.Y. NEW MATERIAL

COPYRIGHT © 1969 BY PRINCETON UNIVERSITY PRESS

SECOND EDITION, 1968

third printing, 1971

fourth printing, 1975

fifth printing, 1977

First Princeton / Bollingen Paperback printing, 1980

THIS EDITION IS BEING PUBLISHED IN THE UNITED STATES OF AMERICA BY PRINCETON UNIVERSITY PRESS, AND IN ENGLAND BY ROUTLEDGE AND KEGAN PAUL, LTD. IN THE AMERICAN EDITION, ALL THE VOLUMES COMPRISING THE COLLECTED WORKS CONSTITUTE NUMBER XX IN BOLLINGEN SERIES, SPONSORED BY BOLLINGEN FOUNDATION. THE PRESENT VOLUME IS NUMBER 9 OF THE COLLECTED WORKS AND WAS THE EIGHTH TO APPEAR. IT IS IN TWO PARTS, PUBLISHED SEPARATELY, THIS BEING PART I.

LIBRARY OF CONGRESS CATALOG CARD NUMBER: 75-156

ISBN 0-691-09761-5

ISBN 0-691-01833-2 PBK.

MANUFACTURED IN THE U. S. A.

BY PRINCETON UNIVERSITY PRESS AT PRINCETON, N. J.

EDITORIAL NOTE

The concept of archetypes and its correlate, that of the collective unconscious, are among the better known theories developed by Professor Jung. Their origins may be traced to his earliest publication, “On the Psychology and Pathology of So-called Occult Phenomena” (1902),* in which he described the fantasies of an hysterical medium. Intimations of the concepts can be found in many of his subsequent writings, and gradually tentative statements crystallized and were reformulated until a stable core of theory was established.

Part I of Volume 9 consists of essays—written from 1933 onward—describing and elaborating the two concepts. The volume is introduced by three essays establishing the theoretical basis, followed by others describing specific archetypes. The relation of these to the process of individuation is defined in essays in the last section.

Part II of the volume, entitled *Aion* and published separately, is devoted to a long monograph on the symbolism of the self as revealed in the “Christian aeon.” Together the two parts give the nucleus of Jung’s work on the theory and meaning of archetypes in relation to the psyche as a whole.

*

While the illustrations that accompany the last two papers are the same subjects published with the Swiss versions in *Gestaltungen des Unbewussten*, they have now been rephotographed and improved in presentation. It has been possible to give the entire pictorial series illustrating “A Study in the Process of Individuation” in colour and to add seven additional pictures, which were chosen by the author from those in his possession (par. 616). Several of the illustrations for “Concerning Mandala Symbolism,” also, are now given in colour. Grateful acknowledgment is made to Mrs. Aniela Jaffé and to Mrs. Margaret Schevill-Link for their kind assistance in connection with the pictures. The frontispiece was published in the Swiss magazine *Du* (April 1955), with the brief article by Professor Jung on mandalas which is given in the appendix. This “Mandala of a Modern Man” was painted in 1916.

EDITORIAL NOTE TO THE SECOND EDITION

Bibliographical citations and entries have been revised in the light of subsequent publications in the *Collected Works* and essential corrections have been made. Jung's acknowledgment in his *Memories, Dreams, Reflections* of having painted the mandala illustrated in the frontispiece, and four other mandalas in this volume, is explained on page 355, n.1.

TRANSLATOR'S NOTE

Grateful acknowledgment is made to those whose translations have been consulted: Mr. W. S. Dell, for help derived from his translations of two papers: "Archetypes of the Collective Unconscious" and "The Meaning of Individuation" (here entitled "Conscious, Unconscious, and Individuation"), both published in *The Integration of the Personality*; Mrs. Cary F. Baynes and Miss Ximena de Angulo, for permission to use, virtually unchanged, long portions of their translations of "Psychological Aspects of the Mother Archetype" and "Concerning Rebirth," issued in *Spring* (New York), 1943 and 1944; and to Miss Hildegard Nagel, for reference to her translation of "The Psychology of the Trickster-Figure," in *Spring*, 1955.

VOLUME 9, PART I ARCHETYPES AND THE COLLECTIVE UNCONSCIOUS

TABLE OF CONTENTS

EDITORIAL NOTE

TRANSLATOR'S NOTE

LIST OF ILLUSTRATIONS

I

Archetypes of the Collective Unconscious

Translated from "Über die Archetypen des kollektiven Unbewussten," *Von den Wurzeln des Bewusstseins* (Zurich: Rascher, 1954).

The Concept of the Collective Unconscious

Originally published in English in the *Journal of St. Bartholomew's Hospital* (London), XLIV (1936/37).

Concerning the Archetypes, with Special Reference to the Anima Concept

Translated from "Über den Archetypus mit besonderer Berücksichtigung des Animabegriffes," *Von den Wurzeln des Bewusstseins* (Zurich: Rascher, 1954).

II

Psychological Aspects of the Mother Archetype

Translated from "Die psychologischen Aspekte des Mutter-Archetypus," *Von den Wurzeln des Bewusstseins* (Zurich: Rascher, 1954).

1. ON THE CONCEPT OF THE ARCHETYPE

2. THE MOTHER ARCHETYPE

3. THE MOTHER-COMPLEX

I. The Mother-Complex of the Son

II. The Mother-Complex of the Daughter

a. Hypertrophy of the Maternal Element

- b. Overdevelopment of Eros
- c. Identity with the Mother
- d. Resistance to the Mother

4. POSITIVE ASPECTS OF THE MOTHER-COMPLEX

- I. The Mother
- II. The Overdeveloped Eros
- III. The “Nothing-But” Daughter
- IV. The Negative Mother-Complex

5. CONCLUSION

III

Concerning Rebirth

Translated from “Über Wiedergeburt,” *Gestaltungen des Unbewussten* (Zurich: Rascher, 1950).

1. FORMS OF REBIRTH

2. THE PSYCHOLOGY OF REBIRTH

- I. Experience of the Transcendence of Life
 - a. Experiences Induced by Ritual
 - b. Immediate Experiences
- II. Subjective Transformation
 - a. Diminution of Personality
 - b. Enlargement of Personality
 - c. Change of Internal Structure
 - d. Identification with a Group
 - e. Identification with a Cult-Hero
 - f. Magical Procedures
 - g. Technical Transformation
 - h. Natural Transformation (Individuation)

3. A TYPICAL SET OF SYMBOLS ILLUSTRATING THE PROCESS OF TRANSFORMATION

IV

The Psychology of the Child Archetype

Translated from “Zur Psychologie des Kind-Archetypus,” *Einführung in das Wesen der Mythologie* (with K. Kerényi), 4th revised edition (Zurich: Rhein-Verlag, 1951).

- I. Introduction
- II. The Psychology of the Child Archetype
 1. The Archetype as a Link with the Past
 2. The Function of the Archetype
 3. The Futurity of the Archetype
 4. Unity and Plurality of the Child Motif
 5. Child God and Child Hero
- III. The Special Phenomenology of the Child Archetype
 1. The Abandonment of the Child
 2. The Invincibility of the Child
 3. The Hermaphroditism of the Child
 4. The Child as Beginning and End
- IV. Conclusion

The Psychological Aspects of the Kore

Translated from “Zum psychologischen Aspekt der Kore-Figur,” *Einführung in das Wesen der Mythologie* (with K. Kerényi), 4th revised edition (Zurich: Rhein-Verlag, 1951).

V

The Phenomenology of the Spirit in Fairytales

Translated from “Zur Phänomenologie des Geistes im Märchen,” *Symbolik des Geistes* (Zurich: Rascher, 1948).

- I. Concerning the Word “Spirit,”
- II. Self-Representation of the Spirit in Dreams
- III. The Spirit in Fairytales
- IV. Theriomorphic Spirit Symbolism in Fairytales
- V. Supplement
- VI. Conclusion

On the Psychology of the Trickster-Figure

Translated from part 5 of *Der Göttliche Schelm*, by Paul Radin, with commentaries by C. G. Jung and Karl Kerényi (Zurich: Rhein-Verlag, 1954).

Conscious, Unconscious, and Individuation

Originally written in English as “The Meaning of Individuation,” in *The Integration of the Personality* (New York: Farrar and Rinehart, 1939; London: Kegan Paul, 1940); here revised in accordance with the German version, “Bewusstsein, Unbewusstes und Individuation,” *Zentralblatt für Psychotherapie und ihre Grenzgebiete* (Leipzig), XI (1939).

A Study in the Process of Individuation

Translated from “Zur Empirie des Individuationsprozesses,” *Gestaltungen des Unbewussten* (Zurich: Rascher, 1950).

Introductory

Picture 1

Picture 2

Picture 3

Picture 4

Picture 5

Picture 6

Picture 7

Picture 8

Picture 9

Picture 10

Picture 11

Pictures 12-24

Conclusion

Concerning Mandala Symbolism

Translated from “Über Mandalasymbolik,” *Gestaltungen des Unbewussten* (Zurich: Rascher, 1950).

APPENDIX: Mandalas

Translated from *Du* (Zurich), XV: 4 (April 1955).

BIBLIOGRAPHY

INDEX

LIST OF ILLUSTRATIONS

Mandala of a Modern Man *frontispiece*

Painting by C. G. Jung, 1916. The microcosmic enclosed within the macrocosmic system of opposites. Macrocosm, top: boy in the winged egg, Erikapaios or Phanes, the spiritual principle with triadic fire-symbol and attributes; bottom, his dark adversary Abraxas, ruler of the physical world, with double pentadic star of natural man and rebirth symbols. Microcosm, left: snake with phallus, the procreative principle; right, dove of Holy Ghost with double beaker of Sophia. Inner sun (jagged circle) encloses repetitions of this system on a diminishing scale, with inner microcosm at the centre. (From *Du*, Zurich, April 1955, where the mandala was reproduced. Cf. *Memories, Dreams, Reflections*, p. 195, U.S.; 187, Brit.)

FOR "A STUDY IN THE PROCESS OF INDIVIDUATION"

Pictures 1–24

Water-colour or tempera paintings, as described in the text; from the author's collection

Fig. 1. Mandala from Böhme's *XL Questions concerning the Soule* (1620)

Fig. 2. Sketch of a picture from the year 1916

Fig. 3. Sketch of a drawing by a young woman patient with psychogenic depression

Fig. 4. Neolithic relief from Tarxien, Malta

Fig. 5. Mandala by a woman patient

FOR "CONCERNING MANDALA SYMBOLISM"

Figures 1–54

As described in the text; mainly from the author's collection

I

**ARCHETYPES OF THE
COLLECTIVE UNCONSCIOUS**

THE CONCEPT OF THE COLLECTIVE UNCONSCIOUS



**CONCERNING THE ARCHETYPES,
WITH SPECIAL REFERENCE
TO THE ANIMA CONCEPT**

ARCHETYPES OF THE COLLECTIVE UNCONSCIOUS¹

- [1] The hypothesis of a collective unconscious belongs to the class of ideas that people at first find strange but soon come to possess and use as familiar conceptions. This has been the case with the concept of the unconscious in general. After the philosophical idea of the unconscious, in the form presented chiefly by Carus and von Hartmann, had gone down under the overwhelming wave of materialism and empiricism, leaving hardly a ripple behind it, it gradually reappeared in the scientific domain of medical psychology.
- [2] At first the concept of the unconscious was limited to denoting the state of repressed or forgotten contents. Even with Freud, who makes the unconscious—at least metaphorically—take the stage as the acting subject, it is really nothing but the gathering place of forgotten and repressed contents, and has a functional significance thanks only to these. For Freud, accordingly, the unconscious is of an exclusively personal nature,² although he was aware of its archaic and mythological thought-forms.
- [3] A more or less superficial layer of the unconscious is undoubtedly personal. I call it the *personal unconscious*. But this personal unconscious rests upon a deeper layer, which does not derive from personal experience and is not a personal acquisition but is inborn. This deeper layer I call the *collective unconscious*. I have chosen the term “collective” because this part of the unconscious is not individual but universal; in contrast to the personal psyche, it has contents and modes of behaviour that are more or less the same everywhere and in all individuals. It is, in other words, identical in all men and thus constitutes a common psychic substrate of a suprapersonal nature which is present in every one of us.
- [4] Psychic existence can be recognized only by the presence of contents that are *capable of consciousness*. We can therefore speak of an unconscious only in so far as we are able to demonstrate its contents. The contents of the personal unconscious are chiefly the *feeling-toned complexes*, as they are called; they constitute the personal and private side of psychic life. The contents of the collective unconscious, on the other hand, are known as *archetypes*.
- [5] The term “archetype” occurs as early as Philo Judaeus,³ with reference to the *Imago Dei* (God-image) in man. It can also be found in Irenaeus, who says: “The

creator of the world did not fashion these things directly from himself but copied them from archetypes outside himself.”⁴ In the *Corpus Hermeticum*,⁵ God is called τὸ ἀρχέτυπον φῶς (archetypal light). The term occurs several times in Dionysius the Areopagite, as for instance in *De caelesti hierarchia*, II, 4: “immaterial Archetypes,”⁶ and in *De divinis nominibus*, I, 6: “Archetypal stone.”⁷ The term “archetype” is not found in St. Augustine, but the idea of it is. Thus in *De diversis quaestionibus LXXXIII* he speaks of “*ideae principales*, ‘which are themselves not formed ... but are contained in the divine understanding.’”⁸ “Archetype” is an explanatory paraphrase of the Platonic εἶδος. For our purposes this term is apposite and helpful, because it tells us that so far as the collective unconscious contents are concerned we are dealing with archaic or—I would say—primordial types, that is, with universal images that have existed since the remotest times. The term “représentations collectives,” used by Lévy-Bruhl to denote the symbolic figures in the primitive view of the world, could easily be applied to unconscious contents as well, since it means practically the same thing. Primitive tribal lore is concerned with archetypes that have been modified in a special way. They are no longer contents of the unconscious, but have already been changed into conscious formulae taught according to tradition, generally in the form of esoteric teaching. This last is a typical means of expression for the transmission of collective contents originally derived from the unconscious.

[6] Another well-known expression of the archetypes is myth and fairytale. But here too we are dealing with forms that have received a specific stamp and have been handed down through long periods of time. The term “archetype” thus applies only indirectly to the “représentations collectives,” since it designates only those psychic contents which have not yet been submitted to conscious elaboration and are therefore an immediate datum of psychic experience. In this sense there is a considerable difference between the archetype and the historical formula that has evolved. Especially on the higher levels of esoteric teaching the archetypes appear in a form that reveals quite unmistakably the critical and evaluating influence of conscious elaboration. Their immediate manifestation, as we encounter it in dreams and visions, is much more individual, less understandable, and more naïve than in myths, for example. The archetype is essentially an unconscious content that is altered by becoming conscious and by being perceived, and it takes its colour from the individual consciousness in which it happens to appear.⁹

[7] What the word “archetype” means in the nominal sense is clear enough, then, from its relations with myth, esoteric teaching, and fairytale. But if we try to establish what an archetype is *psychologically*, the matter becomes more complicated. So far mythologists have always helped themselves out with solar, lunar, meteorological, vegetal, and other ideas of the kind. The fact that myths are first and foremost psychic phenomena that reveal the nature of the soul is something they have

absolutely refused to see until now. Primitive man is not much interested in objective explanations of the obvious, but he has an imperative need—or rather, his unconscious psyche has an irresistible urge—to assimilate all outer sense experiences to inner, psychic events. It is not enough for the primitive to see the sun rise and set; this external observation must at the same time be a psychic happening: the sun in its course must represent the fate of a god or hero who, in the last analysis, dwells nowhere except in the soul of man. All the mythologized processes of nature, such as summer and winter, the phases of the moon, the rainy seasons, and so forth, are in no sense allegories¹⁰ of these objective occurrences; rather they are symbolic expressions of the inner, unconscious drama of the psyche which becomes accessible to man's consciousness by way of projection—that is, mirrored in the events of nature. The projection is so fundamental that it has taken several thousand years of civilization to detach it in some measure from its outer object. In the case of astrology, for instance, this age-old “scientia intuitiva” came to be branded as rank heresy because man had not yet succeeded in making the psychological description of character independent of the stars. Even today, people who still believe in astrology fall almost without exception for the old superstitious assumption of the influence of the stars. And yet anyone who can calculate a horoscope should know that, since the days of Hipparchus of Alexandria, the spring-point has been fixed at 0° Aries, and that the zodiac on which every horoscope is based is therefore quite arbitrary, the spring-point having gradually advanced, since then, into the first degrees of Pisces, owing to the precession of the equinoxes.

[8] Primitive man impresses us so strongly with his subjectivity that we should really have guessed long ago that myths refer to something psychic. His knowledge of nature is essentially the language and outer dress of an unconscious psychic process. But the very fact that this process is unconscious gives us the reason why man has thought of everything except the psyche in his attempts to explain myths. He simply didn't know that the psyche contains all the images that have ever given rise to myths, and that our unconscious is an acting and suffering subject with an inner drama which primitive man rediscovers, by means of analogy, in the processes of nature both great and small.¹¹

[9] “The stars of thine own fate lie in thy breast,”¹² says Seni to Wallenstein—a dictum that should satisfy all astrologers if we knew even a little about the secrets of the heart. But for this, so far, men have had little understanding. Nor would I dare to assert that things are any better today.

[10] Tribal lore is always sacred and dangerous. All esoteric teachings seek to apprehend the unseen happenings in the psyche, and all claim supreme authority for themselves. What is true of primitive lore is true in even higher degree of the ruling

world religions. They contain a revealed knowledge that was originally hidden, and they set forth the secrets of the soul in glorious images. Their temples and their sacred writings proclaim in image and word the doctrine hallowed from of old, making it accessible to every believing heart, every sensitive vision, every farthest range of thought. Indeed, we are compelled to say that the more beautiful, the more sublime, the more comprehensive the image that has evolved and been handed down by tradition, the further removed it is from individual experience. We can just feel our way into it and sense something of it, but the original experience has been lost.

[11] Why is psychology the youngest of the empirical sciences? Why have we not long since discovered the unconscious and raised up its treasure-house of eternal images? Simply because we had a religious formula for everything psychic—and one that is far more beautiful and comprehensive than immediate experience. Though the Christian view of the world has paled for many people, the symbolic treasure-rooms of the East are still full of marvels that can nourish for a long time to come the passion for show and new clothes. What is more, these images—be they Christian or Buddhist or what you will—are lovely, mysterious, richly intuitive. Naturally, the more familiar we are with them the more does constant usage polish them smooth, so that what remains is only banal superficiality and meaningless paradox. The mystery of the Virgin Birth, or the homoousia of the Son with the Father, or the Trinity which is nevertheless not a triad—these no longer lend wings to any philosophical fancy. They have stiffened into mere objects of belief. So it is not surprising if the religious need, the believing mind, and the philosophical speculations of the educated European are attracted by the symbols of the East—those grandiose conceptions of divinity in India and the abysses of Taoist philosophy in China—just as once before the heart and mind of the men of antiquity were gripped by Christian ideas. There are many Europeans who began by surrendering completely to the influence of the Christian symbol until they landed themselves in a Kierkegaardian neurosis, or whose relation to God, owing to the progressive impoverishment of symbolism, developed into an unbearably sophisticated I-You relationship—only to fall victims in their turn to the magic and novelty of Eastern symbols. This surrender is not necessarily a defeat; rather it proves the receptiveness and vitality of the religious sense. We can observe much the same thing in the educated Oriental, who not infrequently feels drawn to the Christian symbol or to the science that is so unsuited to the Oriental mind, and even develops an enviable understanding of them. That people should succumb to these eternal images is entirely normal, in fact it is what these images are for. They are meant to attract, to convince, to fascinate, and to overpower. They are created out of the primal stuff of revelation and reflect the ever-unique experience of divinity. That is why they always give man a premonition of the divine while at the same time safeguarding him from immediate experience of it.

Thanks to the labours of the human spirit over the centuries, these images have become embedded in a comprehensive system of thought that ascribes an order to the world, and are at the same time represented by a mighty, far-spread, and venerable institution called the Church.

[12] I can best illustrate my meaning by taking as an example the Swiss mystic and hermit, Brother Nicholas of Flüe,¹³ who has recently been canonized. Probably his most important religious experience was the so-called Trinity Vision, which preoccupied him to such an extent that he painted it, or had it painted, on the wall of his cell. The painting is still preserved in the parish church at Sachseln. It is a mandala divided into six parts, and in the centre is the crowned countenance of God. Now we know that Brother Klaus investigated the nature of his vision with the help of an illustrated devotional booklet by a German mystic, and that he struggled to get his original experience into a form he could understand. He occupied himself with it for years. This is what I call the “elaboration” of the symbol. His reflections on the nature of the vision, influenced as they were by the mystic diagrams he used as a guiding thread, inevitably led him to the conclusion that he must have gazed upon the Holy Trinity itself—the *summum bonum*, eternal love. This is borne out by the “expurgated” version now in Sachseln.

[13] The original experience, however, was entirely different. In his ecstasy there was revealed to Brother Klaus a sight so terrible that his own countenance was changed by it—so much so, indeed, that people were terrified and felt afraid of him. What he had seen was a vision of the utmost intensity. Woelflin,¹⁴ our oldest source, writes as follows:

All who came to him were filled with terror at the first glance. As to the cause of this, he himself used to say that he had seen a piercing light resembling a human face. At the sight of it he feared that his heart would burst into little pieces. Therefore, overcome with terror, he instantly turned his face away and fell to the ground. And that was the reason why his face was now terrible to others.

[14] This vision has rightly been compared¹⁵ with the one in Revelation 1 : 13ff., that strange apocalyptic Christ-image, which for sheer gruesomeness and singularity is surpassed only by the monstrous seven-eyed lamb with seven horns (Rev. 5 : 6f.). It is certainly very difficult to see what is the relationship between this figure and the Christ of the gospels. Hence Brother Klaus’s vision was interpreted in a quite definite way by the earliest sources. In 1508, the humanist Karl Bovillus (Charles de Bouelles) wrote to a friend:

I wish to tell you of a vision which appeared to him in the sky, on a night when the stars were shining and he stood in prayer and contemplation. He saw the head of a

human figure with a terrifying face, full of wrath and threats.¹⁶

[15] This interpretation agrees perfectly with the modern amplification furnished by Revelation 1 : 13.¹⁷ Nor should we forget Brother Klaus's other visions, for instance, of Christ in the bearskin, of God the Father and God the Mother, and of himself as the Son. They exhibit features which are very undogmatic indeed.

[16] Traditionally this great vision was brought into connection with the Trinity picture in the church at Sachseln, and so, likewise, was the wheel symbolism in the so-called "Pilgrim's Tract."¹⁸ Brother Klaus, we are told, showed the picture of the wheel to a visiting pilgrim. Evidently this picture had preoccupied him for some time. Blanke is of the opinion that, contrary to tradition, there is no connection between the vision and the Trinity picture.¹⁹ This scepticism seems to me to go too far. There must have been some reason for Brother Klaus's interest in the wheel. Visions like the one he had often cause mental confusion and disintegration (witness the heart bursting "into little pieces"). We know from experience that the protective circle, the mandala, is the traditional antidote for chaotic states of mind. It is therefore only too clear why Brother Klaus was fascinated by the symbol of the wheel. The interpretation of the terrifying vision as an experience of God need not be so wide of the mark either. The connection between the great vision and the Trinity picture, and of both with the wheel-symbol, therefore seems to me very probable on psychological grounds.

[17] This vision, undoubtedly fearful and highly perturbing, which burst like a volcano upon his religious view of the world, without any dogmatic prelude and without exegetical commentary, naturally needed a long labour of assimilation in order to fit it into the total structure of the psyche and thus restore the disturbed psychic balance. Brother Klaus came to terms with his experience on the basis of dogma, then firm as a rock; and the dogma proved its powers of assimilation by turning something horribly alive into the beautiful abstraction of the Trinity idea. But the reconciliation might have taken place on a quite different basis provided by the vision itself and its unearthly actuality—much to the disadvantage of the Christian conception of God and no doubt to the still greater disadvantage of Brother Klaus himself, who would then have become not a saint but a heretic (if not a lunatic) and would probably have ended his life at the stake.

[18] This example demonstrates the use of the dogmatic symbol: it formulates a tremendous and dangerously decisive psychic experience, fittingly called an "experience of the Divine," in a way that is tolerable to our human understanding, without either limiting the scope of the experience or doing damage to its overwhelming significance. The vision of divine wrath, which we also meet in Jakob Böhme, ill accords with the God of the New Testament, the loving Father in heaven,

and for this reason it might easily have become the source of an inner conflict. That would have been quite in keeping with the spirit of the age—the end of the fifteenth century, the time of Nicholas Cusanus, whose formula of the “*complexio oppositorum*” actually anticipated the schism that was imminent. Not long afterwards the Yahwistic conception of God went through a series of rebirths in Protestantism. Yahweh is a God-concept that contains the opposites in a still undivided state.

[19] Brother Klaus put himself outside the beaten track of convention and habit by leaving his home and family, living alone for years, and gazing deep into the dark mirror, so that the wondrous and terrible boon of original experience befell him. In this situation the dogmatic image of divinity that had been developed over the centuries worked like a healing draught. It helped him to assimilate the fatal incursion of an archetypal image and so escape being torn asunder. Angelus Silesius was not so fortunate; the inner conflict tore him to pieces, because in his day the stability of the Church that dogma guarantees was already shattered.

[20] Jakob Böhme, too, knew a God of the “Wrath-fire,” a real *Deus absconditus*. He was able to bridge the profound and agonizing contradiction on the one hand by means of the Christian formula of Father and Son and embody it speculatively in his view of the world—which, though Gnostic, was in all essential points Christian. Otherwise he would have become a dualist. On the other hand it was undoubtedly alchemy, long brewing the union of opposites in secret, that came to his aid. Nevertheless the opposition has left obvious traces in the mandala appended to his *XL Questions concerning the Soule*,²⁰ showing the nature of the divinity. The mandala is divided into a dark and a light half, and the semicircles that are drawn round them, instead of joining up to form a ring, are turned back to back.²¹

[21] Dogma takes the place of the collective unconscious by formulating its contents on a grand scale. The Catholic way of life is completely unaware of psychological problems in this sense. Almost the entire life of the collective unconscious has been channelled into the dogmatic archetypal ideas and flows along like a well-controlled stream in the symbolism of creed and ritual. It manifests itself in the inwardness of the Catholic psyche. The collective unconscious, as we understand it today, was never a matter of “psychology,” for before the Christian Church existed there were the antique mysteries, and these reach back into the grey mists of neolithic prehistory. Mankind has never lacked powerful images to lend magical aid against all the uncanny things that live in the depths of the psyche. Always the figures of the unconscious were expressed in protecting and healing images and in this way were expelled from the psyche into cosmic space.

[22] The iconoclasm of the Reformation, however, quite literally made a breach in the protective wall of sacred images, and since then one image after another has

crumbled away. They became dubious, for they conflicted with awakening reason. Besides, people had long since forgotten what they meant. Or had they really forgotten? Could it be that men had never really known what they meant, and that only in recent times did it occur to the Protestant part of mankind that actually we haven't the remotest conception of what is meant by the Virgin Birth, the divinity of Christ, and the complexities of the Trinity? It almost seems as if these images had just lived, and as if their living existence had simply been accepted without question and without reflection, much as everyone decorates Christmas trees or hides Easter eggs without ever knowing what these customs mean. The fact is that archetypal images are so packed with meaning in themselves that people never think of asking what they really do mean. That the gods die from time to time is due to man's sudden discovery that they do not mean anything, that they are made by human hands, useless idols of wood and stone. In reality, however, he has merely discovered that up till then he has never thought about his images at all. And when he starts thinking about them, he does so with the help of what he calls "reason"—which in point of fact is nothing more than the sum-total of all his prejudices and myopic views.

[23] The history of Protestantism has been one of chronic iconoclasm. One wall after another fell. And the work of destruction was not too difficult once the authority of the Church had been shattered. We all know how, in large things as in small, in general as well as in particular, piece after piece collapsed, and how the alarming poverty of symbols that is now the condition of our life came about. With that the power of the Church has vanished too—a fortress robbed of its bastions and casemates, a house whose walls have been plucked away, exposed to all the winds of the world and to all dangers.

[24] Although this is, properly speaking, a lamentable collapse that offends our sense of history, the disintegration of Protestantism into nearly four hundred denominations is yet a sure sign that the restlessness continues. The Protestant is cast out into a state of defencelessness that might well make the natural man shudder. His enlightened consciousness, of course, refuses to take cognizance of this fact, and is quietly looking elsewhere for what has been lost to Europe. We seek the effective images, the thought-forms that satisfy the restlessness of heart and mind, and we find the treasures of the East.

[25] There is no objection to this, in and for itself. Nobody forced the Romans to import Asiatic cults in bulk. If Christianity had really been—as so often described—"alien" to the Germanic tribes, they could easily have rejected it when the prestige of the Roman legions began to wane. But Christianity had come to stay, because it fits in with the existing archetypal pattern. In the course of the centuries, however, it turned into something its founder might well have wondered at had he lived to see it;

and the Christianity of Negroes and other dark-skinned converts is certainly an occasion for historical reflections. Why, then, should the West not assimilate Eastern forms? The Romans too went to Eleusis, Samothrace, and Egypt in order to get themselves initiated. In Egypt there even seems to have been a regular tourist trade in this commodity.

[26] The gods of Greece and Rome perished from the same disease as did our Christian symbols: people discovered then, as today, that they had no thoughts whatever on the subject. On the other hand, the gods of the strangers still had unexhausted mana. Their names were weird and incomprehensible and their deeds portentously dark—something altogether different from the hackneyed *chronique scandaleuse* of Olympus. At least one couldn't understand the Asiatic symbols, and for this reason they were not banal like the conventional gods. The fact that people accepted the new as unthinkingly as they had rejected the old did not become a problem at that time.

[27] Is it becoming a problem today? Shall we be able to put on, like a new suit of clothes, ready-made symbols grown on foreign soil, saturated with foreign blood, spoken in a foreign tongue, nourished by a foreign culture, interwoven with foreign history, and so resemble a beggar who wraps himself in kingly raiment, a king who disguises himself as a beggar? No doubt this is possible. Or is there something in ourselves that commands us to go in for no mummeries, but perhaps even to sew our garment ourselves?

[28] I am convinced that the growing impoverishment of symbols has a meaning. It is a development that has an inner consistency. Everything that we have not thought about, and that has therefore been deprived of a meaningful connection with our developing consciousness, has got lost. If we now try to cover our nakedness with the gorgeous trappings of the East, as the theosophists do, we would be playing our own history false. A man does not sink down to beggary only to pose afterwards as an Indian potentate. It seems to me that it would be far better stoutly to avow our spiritual poverty, our symbol-lessness, instead of feigning a legacy to which we are not the legitimate heirs at all. We are, surely, the rightful heirs of Christian symbolism, but somehow we have squandered this heritage. We have let the house our fathers built fall into decay, and now we try to break into Oriental palaces that our fathers never knew. Anyone who has lost the historical symbols and cannot be satisfied with substitutes is certainly in a very difficult position today: before him there yawns the void, and he turns away from it in horror. What is worse, the vacuum gets filled with absurd political and social ideas, which one and all are distinguished by their spiritual bleakness. But if he cannot get along with these pedantic dogmatisms, he sees himself forced to be serious for once with his alleged trust in

God, though it usually turns out that his fear of things going wrong if he did so is even more persuasive. This fear is far from unjustified, for where God is closest the danger seems greatest. It is dangerous to avow spiritual poverty, for the poor man has desires, and whoever has desires calls down some fatality on himself. A Swiss proverb puts it drastically: “Behind every rich man stands a devil, and behind every poor man two.”

[29] Just as in Christianity the vow of worldly poverty turned the mind away from the riches of this earth, so spiritual poverty seeks to renounce the false riches of the spirit in order to withdraw not only from the sorry remnants—which today call themselves the Protestant church—of a great past, but also from all the allurements of the odorous East; in order, finally, to dwell with itself alone, where, in the cold light of consciousness, the blank barrenness of the world reaches to the very stars.

[30] We have inherited this poverty from our fathers. I well remember the confirmation lessons I received at the hands of my own father. The catechism bored me unspeakably. One day I was turning over the pages of my little book, in the hope of finding something interesting, when my eye fell on the paragraphs about the Trinity. This interested me at once, and I waited impatiently for the lessons to get to that section. But when the longed-for lesson arrived, my father said: “We’ll skip this bit; I can’t make head or tail of it myself.” With that my last hope was laid in the grave. I admired my father’s honesty, but this did not alter the fact that from then on all talk of religion bored me to death.

[31] Our intellect has achieved the most tremendous things, but in the meantime our spiritual dwelling has fallen into disrepair. We are absolutely convinced that even with the aid of the latest and largest reflecting telescope, now being built in America, men will discover behind the farthest nebulae no fiery empyrean; and we know that our eyes will wander despairingly through the dead emptiness of interstellar space. Nor is it any better when mathematical physics reveals to us the world of the infinitely small. In the end we dig up the wisdom of all ages and peoples, only to find that everything most dear and precious to us has already been said in the most superb language. Like greedy children we stretch out our hands and think that, if only we could grasp it, we would possess it too. But what we possess is no longer valid, and our hands grow weary from the grasping, for riches lie everywhere, as far as the eye can reach. All these possessions turn to water, and more than one sorcerer’s apprentice has been drowned in the waters called up by himself—if he did not first succumb to the saving delusion that *this* wisdom was good and *that* was bad. It is from these adepts that there come those terrifying invalids who think they have a prophetic mission. For the artificial sundering of true and false wisdom creates a

tension in the psyche, and from this there arises a loneliness and a craving like that of the morphine addict, who always hopes to find companions in his vice.

[32] When our natural inheritance has been dissipated, then the spirit too, as Heraclitus says, has descended from its fiery heights. But when spirit becomes heavy it turns to water, and with Luciferian presumption the intellect usurps the seat where once the spirit was enthroned. The spirit may legitimately claim the *patria potestas* over the soul; not so the earth-born intellect, which is man's sword or hammer, and not a creator of spiritual worlds, a father of the soul. Hence Ludwig Klages²² and Max Scheler²³ were moderate enough in their attempts to rehabilitate the spirit, for both were children of an age in which the spirit was no longer up above but down below, no longer fire but water.

[33] Therefore the way of the soul in search of its lost father—like Sophia seeking Bythos—leads to the water, to the dark mirror that reposes at its bottom. Whoever has elected for the state of spiritual poverty, the true heritage of Protestantism carried to its logical conclusion, goes the way of the soul that leads to the water. This water is no figure of speech, but a living symbol of the dark psyche. I can best illustrate this by a concrete example, one out of many:

[34] A Protestant theologian often dreamed the same dream: *He stood on a mountain slope with a deep valley below, and in it a dark lake. He knew in the dream that something had always prevented him from approaching the lake. This time he resolved to go to the water. As he approached the shore, everything grew dark and uncanny, and a gust of wind suddenly rushed over the face of the water. He was seized by a panic fear, and awoke.*

[35] This dream shows us the natural symbolism. The dreamer descends into his own depths, and the way leads him to the mysterious water. And now there occurs the miracle of the pool of Bethesda: an angel comes down and touches the water, endowing it with healing power. In the dream it is the wind, the *pneuma*, which bloweth where it listeth. Man's descent to the water is needed in order to evoke the miracle of its coming to life. But the breath of the spirit rushing over the dark water is uncanny, like everything whose cause we do not know—since it is not ourselves. It hints at an unseen presence, a numen to which neither human expectations nor the machinations of the will have given life. It lives of itself, and a shudder runs through the man who thought that "spirit" was merely what he believes, what he makes himself, what is said in books, or what people talk about. But when it happens spontaneously it is a spookish thing, and primitive fear seizes the naïve mind. The elders of the Elgoni tribe in Kenya gave me exactly the same description of the nocturnal god whom they call the "maker of fear." "He comes to you," they said, "like a cold gust of wind, and you shudder, or he goes whistling round in the tall

grass”—an African Pan who glides among the reeds in the haunted noontide hour, playing on his pipes and frightening the shepherds.

[36] Thus, in the dream, the breath of the pneuma frightened another pastor, a shepherd of the flock, who in the darkness of the night trod the reed-grown shore in the deep valley of the psyche. Yes, that erstwhile fiery spirit has made a descent to the realm of nature, to the trees and rocks and the waters of the psyche, like the old man in Nietzsche’s *Zarathustra*, who, wearied of humankind, withdrew into the forest to growl with the bears in honour of the Creator.

[37] We must surely go the way of the waters, which always tend downward, if we would raise up the treasure, the precious heritage of the father. In the Gnostic hymn to the soul,²⁴ the son is sent forth by his parents to seek the pearl that fell from the King’s crown. It lies at the bottom of a deep well, guarded by a dragon, in the land of the Egyptians—that land of fleshpots and drunkenness with all its material and spiritual riches. The son and heir sets out to fetch the jewel, but forgets himself and his task in the orgies of Egyptian worldliness, until a letter from his father reminds him what his duty is. He then sets out for the water and plunges into the dark depths of the well, where he finds the pearl on the bottom, and in the end offers it to the highest divinity.

[38] This hymn, ascribed to Bardesanes, dates from an age that resembled ours in more than one respect. Mankind looked and waited, and it was a *fish*—“levatus de profundo” (drawn from the deep)²⁵—that became the symbol of the saviour, the bringer of healing.

[39] As I wrote these lines, I received a letter from Vancouver, from a person unknown to me. The writer is puzzled by his dreams, which are always about water: “Almost every time I dream it is about water: *either I am having a bath, or the water-closet is overflowing, or a pipe is bursting, or my home has drifted down to the water’s edge, or I see an acquaintance about to sink into water, or I am trying to get out of water, or I am having a bath and the tub is about to overflow,*” etc.

[40] Water is the commonest symbol for the unconscious. The lake in the valley is the unconscious, which lies, as it were, underneath consciousness, so that it is often referred to as the “subconscious,” usually with the pejorative connotation of an inferior consciousness. Water is the “valley spirit,” the water dragon of Tao, whose nature resembles water—a *yang* embraced in the *yin*. Psychologically, therefore, water means spirit that has become unconscious. So the dream of the theologian is quite right in telling him that down by the water he could experience the working of the living spirit like a miracle of healing in the pool of Bethesda. The descent into the depths always seems to precede the ascent. Thus another theologian²⁶ dreamed that *he saw on a mountain a kind of Castle of the Grail. He went along a road that*

seemed to lead straight to the foot of the mountain and up it. But as he drew nearer he discovered to his great disappointment that a chasm separated him from the mountain, a deep, darksome gorge with underworldly water rushing along the bottom. A steep path led downwards and toilsomely climbed up again on the other side. But the prospect looked uninviting, and the dreamer awoke. Here again the dreamer, thirsting for the shining heights, had first to descend into the dark depths, and this proves to be the indispensable condition for climbing any higher. The prudent man avoids the danger lurking in these depths, but he also throws away the good which a bold but imprudent venture might bring.

[41] The statement made by the dream meets with violent resistance from the conscious mind, which knows “spirit” only as something to be found in the heights. “Spirit” always seems to come from above, while from below comes everything that is sordid and worthless. For people who think in this way, spirit means highest freedom, a soaring over the depths, deliverance from the prison of the chthonic world, and hence a refuge for all those timorous souls who do not want to become anything different. But water is earthy and tangible, it is also the fluid of the instinct-driven body, blood and the flowing of blood, the odour of the beast, carnality heavy with passion. The unconscious is the psyche that reaches down from the daylight of mentally and morally lucid consciousness into the nervous system that for ages has been known as the “sympathetic.” This does not govern perception and muscular activity like the cerebrospinal system, and thus control the environment; but, though functioning without sense-organs, it maintains the balance of life and, through the mysterious paths of sympathetic excitation, not only gives us knowledge of the innermost life of other beings but also has an inner effect upon them. In this sense it is an extremely collective system, the operative basis of all *participation mystique*, whereas the cerebrospinal function reaches its high point in separating off the specific qualities of the ego, and only apprehends surfaces and externals—always through the medium of space. It experiences everything as an outside, whereas the sympathetic system experiences everything as an inside.

[42] The unconscious is commonly regarded as a sort of incapsulated fragment of our most personal and intimate life—something like what the Bible calls the “heart” and considers the source of all evil thoughts. In the chambers of the heart dwell the wicked blood-spirits, swift anger and sensual weakness. This is how the unconscious looks when seen from the conscious side. But consciousness appears to be essentially an affair of the cerebrum, which sees everything separately and in isolation, and therefore sees the unconscious in this way too, regarding it outright as *my* unconscious. Hence it is generally believed that anyone who descends into the unconscious gets into a suffocating atmosphere of egocentric subjectivity, and in this

blind alley is exposed to the attack of all the ferocious beasts which the caverns of the psychic underworld are supposed to harbour.

[43] True, whoever looks into the mirror of the water will see first of all his own face. Whoever goes to himself risks a confrontation with himself. The mirror does not flatter, it faithfully shows whatever looks into it; namely, the face we never show to the world because we cover it with the *persona*, the mask of the actor. But the mirror lies behind the mask and shows the true face.

[44] This confrontation is the first test of courage on the inner way, a test sufficient to frighten off most people, for the meeting with ourselves belongs to the more unpleasant things that can be avoided so long as we can project everything negative into the environment. But if we are able to see our own shadow and can bear knowing about it, then a small part of the problem has already been solved: we have at least brought up the personal unconscious. The shadow is a living part of the personality and therefore wants to live with it in some form. It cannot be argued out of existence or rationalized into harmlessness. This problem is exceedingly difficult, because it not only challenges the whole man, but reminds him at the same time of his helplessness and ineffectuality. Strong natures—or should one rather call them weak?—do not like to be reminded of this, but prefer to think of themselves as heroes who are beyond good and evil, and to cut the Gordian knot instead of untying it. Nevertheless, the account has to be settled sooner or later. In the end one has to admit that there are problems which one simply cannot solve on one's own resources. Such an admission has the advantage of being honest, truthful, and in accord with reality, and this prepares the ground for a compensatory reaction from the collective unconscious: you are now more inclined to give heed to a helpful idea or intuition, or to notice thoughts which had not been allowed to voice themselves before. Perhaps you will pay attention to the dreams that visit you at such moments, or will reflect on certain inner and outer occurrences that take place just at this time. If you have an attitude of this kind, then the helpful powers slumbering in the deeper strata of man's nature can come awake and intervene, for helplessness and weakness are the eternal experience and the eternal problem of mankind. To this problem there is also an eternal answer, otherwise it would have been all up with humanity long ago. When you have done everything that could possibly be done, the only thing that remains is what you could still do if only you knew it. But how much do we know of ourselves? Precious little, to judge by experience. Hence there is still a great deal of room left for the unconscious. Prayer, as we know, calls for a very similar attitude and therefore has much the same effect.

[45] The necessary and needful reaction from the collective unconscious expresses itself in archetypally formed ideas. The meeting with oneself is, at first, the meeting

with one's own shadow. The shadow is a tight passage, a narrow door, whose painful constriction no one is spared who goes down to the deep well. But one must learn to know oneself in order to know who one is. For what comes after the door is, surprisingly enough, a boundless expanse full of unprecedented uncertainty, with apparently no inside and no outside, no above and no below, no here and no there, no mine and no thine, no good and no bad. It is the world of water, where all life floats in suspension; where the realm of the sympathetic system, the soul of everything living, begins; where I am indivisibly this *and* that; where I experience the other in myself and the other-than-myself experiences me.

[46] No, the collective unconscious is anything but an incapsulated personal system; it is sheer objectivity, as wide as the world and open to all the world. There I am the object of every subject, in complete reversal of my ordinary consciousness, where I am always the subject that has an object. There I am utterly one with the world, so much a part of it that I forget all too easily who I really am. "Lost in oneself" is a good way of describing this state. But this self is the world, if only a consciousness could see it. That is why we must know who we are.

[47] The unconscious no sooner touches us than we *are* it—we become unconscious of ourselves. That is the age-old danger, instinctively known and feared by primitive man, who himself stands so very close to this pleroma. His consciousness is still uncertain, wobbling on its feet. It is still childish, having just emerged from the primal waters. A wave of the unconscious may easily roll over it, and then he forgets who he was and does things that are strange to him. Hence primitives are afraid of uncontrolled emotions, because consciousness breaks down under them and gives way to possession. All man's strivings have therefore been directed towards the consolidation of consciousness. This was the purpose of rite and dogma; they were dams and walls to keep back the dangers of the unconscious, the "perils of the soul." Primitive rites consist accordingly in the exorcizing of spirits, the lifting of spells, the averting of the evil omen, propitiation, purification, and the production by sympathetic magic of helpful occurrences.

[48] It is these barriers, erected in primitive times, that later became the foundations of the Church. It is also these barriers that collapse when the symbols become weak with age. Then the waters rise and boundless catastrophes break over mankind. The religious leader of the Taos pueblo, known as the Loco Tenente Gobernador, once said to me: "The Americans should stop meddling with our religion, for when it dies and we can no longer help the sun our Father to cross the sky, the Americans and the whole world will learn something in ten years' time, for then the sun won't rise any more." In other words, night will fall, the light of consciousness is extinguished, and the dark sea of the unconscious breaks in.

[49] Whether primitive or not, mankind always stands on the brink of actions it performs itself but does not control. The whole world wants peace and the whole world prepares for war, to take but one example. Mankind is powerless against mankind, and the gods, as ever, show it the ways of fate. Today we call the gods “factors,” which comes from *facere*, ‘to make.’ The makers stand behind the wings of the world-theatre. It is so in great things as in small. In the realm of consciousness we are our own masters; we seem to be the “factors” themselves. But if we step through the door of the shadow we discover with terror that we are the objects of unseen factors. To know this is decidedly unpleasant, for nothing is more disillusioning than the discovery of our own inadequacy. It can even give rise to primitive panic, because, instead of being believed in, the anxiously guarded supremacy of consciousness—which is in truth one of the secrets of human success—is questioned in the most dangerous way. But since ignorance is no guarantee of security, and in fact only makes our insecurity still worse, it is probably better despite our fear to know where the danger lies. To ask the right question is already half the solution of a problem. At any rate we then know that the greatest danger threatening us comes from the unpredictability of the psyche’s reactions. Discerning persons have realized for some time that external historical conditions, of whatever kind, are only occasions, jumping-off grounds, for the real dangers that threaten our lives. These are the present politico-social delusional systems. We should not regard them causally, as necessary consequences of external conditions, but as decisions precipitated by the collective unconscious.

[50] This is a new problem. All ages before us have believed in gods in some form or other. Only an unparalleled impoverishment of symbolism could enable us to rediscover the gods as psychic factors, that is, as archetypes of the unconscious. No doubt this discovery is hardly credible at present. To be convinced, we need to have the experience pictured in the dream of the theologian, for only then do we experience the self-activity of the spirit moving over the waters. Since the stars have fallen from heaven and our highest symbols have paled, a secret life holds sway in the unconscious. That is why we have a psychology today, and why we speak of the unconscious. All this would be quite superfluous in an age or culture that possessed symbols. Symbols are spirit from above, and under those conditions the spirit is above too. Therefore it would be a foolish and senseless undertaking for such people to wish to experience or investigate an unconscious that contains nothing but the silent, undisturbed sway of nature. Our unconscious, on the other hand, hides living water, spirit that has become nature, and that is why it is disturbed. Heaven has become for us the cosmic space of the physicists, and the divine empyrean a fair memory of things that once were. But “the heart glows,” and a secret unrest gnaws at the roots of our being. In the words of the *Völuspá* we may ask:

What murmurs Wotan over Mimir's head?

Already the spring boils ...

[51] Our concern with the unconscious has become a vital question for us—a question of spiritual being or non-being. All those who have had an experience like that mentioned in the dream know that the treasure lies in the depths of the water and will try to salvage it. As they must never forget who they are, they must on no account imperil their consciousness. They will keep their standpoint firmly anchored to the earth, and will thus—to preserve the metaphor—become fishers who catch with hook and net what swims in the water. There may be consummate fools who do not understand what fishermen do, but the latter will not mistake the timeless meaning of their action, for the symbol of their craft is many centuries older than the still unfaded story of the Grail. But not every man is a fisherman. Sometimes this figure remains arrested at an early, instinctive level, and then it is an otter, as we know from Oskar Schmitz's fairytales.²⁷

[52] Whoever looks into the water sees his own image, but behind it living creatures soon loom up; fishes, presumably, harmless dwellers of the deep—harmless, if only the lake were not haunted. They are water-beings of a peculiar sort. Sometimes a nixie gets into the fisherman's net, a female, half-human fish.²⁸

Nixies are entrancing creatures:

Half drew she him,
Half sank he down
And nevermore was seen.

[53] The nixie is an even more instinctive version of a magical feminine being whom I call the *anima*. She can also be a siren, *melusina* (mermaid),²⁹ wood-nymph, Grace, or Erlking's daughter, or a lamia or succubus, who infatuates young men and sucks the life out of them. Moralizing critics will say that these figures are projections of soulful emotional states and are nothing but worthless fantasies. One must admit that there is a certain amount of truth in this. But is it the whole truth? Is the nixie really nothing but a product of moral laxity? Were there not such beings long ago, in an age when dawning human consciousness was still wholly bound to nature? Surely there were spirits of forest, field, and stream long before the question of moral conscience ever existed. What is more, these beings were as much dreaded as adored, so that their rather peculiar erotic charms were only one of their characteristics. Man's consciousness was then far simpler, and his possession of it absurdly small. An unlimited amount of what we now feel to be an integral part of our psychic being disports itself merrily for the primitive in projections ranging far and wide.

[54] The word “projection” is not really appropriate, for nothing has been cast out of the psyche; rather, the psyche has attained its present complexity by a series of acts of introjection. Its complexity has increased in proportion to the despiritualization of nature. An alluring nixie from the dim bygone is today called an “erotic fantasy,” and she may complicate our psychic life in a most painful way. She comes upon us just as a nixie might; she sits on top of us like a succubus; she changes into all sorts of shapes like a witch, and in general displays an unbearable independence that does not seem at all proper in a psychic content. Occasionally she causes states of fascination that rival the best bewitchment, or unleashes terrors in us not to be outdone by any manifestation of the devil. She is a mischievous being who crosses our path in numerous transformations and disguises, playing all kinds of tricks on us, causing happy and unhappy delusions, depressions and ecstasies, outbursts of affect, etc. Even in a state of reasonable introjection the nixie has not laid aside her roguery. The witch has not ceased to mix her vile potions of love and death; her magic poison has been refined into intrigue and self-deception, unseen though none the less dangerous for that.

[55] But how do we dare to call this elfin being the “anima”? Anima means soul and should designate something very wonderful and immortal. Yet this was not always so. We should not forget that this kind of soul is a dogmatic conception whose purpose it is to pin down and capture something uncannily alive and active. The German word *Seele* is closely related, via the Gothic form *saiwalô*, to the Greek word *αἶολος*, which means ‘quick-moving,’ ‘changeful of hue,’ ‘twinkling,’ something like a butterfly—*ψυχή* in Greek—which reels drunkenly from flower to flower and lives on honey and love. In Gnostic typology the *ἄνθρωπος ψυχικός*, ‘psychic man,’ is inferior to the *πνευματικός*, ‘spiritual man,’ and finally there are wicked souls who must roast in hell for all eternity. Even the quite innocent soul of the unbaptized newborn babe is deprived of the contemplation of God. Among primitives, the soul is the magic breath of life (hence the term “anima”), or a flame. An uncanonical saying of our Lord’s aptly declares: “Whoso is near unto me is near to the fire.” For Heraclitus the soul at the highest level is fiery and dry, because *ψυχή* as such is closely akin to “cool breath”—*ψύχαιεν* means ‘to breathe,’ ‘to blow’; *ψυχρός* and *ψῦχος* mean ‘cold,’ ‘chill,’ ‘damp.’

[56] Being that has soul is living being. Soul is the living thing in man, that which lives of itself and causes life. Therefore God breathed into Adam a living breath, that he might live. With her cunning play of illusions the soul lures into life the inertness of matter that does not want to live. She makes us believe incredible things, that life may be lived. She is full of snares and traps, in order that man should fall, should reach the earth, entangle himself there, and stay caught, so that life should be lived; as Eve in the garden of Eden could not rest content until she had convinced Adam of

the goodness of the forbidden apple. Were it not for the leaping and twinkling of the soul, man would rot away in his greatest passion, idleness.³⁰ A certain kind of reasonableness is its advocate, and a certain kind of morality adds its blessing. But to have soul is the whole venture of life, for soul is a life-giving daemon who plays his elfin game above and below human existence, for which reason—in the realm of dogma—he is threatened and propitiated with superhuman punishments and blessings that go far beyond the possible deserts of human beings. Heaven and hell are the fates meted out to the soul and not to civilized man, who in his nakedness and timidity would have no idea of what to do with himself in a heavenly Jerusalem.

[57] The anima is not the soul in the dogmatic sense, not an *anima rationalis*, which is a philosophical conception, but a natural archetype that satisfactorily sums up all the statements of the unconscious, of the primitive mind, of the history of language and religion. It is a “factor” in the proper sense of the word. Man cannot make it; on the contrary, it is always the *a priori* element in his moods, reactions, impulses, and whatever else is spontaneous in psychic life. It is something that lives of itself, that makes us live; it is a life behind consciousness that cannot be completely integrated with it, but from which, on the contrary, consciousness arises. For, in the last analysis, psychic life is for the greater part an unconscious life that surrounds consciousness on all sides—a notion that is sufficiently obvious when one considers how much unconscious preparation is needed, for instance, to register a sense-impression.

[58] Although it seems as if the whole of our unconscious psychic life could be ascribed to the anima, she is yet only one archetype among many. Therefore, she is not characteristic of the unconscious in its entirety. She is only one of its aspects. This is shown by the very fact of her femininity. What is not—I, not masculine, is most probably feminine, and because the not—I is felt as not belonging to me and therefore as outside me, the anima-image is usually projected upon women. Either sex is inhabited by the opposite sex up to a point, for, biologically speaking, it is simply the greater number of masculine genes that tips the scales in favour of masculinity. The smaller number of feminine genes seems to form a feminine character, which usually remains unconscious because of its subordinate position.

[59] With the archetype of the anima we enter the realm of the gods, or rather, the realm that metaphysics has reserved for itself. Everything the anima touches becomes numinous—unconditional, dangerous, taboo, magical. She is the serpent in the paradise of the harmless man with good resolutions and still better intentions. She affords the most convincing reasons for not prying into the unconscious, an occupation that would break down our moral inhibitions and unleash forces that had better been left unconscious and undisturbed. As usual, there is something in what

the anima says; for life in itself is not good only, it is also bad. Because the anima wants life, she wants both good and bad. These categories do not exist in the elfin realm. Bodily life as well as psychic life have the impudence to get along much better without conventional morality, and they often remain the healthier for it.

[60] The anima believes in the *καλόν κάγαθόν*, the ‘beautiful and the good,’ a primitive conception that antedates the discovery of the conflict between aesthetics and morals. It took more than a thousand years of Christian differentiation to make it clear that the good is not always the beautiful and the beautiful not necessarily good. The paradox of this marriage of ideas troubled the ancients as little as it does the primitives. The anima is conservative and clings in the most exasperating fashion to the ways of earlier humanity. She likes to appear in historic dress, with a predilection for Greece and Egypt. In this connection we would mention the classic anima stories of Rider Haggard and Pierre Benoît. The Renaissance dream known as the *Ipnerotomachia* of Poliphilo,³¹ and Goethe’s *Faust*, likewise reach deep into antiquity in order to find “le vrai mot” for the situation. Poliphilo conjured up Queen Venus; Goethe, Helen of Troy. Aniela Jaffé³² has sketched a lively picture of the anima in the age of Biedermeier and the Romantics. If you want to know what happens when the anima appears in modern society, I can warmly recommend John Erskine’s *Private Life of Helen of Troy*. She is not a shallow creation, for the breath of eternity lies over everything that is really alive. The anima lives beyond all categories, and can therefore dispense with blame as well as with praise. Since the beginning of time man, with his wholesome animal instinct, has been engaged in combat with his soul and its daemonism. If the soul were uniformly dark it would be a simple matter. Unfortunately this is not so, for the anima can appear also as an angel of light, a psychopomp who points the way to the highest meaning, as we know from *Faust*.

[61] If the encounter with the shadow is the “apprentice-piece” in the individual’s development, then that with the anima is the “master-piece.” The relation with the anima is again a test of courage, an ordeal by fire for the spiritual and moral forces of man. We should never forget that in dealing with the anima we are dealing with psychic facts which have never been in man’s possession before, since they were always found “outside” his psychic territory, so to speak, in the form of projections. For the son, the anima is hidden in the dominating power of the mother, and sometimes she leaves him with a sentimental attachment that lasts throughout life and seriously impairs the fate of the adult. On the other hand, she may spur him on to the highest flights. To the men of antiquity the anima appeared as a goddess or a witch, while for medieval man the goddess was replaced by the Queen of Heaven and Mother Church. The desymbolized world of the Protestant produced first an unhealthy sentimentality and then a sharpening of the moral conflict, which, because it was so unbearable, led logically to Nietzsche’s “beyond good and evil.” In centres

of civilization this state shows itself in the increasing insecurity of marriage. The American divorce rate has been reached, if not exceeded, in many European countries, which proves that the anima projects herself by preference on the opposite sex, thus giving rise to magically complicated relationships. This fact, largely because of its pathological consequences, has led to the growth of modern psychology, which in its Freudian form cherishes the belief that the essential cause of all disturbances is sexuality—a view that only exacerbates the already existing conflict.³³ There is a confusion here between cause and effect. The sexual disturbance is by no means the cause of neurotic difficulties, but is, like these, one of the pathological effects of a maladaptation of consciousness, as when consciousness is faced with situations and tasks to which it is not equal. Such a person simply does not understand how the world has altered, and what his attitude would have to be in order to adapt to it.

[62] In dealing with the shadow or anima it is not sufficient just to know about these concepts and to reflect on them. Nor can we ever experience their content by feeling our way into them or by appropriating other people's feelings. It is no use at all to learn a list of archetypes by heart. Archetypes are complexes of experience that come upon us like fate, and their effects are felt in our most personal life. The anima no longer crosses our path as a goddess, but, it may be, as an intimately personal misadventure, or perhaps as our best venture. When, for instance, a highly esteemed professor in his seventies abandons his family and runs off with a young red-headed actress, we know that the gods have claimed another victim. This is how daemonic power reveals itself to us. Until not so long ago it would have been an easy matter to do away with the young woman as a witch.

[63] In my experience there are very many people of intelligence and education who have no trouble in grasping the idea of the anima and her relative autonomy, and can also understand the phenomenology of the animus in women. Psychologists have more difficulties to overcome in this respect, probably because they are under no compulsion to grapple with the complex facts peculiar to the psychology of the unconscious. If they are doctors as well, their somato-psychological thinking gets in the way, with its assumption that psychological processes can be expressed in intellectual, biological, or physiological terms. Psychology, however, is neither biology nor physiology nor any other science than just this knowledge of the psyche.

[64] The picture I have drawn of the anima so far is not complete. Although she may be the chaotic urge to life, something strangely meaningful clings to her, a secret knowledge or hidden wisdom, which contrasts most curiously with her irrational elfin nature. Here I would like to refer again to the authors already cited. Rider Haggard calls She "Wisdom's Daughter"; Benoît's Queen of Atlantis has an excellent library

that even contains a lost book of Plato. Helen of Troy, in her reincarnation, is rescued from a Tyrian brothel by the wise Simon Magus and accompanies him on his travels. I purposely refrained from mentioning this thoroughly characteristic aspect of the anima earlier, because the first encounter with her usually leads one to infer anything rather than wisdom.³⁴ This aspect appears only to the person who gets to grips with her seriously. Only then, when this hard task has been faced,³⁵ does he come to realize more and more that behind all her cruel sporting with human fate there lies something like a hidden purpose which seems to reflect a superior knowledge of life's laws. It is just the most unexpected, the most terrifyingly chaotic things which reveal a deeper meaning. And the more this meaning is recognized, the more the anima loses her impetuous and compulsive character. Gradually breakwaters are built against the surging of chaos, and the meaningful divides itself from the meaningless. When sense and nonsense are no longer identical, the force of chaos is weakened by their subtraction; sense is then endued with the force of meaning, and nonsense with the force of meaninglessness. In this way a new cosmos arises. This is not a new discovery in the realm of medical psychology, but the age-old truth that out of the richness of a man's experience there comes a teaching which the father can pass on to the son.³⁶

[65] In elfin nature wisdom and folly appear as one and the same; and they *are* one and the same as long as they are acted out by the anima. Life is crazy and meaningful at once. And when we do not laugh over the one aspect and speculate about the other, life is exceedingly drab, and everything is reduced to the littlest scale. There is then little sense and little nonsense either. When you come to think about it, nothing has any meaning, for when there was nobody to think, there was nobody to interpret what happened. Interpretations are only for those who don't understand; it is only the things we don't understand that have any meaning. Man woke up in a world he did not understand, and that is why he tries to interpret it.

[66] Thus the anima and life itself are meaningless in so far as they offer no interpretation. Yet they have a nature that can be interpreted, for in all chaos there is a cosmos, in all disorder a secret order, in all caprice a fixed law, for everything that works is grounded on its opposite. It takes man's discriminating understanding, which breaks everything down, into antinomial judgments, to recognize this. Once he comes to grips with the anima, her chaotic capriciousness will give him cause to suspect a secret order, to sense a plan, a meaning, a purpose over and above her nature, or even—we might almost be tempted to say—to "postulate" such a thing, though this would not be in accord with the truth. For in actual reality we do not have at our command any power of cool reflection, nor does any science or philosophy help us, and the traditional teachings of religion do so only to a limited degree. We are caught and entangled in aimless experience, and the judging intellect with its

categories proves itself powerless. Human interpretation fails, for a turbulent life-situation has arisen that refuses to fit any of the traditional meanings assigned to it. It is a moment of collapse. We sink into a final depth—Apuleius calls it “a kind of voluntary death.” It is a surrender of our own powers, not artificially willed but forced upon us by nature; not a voluntary submission and humiliation decked in moral garb but an utter and unmistakable defeat crowned with the panic fear of demoralization. Only when all props and crutches are broken, and no cover from the rear offers even the slightest hope of security, does it become possible for us to experience an archetype that up till then had lain hidden behind the meaningful nonsense played out by the anima. This is the *archetype of meaning*, just as the anima is the *archetype of life itself*.

[67] It always seems to us as if meaning—compared with life—were the younger event, because we assume, with some justification, that we assign it of ourselves, and because we believe, equally rightly no doubt, that the great world can get along without being interpreted. But how do we assign meaning? From what source, in the last analysis, do we derive meaning? The forms we use for assigning meaning are historical categories that reach back into the mists of time—a fact we do not take sufficiently into account. Interpretations make use of certain linguistic matrices that are themselves derived from primordial images. From whatever side we approach this question, everywhere we find ourselves confronted with the history of language, with images and motifs that lead straight back to the primitive wonder-world.

[68] Take, for instance, the word “idea.” It goes back to the εἶδος concept of Plato, and the eternal ideas are primordial images stored up ἐν ὑπερορανίῳ τοῦ πῶ (in a supracelestial place) as eternal, transcendent forms. The eye of the seer perceives them as “imagines et lares,” or as images in dreams and revelatory visions. Or let us take the concept of energy, which is an interpretation of physical events. In earlier times it was the secret fire of the alchemists, or phlogiston, or the heat-force inherent in matter, like the “primal warmth” of the Stoics, or the Heraclitean πῦρ αἰεί ζῶον (ever-living fire), which borders on the primitive notion of an all-pervading vital force, a power of growth and magic healing that is generally called *mana*.

[69] I will not go on needlessly giving examples. It is sufficient to know that there is not a single important idea or view that does not possess historical antecedents. Ultimately they are all founded on primordial archetypal forms whose concreteness dates from a time when consciousness did not *think*, but only *perceived*. “Thoughts” were objects of inner perception, not thought at all, but sensed as external phenomena—seen or heard, so to speak. Thought was essentially revelation, not invented but forced upon us or bringing conviction through its immediacy and actuality. Thinking of this kind precedes the primitive ego-consciousness, and the latter is more its object

than its subject. But we ourselves have not yet climbed the last peak of consciousness, so we also have a pre-existent thinking, of which we are not aware so long as we are supported by traditional symbols—or, to put it in the language of dreams, so long as the father or the king is not dead.

[70] I would like to give you an example of how the unconscious “thinks” and paves the way for solutions. It is the case of a young theological student, whom I did not know personally. He was in great straits because of his religious beliefs, and about this time he dreamed the following dream:³⁷

[71] *He was standing in the presence of a handsome old man dressed entirely in black. He knew it was the white magician. This personage had just addressed him at considerable length, but the dreamer could no longer remember what it was about. He had only retained the closing words: “And for this we need the help of the black magician.” At that moment the door opened and in came another old man exactly like the first, except that he was dressed in white. He said to the white magician, “I need your advice,” but threw a sidelong, questioning look at the dreamer, whereupon the white magician answered: “You can speak freely, he is an innocent.” The black magician then began to relate his story. He had come from a distant land where something extraordinary had happened. The country was ruled by an old king who felt his death near. He—the king—had sought out a tomb for himself. For there were in that land a great number of tombs from ancient times, and the king had chosen the finest for himself. According to legend, a virgin had been buried in it. The king caused the tomb to be opened, in order to get it ready for use. But when the bones it contained were exposed to the light of day, they suddenly took on life and changed into a black horse, which at once fled into the desert and there vanished. The black magician had heard of this story and immediately set forth in pursuit of the horse. After a journey of many days, always on the tracks of the horse, he came to the desert and crossed to the other side, where the grasslands began again. There he met the horse grazing, and there also he came upon the find on whose account he now needed the advice of the white magician. For he had found the lost keys of paradise, and he did not know what to do with them. At this exciting moment the dreamer awoke.*

[72] In the light of our earlier remarks the meaning of the dream is not hard to guess: the old king is the ruling symbol that wants to go to its eternal rest, and in the very place where similar “dominants” lie buried. His choice falls, fittingly enough, on the grave of anima, who lies in the death trance of a Sleeping Beauty so long as the king is alive—that is, so long as a valid principle (Prince or *princeps*) regulates and expresses life. But when the king draws to his end,³⁸ she comes to life again and changes into a black horse, which in Plato’s parable stands for the unruliness of the

passions. Anyone who follows this horse comes into the desert, into a wild land remote from men—an image of spiritual and moral isolation. But there lie the keys of paradise.

[73] Now what is paradise? Clearly, the Garden of Eden with its two-faced tree of life and knowledge and its four streams. In the Christian version it is also the heavenly city of the Apocalypse, which, like the Garden of Eden, is conceived as a mandala. But the mandala is a symbol of individuation. So it is the *black* magician who finds the keys to the solution of the problems of belief weighing on the dreamer, the keys that open the way of individuation. The contrast between desert and paradise therefore signifies isolation as contrasted with individuation, or the becoming of the self.

[74] This part of the dream is a remarkable paraphrase of the Oxyrhynchus sayings of Jesus,³⁹ in which the way to the kingdom of heaven is pointed out by animals, and where we find the admonition: “Therefore know yourselves, for you are the city, and the city is the kingdom.” It is also a paraphrase of the serpent of paradise who persuaded our first parents to sin, and who finally leads to the redemption of mankind through the Son of God. As we know, this causal nexus gave rise to the Ophitic identification of the serpent with the Σωτήρ (Saviour). The black horse and the black magician are half-evil elements whose relativity with respect to good is hinted at in the exchange of garments. The two magicians are, indeed, two aspects of the *wise old man*, the superior master and teacher, the archetype of the spirit, who symbolizes the pre-existent meaning hidden in the chaos of life. He is the father of the soul, and yet the soul, in some miraculous manner, is also his virgin mother, for which reason he was called by the alchemists the “first son of the mother.” The black magician and the black horse correspond to the descent into darkness in the dreams mentioned earlier.

[75] What an unbearably hard lesson for a young student of theology! Fortunately he was not in the least aware that the father of all prophets had spoken to him in the dream and placed a great secret almost within his grasp. One marvels at the inappropriateness of such occurrences. Why this prodigality? But I have to admit that we do not know how this dream affected the student in the long run, and I must emphasize that to me, at least, the dream had a very great deal to say. It was not allowed to get lost, even though the dreamer did not understand it.

[76] The old man in this dream is obviously trying to show how good and evil function together, presumably as an answer to the still unresolved moral conflict in the Christian psyche. With this peculiar relativization of opposites we find ourselves approaching nearer to the ideas of the East, to the *nirvandva* of Hindu philosophy, the freedom from opposites, which is shown as a possible way of solving the conflict

through reconciliation. How perilously fraught with meaning this Eastern relativity of good and evil is, can be seen from the Indian aphoristic question: “Who takes longer to reach perfection, the man who loves God, or the man who hates him?” And the answer is: “He who loves God takes seven reincarnations to reach perfection, and he who hates God takes only three, for he who hates God will think of him more than he who loves him,” Freedom from opposites presupposes their functional equivalence, and this offends our Christian feelings. Nonetheless, as our dream example shows, the balanced co-operation of moral opposites is a natural truth which has been recognized just as naturally by the East. The clearest example of this is to be found in Taoist philosophy. But in the Christian tradition, too, there are various sayings that come very close to this standpoint. I need only remind you of the parable of the unjust steward.

[77] Our dream is by no means unique in this respect, for the tendency to relativize opposites is a notable peculiarity of the unconscious. One must immediately add, however, that this is true only in cases of exaggerated moral sensibility; in other cases the unconscious can insist just as inexorably on the irreconcilability of the opposites. As a rule, the standpoint of the unconscious is relative to the conscious attitude. We can probably say, therefore, that our dream presupposes the specific beliefs and doubts of a theological consciousness of Protestant persuasion. This limits the statement of the dream to a definite set of problems. But even with this paring down of its validity the dream clearly demonstrates the superiority of its standpoint. Fittingly enough, it expresses its meaning in the opinion and voice of a wise magician, who goes back in direct line to the figure of the medicine man in primitive society. He is, like the anima, an immortal daemon that pierces the chaotic darknesses of brute life with the light of meaning. He is the enlightener, the master and teacher, a psychopomp whose personification even Nietzsche, that breaker of tablets, could not escape—for he had called up his reincarnation in Zarathustra, the lofty spirit of an almost Homeric age, as the carrier and mouthpiece of his own “Dionysian” enlightenment and ecstasy. For him God was dead, but the driving daemon of wisdom became as it were his bodily double. He himself says:

Then one was changed to two
And Zarathustra passed me by.

[78] Zarathustra is more for Nietzsche than a poetic figure; he is an involuntary confession, a testament. Nietzsche too had lost his way in the darknesses of a life that turned its back upon God and Christianity, and that is why there came to him the revealer and enlightener, the speaking fountainhead of his soul. Here is the source of the hieratic language of *Zarathustra*, for that is the style of this archetype.

[79] Modern man, in experiencing this archetype, comes to know that most ancient form of thinking as an autonomous activity whose object he is. Hermes Trismegistus or the Thoth of Hermetic literature, Orpheus, the Poimandres (shepherd of men) and his near relation the Poimen of Hermes,⁴⁰ are other formulations of the same experience. If the name “Lucifer” were not prejudicial, it would be a very suitable one for this archetype. But I have been content to call it the *archetype of the wise old man*, or *of meaning*. Like all archetypes it has a positive and a negative aspect, though I don’t want to enter into this here. The reader will find a detailed exposition of the two-facedness of the wise old man in “The Phenomenology of the Spirit in Fairytales.”

[80] The three archetypes so far discussed—the shadow, the anima, and the wise old man—are of a kind that can be directly experienced in personified form. In the foregoing I tried to indicate the general psychological conditions in which such an experience arises. But what I conveyed were only abstract generalizations. One could, or rather should, really give a description of the process as it occurs in immediate experience. In the course of this process the archetypes appear as active personalities in dreams and fantasies. But the process itself involves another class of archetypes which one could call the *archetypes of transformation*. They are not personalities, but are typical situations, places, ways and means, that symbolize the kind of transformation in question. Like the personalities, these archetypes are true and genuine symbols that cannot be exhaustively interpreted, either as signs or as allegories. They are genuine symbols precisely because they are ambiguous, full of half-glimpsed meanings, and in the last resort inexhaustible. The ground principles, the *ἀρχαί*, of the unconscious are indescribable because of their wealth of reference, although in themselves recognizable. The discriminating intellect naturally keeps on trying to establish their singleness of meaning and thus misses the essential point; for what we can above all establish as the one thing consistent with their nature is their *manifold meaning*, their almost limitless wealth of reference, which makes any unilateral formulation impossible. Besides this, they are in principle paradoxical, just as for the alchemists the spirit was conceived as “senex et iuvenis simul”—an old man and a youth at once.

[81] If one wants to form a picture of the symbolic process, the series of pictures found in alchemy are good examples, though the symbols they contain are for the most part traditional despite their often obscure origin and significance. An excellent Eastern example is the Tantric *chakra* system,⁴¹ or the mystical nerve system of Chinese yoga.⁴² It also seems as if the set of pictures in the Tarot cards were distantly descended from the archetypes of transformation, a view that has been confirmed for me in a very enlightening lecture by Professor Bernoulli.⁴³

[82] The symbolic process is an experience *in images and of images*. Its development usually shows an enantiodromian structure like the text of the *I Ching*, and so presents a rhythm of negative and positive, loss and gain, dark and light. Its beginning is almost invariably characterized by one's getting stuck in a blind alley or in some impossible situation; and its goal is, broadly speaking, illumination or higher consciousness, by means of which the initial situation is overcome on a higher level. As regards the time factor, the process may be compressed into a single dream or into a short moment of experience, or it may extend over months and years, depending on the nature of the initial situation, the person involved in the process, and the goal to be reached. The wealth of symbols naturally varies enormously from case to case. Although everything is experienced in image form, i.e., symbolically, it is by no means a question of fictitious dangers but of very real risks upon which the fate of a whole life may depend. The chief danger is that of succumbing to the fascinating influence of the archetypes, and this is most likely to happen when the archetypal images are not made conscious. If there is already a predisposition to psychosis, it may even happen that the archetypal figures, which are endowed with a certain autonomy anyway on account of their natural numinosity, will escape from conscious control altogether and become completely independent, thus producing the phenomena of possession. In the case of an anima-possession, for instance, the patient will want to change himself into a woman through self-castration, or he is afraid that something of the sort will be done to him by force. The best-known example of this is Schreber's *Memoirs of My Nervous Illness*. Patients often discover a whole anima mythology with numerous archaic motifs. A case of this kind was published some time ago by Nelken.⁴⁴ Another patient has described his experiences himself and commented on them in a book.⁴⁵ I mention these examples because there are still people who think that the archetypes are subjective chimeras of my own brain.

[83] The things that come to light brutally in insanity remain hidden in the background in neurosis, but they continue to influence consciousness nonetheless. When, therefore, the analysis penetrates the background of conscious phenomena, it discovers the same archetypal figures that activate the deliriums of psychotics. Finally, there is any amount of literary and historical evidence to prove that in the case of these archetypes we are dealing with normal types of fantasy that occur practically everywhere and not with the monstrous products of insanity. The pathological element does not lie in the existence of these ideas, but in the dissociation of consciousness that can no longer control the unconscious. In all cases of dissociation it is therefore necessary to integrate the unconscious into consciousness. This is a synthetic process which I have termed the "individuation process."

[84] As a matter of fact, this process follows the natural course of life—a life in which the individual becomes what he always was. Because man has consciousness, a development of this kind does not run very smoothly; often it is varied and disturbed, because consciousness deviates again and again from its archetypal, instinctual foundation and finds itself in opposition to it. There then arises the need for a synthesis of the two positions. This amounts to psychotherapy even on the primitive level, where it takes the form of restitution ceremonies. As examples I would mention the identification of the Australian aborigines with their ancestors in the *alcheringa* period, identification with the “sons of the sun” among the Pueblos of Taos, the Helios apotheosis in the Isis mysteries, and so on. Accordingly, the therapeutic method of complex psychology consists on the one hand in making as fully conscious as possible the constellated unconscious contents, and on the other hand in synthesizing them with consciousness through the act of recognition. Since, however, civilized man possesses a high degree of dissociability and makes continual use of it in order to avoid every possible risk, it is by no means a foregone conclusion that recognition will be followed by the appropriate action. On the contrary, we have to reckon with the singular ineffectiveness of recognition and must therefore insist on a meaningful application of it. Recognition by itself does not as a rule do this, nor does it imply, as such, any moral strength. In these cases it becomes very clear how much the cure of neurosis is a moral problem.

[85] As the archetypes, like all numinous contents, are relatively autonomous, they cannot be integrated simply by rational means, but require a dialectical procedure, a real coming to terms with them, often conducted by the patient in dialogue form, so that, without knowing it, he puts into effect the alchemical definition of the *meditatio*: “an inner colloquy with one’s good angel.”⁴⁶ Usually the process runs a dramatic course, with many ups and downs. It expresses itself in, or is accompanied by, dream symbols that are related to the “représentations collectives,” which in the form of mythological motifs have portrayed psychic processes of transformation since the earliest times.⁴⁷

[86] In the short space of a lecture I must content myself with giving only a few examples of archetypes. I have chosen the ones that play the chief part in an analysis of the masculine psyche, and have tried to give you some idea of the transformation process in which they appear. Since this lecture was first published, the figures of the shadow, anima, and wise old man, together with the corresponding figures of the feminine unconscious, have been dealt with in greater detail in my contributions to the symbolism of the self,⁴⁸ and the individuation process in its relation to alchemical symbolism has also been subjected to closer investigation.⁴⁹

THE CONCEPT OF THE COLLECTIVE UNCONSCIOUS¹

[87] Probably none of my empirical concepts has met with so much misunderstanding as the idea of the collective unconscious. In what follows I shall try to give (1) a definition of the concept, (2) a description of what it means for psychology, (3) an explanation of the method of proof, and (4) an example.

1. *Definition*

[88] The collective unconscious is a part of the psyche which can be negatively distinguished from a personal unconscious by the fact that it does not, like the latter, owe its existence to personal experience and consequently is not a personal acquisition. While the personal unconscious is made up essentially of contents which have at one time been conscious but which have disappeared from consciousness through having been forgotten or repressed, the contents of the collective unconscious have never been in consciousness, and therefore have never been individually acquired, but owe their existence exclusively to heredity. Whereas the personal unconscious consists for the most part of *complexes*, the content of the collective unconscious is made up essentially of *archetypes*.

[89] The concept of the archetype, which is an indispensable correlate of the idea of the collective unconscious, indicates the existence of definite forms in the psyche which seem to be present always and everywhere. Mythological research calls them “motifs”; in the psychology of primitives they correspond to Lévy-Bruhl’s concept of “représentations collectives,” and in the field of comparative religion they have been defined by Hubert and Mauss as “categories of the imagination.” Adolf Bastian long ago called them “elementary” or “primordial thoughts.” From these references it should be clear enough that my idea of the archetype—literally a pre-existent form—does not stand alone but is something that is recognized and named in other fields of knowledge.

[90] My thesis, then, is as follows: In addition to our immediate consciousness, which is of a thoroughly personal nature and which we believe to be the only empirical psyche (even if we tack on the personal unconscious as an appendix), there exists a second psychic system of a collective, universal, and impersonal nature

which is identical in all individuals. This collective unconscious does not develop individually but is inherited. It consists of pre-existent forms, the archetypes, which can only become conscious secondarily and which give definite form to certain psychic contents.

2. *The Psychological Meaning of the Collective Unconscious*

[91] Medical psychology, growing as it did out of professional practice, insists on the *personal* nature of the psyche. By this I mean the views of Freud and Adler. It is a *psychology of the person*, and its aetiological or causal factors are regarded almost wholly as personal in nature. Nonetheless, even this psychology is based on certain general biological factors, for instance on the sexual instinct or on the urge for self-assertion, which are by no means merely personal peculiarities. It is forced to do this because it lays claim to being an explanatory science. Neither of these views would deny the existence of *a priori* instincts common to man and animals alike, or that they have a significant influence on personal psychology. Yet instincts are impersonal, universally distributed, hereditary factors of a dynamic or motivating character, which very often fail so completely to reach consciousness that modern psychotherapy is faced with the task of helping the patient to become conscious of them. Moreover, the instincts are not vague and indefinite by nature, but are specifically formed motive forces which, long before there is any consciousness, and in spite of any degree of consciousness later on, pursue their inherent goals. Consequently they form very close analogies to the archetypes, so close, in fact, that there is good reason for supposing that the archetypes are the unconscious images of the instincts themselves, in other words, that they are *patterns of instinctual behaviour*.

[92] The hypothesis of the collective unconscious is, therefore, no more daring than to assume there are instincts. One admits readily that human activity is influenced to a high degree by instincts, quite apart from the rational motivations of the conscious mind. So if the assertion is made that our imagination, perception, and thinking are likewise influenced by inborn and universally present formal elements, it seems to me that a normally functioning intelligence can discover in this idea just as much or just as little mysticism as in the theory of instincts. Although this reproach of mysticism has frequently been levelled at my concept, I must emphasize yet again that the concept of the collective unconscious is neither a speculative nor a philosophical but an empirical matter. The question is simply this: are there or are there not unconscious, universal forms of this kind? If they exist, then there is a region of the psyche which one can call the collective unconscious. It is true that the diagnosis of the collective unconscious is not always an easy task. It is not sufficient to point out the often obviously archetypal nature of unconscious products, for these

can just as well be derived from acquisitions through language and education. Cryptomnesia should also be ruled out, which it is almost impossible to do in certain cases. In spite of all these difficulties, there remain enough individual instances showing the autochthonous revival of mythological motifs to put the matter beyond any reasonable doubt. But if such an unconscious exists at all, psychological explanation must take account of it and submit certain alleged personal aetiologies to sharper criticism.

[93] What I mean can perhaps best be made clear by a concrete example. You have probably read Freud's discussion² of a certain picture by Leonardo da Vinci: St. Anne with the Virgin Mary and the Christ-child. Freud interprets this remarkable picture in terms of the fact that Leonardo himself had two mothers. This causality is personal. We shall not linger over the fact that this picture is far from unique, nor over the minor inaccuracy that St. Anne happens to be the grandmother of Christ and not, as required by Freud's interpretation, the mother, but shall simply point out that interwoven with the apparently personal psychology there is an impersonal motif well known to us from other fields. This is the motif of the *dual mother*, an archetype to be found in many variants in the field of mythology and comparative religion and forming the basis of numerous "représentations collectives." I might mention, for instance, the motif of the *dual descent*, that is, descent from human and divine parents, as in the case of Heracles, who received immortality through being unwittingly adopted by Hera. What was a myth in Greece was actually a ritual in Egypt: Pharaoh was both human and divine by nature. In the birth chambers of the Egyptian temples Pharaoh's second, divine conception and birth is depicted on the walls; he is "twice-born." It is an idea that underlies all rebirth mysteries, Christianity included. Christ himself is "twiceborn": through his baptism in the Jordan he was regenerated and reborn from water and spirit. Consequently, in the Roman liturgy the font is designated the "uterus ecclesiae," and, as you can read in the Roman missal, it is called this even today, in the "benediction of the font" on Holy Saturday before Easter. Further, according to an early Christian-Gnostic idea, the spirit which appeared in the form of a dove was interpreted as Sophia-Sapientia—Wisdom and the Mother of Christ. Thanks to this motif of the dual birth, children today, instead of having good and evil fairies who magically "adopt" them at birth with blessings or curses, are given sponsors—a "godfather" and a "godmother."

[94] The idea of a second birth is found at all times and in all places. In the earliest beginnings of medicine it was a magical means of healing; in many religions it is the central mystical experience; it is the key idea in medieval, occult philosophy, and, last but not least, it is an infantile fantasy occurring in numberless children, large and small, who believe that their parents are not their real parents but merely foster-

parents to whom they were handed over. Benvenuto Cellini also had this idea, as he himself relates in his autobiography.

[95] Now it is absolutely out of the question that all the individuals who believe in a dual descent have in reality always had two mothers, or conversely that those few who shared Leonardo's fate have infected the rest of humanity with their complex. Rather, one cannot avoid the assumption that the universal occurrence of the dual-birth motif together with the fantasy of the two mothers answers an omnipresent human need which is reflected in these motifs. If Leonardo da Vinci did in fact portray his two mothers in St. Anne and Mary—which I doubt—he nonetheless was only expressing something which countless millions of people before and after him have believed. The vulture symbol (which Freud also discusses in the work mentioned) makes this view all the more plausible. With some justification he quotes as the source of the symbol the *Hieroglyphica* of Horapollo,³ a book much in use in Leonardo's time. There you read that vultures are female only and symbolize the mother. They conceive through the wind (*pneuma*). This word took on the meaning of "spirit" chiefly under the influence of Christianity. Even in the account of the miracle at Pentecost the *pneuma* still has the double meaning of wind and spirit. This fact, in my opinion, points without doubt to Mary, who, a virgin by nature, conceived through the *pneuma*, like a vulture. Furthermore, according to Horapollo, the vulture also symbolizes Athene, who sprang, unbegotten, directly from the head of Zeus, was a virgin, and knew only spiritual motherhood. All this is really an allusion to Mary and the rebirth motif. There is not a shadow of evidence that Leonardo meant anything else by his picture. Even if it is correct to assume that he identified himself with the Christ-child, he was in all probability representing the mythological dual-mother motif and by no means his own personal prehistory. And what about all the other artists who painted the same theme? Surely not all of them had two mothers?

[96] Let us now transpose Leonardo's case to the field of the neuroses, and assume that a patient with a mother complex is suffering from the delusion that the cause of his neurosis lies in his having really had two mothers. The personal interpretation would have to admit that he is right—and yet it would be quite wrong. For in reality the cause of his neurosis would lie in the reactivation of the dual-mother archetype, quite regardless of whether he had one mother or two mothers, because, as we have seen, this archetype functions individually and historically without any reference to the relatively rare occurrence of dual motherhood.

[97] In such a case, it is of course tempting to presuppose so simple and personal a cause, yet the hypothesis is not only inexact but totally false. It is admittedly difficult to understand how a dual-mother motif—unknown to a physician trained only in medicine—could have so great a determining power as to produce the effect of a

traumatic condition. But if we consider the tremendous powers that lie hidden in the mythological and religious sphere in man, the aetiological significance of the archetype appears less fantastic. In numerous cases of neurosis the cause of the disturbance lies in the very fact that the psychic life of the patient lacks the cooperation of these motive forces. Nevertheless a purely personalistic psychology, by reducing everything to personal causes, tries its level best to deny the existence of archetypal motifs and even seeks to destroy them by personal analysis. I consider this a rather dangerous procedure which cannot be justified medically. Today you can judge better than you could twenty years ago the nature of the forces involved. Can we not see how a whole nation is reviving an archaic symbol, yes, even archaic religious forms, and how this mass emotion is influencing and revolutionizing the life of the individual in a catastrophic manner? The man of the past is alive in us today to a degree undreamt of before the war, and in the last analysis what is the fate of great nations but a summation of the psychic changes in individuals?

[98] So far as a neurosis is really only a private affair, having its roots exclusively in personal causes, archetypes play no role at all. But if it is a question of a general incompatibility or an otherwise injurious condition productive of neuroses in relatively large numbers of individuals, then we must assume the presence of constellated archetypes. Since neuroses are in most cases not just private concerns, but *social* phenomena, we must assume that archetypes are constellated in these cases too. The archetype corresponding to the situation is activated, and as a result those explosive and dangerous forces hidden in the archetype come into action, frequently with unpredictable consequences. There is no lunacy people under the domination of an archetype will not fall a prey to. If thirty years ago anyone had dared to predict that our psychological development was tending towards a revival of the medieval persecutions of the Jews, that Europe would again tremble before the Roman fasces and the tramp of legions, that people would once more give the Roman salute, as two thousand years ago, and that instead of the Christian Cross an archaic swastika would lure onward millions of warriors ready for death—why, that man would have been hooted at as a mystical fool. And today? Surprising as it may seem, all this absurdity is a horrible reality. Private life, private aetiologies, and private neuroses have become almost a fiction in the world of today. The man of the past who lived in a world of archaic “*représentations collectives*” has risen again into very visible and painfully real life, and this not only in a few unbalanced individuals but in many millions of people.

[99] There are as many archetypes as there are typical situations in life. Endless repetition has engraved these experiences into our psychic constitution, not in the form of images filled with content, but at first only as *forms without content*, representing merely the possibility of a certain type of perception and action. When a

situation occurs which corresponds to a given archetype, that archetype becomes activated and a compulsiveness appears, which, like an instinctual drive, gains its way against all reason and will, or else produces a conflict of pathological dimensions, that is to say, a neurosis.

3. *Method of Proof*

[100] We must now turn to the question of how the existence of archetypes can be produce. Since archetypes are supposed to produce certain psychic forms, we must discuss how and where one can get hold of the material demonstrating these forms. The main source, then, is *dreams*, which have the advantage of being involuntary, spontaneous products of the unconscious psyche and are therefore pure products of nature not falsified by any conscious purpose. By questioning the individual one can ascertain which of the motifs appearing in the dream are known to him. From those which are unknown to him we must naturally exclude all motifs which *might* be known to him, as for instance—to revert to the case of Leonardo—the vulture symbol. We are not sure whether Leonardo took this symbol from Horapollo or not, although it would have been perfectly possible for an educated person of that time, because in those days artists were distinguished for their wide knowledge of the humanities. Therefore, although the bird motif is an archetype par excellence, its existence in Leonardo's fantasy would still prove nothing. Consequently, we must look for motifs which could not possibly be known to the dreamer and yet behave functionally in his dream in such a manner as to coincide with the functioning of the archetype known from historical sources.

[101] Another source for the material we need is to be found in “active imagination.” By this I mean a sequence of fantasies produced by deliberate concentration. I have found that the existence of unrealized, unconscious fantasies increases the frequency and intensity of dreams, and that when these fantasies are made conscious the dreams change their character and become weaker and less frequent. From this I have drawn the conclusion that dreams often contain fantasies which “want” to become conscious. The sources of dreams are often repressed instincts which have a natural tendency to influence the conscious mind. In cases of this sort, the patient is simply given the task of contemplating any one fragment of fantasy that seems significant to him—a chance idea, perhaps, or something he has become conscious of in a dream—until its context becomes visible, that is to say, the relevant associative material in which it is embedded. It is not a question of the “free association” recommended by Freud for the purpose of dream-analysis, but of elaborating the fantasy by observing the further fantasy material that adds itself to the fragment in a natural manner.

[102] This is not the place to enter upon a technical discussion of the method. Suffice it to say that the resultant sequence of fantasies relieves the unconscious and produces material rich in archetypal images and associations. Obviously, this is a method that can only be used in certain carefully selected cases. The method is not entirely without danger, because it may carry the patient too far away from reality. A warning against thoughtless application is therefore in place.

[103] Finally, very interesting sources of archetypal material are to be found in the delusions of paranoiacs, the fantasies observed in trance-states, and the dreams of early childhood, from the third to the fifth year. Such material is available in profusion, but it is valueless unless one can adduce convincing mythological parallels. It does not, of course, suffice simply to connect a dream about a snake with the mythological occurrence of snakes, for who is to guarantee that the functional meaning of the snake in the dream is the same as in the mythological setting? In order to draw a valid parallel, it is necessary to know the functional meaning of the individual symbol, and then to find out whether the apparently parallel mythological symbol has a similar context and therefore the same functional meaning. Establishing such facts not only requires lengthy and wearisome researches, but is also an ungrateful subject for demonstration. As the symbols must not be torn out of their context, one has to launch forth into exhaustive descriptions, personal as well as symbological, and this is practically impossible in the framework of a lecture. I have repeatedly tried it at the risk of sending one half of my audience to sleep.

4. *An Example*

[104] I am choosing as an example a case which, though already published, I use again because its brevity makes it peculiarly suitable for illustration. Moreover, I can add certain remarks which were omitted in the previous publication.⁴

[105] About 1906 I came across a very curious delusion in a paranoid schizophrenic who had been interned for many years. The patient had suffered since his youth and was incurable. He had been educated at a State school and been employed as a clerk in an office. He had no special gifts, and I myself knew nothing of mythology or archaeology in those days, so the situation was not in any way suspect. One day I found the patient standing at the window, wagging his head and blinking into the sun. He told me to do the same, for then I would see something very interesting. When I asked him what he saw, he was astonished that I could see nothing, and said: "Surely you see the sun's penis—when I move my head to and fro, it moves too, and that is where the wind comes from." Naturally I did not understand this strange idea in the least, but I made a note of it. Then about four years later, during my mythological studies, I came upon a book by the late Albrecht Dieterich,⁵ the well-known

philologist, which threw light on this fantasy. The work, published in 1910, deals with a Greek papyrus in the Bibliothèque Nationale, Paris. Dieterich believed he had discovered a Mithraic ritual in one part of the text. The text is undoubtedly a religious prescription for carrying out certain incantations in which Mithras is named. It comes from the Alexandrian school of mysticism and shows affinities with certain passages in the Leiden papyri and the *Corpus Hermeticum*. In Dieterich's text we read the following directions:

Draw breath from the rays, draw in three times as strongly as you can and you will feel yourself raised up and walking towards the height, and you will seem to be in the middle of the aerial region.... The path of the visible gods will appear through the disc of the sun, who is God my father. Likewise the so-called tube, the origin of the ministering wind. For you will see hanging down from the disc of the sun something that looks like a tube. And towards the regions westward it is as though there were an infinite east wind. But if the other wind should prevail towards the regions of the east, you will in like manner see the vision veering in that direction.⁶

[106] It is obviously the author's intention to enable the reader to experience the vision which he had, or which at least he believes in. The reader is to be initiated into the inner religious experience either of the author, or—what seems more likely—of one of those mystic communities of which Philo Judaeus gives contemporary accounts. The fire- or sun-god here invoked is a figure which has close historical parallels, for instance with the Christ-figure of the Apocalypse. It is therefore a “représentation collective,” as are also the ritual actions described, such as the imitating of animal noises, etc. The vision is embedded in a religious context of a distinctly ecstatic nature and describes a kind of initiation into mystic experience of the Deity.

[107] Our patient was about ten years older than I. In his megalomania, he thought he was God and Christ in one person. His attitude towards me was patronizing; he liked me probably because I was the only person with any sympathy for his abstruse ideas. His delusions were mainly religious, and when he invited me to blink into the sun like he did and waggle my head he obviously wanted to let me share his vision. He played the role of the mystic sage and I was the neophyte. He felt he was the sun-god himself, creating the wind by wagging his head to and fro. The ritual transformation into the Deity is attested by Apuleius in the Isis mysteries, and moreover in the form of a Helios apotheosis. The meaning of the “ministering wind” is probably the same as the procreative pneuma, which streams from the sun-god into the soul and fructifies it. The association of sun and wind frequently occurs in ancient symbolism.

[108] It must now be shown that this is not a purely chance coincidence of two isolated cases. We must therefore show that the idea of a wind-tube connected with God or the sun exists independently of these two testimonies and that it occurs at other times

and in other places. Now there are, as a matter of fact, medieval paintings that depict the fructification of Mary with a tube or hose-pipe coming down from the throne of God and passing into her body, and we can see the dove or the Christ-child flying down it. The dove represents the fructifying agent, the wind of the Holy Ghost.

[109] Now it is quite out of the question that the patient could have had any knowledge whatever of a Greek papyrus published four years later, and it is in the highest degree unlikely that his vision had anything to do with the rare medieval representations of the Conception, even if through some incredibly improbable chance he had ever seen a copy of such a painting. The patient was certified in his early twenties. He had never travelled. And there is no such picture in the public art gallery in Zurich, his native town.

[110] I mention this case not in order to prove that the vision is an archetype but only to show you my method of procedure in the simplest possible form. If we had only such cases, the task of investigation would be relatively easy, but in reality the proof is much more complicated. First of all, certain symbols have to be isolated clearly enough to be recognizable as typical phenomena, not just matters of chance. This is done by examining a series of dreams, say a few hundred, for typical figures, and by observing their development in the series. The same method can be applied to the products of active imagination. In this way it is possible to establish certain continuities or modulations of one and the same figure. You can select any figure which gives the impression of being an archetype by its behaviour in the series of dreams or visions. If the material at one's disposal has been well observed and is sufficiently ample, one can discover interesting facts about the variations undergone by a single type. Not only the type itself but its variants too can be substantiated by evidence from comparative mythology and ethnology. I have described the method of investigation elsewhere⁷ and have also furnished the necessary case material.

CONCERNING THE ARCHETYPES, WITH SPECIAL REFERENCE TO THE ANIMA CONCEPT¹

[111] Although modern man appears to believe that the non-empirical approach to psychology is a thing of the past, his general attitude remains very much the same as it was before, when psychology was identified with some theory about the psyche. In academic circles, a drastic revolution in methodology, initiated by Fechner² and Wundt,³ was needed in order to make clear to the scientific world that psychology was a field of experience and not a philosophical theory. To the increasing materialism of the late nineteenth century, however, it meant nothing that there had once been an “experimental psychology,”⁴ to which we owe many descriptions that are still valuable today. I have only to mention Dr. Justinus Kernel’s *Seherin von Prevorst*.⁵ All “romantic” descriptions in psychology were anathema to the new developments in scientific method. The exaggerated expectations of this experimental laboratory science were reflected in Fechner’s “psychophysics,” and its results today take the form of “psychological tests” and a general shifting of the scientific standpoint in favour of phenomenology.

[112] Nevertheless, it cannot be maintained that the phenomenological point of view has made much headway. Theory still plays far too great a role, instead of being included in phenomenology as it should. Even Freud, whose empirical attitude is beyond doubt, coupled his theory as a *sine qua non* with his method, as if psychic phenomena had to be viewed in a certain light in order to mean something. All the same, it was Freud who cleared the ground for the investigation of complex phenomena, at least in the field of neurosis. But the ground he cleared extended only so far as certain basic physiological concepts permitted, so that it looked almost as if psychology were an offshoot of the physiology of the instincts. This limitation of psychology was very welcome to the materialistic outlook of that time, nearly fifty years ago, and, despite our altered view of the world, it still is in large measure today. It gives us not only the advantage of a “delimited field of work,” but also an excellent excuse not to bother with what goes on in a wider world.

[113] Thus it was overlooked by the whole of medical psychology that a psychology of the neuroses, such as Freud’s, is left hanging in mid air if it lacks knowledge of a general phenomenology. It was also overlooked that in the field of the neuroses

Pierre Janet, even before Freud, had begun to build up a descriptive methodology⁶ without loading it with too many theoretical and philosophical assumptions. Biographical descriptions of psychic phenomena, going beyond the strictly medical field, were represented chiefly by the work of the philosopher Théodore Flournoy, of Geneva, in his account of the psychology of an unusual personality.⁷ This was followed by the first attempt at synthesis: William James's *Varieties of Religious Experience* (1902). I owe it mainly to these two investigators that I learnt to understand the nature of psychic disturbances within the setting of the human psyche as a whole. I myself did experimental work for several years, but, through my intensive studies of the neuroses and psychoses, I had to admit that, however desirable quantitative definitions may be, it is impossible to do without qualitatively descriptive methods. Medical psychology has recognized that the salient facts are extraordinarily complex and can be grasped only through descriptions based on case material. But this method presupposes freedom from theoretical prejudice. Every science is descriptive at the point where it can no longer proceed experimentally, without on that account ceasing to be scientific. But an experimental science makes itself impossible when it delimits its field of work in accordance with theoretical concepts. The psyche does not come to an end where some physiological assumption or other stops. In other words, in each individual case that we observe scientifically, we have to consider the manifestations of the psyche in their totality.

[114] These reflections are essential when discussing an empirical concept like that of the anima. As against the constantly reiterated prejudice that this is a theoretical invention or—worse still—sheer mythology, I must emphasize that the concept of the anima is a purely empirical concept, whose sole purpose is to give a name to a group of related or analogous psychic phenomena. The concept does no more and means no more than, shall we say, the concept “arthropods,” which includes all animals with articulated body and limbs and so gives a name to this phenomenological group. The prejudice I have mentioned stems, regrettable though this is, from ignorance. My critics are not acquainted with the phenomena in question, for these lie mostly outside the pale of merely medical knowledge, in a realm of universal human experience. But the psyche, which the medical man has to do with, does not worry about the limitations of his knowledge; it manifests a life of its own and reacts to influences coming from every field of human experience. Its nature shows itself not merely in the personal sphere, or in the instinctual or social, but in phenomena of world-wide distribution. So if we want to understand the psyche, we have to include the whole world. For practical reasons we can, indeed must, delimit our fields of work, but this should be done only with the conscious recognition of limitation. The more complex the phenomena which we have to do with in practical treatment, the wider must be our frame of reference and the greater the corresponding knowledge.

[115] Anyone, therefore, who does not know the universal distribution and significance of the *syzygy* motif in the psychology of primitives,⁸ in mythology, in comparative religion, and in the history of literature, can hardly claim to say anything about the concept of the anima. His knowledge of the psychology of the neuroses may give him some idea of it, but it is only a knowledge of its general phenomenology that could open his eyes to the real meaning of what he encounters in individual cases, often in pathologically distorted form.

[116] Although common prejudice still believes that the sole essential basis of our knowledge is given exclusively from outside, and that “*nihil est in intellectu quod non antea fuerit in sensu*,” it nevertheless remains true that the thoroughly respectable atomic theory of Leucippus and Democritus was not based on any observations of atomic fission but on a “mythological” conception of smallest particles, which, as the smallest animated parts, the soul-atoms, are known even to the still palaeolithic inhabitants of central Australia.⁹ How much “soul” is projected into the unknown in the world of external appearances is, of course, familiar to anyone acquainted with the natural science and natural philosophy of the ancients. It is, in fact, so much that we are absolutely incapable of saying how the world is constituted in itself—and always shall be, since we are obliged to convert physical events into psychic processes as soon as we want to say anything about knowledge. But who can guarantee that this conversion produces anything like an adequate “objective” picture of the world? That could only be if the physical event were also a psychic one. But a great distance still seems to separate us from such an assertion. Till then, we must for better or worse content ourselves with the assumption that the psyche supplies those images and forms which alone make knowledge of objects possible.

[117] These forms are generally supposed to be transmitted by tradition, so that we speak of “atoms” today because we have heard, directly or indirectly, of the atomic theory of Democritus. But where did Democritus, or whoever first spoke of minimal constitutive elements, hear of atoms? This notion had its origin in archetypal ideas, that is, in primordial images which were never reflections of physical events but are spontaneous products of the psychic factor. Despite the materialistic tendency to understand the psyche as a mere reflection or imprint of physical and chemical processes, there is not a single proof of this hypothesis. Quite the contrary, innumerable facts prove that the psyche translates physical processes into sequences of images which have hardly any recognizable connection with the objective process. The materialistic hypothesis is much too bold and flies in the face of experience with almost metaphysical presumption. The only thing that can be established with certainty, in the present state of our knowledge, is our ignorance of the nature of the psyche. There is thus no ground at all for regarding the psyche as something secondary or as an epiphenomenon; on the contrary, there is every reason to regard it,

at least hypothetically, as a factor *sui generis*, and to go on doing so until it has been sufficiently proved that psychic processes can be fabricated in a retort. We have laughed at the claims of the alchemists to be able to manufacture a *lapis philosophorum* consisting of body, soul, and spirit, as impossible, hence we should stop dragging along with us the logical consequence of this medieval assumption, namely the materialistic prejudice regarding the psyche, as though it were a proven fact.

[118] It will not be so easy to reduce complex psychic facts to a chemical formula. Hence the psychic factor must, *ex hypothesi*, be regarded for the present as an autonomous reality of enigmatic character, primarily because, judging from all we know, it appears to be *essentially different* from physicochemical processes. Even if we do not ultimately know what its substantiality is, this is equally true of physical objects and of matter in general. So if we regard the psyche as an independent factor, we must logically conclude that there is a psychic life which is not subject to the caprices of our will. If, then, those qualities of elusiveness, superficiality, shadowiness, and indeed of futility attach to anything psychic, this is primarily true of the subjective psychic, i.e., the contents of consciousness, but not of the objective psychic, the unconscious, which is an *a priori* conditioning factor of consciousness and its contents. From the unconscious there emanate determining influences which, independently of tradition, guarantee in every single individual a similarity and even a sameness of experience, and also of the way it is represented imaginatively. One of the main proofs of this is the almost universal parallelism between mythological motifs, which, on account of their quality as primordial images, I have called *archetypes*.

[119] One of these archetypes, which is of paramount practical importance for the psychotherapist, I have named the anima. This Latin expression is meant to connote something that should not be confused with any dogmatic Christian idea of the soul or with any of the previous philosophical conceptions of it. If one wishes to form anything like a concrete conception of what this term covers, one would do better to go back to a classical author like Macrobius,¹⁰ or to classical Chinese philosophy,¹¹ where the anima (*p'o* or *kuei*) is regarded as the feminine and chthonic part of the soul. A parallel of this kind always runs the risk of metaphysical concretism, which I do my best to avoid, though any attempt at graphic description is bound to succumb to it up to a point. For we are dealing here not with an abstract concept but with an empirical one, and the form in which it appears necessarily clings to it, so that it cannot be described at all except in terms of its specific phenomenology.

[120] Unperturbed by the philosophical pros and cons of the age, a scientific psychology must regard those transcendental intuitions that sprang from the human

mind in all ages as *projections*, that is, as psychic contents that were extrapolated in metaphysical space and hypostatized.¹² We encounter the anima historically above all in the divine syzygies, the male-female pairs of deities. These reach down, on the one side, into the obscurities of primitive mythology,¹³ and up, on the other, into the philosophical speculations of Gnosticism¹⁴ and of classical Chinese philosophy, where the cosmogonic pair of concepts are designated *yang* (masculine) and *yin* (feminine).¹⁵ We can safely assert that these syzygies are as universal as the existence of man and woman. From this fact we may reasonably conclude that man's imagination is bound by this motif, so that he was largely compelled to project it again and again, at all times and in all places.¹⁶

[121] Now, as we know from psychotherapeutic experience, projection is an unconscious, automatic process whereby a content that is unconscious to the subject transfers itself to an object, so that it seems to belong to that object. The projection ceases the moment it becomes conscious, that is to say when it is seen as belonging to the subject.¹⁷ Thus the polytheistic heaven of the ancients owes its depotentiation not least to the view first propounded by Euhemeros,¹⁸ who maintained that the gods were nothing but reflections of human character. It is indeed easy to show that the divine pair is simply an idealization of the parents or of some other human couple, which for some reason appeared in heaven. This assumption would be simple enough if projection were not an unconscious process but were a conscious intention. It would generally be supposed that one's own parents are the best known of all individuals, the ones of which the subject is most conscious. But precisely for this reason they could not be projected, because projection always contains something of which the subject is not conscious and which seems not to belong to him. The image of the parents is the very one that could be projected least, because it is too conscious.

[122] In reality, however, it is just the parental imagos that seem to be projected most frequently, a fact so obvious that one could almost draw the conclusion that it is precisely the conscious contents which are projected. This can be seen most plainly in cases of transference, where it is perfectly clear to the patient that the father-*imago* (or even the mother-*imago*) is projected on to the analyst and he even sees through the incest-fantasies bound up with them, without, however, being freed from the reactive effect of his projection, i.e., from the transference. In other words, he behaves exactly as if he had not seen through his projection at all. Experience shows that projection is never conscious: projections are always there first and are recognized afterwards. We must therefore assume that, over and above the incest-fantasy, highly emotional contents are still bound up with the parental imagos and need to be made conscious. They are obviously more difficult to make conscious than the incest-fantasies, which are supposed to have been repressed through violent

resistance and to be unconscious for that reason. Supposing this view is correct, we are driven to the conclusion that besides the incest-fantasy there must be contents which are repressed through a still greater resistance. Since it is difficult to imagine anything more repellent than incest, we find ourselves rather at a loss to answer this question.

[123] If we let practical experience speak, it tells us that, apart from the incest-fantasy, religious ideas are associated with the parental imagos. I do not need to cite historical proofs of this, as they are known to all. But what about the alleged objectionableness of religious associations?

[124] Someone once observed that in ordinary society it is more embarrassing to talk about God at table than to tell a risqué story. Indeed, for many people it is more bearable to admit their sexual fantasies than to be forced to confess that their analyst is a saviour, for the former are biologically legitimate, whereas the latter instance is definitely pathological, and this is something we greatly fear. It seems to me, however, that we make too much of "resistance." The phenomena in question can be explained just as easily by lack of imagination and reflectiveness, which makes the act of conscious realization so difficult for the patient. He may perhaps have no particular resistance to religious ideas, only the thought has never occurred to him that he could seriously regard his analyst as a God or saviour. Mere reason alone is sufficient to protect him from such illusions. But he is less slow to assume that his analyst thinks himself one. When one is dogmatic oneself, it is notoriously easy to take other people for prophets and founders of religions.

[125] Now religious ideas, as history shows, are charged with an extremely suggestive, emotional power. Among them I naturally reckon all *représentations collectives*, everything that we learn from the history of religion, and anything that has an "-ism" attached to it. The latter is only a modern variant of the denominational religions. A man may be convinced in all good faith that he has no religious ideas, but no one can fall so far away from humanity that he no longer has any dominating *représentation collective*. His very materialism, atheism, communism, socialism, liberalism, intellectualism, existentialism, or what not, testifies against his innocence. Somewhere or other, overtly or covertly, he is possessed by a supraordinate idea.

[126] The psychologist knows how much religious ideas have to do with the parental imagos. History has preserved overwhelming evidence of this, quite apart from modern medical findings, which have even led certain people to suppose that the relationship to the parents is the real origin of religious ideas. This hypothesis is based on very poor knowledge of the facts. In the first place, one should not simply translate the family psychology of modern man into a context of primitive conditions, where things are so very different; secondly, one should beware of ill-considered

tribal-father and primal-horde fantasies; thirdly and most importantly, one should have the most accurate knowledge of the phenomenology of religious experience, which is a subject in itself. Psychological investigations in this field have so far not fulfilled any of these three conditions.

[127] The only thing we know positively from psychological experience is that theistic ideas are associated with the parental imagos, and that our patients are mostly unconscious of them. If the corresponding projections cannot be withdrawn through insight, then we have every reason to suspect the presence of emotional contents of a religious nature, regardless of the rationalistic resistance of the patient.

[128] So far as we have any information about man, we know that he has always and everywhere been under the influence of dominating ideas. Any one who alleges that he is not can immediately be suspected of having exchanged a known form of belief for a variant which is less known both to himself and to others. Instead of theism he is a devotee of atheism, instead of Dionysus he favours the more modern Mithras, and instead of heaven he seeks paradise on earth.

[129] A man without a dominating *représentation collective* would be a thoroughly abnormal phenomenon. But such a person exists only in the fantasies of isolated individuals who are deluded about themselves. They are mistaken not only about the existence of religious ideas, but also and more especially about their intensity. The archetype behind a religious idea has, like every instinct, its specific energy, which it does not lose even if the conscious mind ignores it. Just as it can be assumed with the greatest probability that every man possesses all the average human functions and qualities, so we may expect the presence of normal religious factors, the archetypes, and this expectation does not prove fallacious. Any one who succeeds in putting off the mantle of faith can do so only because another lies close to hand. No one can escape the prejudice of being human.

[130] The *représentations collectives* have a dominating power, so it is not surprising that they are repressed with the most intense resistance. When repressed, they do not hide behind any trifling thing but behind ideas and figures that have already become problematical for other reasons, and intensify and complicate their dubious nature. For instance, everything that we would like, in infantile fashion, to attribute to our parents or blame them for is blown up to fantastic proportions from this secret source, and for this reason it remains an open question how much of the ill-reputed incest-fantasy is to be taken seriously. Behind the parental pair, or pair of lovers, lie contents of extreme tension which are not apperceived in consciousness and can therefore become perceptible only through projection. That projections of this kind do actually occur and are not just traditional opinions is attested by historical documents. These show that syzygies were projected which were in complete

contradiction to the traditional beliefs, and that they were often experienced in the form of a vision.¹⁹

[131] One of the most instructive examples in this respect is the vision of the recently canonized Nicholas of Flüe, a Swiss mystic of the fifteenth century, of whose visions we possess reports by his contemporaries.²⁰ In the visions that marked his initiation into the state of adoption by God, God appeared in dual form, once as a majestic *father* and once as a majestic *mother*. This representation could not be more unorthodox, since the Church had eliminated the feminine element from the Trinity a thousand years earlier as heretical. Brother Klaus was a simple unlettered peasant who doubtless had received none but the approved Church teaching, and was certainly not acquainted with the Gnostic interpretation of the Holy Ghost as the feminine and motherly Sophia.²¹ His so-called Trinity Vision is at the same time a perfect example of the intensity of projected contents. Brother Klaus's psychological situation was eminently suited to a projection of this kind, for his conscious idea of God was so little in accord with the unconscious content that the latter had to appear in the form of an alien and shattering experience. We must conclude from this that it was not the traditional idea of God but, on the contrary, an "heretical" image²² that realized itself in visionary form; an archetypal interpretation which came to life again spontaneously, independently of tradition. It was the archetype of the divine pair, the syzygy.

[132] There is a very similar case in the visions of Guillaume de Digulleville,²³ which are described in *Le Pèlerinage de l'âme*. He saw God in the highest heaven as the King on a shining round throne, and beside him sat the Queen of Heaven on a throne of brown crystal. For a monk of the Cistercian Order, which as we know is distinguished for its severity, this vision is exceedingly heretical. So here again the condition for projection is fulfilled.

[133] Another impressive account of the syzygy vision can be found in the work of Edward Maitland, who wrote the biography of Anna Kingsford. There he describes in detail his own experience of God, which, like that of Brother Klaus, consisted in a vision of light. He says: "This was ... God as the Lord, proving by His duality that God is Substance as well as Force, Love as well as Will, feminine as well as masculine, Mother as well as Father."²⁴

[134] These few examples may suffice to characterize the experience of projection and those features of it which are independent of tradition. We can hardly get round the hypothesis that an emotionally charged content is lying ready in the unconscious and springs into projection at a certain moment. This content is the syzygy motif, and it expresses the fact that a masculine element is always paired with a feminine one. The wide distribution and extraordinary emotionality of this motif prove that it is a

fundamental psychic factor of great practical importance, no matter whether the individual psychotherapist or psychologist understands where and in what way it influences his special field of work. Microbes, as we know, played their dangerous role long before they were discovered.

[135] As I have said, it is natural to suspect the parental pair in all syzygies. The feminine part, the mother, corresponds to the anima. But since, for the reasons discussed above, consciousness of the object prevents its projection, there is nothing for it but to assume that parents are also the least known of all human beings, and consequently that an unconscious reflection of the parental pair exists which is as unlike them, as utterly alien and incommensurable, as a man compared with a god. It would be conceivable, and has as we know been asserted, that the unconscious reflection is none other than the image of father and mother that was acquired in early childhood, overvalued, and later repressed on account of the incest-fantasy associated with it. This hypothesis presupposes that the image was once *conscious*, otherwise it could not have been “repressed.” It also presupposes that the act of moral repression has itself become unconscious, for otherwise the act would remain preserved in consciousness together with the memory of the repressive moral reaction, from which the nature of the thing repressed could easily be recognized. I do not want to enlarge on these misgivings, but would merely like to emphasize that there is general agreement on one point: that the parental imago comes into existence not in the pre-puberal period or at a time when consciousness is more or less developed, but in the initial stages between the first and fourth year, when consciousness does not show any real continuity and is characterized by a kind of island-like discontinuity. The ego-relationship that is required for continuity of consciousness is present only in part, so that a large proportion of psychic life at this stage runs on in a state which can only be described as relatively unconscious. At all events it is a state which would give the impression of a somnambulistic, dream, or twilight state if observed in an adult. These states, as we know from the observation of small children, are always characterized by an apperception of reality filled with fantasies. The fantasy-images outweigh the influence of sensory stimuli and mould them into conformity with a *pre-existing psychic image*.

[136] It is in my view a great mistake to suppose that the psyche of a new-born child is a *tabula rasa* in the sense that there is absolutely nothing in it. In so far as the child is born with a differentiated brain that is predetermined by heredity and therefore individualized, it meets sensory stimuli coming from outside not with *any* aptitudes, but with *specific* ones, and this necessarily results in a particular, individual choice and pattern of apperception. These aptitudes can be shown to be inherited instincts and preformed patterns, the latter being the *a priori* and formal conditions of apperception that are based on instinct. Their presence gives the world of the child

and the dreamer its anthropomorphic stamp. They are the archetypes, which direct all fantasy activity into its appointed paths and in this way produce, in the fantasy-images of children's dreams as well as in the delusions of schizophrenia, astonishing mythological parallels such as can also be found, though in lesser degree, in the dreams of normal persons and neurotics. It is not, therefore, a question of inherited *ideas* but of inherited *possibilities* of ideas. Nor are they individual acquisitions but, in the main, common to all, as can be seen from the universal occurrence of the archetypes.²⁵

[137] Just as the archetypes occur on the ethnological level as myths, so also they are found in every individual, and their effect is always strongest, that is, they anthropomorphize reality most, where consciousness is weakest and most restricted, and where fantasy can overrun the facts of the outer world. This condition is undoubtedly present in the child during the first years of its life. It therefore seems to me more probable that the archetypal form of the divine syzygy first covers up and assimilates the image of the real parents until, with increasing consciousness, the real figures of the parents are perceived—often to the child's disappointment. Nobody knows better than the psychotherapist that the mythologizing of the parents is often pursued far into adulthood and is given up only with the greatest resistance.

[138] I remember a case that was presented to me as the victim of a high-grade mother and castration complex, which had still not been overcome in spite of psychoanalysis. Without any hint from me, the man had made some drawings which showed the mother first as a superhuman being, and then as a figure of woe, with bloody mutilations. I was especially struck by the fact that a castration had obviously been performed on the mother, for in front of her gory genitals lay the cut-off male sexual organs. The drawings clearly represented a diminishing climax: first the mother was a divine hermaphrodite, who then, through the son's disappointing experience of reality, was robbed of its androgynous, Platonic perfection and changed into the woeful figure of an ordinary old woman. Thus from the very beginning, from the son's earliest childhood, the mother was assimilated to the archetypal idea of the syzygy, or conjunction of male and female, and for this reason appeared perfect and superhuman.²⁶ The latter quality invariably attaches to the archetype and explains why the archetype appears strange and as if not belonging to consciousness, and also why, if the subject identifies with it, it often causes a devastating change of personality, generally in the form of megalomania or its opposite.

[139] The son's disappointment effected a castration of the hermaphroditic mother: this was the patient's so-called castration complex. He had tumbled down from his childhood Olympus and was no longer the son-hero of a divine mother. His so-called fear of castration was fear of real life, which refused to come up to his erstwhile

childish expectations, and everywhere lacked that mythological meaning which he still dimly remembered from his earliest youth. His life was, in the truest sense of the word, “godless.” And that, for him—though he did not realize it—meant a dire loss of hope and energy. He thought of himself as “castrated,” which is a very plausible neurotic misunderstanding—so plausible that it could even be turned into a theory of neurosis.

[140] Because people have always feared that the connection with the instinctive, archetypal stage of consciousness might get lost in the course of life, the custom has long since been adopted of giving the new-born child, in addition to his bodily parents, two godparents, a “godfather” and a “godmother,” who are supposed to be responsible for the spiritual welfare of their godchild. They represent the pair of gods who appear at its birth, thus illustrating the “dual birth” motif.²⁷

The anima image, which lends the mother such superhuman glamour in the eyes of the son, gradually becomes tarnished by commonplace reality and sinks back into the unconscious, but without in any way losing its original tension and instinctivity. It is ready to spring out and project itself at the first opportunity, the moment a woman makes an impression that is out of the ordinary. We then have Goethe’s experience with Frau von Stein, and its repercussions in the figures of Mignon and Gretchen, all over again. In the case of Gretchen, Goethe also showed us the whole underlying “metaphysic.” The love life of a man reveals the psychology of this archetype in the form either of boundless fascination, overvaluation, and infatuation, or of misogyny in all its gradations and variants, none of which can be explained by the real nature of the “object” in question, but only by a transference of the mother complex. The complex, however, was caused in the first place by the assimilation of the mother (in itself a normal and ubiquitous phenomenon) to the pre-existent, feminine side of an archetypal “male-female” pair of opposites, and secondly by an abnormal delay in detaching from the primordial image of the mother. Actually, nobody can stand the total loss of the archetype. When that happens, it gives rise to that frightful “discontent in our culture,” where nobody feels at home because a “father” and “mother” are missing. Everyone knows the provisions that religion has always made in this respect. Unfortunately there are very many people who thoughtlessly go on asking whether these provisions are “true,” when it is really a question of a psychological need. Nothing is achieved by explaining them away rationalistically.

[142] When projected, the anima always has a feminine form with definite characteristics. This empirical finding does not mean that the archetype is constituted like that *in itself*. The male-female syzygy is only one among the possible pairs of opposites, albeit the most important one in practice and the commonest. It has

numerous connections with other pairs which do not display any sex differences at all and can therefore be put into the sexual category only by main force. These connections, with their manifold shades of meaning, are found more particularly in Kundalini yoga,²⁸ in Gnosticism,²⁹ and above all in alchemical philosophy,³⁰ quite apart from the spontaneous fantasy-products in neurotic and psychotic case material. When one carefully considers this accumulation of data, it begins to seem probable that an archetype in its quiescent, unprojected state has no exactly determinable form but is in itself an indefinite structure which can assume definite forms only in projection.

[143] This seems to contradict the concept of a “type.” If I am not mistaken, it not only seems but actually *is* a contradiction. Empirically speaking, we are dealing all the time with “types,” definite forms that can be named and distinguished. But as soon as you divest these types of the phenomenology presented by the case material, and try to examine them in relation to other archetypal forms, they branch out into such far-reaching ramifications in the history of symbols that one comes to the conclusion that the basic psychic elements are infinitely varied and ever changing, so as utterly to defy our powers of imagination. The empiricist must therefore content himself with a theoretical “as if.” In this respect he is no worse off than the atomic physicist, even though his method is not based on quantitative measurement but is a morphologically descriptive one.

[144] The anima is a factor of the utmost importance in the psychology of a man wherever emotions and affects are at work. She intensifies, exaggerates, falsifies, and mythologizes all emotional relations with his work and with other people of both sexes. The resultant fantasies and entanglements are all her doing. When the anima is strongly constellated, she softens the man’s character and makes him touchy, irritable, moody, jealous, vain, and unadjusted. He is then in a state of “discontent” and spreads discontent all around him. Sometimes the man’s relationship to the woman who has caught his anima accounts for the existence of this syndrome.

[145] The anima, as I have remarked elsewhere,³¹ has not escaped the attentions of the poets. There are excellent descriptions of her, which at the same time tell us about the symbolic context in which the archetype is usually embedded. I give first place to Rider Haggard’s novels *She*, *The Return of She*, and *Wisdom’s Daughter*, and Benoît’s *L’Atlantide*. Benoît was accused of plagiarizing Rider Haggard, because the two accounts are disconcertingly alike. But it seems he was able to acquit himself of this charge. Spitteler’s *Prometheus* contains some very subtle observations, too, and his novel *Imago* gives an admirable description of projection.

[146] The question of *therapy* is a problem that cannot be disposed of in a few words. It was not my intention to deal with it here, but I would like to outline my point of

view. Younger people, who have not yet reached the middle of life (around the age of 35), can bear even the total loss of the anima without injury. The important thing at this stage is for a man to be a man. The growing youth must be able to free himself from the anima fascination of his mother. There are exceptions, notably artists, where the problem often takes a different turn; also homosexuality, which is usually characterized by identity with the anima. In view of the recognized frequency of this phenomenon, its interpretation as a pathological perversion is very dubious. The psychological findings show that it is rather a matter of incomplete detachment from the hermaphroditic archetype, coupled with a distinct resistance to identify with the role of a one-sided sexual being. Such a disposition should not be adjudged negative in all circumstances, in so far as it preserves the archetype of the Original Man, which a one-sided sexual being has, up to a point, lost.

[147] After the middle of life, however, permanent loss of the anima means a diminution of vitality, of flexibility, and of human kindness. The result, as a rule, is premature rigidity, crustiness, stereotypy, fanatical one-sidedness, obstinacy, pedantry, or else resignation, weariness, sloppiness, irresponsibility, and finally a childish *ramollissement* with a tendency to alcohol. After middle life, therefore, the connection with the archetypal sphere of experience should if possible be re-established.³²

II

PSYCHOLOGICAL ASPECTS OF THE MOTHER ARCHETYPE

[First published as a lecture, “Die psychologischen Aspekte des Mutterarchetypus,” in *Eranos-Jahrbuch 1938*. Later revised and published in *Von den Wurzeln des Bewusstseins* (Zurich, 1954). The present translation is of the latter, but it is also based partially on a translation of the 1938 version by Cary F. Baynes and Ximena de Angulo, privately issued in *Spring* (New York), 1943.—EDITORS.]

1. ON THE CONCEPT OF THE ARCHETYPE

[148] The concept of the Great Mother belongs to the field of comparative religion and embraces widely varying types of mother-goddess. The concept itself is of no immediate concern to psychology, because the image of a Great Mother in this form is rarely encountered in practice, and then only under very special conditions. The symbol is obviously a derivative of the *mother archetype*. If we venture to investigate the background of the Great Mother image from the standpoint of psychology, then the mother archetype, as the more inclusive of the two, must form the basis of our discussion. Though lengthy discussion of the *concept* of an archetype is hardly necessary at this stage, some preliminary remarks of a general nature may not be out of place.

[149] In former times, despite some dissenting opinion and the influence of Aristotle, it was not too difficult to understand Plato's conception of the Idea as supraordinate and pre-existent to all phenomena. "Archetype," far from being a modern term, was already in use before the time of St. Augustine, and was synonymous with "Idea" in the Platonic usage. When the *Corpus Hermeticum*, which probably dates from the third century, describes God as τὸ ἀρέετιπον φς, the 'archetypal light,' it expresses the idea that he is the prototype of all light; that is to say, pre-existent and supraordinate to the phenomenon "light." Were I a philosopher, I should continue in this Platonic strain and say: Somewhere, in "a place beyond the skies," there is a prototype or primordial image of the mother that is pre-existent and supraordinate to all phenomena in which the "maternal," in the broadest sense of the term, is manifest. But I am an empiricist, not a philosopher; I cannot let myself presuppose that my peculiar temperament, my own attitude to intellectual problems, is universally valid. Apparently this is an assumption in which only the philosopher may indulge, who always takes it for granted that his own disposition and attitude are universal, and will not recognize the fact, if he can avoid it, that his "personal equation" conditions his philosophy. As an empiricist, I must point out that there is a temperament which regards ideas as real entities and not merely as *nomina*. It so happens—by the merest accident, one might say—that for the past two hundred years we have been living in an age in which it has become unpopular or even unintelligible to suppose that ideas could be anything but *nomina*. Anyone who continues to think as Plato did must pay for his anachronism by seeing the "supracelestial," i.e., metaphysical, essence of the Idea relegated to the unverifiable realm of faith and superstition, or charitably left to the poet. Once again, in the age-old controversy over universals, the nominalistic standpoint has triumphed over the realistic, and the Idea has evaporated into a mere *flatus vocis*. This change was accompanied—and, indeed, to a considerable degree

caused—by the marked rise of empiricism, the advantages of which were only too obvious to the intellect. Since that time the Idea is no longer something *a priori*, but is secondary and derived. Naturally, the new nominalism promptly claimed universal validity for itself in spite of the fact that it, too, is based on a definite and limited thesis coloured by temperament. This thesis runs as follows: we accept as valid anything that comes from outside and can be verified. The ideal instance is verification by experiment. The antithesis is: we accept as valid anything that comes from inside and cannot be verified. The hopelessness of this position is obvious. Greek natural philosophy with its interest in matter, together with Aristotelian reasoning, has achieved a belated but overwhelming victory over Plato.

[150] Yet every victory contains the germ of future defeat. In our own day signs foreshadowing a change of attitude are rapidly increasing. Significantly enough, it is Kant's doctrine of categories, more than anything else, that destroys in embryo every attempt to revive metaphysics in the old sense of the word, but at the same time paves the way for a rebirth of the Platonic spirit. If it be true that there can be no metaphysics transcending human reason, it is no less true that there can be no empirical knowledge that is not already caught and limited by the *a priori* structure of cognition. During the century and a half that have elapsed since the appearance of the *Critique of Pure Reason*, the conviction has gradually gained ground that thinking, understanding, and reasoning cannot be regarded as independent processes subject only to the eternal laws of logic, but that they are *psychic functions* coordinated with the personality and subordinate to it. We no longer ask, "Has this or that been seen, heard, handled, weighed, counted, thought, and found to be logical?" We ask instead, "Who saw, heard, or thought?" Beginning with "the personal equation" in the observation and measurement of minimal processes, this critical attitude has gone on to the creation of an empirical psychology such as no time before ours has known. Today we are convinced that in all fields of knowledge psychological premises exist which exert a decisive influence upon the choice of material, the method of investigation, the nature of the conclusions, and the formulation of hypotheses and theories. We have even come to believe that Kant's personality was a decisive conditioning factor of his *Critique of Pure Reason*. Not only our philosophers, but our own predilections in philosophy, and even what we are fond of calling our "best" truths are affected, if not dangerously undermined, by this recognition of a personal premise. All creative freedom, we cry out, is taken away from us! What? Can it be possible that a man only thinks or says or does what he himself is?

[151] Provided that we do not again exaggerate and so fall a victim to unrestrained "psychologizing," it seems to me that the critical standpoint here defined is inescapable. It constitutes the essence, origin, and method of modern psychology.

There is an *a priori* factor in all human activities, namely the inborn, preconscious and unconscious individual structure of the psyche. The preconscious psyche—for example, that of a new-born infant—is not an empty vessel into which, under favourable conditions, practically anything can be poured. On the contrary, it is a tremendously complicated, sharply defined individual entity which appears indeterminate to us only because we cannot see it directly. But the moment the first visible manifestations of psychic life begin to appear, one *would* have to be blind not to recognize their individual character, that is, the unique personality behind them. It is hardly possible to suppose that all these details come into being only at the moment in which they appear. When it is a case of morbid predispositions already present in the parents, we infer hereditary transmission through the germ-plasm; it would not occur to us to regard epilepsy in the child of an epileptic mother as an unaccountable mutation. Again, we explain by heredity the gifts and talents which can be traced back through whole generations. We explain in the same way the reappearance of complicated instinctive actions in animals that have never set eyes on their parents and therefore could not possibly have been “taught” by them.

[152] Nowadays we have to start with the hypothesis that, so far as predisposition is concerned, there is no essential difference between man and all other creatures. Like every animal, he possesses a preformed psyche which breeds true to his species and which, on closer examination, reveals distinct features traceable to family antecedents. We have not the slightest reason to suppose that there are certain human activities or functions that could be exempted from this rule. We are unable to form any idea of what those dispositions or aptitudes are which make instinctive actions in animals possible. And it is just as impossible for us to know the nature of the preconscious psychic disposition that enables a child to react in a human manner. We can only suppose that his behaviour results from patterns of functioning, which I have described as *images*. The term “image” is intended to express not only the form of the activity taking place, but the typical situation in which the activity is released.¹ These images are “primordial” images in so far as they are peculiar to whole species, and if they ever “originated” their origin must have coincided at least with the beginning of the species. They are the “human quality” of the human being, the specifically human form his activities take. This specific form is hereditary and is already present in the germ-plasm. The idea that it is not inherited but comes into being in every child anew would be just as preposterous as the primitive belief that the sun which rises in the morning is a different sun from that which set the evening before.

[153] Since everything psychic is preformed, this must also be true of the individual functions, especially those which derive directly from the unconscious predisposition. The most important of these is creative fantasy. In the products of

fantasy the primordial images are made visible, and it is here that the concept of the archetype finds its specific application. I do not claim to have been the first to point out this fact. The honour belongs to Plato. The first investigator in the field of ethnology to draw attention to the widespread occurrence of certain “elementary ideas” was Adolf Bastian. Two later investigators, Hubert and Mauss,² followers of Dürkheim, speak of “categories” of the imagination. And it was no less an authority than Hermann Usener³ who first recognized unconscious preformation under the guise of “unconscious thinking.” If I have any share in these discoveries, it consists in my having shown that archetypes are not disseminated only by tradition, language, and migration, but that they can rearise spontaneously, at any time, at any place, and without any outside influence.

[154] The far-reaching implications of this statement must not be overlooked. For it means that there are present in every psyche forms which are unconscious but nonetheless active—living dispositions, ideas in the Platonic sense, that preform and continually influence our thoughts and feelings and actions.

[155] Again and again I encounter the mistaken notion that an archetype is determined in regard to its content, in other words that it is a kind of unconscious idea (if such an expression be admissible). It is necessary to point out once more that archetypes are not determined as regards their content, but only as regards their form and then only to a very limited degree. A primordial image is determined as to its content only when it has become conscious and is therefore filled out with the material of conscious experience. Its form, however, as I have explained elsewhere, might perhaps be compared to the axial system of a crystal, which, as it were, preforms the crystalline structure in the mother liquid, although it has no material existence of its own. This first appears according to the specific way in which the ions and molecules aggregate. The archetype in itself is empty and purely formal, nothing but a *facultas praeformandi*, a possibility of representation which is given *a priori*. The representations themselves are not inherited, only the forms, and in that respect they correspond in every way to the instincts, which are also determined in form only. The existence of the instincts can no more be proved than the existence of the archetypes, so long as they do not manifest themselves concretely. With regard to the definiteness of the form, our comparison with the crystal is illuminating inasmuch as the axial system determines only the stereometric structure but not the concrete form of the individual crystal. This may be either large or small, and it may vary endlessly by reason of the different size of its planes or by the growing together of two crystals. The only thing that remains constant is the axial system, or rather, the invariable geometric proportions underlying it. The same is true of the archetype. In principle, it can be named and has an invariable nucleus of meaning—but always only in principle, never as regards its concrete manifestation. In the same way, the specific

appearance of the mother-image at any given time cannot be deduced from the mother archetype alone, but depends on innumerable other factors.

2. THE MOTHER ARCHETYPE

Like any other archetype, the mother archetype appears under an almost infinite variety of aspects. I mention here only some of the more characteristic. First in importance are the personal mother and grandmother, stepmother and mother-in-law; then any woman with whom a relationship exists—for example, a nurse or governess or perhaps a remote ancestress. Then there are what might be termed mothers in a figurative sense. To this category belongs the goddess, and especially the Mother of God, the Virgin, and Sophia. Mythology offers many variations of the mother archetype, as for instance the mother who reappears as the maiden in the myth of Demeter and Kore; or the mother who is also the beloved, as in the Cybele-Attis myth. Other symbols of the mother in a figurative sense appear in things representing the goal of our longing for redemption, such as Paradise, the Kingdom of God, the Heavenly Jerusalem. Many things arousing devotion or feelings of awe, as for instance the Church, university, city or country, heaven, earth, the woods, the sea or any still waters, matter even, the underworld and the moon, can be mother-symbols. The archetype is often associated with things and places standing for fertility and fruitfulness: the cornucopia, a ploughed field, a garden. It can be attached to a rock, a cave, a tree, a spring, a deep well, or to various vessels such as the baptismal font, or to vessel-shaped flowers like the rose or the lotus. Because of the protection it implies, the magic circle or mandala can be a form of mother archetype. Hollow objects such as ovens and cooking vessels are associated with the mother archetype, and, of course, the uterus, *yoni*, and anything of a like shape. Added to this list there are many animals, such as the cow, hare, and helpful animals in general.

[157] All these symbols can have a positive, favourable meaning or a negative, evil meaning. An ambivalent aspect is seen in the goddesses of fate (Moiras, Graeae, Norns). Evil symbols are the witch, the dragon (or any devouring and entwining animal, such as a large fish or a serpent), the grave, the sarcophagus, deep water, death, nightmares and bogies (Empusa, Lilith, etc.). This list is not, of course, complete; it presents only the most important features of the mother archetype.

[158] The qualities associated with it are maternal solicitude and sympathy; the magic authority of the female; the wisdom and spiritual exaltation that transcend reason; any helpful instinct or impulse; all that is benign, all that cherishes and sustains, that fosters growth and fertility. The place of magic transformation and rebirth, together with the underworld and its inhabitants, are presided over by the mother. On the negative side the mother archetype may connote anything secret, hidden, dark; the

abyss, the world of the dead, anything that devours, seduces, and poisons, that is terrifying and inescapable like fate. All these attributes of the mother archetype have been fully described and documented in my book *Symbols of Transformation*. There I formulated the ambivalence of these attributes as “the loving and the terrible mother.” Perhaps the historical example of the dual nature of the mother most familiar to us is the Virgin Mary, who is not only the Lord’s mother, but also, according to the medieval allegories, his cross. In India, “the loving and terrible mother” is the paradoxical Kali. Sankhya philosophy has elaborated the mother archetype into the concept of *prakrti* (matter) and assigned to it the three *gunas* or fundamental attributes: *sattva*, *rajas*, *tamas*: goodness, passion, and darkness.¹ These are three essential aspects of the mother: her cherishing and nourishing goodness, her orgiastic emotionality, and her Stygian depths. The special feature of the philosophical myth, which shows Prakrti dancing before Purusha in order to remind him of “discriminating knowledge,” does not belong to the mother archetype but to the archetype of the anima, which in a man’s psychology invariably appears, at first, mingled with the mother-image.

[159] Although the figure of the mother as it appears in folklore is more or less universal, this image changes markedly when it appears in the individual psyche. In treating patients one is at first impressed, and indeed arrested, by the apparent significance of the personal mother. This figure of the personal mother looms so large in all personalistic psychologies that, as we know, they never got beyond it, even in theory, to other important aetiological factors. My own view differs from that of other medico-psychological theories principally in that I attribute to the personal mother only a limited aetiological significance. That is to say, all those influences which the literature describes as being exerted on the children do not come from the mother herself, but rather from the archetype projected upon her, which gives her a mythological background and invests her with authority and numinosity.² The aetiological and traumatic effects produced by the mother must be divided into two groups: (1) those corresponding to traits of character or attitudes actually present in the mother, and (2) those referring to traits which the mother only seems to possess, the reality being composed of more or less fantastic (i.e., archetypal) projections on the part of the child. Freud himself had already seen that the real aetiology of neuroses does not lie in traumatic effects, as he at first suspected, but in a peculiar development of infantile fantasy. This is not to deny that such a development can be traced back to disturbing influences emanating from the mother. I myself make it a rule to look first for the cause of infantile neuroses in the mother, as I know from experience that a child is much more likely to develop normally than neurotically, and that in the great majority of cases definite causes of disturbances can be found in the parents, especially in the mother. The contents of the child’s abnormal fantasies

can be referred to the personal mother only in part, since they often contain clear and unmistakable allusions which could not possibly have reference to human beings. This is especially true where definitely mythological products are concerned, as is frequently the case in infantile phobias where the mother may appear as a wild beast, a witch, a spectre, an ogre, a hermaphrodite, and so on. It must be borne in mind, however, that such fantasies are not always of unmistakably mythological origin, and even if they are, they may not always be rooted in the unconscious archetype but may have been occasioned by fairytales or accidental remarks. A thorough investigation is therefore indicated in each case. For practical reasons, such an investigation cannot be made so readily with children as with adults, who almost invariably transfer their fantasies to the physician during treatment—or, to be more precise, the fantasies are projected upon him automatically.

[160] When that happens, nothing is gained by brushing them aside as ridiculous, for archetypes are among the inalienable assets of every psyche. They form the “treasure in the realm of shadowy thoughts” of which Kant spoke, and of which we have ample evidence in the countless treasure motifs of mythology. An archetype is in no sense just an annoying prejudice; it becomes so only when it is in the wrong place. In themselves, archetypal images are among the highest values of the human psyche; they have peopled the heavens of all races from time immemorial. To discard them as valueless would be a distinct loss. Our task is not, therefore, to deny the archetype, but to dissolve the projections, in order to restore their contents to the individual who has involuntarily lost them by projecting them outside himself.

3. THE MOTHER-COMPLEX

[161] The mother archetype forms the foundation of the so-called mother-complex. It is an open question whether a mother-complex can develop without the mother having taken part in its formation as a demonstrable causal factor. My own experience leads me to believe that the mother always plays an active part in the origin of the disturbance, especially in infantile neuroses or in neuroses whose aetiology undoubtedly dates back to early childhood. In any event, the child's instincts are disturbed, and this constellates archetypes which, in their turn, produce fantasies that come between the child and its mother as an alien and often frightening element. Thus, if the children of an overanxious mother regularly dream that she is a terrifying animal or a witch, these experiences point to a split in the child's psyche that predisposes it to a neurosis.

I. THE MOTHER-COMPLEX OF THE SON

[162] The effects of the mother-complex differ according to whether it appears in a son or a daughter. Typical effects on the son are homosexuality and Don Juanism, and sometimes also impotence.¹ In homosexuality, the son's entire heterosexuality is tied to the mother in an unconscious form; in Don Juanism, he unconsciously seeks his mother in every woman he meets. The effects of a mother-complex on the son may be seen in the ideology of the Cybele and Attis type: self-castration, madness, and early death. Because of the difference in sex, a son's mother-complex does not appear in pure form. This is the reason why in every masculine mother-complex, side by side with the mother archetype, a significant role is played by the image of the man's sexual counterpart, the anima. The mother is the first feminine being with whom the man-to-be comes in contact, and she cannot help playing, overtly or covertly, consciously or unconsciously, upon the son's masculinity, just as the son in his turn grows increasingly aware of his mother's femininity, or unconsciously responds to it by instinct. In the case of the son, therefore, the simple relationships of identity or of resistance and differentiation are continually cut across by erotic attraction or repulsion, which complicates matters very considerably. I do not mean to say that for this reason the mother-complex of a son ought to be regarded as more serious than that of a daughter. The investigation of these complex psychic phenomena is still in the pioneer stage. Comparisons will not become feasible until we have some statistics at our disposal, and of these, so far, there is no sign.

[163] Only in the daughter is the mother-complex clear and uncomplicated. Here we have to do either with an overdevelopment of feminine instincts indirectly caused by the mother, or with a weakening of them to the point of complete extinction. In the first case, the preponderance of instinct makes the daughter unconscious of her own personality; in the latter, the instincts are projected upon the mother. For the present we must content ourselves with the statement that in the daughter a mother-complex either unduly stimulates or else inhibits the feminine instinct, and that in the son it injures the masculine instinct through an unnatural sexualization.

[164] Since a “mother-complex” is a concept borrowed from psychopathology, it is always associated with the idea of injury and illness. But if we take the concept out of its narrow psychopathological setting and give it a wider connotation, we can see that it has positive effects as well. Thus a man with a mother-complex may have a finely differentiated Eros² instead of, or in addition to, homosexuality. (Something of this sort is suggested by Plato in his *Symposium*.) This gives him a great capacity for friendship, which often creates ties of astonishing tenderness between men and may even rescue friendship between the sexes from the limbo of the impossible. He may have good taste and an aesthetic sense which are fostered by the presence of a feminine streak. Then he may be supremely gifted as a teacher because of his almost feminine insight and tact. He is likely to have a feeling for history, and to be conservative in the best sense and cherish the values of the past. Often he is endowed with a wealth of religious feelings, which help to bring the *ecclesia spiritualis* into reality; and a spiritual receptivity which makes him responsive to revelation.

[165] In the same way, what in its negative aspect is Don Juanism can appear positively as bold and resolute manliness; ambitious striving after the highest goals; opposition to all stupidity, narrow-mindedness, injustice, and laziness; willingness to make sacrifices for what is regarded as right, sometimes bordering on heroism; perseverance, inflexibility and toughness of will; a curiosity that does not shrink even from the riddles of the universe; and finally, a revolutionary spirit which strives to put a new face upon the world.

[166] All these possibilities are reflected in the mythological motifs enumerated earlier as different aspects of the mother archetype. As I have already dealt with the mother-complex of the son, including the anima complication, elsewhere, and my present theme is the archetype of the mother, in the following discussion I shall relegate masculine psychology to the background.

II. THE MOTHER-COMPLEX OF THE DAUGHTER³

[167] (a) *Hypertrophy of the Maternal Element*.—We have noted that in the daughter the mother-complex leads either to a hypertrophy of the feminine side or to its

atrophy. The exaggeration of the feminine side means an intensification of all female instincts, above all the maternal instinct. The negative aspect is seen in the woman whose only goal is childbirth. To her the husband is obviously of secondary importance; he is first and foremost the instrument of procreation, and she regards him merely as an object to be looked after, along with children, poor relations, cats, dogs, and household furniture. Even her own personality is of secondary importance; she often remains entirely unconscious of it, for her life is lived in and through others, in more or less complete identification with all the objects of her care. First she gives birth to the children, and from then on she clings to them, for without them she has no existence whatsoever. Like Demeter, she compels the gods by her stubborn persistence to grant her the right of possession over her daughter. Her Eros develops exclusively as a maternal relationship while remaining unconscious as a personal one. An unconscious Eros always expresses itself as will to power.⁴ Women of this type, though continually “living for others,” are, as a matter of fact, unable to make any real sacrifice. Driven by ruthless will to power and a fanatical insistence on their own maternal rights, they often succeed in annihilating not only their own personality but also the personal lives of their children. The less conscious such a mother is of her own personality, the greater and the more violent is her unconscious will to power. For many such women Baubo rather than Demeter would be the appropriate symbol. The mind is not cultivated for its own sake but usually remains in its original condition, altogether primitive, unrelated, and ruthless, but also as true, and sometimes as profound, as Nature herself.⁵ She herself does not know this and is therefore unable to appreciate the wittiness of her mind or to marvel philosophically at its profundity; like as not she will immediately forget what she has said.

[168] (b) *Overdevelopment of Eros.*—It by no means follows that the complex induced in a daughter by such a mother must necessarily result in hypertrophy of the maternal instinct. Quite the contrary, this instinct may be wiped out altogether. As a substitute, an overdeveloped Eros results, and this almost invariably leads to an unconscious incestuous relationship with the father.⁶ The intensified Eros places an abnormal emphasis on the personality of others. Jealousy of the mother and the desire to outdo her become the leitmotifs of subsequent undertakings, which are often disastrous. A woman of this type loves romantic and sensational episodes for their own sake, and is interested in married men, less for themselves than for the fact that they are married and so give her an opportunity to wreck a marriage, that being the whole point of her manoeuvre. Once the goal is attained, her interest evaporates for lack of any maternal instinct, and then it will be someone else’s turn.⁷ This type is noted for its remarkable unconsciousness. Such women really seem to be utterly blind to what they are doing,⁸ which is anything but advantageous either for themselves or for their victims. I need

hardly point out that for men with a passive Eros this type offers an excellent hook for anima projections.

[169] (c) *Identity with the Mother*.—It a mother-complex in a woman does not produce an overdeveloped Eros, it leads to identification with the mother and to paralysis of the daughter's feminine initiative. A complete projection of her personality on to the mother then takes place, owing to the fact that she is unconscious both of her maternal instinct and of her Eros. Everything which reminds her of motherhood, responsibility, personal relationships, and erotic demands arouses feelings of inferiority and compels her to run away—to her mother, naturally, who lives to perfection everything that seems unattainable to her daughter. As a sort of superwoman (admired involuntarily by the daughter), the mother lives out for her beforehand all that the girl might have lived for herself. She is content to cling to her mother in selfless devotion, while at the same time unconsciously striving, almost against her will, to tyrannize over her, naturally under the mask of complete loyalty and devotion. The daughter leads a shadow-existence, often visibly sucked dry by her mother, and she prolongs her mother's life by a sort of continuous blood transfusion. These bloodless maidens are by no means immune to marriage. On the contrary, despite their shadowiness and passivity, they command a high price on the marriage market. First, they are so empty that a man is free to impute to them anything he fancies. In addition, they are so unconscious that the unconscious puts out countless invisible feelers, veritable octopus-tentacles, that suck up all masculine projections; and this pleases men enormously. All that feminine indefiniteness is the longed-for counterpart of male decisiveness and single-mindedness, which can be satisfactorily achieved only if a man can get rid of everything doubtful, ambiguous, vague, and muddled by projecting it upon some charming example of feminine innocence.⁹ Because of the woman's characteristic passivity, and the feelings of inferiority which make her continually play the injured innocent, the man finds himself cast in an attractive role: he has the privilege of putting up with the familiar feminine foibles with real superiority, and yet with forbearance, like a true knight. (Fortunately, he remains ignorant of the fact that these deficiencies consist largely of his own projections.) The girl's notorious helplessness is a special attraction. She is so much an appendage of her mother that she can only flutter confusedly when a man approaches. She just doesn't know a thing. She is so inexperienced, so terribly in need of help, that even the gentlest swain becomes a daring abductor who brutally robs a loving mother of her daughter. Such a marvellous opportunity to pass himself off as a gay Lothario does not occur every day and therefore acts as a strong incentive. This was how Pluto abducted Persephone from the inconsolable Demeter. But, by a decree of the gods, he had to surrender his wife every year to his mother-in-

law for the summer season. (The attentive reader will note that such legends do not come about by chance!)

[170] (d) *Resistance to the Mother*.— These three extreme types are linked together by many intermediate stages, of which I shall mention only one important example. In the particular intermediate type I have in mind, the problem is less an overdevelopment or an inhibition of the feminine instincts than an overwhelming resistance to maternal supremacy, often to the exclusion of all else. It is the supreme example of the negative mother-complex. The motto of this type is: Anything, so long as it is not like Mother! On one hand we have a fascination which never reaches the point of identification; on the other, an intensification of Eros which exhausts itself in jealous resistance. This kind of daughter knows what she does *not* want, but is usually completely at sea as to what she would choose as her own fate. All her instincts are concentrated on the mother in the negative form of resistance and are therefore of no use to her in building her own life. Should she get as far as marrying, either the marriage will be used for the sole purpose of escaping from her mother, or else a diabolical fate will present her with a husband who shares all the essential traits of her mother's character. All instinctive processes meet with unexpected difficulties; either sexuality does not function properly, or the children are unwanted, or maternal duties seem unbearable, or the demands of marital life are responded to with impatience and irritation. This is quite natural, since none of it has anything to do with the realities of life when stubborn resistance to the power of the mother in every form has come to be life's dominating aim. In such cases one can often see the attributes of the mother archetype demonstrated in every detail. For example, the mother as representative of the family (or clan) causes either violent resistances or complete indifference to anything that comes under the head of family, community, society, convention, and the like. Resistance to the mother as *uterus* often manifests itself in menstrual disturbances, failure of conception, abhorrence of pregnancy, hemorrhages and excessive vomiting during pregnancy, miscarriages, and so on. The mother as *materia*, 'matter,' may be at the back of these women's impatience with objects, their clumsy handling of tools and crockery and bad taste in clothes.

[171] Again, resistance to the mother can sometimes result in a spontaneous development of intellect for the purpose of creating a sphere of interest in which the mother has no place. This development springs from the daughter's own needs and not at all for the sake of a man whom she would like to impress or dazzle by a semblance of intellectual comradeship. Its real purpose is to break the mother's power by intellectual criticism and superior knowledge, so as to enumerate to her all her stupidities, mistakes in logic, and educational shortcomings. Intellectual development is often accompanied by the emergence of masculine traits in general.

4. POSITIVE ASPECTS OF THE MOTHER-COMPLEX

I. THE MOTHER

[172] The positive aspect of the first type of complex, namely the overdevelopment of the maternal instinct, is identical with that well-known image of the mother which has been glorified in all ages and all tongues. This is the mother-love which is one of the most moving and unforgettable memories of our lives, the mysterious root of all growth and change; the love that means homecoming, shelter, and the long silence from which everything begins and in which everything ends. Intimately known and yet strange like Nature, lovingly tender and yet cruel like fate, joyous and untiring giver of life—*mater dolorosa* and mute implacable portal that closes upon the dead. Mother is mother-love, *my* experience and *my* secret. Why risk saying too much, too much that is false and inadequate and beside the point, about that human being who was our mother, the accidental carrier of that great experience which includes herself and myself and all mankind, and indeed the whole of created nature, the experience of life whose children we are? The attempt to say these things has always been made, and probably always will be; but a sensitive person cannot in all fairness load that enormous burden of meaning, responsibility, duty, heaven and hell, on to the shoulders of one frail and fallible human being—so deserving of love, indulgence, understanding, and forgiveness—who was our mother. He knows that the mother carries for us that inborn image of the *mater natura* and *mater spiritualis*, of the totality of life of which we are a small and helpless part. Nor should we hesitate for one moment to relieve the human mother of this appalling burden, for our own sakes as well as hers. It is just this massive weight of meaning that ties us to the mother and chains her to her child, to the physical and mental detriment of both. A mother-complex is not got rid of by blindly reducing the mother to human proportions. Besides that we run the risk of dissolving the experience “Mother” into atoms, thus destroying something supremely valuable and throwing away the golden key which a good fairy laid in our cradle. That is why mankind has always instinctively added the pre-existent divine pair to the personal parents—the “god”-father and “god”-mother of the newborn child—so that, from sheer unconsciousness or shortsighted rationalism, he should never forget himself so far as to invest his own parents with divinity.

[173] The archetype is really far less a scientific problem than an urgent question of psychic hygiene. Even if all proofs of the existence of archetypes were lacking, and all the clever people in the world succeeded in convincing us that such a thing could

not possibly exist, we would have to invent them forthwith in order to keep our highest and most important values from disappearing into the unconscious. For when these fall into the unconscious the whole elemental force of the original experience is lost. What then appears in its place is fixation on the mother-*imago*; and when this has been sufficiently rationalized and “corrected,” we are tied fast to human reason and condemned from then on to believe exclusively in what is rational. That is a virtue and an advantage on the one hand, but on the other a limitation and impoverishment, for it brings us nearer to the bleakness of doctrinairism and “enlightenment.” This *Déesse Raison* emits a deceptive light which illuminates only what we know already, but spreads a darkness over all those things which it would be most needful for us to know and become conscious of. The more independent “reason” pretends to be, the more it turns into sheer intellectuality which puts doctrine in the place of reality and shows us man not as he is but how it wants him to be.

[174] Whether he understands them or not, man must remain conscious of the world of the archetypes, because in it he is still a part of Nature and is connected with his own roots. A view of the world or a social order that cuts him off from the primordial images of life not only is no culture at all but, in increasing degree, is a prison or a stable. If the primordial images remain conscious in some form or other, the energy that belongs to them can flow freely into man. But when it is no longer possible to maintain contact with them, then the tremendous sum of energy stored up in these images, which is also the source of the fascination underlying the infantile parental complex, falls back into the unconscious. The unconscious then becomes charged with a force that acts as an irresistible *vis a tergo* to whatever view or idea or tendency our intellect may choose to dangle enticingly before our desiring eyes. In this way man is delivered over to his conscious side, and reason becomes the arbiter of right and wrong, of good and evil. I am far from wishing to belittle the divine gift of reason, man’s highest faculty. But in the role of absolute tyrant it has no meaning—no more than light would have in a world where its counterpart, darkness, was absent. Man would do well to heed the wise counsel of the mother and obey the inexorable law of nature which sets limits to every being. He ought never to forget that the world exists only because opposing forces are held in equilibrium. So, too, the rational is counterbalanced by the irrational, and what is planned and purposed by what *is*.

[175] This excursion into the realm of generalities was unavoidable, because the mother is the first world of the child and the last world of the adult. We are all wrapped as her children in the mantle of this great Isis. But let us now return to the different types of feminine mother-complex. It may seem strange that I am devoting so much more time to the mother-complex in woman than to its counterpart in man.

The reason for this has already been mentioned: in a man, the mother-complex is never “pure,” it is always mixed with the anima archetype, and the consequence is that a man’s statements about the mother are always emotionally prejudiced in the sense of showing “animosity.” Only in women is it possible to examine the effects of the mother archetype without admixture of animosity, and even this has prospects of success only when no compensating animus has developed.

II. THE OVERDEVELOPED EROS

[176] I drew a very unfavourable picture of this type as we encounter it in the field of psychopathology. But this type, uninviting as it appears, also has positive aspects which society could ill afford to do without. Indeed, behind what is possibly the worst effect of this attitude, the unscrupulous wrecking of marriages, we can see an extremely significant and purposeful arrangement of nature. This type often develops in reaction to a mother who is wholly a thrall of nature, purely instinctive and therefore all-devouring. Such a mother is an anachronism, a throw-back to a primitive state of matriarchy where the man leads an insipid existence as a mere procreator and serf of the soil. The reactive intensification of the daughter’s Eros is aimed at some man who ought to be rescued from the preponderance of the female-maternal element in his life. A woman of this type instinctively intervenes when provoked by the unconsciousness of the marriage partner. She will disturb that comfortable ease so dangerous to the personality of a man but frequently regarded by him as marital faithfulness. This complacency leads to blank unconsciousness of his own personality and to those supposedly ideal marriages where he is nothing but Dad and she is nothing but Mom, and they even call each other that. This is a slippery path that can easily degrade marriage to the level of a mere breeding-pen.

[177] A woman of this type directs the burning ray of her Eros upon a man whose life is stifled by maternal solicitude, and by doing so she arouses a moral conflict. Yet without this there can be no consciousness of personality. “But why on earth,” you may ask, “should it be necessary for man to achieve, by hook or by crook, a higher level of consciousness?” This is truly the crucial question, and I do not find the answer easy. Instead of a real answer I can only make a confession of faith: I believe that, after thousands and millions of years, someone had to realize that this wonderful world of mountains and oceans, suns and moons, galaxies and nebulae, plants and animals, *exists*. From a low hill in the Athi plains of East Africa I once watched the vast herds of wild animals grazing in soundless stillness, as they had done from time immemorial, touched only by the breath of a primeval world. I felt then as if I were the first man, the first creature, to know that all this *is*. The entire world round me was still in its primeval state; it did not know that it *was*. And then, in that one moment in which I came to know, the world sprang into being; without that moment

it would never have been. All Nature seeks this goal and finds it fulfilled in man, but only in the most highly developed and most fully conscious man. Every advance, even the smallest, along this path of conscious realization adds that much to the world.

[178] There is no consciousness without discrimination of opposites. This is the paternal principle, the Logos, which eternally struggles to extricate itself from the primal warmth and primal darkness of the maternal womb; in a word, from unconsciousness. Divine curiosity yearns to be born and does not shrink from conflict, suffering, or sin. Unconsciousness is the primal sin, evil itself, for the Logos. Therefore its first creative act of liberation is matricide, and the spirit that dared all heights and all depths must, as Synesius says, suffer the divine punishment, enchainment on the rocks of the Caucasus. Nothing can exist without its opposite; the two were one in the beginning and will be one again in the end. Consciousness can only exist through continual recognition of the unconscious, just as everything that lives must pass through many deaths.

[179] The stirring up of conflict is a Luciferian virtue in the true sense of the word. Conflict engenders fire, the fire of affects and emotions, and like every other fire it has two aspects, that of combustion and that of creating light. On the one hand, emotion is the alchemical fire whose warmth brings everything into existence and whose heat burns all superfluities to ashes (*omnes superfluitates comburit*). But on the other hand, emotion is the moment when steel meets flint and a spark is struck forth, for emotion is the chief source of consciousness. There is no change from darkness to light or from inertia to movement without emotion.

[180] The woman whose fate it is to be a disturbing element is not solely destructive, except in pathological cases. Normally the disturber is herself caught in the disturbance; the worker of change is herself changed, and the glare of the fire she ignites both illuminates and enlightens all the victims of the entanglement. What seemed a senseless upheaval becomes a process of purification:

So that all that is vain
Might dwindle and wane.¹

[181] If a woman of this type remains unconscious of the meaning of her function, if she does not know that she is

Part of that power which would
Ever work evil but engenders good,²

she will herself perish by the sword she brings. But consciousness transforms her into a deliverer and redeemer.

III. THE "NOTHING-BUT" DAUGHTER

[182] The woman of the third type, who is so identified with the mother that her own instincts are paralysed through projection, need not on that account remain a hopeless nonentity forever. On the contrary, if she is at all normal, there is a good chance of the empty vessel being filled by a potent anima projection. Indeed, the fate of such a woman depends on this eventuality; she can never find herself at all, not even approximately, without a man's help; she has to be literally abducted or stolen from her mother. Moreover, she must play the role mapped out for her for a long time and with great effort, until she actually comes to loathe it. In this way she may perhaps discover who she really is. Such women may become devoted and self-sacrificing wives of husbands whose whole existence turns on their identification with a profession or a great talent, but who, for the rest, are unconscious and remain so. Since they are nothing but masks themselves, the wife, too, must be able to play the accompanying part with a semblance of naturalness. But these women sometimes have valuable gifts which remained undeveloped only because they were entirely unconscious of their own personality. They may project the gift or talent upon a husband who lacks it himself, and then we have the spectacle of a totally insignificant man who seemed to have no chance whatsoever suddenly soaring as if on a magic carpet to the highest summits of achievement. *Cherchez la femme*, and you have the secret of his success. These women remind me—if I may be forgiven the impolite comparison—of hefty great bitches who turn tail before the smallest cur simply because he is a terrible male and it never occurs to them to bite him.

[183] Finally, it should be remarked that *emptiness* is a great feminine secret. It is something absolutely alien to man; the chasm, the unplumbed depths, the *yin*. The pitifulness of this vacuous nonentity goes to his heart (I speak here as a man), and one is tempted to say that this constitutes the whole "mystery" of woman. Such a female is fate itself. A man may say what he likes about it; be for it or against it, or both at once; in the end he falls, absurdly happy, into this pit, or, if he doesn't, he has missed and bungled his only chance of making a man of himself. In the first case one cannot disprove his foolish good luck to him, and in the second one cannot make his misfortune seem plausible. "The Mothers, the Mothers, how eerily it sounds!"³ With this sigh, which seals the capitulation of the male as he approaches the realm of the Mothers, we will turn to the fourth type.

IV. THE NEGATIVE MOTHER-COMPLEX

[184] As a pathological phenomenon this type is an unpleasant, exacting, and anything but satisfactory partner for her husband, since she rebels in every fibre of her being against everything that springs from natural soil. However, there is no reason why increasing experience of life should not teach her a thing or two, so that for a start she

gives up fighting the mother in the personal and restricted sense. But even at her best she will remain hostile to all that is dark, unclear, and ambiguous, and will cultivate and emphasize everything certain and clear and reasonable. Excelling her more feminine sister in her objectivity and coolness of judgment, she may become the friend, sister, and competent adviser of her husband. Her own masculine aspirations make it possible for her to have a human understanding of the individuality of her husband quite transcending the realm of the erotic. The woman with this type of mother-complex probably has the best chance of all to make her marriage an outstanding success during the second half of life. But this is true only if she succeeds in overcoming the hell of “nothing but femininity,” the chaos of the maternal womb, which is her greatest danger because of her negative complex. As we know, a complex can be really overcome only if it is lived out to the full. In other words, if we are to develop further we have to draw to us and drink down to the very dregs what, because of our complexes, we have held at a distance.

[185] This type started out in the world with averted face, like Lot’s wife looking back on Sodom and Gomorrah. And all the while the world and life pass by her like a dream—an annoying source of illusions, disappointments, and irritations, all of which are due solely to the fact that she cannot bring herself to look straight ahead for once. Because of her merely unconscious, reactive attitude toward reality, her life actually becomes dominated by what she fought hardest against—the exclusively maternal feminine aspect. But if she should later turn her face, she will see the world for the first time, so to speak, in the light of maturity, and see it embellished with all the colours and enchanting wonders of youth, and sometimes even of childhood. It is a vision that brings knowledge and discovery of truth, the indispensable prerequisite for consciousness. A part of life was lost, but the meaning of life has been salvaged for her.

[186] The woman who fights against her father still has the possibility of leading an instinctive, feminine existence, because she rejects only what is alien to her. But when she fights against the mother she may, at the risk of injury to her instincts, attain to greater consciousness, because in repudiating the mother she repudiates all that is obscure, instinctive, ambiguous, and unconscious in her own nature. Thanks to her lucidity, objectivity, and masculinity, a woman of this type is frequently found in important positions in which her tardily discovered maternal quality, guided by a cool intelligence, exerts a most beneficial influence. This rare combination of womanliness and masculine understanding proves valuable in the realm of intimate relationships as well as in practical matters. As the spiritual guide and adviser of a man, such a woman, unknown to the world, may play a highly influential part. Owing to her qualities, the masculine mind finds this type easier to understand than women with other forms of mother-complex, and for this reason men often favour her with

the projection of positive mother-complexes. The excessively feminine woman terrifies men who have a mother-complex characterized by great sensitivity. But this woman is not frightening to a man, because she builds bridges for the masculine mind over which he can safely guide his feelings to the opposite shore. Her clarity of understanding inspires him with confidence, a factor not to be underrated and one that is absent from the relationship between a man and a woman much more often than one might think. The man's Eros does not lead upward only but downward into that uncanny dark world of Hecate and Kali, which is a horror to any intellectual man. The understanding possessed by this type of woman will be a guiding star to him in the darkness and seemingly unending mazes of life.

5. CONCLUSION

[187] From what has been said it should be clear that in the last analysis all the statements of mythology on this subject as well as the observed effects of the mother-complex, when stripped of their confusing detail, point to the unconscious as their place of origin. How else could it have occurred to man to divide the cosmos, on the analogy of day and night, summer and winter, into a bright day-world and a dark night-world peopled with fabulous monsters, unless he had the prototype of such a division in himself, in the polarity between the conscious and the invisible and unknowable unconscious? Primitive man's perception of objects is conditioned only partly by the objective behaviour of the things themselves, whereas a much greater part is often played by intrapsychic facts which are not related to the external objects except by way of projection.¹ This is due to the simple fact that the primitive has not yet experienced that ascetic discipline of mind known to us as the critique of knowledge. To him the world is a more or less fluid phenomenon within the stream of his own fantasy, where subject and object are undifferentiated and in a state of mutual interpenetration. "All that is outside, also is inside," we could say with Goethe. But this "inside," which modern rationalism is so eager to derive from "outside," has an *a priori* structure of its own that antedates all conscious experience. It is quite impossible to conceive how "experience" in the widest sense, or, for that matter, anything psychic, could originate exclusively in the outside world. The psyche is part of the inmost mystery of life, and it has its own peculiar structure and form like every other organism. Whether this psychic structure and its elements, the archetypes, ever "originated" at all is a metaphysical question and therefore unanswerable. The structure is something given, the precondition that is found to be present in every case. And this is the *mother*, the matrix—the form into which all experience is poured. The *father*, on the other hand, represents the *dynamism* of the archetype, for the archetype consists of both—form and energy.

[188] The carrier of the archetype is in the first place the personal mother, because the child lives at first in complete participation with her, in a state of unconscious identity. She is the psychic as well as the physical precondition of the child. With the awakening of ego-consciousness the participation gradually weakens, and consciousness begins to enter into opposition to the unconscious, its own precondition. This leads to differentiation of the ego from the mother, whose personal peculiarities gradually become more distinct. All the fabulous and mysterious qualities attaching to her image begin to fall away and are transferred to the person

closest to her, for instance the grandmother. As the mother of the mother, she is “greater” than the latter; she is in truth the “grand” or “Great Mother.” Not infrequently she assumes the attributes of wisdom as well as those of a witch. For the further the archetype recedes from consciousness and the clearer the latter becomes, the more distinctly does the archetype assume mythological features. The transition from mother to grandmother means that the archetype is elevated to a higher rank. This is clearly demonstrated in a notion held by the Bataks. The funeral sacrifice in honour of a dead father is modest, consisting of ordinary food. But if the son has a son of his own, then the father has become a grandfather and has consequently attained a more dignified status in the Beyond, and very important offerings are made to him.²

[189] As the distance between conscious and unconscious increases, the grandmother’s more exalted rank transforms her into a “Great Mother,” and it frequently happens that the opposites contained in this image split apart. We then get a good fairy and a wicked fairy, or a benevolent goddess and one who is malevolent and dangerous. In Western antiquity and especially in Eastern cultures the opposites often remain united in the same figure, though this paradox does not disturb the primitive mind in the least. The legends about the gods are as full of contradictions as are their moral characters. In the West, the paradoxical behaviour and moral ambivalence of the gods scandalized people even in antiquity and gave rise to criticism that led finally to a devaluation of the Olympians on the one hand and to their philosophical interpretation on the other. The clearest expression of this is the Christian reformation of the Jewish concept of the Deity: the morally ambiguous Yahweh became an exclusively good God, while everything evil was united in the devil. It seems as if the development of the feeling function in Western man forced a choice on him which led to the moral splitting of the divinity into two halves. In the East the predominantly intuitive intellectual attitude left no room for feeling values, and the gods—Kali is a case in point—could retain their original paradoxical morality undisturbed. Thus Kali is representative of the East and the Madonna of the West. The latter has entirely lost the shadow that still distantly followed her in the allegories of the Middle Ages. It was relegated to the hell of popular imagination, where it now leads an insignificant existence as the devil’s grandmother.³ Thanks to the development of feeling-values, the splendour of the “light” god has been enhanced beyond measure, but the darkness supposedly represented by the devil has localized itself in man. This strange development was precipitated chiefly by the fact that Christianity, terrified of Manichaeism, strove to preserve its monotheism by main force. But since the reality of darkness and evil could not be denied, there was no alternative but to make man responsible for it. Even the devil was largely, if not entirely, abolished, with the result that this metaphysical figure, who at one time

was an integral part of the Deity, was introjected into man, who thereupon became the real carrier of the *mysterium iniquitatis*: “omne bonum a Deo, omne malum ab homine.” In recent times this development has suffered a diabolical reverse, and the wolf in sheep’s clothing now goes about whispering in our ear that evil is really nothing but a misunderstanding of good and an effective instrument of progress. We think that the world of darkness has thus been abolished for good and all, and nobody realizes what a poisoning this is of man’s soul. In this way he turns himself into the devil, for the devil is half of the archetype whose irresistible power makes even unbelievers ejaculate “Oh God!” on every suitable and unsuitable occasion. If one can possibly avoid it, one ought never to identify with an archetype, for, as psychopathology and certain contemporary events show, the consequences are terrifying.

[190] Western man has sunk to such a low level spiritually that he even has to deny the apotheosis of untamed and untameable psychic power—the divinity itself—so that, after swallowing evil, he may possess himself of the good as well. If you read Nietzsche’s *Zarathustra* with attention and psychological understanding, you will see that he has described with rare consistency and with the passion of a truly religious person the psychology of the “Superman” for whom God is dead, and who is himself burst asunder because he tried to imprison the divine paradox within the narrow framework of the mortal man. Goethe has wisely said: “What terror then shall seize the Superman!”—and was rewarded with a supercilious smile from the Philistines. His glorification of the Mother who is great enough to include in herself both the Queen of Heaven and Maria Aegyptiaca is supreme wisdom and profoundly significant for anyone willing to reflect upon it. But what can one expect in an age when the official spokesmen of Christianity publicly announce their inability to understand the foundations of religious experience! I extract the following sentence from an article by a Protestant theologian: “We understand ourselves—whether naturalistically or idealistically—to be *homogeneous creatures who are not so peculiarly divided that alien forces can intervene in our inner life*, as the New Testament supposes.”⁴ (Italics mine.) The author is evidently unacquainted with the fact that science demonstrated the lability and dissociability of consciousness more than half a century ago and proved it by experiment. Our conscious intentions are continually disturbed and thwarted, to a greater or lesser degree, by unconscious intrusions whose causes are at first strange to us. The psyche is far from being a homogeneous unit—on the contrary, it is a boiling cauldron of contradictory impulses, inhibitions, and affects, and for many people the conflict between them is so insupportable that they even wish for the deliverance preached by theologians. Deliverance from what? Obviously, from a highly questionable psychic state. The unity of consciousness or of the so-called personality is not a reality at all but a

desideratum. I still have a vivid memory of a certain philosopher who also raved about this unity and used to consult me about his neurosis: he was obsessed by the idea that he was suffering from cancer. I do not know how many specialists he had consulted already, and how many X-ray pictures he had had made. They all assured him that he had no cancer. He himself told me: "I know I have no cancer, but I still could have one." Who is responsible for this "imaginary" idea? He certainly did not make it himself; it was forced on him by an "alien" power. There is little to choose between this state and that of the man possessed in the New Testament. Now whether you believe in a demon of the air or in a factor in the unconscious that plays diabolical tricks on you is all one to me. The fact that man's imagined unity is menaced by alien powers remains the same in either case. Theologians would do better to take account for once of these psychological facts than to go on "demythologizing" them with rationalistic explanations that are a hundred years behind the times.

*

[191] I have tried in the foregoing to give a survey of the psychic phenomena that may be attributed to the predominance of the mother-image. Although I have not always drawn attention to them, my reader will presumably have had no difficulty in recognizing those features which characterize the Great Mother mythologically, even when they appear under the guise of personalistic psychology. When we ask patients who are particularly influenced by the mother-image to express in words or pictures what "Mother" means to them—be it positive or negative—we invariably get symbolical figures which must be regarded as direct analogies of the mythological mother-image. These analogies take us into a field that still requires a great deal more work of elucidation. At any rate, I personally do not feel able to say anything definitive about it. If, nevertheless, I venture to offer a few suggestions, they should be regarded as altogether provisional and tentative.

[192] Above all, I should like to point out that the mother-image in a man's psychology is entirely different in character from a woman's. For a woman, the mother typifies her own conscious life as conditioned by her sex. But for a man the mother typifies something alien, which he has yet to experience and which is filled with the imagery latent in the unconscious. For this reason, if for no other, the mother-image of a man is essentially different from a woman's. The mother has from the outset a decidedly symbolical significance for a man, which probably accounts for his strong tendency to idealize her. Idealization is a hidden apotropaism; one idealizes whenever there is a secret fear to be exorcized. What is feared is the unconscious and its magical influence.⁵

[193] Whereas for a man the mother is *ipso facto* symbolical, for a woman she becomes a symbol only in the course of her psychological development. Experience reveals the striking fact that the Urania type of mother-image predominates in masculine psychology, whereas in a woman the chthonic type, or Earth Mother, is the most frequent. During the manifest phase of the archetype an almost complete identification takes place. A woman can identify directly with the Earth Mother, but a man cannot (except in psychotic cases). As mythology shows, one of the peculiarities of the Great Mother is that she frequently appears paired with her male counterpart. Accordingly the man identifies with the son-lover on whom the grace of Sophia has descended, with a *puer aeternus* or a *filius sapientiae*. But the companion of the chthonic mother is the exact opposite: an ithyphallic Hermes (the Egyptian Bes) or a lingam. In India this symbol is of the highest spiritual significance, and in the West Hermes is one of the most contradictory figures of Hellenistic syncretism, which was the source of extremely important spiritual developments in Western civilization. He is also the god of revelation, and in the unofficial nature philosophy of the early Middle Ages he is nothing less than the world-creating Nous itself. This mystery has perhaps found its finest expression in the words of the *Tabula smaragdina*: “omne superius sicut inferius” (as it is above, so it is below).

[194] It is a psychological fact that as soon as we touch on these identifications we enter the realm of the syzygies, the paired opposites, where the One is never separated from the Other, its antithesis. It is a field of personal experience which leads directly to the experience of individuation, the attainment of the self. A vast number of symbols for this process could be mustered from the medieval literature of the West and even more from the storehouses of Oriental wisdom, but in this matter words and ideas count for little. Indeed, they may become dangerous bypaths and false trails. In this still very obscure field of psychological experience, where we are in direct contact, so to speak, with the archetype, its psychic power is felt in full force. This realm is so entirely one of immediate experience that it cannot be captured by any formula, but can only be hinted at to one who already knows. He will need no explanations to understand what was the tension of opposites expressed by Apuleius in his magnificent prayer to the Queen of Heaven, when he associates “heavenly Venus” with “Proserpina, who striketh terror with midnight ululations”:⁶ it was the terrifying paradox of the primordial mother-image.

*

[195] When, in 1938, I originally wrote this paper, I naturally did not know that twelve years later the Christian version of the mother archetype would be elevated to the rank of a dogmatic truth. The Christian “Queen of Heaven” has, obviously, shed all her Olympian qualities except for her brightness, goodness, and eternity; and even

her human body, the thing most prone to gross material corruption, has put on an ethereal incorruptibility. The richly varied allegories of the Mother of God have nevertheless retained some *connection* with her pagan prefigurations in Isis (Io) and Semele. Not only are Isis and the Horus-child iconological exemplars, but the ascension of Semele, the originally mortal mother of Dionysus, likewise anticipates the Assumption of the Blessed Virgin. Further, this son of Semele is a dying and resurgent god and the youngest of the Olympians. Semele herself seems to have been an earth-goddess, just as the Virgin Mary is the earth from which Christ was born. This being so, the question naturally arises for the psychologist: what has become of the characteristic relation of the mother-image to the earth, darkness, the abysmal side of the bodily man with his animal passions and instinctual nature, and to “matter” in general? The declaration of the dogma comes at a time when the achievements of science and technology, combined with a rationalistic and materialistic view of the world, threaten the spiritual and psychic heritage of man with instant annihilation. Humanity is arming itself, in dread and fascinated horror, for a stupendous crime. Circumstances might easily arise when the hydrogen bomb would have to be used and the unthinkable frightful deed became unavoidable in legitimate self-defence. In striking contrast to this disastrous turn of events, the Mother of God is now enthroned in heaven; indeed, her Assumption has actually been interpreted as a deliberate counterstroke to the materialistic doctrinairism that provoked the chthonic powers into revolt. Just as Christ’s appearance in his own day created a real devil and adversary of God out of what was originally a son of God dwelling in heaven, so now, conversely, a heavenly figure has split off from her original chthonic realm and taken up a counter-position to the titanic forces of the earth and the underworld that have been unleashed. In the same way that the Mother of God was divested of all the essential qualities of materiality, matter became completely de-souled, and this at a time when physics is pushing forward to insights which, if they do not exactly “de-materialize” matter, at least endue it with properties of its own and make its relation to the psyche a problem that can no longer be shelved. For just as the tremendous advancement of science led at first to a premature dethronement of mind and to an equally ill-considered deification of matter, so it is this same urge for scientific knowledge that is now attempting to bridge the huge gulf that has opened out between the two *Weltanschauungen*. The psychologist inclines to see in the dogma of the Assumption a symbol which, in a sense, anticipates this whole development. For him the relationship to the earth and to matter is one of the inalienable qualities of the mother archetype. So that when a figure that is conditioned by this archetype is represented as having been taken up into heaven, the realm of the spirit, this indicates a union of earth and heaven, or of matter and spirit. The approach of natural science will almost certainly be from the other direction: it will see in matter itself the equivalent of spirit, but this “spirit” will appear divested

of all, or at any rate most, of its known qualities, just as earthly matter was stripped of its specific characteristics when it staged its entry into heaven. Nevertheless, the way will gradually be cleared for a union of the two principles.

[196] Understood concretely, the Assumption is the absolute opposite of materialism. Taken in this sense, it is a counterstroke that does nothing to diminish the tension between the opposites, but drives it to extremes.

[197] Understood symbolically, however, the Assumption of the body is a recognition and acknowledgment of matter, which in the last resort was identified with evil only because of an overwhelmingly “pneumatic” tendency in man. In themselves, spirit and matter are neutral, or rather, “*utriusque capax*”—that is, capable of what man calls good or evil. Although as names they are exceedingly relative, underlying them are very real opposites that are part of the energetic structure of the physical and of the psychic world, and without them no existence of any kind could be established. There is no position without its negation. In spite or just because of their extreme opposition, neither can exist without the other. It is exactly as formulated in classical Chinese philosophy: *yang* (the light, warm, dry, masculine principle) contains within it the seed of *yin* (the dark, cold, moist, feminine principle), and vice versa. Matter therefore would contain the seed of spirit and spirit the seed of matter. The long-known “synchronistic” phenomena that have now been statistically confirmed by Rhine’s experiments⁷ point, to all appearances, in this direction. The “psychization” of matter puts the absolute immateriality of spirit in question, since this would then have to be accorded a kind of substantiality. The dogma of the Assumption, proclaimed in an age suffering from the greatest political schism history has ever known, is a compensating symptom that reflects the strivings of science for a uniform world-picture. In a certain sense, both developments were anticipated by alchemy in the *hieros gamos* of opposites, but only in symbolic form. Nevertheless, the symbol has the great advantage of being able to unite heterogeneous or even incommensurable factors in a *single* image. With the decline of alchemy the symbolical unity of spirit and matter fell apart, with the result that modern man finds himself uprooted and alienated in a de-souled world.

[198] The alchemist saw the union of opposites under the symbol of the tree, and it is therefore not surprising that the unconscious of present-day man, who no longer feels at home in his world and can base his existence neither on the past that is no more nor on the future that is yet to be, should hark back to the symbol of the cosmic tree rooted in this world and growing up to heaven—the tree that is also man. In the history of symbols this tree is described as the way of life itself, a growing into that which eternally is and does not change; which springs from the union of opposites and, by its eternal presence, also makes that union possible. It seems as if it were

only through an experience of symbolic reality that man, vainly seeking his own “existence” and making a philosophy out of it, can find his way back to a world in which he is no longer a stranger.

III

CONCERNING REBIRTH

This paper represents the substance of a lecture which I delivered on the spur of the moment at the Eranos meeting in 1939. In putting it into written form I have made use of the stenographic notes which were taken at the meeting. Certain portions had to be omitted, chiefly because the requirements of a printed text are different from those of the spoken word. However, so far as possible, I have carried out my original intention of summing up the content of my lecture on the theme of rebirth, and have also endeavoured to reproduce my analysis of the Eighteenth Sura of the Koran as an example of a rebirth mystery. I have added some references to source material, which the reader may welcome. My summary does not purport to be more than a survey of a field of knowledge which can only be treated very superficially in the framework of a lecture.—C. G. J.

[First published as a lecture, “Die verschiedenen Aspekte der Wiedergeburt,” in *Eranos-Jahrbuch 1939* (Zurich, 1940). Revised and expanded as “Über Wiedergeburt,” *Gestaltungen des Unbewussten* (Zurich, 1950), from which the present translation is made.—EDITORS.]

1. FORMS OF REBIRTH

[199] The concept of rebirth is not always used in the same sense. Since this concept has various aspects, it may be useful to review its different meanings. The five different forms which I am going to enumerate could probably be added to if one were to go into greater detail, but I venture to think that my definitions cover at least the cardinal meanings. In the first part of my exposition, I give a brief summary of the different forms of rebirth, while the second part presents its various psychological aspects. In the third part, I give an example of a rebirth mystery from the Koran.

[200] 1. *Metempsychosis*. The first of the five aspects of rebirth to which I should like to draw attention is that of metempsychosis, or transmigration of souls. According to this view, one's life is prolonged in time by passing through different bodily existences; or, from another point of view, it is a life-sequence interrupted by different reincarnations. Even in Buddhism, where this doctrine is of particular importance—the Buddha himself experienced a very long sequence of such rebirths—it is by no means certain whether continuity of personality is guaranteed or not: there may be only a continuity of *karma*. The Buddha's disciples put this question to him during his lifetime, but he never made any definite statement as to whether there is or is not a continuity of personality.¹

[201] 2. *Reincarnation*. This concept of rebirth necessarily implies the continuity of personality. Here the human personality is regarded as continuous and accessible to memory, so that, when one is incarnated or born, one is able, at least potentially, to remember that one has lived through previous existences and that these existences were one's own, i.e., that they had the same ego-form as the present life. As a rule, reincarnation means rebirth in a human body.

[202] 3. *Resurrection*. This means a re-establishment of human existence after death. A new element enters here: that of the change, transmutation, or transformation of one's being. The change may be either essential, in the sense that the resurrected being is a different one; or nonessential, in the sense that only the general conditions of existence have changed, as when one finds oneself in a different place or in a body which is differently constituted. It may be a carnal body, as in the Christian assumption that this body will be resurrected. On a higher level, the process is no longer understood in a gross material sense; it is assumed that the resurrection of the dead is the raising up of the *corpus glorificationis*, the "subtle body," in the state of incorruptibility.

[203] 4. *Rebirth (renovatio)*. The fourth form concerns rebirth in the strict sense; that is to say, rebirth within the span of individual life. The English word *rebirth* is the exact equivalent of the German *Wiedergeburt*, but the French language seems to lack a term having the peculiar meaning of “rebirth.” This word has a special flavour; its whole atmosphere suggests the idea of *renovatio*, renewal, or even of improvement brought about by magical means. Rebirth may be a renewal without any change of being, inasmuch as the personality which is renewed is not changed in its essential nature, but only its functions, or parts of the personality, are subjected to healing, strengthening, or improvement. Thus even bodily ills may be healed through rebirth ceremonies.

[204] Another aspect of this fourth form is essential transformation, i.e., total rebirth of the individual. Here the renewal implies a change of his essential nature, and may be called a transmutation. As examples we may mention the transformation of a mortal into an immortal being, of a corporeal into a spiritual being, and of a human into a divine being. Well-known prototypes of this change are the transfiguration and ascension of Christ, and the assumption of the Mother of God into heaven after her death, together with her body. Similar conceptions are to be found in [Part II](#) of Goethe’s *Faust*; for instance, the transformation of Faust into the boy and then into Doctor Marianus.

[205] 5. *Participation in the process of transformation*. The fifth and last form is indirect rebirth. Here the transformation is brought about not directly, by passing through death and rebirth oneself, but indirectly, by participating in a process of transformation which is conceived of as taking place outside the individual. In other words, one has to witness, or take part in, some rite of transformation. This rite may be a ceremony such as the Mass, where there is a transformation of substances. Through his presence at the rite the individual participates in divine grace. Similar transformations of the Deity are to be found in the pagan mysteries; there too the initiate sharing the experience is vouchsafed the gift of grace, as we know from the Eleusinian mysteries. A case in point is the confession of the initiate in the Eleusinian mysteries, who praises the grace conferred through the certainty of immortality.²

2. THE PSYCHOLOGY OF REBIRTH

[206] Rebirth is not a process that we can in any way observe. We can neither measure nor weigh nor photograph it. It is entirely beyond sense perception. We have to do here with a purely *psychic* reality, which is transmitted to us only indirectly through personal statements. One speaks of rebirth; one professes rebirth; one is filled with rebirth. This we accept as sufficiently real. We are not concerned here with the question: is rebirth a tangible process of some sort? We have to be content with its psychic reality. I hasten to add that I am not alluding to the vulgar notion that anything “psychic” is either nothing at all or at best even more tenuous than a gas. Quite the contrary; I am of the opinion that the psyche is the most tremendous fact of human life. Indeed, it is the mother of all human facts; of civilization and of its destroyer, war. All this is at first psychic and invisible. So long as it is “merely” psychic it cannot be experienced by the senses, but is nonetheless indisputably real. The mere fact that people talk about rebirth, and that there is such a concept at all, means that a store of psychic experiences designated by that term must actually exist. What these experiences are like we can only infer from the statements that have been made about them. So, if we want to find out what rebirth really is, we must turn to history in order to ascertain what “rebirth” has been understood to mean.

[207] Rebirth is an affirmation that must be counted among the primordial affirmations of mankind. These primordial affirmations are based on what I call archetypes. In view of the fact that all affirmations relating to the sphere of the suprasensual are, in the last analysis, invariably determined by archetypes, it is not surprising that a concurrence of affirmations concerning rebirth can be found among the most widely differing peoples. There must be psychic events underlying these affirmations which it is the business of psychology to discuss—without entering into all the metaphysical and philosophical assumptions regarding their significance. In order to obtain a general view of their phenomenology, it is necessary to sketch the whole field of transformation experiences in sharper outline. Two main groups of experience may be distinguished: that of the transcendence of life, and that of one’s own transformation.

I. EXPERIENCE OF THE TRANSCENDENCE OF LIFE

[208] a. *Experiences induced by ritual.* By the “transcendence of life” I mean those aforementioned experiences of the initiate who takes part in a sacred rite which reveals to him the perpetual continuation of life through transformation and renewal.

In these mystery-dramas the transcendence of life, as distinct from its momentary concrete manifestations, is usually represented by the fateful transformations—death and rebirth—of a god or a godlike hero. The initiate may either be a mere witness of the divine drama or take part in it or be moved by it, or he may see himself identified through the ritual action with the god. In this case, what really matters is that an objective substance or form of life is ritually transformed through some process going on independently, while the initiate is influenced, impressed, “consecrated,” or granted “divine grace” on the mere ground of his presence or participation. The transformation process takes place not within him but outside him, although he may become involved in it. The initiate who ritually enacts the slaying, dismemberment, and scattering of Osiris, and afterwards his resurrection in the green wheat, experiences in this way the permanence and continuity of life, which outlasts all changes of form and, phoenix-like, continually rises anew from its own ashes. This participation in the ritual event gives rise, among other effects, to that hope of immortality which is characteristic of the Eleusinian mysteries.¹

[209] A living example of the mystery drama representing the permanence as well as the transformation of life is the Mass. If we observe the congregation during this sacred rite we note all degrees of participation, from mere indifferent attendance to the profoundest emotion. The groups of men standing about near the exit, who are obviously engaged in every sort of worldly conversation, crossing themselves and genuflecting in a purely mechanical way—even they, despite their inattention, participate in the sacral action by their mere presence in this place where grace abounds. The Mass is an extramundane and extratemporal act in which Christ is sacrificed and then resurrected in the transformed substances; and this rite of his sacrificial death is not a repetition of the historical event but the original, unique, and eternal act. The experience of the Mass is therefore a participation in the transcendence of life, which overcomes all bounds of space and time. It is a moment of eternity in time.²

[210] b. *Immediate Experiences*. All that the mystery drama represents and brings about in the spectator may also occur in the form of a spontaneous, ecstatic, or visionary experience, without any ritual. Nietzsche’s Noontide Vision is a classic example of this kind.³ Nietzsche, as we know, substitutes for the Christian mystery the myth of Dionysus-Zagreus, who was dismembered and came to life again. His experience has the character of a Dionysian nature myth: the Deity appears in the garb of Nature, as classical antiquity saw it,⁴ and the moment of eternity is the noonday hour, sacred to Pan: “Hath time flown away? Do I not fall? Have I not fallen—hark!—into the well of eternity?” Even the “golden ring,” the “ring of return,” appears to him as a promise of resurrection and life.⁵ It is just as if Nietzsche had been present at a performance of the mysteries.

[211] Many mystic experiences have a similar character: they represent an action in which the spectator becomes involved though his nature is not necessarily changed. In the same way, the most beautiful and impressive dreams often have no lasting or transformative effect on the dreamer. He may be impressed by them, but he does not necessarily see any problem in them. The event then naturally remains “outside,” like a ritual action performed by others. These more aesthetic forms of experience must be carefully distinguished from those which indubitably involve a change of one’s nature.

II. SUBJECTIVE TRANSFORMATION

[212] Transformations of personality are by no means rare occurrences. Indeed, they play a considerable role in psychopathology, although they are rather different from the mystical experiences just discussed, which are not easily accessible to psychological investigation. However, the phenomena we are now about to examine belong to a sphere quite familiar to psychology.

[213] a. *Diminution of personality.* An example of the alteration of personality in the sense of diminution is furnished by what is known in primitive psychology as “loss of soul.” The peculiar condition covered by this term is accounted for in the mind of the primitive by the supposition that a soul has gone off, just like a dog that runs away from his master overnight. It is then the task of the medicine-man to fetch the fugitive back. Often the loss occurs suddenly and manifests itself in a general malaise. The phenomenon is closely connected with the nature of primitive consciousness, which lacks the firm coherence of our own. We have control of our will power, but the primitive has not. Complicated exercises are needed if he is to pull himself together for any activity that is conscious and intentional and not just emotional and instinctive. Our consciousness is safer and more dependable in this respect; but occasionally something similar can happen to civilized man, only he does not describe it as “loss of soul” but as an “*abaissement du niveau mental*,” Janet’s apt term for this phenomenon.⁶ It is a slackening of the tensity of consciousness, which might be compared to a low barometric reading, presaging bad weather. The tonus has given way, and this is felt subjectively as listlessness, moroseness, and depression. One no longer has any wish or courage to face the tasks of the day. One feels like lead, because no part of one’s body seems willing to move, and this is due to the fact that one no longer has any disposable energy.⁷ This well-known phenomenon corresponds to the primitive’s loss of soul. The listlessness and paralysis of will can go so far that the whole personality falls apart, so to speak, and consciousness loses its unity; the individual parts of the personality make themselves independent and thus escape from the control of the conscious mind, as in the case of anaesthetic areas or systematic amnesias. The latter are well known as hysterical

“loss of function” phenomena. This medical term is analogous to the primitive loss of soul.

[214] *Abaissement du niveau mental* can be the result of physical and mental fatigue, bodily illness, violent emotions, and shock, of which the last has a particularly deleterious effect on one’s self-assurance. The *abaissement* always has a restrictive influence on the personality as a whole. It reduces one’s self-confidence and the spirit of enterprise, and, as a result of increasing ego-centricity, narrows the mental horizon. In the end it may lead to the development of an essentially negative personality, which means that a falsification of the original personality has supervened.

[215] b. *Enlargement of personality*. The personality is seldom, in the beginning, what it will be later on. For this reason the possibility of enlarging it exists, at least during the first half of life. The enlargement may be effected through an accretion from without, by new vital contents finding their way into the personality from outside and being assimilated. In this way a considerable increase of personality may be experienced. We therefore tend to assume that this increase comes *only* from without, thus justifying the prejudice that one becomes a personality by stuffing into oneself as much as possible from outside. But the more assiduously we follow this recipe, and the more stubbornly we believe that all increase has to come from without, the greater becomes our inner poverty. Therefore, if some great idea takes hold of us from outside, we must understand that it takes hold of us only because something in us responds to it and goes out to meet it. Richness of mind consists in mental receptivity, not in the accumulation of possessions. What comes to us from outside, and, for that matter, everything that rises up from within, can only be made our own if we are capable of an inner amplitude equal to that of the incoming content. Real increase of personality means consciousness of an enlargement that flows from inner sources. Without psychic depth we can never be adequately related to the magnitude of our object. It has therefore been said quite truly that a man grows with the greatness of his task. But he must have within himself the capacity to grow; otherwise even the most difficult task is of no benefit to him. More likely he will be shattered by it.

[216] A classic example of enlargement is Nietzsche’s encounter with Zarathustra, which made of the critic and aphorist a tragic poet and prophet. Another example is St. Paul, who, on his way to Damascus, was suddenly confronted by Christ. True though it may be that this Christ of St. Paul’s would hardly have been possible without the historical Jesus, the apparition of Christ came to St. Paul not from the historical Jesus but from the depths of his own unconscious.

[217] When a summit of life is reached, when the bud unfolds and from the lesser the greater emerges, then, as Nietzsche says, “One becomes Two,” and the greater figure, which one always was but which remained invisible, appears to the lesser personality with the force of a revelation. He who is truly and hopelessly little will always drag the revelation of the greater down to the level of his littleness, and will never understand that the day of judgment for his littleness has dawned. But the man who is inwardly great will know that the long expected friend of his soul, the immortal one, has now really come, “to lead captivity captive”;⁸ that is, to seize hold of him by whom this immortal had always been confined and held prisoner, and to make his life flow into that greater life—a moment of deadliest peril! Nietzsche’s prophetic vision of the Tightrope Walker⁹ reveals the awful danger that lies in having a “tightrope-walking” attitude towards an event to which St. Paul gave the most exalted name he could find.

[218] Christ himself is the perfect symbol of the hidden immortal within the mortal man.¹⁰ Ordinarily this problem is symbolized by a dual motif such as the Dioscuri, one of whom is mortal and the other immortal. An Indian parallel is the parable of the two friends:

Behold, upon the selfsame tree,
Two birds, fast-bound companions, sit.
This one enjoys the ripened fruit,
The other looks, but does not eat.
On such a tree my spirit crouched,
Deluded by its powerlessness,
Till seeing with joy how great its Lord,
It found from sorrow swift release....¹¹

[219] Another notable parallel is the Islamic legend of the meeting of Moses and Khidr,¹² to which I shall return later on. Naturally the transformation of personality in this enlarging sense does not occur only in the form of such highly significant experiences. There is no lack of more trivial instances, a list of which could easily be compiled from the clinical history of neurotic patients. Indeed, any case where the recognition of a greater personality seems to burst an iron ring round the heart must be included in this category.¹³

[220] *c. Change of internal structure.* We now come to changes of personality which imply neither enlargement nor diminution but a structural alteration. One of the most important forms is the phenomenon of possession: some content, an idea or a part of the personality, obtains mastery of the individual for one reason or another. The contents which thus take possession appear as peculiar convictions, idiosyncrasies,

stubborn plans, and so forth. As a rule, they are not open to correction. One has to be an especially good friend of the possessed person and willing to put up with almost anything if one is to attempt to deal with such a condition. I am not prepared to lay down any hard and fast line of demarcation between possession and paranoia. Possession can be formulated as identity of the ego-personality with a complex.¹⁴

[221] A common instance of this is identity with the persona, which is the individual's system of adaptation to, or the manner he assumes in dealing with, the world. Every calling or profession, for example, has its own characteristic persona. It is easy to study these things nowadays, when the photographs of public personalities so frequently appear in the press. A certain kind of behaviour is forced on them by the world, and professional people endeavour to come up to these expectations. Only, the danger is that they become identical with their personas—the professor with his textbook, the tenor with his voice. Then the damage is done; henceforth he lives exclusively against the background of his own biography. For by that time it is written: "... then he went to such and such a place and said this or that," etc. The garment of Deianeira has grown fast to his skin, and a desperate decision like that of Heracles is needed if he is to tear this Nessus shirt from his body and step into the consuming fire of the flame of immortality, in order to transform himself into what he really is. One could say, with a little exaggeration, that the persona is that which in reality one is not, but which oneself as well as others think one is.¹⁵ In any case the temptation to be what one seems to be is great, because the persona is usually rewarded in cash.

[222] There are still other factors which may take possession of the individual, one of the most important being the so-called "inferior function." This is not the place to enter into a detailed discussion of this problem;¹⁶ I should only like to point out that the inferior function is practically identical with the dark side of the human personality. The darkness which clings to every personality is the door into the unconscious and the gateway of dreams, from which those two twilight figures, the shadow and the anima, step into our nightly visions or, remaining invisible, take possession of our ego-consciousness. A man who is possessed by his shadow is always standing in his own light and falling into his own traps. Whenever possible, he prefers to make an unfavourable impression on others. In the long run luck is always against him, because he is living below his own level and at best only attains what does not suit him. And if there is no doorstep for him to stumble over, he manufactures one for himself and then fondly believes he has done something useful.

[223] Possession caused by the anima or animus presents a different picture. Above all, this transformation of personality gives prominence to those traits which are characteristic of the opposite sex; in man the feminine traits, and in woman the

masculine. In the state of possession both figures lose their charm and their values; they retain them only when they are turned away from the world, in the introverted state, when they serve as bridges to the unconscious. Turned towards the world, the anima is fickle, capricious, moody, uncontrolled and emotional, sometimes gifted with daemonic intuitions, ruthless, malicious, untruthful, bitchy, double-faced, and mystical.¹⁷ The animus is obstinate, harping on principles, laying down the law, dogmatic, world-reforming, theoretic, word-mongering, argumentative, and domineering.¹⁸ Both alike have bad taste: the anima surrounds herself with inferior people, and the animus lets himself be taken in by second-rate thinking.

[224] Another form of structural change concerns certain unusual observations about which I speak only with the utmost reserve. I refer to states of possession in which the possession is caused by something that could perhaps most fitly be described as an “ancestral soul,” by which I mean the soul of some definite forebear. For all practical purposes, such cases may be regarded as striking instances of identification with deceased persons. (Naturally, the phenomena of identity only occur after the “ancestor’s” death.) My attention was first drawn to such possibilities by Léon Daudet’s confused but ingenious book *L’Hérédo*. Daudet supposes that, in the structure of the personality, there are ancestral elements which under certain conditions may suddenly come to the fore. The individual is then precipitately thrust into an ancestral role. Now we know that ancestral roles play a very important part in primitive psychology. Not only are ancestral spirits supposed to be reincarnated in children, but an attempt is made to implant them into the child by naming him after an ancestor. So, too, primitives try to change themselves back into their ancestors by means of certain rites. I would mention especially the Australian conception of the *alcheringamijina*,¹⁹ ancestral souls, half man and half animal, whose reactivation through religious rites is of the greatest functional significance for the life of the tribe. Ideas of this sort, dating back to the Stone Age, were widely diffused, as may be seen from numerous other traces that can be found elsewhere. It is therefore not improbable that these primordial forms of experience may recur even today as cases of identification with ancestral souls, and I believe I have seen such cases.

[225] d. *Identification with a group*. We shall now discuss another form of transformation experience which I would call identification with a group. More accurately speaking, it is the identification of an individual with a number of people who, as a group, have a collective experience of transformation. This special psychological situation must not be confused with participation in a transformation rite, which, though performed before an audience, does not in any way depend upon group identity or necessarily give rise to it. To experience transformation in a group and to experience it in oneself are two totally different things. If any considerable group of persons are united and identified with one another by a particular frame of

mind, the resultant transformation experience bears only a very remote resemblance to the experience of individual transformation. A group experience takes place on a lower level of consciousness than the experience of an individual. This is due to the fact that, when many people gather together to share one common emotion, the total psyche emerging from the group is below the level of the individual psyche. If it is a very large group, the collective psyche will be more like the psyche of an animal, which is the reason why the ethical attitude of large organizations is always doubtful. The psychology of a large crowd inevitably sinks to the level of mob psychology.²⁰ If, therefore, I have a so-called collective experience as a member of a group, it takes place on a lower level of consciousness than if I had the experience by myself alone. That is why this group experience is very much more frequent than an individual experience of transformation. It is also much easier to achieve, because the presence of so many people together exerts great suggestive force. The individual in a crowd easily becomes the victim of his own suggestibility. It is only necessary for something to happen, for instance a proposal backed by the whole crowd, and we too are all for it, even if the proposal is immoral. In the crowd one feels no responsibility, but also no fear.

[226] Thus identification with the group is a simple and easy path to follow, but the group experience goes no deeper than the level of one's own mind in that state. It does work a change in you, but the change does not last. On the contrary, you must have continual recourse to mass intoxication in order to consolidate the experience and your belief in it. But as soon as you are removed from the crowd, you are a different person again and unable to reproduce the previous state of mind. The mass is swayed by *participation mystique*, which is nothing other than an unconscious identity. Supposing, for example, you go to the theatre: glance meets glance, everybody observes everybody else, so that all those who are present are caught up in an invisible web of mutual unconscious relationship. If this condition increases, one literally feels borne along by the universal wave of identity with others. It may be a pleasant feeling—one sheep among ten thousand! Again, if I feel that this crowd is a great and wonderful unity, I am a hero, exalted along with the group. When I am myself again, I discover that I am Mr. So-and-So, and that I live in such and such a street, on the third floor. I also find that the whole affair was really most delightful, and I hope it will take place again tomorrow so that I may once more feel myself to be a whole nation, which is much better than being just plain Mr. X. Since this is such an easy and convenient way of raising one's personality to a more exalted rank, mankind has always formed groups which made collective experiences of transformation—often of an ecstatic nature—possible. The regressive identification with lower and more primitive states of consciousness is invariably accompanied by

a heightened sense of life; hence the quickening effect of regressive identifications with half-animal ancestors²¹ in the Stone Age.

[227] The inevitable psychological regression within the group is partially counteracted by ritual, that is to say through a cult ceremony which makes the solemn performance of sacred events the centre of group activity and prevents the crowd from relapsing into unconscious instinctuality. By engaging the individual's interest and attention, the ritual makes it possible for him to have a comparatively individual experience even within the group and so to remain more or less conscious. But if there is no relation to a centre which expresses the unconscious through its symbolism, the mass psyche inevitably becomes the hypnotic focus of fascination, drawing everyone under its spell. That is why masses are always breeding-grounds of psychic epidemics,²² the events in Germany being a classic example of this.

[228] It will be objected to this essentially negative evaluation of mass psychology that there are also positive experiences, for instance a positive enthusiasm which spurs the individual to noble deeds, or an equally positive feeling of human solidarity. Facts of this kind should not be denied. The group can give the individual a courage, a bearing, and a dignity which may easily get lost in isolation. It can awaken within him the memory of being a man among men. But that does not prevent something else from being added which he would not possess as an individual. Such unearned gifts may seem a special favour of the moment, but in the long run there is a danger of the gift becoming a loss, since human nature has a weak habit of taking gifts for granted; in times of necessity we demand them as a right instead of making the effort to obtain them ourselves. One sees this, unfortunately, only too plainly in the tendency to demand everything from the State, without reflecting that the State consists of those very individuals who make the demands. The logical development of this tendency leads to Communism, where each individual enslaves the community and the latter is represented by a dictator, the slave-owner. All primitive tribes characterized by a communistic order of society also have a chieftain over them with unlimited powers. The Communist State is nothing other than an absolute monarchy in which there are no subjects, but only serfs.

[229] e. *Identification with a cult-hero.* Another important identification underlying the transformation experience is that with the god or hero who is transformed in the sacred ritual. Many cult ceremonies are expressly intended to bring this identity about, an obvious example being the *Metamorphosis* of Apuleius. The initiate, an ordinary human being, is elected to be Helios; he is crowned with a crown of palms and clad in the mystic mantle, whereupon the assembled crowd pays homage to him. The suggestion of the crowd brings about his identity with the god. The participation of the community can also take place in the following way: there is no apotheosis of

the initiate, but the sacred action is recited, and then, in the course of long periods of time, psychic changes gradually occur in the individual participants. The Osiris cult offers an excellent example of this. At first only Pharaoh participated in the transformation of the god, since he alone “had an Osiris”; but later the nobles of the Empire acquired an Osiris too, and finally this development culminated in the Christian idea that everyone has an immortal soul and shares directly in the Godhead. In Christianity the development was carried still further when the outer God or Christ gradually became the inner Christ of the individual believer, remaining one and the same though dwelling in many. This truth had already been anticipated by the psychology of totemism: many exemplars of the totem animal are killed and consumed during the totem meals, and yet it is only the One who is being eaten, just as there is only one Christ-child and one Santa Claus.

[230] In the mysteries, the individual undergoes an indirect transformation through his participation in the fate of the god. The transformation experience is also an indirect one in the Christian Church, inasmuch as it is brought about by participation in something acted or recited. Here the first form, the *dromenon*, is characteristic of the richly developed ritual of the Catholic Church; the second form, the recitation, the “Word” or “gospel,” is practised in the “preaching of the Word” in Protestantism.

[231] f. *Magical procedures*. A further form of transformation is achieved through a rite used directly for this purpose. Instead of the transformation experience coming to one through participation in the rite, the rite is used for the express purpose of effecting the transformation. It thus becomes a sort of technique to which one submits oneself. For instance, a man is ill and consequently needs to be “renewed.” The renewal must “happen” to him from outside, and to bring this about, he is pulled through a hole in the wall at the head of his sick-bed, and now he is reborn; or he is given another name and thereby another soul, and then the demons no longer recognize him; or he has to pass through a symbolical death; or, grotesquely enough, he is pulled through a leathern cow, which devours him, so to speak, in front and then expels him behind; or he undergoes an ablution or baptismal bath and miraculously changes into a semi-divine being with a new character and an altered metaphysical destiny.

[232] g. *Technical transformation*. Besides the use of the rite in the magical sense, there are still other special techniques in which, in addition to the grace inherent in the rite, the personal endeavour of the initiate is needed in order to achieve the intended purpose. It is a transformation experience induced by technical means. The exercises known in the East as yoga and in the West as *exercitia spiritualia* come into this category. These exercises represent special techniques prescribed in advance and intended to achieve a definite psychic effect, or at least to promote it. This is true

both of Eastern yoga and of the methods practised in the West.²³ They are, therefore, technical procedures in the fullest sense of the word; elaborations of the originally natural processes of transformation. The natural or spontaneous transformations that occurred earlier, before there were any historical examples to follow, were thus replaced by techniques designed to induce the transformation by imitating this same sequence of events. I will try to give an idea of the way such techniques may have originated by relating a fairy story:

[233] There was once a queer old man who lived in a cave, where he had sought refuge from the noise of the villages. He was reputed to be a sorcerer, and therefore he had disciples who hoped to learn the art of sorcery from him. But he himself was not thinking of any such thing. He was only seeking to know what it was that he did not know, but which, he felt certain, was always happening. After meditating for a very long time on that which is beyond meditation, he saw no other way of escape from his predicament than to take a piece of red chalk and draw all kinds of diagrams on the walls of his cave, in order to find out what that which he did not know might look like. After many attempts he hit on the circle. “That’s right,” he felt, “and now for a quadrangle inside it!”—which made it better still. His disciples were curious; but all they could make out was that the old man was up to something, and they would have given anything to know what he was doing. But when they asked him: “What are you doing there?” he made no reply. Then they discovered the diagrams on the wall and said: “That’s it!”—and they all imitated the diagrams. But in so doing they turned the whole process upside down, without noticing it: they anticipated the result in the hope of making the process repeat itself which had led to that result. This is how it happened then and how it still happens today.

[234] h. *Natural transformation (individuation)*. As I have pointed out, in addition to the technical processes of transformation there are also natural transformations. All ideas of rebirth are founded on this fact. Nature herself demands a death and a rebirth. As the alchemist Democritus says: “Nature rejoices in nature, nature subdues nature, nature rules over nature.” There are natural transformation processes which simply happen to us, whether we like it or not, and whether we know it or not. These processes develop considerable psychic effects, which would be sufficient in themselves to make any thoughtful person ask himself what really happened to him. Like the old man in our fairytale, he, too, will draw mandalas and seek shelter in their protective circle; in the perplexity and anguish of his self-chosen prison, which he had deemed a refuge, he is transformed into a being akin to the gods. Mandalas are birth-places, vessels of birth in the most literal sense, lotus-flowers in which a Buddha comes to life. Sitting in the lotus-seat, the yogi sees himself transfigured into an immortal.

[235] Natural transformation processes announce themselves mainly in dreams. Elsewhere²⁴ I have presented a series of dream-symbols of the process of individuation. They were dreams which without exception exhibited rebirth symbolism. In this particular case there was a long-drawn-out process of inner transformation and rebirth into another being. This “other being” is the other person in ourselves—that larger and greater personality maturing within us, whom we have already met as the inner friend of the soul. That is why we take comfort whenever we find the friend and companion depicted in a ritual, an example being the friendship between Mithras and the sun-god. This relationship is a mystery to the scientific intellect, because the intellect is accustomed to regard these things unsympathetically. But if it made allowance for feeling, we would discover that it is the friend whom the sun-god takes with him on his chariot, as shown in the monuments. It is the representation of a friendship between two men which is simply the outer reflection of an inner fact: it reveals our relationship to that inner friend of the soul into whom Nature herself would like to change us—that other person who we also are and yet can never attain to completely. We are that pair of Dioscuri, one of whom is mortal and the other immortal, and who, though always together, can never be made completely one. The transformation processes strive to approximate them to one another, but our consciousness is aware of resistances, because the other person seems strange and uncanny, and because we cannot get accustomed to the idea that we are not absolute master in our own house. We should prefer to be always “I” and nothing else. But we are confronted with that inner friend or foe, and whether he is our friend or our foe depends on ourselves.

[236] You need not be insane to hear his voice. On the contrary, it is the simplest and most natural thing imaginable. For instance, you can ask yourself a question to which “he” gives answer. The discussion is then carried on as in any other conversation. You can describe it as mere “associating” or “talking to oneself,” or as a “meditation” in the sense used by the old alchemists, who referred to their interlocutor as *aliquem alium internum*, ‘a certain other one, within.’²⁵ This form of colloquy with the friend of the soul was even admitted by Ignatius Loyola into the technique of his *Exercitia spiritualia*,²⁶ but with the limiting condition that only the person meditating is allowed to speak, whereas the inner responses are passed over as being merely human and therefore to be repudiated. This state of things has continued down to the present day. It is no longer a moral or metaphysical prejudice, but—what is much worse—an intellectual one. The “voice” is explained as nothing but “associating,” pursued in a witless way and running on and on without sense or purpose, like the works of a clock that has no dial. Or we say “It is only my own thoughts!” even if, on closer inspection, it should turn out that they are thoughts which we either reject or had never consciously thought at all—as if everything psychic that is glimpsed by the

ego had always formed part of it! Naturally this hybris serves the useful purpose of maintaining the supremacy of ego-consciousness, which must be safeguarded against dissolution into the unconscious. But it breaks down ignominiously if ever the unconscious should choose to let some nonsensical idea become an obsession or to produce other psychogenic symptoms, for which we would not like to accept responsibility on any account.

[237] Our attitude towards this inner voice alternates between two extremes: it is regarded either as undiluted nonsense or as the voice of God. It does not seem to occur to any one that there might be something valuable in between. The “other” may be just as one-sided in one way as the ego is in another. And yet the conflict between them may give rise to truth and meaning—but only if the ego is willing to grant the other its rightful personality. It has, of course, a personality anyway, just as have the voices of insane people; but a real colloquy becomes possible only when the ego acknowledges the existence of a partner to the discussion. This cannot be expected of everyone, because, after all, not everyone is a fit subject for *exercitia spiritualia*. Nor can it be called a colloquy if one speaks only to oneself or only addresses the other, as is the case with George Sand in her conversations with a “spiritual friend”:^{26a} for thirty pages she talks exclusively to herself while one waits in vain for the other to reply. The colloquy of the *exercitia* may be followed by that silent grace in which the modern doubter no longer believes. But what if it were the supplicated Christ himself who gave immediate answer in the words of the sinful human heart? What fearful abysses of doubt would then be opened? What madness should we not then have to fear? From this one can understand that images of the gods are better mute, and that ego-consciousness had better believe in its own supremacy rather than go on “associating.” One can also understand why that inner friend so often seems to be our enemy, and why he is so far off and his voice so low. For he who is near to him “is near to the fire.”

[238] Something of this sort may have been in the mind of the alchemist who wrote: “Choose for your Stone him through whom kings are honoured in their crowns, and through whom physicians heal their sick, for he is near to the fire.”²⁷ The alchemists projected the inner event into an outer figure, so for them the inner friend appeared in the form of the “Stone,” of which the *Tractatus aureus* says: “Understand, ye sons of the wise, what this exceeding precious Stone crieth out to you: Protect me and I will protect thee. Give me what is mine that I may help thee.”²⁸ To this a scholiast adds: “The seeker after truth hears both the Stone and the Philosopher speaking as if out of one mouth.”²⁹ The Philosopher is Hermes, and the Stone is identical with Mercurius, the Latin Hermes.³⁰ From the earliest times, Hermes was the mystagogue and psychopomp of the alchemists, their friend and counsellor, who leads them to the goal of their work. He is “like a teacher mediating between the stone and the

disciple.”³¹ To others the friend appears in the shape of Christ or Khidr or a visible or invisible guru, or some other personal guide or leader figure. In this case the colloquy is distinctly one-sided: there is no inner dialogue, but instead the response appears as the action of the other, i.e., as an outward event. The alchemists saw it in the transformation of the chemical substance. So if one of them sought transformation, he discovered it outside in matter, whose transformation cried out to him, as it were, “I am the transformation!” But some were clever enough to know, “It is my own transformation—not a personal transformation, but the transformation of what is mortal in me into what is immortal. It shakes off the mortal husk that I am and awakens to a life of its own; it mounts the sun-barge and may take me with it.”³²

[239] This is a very ancient idea. In Upper Egypt, near Aswan, I once saw an ancient Egyptian tomb that had just been opened. Just behind the entrance-door was a little basket made of reeds, containing the withered body of a new-born infant, wrapped in rags. Evidently the wife of one of the workmen had hastily laid the body of her dead child in the nobleman’s tomb at the last moment, hoping that, when he entered the sun-barge in order to rise anew, it might share in his salvation, because it had been buried in the holy precinct within reach of divine grace.

3. A TYPICAL SET OF SYMBOLS ILLUSTRATING THE PROCESS OF TRANSFORMATION

[240] I have chosen as an example a figure which plays a great role in Islamic mysticism, namely Khidr, “the Verdant One.” He appears in the Eighteenth Sura of the Koran, entitled “The Cave.”¹ This entire Sura is taken up with a rebirth mystery. The cave is the place of rebirth, that secret cavity in which one is shut up in order to be incubated and renewed. The Koran says of it: “You might have seen the rising sun decline to the right of their cavern, and as it set, go past them on the left, while they [the Seven Sleepers] stayed in the middle.” The “middle” is the centre where the jewel reposes, where the incubation or the sacrificial rite or the transformation takes place. The most beautiful development of this symbolism is to be found on Mithraic altarpieces² and in alchemical pictures of the transformative substance,³ which is always shown between sun and moon. Representations of the crucifixion frequently follow the same type, and a similar symbolical arrangement is also found in the transformation or healing ceremonies of the Navahos.⁴ Just such a place of the centre or of transformation is the cave in which those seven had gone to sleep, little thinking that they would experience there a prolongation of life verging on immortality. When they awoke, they had slept 309 years.

[241] The legend has the following meaning: Anyone who gets into that cave, that is to say into the cave which everyone has in himself, or into the darkness that lies behind consciousness, will find himself involved in an—at first—unconscious process of transformation. By penetrating into the unconscious he makes a connection with his unconscious contents. This may result in a momentous change of personality in the positive or negative sense. The transformation is often interpreted as a prolongation of the natural span of life or as an earnest of immortality. The former is the case with many alchemists, notably Paracelsus (in his treatise *De vita longa*⁵), and the latter is exemplified in the Eleusinian mysteries.

[242] Those seven sleepers indicate by their sacred number⁶ that they are gods,⁷ who are transformed during sleep and thereby enjoy eternal youth. This helps us to understand at the outset that we are dealing with a mystery legend. The fate of the numinous figures recorded in it grips the hearer, because the story gives expression to parallel processes in his own unconscious which in that way are integrated with consciousness again. The repristination of the original state is tantamount to attaining once more the freshness of youth.

[243] The story of the sleepers is followed by some moral observations which appear to have no connection with it. But this apparent irrelevance is deceptive. In reality, these edifying comments are just what are needed by those who cannot be reborn themselves and have to be content with moral conduct, that is to say with adherence to the law. Very often behaviour prescribed by rule is a substitute for spiritual transformation.⁸ These edifying observations are then followed by the story of Moses and his servant Joshua ben Nun:

And Moses said to his servant: "I will not cease from my wanderings until I have reached the place where the two seas meet, even though I journey for eighty years."

But when they had reached the place where the two seas meet, they forgot their fish, and it took its way through a stream to the sea.

And when they had journeyed past this place, Moses said to his servant: "Bring us our breakfast, for we are weary from this journey."

But the other replied: "See what has befallen me! When we were resting there by the rock, I forgot the fish. Only Satan can have put it out of my mind, and in wondrous fashion it took its way to the sea."

Then Moses said: "That is the place we seek." And they went back the way they had come. And they found one of Our servants, whom We had endowed with Our grace and Our wisdom. Moses said to him: "Shall I follow you, that you may teach me for my guidance some of the wisdom you have learnt?"

But he answered: "You will not bear with me, for how should you bear patiently with things you cannot comprehend?"

Moses said: "If Allah wills, you shall find me patient; I shall not in anything disobey you."

He said: "If you are bent on following me, you must ask no question about anything till I myself speak to you concerning it."

The two set forth, but as soon as they embarked, Moses' companion bored a hole in the bottom of the ship.

"A strange thing you have done!" exclaimed Moses. "Is it to drown her passengers that you have bored a hole in her?"

"Did I not tell you," he replied, "that you would not bear with me?"

"Pardon my forgetfulness," said Moses. "Do not be angry with me on this account."

They journeyed on until they fell in with a certain youth. Moses' companion slew him, and Moses said: "You have killed an innocent man who has done no harm. Surely you have committed a wicked crime."

"Did I not tell you," he replied, "that you would not bear with me?"

Moses said: "If ever I question you again, abandon me; for then I should deserve it."

They travelled on until they came to a certain city. They asked the people for some food, but the people declined to receive them as their guests. There they found a wall on the point of falling down. The other raised it up, and Moses said: "Had you wished, you could have demanded payment for your labours."

"Now the time has arrived when we must part," said the other. "But first I will explain to you those acts of mine which you could not bear with in patience.

"Know that the ship belonged to some poor fishermen. I damaged it because in their rear was a king who was taking every ship by force.

"As for the youth, his parents both are true believers, and we feared lest he should plague them with his wickedness and unbelief. It was our wish that their Lord should grant them another in his place, a son more righteous and more filial.

"As for the wall, it belonged to two orphan boys in the city whose father was an honest man. Beneath it their treasure is buried. Your Lord decreed in His mercy that they should dig out their treasure when they grew to manhood. What I did was not done by caprice. That is the meaning of the things you could not bear with in patience."

[244] This story is an amplification and elucidation of the legend of the seven sleepers and the problem of rebirth. Moses is the man who seeks, the man on the "quest." On this pilgrimage he is accompanied by his "shadow," the "servant" or "lower" man (*pneumatikos* and *sarkikos* in two individuals). Joshua is the son of Nun, which is a name for "fish,"⁹ suggesting that Joshua had his origin in the depths of the waters, in the darkness of the shadow-world. The critical place is reached "where the two seas meet," which is interpreted as the isthmus of Suez, where the Western and the Eastern seas come close together. In other words, it is that "place of the middle" which we have already met in the symbolic preamble, but whose significance was not recognized at first by the man and his shadow. They had "forgotten their fish," the humble source of nourishment. The fish refers to Nun, the father of the shadow, of the carnal man, who comes from the dark world of the Creator. For the fish came alive again and leapt out of the basket in order to find its way back to its homeland, the sea. In other words, the animal ancestor and creator of life separates himself from the conscious man, an event which amounts to loss of the instinctive psyche. This process is a symptom of dissociation well known in the psychopathology of the neuroses; it is always connected with one-sidedness of the conscious attitude. In view of the fact, however, that neurotic phenomena are nothing but exaggerations of normal processes, it is not to be wondered at that very similar phenomena can also be found within the scope of the normal. It is a question of that well-known "loss of soul" among primitives, as described above in the section on diminution of the personality; in scientific language, an *abaissement du niveau mental*.

[245] Moses and his servant soon notice what has happened. Moses had sat down, “worn out” and hungry. Evidently he had a feeling of insufficiency, for which a physiological explanation is given. Fatigue is one of the most regular symptoms of loss of energy or libido. The entire process represents something very typical, namely the *failure to recognize a moment of crucial importance*, a motif which we encounter in a great variety of mythical forms. Moses realizes that he has unconsciously found the source of life and then lost it again, which we might well regard as a remarkable intuition. The fish they had intended to eat is a content of the unconscious, by which the connection with the origin is re-established. He is the reborn one, who has awakened to new life. This came to pass, as the commentaries say, through the contact with the water of life: by slipping back into the sea, the fish once more becomes a content of the unconscious, and its offspring are distinguished by having only one eye and half a head.¹⁰

[246] The alchemists, too, speak of a strange fish in the sea, the “round fish lacking bones and skin,”¹¹ which symbolizes the “round element,” the germ of the “animate stone,” of the *filius philosophorum*. The water of life has its parallel in the *aqua permanens* of alchemy. This water is extolled as “vivifying,” besides which it has the property of dissolving all solids and coagulating all liquids. The Koran commentaries state that, on the spot where the fish disappeared, the sea was turned to solid ground, whereon the tracks of the fish could still be seen.¹² On the island thus formed Khidr was sitting, in the place of the middle. A mystical interpretation says that he was sitting “on a throne consisting of light, between the upper and the lower sea,”¹³ again in the middle position. The appearance of Khidr seems to be mysteriously connected with the disappearance of the fish. It looks almost as if he himself had been the fish. This conjecture is supported by the fact that the commentaries relegate the source of life to the “place of darkness.”¹⁴ The depths of the sea are dark (*mare tenebrositatis*). The darkness has its parallel in the alchemical *nigredo*, which occurs after the *coniunctio*, when the female takes the male into herself.¹⁵ From the *nigredo* issues the Stone, the symbol of the immortal self; moreover, its first appearance is likened to “fish eyes.”¹⁶

[247] Khidr may well be a symbol of the self. His qualities signalize him as such: he is said to have been born in a cave, i.e., in darkness. He is the “Long-lived One,” who continually renews himself, like Elijah. Like Osiris, he is dismembered at the end of time, by Antichrist, but is able to restore himself to life. He is analogous to the Second Adam, with whom the reanimated fish is identified;¹⁷ he is a counsellor, a Paraclete, “Brother Khidr.” Anyway Moses accepts him as a higher consciousness and looks up to him for instruction. Then follow those incomprehensible deeds which show how ego-consciousness reacts to the superior guidance of the self through the twists and turns of fate. To the initiate who is capable of transformation it is a

comforting tale; to the obedient believer, an exhortation not to murmur against Allah's incomprehensible omnipotence. Khidr symbolizes not only the higher wisdom but also a way of acting which is in accord with this wisdom and transcends reason.

[248] Anyone hearing such a mystery tale will recognize himself in the questing Moses and the forgetful Joshua, and the tale shows him how the immortality-bringing rebirth comes about. Characteristically, it is neither Moses nor Joshua who is transformed, but the forgotten fish. Where the fish disappears, there is the birthplace of Khidr. The immortal being issues from something humble and forgotten, indeed, from a wholly improbable source. This is the familiar motif of the hero's birth and need not be documented here.¹⁸ Anyone who knows the Bible will think of Isaiah 53:2ff., where the "servant of God" is described, and of the gospel stories of the Nativity. The nourishing character of the transformative substance or deity is borne out by numerous cult-legends: Christ is the bread, Osiris the wheat, Mondamin the maize,¹⁹ etc. These symbols coincide with a psychic fact which obviously, from the point of view of consciousness, has the significance merely of something to be assimilated, but whose real nature is overlooked. The fish symbol shows immediately what this is: it is the "nourishing" influence of unconscious contents, which maintain the vitality of consciousness by a continual influx of energy; for consciousness does not produce its energy by itself. What is capable of transformation is just this root of consciousness, which—inconspicuous and almost invisible (i.e., unconscious) though it is—provides consciousness with all its energy. Since the unconscious gives us the feeling that it is something alien, a non-ego, it is quite natural that it should be symbolized by an alien figure. Thus, on the one hand, it is the most insignificant of things, while on the other, so far as it potentially contains that "round" wholeness which consciousness lacks, it is the most significant of all. This "round" thing is the great treasure that lies hidden in the cave of the unconscious, and its personification is this personal being who represents the higher unity of conscious and unconscious. It is a figure comparable to Hiranyagarbha, Purusha, Atman, and the mystic Buddha. For this reason I have elected to call it the "self," by which I understand a psychic totality and at the same time a centre, neither of which coincides with the ego but includes it, just as a larger circle encloses a smaller one.

[249] The intuition of immortality which makes itself felt during the transformation is connected with the peculiar nature of the unconscious. It is, in a sense, non-spatial and non-temporal. The empirical proof of this is the occurrence of so-called telepathic phenomena, which are still denied by hypersceptical critics, although in reality they are much more common than is generally supposed.²⁰ The feeling of immortality, it seems to me, has its origin in a peculiar feeling of extension in space

and time, and I am inclined to regard the deification rites in the mysteries as a projection of this same psychic phenomenon.

[250] The character of the self as a personality comes out very plainly in the Khidr legend. This feature is most strikingly expressed in the non-Koranic stories about Khidr, of which Vollers gives some telling examples. During my trip through Kenya, the headman of our safari was a Somali who had been brought up in the Sufi faith. To him Khidr was in every way a living person, and he assured me that I might at any time meet Khidr, because I was, as he put it, a *M'tu-ya-kitabu*,²¹ a 'man of the Book,' meaning the Koran. He had gathered from our talks that I knew the Koran better than he did himself (which was, by the way, not saying a great deal). For this reason he regarded me as "islamu." He told me I might meet Khidr in the street in the shape of a man, or he might appear to me during the night as a pure white light, or—he smilingly picked a blade of grass—the Verdant One might even look like that. He said he himself had once been comforted and helped by Khidr, when he could not find a job after the war and was suffering want. One night, while he slept, he dreamt he saw a bright white light near the door and he knew it was Khidr. Quickly leaping to his feet (in the dream), he reverentially saluted him with the words *salem aleikum*, 'peace be with you,' and then he knew that his wish would be fulfilled. He added that a few days later he was offered the post as headman of a safari by a firm of outfitters in Nairobi.

[251] This shows that, even in our own day, Khidr still lives on in the religion of the people, as friend, adviser, comforter, and teacher of revealed wisdom. The position assigned to him by dogma was, according to my Somali, that of *maleika kwanza-yamungu*, 'First Angel of God'—a sort of "Angel of the Face," an *angelos* in the true sense of the word, a messenger.

[252] Khidr's character as a friend explains the subsequent part of the Eighteenth Sura, which reads as follows:

They will ask you about Dhulqarnein. Say: "I will give you an account of him.

"We made him mighty in the land and gave him means to achieve all things. He journeyed on a certain road until he reached the West and saw the sun setting in a pool of black mud. Hard by he found a certain people.

"'Dhulqarnein,' We said, 'you must either punish them or show them kindness.'

"He replied: 'The wicked We shall surely punish. Then they shall return to their Lord and be sternly punished by Him. As for those that have faith and do good works, we shall bestow on them a rich reward and deal indulgently with them.'

"He then journeyed along another road until he reached the East and saw the sun rising upon a people whom We had utterly exposed to its flaming rays. So he did; and

We had full knowledge of all the forces at his command.

“Then he followed yet another route until he came between the Two Mountains and found a people who could barely understand a word. ‘Dhulqarnein,’ they said, ‘Gog and Magog are ravaging this land. Build us a rampart against them and we will pay you tribute.’

“He replied: ‘The power which my Lord has given me is better than any tribute. Lend me a force of labourers, and I will raise a rampart between you and them. Come, bring me blocks of iron.’

“He dammed up the valley between the Two Mountains, and said: ‘Ply your bellows.’ And when the iron blocks were red with heat, he said: ‘Bring me molten brass to pour on them.’

“Gog and Magog could not scale it, nor could they dig their way through it. He said: ‘This is a blessing from my Lord. But when my Lord’s promise is fulfilled, He will level it to dust. The promise of my Lord is true.’”

On that day We will let them come in tumultuous throngs. The Trumpet shall be sounded and We will gather them all together.

On that day Hell shall be laid bare before the unbelievers, who have turned a blind eye to My admonition and a deaf ear to My warning.

[253] We see here another instance of that lack of coherence which is not uncommon in the Koran. How are we to account for this apparently abrupt transition to Dhulqarnein, the Two-horned One, that is to say, Alexander the Great? Apart from the unheard-of anachronism (Mohammed’s chronology in general leaves much to be desired), one does not quite understand why Alexander is brought in here at all. But it has to be borne in mind that Khidr and Dhulqarnein are *the* great pair of friends, altogether comparable to the Dioscuri, as Vollers rightly emphasizes. The psychological connection may therefore be presumed to be as follows: Moses has had a profoundly moving experience of the self, which brought unconscious processes before his eyes with overwhelming clarity. Afterwards, when he comes to his people, the Jews, who are counted among the infidels, and wants to tell them about his experience, he prefers to use the form of a mystery legend. Instead of speaking about himself, he speaks about the Two-horned One. Since Moses himself is also “horned,” the substitution of Dhulqarnein appears plausible. Then he has to relate the history of this friendship and describe how Khidr helped his friend. Dhulqarnein makes his way to the setting of the sun and then to its rising. That is, he describes the way of the renewal of the sun, through death and darkness to a new resurrection. All this again indicates that it is Khidr who not only stands by man in his bodily needs but also helps him to attain rebirth.²² The Koran, it is true, makes no distinction in this narrative between Allah, who is speaking in the first person plural, and Khidr. But it

is clear that this section is simply a continuation of the helpful actions described previously, from which it is evident that Khidr is a symbolization or “incarnation” of Allah. The friendship between Khidr and Alexander plays an especially prominent part in the commentaries, as does also the connection with the prophet Elijah. Vollers does not hesitate to extend the comparison to that other pair of friends, Gilgamesh and Enkidu.²³

[254] To sum up, then: Moses has to recount the deeds of the two friends to his people in the manner of an impersonal mystery legend. Psychologically this means that the transformation has to be described or felt as happening to the “other.” Although it is Moses himself who, in his experience with Khidr, stands in Dhulqarnein’s place, he has to name the latter instead of himself in telling the story. This can hardly be accidental, for the great psychic danger which is always connected with individuation, or the development of the self, lies in the identification of ego-consciousness with the self. This produces an inflation which threatens consciousness with dissolution. All the more primitive or older cultures show a fine sense for the “perils of the soul” and for the dangerousness and general unreliability of the gods. That is, they have not yet lost their psychic instinct for the barely perceptible and yet vital processes going on in the background, which can hardly be said of our modern culture. To be sure, we have before our eyes as a warning just such a pair of friends distorted by inflation—Nietzsche and Zarathustra—but the warning has not been heeded. And what are we to make of Faust and Mephistopheles? The Faustian hybris is already the first step towards madness. The fact that the unimpressive beginning of the transformation in *Faust* is a dog and not an edible fish, and that the transformed figure is the devil and not a wise friend, “endowed with Our grace and Our wisdom,” might, I am inclined to think, offer a key to our understanding of the highly enigmatic Germanic soul.

[255] Without entering into other details of the text, I would like to draw attention to one more point: the building of the rampart against Gog and Magog (also known as Yajuj and Majuj). This motif is a repetition of Khidr’s last deed in the previous episode, the rebuilding of the town wall. But this time the wall is to be a strong defence against Gog and Magog. The passage may possibly refer to Revelation 20:7f. (AV):

And when the thousand years are expired, Satan shall be loosed out of his prison, and shall go out to deceive the nations which are in the four quarters of the earth, Gog and Magog, to gather them together for battle: the number of whom is as the sand of the sea. And they went up on the breadth of the earth, and compassed the camp of the saints about, and the beloved city.

[256] Here Dhulqarnein takes over the role of Khidr and builds an unscalable rampart for the people living “between Two Mountains.” This is obviously the same place in the middle which is to be protected against Gog and Magog, the featureless, hostile masses. Psychologically, it is again a question of the self, enthroned in the place of the middle, and referred to in Revelation as the beloved city (Jerusalem, the centre of the earth). The self is the hero, threatened already at birth by envious collective forces; the jewel that is coveted by all and arouses jealous strife; and finally the god who is dismembered by the old, evil power of darkness. In its psychological meaning, individuation is an *opus contra naturam*, which creates a *horror vacui* in the collective layer and is only too likely to collapse under the impact of the collective forces of the psyche. The mystery legend of the two helpful friends promises protection²⁴ to him who has found the jewel on his quest. But there will come a time when, in accordance with Allah’s providence, even the iron rampart will fall to pieces, namely, on the day when the world comes to an end, or psychologically speaking, when individual consciousness is extinguished in the waters of darkness, that is to say when a *subjective* end of the world is experienced. By this is meant the moment when consciousness sinks back into the darkness from which it originally emerged, like Khidr’s island: the moment of death.

[257] The legend then continues along eschatological lines: on that day (the day of the Last Judgment) the light returns to eternal light and the darkness to eternal darkness. The opposites are separated and a timeless state of permanence sets in, which, because of the absolute separation of opposites, is nevertheless one of supreme tension and therefore corresponds to the improbable initial state. This is in contrast to the view which sees the end as a *complexio oppositorum*.

[258] With this prospect of eternity, Paradise, and Hell the Eighteenth Sura comes to an end. In spite of its apparently disconnected and allusive character, it gives an almost perfect picture of a psychic transformation or rebirth which today, with our greater psychological insight, we would recognize as an individuation process. Because of the great age of the legend and the Islamic prophet’s primitive cast of mind, the process takes place entirely outside the sphere of consciousness and is projected in the form of a mystery legend of a friend or a pair of friends and the deeds they perform. That is why it is all so allusive and lacking in logical sequence. Nevertheless, the legend expresses the obscure archetype of transformation so admirably that the passionate religious *eros* of the Arab finds it completely satisfying. It is for this reason that the figure of Khidr plays such an important part in Islamic mysticism.

IV

THE PSYCHOLOGY OF THE CHILD ARCHETYPE



THE PSYCHOLOGICAL ASPECTS OF THE KORE

[These two studies were first published, under the respective titles “Zur Psychologie des Kind-Archetypus” and “Zum psychologischen Aspekt der Kore-Figur,” in two small volumes: *Das göttliche Kind* (Albae Vigiliae VI/VII, Amsterdam and Leipzig, 1940) and *Das göttliche Mädchen* (same series, VIII/IX, 1941). Each volume contained a companion essay by K. Kerényi. The two volumes were united, with additional material by Professor Kerényi, under the title *Einführung in das Wesen der Mythologie* (Amsterdam, Leipzig, and Zurich, 1941). This combined volume was translated by R. F. C. Hull as *Essays on a Science of Mythology* (Bollingen Series XXII; New York, 1949), of which the London (1950) edition was titled *Introduction to a Science of Mythology*; the text of the two studies here presented is a revision of that of 1949/50. The complete German volume was published in a new edition in 1951. In 1963, the English version appeared in Harper Torchbooks (New York; paperback), with the present Jung translation and a revised Kerényi translation.—EDITORS.]

THE PSYCHOLOGY OF THE CHILD ARCHETYPE

I. INTRODUCTION

[259] The author of the companion essay¹ on the mythology of the “child” or the child god has asked me for a psychological commentary on the subject of his investigations. I am glad to accede to his request, although the undertaking seems to me no small venture in view of the great significance of the child motif in mythology. Kerényi himself has enlarged upon the occurrence of this motif in Greece and Rome, with parallels drawn from Indian, Finnish, ‘and other sources, thus indicating that the presentation of the theme would allow of yet further extensions. Though a comprehensive description would contribute nothing decisive in principle, it would nevertheless produce an overwhelming impression of the world-wide incidence and frequency of the motif. The customary treatment of mythological motifs so far in separate departments of science, such as philology, ethnology, the history of civilization, and comparative religion, was not exactly a help to us in recognizing their universality; and the psychological problems raised by this universality could easily be shelved by hypotheses of migration. Consequently Adolf Bastian’s² ideas met with little success in their day. Even then there was sufficient empirical material available to permit far-reaching psychological conclusions, but the necessary premises were lacking. Although the psychological knowledge of that time included myth-formation in its province—witness Wundt’s *Völkerpsychologie*—it was not in a position to demonstrate this same process as a living function actually present in the psyche of civilized man, any more than it could understand mythological motifs as structural elements of the psyche. True to its history, when psychology was metaphysics first of all, then the study of the senses and their functions, and then of the conscious mind and *its* functions, psychology identified its proper subject with the conscious psyche and its contents and thus completely overlooked the existence of a nonconscious psyche. Although various philosophers, among them Leibniz, Kant, and Schelling, had already pointed very clearly to the problem of the dark side of the psyche, it was a physician who felt impelled, from his scientific and medical experience, to point to the *unconscious* as the essential basis of the psyche. This was C. G. Carus,³ the authority whom Eduard von Hartmann followed. In recent times it was, once again, medical psychology that approached the problem of the unconscious without philosophical preconceptions. It became clear from many separate

investigations that the psychopathology of the neuroses and of many psychoses cannot dispense with the hypothesis of a dark side of the psyche, i.e., the unconscious. It is the same with the psychology of dreams, which is really the *terra intermedia* between normal and pathological psychology. In the dream, as in the products of psychoses, there are numberless interconnections to which one can find parallels only in mythological associations of ideas (or perhaps in certain poetic creations which are often characterized by a borrowing, not always conscious, from myths). Had thorough investigation shown that in the majority of such cases it was simply a matter of forgotten knowledge, the physician would not have gone to the trouble of making extensive researches into individual and collective parallels. But, in point of fact, typical mythologems were observed among individuals to whom all knowledge of this kind was absolutely out of the question, and where indirect derivation from religious ideas that might have been known to them, or from popular figures of speech, was impossible.⁴ Such conclusions forced us to assume that we must be dealing with “autochthonous” revivals independent of all tradition, and, consequently, that “myth-forming” structural elements must be present in the unconscious psyche.⁵

[260] These products are never (or at least very seldom) myths with a definite form, but rather mythological components which, because of their typical nature, we can call “motifs,” “primordial images,” types or—as I have named them—*archetypes*. The child archetype is an excellent example. Today we can hazard the formula that the archetypes appear in myths and fairytales just as they do in dreams and in the products of psychotic fantasy. The medium in which they are embedded is, in the former case, an ordered and for the most part immediately understandable context, but in the latter case a generally unintelligible, irrational, not to say delirious sequence of images which nonetheless does not lack a certain hidden coherence. In the individual, the archetypes appear as involuntary manifestations of unconscious processes whose existence and meaning can only be inferred, whereas the myth deals with traditional forms of incalculable age. They hark back to a prehistoric world whose spiritual preconceptions and general conditions we can still observe today among existing primitives. Myths on this level are as a rule tribal history handed down from generation to generation by word of mouth. Primitive mentality differs from the civilized chiefly in that the conscious mind is far less developed in scope and intensity. Functions such as thinking, willing, etc. are not yet differentiated; they are pre-conscious, and in the case of thinking, for instance, this shows itself in the circumstance that the primitive does not think *consciously*, but that thoughts *appear*. The primitive cannot assert that he thinks; it is rather that “something thinks in him.” The spontaneity of the act of thinking does not lie, causally, in his conscious mind, but in his unconscious. Moreover, he is incapable of any conscious effort of will; he

must put himself beforehand into the “mood of willing,” or let himself be put—hence his *rites d’entrée et de sortie*. His consciousness is menaced by an almighty unconscious: hence his fear of magical influences which may cross his path at any moment; and for this reason, too, he is surrounded by unknown forces and must adjust himself to them as best he can. Owing to the chronic twilight state of his consciousness, it is often next to impossible to find out whether he merely dreamed something or whether he really experienced it. The spontaneous manifestation of the unconscious and its archetypes intrudes everywhere into his conscious mind, and the mythical world of his ancestors—for instance, the *alchera* or *bugari* of the Australian aborigines—is a reality equal if not superior to the material world.⁶ It is not the world as we know it that speaks out of his unconscious, but the unknown world of the psyche, of which we know that it mirrors our empirical world only in part, and that, for the other part, it moulds this empirical world in accordance with its own psychic assumptions. The archetype does not proceed from physical facts, but describes how the psyche experiences the physical fact, and in so doing the psyche often behaves so autocratically that it denies tangible reality or makes statements that fly in the face of it.

[261] The primitive mentality does not *invent* myths, it *experiences* them. Myths are original revelations of the preconscious psyche, involuntary statements about unconscious psychic happenings, and anything but allegories of physical processes.⁷ Such allegories would be an idle amusement for an unscientific intellect. Myths, on the contrary, have a vital meaning. Not merely do they represent, they *are* the psychic life of the primitive tribe, which immediately falls to pieces and decays when it loses its mythological heritage, like a man who has lost his soul. A tribe’s mythology is its living religion, whose loss is always and everywhere, even among the civilized, a moral catastrophe. But religion is a vital link with psychic processes independent of and beyond consciousness, in the dark hinterland of the psyche. Many of these unconscious processes may be indirectly occasioned by consciousness, but never by conscious choice. Others appear to arise spontaneously, that is to say, from no discernible or demonstrable conscious cause.

[262] Modern psychology treats the products of unconscious fantasy-activity as self-portraits of what is going on in the unconscious, or as statements of the unconscious psyche about itself. They fall into two categories. First, fantasies (including dreams) of a personal character, which go back unquestionably to personal experiences, things forgotten or repressed, and can thus be completely explained by individual anamnesis. Second, fantasies (including dreams) of an impersonal character, which cannot be reduced to experiences in the individual’s past, and thus cannot be explained as something individually acquired. These fantasy-images undoubtedly have their closest analogues in mythological types. We must therefore assume that

they correspond to certain *collective* (and not personal) structural elements of the human psyche in general, and, like the morphological elements of the human body, are *inherited*. Although tradition and transmission by migration certainly play a part, there are, as we have said, very many cases that cannot be accounted for in this way and drive us to the hypothesis of “autochthonous revival.” These cases are so numerous that we are obliged to assume the existence of a collective psychic substratum. I have called this the *collective unconscious*.

[263] The products of this second category resemble the types of structures to be met with in myth and fairytale so much that we must regard them as related. It is therefore wholly within the realm of possibility that both, the mythological types as well as the individual types, arise under quite similar conditions. As already mentioned, the fantasy-products of the second category (as also those of the first) arise in a state of reduced intensity of consciousness (in dreams, delirium, reveries, visions, etc.). In all these states the check put upon unconscious contents by the concentration of the conscious mind ceases, so that the hitherto unconscious material streams, as though from opened side-slucices, into the field of consciousness. This mode of origination is the general rule.⁸

[264] Reduced intensity of consciousness and absence of concentration and attention, Janet’s *abaissement du niveau mental*, correspond pretty exactly to the primitive state of consciousness in which, we must suppose, myths were originally formed. It is therefore exceedingly probable that the mythological archetypes, too, made their appearance in much the same manner as the manifestations of archetypal structures among individuals today.

[265] The methodological principle in accordance with which psychology treats the products of the unconscious is this: Contents of an archetypal character are manifestations of processes in the collective unconscious. Hence they do not refer to anything that is or has been conscious, but to something essentially unconscious. In the last analysis, therefore, it is impossible to say what they refer to. Every interpretation necessarily remains an “as-if.” The ultimate core of meaning may be circumscribed, but not described. Even so, the bare circumscription denotes an essential step forward in our knowledge of the pre-conscious structure of the psyche, which was already in existence when there was as yet no unity of personality (even today the primitive is not securely possessed of it) and no consciousness at all. We can also observe this pre-conscious state in early childhood, and as a matter of fact it is the dreams of this early period that not infrequently bring extremely remarkable archetypal contents to light.⁹

[266] If, then, we proceed in accordance with the above principle, there is no longer any question whether a myth refers to the sun or the moon, the father or the mother,

sexuality or fire or water; all it does is to circumscribe and give an approximate description of an *unconscious core of meaning*. The ultimate meaning of this nucleus was never conscious and never will be. It was, and still is, only interpreted, and every interpretation that comes anywhere near the hidden sense (or, from the point of view of scientific intellect, nonsense, which comes to the same thing) has always, right from the beginning, laid claim not only to absolute truth and validity but to instant reverence and religious devotion. Archetypes were, and still are, living psychic forces that demand to be taken seriously, and they have a strange way of making sure of their effect. Always they were the bringers of protection and salvation, and their violation has as its consequence the “perils of the soul” known to us from the psychology of primitives. Moreover, they are the unfailing causes of neurotic and even psychotic disorders, behaving exactly like neglected or maltreated physical organs or organic functional systems.

[267] An archetypal content expresses itself, first and foremost, in metaphors. If such a content should speak of the sun and identify with it the lion, the king, the hoard of gold guarded by the dragon, or the power that makes for the life and health of man, it is neither the one thing nor the other, but the unknown third thing that finds more or less adequate expression in all these similes, yet—to the perpetual vexation of the intellect—remains unknown and not to be fitted into a formula. For this reason the scientific intellect is always inclined to put on airs of enlightenment in the hope of banishing the spectre once and for all. Whether its endeavours were called euhemerism, or Christian apologetics, or Enlightenment in the narrow sense, or Positivism, there was always a myth hiding behind it, in new and disconcerting garb, which then, following the ancient and venerable pattern, gave itself out as ultimate truth. In reality we can never legitimately cut loose from our archetypal foundations unless we are prepared to pay the price of a neurosis, any more than we can rid ourselves of our body and its organs without committing suicide. If we cannot deny the archetypes or otherwise neutralize them, we are confronted, at every new stage in the differentiation of consciousness to which civilization attains, with the task of finding a new *interpretation* appropriate to this stage, in order to connect the life of the past that still exists in us with the life of the present, which threatens to slip away from it. If this link-up does not take place, a kind of rootless consciousness comes into being no longer oriented to the past, a consciousness which succumbs helplessly to all manner of suggestions and, in practice, is susceptible to psychic epidemics. With the loss of the past, now become “insignificant,” devalued, and incapable of revaluation, the saviour is lost too, for the saviour is either the insignificant thing itself or else arises out of it. Over and over again in the “metamorphosis of the gods” he rises up as the prophet or first-born of a new generation and appears unexpectedly

in the unlikeliest places (sprung from a stone, tree, furrow, water, etc.) and in ambiguous form (Tom Thumb, dwarf, child, animal, and so on).

[268] This archetype of the “child god” is extremely widespread and intimately bound up with all the other mythological aspects of the child motif. It is hardly necessary to allude to the still living “Christ-child,” who, in the legend of Saint Christopher, also has the typical feature of being “smaller than small and bigger than big.” In folklore the child motif appears in the guise of the *dwarf* or the *elf* as personifications of the hidden forces of nature. To this sphere also belongs the little metal man of late antiquity, the *άνθρωπάριον*,¹⁰ who, till far into the Middle Ages, on the one hand inhabited the mine-shafts,¹¹ and on the other represented the alchemical metals,¹² above all Mercurius reborn in perfect form (as the hermaphrodite, *filius sapientiae*, or *in-fans noster*).¹³ Thanks to the religious interpretation of the “child,” a fair amount of evidence has come down to us from the Middle Ages showing that the “child” was not merely a traditional figure, but a vision spontaneously experienced (as a so-called “irruption of the unconscious”). I would mention Meister Eckhart’s vision of the “naked boy” and the dream of Brother Eustachius.¹⁴ Interesting accounts of these spontaneous experiences are also to be found in English ghost-stories, where we read of the vision of a “Radiant Boy” said to have been seen in a place where there are Roman remains.¹⁵ This apparition was supposed to be of evil omen. It almost looks as though we were dealing with the figure of a *puer aeternus* who had become inauspicious through “metamorphosis,” or in other words had shared the fate of the classical and the Germanic gods, who have all become bugbears. The mystical character of the experience is also confirmed in [Part II](#) of Goethe’s *Faust*, where Faust himself is transformed into a boy and admitted into the “choir of blessed youths,” this being the “larval stage” of Doctor Marianus.¹⁶

[269] In the strange tale called *Das Reich ohne Raum*, by Bruno Goetz, a *puer aeternus* named Fo (= Buddha) appears with whole troops of “unholy” boys of evil significance. (Contemporary parallels are better let alone.) I mention this instance only to demonstrate the enduring vitality of the child archetype.

[270] The child motif not infrequently occurs in the field of psychopathology. The “imaginary” child is common among women with mental disorders and is usually interpreted in a Christian sense. Homunculi also appear, as in the famous Schreber case,¹⁷ where they come in swarms and plague the sufferer. But the clearest and most significant manifestation of the child motif in the therapy of neuroses is in the maturation process of personality induced by the analysis of the unconscious, which I have termed the process of *individuation*.¹⁸ Here we are confronted with preconscious processes which, in the form of more or less well-formed fantasies, gradually pass over into the conscious mind, or become conscious as dreams, or, lastly, are made

conscious through the method of active imagination.¹⁹ This material is rich in archetypal motifs, among them frequently that of the child. Often the child is formed after the Christian model; more often, though, it develops from earlier, altogether non-Christian levels—that is to say, out of chthonic animals such as crocodiles, dragons, serpents, or monkeys. Sometimes the child appears in the cup of a flower, or out of a golden egg, or as the centre of a mandala. In dreams it often appears as the dreamer's son or daughter or as a boy, youth, or young girl; occasionally it seems to be of exotic origin, Indian or Chinese, with a dusky skin, or, appearing more cosmically, surrounded by stars or with a starry coronet; or as the king's son or the witch's child with daemonic attributes. Seen as a special instance of "the treasure hard to attain" motif,²⁰ the child motif is extremely variable and assumes all manner of shapes, such as the jewel, the pearl, the flower, the chalice, the golden egg, the quaternity, the golden ball, and so on. It can be interchanged with these and similar images almost without limit.

II. THE PSYCHOLOGY OF THE CHILD ARCHETYPE

1. *The Archetype as a Link with the Past*

[271] As to the *psychology* of our theme I must point out that every statement going beyond the purely phenomenal aspects of an archetype lays itself open to the criticism we have expressed above. Not for a moment dare we succumb to the illusion that an archetype can be finally explained and disposed of. Even the best attempts at explanation are only more or less successful translations into another metaphorical language. (Indeed, language itself is only an image.) The most we can do is to *dream the myth onwards* and give it a modern dress. And whatever explanation or interpretation does to it, we do to our own souls as well, with corresponding results for our own well-being. The archetype—let us never forget this—is a psychic organ present in all of us. A bad explanation means a correspondingly bad attitude to this organ, which may thus be injured. But the ultimate sufferer is the bad interpreter himself. Hence the "explanation" should always be such that the functional significance of the archetype remains unimpaired, so that an adequate and meaningful connection between the conscious mind and the archetypes is assured. For the archetype is an element of our psychic structure and thus a vital and necessary component in our psychic economy. It represents or personifies certain instinctive data of the dark, primitive psyche, the real but invisible roots of consciousness. Of what elementary importance the connection with these roots is, we see from the preoccupation of the primitive mentality with certain "magic" factors, which are nothing less than what we would call archetypes. This original form of

religio (“linking back”) is the essence, the working basis of all religious life even today, and always will be, whatever future form this life may take.

[272] There is no “rational” substitute for the archetype any more than there is for the cerebellum or the kidneys. We can examine the physical organs anatomically, histologically, and embryologically. This would correspond to an outline of archetypal phenomenology and its presentation in terms of comparative history. But we only arrive at the *meaning* of a physical organ when we begin to ask teleological questions. Hence the query arises: What is the biological purpose of the archetype? Just as physiology answers such a question for the body, so it is the business of psychology to answer it for the archetype.

[273] Statements like “The child motif is a vestigial memory of one’s own childhood” and similar explanations merely beg the question. But if, giving this proposition a slight twist, we were to say, “The child motif is a picture of certain *forgotten* things in our childhood,” we are getting closer to the truth. Since, however, the archetype is always an image belonging to the whole human race and not merely to the individual, we might put it better this way: “The child motif represents the preconscious, childhood aspect of the collective psyche.”²¹

[274] We shall not go wrong if we take this statement for the time being *historically*, on the analogy of certain psychological experiences which show that certain phases in an individual’s life can become autonomous, can personify themselves to the extent that they result in a *vision of oneself*—for instance, one sees oneself as a child. Visionary experiences of this kind, whether they occur in dreams or in the waking state, are, as we know, conditional on a dissociation having previously taken place between past and present. Such dissociations come about because of various incompatibilities; for instance, a man’s present state may have come into conflict with his childhood state, or he may have violently sundered himself from his original character in the interests of some arbitrary persona²² more in keeping with his ambitions. He has thus become unchildlike and artificial, and has lost his roots. All this presents a favourable opportunity for an equally vehement confrontation with the primary truth.

[275] In view of the fact that men have not yet ceased to make statements about the child god, we may perhaps extend the individual analogy to the life of mankind and say in conclusion that humanity, too, probably always comes into conflict with its childhood conditions, that is, with its original, unconscious, and instinctive state, and that the danger of the kind of conflict which induces the vision of the “child” actually exists. Religious observances, i.e., the retelling and ritual repetition of the mythical event, consequently serve the purpose of bringing the image of childhood, and

everything connected with it, again and again before the eyes of the conscious mind so that the link with the original condition may not be broken.

2. *The Function of the Archetype*

[276] The child motif represents not only something that existed in the distant past but also something that exists *now*; that is to say, it is not just a vestige but a system functioning in the present whose purpose is to compensate or correct, in a meaningful manner, the inevitable one-sidednesses and extravagances of the conscious mind. It is in the nature of the conscious mind to concentrate on relatively few contents and to raise them to the highest pitch of clarity. A necessary result and precondition is the exclusion of other potential contents of consciousness. The exclusion is bound to bring about a certain one-sidedness of the conscious contents. Since the differentiated consciousness of civilized man has been granted an effective instrument for the practical realization of its contents through the dynamics of his will, there is all the more danger, the more he trains his will, of his getting lost in one-sidedness and deviating further and further from the laws and roots of his being. This means, on the one hand, the possibility of human freedom, but on the other it is a source of endless transgressions against one's instincts. Accordingly, primitive man, being closer to his instincts, like the animal, is characterized by fear of novelty and adherence to tradition. To our way of thinking he is painfully backward, whereas we exalt progress. But our progressiveness, though it may result in a great many delightful wish-fulfillments, piles up an equally gigantic Promethean debt which has to be paid off from time to time in the form of hideous catastrophes. For ages man has dreamed of flying, and all we have got for it is saturation bombing! We smile today at the Christian hope of a life beyond the grave, and yet we often fall into chimeras a hundred times more ridiculous than the notion of a happy Hereafter. Our differentiated consciousness is in continual danger of being uprooted; hence it needs compensation through the still existing state of childhood.

[277] The symptoms of compensation are described, from the progressive point of view, in scarcely flattering terms. Since, to the superficial eye, it looks like a retarding operation, people speak of inertia, backwardness, scepticism, fault-finding, conservatism, timidity, pettiness, and so on. But inasmuch as man has, in high degree, the capacity for cutting himself off from his own roots, he may also be swept uncritically to catastrophe by his dangerous one-sidedness. The retarding ideal is always more primitive, more natural (in the good sense as in the bad), and more "moral" in that it keeps faith with law and tradition. The progressive ideal is always more abstract, more unnatural, and less "moral" in that it demands disloyalty to tradition. Progress enforced by will is always *convulsive*. Backwardness may be closer to naturalness, but in its turn it is always menaced by painful awakenings. The

older view of things realized that progress is only possible *Deo concedente*, thus proving itself conscious of the opposites and repeating the age-old *rites d'entrée et de sortie* on a higher plane. The more differentiated consciousness becomes, the greater the danger of severance from the root-condition. Complete severance comes when the *Deo concedente* is forgotten. Now it is an axiom of psychology that when a part of the psyche is split off from consciousness it is only *apparently* inactivated; in actual fact it brings about a possession of the personality, with the result that the individual's aims are falsified in the interests of the split-off part. If, then, the childhood state of the collective psyche is repressed to the point of total exclusion, the unconscious content overwhelms the conscious aim and inhibits, falsifies, even destroys its realization. Viable progress only comes from the co-operation of both.

3. *The Futurity of the Archetype*

[278] One of the essential features of the child motif is its futurity. The child is potential future. Hence the occurrence of the child motif in the psychology of the individual signifies as a rule an anticipation of future developments, even though at first sight it may seem like a retrospective configuration. Life is a flux, a flowing into the future, and not a stoppage or a backwash. It is therefore not surprising that so many of the mythological saviours are child gods. This agrees exactly with our experience of the psychology of the individual, which shows that the "child" paves the way for a future change of personality. In the individuation process, it anticipates the figure that comes from the synthesis of conscious and unconscious elements in the personality. It is therefore a symbol which unites the opposites;²³ a mediator, bringer of healing, that is, one who makes whole. Because it has this meaning, the child motif is capable of the numerous transformations mentioned above: it can be expressed by roundness, the circle or sphere, or else by the quaternity as another form of wholeness.²⁴ I have called this wholeness that transcends consciousness the "self."²⁵ The goal of the individuation process is the synthesis of the self. From another point of view the term "entelechy" might be preferable to "synthesis." There is an empirical reason why "entelechy" is, in certain conditions, more fitting: the symbols of wholeness frequently occur at the beginning of the individuation process, indeed they can often be observed in the first dreams of early infancy. This observation says much for the *a priori* existence of potential wholeness,²⁶ and on this account the idea of *entelechy* instantly recommends itself. But in so far as the individuation process occurs, empirically speaking, as a synthesis, it looks, paradoxically enough, as if something already existent were being put together. From this point of view, the term "synthesis" is also applicable.

4. *Unity and Plurality of the Child Motif*

[279] In the manifold phenomenology of the “child” we have to distinguish between the *unity* and *plurality* of its respective manifestations. Where, for instance, numerous homunculi, dwarfs, boys, etc., appear, having no individual characteristics at all, there is the probability of a *dissociation*. Such forms are therefore found especially in schizophrenia, which is essentially a fragmentation of personality. The many children then represent the products of its dissolution. But if the plurality occurs in normal people, then it is the representation of an as yet incomplete synthesis of personality. The personality (viz., the “self”) is still in the *plural stage*, i.e., an ego may be present, but it cannot experience its wholeness within the framework of its own personality, only within the community of the family, tribe, or nation; it is still in the stage of unconscious identification with the plurality of the group. The Church takes due account of this widespread condition in her doctrine of the *corpus mysticum*, of which the individual is by nature a member.

[280] If, however, the child motif appears in the form of a unity, we are dealing with an unconscious and provisionally complete synthesis of the personality, which in practice, like everything unconscious, signifies no more than a possibility.

5. *Child God and Child Hero*

[281] Sometimes the “child” looks more like a *child god*, sometimes more like a young *hero*. Common to both types is the miraculous birth and the adversities of early childhood—abandonment and danger through persecution. The god is by nature wholly supernatural; the hero’s nature is human but raised to the limit of the supernatural—he is “semi-divine.” While the god, especially in his close affinity with the symbolic animal, personifies the collective unconscious which is not yet integrated into a human being, the hero’s supernaturalness includes human nature and thus represents a synthesis of the (“divine,” i.e., not yet humanized) unconscious and human consciousness. Consequently he signifies the potential anticipation of an individuation process which is approaching wholeness.

[282] For this reason the various “child”-fates may be regarded as illustrating the kind of psychic events that occur in the entelechy or genesis of the “self.” The “miraculous birth” tries to depict the way in which this genesis is experienced. Since it is a psychic genesis, everything must happen non-empirically, e.g., by means of a virgin birth, or by miraculous conception, or by birth from unnatural organs. The motifs of “insignificance,” exposure, abandonment, danger, etc. try to show how precarious is the psychic possibility of wholeness, that is, the enormous difficulties to be met with in attaining this “highest good.” They also signify the powerlessness and helplessness of the life-urge which subjects every growing thing to the law of maximum self-fulfilment, while at the same time the environmental influences place

all sorts of insuperable obstacles in the way of individuation. More especially the threat to one's inmost self from dragons and serpents points to the danger of the newly acquired consciousness being swallowed up again by the instinctive psyche, the unconscious. The lower vertebrates have from earliest times been favourite symbols of the collective psychic substratum,²⁷ which is localized anatomically in the subcortical centres, the cerebellum and the spinal cord. These organs constitute the snake.²⁸ Snake-dreams usually occur, therefore, when the conscious mind is deviating from its instinctual basis.

[283] The motif of "smaller than small yet bigger than big" complements the impotence of the child by means of its equally miraculous deeds. This paradox is the essence of the hero and runs through his whole destiny like a red thread. He can cope with the greatest perils, yet, in the end, something quite insignificant is his undoing: Baldur perishes because of the mistletoe, Maui because of the laughter of a little bird, Siegfried because of his one vulnerable spot, Heracles because of his wife's gift, others because of common treachery, and so on.

[284] The hero's main feat is to overcome the monster of darkness: it is the long-hoped-for and expected triumph of consciousness over the unconscious. Day and light are synonyms for consciousness, night and dark for the unconscious. The coming of consciousness was probably the most tremendous experience of primeval times, for with it a world came into being whose existence no one had suspected before. "And God said: 'Let there be light!'" is the projection of that immemorial experience of the separation of the conscious from the unconscious. Even among primitives today the possession of a soul is a precarious thing, and the "loss of soul" a typical psychic malady which drives primitive medicine to all sorts of psychotherapeutic measures. Hence the "child" distinguishes itself by deeds which point to the conquest of the dark.

III. THE SPECIAL PHENOMENOLOGY OF THE CHILD ARCHETYPE

1. *The Abandonment of the Child*

[285] Abandonment, exposure, danger, etc. are all elaborations of the "child's" insignificant beginnings and of its mysterious and miraculous birth. This statement describes a certain psychic experience of a creative nature, whose object is the emergence of a new and as yet unknown content. In the psychology of the individual there is always, at such moments, an agonizing situation of conflict from which there seems to be no way out—at least for the conscious mind, since as far as this is concerned, *tertium non datur*. But out of this collision of opposites the unconscious psyche always creates a third thing of an irrational nature,²⁹ which the conscious mind neither expects nor understands. It presents itself in a form that is neither a

straight “yes” nor a straight “no,” and is consequently rejected by both. For the conscious mind knows nothing beyond the opposites and, as a result, has no knowledge of the thing that unites them. Since, however, the solution of the conflict through the union of opposites is of vital importance, and is moreover the very thing that the conscious mind is longing for, some inkling of the creative act, and of the significance of it, nevertheless gets through. From this comes the numinous character of the “child.” A meaningful but unknown content always has a secret fascination for the conscious mind. The new configuration is a nascent whole; it is on the way to wholeness, at least in so far as it excels in “wholeness” the conscious mind when torn by opposites and surpasses it in completeness. For this reason all uniting symbols have a redemptive significance.

[286] Out of this situation the “child” emerges as a symbolic content, manifestly separated or even isolated from its background (the mother), but sometimes including the mother in its perilous situation, threatened on the one hand by the negative attitude of the conscious mind and on the other by the *horror vacui* of the unconscious, which is quite ready to swallow up all its progeny, since it produces them only in play, and destruction is an inescapable part of its play. Nothing in all the world welcomes this new birth, although it is the most precious fruit of Mother Nature herself, the most pregnant with the future, signifying a higher stage of self-realization. That is why Nature, the world of the instincts, takes the “child” under its wing: it is nourished or protected by animals.

[287] “Child” means something evolving towards independence. This it cannot do without detaching itself from its origins: abandonment is therefore a necessary condition, not just a concomitant symptom. The conflict is not to be overcome by the conscious mind remaining caught between the opposites, and for this very reason it needs a symbol to point out the necessity of detaching itself from its origins. Because the symbol of the “child” fascinates and grips the conscious mind, its redemptive effect passes over into consciousness and brings about that separation from the conflict-situation which the conscious mind by itself was unable to achieve. The symbol anticipates a nascent state of consciousness. So long as this is not actually in being, the “child” remains a mythological projection which requires religious repetition and renewal by ritual. The Christ Child, for instance, is a religious necessity only so long as the majority of men are incapable of giving psychological reality to the saying: “Except ye become as little children....” Since all such developments and transitions are extraordinarily difficult and dangerous, it is no wonder that figures of this kind persist for hundreds or even thousands of years. Everything that man should, and yet cannot, be or do—be it in a positive or negative sense—lives on as a mythological figure and anticipation alongside his consciousness, either as a religious projection or—what is still more dangerous—as

unconscious contents which then project themselves spontaneously into incongruous objects, e.g., hygienic and other “salvationist” doctrines or practices. All these are so many rationalized substitutes for mythology, and their unnaturalness does more harm than good.

[288] The conflict-situation that offers no way out, the sort of situation that produces the “child” as the irrational third, is of course a formula appropriate only to a psychological, that is, modern stage of development. It is not strictly applicable to the psychic life of primitives, if only because primitive man’s childlike range of consciousness still excludes a whole world of possible psychic experiences. Seen on the nature-level of the primitive, our modern *moral* conflict is still an *objective* calamity that threatens life itself. Hence not a few child-figures are culture-heroes and thus identified with things that promote culture, e.g., fire,³⁰ metal, corn, maize, etc. As bringers of light, that is, enlargers of consciousness, they overcome darkness, which is to say that they overcome the earlier unconscious state. Higher consciousness, or knowledge going beyond our present-day consciousness, is equivalent to being *all alone in the world*. This loneliness expresses the conflict between the bearer or symbol of higher consciousness and his surroundings. The conquerors of darkness go far back into primeval times, and, together with many other legends, prove that there once existed a state of *original psychic distress*, namely *unconsciousness*. Hence in all probability the “irrational” fear which primitive man has of the dark even today. I found a form of religion among a tribe living on Mount Elgon that corresponded to pantheistic optimism. Their optimistic mood was, however, always in abeyance between six o’clock in the evening and six o’clock in the morning, during which time it was replaced by fear, for in the night the dark being Ayik has his dominion—the “Maker of Fear.” During the daytime there were no monster snakes anywhere in the vicinity, but at night they were lurking on every path. At night the whole of mythology was let loose.

2. *The Invincibility of the Child*

[289] It is a striking paradox in all child myths that the “child” is on the one hand delivered helpless into the power of terrible enemies and in continual danger of extinction, while on the other he possesses powers far exceeding those of ordinary humanity. This is closely related to the psychological fact that though the child may be “insignificant,” unknown, “a mere child,” he is also divine. From the conscious standpoint we seem to be dealing with an insignificant content that has no releasing, let alone redeeming, character. The conscious mind is caught in its conflict-situation, and the combatant forces seem so overwhelming that the “child” as an isolated content bears no relation to the conscious factors. It is therefore easily overlooked and falls back into the unconscious. At least, this is what we should have to fear if

things turned out according to our conscious expectations. Myth, however, emphasizes that it is not so, but that the “child” is endowed with superior powers and, despite all dangers, will unexpectedly pull through. The “child” is born out of the womb of the unconscious, begotten out of the depths of human nature, or rather out of living Nature herself. It is a personification of vital forces quite outside the limited range of our conscious mind; of ways and possibilities of which our one-sided conscious mind knows nothing; a wholeness which embraces the very depths of Nature. It represents the strongest, the most ineluctable urge in every being, namely the urge to realize itself. It is, as it were, an incarnation of *the inability to do otherwise*, equipped with all the powers of nature and instinct, whereas the conscious mind is always getting caught up in its supposed ability to do otherwise. The urge and compulsion to self-realization is a law of nature and thus of invincible power, even though its effect, at the start, is insignificant and improbable. Its power is revealed in the miraculous deeds of the child hero, and later in the *athla* (‘works’) of the bondsman or thrall (of the Heracles type), where, although the hero has outgrown the impotence of the “child,” he is still in a menial position. The figure of the thrall generally leads up to the real epiphany of the semi-divine hero. Oddly enough, we have a similar modulation of themes in alchemy—in the synonyms for the *lapis*. As the *materia prima*, it is the *lapis exilis et vilis*. As a substance in process of transmutation, it is *servus rubeus* or *fugitivus*; and finally, in its true apotheosis, it attains the dignity of a *filius sapientiae* or *deus terrenus*, a “light above all lights,” a power that contains in itself all the powers of the upper and nether regions. It becomes a *corpus glorificatum* which enjoys everlasting incorruptibility and is therefore a panacea (“bringer of healing”).³¹ The size and invincibility of the “child” are bound up in Hindu speculation with the nature of the atman, which corresponds to the “smaller than small yet bigger than big” motif. As an individual phenomenon, the self is “smaller than small”; as the equivalent of the cosmos, it is “bigger than big.” The self, regarded as the counter-pole of the world, its “absolutely other,” is the *sine qua non* of all empirical knowledge and consciousness of subject and object. Only because of this psychic “otherness” is consciousness possible at all. Identity does not make consciousness possible; it is only separation, detachment, and agonizing confrontation through opposition that produce consciousness and insight. Hindu introspection recognized this psychological fact very early and consequently equated the subject of cognition with the subject of ontology in general. In accordance with the predominantly introverted attitude of Indian thinking, the object lost the attribute of absolute reality and, in some systems, became a mere illusion. The Greek-Occidental type of mind could not free itself from the conviction of the world’s absolute existence—at the cost, however, of the cosmic significance of the self. Even today Western man finds it hard to see the psychological necessity for a transcendental subject of cognition as the counter-pole of the empirical universe,

although the postulate of a world-confronting self, at least as a *point of reflection*, is a logical necessity. Regardless of philosophy's perpetual attitude of dissent or only half-hearted assent, there is always a compensating tendency in our unconscious psyche to produce a symbol of the self in its cosmic significance. These efforts take on the archetypal forms of the hero myth such as can be observed in almost any individuation process.

[290] The phenomenology of the "child's" birth always points back to an original psychological state of non-recognition, i.e., of darkness or twilight, of non-differentiation between subject and object, of unconscious identity of man and the universe. This phase of non-differentiation produces the *golden egg*, which is both man and universe and yet neither, but an irrational third. To the twilight consciousness of primitive man it seems as if the egg came out of the womb of the wide world and were, accordingly, a cosmic, objective, external occurrence. To a differentiated consciousness, on the other hand, it seems evident that this egg is nothing but a symbol thrown up by the psyche or—what is even worse—a fanciful speculation and therefore "nothing but" a primitive phantasm to which no "reality" of any kind attaches. Present-day medical psychology, however, thinks somewhat differently about these "phantasms." It knows only too well what dire disturbances of the bodily functions and what devastating psychic consequences can flow from "mere" fantasies. "Fantasies" are the natural expressions of the life of the unconscious. But since the unconscious is the psyche of all the body's autonomous functional complexes, its "fantasies" have an aetiological significance that is not to be despised. From the psychopathology of the individuation process we know that the formation of symbols is frequently associated with physical disorders of a psychic origin, which in some cases are felt as decidedly "real." In medicine, fantasies are *real things* with which the psychotherapist has to reckon very seriously indeed. He cannot therefore deprive of all justification those primitive phantasms whose content is so real that it is projected upon the external world. In the last analysis the human body, too, is built of the stuff of the world, the very stuff wherein fantasies become visible; indeed, without it they could not be experienced at all. Without this stuff they would be like a sort of abstract crystalline lattice in a solution where the crystallization process had not yet started.

[291] The symbols of the self arise in the depths of the body and they express its materiality every bit as much as the structure of the perceiving consciousness. The symbol is thus a living body, *corpus et anima*; hence the "child" is such an apt formula for the symbol. The uniqueness of the psyche can never enter wholly into reality, it can only be realized approximately, though it still remains the absolute basis of all consciousness. The deeper "layers" of the psyche lose their individual uniqueness as they retreat farther and farther into darkness. "Lower down," that is to

say as they approach the autonomous functional systems, they become increasingly collective until they are universalized and extinguished in the body's materiality, i.e., in chemical substances. The body's carbon is simply carbon. Hence "at bottom" the psyche is simply "world." In this sense I hold Kerényi to be absolutely right when he says that in the symbol the *world itself* is speaking. The more archaic and "deeper," that is the more *physiological*, the symbol is, the more collective and universal, the more "material" it is. The more abstract, differentiated, and specific it is, and the more its nature approximates to conscious uniqueness and individuality, the more it sloughs off its universal character. Having finally attained full consciousness, it runs the risk of becoming a mere allegory which nowhere oversteps the bounds of conscious comprehension, and is then exposed to all sorts of attempts at rationalistic and therefore inadequate explanation.

3. *The Hermaphroditism of the Child*

[292] It is a remarkable fact that perhaps the majority of cosmogonic gods are of a bisexual nature. The hermaphrodite means nothing less than a union of the strongest and most striking opposites. In the first place this union refers back to a primitive state of mind, a twilight where differences and contrasts were either barely separated or completely merged. With increasing clarity of consciousness, however, the opposites draw more and more distinctly and irreconcilably apart. If, therefore, the hermaphrodite were only a product of primitive non-differentiation, we would have to expect that it would soon be eliminated with increasing civilization. This is by no means the case; on the contrary, man's imagination has been preoccupied with this idea over and over again on the high and even the highest levels of culture, as we can see from the late Greek and syncretic philosophy of Gnosticism. The hermaphroditic *rebis* has an important part to play in the natural philosophy of the Middle Ages. And in our own day we hear of Christ's androgyny in Catholic mysticism.³²

[293] We can no longer be dealing, then, with the continued existence of a primitive phantasm, or with an original contamination of opposites. Rather, as we can see from medieval writings,³³ the primordial idea has become a *symbol of the creative union of opposites*, a "uniting symbol" in the literal sense. In its functional significance the symbol no longer points back, but forward to a goal not yet reached. Notwithstanding its monstrosity, the hermaphrodite has gradually turned into a subduer of conflicts and a bringer of healing, and it acquired this meaning in relatively early phases of civilization. This vital meaning explains why the image of the hermaphrodite did not fade out in primeval times but, on the contrary, was able to assert itself with increasing profundity of symbolic content for thousands of years. The fact that an idea so utterly archaic could rise to such exalted heights of meaning not only points to the vitality of archetypal ideas, it also demonstrates the rightness of the principle

that the archetype, because of its power to unite opposites, mediates between the unconscious substratum and the conscious mind. It throws a bridge between present-day consciousness, always in danger of losing its roots, and the natural, unconscious, instinctive wholeness of primeval times. Through this mediation the uniqueness, peculiarity, and one-sidedness of our present individual consciousness are linked up again with its natural, racial roots. Progress and development are ideals not lightly to be rejected, but they lose all meaning if man only arrives at his new state as a fragment of himself, having left his essential hinterland behind him in the shadow of the unconscious, in a state of primitivity or, indeed, barbarism. The conscious mind, split off from its origins, incapable of realizing the meaning of the new state, then relapses all too easily into a situation far worse than the one from which the innovation was intended to free it—*exempla sunt odiosa!* It was Friedrich Schiller who first had an inkling of this problem; but neither his contemporaries nor his successors were capable of drawing any conclusions. Instead, people incline more than ever to educate *children* and nothing more. I therefore suspect that the *furor paedagogicus* is a god-sent method of by-passing the central problem touched on by Schiller, namely the *education of the educator*. Children are educated by what the grownup *is* and not by what he *says*. The popular faith in words is a veritable disease of the mind, for a superstition of this sort always leads farther and farther away from man's foundations and seduces people into a disastrous identification of the personality with whatever slogan may be in vogue. Meanwhile everything that has been overcome and left behind by so-called "progress" sinks deeper and deeper into the unconscious, from which there re-emerges in the end the primitive condition of *identity with the mass*. Instead of the expected progress, this condition now becomes reality.

[294] As civilization develops, the bisexual primordial being turns into a symbol of the unity of personality, a symbol of the self, where the war of opposites finds peace. In this way the primordial being becomes the distant goal of man's self-development, having been from the very beginning a projection of his unconscious wholeness. Wholeness consists in the union of the conscious and the unconscious personality. Just as every individual derives from masculine and feminine genes, and the sex is determined by the predominance of the corresponding genes, so in the psyche it is only the conscious mind, in a man, that has the masculine sign, while the unconscious is by nature feminine. The reverse is true in the case of a woman. All I have done in my anima theory is to rediscover and reformulate this fact.³⁴ It had long been known.

[295] The idea of the *coniunctio* of male and female, which became almost a technical term in Hermetic philosophy, appears in Gnosticism as the *mysterium iniquitatis*, probably not uninfluenced by the Old Testament "divine marriage" as performed, for

instance, by Hosea.³⁵ Such things are hinted at not only by certain traditional customs,³⁶ but by the quotation from the Gospel according to the Egyptians in the second epistle of Clement: “When the two shall be one, the outside as the inside, and the male with the female neither male nor female.”³⁷ Clement of Alexandria introduces this logion with the words: “When ye have trampled on the garment of shame (with thy feet)...,”³⁸ which probably refers to the body; for Clement as well as Cassian (from whom the quotation was taken over), and the pseudo-Clement, too, interpreted the words in a spiritual sense, in contrast to the Gnostics, who would seem to have taken the *coniunctio* all too literally. They took care, however, through the practice of abortion and other restrictions, that the biological meaning of their acts did not swamp the religious significance of the rite. While, in Church mysticism, the primordial image of the *hieros gamos* was sublimated on a lofty plane and only occasionally—as for instance with Mechthild of Magdeburg³⁹—approached the physical sphere in emotional intensity, for the rest of the world it remained very much alive and continued to be the object of especial psychic preoccupation. In this respect the symbolical drawings of Opicinus de Canistris⁴⁰ afford us an interesting glimpse of the way in which this primordial image was instrumental in uniting opposites, even in a pathological state. On the other hand, in the Hermetic philosophy that thrived in the Middle Ages the *coniunctio* was performed wholly in the physical realm in the admittedly abstract theory of the *coniugium solis et lunae*, which despite this drawback gave the creative imagination much occasion for anthropomorphic flights.

[296] Such being the state of affairs, it is readily understandable that the primordial image of the hermaphrodite should reappear in modern psychology in the guise of the male-female antithesis, in other words as *male* consciousness and personified *female* unconscious. But the psychological process of bringing things to consciousness has complicated the picture considerably. Whereas the old science was almost exclusively a field in which only the man’s unconscious could project itself, the new psychology had to acknowledge the existence of an autonomous female psyche as well. Here the case is reversed, and a feminine consciousness confronts a masculine personification of the unconscious, which can no longer be called *anima* but *animus*. This discovery also complicates the problem of the *coniunctio*.

[297] Originally this archetype played its part entirely in the field of fertility magic and thus remained for a very long time a purely biological phenomenon with no other purpose than that of fecundation. But even in early antiquity the symbolical meaning of the act seems to have increased. Thus, for example, the physical performance of the *hieros gamos* as a sacred rite not only became a mystery—it faded to a mere conjecture.⁴¹ As we have seen, Gnosticism, too, endeavoured in all seriousness to subordinate the physiological to the metaphysical. Finally, the Church severed the

coniunctio from the physical realm altogether, and natural philosophy turned it into an abstract *theoria*. These developments meant the gradual transformation of the archetype into a psychological process which, in theory, we can call a combination of conscious and unconscious processes. In practice, however, it is not so simple, because as a rule the feminine unconscious of a man is projected upon a feminine partner, and the masculine unconscious of a woman is projected upon a man. The elucidation of these problems is a special branch of psychology and has no part in a discussion of the mythological hermaphrodite.

4. *The Child as Beginning and End*

[298] Faust, after his death, is received as a boy into the “choir of blessed youths.” I do not know whether Goethe was referring, with this peculiar idea, to the *cupids* on antique grave-stones. It is not unthinkable. The figure of the *cucullatus* points to the hooded, that is, the *invisible* one, the genius of the departed, who reappears in the child-like frolics of a new life, surrounded by the sea-forms of dolphins and tritons. The sea is the favourite symbol for the unconscious, the mother of all that lives. Just as the “child” is, in certain circumstances (e.g., in the case of Hermes and the Dactyls), closely related to the phallus, symbol of the begetter, so it comes up again in the sepulchral phallus, symbol of a renewed begetting.

[299] The “child” is therefore *renatus in novam infantiam*. It is thus both beginning and end, an initial and a terminal creature. The initial creature existed before man was, and the terminal creature will be when man is not. Psychologically speaking, this means that the “child” symbolizes the pre-conscious and the post-conscious essence of man. His pre-conscious essence is the unconscious state of earliest childhood; his post-conscious essence is an anticipation by analogy of life after death. In this idea the all-embracing nature of psychic wholeness is expressed. Wholeness is never comprised within the compass of the conscious mind—it includes the indefinite and indefinable extent of the unconscious as well. Wholeness, empirically speaking, is therefore of immeasurable extent, older and younger than consciousness and enfolding it in time and space. This is no speculation, but an immediate psychic experience. Not only is the conscious process continually accompanied, it is often guided, helped, or interrupted, by unconscious happenings. The child had a psychic life before it had consciousness. Even the adult still says and does things whose significance he realizes only later, if ever. And yet he said them and did them as if he knew what they meant. Our dreams are continually saying things beyond our conscious comprehension (which is why they are so useful in the therapy of neuroses). We have intimations and intuitions from unknown sources. Fears, moods, plans, and hopes come to us with no visible causation. These concrete experiences

are at the bottom of our feeling that we know ourselves very little; at the bottom, too, of the painful conjecture that we might have surprises in store for ourselves.

[300] Primitive man is no puzzle to himself. The question “What is man?” is the question that man has always kept until last. Primitive man has so much psyche outside his conscious mind that the experience of something psychic outside him is far more familiar to him than to us. Consciousness hedged about by psychic powers, sustained or threatened or deluded by them, is the age-old experience of mankind. This experience has projected itself into the archetype of the child, which expresses man’s wholeness. The “child” is all that is abandoned and exposed and at the same time divinely powerful; the insignificant, dubious beginning, and the triumphal end. The “eternal child” in man is an indescribable experience, an incongruity, a handicap, and a divine prerogative; an imponderable that determines the ultimate worth or worthlessness of a personality.

IV. CONCLUSION

[301] I am aware that a psychological commentary on the child archetype without detailed documentation must remain a mere sketch. But since this is virgin territory for the psychologist, my main endeavour has been to stake out the possible extent of the problems raised by our archetype and to describe, at least cursorily, its different aspects. Clear-cut distinctions and strict formulations are quite impossible in this field, seeing that a kind of fluid interpenetration belongs to the very nature of all archetypes. They can only be roughly circumscribed at best. Their living meaning comes out more from their presentation as a whole than from a single formulation. Every attempt to focus them more sharply is immediately punished by the intangible core of meaning losing its luminosity. No archetype can be reduced to a simple formula. It is a vessel which we can never empty, and never fill. It has a potential existence only, and when it takes shape in matter it is no longer what it was. It persists throughout the ages and requires interpreting ever anew. The archetypes are the imperishable elements of the unconscious, but they change their shape continually.

[302] It is a well-nigh hopeless undertaking to tear a single archetype out of the living tissue of the psyche; but despite their interwovenness they do form units of meaning that can be apprehended intuitively. Psychology, as one of the many expressions of psychic life, operates with ideas which in their turn are derived from archetypal structures and thus generate a somewhat more abstract kind of myth. Psychology therefore translates the archaic speech of myth into a modern mythologem—not yet, of course, recognized as such—which constitutes one element of the myth “science.” This seemingly hopeless undertaking is a *living and lived myth*, satisfying to persons

of a corresponding temperament, indeed beneficial in so far as they have been cut off from their psychic origins by neurotic dissociation.

[303] As a matter of experience, we meet the child archetype in spontaneous and in therapeutically induced individuation processes. The first manifestation of the “child” is as a rule a totally unconscious phenomenon. Here the patient identifies himself with his personal infantilism. Then, under the influence of therapy, we get a more or less gradual separation from and objectification of the “child,” that is, the identity breaks down and is accompanied by an intensification (sometimes technically induced) of fantasy, with the result that archaic or mythological features become increasingly apparent. Further transformations run true to the hero myth. The theme of “mighty feats” is generally absent, but on the other hand the mythical dangers play all the greater part. At this stage there is usually another identification, this time with the hero, whose role is attractive for a variety of reasons. The identification is often extremely stubborn and dangerous to the psychic equilibrium. If it can be broken down and if consciousness can be reduced to human proportions, the figure of the hero can gradually be differentiated into a symbol of the self.

[304] In practical reality, however, it is of course not enough for the patient merely to *know about* such developments; what counts is his experience of the various transformations. The initial stage of personal infantilism presents the picture of an “abandoned” or “misunderstood” and unjustly treated child with overweening pretensions. The epiphany of the hero (the second identification) shows itself in a corresponding inflation: the colossal pretension grows into a conviction that one is something extraordinary, or else the impossibility of the pretension ever being fulfilled only proves one’s own inferiority, which is favourable to the role of the heroic sufferer (a negative inflation). In spite of their contradictoriness, both forms are identical, because conscious megalomania is balanced by unconscious compensatory inferiority and conscious inferiority by unconscious megalomania (you never get one without the other). Once the reef of the second identification has been successfully circumnavigated, conscious processes can be cleanly separated from the unconscious, and the latter observed objectively. This leads to the possibility of an accommodation with the unconscious, and thus to a possible synthesis of the conscious and unconscious elements of knowledge and action. This in turn leads to a shifting of the centre of personality from the ego to the self.⁴²

[305] In this psychological framework the motifs of abandonment, invincibility, hermaphroditism, and beginning and end take their place as distinct categories of experience and understanding.

THE PSYCHOLOGICAL ASPECTS OF THE KORE

[306] Not only is the figure of Demeter and the Kore in its threefold aspect as maiden, mother, and Hecate not unknown to the psychology of the unconscious, it is even something of a practical problem. The “Kore” has her psychological counterpart in those archetypes which I have called the *self* or *supraordinate personality* on the one hand, and the *anima* on the other. In order to explain these figures, with which I cannot assume all readers to be familiar, I must begin with some remarks of a general nature.

[307] The psychologist has to contend with the same difficulties as the mythologist when an exact definition or clear and concise information is demanded of him. The picture is concrete, clear, and subject to no misunderstandings only when it is seen in its habitual context. In this form it tells us everything it contains. But as soon as one tries to abstract the “real essence” of the picture, the whole thing becomes cloudy and indistinct. In order to understand its living function, we must let it remain an organic thing in all its complexity and not try to examine the anatomy of its corpse in the manner of the scientist, or the archaeology of its ruins in the manner of the historian. Naturally this is not to deny the justification of such methods when applied in their proper place.

[308] In view of the enormous complexity of psychic phenomena, a purely phenomenological point of view is, and will be for a long time, the only possible one and the only one with any prospect of success. “Whence” things come and “what” they are, these, particularly in the field of psychology, are questions which are apt to call forth untimely attempts at explanation. Such speculations are moreover based far more on unconscious philosophical premises than on the nature of the phenomena themselves. Psychic phenomena occasioned by unconscious processes are so rich and so multifarious that I prefer to *describe* my findings and observations and, where possible, to classify them—that is, to arrange them under certain definite types. That is the method of natural science, and it is applied wherever we have to do with multifarious and still unorganized material. One may question the utility or the appropriateness of the categories or types used in the arrangement, but not the correctness of the method itself.

[309] Since for years I have been observing and investigating the products of the unconscious in the widest sense of the word, namely dreams, fantasies, visions, and delusions of the insane, I have not been able to avoid recognizing certain regularities, that is, *types*. There are types of *situations* and types of *figures* that repeat themselves frequently and have a corresponding meaning. I therefore employ the term “motif” to designate these repetitions. Thus there are not only typical dreams but typical motifs in the dreams. These may, as we have said, be situations or figures. Among the latter there are human figures that can be arranged under a series of archetypes, the chief of them being, according to my suggestion,¹ the *shadow*, the *wise old man*, the *child* (including the child hero), the *mother* (“Primordial Mother” and “Earth Mother”) as a supraordinate personality (“daemonic” because supraordinate), and her counterpart the *maiden*, and lastly the *anima* in man and the *animus* in woman.

[310] The above types are far from exhausting all the statistical regularities in this respect. The figure of the Kore that interests us here belongs, when observed in a man, to the *anima* type; and when observed in a woman to the type of *supraordinate personality*. It is an essential characteristic of psychic figures that they are duplex or at least capable of duplication; at all events they are bipolar and oscillate between their positive and negative meanings. Thus the “supraordinate” personality can appear in a despicable and distorted form, like for instance Mephistopheles, who is really more positive as a personality than the vapid and unthinking careerist Faust. Another negative figure is the Tom Thumb or Tom Dumb of the folktales. The figure corresponding to the Kore in a woman is generally a double one, i.e., a mother and a maiden, which is to say that she appears now as the one, now as the other. From this I would conclude, for a start, that in the formation of the Demeter-Kore myth the feminine influence so far outweighed the masculine that the latter had practically no significance. The man’s role in the Demeter myth is really only that of seducer or conqueror.

[311] As a matter of practical observation, the Kore often appears in woman as an *unknown young girl*, not infrequently as Gretchen or the unmarried mother.² Another frequent modulation is the *dancer*, who is often formed by borrowings from classical knowledge, in which case the “maiden” appears as the *corybant*, *maenad*, or *nymph*. An occasional variant is the nixie or water-sprite, who betrays her superhuman nature by her fishtail. Sometimes the Kore- and mother-figures slither down altogether to the animal kingdom, the favourite representatives then being the *cat* or the *snake* or the *bear*, or else some black monster of the underworld like the crocodile, or other salamander-like, saurian creatures.³ The maiden’s helplessness exposes her to all sorts of *dangers*, for instance of being devoured by reptiles or ritually slaughtered like a beast of sacrifice. Often there are bloody, cruel, and even obscene *orgies* to which the innocent child falls victim. Sometimes it is a true *nekylia*, a descent into

Hades and a quest for the “treasure hard to attain,” occasionally connected with orgiastic sexual rites or offerings of menstrual blood to the moon. Oddly enough, the various tortures and obscenities are carried out by an “Earth Mother.” There are *drinkings of blood* and *bathings in blood*,⁴ also crucifixions. The maiden who crops up in case histories differs not inconsiderably from the vaguely flower-like Kore in that the modern figure is more sharply delineated and not nearly so “unconscious,” as the following examples will show.

[312] The figures corresponding to Demeter and Hecate are supra-ordinate, not to say over-life-size “Mothers” ranging from the Pietà type to the Baubo type. The unconscious, which acts as a counterbalance to woman’s conventional innocuousness, proves to be highly inventive in this latter respect. I can recall only very few cases where Demeter’s own noble figure in its pure form breaks through as an image rising spontaneously from the unconscious. I remember a case, in fact, where a maiden-goddess appears clad all in purest white, but carrying a black monkey in her arms. The Earth Mother is always chthonic and is occasionally related to the moon, either through the blood-sacrifice already mentioned, or through a child-sacrifice, or else because she is adorned with a sickle moon.⁵ In pictorial or plastic representations the Mother is dark deepening to *black*, or *red* (these being her principal colours), and with a primitive or animal expression of face; in form she not infrequently resembles the *neolithic ideal* of the “Venus” of Brassempouy or that of Willendorf, or again the sleeper of Hal Saflieni.⁶ Now and then I have come across *multiple breasts*, arranged like those of a sow. The Earth Mother plays an important part in the woman’s unconscious, for all her manifestations are described as “powerful.” This shows that in such cases the Earth Mother element in the conscious mind is abnormally weak and requires strengthening.

[313] In view of all this it is, I admit, hardly understandable why such figures should be reckoned as belonging to the type of “supraordinate personality.” In a scientific investigation, however, one has to disregard moral or aesthetic prejudices and let the facts speak for themselves. The *maiden* is often described as not altogether human in the usual sense; she is either of unknown or peculiar origin, or she looks strange or undergoes strange experiences, from which one is forced to infer the maiden’s extraordinary, myth-like nature. Equally and still more strikingly, the Earth Mother is a divine being—in the classical sense. Moreover, she does not by any means always appear in the guise of Baubo, but, for instance, more like Queen Venus in the *Hypnerotomachia Poliphili*, though she is invariably heavy with destiny. The often unaesthetic forms of the Earth Mother are in keeping with a prejudice of the modern feminine unconscious; this prejudice was lacking in antiquity. The underworld nature of Hecate, who is closely connected with Demeter, and Persephone’s fate both point

nevertheless to the dark side of the human psyche, though not to the same extent as the modern material.

[314] The “supraordinate personality” is the total man, i.e., man as he really is, not as he appears to himself. To this wholeness the unconscious psyche also belongs, which has its requirements and needs just as consciousness has. I do not want to interpret the unconscious personalistically and assert, for instance, that fantasy-images like those described above are the “wish-fulfilments” due to repression. These images were as such never conscious and consequently could never have been repressed. I understand the unconscious rather as an *impersonal* psyche common to all men, even though it expresses itself through a personal consciousness. When anyone breathes, his breathing is not a phenomenon to be interpreted personally. The mythological images belong to the structure of the unconscious and are an impersonal possession; in fact, the great majority of men are far more *possessed by* them than possessing them. Images like those described above give rise under certain conditions to corresponding disturbances and symptoms, and it is then the task of medical therapy to find out whether and how and to what extent these impulses can be integrated with the conscious personality, or whether they are a secondary phenomenon which some defective orientation of consciousness has brought out of its normal potential state into actuality. Both possibilities exist in practice.

[315] I usually describe the supraordinate personality as the “self,” thus making a sharp distinction between the ego, which, as is well known, extends only as far as the conscious mind, and the *whole* of the personality, which includes the unconscious as well as the conscious component. The ego is thus related to the self as part to whole. To that extent the self is supraordinate. Moreover, the self is felt empirically not as subject but as object, and this by reason of its unconscious component, which can only come to consciousness indirectly, by way of projection. Because of its unconscious component the self is so far removed from the conscious mind that it can only be partially expressed by human figures; the other part of it has to be expressed by objective, abstract symbols. The human figures are father and son, mother and daughter, king and queen, god and goddess. Theriomorphic symbols are the dragon, snake, elephant, lion, bear, and other powerful animals, or again the spider, crab, butterfly, beetle, worm, etc. Plant symbols are generally flowers (lotus and rose). These lead on to geometrical figures like the circle, the sphere, the square, the quaternity, the clock, the firmament, and so on.⁷ The indefinite extent of the unconscious component makes a comprehensive description of the human personality impossible. Accordingly, the unconscious supplements the picture with living figures ranging from the animal to the divine, as the two extremes outside man, and rounds out the animal extreme, through the addition of vegetable and inorganic

abstractions, into a microcosm. These addenda have a high frequency in anthropomorphic divinities, where they appear as “attributes.”

[316] Demeter and Kore, mother and daughter, extend the feminine consciousness both upwards and downwards. They add an “older and younger,” “stronger and weaker” dimension to it and widen out the narrowly limited conscious mind bound in space and time, giving it intimations of a greater and more comprehensive personality which has a share in the eternal course of things. We can hardly suppose that myth and mystery were invented for any conscious purpose; it seems much more likely that they were the involuntary revelation of a psychic, but unconscious, pre-condition. The psyche pre-existent to consciousness (e.g., in the child) participates in the maternal psyche on the one hand, while on the other it reaches across to the daughter psyche. We could therefore say that every mother contains her daughter in herself and every daughter her mother, and that every woman extends backwards into her mother and forwards into her daughter. This participation and intermingling give rise to that peculiar uncertainty as regards *time*: a woman lives earlier as a mother, later as a daughter. The conscious experience of these ties produces the feeling that her life is spread out over generations—the first step towards the immediate experience and conviction of being outside time, which brings with it a feeling of *immortality*. The individual’s life is elevated into a type, indeed it becomes the archetype of woman’s fate in general. This leads to a restoration or *apocatastasis* of the lives of her ancestors, who now, through the bridge of the momentary individual, pass down into the generations of the future. An experience of this kind gives the individual a place and a meaning in the life of the generations, so that all unnecessary obstacles are cleared out of the way of the life-stream that is to flow through her. At the same time the individual is rescued from her isolation and restored to wholeness. All ritual preoccupation with archetypes ultimately has this aim and this result.

[317] It is immediately clear to the psychologist what cathartic and at the same rejuvenating effects must flow from the Demeter cult into the feminine psyche, and what a lack of psychic hygiene characterizes our culture, which no longer knows the kind of wholesome experience afforded by Eleusinian emotions.

[318] I take full account of the fact that not only the psychologically minded layman but the professional psychologist and psychiatrist as well, and even the psychotherapist, do not possess an adequate knowledge of their patients’ archetypal material, in so far as they have not specially investigated this aspect of the phenomenology of the unconscious. For it is precisely in the field of psychiatric and psychotherapeutic observation that we frequently meet with cases characterized by a rich crop of archetypal symbols.⁸ Since the necessary historical knowledge is lacking to the physician observing them, he is not in a position to perceive the parallelism

between his observations and the findings of anthropology and the humane sciences in general. Conversely, an expert in mythology and comparative religion is as a rule no psychiatrist and consequently does not know that his mythologems are still fresh and living—for instance, in dreams and visions—in the hidden recesses of our most personal life, which we would on no account deliver up to scientific dissection. The archetypal material is therefore the great unknown, and it requires special study and preparation even to collect such material.

[319] It does not seem to me superfluous to give a number of examples from my case histories which bring out the occurrence of archetypal images in dreams or fantasies. Time and again with my public I come across the difficulty that they imagine illustration by “a few examples” to be the simplest thing in the world. In actual fact it is almost impossible, with a few words and one or two images torn out of their context, to demonstrate anything. This only works when dealing with an expert. What Perseus has to do with the Gorgon’s head would never occur to anyone who did not know the myth. So it is with the individual images: they need a context, and the context is not only a myth but an individual anamnesis. Such contexts, however, are of enormous extent. Anything like a complete series of images would require for its proper presentation a book of about two hundred pages. My own investigation of the Miller fantasies gives some idea of this.⁹ It is therefore with the greatest hesitation that I make the attempt to illustrate from case-histories. The material I shall use comes partly from normal, partly from slightly neurotic, persons. It is part dream, part vision, or dream mixed with vision. These “visions” are far from being hallucinations or ecstatic states; they are spontaneous, visual images of fantasy or so-called *active imagination*. The latter is a method (devised by myself) of introspection for observing the stream of interior images. One concentrates one’s attention on some impressive but unintelligible dream-image, or on a spontaneous visual impression, and observes the changes taking place in it. Meanwhile, of course, all criticism must be suspended and the happenings observed and noted with absolute objectivity. Obviously, too, the objection that the whole thing is “arbitrary” or “thought up” must be set aside, since it springs from the anxiety of an ego-consciousness which brooks no master besides itself in its own house. In other words, it is the inhibition exerted by the conscious mind on the unconscious.

[320] Under these conditions, long and often very dramatic series of fantasies ensue. The advantage of this method is that it brings a mass of unconscious material to light. Drawing, painting, and modelling can be used to the same end. Once a visual series has become dramatic, it can easily pass over into the auditive or linguistic sphere and give rise to dialogues and the like. With slightly pathological individuals, and particularly in the not infrequent cases of latent schizophrenia, the method may, in certain circumstances, prove to be rather dangerous and therefore requires medical

control. It is based on a deliberate weakening of the conscious mind and its inhibiting effect, which either limits or suppresses the unconscious. The aim of the method is naturally therapeutic in the first place, while in the second it also furnishes rich empirical material. Some of our examples are taken from this. They differ from dreams only by reason of their better form, which comes from the fact that the contents were perceived not by a dreaming but by a waking consciousness. The examples are from women in middle life.

1. Case X (*spontaneous visual impressions, in chronological order*)

[321] i. *“I saw a white bird with outstretched wings. It alighted on the figure of a woman, clad in blue, who sat there like an antique statue. The bird perched on her hand, and in it she held a grain of wheat. The bird took it in its beak and flew into the sky again.”*

[322] For this X painted a picture: a blue-clad, archaically simple “Mother”-figure on a white marble base. Her maternity is emphasized by the large breasts.

[323] ii. *A bull lifts a child up from the ground and carries it to the antique statue of a woman. A naked young girl with a wreath of flowers in her hair appears, riding on a white bull. She takes the child and throws it into the air like a ball and catches it again. The white bull carries them both to a temple. The girl lays the child on the ground, and so on (initiation follows).*

[324] In this picture the *maiden* appears, rather in the form of Europa. (Here a certain school knowledge is being made use of.) Her nakedness and the wreath of flowers point to Dionysian abandonment. The game of ball with the child is the motif of some secret rite which always has to do with “child-sacrifice.” (Cf. the accusations of ritual murder levelled by the pagans against the Christians and by the Christians against the Jews and Gnostics; also the Phoenician child-sacrifices, rumours about the Black Mass, etc., and “the ball-game in church.”)¹⁰

[325] iii. *“I saw a golden pig on a pedestal. Beast-like beings danced round it in a circle. We made haste to dig a hole in the ground. I reached in and found water. Then a man appeared in a golden carriage. He jumped into the hole and began swaying back and forth, as if dancing... I swayed in rhythm with him. Then he suddenly leaped out of the hole, raped me, and got me with child.”*

[326] X is identical with the young girl, who often appears as a *youth*, too. This youth is an animus-figure, the embodiment of the masculine element in a woman. Youth and young girl together form a syzygy or *coniunctio* which symbolizes the essence of wholeness (as also does the Platonic hermaphrodite, who later became the symbol of perfected wholeness in alchemical philosophy). X evidently dances with the rest,

hence “we made haste.” The parallel with the motifs stressed by Kerényi seems to me remarkable.

[327] iv. *“I saw a beautiful youth with golden cymbals, dancing and leaping in joy and abandonment.... Finally he fell to the ground and buried his face in the flowers. Then he sank into the lap of a very old mother. After a time he got up and jumped into the water, where he sported like a dolphin.... I saw that his hair was golden. Now we were leaping together, hand in hand. So we came to a gorge....” In leaping the gorge the youth falls into the chasm. X is left alone and comes to a river where a white sea-horse is waiting for her with a golden boat.*

[328] In this scene X is the youth; therefore he disappears later, leaving her the sole heroine of the story. She is the child of the “very old mother,” and is also the dolphin, the youth lost in the gorge, and the bride evidently expected by Poseidon. The peculiar overlapping and displacement of motifs in all this individual material is about the same as in the mythological variants. X found the youth in the lap of the mother so impressive that she painted a picture of it. The figure is the same as in item i; only, instead of the grain of wheat in her hand, there is the body of the youth lying completely exhausted in the lap of the gigantic mother.

[329] v. *There now follows a sacrifice of sheep, during which a game of ball is likewise played with the sacrificial animal. The participants smear themselves with the sacrificial blood, and afterwards bathe in the pulsing gore. X is thereupon transformed into a plant.*

[330] vi. *After that X comes to a den of snakes, and the snakes wind all round her.*

[331] vii. *In a den of snakes beneath the sea there is a divine woman, asleep. (She is shown in the picture as much larger than the others.) She is wearing a blood-red garment that covers only the lower half of her body. She has a dark skin, full red lips, and seems to be of great physical strength. She kisses X, who is obviously in the role of the young girl, and hands her as a present to the many men who are standing by, etc.*

[332] This chthonic goddess is the typical Earth Mother as she appears in so many modern fantasies.

[333] viii. *As X emerged from the depths and saw the light again, she experienced a kind of illumination: white flames played about her head as she walked through waving fields of grain.*

[334] With this picture the Mother-episode ended. Although there is not the slightest trace of any known myth being repeated, the motifs and the connections between them are all familiar to us from mythology. These images present themselves spontaneously and are based on no conscious knowledge whatever. I have applied the

method of active imagination to myself over a long time and have observed numerous symbols and symbolic associations which in many cases I was only able to verify years afterwards in texts of whose existence I was totally ignorant. It is the same with dreams. Some years ago I dreamed for example that: *I was climbing slowly and toilsomely up a mountain. When I had reached, as I imagined, the top, I found that I was standing on the edge of a plateau. The crest that represented the real top of the mountain only rose far off in the distance. Night was coming on, and I saw, on the dark slope opposite, a brook flowing down with a metallic shimmer, and two paths leading upwards, one to the left, the other to the right, winding like serpents. On the crest, to the right, there was a hotel. Down below, the brook ran to the left with a bridge leading across.*

[335] Not long afterwards I discovered the following “allegory” in an obscure alchemical treatise. In his *Speculativae philosophiae*¹¹ the Frankfurt physician Gerard Dorn, who lived in the second half of the sixteenth century, describes the “Mundi peregrinatio, quam erroris viam appellamus” (Tour of the world, which we call the way of error) on the one hand and the “Via veritatis” on the other. Of the first way the author says:

The human race, whose nature it is to resist God, does not cease to ask how it may, by its own efforts, escape the pitfalls which it has laid for itself. But it does not ask help from Him on whom alone depends every gift of mercy. Hence it has come about that men have built for themselves a great Workshop on the left-hand side of the road ... presided over by Industry. After this has been attained, they turn aside from Industry and bend their steps towards the *second region of the world*, making their crossing *on the bridge of infirmity*.... But because the good God desires to draw them back. He allows their infirmities to rule over them; then, seeking as before a remedy in themselves [industry!], they flock *to the great Hospital likewise built on the left*, presided over by Medicine. Here there is a great multitude of apothecaries, surgeons, and physicians, [etc.].¹²

[336] Of the “way of truth,” which is the “right” way, our author says: “... you will come to the camp of Wisdom and on being received there, you will be refreshed with food far more powerful than before.” Even the brook is there: “... a stream of living water flowing with such wonderful artifice from the mountain peak. (From the Fountain of Wisdom the waters gush forth.)”¹³

[337] An important difference, compared with my dream, is that here, apart from the situation of the hotel being reversed, the river of Wisdom is on the right and not, as in my dream, in the middle of the picture.

[338] It is evident that in my dream we are not dealing with any known “myth” but with a group of ideas which might easily have been regarded as “individual,” i.e.,

unique. A thorough analysis, however, could show without difficulty that it is an archetypal image such as can be reproduced over and over again in any age and any place. But I must admit that the archetypal nature of the dream-image only became clear to me when I read Dorn. These and similar incidents I have observed repeatedly not only in myself but in my patients. But, as this example shows, it needs special attention if such parallels are not to be missed.

[339] The antique Mother-image is not exhausted with the figure of Demeter. It also expresses itself in Cybele-Artemis. The next case points in this direction.

2. Case Y (dreams)

[340] i. *“I am wandering over a great mountain; the way is lonely, wild, and difficult. A woman comes down from the sky to accompany and help me. She is all bright with light hair and shining eyes. Now and then she vanishes. After going on for some time alone I notice that I have left my stick somewhere, and must turn back to fetch it. To do this I have to pass a terrible monster, an enormous bear. When I came this way the first time I had to pass it, but then the sky-woman protected me. Just as I am passing the beast and he is about to come at me, she stands beside me again, and at her look the bear lies down quietly and lets us pass. Then the sky-woman vanishes.”*

[341] Here we have a maternally protective goddess related to bears, a kind of Diana or the Gallo-Roman Dea Artio. The sky-woman is the positive, the bear the negative aspect of the “supraordinate personality,” which extends the conscious human being upwards into the celestial and downwards into the animal regions.

[342] ii. *“We go through a door into a tower-like room, where we climb a long flight of steps. On one of the topmost steps I read an inscription: ‘Vis ut sis.’ The steps end in a temple situated on the crest of a wooded mountain, and there is no other approach. It is the shrine of Ursanna, the bear-goddess and Mother of God in one. The temple is of red stone. Bloody sacrifices are offered there. Animals are standing about the altar. In order to enter the temple precincts one has to be transformed into an animal—a beast of the forest. The temple has the form of a cross with equal arms and a circular space in the middle, which is not roofed, so that one can look straight up at the sky and the constellation of the Bear. On the altar in the middle of the open space there stands the moon-bowl, from which smoke or vapour continually rises. There is also a huge image of the goddess, but it cannot be seen clearly. The worshippers, who have been changed into animals and to whom I also belong, have to touch the goddess’s foot with their own foot, whereupon the image gives them a sign or an oracular utterance like ‘Vis ut sis.’”*

[343] In this dream the bear-goddess emerges plainly, although her statue “cannot be seen clearly.” The relationship to the self, the supraordinate personality, is indicated

not only by the oracle “Vis ut sis” but by the quaternity and the circular central precinct of the temple. From ancient times any relationship to the stars has always symbolized eternity. The soul comes “from the stars” and returns to the stellar regions. “Ursanna’s” relation to the moon is indicated by the “moon-bowl.”

[344] The moon-goddess also appears in children’s dreams. A girl who grew up in peculiarly difficult psychic circumstances had a recurrent dream between her seventh and tenth years: “*The moon-lady was always waiting for me down by the water at the landing-stage, to take me to her island.*” Unfortunately she could never remember what happened there, but it was so beautiful that she often prayed she might have this dream again. Although, as is evident, the two dreamers are not identical, the *island motif* also occurred in the previous dream as the inaccessible mountain crest.

[345] Thirty years later, the dreamer of the moon-lady had a dramatic fantasy:

[346] “*I am climbing a steep dark mountain, on top of which stands a domed castle. I enter and go up a winding stairway to the left. Arriving inside the dome, I find myself in the presence of a woman wearing a head-dress of cow’s horns. I recognize her immediately as the moon-lady of my childhood dreams. At her behest I look to the right and see a dazzlingly bright sun shining on the other side of a deep chasm. Over the chasm stretches a narrow, transparent bridge, upon which I step, conscious of the fact that in no circumstances must I look down. An uncanny fear seizes me, and I hesitate. Treachery seems to be in the air, but at last I go across and stand before the sun. The sun speaks: ‘If you can approach me nine times without being burned, all will be well.’ But I grow more and more afraid, finally I do look down, and I see a black tentacle like that of an octopus groping towards me from underneath the sun. I step back in fright and plunge into the abyss. But instead of being dashed to pieces I lie in the arms of the Earth Mother. When I try to look into her face, she turns to clay, and I find myself lying on the earth.*”

[347] It is remarkable how the beginning of this fantasy agrees with the dream. The moon-lady above is clearly distinguished from the Earth Mother below. The former urges the dreamer to her somewhat perilous adventure with the sun; the latter catches her protectively in her maternal arms. The dreamer, as the one in danger, would therefore seem to be in the role of the Kore.

[348] Let us now turn back to our dream-series:

[349] iii. *Y sees two pictures in a dream, painted by the Scandinavian painter Hermann Christian Lund.*

I. “*The first picture is of a Scandinavian peasant room. Peasant girls in gay costumes are walking about arm in arm (that is, in a row). The middle one is*

smaller than the rest and, besides this, has a hump and keeps turning her head back. This, together with her peculiar glance, gives her a witchlike look.”

II. *“The second picture shows a dragon with its neck stretched out over the whole picture and especially over a girl, who is in the dragon’s power and cannot move, for as soon as she moves, the dragon, which can make its body big or little at will, moves too; and when the girl wants to get away it simply stretches out its neck over her, and so catches her again. Strangely enough, the girl has no face, at least I couldn’t see it.”*

[350] The painter is an invention of the dream. The animus often appears as a painter or has some kind of projection apparatus, or is a cinema-operator or owner of a picture-gallery. All this refers to the animus as the function mediating between conscious and unconscious: the unconscious contains pictures which are transmitted, that is, made manifest, by the animus, either as fantasies or, unconsciously, in the patient’s own life and actions. The animus-projection gives rise to fantasied relations of love and hatred for “heroes” or “demons.” The favourite victims are tenors, artists, movie-stars, athletic champions, etc. In the first picture the maiden is characterized as demonic, with a hump and an evil look “over her shoulder.” (Hence amulets against the evil eye are often worn by primitives on the nape of the neck, for the vulnerable spot is at the back, where you can’t see.)

[351] In the second picture the “maiden” is portrayed as the innocent victim of the monster. Just as before there was a relationship of identity between the sky-woman and the bear, so here between the young girl and the dragon—which in practical life is often rather more than just a bad joke. Here it signifies a widening of the conscious personality, i.e., through the helplessness of the victim on the one hand and the dangers of the humpback’s evil eye and the dragon’s might on the other.

[352] iv (part dream, part visual imagination). *“A magician is demonstrating his tricks to an Indian prince. He produces a beautiful young girl from under a cloth. She is a dancer, who has the power to change her shape or at least hold her audience spell-bound by faultless illusion. During the dance she dissolves with the music into a swarm of bees. Then she changes into a leopard, then into a jet of water, then into an octopus that has twined itself about a young pearl-fisher. Between times, she takes human form again at the dramatic moment. She appears as a she-ass bearing two baskets of wonderful fruits. Then she becomes a many-coloured peacock. The prince is beside himself with delight and calls her to him. But she dances on, now naked, and even tears the skin from her body, and finally falls down—a naked skeleton. This is buried, but at night a lily grows out of the grave, and from its cup there rises a white lady, who floats slowly up to the sky.”*

[353] This piece describes the successive transformations of the illusionist (artistry in illusion being a specifically feminine talent) until she becomes a transfigured personality. The fantasy was not invented as a sort of allegory; it was part dream, part spontaneous imagery.

[354] v. “*I am in a church made of grey sandstone. The apse is built rather high. Near the tabernacle a girl in a red dress is hanging on the stone cross of the window. (Suicide?)*”

[355] Just as in the preceding cases the sacrifice of a child or a sheep played a part, so here the sacrifice of the maiden hanging on the “cross.” The death of the dancer is also to be understood in this sense, for these maidens are always doomed to die, because their exclusive domination of the feminine psyche hinders the individuation process, that is, the maturation of personality. The “maiden” corresponds to the anima of the man and makes use of it to gain her natural ends, in which illusion plays the greatest role imaginable. But as long as a woman is content to be a *femme à homme*, she has no feminine individuality. She is empty and merely glitters—a welcome vessel for masculine projections. Woman as a personality, however, is a very different thing: here illusion no longer works. So that when the question of personality arises, which is as a rule the painful fact of the second half of life, the childish form of the self disappears too.

[356] All that remains for me now is to describe the Kore as observable in man, the *anima*. Since a man’s wholeness, in so far as he is not constitutionally homosexual, can only be a masculine personality, the feminine figure of the anima cannot be catalogued as a type of supraordinate personality but requires a different evaluation and position. In the products of unconscious activity, the anima appears equally as maiden and mother, which is why a personalistic interpretation always reduces her to the personal mother or some other female person. The real meaning of the figure naturally gets lost in the process, as is inevitably the case with all these reductive interpretations whether in the sphere of the psychology of the unconscious or of mythology. The innumerable attempts that have been made in the sphere of mythology to interpret gods and heroes in a solar, lunar, astral, or meteorological sense contribute nothing of importance to the understanding of them; on the contrary, they all put us on a false track. When, therefore, in dreams and other spontaneous products, we meet with an unknown female figure whose significance oscillates between the extremes of goddess and whore, it is advisable to let her keep her independence and not reduce her arbitrarily to something known. If the unconscious shows her as an “unknown,” this attribute should not be got rid of by main force with a view to arriving at a “rational” interpretation. Like the “supraordinate personality,” the anima is bipolar and can therefore appear positive one moment and negative the

next; now young, now old; now mother, now maiden; now a good fairy, now a witch; now a saint, now a whore. Besides this ambivalence, the anima also has “occult” connections with “mysteries,” with the world of darkness in general, and for that reason she often has a religious tinge. Whenever she emerges with some degree of clarity, she always has a peculiar relationship to *time*: as a rule she is more or less immortal, because outside time. Writers who have tried their hand at this figure have never failed to stress the anima’s peculiarity in this respect. I would refer to the classic descriptions in Rider Haggard’s *She* and *The Return of She*, in Pierre Benoît’s *L’Atlantide*, and above all in the novel of the young American author, William M. Sloane, *To Walk the Night*. In all these accounts, the anima is outside time as we know it and consequently immensely old or a being who belongs to a different order of things.

[357] Since we can no longer or only partially express the archetypes of the unconscious by means of figures in which we religiously believe, they lapse into unconsciousness again and hence are unconsciously projected upon more or less suitable human personalities. To the young boy a clearly discernible anima-form appears in his mother, and this lends her the radiance of power and superiority or else a daemonic aura of even greater fascination. But because of the anima’s ambivalence, the projection can be entirely negative. Much of the fear which the female sex arouses in men is due to the projection of the anima-image. An infantile man generally has a maternal anima; an adult man, the figure of a younger woman. The senile man finds compensation in a very young girl, or even a child.

[3. Case Z]

[358] The anima also has affinities with animals, which symbolize her characteristics. Thus she can appear as a snake or a tiger or a bird. I quote by way of example a dream-series that contains transformations of this kind.¹⁴

[359] i. *A white bird perches on a table. Suddenly it changes into a fair-haired seven-year-old girl and just as suddenly back into a bird, which now speaks with a human voice.*

[360] ii. *In an underground house, which is really the underworld, there lives an old magician and prophet with his “daughter.” She is, however, not really his daughter; she is a dancer, a very loose person, but is blind and seeks healing.*

[361] iii. *A lonely house in a wood, where an old scholar is living. Suddenly his daughter appears, a kind of ghost, complaining that people only look upon her as a figment of fancy.*

- [362] iv. *On the façade of a church there is a Gothic Madonna, who is alive and is the “unknown and yet known woman.” Instead of a child, she holds in her arms a sort of flame or a snake or a dragon.*
- [363] v. *A black-clad “countess” kneels in a dark chapel. Her dress is hung with costly pearls. She has red hair, and there is something uncanny about her. Moreover, she is surrounded by the spirits of the dead.*
- [364] vi. *A female snake comports herself tenderly and insinuatingly, speaking with a human voice. She is only “accidentally” shaped like a snake.*
- [365] vii. *A bird speaks with the same voice, but shows herself helpful by trying to rescue the dreamer from a dangerous situation.*
- [366] viii. *The unknown woman sits, like the dreamer, on the tip of a church-spire and stares at him uncannily across the abyss.*
- [367] ix. *The unknown woman suddenly appears as an old female attendant in an underground public lavatory with a temperature of 40° below zero.*
- [368] x. *The unknown woman leaves the house as a petite bourgeoisie with a female relation, and in her place there is suddenly an over-life-size goddess clad in blue, looking like Athene.*
- [369] xi. *Then she appears in a church, taking the place of the altar, still over-life-size but with veiled face.*
- [370] In all these dreams¹⁵ the central figure is a mysterious feminine being with qualities like those of no woman known to the dreamer. The unknown is described as such in the dreams themselves, and reveals her extraordinary nature firstly by her power to change shape and secondly by her paradoxical ambivalence. Every conceivable shade of meaning glitters in her, from the highest to the lowest.
- [371] *Dream i* shows the anima as elflike, i.e., only partially human. She can just as well be a bird, which means that she may belong wholly to nature and can vanish (i.e., become unconscious) from the human sphere (i.e., consciousness).
- [372] *Dream ii* shows the unknown woman as a mythological figure from the beyond (the unconscious). She is the *soror* or *filia mystica* of a hierophant or “philosopher,” evidently a parallel to those mystic syzygies which are to be met with in the figures of Simon Magus and Helen, Zosimus and Theosebeia, Comarius and Cleopatra, etc. Our dream-figure fits in best with Helen. A really admirable description of anima-psychology in a woman is to be found in Erskine’s *Helen of Troy*.
- [373] *Dream iii* presents the same theme, but on a more “fairytale-like” plane. Here the anima is shown as rather spookish.

- [374] *Dream iv* brings the anima nearer to the Mother of God. The “child” refers to the mystic speculations on the subject of the redemptive serpent and the “fiery” nature of the redeemer.
- [375] In *dream v*, the anima is visualized somewhat romantically as the “distinguished” fascinating woman, who nevertheless has dealings with spirits.
- [376] *Dreams vi and vii* bring theriomorphic variations. The anima’s identity is at once apparent to the dreamer because of the voice and what it says. The anima has “accidentally” taken the form of a snake, just as in *dream i* she changed with the greatest ease into a bird and back again. As a snake, she is playing the negative role, as a bird the positive.
- [377] *Dream viii* shows the dreamer confronted with his anima. This takes place high above the ground (i.e., above human reality). Obviously it is a case of dangerous fascination by the anima.
- [378] *Dream ix* signifies the anima’s deep plunge into an extremely “subordinate” position, where the last trace of fascination has gone and only human sympathy is left.
- [379] *Dream x* shows the paradoxical double nature of the anima: banal mediocrity and Olympian divinity.
- [380] *Dream xi* restores the anima to the Christian church, not as an icon but as the altar itself. The altar is the place of sacrifice and also the receptacle for consecrated relics.
- [381] To throw even a moderate light on all these anima associations would require special and very extensive investigation, which would be out of place here because, as we have already said, the anima has only an indirect bearing on the interpretation of the Kore figure. I have presented this dream-series simply for the purpose of giving the reader some idea of the empirical material on which the idea of the anima is based.¹⁶ From this series and others like it we get an average picture of that strange factor which has such an important part to play in the masculine psyche, and which naïve presumption invariably identifies with certain women, imputing to them all the illusions that swarm in the male Eros.
- [382] It seems clear enough that the man’s anima found occasion for projection in the Demeter cult. The Kore doomed to her subterranean fate, the two-faced mother, and the theriomorphic aspects of both afforded the anima ample opportunity to reflect herself, shimmering and equivocal, in the Eleusinian cult, or rather to experience herself there and fill the celebrants with her unearthly essence, to their lasting gain. For a man, anima experiences are always of immense and abiding significance.

[383] But the Demeter-Kore myth is far too feminine to have been merely the result of an anima-projection. Although the anima can, as we have said, experience herself in Demeter-Kore, she is yet of a wholly different nature. She is in the highest degree *femme à homme*, whereas Demeter-Kore exists on the plane of mother-daughter experience, which is alien to man and shuts him out. In fact, the psychology of the Demeter cult bears all the features of a matriarchal order of society, where the man is an indispensable but on the whole disturbing factor.

V

**THE PHENOMENOLOGY
OF THE SPIRIT IN FAIRYTALES**

ON THE PSYCHOLOGY OF THE TRICKSTER-FIGURE

THE PHENOMENOLOGY OF THE SPIRIT IN FAIRYTALES¹

[384] One of the unbreakable rules in scientific research is to take an object as known only so far as the inquirer is in a position to make scientifically valid statements about it. “Valid” in this sense simply means what can be verified by facts. The object of inquiry is the natural phenomenon. Now in psychology, one of the most important phenomena is the *statement*, and in particular its form and content, the latter aspect being perhaps the more significant with regard to the nature of the psyche. The first task that ordinarily presents itself is the description and arrangement of events, then comes the closer examination into the laws of their living behaviour. To inquire into the *substance* of what has been observed is possible in natural science only where there is an Archimedean point outside. For the psyche, no such outside standpoint exists—only the psyche can observe the psyche. Consequently, knowledge of the psychic substance is impossible for us, at least with the means at present available. This does not rule out the possibility that the atomic physics of the future may supply us with the said Archimedean point. For the time being, however, our subtlest lucubrations can establish no more than is expressed in the statement: this is how the psyche behaves. The honest investigator will piously refrain from meddling with questions of substance. I do not think it superfluous to acquaint my reader with the necessary limitations that psychology voluntarily imposes on itself, for he will then be in a position to appreciate the phenomenological standpoint of modern psychology, which is not always understood. This standpoint does not exclude the existence of faith, conviction, and experienced certainties of whatever description, nor does it contest their possible validity. Great as is their importance for the individual and for collective life, psychology completely lacks the means to prove their validity in the scientific sense. One may lament this incapacity on the part of science, but that does not enable it to jump over its own shadow.

I. CONCERNING THE WORD ‘SPIRIT’

[385] The word “spirit” possesses such a wide range of application that it requires considerable effort to make clear to oneself all the things it can mean. Spirit, we say, is the principle that stands in opposition to matter. By this we understand an immaterial substance or form of existence which on the highest and most universal level is called “God.” We imagine this immaterial substance also as the vehicle of psychic phenomena or even of life itself. In contradiction to this view there stands the

antithesis: spirit and nature. Here the concept of spirit is restricted to the supernatural or anti-natural, and has lost its substantial connection with psyche and life. A similar restriction is implied in Spinoza's view that spirit is an attribute of the One Substance. Hylozoism goes even further, taking spirit to be a quality of matter.

[386] A very widespread view conceives spirit as a higher and psyche as a lower principle of activity, and conversely the alchemists thought of spirit as the *ligamentum animae et corporis*, obviously regarding it as a *spiritus vegetativus* (the later life-spirit or nerve-spirit). Equally common is the view that spirit and psyche are essentially the same and can be separated only arbitrarily. Wundt takes spirit as "the inner being, regardless of any connection with an outer being." Others restrict spirit to certain psychic capacities or functions or qualities, such as the capacity to think and reason in contradistinction to the more "soulful" sentiments. Here spirit means the sum-total of all the phenomena of rational thought, or of the intellect, including the will, memory, imagination, creative power, and aspirations motivated by ideals. Spirit has the further connotation of *sprightliness*, as when we say that a person is "spirited," meaning that he is versatile and full of ideas, with a brilliant, witty, and surprising turn of mind. Again, spirit denotes a certain attitude or the principle underlying it, for instance, one is "educated in the spirit of Pestalozzi," or one says that the "spirit of Weimar is the immortal German heritage." A special instance is the time-spirit, or spirit of the age, which stands for the principle and motive force behind certain views, judgments, and actions of a collective nature. Then there is the "objective spirit,"² by which is meant the whole stock of man's cultural possessions with particular regard to his intellectual and religious achievements.

[387] As linguistic usage shows, spirit in the sense of an attitude has unmistakable leanings towards personification: the spirit of Pestalozzi can also be taken concretistically as his ghost or imago, just as the spirits of Weimar are the personal spectres of Goethe and Schiller; for spirit still has the spookish meaning of the soul of one departed. The "cold breath of the spirits" points on the one hand to the ancient affinity of *ψυχή* with *ψυχός* and *ψῦχος*, which both mean 'cold,' and on the other hand to the original meaning of *πνεῦμα*, which simply denoted 'air in motion'; and in the same way *animus* and *anima* were connected with *άνεμος*, 'wind.' The German word *Geist* probably has more to do with something frothing, effervescing, or fermenting; hence affinities with *Gischt* (foam), *Gäsch* (yeast), *ghost*, and also with the emotional *ghastly* and *aghast*, are not to be rejected. From time immemorial emotion has been regarded as possession, which is why we still say today, of a hot-tempered person, that he is possessed of a devil or that an evil spirit has entered into him.³ Just as, according to the old view, the spirits or souls of the dead are of a subtle disposition like a vapour or a smoke, so to the alchemist *spiritus* was a subtle, volatile, active, and vivifying essence, such as alcohol was understood to be, and all

the arcane substances. On this level, spirit includes spirits of salts, spirits of ammonia, formic spirit, etc.

[388] This score or so of meanings and shades of meaning attributable to the word “spirit” make it difficult for the psychologist to delimit his subject conceptually, but on the other hand they lighten the task of describing it, since the many different aspects go to form a vivid and concrete picture of the phenomenon in question. We are concerned with a functional complex which originally, on the primitive level, was felt as an invisible, breathlike “presence.” William James has given us a lively account of this primordial phenomenon in his *Varieties of Religious Experience*. Another well-known example is the wind of the Pentecostal miracle. The primitive mentality finds it quite natural to personify the invisible presence as a ghost or demon. The souls or spirits of the dead are identical with the psychic activity of the living; they merely continue it. The view that the psyche is a spirit is implicit in this. When therefore something psychic happens in the individual which he feels as belonging to himself, that something is his own spirit. But if anything psychic happens which seems to him strange, then it is somebody else’s spirit, and it may be causing a possession. The spirit in the first case corresponds to the subjective attitude, in the latter case to public opinion, to the time-spirit, or to the original, not yet human, anthropoid disposition which we also call the *unconscious*.

[389] In keeping with its original wind-nature, spirit is always an active, winged, swift-moving being as well as that which vivifies, stimulates, incites, fires, and inspires. To put it in modern language, spirit is the dynamic principle, forming for that very reason the classical antithesis of matter—the antithesis, that is, of its stasis and inertia. Basically it is the contrast between life and death. The subsequent differentiation of this contrast leads to the actually very remarkable opposition of spirit and nature. Even though spirit is regarded as essentially alive and enlivening, one cannot really feel nature as unspiritual and dead. We must therefore be dealing here with the (Christian) postulate of a spirit whose life is so vastly superior to the life of nature that in comparison with it the latter is no better than death.

[390] This special development in man’s idea of spirit rests on the recognition that its invisible presence is a psychic phenomenon, i.e., one’s own spirit, and that this consists not only of uprushes of life but of formal products too. Among the first, the most prominent are the images and shadowy presentations that occupy our inner field of vision; among the second, thinking and reason, which organize the world of images. In this way a transcendent spirit superimposed itself upon the original, natural life-spirit and even swung over to the opposite position, as though the latter were merely naturalistic. The transcendent spirit became the supranatural and transmundane cosmic principle of order and as such was given the name of “God,” or

at least it became an attribute of the One Substance (as in Spinoza) or one Person of the Godhead (as in Christianity).

[391] The corresponding development of spirit in the reverse, hylozoistic direction—a *maiori ad minus*—took place under anti-Christian auspices in materialism. The premise underlying this reaction is the exclusive certainty of the spirit's identity with psychic functions, whose dependence upon brain and metabolism became increasingly clear. One had only to give the One Substance another name and call it "matter" to produce the idea of a spirit which was entirely dependent on nutrition and environment, and whose highest form was the intellect or reason. This meant that the original pneumatic presence had taken up its abode in man's physiology, and a writer like Klages could arraign the spirit as the "adversary of the soul."⁴ For it was into this latter concept that the original spontaneity of the spirit withdrew after it had been degraded to a servile attribute of matter. Somewhere or other the *deus ex machina* quality of spirit had to be preserved—if not in the spirit itself, then in its synonym the soul, that glancing, Aeolian⁵ thing, elusive as a butterfly (anima, ψυχή).

[392] Even though the materialistic conception of the spirit did not prevail everywhere, it still persisted, outside the sphere of religion, in the realm of conscious phenomena. Spirit as "subjective spirit" came to mean a purely endopsychic phenomenon, while "objective spirit" did not mean the universal spirit, or God, but merely the sum total of intellectual and cultural possessions which make up our human institutions and the content of our libraries. Spirit had forfeited its original nature, its autonomy and spontaneity over a very wide area, with the solitary exception of the religious field, where, at least in principle, its pristine character remained unimpaired.

In this résumé we have described an entity which presents itself to us as an immediate psychic phenomenon distinguished from other psychisms whose existence is naïvely believed to be causally dependent upon physical influences. A connection between spirit and physical conditions is not immediately apparent, and for this reason it was credited with immateriality to a much higher degree than was the case with psychic phenomena in the narrower sense. Not only is a certain physical dependence attributed to the latter, but they are themselves thought of as possessing a kind of materiality, as the idea of the subtle body and the Chinese *kuei-soul* clearly show. In view of the intimate connection that exists between certain psychic processes and their physical parallels we cannot very well accept the total immateriality of the psyche. As against this, the *consensus omnium* insists on the immateriality of spirit, though not everyone would agree that it also has a reality of its own. It is, however, not easy to see why our hypothetical "matter," which looks quite different from what it did even thirty years ago, alone should be real, and spirit not. Although the idea of immateriality does not in itself exclude that of reality,

popular opinion invariably associates reality with materiality. Spirit and matter may well be forms of one and the same transcendental being. For instance the Tantrists, with as much right, say that matter is nothing other than the concreteness of God's thoughts. The sole immediate reality is the psychic reality of conscious contents, which are as it were labelled with a spiritual or material origin as the case may be.

[393] The hallmarks of spirit are, firstly, the principle of spontaneous movement and activity; secondly, the spontaneous capacity to produce images independently of sense perception; and thirdly, the autonomous and sovereign manipulation of these images. This spiritual entity approaches primitive man from outside; but with increasing development it gets lodged in man's consciousness and becomes a subordinate function, thus apparently forfeiting its original character of autonomy. That character is now retained only in the most conservative views, namely in the religions. The descent of spirit into the sphere of human consciousness is expressed in the myth of the divine *voūς* caught in the embrace of *φύσις*. This process, continuing over the ages, is probably an unavoidable necessity, and the religions would find themselves in a very forlorn situation if they believed in the attempt to hold up evolution. Their task, if they are well advised, is not to impede the ineluctable march of events, but to guide it in such a way that it can proceed without fatal injury to the soul. The religions should therefore constantly recall to us the origin and original character of the spirit, lest man should forget what he is drawing into himself and with what he is filling his consciousness. He himself did not create the spirit, rather the spirit makes *him* creative, always spurring him on, giving him lucky ideas, staying power, "enthusiasm" and "inspiration." So much, indeed, does it permeate his whole being that he is in gravest danger of thinking that he actually created the spirit and that he "has" it. In reality, however, the primordial phenomenon of the spirit takes possession of *him*, and, while appearing to be the willing object of human intentions, it binds his freedom, just as the physical world does, with a thousand chains and becomes an obsessive *idée-force*. Spirit threatens the naïve-minded man with inflation, of which our own times have given us the most horribly instructive examples. The danger becomes all the greater the more our interest fastens upon external objects and the more we forget that the differentiation of our relation to nature should go hand in hand with a correspondingly differentiated relation to the spirit, so as to establish the necessary balance. If the outer object is not offset by an inner, unbridled materialism results, coupled with maniacal arrogance or else the extinction of the autonomous personality, which is in any case the ideal of the totalitarian mass state.

[394] As can readily be seen, the common modern idea of spirit ill accords with the Christian view, which regards it as the *sum-mum bonum*, as God himself. To be sure, there is also the idea of an evil spirit. But the modern idea cannot be equated with

that either, since for us spirit is not necessarily evil; we would have to call it morally indifferent or neutral. When the Bible says “God is spirit,” it sounds more like the definition of a substance, or like a qualification. But the devil too, it seems, is endowed with the same peculiar spiritual substance, albeit an evil and corrupt one. The original identity of substance is still expressed in the idea of the fallen angel, as well as in the close connection between Jehovah and Satan in the Old Testament. There may be an echo of this primitive connection in the Lord’s Prayer, where we say “Lead us not into temptation”—for is not this really the business of the *tempter*, the devil himself?

[395] This brings us to a point we have not considered at all in the course of our observations so far. We have availed ourselves of cultural and everyday conceptions which are the product of human consciousness and its reflections, in order to form a picture of the psychic modes of manifestation of the factor “spirit.” But we have yet to consider that because of its original autonomy,⁶ about which there can be no doubt in the psychological sense, the spirit is quite capable of staging its own manifestations spontaneously.

II. SELF-REPRESENTATION OF THE SPIRIT IN DREAMS

[396] The psychic manifestations of the spirit indicate at once that they are of an archetypal nature—in other words, the phenomenon we call spirit depends on the existence of an autonomous primordial image which is universally present in the preconscious makeup of the human psyche. As usual, I first came up against this problem when investigating the dreams of my patients. It struck me that a certain kind of father-complex has a “spiritual” character, so to speak, in the sense that the father-image gives rise to statements, actions, tendencies, impulses, opinions, etc., to which one could hardly deny the attribute “spiritual.” In men, a positive father-complex very often produces a certain credulity with regard to authority and a distinct willingness to bow down before all spiritual dogmas and values; while in women, it induces the liveliest spiritual aspirations and interests. In dreams, it is always the father-figure from whom the decisive convictions, prohibitions, and wise counsels emanate. The invisibility of this source is frequently emphasized by the fact that it consists simply of an authoritative voice which passes final judgments.⁷ Mostly, therefore, it is the figure of a “wise old man” who symbolizes the spiritual factor. Sometimes the part is played by a “real” spirit, namely the ghost of one dead, or, more rarely, by grotesque gnomelike figures or talking animals. The dwarf forms are found, at least in my experience, mainly in women; hence it seems to me logical that in Ernst Barlach’s play *Der tote Tag* (1912), the gnomelike figure of Steissbart (“Rumpbeard”) is associated with the mother, just as Bes is associated with the mother-goddess at Karnak. In both sexes the spirit can also take the form of a boy or

a youth. In women he corresponds to the so-called “positive” animus who indicates the possibility of conscious spiritual effort. In men his meaning is not so simple. He can be positive, in which case he signifies the “higher” personality, the self or *filius regius* as conceived by the alchemists.⁸ But he can also be negative, and then he signifies the infantile shadow.⁹ In both cases the boy means some form of spirit.¹⁰ Graybeard and boy belong together. The pair of them play a considerable role in alchemy as symbols of Mercurius.

[397] It can never be established with one-hundred-per-cent certainty whether the spirit-figures in dreams are morally good. Very often they show all the signs of duplicity, if not of outright malice. I must emphasize, however, that the grand plan on which the unconscious life of the psyche is constructed is so inaccessible to our understanding that we can never know what evil may not be necessary in order to produce good by enantiodromia, and what good may very possibly lead to evil. Sometimes the *probate spiritus* recommended by John cannot, with the best will in the world, be anything other than a cautious and patient waiting to see how things will finally turn out.

[398] The figure of the wise old man can appear so plastically, not only in dreams but also in visionary meditation (or what we call active imagination”), that, as is sometimes apparently the case in India, it takes over the role of a guru.¹¹ The wise old man appears in dreams in the guise of a magician, doctor, priest, teacher, professor, grandfather, or any other person possessing authority. The archetype of spirit in the shape of a man, hobgoblin, or animal always appears in a situation where insight, understanding, good advice, determination, planning, etc., are needed but cannot be mustered on one’s own resources. The archetype compensates this state of spiritual deficiency by contents designed to fill the gap. An excellent example of this is the dream about the white and black magicians, which tried to compensate the spiritual difficulties of a young theological student. I did not know the dreamer myself, so the question of my personal influence is ruled out. He dreamed *he was standing in the presence of a sublime hieratic figure called the “white magician,” who was nevertheless clothed in a long black robe. This magician had just ended a lengthy discourse with the words “And for that we require the help of the black magician.” Then the door suddenly opened and another old man came in, the “black magician,” who however was dressed in a white robe. He too looked noble and sublime. The black magician evidently wanted to speak with the white, but hesitated to do so in the presence of the dreamer. At that the white magician, pointing to the dreamer, said, “Speak, he is an innocent.” So the black magician began to relate a strange story of how he had found the lost keys of Paradise and did not know how to use them. He had, he said, come to the white magician for an explanation of the secret of the keys. He told him that the king of the country in which he lived was seeking a suitable tomb*

for himself. His subjects had chanced to dig up an old sarcophagus containing the mortal remains of a virgin. The king opened the sarcophagus, threw away the bones, and had the empty sarcophagus buried again for later use. But no sooner had the bones seen the light of day than the being to whom they once had belonged—the virgin—changed into a black horse that galloped off into the desert. The black magician pursued it across the sandy wastes and beyond, and there after many vicissitudes and difficulties he found the lost keys of Paradise. That was the end of his story, and also, unfortunately, of the dream.

[399] Here the compensation certainly did not fall out as the dreamer would wish, by handing him a solution on a plate; rather it confronted him with a problem to which I have already alluded, and one which life is always bringing us up against: namely, the uncertainty of all moral valuation, the bewildering interplay of good and evil, and the remorseless concatenation of guilt, suffering, and redemption. This path to the primordial religious experience is the right one, but how many can recognize it? It is like a still small voice, and it sounds from afar. It is ambiguous, questionable, dark, presaging danger and hazardous adventure; a razor-edged path, to be trodden for God's sake only, without assurance and without sanction.

III. THE SPIRIT IN FAIRYTALES

[400] I would gladly present the reader with some more modern dream-material, but I fear that the individualism of dreams would make too high a demand upon our exposition and would claim more space than is here at our disposal. We shall therefore turn to folklore, where we need not get involved in the grim confrontations and entanglements of individual case histories and can observe the variations of the spirit motif without having to consider conditions that are more or less unique. In myths and fairytales, as in dreams, the psyche tells its own story, and the interplay of the archetypes is revealed in its natural setting as “formation, transformation / the eternal Mind's eternal recreation.”

[401] The frequency with which the spirit-type appears as an old man is about the same in fairytales as in dreams.¹² The old man always appears when the hero is in a hopeless and desperate situation from which only profound reflection or a lucky idea—in other words, a spiritual function or an endopsychic automatism of some kind—can extricate him. But since, for internal and external reasons, the hero cannot accomplish this himself, the knowledge needed to compensate the deficiency comes in the form of a personified thought, i.e., in the shape of this sagacious and helpful old man. An Estonian fairytale,¹³ for instance, tells how an ill-treated little orphan boy who had let a cow escape was afraid to return home again for fear of more punishment. So he ran away, chancing to luck. He naturally got himself into a hopeless situation, with no visible way out. Exhausted, he fell into a deep sleep.

When he awoke, “it seemed to him that he had something liquid in his mouth, and he saw a little old man with a long grey beard standing before him, who was in the act of replacing the stopper in his little milk-flask. ‘Give me some more to drink,’ begged the boy. ‘You have had enough for today,’ replied the old man. ‘If my path had not chanced to lead me to you, that would assuredly have been your last sleep, for when I found you, you were half dead.’ Then the old man asked the boy who he was and where he wanted to go. The boy recounted everything he could remember happening to him up to the beating he had received the previous evening. ‘My dear child,’ said the old man, ‘you are no better and no worse off than many others whose dear protectors and comforters rest in their coffins under the earth. You can no longer turn back. Now that you have run away, you must seek a new fortune in the world. As I have neither house nor home, nor wife nor child, I cannot take further care of you, but I will give you some good advice for nothing.’”

[402] So far the old man has been expressing no more than what the boy, the hero of the tale, could have thought out for himself. Having given way to the stress of emotion and simply run off like that into the blue, he would at least have had to reflect that he needed food. It would also have been necessary, at such a moment, to consider his position. The whole story of his life up to the recent past would then have passed before his mind, as is usual in such cases. An anamnesis of this kind is a purposeful process whose aim is to gather the assets of the whole personality together at the critical moment, when all one’s spiritual and physical forces are challenged, and with this united strength to fling open the door of the future. No one can help the boy to do this; he has to rely entirely on himself. There is no going back. This realization will give the necessary resolution to his actions. By forcing him to face the issue, the old man saves him the trouble of making up his mind. Indeed the old man is himself this purposeful reflection and concentration of moral and physical forces that comes about spontaneously in the psychic space outside consciousness when conscious thought is not yet—or is no longer—possible. The concentration and tension of psychic forces have something about them that always looks like magic: they develop an unexpected power of endurance which is often superior to the conscious effort of will. One can observe this experimentally in the artificial concentration induced by hypnosis: in my demonstrations I used regularly to put an hysteric, of weak bodily build, into a deep hypnotic sleep and then get her to lie with the back of her head on one chair and her heels resting on another, stiff as a board, and leave her there for about a minute. Her pulse would gradually go up to 90. A husky young athlete among the students tried in vain to imitate this feat with a conscious effort of will. He collapsed in the middle with his pulse racing at 120.

[403] When the clever old man had brought the boy to this point he could begin his good advice, i.e., the situation no longer looked hopeless. He advised him to continue

his wanderings, always to the eastward, where after seven years he would reach the great mountain that betokened his good fortune. The bigness and tallness of the mountain are allusions to his adult personality.¹⁴ Concentration of his powers brings assurance and is therefore the best guarantee of success.¹⁵ From now on he will lack for nothing. “Take my srip and my flask,” says the old man, “and each day you will find in them all the food and drink you need.” At the same time he gave him a burdock leaf that could change into a boat whenever the boy had to cross water.

[404] Often the old man in fairytales asks questions like who? why? whence? and whither?¹⁶ for the purpose of inducing self-reflection and mobilizing the moral forces, and more often still he gives the necessary magical talisman,¹⁷ the unexpected and improbable power to succeed, which is one of the peculiarities of the unified personality in good or bad alike. But the intervention of the old man—the spontaneous objectivation of the archetype—would seem to be equally indispensable, since the conscious will by itself is hardly ever capable of uniting the personality to the point where it acquires this extraordinary power to succeed. For that, not only in fairytales but in life generally, the objective intervention of the archetype is needed, which checks the purely affective reactions with a chain of inner confrontations and realizations. These cause the who? where? how? why? to emerge clearly and in this wise bring knowledge of the immediate situation as well as of the goal. The resultant enlightenment and untying of the fatal tangle often has something positively magical about it—an experience not unknown to the psychotherapist.

[405] The tendency of the old man to set one thinking also takes the form of urging people to “sleep on it.” Thus he says to the girl who is searching for her lost brothers: “Lie down: morning is cleverer than evening.”¹⁸ He also sees through the gloomy situation of the hero who has got himself into trouble, or at least can give him such information as will help him on his journey. To this end he makes ready use of animals, particularly birds. To the prince who has gone in search of the kingdom of heaven the old hermit says: “I have lived here for three hundred years, but never yet has anybody asked me about the kingdom of heaven. I cannot tell you myself; but up there, on another floor of the house, live all kinds of birds, and they can surely tell you.”¹⁹ The old man knows what roads lead to the goal and points them out to the hero.²⁰ He warns of dangers to come and supplies the means of meeting them effectively. For instance, he tells the boy who has gone to fetch the silver water that the well is guarded by a lion who has the deceptive trick of sleeping with his eyes open and watching with his eyes shut,²¹ or he counsels the youth who is riding to a magic fountain in order to fetch the healing draught for the king, only to draw the water at a trot because of the lurking witches who lasso everybody that comes to the fountain.²² He charges the princess whose lover has been changed into a werewolf to make a fire and put a cauldron of tar over it. Then she must plunge her beloved white

lily into the boiling tar, and when the werewolf comes, she must empty the cauldron over its head, which will release her lover from the spell.²³ Occasionally the old man is a very critical old man, as in the Caucasian tale of the youngest prince who wanted to build a flawless church for his father, so as to inherit the kingdom. This he does, and nobody can discover a single flaw, but then an old man comes along and says, "That's a fine church you've built, to be sure! What a pity the main wall is a bit crooked!" The prince has the church pulled down again and builds a new one, but here too the old man discovers a flaw, and so on for the third time.²⁴

[406] The old man thus represents knowledge, reflection, insight, wisdom, cleverness, and intuition on the one hand, and on the other, moral qualities such as goodwill and readiness to help, which make his "spiritual" character sufficiently plain. Since the archetype is an autonomous content of the unconscious, the fairytale, which usually concretizes the archetypes, can cause the old man to appear in a dream in much the same way as happens in modern dreams. In a Balkan tale the old man appears to the hard-pressed hero in a dream and gives him good advice about accomplishing the impossible tasks that have been imposed upon him.²⁵ His relation to the unconscious is clearly expressed in one Russian fairytale, where he is called the "King of the Forest." As the peasant sat down wearily on a tree stump, a little old man crept out: "all wrinkled he was and a green beard hung down to his knees." "Who are you?" asked the peasant. "I am Och, King of the Forest," said the manikin. The peasant hired out his profligate son to him, "and the King of the Forest departed with the young man, and conducted him to that other world under the earth and brought him to a green hut. ... In the hut everything was green: the walls were green and the benches, Och's wife was green and the children were green ... and the little water-women who waited on him were as green as rue." Even the food was green. The King of the Forest is here a vegetation or tree numen who reigns in the woods and, through the nixies, also has connections with water, which clearly shows his relation to the unconscious since the latter is frequently expressed through wood and water symbols.

[407] There is equally a connection with the unconscious when the old man appears as a dwarf. The fairytale about the princess who was searching for her lover says: "Night came and the darkness, and still the princess sat in the same place and wept. As she sat there lost in thought, she heard a voice greeting her: 'Good evening, pretty maid! Why are you sitting here so lonely and sad?' She sprang up hastily and felt very confused, and that was no wonder. But when she looked round there was only a tiny little old man standing before her, who nodded his head at her and looked so kind and simple." In a Swiss fairytale, the peasant's son who wants to bring the king's daughter a basket of apples encounters "es chlis isigs Männli, das frogt-ne, was er do i dem Chratte häig?" (a little iron man who asked what he had there in the

basket). In another passage the “Männkli” has “es isigs Chlaidli a” (iron clothes on). By “isig” presumably “eisern” (iron) is meant, which is more probable than “eisig” (icy). In the latter case it would have to be “es Chlaidli vo Is” (clothes of ice).²⁶ There are indeed little ice men, and little metal men too; in fact, in a modern dream I have even come across a little black iron man who appeared at a critical juncture, like the one in this fairytale of the country bumpkin who wanted to marry the princess.

[408] In a modern series of visions in which the figure of the wise old man occurred several times, he was on one occasion of normal size and appeared at the very bottom of a crater surrounded by high rocky walls; on another occasion he was a tiny figure on the top of a mountain, inside a low, stony enclosure. We find the same motif in Goethe’s tale of the dwarf princess who lived in a casket.²⁷ In this connection we might also mention the Anthroparion, the little leaden man of the Zosimos vision,²⁸ as well as the metallic men who dwell in the mines, the crafty dactyls of antiquity, the homunculi of the alchemists, and the gnomic throng of hobgoblins, brownies, gremlins, etc. How “real” such conceptions are became clear to me on the occasion of a serious mountaineering accident: after the catastrophe two of the climbers had the collective vision, in broad daylight, of a little hooded man who scrambled out of an inaccessible crevasse in the ice face and passed across the glacier, creating a regular panic in the two beholders. I have often encountered motifs which made me think that the unconscious must be the world of the infinitesimally small. Such an idea could be derived rationalistically from the obscure feeling that in all these visions we are dealing with something endopsychic, the inference being that a thing must be exceedingly small in order to fit inside the head. I am no friend of any such “rational” conjectures, though I would not say that they are all beside the mark. It seems to me more probable that this liking for diminutives on the one hand and for superlatives—giants, etc.—on the other is connected with the queer uncertainty of spatial and temporal relations in the unconscious.²⁹ Man’s sense of proportion, his rational conception of big and small, is distinctly anthropomorphic, and it loses its validity not only in the realm of physical phenomena but also in those parts of the collective unconscious beyond the range of the specifically human. The atman is “smaller than small and bigger than big,” he is “the size of a thumb” yet he “encompasses the earth on every side and rules over the ten-finger space.” And of the Cabiri Goethe says: “little in length / mighty in strength.” In the same way, the archetype of the wise old man is quite tiny, almost imperceptible, and yet it possesses a fateful potency, as anyone can see when he gets down to fundamentals. The archetypes have this peculiarity in common with the atomic world, which is demonstrating before our eyes that the more deeply the investigator penetrates into the universe of microphysics the more devastating are the explosive forces he finds enchained there. That the greatest effects come from the smallest causes has become

patently clear not only in physics but in the field of psychological research as well. How often in the critical moments of life everything hangs on what appears to be a mere nothing!

[409] In certain primitive fairytales, the illuminating quality of our archetype is expressed by the fact that the old man is identified with the sun. He brings a firebrand with him which he uses for roasting a pumpkin. After he has eaten, he takes the fire away again, which causes mankind to steal it from him.³⁰ In a North American Indian tale, the old man is a witch-doctor who owns the fire.³¹ Spirit too has a fiery aspect, as we know from the language of the Old Testament and from the story of the Pentecostal miracle.

[410] Apart from his cleverness, wisdom, and insight, the old man, as we have already mentioned, is also notable for his moral qualities; what is more, he even tests the moral qualities of others and makes his gifts dependent on this test. There is a particularly instructive example of this in the Estonian fairytale of the stepdaughter and the real daughter. The former is an orphan distinguished for her obedience and good behaviour. The story begins with her distaff falling into a well. She jumps in after it, but does not drown, and comes to a magic country where, continuing her quest, she meets a cow, a ram, and an apple tree whose wishes she fulfils. She now comes to a wash-house where a dirty old man is sitting who wants her to wash him. The following dialogue develops: “Pretty maid, pretty maid, wash me, do, it is hard for me to be so dirty!” “What shall I heat the stove with?” “Collect wooden pegs and crows’ dung and make a fire with that.” But she fetches sticks, and asks, “Where shall I get the bath-water?” “Under the barn there stands a white mare. Get her to piss into the tub!” But she takes clean water, and asks, “Where shall I get a bath-switch?” “Cut off the white mare’s tail and make a bath-switch of that!” But she makes one out of birch-twigs, and asks, “Where shall I get soap?” “Take a pumice-stone and scrub me with that!” But she fetches soap from the village and with that she washes the old man.

[411] As a reward he gives her a bag full of gold and precious stones. The daughter of the house naturally becomes jealous, throws her distaff into the well, where she finds it again instantly. Nevertheless she goes on and does everything wrong that the stepdaughter had done right, and is rewarded accordingly. The frequency of this motif makes further examples superfluous.

[412] The figure of the superior and helpful old man tempts one to connect him somehow or other with God. In the German tale of the soldier and the black princess³² it is related how the princess, on whom a curse has been laid, creeps out of her iron coffin every night and devours the soldier standing guard over the tomb. One soldier, when his turn came, tried to escape. “That evening he stole away, fled over

the fields and mountains, and came to a beautiful meadow. Suddenly a little man stood before him with a long grey beard, but it was none other than the Lord God himself, who could no longer go on looking at all the mischief the devil wrought every night. ‘Whither away?’ said the little grey man, ‘may I come with you?’ And because the little old man looked so friendly the soldier told him that he had run away and why he had done so.” Good advice follows, as always. In this story the old man is taken for God in the same naïve way that the English alchemist, Sir George Ripley,³³ describes the “old king” as “antiquus dierum”—“the Ancient of Days.”

[413] Just as all archetypes have a positive, favourable, bright side that points upwards, so also they have one that points downwards, partly negative and unfavourable, partly chthonic, but for the rest merely neutral. To this the spirit archetype is no exception. Even his dwarf form implies a kind of limitation and suggests a naturalistic vegetation-numen sprung from the underworld. In one Balkan tale, the old man is handicapped by the loss of an eye. It has been gouged out by the Vili, a species of winged demon, and the hero is charged with the task of getting them to restore it to him. The old man has therefore lost part of his eyesight—that is, his insight and enlightenment—to the daemonic world of darkness; this handicap is reminiscent of the fate of Osiris, who lost an eye at the sight of a black pig (his wicked brother Set), or again of Wotan, who sacrificed his eye at the spring of Mimir. Characteristically enough, the animal ridden by the old man in our fairytale is a goat, a sign that he himself has a dark side. In a Siberian tale, he appears as a one-legged, one-handed, and one-eyed greybeard who wakens a dead man with an iron staff. In the course of the story the latter, after being brought back to life several times, kills the old man by a mistake, and thus throws away his good fortune. The story is entitled “The One-sided Old Man,” and in truth his handicap shows that he consists of one half only. The other half is invisible, but appears in the shape of a murderer who seeks the hero’s life. Eventually the hero succeeds in killing his persistent murderer, but in the struggle he also kills the one-sided old man, so that the identity of the two victims is clearly revealed. It is thus possible that the old man is his own opposite, a life-bringer as well as a death-dealer—“ad utrumque peritus” (skilled in both), as is said of Hermes.³⁴

[414] In these circumstances, whenever the “simple” and “kindly” old man appears, it is advisable for heuristic and other reasons to scrutinize the context with some care. For instance, in the Estonian tale we first mentioned, about the hired boy who lost the cow, there is a suspicion that the helpful old man who happened to be on the spot so opportunely had surreptitiously made away with the cow beforehand in order to give his protégé an excellent reason for taking to flight. This may very well be, for everyday experience shows that it is quite possible for a superior, though subliminal, foreknowledge of fate to contrive some annoying incident for the sole purpose of

bullying our Simple Simon of an ego-consciousness into the way he should go, which for sheer stupidity he would never have found by himself. Had our orphan guessed that it was the old man who had whisked off his cow as if by magic, he would have seemed like a spiteful troll or a devil. And indeed the old man has a wicked aspect too, just as the primitive medicine-man is a healer and helper and also the dreaded concocter of poisons. The very word *φάρμακον* means ‘poison’ as well as ‘antidote,’ and poison can in fact be both.

[415] The old man, then, has an ambiguous elfin character—witness the extremely instructive figure of Merlin—seeming, in certain of his forms, to be good incarnate and in others an aspect of evil. Then again, he is the wicked magician who, from sheer egoism, does evil for evil’s sake. In a Siberian fairytale, he is an evil spirit “on whose head were two lakes with two ducks swimming in them.” He feeds on human flesh. The story relates how the hero and his companions go to a feast in the next village, leaving their dogs at home. These, acting on the principle “when the cat’s away the mice do play,” also arrange a feast, at the climax of which they all hurl themselves on the stores of meat. The men return home and chase out the dogs, who dash off into the wilderness. “Then the Creator spoke to Ememqut [the hero of the tale]: ‘Go and look for the dogs with your wife.’” But he gets caught in a terrible snow-storm and has to seek shelter in the hut of the evil spirit. There now follows the well-known motif of the biter bit. The “Creator” is Ememqut’s father, but the father of the Creator is called the “Self-created” because he created himself. Although we are nowhere told that the old man with the two lakes on his head lured the hero and his wife into the hut in order to satisfy his hunger, it may be conjectured that a very peculiar spirit must have got into the dogs to cause them to celebrate a feast like the men and afterwards—contrary to their nature—to run away, so that Ememqut had to go out and look for them; and that the hero was then caught in a snow-storm in order to drive him into the arms of the wicked old man. The fact that the Creator, son of the Self-created, was a party to the advice raises a knotty problem whose solution we had best leave to the Siberian theologians.

[416] In a Balkan fairytale the old man gives the childless Czarina a magic apple to eat, from which she becomes pregnant and bears a son, it being stipulated that the old man shall be his godfather. The boy, however, grows up into a horrid little tough who bullies all the children and slaughters the cattle. For ten years he is given no name. Then the old man appears, sticks a knife into his leg, and calls him the “Knife Prince.” The boy now wants to set forth on his adventures, which his father, after long hesitation, finally allows him to do. The knife in his leg is of vital importance: if he draws it out himself, he will live; if anybody else does so, he will die. In the end the knife becomes his doom, for an old witch pulls it out when he is asleep. He dies, but is restored to life by the friends he has won.³⁵ Here the old man is a helper, but

also the contriver of a dangerous fate which might just as easily have turned out for the bad. The evil showed itself early and plainly in the boy's villainous character.

[417] In another Balkan tale, there is a variant of our motif that is worth mentioning: A king is looking for his sister who has been abducted by a stranger. His wanderings bring him to the hut of an old woman, who warns him against continuing the search. But a tree laden with fruit, ever receding before him, lures him away from the hut. When at last the tree comes to a halt, an old man climbs down from the branches. He regales the king and takes him to a castle, where the sister is living with the old man as his wife. She tells her brother that the old man is a wicked spirit who will kill him. And sure enough, three days afterwards, the king vanishes without trace. His younger brother now takes up the search and kills the wicked spirit in the form of a dragon. A handsome young man is thereby released from the spell and forthwith marries the sister. The old man, appearing at first as a tree-numen, is obviously connected with the sister. He is a murderer. In an interpolated episode, he is accused of enchanting a whole city by turning it to iron, i.e., making it immovable, rigid, and locked up.³⁶ He also holds the king's sister a captive and will not let her return to her relatives. This amounts to saying that the sister is animus-possessed. The old man is therefore to be regarded as her animus. But the manner in which the king is drawn into this possession, and the way he seeks for his sister, make us think that she has an anima significance for her brother. The fateful archetype of the old man has accordingly first taken possession of the king's anima—in other words, robbed him of the archetype of life which the anima personifies—and forced him to go in search of the lost charm, the “treasure hard to attain,” thus making him the mythical hero, the higher personality who is an expression of the self. Meanwhile, the old man acts the part of the villain and has to be forcibly removed, only to appear at the end as the husband of the sister-anima, or more properly as the bridegroom of the soul, who celebrates the sacred incest that symbolizes the union of opposites and equals. This bold enantiodromia, a very common occurrence, not only signifies the rejuvenation and transformation of the old man, but hints at a secret inner relation of evil to good and vice versa.

[418] So in this story we see the archetype of the old man in the guise of an evil-doer, caught up in all the twists and turns of an individuation process that ends suggestively with the *hieros gamos*. Conversely, in the Russian tale of the Forest King, he starts by being helpful and benevolent, but then refuses to let his hired boy go, so that the main episodes in the story deal with the boy's repeated attempts to escape from the clutches of the magician. Instead of the quest we have flight, which nonetheless appears to win the same reward as adventures valiantly sought, for in the end the hero marries the king's daughter. The magician, however, must rest content with the role of the biter bit.

[419] The description of our archetype would not be complete if we omitted to consider one special form of its manifestation, namely its animal form. This belongs essentially to the theriomorphism of gods and demons and has the same psychological significance. The animal form shows that the contents and functions in question are still in the extrahuman sphere, i.e., on a plane beyond human consciousness, and consequently have a share on the one hand in the daemonically superhuman and on the other in the bestially subhuman. It must be remembered, however, that this division is only true within the sphere of consciousness, where it is a necessary condition of thought. Logic says *tertium non datur*, meaning that we cannot envisage the opposites in their oneness. In other words, while the abolition of an obstinate antinomy can be no more than a postulate for us, this is by no means so for the unconscious, whose contents are without exception paradoxical or antinomial by nature, not excluding the category of being. If anyone unacquainted with the psychology of the unconscious wants to get a working knowledge of these matters, I would recommend a study of Christian mysticism and Indian philosophy, where he will find the clearest elaboration of the antinomies of the unconscious.

[420] Although the old man has, up to now, looked and behaved more or less like a human being, his magical powers and his spiritual superiority suggest that, in good and bad alike, he is outside, or above, or below the human level. Neither for the primitive nor for the unconscious does his animal aspect imply any devaluation, for in certain respects the animal is superior to man. It has not yet blundered into consciousness nor pitted a self-willed ego against the power from which it lives; on the contrary, it fulfils the will that actuates it in a well-nigh perfect manner. Were it conscious, it would be morally better than man. There is deep doctrine in the legend of the fall: it is the expression of a dim presentiment that the emancipation of ego-consciousness was a Luciferian deed. Man's whole history consists from the very beginning in a conflict between his feeling of inferiority and his arrogance. Wisdom seeks the middle path and pays for this audacity by a dubious affinity with daemon and beast, and so is open to moral misinterpretation.

[421] Again and again in fairytales we encounter the motif of helpful animals. These act like humans, speak a human language, and display a sagacity and a knowledge superior to man's. In these circumstances we can say with some justification that the archetype of the spirit is being expressed through an animal form. A German fairytale³⁷ relates how a young man, while searching for his lost princess, meets a wolf, who says, "Do not be afraid! But tell me, where is your way leading you?" The young man recounts his story, whereupon the wolf gives him as a magic gift a few of his hairs, with which the young man can summon his help at any time. This intermezzo proceeds exactly like the meeting with the helpful old man. In the same

story, the archetype also displays its other, wicked side. In order to make this clear I shall give a summary of the story:

[422] While the young man is watching his pigs in the wood, he discovers a large tree, whose branches lose themselves in the clouds. “How would it be,” says he to himself, “if you were to look at the world from the top of that great tree?” So he climbs up, all day long he climbs, without even reaching the branches. Evening comes, and he has to pass the night in a fork of the tree. Next day he goes on climbing and by noon has reached the foliage. Only towards evening does he come to a village nestling in the branches. The peasants who live there give him food and shelter for the night. In the morning he climbs still further. Towards noon, he reaches a castle in which a young girl lives. Here he finds that the tree goes no higher. She is a king’s daughter, held prisoner by a wicked magician. So the young man stays with the princess, and she allows him to go into all the rooms of the castle: one room alone she forbids him to enter. But curiosity is too strong. He unlocks the door, and there in the room he finds a raven fixed to the wall with three nails. One nail goes through his throat, the two others through the wings. The raven complains of thirst and the young man, moved by pity, gives him water to drink. At each sip a nail falls out, and at the third sip the raven is free and flies out at the window. When the princess hears of it she is very frightened and says, “That was the devil who enchanted me! It won’t be long now before he fetches me again.” And one fine morning she has indeed vanished.

[423] The young man now sets out in search of her and, as we have described above, meets the wolf. In the same way he meets a bear and a lion, who also give him some hairs. In addition the lion informs him that the princess is imprisoned nearby in a hunting-lodge. The young man finds the house and the princess, but is told that flight is impossible, because the hunter possesses a three-legged white horse that knows everything and would infallibly warn its master. Despite that, the young man tries to flee away with her, but in vain. The hunter overtakes him but, because he had saved his life as a raven, lets him go and rides off again with the princess. When the hunter has disappeared into the wood, the young man creeps back to the house and persuades the princess to wheedle from the hunter the secret of how he obtained his clever white horse. This she successfully does in the night, and the young man, who has hidden himself under the bed, learns that about an hour’s journey from the hunting-lodge there dwells a witch who breeds magic horses. Whoever was able to guard the foals for three days might choose a horse as a reward. In former times, said the hunter, she used to make a gift of twelve lambs into the bargain, in order to satisfy the hunger of the twelve wolves who lived in the woods near the farmstead, and prevent them from attacking; but to him she gave no lambs. So the wolves followed him as he rode away, and while crossing the borders of her domain they succeeded in tearing off one of his horse’s hoofs. That was why it had only three legs.

[424] Then the young man made haste to seek out the witch and agreed to serve her on condition that she gave him not only a horse of his own choosing but twelve lambs as well. To this she consented. Instantly she commanded the foals to run away, and, to make him sleepy, she gave him brandy. He drinks, falls asleep, and the foals escape. On the first day he catches them with the help of the wolf, on the second day the bear helps him, and on the third the lion. He can now go and choose his reward. The witch's little daughter tells him which horse her mother rides. This is naturally the best horse, and it too is white. Hardly has he got it out of the stall when the witch pierces the four hoofs and sucks the marrow out of the bones. From this she bakes a cake and gives it to the young man for his journey. The horse grows deathly weak, but the young man feeds it on the cake, whereupon the horse recovers its former strength. He gets out of the woods unscathed after quieting the twelve wolves with the twelve lambs. He then fetches the princess and rides away with her. But the three-legged horse calls out to the hunter, who sets off in pursuit and quickly catches up with them, because the four-legged horse refuses to gallop. As the hunter approaches, the four-legged horse cries out to the three-legged, "Sister, throw him off!" The magician is thrown and trampled to pieces by the two horses. The young man sets the princess on the three-legged horse, and the pair of them ride away to her father's kingdom, where they get married. The four-legged horse begs him to cut off both their heads, for otherwise they would bring disaster upon him. This he does, and the horses are transformed into a handsome prince and a wonderfully beautiful princess, who after a while repair "to their own kingdom." They had been changed into horses by the hunter, long ago.

[425] Apart from the theriomorphic spirit symbolism in this tale, it is especially interesting to note that the function of knowing and intuition is represented by a riding-animal. This is as much as to say that the spirit can be somebody's property. The three-legged white horse is thus the property of the demonic hunter, and the four-legged one the property of the witch. Spirit is here partly a function, which like any other object (horse) can change its owner, and partly an autonomous subject (magician as owner of the horse). By obtaining the four-legged horse from the witch, the young man frees a spirit or a thought of some special kind from the grip of the unconscious. Here as elsewhere, the witch stands for a *mater natura* or the original "matriarchal" state of the unconscious, indicating a psychic constitution in which the unconscious is opposed only by a feeble and still-dependent consciousness. The four-legged horse shows itself superior to the three-legged, since it can command the latter. And since the quaternity is a symbol of wholeness and wholeness plays a considerable role in the picture-world of the unconscious,³⁸ the victory of four-leggedness over three-leggedness is not altogether unexpected. But what is the meaning of the opposition between threeness and fourness, or rather, what does

threeness mean as compared with wholeness? In alchemy this problem is known as the axiom of Maria and runs all through alchemical philosophy for more than a thousand years, finally to be taken up again in the Cabiri scene in *Faust*. The earliest literary version of it is to be found in the opening words of Plato's *Timaeus*³⁹ of which Goethe gives us a reminder. Among the alchemists we can see clearly how the divine Trinity has its counterpart in a lower, chthonic triad (similar to Dante's three-headed devil). This represents a principle which, by reason of its symbolism, betrays affinities with evil, though it is by no means certain that it expresses nothing but evil. Everything points rather to the fact that evil, or its familiar symbolism, belongs to the family of figures which describe the dark, nocturnal, lower, chthonic element. In this symbolism the lower stands to the higher as a correspondence⁴⁰ in reverse; that is to say it is conceived, like the upper, as a triad. Three, being a masculine number, is logically correlated with the wicked hunter, who can be thought of alchemically as the lower triad. Four, a feminine number, is assigned to the old woman. The two horses are miraculous animals that talk and know and thus represent the unconscious spirit, which in one case is subordinated to the wicked magician and in the other to the old witch.

[426] Between the three and the four there exists the primary opposition of male and female, but whereas fourness is a symbol of wholeness, threeness is not. The latter, according to alchemy, denotes polarity, since one triad always presupposes another, just as high presupposes low, lightness darkness, good evil. In terms of energy, polarity means a potential, and wherever a potential exists there is the possibility of a current, a flow of events, for the tension of opposites strives for balance. If one imagines the quaternity as a square divided into two halves by a diagonal, one gets two triangles whose apices point in opposite directions. One could therefore say metaphorically that if the wholeness symbolized by the quaternity is divided into equal halves, it produces two opposing triads. This simple reflection shows how three can be derived from four, and in the same way the hunter of the captured princess explains how his horse, from being four-legged, became three-legged, through having one hoof torn off by the twelve wolves. The three-leggedness is due to an accident, therefore, which occurred at the very moment when the horse was leaving the territory of the dark mother. In psychological language we should say that when the unconscious wholeness becomes manifest, i.e., leaves the unconscious and crosses over into the sphere of consciousness, one of the four remains behind, held fast by the *horror vacui* of the unconscious. There thus arises a triad, which as we know—not from the fairytale but from the history of symbolism—constellates a corresponding triad in opposition to it⁴¹—in other words, a conflict ensues. Here too we could ask with Socrates, “One, two, three—but, my dear Timaeus, of those who yesterday were the banqueters and today are the banquet-givers, where is the

fourth?”⁴² He has remained in the realm of the dark mother, caught by the wolfish greed of the unconscious, which is unwilling to let anything escape from its magic circle save at the cost of a sacrifice.

[427] The hunter or old magician and the witch correspond to the negative parental imagos in the magic world of the unconscious. The hunter first appears in the story as a black raven. He has stolen away the princess and holds her a prisoner. She describes him as “the devil.” But it is exceedingly odd that he himself is locked up in the one forbidden room of the castle and fixed to the wall with three nails, as though *crucified*. He is imprisoned, like all jailers, in his own prison, and bound like all who curse. The prison of both is a magic castle at the top of a gigantic tree, presumably the world-tree. The princess belongs to the upper region of light near the sun. Sitting there in captivity on the world-tree, she is a kind of *anima mundi* who has got herself into the power of darkness. But this catch does not seem to have done the latter much good either, seeing that the captor is crucified and moreover with three nails. The crucifixion evidently betokens a state of agonizing bondage and suspension, fit punishment for one foolhardy enough to venture like a Prometheus into the orbit of the opposing principle. This was what the raven, who is identical with the hunter, did when he ravished a precious soul from the upper world of light; and so, as a punishment, he is nailed to the wall in that upper world. That this is an inverted reflection of the primordial Christian image should be obvious enough. The Saviour who freed the soul of humanity from the dominion of the prince of this world was nailed to a cross down below on earth, just as the thieving raven is nailed to the wall in the celestial branches of the world-tree for his presumptuous meddling. In our fairytale, the peculiar instrument of the magic spell is the triad of nails. Who it was that made the raven captive is not told in the tale, but it sounds as if a spell had been laid upon him in the triune name.⁴³

[428] Having climbed up the world-tree and penetrated into the magic castle where he is to rescue the princess, our young hero is permitted to enter all the rooms but one, the very room in which the raven is imprisoned. Just as in paradise there was one tree of which it was forbidden to eat, so here there is one room that is not to be opened, with the natural result that it is entered at once. Nothing excites our interest more than a prohibition. It is the surest way of provoking disobedience. Obviously there is some secret scheme afoot to free not so much the princess as the raven. As soon as the hero catches sight of him, the raven begins to cry piteously and to complain of thirst,⁴⁴ and the young man, moved by the virtue of compassion, slakes it, not with hyssop and gall, but with quickening water, whereupon the three nails fall out and the raven escapes through the open window. Thus the evil spirit regains his freedom, changes into the hunter, steals the princess for the second time, but this time locks her up in his hunting-lodge on earth. The secret scheme is partially unveiled: the princess

must be brought down from the upper world to the world of men, which was evidently not possible without the help of the evil spirit and man's disobedience.

[429] But since in the human world, too, the hunter of souls is the princess's master, the hero has to intervene anew, to which end, as we have seen, he filches the four-legged horse from the witch and breaks the three-legged spell of the magician. It was the triad that first transfixed the raven, and the triad also represents the power of the evil spirit. These are the two triads that point in opposite directions.

[430] Turning now to quite another field, the realm of psychological experience, we know that three of the four functions of consciousness can become differentiated, i.e., conscious, while the other remains connected with the matrix, the unconscious, and is known as the "inferior" function. It is the Achilles heel of even the most heroic consciousness: somewhere the strong man is weak, the clever man foolish, the good man bad, and the reverse is also true. In our fairytale the triad appears as a mutilated quaternity. If only one leg could be added to the other three, it would make a whole. The enigmatic axiom of Maria runs: "... from the third comes the one as the fourth" (ἔκ τοῦ τρίτου τὸ ἕν τέταρτον) —which presumably means, when the third produces the fourth it at once produces unity. The lost component which is in the possession of the wolves belonging to the Great Mother is indeed only a quarter, but, together with the three, it makes a whole which does away with division and conflict.

[431] But how is it that a quarter, on the evidence of symbolism, is at the same time a triad? Here the symbolism of our fairytale leaves us in the lurch, and we are obliged to have recourse to the facts of psychology. I have said previously that three functions can become differentiated, and only one remains under the spell of the unconscious. This statement must be defined more closely. It is an empirical fact that only *one* function becomes more or less successfully differentiated, which on that account is known as the superior or main function, and together with extraversion or introversion constitutes the type of conscious attitude. This function has associated with it one or two partially differentiated auxiliary functions which hardly ever attain the same degree of differentiation as the main function, that is, the same degree of applicability by the will. Accordingly they possess a higher degree of spontaneity than the main function, which displays a large measure of reliability and is amenable to our intentions. The fourth, inferior function proves on the other hand to be inaccessible to our will. It appears now as a teasing and distracting imp, now as a *deus ex machina*. But always it comes and goes of its own volition. From this it is clear that even the differentiated functions have only partially freed themselves from the unconscious; for the rest they are still rooted in it and to that extent they operate under its rule. Hence the three "differentiated" functions at the disposal of the ego have three corresponding unconscious components that have not yet broken loose

from the unconscious.⁴⁵ And just as the three conscious and differentiated parts of these functions are confronted by a fourth, undifferentiated function which acts as a painfully disturbing factor, so also the superior function seems to have its worst enemy in the unconscious. Nor should we omit to mention one final turn of the screw: like the devil who delights in disguising himself as an angel of light, the inferior function secretly and mischievously influences the superior function most of all, just as the latter represses the former most strongly.⁴⁶

[432] These unfortunately somewhat abstract formulations are necessary in order to throw some light on the tricky and allusive associations in our—save the mark! —“childishly simple” fairytale. The two antithetical triads, the one banning and the other representing the power of evil, tally to a hair’s breadth with the functional structure of the conscious and unconscious psyche. Being a spontaneous, naïve, and uncontrived product of the psyche, the fairytale cannot very well express anything except what the psyche actually is. It is not only *our* fairytale that depicts these structural psychic relations, but countless other fairytales do the same.⁴⁷

[433] Our fairytale reveals with unusual clarity the essentially antithetical nature of the spirit archetype, while on the other hand it shows the bewildering play of antinomies all aiming at the great goal of higher consciousness. The young swineherd who climbs from the animal level up to the top of the giant world-tree and there, in the upper world of light, discovers his captive anima, the high-born princess, symbolizes the ascent of consciousness, rising from almost bestial regions to a lofty perch with a broad outlook, which is a singularly appropriate image for the enlargement of the conscious horizon.⁴⁸ Once the masculine consciousness has attained this height, it comes face to face with its feminine counterpart, the anima.⁴⁹ She is a personification of the unconscious. The meeting shows how inept it is to designate the latter as the “subconscious”: it is not merely “below” consciousness but also above it, so far above it indeed that the hero has to climb up to it with considerable effort. This “upper” unconscious, however, is far from being a “supercon-conscious” in the sense that anyone who reaches it, like our hero, would stand as high above the “subconscious” as above the earth’s surface. On the contrary, he makes the disagreeable discovery that his high and mighty anima, the Princess Soul, is bewitched up there and no freer than a bird in a golden cage. He may pat himself on the back for having soared up from the flatlands and from almost bestial stupidity, but his soul is in the power of an evil spirit, a sinister father-imago of subterrene nature in the guise of a raven, the celebrated theriomorphic figure of the devil. What use now is his lofty perch and his wide horizon, when his own dear soul is languishing in prison? Worse, she plays the game of the underworld and ostensibly tries to stop the young man from discovering the secret of her imprisonment, by forbidding him to enter that one room. But secretly she leads him to it by the very

fact of her veto. It is as though the unconscious had two hands of which one always does the opposite of the other. The princess wants and does not want to be rescued. But the evil spirit too has got himself into a fix, by all accounts: he wanted to filch a fine soul from the shining upper world—which he could easily do as a winged being—but had not bargained on being shut up there himself. Black spirit though he is, he longs for the light. That is his secret justification, just as his being spellbound is a punishment for his transgression. But so long as the evil spirit is caught in the upper world, the princess cannot get down to earth either, and the hero remains lost in paradise. So now he commits the sin of disobedience and thereby enables the robber to escape, thus causing the abduction of the princess for the second time—a whole chain of calamities. In the result, however, the princess comes down to earth and the devilish raven assumes the human shape of the hunter. The other-worldly anima and the evil principle both descend to the human sphere, that is, they dwindle to human proportions and thus become approachable. The three-legged, all-knowing horse represents the hunter's own power: it corresponds to the unconscious components of the differentiated functions.⁵⁰ The hunter himself personifies the inferior function, which also manifests itself in the hero as his inquisitiveness and love of adventure. As the story unfolds, he becomes more and more like the hunter: he too obtains his horse from the witch. But, unlike him, the hunter omitted to obtain the twelve lambs in order to feed the wolves, who then injured his horse. He forgot to pay tribute to the chthonic powers because he was nothing but a robber. Through this omission the hero learns that the unconscious lets its creatures go only at the cost of sacrifice.⁵¹ The number 12 is presumably a time symbol, with the subsidiary meaning of the twelve labours (ἄθλα)⁵² that have to be performed for the unconscious before one can get free.⁵³ The hunter looks like a previous unsuccessful attempt of the hero to gain possession of his soul through robbery and violence. But the conquest of the soul is in reality a work of patience, self-sacrifice, and devotion. By gaining possession of the four-legged horse the hero steps right into the shoes of the hunter and carries off the princess as well. The quaternity in our tale proves to be the greater power, for it integrates into its totality that which it still needed in order to become whole.

[434] The archetype of the spirit in this, be it said, by no means primitive fairytale is expressed theriomorphically as a system of three functions which is subordinated to a unity, the evil spirit, in the same way that some unnamed authority has crucified the raven with a triad of three nails. The two supraordinate unities correspond in the first case to the inferior function which is the arch-enemy of the main function, namely to the hunter; and in the second case to the main function, namely to the hero. Hunter and hero are ultimately equated with one another, so that the hunter's function is resolved in the hero. As a matter of fact, the hero lies dormant in the hunter from the very beginning, egging him on, with all the unmoral means at his disposal, to carry

out the rape of the soul, and then causing him to play her into the hero's hands against the hunter's will. On the surface a furious conflict rages between them, but down below the one goes about the other's business. The knot is unravelled directly the hero succeeds in capturing the quaternity—or in psychological language, when he assimilates the inferior function into the ternary system. That puts an end to the conflict at one blow, and the figure of the hunter melts into thin air. After this victory, the hero sets his princess upon the three-legged steed and together they ride away to her father's kingdom. From now on she rules and personifies the realm of spirit that formerly served the wicked hunter. Thus the anima is and remains the representative of that part of the unconscious which can never be assimilated into a humanly attainable whole.

[435] *Postscript.* Only after the completion of my manuscript was my attention drawn by a friend to a Russian variant of our story. It bears the title “Maria Morevna.”⁵⁴ The hero of the story is no swineherd, but Czarevitch Ivan. There is an interesting explanation of the three helpful animals: they correspond to Ivan's three sisters and their husbands, who are really birds. The three sisters represent an unconscious triad of functions related to both the animal and spiritual realms. The bird-men are a species of angel and emphasize the auxiliary nature of the unconscious functions. In the story they intervene at the critical moment when the hero—unlike his German counterpart—gets into the power of the evil spirit and is killed and dismembered (the typical fate of the God-man!).⁵⁵ The evil spirit is an old man who is often shown naked and is called Koschei⁵⁶ the Deathless. The corresponding witch is the well-known Baba Yaga. The three helpful animals of the German variant are doubled here, appearing first as the bird-men and then as the lion, the strange bird, and the bees. The princess is Queen Maria Morevna, a redoubtable martial leader—Mary the queen of heaven is lauded in the Russian Orthodox hymnal as “leader of hosts”!—who has chained up the evil spirit with twelve chains in the forbidden room in her castle. When Ivan slakes the old devil's thirst he makes off with the queen. The magic riding animals do not in the end turn into human beings. This Russian story has a distinctly more primitive character.

V. SUPPLEMENT

[436] The following remarks lay no claim to general interest, being in the main technical. I wanted at first to delete them from this revised version of my essay, but then I changed my mind and appended them in a supplement. The reader who is not specifically interested in psychology can safely skip this section. For, in what follows, I have dealt with the abstruse-looking problem of the three- and four-leggedness of the magic horses, and presented my reflections in such a way as to demonstrate the method I have employed. This piece of psychological reasoning rests

firstly on the irrational data of the material, that is, of the fairytale, myth, or dream, and secondly on the conscious realization of the “latent” rational connections which these data have with one another. That such connections exist at all is something of a hypothesis, like that which asserts that dreams have a meaning. The truth of this assumption is not established *a priori*: its usefulness can only be proved by application. It therefore remains to be seen whether its methodical application to irrational material enables one to interpret the latter in a meaningful way. Its application consists in approaching the material as if it had a coherent inner meaning. For this purpose most of the data require a certain amplification, that is, they need to be clarified, generalized, and approximated to a more or less general concept in accordance with Cardan’s rule of interpretation. For instance, the three-leggedness, in order to be recognized for what it is, has first to be separated from the horse and then approximated to its specific principle—the principle of threeness. Likewise, the four-leggedness in the fairytale, when raised to the level of a general concept, enters into relationship with the threeness, and as a result we have the enigma mentioned in the *Timaeus*, the problem of three and four. Triads and tetrads represent archetypal structures that play a significant part in all symbolism and are equally important for the investigation of myths and dreams. By raising the irrational datum (three-leggedness and four-leggedness) to the level of a general concept we elicit the universal meaning of this motif and encourage the inquiring mind to tackle the problem seriously. This task involves a series of reflections and deductions of a technical nature which I would not wish to withhold from the psychologically interested reader and especially from the professional, the less so as this labour of the intellect represents a typical unravelling of symbols and is indispensable for an adequate understanding of the products of the unconscious. Only in this way can the nexus of unconscious relationships be made to yield their own meaning, in contrast to those deductive interpretations derived from a preconceived theory, e.g., interpretations based on astronomy, meteorology, mythology, and—last but not least—the sexual theory.

[437] The three-legged and four-legged horses are in truth a recondite matter worthy of closer examination. The three and the four remind us not only of the dilemma we have already met in the theory of psychological functions, but also of the axiom of Maria Prophetissa, which plays a considerable role in alchemy. It may therefore be rewarding to examine more closely the meaning of the miraculous horses.

[438] The first thing that seems to me worthy of note is that the three-legged horse which is assigned to the princess as her mount is a mare, and is moreover herself a bewitched princess. Threeness is unmistakably connected here with femininity, whereas from the dominating religious standpoint of consciousness it is an exclusively masculine affair, quite apart from the fact that 3, as an uneven number, is

masculine in the first place. One could therefore translate threeness as “masculinity” outright, this being all the more significant when one remembers the ancient Egyptian triunity of God, Ka-mutef,⁵⁷ and Pharaoh.

[439] Three-leggedness, as the attribute of some animal, denotes the unconscious masculinity immanent in a female creature. In a real woman it would correspond to the animus who, like the magic horse, represents “spirit.” In the case of the anima, however, threeness does not coincide with any Christian idea of the Trinity but with the “lower triangle,” the inferior function triad that constitutes the “shadow.” The inferior half of the personality is for the greater part unconscious. It does not denote the whole of the unconscious, but only the personal segment of it. The anima, on the other hand, so far as she is distinguished from the shadow, personifies the collective unconscious. If threeness is assigned to her as a riding-animal, it means that she “rides” the shadow, is related to it as the *mar*.⁵⁸ In that case she possesses the shadow. But if she herself is the horse, then she has lost her dominating position as a personification of the collective unconscious and is “ridden”—possessed—by Princess A, spouse of the hero. As the fairytale rightly says, she has been changed by witchcraft into the three-legged horse (Princess B).

We can sort out this imbroglio more or less as follows:

[440] 1. Princess A is the anima⁵⁹ of the hero. She rides—that is, possesses—the three-legged horse, who is the shadow, the inferior function-triad of her later spouse. To put it more simply: she has taken possession of the inferior half of the hero’s personality. She has caught him on his weak side, as so often happens in ordinary life, for where one is weak one needs support and completion. In fact, a woman’s place is on the weak side of a man. This is how we would have to formulate the situation if we regarded the hero and Princess A as two ordinary people. But since it is a fairy-story played out mainly in the world of magic, we are probably more correct in interpreting Princess A as the hero’s anima. In that case the hero has been wafted out of the profane world through his encounter with the anima, like Merlin by his fairy: as an ordinary man he is like one caught in a marvellous dream, viewing the world through a veil of mist.

[441] 2. The matter is now considerably complicated by the unexpected fact that the three-legged horse is a mare, an equivalent of Princess A. She (the mare) is Princess B, who in the shape of a horse corresponds to Princess A’s shadow (i.e., her inferior function-triad). Princess B, however, differs from Princess A in that, unlike her, she does not ride the horse but is contained in it: she is bewitched and has thus come under the spell of a masculine triad. Therefore, she is possessed by a shadow.

[442] 3. The question now is, *whose* shadow? It cannot be the shadow of the hero, for this is already taken up by the latter’s anima. The fairytale gives us the answer: it is

the hunter or magician who has bewitched her. As we have seen, the hunter is somehow connected with the hero, since the latter gradually puts himself in his shoes. Hence one could easily arrive at the conjecture that the hunter is at bottom none other than the shadow of the hero. But this supposition is contradicted by the fact that the hunter stands for a formidable power which extends not only to the hero's anima but much further, namely to the royal brother-sister pair of whose existence the hero and his anima have no notion, and who appear very much out of the blue in the story itself. The power that extends beyond the orbit of the individual has a more than individual character and cannot therefore be identified with the shadow, if we conceive and define this as the dark half of the personality. As a supra-individual factor the numen of the hunter is a dominant of the collective unconscious, and its characteristic features—hunter, magician, raven, miraculous horse, crucifixion or suspension high up in the boughs of the world-tree⁶⁰—touch the Germanic psyche very closely. Hence the Christian *Weltanschauung*, when reflected in the ocean of the (Germanic) unconscious, logically takes on the features of Wotan.⁶¹ In the figure of the hunter we meet an *imago dei*, a God-image, for Wotan is also a god of winds and spirits, on which account the Romans fittingly interpreted him as Mercury.

[443] 4. The Prince and his sister, Princess B, have therefore been seized by a pagan god and changed into horses, i.e., thrust down to the animal level, into the realm of the unconscious. The inference is that in their proper human shape the pair of them once belonged to the sphere of collective consciousness. But who are they?

[444] In order to answer this question we must proceed from the fact that these two are an undoubted counterpart of the hero and Princess A. They are connected with the latter also because they serve as their mounts, and in consequence they appear as their lower, animal halves. Because of its almost total unconsciousness, the animal has always symbolized the psychic sphere in man which lies hidden in the darkness of the body's instinctual life. The hero rides the stallion, characterized by the even (feminine) number 4; Princess A rides the mare who has only three legs (3 = a masculine number). These numbers make it clear that the transformation into animals has brought with it a modification of sex character: the stallion has a feminine attribute, the mare a masculine one. Psychology can confirm this development as follows: to the degree that a man is overpowered by the (collective) unconscious there is not only a more unbridled intrusion of the instinctual sphere, but a certain feminine character also makes its appearance, which I have suggested should be called "anima." If, on the other hand, a woman comes under the domination of the unconscious, the darker side of her feminine nature emerges all the more strongly, coupled with markedly masculine traits. These latter are comprised under the term "animus."⁶²

[445] 5. According to the fairytale, however, the animal form of the brother-sister pair is “unreal” and due simply to the magic influence of the pagan hunter-god. If they were nothing but animals, we could rest content with this interpretation. But that would be to pass over in unmerited silence the singular allusion to a modification of sex character. The white horses are no ordinary horses: they are miraculous beasts with supernatural powers. Therefore the human figures out of which the horses were magically conjured must likewise have had something supernatural about them. The fairytale makes no comment here, but if our assumption is correct that the two animal forms correspond to the subhuman components of hero and princess, then it follows that the human forms—Prince and Princess B—must correspond to their superhuman components. The superhuman quality of the original swineherd is shown by the fact that he becomes a hero, practically a half-god, since he does not stay with his swine but climbs the world-tree, where he is very nearly made its prisoner, like Wotan. Similarly, he could not have become like the hunter if he did not have a certain resemblance to him in the first place. In the same way the imprisonment of Princess A on the top of the world-tree proves her electness, and in so far as she shares the hunter’s bed, as stated by the tale, she is actually the bride of God.

[446] It is these extraordinary forces of heroism and election, bordering on the superhuman, which involve two quite ordinary humans in a superhuman fate. Accordingly, in the profane world a swineherd becomes a king, and a princess gets an agreeable husband. But since, for fairytales, there is not only a profane but also a magical world, human fate does not have the final word. The fairytale therefore does not omit to point out what happens in the world of magic. There too a prince and princess have got into the power of the evil spirit, who is himself in a tight corner from which he cannot extricate himself without extraneous help. So the human fate that befalls the swineherd and Princess A is paralleled in the world of magic. But in so far as the hunter is a pagan God-image and thus exalted above the world of heroes and paramours of the gods, the parallelism goes beyond the merely magical into a divine and spiritual sphere, where the evil spirit, the Devil himself—or at least a devil—is bound by the spell of an equally mighty or even mightier counter-principle indicated by the three nails. This supreme tension of opposites, the mainspring of the whole drama, is obviously the conflict between the upper and lower triads, or, to put it in theological terms, between the Christian God and the devil who has assumed the features of Wotan.⁶³

[447] 6. We must, it seems, start from this highest level if we want to understand the story correctly, for the drama takes its rise from the initial transgression of the evil spirit. The immediate consequence of this is his crucifixion. In that distressing situation he needs outside help, and as it is not forthcoming from above, it can only be summoned from below. A young swineherd, possessed with the boyish spirit of

adventure, is reckless and inquisitive enough to climb the world-tree. Had he fallen and broken his neck, no doubt everybody would have said, "What evil spirit could have given him the crazy idea of climbing up an enormous tree like that!" Nor would they have been altogether wrong, for that is precisely what the evil spirit was after. The capture of Princess A was a transgression in the profane world, and the bewitching of the—as we may suppose—semidivine brother-sister pair was just such an enormity in the magical world. We do not know, but it is possible, that this heinous crime was committed before the bewitching of Princess A. At any rate, both episodes point to a transgression of the evil spirit in the magical world as well as in the profane.

[448] It is assuredly not without a deeper meaning that the rescuer or redeemer should be a swineherd, like the Prodigal Son. He is of lowly origin and has this much in common with the curious conception of the redeemer in alchemy. His first liberating act is to deliver the evil spirit from the divine punishment meted out to him. It is from this act, representing the first stage of the lysis, that the whole dramatic tangle develops.

[449] 7. The moral of this story is in truth exceedingly odd. The finale satisfies in so far as the swineherd and Princess A are married and become the royal pair. Prince and Princess B likewise celebrate their wedding, but this—in accordance with the archaic prerogative of kings—takes the form of incest, which, though somewhat repellent, must be regarded as more or less habitual in semidivine circles.⁶⁴ But what, we may ask, happens to the evil spirit, whose rescue from condign punishment sets the whole thing in motion? The wicked hunter is trampled to pieces by the horses, which presumably does no lasting damage to a spirit. Apparently he vanishes without trace, but only apparently, for he does after all leave a trace behind him, namely a hard-won happiness in both the profane and the magical world. Two halves of the quaternity, represented on one side by the swineherd and Princess A and on the other by Prince and Princess B, have each come together and united: two marriage-pairs now confront one another, parallel but otherwise divided, inasmuch as the one pair belongs to the profane and the other to the magical world. But in spite of this indubitable division, secret psychological connections, as we have seen, exist between them which allow us to derive the one pair from the other.

[450] Speaking in the spirit of the fairytale, which unfolds its drama from the highest point, one would have to say that the world of half-gods is anterior to the profane world and produces it out of itself, just as the world of half-gods must be thought of as proceeding from the world of gods. Conceived in this way, the swineherd and Princess A are nothing less than earthly simulacra of Prince and Princess B, who in their turn would be the descendants of divine prototypes. Nor should we forget that

the horse-breeding witch belongs to the hunter as his female counterpart, rather like an ancient Epona (the Celtic goddess of horses). Unfortunately we are not told how the magical conjuration into horses happened. But it is evident that the witch had a hand in the game because both the horses were raised from her stock and are thus, in a sense, her productions. Hunter and witch form a pair—the reflection, in the nocturnalchthonic part of the magical world, of a divine parental pair. The latter is easily recognized in the central Christian idea of *sponsus et sponsa*, Christ and his bride, the Church.

[451] If we wanted to explain the fairytale personalistically, the attempt would founder on the fact that archetypes are not whimsical inventions but autonomous elements of the unconscious psyche which were there before any invention was thought of. They represent the unalterable structure of a psychic world whose “reality” is attested by the determining effects it has upon the conscious mind. Thus, it is a significant psychic reality that the human pair⁶⁵ is matched by another pair in the unconscious, the latter pair being only in appearance a reflection of the first. In reality the royal pair invariably comes first, as an *a priori*, so that the human pair has far more the significance of an individual concretization, in space and time, of an eternal and primordial image—at least in its mental structure, which is imprinted upon the biological continuum.

[452] We could say, then, that the swineherd stands for the “animal” man who has a soul-mate somewhere in the upper world. By her royal birth she betrays her connection with the pre-existent, semidivine pair. Looked at from this angle, the latter stands for everything a man can become if only he climbs high enough up the world-tree.⁶⁶ For to the degree that the young swineherd gains possession of the patrician, feminine half of himself, he approximates to the pair of half-gods and lifts himself into the sphere of royalty, which means universal validity. We come across the same theme in Christian Rosencreutz’s *Chymical Wedding*, where the king’s son must first free his bride from the power of a Moor, to whom she has voluntarily given herself as a concubine. The Moor represents the alchemical *nigredo* in which the arcane substance lies hidden, an idea that forms yet another parallel to our mythologem, or, as we would say in psychological language, another variant of this archetype.

[453] As in alchemy, our fairytale describes the unconscious processes that compensate the conscious, Christian situation. It depicts the workings of a spirit who carries our Christian thinking beyond the boundaries set by ecclesiastical concepts, seeking an answer to questions which neither the Middle Ages nor the present day have been able to solve. It is not difficult to see in the image of the second royal pair a correspondence to the ecclesiastical conception of bridegroom and bride, and in that

of the hunter and witch a distortion of it, veering towards an atavistic, unconscious Wotanism. The fact that it is a *German* fairytale makes the position particularly interesting, since this same Wotanism was the psychological godfather of National Socialism, a phenomenon which carried the distortion to the lowest pitch before the eyes of the world.⁶⁷ On the other hand, the fairytale makes it clear that it is possible for a man to attain totality, to become whole, only with the co-operation of the spirit of darkness, indeed that the latter is actually a *causa instrumentalis* of redemption and individuation. In utter perversion of this goal of spiritual development, to which all nature aspires and which is also prefigured in Christian doctrine, National Socialism destroyed man's moral autonomy and set up the nonsensical totalitarianism of the State. The fairytale tells us how to proceed if we want to overcome the power of darkness: we must turn his own weapons against him, which naturally cannot be done if the magical underworld of the hunter remains unconscious, and if the best men in the nation would rather preach dogmatisms and platitudes than take the human psyche seriously.

VI. CONCLUSION

[454] When we consider the spirit in its archetypal form as it appears to us in fairytales and dreams, it presents a picture that differs strangely from the conscious idea of spirit, which is split up into so many meanings. Spirit was originally a spirit in human or animal form, a *daimonion* that came upon man from without. But our material already shows traces of an expansion of consciousness which has gradually begun to occupy that originally unconscious territory and to transform those *daimonia*, at least partially, into voluntary acts. Man conquers not only nature, but spirit also, without realizing what he is doing. To the man of enlightened intellect it seems like the correction of a fallacy when he recognizes that what he took to be spirits is simply the human spirit and ultimately his own spirit. All the superhuman things, whether good or bad, that former ages predicated of the *daimonia*, are reduced to "reasonable" proportions as though they were pure exaggeration, and everything seems to be in the best possible order. But were the unanimous convictions of the past really and truly only exaggerations? If they were not, then the integration of the spirit means nothing less than its demonization, since the superhuman spiritual agencies that were formerly tied up in nature are introjected into human nature, thus endowing it with a power which extends the bounds of the personality *ad infinitum*, in the most perilous way. I put it to the enlightened rationalist: has his rational reduction led to the beneficial control of matter and spirit? He will point proudly to the advances in physics and medicine, to the freeing of the mind from medieval stupidity and—as a well-meaning Christian—to our deliverance from the fear of demons. But we continue to ask: what have all our other cultural achievements led to? The fearful answer is there before our eyes: man has been delivered from no fear,

a hideous nightmare lies upon the world. So far reason has failed lamentably, and the very thing that everybody wanted to avoid rolls on in ghastly progression. Man has achieved a wealth of useful gadgets, but, to offset that, he has torn open the abyss, and what will become of him now—where can he make a halt? After the last World War we hoped for reason: we go on hoping. But already we are fascinated by the possibilities of atomic fission and promise ourselves a Golden Age—the surest guarantee that the abomination of desolation will grow to limitless dimensions. And who or what is it that causes all this? It is none other than that harmless (!), ingenious, inventive, and sweetly reasonable human spirit who unfortunately is abysmally unconscious of the demonism that still clings to him. Worse, this spirit does everything to avoid looking himself in the face, and we all help him like mad. Only, heaven preserve us from psychology—*that* depravity might lead to self-knowledge I Rather let us have wars, for which somebody else is always to blame, nobody seeing that all the world is driven to do just what all the world flees from in terror.

[455] It seems to me, frankly, that former ages did not exaggerate, that the spirit has not sloughed off its demonisms, and that mankind, because of its scientific and technological development, has in increasing measure delivered itself over to the danger of possession. True, the archetype of the spirit is capable of working for good as well as for evil, but it depends upon man's free—i.e., conscious—decision whether the good also will be perverted into something satanic. Man's worst sin is unconsciousness, but it is indulged in with the greatest piety even by those who should serve mankind as teachers and examples. When shall we stop taking man for granted in this barbarous manner and in all seriousness seek ways and means to exorcize him, to rescue him from possession and unconsciousness, and make this the most vital task of civilization? Can we not understand that all the outward tinkering and improvements do not touch man's inner nature, and that everything ultimately depends upon whether the man who wields the science and the technics is capable of responsibility or not? Christianity has shown us the way, but, as the facts bear witness, it has not penetrated deeply enough below the surface. What depths of despair are still needed to open the eyes of the world's responsible leaders, so that at least they can refrain from leading themselves into temptation?

ON THE PSYCHOLOGY OF THE TRICKSTER-FIGURE¹

[456] It is no light task for me to write about the figure of the trickster in American Indian mythology within the confined space of a commentary. When I first came across Adolf Bandelier's classic on this subject, *The Delight Makers*, many years ago, I was struck by the European analogy of the carnival in the medieval Church, with its reversal of the hierarchic order, which is still continued in the carnivals held by student societies today. Something of this contradictoriness also inheres in the medieval description of the devil as *simia dei* (the ape of God), and in his characterization in folklore as the "simpleton" who is "fooled" or "cheated." A curious combination of typical trickster motifs can be found in the alchemical figure of Mercurius; for instance, his fondness for sly jokes and malicious pranks, his powers as a shape-shifter, his dual nature, half animal, half divine, his exposure to all kinds of tortures, and—last but not least—his approximation to the figure of a saviour. These qualities make Mercurius seem like a daemonic being resurrected from primitive times, older even than the Greek Hermes. His rogueries relate him in some measure to various figures met with in folklore and universally known in fairytales: Tom Thumb, Stupid Hans, or the buffoon-like Hanswurst, who is an altogether negative hero and yet manages to achieve through his stupidity what others fail to accomplish with their best efforts. In Grimm's fairytale, the "Spirit Mercurius" lets himself be outwitted by a peasant lad, and then has to buy his freedom with the precious gift of healing.

[457] Since all mythical figures correspond to inner psychic experiences and originally sprang from them, it is not surprising to find certain phenomena in the field of parapsychology which remind us of the trickster. These are the phenomena connected with poltergeists, and they occur at all times and places in the ambience of pre-adolescent children. The malicious tricks played by the poltergeist are as well known as the low level of his intelligence and the fatuity of his "communications." Ability to change his shape seems also to be one of his characteristics, as there are not a few reports of his appearance in animal form. Since he has on occasion described himself as a soul in hell, the motif of subjective suffering would seem not to be lacking either. His universality is co-extensive, so to speak, with that of shamanism, to which, as we know, the whole phenomenology of spiritualism belongs. There is something of the trickster in the character of the shaman and medicine-man, for he, too, often plays

malicious jokes on people, only to fall victim in his turn to the vengeance of those whom he has injured. For this reason, his profession sometimes puts him in peril of his life. Besides that, the shamanistic techniques in themselves often cause the medicine-man a good deal of discomfort, if not actual pain. At all events the “making of a medicine-man” involves, in many parts of the world, so much agony of body and soul that permanent psychic injuries may result. His “approximation to the saviour” is an obvious consequence of this, in confirmation of the mythological truth that the wounded wounder is the agent of healing, and that the sufferer takes away suffering.

[458] These mythological features extend even to the highest regions of man’s spiritual development. If we consider, for example, the daemonic features exhibited by Yahweh in the Old Testament, we shall find in them not a few reminders of the unpredictable behaviour of the trickster, of his senseless orgies of destruction and his self-imposed sufferings, together with the same gradual development into a saviour and his simultaneous humanization. It is just this transformation of the meaningless into the meaningful that reveals the trickster’s compensatory relation to the “saint.” In the early Middle Ages, this led to some strange ecclesiastical customs based on memories of the ancient saturnalia. Mostly they were celebrated on the days immediately following the birth of Christ—that is, in the New Year—with singing and dancing. The dances were the originally harmless *tripudia* of the priests, lower clergy, children, and subdeacons and took place in church. An *episcopus puerorum* (children’s bishop) was elected on Innocents’ Day and dressed in pontifical robes. Amid uproarious rejoicings he paid an official visit to the palace of the archbishop and bestowed the episcopal blessing from one of the windows. The same thing happened at the *tripudium hypodiaconorum*, and at the dances for other priestly grades. By the end of the twelfth century, the subdeacons’ dance had degenerated into a real *festum stultorum* (fools’ feast). A report from the year 1198 says that at the Feast of the Circumcision in Notre Dame, Paris, “so many abominations and shameful deeds” were committed that the holy place was desecrated “not only by smutty jokes, but even by the shedding of blood.” In vain did Pope Innocent III inveigh against the “jests and madness that make the clergy a mockery,” and the “shameless frenzy of their play-acting.” Two hundred and fifty years later (March 12, 1444), a letter from the Theological Faculty of Paris to all the French bishops was still fulminating against these festivals, at which “even the priests and clerics elected an archbishop or a bishop or pope, and named him the Fools’ Pope” (*fatuorum papam*). “In the very midst of divine service masqueraders with grotesque faces, disguised as women, lions, and mummers, performed their dances, sang indecent songs in the choir, ate their greasy food from a corner of the altar near the priest celebrating mass, got out their games of dice, burned a stinking incense made of old shoe leather, and ran and hopped about all over the church.”²

[459] It is not surprising that this veritable witches' sabbath was uncommonly popular, and that it required considerable time and effort to free the Church from this pagan heritage.³

[460] In certain localities even the priests seem to have adhered to the "libertas decembrica," as the Fools' Holiday was called, in spite (or perhaps because?) of the fact that the older level of consciousness could let itself rip on this happy occasion with all the wildness, wantonness, and irresponsibility of paganism.⁴ These ceremonies, which still reveal the spirit of the trickster in his original form, seem to have died out by the beginning of the sixteenth century. At any rate, the various conciliar decrees issued from 1581 to 1585 forbade only the *festum puerorum* and the election of an *episcopus puerorum*.

[461] Finally, we must also mention in this connection the *festum asinorum*, which, so far as I know, was celebrated mainly in France. Although considered a harmless festival in memory of Mary's flight into Egypt, it was celebrated in a somewhat curious manner which might easily have given rise to misunderstandings. In Beauvais, the ass procession went right into the church.⁵ At the conclusion of each part (Introit, Kyrie, Gloria, etc.) of the high mass that followed, the whole congregation *brayed*, that is, they all went "Y-a" like a donkey ("hac modulatione hinham concludebantur"). A codex dating apparently from the eleventh century says: "At the end of the mass, instead of the words 'Ite missa est,' the priest shall bray three times (*ter hinhamabit*), and instead of the words 'Deo gratias,' the congregation shall answer 'Y-a' (*hinham*) three times."

[462] Du Cange cites a hymn from this festival:

Orientis partibus
Adventavit Asinus
Pulcher et fortissimus
Sarcinis aptissimus.

Each verse was followed by the French refrain:

Hez, Sire Asnes, car chantez
Belle bouche rechignez
Vous aurez du foin assez
Et de l'avoine à plantez.

The hymn had nine verses, the last of which was:

Amen, dicas, Asine (*hie genuflectebatur*)
Jam satur de gramine.

[463] Du Cange says that the more ridiculous this rite seemed, the greater the enthusiasm with which it was celebrated. In other places the ass was decked with a golden canopy whose corners were held “by distinguished canons”; the others present had to “don suitably festive garments, as at Christmas.” Since there were certain tendencies to bring the ass into symbolic relationship with Christ, and since, from ancient times, the god of the Jews was vulgarly conceived to be an ass—a prejudice which extended to Christ himself,⁷ as is shown by the mock crucifixion scratched on the wall of the Imperial Cadet School on the Palatine⁸—the danger of theriomorphism lay uncomfortably close. Even the bishops could do nothing to stamp out this custom, until finally it had to be suppressed by the “auctoritas supremi Senatus.” The suspicion of blasphemy becomes quite open in Nietzsche’s “Ass Festival,” which is a deliberately blasphemous parody of the mass.⁹

[464] These medieval customs demonstrate the role of the trickster to perfection, and, when they vanished from the precincts of the Church, they appeared again on the profane level of Italian theatricals, as those comic types who, often adorned with enormous ithyphallic emblems, entertained the far from prudish public with ribaldries in true Rabelaisian style. Callot’s engravings have preserved these classical figures for posterity—the Pulcinellas, Cucorognas, Chico Sgarras, and the like.¹⁰

[465] In picaresque tales, in carnivals and revels, in magic rites of healing, in man’s religious fears and exaltations, this phantom of the trickster haunts the mythology of all ages, sometimes in quite unmistakable form, sometimes in strangely modulated guise.¹¹ He is obviously a “psychologem,” an archetypal psychic structure of extreme antiquity. In his clearest manifestations he is a faithful reflection of an absolutely undifferentiated human consciousness, corresponding to a psyche that has hardly left the animal level. That this is how the trickster figure originated can hardly be contested if we look at it from the causal and historical angle. In psychology as in biology we cannot afford to overlook or underestimate this question of origins, although the answer usually tells us nothing about the functional meaning. For this reason biology should never forget the question of purpose, for only by answering that can we get at the meaning of a phenomenon. Even in pathology, where we are concerned with lesions which have no meaning in themselves, the exclusively causal approach proves to be inadequate, since there are a number of pathological phenomena which only give up their meaning when we inquire into their purpose. And where we are concerned with the normal phenomena of life, this question of purpose takes undisputed precedence.

[466] When, therefore, a primitive or barbarous consciousness forms a picture of itself on a much earlier level of development and continues to do so for hundreds or even thousands of years, undeterred by the contamination of its archaic qualities with differentiated, highly developed mental products, then the causal explanation is that the older the archaic qualities are, the more conservative and pertinacious is their behaviour. One simply cannot shake off the memory-image of things as they were, and drags it along like a senseless appendage.

[467] This explanation, which is facile enough to satisfy the rationalistic requirements of our age, would certainly not meet with the approval of the Winnebagos, the nearest possessors of the trickster cycle. For them the myth is not in any sense a remnant—it is far too amusing for that, and an object of undivided enjoyment. For them it still “functions,” provided that they have not been spoiled by civilization. For them there is no earthly reason to theorize about the meaning and purpose of myths, just as the Christmas-tree seems no problem at all to the naïve European. For the thoughtful observer, however, both trickster and Christmas-tree afford reason enough for reflection. Naturally it depends very much on the mentality of the observer what he thinks about these things. Considering the crude primitivity of the trickster cycle, it would not be surprising if one saw in this myth simply the reflection of an earlier, rudimentary stage of consciousness, which is what the trickster obviously seems to be.¹²

[468] The only question that would need answering is whether such personified reflections exist at all in empirical psychology. As a matter of fact they do, and these experiences of split or double personality actually form the core of the earliest psychopathological investigations. The peculiar thing about these dissociations is that the split-off personality is not just a random one, but stands in a complementary or compensatory relationship to the ego-personality. It is a personification of traits of character which are sometimes worse and sometimes better than those the ego-personality possesses. A collective personification like the trickster is the product of an aggregate of individuals and is welcomed by each individual as something known to him, which would not be the case if it were just an individual outgrowth.

[469] Now if the myth were nothing but an historical remnant, one would have to ask why it has not long since vanished into the great rubbish-heap of the past, and why it continues to make its influence felt on the highest levels of civilization, even where, on account of his stupidity and grotesque scurrility, the trickster no longer plays the role of a “delight-maker.” In many cultures his figure seems like an old river-bed in which the water still flows. One can see this best of all from the fact that the trickster motif does not crop up only in its mythical form but appears just as naïvely and authentically in the unsuspecting modern man—whenever, in fact, he feels himself at

the mercy of annoying “accidents” which thwart his will and his actions with apparently malicious intent. He then speaks of “hoodoos” and “jinxes” or of the “mischievousness of the object.” Here the trickster is represented by counter-tendencies in the unconscious, and in certain cases by a sort of second personality, of a puerile and inferior character, not unlike the personalities who announce themselves at spiritualistic séances and cause all those ineffably childish phenomena so typical of poltergeists. I have, I think, found a suitable designation for this character-component when I called it the *shadow*.¹³ On the civilized level, it is regarded as a personal “gaffe,” “slip,” “faux pas,” etc., which are then chalked up as defects of the conscious personality. We are no longer aware that in carnival customs and the like there are remnants of a collective shadow figure which prove that the personal shadow is in part descended from a numinous collective figure. This collective figure gradually breaks up under the impact of civilization, leaving traces in folklore which are difficult to recognize. But the main part of him gets personalized and is made an object of personal responsibility.

[470] Radin’s trickster cycle preserves the shadow in its pristine mythological form, and thus points back to a very much earlier stage of consciousness which existed before the birth of the myth, when the Indian was still groping about in a similar mental darkness. Only when his consciousness reached a higher level could he detach the earlier state from himself and objectify it, that is, say anything about it. So long as his consciousness was itself trickster-like, such a confrontation could obviously not take place. It was possible only when the attainment of a newer and higher level of consciousness enabled him to look back on a lower and inferior state. It was only to be expected that a good deal of mockery and contempt should mingle with this retrospect, thus casting an even thicker pall over man’s memories of the past, which were pretty unedifying anyway. This phenomenon must have repeated itself innumerable times in the history of his mental development. The sovereign contempt with which our modern age looks back on the taste and intelligence of earlier centuries is a classic example of this, and there is an unmistakable allusion to the same phenomenon in the New Testament, where we are told in Acts 17:30 that God looked down from above (ὑπεριδῶν, *despiciens*) on the *Χρόνοι τῆς ἀγνοίας*, the times of ignorance (or unconsciousness).

[471] This attitude contrasts strangely with the still commoner and more striking idealization of the past, which is praised not merely as the “good old days” but as the Golden Age—and not just by uneducated and superstitious people, but by all those legions of theosophical enthusiasts who resolutely believe in the former existence and lofty civilization of Atlantis.

[472] Anyone who belongs to a sphere of culture that seeks the perfect state somewhere in the past must feel very queerly indeed when confronted by the figure of the trickster. He is a forerunner of the saviour, and, like him, God, man, and animal at once. He is both subhuman and superhuman, a bestial and divine being, whose chief and most alarming characteristic is his unconsciousness. Because of it he is deserted by his (evidently human) companions, which seems to indicate that he has fallen below their level of consciousness. He is so unconscious of himself that his body is not a unity, and his two hands fight each other. He takes his anus off and entrusts it with a special task. Even his sex is optional despite its phallic qualities: he can turn himself into a woman and bear children. From his penis he makes all kinds of useful plants. This is a reference to his original nature as a Creator, for the world is made from the body of a god.

[473] On the other hand he is in many respects stupider than the animals, and gets into one ridiculous scrape after another. Although he is not really evil, he does the most atrocious things from sheer unconsciousness and unrelatedness. His imprisonment in animal unconsciousness is suggested by the episode where he gets his head caught inside the skull of an elk, and the next episode shows how he overcomes this condition by imprisoning the head of a hawk inside his own rectum. True, he sinks back into the former condition immediately afterwards, by falling under the ice, and is outwitted time after time by the animals, but in the end he succeeds in tricking the cunning coyote, and this brings back to him his saviour nature. The trickster is a primitive "cosmic" being of *divine-animal* nature, on the one hand superior to man because of his superhuman qualities, and on the other hand inferior to him because of his unreason and unconsciousness. He is no match for the animals either, because of his extraordinary clumsiness and lack of instinct. These defects are the marks of his *human* nature, which is not so well adapted to the environment as the animal's but, instead, has prospects of a much higher development of consciousness based on a considerable eagerness to learn, as is duly emphasized in the myth.

[474] What the repeated telling of the myth signifies is the therapeutic anamnesis of contents which, for reasons still to be discussed, should never be forgotten for long. If they were nothing but the remnants of an inferior state it would be understandable if man turned his attention away from them, feeling that their reappearance was a nuisance. This is evidently by no means the case, since the trickster has been a source of amusement right down to civilized times, where he can still be recognized in the carnival figures of Pulcinella and the clown. That is one important reason for his still continuing to function. But it is not the only one, and certainly not the reason why this reflection of an extremely primitive state of consciousness solidified into a mythological personage. Mere vestiges of an early state that is dying out usually lose their energy at an increasing rate, otherwise they would never disappear. The last

thing we would expect is that they would have the strength to solidify into a mythological figure with its own cycle of legends—unless, of course, they received energy from outside, in this case from a higher level of consciousness or from sources in the unconscious which are not yet exhausted. To take a legitimate parallel from the psychology of the individual, namely the appearance of an impressive shadow figure antagonistically confronting a personal consciousness: this figure does not appear merely because it *still* exists in the individual, but because it rests on a dynamism whose existence can only be explained in terms of his actual situation, for instance because the shadow is so disagreeable to his ego-consciousness that it has to be repressed into the unconscious. This explanation does not quite meet the case here, because the trickster obviously represents a vanishing level of consciousness which increasingly lacks the power to take express and assert itself. Furthermore, repression would prevent it from vanishing, because repressed contents are the very ones that have the best chance of survival, as we know from experience that nothing is corrected in the unconscious. Lastly, the story of the trickster is not in the least disagreeable to the Winnebago consciousness or incompatible with it but, on the contrary, pleasurable and therefore not conducive to repression. It looks, therefore, as if the myth were actively sustained and fostered by consciousness. This may well be so, since that is the best and most successful method of keeping the shadow figure conscious and subjecting it to conscious criticism. Although, to begin with, this criticism has more the character of a positive evaluation, we may expect that with the progressive development of consciousness the cruder aspects of the myth will gradually fall away, even if the danger of its rapid disappearance under the stress of white civilization did not exist. We have often seen how certain customs, originally cruel or obscene, became mere vestiges in the course of time.¹⁴

[475] The process of rendering this motif harmless takes an extremely long time, as its history shows; one can still detect traces of it even at a high level of civilization. Its longevity could also be explained by the strength and vitality of the state of consciousness described in the myth, and by the secret attraction and fascination this has for the conscious mind. Although purely causal hypotheses in the biological sphere are not as a rule very satisfactory, due weight must nevertheless be given to the fact that in the case of the trickster a higher level of consciousness has covered up a lower one, and that the latter was already in retreat. His recollection, however, is mainly due to the interest which the conscious mind brings to bear on him, the inevitable concomitant being, as we have seen, the gradual civilizing, i.e., assimilation, of a primitive daemonic figure who was originally autonomous and even capable of causing possession.

[476] To supplement the causal approach by a final one therefore enables us to arrive at more meaningful interpretations not only in medical psychology, where we are

concerned with individual fantasies originating in the unconscious, but also in the case of collective fantasies, that is myths and fairytales.

[477] As Radin points out, the civilizing process begins within the framework of the trickster cycle itself, and this is a clear indication that the original state has been overcome. At any rate the marks of deepest unconsciousness fall away from him; instead of acting in a brutal, savage, stupid, and senseless fashion, the trickster's behaviour towards the end of the cycle becomes quite useful and sensible. The devaluation of his earlier unconsciousness is apparent even in the myth, and one wonders what has happened to his evil qualities. The naïve reader may imagine that when the dark aspects disappear they are no longer there in reality. But that is not the case at all, as experience shows. What actually happens is that the conscious mind is then able to free itself from the fascination of evil and is no longer obliged to live it compulsively. The darkness and the evil have not gone up in smoke, they have merely withdrawn into the unconscious owing to loss of energy, where they remain unconscious so long as all is well with the conscious. But if the conscious should find itself in a critical or doubtful situation, then it soon becomes apparent that the shadow has not dissolved into nothing but is only waiting for a favourable opportunity to reappear as a projection upon one's neighbour. If this trick is successful, there is immediately created between them that world of primordial darkness where everything that is characteristic of the trickster can happen—even on the highest plane of civilization. The best examples of these "monkey tricks," as popular speech aptly and truthfully sums up this state of affairs in which everything goes wrong and nothing intelligent happens except by mistake at the last moment, are naturally to be found in politics.

[478] The so-called civilized man has forgotten the trickster. He remembers him only figuratively and metaphorically, when, irritated by his own ineptitude, he speaks of fate playing tricks on him or of things being bewitched. He never suspects that his own hidden and apparently harmless shadow has qualities whose dangerousness exceeds his wildest dreams. As soon as people get together in masses and submerge the individual, the shadow is mobilized, and, as history shows, may even be personified and incarnated.

[479] The disastrous idea that everything comes to the human psyche from outside and that it is born a *tabula rasa* is responsible for the erroneous belief that under normal circumstances the individual is in perfect order. He then looks to the State for salvation, and makes society pay for his inefficiency. He thinks the meaning of existence would be discovered if food and clothing were delivered to him gratis on his own doorstep, or if everybody possessed an automobile. Such are the puerilities that rise up in place of an unconscious shadow and keep it unconscious. As a result of

these prejudices, the individual feels totally dependent on his environment and loses all capacity for introspection. In this way his code of ethics is replaced by a knowledge of what is permitted or forbidden or ordered. How, under these circumstances, can one expect a soldier to subject an order received from a superior to ethical scrutiny? He has not yet made the discovery that he might be capable of spontaneous ethical impulses, and of performing them—even when no one is looking.

[480] From this point of view we can see why the myth of the trickster was preserved and developed: like many other myths, it was supposed to have a therapeutic effect. It holds the earlier low intellectual and moral level before the eyes of the more highly developed individual, so that he shall not forget how things looked yesterday. We like to imagine that something which we do not understand does not help us in any way. But that is not always so. Seldom does a man understand with his head alone, least of all when he is a primitive. Because of its numinosity the myth has a direct effect on the unconscious, no matter whether it is understood or not. The fact that its repeated telling has not long since become obsolete can, I believe, be explained by its usefulness. The explanation is rather difficult because two contrary tendencies are at work: the desire on the one hand to get out of the earlier condition and on the other hand not to forget it.¹⁵ Apparently Radin has also felt this difficulty, for he says: “Viewed psychologically, it might be contended that the history of civilization is largely the account of the attempts of man to forget his transformation from an animal into a human being.”¹⁶ A few pages further on he says (with reference to the Golden Age): “So stubborn a refusal to forget is not an accident.”¹⁷ And it is also no accident that we are forced to contradict ourselves as soon as we try to formulate man’s paradoxical attitude to myth. Even the most enlightened of us will set up a Christmas-tree for his children without having the least idea what this custom means, and is invariably disposed to nip any attempt at interpretation in the bud. It is really astonishing to see how many so-called superstitions are rampant nowadays in town and country alike, but if one took hold of the individual and asked him, loudly and clearly, “Do you believe in ghosts? in witches? in spells and magic?” he would deny it indignantly. It is a hundred to one he has never heard of such things and thinks it all rubbish. But in secret he is all for it, just like a jungle-dweller. The public knows very little of these things anyway, for everyone is convinced that in our enlightened society that kind of superstition has long since been eradicated, and it is part of the general convention to act as though one had never heard of such things, not to mention believing in them.

[481] But nothing is ever lost, not even the blood pact with the devil. Outwardly it is forgotten, but inwardly not at all. We act like the natives on the southern slopes of Mount Elgon, in East Africa, one of whom accompanied me part of the way into the

bush. At a fork in the path we came upon a brand new “ghost trap,” beautifully got up like a little hut, near the cave where he lived with his family. I asked him if he had made it. He denied it with all the signs of extreme agitation, asserting that only children would make such a “ju-ju.” Whereupon he gave the hut a kick, and the whole thing fell to pieces.

[482] This is exactly the reaction we can observe in Europe today. Outwardly people are more or less civilized, but inwardly they are still primitives. Something in man is profoundly disinclined to give up his beginnings, and something else believes it has long since got beyond all that. This contradiction was once brought home to me in the most drastic manner when I was watching a “Strudel” (a sort of local witch-doctor) taking the spell off a stable. The stable was situated immediately beside the Gotthard railway line, and several international expresses sped past during the ceremony. Their occupants would hardly have suspected that a primitive ritual was being performed a few yards away.

[483] The conflict between the two dimensions of consciousness is simply an expression of the polaristic structure of the psyche, which like any other energetic system is dependent on the tension of opposites. That is also why there are no general psychological propositions which could not just as well be reversed; indeed, their reversibility proves their validity. We should never forget that in any psychological discussion we are not saying anything *about* the psyche, but that the psyche is always speaking about *itself*. It is no use thinking we can ever get beyond the psyche by means of the “mind,” even though the mind asserts that it is not dependent on the psyche. How could it prove that? We can say, if we like, that one statement comes from the psyche, is psychic and nothing but psychic, and that another comes from the mind, is “spiritual” and therefore superior to the psychic one. Both are mere assertions based on the postulates of belief.

[484] The fact is, that this old trichotomous hierarchy of psychic contents (hyleic, psychic, and pneumatic) represents the polaristic structure of the psyche, which is the only immediate object of experience. The unity of our psychic nature lies in the middle, just as the living unity of the waterfall appears in the dynamic connection between above and below. Thus, the living effect of the myth is experienced when a higher consciousness, rejoicing in its freedom and independence, is confronted by the autonomy of a mythological figure and yet cannot flee from its fascination, but must pay tribute to the overwhelming impression. The figure works, because secretly it participates in the observer’s psyche and appears as its reflection, though it is not recognized as such. It is split off from his consciousness and consequently behaves like an autonomous personality. The trickster is a collective shadow figure, a summation of all the inferior traits of character in individuals. And since the

individual shadow is never absent as a component of personality, the collective figure can construct itself out of it continually. Not always, of course, as a mythological figure, but, in consequence of the increasing repression and neglect of the original mythologems, as a corresponding projection on other social groups and nations.

[485] If we take the trickster as a parallel of the individual shadow, then the question arises whether that trend towards meaning, which we saw in the trickster myth, can also be observed in the subjective and personal shadow. Since this shadow frequently appears in the phenomenology of dreams as a well-defined figure, we can answer this question positively: the shadow, although by definition a negative figure, sometimes has certain clearly discernible traits and associations which point to a quite different background. It is as though he were hiding meaningful contents under an unprepossessing exterior. Experience confirms this; and what is more important, the things that are hidden usually consist of increasingly numinous figures. The one standing closest behind the shadow is the anima,¹⁸ who is endowed with considerable powers of fascination and possession. She often appears in rather too youthful form, and hides in her turn the powerful archetype of the wise old man (sage, magician, king, etc.). The series could be extended, but it would be pointless to do so, as psychologically one only understands what one has experienced oneself. The concepts of complex psychology are, in essence, not intellectual formulations but names for certain areas of experience, and though they can be described they remain dead and irrepresentable to anyone who has not experienced them. Thus, I have noticed that people usually have not much difficulty in picturing to themselves what is meant by the shadow, even if they would have preferred instead a bit of Latin or Greek jargon that sounds more “scientific.” But it costs them enormous difficulties to understand what the anima is. They accept her easily enough when she appears in novels or as a film star, but she is not understood at all when it comes to seeing the role she plays in their own lives, because she sums up everything that a man can never get the better of and never finishes coping with. Therefore it remains in a perpetual state of emotionality which must not be touched. The degree of unconsciousness one meets with in this connection is, to put it mildly, astounding. Hence it is practically impossible to get a man who is afraid of his own femininity to understand what is meant by the anima.

[486] Actually, it is not surprising that this should be so, since even the most rudimentary insight into the shadow sometimes causes the greatest difficulties for the modern European. But since the shadow is the figure nearest his consciousness and the least explosive one, it is also the first component of personality to come up in an analysis of the unconscious. A minatory and ridiculous figure, he stands at the very beginning of the way of individuation, posing the deceptively easy riddle of the Sphinx, or grimly demanding answer to a “quaestio crocodilina.”¹⁹

[487] If, at the end of the trickster myth, the saviour is hinted at, this comforting premonition or hope means that some calamity or other has happened and been consciously understood. Only out of disaster can the longing for the saviour arise—in other words, the recognition and unavoidable integration of the shadow create such a harrowing situation that nobody but a saviour can undo the tangled web of fate. In the case of the individual, the problem constellated by the shadow is answered on the plane of the anima, that is, through relatedness. In the history of the collective as in the history of the individual, everything depends on the development of consciousness. This gradually brings liberation from imprisonment in *ἀγνοία*, ‘unconsciousness,’²⁰ and is therefore a bringer of light as well as of healing.

[488] As in its collective, mythological form, so also the individual shadow contains within it the seed of an enantiodromia, of a conversion into its opposite.

VI

CONSCIOUS, UNCONSCIOUS, AND INDIVIDUATION



A STUDY IN THE PROCESS OF INDIVIDUATION



CONCERNING MANDALA SYMBOLISM

CONSCIOUS, UNCONSCIOUS, AND INDIVIDUATION¹

[489] The relation between the conscious and the unconscious on the one hand, and the individuation process on the other, are problems that arise almost regularly during the later stages of analytical treatment. By “analytical” I mean a procedure that takes account of the existence of the unconscious. These problems do not arise in a procedure based on suggestion. A few preliminary words may not be out of place in order to explain what is meant by “individuation.”

[490] I use the term “individuation” to denote the process by which a person becomes a psychological “in-dividual,” that is, a separate, indivisible unity or “whole.”² It is generally assumed that consciousness is the whole of the psychological individual. But knowledge of the phenomena that can only be explained on the hypothesis of unconscious psychic processes makes it doubtful whether the ego and its contents are in fact identical with the “whole.” If unconscious processes exist at all, they must surely belong to the totality of the individual, even though they are not components of the conscious ego. If they were part of the ego they would necessarily be conscious, because everything that is directly related to the ego is conscious. Consciousness can even be equated with the relation between the ego and the psychic contents. But unconscious phenomena are so little related to the ego that most people do not hesitate to deny their existence outright. Nevertheless, they manifest themselves in an individual’s behaviour. An attentive observer can detect them without difficulty, while the observed person remains quite unaware of the fact that he is betraying his most secret thoughts or even things he has never thought consciously. It is, however, a great prejudice to suppose that something we have never thought consciously does not exist in the psyche. There is plenty of evidence to show that consciousness is very far from covering the psyche in its totality. Many things occur semiconsciously, and a great many more remain entirely unconscious. Thorough investigation of the phenomena of dual and multiple personalities, for instance, has brought to light a mass of material with observations to prove this point. (I would refer the reader to the writings of Pierre Janet, Théodore Flournoy, Morton Prince, and others.³)

[491] The importance of such phenomena has made a deep impression on medical psychology, because they give rise to all sorts of psychic and physiological symptoms. In these circumstances, the assumption that the ego expresses the totality

of the psyche has become untenable. It is, on the contrary, evident that the whole must necessarily include not only consciousness but the illimitable field of unconscious occurrences as well, and that the ego can be no more than the centre of the field of consciousness.

[492] You will naturally ask whether the unconscious possesses a centre too. I would hardly venture to assume that there is in the unconscious a ruling principle analogous to the ego. As a matter of fact, everything points to the contrary. If there were such a centre, we could expect almost regular signs of its existence. Cases of dual personality would then be frequent occurrences instead of rare curiosities. As a rule, unconscious phenomena manifest themselves in fairly chaotic and unsystematic form. Dreams, for instance, show no apparent order and no tendency to systematization, as they would have to do if there were a personal consciousness at the back of them. The philosophers Carus and von Hartmann treat the unconscious as a metaphysical principle, a sort of universal mind, without any trace of personality or ego-consciousness, and similarly Schopenhauer's "Will" is without an ego. Modern psychologists, too, regard the unconscious as an egoless function below the threshold of consciousness. Unlike the philosophers, they tend to derive its subliminal functions from the conscious mind. Janet thinks that there is a certain weakness of consciousness which is unable to hold all the psychic processes together. Freud, on the other hand, favours the idea of conscious factors that suppress certain incompatible tendencies. Much can be said for both theories, since there are numerous cases where a weakness of consciousness actually causes certain contents to fall below the threshold, or where disagreeable contents are repressed. It is obvious that such careful observers as Janet and Freud would not have constructed theories deriving the unconscious mainly from conscious sources had they been able to discover traces of an independent personality or of an autonomous will in the manifestations of the unconscious.

[493] If it were true that the unconscious consists of nothing but contents accidentally deprived of consciousness but otherwise indistinguishable from the conscious material, then one could identify the ego more or less with the totality of the psyche. But actually the situation is not quite so simple. Both theories are based mainly on observations in the field of neurosis. Neither Janet nor Freud had any specifically psychiatric experience. If they had, they would surely have been struck by the fact that the unconscious displays contents that are utterly different from conscious ones, so strange, indeed, that nobody can understand them, neither the patient himself nor his doctors. The patient is inundated by a flood of thoughts that are as strange to him as they are to a normal person. That is why we call him "crazy": we cannot understand his ideas. We understand something only if we have the necessary premises for doing so. But here the premises are just as remote from our

consciousness as they were from the mind of the patient before he went mad. Otherwise he would never have become insane.

[494] There is, in fact, no field directly known to us from which we could derive certain pathological ideas. It is not a question of more or less normal contents that became unconscious just by accident. They are, on the contrary, products whose nature is at first completely baffling. They differ in every respect from neurotic material, which cannot be said to be at all bizarre. The material of a neurosis is understandable in human terms, but that of a psychosis is not.⁴

[495] This peculiar psychotic material cannot be derived from the conscious mind, because the latter lacks the premises which would help to explain the strangeness of the ideas. Neurotic contents can be integrated without appreciable injury to the ego, but psychotic ideas cannot. They remain inaccessible, and ego-consciousness is more or less swamped by them. They even show a distinct tendency to draw the ego into their "system."

[496] Such cases indicate that under certain conditions the unconscious is capable of taking over the role of the ego. The consequence of this exchange is insanity and confusion, because the unconscious is not a second personality with organized and centralized functions but in all probability a decentralized congeries of psychic processes. However, nothing produced by the human mind lies absolutely outside the psychic realm. Even the craziest idea must correspond to something in the psyche. We cannot suppose that certain minds contain elements that do not exist at all in other minds. Nor can we assume that the unconscious is capable of becoming autonomous only in certain people, namely in those predisposed to insanity. It is very much more likely that the tendency to autonomy is a more or less general peculiarity of the unconscious. Mental disorder is, in a sense, only one outstanding example of a hidden but none the less general condition. This tendency to autonomy shows itself above all in affective states, including those of normal people. When in a state of violent affect one says or does things which exceed the ordinary. Not much is needed: love and hate, joy and grief, are often enough to make the ego and the unconscious change places. Very strange ideas indeed can take possession of otherwise healthy people on such occasions. Groups, communities, and even whole nations can be seized in this way by psychic epidemics.

[497] The autonomy of the unconscious therefore begins where emotions are generated. Emotions are instinctive, involuntary reactions which upset the rational order of consciousness by their elemental outbursts. Affects are not "made" or wilfully produced; they simply happen. In a state of affect a trait of character sometimes appears which is strange even to the person concerned, or hidden contents may irrupt involuntarily. The more violent an affect the closer it comes to the pathological, to a

condition in which the ego-consciousness is thrust aside by autonomous contents that were unconscious before. So long as the unconscious is in a dormant condition, it seems as if there were absolutely nothing in this hidden region. Hence we are continually surprised when something unknown suddenly appears “from nowhere.” Afterwards, of course, the psychologist comes along and shows that things had to happen as they did for this or that reason. But who could have said so beforehand?

[498] We call the unconscious “nothing,” and yet it is a reality *in potentia*. The thought we shall think, the deed we shall do, even the fate we shall lament tomorrow, all lie unconscious in our today. The unknown in us which the affect uncovers was always there and sooner or later would have presented itself to consciousness. Hence we must always reckon with the presence of things not yet discovered. These, as I have said, may be unknown quirks of character. But possibilities of future development may also come to light in this way, perhaps in just such an outburst of affect which sometimes radically alters the whole situation. The unconscious has a Janus-face: on one side its contents point back to a preconscious, prehistoric world of instinct, while on the other side it potentially anticipates the future—precisely because of the instinctive readiness for action of the factors that determine man’s fate. If we had complete knowledge of the ground plan lying dormant in an individual from the beginning, his fate would be in large measure predictable.

[499] Now, to the extent that unconscious tendencies—be they backward-looking images or forward-looking anticipations—appear in dreams, dreams have been regarded, in all previous ages, less as historical regressions than as anticipations of the future, and rightly so. For everything that will be happens on the basis of what has been, and of what—consciously or unconsciously—still exists as a memory-trace. In so far as no man is born totally new, but continually repeats the stage of development last reached by the species, he contains unconsciously, as an *a priori* datum, the entire psychic structure developed both upwards and downwards by his ancestors in the course of the ages. That is what gives the unconscious its characteristic “historical” aspect, but it is at the same time the *sine qua non* for shaping the future. For this reason it is often very difficult to decide whether an autonomous manifestation of the unconscious should be interpreted as an *effect* (and therefore historical) or as an *aim* (and therefore teleological and anticipatory). The conscious mind thinks as a rule without regard to ancestral preconditions and without taking into account the influence this *a priori* factor has on the shaping of the individual’s fate. Whereas we think in periods of years, the unconscious thinks and lives in terms of millennia. So when something happens that seems to us an unexampled novelty, it is generally a very old story indeed. We still forget, like children, what happened yesterday. We are still living in a wonderful new world where man thinks himself astonishingly new and “modern.” This is unmistakable

proof of the youthfulness of human consciousness, which has not yet grown aware of its historical antecedents.

[500] As a matter of fact, the “normal” person convinces me far more of the autonomy of the unconscious than does the insane person. Psychiatric theory can always take refuge behind real or alleged organic disorders of the brain and thus detract from the importance of the unconscious. But such a view is no longer applicable when it comes to normal humanity. What one sees happening in the world is not just a “shadowy vestige of activities that were once conscious,” but the expression of a living psychic condition that still exists and always will exist. Were that not so, one might well be astonished. But it is precisely those who give least credence to the autonomy of the unconscious who are the most surprised by it. Because of its youthfulness and vulnerability, our consciousness tends to make light of the unconscious. This is understandable enough, for a young man should not let himself be overawed by the authority of his parents if he wants to start something on his own account. Historically as well as individually, our consciousness has developed out of the darkness and somnolence of primordial unconsciousness. There were psychic processes and functions long before any ego-consciousness existed. “Thinking” existed long before man was able to say: “I am conscious of thinking.”

[501] The primitive “perils of the soul” consist mainly of dangers to consciousness. Fascination, bewitchment, “loss of soul,” possession, etc. are obviously phenomena of the dissociation and suppression of consciousness caused by unconscious contents. Even civilized man is not yet entirely free of the darkness of primeval times. The unconscious is the mother of consciousness. Where there is a mother there is also a father, yet he seems to be unknown. Consciousness, in the pride of its youth, may deny its father, but it cannot deny its mother. That would be too unnatural, for one can see in every child how hesitantly and slowly its ego-consciousness evolves out of a fragmentary consciousness lasting for single moments only, and how these islands gradually emerge from the total darkness of mere instinctuality.

[502] Consciousness grows out of an unconscious psyche which is older than it, and which goes on functioning together with it or even in spite of it. Although there are numerous cases of conscious contents becoming unconscious again (through being repressed, for instance), the unconscious as a whole is far from being a mere remnant of consciousness. Or are the psychic functions of animals remnants of consciousness?

[503] As I have said, there is little hope of our finding in the unconscious an order equivalent to that of the ego. It certainly does not look as if we were likely to discover an unconscious ego-personality, something in the nature of a Pythagorean “counter-earth.” Nevertheless, we cannot overlook the fact that, just as consciousness arises from the unconscious, the ego-centre, too, crystallizes out of a dark depth in

which it was somehow contained *in potentia*. Just as a human mother can only produce a human child, whose deepest nature lay hidden during its potential existence within her, so we are practically compelled to believe that the unconscious cannot be an entirely chaotic accumulation of instincts and images. There must be something to hold it together and give expression to the whole. Its centre cannot possibly be the ego, since the ego was born out of it into consciousness and turns its back on the unconscious, seeking to shut it out as much as possible. Or can it be that the unconscious loses its centre with the birth of the ego? In that case we would expect the ego to be far superior to the unconscious in influence and importance. The unconscious would then follow meekly in the footsteps of the conscious, and that would be just what we wish.

[504] Unfortunately, the facts show the exact opposite: consciousness succumbs all too easily to unconscious influences, and these are often truer and wiser than our conscious thinking. Also, it frequently happens that unconscious motives overrule our conscious decisions, especially in matters of vital importance. Indeed, the fate of the individual is largely dependent on unconscious factors. Careful investigation shows how very much our conscious decisions depend on the undisturbed functioning of memory. But memory often suffers from the disturbing interference of unconscious contents. Moreover, it functions as a rule automatically. Ordinarily it uses the bridges of association, but often in such an extraordinary way that another thorough investigation of the whole process of memory-reproduction is needed in order to find out how certain memories managed to reach consciousness at all. And sometimes these bridges cannot be found. In such cases it is impossible to dismiss the hypothesis of the spontaneous activity of the unconscious. Another example is intuition, which is chiefly dependent on unconscious processes of a very complex nature. Because of this peculiarity, I have defined intuition as “perception via the unconscious.”

[505] Normally the unconscious collaborates with the conscious without friction or disturbance, so that one is not even aware of its existence. But when an individual or a social group deviates too far from their instinctual foundations, they then experience the full impact of unconscious forces. The collaboration of the unconscious is intelligent and purposive, and even when it acts in opposition to consciousness its expression is still compensatory in an intelligent way, as if it were trying to restore the lost balance.

[506] There are dreams and visions of such an impressive character that some people refuse to admit that they could have originated in an unconscious psyche. They prefer to assume that such phenomena derive from a sort of “superconsciousness.” Such people make a distinction between a quasi-physiological or instinctive unconscious

and a psychic sphere or layer “above” consciousness, which they style the “superconscious.” As a matter of fact, this psyche, which in Indian philosophy is called the “higher” consciousness, corresponds to what we in the West call the “unconscious.” Certain dreams, visions, and mystical experiences do, however, suggest the existence of a consciousness in the unconscious. But, if we assume a consciousness in the unconscious, we are at once faced with the difficulty that no consciousness can exist without a subject, that is, an ego to which the contents are related. Consciousness needs a centre, an ego to which something is conscious. We know of no other kind of consciousness, nor can we imagine a consciousness without an ego. There can be no consciousness when there is no one to say: “*I am conscious.*”

[507] It is unprofitable to speculate about things we cannot know. I therefore refrain from making assertions that go beyond the bounds of science. It was never possible for me to discover in the unconscious anything like a personality comparable with the ego. But although a “second ego” cannot be discovered (except in the rare cases of dual personality), the manifestations of the unconscious do at least show *traces of personalities*. A simple example is the dream, where a number of real or imaginary people represent the dream-thoughts. In nearly all the important types of dissociation, the manifestations of the unconscious assume a strikingly personal form. Careful examination of the behaviour and mental content of these personifications, however, reveals their fragmentary character. They seem to represent complexes that have split off from a greater whole, and are the very reverse of a personal centre of the unconscious.

[508] I have always been greatly impressed by the character of dissociated fragments as personalities. Hence I have often asked myself whether we are not justified in assuming that, if such fragments have personality, the whole from which they were broken off must have personality to an even higher degree. The inference seemed logical, since it does not depend on whether the fragments are large or small. Why, then, should not the whole have personality too? *Personality need not imply consciousness. It can just as easily be dormant or dreaming.*

[509] The general aspect of unconscious manifestations is in the main chaotic and irrational, despite certain symptoms of intelligence and purposiveness. The unconscious produces dreams, visions, fantasies, emotions, grotesque ideas, and so forth. This is exactly what we would expect a dreaming personality to do. It seems to be a personality that was never awake and was never conscious of the life it had lived and of its own continuity. The only question is whether the hypothesis of a dormant and hidden personality is possible or not. It may be that all of the personality to be found in the unconscious is contained in the fragmentary personifications mentioned

before. Since this is very possible, all my conjectures would be in vain—unless there were evidence of much less fragmentary and more complete personalities, even though they are hidden.

[510] I am convinced that such evidence exists. Unfortunately, the material to prove this belongs to the subtleties of psychological analysis. It is therefore not exactly easy to give the reader a simple and convincing idea of it.

[511] I shall begin with a brief statement: in the unconscious of every man there is hidden a feminine personality, and in that of every woman a masculine personality.

[512] It is a well-known fact that sex is determined by a majority of male or female genes, as the case may be. But the minority of genes belonging to the other sex does not simply disappear. A man therefore has in him a feminine side, an unconscious feminine figure—a fact of which he is generally quite unaware. I may take it as known that I have called this figure the “anima,” and its counterpart in a woman the “animus.” In order not to repeat myself, I must refer the reader to the literature.⁵ This figure frequently appears in dreams, where one can observe all the attributes I have mentioned in earlier publications.

[513] Another, no less important and clearly defined figure is the “shadow.” Like the anima, it appears either in projection on suitable persons, or personified as such in dreams. The shadow coincides with the “personal” unconscious (which corresponds to Freud’s conception of the unconscious). Again like the anima, this figure has often been portrayed by poets and writers. I would mention the Faust-Mephistopheles relationship and E. T. A. Hoffmann’s tale *The Devil’s Elixir* as two especially typical descriptions. The shadow personifies everything that the subject refuses to acknowledge about himself and yet is always thrusting itself upon him directly or indirectly—for instance, inferior traits of character and other incompatible tendencies.⁶

[514] The fact that the unconscious spontaneously personifies certain affectively toned contents in dreams is the reason why I have taken over these personifications in my terminology and formulated them as names.

[515] Besides these figures there are still a few others, less frequent and less striking, which have likewise undergone poetic as well as mythological formulation. I would mention, for instance, the figure of the hero⁷ and of the wise old man,⁸ to name only two of the best known.

[516] All these figures irrupt autonomously into consciousness as soon as it gets into a pathological state. With regard to the anima, I would particularly like to draw attention to the case described by Nelken.⁹ Now the remarkable thing is that these figures show the most striking connections with the poetic, religious, or mythological

formulations, though these connections are in no way factual. That is to say, they are spontaneous products of analogy. One such case even led to the charge of plagiarism: the French writer Benoît gave a description of the anima and her classic myth in his book *L'Atlantide*, which is an exact parallel of Rider Haggard's *She*. The lawsuit proved unsuccessful; Benoît had never heard of *She*. (It might, in the last analysis, have been an instance of cryptomnesic deception, which is often extremely difficult to rule out.) The distinctly "historical" aspect of the anima and her condensation with the figures of the sister, wife, mother, and daughter, plus the associated incest motif, can be found in Goethe ("You were in times gone by my wife or sister"),¹⁰ as well as in the anima figure of the *regina* or *femina alba* in alchemy. The English alchemist Eirenaeus Philalethes ("lover of truth"), writing about 1645, remarks that the "Queen" was the King's "sister, mother, or wife."¹¹ The same idea can be found, ornately elaborated, in Nelken's patient and in a whole series of cases observed by me, where I was able to rule out with certainty any possibility of literary influence. For the rest, the anima complex is one of the oldest features of Latin alchemy.¹²

[517] When one studies the archetypal personalities and their behaviour with the help of the dreams, fantasies, and delusions of patients,¹³ one is profoundly impressed by their manifold and unmistakable connections with mythological ideas completely unknown to the layman. They form a species of singular beings whom one would like to endow with ego-consciousness; indeed, they almost seem capable of it. And yet this idea is not borne out by the facts. There is nothing in their behaviour to suggest that they have an ego-consciousness as we know it. They show, on the contrary, all the marks of fragmentary personalities. They are masklike, wraithlike, without problems, lacking self-reflection, with no conflicts, no doubts, no sufferings; like gods, perhaps, who have no philosophy, such as the Brahma-gods of the *Samyutta-nikāya*, whose erroneous views needed correction by the Buddha. Unlike other contents, they always remain strangers in the world of consciousness, unwelcome intruders saturating the atmosphere with uncanny forebodings or even with the fear of madness.

[518] If we examine their content, i.e., the fantasy material constituting their phenomenology, we find countless archaic and "historical" associations and images of an archetypal nature.¹⁴ This peculiar fact permits us to draw conclusions about the "localization" of anima and animus in the psychic structure. They evidently live and function in the deeper layers of the unconscious, especially in that phylogenetic substratum which I have called the collective unconscious. This localization explains a good deal of their strangeness: they bring into our ephemeral consciousness an unknown psychic life belonging to a remote past. It is the mind of our unknown ancestors, their way of thinking and feeling, their way of experiencing life and the world, gods and men. The existence of these archaic strata is presumably the source

of man's belief in reincarnations and in memories of "previous existences." Just as the human body is a museum, so to speak, of its phylogenetic history, so too is the psyche. We have no reason to suppose that the specific structure of the psyche is the only thing in the world that has no history outside its individual manifestations. Even the conscious mind cannot be denied a history reaching back at least five thousand years. It is only our ego-consciousness that has forever a new beginning and an early end. The unconscious psyche is not only immensely old, it is also capable of growing into an equally remote future. It moulds the human species and is just as much a part of it as the human body, which, though ephemeral in the individual, is collectively of immense age.

[519] The anima and animus live in a world quite different from the world outside—in a world where the pulse of time beats infinitely slowly, where the birth and death of individuals count for little. No wonder their nature is strange, so strange that their irruption into consciousness often amounts to a psychosis. They undoubtedly belong to the material that comes to light in schizophrenia.

[520] What I have said about the collective unconscious may give you a more or less adequate idea of what I mean by this term. If we now turn back to the problem of individuation, we shall see ourselves faced with a rather extraordinary task: the psyche consists of two incongruous halves which together should form a whole. One is inclined to think that ego-consciousness is capable of assimilating the unconscious, at least one hopes that such a solution is possible. But unfortunately the unconscious really is unconscious; in other words, it is unknown. And how can you assimilate something unknown? Even if you can form a fairly complete picture of the anima and animus, this does not mean that you have plumbed the depths of the unconscious. One hopes to control the unconscious, but the past masters in the art of self-control, the yogis, attain perfection in *samadhi*, a state of ecstasy, which so far as we know is equivalent to a state of unconsciousness. It makes no difference whether they call our unconscious a "universal consciousness"; the fact remains that in their case the unconscious has swallowed up ego-consciousness. They do not realize that a "universal consciousness" is a contradiction in terms, since exclusion, selection, and discrimination are the root and essence of everything that lays claim to the name "consciousness." "Universal consciousness" is logically identical with unconsciousness. It is nevertheless true that a correct application of the methods described in the Pāli Canon or in the *Yoga-sūtra* induces a remarkable extension of consciousness. But, with increasing extension, the contents of consciousness lose in clarity of detail. In the end, consciousness becomes all-embracing, but nebulous; an infinite number of things merge into an indefinite whole, a state in which subject and object are almost completely identical. This is all very beautiful, but scarcely to be recommended anywhere north of the Tropic of Cancer.

[521] For this reason we must look for a different solution. We believe in ego-consciousness and in what we call reality. The realities of a northern climate are somehow so convincing that we feel very much better off when we do not forget them. For us it makes sense to concern ourselves with reality. Our European ego-consciousness is therefore inclined to swallow up the unconscious, and if this should not prove feasible we try to suppress it. But if we understand anything of the unconscious, we know that it cannot be swallowed. We also know that it is dangerous to suppress it, because the unconscious is life and this life turns against us if suppressed, as happens in neurosis.

[522] Conscious and unconscious do not make a whole when one of them is suppressed and injured by the other. If they must contend, let it at least be a fair fight with equal rights on both sides. Both are aspects of life. Consciousness should defend its reason and protect itself, and the chaotic life of the unconscious should be given the chance of having its way too—as much of it as we can stand. This means open conflict and open collaboration at once. That, evidently, is the way human life should be. It is the old game of hammer and anvil: between them the patient iron is forged into an indestructible whole, an “individual.”

[523] This, roughly, is what I mean by the individuation process. As the name shows, it is a process or course of development arising out of the conflict between the two fundamental psychic facts. I have described the problems of this conflict, at least in their essentials, in my essay “The Relations between the Ego and the Unconscious.” A special chapter, however, is the *symbolism* of the process, which is of the utmost importance for understanding the final stages of the encounter between conscious and unconscious, in practice as well as in theory. My investigations during these last years have been devoted mainly to this theme. It turned out, to my own great astonishment, that the symbol formation has the closest affinities with alchemical ideas, and especially with the conceptions of the “uniting symbol,”¹⁵ which yield highly significant parallels. Naturally these are processes which have no meaning in the initial stages of psychological treatment. On the other hand, more difficult cases, such as cases of unresolved transference, develop these symbols. Knowledge of them is of inestimable importance in treating cases of this kind, especially when dealing with cultured patients.

[524] How the harmonizing of conscious and unconscious data is to be undertaken cannot be indicated in the form of a recipe. It is an irrational life-process which expresses itself in definite symbols. It may be the task of the analyst to stand by this process with all the help he can give. In this case, knowledge of the symbols is indispensable, for it is in them that the union of conscious and unconscious contents is consummated. Out of this union emerge new situations and new conscious

attitudes. I have therefore called the union of opposites the “transcendent function.”¹⁶
This rounding out of the personality into a whole may well be the goal of any psychotherapy that claims to be more than a mere cure of symptoms.

A STUDY IN THE PROCESS OF INDIVIDUATION¹

Tao's working of things is vague and obscure.
Obscure! Oh vague!
In it are images.
Vague! Oh obscure!
In it are things.
Profound! Oh dark indeed!
In it is seed.
Its seed is very truth.
In it is trustworthiness.
From the earliest Beginning until today
Its name is not lacking
By which to fathom the Beginning of all things.
How do I know it is the Beginning of all things?
Through *it!*

LAO-TZU, *Tao Teh Ching*, ch. 21.

Introductory

[525] During the 1920's, I made the acquaintance in America of a lady with an academic education—we will call her Miss X—who had studied psychology for nine years. She had read all the more recent literature in this field. In 1928, at the age of fifty-five, she came to Europe in order to continue her studies under my guidance. As the daughter of an exceptional father she had varied interests, was extremely cultured, and possessed a lively turn of mind. She was unmarried, but lived with the unconscious equivalent of a human partner, namely the animus (the personification of everything masculine in a woman), in that characteristic liaison so often met with in women with an academic education. As frequently happens, this development of hers was based on a positive father complex: she was “fille à papa” and consequently did not have a good relation to her mother. Her animus was not of the kind to give her cranky ideas. She was protected from this by her natural intelligence and by a remarkable readiness to tolerate the opinions of other people. This good quality, by

no means to be expected in the presence of an animus, had, in conjunction with some difficult experiences that could not be avoided, enabled her to realize that she had reached a limit and “got stuck,” and this made it urgently necessary for her to look round for ways that might lead her out of the impasse. That was one of the reasons for her trip to Europe. Associated with this there was another—not accidental—motive. On her mother’s side she was of Scandinavian descent. Since her relation to her mother left very much to be desired, as she herself clearly realized, the feeling had gradually grown up in her that this side of her nature might have developed differently if only the relation to her mother had given it a chance. In deciding to go to Europe she was conscious that she was turning back to her own origins and was setting out to reactivate a portion of her childhood that was bound up with the mother. Before coming to Zurich she had gone back to Denmark, her mother’s country. There the thing that affected her most was the landscape, and unexpectedly there came over her the desire to paint—above all, landscape motifs. Till then she had noticed no such aesthetic inclinations in herself, also she lacked the ability to paint or draw. She tried her hand at water-colours, and her modest landscapes filled her with a strange feeling of contentment. Painting them, she told me, seemed to fill her with new life. Arriving in Zurich, she continued her painting efforts, and on the day before she came to me for the first time she began another landscape—this time from memory. While she was working on it, a fantasy-image suddenly thrust itself between her and the picture: she saw herself with the lower half of her body in the earth, stuck fast in a block of rock. The region round about was a beach strewn with boulders. In the background was the sea. She felt caught and helpless. Then she suddenly saw me in the guise of a medieval sorcerer. She shouted for help, I came along and touched the rock with a magic wand. The stone instantly burst open, and she stepped out uninjured. She then painted this fantasy-image instead of the landscape and brought it to me on the following day.

Picture 1

[526] As usually happens with beginners and people with no skill of hand, the drawing of the picture cost her considerable difficulties. In such cases it is very easy for the unconscious to slip its subliminal images into the painting. Thus it came about that the big boulders would not appear on the paper in their real form but took on unexpected shapes. They looked, some of them, like hardboiled eggs cut in two, with the yolk in the middle. Others were like pointed pyramids. It was in one of these that Miss X was stuck. Her hair, blown out behind her, and the movement of the sea suggested a strong wind.

[527] The picture shows first of all her imprisoned state, but not yet the act of liberation. So it was there that she was attached to the earth, in the land of her mother.

Psychologically this state means being caught in the unconscious. Her inadequate relation to her mother had left behind something dark and in need of development. Since she succumbed to the magic of her motherland and tried to express this by painting, it is obvious that she is still stuck with half her body in Mother Earth: that is, she is still partly identical with the mother and, what is more, through that part of the body which contains just that secret of the mother which she had never inquired into.

[528] Since Miss X had discovered all by herself the method of active imagination I have long been accustomed to use, I was able to approach the problem at just the point indicated by the picture: she is caught in the unconscious and expects magical help from me, as from a sorcerer. And since her psychological knowledge had made her completely *au fait* with certain possible interpretations, there was no need of even an understanding wink to bring to light the apparent *sous-entendu* of the liberating magician's wand. The sexual symbolism, which for many naïve minds is of such capital importance, was no discovery for her. She was far enough advanced to know that explanations of this kind, however true they might be in other respects, had no significance in her case. She did not want to know how liberation might be possible in a *general* way, but how and in what way it could come about for *her*. And about this I knew as little as she. I know that such solutions can only come about in an individual way that cannot be foreseen. One cannot think up ways and means artificially, let alone know them in advance, for such knowledge is merely collective, based on average experience, and can therefore be completely inadequate, indeed absolutely wrong, in individual cases. And when, on top of that, we consider the patient's age, we would do well to abandon from the start any attempt to apply ready-made solutions and warmed-up generalities of which the patient knows just as much as the doctor. Long experience has taught me not to know anything in advance and not to know better, but to let the unconscious take precedence. Our instincts have ridden so infinitely many times, unharmed, over the problems that arise at this stage of life that we may be sure the transformation processes which make the transition possible have long been prepared in the unconscious and are only waiting to be released.

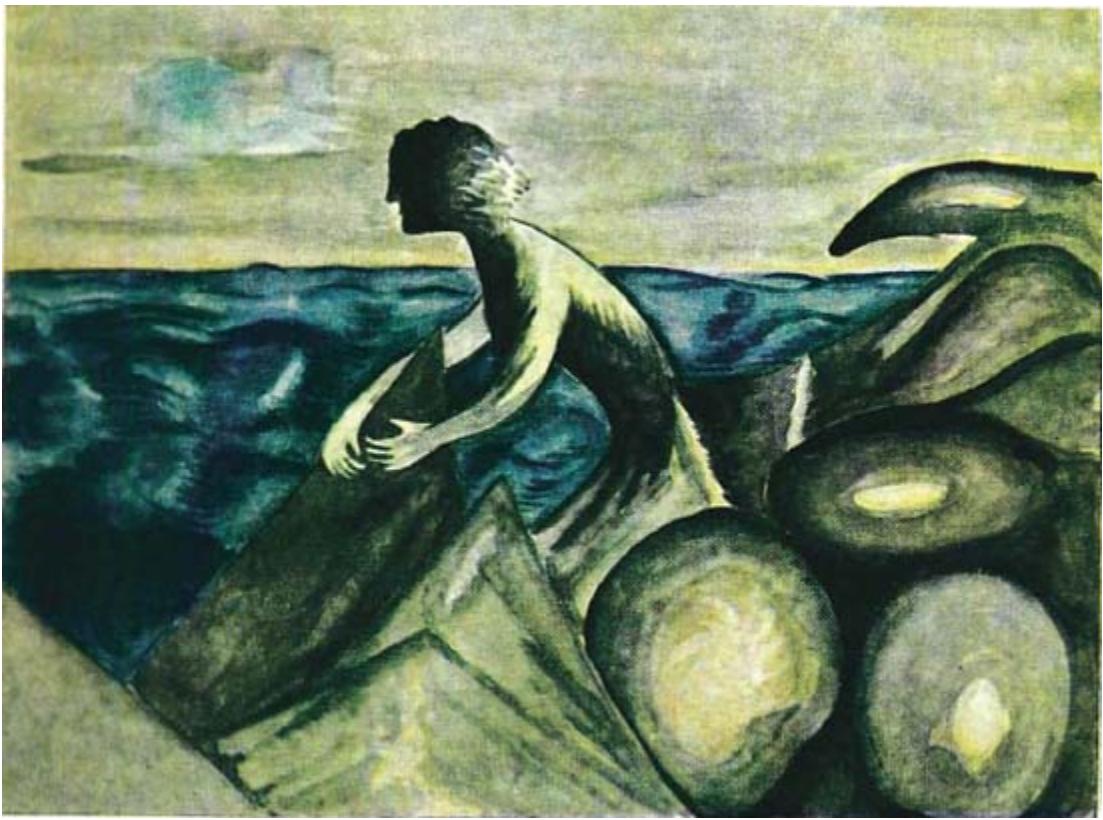

Picture 1



Picture 2



Picture 3

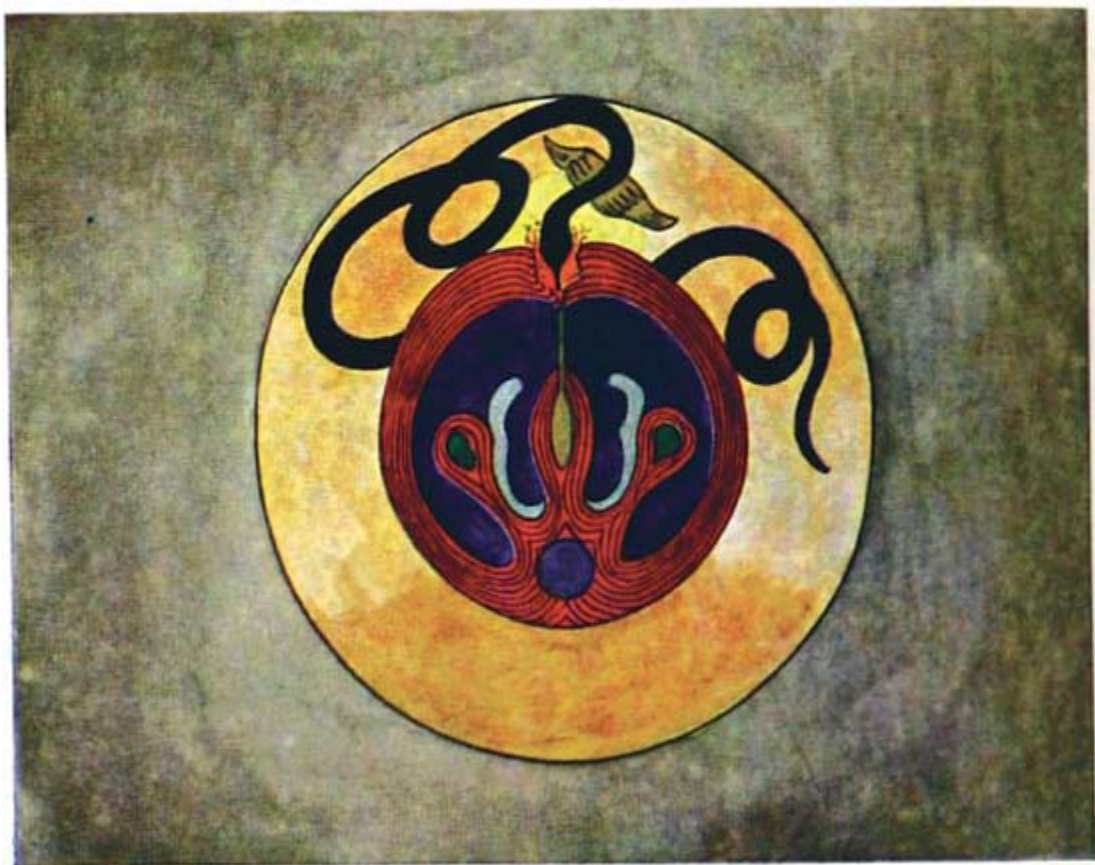

Picture 4



Picture 5



Picture 6



Picture 7



Picture 8



Picture 9



Picture 10



Picture 11



Picture 12



Picture 13



Picture 14



Picture 15



Picture 16



Picture 17



Picture 18



Picture 19



Picture 20



Picture 21



Picture 22



Picture 23



Picture 24

[529] I had already seen from her previous history how the unconscious made use of the patient's inability to draw in order to insinuate its own suggestions. I had not overlooked the fact that the boulders had surreptitiously transformed themselves into *eggs*. The egg is a germ of life with a lofty symbolical significance. It is not just a cosmogonic symbol—it is also a “philosophical” one. As the former it is the Orphic egg, the world's beginning; as the latter, the philosophical egg of the medieval natural philosophers, the vessel from which, at the end of the *opus alchymicum*, the homunculus emerges, that is, the Anthropos, the spiritual, inner and complete man, who in Chinese alchemy is called the *chen-yen* (literally, “perfect man”).²

[530] From this hint, therefore, I could already see what solution the unconscious had in mind, namely individuation, for this is the transformation process that loosens the attachment to the unconscious. It is a definitive solution, for which all other ways serve as auxiliaries and temporary makeshifts. This knowledge, which for the time being I kept to myself, bade me act with caution. I therefore advised Miss X not to let it go at a mere fantasy-image of the act of liberation, but to try to make a picture of it. How this would turn out I could not guess, and that was a good thing, because otherwise I might have put Miss X on the wrong track from sheer helpfulness. She found this task terribly difficult owing to her artistic inhibitions. So I counselled her to content herself with what was possible and to use her fantasy for the purpose of circumventing technical difficulties. The object of this advice was to introduce as much fantasy as possible into the picture, for in that way the unconscious has the best chance of revealing its contents. I also advised her not to be afraid of bright colours, for I knew from experience that vivid colours seem to attract the unconscious. Thereupon, a new picture arose.

Picture 2

[531] Again there are boulders, the round and pointed forms; but the round ones are no longer eggs, they are complete circles, and the pointed ones are tipped with golden light. One of the round forms has been blasted out of its place by a golden flash of lightning. The magician and magic wand are no longer there. The personal relationship to me seems to have ceased: the picture shows an impersonal natural process.



[532] While Miss X was painting this picture she made all sorts of discoveries. Above all, she had no notion of what picture she was going to paint. She tried to reimagine the initial situation; the rocky shore and the sea are proof of this. But the eggs turned into abstract spheres or circles, and the magician's touch became a flash of lightning cutting through her unconscious state. With this transformation she had rediscovered the historical synonym of the philosophical egg, namely the *rotundum*, the round,

original form of the Anthropos (or *στοιχάειον στρογγυλόν*, ‘round element,’ as Zosimos calls it). This is an idea that has been associated with the Anthropos since ancient times.³ The soul, too, according to tradition, has a round form. As the Monk of Heisterbach says, it is not only “like to the sphere of the moon, but is furnished on all sides with eyes” (*ex omni parte oculata*). We shall come back to this motif of polyophthalmia later on. His remark refers in all probability to certain parapsychological phenomena, the “globes of light” or globular luminosities which, with remarkable consistency, are regarded as “souls” in the remotest parts of the world.⁴

[533] The liberating flash of lightning is a symbol also used by Paracelsus⁵ and the alchemists for the same thing. Moses’ rock-splitting staff, which struck forth the living water and afterwards changed into a serpent, may have been an unconscious echo in the background.⁶ Lightning signifies a sudden, unexpected, and overpowering change of psychic condition.⁷

[534] “In this Spirit of the Fire-flash consists the Great Almighty Life,” says Jakob Böhme.⁸ “For when you strike upon the *sharp* part of the stone, the bitter sting of Nature sharpens itself, and is stirred in the highest degree. For Nature is dissipated or *broken asunder* in the sharpness, so that the *Liberty shines forth as a Flash.*”⁹ The flash is the “*Birth of the light.*”¹⁰ It has transformative power: “For if I could in my Flesh comprehend the Flash, which I very well see and know how it is, I could clarify or trans figure my Body therewith, so that it would shine with a bright light and glory. And then it would no more resemble and be conformed to the bestial Body, but to the angels of God.”¹¹ Elsewhere Böhme says: “As when the Flash of Life rises up in the centre of the Divine Power, wherein all the spirits of God attain their life, and highly rejoice.”¹² Of the “Source-spirit” *Mercurius*, he says that it “arises in the Fire-flash.” *Mercurius* is the “animal spirit” which, from *Lucifer’s* body, “struck into the Salniter¹³ of God like a *fiery serpent* from its hole, as if there went a fiery Thunderbolt into God’s Nature, or a fierce Serpent, which tyrannizes, raves, and rages, as if it would tear and rend Nature all to pieces.”¹⁴ Of the “innermost *birth of the soul*” the bestial body “attains only a glimpse, just as if it lightened.”¹⁵ “The triumphing *divine Birth* lasteth in us men only so long as the flash lasteth; therefore our knowledge is but in part, whereas in God the flash stands unchangeably, always eternally thus.”¹⁶ (Cf. Fig. 1.)

[535] In this connection I would like to mention that Böhme associates lightning with something else too. That is the *quaternity*, which plays a great role in the following pictures. When caught and assuaged in the four “Qualities” or four “Spirits,”¹⁷ “the Flash, or the Light, subsists in the *Midst or Centre as a Heart.*”¹⁸ Now when that Light, which stands in the *Midst or Centre*, shines into the four Spirits, then the

Power of the four Spirits rises up in the Light, and they become Living, and love the Light; that is, they take it into them, and are *impregnated* with it.”¹⁷ “The Flash, or *Stock*,²⁰ or Pith, or the Heart, which is generated in the Powers, remains standing in the Midst or Centre, and that is the *Son*. ... And this is the true *Holy Ghost*, whom we Christians honour and adore for the third Person in the Deity.”²¹ Elsewhere Böhme says: “When the Fire-flash reaches the dark substance,²² it is a great terror, from which the Cold Fire draws back in affright as if it would perish, and becomes impotent, and sinks into itself, ... But now the Flash ... makes in its Rising a Cross²³ with the Comprehension of all Properties; for here arises the Spirit in the Essence, and it stands thus: . If thou hast here understanding, thou needest ask no more; it is Eternity and Time, God in Love and Anger, also Heaven and Hell. The lower part, which is thus marked , is the first Principle, and is the Eternal Nature in the Anger, viz. the Kingdom of Darkness dwelling in itself; and the upper Part, with this figure , is the Salniter;²⁴ the Upper Cross above the Circle is the Kingdom of Glory, which in the Flagrat of Joy in the Will of the free Lubet²⁵ proceeds from the Fire in the Lustre of the Light into the power of the Liberty; and this spiritual Water²⁶ ... is the Corporality of the free Lubet ... wherein the Lustre from the Fire and Light makes a Tincture, viz. a budding and growing and a Manifestation of Colours from the Fire and Light.”²⁷

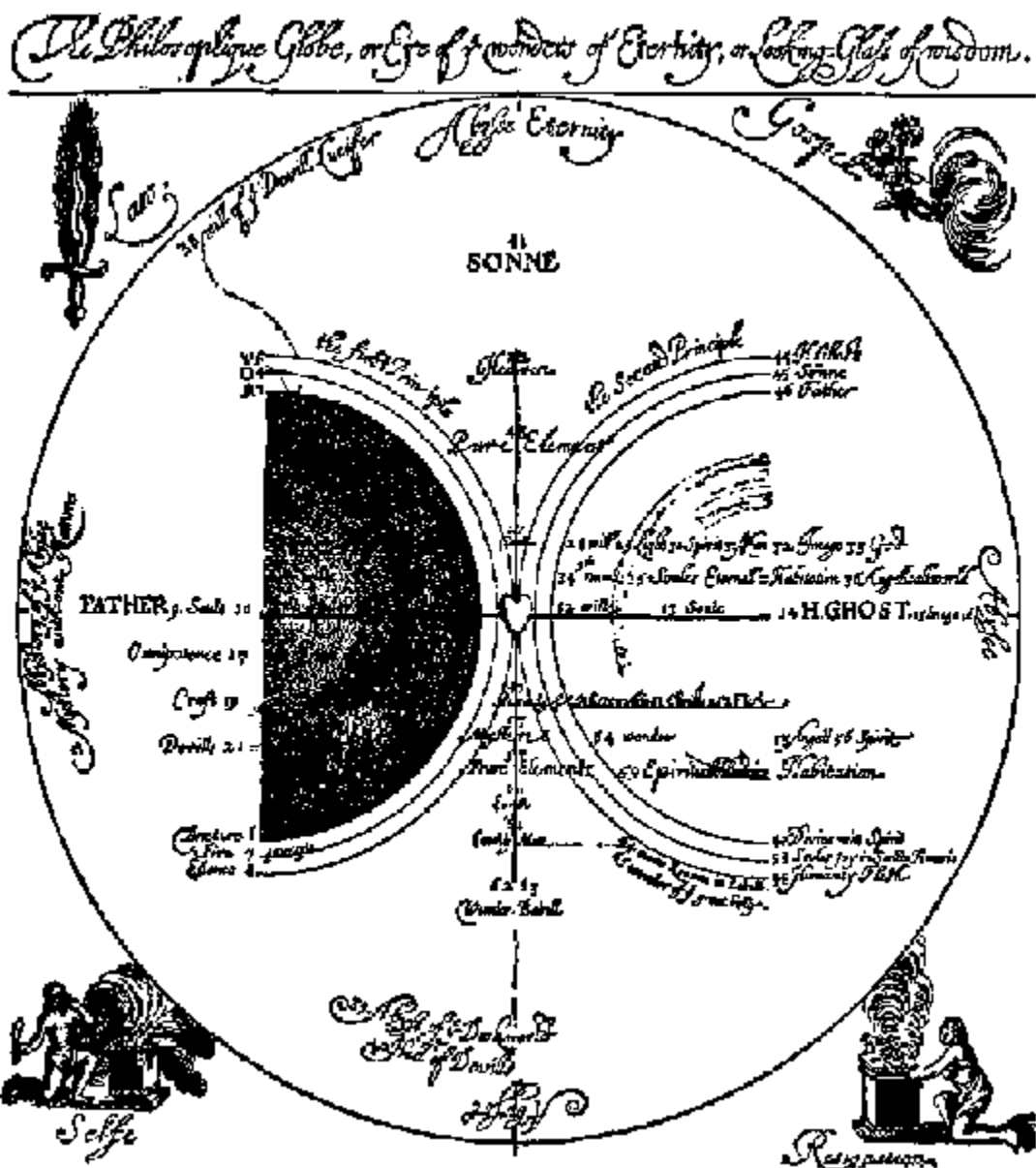









Fig. 1. Mandala from Jakob Böhme's *XL Questions concerning the Soule* (1620)

The picture is taken from the English edition of 1647. The quaternity consists of *Father*, *H. Ghost*, *Sonne*, and *Earth* or *Earthly Man*. It is characteristic that the two semicircles are turned back to back instead of closing.

[536] I have purposely dwelt at some length on Böhme's disquisition on the lightning, because it throws a good deal of light on the psychology of our pictures. However, it anticipates some things that will only become clear when we examine the pictures themselves. I must therefore ask the reader to bear Böhme's views in mind in the following commentary. I have put the most important points in italics. It is clear from the quotations what the lightning meant to Böhme and what sort of a role it plays in the present case. The last quotation in particular deserves special attention, as it anticipates various key motifs in the subsequent pictures done by my patient, namely the cross, the quaternity, the divided mandala, the lower half of which is virtually equivalent to hell and the upper half to the lighter realm of the "Salniter." For Böhme

the lower half signifies the “everlasting darkness” that “extends into the fire,”²⁸ while the upper, “salnitrous” half corresponds to the third Principle, the “visible, elemental world, which is an emanation of the first and other Principle.”²⁹ The cross, in turn, corresponds to the second Principle, the “Kingdom of Glory,” which is revealed through “magic fire,” the lightning, which he calls a “Revelation of Divine Motion.”³⁰ The “lustre of the fire” comes from the “unity of God” and reveals his will. The mandala therefore represents the “Kingdom of Nature,” which “in itself is the great everlasting Darkness.” The “Kingdom of God,” on the other hand, or the “Glory” (i.e., the Cross), is the Light of which John 1 : 5 speaks: “And the light shineth in the darkness, and the darkness comprehendeth it not.” The Life that “breaks itself off from the eternal Light and enters into the Object, as into the selfhood of Properties,” is “only fantastic and foolish, even such as the Devils were, and the souls of the damned are; as can be seen ... from the fourth number.”³¹ For the “fire of Nature” is called by Böhme the *fourth form*, and he understands it as a “spiritual Life-Fire, that exists from a continual conjunction ... of Hardness [i.e., the solidified, dry Salniter] and Motion [the Divine Will].”³² Quite in keeping with John 1 : 5 the quaternity of the lightning, the Cross, pertains to the Kingdom of Glory, whereas Nature, the visible world and the dark abyss remain untouched by the fourfold light and abide in darkness.

[537] For the sake of completeness I should mention that ☉ is the sign for *cinnabar*, the most important quicksilver ore (HgS).³³ The coincidence of the two symbols can hardly be accidental in view of the significance which Böhme attributes to Mercurius. Ruland finds it rather hard to define exactly what was meant by *cinnabar*.³⁴ The only certain thing is that there was a *κιννάβαρις τῶν φιλοσόφων* (*cinnabar of the philosophers*) in Greek alchemy, and that it stood for the *rubedo* stage of the transforming substance. Thus Zosimos says: “(After the preceding process) you will find the gold coloured fiery red like blood. That is the *cinnabar of the philosophers* and the *copper man* (*χαλκάνθρωπος*, turned to gold.”³⁵ *Cinnabar* was also supposed to be identical with the *uroboros* dragon.³⁶ Even in Pliny, *cinnabar* is called *sanguis draconis*, ‘dragon’s blood,’ a term that lasted all through the Middle Ages.³⁷ On account of its redness it was often identified with the philosophical sulphur. A special difficulty is the fact that the wine-red *cinnabar* crystals were classed with the *άνθρακες*, *carbons*, to which belong all reddish and red-tinted stones like *rubies*, *garnets*, *amethysts*, etc. They all shine like glowing coals.³⁸ The *λιθάνθρακες* (*anthracites*), on the other hand, were regarded as “quenched” coals. These associations explain the similarity of the alchemical signs for gold, antimony, and garnet. Gold ☉, after mercury the most important “philosophical” substance, shares its sign with what is known as “*regulus*” or “*button*” antimony,³⁹ and during the two decades prior to the writing of *Signatura return* (1622), from which our

quotation comes, this had enjoyed particular fame as the new transformative substance⁴⁰ and panacea.⁴¹ Basilius Valentinus' *Triumphal Car of Antimony* was published about the first decade of the seventeenth century (the first edition possibly in 1611) and soon found the widest acclaim.⁴² The sign for garnet is , and  means salt. A cross with a little circle in it  means copper (from the "Cyprian," Venus ). Medicinal tartaric acid is denoted by , and hydrogen potassium tartrate (tartar) has the signs  .⁴³ Tartar settles on the bottom of the vessel, which in the language of the alchemists means: in the underworld, Tartarus.⁴⁴

[538] I will not attempt here any interpretation of Böhme's symbols, but will only point out that in our picture the lightning, striking into the darkness and "hardness," has blasted a *rotundum* out of the dark *massa confusa* and kindled a light in it. There can be no doubt that the dark stone means the blackness, i.e., the unconscious, just as the sea and sky and the upper half of the woman's figure indicate the sphere of consciousness. We may safely assume that Böhme's symbol refers to a similar situation. The lightning has released the spherical form from the rock and so caused a kind of liberation. But, just as the magician has been replaced by the lightning, so the patient has been replaced by the sphere. The unconscious has thus presented her with ideas which show that she had gone on thinking without the aid of consciousness and that this radically altered the initial situation. It was again her inability to draw that led to this result. Before finding this solution, she had made two attempts to portray the act of liberation with human figures, but with no success. She had overlooked the fact that the initial situation, her imprisonment in the rock, was already irrational and symbolic and therefore could not be solved in a rational way. It had to be done by an equally irrational process. That was why I advised her, should she fail in her attempt to draw human figures, to use some kind of hieroglyph. It then suddenly struck her that the sphere was a suitable symbol for the individual human being. That it was a chance idea (*Einfall*) is proved by the fact that it was not her conscious mind that thought up this typification, but the unconscious, for an *Einfall* "falls in" quite of its own accord. It should be noted that she represents only herself as a sphere, not me. I am represented only by the lightning, purely functionally, so that for her I am simply the "precipitating" cause. As a magician I appeared to her in the apt role of Hermes Kyllenios, of whom the *Odyssey* says: "Meanwhile Cyllenian Hermes was gathering in the souls of the suitors, armed with the splendid golden wand that he can use at will to cast a spell on our eyes or wake us from the soundest sleep."⁴⁵ Hermes is the *ψυχῶν αἰτίος*, 'originator of souls.' He is also the *ἡγήτωρ ονειρώων*, 'guide of dreams.'⁴⁶ For the following pictures it is of special importance that Hermes has the number 4 attributed to him. Martianus Capella says: "The number four is assigned to the Cyllenian, for he alone is held to be a fourfold god."⁴⁷

[539] The form the picture had taken was not unreservedly welcome to the patient's conscious mind. Luckily, however, while painting it Miss X had discovered that two factors were involved. These, in her own words, were *reason* and the *eyes*. Reason always wanted to make the picture as *it* thought it ought to be; but the eyes held fast to their vision and finally forced the picture to come out as it actually did and not in accordance with rationalistic expectations. Her reason, she said, had really intended a daylight scene, with the sunshine melting the sphere free, but the eyes favoured a nocturne with "shattering, dangerous lightning." This realization helped her to acknowledge the actual result of her artistic efforts and to admit that it was in fact an objective and impersonal process and not a personal relationship.

[540] For anyone with a personalistic view of psychic events, such as a Freudian, it will not be easy to see in this anything more than an elaborate repression. But if there was any repression here we certainly cannot make, the conscious mind responsible for it, because the conscious mind would undoubtedly have preferred a personal imbroglio as being far more interesting. The repression must have been manoeuvred by the unconscious from the start. One should consider what this means: instinct, the most original force of the unconscious, is suppressed or turned back on itself by an arrangement stemming from this same unconscious! It would be idle indeed to talk of "repression" here, since we know that the unconscious goes straight for its goal and that this does not consist solely in pairing two animals but in allowing an individual to become whole. For this purpose wholeness—represented by the sphere—is emphasized as the essence of personality, while I am reduced to the fraction of a second, the duration of a lightning flash.

[541] The patient's association to lightning was that it might stand for *intuition*, a conjecture that is not far off the mark, since intuitions often come "like a flash." Moreover, there are good grounds for thinking that Miss X was a *sensation* type. She herself thought she was one. The "inferior" function would then be intuition. As such, it would have the significance of a releasing or "redeeming" function. We know from experience that the inferior function always compensates, complements, and balances the "superior" function.⁴⁸ My psychic peculiarity would make me a suitable projection carrier in this respect. The inferior function is the one of which least conscious use is made. This is the reason for its undifferentiated quality, but also for its freshness and vitality. It is not at the disposal of the conscious mind, and even after long use it never loses its autonomy and spontaneity, or only to a very limited degree. Its role is therefore mostly that of a *deus ex machina*. It depends not on the ego but on the *self*. Hence it hits consciousness unexpectedly, like lightning, and occasionally with devastating consequences. It thrusts the ego aside and makes room for a supraordinate factor, the totality of a person, which consists of conscious and unconscious and consequently extends far beyond the ego. This self was always

present,⁴⁹ but sleeping, like Nietzsche's "image in the stone."⁵⁰ It is, in fact, the secret of the stone, of the *lapis philosophorum*, in so far as this is the *prima materia*. In the stone sleeps the spirit *Mercurius*, the "circle of the moon," the "round and square,"⁵¹ the homunculus, Tom Thumb and Anthropos at once,⁵² whom the alchemists also symbolized as their famed *lapis philosophorum*.⁵³

[542] All these ideas and inferences were naturally unknown to my patient, and they were known to me at the time only in so far as I was able to recognize the circle as a *mardala*,⁵⁴ the psychological expression of the totality of the self. Under these circumstances there could be no question of my having unintentionally infected her with alchemical ideas. The pictures are, in all essentials, genuine creations of the unconscious; their inessential aspects (landscape motifs) are derived from conscious contents.

[543] Although the sphere with its glowing red centre and the golden flash of lightning play the chief part, it should not be overlooked that there are several other eggs or spheres as well. If the sphere signifies the self of the patient, we must apply this interpretation to the other spheres, too. They must therefore represent other people who, in all probability, were her intimates. In both the pictures two other spheres are clearly indicated. So I must mention that Miss X had two women friends who shared her intellectual interests and were joined to her in a lifelong friendship. All three of them, as if bound together by fate, are rooted in the same "earth," i.e., in the collective unconscious, which is one and the same for all. It is probably for this reason that the second picture has the decidedly *nocturnal* character intended by the unconscious and asserted against the wishes of the conscious mind. It should also be mentioned that the pointed pyramids of the first picture reappear in the second, where their points are actually gilded by the lightning and strongly emphasized. I would interpret them as unconscious contents "pushing up" into the light of consciousness, as seems to be the case with many contents of the collective unconscious.⁵⁵ In contrast to the first picture, the second is painted in more vivid colours, red and gold. Gold expresses sunlight, value, divinity even. It is therefore a favourite synonym for the *lapis*, being the *aurum philosophicum* or *aurum potable* or *aurum vitreum*.⁵⁶

[544] As already pointed out, I was not at that time in a position to reveal anything of these ideas to Miss X, for the simple reason that I myself knew nothing of them. I feel compelled to mention this circumstance yet again, because the third picture, which now follows, brings a motif that points unmistakably to alchemy and actually gave me the definitive incentive to make a thorough study of the works of the old adepts.

[545] The third picture, done as spontaneously as the first two, is distinguished most of all by its light colours. Free-floating in space, among clouds, is a dark blue sphere with a wine-red border. Round the middle runs a wavy silver band, which keeps the sphere balanced by “equal and opposite forces,” as the patient explained. To the right, above the sphere, floats a snake with golden rings, its head pointing at the sphere—an obvious development of the golden lightning in Picture 2. But she drew the snake in afterwards, on account of certain “reflections.” The whole is “a planet in the making.” In the middle of the silver band is the number 12. The band was thought of as being in rapid vibratory motion; hence the wave motif. It is like a vibrating belt that keeps the sphere afloat. Miss X compared it to the ring of Saturn. But unlike this, which is composed of disintegrated satellites, her ring was the origin of future moons such as Jupiter possesses. The black lines in the silver band she called “lines of force”; they were meant to indicate that it was in motion. As if asking a question, I made the remark: “Then it is the vibrations of the band that keep the sphere floating?” “Naturally,” she said, “they are the wings of Mercury, the messenger of the gods. The silver is *quicksilver!*” She went on at once: “Mercury, that is Hermes, is the *Nous*, the mind or reason, and that is the animus, who is here outside instead of inside. He is like a veil that hides the true personality.”⁵⁷ We shall leave this latter remark alone for the moment and turn first to the wider context, which, unlike that of the two previous pictures, is especially rich.

[546] While Miss X was painting this picture, she felt that two earlier dreams were mingling with her vision. They were the two “big” dreams of her life. She knew of the attribute “big” from my stories of the dream life of African primitives I had visited. It has become a kind of “colloquial term” for characterizing archetypal dreams, which as we know have a peculiar numinosity. It was used in this sense by the dreamer. Several years previously, she had undergone a major operation. Under narcosis she had the following dream-vision: *She saw a grey globe of the world. A silver band rotated about the equator and, according to the frequency of its vibrations, formed alternate zones of condensation and evaporation. In the zones of condensation appeared the numbers 1 to 3, but they had the tendency to increase up to 12. These numbers signified “nodal points” or “great personalities” who played a part in man’s historical development. “The number 12 meant the most important nodal point or great man (still to come), because it denotes the climax or turning point of the process of development.”* (These are her own words.)

[547] The other dream that intervened had occurred a year before the first one: *She saw a golden snake in the sky. It demanded the sacrifice, from among a great crowd of people, of a young man, who obeyed this demand with an expression of sorrow. The dream was repeated a little later, but this time the snake picked on the dreamer*

herself. The assembled people regarded her compassionately, but she took her fate “proudly” on herself.

[548] She was, as she told me, born immediately after midnight, so soon afterwards, indeed, that there was some doubt as to whether she came into the world on the 28th or on the 29th. Her father used to tease her by saying that she was obviously born before her time, since she came into the world just at the beginning of a new day, but “only just,” so that one could almost believe she was born “at the twelfth hour.” The number 12, as she said, meant for her the culminating point of her life, which she had only now reached. That is, she felt the “liberation” as the climax of her life. It is indeed an hour of birth—not of the dreamer but of the self. This distinction must be borne in mind.

[549] The context to Picture 3 here established needs a little commentary. First, it must be emphasized that the patient felt the moment of painting this picture as the “climax” of her life and also described it as such. Second, two “big” dreams have amalgamated in the picture, which heightens its significance still more. The sphere blasted from the rock in Picture 2 has now, in the brighter atmosphere, floated up to heaven. The nocturnal darkness of the earth has vanished. The increase of light indicates conscious realization: the liberation has become a fact that is integrated into consciousness. The patient has understood that the floating sphere symbolizes the “true personality.” At present, however, it is not quite clear how she understands the relation of the ego to the “true personality.” The term chosen by her coincides in a remarkable way with the Chinese *chen-yen*, the “true” or “complete” man, who has the closest affinity with the *homo quadratus*⁵⁸ of alchemy.⁵⁹ As we pointed out in the analysis of Picture 2, the *rotundum* of alchemy is identical with Mercurius, the “round and square.”⁶⁰ In Picture 3 the connection is shown concretely through the mediating idea of the wings of Mercury, who, it is evident, has entered the picture in his own right and not because of any non-existent knowledge of Böhme’s writings.⁶¹

[550] For the alchemists the process of individuation represented by the *opus* was an analogy of the creation of the world, and the *opus* itself an analogy of God’s work of creation. Man was seen as a microcosm, a complete equivalent of the world in miniature. In our picture, we see what it is in man that corresponds to the cosmos, and what kind of evolutionary process is compared with the creation of the world and the heavenly bodies: it is the *birth of the self*, the latter appearing as a microcosm.⁶² It is not the empirical man that forms the “correspondentia” to the world, as the medievalists thought, but rather the indescribable totality of the psychic or spiritual man, who cannot be described because he is compounded of consciousness as well as of the indeterminable extent of the unconscious.⁶³ The term microcosm proves the existence of a common intuition (also present in my patient) that the “total” man is as

big as the world, like an Anthropos. The cosmic analogy had already appeared in the much earlier dream under narcosis, which likewise contained the problem of personality: the nodes of the vibrations were great personalities of historical importance. As early as 1916, I had observed a similar individuation process, illustrated by pictures, in another woman patient. In her case too there was a world creation, depicted as follows (see [Fig. 2](#)):

[551] To the left, from an unknown source, three drops fall, dissolving into four lines,⁶⁴ or two pairs of lines. These lines move and form four separate paths, which then unite periodically in a nodal point and thus build a system of vibrations. The nodes are “great personalities and founders of religions,” as my erstwhile patient told me. It is obviously the same conception as in our case, and we can call it archetypal in so far as there exist universal ideas of world periods, critical transitions, gods and half gods who personify the aeons. The unconscious naturally does not produce its images from conscious reflections, but from the worldwide propensity of the human system to form such conceptions as the world periods of the Parsees, the yugas and avatars of Hinduism, and the Platonic months of astrology with their bull and ram deities and the “great” Fish of the Christian aeon.⁶⁵

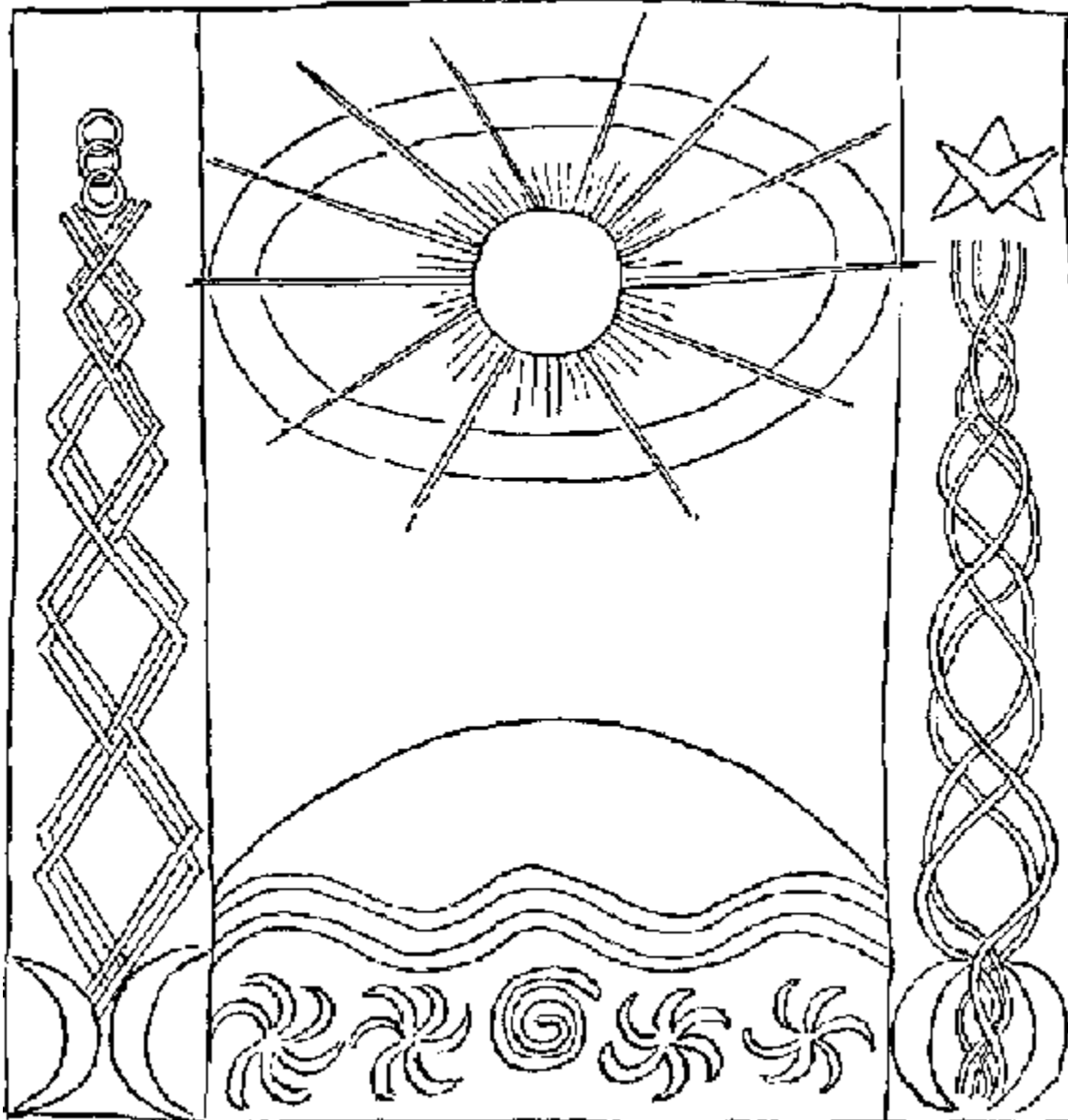

Fig. 2. Sketch of a picture from the year 1916

At the top, the sun, surrounded by a rainbow-coloured halo divided into twelve parts, like the zodiac. To the left, the descending, to the right, the ascending, transformation process.

[552] That the nodes in our patient's picture signify or contain numbers is a bit of unconscious number mysticism that is not always easy to unravel. So far as I can see, there are two stages in this arithmetical phenomenology: the first, earlier stage goes up to 3, the second, later stage up to 12. Two numbers, 3 and 12, are expressly mentioned. Twelve is four times three. I think we have here stumbled again on the axiom of Maria, that peculiar dilemma of three and four,⁶⁶ which I have discussed many times before because it plays such a great role in alchemy.⁶⁷ I would hazard that we have to do here with a *tetrameria* (as in Greek alchemy), a transformation process divided into four stages⁶⁸ of three parts each, analogous to the twelve transformations of the zodiac and its division into four. As not infrequently happens, the number 12

would then have a not merely individual significance (as the patient's birth number, for instance), but a time-conditioned one too, since the present aeon of the Fishes is drawing to its end and is at the same time the twelfth house of the zodiac. One is reminded of similar Gnostic ideas, such as those in the gnosis of Justin: The "Father" (Elohim) begets with Edem, who was half woman and half snake, twelve "fatherly" angels, and Edem gives birth besides these to twelve "motherly" angels, who—in psychological parlance—represent the shadows of the twelve "fatherly" ones. The "motherly" angels divide themselves into four categories (*μέρη*) of three each, corresponding to the four rivers of Paradise. These angels dance round in a circle (*ἐν χόρῳ κυκλικῷ*).⁶⁹ It is legitimate to bring these seemingly remote associations into hypothetical relationship, because they all spring from a common root, i.e., the collective unconscious.

[553] In our picture Mercurius forms a world-encircling band, usually represented by a snake.⁷⁰ Mercurius is a serpent or dragon in alchemy ("serpens mercurialis"). Oddly enough, this serpent is some distance away from the sphere and is aiming down at it, as if to strike. The sphere, we are told, is kept afloat by equal and opposite forces, represented by the quicksilver or somehow connected with it. According to the old view, Mercurius is duplex, i.e., he is himself an antithesis.⁷¹ Mercurius or Hermes is a magician and god of magicians. As Hermes Trismegistus he is the patriarch of alchemy. His magician's wand, the caduceus, is entwined by two snakes. The same attribute distinguishes Asklepios, the god of physicians.⁷² The archetype of these ideas was projected on to me by the patient before ever the analysis had begun.

[554] The primordial image underlying the sphere girdled with quicksilver is probably that of the world egg encoiled by a snake.⁷³ But in our case the snake symbol of Mercurius is replaced by a sort of pseudo-physicistic notion of a field of vibrating molecules of quicksilver. This looks like an intellectual disguising of the true situation, that the self, or its symbol, is entwined by the mercurial serpent. As the patient remarked more or less correctly, the "true personality" is veiled by it. This, presumably, would then be something like an Eve in the coils of the paradisaical serpent. In order to avoid giving this appearance, Mercurius has obligingly split into his two forms, according to the old-established pattern: the *mercurius crudus* or *vulgi* (crude or ordinary quicksilver), and the *Mercurius Philosophorum* (the *spiritus mercurialis* or the spirit Mercurius, Hermes-Nous), who hovers in the sky as the golden lightning-serpent or Nous Serpent, at present inactive. In the vibrations of the quicksilver band we may discern a certain tremulous excitement, just as the suspension expresses tense expectation: "Hover and haver suspended in pain!" For the alchemists quicksilver meant the concrete, material manifestation of the spirit Mercurius, as the above-mentioned mandala in the scholia to the *Tractatus aureus* shows: the central point is Mercurius, and the square is Mercurius divided into the

four elements. He is the *anima mundi*, the innermost point and at the same time the encompasser of the world, like the atman in the Upanishads. And just as quicksilver is a materialization of Mercurius, so the gold is a materialization of the sun in the earth.⁷⁴

[555] A circumstance that never ceases to astonish one is this: that at all times and in all places alchemy brought its conception of the *lapis* or its *minera* (raw material) together with the idea of the *homo altus* or *maximus*, that is, with the Anthropos.⁷⁵ Equally, one must stand amazed at the fact that here too the conception of the dark round stone blasted out of the rock should represent such an abstract idea as the psychic totality of man. The earth and in particular the heavy cold stone is the epitome of materiality, and so is the metallic quicksilver which, the patient thought, meant the animus (mind, *nous*). We would expect pneumatic symbols for the idea of the self and the animus, images of air, breath, wind. The ancient formula *λίθος οὐ λίθος* (the stone that is no stone) expresses this dilemma: we are dealing with a *complexio oppositorum*, with something like the nature of light, which under some conditions behaves like particles and under others like waves, and is obviously in its essence both at once. Something of this kind must be conjectured with regard to these paradoxical and hardly explicable statements of the unconscious. They are not inventions of any conscious mind, but are spontaneous manifestations of a psyche not controlled by consciousness and obviously possessing all the freedom it wants to express views that take no account of our conscious intentions. The duplicity of Mercurius, his simultaneously metallic and pneumatic nature, is a parallel to the symbolization of an extremely spiritual idea like the Anthropos by a corporeal, indeed metallic, substance (gold). One can only conclude that the unconscious tends to regard spirit and matter not merely as equivalent but as actually identical, and this in flagrant contrast to the intellectual one-sidedness of consciousness, which would sometimes like to spiritualize matter and at other times to materialize spirit. That the *lapis*, or in our case the floating sphere, has a double meaning is clear from the circumstance that it is characterized by two symbolical colours: red means blood and affectivity, the physiological reaction that joins spirit to body, and blue means the spiritual process (mind or *nous*). This duality reminds one of the alchemical duality *corpus* and *spiritus*, joined together by a third, the *anima* as the *ligamentum corporis et spiritus*. For Böhme a “high deep blue” mixed with green signifies “Liberty,” that is, the inner “Kingdom of Glory” of the reborn soul. Red leads to the region of fire and the “abyss of darkness,” which forms the periphery of Böhme’s mandala (see Fig. 1).

[556] Picture 4, which now follows, shows a significant change: the sphere has divided into an outer membrane and an inner nucleus. The outer membrane is flesh coloured, and the originally rather nebulous red nucleus in Picture 2 now has a differentiated internal structure of a decidedly ternary character. The “lines of force” that originally belonged to the band of quicksilver now run through the whole nuclear body, indicating that the excitation is no longer external only but has seized the innermost core. “An enormous inner activity now began,” the patient told me. The nucleus with its ternary structure is presumably the female organ, stylized to look like a plant, in the act of fecundation: the spermatozoon is penetrating the nuclear membrane. Its role is played by the mercurial serpent: the snake is black, dark, chthonic, a subterranean and ithyphallic Hermes; but it has the golden wings of Mercury and consequently possesses his pneumatic nature. The alchemists accordingly represented their *Mercurius duplex* as the winged and wingless dragon, calling the former feminine and the latter masculine.

[557] The serpent in our picture represents not so much the spermatozoon but, more accurately, the phallus. Leone Ebreo,⁷⁶ in his *Dialoghi d’amore*, calls the planet Mercury the *membrum virile* of heaven, that is, of the macrocosm conceived as the *homo maximus*.⁷⁷ The spermatozoon seems, rather, to correspond to the golden substance which the snake is injecting into the invaginated ectoderm of the nucleus.⁷⁸ The two silver petals (?) probably represent the receptive vessel, the moon-bowl in which the sun’s seed (gold) is destined to rest.⁷⁹ Underneath the flower is a small violet circle inside the ovary, indicating by its colour that it is a “united double nature,” spirit and body (blue and red).⁸⁰ The snake has a pale yellow halo, which is meant to express its numinosity.

[558] Since the snake evolved out of the flash of lightning or is a modulated form of it, I would like to instance a parallel where the lightning has the same illuminating, vivifying, fertilizing, transforming and healing function that in our case falls to the snake (cf. Fig. 3). Two phases are represented: first, a black sphere, signifying a state of profound depression; and second, the lightning that strikes into this sphere. Ordinary speech makes use of the same imagery: something “strikes home” in a “flash of revelation.” The only difference is that generally the image comes first, and only afterwards the realization which enables the patient to say: “This has struck home.”

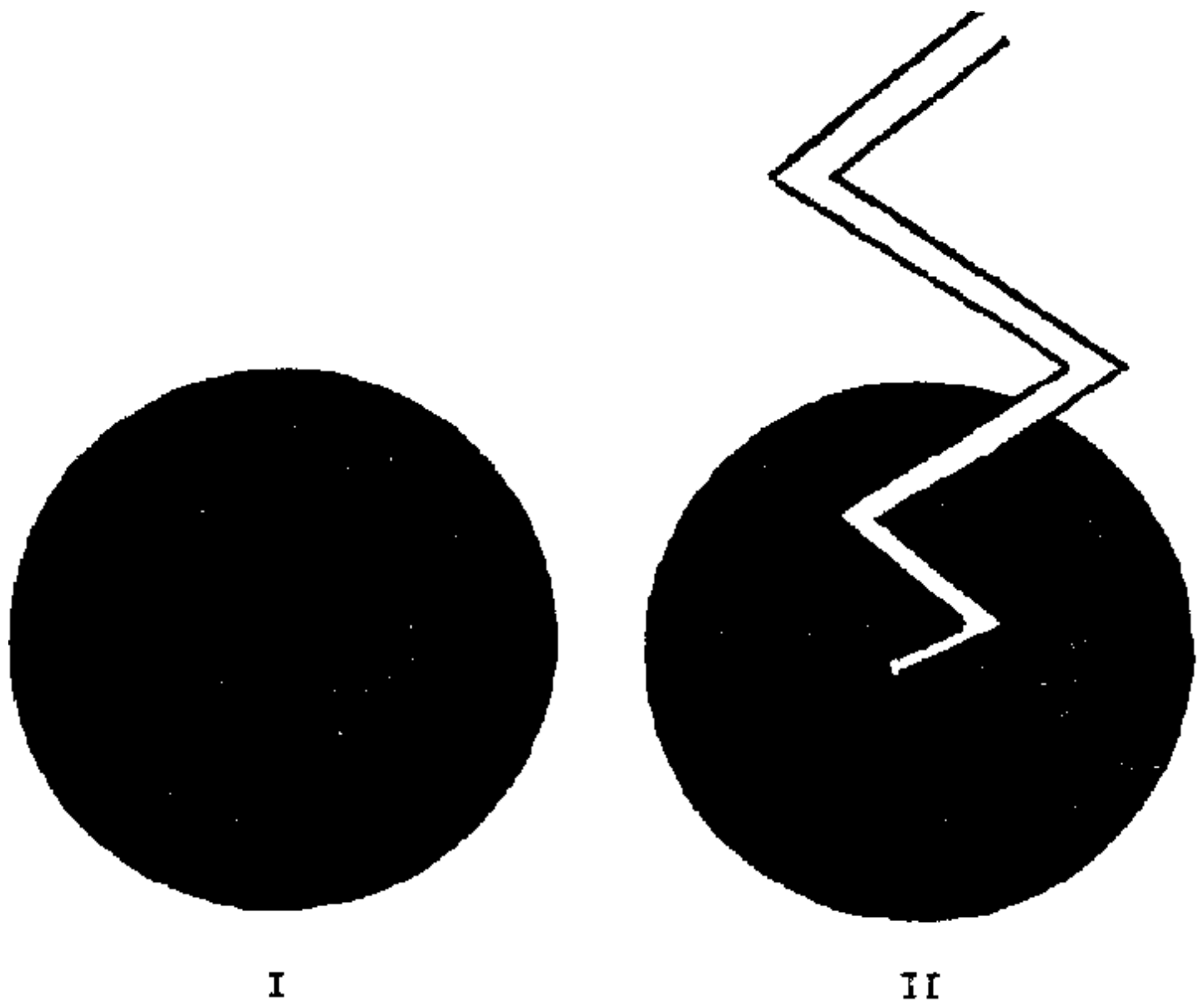

Fig. 3. Sketch of a drawing by a young woman patient with psychogenic depression from the beginning of the treatment

I. State of black hopelessness / II. Beginning of the therapeutic effect

In an earlier picture the sphere lay on the bottom of the sea. As a series of pictures shows, it arose in the first place because a black snake had swallowed the sun. There then followed an eight-rayed, completely black mandala with a wreath of eight silver stars. In the centre was a black homunculus. Next the black sphere developed a red centre, from which red rays, or streams of blood, ran out into tentacle-like extremities. The whole thing looked rather like a crab or an octopus. As the later pictures showed, the patient herself was shut up in the sphere.

[559] As to the context of Picture 4, Miss X emphasized that what disturbed her most was the band of quicksilver in Picture 3. She felt the silvery substance ought to be “inside,” the black lines of force remaining outside to form a black snake. This would now encircle the sphere.⁸¹ She felt the snake at first as a “terrible danger,” as something threatening the “integrity of the sphere.” At the point where the snake

penetrates the nuclear membrane, fire breaks out (emotion). Her conscious mind interpreted this conflagration as a defensive reaction on the part of the sphere, and accordingly she tried to depict the attack as having been repulsed. But this attempt failed to satisfy the “eyes,” though she showed me a pencil sketch of it. She was obviously in a dilemma: she could not accept the snake, because its sexual significance was only too clear to her without any assistance from me. I merely remarked to her: “This is a well-known process⁸² which you can safely accept,” and showed her from my collection a similar picture, done by a man, of a floating sphere being penetrated *from below* by a black phallus-like object. Later she said: “I suddenly understood the whole process in a more impersonal way.” It was the realization of a law of life to which sex is subordinated. “The ego was not the centre, but, following a universal law, I circled round a sun.” Thereupon she was able to accept the snake “as a necessary part of the process of growth” and finish the picture quickly and satisfactorily. Only one thing continued to give difficulty: she had to put the snake, she said, “One hundred per cent at the top, in the middle, in order to satisfy the eyes.” Evidently the unconscious would only be satisfied with the most important position at the top and in the middle—in direct contrast to the picture I had previously shown her. This, as I said, was done by a man and showed the menacing black symbol entering the mandala from below. For a woman, the typical danger emanating from the unconscious comes *from above*, from the “spiritual” sphere personified by the animus, whereas for a man it comes from the chthonic realm of the “world and woman,” i.e., the anima projected on to the world.

[560] Once again we must recall similar ideas found in Justin’s gnosis: the third of the fatherly angels is Baruch. He is also the tree of life in paradise. His counterpart on the motherly side is Naas, the serpent, who is the tree of knowledge of good and evil.⁸³ When Elohim left Edem, because, as the second member, he had retreated to the first member of the divine triad (which consisted of the “Good,” the “Father,” and Edem), Edem pursued the pneuma of the Father, which he had left behind in man, and caused it to be tormented by Naas (*ἵνα πάσαις κολάσει κολάζη τό ὄν πνευμα του Ἐλωειμ τὸ ἐν τοῖς ἀνθρώποις*), Naas defiled Eve and also used Adam as a catamite. Edem, however, is the soul; Elohim is spirit. “The soul is against the spirit, and the spirit against the soul” (*κατὰ τῆς ψυχῆς τετάκται*).⁸⁴ This idea sheds light on the polarity of red and blue in our mandala, and also on the attack by the snake, who represents knowledge. That is why we fear knowledge of the truth, in this case, of the shadow. Therefore Baruch sent to mankind Jesus, that they might be led back to the “Good.” But the “Good One is Priapus.”⁸⁵ Elohim is the swan, Edem is Leda; he the gold, she Danae. Nor should we forget that the god of revelation has from of old the form of a snake—e.g., the *agathodaimon*. Edem too, as a snake-maiden, has a dual nature,

“two-minded, two-bodied” (*δίγυνωμος, δίσωμος*), and in medieval alchemy her figure became the symbol of the androgynous Mercurius.⁸⁶

[561] Let us remember that in Picture 3 *Mercurius vulgi*, ordinary quicksilver, encircles the sphere. This means that the mysterious sphere is enveloped or veiled by a “vulgar” or crude understanding. The patient herself opined that “the animus veils the true personality.” We shall hardly be wrong in assuming that a banal, everyday view of the world, allegedly biological, has here got hold of the sexual symbol and concretized it after the approved pattern. A pardonable error! Another, more correct view is so much more subtle that one naturally prefers to fall back on something well-known and ready to hand, thus gratifying one’s own “rational” expectations and earning the applause of one’s contemporaries—only to discover that one has got hopelessly stuck and has arrived back at the point from which one set forth on the great adventure. It is clear what is meant by the ithyphallic serpent: from above comes all that is aerial, intellectual, spiritual, and from below all that is passionate, corporeal, and dark. The snake, contrary to expectation, turns out to be a pneumatic symbol,⁸⁷ a *Mercurius spiritualis*—a realization which the patient herself formulated by saying that the ego, despite its capricious manipulation of sexuality, is subject to a universal law. Sex in this case is therefore no problem at all, as it has been subjected to a higher transformation process and is contained in it; not repressed, only without an object.

[562] Miss X subsequently told me that she felt Picture 4 was the most difficult, as if it denoted the turning point of the whole process. In my view she may not have been wrong in this, because the clearly felt, ruthless setting aside of the so beloved and so important ego is no light matter. Not for nothing is this “letting go” the *sine qua non* of all forms of higher spiritual development, whether we call it meditation, contemplation, yoga, or spiritual exercises. But, as this case shows, relinquishing the ego is not an act of the will and not a result arbitrarily produced; it is an event, an occurrence, whose inner, compelling logic can be disguised only by wilful self-deception.

[563] In this case and at this moment the ability to “let go” is of decisive importance. But since everything passes, the moment may come when the relinquished ego must be reinstated in its functions. Letting go gives the unconscious the opportunity it has been waiting for. But since it consists of opposites—day and night, bright and dark, positive and negative—and is good and evil and therefore ambivalent, the moment will infallibly come when the individual, like the exemplary Job, must hold fast so as not to be thrown catastrophically off balance—when the wave rebounds. The holding fast can be achieved only by a conscious will, i.e., by the ego. That is the great and irreplaceable significance of the ego, but one which, as we see here, is nonetheless relative. Relative, too, is the gain won by integrating the unconscious. We add to

ourselves a bright and a dark, and more light means more night.⁸⁸ The urge of consciousness towards wider horizons, however, cannot be stopped; they must needs extend the scope of the personality, if they are not to shatter it.

Picture 5

[564] Picture 5, Miss X said, followed naturally from Picture 4, with no difficulty. The sphere and the snake have drawn apart. The snake is sinking downwards and seems to have lost its threateningness. But the sphere has been fecundated with a vengeance: it has not only got bigger, but blossoms in the most vivid colours.⁸⁹ The nucleus has divided into four; something like a segmentation has occurred. This is not due to any conscious reflection, such as might come naturally to a biologically educated person; the division of the process or of the central symbol into four has always existed, beginning with the four sons of Horus, or the four seraphim of Ezekiel, or the birth of the four Aeons from the Metra (uterus) impregnated by the pneuma in Barbelo-Gnosis, or the cross formed by the lightning (snake) in Böhme's system,⁹⁰ and ending with the tetrameria of the *opus alchymicum* and its components (the four elements, qualities, stages, etc.).⁹¹ In each case the quaternity forms a unity; here it is the green circle at the centre of the four. The four are undifferentiated, and each of them forms a vortex, apparently turning to the left. I think I am not mistaken in regarding it as probable that, in general, a leftward movement indicates movement towards the unconscious, while a rightward (clockwise) movement goes towards consciousness.⁹² The one is "sinister," the other "right," "rightful," "correct." In Tibet, the leftward-moving swastika is a sign of the Bön religion, of black magic. Stupas and chörtens must therefore be circumambulated clockwise. The leftward-spinning eddies spin into the unconscious; the rightward-spinning ones spin out of the unconscious chaos. The rightward-moving swastika in Tibet is therefore a Buddhist emblem.⁹³ (Cf. also [Fig. 4.](#))

[565] For our patient the process appeared to mean, first and foremost, a differentiation of consciousness. From the treasures of her psychological knowledge she interpreted the four as the four orienting functions of consciousness: thinking, feeling, sensation, intuition. She noticed, however, that the four were all alike, whereas the four functions are all unlike. This raised no question for her, but it did for me. What are these four if they are *not* the four functional aspects of consciousness? I doubted whether this could be a sufficient interpretation of them. They seemed to be much more than that, and that is probably the reason why they are not different but identical. They do not form four functions, different by definition, but they might well represent the *a priori* possibility for the formation of the four functions. In this picture we have the quaternity, the archetypal 4, which is capable of numerous interpretations, as history shows and as I have demonstrated elsewhere. It illustrates

the coming to consciousness of an unconscious content; hence it frequently occurs in cosmogonic myths. What is the precise significance of the fact that the four eddies are apparently turning to the left, when the division of the mandala into four denotes a process of becoming conscious, is a point about which I would rather not speculate. I lack the necessary material. Blue means air or pneuma, and the leftward movement an intensification of the unconscious influence. Possibly this should be taken as a pneumatic compensation for the strongly emphasized red colour, which signifies affectivity.

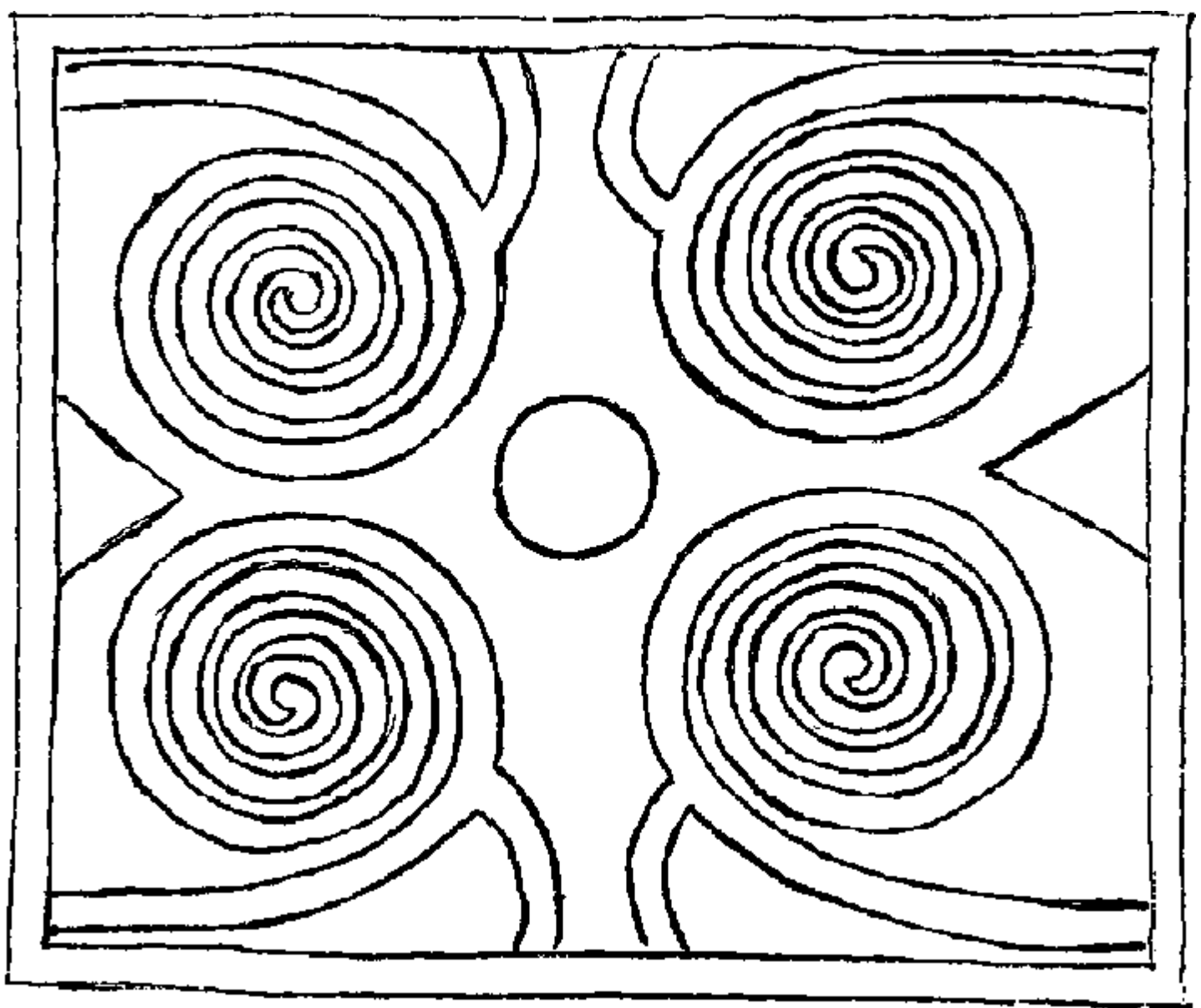

Fig. 4. Neolithic relief from Tarxien, Malta

The spirals represent vine tendrils.

[566] The mandala itself is bright red, but the four eddies have in the main a cool, greenish-blue colour, which the patient associated with “water.” This might hang together with the leftward movement, since water is a favourite symbol for the unconscious.⁹⁴ The green of the circle in the middle signifies life in the chthonic sense. It is the “*benedicta viriditas*” of the alchemists.

[567] The problematical thing about this picture is the fact that the black snake is outside the totality of the symbolic circle. In order to make the totality actual, it ought really to be inside. But if we remember the unfavourable significance of the snake, we shall understand why its assimilation into the symbol of psychic wholeness presents certain difficulties. If our conjecture about the leftward movement of the four eddies is correct, this would denote a trend towards the deep and dark side of the spirit,⁹⁵ by means of which the black snake could be assimilated. The snake, like the

devil in Christian theology, represents the shadow, and one which goes far beyond anything personal and could therefore best be compared with a principle, such as the principle of evil.⁹⁶ It is the colossal shadow thrown by man, of which our age had to have such a devastating experience. It is no easy matter to fit this shadow into our cosmos. The view that we can simply turn our back on evil and in this way eschew it belongs to the long list of antiquated naïveties. This is sheer ostrich policy and does not affect the reality of evil in the slightest. Evil is the necessary opposite of good, without which there would be no good either. It is impossible even to think evil out of existence. Hence the fact that the black snake remains outside expresses the critical position of evil in our traditional view of the world.⁹⁷

[568] The background of the picture is pale, the colour of parchment. I mention this fact in particular, as the pictures that follow show a characteristic change in this respect.

Picture 6

[569] The background of Picture 6 is a cloudy grey. The mandala itself is done in the vividest colours, bright red, green, and blue. Only where the red outer membrane enters the blue-green nucleus does the red deepen to blood colour and the pale blue to a dark ultramarine. The wings of Mercury, missing in the previous picture, reappear here at the neck of the blood-red pistons (as previously on the neck of the black snake in Picture 4). But the most striking thing is the appearance of a swastika, undoubtedly wheeling to the right. (I should add that these pictures were painted in 1928 and had no direct connection with contemporary fantasies, which at that time were still unknown to the world at large.) Because of its green colour, the swastika suggests something plantlike, but at the same time it has the wavelike character of the four eddies in the previous picture.

[570] In this mandala an attempt is made to unite the opposites red and blue, outside and inside. Simultaneously, the rightward movement aims at bringing about an ascent into the light of consciousness, presumably because the background has become noticeably darker. The black snake has disappeared, but has begun to impart its darkness to the entire background. To compensate this, there is in the mandala an upwards movement towards the light, apparently an attempt to rescue consciousness from the darkening of the environment. The picture was associated with a dream that occurred a few days before. Miss X dreamt that *she returned to the city after a holiday in the country. To her astonishment she found a tree growing in the middle of the room where she worked. She thought: "Well, with its thick bark this tree can withstand the heat of an apartment."* Associations to the tree led to its maternal significance. The tree would explain the plant motif in the mandala, and its sudden growth represents the higher level or freeing of consciousness induced by the

movement to the right. For the same reason the “philosophical” tree is a symbol of the alchemical *opus*, which as we know is an individuation process.

[571] We find similar ideas in Justin’s gnosis. The angel Baruch stands for the pneuma of Elohim, and the “motherly” angel Naas for the craftiness of Edem. But both angels, as I have said, were also trees: Baruch the tree of life, Naas the tree of knowledge. Their division and polarity are in keeping with the spirit of the times (second-third centuries A.D.). But in those days, too, they knew of an individuation process, as we can see from Hippolytus.⁹⁸ Elohim, we are told, set the “prophet” Heracles the task of delivering the “Father” (the pneuma) from the power of the twelve wicked angels. This resulted in his twelve labours. Now the Heracles myth has in fact all the characteristic features of an individuation process: the journeys to the four directions,⁹⁹ four sons, submission to the feminine principle (Omphale) that symbolizes the unconscious, and the self-sacrifice and rebirth caused by Deianeira’s robe.

[572] The “thick bark” of the tree suggests the motif of protection, which appears in the mandala as the “formation of skins” (see par. 576). This is expressed in the motif of the protective black bird’s wings, which shield the contents of the mandala from outside influences. The piston-shaped prolongations of the peripheral red substance are phallic symbols, indicating the entry of affectivity into the pneumatic interior. They are obviously meant to activate and enrich the spirit dwelling within. This “spirit” has of course nothing to do with intellect, rather with something that we would have to call spiritual substance (pneuma) or—in modern terms—“spiritual life.” The underlying symbolical thought is no doubt the same as the view developed in the Clementine Homilies, that *πνεῦμα* (spirit) and *σῶμα* (body) are one in God.¹⁰⁰ The mandala, though only a symbol of the self as the psychic totality, is at the same time a God-image, for the central point, circle, and quaternity are well-known symbols for the deity. The impossibility of distinguishing empirically between “self” and “God” leads, in Indian theosophy, to the identity of the personal and supra-personal Purusha-Atman. In ecclesiastical as in alchemical literature the saying is often quoted: “God is an infinite circle (or sphere) whose centre is everywhere and the circumference nowhere.”¹⁰¹ This idea can be found in full development as early as Parmenides. I will cite the passage, because it alludes to the same motifs that underlie our mandala: “For the narrower rings¹⁰² were filled with unmixed Fire, and those next to them with Night, but between these rushes the portion of Flame. And in the centre of these is the goddess¹⁰³ who guides everything; for throughout she rules over cruel Birth and Mating, sending the female to mate with the male, and conversely again the male with the female.”¹⁰⁴

[573] The learned Jesuit, Nicholas Caussin, apropos the report in Clement of Alexandria that, on certain occasions, wheels were rolled round in the Egyptian temples,¹⁰⁵ comments that Democritus of Abdera called God *νοῦν ἐν πυρὶ σφαιροειδεῖ*¹⁰⁶ (*mentem in igne orbiculari*, ‘mind in the spherical fire’). He goes on: “This was the view also of Parmenides, who defined God as *σφάραν*, ‘crown,’ a circle consisting of glowing light.¹⁰⁷ And it has been very clearly established by Iamblichus, in his book on the mysteries, that the Egyptians customarily represent God, the Lord of the world, as sitting in the lotus, a water-plant, the fruits as well as the leaves of which are round,¹⁰⁸ thereby indicating the circular motion of the mind, which everywhere returns into itself.” This is also the origin, he says, of the ritual transformations or circuits (“circuitiones”) that imitate the motion of the heavens. But the Stoics named the heavens a “round and revolving God” (*rotundum et volubilem Deum*). Caussin says it is to this that the “mystical” (*mystice* = symbolical) explanation of Psalm 12 : 8 refers: “In circuitu impii ambulant” (the ungodly wander in a circle);¹⁰⁹ they only walk round the periphery without ever reaching the centre, which is God. Here I would mention the wheel motif in mandala symbolism only in passing, as I have dealt with it in detail elsewhere.¹¹⁰

Picture 7

[574] In Picture 7 it has indeed turned to night: the entire sheet which the mandala is painted on is black. All the light is concentrated in the sphere. The colours have lost their brightness but have gained in intensity. It is especially striking that the black has penetrated as far as the centre, so that something of what we feared has already occurred: the blackness of the snake and of the sombre surroundings has been assimilated by the nucleus and, at the same time, as the picture shows, is compensated by a golden light radiating out from the centre. The rays form an equal-armed cross, to replace the swastika of the previous picture, which is here represented only by four hooks suggesting a rightwards rotation. With the attainment of absolute blackness, and particularly its presence in the centre, the upward movement and rightward rotation seem to have come to an end. On the other hand, the wings of Mercury have undergone a noticeable differentiation, which presumably means that the sphere has sufficient power to keep itself afloat and not sink down into total darkness. The golden rays forming the cross bind the four together.¹¹¹ This produces an inner bond and consolidation as a defence against destructive influences¹¹² emanating from the black substance that has penetrated to the centre. For us the cross symbol always has the connotation of *suffering*, so we are probably not wrong in assuming that the mood of this picture is one of more or less painful *suspension*—remember the wings!—over the dark abyss of inner loneliness.

[575] Earlier, I mentioned Böhme's lightning that "makes a cross," and I brought this cross into connection with the four elements. As a matter of fact, John Dee symbolizes the elements by an equal-armed cross.¹¹³ As we said, the cross with a little circle in it is the alchemical sign for copper (*cuprum*, from Kypris, Aphrodite), and the sign for Venus is ♀. Remarkably enough, ♀ is the old apothecary's sign for *spiritus Tartari* (tartaric acid), which, literally translated, means 'spirit of the underworld.' ⚗ is also the sign for red hematite (bloodstone). Hence there seems to be not only a cross that comes from above, as in Böhme's case and in our mandala, but also one that comes from below. In other words, the lightning—to keep to Böhme's image—can come from below out of the blood, from Venus or from Tartarus. Böhme's neutral "Salniter" is identical with salt in general, and one of the signs for this is ⚗. One can hardly imagine a better sign for the arcane substance, which salt was considered to be by the sixteenth- and seventeenth-century alchemists. Salt, in ecclesiastical as well as alchemical usage, is the symbol for Sapientia and also for the distinguished or elect *personality*, as in Matthew 5 : 13: "Ye are the salt of the earth."

[576] The numerous wavy lines or layers in the mandala could be interpreted as representing the formation of *layers of skin*, giving protection against outside influences. They serve the same purpose as the inner consolidation. These cortices probably have something to do with the dream of the tree in the workroom, which had a "thick bark." The formation of skins is also found in other mandalas, and it denotes a hardening or sealing off against the outside, the production of a regular rind or "hide." It is possible that this phenomenon would account for the cortices or *putamina* ('shards') mentioned in the cabala.¹¹⁴ "For such is the name for that which abides outside holiness," such as the seven fallen kings and the four Achurayim.¹¹⁵ From them come the "kliploth" or cortices. As in alchemy, these are the scoriae or slag, to which adheres the quality of plurality and of death. In our mandala the cortices are boundary lines marking off the inner unity and protecting it against the outer blackness with its disintegrating influences, personified by the snake.¹¹⁶ The same motif is expressed by the petals of the lotus and by the skins of the onion: the outer layers are withered and desiccated, but they protect the softer, inner layers. The lotus seat of the Horus-child, of the Indian divinities, and of the Buddha must be understood in this sense. Hölderlin makes use of the same image:

Fateless, like the sleeping

Infant, breathe the heavenly ones,

Chastely guarded

In modest bud; their spirits

- [577] In Christian metaphor, Mary is the flower in which God lies hidden; or again, the rose window in which the *rex gloriae* and judge of the world is enthroned.
- [578] The idea of circular layers is to be found, by implication, in Böhme, for the outermost ring of his three-dimensional mandala¹¹⁸ is labelled “will of ye Devill Lucifer,” “Abyesse (of) Eternity,” “Abyss of ye Darkness,” “Hell of Devills,” etc. (See Fig. 1.) Böhme says of this in his *Aurora* (ch. XVII, sec. 6): “Behold, when Lucifer with his hosts aroused the Wrath-fire in God’s nature, so that God waxed wroth in Nature in the place of Lucifer, the outermost Birth in Nature acquired another Quality, wholly wrathful, dry, cold, vehement, bitter, and sour. The raging Spirit, that before had a subtle, gentle Quality in Nature, became in his outermost Birth wholly presumptuous and terrible, and now in his outermost Birth is called the Wind, or the element Air.” In this way the four elements arose—the earth, in particular, by a process of contraction and desiccation.
- [579] Cabalistic influences may be conjectured here, though Böhme knew not much more about the Cabala than did Paracelsus. He regarded it as a species of magic. The four elements correspond to the four Achurayim.¹¹⁹ They constitute a sort of second quaternity, proceeding from the inner, pneumatic quaternity but of a physical nature. The alchemists, too, allude to the Achurayim. Mennens,¹²⁰ for instance, says: “And although the holy name of God reveals the Tetragrammaton or the Four Letters, yet if you should look at it aright, only three Letters are found in it. The letter *he* [n] is found twice, since they are the same, namely Air and Water, which signifies the Son; Earth the Father, and Fire the Holy Ghost. Thus the Four Letters of God’s name manifestly signify the Most Holy Trinity and Matter, which likewise is threefold (*triplex*)¹²¹ ... and which is also called the shadow of the same [i.e., of God], and is named by Moyses¹²² the back of God [*Dei posteriora*], which seems to be created out of it [matter].”¹²³ This statement bears out Böhme’s view.
- [580] To return to our mandala. The original four eddies have coalesced into the wavy squares in the middle of the picture. Their place is taken by golden points at the outer rim (developed from the previous picture), emitting rainbow colours. These are the colours of the *peacock’s eye*, which play a great role as the *cauda pavonis* in alchemy.¹²⁴ The appearance of these colours in the *opus* represents an intermediate stage preceding the definitive end result. Böhme speaks of a “love-desire or a Beauty of Colours; and here all Colours arise.”¹²⁵ In our mandala, too, the rainbow colours spring from the red layer that means affectivity. Of the “life of Nature and Spirit” that is united in the “spherical wheel”¹²⁶ Böhme says: “Thus is made known to us an eternal Essence of Nature, like to Water and Fire, which stand as it were mixed into one another. For there comes a *bright-blue* colour, like the *Lightning* of the Fire; and

then it has a form like a *Ruby*¹²⁷ mingled with Crystals into one Essence, or like *yellow, white, red, and blue* mingled in *dark Water*: for it is like blue in green, since each still has its brightness and shines, and the Water only resists their Fire, so that there is no wasting anywhere, but one eternal Essence in two Mysteries mingled together, notwithstanding the difference of two Principles, viz. two kinds of life.” The phenomenon of the colours owes its existence to the “Imagination of the great Mystery, where a wondrous essential Life is born.”¹²⁸

[581] It is abundantly clear from this that Böhme was preoccupied with the same psychic phenomenon that fascinated Miss X—and many other patients too. Although Böhme took the idea of the *cauda pavonis* and the tetrameria from alchemy,¹²⁹ he, like the alchemists, was working on an empirical basis which has since been rediscovered by modern psychology. There are products of active imagination, and also dreams, which reproduce the same patterns and arrangements with a spontaneity that cannot be influenced. A good example is the following dream: A patient dreamt that *she was in a drawing-room. There was a table with three chairs beside it. An unknown man standing beside her invited her to sit down. For this purpose she fetched a fourth chair that stood further off. She then sat at the table and began turning over the pages of a book, containing pictures of blue and red cubes, as for a building game. Suddenly it occurred to her that she had something else to attend to. She left the room and went to a yellow house. It was raining in torrents, and she sought shelter under a green laurel tree.*

[582] The table, the three chairs, the invitation to sit down, the other chair that had to be fetched to make four chairs, the cubes, and the building game all suggest a process of *composition*. This takes place in stages: a combination first of blue and red, then of yellow and green. These four colours symbolize four qualities, as we have seen, which can be interpreted in various ways. Psychologically this quaternity points to the orienting functions of consciousness, of which at least one is unconscious and therefore not available for conscious use. Here it would be the green, the sensation function,¹³⁰ because the patient’s relation to the real world was uncommonly complicated and clumsy. The “inferior” function, however, just because of its unconsciousness, has the great advantage of being contaminated with the collective unconscious and can be used as a bridge to span the gulf between conscious and unconscious and thus restore the vital connection with the latter. This is the deeper reason why the dream represents the inferior function as a laurel. The laurel in this dream has the same connection with the processes of inner growth as the tree that Miss X dreamt grew in her room. It is essentially the same tree as the *arbor philosophica* of the alchemists, about which I have written in *Psychology and Alchemy*.¹³¹ We should also remember that, according to tradition, the laurel is not injured either by lightning or by cold—“*intacta triumphat.*” Hence it symbolized the

Virgin Mary,¹³² the model for all women, just as Christ is the model for men. In view of its historical interpretation the laurel, like the alchemical tree, should be taken in this context as a symbol of the self.¹³³ The ingenuousness of patients who produce such dreams is always very impressive.

[583] To turn back again to our mandala. The golden lines that end in pistons recapitulate the spermatozoon motif and therefore have a spermatic significance, suggesting that the quaternity will be reproduced in a new and more distinct form. In so far as the quaternity has to do with conscious realization, we can infer from these symptoms an intensification of the latter, as is also suggested by the golden light radiating from the centre. Probably a kind of inner illumination is meant.

[584] Two days before painting this picture, Miss X dreamt that *she was in her father's room in their country house. "But my mother had moved my bed away from the wall into the middle of the room and had slept in it. I was furious, and moved the bed back to its former place. In the dream the bed-cover was red—exactly the red reproduced in the picture."*

[585] The mother significance of the tree in her previous dream has here been taken up by the unconscious: this time the mother has slept in the middle of the room. This seems to be for Miss X an annoying intrusion into her sphere, symbolized by the room of her father, who has an animus significance for her. Her sphere is therefore a spiritual one, and she has usurped it just as she usurped her father's room. She has thus identified with the "spirit." Into this sphere her mother has intruded and installed herself in the centre, at first under the symbol of the tree. She therefore stands for physis opposed to spirit, i.e., for the natural feminine being which the dreamer also is, but which she would not accept because it appeared to her as a black snake. Although she remedied the intrusion at once, the dark chthonic principle, the black substance, has nevertheless penetrated to the centre of her mandala, as Picture 7 shows. But just because of this the golden light can appear: "e tenebris lux!" We have to relate the mother to Böhme's idea of the matrix. For him the matrix is the *sine qua non* of all differentiation or realization, without which the spirit remains suspended and never comes down to earth. The collision between the paternal and the maternal principle (spirit and nature) works like a shock.

[586] After this picture, she felt the renewed penetration of the red colour, which she associated with feeling, as something disturbing, and she now discovered that her "rapport" with me, her analyst (= father), was unnatural and unsatisfactory. She was giving herself airs, she said, and was posing as an intelligent, understanding pupil (usurpation of spirituality!). But she had to admit that she felt very silly and was very silly, regardless of what I thought about it. This admission brought her a feeling of great relief and helped her to see at last that sex was "not, on the one hand, merely a

mechanism for producing children and not, on the other, only an expression of supreme passion, but was also banally physiological and autoerotic.” This belated realization led her straight into a fantasy state where she became conscious of a series of obscene images. At the end she saw the image of a large bird, which she called the “earth bird,” and which alighted on the earth. Birds, as aerial beings, are well-known spirit symbols. It represented the transformation of the “spiritual” image of herself into a more earthy version that is more characteristic of women. This “tailpiece” confirms our suspicion that the intensive upward and rightward movement has come to a halt: the bird is coming down to earth. This symbolization denotes a further and necessary differentiation of what Böhme describes in general as “Love-desire.” Through this differentiation consciousness is not only widened but also brought face to face with the reality of things, so that the inner experience is tied, so to speak, to a definite spot.

[587] On the days following, the patient was overcome by feelings of self-pity. It became clear to her how much she regretted never having had any children. She felt like a neglected animal or a lost child. This mood grew into a regular *Weltschmerz*, and she felt like the “all-compassionate Tathagata” (Buddha). Only when she had completely given way to these feelings could she bring herself to paint another picture. Real liberation comes not from glossing over or repressing painful states of feeling, but only from experiencing them to the full.

Picture 8

[588] The thing that strikes us at once in Picture 8 is that almost the whole interior is filled with the black substance. The blue-green of the water has condensed to a dark blue quaternity, and the golden light in the centre turns in the reverse direction, anti-clockwise: the bird is coming down to earth. That is, the mandala is moving towards the dark, chthonic depths. It is still floating—the wings of Mercury show this—but it has come much closer to the blackness. The inner, undifferentiated quaternity is balanced by an outer, differentiated one, which Miss X equated with the four functions of consciousness. To these she assigned the following colours: yellow = intuition, light blue = thinking, flesh pink = feeling, brown = sensation.¹³⁴ Each of these quarters is divided into three, thus producing the number 12 again. The separation and characterization of the two quaternities is worth noting. The outer quaternity of wings appears as a differentiated realization¹³⁵ of the undifferentiated inner one, which really represents the archetype. In the cabala this relationship corresponds to the quaternity of Merkabah¹³⁶ on the one hand and of the Achurayim on the other, and in Böhme they are the four Spirits of God¹³⁷ and the four elements.

[589] The plantlike form of the cross in the middle of the mandala, also noted by the patient, refers back to the tree (“tree of the cross”) and the mother.¹³⁸ She thus makes it clear that this previously taboo element has been accepted and now holds the central place. She was fully conscious of this—which of course was a great advance on her previous attitude.

[590] In contrast to the previous picture there are no inner cortices. This is a logical development, because the thing they were meant to exclude is now in the centre, and defence has become superfluous. Instead, the cortices spread out into the darkness as golden rings, expanding concentrically like waves. This would mean a far-reaching influence on the environment emanating from the sealed-off self.

[591] Four days before she painted this mandala she had the following dream: *“I drew a young man to the window and, with a brush dipped in white oil, removed a black fleck from the cornea of his eye. A little golden lamp then became visible in the centre of the pupil. The young man felt greatly relieved, and I told him he should come again for treatment. I woke up saying the words: ‘If therefore thine eye be single, thy whole body shall be full of light.’”*S (Matthew 6 : 22.)

[592] This dream describes the change: the patient is no longer identical with her animus. The animus has, so to speak, become *her* patient, since he has eye trouble. As a matter of fact the animus usually sees things “cock-eyed” and often very unclearly. Here a black fleck on the cornea obscures the golden light shining from inside the eye. He has “seen things too blackly.” The eye is the prototype of the mandala, as is evident from Böhme, who calls his mandala “The Philosophique Globe, or Eye of ye Wonders of Eternity, or Looking-Glass of Wisdom.” He says: “The substance and Image of the Soul may be resembled to the Earth, having a fair Flower growing out of it, and also to the Fire and Light; as we see that Earth is a Centre, but no life; yet it is essential, and a fair flower grows out of it, which is not like Earth ... and yet the Earth is the Mother of the Flower.” The soul is a “fiery Eye, and similitude of the First Principle,” a “Centre of Nature.”¹³⁹

[593] Our mandala is indeed an “eye,” the structure of which symbolizes the centre of order in the unconscious. The eye is a hollow sphere, black inside, and filled with a semi-liquid substance, the vitreous humour. Looking at it from outside, one sees a round, coloured surface, the iris, with a dark centre, from which a golden light shines. Böhme calls it a “fiery eye,” in accordance with the old idea that seeing emanates from the eye. The eye may well stand for consciousness (which is in fact an organ of perception), looking into its own background. It sees its own light there, and when this is clear and pure the whole body is filled with light. Under certain conditions consciousness has a purifying effect. This is probably what is meant by Matthew 6 : 22ff., an idea expressed even more clearly in Luke 11: 33ff.

[594] The eye is also a well-known symbol for God. Hence Böhme calls his “Philosophique Globe” the “Eye of Eternity,” the “Essence of all Essences,” the “Eye of God.”¹⁴⁰

[595] By accepting the darkness, the patient has not, to be sure, changed it into light, but she has kindled a light that illuminates the darkness within. By day no light is needed, and if you don’t know it is night you won’t light one, nor will any light be lit for you unless you have suffered the horror of darkness. This is not an edifying text but a mere statement of the psychological facts. The transition from Picture 7 to Picture 8 gives one a working idea of what I mean by “accepting the dark principle.” It has sometimes been objected that nobody can form a clear conception of what this means, which is regrettable, because it is an ethical problem of the first order. Here, then, is a practical example of this “acceptance,” and I must leave it to the philosophers to puzzle out the ethical aspects of the process.¹⁴¹

Picture 9

[596] In Picture 9 we see for the first time the blue “soul-flower,” on a red background, also described as such by Miss X (naturally without knowledge of Böhme).¹⁴² In the centre is the golden light in the form of a lamp, as she herself stated. The cortices are very pronounced, but they consist of light (at least in the upper half of the mandala) and radiate outwards.¹⁴³ The light is composed of the rainbow hues of the rising sun; it is a real *cauda pavonis*. There are six sets of sunbeams. This recalls the Buddha’s Discourse on the Robe, from the Collection of the Pali Canon:

His heart overflowing with lovingkindness ... with compassion ... with joyfulness ... with equanimity, he abides, raying forth lovingkindness, compassion, joyfulness, equanimity, towards one quarter of space, then towards the second, then towards the third, then towards the fourth, and above and below, thus, all around. Everywhere, into all places the wide world over, his heart overflowing with compassion streams forth, wide, deep, illimitable, free from enmity, free from all ill-will....¹⁴⁴

[597] But a parallel with the Buddhist East cannot be carried through here, because the mandala is divided into an upper and a lower half.¹⁴⁵ Above, the rings shine many-hued as a rainbow; below, they consist of brown earth. Above, there hover three white birds (*pneumata* signifying the Trinity); below, a goat is rising up, accompanied by two ravens (Wotan’s birds)¹⁴⁶ and twining snakes. This is not the sort of picture a Buddhist holy man would make, but that of a Western person with a Christian background, whose light throws a dark shadow. What is more, the three birds float in a jet black sky, and the goat, rising out of dark clay, is shown against a field of bright orange. This, oddly enough, is the colour of the Buddhist monk’s robe, which was certainly not a conscious intention of the patient. The underlying thought

is clear: no white without black, and no holiness without the devil. Opposites are brothers, and the Oriental seeks to liberate himself from them by his *nirvanda* (“free from the two”) and his *neti neti* (“not this, not that”), or else he puts up with them in some mysterious fashion, as in Taoism. The connection with the East is deliberately stressed by the patient, through her painting into the mandala four hexagrams from the *I Ching*.¹⁴⁷

[598] The sign in the left top half is “Yü, ENTHUSIASM” (NO. 16). It means “Thunder comes resounding out of the earth,” i.e., a movement coming from the unconscious, and expressed by music and dancing. Confucius comments as follows:

Firm as a rock, what need of a whole day?

The judgment can be known.

The superior man knows what is hidden and what is evident.

He knows weakness, he knows strength as well.

Hence the myriads look up to him.

Enthusiasm can be the source of beauty, but it can also delude.

[599] The second hexagram at the top is “Sun, DECREASE” (NO. 41). The upper trigram means Mountain, the lower trigram means Lake. The mountain towers above the lake and “restrains” it. That is the “image” whose interpretation points to self-restraint and reserve, i.e., a seeming decrease of oneself. This is significant in the light of “ENTHUSIASM.” In the top line of the hexagram, “But [one] no longer has a separate home,” the homelessness of the Buddhist monk is meant. On the psychological level this does not, of course, refer to so drastic a demonstration of renunciation and independence, but to the patient’s irreversible insight into the conditioned quality of all relationships, into the relativity of all values, and the transience of all things.

[600] The sign in the bottom half to the right is “Sheng, PUSHING UPWARD” (No. 46). “Within the earth, wood grows: The image of Pushing Upward.” It also says: “One pushes upward into an empty city,” and “The king offers him Mount Ch’i.” So this hexagram means growth and development of the personality, like a plant pushing out of the earth—a theme already anticipated by the plant motif in an earlier mandala. This is an allusion to the important lesson which Miss X has learnt from her experience: that there is no development unless the shadow is accepted.

[601] The hexagram to the left is “Ting, THE CAULDRON” (No. 50). This is a bronze sacrificial vessel equipped with handles and legs, which held the cooked viands used for festive occasions. The lower trigram means Wind and Wood, the upper one Fire. The “Cauldron” is thus made up of “fire over wood,” just as the alchemical vessel consists of fire or water.¹⁴⁸ There is “delicious food” in it (the “fat of the pheasant”),

but it is not eaten because “the handle of the *ting* is altered” and its “legs are broken,” making it unusable. But, as a result of “constant self-abnegation,” the personality becomes differentiated (“the *ting* has golden carrying rings” and even “rings of jade”) and purified, until it acquires the “hardness and soft lustre” of precious jade.¹⁴⁹

[602] Though the four hexagrams were put into the mandala on purpose, they are authentic results of preoccupation with the *I Ching*. The phases and aspects of my patient’s inner process of development can therefore express themselves easily in the language of the *I Ching*, because it too is based on the psychology of the individuation process that forms one of the main interests of Taoism and of Zen Buddhism.¹⁵⁰ Miss X’s interest in Eastern philosophy was due to the deep impression which a better knowledge of her life and of herself had made upon her—an impression of the tremendous contradictions in human nature. The insoluble conflict she was faced with makes her preoccupation with Eastern therapeutic systems, which seem to get along without conflict, doubly interesting. It may be partly due to this acquaintance with the East that the opposites, irreconcilable in Christianity, were not blurred or glossed over, but were seen in all their sharpness, and in spite (or perhaps just because) of this, were brought together into the unity of the mandala. Böhme was never able to achieve this union; on the contrary, in his mandala the bright and dark semi-circles are turned back to back. The bright half is labelled “H. Ghost,” the dark half “Father,” i.e., *auctor rerum*¹⁵¹ or “First Principle,” whereas the Holy Ghost is the “Second Principle.” This polarity is crossed by the paired opposites “Sonne” and “Earthly Man.” The “Devils” are all on the side of the dark “Father” and constitute his “Wrath-fire,” just as on the periphery of the mandala.

[603] Böhme’s starting-point was philosophical alchemy, and to my knowledge he was the first to try to organize the Christian cosmos, as a total reality, into a mandala.¹⁵² The attempt failed, inasmuch as he was unable to unite the two halves in a circle. Miss X’s mandala, on the other hand, comprises and contains the opposites, as a result, we may suppose, of the support afforded by the Chinese doctrine of Yang and Yin, the two metaphysical principles whose co-operation makes the world go round. The hexagrams, with their firm (yang) and yielding (yin) lines, illustrate certain phases of this process. It is therefore right that they should occupy a mediating position between above and below. Lao-tzu says: “High stands on low.” This indisputable truth is secretly suggested in the mandala: the three white birds hover in a black field, but the grey-black goat has a bright orange-coloured background. Thus the Oriental truth insinuates itself and makes possible—at least by symbolic anticipation—a union of opposites within the irrational life process formulated by the *I Ching*. That we are really concerned here with opposite phases of one and the same process is shown by the picture that now follows.

[604] In Picture 10, begun in Zurich but only completed when Miss X again visited her motherland, we find the same division as before into above and below. The “soul-flower”¹⁵³ in the centre is the same, but it is surrounded on all sides by a dark blue night sky, in which we see the four phases of the moon, the new moon coinciding with the world of darkness below. The three birds have become two. Their plumage has darkened, but on the other hand the goat has turned into two semi-human creatures with horns and light faces, and only two of the four snakes remain. A notable innovation is the appearance of two *crabs* in the lower, chthonic hemisphere that also represents the body. The crab has essentially the same meaning as the astrological sign Cancer.¹⁵⁴ Unfortunately Miss X gave no context here. In such cases it is usually worth investigating what use has been made in the past of the object in question. In earlier, prescientific ages hardly any distinction was drawn between longtailed crabs (*Macrura*, crayfish) and short-tailed crabs (*Brachyura*). As a zodiacal sign Cancer signifies *resurrection*, because the crab sheds its shell.¹⁵⁵ The ancients had in mind chiefly *Pagurus bernhardus*, the hermit crab. It hides in its shell and cannot be attacked. Therefore it signifies *caution* and *foresight, knowledge of coming events*¹⁵⁶. It “depends on the moon, and waxes with it.”¹⁵⁷ It is worth noting that the crab appears just in the mandala in which we see the phases of the moon for the first time. Astrologically, Cancer is the house of the moon. Because of its backwards and sideways movement, it plays the role of an unlucky animal in superstition and colloquial speech (“crabbed,” “catch a crab,” etc.). Since ancient times cancer (*καρκίνοῦ*) has been the name for a malignant tumour of the glands. Cancer is the zodiacal sign in which the sun begins to retreat, when the days grow shorter. Pseudo-Kallisthenes relates that crabs dragged Alexander’s ships down into the sea.¹⁵⁸ “Karkinos” was the name of the crab that bit Heracles in the foot in his fight with the Lernaean monster. In gratitude, Hera set her accomplice among the stars.¹⁵⁹

[605] In astrology, Cancer is a feminine and watery sign,¹⁶⁰ and the summer solstice takes place in it. In the *melothesia*¹⁶¹ it is correlated with the *breast*. It rules over the *Western sea*. In Propertius it makes a sinister appearance: “Octipedis Cancrī terga sinistra time” (Fear thou the ill-omened back of the eight-footed crab).¹⁶² De Gubernatis says: “The crab ... causes now the death of the solar hero and now that of the monster.”¹⁶³ The *Panchatantra* (V, 2) relates how a crab, which the mother gave to her son as apotropaic magic, saved his life by killing a black snake.¹⁶⁴ As De Gubernatis thinks, the crab stands now for the sun and now for the moon,¹⁶⁵ according to whether it goes forwards or backwards.

[606] Miss X was born in the first degrees of Cancer (actually about 3°). She knew her horoscope and was well aware of the significance of the moment of birth; that is, she realized that the degree of the rising sign (the ascendent) conditions the individuality of the horoscope. Since she obviously guessed the horoscope's affinity with the mandala, she introduced her individual sign into the painting that was meant to express her psychic self.¹⁶⁶

[607] The essential conclusion to be drawn from Picture 10 is that the dualities which run through it are always inwardly balanced, so that they lose their sharpness and incompatibility. As Multatuli says: "Nothing is quite true, and even that is not quite true." But this loss of strength is counterbalanced by the unity of the centre, where the lamp shines, sending out coloured rays to the eight points of the compass.¹⁶⁷

[608] Although the attainment of inner balance through symmetrical pairs of opposites was probably the main intention of this mandala, we should not overlook the fact that the *duplication motif* also occurs when unconscious contents are about to become conscious and differentiated. They then split, as often happens in dreams, into two identical or slightly different halves corresponding to the conscious and still unconscious aspects of the nascent content. I have the impression, from this picture, that it really does represent a kind of solstice or climax, where decision and division take place. The dualities are, at bottom, Yes and No, the irreconcilable opposites, but they *have* to be held together if the balance of life is to be maintained. This can only be done by holding unswervingly to the centre, where action and suffering balance each other. It is a path "sharp as the edge of a razor." A climax like this, where universal opposites clash, is at the same time a moment when a wide perspective often opens out into the past and future. This is the psychological moment when, as the *consensus gentium* has established since ancient times, synchronistic phenomena occur—that is, when the far appears near: sixteen years later, Miss X became fatally ill with cancer of the breast.¹⁶⁸

Picture 11

[609] Here I will only mention that the coloured rays emanating from the centre have become so rarified that, in the next few pictures, they disappear altogether. Sun and moon are now outside, no longer included in the microcosm of the mandala. The sun is not golden, but has a dull, ochrous hue and in addition is clearly turning to the left: it is moving towards its own obscuration, as had to happen after the cancer picture (solstice). The moon is in the first quarter. The roundish masses near the sun are probably meant to be cumulus clouds, but with their grey-red hues they look suspiciously like bulbous swellings. The interior of the mandala now contains a quincunx of stars, the central star being silver and gold. The division of the mandala

into an aerial and an earthy hemisphere has transferred itself to the outside world and can no longer be seen in the interior. The silvery rim of the aerial hemisphere in the preceding picture now runs round the entire mandala and recalls the band of quicksilver that, as *Mercurius vulgaris*, “veils the true personality.” At all events, it is probable that the influence and importance of the outside world are becoming so strong in this picture as to bring about an impairment and devaluation of the mandala. It does not break down or burst (as can easily happen under similar circumstances), but is removed from the telluric influence through the symbolical constellation of stars and heavenly bodies.

Picture 12-24

[610] In Picture 12 the sun is in fact sinking below the horizon and the moon is coming out of the first quarter. The radiation of the mandala has ceased altogether, but the equivalents of sun and moon, and also of the earth, have been assimilated into it. A remarkable feature is its sudden inner animation by two human figures and various animals. The constellation character of the centre has vanished and given way to a kind of flower motif. What this animation means cannot be established, unfortunately, as we have no commentary.

[611] In Picture 13 the source of radiation is no longer in the mandala but outside, in the shape of the full moon, from which rings of rainbow-coloured light radiate in concentric circles. The mandala is laced together by four black and golden snakes, the heads of three of them pointing to the centre, while the fourth rears upwards. In between the snakes and the centre there are indications of the spermatozoon motif. This may mean an intensive penetration on the part of the outside world, but it could also mean magical protection. The breaking down of the quaternity into 3 plus 1 is in accord with the archetype.¹⁶⁹

[612] In Picture 14 the mandala is suspended over the lit-up ravine of Fifth Avenue, New York, whither Miss X in the meantime returned. On the blue flower in the centre the *coniunctio* of the “royal” pair is represented by the sacrificial fire burning between them. The King and Queen are assisted by two kneeling figures of a man and a woman. It is a typical marriage quaternio, and for an understanding of its psychology I must refer the reader to my account in the “Psychology of the Transference.”¹⁷⁰ This inner bond should be thought of as a compensatory “consolidation” against disintegrating influences from without.

[613] In Picture 15 the mandala floats between Manhattan and the sea. It is daylight again, and the sun is just rising. Out of the blue centre blue snakes penetrate into the red flesh of the mandala: the enantiodynamia is setting in, after the introversion of

feeling caused by the shock of New York had passed its climax. The blue colour of the snakes indicates that they have acquired a pneumatic nature.

[614] From Picture 16 onwards, the drawing and painting technique shows a decided improvement. The mandalas gain in aesthetic value. In Picture 17 a kind of *eye motif* appears, which I have also observed in the mandalas of other persons. It seems to me to link up with the motif of *polyophtalmia* and to point to the peculiar nature of the unconscious, which can be regarded as a “multiple consciousness.” I have discussed this question in detail elsewhere.¹⁷¹ (See also [Fig. 5.](#))



Fig. 5. Mandala by a woman patient

Aged 58, artistic and technically accomplished. In the centre is the egg encircled by the snake; outside, apotropaic wings and eyes. The mandala is exceptional in that it has a pentadic structure. (The patient also produced triadic mandalas. She was fond of playing with forms irrespective of their meaning—a consequence of her artistic gift.)

[615] The enantiodromia only reached its climax the following year, in Picture 19.¹⁷² In that picture the red substance is arranged round the golden, four-rayed star in the centre, and the blue substance is pushing everywhere to the periphery. Here the rainbow-coloured radiation of the mandala begins again for the first time, and from then on was maintained for over ten years (in mandalas not reproduced here).

[616] I will not comment on the subsequent pictures, nor reproduce them all—as I say, they extend over more than ten years—because I feel I do not understand them properly. In addition, they came into my hands only recently, after the death of the

patient, and unfortunately without text or commentary. Under these circumstances the work of interpretation becomes very uncertain, and is better left unattempted. Also, this case was meant only as an example of how such pictures come to be produced, what they mean, and what reflections and observations their interpretation requires. It is not intended to demonstrate how an entire lifetime expresses itself in symbolic form. The individuation process has many stages and is subject to many vicissitudes, as the fictive course of the *opus alchymicum* amply shows.

Conclusion

[617] Our series of pictures illustrates the initial stages of the way of individuation. It would be desirable to know what happens afterwards. But, just as neither the philosophical gold nor the philosophers' stone was ever made in reality, so nobody has ever been able to tell the story of the whole way, at least not to mortal ears, for it is not the story-teller but death who speaks the final "consummatum est." Certainly there are many things worth knowing in the later stages of the process, but, from the point of view of teaching as well as of therapy, it is important not to skip too quickly over the initial stages. As these pictures are intuitive anticipations of future developments, it is worth while lingering over them for a long time, in order, with their help, to integrate so many contents of the unconscious into consciousness that the latter really does reach the stage it sees ahead. These psychic evolutions do not as a rule keep pace with the tempo of intellectual developments. Indeed, their very first goal is to bring a consciousness that has hurried too far ahead into contact again with the unconscious background with which it should be connected. This was the problem in our case too. Miss X had to turn back to her "motherland" in order to find her earth again—*vestigia retro!* It is a task that today faces not only individuals but whole civilizations. What else is the meaning of the frightful regressions of our time? The tempo of the development of consciousness through science and technology was too rapid and left the unconscious, which could no longer keep up with it, far behind, thereby forcing it into a defensive position which expresses itself in a universal will to destruction. The political and social isms of our day preach every conceivable ideal, but, under this mask, they pursue the goal of lowering the level of our culture by restricting or altogether inhibiting the possibilities of individual development. They do this partly by creating a chaos controlled by terrorism, a primitive state of affairs that affords only the barest necessities of life and surpasses in horror the worst times of the so-called "Dark" Ages. It remains to be seen whether this experience of degradation and slavery will once more raise a cry for greater spiritual freedom.

[618] This problem cannot be solved collectively, because the masses are not changed unless the individual changes. At the same time, even the best-looking solution cannot be forced upon him, since it is a good solution only when it is combined with

a natural process of development. It is therefore a hopeless undertaking to stake everything on collective recipes and procedures. The bettering of a general ill begins with the individual, and then only when he makes himself and not others responsible. This is naturally only possible in freedom, but not under a rule of force, whether this be exercised by a self-elected tyrant or by one thrown up by the mob.

[619] The initial pictures in our series illustrate the characteristic psychic processes which set in the moment one gives a mind to that part of the personality which has remained behind, forgotten. Scarcely has the connection been established when symbols of the self appear, trying to convey a picture of the total personality. As a result of this development, the unsuspecting modern gets into paths trodden from time immemorial—the *via sancta*, whose milestones and signposts are the religions.¹⁷³ He will think and feel things that seem strange to him, not to say unpleasant. Apuleius relates that in the Isis mysteries he “approached the very gates of death and set one foot on Proserpina’s threshold, yet was permitted to return, rapt through all the elements. At midnight I saw the sun shining as if it were noon; I entered the presence of the gods of the underworld and the gods of the upper world, stood near and worshipped them.”¹⁷⁴ Such experiences are also expressed in our mandalas; that is why we find in religious literature the best parallels to the symbols and moods of the situations they formulate. These situations are intense inner experiences which can lead to lasting psychic growth and a ripening and deepening of the personality, if the individual affected by them has the moral capacity for πίστις, loyal trust and confidence. They are the age-old psychic experiences that underlie “faith” and ought to be its unshakable foundation—and not of faith alone, but also of knowledge.

[620] Our case shows with singular clarity the spontaneity of the psychic process and the transformation of a personal situation into the problem of individuation, that is, of becoming whole, which is the answer to the great question of our day: How can consciousness, our most recent acquisition, which has bounded ahead, be linked up again with the oldest, the unconscious, which has lagged behind? The oldest of all is the instinctual foundation. Anyone who overlooks the instincts will be ambuscaded by them, and anyone who does not humble himself will be humbled, losing at the same time his freedom, his most precious possession.

[621] Always when science tries to describe a “simple” life-process, the matter becomes complicated and difficult. So it is no wonder that the details of a transformation process rendered visible through active imagination make no small demands on our understanding. In this respect they may be compared with all other biological processes. These, too, require specialized knowledge to become comprehensible. Our example also shows, however, that this process can begin and

run its course without any special knowledge having to stand sponsor to it. But if one wants to understand anything of it and assimilate it into consciousness, then a certain amount of knowledge is needed. If the process is not understood at all, it has to build up an unusual intensity so as not to sink back again into the unconscious without result. But if its affects rise to an unusual pitch, they will enforce some kind of understanding. It depends on the correctness of this understanding whether the consequences turn out more pathologically or less. Psychic experiences, according to whether they are rightly or wrongly understood, have very different effects on a person's development. It is one of the duties of the psychotherapist to acquire such knowledge of these things as will enable him to help his patient to an adequate understanding. Experiences of this kind are not without their dangers, for they are also, among other things, the matrix of the psychoses. Stiffnecked and violent interpretations should under all circumstances be avoided, likewise a patient should never be forced into a development that does not come naturally and spontaneously. But once it has set in, he should not be talked out of it again, unless the possibility of a psychosis has been definitely established. Thorough psychiatric experience is needed to decide this question, and it must constantly be borne in mind that the constellation of archetypal images and fantasies is not in itself pathological. The pathological element only reveals itself in the way the individual reacts to them and how he interprets them. The characteristic feature of a pathological reaction is, above all, *identification with the archetype*. This produces a sort of inflation and possession by the emergent contents, so that they pour out in a torrent which no therapy can stop. Identification can, in favourable cases, sometimes pass off as a more or less harmless inflation. But in all cases identification with the unconscious brings a weakening of consciousness, and herein lies the danger. You do not "make" an identification, you do not "identify yourself," but you experience your identity with the archetype in an unconscious way and so are possessed by it. Hence in more difficult cases it is far more necessary to strengthen and consolidate the ego than to understand and assimilate the products of the unconscious. The decision must be left to the diagnostic and therapeutic tact of the analyst.

*

[622] This paper is a groping attempt to make the inner processes of the mandala more intelligible. They are, as it were, self-delineations of dimly sensed changes going on in the background, which are perceived by the "reversed eye" and rendered visible with pencil and brush, just as they are, uncomprehended and unknown. The pictures represent a kind of ideogram of unconscious contents. I have naturally used this method on myself too and can affirm that one can paint very complicated pictures without having the least idea of their real meaning. While painting them, the picture

seems to develop out of itself and often in opposition to one's conscious intentions. It is interesting to observe how the execution of the picture frequently thwarts one's expectations in the most surprising way. The same thing can be observed, sometimes even more clearly, when writing down the products of active imagination.¹⁷⁵

[623] The present work may also serve to fill a gap I myself have felt in my exposition of therapeutic methods. I have written very little on active imagination, but have talked about it a great deal. I have used this method since 1916, and I sketched it out for the first time in "The Relations between the Ego and the Unconscious." I first mentioned the mandala in 1929, in *The Secret of the Golden Flower*.¹⁷⁶ For at least thirteen years I kept quiet about the results of these methods in order to avoid any suggestion. I wanted to assure myself that these things—mandalas especially—really are produced spontaneously and were not suggested to the patient by my own fantasy. I was then able to convince myself, through my own studies, that mandalas were drawn, painted, carved in stone, and built, at all times and in all parts of the world, long before my patients discovered them. I have also seen to my satisfaction that mandalas are dreamt and drawn by patients who were being treated by psychotherapists whom I had not trained. In view of the importance and significance of the mandala symbol, special precautions seemed to be necessary, seeing that this motif is one of the best examples of the universal operation of an archetype. In a seminar on children's dreams, which I held in 1939–40,¹⁷⁷ I mentioned the dream of a ten-year-old girl who had absolutely no possibility of ever hearing about the quaternity of God. The dream was written down by the child herself and was sent to me by an acquaintance: "*Once in a dream I saw an animal that had lots of horns. It spiked up other little animals with them. It wriggled like a snake and that was how it lived. Then a blue fog came out of all the four corners, and it stopped eating. Then God came, but there were really four Gods in the four corners. Then the animal died, and all the animals it had eaten came out alive again.*"

[624] This dream describes an unconscious individuation process: all the animals are eaten by the one animal. Then comes the enantiodromia: the dragon changes into pneuma, which stands for a divine quaternity. Thereupon follows the apocatastasis, a resurrection of the dead. This exceedingly "unchildish" fantasy can hardly be termed anything but archetypal. Miss X, in Picture 12, also put a whole collection of animals into her mandala—two snakes, two tortoises, two fishes, two lions, two pigs, a goat and a ram.¹⁷⁸ Integration gathers many into one. To the child who had this dream, and to Miss X likewise, it was certainly not known that Origen had already said (speaking of the sacrificial animals): "Seek these sacrifices within thyself, and thou wilt find them within thine own soul. Understand that thou hast within thyself flocks of cattle ... flocks of sheep and flocks of goats. ... Understand that the birds of the sky are also within thee. Marvel not if we say that these are within thee, but understand that

thou thyself art even another little world, and hast within thee the sun and the moon, and also the stars.”¹⁷⁹

[625] The same idea occurs again in another passage, but this time it takes the form of a psychological statement: “For look upon the countenance of a man who is at one moment angry, at the next sad, a short while afterward joyful, then troubled again, and then contented. ... See how he who thinks himself one is not one, but seems to have as many personalities as he has moods, as also the Scripture says: A fool is changed as the moon. ...¹⁸⁰ God, therefore, is unchangeable, and is called one for the reason that he changes not. Thus also the true imitator of God, who is made after God’s image, is called one and the selfsame [*unus et ipse*] when he comes to perfection, for he also, when he is fixed on the summit of virtue, is not changed, but remains alway one. For every man, whiles he is in wickedness [*malitia*], is divided among many things and torn in many directions; and while he is in many kinds of evil he cannot be called one.”¹⁸¹

[626] Here the many animals are affective states to which man is prone. The individuation process, clearly alluded to in this passage, subordinates the many to the One. But the One is God, and that which corresponds to him in us is the *imago Dei*, the God-image. But the God-image, as we saw from Jakob Böhme, expresses itself in the mandala.

CONCERNING MANDALA SYMBOLISM¹

[627] In what follows I shall try to describe a special category of symbols, the *mandala*, with the help of a wide selection of pictures. I have dealt with this theme on several occasions before, and in *Psychology and Alchemy* I gave a detailed account, with running commentary, of the mandala symbols that came up in the course of an individual analysis. I repeated the attempt in the preceding paper of the present volume, but there the mandalas did not derive from dreams but from active imagination. In this paper I shall present mandalas of the most varied provenance, on the one hand to give the reader an impression of the astonishing wealth of forms produced by individual fantasy, and on the other hand to enable him to form some idea of the regular occurrence of the basic elements.

[628] As regards the interpretation, I must refer the reader to the literature. In this paper I shall content myself with hints, because a more detailed explanation would lead much too far, as the mandalas described in “Psychology and Religion” and in the preceding paper of this volume show.

[629] The Sanskrit word *mandala* means ‘circle.’ It is the Indian term for the circles drawn in religious rituals. In the great temple of Madura, in southern India, I saw how a picture of this kind was made. It was drawn by a woman on the floor of the *mandapam* (porch), in coloured chinks, and measured about ten feet across. A pandit who accompanied me said in reply to my questions that he could give me no information about it. Only the women who drew such pictures knew what they meant. The woman herself was non-committal; she evidently did not want to be disturbed in her work. Elaborate mandalas, executed in red chalk, can also be found on the whitewashed walls of many huts. The best and most significant mandalas are found in the sphere of Tibetan Buddhism.² I shall use as an example a Tibetan mandala, to which my attention was drawn by Richard Wilhelm.

Figure 1

[630] A mandala of this sort is known in ritual usage as a *yantra*, an instrument of contemplation. It is meant to aid concentration by narrowing down the psychic field of vision and restricting it to the centre. Usually the mandala contains three circles, painted in black or dark blue. They are meant to shut out the outside and hold the

inside together. Almost regularly the outer rim consists of fire, the fire of *concupiscentia*, 'desire,' from which proceed the torments of hell. The horrors of the burial ground are generally depicted on the outer rim. Inside this is a garland of lotus leaves, characterizing the whole mandala as a *padma*, 'lotus-flower.' Then comes a kind of monastery courtyard with four gates. It signifies sacred seclusion and concentration. Inside this courtyard there are as a rule the four basic colours, red, green, white, and yellow, which represent the four directions and also the psychic functions, as the Tibetan Book of the Dead³ shows. Then, usually marked off by another magic circle, comes the centre as the essential object or goal of contemplation.

[631] This centre is treated in very different ways, depending on the requirements of the ritual, the grade of initiation of the contemplator, and the sect he belongs to. As a rule it shows Shiva in his world-creating emanations. Shiva, according to Tantric doctrine, is the One Existent, the Timeless in its perfect state. Creation begins when this unextended point—known as *Shiva-bindu*—appears in the eternal embrace of its feminine side, the Shakti. It then emerges from the state of being-in-itself and attains the state of being-for-itself, if I may use the Hegelian terminology.



Figure 1

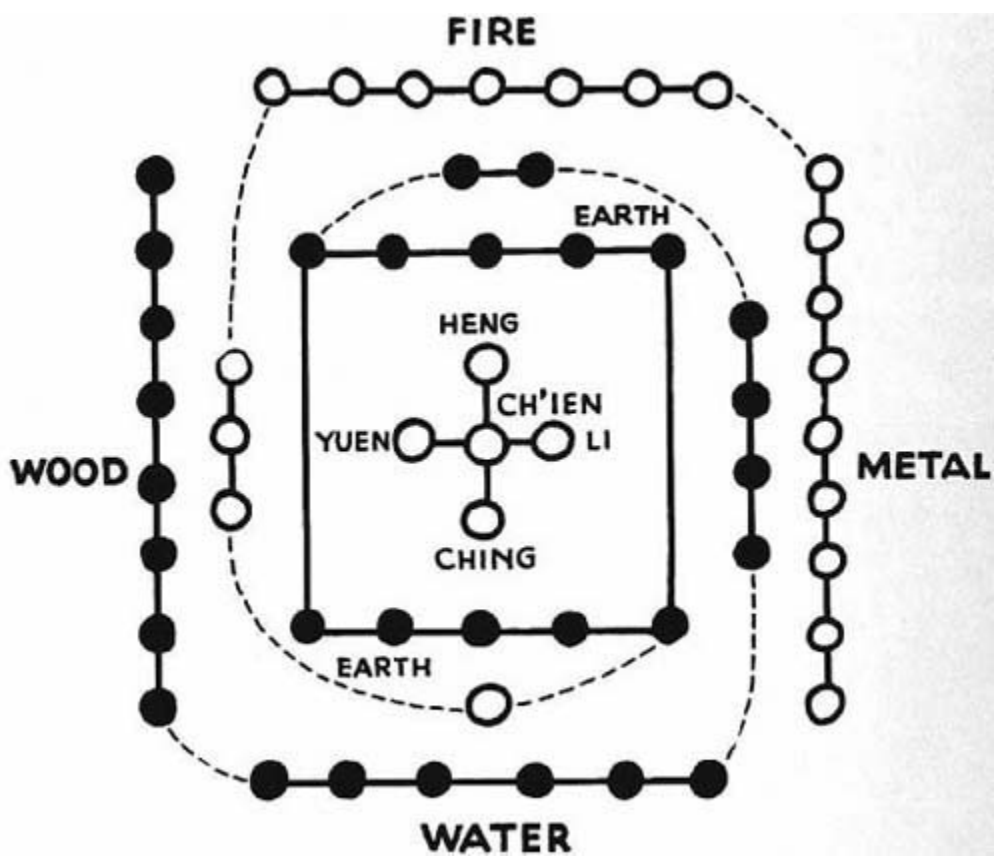

Figure 2



Figure 3

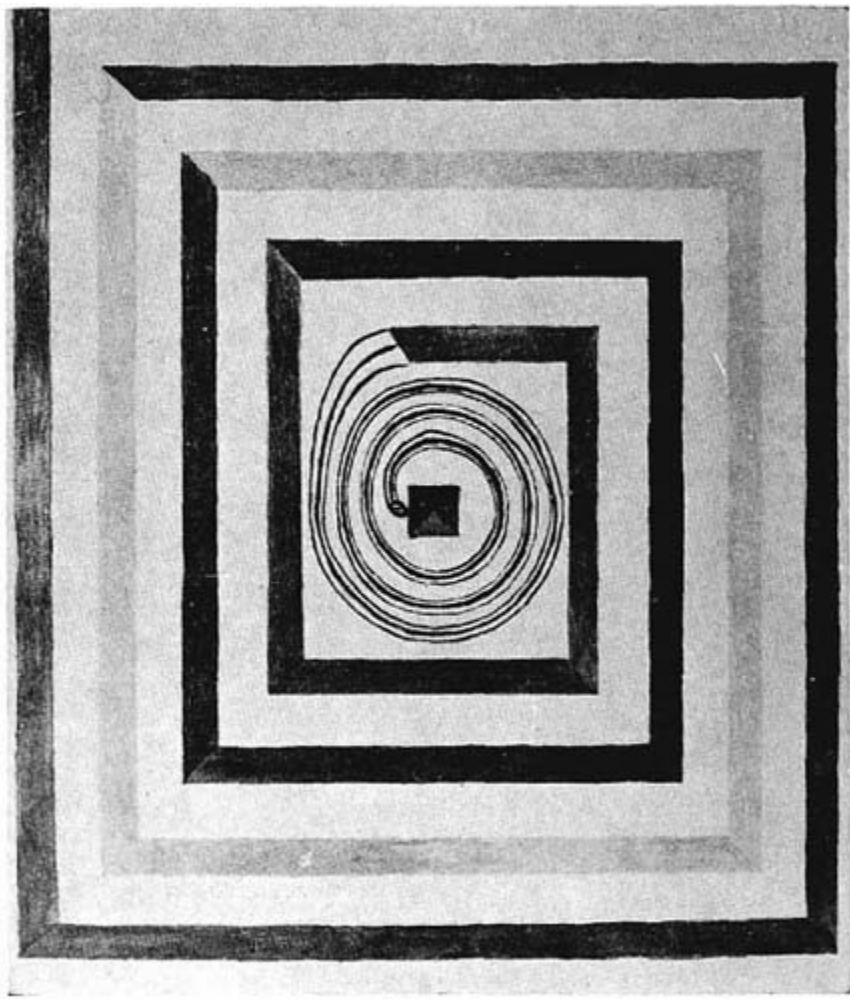

Figure 4

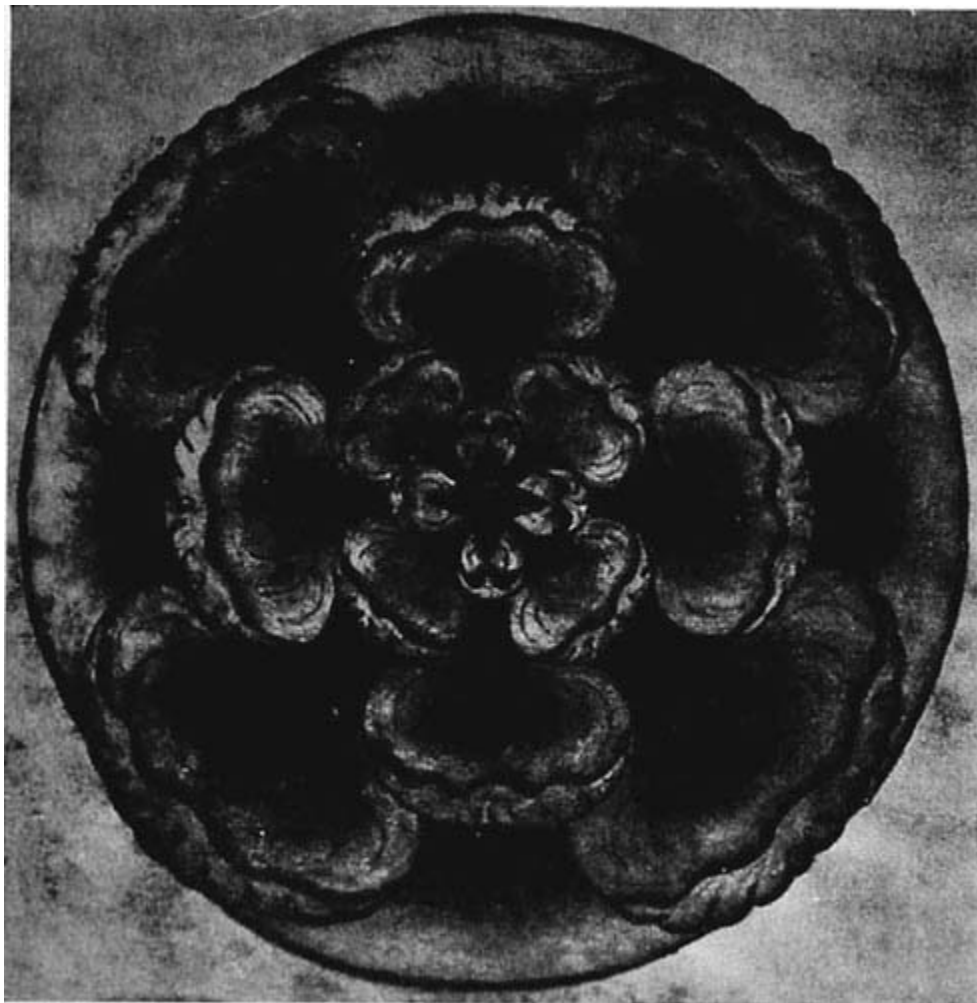

Figure 5



Figure 6

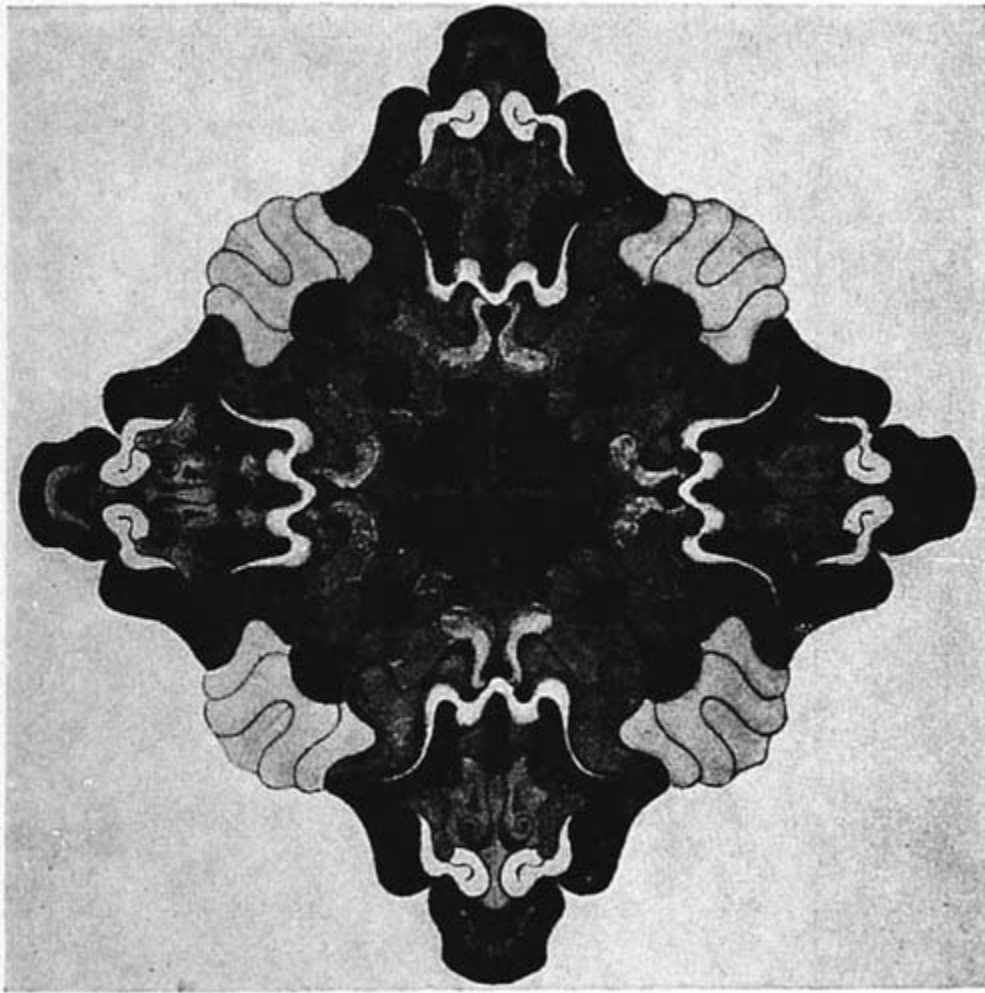

Figure 7

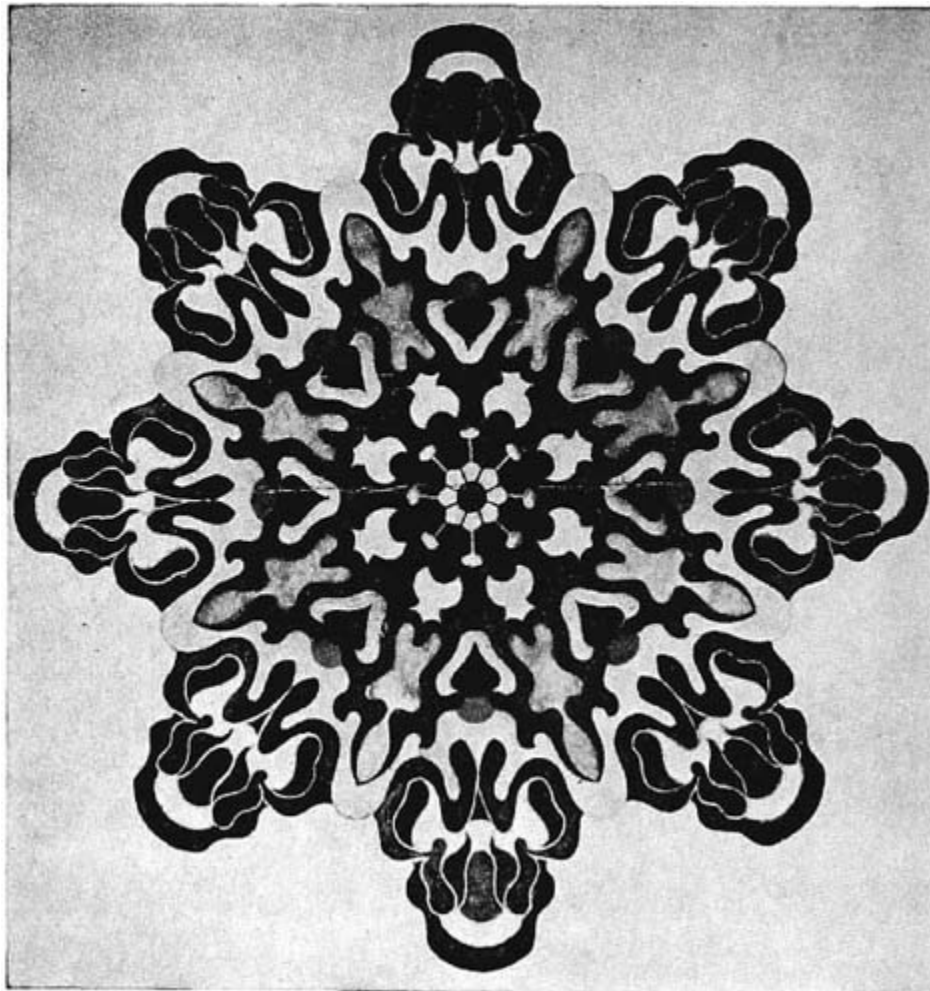

Figure 8

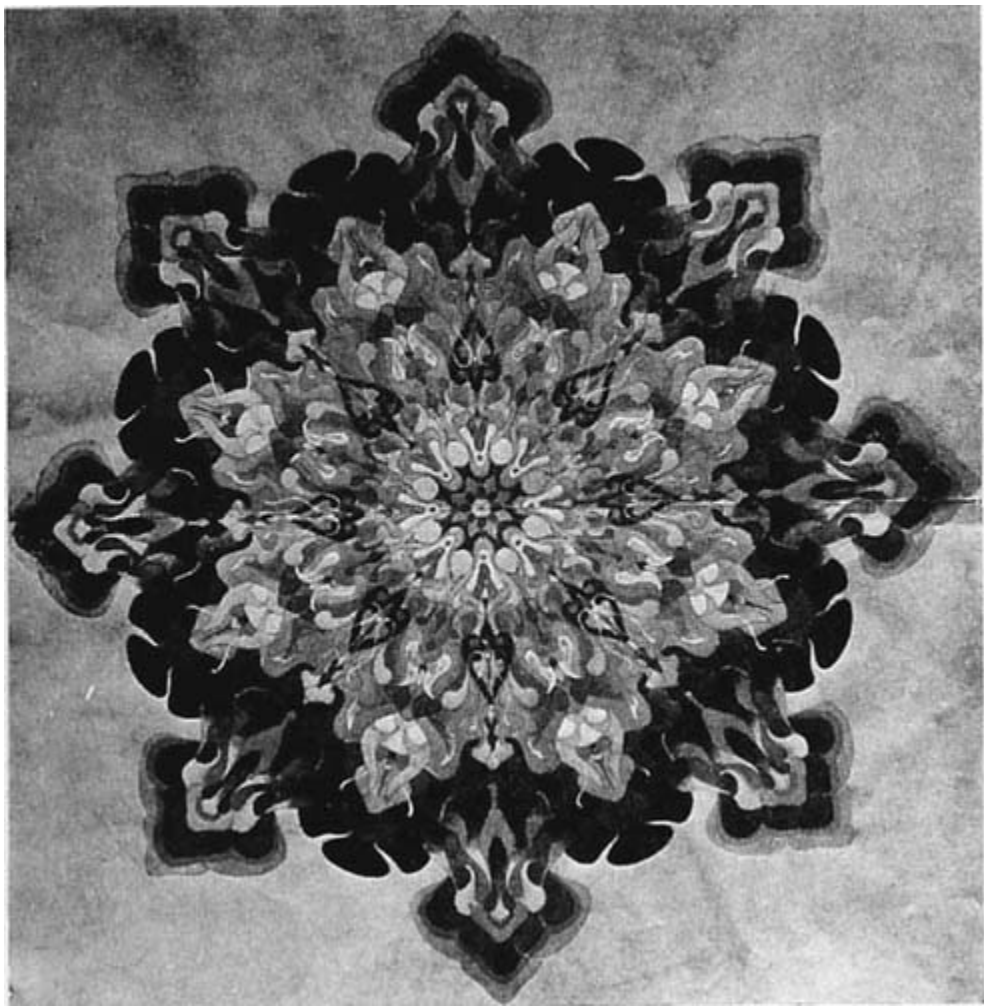

Figure 9

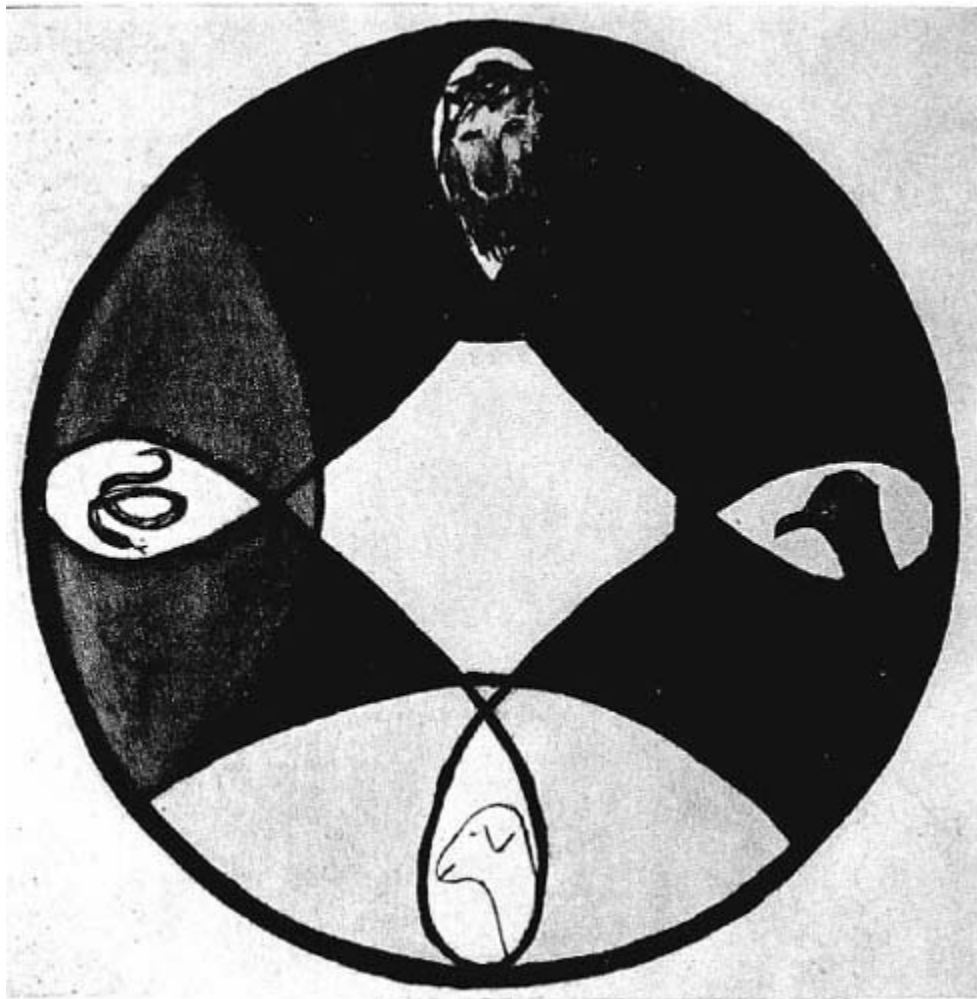

Figure 10

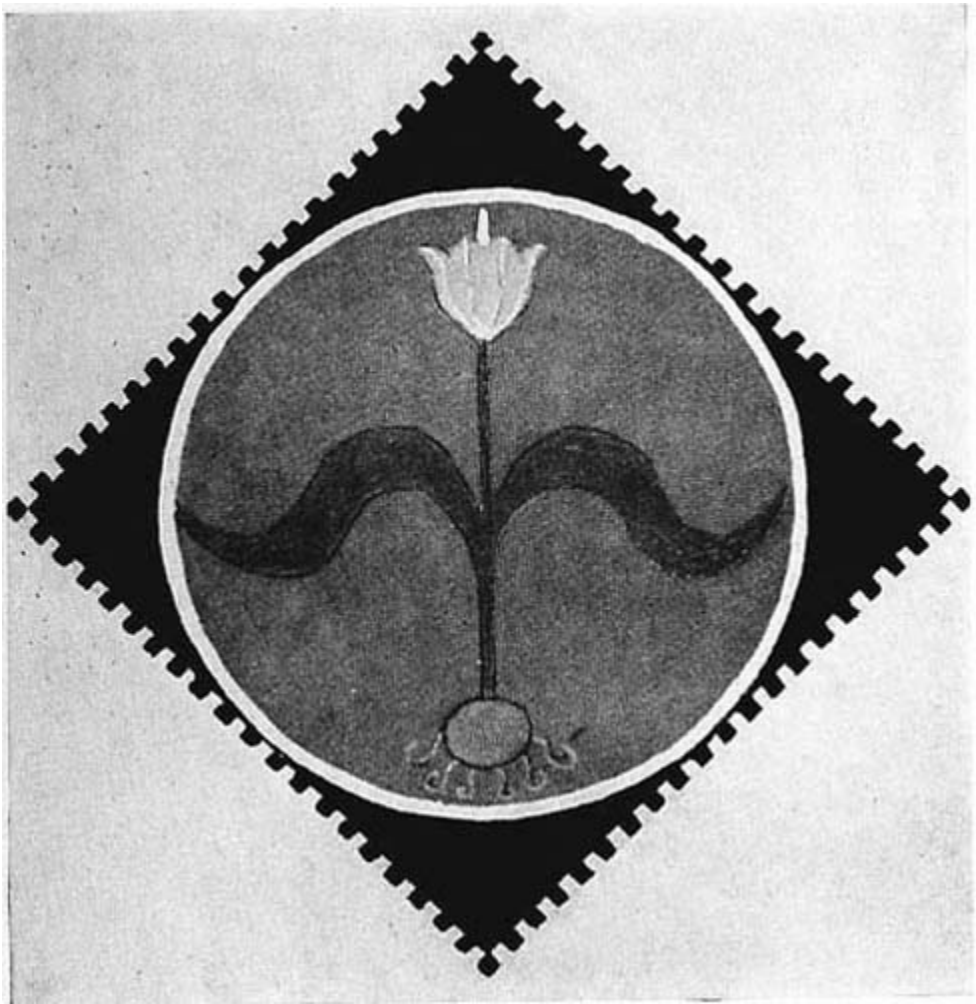

Figure 11

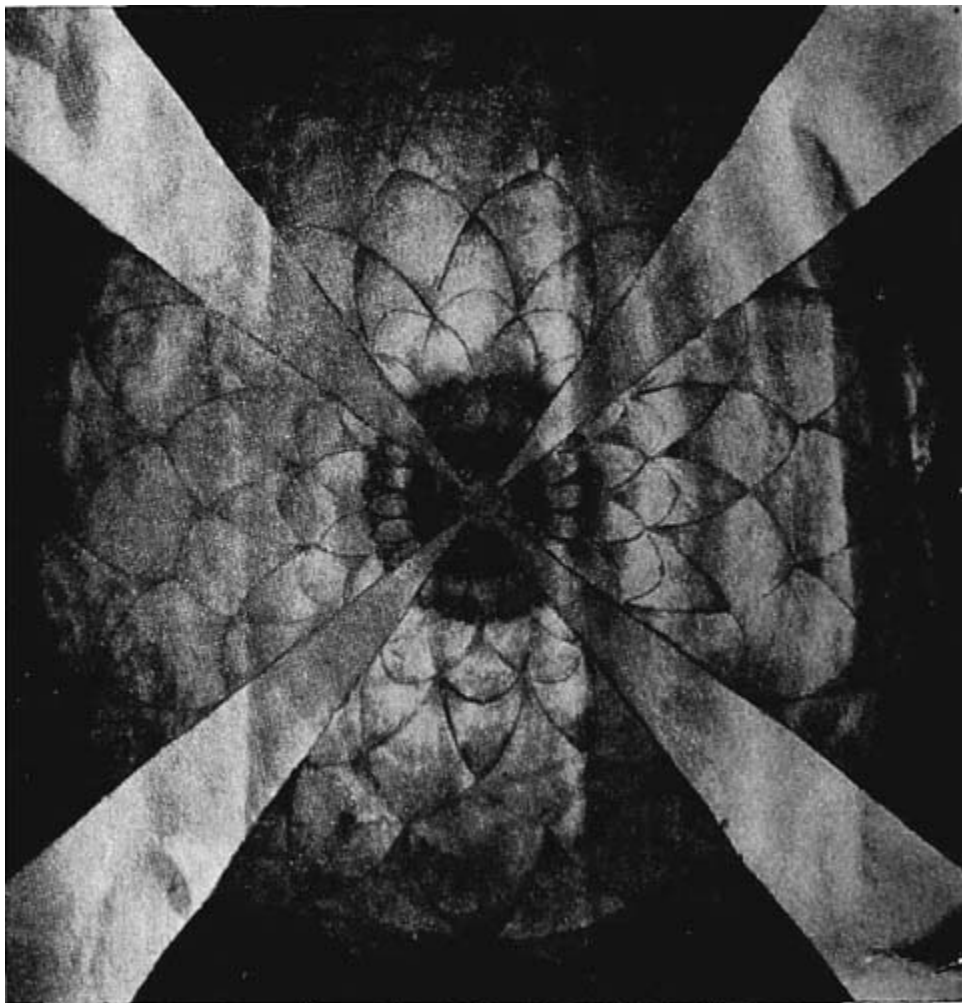

Figure 12

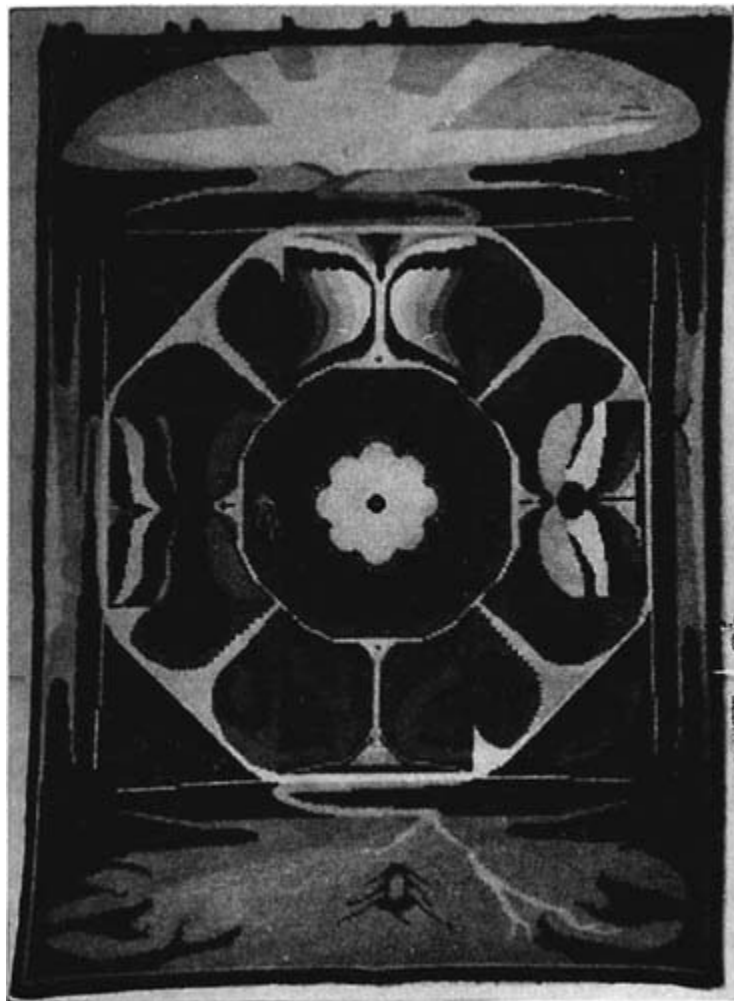

Figure 13

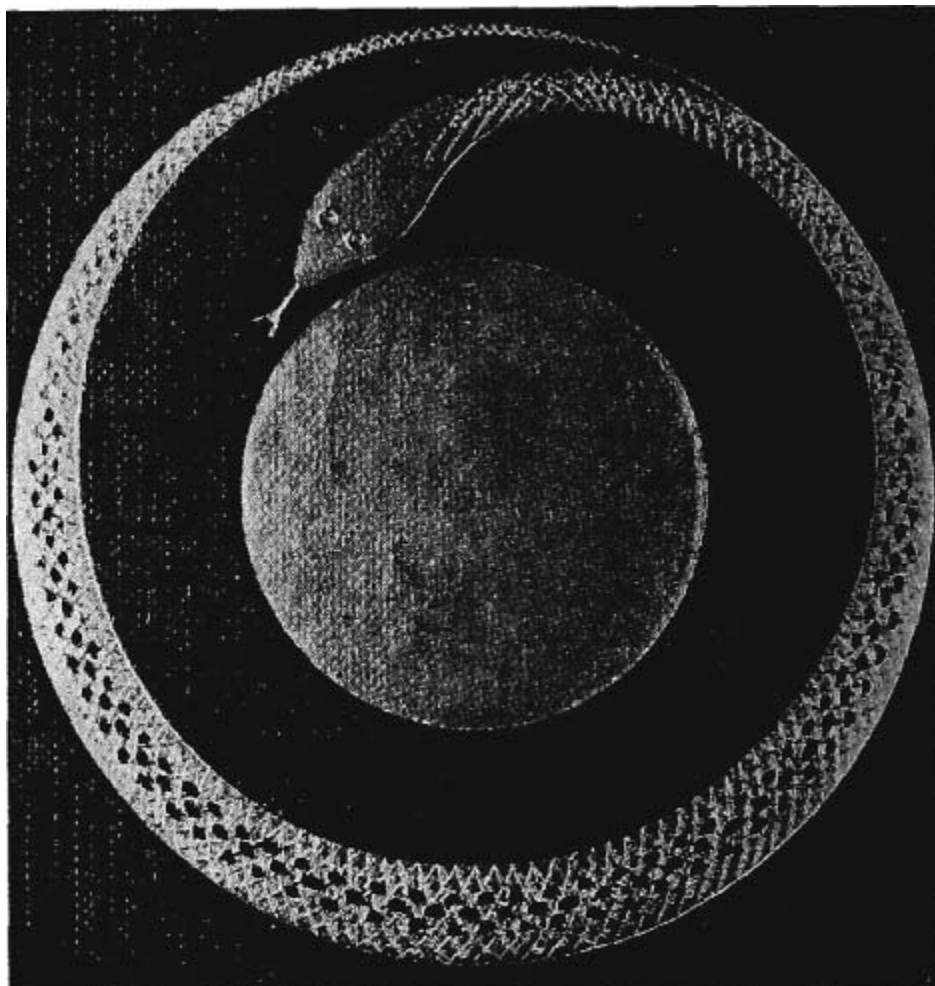

Figure 14

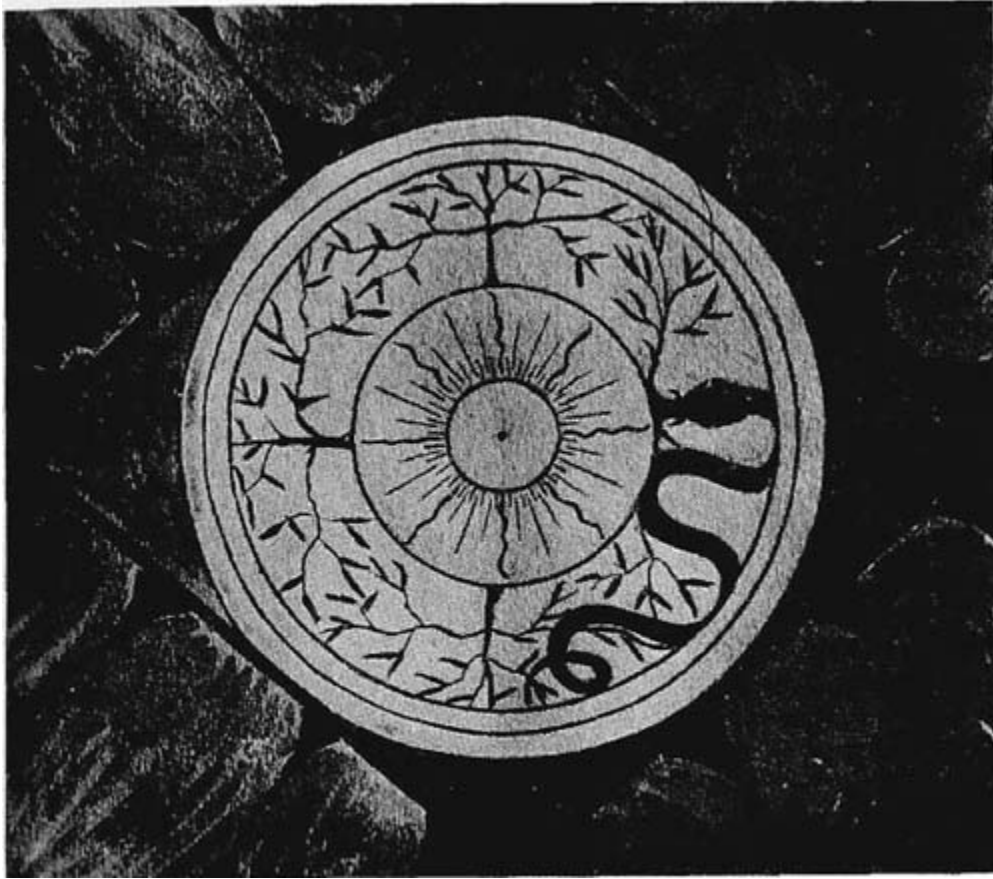

Figure 15

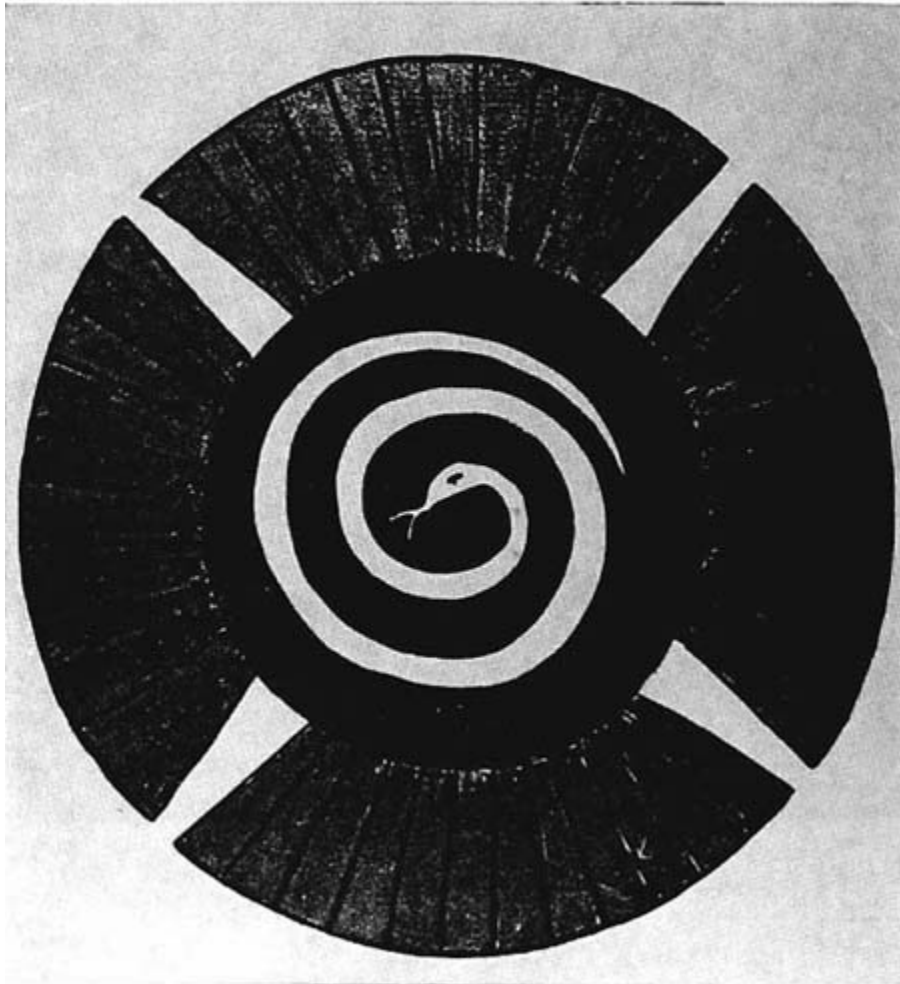

Figure 16

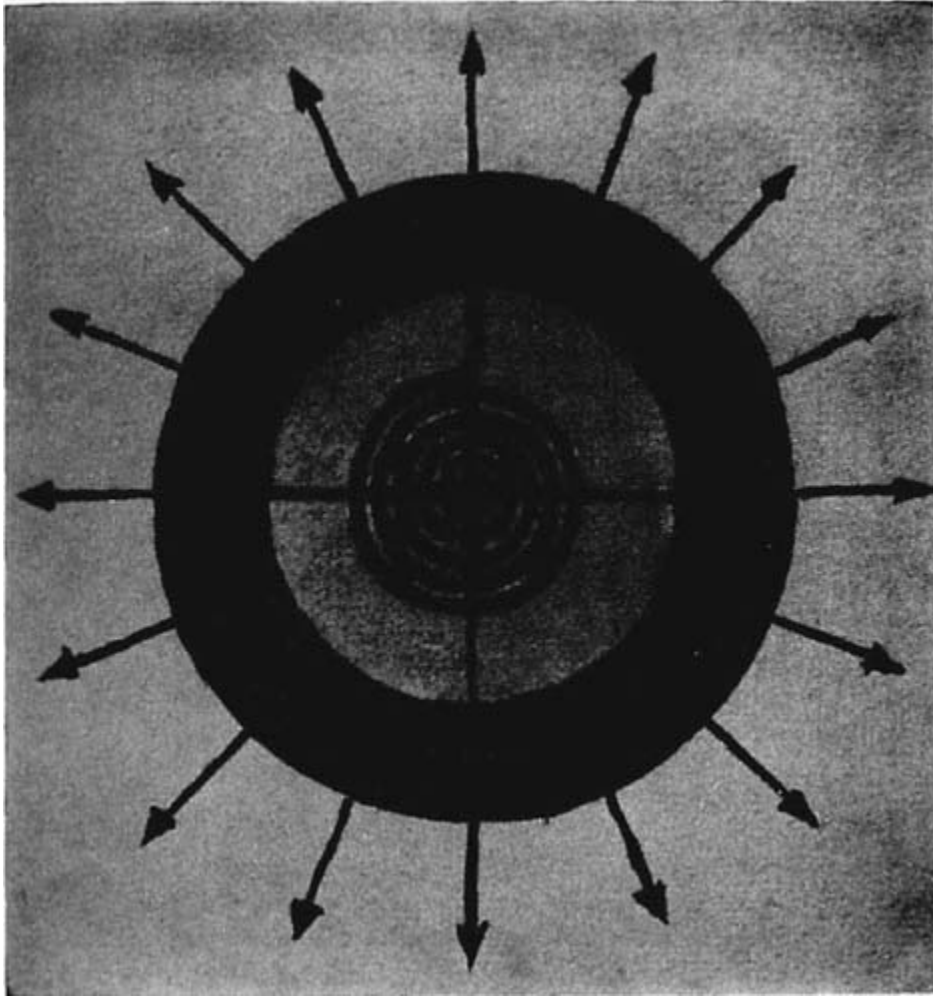

Figure 17

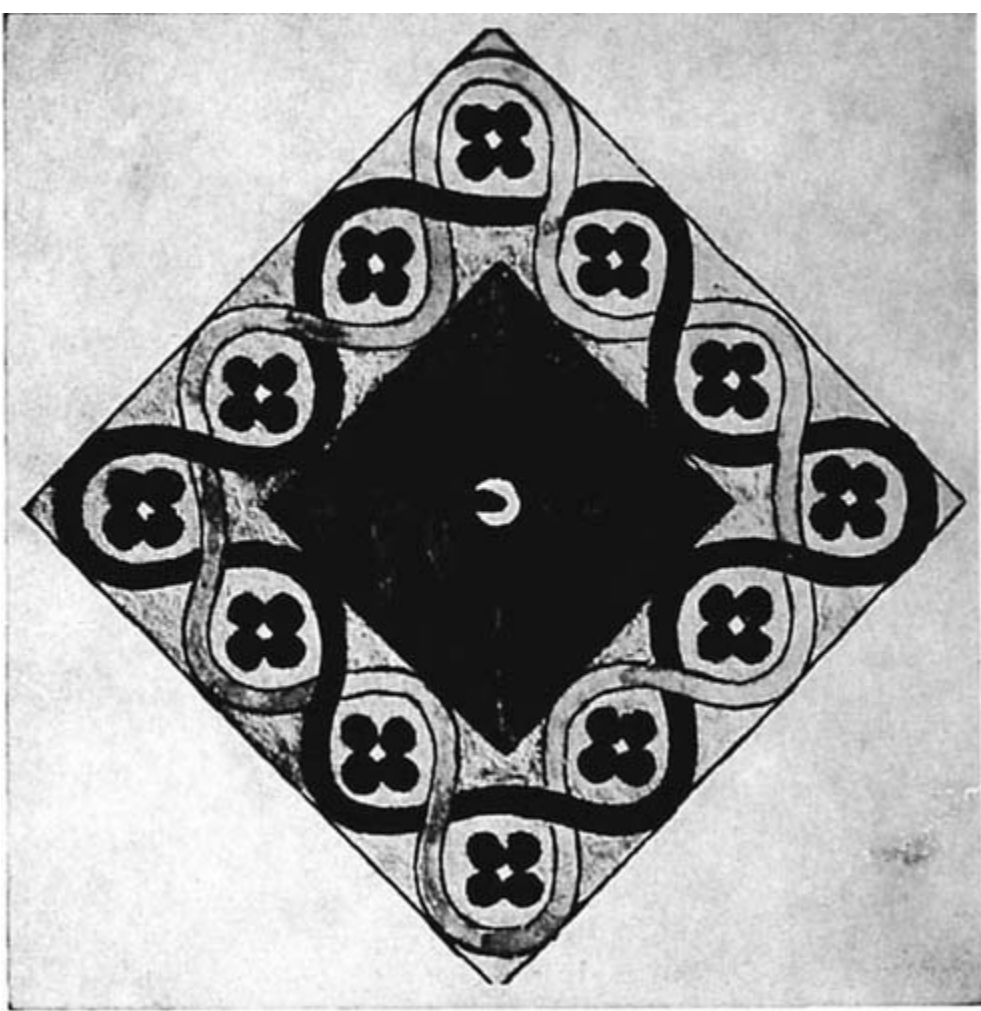

Figure 18

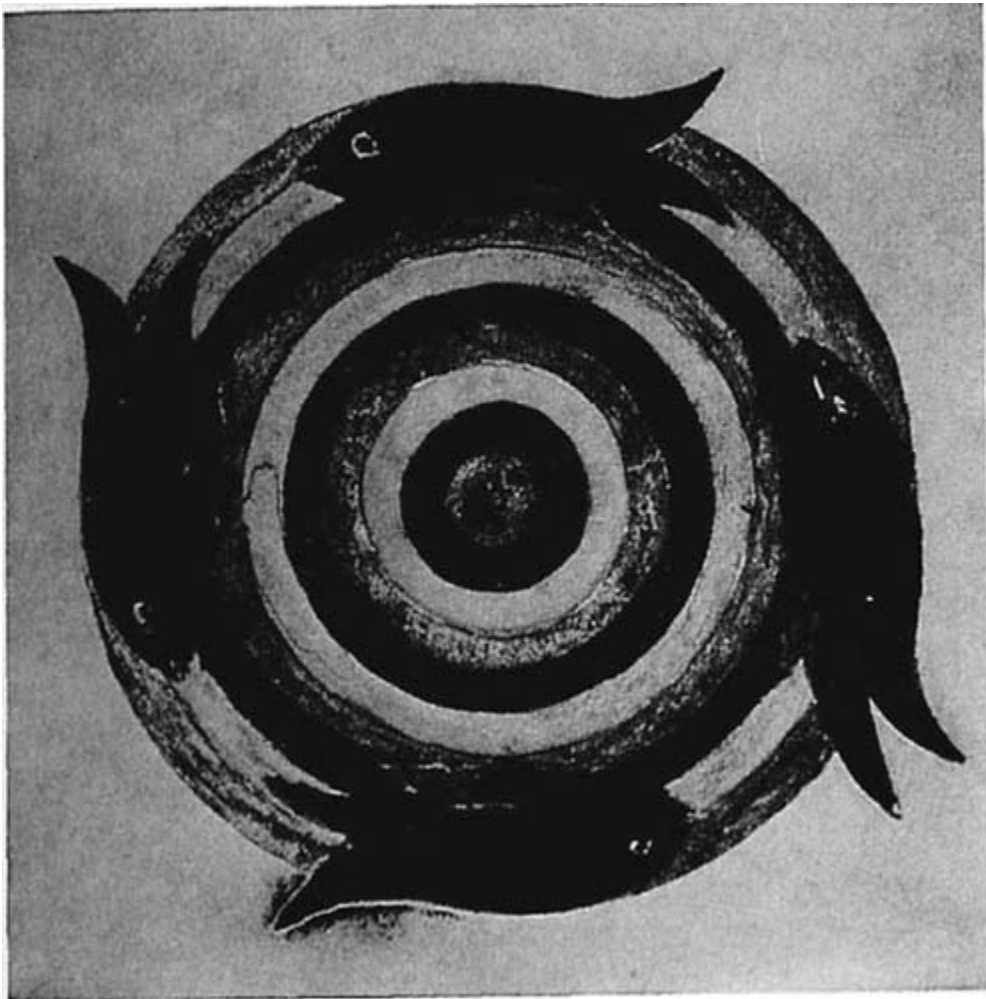

Figure 19

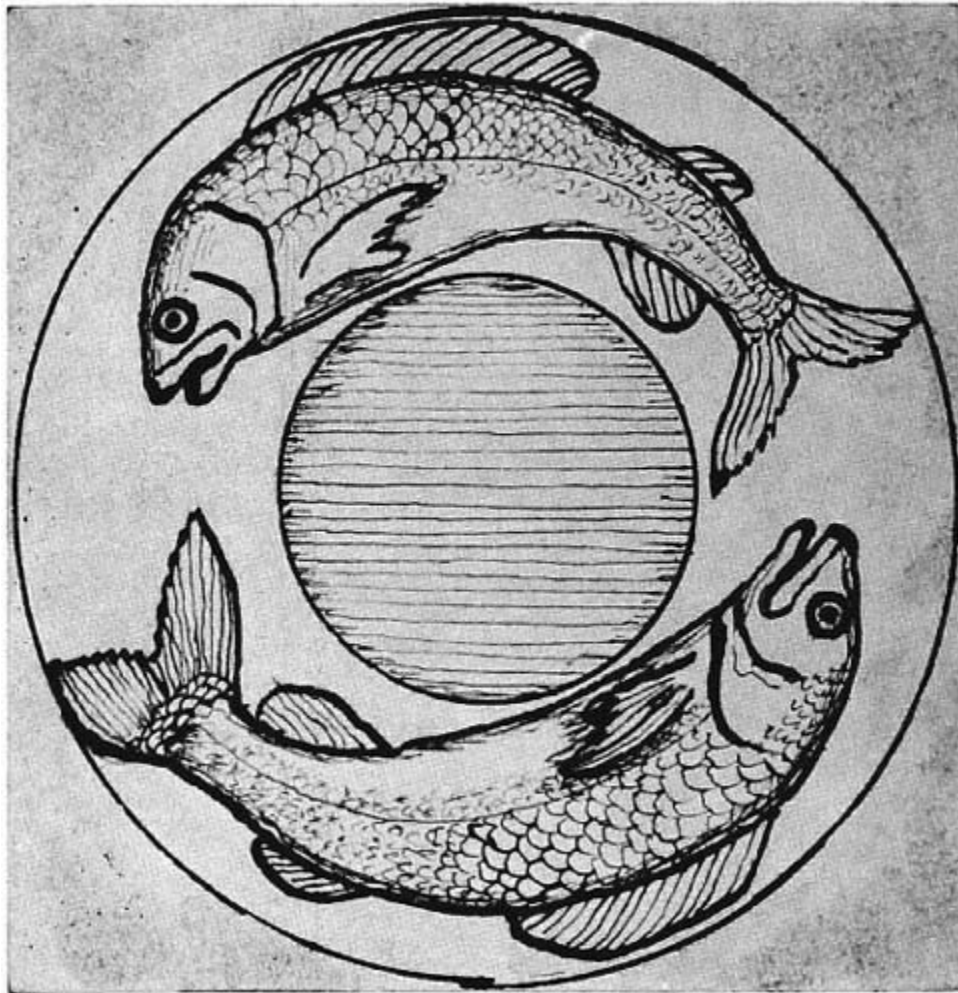

Figure 20



Figure 21



Figure 22

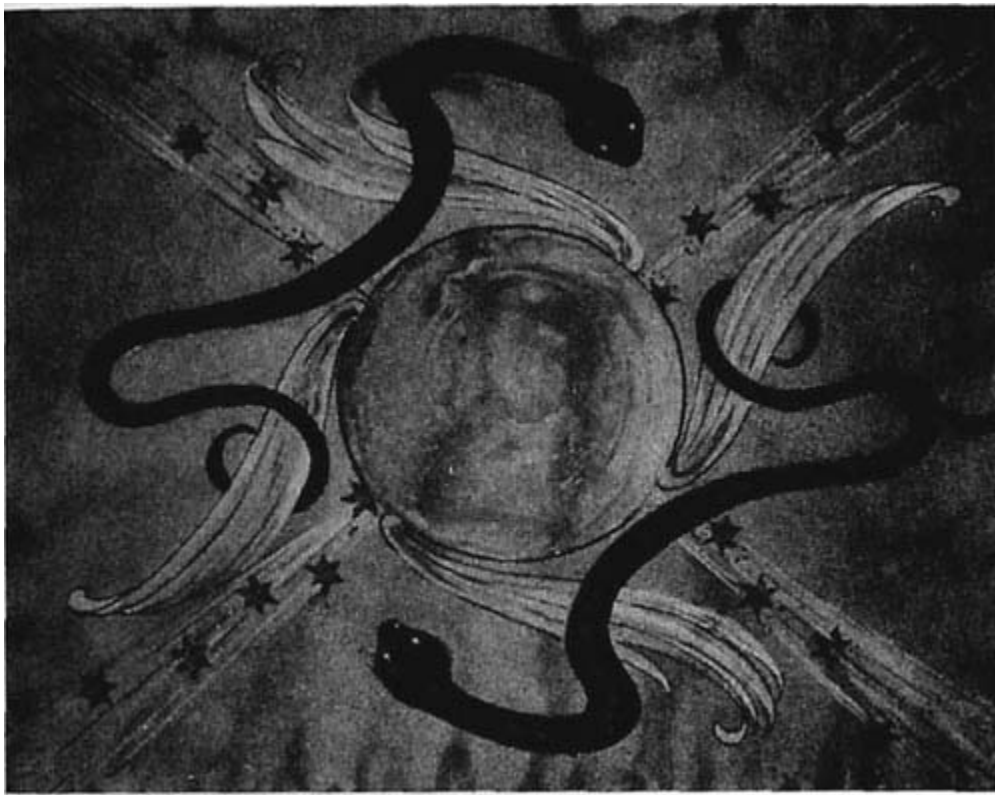

Figure 23



Figure 24



Figure 25

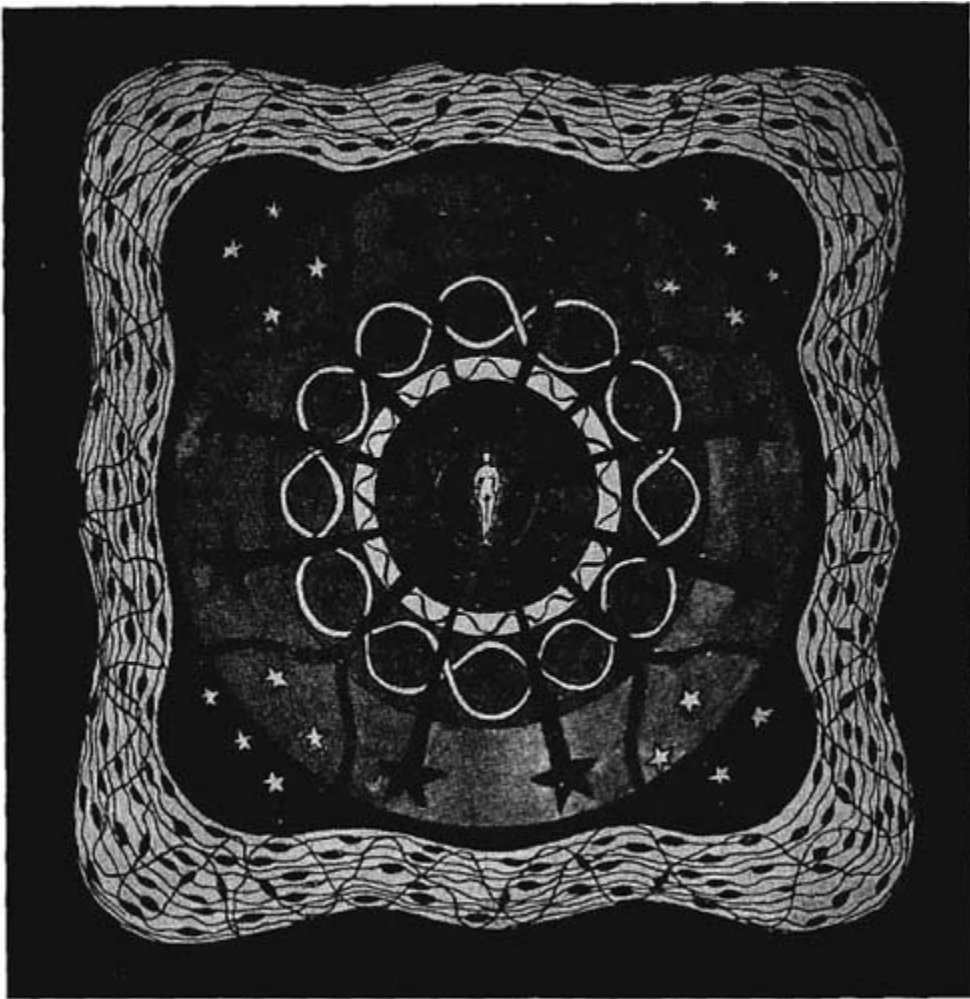

Figure 26

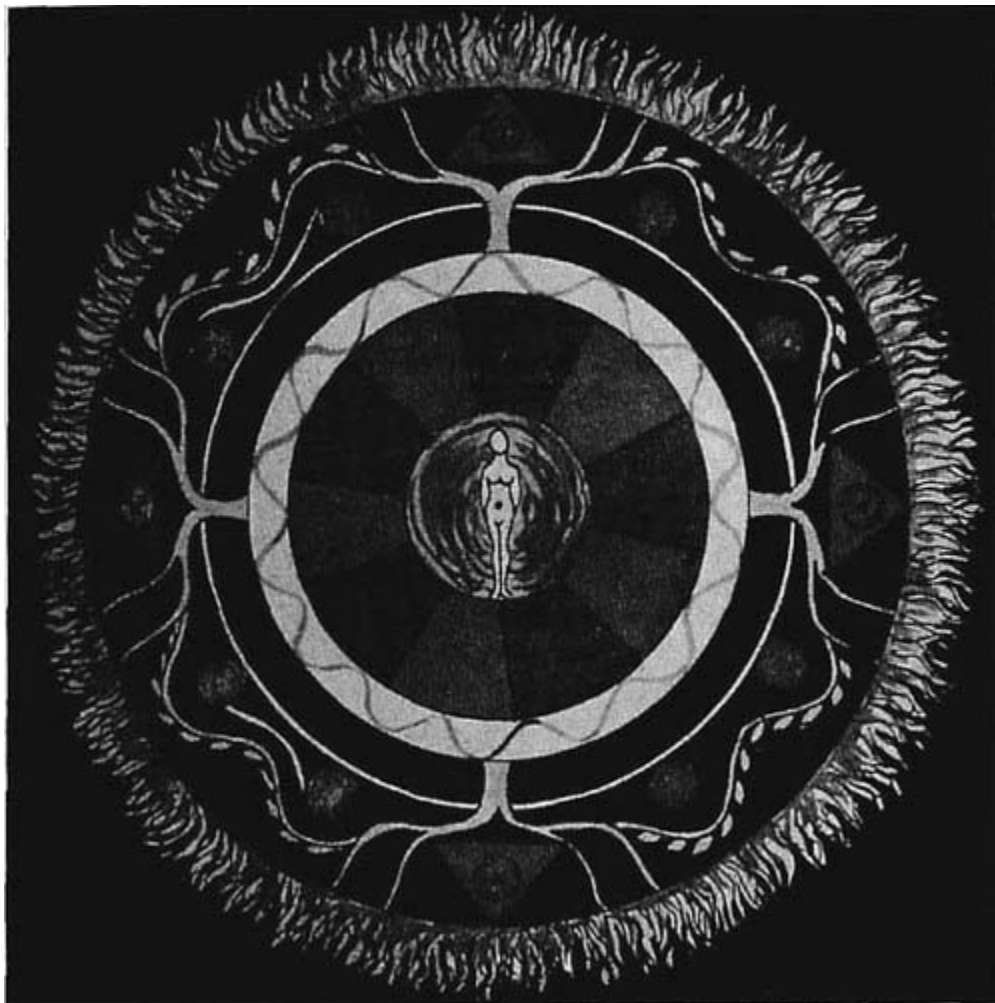

Figure 27

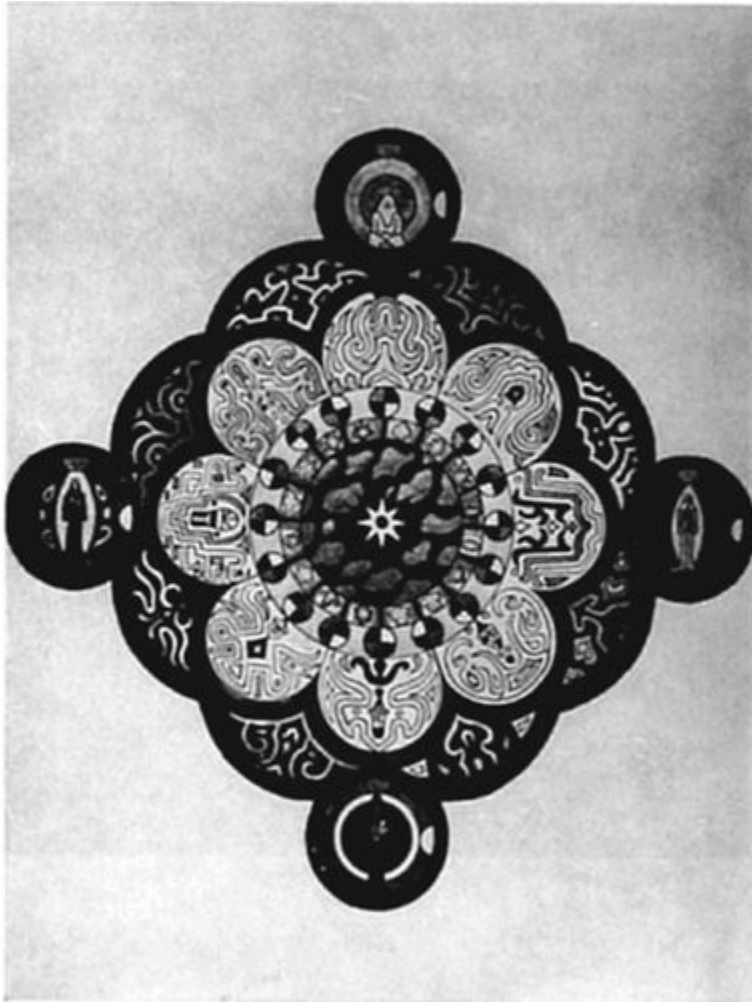

Figure 28



Figure 29

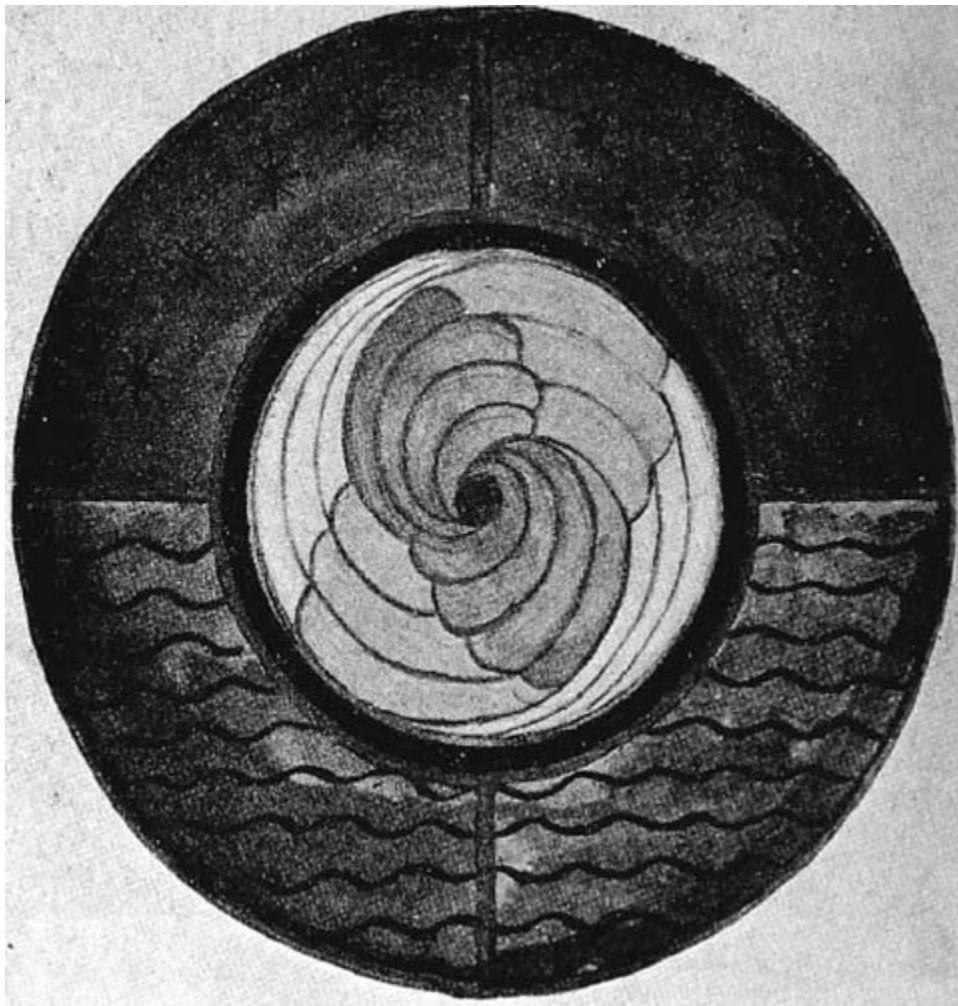

Figure 30

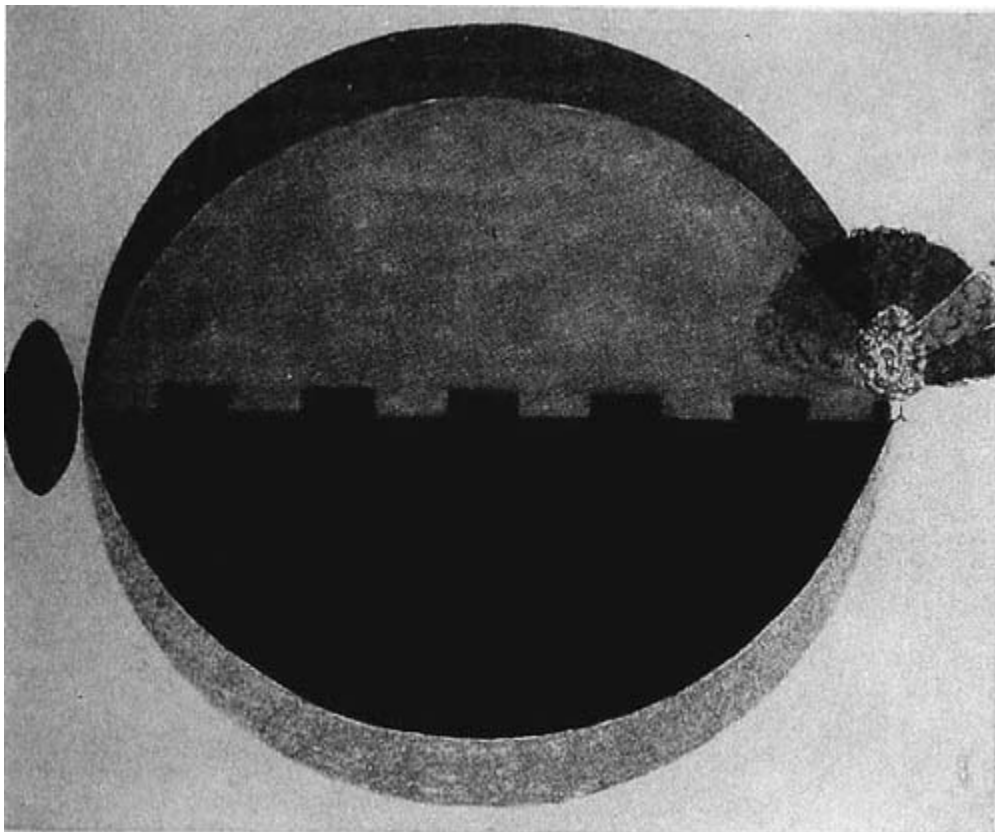

Figure 31

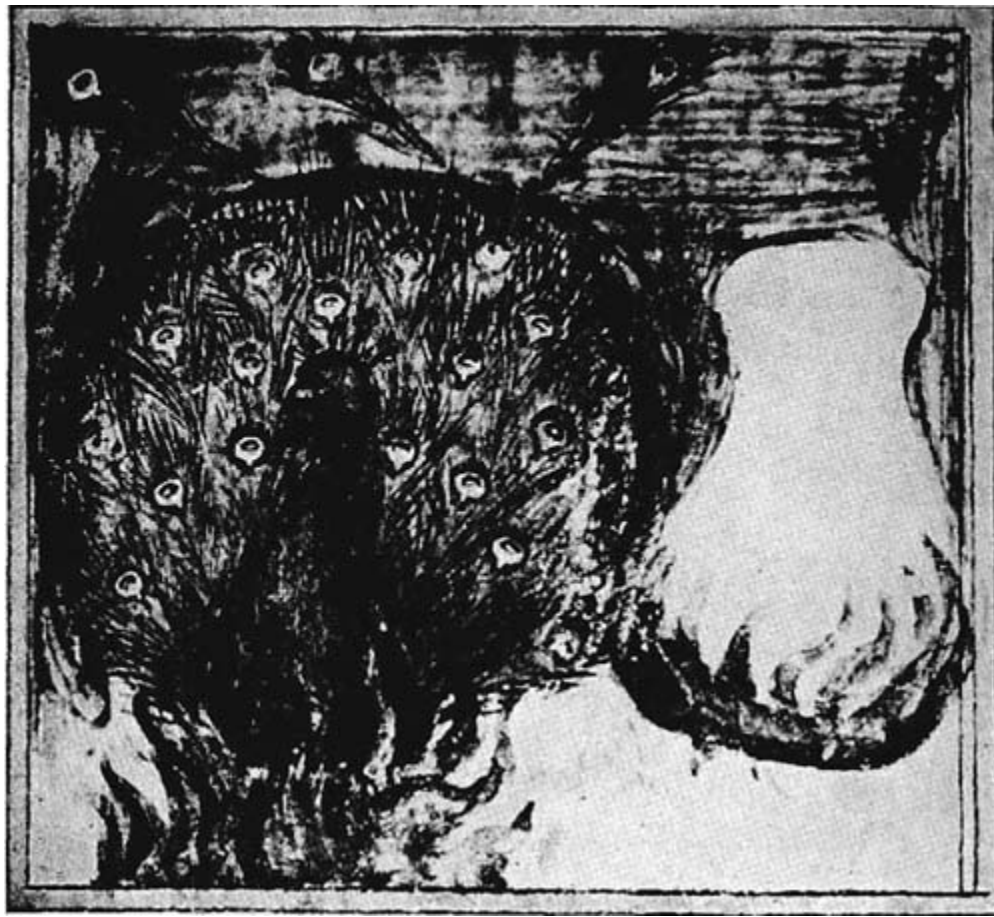

Figure 32

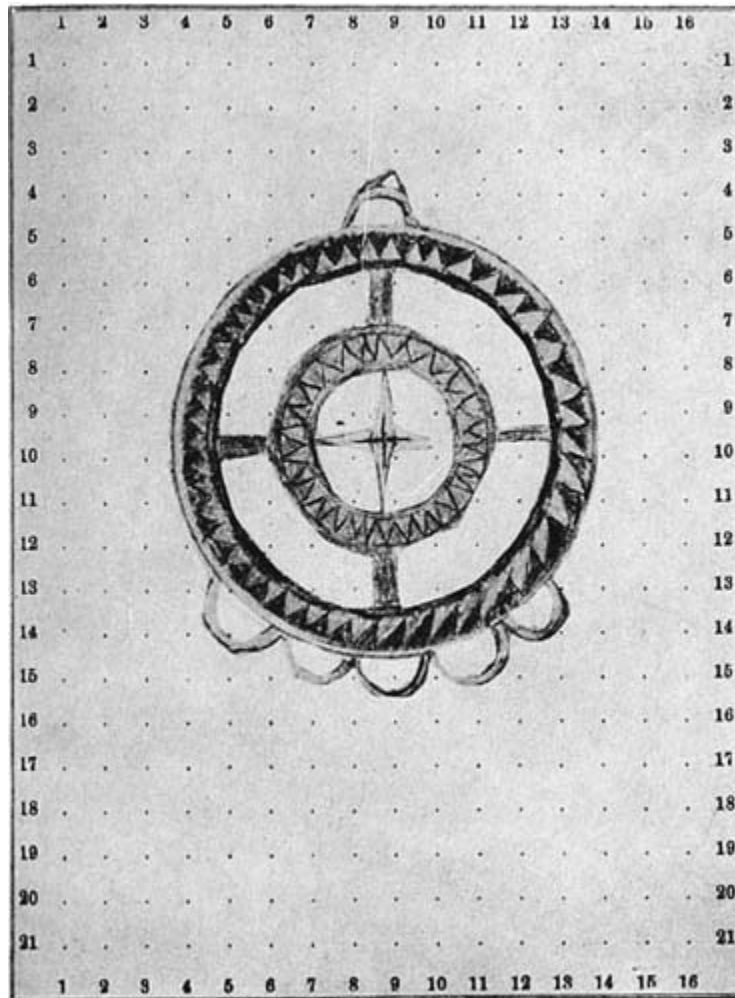

Figure 33

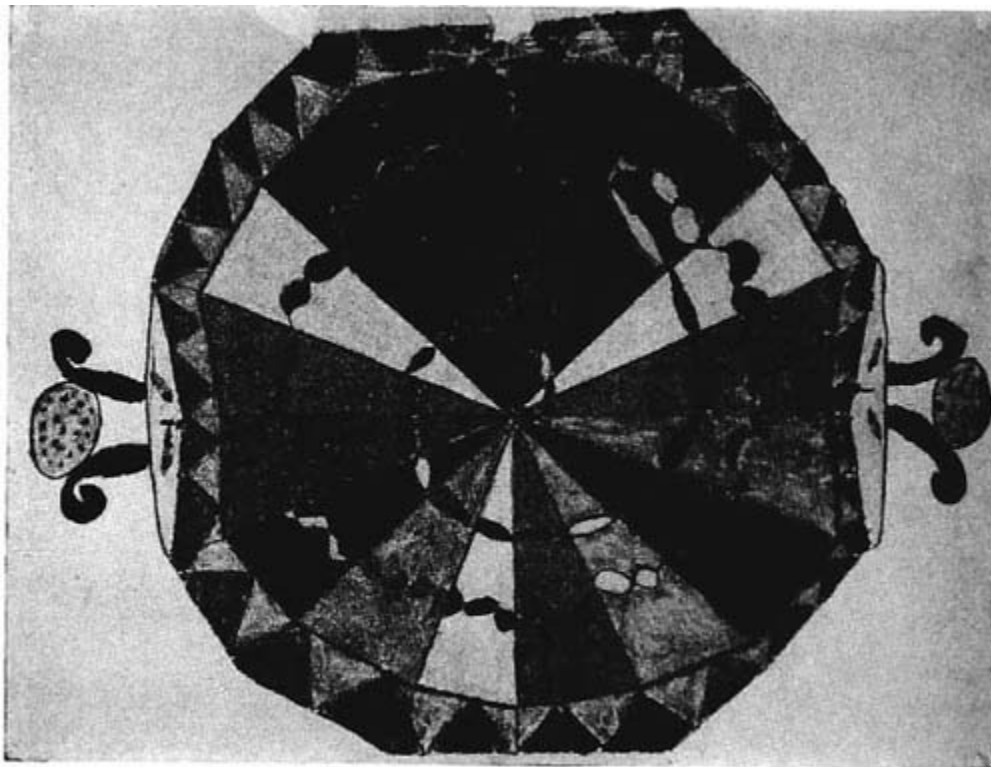

Figure 34

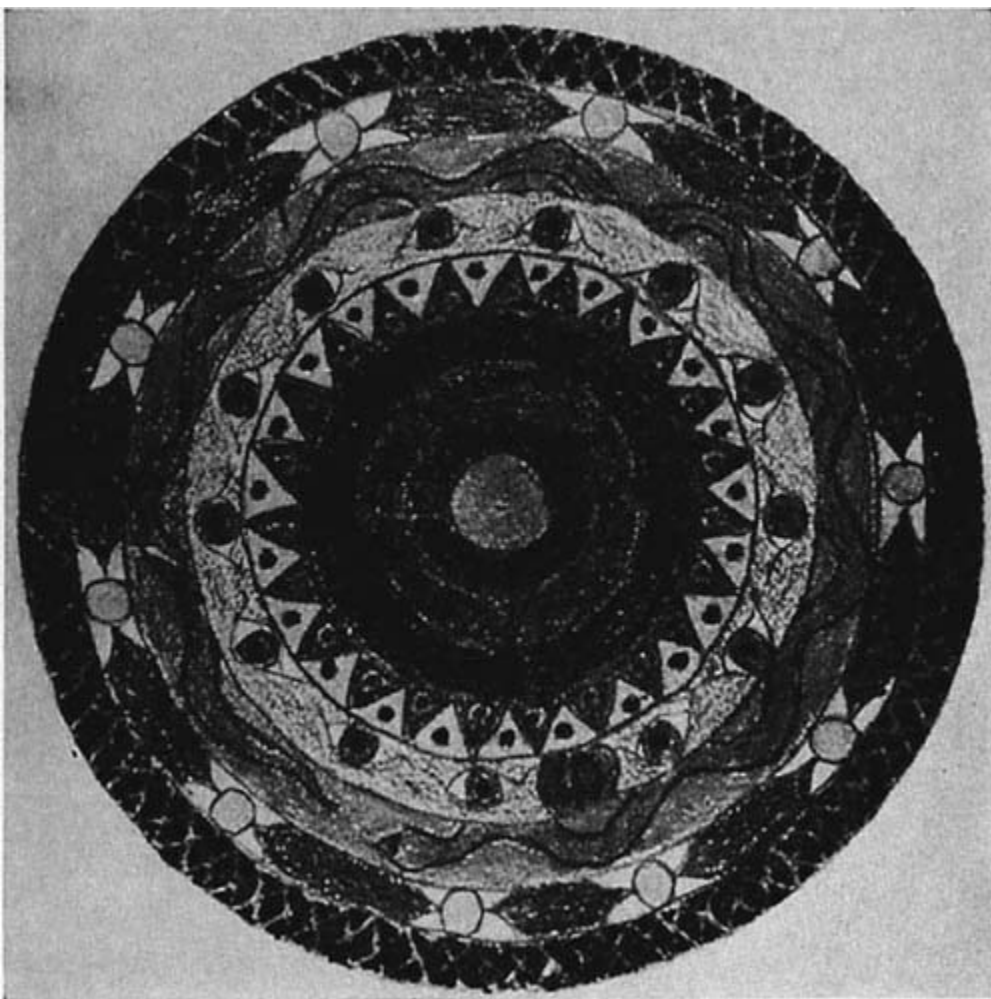

Figure 35



Figure 36



Figure 37

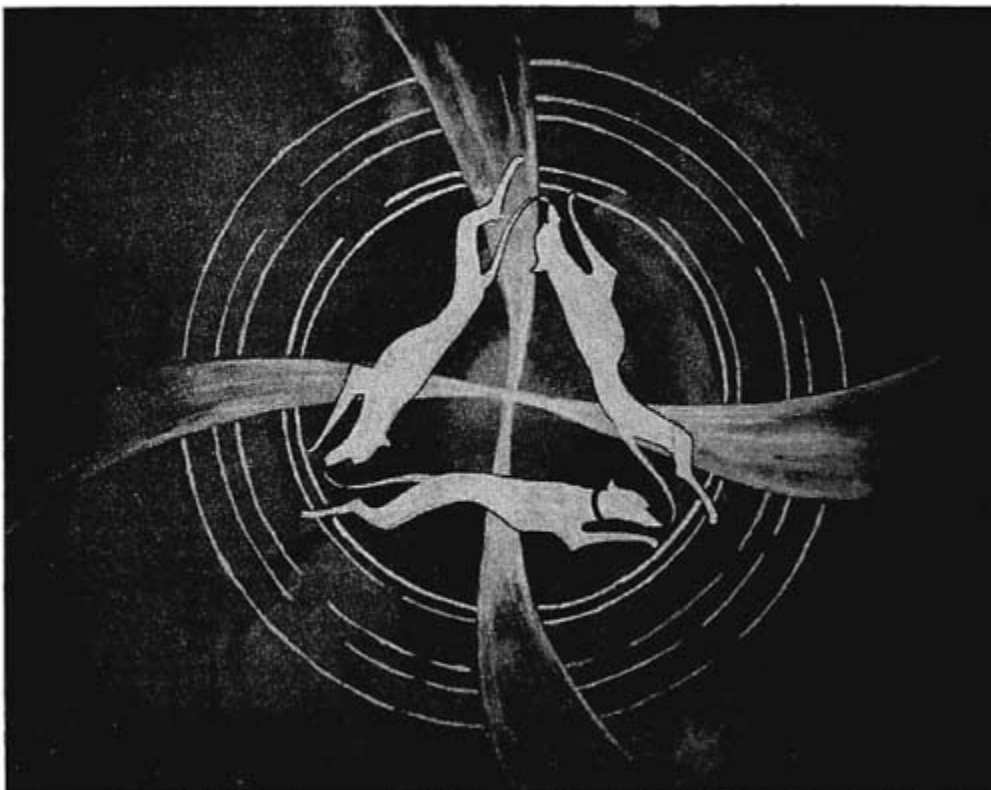

Figure 38



Figure 39

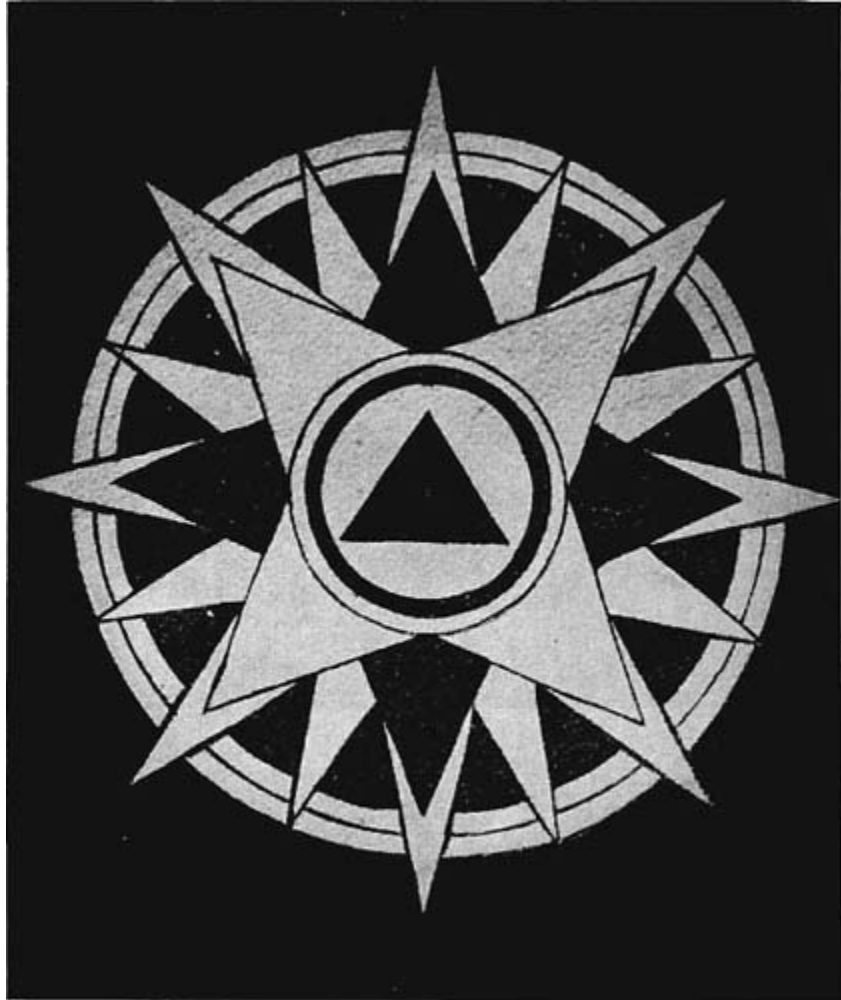

Figure 40



Figure 41

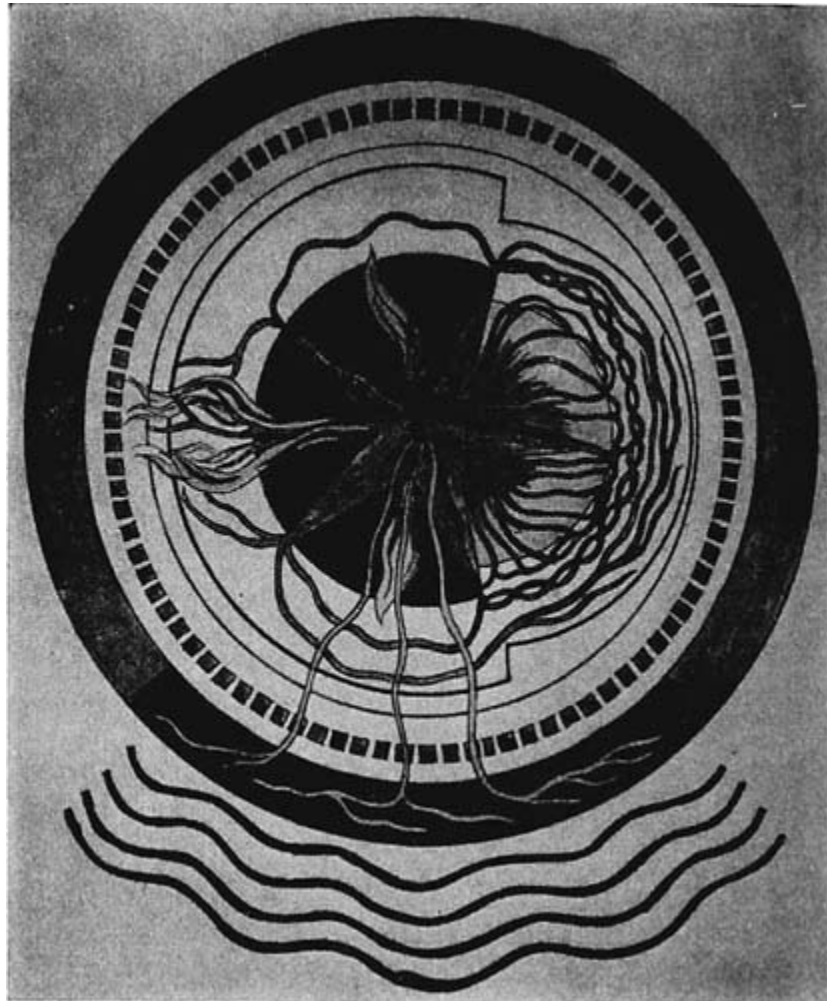

Figure 42

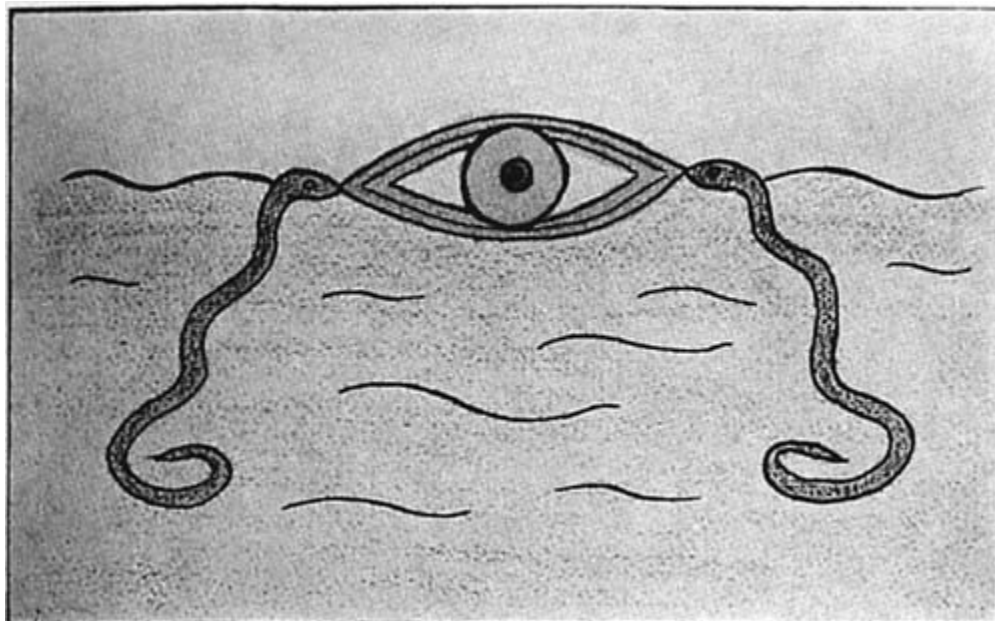

Figure 43

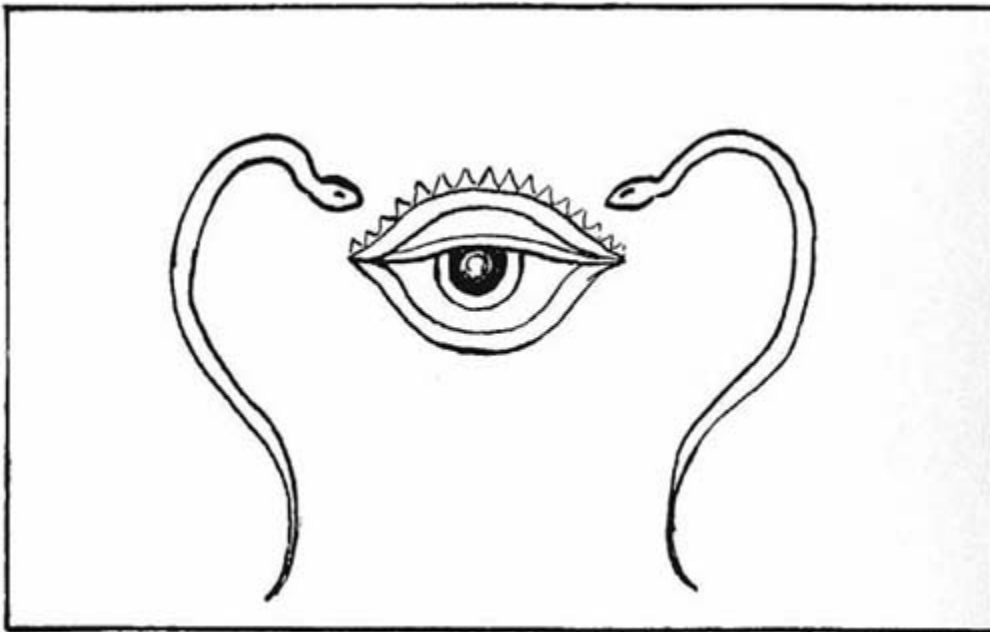

Figure 44

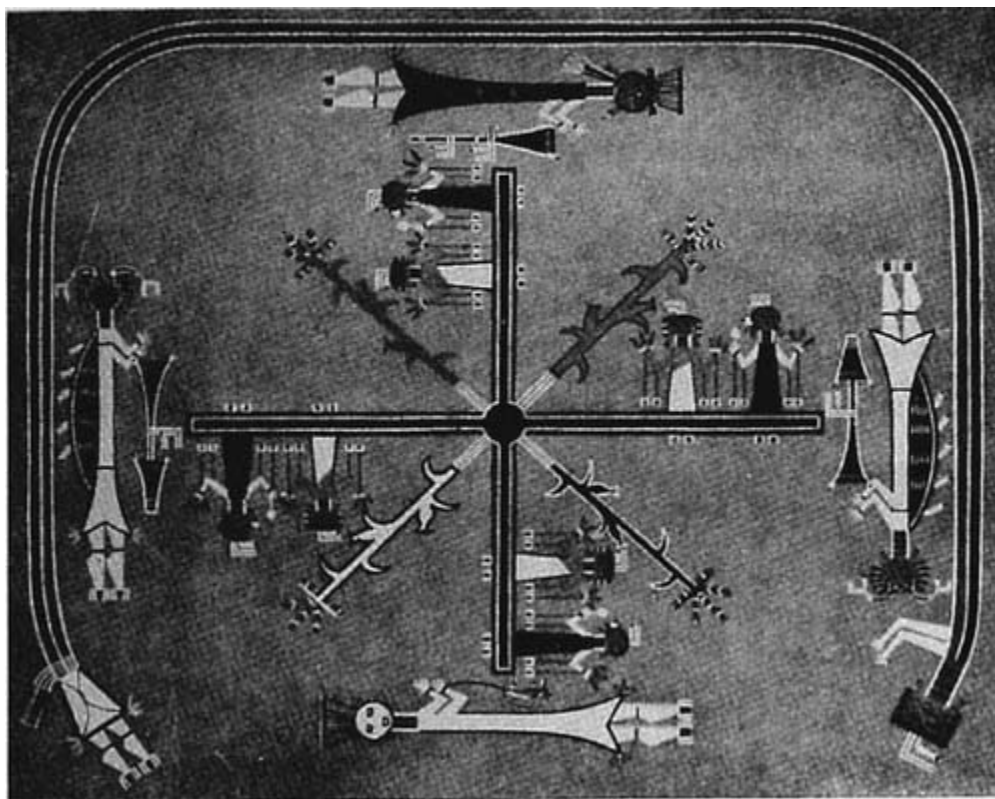

Figure 45

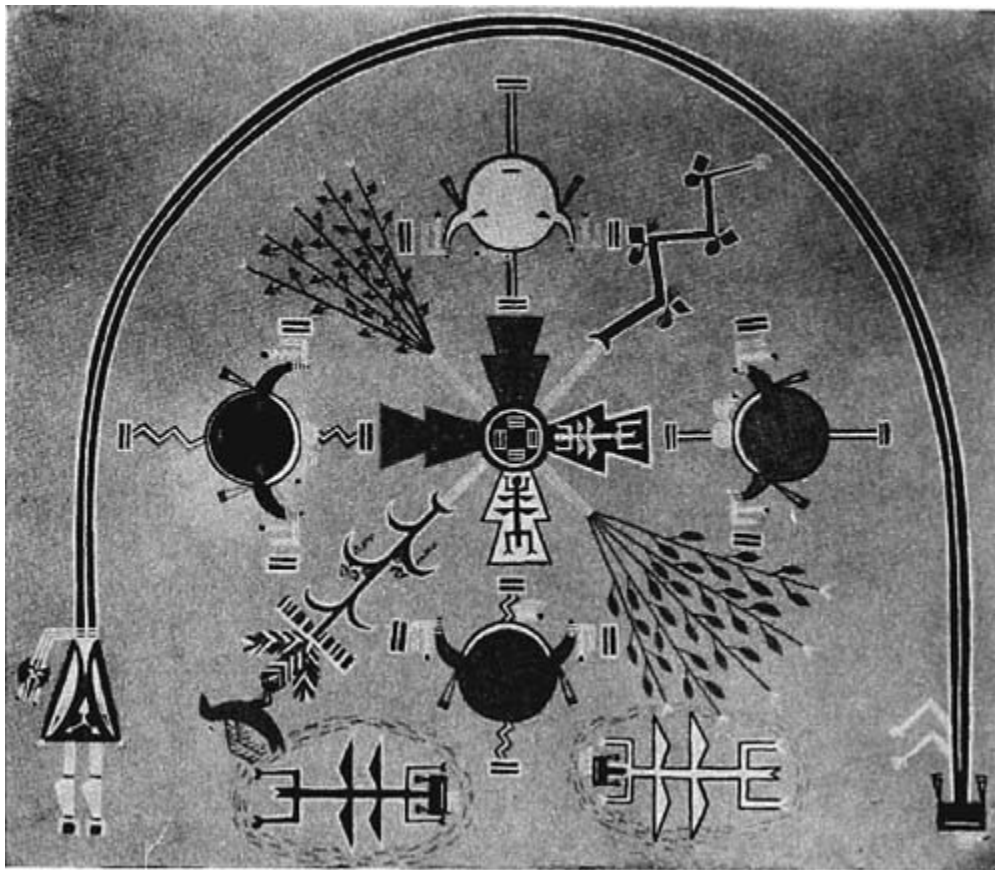

Figure 46

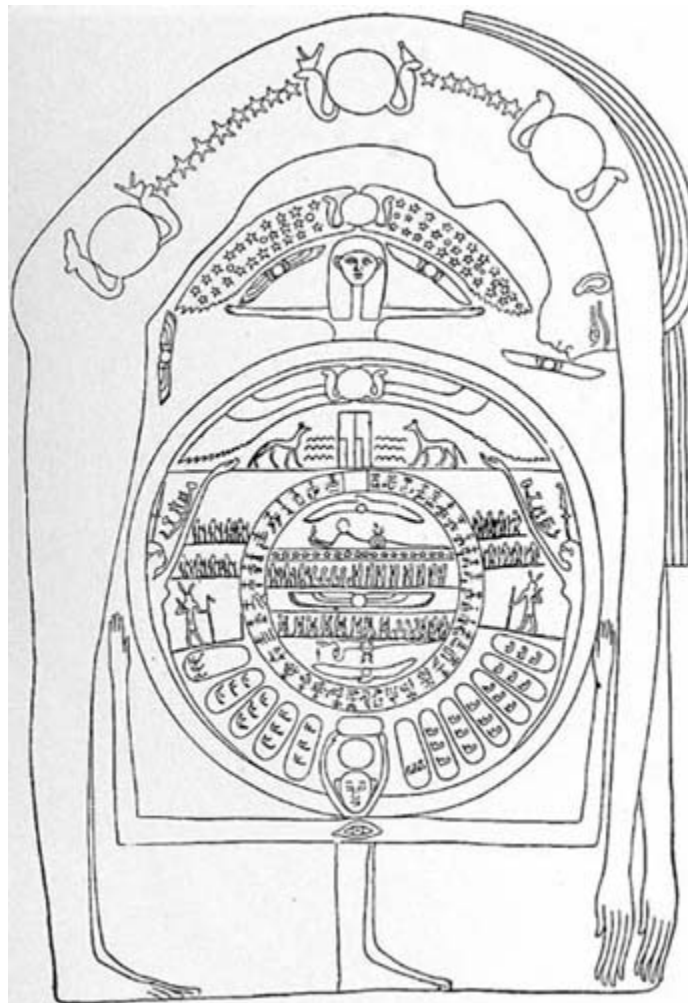

Figure 47

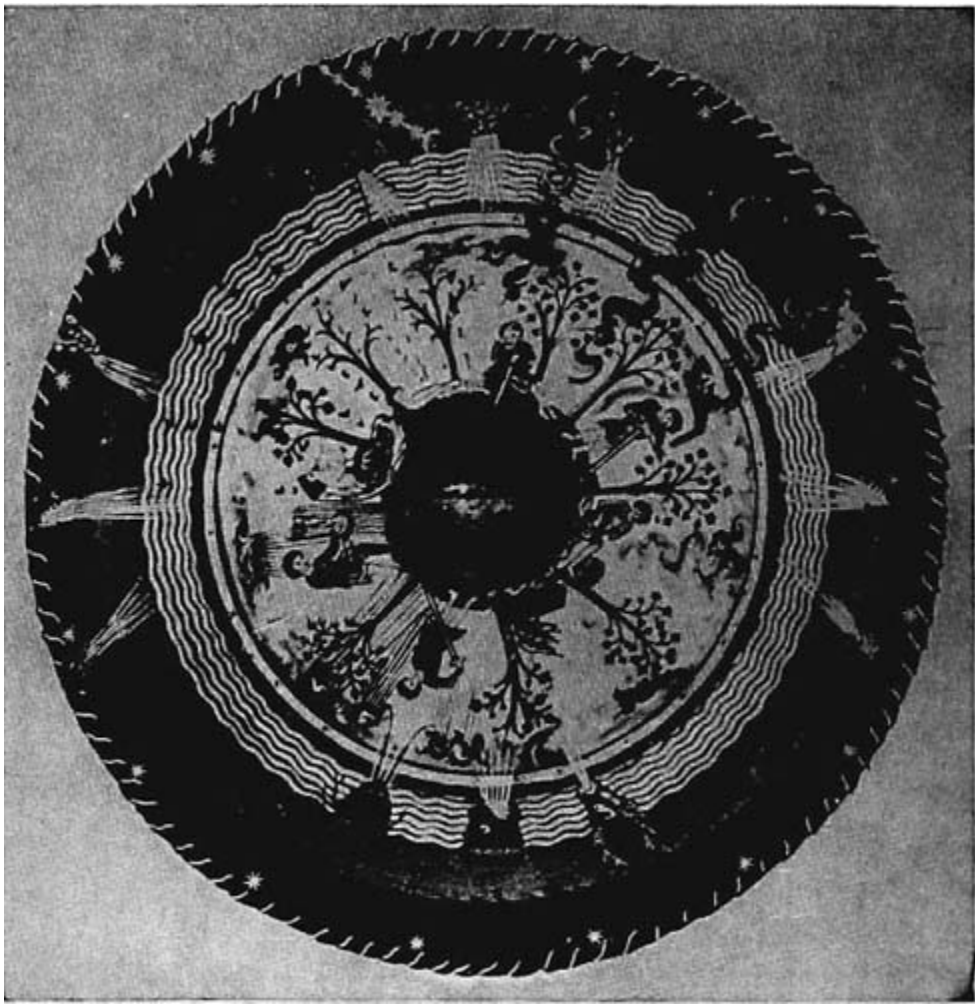

Figure 48



Figure 49

DECIMA FIGURA.



Figure 50



Figure 51



Figure 52

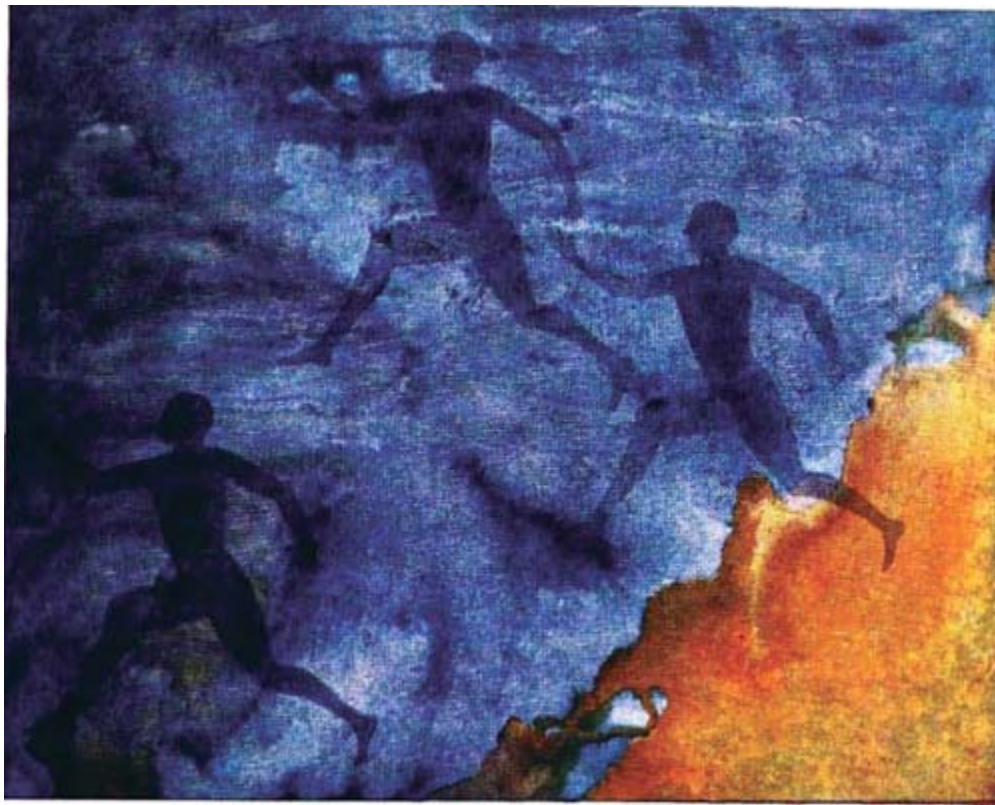

Figure 53



Figure 54

[632] In *kundalini* yoga symbolism, Shakti is represented as a snake wound three and a half times round the *lingam*, which is Shiva in the form of a phallus. This image shows the *possibility* of manifestation in space. From Shakti comes Maya, the building material of all individual things; she is, in consequence, the creatrix of the real world. This is thought of as illusion, as being and not-being. It *is*, and yet remains dissolved in Shiva. Creation therefore begins with an act of division of the opposites that are united in the deity. From their splitting arises, in a gigantic explosion of energy, the multiplicity of the world.

[633] The goal of contemplating the processes depicted in the mandala is that the yogi shall become inwardly aware of the deity. Through contemplation, he recognizes himself as God again, and thus returns from the illusion of individual existence into the universal totality of the divine state.

[634] As I have said, mandala means ‘circle.’ There are innumerable variants of the motif shown here, but they are all based on the squaring of a circle. Their basic motif is the premonition of a centre of personality, a kind of central point within the psyche, to which everything is related, by which everything is arranged, and which is itself a source of energy. The energy of the central point is manifested in the almost irresistible compulsion and urge to *become what one is*, just as every organism is driven to assume the form that is characteristic of its nature, no matter what the circumstances. This centre is not felt or thought of as the ego but, if one may so express it, as the *self*. Although the centre is represented by an innermost point, it is surrounded by a periphery containing everything that belongs to the self—the paired opposites that make up the total personality. This totality comprises consciousness first of all, then the personal unconscious, and finally an indefinitely large segment of the collective unconscious whose archetypes are common to all mankind. A certain number of these, however, are permanently or temporarily included within the scope of the personality and, through this contact, acquire an individual stamp as the shadow, anima, and animus, to mention only the best-known figures. The self, though on the one hand simple, is on the other hand an extremely composite thing, a “conglomerate soul,” to use the Indian expression.

[635] Lamaic literature gives very detailed instructions as to how such a circle must be painted and how it should be used. Form and colour are laid down by tradition, so the variants move within fairly narrow limits. The ritual use of the mandala is actually non-Buddhist; at any rate it is alien to the original Hínayāna Buddhism and appears first in Mahāyāna Buddhism.

[636] The mandala shown here depicts the state of one who has emerged from contemplation into the absolute state. That is why representation of hell and the horrors of the burial ground are missing. The diamond thunderbolt, the *dorje* in the

centre, symbolizes the perfect state where masculine and feminine are united. The world of illusions has finally vanished. All energy has gathered together in the initial state.

[637] The four *dorjes* in the gates of the inner courtyard are meant to indicate that life's energy is streaming inwards; it has detached itself from objects and now returns to the centre. When the perfect union of all energies in the four aspects of wholeness is attained, there arises a static state subject to no more change. In Chinese alchemy this state is called the "Diamond Body," corresponding to the *corpus incorruptibile* of medieval alchemy, which is identical with the *corpus glorificationis* of Christian tradition, the incorruptible body of resurrection. This mandala shows, then, the union of all opposites, and is embedded between *yang* and *yin*, heaven and earth; the state of everlasting balance and immutable duration.

[638] For our more modest psychological purposes we must abandon the colourful metaphysical language of the East. What yoga aims at in this exercise is undoubtedly a psychic change in the adept. The ego is the expression of individual existence. The yogin exchanges his ego for Shiva or the Buddha; in this way he induces a shifting of the psychological centre of personality from the personal ego to the impersonal non-ego, which is now experienced as the real "Ground" of the personality.

[639] In this connection I would like to mention a similar Chinese conception, namely the system on which the *I Ching* is based.

Figure 2

[640] In the centre is *ch'ien*, 'heaven,' from which the four emanations go forth, like the heavenly forces extending through space. Thus we have:

ch'ien: self-generated creative energy, corresponding to Shiva.

heng: all-pervading power.

yuen: generative power.

li: beneficent power.

ching: unchangeable, determinative power.

[641] Round this masculine power-centre lies the earth with its formed elements. It is the same conception as the Shiva-Shakti union in *kundalini* yoga, but here represented as the earth receiving into itself the creative power of heaven. The union of heaven with *kun*, the feminine and receptive, produces the *tetraktys*, which, as in Pythagoras, underlies all existence.

[642] The "River Map" is one of the legendary foundations of the *I Ching*, which in its present form derives partly from the twelfth century B.C. According to the legend, a

dragon dredged the magical signs of the “River Map” from a river. On it the sages discovered the drawing, and in the drawing the laws of the world-order. This drawing, in accordance with its extreme age, shows the knotted cords that signify numbers. These numbers have the usual primitive character of qualities, chiefly masculine and feminine. All uneven numbers are masculine, even numbers feminine.

[643] Unfortunately I do not know whether this primitive conception influenced the formation of the much younger Tantric mandala. But the parallels are so striking that the European investigator has to ask himself: Which view influenced the other? Did the Chinese develop from the Indian, or the Indian from the Chinese? An Indian whom I asked answered: “Naturally the Chinese developed from the Indian.” But he did not know how old the Chinese conceptions are. The bases of the *I Ching* go back to the third millennium B.C. My late friend Richard Wilhelm, the eminent expert on classical Chinese philosophy, was of the opinion that no direct connections could be assumed. Nor, despite the fundamental similarity of the symbolic ideas, does there need to be any direct influence, since the ideas, as experience shows and as I think I have demonstrated, arise autochthonously again and again, independently of one another, out of a psychic matrix that seems to be ubiquitous.

Figure 3

[644] As a counterpart to the Lamaic mandala, I now reproduce the Tibetan “World Wheel,” which should be sharply distinguished from the former, since it represents the world. In the centre are the three principles: cock, snake, and pig, symbolizing lust, envy, and unconsciousness. The wheel has, near the centre, six spokes, and twelve spokes round the edge. It is based on a triadic system. The wheel is held by the god of death, Yama. (Later we shall meet other “shield-holders”: Figs. 34 and 47.) It is understandable that the sorrowful world of old age, sickness, and death should be held in the claws of the death-demon. The incomplete state of existence is, remarkably enough, expressed by a triadic system, and the complete (spiritual) state by a tetradic system. The relation between the incomplete and the complete state therefore corresponds to the “sesquitertian proportion” of 3 : 4. This relation is known in Western alchemical tradition as the axiom of Maria. It also plays a not inconsiderable role in dream symbolism.⁴

*

[645] We shall now pass on to individual mandalas spontaneously produced by patients in the course of an analysis of the unconscious. Unlike the mandalas so far discussed, these are not based on any tradition or model, seeming to be free creations of fantasy, but determined by certain archetypal ideas unknown to their creators. For this reason

the fundamental motifs are repeated so often that marked similarities occur in drawings done by the most diverse patients. The pictures come as a rule from educated persons who were unacquainted with the ethnic parallels. The pictures differ widely, according to the stage of the therapeutic process; but certain important stages correspond to definite motifs. Without going into therapeutic details, I would only like to say that a rearranging of the personality is involved, a kind of new centring. That is why mandalas mostly appear in connection with chaotic psychic states of disorientation or panic. They then have the purpose of reducing the confusion to order, though this is never the conscious intention of the patient. At all events they express order, balance, and wholeness. Patients themselves often emphasize the beneficial or soothing effect of such pictures. Usually the mandalas express religious, i.e., numinous, thoughts and ideas, or, in their stead, philosophical ones. Most mandalas have an intuitive, irrational character and, through their symbolical content, exert a retroactive influence on the unconscious. They therefore possess a “magical” significance, like icons, whose possible efficacy was never consciously felt by the patient. In fact, it is from the effect of their own pictures that patients discover what icons can mean. Their pictures work not because they spring from the patients’ own fantasy but because they are impressed by the fact that their subjective imagination produces motifs and symbols of the most unexpected kind that conform to law and express an idea or situation which their conscious mind can grasp only with difficulty. Confronted with these pictures, many patients suddenly realize for the first time the reality of the collective unconscious as an autonomous entity. I will not labour the point here; the strength of the impression and its effect on the patient are obvious enough from some of the pictures.

[646] I must preface the pictures that now follow with a few remarks on the formal elements of mandala symbolism. These are primarily:

1. *Circular, spherical, or egg-shaped formation.*

2. The circle is elaborated into a *flower* (rose, lotus) or a *wheel*.
3. A centre expressed by a *sun, star, or cross*, usually with four, eight, or twelve rays.
4. The circles, spheres, and cruciform figures are often represented in *rotation* (swastika).
5. The circle is represented by a *snake* coiled about a centre, either ring-shaped (uroboros) or spiral (Orphic egg).
6. *Squaring of the circle*, taking the form of a circle in a square or vice versa.
7. *Castle, city, and courtyard (temenos)* motifs, quadratic or circular.
8. *Eye* (pupil and iris).
9. Besides the tetradic figures (and multiples of four), there are also triadic and pentadic ones, though these are much rarer.

They should be regarded as “disturbed” totality pictures, as we shall see below.

Figure 4

[647] This mandala was done by a woman patient in her middle years, who first saw it in a dream. Here we see at once the difference from the Eastern mandala. It is poor in form, poor in ideas, but nevertheless expresses the individual attitude of the patient far more clearly than the Eastern pictures, which have been subjected to a collective and traditional configuration. Her dream ran: “*I was trying to decipher an embroidery pattern. My sister knew how. I asked her if she had made an elaborate hemstitched handkerchief. She said, “No, but I know how it was done.” Then I saw it with the threads drawn, but the work not yet done. One must go around and around the square until near the centre, then go in circles.*”

[648] The spiral is painted in the typical colours red, green, yellow, and blue. According to the patient, the square in the centre represents a *stone*, its four facets showing the four basic colours. The inner spiral represents the snake that, like Kundalini, winds three and a half times⁵ round the centre.

[649] The dreamer herself had no notion of what was going on in her, namely the beginning of a new orientation, nor would she have understood it consciously. Also, the parallels from Eastern symbolism were completely unknown to her, so that any influence is out of the question. The symbolic picture came to her spontaneously, when she had reached a certain point in her development.

[650] It is, unfortunately, not possible for me to say exactly under what circumstances each of these pictures arose. That would lead us too far. The sole aim of this paper is to give a survey of the formal parallels to the individual and collective mandala. I regret also that for the same reason no single picture can be interpreted circumstantially and in detail, as that would inevitably require a comprehensive account of the analytical situation of the patient. Wherever it is possible to shed light on the origins of the picture by a passing hint, as in the present case, I shall do so.

[651] As to the interpretation of the picture, it must be emphasized that the snake, arranged in angles and then in circles round the square, signifies the circumambulation of, and way to, the centre. The snake, as a chthonic and at the same time spiritual being, symbolizes the unconscious. The stone in the centre, presumably a cube, is the quaternary form of the *lapis philosophorum*. The four colours also point in this direction.⁶ It is evident that the stone in this case signifies the new centre of personality, the self, which is also symbolized by a vessel.

Figure 5

[652] The painter was a middle-aged woman of schizoid disposition. She had several times drawn mandalas spontaneously, because they always had an ordering effect on her chaotic psychic states. The picture shows a rose, the Western equivalent of the lotus. In India the lotus-flower (*padma*) is interpreted by the Tantrists as the womb. We know this symbol from the numerous pictures of the Buddha (and other Indian deities) in the lotus-flower.⁷ It corresponds to the “Golden Flower” of Chinese alchemy, the rose of the Rosicrucians, and the mystic rose in Dante’s *Paradiso*. Rose and lotus are usually arranged in groups of four petals, indicating the squaring of the circle or the united opposites. The significance of the rose as the maternal womb was nothing strange to our Western mystics, for we read in a prayer inspired by the Litany of Loreto:

O Rose-wreath, thy blossoming makes men weep for joy.

O rosy sun, thy burning makes men to love.

O son of the sun,

Rose-child,

Sun-beam.

Flower of the Cross, pure Womb that blossoms

Over all blooming and burning,

Sacred Rose,

Mary.

[653] At the same time, the vessel motif is an expression of the content, just as Shakti represents the actualization of Shiva. As alchemy shows, the self is androgynous and consists of a masculine and a feminine principle. Conrad of Würzburg speaks of Mary, the flower of the sea in which Christ lies hidden. And in an old hymn we read:

O'er all the heavens a rose appears

And a bright dress of blossom wears.

Its light glows in the Three-in-One

For God himself has put it on.

Figure 6

[654] The rose in the centre is depicted as a ruby, its outer ring being conceived as a wheel or a wall with gates (so that nothing can come out from inside or go in from outside). The mandala was a spontaneous product from the analysis of a male patient. It was based on a dream: *The dreamer found himself with three younger travelling companions in Liverpool.*⁸ *It was night, and raining. The air was full of smoke and soot. They climbed up from the harbour to the “upper city.”* The dreamer said: “It

was terribly dark and disagreeable, and we could not understand how anyone could stick it here. We talked about this, and one of my companions said that, remarkably enough, a friend of his had settled here, which astonished everybody. During this conversation we reached a sort of public garden in the middle of the city. The park was square, and in the centre was a lake or large pool. A few street lamps just lit up the pitch darkness, and I could see a little island in the pool. On it there was a single tree, a red-flowering magnolia, which miraculously stood in everlasting sunshine. I noticed that my companions had not seen this miracle, whereas I was beginning to understand why the man had settled here.”

[655] The dreamer went on: “I tried to paint this dream. But as so often happens, it came out rather different. The magnolia turned into a sort of rose made of ruby-coloured glass. It shone like a four-rayed star. The square represents the wall of the park and at the same time a street leading round the park in a square. From it there radiate eight main streets, and from each of these eight side-streets, which meet in a shining red central point, rather like the Étoile in Paris. The acquaintance mentioned in the dream lived in a house at the corner of one of these stars.” The mandala thus combines the classic motifs of flower, star, circle, precinct (*temenos*), and plan of city divided into quarters with citadel. “The whole thing seemed like a window opening on to eternity,” wrote the dreamer.

Figure 7

[656] Flower motif with cross in the centre. The square, too, is arranged like a flower. The four faces at the corners correspond to the four cardinal points, which are often depicted as four deities. Here they have a demonic character. This may be connected with the fact that the patient was born in the Dutch East Indies, where she sucked up the peculiar local demonology with the mother’s milk of her native ayah. Her numerous drawings all had a distinctly Eastern character, and thereby helped her to assimilate influences that at first could not be reconciled with her Western mentality.⁹

[657] In the picture that followed, the demon faces were ornamentally elaborated in eight directions. For the superficial observer the flowerlike character of the whole may disguise the demonic element the mandala is meant to ward off. The patient felt that the “demonic” effect came from the European influence with its moralism and rationalism. Brought up in the East Indies until her sixth year, she came later into a conventional European milieu, and this had a devastating effect on the flowerlike quality of her Eastern spirit and caused a prolonged psychic trauma. Under treatment her native world, long submerged, came up again in these drawings, bringing with it psychic recovery.

Figure 8

[658] The flowerlike development has got stronger and is beginning to overgrow the “demonishness” of the faces.

Figure 9

[659] A later stage is shown here. Minute care in the draughtsmanship vies with richness of colour and form. From this we can discern not only the extraordinary concentration of the patient but the triumph of Eastern “flowerlikeness” over the demon of Western intellectualism, rationalism, and moralism. At the same time the new centring of the personality becomes visible.

Figure 10

[660] In this painting, done by another young woman patient, we see at the cardinal points four creatures: a bird, a sheep, a snake, and a lion with a human face. Together with the four colours in which the four regions are painted, they embody four principles. The interior of the mandala is empty. Or rather, it contains a “Nothing” that is expressed by a quaternity. This is in accord with the overwhelming majority of individual mandalas: as a rule the centre contains the motif of the *rotundum*, known to us from alchemy, or the four-fold emanation or the squaring of the circle, or—more rarely—the figure of the patient in a universal human sense, representing the *Anthropos*.¹⁰ We find this motif, too, in alchemy. The four animals remind us of the cherubim in Ezekiel’s vision, and also of the four symbols of the evangelists and the four sons of Horus, which are sometimes depicted in the same way, three with animal heads and one with a human head. Animals generally signify the instinctive forces of the unconscious, which are brought into unity within the mandala. This integration of the instincts is a prerequisite for individuation.

Figure 11

[661] Painting by an older patient. Here the flower is seen not in the basic pattern of the mandala, but in elevation. The circular form has been preserved inside the square, so that despite its different execution this picture can still be regarded as a mandala. The plant stands for growth and development, like the green shoot in the diaphragm *chakra* of the *kundalini* yoga system. The shoot symbolizes Shiva and represents the centre and the male, whereas the calyx represents the female, the place of germination and birth.¹¹ Thus the Buddha sitting in the lotus is shown as the germinating god. It is the god in his rising, the same symbol as Ra the falcon, or the phoenix rising from the nest, or Mithras in the tree-top, or the Horus-child in the lotus. They are all symbolizations of the *status nascendi* in the seeding-place of the matrix. In medieval hymns Mary too is praised as the cup of the flower in which

Christ, coming down as a bird, makes his nest. Psychologically Christ means unity, which clothes itself in the *corpus mysticum* of the Church or in the body of the Mother of God (“mystic rose”), surrounded as with flower-petals, and thus reveals itself in reality. Christ as an image is a symbol of the self.¹² Just as the plant stands for growth, so the flower depicts the unfolding from a centre.

Figure 12

[662] Here the four rays emanating from the centre spread across the whole picture. This gives the centre a dynamic character. The structure of the flower is a multiple of four. The picture is typical of the marked personality of the patient, who had some artistic talent. (She also painted Fig. 5.) Besides that she had a strong feeling for Christian mysticism, which played a great role in her life. It was important for her to experience the archetypal background of Christian symbolism.

Figure 13

[663] Photograph of a rug woven by a middle-aged woman, Penelope-like, at a time of great inner and outer distress. She was a doctor and she wove this magic circle round herself, working at it every day for months, as a counterbalance to the difficulties of her life. She was not my patient and could not have been influenced by me. The rug contains an eight-petalled flower. A special feature of the rug is that it has a real “above and below.” Above is light; below, relative darkness. In it, there is a creature like a beetle, representing an unconscious content, and comparable with the sun in the form of Khepera. Occasionally the “above and below” are outside the protective circle, instead of inside. In that case the mandala affords protection against extreme opposites; that is, the sharpness of the conflict is not yet realized or else is felt as intolerable. The protective circle then guards against possible disruption due to the tension of opposites.

Figure 14

[664] An Indian picture of *Shiva-bindu*, the unextended point. It shows the divine power before the creation: the opposites are still united. The god rests in the point. Hence the snake signifies extension, the mother of Becoming, the creation of the world of forms. In India this point is also called *Hiranyagarbha*, ‘golden germ’ or ‘golden egg.’ We read in the *Sanatsugatiya*: “That pure great light which is radiant, that great glory which the gods worship, which makes the sun shine forth, that divine, eternal Being is perceived by the faithful.”¹³

Figure 15

[665] This picture, also by a middle-aged woman patient, shows the squaring of the circle. The plants again denote germination and growth. In the centre is a sun. As the snake-and-tree motif shows, we have here a conception of Paradise. A parallel is the Gnostic conception of Edem with the four rivers of Paradise in the Naassene gnosis. For the functional significance of the snake in relation to the mandala, see the preceding paper (comments on pictures 3, 4, and 5).

Figure 16

[666] This picture was painted by a neurotic young woman. The snake is somewhat unusual in that it lies in the centre itself, its head coinciding with this. Usually it is outside the inner circle, or at least coiled round the central point. One suspects (rightly, as it turned out) that the inner darkness does not conceal the longed-for unity, the self, but rather the chthonic, feminine nature of the patient. In a later picture the mandala bursts and the snake comes out.

Figure 17

[667] The picture was done by a young woman. This mandala is “legitimate” in so far as the snake is coiled round the four-rayed middle point. It is trying to get out: it is the awakening of Kundalini, meaning that the patient’s chthonic nature is becoming active. This is also indicated by the arrows pointing outwards. In practice it means becoming conscious of one’s instinctual nature. The snake in ancient times personified the spinal ganglia and the spinal cord. Arrows pointing outwards may in other cases mean the opposite: protection of the inside from danger.

Figure 18

[668] Drawn by an older patient. Unlike the previous picture, this one is “introverted.” The snake is coiled round the four-rayed centre and has laid its head on the white, central point (*Shiva-bindu*), so that it looks as if it were wearing a halo. There seems to be a kind of incubation of the middle point—the motif of the snake guarding the treasure. The centre is often characterized as the “treasure hard to attain.”¹⁴

Figure 19

[669] Done by a middle-aged woman. The concentric circles express concentration. This is further emphasized by the fishes circumnavigating the centre. The number 4 has the meaning of total concentration. The movement to the left presumably indicates movement towards the unconscious, i.e., immersion in it.

Figure 20

[670] This is a parallel to [Figure 19](#): sketch of a fish-motif which I saw on the ceiling of the Maharajah's pavilion in Benares.

Figure 21

[671] A fish instead of a snake. Fish and snake are simultaneously attributes of both Christ and the devil. The fish is making a whirlpool in the sea of the unconscious, and in its midst the precious pearl is being formed. A Rig-Veda hymn says:

Darkness there was, concealed in darkness,
A Lightless ocean lost in night.
Then the One, that was hidden in the shell,
Was born through the power of fiery torment.
From it arose in the beginning love,
Which is the germ and the seed of knowledge.¹⁵

[672] As a rule the snake personifies the unconscious, whereas the fish usually represents one of its contents. These subtle distinctions must be borne in mind when interpreting a mandala, because the two symbols very probably correspond to two different stages of development, the snake representing a more primitive and more instinctual state than the fish, which in history as well was endowed with higher authority than the snake (cf. the Ichthys-symbol).

Figure 22

[673] In this picture by a young woman the fish has produced a differentiated centre by circumnavigation, and in it a mother and child stand before a stylized Tree of Life or of Knowledge. Here the fish has a dragonlike nature; it is a monster, a sort of Leviathan, which, as the texts from Ras Shamra show, was originally a snake.¹⁶ Once more the movement is to the left.

Figure 23

[674] The golden ball corresponds to the golden germ (Hiranyagarbha). It is rotating, and the Kundalini winding round it has doubled. This indicates conscious realization, since a content rising out of the unconscious splits at a certain moment into two halves, a conscious and an unconscious one. The doubling is not made by the conscious mind, but appears spontaneously in the products of the unconscious. The rightwards rotation, expressed by the wings (swastika-motif), likewise indicates conscious realization. The stars show that the centre has a cosmic structure. It has four rays, and thus behaves like a heavenly body. The Shatapatha-Brahmana says:

Then he looks up to the sun, for that is the final goal, that the safe resort. To that final goal, to that resort he goes; for this reason he looks up to the sun.

He looks up, saying, “Self-existent art thou, the best ray of light!” The sun is indeed the best ray of light, and therefore he says, “Self-existent art thou, the best ray of light!” “Light-bestowing art thou: give me light (*varkas*)!” “So say I,” said Yajñavalkya, “and for this indeed the Brahmin should strive, if he would be *brahmavarkasin*, illumined by brahma.”

He then turns from left to right, saying, “I move along the course of the sun.” Having reached that final goal, that safe resort, he now moves along the course of yonder sun.¹⁷

[675] This sun has seven rays. A commentator remarks that four of them point to the four quarters; one points upwards, another downwards, but the seventh and “best” points inwards. It is at the same time the sun’s disc, named Hiranyagarbha. This, according to Ramanuja’s commentary on the Vedanta Sutas,¹⁸ is the highest self, the “collective aggregate of all individual souls.” It is the body of the highest Brahma and represents the collective psyche. For the idea of the self as compounded of many, compare Origen’s “Each of us is not one, but many” and “All are righteous, but one receiveth the crown.”¹⁹

[676] The patient was a woman of sixty, artistically gifted. The individuation process, long blocked but released by the treatment, stimulated her creative activity (Fig. 21 derives from the same source) and gave rise to a series of happily coloured pictures which eloquently express the intensity of her experience.

Figure 24

[677] Done by the same patient. She herself is shown practising contemplation or concentration on the centre: she has taken the place of the fish and the snakes. An ideal image of herself is laid round the precious egg. The legs are flexible, like a nixie’s. The psychology of such a picture reappears in ecclesiastical tradition. The Shiva-Shakti of the East is known in the West as the “man encompassed by a woman,” Christ and his bride the Church. Compare the Maitrayana-Brahmana Upanishad:

He [the Self] is also he who warms, the Sun, hidden by the thousand-eyed golden egg, as one fire by another. He is to be thought after, he is to be sought after. Having said farewell to all living things, having gone to the forest, and having renounced all sensuous objects, let a man perceive the Self from his own body.²⁰

[678] Here too the radiation from the centre spreads out beyond the protective circle into the distance. This expresses the idea of the far-reaching effect of the introverted

state of consciousness. It could also be described as an *unconscious* connection with the world.

Figure 25

[679] This picture was done by another middle-aged patient. It shows various phases of the individuation process. Down below she is caught in a chthonic tangle of roots (the *mūlādhāra* of *kundalini* yoga). In the middle she studies a book, cultivating her mind and augmenting her knowledge and consciousness. At the top, reborn, she receives illumination in the form of a heavenly sphere that widens and frees the personality, its round shape again representing the mandala in its “Kingdom of God” aspect, whereas the lower, wheel-shaped mandala is chthonic. There is a confrontation of the natural and spiritual totalities. The mandala is unusual on account of its six rays, six mountain peaks, six birds, three human figures. In addition, it is located between a distinct Above and Below, also repeated in the mandala itself. The upper, bright sphere is in the act of descending into the hexad or triad and has already passed the rim of the wheel. According to old tradition the number 6 means creation and evolution, since it is a *coniunctio* of 2 and 3 (even and odd = female and male). Philo Judaeus therefore calls the *senarius* (6) the “number most suited to generation.”²¹ The number 3, he says, denotes the surface or flatness, whereas 4 means height or depth. The *quaternarius* “shows the nature of solids,” whereas the three first numbers characterize or produce incorporeal intelligences. The number 4 appears as a three-sided pyramid.²² The hexad shows that the mandala consists of two triads, and the upper one is making itself into a quaternity, the state of “equability and justice,” as Philo says. Down below lurk unintegrated dark clouds. This picture demonstrates the not uncommon fact that the personality needs to be extended both upwards and downwards.

Figure 26 and 27

[680] These mandalas are in part atypical. Both were done by the same young woman. In the centre, as in the previous mandala, is a female figure, as if enclosed in a glass sphere or transparent bubble. It looks almost as if an homunculus were in the making. In addition to the usual four or eight rays, both mandalas show a pentadic element. There is thus a dilemma between four and five. Five is the number assigned to the “natural” man, in so far as he consists of a trunk with five appendages. Four, on the other hand, signifies a *conscious* totality. It describes the ideal, “spiritual” man and formulates him as a totality in contrast to the pentad, which describes the corporeal man. It is significant that the swastika symbolizes the “ideal” man,²³ whereas the five-pointed star symbolizes the material and bodily man.²⁴ The dilemma of four and five corresponds to the conflict between “culture” and “nature.” That was the

problem of the patient. In [Figure 26](#) the dilemma is indicated by the four groups of stars: two of them contain four stars and two of them five stars. On the rims of both mandalas we see the “fire of desire.” In [Figure 27](#) the rim is made of something that looks like lighted tissue. In characteristic contrast to the “shining” mandala, both these (especially the second one) are “burning.” It is flaming desire, comparable to the longing of the homunculus in the retort (*Faust*, [Part II](#)), which was finally shattered against the throne of Galatea. The fire represents an erotic demand but at the same time an *amor fati* that burns in the innermost self, trying to shape the patient’s fate and thus help the self into reality. Like the homunculus in *Faust*, the figure shut up in the vessel wants to “become.”

[681] The patient was herself aware of the conflict, for she told me she had no peace after painting the second picture. She had reached the afternoon of her life, and was in her thirty-fifth year. She was in doubt as to whether she ought to have another child. She decided for a child, but fate did not let her, because the development of her personality was evidently pursuing a different goal, not a biological but a cultural one. The conflict was resolved in the interests of the latter.

Figure 28

[682] Picture by a middle-aged man. In the centre is a star. The blue sky contains golden clouds. At the four cardinal points we see human figures: at the top, an old man in the attitude of contemplation; at the bottom, Loki or Hephaestus with red, flaming hair, holding in his hands a temple. To the right and left are a light and a dark female figure. Together they indicate four aspects of the personality, or four archetypal figures belonging, as it were, to the periphery of the self. The two female figures can be recognized without difficulty as the two aspects of the anima. The old man corresponds to the archetype of meaning, or of the spirit, and the dark chthonic figure to the opposite of the Wise Old Man, namely the magical (and sometimes destructive) Luciferian element. In alchemy it is Hermes Trismegistus versus Mercurius, the evasive “trickster.”²⁵ The circle enclosing the sky contains structures or organisms that look like protozoa. The sixteen globes painted in four colours just outside this circle derived originally from an eye motif and therefore stand for the observing and discriminating consciousness. Similarly, the ornaments in the next circle, all opening inwards, are rather like vessels pouring out their content towards the centre.²⁶ On the other hand the ornaments along the rim open outwards, as if to receive something from outside. That is, in the individuation process what were originally projections stream back “inside” and are integrated into the personality again. Here, in contrast to [Figure 25](#), “Above” and “Below,” male and female, are integrated, as in the alchemical hermaphrodite.

Figure 29

[683] Once again the centre is symbolized by a star. This very common image is consistent with the previous pictures, where the sun represents the centre. The sun, too, is a star, a radiant cell in the ocean of the sky. The picture shows the self appearing as a star out of chaos. The four-rayed structure is emphasized by the use of four colours. This picture is significant in that it sets the structure of the self as a principle of order against chaos.²⁷ It was painted by the same man who did [Figure 28](#).

Figure 30

[684] This mandala, by an older woman patient, is again split into Above and Below: heaven above, the sea below, as indicated by the golden waves on a green ground. Four wings revolve leftwards about the centre, which is marked only by an orange-red spot. Here too the opposites are integrated and are presumably the cause of the centre's rotation.

Figure 31

[685] An atypical mandala, based on a dyad. A golden moon and a silver moon form the upper and lower edges. The inside is blue sky above and something like a black crenellated wall below. On it there sits a peacock, fanning out its tail, and to the left there is an egg, presumably the peacock's. In view of the important role which the peacock and the peacock's egg together play in alchemy and also in Gnosticism, we may expect the miracle of the *cauda pavonis*, the appearance of "all Colours" (Böhme), the unfolding and realization of wholeness, once the dark dividing wall has broken down. (See [Fig. 32](#).) The patient thought the egg might split and produce something new, maybe a snake. In alchemy the peacock is synonymous with the Phoenix. A variant of the Phoenix legend relates that the Semenda Bird consumes itself, a worm forms from the ashes, and from the worm the bird rises anew.

Figure 32

[686] This picture is reproduced from the Codex Alchemicus Rhenoviensis, Central Library, Zurich. Here the peacock represents the Phoenix rising newborn from the fire. There is a similar picture in a manuscript in the British Museum, only there the peacock is enclosed in a flask, the *vas hermeticum*, like the homunculus.²⁸ The peacock is an old emblem of rebirth and resurrection, quite frequently found on Christian sarcophagi. In the vessel standing beside the peacock the colours of the *cauda pavonis* appear, as a sign that the transformation process is nearing its goal. In

the alchemical process the *serpens mercurialis*, the dragon, is changed into the eagle, the peacock, the goose of Hermes, or the Phoenix.²⁹

Figure 33

[687] This picture was done by a seven-year-old boy, offspring of a problem marriage. He had done a whole series of these drawings of circles and hung them up round his bed. He called them his “loves” and would not go to sleep without them. This shows that the “magical” pictures still functioned for him in their original sense, as a protective magic circle.

Figure 34

[688] An eleven-year-old girl, whose parents were divorced, had, at a time of great difficulties and upsets, drawn a number of pictures which clearly reveal a mandala structure. Here too they were magic circles intended to stop the difficulties and adversities of the outside world from entering into the inner psychic space. They represent a kind of self-protection.

[689] As on the *kilkhor*, the Tibetan World Wheel (Fig. 3), you can see at either side of this picture something that looks like horns, which as we know belong to the devil or to one of his theriomorphic symbols. The slanting eye-slits underneath them, and the two strokes for nose and mouth, are also the devil's. This amounts to saying: Behind the mandala lurks the devil. Either the “demons” are covered up by the magically powerful picture, and thereby eliminated—which would be the purpose of the mandala—or, as in the case of the Tibetan World Wheel, the world is caught in the claws of the demon of death. In this picture the devils merely peek out over the edge. I have seen what this means from another case: An artistically gifted patient produced a typical tetradic mandala and stuck it on a sheet of thick paper. On the back there was a circle to match, filled with drawings of sexual perversions. This shadow aspect of the mandala represented the disorderly, disruptive tendencies, the “chaos” that hides behind the self and bursts out in a dangerous way as soon as the individuation process comes to a standstill, or when the self is not realized and so remains unconscious. This piece of psychology was expressed by the alchemists in their Mercurius duplex, who on the one hand is Hermes the mystagogue and psychopomp, and on the other hand is the poisonous dragon, the evil spirit and “trickster.”

Figure 35

[690] Drawing by the same girl. Round the sun is a circle with eyes, and round this an uroboros. The motif of polyophtalmia frequently occurs in individual mandalas.

(See Picture 17 and Fig. 5 in the preceding paper.) In the Maitrayana-Brahmana Upanishad VI, 8 the egg (Hiranyagarbha) is described as “thousand-eyed.” The eyes in the mandala no doubt signify the observing consciousness, but it must also be borne in mind that the texts as well as the pictures both attribute the eyes to a mythic figure, e.g., an Anthropos, who does the seeing. This seems to me to point to the fascination which, through a kind of magical stare, attracts the attention of the conscious mind. (Cf. Figs. 38 and 39.)

Figure 36

[691] Painting of a medieval city with walls and moats, streets and churches, arranged quadratically. The inner city is again surrounded by walls and moats, like the Imperial City in Peking. The buildings all open inwards, towards the centre, represented by a castle with a golden roof. It too is surrounded by a moat. The ground round the castle is laid with black and white tiles, representing the united opposites. This mandala was done by a middle-aged man (cf. Figs. 6, 28, 29). A picture like this is not unknown in Christian symbolism. The Heavenly Jerusalem of Revelation is known to everybody. Coming to the Indian world of ideas, we find the city of Brahma on the world mountain, Meru. We read in the *Golden Flower*: “The *Book of the Yellow Castle* says: ‘In the square inch field of the square foot house, life can be regulated.’ The square foot house is the face. The square inch field in the face: what could that be other than the heavenly heart? In the middle of the square inch dwells the splendour. In the purple hall of the city of jade dwells the God of Utmost Emptiness and Life.”³⁰

Figure 37

[692] Painted by the same patient who did Figures 11 and 30. Here the “seeding-place” is depicted as a child enclosed in a revolving sphere. The four “wings” are painted in the four basic colours. The child corresponds to Hiranyagarbha and to the homunculus of the alchemists. The mythologem of the “Divine Child” is based on ideas of this sort.³¹

Figure 38

[693] Mandala in rotation, by the same patient, who did Figures 21 and 23. A notable feature is the quaternary structure of the golden wings in combination with the triad of three dogs running round the centre. They have their backs to it, indicating that for them the centre is in the unconscious. The mandala contains—another unusual feature—a triadic motif turning to the left, while the wings turn to the right. This is not accidental. The dogs represent consciousness “scenting” or “intuiting” the

unconscious; the wings show the movement of the unconscious towards consciousness, as corresponded to the patient's situation at the time. It is as if the dogs were fascinated by the centre although they cannot see it. They seem to represent the fascination felt by the conscious mind. The picture embodies the above-mentioned sesquitertian proportion (3 : 4).

Figure 39

[694] The same motif as before, but represented by hares. From a Gothic window in the cathedral at Paderborn. There is no recognizable centre though the rotation presupposes one.

Figure 40

[695] Picture by a young woman patient. It too exhibits the sesquitertian proportion and hence the dilemma with which Plato's *Timaeus* begins, and which as I said plays a considerable role in alchemy, as the axiom of Maria.³²

Figure 41

[696] This picture was done by a young woman patient with a schizoid disposition. The pathological element is revealed in the "breaking lines" that split up the centre. The sharp, pointed forms of these breaking lines indicate evil, hurtful, and destructive impulses which might hinder the desired synthesis of personality. But it seems as if the regular structure of the surrounding mandala might be able to restrain the dangerous tendencies to dissociation. And this proved to be the case in the further course of the treatment and subsequent development of the patient.

Figure 42

[697] A neurotically disturbed mandala. It was drawn by a young, unmarried woman patient at a time that was full of conflict: she was in a dilemma between two men. The outer rim shows four different colours. The centre is doubled in a curious way: fire breaks out from behind the blue star in the black field, while to the right a sun appears, with blood vessels running through it. The five-pointed star suggests a pentagram symbolizing man, the arms, legs, and head all having the same value. As I have said, it signifies the purely instinctual, chthonic, unconscious man. (Cf. Figs. 26 and 27.) The colour of the star is blue—of a cool nature, therefore. But the nascent sun is yellow and red—a warm colour. The sun itself (looking rather like the yolk of an incubated egg) usually denotes consciousness, illumination, understanding. Hence we could say of this mandala: a light is gradually dawning on the patient, she is

waking out of her formerly unconscious state, which corresponded to a purely biological and rational existence. (Rationalism is no guarantee of higher consciousness, but merely of a one-sided one!) The new state is characterized by red (feeling) and yellow or gold (intuition). There is thus a shifting of the centre of personality into the warmer region of heart and feeling, while the inclusion of intuition suggests a groping, irrational apprehension of wholeness.

Figure 43

[698] This picture was done by a middle-aged woman who, without being neurotic, was struggling for spiritual development and used for this purpose the method of active imagination. These efforts induced her to make a drawing of the birth of a new insight or conscious awareness (eye) from the depths of the unconscious (sea). Here the eye signifies the self.

Figure 44

[699] Drawing of motif from a Roman mosaic on the floor of a house in Moknine, Tunis, which I photographed. It represents an apotropaism against the evil eye.

Figure 45

[700] Mandala from the Navaho Indians, who with great toil prepare such mandalas from coloured sand for curative purposes. It is part of the Mountain Chant Rite performed for the sick. Around the centre there runs, in a wide arc, the body of the Rainbow Goddess. A square head denotes a female deity, a round one a male deity. The arrangement of the four pairs of deities on the arms of the cross suggests a swastika wheeling to the right. The four male deities who surround the swastika are making the same movement.

Figure 46

[701] Another sand-painting by the Navahos, from the Male Shooting Chant. The four horned heads are painted in the four colours that correspond to the four directions.³³

Figure 47

[702] Here, for comparison, is a painting of the Egyptian Sky Mother, bending, like the Rainbow Goddess, over the “Land” with its round horizon. Behind the mandala stands—presumably—the Air God, like the demon in [Figures 3](#) and [34](#). Underneath, the arms of the *ka*, raised in adoration and decked with the eye motif, hold the mandala, which probably signifies the wholeness of the “Two Lands.”³⁴

Figure 48

[703] This picture, from a manuscript of Hildegard of Bingen, shows the earth surrounded by the ocean, realm of air, and starry heaven. The actual globe of the earth in the centre is divided into four.³⁵

[704] Böhme has a mandala in his book *XL Questions concerning the Soule* (see Fig. 1 of preceding paper). The periphery contains a bright and a dark hemisphere turning their backs to one another. They represent un-united opposites, which presumably should be bound together by the heart standing between them. This drawing is most unusual, but aptly expresses the insoluble moral conflict underlying the Christian view of the world. “The Soul,” Böhme says, “is an Eye in the Eternal Abyss, a similitude of Eternity, a perfect Figure and Image of the first Principle, and resembles God the Father in his Person, as to the eternal Nature. The Essence and Substance of it, merely as to what it is purely in itself, is first the wheel of Nature, with the first four Forms.” In the same treatise Böhme says: “The substance and Image of the soul may be resembled to the Earth, having a fair flower growing out of it...” “The Soul is a fiery Eye ... from the eternal Centre of Nature ... a similitude of the First Principle.”³⁶ As an eye, the soul “receives the Light, as the Moon does the glance of the Sun ... for the life of the soul has its original in the Fire.”³⁷

Figure 49 and 50

[705] Figure 49 is especially interesting because it shows us very clearly in what relationship the picture stands to the painter. The patient (the same as did Fig. 42) has a shadow problem. The female figure in the picture represents her dark, chthonic side. She is standing in front of a wheel with four spokes, the two together forming an eight-rayed mandala. From her head spring four snakes,³⁸ expressing the tetradic nature of consciousness, but—in accordance with the demonic character of the picture—they do this in an evil and nefarious way, since they represent evil and destructive thoughts. The entire figure is wrapped in flames, emitting a dazzling light. She is like a fiery demon, a salamander, the medieval conception of a fire sprite. Fire expresses an intense transformation process. Hence the *prima materia* in alchemy was symbolized by the salamander in the fire, as the next picture shows.³⁹ The spear- or arrow-head expresses “direction”: it is pointing upwards from the middle of the head. Everything that the fire consumes rises up to the seat of the gods. The dragon glowing in the fire becomes volatilized; illumination comes through the fiery torment. Figure 49 tells us something about the background of the transformation process. It depicts a state of suffering, reminiscent on the one hand of crucifixion and on the other of Ixion bound to the wheel. From this it is evident that individuation, or becoming whole, is neither a *summum bonum* nor a *summum*

desideratum, but the painful experience of the union of opposites. That is the real meaning of the cross in the circle, and that is why the cross has an apotropaic effect, because, pointed at evil, it shows evil that it is already included and has therefore lost its destructive power.

Figure 51

[706] This picture was done by a sixty-year-old woman patient with a similar problem: A fiery demon mounts through the night towards a star. There he passes over from a chaotic into an ordered and fixed state. The star stands for the transcendent totality, the demon for the animus, who, like the anima, is the connecting link between conscious and unconscious. The picture recalls the antique symbolism found, for instance, in Plutarch:⁴⁰ The soul is only partly in the body, the other part is outside it and soars above man like a star symbolizing his “genius.” The same conception can be found among the alchemists.

Figure 52

[707] Picture by the same patient as before, showing flames with a soul rising up from them, as if swimming. The motif is repeated in [Figure 53](#). Exactly the same thing—and with the same meaning—can be found in the Codex Rhenoviensis (fifteenth century), Zurich (Fig. 54). The souls of the calcined *prima materia* escape as vapours, in the form of human figures looking like children (homunculi). In the fire is the dragon, the chthonic form of the *anima mundi*, which is being transmuted.

Figure 53 and 54

[708] Here I must remark that not only did the patient have no knowledge of alchemy but that I myself knew nothing at that time of the alchemical picture material. The resemblance between these two pictures, striking as it is, is nothing extraordinary, since the great problem and concern of philosophical alchemy was the same as underlies the psychology of the unconscious, namely individuation, the integration of the self. Similar causes (other things being equal) have similar effects, and similar psychological situations make use of the same symbols, which on their side rest on archetypal foundations, as I have shown in the case of alchemy.

Conclusion

[709] I hope I have succeeded in giving the reader some idea of mandala symbolism with the help of these pictures. Naturally my exposition aims at nothing more than a superficial survey of the empirical material on which comparative research is based. I

have indicated a few parallels that may point the way to further historical and ethnic comparisons, but have refrained from a more complete and more thorough exposition because it would have taken me too far.

[710] I need say only a few words about the functional significance of the mandala, as I have discussed this theme several times before. Moreover, if we have a little feeling in our fingertips we can guess from these pictures, painted with the greatest devotion but with unskilful hands, what is the deeper meaning that the patients tried to put into them and express through them. They are *yantras* in the Indian sense, instruments of meditation, concentration, and self-immersion, for the purpose of realizing inner experience, as I have explained in the commentary to the *Golden Flower*. At the same time they serve to produce an inner order—which is why, when they appear in a series, they often follow chaotic, disordered states marked by conflict and anxiety. They express the idea of a safe refuge, of inner reconciliation and wholeness.

[711] I could produce many more pictures from all parts of the world, and one would be astonished to see how these symbols are governed by the same fundamental laws that can be observed in individual mandalas. In view of the fact that all the mandalas shown here were new and uninfluenced products, we are driven to the conclusion that there must be a transconscious disposition in every individual which is able to produce the same or very similar symbols at all times and in all places. Since this disposition is usually not a conscious possession of the individual I have called it the *collective unconscious*, and, as the bases of its symbolical products, I postulate the existence of primordial images, the *archetypes*. I need hardly add that the identity of unconscious individual contents with their ethnic parallels is expressed not merely in their form but in their meaning.

[712] Knowledge of the common origin of these unconsciously preformed symbols has been totally lost to us. In order to recover it, we have to read old texts and investigate old cultures, so as to gain an understanding of the things our patients bring us today in explanation of their psychic development. And when we penetrate a little more deeply below the surface of the psyche, we come upon historical layers which are not just dead dust, but alive and continuously active in everyone—maybe to a degree that we cannot imagine in the present state of our knowledge.

APPENDIX

MANDALAS¹

[713] The Sanskrit word *mandala* means “circle” in the ordinary sense of the word. In the sphere of religious practices and in psychology it denotes circular images, which are drawn, painted, modelled, or danced. Plastic structures of this kind are to be found, for instance, in Tibetan Buddhism, and as dance figures these circular patterns occur also in Dervish monasteries. As psychological phenomena they appear spontaneously in dreams, in certain states of conflict, and in cases of schizophrenia. Very frequently they contain a quaternity or a multiple of four, in the form of a cross, a star, a square, an octagon, etc. In alchemy we encounter this motif in the form of *quadratura circuli*.

[714] In Tibetan Buddhism the figure has the significance of a ritual instrument (*yantra*), whose purpose is to assist meditation and concentration. Its meaning in alchemy is somewhat similar, inasmuch as it represents the synthesis of the four elements which are forever tending to fall apart. Its spontaneous occurrence in modern individuals enables psychological research to make a closer investigation into its functional meaning. As a rule a mandala occurs in conditions of psychic dissociation or disorientation, for instance in the case of children between the ages of eight and eleven whose parents are about to be divorced, or in adults who, as the result of a neurosis and its treatment, are confronted with the problem of opposites in human nature and are consequently disoriented; or again in schizophrenics whose view of the world has become confused, owing to the invasion of incomprehensible contents from the unconscious. In such cases it is easy to see how the severe pattern imposed by a circular image of this kind compensates the disorder and confusion of the psychic state—namely, through the construction of a central point to which everything is related, or by a concentric arrangement of the disordered multiplicity and of contradictory and irreconcilable elements. This is evidently an *attempt at self-healing* on the part of Nature, which does not spring from conscious reflection but from an instinctive impulse. Here, as comparative research has shown, a fundamental schema is made use of, an archetype which, so to speak, occurs everywhere and by no means owes its individual existence to tradition, any more than the instincts would need to be transmitted in that way. Instincts are given in the case of every newborn individual and belong to the inalienable stock of those qualities which characterize a species. What psychology designates as archetype is really a particular, frequently occurring, formal aspect of instinct, and is just as much an *a priori* factor as the latter.

Therefore, despite external differences, we find a fundamental conformity in mandalas regardless of their origin in time and space.

[715] The “squaring of the circle” is one of the many archetypal motifs which form the basic patterns of our dreams and fantasies. But it is distinguished by the fact that it is one of the most important of them from the functional point of view. Indeed, it could even be called the *archetype of wholeness*. Because of this significance, the “quaternity of the One” is the schema for all images of God, as depicted in the visions of Ezekiel, Daniel, and Enoch, and as the representation of Horus with his four sons also shows. The latter suggests an interesting differentiation, inasmuch as there are occasionally representations in which three of the sons have animals’ heads and only one a human head, in keeping with the Old Testament visions as well as with the emblems of the seraphim which were transferred to the evangelists, and—last but not least—with the nature of the Gospels themselves: three of which are synoptic and one “Gnostic.” Here I must add that, ever since the opening of Plato’s *Timaeus* (“One, two, three ... but where, my dear Socrates, is the fourth?”) and right up to the Cabiri scene in *Faust*, the motif of four as three and one was the ever-recurring preoccupation of alchemy.

[716] The profound significance of the quaternity with its singular process of differentiation extending over the centuries, and now manifest in the latest development of the Christian symbol,² may explain why *Du* chose just the archetype of wholeness as an example of symbol formation. For, just as this symbol claims a central position in the historical documents, individually too it has an outstanding significance. As is to be expected, individual mandalas display an enormous variety. The overwhelming majority are characterized by the circle and the quaternity. In a few, however, the three or the five predominates, for which there are usually special reasons.

[717] Whereas ritual mandalas always display a definite style and a limited number of typical motifs as their content, individual mandalas make use of a well-nigh unlimited wealth of motifs and symbolic allusions, from which it can easily be seen that they are endeavouring to express either the totality of the individual in his inner or outer experience of the world, or its essential point of reference. Their object is the *self* in contradistinction to the *ego*, which is only the point of reference for consciousness, whereas the self comprises the totality of the psyche altogether, i.e., conscious *and* unconscious. It is therefore not unusual for individual mandalas to display a division into a light and a dark half, together with their typical symbols. An historical example of this kind is Jakob Böhme’s mandala, in his treatise *XL Questions concerning the Soule*. It is at the same time an image of God and is designated as such. This is not a matter of chance, for Indian philosophy, which

developed the idea of the self, Atman or Purusha, to the highest degree, makes no distinction in principle between the human essence and the divine. Correspondingly, in the Western mandala, the *scintilla* or soul-spark, the innermost divine essence of man, is characterized by symbols which can just as well express a God-image, namely the image of Deity unfolding in the world, in nature, and in man.

[718] The fact that images of this kind have under certain circumstances a considerable therapeutic effect on their authors is empirically proved and also readily understandable, in that they often represent very bold attempts to see and put together apparently irreconcilable opposites and bridge over apparently hopeless splits. Even the mere attempt in this direction usually has a healing effect, but only when it is done spontaneously. Nothing can be expected from an artificial repetition or a deliberate imitation of such images.

BIBLIOGRAPHY

BIBLIOGRAPHY

The items of the bibliography are arranged alphabetically under two headings: *A.* Ancient volumes containing collections of alchemical tracts by various authors; *B.* General bibliography, including cross-references to the material in section *A.* Short titles of the ancient volumes are printed in capital letters.

A. ANCIENT VOLUMES CONTAINING COLLECTIONS OF ALCHEMICAL TRACTS BY VARIOUS AUTHORS

ARS CHEMICA, quod sit licita recte exercentibus, probationes doctissimorum iurisconsultorum... Argentorati [Strasbourg], 1566.

Contents quoted in this volume:

Septem tractatus seu capitula Hermetis Trismegisti aurei [pp. 7–31; usually referred to as “Tractatus aureus”]

ARTIS AURIFERAE quam chemiam vocant... Basileae [Basel], [1593]. 2 vols.

Contents quoted in this volume:

VOLUME I

- i. Allegoriae super librum Turbae [pp. 139–45]
- ii. Aurora consurgens, quae dicitur Aurea hora [pp. 185–246]
- iii. [Zosimus:] Rosinus ad Sarratantam episcopum [pp. 277–319]
- iv. [Kallid:] Calidis Liber secretorum [pp. 325–51]
- v. Tractatulus Aristotelis de practica lapidis philosophici [pp. 361–73]
- vi. Rachaidibus: De materia philosophici lapidis [pp. 397–404]
- vii. Liber de arte chymica [pp. 575–631]

VOLUME II

- viii Rosarium philosophorum [pp. 204–384]; contains a version of the “Visio Arislei,” pp. 246ff. Another edition of the *Artis auriferae*, occasionally quoted in this volume, appeared in 1572 at Basel; contains the “Tractatus aureus,” pp. 641ff.

MANGETUS, JOANNES JACOBUS (ed.). *BIBLIOTHECA CHEMICA CURIOSA, seu Rerum ad alchemiam pertinentium thesaurus instructissimus ...* Coloniae Allobrogum [Geneva], 1702, 2 vols.

Contents quoted in this volume:

VOLUME I

- i Hermes Trismegistus: Tractatus aureus de lapidis physici secreto [pp. 400–45]

ii Morienus: Liber de compositione alchemiae [pp. 509–19]

VOLUME II

iii Sendivogius: Epistola XIII [p. 496]

THEATRUM CHEMICUM, praecipuos selectorum auctorum tractatus ... continens. Ursellis [Ursel] and Argentorati [Strasbourg], 1602–61. 6 vols. (Vols. I–III, Ursel, 1602; Vols. IV–VI, Strasbourg, 1613, 1622, 1661 respectively.)

Contents quoted in this volume:

VOLUME I

i Dorn: Speculativae philosophiae, gradus septem vel decem continens [pp. 255–310]

ii Dorn: De tenebris contra Naturam et vita brevi [pp. 518–35]

iii Dorn: De transmutatione metallorum [pp. 563–646]

VOLUME II

iv Dee: Monas hieroglyphica [pp. 218–43]

VOLUME IV

v Hermetis Trismegisti Tractatus vere aureus de lapide philosophici secreto [pp. 672–797; usually referred to as “Tractatus aureus”]

vi David Lagneus: Harmonia seu Consensus philosophorum chemicorum (frequently called Harmonia chemica) [pp. 813–903]

VOLUME V

vii Mennens: De aureo vellere ... libri tres [pp. 267–470]

VOLUME VI

viii. Vigenerus (Blaise de Vigenère): Tractatus de igne et sale [pp.1–139]

B. GENERAL BIBLIOGRAPHY

ABRAHAM, KARL. *Dreams and Myths*. Translated by William A. White. (Nervous and Mental Disease Monograph Series, 15.) New York, 1913. (Original: *Traum und Mythos*. Schriften zur angewandten Seelenkunde, 4. Vienna, 1909.)

ADLER, GERHARD. *Studies in Analytical Psychology*. London, 1948; 2nd edn., London, 1966, New York, 1967.

AELIAN. *De natura animalium*, etc. Edited by Rudolf Hercher. Paris, 1858.

AETIUS. *De placitis philosophorum reliquiae*. In: HERMANN DIELS (ed.). *Doxographi Graeci*. Berlin, 1879.

AFANAS'EV, E. N. *Russian Fairy Tales*. Translated by Norbert Guterman. New York, [1946].

AGRICOLA, GEORG. *De animantibus subterraneis*. Basel, 1549.

ALDROVANDUS, ULYSSES [Ulisse Aldrovandi]. *Dendrologiae libri duo*. Bologna, 1668; another edn., 1671.

“Allegoriae sapientum supra librum Turbae.” See (A) *Artis auriferae*, i.

- Amitāyur-dhyāna Sūtra*. In: *Buddhist Mahāyāna Sūtras*, Part II. Translated by F. Max Müller and Junjiro Takakusu. (Sacred Books of the East, 49.) Oxford, 1894.
- APTOWITZER, VICTOR. "Arabisch-Jüdische Schöpfungstheorien," *Hebrew Union College Annual* (Cincinnati), VI (1929).
- APULEIUS, LUCIUS. *The Golden Ass*. Translated by Robert Graves. (Penguin Classics.) Harmondsworth, 1954.
- ARISLEUS. "Visio Arislei." See (A) *Artis auriferae*, viii.
- AUGUSTINE, SAINT. *The Confessions: Books I–X*. Translated by F. J. Sheed. London and New York, 1942. See also *Confessiones*, in MIGNE, P.L., vol. 32.
- _____. *De diversis quaestionibus LXXXIII*. See MIGNE, P.L., vol. 40, cols. 11–100.
- "Aurea hora." See "Aurora consurgens."
- "Aurora consurgens." See (A) *Artis auriferae*, ii.
- AVALON, ARTHUR, pseud. (Sir John Woodroffe) (ed. and trans.) *The Serpent Power (Shat-chakra-nirupana and Paduka-panchaka)*. (Tantrik Texts.) London, 1919.
- _____(ed.) *Shrī-chakra-sambhāra Tantra*. Translated by Kazi Dawa-Samdub. (Tantrik Texts, 7.) London and Calcutta, 1919.
- _____. See also WOODROFFE.
- BACON, JOSEPHINE DASKAM. *In the Border Country*. New York, 1919.
- BANDELIER, ADOLPH FRANCIS ALPHONSE. *The Delight Makers*. New York, 1890; 2nd edn., 1918.
- BÄNZIGER, HANS. "Persönliches und Archetypisches in Individuationsprozess," *Schweizerische Zeitschrift für Psychologie und ihre Anwendungen* (Bern), VI (1947), 272–83.
- BARLACH, ERNST. *Der tote Tag*. Berlin, 1912; 2nd edn., 1918.
- Baruch, Syrian Apocalypse of. See CHARLES, vol. 2, pp. 470–526.
- BASTIAN, ADOLF. *Der Mensch in der Geschichte*. Leipzig, 1860. 3 vols.
- BAUMGARTNER, MATHIAS. *Die Philosophie des Alanus de Insulis*. (Beiträge zur Geschichte der Philosophie des Mittelalters, 2:4.) Munster, 1896.
- BAYNES, H. G. *Mythology of the Soul*. London, 1940.
- BELLOWS, HENRY ADAMS (trans.). *The Poetic Edda*. New York, 1923.
- BENOÎT, PIERRE. *Atlantida*. Translated by Mary C. Tongue and Mary Ross. New York, 1920. (Original: *L'Atlantide*. Paris, 1920.)
- BERNOULLI, RUDOLF. "Zur Symbolik geometrischer Figuren und Zahlen," *Eranos Jahrbuch 1934* (Zurich, 1935), 369–415.
- BERTHELOT, MARCELLIN. *La Chimie au moyen âge*. Paris, 1893. 3 vols.
- _____. *Collection des anciens alchimistes grecs*. Paris, 1887–88. 3 vols.
- BIN GORION, MICHA JOSEPH (pseud. of Micah Joseph Berdyczewski). *Der Born Judas*. Leipzig, 1916–23. 6 vols.
- BLANKE, FRITZ. *Bruder Klaus von Flüe*. Zurich, 1948.

BLOCK, RAYMOND DE. *Euhémère, son livre et sa doctrine.* (Liège University dissertation.) Mons, 1876.

[BÖHME, JAKOB.] *XL Questions concerning the Soule, propounded by Dr. Balthasar Walter and answered by Jacob Behmen.* London, 1647.

_____. *Des gottseligen hocherleuchteten Jacob Böhmen Teutonici Philosophi Alle Theosophische Schriften.* Amsterdam, 1682. (This edition of Böhme's works consists of a number of parts, each separately paginated and variously bound up. The parts are not numbered. It includes, *inter alia*, the following works referred to in the present volume. The bracketed English titles and volume references following the German title of each work refer to the 1764–81 London translation cited below.)

Aurora. Morgenröte im Ausgang ... [Aurora: Vol. I.]

[*Drey principia.*] *Beschreibung der drey Principien Göttliches Wesens.* [Three Principles of the Divine Essence: Vol. I.]

Hohe und tiefe Gründe von dem dreyfachen Leben des Menschen. [The High and Deep Searching of the Threefold Life of Man: Vol. II]

Signatura rerum. [Signatura rerum: Vol. IV.]

Tabulae principiorum. [Four Tables of Divine Revelation: Vol. III.]

[*Quaestiones Theosophicae.*] *Theosophische Fragen in Betrachtung Göttliche Offenbharung ...* [Not included in English collection.]

Vierzig Fragen von der Seelen Urstand ... verfasst von Dr. Balthasar Walter und beantwortet durch Jacob Böhme. [Forty Questions concerning the Soul: Vol. II.]

Die Umgewandte Auge. [A Summary Appendix of the Soul: Vol. II.]

_____. *Mysterium pansophicum, oder Gründliche Bericht vom irdischen und himmlischen Mysterio.* In: *Jakob Böhme's sämtliche Werke.* Edited by K. W. Schiebler. Leipzig, 1831–46. 6 vols. (Vol. 6, pp. 411–24.)

_____. *The Works of Jacob Behmen.* [Edited by G. Ward and T. Langcake.] London, 1764–81. 4 vols.

BOUCHÉ-LECLERCQ, AUGUSTE. *L'Astrologie grecque.* Paris, 1899.

BOUSETT, WILHELM. *Hauptprobleme der Gnosis.* (Forschungen zur Religion und Literatur des Alten und Neuen Testaments, 10.) Göttingen, 1907.

BOVILLUS, KARL (Charles de Bouelles). *Ein gesichte Bruder Clausen ynn Schweytz und seine deutunge.* Wittemberg, 1528.

BOZZANO, ERNESTO. *Popoli primitivi e Manifestazioni supernormali.* Verona, 1941.

BUDGE, E. A. WALLIS. *The Gods of the Egyptians.* London, 1904. 2 vols.

BURI, F. "Theologie und Philosophie," *Theologische Zeitschrift* (Basel), VIII (1952), 116–34.

CAESARIUS OF HEISTERBACH. *The Dialogue on Miracles.* Translated by H. von E. Scott and C. C. Swinton Bland. London, 1929. 2 vols. (Original: *Dialogus Miraculorum.* Edited by J. Strange, 1851.)

Calidis Liber Secretorum. See KALLID.

CANTRIL, HADLEY. *The Invasion from Mars.* Princeton, 1940.

CARUS, CARL GUSTAV. *Psyche.* Pforzheim, 1846.

- CAUSSIN, NICHOLAS. *De symbolica Aegyptiorum sapientia. Polyhistor symbolicus, Electorum symbolorum, & Parabolarum historicarum stromata*. Paris, [1618 and] 1631.
- CELLINI, BENVENUTO. *Autobiography*. Translated by John Addington Symonds. London, 1887.
- CHANTEPIE DE LA SAUSSAYE, P. D. *Lehrbuch der Religionsgeschichte*. Tübingen, 1905. 2 vols.
- CHARLES, ROBERT HENRY (ed.). *The Apocrypha and Pseudepigrapha of the Old Testament in English*. Oxford, 1913. 2 vols.
- CICERO, MARCUS TULLIUS. *De natura deorum: Academica*. With an English text by H. Rackham. (Loeb Classical Library.) London and New York, 1933.
- CLEMENT OF ALEXANDRIA. *Stromata*. In: CLEMENS ALEXANDRINUS. *Werke*, Vol. II. Edited by Otto Stühlin. (Griechische christliche Schriftsteller.) Leipzig, 1906. For translation see: *The Writings of Clement of Alexandria*. Translated by William Wilson. (Ante-Nicene Christian Library, 4, 12.) Edinburgh, 1867, 1869. 2 vols.
- CRAWLEY, ALFRED ERNEST. *The Idea of the Soul*. London, 1909.
- CUMONT, FRANZ. *Textes et monuments figurés relatifs aux mystères de Mithra*. Brussels, 1894–99. 2 vols.
- CUSTANCE, JOHN. *Wisdom, Madness and Folly*. New York and London, 1951.
- DAUDET, LÉON. *L'Hérédo*. Paris, 1916.
- “De arte chymica.” See (A) *Artis auriferae*, vii.
- DEE, JOHN. “Monas hieroglyphica.” See (A) *Theatrum chemicum*, iv.
- DE GUBERNATIS, ANGELO. *Zoological Mythology*. London, 1872. 2 vols.
- DELACOTTE, JOSEPH. *Guillaume de Digulleville... Trois romans-poèmes du XIV^e siècle*. Paris, 1932.
- DELATTE, LOUIS (ed.). *Textes latins et vieux français relatifs aux Cyranides*. (Bibliothèque de la Faculté de Philosophie et Lettres de l'Université de Liège, fasc. 93.) Liège and Paris, 1942.
- DEUSSEN, PAUL. *Allgemeine Geschichte der Philosophie*. Leipzig, 1894–1917. 2 vols.
- DIELS, HERMANN. *Fragmente der Vorsokratiker*. 5th edn., Berlin, 1934–37. 3 vols.
- DIETERICH, ALBRECHT. *Eine Mithrasliturgie*. Leipzig, 1903; 2nd edn., 1910.
- DIONYSIUS THE AREOPAGITE, pseud. *De divinis nominibus*. See MIGNE, P.G., vol. 3, cols. 585–996. For translation, see: *On the Divine Names and the Mystical Theology*. Translated by C. E. Rolt. London, 1920.
- _____. *De caelesti hierarchia [De caelestibus hierarchiis]*. See MIGNE, P.G., vol. 3, cols. 119–30. For translation, see: *The Celestial Hierarchies*. Translated by the Editors of the Shrine of Wisdom. London, 1935.
- DORN, GERHARD (Gerardus Dorneus). See (A) *Theatrum chemicum*, i–iii.
- DU CANGE, CHARLES. *Glossarium ad scriptores mediae et infirmae latinitatis*. Paris, 1733–36. 6 vols. New edn., Graz, 1954. 5 vols.
- DUCHESNE, LOUIS. *Christian Worship: Its Origin and Evolution*. Translated by M. L. McClure. 5th edn., London, 1919. (Original: *Origines du culte chrétien*. 3rd edn., revised, Paris, 1903.)
- [ECKHART, MEISTER.] *Meister Eckhart*. By Franz Pfeiffer. Translated by C. de B. Evans. London, 1924–52. 2 vols.
- EISLER, ROBERT. *Weltenmantel und Himmelszelt*. Munich, 1910. 2 vols.

- ELEAZAR, R. ABRAHAM. *Uraltes Chymisches Werk*. Leipzig, 1760.
- ELIADE, MIRCEA. *Shamanism: Archaic Techniques of Ecstasy*. Translated by Willard R. Trask. New York (Bollingen Series) and London, 1964.
- ERMAN, ADOLF. *Handbook of Egyptian Religion*. London, 1907.
- _____. *Die Religion der Agypter*. Berlin and Leipzig, 1934.
- ERSKINE, JOHN. *Private Life of Helen of Troy*. New York, 1925; London, 1926.
- FECHNER, GUSTAV THEODOR. *Elemente der Psychophysik*. Leipzig, 1860.
- FENDT, LEONHARD. *Gnostische Mysterien*. Munich, 1922.
- FICINO, MARSILIO. *Commentary on Plato's Symposium*. Text and translation with introduction by Sears Reynolds Jayne. (University of Missouri Studies, 19: 1.) Columbia, Mo., 1944.
- [FIERZ-DAVID, LINDA.] *The Dream of Poliphilo*. Related and interpreted by Linda Fierz-David. Translated by Mary Hottinger. (Bollingen Series XXV.) New York, 1950.
- FLAMEL, NICHOLAS. *Exposition of the Hieroglyphicall Figures ...* Translated by Eirenaeus Orandus. London, 1624.
- FLOURNOY, THÉODORE. *From India to the Planet Mars*. Translated by D. B. Vermilye. New York and London, 1900. (Original: *Des Indes à la Planète Mars*. Paris and Geneva, 3rd edn., 1900.)
- _____. "Nouvelles Observations sur un cas de somnambulisme avec glossolalie," *Archives de psychologie* (Neuchâtel), I (1901): 2.
- Folktales. (The following volumes are all from the series *Die Märchen der Weltliteratur*, edited by Friedrich von der Leyen and Paul Zaunert, Jena.)
- Balkanmärchen aus Albanien, Bulgarien, Serbien und Kroatien*. Edited by A. Laskien. 1915.
- Chinesische Volksmärchen*. Edited by R. Wilhelm. 1913.
- Deutsche Märchen seit Grimm*. Edited by Paul Zaunert. 1912.
- Finnische und Estnische Volksmärchen*. Edited by August von Löwis of Menar. 1922.
- Indianermärchen aus Nordamerika*. Edited by Walter Krickeberg. 1924.
- Indianermärchen aus Südamerika*. Edited by T. Koch-Grünberg. 1920.
- Kaukasische Märchen*. Edited by A. Dirr. 1919.
- Märchen aus Iran*. 1939.
- Märchen aus Sibirien*. 2nd edn., 1940.
- Nordische Volksmärchen*. Edited by K. Stroebe. 1915–22. 2 vols.
- Russische Volksmärchen*. Edited by August von Löwis of Menar. 1914.
- Spanische und Portugiesische Märchen*. Edited by Harri Meier. 1940.
- See also AFANAS'EV; GRIMM.
- FORDHAM, MICHAEL. *The Life of Childhood*. London, 1944.
- FOUCART, PAUL FRANÇOIS. *Les Mystères d'Eleusis*. Paris, 1914.
- FREEMAN, KATHLEEN. *Ancilla to the Pre-Socratic Philosophers*. Oxford, 1948.

- FREUD, SIGMUND. *The Interpretation of Dreams*. Translated by James Strachey et al. In: Standard Edition of the Complete Psychological Works, 4–5. London, 1953. 2 vols.
- _____. “Psycho-Analytic Notes on an Autobiographical Account of a Case of Paranoia.” [Translated by Alix and James Strachey.] In: Standard Edition of the Complete Psychological Works, 12. London, 1958.
- _____. “Leonardo da Vinci and a Memory of His Childhood.” Translated by Alan Tyson. In: Standard Edition of the Complete Psychological Works, 11. London, 1957.
- FROBENIUS, LEO. *Schicksalskunde*. (Schriften zur Schicksalskunde, 5.) Weimar, 1938.
- GARBE, RICHARD. *Die Samkhya Philosophie*. Leipzig, 1894.
- GESSMANN, GUSTAV WILHELM. *Die Geheimsymbole der Alchymie, Arzneykunde und Astrologie des Mittelalters*. 2nd edn., Berlin, 1922.
- GLAUBER, JOHANN RUDOLPH. *Tractatus de natura salium*. Amsterdam, 1658. 2 parts.
- GOETHE, JOHANN WOLFGANG VON. “Die neue Melusine.” See *Wilhelm Meisters Wanderjahre*, in *Werke*, q.v., VIII, pp. 380ff.
- _____. *Faust, Part One*. Translated by Philip Wayne. (Penguin Classics.) Harmondsworth, 1949.
- _____. *Werke*. (Gedankausgabe.) Edited by Ernst Beutler. Zurich, 1948–54. 24 vols. (Vols. I–II: *Sämtliche Gedichte*.)
- GOETZ, BRUNO. *Das Reich ohne Raum*. Potsdam, 1919. 2nd enl. edn., Constance, 1925.
- GRIMM, THE BROTHERS. *Fairy Tales*. Translated by Margaret Hunt. Revised by James Stern. New York, 1944.
- HAGGARD, H. RIDER. *Ayesha: the Return of She*. London, 1905.
- _____. *She*. London, 1887.
- _____. *Wisdom’s Daughter*. London, 1923.
- HARDING, M. ESTHER. *Psychic Energy: Its Source and Goal*. (Bollingen Series X.) New York, 1948; 2nd edn., 1963: *Psychic Energy: Its Source and Its Transformation*.
- HAUCK, ALBERT (ed.). *Real-encyclopädie für protestantische Theologie und Kirche*. Leipzig, 1896–1913. 24 vols.
- HERMES TRISMEGISTUS. See “Septem tractatus.”
- _____. *Tractatus vere aureus de Lapidis Philosophici secreto*. Opere et studio Dominici Gnosii ... in lucem editus. Leipzig, 1610. See also (A) *Ars chemica; Theatrum chemicum*, v.
- HILDEGARDE OF BINGEN, SAINT. “Liber divinatorum operum.” Bibliotheca governativa, Lucca, Codex 1942.
- HIPPOLYTUS, *Elenchos (Refutatio omnium haeresium)*. In: *Hippolytus’ Werke*. Edited by Paul Wendland. (Griechische christliche Schriftsteller.) Vol. III. Leipzig, 1916. For translation, see: *Philosophumena: or. The Refutation of all Heresies*. Translated by Francis Legge. London and New York, 1921. 2 vols.
- HOFFMANN, ERNST THEODORE WILHELM [AMADEUS]. *The Devil’s Elixir*. Edinburgh, 1824. 2 vols.
- HOFFMANN-KRAYER, E., and BÄCHTOLD-STÄUBLI, HANNS. *Handwörterhuch des deutschen Aberglaubens*. (Handwörterbücher für deutschen Volkskunde, Abt. I.) Berlin and Leipzig, 1927–37. 8 vols.
- HÖLDERLIN, JOHANN CHRISTIAN FRIEDRICH. *Gedichte*. Edited by Franz Zinkernagel. Leipzig, 1992.

- HOLLANDUS, JOANNES ISAACS. *Opera mineralia*. Middelburg, 1600.
- HOMER. *The Odyssey*. Translated by E. V. Rieu. (Penguin Classics.) Harmondsworth, 1958.
- Homeric Hymns. See: *Hesiod, the Homeric Hymns, and Homerica*. With an English translation by Hugh G. Evelyn-White. (Loeb Classical Library.) London and New York, 1914.
- HONORIUS OF AUTUN. *Expositio in Cantica canticorum*. See MIGNE, P.L., vol. 172, cols. 347–496.
- HORAPOLLO NILIACUS. *Hieroglyphica*. See: *The Hieroglyphics of Horapollo*. Translated by George Boas. (Bollingen Series XXIII.) New York, 1950. (Original: *Selecta Hieroglyphica*. Rome, 1597.)
- HORNEFFER, ERNST. *Nietzsches Lehre von der ewigen Wiederkunft*. Leipzig, 1900.
- Hovamol*. See BELLOWS.
- HUBERT, HENRI, and MAUSS, MARCEL. *Mélanges d'histoire des religions*. Paris, 1909.
- HUME, ROBERT ERNEST (trans.). *The Thirteen Principal Upanishads*. Oxford, 1921. (Shvetashvatara Upanishad, pp. 394–411.)
- I Ching, or Book of Changes*. The German translation by Richard Wilhelm, rendered into English by Cary F. Baynes. New York (Bollingen Series XIX) and London, 1950; 3rd edn., 1967.
- INGRAM, JOHN H. *The Haunted Homes and Family Traditions of Great Britain*. London, 1890.
- IRENAEUS, SAINT. *Adversus [or Contra] haereses libri quinque*. See MIGNE, P.G., vol. 7, cols. 433–1224. For translation, see: *The Writings of Irenaeus*. Translated by Alexander Roberts and W. H. Rambaut. (Ante-Nicene Christian Library, 5, 9.) Edinburgh, 1868. 2 vols.
- IZQUIERDO, SEBASTIAN. *Pratica di alcuni Esercitij Spirituali di S. Ignatio*. Rome, 1686.
- JACOBI, JOLANDE. *Complex/Archetype/Symbol*. Translated by Ralph Manheim. New York (Bollingen Series) and London, 1959.
- JACOBSON, HELMUTH. “Die dogmatische Stellung des Königs in der Theologie der alten Aegypter,” *Aegyptologische Forschungen* (Glückstadt), no. 8 (1939).
- JAEFÉ, ANIELA. “Bilder und Symbole aus E. T. A. Hoffmanns Märchen ‘Der Goldne Topf,’” in: C. G. JUNG. *Gestaltungen des Unbewussten*. Zurich, 1950.
- JAMES, M. R. (trans.) *The Apocryphal New Testament*. Oxford, 1924.
- JAMES, WILLIAM. *The Varieties of Religious Experience*. London, 1902.
- JANET, PIERRE. *L'Automatisme psychologique*. Paris, 1889.
- _____. *L'État mental des hystériques*. Paris [1893]. For translation, see: *The Mental State of Hystericals*. Translated by Caroline Rollin Corson. New York and London, 1901.
- _____. *Les Névroses*. Paris, 1909.
- _____. *Névroses et idées fixes*. Paris, 1898. 2 vols.
- JEROME, SAINT. *Epistola II ad Theodosium et ceteros Anachoretas*. In: *Hieronimi Epistularum Pars I*. (Corpus Scriptorum Ecclesiasticorum Latinorum, 54.) Vienna and Leipzig, 1910.

- JUNG, CARL GUSTAV. "The Aims of Psychotherapy." In: *The Practice of Psychotherapy. Collected Works,** Vol. 16. New York and London, 2nd edn., 1966.
- _____. *Aion: Researches into the Phenomenology of the Self. Collected Works,** Vol. 9, Part II. New York and London, 2nd edn., 1968.
- _____. *Alchemical Studies. Collected Works,** Vol. 13. New York and London, 1968.
- _____. "Answer to Job." In: *Psychology and Religion: West and East*, q.v.
- _____. "Brother Klaus." In: *Psychology and Religion: West and East*, q.v.
- _____. *Civilization in Transition. Collected Works,** Vol. 10. New York and London, 1964.
- _____. *Collected Papers on Analytical Psychology*. Edited by Constance Long. 2nd edn., London, 1917; New York, 1920.
- _____. Commentary on "The Secret of the Golden Flower." In: *Alchemical Studies*. (See also WILHELM and JUNG, *The Secret of the Golden Flower*.)
- _____. "The Enigma of Bologna." In: *Mysterium Coniunctionis*, q.v., pars. 51 ff.
- _____. "Instinct and the Unconscious." In: *The Structure and Dynamics of the Psyche*, q.v.
- _____. *The Integration of the Personality*. Translated by Stanley Dell. New York, 1939; London, 1940.
- _____. *Memories, Dreams, Reflections*. Recorded and edited by Aniela Jaffé. Translated by Richard and Clara Winston. New York and London, 1963. (U.S. and Brit. edns. separately paginated.)
- _____. *Mysterium Coniunctionis. Collected Works,** Vol. 14. New York and London, 1963.
- _____. "On the Nature of the Psyche." In: *The Structure and Dynamics of the Psyche*, q.v.
- _____. "On the Psychology and Pathology of So-called Occult Phenomena." In: *Psychiatric Studies*, q.v.
- _____. "Paracelsus as a Spiritual Phenomenon." In: *Alchemical Studies*, q.v.
- _____. "The Philosophical Tree." In: *Alchemical Studies*, q.v.
- _____. *The Practice of Psychotherapy. Collected Works,** Vol. 16. New York and London, 2nd edn., 1966.
- _____. *Psychiatric Studies. Collected Works,** Vol. 1. New York and London, 1957.
- _____. "A Psychological Approach to the Dogma of the Trinity." In: *Psychology and Religion: West and East*, q.v.
- _____. Psychological Commentary on "The Tibetan Book of the Dead." In: *ibid*.
- _____. *Psychological Types. Collected Works,** Vol. 6. (Alternative source: translation by H. G. Baynes, London and New York, 1923.)
- _____. *Psychology and Alchemy. Collected Works,** Vol. 12. New York and London, 2nd edn., 1968.
- _____. "The Psychology of Eastern Meditation." In: *Psychology and Religion: West and East*, q.v.
- _____. "Psychology and Education." In: *The Development of Personality. Collected Works,** Vol. 17. New York and London, 1954.
- _____. "Psychology and Religion" (The Terry Lectures). In: *Psychology and Religion: West and East*, q.v.
- _____. *Psychology and Religion: West and East. Collected Works,** Vol. 11. New York and London, 1958.
- _____. "The Psychology of the Transference." In: *The Practice of Psychotherapy*, q.v.

- _____. *Psychology of the Unconscious*. Translated by Beatrice M. Hinkle. New York, 1916; London, 1917. (Superseded by *Symbols of Transformation*, q.v.)
- _____. “The Relations between the Ego and the Unconscious.” In: *Two Essays on Analytical Psychology*, q.v.
- _____. “Spirit and Life.” In: *The Structure and Dynamics of the Psyche*, q.v.
- _____. “The Spirit Mercurius.” In: *Alchemical Studies*, q.v.
- _____. *The Structure and Dynamics of the Psyche, Collected Works,** Vol. 8. New York and London, 1960.
- _____. “The Structure of the Psyche.” In: *The Structure and Dynamics of the Psyche*, q.v.
- _____. *Symbols of Transformation. Collected Works,** Vol. 5. New York and London, 2nd edn., 1967.
- _____. “Synchronicity: An Acausal Connecting Phenomenon,” In: *The Structure and Dynamics of the Psyche*, q.v.
- _____. “The Transcendent Function.” In: *ibid.*
- _____. “Transformation Symbolism in the Mass.” In: *Psychology and Religion: West and East*, q.v.
- _____. *Two Essays on Analytical Psychology. Collected Works,** Vol. 7. New York and London, 2nd edn., 1966.
- _____. “The Visions of Zosimos.” In: *Alchemical Studies*, q.v.
- _____. *Von den Wurzeln des Bewusstseins*. Zurich, 1954.
- _____. *Wandlungen und Symbole der Libido*. Leipzig and Vienna, 1912.
- _____. “Wotan.” In: *Civilization in Transition*, q.v.
- JUNG, EMMA. “On the Nature of the Animus.” Translated by Cary F. Baynes, in: *Animus and Anima*. (The Analytical Psychology Club of New York.) New York, 1957.
- Kabbala Denudata*. See KNORR VON ROSENROTH.
- [KALLID (Khalid ibn-Jazid ibn-Muawiyah).] “Liber secretorum.” See (A) *Artis auriferae*, iv.
- KERÉNYI, KARL. “Hermes der Seelenführer,” *Eranos Jahrbuch 1942* (Zurich, 1943), 9–107.
- _____. “Kore” and “The Primordial Child in Primordial Times.” In: KERÉNYI and C. G. JUNG. *Essays on a Science of Mythology*. (Bollingen Series XXII.) New York, 1949. (Also pub. as *Introduction to a Science of Mythology*, London, 1950.) See also Torch-books edn., rev., 1963.
- KERNER, JUSTINUS. *Die Seherin von Prevorst*. Stuttgart and Tübingen, 1829. 2 vols. For translation, see: *The Seeress of Prevorst*. Translated by Mrs. [Catherine] Crowe. New York, 1859.
- KEYSERLING, HERMANN COUNT VON. *South-American Meditations*. Translated by Therese Duerr. New York and London, 1932. (Original: *Südamerikanische Meditationen*. Stuttgart, 1932.)
- KHUNRATH, HENRICUS. *Von hylealischen, das ist, pri-materialischen ... Chaos*. Magdeburg, 1597.
- KIRCHER, ATHANASIVS. *Mundus subterraneus*. Amsterdam, 1678.
- KLAGES, LUDWIG. *Der Geist als Widersacher der Seele*. Leipzig, 1929–32. 3 vols.
- KNORR VON ROSENROTH, CHRISTIAN. *Kabbala Denudata*. Sulzbach, 1677–78 (Vol. I); Frankfurt a. M., 1684 (Vol. II). 2 vols. (*Adumbratio Kabbalae Christianae* is an appendix to Vol. II.) For partial translation, see: S. LIDELL MACGREGOR MATHERS. *The Kabbalah Unveiled*. London, 1887.
- KOEPGEN, GEORG. *Die Gnosis des Christentums*. Salzburg, 1939.

- KÖHLER, REINHOLD. *Kleinere Schriften zur Märchenforschung*. Weimar, 1898.
- Koran, The. Translated by N. J. Dawood. (Penguin Classics.) Harmondsworth, 1956.
- LACTANTIUS FIRMIANUS. *Divinae institutiones*. In: *Opera omnia*. Edited by Samuel Brandt and Georg Laubmann. (Corpus scriptorum ecclesiasticorum Latinorum.) Vienna, 1890–97. 3 vols. Vol. I. For translation, see: *The Works of Lactantius*. Translated by William Fletcher. (Ante-Nicene Christian Library, 21, 22.) Edinburgh, 1871. 2 vols.
- LAGNEUS, DAVID. “Harmonia seu Consensus philosophorum chemicorum” (*Harmonia chemica*). See (A) *Theatrum chemicum*, vi.
- LAMBSRINGK. See WAITE.
- LA ROCHEFOUCAULD, FRANÇOIS DE. *The Moral Maxims and Reflections of the Duke de la Rochefoucauld*. Translated by George H. Powell. London, 1903.
- LAVAUD, BENOÎT. *Vie Profonde de Nicolas de Flue*. Fribourg, 1942.
- LE BON, GUSTAVE. *The Crowd*. 19th impr., London, 1947. (English version first published 1896.)
- LEISEGANG, HANS. *Die Gnosis*. Leipzig, 1924.
- LENGLET DU FRESNOY, PIERRE NICOLAS. *Histoire de la philosophie hermétique*. 1742. 3 vols.
- LEONE EBREO (Leo Hebraeus) (Don Judah Abarbanel). *The Philosophy of Love*. Translated by F. Friedeberg-Seeley and Jean H. Barnes. London, 1937.
- LÉVY-BRUHL, LUCIEN. *La Mythologie primitive*. Paris, 1935.
- [*Liber mutus*.] *Mutus liber, in quo tamen tota Philosophia hermetica figuris hieroglyphicis depingitur*. La Rochelle, 1677.
- LONGFELLOW, HENRY WADSWORTH. *The Song of Hiawatha*. Boston, 1855.
- LÜDY, F. *Alchemistische und Chemische Zeichen*. Berlin, 1929.
- MCGLASHAN, ALAN. “Daily Paper Pantheon,” *The Lancet* (London), vol. 264(i) (1953), 238–39.
- MACROBIUS. *Commentary on the Dream of Scipio*. Translated by William Harris Stahl. (Records of Civilization, Sources and Studies, 48.) New York, 1952.
- MAEDER, A. “Essai d’interprétation de quelques rêves,” *Archives de psychologie* (Geneva), VI (1907), 354–75.
- _____. “Die Symbolik in den Legenden, Märchen, Gebrauchten, und Traumen,” *Psychologisch-neurologische Wochenschrift* (Halle), X (1908–9), 45–55.
- MAIER, MICHAEL. *De circulo physico quadrato*. Oppenheim, 1616.
- _____. *Symbola aureae mensae duodecim nationum*. Frankfurt a. M., 1617.
- MAITLAND, EDWARD. *Anna Kingsford: Her Life, Letters, Diary, and Work*. London, 1896. 2 vols.
- Maitrayana-Brahmana Upanishad. In: *The Upanishads, Part II*. Translated by F. Max Müller. (Sacred Books of the East, 15.) Oxford, 1900.
- Majjhima-Nikaya*. See BHIKKHU SILACARA (ed. and trans.). *The First Fifty Discourses from the Collection of the Middle-Length Discourses (Majjhima Nikaya) of Gotama the Buddha*. Breslau and Leipzig, 1912–13. 2 vols.
- MANGETUS, JOANNES JACOBUS. See under (A).

- MASENIUS, JACOBUS. *Speculum imaginum veritatis occultae*. Cologne, 1714. 2 vols.
- MATTHEWS, WASHINGTON. "The Mountain Chant." In: *Fifth Annual Report of the U. S. Bureau of American Ethnology*. Washington, 1887. (Pp. 379–467.)
- MECHTHILD, SAINT. *The Revelations of Mechthild of Magdeburg (1210–1297), or The Flowing Light of the Godhead*. Translated by Lucy Menzies. London, 1953.
- MEIER, C. A. *Antike Inkubation und Moderne Psychotherapie*. Zurich, 1949.
- _____. "Spontanmanifestationen des kollektiven Unbewussten," *Zentralblatt für Psychotherapie* (Leipzig), XI (1939), 284ff.
- MENNENS, GULIELMUS. *Aurei velleris, sive sacrae philosophiae, naturae et artis admirabilium libri tres*. Antwerp, 1604. See also "De aureo vellere" in (A) *Theatrum chemicum*, vii.
- MEYRINK, GUSTAV. *Der weisse Dominikaner*. Vienna, 1921.
- MIGNE, JACQUES PAUL (ed.). *Patrologiae cursus completus*.
[P.L.] Latin series. Paris, 1844–64. 221 vols.
[P.G.] Greek series, Paris, 1857–66. 166 vols.
(These works are referred to in the text as "Migne, P.L.," and "Migne, P.G.," respectively.)
- MORIENUS ROMANUS. "De compositione Alchemiae." See (A) MANGETUS, *Bibliotheca chemica curiosa*, ii. *Musaeum hermeticum*. See WAITE.
- MYLIUS, JOHANN DANIEL. *Philosophia reformata*. Frankfurt a. M., 1622.
- Mythographus Vaticanus III. See: *Classicorum Auctorum e Vaticanis Codicibus Editorum*, Vol. 6: *Complectens Mythographi tres*. Edited by Angelo Mai. Rome, 1831.
- NEEDHAM, JOSEPH. *Science and Civilization in China*. Cambridge, 1954–. (Vols. I and II published.)
- NELKEN, JAN. "Analytische Beobachtungen über Phantasien eines Schizophrenen," *Jahrbuch für psychoanalytische und psychopathologische Forschungen* (Leipzig), IV (1912), 504ff.
- NEUMANN, ERICH. *The Great Mother*. Translated by Ralph Manheim. New York (Bollingen Series XLVII) and London, 1955.
- _____. *The Origins and History of Consciousness*. New York (Bollingen Series XLII) and London, 1954.
- _____. *Tiefenpsychologie und neue Ethik*. Zurich, 1949.
- NEWCOMB, FRANC JOHNSON, and REICHARD, GLADYS A. *Sandpaintings of the Navajo Shooting Chant*. New York, 1938.
- NIETZSCHE, FRIEDRICH. *Beyond Good and Evil*. (Collected Works, 12.) Translated by Helen Zimmern. 2nd edn., London, 1909.
- _____. *Thus Spake Zarathustra*. Translated by Thomas Common, revised by Oscar Levy and John L. Beevers. London, 1932.
- _____. *Gedichte und Sprüche*. Leipzig, 1898.
- NIKLAUS VON DER FLÜE (Brother Klaus). *Ein nützlicher und loblicher Tractat von Bruder Claus und einem Bilger*. Nuremberg, 1488.

- NINCK, MARTIN. *Wodan und germanischer Schicksalsglaube*. Jena, 1935.
- ORANDUS, EIRENAEUS. See FLAMEL.
- ORIGEN. *In Jeremiam homiliae*. In MIGNE, P.G., vol. 13, cols. 255–544.
- _____. *In Leviticum homiliae*. In MIGNE, P.G., vol. 12, cols. 405–574.
- _____. *In libros Regnorum homiliae*. In MIGNE, P.G., vol. 12.
- [Panchatantra.] *The Panchatantra Reconstructed*. By Franklin Edgerton. (American Oriental Series, 2, 3.) New Haven, 1924. 2 vols.
- PARACELSUS (Theophrastus Bombastes of Hohenheim). *De vita longa*. Edited by Adam von Bodenstein. Basel, 1562. Also see: KARL SÜDHOFF (ed.). *Theophrast von Hohenheim genannt Paracelsus sämtliche Werke*. Munich and Berlin, 1922–35. 15 vols. (Vol. III, pp. 247ff.)
- PHILALETHES, EIRENAEUS. *Ripley Reviv'd: or, An Exposition upon Sir George Ripley's Hermetico-Poetical Works*. London, 1678.
- PHILO JUDAEUS. *De opificio mundi*. In: *Philo*. With an English translation by Francis Henry Colson and George Herbert Whitaker. (Loeb Classical Library.) London and New York, 1929–. 12 vols. published. (Vol. I.)
- PICINELLI, FILIPPO. *Mondo simbolico*. Milan, 1669. Translated into Latin as: *Mundus symbolicus*. Cologne, 1680–81.
- PLATO. *The Symposium*. Translated by W. Hamilton. (Penguin Classics.) Harmondsworth, 1959.
- _____. *The Timaeus and the Critias*. The Thomas Taylor translation. (Bollingen Series III.) New York, 1944.
- PLINY. [*Historia naturalis*.] *Natural History*. With an English translation by H. Rackham. (Loeb Classical Library.) London and New York, 1938–. 10 vols, published.
- PLUTARCH. *De genio Socratis*. In: *Moralia*. Edited by C. Hubert et al. Leipzig, 1892–1935. 7 vols (Vol. III, pp. 460–511.)
- PREISENDANZ, KARL. *Papyri Graecae magicae*. Leipzig and Berlin, 1928–31. 2 vols.
- [PROPERTIUS, SEXTUS.] *Propertius*. With an English translation by H. E. Butler. (Loeb Classical Library.) London and New York, 1912.
- PRUDENTIUS. *Contra Symmachum*, In: [*Works*.] With an English translation by H. J. Thomson. (Loeb Classical Library.) London and Cambridge, Mass., 1949 – 53. (Vol. I, p. 344–Vol. II, p. 97.)
- RACHAIDIBUS. “De materia philosophici lapidis.” See (A) *Artis auriferae*, vi.
- RADIN, PAUL. *The World of Primitive Man*. New York, 1953.
- RAHNER, HUGO. “Antenna Crucis II: Das Meer der Welt,” *Zeitschrift für Katholische Theologie* (Innsbruck), LXVI (1942), 89ff.
- _____. “Earth Spirit and Divine Spirit in Patristic Theology.” In: *Spirit and Nature*. (Papers from the Eranos Yearbooks, 1.) Translated by Ralph Manheim. New York (Bollingen Series XXX), 1954; London, 1955.
- _____. “Die seelenheilende Blume,” *Eranos Jahrbuch* (Zurich), XII (C.G. Jung Festgabe, 1945), 117–239.
- RANK, OTTO. *The Myth of the Birth of the Hero*. Translated by F. Robbins and Smith Ely Jelliffe. New York, 1952. (Original: *Der Mythos von der Geburt des Helden*. Leipzig and Vienna, 1922.)

- READ, JOHN. *Prelude to Chemistry*. London, 1939.
- REITZENSTEIN, RICHARD. *Poimandres*. Leipzig, 1904.
- REUSNER, HIERONYMUS. *Pandora: das ist, die edelst Gab Gottes, oder der Werde und heilsame Stein der Weysen*. Basel, 1588.
- RHINE, J. B. *New Frontiers of the Mind*. London, 1937.
- RICHARD OF ST. VICTOR. *Benjamin minor*. In MIGNE, P.L., vol. 196, cols. 1–64.
- Rig-Veda. See: *Hindu Scriptures*. Edited by Nicol MacNicol. (Everyman's Library.) London and New York, 1938.
See also DEUSSEN.
- RIKLIN, F. "Über Gefängnispsychosen," *Psychologisch-neurologische Wochenschrift* (Halle), IX (1907), 269–72.
_____. *Wishfulfilment and Symbolism in Fairy Tales*. Translated by William A. White. (Nervous and Mental Disease Monograph Series, 21.) New York, 1915. (Original: *Wunscherfüllung und Symbolik in Märchen*. Leipzig and Vienna, 1908.)
- RIPLEY, SIR GEORGE. "Cantilena." In: *Opera omnia chemica*. Kassel, 1649.
- Rosarium philosophorum. Secunda pars alchimiae de lapide philosophico*. Frankfurt a. M., 1550. See also (A) *Artis auriferae*, viii.
- ROSCHER, WILHELM HEINRICH. *Ausführliches Lexikon der Griechische und Römische Mythologie*. Leipzig, 1884–1937. 6 vols.
- ROSENCREUTZ, CHRISTIAN. *Chymische Hochzeit*. Strasbourg, 1616. For translation, see: *The Hermetick Romance; or, The Chemical Wedding*. Translated by E. Foxcroft. London, 1690.
- ROSINUS. See ZOSIMUS.
- ROUSSELLE, ERWIN. "Spiritual Guidance in Contemporary Taoism." In: *Spiritual Disciplines*. (Papers from the Eranos Yearbooks, 4). Translated by Ralph Manheim. New York (Bollingen Series XXX) and London, in press.
- RULAND, MARTIN. *A Lexicon of Alchemy*. [London, 1893.] (Original: *Lexicon alchemiae*. Frankfurt a. M., 1612.)
- RUSKA, JULIUS FERDINAND. "Die Vision des Arisleus." In: [KARL SUDHOFF, ed.] *Historische Studien und Skizzen zur Natur- und Heilwissenschaft*. (Memorial volume presented to Georg Sticker on his seventieth birthday.) Berlin, 1930.
- SALOMON, RICHARD. *Opicinus de Canistris*. (Studies of the Warburg Institute, I a and b.) London, 1936. 2 parts.
- Samyutta-Nikaya*. See: *The Book of the Kindred Sayings (Sangyutta-Nikaya)*. [Part II: The Nidana Book \(Nidana-Vagga\)](#). Translated by Mrs. C. A. F. Rhys Davids. London, [1922]. Also: *Dialogues of the Buddha*. [Part II](#). Translated by T. W. and C. A. F. Rhys Davids. (Sacred Books of the Buddhists, 3.) London, 1951.
- Sanatsugatiya*. See: *The Bhagavadgita, with the Sanatsugatiya and the Anugita*. Translated by Kashinath Trimbak Telang. (Sacred Books of the East, 8.) Oxford, 1882.
- [SAND, GEORGE.] *Intimate Journal of George Sand*. Translated and edited by Marie Jenney Howe. New York, 1929.
- SCHELER, MAX FERDINAND. *Die Stellung des Menschen im Kosmos*. Darmstadt, 1928.
- SCHILLER, FRIEDRICH. *Die Piccolomini*. In: *Schillers Werke*. Edited by Paul Brandt. Leipzig, [1923]. 5 vols. (Vol. III, pp. 59–174.)

- SCHMALTZ, GUSTAV. *Östliche Weisheit und Westliche Psychotherapie*. Stuttgart, 1951.
- SCHMITZ, OSKAR A. H. *Märchen aus dem Unbewussten*. Munich, 1932.
- SCHOPENHAUER, ARTHUR. *Aphorismen zur Lebensweisheit*. Translated in: *Essays from the Parerga and Paralipomena*. Translated by T. Bailey Saunders. London, 1951. ("The Wisdom of Life," in section "The Art of Controversy," pp. 56–71.) (Original in: *Sämmtliche Werke*. Edited by Julius Frauenstädt. Vol. V: *Parerga und Paralipomena*, 1. Leipzig, 1877.)
- SCHREBER, DANIEL PAUL. *Memoirs of My Nervous Illness*. Translated by Ida Macalpine and Richard A. Hunter. London, 1955. (Original: *Denkwürdigkeiten eines Nervenkranken*. Leipzig, 1903.)
- SCHUBERT, GOTTHICF HEINRICH VON. *Altes und Neues aus dem Gebiet der inneren Seelenkunde*. Leipzig, 1825–44. 5 vols.
- SCHULTZ, WOLFGANG. *Dokumente der Gnosis*. Jena, 1910.
- SCOTT, WALTER (ed.). *Hermetica*. Oxford, 1924–36. 4 vols.
- SENDIVOGIUS, MICHAEL (Micha Sedziwoj). "Epistola XIII." See (A) MANGETUS, *Bibliotheca chemica curiosa*, iii. "Septem tractatus seu capitula Hermetis Trismegisti." See (A) *Ars chemica*.
- Shatapatha-Brahmana*. Translated by Julius Eggeling. (Sacred Books of the East, 12.) Oxford, 1882.
- Shvetashvatara Upanishad*. See HUME.
- SILBERER, HERBERT. *Problems of Mysticism and Its Symbolism*. New York, 1917.
- SLOANE, WILLIAM M. *To Walk the Night*. New York, 1937.
- SPAMER, ADOLF (ed.). *Texte aus der deutschen Mystik des 14. und 15. Jahrhunderts*. Jena, 1912.
- SPENCER, SIR WALTER B., and GILLEN, FRANCIS JAMES. *The Northern Tribes of Central Australia*. London, 1904.
- SPITTELER, CARL. *Prometheus and Epimetheus*. Translated by James Fullarton Muirhead. London, 1931. (Original: Jena, 1920.)
- _____. *Imago*. Jena, 1919.
- STADE, BERNHARD. *Biblische Theologie des Alten Testaments*. Vol. I (no more published). Tübingen, 1905.
- STEVENSON, JAMES. "Ceremonial of Hasjelti Dailjis and Mythical Sand Painting of the Navaho Indians." In: *Eighth Annual Report of the U. S. Bureau of American Ethnology, 1886–87*. Washington, 1891. (Pp. 229–85.)
- STOECKLI, ALBAN. *Die Visionen des seligen Bruder Klaus*. Einsiedeln, 1933.
- SUZUKI, DAISETSU TEITARQ. *An Introduction to Zen Buddhism*. London, [1948].
- TERTULLIAN. *Apologeticus adversus gentes*. See MIGNE, P.L., vol. 1, cols. 257–536.
- TONQUÉDEC, JOSEPH DE. *Les Maladies nerveuses ou mentales et les manifestations diaboliques*. Paris, 1938.
- "Tractatulus Aristotelis." See (A) *Artis auriferae*, v.
- Tractatus aureus*. See (A) *Artis auriferae*; MANGETUS, *Bibliotheca chemica curiosa*, i; *Ars chemica*, i.
- "Turba philosophorum." See: JULIUS FERDINAND RUSKA. *Turba Philosophorum*. Berlin, 1931.
- Upanishads. See HUME; Maitrayana-Brahmana Upanishad.
- USENER, HERMANN. *Das Weihnachtsfest*. 2nd edn., Bonn, 1911.

- Vedanta-Sutras, with the Commentary of Ramanuga (Ramanuja)*. Translated by George Thibaut. [Part III](#). (Sacred Books of the East, 48.) Oxford, 1904.
- VIGENERUS (Blaise de Vigenère). “Tractatus de igne et sale.” See (A) *Theatrum chemicum*, viii.
- “Visio Arislei.” See *Rosarium philosophorum*, which contains it.
- VITUS, RICHARDUS (Richard White of Basingstoke). *Aelia Laelia Crispis*. Padua, 1568.
- VOLLERS, K. “Chidher,” *Archiv für Religionswissenschaft* (Leipzig), XII (1909), 234–384.
- WAITE, ARTHUR EDWARD (ed. and trans.). *The Hermetic Museum Restored and Enlarged*. London, 1953. 2 vols. (The Book of Lamb-spring, I, pp. 271–306.)
- WARNECKE, JOHANNES. *Die Religion der Batak*. Leipzig, 1909.
- WECKERLING, ADOLF (trans.). *Ananda-rama-makhi. Das Glück des Lebens*. (Arbeiten der deutsch-nordischen Gesellschaft für Geschichte der Medizin, der Zahnheilkunde und der Nervenwissenschaften, 13.) Greifswald, 1937.
- [WEI PO-YANG.] “An Ancient Chinese Treatise on Alchemy entitled Ts’an T’ung Ch’i, written by Wei Po-yang about 142 A.D.” Translated by Lu-ch’iang Wu and Tenney L. Davis. In: *Isis* (Bruges), XVIII (1932), 210–89.
- WELLS, HERBERT GEORGE. *The War of the Worlds*. London, 1898.
- WILHELM, RICHARD, and JUNG, CARL GUSTAV. *The Secret of the Golden Flower*. Translated by Cary F. Baynes. London and New York, 1931; revised edition, 1962.
- _____. See also *I Ching*.
- WILLIAMS, MENTOR L. (ed.). *Schoolcraft’s Indian Legends*. East Lansing, Michigan, 1956.
- WINTHUIS, JOSEF. *Das Zweigeschlechterwesen bei den Zentralaustralern und andern Völkern*. Leipzig, 1928.
- WOLFF, TONI. “Einführung in die Grundlagen der komplexen Psychologie.” In: *Die kulturelle Bedeutung der komplexen Psychologie* Berlin, 1935. (Pp. 1–168.)
- WOODROFFE, SIR JOHN. *Shakti and Shakta*. Madras, 1920.
- _____. See also AVALON.
- WUNDT, WILHELM. *Principles of Physiological Psychology*. Translated from 5th German edition. London, 1904. (Original: *Grundzüge der physiologischen Psychologie*. Leipzig, 1874.)
- _____. *Völkerpsychologie*. Leipzig, 1911–20. 10 vols.
- WYLIE, PHILIP. *Generation of Vipers*. New York, 1942.
- ZIMMER, HEINRICH. *Philosophies of India*. Edited by Joseph Campbell. New York (Bollingen Series XXVI) and London, 1952.
- [ZOSIMUS.] “Rosinus ad Sarratantam Episcopum.” See (A) *Artis auriferae*, iii.

INDEX

INDEX

A

- abaissement du niveau mental*, 119, 120, 139, 155
- abandonment, 167f
- Abarbanel/Abrabanel, Judah, *see* Leone Ebreo
- Abercius inscription, 310n
- ablution, 129
- Abraham, Karl, 153n
- Achurayim, 298n, 328, 329f, 335
- Acts of the Apostles, 263
- Adam, 26f, 317
- Belial, 328n
 - First, 338n
 - Second, 134n, 141
- Adler, Alfred, 43
- Adler, Gerhard, 352n
- Aelian, 236n
- Aeons, 295n, 310, 319, 328n
- aesthetics, and morals, conflict, 28
- Aetius, 325n
- Afanas'ev, E. N., 242n
- Africa, East, 95; *see also* Kenya
- agathodaimon*, 317
- ἀγγολα*, 272
- Agricola, Georg, 158n
- Ain-Soph, 328n
- Air God, 380
- albedo*, 140n
- alchemists/alchemy, 58, 70, 133, 141n, 305, 312, 328, 366, 375, 382

anima in, 286
Böhme and, 12, 341
Chinese, 293, 358
and energy, 33
and fish, 140
hermaphrodite/androgyny in, 192, 384
and individuation, 41
lightning in, 295
mandalas in, 387
and Mercury/Mercurius, 314, 317
and prolongation of life, 136
and spirit, 38, 208, 215
and synonyms for *lapis*, 171
triad in, 234
and union of opposites, 109
and uniting symbol, 289
and wise old man, 35
alcheringa/alchera/alcheringamijina, 40, 125, 126n, 154
alcohol, 209
Aldrovandus, Ulysses, 25n, 124n
Alexander the Great, 144, 145, 343
“Allegoria super librum Turbae,” 158n
allegory, distinguished from symbol, 6n
altar, 202
ambivalence: of anima, 200
 of maternal attributes, 82
America/American, 22, 373n
amethysts, 300
Amitāyur-dhyāna Sūtra, 327n, 344n
amnesias, 120
amulets, 197
anaesthetic areas, 120
analysis, 39
 personal, and archetypes, 47; *see also* dream-analysis

analyst: parental imagos projected on, 60

as saviour, 61; *see also* doctor

anamnesis, 189

ancestors, 188

identification with, 126

ancestral: roles, 124

souls, 125

ancestress, 81

Ancient of Days, 226

androgyny, Christ's, 174

angel(s): fallen, 214

“fatherly” and “motherly,” 310f, 317, 324

first, 143

twelve wicked, 324

angelos, 143

Angelus Silesius, 11

anima, 25ff, 41, 56ff, 123, 175, 177, 239f, 242, 244ff, 247, 270f, 284, 285, 317, 320n, 357, 374, 382

in alchemy, 286

ambivalence of, 200

and animals, 200

an archetype, 27, 37, 82, 94, 182f, 198

archetype of life, 32

autonomy of, 30

bipolar, 199

conservative, 28

derivation, 209

empirical concept, 56

experiences, significance of, 203

femininity of, 27, 69

image, 69

Kore as, 199

as *ligamentum corporis et spiritus*, 313

in literature, 71

localization of, 286

loss of, [71f](#)
as Mercurius, [211n](#)
and mother, [29](#)
in mother complex, [85](#)
old man as, [229](#)
possession caused by, [124](#)
projection of, [29](#), [89](#), [203](#)
religious tinge in, [199](#)
secret knowledge of, [30f](#)
as soul, [26](#), [211](#)
in syzygy, [65](#)
and therapy, [71](#)

Anima Christi, [328n](#)

anima mundi, [236](#), [312](#), [383](#)

animal(s), [158](#), [161n](#)

and anima, [199](#), [200](#)

archetype as, [216](#)

child-protecting, [168](#)

chthonic, [159](#)

in fairytales, [221](#), [230f](#)

helpful, [81](#), [231](#), [242](#)

kingdom of heaven and, [35](#)

in mandala, [366](#)

mother as, [85](#)

poltergeist as, [256](#)

powerful, [187](#)

psyche of, [125](#)

symbolic, [166](#)

talking, [215](#); *see also* bear; bees; beetle; birds; bull; butterfly; cat; cow; coyote; crab, crayfish, crocodile; crow; dog; dolphin; dove; eagle; elephant; elk; falcon; fish; goat; goose; hare; hawk; horse; lamb; leopard; lion; magpie; monkey; octopus; peacock; pig; raven; sea-horse; serpent; sheep; snake; spider; swan; tiger; tortoise; vertebrates; vulture; wolf; worm

animosity, [94](#)

animus, [25n](#), [30](#), [177](#), [183](#), [247](#), [284](#), [290f](#), [306](#), [317](#), [318](#), [333](#), [336](#), [357](#), [382](#)

danger from, 344n
derivation, 209
-figure, 191
localization of, 286
as mediating function, 197
old man as, 229
“positive,” 215
possession by, 124
represented by quicksilver, 312
represents spirit, 244
Anne, St., 44ff, 68n
anthracites, 300
anthrax, 300n, 331n
Anthroparion/ἄνθρωπάριον, 158, 223
anthropology, 189
Anthropos, 293, 294, 304, 308, 312, 313, 366, 377
Antichrist, 141
antimony, 301
ape of God, 255
Aphrodite, 327
Apocalypse, 35
 Christ of, 51; *see also* Revelation, Book of
apocatastasis, 188
Apollo, 236n
apologetics, Christian, 157
apparition, 214n
apperception, 66
apple(s), 27, 223, 228
Aptowitzer, Victor, 331n
Apuleius, 32, 52, 107, 128, 350
aqua permanens, 140
arbor philosophica, 251n, 333; *see also* tree, “philosophical”
archetype(s), 4, 58, 153, 177, 357, 384, 388, *etc.*;
 activated, 48

as active personalities, 38
and archetypal idea, 5n
can rearise spontaneously, 79
cannot be finally explained, 160
constellated, in neuroses, 47
content not determined, 79
contents of collective unconscious, 42, 43
in dreams, 48ff, 53
dynamism of, 102
function of, 162ff
futuraity of, 164ff
gods as, 23
identification with, 351
as link with past, 160ff
loss of, 69
as mediator, 174
mother as carrier of, 102
as myths/mythological, 67, 156
no “rational” substitute for, 161
origin of, 101
patterns of instinctual behaviour, 44
positive and negative sides, 226
proof of, 48ff
psychological meaning, 5
relatively autonomous, 40, 222
specific energy of, 63
of transformation, 38
of wholeness, 388; *see also* anima; animus; child; father; maiden; mother; self;
shadow; wise old man

Aries, 6

Aristotle, 75

Aristotelian reasoning, 76

arrows, 368f

arrow-head, 382

Ars chemica, 133n

Artemis, 195
arthropods, 56
Artio, Dea, 195
Artis auriferae, 134n, 140n, 141n, 158n, 174n, 286n, 331n
artists, and anima, 7
ascension, of Christ, 114
ascent, 19
Asiatic cults, 13
“as-if,” 156
Asklepios, 311
ass(es): feast of, 258
 she-, 198
association, 282
 free, 49
Assumption, *see* Mary, the Virgin
Asterius, Bishop, 177n
Astrampsychos, 133n
astrology, 310, 343, 344n
Aswan, 134
atheism, 62
Athene, 46, 201
Athi plains, 95
athla/ἄθλα, 171, 241
Atlantis, 263
atman/Atman, 142, 171, 224, 325
atoms, 57
 atomic fission, 253
 atomic theory, 57
 atomic world, 224
Attis, *see* Cybele-Attis myth
attitude, 238
 conscious, onesidedness of, 139
attributes, of anthropomorphic divinities, 188
Augustine, St., 4, 18n, 75

“Aurea hora,” [134n](#)

aurum philosophicum/potabile/vitreum, [305](#); see also gold, philosophical

Australian aborigines, [126n](#)

and ancestors, [40](#), [125](#)

soul-atoms and, [57](#) see also *alcheringa*

authority, magic, of female, [82](#)

automatismes téléologiques, [155n](#)

autosuggestion, [63n](#)

Avalon, Arthur, [38n](#), [70n](#), [185n](#), [261n](#); see also Woodroffe, Sir John

avatars, [310](#)

Ayik, [170](#)

B

Baba Yaga, [242](#)

babe, unbaptized, [26](#)

Bacon, Josephine D., [185n](#)

ball: game of, [191](#), [192](#)

— on fools’ feast, [258n](#)

golden, [160](#), [370](#)

path-finding, [220n](#)

Balli di Sfessania, [260n](#)

Bandelier, Adolf, [255](#)

Bänziger, Hans, [352n](#)

baptism of Christ, [45](#)

Barbelo-Gnosis, [319](#)

Bardesanes, [18](#)

Barlach, Ernst, [215](#)

Baruch, angel, [317](#), [324](#)

Baruch, Apocalypse of, [295n](#)

Basel, [265n](#)

Basilides, [331n](#)

Bastian, Adolf, [43](#), [79](#), [151](#)

Bataks, [102](#)

bath, baptismal, [129](#)

Baubo, [88](#), [185](#), [186](#)

Baumgartner, Matthias, 325n
Baynes, H. G., 190n
bear, 184, 187, 195, 198, 232
“beautiful and good,” 28
Beauvais, 258
bed, 333
bees, 198
 “Bees, Woman of the,” 185n
beetle, 187, 367
behaviour: archetypes of instinctual, 44
 pattern of, 5n
Benares, 369
benedicta viriditas, 322
Benoît, Pierre, 28, 30, 71, 200, 285, 286n
Bernoulli, R., 38
Berthelot, Marcellin, 134n, 140n, 158n, 300n, 319n, 330n
Bes, 106, 215
Bethesda, pool of, 17, 19
Bhutia Busty, 320n, 327n
Bible, 20, 141, 237n; *see also* New Testament; Old Testament; *names of individual books*
Biedermeier, 28
Binah, 335n
Bin Gorion, 145n
biology, and purpose, 260
bird(s): black, 324
 dream-symbols, 200ff
 earth, 334
 in fairytales, 221, 242
 in mandala, 366
 three, 342;
 white, 191, 338; *see also* crow; dove; eagle; falcon; goose; hawk; magpie; peacock;
 raven; swan; vulture
birth: of “child,” 172
 dual/second, 45f, 68

miraculous, [166](#), [167](#); *see also* rebirth; twice-born

Birth, Virgin, *see* Virgin Birth

bishop, children's, [257](#)

black, [185](#), [326](#)

blackness, [301](#)

Blanke, Fritz, [9n](#), [10](#)

Block, Raymond de, [60n](#)

blood, [185n](#)

- bathings in, [184](#)
- drinkings of, [184](#)
- sacrificial, [192](#)

bloodstone, [327](#)

boat, self-propelled, [220n](#)

body: one with spirit in God, [324](#)

- subtle, [114](#), [212](#)

bogies, [82](#)

Böhme, Jakob, [11f](#), [295ff](#), [308](#), [313](#), [319](#), [322n](#), [327](#), [329ff](#), [341](#), [354](#), [375](#), [381](#), [389](#)

Bön religion, [320](#), [373n](#)

bondsman, [171](#)

Book of the Dead, Tibetan, [356](#)

book: in mandala, [372](#)

- of secret wisdom, [220n](#)

Bouché-Leclercq, Auguste, [342n](#), [343n](#)

Bouelles, Charles de, *see* Bovillus boulders, [292f](#), [294](#)

Bousset, Wilhelm, [136n](#)

Bovillus, Karl, [9](#)

“Boy, Radiant,” [158](#)

boy(s), [165](#)

- naked, [215n](#)
- spirit as, [215](#)

Bozzano, [295n](#)

Brahma, city of, [377](#)

Brahma-gods, [286](#)

Brassempouy, “Venus” of, [186](#)

bread, Christ as, [141](#)
breast(s), [343](#)
 multiple, [186](#)
bridegroom and bride, [251](#)
Broglie, Louis de, [275](#)
brook, [194](#)
brother-sister pair, royal, [246](#), [247f](#)
brownies, [223](#)
Buddha, [142](#), [286](#), [335](#), [358](#)
 Discourse on the Rule, [338](#)
 lotus seat of, [328f](#), [338n](#), [363](#), [366](#)
 and mandala, [130](#)
 as *puer aeternus*, [159](#)
Buddhism, [319n](#), [373](#)”
 mandala in, [358](#)
 —, in Tibetan, [356](#), [387](#)
 reincarnation in, [113](#)
 swastika and, [320](#); *see also* Hīnayana; Mahāyana; Zen
Budge, Ernest A. Wallis, [136n](#)
bugari, [154](#)
bull, [191](#), [335n](#);
 deities, [310](#)
Bultmann, Rudolf, [104n](#)
Buri, F., [104n](#)
butterfly, [187](#)
Bythos, [17](#)

C

Cabala, [328](#), [329](#), [330n](#), [335](#)
Cabiri, [224](#), [234](#), [388](#)
caduceus, [295n](#), [311](#)
Caesarius of Heisterbach, [294f](#)
“Calidis liber secretorum,” [134n](#)
Callot, Jacques, [260](#)
Cancer (zodiacal sign), [342f](#)

cancer, imaginary, 105
carbons, 300
carbuncle, 331*n*
Cardan, Jerome (Hieronymus Cardanus), 243
carnival, 255, 262
carriage, golden, 191
Carus, C. G., 3, 152, 276
case-histories, 190
Cassian, 176
castle, 361
castration: complex, 68
 of mother, 68
 self-, 39, 85, 177*n*
cat, 184
categories, 67*n*, 76
 of the imagination, 79
Catholic: Church, ritual of, 128
 mysticism, 174
 way of life, 12
cauda pavonis, 330, 332, 338, 375, 376
Caussin, Nicholas, 325, 326, 342*n*
cave, 81, 135, 141
Cellini, Benvenuto, 45, 184*n*
cerebellum, 166
cerebrospinal system, 19*f*
cerebrum, 20
Cervula/Cervulus, 257*n*
chairs, 332
chakra, 38, 261*n*, 366
chalice, 160
Chantepie de la Saussaye, P. D., 59*n*
chaos, and cosmos, 32
Charles, R. H., 295*n*
chen-yen, 293, 307

cherubim, 366

ch'ien (heaven), 358*n*

child, 158, 173, 183

abandonment of, 167*ff*

as archetype, 153*ff*, 178*f*

divine, 170, 378

eternal, 179

as god and hero, 165*ff*

hermaphroditism of, 173*ff*

“imaginary,” 159

invincibility of, 170*ff*

mythology of, 151*ff*, 170

numinous character of, 168; *see also* motif

children, ancestors reincarnated in, 124

childhood, early, dreams of, 50

China, Taoism in, 8

Chinese: alchemy, 293

philosophy, 59, 109

yoga, 38

ching (unchangeable power), 359

Chochmah, 335*n*

chörtens, 320

Christ, 103, 333

in alchemy, 312*n*

androgyny of, 174

of Apocalypse, 51

ascension, 114

as ass, 259

in bearskin, vision of, 10

birth of, festivities, 256*f*

as bread, 141

and the Church, 250, 371

divinity of, 13

fiery nature of, 169

fish and snake attributes, 369
as friend, 133
in inner colloquy, 132
Mother of, *see* Mother of Christ
outer and inner, 128
sacrifice of, in Mass, 118
symbol of immortal man, 121
— of self, 367
transfiguration, 114
twice-born, 45; *see also* Baptism; bread; conception; Jesus; Virgin Birth

Christ-child, 52, 128, 158, 169

Christianity, 128, 254
and Germanic tribes, 13*f*
and Jewish God-concept, 103
monotheism of, 103
of Negroes, 14
and poverty, 15
“second birth” in, 45
spirit in, 46, 211, 213
world-view of, 7

Christianos, 319*n*

Christians, and ritual murder, 191

Christ-image, 9

Christmas tree(s), 13, 261, 268

Christopher, St., 158

Church, the, 22, 81
bride of Christ, 250, 377
as *corpus mysticum*, 165
freedom and obedience in, 137*n*
images represented by, 8
loss of authority, 13
Mother, 29

church, crooked, 221*f*

Cicero, 326*n*

cinnabar, [300](#), [331n](#)
circle(s), [164](#), [187](#), [294](#), [304](#), [365](#)
 cross in, [382](#)
 God as infinite, [325](#)
 magic, [376](#)
 squaring of, [357](#), [361](#), [363](#), [366](#), [368](#), [387f](#)
circuits, [326](#)
Circumcision, Feast of, [257](#)
Cistercian Order, [64](#)
city, [81](#), [361](#)
 beloved, [146](#)
 heavenly, [35](#)
 medieval, [377](#)
Clement, pseudo-, [176](#)
Clement of Alexandria, [176](#), [325](#)
Clementine Homilies, [324](#)
Cleopatra, [202](#)
“climax” of life, [307](#)
clock, [187](#)
clown, [264](#)
cock, [360](#)
Codex Rhenoviensis (Zurich), [375](#), [383](#)
cognition, [76](#), [171](#)
 transcendental subject of, [171](#)
colloquy, internal, [131f](#)
colours, [332](#)
 in Böhme, [313](#), [331](#)
 bright, [294](#)
 four, [308n](#), [375](#), [379](#), [380](#)
 and functions, psychic, [335](#)
 light, [305](#)
 in mandalas, [323](#), [326](#), [362](#), [379](#)
 red/blue, [322](#)
 two symbolical, [313](#); *see also* black; green; red

Comarius, 202
comic strips, 260n
Communism, 127
compass, eight points of, 344n
compensation, 163
complex(es): castration, 67, 68
content of personal unconscious, 42
 father-, 85, 214, 291
 — feminine, 89n
 — in men and women, 214
feeling-toned, 4
mother-, 46, 67, 69, 85ff
 — of daughter, 86
 — feminine, 94
 — negative, 90, 98ff
 — positive, projection of, 99
 — of son, 85ff
possession and, 122
complex psychology, therapeutic method of, 40
complexio oppositorum, 147, 312
 Nicholas Cusanus and, 11; *see also* opposites
composition, 332
concentration, 384
conception; failure of, 91
 miraculous, 166
 of Christ, 52
concupiscentia, 356
confirmation lessons, 15
conflict, 288
Confucius, 339
confusion, 278
coniugium solis et lunae, 176
coniunctio, 140, 175, 176, 177, 191, 346
Conrad of Würzburg, 364

conscious mind: and ego, 187
one-sidedness of, 162
in primitives, 153
widening of, 188

consciousness, 142, 171, 357
and cerebrum, 20
conflict within, 269
consolidation of, 22
differentiation of, 320
dissociation/dissociability of, 40, 104
dissolution of, 145
expansion of, 252
eye as symbol of, 337
higher, 39, 141, 169, 283
— why seek?, 95
inferior, 18
maladaptation of, 30
male, 176
menaced by unconscious, 154
not whole of psyche, 276
primitive, lacks coherence, 119
— and myths, 155f
reduced intensity of, 155
relics of early stages, 261n
requires recognition of unconscious, 96
return to darkness, 147
soul and, 27
subject and object in, 22
supremacy of, 23
unity of, only a desideratum, 104
universal, 287f
urge of, 319
without ego, unknown, 283; *see also* ego-consciousness

contemplation, 318, 357

cooking vessel, 81
copper, 301, 327
Corinthians, Second Epistle of Paul to, 328n
corn, 169
cornucopia, 81
corpus, 313
 glorificationis/glorificatum, 114, 171, 358
 incompactibile, 358
 mysticum, 367
Corpus Hermeticum, 4, 51, 75
cortices, 328, 336, 338
corybant, 184
counter-earth, 281
country, 81
courtyard, 361
cow, 81, 227
 leathern, 129
coyote, 264
crab(s), 187, 315, 342f
 hermit, 342
Crawley, Alfred Ernest, 57
crayfish, 342
creation, 308, 356, 357
crocodile (s), 159, 184, 271n, 342n
cross, 296n
 alchemical symbol, 301
 in Böhme, 298ff, 319, 327
 in circle, 382
 dream symbol, 198
 in mandala, 336, 361
 in Navajo symbolism, 363n
 and swastika, 48, 326
 Virgin Mary as, 82
crow, 330n

crowd: individual in, [126](#)
 psychology of, [125](#)
crown, [326](#)
crucifixion, [135](#), [184f](#), [382](#)
 of evil spirit, [248](#)
 of raven, [235f](#), [241](#)
cryptomnesia, [44](#), [308n](#)
crystal, [79](#), [80](#)
Cucorogna, [260](#)
cucullatus, [177](#)
culture, [373](#)
Cumont, Franz, [135n](#), [311n](#)
cupids, [177](#)
Cusanus, Nicholas, [11](#)
Custance, John, [39n](#)
Cybele, [195](#)
Cybele-Attis myth, [81](#), [85](#)
cymbals, [192](#)
Cyraniades, [331n](#)

D

Dactyls, [178](#), [223](#)
daimonion, [252](#)
Danae, [317](#)
dancer, [184](#), [185n](#), [198](#), [200](#)
dances, [257](#)
dangers, [184](#)
Daniel, [388](#)
Dante, [234](#), [363](#)
dark, fear of, [169](#)
Dark Night of the Soul, [319n](#)
darkness, [147](#)
 place of, [140](#)
Daudet, Léon, [124](#)
daughter: and mother, [188](#)

mother-complex in, 86ff
“nothing-but,” 97f
self expressed by, 187
dead, primitives and souls of, 210
“De arte chymica,” 134n
death, 147
 early, 85
 as symbol/symbolic, 82, 129
 voluntary, 32
Decius, 136n
Dee, John, 327
Déesse Raison, 92
De Gubernatis, Angelo, 343
Deianeira, 123, 324
deification rites, 142
deity(ies): male-female pairs, 59
 symbols for, 324f
Delacotte, Joseph, 64n
Delatte, Louis, 331n
delight-maker, 262
delirium, 155
delusions, 50, 183
Demeter, 81, 88, 90, 115n, 182, 184ff, 188, 195, 203
Democritus (alchemist), 130
Democritus (philosopher) of Abdera, 57 325
demon(s), 197
Deo concedente, 163f
Dervish monasteries, 387
descent, dual, 45f, 68n
deus terrenus, 171
devil, the, 103, 108, 238, 248, 339, 376
 “ape of God,” 255
 in *Faust*, 146
 fish and snake attributes, 369

his grandmother, 103
Leviathan as, 316n
as raven, 240
represents shadow, 322
spiritual character of, 213
as tempter, 214
Dhulqarnein, 143ff
diamond body, 358
Diana, 195
Diels, Hermann, 325n
Dieterich, Albrecht, 51
Digulleville, Guillaume de, *see* Guillaume de Digulleville
diminutives, 224
Dionysius (pseudo-), the Areopagite, 4, 341n
Dionysius Thrax, 325n
Dionysus, 62, 107, 118
Dioscuri, 121, 131, 144, 147n
directions, four, 380
discontent, 70
discontinuity, 275n
dissociation, 139, 165
distaff, 225
Divine, experience of the, 11
divinity, splitting of, 103
divorce, 29, 387
Docetists, 295n
doctor, 216; *see also* analyst
doctrinairism, 93
dog(s): in *Faust*, 146
 in Khidr legend, 136n
 miraculous, 220n
 three, 378
dogma, 11, 12
 and collective unconscious, 12, 22

reward and punishment, 27

dolphin(s), 177, 192

Don Juanism, 85, 87

donkey, *see* ass

dorje, 358

Dorn, Gerard, 193, 194, 330*n*

dove, 45, 52

dragon(s), 159, 166, 197*f*, 383

- in alchemy, 376, 377
- dream-symbol, 201
- evil symbol, 82
- in fairytales, 229
- in mandala, 382, 383
- Mercurius as, 311, 377
- and “River Map,” 359
- sun identified with, 157
- symbol of self, 187
- water, of Tao, 18
- winged and wingless, 314

dragon’s blood, 300

drama, mystery, 117

dream(s), 21, 183, 184*n*, 189, 282, 283

- as anticipation of future, 279
- archetypal, 306
- , images in, 189
- and archetypes, 48*ff*
- “big,” 306, 307
- children’s, 353
- of early childhood, 50
- and individuation, 130*f*
- and mythology, 152
- psychology of, 152
- relation to dreamer, 118
- repressed instincts sources of, 49

spirit in, [214ff](#)
symbols in series, [53](#)
and therapy of neuroses, [178](#)
typical, [183](#)
INSTANCES OF DREAMS (in order of occurrence in text): lake at foot of mountain, [17](#)
water, [18](#)
mountain (Grail Castle), [19](#)
black and white magician, [34](#), [216f](#)
white bird and woman, [191](#)
bull and child, [191](#)
golden pig and hole, [191](#)
youth with cymbals, [192](#)
sheep sacrifice, [192](#)
den of snakes, [192](#)
divine woman sleeping, [192](#)
fields of grain, [193](#)
sky-woman on mountain, [195](#)
bear-goddess, [195f](#)
pictures by H. C. Lund, [197](#)
dancer who changes shape, [198](#)
girl on cross in church, [198](#)
transformations into animals, [200f](#)
grey world-globe, [306](#)
snake requiring sacrifice, [306n](#)
table and chairs, [332](#)
bed moved from its place, [333](#)
young man with lamp in eye, [336](#)
horned animal that ate others, [353](#)
embroidery pattern, [362](#)
magnolia tree in Liverpool, [364](#)
dream-analysis, and free association, [49](#)
dromenon, [128](#)
dualism, Manichaeism, [103](#)
Du Cange, Charles, [257n](#), [258](#), [259](#)

Duchesne, Louis, [185n](#)
duplication motif, [344](#)
Dürkheim, Emile, [79](#)
Dutch East Indies, [365](#)
dwarf(s), [158](#), [165](#), [215](#), [222](#)
dyad, [375](#)

E

eagle, [335n](#), [376](#)
earth, [81](#)
 Mother, *see* Mother; Virgin Mary as, [107](#)
east, symbolism of, attraction of Europeans to, [8](#)
Easter: candle, [185n](#)
 eggs, [13](#)
ecclesia spiritualis, [87](#)
Ecclesiasticus, [354n](#)
Eckhart, Meister, [158](#), [215n](#)
ecstasy, [287](#)
Edem, [310](#), [317](#), [324](#), [330n](#), [368](#)
Eden, Garden of, [27](#), [35](#)
education, of the educator, [175](#)
egg(s), [292ff](#), [304](#), [319n](#), [377](#)
 golden, [159](#), [160](#), [172](#), [368](#)
 in mandala, [347](#), [371](#)
 Orphic, [293](#), [361](#)
 peacock's, [375](#)
 philosophical, [293](#)
 world, [311](#)
ego, [318](#), [319](#), [357](#), [358](#)
 and consciousness, [275](#)
 differentiation from mother, [102](#)
 not centre of unconscious, [281](#)
 and personality, [165](#), [187](#)
 unconscious and role of, [278](#)
ego-consciousness, [141](#), [288](#)

and archetypes, [286](#)

awakening of, [102](#)

emancipation of, [230](#)

identification with self, [145](#)

possessed by shadow and anima, [123](#)

primitive, [33](#)

supremacy of, [132](#)

Egypt, [343n](#)

infant in tomb, [134](#)

initiation in, [14](#)

Mary's flight into, [258](#)

rebirth ritual, [45](#)

Egyptian (s): land of the, [18](#)

representation of God, 326

Egyptians, Gospel according to the, 176

εἶδος, *see* idea, Platonic

eight, *see* numbers

Eisler, Robert, 311*n*

Eleazar, Abraham, 298*n*

elements, four, 319, 329, 335

elephant, 187

Eleusis, 14; *see also* Mysteries

elf, 158

Elgon, Mount, 169, 268

Elgonyi tribe, 17

Eliade, Mircea, 56

Elijah, 141, 145, 237*n*

elk, 264

Elohim, 310, 317, 324

Ememqut, 227*f*

emotion(s), 96, 209, 278

- mass, 47;
- violent, 120

empiricism, 76

emptiness, 98

Empusa, 82

enantiodromia, 215, 229, 239*n*, 272, 346, 348, 353

- in symbolic process, 38

energy, 33

- consciousness and, 142;
- specific, of archetypes, 63

Enkidu, 145

Enlightenment, 157

Enoch, 388

entelechy, 164*f*, 166

enthusiasm, 213

envy, 360

Ephesians, Epistle to the, [12n](#), [342n](#)
Ephesus, [136n](#)
epidemics, psychic, [127](#), [157](#), [278](#)
epilepsy, [78](#)
episcopus puerorum, [257](#), [258](#)
Epona, [250](#)
Erman, Adolf, [326n](#)
Eros, [86](#)
 overdeveloped, [88](#), [94ff](#)
Erskine, John, [28](#), [202](#)
esoteric teaching, [7](#)
 archetypes in, [5](#)
eternity, [147](#), [196](#)
ethnology, [53](#)
euhemerism, [157](#)
Euhemeros, [60](#)
Europa, [191](#)
evangelists: attributes/symbols of, [234n](#), [366](#)
 four, [341n](#), [346n](#)
Eve, [27](#), [312](#), [317](#)
evil, [337n](#)
 chthonic triad and, [234](#)
 cross and, [382](#)
 and good, [103](#), [215](#), [217](#)
 matter and, [109](#)
 reality of, [322f](#), [341n](#)
evil eye, [197](#), [380](#)
evil spirit, [213](#), [249](#), [377](#)
 transgression of, [248](#)
exercitia spiritualia, [129](#), [131f](#)
existences, previous, [287](#)
exposure, of child, [167](#)
extraversion, [238](#)
eye(s), [336](#)

in Böhme, [381](#)
and mandala, [337](#), [361](#), [377](#), [380](#)
motif, [346](#)
of Osiris, [226](#)
peacock's, [330](#)
symbol of consciousness/God, [337](#)
of Wotan, [226](#); *see also* evil eye

Ezekiel, [346n](#)
seraphim of, [319](#)
vision of, [234n](#), [355n](#), [366](#)
wheel of, [329n](#), [388](#)

F

“factor(s)”
 anima as, [27](#)
 gods as, [23](#)
fairytale, [155](#), [207ff](#)
 archetypes in, [5](#), [207ff](#)
 Estonian, [218](#)
 EXAMPLES: Czar's Son and His Two Companions, [228f](#)
 diagrams on wall, [129f](#)
 Ememqut and the Creator, [227f](#)
 How Orphan Boy Found his Luck, [218f](#)
 Maria Morevna, [242](#)
 Onesided Old Man, [226f](#)
 Princess in the Tree, [231ff](#), [235ff](#), [243ff](#)
 Soldier and Black Princess, [225ff](#)
 Son-in-Law from Abroad, [228ff](#)
 Stepdaughter and Real Daughter, [225ff](#)
 see also [218–42](#) *passim*
faith, [208](#), [350](#)
falcon, [367](#)
fall, the, [230](#), [328n](#)
fantasies, [66](#), [172](#), [183](#)

archetypal images in, 189
and dreams, 49
Miller, 189
personal, and impersonal, 155
series of, 190
fantasy: creative, 78
erotic, 25
infantile, 83
intensification of, 180
fasces, 48
fascination, 26, 69, 377, 378
fate, goddess of, 81
father, 102
archetype, 161*n*
-complex, *see* complex
-figure, in dreams, 214
-imago, *see* imago, parental
pneuma as, 324
self expressed by, 187
tribal, 62
unconscious incestuous relationship with, 88
Father and Son, Christian formula of, 12
fatigue, 120, 139
Faust, 284; *see also* Goethe
“fear, maker of,” 17, 170
Fechner, Gustav Theodor, 54
feeling-values, 103
see also functions
femininity, threeness and, 244
Fendt, Leonhard, 176
Fescennia, 260*n*
festum: asinorum, 258
fatuorum, 258*n*
puerorum, 258

stultorum, 257
Ficino, Marsilio, 314n
field, 81
Fierz-David, Linda, 28n, 124n
figures, geometrical, 187
filia mystica, 201
filius: philosophorum, 140
 regius, 215
 sapientiae, 106, 158, 171
Finland, child-motif in, 151
fire, 169, 316, 327n, 356
 ever-living, 33
 fire-god, 51
 wise old man and, 224
firmament, 187
first half of life, 120
fish, 146
 in Abercius inscription, 310n
 alchemical “round,” 140
 content of unconscious, 139
 Great, 310
 in Khidr legend, 138f
 in mandala, 369f
 meals, of early Christians, 141
 “Nun” as, 138
 symbol, 142
 —, of mother, 82
 —, of saviour, 18
 transformation of, 141
Fishes, aeon of, 309, 310
five, *see* numbers
Flamel, Nicholas, 140n
flash, 295f
Flournoy, Théodore, 55, 155n

flower(s), [159](#), [160](#), [187](#), [361](#), [365](#), [367](#)
 Golden, [363](#)
flute, [220n](#)
Fo, [159](#)
fog, blue, [353](#)
folklore, [217](#)
 child motif in, [158](#)
 devil in, [255](#)
folktales, [184](#), [217ff](#)
font: baptismal, [45](#), [81](#)
 benediction of, [45](#)
fools' feast/holiday, [257](#), [258](#)
force, lines of, [306](#), [313](#)
Fordham, Michael, [156n](#)
Forest, King of the, [222](#)
foster-parents, fantasy of, [45](#)
Foucart, Paul François, [177n](#)
fountain, [221](#)
 Mercurial, [140n](#)
four: a feminine number, [234](#); *see also* numbers
fourness, [234](#)
France, [258](#)
Franz, Marie-Louise von, [217n](#)
freedom, [163](#)
Freeman, Kathleen, [325n](#)
Freud, Sigmund: and aetiology of neuroses, [83](#)
 and free association, [49](#)
 on Leonardo, [44](#), [46](#), [68n](#)
 and Oedipus legend, [152–3n](#)
 on religious inhibition of thought, [69n](#)
 theory and method, [54f](#)
 view of psyche, [43](#)
 view of unconscious, [3](#), [277](#), [284](#)
Freudian, [303](#)

psychology, 29
friend(s), 133
 pair of, 147
 two, parable of, 121f
 two helpful, 147
friendship, 86
 of Mithras and sun-god, 131
 of Moses and Khidr, 122
 of two birds, 121f
Frobenius, Leo, 310n
function(s): four psychic, 77, 153, 237f, 320, 332
 —, and colours, 335
 inferior, 123, 237, 238, 241, 244, 303, 332
 loss of, hysterical, 120
 pairs of, 303n
 superior, 238
 three/triad of, 241, 242
 transcendent, 289
 triads of, 330n; *see also* feeling

G

Galatea, 373
gana, 119n
Garbe, Richard, 82n
garden, 81
garnet(s), 300, 301
Gebhurah, 335n
Gedulah, 335n
Geist, 209
genes, 284
Genesis, Book of, 299n
germ, golden, 368, 370
Germanic: soul, 146
 tribes, and Christianity, 13f
Germany, 127

Gessmann, Gustav Wilhelm, 300n

“getting stuck,” 38, 291, 318

ghost, 215

ghost-stories, 158

ghost trap, 268

giant, 161n

Gilgamesh, 145

girl, unknown young, 184

Glauber, Johann Rudolph, 331n

globes, 374

Gnosticism/Gnosis/Gnostic, 12, 191, 310, 368

coniunctio in, 175, 177

hermaphrodite in, 174

and Holy Ghost, 64

of Justin, 317, 324, 330n

Naassene, 368

peacock in, 375

“psychic” and “spiritual” man in, 26

spirit/dove in, 45

syzygies in, 59, 70; *see also* Barbelo-Gnosis Soul, Hymn to the

goat, 226, 338, 339, 342

god(s), 199

child-, 151, 158, 165ff

fire-, 51

“light,” 103

as psychic factors, 23

self expressed by, 187

seven planetary, 136n

sun as, 6, 51

unreliability of, 145f

God, 211

back of, 328n, 330

Christian conception of, 11

dual vision of, 64

as Father, Mother, and Son, in Brother Klaus's vision, 10
four spirits of, 335
and lotus, 326
the mandala as an image of, 389
name of, 330
of New Testament, 11
spirit as, 208, 213
wise old man and, 225
Yahwistic conception of, 11; *see also* Son of God

goddess, 330
anima as, 29
as mother, 81
Mother, 177n
self expressed by, 187

godfather/godmother, 45, 68, 93
godhead, spirit and, 211
God-image, 4, 246, 324, 354; *see also* Imago Dei
Goethe, 69, 101, 104, 209, 223, 224, 285
Faust, 28, 29, 96n, 97n, 98, 114, 146, 158, 159n, 177, 183, 234, 286n, 373, 389
Goetz, Bruno, 159, 215n
Gog, 144, 146
gold, 305, 317
alchemical sign for, 301
hoard of, 157
philosophical, 348, *see also aurum philosophicum*
and sun, 312
symbol of Anthropos, 313

Golden Age, 263, 268
good, *see* evil
goose, of Hermes, 376
gorge, 192
Gorgon's head, 189
gospels(s), 128, 141, 346n, 388
governess, 81

grace, [25](#), [115](#), [117](#), [118](#), [129](#), [132](#), [134](#)

Graeae, [81](#)

grail, [14n](#)

Grail, Castle of the, [19](#), [24](#)

grain, field of, [193](#)

grandfather, [216](#)

grandmother, [81](#), [102](#)

 devil's, [103](#)

grass, [143](#)

grave, [82](#)

Great Mother, *see* Mother s.v. Great

Greece: child-motif in, [151](#)

 gods of, [14](#)

green: in fairytale, [222](#)

 and sensation function, [332](#), [335](#)

gremlins, [223](#)

griffin, [223n](#)

Grimm, Brothers, [223n](#), [255](#)

group: identification with, [125ff](#)

 relation to individual, [127](#)

Guillaume de Digulleville, [64](#)

gunas, [82](#)

guru, [133](#), [216](#)

H

Hades, [140n](#), [184](#)

Haggard, H. Rider, [28](#), [30](#), [71](#), [200](#), [285](#), [286n](#)

hallucination, [214n](#)

Hal Saflieni, [186](#)

Hans, Stupid, [255](#)

Hanswurst, [255](#)

Harding, M. Esther, [316n](#)

hare(s), [81](#), [378](#)

Hartmann, Eduard von, [3](#), [152](#), [276](#)

Hauck, Albert, [324n](#)

hawk, 264
heart, 20, 296
heaven, 24, 27, 81
 kingdom of, 221; *see also* Queen of Heaven
Hecate, 100, 182, 185, 186
Helen (companion of Simon Magus), 202
Helen of Troy, 28, 30f, 202
Helios, 40, 52, 128
hematite, 327
hemorrhage, 91
hemlock, 177n
heng (all-pervading power), 359
Hephaestus, 374
Hera, 45, 343
Heracles, 45, 123, 167, 171, 343
 cycle, 24n
 “Prophet,” 324
Heraclitus/Heraclitean, 16, 26, 33
Hercules Morbida, 301n
heredity, 78
hermaphrodite, 69n 173, 174, 176, 374
 divine, 67
 Mercurius as, 158
 Platonic, 192
hermaphroditism, of child, 173ff
Hermas, “Shepherd” of, 37
Hermes, 133, 178, 227, 255, 306, 307n, 331, 312, 377
 ithyphallic, 106, 314
 Kyllenios, 295, 302
Hermes Trismegistus, 4n, 37, 311, 374
Hermetic philosophy, 60n, 175, 176; *see also* alchemy
hero(es), 197, 199, 218, 229, 285
 birth of, 141
 child, 165ff

—, as culture-, 169, 171, 183
cult-, identification with, 128
myths of, 69n, 172, 180
old man and, 217
self as, 146
sun as/solar, 6, 343n
transformations of, 117

heterosuggestion, 63ra

hexad, 372

hierogamy, of sun and moon, 314n

hieroglyph, 302

hieros gamos, 109, 176, 177, 229

Hildegard of Bingen, St., 381

Hinayana Buddhism, 358

Hindu: philosophy, 36
speculation, 171

Hinduism, 310

Hipparchus, 6

Hippolytus, 166n, 177n, 295n, 302n, 311n, 317n, 324, 331n

Hiranyagarbha, 142, 368, 370, 371, 377, 378

hoard, guarded by dragon, 157

hobgoblin(s), 216, 223

Hoffmann, E. T. A., 284

Hölderlin, Friedrich, 329

Hollandus, Joannes Isaacus, 140n

Holy Ghost, 52, 296
Gnostic interpretation of, 64

Holy Saturday, 45

Homer: Odyssey, 302

Homeric Hymn, 115n

homo: altus/interior/maximus, 380n, 312, 314
philosophicus, 134n
quadratus, 307

homoousia, 8

homosexuality, [71](#), [85](#), [86](#), [199](#)
homunculus(-i), [159](#), [165](#), [223](#), [293](#), [304](#), [315](#), [373](#), [375](#), [378](#), [383](#)
Honorius of Autun, [219n](#)
hooded man, [223](#)
Horace, [260n](#)
Horapollo, [46](#), [49](#), [311n](#)
horde, primal, [62](#)
Horneffer, Ernst, [118n](#)
horns, [353](#), [376](#)
horoscope, [6](#), [344](#)
horse: black, [34](#), [35](#), [217](#)
 three-legged, [232f](#)
Horus, [107](#)
 -child, [328](#), [363n](#), [367](#)
 four sons of, [234n](#), [319](#), [346n](#), [366](#), [388](#)
Hosea, [176](#)
hospital, [194](#)
Hovamol, [246n](#)
Hubert, H., and Mauss, M., [43](#), [67n](#), [79](#)
hun (spirit), [320n](#)
hydrogen bomb, [108](#)
hylozoism, [208](#)
hypnosis, [219](#)

I

Ialdabaoth, [298n](#)
Iamblichus, [326](#)
ice men, [223](#)
I Ching, [38](#), [59n](#), [219n](#), [339n](#), [342](#), [358](#), [359](#)
Ichthys, [370](#); *see also* fish
icons, [361](#)
id, [3n](#)
idea(s): archetypal, [5n](#), [21](#), [57](#)
 history of the word, [33](#)
 inherited, [66](#)

as *nomina*, 76
Platonic, 4, 33, 75f, 79
idealization, 106
identification, 97, 180
 with ancestral souls, 125
 with archetype, 351
 with cult-hero, 128
 with deceased persons, 124
 regressive, 126
 of self and ego-consciousness, 145; *see also* group
identity, group, 125
idleness, 27
Ignatius Loyola, St., 131
illness, 120
illumination, 39
illusion, 198
image(s), 78
 archetypal, 39
 —, meaning of, 13
 eternal, meaning of, 8
 ideas as, 33
 myth-creating, 7
 pre-existing psychic, 66
 primordial, 78, 153
 sacred, Reformation and, 12
 in symbolic process, 38
imagination, active, 49, 53, 155n, 190, 193, 216, 292, 332, 351, 352, 355, 380
Imago Dei, 4, 246, 354; *see also* God-image
imago, parental, 60f, 66
immortality, 117, 136, 142, 188
impotence, 85
incest, 249, 285
 sacred, 229
 theory, 68–69n

incest-fantasies, 60f, 63, 65

India, 8, 106, 216

child-motif in, 151

“loving and terrible mother” in, 82

Indian philosophy, 230, 282, 389, *see also* Hindu philosophy; Sankhya philosophy

individuation, 40, 106, 130, 145ff, 159, 172, 198, 287, 290ff, 348, 350, 353ff, 371ff

and alchemy, 41

analogy of creation, 308

dream-symbols of, 130

goal and symbols of, 164f

hero and, 166

mandala symbol of, 35

meaning, 275, 288

opus as, 324

spirit of darkness and, 252

industry, 193

infans noster, 158

infantilism, 180

infatuation, 69

inferiority, 180

inflation, 145, 180, 213, 351

negative, 180

Ingram, John H., 158n

initiate, 117

Innocent III, Pope, 257

Innocents' Day, 257

insane, delusions of the, 183

insanity, 40, 278

inspiration, 213

instinct(s), 303, 388

analogies to archetypes, 43

a priori, 43

determined in form only, 79

maternal, 87

—, overdevelopment of, 92
physiology of, 55
primitive man and, 163
repressed, and dreams, 49
integration, 31*n*;
intellect: and spirit, 16, 211
 spontaneous development of, 91
interpretation(s), 157
 of anima, 32
 only for the uncomprehending, 31
intoxication, mass, 126
introversion, 238
intuition, 282, 303
invisibility, staff of, 219*n*
invisible one, 177
Io, 107
Irenaeus, 4, 59*n*, 64*n*, 70*n*, 262*n*
Iris, 330*n*
iron man, 223
Isaiah, Book of, 141, 350*n*
Isis, 107
 mysteries of, 40, 52, 350
island motif, 196
“isms,” 61, 62, 349
Ivan, Czarevitch, 242
Ixion, 382
I-You relationship, 8
Izquierdo, Sebastian, 131*n*

J

Jacobi, Jolande, 353*n*
Jacobsohn, Helmuth, 244*n*
Jaffé, Aniela, 28
James, M. R., 18*n*, 35*n*, 176
James, William, 55, 210

Janet, Pierre, [55](#), [119](#), [155](#), [276](#), [277](#)

Jehovah, [214](#); *see also* Yahweh

Jerome, St., [316n](#)

Jerusalem, [146](#)

 heavenly, [81](#), [377](#)

Jesus, [317](#)

 Oxyrhynchus sayings of, [35](#)

 St. Paul and, [121](#)

 uncanonical Gospels, [26](#); *see also* Christ; Virgin Birth

jewel, [160](#)

Jews, [145](#), [191](#)

 concept of God, [103](#);

 persecutions of, [48](#)

Job, [319](#)

 Book of, [237n](#)

John, St. (Evangelist), [136n](#), [299](#), [300](#)

 (author of Epistles), [215](#)

John of the Cross, St., [319n](#)

Jordan, baptism in, [45](#)

Joshua, [137f](#), [141](#)

Judgment, Last, [147](#)

Jung, Carl Gustav:

 CASES IN SUMMARY (*in order of presentation, numbered for reference*):

 [1]Schizophrenic who saw sun's penis. — [50f](#)

 [2] Victim of mother and castration complex. — [67f](#)

 [3] Philosopher with imaginary cancer. — [104f](#)

 [4] Woman with fantasy of primitive mother-figure. — [184n](#)

 [5] "Case X," spontaneous visual impressions of Kore archetype.— [191ff](#)

 [6] "Case Y," dreams of same. — [195ff](#)

 [7] "Case Z," dreams with animal affinities. — [200ff](#)

 [8]American lady in psychic impasse: active imagination expressed in paintings. — [290ff](#)

 [9] Woman fond of playing with forms. — [347](#)

See also [362–83](#);

many of the mandala pictures are from cases

WORKS: “Aims of Psychotherapy, The,” 352n

Aion, 41n, 140n, 14n, 164n, 27on, 285n, 307n, 310n, 367n, 370n

“Answer to Job,” 328n

“Brother Klaus,” 8n, 64n

Collected Papers on Analytical Psychology, 306n

Commentary on “The Secret of the Golden Flower,” 59n, 320n, 352, 384

“Enigma of Bologna, The,” 25n

“Instinct and the Unconscious,” 78n

Integration of the Personality, The, 3n

Memories, Dreams, Reflections, xi, 355n, 364n

Mysterium Coniunctionis, 25n, 155, 226n

“On the Nature of the Psyche,” 5n, 314n, 346n

“On the Psychology and Pathology of So-called Occult Phenomena,” 122n

“Paracelsus as a Spiritual Phenomenon,” 24n, 136n, 295n, 317n

“Philosophical Tree, The,” 333n, 366n

Practice of Psychotherapy, The, 25n, 365n

Psychiatric Studies, 276n

“Psychological Approach to the Dogma of the Trinity, A,” 121n, 122n, 323n, 378n

Psychological Commentary on the *Tibetan Book of the Dead*, 356n

Psychological Types, 123n, 162n, 164n, 167n, 175n, 238n, 284n, 289n, 303n

Psychologische Interpretation von Kinderträumen, 353n

Psychology and Alchemy, 34n, 41n, 53n, 64n, 70n, 130n, 133n, 136n, 159n, 164n, 165n, 171n, 187n, 215n, 234n, 235n, 251n, 284n, 287n, 293n, 300n, 304n, 307n, 310n, 312n, 324n, 326n, 333n, 340n, 355, 356n, 366n, 373n, 374n, 376n, 380n

“Psychology of Eastern Meditation, The,” 129n, 327n, 344n, 375n

“Psychology and Education,” 33n

“Psychology and Religion,” 136n, 164n, 234n, 310n, 328n, 343n, 355

Psychology and Religion: West and East, 234n, 389n

“Psychology of the Transference,” 29n, 72n, 140n, 314n, 346

Psychology of the Unconscious, 50n, 153n

“Relations between the Ego and the Unconscious,” 72n, 159n, 175n, 181n, 284n, 288f, 306n, 352

“Spirit and Life,” 209

“Spirit Mercurius, The,” 133n, 235n, 304n, 307n, 308n, 311n, 333n, 374n

“Structure of the Psyche, The,” 154n

Symbols of Transformation, 27n, 41n, 50n, 82, 107n, 141n, 145n, 153n, 160n, 189n, 190n, 245n, 285n, 287n, 329n, 336n, 369n

“Synchronicity,” 109n, 142n, 344n

“Transcendent Function, The,” 155n, 159n, 289n

“Transformation Symbolism in the Mass,” 118n

Two Essays on Analytical Psychology, 86n, 162n, 164n, 343n

“Visions of Zosimos, The,” 135n, 223n

Von den Wurzeln des Bewusstseins, 3n

Wandlungen und Symbole der Libido, 50n

“Wotan,” 251n

Jung, Emma, 124n, 247n

Jupiter, 306, 335n

Justin (Gnostic), 310, 317, 324, 330n

K

ka, 380

Kabbala Denudata, 314n, 328n, 338n

Kali, 82, 100, 103

Kallid, *see* “Calidis ...”

Kallisthenes, pseudo-, 343

Ka-Mutef, 244

Kant, Emmanuel, 59n, 67n, 76, 77, 84, 152

Karkinos, 343

karma, 113

Karnak, 215

Kenya, 17, 143

Kerényi, Karl, 7n, 117n, 151, 173, 192, 302n

Kerner, Justinus, 54

Kether, 328n

Keyserling, Count, 119n

Khepera, 367

Khidr, 122, 133, 135f 140f, 143ff

Khunrath, Henricus, 298n, 330n, 331n

Kierkegaard, Søren, 8

kilkhor, 376

king(s): in black and white magician dream, 34

four great, 319n

“old,” in alchemy, 34n

seven fallen, 328

sun as, 157

symbol of self, 187

Kingdom of God, 81; *see also* Heaven, Kingdom of

Kings, First Book of, 237n

Kingsford, Anna, 65

Kircher, Athanasius, 158n

Kiswahili, 143n

Klages, Ludwig, 16, 211

Klaus, Brother, *see* Nicholas of Flüe, St.

klipboth, 328

Knife Prince, 228

Knorr von Rosenroth, Christian, 314n

knowledge: critique of, 101

discriminating, 82

Koepgen, Georg, 174n

Köhler, Reinhold, 236n

Koran, 122n, 135ff, 140, 143ff

Kore, 81, 182ff, 188, 197, 199, 202, 203

Koschei the Deathless, 242

“Krates, Book of,” 134n

kuei (-soul), 59, 212

Kundalini, 362, 368, 370

yoga, *see* yoga

Kypris, 327

L

labours, twelve, 241

Lactantius, 295n

lady, white, 198

Lagneus, David, 140n

lamb(s), [232f](#)
 with seven horns, [9](#)
Lambspringk, [382n](#)
lamia, [25](#)
Lands, Two, [381](#)
language, history of, [33](#)
Lao-tzu, [290](#), [341](#)
lapis (philosophorum), [58](#), [304](#), [307n](#), [312](#), [313](#), [340n](#), [363](#)
 synonyms for, [171](#), [305](#)
 exilis et vilis, [171](#)
 as mediator, [174n](#)
La Rochefoucauld, [27n](#)
laurel, [332](#), [333](#)
Lavaud, Benoît, [10n](#)
layers, circular, [329](#)
lead, [332n](#)
leaden man, [223](#)
Le Bon, Gustave, [125n](#)
Leda, [317](#)
legends, of gods, contradictions in, [102](#)
Leibniz, Gottfried Wilhelm, [152](#)
Leiden, papyri, [51](#)
Leisegang, Hans, [166n](#)
Lenglet du Fresnoy, Pierre Nicolas, [330n](#)
Leonardo da Vinci, [44](#), [46](#), [49](#), [68n](#)
Leone Ebreo, [314](#)
leopard, [198](#)
“letting go,” [318](#)
Leucippus, [57](#)
Leviathan, [311n](#), [316n](#), [370](#)
Lévy-Bruhl, Lucien, [5](#), [42](#), [125n](#), [126n](#)
li (beneficent power), [359](#)
liberation, [302](#)
Liber mutus, [25n](#)

libertas decembrica, 258

life: anima as archetype of, 32

perpetual continuation of, 117

prolongation of, 136

stone as, 134n

ligamentum corporis et spiritus, 313

light, 147

archetypal, God as, 4, 75

in Böhme, 296, 299, 389

bringers of, 169

Maitland's vision of God as, 65

wave and particle concepts, 312

lightning, 294ff, 298n, 299ff, 314, 319, 327, 331

Lilith, 82

Lilius, 331n

lily, 198

lingam, 106, 357

Lingdam Gomchen, 327n

lion, 157, 335n

in fairytales, 221, 232

green, 140n

man-faced, 366;

symbol of self, 187

listlessness, 119

literature, syzygy motif in, 56

liver, 364

Liverpool, 364

Loco Tenente Gobernador, 22

Logos, 96

Loki, 374

loneliness, 169

Longfellow, Henry Wadsworth, 142n

“Long-lived One,” 141

Lord's Prayer, 214

Loreto, Litany of, [363](#)
lotus, [81](#), [130](#), [187](#), [326](#), [328](#), [338n](#), [356](#), [361](#), [363](#)
Love-desire, [334](#)
Lucifer, [37](#), [296](#), [322n](#), [329](#)
Lüdy, F., [300n](#)
Luke, Gospel of, [237n](#), [295n](#), [296n](#), [337](#)
Lund, Hermann Christian, [197](#)
Lupulus, *see* Woelflin
lust, [360](#)

M

McGlashan, Alan, [260n](#)
Macrobius, [59](#)
macrocosm, [314](#)
madness, [85](#)
Madonna, [103](#), [201](#); *see also* Mary, the Virgin
Madura, [355](#)
Maeder, A., [153n](#)
maenad, [184](#)
magic: of female, [82](#)

- fertility, [177](#)
- and primitive man, [154](#)
- and rebirth, [114](#), [128f](#)
- sympathetic, [22](#)
- magician, [198](#), [216](#), [235](#)
 - black and white, [34f](#), [216f](#)
 - wicked, [227](#)

magnolia, [364](#)
Magog, [144](#), [146](#)
magpie, [221n](#)
mahatmas, [216n](#)
Mahāyāna Buddhism, [358](#)
maiden, [183](#), [184](#), [185](#), [186](#), [191](#), [198](#); *see also* Kore
Maier, Michael, [60n](#), [301n](#), [312n](#), [331n](#)
Maitland, Edward, [64f](#)

Maitrayana-Brahmana Upanishad, [371](#), [377](#)

maize, [142](#), [169](#)

Majjhima Nikaya, [338n](#)

Majuj, *see* Magog

Male Shooting Chant, [380](#)

Malkhuth, [328n](#)

man, [71](#)

 carnal and spiritual, [137n](#)

 encompassed by a woman, [371](#)

 in Ezekiel's vision, [335n](#)

 feminine traits in, [124](#)

 higher and lower, [137n](#)

 Original, Plato's, [68n](#)

 “psychic,” [26](#)

 “spiritual,” [26](#)

 stone as, [134n](#)

 true, *see chen-yen*

mana, [14](#), [33](#)

mandala, [81](#), [130](#), [296n](#), [297](#), [299](#), [304](#), [307n](#), [312ff](#), [323ff](#), [335ff](#), [387ff](#)

 alchemical, [319n](#)

 antidote for mental chaos, [10](#)

 Böhme's, [12](#)

 in Brother Klaus's vision, [9](#)

 child as, [159](#)

 division into four, [322](#)

 functional significance of, [383f](#)

 heavenly city as, [35](#)

 Lamaic, [358](#), [360](#)

 pentadic, [347](#), [361](#)

 ritual use of, [358](#)

 Tantric, [359](#)

 tetradic, [361](#)

 Tibetan, [338n](#)

 triadic, [347](#), [361](#)

mandapam, [355](#)

Manget, J. J., [133n](#), [159n](#), [174n](#), [319n](#)

Manichaeism, [103](#)

mar, [245](#)

mare tenebrositatis, [140](#)

Maria, axiom of, [234](#), [237](#), [245](#), [300n](#), [310](#), [346n](#), [360](#), [378](#)

Maria Aegyptiaca, [104](#)

Maria Morevna, Queen, [242](#)

Marianus, [159n](#)

marriage: divine, 175

insecurity of, 29

wrecking of, 95

Mars, 335n

Martianus Capella, 302

Mary, the Virgin, 46, 81, 82, 185n, 295n, 329, 367

assumption of, 107, 108, 109, 114, 388n

as earth, 107

flight into Egypt, 258

fructification by tube, 52

laurel and, 333

“leader of hosts,” 242

stone as, 134n

masculine traits, emergence of, 91

Masenius, Jacobus, 343n

mass (mob), 349

identity with, 175

shadow and, 267

state, totalitarian, 213; *see also* emotion, mass; intoxication, mass; psyche, mass;
psychology s.v. mob/mass

Mass, the (religious rite), 115, 117

Black, 191

for the Dead, 298n;

parody of, 260

massa confusa, 301

Mater: Dei, 136n

dolorosa, 92

natura, 92

spiritualis, 92

materia prima, 171

materialism, 109, 211, 213

material: element, hypertrophy of, 87f

instinct, overdevelopment of, 92

matriarchy, primitive, 95

matriarchal society, 203
matrix, 334
matter, 81, 108, 212
 Assumption and, 109
 mother as, 91, 107
 One Substance as, 211
 “psychization” of, 109
 relation to psyche, 108
 and Spirit, 109, 208, 210
Matthew, Gospel of, 336, 337
Matthews, Washington, 135n
Maya, 357
meaning: of anima, 32
 archetype of, 32, 37, 374
 how assigned, 32f
 manifold, of archetypes, 38
 unconscious core, in myths, 156
Mechthild of Magdeburg, 176
mediator, 164
medicine man, 37, 119, 227, 256
meditatio, in alchemy, 40f, 131
meditation, 63n, 318
megalomania, 52, 68, 180
Meier, C. A., 311n, 352n
melothesia, 343
melusina, 24n, 25
memory, 282
Mennens, Gulielmus, 330, 341n
menstrual: blood, 184
 disturbances, 91
Mephistopheles, 136n, 146, 183, 284
Mercurius/Mercury, 158, 304, 306
 anima as, 211n
 in Böhme, 296, 298n, 300

as dragon, 314
duplex/duplicity of, 311, 313, 314, 322n, 377
Edem symbol of, 317
identical, with *rotundum*, 307
—, with stone, 133
in mandala, 311, 312
as mediator, 307n
Philosophorum, 312
as servant, 171n
spirit, 312
spiritualis, 318
symbols of, 215
as trickster, 255, 374
vulgi/vulgaris/crudus, 312, 317, 345
wings of, 308, 323, 327, 335
and Wotan, 246

mercury, *see* quicksilver

Mercury (planet), 314

Merkabah, 335

Merlin, 227, 245

mermaid, 25
 anima and, 251n

Meru, Mount, 377

messenger, 143

Messiah, 295n, 328n

metal (s): alchemical, 158
 child-figure and, 169

metal man, 158, 223

metamorphosis, 158
 of the gods, 157

metaphors, 157

metaphysics, 28, 76

metempsychosis, 113

Metra, 319

Meyrink, Gustav, [221n](#)
microbes, [65](#)
microcosm, [188](#), [308](#)
microphysics, [224](#)
middle, [135](#), [139](#), [140](#)
migration, [151](#), [155](#)
Miller fantasies, [189](#)
Mimir, [226](#)
mind, [312](#), [313](#)
minera, [312](#)
mines, [223](#)
mine-shafts, [158](#)
miscarriages, [91](#)
misogyny, [69](#)
Missal, Roman, [45](#)
Mithras/Mithraism, [51](#), [62](#), [131](#), [367](#)
 Mithraic altarpieces, [135](#)
Mohammed, [331](#)
Moirai, [81](#)
Moknine, [380](#)
Mondamin, [142](#)
monkey(s), [159](#), [185](#)
Monogenes, [295n](#)
monotheism, [103](#)
months, Platonic, [310](#)
moon, [184](#)
 circle of the, [304](#)
 Earth-Mother and, [185](#)
 -goddess, [196](#)
 -lady, [196f](#)
 in mandalas, [342f](#), [345](#), [375](#)
 mother-symbol, [81](#)
moon-bowl, [195f](#), [314](#)
morals, and aesthetics, conflict, [28](#)

Morienus/Morienes, 159

Moses, 295n, 330

and Joshua, 137ff

and Khidr, 122, 141

staff of, 295

mother, 101

aetiological effects produced by, 83

anima in, 29, 200

archetype, 75ff, 161n

—, and mother-complex, 85

—, attributes, 82

assimilation of, 69

Church, *see* Church

complex, *see* complex

and daughter, 188

dual, 45ff, 82

Earth, 106, 183, 184, 185, 186, 193, 197

figurative, 81

God as, in St. Nicholas of Flüe's vision, 64

Great, 75, 102, 105, 106, 185n, 237

identity with, 89

-imago, *see* imagos, parental

loving and terrible, 82

personal, 81, 83, 102, 199

primordial, 183

prototype of, 75

resistance to, 90

self expressed by, 187

unmarried, 184

very old, 192

Mother of Christ, 45

Mother of God, 81, 107, 108, 202, 367

mother-goddess, 75, 177n

mother-image, 80, 105

analogues of, 105
chthonic type and Urania type, 106
fixation on, 93
in man and in woman, 105f
mother-in-law, 81, 90n
mother-love, 92
Mothers, Realm of the, 98
motif(s), 42, 153, 183
 child, 158, 159, 161, 162
 —, unity and plurality of, 165
 in dreams, 183
mountain, 193, 219n
 in dream, 19
Mountain Chant Rite, 380
Mountains, Two, 144, 146
movement, leftward and rightward, 320
M'tu-ya-kitabu, 143
mūlādhāra, 372
Multatuli, 344
murder, ritual, 191
Musaeum hermeticum, 382n
Mylius, Johann Daniel, 140n, 158n, 331n
mysteries, 128
 anima and, 199
 antique, 12
 Eleusinian, 115, 117, 136; *see also* Isis
mysterium iniquitatis, 103, 175
mystical experience, 283
mysticism, 44, 176
 Catholic, 174
 Christian, 230, 367
 Islamic, 135, 147
myth(s): and archetypes, 5, 67, 153
 experienced, 154

hero, [69n](#), [180](#)
living and lived, [179](#)
primarily psychic phenomena, [6](#)
and primitive consciousness, [156](#)
mythologem(s), [179](#), [189](#), [251](#), [378](#)
in dreams, [152](#)
mythology, [189](#), [199](#)
American Indian, [255](#)
comparative, [53](#)
Great Mother in, [106](#)
incest in, [249n](#)
and mother archetype, [101](#)
parallels in fantasy, [66](#)
rationalized substitute for, [169](#)
syzygy motif in, [56](#)

N

Naas, [317](#), [324](#)
name, new, [129](#)
National Socialism, [251](#), [252](#)
nations, fate of, and individual psyche, [47](#)
Nativity, [141](#)
natural philosophy, Greek, [76](#)
nature, [337n](#)
in Böhme, [295f](#)
and culture, [373](#)
Deity garbed as, [118](#)
Democritus on, [130](#)
fire of, [300](#)
processes of, as symbols of psyche, [6](#)
spirit and, [208](#), [210](#)
Navahos, [135](#), [380](#)
nebulae, [16](#)
Needham, Joseph, [59n](#)
Negroes, and Christianity, [14](#)

nekyia, 184

Nelken, Jan, 39, 189n, 278n, 285, 286

neolithic, 186

nerve, mystical, system, 38

Nessus shirt, 123

neti neti, 339

Neumann, Erich, 186n, 272n, 337n

neurosis(-es), 39, 47, 48, 68, 105, 157, 277, 278, 288

aetiology of, 83

archetypes in, 47

dreams and therapy of, 178

dual mother in, 46

Freud and, 55, 83

infantile, mother and, 85

psychology of, and anima, 56

psychopathology of, 139, 152

are social phenomena, 47

therapy of, 159

neurotics, mythological parallels in dreams of, 66

Newcomb, Franc Johnson, and Reichard, Gladys A., 363n

New Testament, 104, 105, 263

God of, 11; *see also names of individual books*

New Year, 257

New York, 127, 346

Nicholas Cusanus, 11

Nicholas of Flüe, St., 8ff, 63f

Nietzsche, Friedrich Wilhelm, 18, 29, 37, 104, 118, 121, 146, 246n, 260, 304

nightmares, 82

nigredo, 140 & n, 251

Nile, 342n

Ninck, Martin, 248n

nirdvandva, 36, 339

nixie(s), 24ff, 184, 222, 371

Noah, 236n

Noah's Ark, [353n](#)
nodes, [308](#)
nominalism and realism, [76](#)
nonad, [136n](#)
non-differentiation, [172](#)
non-recognition, [172](#)
Norns, [81](#)
“nothing but,” [172](#)
Nous/*νοῦς*, [106](#), [212](#), [306](#), [312](#), [313](#), [317n](#), [318n](#)
numbers, [310](#)
 three, [136n](#), [234f](#), [243](#), [247](#), [310](#), [372](#), [389](#)
 four, [136n](#), [234](#), [235](#), [243](#), [247](#), [302](#), [372](#), [373](#)
 five, [373](#), [389](#)
 six, [372](#)
 seven, [136n](#), [140n](#)
 eight, [136n](#)
 twelve, [241](#), [305](#); [306](#), [307](#), [310](#), [335](#); *see also* dyad; triad; tetrad; quaternity; pentad;
 hexad; nonad
 masculine and feminine, [234](#), [244](#), [247](#), [259](#)
numinosity/numinous
 and anima, [28](#)
 of archetypes, [39](#)
Nun, [138](#), [139](#)
nurse, [81](#)
nymph, [184](#)

O

obsession, [132](#)
Ocean, [316n](#)
Och, [222](#)
octopus, [198](#), [315](#)
Oedipus legend, [152n](#)
old man: one-sided, [226](#); *see also* wise old man
Old Testament, [175](#), [214](#), [224](#), [256](#); *see also* names of separate books
omens, evil, averting, [22](#)

Omphale, 324
one-sidedness, 163
onion, 328
ontology, 171
Opicinus de Canistris, 176
opposites, 319
 cannot be envisaged in oneness, 230
 collision of, 167
 conscious mind between, 168
 discrimination of, 96
 equivalence of, 36
 freedom from, 36
 good/evil, 323
 irreconcilability of, 36, 344
 male/female, 69, 70, 234
 paired, 106
 relativization of, 36
 separation of, 147
 symbol uniting, 164
 tension of, 109, 235, 248, 269
 union of, 12, 109, 168, 173, 174, 176, 289, 342, 358, 382
 war of, 175; *see also complexio oppositorum; syzygies*
opus alchymicum, 293, 308, 319, 324, 331, 348
Orandus, Eirenaeus, 140n
orgies, 184
Origen, 169, 353f, 371
Orpheus, 37, 325n
Osiris, 117, 128, 141, 226, 242n
oven, 81
overvaluation, 69
Oxyrhynchus sayings of Jesus, 35

P

Paderborn, 378
padma, *see* lotus

painter, 197
paintings, 291ff
pair: divine, 60, *see also* syzygies
 parental, 65; *see also* brother-sister pair
Palatine, ass graffito, 259
Pan, 17, 118
panacea, 171
Panchatantra, 343
panic, 23
Paracelsus, 24, 136, 295, 329
Paraclete, 141
Paradise, 81, 147, 368
 four rivers/streams of, 35, 310f, 341n, 368
 keys of, 34f, 216f
 tree of, 236, 317
paranoia, 122
paranoiacs, delusions of, 50
parapsychology, 256
parents: projection of, 65
 relationship to, and religious ideas, 62
Paris: Étoile, 365
 Notre Dame, 257
Parmenides, 325, 326n, 330n
Parsees, 310
participation mystique, 20, 126
past, idealization of, 263
pathology, 260
Paul, St., 121
 Epistles of, 137n
peacock(s), 198, 375f
 eye, 330
 sweat, 331n
 tail, 330n; *see also cauda pavonis*
pearl, 18, 160

Peking, Imperial City, 377

pelota, 258n

pentad, 373

pentadic mandala, 361, 373

pentagram, 379

Pentecost, miracle at, 46, 210, 224

“perils of the soul,” 22, 145, 157, 281

persecution, of Christians under Decius, 136n

Persephone, 90, 186; *see also* Proserpina

Perseus, 189

persona, 20, 123, 162

identity with, 122

personalities, traces of, and unconscious, 283

personality: ancestral elements in, 124

centre of, 181, 357

change of, 136

continuity of, 113

dark side of, 123

diminution of, 119f

dual/multiple/double/split, 261, 276, 283

enlargement/widening of, 120, 122n

includes conscious and unconscious, 187

need not imply consciousness, 283

negative, 120

plural stage, 165

supraordinate, 182, 183, 186, 187, 195, 199

transformation of, 124

Pestalozzi, Johann Heinrich, 209

phallus, 178, 295n, 357

serpent as, 314

Pharaoh, 45, 128, 244

φάρμακον 227

phenomenology, 54, 55

of religious experience, 62

Philalethes, Eirenaeus, [171n](#), [285](#)
Philo Judaeus, [4](#), [51](#), [372](#)
phobias, infantile, [83](#)
Phoenicians, child-sacrifice, [191](#)
phoenix, [367](#), [375](#), [376](#)
physics, mathematical, [16](#)
physis/φύσις, [212](#), [334](#)
Picinelli, Filippo, [333n](#), [342n](#)
Pietà, [185](#)
pig, [360](#)
 black, [226](#)
 golden, [191](#)
“Pilgrim’s Tract,” [10](#)
Pisces, [6](#)
pith, [296](#)
planets, [335n](#)
plant, [192](#)
plateau, [193](#)
Plato, [76](#), [79](#), [186](#)
 Original Man, [68n](#)
 parable of passions, [34f](#)
 Symposium, [314n](#)
 Timaeus, [234](#), [235](#), [243](#), [378](#), [389](#); *see also* idea
Pleroma, [295n](#)
Pliny, [300](#)
Plutarch, [382](#)
Pluto, [90](#)
pneuma /πνεῦμα, [46](#), [324](#)
 as Father, [324](#)
 meaning, [209](#)
pneumatikos, [137n](#), [138](#)
p’o, [59](#), [320n](#)
Poimandres, [37](#), [65n](#)
poisons, [227](#)

polarity: red/blue, 317
 threeness and, 234
Poliphilo, 28, 124n, 186
politico-social systems, modern, 23
politics, 267
poltergeists, 256, 262
polyophtalmia, 294, 346, 377
pope, fools', 257
Poseidon, 192
Positivism, 157
possession, 39, 122ff, 164, 209, 253, 281, 351
poverty: Christianity and, 15
 spiritual, 17
Prakrti, 82
prayer, 21, 63n
precession of equinoxes, 6
precinct, *see* temenos
pregnancy: abhorrence of, 91
 disturbances, 91
prehistory, neolithic, 12
Preisendanz, Karl, 304n
Priapus, 317
priest, 216
prima materia, 298n, 304, 382, 383
primal beings, hermaphroditic, 68n
primitive(s) (man), 172, 178
 and ancestors, 125
 and archetypes, 5, 42
 consciousness of, 22
 contemporary, 153
 and magic, 160
 and myths, 6, 154
 perception in, 101
 “perils of the soul,” 157

psychic life of, 169
“soul” among, 26
and spirits, 210
subjectivity of, 6
syzygy motif among, 56
Prince, Morton, 276
princess, black, 225
Priscus, Lucius Agatho, 124n
privatio boni, 341n
Prodigal Son, 249
professor, 216
progress, 163, 174
prohibition, 236
projection (s), 6, 25, 59f, 63, 65, 101, 187
 of anima, 29, 89, 97
 of man’s unconscious on woman, 177
 need to dissolve, 84
 never conscious, 61
Prometheus, 236
Propertius, 343
propitiation, 22
Proserpina, 107, 350; *see also* Persephone
Protestantism: conception of God in, 11
 disintegration of, 13
 icon-oclasm of, 12, 13
 preaching of the Word, 128
 and spiritual poverty, 17
 and Virgin Birth, 13
Protestant/Church, 13, 15, 29, 36
protozoa, 374
Proverbs, Book of, 328n
Prudentius, 227n
Psalms, 237n, 326
psyche/ψυχή, 287

affinity with cold, 209
collective, 125
dark side of, 152
impersonal, unconscious as, 186
individual and group total, 125
and individuation, 147
instinctive/instinctual, 166
“id” of Freud, 3n
loss of, 139; *see also* unconscious
mass, 127
materialist view of, 57
and “mind,” 269
most tremendous fact of life, 116
myth-forming/creating elements in, 7, 152
neonate’s not a *tabula rasa*, 66
nonconscious, 152
not homogeneous, 104
only can observe psyche, 207
part of life’s mystery, 101
is personal, 43
preconscious, 77
relation to spirit, 208
unconscious, 287
uniqueness of individual, 77
unpredictability of reactions, 23
psychic figures, duplex, 183
psychologem, 260
psychology: complex, *see* complex psychology
empirical, 77
experimental, 54
a field of experience, 54
mob/mass, 125, 127
of the person, 43
and physiology of instincts, 55

primitive, 119, 124
sexuality in modern, 29
why youngest of empirical sciences, 7
psychopathology, 159
psychophysics, 54
psychopomp, 37, 133, 377
psychosis(-es), 39, 152, 278, 287
psychotherapy, 40
 and instincts, 43
psychotics, archetypal figures of, 39
Pueblo Indians, *see* Taos
puer aeternus, 106, 158, 159
Pulcinella, 260, 264
pumpkin, 224
purification, 22
Purusha, 82, 142, 325
pyramids, 292, 305
Pythagoras, 359

Q

quadratura circuli, 387; *see also* circle, squaring of
qualities, four, 296n
quaternio, 328
 marriage, 346
quaternarius, 372
quaternity, 234n, 235, 333
 in Böhme, 296, 298n, 300f
 child motif as, 160, 164
 of colours, 332
 dream symbol, 196
 of elements, 330
 in fairytale, 241, 249
 in mandalas, 319f, 335, 366, 387
 symbol of Deity, 324
 —, of self, 187

—, of wholeness, 233
triad as mutilated, 237
queen, self expressed by, 187
Queen of Heaven, 29, 64, 104, 107
quicksilver, 306, 311ff, 316f, 332, 345
Quito, 127

R

Ra, 367
“Rachaidibi fragmentum,” 134n
Radin, Paul, 262, 266, 268
Rahner, Hugo, 227n, 236n, 316n, 342n
Rainbow Goddess, 380
Ramanuja, 371
ram deities, 310
Rank, Otto, 153n
Ras Shamra, 370
rationalism, 379
raven(s), 240, 241
 and evil, 236n
 in fairytale, 231f, 235ff
 in mandala, 339
 thirst of, 236n
Read, John, 375n
realism, *see* nominalism
reason, 13, 94
rebirth, 46, 113ff 141, 147
 indirect, 114f
 magic, and mother, 82
 meanings of concept, 113ff
 primordial affirmation of mankind, 116
 psychic reality, 116
rebis, 174
recognition, of unconscious contents, 40
red, 185

redeemer, 249, 318n
 in alchemy, 249

redemption, 35, 252
 redemptive significance, of uniting symbols, 168

redheaded actress, professorial anima as, 30

Reformation, 12

reincarnation(s), 113, 287

Reitzenstein, Richard, 37n, 133n

religio, 161

religion(s): comparative, 42, 56, 75, 189
 ideas of, and parental imagos, 61f
 and psychic processes, 154
 spirit in, 212
 task of, 213
 world, images in, 7

religious: experience, phenomenology of, 62
 observances, 162

renewal, 117
 magical, 114, 129

renovatio, 114

representations collectives, 5, 41, 42, 45, 48, 51, 61ff

repression, 186, 303
 moral, 65f
 of *représentations collectives*, 63

resistance(s), 61, 131
 to mother, 90
 negative, 91
 of unconscious, 305n

restitution ceremonies, 40

resurrection, 114, 342
 body of, 358
 stone as, 134n

Reusner, Hieronymus, 317n

Revelation, Book of, 9, 10, 146, 305n, 362n, 377

reveries, 155
rex gloriae, 329, 341n
Rhine, J. B., 109, 142n
Richard of St. Victor, 219n
rigidity, premature, 71
Rig-Veda, 369
Riklin, F., 153n
ring of return, 118
Ripley, Sir George, 226, 285n
 “Ripley Scrowle,” 251n, 374n
rishis, 216n
rite/ritual, 269
 and archetypes, 188
 of Catholic Church, 128
 and consolidation of consciousness, 22
 friend depicted in, 131
 Mithraic, 51
 regression and, 127
 and renewal of “child,” 169
 and transcendence of life, 117
 and transformed hero, 128; *see also* transformation
rites d’entrée et de sortie, 154, 163
River Map, 359
rivers, four, of Paradise, *see* Paradise
rock, 81
Romans/Rome: and Asiatic cults, 13, 14
 child-motif in, 151
 Gods of, 14
Romantics, 28
Rome, St. Peter’s, 257n
Roques, Mrs. H. von, 217n
rosarium, 319n
Rosarium philosophorum, 133n, 140n, 141n, 331n
Roscher, Wilhelm Heinrich, 343n

rose: in mandalas, 361, 363, 364
mystic, 367
symbol, of mother, 81
—, of self, 187
rose window, 329
Rosencreutz, Christian, 251, 295n, 331n
Rosicrucians, 363
“Rosinus ad Sarratantam,” 134n
rotation, in mandala, 361
rotundum, 294, 301, 307, 366
roundness, 164
Rousselle, Erwin, 38n
rubedo, 300, 331n
ruby/rubies, 300, 331, 364
rug, 367
Ruland, Martin, 41n, 131n, 295n, 300n
Ruska, Julius, 286n
Russia, 373n

S

Sachseln, 9, 10
sacrifice, child, 191
salamander, 184n, 382
salniter, 296ff, 327
Salomon, Richard, 176
salt, 298n, 301, 327ff
saltpetre, 296, 298n
salute, Roman, 48
samādhi, 287
Samothrace, 14
Samyutta-Nikaya, 113n, 286, 319n
Sanatsugatiya, 368
Sand, George, 132
Sankhya philosophy, 82
Santa Claus, 128

sarcophagus, [82](#), [216](#)
sarkikos [137n](#), [138](#)
Satan, [146](#), [214](#)
Saturn, [4n](#), [298n](#), [305](#), [335n](#)
saturnalia, [256](#)
Saviour, [236](#)
 analyst as, [61](#)
 approximation to, [256](#)
 loss of, [157](#)
 Mercurius as, [255](#)
 and serpent, [35](#)
 trickster forerunner of, [263](#), [270](#)
Scheler, Max, [16](#)
Schelling, F. W. J. von, [152](#)
Schevill, Mrs. Margaret, [380n](#)
Schiller, Friedrich, [7](#), [175](#), [209](#)
schizophrenia, [66](#), [165](#), [190](#), [278n](#), [287](#), [388](#)
Schmaltz, Gustav, [31n](#)
Schmitz, Oskar, [24](#)
Schopenhauer, Arthur, [123n](#), [277](#)
Schreber, Daniel Paul, [39](#), [159](#), [278n](#)
Schubert, G. H. von, [54](#)
Schultz, Wolfgang, [70n](#)
science: danger of, [107f](#)
 and deification of mother, [108](#)
 as myth, [179](#)
scintillae, [140n](#), [390](#)
Scott, Walter (*Hermetica*), [4n](#), [65n](#)
sea: symbol, of mother, [81](#)
 —, of unconscious, [177](#), [380](#)
 Western, [343](#)
sea-horse, [192](#)
second half of life, [98](#), [199](#)
Seele, [26](#)

self, 22, 142, 164, 187, 215

androgynous, 364

as archetype, 182

attainment of, 106

birth of, 308

centre of personality, 357

as hero, 146

identification with ego-consciousness, 145

Khidr as symbol of, 141

mandala as expressing, 304, 389

Moses' experience of, 144

“smaller than small,” 171

symbols of, 173, 333

synthesis of, 164

totality of, 304

vision of, 162

self-assertion, urge for, 43

self-immersion, 384

self-realization, 168

Semele, 107

Semenda bird, 375

senarius, 372

Sendivogius, Michael, 319n

Senex Israel, 328n

sensation, function of, 303, 332, 335

“Septem tractatus ... Hermetis,” 133n

seraphim, 319

serpens mercurialis, 311, 376

serpent(s), 159, 166

anima as, 28

evil symbol, 82

fiery, 296, 322n

ithyphallic, 318

mercurial/Mercury as, 311, 312, 314, 317n, see also *serpens mercurialis*

Moses' staff and, 295
Ophitic, 35
in paradise, 35, 312, 317
redemptive/as Saviour, 35, 202; *see also* snake; uroboros
servant of God, 141
servus rubeus/fugitivus, 171
sesquitertian proportion, 360, 362*n*, 378
Set, 226, 316*n*
seven, *see* numbers
Seven Sleepers, 135, 136, 138, 140*n*
sex(es), 318
 determination of, 284
 interinhabitation of, 27*f*
sexual instinct, and psychology, 43
sexuality, in Freudian psychology, 29
sexual rites, 184
Sgarra, Chico, 269
shadow(s), 20*f*, 29, 30, 37, 41, 123, 183, 244*ff*, 262, 265, 266, 267, 270*f*, 284, 317, 322, 340, 357, 381
 collective, 262
 of "fatherly" angels, 310
 of Madonna, 103
 of Moses, 138*f*
 spirit as, 215
Shakti, 185*n*, 356, 357, 364, 371
shamanism, 56, 256
Shankaracharya, 216*n*
shape, changing, 256
shards, 328
Shatapatha-Brahmana, 370
sheep, 192, 366
Shekinah, 328*n*
shield-holders, 360
Shiva, 356, 357, 358, 364, 366, 371
Shiva-bindu, 356, 368, 369

Shvetasvatara Upanishad, 122

Simon Magus, 31, 202

simpleton, devil as, 255

siren, 25

six, the number, 372

skins, formation of, 324, 328

Sky Mother, Egyptian, 380

sky-woman, 195, 198

Sleepers, Seven, *see* Seven

Sloane, William M., 200

snake(s); anima as, 200, 202

black, 315*f*, 322*f*, 326, 334

den of, 192

dream-symbol, 50, 166, 353

golden, 306

signifying extension, 368

symbol, of envy, 360

—, of Kore, 184

—, of Mercurius, 311, 314

—, in pictures and mandalas, 305, 317*ff*, 328, 342, 346*f*, 361, 362, 366, 368*ff*, 375, 382

—, of self, 187

—, of unconscious, 363, 376; *see also* serpent

solicitude, 82

solidarity, human, 127

σῶμα 324

Somali, 143

son: mother complex in, 85*ff*

self expressed by, 187

Son of God, 35

“sons of the sun,” 40

Sophia, 17, 64, 81, 106

-Sapientia, 45

soror, 201

soul(s), 26f

ancestral, 124

—, in Australia, 125

—, identification with, 125

Christian idea of, 59, 128

conglomerate, 357

derivation, 211n

loss of, 119, 139

projected, 57

and spirit, 211, 307

stone as, 134n

virgin mother of wise old man, 35; *see also* anima; “perils of the soul”

Soul, Hymn to the (Gnostic), 18

soul-atoms, 57

soul-flower, 338, 342

spear-head, 382

spells, 22

Spencer, Sir Walter B., and Gillen, F. J., 57n, 126n

sphere(s), 164, 187, 294, 301ff, 307, 311, 314ff, 372

spider, 187

spinal cord, 166

Spinoza, B., 208, 211

spiral, 362

spirit(s), 17, 24, 324

in alchemy, 38, 208

archetype, antithetical nature of, 239

archetype of, 226, 374

autonomy of, 214

“cold breath of,” 209

comes from above, 19

as dove, 45

in dreams, 214ff

evil, *see* evil spirit

exorcizing of, 22

four, 296
—, of God, 335
hallmarks of, 212
immateriality of, 109, 212
and intellect, 16
“materiality” of, 322n
and matter, 108, 109, 208, 210
meaning, 208ff
and nature, 208, 210
of the age, 209
one with body in God, 324
pneuma as, 46
religions and, 213
seven, 329n
and soul, 211
subjective and objective, 209, 211
theriomorphic symbolism of, 230ff
spiritual exercises, 63n, 318; see also *exercitia spiritualia*
spiritualism, 256
Spiritus, 209, 313
Spitteler, Carl, 71
sponsus et sponsa, in Christianity, 250
sprightliness, 208
spring, 81, 185n
spring-point, 6
sprite: fire, 382
 water, 184
square, 187, 235, 307n, 312, 361; see also circle, squaring of
Stade, Bernhard, 341n
star(s): five-pointed, 373
 in mandala, 361, 365, 373, 374, 382
 seven, 140n
State: and individuals, 127, 267
 totalitarianism and, 252

statement, in psychology, [207](#)
statue, antique, [191](#)
Stein, Frau von, [69](#)
Steissbart, [215](#)
stepdaughter, [225](#)
stepmother, [68n](#), [81](#)
Stevenson, James, [135n](#)
steward, unjust, [36](#)
stock (Böhme), [296](#)
Stoekli, Alban, [10n](#), [64n](#)
Stoics, [33](#), [326](#)
stone: alchemical/philosophers', [133](#), [134n](#), [141n](#), [304](#), [312](#), [348](#), [362](#), [363](#)
 animate, [140](#)
 symbol of self, [140](#)
 “that is no stone,” [312](#); see also *lapis*
Stone Age, [125](#), [126](#)
streams, four, of paradise, see paradise
Strudel, [269](#)
student societies, [255](#)
stupas, [320](#)
“subconscious,” [18](#), [239](#)
subjectivity, egocentric, [20](#)
substance: arcane, [251](#), [298n](#), [327](#)
 One, [211](#)
 spiritual, [324](#)
succubus, [25](#)
Suez, Isthmus of, [139](#)
suffering: subjective, in poltergeist, [256](#)
 symbolized by cross, [327](#)
Sufi, [143](#)
suggestion, [275](#)
sulphur, [300](#)
summum bonum, [9](#), [213](#)
sun, [143](#), [144](#), [157](#), [309](#), [315](#), [379](#)

in alchemy, [140n](#)
in Böhme, [335n](#)
delusory penis of, [50f](#)
in fantasy, [196](#)
in mandala, [345](#), [361](#), [379](#)
materialized in gold, [312](#)
primitives' view of, [6](#)
Pueblo Indians and, [22](#)
wise old man and, [224](#)

sun-barge, [134](#)
sun-child, [326n](#)
sun-god, [51](#), [52](#), [131](#)
superconsciousness, [282](#)
super-ego, [3n](#)
superlatives, [224](#)
supermen, [104](#)
superstitions, [268](#)
Suso, Henry, [10n](#)
Suzuki, Daisetz Teitaro, [340n](#)
swan, [317](#), [331n](#)
swastika, [48](#), [320](#), [323](#), [326](#), [327n](#), [361](#), [373](#), [380](#)
Swedenborg, Emanuel, [4n](#)
symbol(s) [24](#), [39](#)
 distinguished from allegory, [6n](#)
 dogmatic, [11](#)
 elaboration of, [9](#)
 formation of, and psychic disorders, [172](#)
 functional meaning of, [50](#)
 geometrical, [187](#)
 of individuation, [289](#)
 mother-, [81](#)
 plant, [187](#)
 poverty of, [13](#), [14](#)
 theriomorphic, [187](#)

uniting, 168, 174, 289
world itself speaks in, 173
symbolism: alchemical, *see* alchemy
Christian, 15
impoverishment of, 8, 23
of individuation process, 289
of rebirth, 130
sympathetic nervous system, 19f, 21
sympathy, 82
synchronicity/synchronistic phenomena, 109, 344n
syncretism, Hellenistic, 106
Synesius, 96
synthesis, 164f
syzygy (-ies) 106
divine, 59, 64, 67
male/female, 70
motif, 65
—universal distribution, 56
mystic, 202
projection of, 63
youth/girl, 191

T

“Tabula smaragdina,” 106, 234n
talisman, magic, 220
Tantra/Tantrism, 356, 363
chakra system, 38, 261n
and matter, 212; *see also* yoga, Tantric
Tao/Taoism/Taoist philosophy, 8, 18, 36, 290, 320n, 339, 340
Taos pueblo, 22, 40
tar, 221
Tarot cards, 38
tartar, 301
tartaric acid, 301, 327
Tartarus, 298n, 301, 327

Tarxien, 321
teacher, wise old man as, 216
Tebhunah, 328n
telepathy/telepathic phenomena, 142
telescope, 16
temenos, 361, 365
tempter, 214
tension, 147; *see also* opposites, tension of
Tertullian, 259n
tests, psychological, 54
tetrad(s), 243
 tetradic mandala, 361
 —, system, 360
Tetragrammaton, 330
tetraktys, 359
tetrameria, 310, 319, 332
Theatrum chemicum, 133n, 140n, 193n, 327n, 330n
Theodosius II, 136n
theoria, 177
Theosebeia, 202
theosophy/theosophical, 263, 325
theosophists, 14
therapeutics, *see* complex psychology
therapy: anima and, 71
 of neuroses, child motif in, 159
thinking/thought(s): inhibition of, 68–69n
 pre-conscious, 33, 280
 primordial/elementary, 43
 unconscious, 79, 153
Thomas Aquinas, St., 331n
Thoth, 37
thread, ball of, 220n
three: a masculine number, 234, 244; *see also* numbers
three and a half, 362n

threeness, [234](#), [243](#)
 and femininity, [244](#)
thunderbolt, [358](#)
Tibet, [320](#), [373n](#)
tiger, [200](#)
Tightrope Walker, Nietzsche's, [121](#)
Timaeus, see Plato
time, [188](#), [199](#)
 -spirit, [209](#)
toga, Buddhist monk's, [339](#)
Tom Dumb, [184](#)
Tom Thumb, [158](#), [161n](#), [184](#), [255](#), [304](#)
Tonquédec, Joseph de, [122](#)
tortoises, [342n](#)
totalitarianism, [252](#)
"Tractatulus Aristotelis," [134n](#)
"Tractatus aureus," [25n](#), [133](#), [174n](#), [307n](#), [312](#)
tradition, [57](#)
trance-states, [50](#)
transference, [60](#)
 unresolved, [289](#)
transfiguration, [114](#)
transformation(s), [141](#)
 alchemical, [134](#)
 archetypes of, [38](#), [147](#)
 in Christianity, [128](#)
 collective experiences of, [126](#)
 continuation of life through, [117](#)
 of god or hero, [117](#)
 immortality and, [142](#)
 magic and, [128f](#)
 natural, [130ff](#)
 participation in, [114ff](#)
 psychic, [147](#)

rebirth as, 114
rites of, 115, 125
subjective, 119ff
technical, 129f
transmigration of souls, *see* metempsychosis
transmutation, 114
treasure: “hard to attain,” 160, 184, 229, 369
 in water, 24
tree, 296n
 in alchemy, 109
 cosmic/world-, 110, 235, 248f, 251
 dream-figure, 323f, 328, 333
 in fairytales, 228
 of knowledge, 317
 of life, 317, 370
 and mother, 336
 mother archetype and, 81
 paradisal, 236, 317
 “philosophical,” 324
tree-numen, 229
triad(s), 243
 chthonic, 234
 lower, 339n
 Trinity not a, 8
 two antithetical, 235, 237, 239
 triadic, mandala, 361
 —, system, 360
triangle, 235
tribal lore, sacred, 7
trickster, 255ff
 Mercurius as, 374, 377
Trinity, 15, 244, 339n
 Brother Klaus and, 9, 11, 64
 and chthonic triad, 234

feminine element, 64
not a triad, 8
Protestantism and, 13
symbolized by birds, 338
Tetragrammaton and, 330
tripudia, 257
tritons, 177
triunity, Egyptian, 244
tube, depending from sun, 51, 52
twelve, *see* numbers
“twice-born,” 45
Two-horned One, 145; *see also* Dhulqarnein
type(s), 70, 87n, 153
 mythological, and fantasy-images, 155
 of situations and of figures, 183
Typhon, 316n
typology, Gnostic, 26

U

Ueli, 265n
unconscious, *passim*
 antimonies of, 230
 centre of, 276
 collective, *see next heading*
 conditions consciousness, 58
 conscious’s view of, 20
 essential basis of psyche, 152
 female, 176
 Freud’s view of, 3
 and immortality, 142
 as impersonal psyche, 186
 integrating, 319
 irruption of, 158
 “matriarchal” state of, 233
 meaning of concept, 3

as multiple consciousness, 346
personal, *see heading below*
spatial and temporal relations in, 224
and sympathetic system, 19

unconscious, collective, 3f, 155, 304, 311, 357, 384 *et passim*
anima/animus and, 245, 286
definition, 42
diagnosis not always easy, 44
distinction from personal unconscious, 42
identical in all men, 4
is inherited, 43
reaction from, 21
sheer objectivity, 22
why so called, 3f

unconscious, personal, 3, 357
autonomy of, 278, 280
cannot be swallowed, 288
distinction from collective unconscious, 42
fantasies of, 172
mother of consciousness, 281
a potential reality, 279
shadow and, 20, 284

unconsciousness, 271
as egoless, 277
and the Logos, 96
man's worst sin, 253
original psychic distress, 169
symbolized by pig, 360

underworld, 81
unity, 237
universals, 76
university, 81

Upanishads, 312; *see also* Maitrayana-Brahmana Upanishad; Shvetashvatara Upanishad
uroboros, 300, 361, 377

Ursanna, [195f](#)
Usener, Hermann, [79](#)
uterus, [81](#)

V

Valentinians, [59n](#)
Valentinus, Basilius, [301](#)
“valley spirit,” [18](#)
Vancouver, [18](#)
vas hermeticum, [375](#)
Vedanta Sutras, [371](#)
Venus: alchemical sign for, [301](#), [327](#)
 of Brassempouy, [186](#)
 carbuncles and, [331n](#)
 heavenly, [107](#)
 Queen, [28](#), [186](#)
 of Willendorf, [186](#)
vertebrates, as symbols, [166](#)
vessel motif, [364](#) see also *vas hermeticum*
vibrations, [308](#)
Vigenerus, Blasius, [4n](#)
Vili, [226](#)
vine tendrils, [321](#)
Virgin Birth, [8](#), [13](#), [166](#)
Vishnu, [311n](#)
“Visio Arislei,” [140n](#), [286n](#)
vision(s), [155](#), [183](#), [189](#), [282](#)
 of St. Nicholas of Flüe, [63f](#)
 spontaneous, [155n](#)
 syzygies and, [63](#)
 wise old man in, [223](#)
visual impressions, see dreams
vital force, [33](#)
Vitus, Richardus, [25n](#)
Vollers, K., [138n](#), [139n](#), [140n](#), [141n](#), [143](#), [144](#), [145](#)

Volüspa, 24

vomiting, excessive, 91

vulture, 46, 49

W

wall, 364

wand, 296n, 311; *see also* caduceus

warmth, primal, 33

Warnecke, Johannes, 102n

water: dreams about, 18, 191, 198

of life, 140, 145n

Moses' rod and, 295

primordial, 319n

and shadow, 21

-sprite, 184

symbol, of mother, 82

—, of psyche/spirit/unconscious, 17, 18f, 222, 322

treasure in, 24

Weckerling, Adolf, 82n

Weimar, 209

well, 81

Wells, H. G. 127

werewolf, 221

West, the, and Eastern images, 14

wheat: grain of, in vision, 191

Osiris as, 117, 141

wheel(s): in Böhme, 329n, 331

Brother Klaus and symbol of, 10

in Egyptian temples, 325

in mandala, 361, 364, 381

motif, 326

world, 360, 376

whole, ego and, 275

wholeness, 168, 186, 384

essence of personality, 303

four aspects of, 358
fourness symbol of, 234
and individuation process, 165, 166
man's must be masculine, 199
quaternity and, 164
"round," 142
snake and symbol of, 322
syzygy symbolizing, 191f
and threeness, 233f, 235
union of conscious and unconscious, 175, 178
Wilhelm, Richard, 356, 359
 and Jung, *Secret of the Golden Flower*, 304n, 366n, 377, 378n
will, 163
Willendorf, "Venus" of, 186
wind: conception through, 46
 sun-tube and, 51f
wings: in mandala, 378; *see also* Mercurius/Mercury
Winnebagos, 261, 265
Winthuis, Josef, 59n
wisdom: and folly, identity of, 31
 Fountain of, 194
 grandmother and, 102
 higher, 141
wise old man, 41, 183, 285
 archetype of spirit/meaning, 35, 37
 in dreams, 215f
 in fairytales, 217ff
 hidden by anima, 270
 opposite of, 374
wish-fulfilments, 184n, 186
witch(es), 82
 anima as, 25f, 29, 30, 199
 evil symbol, 82
 in fairytales, 221, 228, 232, 235, 237, 242

grandmother as, 102
mother as, 85
witch-doctor, 224
Woelflin, Heinrich, 9
wolf(-ves), 231*f*, 235
Wolff, Toni, 285*n*
Wolfram von Eschenbach, 141*n*
woman: divine, 192
 masculine traits in, 124
 as personality, 199
womb, 363
wood-nymph, 25
Woodroffe, Sir John, 70*n* *see also* Avalon, Arthur (pseudonym)
Word, preaching of the, 128
words, 81
world, end of, subjective, 147
world-guardians, 319*n*
World War, 253
World Wheel, 360, 376
worm, 187, 375
Wotan, 24, 226, 246, 248*n*, 339
Wrath-fire, 12, 341
Wu, Lu-ch'iang, 293*n*
Wundt, Wilhelm, 54, 151, 208
Wylie, Philip, 83*n*

X/Y/Z

Xenocrates, 319*n*
Yahweh, 11, 103, 256, 341*n*; *see also* Jehovah
Yajuj, *see* Gog
Yama, 360
yang and *yin*, 18, 59, 98, 109, 341, 358
yantra, 356, 383, 387
year, dragon as symbol of, 311*n*
Yellow Castle, Book of the, 377

Yesod, [314n](#)
yin, see *yang*
yoga, [219n](#), [318](#)
 Chinese, [38](#)
 Kundalini [70](#), [357](#), [359](#), [366](#), [372](#)
 Tantric, [185n](#)
 and transformation, [129](#)
yogi(s), [287](#), [357](#), [358](#)
Yoga-sūtra, [288](#)
yoni, [81](#)
youth: as animus figure, [191](#)
 spirit as, [215](#)
yuen (generative power), [359](#)
yugas, [310](#)
Zacharias/Zechariah, [140n](#), [295n](#)
Zagreus, [118](#)
Zarathustra, see Nietzsche
Zen Buddhism, [340](#)
Zeus, [46](#)
Zimmer, Heinrich, [82n](#)
zodiac, [6](#), [309](#), [310](#)
Zohar, [328n](#)
Zosimos, [135n](#), [202](#), [223](#), [294](#), [300](#)
Zurich, [52](#)

THE COLLECTED WORKS OF *C. G. JUNG*

THE PUBLICATION of the first complete edition, in English, of the works of C. G. Jung was undertaken by Routledge and Kegan Paul, Ltd., in England and by Bollingen Foundation in the United States. The American edition is number XX in Bollingen Series, which since 1967 has been published by Princeton University Press. The edition contains revised versions of works previously published, such as *Psychology of the Unconscious*, which is now entitled *Symbols of Transformation*; works originally written in English, such as *Psychology and Religion*; works not previously translated, such as *Aion*; and, in general, new translations of virtually all of Professor Jung's writings. Prior to his death, in 1961, the author supervised the textual revision, which in some cases is extensive. Sir Herbert Read (d. 1968), Dr. Michael Fordham, and Dr. Gerhard Adler compose the Editorial Committee; the translator is R. F. C. Hull (except for Volume 2) and William McGuire is executive editor.

The price of the volumes varies according to size; they are sold separately, and may also be obtained on standing order. Several of the volumes are extensively illustrated. Each volume contains an index and in most a bibliography; the final volumes will contain a complete bibliography of Professor Jung's writings and a general index to the entire edition.

In the following list, dates of original publication are given in parentheses (of original composition, in brackets). Multiple dates indicate revisions.

*1. PSYCHIATRIC STUDIES

On the Psychology and Pathology of So-Called Occult Phenomena
(1902)

On Hysterical Misreading (1904)

Cryptomnesia (1905)

On Manic Mood Disorder (1903)

A Case of Hysterical Stupor in a Prisoner in Detention (1902)

On Simulated Insanity (1903)

A Medical Opinion on a Case of Simulated Insanity (1904)

A Third and Final Opinion on Two Contradictory Psychiatric Diagnoses (1906)

On the Psychological Diagnosis of Facts (1905)

†2. EXPERIMENTAL RESEARCHES

Translated by Leopold Stein in collaboration with Diana Riviere

STUDIES IN WORD ASSOCIATION (1904–7, 1910)

The Associations of Normal Subjects (by Jung and F. Riklin)

An Analysis of the Associations of an Epileptic

The Reaction-Time Ratio in the Association Experiment

Experimental Observations on the Faculty of Memory

Psychoanalysis and Association Experiments

The Psychological Diagnosis of Evidence

Association, Dream, and Hysterical Symptom

The Psychopathological Significance of the Association Experiment

Disturbances in Reproduction in the Association Experiment

The Association Method

The Family Constellation

PSYCHOPHYSICAL RESEARCHES (1907–8)

On the Psychophysical Relations of the Association Experiment

Psychophysical Investigations with the Galvanometer and Pneumograph in Normal and Insane Individuals (by F. Peterson and Jung)

Further Investigations on the Galvanic Phenomenon and Respiration in Normal and Insane Individuals (by C. Ricksher and Jung)

Appendix: Statistical Details of Enlistment (1906); New Aspects of Criminal Psychology (1908); The Psychological Methods of Investigation Used in the Psychiatric Clinic of the University of Zurich (1910); On the Doctrine of Complexes ([1911] 1913); On the Psychological Diagnosis of Evidence (1937)

*3 THE PSYCHOGENESIS OF MENTAL DISEASE

The Psychology of Dementia Praecox (1907)

The Content of the Psychoses (1908/1914)

On Psychological Understanding (1914)

A Criticism of Bleuler's Theory of Schizophrenic Negativism (1911)

On the Importance of the Unconscious in Psychopathology (1914)

On the Problem of Psychogenesis in Mental Disease (1919)

Mental Disease and the Psyche (1928)

On the Psychogenesis of Schizophrenia (1939)

Recent Thoughts on Schizophrenia (1957)

Schizophrenia (1958)

+4. FREUD AND PSYCHOANALYSIS

Freud's Theory of Hysteria: A Reply to Aschaffenburg (1906)

The Freudian Theory of Hysteria (1908)

The Analysis of Dreams (1909)

A Contribution to the Psychology of Rumour (1910–11)

On the Significance of Number Dreams (1910–11)

Morton Prince, "The Mechanism and Interpretation of Dreams": A Critical Review (1911)

On the Criticism of Psychoanalysis (1910)

Concerning Psychoanalysis (1912)

The Theory of Psychoanalysis (1913)

General Aspects of Psychoanalysis (1913)

Psychoanalysis and Neurosis (1916)

Some Crucial Points in Psychoanalysis: A Correspondence between Dr. Jung and Dr. Loÿ (1914)

Prefaces to "Collected Papers on Analytical Psychology" (1916, 1917)

The Significance of the Father in the Destiny of the Individual (1909/1949)

Introduction to Kranefeldt's "Secret Ways of the Mind" (1930)

Freud and Jung: Contrasts (1929)

‡5. SYMBOLS OF TRANSFORMATION (1911–12/1952)

PART I

Introduction

Two Kinds of Thinking

The Miller Fantasies: Anamnesis

The Hymn of Creation

The Song of the Moth

PART II

Introduction

The Concept of Libido

The Transformation of Libido

The Origin of the Hero
Symbols of the Mother and of Rebirth
The Battle for Deliverance from the Mother
The Dual Mother
The Sacrifice
Epilogue
Appendix: The Miller Fantasies

*6. PSYCHOLOGICAL TYPES (1921)

Introduction
The Problem of Types in the History of Classical and Medieval
Thought
Schiller's Ideas on the Type Problem
The Apollinian and the Dionysian
The Type Problem in Human Character
The Type Problem in Poetry
The Type Problem in Psychopathology
The Type Problem in Aesthetics
The Type Problem in Modern Philosophy
The Type Problem in Biography
General Description of the Types
Definitions
Epilogue
Four Papers on Psychological Typology (1913, 1925, 1931, 1936)

†7. TWO ESSAYS ON ANALYTICAL PSYCHOLOGY

On the Psychology of the Unconscious (1917/1926/1943)
The Relations between the Ego and the Unconscious (1928)
Appendix: New Paths in Psychology (1912); The Structure of the Unconscious
(1916) (new versions, with variants, 1966)

‡8. THE STRUCTURE AND DYNAMICS OF THE PSYCHE

On Psychic Energy (1928)
The Transcendent Function ([1916]/1957)
A Review of the Complex Theory (1934)
The Significance of Constitution and Heredity in Psychology (1929)

Psychological Factors Determining Human Behavior (1937)

Instinct and the Unconscious (1919)

The Structure of the Psyche (1927/1931)

On the Nature of the Psyche (1947/1954)

General Aspects of Dream Psychology (1916/1948)

On the Nature of Dreams (1945/1948)

The Psychological Foundations of Belief in Spirits (1920/1948)

Spirit and Life (1926)

Basic Postulates of Analytical Psychology (1931)

Analytical Psychology and *Weltanschauung* (1928/1931)

The Real and the Surreal (1933)

The Stages of Life (1930–1931)

The Soul and Death (1934)

Synchronicity: An Acausal Connecting Principle (1952)

Appendix: On Synchronicity (1951)

* 9. PART I. THE ARCHETYPES AND THE COLLECTIVE UNCONSCIOUS

Archetypes of the Collective Unconscious (1934/1954)

The Concept of the Collective Unconscious (1936)

Concerning the Archetypes, with Special Reference to the Anima
Concept (1936/1954)

Psychological Aspects of the Mother Archetype (1938/1954)

Concerning Rebirth (1940/1950)

The Psychology of the Child Archetype (1940)

The Psychological Aspects of the Kore (1941)

The Phenomenology of the Spirit in Fairytales (1945/1948)

On the Psychology of the Trickster-Figure (1954)

Conscious, Unconscious, and Individuation (1939)

A Study in the Process of Individuation (1934/1950)

Concerning Mandala Symbolism (1950)

Appendix: Mandalas (1955)

* 9. PART II. AION (1951)

RESEARCHES INTO THE PHENOMENOLOGY OF THE SELF

The Ego

The Shadow

The Syzygy: Anima and Animus

The Self

Christ, a Symbol of the Self

The Sign of the Fishes

The Prophecies of Nostradamus

The Historical Significance of the Fish

The Ambivalence of the Fish Symbol

The Fish in Alchemy

The Alchemical Interpretation of the Fish

Background to the Psychology of Christian Alchemical Symbolism

Gnostic Symbols of the Self

The Structure and Dynamics of the Self

Conclusion

◦ 10. CIVILIZATION IN TRANSITION

The Role of the Unconscious (1918)

Mind and Earth (1927/1931)

Archaic Man (1931)

The Spiritual Problem of Modern Man (1928/1931)

The Love Problem of a Student (1928)

Woman in Europe (1927)

The Meaning of Psychology for Modern Man (1933/1934)

The State of Psychotherapy Today (1934)

Preface and Epilogue to “Essays on Contemporary Events” (1946)

Wotan (1936)

After the Catastrophe (1945)

The Fight with the Shadow (1946)

The Undiscovered Self (Present and Future) (1957)

Flying Saucers: A Modern Myth (1958)

A Psychological View of Conscience (1958)

Good and Evil in Analytical Psychology (1959)

Introduction to Wolff’s “Studies in Jungian Psychology” (1959)

The Swiss Line in the European Spectrum (1928)

Reviews of Keyserling's "America Set Free" (1930) and "La Révolution Mondiale" (1934)

The Complications of American Psychology (1930)

The Dreamlike World of India (1939)

What India Can Teach Us (1939)

Appendix: Documents (1933–1938)

11 PSYCHOLOGY AND RELIGION: WEST AND EAST

WESTERN RELIGION

Psychology and Religion (The Terry Lectures) (1938/1940)

A Psychological Approach to the Dogma of the Trinity (1942/1948)

Transformation Symbolism in the Mass (1942/1954)

Forewords to White's "God and the Unconscious" and Werblowsky's "Lucifer and Prometheus" (1952)

Brother Klaus (1933)

Psychotherapists or the Clergy (1932)

Psychoanalysis and the Cure of Souls (1928)

Answer to Job (1952)

EASTERN RELIGION

Psychological Commentaries on "The Tibetan Book of the Great Liberation" (1939/1954) and "The Tibetan Book of the Dead" (1935/1953)

Yoga and the West (1936)

Foreword to Suzuki's "Introduction to Zen Buddhism" (1939)

The Psychology of Eastern Meditation (1943)

The Holy Men of India: Introduction to Zimmer's "Der Weg zum Selbst" (1944)

Foreword to the "I Ching" (1950)

12. PSYCHOLOGY AND ALCHEMY (1944)

Prefatory note to the English Edition ([1951?] added 1967)

Introduction to the Religious and Psychological Problems of Alchemy

Individual Dream Symbolism in Relation to Alchemy (1936)

Religious Ideas in Alchemy (1937)

Epilogue

13. ALCHEMICAL STUDIES

Commentary on "The Secret of the Golden Flower" (1929)

The Visions of Zosimos (1938/1954)

Paracelsus as a Spiritual Phenomenon (1942)

The Spirit Mercurius (1943/1948)

The Philosophical Tree (1945/1954)

14. MYSTERIUM CONIUNCTIONIS (1955–56)

AN INQUIRY INTO THE SEPARATION AND
SYNTHESIS OF PSYCHIC OPPOSITES IN ALCHEMY

The Components of the Coniunctio

The Paradoxa

The Personification of the Opposites

Rex and Regina

Adam and Eve

The Conjunction

15. THE SPIRIT IN MAN, ART, AND LITERATURE

Paracelsus (1929)

Paracelsus the Physician (1941)

Sigmund Freud in His Historical Setting (1932)

In Memory of Sigmund Freud (1939)

Richard Wilhelm: In Memoriam (1930)

On the Relation of Analytical Psychology to Poetry (1922)

Psychology and Literature (1930/1950)

“Ulysses”: A Monologue (1932)

Picasso (1932)

16. THE PRACTICE OF PSYCHOTHERAPY

GENERAL PROBLEMS OF PSYCHOTHERAPY

Principles of Practical Psychotherapy (1935)

What Is Psychotherapy? (1935)

Some Aspects of Modern Psychotherapy (1930)

The Aims of Psychotherapy (1931)

Problems of Modern Psychotherapy (1929)

Psychotherapy and a Philosophy of Life (1943)

Medicine and Psychotherapy (1945)

Psychotherapy Today (1945)

Fundamental Questions of Psychotherapy (1951)

SPECIFIC PROBLEMS OF PSYCHOTHERAPY

The Therapeutic Value of Abreaction (1921/1928)

The Practical Use of Dream-Analysis (1934)

The Psychology of the Transference (1946)

Appendix: The Realities of Practical Psychotherapy ([1937] added, 1966)

17. THE DEVELOPMENT OF PERSONALITY

Psychic Conflicts in a Child (1910/1946)

Introduction to Wickes's "Analyses der Kinderseele" (1927/1931)

Child Development and Education (1928)

Analytical Psychology and Education: Three Lectures (1926/1946)

The Gifted Child (1943)

The Significance of the Unconscious in Individual Education (1928)

The Development of Personality (1934)

Marriage as a Psychological Relationship (1925)

18. THE SYMBOLIC LIFE

Miscellaneous Writings

19. GENERAL BIBLIOGRAPHY OF C. G. JUNG'S WRITINGS

20. GENERAL INDEX TO THE COLLECTED WORKS

See also:

C. G. JUNG. LETTERS

Selected and edited by Gerhard Adler, in collaboration with Aniela Jaffé. Translations from the German by R.F.C. Hull.

VOL. 1: 1906–1950

VOL. 2: 1951–1961

THE FREUD/JUNG LETTERS

Edited by William McGuire, translated by
Ralph Manheim and R.F.C. Hull

C. G. JUNG SPEAKING: Interviews and Encounters

Edited by William McGuire and R.F.C. Hull

C. G. JUNG: Word and Image

Edited by Aniela Jaffé

*In *Psychiatric Studies*, vol. 1 of the *Coll. Works*.

¹ [First published in the *Eranos-Jahrbuch 1934*, and later revised and published in *Von den Wurzeln des Bewusstseins* (Zurich, 1954), from which version the present translation is made. The translation of the original version, by Stanley Dell, in *The Integration of the Personality* (New York, 1939; London, 1940), has been freely consulted.—EDITORS.]

² In his later works Freud differentiated the basic view mentioned here. He called the instinctual psyche the “id,” and his “super-ego” denotes the collective consciousness, of which the individual is partly conscious and partly unconscious (because it is repressed).

³ *De opificio mundi*, I, 69. Cf. Colson/Whitaker trans., I, p. 55.

⁴ *Adversus haereses* II, 7, 5: “Mundi fabricator non a semetipso fecit haec, sed de alienis archetypis transtulit.” (Cf. Roberts/Rambaut trans., I, p. 139.)

⁵ Scott, *Hermetica*, I, p. 140.

⁶ In Migne, *P.G.*, vol. 3, col. 144.

⁷ *Ibid.*, col. 595. Cf. *The Divine Names* (trans. by Rolt), pp. 62, 72.

⁸ Migne, *P.L.*, vol. 40, col. 30. “Archetype” is used in the same way by the alchemists, as in the “Tractatus aureus” of Hermes Trismegistus (*Theatrum chemicum*, IV, 1613, p. 718): “As God [contains] all the treasure of his godhead ... hidden in himself as in an archetype [*in se tanquam archetypo absconditum*] ... in like manner Saturn carries the similitudes of metallic bodies hiddenly in himself.” In the “Tractatus de igne et sale” of Vigenerus (*Theatr. chem.*, VI, 1661, p. 3), the world is “ad archetypi sui similitudinem factus” (made after the likeness of its archetype) and is therefore called the “magnus homo” (the “homo maximus” of Swedenborg).

⁹ One must, for the sake of accuracy, distinguish between “archetype” and “archetypal ideas.” The archetype as such is a hypothetical and irrepresentable model, something like the “pattern of behaviour” in biology. Cf. “On the Nature of the Psyche,” sec. 7.

¹⁰ An allegory is a paraphrase of a conscious content, whereas a symbol is the best possible expression for an unconscious content whose nature can only be guessed, because it is still unknown.

¹¹ Cf. my papers on the divine child and the Kore in the present volume, and Kerényi’s complementary essays in *Essays on [or Introduction to] a Science of Mythology*.

¹² [Schiller, *Piccolomini*, II, 6.—EDITORS.]

¹³ Cf. my “Brother Klaus.”

¹⁴ Heinrich Woelflin, also called by the Latin form *Lupulus*, born 1470, humanist and director of Latin studies at Bern. Cited in Fritz Blanke, *Bruder Klaus von Flüe*, pp. 92f.

¹⁵ *Ibid.*, p. 94.

¹⁶ *Ein gesichte Bruder Clausen ynn Schweytz und seine deutunge* (Wittemberg, 1528), p. 5. Cited in Alban Stoeckli, O. M. Cap., *Die Visionen des seligen Bruder Klaus*, p. 34.

¹⁷ M. B. Lavaud, O.P. (*Vie Profonde de Nicolas de Flue*) gives just as apt a parallel with a text from the *Horologium sapientiae* of Henry Suso, where the apocalyptic Christ appears as an infuriated and wrathful avenger, very much in contrast to the Jesus who preached the Sermon on the Mount. [Cf. Suso, *Little Book of Eternal Wisdom*, Clark trans., pp. 77–78.—EDITORS.]

- ¹⁸ *Ein nützlicher und loblicher Tractat von Bruder Claus und einem Bilger* (1488).
- ¹⁹ Blanke, pp. 95ff.
- ²⁰ London, 1647.
- ²¹ Cf. my “Study in the Process of Individuation,” *infra*.
- ²² [Cf. *Der Geist als Widersacher der Seele*.]
- ²³ [Cf., e.g., *Die Stellung des Menschen im Kosmos*.—EDITORS.]
- ²⁴ James, *Apocryphal New Testament*, pp. 411–15.
- ²⁵ Augustine, *Confessions*, Lib. XIII, cap. XXI.
- ²⁶ The fact that it was another theologian who dreamed this dream is not so surprising, since priests and clergymen have a professional interest in the motif of “ascent.” They have to speak of it so often that the question naturally arises as to what they are doing about their own spiritual ascent.
- ²⁷ [The “Fischottermärchen” in *Märchen aus dem Unbewussten*, pp. 14ff., 43ff.—EDITORS.]
- ²⁸ Cf. Paracelsus, *De vita longa* (1562), and my commentary in “Paracelsus as a Spiritual Phenomenon” [concerning Melusina, pars. 179f., 215ff.].
- ²⁹ Cf. the picture of the adept in *Liber mutus* (1677) (fig. 13 in *The Practice of Psychotherapy*, p. 320). He is fishing, and has caught a nixie. His *soror mystica*, however, catches birds in her net, symbolizing the animus. The idea of the anima often turns up in the literature of the 16th and 17th cent., for instance in Richardus Vitus, Aldrovandus, and the commentator of the *Tractatus aureus*. Cf. “The Enigma of Bologna” in my *Mysterium Coniunctionis*, pars. 51ff.
- ³⁰ La Rochefoucauld, *Pensées DLX*. Quoted in *Symbols of Transformation*, p. 174.
- ³¹ Cf. *The Dream of Poliphilo*, ed. by Linda Fierz-David. [For Haggard and Benoît, see the bibliography.—EDITORS.]
- ³² “Bilder und Symbole aus E. T. A. Hoffmanns Märchen ‘Der Goldne Topf.’”
- ³³ I have expounded my views at some length in “Psychology of the Transference.”
- ³⁴ I am referring here to literary examples that are generally accessible and not to clinical material. These are quite sufficient for our purpose.
- ³⁵ I.e., coming to terms with the contents of the collective unconscious in general. This is *the* great task of the integration process.
- ³⁶ A good example is the little book by Gustav Schmalz, *Östliche Weisheit und Westliche Psychotherapie*.
- ³⁷ I have already used this dream in “The Phenomenology of the Spirit in Fairytales,” par. 398, *infra*, and in “Psychology and Education,” pp. 117ff., as an example of a “big” dream, without commenting on it more closely.
- ³⁸ Cf. the motif of the “old king” in alchemy. *Psychology and Alchemy*, pars. 434ff.
- ³⁹ Cf. James, *The Apocryphal New Testament*, pp. 27f.
- ⁴⁰ Reitzenstein interprets the “Shepherd” of Hermas as a Christian rejoinder to the Poimandres writings.
- ⁴¹ Arthur Avalon, *The Serpent Power*.
- ⁴² Erwin Rousselle, “Spiritual Guidance in Contemporary Taoism.”
- ⁴³ R. Bernoulli, “Zur Symbolik geometrischer Figuren und Zahlen,” pp. 397ff.
- ⁴⁴ “Analytische Beobachtungen über Phantasien eines Schizophrenen,” pp. 504ff.

⁴⁵ John Cusance, *Wisdom, Madness, and Folly*.

⁴⁶ Ruland, *Lexicon alchemiae* (1612).

⁴⁷ Cf. *Symbols of Transformation*.

⁴⁸ *Aion*, Part II of this volume.

⁴⁹ *Psychology and Alchemy*.

1 [Originally given as a lecture to the Abernethian Society at St. Bartholomew's Hospital, London, on Oct. 19, 1936, and published in the Hospital's *Journal*, XLIV (1936/37), 46–49, 64–66. The present version has been slightly revised by the author and edited in terminology.—EDITORS.]

2 *Leonardo da Vinci and a Memory of His Childhood*, sec. IV.

3 [Cf. the trans. by George Boas, pp. 63ff., and Freud, *Leonardo*, sec. II.—EDITORS.]

4 *Wandlungen und Symbole der Libido* (orig. 1912). [Trans. as *Psychology of the Unconscious*, 1916. Cf. the revised edition, *Symbols of Transformation*, pars. 149ff., 223.—EDITORS.]

5 *Eine Mithrasliturgie*. [As the author subsequently learned, the 1910 edition was actually the second, there having been a first edition in 1903. The patient had, however, been committed some years before 1903.—EDITORS.]

6 *Ibid.*, pp. 6ff.

7 *Psychology and Alchemy*, Part II.

- 1 [Originally published as “Über den Archetypus mit besonderer Berücksichtigung des Animabegriffes” in the *Zentralblatt für Psychotherapie und ihre Grenzgebiete* (Leipzig), IX (1936) : 5, 259–75. Revised and republished in *Von den Wurzeln des Bewusstseins* (Zurich, 1954), from which version the present translation is made.—EDITORS.]
- 2 *Elemente der Psychophysik* (1860).
- 3 *Principles of Physiological Psychology* (orig. 1874).
- 4 Cf. G. H. von Schubert’s compilation, *Altes und Neues aus dem Gebiet der innern Seelenkunde* (1825–44).
- 5 First published 1829. Trans. as *The Seeress of Prevorst* (1859).
- 6 *L’Automatisme psychologique* (1889); *The Mental State of Hystericals* (orig., 1893); *Névroses et idées fixes* (1898).
- 7 *From India to the Planet Mars* (orig., 1900), and “Nouvelles Observations sur un cas de somnambulisme avec glossolalie.”
- 8 I am thinking especially of shamanism with its idea of the “celestial wife” (Eliade, *Shamanism*, pp. 76–81).
- 9 Spencer and Gillen, *The Northern Tribes of Central Australia*, pp. 331 and elsewhere. Also Crawley, *The Idea of the Soul*, pp. 87f.
- 10 *Commentary on the Dream of Scipio*.
- 11 Cf. my “Commentary on *The Secret of the Golden Flower*,” pars. 57ff., and Chantepie de la Saussaye, *Lehrbuch der Religionsgeschichte*, I, p. 71.
- 12 This standpoint derives from Kant’s theory of knowledge and has nothing to do with materialism.
- 13 Winthuis, *Das Zweigeschlechterwesen bei den Zentralaustralern und anderen Völkern*.
- 14 Especially in the system of the Valentinians. Cf. Irenaeus, *Adversus haereses*.
- 15 Cf. *The I Ching or Book of Changes*. [Also Needham, *Science and Civilization in China*, II, pp. 273f.—EDITORS.]
- 16 Hermetic alchemical philosophy from the 14th to the 17th cents. provides a wealth of instructive examples. For our purposes, a glimpse into Michael Maier’s *Symbola aureae mensae* (1617) would suffice.
- 17 There are of course cases where, in spite of the patient’s seemingly sufficient insight, the reactive effect of the projection does not cease, and the expected liberation does not take place. I have often observed that in such cases meaningful but unconscious contents are still bound up with the projection carrier. It is these contents that keep up the effect of the projection, although it has apparently been seen through.
- 18 Fl. c. 300 B.C. Cf. Block, *Euhémère: son livre et sa doctrine*.
- 19 This is not to overlook the fact that there is probably a far greater number of visions which agree with the dogma. Nevertheless, they are not spontaneous and autonomous projections in the strict sense but are *visualizations of conscious contents*, evoked through prayer, autosuggestion, and heterosuggestion. Most spiritual exercises have this effect, and so do the prescribed meditation practices of the East. In any thorough investigation of such visions it would have to be ascertained, among other things, what the actual vision was and how far dogmatic elaboration contributed to its form.
- 20 Cf. Stoeckli, *Die Visionen des seligen Bruder Klaus*, and Blanke, *Bruder Klaus von Flüe*.
- 21 The peculiar love-story of this youngest Aeon can be found in Irenaeus, *Adv. haer.*, I, 2, 2ff. (Roberts/Rambaut trans., I, pp. 7ff.)
- 22 Cf. my “Brother Klaus.”

²³ Guillaume wrote three *Pèlerinages* in the manner of the Divine Comedy, but independently of Dante, between 1330 and 1350. He was Prior of the Cistercian monastery at Châlis, in Normandy. Cf. Delacotte, *Guillaume de Digulleville: Trois Romans-poèmes du XIV siècle*. [Also cf. *Psychology and Alchemy*, pars. 315ff.—EDITORS.]

²⁴ *Anna Kingsford: Her Life, Letters, Diary, and Work*, I, pp. 130. Maitland's vision is similar in form and meaning to the one in the Poimandres (Scott, *Hermetica*, I, Libellus I, pp. 114ff.), where the spiritual light is described as "male-female." I do not know whether Maitland was acquainted with the Poimandres; probably not.

²⁵ Hubert and Mauss (*Mélanges d'histoire des religions*, preface, p. xxix) call these *a priori* thought-forms "categories," presumably with reference to Kant: "They exist ordinarily as habits which govern consciousness, but are themselves unconscious." The authors conjecture that the primordial images are conditioned by language. This conjecture may be correct in certain cases, but in general it is contradicted by the fact that a great many archetypal images and associations are brought to light by dream psychology and psychopathology which would be absolutely incommunicable through language.

²⁶ Conforming to the bisexual Original Man in Plato, *Symposium*, XIV, and to the hermaphroditic Primal Beings in general.

²⁷ The "dual birth" refers to the motif, well known from hero mythology, which makes the hero descend from divine as well as from human parents. In most mysteries and religions it plays an important role as a baptism or rebirth motif. It was this motif that misled Freud in his study of Leonardo da Vinci. Without taking account of the fact that Leonardo was by no means the only artist to paint the motif of St. Anne, Mary, and the Christ-child, Freud tried to reduce Anne and Mary, the grandmother and mother, to the mother and stepmother of Leonardo; in other words, to assimilate the painting to his theory. But did the other painters all have stepmothers? What prompted Freud to this violent interpretation was obviously the fantasy of dual descent suggested by Leonardo's biography. This fantasy covered up the inconvenient reality that St. Anne was the grandmother, and prevented Freud from inquiring into the biographies of other artists who also painted St. Anne. The "religious inhibition of thought" mentioned on p. 79 (1957 edn.) proved true of the author himself. Similarly, the incest theory on which he lays so much stress is based on another archetype, the well-known incest motif frequently met with in hero myths. It is logically derived from the original hermaphrodite type, which seems to go far back into prehistory. Whenever a psychological theory is forcibly applied, we have reason to suspect that an archetypal fantasy-image is trying to distort reality, thus bearing out Freud's own idea of the "religious inhibition of thought." But to explain the genesis of archetypes by means of the incest theory is about as useful as ladling water from one kettle into another kettle standing beside it, which is connected with the first by a pipe. You cannot explain one archetype by another; that is, it is impossible to say where the archetype comes from, because there is no Archimedean point outside the *a priori* conditions it represents.

²⁸ Cf. Avalon, *The Serpent Power*; *Shrī-Chakra-Sambhara Tantra*; Woodroffe, *Shakti and Shakta*.

²⁹ Schultz, *Dokumente der Gnosis*, especially the lists in Irenaeus, *Adversus haereses*.

³⁰ Cf. *Psychology and Alchemy*.

³¹ Cf. the first paper in this volume.

³² The most important problems for therapy are discussed in my essay "The Relations between the Ego and the Unconscious" and also in the "Psychology of the Transference." For the mythological aspects of the anima, the reader is referred to another paper in this volume, "The Psychological Aspects of the Kore."

1 Cf. my “Instinct and the Unconscious,” par. 277.

2 [Cf. the previous paper, “Concerning the Archetypes,” par. 137, n. 25.—EDITORS.]

3 Usener, *Das Weihnachtsfest*, p. 3.

¹ This is the etymological meaning of the three *gunas*. See Weckerling, *Ananda-rama-makhi: Das Glück des Lebens*, pp. 21ff., and Garbe, *Die Samkhya Philosophie*, pp. 272ff. [Cf. also Zimmer, *Philosophies of India*, index, s.v.—EDITORS.]

² American psychology can supply us with any amount of examples. A blistering but instructive lampoon on this subject is Philip Wylie's *Generation of Vipers*.

1 But the father-complex also plays a considerable part here.

2 [Cf. *Two Essays on Analytical Psychology*, pars. 16ff.—EDITORS.]

3 In the present section I propose to present a series of different “types” of mother-complex; in formulating them, I am drawing on my own therapeutic experiences. “Types” are not individual cases, neither are they freely invented schemata into which all individual cases have to be fitted. “Types” are ideal instances, or pictures of the average run of experience, with which no single individual can be identified. People whose experience is confined to books or psychological laboratories can form no proper idea of the cumulative experience of a practising psychologist.

4 This statement is based on the repeated experience that, where love is lacking, power fills the vacuum.

5 In my English seminars [privately distributed] I have called this the “natural mind.”

6 Here the initiative comes from the daughter. In other cases the father’s psychology is responsible; his projection of the anima arouses an incestuous fixation in the daughter.

7 Herein lies the difference between this type of complex and the feminine father-complex related to it, where the “father” is mothered and coddled.

8 This does not mean that they are unconscious of the *facts*. It is only their *meaning* that escapes them.

9 This type of woman has an oddly disarming effect on her husband, but only until he discovers that the person he has married and who shares his nuptial bed is his mother-in-law.

1 *Faust*, Part II, Act 5.

2 *Ibid.*, Part I, Act 1.

3 *Ibid.*, Part II, Act 1.

1 [Cf. above, “Archetypes of the Collective Unconscious,” par. 7.—EDITORS.]

2 Warnecke, *Die Religion der Batak*.

3 [A familiar figure of speech in German.—EDITORS.]

4 Buri, “Theologie and Philosophie,” p. 117. [Quoting Rudolf Bultmann.—EDS.]

5 Obviously a daughter can idealize her mother too, but for this special circumstances are needed, whereas in a man idealization is almost the normal thing.

6 “Nocturnis ululatibus horrenda Proserpina.” Cf. *Symbols of Transformation*, par. 148.

7 Cf. my “Synchronicity: An Acausal Connecting Principle.”

1 Cf. the *Samyutta-Nikaya (Book of the Kindred Sayings)*, Part II: The Nidana Book, pp. 150f.

2 Cf. the Homeric Hymn to Demeter, verses 480–82: “Blessed is he among men who has seen these mysteries; but he who is uninitiate and has no part in them, never has lot of like good things once he is dead, down in the darkness and gloom.” (Trans. by Evelyn-White, *Hesiod, the Homeric Hymns and Homericica*, p. 323.) And in an Eleusinian epitaph we read:

“Truly the blessed gods have proclaimed a most beautiful secret:
Death comes not as a curse, but as a blessing to men.”

1 [Cf. infra, “The Psychology of the Kore,” and Kerényi’s companion essays in *Essays on a Science of Mythology*.—EDITORS.]

2 Cf. my “Transformation Symbolism in the Mass.”

3 *Thus Spake Zarathustra*, trans. by Common, pp. 315ff.

4 *Ibid.*: “An old, bent and gnarled tree, hung with grapes.”

5 Horneffer, *Nietzsches Lehre von der ewigen Wiederkehr*.

6 *Les Névroses*, p. 358.

7 The *gana* phenomena described by Count Keyserling (*South-American Meditations*, pp. 161ff.) come into this category.

8 Ephesians 4:8.

9 “Thy soul will be dead even sooner than thy body.” *Thus Spake Zarathustra*, p. 74.

10 Cf. “A Psychological Approach to the Dogma of the Trinity,” pars. 226ff.

11 Shvetashvatara Upanishad 4, 6ff. (Trans. based on Hume, *The Thirteen Principal Upanishads* pp. 403ff.).

12 Koran, 18th Sura.

13 I have discussed one such case of a widening of the personality in my inaugural dissertation, “On the Psychology and Pathology of So-called Occult Phenomena.”

14 For the Church’s view of possession see de Tonquédec, *Les Maladies nerveuses ou mentales et les manifestations diaboliques*; also “A Psychological Approach to the Dogma of the Trinity,” p. 163, n. 15.

15 In this connection, Schopenhauer’s “The Wisdom of Life: Aphorisms” (*Essays from the Parerga and Paralipomena*) could be read with profit.

16 This important problem is discussed in detail in Ch. II of *Psychological Types*.

17 Cf. the apt description of the anima in Aldrovandus, *Dendrologiae libri duo* (1668, p. 211): “She appeared both very soft and very hard at the same time, and while for some two thousand years she had made a show of inconstant looks like a Proteus, she bedevilled the love of Lucius Agatho Priscus, then a citizen of Bologna, with anxious cares and sorrows, which assuredly were conjured up from chaos, or from what Plato calls Agathonian confusion.” There is a similar description in Fierz-David, *The Dream of Poliphilo*, pp. 189ff.

18 Cf. Emma Jung, “On the Nature of the Animus.”

19 Cf. Lévy-Bruhl, *La Mythologie primitive*.

20 Le Bon, *The Crowd*.

21 The *alcheringamijina*. Cf. the rites of Australian tribes, in Spencer and Gillen, *The Northern Tribes of Central Australia*; also Lévy-Bruhl, *La Mythologie primitive*.

22 I would remind the reader of the catastrophic panic which broke out in New York on the occasion [1938] of a broadcast dramatization of H. G. Wells’ *War of the Worlds* shortly before the second World War [see Cantril, *The Invasion from Mars* (1940)], and which was later [1949] repeated in Quito.

23 Cf. “The Psychology of Eastern Meditation.”

24 Cf. *Psychology and Alchemy*, Part II.

25 Cf. Ruland, *Lexicon* (1893 edn.), p. 226.

²⁶ Izquierdo, *Pratica di alcuni Eserciti spirituali di S. Ignatio* (Rome, 1686, p. 7): “A colloquy ... is nothing else than to talk and communicate familiarly with Christ.”

^{26a} [“Daily Conversations with Dr. Pifffoel,” in her *Intimate Journal*.—EDITORS.]

²⁷ A Pseudo-Aristotle quotation in *Rosarium philosophorum* (1550), fol. Q.

²⁸ “Largiri vis mihi meum” is the usual reading, as in the first edition (1556) of *Ars chemica*, under the title “Septem tractatus seu capitula Hermetis Trismegisti aurei,” and also in *Theatrum chemicum*, IV (1613), and Manget, *Bibliotheca chemica*, I (1702), pp. 400ff. In the *Rosarium philosophorum* (1550), fol. E, there is a different reading: “Largire mihi ius meum ut te adiuvem” (Give me my due that I may help thee). This is one of the interpretative readings for which the anonymous author of the *Rosarium* is responsible. Despite their arbitrariness they have an important bearing on the interpretation of alchemy. [Cf. *Psychology and Alchemy*, par. 139, n.17.]

²⁹ *Biblio. chem.*, I, p. 430b.

³⁰ Detailed documentation in *Psychology and Alchemy*, par. 84, and “The Spirit Mercurius,” pars. 278ff., 287ff.

³¹ “Tanquam praeceptor intermedius inter lapidem et discipulum.” (*Biblio. chem.*, I, p. 430b.) Cf. the beautiful prayer of Astrampsychos, beginning “Come to me, Lord Hermes,” and ending “I am thou and thou art I.” (Reitzenstein, *Poimandres*, p. 21.)

³² The stone and its transformation are represented:

(1) as the resurrection of the *homo philosophicus*, the Second Adam (“Aurea hora,” *Art is auriferae*, 1593, I, p. 195);

(2) as the human soul (“Book of Krates,” Berthelot, *La Chimie au moyen âge*, III, p. 50);

(3) as a being below and above man: “This stone is under thee, as to obedience; above thee, as to dominion; therefore from thee, as to knowledge; about thee, as to equals” (“Rosinus ad Sarratantam,” *Art. aurif.*, I, p. 310);

(4) as life: “blood is soul and soul is life and life is our Stone” (“Tractatulus Aristotelis,” *ibid.*, p. 364),

(5) as the resurrection of the dead (“Calidis liber secretorum,” *ibid.*, p. 347; also “Rachaidibi fragmentum,” *ibid.*, p. 398);

(6) as the Virgin Mary (“De arte chymica,” *ibid.*, p. 582); and

(7) as man himself: “thou art its ore ... and it is extracted from thee ... and it remains inseparably with thee” (“Rosinus ad Sarratantam,” *ibid.*, p. 311).

1 [The Dawood trans. of the Koran is quoted, sometimes with modifications. The 18th Sura is at pp. 89–98.—EDITORS.]

2 Cumont, *Textes et monuments figurés relatifs aux mystères de Mithra*, II.

3 Cf. especially the crowning vision in the dream of Zosimos: “And another [came] behind him, bringing one adorned round with signs, clad in white and comely to see, who was named the Meridian of the Sun.” Cf. “The Visions of Zosimos,” par. 87 (III, v bis).

4 Matthews, *The Mountain Chant*, and Stevenson, *Ceremonial of Hasjelti Dailjis*.

5 An account of the secret doctrine hinted at in this treatise may be found in my “Paracelsus as a Spiritual Phenomenon,” pars. 169ff.

6 The different versions of the legend speak sometimes of seven and sometimes of eight disciples. According to the account given in the Koran, the eighth is a dog. The 18th Sura mentions still other versions: “Some will say: ‘The sleepers were three: their dog was the fourth.’ Others, guessing at the unknown, will say: ‘They were five; their dog was the sixth.’ And yet others: ‘Seven; their dog was the eighth.’” It is evident, therefore, that the dog is to be taken into account. This would seem to be an instance of that characteristic wavering between seven and eight (or three and four, as the case may be), which I have pointed out in *Psychology and Alchemy*, pars. 200ff. There the wavering between seven and eight is connected with the appearance of Mephistopheles, who, as we know, materialized out of the black poodle. In the case of three and four, the fourth is the devil or the female principle, and on a higher level the Mater Dei. (Cf. “Psychology and Religion,” pars. 124ff.) We may be dealing with the same kind of ambiguity as in the numbering of the Egyptian nonad (*paut* = ‘company of gods’; cf. Budge, *The Gods of the Egyptians*, I, p. 88). The Khidr legend relates to the persecution of the Christians under Decius (c. A.D. 250). The scene is Ephesus, where St. John lay “sleeping,” but not dead. The seven sleepers woke up again during the reign of Theodosius II (408–450); thus they had slept not quite 200 years.

7 The seven are the planetary gods of the ancients. Cf. Bousset, *Hauptprobleme der Gnosis*, pp. 23ff.

8 Obedience under the law on the one hand, and the freedom of the “children of God,” the reborn, on the other, is discussed at length in the Epistles of St. Paul. He distinguishes not only between two different classes of men, who are separated by a greater or lesser development of consciousness, but also between the higher and lower man in one and the same individual. The *sarkikos* (carnal man) remains eternally under the law; the *pneumatikos* (spiritual man) alone is capable of being reborn into freedom. This is quite in keeping with what seems such an insoluble paradox: the Church demanding absolute obedience and at the same time proclaiming freedom from the law. So, too, in the Koran text, the legend appeals to the *pneumatikos* and promises rebirth to him that has ears to hear. But he who, like the *sarkikos*, has no inner ear will find satisfaction and safe guidance in blind submission to Allah’s will.

9 Vollers, “Chidher,” *Archiv für Religionswissenschaft*, XII, p. 241. All quotations from the commentaries are extracted from this article.

¹⁰ *Ibid.*, p. 253.

¹¹ Cf. *Aion*, pars. 195ff.

¹² Vollers, p. 244.

¹³ *Ibid.*, p. 260.

¹⁴ *Ibid.*, p. 258.

¹⁵ Cf. the myth in the “Visio Arislei,” especially the version in the *Rosarium philosophorum* (*Art. aurif.*, II, p. 246), likewise the drowning of the sun in the Mercurial Fountain and the green lion who devours the sun (*Art. aurif.*, II, pp. 315, 366). Cf. “The Psychology of the Transference,” pars. 467ff.

¹⁶ The white stone appears on the edge of the vessel, “like Oriental gems, like fish’s eyes.” Cf. Joannes Isaacus Hollandus, *Opera mineralia* (1600), p. 370. Also Lagneus, “Harmonica chemica.” *Theatrum chemicum*, IV (1613), p. 870. The eyes appear at the end of the *nigredo* and with the beginning of the *albedo*. Another simile of the same sort is the *scintillae* that appear in the dark substance. This idea is traced back to Zacharias 4 : 10 (DV): “And they shall rejoice and see the tin plummet in the hand of Zorobabel. These are the seven eyes of the Lord that run to and fro through the whole earth.” (Cf. Eirenaeus Orandus, in the introduction to Nicholas Flamel’s *Exposition of the Hieroglyphicall Figures*, 1624, fol. A 5.) They are the seven eyes of God on the corner-stone of the new temple (Zach. 3 : 9). The number seven suggests the seven stars, the planetary gods, who were depicted by the alchemists in a cave under the earth (Mylius, *Philosophia reformata*, 1622, p. 167). They are the “sleepers enchained in Hades” (Berthelot, *Collection des anciens alchimistes grecs*, IV, xx, 8). This is an allusion to the legend of the seven sleepers.

¹⁷ Vollers, p. 254. This may possibly be due to Christian influence: one thinks of the fish meals of the early Christians and of fish symbolism in general. Vollers himself stresses the analogy between Christ and Khidr. Concerning the fish symbolism, see *Aion*.

¹⁸ Further examples in *Symbols of Transformation*, Part II. I could give many more from alchemy, but shall content myself with the old verse:

“This is the stone, poor and of little price.
Spurned by the fool, but honoured by the wise.”

(*Ros. phil.*, in *Art. aurif.*, II, p. 210.) The “lapis exilis” may be a connecting-link with the “lapsit exillis,” the grail of Wolfram von Eschenbach.

¹⁹ [The Ojibway legend of Mondamin was recorded by H. R. Schoolcraft and became a source for Longfellow’s *Song of Hiawatha*. Cf. M. L. Williams, *School-craft’s Indian Legends*, pp. 58ff.—EDITORS.]

²⁰ Rhine, *New Frontiers of the Mind*. [Cf. also “Synchronicity: An Acausal Connecting Principle.”—EDITORS.]

²¹ He spoke in Kiswahili, the lingua franca of East Africa. It contains many words borrowed from Arabic, as shown by the above example: *kitab* = book.

²² There are similar indications in the Jewish tales about Alexander. Cf. Bin Gorion, *Der Born Judas*, III, p. 133, for the legend of the “water of life,” which is related to the 18th Sura.

²³ [For a fuller discussion of these relationships, see *Symbols of Transformation*, pars. 282ff.—EDITORS.]

²⁴ Just as the Dioscuri come to the aid of those who are in danger at sea.

1 Kerényi, “The Primordial Child in Primordial Times.”

2 *Der Mensch in der Geschichte* (1860).

3 *Psyche* (1846).

4 A working example in “The Concept of the Collective Unconscious,” pars. 105ff., above.

5 Freud, in his *Interpretation of Dreams* (p. 261), paralleled certain aspects of infantile psychology with the Oedipus legend and observed that its “universal validity” was to be explained in terms of the same infantile premise. The real working out of mythological material was then taken up by my pupils (A. Maeder, “Essai d’interprétation de quelques rêves,” 1907, and “Die Symbolik in den Legenden, Märchen, Gebräuchen, und Träumen,” 1908; F. Riklin, “Über Gefängnispsychosen,” 1907, and *Wishfulfilment and Symbolism in Fairy Tales*, orig. 1908); and by K. Abraham, *Dreams and Myths*, orig. 1909. They were succeeded by Otto Rank of the Viennese school (*The Myth of the Birth of the Hero*, orig. 1922). In the *Psychology of the Unconscious* (orig. 1911; revised and expanded as *Symbols of Transformation*), I presented a somewhat more comprehensive examination of psychic and mythological parallels. Cf. also my essay in this volume, “Concerning the Archetypes, with Special Reference to the Anima Concept.”

6 This fact is well known, and the relevant ethnological literature is too extensive to be mentioned here.

7 Cf. “The Structure of the Psyche,” pars. 330ff.

8 Except for certain cases of spontaneous vision, *automatismes téléologiques* (Flournoy), and the processes in the method of “active imagination” which I have described [e.g., in “The Transcendent Function” and *Mysterium Coniunctionis*, pars. 706, 753f.—EDITORS].

9 The relevant material can be found in the unpublished reports of the seminars I gave at the Federal Polytechnic Institute (ETH) in Zurich in 1936–39, and in Michael Fordham’s book *The Life of Childhood*.

10 Berthelot, *Alchimistes grecs*, III, xxv.

11 Agricola, *De animantibus subterraneis* (1549); Kircher, *Mundus subterraneus* (1678), VIII, 4.

12 Mylius, *Philosophia reformata* (1622).

13 “Allegoria super librum Turbae” in *Artis auriferae*, I (1572), p. 161.

14 *Texte aus der deutschen Mystik des 14. und 15. Jahrhunderts*, ed. Spamer, pp. 143, 150.

15 Ingram, *The Haunted Homes and Family Traditions of Great Britain*, pp. 43ff.

16 An old alchemical authority variously named Morienes, Morienus, Marianus (“De compositione alchemiae,” Manget, *Bibliotheca chemica curiosa*, I, pp. 509ff.). In view of the explicitly alchemical character of *Faust*, Part II, such a connection would not be surprising.

17 Schreber, *Memoirs of My Nervous Illness*.

18 For a general presentation see *infra*, “Conscious, Unconscious, and Individuation.” Special phenomena in the following text, also in *Psychology and Alchemy*, Part II.

19 “The Relations between the Ego and the Unconscious,” Part II, ch. 3 [also “The Transcendent Function.”—EDITORS].

20 *Symbols of Transformation*, index, s.v.

²¹ It may not be superfluous to point out that lay prejudice is always inclined to identify the child motif with the concrete experience “child,” as though the real child were the cause and pre-condition of the existence of the child motif. In psychological reality, however, the empirical idea “child” is only the means (and not the only one) by which to express a psychic fact that cannot be formulated more exactly. Hence by the same token the mythological idea of the child is emphatically not a copy of the empirical child but a *symbol* clearly recognizable as such: it is a wonder-child, a divine child, begotten, born, and brought up in quite extraordinary circumstances, and not—this is the point—a human child. Its deeds are as miraculous or monstrous as its nature and physical constitution. Only on account of these highly unempirical properties is it necessary to speak of a “child motif” at all. Moreover, the mythological “child” has various forms: now a god, giant, Tom Thumb, animal, etc., and this points to a causality that is anything but rational or concretely human. The same is true of the “father” and “mother” archetypes which, mythologically speaking, are equally irrational symbols.

²² *Psychological Types*, Def. 48; and *Two Essays on Analytical Psychology*, index, s.v. “persona.”

²³ *Psychological Types*, ch. V, 3: “The Significance of the Uniting Symbol.”

²⁴ *Psychology and Alchemy*, pars. 327ff.; “Psychology and Religion,” pars. 108ff.

²⁵ *Two Essays on Analytical Psychology*, pars. 399ff. [Cf. also *Aion* (Part II of this volume), ch. 4.—EDITORS.]

²⁶ *Psychology and Alchemy*, pars. 328ff.

²⁷ Higher vertebrates symbolize mainly affects.

²⁸ This interpretation of the snake is found as early as Hippolytus, *Elenchos*, IV, 49–51 (Legge trans., I, p. 117). Cf. also Leisegang, *Die Gnosis*, p. 146.

²⁹ *Psychological Types*, Def. 51.

³⁰ Even Christ is of a fiery nature (“he that is near to me is near to the fire”—Origen, *In Jeremiam Homiliae*, XX. 3); likewise the Holy Ghost.

³¹ The material is collected in *Psychology and Alchemy*, Parts II and III. For Mercurius as a servant, see the parable of Eirenaeus Philalethes, *Ripley Reviv’d: or, An Exposition upon Sir George Ripley’s Hermetico-Poetical Works* (1678).

³² Koepgen, *Die Gnosis des Christentums*, pp. 315ff.

³³ For the *lapis* as mediator and medium, cf. *Tractatus aureus*, in Manget, *Bibliotheca chemica curiosa*, I, p. 408b, and *Artis auriferae* (1572), p. 641.

³⁴ *Psychological Types*, Def. 48; and “Relations between the Ego and the Unconscious,” pars. 296ff.

³⁵ Hosea 1 : 2ff.

³⁶ Cf. Fendt, *Gnostische Mysterien*.

³⁷ James, *The Apocryphal New Testament*, p. 11.

³⁸ Clement, *Stromata*, III, 13, 92, 2.

³⁹ *The Flowing Light of the Godhead*.

⁴⁰ Salomon, *Opicinus de Canistris*.

⁴¹ Cf. the diatribe by Bishop Asterius (Foucart, *Mystères of d’Eleusis*, pp. 477ff.). According to Hippolytus’ account the hierophant actually made himself impotent by a draught of hemlock. The self-castration of priests in the worship

of the Mother Goddess is of similar import.

⁴² A more detailed account of these developments is to be found in “The Relations between the Ego and the Unconscious.”

1 To the best of my knowledge, no other suggestions have been made so far. Critics have contented themselves with asserting that no such archetypes exist. Certainly they do not exist, any more than a botanical system exists in nature! But will anyone deny the existence of natural plant-families on that account? Or will anyone deny the occurrence and continual repetition of certain morphological and functional similarities? It is much the same thing in principle with the typical figures of the unconscious. They are forms existing *a priori*, or biological norms of psychic activity.

2 The “personalistic” approach interprets such dreams as “wish-fulfilments.” To many, this kind of interpretation seems the only possible one. These dreams, however, occur in the most varied circumstances, even in circumstances when the wish-fulfilment theory becomes entirely forced or arbitrary. The investigation of motifs in the field of dreams therefore seems to me the more cautious and the more appropriate procedure.

3 The double vision of a salamander, of which Benvenuto Cellini tells in his autobiography, would be an anima-projection caused by the music his father was playing.

4 One of my patients, whose principal difficulty was a negative mother-complex, developed a series of fantasies on a primitive mother-figure, an Indian woman, who instructed her on the nature of woman in general. In these pronouncements a special paragraph is devoted to blood, running as follows: “A woman’s life is close to the *blood*. Every month she is reminded of this, and birth is indeed a bloody business, destructive and creative. A woman is only *permitted* to give birth, but the new life is not *her* creation. In her heart of hearts she knows this and rejoices in the grace that has fallen to her. She is a little mother, not the *Great Mother*. But her little pattern is like the great pattern. If she understands this she is blessed by nature, because she has submitted in the right way and can thus partake of the nourishment of the Great Mother....”

5 Often the moon is simply “there,” as for instance in a fantasy of the chthonic mother in the shape of the “Woman of the Bees” (Josephine D. Bacon, *In the Border Country*, pp. 14ff.): “The path led to a tiny hut of the same colour as the *four great trees* that stood about it. Its door hung wide open, and in the middle of it, on a low stool, there sat an old woman wrapped in a long cloak, looking kindly at her....” The hut was filled with the steady *humming of bees*. In the corner of the hut there was a deep cold *spring*, in which “a white moon and little stars” were reflected. The old woman exhorted the heroine to remember the duties of a woman’s life. In Tantric yoga an “indistinct hum of swarms of love-mad bees” proceeds from the slumbering Shakti (*Shat-Chakra Nirupana*, in Avalon, *The Serpent Power*, p. 29). Cf. *infra*, the dancer who dissolves into a *swarm of bees*. Bees are also, as an allegory, connected with Mary, as the text for the consecration of the Easter candle shows. See Duchesne, *Christian Worship: Its Origin and Evolution*, p. 253.

6 [See Neumann, *The Great Mother*, Pls. 1a, 3. This entire work elucidates the present study.—EDITORS.]

7 *Psychology and Alchemy*, Part II.

8 I would refer to the thesis of my pupil Jan Nelken, “Analytische Beobachtungen über Phantasien eines Schizophrenen,” as also to my own analysis of a series of fantasies in *Symbols of Transformation*.

9 Cf. *Symbols of Transformation*. H. G. Baynes’ book, *The Mythology of the Soul*, runs to 939 pages and endeavours to do justice to the material provided by only two cases.

10 [Cf. *infra*, “On the Psychology of the Trickster-Figure.”—EDITORS.]

11 *Theatrum chemicum*, I (1602), pp. 286ff.

¹² “Humanum genus, cui Deo resistere iam innatum est, non desistit media quaerere, quibus proprio conatu laqueos evadat, quos sibimet posuit, ab eo non petens auxilium, a quo solo dependet omnis misericordiae munus. Hinc factum est, ut in sinistram viae partem officinam sibi maximam extruxerint ... huic domui praeest industria, etc. Quod postquam adepti fuerint, ab industria recedentes *in secundam mundi regionem* tendunt: *per infirmitatis pontem* facientes transitum.... At quia bonus Deus retrahere vellet, infirmitates in ipsis dominari permittit, turn rursus ut prius remedium [industrial] a se quaerentes, *ad xenodochium etiam a sinistris constructum* et permaximum confluunt, cui medicina praeest. Ibi pharmacopolarum, chirurgorum et physicorum ingens est copia.” (p. 288.)

¹³ “... pervenietis ad Sophiae castra, quibus excepti, longe vehementiori quam antea cibo reficiemini.... viventis aquae fluviuſ tam admirando fluens artificio de montis apice. (De Sophiae fonte scaturiunt aquael)” [Slightly modified by Professor Jung. Cf. Dorn, pp. 279–80.—EDITORS.]

¹⁴ Only extracts from the dreams are given, so far as they bear on the anima.

¹⁵ The following statements are not meant as “interpretations” of the dreams. They are intended only to sum up the various forms in which the anima appears.

¹⁶ Cf. the third paper in this volume.

1 [First published as a lecture, “Zur Psychologie des Geistes,” in the *Eranos-Jahr-buch* 1945. Revised and published as “Zur Phänomenologie des Geistes im Märchen,” in *Symbolik des Geistes* (Zurich, 1948), from which the present translation was made. This translation was published in a slightly different form in *Spirit and Nature* (Papers from the Eranos Yearbooks, 1; New York, 1953; London, 1954).—EDITORS.]

2 [An Hegelian term, roughly equivalent to our “spirit of man.”—TRANS.]

3 See my “Spirit and Life.”

4 Ludwig Klages, *Der Geist als Widersacher der Seele*.

5 *Soul*, from Old German *saiwaló*, may be cognate with *αιόλος*, ‘quick-moving, changeful of hue, shifting.’ It also has the meaning of ‘wily’ or ‘shifty’; hence an air of probability attaches to the alchemical definition of *anima* as Mercurius.

6 Even if one accepts the view that a self-revelation of spirit—an apparition for instance—is nothing but an hallucination, the fact remains that this is a spontaneous psychic event not subject to our control. At any rate it is an autonomous complex, and that is quite sufficient for our purpose.

7 Cf. *Psychology and Alchemy*, par. 115.

8 Cf. the vision of the “naked boy” in Meister Eckhart (trans. by Evans, I, p. 438).

9 I would remind the reader of the “boys” in Bruno Goetz’s novel *Das Reich ohne Raum*.

10 Cf. the paper on the “Child Archetype” in this volume, pars. 268f.

11 Hence the many miraculous stories about rishis and mahatmas. A cultured Indian with whom I once conversed on the subject of gurus told me. when I asked him who his guru had been, that it was Shankaracharya (who lived in the 8th and 9th cents.) “But that’s the celebrated commentator,” I remarked in amazement. Whereupon he replied, “Yes, so he was; but naturally it was his spirit,” not in the least perturbed by my Western bewilderment.

12 I am indebted to Mrs. H. von Roques and Dr. Marie-Louise von Franz for the fairytale material used here.

13 *Finnische und estnische Volksmärchen*, No. 68, p. 208 [“How an Orphan Boy Unexpectedly Found His Luck”]. [All German collections of tales here cited are listed under “Folktales” in the bibliography, q.v. English titles of tales are given in brackets, though no attempt has been made to locate published translations.—EDITORS.]

14 The mountain stands for the goal of the pilgrimage and ascent, hence it often has the psychological meaning of the self. The *I Ching* describes the goal thus: “The king introduces him / To the Western Mountain” (Wilhelm/Baynes trans., 1967, p. 74 —Hexagram 17, *Sui*, “Following”). Cf. Honorius of Autun (*Expositio in Cantica canticorum*, col. 389): “The mountains are prophets.” Richard of St. Victor says: “Vis videre Christum transfiguratum? Ascende in montem istum, disce cognoscere te ipsum” (Do you wish to see the transfigured Christ? Ascend that mountain and learn to know yourself). (*Benjamin minor*, cols. 53–56.)

15 In this respect we would call attention to the phenomenology of yoga.

16 There are numerous examples of this: *Spanische und Portugiesische Volksmärchen*, pp. 158, 199 [“The White Parrot” and “Queen Rose, or Little Tom”]; *Russische Volksmärchen*, p. 149 [“The Girl with No Hands”]; *Balkanmärchen*, p. 64 [“The Shepherd and the Three Samovilas (Nymphs)”]; *Märchen aus Iran*, pp. 150ff. [“The Secret of the Bath of Windburg”]; *Nordische Volksmärchen*, I, p. 231 [“The Werewolf”].

¹⁷ To the girl looking for her brothers he gives a ball of thread that rolls towards them (*Finnische und Estnische Volksmärchen*, p. 260 [“The Contending Brothers”]). The prince who is searching for the kingdom of heaven is given a boat that goes by itself (*Deutsche Märchen seit Grimm*, pp. 381 f. [“The Iron Boots”]). Other gifts are a flute that sets everybody dancing (*Balkanmärchen*, p. 173 [“The Twelve Crumbs”]), or the path-finding ball, the staff of invisibility (*Nordische Volksmärchen*, I, p. 97 [“The Princess with Twelve Pairs of Golden Shoes”]), miraculous dogs (*ibid.*, p. 287 [“The Three Dogs”]), or a book of secret wisdom (*Chinesische Volksmärchen*, p. 258 [“Jang Liang”]).

¹⁸ *Finnische und estnische Volksmärchen*, loc. cit.

¹⁹ *Deutsche Märchen seit Grimm*, p. 382 [op. cit.]. In one Balkan tale (*Balkan-Märchen*, p. 65 [“The Shepherd and the Three Samovilas”]) the old man is called the “Czar of all the birds.” Here the magpie knows all the answers. Cf. the mysterious “master of the dovecot” in Gustav Meyrink’s novel *Der weisse Dominikaner*.

²⁰ *Märchen aus Iran*, p. 152 [op. cit.].

²¹ *Spanische und Portugiesische Märchen*, p. 158 [“The White Parrot”].

²² *Ibid.*, p. 199 [“Queen Rose, or Little Tom”].

²³ *Nordische Volksmärchen*, Vol. I, p. 231f. [“The Werewolf”].

²⁴ *Kauhasische Märchen*, pp. 35f [“The False and the True Nightingale”].

²⁵ *Balkanmärchen*, p. 217 [“The Lubi (She-Devil) and the Fair of the Earth”].

²⁶ This occurs in the tale of the griffin, No. 84 in the volume of children’s fairytales collected by the brothers Grimm (1912), II, pp. 84ff. The text swarms with phonetic mistakes. [The English text (trans. by Margaret Hunt, rev. by James Stern, no. 165) has “hoary.”—TRANS.]

²⁷ Goethe, “Die neue Melusine.”

²⁸ Cf. “The Visions of Zosimos,” Par. 87 (III, i, 2–3).

²⁹ In one Siberian fairytale (*Märchen aus Sibirien*, no. 13 [“The Man Turned to Stone”]) the old man is a white shape towering up to heaven.

³⁰ *Indianermärchen aus Sudamerika*, p. 285 [“The End of the World and the Theft of Fire”—Bolivian].

³¹ *Indianermärchen aus Nordamerika*, p. 74 [Tales of Manabos: “The Theft of Fire”].

³² *Deutsche Märchen seit Grimm*, pp. 189ff.

³³ In his “Cantilena” (15 cent.). [Cf. *Mysterium Coniunctionis*, par. 374.].

³⁴ Prudentius, *Contra Symmachum*, I, 94 (trans. by Thomson, I, p. 356). See Hugo Rahner, “Die seelenheilende Blume.”

³⁵ *Balkanmärchen*, pp. 34ff. [“The Deeds of the Czar’s Son and His Two Companions”].

³⁶ *Ibid.*, pp. 177ff. [“The Son-in-Law from Abroad”].

³⁷ *Deutsche Märchen seit Grimm*, pp. 1ff. [“The Princess in the Tree”].

³⁸ With reference to the quaternity I would call attention to my earlier writings, and in particular to *Psychology and Alchemy* and “Psychology and Religion.”

³⁹ The oldest representation I know of this problem is that of the four sons of Horus, three of whom are occasionally depicted with the heads of animals, and the other with the head of a man. Chronologically this links up with Ezekiel’s

vision of the four creatures, which then reappear in the attributes of the four evangelists. Three have animal heads and one a human head (the angel). [Cf. frontispiece to *Psychology and Religion: West and East*.—EDITORS.]

⁴⁰ According to the dictum in the “*Tabula smaragdina*,” “*Quod est inferius, est sicut quod est superius*” (That which is below is like that which is above).

⁴¹ Cf. *Psychology and Alchemy*, fig. 54 and par. 539; and, for a more detailed account, “*The Spirit Mercurius*,” par. 271.

⁴² This unexplained passage has been put down to Plato’s “drollery.”

⁴³ In *Deutsche Märchen seit Grimm* (I, p. 256 [“*The Mary-Child*”]) it is said that the “*Three-in-One*” is in the forbidden room, which seems to me worth noting.

⁴⁴ Aelian (*De natura animalium*, I, 47) relates that Apollo condemned the ravens to perpetual thirst because a raven sent to fetch water dallied too long. In German folklore it is said that the raven has to suffer from thirst in June or August, the reason given being that he alone did not mourn at the death of Christ, and that he failed to return when Noah sent him forth from the ark. (Köhler, *Kleinere Schriften zur Märchenforschung*, p. 3.) For the raven as an allegory of evil, see the exhaustive account by Hugo Rahner, “*Earth Spirit and Divine Spirit in Patristic Theology*.” On the other hand the raven is closely connected with Apollo as his sacred animal, and in the Bible too he has a positive significance. See Psalm 147 : 9: “*He giveth to the beast his food, and to the young ravens which cry*”; Job 38: 41: “*Who provideth for the raven his food? when his young ones cry unto God, they wander for lack of meat*.” Cf. also Luke 12 : 24. Ravens appear as true “*ministering spirits*” in I Kings 17 : 6, where they bring Elijah the Tishbite his daily fare.

⁴⁵ Pictured as three princesses, buried neck deep, in *Nordische Volksmärchen*, II, pp. 126ff. [“*The Three Princesses in the White Land*”].

⁴⁶ For the function theory, see *Psychological Types*.

⁴⁷ I would like to add, for the layman’s benefit, that the theory of the psyche’s structure was not derived from fairytales and myths, but is grounded on empirical observations made in the field of medico-psychological research and was corroborated only secondarily through the study of comparative symbology, in spheres very far removed from ordinary medical practice.

⁴⁸ A typical enantiodromia is played out here: as one cannot go any higher along this road, one must now realize the other side of one’s being, and climb down again.

⁴⁹ The young man asks himself, on catching sight of the tree, “*How would it be if you were to look at the world from the top of that great tree?*”

⁵⁰ The “*omniscience*” of the unconscious components is naturally an exaggeration. Nevertheless they do have at their disposal—or are influenced by—subliminal perceptions and memories of the unconscious, as well as by its instinctive archetypal contents. It is these that give unconscious activities their unexpectedly accurate information.

⁵¹ The hunter has reckoned without his host, as generally happens. Seldom or never do we think of the price exacted by the spirit’s activity.

⁵² Cf. the Heracles cycle.

⁵³ The alchemists stress the long duration of the work and speak of the “*longissima via*,” “*diuturnitas immensae meditationis*,” etc. The number 12 may be connected with the ecclesiastical year, in which the redemptive work of

Christ is fulfilled. The lamb-sacrifice probably comes from this source too.

⁵⁴ “Daughter of the sea.”—Afanas’ev, *Russian Fairy Tales*, pp. 553ff.

⁵⁵ The old man puts the dismembered body into a barrel which he throws into the sea. This is reminiscent of the fate of Osiris (head and phallus).

⁵⁶ From *kost*, ‘bone,’ and *pakost*, *kapost*, ‘disgusting, dirty.’

⁵⁷ Ka-mutef means “bull of his mother.” See Jacobsohn, “Die dogmatische Stellung des Königs in der Theologie der alten Aegypter,” pp. 17, 35, 41ff.

⁵⁸ Cf. *Symbols of Transformation*, pars. 370ff., 421.

⁵⁹ The fact that she is no ordinary girl, but is of royal descent and moreover the *electa* of the evil spirit, proves her nonhuman, mythological nature. I must assume that the reader is acquainted with the idea of the anima.

⁶⁰ “I ween that I hung / on the windy tree.

Hung there for nights full nine;
With the spear I was wounded, / and offered I was
To Othin, myself to myself,
On the tree that none / may ever know
What root beneath it runs.”

—*Hovamol*, 139 (trans. by H. A. Bellows, p. 60).

⁶¹ Cf. the experience of God as described by Nietzsche in “Ariadne’s Lament”:

“I am but thy quarry,
Cruellest of hunters!
Thy proudest captive,
Thou brigand back of the clouds!”

—*Gedichte und Sprüche*, pp. 155ff.

⁶² Cf. Emma Jung, “On the Nature of the Animus.”

⁶³ As regards the triadic nature of Wotan cf. Ninck, *Wodan una germanischer Schicksalsglaube*, p. 142. His horse is also described as, among other things, three-legged.

⁶⁴ The assumption that they are a brother-sister pair is supported by the fact that the stallion addresses the mare as “sister.” This may be just a figure of speech; on the other hand sister means sister, whether we take it figuratively or non-figuratively. Moreover, incest plays a significant part in mythology as well as in alchemy.

⁶⁵ Human in so far as the anima is replaced by a human person.

⁶⁶ The great tree corresponds to the *arbor philosophica* of the alchemists. The meeting between an earthly human being and the anima, swimming down in the shape of a mermaid, is to be found in the so-called “Ripley Scrowle.” Cf. *Psychology and Alchemy*, fig. 257.

⁶⁷ Cf. my “Wotan.”

¹[Originally published as part 5 of *Der göttliche Schelm*, by Paul Radin, with commentaries by C. G. Jung and Karl Kerényi (Zurich, 1954). The present translation then appeared in the English version of the volume: *The Trickster: A Study in American Indian Mythology* (London and New York, 1956); it is republished here with only minor revisions. —EDITORS.]

²Du Cange, *Glossarium*, s.v. Kalendae, p. 1666. Here there is a note to the effect that the French title “sou-diacres” means literally ‘saturi diaconi’ or ‘diacres saouls’ (drunken deacons).

³These customs seem to be directly modelled on the pagan feast known as “Cervula” or “Cervulus.” It took place on the kalends of January and was a kind of New Year’s festival, at which people exchanged *strenae* (étrennes, ‘gifts’), dressed up as animals or old women, and danced through the streets singing, to the applause of the populace. According to Du Cange (s.v. cervulus), sacrilegious songs were sung. This happened even in the immediate vicinity of St. Peter’s in Rome.

⁴Part of the *festum fatuorum* in many places was the still unexplained ball-game played by the priests and captained by the bishop or archbishop, “ut etiam sese ad lusum pilae demittent” (that they also may indulge in the game of pelota). *Pila* or *pelota* is the ball which the players throw to one another. See Du Cange, s.v. Kalendae and pelota.

⁵“Puella, quae cum asino a parte Evangelii prope altare collocabatur” (the girl who stationed herself with the ass at the side of the altar where the gospel is read). Du Cange, s.v. festum asinorum.

⁶*Caetera* instead of *vetera*? [Trans. by A. S. B. Glover:

From the furthest Eastern clime

Came the Ass in olden time,

Comely, sturdy for the road,

Fit to bear a heavy load.

Sing then loudly, master Ass,

Let the tempting titbit pass:

You shall have no lack of hay

And of oats find good supply.

Say Amen, Amen, good ass, (here a *genuflection* is made)

Now you’ve had your fill of grass;

Ancient paths are left behind:

Sing Amen with gladsome mind.]

⁷Cf. also Tertullian, *Apologeticus adversus gentes*, XVI.

⁸[Reproduced in *Symbols of Transformation*, pl. XLIII.—EDITORS.]

⁹Thus *Spake Zarathustra*, Part. IV, ch. LXXVIII.

¹⁰I am thinking here of the series called “Balli di Sfessania.” The name is probably a reference to the Etrurian town of Fescennia, which was famous for its lewd songs. Hence “Fescennina licentia” in Horace, Fescenninus being the equivalent of *σαλλικός*.

¹¹Cf. the article “Daily Paper Pantheon,” by A. McGlashan, in *The Lancet* (1953), p. 238, pointing out that the figures in comic-strips have remarkable archetypal analogies.

¹²Earlier stages of consciousness seem to leave perceptible traces behind them. For instance, the chakras of the Tantric system correspond by and large to the regions where consciousness was earlier localized, *anahata* corresponding to the breast region, *manipura* to the abdominal region, *svadhistana* to the bladder region, and *visuddha* to the larynx and the speech-consciousness of modern man. Cf. Avalon, *The Serpent Power*.

¹³The same idea can be found in the Church Father Irenaeus, who calls it the “umbra.” *Adversus haereses*, I, ii, 1.

¹⁴For instance, the ducking of the “Ueli” (from Udalricus = Ulrich, yokel, oaf, fool) in Basel during the second half of January was, if I remember correctly, forbidden by the police in the 1860’s, after one of the victims died of pneumonia.

¹⁵Not to forget something means keeping it in consciousness. If the enemy disappears from my field of vision, then he may possibly be behind me—and even more dangerous.

¹⁶Radin, *The World of Primitive Man*, p. 3.

¹⁷*Ibid.*, p. 5.

¹⁸By the metaphor “standing behind the shadow” I am attempting to illustrate the fact that, to the degree in which the shadow is recognized and integrated, the problem of the anima, i.e., of relationship, is constellated. It is understandable that the encounter with the shadow should have an enduring effect on the relations of the ego to the inside and outside world, since the integration of the shadow brings about an alteration of personality. Cf. *Aion*, Part II of this vol., pars. 13ff.

¹⁹A crocodile stole a child from its mother. On being asked to give it back to her, the crocodile replied that he would grant her wish if she could give a true answer to his question: “Shall I give the child back?” If she answers “Yes,” it is not true, and she won’t get the child back. If she answers “No,” it is again not true, so in either case the mother loses the child.

²⁰Neumann, *The Origins and History of Consciousness*, passim.

1 [Originally written in English as “The Meaning of Individuation,” the introductory chapter of *The Integration of the Personality* (New York, 1939; London, 1940), a collection of papers otherwise translated by Stanley Dell. Professor Jung afterward rewrote the paper, with considerable revision, in German and published it as “Bewusstsein, Unbewusstes und Individuation,” *Zentralblatt für Psychotherapie und ihre Grenzgebiete* (Leipzig), XI (1939) : 5, 257–70. The original English version was slightly longer, owing to material which Mr. Dell edited into it from other writings of Jung’s, for the special requirements of the *Integration* volume. It is the basis of the present version, together with the 1939 German version.—EDITORS.]

2 Modern physicists (Louis de Broglie, for instance) use instead of this the concept of something “discontinuous.”

3 [See also Jung’s *Psychiatric Studies*, index, s. vv.—EDITORS.]

4 By this I mean only certain cases of schizophrenia, such as the famous Schreber case (*Memoirs of My Nervous Illness*) or the case published by Nelken (“Analytische Beobachtungen über Phantasien eines Schizophrenen,” 1912).

5 *Psychological Types*, Def. 48; “The Relations between the Ego and the Unconscious,” pars. 296ff.; *Psychology and Alchemy*, Part II. Cf. also the third paper in this volume.

6 Toni Wolff, “Einführung in die Grundlagen der Komplexen Psychologie,” p. 107. [Also *Aion*, ch. 2.—EDITORS.]

7 *Symbols of Transformation*, Part II.

8 Cf. supra, “The Phenomenology of the Spirit in Fairytales.”

9 See n. 4, above.

10 [Untitled poem (“Warum gabst du uns die tiefen Blicke”) in *Werke*, II, p. 43.—EDITORS.]

11 *Ripley Reviv’d; or, An Exposition upon Sir George Ripley’s Hermetico-Poetical Works* (1678), trans. into German in 1741 and possibly known to Goethe.

12 Cf. the celebrated “Visio Arislei” (*Artis auriferae*, 1593, II, pp. 246ff.), also available in German: Ruska, *Die Vision des Arisleus*, p. 22.

13 For an example of the method, see *Psychology and Alchemy*, Part II.

14 In my *Symbols of Transformation*, I have described the case of a young woman with a “hero-story,” i.e., an animus fantasy that yielded a rich harvest of mythological material. Rider Haggard, Benoît, and Goethe (in *Faust*) have all stressed the historical character of the anima.

15 [*Psychological Types*, Def. 51 and ch. V, 3c. In the *Collected Works*, the term “uniting symbol” supersedes the earlier translation “reconciling symbol.”—EDITORS.]

16 [Cf. “The Transcendent Function.”—EDITORS.]

1 [Translated from “Zur Empirie des Individuationsprozesses,” *Gestaltungen des Unbewussten* (Zurich, 1950), where it carries the author’s note that it is a “thoroughly revised and enlarged version of the lecture of the same title first published in the *Eranos-Jahrbuch 1933*,” i.e., in 1934. The original version was translated by Stanley Dell and published in *The Integration of the Personality* (New York, 1939; London, 1940). The motto by Lao-tzu is from a translation by Carol Baumann in her article “Time and Tao,” *Spring*, 1951, p. 30.—EDITORS.]

2 Cf. *Psychology and Alchemy*, pars. 138f., 306, and Wei Po-yang, “An Ancient Chinese Treatise on Alchemy.”

3 *Psychology and Alchemy*, par. 109, n. 38.

4 Caesarius of Heisterbach, *The Dialogue on Miracles*, trans. by Scott and Bland, Dist. IV, c. xxxiv (p. 231) and Dist. I, c. xxxii (p. 42): “His soul was like a glassy spherical vessel, that had eyes before and behind.” A collection of similar reports in Bozzano, *Popoli primitivi e Manifestation supernormali*.

5 Cf. my “Paracelsus as a Spiritual Phenomenon,” par. 190. It is Hermes Kyllenios, who calls up the souls. The caduceus corresponds to the phallus. Cf. Hippolytus, *Elenchos*, V, 7, 30.

6 The same association in *Elenchos*, V, 16, 8: serpent = δούναμις of Moses.

7 Ruland (*Lexicon*, 1612) speaks of “the gliding of the mind or spirit into another world.” In the *Chymical Wedding* of Rosencreutz the lightning causes the royal pair to come alive. The Messiah appears as lightning in the Syrian Apocalypse of Baruch (Charles, *Apocrypha*, II, p. 510). Hippolytus (*Elenchos*, VIII, 10, 3) says that, in the view of the Docetists, the Monogenes drew together “like the greatest lightning-flash into the smallest body” (because the Aeons could not stand the effulgence of the Pleroma), or like “light under the eyelids.” In this form he came into the world through Mary (VIII, 10, 5). Lactantius (*Works*, trans. by Fletcher, I, p. 470) says: “... the light of the descending God may be manifest in all the world as lightning.” This refers to Luke 17 : 24: “... as the lightning that lighteneth ... so shall the Son of man be in his day.” Similarly Zach. 9: 14: “And the Lord God ... his dart shall go forth as lightning” (DV).

8 *Forty Questions concerning the Soul* (*Works*, ed. Ward and Langcake, II, p. 17).

9 *The High and Deep Searching of the Threefold Life of Man* (*Works*, II), p. 11.

10 *Aurora* (*Works*, I), X.17, p. 84.

11 *Ibid.*, X. 38, p. 86.

12 *Ibid.*, X. 53, p. 87.

13 Salniter = *sal nitri* = Saltpetre; like salt, *the prima materia*. *Three Principles of the Divine Essence* (*Works*, I), I. 9, p. 10.

14 *Aurora*, XV. 84, p. 154. Here the lightning is not a revelation of God’s will but a Satanic change of state. Lightning is also a manifestation of the devil (Luke 10: 18).

15 *Ibid.*, XIX. 19, p. 185.

16 *Ibid.*, XI. 10, p. 93.

17 For Böhme the four “qualities” coincide partly with the four elements but also with dry, wet, warm, cold, the four qualities of taste (e.g., sharp, bitter, sweet, sour), and the four colours.

18 A heart forms the centre of the mandala in the *Forty Questions*. See Fig. 1.

19 *Aurora*, XI, 27–28, p. 94.

²⁰ “Stock” in this context can mean tree or cross (*σταυρός*, ‘stake, pole, post’), but it could also refer to a staff or stick. It would then be the magical wand that, in the subsequent development of these pictures, begins to sprout like a tree. Cf. *infra*, par. 570.

²¹ *Aurora*, XI. 37, p. 95.

²² The lower darkness corresponds to the elemental world, which has a quaternary character. Cf. the four Achorayim mentioned in the commentary to Picture 7.

²³ The reason for this is that the lightning is caught by the quaternity of elements and qualities and so divided into four.

²⁴ Saltpetre is the arcane substance, synonymous with *Sal Saturni* and *Sal Tartan mundi maioris* (Khunrath, *Von hylealischen Chaos*, 1597, p. 263). Tartarus has a double meaning in alchemy: on the one hand it means tartar (hydrogen potassium tartrate); on the other, the lower half of the cooking vessel and also the arcane substance (Eleazar, *Uraltes Chymisches Werk*, 1760, II, p. 91, no. 32). The metals grow in the “cavitates terrae” (Tartarus). Salt, according to Khunrath, is the “centrum terrae physicum.” Eleazar says that the “Heaven and Tartarus of the wise” change all metals back into mercury. Saturn is a dark “malefic” star. There is the same symbolism in the Offertory from the Mass for the Dead: “Deliver the souls of all the faithful departed from the pains of hell and from the deep pit; deliver them from the mouth of the lion [attribute of Ialdabaoth, Saturn], lest Tartarus lay hold on them, and they fall into darkness.” Saturn “maketh darkness” (Böhme, *Threefold Life*, IX. 85, p. 96) and is one aspect of the Salniter (*Signatura rerum*, XIV. 46–48, p. 118). Salniter is the “dried” or “fixed” form and embodiment of the seven “Source Spirits” of God, who are all contained in the seventh, Mercury, the “Word of God” (*Aurora*, XI. 86f., p. 99 and XV. 49, p. 151; *Sig. rer.*, IV. 35, p. 28). Salniter, like mercury, is the mother and cause of all metals and salts (*Sig. rer.*, XIV. 46 and III. 16, pp. 118 and 19). It is a subtle body, the paradisaal earth and the spotless state of the body before the Fall, and hence the epitome of the *prima materia*.

²⁵ [“Flagrat” and “lubet” are used by Böhme to signify respectively “flash, flame, burning” And “Desire, Affect.”—EDITORS.]

²⁶ Reference to the “waters which were above the firmament” (Gen. 1 : 7).

²⁷ *Sig. rer.*, XIV. 32–33, p. 116.

²⁸ *Tabula principiorum*, 3 (Amsterdam edn., 1682, p. 271).

²⁹ *Ibid.*, 5, p. 271.

³⁰ *Ibid.*, 42, p. 279.

³¹ *Four Tables of Divine Revelation*, p. 14.

³² *Ibid.*, p. 13.

³³ Its official name is *hydrargyrum sulfuratum rubrum*. Another version of its sign is : cf. Lüdy, *Alchemistische und Chemische Zeichen*, and Gessmann, *Die Geheimsymbole der Alchymie, Arzneikunde und Astrologie des Mittelalters*.

³⁴ “There is very great doubt among doctors as to what is actually signified by Cinnabar, for the term is applied by different authorities to very diverse substances.” Ruland, *Lexicon*, p. 102.

³⁵ Berthelot, *Alch. grecs*, III, xxix, 24.

- ³⁶ Ibid., I, V, 1. It may be remarked that the dragon has three ears and four legs (The axiom of Maria! Cf. *Psychology and Alchemy*, pars. 209f.)
- ³⁷ *Hist. nat.*, Lib. XXXIII, cap. vii.
- ³⁸ The medical term *anthrax* means ‘carbuncle, abscess.’
- ³⁹ Antimony is also denoted by ⚛. Regulus = “The impure mass of metal formed beneath the slag in melting and reducing ores” (Merriam-Webster).
- ⁴⁰ Michael Maier (*Symbola aureae mensae*, 1617, p. 380) says: “The true antimony of the Philosophers lies hidden in the deep sea, like the son of the King.”
- ⁴¹ Praised as Hercules Morbicida, “slayer of diseases” (ibid., p. 378).
- ⁴² The book was (first?) mentioned by Maier, ibid., pp. 379ff.
- ⁴³ Also , a pure quaternary.
- ⁴⁴ Τάρταρος, like βόρβορος, βάρβαρος, etc. is probably onomatopoeic, expressing terror. Τάργανου means ‘vinegar, spoilt wine.’ Derived from τάρσσω, ‘to stir up, disturb, frighten’ (τάρραγμα, ‘trouble, confusion’) and τάρβος, ‘terror, awe.’
- ⁴⁵ Rieu trans., p. 351.
- ⁴⁶ Hippolytus, *Elenchos*, V, 7, 30; Kerényi, “Hermes der Seelenführer,” p. 29.
- ⁴⁷ Ibid., p. 30.
- ⁴⁸ The Pairs of functions are thinking/feeling, sensation/intuition. see *Psychological Types*, definitions.
- ⁴⁹ Cf. *Psychology and Alchemy*, par. 329, for the *a priori* presence of the mandala symbol.
- ⁵⁰ Details in ibid., par. 406.
- ⁵¹ Preisendanz, *Papyri Graecae Magicae*, II, p. 139.
- ⁵² “The Spirit Mercurius,” pars. 267ff.
- ⁵³ *Psychology and Alchemy*, Part III, ch. 5.
- ⁵⁴ Cf. Wilhelm and Jung, *The Secret of the Golden Flower*.
- ⁵⁵ Though we talk a great deal and with some justice about the resistance which the unconscious puts up against becoming conscious, it must also be emphasized that it has a kind of gradient towards consciousness, and this acts as an urge to become conscious.
- ⁵⁶ The last-named refers to Rev. 21 : 21.
- ⁵⁷ Miss X was referring to my remarks in “The Relations between the Ego and the Unconscious,” which she knew in its earlier version in *Collected Papers on Analytical Psychology* (2nd. edn., 1920).
- ⁵⁸ The expressions “square,” “four-square,” are used in English in this sense.
- ⁵⁹ The “squared figure” in the centre of the alchemical mandala, symbolizing the *lapis*, and whose midpoint is Mercurius, is called the “mediator making peace between the enemies or elements.” [Cf. *Aion* (Part II of this vol.), pars. 377f.—EDITORS.]
- ⁶⁰ So called in an invocation to Hermes. Cf. Preisendanz, II, p. 139. Further particulars in *Psychology and Alchemy*, par. 172; fig. 214 is a repetition of the *quadrangulum secretum sapientum* from the *Tractatus aureus* (1610), p. 43. Cf. also my “The Spirit Mercurius,” par. 272.

- ⁶¹ Despite my efforts I could find no other source for the “mercury.” Naturally cryptomnesia cannot be ruled out. considering the definiteness of the idea and the astonishing coincidence of its appearance (as in Böhme), I incline to the hypothesis of spontaneous emergence, which does not eliminate the archetype but, on the contrary, presupposes it.
- ⁶² Cf. the “innermost Birth of the soul” in Böhme.
- ⁶³ This *homo interior* or *altus* was Mercurius, or was at least derived from him. Cf. “The Spirit Mercurius,” pars. 284ff.
- ⁶⁴ The lines are painted in the classical four colours.
- ⁶⁵ The “giant” fish of the Abercius inscription (c. A.D. 200). [Cf. *Aion*, par. 127, n. 4.—EDITORS.]
- ⁶⁶ cf. Frobenius, *Schicksalskunde*, pp. 119f. The author’s interpretations seem to me questionable in some respects.
- ⁶⁷ *Psychology and Alchemy*, par. 204; “The Phenomenology of the Spirit in Fairytales,” pars. 425 and 430; and *Psychology and Religion*, par. 184.
- ⁶⁸ *Psychology and Alchemy*, index, s.v. “quartering.”
- ⁶⁹ Hippolytus, *Elenchos*, V, 26, 1ff.
- ⁷⁰ Cf. the “account ... of a many-coloured and many-shaped sphere” from the Cod. Vat. 190 (cited by Cumont in *Textes et monuments figurés relatifs aux mystères de Mithra*), which says: “The all-wise God fashioned an immensely great dragon of gigantic length, breadth and thickness, having its dark-coloured head ... towards sunrise, and its tail ... towards sunset.” Of the dragon the text says: “Then the all-wise Demiurge, by his highest command, set in motion the great dragon with the spangled crown, I mean the twelve signs of the zodiac which it carried on its back.” Eisler (*Weltenmantel und Himmelszelt*, p. 389) connects this zodiacal serpent with Leviathan. For the dragon as symbol of the year, see the Mythographus Vaticanus III, in *Classicorum Auctorum e Vaticanis Codicibus Editorum*, VI(1831), p. 162. There is a similar association in Horapollo, *Hieroglyphica*, trans. by Boas, p. 57.
- ⁷¹ “The Spirit Mercurius,” ch. 6.
- ⁷² Meier, *Antike Inkubation und moderne Psychotherapie*.
- ⁷³ Vishnu is described as *dāmodara*, ‘bound about the body with a rope.’ I am not sure whether this symbol should be considered here; I mention it only for the sake of completeness.
- ⁷⁴ Michael Maier, *De circulo physico quadrato* (1616), ch. I.
- ⁷⁵ Christ in medieval alchemy. Cf. *Psychology and Alchemy*, Part III, ch. 5.
- ⁷⁶ The writings of the physician and philosopher Leone Ebreo (c. 1460–1520) enjoyed widespread popularity in the sixteenth century and exercised a far-reaching influence on his contemporaries and their successors. His work is a continuation of the Neoplatonist thought developed by the physician and alchemist Marsilio Ficino(1433–99) in his commentary on Plato’s *Symposium*. Ebreo’s real name was Don Judah Abrabanel, of Lisbon. (Sometimes the texts have Abrabanel, sometimes Abarbanel.)
- ⁷⁷ Cf. the English version, *The Philosophy of Love*, trans. by Friedeberg-Seeley and Barnes, pp. 92 and 94. The source of this view can be found in the cabalistic interpretation of Yesod (Knorr von Rosenroth, *Kabbala Denudata*, 1677–84).
- ⁷⁸ This pseudo-biological terminology fits in with the patient’s scientific education.

- ⁷⁹ Another alchemical idea: the *synodos Lunae cum Sole*, or hierogamy of sun and moon. Cf. “The Psychology of the Transference,” par. 421, n. 17.
- ⁸⁰ More on this in “On the Nature of the Psyche,” par. 498.
- ⁸¹ Here one must think of the world-encircling Ocean and the world-snake hidden in it: Leviathan, the “dragon in the sea,” which, in accordance with the Egyptian tradition of Typhon (Set) and the sea he rules over, is the devil. “The devil ... surrounds the seas and the ocean on all sides” (St. Jerome, *Epistolae*, Part I, p. 12). Further particulars in Rahner, “Antenna Crucis II: Das Meer der Welt,” pp. 89ff.
- ⁸² We find the same motif in the two mandalas published by Esther Harding in *Psychic Energy: Its Source and Its Transformation* [Pls. XVI, XVII].
- ⁸³ Naas is the same as the snakelike nous and mercurial serpent of alchemy.
- ⁸⁴ Hippolytus, *Elenchos*, V, 26, 21ff. This tale of Adam and Eve and the serpent was preserved until well into the Middle Ages.
- ⁸⁵ Apparently a play on the words **Πρίαπος** and **ἐπριοποίησε τὰ πάντα** (‘created all’). *Elenchos*, V, 26, 33.
- ⁸⁶ See the illustration from Reusner’s *Pandora* (1588) in my “Paracelsus as a Spiritual Phenomenon,” Fig.B4.
- ⁸⁷ In accordance with the classical view that the snake is *πνευματικώτατον ζωον*, ‘the most spiritual animal.’ For this reason it was a symbol for the Nous and the Redeemer.
- ⁸⁸ Cf. what St. John of the Cross says about the “dark night of the soul.” His interpretation is as helpful as it is psychological.
- ⁸⁹ Hence the alchemical mandala was likened to a *rosarium* (rose-garden).
- ⁹⁰ In Buddhism the “four great kings” (*lokapata*), the world-guardians, form the quaternity. Cf. the *Samyutta-Nikaya*, in *Dialogues of the Buddha*, Part II, p. 242.
- ⁹¹ “God separated and divided this primordial water by a kind of mystical distillation into four parts and regions” (Sendivogius, *Epist. XIII*, in Manget, *Bibliotheca chemica*, 1702, II, p. 496). In Christianos (Berthelot, *Alch. grecs*, VI, ix, 1 and x, 1) the egg, and matter itself, consist of four components. (Cited from Xenocrates, *ibid.*, VI, xv, 8.)
- ⁹² In Taoist philosophy, movement to the right means a “falling” life-process, as the spirit is then under the influence of the feminine *p’o-soul*, which embodies the *yin* principle and is by nature passionate. Its designation as the anima (cf. my “Commentary on *The Secret of the Golden Flower*,” pars. 57ff.) is psychologically correct, although this touches only one aspect of it. The *p’o-soul* entangles *hun*, the spirit, in the world-process and in reproduction. A leftward or backward movement, on the other hand, means the “rising” movement of life. A “deliverance from outward things” occurs and the spirit obtains control over the anima. This idea agrees with my findings, but it does not take account of the fact that a person can easily have the spirit outside and the anima inside.
- ⁹³ This was told to me by the Rimpoche of Bhutia Busty, Sikkim.
- ⁹⁴ Water also symbolizes the “materiality” of the spirit when it has become a “fixed” doctrine. One is reminded, too, of the blue-green colour in böhme, signifying “liberty.”
- ⁹⁵ For the double nature of the spirit (*Mercurius duplex* of the alchemists) see “The Phenomenology of the spirit in Fairytales,” supra.
- ⁹⁶ Cf. the fiery serpent of Lucifer in Böhme.

⁹⁷ Cf. “A Psychological Approach to the Dogma of the Trinity,” pars. 243ff.

⁹⁸ *Elenchos*, V, 26, 27ff.

⁹⁹ *Psychology and Alchemy*, par. 457.

¹⁰⁰ Hauck, *Realencyclopädie für protestantische Theologie*, IV, p. 173, li. 59.

¹⁰¹ Baumgartner (*Die Philosophie des Alarms de Insults*, II, [Part 4](#), p. 118) traces this saying to a *liber Hermetis* or *liber Trismegisti*, Cod. Par. 6319 and Cod. Vat. 3060.

¹⁰² **Στεφάναι** — *coronae*.

¹⁰³ *Δαίμων ἢ πάντα κυβέρναι*, a feminine *daemonium*.

¹⁰⁴ Freeman, *Ancilla to the Pre-Socratic Philosophers*, p. 45.

¹⁰⁵ *Writings of Clement of Alexandria*, trans. by Wilson, II, p. 248: “Also Dionysius Thrax, the grammarian, in his book *Respecting the Exposition of the Symbolical Signification of Circles*, says expressly, ‘Some signified actions not by words only, but also by symbols: ... as the wheel that is turned in the temples of the gods [by] the Egyptians, and the branches that are given to the worshippers. For the Thracian Orpheus says:

For the works of mortals on earth are like branches,
Nothing has but one fate in the mind, but all things
Revolve in a circle, nor is it lawful to abide in one place,
But each keeps its own course wherewith it began.”

[Verses translated from the Overbeck version in German quoted by the author.—
TRANS.]

¹⁰⁶ Diels, *Fragmente der Vorsokratiker*, II, p. 102. Aetius, *De plac. phil*, 1, 7, 16.

¹⁰⁷ A Reference to Cicero, *De natura deorum* (trans. by Rackham, p. 31): “Parmenides ... invents a purely fanciful something resembling a crown—*stephane* is his name for it—an unbroken ring of glowing lights encircling the sky, which he entitles god; but no one can imagine this to possess divine form, or sensation.” This ironic remark of Cicero’s shows that he was the child of another age, already very far from the primordial images.

¹⁰⁸ There are innumerable representations of the sun-child sitting in the lotus. Cf. Erman, *Die Religion der Aegypter*, p. 62 and *Handbook of Egyptian Religion*, p. 26. It is also found on Gnostic gems [*Psychology and Alchemy*, fig. 52]. The lotus is the customary seat of the gods in India.

¹⁰⁹ [Or, as in the DV, “The wicked walk round about.”—EDITORS.]

¹¹⁰ *Psychology and Alchemy*, pars. 214f

¹¹¹ This interpretation was confirmed for me by my Tibetan mentor, Lingdam Gomchen, abbot of Bhutia Busty: the swastika, he said, is that which “cannot be broken, divided, or spoilt.” Accordingly, it would amount to an inner consolidation of the mandala.

¹¹² Cf. the similar motif in the mandala of the *Amitāyur-dhyāna Sūtra*, in “The Psychology of Eastern Meditation,” pars. 917, 930.

¹¹³ “Monas hieroglyphica,” *Theatr. chem.* (1602), II, p. 220. Dee also associates the cross with fire.

¹¹⁴ [Cf. “Answer to Job,” *Psychology and Religion*, par. 595, n. 8.—EDITORS.]

¹¹⁵ The seven kings refer to previous aeons, “perished” worlds, and the four Achurayim are the so-called “back of God”: “All belong to Malkhuth; which is so called because it is last in the system of Aziluth ... they exist in the depths of the Shckinah” (*Kabbala Denudata*, I, p. 72). They form a masculine-feminine quaternio “of the Father and Mother of the highest, and of the Senex Israel and Tebhunah” (I, p. 675). The Senex is Ain-Soph or Kether (I, p. 635), Tebhunah is Binah, intelligence (I, p. 726). The shards also mean unclean spirits.

¹¹⁶ *Kabbala Denudata*, 1, pp. 675L The shards also stand for evil. (*Zohar*, I, 137aff., II, 34b.). According to a Christian interpretation from the 17th century, Adam Belial is the body of the Messiah, the “entire body or the host of shards.” (Cf. II Cor. 6 : 15.) In consequence of the Fall, the host of shards irrupted into Adam’s body, its outer layers being more infected than the inner ones. The “Anima Christi” fought and finally destroyed the shards, which signify matter. In connection with Adam Belial the text refers to Proverbs 6 : 12: “A naughty person, a wicked man, walketh with a froward mouth” (AV). (*Kabbala Denudata*, II, Appendix, cap. IX, sec.2, p. 56.)

¹¹⁷ “Hyperion’s Song Of Fate,” in *Gedichte*, p. 315. (Trans. as in Jung, *Symbols of Transformation*, p. 399.)

¹¹⁸ Concerning the total vision of the “Life of Spirit and Nature,” Böhme says: “We may then liken it to a round spherical Wheel, which goes on all sides, as the Wheel in Ezekiel shows” (*Mysterium pansophicum*, Sämmtliche Werke, ed. Schiebler, VI, p. 416).

¹¹⁹ *Quaestiones Theosophicae* (Amsterdam edn., 1682), p. 23. *Aurora*, XVII.9, p. 168, mentions the “seven Spirits, which kindled themselves in their outermost Birth or Geniture.” They are the Spirits of God, “Source-Spirits” of eternal and timeless Nature, corresponding to the seven planets and forming the “Wheel of the Centre” (*Sig. rer.*, IX, 8ff., p. 60). These seven Spirits are the seven above-mentioned “Qualities” which all come from one mother. She is the “twofold Source, evil and good in all things” (*Aurora*, p. 27). Cf. the “goddess” in Parmenides and the two-bodied Edem in Justin's gnosis.

¹²⁰ Gulielmus Mennens(1525–1608), a learned Flemish alchemist, wrote a book entitled *Aurei velleris, sive sacrae philosophiae, naturae et artis admirabilium libri tres* (Antwerp, 1604). Printed in *Theatr. chem.*, V(1622), pp. 267ft.

¹²¹ “As therefore God is three and one, so also the matter from which he created all things is triplex and one.” This is the alchemical equivalent of the conscious and uncon-cious triads of functions in psychology. Cf. supra, “The Phenomenology of the Spirit in Fairytales,” pars. 425 and 436ff.

¹²² Mennens seems to refer not to the Cabala direct, but to a text ascribed to Moses, which I have not been able to trace. It is certainly not a reference to the Greek text called by Berthelot “Chimie de Moise” (*Alch. grecs*, IV, xxii). Moses is mentioned now and then in the old literature, and Lenglet du Frcsnoy (*Histoire de la philosophie hermétique*, 1742, III, p. 22) cites under No. 26 a MS from the Vienna Bibliothek entitled: “Moysis Prophetae et Legislatoris Hebraeorum secretum Chemicum” (Ouvrage supposé).

¹²³ “Aurei velleris,” I, Cap. X, in *Theatr. chem.*, V, pp. 334t.

¹²⁴ The *cauda pavonis* is identified by Khunrath with Iris, the “nuncia Dei.” Dorn (“De transmutatione metallorum,” *Theatr. chem.*, I, p. 599) explains it as follows: “This is the bird which flies by night without wings, which the early dew of heaven, continually acting by upward and downward ascent and descent, turns into the head of a crow (*caput corvi*), then into the tail of a peacock, and afterwards it acquires the bright wings of a swan, and lastly an extreme redness, an index of its fiery nature.” In Basilides (Hippolytus, *Elenchos*, X, 14, 1) the peacock’s egg is synonymous with the *sperma mundi*, the *κόκκος σινάπεως*. It contains the “fullness of colours,” 365 of them. The golden colour should be produced from the peacock’s eggs, we are told in the Cyranides (Delatte, *Textes latins et vieux*

français relatifs aux Cyranides, p. 171). The light of Mohammed has the form of a peacock, and the angels were made out of the peacock's sweat (Aptowitz, "Arabisch-Judische Schopfungstheorien," pp. 209, 233).

¹²⁵ *Sig. rer.*, XIV, 10ff., pp. 112f.

¹²⁶ See n. 118.

¹²⁷ The carbuncle is a synonym for the *lapis*. "The king bright as a carbuncle" (Lilius, an old source in the "Rosarium philosophorum," *Art. aurif.*, 1593, II, p. 329). "A ray ... in the earth, shining in the darkness after the manner of a carbuncle gathered into itself" (from Michael Maier's exposition of the theory of Thomas Aquinas, in *Symbola aureae tensesae*, p. 377). "I found a certain stone, red, shining, transparent, and brilliant, and in it I saw all the forms of the elements and also their contraries" (quotation from Thomas in Mylius, *Philosophia reformata*, p. 42). For heaven, gold, and carbuncle as synonyms for the *rubedo*, see *ibid.*, p. 104. The *lapis* is "shimmering carbuncle light" (Khunrath, *Von hyleal. Chaos*, p. 237). Ruby or carbuncle is the name for the *corpus glorificatum* (Glauber, *Tractatus de natura salium*, Part I, p. 42). In Rosencreutz's *Chemical Wedding* (1616) the bed-chamber of Venus is lit by carbuncles (p. 97). Cf. what was said above about *anthrax* (ruby and cinnabar).

¹²⁸ *Mysterium pansophicum*, pp. 416f

¹²⁹ The chemical causes of the *cauda pavonis* are probably the iridescent skin on molten metals and the vivid colours of certain compounds of mercury and lead. These two metals were often used as the primary material.

¹³⁰ Statistically, at least, green is correlated with the sensation function.

¹³¹ [See the index, s.v.; also Jung, "The Philosophical Tree."—EDITORS.]

¹³² "Lovely laurel, evergreen in all its parts, standing midmost among many trees smitten by lightning, bears the inscription: 'untouched it triumphs.' this similitude refers to mary the virgin, alone among all creatures undefiled by any lightning-flash of sin." picinelli, *Mondo simbolico* (1669), Lib. IX, cap. XVI.

¹³³ cf. "The Spirit Mercurius," par. 241.

¹³⁴ The colour correlated with sensation in the mandalas of other persons is usually green.

¹³⁵ Cf. the Achurayim quaternity.

¹³⁶ Chochmah (= face of the man), Binah (= eagle), Gedulah (= lion), Gebhurah (= bull), the four symbolical angels in Ezekiel's vision.

¹³⁷ He gives them the names of planets and describes them as the "four Bailiffs, who hold government in the Mother, the Birth-giver," They are Jupiter, Saturn, Mars, and Sun. "In these four Forms the Spirit's Birth consists, viz. the true Spirit both in the inward and outward Being" (*Sig. rer.*, IX, 9ff., p. 61).

¹³⁸ The connection between tree and mother, especially in Christian tradition, is discussed at length in *Symbols of Transformation*, Part II.

¹³⁹ *A Summary Appendix of the Soul*, p. 117.

¹⁴⁰ *Forty Questions*, pp. 24ff.

¹⁴¹ I do not feel qualified to go into the ethics of what "venerable Mother Nature" has to do in order to unfold her precious flower. Some people can, and those whose temperament makes them feel an ethical compulsion must do this in order to satisfy a need that is also felt by others. Erich Neumann has discussed these problems in a very interesting way in his *Tiefenpsychologie und Neue Ethik*. It will be objected that my respect for Nature is a very unethical attitude, and I shall be accused of shirking "decisions." People who think like this evidently know all about good and

evil, and why and for what one has to decide. Unfortunately I do not know all this so precisely, but I hope for my patients and for myself that everything, light and darkness, decision and agonizing doubt, may turn to “good”—and by “good” I mean a development such as is here described, an unfolding which does no damage to either of them but conserves the possibilities of life.

¹⁴² *The Secret of the Golden Flower* had not been published then. Picture 9 was reproduced in it.

¹⁴³ Cf. *Kabbala Denudata*, Appendix, ch. IV, sec.2, p. 26: “The beings created by the infinite Deity through the First Adam were all spiritual beings, viz. they were simple, shining acts, being one in themselves, partaking of a being that may be thought of as the midpoint of a sphere, and partaking of a life that may be imagined as a sphere emitting rays.”

¹⁴⁴ “Parable of the Cloth,” in *The First Fifty Discourses from the Collection of the Middle-Length Discourses (Majjhima Nikaya) of Gotama the Buddha*, I, pp. 39f., modified. This reference to the Buddha is not accidental, since the figure of the Tathagata in the lotus seat occurs many times in the patient’s mandalas.

¹⁴⁵ Tibetan mandalas are not so divided, but very often they are embedded between heaven and hell, i.e., between the benevolent and the wrathful deities.

¹⁴⁶ This is the lower triad that corresponds to the Trinity, just as the devil is occasionally depicted with three heads. Cf. supra, “Phenomenology of the spirit in fairytales,” pars. 425 and 436ff.

¹⁴⁷ Trans. by Wilhelm and Baynes (1967), pp. 67ff.

¹⁴⁸ *Psychology ana Alchemy*, par. 338.

¹⁴⁹ The same idea as the transformation into the *lapis*. Cf. *ibid.*, par. 378.

¹⁵⁰ Good examples are *The secret of the Golden Flower* and Suzuki, *Introduction to Zen Buddhism*.

¹⁵¹ Cf. the above quotation from the “Aureum vellus” of Mennens, where earth signifies the Father and his “shadow” signifies matter. Böhme’s view is thoroughly consistent with the character of Yahweh, who, despite his role as the guardian of justice and morality, is amoral and unjust. cf. stade, *biblische théologie des alten testaments*, I, pp. 88f.

¹⁵² I am purposely disregarding the numerous arrangements in a circle such as the *rex gloriae* with the four evangelists, Paradise with its four rivers, the heavenly hierarchies of Dionysius the Areopagite, etc. These all ignore the reality of evil, because they regard it as a mere *privatio boni* and thereby dismiss it with a euphemism.

¹⁵³ Cf. Rahner, “Die seelenheilende Blume.”

¹⁵⁴ Cf. Bouché-Leclercq, *L’Astrologie grecque*, p. 136: Cancer = “crabe ou écrevisse.” The constellation was usually represented as a tailless crab.

¹⁵⁵ “The crab is wont to change with the changing seasons; casting off its old shell, it puts on a new and fresh one.” This, says Picinelli, is an “emblema” of the resurrection of the dead, and cites Ephesians 4: 23: “... be renewed in the spirit of your minds” (RSV). (*Mondo simbolico*, Lib. VI, No. 45.)

¹⁵⁶ Foreseeing the flooding of the Nile, the crabs (like the tortoises and crocodiles) bring their eggs in safety to a higher place. “They foresee the future in their mind long before it comes,” Caussin, *Polyhistor symbolicus* (1618), p. 442.

¹⁵⁷ Masenius, *Speculum imaginum veritatis occultae* (1714), cap. LXVII, 30, p. 768.

¹⁵⁸ De Gubernatis, *Zoological Mythology*, II, p. 355.

- ¹⁵⁹ Roscher, *Lexikon*, II, col.959, s.v. “Karkinos.” The same motif occurs in a dream described in *Two Essays on Analytical Psychology*, pars. 80ff.
- ¹⁶⁰ In Egypt, the heliacal rising of Cancer indicates the beginning of the annual flooding of the Nile and hence the beginning of the year. Bouché-Leclercq, p. 137.
- ¹⁶¹ [Cf. “Psychology and Religion,” p. 67, n. 5.—EDITORS.]
- ¹⁶² Propertius, trans. by Butler, p. 875.
- ¹⁶³ De Gubernatis, II, p. 356.
- ¹⁶⁴ *The Panchatantra Reconstructed*, ed. by Edgerton, II, pp. 403f Cf. also Hoffmann-Krayer et al., *Handwörterbuch des Deutschen Aberglaubens*, V, col. 448, s.v. “Krebs.”
- ¹⁶⁵ De Gubernatis, II, p. 356.
- ¹⁶⁶ Her horoscope shows four earth signs but no air sign. The danger coming from the animus is reflected in ☾ □ ☿.
- ¹⁶⁷ Cf. the Buddhist conception of the “eight points of the compass” in the *Amitāyur-dhyāna Sūtra*; cf. “The Psychology of Eastern Meditation,” pp. 560ff.
- ¹⁶⁸ I do not hesitate to take the synchronistic phenomena that underlie astrology seriously. Just as there is an eminently psychological reason for the existence of alchemy, so too in the case of astrology. Nowadays it is no longer interesting to know how far these two fields are aberrations; we should rather investigate the psychological foundations on which they rest. [Cf. Jung, “Synchronicity: An Acausal Connecting Principle,” *passim*.—EDITORS.]
- ¹⁶⁹ An instance of the axiom of Maria. Other well-known examples are Horus and his 4 (or 3 + 1) sons, the 4 symbolical figures in Ezekiel, the 4 evangelists and—last but not least—the 3 synoptic gospels and the 1 gospel of St. John.
- ¹⁷⁰ [Ch. 2, pp. 211ff.—EDITORS.]
- ¹⁷¹ “On the Nature of the Psyche,” sec. 6.
- ¹⁷² [Pictures 18–24, which were not reproduced with the earlier versions of this essay, were chosen by Professor Jung from among those painted by the patient after the termination of analytical work. The dates of the entire series of pictures were as follows: 1–6, Oct. 1928; 7–9, Nov. 1928; 10, Jan.; 11, Feb.; 12, June.; 13, Aug.; 14, Sept.; 15, Oct.; 16, 17, Nov, all 1920; 18, Feb. 1930; 19, Aug. 1930; 20, March 1931; 21, July 1933; 22, Aug 1933 23, 1935; 24, “Night-blooming cereus, done May 1938, on last trip to Jung” (patient’s notation).—EDITORS.]
- ¹⁷³ Isaiah 45 : 8: “And a highway shall be there, and it shall be called the Holy Way” (RSV).
- ¹⁷⁴ *The Golden Ass*, trans. by Graves, p. 286.
- ¹⁷⁵ Case material in Meier, “Spontanmanifestationen des kollektiven Unbewussten,” 284ff.; Bänziger, “Persönliches und Archetypisches im Individuationsprozess,” p. 272; Gerhard Adler, *Studies in Analytical Psychology*, pp. 90ff.
- ¹⁷⁶ Active imagination is also mentioned in “The Aims of Psychotherapy,” pars. 101 ff. Cf. also “The Transcendent Function.” For other pictures of mandalas see the next paper in the present vol.
- ¹⁷⁷ [*Psychologische Interpretation von Kinderträumen*, winter semester, 1939–40, Federal Polytechnic Institute, Zurich (mimeographed stenographic record). The same dream is discussed by Dr. Jacobi in *Complex/Archetype/Symbol*, pp. 1398:.—EDITORS.]
- ¹⁷⁸ One thinks here of a Noah’s Ark that crosses over the waters of death and leads to a rebirth of all life.

¹⁷⁹ *In Leviticum Homiliae*, V, 2 (Migne, P.G., vol.12, col. 449).

¹⁸⁰ Ecclesiasticus 27 : 11.

¹⁸¹ *In libros Regnorum homiliae*, I, 4 (Migne, P.G., vol. 12, cols. 998–99).

1 [First published, as “Über Mandalasymbolik,” in *Gestaltungen des Unbewussten* (Psychologische Abhandlungen, VII; Zurich, 1950). The illustrations had originally been collected for a seminar which Professor Jung gave at Berlin in 1930. Nine of them (Figs. 1, 6, 9, 25, 26, 28, 36, 37, 38) were published with brief comments as “Examples of European Mandalas” in *Das Geheimnis der goldenen Blüte*, by Jung and Richard Wilhelm (Munich, 1929; 2nd edn., Zurich, 1938), translated by C. F. Baynes as *The Secret of the Golden Flower* (London and New York, 1931; rev. edn., 1962); subsequently published in *Coll. Works*, vol. 13. In his *Memories, Dreams, Reflections* Jung acknowledged having painted the mandalas in Figs. 6 and 36 (thus also those in Figs. 28 and 29) and the frontispiece; see U.S. edn., pp. 197, 195; Brit. edn., pp. 188ff., 187.—EDITORS.]

2 Cf. *Psychology and Alchemy*, pars. 122ff.

3 [Cf. Jung, Psychological Commentary on the *Tibetan Book of the Dead*, par. 850.—EDITORS.]

4 Cf. the preceding paper, par. 552.

5 The motif of 3½ (the Apocalyptic number of days of affliction; cf. Rev. 11 : 9 and 11) refers to the alchemical dilemma “3 or 4?” or to the sesquitertian proportion (3 : 4). The *sesquiertius* is $3 + \frac{1}{3}$.

6 There is a very interesting American Indian parallel to this mandala: a white snake coiled round a centre shaped like a cross in four colours. Cf. Newcomb and Reichard, *Sandpaintings of the Navajo Shooting Chant*, Pl. XIII, pp. 13 and 78. The book contains a large number of interesting mandalas in colour.

7 The Egyptian Horus-child is likewise shown sitting in the lotus.

8 Note the allusion in the name “Liver-pool.” The liver is that which causes to live, the seat of life. [Cf. *Memories, Dreams, Reflections*, pp. 197f./195f.]

9 [Cf. *The Practice of Psychotherapy*, 2nd edn., appendix, esp. par. 557.—EDITORS.]

10 [Cf. “Psychology and Religion,” pars. 136f., 156f.]

11 [Cf. “The Philosophical Tree,” par. 336 and fig. 27.—EDITORS.]

12 Cf. *Aion* (Part II of this volume), ch.5.

13 *Sacred Books of the East*, VIII, p. 186, modified.

14 Cf. *Symbols of Transformation*, Part II, ch. 7.

15 Rig-Veda, X, 129, from Deussen trans., I, p. 123.

16 [Cf. *Aion*, pars. 181f.—EDITORS.]

17 I, 9, 3, 15ff. Trans. from *Sacred Books of the East*, XII, pp. 271f., modified.

18 Trans. from *Sacred Books of the East*, XLVIII, p. 578.

19 *In libros Regnorum homiliae*, I, 4 (Migne, P.G., vol.12, cols.998, 999).

20 VI, 8. Trans. from *Sacred Books of the East*, XV, p. 311.

21 *De opificio mundi*. Cf. Colson trans., I, p. 13.

22 *Ibid.*, p. 79.

23 It depends very much on whether the swastika revolves to the right or to the left. In Tibet, the one that revolves to the left is supposed to symbolize the Bδn religion of black magic as opposed to Buddhism.

- ²⁴ The symbol of the star is favoured both by Russia and America. The one is red, the other white. For the significance of these colours see *Psychology and Alchemy*, index, s.v. “colours.”
- ²⁵ Cf. the eighth and the ninth papers in this volume; and “The spirit mercurius.”
- ²⁶ There is a similar conception in alchemy, in the Ripley Scrowle and its variants (*Psychology and Alchemy*, fig. 257). There it is the planetary gods who are pouring their qualities into the bath of rebirth.
- ²⁷ Cf. “The psychology of Eastern Meditation,” par. 942.
- ²⁸ Cf. John Read, *Prelude to Chemistry*, frontispiece.
- ²⁹ Cf. *Psychology and Alchemy*, pars. 334 and 404.
- ³⁰ *The Secret of the Golden Flower* (1962), p. 22.
- ³¹ Cf. the sixth and seventh papers in this volume.
- ³² Cf. “A Psychological Approach to the Dogma of the Trinity,” par. 184.
- ³³ I am indebted to Mrs. Margaret Schevill for both these pictures. Figure 45 is a variant of the sand-painting reproduced in *Psychology and Alchemy*, fig. 110.
- ³⁴ The drawing was sent to me from the British Museum, London. The original painting appears to be in New York.
- ³⁵ Lucca, Bibliotheca governativa, Cod.1942, fol.37’.
- ³⁶ *A Summary Appendix of the Soul*, p. 117.
- ³⁷ *Ibid.*, p. 118.
- ³⁸ Cf. the four snakes in the chthonic, shadow-half of Picture 9 in the preceding paper.
- ³⁹ Figure X from Lambspringk’s Symbols in the *Musaeum hermeticum* (Waite trans., I, p. 295).
- ⁴⁰ *De genio Socratis*, cap. XXII.

1 [Written especially for *Du: Schweizerische Monatsschrift* (Zurich), XV:4 (April 1955), 16, 21 and subscribed "January 1955." The issue was devoted to the Eranos conferences at Ascona, Switzerland, and the work of C. G. Jung. (An anonymous translation into English accompanying the article has been consulted.) With Dr. Jung's article also were several examples of mandalas, including the frontispiece of this volume and fig. 1, p. 297. While this brief article duplicates some material given elsewhere in this volume, it is presented here as a concise popular statement on the subject.—EDITORS.]

2 [Proclamation of the dogma of the Assumption of the Virgin, in 1950. Cf. *Psychology and Religion: West and East*, pars. 119ff., 251f., 748ff.—EDITORS.]

* For details of the *Collected Works of C. G. Jung*, see end of this volume.

* For details of the *Collected Works of C. G. Jung*, see end of this volume.

- * Published 1957; 2nd edn., 1970.
- + Published 1973.
- * Published 1960.
- + Published 1961.
- ‡ Published 1956; 2nd edn., 1967. (65 plates, 43 text figures.)
- * Published 1971.
- + Published 1953; 2nd edn., 1966.
- ‡ Published 1960 2nd edn., 1969.
- * Published 1959; 2nd edn., 1968. (Part I: 79 plates, with 29 in colour.)
- * Published 1964; 2nd edn., 1970. (8 plates.)
- † Published 1958; 2nd edn., 1969.
- * Published 1953; 2nd edn., completely revised, 1968. (270 illustrations.)
- † Published 1968. (50 plates, 4 text figures.)
- ‡ Published 1963; 2nd edn., 1970. (10 plates.)
- * Published 1966.
- † Published 1954; 2nd edn., revised and augmented, 1966. (13 illustrations.)
- ‡ Published 1954.
- * Published 1976.
- † Published 1979.

B O L L I N G E N S E R I E S X X

THE COLLECTED WORKS

OF

C. G. JUNG

VOLUME 9, PART II

EDITORS

†SIR HERBERT READ

MICHAEL FORDHAM, M.D., M.R.C.P.

GERHARD ADLER, PH.D.

WILLIAM MCGUIRE, *executive editor*



The Mithraic god Aion
Roman, 2nd–3rd century

AION

RESEARCHES INTO THE
PHENOMENOLOGY OF THE SELF

C. G. JUNG

SECOND EDITION

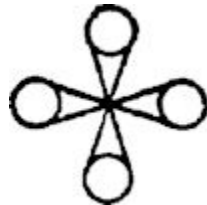

TRANSLATED BY R. F. C. HULL

BOLLINGEN SERIES XX

PRINCETON UNIVERSITY PRESS

COPYRIGHT © 1959 BY BOLLINGEN FOUNDATION INC., NEW YORK, N.Y.

PUBLISHED BY PRINCETON UNIVERSITY PRESS, PRINCETON, N.J.

ALL RIGHTS RESERVED

Second hardcover edition, with corrections and minor revisions, 1968

Fifth hardcover printing, with additional corrections, 1978

First Princeton / Bollingen Paperback printing, 1979

This book is a paperback reprint of Volume 9, part ii, of the Collected Works of C. G. Jung. All the volumes comprising the Collected Works constitute number XX in Bollingen Series, under the editorship of Herbert Read (d. 1968), Michael Fordham, and Gerhard Adler; executive editor, William McGuire.

Translated from the first part of *Aion: Untersuchungen zur Symbolgeschichte* (Psychologische Abhandlungen, VIII), published by Rascher Verlag, Zurich, 1951.

ISBN 0-691-01826-X (paperback edition)

ISBN 0-691-09775-5 (hardcover edition)

LIBRARY OF CONGRESS CATALOG CARD NUMBER 75-156

EDITORIAL NOTE

Volume 9 of the Collected Works is devoted to studies of the specific archetypes of the collective unconscious. Part I, entitled *The Archetypes and the Collective Unconscious*, is composed of shorter essays; Part II, *Aion*, is a long monograph on the archetype of the self. The author has agreed to a modification of the sub-title of *Aion*, which in the Swiss edition appeared in two forms, “Researches into the History of Symbols” and “Contributions to the Symbolism of the Self.” The first five chapters were previously published, with small differences, in *Psyche and Symbol: A Selection from the Writings of C. G. Jung*, edited by Violet S. de Laszlo (Anchor Books, Garden City, New York, 1958).

EDITORIAL NOTE TO THE SECOND EDITION

For this edition corrections have been made in the text and footnotes and the bibliographical references have been brought up to date in relation to the *Collected Works*. The translation has been corrected in light of further experience of translating Jung's works.

TRANSLATOR'S NOTE

Grateful acknowledgment is made to the following persons, whose translations have been consulted during the preparation of the present work: Mr. William H. Kennedy, for extensive use of his translation of portions of [chapters 2](#) and [3](#), issued as “Shadow, Animus, and Anima” by the Analytical Psychology Club of New York, 1950; Dr. Hildegarde Nagel, for reference to her translation of the original *Eranos-Jahrbuch* version (1949) of “Concerning the Self,” in *Spring*, 1951, which original version the author later expanded into *Aion*, [chapters 4](#) and [5](#); and Miss Barbara Hannah and Dr. Marie-Louise von Franz, for helpful advice with the remaining chapters. Especial thanks are due to Mr. A. S. B. Glover, who (unless otherwise noted) translated the Latin and Greek texts throughout. References to published sources are given for the sake of completeness.

VOLUME 9, PART II
AION: RESEARCHES INTO THE PHENOMENOLOGY OF THE SELF

TABLE OF CONTENTS

EDITORIAL NOTES

TRANSLATOR'S NOTE

LIST OF PLATES

FOREWORD

I. The Ego

II. The Shadow

III. The Syzygy: Anima and Animus

IV. The Self

V. Christ, a Symbol of the Self

VI. The Sign of the Fishes

VII. The Prophecies of Nostradamus

VIII. The Historical Significance of the Fish

IX. The Ambivalence of the Fish Symbol

X. The Fish in Alchemy

1. *The Medusa*

2. *The Fish*

3. *The Fish Symbol of the Cathars*

XI. The Alchemical Interpretation of the Fish

XII. Background to the Psychology of Christian Alchemical Symbolism

XIII. Gnostic Symbols of the Self

XIV. The Structure and Dynamics of the Self

XV. Conclusion

BIBLIOGRAPHY

INDEX

LIST OF PLATES

The Mithraic god Aion

Roman, 2nd–3rd century. Museo Profano, Vatican. p: Alinari.

I. The Four Elements

Michael Maier, *Scrutinium chymicum* (1687), Emblema XVII, p. 49.

II. The Trinity

From a manuscript by Joachim of Flora. Graphics Collection, Zurich Central Library, B
× 606.

FOREWORD

The theme of this work¹ is the idea of the Aeon (Greek, *Aion*). My investigation seeks, with the help of Christian, Gnostic, and alchemical symbols of the self, to throw light on the change of psychic situation within the “Christian aeon.” Christian tradition from the outset is not only saturated with Persian and Jewish ideas about the beginning and end of time, but is filled with intimations of a kind of enantiodromian reversal of dominants. I mean by this the dilemma of Christ and Antichrist. Probably most of the historical speculations about time and the division of time were influenced, as the Apocalypse shows, by astrological ideas. It is therefore only natural that my reflections should gravitate mainly round the symbol of the *Fishes*, for the Pisces aeon is the synchronistic concomitant of two thousand years of Christian development. In this time-period not only was the figure of the Anthropos (the “Son of Man”) progressively amplified symbolically, and thus assimilated psychologically, but it brought with it changes in man’s attitude that had already been anticipated by the expectation of the Antichrist in the ancient texts. Because these texts relegate the appearance of Antichrist to the end of time, we are justified in speaking of a “Christian aeon,” which, it was presupposed, would find its end with the Second Coming. It seems as if this expectation coincides with the astrological conception of the “Platonic month” of the *Fishes*.

The immediate occasion for my proposing to discuss these historical questions is the fact that the archetypal image of wholeness, which appears so frequently in the products of the unconscious, has its forerunners in history. These were identified very early with the figure of Christ, as I have shown in my book *Psychology and Alchemy*.² I have been requested so often by my readers to discuss the relations between the traditional Christ-figure and the natural symbols of wholeness, or the self, that I finally decided to take this task in hand. Considering the unusual difficulties of such an undertaking, my decision did not come easily to me, for, in order to surmount all the obstacles and possibilities of error, a knowledge and caution would be needed which, unfortunately, are vouchsafed me only in limited degree. I am moderately certain of my observations on the empirical material, but I am fully aware of the risk I am taking in drawing the testimonies of history into the scope of my reflections. I think I also know the responsibility I am taking upon myself when, as though continuing the historical process of assimilation, I add to the many symbolical amplifications of the Christ-figure yet another, the psychological one, or even, so it might seem, reduce the Christ-symbol to a psychological image of wholeness. My reader should never forget, however, that I am not making a confession of faith or writing a tendentious tract, but am simply considering how certain things could be understood from the standpoint of our modern

consciousness—things which I deem it valuable to understand, and which are obviously in danger of being swallowed up in the abyss of incomprehension and oblivion; things, finally, whose understanding would do much to remedy our philosophic disorientation by shedding light on the psychic background and the secret chambers of the soul. The essence of this book was built up gradually, in the course of many years, in countless conversations with people of all ages and all walks of life; with people who in the confusion and uprootedness of our society were likely to lose all contact with the meaning of European culture and to fall into that state of suggestibility which is the occasion and cause of the Utopian mass-psychoses of our time.

I write as a physician, with a physician's sense of responsibility, and not as a proselyte. Nor do I write as a scholar, otherwise I would wisely barricade myself behind the safe walls of my specialism and not, on account of my inadequate knowledge of history, expose myself to critical attack and damage my scientific reputation. So far as my capacities allow, restricted as they are by old age and illness, I have made every effort to document my material as reliably as possible and to assist the verification of my conclusions by citing the sources.

C. G. JUNG

May 1950

AION

RESEARCHES INTO THE PHENOMENOLOGY OF THE SELF

These things came to pass, they say, that Jesus might be made the first sacrifice in the discrimination of composite natures.

HIPPOLYTUS, *Elenchos*, VII, 27, 8

THE EGO

- [1] Investigation of the psychology of the unconscious confronted me with facts which required the formulation of new concepts. One of these concepts is the *self*. The entity so denoted is not meant to take the place of the one that has always been known as the *ego*, but includes it in a supraordinate concept. We understand the ego as the complex factor to which all conscious contents are related. It forms, as it were, the centre of the field of consciousness; and, in so far as this comprises the empirical personality, the ego is the subject of all personal acts of consciousness. The relation of a psychic content to the ego forms the criterion of its consciousness, for no content can be conscious unless it is represented to a subject.
- [2] With this definition we have described and delimited the *scope* of the subject. Theoretically, no limits can be set to the field of consciousness, since it is capable of indefinite extension. Empirically, however, it always finds its limit when it comes up against the *unknown*. This consists of everything we do not know, which, therefore, is not related to the ego as the centre of the field of consciousness. The unknown falls into two groups of objects: those which are outside and can be experienced by the senses, and those which are inside and are experienced immediately. The first group comprises the unknown in the outer world; the second the unknown in the inner world. We call this latter territory the *unconscious*.
- [3] The ego, as a specific content of consciousness, is not a simple or elementary factor but a complex one which, as such, cannot be described exhaustively. Experience shows that it rests on two seemingly different bases: the *somatic* and the *psychic*. The somatic basis is inferred from the totality of endosomatic perceptions, which for their part are already of a psychic nature and are associated with the ego, and are therefore conscious. They are produced by endosomatic stimuli, only some of which cross the threshold of consciousness. A considerable proportion of these stimuli occur unconsciously, that is, subliminally. The fact that they are subliminal does not necessarily mean that their status is merely physiological, any more than this would be true of a psychic content. Sometimes they are capable of crossing the threshold, that is, of becoming perceptions. But there is no doubt that a large proportion of these endosomatic stimuli are simply incapable of consciousness and are so elementary that there is no reason to assign them a psychic nature—unless of course one favours the philosophical view that all life-processes are psychic anyway.

The chief objection to this hardly demonstrable hypothesis is that it enlarges the concept of the psyche beyond all bounds and interprets the life-process in a way not absolutely warranted by the facts. Concepts that are too broad usually prove to be unsuitable instruments because they are too vague and nebulous. I have therefore suggested that the term “psychic” be used only where there is evidence of a will capable of modifying reflex or instinctual processes. Here I must refer the reader to my paper “On the Nature of the Psyche,”¹ where I have discussed this definition of the “psychic” at somewhat greater length.

[4] The somatic basis of the ego consists, then, of conscious and unconscious factors. The same is true of the psychic basis: on the one hand the ego rests on the *total field of consciousness*, and on the other, on the *sum total of unconscious contents*. These fall into three groups: first, temporarily subliminal contents that can be reproduced voluntarily (memory); second, unconscious contents that cannot be reproduced voluntarily; third, contents that are not capable of becoming conscious at all. Group two can be inferred from the spontaneous irruption of subliminal contents into consciousness. Group three is hypothetical; it is a logical inference from the facts underlying group two. It contains contents which have *not yet* irrupted into consciousness, or which never will.

[5] When I said that the ego “rests” on the total field of consciousness I do not mean that it *consists* of this. Were that so, it would be indistinguishable from the field of consciousness as a whole. The ego is only the latter’s point of reference, grounded on and limited by the somatic factor described above.

[6] Although its bases are in themselves relatively unknown and unconscious, the ego is a conscious factor par excellence. It is even acquired, empirically speaking, during the individual’s lifetime. It seems to arise in the first place from the collision between the somatic factor and the environment, and, once established as a subject, it goes on developing from further collisions with the outer world and the inner.

[7] Despite the unlimited extent of its bases, the ego is never more and never less than consciousness as a whole. As a conscious factor the ego could, theoretically at least, be described completely. But this would never amount to more than a picture of the *conscious personality*; all those features which are unknown or unconscious to the subject would be missing. A total picture would have to include these. But a total description of the personality is, even in theory, absolutely impossible, because the unconscious portion of it cannot be grasped cognitively. This unconscious portion, as experience has abundantly shown, is by no means unimportant. On the contrary, the most decisive qualities in a person are often unconscious and can be perceived only by others, or have to be laboriously discovered with outside help.

- [8] Clearly, then, the *personality as a total phenomenon* does not coincide with the ego, that is, with the conscious personality, but forms an entity that has to be distinguished from the ego. Naturally the need to do this is incumbent only on a psychology that reckons with the fact of the unconscious, but for such a psychology the distinction is of paramount importance. Even for jurisprudence it should be of some importance whether certain psychic facts are conscious or not—for instance, in adjudging the question of responsibility.
- [9] I have suggested calling the total personality which, though present, cannot be fully known, the *self*. The ego is, by definition, subordinate to the self and is related to it like a part to the whole. Inside the field of consciousness it has, as we say, free will. By this I do not mean anything philosophical, only the well-known psychological fact of “free choice,” or rather the subjective feeling of freedom. But, just as our free will clashes with necessity in the outside world, so also it finds its limits outside the field of consciousness in the subjective inner world, where it comes into conflict with the facts of the self. And just as circumstances or outside events “happen” to us and limit our freedom, so the self acts upon the ego like an *objective occurrence* which free will can do very little to alter. It is, indeed, well known that the ego not only can do nothing against the self, but is sometimes actually assimilated by unconscious components of the personality that are in the process of development and is greatly altered by them.
- [10] It is, in the nature of the case, impossible to give any general description of the ego except a formal one. Any other mode of observation would have to take account of the *individuality* which attaches to the ego as one of its main characteristics. Although the numerous elements composing this complex factor are, in themselves, everywhere the same, they are infinitely varied as regards clarity, emotional colouring, and scope. The result of their combination—the ego—is therefore, so far as one can judge, individual and unique, and retains its identity up to a certain point. Its stability is relative, because far-reaching changes of personality can sometimes occur. Alterations of this kind need not always be pathological; they can also be developmental and hence fall within the scope of the normal.
- [11] Since it is the point of reference for the field of consciousness, the ego is the subject of all successful attempts at adaptation so far as these are achieved by the will. The ego therefore has a significant part to play in the psychic economy. Its position there is so important that there are good grounds for the prejudice that the ego is the centre of the personality, and that the field of consciousness is the psyche *per se*. If we discount certain suggestive ideas in Leibniz, Kant, Schelling, and Schopenhauer, and the philosophical excursions of Carus and von Hartmann, it is only since the end of the nineteenth century that modern psychology, with its

inductive methods, has discovered the foundations of consciousness and proved empirically the existence of a psyche outside consciousness. With this discovery the position of the ego, till then absolute, became relativized; that is to say, though it retains its quality as the centre of the field of consciousness, it is questionable whether it is the centre, of the personality. It is part of the personality but not the whole of it. As I have said, it is simply impossible to estimate how large or how small its share is; how free or how dependent it is on the qualities of this “extra-conscious” psyche. We can only say that its freedom is limited and its dependence proved in ways that are often decisive. In my experience one would do well not to underestimate its dependence on the unconscious. Naturally there is no need to say this to persons who already overestimate the latter’s importance. Some criterion for the right measure is afforded by the psychic consequences of a wrong estimate, a point to which we shall return later on.

[12] We have seen that, from the standpoint of the psychology of consciousness, the unconscious can be divided into three groups of contents. But from the standpoint of the psychology of the personality a twofold division ensues: an “extra-conscious” psyche whose contents are *personal*, and an “extra-conscious” psyche whose contents are *impersonal* and *collective*. The first group comprises contents which are integral components of the individual personality and could therefore just as well be conscious; the second group forms, as it were, an omnipresent, unchanging, and everywhere identical *quality or substrate of the psyche per se*. This is, of course, no more than a hypothesis. But we are driven to it by the peculiar nature of the empirical material, not to mention the high probability that the general similarity of psychic processes in all individuals must be based on an equally general and impersonal principle that conforms to law, just as the instinct manifesting itself in the individual is only the partial manifestation of an instinctual substrate common to all men.

II

THE SHADOW

[13] Whereas the contents of the personal unconscious are acquired during the individual's lifetime, the contents of the collective unconscious are invariably archetypes that were present from the beginning. Their relation to the instincts has been discussed elsewhere.¹ The archetypes most clearly characterized from the empirical point of view are those which have the most frequent and the most disturbing influence on the ego. These are the *shadow*, the *anima*, and the *animus*.² The most accessible of these, and the easiest to experience, is the shadow, for its nature can in large measure be inferred from the contents of the personal unconscious. The only exceptions to this rule are those rather rare cases where the positive qualities of the personality are repressed, and the ego in consequence plays an essentially negative or unfavourable role.

[14] The shadow is a moral problem that challenges the whole ego-personality, for no one can become conscious of the shadow without considerable moral effort. To become conscious of it involves recognizing the dark aspects of the personality as present and real. This act is the essential condition for any kind of self-knowledge, and it therefore, as a rule, meets with considerable resistance. Indeed, self-knowledge as a psychotherapeutic measure frequently requires much painstaking work extending over a long period.

[15] Closer examination of the dark characteristics—that is, the inferiorities constituting the shadow—reveals that they have an *emotional* nature, a kind of autonomy, and accordingly an obsessive or, better, possessive quality. Emotion, incidentally, is not an activity of the individual but something that happens to him. Affects occur usually where adaptation is weakest, and at the same time they reveal the reason for its weakness, namely a certain degree of inferiority and the existence of a lower level of personality. On this lower level with its uncontrolled or scarcely controlled emotions one behaves more or less like a primitive, who is not only the passive victim of his affects but also singularly incapable of moral judgment.

[16] Although, with insight and good will, the shadow can to some extent be assimilated into the conscious personality, experience shows that there are certain features which offer the most obstinate resistance to moral control and prove almost impossible to influence. These resistances are usually bound up with *projections*,

which are not recognized as such, and their recognition is a moral achievement beyond the ordinary. While some traits peculiar to the shadow can be recognized without too much difficulty as one's own personal qualities, in this case both insight and good will are unavailing because the cause of the emotion appears to lie, beyond all possibility of doubt, in the *other person*. No matter how obvious it may be to the neutral observer that it is a matter of projections, there is little hope that the subject will perceive this himself. He must be convinced that he throws a very long shadow before he is willing to withdraw his emotionally-toned projections from their object.

[17] Let us suppose that a certain individual shows no inclination whatever to recognize his projections. The projection-making factor then has a free hand and can realize its object—if it has one—or bring about some other situation characteristic of its power. As we know, it is not the conscious subject but the unconscious which does the projecting. Hence one meets with projections, one does not make them. The effect of projection is to isolate the subject from his environment, since instead of a real relation to it there is now only an illusory one. Projections change the world into the replica of one's own unknown face. In the last analysis, therefore, they lead to an autoerotic or autistic condition in which one dreams a world whose reality remains forever unattainable. The resultant *sentiment d'incomplétude* and the still worse feeling of sterility are in their turn explained by projection as the malevolence of the environment, and by means of this vicious circle the isolation is intensified. The more projections are thrust in between the subject and the environment, the harder it is for the ego to see through its illusions. A forty-five-year-old patient who had suffered from a compulsion neurosis since he was twenty and had become completely cut off from the world once said to me: "But I can never admit to myself that I've wasted the best twenty-five years of my life!"

[18] It is often tragic to see how blatantly a man bungles his own life and the lives of others yet remains totally incapable of seeing how much the whole tragedy originates in himself, and how he continually feeds it and keeps it going. Not *consciously*, of course—for consciously he is engaged in bewailing and cursing a faithless world that recedes further and further into the distance. Rather, it is an unconscious factor which spins the illusions that veil his world. And what is being spun is a cocoon, which in the end will completely envelop him.

[19] One might assume that projections like these, which are so very difficult if not impossible to dissolve, would belong to the realm of the shadow—that is, to the negative side of the personality. This assumption becomes untenable after a certain point, because the symbols that then appear no longer refer to the same but to the opposite sex, in a man's case to a woman and vice versa. The source of projections is no longer the shadow—which is always of the same sex as the subject—but a

contrasexual figure. Here we meet the animus of a woman and the anima of a man, two corresponding archetypes whose autonomy and unconsciousness explain the stubbornness of their projections. Though the shadow is a motif as well known to mythology as anima and animus, it represents first and foremost the personal unconscious, and its content can therefore be made conscious without too much difficulty. In this it differs from anima and animus, for whereas the shadow can be seen through and recognized fairly easily, the anima and animus are much further away from consciousness and in normal circumstances are seldom if ever realized. With a little self-criticism one can see through the shadow—so far as its nature is personal. But when it appears as an archetype, one encounters the same difficulties as with anima and animus. In other words, it is quite within the bounds of possibility for a man to recognize the relative evil of his nature, but it is a rare and shattering experience for him to gaze into the face of absolute evil.

III

THE SYZYGY: ANIMA AND ANIMUS

[20] What, then, is this projection-making factor? The East calls it the “Spinning Woman”¹—Maya, who creates illusion by her dancing. Had we not long since known it from the symbolism of dreams, this hint from the Orient would put us on the right track: the enveloping, embracing, and devouring element points unmistakably to the mother,² that is, to the son’s relation to the real mother, to her imago, and to the woman who is to become a mother for him. His Eros is passive like a child’s; he hopes to be caught, sucked in, enveloped, and devoured. He seeks, as it were, the protecting, nourishing, charmed circle of the mother, the condition of the infant released from every care, in which the outside world bends over him and even forces happiness upon him. No wonder the real world vanishes from sight!

[21] If this situation is dramatized, as the unconscious usually dramatizes it, then there appears before you on the psychological stage a man living regressively, seeking his childhood and his mother, fleeing from a cold cruel world which denies him understanding. Often a mother appears beside him who apparently shows not the slightest concern that her little son should become a man, but who, with tireless and self-immolating effort, neglects nothing that might hinder him from growing up and marrying. You behold the secret conspiracy between mother and son, and how each helps the other to betray life.

[22] Where does the guilt lie? With the mother, or with the son? Probably with both. The unsatisfied longing of the son for life and the world ought to be taken seriously. There is in him a desire to touch reality, to embrace the earth and fructify the field of the world. But he makes no more than a series of fitful starts, for his initiative as well as his staying power are crippled by the secret memory that the world and happiness may be had as a gift—from the mother. The fragment of world which he, like every man, must encounter again and again is never quite the right one, since it does not fall into his lap, does not meet him half way, but remains resistant, has to be conquered, and submits only to force. It makes demands on the masculinity of a man, on his ardour, above all on his courage and resolution when it comes to throwing his whole being into the scales. For this he would need a faithless Eros, one capable of forgetting his mother and undergoing the pain of relinquishing the first love of his life. The mother, foreseeing this danger, has carefully inculcated into him the virtues of faithfulness, devotion, loyalty, so as to protect him from the moral disruption

which is the risk of every life adventure. He has learnt these lessons only too well, and remains true to his mother. This naturally causes her the deepest anxiety (when, to her greater glory, he turns out to be a homosexual, for example) and at the same time affords her an unconscious satisfaction that is positively mythological. For, in the relationship now reigning between them, there is consummated the immemorial and most sacred archetype of the marriage of mother and son. What, after all, has commonplace reality to offer, with its registry offices, pay envelopes, and monthly rent, that could outweigh the mystic awe of the *hieros gamos*? Or the star-crowned woman whom the dragon pursues, or the pious obscurities veiling the marriage of the Lamb?

[23] This myth, better than any other, illustrates the nature of the collective unconscious. At this level the mother is both old and young, Demeter and Persephone, and the son is spouse and sleeping suckling rolled into one. The imperfections of real life, with its laborious adaptations and manifold disappointments, naturally cannot compete with such a state of indescribable fulfilment.

[24] In the case of the son, the projection-making factor is identical with the mother-*imago*, and this is consequently taken to be the real mother. The projection can only be dissolved when the son sees that in the realm of his psyche there is an *imago* not only of the mother but of the daughter, the sister, the beloved, the heavenly goddess, and the chthonic Baubo. Every mother and every beloved is forced to become the carrier and embodiment of this omnipresent and ageless image, which corresponds to the deepest reality in a man. It belongs to him, this perilous image of Woman; she stands for the loyalty which in the interests of life he must sometimes forgo; she is the much needed compensation for the risks, struggles, sacrifices that all end in disappointment; she is the solace for all the bitterness of life. And, at the same time, she is the great illusionist, the seductress, who draws him into life with her *Maya*—and not only into life's reasonable and useful aspects, but into its frightful paradoxes and ambivalences where good and evil, success and ruin, hope and despair, counterbalance one another. Because she is his greatest danger she demands from a man his greatest, and if he has it in him she will receive it.

[25] This image is "My Lady Soul," as Spitteler called her. I have suggested instead the term "anima," as indicating something specific, for which the expression "soul" is too general and too vague. The empirical reality summed up under the concept of the *anima* forms an extremely dramatic content of the unconscious. It is possible to describe this content in rational, scientific language, but in this way one entirely fails to express its living character. Therefore, in describing the living processes of the psyche, I deliberately and consciously give preference to a dramatic, mythological

way of thinking and speaking, because this is not only more expressive but also more exact than an abstract scientific terminology, which is wont to toy with the notion that its theoretic formulations may one fine day be resolved into algebraic equations.

[26] The projection-making factor is the anima, or rather the unconscious as represented by the anima. Whenever she appears, in dreams, visions, and fantasies, she takes on personified form, thus demonstrating that the factor she embodies possesses all the outstanding characteristics of a feminine being.³ She is not an invention of the conscious, but a spontaneous product of the unconscious. Nor is she a substitute figure for the mother. On the contrary, there is every likelihood that the numinous qualities which make the mother-imago so dangerously powerful derive from the collective archetype of the anima, which is incarnated anew in every male child.

[27] Since the anima is an archetype that is found in men, it is reasonable to suppose that an equivalent archetype must be present in women; for just as the man is compensated by a feminine element, so woman is compensated by a masculine one. I do not, however, wish this argument to give the impression that these compensatory relationships were arrived at by deduction. On the contrary, long and varied experience was needed in order to grasp the nature of anima and animus empirically. Whatever we have to say about these archetypes, therefore, is either directly verifiable or at least rendered probable by the facts. At the same time, I am fully aware that we are discussing pioneer work which by its very nature can only be provisional.

[28] Just as the mother seems to be the first carrier of the projection-making factor for the son, so is the father for the daughter. Practical experience of these relationships is made up of many individual cases presenting all kinds of variations on the same basic theme. A concise description of them can, therefore, be no more than schematic.

[29] Woman is compensated by a masculine element and therefore her unconscious has, so to speak, a masculine imprint. This results in a considerable psychological difference between men and women, and accordingly I have called the projection-making factor in women the animus, which means mind or spirit. The animus corresponds to the paternal Logos just as the anima corresponds to the maternal Eros. But I do not wish or intend to give these two intuitive concepts too specific a definition. I use Eros and Logos merely as conceptual aids to describe the fact that woman's consciousness is characterized more by the connective quality of Eros than by the discrimination and cognition associated with Logos. In men, Eros, the function of relationship, is usually less developed than Logos. In women, on the other hand, Eros is an expression of their true nature, while their Logos is often only a regrettable accident. It gives rise to misunderstandings and annoying interpretations in the family

circle and among friends. This is because it consists of *opinions* instead of reflections, and by opinions I mean *a priori* assumptions that lay claim to absolute truth. Such assumptions, as everyone knows, can be extremely irritating. As the animus is partial to argument, he can best be seen at work in disputes where both parties know they are right. Men can argue in a very womanish way, too, when they are anima-possessed and have thus been transformed into the animus of their own anima. With them the question becomes one of personal vanity and touchiness (as if they were females); with women it is a question of *power*, whether of truth or justice or some other “ism”—for the dressmaker and hairdresser have already taken care of their vanity. The “Father” (i.e., the sum of conventional opinions) always plays a great role in female argumentation. No matter how friendly and obliging a woman’s Eros may be, no logic on earth can shake her if she is ridden by the animus. Often the man has the feeling—and he is not altogether wrong—that only seduction or a beating or rape would have the necessary power of persuasion. He is unaware that this highly dramatic situation would instantly come to a banal and unexciting end if he were to quit the field and let a second woman carry on the battle (his wife, for instance, if she herself is not the fiery war horse). This sound idea seldom or never occurs to him, because no man can converse with an animus for five minutes without becoming the victim of his own anima. Anyone who still had enough sense of humour to listen objectively to the ensuing dialogue would be staggered by the vast number of commonplaces, misapplied truisms, clichés from newspapers and novels, shop-soiled platitudes of every description interspersed with vulgar abuse and brain-splitting lack of logic. It is a dialogue which, irrespective of its participants, is repeated millions and millions of times in all the languages of the world and always remains essentially the same.

[30] This singular fact is due to the following circumstance: when animus and anima meet, the animus draws his sword of power and the anima ejects her poison of illusion and seduction. The outcome need not always be negative, since the two are equally likely to fall in love (a special instance of love at first sight). The language of love is of astonishing uniformity, using the well-worn formulas with the utmost devotion and fidelity, so that once again the two partners find themselves in a banal collective situation. Yet they live in the illusion that they are related to one another in a most individual way.

[31] In both its positive and its negative aspects the anima/animus relationship is always full of “animosity,” i.e., it is emotional, and hence collective. Affects lower the level of the relationship and bring it closer to the common instinctual basis, which no longer has anything individual about it. Very often the relationship runs its course heedless of its human performers, who afterwards do not know what happened to them.

- [32] Whereas the cloud of “animosity” surrounding the man is composed chiefly of sentimentality and resentment, in woman it expresses itself in the form of opinionated views, interpretations, insinuations, and misconstructions, which all have the purpose (sometimes attained) of severing the relation between two human beings. The woman, like the man, becomes wrapped in a veil of illusions by her demon-familiar, and, as the daughter who alone understands her father (that is, is eternally right in everything), she is translated to the land of sheep, where she is put to graze by the shepherd of her soul, the animus.
- [33] Like the anima, the animus too has a positive aspect. Through the figure of the father he expresses not only conventional opinion but—equally—what we call “spirit,” philosophical or religious ideas in particular, or rather the attitude resulting from them. Thus the animus is a psychopomp, a mediator between the conscious and the unconscious and a personification of the latter. Just as the anima becomes, through integration, the Eros of consciousness, so the animus becomes a Logos; and in the same way that the anima gives relationship and relatedness to a man’s consciousness, the animus gives to woman’s consciousness a capacity for reflection, deliberation, and self-knowledge.
- [34] The effect of anima and animus on the ego is in principle the same. This effect is extremely difficult to eliminate because, in the first place, it is uncommonly strong and immediately fills the ego-personality with an unshakable feeling of rightness and righteousness. In the second place, the cause of the effect is projected and appears to lie in objects and objective situations. Both these characteristics can, I believe, be traced back to the peculiarities of the archetype. For the archetype, of course, exists *a priori*. This may possibly explain the often totally irrational yet undisputed and indisputable existence of certain moods and opinions. Perhaps these are so notoriously difficult to influence because of the powerfully suggestive effect emanating from the archetype. Consciousness is fascinated by it, held captive, as if hypnotized. Very often the ego experiences a vague feeling of moral defeat and then behaves all the more defensively, defiantly, and self-righteously, thus setting up a vicious circle which only increases its feeling of inferiority. The bottom is then knocked out of the human relationship, for, like megalomania, a feeling of inferiority makes mutual recognition impossible, and without this there is no relationship.
- [35] As I said, it is easier to gain insight into the shadow than into the anima or animus. With the shadow, we have the advantage of being prepared in some sort by our education, which has always endeavoured to convince people that they are not one-hundred-per-cent pure gold. So everyone immediately understands what is meant by “shadow,” “inferior personality,” etc. And if he has forgotten, his memory can easily be refreshed by a Sunday sermon, his wife, or the tax collector. With the anima

and animus, however, things are by no means so simple. Firstly, there is no moral education in this respect, and secondly, most people are content to be self-righteous and prefer mutual vilification (if nothing worse!) to the recognition of their projections. Indeed, it seems a very natural state of affairs for men to have irrational moods and women irrational opinions. Presumably this situation is grounded on instinct and must remain as it is to ensure that the Empedoclean game of the hate and love of the elements shall continue for all eternity. Nature is conservative and does not easily allow her courses to be altered; she defends in the most stubborn way the inviolability of the preserves where anima and animus roam, Hence it is much more difficult to become conscious of one's anima/animus projections than to acknowledge one's shadow side. One has, of course, to overcome certain moral obstacles, such as vanity, ambition, conceit, resentment, etc., but in the case of projections all sorts of purely intellectual difficulties are added, quite apart from the contents of the projection which one simply doesn't know how to cope with. And on top of all this there arises a profound doubt as to whether one is not meddling too much with nature's business by prodding into consciousness things which it would have been better to leave asleep.

[36] Although there are, in my experience, a fair number of people who can understand without special intellectual or moral difficulties what is meant by anima and animus, one finds very many more who have the greatest trouble in visualizing these empirical concepts as anything concrete. This shows that they fall a little outside the usual range of experience. They are unpopular precisely because they seem unfamiliar. The consequence is that they mobilize prejudice and become taboo like everything else that is unexpected.

[37] So if we set it up as a kind of requirement that projections should be dissolved, because it is wholesomer that way and in every respect more advantageous, we are entering upon new ground. Up till now everybody has been convinced that the idea "my father," "my mother," etc., is nothing but a faithful reflection of the real parent, corresponding in every detail to the original, so that when someone says "my father" he means no more and no less than what his father is in reality. This is actually what he supposes he does mean, but a supposition of identity by no means brings that identity about. This is where the fallacy of the *enkekalymmenos* ('the veiled one') comes in.⁴ If one includes in the psychological equation X's picture of his father, which he takes for the real father, the equation will not work out, because the unknown quantity he has introduced does not tally with reality. X has overlooked the fact that his idea of a person consists, in the first place, of the possibly very incomplete picture he has received of the real person and, in the second place, of the subjective modifications he has imposed upon this picture. X's idea of his father is a complex quantity for which the real father is only in part responsible, an indefinitely

larger share falling to the son. So true is this that every time he criticizes or praises his father he is unconsciously hitting back at himself, thereby bringing about those psychic consequences that overtake people who habitually disparage or overpraise themselves. If, however, X carefully compares his reactions with reality, he stands a chance of noticing that he has miscalculated somewhere by not realizing long ago from his father's behaviour that the picture he has of him is a false one. But as a rule X is convinced that he is right, and if anybody is wrong it must be the other fellow. Should X have a poorly developed Eros, he will be either indifferent to the inadequate relationship he has with his father or else annoyed by the inconsistency and general incomprehensibility of a father whose behaviour never really corresponds to the picture X has of him. Therefore X thinks he has every right to feel hurt, misunderstood, and even betrayed.

[38] One can imagine how desirable it would be in such cases to dissolve the projection. And there are always optimists who believe that the golden age can be ushered in simply by telling people the right way to go. But just let them try to explain to these people that they are acting like a dog chasing its own tail. To make a person see the shortcomings of his attitude considerably more than mere "telling" is needed, for more is involved than ordinary common sense can allow. What one is up against here is the kind of fateful misunderstanding which, under ordinary conditions, remains forever inaccessible to insight. It is rather like expecting the average respectable citizen to recognize himself as a criminal.

[39] I mention all this just to illustrate the order of magnitude to which the anima/animus projections belong, and the moral and intellectual exertions that are needed to dissolve them. Not all the contents of the anima and animus are projected, however. Many of them appear spontaneously in dreams and so on, and many more can be made conscious through active imagination. In this way we find that thoughts, feelings, and affects are alive in us which we would never have believed possible. Naturally, possibilities of this sort seem utterly fantastic to anyone who has not experienced them himself, for a normal person "knows what he thinks." Such a childish attitude on the part of the "normal person" is simply the rule, so that no one without experience in this field can be expected to understand the real nature of anima and animus. With these reflections one gets into an entirely new world of psychological experience, provided of course that one succeeds in realizing it in practice. Those who do succeed can hardly fail to be impressed by all that the ego does not know and never has known. This increase in self-knowledge is still very rare nowadays and is usually paid for in advance with a neurosis, if not with something worse.

[40] The autonomy of the collective unconscious expresses itself in the figures of anima and animus. They personify those of its contents which, when withdrawn from projection, can be integrated into consciousness. To this extent, both figures represent *functions* which filter the contents of the collective unconscious through to the conscious mind. They appear or behave as such, however, only so long as the tendencies of the conscious and unconscious do not diverge too greatly. Should any tension arise, these functions, harmless till then, confront the conscious mind in personified form and behave rather like systems split off from the personality, or like part souls. This comparison is inadequate in so far as nothing previously belonging to the ego-personality has split off from it; on the contrary, the two figures represent a disturbing accretion. The reason for their behaving in this way is that though the *contents* of anima and animus can be integrated they themselves cannot, since they are archetypes. As such they are the foundation stones of the psychic structure, which in its totality exceeds the limits of consciousness and therefore can never become the object of direct cognition. Though the effects of anima and animus can be made conscious, they themselves are factors transcending consciousness and beyond the reach of perception and volition. Hence they remain autonomous despite the integration of their contents, and for this reason they should be borne constantly in mind. This is extremely important from the therapeutic standpoint, because constant observation pays the unconscious a tribute that more or less guarantees its cooperation. The unconscious as we know can never be "done with" once and for all. It is, in fact, one of the most important tasks of psychic hygiene to pay continual attention to the symptomatology of unconscious contents and processes, for the good reason that the conscious mind is always in danger of becoming one-sided, of keeping to well-worn paths and getting stuck in blind alleys. The complementary and compensating function of the unconscious ensures that these dangers, which are especially great in neurosis, can in some measure be avoided. It is only under ideal conditions, when life is still simple and unconscious enough to follow the serpentine path of instinct without hesitation or misgiving, that the compensation works with entire success. The more civilized, the more conscious and complicated a man is, the less he is able to follow his instincts. His complicated living conditions and the influence of his environment are so strong that they drown the quiet voice of nature. Opinions, beliefs, theories, and collective tendencies appear in its stead and back up all the aberrations of the conscious mind. Deliberate attention should then be given to the unconscious so that the compensation can set to work. Hence it is especially important to picture the archetypes of the unconscious not as a rushing phantasmagoria of fugitive images but as constant, autonomous factors, which indeed they are.

[41] Both these archetypes, as practical experience shows, possess a fatality that can on occasion produce tragic results. They are quite literally the father and mother of all the disastrous entanglements of fate and have long been recognized as such by the whole world. Together they form a divine pair,⁵ one of whom, in accordance with his Logos nature, is characterized by *pneuma* and *nous*, rather like Hermes with his ever-shifting hues, while the other, in accordance with her Eros nature, wears the features of Aphrodite, Helen (Selene), Persephone, and Hecate. Both of them are unconscious powers, “gods” in fact, as the ancient world quite rightly conceived them to be. To call them by this name is to give them that central position in the scale of psychological values which has always been theirs whether consciously acknowledged or not; for their power grows in proportion to the degree that they remain unconscious. Those who do not see them are in their hands, just as a typhus epidemic flourishes best when its source is undiscovered. Even in Christianity the divine syzygy has not become obsolete, but occupies the highest place as Christ and his bride the Church.⁶ Parallels like these prove extremely helpful in our attempts to find the right criterion for gauging the significance of these two archetypes. What we can discover about them from the conscious side is so slight as to be almost imperceptible. It is only when we throw light into the dark depths of the psyche and explore the strange and tortuous paths of human fate that it gradually becomes clear to us how immense is the influence wielded by these two factors that complement our conscious life.

[42] Recapitulating, I should like to emphasize that the integration of the shadow, or the realization of the personal unconscious, marks the first stage in the analytic process, and that without it a recognition of anima and animus is impossible. The shadow can be realized only through a relation to a partner, and anima and animus only through a relation to a partner of the opposite sex, because only in such a relation do their projections become operative. The recognition of the anima gives rise, in a man, to a triad, one third of which is transcendent: the masculine subject, the opposing feminine subject, and the transcendent anima. With a woman the situation is reversed. The missing fourth element that would make the triad a quaternity is, in a man, the archetype of the Wise Old Man, which I have not discussed here, and in a woman the Chthonic Mother. These four constitute a half immanent and half transcendent quaternity, an archetype which I have called the *marriage quaternio*.⁷ The marriage quaternio provides a schema not only for the self but also for the structure of primitive society with its cross-cousin marriage, marriage classes, and division of settlements into quarters. The self, on the other hand, is a God-image, or at least cannot be distinguished from one. Of this the early Christian spirit was not ignorant, otherwise Clement of Alexandria could never have said that he who knows himself knows God.⁸

IV

THE SELF¹

[43] We shall now turn to the question of whether the increase in self-knowledge resulting from the withdrawal of impersonal projections—in other words, the integration of the contents of the collective unconscious—exerts a specific influence on the ego-personality. To the extent that the integrated contents are *parts of the self*, we can expect this influence to be considerable. Their assimilation augments not only the area of the field of consciousness but also the importance of the ego, especially when, as usually happens, the ego lacks any critical approach to the unconscious. In that case it is easily overpowered and becomes identical with the contents that have been assimilated. In this way, for instance, a masculine consciousness comes under the influence of the anima and can even be possessed by her.

[44] I have discussed the wider effects of the integration of unconscious contents elsewhere² and can therefore omit going into details here. I should only like to mention that the more numerous and the more significant the unconscious contents which are assimilated to the ego, the closer the approximation of the ego to the self, even though this approximation must be a never-ending process. This inevitably produces an inflation of the ego,³ unless a critical line of demarcation is drawn between it and the unconscious figures. But this act of discrimination yields practical results only if it succeeds in fixing reasonable boundaries to the ego and in granting the figures of the unconscious—the self, anima, animus, and shadow—relative autonomy and reality (of a psychic nature). To psychologize this reality out of existence either is ineffectual, or else merely increases the inflation of the ego. One cannot dispose of facts by declaring them unreal. The projection-making factor, for instance, has undeniable reality. Anyone who insists on denying it becomes identical with it, which is not only dubious in itself but a positive danger to the well-being of the individual. Everyone who has dealings with such cases knows how perilous an inflation can be. No more than a flight of steps or a smooth floor is needed to precipitate a fatal fall. Besides the “pride goeth before a fall” motif there are other factors of a no less disagreeable psychosomatic and psychic nature which serve to reduce “puffed-up-ness.” This condition should not be interpreted as one of conscious self-aggrandizement. Such is far from being the rule. In general we are not directly conscious of this condition at all, but can at best infer its existence indirectly from the symptoms. These include the reactions of our immediate environment.

Inflation magnifies the blind spot in the eye, and the more we are assimilated by the projection-making factor, the greater becomes the tendency to identify with it. A clear symptom of this is our growing disinclination to take note of the reactions of the environment and pay heed to them.

[45] It must be reckoned a psychic catastrophe when the *ego is assimilated by the self*. The image of wholeness then remains in the unconscious, so that on the one hand it shares the archaic nature of the unconscious and on the other finds itself in the psychically relative space-time continuum that is characteristic of the unconscious as such.⁴ Both these qualities are numinous and hence have an unlimited determining effect on ego-consciousness, which is differentiated, i.e., separated, from the unconscious and moreover exists in an absolute space and an absolute time. It is a vital necessity that this should be so. If, therefore, the ego falls for any length of time under the control of an unconscious factor, its adaptation is disturbed and the way opened for all sorts of possible accidents.

[46] Hence it is of the greatest importance that the ego should be anchored in the world of consciousness and that consciousness should be reinforced by a very precise adaptation. For this, certain virtues like attention, conscientiousness, patience, etc., are of great value on the moral side, just as accurate observation of the symptomatology of the unconscious and objective selfcriticism are valuable on the intellectual side.

[47] However, accentuation of the ego personality and the world of consciousness may easily assume such proportions that the figures of the unconscious are psychologized and the *self consequently becomes assimilated to the ego*. Although this is the exact opposite of the process we have just described it is followed by the same result: inflation. The world of consciousness must now be levelled down in favour of the reality of the unconscious. In the first case, reality had to be protected against an archaic, “eternal” and “ubiquitous” dream-state: in the second, room must be made for the dream at the expense of the world of consciousness. In the first case, mobilization of all the virtues is indicated; in the second, the presumption of the ego can only be damped down by moral defeat. This is necessary, because otherwise one will never attain that median degree of modesty which is essential for the maintenance of a balanced state. It is not a question, as one might think, of relaxing morality itself but of making a moral effort in a different direction. For instance, a man who is not conscientious enough has to make a moral effort in order to come up to the mark; while for one who is sufficiently rooted in the world through his own efforts it is no small moral achievement to inflict defeat on his virtues by loosening his ties with the world and reducing his adaptive performance. (One thinks in this

connection of Brother Klaus, now canonized, who for the salvation of his soul left his wife to her own devices, along with numerous progeny.)

[48] Since real moral problems all begin where the penal code leaves off, their solution can seldom or never depend on precedent, much less on precepts and commandments. The real moral problems spring from *conflicts of duty*. Anyone who is sufficiently humble, or easy-going, can always reach a decision with the help of some outside authority. But one who trusts others as little as himself can never reach a decision at all, unless it is brought about in the manner which Common Law calls an “Act of God.” The Oxford Dictionary defines this concept as the “action of uncontrollable natural forces.” In all such cases there is an unconscious authority which puts an end to doubt by creating a *fait accompli*. (In the last analysis this is true also of those who get their decision from a higher authority, only in more veiled form.) One can describe this authority either as the “will of God” or as an “action of uncontrollable natural forces,” though psychologically it makes a good deal of difference how one thinks of it. The rationalistic interpretation of this inner authority as “natural forces” or the instincts satisfies the modern intellect but has the great disadvantage that the apparent victory of instinct offends our moral self-esteem; hence we like to persuade ourselves that the matter has been decided solely by the rational motions of the will. Civilized man has such a fear of the “*crimen laesae maiestatis humanae*” that whenever possible he indulges in a retrospective coloration of the facts in order to cover up the feeling of having suffered a moral defeat. He prides himself on what he believes to be his self-control and the omnipotence of his will, and despises the man who lets himself be outwitted by mere nature.

[49] If, on the other hand, the inner authority is conceived as the “will of God” (which implies that “natural forces” are divine forces), our self-esteem is benefited because the decision then appears to be an act of obedience and the result a divine intention. This way of looking at it can, with some show of justice, be accused not only of being very convenient but of cloaking moral laxity in the mantle of virtue. The accusation, however, is justified only when one is in fact knowingly hiding one’s own egoistic opinion behind a hypocritical façade of words. But this is by no means the rule, for in most cases instinctive tendencies assert themselves for or against one’s subjective interests no matter whether an outside authority approves or not. The inner authority does not need to be consulted first, as it is present at the outset in the intensity of the tendencies struggling for decision. In this struggle the individual is never a spectator only; he takes part in it more or less “voluntarily” and tries to throw the weight of his feeling of moral freedom into the scales of decision. Nevertheless, it remains a matter of doubt how much his seemingly free decision has a causal, and possibly unconscious, motivation. This may be quite as much an “act of God” as any natural cataclysm. The problem seems to me unanswerable, because we do not know

where the roots of the feeling of moral freedom lie; and yet they exist no less surely than the instincts, which are felt as compelling forces.

[50] All in all, it is not only more beneficial but more “correct” psychologically to explain as the “will of God” the natural forces that appear in us as instincts. In this way we find ourselves living in harmony with the *habitus* of our ancestral psychic life; that is, we function as man has functioned at all times and in all places. The existence of this *habitus* is proof of its viability, for, if it were not viable, all those who obeyed it would long since have perished of maladaptation. On the other hand, by conforming to it one has a reasonable life expectancy. When an habitual way of thinking guarantees as much as this there is not only no ground for declaring it incorrect but, on the contrary, every reason to take it as “true” or “correct” in the psychological sense. Psychological truths are not metaphysical insights; they are habitual modes of thinking, feeling, and behaving which experience has proved appropriate and useful.

[51] So when I say that the impulses which we find in ourselves should be understood as the “will of God,” I wish to emphasize that they ought not to be regarded as an arbitrary wishing and willing, but as absolutes which one must learn how to handle correctly. The will can control them only in part. It may be able to suppress them, but it cannot alter their nature, and what is suppressed comes up again in another place in altered form, but this time loaded with a resentment that makes the otherwise harmless natural impulse our enemy. I should also like the term “God” in the phrase “the will of God” to be understood not so much in the Christian sense as in the sense intended by Diotima, when she said: “Eros, dear Socrates, is a mighty daemon.” The Greek words *daimon* and *daimonion* express a determining power which comes upon man from outside, like providence or fate, though the ethical decision is left to man. He must know, however, what he is deciding about and what he is doing. Then, if he obeys he is following not just his own opinion, and if he rejects he is destroying not just his own invention.

[52] The purely biological or scientific standpoint falls short in psychology because it is, in the main, intellectual only. That this should be so is not a disadvantage, since the methods of natural science have proved of great heuristic value in psychological research. But the psychic phenomenon cannot be grasped in its totality by the intellect, for it consists not only of *meaning* but also of *value*, and this depends on the intensity of the accompanying feeling-tones. Hence at least the two “rational” functions⁵ are needed in order to map out anything like a complete diagram of a given psychic content.

[53] If, therefore, in dealing with psychic contents one makes allowance not only for intellectual judgments but for value judgments as well, not only is the result a more

complete picture of the content in question, but one also gets a better idea of the particular position it holds in the hierarchy of psychic contents in general. The feeling-value is a very important criterion which psychology cannot do without, because it determines in large measure the role which the content will play in the psychic economy. That is to say, the affective value gives the measure of the intensity of an idea, and the intensity in its turn expresses that idea's energetic tension, its effective potential. The shadow, for instance, usually has a decidedly negative feeling-value, while the anima, like the animus, has more of a positive one. Whereas the shadow is accompanied by more or less definite and describable feeling-tones, the anima and animus exhibit feeling qualities that are harder to define. Mostly they are felt to be fascinating or numinous. Often they are surrounded by an atmosphere of sensitivity, touchy reserve, secretiveness, painful intimacy, and even absoluteness. The relative autonomy of the anima- and animus-figures expresses itself in these qualities. In order of affective rank they stand to the shadow very much as the shadow stands in relation to ego-consciousness. The main affective emphasis seems to lie on the latter; at any rate it is able, by means of a considerable expenditure of energy, to repress the shadow, at least temporarily. But if for any reason the unconscious gains the upper hand, then the valency of the shadow and of the other figures increases proportionately, so that the scale of values is reversed. What lay furthest away from waking consciousness and seemed unconscious assumes, as it were, a threatening shape, and the affective value increases the higher up the scale you go: ego-consciousness, shadow, anima, self. This reversal of the conscious waking state occurs regularly during the transition from waking to sleeping, and what then emerge most vividly are the very things that were unconscious by day. Every *abaissement du niveau mental* brings about a relative reversal of values.

[54] I am speaking here of the *subjective* feeling-value, which is subject to the more or less periodic changes described above. But there are also *objective* values which are founded on a *consensus omnium*—moral, aesthetic, and religious values, for instance, and these are universally recognized ideals or feeling-toned collective ideas (Lévy-Bruhl's "representations collectives").⁶ The subjective feeling-tones or "value quanta" are easily recognized by the kind and number of constellations, or symptoms of disturbance,⁷ they produce. Collective ideals often have no subjective feeling-tone, but nevertheless retain their feeling-value. This value, therefore, cannot be demonstrated by subjective symptoms, though it may be by the attributes attaching to these collective ideas and by their characteristic symbolism, quite apart from their suggestive effect.

[55] The problem has a practical aspect, since it may easily happen that a collective idea, though significant in itself, is—because of its lack of subjective feeling-tone—represented in a dream only by a subsidiary attribute, as when a god is represented by

his theriomorphic attribute, etc. Conversely, the idea may appear in consciousness lacking the affective emphasis that properly belongs to it, and must then be transposed back into its archetypal context—a task that is usually discharged by poets and prophets. Thus Hölderlin, in his “Hymn to Liberty,” lets this concept, worn stale by frequent use and misuse, rise up again in its pristine splendour:

Since her arm out of the dust has raised me,
Beats my heart so boldly and serene;
And my cheek still tingles with her kisses,
Flushed and glowing where her lips have been.
Every word she utters, by her magic
Rises new-created, without flaw;
Hearken to the tidings of my goddess,
Hearken to the Sovereign, and adore!⁸

[56] It is not difficult to see here that the idea of liberty has been changed back to its original dramatic state—into the shining figure of the anima, freed from the weight of the earth and the tyranny of the senses, the psychopomp who leads the way to the Elysian fields.

[57] The first case we mentioned, where the collective idea is represented in a dream by a lowly aspect of itself, is certainly the more frequent: the “goddess” appears as a black cat, and the Deity as the *lapis exilis* (stone of no worth). Interpretation then demands a knowledge of certain things which have less to do with zoology and mineralogy than with the existence of an historical *consensus omnium* in regard to the object in question. These “mythological” aspects are always present, even though in a given case they may be unconscious. If for instance one doesn’t happen to recall, when considering whether to paint the garden gate green or white, that green is the colour of life and hope, the symbolic aspect of “green” is nevertheless present as an unconscious *sous-entendu*. So we find something which has the highest significance for the life of the unconscious standing lowest on the scale of conscious values, and vice versa. The figure of the shadow already belongs to the realm of bodiless phantoms—not to speak of anima and animus, which do not seem to appear at all except as projections upon our fellow human beings. As for the self, it is completely outside the personal sphere, and appears, if at all, only as a religious mythologem, and its symbols range from the highest to the lowest. Anyone who identifies with the daylight half of his psychic life will therefore declare the dreams of the night to be null and void, notwithstanding that the night is as long as the day and that all consciousness is manifestly founded on unconsciousness, is rooted in it and every night is extinguished in it. What is more, psychopathology knows with tolerable certainty what the unconscious can do to the conscious, and for this reason devotes to

the unconscious an attention that often seems incomprehensible to the layman. We know, for instance, that what is small by day is big at night, and the other way round; thus we also know that besides the small by day there always looms the big by night, even when it is invisible.

[58] This knowledge is an essential prerequisite for any integration—that is to say a content can only be integrated when its double aspect has become conscious and when it is grasped not merely intellectually but understood according to its feeling-value. Intellect and feeling, however, are difficult to put into one harness—they conflict with one another by definition. Whoever identifies with an intellectual standpoint will occasionally find his feeling confronting him like an enemy in the guise of the anima; conversely, an intellectual animus will make violent attacks on the feeling standpoint. Therefore, anyone who wants to achieve the difficult feat of realizing something not only intellectually, but also according to its feeling-value, must for better or worse come to grips with the anima/animus problem in order to open the way for a higher union, a *coniunctio oppositorum*. This is an indispensable prerequisite for wholeness.

[59] Although “wholeness” seems at first sight to be nothing but an abstract idea (like anima and animus), it is nevertheless empirical in so far as it is anticipated by the psyche in the form of spontaneous or autonomous symbols. These are the quaternity or mandala symbols, which occur not only in the dreams of modern people who have never heard of them, but are widely disseminated in the historical records of many peoples and many epochs. Their significance as *symbols of unity and totality* is amply confirmed by history as well as by empirical psychology. What at first looks like an abstract idea stands in reality for something that exists and can be experienced, that demonstrates its *a priori* presence spontaneously. Wholeness is thus an objective factor that confronts the subject independently of him, like anima or animus; and just as the latter have a higher position in the hierarchy than the shadow, so wholeness lays claim to a position and a value superior to those of the syzygy. The syzygy seems to represent at least a substantial portion of it, if not actually two halves of the totality formed by the royal brother-sister pair, and hence the tension of opposites from which the divine child⁹ is born as the symbol of unity.

[60] Unity and totality stand at the highest point on the scale of objective values because their symbols can no longer be distinguished from the *imago Dei*. Hence all statements about the God-image apply also to the empirical symbols of totality. Experience shows that individual mandalas are symbols of *order*, and that they occur in patients principally during times of psychic disorientation or re-orientation. As magic circles they bind and subdue the lawless powers belonging to the world of darkness, and depict or create an order that transforms the chaos into a cosmos.¹⁰ The

mandala at first comes into the conscious mind as an unimpressive point or dot,¹¹ and a great deal of hard and painstaking work as well as the integration of many projections are generally required before the full range of the symbol can be anything like completely understood. If this insight were purely intellectual it could be achieved without much difficulty, for the world-wide pronouncements about the God within us and above us, about Christ and the *corpus mysticum*, the personal and suprapersonal atman, etc., are all formulations that can easily be mastered by the philosophic intellect. This is the common source of the illusion that one is then in possession of the thing itself. But actually one has acquired nothing more than its name, despite the age-old prejudice that the name magically represents the thing, and that it is sufficient to pronounce the name in order to posit the thing's existence. In the course of the millennia the reasoning mind has been given every opportunity to see through the futility of this conceit, though that has done nothing to prevent the intellectual mastery of a thing from being accepted at its face value. It is precisely our experiences in psychology which demonstrate as plainly as could be wished that the intellectual "grasp" of a psychological fact produces no more than a concept of it, and that a concept is no more than a name, a *flatus vocis*. These intellectual counters can be bandied about easily enough. They pass lightly from hand to hand, for they have no weight or substance. They sound full but are hollow; and though purporting to designate a heavy task and obligation, they commit us to nothing. The intellect is undeniably useful in its own field, but is a great cheat and illusionist outside of it whenever it tries to manipulate values.

[61] It would seem that one can pursue any science with the intellect alone except psychology, whose subject—the psyche—has more than the two aspects mediated by sense-perception and thinking. The function of value—feeling—is an integral part of our conscious orientation and ought not to be missing in a psychological judgment of any scope, otherwise the model we are trying to build of the real process will be incomplete. Every psychic process has a value quality attached to it, namely its feeling-tone. This indicates the degree to which the subject is *affected* by the process or how much it means to him (in so far as the process reaches consciousness at all). It is through the "affect" that the subject becomes involved and so comes to feel the whole weight of reality. The difference amounts roughly to that between a severe illness which one reads about in a textbook and the real illness which one has. In psychology one possesses nothing unless one has experienced it in reality. Hence a purely intellectual insight is not enough, because one knows only the words and not the substance of the thing from inside.

[62] There are far more people who are afraid of the unconscious than one would expect. They are even afraid of their own shadow. And when it comes to the anima and animus, this fear turns to panic. For the syzygy does indeed represent the psychic

contents that irrupt into consciousness in a psychosis (most clearly of all in the paranoid forms of schizophrenia).¹² The overcoming of this fear is often a moral achievement of unusual magnitude, and yet it is not the only condition that must be fulfilled on the way to a real experience of the self.

[63] The shadow, the syzygy, and the self are psychic factors of which an adequate picture can be formed only on the basis of a fairly thorough experience of them. Just as these concepts arose out of an experience of reality, so they can be elucidated only by further experience. Philosophical criticism will find everything to object to in them unless it begins by recognizing that they are concerned with *facts*, and that the “concept” is simply an abbreviated description or definition of these facts. Such criticism has as little effect on the object as zoological criticism on a duck-billed platypus. It is not the concept that matters; the concept is only a word, a counter, and it has meaning and use only because it stands for a certain sum of experience. Unfortunately I cannot pass on this experience to my public. I have tried in a number of publications, with the help of case material, to present the nature of these experiences and also the method of obtaining them. Wherever my methods were really applied the facts I give have been confirmed. One could see the moons of Jupiter even in Galileo’s day if one took the trouble to use his telescope.

[64] Outside the narrower field of professional psychology these figures meet with understanding from all who have any knowledge of comparative mythology. They have no difficulty in recognizing the shadow as the adverse representative of the dark chthonic world, a figure whose characteristics are universal. The syzygy is immediately comprehensible as the psychic prototype of all divine couples. Finally the self, on account of its empirical peculiarities, proves to be the *eidos* behind the supreme ideas of unity and totality that are inherent in all monotheistic and monistic systems.

[65] I regard these parallels as important because it is possible, through them, to relate so-called *metaphysical* concepts, which have lost their root connection with natural experience, to living, universal psychic processes, so that they can recover their true and original meaning. In this way the connection is reestablished between the ego and projected contents now formulated as “metaphysical” ideas. Unfortunately, as already said, the fact that metaphysical ideas exist and are believed in does nothing to prove the actual existence of their content or of the object they refer to, although the coincidence of idea and reality in the form of a special psychic state, a state of grace, should not be deemed impossible, even if the subject cannot bring it about by an act of will. Once metaphysical ideas have lost their capacity to recall and evoke the original experience they have not only become useless but prove to be actual impediments on the road to wider development. One clings to possessions that have

once meant wealth; and the more ineffective, incomprehensible, and lifeless they become the more obstinately people cling to them. (Naturally it is only sterile ideas that they cling to; living ideas have content and riches enough, so there is no need to cling to them.) Thus in the course of time the meaningful turns into the meaningless. This is unfortunately the fate of metaphysical ideas.

[66] Today it is a real problem what on earth such ideas can mean. The world—so far as it has not completely turned its back on tradition—has long ago stopped wanting to hear a “message”; it would rather be told what the message means. The words that resound from the pulpit are incomprehensible and cry for an explanation. How has the death of Christ brought us redemption when no one feels redeemed? In what way is Jesus a God-man and what is such a being? What is the Trinity about, and the parthenogenesis, the eating of the body and the drinking of the blood, and all the rest of it? What connection can there be between the world of such concepts and the everyday world, whose material reality is the concern of natural science on the widest possible scale? At least sixteen hours out of twenty-four we live exclusively in this everyday world, and the remaining eight we spend preferably in an unconscious condition. Where and when does anything take place to remind us even remotely of phenomena like angels, miraculous feedings, beatitudes, the resurrection of the dead, etc.? It was therefore something of a discovery to find that during the unconscious state of sleep intervals occur, called “dreams,” which occasionally contain scenes having a not inconsiderable resemblance to the motifs of mythology. For myths are miracle tales and treat of all those things which, very often, are also objects of belief.

[67] In the everyday world of consciousness such things hardly exist; that is to say, until 1933 only lunatics would have been found in possession of living fragments of mythology. After this date the world of heroes and monsters spread like a devastating fire over whole nations, proving that the strange world of myth had suffered no loss of vitality during the centuries of reason and enlightenment. If metaphysical ideas no longer have such a fascinating effect as before, this is certainly not due to any lack of primitivity in the European psyche, but simply and solely to the fact that the erstwhile symbols no longer express what is now welling up from the unconscious as the end-result of the development of Christian consciousness through the centuries. This end-result is a true *antimimon pneuma*, a false spirit of arrogance, hysteria, woolly-mindedness, criminal amorality, and doctrinaire fanaticism, a purveyor of shoddy spiritual goods, spurious art, philosophical stutterings, and Utopian humbug, fit only to be fed wholesale to the mass man of today. That is what the post-Christian spirit looks like.

V

CHRIST, A SYMBOL OF THE SELF

[68] The dechristianization of our world, the Luciferian development of science and technology, and the frightful material and moral destruction left behind by the second World War have been compared more than once with the *eschatological* events foretold in the New Testament. These, as we know, are concerned with the coming of the Antichrist: “This is Antichrist, who denieth the Father and the Son.”¹ “Every spirit that dissolveth Jesus ... is Antichrist ... of whom you have heard that he cometh.”² The Apocalypse is full of expectations of terrible things that will take place at the end of time, before the marriage of the Lamb. This shows plainly that the *anima christiana* has a sure knowledge not only of the existence of an adversary but also of his future usurpation of power.

[69] Why—my reader will ask—do I discourse here upon Christ and his adversary, the Antichrist? Our discourse necessarily brings us to Christ, because he is the still living myth of our culture. He is our culture hero, who, regardless of his historical existence, embodies the myth of the divine Primordial Man, the mystic Adam. It is he who occupies the centre of the Christian mandala, who is the Lord of the Tetramorph, i.e., the four symbols of the evangelists, which are like the four columns of his throne. He is in us and we in him. His kingdom is the pearl of great price, the treasure buried in the field, the grain of mustard seed which will become a great tree, and the heavenly city.³ As Christ is in us, so also is his heavenly kingdom.⁴

[70] These few, familiar references should be sufficient to make the psychological position of the Christ symbol quite clear. *Christ exemplifies the archetype of the self.*⁵ He represents a totality of a divine or heavenly kind, a glorified man, a son of God *sine macula peccati*, unspotted by sin. As *Adam secundus* he corresponds to the first Adam before the Fall, when the latter was still a pure image of God, of which Tertullian (d. 222) says: “And this therefore is to be considered as the image of God in man, that the human spirit has the same motions and senses as God has, though not in the same way as God has them.”⁶ Origen (185–254) is very much more explicit: The *imago Dei* imprinted on the soul, not on the body,⁷ is an image of an image, “for my soul is not directly the image of God, but is made after the likeness of the former image.”⁸ Christ, on the other hand, is the true image of God,⁹ after whose likeness our inner man is made, invisible, incorporeal, incorrupt, and immortal.¹⁰ The God-image in us reveals itself through “*prudentia, iustitia, moderatio, virtus, sapientia et disciplina.*”¹¹

[71] St. Augustine (354–430) distinguishes between the God-image which is Christ and the image which is implanted in man as a means or possibility of becoming like God.¹² The God-image is not in the corporeal man, but in the *anima rationalis*, the possession of which

distinguishes man from animals. “The God-image is within, not in the body. ... Where the understanding is, where the mind is, where the power of investigating truth is, there God has his image.”¹³ Therefore we should remind ourselves, says Augustine, that we are fashioned after the image of God nowhere save in the understanding: “... but where man knows himself to be made after the image of God, there he knows there is something more in him than is given to the beasts.”¹⁴ From this it is clear that the God-image is, so to speak, identical with the *anima rationalis*. The latter is the higher spiritual man, the *homo coelestis* of St Paul.¹⁵ Like Adam before the Fall, Christ is an embodiment of the God-image,¹⁶ whose totality is specially emphasized by St. Augustine. “The Word,” he says, “took on complete manhood, as it were in its fulness: the soul and body of a man. And if you would have me put it more exactly—since even a beast of the field has a ‘soul’ and a body—when I say a human soul and human flesh, I mean he took upon him a complete human soul.”¹⁷

[72] The God-image in man was not destroyed by the Fall but was only damaged and corrupted (“deformed”), and can be restored through God’s grace. The scope of the integration is suggested by the *descensus ad inferos*, the descent of Christ’s soul to hell, its work of redemption embracing even the dead. The psychological equivalent of this is the integration of the collective unconscious which forms an essential part of the individuation process. St. Augustine says: “Therefore our end must be our perfection, but our perfection is Christ,”¹⁸ since he is the perfect God-image. For this reason he is also called “King.” His bride (*sponsa*) is the human soul, which “in an inwardly hidden spiritual mystery is joined to the Word, that two may be in one flesh,” to correspond with the mystic marriage of Christ and the Church.¹⁹ Concurrently with the continuance of this *hieros gamos* in the dogma and rites of the Church, the symbolism developed in the course of the Middle Ages into the alchemical conjunction of opposites, or “chymical wedding,” thus giving rise on the one hand to the concept of the *lapis philosophorum*, signifying totality, and on the other hand to the concept of chemical combination.

[73] The God-image in man that was damaged by the first sin can be “reformed”²⁰ with the help of God, in accordance with Romans 12:2: “And be not conformed to this world, but be transformed by the renewal of your mind, that you may prove what is ... the will of God” (RSV). The totality images which the unconscious produces in the course of an individuation process are similar “reformations” of an *a priori* archetype (the mandala).²¹ As I have already emphasized, the spontaneous symbols of the self, or of wholeness, cannot in practice be distinguished from a God-image. Despite the word *μεταμορφουῖσθε* (‘be transformed’) in the Greek text of the above quotation, the “renewal” (*ἀνακαίνωσις*, *reformatio*) of the mind is not meant as an actual alteration of consciousness, but rather as the restoration of an original condition, an apocatastasis. This is in exact agreement with the empirical findings of psychology, that there is an ever-present archetype of wholeness²² which may easily disappear from the purview of consciousness or may never be perceived at all until a consciousness illuminated by conversion recognizes it in the figure of Christ. As a result of this “anamnesis” the original state of oneness with the God-image is restored. It brings about an integration, a bridging of the split in the personality caused by the instincts striving apart in different and mutually contradictory directions. The only time the

split does not occur is when a person is still as legitimately unconscious of his instinctual life as an animal. But it proves harmful and impossible to endure when an artificial unconsciousness—a repression—no longer reflects the life of the instincts.

[74] There can be no doubt that the original Christian conception of the *imago Dei* embodied in Christ meant an all-embracing totality that even includes the animal side of man. Nevertheless the Christ-symbol lacks wholeness in the modern psychological sense, since it does not include the dark side of things but specifically excludes it in the form of a Luciferian opponent. Although the exclusion of the power of evil was something the Christian consciousness was well aware of, all it lost in effect was an insubstantial shadow, for, through the doctrine of the *privatio boni* first propounded by Origen, evil was characterized as a mere diminution of good and thus deprived of substance. According to the teachings of the Church, evil is simply “the accidental lack of perfection.” This assumption resulted in the proposition “omne bonum a Deo, omne malum ab homine.” Another logical consequence was the subsequent elimination of the devil in certain Protestant sects.

[75] Thanks to the doctrine of the *privatio boni*, wholeness seemed guaranteed in the figure of Christ. One must, however, take evil rather more substantially when one meets it on the plane of empirical psychology. There it is simply the opposite of good. In the ancient world the Gnostics, whose arguments were very much influenced by psychic experience, tackled the problem of evil on a broader basis than the Church Fathers. For instance, one of the things they taught was that Christ “cast off his shadow from himself.”²³ If we give this view the weight it deserves, we can easily recognize the cut-off counterpart in the figure of Antichrist. The Antichrist develops in legend as a perverse imitator of Christ’s life. He is a true ἀντιμιμῶν πνεῦμα, an imitating spirit of evil who follows in Christ’s footsteps like a shadow following the body. This complementing of the bright but one-sided figure of the Redeemer—we even find traces of it in the New Testament—must be of especial significance. And indeed, considerable attention was paid to it quite early.

[76] If we see the traditional figure of Christ as a parallel to the psychic manifestation of the self, then the Antichrist would correspond to the shadow of the self, namely the dark half of the human totality, which ought not to be judged too optimistically. So far as we can judge from experience, light and shadow are so evenly distributed in man’s nature that his psychic totality appears, to say the least of it, in a somewhat murky light. The psychological concept of the self, in part derived from our knowledge of the whole man, but for the rest depicting itself spontaneously in the products of the unconscious as an archetypal quaternity bound together by inner antinomies, cannot omit the shadow that belongs to the light figure, for without it this figure lacks body and humanity. In the empirical self, light and shadow form a paradoxical unity. In the Christian concept, on the other hand, the archetype is hopelessly split into two irreconcilable halves, leading ultimately to a metaphysical dualism—the final separation of the kingdom of heaven from the fiery world of the damned.

[77] For anyone who has a positive attitude towards Christianity the problem of the Antichrist is a hard nut to crack. It is nothing less than the counterstroke of the devil,

provoked by God's Incarnation; for the devil attains his true stature as the adversary of Christ, and hence of God, only after the rise of Christianity, while as late as the Book of Job he was still one of God's sons and on familiar terms with Yahweh.²⁴ Psychologically the case is clear, since the dogmatic figure of Christ is so sublime and spotless that everything else turns dark beside it. It is, in fact, so one-sidedly perfect that it demands a psychic complement to restore the balance. This inevitable opposition led very early to the doctrine of the two sons of God, of whom the elder was called Satanaël.²⁵ The coming of the Antichrist is not just a prophetic prediction—it is an inexorable psychological law whose existence, though unknown to the author of the Johannine Epistles, brought him a sure knowledge of the impending enantiodromia. Consequently he wrote as if he were conscious of the inner necessity for this transformation, though we may be sure that the idea seemed to him like a divine revelation. In reality every intensified differentiation of the Christ-image brings about a corresponding accentuation of its unconscious complement, thereby increasing the tension between above and below.

[78] In making these statements we are keeping entirely within the sphere of Christian psychology and symbolism. A factor that no one has reckoned with, however, is the fatality inherent in the Christian disposition itself, which leads inevitably to a reversal of its spirit—not through the obscure workings of chance but in accordance with psychological law. The ideal of spirituality striving for the heights was doomed to clash with the materialistic earth-bound passion to conquer matter and master the world. This change became visible at the time of the "Renaissance." The word means "rebirth," and it referred to the renewal of the antique spirit. We know today that this spirit was chiefly a mask; it was not the spirit of antiquity that was reborn, but the spirit of medieval Christianity that underwent strange pagan transformations, exchanging the heavenly goal for an earthly one, and the vertical of the Gothic style for a horizontal perspective (voyages of discovery, exploration of the world and of nature). The subsequent developments that led to the Enlightenment and the French Revolution have produced a worldwide situation today which can only be called "antichristian" in a sense that confirms the early Christian anticipation of the "end of time." It is as if, with the coming of Christ, opposites that were latent till then had become manifest, or as if a pendulum had swung violently to one side and were now carrying out the complementary movement in the opposite direction. No tree, it is said, can grow to heaven unless its roots reach down to hell. The double meaning of this movement lies in the nature of the pendulum. Christ is without spot, but right at the beginning of his career there occurs the encounter with Satan, the Adversary, who represents the counterpole of that tremendous tension in the world psyche which Christ's advent signified. He is the "mysterium iniquitatis" that accompanies the "sol iustitiae" as inseparably as the shadow belongs to the light, in exactly the same way, so the Ebionites²⁶ and Euchites²⁷ thought, that one brother cleaves to the other. Both strive for a kingdom: one for the kingdom of heaven, the other for the "principatus huius mundi." We hear of a reign of a "thousand years" and of a "coming of the Antichrist," just as if a partition of worlds and epochs had taken place between two royal brothers. The meeting with Satan was therefore more than mere chance; it was a link in the chain.

[79] Just as we have to remember the gods of antiquity in order to appreciate the psychological value of the anima/animus archetype, so Christ is our nearest analogy of the self and its meaning. It is naturally not a question of a collective value artificially manufactured or arbitrarily awarded, but of one that is effective and present *per se*, and that makes its effectiveness felt whether the subject is conscious of it or not. Yet, although the attributes of Christ (consubstantiality with the Father, coeternity, filiation, parthenogenesis, crucifixion, Lamb sacrificed between opposites, One divided into Many, etc.) undoubtedly mark him out as an embodiment of the self, looked at from the psychological angle he corresponds to only one half of the archetype. The other half appears in the Antichrist. The latter is just as much a manifestation of the self, except that he consists of its dark aspect. Both are Christian symbols, and they have the same meaning as the image of the Saviour crucified between two thieves. This great symbol tells us that the progressive development and differentiation of consciousness leads to an ever more menacing awareness of the conflict and involves nothing less than a crucifixion of the ego, its agonizing suspension between irreconcilable opposites.²⁸ Naturally there can be no question of a total extinction of the ego, for then the focus of consciousness would be destroyed, and the result would be complete unconsciousness. The relative abolition of the ego affects only those supreme and ultimate decisions which confront us in situations where there are insoluble conflicts of duty. This means, in other words, that in such cases the ego is a suffering bystander who decides nothing but must submit to a decision and surrender unconditionally. The “genius” of man, the higher and more spacious part of him whose extent no one knows, has the final word. It is therefore well to examine carefully the psychological aspects of the individuation process in the light of Christian tradition, which can describe it for us with an exactness and impressiveness far surpassing our feeble attempts, even though the Christian image of the self—Christ—lacks the shadow that properly belongs to it.

[80] The reason for this, as already indicated, is the doctrine of the Summum Bonum. Irenaeus says very rightly, in refuting the Gnostics, that exception must be taken to the “light of their Father,” because it “could not illuminate and fill even those things which were within it,”²⁹ namely the shadow and the void. It seemed to him scandalous and reprehensible to suppose that within the pleroma of light there could be a “dark and formless void.” For the Christian neither God nor Christ could be a paradox; they had to have a single meaning, and this holds true to the present day. No one knew, and apparently (with a few commendable exceptions) no one knows even now, that the hybris of the speculative intellect had already emboldened the ancients to propound a philosophical definition of God that more or less obliged him to be the Summum Bonum. A Protestant theologian has even had the temerity to assert that “God *can* only be good.” Yahweh could certainly have taught him a thing or two in this respect, if he himself is unable to see his intellectual trespass against God’s freedom and omnipotence. This forcible usurpation of the Summum Bonum naturally has its reasons, the origins of which lie far back in the past (though I cannot enter into this here). Nevertheless, it is the effective source of the concept of the *privatio boni*, which nullifies the reality of evil and can be found as early as Basil the

Great (330–79) and Dionysius the Areopagite (2nd half of the 4th century), and is fully developed in Augustine.

[81] The earliest authority of all for the later axiom “Omne bonum a Deo, omne malum ab homine” is Tatian (2nd century), who says: “Nothing evil was created by God; we ourselves have produced all wickedness.”³⁰ This view is also adopted by Theophilus of Antioch (2nd century) in his treatise *Ad Autolyicum*.³¹

[82] Basil says:

You must not look upon God as the author of the existence of evil, nor consider that evil has any subsistence in itself [ιδίαν ὑπόστασιν τοῦ κακοῦ εἶναι]. For evil does not subsist as a living being does, nor can we set before our eyes any substantial essence [οὐσίαν ἐνυπόστατον] thereof. For evil is the privation [στέρησις] of good. ... And thus evil does not inhere in its own substance [ἐν ἰδίᾳ ὑπάρξει], but arises from the mutilation [πηρώμασιν] of the soul.³² Neither is it uncreated, as the wicked say who set up evil for the equal of good ... nor is it created. For if all things are of God, how can evil arise from good?³³

[83] Another passage sheds light on the logic of this statement. In the second homily of the *Hexaemeron*, Basil says:

It is equally impious to say that evil has its origin from God, because the contrary cannot proceed from the contrary. Life does not engender death, darkness is not the origin of light, sickness is not the maker of health. ... Now if evil is neither uncreated nor created by God, whence comes its nature? That evil exists no one living in the world will deny. What shall we say, then? That evil is not a living and animated entity, but a condition [δι᾿ ἄθεσις] of the soul opposed to virtue, proceeding from light-minded [ῥαθύμοις] persons on account of their falling away from good. ... Each of us should acknowledge that he is the first author of the wickedness in him.³⁴

[84] The perfectly natural fact that when you say “high” you immediately postulate “low” is here twisted into a causal relationship and reduced to absurdity, since it is sufficiently obvious that darkness produces no light and light produces no darkness. The idea of good and evil, however, is the premise for any moral judgment. They are a logically equivalent pair of opposites and, as such, the *sine qua non* of all acts of cognition. From the empirical standpoint we cannot say more than this. And from this standpoint we would have to assert that good and evil, being coexistent halves of a moral judgment, do not derive from one another but are always there together. Evil, like good, belongs to the category of human values, and we are the authors of moral value judgments, but only to a limited degree are we authors of the facts submitted to our moral judgment. These facts are called by one person good and by another evil. Only in capital cases is there anything like a *consensus generalis*. If we hold with Basil that man is the author of evil, we are saying in the same breath that he is also the author of good. But man is first and foremost the author merely of judgments; in relation to the facts judged, his responsibility is not so easy to determine. In order to do this,

we would have to give a clear definition of the extent of his free will. The psychiatrist knows what a desperately difficult task this is.

[85] For these reasons the psychologist shrinks from metaphysical assertions but must criticize the admittedly human foundations of the *privatio boni*. When therefore Basil asserts on the one hand that evil has no substance of its own but arises from a “mutilation of the soul,” and if on the other hand he is convinced that evil really exists, then the relative reality of evil is grounded on a real “mutilation” of the soul which must have an equally real cause. If the soul was originally created good, then it has really been corrupted and by something that is real, even if this is nothing more than carelessness, indifference, and frivolity, which are the meaning of the word ῥαθυμία. When something—I must stress this with all possible emphasis—is traced back to a psychic condition or fact, it is very definitely not reduced to nothing and thereby nullified, but is shifted on to the plane of *psychic reality*, which is very much easier to establish empirically than, say, the reality of the devil in dogma, who according to the authentic sources was not invented by man at all but existed long before he did. If the devil fell away from God of his own free will, this proves firstly that evil was in the world before man, and therefore that man cannot be the sole author of it, and secondly that the devil already had a “mutilated” soul for which we must hold a real cause responsible. The basic flaw in Basil’s argument is the *petitio principii* that lands him in insoluble contradictions: it is laid down from the start that the independent existence of evil must be denied even in face of the eternity of the devil as asserted by dogma. The historical reason for this was the threat presented by Manichaeism. This is especially clear in the treatise of Titus of Bostra (d. c. 370), entitled *Adversus Manichaeos*³⁵ where he states in refutation of the Manichaeans that, so far as substance is concerned, there is no such thing as evil.

[86] John Chrysostom (c. 344–407) uses, instead of στέρησις (*privatio*), the expression ἐκτροπή τοῦ καλοῦ (deviation, or turning away, from good). He says: “Evil is nothing other than a turning away from good, and therefore evil is secondary in relation to good.”³⁶

[87] Dionysius the Areopagite gives a detailed explanation of evil in the fourth chapter of *De divinis nominibus*. Evil, he says, cannot come from good, because if it came from good it would not be evil. But since everything that exists comes from good, everything is in some way good, but “evil does not exist at all” (τὸ δὲ κακὸν οὔτε ὄν ἐστίν).

[88] Evil in its nature is neither a thing nor does it bring anything forth.

Evil does not exist at all and is neither good nor productive of good [οὐκ ἔστι καθόλου τὸ κακὸν οὔτε ἀγαθὸν οὔτε ἀγαθοποιόν].

All things which are, by the very fact that they are, are good and come from good; but in so far as they are deprived of good, they are neither good nor do they exist.

That which has no existence is not altogether evil, for the absolutely non-existent will be nothing, unless it be thought of as subsisting in the good superessentially [κατὰ τὸ ὑπερούσιον]. Good, then, as absolutely existing and as absolutely non-existing, will stand in the foremost and highest place [πολλῶ πρότερον ὑπεριδρίμενον], while evil is

neither in that which exists nor in that which does not exist [τὸ δὲ κακὸν οὔτε ἐν τοῖς οὐσίῳ, οὔτε ἐν τοῖς μὴ οὐσίῳ].³⁷

[89] These quotations show with what emphasis the reality of evil was denied by the Church Fathers. As already mentioned, this hangs together with the Church's attitude to Manichaeism, as can plainly be seen in St. Augustine. In his polemic against the Manichaeans and Marcionites he makes the following declaration:

For this reason all things are good, since some things are better than others and the goodness of the less good adds to the glory of the better. ... Those things we call evil, then, are defects in good things, and quite incapable of existing in their own right outside good things. ... But those very defects testify to the natural goodness of things. For what is evil by reason of a defect must obviously be good of its own nature. For a defect is something contrary to nature, something which damages the nature of a thing—and it can do so only by diminishing that thing's goodness. *Evil therefore is nothing but the privation of good.* And thus it can have no existence anywhere except in some good thing. ... So there can be things which are good without any evil in them, such as God himself, and the higher celestial beings; but there can be no evil things without good. For if evils cause no damage to anything, they are not evils; if they do damage something, they diminish its goodness; and if they damage it still more, it is because it still has some goodness which they diminish; and if they swallow it up altogether, nothing of its nature is left to be damaged. And so there will be no evil by which it can be damaged, since there is then no nature left whose goodness any damage can diminish.³⁸

[90] The *Liber Sententiarum ex Augustino* says (CLXXVI): “Evil is not a substance,³⁹ for as it has not God for its author, it does not exist; and so the defect of corruption is nothing else than the desire or act of a misdirected will.”⁴⁰ Augustine agrees with this when he says: “The steel is not evil; but the man who uses the steel for a criminal purpose, he is evil.”⁴¹

[91] These quotations clearly exemplify the standpoint of Dionysius and Augustine: evil has no substance or existence in itself, since it is merely a diminution of good, which alone has substance. Evil is a *vitium*, a bad use of things as a result of erroneous decisions of the will (blindness due to evil desire, etc.). Thomas Aquinas, the great theoretician of the Church, says with reference to the above quotation from Dionysius:

One opposite is known through the other, as darkness is known through light. Hence also what evil is must be known from the nature of good. Now we have said above that good is everything appetible; and thus, since every nature desires its own being and its own perfection, it must necessarily be said that the being and perfection of every created thing is essentially good. Hence it cannot be that evil signifies a being, or any form or nature. Therefore it must be that by the name of evil is signified the absence of good.⁴²

Evil is not a being, whereas good is a being.⁴³

That every agent works for an end clearly follows from the fact that every agent tends to something definite. Now that to which an agent tends definitely must needs be befiting to that agent, since the latter would not tend to it save on account of some fittingness thereto.

But that which is befitting to a thing is good for it. Therefore every agent works for a good.⁴⁴

[92] St. Thomas himself recalls the saying of Aristotle that “the thing is the whiter, the less it is mixed with black,”⁴⁵ without mentioning, however, that the reverse proposition: “the thing is the blacker, the less it is mixed with white,” not only has the same validity as the first but is also its logical equivalent. He might also have mentioned that not only darkness is known through light, but that, conversely, light is known through darkness.

[93] As only that which works is real, so, according to St. Thomas, only good is real in the sense of “existing.” His argument, however, introduces a good that is tantamount to “convenient, sufficient, appropriate, suitable.” One ought therefore to translate “omne agens agit propter bonum” as: “Every agent works for the sake of what suits it.” That’s what the devil does too, as we all know. He too has an “appetite” and strives after perfection—not in good but in evil. Even so, one could hardly conclude from this that his striving is “essentially good.”

[94] Obviously evil can be represented as a diminution of good, but with this kind of logic one could just as well say: The temperature of the Arctic winter, which freezes our noses and ears, is relatively speaking only a little below the heat prevailing at the equator. For the Arctic temperature seldom falls much lower than 230° C. above absolute zero. All things on earth are “warm” in the sense that nowhere is absolute zero even approximately reached. Similarly, all things are more or less “good,” and just as cold is nothing but a diminution of warmth, so evil is nothing but a diminution of good. The *privatio boni* argument remains a euphemistic *petitio principii* no matter whether evil is regarded as a lesser good or as an effect of the finiteness and limitedness of created things. The false conclusion necessarily follows from the premise “Deus = Summum Bonum,” since it is unthinkable that the perfect good could ever have created evil. It merely created the good and the less good (which last is simply called “worse” by laymen).⁴⁶ Just as we freeze miserably despite a temperature of 230° above absolute zero, so there are people and things that, although created by God, are good only to the minimal and bad to the maximal degree.

[95] It is probably from this tendency to deny any reality to evil that we get the axiom “Omne bonum a Deo, omne malum ab homine.” This is a contradiction of the truth that he who created the heat is also responsible for the cold (“the goodness of the less good”). We can certainly hand it to Augustine that all natures are good, yet just not good enough to prevent their badness from being equally obvious.

*

[96] One could hardly call the things that have happened, and still happen, in the concentration camps of the dictator states an “accidental lack of perfection”—it would sound like mockery.

[97] Psychology does not know what good and evil are in themselves; it knows them only as judgments about relationships. “Good” is what seems suitable, acceptable, or valuable from

a certain point of view; evil is its opposite. If the things we call good are “really” good, then there must be evil things that are “real” too. It is evident that psychology is concerned with a more or less subjective judgment, i.e., with a psychic antithesis that cannot be avoided in naming value relationships: “good” denotes something that is not bad, and “bad” something that is not good. There are things which from a certain point of view are extremely evil, that is to say dangerous. There are also things in human nature which are very dangerous and which therefore seem proportionately evil to anyone standing in their line of fire. It is pointless to gloss over these evil things, because that only lulls one into a sense of false security. Human nature is capable of an infinite amount of evil, and the evil deeds are as real as the good ones so far as human experience goes and so far as the psyche judges and differentiates between them. Only unconsciousness makes no difference between good and evil. Inside the psychological realm one honestly does not know which of them predominates in the world. We hope, merely, that good does—i.e., what seems suitable to us. No one could possibly say what the general good might be. No amount of insight into the relativity and fallibility of our moral judgment can deliver us from these defects, and those who deem themselves beyond good and evil are usually the worst tormentors of mankind, because they are twisted with the pain and fear of their own sickness.

[98] Today as never before it is important that human beings should not overlook the danger of the evil lurking within them. It is unfortunately only too real, which is why psychology must insist on the reality of evil and must reject any definition that regards it as insignificant or actually non-existent. Psychology is an empirical science and deals with realities. As a psychologist, therefore, I have neither the inclination nor the competence to mix myself up with metaphysics. Only, I have to get polemical when metaphysics encroaches on experience and interprets it in a way that is not justified empirically. My criticism of the *privatio boni* holds only so far as psychological experience goes. From the scientific point of view the *privatio boni*, as must be apparent to everyone, is founded on a *petitio principii*, where what invariably comes out at the end is what you put in at the beginning. Arguments of this kind have no power of conviction. But the fact that such arguments are not only used but are undoubtedly believed is something that cannot be disposed of so easily. It proves that there is a tendency, existing right from the start, to give priority to “good,” and to do so with all the means in our power, whether suitable or unsuitable. So if Christian metaphysics clings to the *privatio boni*, it is giving expression to the tendency always to increase the good and diminish the bad. The *privatio boni* may therefore be a metaphysical truth. I presume to no judgment on this matter. I must only insist that in our field of experience white and black, light and dark, good and bad, are equivalent opposites which always predicate one another.

[99] This elementary fact was correctly appreciated in the so-called Clementine Homilies,⁴⁷ a collection of Gnostic-Christian writings dating from about A.D. 150. The unknown author understands good and evil as the right and left hand of God, and views the whole of creation in terms of syzygies, or pairs of opposites. In much the same way the follower of Bardesanes, Marinus, sees good as “light” and pertaining to the right hand (δεξιόν), and evil as “dark” and pertaining to the left hand (ἀριστερόν).⁴⁸ The left also corresponds to the

feminine. Thus in Irenaeus (*Adv. haer.*, I, 30, 3), Sophia Prounikos is called Sinistra. Clement finds this altogether compatible with the idea of God's unity. Provided that one has an anthropomorphic God-image—and every God-image is anthropomorphic in a more or less subtle way—the logic and naturalness of Clement's view can hardly be contested. At all events this view, which may be some two hundred years older than the quotations given above, proves that the reality of evil does not necessarily lead to Manichaean dualism and so does not endanger the unity of the God-image. As a matter of fact, it guarantees that unity on a plane beyond the crucial difference between the Yahwistic and the Christian points of view. Yahweh is notoriously unjust, and injustice is not good. The God of Christianity, on the other hand, is *only* good. There is no denying that Clement's theology helps us to get over this contradiction in a way that fits the psychological facts.

[100] It is therefore worth following up Clement's line of thought a little more closely. "God," he says, "appointed two kingdoms [βασιλείας] and two ages [αἰῶνας], determining that the present world should be given over to evil [πονηρῶ], because it is small and passes quickly away. But he promised to preserve the future world for good, because it is great and eternal." Clement goes on to say that this division into two corresponds to the structure of man: the body comes from the female, who is characterized by emotionality; the spirit comes from the male, who stands for rationality. He calls body and spirit the "two triads."⁴⁹

Man is a compound of two mixtures [ἄνθρωπος, lit. 'paste'], the female and the male. Wherefore also two ways have been laid before him—those of obedience and of disobedience to law; and two kingdoms have been established—the one called the kingdom of heaven, and the other the kingdom of those who are now rulers upon earth. ... Of these two, the one does violence to the other. Moreover these two rulers are the swift hands of God.

That is a reference to Deuteronomy 32 : 39: "I will kill and I will make to live" (DV). He kills with the left hand and saves with the right.

These two principles have not their substance outside of God, for there is no other primal source [ἀρχὴ]. Nor have they been sent forth from God as animals, for they were of the same mind [ὁμόδοξοι] with him. ... But from God were sent forth the four first elements—hot and cold, moist and dry. In consequence of this, he is the Father of every substance [οὐσίας], but not of the knowledge which arises from the mixing of the elements.⁵⁰ For when these were combined from without, choice [προαίρεσις] was begotten in them as a child.⁵¹

That is to say, through the mixing of the four elements inequalities arose which caused uncertainty and so necessitated decisions or acts of choice. The four elements form the fourfold substance of the body (τετραγενῆς τοῦ σώματος οὐσία) and also of evil (τοῦ πονηροῦ). This substance was "carefully discriminated and sent forth from God, but when it was combined from without, according to the will of him who sent it forth, there arose, as a result of the combination, the preference which rejoices in evils [ἡ κακοῖς χαίρουσα προαίρεσις]."⁵²

[101] The last sentence is to be understood as follows: The fourfold substance is eternal (οὔσα αἰεί) and God's child. But the tendency to evil was added from outside to the mixture willed by God (κατὰ τὴν τοῦ θεοῦ βούλησιν ἔξω τῆ κράσει συμβέβηκεν). Thus evil is not created by God or by any one else, nor was it projected out of him, nor did it arise of itself. Peter, who is engaged in these reflections, is evidently not quite sure how the matter stands.

[102] It seems as if, without God's intending it (and possibly without his knowing it) the mixture of the four elements took a wrong turning, though this is rather hard to square with Clement's idea of the opposite hands of God "doing violence to one another." Obviously Peter, the leader of the dialogue, finds it rather difficult to attribute the cause of evil to the Creator in so many words.

[103] The author of the Homilies espouses a Petrine Christianity distinctly "High Church" or ritualistic in flavour. This, taken together with his doctrine of the dual aspect of God, brings him into close relationship with the early Jewish-Christian Church, where, according to the testimony of Epiphanius, we find the Ebionite notion that God had two sons, an elder one, Satan, and a younger one, Christ.⁵³ Michaias, one of the speakers in the dialogue, suggests as much when he remarks that if good and evil were begotten in the same way they must be brothers.⁵⁴

[104] In the (Jewish-Christian?) apocalypse, the "Ascension of Isaiah," we find, in the middle section, Isaiah's vision of the seven heavens through which he was rapt.⁵⁵ First he saw Sammaël and his hosts, against whom a "great battle" was raging in the firmament. The angel then wafted him beyond this into the first heaven and led him before a throne. On the right of the throne stood angels who were more beautiful than the angels on the left. Those on the right "all sang praises with *one* voice," but the ones on the left sang *after* them, and their singing was not like the singing of the first. In the second heaven all the angels were more beautiful than in the first heaven, and there was no difference between them, either here or in any of the higher heavens. Evidently Sammaël still has a noticeable influence on the first heaven, since the angels on the left are not so beautiful there. Also, the lower heavens are not so splendid as the upper ones, though each surpasses the other in splendour. The devil, like the Gnostic archons, dwells in the firmament, and he and his angels presumably correspond to astrological gods and influences. The gradation of splendour, going all the way up to the topmost heaven, shows that his sphere interpenetrates with the divine sphere of the Trinity, whose light in turn filters down as far as the lowest heaven. This paints a picture of complementary opposites balancing one another like right and left hands. Significantly enough, this vision, like the Clementine Homilies, belongs to the pre-Manichaeic period (second century), when there was as yet no need for Christianity to fight against its Manichaeic competitors. It might easily be a description of a genuine yang-yin relationship, a picture that comes closer to the actual truth than the *privatio boni*. Moreover, it does not damage monotheism in any way, since it unites the opposites just as yang and yin are united in Tao (which the Jesuits quite logically translated as "God"). It is as if Manichaeic dualism first made the Fathers conscious of the fact that until then, without clearly realizing it, they had always believed firmly in the substantiality of evil. This sudden

realization might well have led them to the dangerously anthropomorphic assumption that what man cannot unite, God cannot unite either. The early Christians, thanks to their greater unconsciousness, were able to avoid this mistake.

[105] Perhaps we may risk the conjecture that the problem of the Yahwistic God-image, which had been constellated in men's minds ever since the Book of Job, continued to be discussed in Gnostic circles and in syncretistic Judaism generally, all the more eagerly as the Christian answer to this question—namely the unanimous decision in favour of God's goodness⁵⁶—did not satisfy the conservative Jews. In this respect, therefore, it is significant that the doctrine of the two antithetical sons of God originated with the Jewish Christians living in Palestine. Inside Christianity itself the doctrine spread to the Bogomils and Cathars; in Judaism it influenced religious speculation and found lasting expression in the two sides of the cabalistic Tree of the Sephiroth, which were named *hesed* (love) and *din* (justice). A rabbinical scholar, Zwi Werblowsky, has been kind enough to put together for me a number of passages from Hebrew literature which have bearing on this problem.

[106] R. Joseph taught: "What is the meaning of the verse, 'And none of you shall go out at the door of his house until the morning?' (Exodus 12 : 22.)⁵⁷ Once permission has been granted to the destroyer, he does not distinguish between the righteous and the wicked. Indeed, he even begins with the righteous."⁵⁸ Commenting on Exodus 33 : 5 ("If for a single moment I should go up among you, I would consume you"), the midrash says: "Yahweh means he could wax wroth with you for a moment—for that is the length of his wrath, as is said in Isaiah 26 : 20, 'Hide yourselves for a little moment until the wrath is past'—and destroy you." Yahweh gives warning here of his unbridled irascibility. If in this moment of divine wrath a curse is uttered, it will indubitably be effective. That is why Balaam, "who knows the thoughts of the Most High,"⁵⁹ when called upon by Balak to curse Israel, was so dangerous an enemy, because he knew the moment of Yahweh's wrath.⁶⁰

[107] God's love and mercy are named his right hand, but his justice and his administration of it are named his left hand. Thus we read in I Kings 22 : 19: "I saw the Lord sitting on his throne, and all the host of heaven standing beside him on his right hand and on his left." The midrash comments: "Is there right and left on high? This means that the intercessors stand on the right and the accusers on the left."⁶¹ The comment on Exodus 15 : 6 ("Thy right hand, O Lord, glorious in power, thy right hand, O Lord, shatters the enemy") runs: "When the children of Israel perform God's will, they make the left hand his right hand. When they do not do his will, they make even the right hand his left hand."⁶² "God's left hand dashes to pieces; his right hand is glorious to save."⁶³

[108] The dangerous aspect of Yahweh's justice comes out in the following passage: "Even so said the Holy One, blessed be He: If I create the world on the basis of mercy alone, its sins will be great; but on the basis of justice alone the world cannot exist. Hence I will create it on the basis of justice and mercy, and may it then stand!"⁶⁴ The midrash on Genesis 18 : 23 (Abraham's plea for Sodom) says (Abraham speaking): "If thou desirest the world to endure, there can be no absolute justice, while if thou desirest absolute justice, the world

cannot endure. Yet thou wouldst hold the cord by both ends, desiring both the world and absolute justice. Unless thou forgoest a little, the world cannot endure.”⁶⁵

[109] Yahweh prefers the repentant sinners even to the righteous, and protects them from his justice by covering them with his hand or by hiding them under his throne.⁶⁶

[110] With reference to Habakkuk 2 : 3 (“For still the vision awaits its time. ... If it seem slow, wait for it”), R. Jonathan says: “Should you say, *We* wait [for his coming] but *He* does not, it stands written (Isaiah 30 : 18), ‘Therefore will the Lord wait, that he may be gracious unto you.’ ... But since we wait and he waits too. what delays his coming? Divine justice delays it.”⁶⁷ It is in this sense that we have to understand the prayer of R. Jochanan: “May it be thy will, O Lord our God, to look upon our shame and behold our evil plight. Clothe thyself in thy mercies, cover thyself in thy strength, wrap thyself in thy loving-kindness, and gird thyself with thy graciousness, and may thy goodness and gentleness come before thee.”⁶⁸ God is properly exhorted to remember his good qualities. There is even a tradition that God prays to himself: “May it be My will that My mercy may suppress My anger, and that My compassion may prevail over My other attributes.”⁶⁹ This tradition is borne out by the following story:

R. Ishmael the son of Elisha said: I once entered the innermost sanctuary to offer incense, and there I saw Akathriel⁷⁰ Jah Jahweh Zebaoth⁷¹ seated upon a high and exalted throne. He said to me, Ishmael, my son, bless me! And I answered him: May it be Thy will that Thy mercy may suppress Thy anger, and that Thy compassion may prevail over Thy other attributes, so that Thou mayest deal with Thy children according to the attribute of mercy and stop short of the limit of strict justice! And He nodded to me with His head.⁷²

[111] It is not difficult to see from these quotations what was the effect of Job’s contradictory God-image. It became a subject for religious speculation inside Judaism and, through the medium of the Cabala, it evidently had an influence on Jakob Böhme. In his writings we find a similar ambivalence, namely the love and the “wrath-fire” of God, in which Lucifer burns for ever.⁷³

[112] Since psychology is not metaphysics, no metaphysical dualism can be derived from, or imputed to, its statements concerning the equivalence of opposites.⁷⁴ It knows that equivalent opposites are necessary conditions inherent in the act of cognition, and that without them no discrimination would be possible. It is not exactly probable that anything so intrinsically bound up with the act of cognition should be at the same time a property of the object. It is far easier to suppose that it is primarily our consciousness which names and evaluates the differences between things, and perhaps even creates distinctions where no differences are discernible.

[113] I have gone into the doctrine of the *privatio boni* at such length because it is in a sense responsible for a too optimistic conception of the evil in human nature and for a too pessimistic view of the human soul. To offset this, early Christianity, with unerring logic, balanced Christ against an Antichrist. For how can you speak of “high” if there is no “low,” or “right” if there is no “left,” of “good” if there is no “bad,” and the one is as real as the

other? Only with Christ did a devil enter the world as the real counterpart of God, and in early Jewish-Christian circles Satan, as already mentioned, was regarded as Christ's elder brother.

[114] But there is still another reason why I must lay such critical stress on the *privatio boni*. As early as Basil we meet with the tendency to attribute evil to the disposition (*διάθεσις*) of the soul, and at the same time to give it a “non-existent” character. Since, according to this author, evil originates in human frivolity and therefore owes its existence to mere negligence, it exists, so to speak, only as a by-product of psychological oversight, and this is such a *quantité négligeable* that evil vanishes altogether in smoke. Frivolity as a cause of evil is certainly a factor to be taken seriously, but it is a factor that can be got rid of by a change of attitude. We *can* act differently, if we want to. Psychological causation is something so elusive and seemingly unreal that everything which is reduced to it inevitably takes on the character of futility or of a purely accidental mistake and is thereby minimized to the utmost. It is an open question how much of our modern undervaluation of the psyche stems from this prejudice. This prejudice is all the more serious in that it causes the psyche to be suspected of being the birthplace of all evil. The Church Fathers can hardly have considered what a fatal power they were ascribing to the soul. One must be positively blind not to see the colossal role that evil plays in the world. Indeed, it took the intervention of God himself to deliver humanity from the curse of evil, for without his intervention man would have been lost. If this paramount power of evil is imputed to the soul, the result can only be a negative inflation—i.e., a daemonic claim to power on the part of the unconscious which makes it all the more formidable. This unavoidable consequence is anticipated in the figure of the Antichrist and is reflected in the course of contemporary events, whose nature is in accord with the Christian aeon of the Fishes, now running to its end.

[115] In the world of Christian ideas Christ undoubtedly represents the self.⁷⁵ As the apotheosis of individuality, the self has the attributes of uniqueness and of occurring once only in time. But since the psychological self is a transcendent concept, expressing the totality of conscious and unconscious contents, it can only be described in antinomial terms;⁷⁶ that is, the above attributes must be supplemented by their opposites if the transcendental situation is to be characterized correctly. We can do this most simply in the form of a quaternion of opposites:

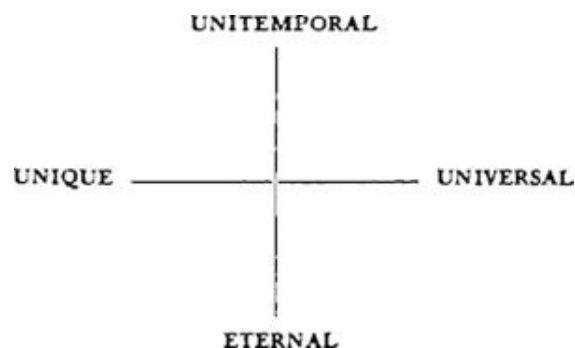

[116] This formula expresses not only the psychological self but also the dogmatic figure of Christ. As an historical personage Christ is unitemporal and unique; as God, universal and eternal. Likewise the self: as the essence of individuality it is unitemporal and unique; as an

archetypal symbol it is a God-image and therefore universal and eternal.⁷⁷ Now if theology describes Christ as simply “good” and “spiritual,” something “evil” and “material”—or “chthonic”—is bound to arise on the other side, to represent the Antichrist. The resultant quaternion of opposites is united on the psychological plane by the fact that the self is not deemed exclusively “good” and “spiritual”; consequently its shadow turns out to be much less black. A further result is that the opposites of “good” and “spiritual” need no longer be separated from the whole:

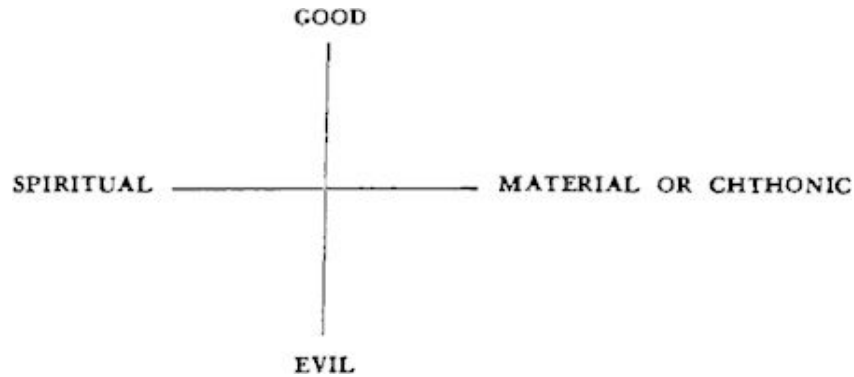

[117] This *quaternio* characterizes the psychological self. Being a totality, it must by definition include the light and dark aspects, in the same way that the self embraces both masculine and feminine and is therefore symbolized by the marriage *quaternio*.⁷⁸ This last is by no means a new discovery, since according to Hippolytus it was known to the Naassenes.⁷⁹ Hence individuation is a “mysterium coniunctionis,” the self being experienced as a nuptial union of opposite halves⁸⁰ and depicted as a composite whole in mandalas that are drawn spontaneously by patients.

[118] It was known, and stated, very early that the man Jesus, the son of Mary, was the *principium individuationis*. Thus Basilides⁸¹ is reported by Hippolytus as saying: “Now Jesus became the first sacrifice in the discrimination of the natures [φυλοκρίνησις], and the Passion came to pass for no other reason than the discrimination of composite things. For in this manner, he says, the sonship that had been left behind in a formless state [ἀμορφία] ... needed separating into its components [φυλοκρινηθῆναι], in the same way that Jesus was separated.”⁸² According to the rather complicated teachings of Basilides, the “non-existent” God begot a threefold sonship (*υἱοτήs*). The first “son,” whose nature was the finest and most subtle, remained up above with the Father. The second son, having a grosser (*παχυμερέστερα*) nature, descended a bit lower, but received “some such wing as that with which Plato ... equips the soul in his *Phaedrus*.”⁸³ The third son, as his nature needed purifying (*ἀποκαθάρσις*), fell deepest into “formlessness.” This third “sonship” is obviously the grossest and heaviest because of its impurity. In these three emanations or manifestations of the non-existent God it is not hard to see the trichotomy of spirit, soul, and body (*πνευματικόν, Ψυχικόν, σαρκικόν*). Spirit is the finest and highest; soul, as the *ligamentum spiritus et corporis*, is grosser than spirit, but has “the wings of an eagle,”⁸⁴ so that it may lift its heaviness up to the higher regions. Both are of a “subtle” nature and dwell, like the ether and the eagle, in or near the region of light, whereas the body, being heavy, dark, and impure, is deprived of the light but nevertheless contains the divine seed of the third sonship, though still *unconscious and formless*. This seed is as it were awakened

by Jesus, purified and made capable of ascension (ἀναδρομή),⁸⁵ by virtue of the fact that the opposites were separated in Jesus through the Passion (i.e., through his division into four).⁸⁶ Jesus is thus the prototype for the awakening of the third sonship slumbering in the darkness of humanity. He is the “spiritual inner man.”⁸⁷ He is also a complete trichotomy in himself, for Jesus the son of Mary represents the incarnate man, but his immediate predecessor is the second Christ, the son of the highest archon of the hebdomad, and his first prefiguration is Christ the son of the highest archon of the ogdoad, the demiurge Yahweh.⁸⁸ This trichotomy of Anthropos figures corresponds exactly to the three sonships of the non-existing God and to the division of human nature into three parts. We have therefore three trichotomies:

I	II	III
<i>First sonship</i>	<i>Christ of the Ogdoad</i>	<i>Spirit</i>
<i>Second sonship</i>	<i>Christ of the Hebdomad</i>	<i>Soul</i>
<i>Third sonship</i>	<i>Jesus the Son of Mary</i>	<i>Body</i>

[119] It is in the sphere of the dark, heavy body that we must look for the ἀμορφία, the “formlessness” wherein the third sonship lies hidden. As suggested above, this formlessness seems to be practically the equivalent of “unconsciousness.” G. Quispel has drawn attention to the concepts of ἀγνώσια in Epiphanius⁸⁹ and ἀνόητον in Hippolytus,⁹⁰ which are best translated by “unconscious.” Ἀμορφία, ἀγνώσια, and ἀνόητον all refer to the initial state of things, to the potentiality of unconscious contents, aptly formulated by Basilides as οὐκ ὄν σπέρρα τοῦ κόσμου πολύμορφον ὁμοῦ καὶ πολυούσιον (the non-existent, many-formed, and all-empowering seed of the world).⁹¹

[120] This picture of the third sonship has certain analogies with the medieval *filius philosophorum* and the *filius macrocosmi*, who also symbolize the world-soul slumbering in matter.⁹² Even with Basilides the body acquires a special and unexpected significance, since in it and its materiality is lodged a third of the revealed Godhead. This means nothing less than that matter is predicated as having considerable numinosity in itself, and I see this as an anticipation of the “mystic” significance which matter subsequently assumed in alchemy and—later on—in natural science. From a psychological point of view it is particularly important that Jesus corresponds to the third sonship and is the prototype of the “awakener” because the opposites were separated in him through the Passion and so became conscious, whereas in the third sonship itself they remain unconscious so long as the latter is formless and undifferentiated. This amounts to saying that in unconscious humanity there is a latent seed that corresponds to the prototype Jesus. Just as the man Jesus became conscious only through the light that emanated from the higher Christ and separated the natures in him, so the seed in unconscious humanity is awakened by the light emanating from Jesus, and is thereby impelled to a similar discrimination of opposites. This view is entirely in accord with the psychological fact that the archetypal image of the self has been shown to occur in dreams even when no such conceptions exist in the conscious mind of the dreamer.⁹³

[121] I would not like to end this chapter without a few final remarks that are forced on me by the importance of the material we have been discussing. The standpoint of a psychology whose subject is the phenomenology of the psyche is evidently something that is not easy to grasp and is very often misunderstood. If, therefore, at the risk of repeating myself, I come back to fundamentals, I do so only in order to forestall certain wrong impressions which might be occasioned by what I have said, and to spare my reader unnecessary difficulties.

[122] The parallel I have drawn here between Christ and the self is not to be taken as anything more than a psychological one, just as the parallel with the fish is mythological. There is no question of any intrusion into the sphere of metaphysics, i.e., of faith. The images of God and Christ which man's religious fantasy projects cannot avoid being anthropomorphic and are admitted to be so; hence they are capable of psychological elucidation like any other symbols. Just as the ancients believed that they had said something important about Christ with their fish symbol, so it seemed to the alchemists that their parallel with the stone served to illuminate and deepen the meaning of the Christ-image. In the course of time, the fish symbolism disappeared completely, and so likewise did the *lapis philosophorum*. Concerning this latter symbol, however, there are plenty of statements to be found which show it in a special light—views and ideas which attach such importance to the stone that one begins to wonder whether, in the end, it was Christ who was taken as a symbol of the stone rather than the other way round. This marks a development which—with the help of certain ideas in the epistles of John and Paul—includes Christ in the realm of immediate inner experience and makes him appear as the figure of the total man. It also links up directly with the psychological evidence for the existence of an archetypal content possessing all those qualities which are characteristic of the Christ-image in its archaic and medieval forms. Modern psychology is therefore confronted with a question very like the one that faced the alchemists: Is the self a symbol of Christ, or is Christ a symbol of the self?

[123] In the present study I have affirmed the latter alternative. I have tried to show how the traditional Christ-image concentrates upon itself the characteristics of an archetype—the archetype of the self. My aim and method do not purport to be anything more in principle than, shall we say, the efforts of an art historian to trace the various influences which have contributed towards the formation of a particular Christ-image. Thus we find the concept of the archetype in the history of art as well as in philology and textual criticism. The psychological archetype differs from its parallels in other fields only in one respect: it refers to a living and ubiquitous psychic fact, and this naturally shows the whole situation in a rather different light. One is then tempted to attach greater importance to the immediate and living presence of the archetype than to the idea of the historical Christ. As I have said, there is among certain of the alchemists, too, a tendency to give the *lapis* priority over Christ. Since I am far from cherishing any missionary intentions, I must expressly emphasize that I am not concerned here with confessions of faith but with proven scientific facts. If one inclines to regard the archetype of the self as the real agent and hence takes

Christ as a symbol of the self, one must bear in mind that there is a considerable difference between *perfection* and *completeness*. The Christ-image is as good as perfect (at least it is meant to be so), while the archetype (so far as known) denotes completeness but is far from being perfect. It is a paradox, a statement about something indescribable and transcendental. Accordingly the realization of the self, which would logically follow from a recognition of its supremacy, leads to a fundamental conflict, to a real suspension between opposites (reminiscent of the crucified Christ hanging between two thieves), and to an approximate state of wholeness that lacks perfection. To strive after teleiosis in the sense of perfection is not only legitimate but is inborn in man as a peculiarity which provides civilization with one of its strongest roots. This striving is so powerful, even, that it can turn into a passion that draws everything into its service. Natural as it is to seek perfection in one way or another, the archetype fulfils itself in completeness, and this is a *τελείωσις* of quite another kind. Where the archetype predominates, completeness is *forced* upon us against all our conscious strivings, in accordance with the archaic nature of the archetype. The individual may strive after perfection (“Be you therefore perfect—τέλειοι—also your heavenly Father is perfect.”⁹⁴) but must suffer from the opposite of his intentions for the sake of his completeness. “I find then a law, that, when I would do good, evil is present with me.”⁹⁵

[124] The Christ-image fully corresponds to this situation: Christ is the perfect man who is crucified. One could hardly think of a truer picture of the goal of ethical endeavour. At any rate the transcendental idea of the self that serves psychology as a working hypothesis can never match that image because, although it is a symbol, it lacks the character of a revelatory historical event. Like the related ideas of *atman* and *tao* in the East, the idea of the self is at least in part a product of cognition, grounded neither on faith nor on metaphysical speculation but on the experience that under certain conditions the unconscious spontaneously brings forth an archetypal symbol of wholeness. From this we must conclude that some such archetype occurs universally and is endowed with a certain numinosity. And there is in fact any amount of historical evidence as well as modern case material to prove this.⁹⁶ These naive and completely uninfluenced pictorial representations of the symbol show that it is given central and supreme importance precisely because it stands for the conjunction of opposites. Naturally the conjunction can only be understood as a paradox, since a union of opposites can be thought of only as their annihilation. Paradox is a characteristic of all transcendental situations because it alone gives adequate expression to their indescribable nature.

[125] Whenever the archetype of the self predominates, the inevitable psychological consequence is a state of conflict vividly exemplified by the Christian symbol of crucifixion—that acute state of unredeemedness which comes to an end only with the words “consummatum est.” Recognition of the archetype, therefore, does not in any way circumvent the Christian mystery; rather, it forcibly creates the psychological preconditions without which “redemption” would appear meaningless. “Redemption” does not mean that a burden is taken from one’s shoulders which one was never meant to bear. Only the “complete” person knows how unbearable man is to himself. So far as I can see, no relevant objection could be raised from the Christian point of view against anyone accepting the task

of individuation imposed on us by nature, and the recognition of our wholeness or completeness, as a binding personal commitment. If he does this consciously and intentionally, he avoids all the unhappy consequences of repressed individuation. In other words, if he voluntarily takes the burden of completeness on himself, he need not find it “happening” to him against his will in a negative form. This is as much as to say that anyone who is destined to descend into a deep pit had better set about it with all the necessary precautions rather than risk falling into the hole backwards.

[126] The irreconcilable nature of the opposites in Christian psychology is due to their moral accentuation. This accentuation seems natural to us, although, looked at historically, it is a legacy from the Old Testament with its emphasis on righteousness in the eyes of the law. Such an influence is notably lacking in the East, in the philosophical religions of India and China. Without stopping to discuss the question of whether this exacerbation of the opposites, much as it increases suffering, may not after all correspond to a higher degree of truth, I should like merely to express the hope that the present world situation may be looked upon in the light of the psychological rule alluded to above. Today humanity, as never before, is split into two apparently irreconcilable halves. The psychological rule says that when an inner situation is not made conscious, it happens outside, as fate. That is to say, when the individual remains undivided and does not become conscious of his inner opposite, the world must perforce act out the conflict and be torn into opposing halves.

VI

THE SIGN OF THE FISHES

[127] The figure of Christ is not as simple and unequivocal as one could wish. I am not referring here to the enormous difficulties arising out of a comparison of the Synoptic Christ with the Johannine Christ, but to the remarkable fact that in the hermeneutic writings of the Church Fathers, which go right back to the days of primitive Christianity, Christ has a number of symbols or “allegories” in common with the devil. Of these I would mention the lion, snake (*coluber*, ‘viper’), bird (devil = *nocturna avis*), raven (Christ = *nycticorax*, ‘night-heron’), eagle, and fish. It is also worth noting that Lucifer, the Morning Star, means Christ as well as the devil.¹ Apart from the snake, the fish is one of the oldest allegories. Nowadays we would prefer to call them symbols, because these synonyms always contain more than mere allegories, as is particularly obvious in the case of the fish symbol. It is unlikely that ’Ιχθῦς is simply an anagrammatic abbreviation of ’Ι[ησοῦς] Χ[ριστός] Θ[εοῦ] Υ[ιὸς] Σ[ωτήρ],² but rather the symbolical designation for something far more complex. (As I have frequently pointed out in my other writings, I do not regard the symbol as an allegory or a sign, but take it in its proper sense as the best possible way of describing and formulating an object that is not completely knowable. It is in this sense that the creed is called a “symbolum.”) The order of the words gives one more the impression that they were put together for the purpose of explaining an already extant and widely disseminated “Ichthys.”³ For the fish symbol, in the Near and Middle East especially, has a long and colourful prehistory, from the Babylonian fish-god Oannes and his priests who clothed themselves in fish-skins, to the sacred fish-meals in the cult of the Phoenician goddess Derceto-Atargatis and the obscurities of the Abercius inscription.⁴ The symbol ranges from the redeemer-fish of Manu in farthest India to the Eucharistic fish-feast celebrated by the “Thracian riders” in the Roman Empire.⁵ For our purpose it is hardly necessary to go into this voluminous material more closely. As Doelger and others have shown, there are plenty of occasions for fish symbolism within the original, purely Christian world of ideas. I need only mention the regeneration in the font, in which the baptized swim like fishes.⁶

[128] In view of this wide distribution of the fish symbol, its appearance at a particular place or at a particular moment in the history of the world is no cause for wonder. But the sudden activation of the symbol, and its identification with Christ even in the early days of the Church, lead one to conjecture a second source. This

source is astrology, and it seems that Friedrich Muenther⁷ was the first to draw attention to it. Jeremias⁸ adopts the same view and mentions that a Jewish commentary on Daniel, written in the fourteenth century, expected the coming of the Messiah in the sign of the Fishes. This commentary is mentioned by Muenther in a later publication⁹ as stemming from Don Isaac Abarbanel, who was born in Lisbon in 1437 and died in Venice in 1508.¹⁰ It is explained here that the House of the Fishes (♋) is the house of justice and of brilliant splendour (♃ in ♋). Further, that in *anno mundi* 2365,¹¹ a great conjunction of Saturn (♄) and Jupiter (♃) took place in Pisces.¹² These two great planets, he says, are also the most important for the destiny of the world, and especially for the destiny of the Jews. The conjunction took place three years before the birth of Moses. (This is of course legendary.) Abarbanel expects the coming of the Messiah when there is a conjunction of Jupiter and Saturn in Pisces. He was not the first to express such expectations. Four hundred years earlier we find similar pronouncements; for instance, Rabbi Abraham ben Hiyya, who died about 1136, is said to have decreed that the Messiah was to be expected in 1464, at the time of the great conjunction in Pisces; and the same is reported of Solomon ben Gabirol (1020–70).¹³ These astrological ideas are quite understandable when one considers that Saturn is the star of Israel, and that Jupiter means the “king” (of justice). Among the territories ruled by the Fishes, the house of Jupiter, are Mesopotamia, Bactria, the Red Sea, and Palestine.¹⁴ Chiun (Saturn) is mentioned in Amos 5 : 26 as “the star of your god.”¹⁵ James of Sarug (d. 521) says the Israelites worshipped Saturn. The Sabaeans called him the “god of the Jews.”¹⁶ The Sabbath is Saturday, Saturn’s Day. Albumasar¹⁷ testifies that Saturn is the star of Israel.¹⁸ In medieval astrology Saturn was believed to be the abode of the devil.¹⁹ Both Saturn and Ialdabaoth, the demiurge and highest archon, have lion’s faces. Origen elicits from the diagram of Celsus that Michael, the first angel of the Creator, has “the shape of a lion.”²⁰ He obviously stands in the place of Ialdabaoth, who is identical with Saturn, as Origen points out.²¹ The demiurge of the Naassenes is a “fiery god, the fourth by number.”²² According to the teachings of Apelles, who had connections with Marcion, there was a “third god who spoke to Moses, a fiery one, and there was also a fourth, the author of evil.”²³ Between the god of the Naassenes and the god of Apelles there is evidently a close relationship, and also, it appears, with Yahweh, the demiurge of the Old Testament.

[129] Saturn is a “black” star,²⁴ anciently reputed a “maleficus.” “Dragons, serpents, scorpions, vipères, renards, chats et souris, oiseaux nocturnes et autres engeances surnoisies sont le lot de Saturne,” says Bouché-Leclercq.²⁵ Remarkably enough, Saturn’s animals also include the ass,²⁶ which on that account was rated a theriomorphic form of the Jewish god. A pictorial representation of it is the well-known mock crucifixion on the Palatine.²⁷ Similar traditions can be found in Plutarch,²⁸ Diodorus, Josephus,²⁹ and Tacitus.³⁰ Sabaoth, the seventh archon, has the

form of an ass.³¹ Tertullian is referring to these rumours when he says: “You are under the delusion that our God is an ass’s head,” and that “we do homage only to an ass.”³² As we have indicated, the ass is sacred to the Egyptian Set.³³ In the early texts, however, the ass is the attribute of the sun-god and only later became an emblem of the underworldly Apep and of evil (Set).³⁴

[130] According to medieval tradition, the religion of the Jews originated in a conjunction of Jupiter with Saturn, Islam in ♃ ♄ ♀, Christianity in ♃ ♄ ♀, and the Antichrist in ♃ ♄ ☿.³⁵ Unlike Saturn, Jupiter is a beneficent star. In the Iranian view Jupiter signifies life, Saturn death.³⁶ The conjunction of the two therefore signifies the *union of extreme opposites*. In the year 7 B.C. this famed conjunction took place no less than three times in the sign of the Fishes. The greatest approximation occurred on May 29 of that year, the planets being only 0.21 degrees apart, less than half the width of the full moon.³⁷ The conjunction took place in the middle of the commissure, “near the bend in the line of the Fishes.” From the astrological point of view this conjunction must appear especially significant, because the approximation of the two planets was exceptionally large and of an impressive brilliance. In addition, seen heliocentrically, it took place near the equinoctial point, which at that time was located between ♋ and ♌, that is, between fire and water.³⁸ The conjunction was characterized by the important fact that Mars was in opposition (♂ ♄ ♃ ♅), which means, astrologically, that the planet correlated with the instincts stood in a hostile relationship to it, which is peculiarly characteristic of Christianity. If we accept Gerhardt’s calculation that the conjunction took place on May 29, in the year 7 B.C., then the position of the sun—especially important in a man’s nativity—at Christ’s birth would be in the double sign of the *Twins*.³⁹ One thinks involuntarily of the ancient Egyptian pair of hostile brothers, Horus and Set, the sacrificer and the sacrificed (cf. n. 27, on Set’s “martyrdom”), who in a sense prefigure the drama of the Christian myth. In the Egyptian myth it is the evil one who is sacrificed on the “slave’s post.”⁴⁰ But the pair of brothers Heru-ur (the “older Horus”) and Set are sometimes pictured as having one body with two heads. The planet Mercury is correlated with Set, and this is interesting in view of the tradition that Christianity originated in a conjunction of Jupiter with Mercury. In the New Kingdom (XIXth dynasty) Set appears as Sutech in the Nile delta. In the new capital built by Rameses II, one district was dedicated to Amon, the other to Sutech.⁴¹ It was here that the Jews were supposed to have done slave-labour.

[131] In considering the double aspect of Christ, mention might be made of the legend of Pistis Sophia (3rd cent.), which also originated in Egypt. Mary says to Jesus:

When thou wert a child, before the spirit had descended upon thee, when thou wert in the vineyard with Joseph, the spirit came down from the height, and came unto me in

the house, like unto thee, and I knew him not, but thought that he was thou. And he said unto me, “Where is Jesus, my brother, that I may go to meet him?” And when he had said this unto me, I was in doubt, and thought it was a phantom tempting me. I seized him and bound him to the foot of the bed which was in my house, until I had gone to find you in the field, thee and Joseph; and I found you in the vineyard, where Joseph was putting up the vine-poles. And it came to pass, when thou didst hear me saying this thing unto Joseph, that thou didst understand, and thou wert joyful, and didst say, “Where is he, that I may see him?” And it came to pass, when Joseph heard thee say these words, that he was disturbed. We went up together, entered into the house and found the spirit bound to the bed, and we gazed upon thee and him, and found that thou wert like unto him. And he that was bound to the bed was unloosed, he embraced thee and kissed thee, and thou also didst kiss him, and you became one.⁴²

[132] It appears from the context of this fragment that Jesus is the “truth sprouting from the earth,” whereas the spirit that resembled him is “justice [δικαιοσύνη] looking down from heaven.” The text says: “Truth is the power which issued from thee when thou wast in the lower regions of chaos. For this cause thy power hath said through David, ‘Truth hath sprouted out of the earth,’ because thou wert in the lower regions of chaos.”⁴³ Jesus, accordingly, is conceived as a double personality, part of which rises up from the chaos or *hyle*, while the other part descends as *pneuma* from heaven.

[133] One could hardly find the *φυλοκρίνησις*, or ‘discrimination of the natures’ that characterizes the Gnostic Redeemer, exemplified more graphically than in the astrological determination of time. The astrological statements that were quite possible in antiquity all point to the prominent double aspect⁴⁴ of the birth that occurred at this particular moment of time, and one can understand how plausible was the astrological interpretation of the Christ-Antichrist myth when it entered into manifestation at the time of the Gnostics. A fairly old authority, earlier anyway than the sixth century, which bears striking witness to the antithetical nature of the Fishes is the Talmud. This says:

Four thousand two hundred and ninety-one years after the Creation [A.D. 530], the world will be orphaned. There will follow the war of the *tanninim* [sea-monsters], the war of Gog and Magog,⁴⁵ and then the Messianic era; only after seven thousand years will the Holy One, blessed be He, set up his world anew. R. Abba, the son of Raba, said, It was taught: after five thousand years.⁴⁶

The Talmud commentator Solomon ben Isaac, alias Rashi (1039–1105), remarks that the *tanninim* are fishes, presumably basing himself on an older source, since he does

not give this as his own opinion, as he usually does. This remark is important, firstly because it takes the battle of the fishes as an eschatological event (like the fight between Behemoth and Leviathan), and secondly because it is probably the oldest testimony to the antithetical nature of the fishes. From about this period, too—the eleventh century—comes the apocryphal text of a Johannine Genesis in which the two fishes are mentioned, this time in unmistakably astrological form.^{46a} Both documents fall within the critical epoch that opened with the second millennium of the Christian era, about which I shall have more to say in due course.

[134] The year 531 is characterized astronomically by a conjunction of ♊ and ♋ in Gemini. This sign stands for a pair of brothers, and they too have a somewhat antithetical nature. The Greeks interpreted them as the Dioscuri ('boys of Zeus'), the sons of Leda who were begotten by the swan and hatched out of an egg. Pollux was immortal, but Castor shared the human lot. Another interpretation takes them as representing Apollo and Heracles or Apollo and Dionysus. Both interpretations suggest a certain polarity. Astronomically, at any rate, the air sign Gemini stands in a quartile and therefore unfavourable aspect to the conjunction that took place in the year 7 B.C. The inner polarity of ♊ may perhaps shed light on the prophecy about the war of the *tanninim*, which Rashi interprets as fishes. From the dating of Christ's birth it would appear, as said, that the sun was in Gemini. The motif of the brothers is found very early in connection with Christ, for instance among the Jewish Christians and Ebionites.⁴⁷

[135] From all this we may risk the conjecture that the Talmudic prophecy was based on astrological premises.

[136] The precession of the equinoxes was a fact well known to the astrologers of antiquity. Origen, helped out by the observations and calculations of Hipparchus,⁴⁸ uses it as a cogent argument against an astrology based on the so-called "morphomata" (the actual constellations).⁴⁹ Naturally this does not apply to the distinction already drawn in ancient astrology between the morphomata and the ζωδιὰ νοητά (the fictive signs of the zodiac).⁵⁰ If we take the 7,000 years mentioned in the prophecy as *anno mundi* 7000, the year denoted would be A.D. 3239. By then the spring-point will have moved from its present position 18 degrees into Aquarius, the next aeon, that of the Water Carrier. As an astrologer of the second or third century would be acquainted with the precession, we may surmise that these dates were based on astrological considerations. At all events the Middle Ages were much concerned with the calculation of *coniunctiones maximae* and *magnae*, as we know from Pierre d'Ailly and Cardan.⁵¹ Pierre d'Ailly reckoned that the first *coniunctio maxima* (♊ δ ♋ in ♉) after the creation of the world took place in 5027 B.C., while Cardan relegated the tenth conjunction to A.D. 3613.⁵² Both of them assumed

the lapse of too large an interval between conjunctions in the same sign. The correct astronomical interval is about 795 years. Cardan's conjunction would accordingly take place in the year A.D. 3234. For astrological speculation this date is naturally of the greatest importance.

[137] As to the 5,000 years, the date we get is A.D. 1239. This was an epoch noted for its spiritual instability, revolutionary heresies and chiliastic expectations, and at the same time it saw the founding of the mendicant orders, which injected new life into monasticism. One of the most powerful and influential voices to announce the coming of a "new age of the spirit" was Joachim of Flora (d. 1202), whose teachings were condemned by the Fourth Lateran Council in 1215. He expected the opening of the seventh seal in the fairly near future, the advent of the "everlasting gospel" and the reign of the "intellectus spiritualis," the age of the Holy Ghost. This third aeon, he says, had already begun with St. Benedict, the founder of the Benedictine Order (the first monastery was supposed to have been built a few years after 529). One of Joachim's followers, the Franciscan friar Gerard of Borgo San Donnino, proclaimed in his *Introductorius in evangelium aeternum*, which appeared in 1254 in Paris, that Joachim's three main treatises were in fact the everlasting gospel, and that in the year 1260 this would replace the gospel of Jesus Christ.⁵³ As we know, Joachim saw monasticism as the true vehicle of the Holy Ghost and for this reason he dated the secret inception of the new era from the lifetime of St. Benedict, whose founding of the Benedictine Order revived monasticism in the West.

[138] To Pierre d'Ailly the time of Pope Innocent III (1198–1216) had already seemed significant. About the year 1189, he says, the revolutions of Saturn were once again completed ("completae anno Christi 1189 vel circiter"). He complains that the Pope had condemned a treatise of Abbot Joachim,⁵⁴ and also the heretical doctrine of Almaricus.⁵⁵ This last is the theological philosopher Amalric of Bene (d. 1204), who took part in the widespread Holy Ghost movement of that age. It was then, too, he says, that the Dominican and Franciscan mendicant orders came into existence, "which was a great and wonderful thing for the Christian church." Pierre d'Ailly thus lays stress on the same phenomena that struck us as being characteristic of the time, and further regards this epoch as having been foretold in astrology.

[139] The date for the founding of the monastery of Monte Cassino brings us very close to the year 530, which the Talmud prophesied would be a critical one. In Joachim's view not only does a new era begin then, but a new "status" of the world—the age of monasticism and the reign of the Holy Ghost. Its beginning still comes within the domain of the Son, but Joachim surmises in a psychologically correct manner that a new status—or, as we would say, a new attitude—would appear first as a more or less latent preliminary stage, which would then be followed by the

fructificatio, the flower and the fruit. In Joachim's day the fruition was still in abeyance, but one could observe far and wide an uncommon agitation and commotion of men's spirits. Everyone felt the rushing wind of the pneuma; it was an age of new and unprecedented ideas which were blazoned abroad by the Cathari, Patarenes, Concorricci, Waldenses, Poor Men of Lyons, Beghards, Brethren of the Free Spirit, "Bread through God,"⁵⁶ and whatever else these movements were called. Their visible beginnings all lay in the early years of the eleventh century. The contemporary documents amassed by Hahn throw a revealing light on the ideas current in these circles:

Item, they believe themselves to be God by nature without distinction ... and that they are eternal

Item, that they have no need of God or the Godhead.

Item, that they constitute the kingdom of heaven.

Item, that they are immutable in the new rock, that they rejoice in naught and are troubled by naught.

Item, that a man is bound to follow his inner instinct rather than the truth of the Gospel which is preached every day. ... They say that they believe the Gospel to contain poetical matters which are not true.⁵⁷

[140] These few examples may suffice to show what kind of spirit animated these movements. They were made up of people who identified themselves (or were identified) with God, who deemed themselves supermen, had a critical approach to the gospels, followed the promptings of the inner man, and understood the kingdom of heaven to be within. In a sense, therefore, they were modern in their outlook, but they had a religious inflation instead of the rationalistic and political psychosis that is the affliction of our day. We ought not to impute these extremist ideas to Joachim, even though he took part in that great movement of the spirit and was one of its outstanding figures. One must ask oneself what psychological impulse could have moved him and his adherents to cherish such bold expectations as the substitution of the "everlasting gospel" for the Christian message or the supersession of the second Person in the Godhead by the third, who would reign over the new era. This thought is so heretical and subversive that it could never have occurred to him had he not felt himself supported and swept along by the revolutionary currents of the age. He felt it as a revelation of the Holy Ghost, whose life and procreative power no church could bring to a stop. The numinosity of this feeling was heightened by the temporal coincidence—"synchronicity"—of the epoch he lived in with the beginning of the sphere of the "antichristian" fish in Pisces. In consequence, one might feel tempted to regard the Holy Ghost movement and Joachim's central ideas as a direct expression of the antichristian psychology that was then dawning. At any rate the Church's condemnation is thoroughly understandable, for in many ways his attitude to the Church of Jesus Christ comes very close to open insurrection, if not downright apostasy. But if we allow some credence to the conviction of these innovators that

they were moved by the Holy Ghost, then another interpretation becomes not only possible but even probable.

[141] That is to say, just as Joachim supposed that the status of the Holy Ghost had secretly begun with St. Benedict, so we might hazard the conjecture that a new status was secretly anticipated in Joachim himself. Consciously, of course, he thought he was bringing the status of the Holy Ghost into reality, just as it is certain that St. Benedict had nothing else in mind than to put the Church on a firm footing and deepen the meaning of the Christian life through monasticism. But, unconsciously—and this is psychologically what probably happened—Joachim could have been seized by the archetype of the spirit. There is no doubt that his activities were founded on a numinous experience, which is, indeed, characteristic of all those who are gripped by an archetype. He understood the spirit in the dogmatic sense as the third Person of the Godhead, for no other way was possible, but not in the sense of the empirical archetype. This archetype is not of uniform meaning, but was originally an ambivalent dualistic figure⁵⁸ that broke through again in the alchemical concept of spirit after engendering the most contradictory manifestations within the Holy Ghost movement itself. The Gnostics in their day had already had clear intimations of this dualistic figure. It was therefore very natural, in an age which coincided with the beginning of the second Fish and which was, so to speak, forced into ambiguity, that an espousal of the Holy Ghost in its Christian form should at the same time help the archetype of the spirit to break through in all its characteristic ambivalence. It would be unjust to class so worthy a personage as Joachim with the bigoted advocates of that revolutionary and anarchic turbulence, which is what the Holy Ghost movement turned into in so many places. We must suppose, rather, that he himself unwittingly ushered in a new “status,” a religious attitude that was destined to bridge and compensate the frightful gulf that had opened out between Christ and Antichrist in the eleventh century. The antichristian era is to blame that the spirit became non-spiritual and that the vitalizing archetype gradually degenerated into rationalism, intellectualism, and doctrinairism, all of which leads straight to the tragedy of modern times now hanging over our heads like a sword of Damocles. In the old formula for the Trinity, as Joachim knew it, the dogmatic figure of the devil is lacking, for then as now he led a questionable existence somewhere on the fringes of theological metaphysics, in the shape of the *mysterium iniquitatis*. Fortunately for us, the threat of his coming had already been foretold in the New Testament—for the less he is recognized the more dangerous he is. Who would suspect him under those high-sounding names of his, such as public welfare, lifelong security, peace among the nations, etc.? He hides under idealisms, under -isms in general, and of these the most pernicious is doctrinairism, that most unspiritual of all the spirit’s manifestations. The present age must come to terms drastically with the facts as they are, with the

absolute opposition that is not only tearing the world asunder politically but has planted a schism in the human heart. We need to find our way back to the original, living spirit which, because of its ambivalence, is also a mediator and uniter of opposites,⁵⁹ an idea that preoccupied the alchemists for many centuries.

[142] If, as seems probable, the aeon of the fishes is ruled by the archetypal motif of the hostile brothers, then the approach of the next Platonic month, namely Aquarius, will constellate the problem of the union of opposites. It will then no longer be possible to write off evil as the mere privation of good; its real existence will have to be recognized. This problem can be solved neither by philosophy, nor by economics, nor by politics, but only by the individual human being, via his experience of the living spirit, whose fire descended upon Joachim, one of many, and, despite all contemporary misunderstandings, was handed onward into the future. The solemn proclamation of the *Assumptio Mariae* which we have experienced in our own day is an example of the way symbols develop through the ages. The impelling motive behind it did not come from the ecclesiastical authorities, who had given clear proof of their hesitation by postponing the declaration for nearly a hundred years,⁶⁰ but from the Catholic masses, who have insisted more and more vehemently on this development. Their insistence is, at bottom, the urge of the archetype to realize itself.⁶¹

[143] The repercussions of the Holy Ghost movement spread, in the years that followed, to four minds of immense significance for the future. These were Albertus Magnus (1193–1280); his pupil Thomas Aquinas, the philosopher of the Church and an adept in alchemy (as also was Albertus); Roger Bacon (c. 1214–c. 1294), the English forerunner of inductive science; and finally Meister Eckhart (c. 1260–1327), the independent religious thinker, now enjoying a real revival after six hundred years of obscurity. Some people have rightly seen the Holy Ghost movement as the forerunner of the Reformation. At about the time of the twelfth and thirteenth centuries we find also the beginnings of Latin alchemy, whose philosophical and spiritual content I have tried to elucidate in my book *Psychology and Alchemy*. The image mentioned above (par. 139) of “immutability in the new rock” bears a striking resemblance to the central idea of philosophical alchemy, the *lapis philosophorum*, which is used as a parallel to Christ, the “rock,” the “stone,” the “cornerstone.” Priscillian (4th cent.) says: “We have Christ for a rock, Jesus for a cornerstone.”⁶² An alchemical text speaks of the “rock which is smitten thrice with Moses’ rod, so that the waters flow forth freely.”⁶³ The *lapis* is called a “sacred rock” and is described as having four parts.⁶⁴ St. Ambrose says the water from the rock is a prefiguration of the blood that flowed from Christ’s side.⁶⁵ Another alchemical text mentions the “water from the rock” as the equivalent of the universal solvent, the *aqua permanens*.⁶⁶ Khunrath, in his somewhat florid language, even speaks of the “Petroleum

sapientum.”⁶⁷ By the Naassenes, Adam was called the “rock” and the “cornerstone.”⁶⁸ Both these allegories of Christ are mentioned by Epiphanius in his *Ancoratus*, and also by Firmicus Maternus.⁶⁹ This image, common to ecclesiastical and alchemical language alike, goes back to I Corinthians 10 : 4 and I Peter 2 : 4.

[144] The new rock, then, takes the place of Christ, just as the everlasting gospel was meant to take the place of Christ’s message. Through the descent and indwelling of the Holy Ghost the *υιοτης*, sonship, is infused into every individual, so that everybody who possesses the Holy Ghost will be a new rock, in accordance with I Peter 2 : 5: “Be you also as living stones built up.”⁷⁰ This is a logical development of the teaching about the Paraclete and the filiation, as stated in Luke 6 : 35: “You shall be sons of the Highest,” and John 10 : 34: “Is it not written in your law: I said, you are gods?” The Naassenes, as we know, had already made use of these allusions and thus anticipated a whole tract of historical development—a development that led via monasticism to the Holy Ghost movement, via the *Theologia Germanica* direct to Luther, and via alchemy to modern science.

[145] Let us now turn back to the theme of Christ as the fish. According to Doelger, the Christian fish symbol first appeared in Alexandria around A.D. 200;⁷¹ similarly, the baptismal bath was described as a *piscina* (fish-pond) quite early. This presupposes that the believers were fishes, as is in fact suggested by the gospels (for instance Matt. 4 : 19). There Christ wants to make Peter and Andrew “fishers of men,” and the miraculous draught of fishes (Luke 5 : 10) is used by Christ himself as a paradigm for Peter’s missionary activity.

[146] A direct astrological aspect of Christ’s birth is given us in Matthew 2 : 1ff. The Magi from the East were star-gazers who, beholding an extraordinary constellation, inferred an equally extraordinary birth. This anecdote proves that Christ, possibly even at the time of the apostles, was viewed from the astrological standpoint or was at least brought into connection with astrological myths. The latter alternative is fully confirmed when we consider the apocalyptic utterances of St. John. Since this exceedingly complex question has been discussed by those who are more qualified than I, we can support our argument on the well-attested fact that glimpses of astrological mythology may be caught behind the stories of the worldly and otherworldly life of the Redeemer.⁷²

[147] Above all it is the connections with the age of the Fishes which are attested by the fish symbolism, either contemporaneously with the gospels themselves (“fishers of men,” fishermen as the first disciples, miracle of loaves and fishes), or immediately afterwards in the post-apostolic era. The symbolism shows Christ and those who believe in him as fishes, fish as the food eaten at the Agape,⁷³ baptism as immersion in a fish-pond, etc. At first sight, all this points to no more than the fact

that the fish symbols and mythologems which have always existed had assimilated the figure of the Redeemer; in other words, it was a symptom of Christ's assimilation into the world of ideas prevailing at that time. But, to the extent that Christ was regarded as the new aeon, it would be clear to anyone acquainted with astrology that he was born as the first fish of the Pisces era, and was doomed to die as the last ram⁷⁴ (ἀρνίον, lamb) of the declining Aries era.⁷⁵ Matthew 27 : 15ff. hands down this mythologem in the form of the old sacrifice of the seasonal god. Significantly enough, Jesus's partner in the ceremony is called Barabbas, "son of the father." There would be some justification for drawing a parallel between the tension of opposites in early Christian psychology and the fact the zodiacal sign for Pisces (♊) frequently shows two fishes moving in opposite directions, but only if it could be proved that their contrary movement dates from pre-Christian times or is at least contemporary with Christ. Unfortunately, I know of no pictorial representation from this period that would give us any information about the position of the fishes. In the fine bas-relief of the zodia from the Little Metropolis in Athens, Pisces and Aquarius are missing. There is one representation of the fishes, near the beginning of our era, that is certainly free from Christian influence. This is the globe of the heavens from the Farnese Atlas in Naples. The first fish, depicted north of the equator, is vertical, with its head pointing to the celestial Pole; the second fish, south of the equator, is horizontal, with its head pointing West. The picture follows the astronomical configuration and is therefore naturalistic.⁷⁶ The zodiac from the temple of Hathor at Denderah (1st cent. B.C.) shows the fishes, but they both face the same way. The planisphere of Timochares,⁷⁷ mentioned by Hipparchus, has only *one* fish where Pisces should be. On coins and gems from the time of the emperors, and also on Mithraic monuments,⁷⁸ the fishes are shown either facing the same way or moving in opposite directions.⁷⁹ The polarity which the fishes later acquired may perhaps be due to the fact that the astronomical constellation shows the first (northerly) fish as vertical, and the second (southerly) fish as horizontal. They move almost at right angles to one another and hence form a cross. This countermovement, which was unknown to the majority of the oldest sources, was much emphasized in Christian times, and this leads one to suspect a certain tendentiousness.⁸⁰

[148] Although no connection of any kind can be proved between the figure of Christ and the inception of the astrological age of the fishes, the simultaneity of the fish symbolism of the Redeemer with the astrological symbol of the new aeon seems to me important enough to warrant the emphasis we place upon it. If we try to follow up the complicated mythological ramifications of this parallel, we do so with intent to throw light on the multifarious aspects of an archetype that manifests itself on the one hand in a *personality*, and on the other hand synchronistically, in a moment of time determined in advance, before Christ's birth. Indeed, long before that, the archetype

had been written in the heavens by projection, so as then, “when the time was fulfilled,” to coincide with the symbols produced by the new era. The fish, appropriately enough, belongs to the winter rainy season, like Aquarius and Capricorn (*αἰγόκερως*, the goatfish).⁸¹ As a zodiacal sign, therefore, it is not in the least remarkable. It becomes a matter for astonishment only when, through the precession of the equinoxes, the spring-point moves into this sign and thus inaugurates an age in which the “fish” was used as a name for the God who became a man, who was born as a fish and was sacrificed as a ram, who had fishermen for disciples and wanted to make them fishers of men, who fed the multitude with miraculously multiplying fishes, who was himself eaten as a fish, the “holier food,” and whose followers are little fishes, the “pisciculi.” Assume, if you like, that a fairly widespread knowledge of astrology would account for at least some of this symbolism in certain Gnostic-Christian circles.⁸² But this assumption does not apply when it comes to eyewitness accounts in the synoptic gospels. There is no evidence of any such thing. We have no reason whatever to suppose that those stories are disguised astrological myths. On the contrary, one gets the impression that the fish episodes are entirely natural happenings and that there is nothing further to be looked for behind them. They are “Just So” stories, quite simple and natural, and one wonders whether the whole Christian fish symbolism may not have come about equally fortuitously and without premeditation. Hence one could speak just as well of the seemingly fortuitous coincidence of this symbolism with the name of the new aeon, the more so as the age of the fishes seems to have left no very clear traces in the cultures of the East. I could not maintain with any certainty that this is correct, because I know far too little about Indian and Chinese astrology. As against this, the fact that the traditional fish symbolism makes possible a verifiable prediction that had already been made in the New Testament is a somewhat uncomfortable proposition to swallow.

[149] The northerly, or easterly, fish, which the spring-point entered at about the beginning of our era,⁸³ is joined to the southerly, or westerly, fish by the so-called commissure. This consists of a band of faint stars forming the middle sector of the constellation, and the spring-point gradually moved along its southern edge. The point where the ecliptic intersects with the meridian at the tail of the second fish coincides roughly with the sixteenth century, the time of the Reformation, which as we know is so extraordinarily important for the history of Western symbols. Since then the spring-point has moved along the southern edge of the second fish, and will enter Aquarius in the course of the third millennium.⁸⁴ Astrologically interpreted, the designation of Christ as one of the fishes identifies him with the first fish, the vertical one. Christ is followed by the Antichrist, at the end of time. The beginning of the enantiodromia would fall, logically, midway between the two fishes. We have seen

that this is so. The time of the Renaissance begins in the immediate vicinity of the second fish, and with it comes that spirit which culminates in the modern age.⁸⁵

VII

THE PROPHECIES OF NOSTRADAMUS

[150] The course of our religious history as well as an essential part of our psychic development could have been predicted more or less accurately, both as regards time and content, from the precession of the equinoxes through the constellation of Pisces. The prediction, as we saw, was actually made and coincides with the fact that the Church suffered a schism in the sixteenth century. After that an enantiodromian process set in which, in contrast to the “Gothic” striving *upwards* to the heights, could be described as a horizontal movement *outwards*, namely the voyages of discovery and the conquest of Nature. The vertical was cut across by the horizontal, and man’s spiritual and moral development moved in a direction that grew more and more obviously antichristian, so that today we are confronted with a crisis of Western civilization whose outcome appears to be exceedingly dubious.

[151] With this background in mind, I would like to mention the astrological prophecies of Nostradamus, written in a letter¹ to Henry II of France, on June 27, 1558. After detailing a year characterized, among other things, by ♄ ☊ ♀ with ♂ ☐ ♀,² he says:

Then the beginning of that year shall see a greater persecution against the Christian Church than ever was in Africa,³ and it shall be in the year 1792, at which time everyone will think it a renovation of the age. ... And at that time and in those countries the infernal power shall rise against the Church of Jesus Christ. This shall be the second Antichrist, which shall persecute the said Church and its true vicar by means of the power of temporal kings, who through their ignorance shall be seduced by tongues more sharp than any sword in the hands of a madman. ... The persecution of the clergy shall have its beginning in the power of the Northern Kings joined by the Eastern ones. And that persecution shall last eleven years, or a little less, at which time the chief Northern king shall fail.⁴

[152] However, Nostradamus thinks that “a united Southern king” will outlast the Northern one by three years. He sees a return of paganism (“the sanctuary destroyed by paganism”), the Bible will be burned, and an immense blood-bath will take place: “So great tribulations as ever did happen since the first foundation of the Christian Church.” All Latin countries will be affected by it.

[153] There are historical determinants that may have moved Nostradamus to give the year 1792 as the beginning of the new aeon. For instance, Cardinal Pierre d’Ailly, basing himself on Albumasar, writes in his *Concordantia*⁵ on the eighth *coniunctio maxima* (ϛ ϔ ♃ in ♀), which had been calculated for 1693:

And after that shall be the fulfilment of ten revolutions of Saturn in the year 1789, and this will happen after the said conjunction, in the course of ninety-seven years or thereabouts. ... This being so, we say that if the world shall endure until then, which God alone knows, then there will be many and great and marvellous changes and transformations of the world, especially as concerns law-giving and religious sects, for the said conjunction and the revolutions of Saturn will coincide with the revolution or reversal of the upper orb, i.e., the eighth sphere, and from these and other premises the change of sects will be known. ... Whence it may be concluded with some probability that this is the time when the Antichrist shall come with his law and his damnable sects, which are utterly contrary and inimical to the law of Christ; for, being human, we can have no certainty with regard to the time and the moment of his coming. ... Yet, despite the indeterminate statement that he will come at approximately that time, it is possible to have a probable conjecture and a credible hypothesis in accordance with the astronomical indications. If, therefore, the astronomers say that a change of sects will occur about that time, then, according to them, a Mighty One will come after Mahomet, who will set up an evil and magical law. Thus we may surmise with credible probability that after the sect of Mahomet none other will come save the law of the Antichrist.⁶

[154] In connection with the calculation of the year 1693, Pierre d’Ailly quotes Albumasar as saying that the first *coniunctio maxima* of Saturn and Jupiter took place *anno mundi* 3200. To this Albumasar added 960 years, which brings us to A.D. 1693 as the year of the eighth *coniunctio maxima*.⁷ In Part III of his book, [chapter 17](#), Pierre d’Ailly criticizes this view and calls it a “false deduction.” In his treatise against “superstitiosos astronomos,” 1410, he maintains that the Christian religion should not be brought under astrological laws. He was alluding in particular to Roger Bacon, who had revived the theory that Christianity was under the influence of the planet Mercury. Pierre d’Ailly held that only superstitions and heretical opinions were astrologically influenced, and especially the coming of the Antichrist.⁸

[155] We are probably right in assuming that these calculations were known to Nostradamus, who proposed 1792 as an improvement on 1789. Both dates are suggestive, and a knowledge of subsequent events confirms that the things that happened around that time were significant forerunners of developments in our own day. The enthronement of the “Déesse Raison” was, in fact, an anticipation of the antichristian trend that was pursued from then onwards.

[156] The “renovation of the age” might mean a new aeon, and it coincides in a remarkable way with the new system of dating, the revolutionary calendar, which began with September 22, 1792, and had a distinctly antichristian character.⁹ What had been brewing up long beforehand then became a manifest event; in the French Revolution men witnessed the enantiodromia that had set in with the Renaissance and ran parallel with the astrological fish symbol. The time seemed a significant one astrologically, for a variety of reasons. In the first place this was the moment when the precession of the equinoxes reached the tail of the second fish.¹⁰ Then, in the year 1791, Saturn was in ♄, a fiery sign. Besides that, tradition made use of the theory of maximal conjunctions¹¹ and regarded the year of the eighth *coniunctio maxima*—1693—as a starting-point for future calculations.¹² This critical year was combined with another tradition basing itself on periods of ten revolutions of Saturn, each period taking three hundred years. Pierre d’Ailly cites Albumasar, who says in his *Magnae coniunctiones*: “They said that the change shall come when ten revolutions of Saturn have been completed, and that the permutation of Saturn is particularly appropriate to the movable signs” (♄, ♁, ♃, ♅).¹³ According to Pierre d’Ailly, a Saturn period came to an end in 11 B.C., and he connects this with the appearance of Christ. Another period ended in A.D. 289: this he connects with Manichaeism. The year 589 foretells Islam, and 1189 the significant reign of Pope Innocent III; 1489 announces a schism of the Church, and 1789 signalizes—by inference—the coming of the Antichrist. Fantasy could do the rest, for the archetype had long been ready and was only waiting for the time to be fulfilled. That a usurper from the North would seize power¹⁴ is easily understood when we consider that the Antichrist is something infernal, the devil or the devil’s son, and is therefore Typhon or Set, who has his fiery abode in the North. Typhon’s power is triadic, possessing two confederates, one in the East and one in the South. This power corresponds to the “lower triad.”¹⁵

[157] Nostradamus, the learned physician and astrologer, would certainly have been familiar with the idea of the North as the region of the devil, unbelievers, and all things evil. The idea, as St. Eucherius of Lyons (d. 450) remarks,¹⁶ goes back to Jeremiah 1 : 14: “From the north shall an evil wind break forth upon all the inhabitants of the land,”¹⁷ and other passages such as Isaiah 14 : 12f.:

How art thou fallen from heaven, O Lucifer, son of the morning! how art thou cut down to the ground, which didst weaken the nations! For thou hast said in thine heart, I will ascend into heaven, I will exalt my throne above the stars of God, I will sit on the mount of assembly in the far north.¹⁸

The Benedictine monk Rhabanus Maurus (d. 856) says that “the north wind is the harshness of persecution” and “a figure of the old enemy.”¹⁹ The north wind, he adds,

signifies the devil, as is evident from Job 26 : 7: “He stretcheth out the north over the empty space, and hangeth the earth upon nothing.”²⁰ Rhabanus interprets this as meaning that “God allows the devil to rule the minds of those who are empty of his grace.”²¹ St. Augustine says: “Who is that north wind, save him who said: I will set up my seat in the north, I will be like the most High? The devil held rule over the wicked, and possessed the nations,” etc.²²

[158] The Victorine monk Garnerius says that the “malign spirit” was called Aquilo, the north wind. Its coldness meant the “frigidity of sinners.”²³ Adam Scotus imagined there was a frightful dragon’s head in the north from which all evil comes. From its mouth and snout it emitted smoke of a triple nature,²⁴ the “threefold ignorance, namely of good and evil, of true and false, of fitting and unfitting.”²⁵ “That is the smoke,” says Adam Scotus, “which the prophet Ezekiel, in his vision of God, saw coming from the north,”²⁶ the “smoke” of which Isaiah speaks.²⁷ The pious author never stops to think how remarkable it is that the prophet’s vision of God should be blown along on the wings of the north wind, wrapped in this devilish smoke of threefold ignorance. Where there is smoke, there is fire. Hence the “great cloud” had “brightness round about it, and fire flashing forth continually, and in the midst of the fire, as it were gleaming bronze.”²⁸ The north wind comes from the region of fire and, despite its coldness, is a “ventus urens” (burning wind), as Gregory the Great calls it, referring to Job 27 : 21.²⁹ This wind is the malign spirit, “who rouses up the flames of lust in the heart” and kindles every living thing to sin. “Through the breath of evil incitement to earthly pleasures he makes the hearts of the wicked to burn.” As Jeremiah 1:13 says, “I see a boiling pot, facing away from the north.” In these quotations from Gregory we hear a faint echo of the ancient idea of the fire in the north, which is still very much alive in Ezekiel, whose cloud of fire appears from the north, whence “an evil shall break forth upon all the inhabitants of the land.”³⁰

[159] In these circumstances it is hardly surprising that Nostradamus warns against the usurper from the north when foretelling the coming of the Antichrist. Even before the Reformation the Antichrist was a popular figure in folklore, as the numerous editions of the “Entkrist”³¹ in the second half of the fifteenth century show.³² This is quite understandable in view of the spiritual events then impending: the Reformation was about to begin. Luther was promptly greeted as the Antichrist, and it is possible that Nostradamus calls the Antichrist who was to appear after 1792 the “second Antichrist” because the first had already appeared in the guise of the German reformer, or much earlier with Nero or Mohammed.³³ We should not omit to mention in this connection how much capital the Nazis made out of the idea that Hitler was continuing and completing the work of reformation which Luther had left only half finished.

[160] From the existing astrological data, therefore, and from the possibilities of interpreting them it was not difficult for Nostradamus to predict the imminent enantiodromia of the Christian aeon; indeed, by making this prediction, he placed himself firmly in the antichristian phase and served as its mouthpiece.

[161] After this excursion, let us turn back to our fish symbolism.

VIII

THE HISTORICAL SIGNIFICANCE OF THE FISH

[162] In addition to the “pisciculi Christianorum,” the shepherd and the lamb play, as we know only too well, an almost greater role in Christian allegory, and Hermes Kriophoros (the “rambearer”) became the prototype of the “good shepherd,” the tutelary god of flocks. Another prototype, in his capacity as shepherd, was Orpheus.¹ This aspect of the Poimen gave rise to a figure of similar name in the mystery cults, who was popularized in the “Shepherd” of Hermas (2nd century). Like the “giant fish” mentioned in the Abercius inscription,² the shepherd probably has connections with Attis, both temporally and regionally. Reitzenstein even conjectures that the “Shepherd” of Hermas derives from the Poimandres writings, which are of purely pagan origin.³ Shepherd, ram, and lamb symbolism coincides with the expiring aeon of Aries. In the first century of our era the two aeons overlap, and the two most important mystery gods of this period, Attis and Christ, are both characterized as shepherds, rams, and fishes. The Poimen symbolism has undergone such thorough elaboration at the hands of Reitzenstein that I am in no position to add anything illuminating in this respect. The case is somewhat different with the fish symbol. Not only are the sources more copious, but the very nature of the symbol, and in particular its dual aspects, give rise to definite psychological questions which I should like to go into more closely.

[163] Like every hero, Christ had a childhood that was threatened (massacre of the innocents, flight into Egypt). The astrological “interpretation” of this can be found in Revelation 12 : 1: “A woman clothed with the sun, with the moon under her feet, and on her head a crown of twelve stars.” She is in the pangs of birth and is pursued by a dragon. She will give birth to a man-child who shall “rule the nations with a rod of iron.” This story carries echoes of numerous kindred motifs in East and West, for instance that of Leto and Python, of Aphrodite and her son, who, when pursued, leapt into the Euphrates and were changed into fishes,⁴ and of Isis and Horus in Egypt. The Syrian Greeks identified Derceto-Atargatis and her son Ichthys with the constellation of the Fishes.⁵

[164] The mother-goddess—and the star-crowned woman of the Apocalypse counts as one—is usually thought of as a virgin (*παρθένος*, *virgo*). The Christmas message, ‘*Ἡ παρθένος τέτοκεν, αὐξεῖ φῶς* (the virgin has brought forth, the light increases), is

pagan. Speaking of the so-called Korion in Alexandria, Epiphanius⁶ says that on the night of the Epiphany (January 5/6) the pagans held a great festival:

They stay up the whole night singing songs and playing the flute, offering these to the images of the gods; and, when the revelries of the night are over, after cock-crow, they go down with torches into a subterranean sanctuary and bring up a carved wooden image, which is laid naked on a litter. On its forehead it has the sign of the cross, in gold, and on both its hands two other signs of the same shape, and two more on its knees; and the five signs are all fashioned in gold. They carry this carved image seven times round the middle of the temple precincts, to the sound of flutes and tambourines and hymns, and after the procession they carry it down again into the crypt. But if you ask them what this mysterious performance means, they answer: Today, at this hour, the Kore, that is to say the virgin, has given birth to the Aeon.

[165] Epiphanius expressly states that he is not telling this of a Christian sect, but of the worshippers of idols, and he does so in order to illustrate the idea that even the pagans bear involuntary witness to the truth of Christianity.

[166] Virgo, the zodiacal sign, carries either a wheat-sheaf or a child. Some authorities connect her with the “woman” of the Apocalypse.⁷ At any rate, this woman has something to do with the prophecy of the birth of a Messiah at the end of time. Since the author of the Apocalypse was supposed to be a Christian, the question arises: To whom does the woman refer who is interpreted as the mother of the Messiah, or of Christ? And to whom does the son of the woman refer who (translating the Greek literally) shall “pasture (*ποιμαίνειν*) the pagans with an iron staff”?

[167] As this passage contains an allusion on the one hand to the Messianic prophecy in Isaiah 66 : 7,⁸ and on the other to Yahweh’s wrath (Psalm 2 : 9⁹), it would seem to refer in some way to the future rebirth of the Messiah. But such an idea is quite impossible in the Christian sphere. Boll¹⁰ says of the description of the “lamb” in Revelation 5 : 6ff.: “This remarkably bizarre figure with seven horns and seven eyes cannot possibly be explained in Christian terms.” Also, the “lamb” develops some very unexpected peculiarities: he is a *bellicose* lamb, a conqueror (Rev. 17 : 14). The mighty ones of the earth will have to hide from his *wrath* (Rev. 6 : 15ff.). He is likened to the “*lion* of the tribe of Judah” (Rev. 5 : 5). This lamb, who is reminiscent of Psalm 2 : 9 (“Thou shalt break them with a rod of iron, thou shalt dash them in pieces like a potter’s vessel”), rather gives one the sinister impression of a daemonic ram,¹¹ and not at all of a lamb who is led meekly to the slaughter. The lamb of the Apocalypse belongs, without doubt, to the category of horned monsters mentioned in these prophecies. One must therefore consider the question whether the author of the Apocalypse was influenced by an idea that was in some sense antithetical to Christ,

perhaps by a psychological shadow-figure, an “umbra Jesu” which was united at the end of time with the triumphant Christ, through an act of rebirth. This hypothesis would explain the repetition of the birth myth and also the curious fact that so important an eschatological expectation as the coming of the Antichrist receives but scant mention in the Apocalypse. The seven-horned ram is just about everything that Jesus appears not to be.¹² He is a real shadow-figure, but he could not be described as the Antichrist, who is a creature of Satan. For although the monstrous, warlike lamb is a shadow-figure in the sense that he is the counterpart of the lamb who was sacrificed, he is not nearly so irreconcilable with Christ as the Antichrist would have to be. The duplication of the Christ-figure cannot, therefore, be traced back to this split between Christ and Antichrist, but is due rather to the anti-Roman resentment felt by the Jewish Christians, who fell back on their god of vengeance and his warlike Messiah. The author of the Apocalypse may have been acquainted with Jewish speculations known to us through later tradition. We are told in the *Bereshith Rabbati* of Moses ha-Darshan that Elias found in Bethlehem a young woman sitting before her door with a newborn child lying on the ground beside her, flecked with blood. She explained that her son had been born at an evil hour, just when the temple was destroyed. Elias admonished her to look after the child. When he came back again five weeks later, he asked about her son. “He neither walks, nor sees, nor speaks, nor hears, but lies there like a stone,” said the woman. Suddenly a wind blew from the four corners of the earth, bore the child away, and plunged him into the sea. Elias lamented that it was now all up with the salvation of Israel, but a *bath kol* (voice) said to him:

It is not so. He will remain in the great sea for four hundred years, and eighty years in the rising smoke of the children of Korah,¹³ eighty years under the gates of Rome, and the rest of the time he will wander round in the great cities until the end of the days comes.¹⁴

[168] This story describes a Messiah who, though born in Bethlehem, is wafted by divine intervention into the Beyond (sea = unconscious). From the very beginning his childhood is so threatened that he is scarcely able to live. The legend is symptomatic of an extraordinary weakness of the Messianic element in Judaism and the dangers attending it, which would explain the delay in the Messiah’s appearance. For 560 years he remains latent, and only then does his missionary work begin. This interlude is not so far off the 530 years mentioned in the Talmudic prophecy (cf. par. 133), near enough anyway for us to compare them, if we take this legend as referring to Christ. In the limitless sea of Jewish speculation mutual contacts of this sort are more likely to have occurred than not. Thus the deadly threat to the Messiah and his death by violence is a motif that repeats itself in other stories, too. The later, mainly Cabalistic

tradition speaks of two Messiahs, the Messiah ben Joseph (or ben Ephraim) and the Messiah ben David. They were compared to Moses and Aaron, also to two roes, and this on the authority of the Song of Solomon 4 : 5: “Thy two breasts are like two young roes that are twins.”¹⁵ Messiah ben Joseph is, according to Deuteronomy 33 : 17, the “firstling of his bullock,” and Messiah ben David rides on an ass.¹⁶ Messiah ben Joseph is the first, Messiah ben David the second.¹⁷ Messiah ben Joseph must die in order to “atone with his blood for the children of Yahweh.”¹⁸ He will fall in the fight against Gog and Magog, and Armilus will kill him. Armilus is the Anti-Messiah, whom Satan begot on a block of marble.¹⁹ He will be killed by Messiah ben David in his turn. Afterwards, ben David will fetch the new Jerusalem down from heaven and bring ben Joseph back to life.²⁰ This ben Joseph plays a strange role in later tradition. Tabari, the commentator on the Koran, mentions that the Antichrist will be a king of the Jews,²¹ and in Abarbanel’s *Mashmi‘ a Yeshu‘ ah* the Messiah ben Joseph actually is the Antichrist. So he is not only characterized as the suffering Messiah in contrast to the victorious one, but is ultimately thought of as his antagonist.²²

[169] As these traditions show, the above-mentioned weakness of the Messianic element consists in a split which in the end becomes a complete polarity. This development is foreshadowed in Persian religious literature, in the pre-Christian idea of an enantiodromia of the great time-periods, and the deterioration of goodness. The Bahman Yast calls the fourth Iron Age “the evil sovereignty of the demons with dishevelled hair of the race of Wrath.”²³ On the other hand, the splitting of the Messiah into two is an expression of an inner disquiet with regard to the character of Yahweh, whose injustice and unreliability must have shocked every thoughtful believer ever since the time of Job.²⁴ Job puts the problem in unequivocal terms, and Christianity gave an equally unequivocal answer. Jewish mysticism, on the other hand, went its own way, and its speculations hover over depths which Christian thinkers have done their utmost to cover up. I do not want to elaborate this theme here, but will mention as an example a story told by Ibn Ezra. In Spain, he says, there was a great sage who was reputed to be unable to read the Eighty-ninth Psalm because it saddened him too much. The verses in question are:

I will not remove from him my steadfast love,
or be false to my faithfulness.

I will not violate my covenant,
or alter the word that went forth from my lips.

Once for all I have sworn my holiness:

I will not lie to David.

His line shall endure for ever,

his throne as long as the sun before me.
Like the moon it shall be established for ever;
the witness in the skies is sure. Selah!
But now thou hast cast off and rejected,
thou art full of wrath against thy anointed.
Thou hast renounced the covenant with thy servant;
thou hast trodden his crown in the dust.
Thou hast breached all his walls;
thou hast laid his strongholds in ruins.²⁵

[170] It is the same problem as in Job. As the highest value and supreme dominant in the psychic hierarchy, the God-image is immediately related to, or identical with, the self, and everything that happens to the God-image has an effect on the latter. Any uncertainty about the God-image causes a profound uneasiness in the self, for which reason the question is generally ignored because of its painfulness. But that does not mean that it remains unasked in the unconscious. What is more, it is answered by views and beliefs like materialism, atheism, and similar substitutes, which spread like epidemics. They crop up wherever and whenever one waits in vain for the legitimate answer. The *ersatz* product represses the real question into the unconscious and destroys the continuity of historical tradition which is the hallmark of civilization. The result is bewilderment and confusion. Christianity has insisted on God's goodness as a loving Father and has done its best to rob evil of substance. The early Christian prophecy concerning the Antichrist, and certain ideas in late Jewish theology, could have suggested to us that the Christian answer to the problem of Job omits to mention the corollary, the sinister reality of which is now being demonstrated before our eyes by the splitting of our world: *the destruction of the God-image is followed by the annulment of the human personality*. Materialistic atheism with its utopian chimeras forms the religion of all those rationalistic movements which delegate the freedom of personality to the masses and thereby extinguish it. The advocates of Christianity squander their energies in the mere preservation of what has come down to them, with no thought of building on to their house and making it roomier. Stagnation in these matters is threatened in the long run with a lethal end.

[171] As Bousset has plausibly suggested, the duality of the apocalyptic Christ is the outcome of Jewish-Gnostic speculations whose echoes we hear in the traditions mentioned above. The intensive preoccupation of the Gnostics with the problem of evil stands out in startling contrast to the peremptory nullification of it by the Church fathers, and shows that this question had already become topical at the beginning of the third century. In this connection we may recall the view expressed by

Valentinus,²⁶ that Christ was born “not without a kind of shadow” and that he afterwards “cast off the shadow from himself.”²⁷ Valentinus lived sometime in the first half of the second century, and the Apocalypse was probably written about A.D. 90, under Domitian. Like other Gnostics, Valentinus carried the gospels a stage further in his thinking, and for this reason it does not seem to me impossible that he understood the “shadow” as the Yahwistic law under which Christ was born. The Apocalypse and other things in the New Testament could easily have prompted him to such a view, quite apart from the more or less contemporaneous ideas about the demiurge and the prime Ogdoad that consists of light and shadow.²⁸ It is not certain whether Origen’s doubt concerning the ultimate fate of the devil was original;²⁹ at all events, it proves that the possibility of the devil’s reunion with God was an object of discussion in very early times, and indeed had to be if Christian philosophy was not to end in dualism. One should not forget that the theory of the *privatio boni* does not dispose of the eternity of hell and damnation. God’s humanity is also an expression of dualism, as the controversy of the Monophysites and Dyopnysites in the early Church shows. Apart from the religious significance of the decision in favour of a complete union of both natures, I would mention in passing that the Monophysite dogma has a noteworthy psychological aspect: it tells us (in psychological parlance) that since Christ, as a man, corresponds to the ego, and, as God, to the self, he is at once both ego and self, part and whole. Empirically speaking, consciousness can never comprehend the whole, but it is probable that the whole is unconsciously present in the ego. This would be equivalent to the highest possible state of *τελείωσις* (completeness or perfection).

[172] I have dwelt at some length on the dualistic aspects of the Christ-figure because, through the fish symbolism, Christ was assimilated into a world of ideas that seems far removed from the gospels—a world of pagan origin, saturated with astrological beliefs to an extent that we can scarcely imagine today. Christ was born at the beginning of the aeon of the Fishes. It is by no means ruled out that there were educated Christians who knew of the *coniunctio maxima* of Jupiter and Saturn in Pisces in the year 7 B.C., just as, according to the gospel reports, there were Chaldaeans who actually found Christ’s birthplace. The Fishes, however, are a double sign.

[173] At midnight on Christmas Eve, when (according to the old time-reckoning) the sun enters Capricorn, Virgo is standing on the eastern horizon, and is soon followed by the Serpent held by Ophiuchus, the “Serpent-bearer.” This astrological coincidence seems to me worth mentioning, as also the view that the two fishes are mother and son. The latter idea has a quite special significance because this relationship suggests that the two fishes were originally one. In fact, Babylonian and Indian astrology know of only one fish.³⁰ Later, this mother evidently gave birth to a

son, who was a fish like her. The same thing happened to the Phoenician Derceto-Atargatis, who, half fish herself, had a son called Ichthys. It is just possible that “the sign of the prophet Jonah”³¹ goes back to an older tradition about an heroic night sea journey and conquest of death, where the hero is swallowed by a fish (“whale-dragon”) and is then reborn.³² The redemptory name Joshua³³ (Yehoshua, Yeshua, Gr. *Iesus*) is connected with the fish: Joshua is the son of Nun, and Nun means ‘fish.’ The Joshua ben Nun of the Khidr legend had dealings with a fish that was meant to be eaten but was revived by a drop of water from the fountain of life.³⁴

[174] The mythological Great Mothers are usually a danger to their sons. Jeremias mentions a fish representation on an early Christian lamp, showing one fish devouring the other.³⁵ The name of the largest star in the constellation known as the Southern Fish—Fomalhaut, ‘the fish’s mouth’—might be interpreted in this sense, just as in fish symbolism every conceivable form of devouring *concupiscentia* is attributed to fishes, which are said to be “ambitious, libidinous, voracious, avaricious, lascivious”—in short, an emblem of the vanity of the world and of earthly pleasures (“voluptas terrena”).³⁶ They owe these bad qualities most of all to their relationship with the mother- and love-goddess Ishtar, Astarte, Atargatis, or Aphrodite. As the planet Venus, she has her “exaltatio” in the zodiacal sign of the fishes. Thus, in astrological tradition as well as in the history of symbols, the fishes have always had these opprobrious qualities attached to them,³⁷ while on the other hand laying claim to a special and higher significance. This claim is based—at least in astrology—on the fact that anyone born under Pisces may expect to become a fisherman or a sailor, and in that capacity to catch fishes or hold dominion over the sea—an echo of the primitive totemistic identity between the hunter and his prey. The Babylonian culture-hero Oannes was himself a fish, and the Christian Ichthys is a fisher of men par excellence. Symbologically, he is actually the hook or bait on God’s fishing-rod with which the Leviathan—death or the devil—is caught.³⁸ In Jewish tradition the Leviathan is a sort of eucharistic food stored up for the faithful in Paradise. After death, they clothe themselves in fishrobes.³⁹ Christ is not only a fisher but the fish that is “eucharistically” eaten.⁴⁰ Augustine says in his *Confessions*: “But [the earth] eats the fish that was drawn from the deep, at the table which you have prepared for them that believe; for the fish was drawn from the deep in order to nourish the needy ones of the earth.”⁴¹ St. Augustine is referring to the meal of fishes eaten by the disciples at Emmaus (Luke 24 : 43). We come across the “healing fish” in the story of Tobit: the angel Raphael helps Tobit to catch the fish that is about to eat him, and shows him how to make a magic “smoke” against evil spirits from the heart and liver of the fish, and how he can heal his father’s blindness with its gall (Tobit 6 : 1ff.).

[175] St. Peter Damian (d. 1072) describes monks as fishes, because all pious men are little fishes leaping in the net of the Great Fisher.⁴² In the Pectorios inscription

(beginning of the fourth century), believers are called the “divine descendants of the heavenly fish.”⁴³

[176] The fish of Manu is a saviour,⁴⁴ identified in legend with Vishnu, who had assumed the form of a small goldfish. He begs Manu to take him home, because he was afraid of being devoured by the water monsters.⁴⁵ He then grows mightily, fairytale fashion, and in the end rescues Manu from the great flood.⁴⁶ On the twelfth day of the first month of the Indian year a golden fish is placed in a bowl of water and invoked as follows: “As thou, O God, in the form of a fish, hast saved the Vedas that were in the underworld, so save me also, O Keshava!”⁴⁷ De Gubernatis and other investigators after him tried to derive the Christian fish from India.⁴⁸ Indian influence is not impossible, since relations with India existed even before Christ and various spiritual currents from the East made themselves felt in early Christianity, as we know from the reports of Hippolytus and Epiphanius. Nevertheless, there is no serious reason to derive the fish from India, for Western fish symbolism is so rich and at the same time so archaic that we may safely regard it as autochthonous.

[177] Since the Fishes stand for mother and son, the mythological tragedy of the son’s early death and resurrection is already implicit in them. Being the twelfth sign of the Zodiac, Pisces denotes the end of the astrological year and also a new beginning. This characteristic coincides with the claim of Christianity to be the beginning and end of all things, and with its eschatological expectation of the end of the world and the coming of God’s kingdom.⁴⁹ *Thus the astrological characteristics of the fish contain essential components of the Christian myth; first, the cross; second, the moral conflict and its splitting into the figures of Christ and Antichrist; third, the motif of the son of a virgin; fourth, the classical mother-son tragedy; fifth, the danger at birth; and sixth, the saviour and bringer of healing.* It is therefore not beside the point to relate the designation of Christ as a fish to the new aeon then dawning. If this relationship existed even in antiquity, it must obviously have been a tacit assumption or one that was purposely kept secret; for, to my knowledge, there is no evidence in the old literature that the Christian fish symbolism was derived from the zodiac. Moreover, the astrological evidence up to the second century A.D. is by no means of such a kind that the Christ/Antichrist antithesis could be derived *causally* from the polarity of the Fishes, since this, as the material we have cited shows, was not stressed as in any way significant. Finally, as Doelger rightly emphasizes, the Ichthys was always thought of as only *one* fish, though here we must point out that in the astrological interpretation Christ is in fact only one of the fishes, the role of the other fish being allotted to the Antichrist. There are, in short, no grounds whatever for supposing that the zodiac of the Fishes could have served as the Ichthys prototype.

[178] Pagan fish symbolism plays in comparison a far greater role.⁵⁰ The most important is the Jewish material collected by Scheftelowitz. The Jewish “chalice of benediction”⁵¹ was sometimes decorated with pictures of fishes, for fishes were the food of the blessed in Paradise. The chalice was placed in the dead man’s grave as a funerary gift.⁵² Fishes have a wide distribution as sepulchral symbols. The Christian fish occurs mainly in this connection. Devout Israelites who live “in the water of the doctrine” are likened to fishes. This analogy was self-evident around A.D. 100.⁵³ The fish also has a Messianic significance.⁵⁴ According to the Syrian Apocalypse of Baruch, Leviathan shall rise from the sea with the advent of the Messiah.⁵⁵ This is probably the “very great fish” of the Abercius inscription, corresponding to the “fish from the fountain” mentioned in a religious debate at the court of the Sassanids (5th century). The fountain refers to the Babylonian Hera, but in Christian language it means Mary, who in orthodox as well as in Gnostic circles (Acts of Thomas) was invoked as *πηγή*, ‘fountain.’ Thus we read in a hymn of Synesius (c. 350): *Παγά παγῶν, ἀρχῶν ἀρχά, ῥίζα, μονάς Εἶ μονάδων, κτλ.* (Fountain of fountains, source of sources, root of roots, monad of monads art thou.)⁵⁶ The fountain of Hera was also said to contain the one fish (*μόνον ἰχθύον*) that is caught by the “hook of divinity” and “feeds the whole world with its flesh.”⁵⁷ In a Boeotian vase-painting the “lady of the beasts”⁵⁸ is shown with a fish between her legs, or in her body,⁵⁹ presumably indicating that the fish is her son. Although, in the Sassanid debate, the legend of Mary was transferred to Hera, the “one fish” that is hooked does not correspond to the Christian symbol, for in Christian symbology the crucifix is the hook or bait with which God catches Leviathan,⁶⁰ who is either death or the devil (“that ancient serpent”) but not the Messiah. In Jewish tradition, on the other hand, the *pharmakon athanasias* is the flesh of Leviathan, the “Messianic fish,” as Scheftelowitz says. The Talmud Sanhedrin says that the Messiah “will not come until a fish is sought for an invalid and cannot be procured.”⁶¹ According to the Apocalypse of Baruch, Behemoth as well as Leviathan⁶² is a eucharistic food. This is assiduously overlooked. As I have explained elsewhere,⁶³ Yahweh’s two prehistoric monsters seem to represent a pair of opposites, the one being unquestionably a land animal, and the other aquatic.

[179] Since olden times, not only among the Jews but all over the Near East, the birth of an outstanding human being has been identified with the rising of a star. Thus Balaam prophecies (Num. 24 : 17):

I shall see him, but not now,

I shall behold him, but not nigh;

a star shall come forth out of Jacob

[180] Always the hope of a Messiah is connected with the appearance of a star. According to the Zohar, the fish that swallowed Jonah died, but revived after three days and then spewed him out again. “Through the fish we shall find a medicament for the whole world.”⁶⁴ This text is medieval but comes from a trustworthy source. The “very great⁶⁵ and pure fish from the fountain” mentioned in the Abercius inscription is, in the opinion of Scheftelowitz,⁶⁶ none other than Leviathan, which is not only the biggest fish but is held to be pure, as Scheftelowitz shows by citing the relevant passages from Talmudic literature. In this connection we might also mention the “one and only fish” (*εἰς μόνος ἰχθῦς*) recorded in the “Happenings in Persia.”⁶⁷

IX

THE AMBIVALENCE OF THE FISH SYMBOL

[181] According to the Syrian Apocalypse of Baruch (29 : 1ff.), the time preceding the coming of the Messiah falls into twelve parts, and the Messiah will appear in the twelfth. As a time-division, the number twelve points to the zodia, of which the twelfth is the Fishes. Leviathan will then rise out of the sea. “The two great sea monsters which I created on the fifth day of creation and which I have preserved until that time shall then be food for all who are left.”¹ Since Behemoth is unquestionably not a sea-animal, but one which, as a midrash says, “pastures on a thousand mountains,”² the two “sea monsters” must be a duplication of Leviathan. And as a matter of fact, he does appear to be divided as to sex, for there is a male and a female of the species.³ A similar duplication is suggested in Isaiah 27 : 1: “In that day, the Lord with his sore and great strong sword shall punish Leviathan the piercing serpent, even Leviathan that crooked serpent, and he shall slay the dragon [Vulgate: whale] that is in the sea.” This duplication gave rise in medieval alchemy to the idea of two serpents fighting each other, one winged, the other wingless.⁴ In the Book of Job, where Leviathan appears only in the singular, the underlying polarity comes to light in his opposite number, Behemoth. A poem by Meir ben Isaac describes the battle between Leviathan and Behemoth at the end of time, in which the two monsters wound each other to death. Yahweh then cuts them up and serves them as food to the devout.⁵ This idea is probably connected with the old Jewish Passover, which was celebrated in the month of Adar, the fish. In spite of the distinct duplication of Leviathan in the later texts, it is very likely that originally there was only one Leviathan, authenticated at a very early date in the Ugarit texts from Ras Shamra (c. 2000 B.C.). Virolleaud gives the following translation:

Quand tu frapperas Ltn, le serpent brh

Tu achèveras le serpent ‘qltn,

Le puissant aux sept têtes.

[182] He comments: “It is remarkable that the two adjectives *brh* and ‘*qltn* are the ones which qualify, in Isaiah 27 : 1, a particularly dangerous species of serpent which we call Leviathan, in Hebrew Liviatan.”⁶ From this period, too, there are pictures of a fight between Baal and the serpent Ltn,⁷ remarkable in that the conflict is between a god and a monster and not between two monsters, as it was later.

[183] We can see from the example of Leviathan how the great “fish” gradually split into its opposite, after having itself been the opposite of the highest God and hence his shadow, the embodiment of his evil side.⁸

[184] With this splitting of the monster into a new opposite, its original opposition to God takes a back seat, and the monster is now in conflict either with itself or with an equivalent monster (e.g., Leviathan and Behemoth). This relieves God of his own inner conflict, which now appears outside him in the form of a hostile pair of brother monsters. In later Jewish tradition the Leviathan that Yahweh fought with in Isaiah develops a tendency, on the evidence cited by Scheftelowitz, to become “pure” and be eaten as “eucharistic” food, with the result that, if one wanted to derive the Ichthys symbol from this source, Christ as a fish would appear in place of Leviathan, the monstrous animals of tradition having meanwhile faded into mere attributes of death and the devil.

[185] This split corresponds to the doubling of the shadow often met with in dreams, where the two halves appear as different or even as antagonistic figures. This happens when the conscious ego-personality does not contain all the contents and components that it could contain. Part of the personality then remains split off and mixes with the normally unconscious shadow, the two together forming a double—and often antagonistic—personality. If we apply this experience from the domain of practical psychology to the mythological material under discussion, we find that God’s monstrous antagonist produces a double because the God-image is incomplete and does not contain everything it logically ought to contain. Whereas Leviathan is a fishlike creature, primitive and cold-blooded, dwelling in the depths of the ocean, Behemoth is a warm-blooded quadruped, presumably something like a bull, who roams the mountains (at least in later tradition). Hence he is related to Leviathan as a higher, superior creature to a lower, inferior one, rather like the winged and the wingless dragon in alchemy. All winged beings are “volatile,” i.e., vapours and gases, in other words *pneuma*. Just as in Augustine Christ the fish is “drawn from the deep,”⁹ so in II Esdras 13 : 2ff. the “man” came out of the sea like a wind. His appearance was heralded by an eagle and a lion, theriomorphic symbols which greatly affrighted the prophet in the same way that Behemoth inspired chiefly terror in Job. The fish drawn from the deep has a secret connection with Leviathan: he is the bait with which Leviathan is lured and caught. This fish is probably a duplication of the great fish and stands for its pneumatic aspect. It is evident that Leviathan has such an aspect, because he, like the Ichthys, is eucharistic food.¹⁰ That this doubling represents an act of conscious realization is clear from Job 26 : 12, where we are told that Yahweh smote Rahab “by his understanding” (*tebūnā*). Rahab, the sea monster, is cousin german to Tiamat, whom Marduk split asunder by filling her up with Imhullu, the north wind.¹¹ The word *tebūnā* comes from *bīn*, ‘to separate, split, part

asunder’—in other words, to discriminate, which is the essence of conscious realization.¹² In this sense Leviathan and Behemoth represent stages in the development of consciousness whereby they become assimilated and humanized. The fish changes, via the warm-blooded quadruped, into a human being, and in so far as the Messiah became, in Christianity, the second Person of the Trinity, the human figure split off from the fish hints at God’s incarnation.¹³ What was previously missing in the God-image, therefore, was the human element.

[186] The role of the fish in Jewish tradition probably has some connections with the Syrophoenician fish cult of Atargatis. Her temples had pools with sacred fishes in them which no one was allowed to touch.¹⁴ Similarly, meals of fish were ritually eaten in the temples. “This cult and these customs, which originated in Syria, may well have engendered the Ichthys symbolism in Christian times,” says Cumont.¹⁵ In Lycia they worshipped the divine fish Orphos or Diorphos, the son of Mithras and the “sacred stone,” Cybele.¹⁶ This god is a variant of the Semitic fish-deities we have already mentioned, such as Oannes, the Babylonian Nun, Dagon, and Adonis, whom the Greeks called Ichthys. Fish offerings were made to Tanit in Carthage and to Ea and Nina in Babylon. Traces of a fish cult can be found in Egypt too. The Egyptian priests were forbidden to eat fish, for fishes were held to be as unclean as Typhon’s sea. “All abstain from sea-fish,” observes Plutarch. According to Clement of Alexandria, the inhabitants of Syene, Elephantine, and Oxyrhynchus worshipped a fish. Plutarch¹⁷ says it was the custom to eat a broiled fish before the door of one’s house on the ninth day of the first month. Doelger inclines to the view that this custom paved the way for the eucharistic fish in Christianity.¹⁸

[187] The ambivalent attitude towards the fish is an indication of its double nature. It is unclean and an emblem of hatred on the one hand, but on the other it is an object of veneration. It even seems to have been regarded as a symbol for the soul, if we are to judge by a painting on a late Hellenistic sarcophagus. The mummy lies on a lion-shaped bier, and under the bier are the four Canopic jars, the lids representing the four sons of Horus, three of them with animal heads and one with a human head. Over the mummy there floats a fish,¹⁹ instead of the usual soul-bird. It is clear from the painting that the fish is an oxyrhynchus, or barbel, one of the three most abominated fishes, which was said to have devoured the phallus of Osiris after he had been dismembered by Typhon (Set).²⁰ Barbels were sacred to Typhon, who is “that part of the soul which is passionate, impulsive, irrational, and truculent.”²¹ Because of their voraciousness, fishes were regarded in the Middle Ages as an allegory of the damned.²² The fish as an Egyptian soul-symbol is therefore all the more remarkable. The same ambivalence can be seen in the figure of Typhon/Set. In later times he was a god of death, destruction, and the desert, the treacherous opponent of his brother Osiris. But earlier he was closely connected with Horus and was a friend and helper

of the dead. In one of the Pyramid Texts he and Heru-ur (the “older Horus”) help Osiris to climb up to heaven. The floor of heaven consists of an iron plate, which in places is so close to the tops of the mountains that one can climb up to heaven with the help of a ladder. The four corners of the iron plate rest on four pillars, corresponding to the four cardinal points. In the Pyramid Texts of Pepi I, a song of praise is addressed to the “ladder of the twin gods,” and the Unas text says: “Unas cometh forth upon the Ladder which his father Ra hath made for him, and Horus and Set take the hand of Unas, and they lead him into the Tuat.”²³ Other texts show that there was enmity between Heru-ur and Set because one was a god of the day and the other a god of the night. The hieroglyph for Set has as a determinative the sign for a stone, or else the unidentified Set-animal with long ears. There are paintings showing the heads of Heru-ur and Set growing out of the same body, from which we may infer the identity of the opposites they represent. Budge says: “The attributes of Heru-ur changed somewhat in early dynastic times, but they were always the opposite of those of Set, whether we regard the two gods as personifications of two powers of nature, i.e., Light and Darkness, Day and Night, or as Kosmos and Chaos, or as Life and Death, or as Good and Evil.”²⁴

[188] This pair of gods represent the latent opposites contained in Osiris, the higher divinity, just as Behemoth and Leviathan do in relation to Yahweh. It is significant that the opposites have to work together for a common purpose when it comes to helping the *one* god, Osiris, to reach the heavenly quaternity. This quaternity is also personified by the four sons of Horus: Mestha, Hapi, Tuamutef, and Qebhsennuf, who are said to dwell “behind the thigh of the northern heaven,” that is, behind the thigh of Set, whose seat is in the constellation of the Great Bear. The four sons of Horus are Set’s enemies, but on the other hand they are closely connected with him. They are an analogy of the four pillars of heaven which support the four-cornered iron plate. Since three of the sons are often shown with animal heads, and one with a human head, we may point to a similar state of affairs in the visions of Ezekiel, from whose cherubim-figures the well-known symbols of the evangelists (three animals, one angel) are derived.²⁵ Ezekiel says, furthermore (1 : 22): “Over the heads of the living creatures [the cherubim] there was the likeness of a solid plate, shining like terrible crystal, spread out above their heads,” and (1 : 26, RSV): “And above the solid plate that was over their heads there was the likeness of a throne, in appearance like sapphire; and seated above the likeness of a throne was a likeness as it were of a human form.”

[189] In view of the close ties between Israel and Egypt an intermingling of symbols is not unlikely. What is remarkable, however, is that in Arab tradition the region round the heavenly Pole is seen in the form of a *fish*. Qazvini says: “The Pole can be seen. Round it are the smaller *Benat na’sh*²⁶ and dark stars, which together form the

picture of a fish, and in its midst is the Pole.”²⁷ This means that the Pole, which in ancient Egypt denoted the region of Set and was at the same time the abode of the four sons of Horus, was contained, so to speak, in the body of a fish. According to Babylonian tradition Anu has his seat in the northern heaven; likewise Marduk, as the highest god, world-creator and ruler of its courses, is the Pole. The *Enuma Elish* says of him: “He who fixes the course of the stars of heaven, like sheep shall pasture the gods all together.”²⁸

[190] At the northern point of the ecliptic is the region of fire (purgatory and the entrance to the Anu-heaven). Hence the northern corner of the temple built around the tower at Nippur was called the *kibla* (point of orientation). In like manner the Sabaeans and Mandaeans, when praying, turn towards the north.²⁹ We might also mention the Mithraic liturgy in this connection: in the final vision Mithras appears, “holding the golden shoulder of a young bull. This is the constellation of the Bear, which moves and turns the heavens round.” The text piles endless fire-attributes on this god, who obviously hails from the north.³⁰

[191] These Babylonian ideas about the significance of the north make it easier for us to understand why Ezekiel’s vision of God came from that quarter, despite the fact that it is the birthplace of all evil. The coincidence of opposites is the normal thing in a primitive conception of God, since God, not being an object of reflection, is simply taken for granted. At the level of conscious reflection, however, the coincidence of opposites becomes a major problem, which we do everything possible to circumvent. That is why the position of the devil in Christian dogma is so very unsatisfactory. When there are such gaps in our collective ideas, in the dominants of our conscious orientation, we can count with absolute certainty on the existence of complementary or—to be more precise—compensatory developments in the unconscious. These compensating ideas can be found in the speculations of alchemy. We can hardly suppose that ideas of this sort remained totally unconscious so far as the adepts were concerned. What they were aiming at was a more or less conscious restoration of the primitive God-image. Hence they were able to propound paradoxes as shocking as that of God’s love glowing in the midst of hell-fire,³¹ which is represented as being no more than the Christian conception of God in a new but necessary relation to everything hell stands for. Above all it was Jakob Böhme who, influenced by alchemy and the Cabala equally, envisaged a paradoxical God-image in which the good and the bad aspects appertain to the same divine being in a way that bears comparison with the views of Clement of Rome.

[192] Ancient history gives us a divided picture of the region to the north: it is the seat of the highest gods and also of the adversary; thither men direct their prayers, and from thence blows an evil pneuma, the Aquilo, “by the name whereof is to be

understood the evil spirit”;³² and finally, it is the navel of the world and at the same time hell. Bernard of Clairvaux apostrophizes Lucifer thus: “And dost thou strive perversely towards the north? The more thou dost hasten toward the heights, the more speedily shalt thou go down to thy setting.”³³ The “king of the North” in Nostradamus has to be understood in the light of this passage. At the same time, it is clear from St. Bernard’s words that the heights of power to which Lucifer strives are still associated with the north.³⁴

X

THE FISH IN ALCHEMY

1. *The Medusa*

[193] Michel Nostradamus, physician and astrologer, must surely have been acquainted with alchemy, since this art was practised mainly by physicians. Whether he knew that the fish was a symbol for the arcane substance and the *lapis* is perhaps questionable, but it is more than likely that he had read the classics of alchemy. Of these one of the greatest authorities is the *Turba philosophorum*, which had been translated very early (11th–12th cent.) from the Arabic into Latin. At about the same time, or a little later, its appendices were also translated, namely the “*Allegoriae super librum Turbae*,” the “*Allegoriae sapientum supra librum Turbae XXIX distinctiones*,”¹ together with the “*Aenigmata ex Visione Arislei*” and “*In Turbam philosophorum exercitationes*.” The *Turba* belongs to the same sphere of thought as the *Tabula smaragdina*, and hence is one of those late Hellenistic products that were transmitted to us by the Arabs, mainly, perhaps, through the Neoplatonic school of Harran (Thabit ibn Qurrah and others), which flourished at the beginning of the eleventh century.² The ideas preserved in these treatises are “Alexandrian,” and the recipes, particularly those set forth in the “*Allegoriae super librum Turbae*,” adhere closely to the spirit and letter of the *Papyri Graecae Magicae*.³

[194] Now these “*Allegoriae*”⁴ are our earliest source for the alchemical fish symbolism. For this reason we may assign a fairly early date to the alchemical fish—before the eleventh century, in any case.⁵ There is nothing to suggest that it is of Christian origin. That, however, did not prevent it from becoming—through the transformation of the arcane substance which it had at first represented—a symbol of the *lapis*, the latter term denoting the *prima materia* as well as the end product of the process, variously called *lapis philosophorum*, *elixir vitae*, *aurum nostrum*, *infans*, *puer*, *filius philosophorum*, *Hermaphroditus*, and so on. This *filius*, as I have shown elsewhere, was regarded as a parallel of Christ. Thus, by an indirect route, the alchemical fish attains the dignity of a symbol for the *Salvator mundi*. Its father is God, but its mother is the *Sapientia Dei*, or Mercurius as Virgo. The *filius philosophorum* (or *macrocosmi*), otherwise the *lapis*, means nothing other than the self, as I have explained in a detailed examination of its various attributes and peculiarities.

[195] The text containing the earliest reference to the fish runs: “There is in the sea a round fish, lacking bones and cortex, and having in itself a fatness, a wondrous virtue, which, if it is cooked on a slow fire until its fatness and moisture entirely disappear ... is saturated with sea-water until it begins to shine.”⁶ This recipe is repeated in another, possibly later, treatise of the same kind, the “Aenigmata philosophorum.”⁷ Here the “piscis” has become a “pisciculus,” and “lucescat” has become “candescat.” Common to both treatises is the ironic conclusion of the recipe: When the *citrinitas* (*xanthosis*, ‘yellowing’) appears, “there is formed the *collyrium* [eyewash] of the philosophers.” If they wash their eyes with it, they will easily understand the secrets of the philosophy.

[196] This round fish is certainly not a fish in the modern sense, but an invertebrate. This is borne out by the absence of bones and “cortex,” which in medieval Latin simply means a musselshell or mollusc.⁸ At all events, it is some kind of round organism that lives in the sea, presumably a scyphomedusa or jellyfish, which abounded in the seas of the ancient world. Its free-swimming form, the acropedote medusa, has a round, bell-or disc-shaped body of radial construction, which as a rule is divided into eight sections by means of four perradials and four interradians (whose angles may again be halved by adradials). Like all Cnidaria⁹ or Nematophora¹⁰ (to which class the Scyphomedusae belong), they are equipped with tentacles; these contain the thread-cells or nematocysts with which they poison their prey.

[197] Our text remarks that when the “round fish” is warmed or cooked on a slow fire it “begins to shine.” In other words, the heat already present in it becomes visible as light. This suggests that the author of the recipe was influenced either by Pliny himself or by some one in the same tradition. Pliny describes a fish—the *stella marina*, ‘star of the sea’—which, he says, has puzzled several great philosophers.¹¹ This fish was said to be hot and burning, and to consume as with fire everything it touched in the sea.¹² Pliny mentions the *stella marina*¹³ in the same breath¹⁴ as the *pulmo marinus*, which swims freely on the surface,¹⁵ and attributes to the latter so fiery a nature that when you rub it with a stick, you can straightway use the stick as a torch.¹⁶ From this we might conclude that our author did not take zoological distinctions too seriously, and may have confused the *stella marina* with the *pulmones*. However that may be, the Middle Ages with its passion for symbols eagerly seized on the legend of the “starfish.” Nicholas Caussin regarded the “fish” as a starfish and describes it as such. This animal, he says, generates so much heat that it not only sets fire to everything it touches but also cooks its own food. Hence it signifies the “*veri amoris vis inextinguibilis*” (the inextinguishable power of true love).¹⁷

[198] Such an interpretation sounds very strange to modern ears. But for the Middle Ages “alles Vergängliche ist nur ein Gleichnis” was literally true: all ephemeral things were but a symbol of the divine drama, which to modern man has become almost meaningless. Picinellus interprets the fish in the same way, the only difference being that his amplification is much more elaborate. “This fish,” he says, “glows forever in the midst of the waters, and whatsoever it touches grows hot and bursts into flames.” This glow is a fire—the fire of the Holy Ghost. He cites as his authority Ecclesiasticus 48 : 1,¹⁸ and refers also to the fiery tongues of the Pentecostal miracle. The miraculous fact that the fire of the *stella marina* does not go out in the water reminds him of the “divinae gratiae efficacitas” (action of divine grace), which sets on fire the hearts that are drowned in a “sea of sins.” For the same reason the fish means charity and divine love, as the Song of Solomon 8 : 7 testifies: “Many waters cannot quench love, neither can the floods drown it.” The fish, so our author supposes, spreads a radiance about itself from the first moment of its life and thus is an emblem of religion, by whose light the faithful live.

[199] As the quotation from the Song of Solomon shows, the interpretation of the burning starfish brings out its connection with profane love. Picinellus even says that the starfish is the “hieroglyph of a lover’s heart,” whose passion not even the entire sea can extinguish, no matter whether his love be divine or profane. This fish, says our author inconsequently, burns but gives no light. He quotes St. Basil: “Then conceive in your mind a deep pit, impenetrable darkness, fire that has no brightness, having all fire’s power of burning, but without any light. ... Such a conception describes the fire of hell.”¹⁹ This fire is “concupiscentia,” the “scintilla voluptatis” (spark of lechery).

[200] It is curious how often the medieval symbolists give diametrically opposed interpretations of the same symbol, apparently without becoming aware of the far-reaching and dangerous possibility that the unity of the symbol implies the identity of the opposites. Thus we can find certain views in alchemy which maintain that God himself “glows” in this subterranean or submarine²⁰ fire. The “Gloria mundi,” for instance, says:²¹

Take fire or unslaked lime, which the Philosophers say grows on trees. In this fire God himself glows in divine love. ... Likewise the Natural Master says regarding the art of fire, that Mercurius is to be decomposed ... and fixed in the unquenchable or living fire, wherein God himself glows, together with the sun, in divine love, for the solace of all men; and without this fire can the art never be brought to perfection. It is also the fire of the Philosophers, which they keep hidden away and concealed. ... It is also the noblest fire which God created upon earth, for it has a thousand virtues. To these things the teacher replies that God has bestowed upon it such virtue and

efficacy ... that with this fire is mingled the Godhead itself. And this fire purifies, as purgatory does in the lower regions.²²

The fire is “inextinguishable.” “The Philosophers call this fire the fire of the Holy Ghost.”²³ It unites Mercurius with the sun “so that all three make but one thing, which no man shall part asunder.”²⁴ “Just as in these three God the Father, God the Son, and God the Holy Ghost are united, [i.e., as] the Holy Trinity in three Persons, and there yet remains the one single true God, so also the fire unites these three things: body, spirit, and soul, that is, Sun, Mercurius, and Soul.”²⁵ “In this invisible fire the mystery of the Art is enclosed, as God the Father, Son, and Spirit in three Persons is verily included in one essence.”²⁶ This fire is “fire and water at once.” The Philosophers name it the “living fire” in honour of God, “who mingles himself with himself in the living water.”²⁷

[201] Another treatise says of the water that it is the “hiding-place and dwelling-place of the whole treasure.”²⁸ For in its midst is the “fire of Gehenna” which “contains this engine of the world in its own being.”²⁹ The fire is caused by the “primum mobile” and is kindled by the influence of the stars. It never ceases its universal motion and is continually lit through the “influence of celestial forces.”³⁰

[202] It is an “unnatural” fire, “contrary to nature.” It puts bodies to the torture, it is itself the dragon that “burns furiously like hell-fire.”³¹ The life-spirit dwelling in nature, Phyton, has a double aspect: there is an infernal form of it, namely hell-fire, from which a hellish bath can be prepared. The treatise of Abraham Eleazar speaks of Phyton as a “god.”³²

[203] According to Blaise de Vigenère, the fire has not two but four aspects: the intelligible, which is all light; the heavenly, partaking of heat and light; the elemental, pertaining to the lower world and compounded of light, heat, and glow (*ardor*); and finally the infernal, opposed to the intelligible, glowing and burning without any light.³³ Here again we encounter the quaternity which the ancients associated with fire, as we saw from the Egyptian conception of Set and the four sons of Horus,³⁴ and from Ezekiel’s vision of the fiery region to the north. It is not at all likely that Vigenère was thinking of Ezekiel in this connection.³⁵

[204] In the “Introitus apertus” of Philalethes the arcane substance is named “chalybs” (steel). This, he says, is the “auri minera” (the *prima materia* of the gold), “the true key of our Work, without which no skill can kindle the fire of the lamp.” Chalybs is a “spirit pre-eminently pure,” a “secret, infernal, and yet most volatile fire,”³⁶ the “wonder of the world, the system of the higher powers in the lower. For this reason the Almighty has assigned to it a most glorious and rare heavenly conjunction, even that notable sign whose nativity is declared throughout the Philosophical East to the

furthest horizon of its hemisphere. The wise Magi saw it at the [beginning of the] era, and were astonished, and straightway they knew that the most serene King was born in the world. Do you, when you see his star, follow it to the cradle, and there you shall behold the fair infant. Cast aside your defilements, honour the royal child, open your treasure, offer a gift of gold; and after death he will give you flesh and blood, the supreme Medicine in the three monarchies of the earth.”³⁷

[205] This passage is particularly interesting because it allows us to look deep into the world of obscure archetypal ideas that fill the mind of the alchemist. The author goes on to say that the steel, which is at the same time the “infernal fire,” the “key of our Work,” is attracted by the magnet, for which reason “our magnet” is the true “minera” (raw material) of the steel. The magnet has a hidden centre which “with an archetic appetite³⁸ turns towards the Pole, where the virtue of the steel is exalted.” The centre “abounds in salt”—evidently the *sal sapientiae*, for immediately afterwards the text says: “The wise man will rejoice, but the fool will pay small heed to these things, and will not learn wisdom, even though he see the outward-turned central Pole marked with the notable sign³⁹ of the Almighty.”

[206] In the Pole is found the heart of Mercurius, “which is the true fire wherein its Lord has his rest. He who journeys through this great and wide sea may touch at both Indies, may guide his course by the sight of the North Star, which our Magnet will cause to appear unto you.” This is an allusion to the mystic journey, the “peregrinatio.” As I have explained elsewhere, it leads to the four quarters, here indicated by the two Indies—East, West—and by the turning of the compass to the north.⁴⁰ Together they form a cross, i.e., a quaternity, which characterizes the nature of the Pole. For from the Pole the four directions radiate out, and also the division of the hemispheres (east and west of the Greenwich meridian). Thus the northern hemisphere resembles the round body of the hydromedusa, whose spherical surface is divided by four (or multiples of four) radials, and therefore looks like a globe seen from the Pole.

[207] In this connection I would like to mention the dream of a twenty-year-old student, who got into a state of confusion when he found that the philosophical faculty for which he had opted did not suit him. He could discover no reason for this. His disorientation reached the point where he simply did not know what profession he wanted to take up. Then a dream came to his help and showed him his goal in the fullest sense:

[208] *He dreamt that he was walking in a wood. Gradually this grew more and more lonely and wild, and finally he realized that he was in a primeval forest. The trees were so high and the foliage so thick that it was almost dark on the ground. All trace of a path had long since disappeared, but, driven on by a vague sense of expectation*

and curiosity, he pressed forward and soon came to a circular pool, measuring ten to twelve feet across. It was a spring, and the crystal-clear water looked almost black in the dark shadows of the trees. In the middle of the pool there floated a pearly organism, about eighteen inches in diameter, that emitted a faint light. It was a jelly-fish.^{40a} Here the dreamer awoke with a violent emotion: he decided there and then to study science, and he kept to this decision. I must emphasize that the dreamer was not under any psychological influence that might have suggested such an interpretation. The conclusion he drew from the dream was undoubtedly the right one, but it does not by any means exhaust the meaning of the symbol. The dream is archetypal—a “big” dream. The wood that grows dusky and turns into a primeval forest means entry into the unconscious. The round pool with the jelly-fish in it represents a three-dimensional mandala, the self: wholeness as the goal to which the “archetic appetite” points, the magnetic north which gives the traveller his bearings on the “sea of the world.”

[209] Turning back to our text, I would emphasize, by way of recapitulation, that the infernal fire is nothing other than the *Deus absconditus* (hidden God) who dwells at the North Pole and reveals himself through magnetism. His other synonym is Mercurius, whose heart is to be found at the Pole, and who guides men on their perilous voyage over the sea of the world. The idea that the whole machinery of the world is driven by the infernal fire at the North Pole, that this is hell, and that hell is a system of upper powers reflected in the lower—this is a shattering thought. But the same note is struck by Meister Eckhart when he says that, on returning to his true self, he enters an abyss “deeper than hell itself.” Scurrilous as it is, the alchemical idea cannot be denied a certain grandeur. What is particularly interesting, psychologically, is the nature of the image: it is the projection of an archetypal pattern of order,⁴¹ the mandala, which represents the idea of totality. The centering of the image on hell, which at the same time is God, is grounded on the experience that highest and lowest both come from the depths of the soul, and either bring the frail vessel of consciousness to shipwreck or carry it safely to port, with little or no assistance from us. The experience of this “centre” is therefore a numinous one in its own right.

[210] Picinellus feels that his *stella maris*, “this fish which burns in the midst of the water but gives no light,” besides meaning the Holy Ghost, love, grace, and religion, also symbolizes something in man, namely his *tongue*, speech, and powers of expression, for it is in these faculties that all psychic life is manifest. He is evidently thinking of an instinctive, unreflecting psychic activity, because at this point he cites James 3 : 6: “And the tongue is a fire, a world of iniquity among our members, defiling the whole body, setting on fire the wheel of birth, and set on fire by hell.”⁴²

[211] Hence the evil “fish” coincides with our untamed and apparently untameable propensities, which, like a “small fire that sets a great forest ablaze,”⁴³ defiles the whole body and even sets on fire the “wheel of birth.” The τροχός τῆς Γενέσεως (*rota nativitatis*) is a distinctly curious expression to use in this connection. The wheel, it is explained, symbolizes the circle or course or cycle of life. This interpretation presupposes ideas akin to Buddhism, if we are not to conceive the wheel merely as the banal statistical cycle of births and deaths. How the wheel could ever be set on fire is a difficult question that cannot be answered without further reflection. We must consider, rather, that it is meant as a parallel to the defilement of the whole body—in other words, a destruction of the *soul*.

[212] Ever since the *Timaeus* it has been repeatedly stated that the soul is a sphere.⁴⁴ As the *anima mundi*, the soul revolves with the world wheel, whose hub is the Pole. That is why the “heart of Mercurius” is found there, for Mercurius is the *anima mundi*.⁴⁵ The *anima mundi* is really the motor of the heavens. The wheel of the starry universe is reflected in the horoscope, called the “thema” of birth. This is a division of the heavens into twelve houses, calculated at the moment of birth, the first house coinciding with the ascendent. Divided up in this way the firmament looks like a wheel turning, and the astronomer Nigidius⁴⁶ is said to have received the name Figulus (“potter”) because the wheel of heaven turns like a potter’s wheel.⁴⁷ The “thema” (that which is “set” or “ordained”) is indeed a τροχός, ‘wheel’. The basic meaning of the horoscope is that, by mapping out the positions of the planets and their relations to one another (aspects), together with the distribution of the signs of the zodiac at the cardinal points, it gives a picture first of the psychic and then of the physical constitution of the individual. It represents, in essence, a system of original and fundamental qualities in a person’s character, and can therefore be regarded as an equivalent of the individual psyche. Priscillian (d. 385) evidently took the wheel in this sense. He says of Christ: “He alone has the power to join together the Pleiades and to loose the bands of Orion. Knowing the changes of the firmament and destroying the wheel of generation, he has overcome the day of our birth by the renewal of baptism.”⁴⁸ From this it is plain that in the fourth century the wheel of birth was in fact regarded as the horoscope. “Setting fire to the wheel” is therefore a figurative expression for a catastrophic revolt of all the original components of the psyche, a conflagration resembling panic or some other uncontrollable, and hence fatal outburst of emotion.⁴⁹ The total nature of the catastrophe is explained by the central position of the so-called “tongue,” the diabolical element whose destructiveness is an essential part of every psyche. Seen in this light, the *stella maris* stands for the fiery centre in us from which creative or destructive influences come.

2. The Fish

[213] In our discussion of medieval fish symbolism we have so far been concerned with a fish only in name, the jelly-fish, without taking due account of the fact that this is not a fish at all in the zoological sense, and—more important still—is not shaped like one. It was simply the description of the “round fish” that brought it to our attention. That, however, was not the case in the Middle Ages, for we have the testimony of a sixteenth-century adept, Theobald de Hoghelande, which shows that he at least understood the fish to be a real fish. Listing the numerous synonyms for the tincture, he remarks: “Likewise they compared it to fishes. Hence Mundus says in the *Turba*: Take one part fish-gall and one part calf’s urine, etc. And in the ‘Aenigmata sapientum’ it says: There is in our sea a small round fish, without bones or legs [*cruribus*].”⁵⁰ Since the gall mentioned in the quotation can only come from a real fish, Hoghelande obviously took the “small round fish” to be a real one, and since one can imagine a fish without bones, but hardly without skin or some kind of integument, the incomprehensible “corticibus” of the original version⁵¹ had to be changed into “cruribus” (legs). Of course, fishes don’t have legs either. But this passage from a sixteenth-century text proves that the “small round fish” of the “Aenigmata” was understood, in alchemical tradition, as a real fish and not as a jelly-fish. A round and transparent fish of a peculiar sort, without “cortices,” is described in the *Cyranides*: the “cinedian fish” lives in the sea on the shores of Syria, Palestine, and Libya, is six fingers long, and is a “pisciculus rotundus.” It has two stones in its head and another one in the third vertebra of the tail (*spondilo*), or notochord. This stone is especially potent and is used as a love-potion.⁵² The cinedian stone is practically unknown, because it is very rare. It is also called “opsianus,”⁵³ which is interpreted as “serotinus” (of late growth or origin) and “tardus” (slow, hesitant). It pertains to Saturn. “This stone is twin or twofold: the one is opaque and black, but the other though black is brilliant and shining like a mirror.”⁵⁴ This is the stone which many seek, without finding it: for it is the dragon’s stone (*dracontius lapis*).⁵⁵

[214] The only thing that can be elicited with certainty from this involved description is that the animal in question must be a vertebrate, and is therefore presumably a genuine fish. What exactly is the justification for calling it “round” is far from clear. It is obvious that the fish is mainly a mythologem, since it is said to contain the dragon’s stone. This stone was known to Pliny⁵⁶ and also to the medieval alchemists, who named it *draconites*, *dracontias*, or *drachates*.⁵⁷ It was reputed to be a precious stone, which could be obtained by cutting off the head of a sleeping dragon. But it becomes a gem only when a bit of the dragon’s soul remains inside,⁵⁸ and this is the “hate of the monster as it feels itself dying.” The gem is of a *white* colour, and a powerful alexipharmic. Even though there are no dragons nowadays, the text says, these draconites are occasionally found in the heads of water-snakes. Ruland asserts that he has seen such stones, blue or black in colour.

[215] The cinedian stone has a double nature, though, as the text shows, it is not at all clear.⁵⁹ One might almost conjecture that its double nature consisted originally in a white and a black variety, and that a copyist, puzzled by the contradiction, inserted “niger quidem” (‘though black’). But Ruland distinctly emphasizes that “the colour of the Draconite is white.”⁶⁰ Its affinity with Saturn may shed light on this dilemma. Saturn, in astrology the “star of the sun,” is alchemically interpreted as black; it is even called “sol niger” and has a double nature as the arcane substance,⁶¹ being black outside like lead, but white inside. Johannes Grasseus cites the opinion of the Augustinian monk Degenhardus concerning the lead: the lead of the Philosophers, named lead of the air (*Pb aeris*), contains the “shining white dove” which is called the “salt of the metals.”⁶² Vigenère assures us that lead, “than which nothing is more opaque,” can be turned into “hyacinth” and back again to lead.⁶³ Quicksilver, says Mylius,⁶⁴ comes from the “heart of Saturn,” in fact *is* Saturn, the bright silveriness of mercury contrasting with the “blackness” of lead. The “bright” water⁶⁵ that flows from the plant Saturnia is, according to Sir George Ripley, “the most perfect water and the bloom of the world.”⁶⁶ How old this idea is can be seen from the remark of Hippolytus,⁶⁷ that Chronos (Saturn) is a “power of the colour of water, and all-destructive.”

[216] In view of all this, the double nature of the cinedian stone might signify the polarity and union of opposites, which is just what gives the *lapis philosophorum* its peculiar significance as a uniting symbol,⁶⁸ and hence its magical and divine properties. Our draconite, too, is endowed with extraordinary powers (“*potentissimus valde*”), which make it eminently suitable as the “ligature of Aphrodite,” i.e., love-magic. Magic exercises a *compulsion* that prevails over the conscious mind and will of the victim: an alien will rises up in the bewitched and proves stronger than his ego. The only comparable effect capable of psychological verification is that exerted by unconscious contents, which by their compelling power demonstrate their affinity with or dependence on man’s totality, that is, the self and its “karmic” functions.⁶⁹ We have already seen that the alchemical fish symbol points ultimately to an archetype of the order of magnitude of the self. So it should not surprise us to see that the principle of “outward uncomeliness,” which applies to the lead and the *lapis*, is also applied to Christ. The same that is said of the *lapis* is said of Christ by Ephrem the Syrian (d. 373): “He is clothed in figures, he is the bearer of types. ... His treasure is hidden and of small account, but when it is laid open, it is wonderful to look upon.”⁷⁰

[217] In a treatise of the seventeenth century, by an anonymous French author,⁷¹ our strange hybrid, the “round fish,” finally becomes a verifiable vertebrate known to zoology: *Echeneis remora*, the common remora or sucking-fish. It belongs to the mackerel family, and is distinguished by a large, flat, oval-shaped sucker on the top

of the head in place of the dorsal fin. By means of this it attaches itself either to a larger fish or to a ship's bottom and in this wise is transported about the world.

[218] The text says of this fish:

For that which we take, in order to prepare from it the Philosophical Work, is naught else but that little fish the *Echeneis*, which has no blood or spiny bones, and is shut up in that deep mid region of the great universal sea. This little fish is extremely small, alone, and unique in its shape, but the sea is great and vast, and hence it is impossible for those to catch it who do not know in what part of the world it dwells. Believe me verily, that he who, as Theophrastus says, does not well understand the art by which he can draw down the moon from the sky and bring it from heaven to earth, and change it into water and then into earth, will never find the material of the stone of the wise, for it is not more difficult to perform the one than to find the other. Yet none the less, when we speak somewhat in confidence in the ear of a trusted friend, we teach him that hidden secret of the wise, how he can naturally, speedily, and easily catch the little fish called Remora, which is able to hold back the proud vessels of the great Ocean sea (that is the spirit of the world). Those who are not sons of the art are altogether ignorant and know not those precious treasures which are concealed by nature in the precious and heavenly Aqua Vitae of our sea. But, that I may declare to you the clear light of our unique material, or our virgin soil, and teach you in what wise you may acquire the supreme art of the sons of wisdom, it is needful that I instruct you concerning the magnet of the wise, which has the power of attracting the little fish called Echeneis or Remora from out the centre and depth of the sea. If it is caught in accordance with nature, it changes in a natural way first into water and then into earth. And this, when properly prepared by the cunning secret of the wise, has the power of dissolving all solid bodies and making them volatile, and of purifying all bodies that are poisoned.⁷²

[219] We learn from this text that the fish is found, if it can be found at all, in the centre of the ocean. But the ocean is the "spirit of the world." Our text, as the above sample shows, derives from a time when alchemy had almost given up its laboratory work and was becoming more and more of a philosophy. For an alchemist living in the early part of the seventeenth century, the "spirit of the world" is a somewhat unusual term, because the expression more commonly used was the "anima mundi." The world-soul or, in this case, the world-spirit is a projection of the unconscious, there being no method or apparatus which could provide an objective experience of this kind and thus furnish objective proof of the world's animation. This idea is nothing more than an analogy of the animating principle in man which inspires his thoughts and acts of cognition. "Soul" and "spirit," or psyche as such, is in itself totally unconscious. If it is assumed to be somewhere "outside," it cannot be anything

except a projection of the unconscious. This may mean a lot or a little, according to the way you look at it. At any rate, we know that in alchemy “our sea” is a symbol for the unconscious in general, just as it is in dreams. The extremely small fish that dwells in the centre of the universal sea nevertheless has the power to stop the largest ships. From the description of the Echeneis it is evident that the author was acquainted with the “pisciculus rotundus ossibus et corticibus carens” of the “Aenigmata.” Our interpretation of the round fish as the self can, accordingly, be extended to the Echeneis. The symbol of the self appears here as an “extremely small” fish in the vast ocean of the unconscious, like a man alone on the sea of the world. Its symbolization as a fish characterizes the self, in this state, as an unconscious content. There would be no hope whatever of catching this insignificant creature if a “magnet of the wise” did not exist in the conscious subject. This “magnet” is obviously something a master can teach to his pupil; it is the “theoria,” the one solid possession from which the adept can proceed. For the *prima materia* always remains to be found, and the only thing that helps him is the “cunning secret of the wise,” a theory that can be communicated.

[220] This is affirmed by Bernardus Trevisanus (1406–1490) in his treatise “De secretissimo philosophorum opere chemico”: it was the sermons of Parmenides in the *Turba* that first freed him from error and guided him into the right way.⁷³ But Parmenides says the same thing as Arisleus⁷⁴ in the *Turba*: “Nature is not improved save through its own nature,”⁷⁵ and Bernardus adds by way of confirmation: “Thus our material cannot be improved save through itself.” It was the *theory* of Parmenides that helped Bernardus on to the right track after much fruitless laboratory work, and there is a legend that he even succeeded in making the philosophers’ stone. As to the theory, he is obviously of the opinion that its basic thought is expressed in the saying quoted above, that “nature”⁷⁶ can improve or free itself from error only in and through itself. The same idea is expressed in the repeated warning of other treatises not to mix anything from outside with the content of the Hermetic vessel, because the *lapis* “has everything it needs.”⁷⁷

[221] It is not exactly probable that the alchemists always knew what they were writing, otherwise they would have dropped dead at their own enormities, and of this there is no sign in the literature. *Who* has everything he needs? Even the loneliest meteor circles round some distant sun, or hesitantly draws near to a cluster of brother meteors. Everything hangs together with everything else. By definition, only absolute totality contains everything in itself, and neither need nor compulsion attaches it to anything outside. This is undoubtedly the same as the idea of an absolute God who encompasses everything that exists. But which of us can pull himself out of the bog by his own pigtail? Which of us can improve himself in total isolation? Even the holy anchorite who lives three days’ journey off in the desert not only needs to eat and

drink but finds himself utterly and terribly dependent on the ceaseless presence of God.⁷⁸ Only absolute totality can renew itself out of itself and generate itself anew.

[222] What is it, then, that one adept whispers into the ear of another, fearfully looking round lest any betray them, or even guess their secret? Nothing less than this: that through this teaching the One and All, the Greatest in the guise of the Smallest, God himself in his everlasting fires, may be caught like a fish in the deep sea. Further, that he may be “drawn from the deep” by a eucharistic act of integration (called *teoqualo*, ‘God-eating,’ by the Aztecs⁷⁹), and incorporated in the human body.

[223] This teaching is the secret and “cunning” magnet by virtue of which the remora (“little in length / mighty in strength”) stops the proud frigates in the sea, an adventure which befell the quinquereme of the emperor Caligula “in our own day,” as Pliny says in his interesting and edifying tale. The little fish, that was only half a foot long, had sucked fast to the rudder on the return journey from Stura to Entium, and had brought the ship to a standstill. On returning to Rome after this journey, Caligula was murdered by his soldiers. So the Echeneis turned out to be an omen, as Pliny points out. The fish played another such trick on Mark Antony before the naval engagement with Augustus, during which Antony was killed. Pliny cannot marvel enough at the mysterious powers of the Echeneis. His amazement obviously impressed the alchemists so much that they identified the “round fish in our sea” with the remora, and in this way the remora came to symbolize that extremely small thing in the vastness of the unconscious which is charged with such fateful significance: it is the self, the *atman*, “smaller than small, greater than great.”

[224] The alchemical fish symbol, the Echeneis, clearly derives from Pliny. But fishes also crop up in the writings of Sir George Ripley.⁸⁰ What is more, they appear in their “messianic” role: together with the birds, they bring the stone, just as in the Oxyrhynchus sayings of Jesus⁸¹ it is the “fowls of the air and the fishes of the sea and whatsoever is upon or beneath the earth” that point the way to the kingdom of heaven (motif of the “helpful animals”). In Lambspringk’s symbols⁸² the zodiacal fishes that move in opposite directions symbolize the arcane substance. All this theriomorphism is simply a visualization of the unconscious self manifesting itself through “animal” impulses. Some of these can be attributed to known instincts, but for the most part they consist of feelings of certainty, beliefs, compulsions, idiosyncrasies, and phobias that may run directly counter to the so-called biological instincts without necessarily being pathological on that account. Wholeness is perforce paradoxical in its manifestations, and the two fishes going in opposite directions, or the co-operation of birds and fishes, are an instructive illustration of this.⁸³ The arcane substance, as its attributes show, refers to the self, and so, in the Oxyrhynchus sayings, does the “kingdom of heaven” or the conjectural “city.”

3. The Fish Symbol of the Cathars

[225] The use of fishes as symbols for the psychopompos and for the antithetical nature of the self points to another tradition that seems to run parallel with the Echeneis. And there is, in fact, a very remarkable clue to be found, not in the literature of alchemy, but in heresiology. The document in question comes from the archives of the Inquisition at Carcassonne, published by Benoist in his *Histoire des Albigeois et des Vaudois*, in 1691.⁸⁴ It concerns an alleged revelation which Christ's favourite disciple John was vouchsafed as he "rested in the Lord's bosom." John wished to know what Satan's state was before his fall, and the Lord answered: "He was in such splendour that he ruled the powers of heaven." He wanted to be like God, and to this end he descended through the elements of air and water, and found that the earth was covered with water. Penetrating beneath the surface of the earth, "he found two fishes lying upon the waters, and they were like oxen yoked for ploughing the whole earth from sunset to sunrise [or, from West to East] at the command of the invisible Father. And when he went down, he found hanging clouds which covered the broad sea. ... And when he went down, he found set apart therefrom his 'Osob,' which is a kind of fire." On account of the flames he could not descend any further, so he went back to heaven and announced to the angels that he was going to set up his throne on the clouds and be like the All-highest. He then treated the angels as the unjust steward treated his master's debtors, whereupon he and the angels were cast out of heaven by God.⁸⁵ But God took pity on him and allowed him and his angels to do what they liked for a week. During this time Satan, using Genesis 1 as a model, created the world and mankind.

[226] A prominent Cathar, John de Lugio, confesses to a similar belief.⁸⁶ This belief seems to have been known in Catharist circles during the eleventh and twelfth centuries, for the conviction that the world was created by the devil is found in many of the sects. The alchemist Johannes de Rupescissa was in all probability a member of the Poor Men of Lyons,⁸⁷ who were influenced by the Cathars. In any case, he could be considered as a connecting link with this tradition.

[227] What strikes us most of all in this text is the fact that it contains the Old Bulgarian word *Osob*. Karl Meyer, in his Old Church Slavonic dictionary,⁸⁸ gives *особѣ* as *κατ' ἰδίαν: особа (osóba)* means in Russian, Polish, and Czech 'individual, personality.' "His osob" could therefore be translated as "that which is peculiar to him."⁸⁹ This, in the case of the devil, would naturally be fire.⁹⁰

[228] The idea of the two fishes lying on the waters, yoked like oxen for ploughing, is very strange and needs some elucidation. To this end I must recall to the reader St. Augustine's interpretation of the two fishes in the miraculous feeding of the five thousand: for him they represent the *kingly* and the *priestly* person or power,⁹¹

because, like fishes surviving the tempests of the sea, they outlast the turbulence of the multitude. These two powers are united in Christ: he is the king and priest.⁹²

[229] Although the two fishes in the Cathar text certainly do not refer to the miraculous fishes, Augustine's interpretation tells us something of importance about the way people thought in those days: the fishes were regarded as *ruling powers*. Since the text is indubitably heretical and a Bogomil document at that, there can be no question of a uniform interpretation of the two fishes as Christ. It may be that they symbolize, as might easily be conjectured, two different persons or powers, from before the creation of the world: Satanaël the elder son of God, and Christ the younger. In the thirtieth heresy of his *Panarium*, Epiphanius reports that the Ebionites believed in a double sonship: "Two, they maintain, were begotten by God, one of them Christ, the other the devil."⁹³ This doctrine must obviously have spread throughout the Near and Middle East, for it was there that the Bogomil doctrine of Satanaël as the demiurge arose among the Paulicians and Euchites.⁹⁴ Our document is nothing but a Latin version of the report in the *Panoplia* of Euthymios Zigabenos, which in its turn goes back to the confession of faith made before the emperor Alexius Comnenus by the Bogomil bishop Basilius in the year 1111.⁹⁵

[230] Note that Satan finds the two fishes *before* the creation, i.e., "in the beginning," when the spirit of God still brooded upon the dark face of the waters (Gen. 1 : 2). Had it been *one* fish only, we could interpret it as a prefiguration of the Redeemer, as the pre-existent Christ of St. John's gospel, the Logos that "was in the beginning with God." (Christ himself says in this document, with reference to John 1 : 2: "But I shall sit with my Father.") There are, however, two fishes, joined by a commissure (= the yoke), which can refer only to the zodiacal fishes. The zodia are important determinants in horoscopes, modifying the influence of the planets that have moved into them, or, even if there are no planets, giving the individual houses a special character. In the present instance the fishes would characterize the ascendent, the moment of the world's birth.⁹⁶ Now we know that cosmogonic myths are, at bottom, symbols for the coming of consciousness (though I cannot go into this here).⁹⁷ The dawn-state corresponds to the unconscious; in alchemical terms, it is the chaos, the *massa confusa* or *nigredo*; and by means of the *opus*, which the adept likens to the creation of the world, the *albedo* or *dealbatio* is produced, the whitening, which is compared sometimes to the full moon, sometimes to sunrise.⁹⁸ It also means illumination, the broadening of consciousness that goes hand in hand with the "work." Expressed psychologically, therefore, the two fishes which the devil found on the primeval waters would signify the newly arisen world of consciousness.

[231] The comparison of the fishes with a yoke of oxen ploughing merits special attention. Oxen stand for the motive power of the plough. In the same way, the fishes

represent the driving forces of the coming world of consciousness. Since olden times the plough has stood for man's mastery over the earth: wherever man ploughs, he has wrested a patch of soil from the primal state and put it to his own use. That is to say: the fishes will rule this world and subdue it by working astrologically through man and moulding his consciousness. Oddly enough, the ploughing does not begin, like all other things, in the east, but in the west. This motif turns up again in alchemy. "Know," says Ripley, "that your beginning should be made towards sunset, and from there you should turn towards midnight, when the lights cease altogether to shine, and you should remain ninety nights in the dark fire of purgatory without light. Then turn your course towards the east, and you will pass through many different colours," etc.⁹⁹ The alchemical work starts with the descent into darkness (*nigredo*), i.e., the unconscious. The ploughing or mastery of the earth is undertaken "at the command of the Father." Thus God not only foresaw the enantiodromia that began in the year 1000, but also intended it. The Platonic month of the Fishes is to be ruled by two principles. The fishes in our text are parallel, like the oxen, and point to the same goal, although one is Christ and the other the Antichrist.

[232] This, roughly, would be the early medieval line of reasoning (if we can speak of "reasoning" here). I do not know whether the argument we have outlined was ever discussed consciously. Yet it would be possible; the Talmudic prophecy concerning the year 530 (pars. 133ff.) leads one to conjecture astronomical calculations on the one hand and on the other an astrological allusion to the sign of Fishes favoured by the Jewish masters. As against this, it is possible that the fishes in our text are not a conscious reference to astrological ideas but rather a product of the unconscious. That the unconscious is quite capable of "reflections" of this kind we know well enough from dreams and the analysis of myths and fairytales.¹⁰⁰ The image of the fishes as such belonged to the common stock of conscious ideas and may—unconsciously—have expressed the meaning in symbolic form. For it was about this time (11th cent.) that the Jewish astrologers began calculating the birth of the Messiah in Pisces, and the universal feeling that a new age had commenced was given clear expression by Joachim of Flora.

[233] The text of our Johannine revelation can hardly be earlier, or much later, than the eleventh century. With the beginning of this century, which is astrologically the middle of the Pisces aeon, heresies sprang up everywhere like mushrooms, and at the same time Christ's adversary, the second fish, alias the devil, appears as the demiurge. Historically speaking, this idea represents a kind of Gnostic Renaissance, since the Gnostic demiurge was regarded as an inferior being from whom all evil comes.¹⁰¹ The significant thing about this phenomenon is its synchronicity, that is, its occurrence at a time that had been fixed astrologically.

[234] That Catharist ideas found their way into alchemy is not altogether surprising. I have not, however, come across any texts which would prove that the Catharist fish symbol was assimilated into the alchemical tradition and so could be held responsible for Lambspringk's fish symbol, signifying the arcane substance and its inner antinomy. Lambspringk's symbol appeared not much earlier than the end of the sixteenth century and represented a revitalization of the archetype. It shows two reversed fishes swimming in the *sea—nostro mari*—by which was meant the *aqua permanens* or arcane substance. They are designated "spiritus et anima," and like the stag and unicorn, the two lions, the dog and wolf, and the two fighting birds, they indicate the double nature of Mercurius.¹⁰²

[235] If my reflections, which are based on some knowledge of the symbolic thinking of the Middle Ages, are justified, then we have here a remarkable confirmation of the views I expressed in an earlier chapter. With the year 1000 a new world begins, proclaiming its advent in a strange medley of religious movements such as the Bogomils, Cathari, Albigenses, Waldenses, Poor Men of Lyons, Brethren of the Free Spirit, Beguins, Beghards, etc., and in the Holy Ghost Movement of Joachim of Flora. These movements are also associated with the rise of alchemy, Protestantism, the Enlightenment, and natural science, leading ultimately to the increasingly devilish developments we have lived to experience in our own day, and to the evaporation of Christianity under the assaults of rationalism, intellectualism, materialism, and "realism."

[236] In conclusion, I would like to give a concrete example of the way the symbol of the fish springs out of the unconscious autochthonously. The case in question is that of a young woman who had uncommonly lively and plastic dreams. She was very much under the influence of her father, who had a materialistic outlook and was not happily married. She shut herself off from these unfavourable surroundings by developing, at a very early age, an intense inner life of her own. As a small child, she replaced her parents by two trees in the garden. In her sixth or seventh year, she dreamt that God had promised her a golden fish. From this time forth she frequently dreamt of fishes. Later, a little while before starting psychological treatment on account of her manifold problems, she dreamt that she was "*standing on the bank of the Limmat and looking down into the water. A man threw a gold coin into the river, the water became transparent and I could see the bottom.*"¹⁰³ *There was a coral reef and a lot of fishes. One of them had a shining silver belly and a golden back.*" During treatment she had the following dream: "*I came to the bank of a broad, flowing river. I couldn't see much at first, only water, earth, and rock. I threw the pages with my notes on them into the water, with the feeling that I was giving something back to the river. Immediately afterwards I had a fishing-rod in my hand. I sat down on a rock and started fishing. Still I saw nothing but water, earth, and rock. Suddenly a big fish*

bit. He had a silver belly and a golden back. As I drew him to land, the whole landscape became alive: the rock emerged like the primeval foundation of the earth, grass and flowers sprang up, and the bushes expanded into a great forest. A gust of wind blew and set everything in motion. Then, suddenly, I heard behind me the voice of Mr. X [an older man whom she knew only from photographs and from hearsay, but who seems to have been some kind of authority for her]. He said, quietly but distinctly: ‘The patient ones in the innermost realm are given the fish, the food of the deep.’ At this moment a circle ran round me, part of it touching the water. Then I heard the voice again: ‘The brave ones in the second realm may be given victory, for there the battle is fought.’ Immediately another circle ran round me, this time touching the other bank. At the same time I saw into the distance and a colourful landscape was revealed. The sun rose over the horizon. I heard the voice, speaking as if out of the distance: ‘The third and the fourth realms come, similarly enlarged, out of the other two. But the fourth realm’—and here the voice paused for a moment, as if deliberating—‘the fourth realm joins on to the first.’¹⁰⁴ It is the highest and the lowest at once, for the highest and the lowest come together. They are at bottom one.’” Here the dreamer awoke with a roaring in her ears.

[237] This dream has all the marks of a “big” dream, and it also has the quality of something “thought,” which is characteristic of the intuitive type. Even though the dreamer had acquired some knowledge of psychology by this time, she had no knowledge whatever of the historical fish symbol. The details of the dream may be commented on as follows: The bank of the river represents the threshold, so to speak, to the unconscious. Fishing is an intuitive attempt to “catch” unconscious contents (fishes). Silver and gold, in alchemical language, signify feminine and masculine, the hermaphrodite aspect of the fish, indicating that it is a *complexio oppositorum*.¹⁰⁵ It also brings about a magical animation.¹⁰⁶ The older man is a personification of the archetype of the “wise old man.” We know already that the fish is a “miraculous food,” the eucharistic food of the *τέλειοι*. The first circle that touches the water illustrates the partial integration of the unconscious. The battle is the conflict of opposites, maybe between consciousness and the shadow. The second circle touches the “other bank,” where the union of opposites takes place. In the Indian “quicksilver system” the arcane substance is called *para-da*, ‘leading to the other shore’; in the West it is Mercurius.¹⁰⁷ The fourth realm, stressed by a weighty pause, is the One that adds itself to the three and makes all four into a unity.¹⁰⁸ The circles naturally produce a mandala, the outermost circle paradoxically coinciding with the centre, and recalling the old image for God. “God is a circle whose centre is everywhere and the circumference nowhere.”¹⁰⁹ The motif of the first coinciding with the fourth was expressed long ago in the axiom of Maria: “One becomes two, two becomes three, and out of the third comes the One as the fourth.”

[238]

The dream sums up in condensed form the whole symbolism of the individuation process in a person who was totally unacquainted with the literature of the subject. Cases of this kind are by no means rare and ought to make us think. They demonstrate the existence of an unconscious “knowledge” of the individuation process and its historical symbolism.

XI

THE ALCHEMICAL INTERPRETATION OF THE FISH

[239] We shall now turn to the problem raised by the anonymous French author of the “*Instructio de arbore solari*,” the problem of how the fish is caught. The Echeneis exercises an attraction on ships that could best be compared with the influence of a magnet on iron. The attraction, so the historical tradition says, emanates from the fish and brings the vessel, whether powered by sail or oarsmen, to a standstill.¹ I mention this seemingly unimportant feature because, as we shall see, in the alchemical view the attraction no longer proceeds from the fish but from a magnet which man possesses and which exerts the attraction that was once the mysterious property of the fish. If we bear in mind the significance of the fish, it is easy to understand why a powerful attraction should emanate from this arcane centre, which might aptly be compared with the magnetism of the North Pole.² As we shall see in a later chapter, the Gnostics said the same thing about the magnetic effect of their central figure (point, monad, son, etc.). It is therefore a remarkable innovation when the alchemists set out to manipulate an instrument that would exert the same powers as the Echeneis, but on the Echeneis itself. This reversal of direction is important for the psychology of alchemy because it offers a parallel to the adept’s claim to be able to produce the *filius macrocosmi*, the equivalent of Christ—*Deo concedente*—through his art. In this way the artifex or his instrument comes to replace the Echeneis and everything it stood for as the arcane substance. He has, so to speak, inveigled the secret out of the fish and seeks to draw the arcane substance to the surface in order to prepare from it the *filius philosophorum*, the *lapis*.

[240] The “magnet of the wise” which is to draw the wonder-working fish to the surface can, our text says, be *taught*. The content of this secret teaching is the real arcanum of alchemy: the discovery or production of the *prima materia*. The “doctrine” or “theory” is personified—or rather, concretized—as “*Mercurius non vulgi*,” the philosophical mercury. This conception is as ambiguous as the antique Hermes; sometimes Mercurius is a substance like quicksilver, sometimes it is a philosophy. Dom Pernety formulates it somewhat drastically: “[La matière du mercure philosophique] a une vertu aimantive qui attire des rayons du Soleil et de la Lune le mercure des Sages.”³ Concerning the *prima materia* the adepts talk a great deal but say very little—so little that in most cases one can form no conception of it whatever.⁴ This attitude is proof of serious intellectual difficulties—understandably

so, because in the first place no such material existed from which the *lapis* could be prepared, nor did anyone ever succeed in making a *lapis* that would have come up to expectations. Secondly, the names given to the *prima materia* show that it was not a definite substance at all, but rather an intuitive concept for an *initial psychic situation*, symbolized by such terms as water of life, cloud, heaven, shadow, sea, mother, moon, dragon, Venus, chaos, *massa confusa*, Microcosmos, etc.

[241] In the long lists of names one that frequently figures is “magnesia,” though this should certainly not be understood as the magnesium oxide of the pharmacopoeia.⁵ Magnesia is rather the “complete or conjoined mixture from which this moisture is extracted,⁶ i.e., the root-matter of our stone.”⁷ The complicated procedure for producing the magnesia is described in the treatise “Aristoteles de perfecto Magisterio.”⁸ It is the whitened arcane substance.⁹ Pandolfus says in the *Turba*: “I command you to take the hidden and venerable secret thing, which is the white magnesia.”¹⁰ In Khunrath, magnesia is synonymous with “chaos” and “Aes Hermetis.” He calls it “A Catholic or Universal, that is, a Cosmic Ens or Entity, Three-in-One, naturally compounded of Body, Spirit, and Soul, the one and only true Subiectum Catholicon and true Universal Materia lapidis Philosophorum.”¹¹ The magnesia is feminine,¹² just as the magnet is masculine by nature.¹³ Hence it carries “in its belly the sal Armoniacum et vegetabile,” meaning the arcane substance of the stone.¹⁴ Even in Greek alchemy magnesia or “magnes” denoted the hermaphroditic transformative substance.¹⁵ For the alchemists, magnesia is associated with “magnes” (magnet) not only phonetically, but also in meaning, as a recipe of Rosinus shows: “Take therefore this animate stone, the stone which has a soul in it, the mercurial,¹⁶ which is sensible and sensitive to the presence and influence of the magnesia and the magnet, and [which is] the calaminary and the living Stone, yielding and repelling by local motion.”¹⁷

[242] This text shows clearly enough that the real alchemical procedure was not concerned at all with chemical processes, for if it were, the substance to be transformed would not need to be animate or endowed with sensitivity. But a psychic function was absolutely necessary to it when, as in the case of the magnesia, the adept was preoccupied with one of the innumerable expressions used for the unconscious, that is, for the hidden part of the psyche that had slipped into the unknown chemical compound by projection, and that bedevilled and befooled him in the guise of a hundred “arcane substances.” Naturally only the most stupid and unobservant of the alchemists were hoodwinked in this way, for there were plenty of hints in the classical texts that could have put them on the right track. Unfortunately, we today are not so far removed from the Middle Ages: we still have to overcome considerable difficulties before we can begin to understand the real purpose of alchemy.

[243] The “*lapis animalis*” of Rosinus, then, is a live thing, credited with the ability to *feel* or *perceive* the influence of the *magnesia* and the magnet. But the magnet, too, is a live thing. Thus, the juriconsult and alchemist Chrysippus Fanianus, of Basel, says: “But if Thales of Miletus chose to call that stone of Hercules, the magnet, an animate thing, because we see it attract and move iron, why shall we not likewise call salt, which in wondrous wise penetrates, purges, contracts, expands, hinders, and reduces, a living thing?”¹⁸ Dorn writes: “The magnetic stone teaches us, for in it the power of magnetizing and attracting iron is not seen [with the eyes]; it is a spirit hidden within, not perceptible to the sense.”¹⁹ The numinous effect which the incomprehensible power of magnetism had upon our forefathers is graphically described by St. Augustine: “We know that the lodestone draws iron strangely; the which, when I saw it for the first time, did send a cold shiver through me [*vehementer inhorru*].”²⁰ Even the humanist Andrea Alciati (d. 1550) exclaims: “Wherefore he who first perceives and beholds the power of the magnet to attract iron cannot but be rapt in admiration. ... And it is not enough for some to obtrude upon us that there is a certain secret power in these things, which is generally known. For how will they define that hidden force, of which they can tell us nothing but the name?”²¹ The famous anatomist and astrologer Gabriel Fallopius (1490–1563) is said to have considered the magnet, together with quicksilver and purgatives, to be inexplicable marvels, “whose effect is to be wondered at with amazement,” as Libavius relates in his “*Ars prolatoria*.”²² These utterances bear witness to the naïve reaction of intelligent and thoughtful people who took what they saw to be an inexplicable miracle. So it is quite understandable if they felt that such an astonishing object was *alive* (like the “*lapis animatus*,” “*calx viva*,” etc.). The magnet, too, had a soul, like the mysterious stone that could feel. In the “*Duodecim tractatus*”²³ the magnet appears as the symbol of the *aqua roris nostri* (water of our dew), “whose mother is the midpoint of the heavenly and earthly Sun and Moon.” This water, the famed *aqua permanens*, is apostrophized by the anonymous author as follows: “O holy and wonderful nature, which permittest not the sons of the doctrine to err, as thou showest in man’s daily life. Further in these ... treatises I have put forward so many natural reasons, that ... the reader may understand all those things which, by God’s blessing, I have seen with my own eyes.”²⁴

[244] The underlying thought here is the idea of the doctrine, the “*aqua doctrinae*.” As we have seen, the “magnet” or “heavenly dew” can be *taught*. Like the water, it symbolizes the doctrine itself. This is contrasted with the “animate stone” that “perceives” the influence of the magnetic pair, *magnes* and *magnesia*. The animate stone, like the magnet, is an arcane substance, and only such substances can enter into a combination finally leading to the goal of the *lapis philosophorum*. Dorn says: “The pagan Gentiles say that nature seeks after a nature like to itself, and rejoices in

its own nature; if it is joined to another, the work of nature is destroyed.”²⁵ This is an allusion to the axiom usually attributed to the alchemist Democritus: “Nature rejoices in nature; nature subdues nature; nature rules over nature.”²⁶

[245] Just as magnes and magnesia form a pair, so the *lapis animatus sive vegetabilis*²⁷ is a Rebis or hermaphrodite that is born of the royal marriage. We have, then, two contrasting pairs, forming by mutual attraction a *quaternio*, the fourfold basis of wholeness.²⁸ As the symbolism shows, the pairs both signify the same thing: a *complexio oppositorum* or uniting symbol.²⁹ If our texts do not represent them as the same thing and as coinciding with the arcane substance, then there must be a reason for this, though it cannot be ascertained from the symbols used for the two substances to be combined. Sometimes the arcane substance is magnesia, sometimes the water, sometimes the magnet, sometimes the fish; and yet they all mean the *prima materia* from which the miraculous birth ensues. The distinction that the alchemists had in mind is made clear by a passage from a seventeenth-century treatise written by John Colleson, prior of the Benedictine Order:³⁰ “But as to that substance whereby common gold and silver are naturally and Philosophically dissolved, let no man imagine that it is any other than the general soul of the world, which by magnets and Philosophical means is attracted and drawn down from the higher bodies, and especially from the rays of the Sun and Moon. And hence it is clear that they have no knowledge whatever of Mercurius or of the Philosophical fluid who think to dissolve perfect metals by natural and physical means.”³¹

[246] Obviously a distinction must be made between two categories of symbols: first, those which refer to the extrapsychic chemical substance or its metaphysical equivalent, e.g., *serpens mercurialis*, *spiritus*, *anima mundi*, *veritas*, *sapientia*, etc.; second, those denoting the chemical preparations produced by the adept, such as solvents (*aqua*, *acetum*, *lac virginis*) or their “philosophical” equivalent, the *theoria* or *scientia*, which, when it is “right,” has miraculous effects on matter, as Dorn explains in his philosophical treatises.³²

[247] These two categories continually overlap: sometimes the arcane substance is apparently nothing but a chemical body, sometimes an idea, which today we would call a psychic content. Pernety describes this confusion very clearly in his explanation of the magnet: “But it must not be supposed that this magnet is the common magnet. They [the alchemists] have given it this name only because of its natural sympathy with what they call their steel [*adamas*]. This is the ore [*prima materia*] of their gold, and the magnet is the ore of their steel. The centre of this magnet contains a hidden salt, a menstruum for calcining the philosophical gold. This prepared salt forms their Mercury, with which they perform the magistry of the Sages in white and in red. It becomes an ore of heavenly fire, which acts as a ferment

for their stone.”³³ In his view, therefore, the secret of the magnet’s effect lies in a salt prepared by the adept. Whenever an alchemist speaks of “salt,” he does not mean sodium chloride or any other salt, or only in a very limited sense. He could not get away from its symbolic significance, and therefore included the *sal sapientiae* in the chemical substance. That is the salt hidden in the magnet and prepared by the adept—on the one hand, a product of his art; on the other, already present in nature. This contradiction can be resolved very easily by taking it simply as the projection of a psychic content.

[248] A similar state of affairs can be found in Dorn’s writings. In his case it is not a question of the *sal sapientiae* but of the “veritas,” which for him is hidden in natural things and at the same time is obviously a “moral” concept. This truth is the “medicine, improving and transforming that which *is no longer* into that which it *was before* its corruption, and that which *is not* into that which it *ought to be*.”³⁴ It is a “metaphysical substance,” hidden not only in things, but in the human body: “In the human body is concealed a certain metaphysical substance known to very few, which needeth no medicament, being itself an incorrupt medicament.”³⁵ Therefore “it is the study of the Chemists to liberate that unsensual truth from its fetters in things of sense.”³⁶ He that would acquire the chemical art must study the “true Philosophy” and not the “Aristotelian,” adds Dorn, because the true doctrine, in Colleson’s words, is the magnet whereby the “centre of truth” is liberated from bodies and whereby the bodies are transformed. “The Philosophers, through a kind of divine inspiration, knew that this virtue and heavenly vigour can be freed from its fetters; not by its contrary ... but by its like. Since therefore some such a thing is found, whether within man or outside him, which is conformable to this substance, the wise concluded that like things are to be fortified by like, by peace rather than by war.”³⁷

[249] Thus the doctrine, which may be consciously acquired “through a kind of divine inspiration,” is at the same time the instrument whereby the object of the doctrine or theory can be freed from its imprisonment in the body, because the symbol for the doctrine—the “magnet”—is at the same time the mysterious “truth” of which the doctrine speaks. The doctrine enters the consciousness of the adept as a gift of the Holy Ghost. It is a thesaurus of knowledge about the secret of the art, of the treasure hidden in the *prima materia*, which was thought to be outside man. The treasure of the doctrine and the precious secret concealed in the darkness of matter are one and the same thing. For us this is not a discovery, as we have known for some time that such secrets owe their existence to unconscious projections. Dorn was the first thinker to recognize with the utmost clarity the extraordinary dilemma of alchemy: *the arcane substance is one and the same, whether it is found within man or outside him*. The “alchymical” procedure takes place within and without. He who does not understand how to free the “truth” in his own soul from its fetters will never make a

success of the physical opus, and he who knows how to make the stone can only do so on the basis of right doctrine, through which he himself is transformed, or which he creates through his own transformation.

[250] Helped by these reflections, Dorn comes to realize the fundamental importance of self-knowledge: “See, therefore, that thou goest forth such as thou desirest the work to be which thou seekest.”³⁸ In other words, the expectations you put into the work must be applied to your own ego. The production of the arcane substance, the “*generatio Mercurii*,” is possible only for one who has full knowledge of the doctrine; but “we cannot be resolved of any doubt except by experiment, and there is no better way to make it than on ourselves.”³⁹ The doctrine formulates our inner experience or is substantially dependent upon it: “Let him know that man’s greatest treasure is to be found within man, and not outside him. From him it goes forth inwardly ... whereby that is outwardly brought to pass which he sees with his own eyes. Therefore unless his mind be blinded, he will see, that is, understand, who and of what sort he is inwardly, and by the light of nature he will know himself through outward things.”⁴⁰ The secret is first and foremost *in man*; it is his *true self*,⁴¹ which he does not know but learns to know by experience of outward things. Therefore Dorn exhorts the alchemist: “Learn from within thyself to know all that is in heaven and on earth, that thou mayest be wise in all things. Knowest thou not that heaven and the elements were formerly one, and were separated by a divine act of creation from one another, that they might bring forth thee and all things?”⁴²

[251] Since knowledge of the world dwells in his own bosom, the adept should draw such knowledge out of his knowledge of himself, for the self he must seek to know is a part of that nature which was bodied forth by God’s original oneness with the world. It is manifestly *not* a knowledge of the nature of the ego, though this is far more convenient and is fondly confused with self-knowledge. For this reason anyone who seriously tries to know himself as an object is accused of selfishness and eccentricity. But such knowledge has nothing to do with the ego’s subjective knowledge of itself. *That* is a dog chasing its own tail. The other, on the contrary, is a difficult and morally exacting study of which so-called psychology knows nothing and the educated public very little. The alchemist, however, had at the very least an indirect inkling of it: he knew definitely that as part of the whole he had an image of the whole in himself, the “firmament” or “Olympus,” as Paracelsus calls it.⁴³ This interior microcosm was the unwitting object of alchemical research. Today we would call it the collective unconscious, and we would describe it as “objective” because it is identical in all individuals and is therefore *one*. Out of this universal One there is produced in every individual a *subjective* consciousness, i.e., the ego. This is, roughly, how we today would understand Dorn’s “formerly one” and “separated by a divine act of creation.”

[252] This objective knowledge of the self is what the author means when he says: “No one can know himself unless he knows *what*, and not *who*, he is, on what he depends, or whose he is [or: to whom or what he belongs] and for what end he was made.”⁴⁴ The distinction between “quis” and “quid” is crucial: whereas “quis” has an unmistakably personal aspect and refers to the ego, “quid” is neuter, predicating nothing except an object which is not endowed even with personality. Not the subjective ego-consciousness of the psyche is meant, but the psyche itself as the unknown, unprejudiced object that still has to be investigated. The difference between knowledge of the ego and knowledge of the self could hardly be formulated more trenchantly than in this distinction between “quis” and “quid.” An alchemist of the sixteenth century has here put his finger on something that certain psychologists (or those of them who allow themselves an opinion in psychological matters) still stumble over today. “What” refers to the neutral self, the objective fact of totality, since the ego is on the one hand causally “dependent on” or “belongs to” it, and on the other hand is directed towards it as to a goal. This recalls the impressive opening sentence of Ignatius Loyola’s “Foundation”: “Man was created to praise, do reverence to, and serve God our Lord, and thereby to save his soul.”⁴⁵

[253] Man knows only a small part of his psyche, just as he has only a very limited knowledge of the physiology of his body. The causal factors determining his psychic existence reside largely in unconscious processes outside consciousness, and in the same way there are final factors at work in him which likewise originate in the unconscious. Freud’s psychology gives elementary proof of the causal factors, Adler’s of the final ones. Causes and ends thus transcend consciousness to a degree that ought not to be underestimated, and this implies that their nature and action are unalterable and irreversible so long as they have not become objects of consciousness. They can only be corrected through conscious insight and moral determination, which is why self-knowledge, being so necessary, is feared so much. Accordingly, if we divest the opening sentence of the “Foundation” of its theological terminology, it would run as follows: “Man’s consciousness was created to the end that it may (1) recognize (*laudet*) its descent from a higher unity (*Deum*); (2) pay due and careful regard to this source (*reverentiam exhibeat*); (3) execute its commands intelligently and responsibly (*serviat*); and (4) thereby afford the psyche as a whole the optimum degree of life and development (*salvet animam suam*).”

[254] This paraphrase not only sounds rationalistic but is meant to be so, for despite every effort the modern mind no longer understands our two-thousand-year-old theological language unless it “accords with reason.” As a result, the danger that lack of understanding will be replaced by lip-service, affectation, and forced belief or else by resignation and indifference has long since come to pass.

[255] The final factors at work in us are nothing other than those talents which “a certain nobleman” entrusted to his “servants,” that they might trade with them (Luke 19 : 12ff.). It does not require much imagination to see what this involvement in the ways of the world means in the moral sense. Only an infantile person can pretend that evil is not at work everywhere, and the more unconscious he is, the more the devil drives him. It is just because of this inner connection with the black side of things that it is so incredibly easy for the mass man to commit the most appalling crimes without thinking. Only ruthless self-knowledge on the widest scale, which sees good and evil in correct perspective and can weigh up the motives of human action, offers some guarantee that the end-result will not turn out too badly.

[256] We find the crucial importance of self-knowledge for the alchemical process of transformation expressed most clearly in Dorn, who lived in the second half of the sixteenth century. The idea itself is much older and goes back to Morienus Romanus (7th-8th cent.), in the saying which he wrote on the rim of the Hermetic vessel: “All those who have all things with them have no need of outside aid.”⁴⁶ He is not referring to the possession of all the necessary chemical substances; it is far more a moral matter, as the text makes clear.⁴⁷ God, says Morienus, made the world out of four unequal elements and set man as the “greater ornament” between them: “This thing is extracted from thee, for thou art its ore; in thee they find it, and, to speak more plainly, from thee they take it; and when thou hast experienced this, the love and desire for it will be increased in thee.”⁴⁸ This “thing” is the *lapis*, and Morienus says that it contains the four elements and is likened to the cosmos and its structure. The procedure for making the stone “cannot be performed with hands,”⁴⁹ for it is a “human attitude” (*dispositio hominum*). This alone accomplishes the “changing of the natures.” The transformation is brought about by the *coniunctio*, which forms the essence of the work.⁵⁰

[257] The “Rosinus ad Sarratantam Episcopum”—which, if not altogether Arabic in origin, is one of the oldest texts in Arabic style—cites Magus Philosophus:⁵¹ “This stone is below thee, as to obedience; above thee, as to dominion; therefore from thee, as to knowledge; about thee, as to equals.”⁵² The passage is somewhat obscure. Nevertheless, it can be elicited that the stone stands in an undoubted psychic relationship to man: the adept can expect obedience from it, but on the other hand the stone exercises dominion over him. Since the stone is a matter of “knowledge” or science, it springs from man. But it is outside him, in his surroundings, among his “equals,” i.e., those of like mind. This description fits the paradoxical situation of the self, as its symbolism shows. It is the smallest of the small, easily overlooked and pushed aside. Indeed, it is in need of help and must be perceived, protected, and as it were built up by the conscious mind, just as if it did not exist at all and were called into being only through man’s care and devotion. As against this, we know from

experience that it had long been there and is older than the ego, and that it is actually the secret *spiritus rector* of our fate. The self does not become conscious by itself, but has always been taught, if at all, through a tradition of knowing (the *purusha/atman* teaching, for instance). Since it stands for the essence of individuation, and individuation is impossible without a relationship to one's environment, it is found among those of like mind with whom individual relations can be established. The self, moreover, is an archetype that invariably expresses a situation within which the ego is contained. Therefore, like every archetype, the self cannot be localized in an individual ego-consciousness, but acts like a circumambient atmosphere to which no definite limits can be set, either in space or in time. (Hence the synchronistic phenomena so often associated with activated archetypes.)

[258] The treatise of Rosinus contains a parallel to Morienus:⁵³ “This stone is something which is fixed more in thee [than elsewhere], created of God, and thou art its ore, and it is extracted from thee, and wheresoever thou art it remains inseparably with thee. ... And as man is made up of four elements, so also is the stone, and so it is [dug] out of man, and thou art its ore, namely by working; and from thee it is extracted, that is by division; and in thee it remains inseparably, namely by knowledge. [To express it] otherwise, fixed in thee: namely in the Mercurius of the wise; thou art its ore: that is, it is enclosed in thee and thou holdest it⁵⁴ secretly; and from thee it is extracted when it is reduced [to its essence] by thee and dissolved; for without thee it cannot be fulfilled, and without it canst thou not live, and so the end looks to the beginning, and contrariwise.”⁵⁵

[259] This looks like a commentary on Morienus. We learn from it that the stone is implanted in man by God, that the laborant is its *prima materia*, that the extraction corresponds to the so-called *divisio* or *separatio* of the alchemical procedure, and that through his knowledge of the stone man remains inseparably bound to the self. The procedure here described could easily be understood as the realization of an unconscious content. Fixation in the Mercurius of the wise would then correspond to the traditional Hermetic knowledge, since Mercurius symbolizes the Nous;⁵⁶ through this knowledge the self, as a content of the unconscious, is made conscious and “fixed” in the mind. For without the existence of conscious concepts apperception is, as we know, impossible. This explains numerous neurotic disturbances which arise from the fact that certain contents are constellated in the unconscious but cannot be assimilated owing to the lack of apperceptive concepts that would “grasp” them. That is why it is so extremely important to tell children fairytales and legends, and to inculcate religious ideas (dogmas) into grown-ups, because these things are instrumental symbols with whose help unconscious contents can be canalized into consciousness, interpreted, and integrated. Failing this, their energy flows off into conscious contents which, normally, are not much emphasized, and intensifies them

to pathological proportions. We then get apparently groundless phobias and obsessions—crazes, idiosyncrasies, hypochondriac ideas, and intellectual perversions suitably camouflaged in social, religious, or political garb.

[260] The old master saw the alchemical *opus* as a kind of apocatastasis, the restoring of an initial state in an “eschatological” one (“the end looks to the beginning, and contrariwise”). This is exactly what happens in the individuation process, whether it take the form of a Christian transformation (“Except ye become as little children”), or a *satori* experience in Zen (“show me your original face”), or a psychological process of development in which the original propensity to wholeness becomes a conscious happening.

[261] For the alchemist it was clear that the “centre,” or what we would call the self, does not lie in the ego but is outside it, “in us” yet not “in our mind,” being located rather in that which we unconsciously are, the “quid” which we still have to recognize. Today we would call it the unconscious, and we distinguish between a personal unconscious which enables us to recognize the shadow and an impersonal unconscious which enables us to recognize the archetypal symbol of the self. Such a point of view was inaccessible to the alchemist, and having no idea of the theory of knowledge, he had to exteriorize his archetype in the traditional way and lodge it in matter, even though he felt, as Dorn and others undoubtedly did, that the centre was paradoxically in man and yet at the same time outside him.

[262] The “incorrupt medicament,” the *lapis*, says Dorn, can be found nowhere save in heaven, for heaven “pervades all the elements with invisible rays meeting together from all parts at the centre of the earth, and generates and hatches forth all creatures.” “No man can generate in himself, but [only] in that which is like him, which is from the same [heaven].”⁵⁷

[263] We see here how Dorn gets round his paradox: no one can produce anything without an object that is like him. But it is like him because it comes from the same source. If he wants to produce the incorrupt medicament, he can only do so in something that is akin to his own centre, and this is the centre in the earth and in all creatures. It comes, like his own, from the same fountainhead, which is God. Separation into apparently dissimilar things, such as heaven, the elements, man, etc., was necessary only for the work of generation. Everything separated must be united again in the production of the stone, so that the original state of unity shall be restored. But, says Dorn, “thou wilt never make from others the One which thou seekest, except first there be made one thing of thyself. ... For so is the will of God, that the pious shall pursue the pious work which they seek, and the perfect shall perfect the other on which they were intent. ... See therefore that thou goest forth such as thou desirest the work to be which thou seekest.”⁵⁸

[264] The union of opposites in the stone is possible only when the adept has become One himself. The unity of the stone is the equivalent of individuation, by which man is made one; we would say that the stone is a projection of the unified self. This formulation is psychologically correct. It does not, however, take sufficient account of the fact that the stone is a *transcendent* unity. We must therefore emphasize that though the self can become a symbolic content of consciousness, it is, as a supraordinate totality, necessarily transcendental as well. Dorn recognized the identity of the stone with the transformed man when he exclaimed: “Transmute yourselves from dead stones into living philosophical stones!”⁵⁹ But he lacked the concept of an unconscious existence which would have enabled him to express the identity of the subjective psychic centre and the objective alchemical centre in a satisfactory formula. Nevertheless, he succeeded in explaining the magnetic attraction between the imagined symbol—the “theoria”—and the “centre” hidden in matter, or in the interior of the earth or in the North Pole, as the identity of two extremes. That is why the theoria and the arcanum in matter are both called *veritas*. This truth “shines” in us, but it is not of us: it “is to be sought not in us, but in the image of God which is in us.”⁶⁰

[265] Dorn thus equates the transcendent centre in man with the God-image. This identification makes it clear why the alchemical symbols for wholeness apply as much to the arcanum in man as to the Deity, and why substances like mercury and sulphur, or the elements fire and water, could refer to God, Christ, and the Holy Ghost. Indeed, Dorn goes even further and allows the predicate of *being* to this truth, and to this truth alone: “Further, that we may give a satisfactory definition of the truth, we say *it is*, but nothing can be added to it; for what, pray, can be added to the One, what is lacking to it, or on what can it be supported? For in truth nothing exists beside that One.”⁶¹ The only thing that truly exists for him is the transcendental self, which is identical with God.

[266] Dorn was probably the first alchemist to sum up the results of all the symbolical terms and to state clearly what had been the impelling motive of alchemy from the very beginning. It is remarkable that this thinker, who is far more lucid in his formulations than his successor Jakob Böhme, has remained completely unknown to historians of philosophy until today. He thus shares the fate of Hermetic philosophy in general, which, for those unacquainted with modern psychology, remains a closed book sealed with seven seals. But this book has to be opened sometime if we wish to understand the mentality of the present day; for alchemy is the mother of the essential substance as well as the concreteness of modern scientific thinking, and not scholasticism, which was responsible in the main only for the discipline and training of the intellect.

XII

BACKGROUND TO THE PSYCHOLOGY OF CHRISTIAN ALCHEMICAL SYMBOLISM

[267] “Mater Alchimia” could serve as the name of a whole epoch. Beginning, roughly, with Christianity, it gave birth in the sixteenth and seventeenth centuries to the age of science, only to perish, unrecognized and misunderstood, and sink from sight in the stream of the centuries as an age that had been outlived. But, just as every mother was once a daughter, so too was alchemy. It owes its real beginnings to the Gnostic systems, which Hippolytus rightly regarded as philosophic, and which, with the help of Greek philosophy and the mythologies of the Near and Middle East, together with Christian dogmatics and Jewish cabalism, made extremely interesting attempts, from the modern point of view, to synthesize a unitary vision of the world in which the physical and the mystical aspects played equal parts. Had this attempt succeeded, we would not be witnessing today the curious spectacle of two parallel world-views neither of which knows, or wishes to know, anything about the other. Hippolytus was in the enviable position of being able to see Christian doctrine side by side with its pagan sisters, and similar comparisons had also been attempted by Justin Martyr. To the honour of Christian thinking it must be said that up till the time of Kepler there was no lack of praiseworthy attempts to interpret and understand Nature, in the broadest sense, on the basis of Christian dogma.

[268] These attempts, however, inevitably came to grief for lack of any adequate knowledge of natural processes. Thus, in the course of the eighteenth century, there arose that notorious rift between faith and knowledge. Faith lacked experience and science missed out the soul. Instead, science believed fervently in absolute objectivity and assiduously overlooked the fundamental difficulty that the real vehicle and begetter of all knowledge is the *psyche*, the very thing that scientists knew the least about for the longest time. It was regarded as a symptom of chemical reactions, an epiphenomenon of biological processes in the brain-cells—indeed, for some time it did not exist at all. Yet all the while scientists remained totally unaware of the fact that they were using for their observations a photographic apparatus of whose nature and structure they knew practically nothing, and whose very existence many of them were unwilling to admit. It is only quite recently that they have been obliged to take into their calculations the objective reality of this psychic factor. Significantly enough, it is microphysics that has come up against the *psyche* in the

most tangible and unexpected way. Obviously, we must disregard the psychology of the unconscious in this connection, since its working hypothesis consists precisely in the reality of the psyche. What is significant here is the exact opposite, namely the psyche's collision with physics.¹

[269] Now for the Gnostics—and this is their real secret—the psyche existed as a source of knowledge just as much as it did for the alchemists. Aside from the psychology of the unconscious, contemporary science and philosophy know only of what is outside, while faith knows only of the inside, and then only in the Christian form imparted to it by the passage of the centuries, beginning with St. Paul and the gospel of St. John. Faith, quite as much as science with its traditional objectivity, is *absolute*, which is why faith and knowledge can no more agree than Christians can with one another.

[270] Our Christian doctrine is a highly differentiated symbol that expresses the transcendent psychic—the God-image and its properties, to speak with Dorn. The Creed is a “symbolum.” This comprises practically everything of importance that can be ascertained about the manifestations of the psyche in the field of inner experience, but it does not include Nature, at least not in any recognizable form. Consequently, at every period of Christianity there have been subsidiary currents or undercurrents that have sought to investigate the empirical aspect of Nature not only from the outside but also from the inside.

[271] Although dogma, like mythology in general, expresses the quintessence of inner experience and thus formulates the operative principles of the objective psyche, i.e., the collective unconscious, it does so by making use of a language and outlook that have become alien to our present way of thinking. The word “dogma” has even acquired a somewhat unpleasant sound and frequently serves merely to emphasize the rigidity of a prejudice. For most people living in the West, it has lost its meaning as a symbol for a virtually unknowable and yet “actual”—i.e., operative—fact. Even in theological circles any real discussion of dogma had as good as ceased until the recent papal declarations, a sign that the symbol has begun to fade, if it is not already withered. This is a dangerous development for our psychic health, as we know of no other symbol that better expresses the world of the unconscious. More and more people then begin looking round for exotic ideas in the hope of finding a substitute, for example in India. This hope is delusory, for though the Indian symbols formulate the unconscious just as well as the Christian ones do, they each exemplify their own spiritual past. The Indian teachings constitute the essence of several thousand years of experience of Indian life. Though we can learn a lot from Indian thought, it can never express the past that is stored up within us. The premise we start from is and remains Christianity, which covers anything from eleven to nineteen centuries of

Western life. Before that, there was for most Western peoples a considerably longer period of polytheism and polydemonism. In certain parts of Europe Christianity goes back not much more than five hundred years—a mere sixteen generations. The last witch was burnt in Europe the year my grandfather was born, and barbarism with its degradation of human nature has broken out again in the twentieth century.

[272] I mention these facts in order to illustrate how thin is the wall that separates us from pagan times. Besides that, the Germanic peoples never developed organically out of primitive polydemonism to polytheism and its philosophical subtleties, but in many places accepted Christian monotheism and its doctrine of redemption only at the sword's point of the Roman legions, as in Africa the machine-gun is the latent argument behind the Christian invasion.² Doubtless the spread of Christianity among barbarian peoples not only favoured, but actually necessitated, a certain inflexibility of dogma. Much the same thing can be observed in the spread of Islam, which was likewise obliged to resort to fanaticism and rigidity. In India the symbol developed far more organically and pursued a less disturbed course. Even the great Hindu Reformation, Buddhism, is grounded, in true Indian fashion, on yoga, and, in India at least, it was almost completely reassimilated by Hinduism in less than a millennium, so that today the Buddha himself is enthroned in the Hindu pantheon as the avatar of Vishnu, along with Christ, Matsya (the fish), Kurma (the tortoise), Vamana (the dwarf), and a host of others.

[273] The historical development of our Western mentality cannot be compared in any way with the Indian. Anyone who believes that he can simply take over Eastern forms of thought is uprooting himself, for they do not express our Western past, but remain bloodless intellectual concepts that strike no chord in our inmost being. We are rooted in Christian soil. This foundation does not go very deep, certainly, and, as we have seen, it has proved alarmingly thin in places, so that the original paganism, in altered guise, was able to regain possession of a large part of Europe and impose on it its characteristic economic pattern of slavery.

[274] This modern development is in line with the pagan currents that were clearly present in alchemy and had remained alive beneath the Christian surface ever since the days of antiquity. Alchemy reached its greatest efflorescence in the sixteenth and seventeenth centuries, then to all appearances it began to die out. In reality it found its continuation in natural science, which led in the nineteenth century to materialism and in the twentieth century to so-called "realism," whose end is not yet in sight. Despite well-meaning assurances to the contrary, Christianity is a helpless bystander. The Church still has a little power left, but she pastures her sheep on the ruins of Europe. Her message works, *if* one knows how to combine her language, ideas, and customs with an understanding of the present. But for many she no longer speaks, as

Paul did in the market-place of Athens, the language of the present, but wraps her message in sacrosanct words hallowed by age. What success would Paul have had with his preaching if he had had to use the language and myths of the Minoan age in order to announce the gospel to the Athenians? We overlook the unfortunate fact that far greater demands are made on present-day man than were ever made on people living in the apostolic era: for them there was no difficulty at all in believing in the virgin birth of the hero and demigod, and Justin Martyr was still able to use this argument in his apology. Nor was the idea of a redeeming God-man anything unheard of, since practically all Asiatic potentates together with the Roman Emperor were of divine nature. But we have no further use even for the divine right of kings! The miraculous tales in the gospels, which easily convinced people in those days, would be a *petra scandali* in any modern biography and would evoke the very reverse of belief. The weird and wonderful nature of the gods was a self-evident fact in a hundred living myths and assumed a special significance in the no less credible philosophic refinements of those myths. "Hermes ter unus" (Hermes-Thrice-One) was not an intellectual absurdity but a philosophical truth. On these foundations the dogma of the Trinity could be built up convincingly. For modern man this dogma is either an impenetrable mystery or an historical curiosity, preferably the latter. For the man of antiquity the virtue of the consecrated water or the transmutation of substances was in no sense an enormity, because there were dozens of sacred springs whose workings were incomprehensible, and any amount of chemical changes whose nature appeared miraculous. Nowadays every schoolboy knows more, in principle, about the ways of Nature than all the volumes of Pliny's Natural History put together.

[275] If Paul were alive today, and should undertake to reach the ear of intelligent Londoners in Hyde Park, he could no longer content himself with quotations from Greek literature and a smattering of Jewish history, but would have to accommodate his language to the intellectual faculties of the modern English public. If he failed to do this, he would have announced his message badly, for no one, except perhaps a classical philologist, would understand half of what he was saying. That, however, is the situation in which Christian kerygmatics³ finds itself today. Not that it uses a dead foreign language in the literal sense, but it speaks in images that on the one hand are hoary with age and look deceptively familiar, while on the other hand they are miles away from a modern man's conscious understanding, addressing themselves, at most, to his unconscious, and then only if the speaker's whole soul is in his work. The best that can happen, therefore, is that the effect remains stuck in the sphere of feeling, though in most cases it does not get even that far.

[276] The bridge from dogma to the inner experience of the individual has broken down. Instead, dogma is "believed";⁴ it is hypostatized, as the Protestants hypostatize the Bible, illegitimately making it the supreme authority, regardless of its

contradictions and controversial interpretations. (As we know, anything can be authorized out of the Bible.) Dogma no longer formulates anything, no longer expresses anything; it has become a tenet to be accepted in and for itself, with no basis in any experience that would demonstrate its truth.⁵ Indeed, faith has itself become that experience. The faith of a man like Paul, who had never seen our Lord in the flesh, could still appeal to the overwhelming apparition on the road to Damascus and to the revelation of the gospel in a kind of ecstasy. Similarly, the faith of the man of antiquity and of the medieval Christian never ran counter to the *consensus omnium* but was on the contrary supported by it. All this has completely changed in the last three hundred years. But what comparable change has kept pace with this in theological circles?

[277] The danger exists—and of this there can be no doubt—that the new wine will burst the old bottles, and that what we no longer understand will be thrown into the lumber-room, as happened once before at the time of the Reformation. Protestantism then discarded (except for a few pallid remnants) the ritual that every religion needs, and now relies solely on the *sola fides* standpoint. The content of faith, of the symbolum, is continually crumbling away. What is still left of it? The person of Jesus Christ? Even the most benighted layman knows that the personality of Jesus is, for the biographer, the obscurest item of all in the reports of the New Testament, and that, from a human and psychological point of view, his personality must remain an unfathomable enigma. As a Catholic writer pithily remarked, the gospels record the history of a man and a god at the same time. Or is only God left? In that case, what about the Incarnation, the most vital part of the symbolum? In my view one would be well advised to apply the papal dictum: “Let it be as it is, or not be at all,”⁶ to the Creed and leave it at that, because nobody really understands what it is all about. How else can one explain the notorious drift away from dogma?

[278] It may strike my reader as strange that a physician and psychologist should be so insistent about dogma. But I *must* emphasize it, and for the same reasons that once moved the alchemist to attach special importance to his “theoria.” His doctrine was the quintessence of the symbolism of unconscious processes, just as the dogmas are a condensation or distillation of “sacred history,” of the myth of the divine being and his deeds. If we wish to understand what alchemical doctrine means, we must go back to the historical as well as the individual phenomenology of the symbols, and if we wish to gain a closer understanding of dogma, we must perforce consider first the myths of the Near and Middle East that underlie Christianity, and then the whole of mythology as the expression of a universal disposition in man. This disposition I have called the collective unconscious, the existence of which can be inferred only from individual phenomenology. In both cases the investigator comes back to the individual, for what he is all the time concerned with are certain complex thought-

forms, the archetypes, which must be conjectured as the unconscious organizers of our ideas. The motive force that produces these configurations cannot be distinguished from the transconscious factor known as instinct. There is, therefore, no justification for visualizing the archetype as anything other than the image of instinct in man.⁷

[279] From this one should not jump to the conclusion that the world of religious ideas can be reduced to “nothing but” a biological basis, and it would be equally erroneous to suppose that, when approached in this way, the religious phenomenon is “psychologized” and dissolved in smoke. No reasonable person would conclude that the reduction of man’s morphology to a four-legged saurian amounts to a nullification of the human form, or, alternatively, that the latter somehow explains itself. For behind all this looms the vast and unsolved riddle of life itself and of evolution in general, and the question of overriding importance in the end is not the origin of evolution but its goal. Nevertheless, when a living organism is cut off from its roots, it loses the connections with the foundations of its existence and must necessarily perish. When that happens, anamnesis of the origins is a matter of life and death.

[280] Myths and fairytales give expression to unconscious processes, and their retelling causes these processes to come alive again and be recollected, thereby re-establishing the connection between conscious and unconscious. What the separation of the two psychic halves means, the psychiatrist knows only too well. He knows it as dissociation of the personality, the root of all neuroses: the conscious goes to the right and the unconscious to the left. As opposites never unite at their own level (*tertium non datur!*), a supraordinate “third” is always required, in which the two parts can come together. And since the symbol derives as much from the conscious as from the unconscious, it is able to unite them both, reconciling their conceptual polarity through its form and their emotional polarity through its numinosity.

[281] For this reason the ancients often compared the symbol to water, a case in point being *tao*, where *yang* and *yin* are united. *Tao* is the “valley spirit,” the winding course of a river. The symbolum of the Church is the *aqua doctrinae*, corresponding to the wonder-working “divine” water of alchemy, whose double aspect is represented by Mercurius. The healing and renewing properties of this symbolical water—whether it be *tao*, the baptismal water, or the elixir—point to the therapeutic character of the mythological background from which this idea comes. Physicians who were versed in alchemy had long recognized that their arcanum healed, or was supposed to heal, not only the diseases of the body but also those of the mind. Similarly, modern psychotherapy knows that, though there are many interim solutions, there is, at the bottom of every neurosis, a moral problem of opposites that

cannot be solved rationally, and can be answered only by a supraordinate third, by a symbol which expresses both sides. This was the “veritas” (Dorn) or “theoria” (Paracelsus) for which the old physicians and alchemists strove, and they could do so only by incorporating the Christian revelation into their world of ideas. They continued the work of the Gnostics (who were, most of them, not so much heretics as theologians) and the Church Fathers in a new era, instinctively recognizing that new wine should not be put into old bottles, and that, like a snake changing its skin, the old myth needs to be clothed anew in every renewed age if it is not to lose its therapeutic effect.

[282] The problems which the integration of the unconscious sets modern doctors and psychologists can only be solved along the lines traced out by history, and the upshot will be a new assimilation of the traditional myth. This, however, presupposes the continuity of historical development. Naturally the present tendency to destroy all tradition or render it unconscious could interrupt the normal process of development for several hundred years and substitute an interlude of barbarism. Wherever the Marxist utopia prevails, this has already happened. But a predominantly scientific and technological education, such as is the usual thing nowadays, can also bring about a spiritual regression and a considerable increase of psychic dissociation. With hygiene and prosperity alone a man is still far from health, otherwise the most enlightened and most comfortably off among us would be the healthiest. But in regard to neuroses that is not the case at all, quite the contrary. Loss of roots and lack of tradition neuroticize the masses and prepare them for collective hysteria. Collective hysteria calls for collective therapy, which consists in abolition of liberty and terrorization. Where rationalistic materialism holds sway, states tend to develop less into prisons than into lunatic asylums.

*

[283] I have tried, in the foregoing, to indicate the kind of psychic matrix into which the Christ-figure was assimilated in the course of the centuries. Had there not been an affinity—magnet!—between the figure of the Redeemer and certain contents of the unconscious, the human mind would never have been able to perceive the light shining in Christ and seize upon it so passionately. The connecting link here is the archetype of the Godman, which on the one hand became historical reality in Christ, and on the other, being eternally present, reigns over the soul in the form of a supraordinate totality, the self. The God-man, like the priest in the vision of Zosimos, is a *Κύριος τῶν πνευμάτων*, not only “Lord of the spirits,” but “Lord over the (evil) spirits,” which is one of the essential meanings of the Christian Kyrios.⁸

[284] The noncanonical fish symbol led us into this psychic matrix and thus into a realm of experience where the unknowable archetypes become living things, changing their name and guise in never-ending succession and, as it were, disclosing their hidden nucleus by perpetually circumambulating round it. The *lapis* that signifies God become man or man become God “has a thousand names.” It is not Christ; it is his parallel in the subjective realm, which dogma calls Christ. Alchemy gives us, in the *lapis*, a concrete idea of what Christ means in the realm of subjective experience, and under what delusive or illuminative disguises his actual presence may be experienced in its transcendent ineffability. One could demonstrate the same thing in the psychology of a modern individual, as I attempted to do in Part II of *Psychology and Alchemy*.⁹ Only, this would be a much more exacting task, running into great detail and requiring a mass of personal biographical data with which one could fill volumes. Such an undertaking would exceed my powers. I must therefore rest content with having laid some of the historical and conceptual foundations for this work of the future.

[285] In conclusion, I would like to emphasize once again that the fish symbol is a spontaneous assimilation of the Christ-figure of the gospels, and is thus a symptom which shows us in what manner and with what meaning the symbol was assimilated by the unconscious. In this respect the patristic allegory of the capture of Leviathan (with the Cross as the hook, and the Crucified as the bait) is highly characteristic: a content (fish) of the unconscious (sea) has been caught and has attached itself to the Christ-figure. Hence the expression used by St. Augustine: “de profundo levatus” (drawn from the deep). This is true enough of the fish; but of Christ? The image of the fish came out of the depths of the unconscious as an equivalent of the historical Christ figure, and if Christ was invoked as “Ichthys,” this name referred to what had come up out of the depths. The fish symbol is thus the bridge between the historical Christ and the psychic nature of man, where the archetype of the Redeemer dwells. In this way Christ became an inner experience, the “Christ within.”

[286] As I have shown, the alchemical fish symbolism leads direct to the *lapis*, the *salvator*, *servator*, and *deus terrenus*; that is, psychologically, to the self. We now have a new symbol in place of the fish: a psychological concept of human wholeness. In as much or in as little as the fish is Christ does the self mean God. It is something that corresponds, an inner experience, an assimilation of Christ into the psychic matrix, a new realization of the divine Son, no longer in theriomorphic form, but expressed in a conceptual or “philosophic” symbol. This, compared with the mute and unconscious fish, marks a distinct increase in conscious development.¹⁰

XIII

GNOSTIC SYMBOLS OF THE SELF

1

[287] Since all cognition is akin to recognition, it should not come as a surprise to find that what I have described as a gradual process of development had already been anticipated, and more or less prefigured, at the beginning of our era. We meet these images and ideas in Gnosticism, to which we must now give our attention; for Gnosticism was, in the main, a product of cultural assimilation and is therefore of the greatest interest in elucidating and defining the contents constellated by prophecies about the Redeemer, or by his appearance in history, or by the synchronicity of the archetype.¹

[288] In the *Elenchos* of Hippolytus the attraction between the magnet and iron is mentioned, if I am not mistaken, three times. It first appears in the doctrine of the NAASSENES, who taught that the four rivers of Paradise correspond to the eye, the ear, the sense of smell, and the mouth. The mouth, through which prayers go out and food goes in, corresponds to the fourth river, the Euphrates. The well-known significance of the “fourth” helps to explain its connection with the “whole” man, for the fourth always makes a triad into a totality. The text says: “This is the water above the firmament,² of which, they say, the Saviour spoke: ‘If you knew who it is that asks, you would have asked him, and he would have given you a spring of living water to drink.’³ To this water comes every nature to choose its own substances, and from this water goes forth to every nature that which is proper to it, more [certainly] than iron to the Heracleian stone,”⁴ etc.

[289] As the reference to John 4 : 10 shows, the wonderful water of the Euphrates has the property of the *aqua doctrinae*, which perfects every nature in its individuality and thus makes man whole too. It does this by giving him a kind of magnetic power by which he can attract and integrate that which belongs to him. The Naassene doctrine is, plainly, a perfect parallel to the alchemical view already discussed: the doctrine is the magnet that makes possible the integration of man as well as the *lapis*.

[290] In the PERATIC doctrine, so many ideas of this kind reappear that Hippolytus even uses the same metaphors, though the meaning is more subtle. No one, he says, can be saved without the Son:

But this is the serpent. For it is he who brought the signs of the Father down from above, and it is he who carries them back again after they have been awakened from sleep, transferring them thither from hence as substances proceeding from the Substanceless. This, they say, is [what is meant by] the saying, “I am the Door.”⁵ But they say he transfers them to those whose eyelids are closed,⁶ as naphtha draws everywhere the fire to itself,⁷ more than the Heracleian stone draws iron ...⁸ Thus, they say, the perfect race of men, made in the image [of the Father] and of the same substance [*homoousion*], is drawn from the world by the Serpent, even as it was sent down by him; but naught else [is so drawn].⁹

[291] Here the magnetic attraction does not come from the doctrine or the water but from the “Son,” who is symbolized by the serpent, as in John 3 : 14.¹⁰ Christ is the magnet that draws to itself those parts or substances in man that are of divine origin, the *πατρικοί χαρακτήρες* (signs of the Father), and carries them back to their heavenly birthplace. The serpent is an equivalent of the fish. The consensus of opinion interpreted the Redeemer equally as a fish and a serpent; he is a fish because he rose from the unknown depths, and a serpent because he came mysteriously out of the darkness. Fishes and snakes are favourite symbols for describing psychic happenings or experiences that suddenly dart out of the unconscious and have a frightening or redeeming effect. That is why they are so often expressed by the motif of helpful animals. The comparison of Christ with the serpent is more authentic than that with the fish, but, for all that, it was not so popular in primitive Christianity. The Gnostics favoured it because it was an old-established symbol for the “good” *genius loci*, the Agathodaimon, and also for their beloved Nous. Both symbols are of inestimable value when it comes to the natural, instinctive interpretation of the Christ-figure. Theriomorphic symbols are very common in dreams and other manifestations of the unconscious. They express the psychic level of the content in question; that is to say, such contents are at a stage of unconsciousness that is as far from human consciousness as the psyche of an animal. Warm-blooded or cold-blooded vertebrates of all kinds, or even invertebrates, thus indicate the degree of unconsciousness. It is important for psychopathologists to know this, because these contents can produce, at all levels, symptoms that correspond to the physiological functions and are localized accordingly. For instance, the symptoms may be distinctly correlated with the cerebrospinal and the sympathetic nervous system. The Sethians may have guessed something of this sort, for Hippolytus mentions, in connection with the serpent, that they compared the “Father” with the cerebrum (*ἐγκέφαλον*) and the “Son” with the cerebellum and spinal cord (*παρεγκεφαλίζ δροκοντοειδής*). The snake does in fact symbolize “cold-blooded,” inhuman contents and tendencies of an abstractly intellectual as well as a concretely animal nature: in a word, the extra-human quality in man.

[292] The third reference to the magnet is to be found in Hippolytus' account of the SETHIAN doctrine. This has remarkable analogies with the alchemical doctrines of the Middle Ages, though no direct transmission can be proved. It expounds, in Hippolytus' words, a theory of "composition and mixture": the ray of light from above mingles with the dark waters below in the form of a minute spark. At the death of the individual, and also at his figurative death as a mystical experience, the two substances unmix themselves. This mystical experience is the *divisio* and *separatio* of the composite (τὸ διχάσαι καὶ χωρίσαι τὰ συγκεκραμένα). I purposely give the Latin terms used in medieval alchemy, because they denote essentially the same thing as do the Gnostic concepts. The separation or unmixing enables the alchemist to extract the *anima* or *spiritus* from the *prima materia*. During this operation the helpful Mercurius appears with the dividing sword (used also by the adept!), which the Sethians refer to Matthew 10 : 34: "I came not to send peace, but a sword." The result of the unmixing is that what was previously mixed up with the "other" is now drawn to "its own place" and to that which is "proper" or "akin" to it, "like iron to the magnet" (ὡς σίδηρος [πρὸς] Ἡράκλειον λίθον).¹¹ In the same way, the spark or ray of light, "having received from the teaching and learning its proper place, hastens to the Logos, which comes from above in the form of a slave ... more [quickly] than iron [flies] to the magnet."¹²

[293] Here the magnetic attraction comes from the Logos. This denotes a thought or idea that has been formulated and articulated, hence a content and a product of consciousness. Consequently the Logos is very like the *aqua doctrinae*, but whereas the Logos has the advantage of being an autonomous personality, the latter is merely a passive object of human action. The Logos is nearer to the historical Christ-figure, just as the "water" is nearer to the magical water used in ritual (ablution, aspersion, baptism). Our three examples of magnetic action suggest three different forms of magnetic agent:

1. The agent is an inanimate and in itself passive substance, *water*. It is drawn from the depths of the well, handled by human hands, and used according to man's needs. It signifies the visible doctrine, the *aqua doctrinae* or the Logos, communicated to others by word of mouth and by ritual.

2. The agent is an animate, autonomous being, the *serpent*. It appears spontaneously or comes as a surprise; it fascinates; its glance is staring, fixed, unrelated; its blood cold, and it is a stranger to man: it crawls over the sleeper, he finds it in a shoe or in his pocket. It expresses his fear of everything inhuman and his awe of the sublime, of what is beyond human ken. It is the lowest (devil) and the highest (son of God, Logos, Nous, Agathodaimon). The snake's presence is frightening, one finds it in unexpected places at unexpected moments. Like the fish, it

represents and personifies the dark and unfathomable, the watery deep, the forest, the night, the cave. When a primitive says “snake,” he means an experience of something extrahuman. The snake is not an allegory or metaphor, for its own peculiar form is symbolic in itself, and it is essential to note that the “Son” has the form of a snake and not the other way round: the snake does not signify the “Son.”

3. The agent is the *Logos*, a philosophical idea and abstraction of the bodily and personal son of God on the one hand, and on the other the dynamic power of thoughts and words.

[294] It is clear that these three symbols seek to describe the unknowable essence of the incarnate God. But it is equally clear that they are hypostatized to a high degree: it is real water, and not figurative water, that is used in ritual. The Logos was in the beginning, and God was the Logos, long before the Incarnation. The emphasis falls so much on the “serpent” that the Ophites celebrated their eucharistic feast with a live snake, no less realistic than the Aesculapian snake at Epidaurus. Similarly, the “fish” is not just the secret language of the mystery, but, as the monuments show, it meant something in itself. Moreover, it acquired its meaning in primitive Christianity without any real support from the written tradition, whereas the serpent can at least be referred back to an authentic logion.

[295] All three symbols are phenomena of assimilation that are in themselves of a numinous nature and therefore have a certain degree of autonomy. Indeed, had they never made their appearance, it would have meant that the annunciation of the Christ-figure was ineffective. These phenomena not only prove the effectiveness of the annunciation, but provide the necessary conditions in which the annunciation can take effect. In other words, the symbols represent the prototypes of the Christ-figure that were slumbering in man’s unconscious and were then called awake by his actual appearance in history and, so to speak, magnetically attracted. That is why Meister Eckhart uses the same symbolism to describe Adam’s relation to the Creator on the one hand and to the lower creatures on the other.¹³

[296] This magnetic process revolutionizes the ego-oriented psyche by setting up, in contradistinction to the ego, another goal or centre which is characterized by all manner of names and symbols: fish, serpent, centre of the sea-hawk,¹⁴ point, monad, cross, paradise, and so on. The myth of the ignorant demiurge who imagined he was the highest divinity illustrates the perplexity of the ego when it can no longer hide from itself the knowledge that it has been dethroned by a supraordinate authority. The “thousand names” of the *lapis philosophorum* correspond to the innumerable Gnostic designations for the Anthropos, which make it quite obvious what is meant: the greater, more comprehensive Man, that indescribable whole consisting of the sum of conscious and unconscious processes. This objective whole, the antithesis of the

subjective ego-psyche, is what I have called the self, and this corresponds exactly to the idea of the Anthropos.

2

[297] When, in treating a case of neurosis, we try to supplement the inadequate attitude (or adaptedness) of the conscious mind by adding to it contents of the unconscious, our aim is to create a wider personality whose centre of gravity does not necessarily coincide with the ego, but which, on the contrary, as the patient's insights increase, may even thwart his ego-tendencies. Like a magnet, the new centre attracts to itself that which is proper to it, the "signs of the Father," i.e., everything that pertains to the original and unalterable character of the individual ground-plan. All this is older than the ego and acts towards it as the "blessed, nonexistent God" of the Basilidians acted towards the archon of the Ogdoad, the demiurge, and—paradoxically enough—as the son of the demiurge acted towards his father. The son proves superior in that he has knowledge of the message from above and can therefore tell his father that he is not the highest God. This apparent contradiction resolves itself when we consider the underlying psychological experience. On the one hand, in the products of the unconscious the self appears as it were *a priori*, that is, in well-known circle and quaternity symbols which may already have occurred in the earliest dreams of childhood, long before there was any possibility of consciousness or understanding. On the other hand, only patient and painstaking work on the contents of the unconscious, and the resultant synthesis of conscious and unconscious data, can lead to a "totality," which once more uses circle and quaternity symbols for purposes of self-description.¹⁵ In this phase, too, the original dreams of childhood are remembered and understood. The alchemists, who in their own way knew more about the nature of the individuation process than we moderns do, expressed this paradox through the symbol of the uroboros, the snake that bites its own tail.

[298] The same knowledge, formulated differently to suit the age they lived in, was possessed by the Gnostics. The idea of an unconscious was not unknown to them. For instance, Epiphanius quotes an excerpt from one of the Valentinian letters, which says: "In the beginning the Autopator contained in himself everything that is, in a state of unconsciousness [lit., 'not-knowing': ἀγνωσίᾳ]."¹⁶ It was Professor G. Quispel who kindly drew my attention to this passage. He also points out the passage in Hippolytus: ὁ Πατήρ ... ὁ ἀνευνόητος καὶ ἀνούσιος, ὁ μήτε ἄρρεν μήτε θῆλυ, which he translates: "le Père ... qui est dépourvu de conscience et de substance, celui qui est ni masculin, ni féminin."¹⁷ So the "Father" is not only unconscious and without the quality of being, but also *nirdvandva*, without opposites, lacking all qualities and therefore unknowable. This describes the state of the unconscious. The Valentinian text gives the Autopator more positive qualities: "Some called him the ageless Aeon,

eternally young, male and female, who contains everything in himself and is [himself] contained by nothing.” In him was *ἔννοια*, consciousness, which “conveys the treasures of the greatness to those who come from the greatness.” But the presence of *ἔννοια* does not prove that the Autopator himself is conscious, for the differentiation of consciousness results only from the syzygies and tetrads that follow afterwards, all of them symbolizing processes of conjunction and composition. *ἔννοια* must be thought of here as the latent possibility of consciousness. Oehler translates it as *mens*, Cornarius as *intelligentia* and *notio*.

[299] St. Paul’s concept of *ἄγνοια* (*ignorantia*) may not be too far removed from *ἄγνωσία*, since both mean the initial, unconscious condition of man. When God “looked down” on the times of ignorance, the Greek word used here, *ὑπεριδών* (Vulgate: *despiciens*) has the connotation ‘to disdain, despise.’¹⁸ At all events, Gnostic tradition says that when the highest God saw what miserable, unconscious creatures these human beings were whom the demiurge had created, who were not even able to walk upright, he immediately got the work of redemption under way.¹⁹ And in the same passage in the Acts, Paul reminds the Athenians that they were “God’s offspring,”²⁰ and that God, looking back disapprovingly on “the times of ignorance,” had sent the message to mankind, commanding “all men every-where to repent.” Because that earlier condition seemed to be altogether too wretched, the *μετάνοια* (transformation of mind) took on the moral character of repentance of sins, with the result that the Vulgate could translate it as “poenitentiam agere.”²¹ The sin to be repented, of course, is *ἄγνοια* or *ἄγνωσία*, unconsciousness.²² As we have seen, it is not only man who is in this condition, but also, according to the Gnostics, the *ἄνευνόητος*, the God without consciousness. This idea is more or less in line with the traditional Christian view that God was transformed during the passage from the Old Testament to the New, and, from being the God of wrath, changed into the God of Love—a thought that is expressed very clearly by Nicolaus Caussin in the seventeenth century.²³

[300] In this connection I must mention the results of Riwkah Schärf’s examination of the figure of Satan in the Old Testament.²⁴ With the historical transformation of the concept of Satan the image of Yahweh changes too, so that one can well say that there was a differentiation of the God-image even in the Old Testament, not to speak of the New. The idea that the world-creating Deity is not conscious, but may be dreaming, is found also in Hindu literature:

Who knows how it was, and who shall declare

Whence it was born and whence it came?

The gods are later than this creation;

Who knows, then, whence it has sprung?

Whence this created world came,
And whether he made it or not,
He alone who sees all in the highest heaven
Knows—or does not know.²⁵

[301] Meister Eckhart's theology knows a "Godhead" of which no qualities, except unity and being,²⁶ can be predicated;²⁷ it "is becoming," it is not yet Lord of itself, and it represents an absolute coincidence of opposites: "But its simple nature is of forms formless; of becoming becomingless; of beings beingless; of things thingless," etc.²⁸ Union of opposites is equivalent to unconsciousness, so far as human logic goes, for consciousness presupposes a differentiation into subject and object and a relation between them. Where there is no "other," or it does not yet exist, all possibility of consciousness ceases. Only the Father, the God "welling" out of the Godhead, "notices himself," becomes "beknown to himself," and "confronts himself as a Person." So, from the Father, comes the Son, as the Father's thought of his own being. In his original unity "he knows nothing" except the "suprareal" One which he *is*. As the Godhead is essentially unconscious,²⁹ so too is the man who lives in God. In his sermon on "The Poor in Spirit" (Matt. 5 : 3), the Meister says: "The man who has this poverty has everything he was when he lived not in any wise, neither in himself, nor in truth, nor in God. He is so quit and empty of all knowing that no knowledge of God is alive in him; for while he stood in the eternal nature of God, there lived in him not another: what lived there was himself. And so we say this man is as empty of his own knowledge as he was when he was not anything; he lets God work what he will, and he stands empty as when he came from God."³⁰ Therefore he should love God in the following way: "Love him as he is: a not-God, a not-spirit, a not-person, a not-image; as a sheer, pure, clear One, which he is, sundered from all secondness; and in this One let us sink eternally, from nothing to nothing. So help us God. Amen."³¹

[302] The world-embracing spirit of Meister Eckhart knew, without discursive knowledge, the primordial mystical experience of India as well as of the Gnostics, and was itself the finest flower on the tree of the "Free Spirit" that flourished at the beginning of the eleventh century. Well might the writings of this Master lie buried for six hundred years, for "his time was not yet come." Only in the nineteenth century did he find a public at all capable of appreciating the grandeur of his mind.

[303] These utterances on the nature of the Deity express transformations of the God-image which run parallel with changes in human consciousness, though one would be at a loss to say which is the cause of the other. The God-image is not something *invented*, it is an *experience* that comes upon man spontaneously—as anyone can see for himself unless he is blinded to the truth by theories and prejudices. The

unconscious God-image can therefore alter the state of consciousness, just as the latter can modify the God-image once it has become conscious. This, obviously, has nothing to do with the “prime truth,” the unknown God—at least, nothing that could be verified. Psychologically, however, the idea of God’s *ἄγνωσία*, or of the *ἀνεκνόητος θεός*, is of the utmost importance, because it identifies the Deity with the numinosity of the unconscious. The *atman / purusha* philosophy of the East and, as we have seen, Meister Eckhart in the West both bear witness to this.

[304] Now if psychology is to lay hold of this phenomenon, it can only do so if it expressly refrains from passing metaphysical judgments, and if it does not presume to profess convictions to which it is ostensibly entitled on the ground of scientific experience. But of this there can be no question whatever. The one and only thing that psychology can establish is the presence of pictorial symbols, whose interpretation is in no sense fixed beforehand. It can make out, with some certainty, that these symbols have the character of “wholeness” and therefore presumably *mean* wholeness. As a rule they are “uniting” symbols, representing the conjunction of a single or double pair of opposites, the result being either a dyad or a quaternity. They arise from the collision between the conscious and the unconscious and from the confusion which this causes (known in alchemy as “chaos” or “nigredo”). Empirically, this confusion takes the form of restlessness and disorientation. The circle and quaternity symbolism appears at this point as a compensating principle of order, which depicts the union of warring opposites as already accomplished, and thus eases the way to a healthier and quieter state (“salvation”). For the present, it is not possible for psychology to establish more than that the symbols of wholeness mean the wholeness of the individual.³² On the other hand, it has to admit, most emphatically, that this symbolism uses images or schemata which have always, in all the religions, expressed the universal “Ground,” the Deity itself. Thus the circle is a well-known symbol for God; and so (in a certain sense) is the cross, the quaternity in all its forms, e.g., Ezekiel’s vision, the *Rex gloriae* with the four evangelists, the Gnostic Barbelo (“God in four”) and Kolorbas (“all four”); the duality (*tao*, hermaphrodite, father-mother); and finally, the human form (child, son, anthropos) and the individual personality (Christ and Buddha), to name only the most important of the motifs here used.

[305] All these images are found, empirically, to be expressions for the unified wholeness of man. The fact that this goal goes by the name of “God” proves that it has a numinous character; and indeed, experiences, dreams, and visions of this kind do have a fascinating and impressive quality which can be spontaneously felt even by people who are not prejudiced in their favour by prior psychological knowledge. So it is no wonder that naïve minds make no distinction between God and the image they have experienced. Wherever, therefore, we find symbols indicative of psychic

wholeness, we encounter the naive idea that they stand for God. In the case of those quite common Romanesque pictures of the Son of Man accompanied by three angels with animal heads and one with a human head, for example, it would be simpler to assume that the Son of Man meant the ordinary man and that the problem of one against three referred to the well-known psychological schema of one differentiated and three undifferentiated functions. But this interpretation would, according to the traditional view, devalue the symbol, for it means the second Person of the Godhead in its universal, fourfold aspect. Psychology cannot of course adopt this view as its own; it can only establish the existence of such statements and point out, by way of comparison, that essentially the same symbols, in particular the dilemma of one and three, often appear in the spontaneous products of the unconscious, where they demonstrably refer to the psychic totality of the individual. They indicate the presence of an archetype of like nature, one of whose derivatives would seem to be the quaternity of functions that orient consciousness. But, since this totality exceeds the individual's consciousness to an indefinite and indeterminable extent, it invariably includes the unconscious in its orbit and hence the totality of all archetypes. But the archetypes are complementary equivalents of the "outside world" and therefore possess a "cosmic" character. This explains their numinosity and "godlikeness."

3

[306] To make my exposition more complete, I would like to mention some of the Gnostic symbols for the universal "Ground" or arcanum, and especially those synonyms which signify the "Ground." Psychology takes this idea as an image of the unconscious background and begetter of consciousness. The most important of these images is the figure of the demiurge. The Gnostics have a vast number of symbols for the source or origin, the centre of being, the Creator, and the divine substance hidden in the creature. Lest the reader be confused by this wealth of images, he should always remember that each new image is simply another aspect of the divine mystery immanent in all creatures. My list of Gnostic symbols is no more than an amplification of a single transcendental idea, which is so comprehensive and so difficult to visualize in itself that a great many different expressions are required in order to bring out its various aspects.

[307] According to Irenaeus, the Gnostics held that Sophia represents the world of the Ogdoad,³³ which is a double quaternity. In the form of a dove, she descended into the water and begot Saturn, who is identical with Yahweh. Saturn, as we have already mentioned, is the "other sun," the *sol niger* of alchemy. Here he is the "primus Anthropus." He created the first man, who could only crawl like a worm.³⁴ Among the Naassenes, the demiurge Esaldaios, "a fiery god, the fourth by number," is set up against the Trinity of Father, Mother, and Son. The highest is the Father, the

Archanthropos, who is without qualities and is called the higher Adam. In various systems Sophia takes the place of the Protanthropos.³⁵ Epiphanius mentions the Ebionite teaching that Adam, the original man, is identical with Christ.³⁶ In Theodor Bar-Kuni the original man is the five elements (i.e., 4 + 1).³⁷ In the Acts of Thomas, the dragon says of itself: “I am the son ... of him that hurt and smote the four brethren which stood upright.”³⁸

[308] The primordial image of the quaternity coalesces, for the Gnostics, with the figure of the demiurge or Anthropos. He is, as it were, the victim of his own creative act, for, when he descended into Physis, he was caught in her embrace.³⁹ The image of the *anima mundi* or Original Man latent in the dark of matter expresses the presence of a transconscious centre which, because of its quaternary character and its roundness, must be regarded as a symbol of wholeness. We may assume, with due caution, that some kind of psychic wholeness is meant (for instance, conscious + unconscious), though the history of the symbol shows that it was always used as a God-image. Psychology, as I have said, is not in a position to make metaphysical statements. It can only establish that the symbolism of psychic wholeness coincides with the God-image, but it can never prove that the God-image is God himself, or that the self takes the place of God.

[309] This coincidence comes out very clearly in the ancient Egyptian Heb-Sed festival, of which Colin Campbell gives the following description: “The king comes out of an apartment called the sanctuary, then he ascends into a pavilion open at the four sides, with four staircases leading up to it. Carrying the emblems of Osiris, he takes his seat on a throne, and turns to the four cardinal points in succession. ... It is a kind of second enthronement ... and sometimes the king acts as a priest, making offerings to himself. This last act may be regarded as the climax of the deification of the king.”⁴⁰

[310] All kingship is rooted in this psychology, and therefore, for the anonymous individual of the populace, every king carries the symbol of the self. All his insignia—crown, mantle, orb, sceptre, starry orders, etc.—show him as the cosmic Anthropos, who not only begets, but himself is, the world. He is the *homo maximus*, whom we meet again in Swedenborg’s speculations. The Gnostics, too, constantly endeavoured to give visible form and a suitable conceptual dress to this being, suspecting that he was the matrix and organizing principle of consciousness. As the “Phrygians” (Naassenes) say in Hippolytus,⁴¹ he is the “undivided point,” the “grain of mustard seed” that grows into the kingdom of God. This point is “present in the body.” But this is known only to the *πνευματικοί* the “spiritual” men as opposed to the *ψυχικοί* and the *ὕλικοί* (“material” men). He is *τὸ ῥῆμα τοῦ* the utterance of God (*sermo Dei*), and the “matrix of the Aeons, Powers, Intelligences, Gods, Angels, and

Emissary Spirits, of Being and Non-Being, of Begotten and Unbegotten, of the Non-Intelligible Intelligible, of the Years, Moons, Days, Hours" This point, "being nothing and consisting of nothing," becomes a "certain magnitude incomprehensible by thought." Hippolytus accuses the Naassenes of bundling everything into their thought like the syncretists, for he obviously cannot quite understand how the point, the "utterance of God," can have a human form. The Naassenes, he complains, also call him the "polymorphous Attis," the young dying son of the Great Mother, or, as the hymn cited by Hippolytus says, τὸ κατέφες ἄκοναμα 'Ρ'έας, the 'dark rumour of Rhea.' In the hymn he has the synonyms Adonis, Osiris, Adam, Korybas, Pan, Bacchus, and ποιμὴν λευκῶν ἀστρῶν, 'shepherd of white stars.'

[311] The Naassenes themselves considered Naas, the serpent, to be their central deity, and they explained it as the "moist substance," in agreement with Thales of Miletus, who said water was the prime substance on which all life depended. Similarly, all living things depend on the Naas; "it contains within itself, like the horn of the one-horned bull, the beauty of all things." It "pervades everything, like the water that flows out of Eden and divides into four sources" (ἄρχας). "This Eden, they say, is the brain." Three of the rivers of Paradise are sensory functions (Pison = sight, Gihon = hearing, Tigris = smell), but the fourth, the Euphrates, is the mouth, "the seat of prayer and the entrance of food." As the fourth function it has a double significance,⁴² denoting on the one hand the purely material activity of bodily nourishment, while on the other hand it "gladdens,⁴³ feeds, and forms [χαρακτηρίζει] the spiritual, perfect [τέλειον] man."⁴⁴ The "fourth" is something special, ambivalent—a daimonion. A good example of this is in Daniel 3 : 24f., where the three men in the burning fiery furnace are joined by a fourth, whose form was "like a son of God."

[312] The water of the Euphrates is the "water above the firmament," the "living water of which the Saviour spoke,"⁴⁵ and possessing, as we have seen, magnetic properties. It is that miraculous water from which the olive draws its oil and the grape the wine. "That man," continues Hippolytus, as though still speaking of the water of the Euphrates, "is without honour in the world."⁴⁶ This is an allusion to the τέλειος ἄνθρωπος. Indeed, this water is the "perfect man," the ῥῆμα θεοῦ, the Word sent by God. "From the living water we spiritual men choose that which is ours,"⁴⁷ for every nature, when dipped in this water, "chooses its own substances ... and from this water goes forth to every nature that which is proper to it."⁴⁸ The water or, as we could say, this Christ is a sort of panspermia, a matrix of all possibilities, from which the πνευματικός chooses "his Osob," his idiosyncrasy,⁴⁹ that "flies to him more [quickly] than iron to the magnet." But the "spiritual men" attain their proper nature by entering in through the "true door," Jesus Makarios (the blessed), and thus obtaining knowledge of their own wholeness, i.e., of the complete man. This man, unhonoured in the world, is obviously the inner, spiritual man, who becomes

conscious for those who enter in through Christ, the door to life, and are illuminated by him. Two images are blended here: the image of the “strait gate,” 50 and that of John 14 : 6: “I am the way, and the truth, and the life. No one comes to the Father but through me.”⁵¹ They represent an integration process that is characteristic of psychological individuation. As formulated, the water symbol continually coalesces with Christ and Christ with the inner man. This, it seems to me, is not a confusion of thought but a psychologically correct formulation of the facts, since Christ as the “Word” is indeed the “living water” and at the same time the symbol of the inner “complete” man, the self.

[313] For the Naassenes, the universal “Ground” is the Original Man, Adam, and knowledge of him is regarded as the beginning of perfection and the bridge to knowledge of God.⁵² He is male/female; from him come “father and mother”;⁵³ he consists of three parts: the rational (νοερόν), the psychic, and the earthly (χοικόν). These three “came down together into one man, Jesus,” and “these three men spoke together, each of them from his own substance to his own,” i.e., from the rational to the rational, etc. Through this doctrine Jesus is related to the Original Man (Christ as second Adam). His soul is “of three parts and (yet) one”—a Trinity.⁵⁴ As examples of the Original Man the text mentions the Cabiros⁵⁵ and Oannes. The latter had a soul capable of suffering, so that the “figure (πλάσμα) of the great, most beautiful and perfect man, humbled to a slave,” might suffer punishment. He is the “blessed nature, at once hidden and revealed, of everything that has come to be and will be,” “the kingdom of heaven which is to be sought within man” (ἐντός ἀνθρώπου), even “in children of seven years.”⁵⁶ For the Naassenes, says Hippolytus, place the “procreative nature of the Whole in the procreative seed.”⁵⁷ On the face of it, this looks like the beginnings of a “sexual theory” concerning the underlying psychic substance, reminiscent of certain modern attempts in the same vein. But one should not overlook the fact that in reality man’s procreative power is only a special instance of the “procreative nature of the Whole.” “This, for them, is the hidden and mystical Logos,” which, in the text that follows, is likened to the phallus of Osiris—“and they say Osiris is water.” Although the substance of this seed is the cause of all things, it does not partake of their nature. They say therefore: “I become what I will, and I am what I am.” For he who moves everything is himself unmoved. “He, they say, is alone good.”⁵⁸ A further synonym is the ithyphallic Hermes Kyllenios. “For they say Hermes is the Logos, the interpreter and fashioner of what has been, is, and will be.” That is why he is worshipped as the phallus, because he, like the male organ, “has an urge [ὄρμη]ν] from below upwards.”⁵⁹

[314] The fact that not only the Gnostic Logos but Christ himself was drawn into the orbit of sexual symbolism is corroborated by the fragment from the *Interrogationes maiores Mariae*, quoted by Epiphanius.⁶⁰ It is related there that Christ took this Mary with him on to a mountain, where he produced a woman from his side and began to have intercourse with her: “... seminis sui defluxum assumpsisset, indicasse illi, quod oporteat sic facere, ut vivamus.”⁶¹ It is understandable that this crude symbolism should offend our modern feelings. But it also appeared shocking to Christians of the third and fourth centuries; and when, in addition, the symbolism became associated with a concretistic misunderstanding, as appeared to be the case in certain sects, it could only be rejected. That the author of the *Interrogationes* was by no means ignorant of some such reaction is evident from the text itself. It says that Mary received such a shock that she fell to the ground. Christ then said to her: “Wherefore do you doubt me, O you of little faith?” This was meant as a reference to John 3: 12: “If I have told you earthly things and you do not believe, how can you believe if I tell you heavenly things?” and also to John 6 : 53: “Unless you eat the flesh of the Son of man and drink his blood, you have no life in you” (RSV).

[315] This symbolism may well have been based, originally, on some visionary experience, such as happens not uncommonly today during psychological treatment. For the medical psychologist there is nothing very lurid about it. The context itself points the way to the right interpretation. The image expresses a psychologem that can hardly be formulated in rational terms and has, therefore, to make use of a concrete symbol, just as a dream must when a more or less “abstract” thought comes up during the *abaissement du niveau mental* that occurs in sleep. These “shocking” surprises, of which there is certainly no lack in dreams, should always be taken “as-if,” even though they clothe themselves in sensual imagery that stops at no scurrility and no obscenity. They are unconcerned with offensiveness, because they do not really mean it. It is as if they were stammering in their efforts to express the elusive meaning that grips the dreamer’s attention.⁶²

[316] The context of the vision (John 3 : 12) makes it clear that the image should be taken not concretistically but symbolically; for Christ speaks not of earthly things but of a heavenly or spiritual mystery—a “mystery” not because he is hiding something or making a secret of it (indeed, nothing could be more blatant than the naked obscenity of the vision!) but because its meaning is still hidden from consciousness. The modern method of dream-analysis and interpretation follows this heuristic rule.⁶³ If we apply it to the vision, we arrive at the following result:

[317] 1. The MOUNTAIN means ascent, particularly the mystical, spiritual ascent to the heights, to the place of revelation where the spirit is present. This motif is so well known that there is no need to document it.⁶⁴

[318] 2. The central significance of the CHRIST-FIGURE for that epoch has been abundantly proved. In Christian Gnosticism it was a visualization of God as the Archanthropos (Original Man = Adam), and therefore the epitome of man as such: "Man and the Son of Man." Christ is the inner man who is reached by the path of self-knowledge, "the kingdom of heaven within you." As the Anthropos he corresponds to what is empirically the most important archetype and, as judge of the living and the dead and king of glory, to the real organizing principle of the unconscious, the quaternity, or squared circle of the self.⁶⁵ In saying this I have not done violence to anything; my views are based on the experience that mandala structures have the meaning and function of a centre of the unconscious personality.⁶⁶ The quaternity of Christ, which must be borne in mind in this vision, is exemplified by the cross symbol, the *rex gloriae*, and Christ as the year.

[319] 3. The production of the WOMAN from his side suggests that he is interpreted as the second Adam. Bringing forth a woman means that he is playing the role of the Creator-god in Genesis.⁶⁷ Just as Adam, before the creation of Eve, was supposed by various traditions to be male/female,⁶⁸ so Christ here demonstrates his androgyny in a drastic way.⁶⁹ The Original Man is usually hermaphroditic; in Vedic tradition too he produces his own feminine half and unites with her. In Christian allegory the woman sprung from Christ's side signifies the Church as the Bride of the Lamb.

[320] The splitting of the Original Man into husband and wife expresses an act of nascent consciousness; it gives birth to a pair of opposites, thereby making consciousness possible. For the beholder of the miracle, Mary, the vision was the spontaneous visualization or projection of an unconscious process in herself. Experience shows that unconscious processes are compensatory to a definite conscious situation. The splitting in the vision would therefore suggest that it is compensating a conscious condition of unity. This unity probably refers in the first place to the figure of the Anthropos, the incarnate God, who was then in the forefront of religious interest. He was, in Origen's words, the "Vir Unus,"⁷⁰ the One Man. It was with this figure that Mary was confronted in her vision. If we assume that the recipient of the vision was in reality a woman—an assumption that is not altogether without grounds—then what she had been missing in the pure, deified masculinity of Christ was the counterbalancing femininity. Therefore it was revealed to her: "I am both, man and woman." This psychologem is still incorporated today in the Catholic conception of Christ's androgyny as the "Virgo de Virgine," though this is more a *sententia communis* than a *conclusio*. Medieval iconography sometimes shows Christ with breasts, in accordance with Song of Solomon 1 : 1 : "For thy breasts are better than wine" (DV). In Mechthild of Magdeburg, the soul remarks that when the Lord kissed her,⁷¹ he had, contrary to expectation, no beard. The tokens of masculinity were lacking. Mechthild had a vision similar to Mary's, dealing with the same

problem from a different angle: she saw herself transported to a “rocky mountain” where the Blessed Virgin sat, awaiting the birth of the divine child. When it was born, she embraced it and kissed it three times. As the text points out, the mountain is an allegory of the “*spiritualis habitus*,” or spiritual attitude. “Through divine inspiration she knew how the Son is the innermost core [*medulla*] of the Father’s heart.” This *medulla* is “strengthening, healing, and most sweet”; God’s “strength and greatest sweetness” are given to us through the Son, the “Saviour and strongest, sweetest Comforter,” but “the innermost [core] of the soul is that sweetest thing.”⁷² From this it is clear that Mechthild equates the “medulla” with the Father’s heart, the Son, and the inner man. Psychologically speaking, “that sweetest thing” corresponds to the self, which is indistinguishable from the God-image.

[321] There is a significant difference between the two visions. The antique revelation depicts the birth of Eve from Adam on the spiritual level of the second Adam (Christ), from whose side the feminine pneuma, or second Eve, i.e., the soul, appears as Christ’s daughter. As already mentioned, in the Christian view the soul is interpreted as the Church: she is the woman who “embraces the man”⁷³ and anoints the Lord’s feet. Mechthild’s vision is a continuation of the sacred myth: the daughter-bride has become a mother and bears the Father in the shape of the Son. That the Son is closely akin to the self is evident from the emphasis laid on the quaternary nature of Christ: he has a “fourfold voice” (*quadruplex vox*),⁷⁴ his heart has four kinds of pulse,⁷⁵ and from his countenance go forth four rays of light.⁷⁶ In this image a new millennium is speaking. Meister Eckhart, using a different formulation, says that “God is born from the soul,” and when we come to the *Cherubinic Wanderer*⁷⁷ of Angelus Silesius, God and the self coincide absolutely. The times have undergone a profound change: the procreative power no longer proceeds from God, rather is God born from the soul. The mythologem of the young dying god has taken on psychological form—a sign of further assimilation and conscious realization.

[322] 4. But to turn back to the first vision: the bringing forth of the woman is followed by COPULATION. The *hieros gamos* on the mountain is a well-known motif,⁷⁸ just as, in the old alchemical pictures, the hermaphrodite has a fondness for elevated places. The alchemists likewise speak of an Adam who always carries his Eve around with him. Their *coniunctio* is an incestuous act, performed not by father and daughter but, in accordance with the changed times, by brother and sister or mother and son. The latter variant corresponds to the ancient Egyptian mythologem of Amen as Kamutef, which means ‘husband of his mother,’ or of Mut, who is the “mother of her father and daughter of her son.”⁷⁹ The idea of self-copulation is a recurrent theme in descriptions of the world creator: for instance, God splits into his masculine and feminine halves,⁸⁰ or he fertilizes himself in a manner that could easily have served as a model for the *Interrogationes* vision, if literary antecedents must be conjectured.

Thus the relevant passage in the Heliopolitan story of the Creation runs: “I, even I, had union with my clenched hand, I joined myself in an embrace with my shadow, I poured seed into my mouth, my own, I sent forth issue in the form of Shu, I sent forth moisture in the form of Tefnut.”⁸¹

[323] Although the idea of self-fertilization is not touched on in our vision, there can be no doubt that there is a close connection between this and the idea of the cosmogonic self-creator. Here, however, world creation gives place to spiritual renewal. That is why no visible creature arises from the taking in of seed; it means a nourishing of life, “that we may live.” And because, as the text itself shows, the vision should be understood on the “heavenly” or spiritual plane, the pouring out (ἀπόρροια) refers to a λόγος σπερματικός, which in the language of the gospels means a living water “springing up into eternal life.” The whole vision reminds one very much of the related alchemical symbolisms. Its drastic naturalism, unpleasantly obtrusive in comparison with the reticence of ecclesiastical language, points back on the one hand to archaic forms of religion whose ideas and modes of expression had long since been superseded, but forwards, on the other, to a still crude observation of Nature that was just beginning to assimilate the archetype of man. This attempt continued right up to the seventeenth century, when Johannes Kepler recognized the Trinity as underlying the structure of the universe—in other words, when he assimilated this archetype into the astronomer’s picture of the world.⁸²

5

[324] After this digression on the phallic synonyms for the Original Man, we will turn back to Hippolytus’ account of the central symbols of the Naassenes and continue with a list of statements about Hermes.

[325] Hermes is a conjurer of spirits (Ψυχαγωγός), a guide of souls (Ψυχοπομπός), and a begetter of souls (ψυχῶν αἴτιος). But the souls were “brought down from the blessed Man on high, the archman Adamas, ... into the form of clay, that they might serve the demiurge of this creation, Esaldaios, a fiery god, the fourth by number.”⁸³ Esaldaios corresponds to Ialdabaoth, the highest archon, and also to Saturn.⁸⁴ The “fourth” refers to the fourth Person—the devil—who is opposed to the Trinity. Ialdabaoth means “child of chaos”; hence when Goethe, borrowing from alchemical terminology, calls the devil the “strange son of chaos,” the name is a very apt one.

[326] Hermes is equipped with the golden wand.⁸⁵ With it he “drops sleep on the eyes of the dead and wakes up the sleepers.” The Naassenes referred this to Ephesians 5 : 14: “Awake, O sleeper, and arise from the dead, and Christ shall give you light.” Just as the alchemists took the well-known allegory of Christ, the *lapis angularis* or cornerstone, for their *lapis philosophorum*, so the Naassenes took it as symbolizing their Protanthropos Adam, or more precisely, the “inner man,” who is a rock or stone,

since he came from the *πέτρη τοῦ Ἀδάμαντος*, “fallen from Adamas the archman on high.”⁸⁶ The alchemists said their stone was “cut from the mountain without hands,”⁸⁷ and the Naassenes say the same thing of the inner man, who was brought down “into the form of oblivion.”⁸⁸ In Epiphanius the mountain is the Archanthropos Christ, from whom the stone or inner man was cut. As Epiphanius interprets it, this means that the inner man is begotten “without human seed,” “a small stone that becomes a great mountain.”⁸⁹

[327] The Archanthropos is the Logos, whom the souls follow “twittering,” as the bats follow Hermes in the *nekyia*. He leads them to Oceanus and—in the immortal words of Homer—to “the doors of Helios and the land of dreams.” “He [Hermes] is Oceanus, the begetter of gods and men, ever ebbing and flowing, now forth, now back.” Men are born from the ebb, and gods from the flow. “It is this, they say, that stands written: ‘I have said, you are gods, and all of you the sons of the most High.’”⁹⁰ Here the affinity or identity of God and man is explicit, in the Holy Scriptures no less than in the Naassene teachings.

6

[328] The Naassenes, as Hippolytus says,⁹¹ derived all things from a triad, which consists firstly of the “blessed nature of the blessed Man on high, Adamas,” secondly of the mortal nature of the lower man, and thirdly of the “kingless race begotten from above,” to which belong “Mariam the sought-for one, and Jothor⁹² the great wise one, and Sephora⁹³ the seer, and Moses whose generation was not in Egypt.”⁹⁴ Together these four form a marriage *quaternio*⁹⁵ of the classic type:



Their synonyms are:

MOTHER	—	FATHER
QUEEN	—	KING
THE UNKNOWN WOMAN	—	THE DISTANT LOVER
ANIMA	—	ANIMUS

[329] Moses corresponds to the husband, Sephora to the wife; Mariam (Miriam) is the sister of Moses; Jothor (Jethro) is the archetype of the wise old man and corresponds to the father-animus, if the *quaternio* is that of a woman. But the fact that Jothor is called “the great wise one” suggests that the *quaternio* is a man’s. In the case of a woman the accent that falls here on the wise man would fall on Mariam, who would then have the significance of the Great Mother. At all events our *quaternio* lacks the

incestuous brother-sister relationship, otherwise very common. Instead, Miriam has something of a mother significance for Moses (cf. Exodus 2 : 4ff.). As a prophetess (Exodus 15 : 20f.) she is a “magical” personality. When Moses took a Moor to wife—the “Ethiopian woman”—this incensed Miriam so much that she was smitten with leprosy and became “as white as snow” (Numbers 12 : 10). Miriam is therefore not altogether unsuited to play the role of the anima. The best-known anima-figure in the Old Testament, the Shulamite, says: “I am black, but comely” (Song of Songs 1 : 5). In the *Chymical Wedding* of Christian Rosenkreutz, the royal bride is the concubine of the Moorish king. Negroes, and especially Ethiopians, play a considerable role in alchemy as synonyms of the *caput corvi* and the *nigredo*.⁹⁶ They appear in the Passion of St. Perpetua⁹⁷ as representatives of the sinful pagan world.

[330] The triad is characterized by various names that may be onomatopoeic: Kaulakau, Saulasau, Zeesar.⁹⁸ Kaulakau means the higher Adam, Saulasau the lower, mortal man, and Zeesar is named the “upwards-flowing Jordan.” The Jordan was caused by Jesus to flow up-stream; it is the rising flood and this, as already mentioned, is the begetter of gods. “This, they say, is the human hermaphrodite in all creatures, whom the ignorant call ‘Geryon of the threefold body’ [that is, *ὡς ἐκ γῆς ῥέοντα*, ‘flowing from the earth’]; but the Greeks name it the celestial horn of the moon.” The text defines the above-mentioned *quaternio*, which is identical with Zeesar, the upwards-flowing Jordan, the hermaphrodite, Geryon of the threefold body, and the horn of the moon, as the cosmogonic Logos (John 1 : 1ff.), and the “life that was in him” (John 1 : 4) as a “generation of perfect men” (τέλειοι ἄνθρωποι).⁹⁹

[331] This Logos or quaternity is “the cup from which the king, drinking, draws his omens,”¹⁰⁰ or the beaker of Anacreon. The cup leads Hippolytus on to the wine miracle at Cana, which, he says, “showed forth the kingdom of heaven”; for the kingdom of heaven lies within us, like the wine in the cup. Further parallels of the cup are the ithyphallic gods of Samothrace and the Kyllenic Hermes, who signify the Original Man as well as the spiritual man who is reborn. This last is “in every respect consubstantial” with the Original Man symbolized by Hermes. For this reason, says Hippolytus, Christ said that one must eat of his flesh and drink of his blood, for he was conscious of the *individual nature* of each of his disciples, and also of the need of each “to come to his own special nature.”¹⁰¹

[332] Another synonym is Korybas, who was descended from the crown of the head and from the unformed (ἄχαρακτηρίστων) brain, like the Euphrates from Eden, and permeates all things. His image exists—unrecognized—“in earthly form.” He is the god who *dwells in the flood*. I need not describe this symbol here, as I have already discussed it at some length in one of my Paracelsus studies.¹⁰² So far as Korybas is concerned, the parallel between him and the Protanthropos is explained by the

ancient view that the corybants were the original men.¹⁰³ The name “Korybas” does not denote a particular personality, but rather the anonymous member of a collectivity, such as the Curetes, Cabiri, Dactyls, etc. Etymologically, it has been brought into connection with κορυφή (crown of the head), though this is not certain.¹⁰⁴ Korybas seems in our text to be the name of a single personality—the Kyllenian Hermes, who appears here as synonymous with the Cabiri of Samothrace. With reference to this Hermes the text says: “Him the Thracians ... call Korybas.”¹⁰⁵ I have suggested in an earlier publication¹⁰⁶ that this unusual single personality may perhaps be a product of contamination with Korybas, known to us from the Dionysus legend, because he too seems to have been a phallic being, as we learn from a scholium to Lucian’s *De dea Syria*.¹⁰⁷

[333] From the centre of the “perfect man” flows the ocean (where, as we have said, the god dwells). The “perfect” man is, as Jesus says, the “true door,” through which the “perfect” man must go in order to be reborn. Here the problem of how to translate “teleios” becomes crucial; for—we must ask—why should anyone who is “perfect” need renewal through rebirth?¹⁰⁸ One can only conclude that the perfect man was not so perfected that no further improvement was possible. We encounter a similar difficulty in Philippians 3 : 12, where Paul says: “Not that I ... am already perfect” (τετελειώμαι). But three verses further on he writes: “Let us then, as many as are perfect (τέλειοι) be of this mind.” The Gnostic use of τέλειος obviously agrees with Paul’s. The word has only an approximate meaning and amounts to much the same thing as πνευματικός, ‘spiritual,’¹⁰⁹ which is not connected with any conception of a definite degree of perfection or spirituality. The word “perfect” gives the sense of the Greek τέλειος correctly only when it refers to God. But when it applies to a man, who in addition is in need of rebirth, it can at most mean “whole” or “complete,” especially if, as our text says, the complete man cannot even be saved unless he passes through this door.¹¹⁰

[334] The father of the “perfectus” is the higher man or Protanthropos, who is “not clearly formed” and “without qualities.” Hippolytus goes on to say that he is called Papa (Attis) by the Phrygians. He is a bringer of peace and quells “the war of the elements” in the human body,¹¹¹ a statement we meet again word for word in medieval alchemy, where the *filius philosophorum* “makes peace between enemies or the elements.”¹¹² This “Papa” is also called νέκυσ (cadaver), because he is buried in the body like a mummy in a tomb. A similar idea is found in Paracelsus; his treatise *De vita longa* opens with the words: “Life, verily, is naught but a kind of embalmed mummy, which preserves the mortal body from the mortal worms.”¹¹³ The body lives only from the “Mumia,” through which the “peregrinus microcosmus,” the wandering microcosm (corresponding to the macrocosm), rules the physical body.¹¹⁴ His synonyms are the Adech, Archeus, Protothoma, Ides, Idechtrum, etc. He is the

“Protoplast” (the first-created), and, as Ides, “the door whence all created things have come.”¹¹⁵ (Cf. the “true door” above!) The Mumia is born together with the body and sustains it,¹¹⁶ though not to the degree that the “supercelestial Mumia” does.¹¹⁷ The latter would correspond to the higher Adam of the Naassenes. Of the Ideus or Ides Paracelsus says that in it “there is but One Man ... and he is the Protoplast.”¹¹⁸

[335] The Paracelsian Mumia therefore corresponds in every way to the Original Man, who forms the microcosm in the mortal man and, as such, shares all the powers of the macrocosm. Since it is often a question of cabalistic influences in Paracelsus, it may not be superfluous in this connection to recall the figure of the cabalistic *Metatron*. In the *Zohar* the Messiah is described as the “central column” (i.e., of the Sephiroth system), and of this column it is said: “The column of the centre is Metatron, whose name is like that of the Lord. It is created and constituted to be his image and likeness, and it includes all gradations from Above to Below and from Below to Above, and binds [them] together in the centre.”¹¹⁹

[336] The dead man, Hippolytus continues, will rise again by passing through the “door of heaven.” Jacob saw the gate of heaven on his way to Mesopotamia, “but they say Mesopotamia is the stream of the great ocean that flows from the midst of the perfect man.” This is the gate of heaven of which Jacob said: “How terrible is this place! This is no other but the house of God, and the gate of heaven.”¹²⁰ The stream that flows out of the Original Man (the gate of heaven) is interpreted here as the flood-tide of Oceanus, which, as we have seen, generates the gods. The passage quoted by Hippolytus probably refers to John 7 : 38 or to an apocryphal source common to both. The passage in John—“He who believes in me, as the scripture has said, Out of his belly shall flow rivers of living water”—refers to a nonbiblical source, which, however, seemed scriptural to the author. Whoever drinks of this water, in him it shall be a fountain of water springing up into eternal life, says Origen.¹²¹ This water is the “higher” water, the *aqua doctrinae*, the rivers from the belly of Christ, and the divine life as contrasted with the “lower” water, the *aqua abyssi*, where the darkneses are, and where dwell the Prince of this world and the deceiving dragon and his angels.¹²² The river of water is the “Saviour” himself.¹²³ Christ is the river that pours into the world through the four gospels,¹²⁴ like the rivers of Paradise. I have purposely cited the ecclesiastical allegories in greater detail here, so that the reader can see how saturated Gnostic symbolism is in the language of the Church, and how, on the other hand, particularly in Origen, the liveliness of his amplifications and interpretations has much in common with Gnostic views. Thus, to him as to many of his contemporaries and successors, the idea of the cosmic correspondence of the “spiritual inner man” was something quite familiar: in his first Homily on Genesis he says that God first created heaven, the whole spiritual

substance, and that the counterpart of this is “our mind, which is itself a spirit, that is, it is our spiritual inner man which sees and knows God.”¹²⁵

[337] These examples of Christian parallels to the partly pagan views of the Gnostics may suffice to give the reader a picture of the mentality of the first two centuries of our era, and to show how closely the religious teachings of that age were connected with psychic facts.

[338] Now let us come back to the symbols listed by Hippolytus. The Original Man in his *latent state*—so we could interpret the term ἀχαρακτηριστός—is named *Aipolos*, “not because he feeds he-goats and she-goats,” but because he is ἀειπόλος, the Pole that turns the cosmos round.¹²⁶ This recalls the parallel ideas of the alchemists, previously mentioned, about Mercurius, who is found at the North Pole. Similarly the Naassenes named *Aipolos*—in the language of the *Odyssey*—*Proteus*. Hippolytus quotes Homer as follows: “This place is frequented by the Old Man of the Sea, immortal Proteus the Egyptian ... who always tells the truth ... ”¹²⁷ Homer then continues: “ ... who owes allegiance to Poseidon and knows the sea in all its depths.”¹²⁸ Proteus is evidently a personification of the unconscious:¹²⁹ it is difficult to “catch this mysterious old being ... he might see me first, or know I am there and keep away.” One must seize him quickly and hold him fast, in order to force him to speak. Though he lives in the sea, he comes to the lonely shore at the sacred noon-tide hour, like an amphibian, and lies down to sleep among his seals. These, it must be remembered, are warm-blooded—that is to say, they can be thought of as contents of the unconscious that are capable of becoming conscious, and at certain times they appear spontaneously in the light and airy world of consciousness. From Proteus the wandering hero learns how he may make his way homewards “over the fish-giving sea,” and thus the Old Man proves to be a psychopomp.¹³⁰ Οὐ πιπρασκέται, Hippolytus says of him, which can best be translated by the French colloquialism “il ne se laisse pas rouler.” “But,” the text goes on, “he spins round himself and changes his shape.” He behaves, therefore, like a revolving image that cannot be grasped. What he says is νημερτής, ‘in sooth,’ infallible; he is a “soothsayer.” So it is not for nothing that the Naassenes say that “knowledge of the complete man is deep indeed and hard to comprehend.”

[339] Subsequently, Proteus is likened to the green ear of corn in the Eleusinian mysteries. To him is addressed the cry of the celebrants: “The Mistress has borne the divine boy, Brimo has borne Brimos!” A “lower” correspondence to the high Eleusinian initiations, says Hippolytus, is the dark path of Persephone, who was abducted by the god of the underworld; it leads “to the grove of adored Aphrodite, who rouses the sickness of love.” Men should keep to this lower path in order to be initiated “into the great and heavenly” mysteries.¹³¹ For this mystery is “the gate of

heaven” and the “house of God,” where alone the good God dwells, who is destined only for the spiritual men. They should put off their garments and all become νυμφίοι, ‘bridegrooms,’ “robbed of their virility by the virgin spirit.”¹³² This is an allusion to Revelation 14 : 4: “ ... for they are virgins. These ... follow the Lamb whithersoever he goeth.”¹³³

[340] Among the objective symbols of the self I have already mentioned the Naassene conception of the ἄμεριστος στιγμή, the indivisible point. This conception fully accords with that of the “Monad” and “Son of Man” in Monoïmos. Hippolytus says:

Monoïmos ... thinks that there is some such Man as Oceanus, of whom the poet speaks somewhat as follows: Oceanus, the origin of gods and of men.¹³⁴ Putting this into other words, he says that the Man is All, the source of the universe, unbegotten, incorruptible, everlasting; and that there is a Son of the aforesaid Man, who is begotten and capable of suffering, and whose birth is outside time, neither willed nor predetermined ... This Man is a single Monad, uncompounded [and] indivisible, [yet] compounded [and] divisible; loving and at peace with all things [yet] warring with all things and at war with itself in all things; unlike and like [itself], as it were a musical harmony containing all things ... showing forth all things and giving birth to all things. It is its own mother, its own father, the two immortal names. The emblem of the perfect Man, says Monoïmos, is the jot or tittle.¹³⁵ This one tittle is the uncompounded, simple, unmixed Monad, having its composition from nothing whatsoever, yet composed of many forms, of many parts. That single, indivisible jot is the many-faced, thousand-eyed and thousand-named, the jot of the iota. This is the emblem of that perfect and indivisible Man. ... The Son of the Man is the one iota, the one jot flowing from on high, full and filling all things, containing in himself everything that is in the Man, the Father of the Son of Man.¹³⁶

[341] This paradoxical idea of the Monad in Monoïmos describes the psychological nature of the self as conceived by a thinker of the second century under the influence of the Christian message.

[342] A parallel conception is to be found in Plotinus, who lived a little later (c. 205–70). He says in the *Enneads*: “Self-knowledge reveals the fact that the soul’s natural movement is not in a straight line, unless indeed it have undergone some deviation. On the contrary, it circles around something interior, around a centre. Now the centre is that from which proceeds the circle, that is, the soul. The soul will therefore move around the centre, that is, around the principle from which she proceeds; and, trending towards it, she will attach herself to it, as indeed all souls should do. The souls of the divinities ever direct themselves towards it, and that is the secret of their divinity; for divinity consists in being attached to the centre. ... Anyone who withdraws from it is a man who has remained un-unified, or who is a brute.”¹³⁷

- [343] Here the point is the centre of a circle that is created, so to speak, by the circumambulation of the soul. But this point is the “centre of all things,” a God-image. This is an idea that still underlies the mandala-symbols in modern dreams.¹³⁸
- [344] Of equal significance is the idea, also common among the Gnostics, of the σπινθήρ or spark.¹³⁹ It corresponds to the *scintilla vitae*, the “little spark of the soul” in Meister Eckhart,¹⁴⁰ which we meet with rather early in the teachings of Saturninus.¹⁴¹ Similarly Heraclitus, “the physicist,” is said to have conceived the soul as a “spark of stellar essence.”¹⁴² Hippolytus says that in the doctrine of the Sethians the darkness held “the brightness and the spark of light in thrall,”¹⁴³ and that this “very small spark” was finely mingled in the dark waters¹⁴⁴ below.¹⁴⁵ Simon Magus¹⁴⁶ likewise teaches that in semen and milk there is a very small spark which “increases and becomes a power boundless and immutable.”¹⁴⁷
- [345] The symbol of the point is found also in alchemy, where it stands for the arcane substance; in Michael Maier¹⁴⁸ it signifies “the purity or homogeneity of the essence.” It is the “punctum solis”¹⁴⁹ in the egg-yolk, which grows into a chick. In Khunrath it represents Sapientia in the form of the “salt-point”,¹⁵⁰ in Maier it symbolizes gold.¹⁵¹ To the scholiast of the “Tractatus aureus” it is the midpoint, the “circulus exiguus” and “mediator” which reconciles the hostile elements and “by persistent rotation changes the angular form of the square into a circular one like itself.”¹⁵² For Dorn the “punctum vix intelligibile” is the starting point of creation.¹⁵³ Similarly John Dee says that all things originated from the point and the monad.¹⁵⁴ Indeed, God himself is simultaneously both the centre and the circumference. In Mylius the point is called the bird of Hermes.¹⁵⁵ In the “Novum lumen” it is spirit and fire, the life of the arcane substance, similar to the spark.¹⁵⁶ This conception of the point is more or less the same as that of the Gnostics.
- [346] From these citations we can see how Christ was assimilated to symbols that also meant the kingdom of God, for instance the grain of mustard-seed, the hidden treasure, and the pearl of great price. He and his kingdom have the same meaning. Objections have always been made to this dissolution of Christ’s personality, but what has not been realized is that it represents at the same time an assimilation and integration of Christ into the human psyche.¹⁵⁷ The result is seen in the growth of the human personality and in the development of consciousness. These specific attainments are now gravely threatened in our antichristian age, not only by the sociopolitical delusional systems, but above all by the rationalistic hybris which is tearing our consciousness from its transcendent roots and holding before it immanent goals.

XIV

THE STRUCTURE AND DYNAMICS OF THE SELF

[347] The examples given in the previous chapter should be sufficient to describe the progressive assimilation and amplification of the archetype that underlies ego-consciousness. Rather than add to their number unnecessarily, I will try to summarize them so that an over-all picture results. From various hints dropped by Hippolytus, it is clear beyond a doubt that many of the Gnostics were nothing other than psychologists. Thus he reports them as saying that “the soul is very hard to find and to comprehend,”¹ and that knowledge of the whole man is just as difficult. “For knowledge of man is the beginning of wholeness (*τελείωσις*), but knowledge of God is perfect wholeness (*ἀπηρτισμένη τελείωσις*).” Clement of Alexandria says in the *Paedagogus* (III, 1): “Therefore, as it seems, it is the greatest of all disciplines to know oneself; for when a man knows himself, he knows God.” And Monoïmos, in his letter to Theophrastus, writes: “Seek him from out thyself, and learn who it is that taketh possession of everything in thee, saying: *my god, my spirit, my understanding, my soul, my body*; and learn whence is sorrow and joy, and love and hate, and waking though one would not, and sleeping though one would not, and getting angry though one would not, and falling in love though one would not. And if thou shouldst closely investigate these things, thou wilt find Him in thyself, the One and the Many, like to that little point [*κεραία*], for it is in thee that he hath his origin and his deliverance.”²

[348] One cannot help being reminded, in reading this text, of the Indian idea of the Self as brahman and atman, for instance in the Kena Upanishad: “By whom willed and directed does the mind fly forth? By whom commanded does the first breath move? Who sends forth the speech we utter here? What god is it that stirs the eye and ear? The hearing of the ear, the thinking of the mind, the speaking of the speech ... That which speech cannot express, by which speech is expressed ... which the mind cannot think, by which the mind thinks, know that as Brahman.”³

[349] Yajñyavalkya defines it in indirect form in the Brihadāranyaka Upanishad: “He who dwells in all beings, yet is apart from all beings, whom no beings know, whose body is all beings, who controls all beings from within, he is your Self, the inner controller, the immortal. ... There is no other seer but he, no other hearer but he, no other perceiver but he, no other knower but he. He is your Self, the inner controller, the immortal. All else is of sorrow.”⁴

[350] In Monoïmos, who was called “the Arab,” Indian influences are not impossible. His statement is significant because it shows that even in the second century⁵ the ego was considered the exponent of an all-embracing totality, the self—a thought that by no means all psychologists are familiar with even today. These insights, in the Near East as in India, are the product of intense introspective observation that can only be psychological. *Gnosis is undoubtedly a psychological knowledge whose contents derive from the unconscious.* It reached its insights by concentrating on the “subjective factor,”⁶ which consists empirically in the demonstrable influence that the collective unconscious exerts on the conscious mind. This would explain the astonishing parallelism between Gnostic symbolism and the findings of the psychology of the unconscious.

[351] I would like to illustrate this parallelism by summarizing the symbols previously discussed. For this purpose we must first of all review the facts that led psychologists to conjecture an archetype of wholeness, i.e., the self. These are in the first place dreams and visions; in the second place, products of active imagination in which symbols of wholeness appear. The most important of these are geometrical structures containing elements of the circle and quaternity;⁷ namely, circular and spherical forms on the one hand, which can be represented either purely geometrically or as objects; and, on the other hand, quadratic figures divided into four or in the form of a cross. They can also be four objects or persons related to one another in meaning or by the way they are arranged. Eight, as a multiple of four, has the same significance. A special variant of the quaternity motif is the dilemma of 3 + 1. Twelve (3×4) seems to belong here as a solution of the dilemma and as a symbol of wholeness (zodiac, year). Three can be regarded as a relative totality, since it usually represents either a spiritual totality that is a product of thought, like the Trinity,⁸ or else an instinctual, chthonic one, like the triadic nature of the gods of the underworld—the “lower triad.” Psychologically, however, three—if the context indicates that it refers to the self—should be understood as a defective quaternity or as a stepping-stone towards it.⁹ Empirically, a triad has a trinity opposed to it as its complement. The complement of the quaternity is unity.¹⁰

[352] From the circle and quaternity motif is derived the symbol of the geometrically formed crystal and the wonder-working stone. From here analogy formation leads on to the city,¹¹ castle, church,¹² house,¹³ and vessel.¹⁴ Another variant is the wheel (*rota*). The former motif emphasizes the ego’s containment in the greater dimension of the self; the latter emphasizes the rotation which also appears as a ritual circumambulation. Psychologically, it denotes concentration on and preoccupation with a centre, conceived as the centre of a circle and thus formulated as a point. This leads easily enough to a relationship to the heavenly Pole and the starry bowl of heaven rotating round it. A parallel is the horoscope as the “wheel of birth.”

[353] The image of the city, house, and vessel brings us to their content—the inhabitant of the city or house, and the water contained in the vessel. The inhabitant, in his turn, has a relationship to the quaternity, and to the fifth as the unity of the four. The water appears in modern dreams and visions as a blue expanse reflecting the sky, as a lake, as four rivers (e.g., Switzerland as the heart of Europe with the Rhine, Ticino, Rhone, and Inn, or the Garden of Eden with the Gihon, Pison, Hiddekel, and Euphrates), as healing water and consecrated water, etc. Sometimes the water is associated with fire, or even combined with it as fire-water (wine, alcohol).

[354] The inhabitant of the quadratic space leads to the human figure. Apart from the geometrical and arithmetical symbols, this is the commonest symbol of the self. It is either a god or a godlike human being, a prince, a priest, a great man, an historical personality, a dearly loved father, an admired example, the successful elder brother—in short, a figure that transcends the ego personality of the dreamer. There are corresponding feminine figures in a woman's psychology.

[355] Just as the circle is contrasted with the square, so the quaternity is contrasted with the 3 + 1 motif, and the positive, beautiful, good, admirable, and lovable human figure with a daemonic, misbegotten creature who is negative, ugly, evil, despicable and an object of fear. Like all archetypes, the self has a paradoxical, antinomial character. It is male and female, old man and child, powerful and helpless, large and small. The self is a true "complexio oppositorum,"¹⁵ though this does not mean that it is anything like as contradictory in itself. It is quite possible that the seeming paradox is nothing but a reflection of the enantiodromian changes of the conscious attitude which can have a favourable or an unfavourable effect on the whole. The same is true of the unconscious in general, for its frightening figures may be called forth by the fear which the conscious mind has of the unconscious. The importance of consciousness should not be underrated; hence it is advisable to relate the contradictory manifestations of the unconscious causally to the conscious attitude, at least in some degree. But consciousness should not be overrated either, for experience provides too many incontrovertible proofs of the autonomy of unconscious compensatory processes for us to seek the origin of these antinomies only in the conscious mind. Between the conscious and the unconscious there is a kind of "uncertainty relationship," because the observer is inseparable from the observed and always disturbs it by the act of observation. In other words, exact observation of the unconscious prejudices observation of the conscious and vice versa.

[356] Thus the self can appear in all shapes from the highest to the lowest, inasmuch as these transcend the scope of the ego personality in the manner of a daimonion. It goes without saying that the self also has its theriomorphic symbolism. The

commonest of these images in modern dreams are, in my experience, the elephant, horse, bull, bear, white and black birds, fishes, and snakes. Occasionally one comes across tortoises, snails, spiders, and beetles. The principal plant symbols are the flower and the tree. Of the inorganic products, the commonest are the mountain and lake.

[357] Where there is an undervaluation of sexuality the self is symbolized as a phallus. Undervaluation can consist in an ordinary repression or in overt devaluation. In certain differentiated persons a purely biological interpretation and evaluation of sexuality can also have this effect. Any such conception overlooks the spiritual and “mystical” implications of the sexual instinct.¹⁶ These have existed from time immemorial as psychic facts, but are devalued and repressed on rationalistic and philosophical grounds. In all such cases one can expect an unconscious phallicism by way of compensation. A good example of this is the mainly sexualistic approach to the psyche that is to be found in Freud.

2

[358] Coming now to the Gnostic symbols of the self, we find that the Naassenes of Hippolytus lay most emphasis on the human images; of the geometrical and arithmetical symbols the most important are the quaternity, the ogdoad, the trinity, and unity. Here we shall give our attention mainly to the totality symbol of the quaternity, and above all to the symbol mentioned in section 6 of the last chapter, which I would like to call, for short, the Moses Quaternio. We shall then consider the second Naassene Quaternio, the one with the four rivers of Paradise, which I shall call the Paradise Quaternio. Though differently constituted, the two quaternios express roughly the same idea, and in what follows I shall try not only to relate them to one another psychologically, but also to bring out their connection with later (alchemical) quaternary structures. In the course of these investigations, we shall see how far the two quaternios are characteristic of the Gnostic age, and how far they can be correlated with the archetypal history of the mind in the Christian aeon.

[359] The quaternity in the Moses Quaternio¹⁷ is evidently constructed according to the following schema:

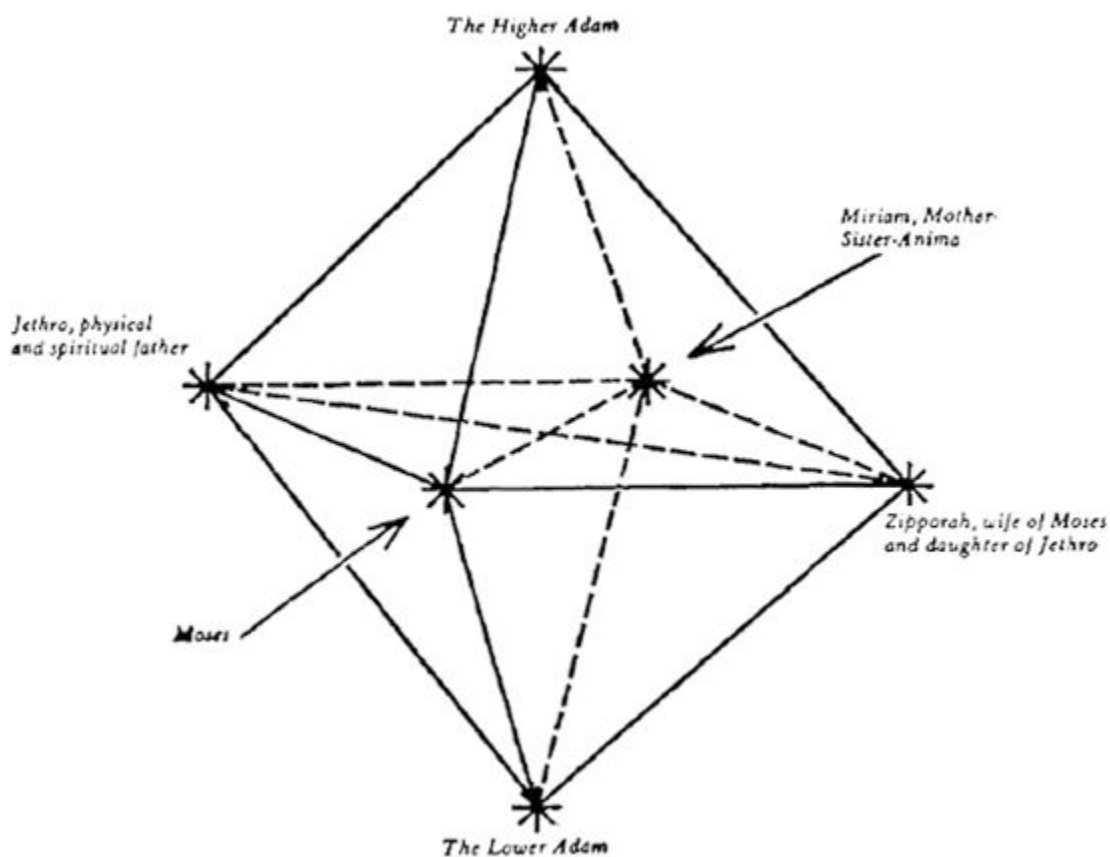

The Moses Quaternio

[360] The “lower Adam” corresponds to the ordinary mortal man, Moses to the culture-hero and lawgiver, and thus, on a personalistic level, to the “father”; Zipporah, as the daughter of a king and priest, to the “higher mother.” For the ordinary man, these two represent the “royal pair,”¹⁸ which for Moses corresponds on the one hand to his “higher man,” and on the other hand to his anima, Miriam. The “higher” man is synonymous with the “spiritual, inner” man, who is represented in the quaternio by Jethro. Such is the meaning of the quaternio when seen from the standpoint of Moses. But since Moses is related to Jethro as the lower Adam, or ordinary man, is to Moses, the quaternio cannot be understood merely as the structure of Moses’ personality, but must be looked at from the standpoint of the lower Adam as well. We then get the following quaternio:

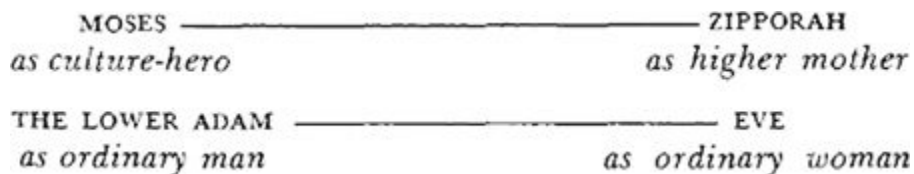

[361] From this we can see that the Naassene quaternio is in a sense unsymmetrical, since it leads to a senarius (hexad) with an exclusively upward tendency: Jethro and Miriam have to be added to the above four as a kind of third storey, as the higher counterparts of Moses and Zipporah. We thus get a gradual progression, or series of steps leading from the lower to the higher Adam. This psychology evidently underlies the elaborate lists of Valentinian syzygies. The lower Adam or somatic man consequently appears as the lowest stage of all, from which there can be only an

ascent. But, as we have seen, the four persons in the Naassene quaternio are chosen so skilfully that it leaves room not only for the incest motif [Jethro-Miriam], which is never lacking in the marriage quaternio, but also for the extension of the ordinary man's psychic structure downwards, towards the sub-human, the dark and evil side represented by the shadow. That is to say, Moses marries the "Ethiopian woman," and Miriam, the prophetess and mother-sister, becomes "leprous," which is clear proof that her relation to Moses has taken a negative turn. This is further confirmed by the fact that Miriam "spoke against" Moses and even stirred up his brother Aaron against him. Accordingly, we get the following senarius:

THE LOWER ADAM _____ EVE
 MOSES _____ ETHIOPIAN WOMAN JETHRO, *the heathen priest*
 _____ MIRIAM, *the "white" leper*

[362] Though nothing is said against Jethro, "the great wise one," in the Bible story, yet as a Midianite priest he did not serve Yahweh and did not belong to the chosen people, but departs from them to his own country.¹⁹ He seems also to have borne the name Reguel ("friend of God") and to have helped Moses with his superior wisdom. He is, accordingly, a numinous personality, the embodiment of an archetype, obviously that of the "wise old man" who personifies the spirit in myth and folklore. The spirit, as I have shown elsewhere,²⁰ has a dichotomous nature. Just as Moses in this case represents his own shadow by taking to wife the black daughter of the earth, so Jethro, in his capacity as heathen priest and stranger, has to be included in the quaternio as the "lower" aspect of himself, with a magical and nefarious significance (though this is not vouched for in the text).²¹

[363] As I have already explained, the Moses Quaternio is an individual variant of the common marriage quaternio found in folklore.²² It could therefore be designated just as well with other mythical names. The basic schema of the cross-cousin marriage:



has numerous variants; for instance the sister can be replaced by the mother or the wife's brother by a fatherlike figure. But the incest motif remains a characteristic feature. Since the schema is a primary one characterizing the psychology of love relationships and also of the transference, it will, like all characterological schemata, obviously manifest itself in a "favourable" and an "unfavourable" form, for the relationships in question also exhibit the same ambivalence: everything a man does has a positive and a negative aspect.

[364] The reader, therefore, should not let himself be put off by the somewhat scurrilous Gnostic nomenclature. The names are accidental, whereas the schema

itself is universally valid. The same is true of the “Shadow Quaternio,” for which I have kept the same names because the biography of Moses offers certain features that are well suited to illustrate the shadow.

[365] The lower senarius reaches its nadir not in the “lower Adam” but in his dark, theriomorphic prefiguration—the *serpent* who was created before man, or the Gnostic *Naas*. Accordingly we have the structures shown on the facing page.

[366] This schema is no idle parlour game, because the texts make it abundantly clear that the Gnostics were quite familiar with the dark aspect of their metaphysical figures, so much so that they caused the greatest offence on that account. (One has only to think of the identification of the good God with Priapus,²³ or of the Anthropos with the ithyphallic Hermes.) It was, moreover, the Gnostics—e.g., Basilides—who exhaustively discussed the problem of evil (*πόθεν τὸ κακόν*;—‘whence comes evil?’). The serpentine form of the Nous and the Agathodaimon does not mean that the serpent has only a good aspect. Just as the Apophis-serpent was the traditional enemy of the Egyptian sun-god, so the devil, “that ancient serpent,”²⁴ is the enemy of Christ, the “novus Sol.” The good, perfect, spiritual God was opposed by an imperfect, vain, ignorant, and incompetent demiurge. There were archontic Powers that gave to mankind a corrupt “chirographum” (handwriting) from which Christ had to redeem them.²⁵

[367] With the dawn of the second millennium the accent shifted more and more towards the dark side. The demiurge became the devil who had created the world, and, a little later, alchemy began to develop its conception of Mercurius as the partly material, partly immaterial spirit that penetrates and sustains all things, from stones and metals to the highest living organisms. In the form of a snake he dwells inside the earth, has a body, soul, and spirit, was believed to have a human shape as the homunculus or *homo altus*, and was regarded as the chthonic God.²⁶ From this we can see clearly that the serpent was either a forerunner of man or a distant copy of the Anthropos, and how justified is the equation $Naas = Nous = Logos = Christ = Higher Adam$. The medieval extension of this equation towards the dark side had, as I have said, already been prepared by Gnostic phallicism. This appears as early as the fifteenth century in the alchemical Codex Ashburnham 1166,²⁷ and in the sixteenth century Mercurius was identified with Hermes Kyllenios.²⁸

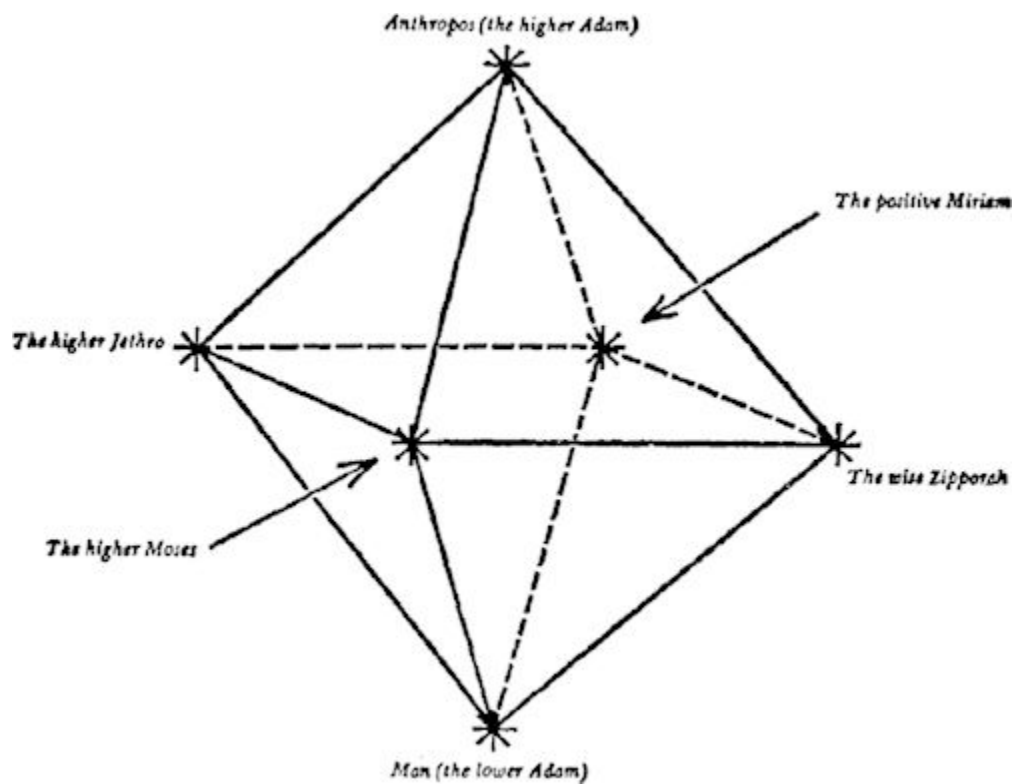

A. The Anthropos Quaternio

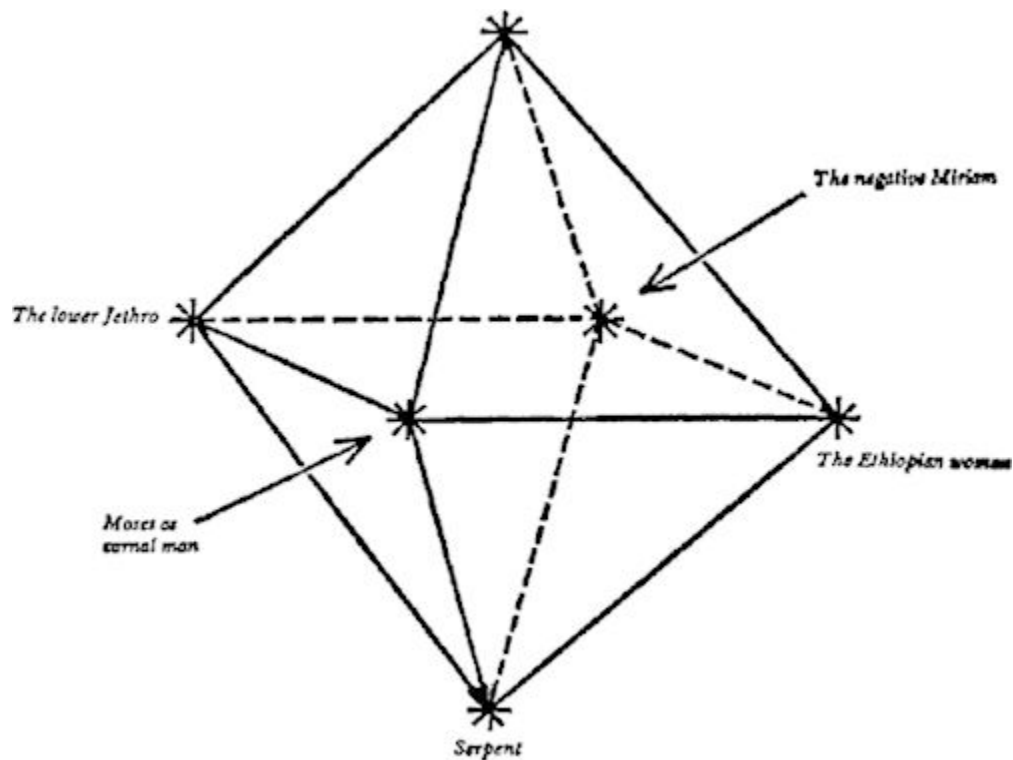

B. The Shadow Quaternio

[368] It is significant that Gnostic philosophy found its continuation in alchemy.²⁹ “Mater Alchimia” is one of the mothers of modern science, and modern science has given us an unparalleled knowledge of the “dark” side of matter. It has also penetrated into the secrets of physiology and evolution, and made the very roots of life itself an object of investigation. In this way the human mind has sunk deep into the sublunary world of matter, thus repeating the Gnostic myth of the Nous, who,

beholding his reflection in the depths below, plunged down and was swallowed in the embrace of Physis. The climax of this development was marked in the eighteenth century by the French Revolution, in the nineteenth century by scientific materialism, and in the twentieth century by political and social “realism,” which has turned the wheel of history back a full two thousand years and seen the recrudescence of the despotism, the lack of individual rights, the cruelty, indignity, and slavery of the pre-Christian world, whose “labour problem” was solved by the “ergastulum” (convict-camp). The “transvaluation of all values” is being enacted before our eyes.

[369] The development briefly outlined here seems to have been anticipated in medieval and Gnostic symbolism, just as the Antichrist was in the New Testament. How this occurred I will endeavour to describe in what follows. We have seen that, as the higher Adam corresponds to the lower, so the lower Adam corresponds to the serpent. For the mentality of the Middle Ages and of late antiquity, the first of the two double pyramids, the *Anthropos Quaternio*, represents the world of the spirit, or metaphysics, while the second, the *Shadow Quaternio*, represents sublunary nature and in particular man’s instinctual disposition, the “flesh”—to use a Gnostic-Christian term—which has its roots in the animal kingdom or, to be more precise, in the realm of warm-blooded animals. The nadir of this system is the cold-blooded vertebrate, the snake,³⁰ for with the snake the psychic rapport that can be established with practically all warm-blooded animals comes to an end. That the snake, contrary to expectation, should be a counterpart of the Anthropos is corroborated by the fact—of especial significance for the Middle Ages—that it is on the one hand a well-known allegory of Christ, and on the other hand appears to be equipped with the gift of wisdom and of supreme spirituality.³¹ As Hippolytus says, the Gnostics identified the serpent with the spinal cord and the medulla. These are synonymous with the reflex functions.

[370] The second of these quaternios is the negative of the first; it is its shadow. By “shadow” I mean the inferior personality, the lowest levels of which are indistinguishable from the instinctuality of an animal. This is a view that can be found at a very early date, in the idea of the *προσφύης ψυχή*, the ‘excremental soul’³² of Isidorus.³³ We also meet it in Origen, who speaks of the animals contained in man.³⁴ Since the shadow, in itself, is unconscious for most people, the snake would correspond to what is totally unconscious and incapable of becoming conscious, but which, as the collective unconscious and as instinct, seems to possess a peculiar wisdom of its own and a knowledge that is often felt to be supernatural. This is the treasure which the snake (or dragon) guards, and also the reason why the snake signifies evil and darkness on the one hand and wisdom on the other. Its unrelatedness, coldness, and dangerousness express the instinctuality that with ruthless cruelty rides roughshod over all moral and any other human wishes and

considerations and is therefore just as terrifying and fascinating in its effects as the sudden glance of a poisonous snake.

[371] In alchemy the snake is the symbol of *Mercurius non vulgi*, who was bracketed with the god of revelation, Hermes. Both have a pneumatic nature. The *serpens Mercurii* is a chthonic spirit who dwells in matter, more especially in the bit of original chaos hidden in creation, the *massa confusa* or *globosa*. The snake-symbol in alchemy points back to historically earlier images. Since the *opus* was understood by the alchemists as a recapitulation or imitation of the creation of the world, the serpent of Mercurius, that crafty and deceitful god, reminded them of the serpent in the Garden of Eden, and therefore of the devil, the tempter, who on their own admission played all sorts of tricks on them during their work. Mephistopheles, whose “aunt is the snake,” is Goethe’s version of the alchemical familiar, Mercurius. Like the dragon, Mercurius is the slippery, evasive, poisonous, dangerous forerunner of the hermaphrodite, and for that reason he has to be overcome.

[372] For the Naassenes Paradise was a quaternity parallel with the Moses quaternio and of similar meaning. Its fourfold nature consisted in the four rivers, Pison, Gihon, Hiddekel, and Phrat.³⁵ The serpent in Genesis is an illustration of the personified treenumen; hence it is traditionally represented in or coiled round the tree. It is the tree’s voice, which persuades Eve—in Luther’s version—that “it would be good to eat of the tree, and pleasant to behold that it is a lusty tree.” In the fairytale of “The Spirit in the Bottle,” Mercurius can likewise be interpreted as a treenumen.³⁶ In the Ripley “Scrowle” Mercurius appears as a snake in the shape of a Melusina descending from the top of the Philosophical Tree (“tree of knowledge”).³⁷ The tree stands for the development and phases of the transformation process,³⁸ and its fruits or flowers signify the consummation of the work.³⁹ In the fairytale Mercurius is hidden in the roots of a great oak-tree, i.e., in the earth. For it is in the interior of the earth that the Mercurial serpent dwells.

[373] For the alchemists Paradise was a favourite symbol of the *albedo*⁴⁰ the regained state of innocence, and the source of its rivers is a symbol of the *aqua permanens*.⁴¹ For the Church Fathers Christ is this source,⁴² and Paradise means the ground of the soul from which the fourfold river of the Logos bubbles forth.⁴³ We find the same symbol in the alchemist and mystic John Pordage: divine Wisdom is a “New Earth, the heavenly Land. ... For from this Earth grew all the Trees of Life. ... Thus did Paradise ... rise up from the Heart and Centre of this New Earth, and thus did the lost Garden of Eden flourish in greenness.”⁴⁴

[374] The snake symbol brings us to the images of Paradise, tree, and earth. This amounts to an evolutionary regression from the animal kingdom back to plants and

inorganic nature, epitomized in alchemy by the secret of matter, the *lapis*. Here the *lapis* is not to be understood as the end product of the *opus* but rather as its initial material. This arcane substance was also called *lapis* by the alchemists. The symbolism here described can be represented diagrammatically as another quaternio or double pyramid:

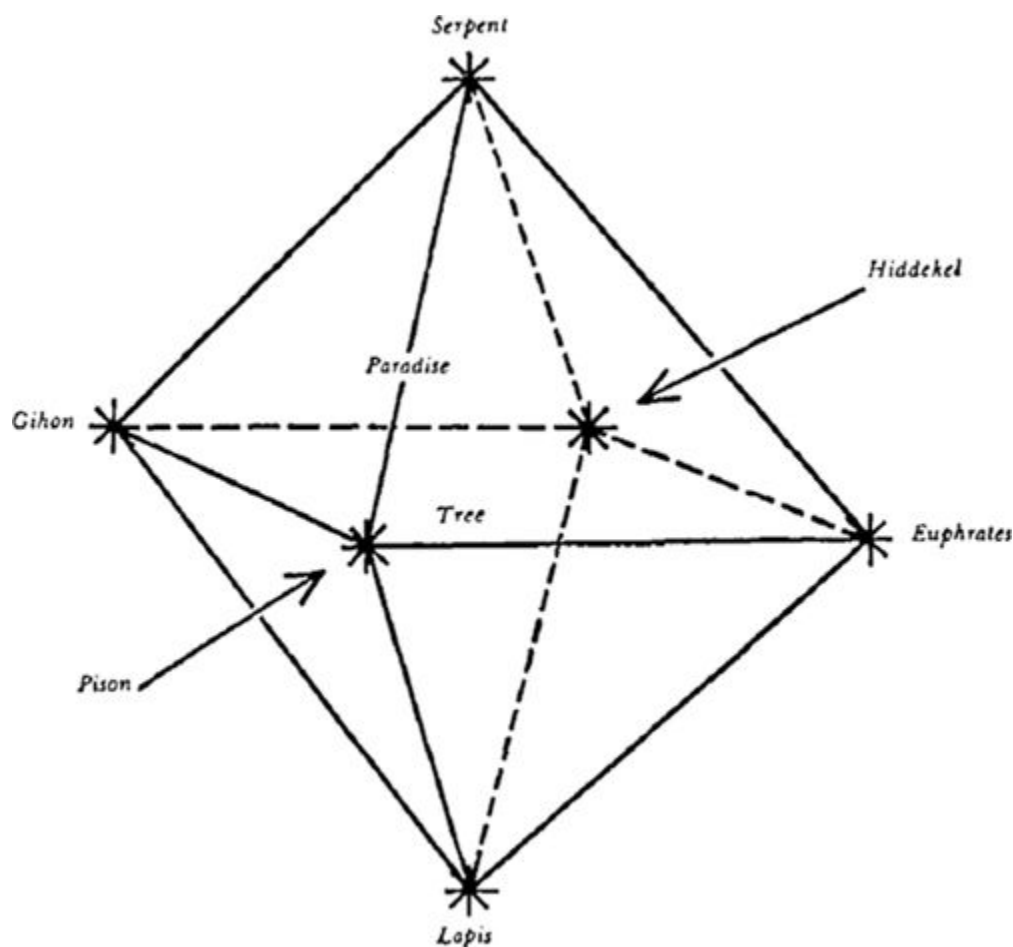

C. The Paradise Quaternio

[375] The *lapis* was thought of as a unity and therefore often stands for the *prima materia* in general. But just as the latter is a bit of the original chaos which was believed to be hidden somewhere in metals, particularly in mercury, or in other substances, and is not in itself a simple thing (as the name “*massa confusa*” shows), so too the *lapis* consists of the four elements or has to be put together from them.⁴⁵ In the chaos the elements are not united, they are merely coexistent and have to be combined through the alchemical procedure. They are even hostile to one another and will not unite of their own accord. They represent, therefore, an original state of conflict and mutual repulsion. This image serves to illustrate the splitting up or unfolding of the original unity into the multiplicity of the visible world. Out of the split-up quaternity the *opus* puts together the unity of the *lapis* in the realm of the inorganic. As the *filius macrocosmi* and a living being, the *lapis* is not just an allegory but is a direct parallel of Christ⁴⁶ and the higher Adam, of the heavenly Original Man, of the second Adam (Christ), and of the serpent. The nadir of this third quaternio is therefore a further counterpart of the Anthropos.

[376] As already mentioned, the constitution of the *lapis* rests on the union of the four elements,⁴⁷ which in their turn represent an unfolding of the unknowable inchoate state, or chaos. This is the *prima materia*, the arcanum, the primary substance, which in Paracelsus and his followers is called the *increated* and is regarded as coeternal with God—a correct interpretation of the Tehom in Genesis 1 : 2: “And the [uncreated] earth was without form and void, and darkness was upon the face of the deep; and the Spirit of God [brooded] over the face of the waters.” This primary substance is round (*massa globosa, rotundum, στοιχείον στρογγύλον*), like the world and the world-soul; it is in fact the world-soul and the world-substance in one. It is the “stone that has a spirit,”⁴⁸ in modern parlance the most elementary building-stone in the architecture of matter, the atom, which is an intellectual model. The alchemists describe the “round element” now as primal water, now as primal fire, or as pneuma, primal earth, or “*corpusculum nostrae sapientiae*,” the little body of our wisdom.⁴⁹ As water or fire it is the universal solvent; as stone and metal it is something that has to be dissolved and changed into air (pneuma, spirit).

[377] This *lapis* symbolism can once more be visualized diagrammatically as a double pyramid:

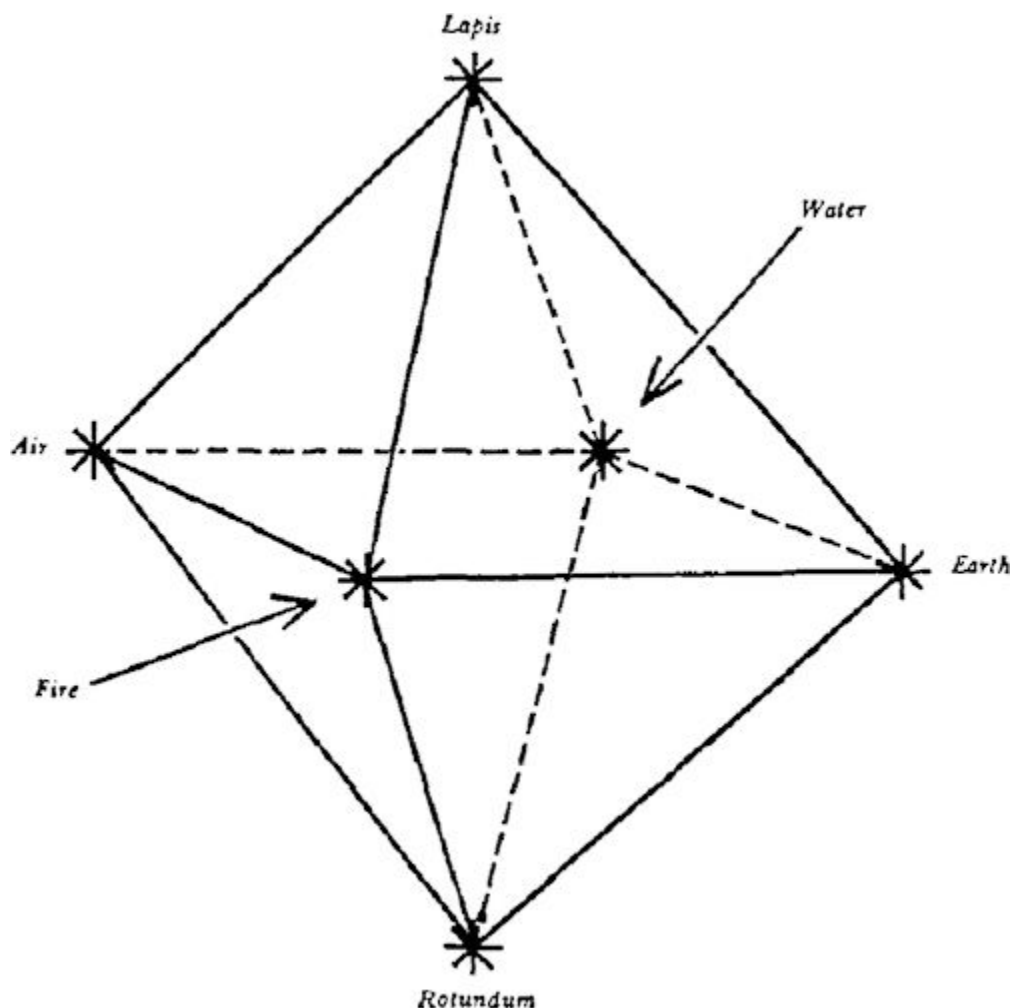

D. The Lapis Quaternio

Zosimos calls the *rotundum* the omega element (Ω), which probably signifies the head.⁵⁰ The skull is mentioned as the vessel of transformation in the Sabaeen treatise “Platonis liber quattorum,”⁵¹ and the “Philosophers” styled themselves “children of the golden head,”⁵² which is probably synonymous with “filii sapientiae.” The *vas* is often synonymous with the *lapis*, so that there is no difference between the vessel and its content; in other words, it is the same arcanum.⁵³ According to the old view the soul is round⁵⁴ and the vessel must be round too, like the heavens or the world.⁵⁵ The form of the Original Man is round. Accordingly Dorn says that the vessel “should be made from a kind of squaring of the circle, so that the spirit and the soul of our material, separated from its body, may raise the body with them to the height of their own heaven.”⁵⁶ The anonymous author of the scholia to the “Tractatus aureus” also writes about the squaring of the circle and shows a square whose corners are formed by the four elements. In the centre there is a small circle. The author says: “Reduce your stone to the four elements, rectify and combine them into one, and you will have the whole magistry. This One, to which the elements must be reduced, is that little circle in the centre of this squared figure. It is the mediator, making peace between the enemies or elements.”⁵⁷ In a later chapter he depicts the vessel, “the true philosophical Pelican,”⁵⁸ as shown on the next page.⁵⁹

[378] He comments: “A is the inside, as it were the origin and source from which the other letters flow, and likewise the final goal to which all the others flow back, as rivers flow into the ocean or into the great sea.” This explanation is enough to show that the vessel is nothing else but a mandala, symbolizing the self or the higher Adam with his four emanations (like Horus with his four sons). The author calls it the “Septenarius magicus occultus” (the hidden magic number, seven).⁶⁰ Likewise Maria the Prophetess says: “The Philosophers teach everything except the Hermetic vessel, because that is divine and is hidden from the Gentiles by the Lord’s wisdom; and they who know it not, know not the true method, because of their ignorance of the vessel of Hermes.” Theobald de Hoghelande adds: “Senior says that the vision thereof is more to be sought after than [knowledge of] the Scriptures.” Maria the Prophetess says: “This is the vessel of Hermes, which the Stoics hid, and it is no nigromantic vessel, but is the measure of thy fire [*mensura ignis tui*].”⁶¹

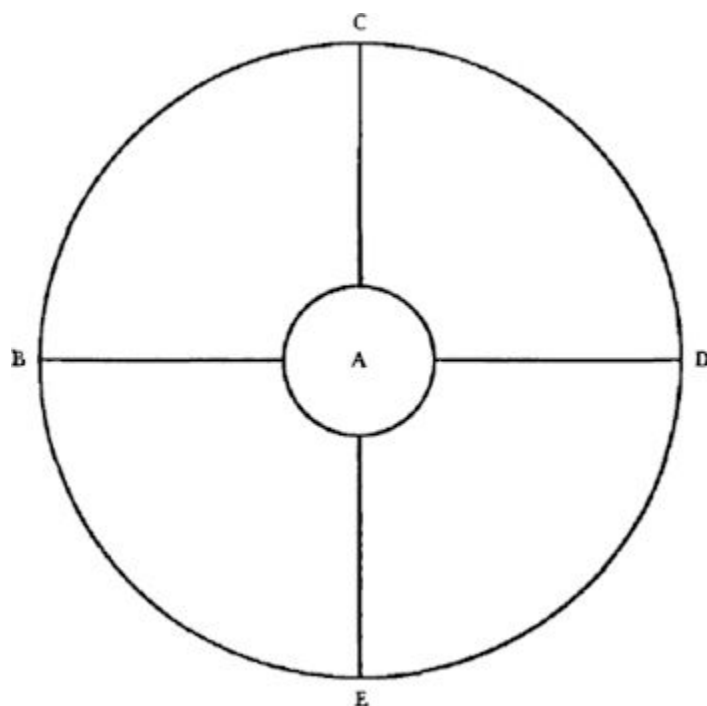

[379] It is clear from these quotations that the vessel had a great and unusual significance.⁶² Philalethes, summing up the innumerable synonyms for Mercurius, says that Mercurius is not only the key to the alchemical art, and “that two-edged sword in the hand of the cherub who guards the way to the tree of life,” but also “our true, hidden vessel, the Philosophic garden, wherein our Sun rises and sets.”⁶³ This helps us to understand, more or less, the strange advice given by Johannes de Rupescissa: “Have a vessel made after the manner of a cherub, which is the figure of God, and have six wings, after the fashion of six arms, turning back on themselves; and above, a round head ... and put within this vessel the said burning water,” etc.⁶⁴ The definition of the cherub as “the figure of God” suggests that Rupescissa is referring here to the vision of Ezekiel, which was arranged in such a way that a horizontal section through it would produce a mandala divided into four parts. This, as I have already mentioned, is equivalent to the squaring of the circle, from which, according to one alchemical recipe, the vessel should be constructed. The mandala signifies the human or divine self, the totality or vision of God, as in this case is quite clear. Naturally a recipe of this sort can only be understood “philosophically,” that is psychologically. It then reads: make the Hermetic vessel out of your psychic wholeness and pour into it the *aqua permanens*, or *aqua doctrinae*, one of whose synonyms is the *vinum ardens* (cf. Rupescissa’s “burning water”). This would be a hint that the adept should “inwardly digest” and transform himself through the alchemical doctrine.

[380] In this connection we can also understand what the *Aurora consurgens* (Part II) means when it speaks of the *vas naturale* as the *matrix*: it is the “One in which there are three things, namely water, air, and fire. They are three glass alembics, in which the son of the Philosophers is begotten. Therefore they have named it tincture, blood,

and egg.”⁶⁵ The three alembics are an allusion to the Trinity. That this is in fact so can be seen from the illustration on [page 249](#) of the 1588 edition of *Pandora*, where, beside the three alembics immersed in a great cooking-pot, there stands the figure of Christ, with blood pouring from the lance wound in his breast (“flumina de ventre Christi”!).⁶⁶ The round Hermetic vessel in which the mysterious transformation is accomplished is God himself, the (Platonic) world-soul and man’s own wholeness. It is, therefore, another counterpart of the Anthropos, and at the same time the universe in its smallest and most material form. So it is easy to see why the first attempts to construct a model of the atom took the planetary system as a prototype.

5

[381] The quaternity is an organizing schema par excellence, something like the crossed threads in a telescope. It is a system of co-ordinates that is used almost instinctively for dividing up and arranging a chaotic multiplicity, as when we divide up the visible surface of the earth, the course of the year, or a collection of individuals into groups,⁶⁷ the phases of the moon, the temperaments, elements, alchemical colours, and so on. Thus, when we come upon a quaternio among the Gnostics, we find in it an attempt, more or less conscious, to organize the chaotic medley of numinous images that poured in upon them. As we have seen, the arrangement took a form that derives from the primitive cross-cousin marriage, namely the marriage quaternio.⁶⁸ This differs from the primitive form in that the sister-exchange marriage has sloughed off its biological character, the sister’s husband no longer being the wife’s brother but another close relative (such as the wife’s father in the Moses Quaternio), or even a stranger. The loss of the cousin- and brother-attribute is compensated as a rule by magical qualities, such as more exalted rank, magical powers, and the like, both in the case of the husband’s sister and the wife’s brother. That is to say, an anima-animus projection takes place. This modification brings with it a great cultural advance, for the very fact of projection points to a constellation of the unconscious in the husband-wife relationship, which means that the marriage has become *psychologically* complicated. It is no longer a state of mere biological and social coexistence, but is beginning to turn into a conscious relationship. This happens when the original cross-cousin marriage becomes obsolete as a result of the further differentiation of marriage classes into a six-, eight-, or twelve-class system. The cause of the activation of the unconscious that goes hand in hand with this development is the regression of the endogamous tendency—the “kinship libido”—which can no longer find adequate satisfaction owing to the increasing strangeness of the marriage partner.⁶⁹

[382] Besides the marriage quaternio, the Gnostics also used the quaternity of the rivers of Paradise as a means of organizing their numerous symbols. There are thus

two (compensatory) attempts, in the symbols we have listed, to organize the apparently disconnected images. This accords with our experience of the series of pictures produced during active imagination and in chaotic psychic states. In both cases quaternity symbols appear from time to time.⁷⁰ They signify stabilization through order as opposed to the instability caused by chaos, and have a compensatory meaning.

[383] The four quaternios depicted above are first and foremost an attempt to arrange systematically the almost limitless wealth of symbols in Gnosticism and its continuation, alchemy. But such an arrangement of principles also proves useful for understanding the individual symbolism of modern dreams. The images we encounter in this field are even more varied, and so confusing in their complexity that some kind of organizing schema is absolutely essential. As it is advisable to proceed historically, I have taken the Moses Quaternio as a starting point, because it derives directly from the primitive schema of the cross-cousin marriage. Naturally this quaternio has only a paradigmatic significance. One could base the system just as easily on any other marriage quaternio, but not on any other quaternity, such as, for instance, Horus and his four sons. This quaternity is not aboriginal enough, for it misses out the antagonistic, feminine element.⁷¹ It is most important that just the extreme opposites, masculine-feminine and so on, should appear linked together. That is why the alchemical pairs of opposites are linked together in quaternities, e.g., warm-cold, dry-moist. Applied to the Moses Quaternio, the following schema of relationships would result:

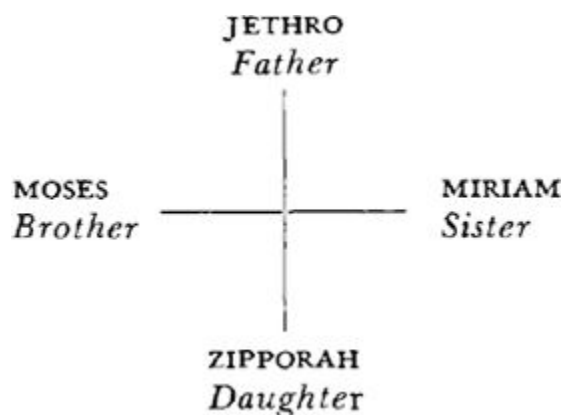

[384] Whereas the first double pyramid, the Anthropos Quaternio, corresponds to the Gnostic model, the second one is a construction derived psychologically from the first, but based on the data contained in the Biblical text used by the Gnostics. The psychological reasons for constructing a second quaternio have already been discussed. That the second must be the “shadow” of the first is due to the fact that the lower Adam, the mortal man, possesses a chthonic psyche and is therefore not adequately expressed by a quaternity supraordinate to him. If he were, he would be an unsymmetrical figure, just as the higher Adam is unsymmetrical and has to be

complemented by a subordinate quaternity related to him like his shadow or his darker reflection.

[385] Now just as the Anthropos Quaternio finds its symmetrical complement in the lower Adam, so the lower Adam is balanced by the subordinate Shadow Quaternio, constructed after the pattern of the upper one. The symmetrical complement of the lower Adam is the *serpent*. The choice of this symbol is justified firstly by the well-known association of Adam with the snake: it is his chthonic daemon, his familiar spirit. Secondly, the snake is the commonest symbol for the dark, chthonic world of instinct. It may—as frequently happens—be replaced by an equivalent cold-blooded animal, such as a dragon, crocodile, or fish. But the snake is not just a nefarious, chthonic being; it is also, as we have already mentioned, a symbol of wisdom, and hence of light, goodness, and healing.⁷² Even in the New Testament it is simultaneously an allegory of Christ and of the devil, just as we have seen that the fish was. Similarly the dragon, which for us has only a negative meaning, has a positive significance in China, and sometimes in Western alchemy too. The inner polarity of the snake-symbol far exceeds that of man. It is overt, whereas man's is partly latent or potential. The serpent surpasses Adam in cleverness and knowledge and can outwit him. She is older than he, and is evidently equipped by God with a superhuman intelligence, like that son of God who took over the role of Satan.⁷³

[386] Just as man culminates above in the idea of a “light” and good God, so he rests below on a dark and evil principle, traditionally described as the devil or as the serpent that personifies Adam's disobedience. And just as we symmetrized man by the serpent, so the serpent has its complement in the second Naassene quaternio, or Paradise Quaternio. Paradise takes us into the world of plants and animals. It is, in fact, a plantation or garden enlivened by animals, the epitome of all the growing things that sprout out of the earth. As *serpens mercurialis*, the snake is not only related to the god of revelation, Hermes, but, as a vegetation numen, calls forth the “blessed greenness,” all the budding and blossoming of plant life.⁷⁴ Indeed, this serpent actually dwells in the interior of the earth and is the pneuma that lies hidden in the *stone*.⁷⁵

[387] The symmetrical complement of the serpent, then, is the *stone* as representative of the earth. Here we enter a later developmental stage of the symbolism, the alchemical stage, whose central idea is the *lapis*. Just as the serpent forms the lower opposite of man, so the *lapis* complements the serpent. It corresponds, on the other hand, to man, for it is not only represented in human form but even has “body, soul, and spirit,” is an homunculus and, as the texts show, a symbol of the self. It is, however, not a human ego but a collective entity, a collective soul, like the Indian *hiranyagarbha*, ‘golden seed.’ The stone is the “father-mother” of the metals, an

hermaphrodite. Though it is an ultimate unity, it is not an elementary but a composite unity that has evolved. For the stone we could substitute all those “thousand names” which the alchemists devised for their central symbol, but nothing different or more fitting would have been said.

[388] This choice of symbol, too, is not arbitrary, but is documented by alchemical literature from the first to the eighteenth century. The *lapis* is produced, as we have already seen, from the splitting and putting together of the four elements, from the *rotundum*. The *rotundum* is a highly abstract, transcendent idea, which by reason of its roundness⁷⁶ and wholeness refers to the Original Man, the Anthropos.

[389] Accordingly our four double pyramids would arrange themselves in a *circle* and form the well-known *uroboros*. As the fifth stage, the *rotundum* would then be identical with the first; that is to say, the heavy darkness of the earth, *metal*, has a secret relationship to the Anthropos. That is obvious in alchemy, but occurs also in the history of religion, where the metals grow from Gayomart’s blood.⁷⁷ This curious relationship is explained by the identity of the lowest, most material thing with the highest and most spiritual, which we have already met in the interpretation of the serpent as a chthonic and at the same time the “most spiritual” animal. In Plato the *rotundum* is the world-soul and a “blessed God.”⁷⁸

[390] We shall now try to condense the argument of the previous chapter and represent it graphically. Vertically arranged, our schema looks like this:

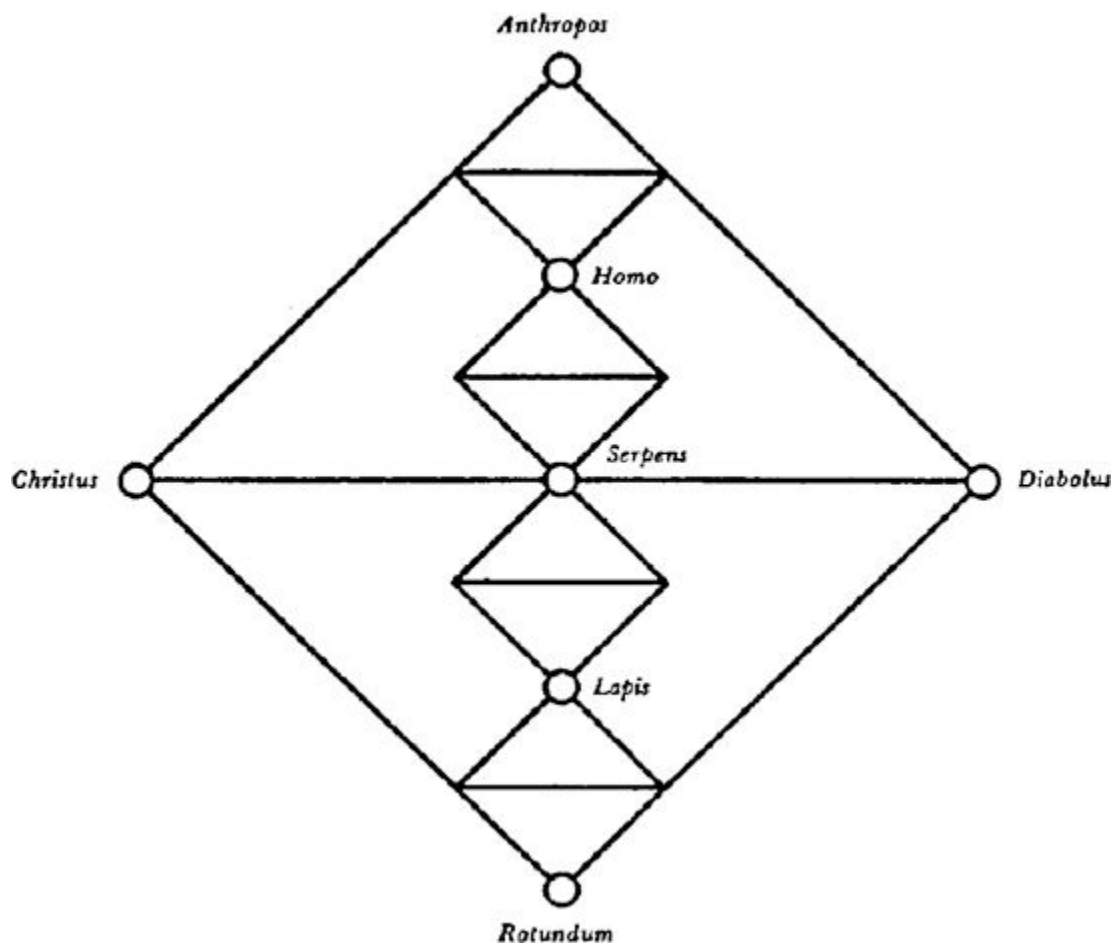

In the diagram I have emphasized the point of greatest tension between the opposites, namely the double significance of the serpent, which occupies the centre of the system. Being an allegory of Christ as well as of the devil, it contains and symbolizes the strongest polarity into which the *Anthropos* falls when he descends into *Physis*. The ordinary man has not reached this point of tension: he has it merely in the unconscious, i.e., in the serpent.⁷⁹ In the *lapis*, the counterpart of man, the opposites are so to speak united, but with a visible seam or suture as in the symbol of the hermaphrodite. This mars the idea of the *lapis* just as much as the all-too-human element mars *Homo sapiens*. In the higher *Adam* and in the *rotundum* the opposition is invisible. But presumably the one stands in absolute opposition to the other, and if both are identical as indistinguishable transcendental entities, this is one of those paradoxes that are the rule: a statement about something metaphysical can only be antinomial.

[391] The arrangement in the uroboros gives the following picture:

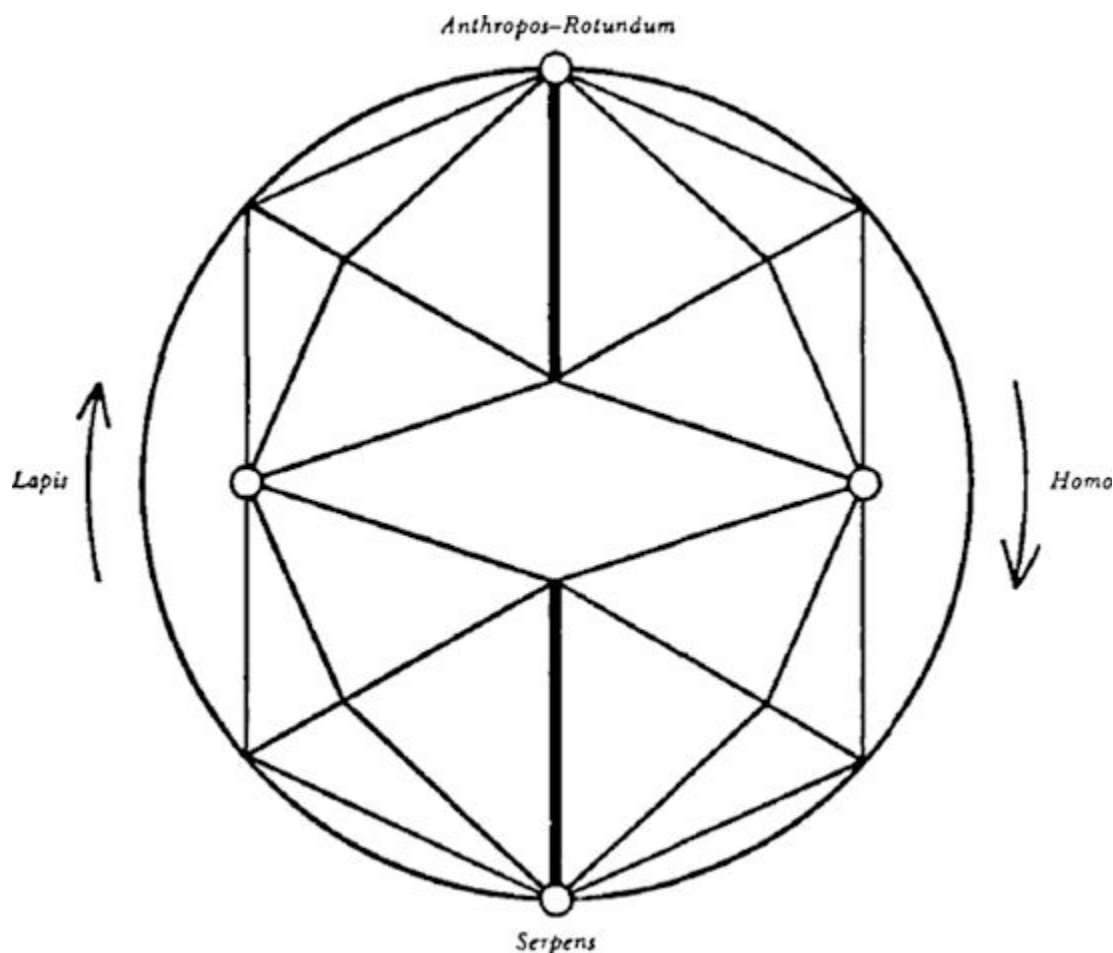

This arrangement shows the stronger tension between *anthropos-rotundum* and *serpens* on the one hand, and the lesser tension between *homo* and *lapis* on the other, expressed by the distance of the points in question from one another. The arrows indicate the descent into *Physis* and the ascent towards the spiritual. The lowest point is the serpent. The *lapis*, however, though of decidedly material nature, is also a spiritual symbol, while the *rotundum* connotes a transcendent entity symbolized by

the secret of matter and thus comparable to the concept of the atom. The antinomial development of the concepts is in keeping with the paradoxical nature of alchemy.

[392] The *lapis* quaternity, which is a product of alchemical gnosis, brings us to the interesting physical speculations of alchemy. In the *Scrutinium chymicum* (1687) of Michael Maier (1568-1622), there is a picture⁸⁰ of the four elements as four different stages of fire (Plate I).

[393] As the picture shows, the four spheres are filled with fire. The author comments with the following verses:

Naturae qui imitaris opus, tibi quattuor orbes
Quaerendi, interius quos levis ignis agat.
Imus Vulcanum referat, bene monstret at alter
Mercurium, Lunam tertius orbis habet:
Quartus, Apollo, tuus, naturae auditur et ignis,
Ducat in arte manus illa catena tuas.

From this we learn that the lowest sphere corresponds to Vulcan, the earthly (?) fire; the second to Mercurius, the vegetative life-spirit; the third to the moon, the female, psychic principle; and the fourth to the sun, the male, spiritual principle. It is evident from Maier's commentary that he is concerned on the one hand with the four *elements* and on the other with the four kinds of *fire* which are responsible for producing different states of aggregation. His *ignis elementalis re et nomine* would, according to its place in the sequence, correspond to Vulcan; the fire of Mercurius to air; the third fire to water and the moon; and the fourth, which would correspond to the sun, he calls "terreus" (earthly). According to Ripley, whom Maier quotes, the *ignis elementalis* is the fire "which lights wood"; it must therefore be the ordinary fire. The sun-fire, on the other hand, seems to be the fire in the earth, which today we would call "volcanic," and corresponds to the solid state of aggregation ("terreus"). We thus get the following series:

VIGENÈRE SERIES ⁸¹	RIPLEY SERIES	
<i>ignis mundi intelligibilis</i>	= <i>ignis naturalise</i> ⁸²	=
<i>ignis caelestis</i>	= <i>ignis innaturalis</i> ⁸³	=
<i>ignis elementaris</i>	= <i>ignis contra naturam</i> ⁸⁴	=
<i>ignis infernalis</i> ⁸¹	= <i>ignis elementalis</i>	=

<i>ignis terreus</i>	= <i>Sulfura et Mercurii</i>	= <i>Sun (Apollo)</i>	= <i>earth</i>
<i>ignis aqueus</i>	= <i>aquae</i>	= <i>Moon (Luna)</i>	= <i>water</i>
<i>ignis aereus</i>	= <i>dracones</i>	= <i>Mercurius</i>	= <i>air</i>
<i>ignis elementalis</i>	= <i>ignis elementalis re et nomine</i>	= <i>Ordinary fire (Vulca)</i>	= <i>fire</i>

STATES OF AGGREGATION

= *solid*= *liquid*= *gas*= *flame*

[394] The remarkable thing about this paralleling of states of aggregation with different kinds of fire is that it amounts to a kind of *phlogiston theory*—not, of course, explicit, but clearly hinted at: fire is peculiar to all the states of aggregation and is therefore responsible for their constitution. This idea is old⁸⁵ and can be found as early as the *Turba*, where Dardaris says: “The sulphurs are four souls [*animae*] which were hidden in the four elements.”⁸⁶ Here the active principle (*anima*) is not fire, but sulphur. The idea, however, is the same, namely that the elements or states of aggregation can be reduced to a common denominator. Today we know that the factor common to antagonistic elements is *molecular movement*, and that the states of aggregation correspond to different degrees of this movement. Molecular movement in its turn corresponds to a certain quantum of energy, so that the common denominator of the elements is energy. One of the stepping-stones to the modern concept of energy is Stahl’s phlogiston theory,⁸⁷ which is based on the alchemical premises discussed above. We can see in them, therefore, the earliest beginnings of a theory of energy.⁸⁸

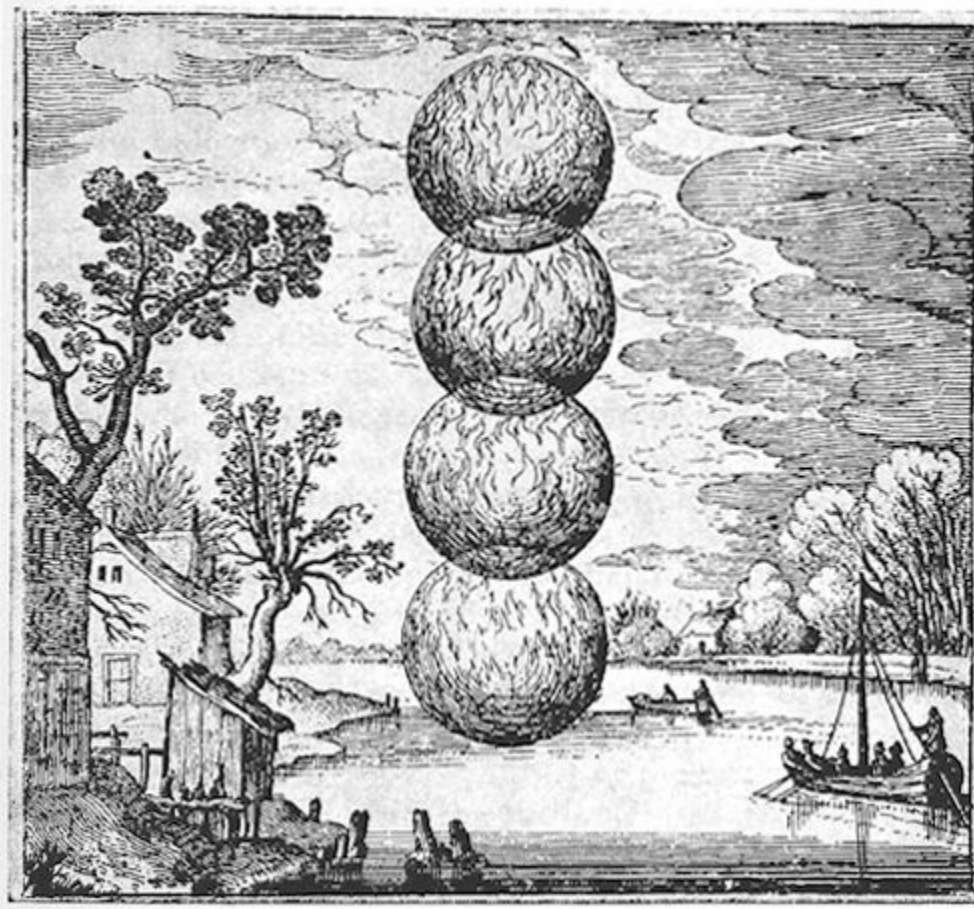

I. The Four Elements From Michael Maier, *Scrutinium chymicum* (1687)

[395] The phlogiston theory adumbrated by the alchemists did not get as far as that, but it points unmistakably in that direction. Moreover, all the mathematical and physical elements from which a theory of energy could have been constructed were known in the seventeenth century. Energy is an abstract concept which is indispensable for exact description of the behaviour of bodies in motion. In the same way bodies in motion can only be apprehended with the help of the system of space-time co-ordinates. Wherever movement is established, it is done by means of the space-time quaternio, which can be expressed either by the axiom of Maria, $3 + 1$, or by the sesquitertian proportion, $3 : 4$. This quaternio could therefore replace that of the four elements, where the unit that corresponds to the time-coordinate, or the fourth in the alchemical series of elements, is characterized by the fact that *one* element has an exceptional position, like fire or earth.⁸⁹

[396] The exceptional position of one of the factors in a quaternity can also be expressed by its *duplex nature*. For instance, the fourth of the rivers of Paradise, the Euphrates, signifies the mouth through which food goes in and prayers go out, as well as the Logos. In the Moses Quaternio, the wife of Moses plays the double role of Zipporah and of the Ethiopian woman. If we construct a quaternity from the divine equivalents of Maier's four elements—Apollo, Luna, Mercurius, Vulcan—we get a marriage quaternio with a brother-sister relationship:

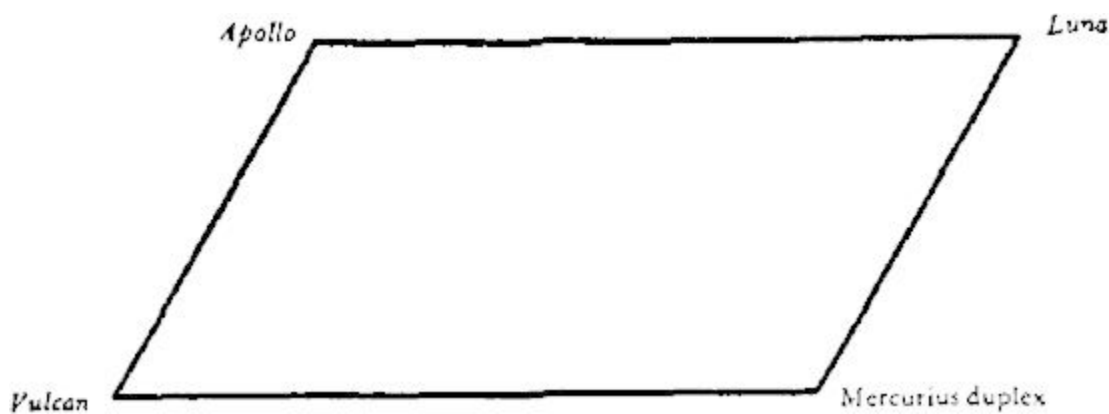

In alchemy Mercurius is male-female and frequently appears as a virgin too. This characteristic (3 + 1, or 3 : 4) is also apparent in the space-time quaternio:

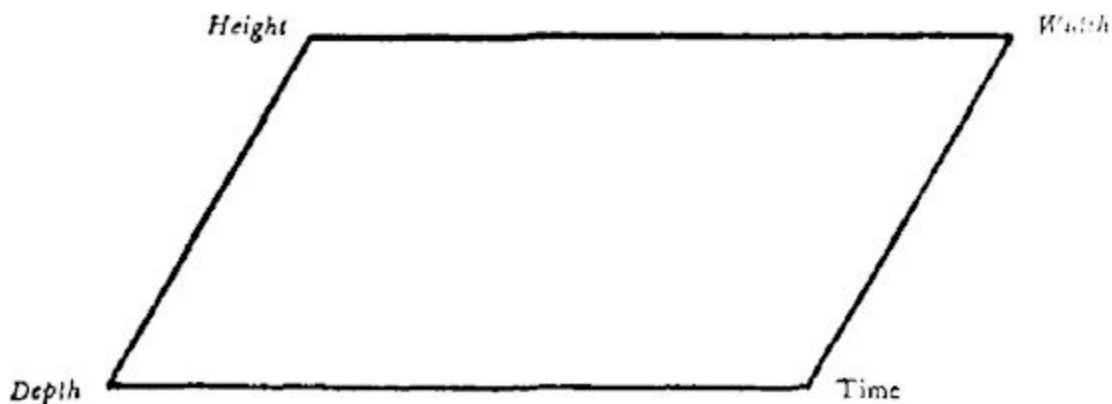

[397] If we look at this quaternio from the standpoint of the three-dimensionality of space, then time can be conceived as a fourth dimension. But if we look at it in terms of the three qualities of time—past, present, future—then static space, in which changes of state occur, must be added as a fourth term. In both cases, the fourth represents an incommensurable Other that is needed for their mutual determination. Thus we measure space by time and time by space. The Other, the fourth, corresponds in the Gnostic quaternities to the fiery god, “the fourth by number,” to the dual wife of Moses (Zipporah and the Ethiopian woman), to the dual Euphrates (river and Logos), to the fire⁹⁰ in the alchemical quaternio of elements, to Mercurius duplex in Maier’s quaternio of gods, and in the “Christian Quaternity”—if such an expression be permitted⁹¹—to Mary or the devil. These two incompatible figures are united in the Mercurius duplex of alchemy.⁹²

[398] The space-time quaternio is the archetypal *sine qua non* for any apprehension of the physical world—indeed, the very possibility of apprehending it. It is the organizing schema par excellence among the psychic quaternities. In its structure it corresponds to the psychological schema of the functions.⁹³ The 3 : 1 proportion frequently occurs in dreams and in spontaneous mandala-drawings.

[399] A modern parallel to the diagram of quaternities arranged on top of one another (cf. par. 390), coupled with the idea of ascent and descent, can be found among the illustrations to my paper on mandala pictures.⁹⁴ The same idea also appears in the

pictures relating to a case described there at some length, and dealing with vibrations that formed “nodes.”⁹⁵ Each of these nodes signified an outstanding personality, as was true also of the picture in the first case. A similar motif may well underlie the representation of the Trinity here appended (Plate II), from the manuscript of a treatise by Joachim of Flora.⁹⁶

[400] I would like, in conclusion, to mention the peculiar theory of world creation in the Clementine Homilies. In God, pneuma and soma are one. When they separate, pneuma appears as the Son and “archon of the future Aeon,” but soma, actual substance (*οὐοία*) or matter *ὑλη*, divides into four, corresponding to the four elements (which were always solemnly invoked at initiations). From the mixing of the four parts there arose the devil, the “archon of this Aeon,” and the *psyche* of this world. Soma had become psychized (*ἐμψύχον*): “God rules this world as much through the devil as through the Son, for both are in his hands.”⁹⁷ God unfolds himself in the world in the form of syzygies (paired opposites), such as heaven/earth, day/night, male/female, etc. The last term of the first series is the Adam/Eve syzygy. At the end of this fragmentation process there follows the return to the beginning, the consummation of the universe (*τελευτὴ τῶν πάντων*) through purification and annihilation.⁹⁸

[401] Anyone who knows alchemy can hardly avoid being struck by the likeness which pseudo-Clement’s theory bears to the basic conceptions of the alchemists, if we disregard its moral aspects. Thus we have the “hostile brothers,” Christ and the devil, who were regarded as brothers in the Jewish-Christian tradition; the tetrameria into four parts or elements; the paired opposites and their ultimate unity; the parallel of the *lapis* and Mercurius with Christ and, because of the snake or dragon symbolism, also with the devil; and finally, the figure of Mercurius duplex and of the *lapis*, which unites the opposites indivisibly in itself.

*

[402] If we look back over the course our argument has taken, we see at the beginning of it two Gnostic quaternities, one of which is supraordinate, and the other subordinate, to man, namely the “Positive Moses” or Anthropos Quaternio, and the Paradise Quaternio.⁹⁹ It is probably no accident that Hippolytus mentions precisely these two quaternities, or that the Naassenes knew only these, for the position of man is, in their system, closely connected with the higher Adam but is separated from the chthonic world of plants and animals, namely Paradise. Only through his shadow has he a relationship to the serpent with its dual meaning. This situation is altogether characteristic of the age of Gnosticism and early Christianity. Man in those days was close to the “kingless [i.e., independent] race,” that is, to the upper quaternity, the

kingdom of heaven, and looked upward. But what begins above does not rise higher, but ends below. Thus we felt impelled to symmetrize the lower Adam of the Naassenes by a Shadow Quaternio, for just as he cannot ascend direct to the higher Adam—since the Moses Quaternio lies in between—so we have to assume a lower, shadowy quaternity corresponding to the upper one, lying between him and the lower principle, the serpent. This operation was obviously unknown in the Gnostic age, because the unsymmetrical upward trend seemed to disturb nobody, but rather to be the very thing desired and “on the programme.” If, therefore, we insert between Man and Serpent a quaternity not mentioned in the texts, we do so because we can no longer conceive of a psyche that is oriented exclusively upwards and that is not balanced by an equally strong consciousness of the lower man. This is a specifically modern state of affairs and, in the context of Gnostic thinking, an obnoxious anachronism that puts man in the centre of the field of consciousness where he had never consciously stood before. Only through Christ could he actually see this consciousness mediating between God and the world, and by making the person of Christ the object of his devotions he gradually came to acquire Christ’s position as mediator. Through the Christ crucified between the two thieves man gradually attained knowledge of his shadow and its duality. This duality had already been anticipated by the double meaning of the serpent. Just as the serpent stands for the power that heals as well as corrupts, so one of the thieves is destined upwards, the other downwards, and so likewise the shadow is on one side regrettable and reprehensible weakness, on the other side healthy instinctivity and the prerequisite for higher consciousness.



II. The Trinity From a manuscript by Joachim of Flora

[403] Thus the Shadow Quaternio that counterbalances man's position as mediator only falls into place when that position has become sufficiently real for him to feel his consciousness of himself or his own existence more strongly than his dependence on and governance by God. Therefore, if we complement the upward-tending pneumatic attitude that characterizes the early Christian and Gnostic mentality by adding its opposite counterpart, this is in line with the historical development. Man's original dependence on a pneumatic sphere, to which he clung like a child to its mother, was threatened by the kingdom of Satan. From him the pneumatic man was delivered by the Redeemer, who broke the gates of hell and deceived the archons; but he was bound to the kingdom of heaven in exactly the same degree. He was separated from evil by an abyss. This attitude was powerfully reinforced by the immediate expectation of the Second Coming. But when Christ did not reappear, a regression was only to be expected. When such a great hope is dashed and such great expectations are not fulfilled, then the libido perforce flows back into man and heightens his consciousness of himself by accentuating his personal psychic processes; in other words, he gradually moves into the centre of his field of consciousness. This leads to separation from the pneumatic sphere and an approach

to the realm of the shadow. Accordingly, man's moral consciousness is sharpened, and, as a parallel to this, his feeling of redemption becomes relativized. The Church has to exalt the significance and power of her ritual in order to put limits to the inrush of reality. In this way she inevitably becomes a "kingdom of this world." The transition from the Anthropos to the Shadow Quaternio illustrates an historical development which led, in the eleventh century, to a widespread recognition of the evil principle as the world creator.

[404] The serpent and its chthonic wisdom form the turning-point of the great drama. The Paradise Quaternio with the *lapis*, that comes next, brings us to the beginnings of natural science (Roger Bacon, 1214–94; Albertus Magnus, 1193–1280; and the alchemists), whose main trend differs from the pneumatic not by 180° but only by 90°—that is to say, it cuts across the spiritual attitude of the Church and is more an embarrassment for faith than a contradiction of it.

[405] From the *lapis*, i.e., from alchemy, the line leads direct to the quaternio of alchemical states of aggregation, which, as we have seen, is ultimately based on the space-time quaternio. The latter comes into the category of archetypal quaternities and proves, like these, to be an indispensable principle for organizing the sense-impressions which the psyche receives from bodies in motion. Space and time form a psychological *a priori*, an aspect of the archetypal quaternity which is altogether indispensable for acquiring knowledge of physical processes.

[406] The development from the Shadow to the Lapis Quaternio illustrates the change in man's picture of the world during the course of the second millennium. The series ends with the concept of the *rotundum*, or of rotation as contrasted with the static quality of the quaternity, which, as we have said, proves to be of prime importance for apprehending reality. The rise of scientific materialism connected with this development appears on the one hand as a logical consequence, on the other hand as a deification of matter. This latter aspect is based, psychologically, on the fact that the *rotundum* coincides with the archetype of the Anthropos.

[407] With this insight the ring of the uroboros closes, that symbol of the *opus circulare* of Nature as well as of the "Art."

7

[408] Our quaternio series could also be expressed in the form of an equation, where *A* stands for the initial state (in this case the Anthropos) and for the end state, and *B C D* for intermediate states. The formations that split off from them are denoted in each case by the small letters *a b c d*. With regard to the construction of the formula, we must bear in mind that we are concerned with the continual process of transformation of one and the same substance. This substance, and its respective state of

transformation, will always bring forth its like; thus A will produce a and B b ; equally, b produces B and c C . It is also assumed that a is followed by b and that the formula runs from left to right. These assumptions are legitimate in a psychological formula.

[409] Naturally the formula cannot be arranged in linear fashion but only in a circle, which for that reason moves to the right. A produces its like, a . From a the process advances by contingency to b , which in turn produces B . The transformation turns rightwards with the sun; that is, it is a process of becoming conscious, as is already indicated by the splitting (discrimination) of A B C D each time into four qualitatively discrete units.¹⁰⁰ Our scientific understanding today is not based on a quaternity but on a trinity of principles (space, time, causality).¹⁰¹ Here, however, we are moving not in the sphere of modern scientific thinking, but in that of the classical and medieval view of the world, which up to the time of Leibniz recognized the principle of *correspondence* and applied it naïvely and unreflectingly. In order to give our judgment on A —expressed by abc —the character of wholeness, we must supplement our time-conditioned thinking by the principle of correspondence or, as I have called it, *synchronicity*.¹⁰² The reason for this is that our description of Nature is in certain respects incomplete and accordingly excludes observable facts from our understanding or else formulates them in an unjustifiably negative way, as for instance in the paradox of “an effect without a cause.”¹⁰³ Our Gnostic quaternity is a naïve product of the unconscious and therefore represents a psychic fact which can be brought into relationship with the four orienting functions of consciousness; for the rightward movement of the process is, as I have said, the expression of conscious discrimination¹⁰⁴ and hence an application of the four functions that constitute the essence of a conscious process.

[410] The whole cycle necessarily returns to its beginning, and does so at the moment when D , in point of contingency the state furthest removed from A , changes into a_3 by a kind of enantiodromia. We thus have:

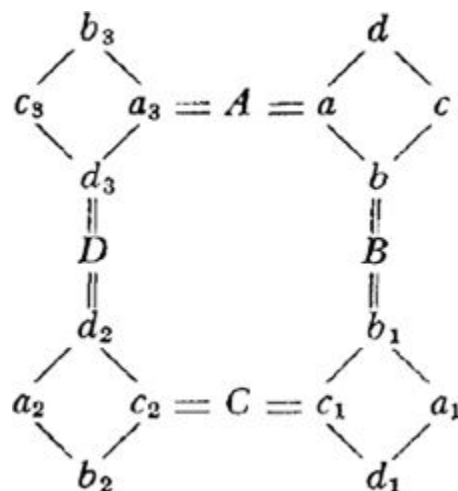

The formula reproduces exactly the essential features of the symbolic process of transformation. It shows the rotation of the mandala,¹⁰⁵ the antithetical play of complementary (or compensatory) processes, then the apocatastasis, i.e., the restoration of an original state of wholeness, which the alchemists expressed through the symbol of the uroboros, and finally the formula repeats the ancient alchemical

tetrameria,¹⁰⁶ which is implicit in the fourfold structure of unity: $A = a \begin{array}{c} d \\ \diagdown \quad \diagup \\ c \\ \diagup \quad \diagdown \\ b \end{array}$. What

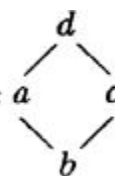

the formula can only hint at, however, is the higher plane that is reached through the process of transformation and integration. The “sublimation” or progress or qualitative change consists in an unfolding of totality into four parts four times, which means nothing less than its becoming conscious. When psychic contents are split up into four aspects, it means that they have been subjected to discrimination by the four orienting functions of consciousness. Only the production of these four aspects makes a total description possible. The process depicted by our formula changes the originally unconscious totality into a conscious one. The Anthropos *A* descends from above through his Shadow *B* into Physis *C* (= serpent), and, through a kind of crystallization process *D* (= lapis) that reduces chaos to order, rises again to the original state, which in the meantime has been transformed from an unconscious into a conscious one. Consciousness and understanding arise from discrimination, that is, through analysis (dissolution) followed by synthesis, as stated in symbolical terms by the alchemical dictum: “Solve et coagula” (dissolve and coagulate). The correspondence is represented by the identity of the letters *a*, *a*₁, *a*₂, *a*₃, and so on. That is to say, we are dealing all the time with the same factor, which in the formula merely changes its place, whereas psychologically its name and quality change too. At the same time it becomes clear that the change of place is always an enantiodromian change of situation, corresponding to the complementary or compensatory changes in the psyche as a whole. It was in this way that the changing of the hexagrams in the *I Ching* was understood by the classical Chinese commentators. Every archetypal arrangement has its own numinosity, as is apparent from the very names given to it. Thus *a* to *d* is the “kingless race,” *a*₁ to *d*₂ is the Shadow Quaternio, which is annoying, because it stands for the all-too-human human being (Nietzsche’s “Ugliest Man”),¹⁰⁷ *a*₂ to *d*₂ is “Paradise,” which speaks for itself, and finally *a*₃ to *d*₃ is the world of matter, whose numinosity in the shape of materialism threatens to suffocate our world. What changes these correspond to in the history of the human mind over the last two thousand years I need hardly specify in detail.

[411] The formula presents a symbol of the self, for the self is not just a static quantity or constant form, but is also a dynamic process. In the same way, the ancients saw the

imago Dei in man not as a mere imprint, as a sort of lifeless, stereotyped impression, but as an active force. The four transformations represent a process of restoration or rejuvenation taking place, as it were, inside the self, and comparable to the carbon-nitrogen cycle in the sun, when a carbon nucleus captures four protons (two of which immediately become neutrons) and releases them at the end of the cycle in the form of an alpha particle. The carbon nucleus itself comes out of the reaction unchanged, “like the Phoenix from the ashes.”¹⁰⁸ The secret of existence, i.e., the existence of the atom and its components, may well consist in a continually repeated process of rejuvenation, and one comes to similar conclusions in trying to account for the numinosity of the archetypes.

[412] I am fully aware of the extremely hypothetical nature of this comparison, but I deem it appropriate to entertain such reflections even at the risk of being deceived by appearances. Sooner or later nuclear physics and the psychology of the unconscious will draw closer together as both of them, independently of one another and from opposite directions, push forward into transcendental territory, the one with the concept of the atom, the other with that of the archetype.

[413] The analogy with physics is not a digression since the symbolical schema itself represents the descent into matter and requires the identity of the outside with the inside. Psyche cannot be totally different from matter, for how otherwise could it move matter? And matter cannot be alien to psyche, for how else could matter produce psyche? Psyche and matter exist in one and the same world, and each partakes of the other, otherwise any reciprocal action would be impossible. If research could only advance far enough, therefore, we should arrive at an ultimate agreement between physical and psychological concepts. Our present attempts may be bold, but I believe they are on the right lines. Mathematics, for instance, has more than once proved that its purely logical constructions which transcend all experience subsequently coincided with the behaviour of things. This, like the events I call synchronistic, points to a profound harmony between all forms of existence.

[414] Since analogy formation is a law which to a large extent governs the life of the psyche, we may fairly conjecture that our—to all appearances—purely speculative construction is not a new invention, but is prefigured on earlier levels of thought. Generally speaking, these prefigurations can be found in the multifarious stages of the mystic transformation process, as well as in the different degrees of initiation into the mysteries. We also find them in the classical as well as Christian trichotomy consisting of the pneumatic, the psychic, and the hylic. One of the most comprehensive attempts of this kind is the sixteenfold schema in the Book of Platonic Tetralogies.¹⁰⁹ I have dealt with this in detail in *Psychology and Alchemy* and can therefore limit myself here to the basic points. The schematization and analogy-

formation start from four first principles: 1. the work of nature, 2. water, 3. composite natures, 4. the senses. Each of these four starting-points has three stages of transformation, which together with the first stage make sixteen parts in all. But besides this fourfold horizontal division of each of the principles, each stage has its correspondence in the vertical series:

I	II	II	IV
1. <i>Opus naturalium</i>	<i>Aqua</i>	<i>Naturae compositae</i>	<i>Sensus</i>
2. <i>Divisio naturae</i>	<i>Terra</i>	<i>Naturae discretae</i>	<i>Discretio intellectualis</i>
3. <i>Anima</i>	<i>Aer</i>	<i>Simplicia</i>	<i>Ratio</i>
4. <i>Intellectus</i>	<i>Ignis</i>	<i>Aetheris simplicioris</i>	<i>Arcanum</i>

[415] This table of correspondences shows the various aspects of the *opus alchemicum*, which was also bound up with astrology and the so-called necromantic arts. This is evident from the use of significant numbers and the invocation or conjuring up of the familiar spirit. Similarly, the age-old art of geomancy¹¹⁰ is based on a sixteen-part schema: four central figures (consisting of Sub- or Superiudex, Iudex, and two Testes), four *nepotes* (grandsons), four sons, four mothers. (The series is written from right to left.) These figures are arranged in a schema of astrological houses, but the centre that is empty in the horoscope is replaced by a square containing the four central figures.

[416] Athanasius Kircher¹¹¹ produced a quaternity system that is worth mentioning in this connection:

I. *Unum = Monas monadikē = Deus = Radix omnium = Mens simplicissima = Divina essentia = Exemplar divinum.*

(The One = First Monad = God = Root of all things = Simplest understanding = Divine Essence = Divine Exemplar.)

II. *10 (1 + 2 + 3 + 4 = 10) = Secunda Monas = dekadikē = Dyas = Mundus intellectualis = Angelica intelligentia = Compositio ab uno et altero = i.e., ex oppositis.*

(... Second Monad = tenth = duality = spiritual world = intelligence of the angels = composition of the One and the Other = i.e., from opposites.)

III. *10² = 100 = Tertia Monas = hekatontadikē = Anima = Intelligentia.*

(... Third Monad = hundredth = soul = intelligence.)

IV. $10^3 = 1000 = \textit{Quarta Monas} = \textit{chiliadikē} = \textit{Omnia sensibilia} = \textit{Corpus} = \textit{ultima et sensibilis Unionum explicatio}$.

(... Fourth Monad = thousandth = all concrete things = body = final and concrete unfolding of unities.)

[417] Kircher comments that whereas the senses affect only the body, the first three unities are objects of understanding. So if one wants to understand what is perceived by the senses (*sensibilia*), this can only be done through the mind. “Everything perceived by the senses must therefore be elevated to reason or to the intelligence or to absolute unity. When in this way we shall have brought the absolute unity back to the infinitely simple from all perceptible, rational or intellectual multiplicity, then nothing more remains to be said, and then the Stone too is not so much *a* Stone as *no* Stone, but everything is the simplest unity. And even as the absolute unity of that concrete and rational Stone has God for an exemplar, so likewise its intellectual unity is the intelligence. You can see from these unities how the perceiving senses go back to reason, and reason to intelligence, and intelligence to God, where in a perfect cycle is found the beginning and the consummation.”¹¹² That Kircher should choose the *lapis* as an example of concrete things and of God’s unity is obvious enough in terms of alchemy, because the *lapis* is the arcanum that contains God or that part of God which is hidden in matter.

[418] Kircher’s system shows certain affinities with our series of quaternios. Thus the Second Monad is a duality consisting of opposites, corresponding to the angelic world that was split by Lucifer’s fall. Another significant analogy is that Kircher conceives his schema as a cycle set in motion by God as the prime cause, and unfolding out of itself, but brought back to God again through the activity of human understanding, so that the end returns once more to the beginning. This, too, is an analogy of our formula. The alchemists were fond of picturing their *opus* as a circulatory process, as a circular distillation or as the uroboros, the snake biting its own tail, and they made innumerable pictures of this process. Just as the central idea of the *lapis Philosophorum* plainly signifies the self, so the *opus* with its countless symbols illustrates the process of individuation, the step-by-step development of the self from an unconscious state to a conscious one. That is why the *lapis*, as *prima materia*, stands at the beginning of the process as well as at the end.¹¹³ According to Michael Maier, the gold, another synonym for the self, comes from the *opus circulatorium* of the sun. This circle is “the line that runs back upon itself (like the serpent that with its head bites its own tail), wherein that eternal painter and potter, God, may be discerned.”¹¹⁴ In this circle, Nature “has related the four qualities to one another and drawn, as it were, an equilateral square, since contraries are bound together by contraries, and enemies by enemies, with the same everlasting bonds.” Maier compares this squaring of the circle to the “homo quadratus,” the four-square man, who “remains himself” come weal come woe.¹¹⁵ He calls it the “golden house,

the twicebisected circle, the four-cornered phalanx, the rampart, the city wall, the four-sided line of battle.”¹¹⁶ This circle is a magic circle consisting of the union of opposites, “immune to all injury.”

[419] Independently of Western tradition, the same idea of the circular *opus* can be found in Chinese alchemy: “When the light is made to move in a circle, all the energies of heaven and earth, of the light and the dark, are crystallized,” says the text of the *Golden Flower*.¹¹⁷

[420] The *ὄργανον κυκλικόν*, the circular apparatus that assists the circular process, is mentioned as early as Olympiodorus.¹¹⁸ Dorn is of the opinion that the “circular movement of the Physiochemists” comes from the earth, the lowest element. For the fire originates in the earth and transforms the finer minerals and water into air, which, rising up to the heavens, condenses there and falls down again. But during their ascent the volatilized elements take “from the higher stars male seeds, which they bring down into the four matrices, the elements, in order to fertilize them spagyrically.” This is the “circular distillation”¹¹⁹ which Rupescissa says must be repeated a thousand times.¹²⁰

[421] The basic idea of ascent and descent can be found in the *Tabula smaragdina*, and the stages of transformation have been depicted over and over again, above all in the Ripley “Scrowle” and its variants. These should be understood as indirect attempts to apprehend the unconscious processes of individuation in the form of pictures.

XV CONCLUSION

[422] I have tried, in this book, to elucidate and amplify the various aspects of the archetype which it is most important for modern man to understand—namely, the archetype of the self. By way of introduction, I described those concepts and archetypes which manifest themselves in the course of any psychological treatment that penetrates at all deeply. The first of these is the SHADOW, that hidden, repressed, for the most part inferior and guilt-laden personality whose ultimate ramifications reach back into the realm of our animal ancestors and so comprise the whole historical aspect of the unconscious. Through analysis of the shadow and of the processes contained in it we uncover the ANIMA/ANIMUS syzygy. Looked at superficially, the shadow is cast by the conscious mind and is as much a privation of light as the physical shadow that follows the body. For this superficial view, therefore, the psychological shadow with its moral inferiority might also be regarded as a privation of good. On closer inspection, however, it proves to be a darkness that hides influential and autonomous factors which can be distinguished in their own right, namely anima and animus. When we observe them in full operation—as the devastating, blindly obstinate demon of opinionatedness in a woman, and the glamorous, possessive, moody, and sentimental seductress in a man—we begin to doubt whether the unconscious can be merely the insubstantial comet's tail of consciousness and nothing but a privation of light and good.

[423] If it has been believed hitherto that the human shadow was the source of all evil, it can now be ascertained on closer investigation that the unconscious man, that is, his shadow, does not consist only of morally reprehensible tendencies, but also displays a number of good qualities, such as normal instincts, appropriate reactions, realistic insights, creative impulses, etc. On this level of understanding, evil appears more as a distortion, a deformation, a misinterpretation and misapplication of facts that in themselves are natural. These falsifications and caricatures now appear as the specific effects of anima and animus, and the latter as the real authors of evil. But we cannot stop even at this realization, for it turns out that all archetypes spontaneously develop favourable and unfavourable, light and dark, good and bad effects. In the end we have to acknowledge that the self is a *complexio oppositorum* precisely because there can be no reality without polarity. We must not overlook the fact that opposites acquire their moral accentuation only within the sphere of human endeavour and action, and that we are unable to give a definition of good and evil that could be

considered universally valid. In other words, we do not know what good and evil are in themselves. It must therefore be supposed that they spring from a need of human consciousness and that for this reason they lose their validity outside the human sphere. That is to say a hypostasis of good and evil as metaphysical entities is inadmissible because it would deprive these terms of meaning. If we call everything that God does or allows “good,” then evil is good too, and “good” becomes meaningless. But suffering, whether it be Christ’s passion or the suffering of the world, remains the same as before. Stupidity, sin, sickness, old age, and death continue to form the dark foll that sets off the joyful splendour of life.

[424] The recognition of anima and animus is a specific experience that seems to be reserved mostly, or at any rate primarily, for psychotherapists. Nevertheless, anyone who has a little knowledge of *belles-lettres* will have no difficulty in forming a picture of the anima; she is a favourite subject for novelists, particularly west of the Rhine.¹ Nor is a careful study of dreams always necessary. It is not quite so easy to recognize the woman’s animus, for his name is legion. But anyone who can stand the animosity of his fellows without being infected by it, and is capable at the same time of examining it critically, cannot help discovering that they are possessed. It is, however, more advantageous and more to the point to subject to the most rigorous scrutiny one’s own *moods* and their changing influence on one’s personality. To know where the other person makes a mistake is of little value. It only becomes interesting when you know where *you* make the mistake, for then you can do something about it. What we can improve in others is of doubtful utility as a rule, if, indeed, it has any effect at all.

[425] Although, to begin with, we meet the anima and animus mostly in their negative and unwelcome form, they are very far from being only a species of bad spirit. They have, as we have said, an equally positive aspect. Because of their numinous, suggestive power they have formed since olden times the archetypal basis of all masculine and feminine divinities and therefore merit special attention, above all from the psychologist, but also from thoughtful laymen. As numina, anima and animus work now for good, now for evil. Their opposition is that of the sexes. They therefore represent a supreme pair of opposites, not hopelessly divided by logical contradiction but, because of the mutual attraction between them, giving promise of union and actually making it possible. The *coniunctio oppositorum* engaged the speculations of the alchemists in the form of the “Chymical Wedding,” and those of the cabalists in the form of Tifereth and Malchuth or God and the Shekhinah,² not to speak of the marriage of the Lamb.

[426] The dual being born of the alchemical union of opposites, the Rebis or Lapis Philosophorum, is so distinctively marked in the literature that we have no difficulty

in recognizing it as a symbol of the self. Psychologically the self is a union of conscious (masculine) and unconscious (feminine). It stands for the psychic totality. So formulated, it is a psychological concept. Empirically, however, the self appears spontaneously in the shape of specific symbols, and its totality is discernible above all in the mandala and its countless variants. Historically, these symbols are authenticated as God-images.

[427] The anima/animus stage is correlated with polytheism, the self with monotheism.³ The natural archetypal symbolism, describing a totality that includes light and dark, contradicts in some sort the Christian but not the Jewish or Yahwistic viewpoint, or only to a relative degree. The latter seems to be closer to Nature and therefore to be a better reflection of immediate experience. Nevertheless, the Christian heresiarchs tried to sail round the rocks of Manichaeism, which was such a danger to the early Church, in a way that took cognizance of the natural symbol, and among the symbols for Christ there are some very important ones which he has in common with the devil, though this had no influence on dogma.

[428] By far the most fruitful attempts, however, to find suitable symbolic expressions for the self were made by the Gnostics. Most of them—Valentinus and Basilides, for instance—were in reality theologians who, unlike the more orthodox ones, allowed themselves to be influenced in large measure by natural inner experience. They are therefore, like the alchemists, a veritable mine of information concerning all those natural symbols arising out of the repercussions of the Christian message. At the same time, their ideas compensate the asymmetry of God postulated by the doctrine of the *privatio boni*, exactly like those well-known modern tendencies of the unconscious to produce symbols of totality for bridging the gap between the conscious and the unconscious, which has widened dangerously to the point of universal disorientation.

[429] I am well aware that this work, far from being complete, is a mere sketch showing how certain Christian ideas look when observed from the standpoint of psychological experience. Since my main concern was to point out the parallelism or the difference between the empirical findings and our traditional views, a consideration of the disparities due to time and language proved unavoidable. This was particularly so in the case of the fish symbol. Inevitably, we move here on uncertain ground and must now and then have recourse to a speculative hypothesis or tentatively reconstruct a context. Naturally every investigator must document his findings as fully as possible, but he should also venture an occasional hypothesis even at the risk of making a mistake. Mistakes are, after all, the foundations of truth, and if a man does not know what a thing *is*, it is at least an increase in knowledge if he knows what it is *not*.

BIBLIOGRAPHY

BIBLIOGRAPHY

The items of the bibliography are arranged alphabetically under two headings: *A.* Ancient volumes containing collections of alchemical tracts by various authors; *B.* General bibliography, including cross-references to the material in section *A.* Short titles of the ancient volumes are printed in capital letters.

A. ANCIENT VOLUMES CONTAINING COLLECTIONS OF ALCHEMICAL TRACTS BY VARIOUS AUTHORS

ARS CHEMICA, quod sit licita recte exercentibus, probationes doctissimorum iurisconsultorum. ... Argentorati [Strasbourg], 1566.

Contents quoted in this volume:

- i Septem tractatus seu capitula Hermetis Trismegisti aurei [pp. 7–31; usually referred to as “Tractatus aureus”]
- ii Tabula smaragdina [pp. 32–33]

ARTIS AURIFERAE quam chemiam vocant. ... Basileae [Basel], [1593]. 2 vols.

Contents quoted in this volume:

VOLUME I

- i Turba philosophorum [two versions: pp. 1–65, 66–139]
- i-a Allegoriae super librum Turbae [pp. 139–45]
- ii Aenigmata ex Visione Arislei philosophi et allegoriis sapientum [pp. 146–54; usually referred to as “Vi Arislei”]
- iii In Turbam philosophorum exercitationes [pp. 154–82]
- iv Aurora consurgens, quae dicitur Aurea hora [pp. 185–246]
- v [Zosimus]: Rosinus ad Sarratantam episcopum [pp. 277–319]
- vi Maria Prophetissa: Practica ... in artem alchemicam [pp. 319–24]
- vii Tractatulus Aristotelis de practica lapidis philosophici [pp. 361–73]
- viii Interpretatio cuiusdam epistolae Alexandri Macedonum regis [pp. 382–88]
- ix Tractatulus Avicennae [pp. 405–37]

VOLUME II

- x Morienus Romanus: Sermo de transmutatione metallica [pp. 7–54]

MANGETUS, JOANNES JACOBUS (ed.). *BIBLIOTHECA CHEMICA CURIOSA, seu Rerum ad alchemiam pertinentium thesaurus instructissimus* ... Coloniae Allobrogum [Geneva], 1702. 2 vols.

Contents quoted in this volume:

VOLUME I

- i Allegoriae sapientum supra librum Turbae philosophorum XXIX distinctiones [pp. 467–79]
- ii Turba philosophorum [pp. 445–65; another version, pp. 480–94]
- iii Allegoriae supra librum Turbae [pp. 494–95]

MUSAEUM HERMETICUM reformatum et amplificatum ... continens tractatus chemicos XXI praestantissimos ... Francofurti [Frankfurt a. M.], 1678. For translation, see (B) WAITE, *The Hermetic Museum*.

Contents quoted in this volume:

- i [Barcius (F. von Sternberg)]: Gloria mundi, alias Paradysi tabula [pp. 203–304]
- ii Lamspringk: De lapide philosophico figurae et emblemata [pp. 337–72]
- iii Sendivogius: Novum lumen chemicum e naturae fonte et manuali experientia depromptum [pp. 545–600]
- iv [Sendivogius:] Novi luminis chemici Tractatus alter de sulphure [pp. 601–46]
- v Philalethes: Introitus apertus ad oclusum regis palatium [pp. 647–700]
- vi Philalethes: Metallorum metamorphosis [pp. 741–74]

THEATRUM CHEMICUM, praecipuos selectorum auctorum tractatus ... continens. Ursellis [Ursel] and Argentorati [Strasbourg], 1602–61. 6 vols. (Vols. I–III, Ursel, 1602; Vols. IV–VI, Strasbourg, 1613, 1622, 1661 respectively.)

Contents quoted in this volume:

VOLUME I

- i Fanianus: De arte metallica metamorphoseos ad Philoponum [pp. 28–48]
- ii Hoghelande: Liber de alchemiae difficultatibus [pp. 121–215]
- iii Dorn: Ars chemistica [pp. 217–54]
- iv Dorn: Speculativae philosophiae, gradus septem vel decem continens [pp. 255–310]
- v Dorn: Physica genesis [pp. 367–404]
- v-a Dorn: Physica Trismegisti [pp. 405–37]
- vi Dorn: Philosophia meditativa [pp. 450–72]
- vii Dorn: Philosophia chemica ad meditativam comparata [pp. 472–517]
- viii Dorn: Congeries Paracelsicae chemicae de transmutationibus metallorum [pp. 557–646]
- ix Bernardus Trevisanus: Liber de alchemia [pp. 773–803]

VOLUME II

- x Ripley: Duodecim portarum axiomata philosophica [pp. 123–39]
- xi Hollandus: Fragmentum de lapide [pp. 142–46]
- xii Dee: Monas hieroglyphica [pp. 218–43]

VOLUME III

- xiii Aristoteles de perfecto Magisterio [pp. 56–118]

VOLUME IV

- xiv Artefius: Clavis maioris sapientiae [pp. 221–40]
- xv Duodecim tractatus de lapide philosophorum [pp. 478–502]
- xvi Beatus: Aurelia occulta philosophorum [pp. 525–81]
- xvii Hermetis Trismegisti Tractatus vere aureus de lapide philosophici secreto [pp. 672–797; usually referred as “Tractatus aureus”]

VOLUME V

- xvii-a Turba philosophorum [pp. 1–57]
- xviii Allegoriae sapientum et distinctiones XXIX supra librum Turbae [pp. 64–100]
- xix Platonis liber quattorum [pp. 114–208]
- xx Tractatus Aristotelis alchymistae ad Alexandrum Magnum de lapide philosophico [pp. 880–92]

VOLUME VI

- xxi Blaise de Vigenère: Tractatus de igne et sale [pp. 1–139]
- xxii Colleson: Idea perfecta philosophiae hermeticae [pp. 143–61]
- xxiii Fidelissima et jucunda instructio de arbore solari [pp. 163–194]
- xxiv Grasseus: Arca arcani artificiosissimi de summis naturae mysteriis [pp. 294–381]
- xxv [Barchius:] Summa libri quae vocatur Gloria mundi, seu Tabula comprehensa [pp. 513–17]
- xxvi Chartier: Scientia plumbi sacri sapientum [pp. 569–99]

B. GENERAL BIBLIOGRAPHY

ABARBANEL, ISAAC (Ishāq Abravanel ben Jehūdā). *Mashmi’ a Yeshu’ ah* [“Proclamation of Salvation”]. (In Hebrew.) Salonica, 1526.

_____. *Ma’yene ha-Yeshu’ ah* [“Sources of Salvation”]. (In Hebrew.) Ferrara, 1551.

Abot de Rabbi Nathan. See NATHAN.

ADAM SCOTUS. *De tripartito tabernaculo*. See MIGNE, *P.L.*, vol. 148, cols. 609–796.

[ADAMANTIUS]. *Der Dialog des Adamantius* *περὶ τῆς εἰς θεὸν ὀρθῆς πίστεως*. Edited by Willem Hendrik van de Sande Bakhuyzen. (Griechischen Christlichen Schriftsteller.) Leipzig, 1908.

“Aenigmata ex Visione Arislei.” See (A) *Artis auriferae*, ii.

- AILLY, PIERRE D' (Petrus de Aliaco). *Concordantia astronomie cum theologia. Concordantia astronomie cum historica narratione. Et elucidarium duarum praecedentium*. Venice, 1490.
- ALBUMASAR. See JA'FAR IBN MUHAMMAD (ABU MA'SHAR) AL-BALKHĪ.
- ALCIATI, ANDREA. *Emblemata*. Padua, 1621 (another edn., 1661).
- ALIACO, PETRUS DE. See AILLY, PIERRE D'.
- "Allegoriae sapientum et distinctiones XXIX supra librum Turbae." See (A) MANGETUS, *Bibliotheca chemica*, i; *Theatrum chemicum*, xviii.
- "Allegoriae supra librum Turbae." See (A) *Artis auriferae*, i-a; MANGETUS, *Bibliotheca chemica*, iii.
- ALLENBY, AMY INGEBORG. *A Psychological Study of the Origins of Monotheism*. Unpublished dissertation, Oxford University.
- AMBROSE, SAINT. *Explanationes in Psalmos*. In: *Sancti Ambrosii Opera*, Pars 6. Edited by M. Petschenig. (Corpus Scriptorum Ecclesiasticorum Latinorum, 64.) Leipzig and Vienna, 1919.
- ANGELUS SILESIVS (Johannes Scheffler). See FLITCH.
- ANGER, RUDOLPH. "Der Stern der Weisen und das Geburtsjahr Christi," *Zeitschrift für die historische Theologie* (Leipzig), 1847, pp. 347–98.
- ARATUS. *Phaenomena*. In: *Callimachus and Lycophron; Aratus*. Translated by A. W. and G. R. Mair. (Loeb Classical Library.) London and New York, 1921.
- ARISLEUS. "Visio Arislei." See (A) *Artis auriferae*, ii.
- "Aristoteles de perfecto Magisterio." See (A) *Theatrum chemicum*, xiii.
- ARTEFIUS. "Clavis maioris sapientiae." See (A) *Theatrum chemicum*, xiv.
- AUGURELLUS, JOANNES AURELIUS. "Chrysopoeia." See GRATAROLUS.
- AUGUSTINE, SAINT. *The City of God*. Translated by John Healey and edited by R. V. G. Tasker. (Everyman's Library.) London and New York, 1945. 2 vols. (Original: *De Civitate Dei*. See MIGNE, *P.L.*, vol. 41, cols. 13–804.)
- _____. *The Confessions: Books I–X*. Translated by F. J. Sheed. London, 1951. (Original: *Confessiones*. See MIGNE, *P.L.*, vol. 32, cols. 659–868.)
- _____. *Contra adversarios legis et prophetarum*. See MIGNE, *P.L.*, vol. 42, cols. 603–666.
- _____. *Contra Faustum*. See MIGNE, *P.L.*, vol. 42, cols. 207–518. For translation, see: *Reply to Faustus the Manichaeon*. Translated by Richard Stothert. (*Works of Aurelius Augustinus*, edited by Marcus Dods, 5.) Edinburgh, 1872.
- _____. *De diversis quaestionibus LXXXIII*. See MIGNE, *P.L.*, vol. 40, cols. 11–100.
- _____. *Dialogus Quaestionum LXV*. See MIGNE, *P.L.*, vol. 40, cols. 733–752.
- _____. *De Trinitate*. See MIGNE, *P.L.*, vol. 42, cols. 819–1098. For translation, see: *Augustine: Later Works*. Selected and translated by John Burnaby. (Library of Christian Classics, 8.) London, 1955. (Pp. 37–181.)
- _____. *Enarrationes in Psalmos*. See MIGNE, *P.L.*, vols. 36, 37.
- _____. *Liber Sententiarum ex Augustino*. See: *Prosperi Aquitani Sententiae ex Augustino delibatae liber unus*. Being Vol. X, Part 2, of *S. Aurelii Augustini ... opera omnia ...*, opere et studio monachorum O.S.B. e Congregatione S. Mauri. Paris, 1835–39. 11 vols.

- _____. *Retractationes*. In MIGNE, *P.L.*, vol. 32, cols. 583–656.
- _____. *Sermo I*. See: *Sermones supposititii*. Being Vol. V of *S. Aurelii Augustini ... opera omnia ...*, opere et studio monachorum O.S.B. e Congregatione S. Mauri. Paris, 1835–39. 11 vols.
- _____. *Sermo XC*. See MIGNE, *P.L.*, vol. 38, cols. 559–66.
- _____. *Sermo CCXXXVII*. See MIGNE, *P.L.*, vol. 38, cols. 1122–24.
- _____. *Tractatus in Joannis Evangelium*. In MIGNE, *P.L.*, vol. 35. For translation, see: *Lectures or Tractates on the Gospel according to Saint John*, Vol. II. Translated by James Innes. (*Works of Aurelius Augustinus*, edited by Marcus Dods, 11.) Edinburgh, 1874.
- “Aurora consurgens.” See (A) *Artis auriferae*, IV; (B) FRANZ, M.L. VON.
- Bahman Yast. In: *Pahlavi Texts*, Part I. Translated by E. W. West. (Sacred Books of the East, 5.) Oxford, 1880.
- Baruch, Apocalypse of, See “2 Baruch (The Syrian Apocalypse of Baruch)” in CHARLES, *Apocrypha*, II, pp. 470–526.
- BASIL THE GREAT, SAINT. *Quod Deus non est auctor malorum*. See MIGNE, *P.G.*, vol. 31, cols. 329–54.
- _____. *Homiliae in Psalmos*. In MIGNE, *P.G.*, vol. 29, cols. 209–494.
- _____. *Homiliae in Hexaemeron*. See MIGNE, *P.G.*, vol. 29, cols. 3–208. For translation, see: *The Treatise De Spiritu Sancto, the Nine Homilies of the Hexaemeron and the Letters of St. Basil the Great*. Translated by the Rev. Blomfield Jackson. (Select Library of Nicene and Post-Nicene Fathers of the Christian Church, Second Series, 8.) Oxford and New York, 1895.
- BAUER, WALTER. *Griechisch-Deutsches Wörterbuch zu den Schriften des neuen Testaments*. 3rd edn., Berlin, 1937.
- BEATUS, GEORGIUS. “Aurelia occulta.” See (A) *Theatrum chemicum*, xvi.
- BENOIST, JEAN. *Histoire des Albigeois et des Vaudois*. Paris, 1691. 2 vols.
- Bereshith Rabba*. See: *Midrash Rabbah translated into English*. Edited by H. Freedman and Maurice Simon. London, 1951. 10 vols.
- BERNARD OF CLAIRVAUX, SAINT. *Tractatus de gradibus superbiae*. See MIGNE, *P.L.*, vol. 182, cols. 957–72.
- BERNARDUS TREVISANUS. “Liber de alchemia.” See (A) *Theatrum chemicum*, ix.
- BERTHELOT, MARCELLIN. *Collection des anciens alchimistes grecs*. Paris, 1887–88. 3 vols.
- Bible. The following versions are cited textually:
 [AV] Authorized (“King James”) Version (cited unless otherwise indicated).
 [DV] Douay-Reims Version. [RSV] Revised Standard Version.
- BÖHME, JAKOB. “Aurora, oder die Morgenröte im Aufgang.” In: *Des gottseligen, hocherleuchteten ... Schrifften*, q.v. For translation, see: *Aurora*. Translated by John Sparrow. London, 1914.
- _____. “Tabula principiorum.” See pp. 269–87 of *De signatura rerum etc.*, in: *Des gottseligen, hocherleuchteten ... Schrifften*, q.v.
- _____. *Des gottseligen, hocherleuchteten Jacob Böhmen Teutonici Philosophi Alle Theosophische Schrifften*. Amsterdam, 1682. (This edition of Böhme’s works consists of a number of parts, each separately paginated, and variously bound up.)
- BOLL, FRANZ JOHANNES. *Sphaera*. Leipzig, 1903.
- _____. *Aus der Offenbarung Johannis*. (ΣΤΟΙΧΕΙΑ, Heft I.) Leipzig and Berlin, 1914.

- BOUCHÉ-LECLERCQ, AUGUSTE. *L'Astrologie grecque*. Paris, 1899.
- BOUSSET, WILHELM. *The Antichrist Legend*. Translated by A. H. Keane. London, 1896. (Original: *Der Antichrist*. Göttingen, 1895.)
- _____. *Hauptprobleme der Gnosis*. (Forschungen zur Religion und Literatur des Alten und Neuen Testaments, 10.) Göttingen, 1907.
- Brihadaranyaka Upanishad. See: Upanishads.
- BRUGSCH, HEINRICH. *Religion und Mythologie der alten Ägypter*. Leipzig, 1885.
- BUDGE, E. A. WALLIS. *The Gods of the Egyptians*. London, 1904. 2 vols.
- _____. *The Papyrus of Ani*. London, 1895.
- CABROL, FERNAND, and LECLERCQ, HENRI. *Dictionnaire d'archéologie chrétienne et de liturgie*. Paris, 1907–53. 15 vols.
- CAESARIUS OF HEISTERBACH. *Dialogue on Miracles*. Translated by H. von E. Scott and C. C. S. Bland. London, 1929. (Original: *Dialogus Miraculorum*. Edited by Joseph Strange. Cologne, 1851.)
- CAMPBELL, COLIN. *The Miraculous Birth of King Amon-Hotep III*. Edinburgh and London, 1912.
- CARDAN, JÉRÔME (Hieronymus Cardanus, Girolamo Cardano). “Commentarium in Ptolernaeum De astrorum Judiciis.” In: *Opera Omnia*. Lyons, 1663. 10 vols. (Vol. V, pp. 93–368.)
- CAUSSIN, NICHOLAS. [*Polyhistor symbolicus*.] *De symbolica Aegyptiorum sapientia. Polyhistor symbolicus, Electorum symbolorum, & Parabolarum historicarum stromata*. Paris, [1618 and] 1631.
- CHARTIER, JEAN. “Scientia plumbi sacri sapientum.” See (A) *Theatrum chemicum*, xxvi.
- CHARLES, R. H. (ed.). *The Apocrypha and Pseudepigrapha of the Old Testament in English*. Oxford, 1913. 2 vols.
- CHRISTENSEN, ARTHUR [EMANUEL]. *Le Premier Homme et le premier roi dans l'histoire légendaire des Iraniens*. (Archives d'Études orientales, 14.) Stockholm, 1918, 1934. 2 parts.
- CHWOLSOHN, DANIEL (Khwolson, Daniil Avraamovich). *Die Ssabier und der Ssabismus*. St. Petersburg [Leningrad], 1856. 2 vols.
- CLEMENT OF ALEXANDRIA. *Paedagogus* (“The Instructor”). See MIGNE, P.G., vol. 8, cols. 247–684. For translation, see *Writings*, below.
- _____. *Stromata* (“Miscellanies”). See MIGNE, P.G., vol. 8, col. 685 – vol. 9, col. 602. For translation, see *Writings*, below.
- _____. *The Writings of Clement of Alexandria*. Translated by William Wilson. (Ante-Nicene Christian Library, 4, 12.) Edinburgh, 1867–69. 2 vols.
- CLEMENT OF ROME, SAINT (Pope Clement I). *Second Epistle to the Corinthians*. In: *The Apostolic Fathers*. With an English translation by Kirsopp Lake. (Loeb Classical Library.) London and New York, 1912–13. 2 vols. (Vol. I, pp. 128–63).
- _____, pseud. *The Clementine Homilies and the Apostolical Constitutions*. Translated by Thomas Smith, Peter Peterson, and James Donaldson. (Ante-Nicene Christian Library, 17.) Edinburgh, 1870.
- COLLESSON, JOHANNES. “Idea perfecta philosophiae hermeticae.” See (A) *Theatrum chemicum*, xxii.
- Compendium theologicae veritatis*. See HUGH OF STRASBOURG.

- CREMER, HERMANN. *Biblich-theologisches Wörterbuch der Neutestamentlichen Gräzität*. 10th edn. (edited by Julius Kögel), Gotha, 1915.
- CUMONT, FRANZ. *Les Religions orientales dans le paganisme romain*. 4th edn., Paris, 1929.
- _____. *Textes et monuments figurés relatifs aux mystères de Mithra*. Brussels, 1894–99. 2 vols.
- DEE, JOHN. “Monas hieroglyphica.” See (A) *Theatrum chemicum*, xii.
- DE GUBERNATIS, ANGELO. *Zoological Mythology*. London, 1872. 2 vols.
- DELATTE, LOUIS. *Textes latins et vieux français relatifs aux Cyranides*. (Bibliothèque de la Faculté de Philosophie et Lettres de l’Université de Liège, fasc. 93.) Liège, 1942.
- DENZINGER, HEINRICH, and BANNWART, KLEMENS. *Enchiridion symbolorum*. 6–7th edn., Freiburg, i. B., 1928.
- DEUSSEN, PAUL. *Allgemeine Geschichte der Philosophie*. Leipzig, 1894–1917. 2 vols. in 6 parts.
- DIDYMUS OF ALEXANDRIA. *De trinitate libri tres*. See MIGNE, P.G., vol. 39, cols. 269–992.
- DIETERICH, ALBRECHT. *Die Grabschrift des Aberkios*. Leipzig, 1896.
- _____. *Eine Mithrasliturgie*. Leipzig, 1903. 2nd edn., 1910.
- DIONYSIUS THE AREOPAGITE, pseud. *De divinis nominibus*. In MIGNE, P.G., vol. 3, cols. 585–996. For translation, see: *Works of Dionysius the Areopagite*. Translated by John Parker. Oxford, 1897–99. 2 vols.
- DOELGER, FRANZ JOSEF. IXΘΥΣ: *Das Fischsymbol in frühchristlicher Zeit*. Rome and Munster, 1910–27. 4 vols.
- DORN, GERHARD (GERARDUS). See (A) *Theatrum chemicum*, ili–viii.
- DOZY, REINHART, and DE GOEJE, M. J. “Nouveaux documents pour l’étude de la religion des Harraniens.” In: *Actes du sixième Congrès international des Orientalistes (1883)*. Leiden, 1885.
- DRAGOMANOV, M. “Zabelezhki vrkhy slavyanskite religioznoeticheski Legendi,” *Sbornik za narodnaya umortvoreniya* (Sofia), X (1894), 3–68.
- DREWS, ARTHUR. *Der Sternhimmel in der Dichtung und Religion der alten Völker und des Christentums*. Jena, 1923.
- DU CANGE, CHARLES. *Glossarium ad scriptores mediae et infimae latinitatis*. Paris, 1733–36. 6 vols. New edn.: Graz, 1954. 10 vols.
- “Duodecim tractatus de lapide philosophorum.” See (A) *Theatrum chemicum*, xv.
- ECKHART, MEISTER. See: PFEIFFER, FRANZ (ed.). *Deutsche Mystiker des Vierzehnten Jahrhunderts*. Leipzig, 1845–57. 2 vols. (Vol. II.)
- _____. [Works.] Translated by C. de B. Evans. London, 1924–52. 2 vols.
- EISLER, ROBERT. “Der Fisch als Sexuelsymbol,” *Imago* (Leipzig and Vienna), III (1914), 165–93.
- _____. *Orpheus–The Fisher*. London, 1921. (An unpublished second volume of this work is preserved in typescript in the British Museum, London.)
- _____. *The Royal Art of Astrology*. London, 1946.
- ELEAZAR, R. ABRAHAM. *Uraltes Chymisches Werk*. Leipzig, 1760.
- EPHREM THE SYRIAN, SAINT. *Hymni et sermones*. Edited by Thomas Joseph Lamy. Mechlin, 1882–1902. 4 vols.
- EPICETUS. *Enchiridion*. See: *Epictetus; The Discourses, etc.* Edited and translated by W. A. Oldfather. (Loeb Classical Library.) London and New York, 1926–28. 2 vols. (Vol. II, pp. 479–537.)

- EPIPHANIUS, SAINT. *Ancoratus*. In: *Epiphanius*, Vol. I. Edited by Karl Holl. (Griechische Christliche Schriftsteller.) Leipzig, 1915.
- _____. *Panarium [Adversus octoginta haereses]*. Edited by Franciscus Oehler. Berlin, 1859–61. 3 parts.
- ERMAN, ADOLF. *Die Religion der Ägypter*. Berlin and Leipzig, 1934.
- Esdras, Second (or Fourth) Book of. In: CHARLES, *Apocrypha and Pseudepigrapha*, q.v. (Vol. II, pp. 561–624.)
- EUCHERIUS OF LYONS, SAINT. *Liber formularum spiritalis intelligentiae*. See MIGNE, *P.L.*, vol. 50, cols. 727–72.
- EUTHYMIOS ZIGABENOS. *Panoplia Dogmatica*. See MIGNE, *P.G.*, vol. 130 (entire).
- FANIANUS, JOANNES CHRYSIPPUS. “De arte metallica metamorphoseos ad Philoponum.” See (A) *Theatrum chemicum*, i.
- FERGUSON, JOHN. *Bibliotheca Chemica*. Glasgow, 1906. 2 vols.
- “Fidelissima et jucunda instructio de arbore solari.” See (A) *Theatrum chemicum*, xxiii.
- FIERZ-DAVID, HANS EDUARD. *Die Entwicklungsgeschichte der Chemie*. (Wissenschaft und Kultur, 2.) Basel, 1945.
- FIERZ-DAVID, LINDA. *The Dream of Poliphilo*. Translated by Mary Hottinger. (Bollingen Series XXV.) New York, 1950.
- FIRMICUS MATERNUS, JULIUS. *De errore profanarum religionum*. Edited by Charles Halm. (Corpus Scriptorum Ecclesiasticorum Latinorum, 2.) Vienna, 1867.
- FLITCH, J. E. CRAWFORD (trans.). *Angelus Silesius: Selections from The Cherubic Wanderer*. London, 1932.
- FLUDD, ROBERT. *Animae intellectualis scientia seu De geomantia*. In: *Fasciculus Geomanticus, in quo varia variorum opera geomantica continentur*, Verona, 1687.
- FRANZ, MARIE-LOUISE VON. “Die Passio Perpetuae.” In: C. G. JUNG. *Aion: Untersuchungen zur Symbolgeschichte*. (Psychologische Abhandlungen, VIII.) Zurich, 1951.
- _____(ed.). *Aurora Consurgens: A Document attributed to Thomas Aquinas on the Problem of Opposites in Alchemy*. Translated by R. F. C. Hull and A. S. B. Glover. New York (Bollingen Series) and London, 1966.
- FROBENIUS, LEO. *Das Zeitalter des Sonnengottes*. Berlin, 1904.
- GAEDECHENS, RUDOLF. *Der Marmorne Himmelsglobus des Fürstlich Waldeckischen Antikencabinetts zu Arolsen*. Göttingen, 1862.
- GAMOW, GEORGE. *Atomic Energy*. Cambridge, 1947.
- GARNERIUS. *Sancti Victoris Parisiensis Gregorianum*. See MIGNE, *P.L.*, vol. 193, cols. 23–462.
- GERHARDT, OSWALD. *Der Stern des Messias*. Leipzig, Erlangen, 1922.
- “Gloria mundi.” See (A) *Musaeum hermeticum*, i.
- GOODENOUGH, ERWIN R. *Jewish Symbols in the Greco-Roman Period*. (Bollingen Series XXXVII.) New York, 1953–68. 13 vols. (Vol. V, *Fish, Bread, and Wine*, contains two chapters on fish symbolism.)
- GRASSEUS, JOHANNES. “Arca arcani artificiosissimi de summis naturae mysteriis.” See (A) *Theatrum chemicum*, xxiv.
- GRATAROLUS, GULIELMUS. *Verae alchemiae artisque metallica, citra aenigmata, doctrina*, etc. Basel, 1561. (Pp. 269–86 contain Augurellus’ “Chrysopoeia.”)
- GREGORY THE GREAT, SAINT. *Expositiones in librum I Regum*. See MIGNE, *P.L.*, vol. 79, cols. 17–468.
- _____. *In Expositionem beati Job Moralia*. See MIGNE, *P.L.*, vol. 75, col. 615 – vol. 76, col. 782.

- GRENFELL, BERNARD P., and HUNT, ARTHUR S. *New Sayings of Jesus and Fragment of a Lost Gospel from Oxyrhynchus*. New York and London, 1904.
- GUIGNEBERT, CHARLES. "Quelques remarques sur la perfection et ses voies dans le mystère paulinien," *Revue d'histoire et de philosophie religieuses* (Strasbourg), Année 8 (1928), pp. 412–29.
- HAGGARD, H. RIDER. *She*. London, 1887.
- HAHN, CHRISTOPH ULRICH. *Geschichte der Ketzer im Mittelalter*. Stuttgart, 1845–50. 3 vols.
- HARNACK, ADOLF. *Lehrbuch der Dogmengeschichte*. 5th edn., Tübingen, 1931.
- HAUCK, ALBERT (ed.). *Realencyklopädie für protestantische Theologie und Kirche*. Leipzig, 1896–1913. 24 vols.
- HEIDEGGER, JOHANN HEINRICH. *Quaestiones ad Textum Lucae VII, 12–17*. 1655.
- HELLWIG, CHRISTOPH VON. *Neu eingerichtetes Lexicon Medico-chymicum, oder Chymisches Lexicon*. Frankfurt a. M. and Leipzig, 1711.
- HENNECKE, EDGAR (ed.). *Neutestamentliche Apokryphen*. 2nd edn., Tübingen, 1924.
- HERMAS. *The Shepherd*. In: *The Apostolic Fathers*. With an English translation by Kirsopp Lake. (Loeb Classical Library.) London and New York, 1912–13. 2 vols. (Vol. II, pp. 6–305.)
- HERMES TRISMEGISTUS. *Tractatus vere aureus de lapidis philosophici secreto*. Opere et studio Dominici Gnosii in lucem editus. Leipzig, 1610. See also (A) *Ars chemica*, i; *Theatrum chemicum*, xvii.
- HERTZ, MARTIN. *De P. Nigidii Figuli Studiis atque operibus*. Berlin, 1845.
- HIPPOLYTUS. *Commentary on Daniel (Eis ton Daniel)*. See: *Hippolytus' Werke*, Vol. I. Edited by G. N. Bonwetsch and H. Achelis. (Griechische Christliche Schriftsteller.) Leipzig, 1897.
- _____. *Elenchos*. See: *Hippolytus' Werke*, Vol. III. Edited by Paul Wendland. (Griechische Christliche Schriftsteller.) Leipzig, 1916. For translation, see: *Philosophumena; or, The Refutation of All Heresies*. Translated by Francis Legge. (Translations of Christian Literature.) London and New York, 1921. 2 vols.
- HOGHELANDE, THEOBALD DE. "Liber de Alchemiae difficultatibus." See (A) *Theatrum chemicum*, ii.
- HÖLDERLIN, FRIEDRICH. *Sämtliche Werke*. Berlin, 1943. 3 vols.
- HOLLANDUS, JOANNES ISAACUS. "Fragmentum de lapide." See (A) *Theatrum chemicum*, xi.
- HOMER. *The Iliad*. Translated by E. V. Rieu. (Penguin Classics.) Harmondsworth, 1954.
- _____. *The Odyssey*. Translated by E. V. Rieu. (Penguin Classics.) Harmondsworth, 1955. Also: *The Story of Odysseus*. Translated by W. H. D. Rouse. London and New York, 1937.
- HONORIUS OF AUTUN. *Speculum de mysteriis ecclesiae*. In MIGNE, P.L., vol. 172, cols. 807–1108.
- HUGH OF STRASBOURG. *Compendium theologiae veritatis*. Venice, 1492.
- HURWITZ, SIGMUND. "Archetypische Motive in der chassidischen Mystik." In: *Zeitlose Dokumente der Seele*. (Studien aus dem C. G. Jung-Institut, 3.) Zurich, 1952.
- I Ching, or Book of Changes*. The Richard Wilhelm [German] translation rendered into English by Cary F. Baynes. Princeton (Bollingen Series XII) and London, 3rd edn., 1967.
- IDELER, CHRISTIAN LUDWIG. *Untersuchungen über den Ursprung und die Bedeutung der Sternnamen*. Berlin, 1809.

- [IGNATIUS OF LOYOLA, SAINT.] *The Spiritual Exercises of St. Ignatius Loyola*. Edited and translated by Joseph Rickaby, S.J. 2nd edn., London, 1923.
- “Instructio de arbore solari.” See (A) *Theatrum chemicum*, xxiii.
- “In Turbam philosophorum exercitationes.” See (A) *Artis auriferae*, iii.
- “Interpretatio cuiusdam epistolae Alexandri Macedonum regis.” See (A) *Artis auriferae*, viii.
- IRENAEUS, SAINT. *Adversus [or Contra] haereses libri quinque*. See MIGNE, P.G., vol. 7, cols. 433–1224. For translation, see: *The Writings of Irenaeus*. Translated by Alexander Roberts and W. H. Rambaut. (Ante-Nicene Christian Library, 5, 9.) Edinburgh, 1868–69. 2 vols.
- ISIDORE OF SEVILLE, SAINT. *Liber etymologiarum*. In MIGNE, P.L., vol. 82, cols. 73–728.
- JACOBI, JOLANDE. *The Psychology of C. G. Jung*. Translated by K. W. Bash. Revised edn., New Haven and London, 1951.
- JA'FAR IBN MUHAMMAD (ABU MA'SHAR) AL-BALKHĪ (Albumasar). *De magnis coniunctionibus*. Venice and Augsburg, 1489.
- JAMES, MONTAGUE RHODES (trans.). *The Apocryphal New Testament*. Oxford, 1924.
- JEREMIAS, ALFRED. *The Old Testament in the Light of the Ancient East*. Translated by C. L. Beaumont. London and New York, 1911. 2 vols.
- JOHN CHRYSOSTOM, ST. *Responsiones ad orthodoxas*. (Among the works falsely attributed to St. Justin Martyr.) See MIGNE, P.G., vol. 6, cols. 1249–1400.
- JOSEPHUS, FLAVIUS. *Contra Apionem*. In: *Josephus*. With an English translation by H. St. J. Thackeray and R. Marcus. (Loeb Classical Library.) London and New York, 1926– . 9 vols. (not yet complete). (Vol. I, pp. 325ff.)
- JUNG, CARL GUSTAV. *Alchemical Studies. Collected Works**, Vol. 13. New York and London, 1968.
- _____. “Answer to Job.” In: *Psychology and Religion: West and East*, q.v.
- _____. *Archetypes and the Collective Unconscious. Collected Works,** Vol. 9, Part I. New York and London; 2nd edn., 1968.
- _____. Commentary on *The Secret of the Golden Flower*. In: *Alchemical Studies*, q.v.
- _____. “Concerning Mandala Symbolism.” In: *Archetypes and the Collective Unconscious*, q.v.
- _____. “Concerning Rebirth.” In: *Archetypes and the Collective Unconscious*, q.v.
- _____. “Instinct and the Unconscious.” In: *The Structure and Dynamics of the Psyche*, q.v.
- _____. *Memories, Dreams, Reflections*. Recorded and edited by Aniela Jaffé. Translated by Richard and Clara Winston. New York and London, 1963. (U.S. and Brit. edns. separately paginated.)
- _____. *Mysterium Coniunctionis. Collected Works,** Vol. 14. New York and London, 1963; 2nd edn., 1970.
- _____. “On the Nature of the Psyche.” In: *The Structure and Dynamics of the Psyche*, q.v.
- _____. “On Psychic Energy.” In: *The Structure and Dynamics of the Psyche*, q.v.
- _____. Paracelsus the Physician.” In: *The Spirit in Man, Art, and Literature*, q.v.
- _____. “Paracelsus as a Spiritual Phenomenon.” In: *Alchemical Studies*, q.v.
- _____. “The Phenomenology of the Spirit in Fairytales.” In: *Archetypes and the Collective Unconscious*, q.v.
- _____. “The Philosophical Tree.” In: *Alchemical Studies*, q.v.

- _____. "A Psychological Approach to the Dogma of the Trinity." In: *Psychology and Religion: West and East*, q.v.
- _____. *Psychological Types. Collected Works,** Vol. 6. (Alternate source: translation by H. G. Baynes, London and New York, 1923.)
- _____. *Psychology and Alchemy. Collected Works,** Vol. 12. New York and London, 2nd edn., 1968.
- _____. "The Psychology of the Child Archetype." In: *The Archetypes and the Collective Unconscious*, q.v.
- _____. "The Psychology of Eastern Meditation." In: *Psychology and Religion: West and East*, q.v.
- _____. "Psychology and Religion" (The Terry Lectures). In: *Psychology and Religion: West and East*, q.v.
- _____. *Psychology and Religion: West and East. Collected Works,** Vol. 11. New York and London, 1958; 2nd edn., 1969.
- _____. "The Psychology of the Transference." In: *The Practice of Psychotherapy. Collected Works,** Vol. 16. New York and London, 2nd edn., 1966.
- _____. "The Psychology of the Trickster Figure." In: *The Archetypes and the Collective Unconscious*, q.v.
- _____. "The Relations between the Ego and the Unconscious." In: *Two Essays on Analytical Psychology. Collected Works,** Vol. 7. New York and London, 2nd edn., 1966.
- _____. *The Spirit in Man, Art, and Literature. Collected Works,** Vol. 15. New York and London, 1967.
- _____. "The Spirit Mercurius." In: *Alchemical Studies*, q.v.
- _____. *The Structure and Dynamics of the Psyche. Collected Works,** Vol. 8. New York and London, 1960.
- _____. "A Study in the Process of Individuation." In: *Archetypes and the Collective Unconscious*, q.v.
- _____. *Symbols of Transformation. Collected Works,** Vol. 5. New York and London, 1956; 2nd edn., 1967.
- _____. "Synchronicity: An Acausal Connecting Principle." In: *The Structure and Dynamics of the Psyche*, q.v.
- _____. "Transformation Symbolism in the Mass." In: *Psychology and Religion: West and East*, q.v.
- _____. "Über das Selbst," *Éranos Jahrbuch 1948* (Zurich, 1949). (Became ch. IV of the present work.)
- KELCHNER, ERNST. *Der Enndkrist*. Frankfurt a. M., 1891.
- Kena Upanishad. See Upanishads.
- KEPLER, JOHANN. *Discurs von der grossen Conjunction*. In: *Johannis Kepleri Astronomi Opera Omnia*. Edited by Ch. Frisch. Frankfurt a. M., 1858–71. 8 vols. (Vol. VII, pp. 697–711.)
- KHUNRATH, HEINRICH CONRAD. *Von hylealischen, das ist, pri-materialischen catholischen, oder algemeinem natürlichen Chaos*. Magdeburg, 1597.
- KIRCHER, ATHANASIVS. *Arithmologia, sive De abditis numerorum mysteriis*. Rome, 1665.
- KIRCHMAIER, GEORG CASPAR. *Disputationes zoologicae*. Jena, 1736.
- KNAPP, MARTIN JOHANN. *Antiskia: Ein Beitrag zum Wissen um die Präzession im Altertum*. Basel, 1927.
- KOHUT, ALEXANDER. "Die talmudisch-midrassische Adamssage," *Zeitschrift der deutschen morgenländischen Gesellschaft* (Leipzig), XXV (1871), 59–94.
- [Koran.] *The Meaning of the Glorious Koran*. An Explanatory Translation. By Marmaduke Pickthall. London, 1930.
- LAGARDE, PAUL ANTON DE (previously P. A. Boetticher). *Clementina*. Leipzig, 1865.

- LAIBLIN, WILHELM. "Vom mythischen Gehalt unserer Märchen," in: WILHELM SCHLOZ and LAIBLIN. *Vom Sinn des Mythos*. Stuttgart, 1936.
- LAMBSPRINGK. "De Lapide philosophico figurae et emblemata." See (A) *Musaeum hermeticum*, ii.
- LAYARD, JOHN. "The Incest Taboo and the Virgin Archetype," *Eranos-Jahrbuch* (Zurich), XII (1945). (Volume for C. G. Jung on His Seventieth Birthday.)
- _____. *Stone Men of Malekula: Vao*. London, 1942.
- Lexicon Medico-chymicum*. See HELLWIG.
- LIBAVIUS, ANDREAS. *Alchymia ... recognita, emendata, et aucta*. Frankfurt a. M., 1606.
- LIGHTFOOT, JOSEPH BARBER. *Notes on Epistles of Saint Paul*. London, 1895.
- MAAG, VICTOR. "Jahwäs Heerscharen," *Schweizerische theologische Umschau* (Bern), XX (1950), 27–52.
- MACROBIUS, AMBROSIIUS THEODOSIUS. *Commentarium in Somnium Scipionis*. In: *Opera*. Edited by F. Eyssenhardt. Leipzig, 1893.
- MAIER, MICHAEL. *De circulo physico quadrato*. Oppenheim, 1616.
- _____. *Secretioris naturae secretorum scrutinium chymicum*. Frankfurt a. M., 1687.
- _____. *Symbola aureae mensae duodecim nationum*. Frankfurt a. M., 1617.
- MAIMONIDES, MOSES. [*More Nebuchim.*] *The Guide for the Perplexed*. Translated by M. Friedlander. London, 1928.
- MANGETUS, JOANNES JACOBUS. See under (A).
- MARIA PROPHETISSA. "Practica ... in artem alchemicam." See (A) *Artis auriferae*, vi.
- MARIETTE, FRANÇOIS AUGUSTE FERDINAND. *Dendérah*. Paris (printed in Alexandria), 1875. Plates, 5 vols., Paris, 1870–74.
- MASENIUS, JACOBUS. *Speculum imaginum veritatis occultae*. Cologne, 1714. 2 vols.
- MECHTHILD, SAINT. *Liber gratiae spiritualis*. Venice, 1522. For translation, see: *The Revelations of Mechthild of Magdeburg, or The Flowing Light of the Godhead*. Translated by Lucy Menzies. London, 1953.
- MEERPOHL, FRANZ. *Meister Eckharts Lehre vom Seelenfünklein*. (Abhandlungen zur Philologie und Psychologie der Religion, 10.) Würzburg, 1926.
- MEYER, KARL H. *Altkirchenslavisch-griechisches Wörterbuch des Codex Suprasliensis*. Glückstadt and Hamburg, 1935.
- Midrash Tanchuma (Shemoth)*. (In Hebrew.) Edited by Solomon Buber. Vilna, 1885.
- MIGNE, JACQUES PAUL (ed.). *Patrologiae cursus completus*.
- [P.L.] Latin series. Paris, 1844–64. 221 vols.
- [P.G.] Greek series. Paris, 1857–66. 166 vols.
- (These works are referred to as "MIGNE, P.L." and "MIGNE, P.G." respectively.)
- MORIENUS ROMANUS. "Sermo de transmutatione metallica." See (A) *Artis auriferae*, x.
- MUHAMMAD IBN JARIR ABŪ-JAFAR AL-TABARĪ *Chronique*. Translated (into French) by Hermann Zotenberg. 4 vols. Paris and (vol. 4) Nogent-le-Rotrou, 1867–74.
- MUENTER, FREDERIK CHRISTIAN KARL HENRIK. *Sinnbilder und Kunstvorstellungen der alten Christen*. Altona, 1825. 2 vols.

- ____ (as Muenther, Friedrich). *Der Stern der Weisen*. Copenhagen, 1827.
- MYLIUS, JOHANN DANIEL. *Philosophia refórmala*. Frankfurt a. M., 1622.
- NATHAN, RABBI. *Abot de Rabbi Nathan*. See: *The Fathers according to Rabbi Nathan*. Translated by Judah Goldin. (Yale Judaica Series, 10.) New Haven, 1955.
- NELKEN, JAN. "Analytische Beobachtungen über Phantasien eines Schizophrenen," *Jahrbuch für psychoanalytische und psychopathologische Forschungen* (Vienna and Leipzig), IV (1912), 504ff.
- NEUMANN, ERICH. *The Great Mother*. Translated by Ralph Manheim. New York (Bollingen Series XLVII) and London, 1955.
- ____. *The Origins and History of Consciousness*. Translated by R. F. C. Hull. New York (Bollingen Series XLII) and London, 1954.
- NIETZSCHE, FRIEDRICH. *Thus Spake Zarathustra*. Translated by Thomas Common, revised by O. Levy and J. L. Beevers. London, 1932.
- NIGIDIUS FIGULUS, PUBLIUS. See HERTZ.
- NOSTRADAMUS, MICHEL (Nostredame). *The Complete Prophecies of Nostradamus*. Translated and edited by Henry C. Roberts. New York, 1949. (Original: *Vrayes Centuries et Prophéties de Maistre Michel Nostredame*. Amsterdam, 1667.)
- "Novi luminis chemici Tractatus . . ." See (A) *Musaeum hermeticum*, iv.
- "Novum lumen chemicum." See (A) *Musaeum hermeticum*, iii.
- ONIANS, RICHARD BROXTON. *The Origins of European Thought*. 2nd edn., Cambridge, 1954.
- ORIGEN. *Commentaria in Genesim*. See MIGNE, P.G., vol. 12, cols. 47–92.
- ____. *Contra Celsum*. See MIGNE, P.G., vol. 11, cols. 641–1632. For translation, see: *Contra Celsum*. Translated by Henry Chadwick. Cambridge, 1953.
- ____. *De principiis*. See MIGNE, P.G., vol. 11, cols. 115–414. For translation, see: *On First Principles*. Translated by G. W. Butter-worth. London, 1936.
- ____. *De oratione*. See MIGNE, P.G., vol. 2, cols. 415–562. For translation, see: *Alexandrian Christianity. Selected Translations of Clement and Origen*. . . By John Ernest Leonard Oulton and Henry Chadwick. (Library of Christian Classics, 2.) London, 1954. (Origen "On Prayer," pp. 180–387.)
- ____. *In Genesim homiliae*. See MIGNE, P.G., vol. 12, cols. 145–262.
- ____. *In Leviticum homiliae*. See MIGNE, P.G., vol. 12, cols. 405–574.
- ____. *In Lucam homiliae*. See MIGNE, P.G., vol. 13, cols. 1801–1902.
- ____. *In Numeros homiliae*. See MIGNE, P.G., vol. 12, cols. 583–806.
- ____. *Selecta in Genesim*. See MIGNE, P.G., vol. 12, cols. 91–146.
- . See also ADAMANTIUS.
- OROSIUS. "Ad Aurelium Augustum commonitorium de errore Priscillianistarum et Origenistarum." In: *Corpus Scriptorum Ecclesiasticorum Latinorum*, Vol. XVIII. Edited by Georg Schepss. Vienna and Leipzig, 1889. (Pp. 151–57.)
- PANTHEUS, JOANNES AUGUSTINUS. *Ars transmutationis metallica*. Venice, 1519.

- [PARACELSUS (Theophrastus Bombastus of Hohenheim).] *Theophrast von Hohenheim genannt Paracelsus Sämtliche Werke*. Edited by Karl Sudhoff. Munich and Berlin, 1922–35. 15 vols. (Vol. III contains: *De vita longa*, pp. 247ff.; *De mumia libellus*, pp. 375f.; *Fragmentarische Ausarbeitungen zur Anatomie*, pp. 459ff.)
- _____. *Volumen Paramirum und Opus Paramirum*. Edited by Franz Strunz. Jena, 1904. (*De causis Morborum invisibilium*, pp. 291ff.)
- PAULI, W. “The Influence of Archetypal Ideas on the Scientific Theories of Kepler.” Translated by Priscilla Silz. In: C. G. JUNG and PAULI. *The Interpretation of Nature and the Psyche*. New York (Bollingen Series LI) and London, 1955.
- PAULINUS OF NOLA, SAINT. See: S. Pontii M. *Paulini Carmina*. Edited by Wilhelm Hartel. (Corpus Scriptorum Ecclesiasticorum Latinorum, 30.) Vienna, 1894.
- PERNETY, A. J. *Dictionnaire mytho-hermétique*. Paris, 1787.
- PETERS, CHRISTIAN HEINRICH FRIEDRICH, and KNOBEL, EDWARD BELL. *Ptolemy’s Catalogue of Stars: A Revision of the Almagest*. Washington, 1915.
- PETRUS DE ALIACO. See AILLY.
- PHILALETHES, EIRENAEUS. “Introitus apertus ...” See (A) *Musaeum hermeticum*, v.
- _____. “Metallorum metamorphosis.” See (A) *Musaeum hermeticum*, vi.
- PICINELLI, FILIPPO (Philippus Picinellus). *Mundus symbolicus*. Cologne, 1680–81.
- Pistis Sophia*. Translated by George Robert Stow Mead. London, 1896.
- “Platonis liber quattorum.” See (A) *Theatrum chemicum*, xix.
- PLINY (Gaius Plinius Secundus). *Natural History*. Translated by H. Rackham and W. H. S. Jones. (Loeb Classical Library.) London and New York, 1938– (not yet completed).
- PLOTINUS. *The Enneads*. Translated by Stephen MacKenna. 2nd edn., revised by B. S. Page. London and New York, 1956.
- PLUTARCH. *De Iside et Osiride*. In: *Plutarch’s Moralia*. With an English translation by Frank Cole Babbitt. (Loeb Classical Library.) London and New York, 1927 ff. 14 vols. (Vol. V, pp. 6–191.)
- _____. *Quaestiones convivales*. In: *Plutarchi Moralia*. Edited by C. Hubert and others. Vol. IV. Leipzig, 1925.
- POHL, OTTO. *Das Ichthysmonument von Autun*. Berlin, 1880.
- POLEMON. *De physiognomia liber*. Edited by Georg Hoffmann. In: *Scriptores Physiognomici Graeci et Latini*. Edited by P. Richard Foerster. Leipzig, 1893. 2 vols. (Vol. I, pp. 93–294.)
- PORDAGE, JOHN. *Sophia: das ist Die Holdseelige ewige Jungfrau der göttlichen Weisheit*. Amsterdam, 1699.
- PREISENDANZ, KARL. *Papyri Graecae Magicae*. Leipzig and Berlin, 1928–31. 2 vols.
- PRISCILLIAN. *Opera quae supersunt*. (Corpus Scriptorum Ecclesiasticorum Latinorum, 18.) Edited by Georg Schepss. Vienna and Leipzig, 1889.
- PROSPER OF AQUITAINE. See AUGUSTINE, *Liber Sententiarum*.
- PSELLUS, MICHAEL. *De daemonibus*. In: *Iamblichus de Mysteriis Aegyptiorum*, etc. Edited by Marsilio Ficino. Venice, 1497. (fol. N–N vi^v.)
- QUISPEL, GILLES. “Philo und die altchristliche Häresie,” *Theologische Zeitschrift* (Basel), V (1949), 429–36.
- _____. “Note sur ‘Basilide’,” *Vigiliae Christianae* (Amsterdam), II (1948), 115–16.

- RAHNER, HUGO. "Flumina de ventre Christi," *Biblica* (Rome), XXII (1941), 269–302; 367–403.
- RAMSAY, WILLIAM MITCHELL. "The Cities and Bishoprics of Phrygia," *Journal of Hellenic Studies* (London), IV (1883), 370–436.
- RASHI (Solomon ben Isaac of Troyes). See: *Pentateuch with Targum Onkelos ... and Rashi's Commentary*. Translated by M. Rosenbaum and A. M. Silbermann. London, 1929–34. 5 vols.
- REITZENSTEIN, RICHARD. *Poimandres*. Leipzig, 1904.
- _____ and SCHÄDER, H. H. *Studien zum antiken Syncretismus aus Iran und Griechenland*. (Studien der Bibliothek Warburg, 7.) Leipzig and Berlin, 1926.
- RHABANUS MAURUS. *Allegoriae in Sacram Scripturam*. See MIGNE, *P.L.*, vol. 112, cols. 849–1088.
- Rig-Veda. See: NICOL MACNICOL (ed.). *Hindu Scriptures*. (Everyman's Library.) London and New York, 1938.
- RIPLEY, GEORGE. "Duodecim portarum axiomata philosophica." See (A) *Theatrum chemicum*, x.
- _____. *Chymische Schrifften*. Erfurt, 1624.
- _____. *Opera omnia chemica*. Kassel, 1649.
- ROBERTS, R. "Jesus or Christ?—a Reply," *The Quest* (London), II (1911), 108–25.
- Rosarium philosophorum*. See (A) *Artis auriferae*, xi.
- ROSCHER, WILHELM HEINRICH. *Ausführliches Lexikon der griechischen und römischen Mythologie*. Leipzig, 1884–1937. 6 vols.
- "Rosinus ad Sarratantam." See (A) *Artis auriferae*, v.
- ROUSSELLE, ERWIN. "Seelische Führung im lebenden Taoismus," *Eranos-Jahrbuch 1933* (Zurich, 1934), 135–99.
- RULAND, MARTIN. *Lexicon alchemiae*. Frankfurt a. M., 1612. Translated as: *A Lexicon of Alchemy*. [London, 1892.]
- RUPESCISSA, JOANNES DE. "De confectione veri lapidis." See GRATAROLUS, in whose work it is contained.
- _____. *La Vertu et la propriété de la quinte essence*. Lyons, 1581.
- RUSKA, JULIUS FERDINAND. *Tabula Smaragdina; ein Beitrag zur Geschichte der hermetischen Literatur*. Heidelberg, 1926.
- _____. *Turba Philosophorum*. Berlin, 1931.
- _____. "Die Vision des Arisleus." In: *Historische Studien und Skizzen zu Natur- und Heilwissenschaft*. Festschrift für Georg Sticker. Berlin, 1930.
- SCHÄRF, RIWKAH. "Die Gestalt des Satans im Alten Testament." In: C. G. JUNG. *Symbolik des Geistes*. Zurich, 1953.
- SCHEFTELOWITZ, I. "Das Fisch-Symbol im Judentum und Christentum," *Archiv für Religionswissenschaft* (Leipzig), XIV (1911), 1–53, 321–92.
- SCHOETTGEN, CHRISTIAN. *Horae Hebraicae et Talmudicae*. Dresden and Leipzig, 1733–42. 2 vols.
- SCHREBER, DANIEL PAUL. *Memoirs of My Nervous Illness*. Translated by Ida Macalpine and Richard A. Hunter. London, 1955. (Original: *Denkwürdigkeiten eines Nervenkranken*. Leipzig, 1903.)
- SCOTT, WALTER (ed.). *Hermetica*. Oxford, 1924–36. 4 vols.
- SENARD, MARCELLE. *Le Zodiaque*. Lausanne, 1948.
- SENDIVOGIUS, MICHAEL. "Novi luminis chemici." See (A) *Musaeum hermeticum*, iv.

Shaare Kedusha. See VITAL, HAYIM.

Shatapatha Brahmana. Translated by Julius Eggeling, (Sacred Books of the East, 12, 26, 41, 43, 44.) Oxford, 1882–1900. 5 vols.

Sibylline Oracles. See: *Oracula Sibyllina*. Edited by John Geffken. (Griechische Christliche Schriftsteller.) Leipzig, 1902.

SILBERER, HERBERT. *Der Zufall und die Koboldstreiche des Unbewussten*. (Schriften zur Seelenkunde und Erziehungskunst, 3.) Bern and Leipzig, 1921.

SMITH, E. M. *The Zodia*. London, 1906.

SÖDERBERG, HANS. *La Religion des Cathares*. Uppsala, 1949.

SPIEGELBERG, W. "Der Fisch als Symbol der Seele," *Archiv für Religionswissenschaft* (Leipzig), XII (1909), 574–75.

STEPHEN OF CANTERBURY. *Liber Allegoricus in Habacuc*. [Facts unavailable.—EDITORS.]

STRAUSS, HEINZ ARTHUR. *Die Astrologie des Johannes Kepler*. Munich and Berlin, 1926.

SYNESIUS OF CYRENE. *Hymni et Opuscula*. Edited by Nicholas Terzaghi. Rome, 1944. 2 vols.

TABARI. See MUHAMMAD IBN JARİR ABŪ-JAFAR AL TABARĪ.

Tabula smaragdina. See (A) *Ars chemica*, ii; RUSKA.

TACITUS, P. CORNELIUS. *Historiarum Liber: The Histories*. Edited by W. A. Spooner. London, 1891. For translation, see: *The Histories*. Translated by W. Hamilton Fyfe. Oxford, 1912. 2 vols.

Talmud. *The Babylonian Talmud*. Translated into English under the editorship of Isidore Epstein. London, 1935–52. 35 vols. (Abbr.: *BT*.)

Targum. *The Targum to The Song of Songs*. Translated by Hermann Gollancz. London, 1908.

TATIAN. *Oratio adversus Graecos*. See MIGNE, *P.G.*, vol. 6, cols. 803–888. For translation, see: *The Writings of Tatian, etc.* Translated by B. P. Pratten [and others]. (Ante-Nicene Christian Library, 3.) Edinburgh, 1867.

TERTULLIAN. *Adversus Marcionem*. See MIGNE, *P.L.*, vol. 2, cols. 239–526. For translation, see: *The Five Books of Tertullianus against Marcion*. Translated by Peter Holmes. (Ante-Nicene Christian Library, 7.) Edinburgh, 1868.

_____. *Apologeticus adversus gentes pro Christianis*. See MIGNE, *P.L.*, vol. 1, cols. 257–536. For translation, see: *The Writings of Quintus Septimus Tertullianus*. Vol. I. Translated by S. Thelwall. (Ante-Nicene Christian Library, 11.) Edinburgh, 1869. (Pp. 53–140.)

_____. *De baptismo*. See MIGNE, *P.L.*, vol. 1, cols. 1197–1224. For translation, see: *The Writings* (as above). (Pp. 231–56.)

THEODOR BAR-KUNI. *Inscriptiones mandäites des coups de Khouabir*. Edited by H. Pognon. Paris, 1898–99. 3 parts (consecutively paginated).

THEOPHILUS OF ANTIOCH. *Ad Autolyicum*. See MIGNE, *P.G.*, vol. 6, cols. 1023–1168.

THIELE, GEORG. *Antike Himmelsbilder*. Berlin, 1898.

THOMAS AQUINAS, SAINT. *Summa contra Gentiles*. Translated by the English Dominican Fathers. London, 1924–29. 5 vols.

_____. *Summa theologica*. Translated by the Fathers of the English Dominican Province. London, 1911–22. 18 vols.

- THOMAS AQUINAS, pseud. "Aurora, sive Aurea hora." In: [H. CONDEESYANUS, pseud., i.e., J. Grasseus.] *Harmoniae imperscrutabilis chymico-philosophicae, sive Philosophorum antiquorum consentientium ... Decas I ... collectae ab H.C.D. ... Decas II ... collecta studio et industria Joannis Rhenani, M. D. Frankfurt a. M., 1625. See also (A) Artis auriferae, iv.*
- THORNDIKE, LYNN. *A History of Magic and Experimental Science*. New York, 1923–57. 8 vols.
- TITUS OF BOSTRA. *Adversus Manichaeos libri III*. See MIGNE, P.G., vol. 18, cols. 1069–1256.
- "Tractatulus Avicennae." See (A) *Artis auriferae, ix*.
- "Tractatus Aristotelis" See (A) *Artis auriferae, vii*; *Theatrum chemicum, xx*.
- "Tractatus aureus." See (A) *Ars chemica, i*; *Theatrum chemicum, xvii*.
- Turba philosophorum*. See RUSKA, *Turba Philosophorum*; (A) *Artis auriferae, i*; MANGETUS, *Bibliotheca chemica, ii*; *Theatrum chemicum, xvii-a*.
- Upanishads. See: *The Principal Upanishads*. Translated by Sarvapalli Radhakrishnan. London, 1953.
- USENER, HERMANN. *Das Weihnachtsfest*. 2nd edn., Bonn, 1911.
- [VAUGHAN, THOMAS.] *The Works of Thomas Vaughan: Eugenius Philaletha*. Edited by A. E. Waite. London, 1919.
- VIGENÈRE, BLAISE DE. See (A) *Theatrum chemicum, xxi*.
- VIROLLEAUD, CHARLES. "Note complémentaire sur le poème de Mot et Alein," *Syria* (Paris), XII (1931), 350–57.
- _____. "La Légende de Baal, Dieu des Phéniciens," *Revue d'études sémitiques* (Paris), C (1935), iii–xxi.
- "Visio Arislei." See (A) *Artis auriferae, ii*.
- VITAL, HAYIM. *Shaare Kedusha* ("The Gates of Holiness"). (In Hebrew.) Jerusalem, 1926. (Orig., Constantinople, 1731.)
- VOLLERS, KARL. "Chidher," *Archiv für Religionswissenschaft* (Leipzig), XII (1909), 234–84.
- WACKERBARTH, GRAF AUGUST JOSEPH LUDWIG VON. *Merkwürdige Geschichte des weitherühmten Gog und Magog*. Hamburg, 1820.
- WAITE, ARTHUR EDWARD. *Lives of Alchemistical Philosophers*. London, 1888 (reprinted, 1955).
- _____(trans.). *The Hermetic Museum Restored and Enlarged*. London, 1893. 2 vols. (Original: (A) *Musaeum hermeticum*.)
- _____. See also VAUGHAN.
- WEISS, JOHANNES. *The History of Primitive Christianity*. London, 1937. 2 vols. (Original: *Das Urchristentum*. Gottingen, 1914–17.)
- WHITE, VICTOR, O.P. "Eranos, 1947, 1948." In his: *Dominican Studies*. Oxford, 1949. 2 vols. (Vol. II, pp. 399–400.)
- WICKES, FRANCES GILLESPEY. *The Inner World of Man*. New York and London, 1950.
- WILHELM, RICHARD. *The Secret of the Golden Flower*. With a European commentary by C. G. Jung. Translated by Cary F. Baynes. London and New York, 1932; revised edn., 1962.
- WIRTH, ALBRECHT. *Aus orientalischen Chroniken*. Frankfurt a. M., 1894.
- WISCHNITZER-BERNSTEIN, RAHEL. *Symbole und Gestalten der jüdischen Kunst*. Berlin, 1935.
- WÜNSCHE, AUGUST. **אדר' המשיח** or *Die Leiden des Messias*. Leipzig, 1870.
- Zohar, The*. Translated by Harry Sperling and Maurice Simon. London, 1931–34. 5 vols.

ZOSIMUS. "Rosinus ad Sarratantam." See (A) *Artis auriferae*, v.

INDEX

INDEX

In entries relating to the books of the Bible, the numbers in parentheses indicate the chapter and verse(s) referred to.

A

Aaron, [107](#), [228](#)

abaissement du niveau mental, [28](#), [202](#)

Abarbanel, Isaac, [74](#), [107](#)

Abba, Rabbi, [80](#)

Abercius inscription, [73](#), [89n](#), [103](#), [115](#), [117](#)

ablution, [187](#)

Abot de Rabbi Nathan, [113n](#)

Abraham, [59](#)

Abraham ben Hiyya, Rabbi, [74](#)

Abu Ma'shar/Abu Mansor, *see* Albumasar

accentuation, moral, of opposites, [70](#)

acetum, [160](#); *see also* vinegar

Achamoth, *see* Sophia

act of God, [25](#)

Acts of the Apostles, (2:3), [135n](#)

(7:43), [75n](#)

(17:29, 30), [191n](#)

Acts of Thomas, *see* *Thomas, Acts of*

Adam, [199](#)

Adam/Eve syzygy, [254](#)

carries Eve with him, [206](#)

Christ and, [39](#), [197](#), [232](#)

Eve's birth from, [205f](#)

first and second, [37](#)

higher, [197](#), [214](#), [232](#), [237](#), [240](#), [248](#), [255](#)
—, and lower, [227](#), [233](#)
lower, [244](#), [255](#)
male/female, [204](#)
mystic, [36](#)
original man/Anthropos/Archanthropos, [200](#), [203](#), [208](#), [218n](#)
relation to creator and creatures, [189](#)
as “rock,” [88](#), [208](#)
second, [201](#), [204](#)
and serpent, [233](#), [244f](#)
Adamantius, dialogue of, [54n](#)
Adamas (arch-man), [208](#)
adamas (steel), [161](#)
Adam Scotus, [100f](#)
adaptation, weak, and emotion, [9](#)
Adar, month of, [119](#)
Adech, [213](#)
Adler, Alfred, [165](#)
Adonis, [121](#), [199](#)
“Aenigmata ex Visione Arislei,” [126](#), [127n](#), [137–38](#), [142](#)
Aeon: Autopator as, [191](#)
birth from Kore, [104](#)
aeon, Christian, [ix](#)
“aes Hermetis,” [156](#)
Aesculapius, serpent of, [245n](#)
affects, [9](#)
and anima/animus, [16](#)
feeling-tone, [33](#)
Africa, [96](#), [175](#)
agape, [90](#)
Agathodaimon, [186](#)
serpent as, [188](#), [230](#), [245n](#)
ages, two, in pseudo-Clement, [55](#)
aggregation, states of, [250f](#), [257](#)

ἄνοια, 191

ἀγνωαία, 190–92, 193n

God's, 194

Ailly, Pierre d', 75n, 76n, 77n, 82, 83, 96, 97, 98n, 99

Aipolos, 216

air, 249

Akathriel, 60

albedo, 148, 235

Albertus Magnus, 77n, 80n, 87, 256

Albigenses, 150

Albumasar (Ja'far ibn Muhammad [Abu Ma'shar] al-Balkhi), 75, 76–78nn, 80n, 95n, 96, 97, 99

alchemy/alchemyists, 89 *et passim*

beginnings of, 173

Catharism and, 150

Chinese, 264

and Christ, 182

Christ-image in, 67

compensation in, 124

conjunction of opposites in, 40

dragon in, 120

eagle in, 64n

fish in, 126ff

Latin, beginnings of, 87

motive of, 171

and natural science, 176

Negroes in, 210

pagan currents in, 176

phenomenology of symbols in, 179

physical speculations of, 249ff

quaternio in, 232ff

rise of, 150

significance of matter in, 66

and "theoria," 179

unconscious in, 142

Alciati, Andrea, [158](#)
alcohol, [225](#)
alembics, three, [241](#)
Alexandria, [89](#), [104](#), [156n](#)
Alexius Comnenus, [148](#)
“Allegoriae sapientum supra librum Turbae,” [126](#)
“Allegoriae super librum Turbae,” [125n](#), [126](#), [127n](#)
allegories, *see* symbols
Allenby, Amy Ingeborg, [268n](#)
Almaricus, *see* Amalric of Bene
Amalric of Bene, [83](#)
ambivalence, [13](#)
 of fish symbol, [118ff](#)
Ambrose, St., [88](#), [235n](#)
Amen, [206](#)
Amitābha land, vision of, [151n](#)
Amon, [78](#)
Amoraim, [80n](#)
Amos, Book of, (5 : 26), [74f](#)
Anacreon, beaker of, [211](#)
analogy formation, [261](#)
analysis, [260](#)
anamnesis, [40](#), [180](#)
Andrew, St., [89](#)
androgyny, of Christ, [204](#), [205](#)
angels, [146](#), [195](#)
Angelus Silesius, [206](#)
Anger, Rudolph, [74n](#)
Ani, Papyrus of, [76n](#)
anima, [8](#), [10](#), [13ff](#), [30f](#), [187](#), [266](#)
 and Eros, [14](#)
 feeling-value of, [28](#)
 liberty as, [30](#)
 Miriam as, [210](#), [228](#)

novelists and, 267
personification of unconscious, 11n
possession by, 23; *see also* anima/animus

anima/animus: appearance of contents, 19
cannot be integrated, 20
effects on ego, 16f
fear of, 33
feeling-value of, 28
as functions, 20
positive aspect, 268
recognition of, 22, 267
relation to each other, 15

anima christiana, 36
anima mundi, 136, 142, 160, 198, 242
anima rationalis, 38f, 212n
anima rerum, 157–58n

animals, helpful, 145, 186

animosity, 16, 267

animus, 8, 10, 14ff, 30f, 33, 266, 267
and logos, 14, 16, 21
positive aspect of, 16; *see also* anima/animus

annunciation, of Christ-figure, 189

Anthropos, 246, 247, 259
Christ as, 204
figures, ix, 65, 204
Gnostic, 197f
—, names of, 189
and Hermes, 230
king as, 198
serpent/snake and, 232f
symbol for God, 195
vessel as counterpart of, 242; *see also* Adam; Archanthropos; Man, original;
Protanthropos

Anthropos quaternio, 231, 233, 244, 254

Anthropus primus, Saturn as, 197

Antichrist, ix, 36, 61, 62, 63, 94, 106

astrological origin, 76

astrological prediction of, 99

as half archetype of self, 44

as King of the Jews, 79n, 107

Nostradamus on, 101

problem of, 42f

prophecies of, 109

second, 96, 102

as shadow of self, 42, 44

antimimon pneuma, 35, 42

Antony, Mark, 144

Anu, 124

Apelles, 75

Apep, 76

Aphrodite, 21, 104, 112, 217

Apocalypse, ix, 36, 90, 105–6, 110; *see also* Revelation of St. John

apocatastasis, 40, 169, 259

Apollo, 81, 252

Apollonius of Tyana, 126n

Apophis-serpent, 230

apperception, 169

aqua, 160

abyssi, 215

doctrinae, 159, 180, 185, 187, 188, 215, 241

permanens, 88, 150, 158, 187n, 235, 239n, 241

roris nostri, 158

Aquarius () , 82, 87, 91, 92, 93

Aquilo, 100, 125

Arab tradition, fish in, 123

Aratus, 92n

arcane substance/arcanum, 152, 157, 159, 160, 163, 187n

artifex as, 155

fishes as, 150

healing power of, 180

called *lapis*, 236

magnesia as, 156

in man and without, 162

refers to self, 145

Archanthropos, 197, 203, 209; *see also Adam*; Anthropos; Man, original; Protanthropos
Archegonos, 201n

archetic appetite, 133, 134

archetype(s), 8, 16f, *et passim*;

in art history, 68

assimilation of, 222

autonomous factors, 21

denotes completeness, 68

good and bad effects of, 267

image of instinct, 179

numinosity of, 184n, 196

self as, 167, 169

of the Spirit, 85

totality of, 196

unconscious organizers of our ideas, 179; *see also anima*; animus; brothers, hostile;
Christ; God-man; marriage quaternio; mother, chthonic; mother-son marriage;
Redeemer; self; shadow; spirit of gravity; wholeness; wise old man

Archeus, 133n, 213

archon(s): Christ and, 65

demiurge, 190

of future/this Aeon, 254

Gnostic, 57, 230

Ialdabaoth, 75, 208

Sabaoth, 76

argument, animus and, 15

Aries (♈), 74n, 82, 90n, 98, 103; *see also Ram*

Arisleus, 143

vision of, 130n

—, *see also* “Aenigmata ex Visione Arislei”

“Aristoteles de perfecto Magisterio,” 156

Aristotle, [51](#)
Armilus, [107](#)
Ars chemica, [187n](#)
art, history of, archetype in, [68](#)
Artefius, [132n](#)
Artis auriferae, [126n](#), [130n](#), [197n](#), [238n](#), [240n](#), [241n](#)
“as if,” [203](#)
ascendent, [82n](#), [148](#)
ascension, [65](#)
Ascension of Isaiah, [57](#)
aspersion, [187](#)
ass, [75f](#)
assimilation, [189](#)
 ego/self, [24f](#)
 by projection-making factor, [24](#)
Assumptio Mariae, see Mary
assumptions, [15](#)
Astarte, [112](#)
astrology, [262](#)
 Fishes in, [111](#)
 Oriental, [93](#)
 Saturn in, [75ff](#)
Atargatis, [73](#), [104](#), [111](#), [112](#), [121](#)
atheism, [109](#)
Athens: Little Metropolis, [91](#)
 St. Paul and, [176](#), [191](#)
atman, [32](#), [69](#), [144](#), [167](#), [194](#), [222](#)
atom, [237](#), [242](#), [249](#), [260](#)
attention, [24](#)
Attis, [213](#), [217n](#)
 as Ichthys, [152n](#)
 “holy shepherd,” [89n](#)
 polymorphous, [199](#)
 Shepherd and, [103](#)

Augurellus, Joannes Aurelius, [232n](#)
Augustine, St., [38–40&nn](#), [46](#), [49–51](#), [52](#), [72n](#), [79n](#), [80n](#), [90n](#), [100](#), [113](#), [120](#), [147](#), [158](#),
[182](#)
Augustus, [144](#)
Aurelia occulta, [187n](#)
Aurora consurgens, [88n](#), [156n](#), [220n](#), [238n](#), [239n](#), [241](#)
aurum nostrum, [127](#)
Authades, [197n](#)
authority, inner, [25–26](#)
autism, [9](#)
autoerotism, projections and, [9](#)
Autogenes, [197n](#)
autonomy: of anima/animus, [20](#), [28](#)
 of archetypes, [21](#)
 of characteristics of shadow, [8](#)
Autopator, [190f](#)
Autun, [89](#)
avatar, [176](#)
Aztecs, [144](#)

B

Baal, [119](#)
Baba Bathra, see Talmud
Baba Kamma, see Talmud
Babylon, [121](#)
Babylonian tradition, [124](#)
Bacchus, [199](#)
Bacon, Roger, [87](#), [97](#), [256](#)
Bactria, [74](#)
Bahman Yast, [108](#)
Balaam, [59](#), [117](#)
Balak, [59](#)
baptism, [89](#), [90](#), [88](#); see also font
Barabbas, [91](#)
barbel, [122](#)

Barbelo, [195](#), [197n](#)
 Barbelo-Gnosis, [196n](#), [197n](#)
Bardesanes, [54](#)
Bar-Kuni, *see* Theodor Bar-Kuni
Baruch, Apocalypse of, [115](#), [116](#), [118](#)
Basil the Great, St., [46–48](#), [82](#), [129](#)
Basilides/Basilidians, [64](#), [66](#), [185n](#), [190](#), [230](#), [234n](#), [269](#)
Basilius (Bogomil bishop), [148](#)
bath kol, [106](#)
Baubo, chthonic, [13](#)
Bauer, Walter, [213n](#)
bear, as symbol, [226](#)
Bear, Great, *see* Great Bear
Beasts, Lady of the, [116](#)
Beatus, Giorgius, [187n](#)
beetle, [226](#)
Beghards, [84](#), [150](#)
Beguins, [150](#)
Behemoth, [115n](#), [118](#), [120](#), [121](#), [123](#), [147n](#)
 battle with Leviathan, [80](#), [118](#)
 eucharistic food, [116](#)
being, in God, [193](#)
Belinus, [126n](#)
beloved, [12](#), [13](#)
Benat na'sh, [124](#)
Benedict, St., [82–83](#), [85](#)
Benoist, Jean, [145](#)
Berakoth, *see* Talmud
Bereshith Rabba(ti), [59n](#), [106](#)
Bernard of Clairvaux, St., [125](#)
Bernardus Trevisanus, [143](#), [239n](#)
Berthelot, Marcellin, [65n](#), [127n](#), [143n](#), [156n](#), [159n](#), [238n](#), [264n](#)
Bethlehem, [106](#)
Bible, Protestants and, [178](#)

bīn, 121

bird(s): allegory of Christ, 72

two fighting, 150

white and black, 226

body, 64–65

in Basilides, 66

body/spirit triads, 55

Bogomils, 58, 147, 150

Böhme, Jakob, 61, 125, 171, 252*n*

Boll, Franz Johannes, 81*n*, 90*n*, 91*n*, 104*n*, 105

Bouché-Leclercq, Auguste, 75*n*, 76*n*, 81*n*, 104*n*, 112*n*

Bousset, Wilhelm, 75*n*, 108*n*, 109, 197*n*, 198*n*, 208*n*, 219*n*, 220*n*

Brahe, Tycho, 81*n*

brahman, 222

“Bread through God,” 84

breasts, Christ’s, 205

Brethren of the Free Spirit, 84, 150

brh, 119

Bṛihadāraṇyaka Upanishad, 223

Brimos, 217

brother-sister pair, 31, 210

brothers, hostile, 80*n*, 81, 87, 254

monsters as, 119

Brugsch, Heinrich, 207*n*

Buddha, symbol for God, 195

Buddhism, 136

and yoga, 176; *see also* Zen

Budge, Ernest Alfred Wallis, 88*n*, 122*n*, 123, 207*n*

bull: Behemoth as, 120

Mithras and, 124

one-horned, 199

as symbol, 226

Bundahish, 246*n*

Cabala/cabalism/cabalists, [58](#), [61](#), [125](#), [173](#), [218n](#), [268](#)

Cabiros/Cabiri, [201](#), [212](#)

Cabrol, Fernand, and Leclercq, Henri, [89n](#)

Caesarius of Heisterbach, [239n](#)

calendar, revolutionary, [98](#)

Caligula, [144](#)

Campbell, Colin, [198](#)

Cana, miracle of, [211](#)

Canopic jars, [122](#)

Canticles, *see* Song of Solomon

Capricorn () , [92](#), [111](#)

caput corvi, [210](#)

carbon-nitrogen cycle, [260](#)

Carcassonne, [145](#)

Cardan, Jerome, [76n](#), [77n](#), [82](#), [95n](#)

Carthage, [121](#)

Carus, C. G., [6](#)

Cassino, Monte, [83](#)

castle, as symbol, [224](#)

Castor, [81](#)

cat, black, [30](#)

Cathari/Cathars, [58](#), [83](#), [146ff](#)

 and alchemy, [150](#)

causation, psychological, [62](#)

causes, [165](#)

Caussin, Nicholas, [128](#), [192](#)

Celsus, [75](#)

centre, [224](#)

 in alchemy, [169](#)

 in man, and God-image, [171](#)

 in one-self and environment, [170](#)

 in Plotinus, [219](#)

 psychic and alchemical, [171](#)

cerebellum, “Son” and, [186](#)

cerebrum, “Father” and, 186
Chaldaeans, 111
chalybs, 132
chaos, 79, 148, 155, 194, 234, 236–37
 and cosmos, 3–2
 magnesia as, 156; see also *massa confusa*
Charles, R. H., 115n, 118n, 147n
Chartier, Jean, 139n
chemical processes, alchemy and, 157
cherub/cherubim, 123, 241
child: divine, 31
 symbol for God, 195
China: circular *opus* in, 264
 dragon symbolism in, 245
 religions of, 70
“chirographum,” 230 & n
Chiun, 74, 75n
choice: four elements and, 56
 free, 5
Christ, 32, 255
 and age of fishes, 92, 114
 as Anthropos, 204
 and Antichrist, 61, 115
 archetype of self, 37
 — of wholeness, x, 40
 assimilation into psyche, 221
 attributes of, and self, 44
 as avatar of Vishnu, 176
 childhood of, 103
 common symbols with devil, 72
 and contents of unconscious, 181
 death of, 35
 descent into hell, 39
 dualistic aspects, 111

both ego and self, 110
as fish, *see* fish(es)
and horoscope, 136–37
horoscopes of, 77*n*
human soul of, 39
as inner man, 203
as king and priest, 39, 147
lamb and, 105–6
male/female, 205
and Mary, in Gnostic legend, 202
as new aeon, 90
the perfect man, 69
pre-existent, 148
as quaternion of opposites, 63
as rock, 88
scriptural symbols of, 221
second, 65
and self, parallel, 42, 44
and serpent, 186, 232
and shadow, 41*n*, 110
spouse of the Church, 21
subjective parallel of, 182
symbol for God, 195
— of self, 36*ff*, 62*n*
synoptic and Johannine, 72
transfiguration of, 122*n*
“uncomeliness” of, 140
“within,” 183
as younger son of God, 57, 147; *see also* Adam; androgyny; Ichthys
Christ-figure: annunciation of, 189
significance of, 203–4
Christ-image: anthropomorphic, 67
perfection of, 68–6g
Christensen, Arthur, 77*n*, 246*n*

Christian doctrine: and nature, 173
and the psyche, 174

Christianity: astrological origin, 76
divine syzygy in, 21
Germanic acceptance of, 175
myths underlying, 179
place in Western life, 175

Christmas Eve, 111

Chronos, 139

chthonic world, shadow and, 34

Church: as Bride of Christ/Lamb, 21, 204
as female, 21n
in modern world, 176
soul as, 206
as symbol, 224

Chwolsohn, Daniel, 75n, 197n

cinedian fish/stone, 138–39

circle(s): character of wholeness, 224n
God as, 153
magic, 32
in Maier, 264
soul as, 219
and square/squaring of, 224–25, 239, 241, 264
squared, of self, 204
symbols, 194
— of God, 195
—, self in, 190

circumambulation, 224

citrinitas, 127

city: heavenly, 37
in Oxyrhynchus sayings, 145
as symbol, 224

Clement of Alexandria, 22, 113n, 121, 222, 234n

Clement of Rome, 125

Second Epistle to Corinthians, [21n](#)
for pseudo-Clement, *see* Clementine Homilies
Clementine Homilies, [54ff](#), [10n](#), [192n](#), [254](#)
cloud, [155](#)
Cnidaria, [128](#)
Codex Ashburnham 1166, [232](#)
cognition, [61](#), [69](#)
collective unconscious, [7](#), [164](#), [223](#), [234](#)
 archetypes and, [8](#)
 autonomy of, [20](#)
 dogma and, [174–75](#)
 and mythology, [179](#)
Collesson, Johannes, [160](#), [162](#)
collision, of conscious and unconscious, [194](#)
collyrium, [127](#)
Colossians, Epistle to the, (2 : 14), [230n](#)
commisure, [93](#), [148](#)
compass, [134](#)
Compendium theologiae veritatis, [80n](#)
compensation: function of unconscious, [20](#)
 in man and woman, [14](#)
completeness: and perfection, [68](#), [69](#), [111](#)
 voluntary, [70](#); *see also* wholeness
complexio oppositorum, [61n](#), [225](#), [267](#); *see also coniunctio oppositorum*
compulsion, [140](#)
 c. neurosis, [10](#)
concept, [33](#)
 merely a name, [32](#)
 metaphysical, [34](#)
Concorricci, [83](#), [146n](#)
concupiscentia, [112](#), [129](#)
confusion, [194](#)
coniunctio, of Adam and Eve, [206](#)
coniunctio(nes) maxima(e), [82](#), [96](#), [97](#), [98](#), [111](#)

coniunctio oppositorum, 31, 152, 159, 167, 268; *see also* opposites, conjunction of
conscientiousness, 24
consciousness: in Autopator, 191
 broadening of, and *opus*, 148
 cannot comprehend whole, 110–11
 and causes and ends, 165
 differentiation of, 191
 and discrimination, 260
 ego and, 3, 24
 ego as subjective, 164
 founded on unconsciousness, 30
 God-image and, 194
 limits of its field, 3
 monsters and development of, 121
 myths and coming of, 148
 relation of unconscious manifestations to, 225
 and splitting of Original Man, 204
 threshold of, 4; *see also* ego
consensus omnium / consensus generalis, 29, 30, 47, 178
constellations, 29
consummation of universe, 254
conversion, 40
copulation, 206
 self-, 207
coral, 125n
Corinthians, First Epistle to, (5 : 2), 23n
 (10 : 4), 88
 (10 : 16), 115n
 (15 : 47), 39n
 Second Epistle to (Clement of Rome), 21n
Cornarius, 191
corpus mysticum, 32
correspondence: in *opus alchemicum*, 262
 principle of, 258; *see also* synchronicity

cortex, [127](#), [137–38](#)
corybants, [211](#)
Corybas, *see* Korybas
cosmos, and chaos, [32](#); *see also* chaos
Cramer, H., [213n](#)
crazes, [169](#)
creation: Heliopolitan story of, [207](#)
 and *opus*, [148](#)
 of world by devil, [146](#)
creator: as dreaming, [192](#)
 Gnostic symbols for, [196](#)
creed, [174](#), [179](#)
crocodile, [244](#)
cross, [65n](#), [182](#), [189](#)
 as quaternity symbol, [204](#), [224](#)
 and snake, [78n](#)
 as symbol of God, [195](#)
crucifixion, [69](#), [70](#)
 punishment for slaves, [78n](#)
crystal, [224](#)
culture hero, Christ as, [36](#)
Cumont, Franz, [91n](#), [115n](#), [121](#)
Curetes, [211](#)
Cybele, [121](#)
Cyprian, St., [112n](#)
Cyranides, [138](#)

D

Dactyls, [212](#)
Dagon, [115n](#), [121](#)
daimon(ion), [27](#), [199](#), [226](#)
Darndad-Nashk, [246n](#)
damnation, eternal, [61n](#)
Daniel, Book of, [74](#)
 (2 : 34), [208n](#)

(2 : 35), [209n](#)
(2 : 45), [88n](#)
(3 : 24f), [199](#)
(3 : 25), [123n](#);
(11 : 36ff), [36n](#)
Dardaris, [250](#)
daughter, [12](#)
 and father, [14](#), [16](#)
David, [79](#)
dawn-state, [148](#)
dealbatio, [148](#)
Dee, John, [221](#)
Degenhardus, [139](#)
De Gubernatis, Angelo, [114](#)
“De igne et sale,” [132n](#)
deliberation, [16](#)
Demeter, [12](#)
demiurge, [110](#), [230](#)
 Basilidian, [190](#)
 devil as, [150](#), [232](#)
 Esaldaios, [208](#)
 Gnostic, [150](#), [196](#), [197–98](#)
 ignorant, myth of, [189](#)
 Satanael as, [147–48](#)
 son of, [190](#)
Democritus (alchemist), [143n](#), [159](#)
Denderah, [76n](#), [91](#)
Denzinger, Heinrich, and Bannwart, Klemens, [52n](#), [83n](#), [253n](#)
Derceto, [73](#), [104](#), [111](#)
descensus ad inferos, [39](#)
Deus absconditus, [135](#)
Deussen, Paul, [152n](#)
Deuteronomy, (32 : 17), [107](#)
 (32 : 39), [55](#)

devaluation, of sexuality, [226](#)
devil: as Adversary, [42](#)
 his body of fire, [132n](#)
 in Christian dogma, [124](#)
 counterpart of God, [61](#)
 as demiurge, [150](#), [232](#)
 and evil, [48](#)
 fourth person, [208](#)
 God ruling world through, [254](#)
 in Joachim of Flora, [86](#)
 Origen and fate of, [110](#)
 in Protestantism, [41](#)
 serpent as, [188](#), [230](#)
 symbols, in common with Christ, [72](#)
 world created by, [146](#); *see also* Satan
dharma, [217n](#)
Didymus of Alexandria, [235n](#)
Dieterich, Albrecht, [89](#), [124n](#)
dilemma, of one and three, [195](#), [224](#), [225](#)
din, [58](#)
Diodoros (Megarian philosopher), [76n](#)
Diodorus, [76](#)
Dionysius the Areopagite, [46](#), [49](#), [51](#)
Dionysus, [81](#), [158](#)
Diorphos, [121](#)
Dioscorides, [156n](#)
Dioscorus, [159n](#)
Dioscuri, [81](#)
Diotima, [27](#)
discrimination, [121](#), [258](#), [260](#)
 of the natures, [79](#)
distillation, circular, [265](#)
disturbance, symptoms of, [29](#)
divisio, [168](#), [187](#); *see also* *separatio*

doctrinairism, 86

doctrine, Christian, *see* Christian doctrine

Doelger, Franz Josef, 73, 89, 113n, 114n, 115, 121

dog, 150

dogma(s), 169, 174–75

barbarian peoples and, 175

“belief” in, 178

believers and, 178n

drift from, 179

prejudice against, 175

reason for insistence on, 179

and “sacred history,” 179; *see also* doctrine

Dominican order, 83

Domitian, 110

Dorn, Gerhard, 157, 159, 160–64, 166, 169–71, 174, 181, 187n, 197n, 220, 221n, 239, 264

dove, 115n, 139, 197

Dozy, Reinhart, and de Goeje, M. J., 75n

drachates / *draconites* / *dracontias*, 138, 139, 140

draconite, *see* *drachates*

Dragomanov, M., 147n

dragon, 155, 197

in China, 245

head of, 100

and snake, 233n, 244

stone of, 138f

winged and wingless, 120

and woman, 12, 103–4

see also snake

dream-analysis, 203

dreams, 25, 30, 35, 142, 223, 243

anima/animus in, 19

childhood, 190

of disoriented student, 134

fire in, 137n

of fishes, 151–52
image of self in, 67
instinctual foundation of, 203n
mandalas in, 31
of Passion play and snake, 78n
quaternary symbols in, 132n
shadow in, 120
symbolism in, 202
Drews, Arthur, 90n
dualism: in archetypal self, 42
 in Christ-figure, 111
 God's humanity and, 110
 Manichaeism, 49, 55, 57n, 58, 61, 269
duality: man's, 255
 symbol for God, 195
du Cange, Charles, 128n, 138n, 154n
“Duodecim portarum axiomata philosophica,” 131n
“Duodecim tractatus,” 156n, 158
duty, conflicts of, 25, 45
dyad, 194
Dyophysites, 110

E

Ea, 121
eagle, 64, 72, 120
earth, 264
East, Philosophical, 132
Ebionites, 44, 81, 147, 197
Ecclesiasticus (9: 18[25]), 135
 (48 : 1), 129
echeneis, 140–42, 144, 145, 154–55
echinus, see *echeneis*
Eckhart, Meister, 87, 135, 189, 193–94, 206, 219
ecliptic, 93, 124
Eden, 225, 234; see also Paradise

education, modern, and dissociation, 181

egg, 220n, 239n

ego, 190

acquired during lifetime, 5

approximation to self, 23

archetypes and, 8

as centre of personality, 6

Christ's correspondence to, 110

complex nature of, 3

conscious and unconscious in, 4

dependence on unconscious, 7

effects of anima/animus on, 16

exponent of self, 223

individuality of, 6

inflation of, 23–24

its knowledge of itself, 163–64

and metaphysical ideas, 34

not coincident with conscious personality, 4

overpowering of, 23

perplexity of, 189

relative abolition of, 45

somatic and psychic bases of, 3, 4

subjective consciousness, 164

subordinate to self, 5

as total consciousness, 5

what it is, 3; *see also* assimilation; personality

ego-consciousness: differentiation from unconscious, 24

and psyche, 164

shadow and, 28

Egypt, 209n

fish-cult in, 121

flight of Christ to, 103

and Israel, common symbols, 123

Jews in, 78

slaying of firstborn in, 58n
eidos, 34
eight, 224
Eisler, Robert, 90n, 91n, 103n, 104n, 116n, 121n
Eleazar, Abraham, 131
electron, 187n
elements, four, 251, 254, 264f, Plate I
 contained in *lapis*, 166, 237 & n;
 hate and love of, 17
 quaternity of, 86, 197n
 as stages of fire, 249
elephant, 226
Elephantine, 121
Eleusis: mysteries of, 217
 priests of, 217n
Elias, 106, 122n
elixir vitae, 127, 180
Elogabal, 89n
Elysian Fields, 30
Emmaus, 113
emotion: not an activity, 9
 and the shadow, 8–9
emotionality, female, 55
Empedocles, 17
enantiodromia, ix, 43, 93, 95, 102, 108, 149, 225, 258
ends, 165
energy, 251
enkekalymmenos, 18
Enlightenment, the, 43, 150
ἔννοια, 191, 197n; *see also* consciousness
“Entkrist,” 101
Enuma Elish, 124
environment: influence of, 21
 projections and, 9–10

Ephesians, Epistle to the: (3 : 18), [88n](#)

(4 : 23), [193n](#)

(5 : 14), [208](#)

Ephrem the Syrian, St., [140](#)

Epictetus, [213n](#)

Epidaurus, [188](#)

Epiphanius, [44n](#), [57](#), [66](#), [72n](#), [76n](#), [81n](#), [88](#), [104](#), [114](#), [147](#), [159n](#), [190n](#), [197](#), [202](#), [208f](#)

Epiphany, [104](#)

epiphenomenon, psyche as, [174](#)

equation, quaternio as, [257ff](#)

equinoctial point, [77&n](#)

Erman, Adolf, [78](#)

Eros, [11](#), [12](#), [19](#)

anima and, [14](#), [16](#), [21](#)

a mighty daimon, [27](#)

Esaldaios, [197](#)

“the fourth,” [208](#)

eschatological state, [169](#)

eschatology, in New Testament, [36](#)

Esdras [11](#), [121n](#)

(6 : 49ff), [147n](#)

(13 : 2ff), [120](#)

(13 : 25), [115n](#)

“Ethiopian woman,” [228](#), [251](#), [252](#)

Ethiopians, [210](#)

Eubulides, [18n](#)

eucharist, fish and, [113](#), [115n](#), [121](#), [152](#)

eucharistic: act of integration, [144](#)

feast, of Ophites, [188](#)

food, Leviathan as, [119f](#)

Eucherius, [72n](#), [100](#)

Euchites, [44](#), [148](#)

Euphrates, [104](#), [184–85](#), [199f](#), [211](#), [225](#), [235](#), [251](#), [252](#)

Euthymios Zigabenos, [148](#)

evangelists, four, 36, 195
symbols of, 123

Eve, 204, 205f, 206, 235; *see also* Adam

Everlasting Gospel, *see* Gospel

evil, 41, 46ff
absolute, 10
anima/animus and, 267
Christianity and, 109
and disposition of soul, 61
Gnostics and, 230
and good, 44–45n, 46ff, 267
and the north, 124
principle of, as creator, 256
shadow and, 266–67
see also *privatio boni*

evolution, 180

exaltatio, of Aphrodite, 112

exaltation, 156n

Exodus, Book of: (2 : 4ff), 210
(12 : 22), 58
(15 : 6), 59
(15 : 20f), 210
(18 : 27), 229n
(33 : 5). 58

experience: intersexual, 21n
sensory and immediate, 3

extrasensory perception, 184n

eyes, seven, 105n

Ezekiel, 101, 105n, 124, 132, 195, 241
(1 : 22), 123
(1 : 26), 123

F

factors: causal and final, of psychic existence, 165; *see also* subjective factor

fairytales, 149, 169, 180

faith: is absolute, 174
 crumbling away of content, 178
 and dogma, 178
 rift from knowledge, 173f

Fall, the, 37, 39

Fallopian, Gabriel, 158

Fanianus, Joannes Chrysippus, 157

Farnese Atlas (Naples), 91

father: and daughter, 14
 demiurge as, 190
 in female argumentation, 15
 God as, 193
 idea of, 18f
 in Moses quaternio, 227
 “signs of the,” 190
 as unconscious, 191

father-animus, 210

father-mother, symbol for God, 195

fear, of unconscious, 33

feeling, 31, 178
 function of value, 32

feeling-tones, 28, 33
 subjective and objective, 29

feeling-value, 28, 31

female, *see* male and female

femininity, man’s, 21n

Ferguson, John, 133n

“Fidelissima et jucunda instructio de arbore solari,” 140n, 154

Fierz-David, Hans Eduard, 251n

Fierz-David, Linda, 13n

fifth, the, 225

filius macrocosmi, 66, 127, 155, 237

filius philosophorum, 66, 127, 155, 213

fire, 101, 264

in alchemy, [130ff](#), [252](#)
as dream-symbol, [132n](#), [137n](#)
four aspects of, [132](#), [249ff](#)
and water, [225](#)

firmament, [164](#)

Firminus Maternus, Julius, [88](#)

firstborn, slaying of the, [58n](#)

fish(es): [189](#), [244](#)
 aeon of the, [62](#)
 allegory of the damned, [122](#)
 in Arab tradition, [123](#)
 assimilation of Christ-figure, [182](#)
 Atargatis cult and, [121](#)
 bad qualities of, [112](#)
 beneath the earth, [145](#)
 Christ and, [92](#), [113](#), [120](#)
 Christ and age of, [92](#), [111](#)
 and Christ as Ichthys, [115](#)
 Christian significance of, [114](#)
 direction of, [91](#)
 “drawn from the deep,” [79n](#), [120](#)
 eaten by Christ, [121n](#)
 and fire, [135–36](#)
 golden, dream of, [151–52](#)
 great, as shadow of God, [119](#)
 —, splitting of, [119](#)
 historical significance of, [103ff](#)
 in Jewish symbolism, [115](#), [121](#)
 Lamborghini’s symbol of reversed, [150](#)
 and Leviathan, [120](#)
 miraculous draught of, [89](#)
 as mother and son, [111](#), [114](#)
 originally one, [111](#)
 pagan symbolism, [115f](#)

Platonic month of, ix, 149
in primitive Christianity, 188
“round,” 127ff, 137–38, 140, 144
as ruling powers, 147, 149
as sepulchral symbol, 115
and serpent, 186
sign (⚖) of the, 72ff, 91
—, a double sign, 111
—, twelfth, of zodiac, 118
Southern, 111n, 112
symbol, ambivalence of, 118ff
—, of Christ, 67, 72ff, 89
—, in Eastern religions, 73
—, of love and religion, 129
—, of self, 226
—, of soul, 122
symbolism of, and self, 183
yoked, 145, 147, 148–49
zodiacal, in Lambspringk, 145

fish-deities, Semitic, 121
fisherman, 112
fish-glue, 127n
five, 224
fixation, 168
Flaccianus, 72n
flatus vocis, 32
“flesh,” the, 233
flood, god who dwells in, 211
flower, as symbol of self, 226
Fludd, Robert, 262n
Fomalhaut, 111n, 112
font, baptismal, 73
formlessness, 66
four, *see* elements s.v. four

“fourth,” the, [184](#), [252](#)
Franciscan order, [83](#)
Franz, Marie-Louise von, [ix](#), [88n](#), [210n](#), [220n](#), [262n](#)
Free Spirit: Brethren of the, [84](#), [150](#)
 and Eckhart, [194](#)
freedom: of ego, limited, [7](#)
 moral, [26](#)
 subjective feeling of, [5](#)
French Revolution, [43](#), [98](#), [233](#)
Freud, Sigmund, [165](#), [203n](#)
 sexualistic approach to psyche, [226](#)
frivolity, and evil, [61–62](#)
Frobenius, Leo, [111n](#)
fructificatio, [83](#)
functions: anima/animus as, [20](#)
 differentiated and undifferentiated, [195](#)
 four, of consciousness, [258](#), [259](#)
 quaternity of, [196](#)
 rational, [28](#)
 reflex, [233](#)
 sensory, rivers as, [199](#)
 and space-time quaternio, [253](#)

G

Gaedechens, Rudolf, [91n](#)
Galileo, [34](#)
gall, fish’s, [137](#)
Gamaliel the Elder, [113n](#)
Gamow, George, [260n](#)
garbha griha, [217n](#)
Gargaros, [206n](#)
Garnerius, [100](#), [125n](#)
gate, narrow, [200](#)
Gayomart, [246](#)
Gehenna, fire of, [131](#)

Gemini (♊), [77](#), [80n](#), [81](#), [83n](#)

Genesis, Book of, [204](#), [235](#)

(1 : 2), [148](#), [237](#)

(1 : 7), [184n](#)

(18 : 23), [59](#)

(28 : 17), [214n](#)

(44 : 5), [211n](#)

Genesis, Johannine, [80](#)

“genius,” man’s, [45](#)

geomancy, [261](#)

Gerard of Borgo San Donnino, [82](#)

Gerhardt, Oswald, [74n](#), [75n](#), [77](#)

Germanic peoples, [175](#)

Geryon, [211](#)

Gihon, [199](#), [225](#), [235](#)

“Gloria mundi,” [88n](#), [130](#)

Gnosticism/Gnostics, [58](#), [93](#), [181](#), [192](#), [196ff](#), [269](#)

and alchemy, [173](#), [232](#)

Christ-figure in, [203](#)

and demiurge, [150n](#)

Eckhart and, [194](#)

and evil, [41](#), [46](#), [109f](#)

and Holy Ghost, [86](#)

and magnetism, [154](#)

and psyche, [174](#)

as psychologists, [222](#)

quaternio among, [242ff](#), [254ff](#)

and symbols of self, [184ff](#)

and unconscious, [190–91](#)

and water, [159n](#)

god: dying, [206](#)

“earthly,” Mercurius as, [232](#)

God: absolute, [143](#)

of Basilidians, [190](#)

fish as shadow of, 119
and man, affinity, 209
in Old and New Testaments, 192
pneuma and soma in, 254
quaternary view of, 253n
symbols for, 195
threefold sonship, 64
two sons of, 147
union of natures in, 110
will of, 26f
without consciousness, 192
of wrath and of love, 192

God-eating, 144

Godhead: in Eckhart, 193

Second Person of, 196

unconscious, 193

God-image: alchemy and, 125

anthropomorphic, 55, 67

centre as, 219

in Christ and man, 38

Christian doctrine as expressing, 174

an experience, 194

human element in, 121

incomplete, 120

reformation of, 40

results of destruction of, 109

self as, 63, 109

and transcendent centre in man, 171

transformations of, and changes in consciousness, 194

and wholeness, 198

Yahwistic, 58

see also *Imago Dei*

God-man, archetype, 181–82

“gods”: anima/animus as, 21

ithyphallic, [211](#)
theriomorphic attributes of, [29](#)
goddess, heavenly, [13](#)
Goethe, J. W. von, [208](#), [234](#)
Gog and Magog, [79](#), [80n](#), [107](#)
gold, in alchemy, [264](#)
good and evil, *see* evil
Goodenough, Erwin R., [73n](#), [90n](#), [113n](#), [115n](#), [117](#), [120n](#), [122n](#), [145n](#)
Gospel, Everlasting, [82](#), [85](#), [88](#)
gospels: miraculous element in, [177](#)
 synoptic, [93](#)
grace: divine, [129](#)
 restoration through, [39](#)
 state of, [34](#)
grape, [200](#)
Grasseus, Johannes, [139](#)
Gratarolus, Gulielmus, [146n](#), [232n](#)
gravity, spirit of, [116n](#)
Great Bear, [123](#), [124](#)
Great Mother(s), [89n](#), [112](#), [199](#), [210](#)
green/greenness, [30](#), [245](#)
Gregory the Great, St., [101](#), [205n](#), [206n](#)
Grenfell, B. P., and Hunt, A. S., [37n](#)
ground, universal, [195](#), [200](#)
 Gnostic symbols for, [196ff](#)
Guignebert, Charles, [213n](#)
gyne (woman), [104n](#)

H

Habakkuk, Book of, (2 : 3), [60](#)
Haggard, H. Rider, [267n](#)
Hahn, Christoph Ulrich, [84](#), [145n](#), [146n](#)
Haly, [239n](#)
Hanan ben Tahlifa, Rabbi, [80n](#)
handwriting, [230](#)

Hapi, 123
Harnack, Adolf, 54n, 254n
Harran, 126
Hartmann, E. von, 6
Hathor, Temple of, 91
heaven(s), 155
 in *Ascension of Isaiah*, 57
 four pillars of, 123
 iron plate in, 122–23
 kingdom of, 145
 lapis in, 170
 northern, 123
Heb-Sed festival, 198
Hecate, 21
Heidegger, Johann Heinrich, 76n
Heimarmene, 93n, 137n
Helen (Selene), 21
Helen (in Simon Magus), 197n
Heliogabalus, 89n
hell, 135
 St. Basil on, 129
 eternity of, 110
 fire of, 131, 132
 God's love in, 125
hemispheres, 134
hemlock, 217n
Hennecke, Edgar, 57n
Henry II, of France, 95
heptad, 197n
Hera, 206n
 Babylonian, 116
Heracles, 81
Heraclitus, 219, 250
heresies, 150

hermaphrodite, [159](#), [211](#), [234](#), [248](#)
and elevated places, [206](#)
Original Man as, [204](#)
stone as, [246](#)
symbol for God, [195](#)

Hermaphroditus, [127](#)

Hermas, “Shepherd” of, [88n](#), [103](#), [224n](#)

Hermes, [21](#), [155](#), [209](#), [234](#), [245](#)
bird of, [221](#)
ithyphallic, [230](#)
Kriophoros, [103](#)
Kyllenian/Kyllenios, [201](#), [211](#), [212](#), [232](#)
Naassene view of, [208](#)
“Ter Unus,” [177](#); *see also* Mercurius/Mercury

Hertz, Martin, [136n](#)

Heru-ur, [78](#), [122–23](#), [132n](#)

hesed, [58](#)

hexad, [228](#)

hexagrams, [260](#)

Hiddekel, [225](#), [235](#)

hieros gamos, [12](#), [39–40](#), [89n](#), [206](#)

Hierosolymus, [76n](#)

Hinduism, and Buddhism, [176](#)

Hipparchus, [81](#), [91](#)

Hippocrates, [201n](#)

Hippolytus, [1](#), [64](#), [65n](#), [66](#), [75n](#), [88n](#), [114](#), [139](#), [173](#), [184](#), [186](#), [187](#), [191](#), [198](#), [199](#), [200](#),
[201](#), [202](#), [208ff](#), [222](#), [223n](#), [226](#), [230n](#), [233](#), [254](#)

hiranyagarbha, [246](#)

Hitler, Adolf, [102](#)

Hoghelande, Theobald de, [137](#), [239n](#), [240](#)

Hölderlin, Friedrich, [29](#)

Hollandus, Johannes Isaacus, [235n](#)

Holy Ghost, [135](#), [162](#)
age of, [82–83](#), [85–86](#)
espousal of, [86](#)

fire of, [129](#), [131](#)
indwelling of, [88](#)
movement, [85–86](#), [87](#), [89](#), [150](#)
Homer: *Iliad*, [206n](#), [218n](#)
Odyssey, [208n](#), [209](#), [216](#)
homo: altus, [232](#)
coelestis, [39](#)
maximus, [198](#)
quadratus, [264](#)
homosexual, [12](#)
homunculus, [232](#), [246](#)
Honorius of Autun, [101n](#)
hook, fish-, [112n](#)
horos, [65n](#)
horoscope, [136–37](#), [224](#)
zodia in, [148](#)
horse, [226](#)
Horus, [104](#), [122](#)
four sons of, [122](#), [123](#), [124](#), [132](#), [240](#), [243](#)
“older,” [78](#)
quaternio, [243](#); *see also* Heru-ur
house, as symbol, [224f](#)
Hugh of Strasbourg, [80n](#), [102n](#)
human figure, as symbol of self, [225](#), [226](#)
Hurwitz, Sigmund, [226n](#), [268n](#)
hyacinth, [139](#)
hydromedusa, [134](#)
hyle, [79](#)
hypochondriac ideas, [169](#)
hysteria, [203n](#)
collective, [181](#)

I

Ialdabaoth, [75](#), [208](#)
Ibn Ezra, [108](#)

I Ching, 118n, 260

Ichthys: Adonis as, 121

Christ as, 183

Christ or Attis as, 152n

Christian, 112, 119–20, 121

son of Derceto, 104, 111; *see also* fish(es)

ideals, collective, 29

Idechtrum, 213

Ideler, Christian Ludwig, 124n

identification, with intellectual standpoint, 31

identity, 18

of hunter and prey, 112

of lowest and highest, 246

Ides/Ideus, 213

idiosyncrasy(-ies), 169, 200

Ignatius Loyola, St., 165

ignis, *see* fire

ignorance, 191

illusion, 11, 16; *see also* *maya*

image of God: Christ and the soul as, 37; *see also* *imago Dei*

imagination, active, 19, 223, 243

imago, of mother, 11, 12, 14

imago Dei, 31, 37, 38n, 41, 260; *see also* God-image; image of God

Imhullu, 120

“immutability in the new rock,” 84, 87

impulses, 27

“In Turbam philosophorum exercitationes,” 126

incarnation, 179

fish and, 121

incest, 206, 210, 228, 229

incomplétude, sentiment d’, 9

increatum, 237

India: development of symbol in, 176, 217n

Eckhart and, 194

fish in, 114
religions of, 70
thought of, 175
Indian influences, 223
Indies, 133–34
individuality, and ego, 6
individuation, 39, 40, 45, 200
 apocatastasis in, 169
 Christianity and, 70
 as *mysterium coniunctionis*, 64
 opus and, 264
 repressed, 70
 self and, 167
 stone compared with, 170
 symbolized in dreams, 153
infans, 127
infection, psychic, 248*n*
inferiority, 9, 17
inflation, 25
 of ego, 23–24
 negative, 62
 peril of, 24
 religious, 84
inhabitant, of house, 225
initiation, in mysteries, 261
Innocent III, Pope, 83, 99
innocents, massacre of, 103
Inquisition, 145
insight, intellectual, insufficiency of, 33
instinct(s), 21, 26, 31, 40–41, 145, 179, 234
 archetype image of, 179
 individual and common, 7
 snake symbol of, 244
“*Instructio de arbore solari*,” 140*n*, 154

integration, [30](#), [40](#), [200](#)
 of collective unconscious, [39](#)
 of contents of anima/animus, [20](#)
 mandala and, [32](#)
 of shadow, [22](#)
 of unconscious contents, [23](#)

intellect, and values, [32](#)

intellectualism, [86](#), [150](#)

intensity, of idea, [28](#)

“Interpretatio ... epistolae Alexandri,” [167n](#)

Interrogationes maiores Mariae, [202](#), [207](#)

Irenaeus, [41n](#), [45–46](#), [54](#), [65n](#), [66n](#), [110n](#), [150n](#), [196](#), [197n](#), [218n](#), [219n](#)

Iron Age, fourth, [108](#)

iron-stone, magnetic, [156n](#)

irrationality, [17](#)

Isaac, [90n](#)

Isaiah, Ascension of, see *Ascension of Isaiah*

Isaiah, Book of: (14 : 12ff), [100](#)
 (14 : 31), [101n](#)
 (26 : 20), [59](#)
 (27 : 1), [118](#), [119](#)
 (28 : 10), [210n](#)
 (30 : 18), [60](#)
 (33 : 14), [144n](#)
 (66 : 7), [105](#)

Ishmael, Rabbi, [60](#)

Ishtar, [112](#)

Isidore of Seville, St., [154n](#)

Isidorus (Gnostic), [234](#)

Isis, [104](#)

Islam, [54n](#), [76](#), [95n](#), [99](#), [176](#)

Israel and Egypt, common symbols, [123](#)

J

Jacob, [214](#)

Jacobi, Jolande, [253n](#)

Ja'far ibn Muhammad (Abu Ma'shar) al-Balkhī, *see* Albumasar

James, Epistle of, [135](#)

(3 : 5), [135n](#)

(3 : 6), [135](#)

James of Sarug, [75](#)

James, Montague Rhodes, [37n](#), [197n](#)

Jeans, Sir James, [258n](#)

jelly-fish, [128](#), [134](#), [137–38](#), [154n](#)

Jeremiah, Book of: (1 : 13), [101](#)

(1 : 14), [100](#)

Jeremias, Alfred, [73n](#), [74](#), [112](#), [124n](#)

Jesuits, [58](#)

Jesus, [1](#), [65](#), [144](#), [201](#)

faith and personality of, [178–79](#)

as God-man, [35](#)

Makarios, [200](#)

Passion of, [64](#), [65](#), [67](#)

in *Pistis Sophia*, [78–79](#)

relation to Christ, [67](#)

and separation of categories, [64](#)

as third sonship, [67](#)

a trichotomy, [65](#)

as “truth sprouting from earth,” [79](#); *see also* Christ

Jethro, [209n](#), [210](#), [228f](#), [244](#)

Joachim of Flora, [82–83](#), [84](#), [86](#), [87](#), [149](#), [150](#), [253](#), [Plate II](#)

Job, [60](#), [108](#), [120](#)

Job, Book of, [42](#), [58](#), [118](#)

(26 : 7), [100](#)

(26 : 12), [120](#)

(26 : 13), [120n](#)

(27 : 21), [101](#)

(41), [119n](#)

Jochanan, Rabbi, [60](#)

Johannes de Lugio, [146n](#)

John, St., [145](#)

Epistles of, [43](#), [68](#)

First Epistle of (4 : 3), [36n](#)

Revelation of, *see* Revelation

John, Gospel of, [148](#)

(1), [218n](#)

(1 : 1ff), [211](#)

(1 : 2), [148](#)

(1 : 4), [211](#)

(3 : 12), [202](#), [203](#)

(4 : 10), [184n](#), [185](#), [199n](#)

(5 : 2), [131n](#)

(6 : 53), [202](#)

(7 : 38), [214](#): (10 : 9), [185n](#)

(10 : 34), [89](#), [209n](#)

(14 : 6), [200](#)

(18 : 36), [37n](#)

John the Baptist, [192n](#)

John Chrysostom, St., [48f](#)

John of Paris, [80n](#)

Jonah, [117](#)

sign of, [111](#)

Jonathan, Rabbi, [60](#)

Jordan, [210–11](#)

Joseph (father of Jesus), [78–79](#)

Josephus, [76](#)

Joshua, [111](#)

jot, [218](#)

Jothor, [209](#), [210](#)

Judaeus (son of Set), [76n](#)

Judaism, [58ff](#)

Messianism in, [107](#)

judgments: good/evil as, [53](#)

moral, 47–48

Jung, Carl Gustav:

CASES: student who dreamed of jelly-fish, 134

young woman with intense inner life who dreamed of fishes, 151–52

WORKS: “Answer to Job,” 87n

Commentary on *The Secret of the Golden Flower*, 182n

“Concerning Mandala Symbolism,” 40n, 219n

“Concerning Rebirth,” 111n

“Instinct and Unconscious,” 8n

Memories, Dreams, Reflections, 134n

Mysterium Coniunctionis, 13n, 235n

“On the Nature of the Psyche,” 4, 8n, 24n, 164n, 174n, 179n

“On Psychic Energy,” 29n

“Paracelsus the Physician,” 133n, 213n

“Paracelsus as a Spiritual Phenomenon,” 211n, 214n, 239n, 242n

“The Phenomenology of the Spirit in Fairytales,” 55n, 85n, 99n, 159n, 203n, 224n, 229n

“The Philosophical Tree,” 235n

“A Psychological Approach to the Dogma of the Trinity,” 37n, 86n, 152n, 153n, 224n, 246n, 253n

Psychological Types, 28n, 116n, 159n, 223n, 224n, 253n

Psychology and Alchemy, 31n, 37n, 40n, 63n, 64n, 67n, 78n, 87, 116n, 125n, 134n, 136n, 140n, 152n, 155n, 182, 190n, 197n, 199n, 237n, 239n, 241n, 243n, 245n, 259n, 262, 264n

“The Psychology of the Child Archetype,” 31n

“The Psychology of Eastern Meditation,” 135n, 151n, 204n

“Psychology and Religion,” 87n, 182n

“Psychology of the Transference,” 13n, 22n, 64n, 159n, 167n, 209n, 225n, 228n, 229n, 242n, 243n

“The Psychology of the Trickster Figure,” 203n

“The Relations between the Ego and the Unconscious,” 21n, 23n, 63n, 182n

“The Spirit Mercurius,” 43n, 86n, 136n, 152n, 168n, 203n, 212n, 232n, 235n, 253n

“A Study in the Process of Individuation,” 65n, 67n, 190n, 204n, 219n, 253n

Symbols of Transformation, 101n, 111n, 132n

“Synchronicity,” 184n, 258n

“Transformation Symbolism in the Mass,” [144n](#), [220n](#), [238n](#)

“Über das Selbst,” [23n](#)

Jupiter ([24](#)), [74](#), [76](#), [77](#), [78](#), [81](#), [82](#), [83n](#), [95](#), [97](#)

moons of, [34](#)

jurisprudence, and consciousness, [5](#)

justice, of Yahweh, *see* Yahweh

Justin Martyr, [173](#), [177](#), [230](#)

K

Ka-mutef, [206](#)

Kant, Immanuel, [6](#)

karma, [140n](#), [271n](#)

Kaulakau, [210](#)

Kelchner, Ernst, [102n](#)

Kena Upanishad, [223](#)

Kepler, Johann, [77n](#), [173](#), [207](#)

kerygmatics, [177](#)

Keshava, [114](#)

Kewan, [75n](#)

Khidr legend, [111](#)

Khunrath, Heinrich Conrad, [88](#), [156](#), [220](#)

kibla, [124](#)

king(s), deification of, [198](#)

divine right of, [177](#)

kingdom(s), heavenly/of God, [37](#)

two, in pseudo-Clement, [55](#)

“kingless race,” [260](#)

Kings, First Book of, [59](#)

([22](#) : [19](#)), [59](#)

kingship, and self, [198](#)

Kircher, Athanasius, [262f](#)

Kirchmaier, Georg Caspar, [116n](#)

Klaus, Brother, [25](#)

Knapp, Martin Johann, [81n](#)

Kohut, Alexander, [246n](#)

Kolorbas, [195](#)

Korah, children of, [106](#)

Koran, [111n](#)

Kore, [104](#)

Korion, [104](#)

Korybas, [199](#), [211–12](#)

krater, [65n](#), [191n](#)

Kurma, [176](#)

Kyrios, [182](#)

L

lac virginis, 160

“Ladder of the Twin Gods,” 122

Lagarde, Paul A. de, 56*n*

Laiblin, Wilhelm, 149*n*

lake, as symbol of self, 226

Lamb, 103

in Apocalypse, 90*n*, 105*f*

Church as Bride of, 204

marriage of the, 12, 36, 268

Lambspringk, 92*n*, 145, 150

lamp, 112

lapis (philosophorum), 68, 87, 127, 139, 143, 155, 159, 182, 208, 236*ff*, 247*ff*, 263

fish as symbol of, 126*ff*

found only in heaven, 170

parallel of Christ, 237

quaternio, 238*ff*

as rock, 88

and serpent, 245

symbol of self, 268

thousand names of, 182, 189

“uncomeliness” of, 140

union of opposites in, 247*f*; *see also* stone

lapis angularis (Christ), 208

lapis animalis, 157

lapis exilis, 30

lapis vegetabilis, 159

Lateran Council, Fourth, 52*n*, 82, 83*n*, 253*n*

lawlessness, man of, 36*n*

Layard, John Willoughby, 242*n*

lead, 139

Leda, 81

left, *see* right and left

legends, 169
Leibniz, Gottfried Wilhelm, 6, 164n, 258
lethargia, 208n
Lethe, and unconscious, 208n
Leto, 104
Leviathan, 123, 147n, 182
 battle with Behemoth, 80, 108
 eucharistic food, 112, 120
 fish and, 120
 male and female, 118
Lévy-Bruhl, Lucien, 29
Lexicon medicochymicum, 154n
Libavius, Andreas, 158
liberty, idea of, 29
libido, 132n, 256
 kinship, 243
Libra () , 77n, 83
Libya, 138
life-process, psychic interpretation of, 4
light, transcendent nature of, 63n
Lightfoot, Joseph Barber, 213n
lime, unslaked, 130; *see also* quick-lime
lingam, 217n
lion(s), 120
 Michael and, 75
 symbol of Christ, 72
 of the tribe of Judah, 105
 two, 150
lodestone, 189n; *see also* magnet
Logos, 148, 187f, 201, 252
 animus and, 14, 16, 21
 cosmogonic, 211
 Gnostic, 202
 Hermes as, 201

as magnetic agent, [188](#)
Protanthropos as, [209](#)
serpent as, [188](#), [232](#)
λόγος σπερματικός, [207](#)
love: fish as symbol of, [129](#)
 at first sight, [15](#)
 God's, in hell, [125](#)
 language of, [15](#)
love-magic, [140](#)
love-potion, [138](#)
Loyola, *see* Ignatius
Lucian, [212](#)
lucidus, [138n](#), [139n](#)
Lucifer, [72](#), [125](#)
Lugio, Johannes de, [146](#)
Luke, Gospel of: (5 : 10), [89](#)
 (6 : 35), [89](#), [209n](#)
 (11 : 29f), [111n](#)
 (16 : 8), [146n](#)
 (16 : 17), [218n](#)
 (17 : 20ff), [37n](#)
 (19 : 12ff), [166](#)
 (19 : 27), [106n](#)
 (24 : 42), [121n](#)
 (24 : 43), [113](#)
Lully (Lull), Raymond, [239n](#)
Luna, [235](#); *see also* moon
Luther, Martin, [89](#), [235](#)
 as Antichrist, [102](#)
Lycia, [121](#)

M

Maag, Victor, [182n](#)
Macrobius, Ambrosius Theodosius, [219n](#)
macrocosm, [214](#)

Magi, [89](#), [132](#)
magic, [140](#), [242](#)
magnesia, [155–57](#), [159](#), [160](#)
magnet, [133](#), [154ff](#), [184](#), [187n](#)
 of the wise, [142](#), [155](#)
magnetic agent, three forms of, [188](#)
magnetism, [133n](#)
 of fish, [154](#)
 Gnostics and, [184ff](#)
Magog, *see* Gog and Magog
Magus, [167n](#)
Mahomet, [97](#); *see also* Mohammed
Maier, Michael, [187n](#), [220](#), [249](#), [252](#), [264](#), pl. I
Maimonides, Moses, [116n](#), [119n](#)
Mainyo-i-Khard, [246n](#)
Majui, [80n](#)
maladaptation, [27](#)
Malchuth, [268](#)
male and female, [55](#)
man: complete, water as, [200](#)
 higher, in Moses quaternio, [228](#)
 inner, [208f](#), [228](#)
 One, [205](#)
 Original, [198](#), [200](#), [201](#), [203](#), [204](#), [211](#), [214](#), [216](#), [237](#), [239](#), *see also* Adam,
 Anthropos, Archanthropos, Protanthropos
 perfect, [212f](#)
 pneumatic, [256](#)
 primordial, [36](#)
“man,” in II Esdras, [120](#)
mana, [251n](#)
Mandaeans, [124](#)
mandala(s), [64](#), [152](#), [219](#), [241](#), [253](#)
 Christ in Christian, [36](#)
 rotation of, [259](#)
 in student’s dream, [134](#)

symbols of order, [31f](#), [135](#)
totality images, [40](#), [268](#)
and unconscious personality, [204](#)
vessel as, [240](#)

Manget, Jean Jacques (Joannes Jacobus Mangetus), [126n](#)

Manichaeans/Manichaeism, [48](#), [49](#), [55](#), [57n](#), [58](#), [61n](#), [99](#), see also dualism

Manu, [73](#)
fish of, [113f](#)

Marcionites, [49](#)

Marduk, [120](#), [124](#)

Maria, axiom of, [153](#), [251](#)

Maria the prophetess, [240](#)

Mariam, see Miriam

Mariette, François A. F., [76n](#)

Marinus, [54](#)

Mark, Gospel of, (10 : 18), [58n](#)

marriage: of Christ and the Church, [39](#)
classes, [22](#)
as conscious relationship, [243](#)
constellation of unconscious in, [242](#)
cross-cousin, [22](#), [209n](#), [229](#), [242f](#)
mingling of subtle with dense, [167n](#)
of mother and son, [12](#)
quaternio, [22](#), [64](#), [209](#), [210](#), [229](#), [242](#), [252](#)

Mars (♂), [79n](#), [95](#)

Marxism, [181](#)

Mary: as fountain, [116](#)
in Gnostic symbolism, [202](#), [204](#), [205](#)
in *Pistis Sophia*, [78](#)

Mary, the Virgin, [205](#)
Assumption, [87](#)
Immaculate Conception, [87n](#)
as substitute for Church, [21n](#)

masculinity, woman's, [21n](#)

Masenius, Jacobus, [154n](#)
mass man and evil, [166](#)
massa confusa, [148](#), [155](#), [234](#), [236](#)
Mater Alchimia, [173](#), [232](#)
materialism, [109](#), [150](#), [176](#), [181](#), [233](#), [257](#), [260](#)
mathematics, [261](#)
Matsya, [176](#)
matter, numinosity of, [66](#), [260](#)
Matthew, Gospel of, [101n](#), [201n](#)
 (2 : 1ff), [89](#)
 (3 : 2), [192n](#)
 (4 : 19), [89](#)
 (5 : 3), [193](#)
 (5 : 8), [217n](#)
 (5 : 18), [218n](#)
 (5 : 48), [69n](#)
 (7 : 14), [200n](#)
 (10 : 34), [187](#)
 (12 : 39), [111n](#)
 (13 : 24), [37n](#)
 (13 : 45), [37n](#)
 (16 : 4), [111n](#)
 (17 : 4), [122n](#)
 (18 : 23), [37n](#)
 (19 : 17), [58n](#), [201n](#)
 (21 : 19), [106n](#)
 (22 : 2), [37n](#)
 (22 : 7), [26n](#)
 (27 : 15ff), [90](#)
maya, [11](#), [13](#)
meaning, [27](#)
Mechthild of Magdeburg, St., [205f](#)
mediator, [237n](#), [239](#)
 animus as, [16](#)

man as, [255f](#)
medicament, incorrupt, [170](#)
medulla, [205](#), [233](#)
medusa, [126ff](#)
Meerpohl, Franz, [219](#)
megalomania, [17](#)
Meir ben Isaac, [118](#)
Melusina, [235](#)
memory, [4](#)
mendicant orders, [82](#), [83](#)
Mephistopheles, [234](#)
Mercurius/Mercury (♿), [76](#), [77n](#), [78](#), [95](#), [97](#), [130](#), [131](#), [161](#), [171](#), [187](#), [232](#), [249f](#), [252](#)
 as *anima mundi*, [136](#)
 and double aspect of water, [180](#)
 double/duplex nature of, [150](#), [252f](#), [254](#)
 “non vulgi,” [155](#), [234](#)
 philosophical, *see* Mercurius “non vulgi”
 and the Pole, [133](#), [135](#)
 synonyms for, [241](#)
 as treenumen, [235](#)
 as trickster, [203n](#)
 as Virgo, [127](#)
mercy, of Yahweh, [59](#), [60](#)
Mesopotamia, [74](#), [214](#)
Messahala, [82n](#)
Messiah(s), [106ff](#), [121](#)
 ben Joseph and ben David, [107](#)
 birth of, [105](#), [149](#)
 coming of, [74](#), [118](#)
 two, [107](#), [108](#)
 in Zohar, [214](#)
Mestha, [123](#)
metals, [246](#)
μετάνοια, [192](#)

metaphysical ideas, [34](#), [35](#)
metaphysics: Jung and, [195n](#)
 psychology and, [54](#), [61](#), [67](#), [194](#), [198](#)
Metatron, [214](#)
Meyer, Karl H., [146](#)
Michael (angel), [75](#)
Michaias, [57](#)
microcosm/microcosmos, [155](#), [164](#), [214](#)
 wandering, [213](#)
microphysics, [174](#)
Midrashim, [59](#)
 Midrash Tanchuma (Shemoth), [59n](#), [118n](#), [119n](#)
mind, transformation of, [192](#)
Miriam, [209](#), [210](#), [228](#), [244](#)
Mithraic: liturgy, [124](#)
 monuments, [91](#)
Mithras, [121](#), [124](#)
modesty, [25](#)
Mohammed, [102](#); *see also* Mahomet
molecular movement, [250f](#)
mollusc, [128](#)
monad(s), [189](#), [218f](#)
 Kircher's, [262–63](#)
 in Sabellius, [253n](#)
monasticism, [82f](#), [85](#), [89](#)
monks, as fishes, [113](#)
Monoimos, [218f](#), [222f](#)
Monophysites, [110](#)
monotheism, [268](#)
monsters: attributes of death, [120](#)
 horned, [105](#); sea, *see* Behemoth, Leviathan
 splitting of, [119f](#)
moods, [17](#)
Moon (☾), [76](#), [77](#), [155](#), [249](#)

celestial horn of, 211
morality, 25
Morienus Romanus, 166, 168
morphomata, 81
Moses, 74, 107, 122n, 209n, 210, 227ff, 244
Moses quaternio, 227ff, 243f, 251, 254f
Moses ha-Darshan, 106
mother, 155
 chthonic, 22
 higher, in Moses quaternio, 228
 search for, 11
 as symbol, 11
 and son, 12; *see also* Great Mother(s); imago
mountain, 203, 209
 as symbol of self, 226
Muenther, Friedrich, 74
mumia, 213f
mummy, 122; *see also* mumia
Mundus, 137
Musaeum hermeticum, 88n, 130n, 131n, 133n, 145n, 150n, 221n, 241n
mussel-shell, 127f
Mut, 206
“mutilation of the soul,” evil as, 48
Mylius, Johann Daniel, 88n, 139, 156n, 187n, 197n, 221, 235n, 237n, 239n
mysteries, Eleusinian, 217
mysterium coniunctionis, 64
mysterium iniquitatis, 44, 86
mysticism, Jewish, 108
mythologem: of Amen, 206
 dying god, 206
 fish as, 138
“mythological” aspects, 30
mythology, 35
 comparative, 34

and dogma, 179
myths, 35, 149
 cosmogonic, 148
 gods in, 177
 and unconscious processes, 180

N

Naas, 199, 230, 232
Naassenes, 64, 75, 88, 89, 184*f*, 197, 198, 199, 200, 201, 208*f*, 241, 226*f*; *see also*
 quaternio
name, and thing, 32
Nanni, Giovanni, 102*n*
naphtha, 185
Naples: Farnese Atlas, 91
Nathan, Rabbi, 113*n*
nature: Christianity and, 174
 improvement of, 143
 individual, of Christ's disciples, 211
 rejoices in nature, 159
 two powers of, 123
natures, changing of the, 166
Nazis, 102
necromancy, 262
negligence, evil and, 62
Negroes, 210
nekyia, 209
Nelken, Jan, 33*n*
Nematophora, 128
Neoplatonists, 126
Nero, 102
Neumann, Erich, 116*n*, 148*n*, 183*n*
neurosis(es), 20, 180, 181, 189
neurotic disturbances, 169
New Testament: devil in, 86
 eschatology, 36

Jesus in, [179](#)
snake in, [245](#); *see also names of individual books*

Nicholas of Cusa, [225n](#)

Nietzsche, Friedrich Wilhelm, [260](#)

night-heron, [72](#)

night sea journey, [111](#)

Nigidius Figulus, Publius, [136](#)

nigredo, [148](#), [149](#), [194](#), [210](#); *see also chaos*

Nina, [121](#)

Nippur, [124](#)

nirdvandva, [191](#)

nodes, [253](#)

North, the, [99ff](#)
in ancient history, [125](#)
Ezekiel and, [124](#)
King of the, [125](#)
Mithras and, [124](#)

North Star, [133](#)

Nostradamus, Michel, [95ff](#), [125](#), [126](#)

“nothing but,” [179](#)

nous, [21](#)
descent to Physis, [233](#)
krater filled with, [191n](#)
Mercurius symbol of, [168](#)
serpent as, [186](#), [188](#), [230](#), [232](#)
unconscious, [203n](#)

“Novi luminis chemici Tractatus alter de sulphure,” [131n](#)

Numbers, Book of: (12 : 10), [210](#)
(16), [106n](#)
(24 : 16), [59n](#)
(24 : 17), [117](#)

Numbers, *see* dyad; triad; quaternity; heptad; ogdoad; three; four; five; eight; twelve

Nun, [111](#), [121](#)

Oannes, 73, 112, 121, 201
observation, uncertainty of, 226
obsessions, 169
obsidian, 138, 139n
ocean/Oceanus, 209, 212, 214, 218
Oehler, Franciscus, 191
ogdoad, 110, 196, 197n, 226
 archon of the, 190
Old Testament, 70; *see also names of individual books*
olive, 200
Olympiodorus, 239n, 264
Olympus, 164
omega element, 238
Onians, Richard Broxton, 212n
Ophites, 188
Ophiuchus, 111
opinionatedness, 16
opinions, 21: archetypes and, 17
 Logos and, 15
opposites: alchemical, linked together, 244
 anima/animus, 268
 annihilation of, 70
 Christ/Satan, 44–45n
 cinedian stone and, 139
 coincidence of, 124
 —, in Godhead, 193
 conjunction of, 40, 70, 194, *see also coniunctio oppositorum*
 day/night, 123
 equivalence of, 61
 Father as without, 191
 good/evil, 47, 123
 Heru-ur/Set, 123
 husband/wife, 204
 identity of, symbols and, 129f

kosmos/chaos, [123](#)
life/death, [123](#)
light/darkness, [223](#)
moral accentuation of, [70](#)
never unite at own level, [180](#)
pairs of, *see also* syzygy(ies)
problem of, and neurosis, [180](#)
serpents, [118n](#)
tension of, [31](#), [91](#), [247f](#)
union of, [264](#)
—, in astrology, [77](#), [87](#)
—, and salvation, [195](#)
—, in stone, [170](#)
—, and unconsciousness, [193](#)
opsianus, [138](#)
opus, [237](#)
 as apocatastasis, [169](#)
 and creation of world, [148](#), [234](#)
 and individuation, [264](#)
Oracula sibyllina, [73n](#)
order: mandalas symbols of, [31](#)
 principle of, [195](#)
Origen, [37](#), [38n](#), [41](#), [44–45n](#), [75](#), [81](#), [90n](#), [114n](#), [204f](#), [215](#), [234](#)
 and the devil, [110](#)
Orion, [136](#)
Orosius, [230n](#)
Orpheus, [103](#)
Orphos, [121](#)
Osiris, [122](#), [123](#), [198](#), [199](#), [201](#)
Osob, [146](#), [147n](#), [200](#)
Ostanes, [159n](#), [237n](#), [245n](#)
oxen, fishes and, [145](#), [147](#), [148f](#)
Oxford English Dictionary, [25](#)
oxyrhynchus (fish), [122](#)

Oxyrhynchus, fish-worship at, [121](#)
Oxyrhynchus fragments, [37n](#), [144](#), [145](#)

P

paganism, [96](#)
 return of, in Europe, [176](#)
pair, royal, in Moses quaternio, [228](#)
Palestine, [74](#), [138](#)
Pan, [199](#)
Pandolfus, [156](#)
Pandora, [241](#)
panic, [33](#)
panspermia, [200](#)
Pantheus, Joannes Augustinus, [139n](#)
Papa, [213](#)
Papyri Graecae Magicae, [126](#)
Paracelsus, [164](#), [181](#), [213](#), [214](#), [237](#)
para-da, [152](#)
Paradise: four rivers of, [184](#), [199](#), [215](#), [227](#), [235](#), [243](#)
 Garden of Eden, [254n](#)
 Leviathan eaten in, [113](#)
 quaternio, [234f](#), [236f](#), [243](#), [245](#), [254](#)
 as symbol, [189](#)
paradox, [70](#)
Parmenides, [137n](#), [143](#)
parthenogenesis, [35](#)
Parthenon, [203n](#)
Passion, of Jesus, *see* Jesus
Passover, [119](#)
Patarenes, [83](#)
patience, [24](#)
Paul, St., [39](#), [174](#), [176](#), [177](#), [178](#), [191](#)
 Epistles of, [68](#); *see also names of separate Epistles*
Pauli, W., [207n](#)
Paulicians, [148](#)

Paulinus of Nola, [65n](#)
pearl, round, [127n](#)
Pectorios inscription, [89n](#), [113](#), [116n](#)
pelican, [239](#)
penetration, [120n](#)
Pentecost, [129](#)
Pepi I, [88n](#), [122](#)
Peratic doctrine, [185f](#)
perception(s): conversion of stimuli into, [4](#)
 endosomatic, [3](#)
 psyche and, [32](#)
Perdition, Son of, [36](#)
peregrinatio, [133](#)
perfection: Christ as, [39](#)
 and completeness, [68f](#)
 evil as lack of, [41](#)
perforation, [120n](#)
Pernety, Antoine Joseph, [155](#), [160f](#)
Perpetua, St., Passion of, [210](#)
Persephone, [12](#), [21](#), [217](#)
personality: changes of, [6](#)
 dissociation of, [180](#)
 double, [120](#)
 ego as centre of, [6](#)
 inferior, *see* shadow
 of Jesus, [178f](#)
 not coincident with ego, [5](#)
 self as total, [5](#)
 total description of, impossible, [5](#)
perversions, intellectual, [169](#)
Pesahim, *see* Talmud
Peter, St., [89](#)
 in Clementine Homilies, [56](#)
Peter, First Epistle of; (2 : 4), [88](#)

(2 : 4f), 171n

(2 : 5), 88

Peter Damian, St., 113

Peter Lombard, 253n

Peters, C. H. F., and Knobel, E. B., 77n, 93n

phallicism: Gnostic, 232

unconscious, 226

phallus, 201f, 226

pharmakon athanasias, 116

phenomenology, individual, and collective unconscious, 179

Philalethes, Eirenaeus, 132, 133n, 241

Philippians, Epistle to the (3 : 12), 212

phlogiston theory, 250f

phobias, 169

Phrat, *see* Euphrates

Phrygians, 198, 213; *see also* Naassenes

phylokrinesis, 64, 79, 258n

physics: collision of psyche with, 174

nuclear, 261

and psychology, 261

Physis, 198, 233, 247, 249, 259

Phyton, 131

Picinellus, Philippus, 112n, 113n, 122n, 129, 135

Pisces: aeon, middle of, 150

zodiacal sign for, 91, 114; *see also* fish(es)

pisciculi Christianorum, 103

piscina, 89

Piscis Austrinus, 111n

Pison, 199, 225, 235

Pistis Sophia, 75n, 78f, 93n, 122n, 137n, 197n

Pius IX, Pope, 87n

planets, influence of, 148

Plato, 246

Phaedrus, 64

Timaeus, 136
Platonic Tetrologies, Book of, see “Platonis liber quartorum”
“Platonis liber quartorum,” 197n, 238, 261n
Pleiades, 136
pleroma, 41n, 46, 66n, 219n
Pliny, 128, 138, 144, 156n, 177
Plotinus, 219
plough, 148f
Plutarch, 76, 121, 122n
pneuma, 21, 83
 and Barbelo, 197n
 feminine, 206
 in God, 254
 hidden in stone, 245
 of Jesus, 79
 winged beings as, 120
πνευματικός (-οί), 212n, 219n
Pohl, Otto, 113n
Poimandres, 103
Poimen, see Hermas
point, 189, 198f, 218, 222
 in alchemy, 220f
pole, 133–34
 centre in North, 171
 heavenly, 123f, 224
 North, hidden God at, 135
 —, magnetism of, 154
Polemon, 76n
Pollux, 81
polydemonism, 175
polytheism, 175, 268
Poor Men of Lyons, 83, 146, 150
Pordage, John, 163n, 235
Poseidon, 216

Prajapati, 207n

precession of equinoxes, 81, 92, 95

prefigurations, 261

Preisendanz, Karl, 126n

Priapus, 230

prima materia, 132, 142, 161, 162, 237

alchemical laborant as, 168

anima and, 187

lapis as, 127, 236, 264

production of, 155

as psychic situation, 155

synonyms of, 160

primum mobile, 131

principium individuationis, 64

Priscillian, 88, 136, 230n

privatio boni/privation of good, 41, 45n, 46, 48, 50, 52, 54, 58, 61, 62n, 110, 269; *see also* evil

problems, moral, 25f

projection(s): anima and, 13

anima/animus, 17, 242

dissolution of, 18

effect of, 9f

impersonal withdrawal of, 23

mandala and, 32

in Mary, 204

and mother-imago, 12

reality of factor making, 24

and reality of psyche, 66n

shadow and, 9

Protanthropos, 213

and Korybas, 211

as Logos, 209

Sophia and, 197; *see also* Adam; Anthropos; Man, original; Archanthropos

Protestantism/Protestants, 150, 178

Proteus, 216f

Protoplast, [214](#)
Protothoma, [213](#)
Prunicus/Προύνικος, [196n](#); *see also* Sophia
Psalms: (2 : 9), [105](#)
 (82 [81] : 6), [209n](#)
 (89), [108f](#)
Psellus, Michael, [44n](#), [148n](#)
psyche, [142](#), [255](#)
 aspects of, [32](#)
 begetter of all knowledge, [173](#)
 ego-consciousness of, [164](#)
 and evil, [62](#)
 field of consciousness, [6](#)
 horoscope and, [136](#)
 and life-processes, [4](#)
 man's knowledge of, [165](#)
 and matter, [261](#)
 objective reality of, scientists and, [174](#)
 outside consciousness, [6](#)
 reality of, [66n](#)
 reasons for undervaluation of, [62](#)
“psychic,” use of term, [4](#)
psychoanalysis, [203n](#)
psychology, and good/evil, [53](#)
psychopathology, [30](#)
psychopomp(os): anima as, [30](#)
 animus as, [16](#)
 fishes as symbols for, [145](#)
 Proteus as, [216](#)
psychosis, [33](#)
 mass, [248n](#)
psychotherapy: and anima/animus, [267](#)
 and problem of opposites, [180](#)
Ptolemy, [74n](#), [94n](#)

puer, 127

“puffed-up-ness,” 24; *see also* inflation

pulmo marinus, 128

punctum/punctus solis, 220n; *see also* point

purusha, 167, 194

Pyramid Texts, 122

Python, 104

Q

Qazvini, 123

Qebhsennuf, 123

'qltn, 119

quaternio/quaternity, 159, 194, 210, 211, 226ff

its character of wholeness, 224

of Christ, 204

Christian, 253

and circle, motif, 224

defective, three as, 224

in fire, 132

in Irenaeus, 197n

Kircher's, 262f

in man, 22

Naassene, 22n, 79n

of opposites, in self and Christ, 63f

as organizing schema, 242

Osiris and, 123

self as, 42

static quality of, 257

as symbols, 31, 195

—, for God, 195

—, self in, 190

unity complement of, 224; *see also* Anthropos quaternio; Horus quaternio; lapis quaternio; marriage quaternio; Moses quaternio; Paradise quaternio; shadow quaternio; space-time quaternio

quick-lime, 158

quicksilver, [139](#), [155](#)
“quicksilver system,” Indian, [152](#)
quid/quis distinction, [164](#), [169](#)
Quinta Essentia, [159n](#)
Quispel, Gilles, [66 & n](#), [190](#), [191](#)

R

Ra, [122](#)
Radhakrishnan, Sarvapalli, [223n](#)
radius, *see* ray
Rahab, [120](#)
Rahner, Hugo, [215n](#), [235n](#)
Raison, Déesse, [98](#)
Ram (𐤓), [77n](#); *see also* Aries
ram: Christ as, [90](#), [92](#)
 daemonic, [105f](#)
 symbol of Christ and Attis, [103](#); *see also* lamb
Rameses II, [78](#)
Ramsay, William Mitchell, [73n](#)
Raphael, [113](#)
Rashi, *see* Solomon ben Isaac
Ras Shamra, [119](#)
rationalism, [86](#), [150](#), [221](#)
rationality, [248n](#)
 male, [55](#)
raven, [72](#)
ray, [187n](#)
realism, [150](#), [176](#), [233](#)
reality: psychic, [48](#)
 requires polarity, [267](#)
realization, conscious, [239n](#)
rebirth, [212](#)
Rebis, [159](#), [268](#)
Red Sea, [74](#)
Redeemer: archetype of, [183](#)

as fish and serpent, 186
Gnostic/Gnosticism and, 79, 184
and unconscious, affinity of, 181
redemption, 35, 70, 175, 191, 256
of the dead, 39
reflection, 16
Reformation, the, 93, 102, 178
Holy Ghost movement and, 87
reformation, of God-image, 40
Reguel, 229; *see also* Jethro
Reitzenstein, Richard, 75n, 103
and Schäder, H. H., 246n
relationship, 17
function of, 14, 16
inadequate, 19
to partner, 22
remora, 140f, 144, 154n
Rempham, 75n
Renaissance, the, 43, 94, 98
renovatio, 98n
renovation of the age, 98
repentance, 192
representations collectives, 29
repression, 226
resentment, 16
resistances, shadow and, 9
responsibility, in jurisprudence, 5
Revelation of St. John: (5 : 5), 105
(5 : 6), 105n
(5 : 6ff), 105
(6 : 15ff), 105
(12 : 1), 103
(12 : 9), 230n
(14 : 4), 217

(17 : 14), [105](#)
(20 : 7f), [79n](#); *see also* Apocalypse
revolution, [98n](#)
Rex gloriae, [195](#), [204](#)
Rhabanus Maurus, [100](#)
Rhea, [199](#)
Rhine, J. B., [184n](#)
right and left, [54](#), [59](#), [258n](#)
righteousness, [70](#)
Rig-Veda, [192n](#)
Ripley, Sir George, [131n](#), [139](#), [144](#), [148n](#), [149](#), [235n](#), [249](#)
Ripley “Scrowle,” [235](#), [265](#)
ritual, [256](#)
 Protestantism and, [178](#)
rivers, four, of Paradise, [184](#), [199](#), [215](#), [225](#), [227](#), [235](#), [243](#)
Roberts, R., [221n](#)
rock: Christ as, [87f](#)
 inner man as, [208](#)
roes, two, [107](#)
Romans, Epistle to: (7 : 21), [69n](#)
 (12 : 2), [40](#)
Romulus, [107n](#)
room, as symbol, [224f](#)
Rosarium philosophorum, [156n](#), [197n](#), [239n](#), [245n](#)
Roscher, Wilhelm Heinrich, [211n](#), [212n](#)
Rosenkreutz, Christian, [210](#)
Rosinus, [156](#), [157](#), [167f](#)
rota nativitatis, [136](#)
rotation, [246n](#), [257](#)
rotundum, [238](#), [239n](#), [246](#), [248f](#), [257](#)
Rousselle, Erwin, [11n](#)
Ruland, Martin, [133n](#), [138n](#), [139](#), [156n](#)
Rupescissa, Johannes de, [146](#), [241](#), [265](#)
Ruska, Julius, [126n](#), [130n](#), [137n](#); [220n](#)

S

- Sabaeans, [75](#), [124](#), [197n](#)
- Sabaoth, [76](#)
- Sabbath, [75](#)
- Sabellius, [253n](#)
- Sagittarius, [74n](#)
- sailor, [112](#)
- sal ammoniac, [154n](#)
- sal sapientiae*, [133](#), [161](#)
- Salmanas, procedure of, [127n](#)
- salt, [133](#), [157](#)
 - in alchemy, [161](#)
 - “of the metals,” [139](#)
- salvation, [195](#)
- Salvator mundi*, [127](#)
- Sammaël, [57](#)
- Samothrace, [211](#), [212](#)
- Sanhedrin*, see Talmud
- sapientia*, [160](#), [220](#)
- Sapientia Dei*, [127](#)
- Sassanids, [116](#)
- Satan, [43f](#), [105n](#)
 - as elder son of God, [57](#), [61](#)
 - in Old Testament, [192](#)
 - state before fall, [145](#)
 - and two fishes, [148](#)
- Satanaël, [43](#), [147](#)
- satori, [169](#)
- Satorneilos, see Saturninus
- Saturn (♄), [74ff](#), [77n](#), [81](#), [82](#), [83](#), [96](#), [97](#), [98](#), [99](#)
 - and Esaldaios, [208](#)
 - as Gnostic symbol, [197](#)
 - Jewish thought and, [74f](#)
 - and quicksilver, [139](#)

stone and, [138f](#)
Saturnia (plant), [139](#)
Saturninus, [219](#)
Saulasau, [210](#)
Saviour, compounded of four things, [197n](#)
Schärf, Riwkah, [42n](#), [121n](#), [192](#), [245n](#)
Scheftelowitz, I., [113n](#), [116](#), [117](#), [118n](#), [119](#)
Schelling, F. W. J., [6](#)
schizophrenia, [33](#)
Schoettgen, Christian, [107n](#), [214n](#)
scholasticism, [172](#)
Schopenhauer, Arthur, [6](#)
Schreber, Daniel Paul, [33n](#)
Schwestrones, [84n](#)
science: alchemy and, [176](#)
 and faith, [173f](#)
 natural, [27](#)
 —, rise of, [150](#)
 modern, [89](#)
 trinity in, [258](#)
scintilla vitae, [219](#)
Scott, Walter, [191n](#)
sculptures, obscene, [217n](#)
scurrility: in dreams, [203](#)
 of Gnostic nomenclature, [230](#)
scyphomedusa, [128](#)
sea, [155](#)
 “our,” [142](#)
sea-hawk, [187n](#)
 centre of the, [189](#)
seal, seventh, opening of, [82](#)
seals, [216](#)
sea-nettle, [128n](#)
sea-urchin, [154n](#)

Second Coming, [ix](#)

expectation of, [256](#)

Secret of the Golden Flower, [182n](#), [224](#), [264](#)

secret of the wise, [143](#)

sects, [96f](#)

Secundus, [110n](#)

Selene, [21](#)

self, [23ff](#), [33](#), [34](#)

Anthropos and, [189](#)

antinomial character, [225](#)

apotheosis of individuality, [62](#)

appearance of in unconscious products, [190](#)

appears in all shapes, [226](#)

as archetype, [167](#)

as brahman and atman, [222](#)

Christ as archetype/symbol of, [36ff](#), [62n](#), [182](#)

Christ's correspondence to, [110](#)

dream-symbols and, [132](#)

“fixation” of, in mind, [168f](#)

Gnostic symbols of, [184ff](#), [226ff](#)

a God-image, [22](#), [205](#)

impersonal unconscious and, [169](#)

lapis as, [127](#), [167](#)

a product of cognition, [69](#)

as quaternion of opposites, [63f](#)

relation to ego, [6](#)

religious mythologem, [30](#)

round fish as, [142](#), [144](#)

supraordinate to ego, [3](#)

as total personality, [5](#)

transcendent(al), [62f](#), [170](#)

union of conscious and unconscious, [268](#); *see also* assimilation; atman

God-image

self-aggrandizement, [24](#); *see also* inflation

self-criticism, 25
self-fertilization, 207
self-knowledge, 16, 162ff, 222
 and alchemy, 166ff
 and ends, 165f
 increased, 19, 23ff
 and knowledge of ego, 164
 shadow and, 8
Senard, Marcelle, 92n
 senarius, 228, 230
Sendivogius, Michael, 131n
Senior, 240
sense-perception, *see* perception
sentimentality, 16
separatio/separation, 168, 170; *see also* *divisio*
Sephiroth, Tree of the, 58
Sephora, 209, 210
septenarius, 240
serpens mercurialis/Mercurii, 160, 234, 245
serpent(s), 111, 189, 232, 255
 fighting, 118
 as magnetic agent, 188
 Naas, 199
 in Peratic doctrine, 185f
 in shadow quaternio, 230, 244
 and stone, 245
 and tension of opposites, 247; *see also* dragon; snake; uroboros
Set, 76, 78, 99, 122f, 124, 132
Sethians, 186f, 219
sexual theory, of psychic substance, 201n
sexuality, 90–91n
 undervaluation of, 226
Shaare Kedusha, 218n
shadow, 8–10, 17, 30, 33, 155, 233f, 255, 259, 260

Antichrist as, 41
of arcane substance, 187n
assimilation into conscious personality, 9
in Christ's birth, 41n, 110
consciousness of, 8
doubling of, 120
fear of, 33
fish as shadow of God, 119
good qualities of, 266
integration of, 22
and Moses quaternio, 228, 244
has negative feeling-value, 28
personal unconscious and, 169
quaternio, 229n, 230f, 233f, 244, 255f; 260
represents chthonic world, 34
Shatapatha Brahmana, 113n, 114n
sheep, land of, 16
Shekinah, 268
shepherd, 103
 good, 103
Shu, 207
Shulamite, 210
Sibyls, Erythraean, 72n
Silberer, Herbert, 164n
Simon Magus, 197, 220
sister, 12
skull, 238
slave's post, 76n, 78
Smith, E. M., 92n, 94n
smoke, 101
snail, 226
snake, 72, 233ff
 Aesculapian, 188
 allegory of Christ, 233, 245, 247

on cross, 78n
Mercurius as, 232
in New Testament, 245
signifies evil/wisdom, 234
and Son, 188
symbolism of, 186
as symbol, of instinct, 244
—, of self, 226
—, of wisdom, 245
Soderberg, Hans, 147n
Sodom, 59
sol niger, Saturn as, 197
Solomon ben Gabirol, 74
Solomon ben Isaac, 80, 81
solvents, 160
soma, in God, 254
son, 185, 186
 as Father's thought of own being, 193
 and mother, 11f
 symbol for God, 195
son of God, serpent as, 188
son of Man, 203, 218
 pictures of, 195
sons of God, two, 42f, 57, 58
Song of Solomon: (1 : 1), 205
 (1 : 5), 210
 (4 : 5), 107
 (8 : 7), 129
sonship, threefold, of God, 64f
Sophia, 65n
 Achamoth, 197n
 Prounikos, 54, 196f
"Soul, My Lady," 13
soul: 64, 142

and anima, 13
animal, 11n
as bride of Christ, 39
“excrescent,” 234
fish as symbol of, 122
human, of Christ, 39
as second Eve, 206
as sphere, 136
“twittering,” 209
world-, *see anima mundi*
“soul in fetters,” 197n, 208n
space-time continuum, 24, 258n
space-time quaternio, 251, 252, 253, 257
spark, 219f
Sphere, the, 93n
 soul as, 136
spider, 226
Spiegelberg, W., 122n
spinal cord, 233
Spinning Woman, 11
spirit, 64, 142
 animus and, 16
 archetype of, 85f
 of the world, 142
“Spirit in the Bottle, the,” 235
spirits, seven, 105n
spiritus, 160, 187
Spitteler, Carl, 13, 267n
splitting, 119f, 120n
 of conscious/unconscious, 247–48n
 of Original Man, 204
spondilo, 138
spring-point, 93
square, and circle, 224f, 264

stabilization, 243

stag, 150

Stahl, G. E., 251

star, rising of, and birth of hero, 117

“star of the sea,” 128

starfish, 128*f*, 154*n*

steel, 133

alchemical, 161; see also *chalybs*

stella marina, 128*f*

stella maris, 135, 137

Stephen, St., 75*n*

Stephen of Canterbury, 112

sterility, feeling of, 9

stimuli: endosomatic, 3

unconscious, 4

stone: animate, 159

as Christ-image, 67

cinedian, 138*f*

complement of serpent, 245

derived from circle and quaternity motif, 224

dragon's, 138

Heracleian, 185

inner man as, 208

making the, a “human attitude,” 166

projection of unified self, 170

psychic relationship to man, 167

symbol of self, 246

unity of, 170; see also *lapis*

Strauss, Heinz Arthur, 82*n*

subject, necessary to consciousness, 3

and object, differentiation in consciousness, 193

“subjective factor,” 223

sublimation, 259

subliminal, see unconscious

substance, metaphysical, 161
sucking-fish, 140
sulphur(s), 171, 239n, 250
Summa Fratris Reneri, 146n
Summum Bonum, God as, 45f, 52
sun, 249, 260
Sutech, 78
swan, 81
Swedenborg, Emanuel, 198
Switzerland, 225
sword, 187
Syene, 121
symbol(s): in alchemy, 179
 autonomous, 31
 of Christ and the devil, 72
 dogma as, 175
 Gnostic, 196ff
 for God, 195
 Indian, 175
 meaning of, 73
 of opposite sex, 10
 pictorial, psychology and, 194
 polarity of, 129f
 quaternary, in dreams, 132
 theriomorphic, 186
 triadic, 243n
 uniting, 194
 of unity and totality, 31; *see also* anima; animus; mandala
symbolism: sexual, Christ and, 202
 theriomorphic, of self, 226
“symbolum”: as *aqua doctrinae*, 180
 creed as, 174
symptoms, localization of, 186
synchronicity, 85, 150, 168, 258

of archetype, 184
Synesius, 159n
Synesius of Cyrene, 116
synthesis, 260
Syria: cult of fish in, 121
 dove and fish in, 115
 round fish in, 138
syzygy(-ies), 33, 191, 254
 Adam/Eve, 254
 anima/animus, 11ff, 266
 in Clementine Homilies, 54
 divine, in Christianity, 21
 prototype of divine couples, 34
 Valentinian, 228
 wholeness superior to, 31; *see also* opposites

T

Tabari, *Chronique* of, 79n, 107
Tabula smaragdina, 126, 265
Tacitus, 76
talents, parable of the, 166
Talmud, Babylonian, 58n, 59n, 60n, 79, 80n, 83, 107, 116, 117, 118, 149
 and astrology, 81
Tanit, 121
tanninim, 79, 80, 81
Tantrism, 217n
Tao, 58, 69
 symbol for God, 195
 as “valley spirit,” 180
Targums, 107n
Tatian, 46
tebūnā, 120
Tefnut, 207
Tehom, 237
τέλειος, 212, 213n

τελείωσις, *see* completeness
temperature, Arctic, 52
tension: conscious/unconscious, 20
 signified by Christ's advent, 44
 in uroboros, 248f; *see also* opposites
tentacles, 128
teoqualo, 144
Tertullian, 37, 76, 90n
tetrads, 191
tetrameria, 254
 alchemical, 259
Tetramorph, 36
Thabit ibn Qurrah, 126
Thales, 157, 199
Theatrum chemicum, 130n, 131n, 132n, 137n, 139n, 140n, 143n, 156n, 157n, 158n,
 160n, 163n, 187n, 197n, 220n, 221n, 235n, 237n, 238n, 239n, 240n, 261n, 265n
thema, 136
Theodor Bar-Kuni, 197
Theologia Germanica, 89
Theophilus of Antioch, 46
Theophrastus, 141, 222
theoria, 142, 171, 179, 181
Thessalonians, Second Epistle to the: (2 : 3ff), 36n
Thiele, Georg, 91n
thieves, two, at crucifixion, 44, 69, 255
thinking, 32
third, superordinate, 180
Thomas, Acts of, 116, 197
Thomas Aquinas, St., 51f, 87, 178n
Thorndike, Lynn, 96n, 98n, 102n
Thracian riders, 73
three: as defective quaternity, 224
 and one, motif, 225, 253; *see also* dilemma
Tiamat, 120
Tifereth, 268

Tigris, 199
Timaeus, 136
Timochares, planisphere of, 91
tincture, synonyms for, 137
Titus of Bostra, 48
Tobit, 113
tongue(s), 135, 137
 fiery, 129, 135n
tortoise, 226
totality, 34, 143f
 becoming conscious, 259
 Christ as divine, 37, 39, 41
 chthonic, 224
 idea of, 62n
 images of, 40
 spiritual, 224
 symbols of, 31, 190; *see also* wholeness
“Tractatulus Avicennae,” 167n
“Tractatus Aristotelis ...,” 235n
Tractatus aureus, 187n, 220, 237n, 239
tradition, 181
transference, 229
transformation: Christian, 169
 formula of, 259
 prefigurations in, 261
 skull as vessel of, 238
 tree as symbol of, 235
transition, from waking to sleeping, 28
treasure, guarded by dragon/snake, 234
tree: philosophical, 235
 and serpent, 235
 as symbol of self, 226
Trevisanus, *see* Bernardus Trevisanus
triad: lower, 99, 224

male and female, in pseudo-Clement, 55
in man, 22
Naassene, 209
opposed to trinity, 224
trichotomies, 65f
trickster, Mercurius as, 203n
Trinity, the, 35, 131, 253, Plate II
 devil lacking in, 86
 divine sphere of, 57
 dogma of, 177
 Jesus' soul as, 201
 Kepler and, 207
 Naassene, 197, 226
 space/time/causality, 258
 spiritual totality, 224
 triad opposed to, 224
Troas, the, 156n
truth(s), 171
 first, 178
 psychological, 27
Tuamutef, 123
Tuat, 122
Turba philosophorum, 126, 137, 143, 220n, 250
Turukalukundram, 217n
twelve, 224
Twins, the, *see* Gemini
 Saviour of the, 79n, 122n
Typhon, 99, 121, 122

U

Ugarit, 119
Uhlhorn, 254n
umbra Jesu, 106
Unas, 122
uncertainty relationship, between conscious and unconscious, 226

uncomeliness, outward, 140

unconscious: alchemy and symbolism of unconscious processes, 179

- cannot be “done with,” 20
- collective, *see* collective unconscious
- compensation in, 124
- contents of, and man’s totality, 140
- contents of ego, three groups, 4, 7
- dawn-state and, 148
- fear of, 33
- fishes as product of, 149
- frightening figures in, 225
- Gnostics and, 190
- in Hippolytus and Epiphanius, 66
- importance of, 5
- integration of contents, 23
- organizing principle of, 204
- “our sea” symbol of, 142
- personal and impersonal, 7, 169
- problems of integration of, 181
- processes, compensatory to conscious, 204
- Proteus personifying, 216
- self and the, 3
- soul as projection of, 142
- theriomorphism and, 145
- as the unknown in the inner world, 3
- without qualities, 191

unconsciousness: and proneness to suggestion, 247–48*n*

- sin of, 192*n*

uncontrollable natural forces, action of, 25*f*

underworld, gods of, 224

unicorn, 150

unity, 31, 34

- complement of quaternity, 224
- in Kircher, 263

as symbol of self, 226
transcendent, stone as, 170
Unknown, the: ego and, 3
two groups of objects in, 3
Upanishads, see *Brihadāranyaka* and *Kena*
Urania, 89n
uroboros, 190, 246, 248, 257, 259, 264

V

Valentinians, 65n, 190, 191, 197n, 228
Valentinus, 41n, 110, 234n, 269
value, 27ff
feeling as function of, 32
value quanta, 29
values, reversal of, 233
Vamana, 176
vas, 238
naturale, 241; see also vessel
Vaughan, Thomas, 133n
Vedas, 204
“veiled one,” 18
Venus (♀), 76, 77n, 112, 155
veritas, 160, 161, 171, 181
prima, 178n
vessel: in alchemy, 238ff
Hermetic/nigromantic, 240
as symbol, 224f
Vigenère, Blaise de, 132, 139, 197n, 250
vinegar, 239n; see also *acetum*
viper, 72
Vir Unus, 205
virgin, mother-goddess as, 104
Virgo (♍), 77n, 80n, 104n, 105
Mercurius as, 127
Virolleaud, Charles, 119

virtues, [24](#), [25](#)

Vishnu, [113](#), [114n](#), [176](#)

“Visio Arislei,” *see* “Aenigmata ex Visione Arislei”

visions, [223](#)

Vitus, Richardus, [13n](#)

voice, fourfold, of Christ, [206](#)

“volatile,” winged beings as, [120](#)

Voltaire, [98n](#)

Vollers, Karl, [111n](#)

Vulcan, [249f](#), [252](#)

W

Wackerbarth, Graf August J. L. von, [80](#)

Waite, Arthur Edward, [133n](#)

Waldenses, [83](#), [150](#)

wand, golden, of Hermes, [208](#)

water: in alchemy, [159f](#), [180](#), [249](#)

 baptismal, [180](#)

 bright, [139](#)

 in dreams, [225](#)

 of life, [155](#)

 living, [184](#), [199f](#), [207](#)

 magical, [187](#)

 as magnetic agent, [188](#)

 prime substance, [199](#)

 real, used in ritual, [188](#)

 of rivers of Paradise, [199f](#)

 symbol and, [180](#)

“wedding, chymical,” [40](#), [268](#)

Weiss, Johannes, [213n](#)

Werblowsky, Zwi, [58](#)

West, and Eastern thought, [176](#)

whale-dragon, [111](#), [118](#)

wheat-sheaf, [105](#)

wheel: as symbol, [224](#)

of birth, [136](#), [137](#), [224](#)
of heaven, [136](#)
White, Victor, O.P., [61n](#), [178n](#)
whitening, [148](#); see also *albedo*; *dealbatio*
whole: present in ego, [111](#)
 procreative nature of, [201](#)
wholeness, [169](#), [183](#)
 archetype of, [40](#)
 in Christ, [41](#), [62n](#)
 empirical, [31](#)
 image of, [x](#), [24](#)
 of individual, [195](#)
 knowledge as, [222](#)
 paradoxical, [145](#)
 psychic, and God-image, [198](#)
 restoration of, [259](#)
 symbols of, [40](#), [171](#), [194](#), [195](#), [198](#)
 —, and God, [195](#); see also completeness; totality
Wickes, Frances G., [220n](#)
Wilhelm, Richard, [264n](#)
will: free, [5f](#)
 of God, [26f](#)
 and impulses, [27](#)
 omnipotence of, [26](#)
 and psyche, [4](#)
wind, north, [100](#), [120](#), [125n](#)
wine, [225](#)
Wirth, Albrecht, [116n](#), [117n](#)
Wischnitzer-Bernstein, Rahel, [115n](#)
wise old man, [22](#), [152](#), [210](#), [229](#)
witches, [175](#)
wolf, [150](#)
woman: in Apocalypse, [105](#)
 clothed with the sun, [103](#)

image of, 13
from side of Christ, 204
star-crowned, 12, 103f
Word, the, 200; *see also* Logos
world situation, present, 70
world-soul/world spirit, *see anima mundi*
world-views, parallel, 173
World War, second, 36
wrath, of Yahweh, *see* Yahweh
“wrath-fire,” God’s, 61
Wünsche, August, 106n, 107n

Y

Yahweh, 46, 229
changing concept of, 192
demiurge, 65, 75
injustice of, 55
justice of, 59
monsters of, 116, 118, 123, *see also* Behemoth, Leviathan
Saturn and, 197
unreliability of, 108
wrath of, 58f, 105
Yajñavalkya, 223
Yajui, 80n
Yama, 217n
yang/yin relationship, 58, 180
year: Christ as, 204
Platonic, 81n
Yehoshua/Yeshua, *see* Joshua
Yima, 246n
yod, 218n
yoga, Buddhism and, 176

Z

Zarathustra, 246n

Zechariah, Book of: (4 : 10), [105n](#)
Zeesar, [210–11](#)
Zen Buddhism, [169](#)
Zeus, [206n](#)
Zipporah, [209n](#), [227f](#), [244](#), [251](#), [252](#)
zodia, [118](#), [148](#)
zodiac, [94n](#)
 signs of, [81](#), [230n](#)
Zohar, [107n](#), [117](#), [214](#)
Zoroaster, [220n](#)
Zosimos, [65n](#), [157n](#), [182](#), [197n](#), [237n](#), [238](#), [245n](#)

THE COLLECTED WORKS OF C. G. JUNG

THE PUBLICATION of the first complete edition, in English, of the works of C. G. Jung was undertaken by Routledge and Kegan Paul, Ltd., in England and by Bollingen Foundation in the United States. The American edition is number XX in Bollingen Series, which since 1967 has been published by Princeton University Press. The edition contains revised versions of works previously published, such as *Psychology of the Unconscious*, which is now entitled *Symbols of Transformation*; works originally written in English, such as *Psychology and Religion*; works not previously translated, such as *Aion*; and, in general, new translations of virtually all of Professor Jung's writings. Prior to his death, in 1961, the author supervised the textual revision, which in some cases is extensive. Sir Herbert Read (d. 1968), Dr. Michael Fordham, and Dr. Gerhard Adler compose the Editorial Committee; the translator is R. F. C. Hull (except for Volume 2) and William McGuire is executive editor.

The price of the volumes varies according to size; they are sold separately, and may also be obtained on standing order. Several of the volumes are extensively illustrated. Each volume contains an index and in most a bibliography; the final volumes will contain a complete bibliography of Professor Jung's writings and a general index to the entire edition.

In the following list, dates of original publication are given in parentheses (of original composition, in brackets). Multiple dates indicate revisions.

*1. PSYCHIATRIC STUDIES

On the Psychology and Pathology of So-Called Occult Phenomena (1902)

On Hysterical Misreading (1904)

Cryptomnesia (1905)

On Manic Mood Disorder (1903)

A Case of Hysterical Stupor in a Prisoner in Detention (1902)

On Simulated Insanity (1903)

A Medical Opinion on a Case of Simulated Insanity (1904)

A Third and Final Opinion on Two Contradictory Psychiatric Diagnoses (1906)

On the Psychological Diagnosis of Facts (1905)

†2. EXPERIMENTAL RESEARCHES

Translated by Leopold Stein in collaboration with Diana Riviere

STUDIES IN WORD ASSOCIATION (1904–7, 1910)

The Associations of Normal Subjects (by Jung and F. Riklin)

An Analysis of the Associations of an Epileptic

The Reaction-Time Ratio in the Association Experiment

Experimental Observations on the Faculty of Memory

Psychoanalysis and Association Experiments

The Psychological Diagnosis of Evidence

Association, Dream, and Hysterical Symptom

The Psychopathological Significance of the Association Experiment

Disturbances in Reproduction in the Association Experiment

The Association Method

The Family Constellation

PSYCHOPHYSICAL RESEARCHES (1907–8)

On the Psychophysical Relations of the Association Experiment

Psychophysical Investigations with the Galvanometer and Pneumograph in Normal and Insane Individuals (by F. Peterson and Jung)

Further Investigations on the Galvanic Phenomenon and Respiration in Normal and Insane Individuals (by C. Ricksher and Jung)

Appendix: Statistical Details of Enlistment (1906); New Aspects of Criminal Psychology (1908); The Psychological Methods of Investigation Used in the Psychiatric Clinic of the University of Zurich (1910); On the Doctrine of Complexes ([1911] 1913); On the Psychological Diagnosis of Evidence (1937)

*3. THE PSYCHOGENESIS OF MENTAL DISEASE

The Psychology of Dementia Praecox (1907)

The Content of the Psychoses (1908/1914)

On Psychological Understanding (1914)

A Criticism of Bleuler's Theory of Schizophrenic Negativism (1911)

On the Importance of the Unconscious in Psychopathology (1914)

On the Problem of Psychogenesis in Mental Disease (1919)

Mental Disease and the Psyche (1928)

On the Psychogenesis of Schizophrenia (1939)

Recent Thoughts on Schizophrenia (1957)

Schizophrenia (1958)

†4. FREUD AND PSYCHOANALYSIS

Freud's Theory of Hysteria: A Reply to Aschaffenburg (1906)

The Freudian Theory of Hysteria (1908)

The Analysis of Dreams (1909)

A Contribution to the Psychology of Rumour (1910–11)

On the Significance of Number Dreams (1910–11)

Morton Prince, "The Mechanism and Interpretation of Dreams": A Critical Review (1911)

On the Criticism of Psychoanalysis (1910)

Concerning Psychoanalysis (1912)

The Theory of Psychoanalysis (1913)

General Aspects of Psychoanalysis (1913)

Psychoanalysis and Neurosis (1916)

Some Crucial Points in Psychoanalysis: A Correspondence between Dr. Jung and Dr. Loÿ (1914)

Prefaces to "Collected Papers on Analytical Psychology" (1916, 1917)

The Significance of the Father in the Destiny of the Individual (1909/1949)

Introduction to Kranefeldt's "Secret Ways of the Mind" (1930)

Freud and Jung: Contrasts (1929)

‡5. SYMBOLS OF TRANSFORMATION (1911–12/1952)

PART I

Introduction

Two Kinds of Thinking

The Miller Fantasies: Anamnesis

The Hymn of Creation

The Song of the Moth

PART II

Introduction

The Concept of Libido

The Transformation of Libido

The Origin of the Hero

Symbols of the Mother and of Rebirth

The Battle for Deliverance from the Mother

The Dual Mother

The Sacrifice

Epilogue

Appendix: The Miller Fantasies

*6. PSYCHOLOGICAL TYPES (1921)

Introduction

The Problem of Types in the History of Classical and Medieval Thought

Schiller's Ideas on the Type Problem

The Apollinian and the Dionysian

The Type Problem in Human Character

The Type Problem in Poetry

The Type Problem in Psychopathology

The Type Problem in Aesthetics

The Type Problem in Modern Philosophy

The Type Problem in Biography

General Description of the Types

Definitions

Epilogue

Four Papers on Psychological Typology (1913, 1925, 1931, 1936)

†7. TWO ESSAYS ON ANALYTICAL PSYCHOLOGY

On the Psychology of the Unconscious (1917/1926/1943)

The Relations between the Ego and the Unconscious (1928)

Appendix: New Paths in Psychology (1912); The Structure of the Unconscious (1916) (new versions, with variants, 1966)

‡8. THE STRUCTURE AND DYNAMICS OF THE PSYCHE

On Psychic Energy (1928)

The Transcendent Function ([1916]/1957)

A Review of the Complex Theory (1934)

The Significance of Constitution and Heredity in Psychology (1929)

Psychological Factors Determining Human Behavior (1937)

Instinct and the Unconscious (1919)

The Structure of the Psyche (1927/1931)

On the Nature of the Psyche (1947/1954)

General Aspects of Dream Psychology (1916/1948)

On the Nature of Dreams (1945/1948)

The Psychological Foundations of Belief in Spirits (1920/1948)

Spirit and Life (1926)

Basic Postulates of Analytical Psychology (1931)

Analytical Psychology and *Weltanschauung* (1928/1931)

The Real and the Surreal (1933)

The Stages of Life (1930–1931)

The Soul and Death (1934)

Synchronicity: An Acausal Connecting Principle (1952)

Appendix: On Synchronicity (1951)

*9. PART I. THE ARCHETYPES AND THE COLLECTIVE UNCONSCIOUS

Archetypes of the Collective Unconscious (1934/1954)

The Concept of the Collective Unconscious (1936)

Concerning the Archetypes, with Special Reference to the Anima Concept
(1936/1954)

Psychological Aspects of the Mother Archetype (1938/1954)

Concerning Rebirth (1940/1950)

The Psychology of the Child Archetype (1940)

The Psychological Aspects of the Kore (1941)

The Phenomenology of the Spirit in Fairytales (1945/1948)

On the Psychology of the Trickster-Figure (1954)

Conscious, Unconscious, and Individuation (1939)

A Study in the Process of Individuation (1934/1950)

Concerning Mandala Symbolism (1950)

Appendix: Mandalas (1955)

*9. PART II. AION (1951)

RESEARCHES INTO THE PHENOMENOLOGY OF THE SELF

The Ego

The Shadow

The Syzygy: Anima and Animus

The Self

Christ, a Symbol of the Self

The Sign of the Fishes

The Prophecies of Nostradamus

The Historical Significance of the Fish

The Ambivalence of the Fish Symbol

The Fish in Alchemy

The Alchemical Interpretation of the Fish

Background to the Psychology of Christian Alchemical Symbolism

Gnostic Symbols of the Self

The Structure and Dynamics of the Self

Conclusion

*10. CIVILIZATION IN TRANSITION

The Role of the Unconscious (1918)

Mind and Earth (1927/1931)

Archaic Man (1931)

The Spiritual Problem of Modern Man (1928/1931)

The Love Problem of a Student (1928)

Woman in Europe (1927)

The Meaning of Psychology for Modern Man (1933/1934)

The State of Psychotherapy Today (1934)

Preface and Epilogue to “Essays on Contemporary Events” (1946)

Wotan (1936)

After the Catastrophe (1945)

The Fight with the Shadow (1946)

The Undiscovered Self (Present and Future) (1957)

Flying Saucers: A Modern Myth (1958)

A Psychological View of Conscience (1958)

Good and Evil in Analytical Psychology (1959)

Introduction to Wolff’s “Studies in Jungian Psychology” (1959)

The Swiss Line in the European Spectrum (1928)

Reviews of Keyserling’s “America Set Free” (1930) and “La Revolution
Mondiale” (1934)

The Complications of American Psychology (1930)

The Dreamlike World of India (1939)

What India Can Teach Us (1939)

†11. PSYCHOLOGY AND RELIGION: WEST AND EAST

WESTERN RELIGION

Psychology and Religion (The Terry Lectures) (1938/1940)

A Psychological Approach to the Dogma of the Trinity (1942/1948)

Transformation Symbolism in the Mass (1942/1954)

Forewords to White's "God and the Unconscious" and Werblowsky's "Lucifer and Prometheus" (1952)

Brother Klaus (1933)

Psychotherapists or the Clergy (1932)

Psychoanalysis and the Cure of Souls (1928)

Answer to Job (1952)

EASTERN RELIGION

Psychological Commentaries on "The Tibetan Book of the Great Liberation" (1939/1954) and "The Tibetan Book of the Dead" (1935/1953)

Yoga and the West (1936)

Foreword to Suzuki's "Introduction to Zen Buddhism" (1939)

The Psychology of Eastern Meditation (1943)

The Holy Men of India: Introduction to Zimmer's "Der Weg zum Selbst" (1944)

Foreword to the "I Ching" (1950)

*12. PSYCHOLOGY AND ALCHEMY (1944)

Prefatory note to the English Edition ([1951?] added 1967) Introduction to the Religious and Psychological Problems of Alchemy Individual Dream Symbolism in Relation to Alchemy (1936)

Religious Ideas in Alchemy (1937)

Epilogue

*13. ALCHEMICAL STUDIES

Commentary on "The Secret of the Golden Flower" (1929)

The Visions of Zosimos (1938/1954)

Paracelsus as a Spiritual Phenomenon (1942)

The Spirit Mercurius (1943/1948)

The Philosophical Tree (1945/1954)

‡14. MYSTERIUM CONIUNCTIONIS (1955–56)

AN INQUIRY INTO THE SEPARATION AND
SYNTHESIS OF PSYCHIC OPPOSITES IN ALCHEMY

The Components of the Coniunctio

The Paradoxa

The Personification of the Opposites

Rex and Regina

Adam and Eve

The Conjunction

*15. THE SPIRIT IN MAN, ART, AND LITERATURE

Paracelsus (1929)

Paracelsus the Physician (1941)

Sigmund Freud in His Historical Setting (1932)

In Memory of Sigmund Freud (1939)

Richard Wilhelm: In Memoriam (1930)

On the Relation of Analytical Psychology to Poetry (1922)

Psychology and Literature (1930/1950)

“Ulysses”: A Monologue (1932)

Picasso (1932)

†16. THE PRACTICE OF PSYCHOTHERAPY

GENERAL PROBLEMS OF PSYCHOTHERAPY

Principles of Practical Psychotherapy (1935)

What Is Psychotherapy? (1935)

Some Aspects of Modern Psychotherapy (1930)

The Aims of Psychotherapy (1931)

Problems of Modern Psychotherapy (1929)

Psychotherapy and a Philosophy of Life (1943)

Medicine and Psychotherapy (1945)

Psychotherapy Today (1945)

Fundamental Questions of Psychotherapy (1951)

SPECIFIC PROBLEMS OF PSYCHOTHERAPY

The Therapeutic Value of Abreaction (1921/1928) The Practical Use of Dream-
Analysis (1934)

The Psychology of the Transference (1946)

‡17. THE DEVELOPMENT OF PERSONALITY

Psychic Conflicts in a Child (1910/1946)

Introduction to Wickes's "Analyse der Kinderseele" (1927/1931)

Child Development and Education (1928)

Analytical Psychology and Education: Three Lectures (1926/1946)

The Gifted Child (1943)

The Significance of the Unconscious in Individual Education (1928)

The Development of Personality (1934)

Marriage as a Psychological Relationship (1925)

*18. THE SYMBOLIC LIFE

Miscellaneous Writings

†19. GENERAL BIBLIOGRAPHY OF C. G. JUNG'S WRITINGS

†20. GENERAL INDEX TO THE COLLECTED WORKS

See also:

C. G. JUNG: LETTERS

Selected and edited by Gerhard Adler, in collaboration with Aniela Jaffé Translations from the German by R.F.C. Hull.

VOL. 1: 1906–1950

VOL. 2: 1951–1961

THE FREUD/JUNG LETTERS

Edited by William McGuire, translated by
Ralph Manheim and R.F.C. Hull

C. G. JUNG SPEAKING: Interviews and Encounters

Edited by William McGuire and R.F.C. Hull

1 [In the Swiss edition, this foreword begins as follows: “In this volume (VIII of the *Psychologische Abhandlungen*) I am bringing out two works which, despite their inner and outer differences, belong together in so far as they both treat of the great theme of this book, namely the idea of the Aeon (Greek, *Aion*). While the contribution of my co-worker, Dr. Marie-Louise von Franz, describes the psychological transition from antiquity to Christianity by analysing the Passion of St. Perpetua, my own investigation seeks, with the help of” etc., as above. Dr. von Franz’s “*Die Passio Perpetuae*” is omitted from the present volume.—EDITORS.]

2 [Ch. 5, “The Lapis-Christ Parallel.”]

1 “Instinct and the Unconscious” and “On the Nature of the Psyche,” pars. 397ff.

2 The contents of this and the following chapter are taken from a lecture delivered to the Swiss Society for Practical Psychology, in Zurich, 1948. The material was first published in the *Wiener Zeitschrift für Nervenheilkunde und deren Grenzgebiete*, I (1948) : 4.

1 Erwin Rousselle, “Seelische Führung im lebenden Taoismus,” Pl. I, pp. 150, 170. Rousselle calls the spinning woman the “animal soul.” There is a saying that runs, “The spinner sets in motion.” I have defined the anima as a personification of the unconscious.

2 Here and in what follows, the word “mother” is not meant in the literal sense but as a symbol of everything that functions as a mother.

3 Naturally, she is a typical figure in *belles-lettres*. Recent publications on the subject of the anima include Linda Fierz-David, *The Dream of Poliphilo*, and my “Psychology of the Transference.” The anima as a psychological idea first appears in the 16th-cent. humanist Richardus Vitus. Cf. my *Mysterium Coniunctionis*, pars. 91ff.

4 The fallacy, which stems from Eubulides the Megarian, runs: “Can you recognize your father?” Yes. “Can you recognize this veiled one?” No. “This veiled one is your father. Hence you can recognize your father and not recognize him.”

5 Naturally this is not meant as a psychological definition, let alone a metaphysical one. As I pointed out in “The Relations between the Ego and the Unconscious” (pars. 296ff.), the syzygy consists of three elements: the femininity pertaining to the man and the masculinity pertaining to the woman; the experience which man has of woman and vice versa; and, finally, the masculine and feminine archetypal image. The first element can be integrated into the personality by the process of conscious realization, but the last one cannot.

6 “For the Scripture says, God made man male and female; the male is Christ, the female is the Church.”—Second Epistle of Clement to the Corinthians, xiv, a (trans. by Lake, I, p. 151). In pictorial representations, Mary often takes the place of the Church.

7 “The Psychology of the Transference,” pars. 425ff. Cf. *infra*, pars. 358ff., the Naassene *quaternio*.

8 Cf. *infra*, par. 347.

- 1 The material for this chapter is drawn from a paper, “Über das Selbst,” published in the *Eranos-Jahrbuch 1948*.
- 2 “The Relations between the Ego and the Unconscious.”
- 3 In the sense of the words used in I Cor. 5 : 2: “Inflati estis [πεφυσωμένοι] et non magis luctum habuistis” (And you are puffed up, and have not rather mourned)—with reference to a case of tolerated incest with the mother (“that a man should have his father’s wife”).
- 4 Cf. “On the Nature of the Psyche,” pars. 414ff., 439ff.
- 5 Cf. *Psychological Types*, Defs., “Rational” and “Irrational.”
- 6 *Les Fonctions mentales dans les sociétés inférieures*.
- 7 “On Psychic Energy,” pars. 14ff., 20ff.
- 8 *Sämtliche Werke*, I, p. 126.
- 9 Cf. my “Psychology of the Child Archetype”; also *Psychology and Alchemy*, index, s.v. “filius Philosophorum,” “child,” “hermaphrodite.”
- 10 Cf. *Psychology and Alchemy*, Part II, ch. 3.
- 11 [Cf. infra, par. 340.]
- 12 A classic case is the one published by Nelken: “Analytische Beobachtungen über Phantasien eines Schizophrenen.” Another is Schreber’s *Memoirs of My Nervous Illness*.

1 I John 2 : 22 (DV).

2 I John 4 : 3 (DV). The traditional view of the Church is based on II Thessalonians 2 : 3ff., which speaks of the apostasy, of the *ἄνθρωπος τῆς ἀνομίας* (man of lawlessness) and the *υἱὸς τῆς ἀπωλείας* (son of perdition) who herald the coming of the Lord. This “lawless one” will set himself up in the place of God, but will finally be slain by the Lord Jesus “with the breath of his mouth.” He will work wonders *κατ’ ἐνέργειαν τοῦ σατανᾶ* (according to the working of Satan). Above all, he will reveal himself by his *lying and deceitfulness*. Daniel 11 : 36ff. is regarded as a prototype.

3 For “city” cf. *Psychology and Alchemy*, pp. 104ff.

4 Ἡ βασιλεία τοῦ θεοῦ ἐντὸς ὑμῶν ἔστιν (The kingdom of God is within you [or “among you”]). “The kingdom of God cometh not with observation: neither shall they say, Lo here! or, lo there!” for it is within and everywhere. (Luke 17 : 20f.) “It is not of this [external] world.” (John 18 : 36.) The likeness of the kingdom of God to man is explicitly stated in the parable of the sower (Matthew 13 : 24. Cf. also Matthew 13 : 45, 18 : 23, 22 : 2). The papyrus fragments from Oxyrhynchus say: ... ἡ βασ[ιλεία τῶν οὐρανῶν] ἐντὸς ὑμῶν [ἐ]στι [καὶ ὅστις ἂν ἑαυτὸν] γινῶ ταύτην εὐρή[σκει] ἑαυταὺς γινώσκει κτλ. (The kingdom of heaven is within you, and whosoever knoweth himself shall find it. Know yourselves.) Cf. James, *The Apocryphal New Testament*, p. 26, and Grenfell and Hunt, *New Sayings of Jesus*, p. 15.

5 Cf. my observations on Christ as archetype in “A Psychological Approach to the Dogma of the Trinity,” pars. 226ff.

6 “Et haec ergo imago censenda est Dei in homine, quod eosdem motus et sensus habeat humanus animus, quos et Deus, licet non tales quales Deus” (*Adv. Marcion., II*, xvi; in Migne, *P.L.*, vol. 2, col. 304).

7 *Contra Celsum*, VIII, 49 (Migne, *P.G.*, vol. 11, col. 1590): “In anima, non in corpore impressus sit imaginis conditoris character” (The character of the image of the Creator is imprinted on the soul, not on the body). (Cf. trans. by H. Chadwick, p. 488.)

8 *In Lucam homilia*, VIII (Migne, *P.G.*, vol. 13, col. 1820): “Si considerem Dominum Salvatorem imaginem esse invisibilis Dei, et videam animam meam factam ad imaginem conditoris, ut imago esset imaginis: neque enim anima mea specialiter imago est Dei, sed ad similitudinem imaginis prioris effecta est” (If I consider that the Lord and Saviour is the image of the invisible God, I see that my soul is made after the image of the Creator, so as to be an image of an image; for my soul is not directly the image of God, but is made after the likeness of the former image).

9 *De principiis*, I, ii, 8 (Migne, *P.G.*, vol. 11, col. 156): “Salvator figura est substantiae vel subsistentiae Dei” (The Saviour is the figure of the substance or subsistence of God). *In Genesim homilia*, I, 13 (Migne, *P.G.*, vol. 12, col. 156): “Quae est ergo alia imago Dei ad cuius imaginis similitudinem factus est homo, nisi Salvator noster, qui est primogenitus omnis creaturae?” (What else therefore is the image of God after the likeness of which image man was made, but our Saviour, who is the first born of every creature?) *Selecta in Genesim*, IX, 6 (Migne, *P.G.*, vol. 12, col. 107): “Imago autem Dei invisibilis salvator” (But the image of the invisible God is the saviour).

10 *In Gen. hom.*, I, 13 (Migne, *P.G.*, vol. 12, col. 155): “Is autem qui ad imaginem Dei factus est et ad similitudinem, interior homo noster est, invisibilis et incorporealis, et incorruptus atque immortalis” (But that which is made after the image and similitude of God is our inner man, invisible, incorporeal, incorrupt, and immortal).

11 *De princip.*, IV, 37 (Migne, *P.G.*, vol. 11, col. 412).

12 *Retractationes*, I, xxvi (Migne, *P.L.*, vol. 32, col. 626): “(Unigenitus) ... tantummodo imago est, non ad imaginem” (The Only-Begotten ... alone is the image, not after the image).

13 *Enarrationes in Psalmos*, XLVIII. Sermo II (Migne, *P.L.*, vol. 36, col. 564): “Imago Dei intus est, non est in corpore ... ubi est intellectus, ubi est mens, ubi ratio investigandae veritatis etc. ibi habet Deus imaginem suam.” Also *ibid.*, Psalm XLII, 6 (Migne, *P.L.*, vol. 36, col. 480): “Ergo intelligimus habere nos aliquid ubi imago Dei est, mentem scilicet atque rationem” (Therefore we understand that we have something in which the image of God is, namely mind and reason). Sermo XC, 10 (Migne, *P.L.*, vol. 38, col. 566): “Veritas quaeritur in Dei imagine” (Truth is sought in the image of God), but against this the *Liber de vera religione* says: “in interiore homine habitat veritas” (truth dwells in the inner man). From this it is clear that the *imago Dei* coincides with the *interior homo*.

14 *Enarr. in Ps.*, LIV, 3 (Migne, *P.L.*, vol. 36, col. 629): “ ... ubi autem homo ad imaginem Dei factum se novit, ibi aliquid in se agnoscit amplius esse quam datum est pecoribus.”

15 I Cor. 15 : 47.

16 In *Joannis Evangelium*, Tract. LXXVIII, 3 (Migne, *P.L.*, vol. 35, col. 1836): “Christus est Deus, anima rationalis et caro” (Christ is God, a rational soul and a body).

17 Sermo CCXXXVII, 4 (Migne, *P.L.*, vol. 38, col. 1124): “(Verbum) suscepit totum quasi plenum hominem, animam et corpus hominis. Et si aliquid scrupulosius vis audire; quia animam et carnem habet et pecus, cum dico animam humanam et carnem humanam, totam animam humanam accepit.”

18 *Enarr. in Ps.*, LIV, 1 (Migne, *P.L.*, vol. 36, col. 628).

19 *Contra Faustum*, XXII, 38 (Migne, *P.L.*, vol. 42, col. 424): “Est enim et sancta Ecclesia Domino Jesu Christo in occulto uxor. Occulte quippe atque intus in abscondito secreto spirituali anima humana inhaeret Verbo Dei, ut sint duo in carne una.” Cf. St. Augustine’s *Reply to Faustus the Manichaean* (trans. by Richard Stothert, p. 433): “The holy Church, too, is in secret the spouse of the Lord Jesus Christ, For it is secretly, and in the hidden depths of the spirit, that the soul of man is joined to the word of God, so that they are two in one flesh.” St. Augustine is referring here to Eph. 5 : 31f.: “For this cause shall a man leave his father and mother, and shall be joined unto his wife, and they two shall be one flesh. This is a great mystery: but I speak concerning Christ and the Church.”

20 Augustine, *De Trinitate*, XIV, 22 (Migne, *P.L.*, vol. 42, col. 1053): “Reformamini in novitate mentis vestrae, ut incipiat illa imago ab illo reformari, a quo formata est” (Be reformed in the newness of your mind; the beginning of the image’s reforming must come from him who first formed it) (trans. by John Burnaby, p. 120).

21 Cf. “Concerning Mandala Symbolism,” in Part I of vol. 9.

22 *Psychology and Alchemy*, pars. 323ff.

23 Irenaeus (*Adversus haereses*, II, 5, 1) records the Gnostic teaching that when Christ, as the demiurgic Logos, created his mother’s being, he “cast her out of the Pleroma—that is, he cut her off from knowledge.” For creation took place outside the pleroma, in the shadow and the void. According to Valentinus (*Adv. haer.*, I, 11, 1), Christ did not spring from the Aeons of the pleroma, but from the mother who was outside it. She bore him, he says, “not without a kind of shadow.” But he, “being masculine,’ cast off the shadow from himself and returned to the Pleroma (καὶ τοῦτον [Χριστὸν] μὲν ἄτε ἄρρενα ὑπάρχοντα ἀποκόψαντα ἀφ’ ἑαυτοῦ τὴν σκιάν, ἀναδραμεῖν εἰς τὸ Πλήρωμα κτλ.), while his mother, “being left behind in the shadow, and deprived of spiritual substance,’ there gave birth to the real “Demiurge and Pantokrator of the lower world.’ But the shadow

which lies over the world is, as we know from the Gospels, the *princeps huius mundi*, the devil. Cf. *The Writings of Irenaeus*, I, pp. 45f.

24 Cf. R. Schärf, “Die Gestalt des Satans im Alten Testament.”

25 “The Spirit Mercurius,” par. 271.

26 Jewish Christians who formed a Gnostic-syncretistic party.

27 A Gnostic sect mentioned in Epiphanius, *Panarium adversus octoginta haereses*, LXXX, 1–3, and in Michael Psellus, *De daemonibus* (in Marsilius Ficinus, *Auctores Platonici [Iamblichus de mysteriis Aegyptiorum]*, Venice, 1497).

28 “Oportuit autem ut alter illorum extremorum isque optimus appellaretur Dei filius propter suam excellentiam; alter vero ipsi *ex diametro oppositus*, mali daemonis, Satanae diabolique filius diceretur” (But it is fitting that one of these two extremes, and that the best, should be called the Son of God because of his excellence, and the other, *diametrically opposed* to him, the son of the evil demon, of Satan and the devil) (Origen, *Contra Celsum*, VI, 45; in Migne, *P.G.*, vol. 11, col. 1367; cf. trans. by Chadwick, p. 362). The opposites even condition one another: “Ubi quid malum est ... ibi necessario bonum esse malo contrarium. ... Alterum ex altero sequitur: proinde aut utrumque tollendum est negandumque bona et mala esse; aut admissio altero maximeque malo, bonum quoque admissum oportet.” (Where there is evil ... there must needs be good contrary to the evil. ... The one follows from the other; hence we must either do away with both, and deny that good and evil exist, or if we admit the one, and particularly evil, we must also admit the good.) (*Contra Celsum*, II, 51; in Migne, *P.G.*, vol. 11, col. 878; cf. trans. by Chadwick, p. 106.) In contrast to this clear, logical statement Origen cannot help asserting elsewhere that the “Powers, Thrones, and Principalities” down to the evil spirits and impure demons “do not have it—the contrary virtue—substantially” (“non substantialiter id habeant scl. virtus adversaria”), and that they were not created evil but chose the condition of wickedness (“malitiae gradus”) of their own free will. (*De principiis*, I, viii, 4; in Migne, *P.G.*, vol. 11, col. 179.) Origen is already committed, at least by implication, to the definition of God as the Summum Bonum, and hence betrays the inclination to deprive evil of substance. He comes very close to the Augustinian conception of the *privatio boni* when he says: “Certum namque est malum esse bono carere” (For it is certain that to be evil means to be deprived of good). But this sentence is immediately preceded by the following: “Recedere autem a bono, non aliud est quam effici in malo” (To turn aside from good is nothing other than to be perfected in evil) (*De principiis*, II, ix, 2; in Migne, *P.G.*, vol. 11, cols. 226–27). This shows clearly that an increase in the one means a diminution of the other, so that good and evil represent equivalent halves of an opposition.

29 *Adv. haer.*, II, 4, 3.

30 *Oratio ad Graecos* (Migne, *P.G.*, vol. 6, col. 829).

31 Migne, *P.G.*, vol. 6, col. 1080.

32 Basil thought that the darkness of the world came from the shadow cast by the body of heaven. *Hexaemeron*, II, 5 (Migne, *P.G.*, vol. 29, col. 40).

33 *Homilia: Quod Deus non est auctor malorum* (Migne, *P.G.*, vol. 31, col. 341).

34 *De spiritu sancto* (Migne, *P.G.*, vol. 29, col. 37). Cf. *Nine Homilies of the Hexaemeron*, trans. by Blomfield Jackson, pp. 61f.

35 Migne, *P.G.*, vol. 18, cols. 1132f.

36 *Responsiones ad orthodoxas* (Migne, P.G., vol. 6, cols. 1313–14).

37 Migne, P.G., vol. 3, cols. 716–18. Cf. the *Works of Dionysius the Areopagite*, trans. by John Parker, I, pp. 53ff.

38 “Nunc vero ideo sunt omnia bona, quia sunt aliis alia meliora, et bonitas inferiorum addit laudibus meliorum. ... Ea vero quae dicuntur mala, aut vitia sunt rerum bonarum, quae omnino extra res bonas per se ipsa alicubi esse non possunt. ... Sed ipsa quoque vitia testimonium perhibent bonitati naturarum. Quod enim malum est per vitium, profecto bonum est per naturam. Vitium quippe contra naturam est, quia naturae nocet; nec noceret, nisi bonum eius minueret. *Non est ergo malum nisi privatio boni*. Ac per hoc nusquam est nisi in re aliqua bona. ... Ac per hoc bona sine malis esse possunt, sicut ipse Deus, et quaeque superiora coelestia; mala vero sine bonis esse non possunt. Si enim nihil nocent, mala non sunt; si autem nocent, bonum minuunt; et si amplius nocent, habent adhuc bonum quod minuant; et si totum consumunt, nihil naturae remanebit qui noceatur; ac per hoc nec malum erit a quo noceatur, quando natura defuerit, cuius bonum nocendo minuitur.” (*Contra adversarium legis et prophetarum*, I, 4f.; in Migne, P.L., vol. 42, cols. 606–7.) Although the *Dialogus Quaestionum LXV* is not an authentic writing of Augustine’s, it reflects his standpoint very clearly. Quaest. XVI: “Cum Deus omnia bona creaverit, nihilque sit quod non ab illo conditum sit, unde malum? Resp. Malum natura non est; sed *privatio boni* hoc nomen accepit. Denique bonum potest esse sine malo, sed malum non potest esse sine bono, nec potest esse malum ubi non fuerit bonum. ... Ideoque quando dicimus bonum, naturam laudamus; quando dicimus malum, non naturam sed vitium, quod est bonae naturae contrarium reprehendimus.” (Question XVI: Since God created all things good and there is nothing which was not created by him, whence arises evil? Answer: Evil is not a natural thing, it is rather the name given to the privation of good. Thus there can be good without evil, but there cannot be evil without good, nor can there be evil where there is no good. ... Therefore, when we call a thing good, we praise its inherent nature; when we call a thing evil, we blame not its nature, but some defect in it contrary to its nature, which is good.)

39 “Iniquity has no substance” (CCXXVIII). “There is a nature in which there is no evil—in which, indeed, there can be no evil. But it is impossible for a nature to exist in which there is no good” (CLX).

40 *Augustini Opera omnia*, Maurist edn., X, Part 2, cols. 2561–2618.

41 *Sermones supposititii*, Sermo I, 3, Maurist edn., V, col. 2287.

42 *Summa theologica*, I, q. 48, ad I (trans. by the Fathers of the English Dominican Province, II, p. 264).

43 *Ibid.*, I, q. 48, ad 3 (trans., p. 268).

44 “ ... Quod autem conveniens est alicui est illi bonum. Ergo omne agens agit propter bonum” (*Summa contra Gentiles*, 111, ch. 3, trans. by the English Dominican Fathers, vol. III, p. 7).

45 *Summa theologica*, I, q. 48, ad 2 (trans., II, p. 266, citing Aristotle’s *Topics*, iii, 4).

46 In the Decrees of the 4th Lateran Council we read: “For the devil and the other demons as created by God were naturally good, but became evil of their own motion.” Denzinger and Bannwart, *Enchiridion symbolorum*, p. 189.

47 Harnack (*Lehrbuch der Dogmengeschichte*, p. 332) ascribes the Clementine Homilies to the beginning of the 4th cent. and is of the opinion that they contain “no source that could be attributed with any certainty to the 2nd century.” He thinks that Islam is far superior to this theology. Yahweh and Allah are unreflected God-images, whereas in the Clementine Homilies there is a psychological and reflective spirit at work. It is not immediately evident why this should bring about a disintegration of the God-concept, as Harnack thinks. Fear of psychology should not be carried too far.

- 48 *Der Dialog des Adamantius*, III, 4 (ed. by van de Sande Bakhuyzen, p, 119).
- 49 The female or somatic triad consist of ἐπιθυμία (desire), ὀργή (anger), and λύπη (grief); the male, of λογισμός (reflection), λογισμός (knowledge), and φόβος (fear). Cf. the triad of functions in “The Phenomenology of the Spirit in Fairytales,” Part I of vol. 9, pars. 425ff.
- 50 P. de Lagarde (*Clementina*, p. 190) has here ... πάσης ούσας ... ούσης. The reading γνώμης.. seems to me to make more sense.
- 51 Ch. III: τῆς μετὰ τὴν κρᾶσιν..
- 52 *The Clementine Homilies and the Apostolical Constitutions*, trans. by Thomas Smith et al., pp. 312ff. (slightly modified).
- 53 *Panarium*, ed. by Oehler, I, p. 267.
- 54 *Clement. Horn.* XX, ch. VII. Since there is no trace in pseudo-Clement of the defensive attitude towards Manichaeism which is so characteristic of the later writers, it is possible that the Homilies date back to the beginning of the 3rd cent., if not earlier.
- 55 Hennecke, *Neutestamentliche Apokryphen*, pp. 309ff.
- 56 Cf. Matt. 19: 17 and Mark 10: 18.
- 57 A reference to the slaying of the first-born in Egypt.
- 58 *Nezikin I*, Baba Kamma 60 (in *The Babylonian Talmud*, trans. and ed. by Isidore Epstein, p. 348 [hereafter abbr. *BT*]; slightly modified).
- 59 Numbers 24 : 16.
- 60 *Zera'im I*, Berakoth 7a (*BT*, p. 31),
- 61 *Midrash Tanchuma Shemoth XVII*.
- 62 Cf. *Pentateuch with Targum Onkelos ... and Rashi's Commentary*, trans. by M. Rosenbaum and A. M. Silbermann, II, p. 76.
- 63 Midrash on Song of Sol. 2 : 6.
- 64 *Bereshith Rabba XII*, 15 (*Midrash Rabbah translated into English*, ed. by H. Freedman and M. Simon, I, p. 99: slightly modified).
- 65 *Ibid.* XXXIX, 6 (p. 315).
- 66 Mo'ed IV, Pesahim 119 (*BT*, p. 613); *Nezikin VI*, Sanhedrin II, 103 (*BT*, pp. 698ff.).
- 67 *Nezikin VI*, Sanhedrin II, 97 (*BT*, p. 659; modified).
- 68 *Zera'im I*, Berakoth 16b (*BT*, p. 98; slightly modified).
- 69 *Ibid.* 7a (p. 30).
- 70 “Akathriel” is a made-up word composed of ktr = *kether* (throne) and *el*, the name of God.
- 71 A string of numinous God names, usually translated as “the Lord of Hosts.”
- 72 *Zera'im I*, Berakoth 7 (*BT*, p. 30; slightly modified).
- 73 *Aurora*, trans. by John Sparrow, p. 423.
- 74 My learned friend Victor White, O.P., in his *Dominican Studies* (II, p. 399), thinks he can detect a Manichaean streak in me. I don't go in for metaphysics, but ecclesiastical philosophy undoubtedly does, and for this reason I must

ask what are we to make of hell, damnation, and the devil, if these things are eternal? Theoretically they consist of nothing, and how does that square with the dogma of eternal damnation? But if they consist of something, that something can hardly be good. So where is the danger of dualism? In addition to this my critic should know how very much I stress the unity of the self, this central archetype which is a *complexio oppositorum* par excellence, and that my leanings are therefore towards the very reverse of dualism.

75 It has been objected that Christ cannot have been a valid symbol of the self, or was only an illusory substitute for it. I can agree with this view only if it refers strictly to the present time, when psychological criticism has become possible, but not if it pretends to judge the pre-psychological age. Christ did not merely *symbolize* wholeness, but, as a psychic phenomenon, he *was* wholeness. This is proved by the symbolism as well as by the phenomenology of the past, for which—be it noted—evil was a *privatio boni*. The idea of totality is, at any given time, as total as one is oneself. Who can guarantee that our conception of totality is not equally in need of completion? The mere concept of totality does not by any means posit it.

76 Just as the transcendent nature of light can only be expressed through the image of waves *and* particles.

77 Cf. *Psychology and Alchemy*, pars. 323ff., and “The Relations between the Ego and the Unconscious,” pars. 398ff.

78 Cf. “The Psychology of the Transference,” pars. 425ff.

79 *Elenchos*, V, 8, 2 (trans. by F. Legge, I, p. 131). Cf. *infra*, pars. 358ff.

80 *Psychology and Alchemy*, par. 334, and “The Psychology of the Transference,” pars. 457ff.

81 Basilides lived in the 2nd cent.

82 *Elenchos*, VII, 27, 12 (cf. Legge trans., II, p. 79).

83 *Ibid.*, VII, 22, 10 (cf. II, pp. 69–70).

84 *Ibid.*, VII, 22, 15 (II, p. 70). The eagle has the same significance in alchemy.

85 This word also occurs in the well-known passage about the *krater* in Zosimos. (Berthelot, *Alch. grecs*, III, li, 8: **ἀναδραρε ἐπὶ τὸ γένος τὸ σόν.**

86 I must say a word here about the *horos* doctrine of the Valentinians in Irenaeus (*Adv. haer.*, I, 2, 2ff.) *Horos* (boundary) is a “power” or numen identical with Christ, or at least proceeding from him. It has the following synonyms: ὁροθέτης (boundary-fixer), **μεταγωγεὺς** (he who leads across), *καρπιστής* (emancipator), *λυτρώτης* (redeemer), *σταυρός* (cross). In this capacity he is the regulator and mainstay of the universe, like Jesus. When Sophia was “formless and shapeless as an embryo, Christ took pity on her, stretched her out through his Cross and gave her form through his power,” so that at least she acquired substance (*Adv. haer.*, I, 4). He also left behind for her an “intimation of immortality.” The identity of the Cross with Horos, or with Christ, is clear from the text, an image that we find also in Paulinus of Nola:

“... regnare deum super omnia Christum,
qui cruce dispensa per quattuor extima ligni
quattuor adtingit dimensum partibus orbem,
ut trahat ad uitam populos ex omnibus oris.”

(Christ reigns over all things as God, who, on the outstretched cross, reaches out through the four extremities of the wood to the four parts of the wide world, that he may draw unto life the peoples from all lands.) (*Carmina*, ed. by Wilhelm Hartel, *Carm.*

XIX, 639ff., p. 140.) For the Cross as God's "lightning" cf. "A Study in the Process of Individuation," pars. 535f.

87 *Elenchos*, VII, 27, 5 (Legge trans., II, p. 78).

88 *Ibid.*, VII, 26, 5 (II, p. 75).

89 *Panarium*, XXXI, 5 (Oehler edn., I, p. 314).

90 *Elenchos*, VII, 22, 16 (Legge trans., II, p. 71). Cf. *infra*, pars. 298ff.

91 *Ibid.*, 20, 5 (cf. II, p. 66). Quispel, "Note sur 'Basilide'."

92 With reference to the psychological nature of Gnostic sayings, see Quispel's "Philo und die altchristliche Háresie," p. 432, where he quotes Irenaeus (*Adv. haer.*, II, 4, 2): "Id quod extra et quod intus dicere eos secundum agnitionem et ignorantiam, sed non secundum localem sententiam" (In speaking of what is outward and what is inward, they refer, not to place, but to what is known and what is not known). (Cf. Legge, I, p. 127.) The sentence that follows immediately after this—"But in the Pleroma, or in that which is contained by the Father, everything that the demiurge or the angels have created is contained by the unspeakable greatness, as the centre in a circle"—is therefore to be taken as a description of unconscious contents. Quispel's view of projection calls for the critical remark that projection does not do away with the *reality* of a psychic content. Nor can a fact be called "unreal" merely because it cannot be described as other than "psychic." Psyche is reality par excellence.

93 Cf. *Psychology and Alchemy*, pars. 528ff., 122ff., and "A Study in the Process of Individuation," pars. 542, 550, 581f.

94 Matt. 5 : 48 (DV).

95 Rom. 7 : 21 (AV).

96 Cf. the last two papers in Part I of vol. 9.

1 Early collections of such allegories in the *Ancoratus* of Epiphanius, and in Augustine, *Contra Faustum*. For *nycticorax* and *aquila* see Eucherius, *Liber formularum spiritalis intelligentiae*, cap. 5 (Migne, *P.L.*, vol. 50, col. 740).

2 Augustine (*City of God*, trans. by J. Healey, II, p. 196) relates how the former proconsul Flaccianus, with whom he had a conversation about Jesus, produced a book containing the songs of the Erythraean Sibyl, and showed him the passage where the above words, forming the acrostic *Ἰχθῦς*, are themselves the acrostic for a whole poem, an apocalyptic prophecy of the Sibyls:

“Iudicii signum tellus sudore madescet,
E coelo Rex adveniet per saecula futurus:
Scilicet in carne praesens ut iudicet orbem.
Unde Deum cernent incredulus atque fidelis
Celsum cum Sanctis, aevi iam termino in ipso.
Sic animae cum carne aderunt quas iudicat ipse ... ”
(In sign of doomsday the whole earth shall sweat.
Ever to reign a king in heavenly seat
Shall come to judge all flesh. The faithful and
Unfaithful too before this God shall stand,
Seeing him high with saints in time’s last end.
Corporeal shall he sit, and thence extend
His doom on souls ...) (Ibid., p. 437.)

The Greek original is in *Oracula Sibyllina*, ed. John Geffcken, p. 142. [For Augustine’s explanation of the discrepancy in the acrostic, see Healey trans., II, p. 196.—EDITORS.]

3 Cf. Jeremias, *The Old Testament in the Light of the Ancient East*, I, p. 76, n. 2.

4 From this inscription I will cite only the middle portion, which says: “Everywhere I had a travelling companion, since I had Paul sitting in the chariot. But everywhere Faith drew me onward, and everywhere he set before me for food a fish from the source, exceeding great and pure, which a holy virgin had caught. And he offered this fish to the friends to eat, having good wine, a mixed drink with bread.” See Ramsay, “The Cities and Bishoprics of Phrygia,” p. 424.

5 Cf. the material in Goodenough, *Jewish Symbols in the Greco-Roman Period*, V, pp. 13ff.

6 Doelger, *ἸΧΘΥΣ: Das Fischsymbol in frühchristlicher Zeit*.

7 *Sinnbilder und Kunstvorstellungen der alten Christen* (1825), p. 49. Muentzer mentions Abrabanel (sic) here, “who in all probability drew on older sources.”

8 Op. cit., p. 76.

9 *Der Stern der Weisen* (1827), pp. 54ff.

10 Isaac Abravanel (Abarbanel) ben Jehuda, *Ma’yene ha-Yeshu’ah* (“Sources of Salvation”—A Commentary on Daniel. Ferrara, 1551).

- 11 Corresponding to 1396 B.C.
- 12 Actually the conjunction took place in Sagittarius (♐). The *coniunctiones magnae* of the water trigon (♊, ♋, ♌) fall in the years 1800 to 1600 and 1000 to 800 B.C.
- 13 Anger, “Der Stern der Weisen und das Geburtsjahr Christi,” p. 396, and Gerhardt, *Der Stern des Messias*, pp. 54f.
- 14 Gerhardt, p. 57. Ptolemy and, following him, the Middle Ages associate Palestine with Aries.
- 15 “Ye have borne Siccuth your king and Chiun your images, the star of your god, which ye made to yourselves” (RV). Stephen refers to this in his defence (Acts 7: 43): “And you took unto you the tabernacle of Moloch and the star of your god Rempham.” “Rempham” (Ῥομφά), is a corruption of Kewan (Chiun).
- 16 Dozy and de Goeje, “Nouveaux documents pour l’étude de la religion des Harraniens,” p. 350.
- 17 Abu Ma’shar, d. 885.
- 18 Gerhardt, p. 57. Also Pierre d’Ailly, *Concordantia astronomie cum theologia*, etc., fol. g4 (Venice, 1490): “But Saturn, as Messahali says, has a meaning which concerns the Jewish people or their faith.”
- 19 Reitzenstein, *Poimandres*, p. 76.
- 20 *Contra Celsum*, VI, 30 (trans. by H. Chadwick, p. 345).
- 21 *Ibid.*, VI, 31: “But they say that this angel like unto a lion has a necessary connection with the star Saturn.” Cf. *Pistis Sophia*, trans. by Mead, p. 47, and Bousset, *Hauptprobleme der Gnosis*, pp. 352ff.
- 22 Hippolytus, *Elenchos*, V, 7, 30 (Legge trans., I, p. 128).
- 23 *Ibid.*, VII, 38, 1 (cf. Legge trans., II, p. 96).
- 24 Hence the image of Saturn worshipped by the Sabaeans was said to be made of lead or black stone. (Chwolsohn, *Die Ssabier und der Ssabismus*, II, p. 383.)
- 25 *L’Astrologie grecque*, p. 317.
- 26 Bouché-Leclercq (p. 318) conjectures one of the known classical “etymologies,” namely an *onos* (ass) contained in *Kronos* (Saturn), based on a joke aimed at the Megarian philosopher Diodoros. But the reason for the Saturn-ass analogy probably lies deeper, that is, in the nature of the ass itself, which was regarded as a “cold, intractable, slow-witted, long-lived animal.” (From the Greek bestiary cited by Bouché-Leclercq.) In Polcmon’s bestiary I find the following description of the wild ass: “Given to flight, timid, stupid, untamed, lustful, jealous, killing its females” (*Scriptores physiognomici graeci et latini*, I, p. 182).
- 27 A possible model might be the Egyptian tradition of the martyrdom of Set, depicted at Denderah. He is shown tied to the “slave’s post,” has an ass’s head, and Horus stands before him with a knife in his hand. (Mariette, *Dendérah*, plates vol. IV, pl. 56.)
- 28 *Quaestiones convivales*, IV, 5.
- 29 *Contra Apionem*, II, 7–8 (80ff.). (Cf. trans. by H. St. J. Thackeray and R. Marcus, I, pp. 325ff.)
- 30 *The Histories*, trans. by W. H. Fyfe, II, pp. 204ff.
- 31 Epiphanius, *Panarium*, ed. Oehler, I, p. 184.
- 32 *Apologeticus adversus gentes*, XVI (Migne, *P.L.*, vol. 1, cols. 364–65; cf. trans. by S. Thelwall, I, pp. 84f.).
- 33 Plutarch, *De Iside et Osiride*, in *Moralia*, pp. 77, 123. In ch. 31 Plutarch states that the legend of Set’s flight on an ass and of the fathering of his two sons Hierosolymus and Judaeus is not Egyptian, but pertained to the Ἰουδαϊκά.

34 In the Papyrus of Ani (ed. E. A. W. Budge, p. 248) a hymn to Ra says: “May I advance upon the earth; may I smite the Ass; may I crush the evil one (Sebau); may I destroy Apep in his hour.”

35 Albumasar, Lib. II, *De magnis coniunctionibus*, tract. I, diff. 4, p. a8^f (1489): “If (Jupiter) is in conjunction with Saturn, it signifies that the faith of the citizens thereof is Judaism. ... And if the moon is in conjunction with Saturn it signifies doubt and revolution and change, and this by reason of the speed of the corruption of the moon and the rapidity of its motion and the shortness of its delay in the sign.” Cf. also Pierre d’Ailly, *Concordantia*, etc., fol. d8^f. J. H. Heidegger (*Quaestiones ad textum Lucae VII, 12–17*, 1655) says in ch. IX that Abu Mansor (= Albumasar), in his sixth tractate, in the *Introductio maior*, connects the life of Christ, like that of Mahomet, with the stars. Cardan ascribes ♃ ♄ ♀ to Christianity, ♃ ♄ ♁ to Judaism, ♃ ♄ ♂ to Islam, and according to him ♃ ♄ ♀ signifies idolatry (“Commentarium in Ptolemaeum De astrorum Iudiciis,” p. 188).

36 Christensen, *Le Premier Homme et le premier roi dans l’histoire légendaire des Iraniens*, part 1, p. 24.

37 Gerhardt, *Stern des Messias*, p. 74.

38 Calculated on the basis of Peters and Knobel, *Ptolemy’s Catalogue of Stars*.

39 Medieval astrologers cast a number of ideal horoscopes for Christ. Albumasar and Albertus Magnus took Virgo as the ascendent; Pierre d’Ailly (1356–1420), on the other hand, took Libra, and so did Cardan. Pierre d’Ailly says: “For Libra is the human sign, that is, of the Liberator of men, [the sign] of a prudent and just and spiritual man” (*Concordantia*, etc., cap. 2). Kepler, in his *Discurs von der grossen Conjunction* (1623; p. 701), says that God himself marked “such great conjunctions as these with extraordinary and marvellous stars visible in high heaven, also with notable works of his divine Providence.” He continues: “Accordingly he appointed the birth of his Son Christ our Saviour exactly at the time of the great conjunction in the signs of the Fishes and the Ram, near the equinoctial point.” Seen heliocentrically, the conjunction took place just in front of the equinoctial point, and this gives it a special significance astrologically. Pierre d’Ailly (*Concordantia*, etc., fol. b^f) says: “But a great conjunction is that of Saturn and Jupiter in the beginning of the Ram.” These conjunctions occur every 20 years and take place every 200 years in the same trigon. But the same position can only recur every 800 years. The most significant positions are those between two trigons. Albumasar (*De magnis coniunc.*, tract. 3, diff. 1, fol. D 8^f) says they manifest themselves “in changes of parties and offices and in changes of the laws and ... in the coming of prophets and of prophesying and of miracles in parties and offices of state.”

40 Crucifixion was a well-known punishment for slaves. The Cross with a snake on it, instead of the Crucified, is often found in medieval times [*Psychology and Alchemy*, fig. 217], and also in the dreams and fantasy-images of modern people who know nothing of this tradition. A characteristic dream of this sort is the following: *The dreamer was watching a Passion play in the theatre. On the way to Golgotha, the actor taking the part of the Saviour suddenly changed into a snake or crocodile.*

41 Erman, *Die Religion der Ägypter*, p. 137.

42 *Pistis Sophia*, Mead trans., pp. 118f., slightly modified.

43 Cf. the fish that Augustine says was “drawn from the deep.”

44 In this connection mention should be made of the “Saviour of the twins” (σωτηρες) in *Pistis Sophia* (Mead trans., pp. 2, 17, and elsewhere).

45 Also mentioned in the *Chronique* of Tabari (I, ch. 23, p. 67). There Antichrist is the king of the Jews, who appears with Gog and Magog. This may be an allusion to Rev. 20: 7f.: “And when the thousand years are expired, Satan shall be loosed out of his prison, and shall go out to deceive the nations which are in the four corners of the earth, Gog and Magog, to gather them together to battle” (AV).

Graf von Wackerbarth (*Merkwürdige Geschichte der weltberühmten Gog und Magog*, p. 19) relates from an English “History of the World,” which came out in German in 1760, that the Arab writers say the “Yajui” were “of more than ordinary size,” whereas the “Majui” were “not more than three spans high.” This story, despite the obscurity of its origins, points to the antithetical nature of Gog and Magog, who thus form a parallel to the Fishes. Augustine interprets “the nations which are in the four corners of the earth, Gog and Magog” as, respectively (Gog), *tectum*, ‘roof’ or ‘house,’ and (Magog) *de tecto*, ‘he that comes out of the house’: “Ut illae sint tectum, ipse de tecto.” That is to say the nations are the house, but the devil dwells in the house and comes out of it. (*City of God*, Healey trans., II, p. 286.) On Augustine is based the *Compendium theologiae veritatis* (Venice, 1492), which was attributed in turn to Albertus Magnus, Hugh of Strasbourg, and John of Paris. It is our main source for the Antichrist legend. With reference to Augustine it says (Libell. 7, cap. 11) that Gog means “occultatio” (concealment), Magog “detectio” (revelation). This corroborates the antithetical nature of Gog and Magog at least for the Middle Ages. It is another instance of the motif of the hostile brothers, or of duplication. Albumasar (tract. 4, diff. 12, f. 8^r) calls the sixth “clima” (inclination towards the Pole) that of Gog and Magog, and correlates it with Gemini and Virgo.

46 *Nezikin VI*, Sanhedrin II (*BT*, p. 658). R. Hanan ben Tahlifa, into whose mouth this prophecy is put, is mentioned in the list of Amoraim (teachers of the Talmud) and lived in the 2nd cent. A.D.

46a Cf. *infra*, pars. 225ff.

47 Epiphanius, *Panarium*, XXX (Oehler edn., I, pp. 240ff.).

48 Hipparchus is supposed to have discovered the precession. Cf. Boll, *Sphaera*, p. 199, n. 1.

49 Origen, *Commentaria in Genesim*, tom. III, i, 14, 11 (Migne, *P.G.*, vol. 12, col. 79): “There is indeed a theory that the zodiacal circle, just like the planets, is carried back from setting to rising [or: from west to east], within a century by one degree; ... since the twelfth part [1 zodiac] is one thing when conceived in the mind, another when perceived by the senses; ye, from that which is conceived only in the mind, and can scarcely, or not even scarcely, be held for certain, the truth of the matter appears.” The Platonic year was then reckoned as 36,000 years. Tycho Brahe reckoned it at 24,120 years. The constant for the precession is 50.3708 seconds and the total cycle (360°) takes 25,725.6 years.

50 Bouché-Leclercq, p. 591, n. 2; Knapp, *Antiskia*; Boll, *Sphaera*.

51 The theory of the conjunctions was set down in writing by the Arabs about the middle of the 9th cent., more particularly by Messahala. Cf. Strauss, *Die Astrologie des Johannes Kepler*.

52 With his estimate of 960 years between two *coniunctiones maximae*, Pierre d’Ailly would also arrive at A.D. 3613.

53 This period around the year 1240 would, from the astrological standpoint, be characterized by the great conjunction of Jupiter and Saturn in Libra, in 1246. Libra is another double sign with a pneumatic nature (air trigon), like Gemini, and for this reason it was taken by Pierre d’Ailly as Christ’s ascendent.

54 At the Lateran Council, 1215. Cf. Denzinger and Bannwart, *Enchiridion symbolorum*, pp. 190ff.

55 “His teaching is to be held not so much heretical as insane,” says the decree.

56 Hahn, *Geschichte der Ketzer im Mittelalter*, II, p. 779: “ ... some who under the name of a false and pretended religious order, whom the common folk call Beghards and Schwestrones or ‘Brod durch Gott’; but they call themselves Little Brethren and Sisters of the fellowship of the Free Spirit and of Voluntary Poverty.”

57 “Item credunt se esse Deum per naturam sine distinctione ... se esse aeternos ...

“Item quod nullo indigent nec Deo nec Deitate.

“Item quod sunt ipsum regnum coelorum.

“Item quod sunt etiam immutabiles in nova rupe, quod de nullo gaudent, et de nullo turbantur.

“Item quod homo magis tenetur sequi instinctum interiorem quam veritatem Evangelii quod cottidie praedicatur ... dicunt, se credere ibi (in Evangelio) esse poetica quae non sunt vera.” (Hahn, II, pp. 779f.)

58 Cf. “The Phenomenology of the Spirit in Fairytales,” pars. 396ff.

59 “The Spirit Mercurius,” pars. 284ff., and “A Psychological Approach to the Dogma of the Trinity,” pars. 257ff.

60 [Although Mary’s Immaculate Conception was declared *de fide* by Pope Pius IX in 1854, by the bull *Ineffabilis Deus*, her Assumption was not defined as part of divine revelation until 1950.—EDITORS.]

61 [Cf. “Psychology and Religion,” par. 122, and “Answer to Job,” pars. 748ff.]

62 *Opera*, ed. G. Schepps, p. 24.

63 Cf. *Aurora Consurgens* (ed. von Franz), p. 127: “this great and wide sea smote the rock and the metallic waters flowed forth.”

64 *Musaeum hermeticum* (1678), p. 212: “Our stone is called the sacred rock, and is understood or signified in four ways.” Cf. Ephesians 3 : 18. The Pyramid Text of Pepi I mentions a god of resurrection with four faces: “Homage to thee, O thou who hast four faces. ... Thou art endowed with a soul, and thou dost rise (like the sun) in thy boat ... carry thou this Pepi with thee in the cabin of thy boat, for this Pepi is the son of the Scarab.” (Budge, *Gods of the Egyptians*, I, p. 85.)

65 *Explanationes in Psalmos*, XXXVIII: “In the shadow there was water from the rock, as it were the blood of Christ.”

66 Mylius, *Philosophia reformata* (1622), p. 112: “Whence the philosopher brought forth water from the rock and oil out of the flinty stone.”

67 *Von hylealischen Chaos* (1597), p. 272.

68 Hippolytus, *Elenchos*, V, 7, 34f. (Legge trans., I, p. 129). Reference is also made here to the “stone cut from the mountain without hands” (Daniel 2 : 45), a metaphor used by the alchemists.

69 *De errore profanarum religionum*, 20, 1.

70 Cf. the building of the seamless tower (church) with “living stones” in the “Shepherd” of Hermas.

71 Doelger, **ΙΧΘΥΣ**: *Das Fischsymbol*, I, p. 18. Though the Abercius inscription, which dates from the beginning of the 3rd cent., (after A.D. 216), is of importance in this connection, it is of doubtful Christian origin. Dieterich (*Die Grabschrift des Aberkios*), in the course of a brilliant argument, demonstrates that the “holy shepherd” mentioned in the inscription is Attis, the Lord of the sacred Ram and the thousand-eyed shepherd of glittering stars. One of his special forms was Elogabal of Emera, the god of the emperor Heliogabalus, who caused the *hieros gamos* of his god to be celebrated with Urania of Carthage, also called *Virgo coelestis*. Heliogabalus was a *gallus* (priest) of the Great

Mother, whose fish only the priests might eat. The fish had to be caught by a virgin. It is conjectured that Abercius had this inscription written in commemoration of his journey to Rome to the great *hieros gamos*, sometime after A.D. 216. For the same reasons there are doubts about the Christianity of the Pectorios inscription at Autun, in which the fish figures too: Ἔσθιε πν ..., ἰχθὺν ἔχων παλάμαις Ἰχθῦϊ χόρταξ ἄρα λιλαίω δέσποτα σῶτερ: “Eat ... (reading uncertain), holding the fish in the hands. Nourish now with the fish, I yearn, Lord Saviour.” Probable reading: πινάων instead of πεινάων. Cf. Cabrol and Leclercq, *Dictionnaire d’archéologie chrétienne*, XIII, cols. 2884ff., “Pectorios.” The first three distichs of the inscription make the acrostic Ichthys. Dating is uncertain (3rd–5th cent.). Cf. Doelger, I, pp. 12ff.

72 I refer particularly to Boll, *Aus der Offenbarung Johannis*. The writings of Arthur Drews have treated the astrological parallels with—one can well say—monomaniacal thoroughness, not altogether to the advantage of this idea. See *Der Sternenhimmel in der Dichtung und Religion der alten Völker und des Christentums*.

73 Religious meal. According to Tertullian (*Adversus Marcionem*, I, cap. XIV; Migne, *P.L.*, vol. 2, col. 262) the fish signifies “the holier food.” Cf. also Goodenough, *Jewish Symbols*, V, pp. 41ff.

74 Origen, *In Genesim hom.* VIII, 9 (Migne, *P.G.*, vol. 12, col. 208): “We said ... that Isaac bore the form of Christ, but that the *ram* also seems no less to bear the form of Christ.” Augustine (*City of God*, XVI, 32, 1) asks: “Who was that ram by the offering whereof was made a complete sacrifice in typical blood ... who was prefigured thereby but Jesus ... ?” For the Lamb as Aries in the Apocalypse see Boll, *Aus der Offenbarung Johannis*.

75 Eisler, *Orpheus—The Fisher*, pp. 51ff. There is also a wealth of material in Eisler’s paper “Der Fisch als Sexuelsymbol,” though it contains little that would help to interpret the fish-symbol, since the question puts the cart before the horse. It has long been known that *all the instinctual forces of the psyche* are involved in the formation of symbolic images, hence sexuality as well. Sex is not “symbolized” in these images, but leaps to the eye, as Eisler’s material clearly shows. In whatsoever a man is involved, there his sexuality will appear too. The indubitably correct statement that St. Peter’s is made of stone, wood, and metal hardly helps us to interpret its meaning, and the same is true of the fish symbol if one continues to be astonished that this image, like all others, has its manifest sexual components. With regard to the terminology, it should be noted that something known is never “symbolized,” but can only be expressed *allegorically* or *semiotically*.

76 Thiele, *Antike Himmelsbilder*, p. 29.

77 Boll, *Sphaera*, Pl. I, and Eisler, *The Royal Art of Astrology*, Pl. 5, following p. 164.

78 Gaedechens, *Der Marmorne Himmelsglobus*.

79 Cumont, *Textes et monuments*, II.

80 See the two fishes in Lambspringk’s symbols (*Mus. herm.*, p. 343), representing at the same time the opposites to be united. Aratus (*Phaenomena*, Mair trans., p. 401) mentions only the higher position of the northern fish as compared with the southern one, without emphasizing their duality or opposition. Their double character is, however, stressed in modern astrological speculation. (E. M. Smith, *The Zodia*, p. 279.) Senard (*Le Zodiaque*, p. 446) says: “The fish ... swimming from above downwards symbolizes the movement of involution of Spirit in Matter; that ... which swims from below upwards, the movement of evolution of the Spirit-Matter composite returning to its Unique Principle.”

81 Capricorn ♄ or ♆.

82 A clear reference to astrology can be found in *Pistis Sophia*, where Jesus converses with the “ordainers of the nativity”: “But Jesus answered and said to Mary: If the ordainers of the nativity find Heimarmene and the Sphere turned to the left in accordance with their first circulation, then their words will be true, and they will say what must come to pass. But if they find Heimarmene or the Sphere turned to the right, then they will not say anything true, because I have changed their influences and their squares and their triangles and their octants.” (Cf. Mead trans., p. 29.)

83 The meridian of the star “O” in the commissure passed through the spring-point in A.D. 11, and that of the star “a 113” in 146 B.C. Calculated on the basis of Peters and Knobel, *Ptolemy’s Catalogue of Stars*.

84 Since the delimitation of the constellations is known to be somewhat arbitrary, this date is very indefinite. It refers to the actual constellation of fixed stars, not to the *zodion noeton*, i.e., the zodiac divided into sectors of 30° each. Astrologically the beginning of the next aeon, according to the starting-point you select, falls between A.D. 2000 and 2200. Starting from star “O” and assuming a Platonic month of 2,143 years, one would arrive at A.D. 2154 for the beginning of the Aquarian Age, and at A.D. 1997 if you start from star “a 113.” The latter date agrees with the longitude of the stars in Ptolemy’s *Almagest*.

85 Modern astrological speculation likewise associates the Fishes with Christ: “The fishes ... the inhabitants of the waters, are fitly an emblem of those whose life being hid with Christ in God, come out of the waters of judgment without being destroyed [an allusion to the fishes which were *not* drowned in the Deluge!—C.G.J.] and shall find their true sphere where life abounds and death is not: where, for ever surrounded with the living water and drinking from its fountain, they ‘shall not perish, but have everlasting life.’ ... Those who shall dwell for ever in the living water are one with Jesus Christ the Son of God, the Living One.” (Smith, *The Zodia*, pp. 280f.)

1 Printed in the Amsterdam edition of the *Vrayes Centuries et Prophéties de Maistre Michel Nostredame* (1667), pp. 96ff.

2 According to the old tradition the conjunction of Jupiter and Mercury, as mentioned above, is characteristic of Christianity. The quartile aspect between Mercury and Mars “injures” Mercury by “martial” violence. According to Cardan, ♃ ♀ ♁ signifies “the law of Mahomet” (*Comment. in Ptol.*, p. 188). This aspect could therefore indicate an attack by Islam. Albumasar regards ♃ ♀ ♁ in the same way: “And if Mars shall be in conjunction with him (Jupiter), it signifies the fiery civilization and the pagan faith” (*De magn. coniunct.*, tract. I, diff. 4, p. a8^f). On the analogy of history the evil events to come are ascribed to the crescent moon, but one never reflects that the opponent of Christianity dwells in the European unconscious. History repeats itself.

3 Where Roman Christendom succumbed to Islam.

4 *The Complete Prophecies of Nostradamus*, trans. and ed. by H. C. Roberts, pp. 231ff.

5 D 7^v to 8^r, div. 2, cap. 60 and 61. Cf. also Thorndike, *A History of Magic and Experimental Science*, IV, p. 102.

6 “Et post illam erit complementum 10 revolutionum saturnalium anno Christi 1789 et hoc erit post dictam coniunctionem per annos 97 vel prope. ... His itaque praesuppositis dicimus quod si mundus usque ad illa tempora duraverit, quod solus deus novit, multae tunc et magnae et mirabiles alterationes mundi et mutationes futurae sunt, et maxime circa leges et sectas, nam cum praedicta coniunctione et illis revolutionibus Saturni ad hoc concurret revolutio seu reversio superioris orbis, id est, octavae sphaerae per quam et per alia praemissa cognoscitur sectarum mutatio ... Unde ex his probabiliter concluditur quod forte circa illa tempora veniet *Antichristus* cum lege sua vel secta damnabili, quae maxime adversa erit et contraria legi Christi; nam licet de adventu sui determinato tempore vel momento haberi non possit humanitus certitudo. ... Tamen indeterminate loquendo quod circa illa tempora venturus sit potest haberi probabilis coniectura et verisimilis suspicio per astronomica iudicia. Cum enim dictum sit secundum astronomos circa illa tempora fieri mutationem sectarum et secundum eos post *machometum* erit aliquis potens, qui legem foedam et magicam constituet. Ideo verisimili probabilitate credi potest, quod post sectam machometi nulla secta veniet, nisi lex antichristi.”

7 *Concordantia*, etc., fol. b 5.

8 Cf. Thorndike, IV, p. 103.

9 In classical usage *renovatio* can have the meaning of the modern word “revolution,” whereas even in late Latin *revolutio* still retains its original meaning of “revolving.” As the text shows, Nostradamus thought of this moment (1791) as the climax of a long-standing persecution of the Church. One is reminded of Voltaire’s “écrasez l’infâme!”

10 There is nothing to suggest that a conscious attempt was made to prophesy on the basis of the precession.

11 Conjunctions in Aries were regarded as such, at least as a rule. O° Aries is the spring-point.

12 I cannot claim to have understood Pierre d’Ailly’s argument. Here is the text (Second treatise, ch. 60, “De octava coniunctione maxima”): “Et post illam erit complementum 10 revolutionum saturnalium anno Christi 1789 et hoc erit post dictam coniunctionem per annos 97 vel prope et inter dictam coniunctionem et illud complementum dictarum 10 revolutionum erit status octavae sphaerae circiter per annos 25 quod sic patet: quia status octavae sphaerae erit anno 444 post situm augmentationum [reading uncertain], quae secundum tabulas astronomicas sunt adaequatae ad annum Christi 1320 perfectum, et ideo anno Christi 1764, quibus annis si addas 25, sunt anni 1789 quos praediximus. Unde iterum patet quod ab hoc anno Christi 1414 usque ad statum octavae sphaerae erunt anni 253 perfecti.” (And after

that shall be the fulfilment of 10 revolutions of Saturn to the year 1789, and this shall be after the said conjunction for 97 years or thereabouts, and between the said conjunction and that fulfilment of the 10 revolutions there shall be a standstill of the eighth sphere for about 25 years, which is evident from this: that the standstill of the eighth sphere shall be in the 444th year after the position of the augmentations, which according to the astronomical tables are assigned to the end of the year of Christ 1320, that is the year of Christ 1764, and if you add 25 years to this, you arrive at the year 1789 aforesaid. Hence it is again evident that from this year of Christ 1414 to the standstill of the eighth sphere there will be 253 complete years.)

13 Fol. d 6.

14 It is not clear from the text whether the same “persecution” is meant, or a new one. The latter would be possible.

15 Cf. “The Phenomenology of the Spirit in Fairytales,” pars. 425f., 436ff.

16 Migne, *P.L.*, vol. 50, col. 740.

17 “Ab Aquilone pendetur malum super omnes habitatores terrae” (DV).

18 “Quomodo cecidisti de coelo, Lucifer, qui mane oriebaris? corruisti in terram qui vulnerabas gentes? Qui dicebas in corde tuo: in caelum conscendam, super astra Dei exaltabo solium meum, sedebo in monte testamenti, in lateribus Aquilonis” (trans. is AV; last line RSV).

19 Migne, *P.L.*, vol. 112, col. 860.

20 This is an obvious analogy of the pneuma brooding on the face of the deep.

21 “ ... quod illorum mentibus, qui gratia sua vacui, diabolum Deus dominari permittit.”

22 *Enar. in Ps. XLVII*, 3; Migne, *P.L.*, vol. 36, col. 534.

23 *Sancti Victoris Parisiensis Gregorianum*; Migne, *P.L.*, vol. 193, cols. 59f.

24 Allusion to the lower triad.

25 De *tripartito tabernaculo*, III, c. 9; Migne, *P.L.*, vol. 198, col. 761. Adam Scotus speaks of the “darkness of the smoke from the north.” Pseudo-Clement (*Homilies*, XIX, 22) stresses “the sins of unconsciousness” (*agnoia*). Honorius of Autun (*Speculum de mysteriis ecclesiae*; Migne, *P.L.*, vol. 172, col. 833) says: “By the north, where the sun lies hidden under the earth, Matthew is meant, who describes the divinity of Christ hidden under the flesh.” This confirms the chthonic nature of the triad.

26 Ezek. 1 : 4: “And I saw, and behold a whirlwind came out of the north, and a great cloud ... ”

27 Isaiah 14 : 31: “Howl, O gate, cry, O city, all Philistia is thrown down, for a smoke shall come from the north, and there is none that shall escape his troop.”

28 Ezek. 1 : 4.

29 “A burning wind shall take him up and carry him away: and as a whirlwind shall snatch him from his place” (*In Expositionem beati Job Moralia*; Migne, *P.L.*, vol. 76, cols. 54, 55).

30 Jer. 1 : 13f.

31 Cf. *Symbols of Transformation*, par. 565.

32 The text of the various mss. is supposed to go back to the *Compendium theologiae veritatis* of Hugh of Strasbourg (13th cent.). Cf. Kelchner, *Der Enndkrist*, p. 7.

33 So in Giovanni Nanni (1432–1502). See Thorndike, IV, pp. 263ff.

1 Eisler, *Orpheus—The Fisher*, pp. 51ff.

2 [Cf. par. 127, n. 4.]

3 *Poimandres*, pp. 32ff.

4 Eisler, *The Royal Art of Astrology*, p. 107.

5 Bouché-Leclercq, *L'Astrologie grecque*, p. 147. For the relation of the *gyne* (woman) to the zodiacal sign Virgo see Boll, *Aus der Offenbarung Johannis*, p. 122.

6 *Panarium*, LI, 22, Oehler edn., Part 3, pp. 632f. This passage is not in the older editions of the *Panarium*, since it was discovered only recently in a ms. at Venice.

7 Boll, pp. 121ff.

8 “Before she travailed, she brought forth; before her pain came, she was delivered of a man child.”

9 “Thou shalt break them with a rod of iron; thou shalt dash them in pieces like a potter’s vessel.”

10 Boll, p. 44.

11 His eyes signify the “seven Spirits of God” (Rev. 5 : 6) or the “seven eyes of the Lord” (Zech. 4 : 10). The Lamb stands with the seven angels before God’s throne, as Satan did with the sons of God (Job 1 : 6), so that God is described under the aspect of Ezekiel’s vision and is thought of in Yahwistic terms—an “umbra in lege”!

12 That is, if we disregard passages like Matt. 21 : 19 and 22 : 7 and Luke 19 : 27.

13 [Cf. Num. 16.—EDITORS.]

14 Wünsche, *Die Leiden des Messias*, p. 91.

15 Targum on Canticles 4 : 5 in *The Targum to The Song of Songs*, p. 50. Wünsche, p. 111. In the *Zohar* the Messiah is called “Mother.” Schoettgen, *Horae Hebraicae et Talmudicae*, II, p. 10. Cf. also the “Saviour of the twins” in *Pistis Sophia* (above, par. 133, n. 44).

16 *Zohar*, trans. by H. Sperling and M. Simon, II, p. 358: “Hence it is written of him [the Messiah] that he will be ‘poor and riding on an ass ... ’ (Zech. 12 : 9).” Also Wünsche, p. 100.

17 *Ibid.*, p. 114.

18 *Ibid.*, p. 115.

19 Armilus or Armillus = *Ῥωμύλος*, the Antichrist. Methodius: “Romulus, who is also Armaeleus.”

20 Wünsche, p. 120.

21 *Chronique* of Tabari, I, ch. 23, p. 67.

22 Bousset, *The Antichrist Legend*, p. 111.

23 *Pahlavi Texts*, trans. by E. W. West, p. 193.

24 Cf. the opposition between mercy and justice in God’s nature, *supra*, pars. 108ff.

25 Psalm 89 : 33ff. (RSV).

26 He was, it seems, a cleric, who is said to have been a candidate for the episcopal see in Rome.

27 Irenaeus, *Adv. haer.*, I, 11, 1 (Roberts/Rambaut trans., I, p. 46).

28 Doctrine of the Valentinian Secundus (*ibid.*, I, p. 46).

29 *De oratione*, 27: "... so that that supreme sinner and blasphemer against the Holy Ghost may be kept from sin through all this present age, and hereafter in the age to come from its beginning to its end be treated I know not how" (... ita ut summus ille peccator et in Spiritum sanctum blasphemus per totum hoc praesens saeculum a peccato detineatur, et post haec in futuro ab initio ad finem sit nescio quomodo tractandus), thus giving rise to the view that "even the devil will some day be saved." [Cf. alternative trans. by J. E. L. Oulton and H. Chadwick, p. 304.]

30 Namely *Piscis Austrinus*, the "Southern Fish," which merges with Pisces and whose principal star is Fomalhaut.

31 Matt. 12 : 39, 16 : 4; Luke 11 : 29f.

32 Cf. Frobenius, *Das Zeitalter des Sonnengottes*, and my *Symbols of Transformation*, pars. 308ff.

33 "Yahweh is salvation."

34 Koran, Sura 18. Cf. "Concerning Rebirth," pars. 244f., and Vollers, "Chidher," p. 241.

35 Jeremias, *The Old Testament in the Light of the Ancient East*, p. 76. This lamp has never been traced.

36 Picinellus, *Mundus symbolicus* (1680–81), Lib. VI, cap. I.

37 Bouché-Leclercq, p. 147.

38 How closely the negative and the positive meanings are related can be seen from the fish-hook motif, attributed to St. Cyprian: "Like a fish which darts at a baited hook, and not only does not lay hold of the bait along with the hook, but is itself hauled up out of the sea; so he who had the power of death did indeed snatch away the body of Jesus unto death, but did not observe that the hook of the Godhead was concealed therein, until he had devoured it; and thereupon remained fixed thereto."

Stephen of Canterbury (*Liber allegoricus in Habacuc*, unavailable to me) says: "It is the bait of longed-for enjoyment that is displayed in the hook, but the tenacious hidden hook is consumed along with the bait. So in fleshly concupiscence the devil displays the bait of pleasure, but the sting of sin lies hid therein." In this regard see Picinellus, Lib. VI, cap. 1.

39 Scheftelowitz, "Das Fisch-Symbol im Judentum und Christentum," p. 365.

40 Cf. Goodenough, *Jewish Symbols*, V, pp. 41ff.

41 Lib. XIII, cap. XXI. (Cf. trans. by F. J. Sheed, p. 275, modified.)

42 "The cloister of a monastery is indeed a fishpond of souls, and fish live therein" (Picinellus, *Mundus*).

An Alexandrian hymn from the 2nd cent. runs:

"Fisher of men, whom Thou to life dost bring!
From the evil sea of sin
And from the billowy strife
Gathering pure fishes in,
Caught with sweet bait of life."

(*Writings of Clement of Alexandria*, trans. by W. Wilson, I, p. 344.) Cf. Doelger, 'ΙΧΘΥΣ, I, p. 4. Tertullian (*De baptismo*, cap. I) says: "But we little fishes, after the example of our 'ΙΧΘΥΣ Jesus Christ, are born in water, nor have we safety in any other way than by permanently abiding in (that) water." (Trans. by S. Thelwall, I, pp. 231–32.) The disciples of Gamaliel the Elder (beginning of 1st cent.) were named after various kinds of fishes. (*Abot de Rabbi Nathan*, cap. 40 [cf. trans. by J. Goldin, p. 166], cited in Scheftelowitz, p. 5.)

- 43 Pohl, *Das Ichthysmonument von Autun*, and Doelger, I, pp. 12ff.
- 44 “I will save thee.” Shatapatha Brahmana (trans. by J. Eggeling, I [i.e., XII], p. 216).
- 45 De Gubernatis, *Zoological Mythology*, II, pp. 334f.
- 46 Shatapatha Brahmana (Eggeling trans., pp. 216ff.).
- 47 Doelger, I, p. 23. Keshava means ‘having much or fine hair,’ a cognomen of Vishnu.
- 48 *Ibid.*, pp. 21ff.
- 49 Origen (*De oratione*, cap. 27): “... as the last month is the end of the year, after which the beginning of another month ensues, so it may be that, since several ages complete as it were a year of ages, the present age is ‘the end,’ after which certain ‘ages to come’ will ensue, of which the age to come is the beginning, and in those coming ages God will ‘shew the riches of his grace in kindness’ [Eph. 2 : 7]” (Oulton/Chadwick trans., p. 304).
- 50 Especially noteworthy is the cult of the dove and the fish in the Syrian area. There too the fish was eaten as “Eucharistic” food. (Cumont, *Les Religions orientales dans le paganisme romain*, pp. 108–9, 255–57.) The chief deity of the Philistines was called Dagon, derived from *dag*, ‘fish.’
- 51 τὸ ποτήριον τῆς εὐλογίας: *calix benedictionis* (I Cor. 10 : 16, DV).
- 52 Scheftelowitz, p. 375.
- 53 *Ibid.*, p. 3.
- 54 Cf. Goodenough, V, pp. 35ff.
- 55 At the same time “Behemoth shall be revealed from his place ... and then they shall be food for all that are left.” (Charles, *Apocrypha and Pseudepigrapha*, II, p. 497.) The idea of Leviathan rising from the sea also links up with the vision in II Esdras 13 : 25, of the “man coming up from the midst of the sea.” Cf. Charles, II, p. 579, and Wischnitzer-Bernstein, *Symbole und Gestalten der jüdischen Kunst*, pp. 122f. and 134f.
- 56 Wirth, *Aus orientalischen Chroniken*, p. 199.
- 57 *Ibid.*, pp. 161, 19f.
- 58 [Cf. Neumann, *The Great Mother*, ch. 14 and pl. 134.—EDITORS.]
- 59 Eisler, *Orpheus—The Fisher*, Pl. LXIV.
- 60 See *Psychology and Alchemy*, fig. 28.
- 61 Scheftelowitz, p. 9; from the Talmud *Nezikin VI*, Sanhedrin II (*BT*, p. 662). Cf. the ἑσθίε πινάων in the Pectorios inscription, *supra*, p. 89n.
- 62 A passage in Moses Maimonides (*Guide for the Perplexed*, trans. by M. Friedlander, p. 303) has bearing on the interpretation of Leviathan. Kirchmaier (*Disputationes Zoologicae*, 1736, p. 73) cites it as follows: “Speaking of these same things Rabbi Moses Maimon says that Leviathan possesses a [universal] combination (*complexum generalem*) of bodily peculiarities found separate in different animals.” Although this rationalistic author dismisses the idea as “nugatory,” it nevertheless seems to me to hint at an archetype (“*complexum generalem*”) of the “spirit of gravity.”
- 63 *Psychological Types*, pars. 456ff.
- 64 Scheftelowitz, p. 10. Cf. Matt. 12 : 39 and 16 : 4, where Christ takes the sign of the prophet Jonah as a sign of the Messianic age and a prefiguration of his own fate. Cf. also Goodenough, *Jewish Symbols*, V, pp. 47ff.

65 Παμμεγέθης.

66 Pp. 7f.

67 Τὰ ἐν Περσίδι πραχθέντα (Wirth, p. 151).

- 1 Charles, II, p. 497, modified.
- 2 *Midrash Tanchuma*, Lev. 11 : 2 and Deut. 29 : 9; cited in Scheftelowitz, pp. 39f.
- 3 Talmud, *Nezikin* III, Baba Bathra (*BT*, I, p. 296). The *female* Leviathan has already been killed by Yahweh, salted, and preserved for the end of time. The male he castrated, for otherwise they would have multiplied and swamped the earth.
- 4 A typical pair of opposites. Cf. the struggle between the two dragons in hexagram 2, line 6, in the *I Ching* (Wilhelm/Baynes trans., 1967, p. 15).
- 5 Cf. the *Midrash Tanchuma*.
- 6 “Note complémentaire sur le poème de Mot et Aleïn,” p. 357.
- 7 Virolleaud, “La légende de Baal, dieu des Phéniciens,” p. ix.
- 8 Perhaps an echo of this psychological development may be found in the views of Moses Maimonides, who writes that in the Book of Job (ch. 41) Yahweh “dwells longest on the nature of the Leviathan, which possesses a combination of bodily peculiarities found separate in different animals, in those that walk, those that swim, and those that fly” (*Guide for the Perplexed*, p. 303). Accordingly Leviathan is a kind of super-animal, just as Yahweh is a kind of superman.
- 9 *Confessions*, Sheed trans., p. 275.
- 10 Cf. Goodenough, V, pp. 51ff.
- 11 The motif of splitting is closely related to that of penetration and perforation in alchemy. Cf. also Job 26: 13: “His hand pierced the fleeing serpent” (RSV).
- 12 For this information I am indebted to Dr. Riwkah Schärf.
- 13 II Esdras is a Jewish text written at the end of the 1st cent. A.D.
- 14 Cumont, *Les Religions orientales*, p. 255.
- 15 *Ibid.*, pp. 108–9, 256.
- 16 Eisler, *Orpheus—The Fisher*, p. 20.
- 17 *De Iside et Osiride*, cap. VII (Babbitt trans., V, p. 19).
- 18 ἸΧΘΥΣ, I, p. 126. The risen Christ ate of a broiled fish (Luke 24 : 42).
- 19 Spiegelberg, “Der Fisch als Symbol der Seele,” p. 574. Cf. Goodenough, V, fig. 9, where the mummy appears in the form of a fish.
- 20 The oxyrhynchus fish was regarded as sacred all over Egypt. Cf. Budge, *The Gods of the Egyptians*, II, p. 382; Plutarch, *De Iside*, cap. XLIX (Babbitt trans., V, p. 19).
- 21 *Ibid.* (pp. 120f.).
- 22 Picinellus, *Mundus symbolicus*, Lib. VI, cap. I.
- 23 Budge, II, pp. 241f. Cf. Christ’s transfiguration in the presence of Moses and Elias (Matt. 17 : 4), and the “Saviour of the twins” in *Pistis Sophia*.
- 24 Budge, II, p. 243.
- 25 Daniel 3 : 25 may be of relevance in this connection: the three men in the burning fiery furnace, who were joined by a fourth, a “son of God.”

26 Lit., ‘daughters of the bier’, presumably mourning women who walk ahead of the coffin. Cf. Ideler, *Untersuchungen über den Ursprung und die Bedeutung der Sternnamen*, p. 11.

27 Ibid., p. 15.

28 Jeremias, p. 22.

29 Ibid., p. 33.

30 Dieterich, *Eine Mithrasliturgie*, pp. 8ff.

31 Cf. *Psychology and Alchemy*, par. 446.

32 Garnerius, in Migne, *P.L.*, vol. 193, col. 49.

33 *Tractatus de gradibus superbiae*, in Migne, *P.L.*, vol. 182, col. 961.

34 One of the bad qualities of the north wind (“The north wind numbs with cold” = the numbness of the evil spirit, who “hardens the hearts of the wicked”), was responsible for an alchemical hypothesis concerning the formation of coral: “The coral is a kind of vegetable which comes into being in the sea, and has roots and branches, and in its original state is moist. But when the wind blows north, it hardens, and turns into a red substance, which the seafarer sees under the water and cuts off; then, when it comes out of the water, it turns into a stone, of a red colour.” (“Allegoriae super librum Turbae,” *Art. aurif.*, 1593, I, p. 143.)

- 1 This treatise was not printed together with the *Turba*, like the others, but it appears to belong to the same category. The 28th *Distinctio* contains the “*Dicta Belini*” (Belinus = Apollonius of Tyana).
- 2 Cf. Ruska, *Turba Philosophorum*.
- 3 Cf. the edn. of Preisendanz.
- 4 Printed in *Artis auriferae* (1593), I, pp. 139ff.; *Theatrum chemicum*, V, pp. 64ff.; and Manget, *Bibliotheca chemica curiosa* (1702), I, pp. 494ff.
- 5 I am not counting the fish as technical alchemical material, in which capacity it was of course known even to the Greek alchemists. I would mention, for instance, the “procedure of Salmanas” (Berthelot, *Alch. grecs*, V, viii, 5) for producing the “round pearl.” Fish-glue was often used as an agglutinant.
- 6 “*Allegoriae*,” in *Art. aurif.*, I, p. 141: “Est in mari piscis rotundus, ossibus et corticibus carens, et habet in se pinguedinem, mirificam virtutem, quae si lento igne coquatur, donec eius pinguedo et humor prorsus recedit ... et quousque luceat, aqua maris imbuatur.”
- 7 “*Aenigmata*,” in *Art. aurif.*, I, p. 149.
- 8 See du Cange, *Glossarium ad scriptores mediae et infimae latinitatis*, s.v. “cortex.” [In the Swiss *Gesammelte Werke*, 11, p. 59, n. 27, “corticibus” in this same passage is translated as “scales.”—EDITORS.]
- 9 From κνίδη, *urtica*, ‘nettle.’ Hence Pliny’s “sea-nettle” (*Hist. nat.*, XXXII, xi, 53).
- 10 From νῆμα, ‘thread, tentacle.’
- 11 Caussin (*Polyhistor symbolicus*, 1618, s.v. “stella”) cites Aristotle as a source.
- 12 *Hist. nat.*, IX, 60. Cf. trans. by Rackham and Jones, III, pp. 346–48.
- 13 This could be conceived as a starfish, since, as Pliny says, it has a hard exterior.
- 14 *Hist. nat.*, XVIII, 35.
- 15 IX, 47 (Rackham/Jones trans., III, p. 220).
- 16 XXXII, 10.
- 17 *Polyhistor symbolicus*, p. 414.
- 18 “And Elias the prophet stood up, as a fire; and his word burnt like a torch” (DV).
- 19 *Homilia in Ps.* 33, in Migne, *P.G.*, vol. 29, col. 371.
- 20 This recalls the Vision of Arisleus, where the philosophers in the glass-house at the bottom of the sea suffer great torment on account of the extraordinary heat. (*Art. aurif.*, I, pp. 146ff., and Ruska, “Die Vision des Arisleus,” pp. 22ff.)
- 21 *Mus. herm.* (1678), pp. 246f. The “*Gloria mundi*” is an anonymous treatise, and it remains uncertain whether it was originally written in Latin or not. So far as is known, it was printed for the first time in 1620, in German. To the best of my knowledge it was first mentioned in the treatises of the 17th cent. It was highly esteemed and was considered especially dangerous. In the *Theatr. chem.* (1661), VI, pp. 513ff., there is a long extract from it, conjuring the reader to be discreet: “I will that all those who possess this book be admonished and besought for the love of Jesus Christ, that they conceal this art from all such as are puffed up, vainglorious, unjust oppressors of the poor, proud, worldly, scoffers, contemners, false accusers, and such unworthy folk, nor permit this writing to come into the

hands of such, if they would escape the wrath of God and the punishments which he is wont to bring down upon those that are presumptuous and profane.”

22 “Recipito ignem, vel calcem vivam, de qua Philosophi loquuntur, quod in arboribus crescat, in quo (igne) Deus ipse ardet amore divino. ... Item. Naturalis Magister ait ad artem hanc de igne, Mercurium putrefaciendum ... et fixandum in igne indelebili, vel vivo, quo in Deus ipse ardeat, sed cum sole in amore divino, ad solatium omnium hominum; et absque isto igne ars numquam perfici poterit. Item, ignis Philosophorum quem occultatum occlusumque illi habent. ... Item, ignis nobilissimus ignis est, quem Deus in terra creavit, millenas enim virtutes habet. Ad haec respondet didascalus quod Deus tantam virtutem efficaciamque tribuerit ... ut divinitas ipsa cum hoc igne commixta siet. Et iste ignis purificat, tamquam purgatorium in inferno ... ”

23 “Philosophi hunc ignem Spiritus Sancti ignem appellant.”

24 “ ... adeo ut omnes tres, una res fiant, quas nemo separaturus siet.”

25 “Pari modo quo in hisce tribus sese uniunt, Deus pater, Deus filius et Deus spiritus sanctus, S. S. Trinitas in tres personas et tamen unicus verus Deus remanet; ita quoque ignis unit hasce tres res: utpote corpus, spiritum et animam, hoc est, Solem, Mercurium et Animam” (p. 247).

26 “In igni hoc invisibili artis mysterium inclusum est, quemadmodum tribus in personis Deus Pater, Filius et Spiritus S. in una essentia vere conclusus est” (p. 248).

27 “ ... qui seipsum sese in vivam aquam miscet” (p. 247). Presumably taken over from the “troubled” water of the pool of Bethesda (John 5 : 2).

28 “Occultatio et domicilium omnis thesauri.”

29 “Continens hanc machinam mundi in suo esse.”

30 Sendivogius, “Novi luminis chemici,” *Mus. herm.*, p. 607.

31 Ripley, “Duodecim portarum,” *Theatr. chem.*, II, p. 128.

32 *Uraltes Chymisches Werk* (1760), pp. 79 and 81.

33 “De igne et sale,” *Theatr. chem.*, VI, p. 39.

34 They are also the sons of Set, in so far as Heru-ur and Set have one body with two heads. [For the association of fire and north, see pp. 99 and 124.]

35 The quaternary symbols that appear spontaneously in dreams always point, so far as I can see, to totality or the self. Fire means passion, affects, desires, and the emotional driving-forces of human nature in general, that is, everything which is understood by the term “libido.” (Cf. *Symbols of Transformation*, Part II, chs. 2 and 3.) When the alchemists attribute a quaternary nature to the fire, this amounts to saying that the self is the source of energy.

36 Hell-fire is identical with the devil, who, on the authority of Artefius (“Clavis maioris sapientiae,” *Theatr. chem.*, IV, p. 237), has an outer body made of air and an inner one of fire.

37 Philalethes, “Introitus apertus,” *Mus. herm.*, pp. 654f.: “ ... ignis infernalis, secretus ... mundi miraculum, virtutum superiorum in inferioribus systema, quare signo illum notabili notavit Omnipotens cuius nativitas per Orientem in Horizonte Hemisphaerii sui philosophicum annunciat. Viderunt Sapientes in Evo Magi, et obstupuerunt statimque agnoverunt Regem serenissimum in mundo natum. Tu cum ejus Astra conspexeris, sequere ad usque cunabula, ibi videbis infantem pulcrum, sordes semovendo, regium puellum honora, gazam aperi, auri

donum offeras, sic tandem post mortem tibi carnem sanguinemque dabit, summam in tribus Terrae Monarchiis medicinam.”

(Cf. Waite, trans., *The Hermetic Museum Restored and Enlarged*, II, pp. 166f.) Philalethes (“lover of truth”) is a pseudonym. Waite (*The Works of Thomas Vaughan: Eugenius Philaletha*) conjectures the Hermetic philosopher Vaughan (1621–65), an hypothesis that is doubtful for several reasons. See also Waite, *Lives of Alchemistical Philosophers*, p. 187, and Ferguson, *Bibliotheca Chemica*, II, pp. 194 and 197.

38 From the Paracelsan concept of the “Archeus.” See my “Paracelsus the Physician,” par. 39 n. 56. Ruland (*Lexicon of Alchemy*, p. 36) defines: “Archeus is a most high, exalted, and invisible spirit, which is separated from bodies, is exalted, and ascends; it is the occult virtue of Nature, universal in all things, the artificer, the healer ... the dispenser and composer of all things.”

39 Probably magnetism is meant.

40 Cf. *Psychology and Alchemy*, par. 457.

40a [Cf. *Memories, Dreams, Reflections*, p. 85 (Brit. edn., p. 91).]

41 “The Psychology of Eastern Meditation,” pars. 942ff.

42 Ecclesiasticus 9 : 18 (Vulg. 25): “A man full of tongue is terrible in his city (DV), Conversely, the fiery tongue is an allegory (or symbol?) of the Holy Ghost: “cloven tongues, as of fire” (Acts 2 : 3).

43 James 3 : 5 (RSV).

44 *Psychology and Alchemy*, par. 109.

45 “The Spirit Mercurius,” par. 263. Cf. *Psychology and Alchemy*, fig. 208.

46 P. Nigidius Figulus lived in the 1st cent. B.C.

47 Hertz, *De P. Nigidii Figuli Studtis atque operibus*, p. 5.

48 Tract. I, 31, in *Opera*. For Christ as destroyer of Heimarmene see *Pistis Sophia*, Mead trans., p. 17.

49 Fire in this sense often appears in dreams.

50 Hoghelande, “Liber de alchemiae difficultatibus,” *Theatr. chem.*, I, p. 163. The quotation from Mundus in the *Turba* (Ruska, p. 128) runs: “Take therefore one part white gum at an intense heat, and one part calf’s urine, and one part fish-gall, and one part substance of the gum, without which it cannot be made free from error.” “Mundus” is a corruption of “Parmenides,” due to Arabic transcription: (Bar)Mnds. See Ruska, p. 25.

51 “Ossibus et corticibus carens.” [Cf. supra, p. 128 n. 8.]

52 Du Cange, *Glossarium*, s.v. “ligaturae”: “*Corrigia* or *ligatura* of Aphrodite. *Ligaturae*, *alligaturae* and *alligamenta* are amulets for dispelling diseases. *Suballigaturae* are magic draughts [poisons], precautionary measures [spells],” etc.

53 *Opsianos lithos* = ‘black stone,’ obsidian.

54 “Iste lapis est geminus vel duplex: unus quidem est obscurus et niger, alter autem niger quidem, lucidus et splendidus est sicut speculum.”

55 Delatte, *Textes latins et vieux français relatifs aux Cyranides*, Fasc. XCIII, p. 56.

56 *Hist. nat.*, XXXVII, 10.

57 Ruland, *Lexicon*, pp. 128–29.

58 *Ibid.*, p. 128: “But unless it is removed while they [the serpents] are alive, it will never become a precious stone.”

59 *Lucidus* (see above, n. 54), ‘brilliant, shining,’ can also mean ‘white,’ thus contrasting with black. But the description would also fit the obsidian.

60 *Lexicon*, p. 203.

61 “The sacred lead of the wise,” from which are extracted mercury, sulphur, and salt. Cf. Chartier, “Scientia plumbi sacri sapientum,” *Theatr. chem.*, VI, p. 571.

62 “Arca arcani,” *ibid.*, p. 314.

63 “De igne et sale,” *ibid.*, p. 131.

64 *Philosophia reformata*, p. 305.

65 Pantheus, *Ars transmutationis metallica* (1519), fol. 9^r.

66 *Opera omnia chemica* (1649), p. 317.

67 *Elenchos*, V, 16, 2 (Legge trans., I, p. 154).

68 *Psychology and Alchemy*, “The Lapis-Christ Parallel.”

69 We could conceive these as hereditary influences, vestiges of ancestral life, although this idea does not suggest as much as *karma* does to the Indian.

70 *Hymni et sermones*, ed. Lamy, II, col. 770.

71 “Fidelissima et Jucunda Instructio ex manuscripto Gallico Philosophi Anonymi desumpta, per quam Pater filio suo omnia declarat, quae ad compositionem et praeparationem Lapidis Sapientum sunt necessaria, decem capitibus comprehensa.” The abbreviated title of this treatise as printed in Vol. VI of *Theatr. chem.* is “Instructio de arbore solari.”

72 “Quia illud quod accipimus ut opus Philosophicum ex eo praeparemus, nihil aliud est quam pisciculus Echen[e]is sanguine et ossibus spinosis carens, et in profunda parte centri magni maris mundi est inclusus. Hic pisc[ic]ulus valde est exiguus, solus et in sua forma unicus, mare autem magnum et vastum, unde ilium capere impossibile est illis, qui qua in parte mundi moretur ignorant. Certam mihi fidem habe, illum qui ut Theophrastus loquitur, artem illam non callet, qua Lunam de firmamento trahat, et de coelo super terram adducat, et in aquam convertat, et postea in terram mutet, nunquam maleriam lapidis sapientum inventurum, unum tamen non est difficilius facere, quam alterum invenire. Nihilominus tamen, cum fido amico aliquid in au[re]m fideliter dicimus, tunc ipsum occultum secretum sapientum docemus, quomodo pisc[ic]ulum Remora dictum naturaliter cito et facile capere possit, qui navigia magni maris Oceani (hoc est spiritus mundi), superba retinere potest, qui cum filii artis non sint, prorsus ignari sunt et preciosos thesauros, per naturam in preciosa et coelesti aqua vitae nostri maris delitescentes, non noverunt. Sed ut clarum lumen unicae nostrae materiae, seu terrae virgineae nostrae tibi tradam summam artem filiorum sapientiae, quomodo videlicet illam acquirere possis, te doceam, necesse est ut prius de magnete sapientum te instruam, qui potestatem habet, pisc[ic]ulum Echen[e]is vel Remora dictum ex centro et profunditate nostri maris attrahendi. Qui si secundum naturam capitur, naturaliter primo in aquam deinde in terram convertitur: Quae per artificiosum secretum sapientum debito modo praeparata potestatem habet, omnia fixa corpora dissolvendi, et volatilia faciendi et omnia corpora venenata purgandi etc.”

73 “Liber de alchemia,” *Theatr. chem.*, I, p. 795.

74 Arisleus is legendary. He was regarded as the author of the *Turba*.

75 “Natura non emendatur nisi in sua natura.”

76 “Natura” and “naturae,” in the language of the *Turba*, correspond to the *φύσεις* of the alchemist Democritus (1st cent.). See Berthelot, *Alch. grecs*. They are substances or states of substances.

77 “Omne quo indiget.”

78 “Who among us shall dwell with the devouring fire? who among us shall dwell with everlasting burnings?” Isaiah 33 : 14.

79 [Cf. “Transformation Symbolism in the Mass,” pars. 339ff.—EDITORS.]

80 *Opera*, p. 10.

81 Grenfell and Hunt, *New Sayings of Jesus*, p. 16.

82 *Mus. herm.*, p. 343.

83 Regarding the combination of fish and bird in ancient mythology, cf. Goodenough, V, pp. 58ff. and figs. 63, 66, 69.

84 Cited by Hahn, *Geschichte der Ketzer im Mittelalter*, II, pp. 815ff.

85 In contradiction to Luke 16 : 8, where “the lord commended the unjust steward, because he had done wisely.”

86 Despite the fact that the sect of this John condemned the Concorricci, with whom our Johannine revelation originated. In the *Summa Fratris Reineri* (“De propriis opinionibus Joh. de Lugio”) we read: “He says this world is of the devil.” Hahn, I, p. 580.

87 Rupescissa, *La Vertu et la propriété de la quinte essence* (1581), p. 31: “Since it is our intention to comfort and strengthen the poor preachers of the gospel [*hommes evangelisans*] by means of our book, to the end that their prayers and supplications be not in vain and lost in this work, and that they be not greatly hindered in this pursuit, I will declare and give to them a secret drawn from the bosom of the secrets of the treasures of Nature, which is a thing truly worthy of wonderment, and is to be honoured.”

In Rupescissa’s treatise “De confectione veri lapidis” (in Gratarolus, *Verae alchemiae artisque metallica*, 1561, II, p. 299) there is the following exhortation, very unusual in alchemical literature: “Credas, vir Evangelice.” Presumably, this was originally an “homme evangelisant.”

88 *Altkirchenslavisch-griechisches Wörterbuch des Codex Suprašliensis*.

89 Dragomanov (“Zabelezhki vrkhy slavyanskite religioznoeticheski Legendi,” p. 7) merely remarks about “suom Osob” that, in a Gipsy legend, the devil was hampered by burning sand when creating the world.

90 Cf. supra, n. 36, on Artefius.

91 “But the two fishes ... seem to signify those two persons by whom that people was governed ... that is, the kingly and the priestly” (*De diversis quaestionibus*, LXI, 2; Migne, *P.L.*, vol. 40, col. 48). The derivation of the two fishes from II Esdras 6 : 49ff. (Soederberg, *La Religion de Cathares*, p. 97) seems to me questionable. The passage runs (Charles, *Apocryphal and Pseudepigrapha*, II, p. 579): “Then didst thou preserve two living creatures; the name of the one thou didst call Behemoth and the name of the other thou didst call Leviathan. And thou didst separate the one from the other. ... ” This image does not fit in at all with the two fishes mentioned in the Cathar text.

92 “So is our Lord Jesus Christ shown to be our king. He is also our priest for ever after the order of Melchisedek” (Augustine, *De diversis quaestionibus*, LXI, 1).

93 Cap. XVI (Oehler edn., I, p. 266).

94 Psellus, “De daemonibus,” in Ficinus, *Auctores Platonici* (1497), fol. N. V^r.

95 Migne, *P.G.*, vol. 130, cols. 1290ff.

96 This interpretation accords with modern astrological speculations.

97 Concerning such symbols, see Neumann, *The Origins and History of Consciousness*.

98 Ripley, *Chymische Schrifften* (1624), p. 25.

99 *Ibid.*, p. 33f.

100 Cf. Laiblin, “Vom mythischen Gehalt unserer Märchen.”

101 According to Irenaeus, the Gnostics held that the demiurge was the younger brother of Christ.

102 *Mus. herm.*, p. 343.

103 The transparency of the water means that attention (value, gold) is given to the unconscious. It is an offering to the genius of the fountain. Cf. the vision of the Amitābha Land in my “Psychology of Eastern Meditation.”

104 Cf. *infra*, pars. 395ff.

105 Cf. *Psychology and Alchemy*, s.v. “coniunctio.”

106 The Ichthys (= Christ or Attis) is the food that bestows (immortal) life.

107 Deussen, *Allgemeine Geschichte der Philosophie*, I, pt. iii, pp. 336ff. and “The Spirit Mercurius,” pars. 282ff.

108 *Psychology and Alchemy*, pars. 26 and 209, and “A Psychological Approach to the Dogma of the Trinity,” pars. 184ff.

109 [For the source of this saying, see “A Psychological Approach to the Dogma of the Trinity,” par. 229, n. 6.—
EDITORS.]

1 “The Echenaïs is a small fish, half a foot in length [*semipedalis*], and takes its name from the fact that it holds back a ship by cleaving to it, so that though winds blow and storms rage, yet the ship seems to stand still as if rooted in the sea, and cannot be moved. ... Hence the Latins call it *delay* (Remora).” (Du Cange, *Glossarium*, s.v. “Echenaïs.” Cited from the ms. of a bestiary.) This passage is taken verbatim from the *Liber etymologiarum* (Lib. XII, cap. VI) of Isidore of Seville. There the name of the fish is “echinus,” which strictly speaking is a sea-urchin. Because of its radial structure, this creature comes into the same class as the starfish and the jelly-fish. (For the “Instructio,” see supra, p. 140, n. 71.)

2 That the power of the Echeneis was understood to be magnetic is clear from the legend that if a salted Echeneis is let down into a mine it will attract the gold and bring it to the surface. Cf. Masenius, *Speculum imaginum veritatis occultae* (1714), s.v. “Echeneis.” “Magnet” is also the name given to sal ammoniac, which, when added to metallic solutions, “instantly draws all that is good in them, be it gold or tincture, to the bottom of the glass.” (*Lexicon medico-chymicum*, 1711, p. 156.)

3 *Dictionnaire mytho-hermétique* (1787), s.v. “Magnès.”

4 Cf. *Psychology and Alchemy*, pars. 425ff.

5 Berthelot says of the “Magnésie”. “Jusqu’au XVIIIe siècle, [le mot] n’a rien eu de commun avec la magnésie des chimistes d’aujourd’hui” (*Alch. grecs*, Introduction, p. 255). In Pliny and Dioscorides it meant the magnetic ironstone.

6 Mylius, *Phil. ref.*, p. 31.

7 The *corpus Magnesia* is the “root of the closed house,” the “belly” in which Sol and Luna are united. (“Aurora consurgens,” Part II, *Art. aurif.*, I, p. 191.)

8 *Theatr. chem.*, III, pp. 88f.

9 Mylius calls the tenth grade of the process “the exaltation, which is the ingenious ennobling of our whitened magnesia” (p. 129). Hence the *Rosarium philosophorum* (*Art. aurif.*, II, p. 231) says: “The magnesia is the full moon.”

10 Sermo XXI.

11 *Von hylealischen Chaos*, pp. 5f.

12 “Magnesia—the Woman.” Ruland, *Lexicon*, p. 216.

13 But in the region of Alexandria and in the Troad there was said to be a magnetic stone “of the feminine sex, and totally useless.” (Ruland, p. 215.)

14 “Duodecim tractatus,” *Theatr. chem.*, IV, p. 499.

15 Berthelot, Intro., p. 255.

16 “Magnesia is further the mixed water congealed in air which offers resistance to the fire, the earth of the stone, our mercury, mixture of the substances. The whole therein is mercury.” Ruland, p. 216.

17 “Rosinus ad Sarratantam” (*Art. aurif.*, I, p. 311): “Recipe ergo hunc lapidem animale: id est animam in se habentem, scilicet Mercurialem sensibilem: id est, sentientem praesentiam et influentiam magnesia et magnetis et calaminarem [et lapidem] per motum localem, prosequendo et fugando vegetabilem” Instead of “et lapidem” the text of 1593 has “ac apicem,” which does not make sense. Rosinus is a corruption of Zosimos due to Arabic transcription.

18 *De arte metallica metamorphoseos ad Philoponum liber singularis* (1576). Reprinted in *Theatr. chem.*, I (1602), p. 44.

19 “Philosophia chemica,” *Theatr. chem.*, I, p. 497. Here Dorn discusses his view of the *anima rerum*: “The body ... of every thing is a prison, wherein the powers of the soul of things are detained and held in fetters, so that their natural spirits are not able freely to impress their powers and activities upon them. The spirit of such insensate things in relation to its subject is similar to and of the same efficacy as undoubting faith is in man.” The divine powers imprisoned in bodies are nothing other than *Dionysus dispersed in matter*.

20 Cf. *City of God*, Healey trans., II, p. 322. Augustine finds quick-lime (*calx viva*) equally wonderful: “Quam mirum est quod cum extinguitur, tunc accenditur” (But the wonder is that when it is killed it is quickened).

21 *Emblemata* (1621), Embl. CLXXI, p. 715 a.

22 *Commentariorum alchymiae* (1606), Part II, p. 101.

23 *Theatr. chem.*, IV, p. 499.

24 The extraordinary importance of the water in alchemy goes back, in my view, to Gnostic sources: “And water is honoured, and they believe in it as if it were a god, going almost so far as to allege that life arises therefrom” (Epiphanius, *Panarium*, LXIII, cap. I).

25 “Inquiunt enim, natura naturam sibi similem appetit, et congaudet suae naturae; si alienae iungatur, destruitur opus naturae” (“Ars chemistica,” *Theatr. chem.*, I, p. 252).

26 Δημοκρίτου φυσικά καὶ μυστικά.—Berthelot, *Alch. grecs*, II, i, 3. According to the story of Democritus, this axiom was revealed to him by his deceased teacher. Synesius, in the treatise addressed to Dioscorus, priest of Serapis (Berthelot, II, iii), says that the teacher of Democritus was Ostanes, and that the axiom came from him.

27 *Vegetabilis* in our texts means ‘living’ when applied to Mercurius, ‘vivifying’ when applied to the Quinta Essentia.

28 Cf. “Psychology of the Transference,” pars. 433ff., and “Phenomenology of the Spirit in Fairytales,” in Part I of vol. 9, pars. 429ff.

29 *Psychological Types*, ch. V, 3.

30 “Idea perfecta philosophiae hermeticae,” *Theatr. chem.* (1661), VI, p. 152. The treatise was first published 1630. Of the author Colleson nothing appears to be known.

31 “Quantum autem ad substantiam, qua naturaliter et Philosophice aurum et argentum vulgare solvuntur, attinet, nemo sibi imaginari debet, ullam aliam, quam animam mundi generalem, quae per magnetes et media Philosophica trahitur et attrahitur de corporibus superioribus, maxime vero de radiis Solis et Lunae. Unde liquet illos Mercurii seu menstrui Philosophici nullam habere cognitionem, qui naturaliter et physice metalla perfecta dissolvere cogitant.”

32 “There is a certain truth in natural things which is not seen with the outward eye, but is perceived by the mind alone, and of this the Philosophers have had experience, and have ascertained that its virtue is such that it performs miracles” (“Speculativa philosophia,” *Theatr. chem.*, I, p. 298).

33 Pernety, *Dictionnaire mytho-hermétique*, s.v. “Aimant.”

34 “... medicina, corrigens et transmutans id, quod non est amplius, in id quod fuit ante corruptionem, ac in melius, et id, quod non est, in id quod esse debet” (p. 267).

- 35 “In corpore humano latet quaedam substantia methaphysica, paucissimis nota, quae nullo ... indiget medicamento, sed ipsa medicamentum est incorruptum” (p. 265).
- 36 “ ... Chemistarum studium, in sensualibus insensualem illam veritatem a suis compedibus liberare” (p. 271).
- 37 “Philosophi divino quodam afflatu cognoverunt hanc virtutem caelestemque vigorem a suis compedibus liberari posse: non contrario ... sed suo simili. Cum igitur tale quid, sive in homine sive extra ipsum inveniatur, quod huic est conforme substantiae, concluderunt sapientes similia similibus esse corroboranda, pace potius quam bello.” (P. 265.)
- 38 “Fac igitur ut talis evadas, quale tuum esse vis quod quaesieris opus” (p. 277).
- 39 “ ... non possumus de quovis dubio certiores fieri, quam experiendo, nec melius quam in nobis ipsis” (“Philosophia meditativa,” *Theatr. chem.*, I, p. 467).
- 40 “Cognoscat hominis in homine thesaurum existere maximum, et non extra ipsum. Ab ipso procedit interius ... per quod operatur extrinsecus id, quod oculariter videt. Ergo nisi mente caecus fuerit, videbit (id est) intelliget, quis et qualis sit intrinsecus, luceque naturae seipsum cognoscet per exteriora.” (“Speculativae philosophiae,” p. 307.)
- 41 The alchemist and mystic John Pordage (1607–81) called the inner “eternal” man an “extract and summary concept of the Macrocosm” (*Sophia*, 1699, p. 34).
- 42 “Disce ex te ipso, quicquid est et in caelo et in terra, cognoscere, ut sapiens fias in omnibus. Ignoras caelum et elementa prius unum fuisse, divino quoque ab invicem artificio separata, ut et te et omnia generare possent?” (“Speculativae philosophiae,” p. 276.)
- 43 An idea that reached its full development 200 years later in Leibniz’ monadology, and then fell into complete oblivion for another 200 years owing to the rise of the scientific trinity—space, time, causality. Herbert Silberer, who was also interested in alchemy, says: “I would almost prefer to surrender entirely to picture-language, and to call the deepest subconsciousness our *internal heaven of fixed stars*.” (*Der Zufall und die Koboldstreiche des Unbewussten*, p. 66.) Further material in “On the Nature of the Psyche,” pars. 389ff.
- 44 “Nemo vero potest cognoscere se, nisi sciat quid, et non quis ipse sit, a quo dependeat, vel cuius sit ... et in quem finem factus sit” (p. 272).
- 45 *Exercitia spiritualia*, “Principio y Fundamento”: “Homo creatus est (ad hunc finem), ut laudet Deum Dominum nostrum, ei reverentiam exhibeat, eique serviat, et per haec salvet animam suam.” See trans. by Rickaby, p. 18.
- 46 “De transmutatione metallica,” *Art. aurif.*, II, p. 11.
- 47 “Not, that is, that I should require of them riches or gifts, but that I should diligently furnish them with spiritual gifts” (p. 10).
- 48 “Haec enim res a te extrahitur: cuius etiam minera tu existis, apud te namque illam inveniunt, et ut verius confitear, a te accipiunt; quod quum probaveris, amor eius (rei) et dilectio in te augebitur” (p. 37).
- 49 Pp. 40f.
- 50 “The whole perfection of the magistry consists in the taking of conjoined and concordant bodies” (p. 43). The “Interpretatio cuiusdam epistolae Alexandri Macedonum regis” (*Art. aurif.*, I, p. 384) says: “And know that nothing is born without male and female.” And in the “Tractatulus Avicennae” it is said: “Marriage is the mingling of the subtle with the dense.” Cf. “Psychology of the Transference,” index, s.v. “coniunctio.”
- 51 The text has “Malus” (*Art. aurif.*, I, p. 310), probably a miswriting of Magus, who is a known author.

- 52 “Hic lapis est subtuus te, quantum ad obedientiam; supra te, quoad dominium; ergo a te, quantum ad scientiam; circa te, quantum ad aequales” (*Art. aurif.*, I, p. 310).
- 53 The dating of these texts is very uncertain. Allowing for error, it seems to me that Morienus is the older.
- 54 The text has “ipsum.” But the object here is “res.”
- 55 “Hic lapis talis est res, quae in te magis fixa est, a Deo creata, et tu eius minera es ac a te extrahitur et ubicunque fueris, tecum inseparabiliter manet. ... Et ut homo ex 4 elementis est compositus, ita et lapis, et ita est ex homine, et tu es eius minera, scil. per operationem; et de te extrahitur, scil. per divisionem; et in te inseparabiliter manet, scil. per scientiam. Aliter in te fixa, scil. in Mercurio sapientum; tu eius minera es; id est, in te est conclusa et ips[a]m occulte tenes, et ex te extrahitur, cum a te reducitur et solvitur; quia sine te compleri non potest, et tu sine ips[a] vivere non potes et sic finis respicit principium et contra.” (*Art. aurif.*, I, pp. 311f.)
- 56 “The Spirit Mercurius,” pars. 264ff.
- 57 “Nemo in se ipso, sed in sui simili, quod etiam ex ipso sit, generare potest” (“Speculativae philosophiae,” p. 276).
- 58 “... ex aliis numquam unum facies quod quaeris, nisi prius ex te ipso fiat unum. ... Nam talis est voluntas Dei, ut pii piis consequantur opus quod quaerunt, et perfecti perficiant aliud cui fuerint intenti. ... Fac igitur ut talis evadas, quale tuum esse vis quod quaesieris opus” (p. 276f.).
- 59 “Transmutemini de lapidibus mortuis in vivos lapides philosophicos!” (p. 267). This is an allusion to I Peter 2 : 4f: “Come to him, to that living stone, rejected by men but in God’s sight chosen and precious; and like living stones be yourselves built [up] ... ” (RSV).
- 60 “Non in nobis quaerenda [veritas], sed in imagine Dei, quae in nobis est” (p. 268).
- 61 “Uterius, ut definitioni veri faciamus satis, dicimus esse, vero nihil adesse, nam uni quid adest, quaeso, quid etiam deest, aut quid contra niti potest? cum nihil vere praeter illud unum existit” (p. 268).

1 Cf. “On the Nature of the Psyche,” pars. 417ff., 438ff.

2 I was able to convince myself on the spot of the existence of this fear.

3 Kerygmatics = preaching, declaration of religious truth.

4 Father Victor White, O.P., has kindly drawn my attention to the concept of the *veritas prima* in St. Thomas Aquinas (*Summa theol.*, II, II, i, 1 and 2): This “first truth” is invisible and unknown. It is this, and not the dogma, that underlies belief.

5 This is not to contest the legitimacy and importance of dogma. The Church is not concerned only with people who have a religious life of their own, but also with those from whom no more can be expected than that they should hold a tenet to be true and confess themselves satisfied with this formula. Probably the great majority of “believers” do not get beyond this level. For them dogma retains its role as a magnet and can therefore claim to be the “final” truth.

6 “Sit, ut est, aut non sit.”

7 “On the Nature of the Psyche,” par. 415.

8 Like the Old Testament “Yahweh Zebaoth,” Lord of Hosts. Cf. Maag, “Jahwäs Heerscharen.”

9 Also in “Psychology and Religion”; “Relations between the Ego and the Unconscious”; and my commentary on *The Secret of the Golden Flower*.

10 For the significance of conscious development in relation to mythological symbolism, see Neumann, *The Origins and History of Consciousness*.

1 Unfortunately it is not possible for me to elucidate or even to document this statement here. But, as Rhine's ESP (extrasensory perception) experiments show, any intense emotional interest or fascination is accompanied by phenomena which can only be explained by a psychic relativity of time, space, and causality. Since the archetypes usually have a certain numinosity, they can arouse just that fascination which is accompanied by synchronistic phenomena. These consist in the *meaningful* coincidence of two or more causally unrelated facts. For details I would refer the reader to my "Synchronicity: An Acausal Connecting Principle."

2 Genesis 1 : 7.

3 Non-verbatim quotation from John 4 : 10.

4 *Elenchos*, V, 9, 18f. (Cf. Legge trans., I, pp. 143f.) "Heracleian stone" = magnet.

5 John 10: 9: "I am the door. By me, if any man enter in, he shall be saved."

6 I use the reading: *καμμύουαιν ὀφθαλμοῦ βλέφαρον*. Does this mean those who close their eyes to the world?

7 The naphtha analogy reappears in the teachings of the Basilidians (*Elenchos*, VII, 24, 6f.). There it refers to the son of the highest archon, who comprehends the *νοήματα ἀπὸ τῆς μακαρίας υἰότητος* (idea of the blessed sonship). Hippolytus' exposition seems to be a trifle confused at this point.

8 Several more metaphors now follow, and it should be noted that they are the same as in the passage previously quoted (V, 9, 19).

9 *Elenchos*, V, 17, 8ff. (Cf. Legge trans., I, pp. 158f.)

10 "And as Moses lifted up the serpent in the wilderness, even so must the Son of man be lifted up."

11 Here, as in the previous passages about the magnet, mention is made of *electron* (amber) and the sea-hawk, emphasis being laid on the bird's *centre*.

12 *Elenchos*, V, 21, 8 (Legge trans., I, p. 168). The ray of light (*radius*) plays an analogous role in alchemy. Dorn (*Theatr. chem.*, I, p. 276) speaks of the "invisible rays of heaven meeting together at the centre of the earth," and there, as Michael Maier says, shining with a "heavenly light like a carbuncle" (*Symbola aureae mensae*, 1617, p. 377). The arcane substance is extracted from the ray, and constitutes its "shadow" (*umbra*), as the "Tractatus aureus" says (*Ars chemica*, 1566, p. 15). The *aqua permanens* is extracted from the rays of the sun and moon by the magnet (Mylius, *Philosophia reformata*, p. 314), or the rays of the sun are united in the "silver water" (Beatus, "Aurelia occulta," *Theatr. chem.*, IV, p. 563).

13 "And therefore the highest power, seeing her stability in God, communicates it to the lowest, that they may discern good and evil. In this union Adam dwelt, and while this union lasted he had all the power of creatures in his highest power. As when a lodestone exerts its power upon a needle and draws it to itself, the needle receives sufficient power to pass on to all the needles beneath, which it raises and attaches to the lodestone." (Meister Eckhart, trans. by Evans, I, p. 274, slightly modified.)

14 [Cf. n. 11, supra.]

15 Cf. *Psychology and Alchemy*, pars. 127ff., and "A Study in the Process of Individuation," in Part I of vol. 9.

16 Ἐξ ἀρχῆς ὁ Αὐτοπάτωρ αὐτὸς ἐν ἑαυτῷ περιεῖχε τὰ πάντα ὄντα ἐν ἑαυτῷ ἐν ἀγνωσίᾳ κτλ. *Panarium*, XXXI, cap. V (Oehler edn., I, p. 314).

17 *Elenchos*, VI, 42, 4; Quispel, "Note sur 'Basilide,'" p. 115.

18 Acts 17 : 30.

19 Cf. Scott, *Hermetica* (I, pp. 150f.) where there is a description of the *krater* filled with Nous which God sent down to earth. Those whose hearts strive after consciousness (*γνωρίζουσα ἐπὶ τὶ γέγονας*) can “baptize” themselves in the *krater* and thereby obtain Nous. “God says that the man filled with Nous should know himself” (pp. 126f.).

20 *Γένος οὖν ὑπάρχοντες τοῦ θεοῦ* (Acts 17: 29).

21 Likewise the *μετανοεῖτε* of the Baptist (Matt. 3 : 2).

22 Cf. the *τὸ τῆς ἀγνοίας ἀμάρτημα*, ‘sin of unconsciousness’ in pseudo-Clement (*Homilies XIX*, cap. XXII), referring to the man who was born blind (John 9 : 1).

23 *Polyhistor symbolicus*, p. 348: “God, formerly the God of vengeance, who with thunders and lightnings brought the world to disorder, took his rest in the lap of a Virgin, nay, in her womb, and was made captive by love.”

24 “Die Gestalt des Satans im Alten Testament.”

25 *Rig-Veda*, X, 129. (Cf. MacNicol trans., *Hindu Scriptures*, p. 37.)

26 “Being” is controversial. The Master says: “God in the Godhead is a spiritual substance, so unfathomable that we can say nothing about it except that it is naught [*niht ensi*]. To say it is aught [*ih*t] were more lying than true.” (Cf. Evans trans., I, p. 354.)

27 “To this end there is no way, it is beyond all ways.” (Cf. *ibid.*, p. 211.)

28 “ ... von formen formelôs, von werdenne werdelôs, von wesenne weselôs und ist von sachen sachelôs.” (Cf. *ibid.*, p. 352.)

29 “[The will] is the nobler in that it plunges into unknowing, which is God.” Cf. *ibid.*, p. 351. Cf. also n. 16, supra: *ἀγνωσία*.

30 Evans, I, p. 219.

31 End of the sermon “Renovamini spiritu” (Eph. 4: 23). *Ibid.*, pp. 247f.

32 There are people who, oddly enough, think it a weakness in me that I refrain from metaphysical judgments. A scientist’s conscience does not permit him to assert things he cannot prove or at least show to be probable. No assertion has ever yet brought anything corresponding to it into existence. “What he says, is” is a prerogative exclusive to God.

33 *Adversus haereses*, I, 30, 3. In the system of Barbelo-Gnosis (*ibid.*, 29, 4) the equivalent of Sophia is *Προύνικος*, who “sinks into the lower regions.” The name Prunicus (*προύνικος*) means both ‘carrying a burden’ and ‘lewd.’ The latter connotation is more probable, because this Gnostic sect believed that, through the sexual act, they could recharge Barbelo with the pneuma that was lost in the world. In Simon Magus it is Helen, the *μήτηρ* and *ἔννοια*, who “descended to the lower regions ... and generated the inferior powers, angels, and firmaments.” She was forcibly held captive by the lower powers (Irenaeus, I, 27, 1–4). She corresponds to the much later alchemical idea of the “soul in fetters” (cf. Dorn, *Theatr. chem.*, I, pp. 298, 497; Mylius, *Phil. ref.*, p. 262; *Rosarium philosophorum* in *Art. aurif.*, II, p. 284; “Platonis liber quartorum,” *Theatr. chem.*, V, pp. 185f.; Vigenère, *Theatr. chem.*, VI, p. 19). The idea derives from Greek alchemy and can be found in Zosimos (Berthelot, *Alch. grecs*, III, xlix, 7; trans. in *Psychology and Alchemy*, pars. 456ff.). In the “Liber quartorum” it is of Sabaeen origin. See Chwolsohn, *Die Ssabier und der Ssabismus* (II, p. 494): “The soul once turned towards matter, fell in love with it, and, burning with desire to experience bodily pleasures, was no longer willing to tear herself away from it. So was the world born.” Among the

Valentinians, Sophia Achamoth is the Ogdoad. In *Pistis Sophia* (trans. by Mead, p. 362) she is the daughter of Barbelo. Deluded by the false light of the demon Authades, she falls into imprisonment in chaos. Irenaeus (I, 5, 2) calls the demiurge the Heptad, but Achamoth the Ogdoad. In I, 7, 2 he says that the Saviour is compounded of four things in repetition of the first Tetrad. A copy of the Four is the quaternity of elements (I, 17, 1), and so are the four lights that stand round the Autogenes of Barbelo-Gnosis (I, 29, 2).

34 *Adv. haer.*, I, 24, 1.

35 Bousset, *Hauptprobleme der Gnosis*, p. 170.

36 *Panarium*, XXX, 3.

37 Theodor Bar-Kuni, *Inscriptiones mandaites des coupes de Khouabir*, Part 2, p. 185.

38 *The Apocryphal New Testament*, ed. James, p. 379.

39 Bousset, pp. 114ff.

40 *The Miraculous Birth of King Amon-Hotep III*, p. 81.

41 *Elenchos*, V, 9, 5f. (Legge trans., I, pp. 140f.).

42 *Psychology and Alchemy*, index, s.v. “Axiom of Maria.” Cf. infra, pars. 395ff.

43 *εὐφραίνει*, a play on the word *εὐφραθής*, ‘well-speaking.’

44 *Elenchos*, V, 9, 15ff. [Cf. Legge, I, p. 143.]

45 An allusion to John 4 : 10.

46 Legge, I, p. 144.

47 *Elenchos*, V, 9, 21.

48 V, 9, 19 (Legge trans., p. 144).

49 This means the integration of the self, which is also referred to in very similar words in the Bogomil document discussed above (pars. 225ff.), concerning the devil as world creator. He too finds what is “proper” (*ἴδιον*) to him.

50 Matt. 7 : 14: “Strait is the gate, and narrow is the way, which leadeth unto life.”

51 The passage discussed here is in *Elenchos*, V, 9, 4ff. (Legge trans., I, p. 140).

52 *Elenchos*, V, 6, 6: *Θεοῦ δὲ γνῶσις ἀπηρτισμένη τελείωσις* (“Knowledge of God is perfect wholeness”).

53 V, 6, 5 (Legge trans., I, p. 120).

54 V, 6, 6f. (p. 121).

55 Nicknamed *καλλίπαις*, ‘with beautiful children’ or ‘the beautiful child.’ (*Elenchos*, V, 7, 4.)

56 According to Hippocrates, a boy at seven years old is half a father. (*Elenchos*, V, 7, 21.)

57 *τὴν ἀρχέγονον φύσιν τῶν ὄλων ἐν ἀρχέγονῳ σπέρματι*. *Archegonos* is the tribal father.

58 With express reference to Matt. 19: 17: “One is good, God.”

59 Cf. Legge trans., p. 128.

60 *Panarium*, XXVI, cap. VIII.

61 “ ... partaking of his flowing semen, showed that this was to be done, that we might have life.”

62 On the other hand, I cannot rid myself of the impression that dreams do occasionally twist things in a scurrilous way. This may have led Freud to the singular assumption that they disguise and distort for so-called “moral” reasons.

However, this view is contradicted by the fact that dreams just as often do the exact opposite. I therefore incline to the alchemical view that Mercurius—the unconscious Nous—is a “trickster.” [Cf. “The Spirit Mercurius” and “The Psychology of the Trickster Figure.”—EDITORS.]

63 But not the Freudian, “psychoanalytical” method, which dismisses the manifest dream-content as a mere “façade,” on the ground that the psychopathology of hysteria leads one to suspect incompatible wishes as dream-motifs. The fact that the dream as well as consciousness rest on an instinctual foundation has nothing to do either with the meaning of the dream-figures or with that of the conscious contents, for the essential thing in both cases is *what the psyche has made of the instinctual impulse*. The remarkable thing about the Parthenon is not that it consists of stone and was built to gratify the ambitions of the Athenians, but that it is—the Parthenon.

64 Cf. “Phenomenology of the Spirit in Fairytales,” par. 403.

65 Cf. “The Psychology of Eastern Meditation,” pars. 942f.

66 Cf. “A Study in the Process of Individuation.”

67 This is consistent with his nature as the Logos and second Person of the Trinity.

68 Naturally this view is rejected by the Church.

69 Three different interpretations of Christ are combined here. Such contaminations are characteristic not only of Gnostic thinking but of all unconscious image-formation.

70 Gregory the Great, *Expositiones in librum I Regum*, Lib. I, cap. I (Migne, *P.L.*, vol. 79, col. 23): “For God and man is one Christ. Therefore in that he is called one, he is shown to be incomparable.” In accordance with the spirit of the age, his incomparability or uniqueness is explained by the “excellence of his virtue.” It is, however, significant in itself.

71 “He offered her his rosy [sic!] mouth to kiss” (*Liber gratiae spiritualis*, fol. J iv^v).

72 “Medulla vero arrimae est illud dulcissimum.” *Ibid.*, fol. B.

73 Gregory the Great; Migne, *P.L.*, vol. 79, col. 23. Cf. Jerem. 31 : 22: “A woman shall compass a man” (AV).

74 *Liber gratiae spiritualis*, fol. A vii^t. The quaternity refers to the four gospels.

75 *Ibid.*, fol. B ii^v.

76 *Ibid.*, fol. B vii^v.

77 Cf. Flitch, *Angelus Silesius*, pp. 128ff.

78 For instance, the *hieros gamos* of Zeus and Hera on “the heights of Gargaros,” *Iliad*, XIV, 246ff. (Cf. Rieu trans., p. 266.)

79 Brugsch, *Religion und Mythologie der alten Ägypter*, p. 94.

80 In the ancient Egyptian view God is “Father and Mother,” and “begets and gives birth to himself” (Brugsch, p. 97). The Indian Prajapati has intercourse with his own split-off feminine half.

81 Budge, *Gods of the Egyptians*, I, pp. 310f.

82 I owe this idea to a lecture delivered by Professor W. Pauli, in Zurich, on the archetypal foundations of Kepler’s astronomy. Cf. his “The Influence of Archetypal Ideas” etc.

83 *Elenchos*, V, 7, 30f. (Cf. Legge trans., I, p. 128.)

84 Bousset, *Hauptprobleme der Gnosis*, pp. 352f.

85 Here Hippolytus cites the text of *Odyssey*, XXIV, 2.

86 *Elenchos*, V, 7, 36 (Legge trans., I, pp. 129f.).

87 Daniel 2 : 34: “Thus thou sawest, till a stone was cut out of a mountain without hands” (DV). This was the stone that broke in pieces the clay and iron feet of the statue.

88 *Εἰς τὸ πλάσμα τῆς λήθης*, i.e., *lethargia*, the state of forgetfulness and sleep resembling that of the dead. The “inner man” is as if buried in the somatic man. He is the “soul in fetters” or “in the prison of the body,” as the alchemists say. *Lēthē* corresponds to the modern concept of the unconscious.

89 *Ancoratus*, 40. Cf. Daniel 2 : 35: “But the stone that struck the statue became a great mountain and filled the whole earth” (DV).

90 *Elenchos*, V, 7, 37 (Legge trans., I, p. 130). Cf. Psalm 82 (Vulg. 81) : 6, to which reference is made in Luke 6 : 35 and John 10 : 34.

91 V, 8, 2 (ibid., p. 131).

92 *Ἰοθῶρ* = Jethro, the priest-king of Midian and the father-in-law of Moses.

93 Zipporah, the wife of Moses.

94 This is probably an allusion to the pneumatic nature of the “generation” produced by Moses, for, according to *Elenchos*, V, 7, 41, “Egypt is the body” (Legge trans., I, p. 130).

95 The marriage *quaternio* is the archetype to which the cross-cousin marriage corresponds on a primitive level. I have given a detailed account of it in “The Psychology of the Transference,” pars. 425ff.

96 Cf. *Psychology and Alchemy*, par. 484.

97 See the study by Marie-Louise von Franz.

98 These words occur in the Hebrew of Isaiah 28 : 10, where they describe what “men with stammering lips and alien tongue” speak to the people. [The Hebrew runs: “tsaw latsaw, tsaw latsaw, kaw lakaw, kaw lakaw, zeer sham, zeer sham.”—EDITORS.] AV: “For precept must be upon precept, precept upon precept, line upon line, line upon line; here a little and there a little.”

99 Cf. *Psychology and Alchemy*, pars. 550f. [Cf. Legge trans., I, p. 131.]

100 Cf. Genesis 44 : 5.

101 *Elenchos*, V, 8, 12 (Legge trans., I, p. 133).

102 “Paracelsus as a Spiritual Phenomenon,” pars. 181ff.

103 Roscher, *Lexikon*, II, part 1, col. 1608, s.v. “Kuretes.”

104 Ibid., col. 1607. The descent from the brain may be an allusion to the ancient idea that the sperm was conducted down from the head to the genitals, through the spinal cord. [Cf. Onians, *The Origins of European Thought*, p. 234.—EDITORS.]

105 *Elenchos*, V, 8, 13 (Legge trans., I, p. 133).

106 “The Spirit Mercurius,” par. 278.

107 Roscher, col. 1392, s.v. “Korybos,” where the text is given in full.

108 The alchemists say very aptly: “Perfectum non perficitur” (that which is perfect is not perfected).

109 *Elenchos*, V, 8, 22, describes the *πνευματικο* as “perfect men endowed with reason,” from which it is clear that the possession of an *anima rationalis* is what makes the “spiritual” man.

110 *Elenchos*, V, 8, 21 (Legge trans., I, p. 134). Cramer (*Bibl.-theol. Wörterbuch der Neutestamentlichen Gräzität*) gives as the meaning of *τέλειος* ‘complete, perfect, lacking nothing, having reached the destined goal.’ Bauer (*Griech.-deutsch. Wörterbuch zu den Schriften des Neuen Testaments*, col. 1344) has, with reference to age, ‘mature, full-grown,’ and with reference to the mysteries, ‘initiated.’ Lightfoot (*Notes on the Epistles of St Paul*, p. 173) says: “*Τέλειος* is properly that of which the parts are fully developed, as distinguished from *ὀλόκληρος*, that in which none of the parts are wanting, ‘full-grown,’ as opposed to *νήπιος*, ‘childish,’ or *παιδία*, ‘childhood.’” *Teleios* is the man who has received *Nous*: he has *gnosis* (knowledge). Cf. Guignebert, “Quelques remarques sur la perfection (*τελείωσις*) et ses voies dans le mystère paulinien,” p. 419. Weiss (*The History of Primitive Christianity*, II, p. 576) declares that it is just the “consciousness of imperfection and the will to progress that is the sign of perfection.” He bases this on Epictetus (*Enchiridion*, 51, if.), where it says that he who has resolved to progress (*προκόπτειν*) is, by anticipation, already “perfect.”

111 First mentioned at V, 8, 19. [Cf. Legge, I, p. 134.]

112 *Hermetis Trismegisti Tractatus vere Aureus cum scholiis* (1610), p. 44.

113 Published 1562 by Adam von Bodenstein. In *Paracelsus Sämtliche Werke*, ed. Sudhoff, III, p. 249. [Cf. “Paracelsus the Physician,” par. 21.]

114 *De origine Morborum invisibilium*, beginning of Book IV, says of the *Mumia*: “All the power of herbs and of trees is found in the *Mumia*; not only the power of the plants grown of earth, but also of water, all the properties of metals, all the qualities of marcasites, all the essence of precious stones. How should I count all these things, and name them? They are all within man, no fewer and no less, as strong and as powerful, in the *Mumia*.” (*Volumen Paramirum*, pp. 291ff.)

115 *Fragmentarische Ausarbeitungen zur Anatomie* (Sudhoff, III, p. 462).

116 The *Mumia* is, accordingly, an alexipharmic. (*De mumia libellus*; *ibid.*, p. 375.)

117 *De vita longa*, Lib. IV, cap. VII (*ibid.*, p. 284).

118 “Paracelsus as a Spiritual Phenomenon,” par. 168.

119 *Zohar*, cited in Schoettgen, *Horae Hebraicae et Talmudicae*, II, p. 16.

120 Gen. 28 : 17 (DV).

121 *In Genesim hom.* XI, 3 (Migne, *P.G.*, vol. 12, col. 224): “And that ye may see the well of vision, and take from it the living water, which shall be in you a fountain of water springing up unto eternal life.”

122 *Ibid.*, I, 2 (col. 148).

123 *In Numeros hom.* XVII, 4 (Migne, *P.G.*, vol. 12, cols. 707f.): “For these paradises upon the waters are like and akin to that paradise in which is the tree of life. And the waters we may take to be either the writings of the apostles and evangelists, or the aid given by the angels and celestial powers to such souls; for by these they are watered and inundated, and nourished unto all knowledge and understanding of heavenly things; although our Saviour also is the river which maketh glad the city of God; and the Holy Spirit not only is himself that river, but out of those to whom he is given, rivers proceed from their belly.”

124 See the valuable compilation of patristic allegories in Rahner, “Flumina de ventre Christi,” pp. 269ff. The above reference is on p. 370 and comes from Hippolytus’ *Commentary on Daniel*, I, 17 (*Werke*, I, pp. 28f),

125 *In Genesim hom.* I, 2 (Migne, *P.G.*, vol. 12, col. 147).

126 *Elenchos*, V. 8. 34 (Legge, I, p. 137). This is a play on the words *αἰπόλος* (from *αἰγοπóλος*), ‘goat-herd,’ and *ἀειπόλος* (from *del πολεῖν*, ‘ever turning’). Hence *πόλος* = the earth’s axis, the Pole.

127 *Odyssey*, trans. by Rouse, p. 65.

128 *Ibid.*, trans. by Rieu, p. 74.

129 He has something of the character of the “trickster” (cf. n. 62, *supra*).

130 Proteus has much in common with Hermes: above all, the gift of second sight and the power of shape-shifting. In *Faust* (Part II, Act 5) he tells the Homunculus how and where to begin his labours.

131 When I visited the ancient pagoda at Turukalukundram, southern India, a local pundit explained to me that the old temples were purposely covered on the outside, from top to bottom, with obscene sculptures, in order to remind ordinary people of their sexuality. The spirit, he said, was a great danger, because Yama, the god of death, would instantly carry off these people (the “imperfecti”) if they trod the spiritual path directly, without preparation. The erotic sculptures were meant to remind them of their *dharma* (law), which bids them fulfil their ordinary lives. Only when they have fulfilled their *dharma* can they tread the spiritual path. The obscenities were intended to arouse the erotic curiosity of visitors to the temples, so that they should not forget their *dharma*; otherwise they would not fulfil it. Only the man who was qualified by his *karma* (the fate earned through works in previous existences), and who was destined for the life of the spirit, could ignore this injunction with impunity, for to him these obscenities mean nothing. That was also why the two seductresses stood at the entrance of the temple, luring the people to fulfil their *dharma*, because only in this way could the ordinary man attain to higher spiritual development. And since the temple represented the whole world, all human activities were portrayed in it; and because most people are always thinking of sex anyway, the great majority of the temple sculptures were of an erotic nature. For this reason too, he said, the *lingam* (phallus) stands in the sacred cavity of the adyton (Holy of Holies), in the *garbha griha* (house of the womb). This pundit was a Tantrist (scholastic; *tantra* = ‘book’).

132 Their prototypes are the emasculated Attis and the priests of Eleusis, who, before celebrating the *hieros gamos*, were made impotent with a draught of hemlock.

133 Cf. Matt. 5 : 8: “Blessed are the pure in heart, for they shall see God.”

134 A condensation of *Iliad*, XIV, 200f. and 246: “I am going to the ends of the fruitful earth to visit Ocean, the forbear of the gods, and Mother Tethys ... even Ocean Stream himself, who is the forbear of them all.” (Rieu trans., pp. 262f.)

135 The iota (*τὴν μίαν κεραίαν*), the smallest Greek character, corresponding to our “dot” (which did not exist in Greek). Cf. Luke 16 : 17: “And it is easier for heaven and earth to pass than one tittle of the law to fall.” Also Matt. 5: 18. This may well be the origin of the iota symbolism, as Irenaeus (*Adv. haer.*, I, 3, 2) suggests.

136 *Elenchos*, VIII, 12, 5ff. (Legge, pp. 107ff.). All this is a Gnostic paraphrase of John 1 and at the same time a meaningful exposition of the psychological self. The relationship of the to the self is the same as that of the Hebrew letter Yod (י) to the *lapis* in the cabala. The Original Man, Adam, signifies the small hook at the top of the letter Yod. (*Shaare Kedusha*, III, 1.)

137 Ennead, VI, 9. 8 (Guthrie trans., p. 163. slightly mod.).

138 See “A Study in the Process of Individuation” and “Concerning Mandala Symbolism.”

139 Bousset, *Hauptprobleme der Gnosis*, p. 321, says: “[The Gnostics believed] that human beings, or at any rate some human beings, carry within them from the beginning a higher element [the *spinther*] deriving from the world of light, which enables them to rise above the world of the Seven into the upper world of light, where dwell the unknown Father and the heavenly Mother.”

140 Meerpohl, “Meister Eckharts Lehre vom Seelenfünklein.”

141 Irenaeus, *Adv. haer.*, I, 24. The *pneumatikoi* contain a small part of the Pleroma (II, 29). Cf. the doctrine of Satorneilos in Hippolytus, *Elenchos*, VII, 28, 3 (Legge trans., II, pp. 80f.).

142 Macrobius, *Commentarium in Somnium Scipionis*, XIV, 19.

143 *Elenchos*, V, 19, 7: **Ἴνα ἔχη τὸν σπινθῆρα δουλεύοντα.**

144 This idea reappears in alchemy in numerous variations. Cf. Michael Maier, *Symbola aureae mensae*, p. 380, and *Scrutinium chymicum*, Emblema XXXI: “The King swimming in the sea, and crying with a loud voice: Whosoever shall bring me out, shall have a great reward.” Also *Aurora Consurgens* (ed. von Franz), p. 57: “For this cause have I laboured night by night with crying, my jaws become hoarse; who is the man that liveth, knowing and understanding, delivering my soul from the hand of hell?”

145 *Elenchos*, V, 21, 1: **Τὸν σπινθῆρα τὸν ἐλάχιστον ἐν τοῖς σκοτεινοῖς ὕδασι κάτω καταμεμίχθαι λεπτῶς.**

146 *Elenchos*, VI, 17, 7. Cf. “Transformation Symbolism in the Mass,” par. 359.

147 Cf. the vision reported by Wickes, *The Inner World of Man*, p. 245. It is a typical piece of individuation symbolism: “Then I saw that on the shaft there hung a human figure that held within itself all the loneliness of the world and of the spaces. Alone, and hoping for nothing, the One hung and gazed down into the void. For long the One gazed, drawing all solitude unto itself. Then deep in the fathomless dark was born an infinitesimal spark. Slowly it rose from the bottomless depth, and as it rose it grew until it became a star. And the star hung in space just opposite the figure, and the white light streamed upon the Lonely One.” Conversely, it is related of Zoroaster that he drew down sparks from a star, which scorched him. (Bousset, p. 146.)

148 Maier, *De circulo physico quadrato* (1616), p. 27.

149 Or *punctus solis*. “In the egg therefore are four things: earth, water, air, and fire; but the ‘punctum solis’ is apart from these four, in the midst of the yolk (which) is the chick.” (*Turba*, Sermo IV.) Ruska (*Turba philosophorum*, p. 51) puts “saliens” instead of “solis” (“springing point” instead of “sun-point”), in the belief that all the copyists repeated the same error. I am not so sure of this.

150 *Von hylealischen Chaos*, p. 194.

151 *De circulo quadrato*, p. 27.

152 *Theatr. chem.*, IV, p. 691.

153 “Physica genesis,” *Theatr. chem.*, I, p. 382.

154 *Monas hieroglyphica* (first edn., 1564). Also in *Theatr. chem.* (1602), II, p. 218.

155 *Phil. ref.*, p. 131.

156 *Mus. herm.*, p. 559.

157 Here I would like to cite a theological opinion: “Jesus is a synthesis and a growth, and the resultant form is one which tells of a hundred forces which went to its making. But the interesting thing is that the process did not end with the closing of the canon. Jesus is still in the making.” Roberts, “Jesus or Christ?—A Reply,” p. 124.

- 1 *Elenchos*, V, 7, 8 (Legge trans., I, p. 123).
- 2 *Elenchos*, VIII, 15, 1ff. Cf. Legge trans., II, p. 10.
- 3 Based on Radhakrishnan, *The Principal Upanishads*, pp. 581f.
- 4 *Ibid.*, pp. 228f.
- 5 Hippolytus lived c. A.D. 230. Monoïmos must therefore antedate him.
- 6 *Psychological Types*, pars. 620ff.
- 7 The circle has the character of wholeness because of its “perfect” form; the quaternity, because four is the minimum number of parts into which the circle may naturally be divided.
- 8 Cf. “A Psychological Approach to the Dogma of the Trinity,” pars. 182ff.
- 9 Cf. “Spirit in Fairytales” pars. 425f., 436ff., and “Trinity,” pars. 243ff.
- 10 *Five* corresponds to the indistinguishability of quaternity and unity.
- 11 [*Psychology and Alchemy*, pars. 138f., fig. 31.]
- 12 Church built of living stones in the *Shepherd* of Hermas. [*Psychological Types*, ch. V, 4a.]
- 13 *Golden Flower* (1962 edn.), pp. 22, 36.
- 14 *Psychology and Alchemy*, par. 338.
- 15 A definition of God in Nicholas of Cusa. Cf. “The Psychology of the Transference,” par. 537.
- 16 Cf. Hurwitz, “Archetypische Motive in der chassidischen Mystik,” ch. VI.
- 17 *Elenchos*, V, 8, 2.
- 18 Cf. “The Psychology of the Transference,” pars. 410ff.
- 19 Exodus 18 : 27.
- 20 “Phenomenology of the Spirit in Fairytales,” pars. 400ff.
- 21 Since the whole Shadow Quaternio is a symmetrical construction, the “good Wise Man” must here be contrasted with a correspondingly dark, chthonic figure.
- 22 Cf. “Psychology of the Transference,” pars. 425ff.
- 23 In the gnosis of Justin. See Hippolytus, *Elenchos*, V, 26, 32 (Legge trans., I, p. 178):
ὁ δὲ ἀγαθὸς ἐστὶ Πρίπιος (But the Good One is Priapus).
- 24 Rev. 12 : 9.
- 25 Coloss. 2 : 14: “Blotting out the handwriting of the decree that was against us, which was contrary to us. And he hath taken the same out of the way, fastening it to the cross” (DV). The handwriting is imprinted on the *body*. This view is confirmed by Orosius (“Ad Aurelium Augustum commonitorium de errore Priscillianistarum et Origenistarum,” p. 153), who says that in the opinion of Priscillian the soul, on descending through the spheres into birth, was caught by the powers of evil, and at the behest of the victor (“victoris principis”) was cast into separate bodies, upon which a “handwriting” was written. The parts of the soul receive a divine *chirographum*, but the parts of the body are imprinted with the signs of the zodiac (*caeli signa*).
- 26 “The Spirit Mercurius,” esp. pars. 271, 282, 289.
- 27 See *Psychology and Alchemy*, fig. 131.

28 In “Chrysopoeia” (in Gratarolus, *Verae alchemiae artisque metallicae*, 1561, pp. 269ff.), which Augurellus dedicated to Pope Leo X. It contains an invocation of the *alma soror* of Phoebus:

“Tu quoque, nec coeptis *Cylleni* audacibus usquam
Defueris, tibi nam puro de fonte perennis
Rivulus argentum, vulgo quod vivere dicunt,
Sufficit, et tantis praestat primordia rebus.”

(You too, Cyllenian, this bold enterprise
Fail not, the stream from whose pure spring supplies
The silver men call “quick,” the primal state
And first beginning of a work so great. [Trans. by A. S. B. Glover.]

29 In the Western Roman Empire there is a gap in this development, extending from the 3rd to about the 11th cent., that is, to the time of the first translations from the Arabic.

30 Synonymous with the dragon, since *draco* also means snake.

31 *ἡ ψὸν πνευματικωτάτον*, ‘the most spiritual animal.’

32 In Valentinus the “appendages” are spirits indwelling in man. Clement of Alexandria, *Stromata*, II, 20, 112 and 114 (trans. Wilson, II, pp. 64f.).

33 Isidorus was the son of Basilides. See Clement of Alexandria, *ibid.*, II, 20, 113 (Wilson, II, p. 65). The “outgrowths” are animal souls, as of wolves, monkeys, lions, etc.

34 *In Levit. hom.* V, 2 (Migne, *P.G.*, vol. 12, col. 450): “So when thou seest that thou hast all the things the world has, doubt not that thou hast within thee even the animals which are offered in sacrifice.”

35 Euphrates.

36 “The Spirit Mercurius,” Part I.

37 See *Psychology and Alchemy*, fig. 257.

38 *Ibid.*, par. 357.

39 *Ibid.*, fig. 122, and “The Philosophical Tree,” pars. 402ff.

40 Ripley, *Cantilena*, verse 28 [cf. *Mysterium Coniunctionis*, p. 317], and *Chymische Schrifften*, p. 51; also Mylius, *Phil. ref.*, p. 124.

41 “A land to be watered with the clear water of paradise” (Hollandus, “Fragmentum de lapide,” *Theatr. chem.*, II, p. 142). The “Tractatus Aristotelis ad Alexandrum Magnum (conscriptus et collectus a quodam Christiano Philosopho),” *Theatr. chem.*, V, p. 885, compares the “practica Aristotelis” with the water of paradise, which makes man “whole” (*incolumem*) and immortal: “From this water all true Philosophers have had life and infinite riches.”

42 Didymus of Alexandria, *De trinitate* (Migne, *P.G.*, vol. 39, col. 456).

43 St Ambrose, *Explanationes in Psalmos*, Ps. 45, 12 (*Corp. Script. Eccl. Lat.*, LXIV, p. 337). Cf. Rahner, “Flumina de ventre Christi,” pp. 269ff.

44 *Sophia* (1699), p. 9.

45 The *lapis* is made of the four elements, like Adam. The centre of the squared circle is the “mediator, making peace between the enemies or elements, so that they may love one another in a meet embrace” (“Tractatus aureus,” *Theatr.*

chem., IV, p. 691).

46 Cf. the evidence for this in *Psychology and Alchemy*, “The Lapis-Christ Parallel.”

47 Mylius (*Phil. ref.*, p. 15) identifies the elements that constitute the *lapis* with *corpus*, *spiritus*, and *anima*: *corpus* is matter, earth, and *spiritus* is the *nodus* (bond) *animae et corporis*, and therefore corresponds to fire. Water and air, which would properly characterize the *anima*, are also “spirit.” Three of the elements are “moving,” one (earth) “unmoving.” Cf. n. 89, *infra*.

48 Quotation from Ostanes in Zosimos, “Sur l’art” (Berthelot, *Alch. grecs*, III, vi, 5).

49 “Aurora consurgens,” *Art. aurif.*, I, p. 208.

50 Cf. my remarks on the significance of the head in “Transformation Symbolism in the Mass,” pars. 365ff. “Head” also means “beginning,” e.g., “head of the Nile,” etc.

51 *Theatr. chem.*, V, p. 151.

52 Berthelot, III, x, 1.

53 “There is one stone, one medicine, one vessel, one method, one disposition” (*Rosarium philosophorum*, *Art. aurif.*, II, 206). “In our water all modes of things are brought about. ... In the said water they are made as in an artificial vessel, which is a mighty secret” (Mylius, *Phil. ref.*, p. 245). “The Philosophical vessel is their water” (*ibid.*, p. 33). This saying comes from de Hoghelande’s treatise in *Theatr. chem.*, I, p. 199. There we find: “Sulphur also is called by Lully the vessel of Nature,” and Haly’s description of the vessel as “ovum.” The egg is content and container at once. The *vas naturale* is the *aqua permanens* and the “vinegar” of the Philosophers. (“Aurora consurgens,” Part II, *Art. aurif.*, I, p. 203.)

54 Caesarius of Heisterbach, *Dialogue on Miracles*, trans. Scott and Bland, Dist. I, chs. XXXII and XXXIV.

55 In Olympiodorus the transforming vessel is the “spherical phial” or *δργανον κυκλικόν* (circular apparatus). (Berthelot, II, iv, 44.) “The spagiric vessel is to be made after the likeness of the natural vessel. For we see that all heaven and the elements have the likeness of a spherical body” (Dorn, *Theatr. chem.*, I, p. 430). “The end of all this master-work is, that the Philosophic Mercury be placed in the heavenly sphere” (*ibid.*, p. 499). Trevisanus calls the vessel the *rotundum cubile*, “round bridal bed” (“Liber de alchemia,” *Theatr. chem.*, I, p. 790).

56 “Congeries,” *Theatr. chem.*, I, pp. 574f.

57 *Ibid.*, IV, p. 691.

58 “Nor is any other to be sought after in all the world.” The Pelican is a distilling vessel, but the distillate, instead of dripping into the receiver, runs back into the belly of the retort. We could take this as illustrating the process of conscious realization and the reapplication of conscious insights to the unconscious. “It restored their former security of life to those once near to death,” the author says of the Pelican, which, as we know, is an allegory of Christ.

59 Cf. *Psychology and Alchemy*, par. 167, n. 44. [Also “Paracelsus as a Spiritual Phenomenon,” fig. B7.]

60 That is, counting the letters *F* and *G* (not included in the diagram), which signify Above and Below.

61 *Art. aurif.*, I, p. 324; *Theatr. chem.*, I, p. 199; *Art. aurif.*, I, p. 323.

62 Cf. *Psychology and Alchemy*, par. 338.

63 *Mus. herm.*, p. 770.

64 *La Vertu et la propriété de la quinte essence* (1581), p. 26.

65 *Art. aurif.*, I, p. 203.

66 “Paracelsus as a Spiritual Phenomenon,” fig. B4.

67 Marriage classes and settlements.

68 “Psychology of the Transference,” pars. 433ff. [Cf. Layard, *Stone Men of Malekula*, chs. 5 and 6, and “The Incest Taboo and the Virgin Archetype,” pp. 266ff.—EDITORS.]

69 “Psychology of the Transference,” par. 438.

70 Case material in *Psychology and Alchemy*, part II. Triadic symbols also occur, but they are rarer.

71 The Gnostic quaternio is naturally later than the Horus quaternity in point of time, but psychologically it is older, because in it the feminine element reassumes its rightful place, as is not the case with the patriarchal Horus quaternio.

72 Like, for instance, the Aesculapian and Agathodaimon serpent.

73 Schärf, “Die Gestalt des Satans im Alten Testament,” p. 151.

74 “O blessed greenness, which givest birth to all things, whence know that no vegetable and no fruit appears in the bud but that it hath a green colour. Likewise know that the generation of this thing is green, for which reason the Philosophers have called it a bud.” (*Ros. phil.*, *Art. aurif.*, II, p. 220.)

75 Cf. the Ostanès quotation in Zosimos, *Psychology and Alchemy*, par. 405.

76 A hint that rotation may be a principle of matter.

77 According to the report of the Damdad-Nashk (Reitzenstein and Schäfer, *Studien zum antiken Syncretismus aus Iran und Griechenland*, p. 18). Gayomart is the Original Man in the theosophical version of Zarathustra’s system. Yima, on the other hand, is the Original Man of ancient Aryan legend. His name is *Yimó kshaétó*, ‘the shining Yima.’ According to the Mainyo-i-Khard, the metals were created from his body. (Kohut, “Die talmudisch-midrassische Adamsage,” pp. 68, 70.) In the *Bundahish*, Gayomart’s body consisted of metals. (Christensen, “Le Premier Homme et le premier roi dans l’histoire légendaire des Iraniens,” p. 21.)

78 [Cf. “A Psychological Approach to the Dogma of the Trinity,” par. 185.—EDITORS.]

79 Most people do not have sufficient range of consciousness to become aware of the opposites inherent in human nature. The tensions they generate remain for the most part unconscious, but can appear in dreams. Traditionally, the snake stands for the vulnerable spot in man: it personifies his shadow, i.e., his weakness and unconsciousness. The greatest danger about unconsciousness is proneness to suggestion. The effect of suggestion is due to the release of an unconscious dynamic, and the more unconscious this is, the more effective it will be. Hence the ever-widening split between conscious and unconscious increases the danger of psychic infection and mass psychosis. With the loss of symbolic ideas the bridge to the unconscious has broken down. Instinct no longer affords protection against unsound ideas and empty slogans. Rationality without tradition and without a basis in instinct is proof against no absurdity.

80 Emblema XVII, p. 49.

81 Vigenère comments: “The intelligible fire of the world: is all light. The heavenly fire: partakes of heat and light. The elemental fire: less in light, heat, and glow. The infernal fire: opposed to the intelligible, of heat and burning without any light.” (“De igne et sale,” *Theatr. chem.*, VI, p. 39.) [Cf. *supra*, par. 203.]

82 “Is present in everything.”

83 “The heat of ashes and baths.”

84 “Tortures bodies, is the dragon.”

85 The oldest source is Heraclitus.

86 *Turba*, ed. by Ruska, Sermo XLIII, p. 149.

87 G. E. Stahl (1660–1734) supposed that all combustible (i.e., oxidizable) substances contain an igneous principle. It was assumed to be weightless, or even to possess a negative weight. Cf. H. E. Fierz-David, *Die Entwicklungsgeschichte der Chemie*, pp. 148f.

88 Psychologically, of course, the primitive idea of mana is very much older, but here we are talking of *scientific* concepts. The *sulphur = anima* equation still contains a trace of the original mana theory. Earlier, mana was characteristically misunderstood as *animism*.

89 Fire as spiritual, the other elements material; earth unmoving, the others moving.

90 Böhme calls the “fire of Nature” the “fourth form.” “Tabula principiorum,” *De signatura rerum* (1682), p. 279.

91 The doctrine of Sabellius (beginning of the 2nd cent.) concerning the preworldly Monad, the “silent and unacting God” and its three *prosopa* (modes of manifestation), calls for further investigation, as it bequeathed to posterity the first beginnings of a quaternary view of the Deity. Thus Joachim of Flora makes the following accusation against Peter Lombard: “Quod in suis dixit Sententiis, quoniam quaedam summa res est Pater et Filius et Spiritus Sanctus et illa non est generans, neque genita, neque procedens: unde asserit quod ille non tam Trinitatem, quam *quaternitatem* astruebat in Deo, videlicet tres personas, et illam communem essentiam quasi quartam.” (As he [Peter] says in his Book of Sentences, For a certain supreme Something is Father, Son, and Holy Ghost, and It neither begets, nor is begotten, nor proceeds. On this basis Joachim asserts that the Lombard ascribed not Trinity, but Quaternity to God, that is to say, three Persons, and that common Something as a fourth). (Fourth Lateran Council, 1215. Decrees, Cap. 2; Denzinger and Bannwart, *Enchiridion*, p. 190.) Cf. “A Psychological Approach to the Dogma of the Trinity,” pars. 243ff.

92 Cf. “The Spirit Mercurius,” pars. 267ff.

93 The three relatively differentiated functions and one undifferentiated, “inferior” function. Cf. *Psychological Types*, and the diagrams in Jacobi, *The Psychology of C. G. Jung*.

94 “A Study in the Process of Individuation,” fig. 2, p. 309.

95 *Ibid.*, Picture 3 and accompanying text.

96 Zurich Central Library, Graphics Collection, B x 606.

97 Harnack, *Dogmengeschichte*, I, p. 334.

98 Condensed from the reconstruction by Uhlhorn, in *Realencyklopädie für Protestantische Theologie und Kirche*, ed. by Hauck, IV, pp. 173ff.

99 To avoid misunderstandings I would like to emphasize that “Paradise” is used here not in the metaphorical sense, as “future heaven” or the Abode of the Blessed, but in the sense of the earthly Garden of Eden.

100 Corresponding to the *phylokrinesis*. [Cf. *supra*, pars. 118, 133.]

101 I am not counting the space-time continuum of modern physics.

102 Cf. “Synchronicity: An Acausal Connecting Principle.”

103 [Jeans, *Physics and Philosophy*, pp. 127, 151.—EDITORS.]

- 104 The immediate cause is the rightward movement of our writing. The right, so to speak, is ruled by conscious reason: the right is “right” in all senses (upright, downright, forthright, etc.). The left is the side of the heart, the emotions, where one is affected by the unconscious.
- 105 Cf. “Concerning Mandala Symbolism,” figs. 19, 21, 37, 60.
- 106 Cf. *Psychology and Alchemy*, pars. 189 and 209f., in relation to the four *regimina* and *dispositiones*.
- 107 [Cf. *Thus Spake Zarathustra*, trans. by Common, pp. 303ff.—EDITORS.]
- 108 Gamow, *Atomic Energy*, p. 72.
- 109 An anonymous Harranite treatise entitled “Platonis liber quartorum,” printed in *Theatr. chem.*, V (1622), pp. 114ff.; conjectured to have been translated from the Arabic in the 12th cent.
- 110 Fludd, “De animae intellectualis scientia seu Geomantia,” *Fasciculus geomanticus* (1687), pp. 35f.
- 111 *Arithmologia, sive De abditis numerorum mysteriis* (1665), pp. 260ff. I have to thank Dr. M.-L. von Franz for calling my attention to this.
- 112 Ibid, p. 266. [The next sentence is revised and transposed from par. 418. (2nd edn.)]
- 113 Documentation in *Psychology and Alchemy*, esp. pars. 427, n. 4, and 431.
- 114 *De circulo physico quadrato*, p. 16.
- 115 Ibid., p. 17.
- 116 Ibid., p. 19.
- 117 Wilhelm, *The Secret of the Golden Flower* (1962 edn.), p. 30.
- 118 Berthelot, *Alch. grecs*, II, iv, 44.
- 119 “Physica genesis,” *Theatr. chem.*, I, p. 391.
- 120 *La Vertu et la propriété de la quinte essence*, p. 26.

- 1 The outstanding example in Swiss literature is Spitteler's *Imago*. [In English literature, perhaps Rider Haggard's *She*.—EDITORS.]
- 2 Hurwitz, "Archetypische Motive in der chassidischen Mystik," ch. VI.
- 3 This thema is the subject of an Oxford dissertation by Amy I. Allenby: *A Psychological Study of the Origins of Monotheism*.

* For details of the *Collected Works of C. G. Jung*, see end of this volume.

* For details of the *Collected Works of C. G. Jung*, see end of this volume.

* For details of the *Collected Works of C. G. Jung*, see end of this volume.

* Published 1957; 2nd edn., 1970.

†Published 1973.

* Published 1960.

†Published 1961.

‡Published 1956; and edn., 1967. (65 plates, 43 text figures.)

* Published 1971.

†Published 1953; 2nd edn., 1966.

‡Published 1960; 2nd edn., 1969.

* Published 1959; 2nd edn., 1968. (Part I: 79 plates, with 29 in colour.)

* Published 1964; 2nd edn., 1970. (8 plates.)

†Published 1958; 2nd edn., 1969.

* Published 1953; 2nd edn., completely revised, 1968. (270 illustrations.)

†Published 1968. (50 plates, 4 text figures.)

‡Published 1963; 2nd edn., 1970. (10 plates.)

* Published 1966.

†Published 1954; 2nd edn., revised and augmented, 1966. (13 illustrations.)

‡Published 1954.

* Published 1976.

†Published 1979.

B O L L I N G E N S E R I E S X X

THE COLLECTED WORKS

OF

C. G. JUNG

VOLUME 10

EDITORS

SIR HERBERT READ

MICHAEL FORDHAM, M.D., M.R.C.P.

GERHARD ADLER, PH.D.

CIVILIZATION IN TRANSITION

C. G. JUNG

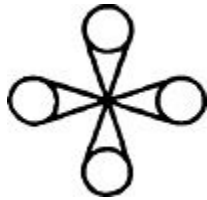

TRANSLATED BY R. F. C. HULL

BOLLINGEN SERIES XX

PRINCETON UNIVERSITY PRESS

COPYRIGHT © 1964 BY BOLLINGEN FOUNDATION
PUBLISHED BY BOLLINGEN FOUNDATION, NEW YORK, N. Y.
DISTRIBUTED BY PANTHEON BOOKS
A DIVISION OF RANDOM HOUSE, INC.

THIS EDITION IS BEING PUBLISHED IN THE UNITED STATES OF AMERICA BY BOLLINGEN FOUNDATION, AND IN ENGLAND BY ROUTLEDGE AND KEGAN PAUL, LTD. IN THE AMERICAN EDITION, ALL THE VOLUMES COMPRISING THE COLLECTED WORKS CONSTITUTE NUMBER XX IN BOLLINGEN SERIES. THE PRESENT VOLUME IS NUMBER 10 OF THE COLLECTED WORKS, AND IS THE THIRTEENTH TO APPEAR.

The Undiscovered Self copyright © 1957, 1958, by C. G. Jung. *Flying Saucers* copyright © 1959 by C. G. Jung. “The Dreamlike World of India” and “What India Can Teach Us” copyright 1938 and 1939 respectively by Editorial Publications, Inc.

LIBRARY OF CONGRESS CATALOG CARD NUMBER: 52-8757
MANUFACTURED IN THE UNITED STATES OF AMERICA BY H. WOLFF
NEW YORK, N. Y.

EDITORIAL NOTE

In 1918 Jung published a paper, "The Role of the Unconscious," which sounds the keynote of the present volume. There he put forward the arresting theory that the conflict in Europe, then almost exclusively interpreted in materialistic terms, was basically a psychological crisis originating in the collective unconscious of the individuals that form groups and nations. Subsequently he wrote a considerable number of essays bearing on the contemporary scene and, in particular, on the relation of the individual to society.

The first two sections of this volume, written during the years between the World Wars, develop the themes broached in the opening essay, and are largely concerned with modern man's discovery of his unconscious premises and the importance of self-knowledge in enabling the individual to maintain himself against social pressures. Specific questions, such as the influence of social changes on the relations between the sexes and of ethnic factors on the development of psychological theories, are also discussed. The third section presents four papers previously published in *Essays on Contemporary Events* (1947). In these Jung shows that the dreams and fantasies of individual patients, no less than social and political upheavals, which he explains as psychic epidemics, can reflect tendencies in the unconscious life of nations. In an essay first published in 1936 Wotan is presented as an archetypal figure symbolizing the unconscious agencies active in Germany which found expression in the Nazi movement.

The psychodynamics which Jung inferred from the behaviour of individuals and groups, though easier to perceive in Germany, had, however, a much wider application, as he made clear in two major essays written in his last years. In "The Undiscovered Self" (1957) he reverts to the relation between the individual and a mass society, and in "Flying Saucers" (1958) he examines the birth of a myth which he regards as compensating the scientific trends of our technological era. Since the crisis in civilization is maintained by Jung to be moral, his late views on good and evil and on the psychological function of conscience, in section six, are necessary and relevant amplifications of his theme.

The reviews and short articles in section seven present Jung's lively and emotional responses to the pronouncements of his contemporary, Count Hermann Keyserling, on national problems, and to his own visits to the United States and India. Finally, the appendix brings together the documents relating to the years when Jung was president of the International General Medical Society for Psychotherapy and editor of its organ,

the *Zentralblatt für Psychotherapie*. His energetic nature and feelings of obligation both to society and to his colleagues compelled him to accept this position as a vantage point from which to combat, to the best of his ability, the threat to psychotherapy in Germany under the Nazis. Unjustly, he was subjected to a barrage of tendentious and largely uninformed criticism because of his action. The aims he consistently sought to achieve are now set forth fully for the first time, with the necessary documentation.

*

Grateful acknowledgment is made to the American-Scandinavian Foundation, New York, for permission to quote from the Bellows translation of *The Poetic Edda*; to the Viking Press, New York, for permission to quote from *The Portable Nietzsche*, translated by Walter Kaufmann and copyright 1954 by the Viking Press, Inc.; and to Otto Müller Verlag, Salzburg, for permission to reproduce an illustration from Maria Böckeler, *Hildegard von Bingen: Wissen die Wege*. For advice and assistance, the Editors are grateful to C. A. Meier, M.D., of Zurich; Walter Cimbald, M.D., of Hamburg; W. Morgenthaler, M.D., of Bern; Miss Liselotte Bendix, librarian of the New York Psychoanalytic Society and Institute; and the staff of the Warburg Institute, London.

**VOLUME 10
CIVILIZATION IN TRANSITION**

TABLE OF CONTENTS

EDITORIAL NOTE

LIST OF PLATES

I

The Role of the Unconscious

Translated from “Über das Unbewusste,” *Schweizerland* (Zurich), IV (1918).

Mind and Earth

Translated from “Seele und Erde,” *Seelenprobleme der Gegenwart* (Zurich: Rascher, 1931).

Archaic Man

Translated from “Der archaische Mensch,” *Seelenprobleme der Gegenwart* (Zurich: Rascher, 1931).

The Spiritual Problem of Modern Man

Translated from “Das Seelenproblem des modernen Menschen,” *Seelenprobleme der Gegenwart* (Zurich: Rascher, 1931).

II

The Love Problem of a Student

Translated from an unpublished ms. (1922?).

Woman in Europe

Translated from “Die Frau in Europa,” *Europäische Revue* (Berlin), III (1927).

The Meaning of Psychology for Modern Man

Translated from “Die Bedeutung der Psychologie für die Gegenwart,” *Wirklichkeit der Seele* (Zurich: Rascher, 1934).

The State of Psychotherapy Today

Translated from “Zur gegenwärtigen Lage der Psychotherapie,” *Zentralblatt für Psychotherapie und ihre Grenzgebiete* (Leipzig), VII (1934).

III

Preface to *Essays on Contemporary Events*

Translated from Vorwort to *Aufsätze zur Zeitgeschichte* (Zurich: Rascher, 1946).

Wotan

Translated from “Wotan,” *Neue Schweizer Rundschau* (Zurich), n.s., III (1936).

After the Catastrophe

Translated from “Nach der Katastrophe,” *Neue Schweizer Rundschau* (Zurich), n.s., XIII (1945).

The Fight with the Shadow

Originally published in English in *The Listener* (London), XXXVI (1946).

Epilogue to *Essays on Contemporary Events*

Translated from Nachwort to *Aufsätze zur Zeitgeschichte* (Zurich: Rascher, 1946).

IV

The Undiscovered Self (Present and Future)

Translated from *Gegenwart und Zukunft* (Zurich: Rascher, 1957).

1. The Plight of the Individual in Modern Society
2. Religion as the Counterbalance to Mass-Mindedness
3. The Position of the West on the Question of Religion
4. The Individual's Understanding of Himself
5. The Philosophical and the Psychological Approach to Life
6. Self-Knowledge
7. The Meaning of Self-Knowledge

V

Flying Saucers: A Modern Myth of Things Seen in the Skies

Translated from *Ein moderner Mythos: Von Dingen, die am Himmel gesehen werden* (Zurich and Stuttgart: Rascher, 1958).

Preface to the First English Edition

Introductory

1. Ufos as Rumours
2. Ufos in Dreams
3. Ufos in Modern Painting
4. Previous History of the Ufo Phenomenon
5. Ufos Considered in a Non-Psychological Light

Epilogue

VI

A Psychological View of Conscience

Translated from “Das Gewissen in psychologischer Sicht,” in *Das Gewissen* (Studien aus dem C. G. Jung-Institut, VII; Zurich: Rascher, 1958).

Good and Evil in Analytical Psychology

Translated from “Gut und Böse in der analytischen Psychologie,” in *Gut und Böse in der Psychotherapie*, ed. by Wilhelm Bitter (Stuttgart: “Arzt und Seelsorger,” 1959).

Introduction to Toni Wolff’s *Studies in Jungian Psychology*

Translated from the Vorrede to Wolff, *Studien zu C. G. Jung’s Psychologie* (Zurich: Rhein, 1959).

VII

The Swiss Line in the European Spectrum

Translated from “Die Bedeutung der schweizerischen Linie im Spektrum Europas,” *Neue Schweizer Rundschau* (Zurich), XXIV (1928).

The Rise of a New World

Translated from “Der Aufgang einer neuen Welt,” *Neue Zürcher Zeitung* (Zurich), 1930.

La Révolution Mondiale

Translated from “Ein neues Buch von Keyserling,” *Basler Nachrichten*, XXVIII (1934).

[The Complications of American Psychology](#)

Originally published in English as “Your Negroid and Indian Behavior,” *Forum* (New York), LXXXIII (1930).

[The Dreamlike World of India](#)

Originally published in English in *Asia* (New York), XXXIX (1939).

[What India Can Teach Us](#)

Originally published in English in *Asia* (New York), XXXIX (1939).

APPENDIX

[Editorial](#)

Translated from the *Zentralblatt*, VI (1933).

[A Rejoinder to Dr. Bally](#)

Translated from the *Neue Zürcher Zeitung*, CLV (1934).

[Circular Letter](#)

Translated from the *Zentralblatt*, VII (1934).

[Editorial](#)

Translated from the *Zentralblatt*, VIII (1935).

[Editorial Note](#)

Translated from the *Zentralblatt*, VIII (1935).

[Presidential Address to the 8th General Medical Congress for Psychotherapy, Bad Nauheim, 1935](#)

Translated from an unpublished ms.

[Contribution to a Discussion on Psychotherapy](#)

Translated from “Votum C. G. Jung,” *Schweizerische Aerztezeitung für Standesfragen* (Bern), XVI (1935).

[Presidential Address to the 9th International Medical Congress for Psychotherapy, Copenhagen, 1937](#)

Translated from an unpublished ms.

Presidential Address to the 10th International Medical Congress for Psychotherapy,
Oxford, 1938

Written in English; not previously published.

BIBLIOGRAPHY

INDEX

LIST OF PLATES

- I. A Ufo Vision
Painting by a patient
- II. E. Jakoby: *The Fire Sower*
Author's collection
- III. P. Birkhäuser: *The Fourth Dimension*
Private collection
- IV. Yves Tanguy: *Painting, 1927*
Title unknown. Private collection
- V. Basel Broadsheet, 1566
Wickiana Collection, Zentralbibliothek, Zurich
- VI. Nuremberg Broadsheet, 1561
Wickiana Collection, Zentralbibliothek, Zurich
- VII. "The Spiritual Pilgrim Discovering Another World"
Woodcut, 19th(?) cent. Van Houten Collection, Bergen, Netherlands
- VIII. "The Quickening of the Child in the Womb"
From the *Scivias*, by Hildegard von Bingen, Rupertsberg Codex, 12th cent., as reproduced in M. Böckeler, *Hildegard von Bingen: Wissen die Wege: Scivias* (Salzburg, 1954)

I

THE ROLE OF THE UNCONSCIOUS

MIND AND EARTH

ARCHAIC MAN

THE SPIRITUAL PROBLEM OF MODERN MAN

THE ROLE OF THE UNCONSCIOUS¹

[1] To the layman's ears, the word "unconscious" has an undertone of something metaphysical and rather mysterious. This peculiarity, attaching to the whole concept of the unconscious, is primarily due to the fact that the term found its way into ordinary speech as a designation for a metaphysical entity. Eduard von Hartmann, for instance, called the unconscious the "Universal Ground." Again, the word was taken up by occultism, because people with these leanings are extremely fond of borrowing scientific terms in order to dress their speculations in a "scientific" guise. In contradiction to this, the experimental psychologists, who for a long time regarded themselves—not unjustly—as the representatives of the only truly scientific psychology, adopted a negative attitude towards the concept of the unconscious, on the ground that everything psychic is conscious and that consciousness alone deserves the name "psyche." They admitted that conscious psychic contents showed varying degrees of clarity, some being "brighter" or "darker" than others, but the existence of unconscious contents was denied as being a contradiction in terms.

[2] This view stemmed very largely from the circumstance that work in the laboratory was confined exclusively to "normal" subjects, and also from the nature of the experiments themselves. These were concerned so far as possible with the most elementary psychic processes, while the investigation of the more complex psychic functions, which by their very nature do not lend themselves to experimental procedures based on exact measurement, was almost entirely absent. But a factor far transcending both these reasons in importance was the segregation of experimental psychology from psychopathology. In France, ever since the time of Ribot, psychologists had kept an alert eye on abnormal psychic phenomena, and one of their most eminent representatives, Binet, even made the pronouncement that the pathological psyche exaggerated certain deviations from the normal which were difficult to understand, and, by throwing them into relief, made them more comprehensible. Another French psychologist, Pierre Janet, working at the Salpêtrière, devoted himself almost exclusively and with great success to the study of psychopathological processes. But it is just the abnormal psychic processes which demonstrate most clearly the existence of an unconscious. For this reason it was the medical men, and above all the specialists in the field of psychic illnesses, who supported the hypothesis of the unconscious and defended it most vigorously. But whereas in France psychology was considerably enriched by the findings of psychopathology and was led to accept the notion of "unconscious" processes, in

Germany it was psychology that enriched psychopathology, supplying it with a number of valuable experimental methods—without, however, taking over from psychopathology its interest in pathological phenomena. This explains in large part why psychopathological research underwent a different development in German science from that followed in France. It became—except for the interest it aroused in academic circles—a task for the medical practitioner, who by his professional work was compelled to understand the complex psychic phenomena exhibited by his patients. In this way there came into being that complex of theoretical views and practical techniques which is known as “psychoanalysis.” The concept of the unconscious underwent a broad development in the psychoanalytic movement, far more so than in the French school, which was more concerned with the various forms in which unconscious processes manifested themselves than with their causation and their specific content. Fifteen years ago, independently of the Freudian school and on the basis of my own experimental researches, I satisfied myself as to the existence and significance of unconscious processes, indicating at the same time the methods by which these processes might be demonstrated. Later, in collaboration with a number of my pupils, I also demonstrated the significance of unconscious processes in the mentally insane.

[3] As a result of this—at first—purely medical development the concept of the unconscious took on a coloration derived from the natural sciences. It has remained a purely medical concept in the Freudian school. According to the views of this school, man, as a civilized being, is unable to act out a large number of instinctive impulses and wishes, for the simple reason that they are incompatible with law and morality. In so far, therefore, as he wants to adapt himself to society, he is obliged to suppress these wishes. The assumption that man has such wishes is altogether plausible, and the truth of it can be seen at any time by every individual with a little application of honesty. But this insight amounts as a rule only to the general statement that socially incompatible and inadmissible wishes exist. Experience shows, however, that the facts are quite different when we come down to individual cases. It then proves, remarkably enough, that very often, as a result of the suppression of an inadmissible wish, the thin wall between wishing and being conscious of the wish is broken, so that the wish becomes unconscious. It is forgotten, and its place is taken by a more or less rational justification—if, indeed, any motivation is sought at all. This process, whereby an inadmissible wish becomes unconscious, is called *repression*, as distinct from *suppression*, which presupposes that the wish remained conscious. Although repressed and forgotten, the incompatible content—whether it consist of wishes or of painful memories—nevertheless exists, and its unperceived presence influences the conscious processes. This influence expresses itself in the form of peculiar disturbances of the conscious, normal functions; we call these disturbances nervous or *psychogenic* disturbances. The remarkable thing is that they do not confine themselves to purely

psychological processes but extend also to physiological ones. In the latter case, as Janet emphasizes, it is never the elementary components of the function that are disturbed, but only the voluntary application of the function under various complex conditions. For instance, an elementary component of the nutritive function consists in the act of swallowing. If choking were regularly to occur whenever food in solid or liquid form was taken, then it would be an anatomical or organic disturbance. But if the choking occurred only in the case of certain foods or at certain meals, or only in the presence of certain persons, or only in certain moods, then it would be a nervous or psychogenic disturbance. The psychogenic disturbance therefore affects merely the act of eating under certain psychological and not physical conditions.

[4] Such disturbances of physiological functions are particularly frequent in hysteria. In another, equally large group of illnesses which French doctors call psychasthenia, their place is taken by purely psychological disturbances. These can assume a great variety of forms, such as obsessional ideas, anxiety states, depressions, moods, fantasies, pathological affects and impulses, and so on. At the root of all these disturbances we find repressed psychic contents, i.e., contents that have become unconscious. On the basis of these purely empirical findings, the concept of the unconscious as the sum-total of all incompatible and repressed wishes, including all painful and repressed memories, gradually took form.

[5] Now it is an easily demonstrated fact that the overwhelming majority of these incompatible contents have to do with the phenomenon of sexuality. Sexuality is a fundamental instinct which, as everyone knows, is the most hedged about with secrecy and with feelings of delicacy. In the form of love, it is the cause of the stormiest emotions, the wildest longings, the profoundest despairs, the most secret sorrows, and, altogether, of the most painful experiences. Sexuality is an important physical and widely ramified psychic function on which the whole future of humanity depends. It is thus at least as important as the function of nutrition, even though it is an instinct of another kind. But whereas we can allow the nutritive function, from the devouring of a simple piece of bread to a guild banquet, to be seen by all eyes in all its variations, and at most must hold it in check because of an attack of intestinal catarrh or a general food shortage, sexuality comes under a moral taboo and has to submit to a large number of legal regulations and restrictions. It is not, like the nutritive function, at the free disposal of the individual. It is therefore understandable that a great many pressing interests and powerful emotions congregate round this question, for as a rule affects are found at places where adaptation is least complete. Furthermore, sexuality, as I have said, is a fundamental instinct in every human being, and this is reason enough for the well-known Freudian theory which reduces everything to sexuality, and sketches a picture of the unconscious which makes it appear as a kind of lumber-room where all the repressed and inadmissible infantile wishes and all the later,

inadmissible sexual wishes are stored. Distasteful as such a view is, we must give it its due if we want to discover all the things that Freud has smuggled into the concept of sexuality. We shall then see that he has widened its boundaries far beyond the permitted limits, so that a better word for what he actually means would be “Eros” in the old, philosophical sense of a Pan-Eros who permeates all nature as a creative and procreative force. “Sexuality” is a most unhappy expression for this. But, such as it is, the concept of sexuality has now been coined and appears to have such definite limits that one even hesitates to use the word “love” as a synonym. And yet Freud, as can easily be shown from numerous passages in his writings, very often means “love” when he speaks merely of sexuality.

[6] The whole Freudian movement has settled firmly for the sexual theory. There is certainly no unprejudiced thinker or investigator who would not instantly acknowledge the extraordinary importance of sexual or erotic experiences and conflicts. But it will never be proved that sexuality is *the* fundamental instinct and *the* activating principle of the human psyche. Any unprejudiced scientist will, on the contrary, admit that the psyche is an extremely complex structure. Though we can approach it from the biological standpoint and seek to explain it in terms of biological factors, it presents us with a great many other puzzles whose solution makes demands which no isolated science, such as biology, is in a position to satisfy. No matter what instincts, drives or dynamisms biologists may postulate or assume both now and in the future, it will assuredly be quite impossible to set up a sharply defined instinct like sexuality as a fundamental principle of explanation. Biology, indeed science in general, has got beyond this stage: we no longer reduce everything to a single manifest force, as the earlier scientists did with phlogiston and electricity. We have learned to employ a modest abstraction, named energy, as an explanatory principle for all quantitative changes.

[7] I am convinced that a truly scientific attitude in psychology must likewise lead to the conclusion that the dynamic processes of the psyche cannot be reduced to this or that concrete instinct—we should merely find ourselves back at the stage of the phlogiston theory. We shall be obliged to take the instincts as constituent parts of the psyche, and then abstract our principle of explanation from their mutual relationship. I have therefore pointed out that we would do well to posit a hypothetical quantity, an “energy,” as a psychological explanatory principle, and to call it “libido” in the classical sense of the word, without harbouring any prejudice with regard to its substantiality. With the help of such a quantity, the psychodynamic processes could be explained in an unobjectionable manner, without that unavoidable distortion which a concrete ground of explanation necessarily entails. Thus, when the Freudian school explains that religious feelings or any other sentiments that pertain to the spiritual sphere are “nothing but” inadmissible sexual wishes which have been repressed and

subsequently “sublimated,” this procedure would be equivalent to a physicist’s explanation that electricity is “nothing but” a waterfall which someone had bought up and piped into a turbine. In other words, electricity is nothing but a “culturally deformed” waterfall—an argument which might conceivably be raised by the Society for the Preservation of Wild Nature but is hardly a piece of scientific ratiocination. In psychology such an explanation would be appropriate only if it could be proved that the dynamic ground of our being is nothing but sexuality, which amounts to saying, in physics, that falling water alone can produce electricity. In that case it could rightly be maintained that electricity is nothing but a waterfall conducted along wires.

[8] So if we reject the exclusively sexual theory of the unconscious and put in its place an energetic view of the psyche, we must say that the unconscious contains everything psychic that has not reached the threshold of consciousness, or whose energy-charge is not sufficient to maintain it in consciousness, or that will reach consciousness only in the future. We can then picture to ourselves how the unconscious must be constituted. We have already taken cognizance of repressions as contents of the unconscious, and to these we must add *everything that we have forgotten*. When a thing is forgotten, it does not mean that it is extinguished; it simply means that the memory has become subliminal. Its energy-charge has sunk so low that it can no longer appear in consciousness; but, though lost to consciousness, it is not lost to the unconscious. It will naturally be objected that this is no more than a *façon de parler*. I would like to make what I mean clear by a hypothetical example. Suppose there are two people, one of whom has never read a book and the other has read a thousand. From the minds of both of them we expunge all memory of the ten years in which the first was merely living and the second was reading his thousand books. Each now knows as little as the other, and yet anyone will be able to find out which of them has read the books and, be it noted, understood them. The experience of reading, though long forgotten, leaves traces behind it, and from these traces the previous experience can be recognized. This long-lasting, indirect influence is due to a fixing of impressions, which are still preserved even when they are no longer capable of reaching consciousness.

[9] Besides things that have been forgotten, subliminal perceptions form part of the contents of the unconscious. These may be sense perceptions occurring below the stimulus-threshold of conscious hearing, or in the peripheral field of vision; or they may be apperceptions, by which are meant perceptions of endopsychic or external processes.

[10] All this material constitutes the *personal unconscious*. We call it personal because it consists entirely of acquisitions deriving from personal life. Therefore, when anything falls into the unconscious it is taken up in the network of associations formed by this unconscious material. Associative connections of high intensity may then be

produced, which cross over or rise up into consciousness in the form of inspirations, intuitions, “lucky ideas,” and so on.

- [11] The concept of a personal unconscious does not, however, enable us fully to grasp the nature of the unconscious. If the unconscious were only personal, it would in theory be possible to trace all the fantasies of an insane person back to individual experiences and impressions. No doubt a large proportion of the fantasy-material could be reduced to his personal history, but there are certain fantasies whose roots in the individual’s previous history one would seek for in vain. What sort of fantasies are these? They are, in a word, *mythological fantasies*. They are elements which do not correspond to any events or experiences of personal life, but only to myths.
- [12] Where do these mythological fantasies come from, if they do not spring from the personal unconscious and hence from the experiences of personal life? Indubitably they come from the brain—indeed, precisely from the brain and not from personal memory-traces, but from the inherited brain-structure itself. Such fantasies always have a highly original and “creative” character. They are like new creations; obviously they derive from the creative activity of the brain and not simply from its mnemonic activity. We receive along with our body a highly differentiated brain which brings with it its entire history, and when it becomes creative it creates out of this history—out of the history of mankind. By “history” we usually mean the history which we “make,” and we call this “objective history.” The truly creative fantasy activity of the brain has nothing to do with this kind of history, but solely with that age-old natural history which has been transmitted in living form since the remotest times, namely, the history of the brain-structure. And this structure tells its own story, which is the story of mankind: the unending myth of death and rebirth, and of the multitudinous figures who weave in and out of this mystery.
- [13] This unconscious, buried in the structure of the brain and disclosing its living presence only through the medium of creative fantasy, is the *suprapersonal unconscious*. It comes alive in the creative man, it reveals itself in the vision of the artist, in the inspiration of the thinker, in the inner experience of the mystic. The suprapersonal unconscious, being distributed throughout the brain-structure, is like an all-pervading, omnipresent, omniscient spirit. It knows man as he always was, and not as he is at this moment; it knows him as myth. For this reason, also, the connection with the suprapersonal or *collective* unconscious means an extension of man beyond himself; it means death for his personal being and a rebirth in a new dimension, as was literally enacted in certain of the ancient mysteries. It is certainly true that without the sacrifice of man as he is, man as he was—and always will be—cannot be attained. And it is the artist who can tell us most about this sacrifice of the personal man, if we are not satisfied with the message of the Gospels.

[14] It should on no account be imagined that there are such things as *inherited ideas*. Of that there can be no question. There are, however, innate possibilities of ideas, *a priori* conditions for fantasy-production, which are somewhat similar to the Kantian categories. Though these innate conditions do not produce any contents of themselves, they give definite form to contents that have already been acquired. Being a part of the inherited structure of the brain, they are the reason for the identity of symbols and myth-motifs in all parts of the earth. The collective unconscious forms the dark background against which the adaptive function of consciousness stands out in sharp relief. One is almost tempted to say that everything of value in the psyche is taken up into the adaptive function, and that everything useless goes to form that inchoate background from which, to the terror of primitive man, menacing shadows and nocturnal spectres detach themselves, demanding sacrifices and ceremonies which to our biologically oriented minds seem futile and meaningless. We laugh at primitive superstitions, thinking ourselves superior, but we completely forget that we are influenced in just as uncanny a fashion as the primitive by this background, which we are wont to scoff at as a museum of stupidities. Primitive man simply has a different theory—the theory of witchcraft and spirits. I find this theory very interesting and very sensible—actually more sensible than the academic views of modern science. Whereas the highly educated modern man tries to figure out what diet best suits his nervous intestinal catarrh and to what dietetic mistakes the new attack may be due, the primitive, quite correctly, looks for psychological reasons and seeks a psychically effective method of cure. The processes in the unconscious influence us just as much as they do primitives; we are possessed by the demons of sickness no less than they, our psyche is just as much in danger of being struck by some hostile influence, we are just as much the prey of malevolent spirits of the dead, or the victims of a magic spell cast by a strange personality. Only, we call all these things by different names, and that is the only advantage we have over primitive man. It is, as we know, a little thing, yet it makes all the difference. For mankind it was always like a deliverance from a nightmare when the new name was found.

[15] This mysterious background, which from time immemorial peopled the nocturnal shadows of the primeval forest with the same yet ever-changing figures, seems like a distorted reflection of life during the day, repeating itself in the dreams and terrors of the night. Shadowily they crowd round, the revenants, the spirits of the dead, fleeting memory-images risen from the prison of the past whence no living thing returns, or feelings left behind by some impressive experience and now personified in spectral form. All this seems but the bitter aftertaste from the emptied beaker of the day, the unwelcome lees, the useless sediment of experience. But if we look closer, we discover that this apparently hostile background sends out powerful emissaries which influence the behaviour of primitives in the highest degree. Sometimes these agencies take on a magical, sometimes a religious form, and sometimes the two forms appear

inextricably mixed. Both of them are the most important factors in the primitive mentality after the struggle for existence. In them the spiritual element manifests itself autonomously to the primitive psyche—whose reflexes are purely animal—in projected, sensuous form, and we Europeans must sometimes be struck with wonder at the tremendous influence the experience of the spirit can have on primitive man. For him, the sensuous immediacy of the object attaches to spiritual phenomena as well. A thought *appears to him*, he does not think it; it appears to him in the form of a projected sensuous perception, almost like an hallucination, or at least like an extremely vivid dream. For this reason a thought, for the primitive, can superimpose itself on sensuous reality to such an extent that if a European were to behave in the same way we should say he was mad.

[16] These peculiarities of primitive psychology, which I can only touch lightly on here, are of great importance for an understanding of the collective unconscious. A simple reflection will bear this out. As civilized human beings, we in Western Europe have a history reaching back perhaps 2,500 years. Before that there is a prehistoric period of considerably greater duration, during which man reached the cultural level of, say, the Sioux Indians. Then come the hundreds of thousands of years of neolithic culture, and before that an unimaginably vast stretch of time during which man evolved from the animal. A mere fifty generations ago many of us in Europe were no better than primitives. The layer of culture, this pleasing patina, must therefore be quite extraordinarily thin in comparison with the powerfully developed layers of the primitive psyche. But it is these layers that form the collective unconscious, together with the vestiges of animality that lose themselves in the nebulous abyss of time.

[17] Christianity split the Germanic barbarian into an upper and a lower half, and enabled him, by repressing the dark side, to domesticate the brighter half and fit it for civilization. But the lower, darker half still awaits redemption and a second spell of domestication. Until then, it will remain associated with the vestiges of the prehistoric age, with the collective unconscious, which is subject to a peculiar and ever-increasing activation. As the Christian view of the world loses its authority, the more menacingly will the “blond beast” be heard prowling about in its underground prison, ready at any moment to burst out with devastating consequences. When this happens in the individual it brings about a psychological revolution, but it can also take a social form.

[18] In my opinion this problem does not exist for the Jews. The Jew already had the culture of the ancient world and on top of that has taken over the culture of the nations amongst whom he dwells. He has two cultures, paradoxical as that may sound. He is domesticated to a higher degree than we are, but he is badly at a loss for that quality in man which roots him to the earth and draws new strength from below. This chthonic quality is found in dangerous concentration in the Germanic peoples. Naturally the Aryan European has not noticed any signs of this for a very long time, but perhaps he

is beginning to notice it in the present war; and again, perhaps not. The Jew has too little of this quality—where has he his own earth underfoot? The mystery of earth is no joke and no paradox. One only needs to see how, in America, the skull and pelvis measurements of all the European races begin to indianize themselves in the second generation of immigrants. That is the mystery of the American earth.

[19] The soil of every country holds some such mystery. We have an unconscious reflection of this in the psyche: just as there is a relationship of mind to body, so there is a relationship of body to earth. I hope the reader will pardon my figurative way of speaking, and will try to grasp what I mean. It is not easy to describe, definite though it is. There are people—quite a number of them—who live outside and above their bodies, who float like bodiless shadows above their earth, their earthy component, which is their body. Others live wholly in their bodies. As a rule, the Jew lives in amicable relationship with the earth, but without feeling the power of the chthonic. His receptivity to this seems to have weakened with time. This may explain the specific need of the Jew to reduce everything to its material beginnings; he needs these beginnings in order to counterbalance the dangerous ascendancy of his two cultures. A little bit of primitivity does not hurt him; on the contrary, I can understand very well that Freud's and Adler's reduction of everything psychic to primitive sexual wishes and power-drives has something about it that is beneficial and satisfying to the Jew, because it is a form of simplification. For this reason, Freud is perhaps right to close his eyes to my objections. But these specifically Jewish doctrines are thoroughly unsatisfying to the Germanic mentality; we still have a genuine barbarian in us who is not to be trifled with, and whose manifestation is no comfort for us and not a pleasant way of passing the time. Would that people could learn the lesson of this war! The fact is, our unconscious is not to be got at with over-ingenious and grotesque interpretations. The psychotherapist with a Jewish background awakens in the Germanic psyche not those wistful and whimsical residues from the time of David, but the barbarian of yesterday, a being for whom matters suddenly become *serious* in the most unpleasant way. This annoying peculiarity of the barbarian was apparent also to Nietzsche—no doubt from personal experience—which is why he thought highly of the Jewish mentality and preached about dancing and flying and not taking things seriously. But he overlooked the fact that it is not the barbarian in us who takes things seriously—they become serious for him. He is gripped by the daemon. And who took things more seriously than Nietzsche himself?

[20] It seems to me that we should take the problem of the unconscious very seriously indeed. The tremendous compulsion towards goodness and the immense moral force of Christianity are not merely an argument in the latter's favour, they are also a proof of the strength of its suppressed and repressed counterpart—the antichristian, barbarian element. The existence within us of something that can turn against us, that

can become a serious matter for us, I regard not merely as a dangerous peculiarity, but as a valuable and congenial asset as well. It is a still untouched fortune, an uncorrupted treasure, a sign of youthfulness, an earnest of rebirth. Nevertheless, to value the unconscious exclusively for the sake of its positive qualities and to regard it as a source of revelation would be fundamentally wrong. The unconscious is, first and foremost, the world of the past, which is activated by the one-sidedness of the conscious attitude. Whenever life proceeds one-sidedly in any given direction, the self-regulation of the organism produces in the unconscious an accumulation of all those factors which play too small a part in the individual's conscious existence. For this reason I have put forward the compensation theory of the unconscious as a complement to the repression theory.

[21] The role of the unconscious is to act compensatorily to the conscious contents of the moment. By this I do not mean that it sets up an opposition, for there are times when the tendency of the unconscious coincides with that of consciousness, namely, when the conscious attitude is approaching the optimum. The nearer it approaches the optimum, the more the autonomous activity of the unconscious is diminished, and the more its value sinks until, at the moment when the optimum is reached, it falls to zero. We can say, then, that so long as all goes well, so long as a person travels the road that is, for him, the individual as well as the social optimum, there is no talk of the unconscious. The very fact that we in our age come to speak of the unconscious at all is proof that everything is not in order. This talk of the unconscious cannot be laid entirely at the door of analytical psychology; its beginnings can be traced back to the time of the French Revolution, and the first signs of it can be found in Mesmer. It is true that in those days they did not speak of the unconscious but of "animal magnetism." This is nothing but a rediscovery of the primitive concept of soul-force or soul-stuff, awakened out of the unconscious by a reactivation of archaic forms of thought. At the time when animal magnetism was spreading throughout the Western world as a regular epidemic of table-turning, amounting in the end to a recrudescence of the belief in fetishes (animation of an inanimate object), Robert Mayer elevated the primitive dynamic idea of energy, which rose up from the unconscious and forced itself on him like an inspiration—as he himself describes—to the level of a scientific concept. Meanwhile, the table-turning epidemic burst its bounds altogether and proliferated into spiritualism, which is a modern belief in spirits and a rebirth of the shamanistic form of religion practised by our remote forefathers. This development of reactivated contents from the unconscious is still going on today, and during the last few decades has led to a popularizing of the next higher stage of differentiation—the eclectic or Gnostic systems of Theosophy and Anthroposophy. At the same time, it laid the foundations of French psychopathology, and in particular of the French school of hypnotism. These, in turn, became the main sources of analytical psychology, which now seeks to investigate scientifically the phenomena of the unconscious—the

same phenomena which the theosophical and Gnostic sects made accessible to the simple-minded in the form of portentous mysteries.

[22] It is evident from this development that analytical psychology does not stand in isolation but finds itself in a definite historical setting. The fact that this whole disturbance or reactivation of the unconscious took place around the year 1800 is, in my view, connected with the French Revolution. This was less a political revolution than a revolution of minds. It was a colossal explosion of all the inflammable matter that had been piling up ever since the Age of Enlightenment. The official deposition of Christianity by the Revolution must have made a tremendous impression on the unconscious pagan in us, for from then on he found no rest. In the greatest German of the age, Goethe, he could really live and breathe, and in Hölderlin he could at least cry loudly for the glory that was Greece. After that, the dechristianization of man's view of the world made rapid progress despite occasional reactionaries. Hand in hand with this went the importation of strange gods. Besides the fetishism and shamanism already mentioned, the prime import was Buddhism, retailed by Schopenhauer. Mystery religions spread apace, including that higher form of shamanism, Christian Science. This picture reminds us vividly of the first centuries of our era, when Rome began to find the old gods ridiculous and felt the need to import new ones on a large scale. As today, they imported pretty well everything that existed, from the lowest, most squalid superstition to the noblest flowerings of the human spirit. Our time is fatally reminiscent of that epoch, when again everything was not in order, and again the unconscious burst forth and brought back things immemorably buried. If anything, the chaos of minds was perhaps less pronounced then than it is today.

[23] As the reader will have remarked, I have omitted to speak here of the medical aspect of the unconscious, for instance the question of how the unconscious produces nervous symptoms. But I have touched on this question in the earlier pages and can now leave it alone. At all events, I am not getting away from my subject, because psychotherapy is concerned not only with family quarrels, unhappy love-affairs, and the like, but with the question of psychological adaptation in general, and the attitude we are to take towards people and things, and also towards ourselves. A doctor who treats the body must know the body, and a doctor who treats the psyche must know the psyche. If he knows the psyche only under the aspect of sexuality or of the personal lust for power, he knows it only in part. This part has to be known, of course, but the other parts are equally important, and particularly the question I have touched on here concerning the relation between conscious and unconscious. A biologically trained eye is not sufficient to grasp this problem, for in practice it is more than a matter of eugenics, and the observation of human life in the light of self-preservation and propagation is too one-sided. Certainly the unconscious presents us with very different aspects; but so far we have fixed our attention too much on certain outward

peculiarities, for instance the archaic language of the unconscious, and have taken it all quite literally. The language of the unconscious is particularly rich in images, as our dreams prove. But it is a primitive language, a faithful reflection of the colourful, ever-changing world. The unconscious is of like nature: it is a compensatory image of the world. In my view it cannot be maintained either that the unconscious has a merely sexual nature or that it is a metaphysical reality, nor can it be exalted into a “universal ground.” It is to be understood as a psychic phenomenon, like consciousness. We no more know what the psyche is than we know what life is. They are interpenetrating mysteries, giving us every reason for uncertainty as to how much “I” am the world, and how much “world” is “I”. The unconscious at any rate is real, because it *works*. I like to visualize the unconscious as a world seen in a mirror: our consciousness presents to us a picture of the outer world, but also of the world within, this being a compensatory mirror-image of the outer world. We could also say that the outer world is a compensatory mirror-image of the inner world. At all events we stand between two worlds, or between two totally different psychological systems of perception; between perception of external sensory stimuli and perception of the unconscious. The picture we have of the outer world makes us understand everything as the effect of physical and physiological forces; the picture of the inner world shows everything as the effect of spiritual agencies. Then, it is no longer the force of gravity that welds the stars together, but the creative hand of a demiurge; love is no longer the effect of a sexual stimulus, but of psychic predestination, and so forth.

[24] The right way may perhaps be found in the approximation of the two worlds. Schiller thought he had found this way in art, in what he called the “symbol” of art. The artist, therefore, should know the secret of the middle path. My own experiences led me to doubt this. I am of the opinion that the union of rational and irrational truth is to be found not so much in art as in the symbol *per se*; for it is the essence of the symbol to contain both the rational and the irrational. It always expresses the one through the other; it comprises both without being either.

[25] How does a symbol originate? This question brings us to the most important function of the unconscious: the *symbol-creating function*. There is something very remarkable about this function, because it has only a relative existence. The compensatory function, on the other hand, is the natural, automatic function of the unconscious and is constantly present. It owes its existence to the simple fact that all the impulses, thoughts, wishes, and tendencies which run counter to the rational orientation of daily life are denied expression, thrust into the background, and finally fall into the unconscious. There all the things which we have repressed and suppressed, which we have deliberately ignored and devalued, gradually accumulate and, in time, acquire such force that they begin to influence consciousness. This influence would be in direct opposition to our conscious orientation if the unconscious

consisted only of repressed and suppressed material. But this, as we have seen, is not the case. The unconscious also contains the dark springs of instinct and intuition, it contains all those forces which mere reasonableness, propriety, and the orderly course of bourgeois existence could never call awake, all those creative forces which lead man onwards to new developments, new forms, and new goals. I therefore call the influence of the unconscious not merely complementary but compensatory, because it adds to consciousness everything that has been excluded by the drying up of the springs of intuition and by the fixed pursuit of a single goal.

[26] This function, as I say, works automatically, but, owing to the notorious atrophy of instinct in civilized man, it is often too weak to swing his one-sided orientation of consciousness in a new direction against the pressures of society. Therefore, artificial aids have always been needed to bring the healing forces of the unconscious into play. It was chiefly the religions that performed this task. By taking the manifestations of the unconscious as divine or daemonic signs, revelations, or warnings, they offered it some idea or view that served as a favourable gradient. In this way they directed particular attention to all phenomena of unconscious origin, whether they were dreams, visions, feelings, fantasies, or projections of the same in strange or unusual personalities, or in any striking processes of organic and inorganic nature. This concentration of attention enabled the unconscious contents and forces to overflow into conscious life, thereby influencing it and altering it. From this standpoint, religious ideas are an artificial aid that benefits the unconscious by endowing its compensatory function—which, if disregarded, would remain ineffective—with a higher value for consciousness. Faith, superstition, or any strongly feeling-toned idea gives the unconscious content a value which ordinarily it does not possess, but which it might in time attain, though in a very unpleasant form. When, therefore, unconscious contents accumulate as a result of being consistently ignored, they are bound to exert an influence that is pathological. There are just as many neurotics among primitives as among civilized Europeans. Hysterical Africans are by no means rare in Africa. These disagreeable manifestations of the unconscious account in large measure for the primitive fear of demons and the resultant rites of propitiation.

[27] The compensatory function of the unconscious naturally does not contain in itself the conscious valuation, although it is wholly dependent on the conscious way of thinking. The unconscious can supply, at most, the germs of conscious convictions or of symbol-formation. We can say, therefore, that the symbol-creating function of the unconscious exists and does not exist, depending on the conditions. It shares this paradoxical quality with symbols in general. One is reminded of the story of the young rabbi who was a pupil of Kant's. One day an old rabbi came to guide him back to the faith of his fathers, but all arguments were in vain. At last the old rabbi drew forth the ominous *shofar*, the horn that is blown at the cursing of heretics (as happened

to Spinoza), and asked the young man if he knew what it was. "Of course I know," answered the young man coolly, "it is the horn of a ram." At that the old rabbi reeled back and fell to the ground in horror.

[28] What is the *shofar*? It is *also* only the horn of a ram. Sometimes a symbol can be no more than that, but only when it is dead. The symbol is killed when we succeed in reducing the *shofar* to a ram's horn. But again, through symbolization a ram's horn can become the *shofar*.

[29] The compensatory function expresses itself in quite definite arrangements of psychic material, for instance in dreams, in which nothing "symbolic" is to be found any more than in a ram's horn. In order to discover their symbolic quality a quite definite conscious attitude is needed, namely, the willingness to understand the dream-content symbolically, first of all as a mere hypothesis, and then leave experience to decide whether it is necessary or desirable to understand the dream in this way. I will give a brief example which may help to elucidate this difficult question. An elderly woman-patient, who, like many others, was upset by the problem of the war, once told me the following dream which she had shortly before she visited me:

[30] *She was singing hymns that put particular emphasis on her belief in Christ, among others the hymn that goes:*

Christ's blood and righteousness shall be
My festal dress and jewellery;
So shall I stand before the Lord
When heaven shall grant me my reward.
They shall be saved at Judgment Day
Who put their trust in Christ alway.

While she was singing it, she saw a bull tearing around madly in front of the window. Suddenly it gave a jump and broke one of its legs. She saw that the bull was in agony, and thought, turning her eyes away, that somebody ought to kill it. Then she awoke.

[31] The bull's agony reminded her of the torturings of animals whose unwilling witness she had been. She abominated such things and was extraordinarily upset by them because of her unconscious identification with the tortured animal. There was something in her that could be expressed by the image of an animal being tortured. This image was evidently evoked by the special emphasis on the belief in Christ in the hymns she was singing, for it was while she was singing that the bull got excited and broke its leg. This odd combination of ideas immediately led to an association concerning the profound religious disquiet she had felt during the war, which shook her belief in the goodness of God and in the adequacy of the Christian view of the world. This shock should have been assuaged by the emphasis on Christian faith in the

hymn, but instead it aroused that animal element in the unconscious which was personified by the bull. This is just the element that is represented by the Christian symbol as having been conquered and offered up in sacrifice. In the Christian mystery it is the sacrificed Lamb, or more correctly, the “little ram.” In its sister-religion, Mithraism, which was also Christianity’s most successful rival, the central symbol of the cult was the sacrifice not of a ram but of a bull. The usual altarpiece showed the overcoming of the bull by the divine saviour Mithras. We have, therefore, a very close historical connection between Christianity and the bull sacrifice. Christianity suppressed this animal element, but the moment the absolute validity of the Christian faith is shaken, that element is thrust into the foreground again. The animal instinct seeks to break out, but in so doing breaks a leg—in other words, instinct cripples itself. From the purely animal drives there also come all those factors which limit the sway of instinct. From the same root that produces wild, untamed, blind instinct there grow up the natural laws and cultural forms that tame and break its pristine power. But when the animal in us is split off from consciousness by being repressed, it may easily burst out in full force, quite unregulated and uncontrolled. An outburst of this sort always ends in catastrophe—the animal destroys itself. What was originally something dangerous now becomes something to be pitied, something that really needs our compassion. The tremendous forces unleashed by the war bring about their own destruction because there is no human hand to preserve and guide them. Our view of the world has proved too narrow to channel these forces into a cultural form.

[32] Had I tried to explain to my elderly woman-patient that the bull was a sexual symbol, she would have got nothing out of it; on the contrary, she would merely have lost her religious point of view and been none the better off. In such cases it is not a question of an either/or explanation. If we are willing to adopt a symbolical standpoint, even if only as an hypothesis, we shall see that the dream is an attempt on the part of the unconscious to bring the Christian principle into harmony with its apparently irreconcilable opposite—animal instinct—by means of understanding and compassion. It is no accident that official Christianity has no relation to the animal. This omission, particularly striking in comparison with Buddhism, is often felt by sensitive people and has moved one modern poet to sing of a Christ who sacrifices his life for the sufferings of dumb animals. The Christian love of your neighbour can extend to the animal too, the *animal in us*, and can surround with love all that a rigidly anthropomorphic view of the world has cruelly repressed. By being repressed into the unconscious, the source from which it originated, the animal in us only becomes more beastlike, and that is no doubt the reason why no religion is so defiled with the spilling of innocent blood as Christianity, and why the world has never seen a bloodier war than the war of the Christian nations. The repressed animal bursts forth in its most savage form when it comes to the surface, and in the process of destroying itself leads to international suicide. If every individual had a better relation to the animal within

him, he would also set a higher value on life. Life would be the absolute, the supreme moral principle, and he would react instinctively against any institution or organization that had the power to destroy life on a large scale.

[33] This dream, then, simply shows the dreamer the value of Christianity and contrasts it with an untamed force of nature, which, left to its raging, hurts itself and demands pity. A purely analytical reduction that traced the religious emotion back to the repression of animal instinct would, in this particular case, be sterile and uselessly destructive. If, on the other hand, we assert that the dream is to be understood symbolically and is trying to give the dreamer an opportunity to become reconciled with herself, we have taken the first step in an interpretation which will bring the contradictory values into harmony and open up a new path of inner development. Subsequent dreams would then, in keeping with this hypothesis, provide the means for understanding the wider implications of the union of the animal component with the highest moral and intellectual achievements of the human spirit. In my experience this is what actually happens, for the unconscious is continuously compensatory in its action upon the conscious situation of the moment. It is therefore not a matter of indifference *what* our conscious attitude is towards the unconscious. The more negative, critical, hostile, or disparaging we are, the more it will assume these aspects, and the more the true value of the unconscious will escape us.

[34] Thus the unconscious has a symbol-creating function only when we are willing to recognize in it a symbolic element. The products of the unconscious are pure nature. *Naturam si sequemur duces, nunquam aberrabimus*,² said the ancients. But nature is not, in herself, a guide, for she is not there for man's sake. Ships are not guided by the phenomenon of magnetism. We have to make the compass a guide and, in addition, allow for a specific correction, for the needle does not even point exactly to the north. So it is with the guiding function of the unconscious. It can be used as a source of symbols, but with the necessary conscious correction that has to be applied to every natural phenomenon in order to make it serve our purpose.

[35] Many people will find this view extremely unscientific, for nowhere do they see any reduction to fundamental causes, so that they could declare with certainty that such-and-such a thing is "nothing but" this or that. For all those who seek to explain things in this way, sexuality as a causative factor is very convenient. Indeed, in the case I have described a sexual explanation could be offered without much difficulty. But—what would the patient get out of it? What use is it to a woman on the threshold of old age if her problem is answered in this way? Or should psychotherapy be reserved for patients under forty?

[36] Naturally we can ask in return: What does the patient get out of an answer that takes religious problems seriously? What is a religious problem anyway? And what has a scientific method to do with religion?

[37] It seems to me that the patient is the proper authority to deal with questions of this sort. What does he get out of them however they are answered? Why should he bother his head about science? If he is a religious person, his relationship to God will mean infinitely more to him than any scientifically satisfactory explanation, just as it is a matter of indifference to a sick man *how* he gets well so long as he does get well. Our patient, indeed any patient, is treated correctly only when he is treated as an individual. This means entering into his particular problem and not giving him an explanation based on “scientific” principles that goes clean over his head although it may be quite correct biologically.

[38] In my view the first duty of a scientific psychologist is to keep close to the living facts of the psyche, to observe these facts carefully, and thus open himself to those deeper experiences of which at present he has absolutely no knowledge. When, therefore, this or that individual psyche has a sexual conflict, and another one has a religious problem, the true scientist will first of all acknowledge the patent difference between them. He will devote himself as much to the religious problem as to the sexual problem, regardless of whether the biologist’s credo allows room for the gods or not. The really unprejudiced investigator will not let his subjective credo influence or in any way distort the material lying before him, and pathological material is no exception to this. Nowadays it is a piece of unwarranted naïveté to regard a neurotic conflict as exclusively a sexual or as exclusively a power problem. This procedure is just as arbitrary as the assertion that there is no such thing as the unconscious and no neurotic conflicts. When we see all round us how powerful ideas can be, we must admit that they must be equally powerful in the psyche of the individual, whether or not he is aware of it. No one doubts that sexuality is a psychologically effective factor, and it cannot be doubted that ideas are psychologically effective factors too. Between the world of ideas and the world of instinct there is, however, a polar difference, so that as a rule only one pole is conscious. The other pole then dominates the unconscious. Thus, when anyone in his conscious life is wholly under the sway of instinct, his unconscious will place just as one-sided an emphasis on the value of ideas. And since the influence of the unconscious does in the end reach consciousness indirectly, and secretly determines its attitude, it gives rise to a compromise formation: instinct surreptitiously becomes a fixed idea, it loses its reality and is blown up by the unconscious into a one-sided, universal principle. We see the contrary often happening too, when a person consciously takes his stand on the world of ideas and is gradually forced to experience how his instinct secretly makes his ideas the instrument of unconscious wishes.

[39] As the contemporary world and its newspapers present the spectacle of a gigantic psychiatric clinic, every attentive observer has ample opportunity to see these formulations being enacted before his eyes. A principle of cardinal importance in

studying these phenomena is the one already stressed by analytical psychology: that the unconscious of one person is projected upon another person, so that the first accuses the second of what he overlooks in himself. This principle is of such alarming general validity that everyone would do well, before railing at others, to sit down and consider very carefully whether the brick should not be thrown at his own head.

[40] This seemingly irrelevant aside brings us to one of the most remarkable features of the unconscious: it is, as it were, present before our eyes in all its parts, and is accessible to observation at any time.

[41] The reason for this paradoxical quality is that the unconscious, in so far as it is activated in any way by small amounts of energy, is projected upon certain more or less suitable objects. The reader will ask how anyone can know this. The existence of projections was gradually recognized when it was found that the process of psychological adaptation was marked by disturbances and defects whose cause appeared to lie in the object. Closer investigation revealed that the “cause” was an unconscious content of the subject, which, because not recognized by him, apparently transferred itself to the object, and there magnified one of its peculiarities to such proportions that it seemed a sufficient cause of the disturbance.

[42] The fact of projection was first recognized from disturbances of psychological adaptation. Later, it was recognized also from what *promoted* adaptation, that is to say from the apparently positive qualities of the object. Here it was the valuable qualities of the subject’s own personality which he had overlooked that appeared in the object and made it especially desirable.

[43] But the full extent of these projections from the unconscious became known through analysis of those obscure and inexplicable feelings and emotions which give some intangible, magical quality to certain places, certain moods of nature, certain works of art, and also to certain ideas and certain people. This magic likewise comes from projection, but a projection of the collective unconscious. If it is inanimate objects that have the “magical” quality, often their mere statistical incidence is sufficient to prove that their significance is due to the projection of a mythological content from the collective unconscious. Mostly these contents are motifs already known to us from myths and fairytales. I would mention as an example the mysterious house where a witch or magician dwells, where some monstrous crime is being committed or has been committed, where there is a ghost, where a hidden treasure lies buried, and so on. The projection of this primordial image can be recognized when, one day, a person somehow comes upon this mysterious house—when, in other words, a real but quite ordinary house makes a magical impression upon him. Generally, too, the whole atmosphere of the place seems symbolic and is, therefore, the projection of a coherent unconscious system.

[44] We find this phenomenon beautifully developed in primitive man. The country he inhabits is at the same time the topography of his unconscious. In that stately tree dwells the thundergod; this spring is haunted by the Old Woman; in that wood the legendary king is buried; near that rock no one may light a fire because it is the abode of a demon; in yonder pile of stones dwell the ancestral spirits, and when any woman passes it she must quickly utter an apotropaic formula lest she become pregnant, for one of the spirits could easily enter her body. All kinds of objects and signs mark these places, and pious awe surrounds the marked spot. Thus does primitive man dwell in his land and at the same time in the land of his unconscious. Everywhere his unconscious jumps out at him, alive and real. How different is our relationship to the land we dwell in! Feelings totally strange to us accompany the primitive at every step. Who knows what the cry of a bird means to him, or the sight of that old tree! A whole world of feeling is closed to us and is replaced by a pale aestheticism. Nevertheless, the world of primitive feeling is not entirely lost to us; it lives on in the unconscious. The further we remove ourselves from it with our enlightenment and our rational superiority, the more it fades into the distance, but is made all the more potent by everything that falls into it, thrust out by our one-sided rationalism. This lost bit of nature seeks revenge and returns in faked, distorted form, for instance as a tango epidemic, as Futurism, Dadaism, and all the other crazes and crudities in which our age abounds.

[45] Even the primitive's distrust of the neighbouring tribe, which we thought we had long ago outgrown thanks to our global organizations, has come back again in this war, swollen to gigantic proportions. It is no longer a matter of burning down the neighbouring village, or of making a few heads roll: whole countries are devastated, millions are slaughtered. The enemy nation is stripped of every shred of decency, and our own faults appear in others, fantastically magnified. Where are the superior minds, capable of reflection, today? If they exist at all, nobody heeds them: instead there is a general running amok, a universal fatality against whose compelling sway the individual is powerless to defend himself. And yet this collective phenomenon is the fault of the individual as well, for nations are made up of individuals. Therefore the individual must consider by what means he can counteract the evil. Our rationalistic attitude leads us to believe that we can work wonders with international organizations, legislation, and other well-meant devices. But in reality only a change in the attitude of the individual can bring about a renewal in the spirit of the nations. Everything begins with the individual.

[46] There are well-meaning theologians and humanitarians who want to break the power principle—in others. We must begin by breaking it in ourselves. Then the thing becomes credible. We should listen to the voice of nature that speaks to us from the

unconscious. Then everyone will be so preoccupied with himself that he will give up trying to put the world to rights.

[47] The layman may feel somewhat astonished that I have included these general problems in my discussion of a psychological concept. They are not a digression from my theme, as might appear, but are an essential part of it. The question of the relations between conscious and unconscious is not a special question, but one which is bound up in the most intimate way with our history, with the present time, and with our view of the world. Very many things are unconscious for us only because our view of the world allows them no room; because by education and training we have never come to grips with them, and, whenever they came to consciousness as occasional fantasies, have instantly suppressed them. The borderline between conscious and unconscious is in large measure determined by our view of the world. That is why we must talk about general problems if we wish to deal adequately with the concept of the unconscious. And if we are to grasp its nature, we must concern ourselves not only with contemporary problems, but also with the history of the human mind.

[48] This preoccupation with the unconscious is a problem of practical as well as theoretical importance. For just as our view of the world up till now has been a decisive factor in the shaping of the unconscious and its contents, so the remoulding of our views in accordance with the active forces of the unconscious is laid upon us as a practical necessity. It is impossible to cure a neurosis permanently with individual nostrums, for man cannot exist merely as an isolated individual outside the human community. The principle on which he builds his life must be one that is generally acceptable, otherwise it will lack that natural morality which is indispensable to man as a member of the herd. But such a principle, if it is not left in the darkness of the unconscious, becomes a formulated view of the world which is felt as a necessity by all who are in the habit of consciously scrutinizing their thoughts and actions. This may explain why I have touched on questions each one of which would need for its full presentation more than one head and more than one lifetime.

MIND AND EARTH¹

[49] The phrase “mind and earth” has a slightly poetic ring. Involuntarily we think, by contrast, of the mind² as subject to the influences of heaven, in much the same way as the Chinese distinguish between a *shen*-soul and a *kwei*-soul, the one relating to heaven, the other to earth. But since we Westerners know nothing about the substance of the mind, and therefore cannot venture to say whether it has in it something of a heavenly nature and something of an earthly nature, we must be content to speak of two different ways of viewing, or two different aspects of, the complicated phenomenon we call mind. Instead of postulating a heavenly *shen*-soul, we could regard mind as a causeless and creative principle; and instead of a *kwei*-soul, mind could be conceived as a product of cause and effect. The latter point of view would be the more appropriate in regard to our theme, for mind would then be understood as a *system of adaptation determined by the conditions of an earthly environment*. I need hardly emphasize that this causal view must necessarily be one-sided, because only one aspect of the mind is properly grasped by it. The other side of the problem must be left out of account as not belonging to my theme.

[50] In approaching the subject of our discussion, it would be as well to define accurately what is to be understood by “mind.” Certain views would limit “mental” or “psychic” strictly to consciousness. But such a limitation would no longer satisfy us today. Modern psychopathology has in its possession a wealth of observations regarding psychic activities that are entirely analogous to conscious functions and yet are unconscious. One can perceive, think, feel, remember, decide, and act, unconsciously. Everything that happens in consciousness can under certain conditions also occur unconsciously. How this is possible can best be seen if one pictures the psychic functions and contents as a night landscape over which the beam of a searchlight is playing. Whatever appears in this light of perception is conscious; what lies in the darkness beyond is unconscious, though none the less real and effective. If the beam of light shifts, the contents that till now were conscious sink into the unconscious, and new contents come into the lighted area of consciousness. The contents that have vanished in the darkness continue to be active and make themselves felt indirectly, most commonly as symptoms. Freud has described these symptomatic disturbances in *The Psychopathology of Everyday Life*. The unconscious aptitudes and inhibitions can also be demonstrated experimentally, by means of association tests.

[51] If, then, we take the investigations of psychopathology into account, the mind appears as an extended area of psychic phenomena which are partly conscious and partly unconscious. The unconscious portion of the mind is not directly accessible—otherwise it would not be unconscious—but can only be inferred from the effects which unconscious processes have on consciousness. Our inferences can never go beyond an “as if.”

[52] Here I must go rather more closely into the nature and structure of the unconscious if I am to deal adequately with the conditioning of the mind by the earth. It is a question that concerns the very beginnings and foundations of the mind—things that from time immemorial have lain buried in the darkness, and not merely the banal facts of sense-perception and conscious adaptation to the environment. These belong to the psychology of consciousness, and, as I have said, I do not equate consciousness with the psyche. The latter is a much more comprehensive and darker field of experience than the narrow, brightly lit area of consciousness, for the psyche also includes the unconscious.

[53] In another essay³ I tried to give a general view of the structure of the unconscious. Its contents, the archetypes, are as it were the hidden foundations of the conscious mind, or, to use another comparison, the roots which the psyche has sunk not only in the earth in the narrower sense but in the world in general. Archetypes are systems of readiness for action, and at the same time images and emotions. They are inherited with the brain-structure—indeed, they are its psychic aspect. They represent, on the one hand, a very strong instinctive conservatism, while on the other hand they are the most effective means conceivable of instinctive adaptation. They are thus, essentially, the chthonic portion of the psyche, if we may use such an expression—that portion through which the psyche is attached to nature, or in which its link with the earth and the world appears at its most tangible. The psychic influence of the earth and its laws is seen most clearly in these primordial images.

[54] This problem is not only very complicated but also a very subtle one. We shall have to reckon with quite unusual difficulties in dealing with it, and the first of these is that the archetype and its function must be understood far more as a part of man's prehistoric, irrational psychology than as a rationally conceivable system. Perhaps I may be allowed a comparison: it is as though we had to describe and explain a building whose upper storey was erected in the nineteenth century, the ground floor dates back to the sixteenth century, and careful examination of the masonry reveals that it was reconstructed from a tower built in the eleventh century. In the cellar we come upon Roman foundations, and under the cellar a choked-up cave with neolithic tools in the upper layer and remnants of fauna from the same period in the lower layers. That would be the picture of our psychic structure. We live on the upper

storey and are only aware that the lower storey is slightly old-fashioned. As to what lies beneath the earth's surface, of that we remain totally unconscious.

[55] This is a lame analogy, like all analogies, for in the psyche there is nothing that is just a dead relic. Everything is alive, and our upper storey, consciousness, is continually influenced by its living and active foundations. Like the building, it is sustained and supported by them. And just as the building rises freely above the earth, so our consciousness stands as if above the earth in space, with a wide prospect before it. But the deeper we descend into the house the narrower the horizon becomes, and the more we find ourselves in the darkness, till finally we reach the naked bed-rock, and with it that prehistoric time when reindeer hunters fought for a bare and wretched existence against the elemental forces of wild nature. The men of that age were still in full possession of their animal instincts, without which life would have been impossible. The free sway of instinct is not compatible with a strongly developed consciousness. The consciousness of primitive man, like that of the child, is sporadic, and his world, like the child's, is very limited. Indeed, in accordance with phylogenetic law, we still recapitulate in childhood reminiscences of the prehistory of the race and of mankind in general. Phylogenetically as well as ontogenetically we have grown up out of the dark confines of the earth; hence the factors that affected us most closely became archetypes, and it is these primordial images which influence us most directly, and therefore seem to be the most powerful. I say "seem" because what seems to us the most important thing psychically is not necessarily the most important, or at least need not remain so.

[56] What, then, are the most immediate archetypes? This question leads us straight to the problem of archetypal functioning, and so to the heart of the difficulty. From what standpoint should we answer the question? From that of the child, or of the primitive, or of our adult modern consciousness? How can we recognize an archetype? And when is it necessary to have recourse to this hypothesis at all?

[57] *I would like to suggest that every psychic reaction which is out of proportion to its precipitating cause should be investigated as to whether it may be conditioned at the same time by an archetype.*⁴

[58] What I mean by this can best be illustrated by an example. Suppose a child is afraid of its mother. We have first to assure ourselves that there is no rational cause for this, a bad conscience, for instance, on the child's part, or violence on the mother's, or something else that may have happened to the child. If there is nothing of this kind to explain the fear, then I would suggest that the situation be regarded as an archetypal one. Usually such fears occur at night, and are wont to show themselves in dreams. The child now dreams of the mother as a witch who pursues children. The conscious material behind these dreams is in some cases the story of

Hänsel and Gretel. It is then said that the child should not have been told such a fairytale, because the tale is thought to be the cause of the fear. That is an erroneous rationalization, but it nevertheless contains a core of truth in so far as the witch-motif is the most suitable expression for childish fears, and always has been. That is why such fairytales exist. Children's night-terrors are a typical event that is constantly repeating itself and has always been expressed in typical fairytale motifs.

[59] But fairytales are only infantile forms of legends, myths, and superstitions taken from the "night religion" of primitives. What I call "night religion" is the magical form of religion, the meaning and purpose of which is intercourse with the dark powers, devils, witches, magicians, and spirits. Just as the childish fairytale is a phylogenetic repetition of the ancient night religion, so the childish fear is a re-enactment of primitive psychology, a phylogenetic relic.

[60] The fact that this relic displays a certain vitality is in no sense abnormal, for nocturnal fears, even in adults living under civilized conditions, are not necessarily an abnormal phenomenon. Only an intensified degree of night-fear can be regarded as abnormal. The question then is, under what circumstances is this night-fear increased? Can the increase be explained solely by the archetype of the witch expressed in the fairytale, or must some other explanatory cause be adduced?

[61] We should make the archetype responsible only for a definite, minimal, normal degree of fear; any pronounced increase, felt to be abnormal, must have special causes. Freud, as we know, explains this fear as due to the collision of the child's incestuous tendency with the incest prohibition. He thus explains it from the standpoint of the child. I have no doubt that children can have "incestuous" tendencies in the extended sense used by Freud, but I doubt very much whether these tendencies can be attributed without more ado to the child's psychology *sui generis*. There are very good reasons for the view that the child-psyche is still under the spell of the parents' psyche, especially the mother's, and to such a degree that the psyche of the child must be regarded as a functional appendage of that of the parents. The psychic individuality of the child develops only later, after a reliable continuity of consciousness has been established. The fact that the child begins by speaking of himself in the third person is in my view a clear proof of the impersonality of his psychology.

[62] I am therefore inclined to explain the possible incestuous tendencies of the child rather from the standpoint of the psychology of the parents, just as every childish neurosis should be considered first and foremost in the light of the parental psychology. Thus, a frequent cause of increased infantile terrors is an especial "complex-proneness" on the part of the parents, that is, their repression and disregard of certain vital problems. Anything that falls into the unconscious takes on a more or

less archaic form. If, for example, the mother represses a painful and terrifying complex, she will feel it as an evil spirit pursuing her—a “skeleton in the cupboard,” as the English say. This formulation shows that the complex has already acquired archetypal force. It sits on her like an incubus, she is tormented by nightmares. Whether she tells “nightmare-stories” to the child or not, she none the less infects the child and awakens in its mind archetypal terror images from her own psychology. Perhaps she has erotic fantasies about a man other than her husband. The child is the visible sign of their marriage tie, and her resistance to the tie is unconsciously directed against the child, who has to be repudiated. On the archaic level this corresponds to child-murder. In this way the mother becomes a wicked witch who devours children.

[63] As in the mother, so in the child the possibilities of archaic representation lie dormant, and the same cause which first produced and laid down the archetype during the course of human history reactivates it again and again today.

[64] This example of the manifestation of an archetype in a child has not been chosen at random. We began with the question of what are the most immediate archetypes. The most immediate is the primordial image of the mother; she is in every way the nearest and most powerful experience, and the one which occurs during the most impressionable period of man’s life. Since consciousness is as yet only poorly developed in childhood, one cannot speak of an “individual” experience at all. On the contrary, the mother is an archetypal experience; she is experienced by the more or less unconscious child not as a definite, individual feminine personality but as *the* mother, an archetype charged with an immensity of possible meanings. As life proceeds the primordial image fades and is replaced by a conscious, relatively individual image, which is assumed to be the only mother-image we have. But in the unconscious the mother always remains a powerful primordial image, colouring and even determining throughout life our relations to woman, to society, to the world of feeling and fact, yet in so subtle a way that, as a rule, there is no conscious perception of the process. We think all this is only a metaphor. But it becomes a very concrete fact when a man marries a wife only because in some way she resembles his mother, or else because she very definitely does not. Mother Germania is for the Germans, like *la douce France* for the French, a figure of the utmost importance behind the political scene, who could be overlooked only by blinkered intellectuals. The all-embracing womb of Mother Church is anything but a metaphor, and the same is true of Mother Earth, Mother Nature, and “matter” in general.

[65] The archetype of the mother is the most immediate one for the child. But with the development of consciousness the father also enters his field of vision, and activates an archetype whose nature is in many respects opposed to that of the mother. Just as

the mother archetype corresponds to the Chinese *yin*, so the father archetype corresponds to the *yang*. It determines our relations to man, to the law and the state, to reason and the spirit and the dynamism of nature. “Fatherland” implies boundaries, a definite localization in space, whereas the land itself is Mother Earth, quiescent and fruitful. The Rhine is a father, as is the Nile, the wind and storm, thunder and lightning. The father is the “auctor” and represents authority, hence also law and the state. He is that which moves in the world, like the wind; the guide and creator of invisible thoughts and airy images. He is the creative wind-breath—the spirit, *pneuma*, *atman*.

[66] Thus the father, too, is a powerful archetype dwelling in the psyche of the child. At first he is *the* father, an all-encompassing God-image, a dynamic principle. In the course of life this authoritarian imago recedes into the background: the father turns into a limited and often all-too-human personality. The father-imago, on the other hand, develops to the full its potential significance. Just as man was late in discovering nature, so he only gradually discovered law, duty, responsibility, the state, the spirit. As the nascent consciousness becomes more capable of understanding, the importance of the parental personality dwindles. The place of the father is taken by the society of men, and the place of the mother by the family.

[67] It would be wrong, in my view, to say that all those things which take the place of the parents are nothing but a substitute for the unavoidable loss of the primordial parental imagos. What appears in their stead is not just a substitute, but a reality that is interwoven with the parents and has impressed itself on the mind of the child through the parental imago. The mother who gives warmth, protection, and nourishment is also the hearth, the sheltering cave or hut, and the surrounding vegetation. She is the provident field, and her son is the godlike grain, the brother and friend of man. She is the milk-giving cow and the herd. The father goes about, talks with other men, hunts, travels, makes war, lets his bad moods loose like thunderstorms, and at the behest of invisible thoughts he suddenly changes the whole situation like a tempest. He is the war and the weapon, the cause of all changes; he is the bull provoked to violence or prone to apathetic laziness. He is the image of all the helpful or harmful elemental powers.

[68] All these things are the early immediacies of the child’s life, impinging on him, directly or indirectly, through the parents. And as the parental imago shrinks and becomes humanized, all those things, which at first seemed only like a background or like marginal effects, begin to stand out more clearly. The earth he plays with, the fire he warms himself at, the rain and wind that chill him, were always realities, but because of his twilight consciousness they were seen and understood only as qualities of the parents. Then, as out of a mist, there emerge the material and dynamic aspects

of the earth, revealing themselves as powers in their own right, and no longer wearing the masks of the parents. They are thus not a substitute but a reality that corresponds to a higher level of consciousness.

[69] Nevertheless something is lost in this development, and that is the irreplaceable feeling of immediate oneness with the parents. This feeling is not just a sentiment, but an important psychological fact which Lévy-Bruhl, in an altogether different context, has called *participation mystique*. The fact denoted by this not immediately understandable expression plays a great role in the psychology of primitives as well as in analytical psychology. To put it briefly, it means *a state of identity in mutual unconsciousness*. Perhaps I should explain this further. If the same unconscious complex is constellated in two people at the same time, it produces a remarkable emotional effect, a projection, which causes either a mutual attraction or a mutual repulsion. When I and another person have an unconscious relation to the same important fact, I become in part identical with him, and because of this I orient myself to him as I would to the complex in question were I conscious of it.

[70] This state of *participation mystique* obtains between parents and children. A well-known example is the stepmother who identifies herself with the daughter and, through her, marries the son-in-law; or the father who thinks he is considering his son's welfare when he naïvely forces him to fulfil his—the father's—wishes, for instance in marriage or in the choice of a profession. The son who identifies himself with the father is an equally well-known figure. But there is an especially close bond between mother and daughter, which in certain cases can actually be demonstrated by the association method.⁵ Although the *participation mystique* is an unconscious fact to the person concerned, he nevertheless feels the change when it no longer exists. There is always a certain difference between the psychology of a man whose father is still living and one whose father is dead. So long as a *participation mystique* with the parents persists, a relatively infantile style of life can be maintained. Through the *participation mystique* life is pumped into us from outside in the form of unconscious motivations, for which, since they are unconscious, no responsibility is felt. Because of this infantile unconsciousness the burden of life is lightened, or at least seems so. One is not alone, but exists unconsciously in twos or threes. In imagination the son is in his mother's lap, protected by the father. The father is reborn in the son—at least as a link in the chain of eternal life. The mother has rejuvenated her father in her youthful husband and so has not lost her youth. I need not cite examples from primitive psychology. A reference to them must suffice.

[71] All this drops away with the broadening and intensification of consciousness. The resultant extension of the parental imagos over the face of the world, or rather, the world's breaking through the mists of childhood, severs the unconscious union with

the parents. This process is even performed consciously in the primitive rites of initiation into manhood. The archetype of the parents is thereby driven into the background; it is, as we say, no longer “constellated.” Instead, a new kind of *participation mystique* begins with the tribe, society, Church, or nation. This participation is general and impersonal, and above all it gives unconsciousness very little scope. If anyone should incline to be too unconscious and too guilelessly trusting, law and society will quickly shake him into consciousness. But sexual maturity also brings with it the possibility of a new personal *participation mystique*, and hence of replacing that part of the personality which was lost in identification with the parents. A new archetype is constellated: in a man it is the archetype of woman, and in a woman the archetype of man. These two figures were likewise hidden behind the mask of the parental imagos, but now they step forth undisguised, even though strongly influenced by the parental imagos, often overwhelmingly so. I have given the feminine archetype in man the name “anima,” and the masculine archetype in woman the name “animus,” for specific reasons which I shall discuss later.⁶

[72] The more a man or woman is unconsciously influenced by the parental imago, the more surely will the figure of the loved one be chosen as either a positive or a negative substitute for the parents. The far-reaching influence of the parental imago should not be considered abnormal; on the contrary, it is a very normal and therefore very common phenomenon. It is, indeed, very important that this should be so, for otherwise the parents are not reborn in the children, and the parental imago becomes so completely lost that all continuity in the life of the individual ceases. He cannot connect his childhood with his adult life, and therefore remains unconsciously a child—a situation that is the best possible foundation for a neurosis. He will then suffer from all those ills that beset parvenus without a history, be they individuals or social groups.

[73] It is normal that children should in a certain sense marry their parents. This is just as important, psychologically, as the biological necessity to infuse new blood if the ancestral tree is to produce a good breed. It guarantees continuity, a reasonable prolongation of the past into the present. Only too much or too little in this direction is harmful.

[74] So long as a positive or negative resemblance to the parents is the deciding factor in a love choice, the release from the parental imago, and hence from childhood, is not complete. Although childhood has to be brought along for the sake of historical continuity, this should not be at the expense of further development. When, towards middle life, the last gleam of childhood illusion fades—this it must be owned is true only of an almost ideal life, for many go as children to their graves—then the

archetype of the mature man or woman emerges from the parental imago: an image of man as woman has known him from the beginning of time, and an image of woman that man carries within him eternally.

[75] There are indeed many men who can describe exactly, even to individual details, the image of woman that they carry in their minds. (I have met few women who could give as exact a picture of the masculine archetype.) Just as the primordial image of the mother is a composite image of all previous mothers, so the image of the anima is a supra-individual image. So true is this that the image reveals closely corresponding features in men who are individually very different, and one can almost reconstruct from it a definite type of woman. The most striking feature about the anima-type is that the maternal element is entirely lacking. She is the companion and friend in her favourable aspect, in her unfavourable aspect she is the courtesan. Often these types are described very accurately, with all their human and daemonic qualities, in fantastic romances, such as Rider Haggard's *She* and *Wisdom's Daughter*, Benoît's *L'Atlantide*, and, fragmentarily, in the second part of *Faust*, in the figure of Helen. But the anima-type is presented in the most succinct and pregnant form in the Gnostic legend of Simon Magus, a caricature of whom appears in the Acts of the Apostles.⁷ Simon Magus was always accompanied on his travels by a girl, whose name was Helen. He had found her in a brothel in Tyre; she was a reincarnation of Helen of Troy. I do not know whether Goethe's Faust-Helen motif was consciously derived from the Simon legend. A similar relationship occurs in Rider Haggard's *Wisdom's Daughter*, where we can be certain that there was no conscious continuity.

[76] The absence of the maternal element demonstrates, on the one hand, the complete release from the mother-imago, and, on the other, the idea of a purely human relationship lacking the natural incentive of procreation. The overwhelming majority of men on the present cultural level never advance beyond the maternal significance of woman, and this is the reason why the anima seldom develops beyond the infantile, primitive level of the prostitute. Consequently, prostitution is one of the main by-products of civilized marriage. In the legend of Simon, however, and in the second part of *Faust* anima symbols of complete maturity are found. This growth of adulthood is synonymous with growth away from nature. Christian and Buddhist monastic ideals grappled with the same problem, but always the flesh was sacrificed. Goddesses and demigoddesses took the place of the personal, human woman who should carry the projection of the anima.

[77] Here we touch on highly controversial territory into which I do not wish to venture further at this point. We shall do better to return to the simpler problem of how we can recognize the existence of such a feminine archetype.

[78] As long as an archetype is not projected and not loved or hated in an object, it is still wholly identical with the individual, who is thus compelled to act it out himself. A man will then act out his own anima. We have a word that aptly characterizes this attitude: it is “animosity.” This expression can best be interpreted as “anima possession,” denoting a condition of uncontrolled emotion. The word “animosity” is used only for unpleasant emotions, but actually the anima can induce pleasant ones as well.⁸

[79] Self-control is a typically masculine ideal, to be achieved by the repression of feeling. Feeling is a specifically feminine virtue, and because a man in trying to attain his ideal of manhood represses all feminine traits—which are really part of him, just as masculine traits are part of a woman’s psychology—he also represses certain emotions as womanish weakness. In so doing he piles up effeminacy or sentimentality in the unconscious, and this, when it breaks out, betrays in him the existence of a feminine being. As we know, it is just the “he-men” who are most at the mercy of their feminine feelings. This might explain the very much greater number of suicides among men, and, conversely, the extraordinary strength and toughness often developed by very feminine women. If we carefully examine the uncontrolled emotions of a man and try to reconstruct the probable personality underlying them, we soon arrive at a feminine figure which I call, as I said, the anima. On the same ground the ancients conceived of a feminine soul, a “psyche” or “anima,” and not without good psychological reasons did the ecclesiastics of the Middle Ages propound the question, *Habet mulier animam?*

[80] With women the case is reversed. When the animus breaks out in a woman, it is not feelings that appear, as in a man, but she begins to argue and to rationalize. And just as his anima-feelings are arbitrary and capricious, so these feminine arguments are illogical and irrational. One can speak of an animus-thinking that is always right and must have the last word, and always end up with “That’s just the reason!” If the anima is irrational feeling, the animus is irrational thinking.

[81] So far as my experience goes, a man always understands fairly easily what is meant by the anima; indeed, as I said, he frequently has a quite definite picture of her, so that from a varied collection of women of all periods he can single out the one who comes closest to the anima-type. But I have, as a rule, found it very difficult to make a woman understand what the animus is, and I have never met any woman who could tell me anything definite about his personality. From this I conclude that the animus does not have a definite personality at all; in other words, he is not so much a unity as a plurality. This fact must somehow be connected with the specific psychology of men and women. On the biological level a woman’s chief interest is to hold a man, while a man’s chief interest is to conquer a woman, and because of his

nature he seldom stops at one conquest. Thus one masculine personality plays a decisive role for a woman, but a man's relation to a woman is much less definite, as he can look on his wife as one among many women. This makes him lay stress on the legal and social character of marriage, whereas a woman sees it as an exclusively personal relationship. Hence, as a rule, a woman's consciousness is restricted to one man, whereas a man's consciousness has a tendency to go beyond the one personal relationship—a tendency that is sometimes opposed to any personal limitations. In the unconscious, therefore, we may expect a compensation by contraries. The man's sharply defined anima figure fulfils this expectation perfectly, as also does the indefinite polymorphism of the woman's animus.

[82] The description of anima and animus that I have given here is necessarily a brief one. But I should be carrying brevity too far if I described the anima merely as a primordial image of woman consisting of irrational feelings, and the animus merely as a primordial image of man consisting of irrational views. Both figures present far-reaching problems, since they are elementary forms of that psychic phenomenon which from primitive times has been called the "soul." They are also the cause of that deep human need to speak of souls or daemons at all.

[83] Nothing that is autonomous in the psyche is impersonal or neutral. Impersonality is a category pertaining to consciousness. All autonomous psychic factors have the character of personality, from the "voices" of the insane to the control-spirits of mediums and the visions of the mystics. Anima and animus, likewise, have a personality character, and this cannot be better expressed than by the word "soul."

[84] Here I would like to guard against a misunderstanding. The concept of "soul" which I am now using can be compared more with the primitive idea of the soul, for instance the *ba*-soul and *ka*-soul of the Egyptians, than with the Christian idea of it, which is an attempt to make a philosophical construct out of a metaphysical individual substance. My conception of the soul has absolutely nothing to do with this, since it is purely phenomenological. I am not indulging in any psychological mysticism, but am simply trying to grasp scientifically the elementary psychic phenomena which underlie the belief in souls.

[85] Since the complex of facts represented by anima and animus best corresponds to what has been described as soul at all times and by all peoples, it is hardly surprising that they bring an uncommonly mystical atmosphere along with them as soon as one tries to examine their contents more closely. Whenever the anima is projected, she immediately surrounds herself with a peculiar historical feeling which Goethe expressed in the words: "In times gone by you were my wife or sister."⁹ Rider Haggard and Benoît had to go back to Greece and Egypt in order to give expression to this insistent historical feeling.

- [86] Curiously enough, the animus seems to be lacking in this mystical sense of history. I would almost say that he is more concerned with the present and the future. He has nomothetical proclivities, preferring to speak grandiosely of things as they should be, or to give an apodictic judgment on the most obscure and controversial matters, and in such positive terms that the woman is relieved of all further (and possibly all too painful) reflection.
- [87] Once again, I can only explain this difference as a compensation by contraries. A man, in his conscious activity, plans ahead and seeks to create the future, while it is a specifically feminine trait to rack one's brains over such questions as who was somebody's great-great-aunt. But it is just this feminine passion for genealogies that comes out very clearly in Rider Haggard, garnished with Anglo-Saxon sentiment, and in Benoît the same thing is served up with the spicy admixture of a *chronique scandaleuse*. Intimations of reincarnation in the form of irrational feelings hang very strongly about a man's anima, while a woman will sometimes consciously admit such feelings if she is not too much under the domination of the man's rationalism.
- [88] This historical feeling always has the quality of momentousness and fatefulness, and therefore leads directly to the problems of immortality and divinity. Even the rationalistic, sceptical Benoît describes those who have died of love as being preserved for all eternity by a peculiarly effective method of mummification, not to mention the full-blown mysticism of Rider Haggard in *Ayesha: The Return of She*—altogether a psychological document of the first rank.
- [89] The animus, not having these emotional qualities, seems to lack entirely the aspect I have been describing, yet in his deepest essence he is just as historically-minded as the anima. Unfortunately there are no good literary examples of the animus. Women writers seem to be deficient in a certain naïve introspection, or at least they prefer to keep the results of their introspection in another compartment, possibly because no feeling is connected with it. I know of only one unprejudiced document of this sort, a novel by Marie Hay, *The Evil Vineyard*. In this very unpretentious story the historical element in the animus comes out in a clever disguise that was surely not intended by the author.
- [90] The animus consists of *a priori* assumptions based on unconsidered judgments. The existence of such judgments can only be inferred from the woman's conscious attitude to certain things. I must give you an example. A woman I knew surrounded her son with the most solemn care and lent him an importance he in no way deserved, with the result that soon after puberty he became neurotic. The reason for her senseless attitude was not at first discernible. Closer investigation, however, revealed the existence of an unconscious dogma that said: My son is the coming Messiah. This is a very ordinary instance of the widespread hero-archetype in women, which is

projected on the father or the husband or the son, in the form of an opinion which then unconsciously regulates the woman's behaviour. A well-known example is Annie Besant, who also discovered a saviour.

[91] In Marie Hay's novel the heroine drives her husband insane by her attitude which is based on the unconscious and unspoken assumption that he is a horrible tyrant who holds her captive in much the same way as ... The uncompleted simile she left to the interpretation of her husband, who finally discovered the appropriate figure for it in a *cinquecento* tyrant with whom he identified himself, and lost his reason in consequence. The historical factor, therefore, is by no means lacking to the animus. But it expresses itself in a way fundamentally different from that of the anima. Similarly, in the religious problems connected with the animus the judging faculties predominate, just as the feeling faculties do in the case of a man.

[92] Finally, I would like to remark that the anima and animus are not the only autonomous figures or "souls" in the unconscious, though in practice they are the most immediate and most important. But, since I would like to touch on still another aspect of the problem of mind and earth, perhaps I may leave this difficult field of extremely subtle inward experience and turn to that other side where we shall no longer grope laboriously in the dark background of the mind, but pass into the wide world of everyday things.

[93] Just as, in the process of evolution, the mind has been moulded by earthly conditions, so the same process repeats itself under our eyes today. Imagine a large section of some European nation transplanted to a strange soil and another climate. We can confidently expect this human group to undergo certain psychic and perhaps also physical changes in the course of a few generations, even without the admixture of foreign blood. We can observe in the Jews of the various European countries marked differences which can only be explained by the peculiarities of the people they live amongst. It is not difficult to tell a Spanish Jew from a North African Jew, a German Jew from a Russian Jew. One can even distinguish the various types of Russian Jew, the Polish from the North Russian and Cossack type. In spite of the similarity of race, there are pronounced differences whose cause is obscure. It is extremely hard to define these differences exactly, though a student of human nature feels them at once.

[94] The greatest experiment in the transplantation of a race in modern times was the colonization of the North American continent by a predominantly Germanic population. As the climatic conditions vary very widely, we would expect all sorts of variations of the original racial type. The admixture of Indian blood is increasingly small, so it plays no role. Boas has shown that anatomical changes begin already in the second generation of immigrants, chiefly in the measurements of the skull. At all

events the “Yankee” type is formed, and this is so similar to the Indian type that on my first visit to the Middle West,¹⁰ while watching a stream of workers coming out of a factory, I remarked to my companion that I should never have thought there was such a high percentage of Indian blood. He answered, laughing, that he was willing to bet that in all these hundreds of men there would not be found a drop of Indian blood. That was many years ago when I had no notion of the mysterious Indianization of the American people. I got to know of this mystery only when I had to treat many American patients analytically. Remarkable differences were revealed in comparison with Europeans.

[95] Another thing that struck me was the great influence of the Negro, a psychological influence naturally, not due to the mixing of blood. The emotional way an American expresses himself, especially the way he laughs, can best be studied in the illustrated supplements of the American papers; the inimitable Teddy Roosevelt laugh is found in its primordial form in the American Negro. The peculiar walk with loose joints, or the swinging of the hips so frequently observed in Americans, also comes from the Negro. American music draws its main inspiration from the Negro, and so does the dance. The expression of religious feeling, the revival meetings, the Holy Rollers and other abnormalities are strongly influenced by the Negro, and the famous American naïveté, in its charming as well as its more unpleasant form, invites comparison with the childlikeness of the Negro. The vivacity of the average American, which shows itself not only at baseball games but quite particularly in his extraordinary love of talking—the ceaseless gabble of American papers is an eloquent example of this—is scarcely to be derived from his Germanic forefathers, but is far more like the chattering of a Negro village. The almost total lack of privacy and the all-devouring mass sociability remind one of primitive life in open huts, where there is complete identity with all members of the tribe. It seemed to me that American houses had their doors open all the time, just as there are no hedges round the gardens in American towns and villages. Everything seems to be street.

[96] It is naturally very difficult to decide how much of all this is due to symbiosis with the Negro, and how much to the fact that America is still a pioneering nation on virgin soil. But taken all in all, the wide influence of the Negro on the general character of the people is unmistakable.

[97] This infection by the primitive can, of course, be observed just as well in other countries, though not to the same degree and in this form. In Africa, for example, the white man is a diminishing minority and must therefore protect himself from the Negro by observing the most rigorous social forms, otherwise he risks “going black.” If he succumbs to the primitive influence he is lost. But in America the Negro, just because he is in a minority, is not a degenerative influence, but rather one which,

peculiar though it is, cannot be termed unfavourable—unless one happens to have a jazz phobia.

[98] The remarkable thing is that one notices little or nothing of the Indian influence. The above-mentioned physiognomical similarities do not point to Africa but are specifically American. Does the body react to America, and the psyche to Africa? I must answer this question by saying that only the outward behaviour is influenced by the Negro, but what goes on in the psyche must be the subject of further investigation.

[99] It is natural that in the dreams of my American patients the Negro should play no small role as an expression of the inferior side of their personality. A European might similarly dream of tramps or other representatives of the lower classes. But as the great majority of dreams, especially those in the early stages of analysis, are superficial, it was only in the course of very thorough and deep analyses that I came upon symbols relating to the Indian. The progressive tendency of the unconscious, as expressed for instance in the hero-motif, chooses the Indian as its symbol, just as certain coins of the Union bear an Indian head. This is a tribute to the once-hated Indian, but it also testifies to the fact that the American hero-motif chooses the Indian as an ideal figure. It would certainly never occur to any American administration to place the head of Cetewayo or any other Negro hero on their coins. Monarchies prefer the head of the sovereign, democratic states honour other symbols of their ideals. I have given a detailed example of a similar American hero-fantasy in my book *Symbols of Transformation*, and I could add dozens of others.

[100] The hero is always the embodiment of man's highest and most powerful aspiration, or of what this aspiration ought ideally to be and what he would most gladly realize. It is therefore of importance what kind of fantasy constitutes the hero-motif. In the American hero-fantasy the Indian's character plays a leading role. The American conception of sport goes far beyond the notions of the easy-going European; only the Indian rites of initiation can compare with the ruthlessness and savagery of a rigorous American training. The performance of American athletes is therefore admirable. In everything on which the American has really set his heart we catch a glimpse of the Indian. His extraordinary concentration on a particular goal, his tenacity of purpose, his unflinching endurance of the greatest hardships—in all this the legendary virtues of the Indian find full expression.¹¹

[101] The hero-motif affects not only the general attitude to life but also the problems of religion. Any absolutist attitude is always a religious attitude, and in whatever respect a man becomes absolute, there you see his religion. I have found in my American patients that their hero-figure possesses traits derived from the religion of the Indians. The most important figure in their religion is the shaman, the medicine-

man or conjurer of spirits. The first American discovery in this field—since taken up in Europe—was spiritualism, and the second was Christian Science and other forms of mental healing. Christian Science is an exorcistic ritual. The demons of sickness are denied, suitable incantations are sung over the refractory body, and Christianity, the product of a high level of culture, is used as healing-magic. Though the poverty of its spiritual content is appalling, Christian Science is a living force; it possesses a strength derived from the soil, and can therefore work those miracles that are sought for in vain in the official churches.

[102] There is no country on earth where the “power-word,” the magic formula, the slogan or advertisement is more effective than in America. We Europeans laugh about this, but we forget that faith in the magical power of the word can move more than mountains. Christ himself was a word, the Word. We have become estranged from this psychology, but in the American it is still alive. It has yet to be seen what America will do with it.

[103] Thus the American presents a strange picture: a European with Negro behaviour and an Indian soul. He shares the fate of all usurpers of foreign soil. Certain Australian primitives assert that one cannot conquer foreign soil, because in it there dwell strange ancestor-spirits who reincarnate themselves in the newborn. There is a great psychological truth in this. The foreign land assimilates its conqueror. But unlike the Latin conquerors of Central and South America, the North Americans preserved their European standards with the most rigid puritanism, though they could not prevent the souls of their Indian foes from becoming theirs. Everywhere the virgin earth causes at least the unconscious of the conqueror to sink to the level of its indigenous inhabitants. Thus, in the American, there is a discrepancy between conscious and unconscious that is not found in the European, a tension between an extremely high conscious level of culture and an unconscious primitivity. This tension forms a psychic potential which endows the American with an indomitable spirit of enterprise and an enviable enthusiasm which we in Europe do not know. The very fact that we still have our ancestral spirits, and that for us everything is steeped in history, keeps us in contact with our unconscious, but we are so caught in this contact and held so fast in the historical vice that the greatest catastrophes are needed in order to wrench us loose and to change our political behaviour from what it was five hundred years ago. Our contact with the unconscious chains us to the earth and makes it hard for us to move, and this is certainly no advantage when it comes to progressiveness and all the other desirable motions of the mind. Nevertheless I would not speak ill of our relation to good Mother Earth. *Plurimi pertransibunt*—but he who is rooted in the soil endures. Alienation from the unconscious and from its historical conditions spells rootlessness. That is the danger that lies in wait for the conqueror of foreign lands, and for every individual who, through one-sided

allegiance to any kind of -ism, loses touch with the dark, maternal, earthy ground of his being.

ARCHAIC MAN¹

[104] The word “archaic” means primal, original. While it is one of the most difficult and thankless of tasks to say anything of importance about the civilized man of today, we are apparently in a more favourable position when it comes to archaic man. In the first case, the speaker finds himself caught in the same presuppositions and is blinded by the same prejudices as those whom he wishes to view from a superior standpoint. In the case of archaic man, however, we are far removed from his world in time, our mental equipment, being more differentiated, is superior to his, so that from this more elevated coign of vantage it is possible for us to survey his world and the meaning it held for him.

[105] With this sentence I have set limits to the subject to be covered in my lecture. Unless I restricted myself to the psychic life of archaic man, I could hardly paint a sufficiently comprehensive picture of him in so small a space. I should like to confine myself to this picture, and shall say nothing about the findings of anthropology. When we speak of man in general, we do not have his anatomy, the shape of his skull, or the colour of his skin in mind, but mean rather his psychic world, his state of consciousness, and his mode of life. Since all this belongs to the subject-matter of psychology, we shall be dealing here chiefly with the psychology of archaic man and with the primitive mentality. Despite this limitation we shall find we have actually widened our theme, because it is not only primitive man whose psychology is archaic. It is the psychology also of modern, civilized man, and not merely of individual “throw-backs” in modern society. On the contrary, every civilized human being, however high his conscious development, is still an archaic man at the deeper levels of his psyche. Just as the human body connects us with the mammals and displays numerous vestiges of earlier evolutionary stages going back even to the reptilian age, so the human psyche is a product of evolution which, when followed back to its origins, shows countless archaic traits.

[106] When we first come into contact with primitive peoples or read about primitive psychology in scientific works, we cannot fail to be deeply impressed with the strangeness of archaic man. Lévy-Bruhl himself, an authority in the field of primitive psychology, never wearies of emphasizing the striking difference between the “prelogical” state of mind and our own conscious outlook. It seems to him, as a civilized man, inexplicable that the primitive should disregard the obvious lessons of experience, should flatly deny the most evident causal connections, and instead of accounting for things as simply due to chance or on reasonable grounds of causality,

should take his “collective representations” as being intrinsically valid. By “collective representations” Lévy-Bruhl means widely current ideas whose truth is held to be self-evident from the start, such as the primitive ideas concerning spirits, witchcraft, the power of medicines, and so forth. While it is perfectly understandable to us that people die of advanced age or as the result of diseases that are recognized to be fatal, this is not the case with primitive man. When old persons die, he does not believe it to be the result of age. He argues that there are persons who have lived to be much older. Likewise, no one dies as the result of disease, for there have been other people who recovered from the same disease, or never contracted it. To him, the real explanation is always magic. Either a spirit has killed the man, or it was sorcery. Many primitive tribes recognize death in battle as the only natural death. Still others regard even death in battle as unnatural, holding that the enemy who caused it must either have been a sorcerer or have used a charmed weapon. This grotesque idea can on occasion take an even more impressive form. For instance, two anklets were found in the stomach of a crocodile shot by a European. The natives recognized the anklets as the property of two women who, some time before, had been devoured by a crocodile. At once the charge of witchcraft was raised; for this quite natural occurrence, which would never have aroused the suspicions of a European, was given an unexpected interpretation in the light of one of those presuppositions which Lévy-Bruhl calls “collective representations.” The natives said that an unknown sorcerer had summoned the crocodile, and had bidden it catch the two women and bring them to him. The crocodile had carried out this command. But what about the anklets in the beast’s stomach? Crocodiles, they explained, never ate people unless bidden to do so. The crocodile had merely received the anklets from the sorcerer as a reward.

[107] This story is a perfect example of that capricious way of explaining things which is characteristic of the “prelogical” state of mind. We call it prelogical, because to us such an explanation seems absurdly illogical. But it seems so to us only because we start from assumptions wholly different from those of primitive man. If we were as convinced as he is of the existence of sorcerers and other mysterious powers, instead of believing in so-called natural causes, his inferences would seem to us perfectly logical. As a matter of fact, primitive man is no more logical or illogical than we are. Only his presuppositions are different, and that is what distinguishes him from us. His thinking and his conduct are based on assumptions quite unlike our own. To all that is in any way out of the ordinary and that therefore disturbs, frightens or astonishes him, he ascribes what we would call a supernatural origin. For him, of course, these things are not supernatural, but belong to his world of experience. We feel we are stating a natural sequence of events when we say: This house was burned down because it was struck by lightning. Primitive man senses an equally natural sequence of events when he says: A sorcerer used the lightning to set fire to this

house. There is absolutely nothing in the world of the primitive—provided that it is at all unusual or impressive—that will not be accounted for on essentially similar grounds. But in explaining things in this way he is acting just like ourselves: he does not examine his assumptions. To him it is an unquestionable truth that disease and other ills are caused by spirits or witchcraft, just as for us it is a foregone conclusion that an illness has a natural cause. We would no more put it down to sorcery than he to natural causes. His mental functioning does not differ in any fundamental way from ours. It is, as I have said, his assumptions alone that distinguish him from ourselves.

[108] It is also supposed that primitive man has other feelings than we, and another kind of morality—that he has, so to speak, a “prelogical” temperament. Undoubtedly he has a different code of morals. When asked about the difference between good and evil, a Negro chieftain declared: “When I steal my enemy’s wives, it is good, when he steals mine, it is bad.” In many regions it is a terrible insult to tread on a person’s shadow, and in others it is an unpardonable sin to scrape a sealskin with an iron knife instead of a flint one. But let us be honest. Do we not think it a sin to eat fish with a steel knife, for a man to keep his hat on in a room, or to greet a lady with a cigar in his mouth? With us, as well as with primitives, such things have nothing to do with ethics. There are good and loyal head-hunters, and there are others who piously and conscientiously perform cruel rites, or commit murder from sacred conviction. The primitive is no less prompt than we are to value an ethical attitude. His good is just as good as ours, and his evil is just as bad as ours. Only the forms under which they appear are different; the process of ethical judgment is the same.

[109] It is likewise thought that primitive man has keener senses than we, or that they are somehow different. But his highly refined sense of direction or of hearing and sight is entirely a matter of professional differentiation. If he is confronted with things that are outside his experience, he is amazingly slow and clumsy. I once showed some native hunters, who were as keen-sighted as hawks, magazine pictures in which any child of ours would instantly have recognized human figures. But my hunters turned the pictures round and round until one of them, tracing the outline with his finger, finally exclaimed: “These are white men!” It was hailed by all as a great discovery.

[110] The incredibly accurate sense of direction shown by many primitives is essentially occupational. It is absolutely necessary that they should be able to find their way in forests and in the bush. Even the European, after a short while in Africa, begins to notice things he would never have dreamed of noticing before—and from fear of going hopelessly astray in spite of his compass.

[111] There is nothing to show that primitive man thinks, feels, or perceives in a way fundamentally different from ours. It is relatively unimportant that he has, or seems to have, a smaller area of consciousness than we, and that he has little or no aptitude for concentrated mental activity. This last, it is true, strikes the European as strange. For instance, I could never hold a palaver for longer than two hours, since by that time the natives declared themselves tired. They said it was too difficult, and yet I had asked only quite simple questions in the most desultory way. But these same people were capable of astonishing concentration and endurance when out hunting or on a journey. My letter-carrier, for instance, could run seventy-five miles at a stretch. I saw a woman in her sixth month of pregnancy, carrying a baby on her back and smoking a long pipe of tobacco, dance almost the whole night through round a blazing fire when the temperature was 95°, without collapsing. It cannot be denied that primitives are quite capable of concentrating on things that interest them. If we have to give our attention to uninteresting matters, we soon notice how feeble our powers of concentration are. We are just as dependent as they are on emotional impulses.

[112] It is true that primitives are simpler and more childlike than we, in good and evil alike. This in itself does not impress us as strange. And yet, when we approach the world of archaic man, we have the feeling of something prodigiously strange. As far as I have been able to analyse it, this feeling comes predominantly from the fact that the primary assumptions of archaic man are essentially different from ours, so that he lives in a different world. Until we come to know his presuppositions, he is a hard riddle to read; but when we know them, all is relatively simple. We might equally well say that primitive man ceases to be a riddle for us as soon as we get to know our *own* presuppositions.

[113] It is a rational presupposition of ours that everything has a natural and perceptible cause. We are convinced of this right from the start. Causality is one of our most sacred dogmas. There is no legitimate place in our world for invisible, arbitrary, and so-called supernatural powers—unless, indeed, we descend with the modern physicist into the obscure, microcosmic world inside the atom, where, it appears, some very curious things happen. But that lies far from the beaten track. We distinctly resent the idea of invisible and arbitrary forces, for it is not so long ago that we made our escape from that frightening world of dreams and superstitions, and constructed for ourselves a picture of the cosmos worthy of our rational consciousness—that latest and greatest achievement of man. We are now surrounded by a world that is obedient to rational laws. It is true that we do not know the causes of everything, but in time they will be discovered, and these discoveries will accord with our reasoned expectations. There are, to be sure, also chance occurrences, but they are merely accidental, and we do not doubt that they have a causality of their

own. Chance happenings are repellent to the mind that loves order. They disturb the regular, predictable course of events in the most absurd and irritating way. We resent them as much as we resent invisible, arbitrary forces, for they remind us too much of Satanic imps or of the caprice of a *deus ex machina*. They are the worst enemies of our careful calculations and a continual threat to all our undertakings. Being admittedly contrary to reason, they deserve all our abuse, and yet we should not fail to give them their due. The Arab shows them greater respect than we. He writes on every letter *Insha' allah*, "If God wills," for only then will the letter arrive. In spite of our resentment and in spite of the fact that events run true to general laws, it is undeniable that we are always and everywhere exposed to incalculable accidents. And what is more invisible and capricious than chance? What is more unavoidable and more annoying?

[114] If we consider the matter, we could as well say that the causal connection of events according to general laws is a theory which is borne out about half the time, while for the rest the demon of chance holds sway. Chance events certainly have their natural causes, and all too often we must discover to our sorrow how commonplace they are. It is not this causality that annoys us; the irritating thing about chance events is that they have to befall us here and now in an apparently arbitrary way. At least that is how it strikes us, and even the most obdurate rationalist may occasionally be moved to curse them. However we interpret chance makes no difference to its power. The more regulated the conditions of life become, the more chance is excluded and the less we need to protect ourselves against it. But despite this everyone in practice takes precautions against chance occurrences or hopes for them, even though there is nothing about chance in the official credo.

[115] It is our assumption, amounting to a positive conviction, that everything has a "natural" cause which, at least in theory, is perceptible. Primitive man, on the other hand, assumes that everything is brought about by invisible, arbitrary powers—in other words, that everything is chance. Only he does not call it chance, but intention. Natural causation is to him a mere pretence and not worthy of mention. If three women go to the river to draw water, and a crocodile seizes the one in the middle and pulls her under, our view of things leads us to the verdict that it was pure chance that that particular woman was seized. The fact that the crocodile seized her at all seems to us quite natural, for these beasts do occasionally eat human beings.

[116] For primitive man such an explanation completely obliterates the facts and accounts for no aspect of the whole exciting story. He rightly finds our explanation superficial or even absurd, for according to this view the accident could just as well not have happened and the same explanation would fit that case too—that it was

“pure chance” it did not. The prejudice of the European does not allow him to see how little he is saying when he explains things in that way.

[117] Primitive man expects far more of an explanation. What we call pure chance is for him wilful intention. It was therefore the intention of the crocodile—as everyone could observe—to seize the middle one of the three women. If it had not had this intention it would have taken one of the others. But why did the crocodile have this intention? Ordinarily these creatures do not eat human beings. That is quite correct—as correct as the statement that it does not ordinarily rain in the Sahara. Crocodiles are rather timid animals, easily frightened. Considering their numbers, they kill astonishingly few people, and it is an unexpected and unnatural event when they devour a man. Such an event calls for an explanation. Of his own accord the crocodile would not take a human life. By whom, then, was he ordered to do so?

[118] It is on the facts of the world around him that primitive man bases his verdicts. When the unexpected occurs he is justifiably astonished and wishes to know the specific causes. To this extent he behaves exactly as we do. But he goes further than we. He has one or more theories about the arbitrary power of chance. We say: Pure chance. He says: Calculating intention. He lays the chief stress on the confusing and confused breaks in the chain of causation, which we call chance—on those occurrences that fail to show the neat causal connections which science expects, and that constitute the other half of happenings in general. He has long ago adapted himself to nature in so far as it conforms to general laws; what he fears is unpredictable chance whose power makes him see in it an arbitrary and incalculable agent. Here again he is right. It is quite understandable that everything out of the ordinary should frighten him. Anteaters are fairly numerous in the regions south of Mount Elgon where I stayed for some time. The anteater is a shy, nocturnal animal that is rarely seen. If one happens to be seen by day, it is an extraordinary and unnatural event which astonishes the natives as much as the discovery of a brook that occasionally flows uphill would astonish us. If we knew of actual cases in which water suddenly overcame the force of gravity, such a discovery would be exceedingly disquieting. We know that tremendous masses of water surround us, and can easily imagine what would happen if water no longer conformed to gravitational law. This is the situation in which primitive man finds himself with respect to the happenings in his world. He is thoroughly familiar with the habits of anteaters, but when one of them suddenly transgresses the natural order of things it acquires for him an unknown sphere of action. Primitive man is so strongly impressed by things as they are that a transgression of the laws of his world exposes him to incalculable possibilities. It is a portent, an omen, comparable to a comet or an eclipse. Since such an unnatural event as the appearance of an anteater by day can have no natural causes, some invisible power must be behind it. And the alarming manifestation of a

power which can transgress the natural order obviously calls for extraordinary measures of placation or defence. The neighbouring villages must be aroused, and the anteater must be dug up with their concerted efforts and killed. The oldest maternal uncle of the man who saw the anteater must then sacrifice a bull. The man descends into the sacrificial pit and receives the first piece of the animal's flesh, whereupon the uncle and the other participants in the ceremony also eat. In this way the dangerous caprice of nature is expiated.

[119] As for us, we should certainly be alarmed if water suddenly began to run uphill for unknown reasons, but are not when an anteater is seen by day, or an albino is born, or an eclipse takes place. We know the meaning and sphere of action of such happenings, while primitive man does not. Ordinary events constitute for him a coherent whole in which he and all other creatures are embraced. He is therefore extremely conservative, and does what others have always done. If something happens, at any point, to break the coherence of this whole, he feels there is a rift in his well-ordered world. Then anything may happen—heaven knows what. All occurrences that are in any way striking are at once brought into connection with the unusual event. For instance, a missionary set up a flagstaff in front of his house so that he could fly the Union Jack on Sundays. But this innocent pleasure cost him dear, for when shortly after his revolutionary action a devastating storm broke out, the flagstaff was of course made responsible. This sufficed to start a general uprising against the missionary.

[120] It is the regularity of ordinary occurrences that gives primitive man a sense of security in his world. Every exception seems to him a threatening act of an arbitrary power that must somehow be propitiated. It is not only a momentary interruption of the ordinary course of things, but a portent of other untoward events. This seems absurd to us, inasmuch as we forget how our grandparents and great-grandparents still felt about the world. A calf is born with two heads and five legs. In the next village a cock has laid an egg. An old woman has had a dream, a comet appears in the sky, there is a great fire in the nearest town, and the following year a war breaks out. In this way history was always written from remote antiquity down to the eighteenth century. This concatenation of events, so meaningless to us, is significant and convincing to primitive man. And, contrary to all expectation, he is right to find it so. His powers of observation can be trusted. From age-old experience he knows that such concatenations actually exist. What seems to us a wholly senseless heaping-up of single, haphazard occurrences—because we pay attention only to single events and their particular causes—is for the primitive a completely logical sequence of omens and of happenings indicated by them. It is a fatal outbreak of demonic power showing itself in a thoroughly consistent way.

[121] The calf with two heads and the war are one and the same, for the calf was only an anticipation of the war. Primitive man finds this connection so unquestionable and convincing because the whims of chance seem to him a far more important factor in the happenings of the world than regularity and conformity to law. Thanks to his close attention to the unusual, he discovered long before us that chance events arrange themselves in groups or series. The law of the duplication of cases is known to all doctors engaged in clinical work. An old professor of psychiatry at Würzburg always used to say of a particularly rare clinical case: "Gentlemen, this case is absolutely unique—tomorrow we shall have another just like it." I myself often observed the same thing during my eight years' practice in an insane asylum. On one occasion a person was committed for a very rare twilight state of consciousness—the first case of this kind I had ever seen. Within two days we had a similar case, and that was the last. "Duplication of cases" is a joke with us in the clinics, but it was also the first object of primitive science. A recent investigator has ventured the statement: "Magic is the science of the jungle." Astrology and other methods of divination may certainly be called the science of antiquity.

[122] What happens regularly is easily observed because we are prepared for it. Knowledge and skill are needed only in situations where the course of events is interrupted in a way hard to fathom. Generally it is one of the shrewdest and wiliest men of the tribe who is entrusted with the observation of meteorological events. His knowledge must suffice to explain all unusual occurrences, and his art to combat them. He is the scholar, the specialist, the expert on chance, and at the same time the keeper of the archives of the tribe's traditional lore. Surrounded by respect and fear, he enjoys great authority, yet not so great but that his tribe is secretly convinced that the neighbouring tribe has a sorcerer who is stronger than theirs. The best medicine is never to be found close at hand, but as far away as possible. I stayed for some time with a tribe who held their old medicine-man in the greatest awe. Nevertheless he was consulted only for the minor ailments of cattle and men. In all serious cases a foreign authority was called in—a *M'ganga* who was brought at a high fee from Uganda—just as with us.

[123] Chance events occur most often in larger or smaller series or groups. An old and well-tried rule for foretelling the weather is this, that when it has rained for several days it will also rain tomorrow. A proverb says, "Misfortunes never come singly." Another has it that "It never rains but it pours." This proverbial wisdom is primitive science. The common people still believe it and fear it, but the educated man smiles at it—until something unusual happens to him. I will tell you a disagreeable story. A woman I know was awakened one morning by a peculiar tinkling on her night-table. After looking about her for a while she discovered the cause: the rim of her tumbler had snapped off in a ring about a quarter of an inch wide. This struck her as peculiar,

and she rang for another glass. About five minutes later she heard the same tinkling, and again the rim of the glass had broken off. This time she was greatly disquieted, and had a third glass brought. Within twenty minutes the rim broke off again with the same tinkling noise. Three such accidents in immediate succession were too much for her. She gave up her belief in natural causes on the spot and brought out in its place a primitive “collective representation”—the conviction that an arbitrary power was at work. Something of this sort happens to many modern people—provided they are not too thick-skulled—when they are confronted with events which natural causation fails to explain. We naturally prefer to deny such occurrences. They are unpleasant because they disrupt the orderly course of our world and make anything seem possible, thus proving that the primitive mind in us is not yet dead.

[124] Primitive man’s belief in an arbitrary power does not arise out of thin air, as was always supposed, but is grounded in experience. The grouping of chance occurrences justifies what we call his superstition, for there is a real measure of probability that unusual events will coincide in time and place. We must not forget that our experience is apt to leave us in the lurch here. Our observation is inadequate because our point of view leads us to overlook these matters. For instance, it would never seriously occur to us to take the following events as a sequence: in the morning a bird flies into your room, an hour later you witness an accident in the street, in the afternoon a relative dies, in the evening the cook drops the soup tureen, and, on coming home at night, you find that you have lost your key. Primitive man would not have overlooked a single item in this chain of events. Every new link would have confirmed his expectations, and he would be right—much more nearly right than we are willing to admit. His anxious expectations are fully justified and serve a purpose. Such a day is ill-omened, and on it nothing should be undertaken. In our world this would be reprehensible superstition, but in the world of the primitive it is highly appropriate shrewdness. In that world man is far more exposed to accidents than we are in our sheltered and well-regulated existence. When you are in the bush you dare not take too many chances. The European soon comes to appreciate this.

[125] When a Pueblo Indian does not feel in the right mood, he stays away from the men’s council. When an ancient Roman stumbled on the threshold as he left his house, he gave up his plans for the day. This seems to us senseless, but under primitive conditions such an omen inclines one at least to be cautious. When I am not in full control of myself, I am hampered in my movements, my attention wanders, I get absent-minded. As a result I knock against something, stumble, drop something, forget something. Under civilized conditions all these are mere trifles, but in the primeval forest they mean mortal danger. I make a false step on a slippery tree-trunk that serves as a bridge over a river teeming with crocodiles. I lose my compass in the high grass. I forget to load my rifle and blunder into a rhinoceros trail in the jungle. I

am preoccupied with my thoughts and step on a puff-adder. At nightfall I forget to put on my mosquito-boots in time and eleven days later I die from an onset of tropical malaria. To forget to keep one's mouth shut while bathing is enough to bring on a fatal attack of dysentery. For us accidents of this kind have their recognizable natural cause in a somewhat distracted psychological state, but for the primitive they are objectively conditioned omens, or sorcery.

[126] It may be rather more than a question of inattention, however. In the Kitoshi region south of Mount Elgon, in East Africa, I went on an expedition into the Kabras forest. There, in the thick grass, I nearly stepped on a puff-adder, and only managed to jump away just in time. That afternoon my companion returned from a hunt, deathly pale and trembling in every limb. He had narrowly escaped being bitten by a seven-foot mamba which darted at him from behind a termite hill. He would undoubtedly have been killed had he not been able to wound the brute with a shot at the last moment. At nine o'clock that night our camp was attacked by a pack of ravenous hyenas which had surprised a man in his sleep the day before and torn him to pieces. In spite of the fire they swarmed into the hut of our cook, who fled screaming over the stockade. Thenceforth there were no accidents throughout the whole of our journey. Such a day gave our Negroes food for thought. For us it was a simple multiplication of chance events, but for them the inevitable fulfilment of an omen that had occurred on the first day of our journey into the wilds. It so happened that we had fallen, Ford car, bridge, and all, into a stream we were trying to cross. Our boys had exchanged glances as if to say: "Well, that's a fine start." To cap this calamity, a tropical thunderstorm blew up and soaked us so thoroughly that I was prostrated with fever for several days. On the evening of the day when my friend had had such a narrow escape out hunting, I could not help saying to him as we white men sat looking at one another: "You know, it seems to me as if the trouble had begun still further back. Do you remember the dream you told me in Zurich just before we left?" At that time he had had a very impressive nightmare. He dreamed he was hunting in Africa, and was suddenly attacked by a huge mamba, so that he woke up with a cry of terror. The dream had disturbed him greatly, and he now confessed to me that he had thought it portended the death of one of us. He had of course assumed that it was my death, because we always hope it is the other fellow. But it was he who later fell ill of a severe malarial fever that brought him to the brink of the grave.

[127] To read of such a conversation in a corner of the world where there are no mambas and no anopheles mosquitoes means very little. One must imagine the velvety blue of a tropical night, the overhanging black masses of gigantic trees standing in the primeval forest, the mysterious voices of the nocturnal spaces, a lonely fire with loaded rifles stacked beside it, mosquito-nets, boiled swamp-water to drink, and above all the conviction expressed by an old Afrikander who knew what

he was talking about: “This isn’t man’s country—it’s God’s country.” There man is not king; it is rather nature, the animals, plants, and the microbes. Given the mood that goes with the place, one understands how it is that we found a dawning significance in things that anywhere else would provoke a smile. That is the world of unrestrained capricious powers which primitive man has to deal with every day. The unusual event is no joke to him. He draws his own conclusions. “This is not a good place,” “The day is unfavourable”—and who knows what dangers he avoids by following such warnings?

[128] “Magic is the science of the jungle.” The portent brings about an immediate alteration of a course of action, the abandonment of a planned undertaking, a change of psychic attitude. These are all highly expedient reactions in view of the fact that chance occurrences tend to fall into sequences and that primitive man is wholly unconscious of psychic causality. Thanks to our one-sided emphasis on so-called natural causes, we have learned to differentiate what is subjective and psychic from what is objective and “natural.” For primitive man, on the contrary, the psychic and the objective coalesce in the external world. In the face of something extraordinary it is not he who is astonished, but rather the thing which is astonishing. It is *mana*—endowed with magic power. What we would call the powers of imagination and suggestion seem to him invisible forces which act on him from without. His country is neither a geographical nor a political entity. It is that territory which contains his mythology, his religion, all his thinking and feeling in so far as he is unconscious of these functions. His fear is localized in certain places that are “not good.” The spirits of the departed inhabit such and such a wood. That cave harbours devils who strangle any man who enters. In yonder mountain lives the great serpent; that hill is the grave of the legendary king; near this spring or rock or tree every woman becomes pregnant; that ford is guarded by snake-demons; this towering tree has a voice that can call certain people. Primitive man is unpsychological. Psychic happenings take place outside him in an objective way. Even the things he dreams about are real to him; that is his only reason for paying attention to dreams. Our Elgonyi porters maintained in all seriousness that they never had dreams—only the medicine-man had them. When I questioned the medicine-man, he declared that he had stopped having dreams when the British entered the land. His father had still had “big” dreams, he told me, and had known where the herds strayed, where the cows took their calves, and when there was going to be a war or a pestilence. It was now the District Commissioner who knew everything, and they knew nothing. He was as resigned as certain Papuans who believe that the crocodiles have for the most part gone over to the British Government. It happened that a native convict who had escaped from the authorities had been badly mangled by a crocodile while trying to cross a river. They therefore concluded that it must have been a police crocodile. God

now speaks in dreams to the British, and not to the medicine-man of the Elgonyi, he told me, because it is the British who have the power. Dream activity has emigrated. Occasionally the souls of the natives wander off too, and the medicine-man catches them in cages as if they were birds, or strange souls come in as immigrants and cause peculiar diseases.

[129] This projection of psychic happenings naturally gives rise to relations between men and men, or between men and animals or things, that to us are inconceivable. A white man shoots a crocodile. At once a crowd of people come running from the nearest village and excitedly demand compensation. They explain that the crocodile was a certain old woman in their village who had died at the moment when the shot was fired. The crocodile was obviously her bush-soul. Another man shot a leopard that was lying in wait for his cattle. Just then a woman died in a neighbouring village. She and the leopard were identical.

[130] Lévy-Bruhl has coined the expression *participation mystique* for these remarkable relationships. It seems to me that the word “mystical” is not happily chosen. Primitive man does not see anything mystical in these matters, but considers them perfectly natural. It is only we who find them so strange, because we appear to know nothing about the phenomena of psychic dissociation. In reality, however, they occur in us too, not in this naïve but in a rather more civilized form. In daily life it happens all the time that we presume that the psychology of other people is the same as ours. We suppose that what is pleasing or desirable to us is the same to others, and that what seems bad to us must also seem bad to them. It is only recently that our courts of law have nerved themselves to admit the psychological relativity of guilt in pronouncing sentence. The tenet *quod licet Jovi non licet bovi* still rankles in the minds of all unsophisticated people; equality before the law is still a precious achievement. And we still attribute to the other fellow all the evil and inferior qualities that we do not like to recognize in ourselves, and therefore have to criticize and attack him, when all that has happened is that an inferior “soul” has emigrated from one person to another. The world is still full of *bêtes noires* and scapegoats, just as it formerly teemed with witches and werewolves.

[131] Projection is one of the commonest psychic phenomena. It is the same as *participation mystique*, which Lévy-Bruhl, to his great credit, emphasized as being an especially characteristic feature of primitive man. We merely give it another name, and as a rule deny that we are guilty of it. Everything that is unconscious in ourselves we discover in our neighbour, and we treat him accordingly. We no longer subject him to the test of drinking poison; we do not burn him or put the screws on him; but we injure him by means of moral verdicts pronounced with the deepest conviction. What we combat in him is usually our own inferior side.

[132] The simple truth is that primitive man is somewhat more given to projection than we because of the undifferentiated state of his mind and his consequent inability to criticize himself. Everything to him is absolutely objective, and his speech reflects this in a drastic way. With a touch of humour we can picture to ourselves what a leopard-woman is like, just as we do when we call a person a goose, a cow, a hen, a snake, an ox, or an ass. These uncomplimentary epithets are familiar to us all. But when primitive man attributes a bush-soul to a person, the poison of moral judgment is absent. He is too naturalistic for that; he is too much impressed by things as they are and much less prone to pass judgment than we. The Pueblo Indians declared in a matter-of-fact way that I belonged to the Bear Totem—in other words, that I was a bear—because I did not come down a ladder standing up like a man, but bunched up on all fours like a bear. If anyone in Europe said I had a bearish nature this would amount to the same thing, but with a rather different shade of meaning. The theme of the bush-soul, which seems so strange to us when we meet with it among primitives, has become with us a mere figure of speech, like so much else. If we take our metaphors concretely we return to the primitive point of view. For instance, we have the expression “to handle a patient.” In concrete terms this means “to lay hands on” a person, “to work at with the hands,” “to manipulate.” And this is precisely what the medicine-man does with his patients.

[133] We find the bush-soul hard to understand because we are baffled by such a concrete way of looking at things. We cannot conceive of a “soul” that splits off completely and takes up its abode in a wild animal. When we describe someone as an ass, we do not mean that he is in every aspect the quadruped called an ass. We mean that he resembles an ass in some particular respect. We split off a bit of his personality or psyche and personify it as an ass. So, too, for primitive man the leopard-woman is a human being, only her bush-soul is a leopard. Since all unconscious psychic life is concrete and objective for him, he supposes that a person describable as a leopard has the soul of a leopard. If the splitting and concretizing go still further, he assumes that the leopard-soul lives in the bush in the form of a real leopard.

[134] These identifications, brought about by projection, create a world in which man is completely contained psychically as well as physically. To a certain extent he coalesces with it. In no way is he master of this world, but only a fragment of it. Primitive man is still far from the glorification of human powers. He does not dream of regarding himself as the lord of creation. In Africa, for instance, his zoological classification does not culminate in *Homo sapiens*, but in the elephant. Next comes the lion, then the python or the crocodile, then man and the lesser creatures. Man is still dovetailed into nature. It never occurs to him that he might be able to rule her; all his efforts are devoted to protecting himself against her dangerous caprices. It is

civilized man who strives to dominate nature and therefore devotes his greatest energies to the discovery of natural causes which will give him the key to her secret laboratory. That is why he strongly resents the idea of arbitrary powers and denies them. Their existence would amount to proof that his attempt to dominate nature is futile after all.

[135] Summing up, we may say that the outstanding trait of archaic man is his attitude towards the arbitrary power of chance, which he considers a far more important factor in the world-process than natural causes. It consists on the one hand in the observed tendency of chance occurrences to take place in a series, and on the other in the projection of unconscious psychic contents through *participation mystique*. For archaic man this distinction does not exist, because psychic happenings are projected so completely that they cannot be distinguished from objective, physical events. For him the vagaries of chance are arbitrary and intentional acts, interventions by animate beings. He does not realize that unusual events stir him so deeply only because he invests them with the power of his own astonishment or fear. Here, it is true, we move on treacherous ground. Is a thing beautiful because I attribute beauty to it? Or is it the objective beauty of the thing that compels me to acknowledge it? As we know, great minds have wrestled with the problem whether it is the glorious sun that illuminates the world, or the sunlike human eye. Archaic man believes it to be the sun, and civilized man believes it to be the eye—so far, at any rate, as he reflects at all and does not suffer from the disease of the poets. He must de-psychize nature in order to dominate her; and in order to see his world objectively he must take back all his archaic projections.

[136] In the archaic world everything has soul—the soul of man, or let us say of mankind, the collective unconscious, for the individual has as yet no soul of his own. We must not forget that what the Christian sacrament of baptism purports to do is a landmark of the utmost significance in the psychic development of mankind. Baptism endows the individual with a living soul. I do not mean that the baptismal rite in itself does this, by a unique and magical act. I mean that the idea of baptism lifts man out of his archaic identification with the world and transforms him into a being who stands above it. The fact that mankind has risen to the level of this idea is baptism in the deepest sense, for it means the birth of the spiritual man who transcends nature.

[137] In the psychology of the unconscious it is an axiom that every relatively independent portion of the psyche has the character of personality, that it is personified as soon as it is given an opportunity for independent expression. We find the clearest instances of this in the hallucinations of the insane and in mediumistic communications. Whenever an autonomous component of the psyche is projected, an invisible person comes into being. In this way the spirits arise at an ordinary

spiritualistic séance. So too among primitives. If an important psychic component is projected on a human being, he becomes *mana*, extraordinarily effective—a sorcerer, witch, werewolf, or the like. The primitive idea that the medicine-man catches the souls that have wandered away by night and puts them in cages like birds is a striking illustration of this. These projections give the medicine-man his *mana*, they cause animals, trees, and stones to speak, and because they are his own psychic components they compel the projicient to obey them absolutely. For this reason an insane person is helplessly at the mercy of his voices; they are projections of his own psychic activity whose unconscious subject he is. He is the one who speaks through his voices, just as he is the one who hears, sees, and obeys.

[138] From a psychological point of view, therefore, the primitive theory that the arbitrary power of chance is the outcome of the intentions of spirits and sorcerers is perfectly natural, because it is an unavoidable inference from the facts as primitive man sees them. Let us not delude ourselves in this connection. If we explain our scientific views to an intelligent native he will accuse us of ludicrous superstitiousness and a disgraceful want of logic, for he believes that the world is lighted by the sun and not by the human eye. My friend Mountain Lake, a Pueblo chief, once called me sharply to account because I had made insinuating use of the Augustinian argument: “Not this sun is our Lord, but he who made this sun.” Pointing to the sun he cried indignantly: “He who goes there is our father. You can see him. From him comes all light, all life—there is nothing that he has not made.” He became greatly excited, struggled for words, and finally cried out: “Even a man in the mountains, who goes alone, cannot make his fire without him.” The archaic standpoint could hardly be more beautifully expressed than by these words. The power that rules us is outside, in the external world, and through it alone are we permitted to live. Religious thought keeps alive the archaic state of mind even today, in a time bereft of gods. Untold millions of people still think like this.

[139] Speaking earlier of primitive man’s attitude to the arbitrary power of chance, I expressed the view that this attitude serves a purpose and therefore has a meaning. Shall we, for the moment at least, venture the hypothesis that the primitive belief in arbitrary powers is justified by the facts and not merely from a psychological point of view? This sounds alarming, but I have no intention of jumping from the frying-pan into the fire and trying to prove that witchcraft actually works. I merely wish to consider the conclusions to which we shall be led if we follow primitive man in assuming that all light comes from the sun, that things are beautiful in themselves, and that a bit of the human soul is a leopard—in other words, that the *mana* theory is correct. According to this theory, beauty moves *us*, it is not we who create beauty. A certain person *is* a devil, we have not projected our own evil on him and in this way made a devil out of him. There are people—*mana* personalities—who are impressive

in their own right and in no way thanks to our imagination. The mana theory maintains that there is something like a widely distributed power in the external world that produces all those extraordinary effects. Everything that exists acts, otherwise it would not *be*. It can *be* only by virtue of its inherent energy. Being is a field of force. The primitive idea of mana, as you can see, has in it the beginnings of a crude theory of energy.

[140] So far we can easily follow this primitive idea. The difficulty arises when we try to carry its implications further, for they reverse the process of psychic projection of which I have spoken. It is then not my imagination or my awe that makes the medicine-man a sorcerer; on the contrary, he *is* a sorcerer and projects his magical powers on me. Spirits are not hallucinations of my mind, but appear to me of their own volition. Although such statements are logical derivatives of the mana idea, we hesitate to accept them and begin to look around for a comfortable theory of psychic projection. The question is nothing less than this: Does the psychic in general—the soul or spirit or the unconscious—originate in *us*, or is the psyche, in the early stages of conscious evolution, actually outside us in the form of arbitrary powers with intentions of their own, and does it gradually take its place within us in the course of psychic development? Were the split-off “souls”—or dissociated psychic contents, as we would call them—ever parts of the psyches of individuals, or were they from the beginning psychic entities existing in themselves according to the primitive view as ghosts, ancestral spirits, and the like? Were they only by degrees embodied in man in the course of development, so that they gradually constituted in him that world which we now call the psyche?

[141] This whole idea strikes us as dangerously paradoxical, but, at bottom, it is not altogether inconceivable. Not only the religious instructor but the educator as well assumes that it is possible to implant something psychic in man that was not there before. The power of suggestion and influence is a fact; indeed, the modern behaviourists have extravagant expectations in this respect. The idea of a complex building-up of the psyche is expressed on a primitive level in a variety of forms, for instance in the widespread belief in possession, the incarnation of ancestral spirits, the immigration of souls, and so forth. When someone sneezes, we still say: “God bless you,” by which is meant: “I hope your new soul will do you no harm.” When in the course of our own development we feel ourselves achieving a unified personality out of a multitude of contradictory tendencies, we experience something like a complex growing-together of the psyche. Since the human body is built up by heredity out of a multitude of Mendelian units, it does not seem altogether out of the question that the human psyche is similarly put together.

[142] The materialistic views of our day have one tendency which they share with archaic thought: both lead to the conclusion that the individual is a mere resultant. In the first case he is the resultant of natural causes, and in the second of chance occurrences. According to both accounts, human individuality is nothing in its own right, but rather the accidental product of forces contained in the objective environment. This is thoroughly consistent with the archaic view of the world, in which the ordinary individual is never important, but always interchangeable with any other and easily dispensable. By the roundabout way of strict causalism, modern materialism has returned to the standpoint of archaic man. But the materialist is more radical, because he is more systematic. Archaic man has the advantage of being inconsistent: he makes an exception of the mana personality. In the course of history these mana personalities were exalted to the position of divine figures; they became heroes and kings who shared the immortality of the gods by eating the food of eternal youth. This idea of the immortality of the individual and of his imperishable worth can be found on the earliest archaic levels, first of all in the belief in spirits, and then in myths of the age when death had not yet gained entry into the world through human carelessness or folly.

[143] Primitive man is not aware of this contradiction in his views. My Elgonyi porters assured me that they had no idea what would happen to them after death. According to them a man is simply dead, he does not breathe any more, and the corpse is carried into the bush where the hyenas eat it. That is what they think by day, but the night teems with spirits of the dead who bring diseases to cattle and men, who attack and strangle the nocturnal traveller and indulge in other forms of violence. The primitive mind is full of such contradictions. They could worry a European out of his skin, and it would never occur to him that something quite similar is to be found in our civilized midst. We have universities where the very thought of divine intervention is considered beneath dispute, but where theology is a part of the curriculum. A research worker in natural science who thinks it positively obscene to attribute the smallest variation of an animal species to an act of divine arbitrariness may have in another compartment of his mind a full-blown Christian faith which he likes to parade on Sundays. Why should we excite ourselves about primitive inconsistency?

[144] It is impossible to derive any philosophical system from the fundamental thoughts of primitive man. They provide only antinomies, but it is just these that are the inexhaustible source of all spiritual problems in all times and in all civilizations. We may ask whether the "collective representations" of archaic man are really profound, or do they only seem so? I cannot answer this most difficult of questions, but I would like, in conclusion, to tell you of an observation I made among the mountain tribe of the Elgonyi. I searched and inquired far and wide for traces of religious ideas and ceremonies, and for weeks on end I discovered nothing. The

natives let me see everything and were willing to give me any information. I could talk with them without the hindrance of a native interpreter, for many of the old men spoke Swahili. At first they were rather reserved, but once the ice was broken I had the friendliest reception. They knew nothing of religious customs. But I did not give up, and finally, at the end of one of many fruitless palavers, an old man suddenly exclaimed: "In the morning, when the sun comes up, we go out of the huts, spit in our hands, and hold them up to the sun." I got them to perform the ceremony for me and describe it exactly. They hold their hands before their faces and spit or blow into them vigorously. Then they turn their hands round and hold the palms towards the sun. I asked them the meaning of what they did—why they blew or spat in their hands. My question was futile. "That is how it has always been done," they said. It was impossible to get an explanation, and it became clear to me that they knew only what they did and not why they did it. They see no meaning in their action. They greet the new moon with the same gesture.

[145] Now let us suppose that I am a total stranger in Zurich and have come to this city to explore the customs of the place. First I settle down on the outskirts near some suburban homes, and come into neighbourly contact with their owners. I then say to Messrs. Müller and Meyer: "Please tell me something about your religious customs." Both gentlemen are taken aback. They never go to church, know nothing about it, and emphatically deny that they practise any such customs. It is spring, and Easter is approaching. One morning I surprise Mr. Müller at a curious occupation. He is busily running about the garden, hiding coloured eggs and setting up peculiar rabbit idols. I have caught him *in flagrante*. "Why did you conceal this highly interesting ceremony from me?" I ask him. "What ceremony?" he retorts. "This is nothing. Everybody does it at Eastertime." "But what is the meaning of these idols and eggs, and why do you hide them?" Mr. Müller is stunned. He does not know, any more than he knows the meaning of the Christmas-tree. And yet he does these things, just like a primitive. Did the distant ancestors of the Elgonyi know any better what they were doing? It is highly improbable. Archaic man everywhere does what he does, and only civilized man knows what he does.

[146] What is the meaning of the Elgonyi ceremony just cited? Clearly it is an offering to the sun, which for these natives is *mungu*—that is, *mana*, or divine—only at the moment of rising. If they have spittle on their hands, this is the substance which, according to primitive belief, contains the personal *mana*, the life-force, the power to heal and to make magic. If they breathe into their hands, breath is wind and spirit—it is *roho*, in Arabic *ruch*, in Hebrew *ruach*, and in Greek *pneuma*. The action means: I offer my living soul to God. It is a wordless, acted prayer, which could equally well be spoken: "Lord, into thy hands I commend my spirit."

[147] Does this merely happen so, or was this thought brooded and willed even before man existed? I must leave this question unanswered.

THE SPIRITUAL PROBLEM OF MODERN MAN¹

[148] The spiritual problem of modern man is one of those questions which are so much a part of the age we live in that we cannot see them in the proper perspective. Modern man is an entirely new phenomenon; a modern problem is one which has just arisen and whose answer still lies in the future. In speaking of the spiritual problem of modern man we can at most frame a question, and we should perhaps frame it quite differently if we had but the faintest inkling of the answer the future will give. The question, moreover, seems rather vague; but the truth is that it has to do with something so universal that it exceeds the grasp of any single individual. We have reason enough, therefore, to approach such a problem in all modesty and with the greatest caution. This open avowal of our limitations seems to me essential, because it is these problems more than any others which tempt us to the use of high-sounding and empty words, and because I shall myself be forced to say certain things which may sound immoderate and incautious, and could easily lead us astray. Too many of us already have fallen victim to our own grandiloquence.

[149] To begin at once with an example of such apparent lack of caution, I must say that the man we call modern, the man who is aware of the immediate present, is by no means the average man. He is rather the man who stands upon a peak, or at the very edge of the world, the abyss of the future before him, above him the heavens, and below him the whole of mankind with a history that disappears in primeval mists. The modern man—or, let us say again, the man of the immediate present—is rarely met with, for he must be conscious to a superlative degree. Since to be wholly of the present means to be fully conscious of one's existence as a man, it requires the most intensive and extensive consciousness, with a minimum of unconsciousness. It must be clearly understood that the mere fact of living in the present does not make a man modern, for in that case everyone at present alive would be so. He alone is modern who is fully conscious of the present.

[150] The man who has attained consciousness of the present is solitary. The “modern” man has at all times been so, for every step towards fuller consciousness removes him further from his original, purely animal *participation mystique* with the herd, from submersion in a common unconsciousness. Every step forward means tearing oneself loose from the maternal womb of unconsciousness in which the mass of men dwells. Even in a civilized community the people who form, psychologically speaking, the lowest stratum live in a state of unconsciousness little different from that of primitives. Those of the succeeding strata live on a level of consciousness which

corresponds to the beginnings of human culture, while those of the highest stratum have a consciousness that reflects the life of the last few centuries. Only the man who is modern in our meaning of the term really lives in the present; he alone has a present-day consciousness, and he alone finds that the ways of life on those earlier levels have begun to pall upon him. The values and strivings of those past worlds no longer interest him save from the historical standpoint. Thus he has become “unhistorical” in the deepest sense and has estranged himself from the mass of men who live entirely within the bounds of tradition. Indeed, he is completely modern only when he has come to the very edge of the world, leaving behind him all that has been discarded and outgrown, and acknowledging that he stands before the Nothing out of which All may grow.²

[151] This sounds so grand that it borders suspiciously on bathos, for nothing is easier than to affect a consciousness of the present. A great horde of worthless people do in fact give themselves a deceptive air of modernity by skipping the various stages of development and the tasks of life they represent. Suddenly they appear by the side of the truly modern man—uprooted wraiths, bloodsucking ghosts whose emptiness casts discredit upon him in his unenviable loneliness. Thus it is that the few present-day men are seen by the undiscerning eyes of the masses only through the dismal veil of those spectres, the pseudo-moderns, and are confused with them. It cannot be helped; the “modern” man is questionable and suspect, and has been so at all times, beginning with Socrates and Jesus.

[152] An honest admission of modernity means voluntarily declaring oneself bankrupt, taking the vows of poverty and chastity in a new sense, and—what is still more painful—renouncing the halo of sanctity which history bestows. To be “unhistorical” is the Promethean sin, and in this sense the modern man is sinful. A higher level of consciousness is like a burden of guilt. But, as I have said, only the man who has outgrown the stages of consciousness belonging to the past, and has amply fulfilled the duties appointed for him by his world, can achieve full consciousness of the present. To do this he must be sound and proficient in the best sense—a man who has achieved as much as other people, and even a little more. It is these qualities which enable him to gain the next highest level of consciousness.

[153] I know that the idea of proficiency is especially repugnant to the pseudo-moderns, for it reminds them unpleasantly of their trickery. This, however, should not prevent us from taking it as our criterion of the modern man. We are even forced to do so, for unless he is proficient, the man who claims to be modern is nothing but a trickster. He must be proficient in the highest degree, for unless he can atone by creative ability for his break with tradition, he is merely disloyal to the past. To deny the past for the sake of being conscious only of the present would be sheer futility. Today has meaning only if it stands between yesterday and tomorrow. It is a process of transition that forms the

link between past and future. Only the man who is conscious of the present in this sense may call himself modern.

[154] Many people call themselves modern—especially the pseudo-moderns. Therefore the really modern man is often to be found among those who call themselves old-fashioned. They do this firstly in order to make amends for their guilty break with tradition by laying all the more emphasis on the past, and secondly in order to avoid the misfortune of being taken for pseudo-moderns. Every good quality has its bad side, and nothing good can come into the world without at once producing a corresponding evil. This painful fact renders illusory the feeling of elation that so often goes with consciousness of the present—the feeling that we are the culmination of the whole history of mankind, the fulfilment and end-product of countless generations. At best it should be a proud admission of our poverty: we are also the disappointment of the hopes and expectations of the ages. Think of nearly two thousand years of Christian Idealism followed, not by the return of the Messiah and the heavenly millennium, but by the World War among Christian nations with its barbed wire and poison gas. What a catastrophe in heaven and on earth!

[155] In the face of such a picture we may well grow humble again. It is true that modern man is a culmination, but tomorrow he will be surpassed. He is indeed the product of an age-old development, but he is at the same time the worst conceivable disappointment of the hopes of mankind. The modern man is conscious of this. He has seen how beneficent are science, technology, and organization, but also how catastrophic they can be. He has likewise seen how all well-meaning governments have so thoroughly paved the way for peace on the principle “in time of peace prepare for war” that Europe has nearly gone to rack and ruin. And as for ideals, neither the Christian Church, nor the brotherhood of man, nor international social democracy, nor the solidarity of economic interests has stood up to the acid test of reality. Today, ten years after the war,³ we observe once more the same optimism, the same organizations, the same political aspirations, the same phrases and catchwords at work. How can we but fear that they will inevitably lead to further catastrophes? Agreements to outlaw war leave us sceptical, even while we wish them every possible success. At bottom, behind every such palliative measure there is a gnawing doubt. I believe I am not exaggerating when I say that modern man has suffered an almost fatal shock, psychologically speaking, and as a result has fallen into profound uncertainty.

[156] These statements make it clear enough that my views are coloured by a professional bias. A doctor always spies out diseases, and I cannot cease to be a doctor. But it is essential to the physician’s art that he should not discover diseases where none exists. I will therefore not make the assertion that Western man, and the white man in particular, is sick, or that the Western world is on the verge of collapse. I am in no way competent to pass such a judgment.

[157] Whenever you hear anyone talking about a cultural or even about a human problem, you should never forget to inquire who the speaker really is. The more general the problem, the more he will smuggle his own, most personal psychology into the account he gives of it. This can, without a doubt, lead to intolerable distortions and false conclusions which may have very serious consequences. On the other hand, the very fact that a general problem has gripped and assimilated the whole of a person is a guarantee that the speaker has really experienced it, and perhaps gained something from his sufferings. He will then reflect the problem for us in his personal life and thereby show us a truth. But if he projects his own psychology into the problem, he falsifies it by his personal bias, and on the pretence of presenting it objectively so distorts it that no truth emerges but merely a deceptive fiction.

[158] It is of course only from my own experience with other persons and with myself that I draw my knowledge of the spiritual problem of modern man. I know something of the intimate psychic life of many hundreds of educated persons, both sick and healthy, coming from every quarter of the civilized, white world; and upon this experience I base my statements. No doubt I can draw only a one-sided picture, for everything I have observed lies in the psyche—it is all *inside*. I must add at once that this is a remarkable fact in itself, for the psyche is not always and everywhere to be found on the inside. There are peoples and epochs where it is found *outside*, because they were wholly unpsychological. As examples we may choose any of the ancient civilizations, but especially that of Egypt with its monumental objectivity and its naïve confession of sins that have not been committed. We can no more feel psychic problems lurking behind the Apis tombs of Saqqara and the Pyramids than we can behind the music of Bach.

[159] Whenever there exists some external form, be it an ideal or a ritual, by which all the yearnings and hopes of the soul are adequately expressed—as for instance in a living religion—then we may say that the psyche is outside and that there is no psychic problem, just as there is then no unconscious in our sense of the word. In consonance with this truth, the discovery of psychology falls entirely within the last decades, although long before that man was introspective and intelligent enough to recognize the facts that are the subject-matter of psychology. It was the same with technical knowledge. The Romans were familiar with all the mechanical principles and physical facts which would have enabled them to construct a steam engine, but all that came of it was the toy made by Hero of Alexandria. The reason for this is that there was no compelling necessity to go further. This need arose only with the enormous division of labour and the growth of specialization in the nineteenth century. So also a spiritual need has produced in our time the “discovery” of psychology. The psychic facts still existed earlier, of course, but they did not attract attention—no one

noticed them. People got along without them. But today we can no longer get along unless we pay attention to the psyche.

[160] It was men of the medical profession who were the first to learn this truth. For the priest, the psyche can only be something that needs fitting into a recognized form or system of belief in order to ensure its undisturbed functioning. So long as this system gives true expression to life, psychology can be nothing but a technical adjuvant to healthy living, and the psyche cannot be regarded as a factor *sui generis*. While man still lives as a herd-animal he has no psyche of his own, nor does he need any, except the usual belief in the immortality of the soul. But as soon as he has outgrown whatever local form of religion he was born to—as soon as this religion can no longer embrace his life in all its fullness—then the psyche becomes a factor in its own right which cannot be dealt with by the customary measures. It is for this reason that we today have a psychology founded on experience, and not upon articles of faith or the postulates of any philosophical system. The very fact that we have such a psychology is to me symptomatic of a profound convulsion of the collective psyche. For the collective psyche shows the same pattern of change as the psyche of the individual. So long as all goes well and all our psychic energies find an outlet in adequate and well-regulated ways, we are disturbed by nothing from within. No uncertainty or doubt besets us, and we *cannot* be divided against ourselves. But no sooner are one or two channels of psychic activity blocked up than phenomena of obstruction appear. The stream tries to flow back against the current, the inner man wants something different from the outer man, and we are at war with ourselves. Only then, in this situation of distress, do we discover the psyche as something which thwarts our will, which is strange and even hostile to us, and which is incompatible with our conscious standpoint. Freud's psychoanalytic endeavours show this process in the clearest way. The very first thing he discovered was the existence of sexually perverse and criminal fantasies which at their face value are wholly incompatible with the conscious outlook of civilized man. A person who adopted the standpoint of these fantasies would be nothing less than a rebel, a criminal, or a madman.

[161] We cannot suppose that the unconscious or hinterland of man's mind has developed this aspect only in recent times. Probably it was always there, in every culture. And although every culture had its destructive opponent, a Herostratus who burned down its temples, no culture before ours was ever forced to take these psychic undercurrents in deadly earnest. The psyche was merely part of a metaphysical system of some sort. But the conscious, modern man can no longer refrain from acknowledging the might of the psyche, despite the most strenuous and dogged efforts at self-defence. This distinguishes our time from all others. We can no longer deny that the dark stirrings of the unconscious are active powers, that psychic forces exist which, for the present at least, cannot be fitted into our rational world order. We have

even elevated them into a science—one more proof of how seriously we take them. Previous centuries could throw them aside unnoticed; for us they are a shirt of Nessus which we cannot strip off.

[162] The revolution in our conscious outlook, brought about by the catastrophic results of the World War, shows itself in our inner life by the shattering of our faith in ourselves and our own worth. We used to regard foreigners as political and moral reprobates, but the modern man is forced to recognize that he is politically and morally just like anyone else. Whereas formerly I believed it was my bounden duty to call others to order, I must now admit that I need calling to order myself, and that I would do better to set my own house to rights first. I admit this the more readily because I realize only too well that my faith in the rational organization of the world—that old dream of the millennium when peace and harmony reign—has grown pale. Modern man's scepticism in this respect has chilled his enthusiasm for politics and world-reform; more than that, it is the worst possible basis for a smooth flow of psychic energies into the outer world, just as doubt concerning the morality of a friend is bound to prejudice the relationship and hamper its development. Through his scepticism modern man is thrown back on himself; his energies flow towards their source, and the collision washes to the surface those psychic contents which are at all times there, but lie hidden in the silt so long as the stream flows smoothly in its course. How totally different did the world appear to medieval man! For him the earth was eternally fixed and at rest in the centre of the universe, circled by a sun that solicitously bestowed its warmth. Men were all children of God under the loving care of the Most High, who prepared them for eternal blessedness; and all knew exactly what they should do and how they should conduct themselves in order to rise from a corruptible world to an incorruptible and joyous existence. Such a life no longer seems real to us, even in our dreams. Science has long ago torn this lovely veil to shreds. That age lies as far behind as childhood, when one's own father was unquestionably the handsomest and strongest man on earth.

[163] Modern man has lost all the metaphysical certainties of his medieval brother, and set up in their place the ideals of material security, general welfare and humanitarianism. But anyone who has still managed to preserve these ideals unshaken must have been injected with a more than ordinary dose of optimism. Even security has gone by the board, for modern man has begun to see that every step forward in material "progress" steadily increases the threat of a still more stupendous catastrophe. The imagination shrinks in terror from such a picture. What are we to think when the great cities today are perfecting defence measures against gas attacks, and even practise them in dress rehearsals? It can only mean that these attacks have already been planned and provided for, again on the principle "in time of peace prepare for war." Let man but accumulate sufficient engines of destruction and the devil within

him will soon be unable to resist putting them to their fated use. It is well known that fire-arms go off of themselves if only enough of them are together.

[164] An intimation of the terrible law that governs blind contingency, which Heraclitus called the rule of *enantiodromia* (a running towards the opposite), now steals upon modern man through the by-ways of his mind, chilling him with fear and paralysing his faith in the lasting effectiveness of social and political measures in the face of these monstrous forces. If he turns away from the terrifying prospect of a blind world in which building and destroying successively tip the scales, and then gazes into the recesses of his own mind, he will discover a chaos and a darkness there which everyone would gladly ignore. Science has destroyed even this last refuge; what was once a sheltering haven has become a cesspool.

[165] And yet it is almost a relief to come upon so much evil in the depths of our own psyche. Here at least, we think, is the root of all the evil in mankind. Even though we are shocked and disillusioned at first, we still feel, just because these things are part of our psyche, that we have them more or less in hand and can correct them or at any rate effectively suppress them. We like to assume that, if we succeeded in this, we should at least have rooted out some fraction of the evil in the world. Given a widespread knowledge of the unconscious, everyone could see when a statesman was being led astray by his own bad motives. The very newspapers would pull him up: "Please have yourself analysed; you are suffering from a repressed father-complex."

[166] I have purposely chosen this grotesque example to show to what absurdities we are led by the illusion that because something is psychic it is under our control. It is, however, true that much of the evil in the world comes from the fact that man in general is hopelessly unconscious, as it is also true that with increasing insight we can combat this evil at its source in ourselves, in the same way that science enables us to deal effectively with injuries inflicted from without.

[167] The rapid and worldwide growth of a psychological interest over the last two decades shows unmistakably that modern man is turning his attention from outward material things to his own inner processes. Expressionism in art prophetically anticipated this subjective development, for all art intuitively apprehends coming changes in the collective unconsciousness.

[168] The psychological interest of the present time is an indication that modern man expects something from the psyche which the outer world has not given him: doubtless something which our religion ought to contain, but no longer does contain, at least for modern man. For him the various forms of religion no longer appear to come from within, from the psyche; they seem more like items from the inventory of the outside world. No spirit not of this world vouchsafes him inner revelation; instead,

he tries on a variety of religions and beliefs as if they were Sunday attire, only to lay them aside again like worn-out clothes.

[169] Yet he is somehow fascinated by the almost pathological manifestations from the hinterland of the psyche, difficult though it is to explain how something which all previous ages have rejected should suddenly become interesting. That there is a general interest in these matters cannot be denied, however much it offends against good taste. I am not thinking merely of the interest taken in psychology as a science, or of the still narrower interest in the psychoanalysis of Freud, but of the widespread and ever-growing interest in all sorts of psychic phenomena, including spiritualism, astrology, Theosophy, parapsychology, and so forth. The world has seen nothing like it since the end of the seventeenth century. We can compare it only to the flowering of Gnostic thought in the first and second centuries after Christ. The spiritual currents of our time have, in fact, a deep affinity with Gnosticism. There is even an “Église gnostique de la France,” and I know of two schools in Germany which openly declare themselves Gnostic. The most impressive movement numerically is undoubtedly Theosophy, together with its continental sister, Anthroposophy; these are pure Gnosticism in Hindu dress. Compared with them the interest in scientific psychology is negligible. What is striking about these Gnostic systems is that they are based exclusively on the manifestations of the unconscious, and that their moral teachings penetrate into the dark side of life, as is clearly shown by the refurbished European version of *Kundalini-yoga*. The same is true of parapsychology, as everyone acquainted with this subject will agree.

[170] The passionate interest in these movements undoubtedly arises from psychic energy which can no longer be invested in obsolete religious forms. For this reason such movements have a genuinely religious character, even when they pretend to be scientific. It changes nothing when Rudolf Steiner calls his Anthroposophy “spiritual science,” or when Mrs. Eddy invents a “Christian Science.” These attempts at concealment merely show that religion has grown suspect—almost as suspect as politics and world-reform.

[171] I do not believe that I am going too far when I say that modern man, in contrast to his nineteenth-century brother, turns to the psyche with very great expectations, and does so without reference to any traditional creed but rather with a view to Gnostic experience. The fact that all the movements I have mentioned give themselves a scientific veneer is not just a grotesque caricature or a masquerade, but a positive sign that they are actually pursuing “science,” i.e., *knowledge*, instead of *faith*, which is the essence of the Western forms of religion. Modern man abhors faith and the religions based upon it. He holds them valid only so far as their knowledge-content seems to accord with his own experience of the psychic background. He wants to *know—to* experience for himself.

[172] The age of discovery has only just come to an end in our day, when no part of the earth remains unexplored; it began when men would no longer *believe* that the Hyperboreans were one-footed monsters, or something of that kind, but wanted to find out and see with their own eyes what existed beyond the boundaries of the known world. Our age is apparently setting out to discover what exists in the psyche beyond consciousness. The question asked in every spiritualistic circle is: What happens after the medium has lost consciousness? Every Theosophist asks: What shall I experience at the higher levels of consciousness? The question which every astrologer asks is: What are the operative forces that determine my fate despite my conscious intention? And every psychoanalyst wants to know: What are the unconscious drives behind the neurosis?

[173] Our age wants to experience the psyche for itself. It wants original experience and not assumptions, though it is willing to make use of all the existing assumptions as a means to this end, including those of the recognized religions and the authentic sciences. The European of yesterday will feel a slight shudder run down his spine when he gazes more deeply into these delvings. Not only does he consider the subject of this so-called research obscure and shuddersome, but even the methods employed seem to him a shocking misuse of man's finest intellectual attainments. What is the professional astronomer to say when he is told that at least a thousand times more horoscopes are cast today than were cast three hundred years ago? What will the educator and advocate of philosophical enlightenment say about the fact that the world has not grown poorer by a single superstition since the days of antiquity? Freud himself, the founder of psychoanalysis, has taken the greatest pains to throw as glaring a light as possible on the dirt and darkness and evil of the psychic background, and to interpret it in such a way as to make us lose all desire to look for anything behind it except refuse and smut. He did not succeed, and his attempt at deterrence has even brought about the exact opposite—an admiration for all this filth. Such a perverse phenomenon would normally be inexplicable were it not that even the scatologists are drawn by the secret fascination of the psyche.

[174] There can be no doubt that from the beginning of the nineteenth century—ever since the time of the French Revolution—the psyche has moved more and more into the foreground of man's interest, and with a steadily increasing power of attraction. The enthronement of the Goddess of Reason in Notre Dame seems to have been a symbolic gesture of great significance for the Western world—rather like the hewing down of Wotan's oak by Christian missionaries. On both occasions no avenging bolt from heaven struck the blasphemer down.

[175] It is certainly more than an amusing freak of history that just at the time of the Revolution a Frenchman, Anquetil du Perron, should be living in India and, at the beginning of the nineteenth century, brought back with him a translation of the

Oupnek'hat, a collection of fifty Upanishads, which gave the West its first deep insight into the baffling mind of the East. To the historian this is a mere coincidence independent of the historical nexus of cause and effect. My medical bias prevents me from seeing it simply as an accident. Everything happened in accordance with a psychological law which is unfailingly valid in personal affairs. If anything of importance is devalued in our conscious life, and perishes—so runs the law—there arises a compensation in the unconscious. We may see in this an analogy to the conservation of energy in the physical world, for our psychic processes also have a quantitative, energetic aspect. No psychic value can disappear without being replaced by another of equivalent intensity. This is a fundamental rule which is repeatedly verified in the daily practice of the psychotherapist and never fails. The doctor in me refuses point blank to consider the life of a people as something that does not conform to psychological law. For him the psyche of a people is only a somewhat more complex structure than the psyche of an individual. Moreover, has not a poet spoken of the “nations of his soul”? And quite correctly, it seems to me, for in one of its aspects the psyche is not individual, but is derived from the nation, from the collectivity, from humanity even. In some way or other we are part of a single, all-embracing psyche, a single “greatest man,” the *homo maximus*, to quote Swedenborg.

[176] And so we can draw a parallel: just as in me, a single individual, the darkness calls forth a helpful light, so it does in the psychic life of a people. In the crowds that poured into Notre Dame, bent on destruction, dark and nameless forces were at work that swept the individual off his feet; these forces worked also upon Anquetil du Perron and provoked an answer which has come down in history and speaks to us through the mouths of Schopenhauer and Nietzsche. For he brought the Eastern mind to the West, and its influence upon us we cannot as yet measure. Let us beware of underestimating it! So far, indeed, there is little of it to be seen on the intellectual surface: a handful of orientalists, one or two Buddhist enthusiasts, a few sombre celebrities like Madame Blavatsky and Annie Besant with her Krishnamurti. These manifestations are like tiny scattered islands in the ocean of mankind; in reality they are the peaks of submarine mountain-ranges. The cultural Philistines believed until recently that astrology had been disposed of long since and was something that could safely be laughed at. But today, rising out of the social deeps, it knocks at the doors of the universities from which it was banished some three hundred years ago. The same is true of Eastern ideas; they take root in the lower levels and slowly grow to the surface. Where did the five or six million Swiss francs for the Anthroposophist temple at Dornach come from? Certainly not from one individual. Unfortunately there are no statistics to tell us the exact number of avowed Theosophists today, not to mention the unavowed. But we can be sure there are several millions of them. To this number we must add a few million Spiritualists of Christian or Theosophist leanings.

[177] Great innovations never come from above; they come invariably from below, just as trees never grow from the sky downward, but upward from the earth. The upheaval of our world and the upheaval of our consciousness are one and the same. Everything has become relative and therefore doubtful. And while man, hesitant and questioning, contemplates a world that is distracted with treaties of peace and pacts of friendship, with democracy and dictatorship, capitalism and Bolshevism, his spirit yearns for an answer that will allay the turmoil of doubt and uncertainty. And it is just the people from the obscurer levels who follow the unconscious drive of the psyche; it is the much-derided, silent folk of the land, who are less infected with academic prejudices than the shining celebrities are wont to be. Looked at from above, they often present a dreary or laughable spectacle; yet they are as impressively simple as those Galileans who were once called blessed. Is it not touching to see the offscourings of man's psyche gathered together in compendia a foot thick? We find the merest babblings, the most absurd actions, the wildest fantasies recorded with scrupulous care in the volumes of *Anthropophyteia*,⁴ while men like Havelock Ellis and Freud have dealt with like matters in serious treatises which have been accorded all scientific honours. Their reading public is scattered over the breadth of the civilized, white world. How are we to explain this zeal, this almost fanatical worship of everything unsavoury? It is because these things are psychological—they are of the substance of the psyche and therefore as precious as fragments of manuscript salvaged from ancient middens. Even the secret and noisome things of the psyche are valuable to modern man because they serve his purpose. But what purpose?

[178] Freud prefixed to his *Interpretation of Dreams* the motto: *Flectere si nequeo superos Acheronta movebo*—"If I cannot bend the gods on high, I will at least set Acheron in uproar." But to what purpose?

[179] The gods whom we are called upon to dethrone are the idolized values of our conscious world. Nothing, as we know, discredited the ancient gods so much as their love-scandals, and now history is repeating itself. People are laying bare the dubious foundations of our belauded virtues and incomparable ideals, and are calling out to us in triumph: "There are your man-made gods, mere snares and delusions tainted with human baseness—whited sepulchres full of dead men's bones and of all uncleanness." We recognize a familiar strain, and the Gospel words which we failed to digest at Confirmation come to life again.

[180] I am deeply convinced that these are not just vague analogies. There are too many persons to whom Freudian psychology is dearer than the Gospels, and to whom Bolshevism means more than civic virtue. And yet they are all our brothers, and in each of us there is at least one voice which seconds them, for in the end there is one psyche which embraces us all.

[181] The unexpected result of this development is that an uglier face is put upon the world. It becomes so ugly that no one can love it any longer; we cannot even love ourselves, and in the end there is nothing in the outer world to draw us away from the reality of the life within. Here, no doubt, we have the true significance of this whole development. After all, what does Theosophy, with its doctrines of *karma* and reincarnation, seek to teach except that this world of appearance is but a temporary health resort for the morally unperfected? It depreciates the intrinsic value of the present-day world no less radically than does the modern outlook, but with the help of a different technique; it does not vilify our world, but grants it only a relative meaning in that it promises other and higher worlds. The result in either case is the same.

[182] I admit that all these ideas are extremely unacademic, the truth being that they touch modern man on the side where he is least conscious. Is it again a mere coincidence that modern thought has had to come to terms with Einstein's relativity theory and with nuclear theories which lead us away from determinism and border on the inconceivable? Even physics is volatilizing our material world. It is no wonder, then, in my opinion, if modern man falls back on the reality of psychic life and expects from it that certainty which the world denies him.

[183] Spiritually the Western world is in a precarious situation, and the danger is greater the more we blind ourselves to the merciless truth with illusions about our beauty of soul. Western man lives in a thick cloud of incense which he burns to himself so that his own countenance may be veiled from him in the smoke. But how do we strike men of another colour? What do China and India think of us? What feelings do we arouse in the black man? And what about all those whom we rob of their lands and exterminate with rum and venereal disease?

[184] I have an American Indian friend who is a Pueblo chieftain. Once when we were talking confidentially about the white man, he said to me: "We don't understand the whites. They are always wanting something, always restless, always looking for something. What is it? We don't know. We can't understand them. They have such sharp noses, such thin, cruel lips, such lines in their faces. We think they are all crazy."

[185] My friend had recognized, without being able to name it, the Aryan bird of prey with his insatiable lust to lord it in every land, even those that concern him not at all. And he had also noted that megalomania of ours which leads us to suppose, among other things, that Christianity is the only truth and the white Christ the only redeemer. After setting the whole East in turmoil with our science and technology, and exacting tribute from it, we send our missionaries even to China. The comedy of Christianity in Africa is really pitiful. There the stamping out of polygamy, no doubt highly pleasing to God, has given rise to prostitution on such a scale that in Uganda alone twenty thousand pounds are spent annually on preventives of venereal infection. And the

good European pays his missionaries for these edifying achievements! Need we also mention the story of suffering in Polynesia and the blessings of the opium trade?

[186] That is how the European looks when he is extricated from the cloud of his own moral incense. No wonder that unearthing the psyche is like undertaking a full-scale drainage operation. Only a great idealist like Freud could devote a lifetime to such unclean work. It was not he who caused the bad smell, but all of us—we who think ourselves so clean and decent from sheer ignorance and the grossest self-deception. Thus our psychology, the acquaintance with our own souls, begins in every respect from the most repulsive end, that is to say with all those things which we do not wish to see.

[187] But if the psyche consisted only of evil and worthless things, no power on earth could induce the normal man to find it attractive. That is why people who see in Theosophy nothing but lamentable intellectual superficiality, and in Freudian psychology nothing but sensationalism, prophesy an early and inglorious end to these movements. They overlook the fact that such movements derive their force from the fascination of the psyche, and that it will express itself in these forms until they are replaced by something better. They are transitional or embryonic stages from which new and riper forms will emerge.

[188] We have not yet realized that Western Theosophy is an amateurish, indeed barbarous imitation of the East. We are just beginning to take up astrology again, which to the Oriental is his daily bread. Our studies of sexual life, originating in Vienna and England, are matched or surpassed by Hindu teachings on this subject. Oriental texts ten centuries old introduce us to philosophical relativism, while the idea of indeterminacy, newly broached in the West, is the very basis of Chinese science. As to our discoveries in psychology, Richard Wilhelm has shown me that certain complicated psychic processes are recognizably described in ancient Chinese texts. Psychoanalysis itself and the lines of thought to which it gives rise—a development which we consider specifically Western—are only a beginner's attempt compared with what is an immemorial art in the East. It may not perhaps be known that parallels between psychoanalysis and yoga have already been drawn by Oscar Schmitz.⁵

[189] Another thing we have not realized is that while we are turning the material world of the East upside down with our technical proficiency, the East with its superior psychic proficiency is throwing our spiritual world into confusion. We have never yet hit upon the thought that while we are overpowering the Orient from without, it may be fastening its hold on us from within. Such an idea strikes us as almost insane, because we have eyes only for obvious causal connections and fail to see that we must lay the blame for the confusion of our intellectual middle class at the doors of Max Müller, Oldenberg, Deussen, Wilhelm, and others like them. What does the example of the Roman Empire teach us? After the conquest of Asia Minor, Rome became

Asiatic; Europe was infected by Asia and remains so today. Out of Cilicia came the Mithraic cult, the religion of the Roman legions, and it spread from Egypt to fog-bound Britain. Need I point out the Asiatic origin of Christianity?

[190] The Theosophists have an amusing idea that certain Mahatmas, seated somewhere in the Himalayas or Tibet, inspire and direct every mind in the world. So strong, in fact, can be the influence of the Eastern belief in magic that Europeans of sound mind have assured me that every good thing I say is unwittingly inspired in me by the Mahatmas, my own inspirations being of no account whatever. This myth of the Mahatmas, widely circulated in the West and firmly believed, far from being nonsense, is—like every myth—an important psychological truth. It seems to be quite true that the East is at the bottom of the spiritual change we are passing through today. Only, this East is not a Tibetan monastery full of Mahatmas, but lies essentially within us. It is our own psyche, constantly at work creating new spiritual forms and spiritual forces which may help us to subdue the boundless lust for prey of Aryan man. We shall perhaps come to know something of that narrowing of horizons which has grown in the East into a dubious quietism, and also something of that stability which human existence acquires when the claims of the spirit become as imperative as the necessities of social life. Yet in this age of Americanization we are still far from anything of the sort; it seems to me that we are only at the threshold of a new spiritual epoch. I do not wish to pass myself off as a prophet, but one can hardly attempt to sketch the spiritual problem of modern man without mentioning the longing for rest in a period of unrest, the longing for security in an age of insecurity. It is from need and distress that new forms of existence arise, and not from idealistic requirements or mere wishes.

[191] To me the crux of the spiritual problem today is to be found in the fascination which the psyche holds for modern man. If we are pessimists, we shall call it a sign of decadence; if we are optimistically inclined, we shall see in it the promise of a far-reaching spiritual change in the Western world. At all events, it is a significant phenomenon. It is the more noteworthy because it is rooted in the deeper social strata, and the more important because it touches those irrational and—as history shows—incalculable psychic forces which transform the life of peoples and civilizations in ways that are unforeseen and unforeseeable. These are the forces, still invisible to many persons today, which are at the bottom of the present “psychological” interest. The fascination of the psyche is not by any means a morbid perversity; it is an attraction so strong that it does not shrink even from what it finds repellent.

[192] Along the great highways of the world everything seems desolate and outworn. Instinctively modern man leaves the trodden paths to explore the by-ways and lanes, just as the man of the Greco-Roman world cast off his defunct Olympian gods and turned to the mystery cults of Asia. Our instinct turns outward, and appropriates

Eastern theosophy and magic; but it also turns inward, and leads us to contemplate the dark background of the psyche. It does this with the same scepticism and the same ruthlessness which impelled the Buddha to sweep aside his two million gods that he might attain the original experience which alone is convincing.

[193] And now we must ask a final question. Is what I have said of modern man really true, or is it perhaps an illusion? There can be no doubt whatever that to many millions of Westerners the facts I have adduced are wholly irrelevant and fortuitous, and regrettable aberrations to a large number of educated persons. But—did a cultivated Roman think any differently when he saw Christianity spreading among the lower classes? Today the God of the West is still a living person for vast numbers of people, just as Allah is beyond the Mediterranean, and the one believer holds the other an inferior heretic, to be pitied and tolerated failing all else. To make matters worse, the enlightened European is of the opinion that religion and such things are good enough for the masses and for women, but of little consequence compared with immediate economic and political questions.

[194] So I am refuted all along the line, like a man who predicts a thunderstorm when there is not a cloud in the sky. Perhaps it is a storm below the horizon, and perhaps it will never reach us. But what is significant in psychic life always lies below the horizon of consciousness, and when we speak of the spiritual problem of modern man we are speaking of things that are barely visible—of the most intimate and fragile things, of flowers that open only in the night. In daylight everything is clear and tangible, but the night lasts as long as the day, and we live in the night-time also. There are people who have bad dreams which even spoil their days for them. And for many people the day's life is such a bad dream that they long for the night when the spirit awakes. I believe that there are nowadays a great many such people, and this is why I also maintain that the spiritual problem of modern man is much as I have presented it.

[195] I must plead guilty, however, to the charge of one-sidedness, for I have passed over in silence the spirit of the times, about which everyone has so much to say because it is so clearly apparent to us all. It shows itself in the ideal of internationalism and supernationalism, embodied in the League of Nations and the like; we see it also in sport and, significantly, in cinema and jazz. These are characteristic symptoms of our time, which has extended the humanistic ideal even to the body. Sport puts an exceptional valuation on the body, and this tendency is emphasized still further in modern dancing. The cinema, like the detective story, enables us to experience without danger to ourselves all the excitements, passions, and fantasies which have to be repressed in a humanistic age. It is not difficult to see how these symptoms link up with our psychological situation. The fascination of the psyche brings about a new self-appraisal, a reassessment of our fundamental human

nature. We can hardly be surprised if this leads to a rediscovery of the body after its long subjection to the spirit—we are even tempted to say that the flesh is getting its own back. When Keyserling sarcastically singles out the chauffeur as the culture-hero of our time, he has struck, as he often does, close to the mark. The body lays claim to equal recognition; it exerts the same fascination as the psyche. If we are still caught in the old idea of an antithesis between mind and matter, this state of affairs must seem like an unbearable contradiction. But if we can reconcile ourselves to the mysterious truth that the spirit is the life of the body seen from within, and the body the outward manifestation of the life of the spirit—the two being really one—then we can understand why the striving to transcend the present level of consciousness through acceptance of the unconscious must give the body its due, and why recognition of the body cannot tolerate a philosophy that denies it in the name of the spirit. These claims of physical and psychic life, incomparably stronger than they were in the past, may seem a sign of decadence, but they may also signify a rejuvenation, for as Hölderlin says:

Where danger is,
Arises salvation also.

[196] And indeed we see, as the Western world strikes up a more rapid tempo—the American tempo—the exact opposite of quietism and world-negating resignation. An unprecedented tension arises between outside and inside, between objective and subjective reality. Perhaps it is a final race between aging Europe and young America; perhaps it is a healthier or a last desperate effort to escape the dark sway of natural law, and to wrest a yet greater and more heroic victory of waking consciousness over the sleep of the nations. This is a question only history can answer.

II

THE LOVE PROBLEM OF A STUDENT

WOMAN IN EUROPE

THE MEANING OF PSYCHOLOGY FOR MODERN MAN

THE STATE OF PSYCHOTHERAPY TODAY

THE LOVE PROBLEM OF A STUDENT¹

[197] It is, I assure you, with no light heart that I undertake the task of opening your discussion of the love problem of a student by reading a general paper on this subject. Such a discussion is an unusual one, and presents difficulties if taken in a spirit of seriousness and with a fitting sense of responsibility.

[198] Love is always a problem, whatever our age may be. In childhood, the love of one's parents is a problem, and for the old man the problem is what he has made of his love. Love is a force of destiny whose power reaches from heaven to hell. We must, I think, understand love in this way if we are to do any sort of justice to the problems it involves. They are of immense scope and complexity, not confined to any particular province but covering every aspect of human life. Love may be an ethical, a social, a psychological, a philosophical, an aesthetic, a religious, a medical, a legal, or a physiological problem, to name only a few aspects of this many-sided phenomenon. This invasion of love into all the collective spheres of life is, however, only a minor difficulty in comparison with the fact that love is also an intensely individual problem. For it means that every general criterion and rule loses its validity, in exactly the same way that religious beliefs, although constantly codified in the course of history, are always, in essence, an individual experience which bows to no traditional rule.

[199] The very word "love" is itself an obstacle to our discussion. What, indeed, has not been called "love"! Beginning with the highest mystery of the Christian religion, we encounter, on the next-lower stages, the *amor Dei* of Origen, the *amor intellectualis Dei* of Spinoza, Plato's love of the Idea, and the *Gottesminne* of the mystics. Goethe's words introduce us to the human sphere of love:

Let now the savage instincts sleep
And all the violence they do;
When human love stirs in the deep
The love of God is stirring too.

[200] Here we find the love of one's neighbour, in the Christian sense as well as in the Buddhist sense of compassion, and the love of mankind as expressed in social service. Next there is love of one's country, and the love for ideal institutions such as the Church. Then comes parental love, above all mother-love, then filial love. When we come to conjugal love we leave the sphere of the spiritual and enter that intermediate realm between spirit and instinct. Here the pure flame of Eros sets fire to sexuality, and the ideal forms of love—love of parents, of country, of one's neighbour, etc.—are

mingled with the lust for personal power and the desire to possess and to rule. This does not mean that all contact with instinct debases love. On the contrary, its beauty and truth and strength become the more perfect the more instinct it can absorb into itself. Only if instinct predominates does the animal come to the surface. Conjugal love can be of the kind of which Goethe says at the end of *Faust*:

Spirit by attraction draws
Elemental matter,
Forges bonds no man can force
And no angel shatter.
Double natures single grown,
Inwardly united,
By Eternal Love alone
Can it be divided.

[201] But it need not necessarily be such a love. It may recall Nietzsche's words: "Two animals have lighted on each other." The love of the lover is again different. Even though the sacrament of marriage be lacking, and the pledge of a life together, this love may be transfigured by the power of fate or by its own tragic nature. But as a rule instinct predominates, with its dark glow or its flickering fires.

[202] Even this has not brought us to the limits of love. By "love" we also mean the sexual act on all levels, from officially sanctioned, wedded cohabitation to the physiological need which drives a man to prostitutes and to the mere business they make or are forced to make of love.

[203] We also speak of "the love of boys," meaning homosexuality, which since classical times has lost its glamour as a social and educative institution, and now ekes out a miserable, terror-stricken existence as a so-called perversion and punishable offence, at least where men are concerned. In Anglo-Saxon countries it seems on the other hand that female homosexuality means rather more than Sapphic lyricism, since it somehow acts as a stimulus to the social and political organization of women, just as male homosexuality was an important factor in the rise of the Greek *polis*.

[204] Finally, the word "love" must be stretched still further to cover all sexual perversions. There is incestuous love, and a masturbatory self-love that goes by the name of narcissism. The word "love" includes every kind of morbid sexual abomination as well as every kind of greed that has ever degraded man to the level of a beast or a machine.

[205] Thus we find ourselves in the awkward position of beginning a discussion about a matter or concept whose outlines are of the vaguest and whose extent is well-nigh illimitable. At least for the purposes of the present discussion, one would like to

restrict the concept of love to the problem of how a young student should come to terms with sex. But this just cannot be done, because all the meanings of the word “love” which I have already mentioned enter actively into the love problem of a student.

[206] We can, however, agree to discuss the question of the way in which the average so-called normal person behaves under the conditions I have described. Disregarding the fact the “normal” person does not exist, we find, nevertheless, sufficient similarities even among individuals of the most varied types to warrant a discussion of the “average” problem. As always, the practical solution of the problem depends on two factors: the demands and capacities of the individual, and the environmental conditions.

[207] It is the duty of a speaker to present a general survey of the question under discussion. Naturally this can be done only if, as a doctor, I can give an objective account of things as they are, and abstain from that stale, moralizing talk which veils the subject with a mixture of bashfulness and hypocrisy. Moreover, I am not here to tell you what ought to be done. That must be left to those who always know what is better for other people.

[208] Our theme is “The Love Problem of a Student,” and I assume that “love problem” means the relation of the two sexes and is not to be construed as the “sexual problem” of a student. This provides a useful limitation of our theme, for the question of sex would need considering only so far as it is a love problem, or a problem of relationship. Hence we can exclude all those sexual phenomena that have nothing to do with relationship, such as sexual perversions (with the exception of homosexuality), masturbation, and intercourse with prostitutes. We cannot exclude homosexuality because very often it is a problem of relationship; but we can exclude prostitution because usually it does not involve a relationship, though there are exceptions which prove the rule.

[209] The average solution of the love problem is, as you know, marriage. But experience shows that this statistical truth does not apply to the student. The immediate reason for this is that a student is generally not in a position to set up house. A further reason is the youthful age of most students, which, partly because of their unfinished studies, and partly because of their need for freedom to move from place to place, does not yet permit the social fixation entailed by marriage. Other factors to be considered are psychological immaturity, childish clinging to home and family, relatively undeveloped capacity for love and responsibility, lack of experience of life and the world, the typical illusions of youth, and so on. A reason that should not be underestimated is the sagacious reserve of the girl students. Their first aim is to complete their studies and take up a profession. They therefore abstain from marriage, especially from marriage with a student, who so long as he remains a student is not a

desirable marriage partner for the reasons already mentioned. Another, very important, reason for the infrequency of student marriages is the question of children. As a rule when a girl marries she wants a child, whereas a man can manage well enough for a time without children. A marriage without children has no special attraction for a woman; she prefers to wait.

[210] In recent years, it is true, student marriages have become more frequent. This is due partly to the psychological changes in our modern outlook, and partly to the spread of contraceptive measures. The psychological changes that have produced, among other things, the phenomenon of the student marriage are probably the result of the spiritual upheavals of the last few decades, the total significance of which we are as yet unable to grasp. All we can say is that, as a consequence of the general dissemination of scientific knowledge and a more scientific way of thinking, a change in the very conception of the love problem has come about. Scientific objectivity has effected a rapprochement between the sacrosanct idea of man as a superior being and man as a natural being, and made it possible for *Homo sapiens* to take his place as part of the natural order. The change has an emotional as well as an intellectual aspect. Such a view works directly on the feelings of the individual. He feels released from the confines of a metaphysical system and from those moral categories which characterized the medieval outlook on the world. The taboos erected on man's exclusion from nature no longer prevail, and the moral judgments which in the last analysis always have their roots in the religious metaphysic of the age have lost their force. Within the traditional moral system everyone knows perfectly why marriage is "right" and why any other form of love is to be abhorred. But outside the system, on the playground and battlefield of nature, where man feels himself to be the most gifted member of the great family of animals, he must orient himself anew. The loss of the old standards and values amounts, at first, to moral chaos. All the hitherto accepted forms are doubted, people begin to discuss things that have long sheltered behind a moral prejudice. They boldly investigate the actual facts and feel an irresistible need to take stock of experience, to know and to understand. The eyes of science are fearless and clear; they do not flinch from gazing into moral darkneses and dirty corners. The man of today can no longer rest content with a traditional judgment; he must know why. This search leads to the creation of new standards of value.

[211] One of these is an evaluation of love in terms of hygiene. Through a franker and more objective discussion of sex a knowledge of the immense dangers of venereal disease has become much more widespread. The obligation to keep oneself healthy has superseded the guilty fears of the old morality. But this process of moral sanitation has not yet progressed to the point where public conscience would allow the same civic measures to be taken for dealing with venereal diseases as with other infectious diseases. Venereal diseases are still considered "indecent," unlike smallpox and

cholera, which are morally acceptable in the drawing room. No doubt these fine distinctions will raise a smile in a more enlightened age.

[212] The widespread discussion of the sexual question has brought the extraordinary importance of sexuality in all its psychic ramifications to the forefront of our social consciousness. A major contribution was made during the last twenty-five years by the much-decried psychoanalytic movement. Today it is no longer possible to brush aside the tremendous psychological importance of sex with a bad joke or a display of moral indignation. People are beginning to see the sexual question in the context of the great human problems and to discuss it with the seriousness it deserves. The natural result of this is that much that was formerly held to be beyond dispute is now open to doubt. There is, for instance, a doubt as to whether the officially sanctioned form of sexuality is the only one that is morally possible, and whether all other forms are to be condemned out of hand. The arguments for and against are gradually losing their moral acerbity, practical considerations force themselves into the discussion, and finally we are beginning to discover that legitimized sex is not *eo ipso* the equivalent of moral superiority.

[213] In addition to this, the marriage problem with its usually sombre background has become a theme for romantic literature. Whereas the romance of the old style concluded with a happy betrothal or a wedding, the modern novel often begins after the marriage. In these novels, which get into everybody's hands, the most intimate problems are often treated with a lack of reticence that is positively painful. Of the veritable flood of more or less undisguised pornographic writings we need hardly speak. A popular scientific book, Forel's *The Sexual Question*, not only had an enormous sale but found a good many imitators. In scientific literature, compilations have been produced which both in scope and in the dubious nature of their contents exceed anything found in Krafft-Ebing's *Psychopathia Sexualis*, in a way that would have been inconceivable thirty or forty years ago.

[214] These widespread and widely known phenomena are a sign of the times. They make it possible for young people today to grasp the full importance of the problem of sex much earlier than they could have at any time during the last two decades. There are some who maintain that this early preoccupation with sex is unhealthy, a sign of urban degeneration. I remember reading an article fifteen years ago in Ostwald's *Annalen der Naturphilosophie*, which said, quite literally: "Primitive people like the Eskimos, Swiss, etc., have no sexual problem." It scarcely needs much reflection to see why primitives have no sexual problem; beyond the concerns of the stomach they have no other problems to worry about. Problems are the prerogative of civilized man. Here in Switzerland we have no great cities and yet such problems exist. I do not think that discussion of the sexual question is unhealthy or in the least degenerate; I see it rather as a symptom of the great psychological revolution of our time and the changes

it has brought about. It seems to me that the more seriously and thoroughly we discuss this question, which is of such vital importance for man's health and happiness, the better it will be for all of us.

[215] It is no doubt the serious interest shown in this question that has led to the hitherto unknown phenomenon of student marriages. Such a very recent phenomenon is difficult to judge for lack of sufficient data. In former times there were early marriages in abundance, also marriages that must have seemed socially very unstable. In itself, therefore, the student marriage is perfectly permissible. The question of children, however, is another matter. If both partners are studying, children must obviously be ruled out. But a marriage that remains artificially childless is always rather problematical. Children are the cement that holds it together as nothing else could. And it is the parents' concentration on the children which in innumerable instances keeps alive the feeling of companionship so essential for the stability of a marriage. When there are no children the interest of each partner is directed to the other, which in itself might be a good thing. In practice, unfortunately, this mutual preoccupation is not always of an amiable kind. Each blames the other for the dissatisfaction felt by both. In these circumstances it is probably better for the wife to be studying, otherwise she is left without an object; for there are many women who cannot endure marriage without children and become unendurable themselves. If she is studying, she at least has a life outside her marriage that is sufficiently satisfying. A woman who is very set on children, and for whom children are more important than a husband, should certainly think twice before embarking on a student marriage. She should also realize that the urge to maternity often appears in imperative form only later, that is, after she is married.

[216] As to whether student marriages are premature, we must take note of a fact that applies to all early marriages, namely, that a girl of twenty is usually older than a man of twenty-five, as far as maturity of judgment is concerned. With many men of twenty-five the period of psychological puberty is not yet over. Puberty is a period of illusion and only partial responsibility. The psychological difference is due to the fact that a boy, up to the time of sexual maturity, is as a rule quite childish, whereas a girl develops much earlier than he does the psychological subtleties that go hand in hand with adolescence. Into this childishness sexuality often breaks with brutal force, while, despite the onset of puberty, it often goes on slumbering in a girl until the passion of love awakens it. There are a surprising number of women whose real sexuality, even though they are married, remains virginal for years; they become conscious of it only when they fall in love with another man. That is the reason why very many women have no understanding at all of masculine sexuality—they are completely unconscious of their own. With men it is different. Sexuality bursts on them like a tempest, filling them with brute desires and needs, and there is scarcely one of them who escapes the

painful problem of masturbation. But a girl can masturbate for years without knowing what she is doing.

[217] The onrush of sexuality in a boy brings about a powerful change in his psychology. He now has the sexuality of a grown man with the soul of a child. Often the flood of obscene fantasies and smutty talk with schoolfellows pours like a torrent of dirty water over all his delicate and childish feelings, sometimes smothering them for ever. Unexpected moral conflicts arise, temptations of every description lie in wait for him and weave themselves into his fantasies. The psychic assimilation of the sexual complex causes him the greatest difficulties even though he may not be conscious of its existence. The onset of puberty also brings about considerable changes in his metabolism, as can be seen from the pimples and acne that so often afflict adolescents. The psyche is disturbed in a similar manner and thrown off its balance. At this age the young man is full of illusions, which are always a sign of psychic disequilibrium. They make stability and maturity of judgment impossible. His tastes, his interests, his plans alter fitfully. He can suddenly fall head over heels in love with a girl, and a fortnight later he cannot conceive how anything of the sort could have happened to him. He is so riddled with illusions that he actually needs these mistakes to make him conscious of his own taste and individual judgment. He is still experimenting with life, and *must* experiment with it in order to learn how to judge things correctly. Hence there are very few men who have not had sexual experience of some kind before they are married. During puberty it is mostly homosexual experiences, and these are much more common than is generally admitted. Heterosexual experiences come later, not always of a very beautiful kind. For the less the sexual complex is assimilated to the whole of the personality, the more autonomous and instinctive it will be. Sexuality is then purely animal and recognizes no psychological distinctions. The most inferior woman will do; it is enough if she has the typical secondary sexual characteristics. A false step of this kind does not entitle us to draw conclusions about a man's character, as the act can easily occur at a time when the sexual complex is still split off from the psyche's influence. Nevertheless, too many experiences of this nature have a bad effect on the formation of the personality, as by force of habit they fix sexuality on too low a level and make it unacceptable to moral judgment. The result is that though the man in question is outwardly a respectable citizen, inwardly he is prey to sexual fantasies of the lowest kind, or else he represses them and on some festive occasion they come leaping to the surface in their primitive form, much to the astonishment of his unsuspecting wife—assuming, of course, that she notices what is going on. A frequent accompaniment is premature coldness towards the wife. Women are often frigid from the first day of marriage because their sensation function does not respond to this kind of sexuality in their husbands. The weakness of a man's judgment at the time of psychological puberty should prompt him to reflect very deeply on the premature choice of a wife.

[218] Let us now turn to other forms of relationship between the sexes that are customary during the student period. There are, as you know, characteristic liaisons between students, chiefly in the great universities of other countries. These relationships are sometimes fairly stable and may even have a psychological value, as they do not consist entirely of sexuality but also, in part, of love. Occasionally the liaison is continued into marriage. The relationship stands, therefore, considerably higher than prostitution. But as a rule it is limited to those students who were careful in the choice of their parents. It is usually a question of money, for most of the girls are dependent on their lovers for financial help, though they could not be said to sell their love for money. Very often the relationship is a beautiful episode in the girl's life, otherwise poor and empty, while for the man it may be his first intimate acquaintance with a woman, and in later life a memory on which he looks back with emotion. Often, again, there is nothing valuable in these affairs, partly owing to the man's crude sensuality, thoughtlessness, and lack of feeling, and partly owing to the frivolity and fickleness of the girl.

[219] Over all these relationships hangs the Damoclean sword of their transitoriness, which prevents the formation of real values. They are passing episodes, experiments of very limited validity. Their injurious effect on the personality is due to the fact that the man gets the girl too easily, so that the value of the love object is depreciated. It is convenient for him to dispose of his sexual problem in such a simple and irresponsible way. He becomes spoilt. But even more, the fact that he is sexually satisfied robs him of a driving-force which no young man can do without. He becomes blasé and can afford to wait. Meanwhile he can calmly review the massed femininity passing before him until the right party turns up. Then the wedding comes along and the latest date is thrown over. This procedure adds little of advantage to his character. The low level of relationship tends to keep sexuality on a correspondingly low level of development, and this can easily lead to difficulties in marriage. Or if his sexual fantasies are repressed, the result is only too likely to be a neurotic or, worse still, a moral zealot.

[220] Homosexual relations between students of either sex are by no means uncommon. So far as I can judge of this phenomenon, I would say that these relationships are less common with us, and on the continent generally, than in certain other countries where boy and girl college students live in strict segregation. I am speaking here not of pathological homosexuals who are incapable of real friendship and meet with little sympathy among normal individuals, but of more or less normal youngsters who enjoy such a rapturous friendship that they also express their feelings in sexual form. With them it is not just a matter of mutual masturbation, which in all school and college life is the order of the day among the younger age groups, but of a higher and more spiritual form which deserves the name "friendship" in the classical sense of the word. When such a friendship exists between an older man and a younger its

educative significance is undeniable. A slightly homosexual teacher, for example, often owes his brilliant educational gifts to his homosexual disposition. The homosexual relation between an older and a younger man can thus be of advantage to both sides and have a lasting value. An indispensable condition for the value of such a relation is the steadfastness of the friendship and their loyalty to it. But only too often this condition is lacking. The more homosexual a man is, the more prone he is to disloyalty and to the seduction of boys. Even when loyalty and true friendship prevail the results may be undesirable for the development of personality. A friendship of this kind naturally involves a special cult of feeling, of the feminine element in a man. He becomes gushing, soulful, aesthetic, over-sensitive, etc.—in a word, effeminate, and this womanish behaviour is detrimental to his character.

[221] Similar advantages and disadvantages can be pointed out in friendships between women, only here the difference in age and the educative factor are not so important. The main value lies in the exchange of tender feelings on the one hand and of intimate thoughts on the other. Generally they are high-spirited, intellectual, and rather masculine women who are seeking to maintain their superiority and to defend themselves against men. Their attitude to men is therefore one of disconcerting self-assurance, with a trace of defiance. Its effect on their character is to reinforce their masculine traits and to destroy their feminine charm. Often a man discovers their homosexuality only when he notices that these women leave him stone-cold.

[222] Normally, the practice of homosexuality is not prejudicial to later heterosexual activity. Indeed, the two can even exist side by side. I know a very intelligent woman who spent her whole life as a homosexual and then at fifty entered into a normal relationship with a man.

[223] Among the sexual relations of the student period we must mention yet another, which is quite normal even if rather peculiar. This is the attachment of a young man to an older woman, possibly married or at any rate widowed. You will perhaps remember Jean Jacques Rousseau and his connection with Mme de Warens; this is the kind of relationship I have in mind. The man is usually rather shy, unsure of himself, inwardly afraid, sometimes infantile. He naturally seeks a mother, perhaps because he has had too much or too little love in his own family. Many women like nothing better than a man who is rather helpless, especially when they are considerably older than he is; they do not love a man's strength, his virtues and his merits, but his weaknesses. They find his infantilisms charming. If he stammers a little, he is enchanting; or perhaps he has a limp, and this excites maternal compassion and a little more besides. As a rule the woman seduces him, and he willingly submits to her mothering.

[224] Not always, however, does a timid youth remain half a child. It may be that this surfeit of maternal solicitude was just what was needed to bring his undeveloped masculinity to the surface. In this way the woman educates his feeling and brings it to

full consciousness. He learns to understand a woman who has experience of life and the world, is sure of herself, and thus he has a rare opportunity for a glimpse behind the scenes. But he can take advantage of it only if he quickly outgrows this relationship, for should he get stuck in it her mothering would ruin him. Maternal tenderness is the most pernicious poison for anyone who has to equip himself for the hard and pitiless struggle of life. If he cannot let go of her apron-strings he will become a spineless parasite—for most of these women have money—and sink to the level of a lap-dog or a pet cat.

[225] We must now discuss those forms of relationship which offer no solution of the sexual question for the reason that they are asexual or “platonic.” If there were any reliable statistics on this subject, I believe they would show that in Switzerland the majority of students prefer a platonic relationship. Naturally, this raises the question of sexual abstinence. One often hears that abstaining from sexual intercourse is injurious to health. This view is incorrect, at least for people of the student age. Abstinence is injurious to health only when a man has reached the age when he could win a woman for himself, and should do so according to his individual inclinations. The extraordinary intensification of the sexual need that is so often felt at this time has the biological aim of forcibly eliminating the man’s scruples, misgivings, doubts, and hesitations. This is very necessary, because the very idea of marriage, with all its doubtful possibilities, often makes a man panicky. It is only to be expected, therefore, that nature will push him over the obstacle. Abstention from sexual intercourse may certainly have injurious effects under these conditions, but not when there is no urgent physical or psychological need for it.

[226] This brings us to the very similar question concerning the injurious effects of masturbation. When for physical or psychological reasons normal intercourse is impossible, masturbation as a safety-valve has no ill effects. Young people who come to the doctor suffering from the harmful effects of masturbation are not by any means excessive masturbationists—these usually have no need of a doctor because they are not in any sense ill—rather, their masturbation has harmful effects because it shows psychic complications and is attended by pangs of conscience or by a riot of sexual fantasies. The latter are particularly common among women. Masturbation with psychic complications is harmful, but not the ordinary, uncomplicated kind. If, however, it is continued up to the age when normal intercourse becomes physically, psychologically, and socially possible, and is indulged in merely in order to avoid the necessary tasks of life, then it is harmful.

[227] Platonic relationships are very important during the student period. The form they most commonly take is flirting. Flirting is the expression of an experimental attitude which is altogether appropriate at this age. It is a voluntary activity which, by tacit agreement, puts neither side under an obligation. This is an advantage and at the same

time a disadvantage. The experimental attitude enables both parties to get to know each other without any immediately undesirable results. Both exercise their judgment and their skill in self-expression, adaptation, and defence. An enormous variety of experiences which are uncommonly valuable in later life can be picked up from flirting. On the other hand, the absence of any obligation can easily lead to one's becoming an habitual flirt, shallow, frivolous, and heartless. The man turns into a drawing-room hero and professional heart-breaker, never dreaming what a boring figure he cuts; the girl a coquette, and a serious man instinctively feels that she is not to be taken seriously.

[228] A phenomenon that is as rare as flirting is common is the conscious cultivation of a serious love. We might call this simply the ideal, without, however, identifying it with traditional romanticism. For the development of personality, there can be no doubt that the timely awakening and conscious cultivation of deeply serious and responsible feelings are of the utmost value. A relationship of this kind can be the most effective shield against the temptations that beset a young man, as well as being a powerful incentive to hard work, loyalty, and reliability. However, there is no value so great that it does not have its unfavourable side. A relationship that is too ideal easily becomes exclusive. Through his love the young man is too much cut off from the acquaintance of other women, and the girl does not learn the art of erotic conquest because she has got her man already. Woman's instinct for possession is a dangerous thing, and it may easily happen that the man will regret all the experiences he never had with women before marriage and will make up for them afterwards.

[229] Hence it must not be concluded that every relationship of this kind is ideal. There are cases where the exact opposite is true—when, for instance, a man or girl trails round with a school sweetheart for no intelligible reason, from mere force of habit. Whether from inertia, or lack of spirit, or helplessness they simply cannot get rid of each other. Perhaps the parents on both sides find the match suitable, and the affair, begun in a moment of thoughtlessness and prolonged by habit, is passively accepted as a *fait accompli*. Here the disadvantages pile up without a single advantage. For the development of personality, acquiescence and passivity are harmful because they are an obstacle to valuable experience and to the exercise of one's specific gifts and virtues. Moral qualities are won only in freedom and prove their worth only in morally dangerous situations. The thief who refrains from stealing merely because he is in prison is not a moral personality. Though the parents may gaze benignly on this touching marriage and add their children's respectability to the tale of their own virtues, it is all a sham and a delusion, lacking real strength, and sapped by moral inertia.

[230] After this brief survey of the problems as we meet them in actual life, I will, in conclusion, turn to the land of heart's desire and utopian possibilities.

[231] Nowadays we can hardly discuss the love problem without speaking of the utopia of free love, including trial marriage. I regard this idea as a wishful fantasy and an attempt to make light of a problem which in actual life is invariably very difficult. It is no more possible to make life easy than it is to grow a herb of immortality. The force of gravity can be overcome only by the requisite application of energy. Similarly, the solution of the love problem challenges all our resources. Anything else would be useless patchwork. Free love would be conceivable only if everyone were capable of the highest moral achievement. The idea of free love was not invented with this aim in view, but merely to make something difficult appear easy. Love requires depth and loyalty of feeling; without them it is not love but mere caprice. True love will always commit itself and engage in lasting ties; it needs freedom only to effect its choice, not for its accomplishment. Every true and deep love is a sacrifice. The lover sacrifices all other possibilities, or rather, the illusion that such possibilities exist. If this sacrifice is not made, his illusions prevent the growth of any deep and responsible feeling, so that the very possibility of experiencing real love is denied him.

[232] Love has more than one thing in common with religious faith. It demands unconditional trust and expects absolute surrender. Just as nobody but the believer who surrenders himself wholly to God can partake of divine grace, so love reveals its highest mysteries and its wonder only to those who are capable of unqualified devotion and loyalty of feeling. And because this is so difficult, few mortals can boast of such an achievement. But, precisely because the truest and most devoted love is also the most beautiful, let no man seek to make it easy. He is a sorry knight who shrinks from the difficulty of loving his lady. Love is like God: both give themselves only to their bravest knights.

[233] I would offer the same criticism of trial marriages. The very fact that a man enters into a marriage on trial means that he is making a reservation; he wants to be sure of not burning his fingers, to risk nothing. But that is the most effective way of forestalling any real experience. You do not experience the terrors of the Polar ice by perusing a travel-book, or climb the Himalayas in a cinema.

[234] Love is not cheap—let us therefore beware of cheapening it! All our bad qualities, our egotism, our cowardice, our worldly wisdom, our cupidity—all these would persuade us not to take love seriously. But love will reward us only when we do. I must even regard it as a misfortune that nowadays the sexual question is spoken of as something distinct from love. The two questions should not be separated, for when there is a sexual problem it can be solved only by love. Any other solution would be a harmful substitute. Sexuality dished out as sexuality is brutish; but sexuality as an expression of love is hallowed. Therefore, never ask what a man does, but how he does it. If he does it from love or in the spirit of love, then he serves a god; and whatever he may do is not ours to judge, for it is ennobled.

[235] I trust that these remarks will have made it clear to you that I pass no sort of moral judgment on sexuality as a natural phenomenon, but prefer to make its moral evaluation dependent on the way it is expressed.

WOMAN IN EUROPE¹

You call yourself free? Your dominant thought I would hear, and not that you have escaped from a yoke. Are you one of those who had the right to escape from a yoke? There are some who threw away their last value when they threw away their servitude.

Thus Spake Zarathustra

[236] To write about woman in Europe today is such a hazardous undertaking that I would scarcely have ventured to do so without a pressing invitation. Have we anything of fundamental importance to say about Europe? Is anyone sufficiently detached? Are we not all involved in some programme or experiment, or caught in some critical retrospect that clouds our judgment? And in regard to woman, cannot the same questions be asked? Moreover, what can a man say about woman, his own opposite? I mean of course something sensible, that is outside the sexual programme, free of resentment, illusion, and theory. Where is the man to be found capable of such superiority? Woman always stands just where the man's shadow falls, so that he is only too liable to confuse the two. Then, when he tries to repair this misunderstanding, he overvalues her and believes her the most desirable thing in the world. Thus it is with the greatest misgivings that I set out to treat of this theme.

[237] One thing, however, is beyond doubt: that woman today is in the same process of transition as man. Whether this transition is a historical turning-point or not remains to be seen. Sometimes, when we look back at history, it seems as though the present time had analogies with certain periods in the past, when great empires and civilizations had passed their zenith and were hastening irresistibly towards decay. But these analogies are deceptive, for there are always renaissances. What *does* move more clearly into the foreground is Europe's position midway between the Asiatic East and the Anglo-Saxon—or shall we say American?—West. Europe now stands between two colossi, both uncouth in their form but implacably opposed to one another in their nature. They are profoundly different not only racially but in their ideals. In the West there is the maximum political freedom with the minimum personal freedom; in the East it is just the opposite. We see in the West a tremendous development of Europe's technological and scientific tendencies, and in the Far East an awakening of all those spiritual forces which, in Europe, these tendencies hold in check. The power of the West is material, that of the East ideal.² The struggle

between these opposites, which in the world of the European man takes place in the realm of the scientifically applied intellect and finds expression on the battlefield and in the state of his bank balance, is, in woman, a psychic conflict.

[238] What makes it so uncommonly difficult to discuss the problem of the modern European woman is that we are necessarily writing about a minority. There is no “modern European woman” properly speaking. Or is the peasant’s wife of today different from her forbears of a hundred years ago? There is, in fact, a large body of the population that only to a very limited extent lives in the present and participates in present-day problems. We speak of a “woman’s problem,” but how many women have problems? In proportion to the sum-total of European women only a dwindling minority really live in the Europe of today; and these are city dwellers and belong—to put it cautiously—to the more complicated of their kind. This must always be so, for it is only the few who clearly express the spirit of the present in any age. In the fourth and fifth centuries of our era there were only a very few Christians who in any way understood the spirit of Christianity, the rest were still practically pagan. The cultural process that is characteristic of an epoch operates most intensely in cities, for it needs large agglomerations of men to make civilization possible, and from these agglomerations culture gradually spreads to the smaller, backward groups. Thus we find the present only in the large centres, and there alone do we encounter the “European woman,” the woman who expresses the social and spiritual aspect of contemporary Europe. The further we go from the influence of the great centres, the more we find ourselves receding into history. In the remote Alpine valleys we can meet people who have never seen a railway, and in Spain, which is also a part of Europe, we plunge to a dark medieval age lacking even an alphabet. The people of those regions, or of the corresponding social strata, do not live in our Europe but in the Europe of 1400, and their problems are those of the bygone age in which they dwell. I have analysed such people, and have found myself carried back into an ambience that was not wanting in historical romance.

[239] The “present” is a thin surface stratum that is laid down in the great centres of civilization. If it is very thin, as in Tsarist Russia, it has no meaning, as events have shown. But once it has attained a certain strength, we can speak of civilization and progress, and then problems arise that are characteristic of an epoch. In this sense Europe has a present, and there are women who live in it and suffer its problems. About these, and these only, are we entitled to speak. Those who are satisfied with a medieval life have no need of the present and its experiments. But the man of the present cannot—no matter what the reason—turn back again to the past without suffering an essential loss. Often this turning back is altogether impossible, even if he were prepared to make the sacrifice. The man of the present must work for the future and leave others to conserve the past. He is therefore not only a builder but also a

destroyer. He and his world have both become questionable and ambiguous. The ways that the past shows him and the answers it gives to his questions are insufficient for the needs of the present. All the old, comfortable ways are blocked, new paths have been opened up, and new dangers have arisen of which the past knew nothing. It is proverbial that one never learns anything from history, and in regard to present-day problems it usually teaches us nothing. The new path has to be made through untrodden regions, without presuppositions and often, unfortunately, without piety. The only thing that cannot be improved upon is morality, for every alteration of traditional morality is by definition an immorality. This *bon mot* has an edge to it, against which many an innovator has barked his shins.

[240] All the problems of the present form a tangled knot, and it is hardly possible to single out one particular problem and treat it independently of the others. Thus there is no problem of “woman in Europe” without man and his world. If she is married, she usually has to depend economically on her husband; if she is unmarried and earning a living, she is working in some profession designed by a man. Unless she is prepared to sacrifice her whole erotic life, she again stands in some essential relationship to man. In numerous ways woman is indissolubly bound up with man’s world and is therefore just as exposed as he is to all the shocks of his world. The war, for instance, has affected woman just as profoundly as it has man, and she has to adapt to its consequences as he must. What the upheavals of the last twenty or thirty years mean for man’s world is apparent to everyone; we can read about it every day in the newspapers. But what it means for woman is not so evident. Neither politically, nor economically, nor spiritually is she a factor of visible importance. If she were, she would loom more largely in man’s field of vision and would have to be considered a rival. Sometimes she is seen in this role, but only as a man, so to speak, who is accidentally a woman. But since as a rule her place is on man’s intimate side, the side of him that merely feels and has no eyes and does not want to see, woman appears as an impenetrable mask behind which everything possible and impossible can be conjectured—and actually seen!—without his getting anywhere near the mark. The elementary fact that a person always thinks another’s psychology is identical with his own effectively prevents a correct understanding of feminine psychology. This is abetted by woman’s own unconsciousness and passivity, useful though these may be from the biological point of view: she allows herself to be convinced by the man’s projected feelings. Of course this is a general human characteristic, but in woman it is given a particularly dangerous twist, because in this respect she is not naïve and it is only too often her *intention* to let herself be convinced by them. It fits in with her nature to keep her ego and her will in the background, so as not to hinder the man in any way, and to invite him to realize his intentions with regard to her person. This is a sexual pattern, but it has far-reaching

ramifications in the feminine psyche. By maintaining a passive attitude with an ulterior purpose, she helps the man to realize his ends and in that way holds him. At the same time she is caught in her own toils, for whoever digs a pit for others falls into it himself.

[241] I admit that this is a rather unkind description of a process which might well be sung in more lyrical strains. But all natural things have two sides, and when something has to be made conscious we must see the shadow side as well as the light.

[242] When we observe the way in which women, since the second half of the nineteenth century, have begun to take up masculine professions, to become active in politics, to sit on committees, etc., we can see that woman is in the process of breaking with the purely feminine sexual pattern of unconsciousness and passivity, and has made a concession to masculine psychology by establishing herself as a visible member of society. She no longer hides behind the mask of Mrs. So-and-so, with the obliging intention of having all her wishes fulfilled by the man, or to make him pay for it if things do not go as she wishes.

[243] This step towards social independence is a necessary response to economic and other factors, but in itself it is only a symptom and not the thing about which we are most concerned. Certainly the courage and capacity for self-sacrifice of such women is admirable, and only the blind could fail to see the good that has come out of all these efforts. But no one can get round the fact that by taking up a masculine profession, studying and working like a man, woman is doing something not wholly in accord with, if not directly injurious to, her feminine nature. She is doing something that would scarcely be possible for a man to do, unless he were a Chinese. Could he, for instance, be a nursemaid or run a kindergarten? When I speak of injury, I do not mean merely physiological injury but above all psychic injury. It is a woman's outstanding characteristic that she can do anything for the love of a man. But those women who can achieve something important for the love of a *thing* are most exceptional, because this does not really agree with their nature. Love for a thing is a man's prerogative. But since masculine and feminine elements are united in our human nature, a man can live in the feminine part of himself, and a woman in her masculine part. None the less the feminine element in man is only something in the background, as is the masculine element in woman. If one lives out the opposite sex in oneself one is living in one's own background, and one's real individuality suffers. A man should live as a man and a woman as a woman. The contrasexual element in either sex is always dangerously close to the unconscious. It is even typical that the effects of the unconscious upon the conscious mind have a contrasexual character. For instance the soul (anima, psyche) has a feminine character which compensates

the masculine consciousness. (Mystical instruction among primitives is exclusively a masculine concern, corresponding to the function of the Catholic priest.)

[244] The immediate presence of the unconscious exerts a magnetic influence on the conscious processes. This explains the fear or even horror we have of the unconscious. It is a purposeful defence-reaction of the conscious mind. The contrasexual element has a mysterious charm tinged with fear, perhaps even with disgust. For this reason its charm is particularly attractive and fascinating, even when it comes to us not directly from outside, in the guise of a woman, but from within, as a psychic influence—for instance in the form of a temptation to abandon oneself to a mood or an affect. This example is not characteristic of women, for a woman's moods and emotions do not come to her directly from the unconscious but are peculiar to her feminine nature. They are therefore never naïve, but are mixed with an unacknowledged purpose. What comes to a woman from the unconscious is a sort of *opinion*, which spoils her mood only secondarily. These opinions lay claim to being absolute truths, and they prove to be the more fixed and incorrigible the less they are subjected to conscious criticism. Like the moods and feelings of a man, they are somewhat hazy and often totally unconscious, and are seldom recognized for what they are. They are in fact collective, having the character of the opposite sex, as though a man—the father, for example—had thought of them.

[245] Thus it can happen—indeed it is almost the rule—that the mind of a woman who takes up a masculine profession is influenced by her unconscious masculinity in a way not noticeable to herself but quite obvious to everybody in her environment. She develops a kind of rigid intellectuality based on so-called principles, and backs them up with a whole host of arguments which always just miss the mark in the most irritating way, and always inject a little something into the problem that is not really there. Unconscious assumptions or opinions are the worst enemy of woman; they can even grow into a positively demonic passion that exasperates and disgusts men, and does the woman herself the greatest injury by gradually smothering the charm and meaning of her femininity and driving it into the background. Such a development naturally ends in profound psychological disunion, in short, in a neurosis.

[246] Naturally, things need not go to this length, but long before this point is reached the mental masculinization of the woman has unwelcome results. She may perhaps be a good comrade to a man without having any access to his feelings. The reason is that her animus (that is, her masculine rationalism, assuredly not true reasonableness!) has stopped up the approaches to her own feeling. She may even become frigid, as a defence against the masculine type of sexuality that corresponds to her masculine type of mind. Or, if the defence-reaction is not successful, she develops, instead of the receptive sexuality of woman, an aggressive, urgent form of

sexuality that is more characteristic of a man. This reaction is likewise a purposeful phenomenon, intended to throw a bridge across by main force to the slowly vanishing man. A third possibility, especially favoured in Anglo-Saxon countries, is optional homosexuality in the masculine role.

[247] It may therefore be said that, whenever the attraction of the animus becomes noticeable, there is a quite special need for the woman to have an intimate relationship with the other sex. Many women in this situation are fully aware of this necessity and proceed—*faute de mieux*— to stir up another of those present-day problems that is no less painful, namely, the marriage problem.

[248] Traditionally, man is regarded as the marriage breaker. This legend comes from times long past, when men still had leisure to pursue all sorts of pastimes. But today life makes so many demands on men that the noble hidalgo, Don Juan, is to be seen nowhere save in the theatre. More than ever man loves his comfort, for ours is an age of neurasthenia, impotence, and easy chairs. There is no energy left for window-climbing and duels. If anything is to happen in the way of adultery it must not be too difficult. In no respect must it cost too much, hence the adventure can only be of a transitory kind. The man of today is thoroughly scared of jeopardizing marriage as an institution. He is a firm believer in doing things on the quiet, and therefore supports prostitution. I would wager that in the Middle Ages, with its notorious bagnios and unrestricted prostitution, adultery was relatively more frequent than it is today. In this respect marriage should be safer now than it ever was. But in reality it is beginning to be discussed. It is a bad sign when doctors begin writing books of advice on how to achieve the “perfect marriage.” Healthy people need no doctors. Marriage today has indeed become rather precarious. In America about a quarter of the marriages end in divorce. And the remarkable thing is that this time the scapegoat is not the man but the woman. She is the one who doubts and feels uncertain. It is not surprising that this is so, for in post-war Europe there is such an alarming surplus of unmarried women that it would be inconceivable if there were no reaction from that quarter. Such a piling up of misery has inescapable consequences. It is no longer a question of a few dozen voluntary or involuntary old maids here and there, but of millions. Our legislation and our social morality give no answer to this question. Or can the Church provide a satisfactory answer? Should we build gigantic nunneries to accommodate all these women? Or should tolerated prostitution be increased? Obviously this is impossible, since we are dealing neither with saints nor sinners but with ordinary women who cannot register their spiritual requirements with the police. They are decent women who want to marry, and if this is not possible, well—the next best thing. When it comes to the question of love, laws and institutions and ideals mean less to woman than ever before. If things cannot go straight they will have to go crooked.

[249] At the beginning of our era, three-fifths of the population of Italy consisted of slaves—human chattels without rights. Every Roman was surrounded by slaves. The slave and his psychology flooded ancient Italy, and every Roman became inwardly a slave. Living constantly in the atmosphere of slaves, he became infected with their psychology. No one can shield himself from this unconscious influence. Even today the European, however highly developed, cannot live with impunity among the Negroes in Africa; their psychology gets into him unnoticed and unconsciously he becomes a Negro. There is no fighting against it. In Africa there is a well-known technical expression for this: “going black.” It is no mere snobbery that the English should consider anyone born in the colonies, even though the best blood may run in his veins, “slightly inferior.” There are facts to support this view.

[250] A direct result of slave influence was the strange melancholy and longing for deliverance that pervaded imperial Rome and found striking expression in Virgil’s Fourth Eclogue. The explosive spread of Christianity, a religion which might be said to have risen from the sewers of Rome—Nietzsche called it a “slave insurrection in morals”—was a sudden reaction that set the soul of the lowest slave on a par with that of the divine Caesar. Similar though perhaps less momentous processes of psychological compensation have repeatedly occurred in the history of the world. Whenever some social or psychological monstrosity is created, a compensation comes along in defiance of all legislation and all expectation.

[251] Something similar is happening to women in present-day Europe. Too much that is inadmissible, that has not been lived, is accumulating in the unconscious, and this is bound to have an effect. Secretaries, typists, shop-girls, all are agents of this process, and through a million subterranean channels creeps the influence that is undermining marriage. For the desire of all these women is not to have sexual adventures—only the stupid could believe that—but to get married. The possessors of that bliss must be ousted, not as a rule by naked force, but by that silent, obstinate desire which, as we know, has magical effects, like the fixed stare of a snake. This was ever the way of women.

[252] What is the attitude of the married woman to all this? She clings to the old idea that man is the scapegoat, that he switches from one love-affair to another as he pleases, and so on. On the strength of these outworn conceptions she can wrap herself still more deeply in her jealousies. But all this is only on the surface. Neither the pride of the Roman patrician nor the thick walls of the imperial palace availed to keep out the slave infection. In the same way, no woman can escape the secret, compelling atmosphere with which her own sister, perhaps, is enveloping her, the stifling atmosphere of a life that has never been lived. Unlived life is a destructive, irresistible force that works softly but inexorably. The result is that the married

woman begins to have doubts about marriage. The unmarried believe in it because they want it. Equally, the man believes in marriage because of his love of comfort and a sentimental belief in institutions, which for him always tend to become objects of feeling.

[253] Since women have to be down to earth in matters of feeling, a certain fact should not escape our notice. This is the possibility of contraceptive measures. Children are one of the main reasons for maintaining a responsible attitude towards marriage. If this reason disappears, then the things that are “not done” happen easily enough. This applies primarily to unmarried women, who thus have an opportunity to contract an “approximate” marriage. But it is a consideration that counts also with all those married women who, as I have shown in my essay “Marriage as a Psychological Relationship,”³ are the “containers.” By this I mean women whose demands as individuals are not satisfied, or not wholly satisfied, by their husbands. Finally, contraception is a fact of enormous importance to women in general, because it does away with the constant fear of pregnancy and the care of an ever-increasing number of children. This deliverance from bondage to nature brings a release of psychic energies that inevitably seek an outlet. Whenever a sum of energy finds no congenial goal it causes a disturbance of the psychic equilibrium. Lacking a conscious goal, it reinforces the unconscious and gives rise to uncertainty and doubt.

[254] Another factor of great importance is the more or less open discussion of the sexual problem. This territory, once so obscure, has now become a focus of scientific and other interests. Things can be heard and said in society that formerly would have been quite impossible. Large numbers of people have learned to think more freely and honestly, and have come to realize how important these matters are. The discussion of the sexual problem is, however, only a somewhat crude prelude to a far deeper question, and that is the question of the psychological relationship between the sexes. In comparison with this the other pales into insignificance, and with it we enter the real domain of woman.

[255] Woman’s psychology is founded on the principle of Eros, the great binder and loosener, whereas from ancient times the ruling principle ascribed to man is Logos. The concept of Eros could be expressed in modern terms as psychic relatedness, and that of Logos as objective interest. In the eyes of the ordinary man, love in its true sense coincides with the institution of marriage, and outside marriage there is only adultery or “platonic” friendship. For woman, marriage is not an institution at all but a human love-relationship—at least that is what she would like to believe. (Since her Eros is not naïve but is mixed with other, unavowed motives—marriage as a ladder to social position, etc.—the principle cannot be applied in any absolute sense.) Marriage means to her an exclusive relationship. She can endure its exclusiveness all the more

easily, without dying of ennui, inasmuch as she has children or near relatives with whom she has a no less intimate relationship than with her husband. The fact that she has no sexual relationship with these others means nothing, for the sexual relationship is of far less importance to her than the psychic relationship. It is enough that she and her husband both believe their relationship to be unique and exclusive. If he happens to be the “container” he feels suffocated by this exclusiveness, especially if he fails to notice that the exclusiveness of his wife is nothing but a pious fraud. In reality she is distributed among the children and among as many members of the family as possible, thus maintaining any number of intimate relationships. If her husband had anything like as many relationships with other people she would be mad with jealousy. Most men, though, are erotically blinded—they commit the unpardonable mistake of confusing Eros with sex. A man thinks he possesses a woman if he has her sexually. He never possesses her less, for to a woman the Eros-relationship is the real and decisive one. For her, marriage is a relationship with sex thrown in as an accompaniment. Since sex is a formidable thing on account of its consequences, it is useful to have it in a safe place. But when it is less of a danger it also becomes less relevant, and then the question of relationship moves into the foreground.

[256] It is just here that the woman runs into great difficulties with her husband, for the question of relationship borders on a region that for him is dark and painful. He can face this question only when the woman carries the burden of suffering, that is, when he is the “contained”—in other words, when she can imagine herself having a relationship with another man, and as a consequence suffering disunion within herself. Then it is she who has the painful problem, and he is not obliged to see his own, which is a great relief to him. In this situation he is not unlike a thief who, quite undeservedly, finds himself in the enviable position of having been forestalled by another thief who has been caught by the police. Suddenly he becomes an honourable, impartial onlooker. In any other situation a man always finds the discussion of personal relations painful and boring, just as his wife would find it boring if he examined her on the *Critique of Pure Reason*. For him, Eros is a shadowland which entangles him in his feminine unconscious, in something “psychic,” while for woman Logos is a deadly boring kind of sophistry if she is not actually repelled and frightened by it.

[257] Just as woman began, towards the end of the nineteenth century, to make a concession to masculinity by taking her place as an independent factor in the social world, so man has made, somewhat hesitantly, a concession to femininity by creating a new psychology of complex phenomena, inaugurated by the sexual psychology of Freud. What this psychology owes to the direct influence of women—psychiatrists’ consulting-rooms are packed with women—is a theme that would fill a large volume.

I am speaking here not only of analytical psychology but of the beginnings of psychopathology in general. By far the greatest number of “classic” cases, beginning with the “Seeress of Prevorst,” were women, who, perhaps unconsciously, took enormous trouble to put their own psychology on view in the most dramatic fashion, and thus demonstrated to the world the whole question of psychic relationship. Women like Frau Hauffe and Hélène Smith⁴ and Miss Beauchamp have assured for themselves a kind of immortality, rather like those worthy folk whose miraculous cures brought fame and prosperity to the wonder-working spot.

[258] An astonishingly high percentage of this material comes from women. This is not as remarkable as it might seem, for women are far more “psychological” than men. A man is usually satisfied with “logic” alone. Everything “psychic,” “unconscious” etc., is repugnant to him; he considers it vague, nebulous, and morbid. He is interested in things, in facts, and not in the feelings and fantasies that cluster round them or have nothing to do with them. To a woman it is generally more important to know how a man feels about a thing than to know the thing itself. All those things which are merely futile impedimenta to a man are important to her. So it is naturally woman who is the most direct exponent of psychology and gives it its richest content. Very many things can be perceived in her with the utmost distinctness which in a man are mere shadowy processes in the background, whose very existence he is unwilling to admit. But, unlike the objective discussion and verification of facts, a human relationship leads into the world of the psyche, into that intermediate realm between sense and spirit, which contains something of both and yet forfeits nothing of its own unique character.

[259] Into this territory a man must venture if he wishes to meet woman half way. Circumstances have forced her to acquire a number of masculine traits, so that she shall not remain caught in an antiquated, purely instinctual femininity, lost and alone in the world of men. So, too, man will be forced to develop his feminine side, to open his eyes to the psyche and to Eros. It is a task he cannot avoid, unless he prefers to go trailing after woman in a hopelessly boyish fashion, worshipping from afar but always in danger of being stowed away in her pocket.

[260] For those in love with masculinity or femininity *per se* the traditional medieval marriage is enough—and a thoroughly praiseworthy, well-trying, useful institution it is. But the man of today finds it extremely difficult to return to it, and for many the way back is simply impossible, because this sort of marriage can exist only by shutting out all contemporary problems. Doubtless there were many Romans who could shut their eyes to the slave problem and to Christianity, and spend their days in a more or less pleasant unconsciousness. They could do this because they had no relation to the present, only to the past. All those for whom marriage contains no

problem are not living in the present, and who shall say they are not blessed! Modern man finds marriage only too problematical. I recently heard a German scholar exclaim before an audience of several hundred people: "Our marriages are sham marriages!" I admired his courage and sincerity. Usually we express ourselves less directly, cautiously offering good advice as to what might be done—in order not to tarnish the ideal. But for the modern woman—let men take note of this—the medieval marriage is an ideal no longer. True, she keeps her doubts to herself, and hides her rebelliousness; one woman because she is married and finds it highly inconvenient if the door of the safe is not hermetically sealed, another because she is unmarried and too virtuous to look her own tendencies squarely in the face. Nevertheless, their newly-won masculinity makes it impossible for either of them to believe in marriage in its traditional form ("He shall be thy master"). Masculinity means knowing what one wants and doing what is necessary to achieve it. Once this lesson has been learned it is so obvious that it can never again be forgotten without tremendous psychic loss. The independence and critical judgment she acquires through this knowledge are positive values and are felt as such by the woman. She can never part with them again. The same is true of the man who, with great efforts, wins that needful feminine insight into his own psyche, often at the cost of much suffering. He will never let it go again, because he is thoroughly aware of the importance of what he has won.

[261] At first glance it might be thought that such a man and woman would be especially likely to make the "perfect marriage." In reality this is not so; on the contrary, a conflict begins immediately. What the woman, in her new-found self-assurance, wants to do is not at all pleasing to the man, while the feelings he has discovered in himself are far from agreeable to the woman. What both have discovered in themselves is not a virtue or anything of intrinsic value; it is something comparatively inferior, and it might justly be condemned if it were understood as the outcome of a personal choice or mood. And that, indeed, is what usually happens. The masculinity of the woman and the femininity of the man *are* inferior, and it is regrettable that the full value of their personalities should be contaminated by something that is less valuable. On the other hand, the shadow belongs to the wholeness of the personality: the strong man must somewhere be weak, somewhere the clever man must be stupid, otherwise he is too good to be true and falls back on pose and bluff. Is it not an old truth that woman loves the weaknesses of the strong man more than his strength, and the stupidity of the clever man more than his cleverness? Her love wants the whole man—not mere masculinity as such but also its negation. The love of woman is not sentiment, as is a man's, but a will that is at times terrifyingly unsentimental and can even force her to self-sacrifice. A man who is loved in this way cannot escape his inferior side, for he can only respond to the

reality of her love with his own reality. And this reality is no fair semblance, but a faithful reflection of that eternal human nature which links together all humanity, a reflection of the heights and depths of human life which are common to us all. In this reality we are no longer differentiated persons (*persona* means a mask), but are conscious of our common human bonds. Here I strip off the distinctiveness of my own personality, social or otherwise, and reach down to the problems of the present day, problems which do not arise out of myself—or so at least I like to imagine. Here I can no longer deny them; I feel and know myself to be one of many, and what moves the many moves me. In our strength we are independent and isolated, and are masters of our own fate; in our weakness we are dependent and bound, and become unwilling instruments of fate, for here it is not the individual will that counts but the will of the species.

[262] What the two sexes have won through mutual assimilation is an inferiority when viewed from the two-dimensional, personal world of appearances, and an immoral pretension if regarded as a personal claim. But in its truest meaning for life and society it is an overcoming of personal isolation and selfish reserve in order to take an active part in the solution of present-day problems. If, therefore, the woman of today consciously or unconsciously loosens the cohesion of the marriage bond by her spiritual or economic independence, this is not the expression of her personal will, but of the will of the species, which makes her, the individual woman, its tool.

[263] The institution of marriage is such a valuable thing, both socially and morally—religious people even regard it as a sacrament—that it is quite understandable that any weakening of it should be felt as undesirable, indeed scandalous. Human imperfection is always a discord in the harmony of our ideals. Unfortunately, no one lives in the world as we desire it, but in the world of actuality where good and evil clash and destroy one another, where no creating or building can be done without dirtying one's hands. Whenever things get really bad, there is always some one to assure us amid great applause that nothing has happened and everything is in order. I repeat, anyone who lives and thinks like this is not living in the present. If we examine any marriage with a really critical eye, we shall find—unless acute pressure of circumstances has completely extinguished all signs of “psychological” trouble—symptoms of its weakening and clandestine disruption, “marriage problems” ranging from unbearable moods to neurosis and adultery. Unfortunately, those who can still bear to remain unconscious cannot be imitated; their example is not infectious enough to induce more conscious people to descend again to the level of mere unconsciousness.

[264] As to all those—and they are many—who are not obliged to live in the present, it is extremely important that they should believe in the ideal of marriage and hold fast

to it. Nothing is gained if a valuable ideal is merely destroyed and not replaced by something better. Therefore even the women hesitate, whether they are married or not, to go over openly to the side of rebellion. But at least they do not follow the lead of that well-known authoress who, after trying out all sorts of experiments, ended up in the secure haven of matrimony, whereupon marriage became the best solution, and all those who did not achieve it could brood on their mistakes and end their days in pious renunciation. For the modern woman marriage is not as easy as that. Her husband would have something to say on this score.

[265] So long as there are legalistic clauses that lay down exactly what adultery is, women will have to remain with their doubts. But do our legislators really know what “adultery” is? Is their definition of it the final embodiment of the truth? From the psychological standpoint, the only one that counts for a woman, it is a wretched piece of bungling, like everything else contrived by men for the purpose of codifying love. For a woman, love has nothing to do with “marital misconduct,” “extramarital intercourse,” “deception of the husband,” or any of the less savoury formulas invented by the erotically blind masculine intellect and echoed by the self-opinionated demon in woman. Nobody but the absolute believer in the inviolability of traditional marriage could perpetrate such breaches of good taste, just as only the believer in God can really blaspheme. Whoever doubts marriage in the first place cannot infringe against it; for him the legal definition is invalid because, like St. Paul, he feels himself beyond the law, on the higher plane of love. But because the believers in the law so frequently trespass against their own laws, whether from stupidity, temptation, or mere viciousness, the modern woman begins to wonder whether she too may not belong to the same category. From the traditional standpoint she does, and she has to realize this in order to smash the idol of her own respectability. To be “respectable” means, as the word tells us, to allow oneself to be seen; a respectable person is one who comes up to public expectations, who wears an ideal mask—in short, is a fraud. “Good form” is not a fraud, but when respectability represses the psyche, the God-given essence of man, then one becomes what Christ called a whited sepulchre.

[266] The modern woman has become conscious of the undeniable fact that only in the state of love can she attain the highest and best of which she is capable, and this knowledge drives her to the other realization that love is beyond the law. Her respectability revolts against this, and one is inclined to identify this reaction with public opinion. That would be the lesser evil; what is worse is that public opinion is in her blood. It comes to her like a voice from within, a sort of conscience, and this is the power that holds her in check. She is unaware that love, her most personal, most prized possession, could bring her into conflict with history. Such a thing would seem

to her most unexpected and absurd. But who, if it comes to that, has fully realized that history is not contained in thick books but lives in our very blood?

[267] So long as a woman lives the life of the past she can never come into conflict with history. But no sooner does she begin to deviate, however slightly, from a cultural trend that has dominated the past than she encounters the full weight of historical inertia, and this unexpected shock may injure her, perhaps fatally. Her hesitation and her doubt are understandable enough, for, if she submits to the law of love, she finds that she is not only in a highly disagreeable and dubious situation, where every kind of lewdness and depravity abounds, but actually caught between two universal forces—historical inertia and the divine urge to create.

[268] Who, then, will blame her for hesitating? Do not most men prefer to rest on their laurels rather than get into a hopeless conflict as to whether they shall or shall not make history? In the end it boils down to this: is one prepared to break with tradition, to be “unhistorical” in order to make history, or not? No one can make history who is not willing to risk everything for it, to carry the experiment with his own life through to the bitter end, and to declare that his life is not a continuation of the past, but a new beginning. Mere continuation can be left to the animals, but inauguration is the prerogative of man, the one thing he can boast of that lifts him above the beasts.

[269] There is no doubt that the woman of today is deeply concerned with this problem. She gives expression to one of the cultural tendencies of our time: the urge to live a completer life, a longing for meaning and fulfilment, a growing disgust with senseless one-sidedness, with unconscious instinctuality and blind contingency. The psyche of the modern European has not forgotten the lesson of the last war, however much it has been banished from his consciousness. Women are increasingly aware that love alone can give them full stature, just as men are beginning to divine that only the spirit can give life its highest meaning. Both seek a psychic relationship, because love needs the spirit, and the spirit love, for its completion.

[270] Woman nowadays feels that there is no real security in marriage, for what does her husband’s faithfulness mean when she knows that his feelings and thoughts are running after others and that he is merely too calculating or too cowardly to follow them? What does her own faithfulness mean when she knows that she is simply using it to exploit her legal right of possession, and warping her own soul? She has intimations of a higher fidelity to the spirit and to a love beyond human weakness and imperfection. Perhaps she will yet discover that what seems like weakness and imperfection, a painful disturbance, or an alarming deviation, must be interpreted in accordance with its dual nature. These are steps that lead down to the lowest human level and finally end in the morass of unconsciousness if the individual lets go of his personal distinctiveness. But if he can hold on to it, he will experience for the first

time the meaning of selfhood, provided that he can simultaneously descend below himself into the undifferentiated mass of humanity. What else can free him from the inner isolation of his personal differentiation? And how else can he establish a psychic bridge to the rest of mankind? The man who stands on high and distributes his goods to the poor is separated from mankind by the height of his own virtue, and the more he forgets himself and sacrifices himself for others the more he is inwardly estranged from them.

[271] The word “human” sounds very beautiful, but properly understood it does not mean anything particularly beautiful, or virtuous, or intelligent, but just a low average. This is the step which Zarathustra could not take, the step to the “Ugliest Man,” who is real man. Our resistance to taking this step, and our fear of it, show how great is the attraction and seductive power of our own depths. To cut oneself off from them is no solution; it is a mere sham, an essential misunderstanding of their meaning and value. For where is a height without depth, and how can there be light that throws no shadow? There is no good that is not opposed by evil. “No man can be redeemed from a sin he has not committed,” says Carpocrates; a deep saying for all who wish to understand, and a golden opportunity for all those who prefer to draw false conclusions. What is down below is not just an excuse for more pleasure, but something we fear because it demands to play its part in the life of the more conscious and more complete man.

[272] What I am saying here is not for the young—it is precisely what they ought not to know—but for the more mature man whose consciousness has been widened by experience of life. No man can begin with the present; he must slowly grow into it, for there would be no present but for the past. A young person has not yet acquired a past, therefore he has no present either. He does not create culture, he merely exists. It is the privilege and the task of maturer people, who have passed the meridian of life, to create culture.

[273] The European psyche has been torn to shreds by the hellish barbarism of the war. While man turns his hand to repairing the outer damage, woman—unconsciously as ever—sets about healing the inner wounds, and for this she needs, as her most important instrument, a psychic relationship. But nothing hampers this more than the exclusiveness of the medieval marriage, for it makes relationship altogether superfluous. Relationship is possible only if there is a psychic distance between people, in the same way that morality presupposes freedom. For this reason the unconscious tendency of woman aims at loosening the marriage structure, but not at the destruction of marriage and the family. That would be not only immoral but a thoroughly pathological misuse of her powers.

[274] It would take volumes of case-material to describe the innumerable ways in which this goal is achieved. It is the way of woman, as of nature, to work indirectly, without naming her goal. To anything unsatisfactory she reacts purposively, with moods, outbursts of affects, opinions, and actions that all have the same end in view, and their apparent senselessness, virulence, and cold-blooded ruthlessness are infinitely distressing to the man who is blind to Eros.

[275] The indirect method of woman is dangerous, for it can hopelessly compromise her aim. That is why she longs for greater consciousness, which would enable her to name her goal and give it meaning, and thus escape the blind dynamism of nature. In any other age it would have been the prevailing religion that showed her where her ultimate goal lay; but today religion leads back to the Middle Ages, back to that soul-destroying unrelatedness from which came all the fearful barbarities of war. Too much soul is reserved for God, too little for man. But God himself cannot flourish if man's soul is starved. The feminine psyche responds to this hunger, for it is the function of Eros to unite what Logos has sundered. The woman of today is faced with a tremendous cultural task—perhaps it will be the dawn of a new era.

THE MEANING OF PSYCHOLOGY FOR MODERN MAN¹

[276] I have always found it uncommonly difficult to make the meaning of psychology intelligible to a wider public. This difficulty dates back to the time when I was a doctor in a mental hospital. Like every psychiatrist, I made the astonishing discovery that it is not we who hold competent opinions on mental health and sickness, but the public, who always know much better than we do. They tell us that the patient does not really climb up the walls, that he knows where he is, that he recognizes his relatives, that he hasn't forgotten his name, that, consequently, he is not really ill but only a little depressed or a little excited, and that the psychiatrist's notion that the man is suffering from such and such an illness is entirely incorrect.

[277] This very common experience introduces us to the field of psychology proper, where things are even worse. Everyone thinks that psychology is what he himself knows best—psychology is always *his* psychology, which he alone knows, and at the time his psychology is everybody else's psychology. Instinctively he supposes that his own psychic constitution is the general one, and that everyone is essentially like everyone else, that is to say like himself. Husbands suppose this of their wives, wives suppose it of their husbands, parents of their children, and children of their parents. It is as though everyone had the most direct access to what is going on inside him, was intimately acquainted with it and competent to pass an opinion on it; as though his own psyche were a kind of master-psyche which suited all and sundry, and entitled him to suppose that his own situation was the general rule. People are profoundly astonished, or even horrified, when this rule quite obviously does not fit—when they discover that another person really is different from themselves. Generally speaking, they do not feel these psychic differences as in any way curious, let alone attractive, but as disagreeable failings that are hard to bear, or as unendurable faults that have to be condemned. The painfully obvious difference seems like a contravention of the natural order, like a shocking mistake that must be remedied as speedily as possible, or a misdemeanour that calls for condign punishment.

[278] As you know, there actually are widely accepted psychological theories which start from the assumption that the human psyche is the same everywhere and can therefore be explained in the same way regardless of circumstances. The appalling monotony presupposed by these theories, however, is contradicted by the fact that individual psychic differences do exist and are capable of almost infinite variation. In addition to this, one of the theories explains the world of psychic phenomena mainly in terms of the sexual instinct, and the other in terms of the power drive. The result of

this inconsistency is that both theories cling all the more rigidly to their principles and show clear tendencies to set themselves up as the one and only source of salvation. Each denies the other, and one asks oneself in vain which of them is right. But although the adherents of both views try their utmost to ignore each other's existence, these tactics do nothing to resolve the contradiction. And yet the answer to the riddle is absurdly simple. It amounts to this: both of them are right, in so far as each theory describes a psychology which resembles that of its adherents. We can well say with Goethe that it "matches the spirit that it comprehends."²

[279] Turning back to our theme, let us consider more closely the well-nigh ineradicable prejudice of simple-minded persons that everybody is exactly the same as them. Although it is true in general that psychic differences are admitted as a theoretical possibility, in practice one always forgets that the other person is different from oneself, that he thinks differently, feels differently, sees differently, and wants quite different things. Even scientific theories, as we have seen, start from the assumption that the shoe pinches everyone in the same place. Quite apart from this entertaining domestic quarrel among psychologists, there are other egalitarian assumptions of a social and political nature which are much more serious, because they forget the existence of the individual psyche altogether.

[280] Instead of vexing myself to no purpose over such narrow-minded and short-sighted views, I began to wonder why they should exist at all, and I tried to discover what the reasons might be. This inquiry led me to study the psychology of primitive peoples. I had long been struck by the fact that there is a certain naïveté and childlikeness about those who are most prejudiced in favour of psychic uniformity. In primitive society one does in fact find that this assumption extends not only to human beings, but to all the objects of nature, the animals, plants, rivers, mountains, and so on. They all have something of man's psychology in them, even trees and stones can speak. And just as there are certain human beings who obviously do not conform to the general rule and are honoured as magicians, witches, chiefs, and medicine-men, so among the animals there are doctor-coyotes, doctor-birds, werewolves, and the like, whose honorific title is conferred whenever an animal behaves in any way out of the ordinary and upsets the tacit assumption of uniformity. This prejudice is evidently a vestige—but a very potent one—of a primitive frame of mind which is based essentially on an insufficiently differentiated consciousness. Individual consciousness or ego-consciousness is a late product of man's development. Its primitive form is a mere group-consciousness, and among the primitive societies that still exist today this is often so poorly developed that many tribes do not even give themselves a name that would distinguish them from other tribes. For instance, in East Africa I came across a tribe who simply called themselves "the people who are there." This primitive group-consciousness goes on living in our own family-consciousness, and we often find that

members of a family can give no account of themselves other than that they are called by such and such a name—which seems entirely satisfactory to the person concerned.

[281] But a group-consciousness in which individuals are interchangeable is still not the lowest level of consciousness, for it already shows traces of differentiation. At the lowest and most primitive level we would find a sort of generalized or cosmic consciousness, with complete unconsciousness of the subject. On this level there are only events, but no acting persons.

[282] Our assumption that what pleases me must necessarily please everybody else is therefore an obvious relic from that primordial night of consciousness where there was no perceptible difference between I and You, and where everyone thought, felt, and acted in the same way. But if anything happened which showed that somebody was not of like mind, there was an immediate disturbance. Nothing arouses so much panic among primitives as something out of the ordinary; it is at once suspected of being dangerous and hostile. This primitive reaction survives in us too: how prompt we are to take offence when somebody does not share our convictions! We are insulted when somebody finds our idea of beauty detestable. We still persecute anyone who thinks differently from ourselves, we still try to force our opinions on others, to convert poor heathens in order to save them from the hell that indubitably lies in wait for them, and we are all abysmally afraid of standing alone with our beliefs.

[283] The psychic equality of all men is an unspoken assumption deriving from the individual's original unconsciousness of himself. In that far-off world there was no individual consciousness, but only a collective psyche from which gradually an individual consciousness emerged on the higher levels of development. The indispensable condition for the existence of an individual consciousness is its difference from other consciousnesses. One could liken the process of conscious development to a rocket that rises up from the darkness and dissolves in a shower of multicoloured stars.

[284] Psychology as an empirical science is of very recent origin. It is not yet fifty years old, and is therefore still in its swaddling-clothes. The premise of equality prevented it from being born earlier. From this we can see how young any kind of differentiated consciousness is. It has just crept out of its long sleep, slowly and clumsily taking cognizance of its own existence. It would be a delusion to imagine that we have attained anything like a high level of consciousness. Our present-day consciousness is a mere child that is just beginning to say "I."

[285] It was one of the greatest experiences of my life to discover how enormously different people's psyches are. If the collective equality of the psyche were not a primordial fact, the origin and matrix of all individual psyches, it would be a gigantic illusion. But despite our individual consciousness it unquestionably continues to exist

as the *collective unconscious*—the sea upon which the ego rides like a ship. For this reason also, nothing of the primordial world of the psyche has ever been lost. Just as the sea stretches its broad tongues between the continents and laps them round like islands, so our original unconsciousness presses round our individual consciousness. In the catastrophe of mental disease the storm-tide of the sea surges over the island and swallows it back into the depths. In neurotic disturbances there is at least a bursting of dikes, and the fruitful lowlands are laid waste by flood. Neurotics are all shore-dwellers—they are the most exposed to the dangers of the sea. So-called normal people live inland, on higher, drier ground, near placid lakes and streams. No flood however high reaches them, and the circumambient sea is so far away that they even deny its existence. Indeed, a person can be so identified with his ego that he loses the common bond of humanity and cuts himself off from all others. As nobody wants to be entirely like everybody else, this is quite a common occurrence. For primitive egoism, however, the standing rule is that it is never “I” who must change, but always the other fellow.

[286] Individual consciousness is surrounded by the treacherous sea of the unconscious. This consciousness of ours has the appearance of being stable and reliable, but in reality it is a fragile thing and rests on very insecure foundations. Often no more than a strong emotion is needed to upset the sensitive balance of consciousness. Our turns of speech are an indication of this. We say that a person was “beside himself” with rage, he “forgot himself completely,” one “couldn’t recognize him,” “the devil had got into him,” etc. Something makes you “jump out of your skin,” “drives you mad,” so that you “no longer know what you are doing.” All these familiar phrases show how easily our ego-consciousness is disrupted by affects. These disturbances do not show themselves only in acute form; often they are chronic and can bring about a lasting change of consciousness. As a result of some psychic upheaval whole tracts of our being can plunge back into the unconscious and vanish from the surface for years and decades. Permanent changes of character are not uncommon. We therefore say, quite correctly, that after some such experience a person was a “changed man.” These things happen not only to people with a bad heredity or to neurotics, but to normal people as well. Disturbances caused by affects are known technically as *phenomena of dissociation*, and are indicative of a psychic split. In every psychic conflict we can discern a split of this kind, which may go so far as to threaten the shattered structure of consciousness with complete disintegration.

[287] But even the inland dwellers, the inhabitants of the normal world who forgot the sea, do not live on firm ground. The soil is so friable that at any moment the sea can rush in through continental fissures and maroon them. Primitive man knows this danger not only from the life of his tribe but from his own psychology. The most important of these “perils of the soul,” as they are technically called, are loss of soul

and possession. Both are phenomena of dissociation. In the first case, he will say that a soul has wandered away from him, and in the second, that a strange soul has taken up its abode in him, generally in some unpleasant form. This way of putting it may sound odd, but it describes exactly the symptoms which today we call phenomena of dissociation or schizoid states. They are not by any means purely pathological symptoms, for they are found just as much in normal people. They may take the form of fluctuations in the general feeling of well-being, irrational changes of mood, unpredictable affects, a sudden distaste for everything, psychic inertia, and so on. Even the schizoid phenomena that correspond to primitive possession can be observed in normal people. They, too, are not immune to the demon of passion; they, too, are liable to possession by an infatuation, a vice, or a one-sided conviction; and these are all things that dig a deep grave between them and those they hold most dear, and create an aching split in their own psyche.

[288] Primitive man feels the splitting of the psyche as something unseemly and morbid, just as we do. Only, we call it a conflict, nervousness, or a mental breakdown. Not for nothing did the Bible story place the unbroken harmony of plant, animal, man, and God, symbolized as Paradise, at the very beginning of all psychic development, and declare that the first dawning of consciousness—"Ye shall be as gods, knowing good and evil"—was a fatal sin. To the naïve mind it must indeed seem a sin to shatter the divine unity of consciousness that ruled the primal night. It was the Luciferian revolt of the individual against the One. It was a hostile act of disharmony against harmony, a separation from the fusion of all with all. Therefore God cursed the serpent and said: "I will put enmity between thee and the woman, and between thy seed and her seed; it shall bruise thy head, and thou shalt bruise his heel."

[289] And yet the attainment of consciousness was the most precious fruit of the tree of knowledge, the magical weapon which gave man victory over the earth, and which we hope will give him a still greater victory over himself.

[290] The fact that individual consciousness means separation and opposition is something that man has experienced countless times in his long history. And just as for the individual a time of dissociation is a time for sickness, so it is in the life of nations. We can hardly deny that ours is a time of dissociation and sickness. The political and social conditions, the fragmentation of religion and philosophy, the contending schools of modern art and modern psychology all have one meaning in this respect. And does anyone who is endowed with the slightest sense of responsibility feel any satisfaction at this turn of events? If we are honest, we must admit that no one feels quite comfortable in the present-day world; indeed, it becomes increasingly uncomfortable. The word "crisis," so often heard, is a medical expression which always tells us that the sickness has reached a dangerous climax.

[291] When man became conscious, the germ of the sickness of dissociation was planted in his soul, for consciousness is at once the highest good and the greatest evil. It is difficult to estimate the sickness of the age in which we live. But if we glance back at the clinical history of mankind, we shall find earlier bouts of sickness which are easier to survey. One of the worst attacks was the malaise that spread through the Roman world in the first centuries after Christ. The dissociation showed itself in an unexampled breakdown of the political and social conditions, in religious and philosophical dissension, and in a deplorable decline of the arts and sciences. If we reduced humanity as it then was to a single individual, we would see before us a highly differentiated personality who, after mastering his environment with sublime self-assurance, split himself up in the pursuit of his separate occupations and interests, forgetting his own origins and traditions, and even losing all memory of his former self, so that he seemed to be now one thing and now another, and thus fell into a hopeless conflict with himself. In the end the conflict led to such a state of enfeeblement that the world he had conquered broke in like a devastating flood and completed the process of destruction.

[292] After long years spent in the investigation of the psyche, there gradually took shape in me, as it had in the minds of other investigators, the fundamental axiom that a psychic phenomenon should never be looked at from one side only, but from the other side as well. Experience has shown that everything has at least two sides, and sometimes several more. Disraeli's maxim that not too much importance should be attached to important things, and that unimportant things are not so unimportant as they seem, is another formulation of the same truth. A third version would be the hypothesis that every psychic phenomenon is compensated by its opposite, in agreement with the proverb, "Les extrêmes se touchent," or, "There is no misfortune so great that no good may come of it."

[293] Thus, the sickness of dissociation in our world is at the same time a process of recovery, or rather, the climax of a period of pregnancy which heralds the throes of birth. A time of dissociation such as prevailed during the Roman Empire is simultaneously an age of rebirth. Not without reason do we date our era from the age of Augustus, for that epoch saw the birth of the symbolical figure of Christ, who was invoked by the early Christians as the Fish, the Ruler of the aeon of Pisces which had just begun.³ He became the ruling spirit of the next two thousand years. Like the teacher of wisdom in Babylonian legend, Oannes, he rose up from the sea, from the primeval darkness, and brought a world-period to an end. It is true that he said, "I am come not to bring peace but a sword." But that which brings division ultimately creates union. Therefore his teaching was one of all-uniting love.

[294] Our distance in time puts us in the favourable position of being able to see these historical events quite clearly. Had we lived in those days we would probably have

been among the many who overlooked them. The Gospel, the joyful tidings, were known only to the humble few; on the surface everything was politics, economic questions, and sport. Religion and philosophy tried to assimilate the spiritual riches that poured into the Roman world from the newly conquered East. Few noticed the grain of mustard-seed that was destined to grow into a great tree.

[295] In classical Chinese philosophy there are two contrary principles, the bright *yang* and the dark *yin*. Of these it is said that always when one principle reaches the height of its power, the counter-principle is stirring within it like a germ. This is another, particularly graphic formulation of the psychological law of compensation by an inner opposite. Whenever a civilization reaches its highest point, sooner or later a period of decay sets in. But the apparently meaningless and hopeless collapse into a disorder without aim or purpose, which fills the onlooker with disgust and despair, nevertheless contains within its darkness the germ of a new light.

[296] But let us go back for a moment to our earlier attempt to construct a single individual from the period of classical decay. I tried to show you how he disintegrated psychologically, how in a disastrous fit of weakness he lost control of his environment, and finally succumbed to the forces of destruction. Let us suppose that this man came to me for a consultation. I would make the following diagnosis: “You are suffering from overstrain as a result of your numerous activities and boundless extraversion. In the profusion and complexity of your business, personal, and human obligations you have lost your head. You are a kind of Ivar Kreuger,⁴ who is a typical representative of the modern European spirit. You must realize, my dear Sir, that you are rapidly going to the dogs.”

[297] This latter realization would be particularly important for him, because patients have in any case a pernicious tendency to go on muddling through in the same old way, even though it has long since proved ineffective, and to make their situation only worse. Waiting is useless. Therefore the question immediately arises: “What is to be done?”

[298] Our patient is an intelligent man. He has tried all the patent medicines, both good and bad, every kind of diet, and all the bits of advice given him by all the clever people. We must therefore proceed with him as with Till Eulenspiegel, who always laughed when the way went uphill, and wept when it went down, in shocking defiance of sound commonsense. But hidden beneath his fool’s garment was a wise man, who when going uphill was rejoicing in the coming descent.

[299] We must direct our patient’s attention to the place where the germ of unity is growing within him, the place of creative birth, which is the deepest cause of all the rifts and schisms on the surface. A civilization does not decay, it regenerates. In the early centuries of our era a man of discernment could have cried out with unshakable

certainty amid the political intrigue and wild speculation of the Caesar-worshipping, circus-besotted Roman world: “The germ of the coming era has even now been born in the darkness, behind all this aimless confusion; the seed of the Tree that will overshadow the nations from Thule in the far West to Poland, from the mountains of the North to Sicily, and unite them in one belief, one culture, and one language.”

[300] That is the psychological law. My patient, in all probability, will not believe a word of it. At the very least he will want to have experienced these things for himself. And here our difficulties begin, for the compensation always makes its appearance just where one would least expect it, and where, objectively considered, it seems least plausible. Let us now suppose that our patient is not the pale abstraction of a long-dead civilization, but a flesh-and-blood man of our own day, who has the misfortune to be a typical representative of our modern European culture. We shall then find that our compensation theory means nothing to him. He suffers most of all from the disease of knowing everything better; there is nothing that he cannot classify and put in the correct pigeonhole. As to his psyche, it is essentially his *own* invention, his *own* will, and it obeys *his* reason exclusively; and if it should happen that it does not do so, if he should nevertheless have psychic symptoms, such as anxiety-states, obsessional ideas, and so on, then it is a clinically identifiable disease with a thoroughly plausible, scientific name. Of the psyche as an original experience which cannot be reduced to anything else he has no knowledge at all and does not know what I am talking about, but he thinks he has understood it perfectly and even writes articles and books in which he bemoans the evils of “psychologism.”

[301] This kind of mentality, barricading itself behind a thick wall of books, newspapers, opinions, social institutions, and professional prejudices, cannot be argued with. Nothing can break through its defences, least of all that little germ of the new which would make him at one with the world and himself. It is so small and ridiculous that for modesty’s sake it would rather give up the ghost at once. Where, then, must we lead our patient in order to give him at least a glimmer of an inkling of something different, something that would counterbalance the everyday world he knows only too well? We must guide him, by devious ways at first, to a dark, ridiculously insignificant, quite unimportant corner of his psyche, following a long-disused path to the longest-known illusion, which as all the world knows is nothing but ... That corner of the psyche is *the dream*, which is nothing but a fleeting, grotesque phantom of the night, and the path is the understanding of dreams.

[302] With Faustian indignation my patient will cry out:

This witch’s quackery disgusts my soul!

Is this your promise then, that I be healed

By crooked counsel in this crazy hole,

In truth by some decrepit dame revealed?

....

Cannot you brew an ichor of your own?⁵

[303] To which I shall reply: “Haven’t you tried one remedy after another? Haven’t you seen for yourself that all your efforts have only led you round in a circle, back to the confusion of your present life? So where will you get that other point of view from, if it cannot be found anywhere in your world?”

[304] Here Mephistopheles murmurs approvingly, “That’s where the witch comes in,” thus giving his own devilish twist to Nature’s secret and perverting the truth that the dream is an inner vision, “mysterious still in open light of day.” The dream is a little hidden door in the innermost and most secret recesses of the soul, opening into that cosmic night which was psyche long before there was any ego-consciousness, and which will remain psyche no matter how far our ego-consciousness extends. For all ego-consciousness is isolated; because it separates and discriminates, it knows only particulars, and it sees only those that can be related to the ego. Its essence is limitation, even though it reach to the farthest nebulae among the stars. All consciousness separates; but in dreams we put on the likeness of that more universal, truer, more eternal man dwelling in the darkness of primordial night. There he is still the whole, and the whole is in him, indistinguishable from nature and bare of all egohood.

[305] It is from these all-uniting depths that the dream arises, be it never so childish, grotesque, and immoral. So flowerlike is it in its candour and veracity that it makes us blush for the deceitfulness of our lives. No wonder that in all the ancient civilizations an impressive dream was accounted a message from the gods! It remained for the rationalism of our age to explain the dream as the remnants left over from the day, as the crumbs that fell into the twilight world from the richly laden table of our consciousness. These dark depths are then nothing but an empty sack, containing no more than what falls into it from above. Why do we always forget that there is nothing majestic or beautiful in the wide domain of human culture that did not grow originally from a lucky idea? What would become of mankind if nobody had lucky ideas any more? It would be far truer to say that our consciousness is that sack, which has nothing in it except what chances to fall into it. We never appreciate how dependent we are on lucky ideas—until we find to our distress that they will not come. A dream is nothing but a lucky idea that comes to us from the dark, all-unifying world of the psyche. What would be more natural, when we have lost ourselves amid the endless particulars and isolated details of the world’s surface, than to knock at the door of dreams and inquire of them the bearings which would bring us closer to the basic facts of human existence?

[306] Here we encounter the obstinate prejudice that dreams are so much froth, they are not real, they lie, they are mere wish-fulfillments. All this is but an excuse not to take dreams seriously, for that would be uncomfortable. Our intellectual hybris of consciousness loves isolation despite all its inconveniences, and for this reason people will do anything rather than admit that dreams are real and speak the truth. There are some saints who had very rude dreams. Where would their saintliness be, the very thing that exalts them above the vulgar rabble, if the obscenity of a dream were a real truth? But it is just the most squalid dreams that emphasize our blood-kinship with the rest of mankind, and most effectively damp down the arrogance born of an atrophy of the instincts. Even if the whole world were to fall to pieces, the unity of the psyche would never be shattered. And the wider and more numerous the fissures on the surface, the more this unity is strengthened in the depths.

[307] No one, of course, who has not experienced it himself will be convinced that there could be any independent psychic activity outside consciousness, and certainly not an activity that takes place not only in me but simultaneously in all men. But when we compare the psychology of modern art with the findings of psychological research, and this again with the products of mythology and philosophy, we shall discover irrefutable proofs of the existence of this collective, unconscious factor.

[308] Our patient, however, is so accustomed to treat his psyche as something he has under his control that he will retort that he has never yet observed anything objective about his psychic processes. They are, on the contrary, the most subjective things one can possibly imagine. To this I rejoin: "Then you can make your anxiety-states and your obsessional ideas disappear at once. The bad moods you are riddled with will be no more. You have only to speak the magic word."

[309] Naturally, in his modern naïveté, he has entirely failed to notice that he is as much possessed by his pathological states as any witch or witch-hunter in the darkest Middle Ages. It is merely a difference of name. In those days they spoke of the devil, today we call it a neurosis. But it comes to the same thing, to the same age-old experience: something objectively psychic and strange to us, not under our control, is fixedly opposed to the sovereignty of our will. We are in no better case than the Prokto-phantasmist in *Faust*, when he exclaimed:

Preposterous! You still intend to stay?

Vanish at once, you've been explained away!

By rules this devil's crew is nothing daunted:

For all our wisdom, Tegel still is haunted.⁶

[310] If our patient can submit to the logic of this argument, much will have been gained. The way to experience of the psyche is open. But soon one comes to another prejudice that blocks further progress. "Granted," he will say, "that I am experiencing

a psychic force that thwarts my will, an objective-psychic factor, if you like to call it that. But it still remains something purely psychological, vague, unreliable, and of no importance in the practical affairs of life.”

[311] It is amazing how people get caught in words. They always imagine that the name postulates the thing—just as if we were doing the devil a serious wrong when we call him a neurosis! This touchingly childlike trait is another remnant left over from the year 1, when mankind still operated with magical words. But what is behind the devil or the neurosis does not bother about the name we give it. Naturally we do not know what the psyche is. We speak of the “unconscious” merely because we are not conscious of what it is in reality. We know this as little as the physicist knows what matter is. He simply has theories about it, certain views, picturing it now in one way and now in another. For a time the picture fits, then a new discovery brings quite a different view. But that has no effect on matter. Or is the reality of matter in some way diminished?

[312] We simply do not know what we are dealing with when we encounter this strange and disturbing factor which we call the unconscious or the objective psyche. With some semblance of justification, it has been defined as the sexual instinct or the power drive. But this does nothing like justice to its real significance. What is behind these instincts, which are certainly not the be-all and end-all of existence, but merely represent the limits of our understanding? In this field every interpretation has free play. You can also take the unconscious as a manifestation of the life-instinct, and equate the force which creates and sustains life with Bergson’s *élan vital*, or even with his *durée créatrice*. Another parallel would be Schopenhauer’s Will. I know people who feel that the strange power in their own psyche is something divine, for the very simple reason that it has given them an understanding of what is meant by religious experience.

[313] I admit that I fully understand the disappointment of my patient and of my public when I point to dreams as a source of information in the spiritual confusion of our modern world. Nothing is more natural than that such a paradoxical gesture should strike one as completely absurd. What can a dream do, this utterly subjective and nugatory thing, in a world brimful of overpowering realities? Realities must be countered with other, equally palpable realities, and not with dreams, which merely disturb our sleep or put us in a bad mood the next day. You cannot build a house with dreams, or pay taxes, or win battles, or overcome the world crisis. Therefore my patient, like all other sensible people, will want me to tell him what can be done in this insufferable situation, and with appropriate, common-sense methods. The only snag is that all the methods that seem appropriate have already been tried out with no success whatever, or consist of wishful fantasies that are impossible in practice. These methods were all chosen with a view to meeting the existing situation. For instance,

when someone gets his business into a mess, he naturally considers how he can set it on its feet again, and he employs all the remedies that are designed to restore his languishing business to health. But what happens when all these remedies have been tried, when, contrary to all reasonable expectations, the situation only slithers from bad to worse? In that case he will be compelled to give up the use of these so-called reasonable methods as speedily as possible.

[314] My patient, and perhaps our whole age, is in this situation. Anxiously he asks me, "What can I do?" And I must answer, "I don't know either." "Then there's nothing to be done?" I reply that mankind has got into these blind alleys countless times during the course of evolution, and no one knew what to do because everybody was busy hatching out clever plans to meet the situation. No one had the courage to admit that they had all taken the wrong turning. And then, suddenly, things somehow began to move again, so that the same old humanity still exists, though somewhat different from before.

[315] When we look at human history, we see only what happens on the surface, and even this is distorted in the faded mirror of tradition. But what has really been happening eludes the inquiring eye of the historian, for the true historical event lies deeply buried, experienced by all and observed by none. It is the most private and most subjective of psychic experiences. Wars, dynasties, social upheavals, conquests, and religions are but the superficial symptoms of a secret psychic attitude unknown even to the individual himself, and transmitted by no historian; perhaps the founders of religions give us the most information in this regard. The great events of world history are, at bottom, profoundly unimportant. In the last analysis, the essential thing is the life of the individual. This alone makes history, here alone do the great transformations first take place, and the whole future, the whole history of the world, ultimately spring as a gigantic summation from these hidden sources in individuals. In our most private and most subjective lives we are not only the passive witnesses of our age, and its sufferers, but also its makers. We make our own epoch.

[316] So when I counsel my patient to pay attention to his dreams, I mean: "Turn back to the most subjective part of yourself, to the source of your being, to that point where you are making world history without being aware of it. Your apparently insoluble difficulty must, it is obvious, remain insoluble, for otherwise you would wear yourself out seeking for remedies of whose ineptitude you are convinced from the start. Your dreams are an expression of your inner life, and they can show you through what false attitude you have landed yourself in this blind alley."

[317] Dreams are impartial, spontaneous products of the unconscious psyche, outside the control of the will. They are pure nature; they show us the unvarnished, natural truth, and are therefore fitted, as nothing else is, to give us back an attitude that

accords with our basic human nature when our consciousness has strayed too far from its foundations and run into an impasse.

[318] To concern ourselves with dreams is a way of reflecting on ourselves—a way of self-reflection. It is not our ego-consciousness reflecting on itself; rather, it turns its attention to the objective actuality of the dream as a communication or message from the unconscious, unitary soul of humanity. It reflects not on the ego but on the self; it recollects that strange self, alien to the ego, which was ours from the beginning, the trunk from which the ego grew. It is alien to us because, through the aberrations of consciousness, we have alienated ourselves from it.

[319] But even if we accept the proposition that dreams are not arbitrary inventions but are natural products of unconscious psychic activity, we shall still, when confronted with a real dream, lack the courage to see in it a message of any importance. Dream-interpretation was one of the accomplishments of witchcraft, and was therefore among the black arts persecuted by the Church. Even though we of the twentieth century are rather more broad-minded in this respect, so much historical prejudice still attaches to the whole idea of dream-interpretation that we do not take kindly to it. Is there, one may ask, any reliable method of dream-interpretation? Can we put faith in any of the various speculations? I admit that I share these misgivings to the full, and I am convinced that there is in fact no absolutely reliable method of interpretation. Absolute reliability in the interpretation of natural events is found only within the narrowest limits—that is to say, when no more comes out of the interpretation than we have put in. Every attempt to explain nature is a hazard. A reliable method does not come into being until long after the pioneer work has been accomplished. We know that Freud has written a book on dream-interpretation, but his interpretation is an example of what we have just said: no more comes out of it than what his theory allows to be put into the dream. This view naturally does not do anything like justice to the boundless freedom of dream-life, with the consequence that the meaning of the dream is concealed rather than revealed. Also, when we consider the infinite variety of dreams, it is difficult to conceive that there could ever be a method or a technical procedure which would lead to an infallible result. It is, indeed, a good thing that no valid method exists, for otherwise the meaning of the dream would be limited in advance and would lose precisely that virtue which makes dreams so valuable for therapeutic purposes—their ability to offer new points of view.

[320] One would do well, therefore, to treat every dream as though it were a totally unknown object. Look at it from all sides, take it in your hand, carry it about with you, let your imagination play round it, and talk about it with other people. Primitives tell each other impressive dreams, in a public palaver if possible, and this custom is also attested in late antiquity, for all the ancient peoples attributed great significance to dreams. Treated in this way, the dream suggests all manner of ideas and associations

which lead us closer to its meaning. The ascertainment of the meaning is, I need hardly point out, an entirely arbitrary affair, and this is where the hazards begin. Narrower or wider limits will be set to the meaning, according to one's experience, temperament, and taste. Some people will be satisfied with little, for others much is still not enough. Also the meaning of the dream, or our interpretation of it, is largely dependent on the intentions of the interpreter, on what he expects the meaning to be or requires it to do. In eliciting the meaning he will involuntarily be guided by certain presuppositions, and it depends very much on the scrupulousness and honesty of the investigator whether he gains something by his interpretation or perhaps only becomes still more deeply entangled in his mistakes. So far as presuppositions are concerned, we may take it as certain that the dream is not an idle invention of the conscious mind but an involuntary, natural phenomenon, even though it should prove true that dreams are in some way distorted by becoming conscious. Anyway this distortion occurs so quickly and automatically that it is barely perceptible. It is therefore safe to assume that it is an integral part of the dream-function. And it is equally safe to assume that dreams arise from the unconscious part of our being and are, consequently, its symptoms, allowing us to make inferences as to the nature of this being. If we wish to investigate our own nature, dreams are the most suitable media for this purpose.

[321] During the work of interpretation one must abstain from all presuppositions that smack of superstition, such as, first and foremost, the notion that the protagonists in dreams are nothing other than these same persons in real life. One should never forget that one dreams in the first place, and almost to the exclusion of all else, of oneself. (Any exceptions are governed by quite definite rules, but I cannot go into this here.) If we acknowledge this truth we shall sometimes find ourselves faced with very interesting problems. I remember two instructive cases: one of my patients dreamed of a drunken tramp who lay in a ditch, and another of a drunken prostitute who rolled about in the gutter. The first patient was a theologian, the second a distinguished lady in high society. Both of them were outraged and horrified, and absolutely refused to admit that they had dreamed of themselves. I gave them both the well-meant advice that they should spend an hour in self-reflection, diligently and devoutly considering in what ways they were not much better than their drunken brother in the ditch and their drunken sister in the gutter. The subtle process of self-knowledge often begins with a bomb-shell like this. The "other" person we dream of is not our friend and neighbour, but the other in us, of whom we prefer to say: "I thank thee, Lord, that I am not as this publican and sinner." Certainly the dream, being a child of nature, has no moralizing intention; it merely exemplifies the well-known law that no trees reach up to heaven.

[322] If, in addition to this, we bear in mind that the unconscious contains everything that is lacking to consciousness, that the unconscious therefore has a compensatory

tendency, then we can begin to draw conclusions—provided, of course, that the dream does not come from too deep a psychic level. If it is a dream of this kind, it will as a rule contain mythological motifs, combinations of ideas or images which can be found in the myths of one's own folk or in those of other races. The dream will then have a collective meaning, a meaning which is the common property of mankind.

[323] This does not contradict my earlier remark that we always dream of ourselves. As individuals we are not completely unique, but are like all other men. Hence a dream with a collective meaning is valid in the first place for the dreamer, but it expresses at the same time the fact that his momentary problem is also the problem of other people. This is often of great practical importance, for there are countless people who are inwardly cut off from humanity and oppressed by the thought that nobody else has their problems. Or else they are those all-too-modest souls who, feeling themselves nonentities, have kept their claim to social recognition on too low a level. Moreover, every individual problem is somehow connected with the problem of the age, so that practically every subjective difficulty has to be viewed from the standpoint of the human situation as a whole. But this is permissible only when the dream really is a mythological one and makes use of collective symbols.

[324] Such dreams are called by primitives “big” dreams. The primitives I observed in East Africa took it for granted that “big” dreams are dreamed only by “big” men—medicine-men, magicians, chiefs, etc. This may be true on a primitive level. But with us these dreams are dreamed also by simple people, more particularly when they have got themselves, mentally or spiritually, in a fix. It is obvious that in handling “big” dreams intuitive guesswork will lead nowhere. Wide knowledge is required, such as a specialist ought to possess. But no dream can be interpreted with knowledge alone. This knowledge, furthermore, should not be dead material that has been memorized; it must possess a living quality, and be infused with the experience of the person who uses it. Of what use is philosophical knowledge in the head, if one is not also a philosopher at heart? Anyone who wishes to interpret a dream must himself be on approximately the same level as the dream, for nowhere can he see anything more than what he is himself.

[325] The art of interpreting dreams cannot be learnt from books. Methods and rules are good only when we can get along without them. Only the man who can do it anyway has real skill, only the man of understanding really understands. No one who does not know himself can know others. And in each of us there is another whom we do not know. He speaks to us in dreams and tells us how differently he sees us from the way we see ourselves. When, therefore, we find ourselves in a difficult situation to which there is no solution, he can sometimes kindle a light that radically alters our attitude—the very attitude that led us into the difficult situation.

[326] The more I engrossed myself in these problems over the years, the stronger became my impression that our modern education is morbidly one-sided. No doubt we are right to open the eyes and ears of our young people to the wide world, but it is the maddest of delusions to think that this really equips them for the task of living. It is the kind of training that enables a young person to adapt himself outwardly to the world and reality, but no one gives a thought to the necessity of adapting to the self, to the powers of the psyche, which are far mightier than all the Great Powers of the earth. A system of education does indeed exist, but it has its origins partly in antiquity and partly in the early Middle Ages. It styles itself the Christian Church. But it cannot be denied that in the course of the last two centuries Christianity, no less than Confucianism in China and Buddhism in India, has largely forfeited its educative activity. Human iniquity is not to blame for this, but rather a gradual and widespread spiritual change, the first symptom of which was the Reformation. It shattered the authority of the Church as a teacher, and thereafter the authoritarian principle itself began to crumble away. The inevitable consequence was an increase in the importance of the individual, which found expression in the modern ideals of humanity, social welfare, democracy, and equality. The decidedly individualistic trend of these latest developments is counterbalanced by a compensatory reversion to the collective man, whose authority at present is the sheer weight of the masses. No wonder that nowadays there is a feeling of catastrophe in the air, as though an avalanche had broken loose which nothing can stop. The collective man threatens to stifle the individual man, on whose sense of responsibility everything valuable in mankind ultimately depends. The mass as such is always anonymous and always irresponsible. So-called leaders are the inevitable symptoms of a mass movement. The true leaders of mankind are always those who are capable of self-reflection, and who relieve the dead weight of the masses at least of their own weight, consciously holding aloof from the blind momentum of the mass in movement.

[327] But who can resist this all-engulfing force of attraction, when each man clings to the next and each drags the other with him? Only one who is firmly rooted not only in the outside world but also in the world within.

[328] Small and hidden is the door that leads inward, and the entrance is barred by countless prejudices, mistaken assumptions, and fears. Always one wishes to hear of grand political and economic schemes, the very things that have landed every nation in a morass. Therefore it sounds grotesque when anyone speaks of hidden doors, dreams, and a world within. What has this vapid idealism got to do with gigantic economic programmes, with the so-called problems of reality?

[329] But I speak not to nations, only to the individual few, for whom it goes without saying that cultural values do not drop down like manna from heaven, but are created by the hands of individuals. If things go wrong in the world, this is because something

is wrong with the individual, because something is wrong with me. Therefore, if I am sensible, I shall put myself right first. For this I need—because outside authority no longer means anything to me—a knowledge of the innermost foundations of my being, in order that I may base myself firmly on the eternal facts of the human psyche.

[330] If I spoke before chiefly of dreams, I did so because I wished to draw attention to one of the most immediate approaches to the world of inner experience. But there are many things besides dreams which I cannot discuss here. The investigation of the deeper levels of the psyche brings to light much that we, on the surface, can at most dream about. No wonder, then, that sometimes the strongest and most original of all man's spiritual activities—the religious activity—is also discovered from our dreams. This is the activity which, more even than sexuality or social adaptation, is thwarted in modern man. I know people for whom the encounter with the strange power within themselves was such an overwhelming experience that they called it "God." So experienced, "God" too is a "theory" in the most literal sense, a way of looking at the world, an image which the limited human mind creates in order to express an unfathomable and ineffable experience. The experience alone is real, not to be disputed; but the image can be soiled or broken to pieces.

[331] Names and words are sorry husks, yet they indicate the quality of what we have experienced. When we call the devil a neurosis, we are signifying that we feel this demonic experience as a sickness which is characteristic of our age. When we call it repressed sexuality or the will to power, this shows that it seriously disturbs even these fundamental instincts. When we call it God, we are trying to describe its profound and universal significance, because this is what we have glimpsed in the experience. Looking at it soberly, and bearing in mind the vast, unknowable background, we must admit that this latter designation is the most cautious and also the most modest, because it sets no limits to the experience and does not squeeze it into any conceptual schema. Unless, of course, someone should hit upon the singular idea that he knew exactly what God is.

[332] Whatever name we may put to the psychic background, the fact remains that our consciousness is influenced by it in the highest degree, and all the more so the less we are conscious of it. The layman can hardly conceive how much his inclinations, moods, and decisions are influenced by the dark forces of his psyche, and how dangerous or helpful they may be in shaping his destiny. Our cerebral consciousness is like an actor who has forgotten that he is playing a role. But when the play comes to an end, he must remember his own subjective reality, for he can no longer continue to live as Julius Caesar or as Othello, but only as himself, from whom he has become estranged by a momentary sleight of consciousness. He must know once again that he was merely a figure on the stage who was playing a piece by Shakespeare, and that

there was a producer as well as a director in the background who, as always, will have something very important to say about his acting.

THE STATE OF PSYCHOTHERAPY TODAY¹

[333] In earlier days, when people were less sophisticated in their ideas, psychotherapy was regarded as a technique which could be applied to practically anybody who had learnt it by heart. In medical treatises and text-books you would come across the wonderful remark: "... in addition, the following may be of use: massage, cold baths, mountain air, and psychotherapy." The nature of this "psychotherapy" was prudently never specified in detail. Certainly, so long as it consisted of hypnotism, suggestion, persuasion, "rééducation de la volonté," Couéism, and so forth, anybody could learn the art by rote and say his piece in season and out of season. The medical profession generally—and this includes psychiatrists and neurologists—is notoriously slow to learn and needs a long period of incubation. And so it happened that, long after psychotherapy had grown to a psychology, and therapeutics had ceased to be a mere technique, the illusion still continued to flourish that psychological treatment was some kind of technical procedure. It would be decidedly too optimistic to say that this illusion has ceased to exist even among the ranks of psychotherapists, nor would it accord with the facts. All that has happened is that now and again voices are heard which demur at the mechanization of psychotherapy and aspire to rescue it from the soullessness of a mere technical procedure. Their aim is to raise it to the higher plane of psychological and philosophical dialectic, where it becomes a discussion between two psychic systems, that is, two human beings confronting one another in their totality.

[334] These doubts and aims were not, as one might think, dragged down from the airless realm of eternal ideas by pernicky minds overloaded with philosophy. On the contrary, they sprang from the deep impression which the unedifying confusion of psychological and therapeutic views cannot fail to make today even on the distant observer. A glance at the chaotic profusion of psychotherapeutic literature is sufficient confirmation of this. Not only are there different schools which until very recently have anxiously avoided any serious communication with one another, there are also groups—self-styled "Societies"—who barricade themselves like cenobites against unbelievers, not to mention the numerous solitaries who are not a little proud of being the only members of their church, to use the well-known *mot* of Coleridge. No doubt this state of affairs is a sure sign of vitality and of the many pressing problems still to be solved in the field of psychotherapy. But it is far from gratifying; and it ill accords with the dignity of science when bigoted dogmatism and personal touchiness hamper the free discussion so necessary to its growth.

[335] What, indeed, could shed a more glaring light on the fact that psychotherapy is anything but a technique than the very multiplicity of techniques, points of view, “psychologies,” and philosophical premises (or lack of them)? Does not this welter of contradictions show in the most striking way that what we are concerned with is far more than a technique? A technique can be modified and improved by all sorts of recipes and dodges, and everybody would welcome a change for the better. But, far from that being the case, we find all too many people entrenching themselves behind precepts which they envelop with the sacrosanct halo of dogma. Ostensibly they are guarding the ultimate scientific truth; but has it ever—except in the most benighted periods of history—been observed that a scientific truth needed to be elevated to the rank of a dogma? Truth can stand on its own feet, only shaky opinions require the support of dogmatization. Fanaticism is ever the brother of doubt.

[336] What is the lesson of these characteristic and, for the history of any science, very noteworthy signs? Beyond a doubt they point to the incontrovertible fact that psychotherapy has outgrown the stage of technique and has already broken into the realm of *opinion*. We can easily agree about a technique, but hardly ever about opinions. Hence the heatedness of discussion—indeed if there be any—or the equally eloquent silence.

[337] It has long been imagined that psychotherapy can be practised “technically,” as though it were a formula, a method of operation, or a colour-test. The general practitioner can use a wide assortment of medical techniques without hesitation, whatever his personal opinions may be about his patients and irrespective of his psychological theories or even of his philosophical and religious assumptions. Psychotherapy cannot be used like that. Whether he likes it or not, the doctor and his assumptions are involved just as much as the patient. It is in fact largely immaterial what sort of technique he uses, for the point is not the technique but the person who uses the technique. The object to which the technique is applied is neither an anatomical specimen nor an abscess nor a chemical substance; it is the totality of the suffering individual. The object of therapy is not the neurosis but the man who has the neurosis. We have long known, for instance, that a cardiac neurosis comes not from the heart, as the old medical mythology would have it, but from the mind of the sufferer. Nor does it come from some obscure corner of the unconscious, as many psychotherapists still struggle to believe; it comes from the totality of a man’s life and from all the experiences that have accumulated over the years and decades, and finally, not merely from his life as an individual but from his psychic experience within the family or even the social group.

[338] In dealing with a neurosis, the doctor is not confronted with a delimited field of illness; he is faced with a sick person who is sick not in one particular mechanism or

focus of disease but in his whole personality. “Technique” cannot cope with that. The personality of the patient demands all the resources of the doctor’s personality and not technical tricks.

[339] Very early on, therefore, I required that the doctor himself should be analysed. Freud seconded this requirement, obviously because he could not escape the conviction that the patient should be confronted by a doctor and not by a technique. It is certainly very laudable in a doctor to try to be as objective and impersonal as possible and to refrain from meddling with the psychology of his patient like an overzealous saviour. But if this attitude is carried to artificial lengths it has unfortunate consequences. The doctor will find that he cannot overstep the bounds of naturalness with impunity. Otherwise he would be setting a bad example to his patient, who certainly did not get ill from an excess of naturalness. Besides, it would be dangerously to underestimate the patients if one imagined that they were all too stupid to notice the artifices of the doctor, his security measures and his little game of prestige. Nor can it conceivably be the doctor’s intention to strengthen the patient everywhere in his natural functioning, and yet to keep him as much as possible in the dark when it comes to the one crucial spot—which concerns the doctor himself—and so in a state of helpless dependence or “transference.” Such a mistake could only be made by an extremely unanalysed doctor whose personal prestige counted for more than the welfare of his patient.

[340] Because the personality and attitude of the doctor are of supreme importance in therapy—whether he appreciates this fact or not—his personal opinions stand out in a disproportionately strong light in the history of psychotherapy and are the cause of apparently irreconcilable schisms. Freud took his stand with fanatical one-sidedness on sexuality, concupiscence—in a word, on the “pleasure principle.” Everything turns on the question of whether one can do what one wants. Repression, sublimation, regression, narcissism, wish-fulfilment and the rest are all concepts that relate to the grand drama of the pleasure principle. It almost looks as if man’s desire and greed have been made the cardinal principle of psychology.

[341] Adler also drew on the wide field of human concupiscence and discovered the need for self-assertion. This tendency of human nature was likewise made a cardinal principle of psychology, and with the same one-sidedness so regrettable in Freud.

[342] Now, there is no doubt that the principle of concupiscence can explain a very large number of cases of neurosis. Indeed, the same case can be explained both in the manner of Freud and in the manner of Adler, nor is either explanation lacking in conviction. As a matter of fact, the one explanation complements the other, which in itself would be a very satisfactory state of affairs did it not also prove that neither explanation can lay claim to absolute validity. Both are relative, heuristic points of

view, and as such unfitted to be universal concepts. But at least they have a bearing on essential partial aspects. The theory of repression is based on certain psychic facts which are met with everywhere, and the same is true of the need for self-assertion or the will to power. Clearly everyone would like to enjoy all he can and at the same time be “on top,” and it is equally obvious that so long as he has this primitive, naïve, infantile attitude he will not be able to avoid a neurosis if ever he makes an attempt to adapt himself to his surroundings. This last condition is very much to the point, for without it there is no neurosis but simply moral insanity or the higher idiocy.

[343] If, then, at least two conditions are necessary to produce a neurosis, both must be of aetiological significance. It is out of the question for only the infantile attitude to be causal, but not the will to adapt. Not only *can* the latter be an aetiological factor, it always is so. Freud and Adler explain a neurosis exclusively from the infantile angle. A more comprehensive explanation would be forced to take account of the will to adapt as well. There need not always be simply an excess of infantilism; there can also be an excess of adaptation. Nor must this latter possibility necessarily be understood as a mere repression of infantilism or as a “substitute formation”; we could equally well explain infantilism as repression of adaptation and call it a “substitute formation.” Neither Freud nor Adler would welcome this reversal, although it is logically unavoidable once we take the aetiological significance of the will to adapt into account. And this we must do—even Freud needs a factor that represses, that does not fulfil wishes, that arouses anxiety, etc. Adler needs something that keeps a man down. If there is no aetiological opposite of equal strength, then all that infantile concupiscence is without object.

[344] Having discovered that every neurotic suffers from infantile concupiscence, we must still ask how it is with his will to adapt, for perhaps he has developed infantile concupiscence merely as a “substitute formation.” In this case it would be purely symptomatic and not genuine at all; and, if explained from the infantile angle, the explanation would be quite beside the point. More, an unforgiveable blunder would have been committed. Unfortunately such blunders are very frequent, because the doctor’s attention is turned too exclusively to the infantile traits. The patient is then automatically charged with inferiority.

[345] Infantilism, however, is something extremely ambiguous. First, it can be either genuine or purely symptomatic; and second, it can be either residuary or embryonic. There is an enormous difference between something that has *remained* infantile and something that is in the process of growth. Both can take an infantile or embryonic form, and more often than not it is impossible to tell at first glance whether we are dealing with a regrettably persistent fragment of infantile life or with a vitally important creative beginning. To deride these possibilities is to act like a dullard who

does not know that the future is more important than the past. For this reason it would be more advisable to examine these “infantile-perverse” fantasies for their creative content than to trace them back to the cradle, and to understand all neurosis more as an attempt at adaptation than as an unsuccessful or otherwise distorted wish-fulfilment.

[346] Naturally, the theory of infantilism has the inestimable advantage of always putting the doctor “on top” as the representative of sound, healthy, superior insight, while the poor patient lies there helpless, the victim of unconscious infantile-perverse wish-fulfilments. This also gives the doctor the opportunity to know better, to avoid meeting the patient’s personality face to face, and to hide behind a technique.

[347] It is not hard to see how much this attitude is aided and abetted by all manner of conscious and unconscious tendencies, and why a theory of infantilism is welcomed by the doctor from the start, even if, as a human being, he were quite ready to acknowledge the personality of his patient. The tremendous influence Freud’s ideas have exerted rests not merely on their agreement with the real or supposed facts, but very largely on the easy opportunity they afford of touching the other fellow on his sore spot, of deflating him and hoisting oneself into a superior position. What a blessed relief it is when one can say in a tight corner, “That’s nothing but resistance!” or when one need no longer take one’s opponent’s argument seriously because it can so easily be explained away as “symbolical”—without, be it noted, ever asking him whether this explanation is acceptable to his psychology.

[348] Besides which, there are numberless patients who, with a great show of coyness, are at bottom only too ready to subscribe to the infantilism theory, because it gives them a broad hint of how to pass off the disturbing “infantilism” as a “nothing but.” And in many cases the theory offers a heaven-sent way out of the unpleasantly acute problems of real life into the blissful meadows of childhood, where, having invoked the aetiological bogey, the patient pretends to discover why he is no good in the present and how it is all the fault of his parents and his upbringing.

[349] Admittedly there is nothing that cannot be used to illegitimate advantage. But one ought to note where the misuse creeps in and how it is being exploited. These things depend very largely on the doctor, who must take his patient with great seriousness in order to detect abuses of this kind. A technique notices nothing, but a human being does—and he alone can develop the sensitiveness necessary to decide whether a neurosis should be treated from the infantile angle or from the adaptation angle.

[350] I need hardly say that technique is necessary up to a point—we are all sufficiently convinced of that. But behind every method there stands the man, who is so much more important because, irrespective of his technique, he has to arrive at decisions which are at least as vital to the patient as any technique however adroitly applied. It

is therefore the duty of the psychotherapist to exercise self-knowledge and to criticize his personal assumptions, whether religious or philosophical, just as asepsis is obligatory for a surgeon. The doctor must know his “personal equation” in order not to do violence to his patient. To this end I have worked out a critical psychology which would enable the psychiatrist to recognize the various typical attitudes, even though the Freudian school asserts that this has nothing to do with psychoanalysis. Psychoanalysis is evidently a technique behind which the human being vanishes, and which always remains the same no matter who practises it. Consequently, the psychoanalyst needs no self-knowledge and no criticism of his assumptions. Apparently the purpose of his training analysis is to make him not a human being but a correct applier of technique.

[351] But even regarded as a technique psychoanalysis is far from simple. In actual fact it is a very complicated and fiendishly tricky affair compared even with the most elaborate chemical procedure, subject to endless variation and well-nigh unpredictable in its results. Anyone who finds that hard to believe should peruse the “technique” of a Freudian dream-analysis in *The Interpretation of Dreams*—for instance, the dream of “Irma’s injection.” To call such a procedure a “technique” requires a strong dose of optimism. And yet dreams are supposed to be the “*via regia* to the unconscious” and to play a not uncertain role in psychoanalysis! Truly one must be smitten with blindness not to see that this kind of “technique” is first and foremost an expression of the man who applies it and of all his subjective assumptions.

[352] These reflections lead us back to the problem of the doctor’s attitude and to the need for criticism of subjective premises. A subjective view of the world should not be imported uncritically into his conception of neurosis, as was the case, for instance, with Freud’s view of the *unconscious* and with his materialistic bias in regard to the religious function of the psyche. The psychotherapist should no longer labour under the delusion that the treatment of neurosis demands nothing more than the knowledge of a technique; he should be absolutely clear in his own mind that psychological treatment of the sick is a *relationship* in which the doctor is involved quite as much as the patient. True psychological treatment can only be individual, and this is why even the best technique has only a relative value. All the more significance, therefore, falls to the general attitude of the doctor, who must know himself well enough not to destroy the peculiar values of the patient entrusted to his care, whatever these may be. If Alfred Adler were to request analytical treatment of his old teacher Freud, Freud would have to adjust himself to seeing Adler’s peculiar psychology, even to the point of admitting its general right to exist; for there are innumerable people whose psychology is that of the son in need of prestige. If, on the other hand, I were to analyse Freud, I would be doing him a great and irreparable wrong if I failed to

take elaborate account of the very real historical significance of the nursery, the importance of the entanglements of the family romance, the bitterness and gravity of early-acquired resentments, and their compensatory accompaniment by wish-fantasies which—unhappily—cannot be fulfilled, and to accept all this as a *fait accompli*. Freud would certainly take it amiss if I told him that resentments are all nothing but a “substitute” for failure to love one’s neighbour, or something of that sort. True as such an assertion might be in other cases, it would be incorrect here, even if I should succeed in persuading Freud of the truth of my idea. Doubtless Freud means what he says, consequently we must take him as the type of person who says such things. Only then is his particular case accepted, and with it all those whose psychology is similarly constituted. But since we can hardly suppose that either Freud or Adler is a universally valid representative of European man, there is some hope that I too may possess my own peculiar psychology, and, with me, all those who cannot subscribe to the primacy of infantile-perverse wish-fantasies or to that of the urge to power.

[353] It goes without saying that this should not be a matter for naïve self-deception; on the contrary, no psychotherapist should let slip the opportunity to study himself critically in the light of these negative psychologies. Freud and Adler have beheld very clearly the shadow that accompanies us all. The Jews have this peculiarity in common with women; being physically weaker, they have to aim at the chinks in the armour of their adversary, and thanks to this technique which has been forced on them through the centuries, the Jews themselves are best protected where others are most vulnerable. Because, again, of their civilization, more than twice as ancient as ours, they are vastly more conscious than we of human weaknesses, of the shadow-side of things, and hence in this respect much less vulnerable than we are. Thanks to their experience of an old culture, they are able, while fully conscious of their frailties, to live on friendly and even tolerant terms with them, whereas we are still too young not to have “illusions” about ourselves. Moreover, we have been entrusted by fate with the task of creating a civilization—and indeed we have need of it—and for this “illusions” in the form of one-sided ideals, convictions, plans, etc. are indispensable. As a member of a race with a three-thousand-year-old civilization, the Jew, like the cultured Chinese, has a wider area of psychological consciousness than we. Consequently it is *in general* less dangerous for the Jew to put a negative value on his unconscious. The “Aryan” unconscious, on the other hand, contains explosive forces and seeds of a future yet to be born, and these may not be devalued as nursery romanticism without psychic danger. The still youthful Germanic peoples are fully capable of creating new cultural forms that still lie dormant in the darkness of the unconscious of every individual—seeds bursting with energy and capable of mighty expansion. The Jew, who is something of a nomad, has never yet created a cultural

form of his own and as far as we can see never will, since all his instincts and talents require a more or less civilized nation to act as host for their development.

[354] The Jewish race as a whole—at least this is my experience—possesses an unconscious which can be compared with the “Aryan” only with reserve. Creative individuals apart, the average Jew is far too conscious and differentiated to go about pregnant with the tensions of unborn futures. The “Aryan” unconscious has a higher potential than the Jewish; that is both the advantage and the disadvantage of a youthfulness not yet fully weaned from barbarism. In my opinion it has been a grave error in medical psychology up till now to apply Jewish categories—which are not even binding on all Jews—indiscriminately to Germanic and Slavic Christendom. Because of this the most precious secret of the Germanic peoples—their creative and intuitive depth of soul—has been explained as a morass of banal infantilism, while my own warning voice has for decades been suspected of anti-Semitism. This suspicion emanated from Freud. He did not understand the Germanic psyche any more than did his Germanic followers. Has the formidable phenomenon of National Socialism, on which the whole world gazes with astonished eyes, taught them better? Where was that unparalleled tension and energy while as yet no National Socialism existed? Deep in the Germanic psyche, in a pit that is anything but a garbage-bin of unrealizable infantile wishes and unresolved family resentments. A movement that grips a whole nation must have matured in every individual as well. That is why I say that the Germanic unconscious contains tensions and potentialities which medical psychology must consider in its evaluation of the unconscious. Its business is not with neuroses but with human beings—that, in fact, is the grand privilege of medical psychology: to treat the whole man and not an artificially segregated function.² And that is why its scope must be widened to reveal to the physician’s gaze not just the pathological aberrations of a disturbed psychic development, but the creative powers of the psyche labouring at the future; not just a dreary fragment but the meaningful whole.

[355] A neurosis is by no means merely a negative thing, it is also something positive. Only a soulless rationalism reinforced by a narrow materialistic outlook could possibly have overlooked this fact. In reality the neurosis contains the patient’s psyche, or at least an essential part of it; and if, as the rationalist pretends, the neurosis could be plucked from him like a bad tooth, he would have gained nothing but would have lost something very essential to him. That is to say, he would have lost as much as the thinker deprived of his doubt, or the moralist deprived of his temptation, or the brave man deprived of his fear. To lose a neurosis is to find oneself without an object; life loses its point and hence its meaning. This would not be a cure, it would be a regular amputation; and it would be cold comfort indeed if the psychoanalyst then assured the patient that he had lost nothing but his infantile

paradise with its wishful chimeras, most of them perverse. Very much more would have been lost, for hidden in the neurosis is a bit of still undeveloped personality, a precious fragment of the psyche lacking which a man is condemned to resignation, bitterness, and everything else that is hostile to life. A psychology of neurosis that sees only the negative elements empties out the baby with the bath-water, since it neglects the positive meaning and value of these “infantile”— i.e., creative—fantasies. So often its main endeavour seems to lie in trying to explain everything backwards and downwards, and there is of course nothing that is not capable of some obscene caricature. But this will never prove that the symbol or symptom so explained really has that meaning; it merely demonstrates the adolescent smutty-mindedness of the explainer.

[356] And here I cannot refrain from remarking how often it happens that otherwise serious-minded physicians, in complete disregard of all the fundamental tenets of scientific caution, will interpret psychological material in the light of subjective conjectures, of which one can make absolutely nothing except that they are all attempts to discover by what obscene joke the material can be related to some oral, anal, urethral, or other sexual abnormality. The poison of the “low-down” interpretation has bitten so deeply into the marrow of these people’s bones that they can no longer think at all except in the infantile-perverse jargon of certain neurotics who display all the peculiarities of a Freudian psychology. It is positively grotesque that the doctor should himself fall into a way of thinking which in others he rightly censures as infantile and wants to cure for that reason. Certainly it is much easier to make conjectures over the head of the patient than to see what the empirical material really means. Nevertheless, one must assume that the patient came to the analyst in order to rid himself of his morbid way of thinking and looking at things, and we may therefore infer—as everywhere else in modern medicine—that the symptom is really the effort of the diseased system to cure itself. But if the analyst’s thoughts, spoken or unspoken, are as negative and disparaging as the patient’s, and if he degrades everything to the level of a “dirty joke” psychology, then we must not be surprised if the patient becomes spiritually blighted and compensates for this blight by incurable intellectualism.

[357] Unfortunately it is true that there are far too many people who justify our mistrust. Too many of them use ideals and meretricious values to pull wool over their own eyes. Often the analyst has to reduce them to a very unpleasant formula indeed in order to bring home to them the truth about themselves. But not all people are like that. At least as many patients need anything rather than distrust and disparagement. They are fundamentally decent folk who play fair and do not prostitute ideals for the adornment of their inferiorities. To treat such people reductively, to impute ulterior motives to them, and to suspect their natural wholesomeness of unnatural obscenities

is not only sinfully stupid but positively criminal. A technique is always a soulless mechanism, and whoever takes psychotherapy for a technique and vaunts it as such runs the risk, at the very least, of committing an unpardonable blunder. A conscientious doctor must be able to doubt all his skills and all his theories, otherwise he is befooled by a system. But all systems mean bigotry and inhumanity. Neurosis—let there be no doubt about this—may be any number of things, but never a “nothing but.” It is the agony of a human soul in all its vast complexity—so vast, indeed, that any and every theory of neurosis is little better than a worthless sketch, unless it be a gigantic picture of the psyche which not even a hundred Fausts could conceive.

[358] The fundamental rule for the psychotherapist should be to consider each case new and unique. That, probably, is the nearest we can get to the truth.

[359] The proper handling of psychic material requires supreme tact and an almost artistic sensitiveness. Without these, it is hardly possible to distinguish what is valuable from what is not. A neurosis, as I have said, consists of two things: infantile unwillingness and the will to adapt. Hence one has first to feel one’s way until one is sure on which side the accent lies, for the road goes on from there. If the accent is on the will to adapt, there is no sense in decrying the attempt at adaptation as an infantile wish-fantasy. The analyst is very liable to make this mistake with his patient, and the patient—to his own great injury—is ever so delighted because he is then protected on medical authority against the feared or hated demands of his neurosis, that is, against the demands of that part of his personality which is concealed in it. But this “other” personality is the very thing he ought never to lose sight of, for it is his own inner antithesis, the conflict that must be fought out again and again if life is to go on. Without this initial opposition there is no flow of energy, no vitality. Lack of opposition brings life to a standstill wherever that lack reaches. But beyond that reach life flows on unconsciously in ever-renewed and ever-changing forms of neurosis. Only if we understand and accept the neurosis as our truest and most precious possession can we be sure of avoiding stagnation and of not succumbing to rigidity and neurotic subterfuge. In the neurosis is hidden one’s worst enemy and best friend. One cannot rate him too highly, unless of course fate has made one hostile to life. There are always deserters, but they have nothing to say to us, nor we to them.

[360] Neurotic symbolism is ambiguous, pointing at once forward and back, downward and up. In general the forward movement is the more important, because the future is coming and the past retreating. Only those who are preparing a retreat will do better to look back. The neurotic has no need to feel himself beaten; he has merely misjudged his necessary adversary, thinking that he could give him the slip. The whole task of his personality lies in the very thing he sought to avoid. Any doctor who deludes him on that score is doing him a disservice. *The patient has not to learn*

how to get rid of his neurosis, but how to bear it. His illness is not a gratuitous and therefore meaningless burden; it is *his own self*, the “other” whom, from childish laziness or fear, or for some other reason, he was always seeking to exclude from his life. In this way, as Freud rightly says, we turn the ego into a “seat of anxiety,” which it would never be if we did not defend ourselves against ourselves so neurotically. As soon as the ego becomes a “seat of anxiety,” we all run away from ourselves and refuse to admit our fear. That dreaded “other self” is the main target of psychoanalysis with its depreciating, undermining technique which is always seeking to wear down the enemy and cripple him for good.

[361] “We should not try to “get rid” of a neurosis, but rather to experience what it means, what it has to teach, what its purpose is. We should even learn to be thankful for it, otherwise we pass it by and miss the opportunity of getting to know ourselves as we really are. A neurosis is truly removed only when it has removed the false attitude of the ego. We do not cure it—it cures us. A man is ill, but the illness is nature’s attempt to heal him. From the illness itself we can learn so much for our recovery, and what the neurotic flings away as absolutely worthless contains the true gold we should never have found elsewhere. The psychoanalyst’s every second word is “nothing but”—just what a dealer would say of an article he wanted to buy on the cheap. In this case it is man’s soul, his hope, his boldest flight, his finest adventure.

[362] No, it will not do, this attempt to buy off the sick man’s neurosis and with it his soul. Moreover it is, at bottom, an impossible undertaking, a fraud: in the long run nobody can dodge his shadow unless he lives in eternal darkness. What the patient encounters in a neurotic dissociation is a strange, unrecognized part of his personality, which seeks to compel his recognition in exactly the same way that any other part of the body, if obstinately denied, would insist on its presence. If anyone set out to deny the existence of his left hand, he would inevitably get entangled in a fantastic web of “nothing but” explanations, just as happens to the neurotic—except that the psychoanalyst dignifies them with the name of a “theory.” The infantile-perverse “nothing but” fantasies are the patient’s efforts to deny his left hand. These efforts are themselves his morbid deviation, and they are interesting only inasmuch as all fantasies contain a secret allusion to the left hand. Everything else about them is unreal, because it is merely contrived for the purpose of concealment. Freud, of course, thinks that the thing concealed is the thing these fantasies more or less openly allude to, i.e., sexuality and all the rest of it. But this is just what that kind of patient is aiming at all the time. He rides the same hobby-horse as his analyst, who may even have handed him a helpful idea or two—the famous infantile sexual trauma, for instance, which we can spend so much time chasing, only to find that we are as far from the truth as ever.

[363] The true reason for a neurosis always lies in the present, since the neurosis exists in the present. It is definitely not a hangover from the past, a *caput mortuum*; it is fed and as it were new-made every day. And it is only in the today, not in our yesterdays, that the neurosis can be “cured.” Because the neurotic conflict has to be fought today, any historical deviation is a detour, if not actually a wrong turning. And because the neurosis contains a part of one’s own personality, an excursus into the thousand and one possibilities of obscene fantasy and unfulfillable infantile wishes is just a pretext for avoiding the essential question.

[364] The essential question is: what will pierce through this fog of verbiage to the conscious personality of the patient, and what must be the nature of his attitude if he is to integrate that split-off fragment, supposing it were ever part of him? But how could it trouble him so much unless it were like his left hand, like the other half of himself? Something, therefore, that belongs to him in the deepest sense, completes him, creates organic balance, and yet for some reason is feared, perhaps because it makes life complicated and sets apparently impossible tasks?

[365] Obviously, the best way to evade these tasks is to replace them by something that can rightly be called impossible—for instance, that world of obscenities whose speediest sublimation is recommended by Freud himself. Freud, it seems, took these neurotic conjectures quite seriously and thus fell into the same trap as the neurotic: on the one hand he seeks a wrong turning at any price, and on the other hand he cannot find the right way out of the maze. He was obviously taken in by the neurotic trick of *euphemistic disparagement*. He undervalued the neurosis and thereby won the applause of patients and doctors alike, who want nothing better than to hear that neurosis is “nothing but ...”

[366] The very word “psychogenic,” however, tells us that certain disturbances come from the psyche. Unfortunately the psyche is not a hormone but a world of almost cosmic proportions. Scientific rationalism completely overlooked this fact. Have psychotherapists ever seriously reflected that they have quite other forbears than Mesmer, Faria, Liébeault, Charcot, Bernheim, Janet, Forel, and the rest?

[367] For thousands of years the mind of man has worried about the sick soul, perhaps even earlier than it did about the sick body. The propitiation of gods, the perils of the soul and its salvation, these are not yesterday’s problems. Religions are psychotherapeutic systems in the truest sense of the word, and on the grandest scale. They express the whole range of the psychic problem in mighty images; they are the avowal and recognition of the soul, and at the same time the revelation of the soul’s nature. From this universal foundation no human soul is cut off; only the individual consciousness that has lost its connection with the psychic totality remains caught in the illusion that the soul is a small circumscribed area, a fit subject for “scientific”

theorizing. The loss of this great relationship is the prime evil of neurosis, and that is why the neurotic loses his way among ever more tortuous back-streets of dubious repute, because he who denies the great must blame the petty. In his book *The Future of an Illusion* Freud has unwittingly shown his hand. He wants to put an end once and for all to the larger aspect of the psychic phenomenon, and in the attempt he continues the baleful work that is going on in every neurotic: destruction of the bond between men and the gods, severance from the universally felt and known bases of the psyche, and hence “denial of the left hand,” of the counterpart man needs for his psychic existence.

[368] Let us not ask who has *not* preached to deaf ears! But did Goethe really write his *Faust* in vain? Hasn't Faust a neurosis as big as your fist? For surely the devil has been proved nonexistent. Consequently his psychic counterpart doesn't exist either—a mystery still to be unriddled, born of Faust's dubious internal secretions! That at least is the opinion of Mephistopheles, who is himself not altogether above reproach sexually—inclined to be bisexual, if anything. This devil who, according to *The Future of an Illusion*, does not exist is yet the scientific object of psychoanalysis, which gleefully busies itself with his non-existent ways of thought. Faust's fate in heaven and on earth may well be “left to the poets,” but meanwhile the topsy-turvy view³ of the human soul is turned into a theory of psychic suffering.

[369] Psychotherapy today, it seems to me, still has a vast amount to unlearn and relearn if it is to do even rough justice to its subject, the full range of the human psyche. But first it must cease thinking neurotically and see the psychic processes in true perspective. Not only the whole conception of neurosis, but our ideas about the psychic functions themselves—for instance the function of dreams—stand in need of radical revision. Very notable blunders have occurred here, as when the perfectly normal function of dreams was viewed from the same angle as disease. It will then become clear that psychotherapy made approximately the same mistake as did the old school of medicine when it attacked the fever in the belief that this was the noxious agent.

[370] It is the fate and misfortune of psychotherapy to have been born in an age of enlightenment, when self-distrust had made the old cultural values inaccessible and there was no psychology anywhere that went much beyond the level of Herbart or Condillac—none at any rate that would have done anything like justice to the complexities and perplexities with which the innocent and wholly unprepared physician was suddenly faced. In this respect we must be grateful to Freud, for at least he created a certain sense of direction in this chaos, and gave the physician sufficient courage to take a case of hysteria seriously, as a scientific proposition. Criticism after the event is easy enough, but all the same there is no sense in an entire

generation of doctors going to sleep on Freud's laurels. Much has still to be learnt about the psyche, and our especial need today is liberation from outworn ideas which have seriously restricted our view of the psyche as a whole.

III

PREFACE TO "ESSAYS ON CONTEMPORARY EVENTS"



WOTAN

—

AFTER THE CATASTROPHE

THE FIGHT WITH THE SHADOW

EPILOGUE TO "ESSAYS ON CONTEMPORARY EVENTS"

PREFACE TO "ESSAYS ON CONTEMPORARY EVENTS"¹

Medical psychotherapy, for practical reasons, has to deal with the whole of the psyche. Therefore it is bound to come to terms with all those factors, biological as well as social and mental, which have a vital influence on psychic life.

We are living in times of great disruption: political passions are aflame, internal upheavals have brought nations to the brink of chaos, and the very foundations of our *Weltanschauung* are shattered. This critical state of things has such a tremendous influence on the psychic life of the individual that the doctor must follow its effects with more than usual attention. The storm of events does not sweep down upon him only from the great world outside; he feels the violence of its impact even in the quiet of his consulting-room and in the privacy of the medical consultation. As he has a responsibility towards his patients, he cannot afford to withdraw to the peaceful island of undisturbed scientific work, but must constantly descend into the arena of world events, in order to join in the battle of conflicting passions and opinions. Were he to remain aloof from the tumult, the calamity of his time would reach him only from afar, and his patient's suffering would find neither ear nor understanding. He would be at a loss to know how to talk to him, and to help him out of his isolation. For this reason the psychologist cannot avoid coming to grips with contemporary history, even if his very soul shrinks from the political uproar, the lying propaganda, and the jarring speeches of the demagogues. We need not mention his duties as a citizen, which confront him with a similar task. As a physician, he has a higher obligation to humanity in this respect.

From time to time, therefore, I have felt obliged to step beyond the usual bounds of my profession. The experience of the psychologist is of a rather special kind, and it seemed to me that the general public might find it useful to hear his point of view. This was hardly a far-fetched conclusion, for surely the most naïve of laymen could not fail to see that many contemporary figures and events were positively asking for psychological elucidation. Were psychopathic symptoms ever more conspicuous than in the contemporary political scene?

It has never been my wish to meddle in the political questions of the day. But in the course of the years I have written a few papers which give my reactions to current events. The present book contains a collection of these occasional essays, all written between 1936 and 1946. It is natural enough that my thoughts should have been especially concerned with Germany, which has been a problem to me ever since the first World War. My statements have evidently led to all manner of misunderstandings, which are chiefly due, no doubt, to the fact that my psychological point of view strikes

many people as new and therefore strange. Instead of embarking upon lengthy arguments in an attempt to clear up these misunderstandings, I have found it simpler to collect all the passages in my other writings which deal with the same theme and to put them in an epilogue.² The reader will thus be in a position to get a clear picture of the facts for himself.

WOTAN¹

En Germanie naistront diverses sectes,
S'approchans fort de l'heureux paganisme:
Le cœur captif et petites receptes
Feront retour à payer la vraye disme.

—*Prophéties de Maistre Michel Nostradamus*, 1555

[371] When we look back to the time before 1914, we find ourselves living in a world of events which would have been inconceivable before the war. We were even beginning to regard war between civilized nations as a fable, thinking that such an absurdity would become less and less possible in our rational, internationally organized world. And what came after the war was a veritable witches' sabbath. Everywhere fantastic revolutions, violent alterations of the map, reversions in politics to medieval or even antique prototypes, totalitarian states that engulf their neighbours and outdo all previous theocracies in their absolutist claims, persecutions of Christians and Jews, wholesale political murder, and finally we have witnessed a light-hearted piratical raid on a peaceful, half-civilized people.²

[372] With such goings on in the wide world it is not in the least surprising that there should be equally curious manifestations on a smaller scale in other spheres. In the realm of philosophy we shall have to wait some time before anyone is able to assess the kind of age we are living in. But in the sphere of religion we can see at once that some very significant things have been happening. We need feel no surprise that in Russia the colourful splendours of the Eastern Orthodox Church have been superseded by the Movement of the Godless—indeed, one breathed a sigh of relief oneself when one emerged from the haze of an Orthodox church with its multitude of lamps and entered an honest mosque, where the sublime and invisible omnipresence of God was not crowded out by a superfluity of sacred paraphernalia. Tasteless and pitifully unintelligent as it is, and however deplorable the low spiritual level of the “scientific” reaction, it was inevitable that nineteenth-century “scientific” enlightenment should one day dawn in Russia.

[373] But what is more than curious—indeed, piquant to a degree—is that an ancient god of storm and frenzy, the long quiescent Wotan, should awake, like an extinct volcano, to new activity, in a civilized country that had long been supposed to have outgrown the Middle Ages. We have seen him come to life in the German Youth Movement, and right at the beginning the blood of several sheep was shed in honour

of his resurrection. Armed with rucksack and lute, blond youths, and sometimes girls as well, were to be seen as restless wanderers on every road from the North Cape to Sicily, faithful votaries of the roving god. Later, towards the end of the Weimar Republic, the wandering role was taken over by the thousands of unemployed, who were to be met with everywhere on their aimless journeys. By 1933 they wandered no longer, but marched in their hundreds of thousands. The Hitler movement literally brought the whole of Germany to its feet, from five-year-olds to veterans, and produced the spectacle of a nation migrating from one place to another. Wotan the wanderer was on the move. He could be seen, looking rather shamefaced, in the meeting-house of a sect of simple folk in North Germany, disguised as Christ sitting on a white horse. I do not know if these people were aware of Wotan's ancient connection with the figures of Christ and Dionysus, but it is not very probable.

[374] Wotan is a restless wanderer who creates unrest and stirs up strife, now here, now there, and works magic. He was soon changed by Christianity into the devil, and only lived on in fading local traditions as a ghostly hunter who was seen with his retinue, flickering like a will o' the wisp through the stormy night. In the Middle Ages the role of the restless wanderer was taken over by Ahasuerus, the Wandering Jew, which is not a Jewish but a Christian legend. The motif of the wanderer who has not accepted Christ was projected on the Jews, in the same way as we always rediscover our unconscious psychic contents in other people. At any rate the coincidence of anti-Semitism with the reawakening of Wotan is a psychological subtlety that may perhaps be worth mentioning.

[375] The German youths who celebrated the solstice with sheep-sacrifices were not the first to hear a rustling in the primeval forest of the unconscious. They were anticipated by Nietzsche, Schuler, Stefan George, and Ludwig Klages.³ The literary tradition of the Rhineland and the country south of the Main has a classical stamp that cannot easily be got rid of; every interpretation of intoxication and exuberance is apt to be taken back to classical models, to Dionysus, to the *puer aeternus* and the cosmogonic Eros.⁴ No doubt it sounds better to academic ears to interpret these things as Dionysus, but Wotan might be a more correct interpretation. He is the god of storm and frenzy, the unleasher of passions and the lust of battle; moreover he is a superlative magician and artist in illusion who is versed in all secrets of an occult nature.

[376] Nietzsche's case is certainly a peculiar one. He had no knowledge of Germanic literature; he discovered the "cultural Philistine"; and the announcement that "God is dead" led to Zarathustra's meeting with an unknown god in unexpected form, who approached him sometimes as an enemy and sometimes disguised as Zarathustra himself. Zarathustra, too, was a soothsayer, a magician, and the storm-wind:

And like a wind shall I come to blow among them, and with my spirit shall take away the breath of their spirit; thus my future wills it.

Truly, a strong wind is Zarathustra to all that are low; and this counsel gives he to his enemies and to all that spit and spew:

“Beware of spitting against the wind.”⁵

[377] And when Zarathustra dreamed that he was guardian of the graves in the “lone mountain fortress of death,” and was making a mighty effort to open the gates, suddenly

A roaring wind tore the gates asunder; whistling, shrieking, and keening, it cast a black coffin before me.

And amid the roaring and whistling and shrieking the coffin burst open and spouted a thousand peals of laughter.

[378] The disciple who interpreted the dream said to Zarathustra:

Are you not yourself the wind with shrill whistling, which bursts open the gates of the fortress of death?

Are you not yourself the coffin filled with life’s gay malice and angel-grimaces?⁶

[379] In 1863 or 1864, in his poem “To the Unknown God,” Nietzsche had written:

I shall and will know thee, Unknown One,

Who searchest out the depths of my soul,

And blowest through my life like a storm,

Ungraspable, and yet my kinsman!

I shall and will know thee, and serve thee.

[380] Twenty years later, in his “Mistral Song,” he wrote:

Mistral wind, chaser of clouds,

Killer of gloom, sweeper of the skies,

Raging storm-wind, how I love thee!

Are we not both the first-fruits

Of the same womb, forever predestined

To the same fate?⁷

[381] In the dithyramb known as “Ariadne’s Lament,” Nietzsche is completely the victim of the hunter-god:

Stretched out, shuddering,

Like a half-dead thing whose feet are warmed,

Shaken by unknown fevers,

Shivering with piercing icy frost arrows,

Hunted by thee, O thought,

Unutterable! Veiled! horrible one!

Thou huntsman behind the clouds.

Struck down by thy lightning bolt,
Thou mocking eye that stares at me from the dark!
Thus I lie,
Writhing, twisting, tormented
With all eternal tortures, Smitten
By thee, cruel huntsman,
Thou unknown—God!⁸

[382] This remarkable image of the hunter-god is not a mere dithyrambic figure of speech but is based on an experience which Nietzsche had when he was fifteen years old, at Pforta. It is described in a book by Nietzsche's sister, Elizabeth Foerster-Nietzsche.⁹ As he was wandering about in a gloomy wood at night, he was terrified by a "blood-curdling shriek from a neighbouring lunatic asylum," and soon afterwards he came face to face with a huntsman whose "features were wild and uncanny." Setting his whistle to his lips "in a valley surrounded by wild scrub," the huntsman "blew such a shrill blast" that Nietzsche lost consciousness—but woke up again in Pforta. It was a nightmare. It is significant that in his dream Nietzsche, who in reality intended to go to Eisleben, Luther's town, discussed with the huntsman the question of going instead to "Teutschenthal" (Valley of the Germans). No one with ears to hear can misunderstand the shrill whistling of the storm-god in the nocturnal wood.

[383] Was it really only the classical philologist in Nietzsche that led to the god being called Dionysus instead of Wotan—or was it perhaps due to his fateful meeting with Wagner?

[384] In his *Reich ohne Raum*, which was first published in 1919, Bruno Goetz saw the secret of coming events in Germany in the form of a very strange vision. I have never forgotten this little book, for it struck me at the time as a forecast of the German weather. It anticipates the conflict between the realm of ideas and life, between Wotan's dual nature as a god of storm and a god of secret musings. Wotan disappeared when his oaks fell and appeared again when the Christian God proved too weak to save Christendom from fratricidal slaughter. When the Holy Father at Rome could only impotently lament before God the fate of the *grex segregatus*, the one-eyed old hunter, on the edge of the German forest, laughed and saddled Sleipnir.

[385] We are always convinced that the modern world is a reasonable world, basing our opinion on economic, political, and psychological factors. But if we may forget for a moment that we are living in the year of Our Lord 1936, and, laying aside our well-meaning, all-too-human reasonableness, may burden God or the gods with the responsibility for contemporary events instead of man, we would find Wotan quite suitable as a causal hypothesis. In fact I venture the heretical suggestion that the unfathomable depths of Wotan's character explain more of National Socialism than all

three reasonable factors put together. There is no doubt that each of these factors explains an important aspect of what is going on in Germany, but Wotan explains yet more. He is particularly enlightening in regard to a general phenomenon which is so strange to anybody not a German that it remains incomprehensible even after the deepest reflection.

[386] Perhaps we may sum up this general phenomenon as *Ergriffenheit*—a state of being seized or possessed. The term postulates not only an *Ergriffener* (one who is seized) but also an *Ergreifer* (one who seizes). Wotan is an *Ergreifer* of men, and, unless one wishes to deify Hitler—which has indeed actually happened—he is really the only explanation. It is true that Wotan shares this quality with his cousin Dionysus, but Dionysus seems to have exercised his influence mainly on women. The maenads were a species of female storm-troopers, and, according to mythical reports, were dangerous enough. Wotan confined himself to the berserkers, who found their vocation as the Blackshirts of mythical kings.

[387] A mind that is still childish thinks of the gods as metaphysical entities existing in their own right, or else regards them as playful or superstitious inventions. From either point of view the parallel between Wotan *redivivus* and the social, political, and psychic storm that is shaking Germany might have at least the value of a parable. But since the gods are without doubt personifications of psychic forces, to assert their metaphysical existence is as much an intellectual presumption as the opinion that they could ever be invented. Not that “psychic forces” have anything to do with the conscious mind, fond as we are of playing with the idea that consciousness and psyche are identical. This is only another piece of intellectual presumption. “Psychic forces” have far more to do with the realm of the unconscious. Our mania for rational explanations obviously has its roots in our fear of metaphysics, for the two were always hostile brothers. Hence anything unexpected that approaches us from that dark realm is regarded either as coming from outside and therefore as real, or else as an hallucination and therefore not true. The idea that anything could be real or true which does *not* come from outside has hardly begun to dawn on contemporary man.

[388] For the sake of better understanding and to avoid prejudice, we could of course dispense with the name “Wotan” and speak instead of the *furor teutonicus*. But we should only be saying the same thing and not as well, for the *furor* in this case is a mere psychologizing of Wotan and tells us no more than that the Germans are in a state of “fury.” We thus lose sight of the most peculiar feature of this whole phenomenon, namely, the dramatic aspect of the *Ergreifer* and the *Ergriffener*. The impressive thing about the German phenomenon is that one man, who is obviously “possessed,” has infected a whole nation to such an extent that everything is set in motion and has started rolling on its course towards perdition.

[389] It seems to me that Wotan hits the mark as an hypothesis. Apparently he really was only asleep in the Kyffhäuser mountain until the ravens called him and announced the break of day. He is a fundamental attribute of the German psyche, an irrational psychic factor which acts on the high pressure of civilization like a cyclone and blows it away. Despite their crankiness, the Wotan-worshippers seem to have judged things more correctly than the worshippers of reason. Apparently everyone had forgotten that Wotan is a Germanic datum of first importance, the truest expression and unsurpassed personification of a fundamental quality that is particularly characteristic of the Germans. Houston Stewart Chamberlain is a symptom which arouses suspicion that other veiled gods may be sleeping elsewhere. The emphasis on the Germanic race (vulgarly called “Aryan”), the Germanic heritage, blood and soil, the *Wagalaweia* songs,¹⁰ the ride of the Valkyries, Jesus as a blond and blue-eyed hero, the Greek mother of St. Paul, the devil as an international Alberich in Jewish or Masonic guise, the Nordic aurora borealis as the light of civilization, the inferior Mediterranean races—all this is the indispensable scenery for the drama that is taking place and at bottom they all mean the same thing: a god has taken possession of the Germans and their house is filled with a “mighty rushing wind.” It was soon after Hitler seized power, if I am not mistaken, that a cartoon appeared in *Punch* of a raving berserker tearing himself free from his bonds. A hurricane has broken loose in Germany while we still believe it is fine weather.

[390] Things are comparatively quiet in Switzerland, though occasionally there is a puff of wind from the north or south. Sometimes it has a slightly ominous sound, sometimes it whispers so harmlessly or even idealistically that no one is alarmed. “Let sleeping dogs lie”—we manage to get along pretty well with this proverbial wisdom. It is sometimes said that the Swiss are singularly averse to making a problem of themselves. I must rebut this accusation: the Swiss do have their problems but they would not say so for anything in the world, even though they see which way the wind is blowing. We thus pay our tribute to the time of storm and stress in Germany, but we never mention it, and this enables us to feel vastly superior.

[391] It is above all the Germans who have an opportunity, perhaps unique in history, to look into their own hearts and to learn what those perils of the soul were from which Christianity tried to rescue mankind. Germany is a land of spiritual catastrophes, where nature never makes more than a pretence of peace with world-ruling reason. The disturber of the peace is a wind that blows into Europe from Asia’s vastness, sweeping in on a wide front from Thrace to the Baltic, scattering the nations before it like dry leaves, or inspiring thoughts that shake the world to its foundations. It is an elemental Dionysus breaking into the Apollonian order. The rouser of this tempest is named Wotan, and we can learn a good deal about him from the political confusion and spiritual upheaval he has caused throughout history. For a more exact

investigation of his character, however, we must go back to the age of myths, which did not explain everything in terms of man and his limited capacities but sought the deeper cause in the psyche and its autonomous powers. Man's earliest intuitions personified these powers as gods, and described them in the myths with great care and circumstantiality according to their various characters. This could be done the more readily on account of the firmly established primordial types or images which are innate in the unconscious of many races and exercise a direct influence upon them. Because the behaviour of a race takes on its specific character from its underlying images we can speak of an archetype "Wotan."¹¹ As an autonomous psychic factor, Wotan produces effects in the collective life of a people and thereby reveals his own nature. For Wotan has a peculiar biology of his own, quite apart from the nature of man. It is only from time to time that individuals fall under the irresistible influence of this unconscious factor. When it is quiescent, one is no more aware of the archetype Wotan than of a latent epilepsy. Could the Germans who were adults in 1914 have foreseen what they would be today? Such amazing transformations are the effect of the god of wind, that "bloweth where it listeth, and thou hearest the sound thereof, but canst not tell whence it cometh, nor whither it goeth." It seizes everything in its path and overthrows everything that is not firmly rooted. When the wind blows it shakes everything that is insecure, whether without or within.

[392] Martin Ninck has recently published a monograph ¹² which is a most welcome addition to our knowledge of Wotan's nature. The reader need not fear that this book is nothing but a scientific study written with academic aloofness from the subject. Certainly the right to scientific objectivity is fully preserved, and the material has been collected with extraordinary thoroughness and presented in unusually clear form. But over and above all this one feels that the author is vitally interested in it, that the chord of Wotan is vibrating in him too. This is no criticism—on the contrary it is one of the chief merits of the book, which without this enthusiasm might easily have degenerated into a tedious catalogue.

[393] Ninck sketches a really magnificent portrait of the German archetype Wotan. He describes him in ten chapters, using all the available sources, as the berserker, the god of storm, the wanderer, the warrior, the *Wunsch-* and *Minne-god*, the lord of the dead and of the *Einherier*,¹³ the master of secret knowledge, the magician, and the god of the poets. Neither the Valkyries nor the *Fylgja*¹⁴ are forgotten, for they form part of the mythological background and fateful significance of Wotan. Ninck's inquiry into the name and its origin is particularly instructive. He shows that Wotan is not only a god of rage and frenzy who embodies the instinctual and emotional aspect of the unconscious. Its intuitive and inspiring side also manifests itself in him, for he understands the runes and can interpret fate.

[394] The Romans identified Wotan with Mercury, but his character does not really correspond to any Roman or Greek god, although there are certain resemblances. He is a wanderer like Mercury, for instance, rules over the dead like Pluto and Kronos, and is connected with Dionysus by his emotional frenzy, particularly in its mantic aspect. It is surprising that Ninck does not mention Hermes, the god of revelation, who as *pneuma* and *nous* is associated with the wind. He would be the connecting-link with the Christian *pneuma* and the miracle of Pentecost. As Poimandres (the shepherd of men) Hermes is an *Ergreifer* like Wotan. Ninck rightly points out that Dionysus and the other Greek gods always remained under the supreme authority of Zeus, which indicates a fundamental difference between the Greek and the Germanic temperament. Ninck assumes an inner affinity between Wotan and Kronos, and the latter's defeat may perhaps be a sign that the Wotan-archetype was once overcome and split up in prehistoric times. At all events, the Germanic god represents a totality on a very primitive level, a psychological condition in which man's will was almost identical with the god's and entirely at his mercy. But the Greeks had gods who helped man against other gods; indeed, All-Father Zeus himself is not far from the ideal of a benevolent, enlightened despot.

[395] It was not in Wotan's nature to linger on and show signs of old age. He simply disappeared when the times turned against him, and remained invisible for more than a thousand years, working anonymously and indirectly. Archetypes are like riverbeds which dry up when the water deserts them, but which it can find again at any time. An archetype is like an old watercourse along which the water of life has flowed for centuries, digging a deep channel for itself. The longer it has flowed in this channel the more likely it is that sooner or later the water will return to its old bed. The life of the individual as a member of society and particularly as part of the State may be regulated like a canal, but the life of nations is a great rushing river which is utterly beyond human control, in the hands of One who has always been stronger than men. The League of Nations, which was supposed to possess supranational authority, is regarded by some as a child in need of care and protection, by others as an abortion. Thus the life of nations rolls on unchecked, without guidance, unconscious of where it is going, like a rock crashing down the side of a hill, until it is stopped by an obstacle stronger than itself. Political events move from one impasse to the next, like a torrent caught in gullies, creeks, and marshes. All human control comes to an end when the individual is caught in a mass movement. Then the archetypes begin to function, as happens also in the lives of individuals when they are confronted with situations that cannot be dealt with in any of the familiar ways. But what a so-called Führer does with a mass movement can plainly be seen if we turn our eyes to the north or south of our country.

[396] The ruling archetype does not remain the same for ever, as is evident from the temporal limitations that have been set to the hoped-for reign of peace, the “thousand-year Reich.” The Mediterranean father-archetype of the just, order-loving, benevolent ruler has been shattered over the whole of northern Europe, as the present fate of the Christian Churches bears witness. Fascism in Italy and the civil war in Spain show that in the south as well the cataclysm has been far greater than one expected. Even the Catholic Church can no longer afford trials of strength.

[397] The nationalist God has attacked Christianity on a broad front. In Russia he is called technology and science, in Italy, Duce, and in Germany, “German Faith,” “German Christianity,” or the State. The “German Christians”¹⁵ are a contradiction in terms and would do better to join Hauer’s “German Faith Movement.”¹⁶ These are decent and well-meaning people who honestly admit their *Ergriffenheit* and try to come to terms with this new and undeniable fact. They go to an enormous amount of trouble to make it look less alarming by dressing it up in a conciliatory historical garb and giving us consoling glimpses of great figures such as Meister Eckhart, who was also a German and also *ergriffen*. In this way the awkward question of who the *Ergreifer* is is circumvented. He was always “God.” But the more Hauer restricts the world-wide sphere of Indo-European culture to the “Nordic” in general and to the *Edda* in particular, and the more “German” this faith becomes as a manifestation of *Ergriffenheit*, the more painfully evident it is that the “German” god is the god of the Germans.

[398] One cannot read Hauer’s book¹⁷ without emotion, if one regards it as the tragic and really heroic effort of a conscientious scholar who, without knowing how it happened to him, was violently summoned by the inaudible voice of the *Ergreifer* and is now trying with all his might, and with all his knowledge and ability, to build a bridge between the dark forces of life and the shining world of historical ideas. But what do all the beauties of the past from totally different levels of culture mean to the man of today, when confronted with a living and unfathomable tribal god such as he has never experienced before? They are sucked like dry leaves into the roaring whirlwind, and the rhythmic alliterations of the *Edda* become inextricably mixed up with Christian mystical texts, German poetry, and the wisdom of the *Upanishads*. Hauer himself is *ergriffen* by the depths of meaning in the primal words lying at the root of the Germanic languages, to an extent that he certainly never knew before. Hauer the Indologist is not to blame for this, nor yet the *Edda*; it is rather the fault of *kairos*—the present moment in time—whose name on closer investigation turns out to be Wotan. I would therefore advise the German Faith Movement to throw aside their scruples. Intelligent people will not confuse them with the crude Wotan-worshippers whose faith is a mere pretence. There are people in the German Faith Movement who are intelligent enough not only to *believe* but to *know* that the god of the *Germans* is

Wotan and not the Christian God. This is a tragic experience and no disgrace. It has always been terrible to fall into the hands of a living god. Yahweh was no exception to this rule, and the Philistines, Edomites, Amorites, and the rest, who were outside the Yahweh experience, must certainly have found it exceedingly disagreeable. The Semitic¹⁸ experience of Allah was for a long time an extremely painful affair for the whole of Christendom. We who stand outside judge the Germans far too much as if they were responsible agents, but perhaps it would be nearer the truth to regard them also as *victims*.

[399] If we apply our admittedly peculiar point of view consistently, we are driven to conclude that Wotan must, in time, reveal not only the restless, violent, stormy side of his character, but also his ecstatic and mantic qualities—a very different aspect of his nature. If this conclusion is correct, National Socialism would not be the last word. Things must be concealed in the background which we cannot imagine at present, but we may expect them to appear in the course of the next few years or decades. Wotan's reawakening is a stepping back into the past; the stream was dammed up and has broken into its old channel. But the obstruction will not last for ever; it is rather a *reculer pour mieux sauter*, and the water will overleap the obstacle. Then at last we shall know what Wotan is saying when he “murmurs with Mimir's head.”

Fast move the sons of Mim, and fate
Is heard in the note of the Gjallarhorn;
Loud blows Heimdall, the horn is aloft,
In fear quake all who on Hel-roads are.

Yggdrasil shakes and shivers on high
The ancient limbs, and the giant is loose;
Wotan murmurs with Mimir's head
But the kinsman of Surt shall slay him soon.

How fare the gods? how fare the elves?
All Jotunheim groans, the gods are at council;
Loud roar the dwarfs by the doors of stone,
The masters of the rocks: would you know yet more?

Now Garm howls loud before Gniphellir;
The fetters will burst, and the wolf run free;
Much do I know, and more can see
Of the fate of the gods, the mighty in fight.

From the east comes Hrym with shield held high;
In giant-wrath does the serpent writhe;

O'er the waves he twists, and the tawny eagle
Gnaws corpses screaming; Naglfar is loose.

O'er the sea from the north there sails a ship
With the people of Hel, at the helm stands Loki;
After the wolf do wild men follow,
And with them the brother of Byleist goes.¹⁹

AFTER THE CATASTROPHE¹

[400] This is the first time since 1936 that the fate of Germany again drives me to take up my pen. The quotation from the *Voluspo* with which I ended the article² I wrote at that time, about Wotan “murmuring with Mimir’s head,” pointed prophetically to the nature of the coming apocalyptic events. The myth has been fulfilled, and the greater part of Europe lies in ruins.

[401] Before the work of reconstruction can begin, there is a good deal of clearing up to be done, and this calls above all for *reflection*. Questions are being asked on all sides about the meaning of the whole tragedy. People have even turned to me for an explanation, and I have had to answer them there and then to the best of my ability. But as the spoken word very quickly gives rise to legends, I have decided—not without considerable hesitations and misgivings—to set down my views once again in the form of an article. I am only too well aware that “Germany” presents an immense problem, and that the subjective views of a medical psychologist can touch on only a few aspects of this gigantic tangle of questions. I must be content with a modest contribution to the work of clearing up, without even attempting to look as far ahead as reconstruction.

[402] While I was working on this article I noticed how churned up one still is in one’s own psyche, and how difficult it is to reach anything approaching a moderate and relatively calm point of view in the midst of one’s emotions. No doubt we should be cold-blooded and superior; but we are, on the whole, much more deeply involved in the recent events in Germany than we like to admit. Nor can we feel compassion, for the heart harbours feelings of a very different nature, and these would like to have the first say. Neither the doctor nor the psychologist can afford to be *only* cold-blooded—quite apart from the fact that they would find it impossible. Their relationship to the world involves them and all their affects, otherwise their relationship would be incomplete. That being so, I found myself faced with the task of steering my ship between Scylla and Charybdis, and—as is usual on such a voyage—stopping my ears to one side of my being and lashing the other to the mast. I must confess that no article has ever given me so much trouble, from a moral as well as a human point of view. I had not realized how much I myself was affected. There are others, I am sure, who will share this feeling with me. This inner identity or *participation mystique* with events in Germany has caused me to experience afresh how painfully wide is the scope of the psychological concept of *collective guilt*. So when I approach this

problem it is certainly not with any feelings of cold-blooded superiority, but rather with an avowed sense of inferiority.

[403] The psychological use of the word “guilt” should not be confused with guilt in the legal or moral sense. Psychologically, it connotes the irrational presence of a subjective feeling (or conviction) of guilt, or an objective imputation of, or imputed share in, guilt. As an example of the latter, suppose a man belongs to a family which has the misfortune to be disgraced because one of its members has committed a crime. It is clear that he cannot be held responsible, either legally or morally. Yet the atmosphere of guilt makes itself felt in many ways. His family name appears to have been sullied, and it gives him a painful shock to hear it bandied about in the mouths of strangers. Guilt can be restricted to the lawbreaker only from the legal, moral, and intellectual point of view, but as a psychic phenomenon it spreads itself over the whole neighbourhood. A house, a family, even a village where a murder has been committed feels the psychological guilt and is made to feel it by the outside world. Would one take a room where one knows a man was murdered a few days before? Is it particularly pleasant to marry the sister or daughter of a criminal? What father is not deeply wounded if his son is sent to prison, and does he not feel injured in his family pride if a cousin of the same name brings dishonour on his house? Would not every decent Swiss feel ashamed—to put it mildly—if our Government had erected a human slaughterhouse like Maidenek in our country? Would we then be surprised if, travelling abroad with our Swiss passports, we heard such remarks at the frontier as “Ces cochons de Suisses!”? Indeed, are we not all a little ashamed—precisely because we are patriots—that Switzerland should have bred so many traitors?

[404] Living as we do in the middle of Europe, we Swiss feel comfortably far removed from the foul vapours that arise from the morass of German guilt. But all this changes the moment we set foot, as Europeans, on another continent or come into contact with an Oriental people. What are we to say to an Indian who asks us: “You are anxious to bring us your Christian culture, are you not? May I ask if Auschwitz and Buchenwald are examples of European civilization?” Would it help matters if we hastened to assure him that these things did not take place where we live, but several hundred miles further east—not in our country at all but in a neighbouring one? How would we react if an Indian pointed out indignantly that India’s black spot lay not in Travancore but in Hyderabad? Undoubtedly we’d say, “Oh well, India is India!” Similarly, the view all over the East is, “Oh well, Europe is Europe!” The moment we so-called innocent Europeans cross the frontiers of our own continent we are made to feel something of the collective guilt that weighs upon it, despite our good conscience. (One might also ask: Is Russia so primitive that she can still feel our “guilt-by-contagion”—as collective guilt might also be called—and for that reason accuses us of Fascism?) The world sees Europe as the continent on whose soil the

shameful concentration camps grew, just as Europe singles out Germany as the land and the people that are enveloped in a cloud of guilt; for the horror happened in Germany and its perpetrators were Germans. No German can deny this, any more than a European or a Christian can deny that the most monstrous crime of all ages was committed in his house. The Christian Church should put ashes on her head and rend her garments on account of the guilt of her children. The shadow of their guilt has fallen on her as much as upon Europe, the mother of monsters. Europe must account for herself before the world, just as Germany must before Europe. The European can no more convince the Indian that Germany is no concern of his, or that he knows nothing at all about that country, than the German can rid himself of his collective guilt by protesting that he did not know. In that way he merely compounds his collective guilt by the sin of unconsciousness.

[405] Psychological collective guilt is a *tragic fate*. It hits everybody, just and unjust alike, everybody who was anywhere near the place where the terrible thing happened. Naturally no reasonable and conscientious person will lightly turn collective into individual guilt by holding the individual responsible without giving him a hearing. He will know enough to distinguish between the individually guilty and the merely collectively guilty. But how many people are either reasonable or conscientious, and how many take the trouble to become so? I am not very optimistic in this respect. Therefore, although collective guilt, viewed on the archaic and primitive level, is a state of *magical uncleanness*, yet precisely because of the general unreasonableness it is a very real fact, which no European outside Europe and no German outside Germany can leave out of account. If the German intends to live on good terms with Europe, he must be conscious that in the eyes of Europeans he is a guilty man. As a German, he has betrayed European civilization and all its values; he has brought shame and disgrace on his European family, so that one must blush to hear oneself called a European; he has fallen on his European brethren like a beast of prey, and tortured and murdered them. The German can hardly expect other Europeans to resort to such niceties as to inquire at every step whether the criminal's name was Müller or Meier. Neither will he be deemed worthy of being treated as a gentleman until the contrary has been proved. Unfortunately, for twelve long years it has been demonstrated with the utmost clarity that the official German was no gentleman.

[406] If a German is prepared to acknowledge his moral inferiority as collective guilt before the whole world, without attempting to minimize it or explain it away with flimsy arguments, then he will stand a reasonable chance, after a time, of being taken for a more or less decent man, and will thus be absolved of his collective guilt at any rate in the eyes of individuals.

[407] It may be objected that the whole concept of psychological collective guilt is a prejudice and a sweepingly unfair condemnation. Of course it is, but that is precisely what constitutes the irrational nature of collective guilt: it cares nothing for the just and the unjust, it is the dark cloud that rises up from the scene of an unexpiated crime. It is a psychic phenomenon, and it is therefore no condemnation of the German people to say that they are collectively guilty, but simply a statement of fact. Yet if we penetrate more deeply into the psychology of this phenomenon, we shall soon discover that the problem of collective guilt has another and more questionable aspect than that merely of a collective judgment.

[408] Since no man lives within his own psychic sphere like a snail in its shell, separated from everybody else, but is connected with his fellow-men by his unconscious humanity, no crime can ever be what it appears to our consciousness to be: an isolated psychic happening. In reality, it always happens over a wide radius. The sensation aroused by a crime, the passionate interest in tracking down the criminal, the eagerness with which the court proceedings are followed, and so on, all go to prove the exciting effect which the crime has on everybody who is not abnormally dull or apathetic. Everybody joins in, feels the crime in his own being, tries to understand and explain it. Something is set aflame by that great fire of evil that flared up in the crime. Was not Plato aware that the sight of ugliness produces something ugly in the soul? Indignation leaps up, angry cries of "Justice!" pursue the murderer, and they are louder, more impassioned, and more charged with hate the more fiercely burns the fire of evil that has been lit in our souls. It is a fact that cannot be denied: the wickedness of others becomes our own wickedness because it kindles something evil in our own hearts. The murder has been suffered by everyone, and everyone has committed it; lured by the irresistible fascination of evil, we have all made this collective psychic murder possible; and the closer we were to it and the better we could see, the greater our guilt. In this way we are unavoidably drawn into the uncleanness of evil, no matter what our conscious attitude may be. No one can escape this, for we are all so much a part of the human community that every crime calls forth a secret satisfaction in some corner of the fickle human heart. It is true that, in persons with a strong moral disposition, this reaction may arouse contrary feelings in a neighbouring compartment of the mind. But a strong moral disposition is a comparative rarity, so that when the crimes mount up, indignation may easily get pitched too high, and evil then becomes the order of the day. Everyone harbours his "statistical criminal" in himself, just as he has his own private madman or saint. Owing to this basic peculiarity in our human make-up, a corresponding suggestibility, or susceptibility to infection, exists everywhere. It is our age in particular—the last half century—that has prepared the way for crime. Has it never

occurred to anybody, for instance, that the vogue for the thriller has a rather questionable side?

[409] Long before 1933 there was a smell of burning in the air, and people were passionately interested in discovering the locus of the fire and in tracking down the incendiary. And when denser clouds of smoke were seen to gather over Germany, and the burning of the Reichstag gave the signal, then at last there was no mistake where the incendiary, evil in person, dwelt. Terrifying as this discovery was, in time it brought a sense of relief: now we knew for certain where all unrighteousness was to be found, whereas we ourselves were securely entrenched in the opposite camp, among respectable people whose moral indignation could be trusted to rise higher and higher with every fresh sign of guilt on the other side. Even the call for mass executions no longer offended the ears of the righteous, and the saturation bombing of German cities was looked upon as the judgment of God. Hate had found respectable motives and had ceased to be a personal idiosyncrasy, indulged in secret. And all the time the esteemed public had not the faintest idea how closely they themselves were living to evil.

[410] One should not imagine for a moment that anybody could escape this play of opposites. Even a saint would have to pray unceasingly for the souls of Hitler and Himmler, the Gestapo and the S.S., in order to repair without delay the damage done to his own soul. The sight of evil kindles evil in the soul—there is no getting away from this fact. The victim is not the only sufferer; everybody in the vicinity of the crime, including the murderer, suffers with him. Something of the abysmal darkness of the world has broken in on us, poisoning the very air we breathe and befouling the pure water with the stale, nauseating taste of blood. True, we are innocent, we are the victims, robbed, betrayed, outraged; and yet for all that, or precisely because of it, the flame of evil glowers in our moral indignation. It must be so, for it is necessary that someone should feel indignant, that someone should let himself be the sword of judgment wielded by fate. Evil calls for expiation, otherwise the wicked will destroy the world utterly, or the good suffocate in their rage which they cannot vent, and in either case no good will come of it.

[411] When evil breaks at any point into the order of things, our whole circle of psychic protection is disrupted. Action inevitably calls up reaction, and, in the matter of destructiveness, this turns out to be just as bad as the crime, and possibly even worse, because the evil must be exterminated root and branch. In order to escape the contaminating touch of evil we need a proper *rite de sortie*, a solemn admission of guilt by judge, hangman, and public, followed by an act of expiation.

[412] The terrible things that have happened in Germany, and the moral downfall of a “nation of eighty millions,” are a blow aimed at all Europeans. (We used to be able to

relegate such things to “Asia!”) The fact that one member of the European family could sink to the level of the concentration camp throws a dubious light on all the others. Who are we to imagine that “it couldn’t happen here”? We have only to multiply the population of Switzerland by twenty to become a nation of eighty millions, and our public intelligence and morality would then automatically be divided by twenty in consequence of the devastating moral and psychic effects of living together in huge masses. Such a state of things provides the basis for collective crime, and it is then really a miracle if the crime is not committed. Do we seriously believe that *we* would have been immune? We, who have so many traitors and political psychopaths in our midst? It has filled us with horror to realize all that man is capable of, and of which, therefore, we too are capable. Since then a terrible doubt about humanity, and about ourselves, gnaws at our hearts.

[413] Nevertheless, it should be clear to everyone that such a state of degradation can come about only under certain conditions. The most important of these is the accumulation of urban, industrialized masses—of people torn from the soil, engaged in one-sided employment, and lacking every healthy instinct, even that of self-preservation. Loss of the instinct of self-preservation can be measured in terms of dependence on the State, which is a bad symptom. Dependence on the State means that everybody relies on everybody else (= State) instead of on himself. Every man hangs on to the next and enjoys a false feeling of security, for one is still hanging in the air even when hanging in the company of ten thousand other people. The only difference is that one is no longer aware of one’s own insecurity. The increasing dependence on the State is anything but a healthy symptom; it means that the whole nation is in a fair way to becoming a herd of sheep, constantly relying on a shepherd to drive them into good pastures. The shepherd’s staff soon becomes a rod of iron, and the shepherds turn into wolves. What a distressing sight it was to see the whole of Germany heave a sigh of relief when a megalomaniac psychopath proclaimed, “I take over the responsibility!” Any man who still possesses the instinct of self-preservation knows perfectly well that only a swindler would offer to relieve him of responsibility, for surely no one in his senses would dream of taking responsibility for the existence of another. The man who promises everything is sure to fulfil nothing, and everyone who promises too much is in danger of using evil means in order to carry out his promises, and is already on the road to perdition. The steady growth of the Welfare State is no doubt a very fine thing from one point of view, but from another it is a doubtful blessing, as it robs people of their individual responsibility and turns them into infants and sheep. Besides this, there is the danger that the capable will simply be exploited by the irresponsible, as happened on a huge scale in Germany. The citizen’s instinct of self-preservation should be safeguarded at all costs, for, once a man is cut off from the nourishing roots of instinct, he becomes

the shuttlecock of every wind that blows. He is then no better than a sick animal, demoralized and degenerate, and nothing short of a catastrophe can bring him back to health.

[414] I own that in saying all this I feel rather like the prophet who, according to Josephus, lifted up his voice in lamentation over the city as the Romans laid siege to Jerusalem. It proved not the slightest use to the city, and a stone missile from a Roman ballista put an end to the prophet.

[415] With the best will in the world we cannot build a paradise on earth, and even if we could, in a very short time we would have degenerated in every way. We would take delight in destroying our paradise, and then, just as foolishly, marvel at what we had done. Moreover, if we happened to be a “nation of eighty millions” we would be convinced that the “others” were to blame, and our self-confidence would be at such a low ebb that we would not even think of shouldering the responsibility or taking the blame for anything.

[416] This is a pathological, demoralized, and mentally abnormal condition: one side of us does things which the other (so-called decent) side prefers to ignore. This side is in a perpetual state of defence against real and supposed accusations. In reality the chief accuser is not outside, but the judge who dwells in our own hearts. Since this is nature’s attempt to bring about a cure, it would be wiser not to persist too long in rubbing the noses of the Germans in their own abominations, lest we drown the voice of the accuser in their hearts—and also in our own hearts and those of our Allies. If only people could realize what an enrichment it is to find one’s own guilt, what a sense of honour and spiritual dignity! But nowhere does there seem to be a glimmering of this insight. Instead, we hear only of attempts to shift the blame on to others—“no one will admit to having been a Nazi.” The Germans were never wholly indifferent to the impression they made on the outside world. They resented disapproval and hated even to be criticized. Inferiority feelings make people touchy and lead to compensatory efforts to impress. As a result, the German thrusts himself forward and seeks to curry favour, or “German efficiency” is demonstrated with such aplomb that it leads to a reign of terror and the shooting of hostages. The German no longer thinks of these things as murder, for he is lost in considerations of his own prestige. Inferiority feelings are usually a sign of inferior feeling—which is not just a play on words. All the intellectual and technological achievements in the world cannot make up for inferiority in the matter of feeling. The pseudo-scientific race-theories with which it was dolled up did not make the extermination of the Jews any more acceptable, and neither do falsifications of history make a wrong policy appear any more trustworthy.

[417] This spectacle recalls the figure of what Nietzsche so aptly calls the “pale criminal,” who in reality shows all the signs of hysteria. He simply will not and cannot admit that he is what he is; he cannot endure his own guilt, just as he could not help incurring it. He will stoop to every kind of self-deception if only he can escape the sight of himself. It is true that this happens everywhere, but nowhere does it appear to be such a national characteristic as in Germany. I am by no means the first to have been struck by the inferiority feelings of the Germans. What did Goethe, Heine, and Nietzsche have to say about their countrymen? A feeling of inferiority does not in the least mean that it is unjustified. Only, the inferiority does not refer to that side of the personality, or to the function, in which it visibly appears, but to an inferiority which none the less really exists even though only dimly suspected. This condition can easily lead to an hysterical dissociation of the personality, which consists essentially in one hand not knowing what the other is doing, in wanting to jump over one’s own shadow, and in looking for everything dark, inferior, and culpable *in others*. Hence the hysteric always complains of being surrounded by people who are incapable of appreciating him and who are activated only by bad motives; by inferior mischief-makers, a crowd of submen who should be exterminated neck and crop so that the Superman can live on his high level of perfection. The very fact that his thinking and feeling proceed along these lines is clear proof of inferiority in action. Therefore all hysterical people are compelled to torment others, because they are unwilling to hurt themselves by admitting their own inferiority. But since nobody can jump out of his skin and be rid of himself, they stand in their own way everywhere as their own evil spirit—and that is what we call an hysterical neurosis.

[418] All these pathological features—complete lack of insight into one’s own character, auto-erotic self-admiration and self-extenuation, denigration and terrorization of one’s fellow men (how contemptuously Hitler spoke of his own people!), projection of the shadow, lying, falsification of reality, determination to impress by fair means or foul, bluffing and double-crossing—all these were united in the man who was diagnosed clinically as an hysteric, and whom a strange fate chose to be the political, moral, and religious spokesman of Germany for twelve years. Is this pure chance?

[419] A more accurate diagnosis of Hitler’s condition would be *pseudologia phantastica*, that form of hysteria which is characterized by a peculiar talent for believing one’s own lies. For a short spell, such people usually meet with astounding success, and for that reason are socially dangerous. Nothing has such a convincing effect as a lie one invents and believes oneself, or an evil deed or intention whose righteousness one regards as self-evident. At any rate they carry far more conviction than the good man and the good deed, or even than the wicked man and his purely

wicked deed. Hitler's theatrical, obviously hysterical gestures struck all foreigners (with a few amazing exceptions) as purely ridiculous. When I saw him with my own eyes, he suggested a psychic scarecrow (with a broomstick for an outstretched arm) rather than a human being. It is also difficult to understand how his ranting speeches, delivered in shrill, grating, womanish tones, could have made such an impression. But the German people would never have been taken in and carried away so completely if this figure had not been a reflected image of the collective German hysteria. It is not without serious misgivings that one ventures to pin the label of "psychopathic inferiority" on to a whole nation, and yet, heaven knows, it is the only explanation which could in any way account for the effect this scarecrow had on the masses. A sorry lack of education, conceit that bordered on madness, a very mediocre intelligence combined with the hysteric's cunning and the power fantasies of an adolescent, were written all over this demagogue's face. His gesticulations were all put on, devised by an hysterical mind intent only on making an impression. He behaved in public like a man living in his own biography, in this case as the sombre, daemonic "man of iron" of popular fiction, the ideal of an infantile public whose knowledge of the world is derived from the deified heroes of trashy films. These personal observations led me to conclude at the time (1937) that, when the final catastrophe came, it would be far greater and bloodier than I had previously supposed. For this theatrical hysteric and transparent impostor was not strutting about on a small stage, but was riding the armoured divisions of the Wehrmacht, with all the weight of German heavy industry behind him. Encountering only slight and in any case ineffective opposition from within, the nation of eighty millions crowded into the circus to witness its own destruction.

[420] Among Hitler's closest associates, Goebbels and Göring stand out as equally striking figures. Göring is the good fellow and *bon vivant* type of cheat, who takes in the simple-minded with his jovial air of respectability; Goebbels, a no-less-sinister and dangerous character, is the typical *Kaffeehausliterat* and card-sharper, handicapped and at the same time branded by nature. Any one partner in this unholy trinity should have been enough to make any man whose instincts were not warped cross himself three times. But what in fact happened? Hitler was exalted to the skies; there were even theologians who looked upon him as the Saviour. Goring was popular on account of his weaknesses; few people would believe his crimes. Goebbels was tolerated because many people think that lying is inseparable from success, and that success justifies everything. Three of these types at one time were really the limit, and one is at a loss to imagine how anything quite so monstrous ever came to power. But we must not forget that we are judging from today, from a knowledge of the events which led to the catastrophe. Our judgment would certainly be very different had our information stopped short at 1933 or 1934. At that time, in

Germany as well as in Italy, there were not a few things that appeared plausible and seemed to speak in favour of the regime. An undeniable piece of evidence in this respect was the disappearance of the unemployed, who used to tramp the German highroads in their hundreds of thousands. And after the stagnation and decay of the post-war years, the refreshing wind that blew through the two countries was a tempting sign of hope. Meanwhile, the whole of Europe looked on at this spectacle like Mr. Chamberlain, who was prepared at most for a heavy shower. But it is just this extreme speciousness that is the peculiar genius of *pseudologia phantastica*, and Mussolini also had a touch of it (kept within bounds, however, while his brother Arnaldo was alive). It introduces its plans in the most innocent way in the world, finding the most appropriate words and the most plausible arguments, and there is nothing to show that its intentions are bad from the start. They may even be good, genuinely good. In the case of Mussolini, for instance, it might be difficult to draw a definite line between black and white. Where *pseudologia* is at work one can never be sure that the intention to deceive is the principal motive. Quite often the “great plan” plays the leading role, and it is only when it comes to the ticklish question of bringing this plan into reality that every opportunity is exploited and any means is good enough, on the principle that “the end justifies the means.” In other words, things only become dangerous when the pathological liar is taken seriously by a wider public. Like Faust, he is bound to make a pact with the devil and thus slips off the straight path. It is even possible that this is more or less what happened to Hitler—let us give him the benefit of the doubt! But the infamies of his book, once it is shorn of its *Schwabinger*³ brand of bombast, make one suspicious, and one cannot help wondering if the evil spirit had not already taken possession of this man long before he seized power. Round about 1936, many people in Germany were asking themselves the same question; they expressed fears that the Führer might fall a victim to “evil influences,” he dabbled too much in “black magic,” etc. Clearly these misgivings came much too late; but even so, it is just conceivable that Hitler himself may have had good intentions at first, and only succumbed to the use of the wrong means, or the misuse of his means, in the course of his development.

[421] But I should like to emphasize above all that it is part and parcel of the pathological liar’s make-up to be plausible. Therefore it is no easy matter, even for experienced people, to form an opinion, particularly while the plan is still apparently in the idealistic stage. It is then quite impossible to foresee how things are likely to develop, and Mr. Chamberlain’s “give-it-a-chance” attitude seems to be the only policy. The overwhelming majority of the Germans were just as much in the dark as people abroad, and quite naturally fell an easy prey to Hitler’s speeches, so artfully attuned to German (and not only German) taste.

[422] Although we may be able to understand why the Germans were misled in the first place, the almost total absence of any reaction is quite incomprehensible. Were there not army commanders who could have ordered their troops to do anything they pleased? Why then was the reaction totally lacking? I can only explain this as the outcome of a peculiar state of mind, a passing or chronic disposition which, in an individual, we call hysteria.

[423] As I cannot take it for granted that the layman knows exactly what is meant by “hysteria,” I had better explain that the “hysterical” disposition forms a sub-division of what are known as “psychopathic inferiorities.” This term by no means implies that the individual or the nation is “inferior” in every respect, but only that there is a place of least resistance, a peculiar instability, which exists independently of all the other qualities. An hysterical disposition means that the opposites inherent in every psyche, and especially those affecting character, are further apart than in normal people. This greater distance produces a higher energetic tension, which accounts for the undeniable energy and drive of the Germans. On the other hand, the greater distance between the opposites produces inner contradictions, conflicts of conscience, disharmonies of character—in short, everything we see in Goethe’s Faust. Nobody but a German could ever have devised such a figure, it is so intrinsically, so infinitely German. In Faust we see the same “hungering for the infinite” born of inner contradiction and dichotomy, the same eschatological expectation of the Great Fulfilment. In him we experience the loftiest flight of the mind and the descent into the depths of guilt and darkness, and still worse, a fall so low that Faust sinks to the level of a mountebank and wholesale murderer as the outcome of his pact with the devil. Faust, too, is split and sets up “evil” outside himself in the shape of Mephistopheles, to serve as an alibi in case of need. He likewise “knows nothing of what has happened,” i.e., what the devil did to Philemon and Baucis. We never get the impression that he has real insight or suffers genuine remorse. His avowed and unavowed worship of success stands in the way of any moral reflection throughout, obscuring the ethical conflict, so that Faust’s moral personality remains misty. He never attains the character of reality: he is not a real human being and cannot become one (at least not in this world). He remains the German idea of a human being, and therefore an image—somewhat overdone and distorted—of the average German.

[424] The essence of hysteria is a systematic dissociation, a loosening of the opposites which normally are held firmly together. It may even go to the length of a splitting of the personality, a condition in which quite literally one hand no longer knows what the other is doing. As a rule there is amazing ignorance of the shadow; the hysteric is only aware of his good motives, and when the bad ones can no longer be denied he

becomes the unscrupulous Superman and *Herrenmensch* who fancies he is ennobled by the magnitude of his aim.

[425] Ignorance of one's other side creates great inner insecurity. One does not really know who one is; one feels inferior somewhere and yet does not wish to know where the inferiority lies, with the result that a new inferiority is added to the original one. This sense of insecurity is the source of the hysteric's prestige psychology, of his need to make an impression, to flaunt his merits and insist on them, of his insatiable thirst for recognition, admiration, adulation, and longing to be loved. It is the cause of that loud-mouthed arrogance, uppishness, insolence, and tactlessness by which so many Germans, who at home grovel like dogs, win a bad reputation for their countrymen abroad. Insecurity is also responsible for their tragic lack of civic courage, criticized by Bismarck (one need only recall the pitiable role of the German generals).

[426] The lack of reality, so striking in Faust, produces a corresponding lack of realism in the German. He merely talks of it, boasting of his "ice-cold" realism, which in itself is enough to expose his hysteria. His realism is nothing but a pose, a stage-realism. He merely acts the part of one who has a sense of reality, but what does he actually want to do? He wants to conquer the world in spite of the whole world. Of course, he has no idea how it can be done. But at least he might know that the enterprise had failed once before. Unfortunately a plausible reason, that explains away the failure by means of lies, is immediately invented and believed. How many Germans were taken in by the legend of the "stab in the back" in 1918? And how many "stab in the back" legends are floating around today? Believing one's own lies when the wish is father to the lie is a well-known hysterical symptom and a distinct sign of inferiority. One would have thought that the bloodbath of the first World War would have been enough, but not a bit of it; glory, conquest, and bloodthirstiness acted like a smoke-screen on the German mind, so that reality, only dimly perceived at best, was completely blotted out. In an individual we call this sort of thing an hysterical twilight-state. When a whole nation finds itself in this condition it will follow a mediumistic Führer over the housetops with a sleep-walker's assurance, only to land in the street with a broken back.

[427] Supposing we Swiss had started such a war and had thrown all our experience, all warnings and all our knowledge of the world to the winds as blindly as the Germans, and had finally gone to the length of establishing an original edition of Buchenwald in our country. We should no doubt feel very disagreeably surprised if a foreigner declared that the Swiss were one and all completely mad. No reasonable person would be surprised at such a verdict, but can we say it about Germany? I wonder what the Germans themselves think. All I know is that at the time of the censorship

in Switzerland we were not permitted to say these things aloud, and now it seems we cannot say them out of consideration for Germany which is laid so low. When on earth, I should like to ask, may one venture to form an opinion of one's own? To my mind, the history of the last twelve years is the case-chart of an hysterical patient. The truth should not be withheld from him, for when the doctor makes a diagnosis he does so as part of his effort to find the remedy, and not in order to hurt, degrade, or insult the sufferer. A neurosis or a neurotic disposition is not a disgrace, it is a handicap, and sometimes merely a *façon de parler*. It is not a fatal disease, but it does grow worse to the degree that one is determined to ignore it. When I say that the Germans are psychically ill it is surely kinder than saying that they are criminals. I have no wish to irritate the notorious sensitiveness of the hysteric, but there comes a time when we can no longer afford to gloss over all the painful symptoms and to help the patient forget what has happened, merely in order that his pathological condition should remain undisturbed. I would not like to insult the healthy-minded and decent German by suspecting him of being a coward who runs away from his own image. We should do him the honour of treating him like a man and telling him the truth, and not conceal from him that our soul is cut to the quick by the terrible things that happened in his country and were perpetrated by the Germans in Europe. We are hurt and indignant and have no particular feelings of loving-kindness—nor can any amount of determination and will-power twist these sentiments into a Christian “love of your neighbour.” For the sake of the healthy-minded and decent Germans one should not attempt to do so; they would surely prefer the truth to insulting forbearance.

[428] Hysteria is never cured by hushing up the truth, whether in an individual or in a nation. But can we say that a whole nation is hysterical? We can say it as much or as little of a nation as of an individual. Even the craziest person is not completely crazy; quite a number of his functions are still normal, and there may even be times when he himself is fairly normal too. This is even truer of hysteria, where there is really nothing wrong except exaggerations and excesses on the one hand, and weakness or temporary paralysis of normal functions on the other. In spite of his psychopathic condition the hysteric is very nearly normal. We may therefore expect many parts of the psychic body-politic to be entirely normal even though the over-all picture can only be described as hysterical.

[429] The Germans undoubtedly have their own peculiar psychology which distinguishes them from their neighbours, in spite of the many human qualities which they share with all mankind. Have they not demonstrated to the world that they consider themselves the *Herrenvolk*, with the right to disregard every human scruple? They have labelled other nations inferior and done their best to exterminate them.

[430] In view of these terrible facts, it is a mere bagatelle to turn the tables on the *Herrenvolk* and apply the diagnosis of inferiority to the murderer instead of the murdered, while remaining fully conscious that one is injuring all those Germans who suffered their nation's tribulation with open eyes. It does indeed hurt one to hurt others. But, as Europeans—a brotherhood which includes the Germans—we are wounded, and if we wound in return it is not with the intention of torturing but, as I said earlier, of discovering the truth. As in the case of collective guilt, the diagnosis of its mental condition extends to the whole nation, and indeed to the whole of Europe, whose mental condition for some time past has hardly been normal. Whether we like it or not we are bound to ask: What is wrong with our art, that most delicate of all instruments for reflecting the national psyche? How are we to explain the blatantly pathological element in modern painting? Atonal music? The far-reaching influence of Joyce's fathomless *Ulysses*? Here we already have the germ of what was to become a political reality in Germany.

[431] The European, or rather the white man in general, is scarcely in a position to judge of his own state of mind. He is too deeply involved. I had always wanted to see Europeans through other eyes, and eventually I was able, on my many journeys, to establish sufficiently close relationships with non-Europeans to see the European through their eyes. The white man is nervous, restless, hurried, unstable, and (in the eyes of non-Europeans) possessed by the craziest ideas, in spite of his energy and gifts which give him the feeling of being infinitely superior. The crimes he has committed against the coloured races are legion, though obviously this is no justification for any fresh crime, just as the individual is no better for being in a vast company of bad people. Primitives dread the sharply focussed stare in the eye of the European, which seems to them like the evil eye. A Pueblo chieftain once confided to me that he thought all Americans (the only white men he knew) were crazy, and the reasons he gave for this view sounded exactly like a description of people who were possessed. Well, perhaps we are. For the first time since the dawn of history we have succeeded in swallowing the whole of primitive animism into ourselves, and with it the spirit that animated nature. Not only were the gods dragged down from their planetary spheres and transformed into chthonic demons, but, under the influence of scientific enlightenment, even this band of demons, which at the time of Paracelsus still frolicked happily in mountains and woods, in rivers and human dwelling-places, was reduced to a miserable remnant and finally vanished altogether. From time immemorial, nature was always filled with spirit. Now, for the first time, we are living in a lifeless nature bereft of gods. No one will deny the important role which the powers of the human psyche, personified as "gods," played in the past. The mere act of enlightenment may have destroyed the spirits of nature, but not the psychic factors that correspond to them, such as suggestibility, lack of criticism, fearfulness,

propensity to superstition and prejudice—in short, all those qualities which make possession possible. Even though nature is depsychized, the psychic conditions which breed demons are as actively at work as ever. The demons have not really disappeared but have merely taken on another form: they have become unconscious psychic forces. This process of reabsorption went hand in hand with an increasing inflation of the ego, which became more and more evident after the sixteenth century. Finally we even began to be aware of the psyche, and, as history shows, the discovery of the unconscious was a particularly painful episode. Just when people were congratulating themselves on having abolished all spooks, it turned out that instead of haunting the attic or old ruins the spooks were flitting about in the heads of apparently normal Europeans. Tyrannical, obsessive, intoxicating ideas and delusions were abroad everywhere, and people began to believe the most absurd things, just as the possessed do.

[432] The phenomenon we have witnessed in Germany was nothing less than the first outbreak of epidemic insanity, an irruption of the unconscious into what seemed to be a tolerably well-ordered world. A whole nation, as well as countless millions belonging to other nations, were swept into the blood-drenched madness of a war of extermination. No one knew what was happening to him, least of all the Germans, who allowed themselves to be driven to the slaughterhouse by their leading psychopaths like hypnotized sheep. Maybe the Germans were predestined to this fate, for they showed the least resistance to the mental contagion that threatened every European. But their peculiar gifts might also have enabled them to be the very people to draw helpful conclusions from the prophetic example of Nietzsche. Nietzsche was German to the marrow of his bones, even to the abstruse symbolism of his madness. It was the psychopath's weakness that prompted him to play with the "blond beast" and the "Superman." It was certainly not the healthy elements in the German nation that led to the triumph of these pathological fantasies on a scale never known before. The weakness of the German character, like Nietzsche's, proved to be fertile soil for hysterical fantasies, though it must be remembered that Nietzsche himself not only criticized the German Philistine very freely but laid himself open to attack on a broad front. Here again the Germans had a priceless opportunity for self-knowledge—and let it slip. And what could they not have learned from the suet-and-syrup of Wagner!

[433] Nevertheless, with the calamitous founding of the Reich in 1871, the devil stole a march on the Germans, dangling before them the tempting bait of power, aggrandizement, national arrogance. Thus they were led to imitate their prophets and to take their words literally, but not to understand them. And so it was that the Germans allowed themselves to be deluded by these disastrous fantasies and succumbed to the age-old temptations of Satan, instead of turning to their abundant spiritual potentialities, which, because of the greater tension between the inner

opposites, would have stood them in good stead. But, their Christianity forgotten, they sold their souls to technology, exchanged morality for cynicism, and dedicated their highest aspirations to the forces of destruction. Certainly everybody else is doing much the same thing, but even so there really are chosen people who have no right to do such things because they should be striving for higher treasures. At any rate the Germans are not among those who may enjoy power and possessions with impunity. Just think for a moment what anti-Semitism means for the German: he is trying to use others as a scapegoat for his own greatest fault! This symptom alone should have told him that he had got on to a hopelessly wrong track.

[434] After the last World War the world should have begun to reflect, and above all Germany, which is the nerve-centre of Europe. But the spirit turned negative, neglected the decisive questions, and sought solutions in its own negation. How different it was at the time of the Reformation! Then the spirit of Germany rose manfully to the needs of Christendom, though the answer—as we might expect from the German tension of opposites—was somewhat too extreme. But at least this spirit did not shrink from its own problems. Goethe, too, was a prophet when he held up before his people the example of Faust's pact with the devil and the murder of Philemon and Baucis. If, as Burckhardt says, Faust strikes a chord in every German soul, this chord has certainly gone on ringing. We hear it echoing in Nietzsche's Superman, the amoral worshipper of instinct, whose God is dead, and who presumes to be God himself, or rather a demon "six thousand feet beyond good and evil." And where has the feminine side, the soul, disappeared to in Nietzsche? Helen has vanished in Hades, and Eurydice will never return. Already we behold the fateful travesty of the denied Christ: the sick prophet is himself the Crucified, and, going back still further, the dismembered Dionysus-Zagreus. The raving prophet carries us back to the long-forgotten past: he had heard the call of destiny in the shrill whistling of the hunter, the god of the rustling forests, of drunken ecstasy, and of the berserkers who were possessed by the spirits of wild animals.

[435] While Nietzsche was prophetically responding to the schism of the Christian world with the art of thinking, his brother in spirit, Richard Wagner, was doing the same thing with the art of music. Germanic prehistory comes surging up, thunderous and stupefying, to fill the gaping breach in the Church. Wagner salved his conscience with *Parsifal*, for which Nietzsche could never forgive him, but the Castle of the Grail vanished into an unknown land. The message was not heard and the omen went unheeded. Only the orgiastic frenzy caught on and spread like an epidemic. Wotan the storm-god had conquered. Ernst Jünger sensed that very clearly: in his book *On the Marble Cliffs* a wild huntsman comes into the land, bringing with him a wave of possession greater than anything known even in the Middle Ages. Nowhere did the

European spirit speak more plainly than it did in Germany, and nowhere was it more tragically misunderstood.

[436] Now Germany has suffered the consequences of the pact with the devil, she has experienced madness and is torn in pieces like Zagreus, she has been ravished by the berserkers of her god Wotan, been cheated of her soul for the sake of gold and worldmastery, and defiled by the scum rising from the lowest depths.

[437] The Germans must understand why the whole world is outraged, for our expectations had been so different. Everybody was unanimous in recognizing their gifts and their efficiency, and nobody doubted that they were capable of great things. The disappointment was all the more bitter. But the fate of Germany should not mislead Europeans into nursing the illusion that the whole world's wickedness is localized in Germany. They should realize that the German catastrophe was only one crisis in the general European sickness. Long before the Hitler era, in fact before the first World War, there were symptoms of the mental change taking place in Europe. The medieval picture of the world was breaking up and the metaphysical authority that ruled it was fast disappearing, only to reappear in man. Did not Nietzsche announce that God was dead and that his heir was the Superman, that doomed rope-dancer and fool? It is an immutable psychological law that when a projection has come to an end it always returns to its origin. So when somebody hits on the singular idea that God is dead, or does not exist at all, the psychic God-image, which is a dynamic part of the psyche's structure, finds its way back into the subject and produces a condition of "God-Almightiness," that is to say all those qualities which are peculiar to fools and madmen and therefore lead to catastrophe.

[438] This, then, is the great problem that faces the whole of Christianity: where now is the sanction for goodness and justice, which was once anchored in metaphysics? Is it really only brute force that decides everything? Is the ultimate authority only the will of whatever man happens to be in power? Had Germany been victorious, one might almost have believed that this was the last word. But as the "thousand-year Reich" of violence and infamy lasted only a few years before it collapsed in ruins, we might be disposed to learn the lesson that there are other, equally powerful forces at work which in the end destroy all that is violent and unjust, and that consequently it does not pay to build on false principles. But unfortunately, as history shows, things do not always turn out so reasonably in this world of ours.

[439] "God-Almightiness" does not make man divine, it merely fills him with arrogance and arouses everything evil in him. It produces a diabolical caricature of man, and this inhuman mask is so unendurable, such a torture to wear, that he tortures others. He is split in himself, a prey to inexplicable contradictions. Here we have the picture of the hysterical state of mind, of Nietzsche's "pale criminal." Fate

has confronted every German with his inner counterpart: Faust is face to face with Mephistopheles and can no longer say, “So that was the essence of the brute!” He must confess instead: “That was my other side, my *alter ego*, my all too palpable shadow which can no longer be denied.”

[440] This is not the fate of Germany alone, but of all Europe. We must all open our eyes to the shadow who looms behind contemporary man. We have no need to hold up the devil’s mask before the Germans. The facts speak a plainer language, and anyone who does not understand it is simply beyond help. As to what should be done about this terrifying apparition, everyone must work this out for himself. It is indeed no small matter to know of one’s own guilt and one’s own evil, and there is certainly nothing to be gained by losing sight of one’s shadow. When we are conscious of our guilt we are in a more favourable position—we can at least hope to change and improve ourselves. As we know, anything that remains in the unconscious is incorrigible; psychological corrections can be made only in consciousness. Consciousness of guilt can therefore act as a powerful moral stimulus. In every treatment of neurosis the discovery of the shadow is indispensable, otherwise nothing changes. In this respect, I rely on those parts of the German body-politic which have remained sound to draw conclusions from the facts. Without guilt, unfortunately, there can be no psychic maturation and no widening of the spiritual horizon. Was it not Meister Eckhart who said: “For this reason God is willing to bear the brunt of sins and often winks at them, mostly sending them to people for whom he has prepared some high destiny. See! Who was dearer to our Lord or more intimate with him than his apostles? Not one of them but fell into mortal sin, and all were mortal sinners.”⁴

[441] Where sin is great, “grace doth much more abound.” Such an experience brings about an inner transformation, and this is infinitely more important than political and social reforms which are all valueless in the hands of people who are not at one with themselves. This is a truth which we are forever forgetting, because our eyes are fascinated by the conditions around us and riveted on them instead of examining our own heart and conscience. Every demagogue exploits this human weakness when he points with the greatest possible outcry to all the things that are wrong in the outside world. But the principal and indeed the only thing that is wrong with the world is man.

[442] If the Germans today are having a hard time of it outwardly, fate has at least given them a unique opportunity of turning their eyes inward to the inner man. In this way they might make amends for a sin of omission of which our whole civilization is guilty. Everything possible has been done for the outside world: science has been refined to an unimaginable extent, technical achievement has reached an almost

uncanny degree of perfection. But what of man, who is expected to administer all these blessings in a reasonable way? He has simply been taken for granted. No one has stopped to consider that neither morally nor psychologically is he in any way adapted to such changes. As blithely as any child of nature he sets about enjoying these dangerous playthings, completely oblivious of the shadow lurking behind him, ready to seize them in its greedy grasp and turn them against a still infantile and unconscious humanity. And who has had a more immediate experience of this feeling of helplessness and abandonment to the powers of darkness than the German who fell into the clutches of the Germans?

[443] If collective guilt could only be understood and accepted, a great step forward would have been taken. But this alone is no cure, just as no neurotic is cured by mere understanding. The question remains: How am I to live with this shadow? What attitude is required if I am to be able to live in spite of evil? In order to find valid answers to these questions a complete spiritual renewal is needed. And this cannot be given gratis, each man must strive to achieve it for himself. Neither can old formulas which once had a value be brought into force again. The eternal truths cannot be transmitted mechanically; in every epoch they must be born anew from the human psyche.

THE FIGHT WITH THE SHADOW¹

[444] The indescribable events of the last decade lead one to suspect that a peculiar psychological disturbance was a possible cause. If you ask a psychiatrist what he thinks about these things, you must naturally expect to get an answer from his particular point of view. Even so, as a scientist, the psychiatrist makes no claim to omniscience, for he regards his opinion merely as one contribution to the enormously complicated task of finding a comprehensive explanation.

[445] When one adopts the standpoint of psychopathology, it is not easy to address an audience which may include people who know nothing of this specialized and difficult field. But there is one simple rule that you should bear in mind: the psychopathology of the masses is rooted in the psychology of the individual. Psychic phenomena of this class can be investigated in the individual. Only if one succeeds in establishing that certain phenomena or symptoms are common to a number of different individuals can one begin to examine the analogous mass phenomena.

[446] As you perhaps already know, I take account of the psychology both of the conscious and of the unconscious, and this includes the investigation of dreams. Dreams are the natural products of unconscious psychic activity. We have known for a long time that there is a biological relationship between the unconscious processes and the activity of the conscious mind. This relationship can best be described as a compensation, which means that any deficiency in consciousness—such as exaggeration, one-sidedness, or lack of a function—is suitably supplemented by an unconscious process.

[447] As early as 1918, I noticed peculiar disturbances in the unconscious of my German patients which could not be ascribed to their personal psychology. Such non-personal phenomena always manifest themselves in dreams as mythological motifs that are also to be found in legends and fairytales throughout the world. I have called these mythological motifs *archetypes*: that is, typical modes or forms in which these collective phenomena are experienced. There was a disturbance of the collective unconscious in every single one of my German patients. One can explain these disorders causally, but such an explanation is apt to be unsatisfactory, as it is easier to understand archetypes by their aim rather than by their causality. The archetypes I had observed expressed primitivity, violence, and cruelty. When I had seen enough of such cases, I turned my attention to the peculiar state of mind then prevailing in Germany. I could only see signs of depression and a great restlessness, but this did

not allay my suspicions. In a paper which I published at that time, I suggested that the “blond beast” was stirring in an uneasy slumber and that an outburst was not impossible.²

[448] This condition was not by any means a purely Teutonic phenomenon, as became evident in the following years. The onslaught of primitive forces was more or less universal. The only difference lay in the German mentality itself, which proved to be more susceptible because of the marked proneness of the Germans to mass psychology. Moreover, defeat and social disaster had increased the herd instinct in Germany, so that it became more and more probable that Germany would be the first victim among the Western nations—victim of a mass movement brought about by an upheaval of forces lying dormant in the unconscious, ready to break through all moral barriers. These forces, in accordance with the rule I have mentioned, were meant to be a compensation. If such a compensatory move of the unconscious is not integrated into consciousness in an individual, it leads to a neurosis or even to a psychosis, and the same would apply to a collectivity. Clearly there must be something wrong with the conscious attitude for a compensatory move of this kind to be possible; something must be amiss or exaggerated, because only a faulty consciousness can call forth a counter move on the part of the unconscious. Well, innumerable things were wrong, as you know, and opinions are thoroughly divided about them. Which is the correct opinion will be learned only *ex effectu*; that is, we can only discover what the defects in the consciousness of our epoch are by observing the kind of reaction they call forth from the unconscious.

[449] As I have already told you, the tide that rose in the unconscious after the first World War was reflected in individual dreams, in the form of collective, mythological symbols which expressed primitivity, violence, cruelty: in short, all the powers of darkness. When such symbols occur in a large number of individuals and are not understood, they begin to draw these individuals together as if by magnetic force, and thus a mob is formed. Its leader will soon be found in the individual who has the least resistance, the least sense of responsibility and, because of his inferiority, the greatest will to power. He will let loose everything that is ready to burst forth, and the mob will follow with the irresistible force of an avalanche.

[450] I had observed the German revolution in the test-tube of the individual, so to speak, and I was fully aware of the immense dangers involved when such people crowd together. But I did not know at the time whether there were enough of them in Germany to make a general explosion inevitable. However, I was able to follow up quite a number of cases and to observe how the uprush of the dark forces deployed itself in the individual test-tube. I could watch these forces as they broke through the individual's moral and intellectual self-control, and as they flooded his conscious

world. There was often terrific suffering and destruction; but when the individual was able to cling to a shred of reason, or to preserve the bonds of a human relationship, a new compensation was brought about in the unconscious by the very chaos of the conscious mind, and this compensation could be integrated into consciousness. New symbols then appeared, of a collective nature, but this time reflecting the forces of *order*. There was measure, proportion, and symmetrical arrangement in these symbols, expressed in their peculiar mathematical and geometrical structure. They represent a kind of axial system and are known as *mandalas*. I am afraid I cannot go into an explanation of these highly technical matters here, but, however incomprehensible they may sound, I must mention them in passing because they represent a gleam of hope, and we need hope very badly in this time of dissolution and chaotic disorder.

[451] The world-wide confusion and disorder reflect a similar condition in the mind of the individual, but this lack of orientation is compensated in the unconscious by the archetypes of order. Here again I must point out that if these symbols of order are not integrated into consciousness, the forces they express will accumulate to a dangerous degree, just as the forces of destruction and disorder did twenty-five years ago. The integration of unconscious contents is an individual act of realization, of understanding, and moral evaluation. It is a most difficult task, demanding a high degree of ethical responsibility. Only relatively few individuals can be expected to be capable of such an achievement, and they are not the political but the moral leaders of mankind. The maintenance and further development of civilization depend on such individuals, for it is obvious enough that the consciousness of the masses has not advanced since the first World War. Only certain reflective minds have been enriched, and their moral and intellectual horizon has been considerably enlarged by the realization of the immense and overwhelming power of evil, and of the fact that mankind is capable of becoming merely its instrument. But the average man is still where he was at the end of the first World War. Therefore it is only too obvious that the vast majority are incapable of integrating the forces of order. On the contrary, it is even probable that these forces will encroach upon consciousness and take it by surprise and violence, against our will. We see the first symptoms everywhere: totalitarianism and State slavery. The value and importance of the individual are rapidly decreasing and the chances of his being heard will vanish more and more.

[452] This process of deterioration will be long and painful, but I fear it is inevitable. Yet in the long run it will prove to be the only way by which man's lamentable unconsciousness, his childishness and individual weakness, can be replaced by a future man, who knows that he himself is the maker of his fate and that the State is his servant and not his master. But man will reach this level only when he realizes that, through his unconsciousness, he has gambled away the fundamental *droits de*

l'homme. Germany has given us a most instructive example of the psychological development in question. There the first World War released the hidden power of evil, just as the war itself was released by the accumulation of unconscious masses and their blind desires. The so-called "Friedenskaiser" was one of the first victims and, not unlike Hitler, he voiced these lawless, chaotic desires and was thus led into war, and into the inevitable catastrophe. The second World War was a repetition of the same psychic process but on an infinitely greater scale.

[453] As I have said, the uprush of mass instincts was symptomatic of a compensatory move of the unconscious. Such a move was possible because the conscious state of the people had become estranged from the natural laws of human existence. Thanks to industrialization, large portions of the population were uprooted and were herded together in large centres. This new form of existence—with its mass psychology and social dependence on the fluctuation of markets and wages—produced an individual who was unstable, insecure, and suggestible. He was aware that his life depended on boards of directors and captains of industry, and he supposed, rightly or wrongly, that they were chiefly motivated by financial interests. He knew that, no matter how conscientiously he worked, he could still fall a victim at any moment to economic changes which were utterly beyond his control. And there was nothing else for him to rely on. Moreover, the system of moral and political education prevailing in Germany had already done its utmost to permeate everybody with a spirit of dull obedience, with the belief that every desirable thing must come from above, from those who by divine decree sat on top of the law-abiding citizen, whose feelings of personal responsibility were overruled by a rigid sense of duty. No wonder, therefore, that it was precisely Germany that fell a prey to mass psychology, though she is by no means the only nation threatened by this dangerous germ. The influence of mass psychology has spread far and wide.

[454] The individual's feeling of weakness, indeed of non-existence, was thus compensated by the eruption of hitherto unknown desires for power. It was the revolt of the powerless, the insatiable greed of the "have-nots." By such devious means the unconscious compels man to become conscious of himself. Unfortunately, there were no values in the conscious mind of the individual which would have enabled him to understand and integrate the reaction when it reached consciousness. Nothing but materialism was preached by the highest intellectual authorities. The Churches were evidently unable to cope with this new situation; they could do nothing but protest and that did not help very much. Thus the avalanche rolled on in Germany and produced its leader, who was elected as a tool to complete the ruin of the nation. But what was his original intention? He dreamed of a "new order." We should be badly mistaken if we assumed that he did not really intend to create an international order of some kind. On the contrary, deep down in his being he was motivated by the

forces of order, which became operative in him the moment desirousness and greed had taken complete possession of his conscious mind. Hitler was the exponent of a “new order,” and that is the real reason why practically every German fell for him. The Germans wanted order, but they made the fatal mistake of choosing the principal victim of disorder and unchecked greed for their leader. Their individual attitude remained unchanged: just as they were greedy for power, so they were greedy for order. Like the rest of the world, they did not understand wherein Hitler’s significance lay, that he symbolized something in every individual. He was the most prodigious personification of all human inferiorities. He was an utterly incapable, unadapted, irresponsible, psychopathic personality, full of empty, infantile fantasies, but cursed with the keen intuition of a rat or a guttersnipe. He represented the shadow, the inferior part of everybody’s personality, in an overwhelming degree, and this was another reason why they fell for him.

[455] But what could they have done? In Hitler, every German should have seen his own shadow, his own worst danger. It is everybody’s allotted fate to become conscious of and learn to deal with this shadow. But how could the Germans be expected to understand this, when nobody in the world can understand such a simple truth? The world will never reach a state of order until this truth is generally recognized. In the meantime, we amuse ourselves by advancing all sorts of external and secondary reasons why it cannot be reached, though we know well enough that conditions depend very largely on the way we take them. If, for instance, the French Swiss should assume that the German Swiss were all devils, we in Switzerland could have the grandest civil war in no time, and we could also discover the most convincing economic reasons why such a war was inevitable. Well—we just don’t, for we learned our lesson more than four hundred years ago. We came to the conclusion that it is better to avoid external wars, so we went home and took the strife with us. In Switzerland we have built up the “perfect democracy,” where our warlike instincts expend themselves in the form of domestic quarrels called “political life.” We fight each other within the limits of the law and the constitution, and we are inclined to think of democracy as a chronic state of mitigated civil war. We are far from being at peace with ourselves: on the contrary, we hate and fight each other because we have succeeded in introverting war. Our peaceful outward demeanour merely serves to safeguard our domestic quarrels from foreign intruders who might disturb us. Thus far we have succeeded, but we are still a long way from the ultimate goal. We still have enemies in the flesh, and we have not yet managed to introvert our political disharmonies. We still labour under the unwholesome delusion that we should be at peace within ourselves. Yet even our national, mitigated state of war would soon come to an end if everybody could see his own shadow and begin the only struggle that is really worth while: the fight against the overwhelming power-

drive of the shadow. We have a tolerable social order in Switzerland because we fight among ourselves. Our order would be perfect if only everybody could direct his aggressiveness inwards, into his own psyche. Unfortunately, our religious education prevents us from doing this, with its false promises of an immediate peace within. Peace may come in the end, but only when victory and defeat have lost their meaning. What did our Lord mean when he said: "I came not to send peace, but a sword"?

[456] To the extent that we are able to found a true democracy—a conditional fight among ourselves, either collective or individual—we realize, we make real, the factors of order, because then it becomes absolutely necessary to live in orderly circumstances. In a democracy you simply cannot afford the disturbing complications of outside interference. How can you run a civil war properly when you are attacked from without? When, on the other hand, you are seriously at variance with yourself, you welcome your fellow human beings as possible sympathizers with your cause, and on this account you are disposed to be friendly and hospitable. But you politely avoid people who want to be helpful and relieve you of your troubles. We psychologists have learned, through long and painful experience, that you deprive a man of his best resource when you help him to get rid of his complexes. You can only help him to become sufficiently aware of them and to start a conscious conflict within himself. In this way the complex becomes a focus of life. Anything that disappears from your psychological inventory is apt to turn up in the guise of a hostile neighbour, who will inevitably arouse your anger and make you aggressive. It is surely better to know that your worst enemy is right there in your own heart. Man's warlike instincts are ineradicable—therefore a state of perfect peace is unthinkable. Moreover, peace is uncanny because it breeds war. True democracy is a highly psychological institution which takes account of human nature as it is and makes allowances for the necessity of conflict within its own national boundaries.

[457] If you now compare the present state of mind of the Germans with my argument you will appreciate the enormous task with which the world is confronted. We can hardly expect the demoralized German masses to realize the import of such psychological truths, no matter how simple. But the great Western democracies have a better chance, so long as they can keep out of those wars that always tempt them to believe in external enemies and in the desirability of internal peace. The marked tendency of the Western democracies to internal dissension is the very thing that could lead them into a more hopeful path. But I am afraid that this hope will be deferred by powers which still believe in the contrary process, in the destruction of the individual and the increase of the fiction we call the State. The psychologist believes firmly in the individual as the sole carrier of mind and life. Society and the State derive their quality from the individual's mental condition, for they are made up

of individuals and the way they are organized. Obvious as this fact is, it has still not permeated collective opinion sufficiently for people to refrain from using the word "State" as if it referred to a sort of super-individual endowed with inexhaustible power and resourcefulness. The State is expected nowadays to accomplish what nobody would expect from an individual. The dangerous slope leading down to mass psychology begins with this plausible thinking in large numbers, in terms of powerful organizations where the individual dwindles to a mere cipher. Everything that exceeds a certain human size evokes equally inhuman powers in man's unconscious. Totalitarian demons are called forth, instead of the realization that all that can really be accomplished is an infinitesimal step forward in the moral nature of the individual. The destructive power of our weapons has increased beyond all measure, and this forces a psychological question on mankind: Is the mental and moral condition of the men who decide on the use of these weapons equal to the enormity of the possible consequences?

EPILOGUE TO “ESSAYS ON CONTEMPORARY EVENTS”¹

[458] Germany has set the world a tremendous problem, a problem that has to be considered from many angles. The psychological aspect is only one of its many facets. As a psychologist, I am naturally inclined to think it an important facet, but I must leave it to my reader to form his own opinion on this point. My professional concern with the psychology of the unconscious often brings to light things which are still hidden from consciousness but exist in embryonic form; and these contents are ready to break through into consciousness long before the individual has any idea of what his psyche holds in store for him. I had an inkling of what was brewing in the unconscious nearly thirty years ago, for I had Germans among my patients. As early as 1918 I wrote:

As the Christian view of the world loses its authority, the more menacingly will the “blond beast” be heard prowling about in its underground prison, ready at any moment to burst out with devastating consequences.²

[459] It hardly requires an Oedipus to guess what is meant by the “blond beast.” I had an idea, however, that this “blond beast” was not restricted to Germany, but stood for the primitive European in general, who was gradually coming to the surface as a result of ever-increasing mass organization. In the same article I went on to say:

Even the primitive’s distrust of the neighbouring tribe, which we thought we had long ago outgrown thanks to our global organizations, has come back again in this war, swollen to gigantic proportions. It is no longer a matter of burning down the neighbouring village, or of making a few heads roll: whole countries are devastated, millions are slaughtered. The enemy nation is stripped of every shred of decency, and our own faults appear in others, fantastically magnified. Where are the superior minds, capable of reflection, today? If they exist at all, nobody heeds them: instead there is a general running amok, a universal fatality against whose compelling sway the individual is powerless to defend himself. And yet this collective phenomenon is the fault of the individual as well, for nations are made up of individuals. Therefore the individual must consider by what means he can counter the evil. Our rationalistic attitude leads us to believe that we can work wonders with international organizations, legislation, and other well-meant devices. But in reality only a change in the attitude of the individual can bring about a renewal in the spirit of the nations. Everything begins with the individual. There are well-meaning theologians and humanitarians who want to break the power principle—in others. We must begin by breaking it in ourselves. Then the thing becomes credible.³

[460] While the first World War was still in progress, I wrote an essay that first appeared in French, which I enlarged and published as a book in Germany in 1928.⁴ Dealing among other things with the subject of mass psychology, I said:

It is a notorious fact that the morality of society as a whole is in inverse ratio to its size; the greater the aggregation of individuals, the more the individual factors are blotted out, and with them morality, which depends entirely on the moral sense of the individual and on the freedom necessary for this. Hence every man is, in a certain sense, unconsciously a worse man when he is in society than when acting alone; for he is carried by society and to that extent relieved of his individual responsibility. Any large company composed of wholly admirable persons has the morality and intelligence of an unwieldy, stupid, and violent animal. The bigger the organization, the more unavoidable is its immorality and blind stupidity. (*Senatus bestia, senatores boni viri.*) Society, by automatically stressing all the collective qualities in its individual representatives, puts a premium on mediocrity, on everything that settles down to vegetate in an easy, irresponsible way. Individuality will inevitably be driven to the wall.... Without freedom there can be no morality. Our admiration for great organizations dwindles when once we become aware of the other side of the wonder: the tremendous piling up and accentuation of all that is primitive in man, and the unavoidable destruction of his individuality in the interests of the monstrosity that every great organization in fact is. The man of today, who resembles more or less the collective ideal, has made his heart into a den of murderers, as can easily be proved by the analysis of his unconscious, even though he himself is not in the least disturbed by this fact. And in so far as he is normally adapted to his environment, it is true that the greatest infamy on the part of his group will not disturb him, so long as the majority of his fellows steadfastly believe in the exalted morality of their social organization.⁵

[461] In the same essay I uttered the almost banal truth: “The best, just because it is the best, holds the seed of evil, and there is nothing so bad but good can come of it.”⁶ I lay particular stress on this sentence, because it always put me in a mood of caution when I had to judge of any particular manifestation of the unconscious. The contents of the collective unconscious, the archetypes, with which we are concerned in any occurrence of psychic mass-phenomena, are always bipolar: they have both a positive and a negative side. Whenever an archetype appears things become critical, and it is impossible to foresee what turn they will take. As a rule this depends on the way consciousness reacts to the situation. During a collective manifestation of archetypes there is always a great danger of a mass movement, and a catastrophe can be avoided only if the effect of the archetype can be intercepted and assimilated by a sufficiently large majority of individuals. At the very least there must be a certain number of individuals who are still capable of making their influence felt.

[462] In February 1933, lecturing in Cologne and Essen, I said:

The decidedly individualistic trend of these latest developments is counterbalanced by a compensatory reversion to the collective man, whose authority at present is the sheer weight of the masses. No wonder that nowadays there is a feeling of catastrophe in the air, as though an avalanche had broken loose which nothing can stop. The collective man threatens to stifle the individual man, on whose sense of responsibility everything valuable in mankind ultimately depends. The mass as such is always anonymous and always irresponsible. So-called leaders are the inevitable symptoms of a mass movement. The true leaders of mankind are always those who are capable

of self-reflection, and who relieve the dead weight of the masses at least of their own weight, consciously holding aloof from the blind momentum of the mass in movement.

But who can resist this all-engulfing force of attraction, when each man clings to the next and each drags the other with him? Only one who is firmly rooted not only in the outside world but also in the world within.

Small and hidden is the door that leads inward, and the entrance is barred by countless prejudices, mistaken assumptions, and fears. Always one wishes to hear of grand political and economic schemes, the very things that have landed every nation in a morass. Therefore it sounds grotesque when anyone speaks of hidden doors, dreams, and a world within. What has this vapid idealism got to do with gigantic economic programmes, with the so-called problems of reality?

But I speak not to nations, only to the individual few, for whom it goes without saying that cultural values do not drop down like manna from heaven, but are created by the hands of individuals. If things go wrong in the world, this is because something is wrong with the individual, because something is wrong with me. Therefore, if I am sensible, I shall put myself right first. For this I need—because outside authority no longer means anything to me—a knowledge of the innermost foundations of my being, in order that I may base myself firmly on the eternal facts of the human psyche.⁷

[463] In the Terry Lectures, which I gave at Yale University in 1937, I said:

We can never be sure that a new idea will not seize either upon ourselves or upon our neighbours. We know from modern as well as from ancient history that such ideas are often so strange, indeed so bizarre, that they fly in the face of reason. The fascination which is almost invariably connected with ideas of this sort produces a fanatical obsession, with the result that all dissenters, no matter how well-meaning or reasonable they are, get burnt alive or have their heads cut off or are disposed of in masses by the more modern machine-gun. We cannot even console ourselves with the thought that such things belong to the remote past. Unfortunately they seem to belong not only to the present, but, quite particularly, to the future. *Homo homini lupus* is a sad yet eternal truism. There is indeed reason enough for man to be afraid of the impersonal forces lurking in his unconscious. We are blissfully unconscious of these forces because they never, or almost never, appear in our personal relations or under ordinary circumstances. But if people crowd together and form a mob, then the dynamisms of the collective man are let loose—beasts or demons that lie dormant in every person until he is part of a mob. Man in the mass sinks unconsciously to an inferior moral and intellectual level, to that level which is always there, below the threshold of consciousness, ready to break forth as soon as it is activated by the formation of a mass....

The change of character brought about by the uprush of collective forces is amazing. A gentle and reasonable being can be transformed into a maniac or a savage beast. One is always inclined to lay the blame on external circumstances, but nothing could explode in us if it had not been already there. As a matter of fact, we are constantly living on the edge of a volcano, and there is, so far as we know, no way of protecting ourselves from a possible outburst that will destroy everybody within reach. It is certainly a good thing to preach reason and common sense, but what if you have a lunatic asylum for an audience or a crowd in a collective frenzy? There is not much difference between them because the madman and the mob are both moved by impersonal, overwhelming forces....⁸

Now we behold the amazing spectacle of states taking over the age-old totalitarian claims of theocracy, which are inevitably accompanied by the suppression of free opinion. Once more we see people cutting each other's throats in support of childish theories of how to create paradise on earth. It is not very difficult to see that the powers of the underworld—not to say of hell—which in former times were more or less successfully chained up in a gigantic spiritual edifice where they could be of some use, are now creating, or trying to create, a State slavery and a State prison devoid of any mental or spiritual charm. There are not a few people nowadays who are convinced that mere human reason is not entirely up to the enormous task of putting a lid on the volcano....

Look at all the incredible savagery going on in our so-called civilized world: it all comes from human beings and their mental condition! Look at the devilish engines of destruction! They are invented by completely innocuous gentlemen, reasonable, respectable citizens who are everything we could wish. And when the whole thing blows up and an indescribable hell of devastation is let loose, nobody seems to be responsible. It simply happens, and yet it is all man-made. But since everybody is blindly convinced that he is nothing more than his own extremely unassuming and insignificant conscious self, which performs its duties decently and earns a moderate living, nobody is aware that this whole rationalistically organized conglomeration we call a state or a nation is driven on by a seemingly impersonal but terrifying power which nobody and nothing can check. This ghastly power is mostly explained as fear of the neighbouring nation, which is supposed to be possessed by a malevolent fiend. Since nobody is capable of recognizing just where and how much he himself is possessed and unconscious, he simply projects his own condition upon his neighbour, and thus it becomes a sacred duty to have the biggest guns and the most poisonous gas. The worst of it is that he is quite right. All one's neighbours are in the grip of some uncontrollable fear, just like oneself. In lunatic asylums it is a well-known fact that patients are far more dangerous when suffering from fear than when moved by rage or hatred.⁹

[464] During the “phoney war,” early in 1940, I published a German translation of these lectures. The book was published just in time to reach Germany, but was soon suppressed on account of the passages just quoted, and I myself figured on the Nazi black list. I was a “marked man.” After the invasion of France the Gestapo destroyed all the French editions of my books they were able to lay their hands on.

[465] I have been blamed in many quarters for allowing myself to speak of German “psychopathy.” I am—and always was—of the opinion that the political mass movements of our time are psychic epidemics, in other words, *mass psychoses*. They are, as their inhuman concomitants show, abnormal mental phenomena, and I refuse to regard such things as normal, to say nothing of whitewashing them as excusable blunders. Murder is murder, and the fact that the whole German nation threw itself with all its might into the most infamous war of aggression in history is a crime that nothing can ever wipe out. It is true that very many individuals stood out against it, but they were a small minority. The behaviour of the Germans in general is abnormal; were it not so, we should long since have been accustomed to look upon this form of war as the normal state of things.

[466] Naturally there were plenty of reasons—political, social, economic, and historical—to drive the Germans to war, just as there are in the case of common murder. Every murderer has motives enough to spur him on, or the crime would never be committed. But, in addition to all this, a special psychic disposition is needed to bring matters to such a point. That is why there is such a thing as criminal psychology. Germany was suffering from a mass psychosis which was bound to lead to crime. But no psychosis ever appears out of the blue, it is always the result of a long-standing predisposition which we call a psychopathic inferiority. Nations have their own peculiar psychology, and in the same way they also have their own particular kind of psychopathology. It consists in the accumulation of a large number of abnormal features, the most striking of which is a suggestibility affecting the entire nation. No doubt there are special reasons for this too, otherwise it would not exist. But the existence of reasons does not do away either with the deed or its character. There are plenty of reasons for both crime and madness, but we do not on that account send our criminals and lunatics to recuperate at the seaside.

[467] I should like to point out that the idea of speaking of mass psychoses did not suddenly occur to me after May 1945; I had done that long before and had given warnings of this tremendous danger, not once but many times. As early as 1916, before the United States entered the first World War, I wrote:

Is the present war supposed to be a war of economics? That is a neutral American “business-like” standpoint, that does not take the blood, tears, unprecedented deeds of infamy and great distress into account, and which completely ignores the fact that this war is really an *epidemic of madness*.¹⁰

Once this function [of the irrational] finds itself in the unconscious, it works unceasing havoc, like an incurable disease whose focus cannot be eradicated because it is invisible. Individual and nation alike are then compelled to live the irrational in their own lives, even devoting their loftiest ideals and their best wits to expressing its madness in the most perfect form.¹¹

[468] In a lecture given at the British Society for Psychical Research in 1919, I said:

If this animation [of the collective unconscious] is due to a complete breakdown of all conscious hopes and expectations, the danger arises that the unconscious may take the place of conscious reality. Such a state is morbid. We actually see something of this kind in the present Russian and German mentality. An outbreak of violent desires and impossible fantasies among the lower strata of the population is analogous to an outburst from the lower strata of the unconscious in an individual.¹²

[469] In 1927 I expressed myself as follows:

The old religions with their sublime and ridiculous, their friendly and fiendish symbols did not drop from the blue, but were born of this human soul that dwells within us at this moment. All those things, in their primal forms, live on in us and may at any time burst in upon us with annihilating force, in the guise of mass-suggestions against which the individual is defenceless. Our fearsome gods have only changed their names: they now rhyme

with *-ism*. Or has anyone the nerve to claim that the World War or Bolshevism was an ingenious discovery? Just as outwardly we live in a world where a whole continent may be submerged at any *moment*, or a pole be shifted, or a new pestilence break out, so inwardly we live in a world where at any moment something similar may occur, albeit in the form of an idea, but no less dangerous and untrustworthy for that. Failure to adapt to this inner world is a negligence entailing just as serious consequences as ignorance and ineptitude in the outer world. It is after all only a tiny fraction of humanity, living mainly on that thickly populated peninsula of Asia which juts out into the Atlantic Ocean, and calling themselves “cultured,” who, because they lack all contact with nature, have hit upon the idea that religion is a peculiar kind of mental disturbance of undiscoverable purport. Viewed from a safe distance, say from central Africa or Tibet, it would certainly look as if this fraction had projected its own unconscious mental derangements upon peoples still possessed of healthy instincts.¹³

[470] In 1928 I wrote that “the normal person ... acts out his psychic disturbances socially and politically, in the form of mass psychoses like wars and revolutions.”¹⁴ A year later, in a book which I published in collaboration with Richard Wilhelm, I remarked:

In this way the fragmentary system is projected and a dangerous situation created, because the disturbing effects are now attributed to an evil will outside ourselves, which is naturally to be found nowhere else than with our neighbour *de l'autre côté de la rivière*. This leads to collective delusions, incitements to war and revolution, in a word, to destructive mass psychoses.¹⁵

[471] In November 1932, the year in which Germany's fate was decided, I gave a lecture at the *Austrian Kulturbund* in Vienna, from which I should like to quote the following passage:

The gigantic catastrophes that threaten us today are not elemental happenings of a physical or biological order, but psychic events. To a quite terrifying degree we are threatened by wars and revolutions which are nothing other than psychic epidemics. At any moment several millions of human beings may be smitten with a new madness, and then we shall have another world war or devastating revolution. Instead of being at the mercy of wild beasts, earthquakes, landslides, and inundations, modern man is battered by the elemental forces of his own psyche. This is the World Power that vastly exceeds all other powers on earth. The Age of Enlightenment, which stripped nature and human institutions of gods, overlooked the God of Terror who dwells in the human soul. If anywhere, fear of God is justified in face of the overwhelming supremacy of the psychic.

But all this is so much abstraction. Everyone knows that the intellect, that clever jackanapes, can put it this way or any other way he pleases. It is a very different thing when the psyche, as an objective fact, hard as granite and heavy as lead, confronts a man as an inner experience and addresses him in an audible voice, saying, “This is what will and must be.” Then he feels himself called, just as the group does when there's a war on, or a revolution, or any other madness. It is not for nothing that our age cries out for the redeemer personality, for the one who can emancipate himself from the grip of the collective and save at least his own soul, who lights a beacon of hope for others, proclaiming that here is at least *one* man who has succeeded in extricating himself from that fatal identity with the group psyche. For the group, because of its unconsciousness, has no freedom of choice, and so psychic activity runs on in it like an uncontrolled force of nature. There is thus set going a chain

reaction that comes to a stop only in catastrophe. The people always long for a hero, a slayer of dragons, when they feel the danger of psychic forces; hence the cry for personality.¹⁶

[472] There is no need to burden the reader with further quotations. Of course I never imagined that such observations would have an effect on any large scale, but it certainly never occurred to me that a time would come when I should be reproached for having said absolutely nothing about these things before 1945, that is, before my article "After the Catastrophe." When Hitler seized power it became quite evident to me that a mass psychosis was boiling up in Germany. But I could not help telling myself that this was after all Germany, a civilized European nation with a sense of morality and discipline. Hence the ultimate outcome of this unmistakable mass movement still seemed to me uncertain, just as the figure of the Führer at first struck me as being merely ambivalent. It is true that in July 1933, when I gave a series of lectures in Berlin, I received an extremely unfavourable impression both of the behaviour of the Party and of the person of Goebbels. But I did not wish to assume from the start that these symptoms were decisive, for I knew other people of unquestionable idealism who sought to prove to me that these things were unavoidable abuses such as are customary in any great revolution. It was indeed not at all easy for a foreigner to form a clear judgment at that time. Like many of my contemporaries, I had my doubts.

[473] As a psychiatrist, accustomed to dealing with patients who are in danger of being overwhelmed by unconscious contents, I knew that it is of the utmost importance, from the therapeutic point of view, to strengthen as far as possible their conscious position and powers of understanding, so that something is there to intercept and integrate the contents that are breaking through into consciousness. These contents are not necessarily destructive in themselves, but are ambivalent, and it depends entirely on the constitution of the intercepting consciousness whether they will turn out to be a curse or a blessing.

[474] National Socialism was one of those psychological mass phenomena, one of those outbreaks of the collective unconscious, about which I had been speaking for nearly twenty years. The driving forces of a psychological mass movement are essentially archetypal. Every archetype contains the lowest and the highest, evil and good, and is therefore capable of producing diametrically opposite results. Hence it is impossible to make out at the start whether it will prove to be positive or negative. My medical attitude towards such things counselled me to wait, for it is an attitude that allows no hasty judgments, does not always know from the start what is better, and is willing to give things "a fair trial." Far from wishing to give the beleaguered consciousness its death-blow, it tries to strengthen its powers of resistance through insight, so that the evil that is hidden in every archetype shall not seize hold of the

individual and drag him to destruction. The therapist's aim is to bring the positive, valuable, and living quality of the archetype—which will sooner or later be integrated into consciousness in any case—into reality, and at the same time to obstruct as far as possible its damaging and pernicious tendencies. It is part of the doctor's professional equipment to be able to summon up a certain amount of optimism even in the most unlikely circumstances, with a view to saving everything that it is still possible to save. He cannot afford to let himself be too much impressed by the real or apparent hopelessness of a situation, even if this means exposing himself to danger. Moreover, it should not be forgotten that Germany, up till the National Socialist era, was one of the most differentiated and highly civilized countries on earth, besides being, for us Swiss, a spiritual background to which we were bound by ties of blood, language, and friendship. I wanted to do everything within my feeble powers to prevent this cultural bond from being broken, for culture is our only weapon against the fearful danger of mass-mindedness.

[475] If an archetype is not brought into reality consciously, there is no guarantee whatever that it will be realized in its favourable form; on the contrary, there is all the more danger of a destructive regression. It seems as if the psyche were endowed with consciousness for the very purpose of preventing such destructive possibilities from happening.

[476] Coming back to the question of "German psychopathy," I am as convinced as ever that National Socialism was the mass psychosis of which I have been speaking for so long. What happened in Germany can be explained, in my view, only by the existence of an abnormal state of mind. But I am open to conviction if anyone can prove to me that the phenomenology of National Socialism belongs to the normal inventory of the psyche. In Italy the mass psychosis took a somewhat milder form. Russia can plead, by way of excuse, the low level of popular education before the Revolution. But Germany was supposed to be a highly civilized country, and yet the horrors there exceeded anything the world has ever known. I therefore maintain that there are peculiar depths in the Germans which present the most violent contrast to their former high achievements. Such a condition is known in psychopathology as a dissociation, and a habitual dissociation is one of the signs of a psychopathic disposition.¹⁷

[477] I am aware that the word "psychopathic" strikes harshly on the layman's ear, and that it conjures up all manner of horrors, such as lunatic asylums and the like. By way of explanation I should like to state that only a very small fraction of so-called psychopaths land in the asylum. The overwhelming majority of them constitute that part of the population which is alleged to be "normal." The concept of "normality" is an ideal construction. In psychology we speak of the "scope of the normal," thus

implicitly admitting that the concept of normality swings between certain limits and cannot therefore be sharply defined. A rather bigger swing, and the psychic process has already entered the sphere of the abnormal. These deviations from the “norm”—and they are very common—pass unnoticed so long as they do not lead to actual signs of disease. But if definite and unmistakable symptoms occur, such as are obvious even to the layman, then the case is clearly “psychopathic” (i.e., a “suffering”—*πάσχειν* of the psyche). The milder forms of psychopathy are the commonest and severe cases are rare. There are countless people who go a little bit beyond the scope of the normal, in one way or another, either temporarily or chronically. If they get together in large numbers—which is what happens in any crowd—abnormal phenomena appear. One need only read what Le Bon¹⁸ has to say on the “psychology of crowds” to understand what I mean: man as a particle in the mass is psychically abnormal. Ignorance of this fact is no protection against it.

[478] So anyone whose ears are offended by the word “psychopathic” is at liberty to suggest a soft, soothing, comforting substitute which correctly reflects the state of mind that gave birth to National Socialism. Far from wishing to insult the German people, my object, as I have said, is to diagnose the suffering that has its roots in their psyche and is the cause of their downfall. Nothing will ever persuade me that Nazism was forced on the German people by the Freemasons, the Jews, or the wicked English—that is really too childish. I have heard that sort of thing too often in the asylum.

[479] Anyone who wishes to get a vivid picture of the workings of psychopathic inferiority has only to study the way in which responsible Germans—i.e., the educated classes—react to the notorious *faits et gestes*. There is no doubt that a very large number of Germans are chiefly annoyed at having lost the war. A large proportion of them are shocked that the regime of the occupying forces is, in places, harsh, unjust, and even brutal—“after all, the war’s over now.” They refuse to listen to the accounts of Germany’s unspeakable behaviour in Bohemia, Poland, Russia, Greece, Holland, Belgium, Norway, and France. “All kinds of regrettable things did happen, of course, but that was during the war.” A slightly larger number admit the concentration camps and the “bad behaviour” in Poland and elsewhere, but in the same breath begin to enumerate the outrages committed by the English, from the Boer War on, without of course mentioning the war launched by their other psychopath, Wilhelm II. It never seems to occur to them that someone else’s sin in no way excuses their own, and that their habit of accusing others merely shows up their own lack of insight.

[480] Finally we come to a smaller number—the better men of the nation—who confess: *Pater, peccavi in caelum et coram te*, “we have our share of guilt in the

desolation that has spread over the world. We know that we must bear the consequences of a war begun in a spirit of wantonness and criminality, and we would not think of trying to escape our hard fate, *not even by complaints and accusations.*”¹⁹ Such a confession can only be answered in the words of the evangelist: “Bring forth the best robe, and put it on him; and put a ring on his hand, and shoes on his feet; and bring hither the fatted calf, and kill it; and let us eat, and be merry: For this my son was dead, and is alive again.”²⁰ It makes us feel something of the joy that reigned in heaven over the repentant sinner, and of the discomfiture of the ninety and nine just persons.

[481] Yet what meets our eye in the very next sentence? “Nevertheless, as people who have declared themselves openly and with honest conviction, as Evangelical Christians, we should and must ... point out with due emphasis that, according to the Gospel, no one is in greater danger than he who, *secure in the consciousness of his own innocence, judges and condemns another....* We cannot, indeed we should not pass over in silence the fact that foreign statesmen and their governments also played a decisive part in that first European catastrophe, through their politics both before and after 1918, *which were likewise power-politics based on injustice*, and that, consequently, they contributed their share to the inflation and the economic crisis, to the impoverishment of the German nation, *and thus prepared the ground for the dragon’s teeth from which National Socialism sprang up.*”

[482] In the first passage we read that no one has any intention of accusing anybody, and in the second comes the accusation. The contradiction passes unnoticed. When confession and repentance are followed by an aggressive defence, the genuineness of the repentance becomes doubtful. As it is hardly credible that the authors of this document consciously set out to sabotage the effect of their confession, we can only conclude—as is unfortunately only too true in innumerable instances where similar arguments are put forward—that there is an astounding unconsciousness of the fatal impression that such an attitude is bound to create.

[483] Furthermore we must ask: Has Germany openly admitted that she is conscious of her guilt, if she now “judges and condemns” others? It seems to have escaped the notice of the authors that there are plenty of people in Europe who are capable of forming their own judgment, and who are not hoodwinked by such unconscious naïvetés. Thus our document turns into a rather indiscreet monologue thoroughly in keeping with the clinical picture. Parents and teachers, judges and psychiatrists, are well acquainted with this mixture of repentance and lust for revenge, this same unconsciousness and indifference to the disastrous impression one makes, this same self-centred disregard of one’s fellow men. Such an attitude defeats its object: it sets out to evoke an impression of repentance, and the next minute it defends itself by

launching an attack. This manoeuvre simply makes the repentance unreal and the defence ineffectual. It is too unconscious to serve any purpose, quite unadapted and not equal to the demands of reality. There is an old saying that goes: "Sickness is diminished adaptation." The kind of adaptation here illustrated is of no value either morally or intellectually; it is inferior, and psychopathically inferior at that.

[484] In saying this it is not my intention to accuse or condemn. I am obliged to mention it only because my diagnosis has been doubted.²¹ A medical diagnosis is not an accusation, and an illness is not a disgrace but a misfortune. As early as 1936 I pleaded for compassion in judging the German mentality.²² Even now I adopt the standpoint of the therapist, and therefore, in the interests of the patient, I *must* emphasize the necessity for complete insight without any extenuating provisos. It avails him nothing to cultivate only a half-consciousness of his condition, and to cover up his other half with illusions whose colossal dangers he has just experienced in the most terrible form. My sympathy with the lot of the Germans is great, and I am only too painfully aware that my chances of being able to help are exceedingly small. I can only hope and pray that one of the worst dangers now threatening Germany, besides economic distress, may soon come to an end, and that is her spiritual isolation. National isolation combined with mass psychology and centralization are Germany's bane. The task she has to fulfil is not political but spiritual, and the gifts she possesses for this are practically unique. We should therefore help and support this side of her nature by all the means within our power.

*

[485] I cannot bring this epilogue to a close without saying a few words about the outlook for the future. No nation has ever fallen so low as the Germans and none has ever branded itself with such a stigma, which generations will not be able to wash away. But when a pendulum swings so violently in one direction, it is capable of swinging just as far in the other—if we may apply this analogy to the psyche of a nation. I do not know whether it is justified from the ethnopsychological point of view. I only know that, in the psyche of an individual with a tendency to dissociation, there can be violent oscillations, with the result that one extreme necessarily leads to its opposite. Provided, however, that he remains in full possession of his human qualities and thus has a mean value, I am inclined to think that the minus is balanced by the plus. In other words, I believe there is a faculty for regeneration in the Germans that might be able to find the right answer to the terrific tension between the opposites which has been so evident during the past twelve years. In this endeavour Germany would not be isolated, for all the positive spiritual forces which are at work throughout the civilized world would stand by her and sustain her effort. The struggle between light and darkness has broken out everywhere. The rift runs through the

whole globe, and the fire that set Germany ablaze is smouldering and glowing wherever we look. The conflagration that broke out in Germany was the outcome of psychic conditions that are universal. The real danger signal is not the fiery sign that hung over Germany, but the unleashing of atomic energy, which has given the human race the power to annihilate itself completely. The situation is about the same as if a small boy of six had been given a bag of dynamite for a birthday present. We are not one hundred per cent convinced by his assurances that no calamity will happen. Will man be able to give up toying with the idea of another war? Can we at last get it into our heads that any government of impassioned patriots which signs the order for mobilization should immediately be executed *en bloc*?

[486] How can we save the child from the dynamite which no one can take away from him? The good spirit of humanity is challenged as never before. The facts can no longer be hushed up or painted in rosy colours. Will this knowledge inspire us to a great inner transformation of mind, to a higher, maturer consciousness and sense of responsibility?

[487] It is time, high time, that civilized man turned his mind to fundamental things. It is now a question of existence or nonexistence, and surely this should be subjected to the most searching investigation and discussion. For the danger that threatens us now is of such dimensions as to make this last European catastrophe seem like a curtain-raiser.

IV

THE UNDISCOVERED SELF (Present and Future)

[Written in spring 1956 and first published as *Gegenwart und Zukunft*, supplement to *Schweizer Monatshefte* (Zurich), March 1957; issued as a book (paperback) later in 1957 (Zurich). Translated from the original ms. by R. F. C. Hull. A section of the translation was published as “God, The Devil, and the Human Soul,” *The Atlantic Monthly* (Boston), CC:5 (Nov., 1957; Centennial Issue); the entire translation, with revisions by the American editors, was published in book form as *The Undiscovered Self* (Boston and London, 1958), carrying the note: “This book was prompted by conversations between Dr. Jung and Dr. Carleton Smith, director of the National Arts Foundation, which brought it to the attention of the editors of the Atlantic Monthly Press,” and a dedication: “To my friend Fowler McCormick.” The present text is a further revision of the original translation.—EDITORS.]

1. THE PLIGHT OF THE INDIVIDUAL IN MODERN SOCIETY

[488] What will the future bring? From time immemorial this question has occupied men's minds, though not always to the same degree. Historically, it is chiefly in times of physical, political, economic, and spiritual distress that men's eyes turn with anxious hope to the future, and when anticipations, utopias, and apocalyptic visions multiply. One thinks, for instance, of the chiliastic expectations of the Augustan age at the beginning of the Christian era, or of the spiritual changes in the West which accompanied the end of the first millennium. Today, as the end of the second millennium draws near, we are again living in an age filled with apocalyptic images of universal destruction. What is the significance of that split, symbolized by the "Iron Curtain," which divides humanity into two halves? What will become of our civilization, and of man himself, if the hydrogen bombs begin to go off, or if the spiritual and moral darkness of State absolutism should spread over Europe?

[489] We have no reason to take this threat lightly. Everywhere in the West there are subversive minorities who, sheltered by our humanitarianism and our sense of justice, hold the incendiary torches ready, with nothing to stop the spread of their ideas except the critical reason of a single, fairly intelligent, mentally stable stratum of the population. One should not overestimate the thickness of this stratum. It varies from country to country in accordance with national temperament. Also, it is regionally dependent on public education and is subject to the influence of acutely disturbing factors of a political and economic nature. Taking plebiscites as a criterion, one could on an optimistic estimate put its upper limit at about forty per cent of the electorate. A rather more pessimistic view would not be unjustified either, since the gift of reason and critical reflection is not one of man's outstanding peculiarities, and even where it exists it proves to be wavering and inconstant, the more so, as a rule, the bigger the political groups are. The mass crushes out the insight and reflection that are still possible with the individual, and this necessarily leads to doctrinaire and authoritarian tyranny if ever the constitutional State should succumb to a fit of weakness.

[490] Rational argument can be conducted with some prospect of success only so long as the emotionality of a given situation does not exceed a certain critical degree. If the affective temperature rises above this level, the possibility of reason's having any effect ceases and its place is taken by slogans and chimerical wish-fantasies. That is to say, a sort of collective possession results which rapidly develops into a psychic epidemic. Under these conditions all those elements whose existence is merely

tolerated as asocial under the rule of reason come to the top. Such individuals are by no means rare curiosities to be met with only in prisons and lunatic asylums. For every manifest case of insanity there are, in my estimation, at least ten latent cases who seldom get to the point of breaking out openly but whose views and behaviour, for all their appearance of normality, are influenced unconsciously by pathological and perverse factors. There are, of course, no medical statistics on the frequency of latent psychoses—for understandable reasons. But even if their number should amount to less than ten times that of the manifest psychoses and of manifest criminality, the relatively small percentage of the population figures they represent is more than compensated for by the peculiar dangerousness of these people. Their mental state is that of a collectively excited group ruled by affective judgments and wish-fantasies. In a milieu of this kind they are the adapted ones, and consequently they feel quite at home in it. They know from their own experience the language of these conditions, and they know how to handle them. Their chimerical ideas, sustained by fanatical resentment, appeal to the collective irrationality and find fruitful soil there; they express all those motives and resentments which lurk in more normal people under the cloak of reason and insight. They are, therefore, despite their small number in comparison with the population as a whole, dangerous as sources of infection precisely because the so-called normal person possesses only a limited degree of self-knowledge.

[491] Most people confuse “self-knowledge” with knowledge of their conscious ego-personalities. Anyone who has any ego-consciousness at all takes it for granted that he knows himself. But the ego knows only its own contents, not the unconscious and its contents. People measure their self-knowledge by what the average person in their social environment knows of himself, but not by the real psychic facts which are for the most part hidden from them. In this respect the psyche behaves like the body, of whose physiological and anatomical structure the average person knows very little too. Although he lives in it and with it, most of it is totally unknown to the layman, and special scientific knowledge is needed to acquaint consciousness with what is known of the body, not to speak of all that is *not* known, which also exists.

[492] What is commonly called “self-knowledge” is therefore a very limited knowledge, most of it dependent on social factors, of what goes on in the human psyche. Hence one is always coming up against the prejudice that such and such a thing does not happen “with us” or “in our family” or among our friends and acquaintances. On the other hand, one meets with equally illusory assumptions about the alleged presence of qualities which merely serve to cover up the true facts of the case.

[493] In this broad belt of unconsciousness, which is immune to conscious criticism and control, we stand defenceless, open to all kinds of influences and psychic infections. As with all dangers, we can guard against the risk of psychic infection only when we know what is attacking us, and how, where and when the attack will come. Since self-knowledge is a matter of getting to know the individual facts, theories are of very little help. For the more a theory lays claim to universal validity, the less capable it is of doing justice to the individual facts. Any theory based on experience is necessarily *statistical*; it formulates an *ideal average* which abolishes all exceptions at either end of the scale and replaces them by an abstract mean. This mean is quite valid, though it need not necessarily occur in reality. Despite this it figures in the theory as an unassailable fundamental fact. The exceptions at either extreme, though equally factual, do not appear in the final result at all, since they cancel each other out. If, for instance, I determine the weight of each stone in a bed of pebbles and get an average weight of five ounces, this tells me very little about the real nature of the pebbles. Anyone who thought, on the basis of these findings, that he could pick up a pebble of five ounces at the first try would be in for a serious disappointment. Indeed, it might well happen that however long he searched he would not find a single pebble weighing exactly five ounces.

[494] The statistical method shows the facts in the light of the ideal average but does not give us a picture of their empirical reality. While reflecting an indisputable aspect of reality, it can falsify the actual truth in a most misleading way. This is particularly true of theories which are based on statistics. The distinctive thing about real facts, however, is their individuality. Not to put too fine a point on it, one could say that the real picture consists of nothing but exceptions to the rule, and that, in consequence, absolute reality has predominantly the character of *irregularity*.

[495] These considerations must be borne in mind whenever there is talk of a theory serving as a guide to self-knowledge. There is and can be no self-knowledge based on theoretical assumptions, for the object of this knowledge is an individual—a relative exception and an irregular phenomenon. Hence it is not the universal and the regular that characterize the individual, but rather the unique. He is not to be understood as a recurrent unit but as something unique and singular which in the last analysis can be neither known nor compared with anything else. At the same time man, as member of a species, can and must be described as a statistical unit; otherwise nothing general could be said about him. For this purpose he has to be regarded as a comparative unit. This results in a universally valid anthropology or psychology, as the case may be, with an abstract picture of man as an average unit from which all individual features have been removed. But it is precisely these features which are of paramount importance for *understanding* man. If I want to understand an individual human being, I must lay aside all scientific knowledge of

the average man and discard all theories in order to adopt a completely new and unprejudiced attitude. I can only approach the task of *understanding* with a free and open mind, whereas *knowledge* of man, or insight into human character, presupposes all sorts of knowledge about mankind in general.

[496] Now whether it is a question of understanding a fellow human being or of self-knowledge, I must in both cases leave all theoretical assumptions behind me. Since scientific knowledge not only enjoys universal esteem but, in the eyes of modern man, counts as the only intellectual and spiritual authority, understanding the individual obliges me to commit the *lèse majesté*, so to speak, of turning a blind eye to scientific knowledge. This is a sacrifice not lightly made, for the scientific attitude cannot rid itself so easily of its sense of responsibility. And if the psychologist happens to be a doctor who wants not only to classify his patient scientifically but also to understand him as a human being, he is threatened with a conflict of duties between the two diametrically opposed and mutually exclusive attitudes of knowledge on the one hand and understanding on the other. This conflict cannot be solved by an either/or but only by a kind of two-way thinking: doing one thing while not losing sight of the other.

[497] In view of the fact that, in principle, the positive advantages of *knowledge* work specifically to the disadvantage of *understanding*, the judgment resulting therefrom is likely to be something of a paradox. Judged scientifically, the individual is nothing but a unit which repeats itself *ad infinitum* and could just as well be designated with a letter of the alphabet. For understanding, on the other hand, it is just the unique individual human being who, when stripped of all those conformities and regularities so dear to the heart of the scientist, is the supreme and only real object of investigation. The doctor, above all, should be aware of this contradiction. On the one hand, he is equipped with the statistical truths of his scientific training, and on the other, he is faced with the task of treating a sick person who, especially in the case of psychic suffering, requires *individual understanding*. The more schematic the treatment is, the more resistances it—quite rightly—calls up in the patient, and the more the cure is jeopardized. The psychotherapist sees himself compelled, willy-nilly, to regard the individuality of a patient as an essential fact in the picture and to arrange his methods of treatment accordingly. Today, over the whole field of medicine, it is recognized that the task of the doctor consists in treating the sick person, not an abstract illness.

[498] This illustration from the realm of medicine is only a special instance of the problem of education and training in general. Scientific education is based in the main on statistical truths and abstract knowledge and therefore imparts an unrealistic, rational picture of the world, in which the individual, as a merely marginal

phenomenon, plays no role. The individual, however, as an irrational datum, is the true and authentic carrier of reality, the *concrete* man as opposed to the unreal ideal or “normal” man to whom the scientific statements refer. What is more, most of the natural sciences try to represent the results of their investigations as though these had come into existence without man’s intervention, in such a way that the collaboration of the psyche—an indispensable factor—remains invisible. (An exception to this is modern physics, which recognizes that the observed is not independent of the observer.) So, in this respect as well, science conveys a picture of the world from which a real human psyche appears to be excluded—the very antithesis of the “humanities.”

[499] Under the influence of scientific assumptions, not only the psyche but the individual man and, indeed, all individual events whatsoever suffer a levelling down and a process of blurring that distorts the picture of reality into a conceptual average. We ought not to underestimate the psychological effect of the statistical world-picture: it thrusts aside the individual in favour of anonymous units that pile up into mass formations. Instead of the concrete individual, you have the names of organizations and, at the highest point, the abstract idea of the State as the principle of political reality. The moral responsibility of the individual is then inevitably replaced by the policy of the State (*raison d'état*). Instead of moral and mental differentiation of the individual, you have public welfare and the raising of the living standard. The goal and meaning of individual life (which is the only *real* life) no longer lie in individual development but in the policy of the State, which is thrust upon the individual from outside and consists in the execution of an abstract idea which ultimately tends to attract all life to itself. The individual is increasingly deprived of the moral decision as to how he should live his own life, and instead is ruled, fed, clothed, and educated as a social unit, accommodated in the appropriate housing unit, and amused in accordance with the standards that give pleasure and satisfaction to the masses. The rulers, in their turn, are just as much social units as the ruled, and are distinguished only by the fact that they are specialized mouthpieces of the State doctrine. They do not need to be personalities capable of judgment, but thoroughgoing specialists who are unusable outside their line of business. State policy decides what shall be taught and studied.

[500] The seemingly omnipotent State doctrine is for its part manipulated in the name of State policy by those occupying the highest positions in the government, where all the power is concentrated. Whoever, by election or caprice, gets into one of these positions is subject to no higher authority; he is the State policy itself and within the limits of the situation can proceed at his own discretion. With Louis XIV he can say, “L'état c'est moi.” He is thus the only individual or, at any rate, one of the few individuals who could make use of their individuality if only they knew how to

differentiate themselves from the State doctrine. They are more likely, however, to be the slaves of their own fictions. Such one-sidedness is always compensated psychologically by unconscious subversive tendencies. Slavery and rebellion are inseparable correlates. Hence, rivalry for power and exaggerated distrust pervade the entire organism from top to bottom. Furthermore, in order to compensate for its chaotic formlessness, a mass always produces a “Leader,” who infallibly becomes the victim of his own inflated ego-consciousness, as numerous examples in history show.

[501] This development becomes logically unavoidable the moment the individual combines with the mass and thus renders himself obsolete. Apart from the agglomeration of huge masses in which the individual disappears anyway, one of the chief factors responsible for psychological mass-mindedness is scientific rationalism, which robs the individual of his foundations and his dignity. As a social unit he has lost his individuality and become a mere abstract number in the bureau of statistics. He can only play the role of an interchangeable unit of infinitesimal importance. Looked at rationally and from outside, that is exactly what he is, and from this point of view it seems positively absurd to go on talking about the value or meaning of the individual. Indeed, one can hardly imagine how one ever came to endow individual human life with so much dignity when the truth to the contrary is as plain as the palm of your hand.

[502] Seen from this standpoint, the individual really is of diminishing importance and anyone who wished to dispute this would soon find himself at a loss for arguments. The fact that the individual feels himself or the members of his family or the esteemed friends in his circle to be important merely underlines the slightly comic subjectivity of his feeling. For what are the few compared with ten thousand or a hundred thousand, let alone a million? This recalls the argument of a thoughtful friend with whom I once got caught up in a huge crowd of people. Suddenly he exclaimed, “Here you have the most convincing reason for not believing in immortality: all *that lot* wants to be immortal!”

[503] The bigger the crowd the more negligible the individual becomes. But if the individual, overwhelmed by the sense of his own puniness and impotence, should feel that his life has lost its meaning—which, after all, is not identical with public welfare and higher standards of living—then he is already on the road to State slavery and, without knowing or wanting it, has become its proselyte. The man who looks only outside and quails before the big battalions has nothing with which to combat the evidence of his senses and his reason. But that is just what is happening today: we are all fascinated and overawed by statistical truths and large numbers and are daily apprised of the nullity and futility of the individual personality, since it is not represented and personified by any mass organization. Conversely, those

personages who strut about on the world stage and whose voices are heard far and wide seem, to the uncritical public, to be borne along on some mass movement or on the tide of public opinion and for this reason are either applauded or execrated. Since mass suggestion plays the predominant role here, it remains a moot point whether their message is their own, for which they are personally responsible, or whether they merely function as a megaphone for collective opinion.

[504] Under these circumstances it is small wonder that individual judgment grows increasingly uncertain of itself and that responsibility is collectivized as much as possible, i.e., is shuffled off by the individual and delegated to a corporate body. In this way the individual becomes more and more a function of society, which in its turn usurps the function of the real life carrier, whereas, in actual fact, society is nothing more than an abstract idea like the State. Both are hypostatized, that is, have become autonomous. The State in particular is turned into a quasi-animate personality from whom everything is expected. In reality it is only a camouflage for those individuals who know how to manipulate it. Thus the constitutional State drifts into the situation of a primitive form of society—the communism of a primitive tribe where everybody is subject to the autocratic rule of a chief or an oligarchy.

2. RELIGION AS THE COUNTERBALANCE TO MASS-MINDEDNESS

[505] In order to free the fiction of the sovereign State—in other words, the whims of the chieftains who manipulate it—from every wholesome restriction, all socio-political movements tending in this direction invariably try to cut the ground from under *religion*. For, in order to turn the individual into a function of the State, his dependence on anything else must be taken from him. Religion means dependence on and submission to the irrational facts of experience. These do not refer directly to social and physical conditions; they concern far more the individual's psychic attitude.

[506] But it is possible to have an attitude to the external conditions of life only when there is a point of reference outside them. Religion gives, or claims to give, such a standpoint, thereby enabling the individual to exercise his judgment and his power of decision. It builds up a reserve, as it were, against the obvious and inevitable force of circumstances to which everyone is exposed who lives only in the outer world and has no other ground under his feet except the pavement. If statistical reality is the only one, then that is the sole authority. There is then only *one* condition, and since no contrary condition exists, judgment and decision are not only superfluous but impossible. Then the individual is bound to be a function of statistics and hence a function of the State or whatever the abstract principle of order may be called.

[507] Religion, however, teaches another authority opposed to that of the “world.” The doctrine of the individual's dependence on God makes just as high a claim upon him as the world does. It may even happen that the absoluteness of this claim estranges him from the world in the same way as he is estranged from himself when he succumbs to the collective mentality. He can forfeit his judgment and power of decision in the former case (for the sake of religious doctrine) quite as much as in the latter. This is the goal which religion openly aspires to unless it compromises with the State. When it does so, I prefer to call it not “religion” but a “creed.” A creed gives expression to a definite collective belief, whereas the word *religion* expresses a subjective relationship to certain metaphysical, extramundane factors. A creed is a confession of faith intended chiefly for the world at large and is thus an intramundane affair, while the meaning and purpose of religion lie in the relationship of the individual to God (Christianity, Judaism, Islam) or to the path of salvation and liberation (Buddhism). From this basic fact all ethics is derived, which without the individual's responsibility before God can be called nothing more than conventional morality.

[508] Since they are compromises with mundane reality, the creeds have accordingly seen themselves obliged to undertake a progressive codification of their views, doctrines, and customs, and in so doing have externalized themselves to such an extent that the authentic religious element in them—the living relationship to and direct confrontation with their extramundane point of reference—has been thrust into the background. The denominational standpoint measures the worth and importance of the subjective religious relationship by the yardstick of traditional doctrine, and where this is not so frequent, as in Protestantism, one immediately hears talk of pietism, sectarianism, eccentricity, and so forth, as soon as anyone claims to be guided by God's will. A creed coincides with the established Church or, at any rate, forms a public institution whose members include not only true believers but vast numbers of people who can only be described as "indifferent" in matters of religion and who belong to it simply by force of habit. Here the difference between a creed and a religion becomes palpable.

[509] To be the adherent of a creed, therefore, is not always a religious matter but more often a social one and, as such, it does nothing to give the individual any foundation. For this he has to depend exclusively on his relation to an authority which is not of this world. The criterion here is not lip service to a creed but the psychological fact that the life of the individual is not determined solely by the ego and its opinions or by social factors, but quite as much, if not more, by a transcendent authority. It is not ethical principles, however lofty, or creeds, however orthodox, that lay the foundations for the freedom and autonomy of the individual, but simply and solely the empirical awareness, the incontrovertible experience of an intensely personal, reciprocal relationship between man and an extramundane authority which acts as a counterpoise to the "world" and its "reason."

[510] This formulation will not please either the mass man or the collective believer. For the former the policy of the State is the supreme principle of thought and action. Indeed, this was the purpose for which he was enlightened, and accordingly the mass man grants the individual a right to exist only in so far as he is a function of the State. The believer, on the other hand, while admitting that the State has a moral and factual claim on him, confesses to the belief that not only man but the State that rules him is subject to the overlordship of "God," and that, in case of doubt, the supreme decision will be made by God and not by the State. Since I do not presume to any metaphysical judgments, I must leave it an open question whether the "world," i.e., the phenomenal world of man, and hence nature in general, is the "opposite" of God or not. I can only point to the fact that the psychological opposition between these two realms of experience is not only vouched for in the New Testament but is still exemplified very plainly today in the negative attitude of the dictator States to religion and of the Church to atheism and materialism.

[511] Just as man, as a social being, cannot in the long run exist without a tie to the community, so the individual will never find the real justification for his existence and his own spiritual and moral autonomy anywhere except in an extramundane principle capable of relativizing the overpowering influence of external factors. The individual who is not anchored in God can offer no resistance on his own resources to the physical and moral blandishments of the world. For this he needs the evidence of inner, transcendent experience which alone can protect him from the otherwise inevitable submersion in the mass. Merely intellectual or even moral insight into the stultification and moral irresponsibility of the mass man is a negative recognition only and amounts to not much more than a wavering on the road to the atomization of the individual. It lacks the driving force of religious conviction, since it is merely rational. The dictator State has one great advantage over bourgeois reason: along with the individual it swallows up his religious forces. The State takes the place of God; that is why, seen from this angle, the socialist dictatorships are religions and State slavery is a form of worship. But the religious function cannot be dislocated and falsified in this way without giving rise to secret doubts, which are immediately repressed so as to avoid conflict with the prevailing trend towards mass-mindedness. The result, as always in such cases, is overcompensation in the form of *fanaticism*, which in its turn is used as a weapon for stamping out the least flicker of opposition. Free opinion is stifled and moral decision ruthlessly suppressed, on the plea that the end justifies the means, even the vilest. The policy of the State is exalted to a creed, the leader or party boss becomes a demigod beyond good and evil, and his votaries are honoured as heroes, martyrs, apostles, missionaries. There is only *one* truth and beside it no other. It is sacrosanct and above criticism. Anyone who thinks differently is a heretic, who, as we know from history, is threatened with all manner of unpleasant things. Only the party boss, who holds the political power in his hands, can interpret the State doctrine authentically, and he does so just as suits him.

[512] When, through mass rule, the individual becomes social unit No. so-and-so and the State is elevated to the supreme principle, it is only to be expected that the religious function too will be sucked into the maelstrom. Religion, as the careful observation and taking account of certain invisible and uncontrollable factors, is an *instinctive* attitude peculiar to man, and its manifestations can be followed all through human history. Its evident purpose is to maintain the psychic balance, for the natural man has an equally natural “knowledge” of the fact that his conscious functions may at any time be thwarted by uncontrollable happenings coming from inside as well as from outside. For this reason he has always taken care that any difficult decision likely to have consequences for himself and others shall be rendered safe by suitable measures of a religious nature. Offerings are made to the invisible powers, formidable blessings are pronounced, and all kinds of solemn rites are performed.

Everywhere and at all times there have been *rites d'entrée et de sortie* whose efficacy is impugned as magic and superstition by rationalists incapable of psychological insight. But magic has above all a psychological effect whose importance should not be underestimated. The performance of a “magical” action gives the person concerned a feeling of security which is absolutely essential for carrying out a decision, because a decision is inevitably somewhat one-sided and is therefore rightly felt to be a risk. Even a dictator thinks it necessary not only to accompany his acts of State with threats but to stage them with all manner of solemnities. Brass bands, flags, banners, parades, and monster demonstrations are no different in principle from ecclesiastical processions, cannonades, and fireworks to scare off demons. Only, the suggestive parade of State power engenders a collective feeling of security which, unlike religious demonstrations, gives the individual no protection against his inner demonism. Hence he will cling all the more to the power of the State, i.e., to the mass, thus delivering himself up to it psychically as well as morally and putting the finishing touch to his social depotentiation. The State, like the Church, demands enthusiasm, selfsacrifice, and love, and if religion requires or presupposes the “fear of God,” then the dictator State takes good care to provide the necessary terror.

[513] When the rationalist directs the main force of his attack against the miraculous effect of the rite as asserted by tradition, he has in reality completely missed the mark. The essential point, the *psychological* effect, is overlooked, although both parties make use of it for directly opposite purposes. A similar situation prevails with regard to their respective conceptions of the goal. The goals of religion—deliverance from evil, reconciliation with God, rewards in the hereafter, and so on—turn into worldly promises about freedom from care for one’s daily bread, the just distribution of material goods, universal prosperity in the future, and shorter working hours. That the fulfilment of these promises is as far off as Paradise only furnishes yet another analogy and underlines the fact that the masses have been converted from an extramundane goal to a purely worldly belief, which is extolled with exactly the same religious fervour and exclusiveness that the creeds display in the other direction.

[514] In order not to repeat myself unnecessarily, I shall not enumerate all the parallels between worldly and otherworldly beliefs, but shall content myself with emphasizing the fact that a natural function which has existed from the beginning, like the religious function, cannot be disposed of with rationalistic and so-called enlightened criticism. You can, of course, represent the doctrinal contents of the creeds as impossible and subject them to ridicule, but such methods miss the point and do not affect the religious function which forms the basis of the creeds. Religion, in the sense of conscientious regard for the irrational factors of the psyche and individual fate, reappears—evilly distorted—in the deification of the State and the dictator: *Naturam expellas furca tamen usque recurret* (You can throw out Nature with a

pitchfork, but she'll always turn up again). The leaders and dictators, having weighed up the situation correctly, are therefore doing their best to gloss over the all too obvious parallel with the deification of Caesar and to hide their real power behind the fiction of the State, though this, of course, alters nothing.¹

[515] As I have already pointed out, the dictator State, besides robbing the individual of his rights, has also cut the ground from under his feet psychically by depriving him of the metaphysical foundations of his existence. The ethical decision of the individual human being no longer counts—what alone matters is the blind movement of the masses, and the *lie* thus becomes the operative principle of political action. The State has drawn the logical conclusions from this, as the existence of many millions of State slaves completely deprived of all rights mutely testifies.

[516] Both the dictator State and denominational religion lay quite particular emphasis on the idea of *community*. This is the basic ideal of “communism,” and it is thrust down the throats of the people so much that it has the exact opposite of the desired effect: it inspires divisive mistrust. The Church, which is no less emphatic, appears on its side as a communal ideal, and where the Church is notoriously weak, as in Protestantism, the hope of or belief in a “communal experience” makes up for the painful lack of cohesion. As can easily be seen, “community” is an indispensable aid in the organization of masses and is therefore a two-edged weapon. Just as the addition of however many zeros will never make a unit, so the value of a community depends on the spiritual and moral stature of the individuals composing it. For this reason one cannot expect from the community any effect that would outweigh the suggestive influence of the environment—that is, a real and fundamental change in individuals, whether for good or for bad. Such changes can come only from the personal encounter between man and man, but not from communistic or Christian baptisms *en masse*, which do not touch the inner man. How superficial the effect of communal propaganda actually is can be seen from recent events in Eastern Europe.² The communal ideal reckons without its host, overlooking the individual human being, who in the end will assert his claims.

3. THE POSITION OF THE WEST ON THE QUESTION OF RELIGION

[517] Confronting this development in the twentieth century of our Christian era, the Western world stands with its heritage of Roman law, the treasures of Judaeo-Christian ethics grounded on metaphysics, and its ideal of the inalienable rights of man. Anxiously it asks itself the question: How can this development be brought to a standstill or put into reverse? It is useless to pillory the socialist dictatorship as utopian and to condemn its economic principles as unreasonable, because, in the first place, the criticizing West has only itself to talk to, its arguments being heard only on this side of the Iron Curtain, and, in the second place, any economic principles you like can be put into practice so long as you are prepared to accept the sacrifices they entail. You can carry through any social and economic reforms you please if, like Stalin, you let three million peasants starve to death and have a few million unpaid labourers at your disposal. A State of this kind has no social or economic crises to fear. So long as its power is intact—that is to say, so long as there is a well-disciplined and well-fed police army in the offing—it can maintain its existence for an indefinitely long period and can go on increasing its power to an indefinite extent. Thanks to its excess birth-rate, it can multiply the number of its unpaid workers almost at will in order to compete with its rivals, regardless of the world market, which is to a large measure dependent on wages. A real danger can come to it only from outside, through the threat of military attack. But this risk grows less every year, firstly because the war potential of the dictator States is steadily increasing, and secondly because the West cannot afford to arouse latent Russian or Chinese nationalism and chauvinism by an attack which would have exactly the opposite effect to the one intended.

[518] So far as one can see, only one possibility remains, and that is a break-down of power from within, which must, however, be left to follow its own inner development. Any support from outside at present would have little effect, in view of the existing security measures and the danger of nationalistic reactions. The absolute State has an army of fanatical missionaries to do its bidding in matters of foreign policy, and these in their turn can count on a fifth column who are guaranteed asylum under the laws and constitutions of the Western States. In addition the communes of believers, very strong in places, considerably weaken Western governments' powers of decision, whereas the West has no opportunity to exert a similar influence on the other side, though we are probably not wrong in surmising that there is a certain amount of opposition among the masses in the East. There are always upright and

truth-loving people to whom lying and tyranny are hateful, but one cannot judge whether they exert any decisive influence on the masses under the police régimes.¹

[519] In view of this uncomfortable situation the question is heard again and again in the West: What can we do to counter this threat from the East? Even though the West has considerable industrial power and a sizable defence potential at its command, we cannot rest content with this, for we know that even the biggest armaments and the heaviest industry coupled with a relatively high living standard are not enough to check the psychic infection spread by religious fanaticism.

[520] The West has unfortunately not yet woken up to the fact that our appeal to idealism and reason and other desirable virtues, delivered with so much enthusiasm, is mere bombination in the void. It is a puff of wind swept away in the storm of religious faith, however twisted this faith may appear to us. We are faced, not with a situation that can be overcome by rational or moral arguments, but with an unleashing of emotional forces and ideas engendered by the spirit of the times; and these, as we know from experience, are not much influenced by rational reflection and still less by moral exhortation. It has been correctly realized in many quarters that the alexipharmic, the antidote, should in this case be an equally potent faith of a different and non-materialistic kind, and that the religious attitude grounded upon it would be the only effective defence against the danger of psychic infection. Unhappily, the little word “should,” which never fails to appear in this connection, points to a certain weakness, if not the absence, of this desideratum. Not only does the West lack a uniform faith that could block the progress of a fanatical ideology, but, as the father of Marxist philosophy, it makes use of exactly the same intellectual assumptions, the same arguments and aims. Although the Churches in the West enjoy full freedom, they are not less full or empty than in the East. Yet they exercise no noticeable influence on the broad course of politics. The disadvantage of a creed as a public institution is that it serves two masters: on the one hand, it derives its existence from the relationship of man to God, and on the other hand, it owes a duty to the State, i.e., to the world, in which connection it can appeal to the saying “Render unto Caesar ...” and various other admonitions in the New Testament.

[521] In early times and until comparatively recently there was, therefore, talk of “powers ordained by God” (Romans 13:1). Today this conception is antiquated. The Churches stand for traditional and collective convictions which in the case of many of their adherents are no longer based on their own inner experience but on *unreflecting belief*, which is notoriously apt to disappear as soon as one begins thinking about it. The content of belief then comes into collision with knowledge, and it often turns out that the irrationality of the former is no match for the ratiocinations of the latter. Belief is no adequate substitute for inner experience, and

where this is absent even a strong faith which came miraculously as a gift of grace may depart equally miraculously. People call faith the true religious experience, but they do not stop to consider that actually it is a secondary phenomenon arising from the fact that something happened to us in the first place which instilled *πίστις* into us—that is, trust and loyalty. This experience has a definite content that can be interpreted in terms of one or other of the denominational creeds. But the more this is so, the more the possibilities of these conflicts with knowledge mount up, which in themselves are quite pointless. That is to say, the standpoint of the creeds is archaic; they are full of impressive mythological symbolism which, if taken literally, comes into insufferable conflict with knowledge. But if, for instance, the statement that Christ rose from the dead is to be understood not literally but symbolically, then it is capable of various interpretations that do not conflict with knowledge and do not impair the meaning of the statement. The objection that understanding it symbolically puts an end to the Christian's hope of immortality is invalid, because long before the coming of Christianity mankind believed in a life after death and therefore had no need of the Easter event as a guarantee of immortality. The danger that a mythology understood too literally, and as taught by the Church, will suddenly be repudiated lock, stock and barrel is today greater than ever. Is it not time that the Christian mythology, instead of being wiped out, was understood symbolically for once?

[522] It is still too early to say what might be the consequences of a general recognition of the fatal parallelism between the State religion of the Marxists and the State religion of the Church. The absolutist claim of a *Civitas Dei* that is represented by man bears an unfortunate resemblance to the “divinity” of the State, and the moral conclusion drawn by Ignatius Loyola from the authority of the Church (“the end sanctifies the means”) anticipates the lie as a political instrument in an exceedingly dangerous way. Both demand unqualified submission to faith and thus curtail man's freedom, the one his freedom before God and the other his freedom before the State, thereby digging the grave for the individual. The fragile existence of this—so far as we know—unique carrier of life is threatened on both sides, despite their respective promises of spiritual and material idylls to come—and how many of us can in the long run fight against the proverbial wisdom of “a bird in the hand is worth two in the bush”? Besides which, the West cherishes the same “scientific” and rationalistic *Weltanschauung* with its statistical levelling-down tendency and materialistic aims as the State religion of the Eastern bloc, as I have explained above.

[523] What, then, has the West, with its political and denominational schisms, to offer to modern man in his need? Nothing, unfortunately, except a variety of paths all leading to one goal which is practically indistinguishable from the Marxist ideal. It requires no special effort of understanding to see where the Communist ideology gets the certainty of its belief that time is on its side, and that the world is ripe for

conversion. The facts speak a language that is all too plain in this respect. It will not help us in the West to shut our eyes to this and not recognize our fatal vulnerability. Anyone who has once learned to submit absolutely to a collective belief and to renounce his eternal right to freedom and the equally eternal duty of individual responsibility will persist in this attitude, and will be able to march with the same credulity and the same lack of criticism in the reverse direction, if another and manifestly “better” belief is foisted upon his alleged idealism. What happened not so long ago to a civilized European nation? We accuse the Germans of having forgotten it all again already, but the truth is that we don’t know for certain whether something similar might not happen elsewhere. It would not be surprising if it did and if another civilized nation succumbed to the infection of a uniform and one-sided idea. We permit ourselves the question: which countries have the biggest Communist parties? America, which—*O quae mutatio rerum!*—forms the real political backbone of Western Europe, seems to be immune because of the outspoken counterposition she has adopted, but in point of fact she is perhaps even more vulnerable than Europe, since her educational system is the most influenced by the scientific *Weltanschauung* with its statistical truths, and her mixed population finds it difficult to strike roots in a soil that is practically without history. The historical and humanistic type of education so sorely needed in such circumstances leads, on the contrary, a Cinderella existence. Though Europe possesses this latter requirement, she uses it to her own undoing in the form of nationalistic egoisms and paralysing scepticism. Common to both is the materialistic and collectivist goal, and both lack the very thing that expresses and grips the whole man, namely, an idea which puts the individual human being in the centre as the measure of all things.

[524] This idea alone is enough to arouse the most violent doubts and resistances on all sides, and one could almost go so far as to assert that the valuelessness of the individual in comparison with large numbers is the one belief that meets with universal and unanimous assent. To be sure, we all say that this is the century of the common man, that he is the lord of the earth, the air, and the water, and that on his decision hangs the historical fate of the nations. This proud picture of human grandeur is unfortunately an illusion and is counterbalanced by a reality that is very different. In this reality man is the slave and victim of the machines that have conquered space and time for him; he is intimidated and endangered by the might of the military technology which is supposed to safeguard his physical existence; his spiritual and moral freedom, though guaranteed within limits in one half of his world, is threatened with chaotic disorientation, and in the other half is abolished altogether. Finally, to add comedy to tragedy, this lord of the elements, this universal arbiter, hugs to his bosom notions which stamp his dignity as worthless and turn his autonomy into an absurdity. All his achievements and possessions do not make him

bigger; on the contrary, they diminish him, as the fate of the factory-worker under the rule of a “just” distribution of goods clearly demonstrates. He pays for his share of the factory with the loss of personal property, he exchanges his freedom of movement for the doubtful pleasure of being tied to his place of employment, he forfeits all means of improving his position if he jibs against being ground down by exhausting piece-work, and if he shows any signs of intelligence, political precepts are thrust down his throat—with a bit of technical knowledge thrown in, if he is lucky. However, a roof over one’s head and a daily feed for the useful animal are not to be sneezed at when the bare necessities of life may be cut off from one day to the next.

4. THE INDIVIDUAL'S UNDERSTANDING OF HIMSELF

[525] It is astounding that man, the instigator, inventor and vehicle of all these developments, the originator of all judgments and decisions and the planner of the future, must make himself such a *quantité négligeable*. The contradiction, the paradoxical evaluation of humanity by man himself, is in truth a matter for wonder, and one can only explain it as springing from an extraordinary uncertainty of judgment—in other words, man is an enigma to himself. This is understandable, seeing that he lacks the means of comparison necessary for self-knowledge. He knows how to distinguish himself from the other animals in point of anatomy and physiology, but as a conscious, reflecting being, gifted with speech, he lacks all criteria for self-judgment. He is on this planet a unique phenomenon which he cannot compare with anything else. The possibility of comparison and hence of self-knowledge would arise only if he could establish relations with quasi-human mammals inhabiting other stars.

[526] Until then man must continue to resemble a hermit who knows that in respect of comparative anatomy he has affinities with the anthropoids but, to judge by appearances, is extraordinarily different from his cousins in respect of his psyche. It is just in this most important characteristic of his species that he cannot know himself and therefore remains a mystery to himself. The differing degrees of self-knowledge within his own species are of little significance compared with the possibilities which would be opened out by an encounter with a creature of similar structure but different origin. Our psyche, which is primarily responsible for all the historical changes wrought by the hand of man on the face of this planet, remains an insoluble puzzle and an incomprehensible wonder, an object of abiding perplexity—a feature it shares with all Nature's secrets. In regard to the latter we still have hope of making more discoveries and finding answers to the most difficult questions. But in regard to the psyche and psychology there seems to be a curious hesitancy. Not only is it the youngest of the empirical sciences, but it has great difficulty in getting anywhere near its proper object.

[527] In the same way that our picture of the world had to be freed by Copernicus from the prejudice of geocentricity, the most strenuous efforts of a well-nigh revolutionary nature were needed to free psychology, first from the spell of mythological ideas, and then from the prejudice that the psyche is, on the one hand, a mere epiphenomenon of a biochemical process in the brain and, on the other hand, a purely personal matter. The connection with the brain does not in itself prove that the psyche is an

epiphenomenon, a secondary function causally dependent on biochemical processes in the physical substrate. Nevertheless, we know only too well how much the psychic function can be disturbed by verifiable processes in the brain, and this fact is so impressive that the subsidiary nature of the psyche seems an almost unavoidable inference. The phenomena of parapsychology, however, warn us to be careful, for they point to a relativization of space and time through psychic factors which casts doubt on our naïve and overhasty explanation in terms of psychophysical parallelism. For the sake of this explanation people deny the findings of parapsychology outright, either for philosophical reasons or from intellectual laziness. This can hardly be considered a scientifically responsible attitude, even though it is a popular way out of a quite extraordinary intellectual difficulty. To assess the psychic phenomenon, we have to take account of all the other phenomena that go with it, and accordingly we can no longer practise any psychology that ignores the existence of the unconscious or of parapsychology.

[528] The structure and physiology of the brain furnish no explanation of the psychic process. The psyche has a peculiar nature which cannot be reduced to anything else. Like physiology, it presents a relatively self-contained field of experience, to which we must attribute a quite special importance because it includes one of the two indispensable conditions for existence as such, namely, the phenomenon of consciousness. Without consciousness there would, practically speaking, be no world, for the world exists for us only in so far as it is consciously reflected by a psyche. *Consciousness is a precondition of being.* Thus the psyche is endowed with the dignity of a cosmic principle, which philosophically and in fact gives it a position co-equal with the principle of physical being. The carrier of this consciousness is the individual, who does not produce the psyche of his own volition but is, on the contrary, preformed by it and nourished by the gradual awakening of consciousness during childhood. If therefore the psyche is of overriding empirical importance, so also is the individual, who is the only immediate manifestation of the psyche.

[529] This fact must be expressly emphasized for two reasons. Firstly, the individual psyche, just because of its individuality, is an exception to the statistical rule and is therefore robbed of one of its main characteristics when subjected to the levelling influence of statistical evaluation. Secondly, the Churches grant it validity only in so far as it acknowledges their dogmas—in other words, when it submits to a collective category. In both cases the will to individuality is regarded as egotistic obstinacy. Science devalues this as subjectivism, and the Churches condemn it morally as heresy and spiritual pride. As to the latter charge, it should not be forgotten that, unlike other religions, Christianity holds up before us a symbol whose content is the individual way of life of a man, the Son of Man, and that it even regards this individuation process as the incarnation and revelation of God himself. Hence the

development of man into a self acquires as significance whose full implications have hardly begun to be appreciated, because too much attention to externals blocks the way to immediate inner experience. Were not the autonomy of the individual the secret longing of many people it would scarcely be able to survive the collective suppression either morally or spiritually.

[530] All these obstacles make it more difficult to arrive at a correct appreciation of the human psyche, but they count for very little beside one other remarkable fact that deserves mentioning. This is the common psychiatric experience that the devaluation of the psyche and other resistances to psychological enlightenment are based in large measure on fear—on panic fear of the discoveries that might be made in the realm of the unconscious. These fears are found not only among persons who are frightened by the picture Freud painted of the unconscious; they also troubled the originator of psychoanalysis himself, who confessed to me that it was necessary to make a dogma of his sexual theory because this was the sole bulwark of reason against a possible “eruption of the black flood of occultism.” In these words Freud was expressing his conviction that the unconscious still harboured many things that might lend themselves to “occult” interpretation, as is in fact the case. These “archaic vestiges,” or archetypal forms grounded on the instincts and giving expression to them, have a numinous quality that sometimes arouses fear. They are ineradicable, for they represent the ultimate foundations of the psyche itself. They cannot be grasped intellectually, and when one has destroyed one manifestation of them, they reappear in altered form. It is this fear of the unconscious psyche which not only impedes self-knowledge but is the gravest obstacle to a wider understanding and knowledge of psychology. Often the fear is so great that one dares not admit it even to oneself. This is a question which every religious person should consider very seriously; he might get an illuminating answer.

[531] A scientifically oriented psychology is bound to proceed abstractly; that is, it removes itself just sufficiently far from its object not to lose sight of it altogether. That is why the findings of laboratory psychology are, for all practical purposes, often so remarkably unenlightening and devoid of interest. The more the individual object dominates the field of vision, the more practical, detailed, and alive will be the knowledge derived from it. This means that the objects of investigation, too, become more and more complicated and that the uncertainty of the individual factors grows in proportion to their number, thus increasing the possibility of error. Understandably enough, academic psychology is scared of this risk and prefers to avoid complex situations by asking ever simpler questions, which it can do with impunity. It has full freedom in the choice of questions it will put to Nature.

[532] Medical psychology, on the other hand, is very far from being in this more or less enviable position. Here the object puts the question and not the experimenter. The analyst is confronted with facts which are not of his choosing and which he probably never *would* choose if he were a free agent. It is the sickness or the patient himself that puts the crucial questions—in other words, Nature experiments with the doctor in expecting an answer from him. The uniqueness of the individual and of his situation stares the analyst in the face and demands an answer. His duty as a physician forces him to cope with a situation swarming with uncertainty factors. At first he will apply principles based on general experience, but he will soon realize that principles of this kind do not adequately express the facts and fail to meet the nature of the case. The deeper his understanding penetrates, the more the general principles lose their meaning. But these principles are the foundation of objective knowledge and the yardstick by which it is measured. With the growth of what both patient and doctor feel to be “understanding,” the situation becomes increasingly subjectivized. What was an advantage to begin with threatens to turn into a dangerous disadvantage. Subjectivation (in technical terms, transference and countertransference) creates isolation from the environment, a social limitation which neither party wishes for but which invariably sets in when understanding predominates and is no longer balanced by knowledge. As understanding deepens, the further removed it becomes from knowledge. An ideal understanding would ultimately result in each party’s unthinkingly going along with the other’s experience—a state of uncritical passivity coupled with the most complete subjectivity and lack of social responsibility. Understanding carried to such lengths is in any case impossible, for it would require the virtual identification of two different individuals. Sooner or later the relationship reaches a point where one partner feels he is being forced to sacrifice his own individuality so that it may be assimilated by that of the other. This inevitable consequence breaks the understanding, for understanding also presupposes the integral preservation of the individuality of both partners. It is therefore advisable to carry understanding only to the point where the balance between understanding and knowledge is reached, for understanding at all costs is injurious to both partners.

[533] This problem arises whenever complex, individual situations have to be known and understood. It is the specific task of the medical psychologist to provide just this knowledge and understanding. It would also be the task of the “director of conscience” zealous in the cure of souls, were it not that his office inevitably obliges him to apply the yardstick of his denominational bias at the critical moment. As a result, the individual’s right to exist as such is cut short by a collective prejudice and often curtailed in the most sensitive area. The only time this does not happen is when the dogmatic symbol, for instance the model life of Christ, is understood concretely

and felt by the individual to be adequate. How far this is the case today I would prefer to leave to the judgment of others. At all events, the analyst very often has to treat patients to whom denominational limitations mean little or nothing. His profession therefore compels him to have as few preconceptions as possible. Similarly, while respecting metaphysical (i.e., nonverifiable) convictions and assertions, he will take care not to credit them with universal validity. This caution is called for because the individual traits of the patient's personality ought not to be twisted out of shape by arbitrary interventions from outside. The analyst must leave this to environmental influences, to the patient's own inner development, and—in the widest sense—to fate with its wise or unwise decrees.

[534] Many people will perhaps find this heightened caution exaggerated. In view of the fact, however, that there is in any case such a multitude of reciprocal influences at work in the dialectical process between two individuals, even if it is conducted with the most tactful reserve, the responsible analyst will refrain from adding unnecessarily to the collective factors to which his patient has already succumbed. Moreover, he knows very well that the preaching of even the worthiest precepts only provokes the patient into open hostility or secret resistance and thus needlessly endangers the aim of the treatment. The psychic situation of the individual is so menaced nowadays by advertising, propaganda, and other more or less well-meant advice and suggestions that for once in his life the patient might be offered a relationship that does not repeat the nauseating “you should,” “you must” and similar confessions of impotence. Against the onslaught from outside no less than against its repercussions in the psyche of the individual the analyst sees himself obliged to play the role of counsel for the defence. Fear that anarchic instincts will thereby be let loose is a possibility that is greatly exaggerated, seeing that obvious safeguards exist within and without. Above all, there is the natural cowardice of most men to be reckoned with, not to mention morality, good taste and—last but not least—the penal code. This fear is nothing compared with the enormous effort it usually costs people to help the first stirrings of individuality into consciousness, let alone put them into effect. And where these individual impulses have broken through too boldly and unthinkingly, the analyst must protect them from the patient's own clumsy recourse to shortsightedness, ruthlessness, and cynicism.

[535] As the dialectical discussion proceeds, a point is reached when an evaluation of these individual impulses becomes necessary. By that time the patient should have acquired enough certainty of judgment to enable him to act on his own insight and decision and not from the mere wish to copy convention—even if he happens to agree with collective opinion. Unless he stands firmly on his own feet, the so-called objective values profit him nothing, since they then only serve as a substitute for character and so help to suppress his individuality. Naturally, society has an

indisputable right to protect itself against arrant subjectivisms, but, in so far as society is itself composed of de-individualized human beings, it is completely at the mercy of ruthless individualists. Let it band together into groups and organizations as much as it likes—it is just this banding together and the resultant extinction of the individual personality that makes it succumb so readily to a dictator. A million zeros joined together do not, unfortunately, add up to one. Ultimately everything depends on the quality of the individual, but our fatally shortsighted age thinks only in terms of large numbers and mass organizations, though one would think that the world had seen more than enough of what a well-disciplined mob can do in the hands of a single madman. Unfortunately, this realization does not seem to have penetrated very far—and our blindness is extremely dangerous. People go on blithely organizing and believing in the sovereign remedy of mass action, without the least consciousness of the fact that the most powerful organizations can be maintained only by the greatest ruthlessness of their leaders and the cheapest of slogans.

[536] Curiously enough, the Churches too want to avail themselves of mass action in order to cast out the devil with Beelzebub—the very Churches whose care is the salvation of the *individual* soul. They do not appear to have heard of the elementary axiom of mass psychology that the individual becomes morally and spiritually inferior in the mass, and for this reason they do not bother themselves overmuch with their real task of helping the individual to achieve a *metanoia*, a rebirth of the spirit—*Deo concedente*. It is, unfortunately, only too clear that if the individual is not truly regenerated in spirit, society cannot be either, for society is the sum total of individuals in need of redemption. I can therefore see it only as a delusion when the Churches try—as they apparently do—to rope the individual into some social organization and reduce him to a condition of diminished responsibility, instead of raising him out of the torpid, mindless mass and making clear to him that *he* is the one important factor and that the salvation of the world consists in the salvation of the individual soul. It is true that mass meetings parade these ideas before him and seek to impress them on his mind by dint of mass suggestion, with the melancholy result that once the intoxication has worn off the mass man promptly succumbs to another even more obvious and still louder slogan. His individual relation to God would be an effective shield against these pernicious influences. Did Christ, perchance, call his disciples to him at a mass meeting? Did the feeding of the five thousand bring him any followers who did not afterwards cry with the rest, “Crucify him!” when even the rock named Peter showed signs of wavering? And are not Jesus and Paul prototypes of those who, trusting their inner experience, have gone their individual ways in defiance of the world?

[537] This argument should certainly not cause us to overlook the reality of the situation confronting the Church. When the Church tries to give shape to the

amorphous mass by uniting individuals into a community of believers and to hold such an organization together with the help of suggestion, it is not only performing a great *social* service, but it also secures for the individual the inestimable boon of a meaningful form of life. These, however, are gifts which as a rule only confirm certain tendencies and do not change them. As experience unfortunately shows, the inner man remains unchanged however much community he has. His environment cannot give him as a gift something which he can win for himself only with effort and suffering. On the contrary, a favourable environment merely strengthens the dangerous tendency to expect everything from outside—even that metamorphosis which external reality cannot provide. By this I mean a far-reaching change of the inner man, which is all the more urgent in view of the mass phenomena of today and the still greater problems of overpopulation looming in the future. It is time we asked ourselves exactly what we are lumping together in mass organizations and what constitutes the nature of the individual human being, i.e., of the real man and not the statistical man. This is hardly possible except by a new process of self-reflection.

[538] All mass movements, as one might expect, slip with the greatest ease down an inclined plane made up of large numbers. Where the many are, there is security; what the many believe must of course be true; what the many want must be worth striving for, and necessary, and therefore good. In the clamour of the many resides the power to snatch wish-fulfilments by force; sweetest of all, however, is that gentle and painless slipping back into the kingdom of childhood, into the paradise of parental care, into happy-go-luckiness and irresponsibility. All the thinking and looking after are done from the top; to all questions there is an answer, and for all needs the necessary provision is made. The infantile dream-state of the mass man is so unrealistic that he never thinks to ask who is paying for this paradise. The balancing of accounts is left to a higher political or social authority, which welcomes the task, for its power is thereby increased; and the more power it has, the weaker and more helpless the individual becomes.

[539] Whenever social conditions of this type develop on a large scale, the road to tyranny lies open and the freedom of the individual turns into spiritual and physical slavery. Since every tyranny is *ipso facto* immoral and ruthless, it has much more freedom in the choice of its methods than an institution which still takes account of the individual. Should such an institution come into conflict with the organized State, it is soon made aware of the very real disadvantage of its morality and therefore feels compelled to avail itself of the same methods as its opponent. In this way the evil spreads almost of necessity, even when direct infection might be avoided. The danger of infection is greater when decisive importance is attached to large numbers and to statistical values, as is everywhere the case in our Western world. The suffocating power of the masses is paraded before our eyes in one form or another every day in

the newspapers, and the insignificance of the individual is rubbed into him so thoroughly that he loses all hope of making himself heard. The outworn ideals of *liberté, égalité, fraternité* help him not at all, as he can direct this appeal only to his executioners, the spokesmen of the masses.

[540] *Resistance to the organized mass can be effected only by the man who is as well organized in his individuality as the mass itself*, I fully realize that this proposition must sound well-nigh unintelligible to the man of today. The helpful medieval view that man is a microcosm, a reflection of the great cosmos in miniature, has long since dropped away from him, although the very existence of his world-embracing and world-conditioning psyche might have taught him better. Not only is the image of the macrocosm imprinted upon his psychic nature, but he also creates this image for himself on an ever-widening scale. He bears this cosmic “correspondence” within him by virtue of his reflecting consciousness on the one hand, and, on the other, thanks to the hereditary, archetypal nature of his instincts, which bind him to his environment. But his instincts not only attach him to the macrocosm, they also, in a sense, tear him apart, because his desires pull him in different directions. In this way he falls into continual conflict with himself and only very rarely succeeds in giving his life an undivided goal—for which, as a rule, he must pay very dearly by repressing other sides of his nature. One often has to ask oneself whether this kind of single-mindedness is worth forcing at all, seeing that the natural state of the human psyche consists in a jostling together of its components and in their contradictory behaviour—that is, in a certain degree of dissociation. The Buddhist name for this is attachment to the “ten thousand things.” Such a condition cries out for order and synthesis.

[541] Just as the chaotic movements of the crowd, all ending in mutual frustration, are impelled in a definite direction by a dictatorial will, so the individual in his dissociated state needs a directing and ordering principle. Ego-consciousness would like to let its own will play this role, but overlooks the existence of powerful unconscious factors which thwart its intentions. If it wants to reach the goal of synthesis, it must first get to know the nature of these factors. It must *experience* them, or else it must possess a numinous *symbol* that expresses them and leads to their synthesis. A religious symbol that comprehended and visibly represented what is seeking expression in modern man might possibly do this; but our conception of the Christian symbol to date has certainly not been able to do so. On the contrary, that frightful world split runs right through the domains of the “Christian” white man, and our Christian outlook on life has proved powerless to prevent the recrudescence of an archaic social order like Communism.

[542] This is not to say that Christianity is finished. I am, on the contrary, convinced that it is not Christianity, but our conception and interpretation of it, that has become antiquated in face of the present world situation. The Christian symbol is a living thing that carries in itself the seeds of further development. It can go on developing; it depends only on us, whether we can make up our minds to meditate again, and more thoroughly, on the Christian premises. This requires a very different attitude towards the individual, towards the microcosm of the self, from the one we have adopted hitherto. That is why nobody knows what ways of approach are open to man, what inner experiences he could still pass through and what psychic facts underlie the religious myth. Over all this hangs so universal a darkness that no one can see why he should be interested or to what end he should commit himself. Before this problem we stand helpless.

[543] This is not surprising, since practically all the trump cards are in the hands of our opponents. They can appeal to the big battalions and their crushing power. Politics, science, and technology stand ranged on their side. The imposing arguments of science represent the highest degree of intellectual certainty yet achieved by the mind of man. So at least it seems to the man of today, who has received hundred-fold enlightenment concerning the backwardness and darkness of past ages and their superstitions. That his teachers have themselves gone seriously astray by making false comparisons between incommensurable factors never enters his head. All the more so as the intellectual *élite* to whom he puts his questions are almost unanimously agreed that what science regards as impossible today was impossible at all other times as well. Above all, the facts of faith, which might give him the chance of an extramundane standpoint, are treated in the same context as the facts of science. Thus, when the individual questions the Churches and their spokesmen, to whom is entrusted the cure of souls, he is informed that to belong to a church—a decidedly worldly institution—is more or less *de rigueur*; that the facts of faith which have become questionable for him were concrete historical events; that certain ritual actions produce miraculous effects; and that the sufferings of Christ have vicariously saved him from sin and its consequences (i.e., eternal damnation). If, with the limited means at his disposal, he begins to reflect on these things, he will have to confess that he does not understand them at all and that only two possibilities remain open to him: either to believe implicitly, or to reject such statements because they are flatly incomprehensible.

[544] Whereas the man of today can easily think about and understand all the “truths” dished out to him by the State, his understanding of religion is made considerably more difficult owing to the lack of explanations. (“Do you understand what you are reading?” And he said, “How can I, unless someone guides me?” Acts 8:30.) If, despite this, he has still not discarded all his religious convictions, this is because the

religious impulse rests on an instinctive basis and is therefore a specifically human function. You can take away a man's gods, but only to give him others in return. The leaders of the mass State could not help being deified, and wherever crudities of this kind have not yet been put over by force, obsessive factors arise in their stead, charged with demonic energy—money, work, political influence, and so forth. When any natural human function gets lost, i.e., is denied conscious and intentional expression, a general disturbance results. Hence, it is quite natural that with the triumph of the Goddess of Reason a general neuroticizing of modern man should set in, a dissociation of personality analogous to the splitting of the world today by the Iron Curtain. This boundary line bristling with barbed wire runs through the psyche of modern man, no matter on which side he lives. And just as the typical neurotic is unconscious of his *shadow side*, so the normal individual, like the neurotic, sees his shadow in his neighbour or in the man beyond the great divide. It has even become a political and social duty to apostrophize the capitalism of the one and the communism of the other as the very devil, so as to fascinate the outward eye and prevent it from looking within. But just as the neurotic, despite unconsciousness of his other side, has a dim premonition that all is not well with his psychic economy, so Western man has developed an instinctive interest in his psyche and in “psychology.”

[545] Thus it is that the psychiatrist is summoned willy-nilly to appear on the world stage, and questions are addressed to him which primarily concern the most intimate and hidden life of the individual, but which in the last analysis are the direct effects of the *Zeitgeist*. Because of its personal symptomatology this material is usually considered to be “neurotic”—and rightly so, since it is made up of infantile fantasies which ill accord with the contents of an adult psyche and are therefore repressed by our moral judgment, in so far as they reach consciousness at all. Most fantasies of this kind do not, in the nature of things, come to consciousness in any form, and it is very improbable, to say the least of it, that they were ever conscious and were consciously repressed. Rather, they seem to have been present from the beginning or, at any rate, to have arisen unconsciously and to have persisted in that state until the psychologist's intervention enabled them to cross the threshold of consciousness. The activation of unconscious fantasies is a process that occurs when consciousness finds itself in a situation of distress. Were that not so, the fantasies would be produced normally and would then bring no neurotic disturbances in their train. In reality, fantasies of this kind belong to the world of childhood and give rise to disturbances only when prematurely strengthened by abnormal conditions of conscious life. This is particularly likely to happen when unfavourable influences emanate from the parents, poisoning the atmosphere and producing conflicts which upset the psychic balance of the child.

[546] When a neurosis breaks out in an adult, the fantasy world of childhood reappears, and one is tempted to explain the onset of the neurosis causally, as due to the presence of infantile fantasies. But that does not explain why the fantasies did not develop any pathological effects during the interim period. These effects develop only when the individual is faced with a situation which he cannot overcome by conscious means. The resultant standstill in the development of personality opens a sluice for infantile fantasies, which, of course, are latent in everybody but do not display any activity so long as the conscious personality can continue on its way unimpeded. When the fantasies reach a certain level of intensity, they begin to break through into consciousness and create a conflict situation that becomes perceptible to the patient himself, splitting him into two personalities with different characters. The dissociation, however, had been prepared long before in the unconscious, when the energy flowing off from consciousness (because unused) reinforced the negative qualities of the unconscious and particularly the infantile traits of the personality.

[547] Since the normal fantasies of a child are nothing other, at bottom, than the *imagination of the instincts*, and may thus be regarded as preliminary exercises in the use of future conscious activities, it follows that the fantasies of the neurotic, even though pathologically altered and perhaps perverted by the regression of energy, contain a core of normal instinct, the hallmark of which is adaptedness. A neurotic illness always implies an unadapted alteration and distortion of normal dynamisms and of the “imagination” proper to them. Instincts, however, are highly conservative and of extreme antiquity as regards both their dynamism and their form. Their form, when represented to the mind, appears as an *image* which expresses the nature of the instinctive impulse visually and concretely, like a picture. If we could look into the psyche of the yucca moth,¹ for instance, we would find in it a pattern of ideas, of a numinous or fascinating character, which not only compels the moth to carry out its fertilizing activity on the yucca plant but helps it to “recognize” the total situation. Instinct is anything but a blind and indefinite impulse, since it proves to be attuned and adapted to a definite external situation. This latter circumstance gives it its specific and irreducible form. Just as instinct is original and hereditary, so, too, its form is age-old, that is to say, *archetypal*. It is even older and more conservative than the body’s form.

[548] These biological considerations naturally apply also to *Homo sapiens*, who still remains within the framework of general biology despite the possession of consciousness, will, and reason. The fact that our conscious activity is rooted in instinct and derives from it its dynamism as well as the basic features of its ideational forms has the same significance for human psychology as for all other members of the animal kingdom. Human knowledge consists essentially in the constant adaptation of the primordial patterns of ideas that were given us *a priori*. These need

certain modifications, because, in their original form, they are suited to an archaic mode of life but not to the demands of a specifically differentiated environment. If the flow of instinctive dynamism into our life is to be maintained, as is absolutely necessary for our existence, then it is imperative that we should remould these archetypal forms into ideas which are adequate to the challenge of the present.

5. THE PHILOSOPHICAL AND THE PSYCHOLOGICAL APPROACH TO LIFE

[549] Our ideas have, however, the unfortunate but inevitable tendency to lag behind the changes in the total situation. They can hardly do otherwise, because, so long as nothing changes in the world, they remain more or less adapted and therefore function in a satisfactory way. There is then no cogent reason why they should be changed and adapted anew. Only when conditions have altered so drastically that there is an unendurable rift between the outer situation and our ideas, now become antiquated, does the general problem of our *Weltanschauung*, or philosophy of life, arise, and with it the question of how the primordial images that maintain the flow of instinctive energy are to be reoriented or readapted. They cannot simply be replaced by a new rational configuration, for this would be moulded too much by the outward situation and not enough by man's biological needs. Moreover, not only would it build no bridge to the original man, but it would block the approach to him altogether. This is in keeping with the aims of Marxist education, which seeks, like God himself, to remake man, but in the image of the State.

[550] Today, our basic convictions are becoming increasingly rationalistic. Our philosophy is no longer a way of life, as it was in antiquity; it has turned into an exclusively intellectual and academic exercise. Our denominational religions with their archaic rites and conceptions—justified enough in themselves—express a view of the world which caused no great difficulties in the Middle Ages but has become strange and unintelligible to modern man. Despite this conflict with the modern scientific outlook, a deep instinct bids him hang on to ideas which, if taken literally, leave out of account all the mental developments of the last five hundred years. The obvious purpose of this is to prevent him from falling into the abyss of nihilistic despair. But even when, as a rationalist, he feels impelled to criticize denominational religion as literalistic, narrow-minded, and obsolescent, he should never forget that it proclaims a doctrine whose symbols, although their interpretation may be disputed, nevertheless possess a life of their own by virtue of their archetypal character. Consequently, intellectual understanding is by no means indispensable in all cases, but is called for only when evaluation through feeling and intuition does not suffice, that is to say, in the case of people for whom the intellect carries the prime power of conviction.

[551] Nothing is more characteristic and symptomatic in this respect than the gulf that has opened out between *faith* and *knowledge*. The contrast has become so enormous that one is obliged to speak of the incommensurability of these two categories and

their way of looking at the world. And yet they are concerned with the same empirical world in which we live, for even the theologians tell us that faith is supported by facts that became historically perceptible in this known world of ours—namely that Christ was born as a real human being, worked many miracles and suffered his fate, died under Pontius Pilate, and rose up in the flesh after his death. Theology rejects any tendency to take the assertions of its earliest records as written myths and, accordingly, to understand them symbolically. Indeed, it is the theologians themselves who have recently made the attempt—no doubt as a concession to “knowledge”—to “demythologize” the object of their faith while drawing the line quite arbitrarily at the crucial points. But to the critical intellect it is only too obvious that myth is an integral component of all religions and therefore cannot be excluded from the assertions of faith without injuring them.

[552] The rupture between faith and knowledge is a symptom of the *split consciousness* which is so characteristic of the mental disorder of our day. It is as if two different persons were making statements about the same thing, each from his own point of view, or as if one person in two different frames of mind were sketching a picture of his experience. If for “person” we substitute “modern society,” it is evident that the latter is suffering from a mental dissociation, i.e., a neurotic disturbance. In view of this, it does not help matters at all if one party pulls obstinately to the right and the other to the left. This is what happens in every neurotic psyche, to its own deep distress, and it is just this distress that brings the patient to the analyst.

[553] As I stated above in all brevity—while not neglecting to mention certain practical details whose omission might have perplexed the reader—the analyst has to establish a relationship with *both* halves of his patient’s personality, because only from them can he put together a whole and complete man, and not merely from one half by suppression of the other half. But this suppression is just what the patient has been doing all along, for the modern *Weltanschauung* leaves him with no alternative. His individual situation is the same in principle as the collective situation. He is a social microcosm, reflecting on the smallest scale the qualities of society at large, or conversely the smallest social unit cumulatively producing the collective dissociation. The latter possibility is the more likely one, as the only direct and concrete carrier of life is the individual personality, while society and the State are conventional ideas and can claim reality only in so far as they are represented by a conglomeration of individuals.

[554] Far too little attention has been paid to the fact that, for all our irreligiousness, the distinguishing mark of the Christian epoch, its highest achievement, has become the congenital vice of our age: *the supremacy of the word*, of the Logos, which stands for the central figure of our Christian faith. The word has literally become our god and so

it has remained, even if we know of Christianity only from hearsay. Words like “Society” and “State” are so concretized that they are almost personified. In the opinion of the man in the street, the “State,” far more than any king in history, is the inexhaustible giver of all good; the “State” is invoked, made responsible, grumbled at, and so on and so forth. Society is elevated to the rank of a supreme ethical principle; indeed, it is even credited with positively creative capacities. No one seems to notice that this worship of the word, which was necessary at a certain phase of man’s mental development, has a perilous shadow side. That is to say, the moment the word, as a result of centuries of education, attains universal validity, it severs its original connection with the divine Person. There is then a personified Church, a personified State; belief in the word becomes credulity, and the word itself an infernal slogan capable of any deception. With credulity come propaganda and advertising to dupe the citizen with political jobbery and compromises, and the lie reaches proportions never known before in the history of the world.

[555] Thus the word, originally announcing the unity of all men and their union in the figure of the one great Man, has in our day become a source of suspicion and distrust of all against all. Credulity is one of our worst enemies, but that is the makeshift the neurotic always resorts to in order to quell the doubter in his own breast or to conjure him out of existence. People think you have only to “tell” a person that he “ought” to do something in order to put him on the right track. But whether he can or will do it is another matter. The psychologist has come to see that nothing is achieved by telling, persuading, admonishing, giving good advice. He must acquaint himself with all the particulars and have an authentic knowledge of the psychic inventory of his patient. He has therefore to relate to the individuality of the sufferer and feel his way into all the nooks and crannies of his mind, to a degree that far exceeds the capacity of a teacher or even of a *directeur de conscience*. His scientific objectivity, which excludes nothing, enables him to see his patient not only as a human being but also as an anthropoid, who is bound to his body like an animal. His training directs his medical interest beyond the conscious personality to the world of unconscious instinct dominated by sexuality and the power drive (or self-assertion), which correspond to the twin moral concepts of Saint Augustine: *concupiscentia* and *superbia*. The clash between these two fundamental instincts (preservation of the species and self-preservation) is the source of numerous conflicts. They are, therefore, the chief object of moral judgment, whose purpose it is to prevent instinctual collisions as far as possible.

[556] As I explained earlier, instinct has two main aspects: on the one hand, that of dynamism and compulsion, and on the other, specific meaning and intention. It is highly probable that all man’s psychic functions have an instinctual foundation, as is obviously the case with animals. It is easy to see that in animals instinct functions as

the *spiritus rector* of all behaviour. This observation lacks certainty only when the learning capacity begins to develop, for instance in the higher apes and in man. In animals, as a result of their learning capacity, instinct under goes numerous modifications and differentiations, and in civilized man the instincts are so split up that only a few of the basic ones can be recognized with any certainty in their original form. The most important are the two fundamental instincts already mentioned and their derivatives, and these have been the exclusive concern of medical psychology so far. But in following up the ramifications of instinct investigators came upon configurations which could not with certainty be ascribed to either group. To take but one example: The discoverer of the power instinct raised the question whether an apparently indubitable expression of the sexual instinct might not be better explained as a “power arrangement,” and Freud himself felt obliged to acknowledge the existence of “ego instincts” in addition to the overriding sexual instinct—a clear concession to the Adlerian standpoint. In view of this uncertainty, it is hardly surprising that in most cases neurotic symptoms can be explained, almost without contradiction, in terms of either theory. This perplexity does not mean that one or the other standpoint is erroneous or that both are. Rather, both are *relatively* valid and, unlike certain one-sided and dogmatic tendencies, admit the existence and competition of still other instincts. Although, as I have said, the question of human instinct is a far from simple matter, we shall probably not be wrong in assuming that the learning capacity, a quality almost exclusive to man, is based on the instinct for imitation found in animals. It is in the nature of this instinct to disturb other instinctive activities and eventually to modify them, as can be observed, for instance, in the songs of birds when they adopt other melodies.

[557] Nothing estranges man more from the ground-plan of his instincts than his learning capacity, which turns out to be a genuine drive for progressive transformation of human modes of behaviour. It, more than anything else, is responsible for the altered conditions of his existence and the need for new adaptations which civilization brings. It is also the ultimate source of those numerous psychic disturbances and difficulties which are occasioned by man’s progressive alienation from his instinctual foundation, i.e., by his uprootedness and identification with his conscious knowledge of himself, by his concern with consciousness at the expense of the unconscious. The result is that modern man knows himself only in so far as he can become conscious of himself—a capacity largely dependent on environmental conditions, knowledge and control of which necessitated or suggested certain modifications of his original instinctive tendencies. His consciousness therefore orients itself chiefly by observing and investigating the world around him, and it is to the latter’s peculiarities that he must adapt his psychic and technical resources. This task is so exacting, and its fulfilment so profitable, that he forgets

himself in the process, losing sight of his instinctual nature and putting his own conception of himself in place of his real being. In this way he slips imperceptibly into a purely conceptual world where the products of his conscious activity progressively take the place of reality.

[558] Separation from his instinctual nature inevitably plunges civilized man into the conflict between conscious and unconscious, spirit and nature, knowledge and faith, a split that becomes pathological the moment his consciousness is no longer able to neglect or suppress his instinctual side. The accumulation of individuals who have got into this critical state starts off a mass movement purporting to be the champion of the suppressed. In accordance with the prevailing tendency of consciousness to seek the source of all ills in the outside world, the cry goes up for political and social changes which, it is supposed, would automatically solve the much deeper problem of split personality. Hence it is that whenever this demand is fulfilled, political and social conditions arise which bring the same ills back again in altered form. What then happens is a simple reversal: the underside comes to the top and the shadow takes the place of the light, and since the former is always anarchic and turbulent, the freedom of the “liberated” underdog must suffer Draconian curtailment. The devil is cast out with Beelzebub. All this is unavoidable, because the root of the evil is untouched and merely the counterposition has come to light.

[559] The Communist revolution has debased man far lower than democratic collective psychology has done, because it robs him of his freedom not only in the social but in the moral and spiritual sphere. Aside from the political difficulties, this entailed a great psychological disadvantage for the West that had already made itself unpleasantly felt in the days of German Nazism: we can now point a finger at the shadow. He is clearly on the other side of the political frontier, while we are on the side of good and enjoy the possession of the right ideals. Did not a well-known statesman recently confess that he had “no imagination for evil”?¹ In the name of the multitude he was expressing the fact that Western man is in danger of losing his shadow altogether, of identifying himself with his fictive personality and the world with the abstract picture painted by scientific rationalism. His spiritual and moral opponent, who is just as real as he, no longer dwells in his own breast but beyond the geographical line of division, which no longer represents an outward political barrier but splits off the conscious from the unconscious man more and more menacingly. Thinking and feeling lose their inner polarity, and where religious orientation has grown ineffective, not even a god can check the sovereign sway of unleashed psychic functions.

[560] Our rational philosophy does not bother itself with whether the other person in us, pejoratively described as the “shadow,” is in sympathy with our conscious plans

and intentions. Evidently it still does not know that we carry in ourselves a real shadow whose existence is grounded in our instinctual nature. No one can overlook either the dynamism or the imagery of the instincts without the gravest injury to himself. Violation or neglect of instinct has painful consequences of a physiological and psychological nature for whose treatment medical help, above all, is required.

[561] For more than fifty years we have known, or could have known, that there is an unconscious counterbalance to consciousness. Medical psychology has furnished all the necessary empirical and experimental proofs of this. There is an unconscious psychic reality which demonstrably influences consciousness and its contents. All this is known, but no practical conclusions have been drawn from this fact. We still go on thinking and acting as before, as if we were *simplex* and not *duplex*. Accordingly, we imagine ourselves to be innocuous, reasonable, and humane. We do not think of distrusting our motives or of asking ourselves how the inner man feels about the things we do in the outside world. But actually it is frivolous, superficial, and unreasonable of us, as well as psychically unhygienic, to overlook the reaction and standpoint of the unconscious. One can regard one's stomach or heart as unimportant and worthy of contempt, but that does not prevent overeating or overexertion from having consequences that affect the whole man. Yet we think that psychic mistakes and their consequences can be got rid of with mere words, for "psychic" means less than air to most people. All the same, nobody can deny that without the psyche there would be no world at all, and still less a human world. Virtually everything depends on the human psyche and its functions. It should be worthy of all the attention we can give it, especially today, when everyone admits that the weal or woe of the future will be decided neither by the threat of wild animals, nor by natural catastrophes, nor by the danger of world-wide epidemics, but simply and solely by the psychic changes in man. It needs only an almost imperceptible disturbance of equilibrium in a few of our rulers' heads to plunge the world into blood, fire, and radioactivity. The technical means necessary for this are present on both sides. And certain conscious deliberations, uncontrolled by any inner opponent, can be put into effect all too easily, as we have seen already from the example of one "Leader." The consciousness of modern man still clings so much to external objects that he makes them exclusively responsible, as if it were on them that the decision depended. That the psychic state of certain individuals could ever emancipate itself from the behaviour of objects is something that is considered far too little, although irrationalities of this sort are observed every day and can happen to everyone.

[562] The forlorn state of consciousness in our world is due primarily to loss of instinct, and the reason for this lies in the development of the human mind over the past aeon. The more power man had over nature, the more his knowledge and skill

went to his head, and the deeper became his contempt for the merely natural and accidental, for all irrational data—including the objective psyche, which is everything that consciousness is not. In contrast to the subjectivism of the conscious mind the unconscious is objective, manifesting itself mainly in the form of contrary feelings, fantasies, emotions, impulses, and dreams, none of which one makes oneself but which come upon one objectively. Even today psychology is still, for the most part, the science of conscious contents, measured as far as possible by collective standards. The individual psyche has become a mere accident, a marginal phenomenon, while the unconscious, which can manifest itself only in the real, “irrationally given” human being, has been ignored altogether. This was not the result of carelessness or of lack of knowledge, but of downright resistance to the mere possibility that there could be a second psychic authority besides the ego. It seems a positive menace to the ego that its monarchy could be doubted. The religious person, on the other hand, is accustomed to the thought of not being sole master in his own house. He believes that God, and not he himself, decides in the end. But how many of us would dare to let the will of God decide, and which of us would not feel embarrassed if he had to say how far the decision came from God himself?

[563] The religious person, so far as one can judge, is directly influenced by the reaction of the unconscious. As a rule, he calls this the operation of *conscience*. But since the same psychic background produces reactions other than moral ones,² the believer is measuring his conscience by the traditional ethical standard and thus by a collective value, in which endeavour he is assiduously supported by his Church. So long as the individual can hold fast to his traditional beliefs, and the circumstances of his time do not demand stronger emphasis on individual autonomy, he can rest content with the situation. But the situation is radically altered when the worldly-minded man who is oriented to external factors and has lost his religious beliefs appears *en masse*, as is the case today. The believer is then forced onto the defensive and must catechize himself on the foundation of his beliefs. He is no longer sustained by the tremendous suggestive power of the *consensus omnium* and is keenly aware of the weakening of the Church and the precariousness of its dogmatic assumptions. To counter this, the Church recommends more faith, as if this gift of grace depended on man’s good will and pleasure. The seat of faith, however, is not consciousness but spontaneous religious experience, which brings the individual’s faith into immediate relation with God.

[564] Here each of us must ask: Have I any religious experience and immediate relation to God, and hence that certainty which will keep me, as an individual, from dissolving in the crowd?

6. SELF-KNOWLEDGE

[565] To this question there is a positive answer only when the individual is willing to fulfil the demands of rigorous self-examination and self-knowledge. If he does this, he will not only discover some important truths about himself but will also have gained a psychological advantage: he will have succeeded in deeming himself worthy of serious attention and sympathetic interest. He will have set his hand, as it were, to a declaration of his own human dignity and taken the first step towards the foundations of his consciousness—that is, towards the unconscious, the only available source of religious experience. This is certainly not to say that what we call the unconscious is identical with God or is set up in his place. It is simply the medium from which religious experience seems to flow. As to what the further cause of such experience may be, the answer to this lies beyond the range of human knowledge. Knowledge of God is a transcendental problem.

[566] The religious person enjoys a great advantage when it comes to answering the crucial question that hangs over our time like a threat: he has a clear idea of the way his subjective existence is grounded in his relation to “God.” I put the word “God” in quotes in order to indicate that we are dealing with an anthropomorphic idea whose dynamism and symbolism are filtered through the medium of the unconscious psyche. Anyone who wants to can at least draw near to the source of such experiences, no matter whether he believes in God or not. Without this approach it is only in rare cases that we witness those miraculous conversions of which Paul’s Damascus experience is the prototype. That religious experiences exist no longer needs proof. But it will always remain doubtful whether what metaphysics and theology call God and the gods is the real ground of these experiences. The question is idle, actually, and answers itself by reason of the subjectively overwhelming numinosity of the experience. Anyone who has had it is *seized* by it and therefore not in a position to indulge in fruitless metaphysical or epistemological speculations. Absolute certainty brings its own evidence and has no need of anthropomorphic proofs.

[567] In view of the general ignorance of and bias against psychology it must be accounted a misfortune that the one experience which makes sense of individual existence should seem to have its origin in a medium that is certain to catch everybody’s prejudices. Once more the doubt is heard: “What good can come out of Nazareth?” The unconscious, if not regarded outright as a sort of refuse bin underneath the conscious mind, is at any rate supposed to be of “merely animal

nature.” In reality, however, and by definition it is of uncertain extent and constitution, so that overvaluation or undervaluation of it is pointless and can be dismissed as mere prejudice. At all events, such judgments sound very queer in the mouths of Christians, whose Lord was himself born on the straw of a stable, among the domestic animals. It would have been more to the taste of the multitude if he had got himself born in a temple. In the same way, the worldly-minded mass man looks for the numinous experience in the mass meeting, which provides an infinitely more imposing background than the individual soul. Even Church Christians share this pernicious delusion.

[568] Psychology’s insistence on the importance of unconscious processes for religious experience is extremely unpopular, no less with the political Right than with the Left. For the former the deciding factor is the historical revelation that came to man from outside; to the latter this is sheer nonsense, and man has no religious function at all, except belief in the party doctrine, when suddenly the most intense faith is called for. On top of this, the various creeds assert quite different things, and each of them claims to possess the absolute truth. Yet today we live in a unitary world where distances are reckoned by hours and no longer by weeks and months. Exotic races have ceased to be peepshows in ethnological museums. They have become our neighbours, and what was yesterday the private concern of the ethnologist is today a political, social, and psychological problem. Already the ideological spheres begin to touch, to interpenetrate, and the time may not be far off when the question of mutual understanding will become acute. To make oneself understood is certainly impossible without far-reaching comprehension of the other’s standpoint. The insight needed for this will have repercussions on both sides. History will undoubtedly pass over those who feel it is their vocation to resist this inevitable development, however desirable and psychologically necessary it may be to cling to what is essential and good in our own tradition. Despite all the differences, the unity of mankind will assert itself irresistibly. On this card Marxist doctrine has staked its life, while the West hopes to achieve its aim with technology and economic aid. Communism has not overlooked the enormous importance of the ideological element and the universality of basic principles. The coloured races share our ideological weakness and in this respect are just as vulnerable as we are.

[569] The underestimation of the psychological factor is likely to take a bitter revenge. It is therefore high time we caught up with ourselves in this matter. For the present this must remain a pious wish, because self-knowledge, as well as being highly unpopular, seems to be an unpleasantly idealistic goal, reeks of morality, and is preoccupied with the psychological shadow, which is normally denied whenever possible or at least not spoken of. The task that faces our age is indeed almost insuperably difficult. It makes the highest demands on our responsibility if we are not

to be guilty of another *trahison des clerics*. It addresses itself to those leading and influential personalities who have the necessary intelligence to understand the situation our world is in. One might expect them to consult their consciences. But since it is a matter not only of intellectual understanding but of moral conclusions, there is unfortunately no cause for optimism. Nature, as we know, is not so lavish with her boons that she joins to a high intelligence the gifts of the heart also. As a rule, where one is present the other is missing, and where one capacity is present in perfection it is generally at the cost of all the others. The discrepancy between intellect and feeling, which get in each other's way at the best of times, is a particularly painful chapter in the history of the human psyche.

[570] There is no sense in formulating the task that our age has forced upon us as a moral demand. We can, at best, merely make the psychological world situation so clear that it can be seen even by the myopic, and give utterance to words and ideas which even the hard of hearing can hear. We may hope for men of understanding and men of good will, and must therefore not grow weary of reiterating those thoughts and insights which are needed. Finally, even the truth can spread and not only the popular lie.

[571] With these words I should like to draw the reader's attention to the main difficulty he has to face. The horror which the dictator States have of late brought upon mankind is nothing less than the culmination of all those atrocities of which our ancestors made themselves guilty in the not so distant past. Quite apart from the barbarities and blood baths perpetrated by the Christian nations among themselves throughout European history, the European has also to answer for all the crimes he has committed against the coloured races during the process of colonization. In this respect the white man carries a very heavy burden indeed. It shows us a picture of the common human shadow that could hardly be painted in blacker colours. The evil that comes to light in man and that undoubtedly dwells within him is of gigantic proportions, so that for the Church to talk of original sin and to trace it back to Adam's relatively innocent slip-up with Eve is almost a euphemism. The case is far graver and is grossly underestimated.

[572] Since it is universally believed that man *is* merely what his consciousness knows of itself, he regards himself as harmless and so adds stupidity to iniquity. He does not deny that terrible things have happened and still go on happening, but it is always "the others" who do them. And when such deeds belong to the recent or remote past, they quickly and conveniently sink into the sea of forgetfulness, and that state of chronic woolly-mindedness returns which we describe as "normality." In shocking contrast to this is the fact that nothing has finally disappeared and nothing has been made good. The evil, the guilt, the profound unease of conscience, the dark

foreboding, are there before our eyes, if only we would see. Man has done these things; I am a man, who has his share of human nature; therefore I am guilty with the rest and bear unaltered and indelibly within me the capacity and the inclination to do them again at any time. Even if, juristically speaking, we were not accessories to the crime, we are always, thanks to our human nature, potential criminals. In reality we merely lacked a suitable opportunity to be drawn into the infernal mêlée. None of us stands outside humanity's black collective shadow. Whether the crime occurred many generations back or happens today, it remains the symptom of a disposition that is always and everywhere present—and one would therefore do well to possess some “imagination for evil,” for only the fool can permanently disregard the conditions of his own nature. In fact, this negligence is the best means of making him an instrument of evil. Harmlessness and naïveté are as little helpful as it would be for a cholera patient and those in his vicinity to remain unconscious of the contagiousness of the disease. On the contrary, they lead to projection of the unrecognized evil into the “other.” This strengthens the opponent's position in the most effective way, because the projection carries the *fear* which we involuntarily and secretly feel for our own evil over to the other side and considerably increases the formidableness of his threat. What is even worse, our lack of insight deprives us of the *capacity to deal with evil*. Here, of course, we come up against one of the main prejudices of the Christian tradition, and one that is a great stumbling block to our policies. We should, so we are told, eschew evil and, if possible, neither touch nor mention it. For evil is also the thing of ill omen, that which is tabooed and feared. This apotropaic attitude towards evil, and the apparent circumventing of it, flatter the primitive tendency in us to shut our eyes to evil and drive it over some frontier or other, like the Old Testament scapegoat, which was supposed to carry the evil into the wilderness.

[573] But if one can no longer avoid the realization that evil, without man's ever having chosen it, is lodged in human nature itself, then it bestrides the psychological stage as the equal and opposite partner of good. This realization leads straight to a psychological dualism, already unconsciously prefigured in the political world schism and in the even more unconscious dissociation in modern man himself. The dualism does not come from this realization; rather, we are in a split condition to begin with. It would be an insufferable thought that we had to take personal responsibility for so much guiltiness. We therefore prefer to localize the evil in individual criminals or groups of criminals, while washing our hands in innocence and ignoring the general proclivity to evil. This sanctimoniousness cannot be kept up in the long run, because the evil, as experience shows, lies in man—unless, in accordance with the Christian view, one is willing to postulate a metaphysical principle of evil. The great advantage of this view is that it exonerates man's conscience of too heavy a responsibility and foists it off on the devil, in correct

psychological appreciation of the fact that man is much more the victim of his psychic constitution than its inventor. Considering that the evil of our day puts everything that has ever agonized mankind in the deepest shade, one must ask oneself how it is that, for all our progress in the administration of justice, in medicine and in technology, for all our concern with life and health, monstrous engines of destruction have been invented which could easily exterminate the human race.

[574] No one will maintain that the atomic physicists are a pack of criminals because it is to their efforts that we owe that peculiar flower of human ingenuity, the hydrogen bomb. The vast amount of intellectual work that went into the development of nuclear physics was put forth by men who dedicated themselves to their task with the greatest exertion and self-sacrifice, and whose moral achievement could therefore just as easily have earned them the merit of inventing something useful and beneficial to humanity. But even though the first step along the road to a momentous invention may be the outcome of a conscious decision, here, as everywhere, the spontaneous idea—the hunch or intuition—plays an important part. In other words, the unconscious collaborates too and often makes decisive contributions. So it is not the conscious effort alone that is responsible for the result; somewhere or other the unconscious, with its barely discernible goals and intentions, has its finger in the pie. If it puts a weapon in your hand, it is aiming at some kind of violence. Knowledge of the truth is the foremost goal of science, and if in pursuit of the longing for light we stumble upon an immense danger, then one has the impression more of fatality than of premeditation. It is not that present-day man is capable of greater evil than the man of antiquity or the primitive. He merely has incomparably more effective means with which to realize his propensity to evil. As his consciousness has broadened and differentiated, so his moral nature has lagged behind. That is the great problem before us today. *Reason alone no longer suffices.*

[575] In theory, it lies within the power of reason to desist from experiments of such hellish scope as nuclear fission if only because of their dangerousness. But fear of the evil which one does not see in one's own bosom but always in somebody else's checks reason every time, although everyone knows that the use of this weapon means the certain end of our present human world. The fear of universal destruction may spare us the worst, yet the possibility of it will nevertheless hang over us like a dark cloud so long as no bridge is found across the world-wide psychic and political split—a bridge as certain as the existence of the hydrogen bomb. If only a world-wide consciousness could arise that all division and all fission are due to the splitting of opposites in the psyche, then we should know where to begin. But if even the smallest and most personal stirrings of the individual psyche—so insignificant in themselves—remain as unconscious and unrecognized as they have hitherto, they will go on accumulating and produce mass groupings and mass movements which

cannot be subjected to reasonable control or manipulated to a good end. All direct efforts to do so are no more than shadow boxing, the most infatuated by illusion being the gladiators themselves.

[576] The crux of the matter is man's own dualism, to which he knows no answer. This abyss has suddenly yawned open before him with the latest events in world history, after mankind had lived for many centuries in the comfortable belief that a unitary God had created man in his own image, as a little unity. Even today people are largely unconscious of the fact that every individual is a cell in the structure of various international organisms and is therefore causally implicated in their conflicts. He knows that as an individual being he is more or less meaningless and feels himself the victim of uncontrollable forces, but, on the other hand, he harbours within himself a dangerous shadow and adversary who is involved as an invisible helper in the dark machinations of the political monster. It is in the nature of political bodies always to see the evil in the opposite group, just as the individual has an ineradicable tendency to get rid of everything he does not know and does not want to know about himself by foisting it off on somebody else.

[577] Nothing has a more divisive and alienating effect upon society than this moral complacency and lack of responsibility, and nothing promotes understanding and *rapprochement* more than the mutual withdrawal of projections. This necessary corrective demands self-criticism, for one cannot just tell the other person to withdraw them. He does not recognize them for what they are any more than one does oneself. We can recognize our prejudices and illusions only when, from a broader psychological knowledge of ourselves and others, we are prepared to doubt the absolute rightness of our assumptions and compare them carefully and conscientiously with the objective facts. Funnily enough, "self-criticism" is an idea much in vogue in Marxist countries, but there it is subordinated to ideological considerations and must serve the State, and not truth and justice in men's dealings with one another. The mass State has no intention of promoting mutual understanding and the relationship of man to man; it strives, rather, for atomization, for the psychic isolation of the individual. The more unrelated individuals are, the more consolidated the State becomes, and vice versa.

[578] There can be no doubt that in the democracies too the distance between man and man is much greater than is conducive to public welfare, let alone beneficial to our psychic needs. True, all sorts of attempts are being made to level out glaring social contrasts by appealing to people's idealism, enthusiasm, and ethical conscience; but, characteristically, one forgets to apply the necessary self-criticism, to answer the question: *Who* is making the idealistic demand? Is it, perchance, someone who jumps over his own shadow in order to hurl himself avidly on some idealistic programme

that offers him a welcome alibi? How much respectability and apparent morality is there, cloaking in deceptive colours a very different inner world of darkness? One would first like to be assured that the man who talks of ideals is himself ideal, so that his words and deeds *are* more than they *seem*. To be ideal is impossible, and remains therefore an unfulfilled postulate. Since we usually have keen noses in this respect, most of the idealisms that are preached and paraded before us sound rather hollow and become acceptable only when their opposite is also openly admitted. Without this counterweight the ideal exceeds our human capacity, becomes incredible because of its humourlessness, and degenerates into bluff, albeit a well-meant one. Bluff is an illegitimate way of overpowering and suppressing others and leads to no good.

[579] Recognition of the shadow, on the other hand, leads to the modesty we need in order to acknowledge imperfection. And it is just this conscious recognition and consideration that are needed whenever a human relationship is to be established. A human relationship is not based on differentiation and perfection, for these only emphasize the differences or call forth the exact opposite; it is based, rather, on imperfection, on what is weak, helpless and in need of support—the very ground and motive for dependence. The perfect have no need of others, but weakness has, for it seeks support and does not confront its partner with anything that might force him into an inferior position and even humiliate him. This humiliation may happen only too easily when high idealism plays too prominent a role.

[580] Reflections of this kind should not be taken as superfluous sentimentalities. The question of human relationship and of the inner cohesion of our society is an urgent one in view of the atomization of the pent-up mass man, whose personal relationships are undermined by general mistrust. Wherever justice is uncertain and police spying and terror are at work, human beings fall into isolation, which, of course, is the aim and purpose of the dictator State, since it is based on the greatest possible accumulation of depotentiated social units. To counter this danger, the free society needs a bond of an affective nature, a principle of a kind like *caritas*, the Christian love of your neighbour. But it is just this love for one's fellow man that suffers most of all from the lack of understanding wrought by projection. It would therefore be very much in the interest of the free society to give some thought to the question of human relationship from the psychological point of view, for in this resides its real cohesion and consequently its strength. Where love stops, power begins, and violence, and terror.

[581] These reflections are not intended as an appeal to idealism, but only to promote a consciousness of the psychological situation. I do not know which is weaker: the idealism or the insight of the public. I only know that it needs time to bring about psychic changes that have any prospect of enduring. Insight that dawns slowly seems

to me to have more lasting effects than a fitful idealism, which is unlikely to hold out for long.

7. THE MEANING OF SELF-KNOWLEDGE

[582] What our age thinks of as the “shadow” and inferior part of the psyche contains more than something merely negative. The very fact that through self-knowledge, that is, by exploring our own souls, we come upon the instincts and their world of imagery should throw some light on the powers slumbering in the psyche, of which we are seldom aware so long as all goes well. They are potentialities of the greatest dynamism, and it depends entirely on the preparedness and attitude of the conscious mind whether the irruption of these forces, and the images and ideas associated with them, will tend towards construction or catastrophe. The psychologist seems to be the only person who knows from experience how precarious the psychic preparedness of modern man is, for he is the only one who sees himself compelled to seek out in man’s own nature those helpful powers and ideas which over and over have enabled him to find the right way through darkness and danger. For this exacting work the psychologist requires all his patience; he may not rely on any traditional oughts and musts, leaving the other person to make all the effort and contenting himself with the easy role of adviser and admonisher. Everyone knows the futility of preaching about things that are desirable, yet the general helplessness in this situation is so great, and the need so dire, that one prefers to repeat the old mistake instead of racking one’s brains over a subjective problem. Besides, it is always a question of treating one single individual only and not ten thousand, when the trouble one takes would ostensibly have more impressive results, though one knows well enough that nothing has happened at all unless the individual changes.

[583] The effect on *all* individuals, which one would like to see realized, may not set in for hundreds of years, for the spiritual transformation of mankind follows the slow tread of the centuries and cannot be hurried or held up by any rational process of reflection, let alone brought to fruition in one generation. What does lie within our reach, however, is the change in individuals who have, or create for themselves, an opportunity to influence others of like mind. I do not mean by persuading or preaching—I am thinking, rather, of the well-known fact that anyone who has insight into his own actions, and has thus found access to the unconscious, involuntarily exercises an influence on his environment. The deepening and broadening of his consciousness produce the kind of effect which the primitives call “mana.” It is an unintentional influence on the unconscious of others, a sort of unconscious prestige, and its effect lasts only so long as it is not disturbed by conscious intention.

[584] Nor is the striving for self-knowledge altogether without prospects of success, since there exists a factor which, though completely disregarded, meets our expectations halfway. This is the unconscious *Zeitgeist*. It compensates the attitude of the conscious mind and anticipates changes to come. An excellent example of this is modern art: though seeming to deal with aesthetic problems, it is really performing a work of psychological education on the public by breaking down and destroying their previous aesthetic views of what is beautiful in form and meaningful in content. The pleasingness of the artistic product is replaced by chill abstractions of the most subjective nature which brusquely slam the door on the naïve and romantic delight in the senses and on the obligatory love for the object. This tells us, in plain and universal language, that the prophetic spirit of art has turned away from the old object-relationship towards the—for the time being—dark chaos of subjectivisms. Certainly art, so far as we can judge of it, has not yet discovered in this darkness what it is that could hold all men together and give expression to their psychic wholeness. Since reflection seems to be needed for this purpose, it may be that such discoveries are reserved for other fields of endeavour.

[585] Great art till now has always derived its fruitfulness from myth, from the unconscious process of symbolization which continues through the ages and, as the primordial manifestation of the human spirit, will continue to be the root of all creation in the future. The development of modern art with its seemingly nihilistic trend towards disintegration must be understood as the symptom and symbol of a mood of universal destruction and renewal that has set its mark on our age. This mood makes itself felt everywhere, politically, socially, and philosophically. We are living in what the Greeks called the *καιρός*—the right moment—for a “metamorphosis of the gods,” of the fundamental principles and symbols. This peculiarity of our time, which is certainly not of our conscious choosing, is the expression of the unconscious man within us who is changing. Coming generations will have to take account of this momentous transformation if humanity is not to destroy itself through the might of its own technology and science.

[586] As at the beginning of the Christian era, so again today we are faced with the problem of the general moral backwardness which has failed to keep pace with our scientific, technical, and social progress. So much is at stake and so much depends on the psychological constitution of modern man. Is he capable of resisting the temptation to use his power for the purpose of staging a world conflagration? Is he conscious of the path he is treading, and what the conclusions are that must be drawn from the present world situation and his own psychic situation? Does he know that he is on the point of losing the life-preserving myth of the inner man which Christianity has treasured up for him? Does he realize what lies in store should this catastrophe ever befall him? Is he even capable of realizing that this would in fact be a

catastrophe? And finally, does the individual know that *he* is the makeweight that tips the scales?

[587] Happiness and contentment, equability of mind and meaningfulness of life—these can be experienced only by the individual and not by a State, which, on the one hand, is nothing but a convention agreed to by independent individuals and, on the other, continually threatens to paralyse and suppress the individual. The psychiatrist is one of those who know most about the conditions of the soul's welfare, upon which so infinitely much depends in the social sum. The social and political circumstances of the time are certainly of considerable significance, but their importance for the weal or woe of the individual has been boundlessly overestimated in so far as they are taken for the sole deciding factors. In this respect all our social goals commit the error of overlooking the psychology of the person for whom they are intended and—very often—of promoting only his illusions.

[588] I hope, therefore, that a psychiatrist, who in the course of a long life has devoted himself to the causes and consequences of psychic disorders, may be permitted to express his opinion, in all the modesty enjoined upon him as an individual, about the questions raised by the world situation today. I am neither spurred on by excessive optimism nor in love with high ideals, but am merely concerned with the fate of the individual human being—that infinitesimal unit on whom a world depends, and in whom, if we read the meaning of the Christian message aright, even God seeks his goal.

V

FLYING SAUCERS

A Modern Myth of Things Seen in the Skies

[First published as *Ein moderner Mythos: Von Dingen, die am Himmel gesehen werden* (Zurich and Stuttgart, 1958); dedicated to “Walter Niehus, the architect, with thanks for inducing me to write this little book.” With the addition of the brief “supplement,” this was translated by R. F. C. Hull and published under the present title (London and New York, 1959). Minor revisions have been made in the present version.—EDITORS.]

PREFACE TO THE FIRST ENGLISH EDITION

The worldwide rumour about Flying Saucers presents a problem that challenges the psychologist for a number of reasons. The primary question—and apparently this is the most important point—is this: are they real or are they mere fantasy products? This question is by no means settled yet. If they are real, exactly what are they? If they are fantasy, why should such a rumour exist?

In this latter respect I have made an interesting and quite unexpected discovery. In 1954 I wrote an article in the Swiss weekly, *Die Weltwoche*, in which I expressed myself in a sceptical way, though I spoke with due respect of the serious opinion of a relatively large number of air specialists who believe in the reality of Ufos (unidentified flying objects). In 1958 this interview was suddenly discovered by the world press and the “news” spread like wildfire from the far West round the earth to the far East, but—alas—in distorted form. I was quoted as a saucer-believer. I issued a statement to the United Press and gave a true version of my opinion, but this time the wire went dead: nobody, so far as I know, took any notice of it, except one German newspaper.

The moral of this story is rather interesting. As the behaviour of the press is a sort of Gallup test with reference to world opinion, one must draw the conclusion that news affirming the existence of Ufos is welcome, but that scepticism seems to be undesirable. To believe that Ufos are real suits the general opinion, whereas disbelief is to be discouraged. This creates the impression that there is a tendency all over the world to believe in saucers and to want them to be real, unconsciously helped along by a press that otherwise has no sympathy with the phenomenon.

This remarkable fact in itself surely merits the psychologist’s interest. Why should it be more desirable for saucers to exist than not? The following pages are an attempt to answer this question. I have relieved the text of cumbersome footnotes, except for a few which give the references for the interested reader.

C. G. JUNG

September, 1958

INTRODUCTORY

[589] It is difficult to form a correct estimate of the significance of contemporary events, and the danger that our judgment will remain caught in subjectivity is great. So I am fully aware of the risk I am taking in proposing to communicate my views concerning certain contemporary events, which seem to me important, to those who are patient enough to hear me. I refer to those reports reaching us from all corners of the earth, rumours of round objects that flash through the troposphere and stratosphere and go by the name of Flying Saucers, *soucoupes*, disks, and “Ufos” (Unidentified Flying Objects). These rumours, or the possible physical existence of such objects, seem to me so significant that I feel myself compelled, as once before¹ when events of fateful consequence were brewing for Europe, to sound a note of warning. I know that, just as before, my voice is much too weak to reach the ear of the multitude. It is not presumption that drives me, but my conscience as a psychiatrist that bids me fulfil my duty and prepare those few who will hear me for coming events which are in accord with the end of an era. As we know from ancient Egyptian history, they are manifestations of psychic changes which always appear at the end of one Platonic month and at the beginning of another. Apparently they are changes in the constellation of psychic dominants, of the archetypes, or “gods” as they used to be called, which bring about, or accompany, long-lasting transformations of the collective psyche. This transformation started in the historical era and left its traces first in the passing of the aeon of Taurus into that of Aries, and then of Aries into Pisces, whose beginning coincides with the rise of Christianity. We are now nearing that great change which may be expected when the spring-point enters Aquarius.

[590] It would be frivolous of me to try to conceal from the reader that such reflections are not only exceedingly unpopular but even come perilously close to those turbid fantasies which becloud the minds of world-reformers and other interpreters of “signs and portents.” But I must take this risk, even if it means putting my hard-won reputation for truthfulness, reliability, and capacity for scientific judgment in jeopardy. I can assure my readers that I do not do this with a light heart. I am, to be quite frank, concerned for all those who are caught unprepared by the events in question and disconcerted by their incomprehensible nature. Since, so far as I know, no one has yet felt moved to examine and set forth the possible psychic consequences of this foreseeable astrological change, I deem it my duty to do what I can in this

respect. I undertake this thankless task in the expectation that my chisel will make no impression on the hard stone it encounters.

[591] Some time ago I published a statement in which I considered the nature of “Flying Saucers.”² I came to the same conclusion as Edward J. Ruppelt, one-time chief of the American Air Force’s project for investigating Ufo reports.³ The conclusion is: *something is seen, but one doesn’t know what*. It is difficult, if not impossible, to form any correct idea of these objects, because they behave not like bodies but like weightless thoughts. Up till now there has been no indisputable proof of the physical existence of Ufos except for the cases picked up by radar. I have discussed the reliability of these radar observations with Professor Max Knoll, a specialist in this field. What he has to say is not encouraging. Nevertheless, there do seem to be authenticated cases where the visual observation was confirmed by a simultaneous radar echo. I would like to call the reader’s attention to Keyhoe’s books, which are based on official material and studiously avoid the wild speculation, naïveté, or prejudice of other publications.⁴

[592] For a decade the physical reality of Ufos remained a very problematical matter, which was not decided one way or the other with the necessary clarity despite the mass of observational material that had accumulated in the meantime. The longer the uncertainty lasted, the greater became the probability that this obviously complicated phenomenon had an extremely important psychic component as well as a possible physical basis. This is not surprising, in that we are dealing with an ostensibly physical phenomenon distinguished on the one hand by its frequent appearances, and on the other by its strange, unknown, and indeed contradictory nature.

[593] Such an object provokes, like nothing else, conscious and unconscious fantasies, the former giving rise to speculative conjectures and pure fabrications, and the latter supplying the mythological background inseparable from these provocative observations. Thus there arose a situation in which, with the best will in the world, one often did not know and could not discover whether a primary perception was followed by a phantasm or whether, conversely, a primary fantasy originating in the unconscious invaded the conscious mind with illusions and visions. The material that has become known to me during the past ten years lends support to both hypotheses. In the first case an objectively real, physical process forms the basis for an accompanying myth; in the second case an archetype creates the corresponding vision. To these two causal relationships we must add a third possibility, namely, that of a “synchronistic,” i.e., acausal, meaningful coincidence—a problem that has occupied men’s minds ever since the time of Geulincx, Leibniz, and Schopenhauer.⁵ It is an hypothesis that has special bearing on phenomena connected with archetypal psychic processes.

[594] As a psychologist, I am not qualified to contribute anything useful to the question of the physical reality of Ufos. I can concern myself only with their undoubted psychic aspect, and in what follows shall deal almost exclusively with their psychic concomitants.

1. UFOS AS RUMOURS

[595] Since the things reported of Ufos not only sound incredible but seem to fly in the face of all our basic assumptions about the physical world, it is very natural that one's first reaction should be the negative one of outright rejection. Surely, we say, it's nothing but illusions, fantasies, and lies. People who report such stuff—chiefly airline pilots and ground staff—cannot be quite right in the head! What is worse, most of these stories come from America, the land of superlatives and of science fiction.

[596] In order to meet this natural reaction, we shall begin by considering the Ufo reports simply as rumours, i.e., as psychic products, and shall draw from this all the conclusions that are warranted by an analytical method of procedure.

[597] Regarded in this light, the Ufo reports may seem to the sceptical mind to be rather like a story that is told all over the world, but differs from an ordinary rumour in that it is expressed in the form of visions,¹ or perhaps owed its existence to them in the first place and is now kept alive by them. I would call this comparatively rare variation a *visionary rumour*. It is closely akin to the collective visions of, say, the crusaders during the siege of Jerusalem, the troops at Mons in the first World War, the faithful followers of the pope at Fatima, Portugal, etc. Apart from collective visions, there are on record cases where one or more persons see something that physically is not there. For instance, I was once at a spiritualistic séance where four of the five people present saw an object like a moon floating above the abdomen of the medium. They showed me, the fifth person present, exactly where it was, and it was absolutely incomprehensible to them that I could see nothing of the sort. I know of three more cases where certain objects were seen in the clearest detail (in two of them by two persons, and in the third by one person) and could afterwards be proved to be non-existent. Two of these cases happened under my direct observation. Even people who are entirely *compos mentis* and in full possession of their senses can sometimes see things that do not exist. I do not know what the explanation is of such happenings. It is very possible that they are less rare than I am inclined to suppose. For as a rule we do not verify things we have “seen with our own eyes,” and so we never get to know that actually they did not exist. I mention these somewhat remote possibilities because, in such an unusual matter as the Ufos, one has to take every aspect into account.

[598] The first requisite for a visionary rumour, as distinct from an ordinary rumour, for whose dissemination nothing more is needed than popular curiosity and sensation-mongering, is always an *unusual emotion*. Its intensification into a vision and delusion of the senses, however, springs from a stronger excitation and therefore from a deeper source.

[599] The signal for the Ufo stories was given by the mysterious projectiles seen over Sweden during the last two years of the war—attributed of course to the Russians—and by the reports about “Foo fighters,” i.e., lights that accompanied the Allied bombers over Germany (Foo = *feu*). These were followed by the strange sightings of “Flying Saucers” in America. The impossibility of finding an earthly base for the Ufos and of explaining their physical peculiarities soon led to the conjecture of an extra-terrestrial origin. With this development the rumour got linked up with the psychology of the great panic that broke out in the United States just before the second World War, when a radio play,² based on a novel by H. G. Wells, about Martians invading New York, caused a regular stampede and numerous car accidents. The play evidently hit the latent emotion connected with the imminence of war.

[600] The motif of an extra-terrestrial invasion was seized upon by the rumour and the Ufos were interpreted as machines controlled by intelligent beings from outer space. The apparently weightless behaviour of space-ships and their intelligent, purposive movements were attributed to the superior technical knowledge and ability of the cosmic intruders. As they did no harm and refrained from all hostile acts it was assumed that their appearance over the earth was due to curiosity or to the need for aerial reconnaissance. It also seemed that airfields and atomic installations in particular held a special attraction for them, from which it was concluded that the dangerous development of atomic physics and nuclear fission had caused a certain disquiet on our neighbouring planets and necessitated a more accurate survey from the air. As a result, people felt they were being observed and spied upon from space.

[601] The rumour actually gained so much official recognition that the armed forces in America set up a special bureau for collecting, analysing, and evaluating all relevant observations. This seems to have been done also in France, Italy, Sweden, the United Kingdom, and other countries. After the publication of Ruppelt’s report the Saucer stories seem to have more or less vanished from the press for about a year. They were evidently no longer “news.” That the interest in Ufos and, probably, the sightings of them have not ceased is shown by the recent press report that an American admiral has suggested that clubs be founded all over the country for collecting Ufo reports and investigating them in detail.

[602] The rumour states that the Ufos are as a rule lens-shaped, but can also be oblong or shaped like cigars; that they shine in various colours or have a metallic glitter;³

that from a stationary position they can reach a speed of about 10,000 miles per hour, and that at times their acceleration is such that if anything resembling a human being were steering them he would be instantly killed. In flight they turn off at angles that would be possible only to a weightless object.

[603] Their flight, accordingly, resembles that of a flying insect. Like this, the Ufo can suddenly hover over an interesting object for quite a time, or circle round it inquisitively, just as suddenly to dart off again and discover new objects in its zigzag flight. Ufos are therefore not to be confused with meteorites or with reflections from so-called "temperature inversion layers." Their alleged interest in airfields and in industrial installations connected with nuclear fission is not always confirmed, since they are also seen in the Antarctic, in the Sahara, and in the Himalayas. For preference, however, they seem to swarm over the United States, though recent reports show that they do a good deal of flying over the Old World and in the Far East. Nobody really knows what they are looking for or want to observe. Our aeroplanes seem to arouse their curiosity, for they often fly towards them or pursue them. But they also fly away from them. Their flights do not appear to be based on any recognizable system. They behave more like groups of tourists unsystematically viewing the countryside, pausing now here for a while and now there, erratically following first one interest and then another, sometimes shooting to enormous altitudes for inexplicable reasons or performing acrobatic evolutions before the noses of exasperated pilots. Sometimes they appear to be up to five hundred yards in diameter, sometimes small as electric street-lamps. There are large mother-ships from which little Ufos slip out or in which they take shelter. They are said to be both manned and unmanned, and in the latter case are remote-controlled. According to the rumour, the occupants are about three feet high and look like human beings or, conversely, are utterly unlike us. Other reports speak of giants fifteen feet high. They are beings who are carrying out a cautious survey of the earth and considerately avoid all encounters with men or, more menacingly, are spying out landing places with a view to settling the population of a planet that has got into difficulties and colonizing the earth by force. Uncertainty in regard to the physical conditions on earth and their fear of unknown sources of infection have held them back temporarily from drastic encounters and even from attempted landings, although they possess frightful weapons which would enable them to exterminate the human race. In addition to their obviously superior technology they are credited with superior wisdom and moral goodness which would, on the other hand, enable them to save humanity. Naturally there are stories of landings, too, when the saucer-men were not only seen at close quarters but attempted to carry off a human being. Even a reliable man like Keyhoe gives us to understand that a squadron of five military aircraft plus

a large seaplane were swallowed up by Ufo mother-ships in the vicinity of the Bahamas, and carried off.

[604] One's hair stands on end when one reads such reports together with the documentary evidence. And when one considers the known possibility of tracking Ufos with radar, then we have all the essentials for an unsurpassable "science-fiction story." Every man who prides himself on his sound common sense will feel distinctly affronted. I shall therefore not enter here into the various attempts at explanation to which the rumour has given rise.

[605] While I was engaged in writing this essay, it so happened that two articles appeared more or less simultaneously in leading American newspapers, showing very clearly how the problem stands at present. The first was a report on the latest Ufo sighting by a pilot who was flying an aircraft to Puerto Rico with forty-four passengers. While he was over the ocean he saw a "fiery, round object, shining with greenish white light," coming towards him at great speed. At first he thought it was a jet-propelled aircraft, but soon saw that it was some unusual and unknown object. In order to avoid a collision, he pulled his aircraft into such a steep climb that the passengers were shot out of their seats and tumbled over one another. Four of them received injuries requiring hospital attention. Seven other aircraft strung out along the same route of about three hundred miles sighted the same object.

[606] The other article, entitled "No Flying Saucers, U.S. Expert Says," concerns the categorical statement made by Dr. Hugh L. Dryden, director of the National Advisory Committee for Aeronautics, that Ufos do not exist. One cannot but respect the unflinching scepticism of Dr. Dryden; it gives stout-hearted expression to the feeling that such preposterous rumours are an offence to human dignity.

[607] If we close our eyes a little so as to overlook certain details, it is possible to side with the reasonable opinion of the majority in whose name Dr. Dryden speaks, and to regard the thousands of Ufo reports and the uproar they have created as a visionary rumour, to be treated accordingly. They would then boil down, objectively, to an admittedly impressive collection of mistaken observations and conclusions into which subjective psychic assumptions have been projected.

[608] But if it is a case of psychological *projection*, there must be a *psychic cause* for it. One can hardly suppose that anything of such worldwide incidence as the Ufo legend is purely fortuitous and of no importance whatever. The many thousands of individual testimonies must have an equally extensive causal basis. When an assertion of this kind is corroborated practically everywhere, we are driven to assume that a corresponding motive must be present everywhere, too. Though visionary rumours may be caused or accompanied by all manner of outward circumstances, they are based essentially on an omnipresent emotional foundation, in this case a

psychological situation common to all mankind. The basis for this kind of rumour is an *emotional tension* having its cause in a situation of collective distress or danger, or in a vital psychic need. This condition undoubtedly exists today, in so far as the whole world is suffering under the strain of Russian policies and their still unpredictable consequences. In the individual, too, such phenomena as abnormal convictions, visions, illusions, etc., only occur when he is suffering from a psychic dissociation, that is, when there is a split between the conscious attitude and the unconscious contents opposed to it. Precisely because the conscious mind does not know about them and is therefore confronted with a situation from which there seems to be no way out, these strange contents cannot be integrated directly but seek to express themselves indirectly, thus giving rise to unexpected and apparently inexplicable opinions, beliefs, illusions, visions, and so forth. Any unusual natural occurrences such as meteors, comets, "rains of blood," a calf with two heads, and suchlike abortions are interpreted as menacing omens, or else signs are seen in the heavens. Things can be seen by many people independently of one another, or even simultaneously, which are not physically real. Also, the association-processes of many people often have a parallelism in time and space, with the result that different people, simultaneously and independently of one another, can produce the same new ideas, as has happened numerous times in history.

[609] In addition, there are cases where the same collective cause produces identical or similar effects, i.e., the same visionary images and interpretations, in the very people who are least prepared for such phenomena and least inclined to believe in them.⁴ This fact gives the eyewitness accounts an air of particular credibility: it is usually emphasized that the witness is above suspicion because he was never distinguished for his lively imagination or credulousness but, on the contrary, for his cool judgment and critical reason. In just these cases the unconscious has to resort to particularly drastic measures in order to make its contents perceived. It does this most vividly by projection, by extrapolating its contents into an object, which then reflects back what had previously lain hidden in the unconscious. Projection can be observed at work everywhere, in mental illness, in ideas of persecution and hallucinations, in so-called normal people who see the mote in their brother's eye without seeing the beam in their own, and finally, in extreme form, in political propaganda.

[610] Projections have what we might call different ranges, according to whether they stem from merely personal conditions or from deeper collective ones. Personal repressions and things of which we are unconscious manifest themselves in our immediate environment, in our circle of relatives and acquaintances. Collective contents, such as religious, philosophical, political and social conflicts, select projection-carriers of a corresponding kind—Freemasons, Jesuits, Jews, Capitalists, Bolsheviks, Imperialists, etc. In the threatening situation of the world today, when

people are beginning to see that everything is at stake, the projection-creating fantasy soars beyond the realm of earthly organizations and powers into the heavens, into interstellar space, where the rulers of human fate, the gods, once had their abode in the planets. Our earthly world is split into two halves, and nobody knows where a helpful solution is to come from. Even people who would never have thought that a religious problem could be a serious matter that concerned them personally are beginning to ask themselves fundamental questions. Under these circumstances it would not be at all surprising if those sections of the community who ask themselves nothing were visited by “visions,” by a widespread myth seriously believed in by some and rejected as absurd by others. Eye-witnesses of unimpeachable honesty announce the “signs in the heavens” which they have seen “with their own eyes,” and the marvellous things they have experienced which pass human understanding.

[611] All these reports have naturally resulted in a clamorous demand for explanation. Initial attempts to explain the Ufos as Russian or American inventions soon came to grief on their apparently weightless behaviour, which is unknown to earth-dwellers. Human fantasy, already toying with the idea of space-trips to the moon, therefore had no hesitation in assuming that intelligent beings of a higher order had learnt how to counteract gravitation and, by dint of using interstellar magnetic fields as sources of power, to travel through space with the speed of light. The recent atomic explosions on the earth, it was conjectured, had aroused the attention of these so very much more advanced dwellers on Mars or Venus, who were worried about possible chain-reactions and the consequent destruction of our planet. Since such a possibility would constitute a catastrophic threat to our neighbouring planets, their inhabitants felt compelled to observe how things were developing on earth, fully aware of the tremendous cataclysm our clumsy nuclear experiments might unleash. The fact that the Ufos neither land on earth nor show the least inclination to get into communication with human beings is met by the explanation that these visitors, despite their superior knowledge, are not at all certain of being well received on earth, for which reason they carefully avoid all intelligent contact with humans. But because they, as befits superior beings, conduct themselves quite inoffensively, they would do the earth no harm and are satisfied with an objective inspection of airfields and atomic installations. Just why these higher beings, who show such a burning interest in the fate of the earth, have still not found some way of communicating with us after ten years—despite their knowledge of languages—remains shrouded in darkness. Other explanations have therefore to be sought, for instance that a planet has got into difficulties, perhaps through the drying up of its water supplies, or loss of oxygen, or overpopulation, and is looking for a *pied-à-terre*. The reconnaissance patrols are going to work with the utmost care and circumspection, despite the fact that they have been giving a benefit performance in the heavens for hundreds, if not

thousands, of years. Since the second World War they have appeared in masses, obviously because an imminent landing is planned. Recently their harmlessness has been doubted. There are also stories by so-called eyewitnesses who declare they have seen Ufos landing with, of course, English-speaking occupants. These space-guests are sometimes idealized figures along the lines of technological angels who are concerned for our welfare, sometimes dwarfs with enormous heads bursting with intelligence, sometimes lemur-like creatures covered with hair and equipped with claws, or dwarfish monsters clad in armour and looking like insects.

[612] There are even “eyewitnesses” like Mr. Adamski, who relates that he has flown in a Ufo and made a round trip of the moon in a few hours. He brings us the astonishing news that the side of the moon turned away from us contains atmosphere, water, forests, and settlements, without being in the least perturbed by the moon’s skittishness in turning just her unhospitable side towards the earth. This physical monstrosity of a story was actually swallowed by a cultivated and well-meaning person like Edgar Sievers.⁵

[613] Considering the notorious camera-mindedness of Americans, it is surprising how few “authentic” photos of Ufos seem to exist, especially as many of them are said to have been observed for several hours at relatively close quarters. I myself happen to know someone who saw a Ufo with hundreds of other people in Guatemala. He had his camera with him, but in the excitement he completely forgot to take a photo, although it was daytime and the Ufo remained visible for an hour. I have no reason to doubt the honesty of his report. He has merely strengthened my impression that Ufos are somehow not photogenic.

[614] As one can see from all this, the observation and interpretation of Ufos have already led to the formation of a regular legend. Quite apart from the thousands of newspaper reports and articles there is now a whole literature on the subject, some of it humbug, some of it serious. The Ufos themselves, however, do not appear to have been impressed; as the latest observations show, they continue their way undeterred. Be that as it may, one thing is certain: they have become a *living myth*. We have here a golden opportunity of seeing how a legend is formed, and how in a difficult and dark time for humanity a miraculous tale grows up of an attempted intervention by extra-terrestrial “heavenly” powers—and this at the very time when human fantasy is seriously considering the possibility of space travel and of visiting or even invading other planets. We on our side want to fly to the moon or to Mars, and on their side the inhabitants of other planets in our system, or even of the fixed stars, want to fly to us. We at least are conscious of our space-conquering aspirations, but that a corresponding extra-terrestrial tendency exists is a purely mythological conjecture, i.e., a projection.

[615] Sensationalism, love of adventure, technological audacity, intellectual curiosity may appear to be sufficient motives for our futuristic fantasies, but the impulse to spin such fantasies, especially when they take such a serious form—witness the sputniks—springs from an underlying cause, namely a situation of distress and the vital need that goes with it. It could easily be conjectured that the earth is growing too small for us, that humanity would like to escape from its prison, where we are threatened not only by the hydrogen bomb but, at a still deeper level, by the prodigious increase in the population figures, which give cause for serious concern. This is a problem which people do not like to talk about, or then only with optimistic references to the incalculable possibilities of intensive food production, as if this were anything more than a postponement of the final solution. As a precautionary measure the Indian government has granted half a million pounds for birth-control propaganda, while the Russians exploit the labour-camp system as one way of skimming off the dreaded excess of births. Since the highly civilized countries of the West know how to help themselves in other ways, the immediate danger does not come from them but from the underdeveloped peoples of Asia and Africa. This is not the place to discuss the question of how far the two World Wars were an outlet for this pressing problem of keeping down the population at all costs. Nature has many ways of disposing of her surplus. Man's living space is, in fact, continually shrinking and for many races the optimum has long been exceeded. The danger of catastrophe grows in proportion as the expanding populations impinge on one another. Congestion creates fear, which looks for help from extra-terrestrial sources since it cannot be found on earth.

[616] Hence there appear "signs in the heavens," superior beings in the kind of space ships devised by our technological fantasy. From a fear whose cause is far from being fully understood and is therefore not conscious, there arise explanatory projections which purport to find the cause in all manner of secondary phenomena, however unsuitable. Some of these projections are so obvious that it seems almost superfluous to dig any deeper.⁶ But if we want to understand a mass rumour which, it appears, is even accompanied by collective visions, we must not remain satisfied with all too rational and superficially obvious motives. The cause must strike at the roots of our existence if it is to explain such an extraordinary phenomenon as the Ufos. Although they were observed as rare curiosities in earlier centuries, they merely gave rise to the usual local rumours.

[617] The universal mass rumour was reserved for our enlightened, rationalistic age. The widespread fantasy about the destruction of the world at the end of the first millennium was metaphysical in origin and needed no Ufos in order to appear rational. Heaven's intervention was quite consistent with the *Weltanschauung* of the age. But nowadays public opinion would hardly be inclined to resort to the

hypothesis of a metaphysical act, otherwise innumerable parsons would already have been preaching about the warning signs in heaven. Our *Weltanschauung* does not expect anything of this sort. We would be much more inclined to think of the possibility of *psychic* disturbances and interventions, especially as our psychic equilibrium has become something of a problem since the last World War. In this respect there is increasing uncertainty. Even our historians can no longer make do with the traditional procedures in evaluating and explaining the developments that have overtaken Europe in the last few decades, but must admit that psychological and psychopathological factors are beginning to widen the horizons of historiography in an alarming way. The growing interest which the thinking public consequently evinces in psychology has already aroused the displeasure of the academies and of incompetent specialists. In spite of the palpable resistance to psychology emanating from these circles, psychologists who are conscious of their responsibilities should not be dissuaded from critically examining a mass phenomenon like the Ufos, since the apparent impossibility of the Ufo reports suggests to common sense that the most likely explanation lies in a psychic disturbance.

[618] We shall therefore turn our attention to the psychic aspect of the phenomenon. For this purpose we shall briefly review the central statements of the rumour. Certain objects are seen in the earth's atmosphere, both by day and by night, which are unlike any known meteorological phenomena. They are not meteors, not misidentified fixed stars, not "temperature inversions," not cloud formations, not migrating birds, not aerial balloons, not balls of fire, and certainly not the delirious products of intoxication or fever, nor the plain lies of eyewitnesses. What as a rule is seen is a body of *round* shape, disk-like or spherical, glowing or shining fierily in different colours, or, more seldom, a cigar-shaped or cylindrical figure of various sizes.⁷ It is reported that occasionally they are invisible to the naked eye but leave a "blip" on the radar screen. The round bodies in particular are figures such as the unconscious produces in dreams, visions, etc. In this case they are to be regarded as *symbols* representing, in visual form, some thought that was not thought consciously, but is merely potentially present in the unconscious in invisible form and attains visibility only through the process of becoming conscious. The visible form, however, expresses the meaning of the unconscious content only approximately. In practice the meaning has to be completed by amplificatory interpretation. The unavoidable errors that result can be eliminated only through the principle of "waiting on events"; that is to say we obtain a consistent and readable text by comparing sequences of dreams dreamt by different individuals. The figures in a rumour can be subjected to the same principles of dream interpretation.

[619] If we apply them to the round object—whether it be a disk or a sphere—we at once get an analogy with the symbol of totality well known to all students of depth

psychology, namely the *mandala* (Sanskrit for circle). This is not by any means a new invention, for it can be found in all epochs and in all places, always with the same meaning, and it reappears time and again, independently of tradition, in modern individuals as the “protective” or apotropaic circle, whether in the form of the prehistoric “sun wheel,” or the magic circle, or the alchemical microcosm, or a modern *symbol of order*, which organizes and embraces the psychic totality. As I have shown elsewhere,⁸ in the course of the centuries the mandala has developed into a definitely psychological totality symbol, as the history of alchemy proves. I would like to show how the mandala appears in a modern person by citing the dream of a six-year-old girl. She dreamt *she stood at the entrance of a large, unknown building. There a fairy was waiting for her, who led her inside, into a long colonnade, and conducted her to a sort of central chamber, with similar colonnades converging from all sides. The fairy stepped into the centre and changed herself into a tall flame. Three snakes crawled round the fire, as if circumambulating it.*

[620] Here we have a classic, archetypal childhood dream such as is not only dreamt fairly often but is sometimes drawn or painted, without any suggestion from outside, for the evident purpose of warding off disagreeable or disturbing family influences and preserving the inner balance.

[621] In so far as the mandala encompasses, protects, and defends the psychic totality against outside influences and seeks to unite the inner opposites, it is at the same time a distinct *individuation symbol* and was known as such even to medieval alchemy. The soul was supposed to have the form of a sphere, on the analogy of Plato’s world-soul, and we meet the same symbol in modern dreams. This symbol, by reason of its antiquity, leads us to the heavenly spheres, to Plato’s “supra-celestial place” where the “Ideas” of all things are stored up. Hence there would be nothing against the naïve interpretation of Ufos as “souls.” Naturally they do not represent our modern conception of the psyche, but give an involuntary archetypal or mythological picture of an unconscious content, a *rotundum*, as the alchemists called it, that expresses the totality of the individual. I have defined this spontaneous image as a symbolical representation of the *self*, by which I mean not the ego but the totality composed of the conscious *and* the unconscious.⁹ I am not alone in this, as the Hermetic philosophy of the Middle Ages had already arrived at very similar conclusions. The archetypal character of this idea is borne out by its spontaneous recurrence in modern individuals who know nothing of any such tradition, any more than those around them. Even people who might know of it never imagine that their children could dream of anything so remote as Hermetic philosophy. In this matter the deepest and darkest ignorance prevails, which is of course the most unsuitable vehicle for a mythological tradition.

[622] If the round shining objects that appear in the sky be regarded as visions, we can hardly avoid interpreting them as archetypal images. They would then be involuntary, automatic projections based on instinct, and as little as any other psychic manifestations or symptoms can they be dismissed as meaningless and merely fortuitous. Anyone with the requisite historical and psychological knowledge knows that circular symbols have played an important role in every age; in our own sphere of culture, for instance, they were not only soul symbols but “God-images.” There is an old saying that “God is a circle whose centre is everywhere and the circumference nowhere.” God in his omniscience, omnipotence, and omnipresence is a totality symbol *par excellence*, something round, complete, and perfect. Epiphanies of this sort are, in the tradition, often associated with fire and light. On the antique level, therefore, the Ufos could easily be conceived as “gods.” They are impressive manifestations of totality whose simple, round form portrays the archetype of the self, which as we know from experience plays the chief role in uniting apparently irreconcilable opposites and is therefore best suited to compensate the split-mindedness of our age. It has a particularly important role to play among the other archetypes in that it is primarily the regulator and orderer of chaotic states, giving the personality the greatest possible unity and wholeness. It creates the image of the divine-human personality, the Primordial Man or Anthropos, a *chên-yên* (true or whole man), an Elijah who calls down fire from heaven, rises up to heaven in a fiery chariot,¹⁰ and is a forerunner of the Messiah, the dogmatized figure of Christ, as well as of Khidr, the Verdant One,¹¹ who is another parallel to Elijah: like him, he wanders over the earth as a human personification of Allah.

[623] The present world situation is calculated as never before to arouse expectations of a redeeming, supernatural event. If these expectations have not dared to show themselves in the open, this is simply because no one is deeply rooted enough in the tradition of earlier centuries to consider an intervention from heaven as a matter of course. We have indeed strayed far from the metaphysical certainties of the Middle Ages, but not so far that our historical and psychological background is empty of all metaphysical hope.¹² Consciously, however, rationalistic enlightenment predominates, and this abhors all leanings towards the “occult.” Desperate efforts are made for a “restitution” of our Christian faith, but we cannot get back to that limited world view which in former times left room for metaphysical intervention. Nor can we resuscitate a genuine Christian belief in an after-life or the equally Christian hope for an imminent end of the world that would put a definite stop to the regrettable error of Creation. Belief in this world and in the power of man has, despite assurances to the contrary, become a practical and, for the time being, irrefragable truth.

[624] This attitude on the part of the overwhelming majority provides the most favourable basis for a projection, that is, for a manifestation of the unconscious background. Undeterred by rationalistic criticism, it thrusts itself to the forefront in the form of a symbolic rumour, accompanied and reinforced by the appropriate visions, and thus activates an archetype that has always expressed order, deliverance, salvation, and wholeness. It is characteristic of our time that the archetype, in contrast to its previous manifestations, should now take the form of an object, a technological construction, in order to avoid the odiousness of mythological personification. Anything that looks technological goes down without difficulty with modern man. The possibility of space travel has made the unpopular idea of a metaphysical intervention much more acceptable. The apparent weightlessness of the Ufos is, of course, rather hard to digest, but then our own physicists have discovered so many things that border on the miraculous: why should not more advanced star-dwellers have discovered a way to counteract gravitation and reach the speed of light, if not more?

[625] Nuclear physics has begotten in the layman's head an uncertainty of judgment that far exceeds that of the physicists and makes things appear possible which but a short while ago would have been declared nonsensical. Consequently the Ufos can easily be regarded and believed in as a physicists' miracle. I still remember, with misgivings, the time when I was convinced that something heavier than air could not fly, only to be taught a painful lesson. The apparently physical nature of the Ufos creates such insoluble puzzles for even the best brains, and on the other hand has built up such an impressive legend, that one feels tempted to take them as a ninety-nine per cent psychic product and subject them accordingly to the usual psychological interpretation. Should it be that an unknown physical phenomenon is the outward cause of the myth, this would detract nothing from the myth, for many myths have meteorological and other natural phenomena as accompanying causes which by no means explain them. A myth is essentially a product of the unconscious archetype and is therefore a symbol which requires psychological interpretation. For primitive man any object, for instance an old tin that has been thrown away, can suddenly assume the importance of a fetish. This effect is obviously not inherent in the tin, but is a psychic product.

2. UFOS IN DREAMS

[626] Not only are Ufos seen, they are of course also dreamt about. This is particularly interesting to the psychologist, because the dreams tell us in what sense they are understood by the unconscious. In order to form anything like a complete picture of an object reflected in the psyche, far more than an exclusively intellectual operation is required. Besides the three other functions of feeling (valuation), sensation (reality-sense), and intuition (perception of possibilities), we need the reaction of the unconscious, which gives a picture of the unconscious associative context. It is this total view that alone makes possible a whole judgment on the psychic situation constellated by the object. An exclusively intellectual approach is bound to be from fifty to seventy-five per cent unsatisfactory.

[627] By way of illustration I shall cite two dreams dreamt by an educated lady. She had never seen a Ufo, but was interested in the phenomenon without being able to form a definite picture of it. She did not know the Ufo literature, nor was she acquainted with my ideas on the subject.

DREAM 1

“I was going down the Champs Elysées in a bus, with many other people. Suddenly the air-raid warning sounded. The bus stopped and all the passengers jumped out, and the next moment they had disappeared into the nearest houses, banging the doors behind them. I was the last to leave the bus. I tried to get into a house, but all the doors with their polished brass knobs were tightly shut, and the whole Champs Elysées was empty. I pressed against the wall of a house and looked up at the sky: instead of the expected bombers I saw a sort of Flying Saucer, a metallic sphere shaped like a drop. It was flying along quite slowly from north to east, and I had the impression that I was being observed. In the silence I heard the high heels of a woman who was walking alone on the empty sidewalk down the Champs Elysées. The atmosphere was most uncanny.”

DREAM 2 (ABOUT A MONTH LATER)

“I was walking, at night, in the streets of a city. Interplanetary ‘machines’ appeared in the sky, and everyone fled. The ‘machines’ looked like large steel cigars. I did not flee. One of the ‘machines’ spotted me and came straight towards me at an oblique angle. I think: Professor Jung says that one should not run away, so I stand

still and look at the machine. From the front, seen close to, it looked like a circular eye, half blue, half white.

“A room in a hospital: my two chiefs come in, very worried, and ask my sister how it was going. My sister replied that the mere sight of the machine had burnt my whole face. Only then did I realize that they were talking about me, and that my whole head was bandaged, although I could not see it.”

COMMENTARY TO DREAM 1

[628] The dream describes, as the exposition of the initial situation, a mass panic as at an air-raid warning. A Ufo appears, having the form of a drop. A fluid body assumes the form of a drop when it is about to fall, from which it is clear that the Ufo is conceived as a liquid falling from the sky, like rain. This surprising drop-form of the Ufo and the analogy with a fluid occur in the literature.¹ Presumably it is meant to express the commonly reported changeability of the Ufo's shape. This “heavenly” fluid must be of a mysterious nature and is probably a conception similar to that of the alchemical *aqua permanens*, the “permanent water,” which was also called “Heaven” in sixteenth-century alchemy and stood for the *quinta essentia*. This water is the *deus ex machina* of alchemy, the wonderful solvent, the word *solutio* being used equally for a chemical solution and for the solution of a problem. Indeed, it is the great magician Mercurius himself, the dissolver and binder (“solve et coagula”), the physical and spiritual panacea, which at the same time can be something threatening and dangerous, and falls as the *aqua coelestis* from heaven.

[629] Just as the alchemists speak of their “stone, which is no stone,” so also of their “philosophical” water, which is no water, but quicksilver, and no ordinary Hg at that, but a “spirit” (pneuma). It represents the arcane substance, which during the alchemical operations changes from a base metal into a spiritual form, often personified as the *filius hermaphroditus*, *filius macrocosmi*, etc. The “water of the Philosophers” is the classic substance that transmutes the chemical elements and during their transformation is itself transformed. It is also the “redeeming spirit.” These ideas began far back in the literature of antiquity, underwent further development during the Middle Ages, and even penetrated into folk-lore and fairy-tale. A very ancient text (possibly first century A.D.) says that in the stone that is found in the Nile there is a spirit. “Reach in thy hand and draw forth the spirit. That is the *exhydrargyrosis*” (the expulsion of the quicksilver). For a period of nearly seventeen hundred years we have ample testimonies to the effectiveness of this animistic archetype. Mercurius is on the one hand a metal, on the other a fluid that can easily be volatilized, i.e., changed into vapour or spirit; this was known as *spiritus Mercurii* and was regarded as a kind of panacea, saviour, and *servator mundi*

(preserver of the world). Mercurius is a “bringer of healing” who “makes peace between enemies”; as the “food of immortality” he saves Creation from sickness and corruption, just as Christ saved mankind. In the language of the Church Fathers Christ is a “springing fountain,” and in the same way the alchemists call Mercurius *aqua permanens*, *ros Gedeonis* (Gideon’s dew), *vinum ardens* (fiery wine), *mare nostrum* (our sea), *sanguis* (blood), etc.

[630] From many of the reports, particularly the early ones, it is evident that the Ufos can appear suddenly and vanish equally suddenly. They can be tracked by radar but remain invisible to the eye, and conversely, can be seen by the eye but not detected by radar. Ufos can make themselves invisible at will, it is said, and must obviously consist of a substance that is visible at one moment and invisible the next. The nearest analogy to this is a volatile liquid which condenses out of an invisible state into the form of drops. In reading the old texts one can still feel the miracle of disappearance and reappearance which the alchemists beheld in the vaporization of water or quicksilver: for them it was the transformation of the “souls that had become water” (Heraclitus) into the invisible pneuma at the touch of Hermes’ wand, and their descent out of the empyrean into visible form again. Zosimos of Panopolis (third century A.D.) has left us a valuable document describing this transformation, which takes place in a cooking-vessel. The fantasies born of musing over the steaming cooking-pot—one of the most ancient experiences of mankind—may also be responsible for the sudden disappearance and reappearance of the Ufo.

[631] The unexpected drop-form in our dream has prompted a comparison with a central conception of alchemy, known to us not only from Europe but also from India and second century China. The extraordinariness of the Ufo is paralleled by the extraordinariness of its psychological context, which has to be adduced if we are to risk any interpretation at all. Considering the essential weirdness of the Ufo phenomenon, we cannot expect the familiar, rationalistic principles of explanation to be in any way adequate. A psychoanalytic approach to the problem could do nothing more than turn the whole idea of Ufos into a sexual fantasy, at most arriving at the conclusion that a repressed uterus was coming down from the sky. This would not fit in too badly with the old medical view of hysteria (*ὑστερος* = womb) as a “wandering of the uterus,” especially in the case of a woman who had an anxiety dream. But then, what about the masculine pilots, who are the chief authors of the rumour? The language of sex is hardly more significant than any other symbolical means of expression. This type of explanation is, at bottom, just as mythological and rationalistic as the technological fables about the nature and purpose of Ufos.

[632] The dreamer knew enough about psychology to realize in her second dream the necessity of not giving in to her fear and running away, as she would dearly have

liked to do. But the unconscious created a situation in which this way out was barred. Consequently she had an opportunity to observe the phenomenon at close quarters. It proved to be harmless. Indeed, the untroubled footsteps of a woman point to someone who either is not aware of it at all or is free from fear.

COMMENTARY TO DREAM 2

[633] The exposition begins with the statement that it is night and dark, a time when normally everyone is asleep and dreaming. As in the previous dream, panic breaks out. A number of Ufos appear. Recalling the first commentary, we could say that the unity of the self as a supraordinate, semi-divine figure has broken up into a plurality. On a mythological level this would correspond to a plurality of gods, god-men, demons, or souls. In Hermetic philosophy the arcane substance has a “thousand names,” but essentially it consists of the One and Only (i.e., God), and this principle only becomes pluralized through being split up (*multiplicatio*). The alchemists were consciously performing an *opus divinum* when they sought to free the “soul in chains,” i.e., to release the demiurge distributed and imprisoned in his own creation and restore him to his original condition of unity.

[634] Looked at psychologically, the plurality of the symbol of unity signifies a splitting into many independent units, into a number of “selves”; the *one* “metaphysical” principle, representing the idea of monotheism, is dissolved into a plurality of subordinate deities. From the standpoint of Christian dogma such an operation could easily be construed as archheresy, were it not that this view is contradicted by the unequivocal saying of Christ, “Ye are gods,” and by the equally emphatic idea that we are all God’s children, both of which presuppose man’s at least potential kinship with God. From the psychological point of view the plurality of Ufos would correspond to the projection of a plurality of human individuals, the choice of symbol (spherical object) indicating that the content of the projection is not the actual people themselves, but rather their ideal psychic totality; not the empirical man as he knows himself to be from experience, but his total psyche, the conscious contents of which have still to be supplemented by the contents of the unconscious. Although we know, from our investigations, a number of things about the unconscious which give us some clue as to its nature, we are still very far from being able to sketch out even a hypothetical picture that is in any way adequate. To mention only one of the greatest difficulties: there are parapsychological experiences which can no longer be denied and have to be taken into account in evaluating psychic processes. The unconscious can no longer be treated as if it were causally dependent on consciousness, since it possesses qualities which are not under conscious control. It should rather be understood as an autonomous entity acting reciprocally with consciousness.

[635] The plurality of Ufos, then, is a projection of a number of psychic images of wholeness which appear in the sky because on the one hand they represent archetypes charged with energy and on the other hand are not recognized as psychic factors. The reason for this is that our present-day consciousness possesses no conceptual categories by means of which it could apprehend the nature of psychic totality. It is still in an archaic state, so to speak, where apperceptions of this kind do not occur, and accordingly the relevant contents cannot be recognized as psychic factors. Moreover, it is so trained that it must think of such images not as forms inherent in the psyche but as existing somewhere in extra-psychic, metaphysical space, or else as historical facts. When, therefore, the archetype receives from the conditions of the time and from the general psychic situation an additional charge of energy, it cannot, for the reasons I have described, be integrated directly into consciousness, but is forced to manifest itself indirectly in the form of spontaneous projections. The projected image then appears as an ostensibly physical fact independent of the individual psyche and its nature. In other words, the rounded wholeness of the mandala becomes a space ship controlled by an intelligent being. The usually lens-shaped form of the Ufos may be influenced by the fact that psychic wholeness, as the historical testimonies show, has always been characterized by certain cosmic affinities: the individual soul was thought to be of “heavenly” origin, a particle of the world soul, and hence a microcosm, a reflection of the macrocosm. Leibniz’s monadology is an eloquent example of this. The macrocosm is the starry world around us, which, appearing to the naïve mind as spherical, gives the soul its traditional spherical form. Actually the astronomical heavens are filled with mainly lens-shaped agglomerations of stars, the galaxies, similar in form to that of the Ufos. This form may possibly be a concession to the recent astronomical findings, for to my knowledge there are no older traditions that speak of the soul having the form of a lens. Here we may have an instance of an older tradition being modified by recent additions to knowledge, an influencing of primordial ideas by the latest acquisitions of consciousness, like the frequent substitution of automobiles and aeroplanes for animals and monsters in modern dreams.

[636] It must be emphasized, however, that there is also the possibility of a natural or absolute “knowledge,” when the unconscious psyche coincides with objective facts. This is a problem that has been raised by the discoveries of parapsychology. “Absolute knowledge” occurs not only in telepathy and precognition, but also in biology, for instance in the attunement of the virus of hydrophobia to the anatomy of dog and man as described by Portmann,² the wasp’s apparent knowledge of where the motor ganglia are located in the caterpillar that is to nourish the wasp’s progeny, the emission of light by certain fishes and insects with almost 100 per cent efficiency, the directional sense of carrier pigeons, the warning of earthquakes given by chickens

and cats, and the amazing co-operation found in symbiotic relationships. We know, too, that the life process itself cannot be explained only by causality, but requires “intelligent” choice. The shape of the Ufos is in this sense analogous to that of the elements composing the structure of space, the galaxies, no matter how ridiculous this seems to human reason.

[637] In our dream the usual lens-shaped form is replaced by the rarer cigar-form, derived apparently from the old dirigible airships. As in Dream I a psychoanalytic approach could resort to a female “symbol,” the uterus, to explain the “drop,” so here the sexual analogy of the phallic form leaps to the eye. The archaic background of the psyche has this much in common with primitive language, that they both translate unknown or incompletely understood things into instinctive and habitual forms of thought, so that Freud could, with some justification, establish that all round or hollow forms have a feminine and all oblong ones a masculine meaning, as for instance nuts and bolts, male and female pipe-joints, etc. In these cases the interest that naturally attaches to sex invites the making of such analogies, not to speak of the amusing illustrations they provide. Still, sex is not the sole instigator of these metaphors, there is also hunger, the urge to eat and drink. In the history of religion there are not only sexual unions with the gods, they are also eaten and drunk. Even sexual attraction has become an object for these metaphors: we like a girl so much that we could “eat” her. Language is full of metaphors which express one instinct in terms of another, but we need not conclude from this that the real and essential thing is always “love” or hunger or the urge to power, etc. The main point is that every situation activates the relevant instinct, which then predominates as a vital need and decides the choice of symbol as well as its interpretation.³

[638] Very probably there is a phallic analogy in the dream, which, in accordance with the meaning of this exceedingly archaic symbol, gives the Ufo the character of something “procreative,” “fructifying,” and, in the broadest sense, “penetrating.” In ancient times the feeling of being “penetrated” by, or of “receiving,” the god was allegorized by the sexual act.⁴ But it would be a gross misunderstanding to interpret a genuine religious experience as a “repressed” sexual fantasy on account of a mere metaphor. The “penetration” can also be expressed by a sword, spear, or arrow.

[639] The dreamer does not flee from the menacing aspect of the Ufo, even when she sees it coming straight at her. During this confrontation the original spherical or lens-shaped aspect reappears in the form of a circular eye. This image corresponds to the traditional eye of God, which, all-seeing, searches the hearts of men, laying bare the truth and pitilessly exposing every cranny of the soul. It is a reflection of one’s insight into the total reality of one’s own being.

[640] The eye is half blue, half white. This corresponds to the colours of the sky, its pure blue and the whiteness of clouds that obscure its transparency. The psychic totality, the self, is a combination of opposites. Without a shadow even the self is not real. It always has two aspects, a bright and a dark, like the pre-Christian idea of God in the Old Testament, which is so much better suited to the facts of religious experience (Rev. 14:7) than the *Summum Bonum*, based as this is on the precarious foundation of a mere syllogism (the *privatio boni*). Even the highly Christian Jacob Boehme could not escape this insight and gave eloquent expression to it in his “Forty Questions concerning the Soul.”

[641] The drop-shaped Ufo, suggesting a fluid substance, a sort of “water,” makes way for a circular structure which not only sees, i.e., emits light (according to the old view light is equivalent to seeing), but also sends out a scorching heat. One immediately thinks of the intolerable radiance that shone from the face of Moses after he had seen God, of “Who among us shall dwell with everlasting burnings?” (Isaiah 33:14), and of the saying of Jesus: “He who is near unto me is near unto the fire.”

[642] Nowadays people who have an experience of this kind are more likely to go running to the doctor or psychiatrist than to the theologian. I have more than once been consulted by people who were terrified by their dreams and visions. They took them for symptoms of mental illness, possibly heralding insanity, whereas in reality they were “dreams sent by God,” real and genuine religious experiences that collided with a mind unprepared, ignorant, and profoundly prejudiced. In this matter there is little choice today: anything out of the ordinary can only be pathological, for that abstraction, the “statistical average,” counts as the ultimate truth, and not reality. All feeling for value is repressed in the interests of a narrow intellect and biased reason. So it is no wonder that after her Ufo experience our patient woke up in hospital with a burned face. This is only to be expected today.

[643] The second dream differs from the first in that it brings out the dreamer’s inner relationship to the Ufo. The Ufo has marked her out and not only turns a searching eye upon her but irradiates her with magical heat, a synonym for her own inner affectivity. Fire is the symbolical equivalent of a very strong emotion or affect, which in this case comes upon her quite unexpectedly. In spite of her justifiable fear of the Ufo she held her ground, as though it were intrinsically harmless, but is now made to realize that it is capable of sending out a deadly heat, a statement we often meet with in the Ufo literature.⁵ This heat is a projection of her own unrealized emotion—of a feeling that has intensified into a physical effect but remains unrecognized. Even her facial expression was altered (burnt) by it. This recalls not only the changed face of Moses but also that of Brother Klaus after his terrifying vision of God.⁶ It points to an “indelible” experience whose traces remain visible to others, because it has brought

about a demonstrable change in the entire personality. Psychologically, of course, such an event betokens only a *potential* change; it has first to be integrated into consciousness. That is why Brother Klaus felt it necessary to spend long years in wearisome study and meditation until he succeeded in recognizing his terrifying vision as a vision of the Holy Trinity, in accordance with the spirit of the age. In this way he transformed the experience into an integrated conscious content that was intellectually and morally binding for him. This work has still to be done by the dreamer, and perhaps also by all those who see Ufos, dream of them, or spread rumours about them.

[644] The symbols of divinity coincide with those of the self: what, on the one side, appears as a psychological experience signifying psychic wholeness, expresses on the other side the idea of God. This is not to assert a metaphysical identity of the two, but merely the empirical identity of the images representing them, which all originate in the human psyche, as our dream shows. What the metaphysical conditions are for the similarity of the images is, like everything transcendental, beyond human knowledge.

[645] The motif of the isolated “God’s eye,” which the unconscious proffers as an interpretation of the Ufo, can be found in ancient Egyptian mythology as the “eye of Horus,” who with its help healed the partial blinding of his father Osiris, caused by Set. The isolated God’s eye also appears in Christian iconography.

[646] In dealing with the products of the collective unconscious, all images that show an unmistakably mythological character have to be examined in their symbological context. They are the inborn language of the psyche and its structure, and, as regards their basic form, are in no sense individual acquisitions. Despite its pre-eminent capacity for learning and for consciousness, the human psyche is a natural phenomenon like the psyche of animals, and is rooted in inborn instincts which bring their own specific forms with them and so constitute the heredity of the species. Volition, intention, and all personal differentiations are acquired late and owe their existence to a consciousness that has emancipated itself from mere instinctivity. Wherever it is a question of archetypal formations, personalistic attempts at explanation lead us astray. The method of comparative symbology, on the other hand, not only proves fruitful on scientific grounds but makes a deeper understanding possible in practice. The symbological or “amplificatory” approach produces a result that looks at first like a translation back into primitive language. And so it would be, if understanding with the help of the unconscious were a purely intellectual exercise and not one that brought our total capacities into play. In other words, besides its formal mode of manifestation the archetype possesses a numinous quality, a feeling-value that is highly effective in practice. One can be unconscious of this value, since it can be repressed artificially; but a repression has neurotic consequences, because

the repressed affect still exists and simply makes an outlet for itself elsewhere, in some unsuitable place.

[647] As our dream shows very clearly, the Ufo comes from the unconscious background which has always expressed itself in numinous ideas and images. It is these that give the strange phenomenon an interpretation that makes it appear in a significant light—significant not merely because they arouse dim historical memories which link up with the findings of comparative psychology, but because actual affective processes are at work.

[648] Today, as never before, men pay an extraordinary amount of attention to the skies, for technological reasons. This is especially true of the airman, whose field of vision is occupied on the one hand by the complicated control apparatus before him, and on the other by the empty vastness of cosmic space. His consciousness is concentrated one-sidedly on details requiring the most careful observation, while at his back, so to speak, his unconscious strives to fill the illimitable emptiness of space. His training and his common sense both preclude him from observing all the things that might rise up from within and become visible in order to compensate for the emptiness and solitude of flight high above the earth. Such a situation provides the ideal conditions for spontaneous psychic phenomena, as everyone knows who has lived sufficiently long in the solitude, silence, and emptiness of deserts, seas, mountains, or in primeval forests. Rationalism and boredom are essentially products of the over-indulged craving for stimulation so characteristic of urban populations. The city-dweller seeks artificial sensations to escape his boredom; the hermit does not seek them, but is plagued by them against his will.

[649] We know from the life of ascetics and anchorites that, whether they would or no, and without any assistance from consciousness, spontaneous psychic phenomena rose up to compensate their biological needs: numinous fantasy images, visions and hallucinations that were evaluated either positively or negatively. Those positively evaluated derived from a sphere of the unconscious felt to be spiritual, the others obviously from the instinctual world they knew only too well, where loaded dishes and flagons and luscious meals stilled their hunger, seductive and voluptuous beings yielded themselves to their pent-up sexual desires, riches and worldly power took the place of poverty and lack of influence, and bustling crowds, noise, and music enlivened the intolerable silence and loneliness. Although it is easy to speak here of images caused by repressed wishes and to explain the projection of fantasies that way, it does not explain the visions that were evaluated positively, because these did not correspond to a repressed wish but to one that was fully conscious and therefore could not produce a projection. A psychic content can only appear as a projection

when its connection with the ego personality is not recognized. For this reason the wish hypothesis must be discarded.

[650] The hermits sought to attain a spiritual experience, and for this purpose they mortified the earthly man. Naturally enough the affronted world of instinct reacted with unseemly projections, but the spiritual sphere, too, responded with projections of a positive nature—most unexpectedly, to our scientific way of thinking. For the spiritual sphere had not been neglected in any way; on the contrary, it was nurtured with the greatest possible devotion by means of prayer, meditation, and other spiritual exercises. So, according to our hypothesis, it should have had no need of compensation; its one-sidedness, which insisted on mortifying the body, was already compensated by the violent reaction on the part of the instincts. Nevertheless the spontaneous appearance of positive projections in the form of numinous images was experienced as grace and felt to be a divine revelation, and indeed they are characterized as such by the content of the visions. Psychologically speaking, these visions function in exactly the same way as the visions produced by the neglected instincts, despite the undeniable fact that the saints did everything to foster their spirituality. They did *not* mortify the spiritual man and therefore needed no compensation in this respect.

[651] If, in the face of this dilemma, we cling to the proven truth of the compensation theory, we are driven to the paradoxical conclusion that, despite appearances to the contrary, the spiritual situation of the hermit was one of deficiency after all, and that it needed an appropriate compensation. Just as physical hunger is sated, at least metaphorically, by the sight of a marvellous meal, so the hunger of the soul is sated by the vision of numinous images. But it is not so easy to see why the anchorite's soul should suffer from "hunger." He stakes his whole life on earning the *panis supersubstantialis*, the "superessential bread" which alone appeases his hunger, and besides that he has the faith, doctrines, and means of grace of the Church at his disposal. Why, then, should he lack anything? All this he has, but the fact remains that he is not nourished by it and his unappeasable desire remains unfulfilled. What, obviously, he still lacks is the *actual and immediate experience of spiritual reality*, however it may turn out. Whether it presents itself to him more or less concretely or symbolically makes little difference. In any case he is not expecting the physical tangibility of any earthly thing, but rather the sublime intangibility of a spiritual vision. This experience is, in itself, a compensation for the barrenness and emptiness of traditional forms, and accordingly he values it above all else. For in fact there appears before him, uncreated by himself, a numinous image which is just as real and "actual" (because it "acts" upon him) as the illusions spun by his neglected instincts. It is, however, as much desired by him on account of its reality and spontaneity as the illusions of his senses are undesired. So long as the numinous contents can avail

themselves, in one way or another, of the traditional forms, there is no cause for disquiet. But when they betray their archaism by assuming unusual and obnoxious features, the matter becomes painfully dubious. The saint then begins to doubt whether they are any less illusory than the delusions of the senses. Indeed, it may even happen that a revelation originally regarded as divine is subsequently damned as a deception of the devil. The criterion of distinction is simply and solely tradition, not reality or unreality as in the case of a real or illusory meal. The vision is a psychic phenomenon, just as are its numinous contents. Here spirit answers spirit, whereas in a fast the need for food is answered by an hallucination and not by a real meal. In the first case the bill is paid in cash, in the second case by an unbacked cheque. The one solution is satisfying, the other obviously not.

[652] But in both cases the structure of the phenomenon is the same. Physical hunger needs a real meal and spiritual hunger needs a numinous content. Such contents are by nature archetypal and have always expressed themselves in the form of natural revelations, for Christian symbolism, like all other religious ideas, is based on archetypal models that go back into prehistory. The “total” character of these symbols includes every kind of human interest and instinct, thereby guaranteeing the numinosity of the archetype. That is why, in comparative religion, we so often find the religious and spiritual aspects associated with those of sexuality, hunger, aggression, power, etc. A particularly fruitful source of religious symbolism is the instinct to which most importance is attached in a given epoch or culture, or which is of most concern to the individual. There are communities in which hunger is more important than sex and vice versa. Our civilization bothers us less with food taboos than with sexual restrictions. In modern society these have come to play the role of an injured deity that is getting its own back in every sphere of human activity, including psychology, where it would reduce “spirit” to sexual repression.

[653] However, a partial interpretation of the symbolism in sexual terms should be taken seriously. If man’s striving for a spiritual goal is not a genuine instinct but merely the result of a particular social development, then an explanation according to sexual principles is the most appropriate and the most acceptable to reason. But even if we grant the striving for wholeness and unity the character of a genuine instinct, and base our explanation mainly on this principle, the fact still remains that there is a close association between sexual instinct and the striving for wholeness. With the exception of religious longings, nothing challenges modern man more consciously and personally than sex. One can also say in good faith that he is possessed even more by the power instinct. This question will be decided according to temperament and one’s own subjective bias. The only thing we cannot doubt is that the most important of the fundamental instincts, the religious instinct for wholeness, plays the least conspicuous part in contemporary consciousness because, as history shows, it

can free itself only with the greatest effort, and with continual backslidings, from contamination with the other two instincts. These can constantly appeal to common, everyday facts known to everyone, but the instinct for unholiness requires for its evidence a more highly differentiated consciousness, thoughtfulness, reflection, responsibility, and sundry other virtues. Therefore it does not commend itself to the relatively unconscious man driven by his natural impulses, because, imprisoned in his familiar world, he clings to the commonplace, the obvious, the probable, the collectively valid, using for his motto: "Thinking is difficult, therefore let the herd pronounce judgment!" It is an enormous relief to him when something that looks complicated, unusual, puzzling and problematical can be reduced to something ordinary and banal, especially when the solution strikes him as surprisingly simple and somewhat droll. The most convenient explanations are invariably sex and the power instinct, and reduction to these two dominants gives rationalists and materialists an ill-concealed satisfaction: they have neatly disposed of an intellectually and morally uncomfortable difficulty, and on top of that can enjoy the feeling of having accomplished a useful work of enlightenment which will free the individual from unnecessary moral and social burdens. In this way they can pose as benefactors of mankind. On closer inspection, however, things look very different: the exemption of the individual from a difficult and apparently insoluble task drives sexuality into an even more pernicious repression, where it is replaced by rationalism or by soul-destroying cynicism, while the power instinct is driven towards some Socialistic ideal that has already turned half the world into the State prison of Communism. This is the exact opposite of what the striving for wholeness wants, namely, to free the individual from the compulsion of the other two instincts. The task before him comes back with all its energies unused, and reinforces, to an almost pathological degree, the very instincts that have always stood in the way of man's higher development. At all events it has a neuroticizing effect characteristic of our time and must bear most of the blame for the splitting of the individual and of the world in general. We just will not admit the shadow, and so the right hand does not know what the left is doing.

[654] Correctly appraising the situation, the Catholic Church, while counting sexual sins among the "venial" ones, therefore keeps a sharp eye upon sexuality as the chief enemy in practice and ferrets it out in all corners. She thus creates an acute consciousness of sex, deleterious to weaker spirits but of advantage in promoting reflection and broadening the consciousness of the stronger. The worldly pomps of the Catholic Church for which she is reproached by the Protestants have the obvious purpose of holding the power of the spirit visibly before the natural power-instinct. This is infinitely more effective than the best logical arguments, which no one likes

following. Only the tiniest fraction of the population learns anything from reflection; everything else consists in the suggestive power of ocular evidence.

[655] After this digression, let us turn back to the problem of sexual interpretation. If we try to define the psychological structure of the religious experience which saves, heals, and makes whole, the simplest formula we can find would seem to be the following: *in religious experience man comes face to face with a psychically overwhelming Other*. As to the existence of this power we have only assertions to go on, but no physical or logical proofs. It comes upon man in psychic guise. We cannot explain it as exclusively spiritual, for experience would immediately compel us to retract such a judgment, since the vision, according to the psychic disposition of the individual, often assumes the form of sexuality or of some other unspiritual impulse. Only something overwhelming, no matter what form of expression it uses, can challenge the whole man and force him to react as a whole. It cannot be proved that such things happen or that they must occur, nor is there any proof that they are anything more than psychic,⁷ since the evidence for them rests solely on personal statements and avowals. This, in view of the crass undervaluation of the psyche in our predominantly materialistic and statistical age, sounds like a condemnation of religious experience. Consequently, the average intelligence takes refuge either in unbelief or in credulity, for to it the psyche is no more than a miserable wisp of vapour. Either there are hard-and-fast facts, or else it is nothing but illusion begotten by repressed sexuality or an over-compensated inferiority complex. As against this I have urged that the psyche be recognized as having its own peculiar reality. Despite the advances in organic chemistry, we are still very far from being able to explain consciousness as a biochemical process. On the contrary, we have to admit that chemical laws do not even explain the selective process of food assimilation, let alone the self-regulation and self-preservation of the organism. Whatever the reality of the psyche may be, it seems to coincide with the reality of life and at the same time to have a connection with the formal laws governing the inorganic world. For the psyche has yet another property which most of us would rather not admit, namely, that peculiar factor which relativizes space and time, and is now the object of intensive parapsychological research.

[656] Since the discovery of the empirical unconscious the psyche and what goes on in it have become a natural fact and are no longer an arbitrary opinion, which they undoubtedly would be if they owed their existence to the caprices of a rootless consciousness. But consciousness, for all its kaleidoscopic mobility, rests as we know on the comparatively static or at least highly conservative foundation of the instincts and their specific forms, the archetypes. This world in the background⁸ proves to be the opponent of consciousness, which, because of its mobility (learning capacity), is often in danger of losing its roots. That is why since earliest times men have felt

compelled to perform rites for the purpose of securing the co-operation of the unconscious. In a primitive world no one reckons without his host; he is constantly mindful of the gods, the spirits, of fate and the magical qualities of time and place, rightly recognizing that man's solitary will is only a fragment of a total situation. Primitive man's actions have a "total" character which civilized man would like to be rid of, as though it were an unnecessary burden. Things seem to go all right without it.

[657] The great advantage of this attitude lies in the development of a discriminating consciousness, but it has the almost equally great disadvantage of breaking down man's original wholeness into separate functions which conflict with one another. This loss has made itself increasingly felt in modern times. I need only remind you of Nietzsche's Dionysian experience of a "breakthrough," and of that trend in German philosophy whose most obvious symptom is the book by Ludwig Klages, *Der Geist als Widersacher der Seele*.⁹ Through this fragmentation process one or other of the functions of consciousness becomes highly differentiated and can then escape the control of the other functions to such an extent that it attains a kind of autonomy, constructing a world of its own into which these other functions are admitted only so far as they can be subjugated to the dominant function. In this way consciousness loses its balance: if the intellect predominates, then the value judgments of feeling are weakened, and vice versa. Again, if sensation is predominant, intuition is barred, this being the function that pays the least attention to tangible facts; and conversely, a man with an excess of intuition lives in a world of unproven possibilities. A useful result of such developments is specialism, but that also promotes a disagreeable one-sidedness.

[658] It is just this capacity for one-sidedness which bids us observe things from one angle only, and if possible to reduce them to a single principle. In psychology this attitude inevitably leads to explanations in terms of one particular bias. For instance, in a case of marked extraversion the whole of the psyche is traced back to environmental influences, while in introversion it is traced back to the hereditary psychophysical disposition and the intellectual and emotional factors that go with it. Both explanations tend to turn the psychic apparatus into a machine. Anyone who tries to be equally fair to both points of view is accused of obscurantism. Yet both of them should be applied, even if a series of paradoxical statements is the result. Hence, in order to avoid multiplying the principles of explanation, one of the easily recognizable basic instincts will be preferred at the expense of the others. Nietzsche bases everything on power, Freud on pleasure and its frustration. While in Nietzsche the unconscious can be felt as a factor of some importance, and in Freud became a *sine qua non* of his theory, though without ever sloughing off the character of being something secondary and "nothing but" the result of repression, in Adler the field of

vision is narrowed down to a subjective “prestige”-psychology, where the unconscious as a possibly decisive factor disappears from sight altogether. This fate has also overtaken Freud’s psychoanalysis as practised by the second generation. The significant beginnings he made towards a psychology of the unconscious stopped short at a single archetype, that of the Oedipus complex, and were not developed further by the more rigorous of his pupils.

[659] The evidence of the sexual instinct is, in the case of the incest complex, so patently obvious that a philosophically limited intelligence could remain satisfied with that. The same is true of Adler’s subjective will to power. Both views remain caught in an instinctual premise which leaves no room for the other and so lands us in the specialist *cul de sac* of fragmentary explanation. Freud’s pioneer work, on the other hand, gave access to the well-documented history of psychic phenomenology, and this allows us something like a synoptic view of the psyche. The psyche does not express itself merely in the narrow subjective sphere of the individual personality but, over and above that, in collective psychic phenomena of whose existence Freud was aware, at least in principle, as his concept of the “superego” shows. For the time being method and theory remained—and remained too long—in the hands of the psychiatrist, who of necessity is concerned only with individuals and their urgent personal problems. An investigation of fundamentals involving historical research is naturally not in his line, nor are his scientific training and his practical work of much help to him in getting at the foundations of psychological knowledge. For this reason Freud saw himself obliged to skip the—admittedly—wearisome stage of comparative psychology and press forward into the conjectural and highly uncertain prehistory of the human psyche. In so doing he lost the ground from under his feet, for he would not let himself be taught by the findings of ethnologists and historians, but transferred the insights he had gained from modern neurotics during consulting hours directly to the broad field of primitive psychology. He did not pay enough attention to the fact that under certain conditions there is a shift of emphasis and other psychic dominants come into play. The Freudian school got stuck at the Oedipus motif, i.e., the archetype of incest, and hence their views remained predominantly sexualistic. They failed to recognize that the Oedipus complex is an exclusively masculine affair, that sexuality is not the only possible dominant in the psychic process, and that incest, because it involves the religious instinct, is far more an expression of the latter than the cause of it. I will not mention my own endeavours in this field, since for most people they have remained a book with seven seals.

[660] The sexual hypothesis nevertheless carries considerable power of conviction because it coincides with one of the principal instincts. The same is true of the power hypothesis, which can appeal to instincts that characterize not only the individual but also political and social movements. A *rapprochement* between the two standpoints

is nowhere in sight, unless we can acknowledge the peculiar nature of the self, which embraces the individual as well as society. As experience shows, the archetypes possess the quality of “transgressiveness”; they can sometimes manifest themselves in such a way that they seem to belong as much to society as to the individual; they are therefore numinous and contagious in their effects. (It is the emotional person who emotionalizes others.) In certain cases this transgressiveness also produces meaningful coincidences, i.e., acausal, synchronistic phenomena, such as the results of Rhine’s ESP experiments.

[661] The instincts are part of the living totality; they are articulated with and subordinate to the whole. Their release as separate entities leads to chaos and nihilism, because it breaks down the unity and totality of the individual and destroys him. It should be the task of psychotherapy, properly understood, to preserve or restore this unity. It cannot be the aim of education to turn out rationalists, materialists, specialists, technicians and others of the kind who, unconscious of their origins, are precipitated abruptly into the present and contribute to the disorientation and fragmentation of society. By the same token, no psychotherapy can lead to satisfactory results if it confines itself to single aspects only. The temptation to do this is so great, and the danger of loss of instinct so threatening in the breathless tempo of modern civilization, that every expression of instinct must be watched very carefully, since it is part of the total picture and is essential for man’s psychic balance.

[662] For these reasons the sexual aspect of the Ufos merits our attention, as it shows that a very powerful instinct like sexuality has its share in the structure of the phenomenon. It is probably no accident that in one of the dreams we have been discussing a feminine symbol appears, and in the other a masculine, in accordance with the reports of lens-shaped and cigar-shaped Ufos, for where one appears, we may also expect its partner.

[663] The vision is a symbol consisting not only of archetypal forms of thought but of instinctual elements as well, so that it can justly lay claim to be a “reality.” It is not only “historical,” but topical and dynamic. Hence it does not appeal only to man’s conscious technological fantasies, or to his philosophical speculations, but strikes deep down into his “animal” nature. This is what we would expect a genuine symbol to do; it must affect and express the whole man. However unsatisfactory a sexual interpretation may be in this case, the contribution it makes should not be overlooked and must be given due consideration.

[664] In the same way the power instinct expresses itself in both dreams; the dreamer appears in a unique situation, she is singled out, indeed “chosen” like one whose countenance is burned by the divine fire. Both interpretations, so far as they claim to

be exclusive, do away with the symbolic meaning of the dreams and eliminate the individual in favour of the instinctual manifestations. The feebleness of the individual in the face of the overwhelming power of instinct is once more established. For anyone who was not yet aware of this fact, such an interpretation would of course be novel and impressive. But our dreamer does not belong to the host of ingénues, and in her case it would be pointless to reduce the dream in this way. She is, on the contrary, one of those moderns who realize what the elimination of the individual means. The paralysing feeling of nothingness and lostness is compensated by the dreams: she is the only one to withstand the panic and to recognize its cause. It is at her that the unearthly thing points, and on her it leaves the visible traces of its power. She is set apart as one of the elect. Such a gesture on the part of the unconscious naturally has a useful meaning only when feelings of inferiority and the senselessness of a merely functional existence threaten to stifle the personality.

[665] This case may serve as a paradigm for the widespread anxiety and insecurity of thoughtful people today, while at the same time revealing the compensating power of the unconscious.

DREAM 3

[666] This dream is an excerpt from a longer dream which a 42-year-old woman patient recorded about six years ago. At the time she had heard nothing of Flying Saucers and the like. *She dreamt she was standing in a garden, when suddenly the humming of an engine became audible overhead. She sat down on the garden wall in order to see what was going on. A black metallic object appeared and circled over her: it was a huge flying spider made of metal, with great dark eyes. It was round in shape, and was a new and unique aeroplane. From the body of the spider there issued a solemn voice, loud and distinct; it uttered a prayer that was intended as an admonition and a warning to everybody, for those on earth as well as for the occupants of the spider. The gist of the prayer was: "Lead us downwards and keep us (safe) below ... Carry us up to the height!" Adjoining the garden was a large administrative building where international decisions were being taken. Flying incredibly low, the spider passed along the windows of the building, for the obvious purpose of letting the voice influence the people inside and point out the way to peace, which was the way to the inner, secret world. They were to take reconciling decisions. There were several other spectators in the garden. She felt somewhat embarrassed because she was not fully clothed.*

[667] In the preceding part of the dream the dreamer's bed had stood close to the garden wall. In her dream, therefore, she had slept under the open sky and been exposed to the free influences of Nature, which means psychologically the impersonal, collective unconscious, for this forms the counterpart to our natural environment and is always projected upon it. The wall denotes a barrier separating the immediate world of the dreamer from a more distant one (administrative building). A round metallic object appears, described as a flying spider. This description fits the Ufos. As regards the designation "spider," we are reminded of the hypothesis that Ufos are a species of insect coming from another planet and possessing a shell or carapace that shines like metal. An analogy would be the metallic-looking, chitinous covering of our beetles. Each Ufo is supposed to be a single insect, not a swarm.¹⁰ In reading the numerous reports I must admit that I, too, was struck by the thought that the peculiar behaviour of the Ufos was reminiscent of certain insects. To the speculative mind there is nothing inherently impossible in the idea that under other conditions Nature could express her "knowledge" in quite other ways than those mentioned earlier; for instance, instead of light-producing insects she might evolve creatures capable of "anti-gravity." In any case our technological imagination often lags a long way behind Nature's. Everything in our experience is subject to the law of gravity with one great exception: the psyche, which, as we experience it, is weightlessness itself. The psychic "object" and gravity are, to the best of our knowledge, incommensurable. They seem to be different in principle. The psyche represents the only opposite of gravity known to us. It is "anti-gravity" in the truest sense of the word. In corroboration of this we could cite the parapsychological experience of levitation and other psychic phenomena, denied only by the ignorant, which relativize time and space.

[668] Obviously the "flying spider" is based on an unconscious fantasy of this kind. In the Ufo literature, too, reference is made to flying spiders in an attempt to explain the alleged "rain of threads" in Oloron and Gaillac.¹¹ Note that the dream cannot help making a concession to modern technological fantasies: it calls the spider a "new and unique aeroplane."

[669] The psychic nature of the spider is shown by the fact that it contains a "voice," evidently issuing from something like a human being. This curious phenomenon reminds one of similar occurrences in insane people, who can hear voices issuing from anything or anybody. "Voices," like visions, are autonomous manifestations of the senses caused by the activity of the unconscious. "Voices from the aether" also occur in the Ufo literature.¹²

[670] Emphasis is laid on the eyes, which denote seeing and the intention to see. The intention is expressed by the voice, whose message is addressed both to the earth

dwellers and to the “occupants of the spider.” The association with “aeroplane” here gives rise to the illogical idea of a machine that transports passengers. The passengers are evidently thought of as quasi-human, for the message is meant for them as well as for human beings. We can therefore suppose that both are simply different aspects of man, e.g., the empirical man below on earth and the spiritual man in heaven.

[671] The cryptic message or “prayer” is spoken by a single voice, by a kind of prayer leader. He addresses himself to that which “leads” and “carries,” and this must be the spider. We are therefore obliged to examine the symbol of the spider somewhat more closely. As we know, although this animal is quite harmless in our latitudes, it is for many people an object of horror and superstitious belief (*araignée du matin, grand chagrin; araignée du soir, grand espoir*).¹³ When someone is not quite right in the head, we say in German that he “spins” and “has cobwebs in the attic.” Spiders, like all animals that are not warm-blooded or have no cerebrospinal nervous system, function in dreams as symbols of a profoundly alien psychic world. So far as I can see, they express contents which, though active, are unable to reach consciousness; they have not yet entered the sphere of the cerebrospinal nervous system but are as though lodged in the deeper-lying sympathetic and parasympathetic systems. In this connection I remember the dream of a patient who had the greatest difficulty in conceiving the idea of the supraordinate totality of the psyche and felt the utmost resistance to it. He had picked up the idea from one of my books but, characteristically enough, was unable to distinguish between the ego and the self, and, because of his hereditary taint, was threatened with a pathological inflation. In this situation he dreamt that he was rummaging about in the attic of his house, looking for something. In one of the attic windows he discovered a beautiful cobweb, with a large garden-spider sitting in the centre. It was of a blue colour, and its body sparkled like a diamond.

[672] The dreamer was deeply impressed by this dream, and it was, in fact, an impressive commentary on his identification with the self—all the more dangerous in view of his heredity. In such cases there is a real weakness of the ego, which cannot therefore afford any suggestion of taking second place, as that would fatally emphasize its littleness and has to be avoided at all costs. Illusions, however, are inimical to life, because they are unhealthy and sooner or later trip you up. The dream therefore attempts a kind of corrective, which, like the Delphic oracle, turns out to be ambivalent. It says in effect: “What is troubling you in the head (attic) is, though you may not know it, a rare jewel. It is like an animal that is strange to you, forming symbolically the centre of many concentric circles, reminiscent of the centre of a large or small world, like the eye of God in medieval pictures of the universe.” Confronted with this, a healthy mind would fight against identification with the centre, because of the danger of paranoiac God-likeness. Anyone who gets into this

spider's net is wrapped round like a cocoon and robbed of his own life. He is isolated from his fellows, so that they can no longer reach him, nor he them. He lives in the loneliness of the world creator, who is everything and has nothing outside himself. If, on top of all this, you have had an insane father, there is the danger that you will begin to "spin" your self, and for this reason the spider has a sinister aspect that should not be overlooked.

[673] The round metallic spider of our dreamer probably has a similar meaning. It has obviously devoured a number of human beings already, or their souls, and might well be a danger to earth dwellers. That is why the prayer, which recognizes the spider as a "divine" being, requests it to lead the souls "downwards" and "keep them safe below," because they are not yet departed spirits but living earthly creatures. As such they are meant to fulfil their earthly existence with conviction and not allow themselves any spiritual inflation, otherwise they will end up in the belly of the spider. In other words, they should not set the ego in the highest place and make it the ultimate authority, but should ever be mindful of the fact that it is not sole master in its own house and is surrounded on all sides by the factor we call the unconscious. What this is in itself we do not know. We know only its paradoxical manifestations. It is our business to understand Nature, and it is no good getting impatient with her because she is so "complicated" and awkward. Not so very long ago there were medical authorities who did not "believe" in bacteria and consequently allowed twenty thousand young women to die of easily avoidable puerperal fever in Germany alone. The psychic catastrophes caused by the mental inertia of "experts" do not appear in any statistics, and from this it is concluded that they are non-existent.

[674] The exhortation to remain below on earth is immediately followed by the paradoxical request: "Carry us up to the height!" One might think of the saying in *Faust*: "Then to the depths! I could as well say height: It's all the same," were it not that the dreamer has clearly separated the two processes by a hiatus. This shows that it is a sequence and not a *coincidentia oppositorum*. Evidently a moral process is envisaged, a katabasis and anabasis: the seven steps downwards and the seven steps upwards, the immersion in the *krater* followed by the ascent to the "heavenly generation" in the transformation mysteries.¹⁴ The Mass, too, begins with the "Confiteor ... quia peccavi nimis." Apparently one has to be "led" downwards, because it is not easy for people to descend from their heights and remain below. In the first place a loss of social prestige is feared, and in the second a loss of moral self-esteem when they have to admit their own darkness. Hence they avoid self-criticism to an amazing degree, preach to others, and know nothing of themselves. They are happy to possess no self-knowledge, because then nothing disturbs the rosy glow of illusions. "Below" means the bed-rock of reality, which despite all self-deceptions is there right enough. To get down to this and remain there seems to be a

matter of pressing importance if it is assumed that people today are living above their proper level. An inference of such general scope is permitted by the dream, which shows the problem in terms of a human group and therefore characterizes it as a collective problem. Actually the dream has the whole of humanity in view, for the spider flies as near as possible to the windows of a building where “international decisions” are being taken. It tries to “influence” the meeting and point the way that leads to the “inner world,” the way to self-knowledge. The dream expects that this will make peace possible. Accordingly the spider plays the role of a saviour who warns and brings a healing message.

[675] At the end the dreamer discovers that she is insufficiently clothed. This very common dream-motif usually indicates lack of adaptation or relative unconsciousness of the situation in which one finds oneself. This reminder of one’s own fallibility and negligence is particularly appropriate at a time when other people are being enlightened, for in such cases there is always a lurking danger of inflation.

[676] The admonition to “remain below” has in our day given rise to theological apprehensions in various quarters. It is feared that this kind of psychology will result in a loosening of moral standards. Psychology, however, gives us a clearer knowledge not only of evil but also of good, and the danger of succumbing to the former is considerably less than when you remain unconscious of it. Nor is psychology always needed if you want to know evil. No one who goes through the world with open eyes can ignore it; moreover he is not so likely to fall into a pit as the blind man. Just as the investigation of the unconscious is suspected by theologians of Gnosticism, so an inquiry into the ethical problems it raises is accused of antinomianism and libertinism. No one in his right senses would suppose that, after a thorough confession of sin accompanied by repentance, he will never sin again. It is a thousand to one that he will sin again the very next minute. Deeper psychological insight shows, in fact, that one cannot live at all without sinning “in thought, word, and deed.” Only an exceedingly naïve and unconscious person could imagine that he is in a position to avoid sin. Psychology can no longer afford childish illusions of this kind; it must ensue the truth and declare that unconsciousness is not only no excuse but is actually one of the most heinous sins. Human law may exempt it from punishment, but Nature avenges herself the more mercilessly, for it is nothing to her whether a man is conscious of his sin or not. We even learn from the parable of the unjust steward that the Lord praised his servant who kept a false account because he had “done wisely,” not to speak of the (expurgated) passage at Luke 6, where Christ says to the defiler of the Sabbath: “Man, if indeed thou knowest what thou doest, thou art blessed; but if thou knowest not, thou art accursed, and a transgressor of the law.”

[677] Increased knowledge of the unconscious brings a deeper experience of life and greater consciousness, and therefore confronts us with apparently new situations that require ethical decision. These situations have, of course, always existed, but they were not clearly grasped, either intellectually or morally, and were often left in a not unintentional half light. In this way one provides oneself with an alibi and can get out of an ethical decision. But, with deeper self-knowledge, one is often confronted with the most difficult problems of all, namely conflicts of duty, which simply cannot be decided by any moral precepts, neither those of the decalogue nor of other authorities. This is where ethical decisions really begin, for the mere observance of a codified "Thou shalt not" is not in any sense an ethical decision, but merely an act of obedience and, in certain circumstances, a convenient loophole that has nothing to do with ethics. In my long life I have never encountered a situation that made a denial of ethical principles easier for me or raised the slightest doubt in this regard; on the contrary, the ethical problem was sharpened with increasing experience and insight, and the moral responsibility became more acute. It has become clear to me that, in contrast to the general view, unconsciousness is no excuse but is far rather a transgression in the literal sense of the word. Although there are, as mentioned above, allusions to this problem in the gospels, the Church has for understandable reasons not taken it up, but left the Gnostics to tackle it more seriously. As a result, Christians rely on the doctrine of the *privatio boni* and always think they know what is good and what is evil, thus substituting the moral code for the truly ethical decision, which is a *free* one. Morality consequently degenerates into legalistic behaviour, and the *felix culpa* remains stuck in the Garden of Eden. We are surprised at the decay of ethics in our century, and we contrast the standstill in this field with the progress of science and technology. But nobody is worried by the fact that a real ethos has disappeared behind a mass of moral precepts. An ethos, however, is a difficult thing that cannot be formulated and codified; it is one of those creative irrationalities upon which any true progress is based. It demands the whole man and not just a differentiated function.

[678] The differentiated function undoubtedly depends on man, on his diligence, patience, perseverance, his striving for power, and his native gifts. With the aid of these things he gets on in the world and "develops." From this he has learnt that development and progress depend on man's own endeavours, his will and ability. But that is only one side of the picture. The other side shows man as he is and as he finds himself to be. Here he can alter nothing, because he is dependent on factors outside his control. Here he is not the doer, but a product that does not know how to change itself. He does not know how he came to be the unique individual he is, and he has only the scantiest knowledge of himself. Until recently he even thought that his psyche consisted of what he knew of himself and was a product of the cerebral

cortex. The discovery of unconscious psychic processes more than fifty years ago is still far from being common knowledge and its implications are still not recognized. Modern man still does not realize that he is entirely dependent on the co-operation of the unconscious, which can actually cut short the very next sentence he proposes to speak. He is unaware that he is continuously sustained by something, while all the time he regards himself exclusively as the doer. He depends on and is sustained by an entity he does not know, but of which he has intimations that “occurred” to—or, as we can more fitly say, *revealed themselves* to—long-forgotten forbears in the grey dawn of history. Whence did they come? Obviously from the unconscious processes, from that so-called unconscious which still precedes consciousness in every new human life, as the mother precedes the child. The unconscious depicts itself in dreams and visions, as it always did, holding before us images which, unlike the fragmented functions of consciousness, emphasize facts that relate to the unknown whole man, and only apparently to the function which interests us to the exclusion of all else. Although dreams usually speak the language of our particular specialism—*canis panem somniat, piscator pisces*—they refer to the whole, or at the very least to what man also is, namely the utterly dependent creature he finds himself to be.

[679] In his striving for freedom man feels an almost instinctive aversion to this kind of knowledge, for he fears, not without reason, its paralysing effect. He may admit that this dependence on unknown powers exists—no matter what they are called—but he turns away from them as speedily as possible, as from a threatening obstacle. So long as everything appears to go well, this attitude may even be an advantage; but things do not always turn out for the best, particularly today, when despite euphoria and optimism we feel a tremor running through the foundations of our world. Our dreamer is certainly not the only person to feel afraid. Accordingly the dream depicts a collective need and utters a collective warning that we should descend to earth and not rise up again unless the spider carries up those who have remained below. For when functionalism dominates consciousness, it is the unconscious that contains the compensatory symbol of wholeness. This is represented by the flying spider, which alone is capable of carrying up the one-sidedness and fragmentariness of the conscious mind. There is no development upwards unless it is facilitated by the unconscious. The conscious will alone cannot compel this creative act, and in order to illustrate this the dream chooses the symbol of *prayer*. Since according to the Pauline view we do not rightly know what we should pray for, the prayer is no more than a “groaning in travail” (Rom. 8:22) which expresses our impotence. This enjoins on us an attitude that compensates the superstitious belief in man’s will and ability. At the same time the spider image denotes a regression of religious ideas to the theriomorphic symbol of supreme power, a reversion to the long forgotten stage where a monkey or a hare personifies the redeemer. Today the Christian Lamb of

God or the Dove of the Holy Ghost has, at most, the value of a metaphor. As against this it must be emphasized that in dream symbolism animals refer to instinctual processes which play a vital part in animal biology. It is these processes which determine and shape the life of an animal. For his everyday life man seems to need no instincts, especially when he is convinced of the sovereign power of his will. He ignores the meaning of instinct and devalues it to the point of atrophy, not seeing how much he endangers his very existence through loss of instinct. When therefore dreams emphasize instinct they are trying to fill a perilous gap in our adaptation to life.

[680] Deviations from instinct show themselves in the form of affects, which in dreams are likewise expressed by animals. Hence uncontrolled affects are rightly regarded as bestial or primitive and should be avoided. But we cannot do this without repressing them, that is, without a splitting of consciousness. In reality we can never escape their power. Somewhere or other they will continue to operate even though they cannot be found in consciousness. At worst they manifest themselves in a neurosis or in an unconscious “arrangement” of inexplicable mishaps. The saint, who seems exempt from these weaknesses, pays for his immunity with suffering and abnegation of the earthly man, without which of course he would not be a saint. The lives of holy men show that the two sides cancel out. None can escape the chain of suffering that leads to sickness, old age and death. We can and should, for the sake of our humanity, “control” our affects and keep them in check, but we should know that we have to pay dearly for it. The choice of currency in which we wish to pay the tribute is—sometimes—even left to us.

[681] Remaining down below and subordinating ourselves to a theriomorphic symbol, which seems very like an insult to our human dignity, means no more than that we should remain conscious of these simple truths and never forget that in point of anatomy and psychology the earthly man, for all his high flights, is first cousin to the anthropoids. Should it be granted to him, however, to develop into something higher without crippling his nature, he is reminded that this transformation is not his to command, for he is dependent on factors he cannot influence. He must content himself with a prayerful yearning and “groaning,” in the hope that something may carry him upward, since he is not likely to make a success of the Munchausen experiment. Through this attitude he constellates helpful and at the same time dangerous powers in the unconscious; helpful if he understands them, dangerous if he misunderstands them. Whatever names he may give to these creative powers and potentialities within him, their actuality remains unchanged. No one can stop a religious-minded person from calling them gods or daemons, or simply “God,” for we know from experience that they act just like that. If certain people use the word “matter” in this connection, believing that they have said something, we must remind

them that they have merely replaced an X by a Y and are no further forward than before. The only certain thing is our profound ignorance, which cannot even know whether we have come nearer to the solution of the great riddle or not. Nothing can carry us beyond an “It seems as if” except the perilous leap of faith, which we must leave to those who are gifted or graced for it. Every real or apparent step forward depends on an experience of facts, the verification of which is, as we know, one of the most difficult tasks confronting the human mind.

DREAM 4

[682] While I was engaged on this paper an acquaintance from abroad unexpectedly sent me a dream he had had on May 27, 1957. Our relationship was limited to one letter each every one or two years. He was an amateur astrologer and was interested in the question of synchronicity. He knew nothing of my preoccupation with Ufos, nor did he connect his dream in any way with the theme that interested me. His sudden and unusual decision to send me the dream comes, rather, into the category of meaningful coincidences, which statistical prejudice dismisses as irrelevant.

[683] This is the dream: *“It was late afternoon or early evening, the sun low on the horizon. The sky was cloudy, and there was a veil of cloud over the sun which did not, however, prevent one from seeing quite clearly his disk in outline behind the cloud. Under such circumstances the sun was white. Suddenly he took on an aspect of extraordinary pallor. The whole western horizon became a dreadful pale white. And the pallor—pallor is the word that I want to stress—of the orb of day became a terrifying wanness. Then a second sun appeared in the west about the same distance above the horizon, only a little more to the north. But as we gazed intently at the sky—there were a great number of people spread over a wide area watching the heavens as I was—the second sun took on the distinctive form of a sphere in contrast with the sun’s disk, or apparent disk. Simultaneously with the setting of the sun and the advent of night the sphere came speeding towards the earth.*

“With the coming of the night, the whole potential of the dream was changed. Whereas words like pallor and wanness exactly describe the vanishing life, strength or potential of the sun, the sky now assumed an aspect of strength and majesty, which inspired not fear but awe. I could not say that I saw any stars, but the night sky was of that kind when thin wreaths of cloud allow an occasional star to be seen. The night certainly spoke of majesty, power and beauty.

“When the sphere approached the earth at high velocity, I thought at first that it was Jupiter in aberration from its proper orbit, but as the sphere came nearer, I saw that, though large, it was much too small for Jupiter.

“And it now became possible to discern the markings on its surface which were lines of longitude or like such, but were decorative and symbolic in character rather than geographical or mathematical. The beauty of the sphere, a subdued grey or opaque white, against the night sky must be emphasized. When we became aware that

the sphere must certainly make a terrific impact upon the earth, we did, of course, feel fear, but it was fear in which awe was more predominant. It was a most awe-inspiring cosmic phenomenon. As we gazed, another and yet another sphere emerged from the horizon and sped towards the earth. Each sphere did in turn crash much as a bomb would crash, but at such a considerable distance that I, at least, could not make out the nature of the explosion or detonation or whatever it was. I think in one case, at least, I saw a flash. These spheres, then, were falling at intervals all around, but all of them ... well beyond the point at which they might annihilate us. There appeared to be a danger of shrapnel....

“Then I must have gone indoors, for I found myself talking to a girl seated in a wicker chair, with an open large-paged notebook on her lap, much engrossed in her work. We were going—the rest of us—I think in a southwesterly direction, perhaps seeking safety, and I said to the girl had she not better come with us. The danger appeared to be great and we could hardly leave her alone there. She was quite definite in her reply. No, she would remain where she was and go on with her work. It was equally dangerous everywhere and one place was just as safe as another. I saw at once that she had reason and common-sense on her side.

“The dream ends by my being confronted with another girl, or, quite possibly, the same very competent and self-possessed young lady that I had left sitting in a wicker chair absorbed in her work. This time she was rather bigger and more realistic, and I could see her face, or at least that she was addressing me fairly and squarely. And she said in extraordinarily distinct tones: ‘J—S—, you will live till eleven eight.’ Nothing could surpass the clarity with which these eight words were articulated. Her authoritative way of enunciating them seemed to imply that I was to be censured for not supposing that I should live till eleven eight.”

DREAMER'S COMMENTARY

[684] This elaborate description was followed by the dreamer's comments, which can give us a number of hints as regards interpretation. As we should expect, he sees a climax in the sudden change of mood at the beginning of the dream, when the deathly, frightening pallor and wanness of the sunset changes into the sombre majesty of the night, and fear to awe. This, he said, was connected with his present preoccupation with the political future of Europe. On the basis of his astrological speculations he feared the coming of a world war in 1960–66. He had even felt impelled to write a letter to an eminent statesman expressing his fears. Afterwards he made the (not uncommon) discovery that his previously apprehensive and agitated mood suddenly changed into one of remarkable calm and even indifference, as though the whole affair no longer concerned him.

[685] All the same, he could not explain to himself why the initial terror should be superseded by such a solemn and, as it were, holy mood. He felt certain, however, that it was a collective and not a personal matter, and he asked himself: “Are we to suppose that by hanging on too earnestly to the daylight of civilization we lose all potential, and that as we advance into what looks a fearful night there is more prospect of strength?” It is not very easy to fit the qualifying epithet “majesty” into

such an interpretation. He himself related it to the fact that “the things that come from outer space are utterly beyond our control.” “We might put it in theistic language by saying that it is utterly impossible to know the counsels of God and that in eternity the night is as significant as the day. Therefore our only possible chance is to accept the rhythm of eternity as night and day, and so the inexorable majesty of the night would become a source of strength.” Evidently the dream underlines this characteristic defeatism by the cosmic interlude of a stellar bombardment to which mankind is helplessly exposed.

[686] The dream contains no trace of sexuality if, as the dreamer said, we disregard the meeting with the young lady. (As if every relationship to the opposite sex was always necessarily based on sexuality!) What disturbed him was the fact that the meeting took place at night. One can carry “sex-consciousness” too far, as this remark shows. The wicker chair is not exactly inviting in this respect, and for the dreamer himself it signified an excellent condition for concentrated mental work, as indicated also by the note-book.

[687] As the dreamer was an ardent student of astrology the combination of the numbers eleven and eight set him a special problem. He thought of XI. 8 as the month and day of his decease. Being an elderly man of more than three score years and ten he was thoroughly justified in such reflections. His astrological calculations led him to relegate this fatal November to the year 1963, the middle of the conjectural World War. But he added cautiously that he was by no means sure.

[688] The dream, he said, left behind a strange feeling of contentment, and of thankfulness that such an experience had been “vouchsafed” him. It was, indeed, a “big” dream, for the like of which many a man has been thankful, even if he did not understand it correctly.

COMMENTARY TO DREAM 4

[689] The dream begins with a sunset, when the sun is hidden by clouds so that all one can see is a disk. This would emphasize the round form, a tendency confirmed by the appearance of a second disk, Jupiter, more round bodies in large numbers, “things from outer space.” For these reasons the dream comes into the category of psychic Ufo phenomena.

[690] The uncanny pallor of the sun is indicative of the fear that spreads over the daylight world in anticipation of catastrophic events to come. These events, much in contrast to his “daylight” views, are of unearthly origin: Jupiter, the father of the gods, seems to have left his orbit and is approaching the earth. We meet this motif in Schreber’s *Memoirs*: the extraordinary happenings going on all round him compel

God to “move nearer to the earth.” The unconscious “interprets” the threat as a divine intervention, which manifests itself in the appearance of smaller replicas of the great Jupiter. The dreamer does not draw the obvious conclusion about Ufos and does not seem to have been influenced in his choice of symbols by any conscious concern with them.

[691] Although to all appearances a cosmic catastrophe is about to happen, the fear changes into a positive mood of a solemn, holy, and reverent kind, as is fitting for an epiphany. For the dreamer, however, the coming of the god signals extreme danger: the heavenly bodies explode on the earth like huge bombs, thus bearing out his fear of a world war. Remarkably enough, they do not cause the expected earthquake, and the detonations seem to be of a strange and unusual nature. No destruction takes place in the vicinity of the dreamer; the hits are so far below the horizon that all he thinks he can see is a single flash. The collision with these planetoids is therefore infinitely less dangerous than it would be in reality. The main point here seems to be fear of the possibility of a third World War, and it is this that gives the scene its terrifying aspect. It is the dreamer’s own interpretation, rather than the phenomenon itself, which causes him to be so agitated. Consequently the whole affair assumes a markedly psychological aspect.

[692] This is immediately borne out by the meeting with the young lady, who keeps her composure, imperturbably goes on with her work, and prophesies the date of his death. She does this in so solemn and impressive a manner that he even feels it necessary to emphasize the number of the words she uses, namely eight. That this number is more than mere chance is proved by the supposed date of death—the 8th of November. This double emphasis on the eight is not without significance, for eight is a double quaternity and, as an individuation symbol in mandalas, plays almost as great a role as the quaternity itself.¹⁵ For lack of association material we shall suggest only a tentative interpretation of the number eleven with the help of the traditional symbolism. Ten is the perfect unfolding of unity, and the numbers one to ten have the significance of a completed cycle. $10 + 1 = 11$ therefore denotes the beginning of a new cycle. Since dream interpretation follows the principle *post hoc ergo propter hoc*, eleven leads to eight, the ogdoad, a totality symbol, and hence to an actualization of wholeness, as already suggested by the appearance of Ufos.

[693] The young lady, who seems to be unknown to the dreamer, may be taken as a compensating anima figure. She represents a more complete aspect of the unconscious than the shadow, since she adds to the personality its feminine traits. As a rule she appears most clearly when the conscious mind is thoroughly acquainted with its shadow, and she exerts her greatest influence as a psychological factor when the feminine qualities of the personality are not yet integrated. If these opposites are

not united, wholeness is not established, and the self as their symbol is still unconscious. But when the self is constellated it appears in projection, though its true nature is hidden by the anima, who at most alludes to it, as in this dream: the anima, with her calmness and certainty, counters the agitations of the dreamer's ego consciousness, and by mentioning the number eight points to the totality, the self, which is present in the Ufo projection.

[694] The intuition of the enormous importance of the self as the organizer of the personality, and also the importance of the collective dominants or archetypes, which as so-called metaphysical principles determine the orientation of consciousness, is responsible for the solemn mood prevailing at the beginning of the dream. It is a mood in keeping with the coming epiphany, though it is feared that this will unleash a world war or a cosmic catastrophe. The anima, however, seems to know better. Anyway the expected destruction remains invisible, there being no real cause for alarm in the dreamer's vicinity except his own subjective panic. The anima ignores his fear of a catastrophe and alludes instead to his own death, which we can well say is the real source of his fear.

[695] Very often the nearness of death forcibly brings about a perfection that no effort of will and no good intentions could achieve. He is the great perfector, drawing his inexorable line under the balance-sheet of human life. In him alone is wholeness—one way or another—attained. Death is the end of the empirical man and the goal of the spiritual man, as the perspicacious Heraclitus says: "It is to Hades that they rage and celebrate their feasts." Everything that is not yet where it ought to be, that has not yet gone where it ought to have gone, fears the end, the final reckoning. We avoid as long as possible making ourselves conscious of those things which wholeness still lacks, thus preventing ourselves from becoming conscious of the self and preparing for death. The self then remains in projection. In our dream it appears as Jupiter, which in approaching the earth changes into a multitude of smaller heavenly bodies, into numberless "selves" or individual souls, and vanishes in the earth, i.e., is integrated with our world. This hints, mythologically, at an incarnation, but psychologically it is the manifestation of an unconscious process in the sphere of consciousness.

[696] Speaking in the language of the dream, I would advise the dreamer to consider the universal fear of catastrophe in the light of his own death. In this connection it is significant that the conjectured year of his death falls in the middle of the critical period 1960–66. The end of the world would therefore be his own death and hence, primarily, a personal catastrophe and a subjective end. But as the symbolism of the dream unmistakably portrays a collective situation, I think it would be better to generalize the subjective aspect of the Ufo phenomenon and assume that a collective

but unacknowledged fear of death is being projected on the Ufos. After the initial optimistic speculations about the visitors from space, people have recently begun to discuss their possible dangerousness and the incalculable consequences of an invasion of the earth. Grounds for an unusually intense fear of death are nowadays not far to seek: they are obvious enough, the more so as all life that is senselessly wasted and misdirected means death too. This may account for the unnatural intensification of the fear of death in our time, when life has lost its deeper meaning for so many people, forcing them to exchange the life-preserving rhythm of the aeons for the dread ticking of the clock. One would therefore wish many people the compensating attitude of the anima in our dream, and would recommend them to choose a motto like that of Hans Hopfer, a native of Basel and pupil of Holbein: “Death is the last line of things. I yield to none.”¹⁶

DREAM 5

[697] This dream comes from a woman with an academic education. It was dreamt several years ago without reference to Ufos: *“Two women were standing on the edge of the world, seeking. The older was taller but lame. The younger was shorter and had her arm under that of the taller, as if supporting her. The older one looked out with courage (I identified her in some way with X), and the younger stood beside her with strength but feared to look. Her head was bowed (I identified myself with this second figure). Above was the crescent moon and the morning star. To the right the rising sun. An elliptical, silvery object came flying from the right. It was peopled around its rim with figures which I think were men, cloaked figures all silvery white. The women were awed and trembled in that unearthly, cosmic space, a position untenable except at the moment of vision.”*

[698] After this extremely impressive dream the dreamer immediately seized a paint brush in order to fix the vision, as shown in Pl. I. The dream describes a typical Ufo phenomenon which, like Dream 1, contains the motif of “manning,” i.e., the presence of human beings. It obviously represents a borderline situation, as the expression “on the edge of the world” shows. Out beyond is cosmic space with its planets and suns; or the beyond may be the land of the dead or the unconscious. The first possibility suggests a space-ship, the technical achievement of more highly developed planetary beings; the second, angels of some kind or departed spirits, who come to earth in order to fetch a soul. This would refer to X, who was already in need of “support,” as she was ill. Her health really did give grounds for anxiety, and in fact she died about two years after the dream. Accordingly the dreamer took it as a premonition. The third possibility, that the beyond is the unconscious, points to a personification of the latter, namely the animus in his characteristic plurality; the festive white robes of the crew suggest the idea of a marital union of opposites. This symbolism, as we know,

also applies to death as a final realization of wholeness. The dreamer's view that the dream gave warning of the death of her friend may therefore be right.

[699] The dream, then, uses the symbol of a disk-like Ufo manned by spirits, a space-ship that comes out of the beyond to the edge of our world in order to fetch the souls of the dead. It is not clear from the vision where the ship comes from, whether from the sun or moon or elsewhere. According to the myth in the *Acta Archelai*, it would be from the waxing moon, which increases in size according to the number of departed souls that are scooped up from the earth to the sun in twelve buckets, and from there are emptied into the moon in a purified state. The idea that the Ufo might be a sort of Charon is certainly one that I have not met in the literature so far. This is hardly surprising, firstly because "classical" allusions of this sort are a rarity in people with a modern education, and secondly because they might lead to very disagreeable conclusions. The apparent increase in Ufo sightings in recent years has caused disquiet in the popular mind and might easily give rise to the conclusion that, if so many space-ships appear from the beyond, a corresponding number of deaths may be expected. We know that such phenomena were interpreted like this in earlier centuries: they were portents of a "great dying," of war and pestilence, like the dark premonitions that underlie our modern fear. One ought not to assume that the great masses are so enlightened that hypotheses of this kind can no longer take root.

[700] The Middle Ages, antiquity, and prehistory have not died out, as the "enlightened" suppose, but live on merrily in large sections of the population. Mythology and magic flourish as ever in our midst and are unknown only to those whose rationalistic education has alienated them from their roots.¹⁷ Quite apart from ecclesiastical symbolism, which embodies six thousand years of spiritual development and is constantly renewing itself, there are also its more disreputable relatives, magical ideas and practices which are still very much alive in spite of all education and enlightenment. One must have lived for many years in the Swiss countryside in order to become acquainted with this background, for it never appears on the surface. But once you have found the key, you stagger from one amazement to the next. Not only do you come across the primitive witch doctor in the guise of the so-called "Strudel" (wizard), you will also find blood pacts with the devil, pin-stickings and spells for drying up the milk of cattle, and regular hand-written books of magic. At the house of one of these rustic wizards I once discovered a book of this kind from the end of the nineteenth century, beginning with the Merseburg magic spell in modern High German and an incantation to Venus of unknown age. These wizards often have a large clientele from town and country. I myself have seen a collection of hundreds of letters of thanks which one of them received for successfully laying ghosts in houses and stables, for taking the curse off men and animals, and for curing all manner of ailments. For those of my readers who are

unaware of these things and think I am exaggerating, I can point to the easily verifiable fact that the heyday of astrology was not in the benighted Middle Ages but is in the middle of the twentieth century, when even the newspapers do not hesitate to publish the week's horoscope. A thin layer of rootless rationalists read with satisfaction in an encyclopaedia that in the year 1723 Mr. So-and-so had horoscopes cast for his children, and yet do not know that nowadays the horoscope has almost attained the rank of a visiting card. Those who have even a nodding acquaintance with this background and are in any way affected by it obey the unwritten but strictly observed convention: "One does not speak of such things." They are only whispered about, no one admits them, for no one wants to be considered all that stupid. In reality, however, it is very different.

[701] I mention these things that infest the roots of our society chiefly on account of the symbolism of our dreams, which sounds so incomprehensible to many people because it is based on historical and contemporary facts that are unknown to them. What would they say if I connected the dream of a quite simple person with Wotan or Baldur? They would accuse me of learned eccentricity, not knowing that in the same village there was a "wizard" who had taken the spell off the dreamer's stable, using for that purpose a book of magic that begins with the Merseburg incantation. Anyone who does not know that "Wotan's host"—enlightenment or no enlightenment—still roams about our Swiss cantons would accuse me of the greatest whimsicality if I referred the anxiety dream of a city dweller on a lonely Alp to the "blessed people" (the dead), when all the time he is surrounded by mountainfolk for whom the "Doggeli"¹⁸ and Wotan's nightly cavalcade are a reality which they fear without admitting it, and profess to know nothing about. It needs so little to bridge the apparent abyss that yawns between the prehistoric world and the present. But we identify so much with the fleeting consciousness of the present that we forget the "timelessness" of our psychic foundations. Everything that has lasted longer, and will last longer, than the whirligig of modern political movements is regarded as fantastical nonsense that should studiously be avoided. But in that way we succumb to the greatest psychic danger that now threatens us—rootless intellectualisms which one and all reckon without their host, i.e., without the real man. Unfortunately people imagine that only the things they are conscious of affect them, and that for everything unknown there is some specialist who has long made a science out of it. This delusion is the more plausible in that nowadays it really has become impossible for one individual to assimilate the things which specialists know about and he doesn't. But since, subjectively, the most effective experiences are the most individual and therefore the most improbable, the questioner will often get no very satisfactory answer from the scientist. A typical example of this is Menzel's book on Ufos.¹⁹ The scientist's interest is too easily restricted to the common, the probable, the average,

for that is after all the basis of every empirical science. Nevertheless a basis has little meaning unless something can be erected upon it that leaves room for the exceptional and extraordinary.

[702] In a borderline situation such as our dream depicts we may expect something extraordinary, or rather, what seems extraordinary to us, though in reality it has always been inherent in such situations: The ship of death approaches with a corona of departed spirits, the deceased joins their company, and the multitudinous dead take the soul with them.

[703] When archetypal ideas of this kind appear they invariably signify something unusual. It is not our interpretation that is far-fetched; it is merely that the dreamer's attention, caught by the many superficial aspects of the dream, has missed the main point, namely the nearness of death, which in a sense concerns her as much as her friend. We have met the motif of the "manning" of the space-ship in the dream of the metallic spider and shall meet it again in the next one. The instinctive resistance we feel for the deeper aspect of this motif may explain why it seems to play no role in the Ufo literature. We might exclaim with Faust: "Summon not the well-known throng!" But there is no need of this summons, because the fear that hangs over the world has already taken care of that.

DREAM 6

[704] The following dream²⁰ comes from California, the classic Saucer country, so to speak. The dreamer is a young woman of 23. *“I was standing outside with someone (a man). It was night time and we seemed to be in a square or the centre of town—a circle. We were watching the sky. All of a sudden I saw something round and fluorescent coming towards us from way in the distance. I realized it was a Flying Saucer. I thought it was a ridiculous joke. It got larger and larger as it came towards us. It was a huge round circle of light. Finally it covered the entire sky. It was so close, I could see figures walking back and forth on the walk round the ship. There was a railing around it. I thought someone was playing a trick, then I thought it was real—I looked up behind me and saw someone with a movie projector. In back of us seemed to be a building, like a hotel. These people were up high and projecting this image into the sky. I told everyone. Then I seemed to be in a sort of studio. There were two producers, competitors—both old men. I kept going from one to the other discussing my part in their pictures. There were many girls involved.... One of the producers was directing this Flying Saucer thing. They were both making science-fiction films and I was going to have the lead in both pictures.”*

[705] The dreamer, a young film actress, was undergoing psychological treatment for a marked dissociation of personality with all the accompanying symptoms. As usual, the dissociation expressed itself in her relations with the opposite sex, that is, in a conflict between two men who corresponded to the two incompatible halves of her personality.

COMMENTARY TO DREAM 6

[706] As in the first two dreams, the dreamer was conscious of Ufos, and here as there the Ufo functions as a symbol carrier. Its appearance is even expected, since the dreamer had already put herself in a “central” position for this purpose—a square or centre of the city. This gives her a central position between the opposites, equidistant from right and left, and allowing her to see or feel both sides. In the light of this “attitude” the Ufo appears to be rather like an exemplification or “projection” of it. The dream insists on the projection character of the Ufo, since it proves to be a cinematographic operation conducted by two rival film producers. We can easily discern in these two figures the rival objects of her dissociated love choice, and hence the underlying conflict, which should be resolved in a reconciliation of opposites. The Ufo appears here in the mediating role we have met before, but it turns out to be an intentional cinematographic effect obviously lacking any reconciling significance. If we remember the important part a film producer plays in the life of a young

actress, then the changing of the two rival lovers into producers suggests that the latter have acquired for her a more exalted rank or an increase in prestige. They have, so to speak, moved into the limelight of her own drama, whereas the Ufo is very much dimmed, if it has not lost its significance altogether as a mere trick. The accent has gone over entirely to the producers; the apparently cosmic phenomenon is nothing more than a meaningless trick staged by them, and the dreamer's interest turns wholly to her professional ambitions. This seals the outcome of the solution offered by the dream.

[707] It is not easy to see why the dream brings in the Ufo at all, only to dispose of it in this disappointing way. In view of the suggestive circumstances at the beginning of the dream—square, centre, circle—and the sensational significance of Ufos, obviously well known to the dreamer, this dénouement is rather unexpected. It is as though the dream wanted to say: “It is not like that at all—on the contrary. It is only a film trick, a bit of science fiction. Think, rather, that you have the chief role in the two pictures.”

[708] From this we can see what was the role intended for the Ufo and why it had to disappear from the scene. The personality of the dreamer takes up a central position on the stage, one that compensates the splitting into opposites and is therefore a means of overcoming the dissociation. For this a powerful affect is needed in order to enforce a consistent attitude. In the affect the pendulum movement of autonomous opposites ceases and a uniform state is produced. This is accomplished by the exciting appearance of the Ufo, which for a moment attracts all attention to itself.

[709] It is clear that the Ufo phenomenon in this dream is unreal and only a means to an end, as though one called out to a person “Look out!” That is why it is immediately devalued: it is not a genuine phenomenon at all, but a trick, and the dream action now proceeds to the personal problem of the dreamer and her conflict between two men. If this well-known and very common situation means more and lasts longer than a passing uncertainty of choice, this is usually due to the fact that the problem is not taken seriously—like Buridan's ass, which could not decide which of two bundles of hay he wanted to eat first. It was an artificial problem: in reality he was not hungry. This seems to be the case with our dreamer: she means neither the one nor the other, but herself. What she really wants is told her by the dream, which changes the lovers into producers, represents the situation as a film project, and gives her the chief role in the pictures. That is what the dreamer really intends: in the interests of her profession she wants to play the chief role, that of the young lover, regardless of any partner. But evidently she cannot quite bring it off in reality, because she is still tempted to regard her partners as real, when in fact they are only playing a role in her own drama. This does not speak very well for her artistic vocation, and she is right to

feel some doubt as to its seriousness for her. In contradistinction to her vacillating conscious attitude, the dream points decidedly to her profession as her true love and thus gives her the solution to her conflict.

[710] Any insight into the nature of the Ufo phenomenon is not to be expected from this dream. The Ufo is used only as a sort of alarm signal, thanks to the collective excitement occasioned by flying saucers. Interesting or even alarming as the phenomenon may be, youth has, or claims, the right to regard the problem of “him and her” as much more fascinating. In this case it is certainly right, for when one is still in the process of development the earth and its laws are of more significance than that message resounding from afar which the signs in heaven proclaim. Since youth lasts for a very long time and its peculiar state of mind is the highest that many human lives attain, this psychological limitation proves equally true of the grey-haired, whose birthdays are nothing more than nostalgic celebrations of their twentieth. At best the outcome is concentration on one’s profession, any further development being regarded as a mere disturbance. Neither age nor position nor education is any protection against this psychological standstill. Human society is after all still very young, for what are three or five thousand years on a longer view!

[711] I have introduced this dream as a paradigm of the way the unconscious can also deal with the problem that concerns us here. I wanted to show that the symbols cannot be interpreted in a uniform manner and that their meaning depends on many different factors. Life cannot go forward except from the place where one happens to be.

[712] In the next chapter I shall discuss some pictures relating to Ufos. The painter of “The Fire Sower” (Pl. II), to whom I had written that certain details seemed to be connected with the strange apparitions in the skies, sent me the following dream, which he had on September 12, 1957:

DREAM 7

“I found myself, together with other people, on the top of a hill, looking out over a beautiful, broad, undulating landscape teeming with lush verdure.

“Suddenly a flying saucer floated into view, paused at eye-level before us and lay there, clear and shining, in the sunlight. It did not look like a machine but like a deep-sea fish, round and flat, but enormously big (about thirty to forty feet in diameter). It was speckled all over with blue, grey, and white spots. Its edges undulated and quivered all the time; they acted as oars and rudders.

“This creature began circling round us, then all at once, as though fired from a cannon, shot straight up into the blue sky, came rushing down again with inconceivable speed, and once more circled round our hill. It was

obviously doing this for our benefit. (Once when it flew quite close, it seemed to be much smaller and looked like a hammer-head shark.)

“Now it had somehow landed in our vicinity.... An occupant got out and came straight towards me. (A semi-human woman?) The other people fled and waited at a respectful distance, looking back at us.

“The woman told me that they knew me well in that other world (from which she had come) and were watching how I fulfilled my task (mission?). She spoke in a stern, almost threatening tone and seemed to attach great importance to the charge laid upon me.”

COMMENTARY TO DREAM 7

[713] The occasion for the dream was the anticipation of a visit which the dreamer intended to pay me during the next few days. The exposition shows a positive, hopeful feeling of expectancy. The dramatic development begins with the sudden appearance of a Ufo, which has the obvious intention of showing itself as clearly as possible to the observer. On closer inspection he sees that it is not a machine but an animal of sorts, a deep-sea fish, something like a giant ray, which, as we know, sometimes makes attempts to fly. Its movements emphasize the relationship of the Ufo to the observers. These overtures lead to a landing. A semi-human figure climbs out of the Ufo, thus revealing an intelligent human relationship between the Ufo and its observers. This impression is strengthened by the fact that it is a feminine figure which, because it is unknown and indefinite, belongs to the anima type. The numinosity of this archetype causes a panic reaction among the “people” present—in other words, the dreamer registers a subjective reaction of flight. The reason for this lies in the fateful significance of the anima figure: she is the Sphinx of Oedipus, a Cassandra, the messenger of the Grail, the “white lady” who gives warning of death, etc. This view is borne out by the message she conveys: she comes from another world where the dreamer is known, and where they watch attentively how he fulfils his “mission.”

[714] The anima personifies the collective unconscious,²¹ the “realm of the Mothers,” which, as experience shows, has a distinct tendency to influence the conscious conduct of life and, when this is not possible, to irrupt violently into consciousness in order to confront it with strange and seemingly incomprehensible contents. The Ufo in the dream is a content of this kind whose strangeness leaves nothing to be desired. The difficulty of integration is in this case so great that the dreamer’s ordinary powers of comprehension fail him and he resorts to mythical means of explanation—star dwellers, angels, spirits, gods—even before he knows what he has seen. So great is the numinosity of these ideas that one never asks oneself whether it might not be a subjective perception of collective unconscious processes. For in the common estimation a subjective observation can only be either “true” or else, as a delusion of

the senses or an hallucination, it can only be “untrue.” The fact that the latter are also true phenomena with sufficient reasons of their own is apparently never taken into account, so long as no obviously pathological disturbance is present. There are, however, manifestations of the unconscious, even in normal people, which can be so “real” and impressive that the observer instinctively resists taking his perception as a delusion or hallucination. His instinct is right: one does not see only from outside inwards, but from inside outwards. When an inner process cannot be integrated it is often projected outside. It is, indeed, the rule that a man’s consciousness projects all perceptions coming from the feminine personification of the unconscious onto an anima figure, i.e., a real woman, to whom he is as much bound as he is in reality to the contents of the unconscious. This explains the fateful quality of the anima, which is also suggested in the dream by her question: How are you fulfilling your life’s task (“mission”), your *raison d’être*, the meaning and purpose of your existence? This is the question of individuation, the most fateful of all questions, which was put to Oedipus in the form of the childish riddle of the Sphinx and was radically misunderstood by him. (Can one imagine an intelligent Athenian playgoer ever being taken in by the “terrible riddles” of the Sphinx?) Oedipus did not use his intelligence to see through the uncanny nature of this childishly simple and all too facile riddle, and therefore fell victim to his tragic fate, because he thought he had answered the question. It was the Sphinx itself that he ought to have answered and not its façade.

[715] Just as Mephistopheles proves to be the “quintessence of the poodle,” so the anima is the quintessence of the Ufo. But Mephistopheles is not the whole of *Faust*, and the anima too is only a part of the whole, which is obscurely alluded to in the deep-sea fish, the “rotundum.” Here the anima plays the role of the mediatrix between the unconscious and the conscious, a dual figure like the Sphinx, compounded of animal instinct (body) and specifically human qualities (head). In her body lie the forces that determine man’s fate, in her head the power to modify them intelligently. (This basic idea is also reflected in the picture we shall reproduce later.) At this point the dream speaks a mythical language that makes use of conceptions of another world and of angelic beings who watch the doings of men. This vividly expresses the symbiosis of conscious and unconscious.

[716] Such, at any rate, would seem to be the nearest we can get to a satisfactory explanation. With regard to the possible metaphysical background we must honestly confess our ignorance and the impossibility of proof. The unmistakable tendency of the dream is the attempt to create a psychologem which we meet again and again in this and many other forms, regardless of whether the Ufos should be understood as concrete realities or as subjective phenomena. The psychologem is a reality in its own right. It is based on a real perception which has no need of the physical reality of Ufos, because it manifested itself long before Ufos were ever heard of.

[717] The end of the dream lays special weight on the woman's message, emphasizing its seriousness, even its menacing quality. The collective parallel to this is the widespread fear that the Ufos may not be harmless after all, and that communication with other planets might have unpredictable consequences. This view is supported by the fact that the suppression of certain information by the American authorities²² cannot be relegated entirely to the realm of fable.

[718] The seriousness, indeed dangerousness, of the problem of individuation cannot be denied in an age in which the destructive effects of mass-mindedness are so clearly apparent, for individuation is the great alternative that faces our Western civilization. It is a fact that in a dictator State the individual is robbed of his freedom, and that we too are threatened by this political development and are not at all sure of the right means of defence. Hence the question arises in all urgency: are we going to let ourselves be robbed of our individual freedom, and what can we do to stop it?

[719] Anxiously we look round for collective measures, thereby reinforcing the very mass-mindedness we want to fight against. There is only one remedy for the levelling effect of all collective measures, and that is to emphasize and increase the value of the individual. A fundamental change of attitude (*metanoia*) is required, a real recognition of the whole man. This can only be the business of the individual and it must begin with the individual in order to be real. That is the message of our dream, a message addressed to the dreamer from the collective, instinctual foundations of humanity. Large political and social organizations must not be ends in themselves, but merely temporary expedients. Just as it was felt necessary in America to break up the great Trusts, so the destruction of huge organizations will eventually prove to be a necessity because, like a cancerous growth, they eat away man's nature as soon as they become ends in themselves and attain autonomy. From that moment they grow beyond man and escape his control. He becomes their victim and is sacrificed to the madness of an idea that knows no master. All great organizations in which the individual no longer counts are exposed to this danger. There seems to be only one way of countering this threat to our lives, and that is the "revaluation" of the individual.

[720] So vitally important a measure cannot, however, be put into effect at will, that is, by planning and insight, because the individual human being is too small and weak. What is needed, rather, is an involuntary faith, a kind of metaphysical command, which no one can manufacture artificially with his own will and understanding. It can only come about spontaneously. A dominant of this kind underlies our dream. My suggestion that certain details of the picture might be connected with the Ufo problem was sufficient to constellate in the dreamer the archetype underlying this collective phenomenon and to give him a numinous insight into the metaphysical

significance of the individual. The empirical man extends beyond his conscious boundaries, his life and fate have far more than a personal meaning. He attracts the interest of “another world”; achievements are expected of him which transcend the empirical realm and its narrow limits. The status of the individual is enhanced, and he acquires a cosmic importance. This numinous transformation is not the result of conscious intention or intellectual conviction, but is brought about by the impact of overwhelming archetypal impressions.

[721] An experience of this kind is not without its dangers, because it often has an inflating effect on the individual. His ego fancies itself magnified and exalted, whereas in reality it is thrust into the background, so much so that the ego almost needs an inflation (the feeling of being one of the elect, for instance) in order not to lose the ground from under its feet, although it is precisely the inflation that lifts it off its foundations. It is not the ego that is exalted; rather, something greater than it makes its appearance: the self, a symbol that expresses the whole man. But the ego loves to think itself the whole man and therefore has the greatest difficulty in avoiding the danger of inflation. This is another reason why such experiences are shunned, indeed feared as pathological, and why the very idea of the unconscious and any preoccupation with it is unwelcome. It was not so long ago that we were living in a primitive state of mind with its “perils of the soul”—loss of soul, states of possession, etc., which threatened the unity of the personality, that is, the ego. These dangers are still a long way from having been overcome in our civilized society. Though they no longer afflict the individual to the same degree, this is certainly not true of social or national groups on a large scale, as contemporary history shows only too clearly. They are psychic epidemics that destroy the individual.

[722] In face of this danger the only thing that helps is for the individual to be seized by a powerful emotion which, instead of suppressing or destroying him, makes him whole. This can only happen when the unconscious man is added to the conscious one. The process of unification is only partly under the control of our will; for the rest it happens involuntarily. With the conscious mind we are able, at most, to get within reach of the unconscious process, and must then wait and see what will happen next. From the conscious standpoint the whole process looks like an adventure or a “quest,” somewhat in the manner of Bunyan’s *Pilgrim’s Progress*. Esther Harding, in a detailed study,²³ has shown that in spite of the difference of language and outlook Bunyan was speaking of the same inward experiences which also befall people today when they choose the “strait and narrow” path. I would recommend her book to anyone who wants to know what the individuation process really is. To the constantly reiterated question “What can I do?” I know no other answer except “Become what you have always been,” namely, the wholeness which we have lost in the midst of our civilized, conscious existence, a wholeness which we

always were without knowing it. Esther Harding's book speaks such a simple and universal language that any man of good will, even though he lack specialized knowledge, can get an idea of what it is all about. He will also understand why, despite the fact that his question, "What on earth can I do in the present threatening world situation, with my feeble powers?" seems so important to him, it were better for him to do nothing and to leave things as they are. To worship collective ideals and work with the big organizations is spectacularly meritorious, but they nevertheless dig the grave for the individual. A group is always of less value than the average run of its members, and when the group consists in the main of shirkers and good-for-nothings, what then? Then the ideals it preaches count for nothing too. Also, the right means in the hands of the wrong man work the wrong way, as a Chinese proverb informs us.

[723] The message which the Ufo brings to the dreamer is a time problem that concerns us all. The signs appear in the heavens so that everyone shall see them. They bid each of us remember his own soul and his own wholeness, because this is the answer the West should give to the danger of mass-mindedness.

3. UFOS IN MODERN PAINTING

[724] Whilst I was collecting the material for this essay, I happened to come across the work of a painter who, profoundly disturbed by the way things are going in the world today, has given expression to the fundamental fear of our age—the catastrophic outbreak of destructive forces which everyone dreads. It is, indeed, a law of painting to give visible shape to the dominant trends of the age, and for some time now painters have taken as their subject the disintegration of forms and the “breaking of tables,” creating pictures which, abstractly detached from meaning and feeling alike, are distinguished by their “meaninglessness” as much as by their deliberate aloofness from the spectator. These painters have immersed themselves in the destructive element and have created a new conception of beauty, one that delights in the alienation of meaning and of feeling. Everything consists of debris, unorganized fragments, holes, distortions, overlappings, infantilisms, and crudities which outdo the clumsiest attempts of primitive art and belie the traditional idea of skill. Just as women’s fashions find every innovation, however absurd and repellent, “beautiful,” so too does modern art of this kind. It is the “beauty” of chaos. That is what this art heralds and eulogizes: the gorgeous rubbish heap of our civilization. It must be admitted that such an undertaking is productive of fear, especially when allied to the political possibilities of our catastrophic age. One can well imagine that in an epoch of the “great destroyers” it is a particular satisfaction to be at least the broom that sweeps the rubbish into the corner.

PLATE II: *The Fire Sower*

[725] The painter in this case has summoned up the courage to admit the existence of a deep-rooted and universal fear and express it in his art, just as other artists have dared—or were driven—to choose as their motif the conscious and unconscious will for destruction and to depict the collapse of our civilization in chaos. They did this with a passionate superiority worthy of Herostratus,¹ with no fear of the consequences. Fear, however, is an admission of inferiority; it shrinks back from chaos and longs for solid, tangible reality, for the continuity of what has been, for meaning and purpose—in a word, for civilization. It is conscious that all destruction is the result of inadequacy, and that we lack something vital which could halt the onrush of chaos. It must counter the fragmentariness of our world by a striving to be healed and made whole. But since this apparently cannot be found in the present, we cannot even conceive what would make us whole. We have become sceptical, and chimerical

ideas of world improvement stand low on the list. The old panaceas have finally failed and are no longer trusted, or only half-heartedly. The lack of any serviceable or even credible ruling ideas has created a situation that resembles a *tabula rasa*—almost anything might appear on it. The phenomenon of the Ufos may well be just such an apparition.

[726] More or less conscious of its analogy with a Ufo, the artist² has painted a round, fiery object rotating in the heavens above the darkening city. Following a naïve impulse to personification, he has given it the suggestion of a human face, so that it became a head separated from the body to which it belongs. Like the head, the body consists of flame. It is the gigantic figure of a spectral “sower, who went forth to sow.” He sows flames, and instead of water fire falls from heaven. It seems to be an invisible fire, a “fire of the Philosophers,”³ for the city takes no notice of it, nor does it start a conflagration. It falls unheeded, apparently to no purpose, like seed from the hand of the sower. Like an immaterial essence the fiery figure strides through the houses of the city—*two worlds which interpenetrate yet do not touch*.

[727] As the “Philosophers,” that is, the old masters of alchemy, assure us, their “water” is at the same time “fire.” Their Mercurius is *hermaphroditus* and *duplex*, a *complexio oppositorum*, the messenger of the gods, the One and All. He is moreover a Hermes *katachthonios* (subterranean Mercurius), a spirit emanating from the earth, shining bright and burning hot, heavier than metal and lighter than air, serpent and eagle at once, poisonous and alexipharmic. He is the panacea itself and the elixir of life, but on the other hand he is a deadly danger for the ignorant. For the educated person of those days, who studied the philosophy of alchemy as part of his general equipment—it was a real *religio medici*—this figure of the Fire Sower would have been full of allusions, and he would have had no difficulty in assimilating it to his stock of knowledge. For us, however, it is a disconcerting oddity, and we look round in vain for anything to compare it with, because what the conscious mind thinks is so utterly different from what the unconscious is aiming at. The picture illustrates the incommensurable nature of two worlds which interpenetrate but do not touch. One could compare it to a dream that is trying to tell the dreamer that consciously he lives in a dully rational world while all the time he is confronted with the nocturnal phantom of a *homo maximus*. Understood as a subjective reflex, the giant figure could be taken as a kind of psychological spectre of the Brocken. In that case one would have to posit a repressed megalomania of which the artist himself is afraid. The whole thing would then be shifted onto a pathological plane and would be nothing more than a neurotic self-confession slyly insinuated into the picture. The frightening spectacle of an apocalyptic world situation would be reduced to the personal, egocentric fear which everyone feels who nurses a secret megalomania—the fear that one’s imagined grandeur will come to grief on colliding with reality. The

tragedy of the world would be turned into the comedy of a little cock of the dung-hill. We know only too well that such jokes occur all too frequently.

[728] So facile an argument is not sufficient to make this descent from the sublime to the ridiculous appear at all plausible. The significance of the figure lies not so much in its size and strangeness as in the numinosity of its unconscious symbolical background. If it were no more than a matter of personal vanity and infantile self-assertion, the choice of a different symbol would have been far more appropriate—the figure of a successful and envied rival in one’s own profession, for instance, suitably got up to impress, or one that increased the artist’s status. But here everything points to the contrary: the figure is in every respect archetypal. It is of superhuman stature, like an archaic king or a god; it consists not of flesh and bone, but of fire; its head is round, like a luminary, or like the angel’s in Revelation 10:1 —“and a rainbow was upon his head, and his face was as it were the sun, and his feet as pillars of fire”—or like the starry heads of the planetary gods in medieval paintings. The head is separated from the body, as if to emphasize its independence, and could be compared to the arcane substance of the alchemists, the philosophical gold, the *aurum non vulgi*, the “head”-element or “omega”-element, a symbol that originated with Zosimos of Panopolis (third century A.D.). The spirit is a wanderer who roams over the earth, sowing fiery grains, like those gods and god-men who wander about and do miracles, whether of destruction or of healing. Psalm 104:4 likens God’s “ministers” to a “flaming fire”; God himself is a “consuming fire.” “Fire” signifies the intensity of affect and is the symbol of the Holy Ghost, who came down in the form of tongues of fire.

[729] The characteristics of this fire-sowing figure are all steeped in tradition, some of them conscious and biblical, some of them derived from the inherited predisposition to reproduce similar but autochthonous ideas. The artist’s more or less conscious allusion to the Ufo phenomenon throws light on the inner relationship between the two sets of ideas: the one interprets the other, because they both spring from the same source. Another picture by the same artist shows a motif in blue and white similar to that of Dream 2. A spring landscape, the blue sky arching above it, softened by silvery vapours. At one point the thin veil of cloud is pierced by a round opening, through which you can see the deep blue of the heavens. To either side of the opening there is a wedge of white cloud, so that the whole looks like an eye. Extremely realistic automobiles rush along on the road below. “They do not see it,” the artist explained to me. In this picture the Ufo is replaced by the traditional eye of God, gazing from heaven.

[730] These symbolical ideas are archetypal images that are not derived from recent Ufo sightings but always existed. There are historical reports of the same kind from

earlier decades and centuries. Thirty years ago, before Flying Saucers were heard of, I myself came across very similar dream-visions, for instance a multitude of little suns or gold coins falling from the sky, or the figure of a boy whose clothes were made of shining golden circles, or a wanderer in a field of stars, or the rising of a sun-like object which in the course of the visions developed into a mandala. I also remember a picture that was shown to me in 1919, of a town stretching along the edge of the sea, an ordinary modern port with smoking factory chimneys, fortifications, soldiers, etc. Above it there lay a thick bank of cloud, and above this there rolled an "austere image,"⁴ a shining disk divided into quadrants by a cross. Here again we have two worlds separated by a bank of cloud and not touching.

[731] From the very beginning the Ufo reports interested me as being, very possibly, symbolical rumours, and since 1947 I have collected all the books I could get hold of on the subject. Ufos seemed to me to have a good deal in common with mandala symbolism, about which I first wrote in 1927, in *The Secret of the Golden Flower*. Though one would like to give honest eyewitnesses and radar experts the benefit of the doubt, it must nevertheless be stressed that there is an unmistakable resemblance between the Ufo phenomena and certain psychic conditions which should not be overlooked in evaluating the observations. Besides affording a possible psychological explanation the comparison sheds light on the psychic compensation of the collective fear weighing on our hearts. The meaning of the rumour is not exhausted by its being explained as a causal symptom; rather, it has the value and significance of a living symbol, i.e., a dynamic factor which, because of the general ignorance and lack of understanding, has to confine itself to producing a visionary rumour. The fact that there is a numinous quality about all archetypal products is responsible not only for the spread of the rumour but also for its persistence. The numinosity of the complex has the further result that it stimulates deeper reflection and more careful research, until finally someone asks: What is the meaning of such a rumour at the present time? What future developments are being prepared in the unconscious of modern man? Long before Pallas Athene sprang, fully armed, from the head of All-Father Zeus, anticipatory and preparatory dreams had revolved round this theme and transmitted abortive sketches of it to the conscious mind. It depends on us whether we help coming events to birth by understanding them, and reinforce their healing effect, or whether we repress them with our prejudices, narrow-mindedness and ignorance, thus turning their effect into its opposite, into poison and destruction.

[732] This brings me to a question I have been asked over and over again by my patients: What is the use of a compensation that, because of its symbolic form, is not understood by the conscious mind? Apart from those not so uncommon cases where only a little reflection is needed to understand the meaning of a dream, we can take it as a general rule that the compensation is not immediately obvious and is therefore

easily overlooked. The language of the unconscious does not have the intentional clarity of conscious language; it is a condensation of numerous data, many of them subliminal, whose connection with conscious contents is not known. These data do not take the form of a directed judgment, but follow an instinctive, archaic “pattern” which, because of its mythological character, is not recognized by the reasoning mind. The reaction of the unconscious is a natural phenomenon that is not concerned to benefit or guide the personal human being, but is regulated exclusively by the demands of psychic equilibrium. Thus there are times when, as I have often seen, a dream that is not understood can still have a compensatory effect, even though as a rule conscious understanding is required on the alchemical principle “Quod natura relinquit imperfectum, ars perficit” (what nature leaves imperfect, the art perfects). Were this not so, human reflection and effort would be superfluous. For its part, the conscious mind often proves incapable of recognizing the full scope and significance of certain vital situations it has created for itself, and so challenges the unconscious to bring up the subliminal context, which, however, is written not in rational language but in an archaic one with two or more meanings. And since the metaphors it uses reach far back into the history of the human mind, its interpreters will need historical knowledge in order to understand its meaning.

[733] This is true also of our painting: it is a picture that reveals its meaning only with the aid of historical amplification. The fear from which it sprang is explained by the collision of the artist’s conscious world with a strange apparition that came from an unknown region of his being. This world behind, below, and above us appears to us as the unconscious, which adds its subliminal contents to the images we consciously create. Thus there arises the figure of a *homo maximus*, an Anthropos and *filius hominis* of fiery nature, whose godlikeness or numinosity is proved by the fact that he immediately evokes similar figures in our minds, such as Enoch, Christ,⁵ or Elijah, or the visions of Daniel and Ezekiel. Since Yahweh’s fire chastises kills and consumes, the spectator is also at liberty to think of Jacob Boehme’s “wrath-fire,” which contains hell itself together with Lucifer. The scattered flames could therefore signify the “enthusiasm” of the Holy Ghost as well as the fire of evil passions—in other words, the extremes of emotion and affect which human nature is capable of, but which in ordinary life are prohibited, suppressed, hidden, or altogether unconscious. It is probably not without good reason that the name “Lucifer” applies to both Christ and the devil. The Temptation in Matthew 4:3ff. describes the split between them, and the fight against the devil and his angels exemplifies the mutual opposition and at the same time the inner relationship between the two sides of a moral judgment. An opposition exists only where two principles conflict with one another, but not where one is and the other not, or where there is only a one-sided dependence, such as when only good has substance but not evil.

[734] The fiery figure is ambiguous and therefore unites the opposites. It is a “uniting symbol,” a totality beyond human consciousness, making whole the fragmentariness of the merely conscious man. It is a bringer of salvation and disaster at once. What it will be, for good or ill, depends on the understanding and ethical decision of the individual. The picture is a kind of message to modern man, admonishing him to meditate on the signs that appear in the heavens and to interpret them aright.

[735] The reflection of the Ufo phenomenon in the artist’s fantasy has produced a picture whose basic features are similar to those already discussed in the dreams. It belongs to another dimension, to a world of gods that seems to have no connection with our reality. The picture gives one the impression of a vision, beheld by one singled out and elect, who was permitted to see what the gods do secretly on earth. The artist’s interpretation of the phenomenon is at an astronomical remove from the popular view that Ufos are controlled space machines.

PLATE III: *The Fourth Dimension*

[736] Like the previous painting, this too is contemporary. In order to avoid misunderstandings I must point out at once that it is painted on canvas and that the peculiar treatment of the background is not the result of the grain of wood showing through. It was the artist’s intention to represent something growing or flowing. Similarly, he uses the skyline of a city to emphasize a horizontal plane cutting through the picture. Whereas Jakoby contrasts the low-lying city with the spacious night sky, Birkhäuser has moved the horizontal upward, to indicate that the essence of the background also flows downward through the depths of the earth. The colour of the city is a soft dark red; the background is a light, watery, greenish blue streaked with pale yellow and vermilion.

[737] In this background there are fourteen more or less distinct circles. Ten of them form the eyes of shadowy faces, half animal, half human. The other four look like knots in wood or like dark objects floating about with haloes round them. From the mouth of the large face at the top there issues a stream of water that flows downward through the city. Neither touches the other: two incommensurable events are taking place on two totally different planes, one vertical, the other horizontal. Since, on the horizontal plane, there is a three-dimensional city bathed in a light that shines from the left of the picture and has nothing to do with the background, this background can only be considered as a *fourth dimension*. The intersecting lines of the two worlds form a cross (city and waterfall). The only discernible connection between the two is the downward glance of the eyes in the large face above the city. The pronounced nostrils and abnormally wide-apart eyes show that the face is only partly human. Of the four other faces, the only unmistakably human one is at the top left. The face at

the bottom left can only be made out very faintly. If we regard the face in the middle, distinguished both by its size and by the fact that the water flows from its mouth, as the main face and as the source, then the ground structure of the picture is a quincunx:

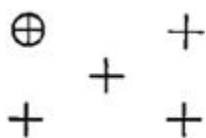

[738] This is a symbol of the *quinta essentia*, which is identical with the Philosophers' Stone. It is the circle divided into four with the centre, or the divinity extended in four directions, or the four functions of consciousness with their unitary substrate, the self. Here the quaternity has a 3 + 1 structure: three animal-daemonic faces and one human one. This peculiar feature of our picture recalls the quaternity discussed by Plato in the *Timaeus* and experienced still earlier by Ezekiel in his vision of the four seraphim. One of them had a human face, the other three had animal faces. The motif appears again in certain representations of the sons of Horus and in the emblems of the evangelists, as well as in the four gospels (three synoptic, one "Gnostic") and in the four Persons of Christian metaphysics: the Trinity and the devil. The 3 + 1 structure is a motif that runs all through alchemy and was attributed to Maria the Copt or Jewess. Goethe took it up again in the Cabiri scene in *Faust*. The number 4 as the natural division of the circle is a symbol of wholeness in alchemical philosophy, and it should not be forgotten that the central Christian symbol is a quaternity too, which, in the form of the long cross, even has the 3 + 1 structure.⁶

[739] This painting, like the previous one, depicts the collision of two incommensurable worlds, vertical and horizontal, which meet only at one point: in the Sower's intention to scatter fire on the earth, and in the downward glance of the eyes.

[740] Coming now to the four circles⁷ that are not eyes, we note that only one of them—on the extreme left—is completely round and solid-looking. The circle on the right of the mouth is light with a dark centre; a third circle appears to be emitting a whitish vapour; a fourth circle is half hidden by the flowing water. They form a differentiated quaternity in contrast to the undifferentiated ogdoad of eyes, which, if we disregard the main face, belong to a quaternity with a 3 + 1 structure.

[741] It is difficult to say how much in the main face is animal and how much is human. But since it represents the "source of living water" (quintessence, *aurum potable*, *aqua permanens*, *vinum ardens*, *elixir vitae*, etc.) and appears to have an animal component, its doubtfully human character is plain enough. One thinks of the figure "having the likeness of a human form" who appeared above the sapphire throne in Ezekiel's vision, and of Yahweh's wildness, which so often breaks through

in the Old Testament. In Christian iconography the Trinity consists of three human persons (occasionally depicted as a tricephalus), while the fourth, the devil, is traditionally represented as half-animal. Our mandala seems to be complementary to the Christian totality.

[742] One further fact deserves notice: the two lower faces, though inverted, are not reflections of the two upper ones, but are independent entities representing a lower as opposed to an upper world. Moreover, one of the two upper faces is light, the other considerably darker, with pointed ears. In contrast to this opposition the water flows uniformly from above downward, thus forming a potential. The source lies not only above the earthly horizontal but also above the middle line of the picture, so that the upper world is characterized as the source of life. Since the three-dimensional human body is ordinarily thought of as the seat of life and strength, this is compensated by placing the source in the fourth dimension. It flows from an ideal centre. The fourth dimension is therefore only apparently symmetrical, in reality it is asymmetrical—a problem that is of importance both to nuclear physics and to the psychology of the unconscious.

[743] The “four-dimensional” background is a “vision,” in the dual sense of seeing and of something seen. It seems to be a matter of pure chance that it has turned out so and not otherwise, when the merest accident could have given it a quite different appearance. The sight of these round blobs aimlessly scattered over a wishy-washy surface, most of them serving for eyes in indistinct animal-human faces lacking any definite expression, fails to arouse our interest. The picture discourages any attempt to find access to it, for the chance products of nature, if they lack aesthetic charm, have no effect on our sensibilities. Their chancefulness makes the slightest attempt to interpret them seem like empty speculation. It needs the interest of the psychologist, so often incomprehensible to the layman, to follow up a vague instinct for order, using for this purpose the most primitive of all devices, namely *counting*. When there are few or no characteristics that can be compared with one another, number remains as the ordering schema. Nevertheless, the little disks or holes are distinctly round and the majority of them are eyes. It is only by chance—I must repeat this—that numbers and other patterns appear whose exact repetition would be extremely improbable. In such cases we must refrain from all statistical or experimental thinking, for a probability test of this picture would involve astronomical figures. Investigations of this kind are only possible when a very simple experiment can be repeated over and over again in the shortest time, like Rhine’s tests. Our picture is a unique and complex occurrence which from the statistical point of view is entirely meaningless. But from the psychological point of view such curiosities may be meaningful, because the conscious mind is involuntarily impressed by their numinosity. We must therefore take account of them, however improbable and irrational they may appear

to be, just because they are important factors in a psychological process. But I must emphasize that nothing will have been proved.

[744] Since psychology touches man on the practical side, it cannot be satisfied with averages, because these only give information about his general behaviour. Instead, it has to turn its attention to the individual exceptions, which are murdered by statistics. The human psyche attains its true meaning not in the average but in the unique, and this does not count in a scientific procedure. Rhine's experiments have taught us, if practical experience has not already done so, that the improbable does occur, and that our picture of the world only tallies with reality when the improbable has a place in it. This point of view is anathema to the exclusively scientific attitude, despite the fact that without exceptions there would be no statistics at all. Moreover, in actual reality the exceptions are almost more important than the rule.

[745] This picture allows some conclusions to be drawn as to the nature of the objects appearing in the sky. The "sky" is not the blue vault we see, nor is it the star-filled universe; it is a strange fourth dimension containing supernatural beings as well as dark disks or round holes. The background has a fluid, watery character in striking contrast to the exclusively fiery nature of the previous picture. Fire symbolizes dynamism, passion, and emotion, whereas water with its coolness and substantiality represents the passive object, detached contemplation, hence the thirst-quenching *aqua doctrinae* and the *refrigerium*⁸ that puts out the fire, like the salamander of alchemy.

[746] As the old masters say: "Our water is fire"—an identity which, as soon as we think about it, splits into opposites, as also does the unconscious God-image. This seeming mystery is characteristic of all that is: it is so and yet not so, especially the unconscious, whose reality we can experience only in parables. In the same way a fourth dimension can be regarded only as a mathematical fiction, an intellectual sophistry, or a revelation of the unconscious, for we have no direct experience of it.

[747] The unconscious arrangement of the elements composing the picture suggests that the Ufos are subliminal contents that have become visible; that they are, in a word, archetypal figures.

PLATE IV: *Painting by Yves Tanguy*

[748] This painting dates from the year 1927, thus anticipating by more than a decade the great bombings of cities. For this is what the picture brings to mind. As a contemporary painting is usually rather difficult to interpret, because its whole aim is to abolish meaning and form and to replace them by something strange and disconcerting, I have followed the method of showing it to as many different people

as possible, in this way conducting a kind of Rorschach test. Most of them took the black and white background, which combines a minimum of intelligibility with a maximum of abstraction, to be a plane surface. This is supported by the fact that the light causes the five central forms to cast shadows. It can be seen that these shadows fall on a plane. The interpretation of this varies considerably: some thought it was a sea covered with drift ice in the Polar night, others a sea of fog at night time, others the bleak surface of a distant planet like Uranus or Neptune, and others a great city illuminated at night, situated along the edge of bays, like San Francisco or New York. The strange quincunx suspended over the “city” left most of them puzzled. Some interpreted it at once as falling bombs and explosions. The form in the middle was taken to be a sea-creature (sea-anemone, octopus, etc.) or a flower, or else a daemonic face with tangled hair (looking down to the left); others saw it as the swirling smoke of a great fire. The four figures surrounding it were understood as sea animals, puffs of smoke, fungi, or, because of the horns, as devils. The one at the top left, whose vivid yellowish-green contrasts with the dull, indeterminate tones of the others, was interpreted as poisonous smoke, a water-plant, flame, a house on fire, etc. I must admit that for me the comparison with a city at night by the sea, viewed from a considerable height as from an aeroplane, was the most convincing. The artist is said to have been a sailor originally, and would thus have had plenty of opportunities for such impressions.

[749] The horizon is lost in cloudy forms over which hangs a faint circular luminosity; to the left of this is a dimly lit cloud bank (?), shaped like a cigar. In the centre of the brightness there is, as if by accident, a barely visible spot of the same colour as the yellowish-green “flame” (top left of the quincunx). A similar, but clearly visible, spot can be seen further down (centre right), directly above the city. A faint line connects it with another yellowish-green spot, apparently a continuation of the flame. The longish second spot points towards the centre of faintly discernible concentric circles that suggest rotation. It is interesting to note that the first-mentioned spot at the top of the picture is also connected with concentric circles. Unfortunately they cannot be seen in the reproduction because it is too dark; they appear only as a circular luminosity surrounding the yellowish spot, but can be felt to the touch as lightly raised lines. Probably they were scratched on with a pointed instrument. There can be no doubt about their circular nature, which is clearly apparent in the lower concentric formation.

[750] These details seem to be a matter of pure chance, the impression also given by the previous picture. Their fortuitous nature cannot be denied, but they assume a rather different aspect when submitted to a comparative procedure. As if by chance two luminous whirls with dark centres, and an equally fortuitous cigar form, appear in the night sky, together with a bright spot and a line connecting the second whirl

with the flame. One can easily let one's imagination run and interpret the flame as belonging to a projectile shot out of the whirl, or, as we would now say, from a Ufo—for Ufos are said to have incendiary tendencies, among other things. Here it is sowing fire, as a distinct line connects it with the flame. There are, however, a number of other wavy lines crossing the picture, like highways or boundary lines. Have they anything to do with the phenomena in the sky? So much in this picture remains conjecture, for instance the indeterminable corporeal shapes, which, together with the "flame," form a quaternity with a 3 + 1 structure. The structure in the middle is equally difficult to interpret, but it is obviously of a different, more nebulous nature and is thereby distinguished from the others, though like them it throws a shadow.

[751] The description of the picture would be incomplete if I omitted to mention an important factor which reveals itself on closer examination: the cylindrical, phallic cloud (?) is aimed straight at the topmost luminous whirl, and this could be interpreted sexualistically as cohabitation. Similarly, from the lower whirl a little flame leaps out, which is connected in turn with the big flame on the left. The latter, in psychological terms, is the One differentiated from the Three, the one differentiated function contrasted with the three undifferentiated functions, and hence the main function (or, alternatively, the inferior function). The four together form an unfolded totality symbol, the self in its empirical aspect. The name of one of the Gnostic deities is Barbelo, "god is four." According to an early Christian idea the unity of the incarnate God rests on the four pillars of the gospels (representing the 3 + 1 structure), just as the Gnostic *monogenes* (*unigenitus*, Only Begotten) stands on the *tetrapeza* (four-footed table). Christ is the head of the Church. As God, he is the unity of the Trinity, and as the historical Son of Man and anthropos he is the prototype of the individual inner man and at the same time the culmination, goal and totality of the empirical man. Thus we arrive at an apparently fortuitous picture of a hierosgamos taking place in the heavens, followed by the birth of a saviour and his epiphany on earth.

[752] The picture is distinguished by a strongly marked horizontal axis. The vertical axis is expressed by the quaternity, and, more dramatically, by the heavenly origin of the fire. The comparison with a bombing is not so far-fetched, since at the time the picture was painted this possibility was in the air, both as a memory of the past and as a premonition of the future. The Ufos in the sky and the remarkable happenings down below together constitute an impressive vertical, which could be interpreted as the intrusion of a different order of things. The accent lies without doubt on the quincunx, which we have dealt with above. It is a decidedly enigmatic structure, and this obviously accords with the artist's intention. He has undoubtedly succeeded in expressing the bleakness, coldness, lifelessness, the cosmic "inhumanness" and infinite desolation of the horizontal, despite the association "city." He thus confirms

the tendency of this kind of modern art to make the object unrecognizable and to cut off the sympathy and understanding of the beholder, who, rebuffed and confused, feels thrown back on himself.

[753] The psychological effect is very like that of the Rorschach test, where a purely fortuitous and irrational picture appeals to the irrational powers of the imagination and brings the observer's unconscious into play. When his extraverted interest is snubbed in this way it falls back on the "subjective factor" and increases the latter's energy charge, a phenomenon that was observed very clearly in the original association tests. The isolated stimulus word uttered by the experimenter bewilders and embarrasses the subject because it may have more than one meaning. He does not quite know what to answer, and this accounts for the extraordinary variety of answers in these tests and—what is more important—for the large number of disturbed reactions⁹ which are caused by the intrusion of unconscious contents.

[754] The rebuffing of interest by unintelligibility results in its introversion and a constellation of the unconscious. Modern art has the same effect. We can therefore attribute to it a conscious or unconscious intention to turn the beholder's eyes away from the intelligible and enjoyable world of the senses and to enforce a revelation of the unconscious as a kind of substitute for the loss of human surroundings. This is also the intention of the association experiment and the Rorschach test: they are meant to supply information concerning the background of consciousness, and this they do with great success. The experimental setup of modern art is evidently the same: it faces the observer with the question "How will you react? What do you think? What kind of fantasy will come up?" In other words, modern art is less concerned with the pictures it produces than with the observer and his involuntary reactions. He peers at the colours on the canvas, his interest is aroused, but all he can discover is a product that defies human understanding. He feels disappointed, and already he is thrown back on a subjective reaction which vents itself in all sorts of exclamations. Anyone who knows how to interpret these will learn a lot about the subjective disposition of the observer but next to nothing about the painting as such. For him it is no more than a psychological test. This may sound disparaging, but only for those who regard the subjective factor merely as a source of discomfort. But if they are interested in their own psyches, they will try to submit their constellated complexes to closer scrutiny.

[755] Since even the boldest fantasy of the creative artist—however much it may exceed the bounds of intelligibility—is always bounded by the limits of the psyche itself, there may easily appear in his pictures unknown forms which indicate certain limiting and predetermined factors. These, in Tanguy's picture, are the quincunx, the quaternity with the 3 + 1 structure, and the "signs in the heavens," the circles and the

cigar-form—in a word, the archetypes. In its attempt to leave the world of visible and intelligible appearances and to float in the boundlessness of chaos, modern art, to a still greater degree than the psychological tests, evokes complexes which have sloughed off their usual personal aspect and appear as what they originally were, namely primordial forms of the instincts. They are of a suprapersonal, collective-unconscious nature. Personal complexes arise wherever there are conflicts with the instinctual disposition. These are the points of faulty adaptation, and their sensitiveness releases affects which tear the mask of adaptedness off the face of civilized man. This also seems to be the goal that modern art is indirectly aiming at. For all the appearance of extreme arbitrariness and boundless chaos, the loss of beauty and meaning is compensated by a strengthening of the unconscious. And since this is not chaotic but pertains to the natural order of things, it is to be expected that forms and patterns will arise which are indicative of this order. This seems to be the case in the examples we have been discussing. As though by chance there appear in the chaos of possibilities unexpected ordering principles which have the closest affinities with the timeless psychic dominants, but at the same time have conjured up a collective fantasy typical of our technological age and painted it in the skies.

[756] Pictures of this kind are rather rare, but not undiscoverable. For that matter, relatively few people have seen a Ufo, yet there can be no doubt about the existence of the rumour. It has even attracted the attention of hard-headed military authorities, despite the fact that for sheer improbability it outdoes anything I have said about the meaning of the pictures. Anyone who wants to get an independent idea of the scope of the Ufo legend should read Edgar Sievers' *Flying Saucers über Südafrika*. Though open to attack at many points, it gives one some notion of the efforts an intelligent and well-meaning person has to make in order to come to terms with the Ufos. It is undoubtedly a challenging matter that has caused the author to move heaven and hell. What he unfortunately lacks is a knowledge of the psychology of the unconscious, perhaps the most important thing here. His book sets forth all the earlier and recent attempts at explanation based on scientific and philosophical premises, but also, unfortunately, on unverifiable theosophical assertions. Credulity and lack of discrimination, which elsewhere would be vices, here serve the useful purpose of bringing together a collection of heterogeneous speculations on the Ufo problem. Anyone who is interested in the psychology of the rumour will read this book with profit, for it offers a comprehensive survey of the psychic phenomenology of the Ufo.

4. PREVIOUS HISTORY OF THE UFO PHENOMENON

[757] Though the Ufos were first publicized only towards the end of the second World War, the phenomenon itself was known long before. It was observed in the first half of this century, and was described in earlier centuries and perhaps even in antiquity. In the Ufo literature there are collections of reports from various sources which need critical evaluation. I shall spare myself this task and give the reader only two examples.

PLATE V: *Basel Broadsheet, 1566*

[758] This is from a broadsheet written by Samuel Coccius, “student of the Holy Scripture and of the free arts, at Basel, in the Fatherland,” in August 1566. He reports that on August 7 of that year, at the time of the sunrise, “many large black globes were seen in the air, moving before the sun with great speed, and turning against each other as if fighting. Some of them became red and fiery and afterwards faded and went out.”

[759] As the illustration shows, this sighting was made in Basel. The dark colour of the Ufos may be due to their having been seen against the light of the rising sun. Some of them were bright and fiery. Their speed and irregular motion are typical Ufo features.

PLATE VI: *Nuremberg Broadsheet, 1561*

[760] This broadsheet relates the story of a “very frightful spectacle” seen by “numerous men and women” at sunrise on April 14, 1561. They saw “globes” of a blood-red, bluish, or black colour, or “plates” in large numbers near the sun, “some three in a row, now and then four in a square, also some standing alone. And amongst these globes some blood-coloured crosses were seen.” Moreover there were “two great tubes”—three in the picture—“in which three, four, and more globes were to be seen. They all began to fight one another.” This went on for about an hour. Then “they all fell—as one sees in the picture—from the sun and sky down to the earth, as if everything were on fire, then it slowly faded away on the earth, producing a lot of steam.” Underneath the globes was a long object, “shaped like a great black spear.” Naturally this “spectacle” was interpreted as a divine warning.

[761] This report, as the reader will have noted, contains certain details already known to us. Above all the “tubes,” which are analogous to the cylindrical objects in the Ufo reports. These, in Ufo language, are the “mother-ships” which are said to carry the

smaller, lens-shaped Ufos for long distances. The picture shows them in operation, releasing Ufos or taking them on board. Especially important, though lacking in the modern Ufo reports, are the indubitable quaternities, seen sometimes as simple crosses, sometimes as disks in the form of a cross, that is, as regular mandalas. There also seems to be a hint of the 3 + 1 motif in the dilemma of three and four. The militaristic interpretation is as characteristic of the sixteenth century as the technological one is of ours. The tubes are cannons and the globes cannonballs, and the shooting to and fro of the globes is an artillery engagement. The great black spearhead, as well as the spearshafts (?), seem to represent the masculine element, especially in its “penetrating” capacity. Similar things are reported in the Ufo literature.

[762] The emphasis on the cross motif is striking. The Christian meaning of the cross can hardly be considered here, since we are dealing with a natural phenomenon, a swarm of round objects in violent motion, shooting in opposite directions and reminding the reporter of a battle. If the Ufos were living organisms, one would think of a swarm of insects rising with the sun, not to fight one another but to mate and celebrate the marriage flight. Here the cross signifies a union of opposites (vertical and horizontal), a “crossing”; as a plus sign, it is also a joining together, an addition. Where the globes are coupled together to form quaternities, they have given rise to the crossed marriage quaternio, which I have discussed in my “Psychology of the Transference.” It forms the model for the primitive “cross cousin marriage,” but is also an individuation symbol, the union of the “four.”

[763] Columns of smoke rise up from the place where the cannonballs have fallen, reminding us of Tanguy’s picture. The moment of sunrise, the *Aurora consurgens* (Aquinas, Boehme), suggests the revelation of the light. Both reports have clear analogies not only with one another but also with the modern saucer stories and with the individual products of the unconscious today.

PLATE VII: *The Spiritual Pilgrim Discovering Another World*

[764] This seventeenth-century woodcut, possibly representing a Rosicrucian illumination, comes from a source unknown to me.¹ On the right it shows the familiar world. The pilgrim, who is evidently on a *pélerinage de l’âme*, has broken through the star-strewn rim of his world and beholds another, supernatural universe filled with what look like layers of cloud or mountain ranges. In it appear the wheels of Ezekiel and disks or rainbowlike figures, obviously representing the “heavenly spheres.” In these symbols we have a prototype of the Ufo vision, which is vouchsafed to the illuminati. They cannot be heavenly bodies belonging to our

empirical world, but are projected “rotunda” from the inner, four-dimensional world. This is even more evident in the next picture.

PLATE VIII: *The Quickening of the Child in the Womb*

[765] This picture comes from the Rupertsberg Codex *Scivias*, written by Hildegard of Bingen (12th cent.). It shows the quickening or “animation” of the child in the body of the mother. From a higher world an influx enters the foetus. This upper world has a remarkable quadratic form divided into three to correspond with the Trinity, but, unlike the latter, which is supposed to consist of three equal parts, the middle section is different from the other two. It contains round objects, whereas the other two are characterized by the eye motif. Like the wheels of Ezekiel, the little rotunda are associated with eyes.

[766] As Hildegard’s text states, the radiance of the “countless eyes” (there are in reality twenty-four in each section) means “God’s knowledge,” that is, his seeing and knowing, with reference to the seven eyes of God that “run to and fro through the whole earth” (Zech. 4:10). The rotunda, on the other hand, are God’s deeds, such as the sending of his son as a saviour (p. 127). Hildegard adds: “All, the bad as well as the good, appear in God’s knowledge, for it is not ever clouded round by any darkness.” The souls of men are “fireballs” (pp. 120, 126, 130, 133), so presumably the soul of Christ was also such a ball, for Hildegard interprets her vision not with reference to the growth of a human child only, but with particular reference to Christ and the Mother of God (p. 127). The square divided into three stands for the Holy Ghost entering into the child (p. 129). The procreative aspect of the Holy Ghost unites the Godhead with matter, as is clear from the sacred legend. The intermediate forms between spirit and matter are obviously the rotunda, early stages of animated bodies, filling the middle section of the square. There are thirty of them, and, however accidental this may be, the number 30 (days of the month) suggests the moon, ruler of the hylical world, whereas twenty-four (hours of the day) suggests the sun, the king. This indicates the motif of the *coniunctio* (☉ and ☽)—an instance of that unconscious readiness which later came to expression in Cusanus’ definition of God as a *complexio oppositorum*. In the miniature the rotunda are fire-coloured, the fiery seeds from which human beings will sprout, a sort of pneumatic roe. This comparison is justified in so far as alchemy compares the rotunda to fish’s eyes. The eyes of a fish are always open, like the eyes of God. They are synonymous with the *scintillae*, “soul-sparks.” It is just possible that these alchemical allusions crept into Hildegard’s text via the atoms of Democritus (*spiritus insertus atomis*).² Another such source may be responsible for the squareness of the Holy Ghost.

[767] The square, being a quaternity, is a totality symbol in alchemy. Having four corners it signifies the earth, whereas a circular form is attributed to the spirit. Earth is feminine, spirit masculine. The square as a symbol of the spiritual world is certainly most unusual, but becomes more intelligible when we take Hildegard's sex into account. This remarkable symbolism is reflected in the squaring of the circle—another *coniunctio oppositorum*. “Squareness” in alchemy is an important feature of the unitary substance, the *Mercurius Philosophorum sive quadratus*, and characterizes its chthonic nature, which it possesses along with spirituality (*spiritus mercurialis*). It is as much a metal as a spirit. Correspondingly, in Christian dogma, the Holy Ghost as the third Person of the Trinity does not remain a prerogative of the incarnate God, but may descend also upon sinful man. Though these ideas were not yet explicitly conscious in Hildegard's day, they were implicitly present in the collective unconscious, activated by the Christ/Mercurius analogy. This reached consciousness in the next century, but had been clearly anticipated in the writings of Zosimos of Panopolis in the third century A.D. We must emphasize, however, that there can hardly be any historical connection between the two; it is more a question of the activated archetype of the Primordial Man or Anthropos.



A Ufo Vision Painting by a patient



E. Jakoby: *The Fire Sower*

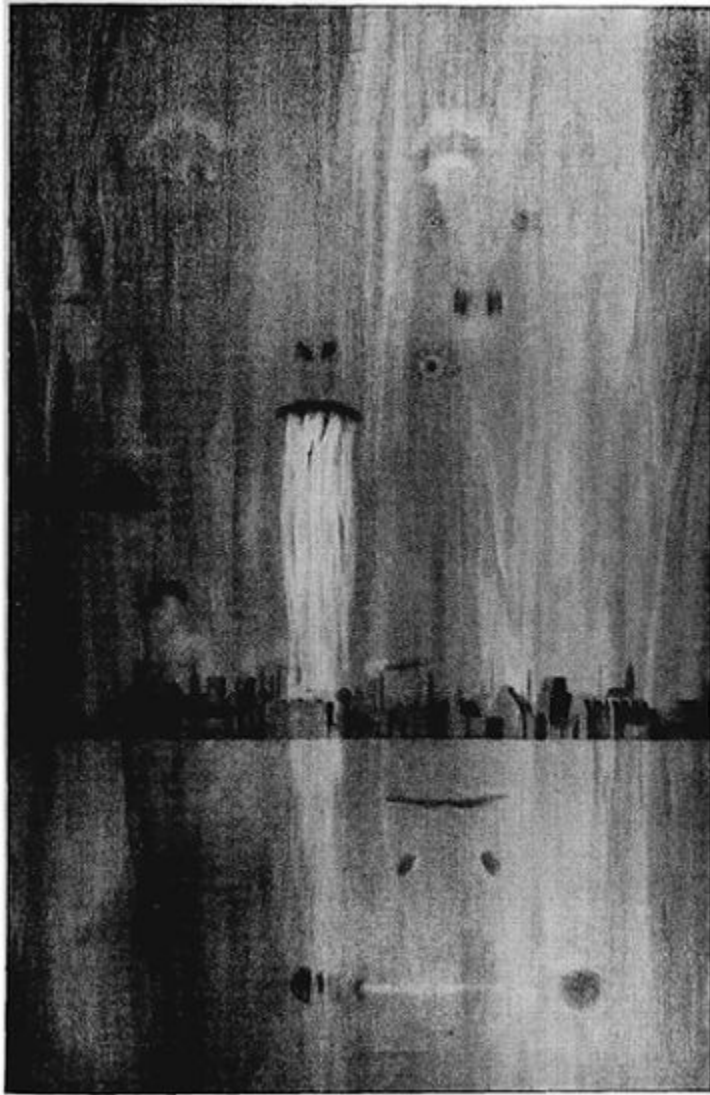

P. Birkhäuser: *The Fourth Dimension*



Yves Tanguy: Painting, 1927

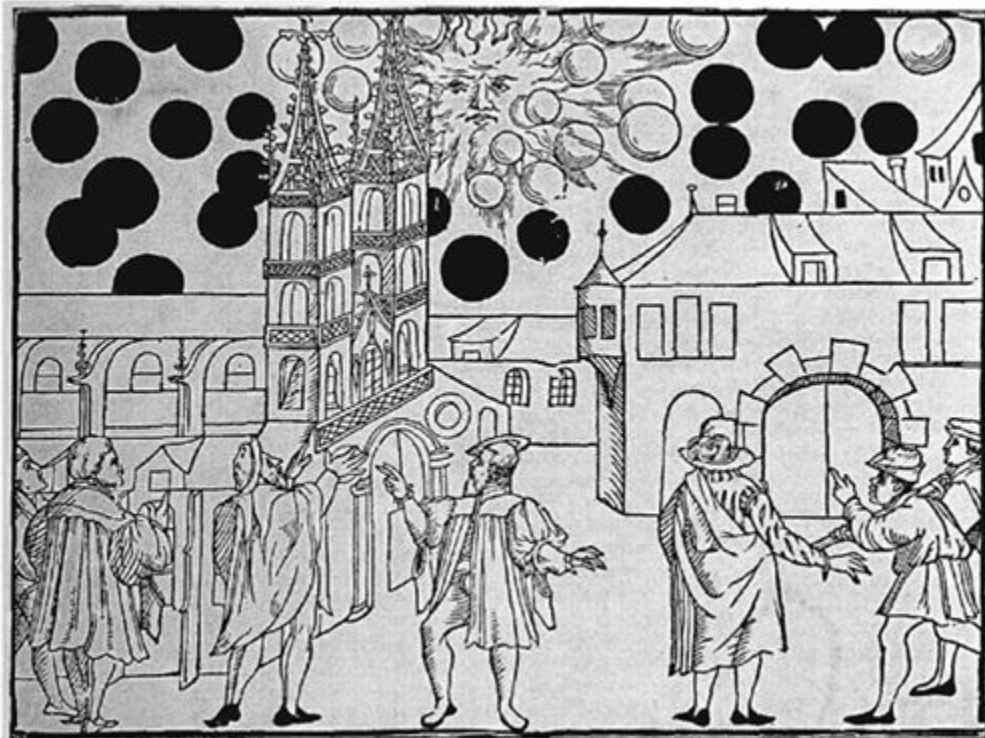

Basel Broadsheet, 1566

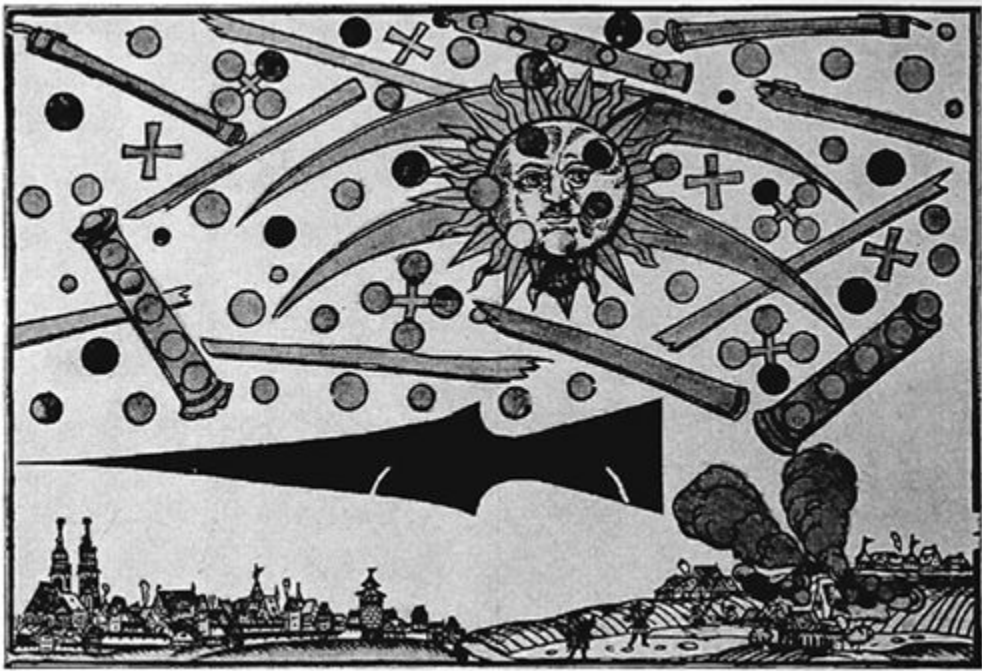

Nuremberg Broadsheet, 1561

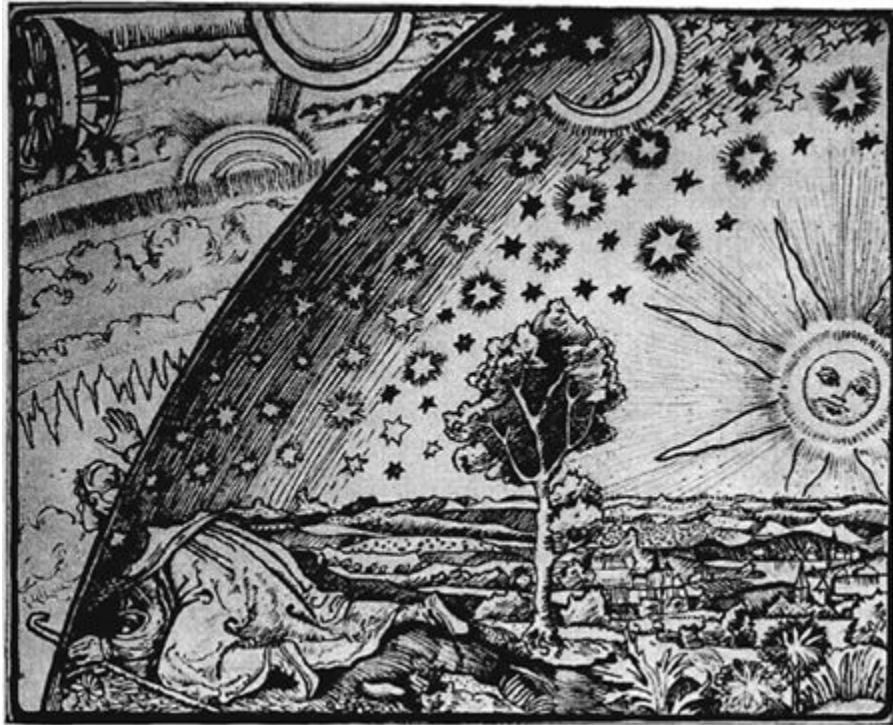

"The Spiritual Pilgrim Discovering Another World" Woodcut, 19th (?) century



“The Quickening of the Child in the Womb”

From the Scivias of Hildegard von Bingen, in a ms. of the 12th century

[768] Equally characteristic of alchemy is the arithmetical structure of the Holy Ghost: he is a unity, consists of two principles (eyes and fireballs), has three parts, and is a square. This motif is known under the name of the Axiom of Maria, who lived in Alexandria in the third century and played a great role in classical alchemy.

[769] The two human groups in the picture typify the fates that preside over the awakening of the soul. There are, as Hildegard says, “people who prepare good or middling or bad cheese.”³ The devil, too, has a hand in the game. The picture shows clearly, like the previous one, that the eyes and fireballs are not identical with the heavenly bodies and are differentiated from the stars in the background. It confirms that the fireballs are souls.

Summary

[770] From the dream examples and the pictures it is evident that the unconscious, in order to portray its contents, makes use of certain fantasy elements which can be compared with the Ufo phenomenon. In dreams 1, 2, 6, and 7, and in the painting of

the Fire Sower, the connection with Ufos was conscious, while in the other dreams and in two of the paintings no conscious connection could be proved. The personal relationship between the Ufo and the observing dream-subject was stressed in some of the dreams, but this is completely lacking in the paintings. In medieval paintings the personal participation in an epiphany or in suchlike visionary experiences is expressed by the visible presence of the recipient of the vision. This view does not fit at all into the programme of modern art, which is more concerned to put as great a distance as possible between the object and the spectator—like the Rorschach ink-blot, which is intentionally *tachiste* in order to avoid any suggestion of meaning and to produce a purely subjective phantasm.

[771] The dreams as well as the paintings, when subjected to careful scrutiny, yield a meaningful content which could be described as an *epiphany*. In the Fire Sower this meaning can be recognized without difficulty. In the other cases an investigation in the light of comparative psychology leads to the same conclusion. For those unacquainted with the psychology of the unconscious I must emphasize that my conclusions are not the product of unbridled fantasy, as is often supposed, but are based on thorough researches into the history of symbols. It was merely in order to avoid overloading my text with annotations that I omitted practically all the references to source material. Anyone, therefore, who feels the need to test the correctness of my conclusions will have to go to the trouble of familiarizing himself with my other writings. The amplificatory method I have used for interpreting the meaning has proved fruitful when applied to historical as well as contemporary material. In the present instance it seems to me sufficiently safe to conclude that in my examples a central archetype consistently appears, which I have called the archetype of the self. It takes the traditional form of an epiphany from heaven, whose nature is in several cases markedly antithetical, e.g., fire and water, corresponding to the “star of David,” , which consists of Δ = fire and ∇ = water. The hexad is a totality symbol: 4 as the natural division of the circle, 2 as the vertical axis (zenith and nadir)—a spatial conception of totality. As a modern development of this symbol we would cite the fourth dimension in Plates II and III.

[772] The *masculine-feminine antithesis* appears in the long and round objects: cigar-form and circle. These may be sexual symbols. The Chinese symbol of the *one* being, Tao, consists of *yang* (fire, hot, dry, south side of the mountain, masculine, etc.) and *yin* (dark, moist, cool, north side of the mountain, feminine). It fully corresponds, therefore, to the Jewish symbol mentioned above. The Christian equivalent can be found in the Church's doctrine of the unity of mother and son and in the androgyny of Christ, not to mention the hermaphroditic Primordial Being in many oriental and primitive religions, the “Father-Mother” of the Gnostics, and the Mercurius hermaphroditus of alchemy.

- [773] The third antithesis is between *Above* and *Below*, as in Plate III, where it seems to have been moved into the fourth dimension. In the other examples it constitutes the difference between what happens in the heavens and down below on earth.
- [774] The fourth antithesis, *unity and quaternity*, appears united in the quincunx (Pls. III, IV), the four forming, as it were, a frame for the one, accentuated as the centre. In the history of symbols, quaternity is the unfolding of unity. The one universal Being cannot be known, because it is not differentiated from anything and cannot be compared with anything. By unfolding into four it acquires distinct characteristics and can therefore be known. This is not a metaphysical argument but simply a psychological formula for describing the process by which an unconscious content becomes conscious. So long as a thing is in the unconscious it has no recognizable qualities and is consequently merged with the universal unknown, with the unconscious All and Nothing, with what the Gnostics called a “non-existent all-being.” But as soon as the unconscious content enters the sphere of consciousness it has already split into the “four,” that is to say it can become an object of experience only by virtue of the four basic functions of consciousness. It is *perceived* as something that exists (sensation); it is *recognized* as this and *distinguished* from that (thinking); it is *evaluated* as pleasant or unpleasant, etc. (feeling); and finally, intuition tells us where it came from and where it is going. This cannot be perceived by the senses or thought by the intellect. Consequently the object’s extension in time and what happens to it is the proper concern of intuition.
- [775] The splitting into four has the same significance as the division of the horizon into four quarters, or of the year into four seasons. That is, through the act of becoming conscious the four basic aspects of a whole judgment are rendered visible. This naturally does not mean that the speculative intellect could not equally well think up 360 other aspects. The four we have named are nothing more than a natural, minimal division of the circle or totality. In my work with patients the quaternity symbol crops up very frequently, the pentad very rarely, and rather less rarely the triad. Since my practice was always cosmopolitan I had plenty of occasion for comparative ethnological observations, and it struck me that the triadic mandalas invariably came from Germans. This seemed to me to have some connection with the fact that, compared with French and Anglo-Saxon literature, the typical anima figure in German novels plays a relatively insignificant role. From a totality standpoint the triadic mandala has a 4–1 structure as opposed to the usual 3 + 1. The fourth function is the undifferentiated or inferior function which characterizes the shadow side of the personality. When this is missing in the totality symbol there is too much emphasis on the conscious side.

[776] The fifth antithesis concerns the contrast between an *enigmatic higher world and the ordinary human world*. This is the most important polarity, which is illustrated in all the examples and can therefore be taken as fundamental both to the dreams and to the pictures. The contrast seems to be intentional as well as being very striking, and, if we take this feeling into account, appears to convey something like a message. The horizontal axis of our empirical consciousness, which except for psychic contents is aware only of bodies in motion, is crossed by another order of being, a dimension of the “psychic”—for the only statements we can safely make about this other order refer to the psychic, something on the one hand *mathematically abstract* and on the other hand *fabulous and mythological*. Now if we conceive numbers as having been *discovered*, and not merely *invented* as an instrument for counting, then on account of their mythological nature they belong to the realm of “godlike” human and animal figures and are just as archetypal as they. Unlike these, however, they are “real” in the sense that they are encountered in the realm of experience as *quantities* and thus form the bridge between the tangible, physical world and the imaginary. Though the latter is unreal, it is “real” in so far as it works, i.e., has an effect on us. There can be no doubt about its effectiveness, particularly at the present time. It is not the behaviour, the lack or surplus, of physical things that directly affects humanity so much as the idea we have of them, or the “imaginary” ideas by which we are obsessed.

[777] The role that numbers play in mythology and in the unconscious gives food for thought. They are an aspect of the physically real as well as of the psychically imaginary. They do not only count and measure, and are not merely quantitative; they also make qualitative statements and are therefore a mysterious something midway between myth and reality, partly discovered and partly invented. Equations, for instance, that were invented as pure mathematical formulae have subsequently proved to be formulations of the quantitative behaviour of physical things. Conversely, owing to their individual qualities, numbers can be vehicles for psychic processes in the unconscious. The structure of the mandala, for instance, is intrinsically mathematical. We may exclaim with the mathematician Jacobi: “In the Olympian host Number eternally reigns.”

[778] These hints are merely intended to point out to the reader that the opposition between the human world and the higher world is not absolute; the two are only relatively incommensurable, for the bridge between them is not entirely lacking. Between them stands the great mediator, Number, whose reality is valid in both worlds, as an archetype in its very essence. Deviation into theosophical speculation does not help us to understand the splitting of the world picture indicated in our examples, for this is simply a matter of names and words which do not point the way to the *unus mundus* (unitary world). Number, however, belongs to both worlds, the

real and the imaginary; it is visible as well as invisible, quantitative as well as qualitative.

[779] Thus it is a fact of singular importance that number also characterizes the “personal” nature of the mediating figure, that it appears as a mediator. From the psychological standpoint, and having regard to the limits set to all scientific knowledge, I have called the mediating or “uniting” symbol which necessarily proceeds from a sufficiently great tension of opposites the “self.” I chose this term in order to make clear that I am concerned primarily with the formulation of empirical facts and not with dubious incursions into metaphysics. There I would trespass upon all manner of religious convictions. Living in the West, I would have to say Christ instead of “self,” in the Near East it would be Khidr, in the Far East atman or Tao or the Buddha, in the Far West maybe a hare or Mondamin, and in cabalism it would be Tifereth. Our world has shrunk, and it is dawning on us that humanity is *one*, with *one* psyche. Humility is a not inconsiderable virtue which should prompt Christians, for the sake of charity—the greatest of all virtues—to set a good example and acknowledge that though there is only *one* truth it speaks in many tongues, and that if we still cannot see this it is simply due to lack of understanding. No one is so godlike that he alone knows the true word. All of us gaze into that “dark glass” in which the dark myth takes shape, adumbrating the invisible truth. In this glass the eyes of the spirit glimpse an image which we call the self, fully conscious of the fact that it is an anthropomorphic image which we have merely named but not explained. By “self” we mean psychic wholeness, but what realities underlie this concept we do not know, because psychic contents cannot be observed in their unconscious state, and moreover the psyche cannot know itself. The conscious can know the unconscious only so far as it has become conscious. We have only a very hazy idea of the changes an unconscious content undergoes in the process of becoming conscious, but no certain knowledge. The concept of psychic wholeness necessarily implies an element of transcendence on account of the existence of unconscious components. Transcendence in this sense is not equivalent to a metaphysical postulate or hypostasis; it claims to be no more than a borderline concept, to quote Kant.

[780] That there is something beyond the borderline, beyond the frontiers of knowledge, is shown by the archetypes and, most clearly of all, by numbers, which this side of the border are quantities but on the other side are autonomous psychic entities, capable of making qualitative statements which manifest themselves in *a priori* patterns of order. These patterns include not only causally explicable phenomena like dream-symbols and such, but remarkable relativizations of time and space which simply cannot be explained causally. They are the parapsychological phenomena which I have summed up under the term “synchronicity” and which have been statistically investigated by Rhine. The positive results of his experiments

elevate these phenomena to the rank of undeniable facts. This brings us a little nearer to understanding the mystery of psychophysical parallelism, for we now know that a factor exists which mediates between the apparent incommensurability of body and psyche, giving matter a kind of “psychic” faculty and the psyche a kind of “materiality,” by means of which the one can work on the other. That the body can work on the psyche seems to be a truism, but strictly speaking all we know is that any bodily defect or illness also expresses itself psychically. Naturally this assumption only holds good if, contrary to the popular materialistic view, the psyche is credited with an existence of its own. But materialism in its turn cannot explain how chemical changes can produce a psyche. Both views, the materialistic as well as the spiritualistic, are metaphysical prejudices. It accords better with experience to suppose that living matter has a psychic aspect, and the psyche a physical aspect. If we give due consideration to the facts of parapsychology, then the hypothesis of the psychic aspect must be extended beyond the sphere of biochemical processes to matter in general. In that case all reality would be grounded on an as yet unknown substrate possessing material and at the same time psychic qualities. In view of the trend of modern theoretical physics, this assumption should arouse fewer resistances than before. It would also do away with the awkward hypothesis of psychophysical parallelism, and afford us an opportunity to construct a new world model closer to the idea of the *unus mundus*. The “acausal” correspondences between mutually independent psychic and physical events, i.e., synchronistic phenomena, and in particular psychokinesis, would then become more understandable, for every physical event would involve a psychic one and vice versa. Such reflections are not idle speculations; they are forced on us in any serious psychological investigation of the Ufo phenomenon, as the next chapter will show.

5. UFOS CONSIDERED IN A NON-PSYCHOLOGICAL LIGHT

[781] As I said at the beginning, it was the purpose of this essay to treat the Ufos primarily as a psychological phenomenon. There were plenty of reasons for this, as is abundantly clear from the contradictory and “impossible” assertions made by the rumour. It is quite right that they should meet with criticism, scepticism, and open rejection, and if anyone should see behind them nothing more than a phantasm that deranges the minds of men and engenders rationalistic resistances, he would have nothing but our sympathy. Indeed, since conscious and unconscious fantasy, and even mendacity, obviously play an important role in building up the rumour, we could be satisfied with the psychological explanation and let it rest at that.

[782] Unfortunately, however, there are good reasons why the Ufos cannot be disposed of in this simple manner. So far as I know it remains an established fact, supported by numerous observations, that Ufos have not only been seen visually but have also been picked up on the radar screen and have left traces on the photographic plate. I base myself here not only on the comprehensive reports by Ruppelt and Keyhoe, which leave no room for doubt in this regard, but also on the fact that the astrophysicist, Professor Menzel, has not succeeded, despite all his efforts, in offering a satisfying scientific explanation of even one authentic Ufo report. It boils down to nothing less than this: that either psychic projections throw back a radar echo, or else the appearance of real objects affords an opportunity for mythological projections.

[783] Here I must remark that even if the Ufos are physically real, the corresponding psychic projections are not actually caused, but are only occasioned, by them. Mythical statements of this kind have always occurred, whether Ufos exist or not. These statements depend in the first place on the peculiar nature of the psychic background, the collective unconscious, and for this reason have always been projected in some form. At various times all sorts of other projections have appeared in the heavens besides the saucers. This particular projection, together with its psychological context, the rumour, is specific of our age and highly characteristic of it. The dominating idea of a mediator and god who became man, after having thrust the old polytheistic beliefs into the background, is now in its turn on the point of evaporating. Untold millions of so-called Christians have lost their belief in a real and living mediator, while the believers endeavour to make their belief credible to primitive people, when it would be so much more fruitful to bestow these much needed efforts on the white man. But it is always so much easier and more affecting to talk and act *down* to people instead of *up* to them. St. Paul spoke to the populace of

Athens and Rome, but what is Albert Schweitzer doing in Lambarene? People like him are needed much more urgently in Europe.

[784] No Christian will contest the importance of a belief like that of the mediator, nor will he deny the consequences which the loss of it entails. So powerful an idea reflects a profound psychic need which does not simply disappear when the expression of it ceases to be valid. What happens to the energy that once kept the idea alive and dominant over the psyche? A political, social, philosophical, and religious conflict of unprecedented proportions has split the consciousness of our age. When such tremendous opposites split asunder, we may expect with certainty that the need for a saviour will make itself felt. Experience has amply confirmed that, in the psyche as in nature, a tension of opposites creates a potential which may express itself at any time in a manifestation of energy. Between above and below flows the waterfall, and between hot and cold there is a turbulent exchange of molecules. Similarly, between the psychic opposites there is generated a "uniting symbol," at first unconscious. This process is running its course in the unconscious of modern man. Between the opposites there arises spontaneously a symbol of unity and wholeness, no matter whether it reaches consciousness or not. Should something extraordinary or impressive then occur in the outside world, be it a human personality, a thing, or an idea, the unconscious content can project itself upon it, thereby investing the projection carrier with numinous and mythical powers. Thanks to its numinosity, the projection carrier has a highly suggestive effect and grows into a saviour myth whose basic features have been repeated countless times.

[785] The impetus for the manifestation of the latent psychic contents was given by the Ufo. The only thing we know with tolerable certainty about Ufos is that they possess a surface which can be seen by the eye and at the same time throws back a radar echo. Everything else is so uncertain that it must remain for the time being an unproven conjecture, or rumour, until we know more about it. We do not know, either, whether they are manned machines or a species of living creature which has appeared in our atmosphere from an unknown source. It is not likely that they are meteoric phenomena, since their behaviour does not give the impression of a process that could be interpreted in physical terms. Their movements indicate volition and psychic relatedness, e.g., evasion and flight, perhaps even aggression and defence. Their progression in space is not in a straight line and of constant velocity like a meteor, but erratic like the flight of an insect and of varying velocity, from zero to several thousand miles per hour. The observed speeds and angles of turn are such that no earthly being could survive them any more than he could the enormous heat generated by friction.

[786] The simultaneous visual and radar sightings would in themselves be a satisfactory proof of their reality. Unfortunately, well-authenticated reports show that there are also cases where the eye sees something that does not appear on the radar screen, or where an object undoubtedly picked up by radar is not seen by the eye. I will not mention other, even more remarkable reports from authoritative sources; they are so bizarre that they tax our understanding and credulity to the limit.

[787] If these things are real—and by all human standards it hardly seems possible to doubt this any longer—then we are left with only two hypotheses: that of their *weightlessness* on the one hand and of their *psychic nature* on the other. This is a question I for one cannot decide. In the circumstances, however, it seemed to me advisable at least to investigate the *psychological aspect* of the phenomenon, so as to throw a little light on this complicated situation. I have limited myself to only a few examples. Unfortunately, after more than ten years' study of the problem I have not managed to collect a sufficient number of observations from which more reliable conclusions could be drawn. I must therefore content myself with having sketched out a few lines for future research. Of course, next to nothing has been gained as regards a physical explanation of the phenomenon. But the psychic aspect plays so great a role that it cannot be left out of account. The discussion of it, as I have tried to show, leads to psychological problems which involve just as fantastic possibilities or impossibilities as the approach from the physical side. If military authorities have felt compelled to set up bureaus for collecting and evaluating Ufo reports, then psychology, too, has not only the right but also the duty to do what it can to shed light on this dark problem.

[788] The question of anti-gravity is one which I must leave to the physicists, who alone can inform us what chances of success such an hypothesis has. The alternative hypothesis that Ufos are something psychic that is endowed with certain physical properties seems even less probable, for where should such a thing come from? If weightlessness is a hard proposition to swallow, then the notion of a materialized psychism opens a bottomless void under our feet. Parapsychology is, of course, acquainted with the fact of materialization. But this phenomenon depends on the presence of one or more mediums who exude a weighable substance, and it occurs only in their immediate vicinity. The psyche can move the body, but only inside the living organism. That something psychic, possessing material qualities and with a high charge of energy, could appear by itself high in the air at a great distance from any human mediums—this surpasses our comprehension. Here our knowledge leaves us completely in the lurch, and it is therefore pointless to speculate any further in this direction.

[789] It seems to me—speaking with all due reserve—that there is a third possibility: that Ufos are real material phenomena of an unknown nature, presumably coming from outer space, which perhaps have long been visible to mankind, but otherwise have no recognizable connection with the earth or its inhabitants. In recent times, however, and just at the moment when the eyes of mankind are turned towards the heavens, partly on account of their fantasies about possible space-ships, and partly in a figurative sense because their earthly existence is threatened, unconscious contents have projected themselves on these inexplicable heavenly phenomena and given them a significance they in no way deserve. Since they seem to have appeared more frequently after the second World War than before, it may be that they are synchronistic phenomena or “meaningful coincidences.” The psychic situation of mankind and the Ufo phenomenon as a physical reality bear no recognizable causal relationship to one another, but they seem to coincide in a meaningful manner. The meaningful connection is the product on the one hand of projection and on the other of round and cylindrical forms which embody the projected meaning and have always symbolized the union of opposites.

[790] Another equally “chance” coincidence is the choice of the national emblems for aircraft in the U.S.S.R. and the U.S.A.: respectively a red and white five-pointed star. For a thousand years red was regarded as the masculine and white as the feminine colour. The alchemists spoke of the *servus rubeus* (red slave) and the *femina candida* (white woman): their copulation produced the supreme union of opposites. When one speaks of Russia, one immediately thinks of “Little Father” Czar and “Little Father” Stalin. One also remembers all the talk about America being a matriarchy because the bulk of American capital is in the hands of women, not to mention Keyserling’s *bon mot* about the “aunt of the nation.”¹ It is clear that these parallels have nothing to do with the choice of symbols, at any rate not as a conscious causality. Comically enough—one must say—red and white are the nuptial colours. They throw an amusing light on Soviet Russia as the reluctant or unrequited lover of the *femina candida* in the White House—even if there is nothing more to it than that.

EPILOGUE

[791] I had already completed my manuscript when a little book fell into my hands which I ought not to leave unmentioned: *The Secret of the Saucers*, by Orfeo M. Angelucci (1955). The author is self-taught and describes himself as a nervous individual suffering from “constitutional inadequacy.” After working at various jobs he was employed as a mechanic in 1952 at the Lockheed Aircraft Corporation at Burbank, California. He seems to lack any kind of humanistic culture, but appears to have a knowledge of science that exceeds what would be expected of a person in his circumstances. He is an Americanized Italian, naïve and—if appearances do not deceive us—serious and idealistic. He makes his living now by preaching the gospel revealed to him by the Saucers. That is the reason why I mention his book.

[792] His career as a prophet began with the sighting of a supposedly authentic Ufo on August 4, 1946. At the time he had no further interest in the problem. He was working in his free hours on a book entitled “The Nature of Infinite Entities,” which he subsequently published at his own expense. He describes its content as “Atomic Evolution, Suspension, and Involution, Origin of the Cosmic Rays,” etc. On May 23, 1952, he underwent the experience that gave him his calling. Towards 11 o’clock in the evening, he says, he felt unwell and had a “prickling” sensation in the upper half of his body, as before an electrical storm. He was working the nightshift, and as he was driving home in his car he saw a faintly red-glowing, oval-shaped object hovering over the horizon, which nobody else seemed to see. On a lonely stretch of the road, where it rose above the level of the surrounding terrain, he saw below him the glowing red disk “pulsating” near the ground only a short distance away. Suddenly it shot upwards with great speed at an angle of 30 to 40 degrees and disappeared towards the west. But before it vanished, it released two balls of green fire from which a man’s voice issued, speaking “perfect English.” He could remember the words: “Don’t be afraid, Orfeo, we are friends!” The voice bade him get out of the car. This he did, and, leaning against the car, he watched the two “pulsating” disks hovering a short distance in front of him. The voice explained to him that the lights were “instruments of transmission and reception” (i.e., a species of sense-organs) and that he was in direct communication with “friends from another world.” It also asked him if he remembered his experience on August 4, 1946. All at once he felt very thirsty, and the voice told him: “Drink from the crystal cup you will find on the fender of your car.” He drank, and it was the “most delicious beverage I had ever tasted.” He felt refreshed and strengthened. The twin disks were about three feet apart. “Suddenly the area between them began to glow with a soft green light which gradually formed into a

luminous three-dimensional screen.” In it there appeared the heads and shoulders of two persons, a man and a woman, “being the ultimate of perfection.” They had large shining eyes, and despite their supernatural perfection they seemed strangely familiar to him. They observed him and the whole scene. It seemed to him that he was in telepathic communication with them. As suddenly as it had come the vision vanished, and the fireballs reassumed their former brilliance. He heard the words, “The road will open, Orfeo,” and the voice continued:

“We see the individuals of Earth as each one really is, Orfeo, and not as perceived by the limited senses of man. The people of your planet have been under observation for centuries, but have only recently been re-surveyed. Every point of progress in your society is registered with us. We know you as you do not know yourselves. Every man, woman, and child is recorded in vital statistics by means of our recording crystal disks. Each of you is infinitely more important to us than to your fellow Earthlings because you are not aware of the true mystery of your being.... We feel a deep sense of brotherhood toward Earth’s inhabitants because of an ancient kinship of our planet with Earth. In you we can look far back in time and recreate certain aspects of our former world. With deep compassion and understanding we have watched your world going through its ‘growing pains.’ We ask that you look upon us simply as older brothers.”

[793] The author was also informed that the Ufos were remote-controlled by a mother-ship. The occupants of Ufos needed in reality no such vessels. As “etheric” entities they needed them only in order to manifest themselves materially to man. The Ufos could travel approximately with the speed of light. “The Speed of Light is the Speed of Truth” (i.e., quick as thought). The heavenly visitors were harmless and filled with the best intentions. “Cosmic law” forbade spectacular landings on earth. The earth was at present threatened by greater dangers than was realized.

[794] After these revelations Angelucci felt exalted and strengthened. It was “as though momentarily I had transcended mortality and was somehow related to these superior beings.” When the lights disappeared, it seemed to him that the everyday world had lost its reality and become an abode of shadows.

[795] On July 23, 1952, he felt unwell and stayed away from work. In the evening he took a walk, and on the way back, in a lonely place, similar sensations came over him as he had felt on May 23. Combined with them was “the dulling of consciousness I had noted on that other occasion,” i.e., the awareness of an *abaissement du niveau mental*, a state which is a very important precondition for the occurrence of spontaneous psychic phenomena. Suddenly he saw a luminous object on the ground before him, like an “igloo” or a “huge, misty soap bubble.” This object visibly increased in solidity, and he saw something like a doorway leading into a brightly lit interior. He stepped inside, and found himself in a vaulted room, about eighteen feet in diameter. The walls were made of some “ethereal mother-of-pearl stuff.”

[796] Facing him was a comfortable reclining chair consisting of the same translucent, shimmering substance. Otherwise the room was empty and silent. He sat down and had the feeling that he was suspended in air. It was as if the chair moulded itself to the shape of his body of its own accord. The door shut as if there had never been a door there at all. Then he heard a kind of humming, a rhythmical sound like a vibration, which put him into a kind of semi-dream state. The room grew dark, and music came from the walls. Then it grew light again. He found on the floor a piece of metal like a coin. When he took it in his hand, it seemed to diminish in size. He had the feeling that the Ufo was carrying him away. Suddenly something like a round window opened, about nine feet in diameter. Outside he saw a planet, the earth, from a distance of over a thousand miles, as a voice he recognized explained to him. He wept with emotion and the voice said: "Weep, Orfeo ... we weep with you for earth and her children. For all its apparent beauty earth is a purgatorial world among the planets evolving intelligent life. Hate, selfishness, and cruelty rise from many parts of it like a dark mist." Then, he says, the craft evidently moved out into cosmic space. Through the window he saw a Ufo about one thousand feet long and ninety feet thick, consisting of a transparent crystalline substance. Music poured from it, bringing visions of harmoniously revolving planets and galaxies. The voice informed him that every being on earth was divinely created, and "upon your world the mortal shadows of those entities are working out their salvation from the plane of darkness." All these entities were either on the good side or on the bad. "We know where you stand, Orfeo." Owing to his physical weakness he had spiritual gifts, and that was why the heavenly beings could enter into communication with him. He was given to understand that the music as well as the voice emanated from this huge spaceship. It moved off slowly, and he noticed at either end of it "vortices of flame" that served as propellers, but they were also instruments for seeing and hearing, "through some method of telepathic contact."

[797] On the way back they met two ordinary Ufos travelling earthwards. The voice entertained him with more explanations concerning the attitude of the higher beings to mankind: man had not kept pace morally and psychologically with his technological development, and therefore the inhabitants of other planets were trying to instil into the earth dwellers a better understanding of their present predicament and to help them particularly in the art of healing. They also wanted to put Orfeo right about Jesus Christ. Jesus, so they said, was called allegorically the son of God. In reality he was the "Lord of the Flame," "an infinite entity of the Sun" and not of earthly origin. "As the Sun spirit who sacrificed Himself for the children of woe he has become a part of the oversoul of mankind and the world spirit. In this he differs from all other cosmic teachers."

[798] Everyone on earth has a “spiritual, unknown self which transcends the material world and consciousness and dwells eternally outside of the Time dimension in spiritual perfection within the unity of the oversoul.” The sole purpose of human existence on earth is to attain reunion with the “immortal consciousness.” Under the searching eye of this “great compassionate consciousness” Orfeo felt like a “crawling worm—unclean, filled with error and sin.” He wept, once more to the accompaniment of appropriate music. The voice spoke and said: “Beloved friend of Earth, we baptize you now in the true light of the worlds eternal.” A white flash of lightning blazed forth: his life lay clear before his eyes, and the remembrance of all his previous existences came back to him. He understood “the mystery of life.” He thought he was going to die, for he knew that at this moment he was wafted into “eternity, into a timeless sea of bliss.”

[799] After this illuminative experience he came to himself again. Accompanied by the obligatory “etheric” music he was borne back to earth. As he left the Ufo, it suddenly vanished without trace. Afterwards, on going to bed, he noticed a burning sensation on the left side of his chest. There he found a stigma the size of a twenty-five-cent piece, an inflamed circle with a dot in the middle. He interpreted this as the “symbol of the hydrogen atom.”

[800] His career as an evangelist dates—true to form—from this experience. He became a witness not only of the word but of the Ufo, and was exposed to the mockery and disbelief that are the lot of the martyr. On the night of August 2 of the same year he saw, with eight other witnesses, an ordinary Ufo in the sky, which disappeared after a short time. He betook himself to the lonely spot he had previously visited, but though he didn't find the Ufo he met a figure who called out to him, “Greetings, Orfeo!” It was the same figure he had seen in the earlier vision, who wished to be called by the name of “Neptune.” He was a tall handsome man with unusually large and expressive eyes. The edges of the figure rippled like water in the wind. Neptune gave him more information concerning the earth, the reasons for its lamentable conditions, and its coming redemption. Then he vanished.

[801] At the beginning of September 1953 he fell into a somnambulistic state which lasted about a week. When he returned to his normal consciousness he remembered everything he had experienced during his “absence.” He had been on a small “planetoid” where Neptune dwelt with his companion Lyra; or rather, he had been in heaven as Orfeo imagined it, with countless flowers, delightful odours, colours, nectar and ambrosia, noble etheric beings and, of course, almost incessant music. There he discovered that his heavenly friend was not called Neptune but Orion, and that “Neptune” had been his own name while he was still dwelling in this heavenly world. Lyra showed him particular marks of attention, to which he, the re-remembered Neptune, in accordance with his earthly nature, responded with erotic feelings, much

to the horror of the celestial company. When he had dehabituated himself, with some effort, from this all-too-human reaction a *noce céleste* was celebrated, a mystic union analogous to the *coniunctio oppositorum* in alchemy.

[802] With this climax I will end the account of this *pélerinage de l'âme*. Without having the faintest inkling of psychology, Angelucci has described in the greatest detail the mystic experience associated with a Ufo vision. A detailed commentary by me is hardly necessary. The story is so naïve and clear that a reader interested in psychology can see at once how far it confirms my previous conclusions. It could even be regarded as a unique document that sheds a great deal of light on the genesis and assimilation of Ufo mythology. That is why I have let Angelucci have his say.

[803] The psychological experience that is associated with the Ufo consists in the vision of the *rotundum*, the symbol of wholeness and the archetype that expresses itself in mandala form. Mandalas, as we know, usually appear in situations of psychic confusion and perplexity. The archetype thereby constellated represents a pattern of order which, like a psychological “viewfinder” marked with a cross or a circle divided into four, is superimposed on the psychic chaos so that each content falls into place and the weltering confusion is held together by the protective circle. The Eastern mandalas in Mahayana Buddhism accordingly represent the cosmic, temporal, and psychological order. At the same time they are *yantras*, instruments with whose help order is brought into being.¹

[804] As our time is characterized by fragmentation, confusion, and perplexity, this fact is also expressed in the psychology of the individual, appearing in spontaneous fantasy images, dreams, and the products of active imagination. I have observed these phenomena in my patients for forty years and have come to the conclusion that this archetype is of central importance, or rather, that it gains in importance to the degree that the importance of the ego is lost. A state of disorientation is particularly apt to depotentiate the ego.

[805] Psychologically, the rotundum or mandala is a symbol of the self. The self is the archetype of order par excellence. The structure of the mandala is arithmetical, for “whole” numbers are likewise archetypes of order. This is true particularly of the number 4, the Pythagorean tetraktys. Since a state of confusion is generally the result of a psychic conflict, we find in practice that the dyad, the conjoined two, is also associated with the mandala. This appears in Angelucci’s vision of the synthesis of opposites.

[806] Its central position gives the symbol a high feeling-value, expressed for instance in Angelucci’s stigmatization. The symbols of the self coincide with the God-images, as, for instance, the *complexio oppositorum* of Cusanus with the dyad, or the definition of God as a “circle whose centre is everywhere and the circumference nowhere” with

Angelucci's sign of the hydrogen atom. He was marked not by the Christian stigmata but by the symbol of the self, of absolute wholeness or, in religious language, God. These psychological connections gave rise to the alchemical equation between Christ and the *lapis Philosophorum*.

[807] The centre is frequently symbolized by an eye: the ever-open eye of the fish in alchemy, or the unsleeping "God's eye" of conscience, or the all-seeing sun. The same symbols are experienced today, not as external light-phenomena but as a psychic revelation. I would like to mention as an example the case of a woman who wrote down her experience in verse form (it had no connection with Ufos):

Vision

Light strikes the pebbled bottom
Of a deep blue pool.
Through swaying grass
A jewel flickers, gleams and turns,
Demands attention as I pass,
A staring fish-eye's glance
Attracts my mind and heart—
The fish, invisible as glass.

A shimmering silver moon,
The fish, assuming shape and form,
Evolves a whirling, swirling dance,
Intensity of light increasing,
The disk becomes a blazing golden sun,
Compelling deeper contemplation.

[808] The water is the depths of the unconscious into which a ray from the light of consciousness has penetrated. A dancing disk, a fish's eye, swims down below in the inner darkness (instead of flying in the heavens), and from it arises a world-illuminating sun, an Ichthys, a *sol invictus*, an ever-open eye which reflects the eye of the beholder and is at the same time something independent of her, a rotundum that expresses the wholeness of the self and cannot be distinguished, except conceptually, from the deity. "Fish" (Ichthys) and "sun" (*novus sol*) are allegories of Christ, which like the "eye" stand for God. In the moon and sun appear the divine mother and her son-lover, as can still be seen today in many churches.

[809] The Ufo vision follows the old rule and appears in the sky. Orfeo's fantasies are played out in an obviously heavenly place and his cosmic friends bear the names of stars. If they are not antique gods and heroes they are at least angels. The author certainly lives up to his name, for just as his wife, *née* Borgianini, is in his opinion a

descendant of the Borgias of unhappy memory, so he, an earthly copy of the “angels” and a messenger bringing Eleusinian tidings of immortality, must style himself a new Orpheus, divinely appointed to initiate us into the mystery of the Ufo. Not even the Orphean strains are lacking. If the name is a deliberately chosen pseudonym, we can only say *è ben trovato*. But if it appears in his birth certificate, then the matter becomes more problematical. Today we can no longer suppose that a magical compulsion attaches to a mere name, else we should have to attribute a correspondingly sinister significance to his spouse, or the anima. Much as we would like to credit him with an intellectually rather limited, naïve good faith, it might be suspected that a “fine Italian hand” is at work. What appears impossible from the conscious standpoint can often be arranged by the unconscious with all the craftiness of nature: *Ce que diable ne peut, femme le fait*. Be that as it may, Orfeo’s book is an essentially naïve production which for that very reason reveals all the more clearly the unconscious background of the Ufo phenomenon and therefore comes like a gift to the psychologist. The individuation process, the central problem of modern psychology, is plainly depicted in it in an unconscious, symbolical form which bears out our previous reflections, although the author with his somewhat primitive mentality has taken it quite literally as a concrete happening.

*

[810] This epilogue was already in the press when I received word of Fred Hoyle’s book, *The Black Cloud* (1957). The author is a well-known authority on astrophysics, and I was already acquainted with his two impressive volumes, *The Nature of the Universe* and *Frontiers of Astronomy*. They are brilliant expositions of the latest developments in astronomy and show their author as a bold and imaginative thinker. The fact that such an author should resort to a science-fiction story aroused my curiosity, and I read the book at once. Hoyle himself, in his preface, describes it as a “frolic,” a jest, and warns against anyone identifying the views of his hero, a mathematician of genius, with his own. No intelligent reader will fall into this error, of course. Nevertheless, he will hold Professor Hoyle responsible for the authorship of his book, and he will ask what it was that induced him to tackle the Ufo problem.

[811] In his “yarn” Hoyle describes how a young astronomer at the Mount Palomar observatory, while looking for supernovae to the south of Orion, discovers a dark circular patch in a dense field of stars. It is a so-called globulus, a dark cloud of gas, which, it transpires, is moving towards our solar system. At the same time, in England, considerable disturbances are detected in the orbits of Jupiter and Saturn. The cause of this is calculated by a Cambridge mathematician, the hero of our story, to be a definite mass which, it then turns out, is located exactly at the spot where the Americans discovered the black cloud. This globulus, whose diameter is approximately equal to the distance of the sun from the earth, consists of hydrogen of

fairly high density and is moving straight towards the earth at forty miles a second. It will reach the earth in about eighteen months. As the black cloud gets nearer, it causes first of all a terrible heat that kills off a large part of the life on earth. This is followed by a total extinction of light and a more than Egyptian darkness lasting for about a month—a *nigredo* like that described in the *Aurora consurgens*, a treatise ascribed to St. Thomas Aquinas: “Beholding from afar I saw a great cloud looming black over all the earth, which had absorbed the earth and covered my soul.”²

[812] When the light reappears again, there follows a period of terrible cold, which causes another appalling catastrophe. Meanwhile, the scientists in question have been shut up by the British government in their experimental location, where, thanks to the security measures they have taken, they survive the catastrophes. By observing certain remarkable ionization phenomena in the atmosphere they come to the conclusion that these are intentionally induced, and that in consequence there must be an intelligent agent in the black cloud. By means of radio they succeed in entering into communication with it, and receive answers. They learn that the cloud is five hundred million years old and is at present engaged in regenerating itself. It has taken up its position near the sun in order to recharge itself with energy. In fact, it is feeding on the sun. The scientists discover that the cloud must eliminate all radioactive substances, as these are harmful to it. This fact is also discovered by the American observers, and at their instigation the cloud is fired at with H-bombs, with the intention of “killing” it. The cloud, meanwhile, has settled in a disk round the sun, consequently threatening the earth every six months with eclipses of several weeks’ duration. The English naturally have a host of questions to ask the cloud, including the “metaphysical” question concerning a greater Being of still greater age, and even deeper wisdom and scientific knowledge. The cloud replies that it has already discussed the matter with other globuli but is as much in the dark about it as human beings. It is willing, however, to communicate its own greater knowledge directly to mankind. A young physicist declares himself ready to submit to the experiment. He gets into a hypnotic condition, but dies of a sort of inflammation of the brain before being able to make any communication. The Cambridge mathematician of genius now offers himself for experiment, on the condition, accepted by the cloud, that the process of communication shall take place very much more slowly. In spite of that he falls into a delirium which ends in his death. The cloud, however, has decided to quit the solar system and seek out another region of fixed stars. The sun emerges again from obscurity and everything is as before, except for the tremendous destruction of earthly life.

[813] It is not difficult to see that the author has here taken up the Ufo problem so characteristic of our epoch: from outer space a round object approaches the earth and causes a world-wide catastrophe. Although the legend usually considers the

catastrophic political situation, or rather nuclear fission, to be the indirect cause of the Ufo phenomenon, there are not a few people who suspect that the real danger lies in the appearance of Ufos themselves—namely an invasion of the earth by star-dwellers, which might give an unexpected and probably undesirable turn to our already questionable situation. The strange idea that the black cloud possesses a sort of nervous system, and a psyche or intelligence to match, is not an original invention of the author's, since speculative ufologists have already arrived at the hypothesis of a "sentient electrical field," and also at the idea that the Ufos are provisioning themselves with something on earth—water, oxygen, small organisms, etc., just as the cloud charged itself with solar energy.

[814] The cloud causes opposite extremes of temperature and an absolute *nigredo* such as the old alchemists dreamed of. This illustrates a characteristic aspect of the psychological problem which arises when the light of day—consciousness—is directly confronted with night, the collective unconscious. Opposites of extreme intensity collide with one another, causing a disorientation and darkening of consciousness which can assume threatening proportions, as in the initial stage of a psychosis. This aspect, i.e., the analogy with a psychic catastrophe, is depicted by Hoyle as the encounter between the psychic content of the cloud and the consciousness of the two unfortunate victims. Just as earthly life is largely wiped out by the collision with the cloud, so the psyche and the life of the two scientists are destroyed by the collision with the unconscious. For although the *rotundum* is a totality symbol, it usually encounters a consciousness that is not prepared for it and does not understand it, indeed is bound to misunderstand it and therefore cannot tolerate it, because it perceives the totality only in projected form, outside itself, and cannot integrate it as a subjective phenomenon. Consciousness commits the same grave mistake as the insane person: it understands the event as a concrete external happening and not as a subjective symbolical process. The result is that the external world gets into hopeless disorder and is actually "destroyed" in so far as the patient loses his relationship to it. The author suggests the analogy with psychosis by the delirious state of the professor. It is not only the insane person who makes this fundamental mistake, but all those who take philosophical or theosophical speculations for objective realities and consider the mere fact that they believe in angels as a guarantee that such things exist in reality.

[815] It is significant that it is the actual hero of the story, the mathematician of genius, who meets with disaster. No author can avoid equipping his hero with some of his own qualities and thus betraying that at least a part of himself is invested in him. What happens to the hero also happens symbolically to the author. In this case it is naturally unpleasant, for it amounts to nothing less than the fear that a collision with the unconscious would involve the destruction of the most differentiated function. It is a

widespread, in fact a normal prejudice that deeper insight into unconscious motives must necessarily entail a fatal disturbance of the conscious performance. The most that can happen is an alteration of the conscious attitude. Since, in our story, everything is projected outside, mankind and all organic life on earth suffer an immense loss. The author makes no particular to-do about this; it is mentioned only as a sort of by-product. From this we may infer a predominantly intellectual attitude of consciousness.

[816] Presumably not altogether unimpressed by a hundred or more H-bombs, which might well upset its nervous system with their radioactivity, the black cloud withdraws as suddenly as it came. Nothing whatever has been learned of its contents, except that it knows as little about a metaphysical Supreme Being as we do. Nevertheless its intelligence proves unendurably high for human beings, so that it comes suspiciously near to having a divine or angel-like nature. Here the great astrophysicist joins hands with the naïve Angelucci.

[817] Understood psychologically, the story is a description of fantasy-contents whose symbolical nature demonstrates their origin in the unconscious. Whenever a confrontation of this kind occurs, there is usually an attempt at integration. This is expressed in the intention of the cloud to remain for some time near the sun, in order to feed on its energy. Psychologically it would mean that the unconscious draws strength and life from its union with the sun. The sun loses no energy, but the earth and its life, signifying man, lose a great deal. Man has to pay the price for this invasion or irruption of the unconscious: his psychic life is threatened with the gravest injury.

[818] What, then—psychologically speaking—is the meaning of this cosmic, or rather psychic, collision? Obviously the unconscious darkens the conscious, since no *rapprochement*, no dialectical process takes place between their contents. For the individual this means that the cloud deprives him of solar energy, in other words his consciousness is overpowered by the unconscious. This is equivalent to a general catastrophe, such as we have experienced in National Socialism and are still experiencing in the Communist inundation, where an archaic social order threatens our freedom with tyranny and slavery. Man replies to this catastrophe with his “best” weapon. Whether for this reason or from a change of mind (as seems more likely), the cloud withdraws to other regions. This means, psychologically: the unconscious, after gaining a certain amount of energy, sinks back again to its former distance. The final outcome is depressing: human consciousness and life in general suffer an incalculable loss through an incomprehensible *lusus naturae* that lacks all human meaning, a “frolic” on a cosmic scale.

[819] This in turn points to something psychic that is not understood by the present. Though the nightmare is over for the survivors, from now on they live in a devastated

world. Consciousness has suffered a loss of its own reality, as though the evil dream had robbed it of something essential and made off with it. The loss consists in missing a unique opportunity, which may never occur again, to come to terms with the contents of the unconscious. Although it was possible to establish an intelligent connection with the cloud, the communication of its contents proved to be unendurable and led to the death of those who submitted to the experiment. Nothing is learnt of the contents from the other side. The encounter with the unconscious ends bootlessly. Our knowledge is not enriched; on this point we remain where we were before the catastrophe. The only thing is that we are at least half a world poorer. The scientific pioneers, the spokesmen of the *avant-garde*, prove too weak or too immature to receive the message from the unconscious. It remains to be seen whether this melancholy outcome is a prophecy or a subjective confession.

[820] If we compare this tale with the naïvetés of Angelucci, we get a valuable picture of the difference between the uneducated and the scientifically educated attitude. Both shift the problem on to a concrete plane, the one in order to make us believe in a saving action from heaven, the other in order to transform this secret yet somewhat sinister expectation into an entertaining literary joke. Both, poles apart though they are, are activated by the same unconscious factor and make use of essentially the same symbolism in order to express the unconscious straits we are in.

Supplement

[821] Another recent book, a novel by John Wyndham called *The Midwich Cuckoos* (1957), attributes to a “thing,” which is obviously a Ufo, a highly significant character. Of unknown but presumably extra-terrestrial origin, this thing casts a spell on a small, remote English village, causing man and beast to fall into an hypnotic sleep which lasts for twenty-four hours. The zone of sleep describes a circle round the village, and any living being that approaches instantly falls asleep when the magical line is crossed. After twenty-four hours everybody revives, and nothing seems to have happened—on the surface.

[822] Several weeks later peculiar discoveries are made: first one and then another of the female population, and finally all its members capable of fecundation, are found to be pregnant. In due course children are born with golden eyes. When they develop, they begin to show signs of uncommon intelligence. Later it becomes known that the same miracle has befallen a village in Siberia, an Eskimo settlement, and an African village. In England, owing to the remoteness and insignificance of the locality, the village authorities succeed in hushing up a public scandal. The extraordinary intelligence of the children inevitably leads to trouble and a special school is founded for them. The amazing fact is discovered that, if one of the boys has learnt something new and hitherto unknown, all the boys know it, and the same is true of the girls, so

that only one boy and one girl have to attend school. Finally the perspicacious schoolteacher can no longer doubt that the children with golden eyes represent a superior type of *Homo sapiens*. Their advanced intelligence is, moreover, coupled with a complete realization of their potential power for world domination. The question of how to deal with this menace leads to different solutions. The Africans kill the children immediately. The Eskimos expose them to the cold. The Russians, after isolating the village, destroy it by bombardment. But in England the favourite teacher introduces some boxes, apparently containing laboratory equipment but actually containing dynamite, into the schoolroom and blows himself up with all the children.

[823] The peculiar parthenogenesis and the golden eyes denote kinship with the sun and characterize the children as divine progeny. Their fathers seem to have been angels of the annunciation who had come down from a “supracelestial place” to take care of the stupidity and backwardness of *Homo sapiens*. It is a divine intervention that gives evolution a definite push forward. Or, to put it in more modern terms, an advanced species of man from some other planet visits the earth in order to make biological experiments with mutation and artificial insemination. But the modern Neanderthal is in no way ready to renounce the prerogatives of the ruling race, and prefers to maintain the *status quo* by the devastating methods which have always been his final argument.

[824] It is obvious that the sun children, miraculously begotten, represent an unexpected capacity for a wider and higher consciousness, superseding a backward and inferior mental state. Nothing is said, however, about a higher level of feeling and morality, which would be necessary to compensate and regulate the possibilities of advanced perception and intellect. Characteristically enough, this aspect does not seem to enter the author’s field of vision. It is sufficient for him that the children have a definite advantage of some kind over contemporary man. What if the children should symbolize the germ of some higher potentiality transcending the hitherto valid form of man? In that case the story looks very like a time-honoured repetition of the hero’s threatened childhood and his early death through treachery. On the other hand there is something definitely suspect about these children: they are not separated individually but live in a permanent state of *participation mystique*, or unconscious identity, that precludes individual differentiation and development. Had they been spared an early extinction, they would have founded an entirely uniform society, the deadly boredom of which would have been the very ideal of a Marxist state. Thus the negative end of the story remains a matter for doubt.

VI

A PSYCHOLOGICAL VIEW OF CONSCIENCE

GOOD AND EVIL IN ANALYTICAL PSYCHOLOGY

INTRODUCTION TO WOLFF'S "STUDIES IN JUNGIAN PSYCHOLOGY"

A PSYCHOLOGICAL VIEW OF CONSCIENCE¹

[825] The etymology of the word “conscience” tells us that it is a special form of “knowledge” or “consciousness.”² The peculiarity of “conscience” is that it is a knowledge of, or certainty about, the emotional value of the ideas we have concerning the motives of our actions. According to this definition, conscience is a complex phenomenon consisting on the one hand in an elementary act of the will, or in an impulse to act for which no conscious reason can be given, and on the other hand in a judgment grounded on rational feeling. This judgment is a value judgment, and it differs from an intellectual judgment in that, besides having an objective, general, and impartial character, it reveals the subjective point of reference. A value judgment always implicates the subject, presupposing that something is good or beautiful *for me*. If, on the other hand, I say that it is good or beautiful for certain other people, this is not necessarily a value judgment but may just as well be an intellectual statement of fact. Conscience, therefore, is made up of two layers, the lower one comprising a particular psychic event, while the upper one is a kind of superstructure representing the positive or negative judgment of the subject.

[826] As we might expect from the complexity of the phenomenon, its empirical phenomenology covers a very wide field. Conscience may appear as an act of conscious reflection which anticipates, accompanies, or follows certain psychic events, or as a mere emotional concomitant of them, in which case its moral character is not immediately evident. Thus, an apparently groundless anxiety state may follow a certain action, without the subject being conscious of the least connection between them. Often the moral judgment is displaced into a dream which the subject does not understand. For example, a business man I knew was made what looked like a perfectly serious and honourable offer which, it turned out much later, would have involved him in a disastrous fraud had he accepted it. The following night after he received this offer, which as I say seemed to him quite acceptable, he dreamt that his hands and forearms were covered with black dirt. He could see no connection with the events of the previous day, because he was unable to admit to himself that the offer had touched him on the vulnerable spot: his expectation of a good business deal. I warned him about this, and he was careful enough to take certain precautions which did in fact save him from more serious harm. Had he examined the situation right at the beginning he would undoubtedly have had a bad conscience, for he would have understood that it was a “dirty business” which his morality would not have allowed

him to touch. He would, as we say, have made his hands dirty. The dream represented this locution in pictorial form.

[827] In this instance the classical characteristic of conscience, the *conscientia peccati* (“consciousness of sin”), is missing. Accordingly the specific feeling-tone of a bad conscience is missing too. Instead, the symbolical image of black hands appeared in a dream, calling his attention to some dirty work. In order to become conscious of his moral reaction, i.e., to feel his conscience, he had to tell the dream to me. This was an act of conscience on his part, in so far as dreams always made him feel rather uncertain. He had got this feeling of uncertainty in the course of an analysis, which showed him that dreams often contribute a great deal to self-knowledge. Without this experience he would probably have overlooked the dream.

[828] From this we learn one important fact: the moral evaluation of an action, which expresses itself in the specific feeling-tone of the accompanying ideas, is not always dependent on consciousness but may function without it. Freud put forward the hypothesis that in these cases there is a repression exerted by a psychic factor, the so-called superego. But if the conscious mind is to accomplish the voluntary act of repression, we must presuppose that there is some recognition of the moral obnoxiousness of the content to be repressed, for without this motive the corresponding impulse of the will cannot be released. But it was just this knowledge which the business man lacked, to such an extent that he not only felt no moral reaction but put only a limited trust in my warning. The reason for this was that he in no way recognized the dubious nature of the offer and therefore lacked any motive for repression. Hence the hypothesis of conscious repression cannot apply in this case.

[829] What happened was in reality an unconscious act which accomplished itself as though it were conscious and intentional—as though, in other words, it were an act of conscience. It is as if the subject recognized the immorality of the offer and this recognition had released the appropriate emotional reaction. But the entire process took place subliminally, and the only trace it left behind was the dream, which, as a moral reaction, remained unconscious. “Conscience,” in the sense in which we defined it above, as a “knowledge” of the ego, a *conscientia*, simply does not exist in this case. If conscience is a kind of knowledge, then it is not the empirical subject who is the knower, but rather an unconscious personality who, to all appearances, behaves like a conscious subject. It knows the dubious nature of the offer, it recognizes the acquisitive greed of the ego, which does not shrink even from illegality, and it causes the appropriate judgment to be pronounced. This means that the ego has been replaced by an unconscious personality who performs the necessary act of conscience.

[830] It was these and similar experiences which led Freud to endow the superego with special significance. The Freudian superego is not, however, a natural and inherited part of the psyche's structure; it is rather the consciously acquired stock of traditional customs, the "moral code" as incorporated, for instance, in the Ten Commandments. The superego is a patriarchal legacy which, as such, is a conscious acquisition and an equally conscious possession. If it appears to be an almost unconscious factor in Freud's writings, this is due to his practical experience, which taught him that, in a surprising number of cases, the act of conscience takes place unconsciously, as in our example. Freud and his school rejected the hypothesis of inherited, instinctive modes of behaviour, termed by us archetypes, as mystical and unscientific, and accordingly explained unconscious acts of conscience as repressions caused by the superego.

[831] The concept of the superego contains nothing that, in itself, would not be recognized as belonging to the common stock of thought. To that extent it is identical with what we call the "moral code." The only peculiar thing about it is that one or the other aspect of the moral tradition proves unconscious in the individual case. We should also mention that Freud admitted the existence of "archaic vestiges" in the superego—of acts of conscience, therefore, which are influenced by archaic motifs. But since Freud disputed the existence of archetypes, that is, of genuine archaic modes of behaviour, we can only assume that by "archaic vestiges" he meant certain conscious traditions which may be unconscious in certain individuals. In no circumstances can it be a question of inborn types, for otherwise they would be, on his own hypothesis, inherited ideas. But that is just what he does mean, though so far as I know there are no proofs of their existence. There are, however, proofs in abundance for the hypothesis of inherited, instinctive modes of behaviour, namely the archetypes. It is therefore probable that the "archaic vestiges" in the superego are a concession to the archetypes theory and imply a fundamental doubt as to the absolute dependence of unconscious contents on consciousness. There are indeed good grounds for doubting this dependence: first, the unconscious is, ontogenetically and phylogenetically, older than consciousness, and secondly, it is a well-known fact that it can hardly be influenced, if at all, by the conscious will. It can only be repressed or suppressed, and only temporarily at that. As a rule its account has to be settled sooner or later. Were that not so, psychotherapy would be no problem. If the unconscious were dependent on consciousness, we could, by insight and application of the will, finally get the better of the unconscious, and the psyche could be completely remodelled to suit our purpose. Only unworldly idealists, rationalists, and other fanatics can indulge in such dreams. The psyche is a phenomenon not subject to our will; it is nature, and though nature can, by skill, knowledge, and patience, be modified at a few points, it cannot be changed into something artificial without

profound injury to our humanity. Man can be transformed into a sick animal but not moulded into an intellectual ideal.

[832] Although people still labour under the delusion that consciousness represents the whole of the psychic man, it is nevertheless only a part, of whose relation to the whole we know very little. Since the unconscious component really is unconscious, no boundaries can be assigned to it: we cannot say where the psyche begins or ends. We know that consciousness and its contents are the modifiable part of the psyche, but the more deeply we seek to penetrate, at least indirectly, into the realm of the unconscious, the more the impression forces itself on us that we are dealing with something autonomous. We must admit that our best results, whether in education or treatment, occur when the unconscious co-operates, that is to say when the goal we are aiming at coincides with the unconscious trend of development, and that, conversely, our best methods and intentions fail when nature does not come to our aid. Without at least some degree of autonomy the common experience of the complementary or compensatory function of the unconscious would not be possible. If the unconscious were really dependent on the conscious, it could not contain more than, and other things than, consciousness contains.

[833] Our dream-example and many other cases of the kind suggest that, since the subliminal moral judgment accords with the moral code, the dream has behaved in the same way as a consciousness backed by traditional moral law, and that, consequently, ordinary morality is a basic law of the unconscious or at any rate influences it. This conclusion stands in flagrant contradiction to the common experience of the autonomy of the unconscious. Although morality as such is a universal attribute of the human psyche, the same cannot be maintained of a given moral code. It cannot, therefore, be an integral part of the psyche's structure. Nevertheless, the fact remains—as our example shows—that the act of conscience operates, in principle, in exactly the same way in the unconscious as in the conscious, follows the same moral precepts, and therefore evokes the impression that the moral code also controls the unconscious process.

[834] This impression is deceptive, because in practice there are just as many, and perhaps even more, examples where the subliminal reaction does not conform at all to the moral code. Thus I was once consulted by a very distinguished lady—distinguished not only for her irreproachable conduct but also for her intensely “spiritual” attitude—on account of her “revolting” dreams. Her dreams did indeed deserve this epithet. She produced a whole series of extremely unsavoury dream-images all about drunken prostitutes, venereal diseases, and a lot more besides. She was horrified by these obscenities and could not understand why she, who had always striven for the highest, should be haunted by these apparitions from the abyss.

She might just as well have asked why the saints are exposed to the vilest temptations. Here the moral code plays the contrary role—if it plays any role at all. Far from uttering moral exhortations, the unconscious delights in spawning every conceivable immorality, as though it had what was morally repulsive exclusively in mind. Experiences of this sort are so common and so regular that even St. Paul could confess: “For the good that I would I do not, but the evil which I would not, that I do” (Rom. 7:19).

[835] In view of the fact that dreams lead astray as much as they exhort, it seems doubtful whether what appears to be a judgment of conscience should be evaluated as such—in other words, whether we should attribute to the unconscious a function which appears moral to us. Obviously we can understand dreams in a moral sense without at the same time assuming that the unconscious, too, connects them with any moral tendency. It seems, rather, that it pronounces moral judgments with the same objectivity with which it produces immoral fantasies. This paradox, or inner contradictoriness of conscience, has long been known to investigators of this question: besides the “right” kind of conscience there is a “wrong” one, which exaggerates, perverts, and twists evil into good and good into evil just as our own scruples do; and it does so with the same compulsiveness and with the same emotional consequences as the “right” kind of conscience. Were it not for this paradox the question of conscience would present no problem; we could then rely wholly on its decisions so far as morality is concerned. But since there is great and justified uncertainty in this regard, it needs unusual courage or—what amounts to the same thing—unshakable faith for a person simply to follow the dictates of his own conscience. As a rule one obeys only up to a certain point, which is determined in advance by the moral code. This is where those dreaded conflicts of duty begin. Generally they are answered according to the precepts of the moral code, but only in a very few cases are they really decided by an individual act of judgment. For as soon as the moral code ceases to act as a support, conscience easily succumbs to a fit of weakness.

[836] In practice it is indeed very difficult to distinguish conscience from the traditional moral precepts. For this reason it is often thought that conscience is nothing more than the suggestive effect of these precepts, and that it would not exist if no moral laws had been invented. But the phenomenon we call “conscience” is found at every level of human culture. Whether an Eskimo has a bad conscience about skinning an animal with an iron knife instead of the traditional flint one, or about leaving a friend in the lurch whom he ought to help, in both cases he feels an inner reproach, a “twinge of conscience,” and in both cases the deviation from an inveterate habit or generally accepted rule produces something like a shock. For the primitive psyche anything unusual or not customary causes an emotional reaction, and the more it runs

counter to the “collective representations” which almost invariably govern the prescribed mode of behaviour, the more violent the reaction will be. It is a peculiarity of the primitive mind to endow everything with mythical derivations that are meant to explain it. Thus everything that we would call pure chance is understood to be intentional and is regarded as a magical influence. Such explanations are in no sense “inventions”; they are spontaneous fantasy-products which appear without premeditation in a natural and quite involuntary way; unconscious, archetypal reactions such as are peculiar to the human psyche. Nothing could be more mistaken than to assume that a myth is something “thought up.” It comes into existence of its own accord, as can be observed in all authentic products of fantasy, and particularly in dreams. It is the hybris of consciousness to pretend that everything derives from *its* primacy, despite the fact that consciousness itself demonstrably comes from an older unconscious psyche. The unity and continuity of consciousness are such late acquisitions that there is still a fear that they might get lost again.

[837] So, too, our moral reactions exemplify the original behaviour of the psyche, while moral laws are a late concomitant of moral behaviour, congealed into precepts. In consequence, they appear to be identical with the moral reaction, that is, with conscience. This delusion becomes obvious the moment a conflict of duty makes clear the difference between conscience and the moral code. It will then be decided which is the stronger: tradition and conventional morality, or conscience. Am I to tell the truth and thereby involve a fellow human being in catastrophe, or should I tell a lie in order to save a human life? In such dilemmas we are certainly not obeying our conscience if we stick obstinately and in all circumstances to the commandment: Thou shalt not lie. We have merely observed the moral code. But if we obey the judgment of conscience, we stand alone and have hearkened to a subjective voice, not knowing what the motives are on which it rests. No one can guarantee that he has only noble motives. We know—some of us—far too much about ourselves to pretend that we are one hundred per cent good and not egotists to the marrow. Always behind what we imagine are our best deeds stands the devil, patting us paternally on the shoulder and whispering, “Well done!”

[838] Where does the true and authentic conscience, which rises above the moral code and refuses to submit to its dictates, get its justification from? What gives it the courage to assume that it is not a false conscience, a self-deception?

[839] John says: “Try the spirits whether they are of God” (I John 4:1), an admonition we could profitably apply to ourselves. Since olden times conscience has been understood by many people less as a psychic function than as a divine intervention; indeed, its dictates were regarded as *vox Dei*, the voice of God. This view shows what value and significance were, and still are, attached to the phenomenon of

conscience. The psychologist cannot disregard such an evaluation, for it too is a well-authenticated phenomenon that must be taken into account if we want to treat the idea of conscience psychologically. The question of “truth,” which is usually raised here in a quite non-objective way, as to whether it has been proved that God himself speaks to us with the voice of conscience, has nothing to do with the psychological problem. The *vox Dei* is an assertion and an opinion, like the assertion that there is such a thing as conscience at all. All psychological facts which cannot be verified with the help of scientific apparatus and exact methods of measurement are assertions and opinions, and, as such, are psychic realities. It is a *psychological truth* that the opinion exists that the voice of conscience is the voice of God.

[840] Since, then, the phenomenon of conscience in itself does not coincide with the moral code, but is anterior to it, transcends its contents and, as already mentioned, can also be “false,” the view of conscience as the voice of God becomes an extremely delicate problem. In practice it is very difficult to indicate the exact point at which the “right” conscience stops and the “false” one begins, and what the criterion is that divides one from the other. Presumably it is the moral code again, which makes it its business to know exactly what is good and what is evil. But if the voice of conscience is the voice of God, this voice must possess an incomparably higher authority than traditional morality. Anyone, therefore, who allows conscience this status should, for better or worse, put his trust in divine guidance and follow his conscience rather than give heed to conventional morality. If the believer had absolute confidence in his definition of God as the *Summum Bonum*, it would be easy for him to obey the inner voice, for he could be sure of never being led astray. But since, in the Lord’s Prayer, we still beseech God not to lead us into temptation, this undermines the very trust the believer should have if, in the darkness of a conflict of duty, he is to obey the voice of conscience without regard to the “world” and, very possibly, act against the precepts of the moral code by “obeying God rather than men” (Acts 5:29).

[841] Conscience—no matter on what it is based—commands the individual to obey his inner voice even at the risk of going astray. We can refuse to obey this command by an appeal to the moral code and the moral views on which it is founded, though with an uncomfortable feeling of having been disloyal. One may think what one likes about an ethos, yet an ethos is and remains an inner value, injury to which is no joke and can sometimes have very serious psychic consequences. These, admittedly, are known to relatively few people, for there are only a few who take objective account of psychic causality. The psyche is one of those things which people know least about, because no one likes to inquire into his own shadow. Even psychology is misused for the purpose of concealing the true causal connections from oneself. The more “scientific” it pretends to be, the more welcome is its so-called objectivity,

because this is an excellent way of getting rid of the inconvenient emotional components of conscience, notwithstanding that these are the real dynamics of the moral reaction. Without its emotional dynamism the phenomenon of conscience loses all meaning—which is, of course, the unconscious goal of the so-called “scientific” approach.

[842] Conscience is, in itself, an autonomous psychic factor. All statements which do not directly deny it are agreed on this point. The clearest in this regard is the *vox Dei* concept. Here conscience is the voice of God, which often cuts sharply across our subjective intentions and may sometimes force an extremely disagreeable decision. If Freud himself attributed an almost daemonic power to the superego, although by definition it is not even a genuine conscience but merely human convention and tradition, this is in no sense an exaggeration: he was simply confirming the regular experience of the practising psychologist. Conscience is a demand that asserts itself in spite of the subject, or at any rate causes him considerable difficulties. This is not to deny that there are cases of lack of conscience. But the idea that conscience as such is only something learnt can be maintained only by those who imagine they were present on those prehistoric occasions when the first moral reactions came into existence. Conscience is far from being the only instance of an inner factor autonomously opposing the will of the subject. Every complex does that, and no one in his right senses would declare that it was “learnt” and that nobody would have a complex if it had not been hammered into him. Even domestic animals, to whom we erroneously deny a conscience, have complexes and moral reactions.

[843] Primitive man regards the autonomy of the psyche as demonism and magic. This, we consider, is only what one would expect in primitive society. On closer inspection one finds, however, that the civilized man of antiquity, such as Socrates, still had his daemon and that there was a widespread and natural belief in superhuman beings who, we would suppose today, were personifications of projected unconscious contents. This belief has not, in principle, disappeared, but still persists in numerous variants. For instance, in the assumption that conscience is the voice of God, or that it is a very important psychic factor (and one which manifests itself according to temperament, seeing that it usually accompanies the most differentiated function, as in the case of a “thinking” or a “feeling” morality). Again, where conscience seems to play no role, it appears indirectly in the form of compulsions or obsessions. These manifestations all go to show that the moral reaction is the outcome of an autonomous dynamism, fittingly called man’s daemon, genius, guardian angel, better self, heart, inner voice, the inner and higher man, and so forth. Close beside these, beside the positive, “right” conscience, there stands the negative, “false” conscience called the devil, seducer, tempter, evil spirit, etc. Everyone who examines his conscience is confronted with this fact, and he must admit that the good exceeds the

bad only by a very little, if at all. It is therefore quite in order for St. Paul to admit to having his “messenger of Satan” (II Corinthians 12:7). We ought to avoid sin and occasionally we can; but, as experience shows, we fall into sin again at the very next step. Only unconscious and wholly uncritical people can imagine it possible to abide in a permanent state of moral goodness. But because most people are devoid of self-criticism, permanent self-deception is the rule. A more developed consciousness brings the latent moral conflict to light, or else sharpens those opposites which are already conscious. Reason enough to eschew self-knowledge and psychology altogether and to treat the psyche with contempt!

[844] There is scarcely any other psychic phenomenon that shows the polarity of the psyche in a clearer light than conscience. Its undoubted dynamism, in order to be understood at all, can only be explained in terms of energy, that is, as a potential based on opposites. Conscience brings these ever-present and necessary opposites to conscious perception. It would be a great mistake to suppose that one could ever get rid of this polarity, for it is an essential element in the psychic structure. Even if the moral reaction could be eliminated by training, the opposites would simply use a mode of expression other than the moral one. They would still continue to exist. But if the *vox Dei* conception of conscience is correct, we are faced logically with a metaphysical dilemma: either there is a dualism, and God’s omnipotence is halved, or the opposites are contained in the monotheistic God-image, as for instance in the Old Testament image of Yahweh, which shows us morally contradictory opposites existing side by side. This figure corresponds to a unitary image of the psyche dynamically based on opposites, like Plato’s charioteer driving the white and the black horses. Alternatively, we must admit with Faust: “Two souls, alas, are housed within my breast,” which no human charioteer can master, as the fate of Faust clearly indicates.

[845] The psychologist can criticize metaphysics as a human assertion, but he is not in a position to make such assertions himself. He can only establish that these assertions exist as a kind of exclamation, well knowing that neither one nor the other can be proved right and objectively valid, although he must acknowledge the legitimacy of subjective assertions as such. Assertions of this kind are manifestations of the psyche which belong to our human nature, and there is no psychic wholeness without them, even though one can grant them no more than subjective validity. Thus the *vox Dei* hypothesis is another subjective exclamation, whose purpose it is to underline the numinous character of the moral reaction. Conscience is a manifestation of *mana*, of the “extraordinarily powerful,” a quality which is the especial peculiarity of archetypal ideas. For, in so far as the moral reaction is only apparently identical with the suggestive effect of the moral code, it falls within the sphere of the collective unconscious, exemplifying an archetypal pattern of behaviour reaching down into the

animal psyche. Experience shows that the archetype, as a natural phenomenon, has a morally ambivalent character, or rather, it possesses no moral quality in itself but is amoral, like the Yahwistic God-image, and acquires moral qualities only through the act of cognition. Thus Yahweh is both just and unjust, kindly and cruel, truthful and deceitful. This is eminently true of the archetype as well. That is why the primitive form of conscience is paradoxical: to burn a heretic is on the one hand a pious and meritorious act—as John Hus himself ironically recognized when, bound to the stake, he espied an old woman hobbling towards him with a bundle of faggots, and exclaimed, “O sancta simplicitas!”—and on the other hand a brutal manifestation of ruthless and savage lust for revenge.

[846] Both forms of conscience, the right and the false, stem from the same source, and both therefore have approximately the same power of conviction. This is also apparent in the symbolic designation of Christ as Lucifer (“bringer of light”), lion, raven (or *nycticorax*: night-heron), serpent, son of God, etc., all of which he shares with Satan; in the idea that the good father-god of Christianity is so vindictive that it takes the cruel sacrifice of his son to reconcile him to humanity; in the belief that the Summum Bonum has a tendency to lead such an inferior and helpless creature as man into temptation, only to consign him to eternal damnation if he is not astute enough to spot the divine trap. Faced with these insufferable paradoxes, which are an affront to our religious feelings, I would suggest reducing the notion of the *vox Dei* to the hypothesis of the archetype, for this at least is understandable and accessible to investigation. The archetype is a pattern of behaviour that has always existed, that is morally indifferent as a biological phenomenon, but possesses a powerful dynamism by means of which it can profoundly influence human behaviour.

[847] The concept of the archetype has been misunderstood so often that one can hardly mention it without having to explain it anew each time. It is derived from the repeated observation that, for instance, the myths and fairytales of world literature contain definite motifs which crop up everywhere. We meet these same motifs in the fantasies, dreams, deliriums, and delusions of individuals living today. These typical images and associations are what I call archetypal ideas. The more vivid they are, the more they will be coloured by particularly strong feeling-tones. This accentuation gives them a special dynamism in our psychic life. They impress, influence, and fascinate us. They have their origin in the archetype, which in itself is an irrepresentable, unconscious, pre-existent form that seems to be part of the inherited structure of the psyche and can therefore manifest itself spontaneously anywhere, at any time. Because of its instinctual nature, the archetype underlies the feeling-toned complexes and shares their autonomy. It is also the psychic precondition of religious assertions and is responsible for the anthropomorphism of all God-images. This fact,

however, affords no ground for any metaphysical judgment, whether positive or negative.

[848] With this view we remain within the framework of what can be experienced and known. The *vox Dei* hypothesis is then no more than an amplificatory tendency peculiar to the archetype—a mythological statement inseparably bound up with numinous experiences which expresses these occurrences and also seeks to explain them. By reducing them to something empirically knowable, we do not in any way prejudice their transcendence. When, for example, someone was struck by lightning, the man of antiquity believed that Zeus had hurled a thunderbolt at him. Instead of this mythical dramatization we content ourselves with the more modest explanation that a sudden discharge of electrical tension happened to take place just at the spot where this unlucky man stood under a tree. The weak point in this argument, of course, is the so-called “accident,” about which several things could be said. On the primitive level there are no accidents of this sort, but only intentional designs.

[849] The reduction of the act of conscience to a collision with the archetype is, by and large, a tenable explanation. On the other hand we must admit that the *psychoid* archetype, that is, its irrepresentable and unconscious essence, is not just a postulate only, but possesses qualities of a parapsychological nature which I have grouped together under the term “synchronicity.” I use this term to indicate the fact that, in cases of telepathy, precognition, and similar inexplicable phenomena, one can very frequently observe an archetypal situation. This may be connected with the collective nature of the archetype, for the collective unconscious, unlike the personal unconscious, is one and the same everywhere, in all individuals, just as all biological functions and all instincts are the same in members of the same species. Apart from the more subtle *synchronicity*, we can also observe in the instincts, for instance in the migratory instinct, a distinct *synchronism*. And since the parapsychological phenomena associated with the unconscious psyche show a peculiar tendency to relativize the categories of time and space, the collective unconscious must have a spaceless and timeless quality. Consequently, there is some probability that an archetypal situation will be accompanied by synchronistic phenomena, as in the case of death, in whose vicinity such phenomena are relatively frequent.

[850] As with all archetypal phenomena, the synchronicity factor must be taken into account in considering conscience. For although the voice of genuine conscience (and not just the recollection of the moral code) may make itself heard in the context of an archetypal situation, it is by no means certain that the reason for this is always a subjective moral reaction. It sometimes happens that a person suffers from a decidedly bad conscience for no demonstrable reason. Naturally there are any number of cases where ignorance and self-deception offer a sufficient explanation.

But this does not alter the fact that one can suddenly have a bad conscience when one is conversing with an unknown person who would have every reason to feel a bad conscience but is unconscious of it. The same is true of fear and other emotions arising from a collision with an archetype. When one is talking with somebody whose unconscious contents are “constellated,” a parallel constellation arises in one’s own unconscious. The same or a similar archetype is activated, and since one is less unconscious than the other person and has no reason for repression, one becomes increasingly aware of its feeling-tone in the form of a growing uneasiness of conscience. When this happens, we naturally tend to ascribe the moral reaction to ourselves, the more easily since no one, actually, has reason to enjoy a perfectly good conscience. But in the case we are discussing the self-criticism, laudable in itself, goes too far. We discover that, as soon as the conversation is ended, the bad conscience stops as suddenly as it began, and after a while it turns out that it is the other person who should take note of his bad conscience. By way of example, one thinks of cases like the one described by Heinrich Zschokke.³ While in Brugg, he visited an inn, where he ate lunch. Opposite him sat a young man. Suddenly Zschokke saw in his mind’s eye this young man standing at a desk, breaking it open, and pocketing the money he found. Zschokke even knew the exact amount and was so sure of it that he took the young man to task. The latter was so flabbergasted by Zschokke’s knowledge that he made a confession on the spot.

[851] This spontaneous reconstruction of an unknown fact can also be expressed in a dream, or give rise to a disagreeable feeling that cannot be put into words, or cause one to guess a situation without knowing to whom it refers. The psychoid archetype has a tendency to behave as though it were not localized in one person but were active in the whole environment. The fact or situation is transmitted in most cases through a subliminal perception of the affect it produces. Animals and primitives have a particularly fine nose for these things. This explanation, however, does not cover parapsychological events.

[852] Experiences of this kind are the common lot of the psychotherapist, or of anybody who has frequent occasion to talk professionally, about their intimate affairs, with people with whom he has no personal relationship. One should not conclude from this that every subjective pang of conscience which seems unfounded is caused by the person one is conversing with. Such a conclusion is justified only when the ever-present guilt component in oneself proves, after mature reflection, to be an inadequate explanation of the reaction. The distinction is often a very delicate matter because, in therapy, ethical values must not be injured on either side if the treatment is to be successful. Yet what happens in the therapeutic process is only a special instance of human relationships in general. As soon as the dialogue between two people touches on something fundamental, essential, and numinous, and a certain

rapport is felt, it gives rise to a phenomenon which Lévy-Bruhl fittingly called *participation mystique*. It is an unconscious identity in which two individual psychic spheres interpenetrate to such a degree that it is impossible to say what belongs to whom. If the problem is one of conscience, the guilt of the one partner is the guilt of the other, and at first there is no possibility of breaking this emotional identity. For this a special act of reflection is required. I have dwelt at some length on this problem because I wanted to show that by the concept of the archetype nothing final is meant, and that it would be wrong to suppose that the essence of conscience could be reduced to nothing but the archetype. The psychoid nature of the archetype contains very much more than can be included in a psychological explanation. It points to the sphere of the *unus mundus*, the unitary world, towards which the psychologist and the atomic physicist are converging along separate paths, producing independently of one another certain analogous auxiliary concepts. Although the first step in the cognitive process is to discriminate and divide, at the second step it will unite what has been divided, and an explanation will be satisfactory only when it achieves a synthesis.

[853] For this reason I have not been able to confine myself exclusively to the psychological nature of conscience, but have had to consider its theological aspect. From this point of view it cannot be presupposed that the act of conscience is something that, of its own nature, can be treated exhaustively by means of a rational psychology. We have, rather, to give priority to the assertion which conscience itself makes—that it is a voice of God. This view is not a contrivance of the intellect, it is a primary assertion of the phenomenon itself: a numinous imperative which from ancient times has been accorded a far higher authority than the human intellect. The daemon of Socrates was not the empirical person of Socrates. Conscience as such, if regarded objectively, without rationalistic assumptions, behaves like a God so far as its demands and authority are concerned, and asserts that it is God's voice. This assertion cannot be overlooked by an objective psychology, which must also include the irrational. Nor can it be pinned down to the question of truth, for this is unanswerable anyway and for epistemological reasons has long since become obsolete. Human knowledge has to be content with constructing models which are "probable"—it would be thoughtless presumption to demand more. For just as knowledge is not faith, so faith is not knowledge. We are concerned here with things that can be disputed, that is, with knowledge, but not with indisputable faith, which precludes critical discussion at the outset. The oft-repeated paradox "knowledge through faith" seeks in vain to bridge the gulf that separates the two.

[854] When, therefore, the psychologist explains genuine conscience as a collision of consciousness with a numinous archetype, he may be right. But he will have to add at once that the archetype *per se*, its psychoid essence, cannot be comprehended, that it

possesses a transcendence which it shares with the unknown substance of the psyche in general. The mythical assertion of conscience that it is the voice of God is an inalienable part of its nature, the foundation of its numen. It is as much a phenomenon as conscience itself.

[855] In conclusion I would like to say that conscience is a psychic reaction which one can call *moral* because it always appears when the conscious mind leaves the path of custom, of the *mores*, or suddenly recollects it. Hence in the great majority of cases conscience signifies primarily the reaction to a real or supposed deviation from the moral code, and is for the most part identical with the primitive fear of anything unusual, not customary, and hence “immoral.” As this behaviour is instinctive and, at best, only partly the result of reflection, it may be “moral” but can raise no claim to being *ethical*. It deserves this qualification only when it is reflective, when it is subjected to conscious scrutiny. And this happens only when a fundamental doubt arises as between two possible modes of moral behaviour, that is to say in a conflict of duty. A situation like this can be “solved” only by suppressing one moral reaction, upon which one has not reflected till now, in favour of another. In this case the moral code will be invoked in vain, and the judging intellect finds itself in the position of Buridan’s ass between two bundles of hay. Only the creative power of the ethos that expresses the whole man can pronounce the final judgment. Like all the creative faculties in man, his ethos flows empirically from two sources: from rational consciousness and from the irrational unconscious. It is a special instance of what I have called the transcendent function, which is the discursive co-operation of conscious and unconscious factors or, in theological language, of reason and grace.

[856] It is not the task of psychological understanding to broaden or to narrow the concept of conscience. “Conscience,” in ordinary usage, means the consciousness of a factor which in the case of a “good conscience” affirms that a decision or an act accords with morality and, if it does not, condemns it as “immoral.” This view, deriving as it does from the *mores*, from what is customary, can properly be called “moral.” Distinct from this is the ethical form of conscience, which appears when two decisions or ways of acting, both affirmed to be moral and therefore regarded as “duties,” collide with one another. In these cases, not foreseen by the moral code because they are mostly very individual, a judgment is required which cannot properly be called “moral” or in accord with custom. Here the decision has no custom at its disposal on which it could rely. The deciding factor appears to be something else: it proceeds not from the traditional moral code but from the unconscious foundation of the personality. The decision is drawn from dark and deep waters. It is true that these conflicts of duty are solved very often and very conveniently by a decision in accordance with custom, that is, by suppressing one of the opposites. But this is not always so. If one is sufficiently conscientious the

conflict is endured to the end, and a creative solution emerges which is produced by the constellated archetype and possesses that compelling authority not unjustly characterized as the voice of God. The nature of the solution is in accord with the deepest foundations of the personality as well as with its wholeness; it embraces conscious and unconscious and therefore transcends the ego.

[857] The concept and phenomenon of conscience thus contains, when seen in a psychological light, two different factors: on the one hand a recollection of, and admonition by, the *mores*; on the other, a conflict of duty and its solution through the creation of a third standpoint. The first is the moral, and the second the ethical, aspect of conscience.

GOOD AND EVIL IN ANALYTICAL PSYCHOLOGY¹

[858] I would like to express my warmest thanks to Professor Seifert² for all he has said to us concerning the problem of the shadow. If I comply with your wish to add a few words, it will be about the purely empirical aspect of good and evil which the therapist has to deal with as a concrete fact. I must confess that I always experience difficulties when discussing the problem of good and evil with philosophers or theologians. I have the impression that they are not talking about the thing itself, but only about words, about the concepts which denote or refer to it. We allow ourselves so easily to be deluded by words, we substitute words for the whole of reality. People talk to me about evil, or about good, and presume that I know what it is. But I don't. When someone speaks of good or evil, it is of what *he* calls good or evil, or what *he* feels as good or evil. Then he speaks about it with great assurance, not knowing whether it really is so or whether what he calls good or evil really corresponds to the facts. Perhaps the speaker's view of the world is not in keeping with the real facts at all, so that an inner, subjective picture is substituted for objectivity.

[859] If we wish to come to an understanding about so complex a question as good and evil, we must start with the following proposition: good and evil are in themselves *principles*, and we must bear in mind that a principle exists long before us and extends far beyond us.

[860] When we speak of good and evil we are speaking concretely of something whose deepest qualities are in reality unknown to us. Whether it is experienced as evil and sinful depends, furthermore, on our subjective judgment, as also does the extent and gravity of the sin.

[861] You probably know the joke about the father confessor in Texas, to whom a young man comes with an awfully long face. "What's the matter?" he inquires. "Something terrible has happened." "But what has happened?" "I've committed murder." "How many?" This shows how differently two people can experience the same fact, the same reality. I call a certain fact bad, often without being sure that it really is so. Some things seem to me bad, though in reality they are not. For instance, after dismissing a patient I have often wanted to kick myself because I thought I had done him an injustice. Perhaps I had been too brutal or did not tell him the right thing. Next time he comes he tells me: "That was a wonderful session—just what I needed to be told." The exact opposite can also happen: I think what an excellent

session it has been, what a successful dream-interpretation—and then it turns out to be all wrong.

[862] Where do we get this belief, this apparent certainty, that we know what is good and what is bad? “Ye shall be as gods, knowing good and evil.” Only the gods know, not us. This is profoundly true in psychology. If you take the attitude: “This thing may be very bad—but on the other hand it may not,” then you have a chance of doing the right thing. But if you already know in advance you are behaving as if you were a god. We are all only limited human beings and we do not know in any fundamental sense what is good and bad in a given case. We know it only abstractly. To see through a concrete situation to the bottom is God’s affair alone. We may perhaps form an opinion about it but we do not know whether it is finally valid. At most we can say cautiously: judged by such and such a standard such and such a thing is good or evil. Something that appears evil to one nation may be regarded as good by another nation. This relativity of values applies also in the realm of aesthetics: a modern work of art is for one person of supreme value, for which he is ready to lay out a large sum of money, whereas another person can make neither head nor tail of it.

[863] In spite of all this we cannot simply abstain from judgment. If we call good something that seems to us bad, we have in effect told a lie. If I tell someone, “What you have written is a masterpiece,” thinking on the quiet that it is worth nothing, that is a lie. Maybe the lie has a positive effect on him for the moment, so that he feels flattered. But a really constructive effect is produced only when I give him the best, a positive recognition that springs from conviction, and give it moreover at the right moment. When we pass emphatic judgments we are in an emotional state of mind and are then least able to apply valid criteria.

[864] My attitude to this problem is empirical, not theoretical or aprioristic. When a patient comes to the therapist he has a conflict, and the question is then how to uncover this conflict situation, which very often is unconscious, and above all to find a way out of the conflict. Probably the only thing I can do is to tell myself cautiously: we don’t know exactly what’s up. It seems to be such and such—but may not another interpretation be given with equal right? The situation may seem rather negative at first, but then one comes to see that this is just what the patient was fated to run into. So I say at most: I hope to God I’m doing the right thing. It may perhaps be an emotionally excessive situation, when the patient, as Albertus Magnus says, is “in an excess of affect.” If we look closely we shall see that good and evil are, as I said, *principles*. The word “principle” comes from *prius*, that which is “first” or “in the beginning.” The ultimate principle we can conceive of is God. Principles, when reduced to their ultimates, are simply aspects of God. Good and evil are principles of

our ethical judgment, but, reduced to their ontological roots, they are “beginnings,” aspects of God, names for God. Whenever, therefore, in an excess of affect, in an emotionally excessive situation, I come up against a paradoxical fact or happening, I am in the last resort encountering an aspect of God, which I cannot judge logically and cannot conquer because it is stronger than me—because, in other words, it has a numinous quality and I am face to face with what Rudolf Otto calls the *tremendum* and *fascinatum*. I cannot “conquer” a *numinosum*, I can only open myself to it, let myself be overpowered by it, trusting in its meaning. A principle is always a supraordinate thing, mightier than I am. I cannot even “conquer” the ultimate principles of physics, they simply confront me, loom over me, as sheer facts, as laws that “prevail.” Here there is something that we cannot conquer.

[865] If I say in an excess of affect, “This is a rotten wine” or “This fellow is a dirty dog,” I shall hardly be in a position to know whether these judgments are right. Another person might judge the same wine and the same man quite differently. We know only the surfaces of things, only how they appear to us—and so we must be very modest. How often have I wished to get rid—so it seemed to me—of some absolutely harmful tendency in a patient, and yet in a deeper sense he was perfectly right to follow it. I want, for instance, to warn somebody of the deadly danger he is running into. If I am successful I think it was a fine therapeutic achievement. Afterwards I see—if he did not take my advice—that it was just the right thing for him to run into this danger. And this raises the question: did he not *have* to be in danger of death? If he had dared nothing, if he had not risked his life, perhaps he would have been poorer by a supremely important experience. He would never have risked his life and therefore would never have gained it.

[866] So in the matter of good and evil, one can, as a therapist, only hope that one is getting the facts straight, though one can never be sure. As a therapist I cannot, in any given case, deal with the problem of good and evil philosophically but can only approach it empirically. *But because I take an empirical attitude it does not mean that I relativize good and evil as such.* I see very clearly: this is evil, but the paradox is just that for this particular person in this particular situation at this particular stage of development it may be good. Contrariwise, good at the wrong moment in the wrong place may be the worst thing possible. If it were not like this everything would be so simple—too simple. If I make no *a priori* judgments and listen to the facts as they are, then I do not always know beforehand what is good for the patient and what is bad. So many factors are involved, but we cannot yet see their meaning, they appear to us veiled in the shadow, and only afterwards does light penetrate the veil. What appears “in the shadow” of the Old Testament is revealed in the New Testament in the light of truth.

[867] So it is in psychology. It is presumptuous to think we can always say what is good or bad for the patient. Perhaps he knows something is really bad and does it anyway and then gets a bad conscience. From the therapeutic, that is to say the empirical, point of view, this may be very good indeed for him. Perhaps he *has* to experience the power of evil and suffer accordingly, because only in that way can he give up his Pharisaic attitude to other people. Perhaps fate or the unconscious or God—call it what you will—had to give him a hard knock and roll him in the dirt, because only such a drastic experience could strike home, pull him out of his infantilism, and make him more mature. How can anyone find out how much he needs to be saved if he is quite sure that there is nothing he needs saving from? He sees his own shadow, his crookedness, but he turns his eyes away, does not confront himself, does not come to terms with himself, risks nothing—and then boasts before God and his fellows of his spotless white garment, which in reality he owes only to his cowardice, his regression, his super-angelic perfectionism. And instead of being ashamed, he stands in the front row of the temple and thanks God he is not as other men.

[868] Such a person thinks he is justified because he knows what wrong is and avoids it. Consequently it never becomes a content of his actual life and he does not know from what he needs to be saved. Even the apocryphal saying: “Man, if thou knowest what thou dost, thou art blessed, but if thou knowest not, thou art accursed and a transgressor of the law,” only gives us half a chance. A man who knows what he is doing when he commits evil may have a chance of being blessed, but in the meantime he is in hell. For the evil you do, even when you do it knowingly, is still evil and works accordingly. Yet if you had not taken this step, if you had not trodden this path, perhaps it would have been a psychic regression, a retrograde step in your inner development, a piece of infantile cowardice. Whoever thinks that by “knowing what you do” you guard against sin or save yourself from sin is wrong; on the contrary, you have steeped yourself in sin. But this saying is so paradoxical that it is terribly shocking to our ordinary feelings. The Church, however, knows of this paradox when she speaks of the *felix culpa* of our first parents (in the Liturgy for Easter Eve). If they had not sinned there would have been no *felix culpa* to bring after it the still greater miracle of the redemption. Nevertheless, evil remains evil. There is nothing for it but to accustom ourselves to thinking in paradoxes.

[869] Without wishing it, we human beings are placed in situations in which the great “principles” entangle us in something, in which God leaves it to us to find a way out. Sometimes a clear path is opened with his help, but when it really comes to the point one has the feeling of having been abandoned by every good spirit. In critical situations the hero always mislays his weapon, and at such moments, as before death, we are confronted with the nakedness of this fact. And one does not know how one

got there. A thousand twists of fate all of a sudden land you in such a situation. This is symbolically represented by Jacob's fight with the angel at the ford. Here a man can do nothing but stand his ground. It is a situation that challenges him to react as a whole man. Then it may turn out that he can no longer keep to the letter of the moral law. That is where his most personal ethics begin: in grim confrontation with the Absolute, in striking out on a path condemned by current morality and the guardians of the law. And yet he may feel that he has never been truer to his innermost nature and vocation, and hence never nearer to the Absolute, because he alone and the Omniscient have seen the actual situation as it were from inside, whereas the judges and condemners see it only from outside.

[870] There is a well-known story of the young man who attained his majority. His father said to him: "Now you are twenty. Ordinary people stick to the Bible and what the parson says. The more intelligent mind the penal code." In other words: you are caught between "official" religion and civic morality. When your own conscience collides with them your most personal ethical decisions begin, in full consciousness of your creative freedom either to observe the moral code or not. I may, for instance, get into a situation where, in order to keep a professional secret, I have to lie. It would be futile to shrink from this with the excuse that I am a "moral" man. To the devil with such self-respect!

[871] I am telling you all this in order to make my attitude in practice clear. I do not see it is my job to discuss these things philosophically. For me they are practical matters. Of course I am also interested in their philosophical aspect, but philosophy butters no parsnips. The reality of good and evil consists in things and situations that happen to you, that are too big for you, where you are always as if facing death. Anything that comes upon me with this intensity I experience as numinous, no matter whether I call it divine or devilish or just "fate." Something stronger than oneself, invincible, is at work and one is up against it. The trouble is that we are so accustomed to thinking these problems out until everything is as clear as twice two makes four. But in practice it does not work like that, we do not reach a solution in principle as to how we should always act. To want one is wrong. It is the same here as with the laws of nature, which we also think of as valid everywhere. Conventional morality is exactly like classical physics: a statistical truth, a statistical wisdom. The modern physicist knows that causality is a statistical truth, but in practice he will always ask what law is valid in this particular case. So it is in the realm of morality. We should not be misled into thinking we have said something absolutely valid when we pass judgment on a particular case: this is bad, this is good. Often we have to pass judgments, we can't get out of it. Perhaps we may even say the truth, hit the mark. But to regard our judgments as absolutely valid would be nonsensical; it would mean wanting to be like God. Often even the person doing the action does not discern its inner moral

quality, the sum of all the conscious and unconscious motives underlying it, and how much less those who judge the action but see it only from the outside, only its appearance, not its deepest essence. Kant rightly requires the individual and society to advance from an “ethic of action” to an “ethic of conviction.” But to see into the ultimate depths of the conviction behind the action is possible only to God. Our judgment, therefore, as to what is good or evil in practice will have to be very cautious and modest, not so apodictic, as though we could see into all the darkest corners. Ideas of morality are often as widely divergent as are views on what constitutes a delicacy for the Eskimo and for ourselves.

[872] My attitude, it may be objected, is empirical in the extreme, but we need such an attitude in order to find a solution. When we observe how people behave when they are faced with a situation that has to be evaluated ethically, we become aware of a strange double effect: suddenly they see both sides. They become aware not only of their moral inferiorities but also, automatically, of their good qualities. They rightly say, “I can’t be as bad as all that.” To confront a person with his shadow is to show him his own light. Once one has experienced a few times what it is like to stand judgingly between the opposites, one begins to understand what is meant by the self. Anyone who perceives his shadow and his light simultaneously sees himself from two sides and thus gets in the middle.

[873] That is the secret of the Eastern attitude: observing the opposites teaches the Easterner the character of Maya. It gives reality the glint of illusion. Behind the opposites and in the opposites is true reality, which sees and comprehends the whole. The Indian calls this Atman. Reflecting on ourselves we can say, “I am he who speaks good and evil,” or better, “I am he through whom good and evil are spoken. The one who is in me, who voices the principles, uses me as a means of expression. He speaks through me.” This corresponds to what the Indian calls Atman—that which, figuratively speaking, “breathes through” me. Not through me alone, but through all; for it is not only the individual Atman but Atman-Purusha, the universal Atman, the pneuma, who breathes through all. We use the word “self” for this, contrasting it with the little ego. From what I have said it will be clear that this self is not just a rather more conscious or intensified ego, as the words “self-conscious,” “self-satisfied,” etc. might lead one to suppose. What is meant by the self is not only in me but in all beings, like the Atman, like Tao. It is psychic totality.

[874] It is a misunderstanding to accuse me of having made out of this an “immanent God” or a “God-substitute.” I am an empiricist and as such I can demonstrate empirically the existence of a totality supraordinate to consciousness. Consciousness experiences this supraordinate totality as something numinous, as a *tremendum* or *fascinosum*. As an empiricist I am interested only in the experiential character of this

totality, which in itself, ontologically considered, is indescribable. This “self” never at any time takes the place of God, though it may perhaps be a vessel for divine grace. Such misunderstandings arise from the assumption that I am an irreligious man who does not believe in God and just needs to be shown the way to belief.

[875] In the history of Indian philosophy, too, there have been constant attempts not to identify the Atman with the monistically conceived Brahman (the Absolute Ground of all being), for instance in Ramanuja as opposed to Shankara, or in Bhakti-Yoga; and Aurobindo thinks that the Indian of today has advanced so far from the level of unconsciousness to conscious realization that his Absolute can no longer have the character of a merely unconscious, impersonal cosmic force. But these are no longer questions for the pure empiricist. As an empiricist I can at least establish that the Easterner like the Westerner is lifted out of the play of Maya, or the play of the opposites, through the experience of the Atman, the “self,” the higher totality. He knows that the world consists of darkness and light. I can master their polarity only by freeing myself from them by contemplating both, and so reaching a middle position. Only there am I no longer at the mercy of the opposites.

[Jung’s talk appears to have ended here. Then followed an unrecorded question, evidently concerning the East.—
EDITORS.]

[876] We have a false picture of the East. From the East comes the humorous question: Who takes longer to be saved, the man who loves God or the man who hates him? Naturally we expect that the man who hates God takes much longer. But the Indian says: If he loves God, it takes seven years, but if he hates him only three. For the man who hates God thinks much more about him. What ruthless subtlety! But the question is absolutely right the way it is meant. It is a sort of quiz question which may be put to the educated public but not to a peasant.

[877] This story reminds me of something I saw in Ceylon. Two peasants had got their carts stuck in a narrow street. One can imagine what a flood of vituperation this would have let loose here in Switzerland. But what actually happened there was this: They bowed to each other and said: “Passing disturbance, no soul.” That is to say the disturbance takes place only outwardly, in the realm of Maya, and not in the realm of true reality, where it neither happened nor left a mark. One might think this almost unbelievable in such simple people. One stands amazed. But this attitude is so ingrained in them that they take it for granted. Richard Wilhelm witnessed much the same thing. Two rickshaw boys were having a fearful argument. Wilhelm thought they were going to let fly with their fists at any moment, and that blood would flow. Just then one of them rushed at the other—but rushed past him and aimed a mighty kick at the wheel of his rickshaw, and that was the end of the argument. I myself saw two boys quarrelling and fighting with their fists, but the fists always stopped in the

air, a few centimetres from the face, and no harm was done. That comes from the way these boys were brought up: it was Ceylon, where the old Buddhism still rules. It is a moral education that has become a habit, and there is nothing especially meritorious about it.

[878] Now, ladies and gentlemen, have you any further questions?

[A question was asked about the devil and his special reality today, since every epoch has its own peculiar devil.]

[879] The devil nowadays is something quite frightful! If you look at our situation you just cannot see where it will end. Things will go on like this as if by force. All the divine powers in creation are gradually being placed in man's hands. Through nuclear fission something tremendous has happened, tremendous power has been given to man. When Oppenheimer saw the first test of an atomic bomb the words of the Bhagavad Gita flashed into his mind: "Brighter than a thousand suns." The forces that hold the fabric of the world together have got into the hands of man, so that he even has the idea of making an artificial sun. God's powers have passed into our hands, our fallible human hands. The consequences are inconceivable. The powers themselves are not evil, but in the hands of man they are an appalling danger—in evil hands. Who says that the evil in the world we live in, that is right in front of us, is not real! Evil is terribly real, for each and every individual. If you regard the principle of evil as a reality you can just as well call it the devil. I personally find it hard to believe that the idea of the *privatio boni* still holds water.

[What should the psychotherapist do? Should he give the patient a hint of how to deal with evil, or should he urge the patient to find out for himself?]

[880] You are tempting me to lay down a rule. But I would rather advise: do the one thing or do the other according to circumstances, and in your therapeutic work do not act on any *a priori*, but in each case listen to what the concrete situation demands. Let that be your only *a priori*. For instance, a patient is still so unconscious that you simply *cannot* take up an attitude towards his problems. He identifies himself, like a psychotic, with his unconscious and would rather regard the analyst as crazy than understand his own inner situation. Try telling a completely unconscious mother, a sort of Kali Durga, who considers herself the best mother in the world, that she is to blame for the neurosis of her elder daughter and the unhappy marriage of her younger daughter—then you will hear something! And above all: the patient is not helped. Something must grow from inside *her*. Another patient has reached a certain level of consciousness and expects orientation from you. It would then be a great mistake not to make your attitude clear. The right thing must be said at the right time in the right place.

[881] A patient should not be regarded as an inferior being whom one lays on a couch while one sits behind him like a god, letting a word drop now and then. Everything suggestive of illness should be avoided. The patient is tending in this direction anyway and would like nothing better than to take refuge in illness: "... now I can give up, now I must just lie there, now I am good and sick." Illness too is a solution of sorts, a way of disposing of life's problems: "I am ill, now the doctor must help!" As a therapist I mustn't be naïve. Unless the patient should really be in bed he should be treated like a normal person, indeed like a partner. That provides a sound basis for the treatment. People often come to me expecting me to let loose some medical magic. Then they are disappointed when I treat them as normal people and myself act like a normal man. One patient had experienced only the strong silent god sitting behind the couch. As soon as I began to talk to her she said astonished, almost horrified: "But you're expressing your affects, you're even telling me what you think!" Naturally I have affects and show them. Nothing is more important than this: every human being should be taken as a real human being and treated according to his peculiarities.

[882] Therefore I say to the young psychotherapist: Learn the best, know the best—and then forget everything when you face the patient. No one has yet become a good surgeon by learning the text-books off by heart. Yet the danger that faces us today is that the whole of reality will be replaced by words. This accounts for that terrible lack of instinct in modern man, particularly the city-dweller. He lacks all contact with the life and breath of nature. He knows a rabbit or a cow only from the illustrated paper, the dictionary, or the movies, and thinks he knows what it is really like—and is then amazed that cowsheds "smell," because the dictionary didn't say so. It is the same with the danger of making a diagnosis. One knows that this disease is treated by So-and-so in chapter seventeen, and one thinks that this is the important thing. But the poor patient goes on suffering.

[883] People speak sometimes of "overcoming" evil. But have we the power to overcome it? It should be remembered, first, that "good" and "evil" are only our judgment in a given situation, or, to put it differently, that certain "principles" have taken possession of our judgment. Secondly, it is often impossible to speak of overcoming evil, because at such times we are in a "closed" situation, in an aporia, where whatever we choose is not good. The important thing is to be aware that we are then in a numinous situation, surrounded on all sides by God, who can bring about either the one or the other and often does. There are plenty of examples of this in the Old Testament. Or think of Teresa of Avila when she had a mishap on a journey: the coach broke down while crossing a small river and she fell into the icy water. "Lord, how can you permit such things?" "Well, that's how I treat my friends." "Aha, that's why you have so few!" Teresa had got into a situation where evil—in

this case physical evil—was done to her; she did not know how to integrate it, but nevertheless felt God’s immediate presence. That is how the “principles,” the “primordial powers,” approach a person—they put him in a numinous situation where there is no rational solution, where he does not feel himself the maker and master of the situation, but rather that it is God. No one can then foresee what will happen. Often we cannot say in such situations how the problem of good and evil will work out. We have to put our trust in the higher powers.

[884] If I am faced with this problem in analysis I may say: “Well, let’s wait and see what the dreams turn up, or whether higher powers will intervene, perhaps through illness or death. In any case don’t decide. You and I are not God.”

[885] In making the shadow conscious we must be very careful that the unconscious does not play yet another trick and prevent a real confrontation with the shadow. A patient may see the darkness in himself for a moment, but the next moment he tells himself that it is not so bad after all, a mere bagatelle. Or else he exaggerates his remorse, because it is so nice to have such a wonderful remorseful feeling, to enjoy it like a warm eiderdown on a cold winter’s morning when one should be getting up. This dishonesty, this refusal to see, ensures that there will be no confrontation with the shadow. Yet if there were a confrontation, then with increasing consciousness the good and the positive features would come to light too. We must therefore beware of the danger of wallowing in affects—remorse, melancholy, etc.—because they are seductive. It is easy enough to pride oneself on being able to feel such beautiful regrets. That is why people love plays, films, or preachers that move them to tears, because they can then enjoy their own emotions.

[886] In the course of our discussion we heard the word “esoteric.”³ It is said, for instance, that the psychology of the unconscious leads to an esoteric form of ethics. But we have to be careful in using such a word. Esotericism means mystification. Yet we never know the real secrets, even the so-called esotericists do not know them. Esotericists—at least earlier—were supposed not to reveal their secrets. But the real secrets cannot be revealed. Nor is it possible to make an “esoteric” science out of them, for the simple reason that they are not known. What are called esoteric secrets are mostly artificial secrets, not real ones. Man needs to have secrets, and since he has no notion of the real ones he fakes them. But the real ones come to him out of the depths of the unconscious, and then he may reveal things which he ought really to have kept secret. Here again we see the numinous character of the reality in the background. It is not we who have secrets, it is the real secrets that have us.

INTRODUCTION TO TONI WOLFF'S "STUDIES IN JUNGIAN PSYCHOLOGY"¹

[887] In writing this introduction I am discharging a debt of thanks: the author of the essays printed in this volume was my friend and collaborator for more than forty years, until her untimely death in 1953, at the age of sixty-five. She took an active part in all phases of the development of analytical psychology, and to her we owe the expression "complex psychology" as a designation for this field of research. Her collaboration was not confined to working out practical methods of analysis and to the task of theoretical formulation, both of which have found visible expression in the published material. She also helped me to carry out, over a period of forty years, a "silent experiment" in group psychology, an experiment which constitutes the life of the Psychological Club in Zurich.

[888] This small group of thirty to seventy members was founded in 1916, and it owes its existence to the realization that analytical treatment (including the "psychoanalytic" method) is a dialectical process between two individuals, and therefore gives results which are necessarily onesided from the collective and social point of view. The individual personality of the analyst represents only one of the infinite possibilities of adaptation which life offers as well as demands. This should not be taken to mean that analysis is a discussion between two individuals who are, at bottom, hopelessly incommensurable, or is nothing more than an approximation between them. Human personality is certainly not individual only, it is also collective, and to such a degree that the individual is rather like an underprivileged minority. Every so-called normal person represents the species *Homo sapiens* and can therefore be regarded as the measure of things human, or as a general example of human behaviour. For this reason, a large part of the analytical work takes place on levels which are common to all, or at any rate most, individuals, and which do not require the discussion of individual differences. The longer the discussion is intentionally restricted to what is common, collective, and average—that is, to theoretical suppositions—the closer it comes to the danger-point where the specifically individual features of the patient are suppressed.

[889] Thanks to her high natural intelligence and quite exceptional psychological insight, the author was one of the first to recognize the extraordinary importance of this psychotherapeutic problem, and devoted herself to it with particular zeal. For many years she was president of the Club and so had a unique opportunity to collect observations on group psychology. For in a group we see operating all those psychic

events which are never constellated by an individual, or may even be unintentionally suppressed. A male analyst, for example, can never constellate the reactions which a woman would release if she were in his place. These modes of behaviour therefore remain latent; or if they appear at all, there is no critical eye to separate the wheat from the chaff. At best they remain hanging in mid-air as theoretical speculations; they are not experienced as realities and so cannot be recognized for what they are. Only what the analyst has become conscious of through his own experience can become an object for psychological discussion. Other objects, which may be put up for discussion by the patient should they reach his consciousness, come to grief on the unconsciousness of the analyst at this particular point. If he can divest himself of his authority, he may be able to compensate for his own defective experience by the experience of another. But there is always a danger that he will counter the psychological reality by some schematic theorem, because his fear of feeling inferior prevents him from admitting his defect. This danger is particularly great for the analyst, who is always expected to show authority. As a result, it happens all too easily that the balance between theoretical prejudice and uncritical acceptance can no longer be preserved, so that the analyst is unable to distinguish between justified and unjustified resistances on the part of his patient.

[890] This problem, a very important one in practice, led the author to pay particular attention to the typical modes of behaviour, especially of women. As every intelligent person knows, a typology of this sort does not aim in the least at a statistical classification; its purpose is to afford insight into the structure of normal modes of behaviour. These are typical forms of reaction whose existence is quite justified, and which should not be regarded as pathological merely because the analyst belongs to a different type. A typology is therefore designed, first and foremost, as an aid to a psychological critique of knowledge. Empirical psychology is so rich that one can set up hundreds of typological criteria without necessarily endowing any one of them with special significance, unless it happened to be a particularly common and instructive criterion. The valuable thing here is the critical attempt to prevent oneself from taking one's own prejudices as the criterion of normality. Unfortunately, this happens only too easily; for instance, extraversion is "normal," but introversion is pathological auto-eroticism.

[891] Her study of the difficulties that arise in a group provided the author with a mass of empirical material of which she made valuable use. Like the individual, a group is influenced by numerous typical factors, such as the family milieu, society, politics, outlook on life, religion. The bigger the group, the more the individuals composing it function as a collective entity, which is so powerful that it can reduce individual consciousness to the point of extinction, and it does this the more easily if the individual lacks spiritual possessions of his own with an individual stamp. The group

and what belongs to it cover up the lack of genuine individuality, just as parents act as substitutes for everything lacking in their children. In this respect the group exerts a seductive influence, for nothing is easier than a perseveration of infantile ways or a return to them. Only the man who knows how to acquire spiritual possessions of his own is proof against this danger.

[892] Group observations have confirmed over and over again that the group subtly entices its members into mutual imitation and dependence, thereby holding out the promise of sparing them a painful confrontation with themselves. People still do not realize that fate will reach them all the same, if not directly then indirectly. A State that protects us from everything also takes away from us everything that makes life worth living. We need not stress the social advantages of living in a group, let alone the necessary and vital protection afforded by society. They are known to everyone. On the other hand, nobody likes or dares to mention in so many words the negative effects of group-existence, because this might bring up the frightening problem of self-knowledge and individuation. In any analytical treatment that seeks to be a psychological process of dialectic between two individuals the odious question is bound to arise: What is mine and what is thine?

[893] The answer to this question necessitates a thorough examination of psychic contents, of meanings and values, on a plane beyond the collective “should” and “must.” A much needed consideration of what is essential to the individual proves to be the first task, for no one can get anywhere near independence unless he is conscious of his own singularity. Belief in general rules and precepts will never make a man anything more than a collective being, whereas in reality he is an individual different from others and should therefore be in possession of his own individual consciousness. Without the physical and spiritual possessions that go with this he is in danger of being submerged in the collective. As this runs counter to the specific, biological urge of man to develop an individually differentiated consciousness, a great variety of injurious effects may be produced.

[894] The more “scientific” our education attempts to be, the more it orients itself by general precepts and thus suppresses the individual development of the child. One of these general precepts states: “The individuality of the child should be taken into account and protected.”

[895] This principle, praiseworthy in itself, is reduced to absurdity in practice if the numerous peculiarities of the child are not adjusted to the values of the collectivity. One is then protecting and developing merely the peculiarities, without considering whether they will be useful or harmful to the child later on in social life. He is being robbed of the important experience that peculiarities are not admissible just because he has them. Their differentiation and evaluation demand so much tact, experience,

and sense of values on the part of the educator that the above precept cannot be realized without danger to the pupil. It is very likely that too general an application of the principle will produce unadapted individualists rather than individuals capable of adaptation. The former are ruled by a ruthless ego, but the latter recognize the existence of factors which are equal if not superior to their own will.

[896] The possession of individual peculiarities is neither a merit nor, in itself, a valuable gift of nature. It is "just one of those things," and it becomes significant only to the degree that consciousness reflects upon it, evaluates it, and subjects it to ethical decision. The authority needed for this is represented by the educator. It has to be supposed that he himself really *is* such an authority. But he can become so only when he has accomplished the act of self-knowledge on himself. Otherwise children are the first to find out that he merely *talks*, but *is* not. He has a right to peculiarities only if he has earned them, and only by earning them does he possess authority, in other words, self-reliance and individuality. These can never be obtained by mollycoddling one's own desires.

[897] These educational commonplaces seem to have been generally forgotten today. Ignorance of them is one of the chief causes of the terrifying increase in juvenile delinquency. Since nobody is educated by general precepts and by giving peculiarities free rein, the young person loses all sense for authority and thus falls a victim to his inner chaos of undifferentiated values. The development of his personality comes to a standstill, he feels himself to be suppressed, robbed of his individual nature. That is why, paradoxically, the juvenile delinquent struggles to regain his birthright, and even goes to the length of committing a crime in order to take by force something that shall be irrevocably "his." It is a collective protest against the levelling platitudes of the so-called scientific view of the world, and against the destruction of the instinctual and emotional forces which results from it.

[898] The spiritual and moral value of a group is measured by the average value of its individual members. If they are without value, then no group ideal can help. Group experiences therefore always lead back to the question of the value of the individual and his development.

[899] The author of these essays accordingly turned her attention to the psychic contents of the individuals composing a group, and to the discussion of them for the purpose of intensifying consciousness. The peculiar nature of discussions of this kind, which the layman often finds very puzzling, is due to the fact that they are not philosophical in the conventional sense, but are psychological. That is to say, they are concerned with the affects, emotions, and values of individuals, and their subject-matter is taken not from the abstract world of concepts but from everyday life, from the experiences, dreams, and fantasies of individual human beings. The discussion

tries to bring order into this chaos of disconnected and uncomprehended details by examining their unknown connections with the human mind in general in the light of consciousness, so far as this is possible with the help of understanding and of our present means of communication. This therapeutic activity is naturally not philosophy in the current sense of the word, even though those who are not familiar with the psychological material always make the mistake of confusing purely empirical and pragmatic terms with philosophical concepts, or of taking them as metaphysical assertions.

[900] For anyone who knows the material these essays are uncommonly instructive and stimulating. They will tell the educated layman many things about which the learned specialists have little to say. They are answers to questions which affect the psyche of our contemporaries far more closely than those given by the academic specialist. Though the latter would certainly do well, in the interests of scientific objectivity, to exclude from his work all feeling-values, and, in particular, all subjective reactions and excursions into neighbouring territories in which he himself is a layman, the psychologist is ill-advised to disregard the emotional connections and analogies which are the essence of psychic life. In order to sketch an adequate picture of psychic events, and of the manifold connections between them, he must stress just those aspects which the specialist anxiously excludes from his field of study. An empirical psychology of complex phenomena therefore occupies a difficult position in the world of specialism. Whereas the specialist, guided by general principles, pushes forward to an ever more exact understanding of the smallest details, the empirical psychologist has to start from a very limited field in which he himself is the only expert—an expert, that is to say, in his personal knowledge of himself. But even here he will find it exceedingly difficult to rid himself of the prejudice that what he is practising is some kind of “objective psychology.” If he really has any talent in this respect, he will soon discover that he is surrounded by a number of similar experts who all have assumptions of their own and, like him, are inclined to regard their personal prejudices as generally valid psychological knowledge. Empirical knowledge, however, is composed of numerous individual observations by numerous individual observers, who have previously assured themselves of the identity of their methods of observation as well as of the objects observed. Because complex psychic phenomena are amenable to experimental methods only in minimal degree, we have to depend on descriptions of them, and can attempt to interpret them only by means of amplification and comparison. This procedure is the exact opposite of what the specialist is at pains to achieve. He wants to know the object in its truest essence and in all its peculiarity; whereas the comparative psychologist, in order to understand its irrational and apparently accidental details, must not fight shy even of the most obvious and superficial analogies, however fortuitous they may seem, because they

serve as bridges for psychic associations. Just as he horrifies the philosopher who has no interest in psychology by what must seem to him a special brand of inferior philosophy, so he annoys the scientific specialist unacquainted with psychotherapeutic problems by the inexactitude and superficiality of his “fantastic” analogies. What then must he expect of the theologian, whose propositions he blasphemously regards as “statements” of the psyche, i.e., as psychic products, reducing them to the same level as the statements of other religions, which are one and all erroneous?

[901] Psychological treatment, taken in its widest sense, seeks the values that satisfy the psychic needs of contemporary man, so that he shall not fall victim to the destructive influence of mass psychology. Words like “should” and “must” are useless remedies that have long since lost their efficacy. In order to find a proper remedy we need a knowledge of the real and whole man, and this is not possible without taking account of all those spheres of knowledge which immediately affect him and his conduct of life.

[902] Several of the essays in this volume bear witness to the efforts which the author has made in this regard. They are visible examples of the endeavour of complex psychology to fill the gap which the invasion of the natural sciences has created in the higher education of man.

VII

REVIEWS AND SHORT ARTICLES

THE SWISS LINE IN THE EUROPEAN SPECTRUM¹

[903] Count Keyserling is a phenomenon that needs to be judged with extreme caution. On no account should one think the judgment final; the phenomenon is far too complex. There is no merit in stressing its darker aspects, for they fairly leap to the eye. Moreover, so much light emanates from Keyserling that one wonders whether these shadows are not an integral part of him—not just a physical concomitant, so to speak, but the necessary condition for his peculiar intuitive capacity. Light presupposes darkness. Darkness fosters vision, obscurity demands clarification, diversity calls for unity and discord for harmony.

[904] It is easy to poke fun at Keyserling as an aristocrat who peers at the world through a monocle. Keyserling is not to be taken as a joke, though he himself suffers from the delusion that his book was written with a sense of humour. I do not find his book humorous; his style is mordant, and often one hears the crack of a whip. Instead of evoking hearty laughter it makes one think. What Keyserling calls humour is a light, jesting, sometimes brilliant manner, but cold to the touch and lacking in geniality, a cavalier wit—in short, a mock-humour. His humour is put on; it is one of the many ways of lending wings to his intuition and keeping it soaring high above the weltering darkness; a pardonable attempt to lighten what is, at bottom, an extremely difficult task. The thoughtful reader will not misunderstand this alleged joker, for he will guess that the book is Keyserling himself, in the act of approaching the earth from afar, and Europe in particular.

[905] What! Take Keyserling seriously? Regardless of his own different personal opinion, I think we should be well advised not to treat him with levity and shrug off his book as a “humorous one.” His attempt to get a bird’s-eye view of Europe is no mean achievement. The chief value and meaning of the book, as I see it, is that it gives clear expression to the need for the intellectual today to wean himself from the purely rational point of view. It bears witness to a psychological reality which has vanished from sight ever since the days of a common Latin language, the one universal Christian Church, and a universal Gothic style, so completely that one never even thinks of it. Keyserling advocates a return to a psychological view of the world, where nations are seen as functions, as the various activities and expressions of the one, great, indivisible man. This view is tremendously idealistic, not to say “metaphysical,” and is indisputable proof of Keyserling’s remoteness from the earth. The stand he has taken has the undeniable character of spirituality, with all the advantages and disadvantages this entails.

[906] In order to proclaim these welcome tidings, Keyserling needs his world-scorning, aristocratic stance, as it gives him the necessary elevation, distance, and solitude. If he should need a monocle as well, I would not hold it against him, for I know what ulterior purpose it serves. Even the “megalomania” of which he has so often been accused (though in this book of Keyserling’s it expresses itself in much milder form than in his other writings) is an excusable adjunct, being nothing other than a somewhat too convulsive effort to hold his own against the whole world. It is a declaration flung in the face of nothingness, incomprehensible only to those who have never lost their foothold on the earth. Megalomania simply keeps one’s courage up; otherwise it signifies nothing.

[907] Keyserling hails from the far-away regions of the spirit, hence he has trouble in understanding what he sees on earth. He talks such a lot about “meaning” only because he is looking for it. And one certainly has to look for it, for at first one sees only nonsense, especially in our present-day world. It is, indeed, extremely difficult to glimpse a meaning anywhere. And the search for it is hopelessly complicated by the fact that there are far too many “meanings” already—millions of short-lived, short-sighted, short-winded *ad hoc* meanings which seem uncommonly sensible to all who are struck with them, the more so the more senseless they are. This dreary spectacle becomes quite dismaying when we turn our gaze from the limited and less lugubrious sphere of the individual and see it parading as the alleged “soul of the nation.” Keyserling is condemned to begin at the most senseless and hopeless end—with an attempt to understand the national psyche. Every harsh word, every crack of the whip, every distortion of judgment becomes fully understandable as an involuntary expression of his irritation and impatience with this thankless, tightly knotted, refractory material. Keyserling *has* to boast of being a Russian, a German, a Frenchman as well as a Balt; he has to name himself in one breath with Napoleon, Socrates, and Genghis Khan in order to escape the thousand tentacles of the national psyche and be able to think and judge. He cannot allow himself to belong to any nation, not even to the human race. He is neither “human” nor “inhuman,” he is a unique phenomenon. Unfortunately, psychology has no acceptable name for this quality, but at any rate it is one which enables Keyserling to see humanity from the outside.

[908] This cosmic view of humanity—to use a term that suits his comet-like psychology—comprehensive though it is, is limited by the earth’s visibility. It is confined to daylight, and takes no account of things that are under the earth. Whatever may be perceived on the broad surface, Keyserling sees brilliantly. The chapters on Italy and Holland are superb. With regard to France, he has hit the nail on its head (which is Paris), but the Frenchman buried in the countryside remains invisible, essential though he is to the picture. In Spain Keyserling saw, no doubt

correctly, the still surviving Gothic man, without naming him as such. That part of the Englishman which is hidden in the earth and sea has received the name of the “beast-man”—not very complimentary, but objectively correct. Somehow I am not satisfied with his Germany, but I know of no one who could have made a better job of it. Austria has planted her cosy culture very evidently in Vienna; as an Alpine country she is stuck in the earth and for Keyserling invisible. Russia, Rumania, Hungary, Greece, and Turkey I know nothing of from personal experience.

[909] And now for Switzerland, which concerns us so closely and so painfully! Undeniably, Switzerland comes off worst. Keyserling has named me, together with Herr Badrutt of St. Moritz, the model Swiss, which must have astonished and delighted Herr Badrutt even more than it did me. However, I deserve this elevation in status probably less than he does, seeing that I have been Swiss for some five hundred years only on my mother’s side, but on my father’s side only for one hundred and six years (as C. A. Bernoulli pointed out in the *Basler Nachrichten* when my family-tree was questioned). I must therefore beg the reader to see my “relatively Swiss” attitude as the result of my little more than hundred-year-old Swiss nationality.

[910] I admit unblushingly that Keyserling’s criticism of the visible Swiss character, however harsh and fault-finding, is absolutely true. The fewer illusions we have in this respect the better for us. We ought to know how we look from the outside, and we should be grateful that he has been so unsparing. It is unfortunately impossible to deny that to every unpleasant sentence he has written about us, we could add at least half a dozen highly illustrative examples from our daily experience.² It is indeed an unedifying picture which he has painted of our Switzerland. The good things he mentions pale into insignificance beside the bad. I must own that I felt insulted and irritated by some of them. This is because willy-nilly we identify ourselves with the nation, chalking up its supposed good qualities to our own account, and attributing our own bad qualities to others. This unconscious symbiosis is practically unavoidable, but it has the disadvantage that the more we hide behind the nation the less conscious we are of ourselves. As soon, therefore, as I became aware of my ruffled national pride, I read the chapter on Switzerland as though Keyserling had been writing about me personally, and behold! my irritation vanished.

[911] It became clear to me that when I took his criticism personally, I found I was being judged only from the outside. We have to put up with such criticism, of course; but the essential thing is that we should be able to stand up to our criticism of ourselves. From outside this attitude looks like self-righteousness, but it is so only if we are incapable of criticizing ourselves. If we can exercise self-criticism, criticism from outside will affect us only on the outside and not pierce to the heart, for we feel

that we have a sterner critic within us than any who could judge us from without. And anyway, there are as many opinions as there are heads to think them. We come to realize that our own judgment has as much value as the judgment of others. One cannot please everybody, therefore it is better to be at peace with oneself. “One claps his eyes on it, another a price on it, a third man despises it—what does it matter?”³ Keyserling pitches on this genuine piece of Swiss wisdom and exclaims indignantly: “For any cultured person or someone in a higher social position this way of thinking, inimical to all values, is merely irresponsible and unprincipled.”

[912] Herein lies the most glaring difference between the man of the Keyserling breed and the Swiss. The judgment of others is not in itself a standard of value, it may be no more than a useful piece of information. The individual has a right, indeed it is his duty, to set up and apply his own standard of value. In the last resort ethics are the concern of the individual, as Albert Schweitzer has pointed out so forcefully. And for that matter, what is the attitude of the aristocrat? Does he bother about the judgment of others? Sitting on his peak he can look down superciliously on the multitude, unmoved by the hubbub of opinion. (“The dogs bark, but the caravan passes on.”) Why shouldn’t the least aristocratic of nations do the same? Or is it a case of “quod licet Jovi, non licet bovi”? But this would be to forget that the word “subject” (*Untertan*) has not existed in Switzerland for a very long time and that, historically, the psychological attitude of the Swiss, including the one-time “subject lands,” was moulded not by the latter but by the thirteen members of the old Confederation. The fact remains that the typical Swiss attitude of not bothering about the opinions of others bears a curious resemblance to the attitude of the aristocrat. I admire that blunt Swiss who sits in his modest house and lets the world know that he has his own sense of values and can let the opinions of others roll off him. He is an “aristocrat” in his way, not “au-dessus de la mêlée,” like the feudal lord of the manor, but—captious as this sounds—“au-dessous de la mêlée.” I am not just playing with words: the tumult and the shouting are always found where the opposites clash, and that is always midway between above and below. Above is aristocratic, below unaristocratic. The aristocrat, so long as he remains above, is outside the mêlée; the non-aristocrat, so long as he remains below, equally so. Above and below have always been brothers, as we learn from the wise saying in the *Tabula smaragdina*: “Heaven above, heaven below.”

[913] “Aristocratic” and “unaristocratic” are value-judgments, subjective and arbitrary, and are therefore best left out of the discussion. The very word “aristocrat” is a value-judgment. Let us speak rather of the “man of the spirit” and the “man of earth.” The spirit, as we know, is always above, a shining, fiery, aerial being, a mighty rushing wind, while the earth lies below, solid and dark and cold. This perennial image is expressed in the *yang* and *yin* of classical Chinese philosophy. The “man of the

spirit” represents the *yang* principle; his chief characteristic is an attitude conditioned by ideas, often called “idealistic” or “spiritual.” The “man of earth” represents *yin*, and he is characterized by an earth-bound attitude. *Yang* and *yin* are deadly enemies who need one another. The man whose attitude is permeated by the earth under his feet is the exponent of a principle that leaves nothing to be desired in the way of aristocratic panache, for it is the eternal adversary and partner of the spirit. Keyserling’s man is the aristocrat of *yang*, the Swiss the aristocrat of *yin*. So at least does Keyserling conceive him, when he calls him the non-aristocrat *par excellence*. I fully agree, but with the proviso that this judgment includes all those nations and parts of nations upon whom nature has set her mighty seal.

[914] Our loveliest mountain, which dominates Switzerland far and wide, is called the Jungfrau—the “Virgin.” The Virgin Mary is the female patron saint of the Swiss. Of her Tertullian says: “... that virgin earth, not yet watered by the rains,” and Augustine: “Truth has arisen from the earth, because Christ is born of a virgin.” These are living reminders that the virgin mother is the earth. From olden times the astrological sign for Switzerland was either Virgo or Taurus; both are earth-signs, a sure indication that the earthy character of the Swiss had not escaped the old astrologers. From the earth-boundness of the Swiss come all their bad as well as their good qualities: their down-to-earthness, their limited outlook, their non-spirituality, their parsimony, stolidity, stubbornness, dislike of foreigners, mistrustfulness, as well as that awful *Schwizerdütsch* and their refusal to be bothered, or to put it in political terms, their neutrality. Switzerland consists of numerous valleys, depressions in the earth’s crust, in which the settlements of man are embedded. Nowhere are there measureless plains, where it is a matter of indifference where a man lives; nowhere is there a coast against which the ocean beats with its lore of distant lands. Buried deep in the backbone of the continent, sunk in the earth, the Alpine dweller lives like a troglodyte, surrounded by more powerful nations that are linked with the wide world, that expand into colonies or can grow rich on the treasures of their soil. The Swiss cling to what they have, for the others, the more powerful ones, have grabbed everything else. Under no circumstances will the Swiss be robbed of their own. Their country is small, their possessions limited. If they lose what they have, what is going to replace it?

[915] From this comes their national resentment, which, as Keyserling rightly remarks, is not unlike that of the Jews. This is understandable enough, since the Jews as a people are in the same precarious situation and are forced to develop the same defence-mechanisms. Resentment is a defence reaction against the threat of interference.

[916] There are two kinds of interference which cause the hackles of the Swiss to rise: political and spiritual. Everyone can understand why they should defend themselves to the utmost against political interference, and this utmost is the art of neutrality born of necessity. But why they should defend themselves against spiritual interference is rather more mysterious. It is, however, a fact, as I can confirm from my own experience. English, American, and German patients are far more open to new ideas than the Swiss. A new idea for the Swiss is always something of a risk; it is like an unknown, dangerous animal, which must if possible be circumvented or else approached with extreme caution. (This, I may add, accounts for the remarkably poor intuitive capacity of the Swiss.)

[917] Thus far, I find everything quite as it should be. I believe that the spirit is a dangerous thing and I do not believe in its paramountcy. I believe only in the Word become flesh, in the spirit-filled body, where *yang* and *yin* are wedded into a living form.

[918] The danger inherent in the spirit is that it will uproot man, bear him away from the earth and inspire him to Icarian flights, only to let him plunge into the bottomless sea. The chthonic man is rightly afraid of this and instinctively defends himself against it, but in the most unpleasant way—by his “resentment.” Conversely, the man of the spirit fears and loathes the prison of the earth. It is, at bottom, the same kind of prejudice which the intuitive type has in regard to the sensation type: he confuses the latter with his own inferior sensation function. Naturally the sensation type has the same prejudice against the intuitive. When the two clash, both are aggrieved, because they feel that their most essential values have been misunderstood. The “other” in us always seems alien and unacceptable; but if we let ourselves be aggrieved the feeling sinks in, and we are the richer for this little bit of self-knowledge.

[919] The unpleasant reaction Keyserling has evoked in Switzerland is not a sign of repudiation—it merely proves that the cap fits. Everybody reads him, and his book is discussed at every social gathering. An influence like this is usually not unilateral. Something emanating from Switzerland has had its effect on Keyserling, as every attentive reader will have observed; and this something is indigenous to Switzerland.

[920] If it be true that we are the most backward, conservative, stiff-necked, self-righteous, smug, and churlish of all European nations, this would mean that in Switzerland the European is truly at home in his geographical and psychological centre. There he is attached to the earth, unconcerned, self-reliant, conservative, and backward—in other words, still intimately connected with the past, occupying a neutral position between the fluctuating and contradictory aspirations and opinions of the other nations or functions. That wouldn't be a bad role for the Swiss: to act as Europe's centre of gravity.

[921] I do not wish to evoke the impression that I am trying to turn our national vices into a virtue. I do not deny the ugly side of the earthbound character, but I take it as a given fact and am merely trying to discover what its meaning might be for Europe. We need not be ashamed of ourselves as a nation, nor can we alter its character. Only the individual can alter or improve himself, provided he can outgrow his national prejudices in the course of his psychic development. The national character is imprinted on a man as a fate he has not chosen—like a beautiful or an ugly body. It is not the will of individuals that moulds the destinies of nations, but suprapersonal factors, the spirit and the earth, which work in mysterious ways and in unfathomable darkness. It is useless to attack or to praise nations since no one can alter them. Moreover the “nation” (like the “state”) is a personified concept that corresponds in reality only to a specific nuance of the individual psyche. The nation has no life of its own apart from the individual, and is therefore not an end in itself. It is nothing but an inborn character, and this may be a handicap or an advantage, and is at best only a means to an end. Thus in many ways it is an advantage to have been imprinted with the English national character in one’s cradle. You can then travel in the most god-forsaken countries and when anybody asks, “Are you a foreigner?” you can answer, “No, I am English” (as Schmitz tells in his autobiography).⁴ This blissful self-assurance is enviable, but not in itself a merit.

[922] By logically transforming nations into functions, Keyserling destroys their fictitious substance, though Europe would still continue to exist as a substantial unity. With the help of this conception he breaks through our nationalistic limitations: responsibility to the nation is legitimate only in so far as it answers to the needs of Europe as a whole. A nation can no longer be its own fulfilment; it can fulfil itself only as one function within a functional system. Does neutral Switzerland, with its backward, earthy nature, fulfil any meaningful function in the European system? I think we must answer this question affirmatively. The answer to political or cultural questions need not be only: Progress and Change, but also: Stand still! Hold fast! These days one can doubt in good faith whether the condition of Europe shows any change for the better since the war. Opinions, as we know, are very divided, and we have just heard Spengler’s lamentations on the decline of the West. Progress can occasionally go down-hill, and in the face of a dangerously rapid tempo standing still can be a life-saver. Nations, too, get tired and long for political and social stabilization. The Pax Romana meant a good deal to the Roman Empire.

[923] All life is individual life, in which alone the ultimate meaning is to be found. Here I would like to quote the deepest thought in Keyserling’s book: “If we now lift ourselves to the highest point of view attainable by earthbound man, we must say: The ultimate goal does not lie in the fulfilment of nations as such; how could it ever have been thought otherwise? Their life is only a means to a higher end; were it not

so, no pessimism would be black enough.” From this point of view, of course, the nation as an outward characteristic of a human society is a negligible factor. What would it then matter to the individual whether his “nation” lay peacefully ruminating in a lush meadow or not? But wasn’t it the highest ambition of some of the wisest rulers to achieve precisely this? Is it so certain, then, that this state of stagnation is absolutely worthless? One of the most fundamental characteristics of every civilization is the quality of permanence, something created by man and wrested from the meaningless flux of nature. Every house, every bridge, every street, is a witness to the value of duration in the midst of change.

[924] The neutral stability of Switzerland, despite all the disadvantages of our national character, seems to me to mean more for the European psyche than Keyserling is willing to admit. From his lofty point of view Switzerland must appear just as he describes it. And so indeed it is, seen from the outside. It is the diametrical opposite of Keyserling’s nature, its earthiness contradicts his intuitive temperament, for which mere existence is an abomination. That is why he waxes so indignant about people who have money and do not spend it. Why should they spend it, if saving it gives them more pleasure? For other people, spending is a pleasure. But saving is the standstill that Keyserling dreads, and spending the liberating movement for which every intuitive longs. What Keyserling holds against Switzerland is, in the last analysis, its whole *raison d’être*. The Swiss national character that has been built up over the centuries was not formed by chance; it is a meaningful response to the dangerously undermining influence of the environment. We Swiss should certainly understand why a mind like Keyserling’s judges us so harshly, but he should also understand that the very things he taxes us with belong to our most necessary possessions.

THE RISE OF A NEW WORLD¹

[925] “The Rise of a New World” is the subtitle of the German edition of Keyserling’s *America Set Free*, and is in every respect the most succinct résumé of the theme of the book. For this book is not purely and simply about America, any more than *The Spectrum of Europe* was purely and simply about Europe. It presents an extremely variegated picture that glitters in all the colours of the rainbow, sombre and gay, pessimistic and optimistic—a veritable spectrum, which is often more like a spectre, of America. The immediate cause of its birth is the abrasive surface of the transatlantic continent, across which Keyserling’s aerial and procreative spirit flew, crackling and striking sparks as it went. The book is like an independent organism that exhibits as many characteristic features of its mother as of its father. This is particularly evident in the fact that America has become for the author a symbol of the rise of a new world. At first it looks as if this “new world” was America, but at the end of the book it becomes clear that the new world includes old Europe—that is, ourselves. “The Rise of a New World” is as much concerned with Europe as with America, for the book is the product of the mutual impact of Keyserling and the United States. (Another book of his will deal with South America.²) One must bear this fact in mind, because it provides a clue to a correct understanding of the book’s subjectivity. It is not unintentionally subjective, as if by regrettable accident, but is meant to be so. To this it owes its dual aspect: America seen through European eyes. Unavoidably, European psychology is translated into American terms that sound foreign to our ears, and this gives rise to a disconcerting and fascinating play of light and shadow, through which two fundamentally incommensurable worlds are alternately compared and contrasted.

[926] Never before have I realized more clearly how difficult, if not impossible, it is fully to understand anything foreign, and to give an exhaustive account of it. A purely objective comparison would remain stuck in superficialities. Hence anyone who undertakes a comparison must call upon all his subjectivity for assistance if he is to produce a picture that will really tell us something about the foreigner. One should never read Keyserling in the belief that what he says about something is really so—or even that he thinks it is. Temperamental and downright as his utterances are, they are never hypostatizations. He simply expresses his opinion, and for this we can only be grateful. This book contains a wealth of the most deliberate, serious, and trenchant opinions, and there is every advantage to be gained from reflecting on them, even if one does not agree with them at first, if at all. Judging by my own experience of life

in America, I have no fundamental objection to make against Keyserling's views. I begin to have misgivings only when he sets foot on that most hazardous territory of all, namely that of prognosis. But apart from that, his picture of America is splendidly compendious. The most striking thing is the fact that—very much in contrast with his standpoint in *The Spectrum of Europe*—he lets the American *earth* have its say. The immensity and massiveness of the continent must have done something to him. He feels its primeval, not yet “humanized” character. He misses the “psychic atmosphere” in the North American landscape. “No gods have yet sprung from its union with man,” America has “no soul yet,” because the conquerors of a foreign land “may take their bodies with them, but not their souls.”

[927] This categorical judgment certainly sounds rather bleak, but Keyserling has said something very true which offers a key to the locked recesses of American psychology. His analysis does not, to be sure, penetrate to these depths, but it does move within the wide field of American phenomenology, which, from the psychological point of view, offers material that is well-nigh inexhaustible. The vastness of the continental land-mass, the preponderance of immense open spaces, produce, so the author thinks, an atmosphere which resembles that of Russia and Central Asia. This bold comparison is a leitmotif of the book, and it comes up again and again in his discussion of the contrasting parallel between American private enterprise and Russian Bolshevism. “[America's] very spirit is one of width and vastness. This spirit of width and vastness is similar to that of Russia and Central Asia, and entirely different from that of Europe” (p. 70). That is why America might be compared, not with Europe, but with China (p. 73). For this reason America should not be ashamed of her Babbitts. “Babbitt ... is today the soundest and most reliable representative of the entire continent” (p. 75), precisely because he is the type who is closest to the earth. This type will survive and, in time, will cause all European, and particularly all Anglo-Saxon, influences to disappear.

[928] Keyserling regards the philosophers Emerson and William James as “contrasting ideologists” (p. 100). Dewey, on the other hand, he regards as the “most representative American” (p. 112), and the reasons he gives for this are not bad. He has an equally convincing view of the founder of Behaviourism, John B. Watson, as *the* American psychologist, and adds that his “psychology” means as little to the European as does Dewey's “philosophy.” To make up for this, Dewey means all the more to the Asiatic (i.e., Russia and China), because his philosophy is really “psychology bent on education” (p. 113). The fact that Dewey's importance extends even to Asia (an example being the educational reforms in China) proves the curious similarity of their respective psychic situations despite all the differences. Here again Keyserling, it seems to me, hits the mark, for in Asia as well as in the chaotic mixture of races and cultures in America there is a social and educational problem of first

rank to be faced. The European emigrant is rejuvenated on American soil; in that primitive atmosphere he can revert to the psychological patterns of his youth—hence his adolescent psychology with all the educational problems this entails. As a matter of fact, the moral condition of post-war youth in America presents the country with an immense educational task, compared with which other cultural tasks that seem of more importance to the European must inevitably take second place.

[929] Keyserling considers that the ideal of a high living standard is the mainspring of American morality. It expresses itself in the idea of “social service,” and also in the idea of social welfare. Keyserling calls this the “animal ideal” (p. 158). “What animal, if it could think, would not enlist under the banner of the highest possible standard of living?” exclaims Keyserling (p. 164). And it is this ideal that constitutes the essential core of the typically American outlook on life: behaviourism. Watson is therefore “one of the foremost representatives of what the United States stood for in the twentieth century” (p. 167). At the same time, behaviourism provides the intellectual link with Bolshevik psychology. For this reason the American, for all his hustling, is mentally the most passive of men (p. 271), and “American civilization is the most uniform that has ever existed.” “The ideal of health, then, contributes in its turn to the animalization of the American. But the same is true of education as it is generally understood. It is becoming more and more a form of training such as animals can be submitted to.”

[930] This mental condition goes hand in hand with the lack of authority in the States. “The State and the Government are not considered as institutions ranging above the private individual. On the contrary, they are supposed to be mere executives of his will” (p. 235). “Every American citizen rejoices in [American political institutions] and will do his utmost to uphold their prestige in foreign countries. But as regards his own person he views them in a totally different light. At home he is, first and last, a private entrepreneur” (p. 236). “The United States are one gigantic Canton Appenzell—the most provincial province in Switzerland” (pp. 237–38).

[931] There is no lack of *bons mots* in this book, for instance the club-woman as the “aunt of the nation,” who does her best to deprive her naughty little nephew of alcohol, on the ground that it is injurious to health. There is also the crack about the “kindergarten” (p. 271) psychology of adult Americans, and many other entertainingly apt drolleries.

[932] The chapter on “The Overrated Child” seems to me the best in the book. “America,” we are told, “is fundamentally the land of the overrated child” (p. 267)—an expression of the nation’s youthfulness and at the same time an attempt to perpetuate it. What Keyserling has to say about the relation of the sexes and of members of the family to one another, and about parents, husbands and wives,

marriage, the upbringing of children, the demasculinization of men and the masculinization of women is very well worth reading, not merely because it concerns America but because we Europeans can learn something from it of value to ourselves. Anyone who still does not know how much the American way of life is infecting Europe's upper classes, just as Asiatic Bolshevism is seeping into European Communism, should take this opportunity to find out. Europe is dangerously close to becoming a mere hyphen between America and Asia. It cannot yet be said that the European has "only the fearful choice" between Americanization and Bolshevism. Europe, thank God, still exists in her own right. But we should realize all the more clearly how far the Americanization of the social upper crust has advanced. That is why I wish Keyserling as devoted a public in Europe as in America. Above all, one should not let oneself be irritated, even when it sometimes looks as if a nasty-tempered dog were mercilessly shaking its victim, or as if a universal schoolmaster were giving the boys good advice for their journey through life. One should never get annoyed with Keyserling, for at bottom he means it well. And how often he hits the mark! Everything he says about America from the European point of view may be arbitrary, cock-eyed, or just plain wrong, and yet the thoughtful European can derive plenty of stimulation from this book, not only for himself as a European, collective being, but for himself as an individual. After all, the American is a human being like ourselves, and his ideals and moral motives belong to the same Christian era as ours. Hence any criticism of him affects us as well. The reader will be particularly impressed by this in the final chapter, on "Spirituality." Here Keyserling seems to be talking about America, but in reality he is making a profession of faith, and expressing a hope for the future, which apply to Europe in a higher sense than to America, although they are also of profound significance for any American living in a Christian era.

[933] It had never struck me so clearly before how much Keyserling is the mouthpiece of the collective spirit, until I read this chapter. One might easily expect from Keyserling, the "intellectual aristocrat," lofty pronouncements borne along on the rarefied breezes that blow from the differentiated academic mind. But nothing of the sort happens here. On the contrary, he speaks of things that are not only remote from the academic mind, but are unknown to it and are even regarded with contempt. They are things which really do concern the psyche of modern man, which do not appear on the surface, but which become visible to anyone who is interested in the background and who has occasion to speak with people who usually do not talk very loudly. But the "silent ones in the land" are greater in number than the makers of noise. In this chapter, Keyserling speaks from the background, and to those who dwell in the background. Here he is no longer the *enfant terrible*, no longer the brilliant talker; here he grips you. We hear a Keyserling who commands attention,

one who speaks with the voice of many, and so gives expression to a great time of change. The man of this age undoubtedly speaks through him when he rates understanding above faith and experience above a credo. The individual, “master of himself and freed from the shackles of tradition, is beginning to understand the old truths, in so far as they are truths which in earlier times were simply accepted on authority, in a new and personal way. At the very time when the old forms are disintegrating, advanced minorities are beginning to experience their essential meaning, their living and immortal substance, more profoundly than at any time since the golden age of Christianity, when Greek thinkers were giving shape to the Christian view of the world. This means nothing less than that the age of the Holy Ghost is now at hand” (p. 464).

[934] Who would have thought that? Or rather, who actually thinks like that? Who are these “advanced minorities”? Where are they? I will tell you: your next-door neighbours, the Meiers and the Müllers, of whom you would never have expected it, think like that. Sometimes they know it and sometimes they don’t. If they do, they conceal this knowledge more carefully than the worst scandal. Nowadays it is no longer the old-fashioned objects of modesty that are guarded by a feeling of shame, but a secret spirituality. There are millions of people today who make “spiritual” experiments on themselves, and who are so shamefully conscious of their incompetent and illegitimate behaviour that more often than not they close their eyes to what they are doing. Their numbers justify Keyserling in speaking out so confidently, in saying something so unprecedented and so unbelievable that he should know that all Churches, all academies, all governments, and all joint-stock companies will shake their wise and venerable heads at it. How many of these “silent ones in the land” would dare to shake the good Count democratically by the hand on the strength of this confession?

LA RÉVOLUTION MONDIALE¹

[935] It is perhaps a sign of the times that in his new book, *La Révolution mondiale et la responsabilité de l'Esprit*, Keyserling addresses his public in French. One feels oneself transported back to the eighteenth century in Germany, when not only statesmen but philosophers and scholars preferred a more refined, cultured, and elegant language like French to their complicated and clumsy German, politely dressing up their subject in a courtly Sunday suit. *La Révolution mondiale* is certainly not a subject that calls for any such old-fashioned allurements, so it must be quite other reasons that impelled the author to write in French. I wish the book had been written in German, for, in my unqualified opinion, its spirit is as un-French as it could possibly be. Even the words “la responsabilité de l'esprit” expresses a kind of “spirit” (*Geist*) that can hardly be imputed to the French “esprit.” Keyserling looks foreign and odd in French dress. German or perhaps Russian expresses the peculiar nature of his spirituality much better. If his public had been Chinese, or people who could read Chinese, both they and he would have benefited had he written in Chinese characters.

[936] Every Chinese character is a complicated structure of meaning, in which sometimes whole families of ideas are gathered under one roof. Characters such as these are admirably suited to reproduce the infinite, protean diversity of Keyserling's ideas, and at the same time vague enough to convey to the reader all those flashes of intuition that are so typical of Keyserling's mind. They would also give the reader the great satisfaction of thinking that he had perceived all this for himself. But in French it sounds as if Keyserling alone had perceived everything.

[937] The book shows Keyserling's reaction to what is going on in the world today, just as his earlier book, *South-American Meditations*, describes the impact which South America, a continent that is not controllable by the spirit, made upon him. It is no doubt from this book that the “telluric powers” are derived, whose revolt the author feels to be the cause and content of the present European crisis. They seem to him—no doubt again in recollection of the South American *gana*-world—to be essentially passive, not only in need of direction by the spirit, but capable of being so directed. The spiritual and the telluric are the contrapuntal poles of this book and also of the world crisis. Nietzsche's “slave-insurrection in morals” changes here into a mass-insurrection against the spirit. Keyserling is clear-sighted enough to see that this revolt is not just a negative phenomenon but that it also has its positive side; it turns out that the revolt of the “telluric” man brings with it an efflorescence of “faith and

courage.” “The primordial expressions of the spirit are courage and faith, and its eternal prototype is the religious spirit.” A certain amount of barbarization is inevitable, but “the rebirth of blind faith ... is simply a sign of the renewal of youth, and thus of increased vitality.”

[938] In order to find the criterion for contemporary events, Keyserling harks back to the rise of Islam and, even more, to that of Christianity. For him we are in the midst of a “world change,” and it is no longer a question of social or political happenings, of “repentance,” and certainly not of leadership, planned economy, and the like. He has set his picture of our contemporary world in the widest possible framework, filling it with a multitude of aspects and cross-relationships which are all, at bottom, products of his own congenitally mixed nature. His heritage, stemming from a diversity of widely separated races and peoples as well as from all sorts of different cultural levels, produces in Keyserling an enormous range of reactions and points of view which give this book, like all his others, its glitter and variety. He is no doubt speaking from his own most personal experience when he says: “Consequently, there is only one attitude which is appropriate: to take human nature as it is, in all the diversity of its strata and all its queer disequilibrium.”

[939] This sentence holds good for the author but not for the masses, for in the latter case we should have no substitute “uniformity” for “diversity” and “hopeless balance” for “disequilibrium.” The masses as we know follow the law of their own inertia and seek, if disturbed, to restore the state of balance as speedily as possible, no matter how uncomfortable it may be. In this respect the masses are uncommonly “telluric.” No wonder these “telluric powers” seem to Keyserling the most unspiritual thing imaginable. For him the “spirit” is its polar opposite. This is a genuinely Western point of view, and in this matter, therefore, Keyserling feels himself at odds with classical philosophy, which, he says, makes this Western antithesis unreal. One can only ask oneself whether such an opposition between heaven and earth has always existed, and whether the *I Ching* may not be right after all, when it says that heaven and earth only occasionally draw apart and come into conflict with one another. Chinese wisdom regards this state merely as a passing one that contradicts the ordinances of heaven. Heaven and earth belong together, *yang* and *yin* give birth to one another and devour one another in a way that accords with the heavenly order of things. Europeans take it for granted that crocodiles are wicked, man-eating monsters, but the primitive takes just the opposite view, for to his way of thinking crocodiles eat people only in exceptional circumstances, and then only when they have been put up to it by a hostile medicine-man. If one is the crocodile’s brother, then there is no danger at all. So, too, we in the West have perpetuated the purely exceptional opposition between heaven and earth, and, as a result, find ourselves in a perpetual state of ethical conflict. The Chinese believe in what Nietzsche called the

“spirit of gravity,” and the dragon, which we like to think lives in gloomy caverns, sparkles for them in the heavens as a merry firework, and drives away the magic wrought by evil spirits. For the Chinese, “spirit” does not signify order, meaning, and everything that is good; on the contrary, it is a fiery and sometimes dangerous power.

[940] It might therefore be objected that the “telluric powers” are not at all unspiritual, but are, on the contrary, endowed with a dangerous spirit, a spirit so powerful that the spirit of the West must indeed reflect with all its might on its “responsibility,” compiling, as in Keyserling’s book, a list of “should”s and “must”s, though “with how little success,” as the author resignedly remarks.

[941] I fear Keyserling makes rather too much use of a spirit which in the past found itself in hopeless opposition to the earth. “Accepting human nature as it is” means nothing less than swallowing the “telluric essence”—which constitutes “eighty per cent of man’s nature”—as a bitter medicine, however unspiritual it may be. It almost seems as if this time earth might have something to say to heaven, and that, consequently, the aerial spirit had better pay attention. When Keyserling hopes to save the “spirit” by appealing to “creative understanding,” he seems to me to be entrapped in the idea—so typical of the age of enlightenment and progress—that in the end everything can be understood. But the earth will show us clearly enough that there are some things man will never understand, that there are times when the spirit is completely darkened because it needs to be reborn. We should not try to escape this night by “understanding,” nor shall we ever succeed in soaring above the chaos by adopting a positive attitude to everything. (“What is needed today is an *absolutely* positive attitude towards everything that, on the empirical level, is different from oneself.”) The “telluric powers” will do their utmost to convince us that we are neither reasonable, nor spiritual, nor capable of understanding, nor positive, nor God knows what, for the essence of the old spirit consisted precisely in the conceit that we were all these things. Keyserling brands American pragmatism as “profoundly unspiritual” (I hope, by the way, he doesn’t mean William James!), but by his “positive attitude” he runs the risk of succumbing to Schiller’s brand of pragmatism—anything rather than capitulate.

[942] How can that religious renewal, predicted by Keyserling as necessary and imminent, come about at all unless our much-vaunted spirit—which wants to understand everything and take a positive attitude to everything, and, above all, feels responsible for our ethical behaviour—can gracefully die? It has indeed become a human spirit, fallible and limited; it “needs a death” in order to be renewed, and it cannot do this by itself. What does the supremacy of the “telluric powers” mean, except that the “spirit” has once again grown weak with age, because it has been too much humanized?

[943] Keyserling takes up Nietzsche's idea of a "cultural monastery," stimulated thereto by the "Entretiens sur l'avenir de l'esprit européen" organized by the French under the presidency of Paul Valéry, which took place in Paris in October 1933,² and was the immediate occasion of *La Révolution mondiale*. He says: "In short, the solution we advocate has a good deal in common with that offered by the monasteries at the beginning of the Middle Ages." What moving spirits will belong to the New Order?

Of what kind would the men be who were capable of giving direction to the masses who now determine the course of history? Surely the very men we have been describing: absolutely free, haughtily independent, concerned with quality alone, conscious of their uniqueness, determined to acknowledge no authority outside themselves, proud to be a tiny minority, as active mentally as the mob is passive. Men whose consciousness is naturally centred on a plane superior to earthly happenings, to country, to race, to social or political necessities; men who in their deepest aspirations are completely free of all external considerations, of glory, influence, status; ascetics, in short, of a single pattern, forming a nobility of a kind hitherto unknown.

[944] The heaping together of paintings by Old Masters in museums is a catastrophe; likewise, a collection of a hundred Great Brains makes one big fathead. An "Order" is constituted, firstly, by the grace of God, and secondly, by a majority of highly insignificant people. Those noble souls who float before the eyes of the author will constitute an order, or will be fit to be received into such, when (in keeping with the author's list of qualities) they (1) are conscious of their lack of freedom, (2) humbly recognize their dependence, (3) have forgotten their so-called uniqueness, (4) can adapt to the eternal powers outside themselves, (5) can endure being a small minority, (6) have their natural centre of consciousness in their earth, in their race, and in social and political necessities, and (lastly) when, through the presence of God, which curiously enough always coincides with a time of great distress, there has grown up in them a need for true human fellowship from a profound experience of the nullity of human existence.

[945] If our esteemed author, Count Keyserling, were to become a lay brother charged with working in the kitchens of the cultural monastery, then I would believe in the feasibility of this idea, but not before. I even believe that the reader would be doing the book an injustice if he took such ideas quite literally. Ideas are images for something, and not its essence; they are symbols, and even symptoms. By taking them literally we block the approach to Keyserling's world of ideas. He is, in the truest sense, the mouthpiece of the *Zeitgeist*, or, to be more accurate, the *Zeitgeist* of the spiritual man. When one takes him like this, even his cultural monastery presents no difficulty: it is symptomatic of that chiliastic mood which no conscious person nowadays should dismiss as worthless. The time is as great as one thinks it, and man grows to the stature of the time. Keyserling's mediumistic gifts have gathered together the loose, fluttering, fragmentary thoughts of a whole epoch. Like Ortega y

Gasset, he condenses the symptomatic utterances of the collective spirit, speaking through a thousand tongues, into a single discourse addressed to his contemporaries. That is why everyone will hear his own voice in this discourse. And because it is extremely useful and desirable to know what one is thinking (which is not always the case, by any means), one should read this book assiduously. There is probably no other work which describes the spiritual imponderabilia of our age more lucidly than *La Révolution mondiale*.

THE COMPLICATIONS OF AMERICAN PSYCHOLOGY¹

[946] It would never occur to the naïve European to regard the psychology of the average American as particularly complicated or even sophisticated. On the contrary he is rather impressed by the simplicity and straightforwardness of American thought and manners. He likes to think of Americans as being a very active, business-like, and astonishingly efficient people, concentrated upon a single goal (viz., the yellow god), and a bit handicapped by what certain English magazines call “Americana”—something on the border-line of mild insanity, “colonials are liable to be a bit odd, don’t you know, like our South African cousins.”

[947] Thus, when I have to say something serious about Americans and their peculiar psychology, my European audience is not shocked exactly, but at all events somewhat puzzled and inclined to disapprove. What the Americans will feel about my ideas, remains to be seen.

[948] In 1909 I paid my first short visit to the United States. This was my first impression of the American people as a whole; before that I had known individuals only. I remember, when walking through the streets of Buffalo, I came across hundreds of workmen leaving a factory. The naïve European traveller I was then could not help remarking to his American companion: “I really had no idea there was such an amazing amount of Indian blood in your people.” “What,” said he, “Indian blood? I bet there is not one drop of it in this whole crowd.” I replied: “But don’t you see their faces? They are more Indian than European.” Whereupon I was informed that probably most of these workmen were of Irish, Scottish, and German extraction without a trace of Indian blood in their veins. I was puzzled and half incredulous. Subsequently I learned to see how ridiculous my hypothesis had been. Nevertheless, the impression of facial similarity remained and later years only enhanced it. As Professor Boas maintains, there are even measurable anatomical changes in many American immigrants, changes which are already noticeable in the second generation. His findings, however, have not been accepted by other authorities.

[949] I remember a New York family of German immigrants of which three of the children were born in Germany and four in America. The latter were unmistakably Americans, the first three were clearly Germans. To a keen European eye there is an indefinable yet undeniable something in the whole makeup of the born American that distinguishes him from the born European. It is not so much in the anatomical features as in the general behaviour, physical and mental. One finds it in the

language, the gestures, the mentality, in the movements of the body, and in certain things even more subtle than that.

[950] When I returned from America, I was left with the peculiarly dissatisfied feeling of one who has somehow missed the point. I had to confess that I was unable “to size them up.” I only knew that a subtle difference existed between the American and the European, just as it does between the Australian and the South African. You can say many witty or clever things about that difference, and yet you miss the point somehow. But another impression also stuck in my mind. I had not noticed it at first, but it kept on coming back like all those things that have a certain importance and yet have not been understood. I was once the guest of a pretty stiff and solemn New England family of a rather terrifying respectability. It felt almost like home. (There are very conservative and highly respectable folk in Switzerland, too. We might even better the American record in this respect.) There were Negro servants waiting at table. I felt at first as if I were eating lunch in a circus and I found myself diffidently scrutinizing the dishes, looking for the imprint of those black fingers. A solemnity brooded over the meal for which I could see no reason, but I supposed it was the solemnity or serenity of great virtue or something like that which vibrated through the room. At all events nobody laughed. Everyone was just too nice and too polite. Eventually I could stand it no longer, and I began to crack jokes for better or worse. These were greeted with condescending smiles. But I could not arouse that hearty and generous American laugh which I love and admire. “Well,” I thought, “Indian blood, wooden faces, camouflaged Mongols, why not try some Chinese on them?” So I came to my last story, really a good one—and no sooner had I finished than right behind my chair an enormous avalanche of laughter broke loose. It was the Negro servant, and it was the real American laughter, that grand, unrestrained, unsophisticated laughter revealing rows of teeth, tongue, palate, everything, just a trifle exaggerated perhaps and certainly less than sixteen years old. How I loved that African brother.

[951] I admit it is a rather foolish story, all the more so as I could not then see the reason why the incident should stick in my mind. Only much later did I discover the underlying significance of this and of that other impression I had received at Buffalo.

[952] Our convictions often have a humble origin. I do not hesitate, therefore, to tell my reader exactly how my ideas about American psychology started. Those two little impressions really hold in a nutshell everything I subsequently learned in the course of twenty-five years’ work with American patients.

[953] The American laugh is most impressive. Laughing is a very important emotional expression and one learns a lot about character from a careful observation of the way people laugh. There are people who suffer from a crippled laughter. It’s just painful

to see them laugh and the sound of that shrill, evil, compressed rattle almost makes you sick. America as a nation can laugh, and that means a lot. There is still a childlikeness, a soundness of emotion, an immediate rapport with your fellow being.

[954] This laughter goes hand in hand with a remarkable vivacity and a great ease of expression. Americans are great talkers. Gossip and chattering spill over into monstrously big newspapers. The talking goes on even when you are reading. The style of "good" American writing is a talking style. When it is not too flat, it is just as refreshing and exhilarating for us Europeans as your laughter. But often, alas, it is just chattering, the vibrating noise of a big ant-heap.

[955] One of the greatest advantages of the American language is its slang. I am far from sniffing at American slang, on the contrary I like it profoundly. Slang means a language in the making, a thing fully alive. Its images are not worn-out and worm-eaten metaphors, pale reflections hallowed by immemorial age, smooth, correct, and concise conventions, but figures full of life, carrying all the stamina of their earthly origin, and the incomparable flavour of local conditions peculiar to the strange and unprejudiced soil of a new country. One feels a new current of strange life in the flow of the old English language, and one wonders where it comes from. Is it the new country only? I doubt it.

[956] The way the American moves shows a strong tendency to nonchalance. When we analyse the way he walks, how he wears his hat, how he holds his cigar, how he speaks, we discover a marked nonchalance. One hears an unusual amount of unrestrained voices in the talk going on around one. There is a lack of restraint in the way people sit, sometimes at the expense of your furniture, or on Sundays you see streets punctuated with feet showing over the window-sills. There is a tendency to move with loose joints, with a minimum of innervation. In speech one notices this nonchalance in an insufficient innervation of the soft palate, which causes the nasal intonation that is so common with Americans. The swaying hip which you can observe in primitive, particularly Negro women is frequently seen in American women, and the swinging gait of the man is fairly usual.

[957] The most amazing feature of American life is its boundless publicity. Everybody has to meet everybody, and they even seem to enjoy this enormity. To a central European such as I am, this American publicity of life, the lack of distance between people, the absence of hedges or fences round the gardens, the belief in popularity, the gossip columns of the newspapers, the open doors in the houses (one can look from the street right through the sitting-room and the adjoining bedroom into the backyard and beyond), the defencelessness of the individual against the onslaught of the press, all this is more than disgusting, it is positively terrifying. You are immediately swallowed by a hot and all-engulfing wave of desirousness and

emotional incontinence. You are simply reduced to a particle in the mass, with no other hope or expectation than the illusory goals of an eager and excited collectivity. You just swim for life, that's all. You feel free—that's the queerest thing—yet the collective movement grips you faster than any old gnarled roots in European soil would have done. Even your head gets immersed. There is a peculiar lack of restraint about the emotions of an American collectivity. You see it in the eagerness and in the hustle of everyday life, in all sorts of enthusiasms, in orgiastic sectarian outbursts, in the violence of public admiration and opprobrium. The overwhelming influence of collective emotions spreads into everything. If it were possible, everything would be done collectively, because there seems to be an astonishingly feeble resistance to collective influences. It is true that collective action is always less laborious than an individual attempt. The momentum of collective action carries much further than even concentrated individual effort, since it makes people unaware of themselves and heedless of risks. On the other hand, it easily goes too far and leads people into situations which individual deliberation would hardly ever have chosen. It has a decidedly flattening influence on people's psychology.

[958] You see this particularly in the American sex problem as it had developed since the war. There is a marked tendency to promiscuity, which shows not only in the frequency of divorces but quite particularly in the peculiar liberation from sex prejudices in the younger generation. As an inevitable consequence the individual rapport between the sexes will suffer. An easy access never calls forth and therefore never develops the values of character, and at the same time it is a most serious obstacle to any deeper mutual understanding. Such an understanding, without which no real love can exist, is reached only by overcoming all the difficulties due to the psychological difference between the sexes. Promiscuity paralyses all these efforts by offering easy opportunities of escape. Individual rapport becomes quite superfluous. But the more a so-called unprejudiced freedom and easy promiscuity prevail, the more love becomes flat and degenerates into transitory sex interludes. The most recent developments in the field of sexual morality tend toward sexual primitivity, analogous to the instability of the moral habits of primitive peoples, where under the influence of collective emotion all sex taboos instantly disappear.

[959] All American life seems to be the life of the big settlement—real town-life. Even the smallest settlement denies itself the character of a village and tends to become a city. The town rules the whole style of living, even in the country. It seems as though everything were collective and standardized. Once on a visit to a so-called camp with so-called country life, a European friend who was travelling with me whispered to me in a quiet moment: "I bet they even have a text-book on how to camp," and—there it was, evilly glistening in red and gold upon the shelf!

[960] The country is wonderful, nay, just divine, still with the faint perfume of unhistorical eternity in the air, and those lovely crickets not yet shy of man. They don't know yet that they are living in America, like some Navahos. And the bullfrog talks in the night with his prehistoric booming voice. Beautiful immense nights, and days blessed with sunshine. There is real country and nobody seems to be up to it, certainly not that hustling, noisily chattering, motoring townfolk. They are not even down to it, as the Red Indians are, with whom one feels peculiarly at ease because they are obviously under the spell of their country and not on top of it. So there at last is the peace of God.

[961] I know the mother-nations of North America pretty well, but I would be completely at a loss to explain, if I relied solely on the theory of heredity, how the Americans descended from them acquired their striking peculiarities. One might suppose that some of them were the product of the old pioneer and colonist attitude. But I fail to see how the particular qualities I have mentioned have anything to do with the character of the early farmer colonist. There is a much better hypothesis to explain the peculiarities of the American temperament. It is the fact that the States are pervaded by the Negro, that most striking and suggestive figure. Some States are particularly black, a fact that may astonish the naïve European, who thinks of America as a white nation. It is not wholly white, if you please, but piebald. It cannot be helped, it just is so.

[962] What is more contagious than to live side by side with a rather primitive people? Go to Africa and see what happens. When it is so obvious that you stumble over it, you call it "going black." But if it is not so obvious it is explained as "the sun." In India it is always the sun. In reality it is a mitigated going black, counterbalanced by a particularly stiffnecked conventionality (with its subdivisions of righteousness and conspicuous respectability). Under the pressure of all this conventionality people simply dry up, though they make the sun responsible. It is much easier for us Europeans to be a trifle immoral, or at least a bit lax, because we do not have to maintain the moral standard against the heavy downward pull of primitive life. The inferior man has a tremendous pull because he fascinates the inferior layers of our psyche, which has lived through untold ages of similar conditions—"on revient toujours à ses premiers amours." He reminds us—or not so much our conscious as our unconscious mind—not only of childhood but of our prehistory, which would take us back not more than about twelve hundred years so far as the Germanic races are concerned. The barbarian in us is still wonderfully strong and he yields easily to the lure of his youthful memories. Therefore he needs very definite defences. The Latin peoples being older don't need to be so much on their guard, hence their approach to the coloured man is different.

[963] But the defences of the Germanic man reach only as far as consciousness reaches. Below the threshold of consciousness the contagion meets with little resistance. Just as the coloured man lives in your cities and even within your houses, so also he lives under your skin, subconsciously. Naturally it works both ways. Just as every Jew has a Christ complex, so every Negro has a white complex and every American a Negro complex. As a rule the coloured man would give anything to change his skin, and the white man hates to admit that he has been touched by the black.

[964] Now for the facts. What about that American laughter? What about the boundless noisy sociality? The pleasure in movement and in stunts of all sorts? The loose-jointed walk, the Negroid dancing and music? The rhythm of jazz is the same as the *n'goma*, the African dance. You can dance the Central African *n'goma* with all its jumping and rocking, its swinging shoulders and hips, to American jazz. American music is most obviously pervaded by the African rhythm and the African melody.

[965] It would be difficult not to see that the coloured man, with his primitive motility, his expressive emotionality, his childlike directness, his sense of music and rhythm, his funny and picturesque language, has infected the American "behaviour." As any psychologist and any doctor knows, nothing is more contagious than tics, stammering, choreic movements, signs of emotion, above all laughter and peculiarities of speech. Even if your mind and heart are elsewhere, even if you don't understand a joke in a foreign language, you can't help smiling when everybody else smiles. Stammering can have a most infectious quality, so that you hardly can refrain from imitating it involuntarily. Melody and rhythm are most insidious, they can obsess you for days, and as to language it is most disturbing how its metaphors and different ways of pronunciation affect you, beginning with some apologetic quotation, and then because you just can't help it.

[966] The white man is a most terrific problem to the Negro, and whenever you affect somebody so profoundly, then, in a mysterious way, something comes back from him to yourself. The Negro by his mere presence is a source of temperamental and mimetic infection, which the European can't help noticing just as much as he sees the hopeless gap between the American and the African Negro. Racial infection is a most serious mental and moral problem where the primitive outnumbers the white man. America has this problem only in a relative degree, because the whites far outnumber the coloured. Apparently he can assimilate the primitive influence with little risk to himself. What would happen if there were a considerable increase in the coloured population is another matter.

[967] I am quite convinced that some American peculiarities can be traced back directly to the coloured man, while others result from a compensatory defence

against his laxity. But they remain externals leaving the inner quick of the American character untouched, which is not the case where “going black” is concerned. Since I am not a behaviourist, I take leave to suppose that you are still very far from the real man when you observe only his behaviour. I regard behaviour as a mere husk that conceals the living substance within. Thus I can discern the white man clearly enough through his slightly Negroid mannerisms, and my question is: Is this American white man nothing but a simple white man, or is he in some way different from the European representative of the species? I believe there is a marked difference between them within as well as without. European magazines have recently published pictures of well-known Americans in Indian headdress, and some Red Indians in European costume in the opposite column, with the question: Who are the Indians?

[968] This is not just a joke. There is something in it that can hardly be denied. It may seem mysterious and unbelievable, yet it is a fact that can be observed in other countries just as well. Man can be assimilated by a country. There is an x and a y in the air and in the soil of a country, which slowly permeate and assimilate him to the type of the aboriginal inhabitant, even to the point of slightly remodelling his physical features. The verification of such facts in terms of exact measurement, overwhelmingly obvious though they sometimes are, is—I admit—exceedingly difficult. But there are many such things that elude all our means of exact scientific verification despite their obvious and indubitable character. Think of all the subtleties of expression in the eyes, gestures, and intonation. In practice everybody goes by them and no idiot could misunderstand them, yet one is faced with a most ticklish task when it comes to giving an absolutely scientific description of them. I know a man who could tell from a series of photographs of Jews of different countries with almost infallible certainty: This is a Polish, that a Cossack, and that a German Jew, and so on.

[969] Undoubtedly there are these subtle indications in man: sometimes they lurk in the lines of his face, sometimes in his gestures, his facial expression, the look in his eyes, and sometimes in his psyche, that shines forth through the transparent veil of his body. At all events it is often possible to tell in what country he was born. I know quite a number of cases where children of purely European parents were born in Eastern countries and exhibited the marks of their respective birthplaces either in the imponderabilia of their appearance or in their mental make-up or in both, and to such a degree that not only I myself but other people who were entirely ignorant of the circumstances could make the diagnosis. The foreign country somehow gets under the skin of those born in it. Certain very primitive tribes are convinced that it is not possible to usurp foreign territory, because the children born there would inherit the

wrong ancestor-spirits who dwell in the trees, the rocks, and the water of that country. There seems to be some subtle truth in this primitive intuition.

[970] That would mean that the spirit of the Indian gets at the American from within and without. Indeed, there is often an astonishing likeness in the cast of the American face to that of the Red Indian, more I think in the men's faces than in the women's. But women are always the more conservative element in spite of their conspicuous affectation of modernity. It is a paradox certainly, yet such is human nature.

[971] The external assimilation to the peculiarities of a country is a thing one could almost expect. There is nothing astonishing in it. But the external similarity is feeble in comparison with the less visible but all the more intense influence on the mind. It is just as though the mind were an infinitely more sensitive and suggestible medium than the body. It is probable that long before the body reacts the mind has already undergone considerable changes, changes that are not obvious to the individual himself or to his immediate circle, but only to an outsider. Thus I would not expect the average American, who has not lived for some years in Europe, to realize how different his mental attitude is from the European's, just as I would not expect the average European to be able to discern his difference from the American. That is the reason why so many things that are really characteristic of a country seem to be merely odd or ridiculous: the conditions from which they arise are either not known or not understood. They wouldn't be odd or ridiculous if one could feel the local atmosphere to which they belong and which makes them perfectly comprehensible and logical.

[972] Almost every great country has its collective attitude, which one might call its genius or *spiritus loci*. Sometimes you can catch it in a formula, sometimes it is more elusive, yet nonetheless it is indescribably present as a sort of atmosphere that permeates everything, the look of the people, their speech, behaviour, clothing, smell, their interests, ideals, politics, philosophy, art, and even their religion. In a well-defined civilization with a solid historical background, such as for instance the French, you can easily discover the keynote of the French *esprit*: it is "la gloire," a most marked prestige psychology in its noblest as well as its most ridiculous forms. You find it in their speech, gestures, beliefs, in the style of everything, in politics and even in science.

[973] In Germany it is the "Idea" that is impersonated by everybody. There are no ordinary human beings, you are "Herr Professor" or "Herr Geheimrat," "Herr Oberrechnungsrat," and even longer things than that. Sometimes the German idea is right and sometimes it is wrong, but it never ceases to be an idea whether it belongs to the highest philosophy or is merely a foolish bias. Even when you die in Germany,

you don't die in mere human misery, you die in the ideal form of "Hausbesitzersgattin" or something of the sort.

[974] England's innermost truth and at the same time her most valuable contribution to the assets of the human family is the "gentleman," rescued from the dusty chivalry of the early Middle Ages and now penetrating into the remotest corner of modern English life. It is an ultimate principle that never fails to carry conviction, the shining armour of the perfect knight in soul and body, and the miserable coffin of poor natural feelings.

[975] But could one "size up" other countries like Italy, Austria, Spain, Netherlands, Switzerland, just as easily? They are all very characteristic countries, yet their spirit is more difficult to catch. It would need not one word but at least a couple of sentences. America is also one of those countries that are not settled by one shot. European prejudice would say: Money. But only people who have no idea of what money means to Americans can think like that. Yes, if they themselves are Americans, it would be money. But America is not as simple as that. Of course there is any amount of ordinary materialism in America as everywhere else, but also a most admirable idealism which hardly finds its equal anywhere else. Money with us has still something of the magic of the old taboo, dating from the times when any money business like banking, or usury, was considered dishonest. It is still something of a forbidden pleasure in the old countries. That is why it is good form with us to hush up money matters. The American, unhampered by the burden of historical conditions, can make and spend money for what it is worth. America is peculiarly free from the spell of money, yet she makes a lot of it. How can the European understand this puzzle?

[976] America has a principle or idea or attitude, but it is surely not money. Often, when I was searching through the conscious and the unconscious mind of my American patients and pupils, I found something which I can only describe as a sort of Heroic Ideal. Your most idealistic effort is concerned with bringing out the best in every man, and when you find a good man you naturally support him and push him on, until at last he is liable to collapse from sheer exertion, success, and triumph. It is done in every family, where ambitious mothers egg their boys on with the idea that they must be heroes of some sort, or you find it in the factory, where the whole system anxiously tries to get the best man into the best place. Or again in the schools where every child is trained to be brave, courageous, efficient, and a "good sport," a hero in short. There is no record which people will not kill themselves to break, even if it is the most appalling nonsense. The moving pictures abound with heroes of every description. American applause holds the world's record. The "great" and "famous" man gets mobbed by enthusiastic crowds, whatever he may be "great" in; even

Valentino got his full share. In Germany you are great if your titles are two yards long, in England if you are a gentleman as well, in France if you coincide with the prestige of the country. In small countries there is, as a rule, no greatness when you are alive, because things need to be small, therefore it is usually posthumous. America is perhaps the only country where “greatness” is unrestricted, because it expresses the most fundamental hopes, desires, ambitions, and convictions of the nation.

[977] I admit that to an American these things seem to be fairly natural, but not to a European. There are many Europeans who are infected by feelings of inferiority when they contact America and meet her heroic ideal. As a rule they don't admit it, and so they boast of Europe all the louder or begin to ridicule the many things in America which are open to criticism, such as roughness, brutality and primitivity. Often they get their first and decisive shock in the custom-house, so that their appetite is ruined for the rest of the States. It is inevitable that the heroic attitude should be coupled with a sort of primitivity, because it has always been the ideal of a somewhat sporty, primitive society. And this is where the real historical spirit of the Red Man enters the game. Look at your sports! They are the toughest, the most reckless, and the most efficient in the world. The idea of mere play has almost entirely disappeared, while in other parts of the world the idea of play still prevails rather than that of professional sport. Your sport demands a training that is almost cruel and an application that is almost inhuman. Your sportsmen are gladiators, every inch of them, and the excitement of the spectators derives from ancient instincts that are akin to bloodlust. Your students go through initiations and form secret societies like the best among barbarous tribes. Secret societies of every description abound all over the country from the Ku Klux Klan to the Knights of Columbus, and their rites are analogous to any primitive mystery religion. America has resuscitated the ghosts of Spiritualism, of which she is the original home, and cures diseases by Christian Science, which has more to do with the shaman's mental healing than with any recognizable kind of science. Moreover it is proving to be pretty effective, just as were the cures of the shaman.

[978] The old European inheritance looks rather pale beside these vigorous primitive influences. Have you ever compared the skyline of New York or any great American city with that of a pueblo like Taos? And did you see how the houses pile up to towers towards the centre? Without conscious imitation the American unconsciously fills out the spectral outline of the Red Man's mind and temperament.

[979] There is nothing miraculous about this. It always has been so: the conqueror overcomes the old inhabitant in the body but succumbs to his spirit. Rome at the zenith of her power contained within her walls all the mystery cults of the East; yet

the spirit of the humblest among them, a Jewish mystery society, transformed the greatest of all cities from top to bottom. The conqueror gets the wrong ancestor-spirits, the primitives would say: I like this picturesque way of putting it. It is pithy and expresses every conceivable implication.

[980] People rarely want to know what a thing is in itself, they want to know whether it is favourable or unfavourable, advisable or evil, as if there were indubitably good or bad things. Things are as we take them. Moreover, anything that moves is a risk. Thus a nation in the making is naturally a big risk, to itself as well as others. It is certainly not my task to play the role of a prophet or of a ridiculous adviser of nations, and moreover there is nothing to give advice about. Facts are neither favourable nor unfavourable; they are merely interesting. And the most interesting of all is that this childlike, impetuous, “naïve” America has probably the most complicated psychology of all nations.

THE DREAMLIKE WORLD OF INDIA¹

[981] A first impression of a country is very often like meeting a person for the first time: your impression may be quite inaccurate, even definitely wrong in many respects, yet you are likely to perceive certain qualities or certain shadows which would very probably be blurred by the more accurate impressions of a second or third visit. My reader would make a great mistake if he were to take any statements I make about India for gospel truth. Think of a man coming to Europe for the first time in his life; he spends some six to seven weeks travelling from Lisbon to Moscow and from Norway to Sicily, he does not understand a single European language except English and he has a most superficial knowledge of the peoples, their history, and their actual life. Would he be likely to produce anything more than a mildly delirious phantasmagoria of hasty impressions, snapshot sentiments, and impatient opinions? I am afraid he would have little chance of escaping the charge of utter incompetence and inadequacy. I am very much in the same position in daring to say anything about India. I am told that I have the excuse of being a psychologist, and therefore am supposed to see more, or at least something peculiar which other fellows might be expected to overlook. I do not know. I must leave the final verdict to my reader.

[982] The flat expanse of Bombay and its low dark green hills, rising almost suddenly above the horizon, give you the feeling of the vastness of a continent behind. This impression explains my first reaction directly I disembarked: I took a car and went out of town, away into the country. That felt a great deal better—yellow grass, dusty fields, native huts, great, dark-green, weird banyan trees, sickly palmyra palms sucked dry of their life-juice (it is run into bottles near the top to make palm-wine, which I never tasted), emaciated cattle, thin-legged men, the colourful saris of women, all in leisurely haste or in hasty leisure, with no need of being explained or of explaining themselves, because obviously they are what they are. They were unconcerned and unimpressed; I was the only one who did not belong to India. We drove through a strip of jungle near a blue lake. We pulled up suddenly, but instead of having run over a lurking tiger we found ourselves in the midst of a native movie-scene: something presumably was going to happen to a white girl, dressed up as a *dompteuse* escaped from a circus. Cameras, megaphone, and excited shirt-sleeves were in full action—the shock was so great that we instinctively stepped on the gas. After this I felt that I could go back to the city, which I had not yet really seen.

[983] The Anglo-Indian style of architecture of the past fifty years is not interesting, but it gives a peculiar character to Bombay, as if one had already seen it somewhere

else. It has more to do with the “English character” than with India. I make an exception of the “Gateway of India,” that huge portal at the head of the royal road to Delhi. In a way it repeats the splendid ambition to be found in the “Gate of Victory,” built by Akbar the Great in Fatehpur-Sikri, that soon-deserted town lying in ruins—red sandstone glowing in the Indian sun for long centuries, past and to come—a wave that crashed on the shore of time and left a strip of foam.

[984] That is India, as I saw her: certain things last forever—yellow plains, green spirit-trees, dark-brown boulders of gigantic size, emerald-green watered fields, crowned by that metaphysical fringe of ice and rock away up north, that inexorable barrier beyond human conception. The other things unroll like a film, unimaginably rich in colour and shape, ever-changing, lasting a few days or a few centuries, but essentially transitory, dreamlike, a multi-coloured veil of *maya*. Today it is the still youthful British Empire that is going to leave a mark on India, like the empire of the Moguls, like Alexander the Great, like numberless dynasties of native kings, like the Aryan invaders—yet India somehow never changes her majestic face. Human life appears to be curiously flimsy in every respect. The native town of Bombay seems to be a jumble of incidentally piled-up human habitations. The people carry on an apparently meaningless life, eagerly, busily, noisily. They die and are born in ceaseless waves, always much the same, a gigantic monotony of endlessly repeated life.

[985] In all that flimsiness and vain tumult, one is conscious of immeasurable age with no history. After all why should there be recorded history? In a country like India one does not really miss it. All her native greatness is in any case anonymous and impersonal, like the greatness of Babylon and Egypt. History makes sense in European countries, where, in a relatively recent, barbarous, and unhistorical past, things began to take shape. Castles, temples, and cities were built, roads and bridges were made, and the peoples discovered that they had names, that they lived somewhere, that their cities multiplied and that their world grew bigger every century. When they saw that things developed, they naturally became interested in the changes of things, and it seemed worth while to record beginnings and later developments—for everything was going somewhere, and everybody hoped for unheard-of possibilities and improvements in the future, spiritual as well as secular.

[986] But in India there seems to be nothing that has not lived a hundred thousand times before. Even the unique individual of today has already lived innumerable times in past ages. The world itself is nothing but a renewal of world existence, which has happened many times before. Even India’s greatest individual, the unique Gautama Buddha, was preceded by more than a score of other Buddhas and is still not the last. No wonder, then, that the gods too have their numerous avatars. *Plus ça change, plus c’est la même chose*—why any history under such circumstances?

Moreover, time is relative: the yogi sees the past as well as the future. If you walk the “noble eightfold path,” you will remember what you were ten thousand lives ago. Space is relative: the yogi walks in his spirit-body with the speed of thought over lands, seas, and heavens. What you call real—all the good and ill of human life—is illusion. What you call unreal—sentimental, grotesque, obscene, monstrous, blood-curdling gods—unexpectedly becomes self-evident reality when you listen for half a hot night to an incessant, clever drumming that shakes up the dormant solar plexus of the European. He is used to regarding his head as the only instrument for grasping the world, and the *kathakali*, as he follows it with his eyes, would remain a grotesque dance were it not for the drumming that creates a new reality rising from the bowels.

[987] A walk through the bustle of Bombay’s bazaars set me thinking. I had felt the impact of the dreamlike world of India. I am convinced that the average Hindu does not feel his world as dreamlike: on the contrary, his every reaction shows how much he is impressed and gripped by its realities. If he were not enthralled by his world, he would not need his religious and philosophic teaching about the Great Illusion, any more than we ourselves would need the Christian message of love if we were other than we are. (The essence of teaching is to convey knowledge of things about which we know too little!) Perhaps I myself had been thrown into a dreamlike state by moving among fairytale figures of the Thousand and One Nights. My own world of European consciousness had become peculiarly thin, like a network of telegraph wires high above the ground, stretching in straight lines all over the surface of an earth looking treacherously like a geographic globe.

[988] It is quite possible that India is the real world, and that the white man lives in a madhouse of abstractions. To be born, to die, to be sick, greedy, dirty, childish, ridiculously vain, miserable, hungry, vicious; to be manifestly stuck in illiterate unconsciousness, to be suspended in a narrow universe of good and evil gods and to be protected by charms and helpful *mantras*, that is perhaps the real life, life as it was meant to be, the life of the earth. Life in India has not yet withdrawn into the capsule of the head. It is still the whole body that lives. No wonder the European feels dreamlike: the complete life of India is something of which he merely dreams. When you walk with naked feet, how can you ever forget the earth? It needs all the acrobatics of the higher yoga to make you unconscious of the earth. One would need some sort of yoga if one tried seriously to live in India. But I did not see one European in India who really lived there. They were all living in Europe, that is, in a sort of bottle filled with European air. One would surely go under without the insulating glass wall; one would be drowned in all the things which we Europeans have conquered in our imagination. In India they become formidable realities directly you step beyond the glass wall.

[989] Northern India is characterized by the fact that it is part of the immense Asiatic continent. I noticed a frequent note of harshness in the way the people talked to each other, recalling harassed camel-drivers or irritable horse-dealers. The variety of Asiatic costumes here supersedes the immaculate whiteness of the mild plant-eaters. Women's dresses are gay and provocative. The many Pathans, proud, unconcerned, and ruthless, and the bearded Sikhs, with their contradictory character—over-masculine brutality combined with melting sentimentality—give a strong Asiatic tinge to the appearance of the masses. The architecture shows clearly how much the Hindu element has succumbed to the predominating Asiatic influence. Even the temples of Benares are small and not very impressive, if it were not for their noisiness and dirt. Shiva, the destroyer, and the bloodthirsty and blood-curdling Kali seem to be in the foreground. The fat, elephant-headed Ganesha is also much in demand to bring good luck.

[990] In comparison, Islam seems to be a superior, more spiritual, and more advanced religion. Its mosques are pure and beautiful, and of course wholly Asiatic. There is not much mind about it, but a great deal of feeling. The cult is one wailing outcry for the All-Merciful. It is a desire, an ardent longing and even greed for God; I would not call it love. But there is love, the most poetic, most exquisite love of beauty in these old Moguls. In a world of tyranny and cruelty, a heavenly dream crystallized in stone: the Taj Mahal. I cannot conceal my unmitigated admiration for this supreme flower, for this jewel beyond price, and I marvel at that love which discovered the genius of Shah Jehan and used it as an instrument of self-realization. This is the one place in the world where the—alas—all too invisible and all too jealously guarded beauty of the Islamic Eros has been revealed by a well-nigh divine miracle. It is the delicate secret of the rose gardens of Shiraz and of the silent patios of Arabian palaces, torn out of the heart of a great lover by a cruel and incurable loss. The mosques of the Moguls and their tombs may be pure and austere, their *divans*, or audience halls, may be of impeccable beauty, but the Taj Mahal is a revelation. It is thoroughly un-Indian. It is more like a plant that could thrive and flower in the rich Indian earth as it could nowhere else. It is Eros in its purest form; there is nothing mysterious, nothing symbolic about it. It is the sublime expression of human love for a human being.

[991] On the same plains of Northern India, almost two thousand years before the time of the Moguls, the spirit of India had borne its ripest fruit, the very essence of its life, the perfect Lord Buddha. Not very far from Agra and Delhi is the hill of Sanchi with its famous stupa. We were there on a brisk morning. The intense light and the extraordinary clarity of the air brought out every detail. There on the top of a rocky hill, with a distant view over the plains of India, you behold a huge globe of masonry,

half-buried in the earth. According to the *Maha-Parinibbana-Sutta*, Buddha himself indicated the way in which his remains were to be buried. He took two rice bowls and covered the one with the other. The visible stupa is just the bowl on top. One has to imagine the lower one, buried in the earth. The roundness, a symbol of perfection since olden days, seems a suitable as well as an expressive monument for a Tathagata. It is of immense simplicity, austerity, and lucidity, perfectly in keeping with the simplicity, austerity, and lucidity of Buddha's teaching.

[992] There is something unspeakably solemn about this place in its exalted loneliness, as if it were still witnessing the moment in the history of India when the greatest genius of her race formulated her supreme truth. This place, together with its architecture, its silence, and its peace beyond all turmoils of the heart, its very forgetfulness of human emotions, is truly and essentially Indian; it is as much the "secret" of India as the Taj Mahal is the secret of Islam. And just as the perfume of Islamic culture still lingers in the air, so Buddha, though forgotten on the surface, is still the secret breath of life in modern Hinduism. He is suffered at least to be an avatar of Vishnu.

*

[993] Travelling with the British delegates to the Indian Science Congress in Calcutta, I was hustled through a good many dinners and receptions. I had a chance at these to talk to educated Indian women. This was a novelty. Their costume stamps them as women. It is the most becoming, the most stylish and, at the same time, the most meaningful dress ever devised by women. I hope fervently that the sexual disease of the West, which tries to transform woman into a sort of awkward boy, will not creep into India in the wake of that fad "scientific education." It would be a loss to the whole world if the Indian woman should cease to wear her native costume. India (and perhaps China, which I do not know) is practically the only civilized country where one can see on living models how women can and should dress.

[994] The costume of the Indian woman conveys far more than the meaningless half-nakedness of the Western woman's evening dress. There is something left which can be unveiled or revealed, and, on the other hand, one's taste is not offended by the sight of aesthetic flaws. The European evening dress is one of the most obvious symptoms of our sexual morbidity: it is compounded of shamelessness, exhibitionism, impotent provocation, and a ridiculous attempt to make the relation between the sexes cheap and easy. Yet everybody is, or ought to be, profoundly aware of the fact that the secret of sexual attraction is neither cheap nor easy, but is one of the demons which no "scientific education" has yet mastered. Women's fashions with us are mostly invented by men: you can guess the result. After having exhausted all the means of producing the semblance of a fertile brood-mare with

corsets and bustles, they are now trying to create the adolescent hermaphrodite, an athletic, semimasculine body, despite the fact that the body of the Northern woman already has a painful tendency toward bony coarseness. They try coeducation in order to make the sexes equal to each other, instead of stressing the difference. But the worst sight—oh—is the women in trousers parading the decks! I often wondered if they knew how mercilessly ugly they looked. Usually they were very decent middle-class types and were not smart at all, but only touched by the current rage for hermaphroditosis. It is a sad truth, but the European woman, and particularly her hopelessly wrong dress, put up no show at all when compared with the dignity and elegance of the Indian woman and her costume. Even fat women have a chance in India; with us they can only starve themselves to death.

[995] Talking of costumes, I must say that the Hindu man is too fond of ease and coolness. He wears a long piece of cotton cloth wound round and between his legs. The front of the legs is well covered, but the back is ridiculously bare. There is something effeminate and babyish about it. You simply cannot imagine a soldier with such garlands of cloth between his legs. Many wear a shirt over this or a European jacket. It is quaint, but not very masculine. The northern type of costume is Persian and looks fine and manly. The garland type is chiefly southern, perhaps because of the matriarchal trend which prevails in the south. The “garland” looks like a sort of overgrown diaper. It is an essentially unwarlike dress and suits the pacifist mentality of the Hindu perfectly.

[996] A real fight, in such a contrivance, is well-nigh impossible. The combatants would be trapped in no time by the many circumvolutions of their ridiculous sheets. Yet they are free with words and gestures, but, when you are expecting the worst, they confine themselves to attacking the other’s shirt and diaper. I once watched two boys of about eight or nine having a heated quarrel over a game. They came to blows. We can all remember pretty well what a fight between boys at that age means. But the performance of the Hindu boys was really worth seeing: they struck out violently, but the dangerous-looking fists remained miraculously arrested about an inch from the enemy’s face—and afterwards it was exactly as if they had had a really good fight! They are profoundly civilized. This was in the south; the Mohammedan element in the north is probably much nearer the real stuff when it comes to a fight.

*

[997] The impression of softness that the Hindu conveys points to a predominance of the feminine element in the family, presumably of the *mother*. It seems to be a style which is dependent on old matriarchal traditions. The educated Hindu has very much the character of the “family boy,” of the “good” son, who knows that he has to deal with a mother and, moreover, knows how to do it. But one gets much the same

impression from the women. They show a studied and stylish kind of modesty and inconspicuousness, which immediately gives you the feeling of dealing with an extremely domesticated and socialized person. There is no harshness or arrogance, no mannishness or stridency in their voice. This is a most agreeable contrast to certain European women I have known, whose strained, overloud, and spastic voices betray a peculiarly forced and unnatural attitude.

[998] I had many opportunities to study the English voice in India. Voices are treacherous; they reveal far too much. You marvel at the fantastic efforts people make to sound gay, fresh, welcoming, enterprising, jolly, benevolent, full of good comradeship, and so on. And you know it is merely an attempt to cover up the real truth, which is very much the reverse. It makes you tired listening to those unnatural sounds, and you long for somebody to say something unkind or brutally offensive. You cannot help noticing how a great number of perfectly nice and decent Englishmen elaborately imitate a he-man voice, God knows why. It sounds as if they were trying to impress the world with their throaty rumbling tones, or as if they were addressing a political meeting, which has to be convinced of the profound honesty and sincerity of the speaker. The usual brand is the bass voice, of the colonel for instance, or the master of a household of numerous children and servants who must be duly impressed. The Father Christmas voice is a special variety, usually affected by academically trained specimens. I discovered that particularly terrific boomers were quite modest and decent chaps, with a noticeable feeling of inferiority. What a superhuman burden it is to be the overlords of a continent like India!

[999] The Indians speak without affectation. They represent nothing. They belong to the three hundred and sixty million people of India. The women represent less than nothing. They belong to large families incidentally and geographically living in a country called India. And you have to adapt yourself to the family and know how to talk and how to behave, when twenty-five to thirty members of a family are crowded together in a small house, with a grandmother on top. That teaches you to speak modestly, carefully, politely. It explains that small twittering voice and that flowerlike behaviour. The crowding together in families has the contrary effect with us. It makes people nervous, irritable, rough, and even violent. But India takes the family seriously. There is no amateurishness or sentimentality about it. It is understood to be the indispensable form of life, inescapable, necessary, and self-evident. It needs a religion to break this law and to make "homelessness" the first step to saintliness. It certainly seems as if Indians would be unusually pleasant and easy to live with, particularly the women; and, if the style were the whole man, Indian life would be almost ideal. But softness of manners and sweetness of voice are also a part of secrecy and diplomacy. I guess Indians are just human, and so no generalization is quite true.

[1000] As a matter of fact, you stub your toes time and again against a peculiar obliqueness when you ask for definite information. You often find then that people are less concerned with your question than with deliberations about your possible motives or about how it would be possible to wriggle out of a tight corner without getting hurt. Overcrowding has surely much to do with this widespread and very characteristic defect in the Indian character, for only the art of deception can preserve the privacy of the individual in a crowd. The woman's whole manner is directed towards the mother as well as the man. To the former she is a daughter, to the latter the woman whose skilful behaviour gives him a reasonable chance to feel like a man. At least I did not meet a single "battleship," so typical of the Western drawing-room, the sight of which makes a man feel about as comfortable as a mouse drowning before breakfast in cold water.

[1001] The Indians mean and are meant to live in India. Therefore they have settled down to a degree of domestication which we cannot attain, even with the aid of ideals and frantic moral efforts. Our migrations have not yet come to an end. It was only a short while ago that the Anglo-Saxons immigrated from northern Germany to their new homeland. The Normans arrived there from Scandinavia, via northern France, quite a while later, and it is much the same with practically every nation in Europe. Our motto is still: *ubi bene, ibi patria*. Because of this truth we are all fervent patriots. Because we still can and will wander, we imagine that we can live more or less anywhere. Not yet convinced that we ought to be able to get along with one another in closely packed families, we feel that we can afford to quarrel, for there is still good open country "out West" if things come to the worst. At least it seems so. But it is no longer quite true. Even the Englishman is not settled in India; he is really condemned to serve his term there and to make the best of it. Hence all those hopeful, jolly, eager, energetic, powerful voices issue from people who are thinking and dreaming of spring in Sussex.

WHAT INDIA CAN TEACH US¹

[1002] India lies between the Asiatic north and the Pacific south, between Tibet and Ceylon. India ends abruptly at the foothills of the Himalaya, and at Adam's Bridge. At one end, a Mongolian world begins, at the other, the "paradise" of a South Sea island. Ceylon is as strangely different from India as is Tibet. Curiously enough, at either end one finds the "spoor of the elephant," as the Pali Canon² calls the teaching of the Lord Buddha.

[1003] Why has India lost her greatest light, Buddha's path of redemption, that glorious synthesis of philosophy and *opus divinum*? It is common knowledge that mankind can never remain on an apex of illumination and spiritual endeavour. Buddha was an untimely intruder, upsetting the historical process, which afterwards got the better of him. Indian religion is like a *vimana*, or pagoda. The gods climb over one another like ants, from the elephants carved on the base to the abstract lotus which crowns the top of the building. In the long run, the gods become philosophical concepts. Buddha, a spiritual pioneer for the whole world, said, and tried to make it true, that the enlightened man is even the teacher and redeemer of his gods (not their stupid denier, as Western "enlightenment" will have it). This was obviously too much, because the Indian mind was not at all ready to integrate the gods to such an extent as to make them psychologically dependent upon man's mental condition. How Buddha himself could obtain such insight without losing himself in a complete mental inflation borders on a miracle. (But any genius is a miracle.)

[1004] Buddha disturbed the historical process by interfering with the slow transformation of the gods into ideas. The true genius nearly always intrudes and disturbs. He speaks to a temporal world out of a world eternal. Thus he says the wrong things at the right time. Eternal truths are never true at any given moment in history. The process of transformation has to make a halt in order to digest and assimilate the utterly impractical things that the genius has produced from the storehouse of eternity. Yet the genius is the healer of his time, because anything he reveals of eternal truth is healing.

[1005] The remote goal of the transformation process, however, is very much what Buddha intended. But to get there is possible neither in one generation nor in ten. It obviously takes much longer, thousands of years at all events, since the intended transformation cannot be realized without an enormous development of human consciousness. It can only be "believed," which is what Buddha's, as well as Christ's,

followers obviously did, assuming—as “believers” always do—that belief is the whole thing. Belief is a great thing, to be sure, but it is a substitute for a conscious reality which the Christians wisely relegate to a life in the hereafter. This “hereafter” is really the intended future of mankind, anticipated by religious intuition.

[1006] Buddha has disappeared from Indian life and religion more than we could ever imagine Christ disappearing in the aftermath of some future catastrophe to Christianity, more even than the Greco-Roman religions have disappeared from present-day Christianity. India is not ungrateful to her master minds. There is a considerable revival of interest in classical philosophy. Universities like Calcutta and Benares have important philosophy departments. Yet the main emphasis is laid on classical Hindu philosophy and its vast Sanskrit literature. The Pali Canon is not precisely within their scope. Buddha does not represent a proper philosophy. He challenges man! This is not exactly what philosophy wants. It, like any other science, needs a good deal of intellectual free play, undisturbed by moral and human entanglements. But also, small and fragmentary people must be able to “do something about it” without getting fatally involved in big issues far beyond their powers of endurance and accomplishment. This is on the right road after all, though it is indeed a *longissima via*. The divine impatience of a genius may disturb or even upset the small man. But after a few generations he will reassert himself by sheer force of numbers, and this too seems to be right.

[1007] I am now going to say something which may offend my Indian friends, but actually no offence is intended. I have, so it seems to me, observed the peculiar fact that an Indian, inasmuch as he is really Indian, does not think, at least not what we call “think.” *He rather perceives the thought.* He resembles the primitive in this respect. I do not say that he *is* primitive, but that the process of his thinking reminds me of the primitive way of thought-production. The primitive’s reasoning is mainly an unconscious function, and he perceives its results. We should expect such a peculiarity in any civilization which has enjoyed an almost unbroken continuity from primitive times.

[1008] Our western evolution from a primitive level was suddenly interrupted by the invasion of a psychology and spirituality belonging to a much higher level of civilization. Our case was not so bad as that of the Negroes or the Polynesians, who found themselves suddenly confronted with the infinitely higher civilization of the white man, but in essence it was the same. We were stopped in the midst of a still barbarous polytheism, which was eradicated or suppressed in the course of centuries and not so very long ago. I suppose that this fact has given a peculiar twist to the Western mind. Our mental existence was transformed into something which it had not yet reached and which it could not yet truly be. And this could only be brought

about by a dissociation between the conscious part of the mind and the unconscious. It was a liberation of consciousness from the burden of irrationality and instinctive impulsiveness at the expense of the totality of the individual. Man became split into a conscious and an unconscious personality. The conscious personality could be domesticated, because it was separated from the natural and primitive man. Thus we became highly disciplined, organized, and rational on one side, but the other side remained a suppressed primitive, cut off from education and civilization.

[1009] This explains our many relapses into the most appalling barbarity, and it also explains the really terrible fact that, the higher we climb the mountain of scientific and technical achievement, the more dangerous and diabolical becomes the misuse of our inventions. Think of the great triumph of the human mind, the power to fly: we have accomplished the age-old dream of humanity! And think of the bombing raids of modern warfare! Is this what civilization means? Is it not rather a convincing demonstration of the fact that, when our mind went up to conquer the skies, our other man, that suppressed barbarous individual, went down to hell? Certainly our civilization can be proud of its achievements, yet we have to be ashamed of ourselves.

[1010] This surely is not the only way in which man can become civilized, at all events it is not an ideal way. One could think of another more satisfactory possibility. Instead of differentiating only one side of man, one could differentiate the whole man. By burdening the conscious man with the earthbound weight of his primitive side one could avoid that fatal dissociation between an upper and a lower half. Of course it would be no mean *tour de force* to experiment with the white man of today along these lines. It would obviously lead to devilishly intricate moral and intellectual problems. But, if the white man does not succeed in destroying his own race with his brilliant inventions, he will eventually have to settle down to a desperately serious course of self-education.

[1011] Whatever the ultimate fate of the white man may be, we can at least behold one example of a civilization which has brought every essential trace of primitivity with it, embracing the whole man from top to bottom. India's civilization and psychology resemble her temples, which represent the universe in their sculptures, including man and all his aspects and activities, whether as saint or brute. That is presumably the reason why India seems so dreamlike: one gets pushed back into the unconscious, into that unredeemed, uncivilized, aboriginal world, of which we only dream, since our consciousness denies it. India represents the other way of civilizing man, the way without suppression, without violence, without rationalism. You see them there side by side, in the same town, in the same street, in the same temple, within the same square mile: the most highly cultivated mind and the primitive. In the mental make-

up of the most spiritual you discern the traits of the living primitive, and in the melancholy eyes of the illiterate half-naked villager you divine an unconscious knowledge of mysterious truths.

[1012] I say all this in order to explain what I mean by not-thinking. I could just as well say: Thank heaven there is a man left who has not learned to think, but is still able to perceive his thoughts, as if they were visions or living things; a man who has transformed, or is still going to transform, his gods into visible thoughts based upon the reality of the instincts. He has rescued his gods, and they live with him. It is true that it is an irrational life, full of crudeness, gruesomeness, misery, disease, and death, yet somehow complete, satisfactory and of an unfathomable emotional beauty. It is true that the logical processes of India are funny, and it is bewildering to see how fragments of Western science live peacefully side by side with what we, shortsightedly, would call superstitions. Indians do not mind seemingly intolerable contradictions. If they exist, they are the peculiarity of such thinking, and man is not responsible for them. He does not make them, since thoughts appear by themselves. The Indian does not fish out infinitesimal details from the universe. His ambition is to have a vision of the whole. He does not yet know that you can screw the living world up tightly between two concepts. Did you ever stop to think how much of the conqueror (not to say thief or robber) lies in that very term “concept”? It comes from the Latin *concupere*, ‘to take something by grasping it thoroughly.’ That is how we get at the world. But Indian “thinking” is an increase of vision and not a predatory raid into the yet unconquered realms of nature.

[1013] If you want to learn the greatest lesson India can teach you, wrap yourself in the cloak of your moral superiority, go to the Black Pagoda of Konarak, sit down in the shadow of the mighty ruin that is still covered with the most amazing collection of obscenities, read Murray’s cunning old *Handbook for India*, which tells you how to be properly shocked by this lamentable state of affairs, and how you should go into the temples in the evening, because in the lamplight they look if possible “more [and how beautifully!] wicked”; and then analyse carefully and with the utmost honesty all your reactions, feelings, and thoughts. It will take you quite a while, but in the end, if you have done good work, you will have learned something about yourself, and about the white man in general, which you have probably never heard from any one else. I think, if you can afford it, a trip to India is on the whole most edifying and, from a psychological point of view, most advisable, although it may give you considerable headaches.

APPENDIX

EDITORIAL (1933)¹

[1014] Owing to the resignation of Professor Kretschmer, the president of the General Medical Society for Psychotherapy,² the presidency and with it the administration of the *Zentralblatt für Psychotherapie* have fallen to me. This change coincided with the great political upheaval in Germany. Although as a science psychotherapy has nothing to do with politics, fate has willed it that I should take over the editorship of the *Zentralblatt* at a moment when the state of affairs in psychotherapy is marked by a confusion of doctrines and views not unlike the previous state of affairs in politics. One-sided and mutually exclusive methods of observation have exerted too far-reaching an influence not only on specialized medical opinion but also on the psychological views of many educated laymen. The resulting contradictions have only been sharpened by the spread of my own—very different—ideas, so that we can well speak of confusion being worse confounded. It will therefore be the primary task of the *Zentralblatt* to give impartial appreciation to all objective contributions, and to promote an over-all view which will do greater justice to the basic facts of the human psyche than has been the case up till now. The differences which actually do exist between Germanic and Jewish psychology and which have long been known to every intelligent person are no longer to be glossed over, and this can only be beneficial to science. In psychology more than in any other science there is a “personal equation,” disregard of which falsifies the practical and theoretical findings. At the same time I should like to state expressly that this implies no depreciation of Semitic psychology,³ any more than it is a depreciation of the Chinese to speak of the peculiar psychology of the Oriental.

[1015] Psychotherapy has long ceased to be an exclusive province for specialists. The interest of the whole world is directed upon the psychological discoveries of medical men. Psychotherapy will therefore be obliged to take the whole of the psyche into account when constructing its theories, and to extend its vision beyond the merely pathological and personal. The efforts of the *Zentralblatt* will be directed to this end.

C. G. JUNG

A REJOINDER TO DR. BALLY¹

I

[1016] I wish to discuss no surmises with Dr. Bally, but prefer to report the facts which led me to take over the editorship of the *Zentralblatt für Psychotherapie*. About three years ago I was elected honorary [vice-] president of the General Medical Society for Psychotherapy. When, owing to the political upheaval, Professor Kretschmer resigned from the presidency, and the Society like so many other scientific organizations in Germany received a profound shock, some leading members pressed me—I may say, fervently—to take the chair. This, I would expressly emphasize, was the presidency not of the *German* but of the *International* Society, as is stated in the issue from which Dr. Bally quotes.² Thus a moral conflict arose for me as it would for any decent man in this situation. Should I, as a prudent neutral, withdraw into security this side of the frontier and wash my hands in innocence, or should I—as I was well aware—risk my skin and expose myself to the inevitable misunderstandings which no one escapes who, from higher necessity, has to make a pact with the existing political powers in Germany? Should I sacrifice the interests of science, loyalty to colleagues, the friendship which attaches me to some German physicians, and the living link with the humanities afforded by a common language—sacrifice all this to egotistic comfort and my different political sentiments? I have seen too much of the distress of the German middle class, learned too much about the boundless misery that often marks the life of a German doctor today, know too much about the general spiritual wretchedness to be able to evade my plain human duty under the shabby cloak of political subterfuge. Consequently no other course remained for me but to answer for my friends with the weight of my name and independent position.

[1017] As conditions then were, a single stroke of the pen in high places would have sufficed to sweep all psychotherapy³ under the table. That had to be prevented at all costs for the sake of suffering humanity, doctors, and—last but not least—science and civilization.

[1018] Anybody who has the least notion about present-day Germany knows that no newspaper, no society, nothing, absolutely nothing can exist unless it has been *gleichgeschaltet* (conformed) by the government. Consequently the organization of a journal or a society is an affair that has two sides. I can wish, but whether things will turn out as I wish is another question, the decision for which rests neither with me nor with my colleagues. Anyone who has to deal with Germany today knows how

rapidly things can alter, how one unforeseen decree follows another, and how the political scene changes like lightning. It is quite impossible to keep abreast of events from abroad, when even inside Germany people are unable, with the best will in the world, to get the political authorities to adopt a clear and binding attitude.

[1019] Since the German section of the International Society *has to be gleichgeschaltet*, and since, moreover, the *Zentralblatt* is published in Germany, there naturally arose so many difficulties that more than once we doubted the possibility of a reorganization. One of these concerned the oath of allegiance and the “purity of political sentiment” required of the German Society. We in Switzerland can hardly understand such a thing, but we are immediately in the picture if we transport ourselves back three or four centuries to a time when the Church had totalitarian presumptions. Barbed wire had not been invented then, so there were probably no concentration camps; instead, the Church used large quantities of faggots. The “modernist” oath of today is a pale and feeble offshoot of an earlier, much more robust and palpable *Gleichschaltung*. As the authority of the Church fades, the State becomes the Church, since the totalitarian claim is bound to come out somewhere. First it was Socialism that entered into the Catholic heritage and again is experimenting with the crassest kind of *Gleichschaltung*—not, indeed, with a view to buttressing up the kingdom of heaven but to producing an equally millenarian state of bliss (or its substitute) on earth. Russian Communism has therefore, quite logically, become the totalitarian Church, where even the poorest mouse emits the Bolshevik squeak. No wonder National Socialism makes the same claims! It is only consistent with the logic of history that after an age of clerical *Gleichschaltung* the turn should come for one practised by the secular State.

[1020] But even in such an age the spirit is at work in science, in art, philosophy, and religious experience, heedless of whether the contemporary situation be favourable or unfavourable, for there is something in man that is of divine nature and is not condemned to its own treadmill and imprisoned in its own structure. This spirit wants to live—which is why old Galileo, when they had done torturing him, recanted, and afterwards, so the story goes, said “But it does move”—only very softly, I’ll wager. Martyrdom is a singular calling for which one must have a special gift. Therefore it seems to me at least as intelligent not to worry the high inquisition for a while with the exciting news that one has discovered the moons of Jupiter without the authorization of Aristotle. Galileo had the childlike eyes of the great discoverer and was not at all wise to his *gleichgeschaltet* age. Were he alive today he could sun himself on the beach at Los Angeles in company with Einstein and would be a made man, since a liberal age worships God in the form of science. But the “metamorphosis of the gods” rolls rumbling on and the State becomes lord of this world: more than half Europe is already swallowed up. Science and every healing art

get seven fat years, then come the seven lean. They must learn to adapt themselves. To protest is ridiculous—how protest against an avalanche? It is better to look out. Science has no interest in calling down avalanches; it must preserve its intellectual heritage even under the changed conditions.

[1021] That is how things stand today. Neither I nor my German colleagues are responsible for them. If the German section of the Society wants to exist at all the oath of allegiance is inescapable, as any reasonable person will understand. It was therefore planned that the managing editor of the *Zentralblatt*, Dr. Cimbal of Hamburg, would bring out a special issue with statements by leading German psychotherapists, together with a signed introductory statement by the president of the German Society, Professor Göring of Elberfeld, for exclusive circulation in Germany. Such, too, were the instructions which I gave to the managing editor. To my great surprise and disappointment Professor Göring's political manifesto was suddenly printed in the current issue of the *Zentralblatt* [VI:3]. I do not doubt that there were inside political reasons for this, but it was one of those lamentable tactical gaffes which were the bane of German foreign policy even in the Wilhelm era. In this way my name unexpectedly appeared over a National Socialist manifesto, which to me personally was anything but agreeable. And yet after all—what is help or friendship that costs nothing? The incident is naturally so incriminating as to put my editorship seriously in question.

[1022] In Germany everything *must* be “German” at present if it is to survive. Even the healing art must be “German,” and this for political reasons. From the standpoint of medicine itself, it is unimportant whether it is called “German” or “French,” but it is extremely important that it should live, even if under undeniably difficult conditions, as I know only too well. It is a cheap jibe to ridicule “Germanic psychotherapy,” but a very different thing to have to rescue medicine for humanity's sake from the seething chaos of revolution. It is easy to stand by and be funny when the main point is to get a young and insecure science into a place of safety during an earthquake, and that was my aim in helping to reorganize the psychotherapeutic movement in Germany. Medicine has nothing to do with politics—I only wish it had!—and therefore it can and should be practised for the good of suffering humanity under all governments. If the doctors of Petersburg [*sic*] or Moscow had sought my help I would have acceded without hesitation, because I am concerned with human beings and not with Bolsheviks—and if I was then inevitably branded a Bolshevik it would have bothered me just as little. Man after all still has a soul and is not just an ox fatted for political slaughter. If I am called into the arena for the sake of the soul I shall follow the call wherever it may be. This naïve belief of mine in the human soul may, from the Olympian standpoint of a hypertrophied intellect or of partisan blindness, appear laughable, suspect, unpatriotic, and God knows what. I do not pride

myself on being a good Christian, but I do believe in the saying, “Render unto Caesar the things that are Caesar’s, and unto God the things that are God’s.” The doctor who, in wartime, gives his help to the wounded of the other side will surely not be held a traitor to his country.

||

[1023] There is no sense in us doctors facing the National Socialist regime as if we were a party. As doctors we are first and foremost men who serve our fellows, if necessary under all the aggravations of a given political situation. We are neither obliged nor called upon to make protests from a sudden access of untimely political zeal and thus gravely to endanger our medical activity. My support of the German doctors has nothing to do with any political attitude. If it is interpreted politically—which has doubtless happened already or soon will—the interpretations are a reflection on those who make them. I have never been in a position to stop the formation of myths.

[1024] Admittedly I was incautious, so incautious as to do the very thing most open to misunderstanding at the present moment: I have tabled the Jewish question. This I did deliberately. My esteemed critic appears to have forgotten that the first rule of psychotherapy is to talk in the greatest detail about all the things that are the most ticklish and dangerous, and the most misunderstood. The Jewish problem is a regular complex, a festering wound, and no responsible doctor could bring himself to apply methods of medical hush-hush in this matter.

[1025] As to the difference between Jewish and “Aryan-Germanic-Christian-European” psychology, it can of course hardly be seen in the individual products of science as a whole. But we are not so much concerned with these as with the fundamental fact that in psychology the object of knowledge is at the same time the organ of knowledge, which is true of no other science. It has therefore been doubted in all sincerity whether psychology is possible as a science at all. In keeping with this doubt I suggested years ago that every psychological theory should be criticized in the first instance as a subjective confession. For, if the organ of knowledge is its own object, we have every reason to examine the nature of that organ very closely indeed, since the subjective premise is at once the object of knowledge which is therefore limited from the start. This subjective premise is identical with our psychic idiosyncrasy. The idiosyncrasy is conditioned (1) by the individual, (2) by the family, (3) by the nation, race, climate, locality, and history.

[1026] I have in my time been accused of “Swiss wooden-headedness.” Not that I have anything against possessing the national vices of the Swiss; I am also quite ready to suppose that I am a bigoted Swiss in every respect. I am perfectly content to let my

psychological confession, my so-called “theories,” be criticized as a product of Swiss wooden-headedness or queer-headedness, as betraying the sinister influence of my theological and medical forbears, and, in general, of our Christian and German heritage, as exemplified for instance by Schiller and Meister Eckhart. I am not affronted when people call me “Teutonically confused,” “mystical,” “moralistic,” etc. I am proud of my subjective premises, I love the Swiss earth in them, I am grateful to my theological forbears for having passed on to me the Christian premise, and I also admit my so-called “father complex”: I do not want to knuckle under to any “fathers” and never shall (see “queer-headedness”).

[1027] May it not therefore be said that there is a Jewish psychology too, which admits the prejudice of its blood and its history? And may it not be asked wherein lie the peculiar differences between an essentially Jewish and an essentially Christian outlook? Can it really be maintained that I alone among psychologists have a special organ of knowledge with a subjective bias, whereas the Jew is apparently insulted to the core if one assumes him to be a Jew? Presumably he would not have one assume that his insights are the products of a mere cipher, or that his brain emerged only today from the featureless ocean of non-history. I must confess my total inability to understand why it should be a crime to speak of “Jewish” psychology.

[1028] If I were in the position—as Dr. Bally supposes me to be—of not being able to point to a single difference between the two psychologies, it would amount to exactly the same thing as not being able to make plausible the difference between the peculiarities of the English and the Americans, or the French and the Germans. I have not invented these differences; you can read about them in innumerable books and newspapers; as jokes they are on everybody’s tongue, and anyone who fails to see that there are one or two psychological differences between Frenchmen and Germans must have come from the back of beyond and know nothing about our European madhouse. Are we really to believe that a tribe which has wandered through history for several thousand years as “God’s chosen people” was not put up to such an idea by some quite special psychological peculiarity? If no differences exist, how do we recognize Jews at all?

[1029] Psychological differences obtain between all nations and races, and even between the inhabitants of Zurich, Basel, and Bern. (Where else would all the good jokes come from?) There are in fact differences between families and between individuals. That is why I attack every levelling psychology when it raises a claim to universal validity, as for instance the Freudian and the Adlerian. All levelling produces hatred and venom in the suppressed and misjudged; it prevents any broad human understanding. All branches of mankind unite in one stem—yes, but what is a stem without separate branches? Why this ridiculous touchiness when anybody dares

to say anything about the psychological difference between Jews and Christians? Every child knows that differences exist.

[1030] It seems to be generally assumed that in tabling the discussion of ethnological differences my sole purpose was to blurt out my “notorious” anti-Semitism. Apparently no one believes that I—and others—might also have something good and appreciative to say. Whatever it be, and however critical it be, I would never have the audacity to maintain that “ten tribes are accursed and two alone holy.” That saying comes from no Christian. My criticism and appreciation will always keep well outside this glaring contrast, and will contain nothing that cannot be discussed civilly.

[1031] I express no value-judgments, nor do I intend any veiled ones. I have been engaged for many years on the problem of imponderable differences which everybody knows and nobody can really define. They are among the most difficult problems of psychology and probably for that reason are a taboo area which none may enter on pain of death. To many people it is an insult if one credits them with a special psychological idiosyncrasy, and in dealing with parties and nations one must be even more careful. That is why any investigation of these imponderables is so extraordinarily difficult, because, as well as doing his work, the investigator has to perform a grotesque egg-balancing dance around highly charged sensibilities. It is high time the practising psychologist understood more about these psychic imponderabilia, because from them arise a good half of the things that go wrong in the world. Anyone who could define the nature of these imponderable differences would truly have gazed deep into the mystery of the human soul. For my part, I do not belong to those savants who concern themselves exclusively with what is known already—an extremely useful activity, no doubt—but prefer to sniff around territories where nothing is yet known.

[1032] Consequently I am amused to find myself cast in the role of the nitwit who is unable to spot a single difference between Jews and Christians. It is, in spite of Bally, an undoubted fact that the difference exists, just as water existed before the chemist discovered H₂O; but it cannot be grasped as yet, because all the views that have been put forward so far are unsatisfactory. These purely cognitive difficulties have, however, nothing to do with the question of whether the imponderables exist. I intend shortly to publish a few no doubt very inadequate and arguable *aperçus* on this subject. I am as little capable as anybody else of putting forward anything final, but I shall be content if I succeed in provoking discussion. I would like to bring the parties together round a conference-table, so that they could at last get to know and acknowledge their differences. Very often this sort of knowledge is the way to understanding. I wish I could do the same for the brothers in enmity on the left and

right of the Rhine. Naturally nothing like this can be attempted without inviting the kicks of both sides.

[1033] Would the cure be successful? The possibility of defeat in a good cause has never alarmed me.

[1034] But, my public will object, why raise the Jewish problem today of all days and in Germany of all places? Pardon me, I raised it long ago, as anybody knows who is acquainted with the literature. I did not speak about it only since the revolution; I have been officially campaigning for criticism of subjective psychological premises as a necessary reform in psychology ever since 1913.⁴ This has nothing to do with the form of the German state. If I am to be exploited for political ends, there's nothing I can do to stop it. Or can anyone stop anything he pleases in Germany? It is rather late in the day for my critical attitude to attract attention only now, and it is, alas, characteristic that it should be construed in such a way as to suggest that Nazism alone has lent wings to my criticism. It is, I frankly admit, a highly unfortunate and disconcerting coincidence that my scientific programme should, without any assistance of mine and against my express wish, have been lined up with a political manifesto. But an event of this kind, although regrettable in itself, often has the consequence of ventilating problems which would otherwise be sedulously avoided.⁵

CIRCULAR LETTER (1934)¹

Esteemed colleagues:

[1035] At the last Congress² of the International General Medical Society for Psychotherapy, it was decided to constitute the Society in the form of national groups.³ Therefore, national groups have now been formed or are being formed in the various countries that were represented at the Congress (Denmark, Germany, Netherlands, Sweden, and Switzerland). The conditions of membership in these national groups vary according to the local bylaws. Because of the political circumstances and because national groups do not yet exist in all countries, so that individuals as such cannot join their respective groups, it has been decided that association with a national group is on a purely voluntary basis; in other words, individual membership is possible within the framework of the International General Medical Society for Psychotherapy.⁴

[1036] The International Society is neutral as to politics and creed. Persons wishing to become members of it are invited to communicate with the general secretariat of the International Society, represented by Dr. W. Cimal, Altona, or with the president's general secretary, Dr. C. A. Meier, Burghölzli, Zurich.

[1037] The organ of the Society is the *Zentralblatt für Psychotherapie*, Verlag S. Hirzel, Leipzig; subscription to members, 15 Reichsmarks per year, post-paid.

[1038] We therefore respectfully invite you to join the International General Medical Society for Psychotherapy.

DR. C. G. JUNG

Zurich-Küsnacht
December 1, 1934

EDITORIAL (1935)¹

[1039] Although severely shaken by contemporary events, the International General Medical Society for Psychotherapy and its organ the *Zentralblatt* have consolidated their position during the past year, which began with the Congress at Bad Nauheim.²

[1040] Psychotherapy, after outgrowing the initial chaos of unsystematized tricks and techniques used by all branches of medicine that came into contact with the neuroses, gradually developed into a discipline whose scope and content entitled it to be called “medical psychology,” and to be accounted a specialized subject on its own. At one time its arsenal of knowledge consisted merely of a few tags of popular wisdom, a dose of “sound common sense,” and a tip or two from suggestion therapy; but today it has become an extensive field of science with continually widening problems. These undoubtedly raise, and have already raised, philosophical issues. The proper subject of medical psychology—the sick psyche—cannot be artificially separated from its wider background, the human psyche in general, though in practice this separation is effected by the illness itself. And although it is necessary to trace the deviations of pathological psychic development in all its details, in evaluating its findings medical research must in the end take its stand on normal observations and average values. As a result, any psychopathology that claims to be practical is inevitably led beyond itself into the sphere of normal psychology, and thus into the domain of philosophy. This is one of the many overlappings so characteristic of modern medicine: one has only to think of physiological chemistry and microbiology. Thus what began as psychotherapy has become an independent branch of science which has already swallowed up all that was formerly meant by psychopathology. Today no psychopathology is conceivable that could get along without the insights and discoveries of the psychotherapists.

[1041] For a long time past, practical psychological treatment has driven the specialist to elaborate his views in the form of theories, because these are indispensable for an orderly presentation of the empirical facts. Science cannot exist without hypotheses. But if hypotheses are made, intellectual integrity inevitably demands, in my view, a criticism of the premises. An hypothesis does not rest only on the apparent testimony of experience, it rests also on the judgment of the observer. If criticism of the premises underlying a judgment is needed anywhere, it is needed in psychology. (This is not the place for lengthy philosophical discussions, therefore a hint must suffice.)

[1042] The accusation has been made in certain quarters that the newer psychotherapy is concerned too much with philosophical problems and not enough with the minutiae of case-histories. This accusation must be emphatically rebutted, because philosophical problems belong in the highest degree to any empirical study of the psyche, as fit subjects both for research and for philosophical criticism. The empirical intellect, occupying itself with the minutiae of case-histories, involuntarily imports its own philosophical premises not only into the arrangement but also into the judgment of the material, and even into the apparently objective presentation of the data. If psychotherapists today are beginning to talk about a *Weltanschauung*, a philosophy of life, this merely proves that they have discovered the existence of certain broad assumptions which were formerly overlooked in the most ingenuous manner. What is the use of even the most accurate and punctilious work if it is prejudiced by an unavowed assumption? Any science worthy of the name must criticize its own assumptions. Freud himself did not shrink from the major philosophical task of debunking religious assumptions "once and for all." His intellectual development shows very clearly how the problems of medical psychology logically culminate in criticism, or at any rate polemical discussion, of its own premises. A departure of this kind is not an aberration; it is the positive duty of any growing science, and moreover it brings about a broadening, deepening, and enriching of its discoveries.

[1043] Since psychotherapy purports to be a method of healing, it must include among its aims the need to change a less adapted attitude, such as we see in every morbid state, into a normally adapted attitude. The adaptedness of a psychic system, however, is always related to the situation of the moment, and is therefore not fixed in an unchanging pattern. Adaptedness is not a permanent and permanently valid state which, once reached, can be maintained for ever; it is a continually advancing process which has as its indispensable premise the constant observation of changes occurring both within and without. A system of healing that fails to take account of the epoch-making *représentations collectives* of a political, economic, philosophical, or religious nature, or assiduously refuses to recognize them as actual forces, hardly deserves the name of therapy. It is more a deviation into a pathologically exaggerated attitude of protest which is the very reverse of adapted. Adaptedness as a criterion of cure is absolutely necessary, though of course it is not the only one.

[1044] Discussion of general assumptions and leading ideas is a most important item in the present phase of psychotherapy, because it brings into the limelight assumptions that tacitly exist and are all the more dangerous for that reason. In no circumstances can psychotherapy be a single method or a single system. Individuals and their temperaments vary so fundamentally that all forms of schematism and dogmatism cannot be got rid of quickly enough if psychotherapy is not to come to a dead end.

[1045] The peculiar nature of psychogenic insecurity and disease, as well as their enormous incidence, make the extension of psychotherapy to wider fields an urgent necessity, more particularly because paedagogics, by definition, does not bother about the education of adults, and the churches have nothing to say to vast numbers of people. The churches, it is true, have only themselves to blame if people confuse religion with a creed and, seeing no need to believe in anything, promptly take that as a proof that religion is superfluous. Experience shows that religion is, at the very least, a psychic fact that has existed from time immemorial and expresses itself in a thousand different forms. Protestant theology, strangely deluded, calls this view “psychologism” and in so doing robs itself of the most effective means of combatting man’s insecurity—the confessional, which the Catholic Church has wisely appropriated for the benefit of mankind. Modern psychotherapy has no such aspirations, but often it is virtually compelled to assume spiritual guidance in a realm that properly and originally belonged to the pastoral cure of souls, and is thus faced with an educative task which makes the most exacting demands on the knowledge and competence of the therapist. Though he may decline to cope with them on the plea of professional incompetence, they are really quite manageable if only he will fulfil the necessary conditions. At this point practical treatment impinges directly upon such questions as a philosophy of life, and there is no sense whatever in brushing them aside as irrelevant, thus cutting the patient off from that much needed relationship and adaptation to the great problems of the age and condemning him to a neurotic hole-and-corner existence. That would be the very thing that psychotherapy does *not* envisage.

[1046] The human psyche, even when in a pathological condition, is a complex whole actuated not only by instinctual processes and personal relationships but by the spiritual needs and suprapersonal currents of the time. And just as the general practitioner is rightly expected to know the *normal* anatomy and physiology of the body he has to treat, so the psychotherapist will sooner or later feel constrained to know everything that is of vital importance to the life of the psyche. He will, in short, have to approach psychology as one of the humane sciences. That this may prove inconvenient to a doctor trained mainly in the natural sciences is altogether understandable; but the growth of medicine has demonstrated again and again that its disciples, after a little hesitation, were ready to learn more. Psychotherapy is an intermediate field of research which requires the collaboration of many different branches of learning. It will be the task of the future to decide very carefully wherein the competence of each branch lies.

[1047] In accordance with the line of development suggested here, the next Congresses will be concerned on the one hand with the specifically medical relations between

psychology and endocrinology, and on the other hand with its relation, as a humane science, to oriental symbolism.

[1048] During the past year the organization of the International Society has made, in some part, satisfactory progress. The German group was, at the time of the last Congress, already firmly organized under the direction of Professor Göring. Since then there have been added a Dutch group, the “Netherlands Society for Psychotherapy,” with thirty-two members under the presidency of Dr. van der Hoop in Amsterdam, and a Danish group with ten members under the presidency of Dr. O. Brüel in Copenhagen. Finally, a Swiss group with fourteen members under the presidency of the undersigned was recently founded in Zurich, bearing the name of the “Swiss Society for Practical Psychology.”

[1049] The difficulties of establishing relations with neurological and psychiatric societies, not unknown elsewhere, have placed considerable obstacles in the way of founding a Swedish group by Dr. Poul Bjerre in Stockholm, so that no agreement has been reached up to the present.

[1050] The work of the groups outside Germany is organized in different ways. Copenhagen has two or three meetings a year, with lectures on specialized subjects. Amsterdam has four meetings a year. Zurich has a meeting every month, with a common programme of work in which, at present, the psychology of dreams is being worked out systematically.

[1051] The fragmentation of psychology into various schools and into even more numerous separate theories makes it desirable that discussion in the spirit of collaboration among colleagues should be fostered more than ever in the future. In this way certain misunderstandings would be removed and many questions clarified which at present remain unsolved for want of co-operation.

C. G. JUNG

EDITORIAL NOTE (1935)¹

[1052] Earlier, a Scandinavian and a Dutch issue were published by the *Zentralblatt*, and a Swiss issue is now being presented this year. As Switzerland is a trilingual country, we have not hesitated to include a contribution in French (by Professor Baudouin, Geneva). There are also two contributions in English by two writers who have spent several years studying in Zurich. They are H. G. Baynes, London, who was my assistant for several years, and Esther Harding, New York, author of the deservedly well-known works *The Way of All Women* and *Woman's Mysteries*. Although English is not one of the three official languages of Switzerland, unofficially it is the fourth, as is shown among other things by the fact that for years I have been invited to give English lectures in Zurich.

[1053] The greatest danger that threatens psychology is one-sidedness and insistence on a single standpoint. In order to do justice to the phenomena of the psyche, a variety of viewpoints is needed. Just as there are points of view based on race psychology, so also there are national ones, and we may welcome it as an enrichment of our experience that we have succeeded in including in our issues contributions from the Romance and the Anglo-Saxon mind.

[1054] The problems of psychiatry are not simplified by concentrating on one single aspect to the exclusion of all the others, for each individual psychic fact is decisively influenced by its relation to the whole; indeed, its real significance can be discovered only when its position in the whole has been ascertained. It would therefore seem more valuable at present to map out the scope of the whole than to investigate individual psychic processes in detail, on a general assumption that is as unconscious as it is incorrect. To this end we need the *consensus gentium*, which is in any case the foundation stone of an international Society and its organ. To promote international collaboration is one of the cultural characteristics of Switzerland, and this should also give the Swiss issue its own peculiar stamp.

C. G. JUNG

PRESIDENTIAL ADDRESS TO THE 8TH GENERAL MEDICAL CONGRESS FOR PSYCHOTHERAPY, BAD NAUHEIM, 1935¹

[1055] It is now a year since the International Medical Society for Psychotherapy was founded. During that year the German group has been organized under the successful leadership of Dr. Göring. Then the Netherlands Society for Psychotherapy joined the International Society under the leadership of Dr. van der Hoop. In Copenhagen, a Danish group was organized by Dr. Brüel. A Swiss group has recently been founded in Zurich under my presidency. Dr. Bjerre writes to me from Stockholm that, owing to external difficulties, it has so far not been possible for him to organize a Swedish group. Let us hope that the second year in the life of our Society will find him more successful. A little while ago Professor Stransky, of Vienna, got in touch with me about the founding of an Austrian group, so there appears to be a good chance that the Society will also include Austria.

[1056] It seems, however, that it is not particularly easy to bring all those doctors and psychologists who are concerned with psychotherapy or applied psychology into a neutral organization. The reasons for this—apart from the fact that some of them may have become understandably tired of societies—fall into two groups. The first comprises all those difficulties which a young science always has to contend with. Psychotherapy is still a child that is not very sure of itself. Moreover, it has two elder sisters who watch over its growth with somewhat mixed feelings and often dispute its right to independence. These sisters are psychiatry and neurology. Although there are praiseworthy exceptions among the practitioners of these sciences, psychotherapy, being pre-eminently psychological in its outlook and its methods, has as a rule eked out an exceedingly scanty existence under their auspices. I do not want to reproach them for this, for both psychiatry and neurology have a perfect right to their own special problems, which have little enough in common with those of psychotherapy. On the other hand, it is not permissible for them to claim a right to take psychotherapy under their wing merely because the one is concerned with mental diseases and the other with nervous diseases. The functional psychological disturbances, or psychoneuroses, are by nature a special field impinging neither on the psychiatric clinic nor on the domain of neurology. Modern psychotherapy has developed beyond that early stage of its career when it was nothing more than fatherly advice or suggestion with or without hypnosis, and has become a proper method of psychological treatment for the use of specialists. This fact is overlooked not only by the public but, all too often, by doctors as well.

[1057] The other reasons why the organization of our professional colleagues meets with difficulties have to do with psychological cross-currents within the profession itself. Objective discussion among professionals is not yet possible to the degree that a strictly scientific approach would require. There are certain groups of doctors who put forward theories with totalitarian pretensions and barricade themselves against criticism to such an extent that their scientific convictions are more like a confession of faith. This kind of attitude is a substitute for religion, though no objection could be made to this if only it were admitted. On the contrary, we could understand very well that it is the psychotherapists who feel most acutely the need for religious convictions, since the religions are in fact the oldest systems for healing the sufferings of the soul. But unlike religious ideas, these psychological theories are notably intellectualistic as well as anti-religious. Thus, we are confronted with the uncomfortable fact that in psychotherapy there are not only different theories—which in itself would be a matter for congratulation—but different convictions which are apparently indisputable—a phenomenon that is otherwise found only in the realm of political or religious controversy.

[1058] In the face of all these difficulties, the International Society maintains, first of all, that psychotherapy is an independent branch of medicine and, secondly, that scientific truths cannot be substantiated by uncritical and one-sided convictions. Accordingly, it welcomes adherents of all schools so far as they are willing to adopt an objective standpoint.

[1059] I therefore earnestly hope that in the course of time all those of our colleagues who wish to see psychotherapy developing along broader lines will associate themselves with us.

CONTRIBUTION TO A DISCUSSION ON PSYCHOTHERAPY¹

[1060] I can only agree with the general statements and intentions of the report we have just heard.² The same difficulties that exist in Switzerland for psychotherapy also exist abroad. As a member of the board of the International Society I have sought for years to bring about understanding between the different schools of psychotherapy. No less than three works have been written by members of my school (W. M. Kranefeldt, G. R. Heyer, Gerhard Adler), which all endeavour to give a fair survey of the different scientific standpoints. I had been honorary president of the Society for several years when the revolution in Germany broke out. The then president resigned, and a group of leading German psychotherapists came to me with the request that I take over the presidency, firstly in order to support a beleaguered psychotherapy in its struggle for existence, and secondly in order to preserve its international contacts. Out of regard for the position of psychotherapy in Europe I felt I had no right to withdraw from this difficult and painful task, and therefore decided to accept the presidency of the International Society. In doing so, I was not for one moment unaware that in these days it is a matter of the greatest difficulty to establish an international association without excluding Germany, although it is a *medical* society far removed from any political activity. The *Gleichschaltung*³ of the German group was inevitable. Protest would simply have put an end to psychotherapy in Germany. In these circumstances one had to be content with saving what was possible. Jewish doctors are excluded from the German group by the Aryan regulations, but I have succeeded in getting the draft of the international statutes amended so that German Jewish doctors can individually become members of the Society as a whole.⁴ National groups now exist in the Netherlands, Denmark, and Switzerland. The Freudian spirit of sectarianism put the greatest obstacles in the way of an Austrian group, and a political campaign was started in the press by the corresponding elements in Switzerland. These regrettable attempts to render objective discussion impossible from the start by sowing political suspicion on the one hand and sectarian discord on the other should not prevent fair-minded doctors who have the scientific development of their work at heart from doing their utmost to reach agreement. I have therefore gladly accepted the invitation to take part in the programme of work proposed by the planning committee.

[1061] For a variety of reasons it is probably better if psychotherapists, with a view to safeguarding their scientific and professional interests, do not constitute a group within a psychiatric society. The divergence of interests is too great for direct

collaboration to be profitable. In Germany too the separation of psychotherapy from psychiatry has proved to be a compelling necessity. But if psychotherapy is to achieve its independence, its representatives must for better or worse gather round the conference table and lay aside the autistic fads and fancies which have been so very rightly stressed by Dr. Morgenthaler.

[1062] It is, in my humble opinion, high time for psychotherapists to become conscious of their social responsibilities. The concept of psychotherapy has reached the wider public; there are large numbers of psychotherapists—so many that one can without exaggeration speak of them as a “profession”; a copious literature exists and has an eager following; and finally psychotherapy, originally the concern of medical men, has come to extend so far beyond its original boundaries that its oldest initiator, Freud himself, today thinks very differently about lay therapy from what he did before. The psychotherapist is now firmly entrenched with the public, so his social responsibility has already begun. But it becomes an urgent problem in view of the incontrovertible fact that the practice of psychotherapy today is largely in the hands of “medical laymen.” To anticipate at once, I am not speaking of those incompetent and irresponsible quacks whom the law is quite capable of catching, but of altogether serious teachers and psychologists whose previous training enables them to exert an educative influence. Since applied psychotherapy is largely educative in essence, it can hardly refrain from collaborating with the educator without impoverishing itself. Just as the medical practitioner makes plentiful use of lay assistants, and is even dependent on them in large measure, so the psychotherapist has need of auxiliary methods which he is bound to leave to helpers who are not medically trained. I need only mention physiotherapy and its various uses, special educative techniques, and so on. In my opinion it would be quite wrong for medical psychotherapists to shun these natural fellow-workers and brand them all quacks. On the other hand, the doctor has every interest in not allowing the pretentious aspirations that are fostered in numerous pedagogic institutes and in certain philosophy departments to run riot; instead, he will gradually confine the various fields of activity within their proper limits by wise collaboration. But if he shuts his eyes to the very existence of legitimate psychological workers, he not only fails to eliminate those tendencies by this ostrich policy, but denies himself the much-needed insight into the manifold branches of educational therapy today, and, furthermore, deprives them of the one essential: eventual medical surveillance and control. The International Medical Society for Psychotherapy is concerning itself in a positive way with the problem of practising psychologists and technical assistants when it clearly recognizes the dangers of a wildly proliferating and medically uncontrollable psychological lay movement.

[1063] Recently, as so often in the course of the last twenty years, it has been asserted that lay interest in psychological questions is on the decrease and that, because neuroses are either endocrine disturbances or mild forms of psychosis, all psychotherapy is superfluous. I would like to utter an urgent warning against such errors. Various psychological trends may fall out of fashion, but psychological problems in general are far more deeply rooted in the public than is realized outside the psychotherapeutic profession. In this respect the psychotherapist is faced with social responsibilities which sooner or later will make closer association with his fellow-workers an absolute necessity, quite apart from the economic considerations to which Dr. Morgenthaler has drawn attention.

PRESIDENTIAL ADDRESS TO THE 9TH INTERNATIONAL MEDICAL CONGRESS FOR PSYCHOTHERAPY, COPENHAGEN, 1937¹

[1064] For the first time our Society is convening here in Copenhagen, at the friendly invitation of the Scandinavian national groups. Our decision to hold the Congress outside its previous confines demonstrates its international nature. The Society has long felt the need not only to overcome the geographical and linguistic barriers but, even more important, to extend the frontiers of medical psychotherapy as a science. However much the psychotherapist in his practical work must concentrate on the individual patient and on the most minute details, as a scientist he needs a viewpoint that widens his horizon, not just for his own sake, but for that of his patients, whose almost limitless differences demand of him a correspondingly broad understanding. Any narrow adherence to artificial limits would be a catastrophe for our science, whether these limits be national, political, linguistic, religious, or philosophical. Although every investigator is limited as an individual, and must work within his individual limits, his self-limitation loses all meaning if there is no living contact with the diversity of other points of view. So if in the course of the last few years we have succeeded, despite considerable external difficulties, not only in preserving our original Society but in establishing its internationality on a series of national groups—German, Dutch, Danish, Swedish, Austrian, and Swiss—we have at least laid the foundations of its further development. It is our liveliest wish to welcome our French and English colleagues also as future members of our Society. At a time like this, when historical necessity lays so much stress on the development of national individuality, the problem of international relationships becomes equally urgent by way of compensation. The nations of Europe form a European family, which like every family has its own special spirit. However far apart the political goals may lie, they rest ultimately on the common European psyche, with whose aspects the practising psychologist should be familiar.

[1065] You will I am sure agree with me that the conditions for an international organization are extremely precarious today. But this should not deter us from doing everything in our power, however limited it may be in these unfavourable times, to preserve the human and psychic ties of the European family and also to practise in the international sphere what we daily seek to inculcate in our patients. By this I mean the avoidance of that basic evil, *projections upon our neighbour*. For everything that exists there are, as we know only too well, sufficient reasons, and only a bad psychologist will fail to appreciate their full significance. It is the task of

our science to understand and classify all varieties of human behaviour. Faced with such a bewildering diversity of aspects and viewpoints, psychology can continue to function only if it abandons all hasty commitment to dogmas and doctrinaire convictions and allows every view to express itself freely so far as there are sufficient reasons to support it. In science there is no spirit of sectarianism which decides the truth. Being the science of the psyche, psychology is the sum total of what the psyche says about itself. Hence everything is psychologically true that psychologically exists. But the things that psychologically exist are innumerable. I can therefore wish nothing better for our Society, and in particular for this Congress, than that every opinion should be expressed and listened to, and that as many nations as possible should make their own particular contribution to the total picture of the European psyche.

[1066] I still have the painful duty of recalling a loss that our Society has suffered during the past year. Robert Sommer, the co-founder and for many years the first president of the General Medical Society for Psychotherapy, died on February 3rd. Thanks to his wide knowledge of philosophy and psychology, and especially of familial research, he was drawn to our special field and its working hypotheses. His decision to throw in his lot with us and his readiness to collaborate with our endeavours deserve not only our heartfelt thanks but also the highest praise, as this happened at a time when the psychological point of view in medicine was still open to public attack. In these circumstances it was an act of courage that made psychotherapy possible in Germany and to a large extent kept it alive. Sommer's support for psychotherapy was, together with Eugen Bleuler's, of decisive importance for the further development of the new ideas.

[1067] I would like to ask you to rise from your seats in memory of our loyal friend and supporter.

[1068] Ladies and Gentlemen, the 9th Congress of the International General Medical Society for Psychotherapy is opened. To the organizing committee, and to Dr. Brüel and Dr. Bjerre in particular, I express the Society's thanks for the invitation as well as for the work of preparing the Congress. I now leave the floor to Dr. Brüel.

PRESIDENTIAL ADDRESS TO THE 10TH INTERNATIONAL MEDICAL CONGRESS FOR PSYCHOTHERAPY, OXFORD, 1938¹

[1069] When we met at Copenhagen last year, it was the first time that our Congress had been held outside Germany. And soon afterwards our British colleagues suggested arranging a meeting in England. It has always been my desire to establish a line of communication between continental psychological medicine and England, where, within the last ten years, so much has been done for the cause of psychotherapy and where there are already so many physicians interested either in the treatment of neuroses or in the psychological aspect of illness in general. I am sure that I speak in the name of all my continental colleagues when I express my profound gratitude to this good town of Oxford, of ancient fame, to our English friends, and to all those whose benevolence and friendly support has made the organization of the Congress possible. We are deeply indebted to the organizing committee, in particular to Dr. Baynes, Dr. Strauss, and Dr. Squires, for their generous advice and help.

[1070] Before we begin the actual work I should like, if you will permit me, to make some remarks about the way in which the general intentions of our Congress should be understood. One of the most serious obstacles to collaboration in the field of psychotherapy is the peculiar fact of there being different schools of thought which are apparently incompatible with each other. Not that such a fact would be any novelty in the history of medicine, but it is an annoying encumbrance which has delayed the union and collaboration of the numerous workers in the field of psychotherapy. Medical psychology is still a delicate plant which needs careful nursing if it is to lead a reasonably independent existence in the near future. But how can anyone take care of its development when not even its own representatives are at one among themselves as to what the thing is? It has recently become a serious question, in more countries than one, whether psychotherapy could or should be taught at the universities. Many physicians have realized that quite ordinary diseases are accompanied by psychological disturbances which are causally related to the organic ailment. Psychiatrists have become aware that even psychoses often have a remarkably psychological aspect, and psychotherapists have found that borderline cases, ominously labelled as schizophrenia, are not inaccessible to psychological treatment. In education, considerable use has already been made of the psychological points of view elaborated by medical psychologists. And even the clergy, Catholic as well as Protestant, are beginning to be interested in our work, because they are

human beings like ourselves who are burdened and even harassed at times by the intricate moral problems of the people who consult them. We can safely speak of an enormous increase of public interest in our work within the last ten years. Interest in psychology is serious in our day and is no longer a ridiculous fad as it was twenty years ago. Today we ought to think hard and make a serious effort to bring together all men of good will in our profession, in order to meet the needs and demands of the time. In Switzerland we had a committee for psychotherapy elected by the Swiss Society of Psychiatry many years ago. And, as one might expect, for as many years nothing happened. Recently, however, we made a move, but one of our faculties of medicine said: "What are you going to teach? You do not even agree with each other about your own theories."

[1071] This remark hits the nail on the head. Yet the nail of psychotherapy has several heads and only one of these is struck by this criticism. Those who are not professionally acquainted with psychology do not realize that it includes a very large and equally important practical part which has little or nothing to do with a particular theory. But it is the latter which is loudly proclaimed before the public, and thus the prejudice is aroused that psychotherapy amounts to nothing but the preaching of a particular theory. This is a gross mistake. As a matter of fact each psychotherapist in his practical work follows a line that is more or less common to all his colleagues (provided they do not use hypnotism). And each of them, no matter to what school he belongs, follows his own line because he knows from experience that good work demands the whole man and is never achieved by mere routine or by a theoretical creed. The very nature of the cases we are treating forces us occasionally to change our method or our theoretical explanation. We know that a neurosis is not a typical infection by a specific microbe, but the morbid development of the whole of a personality. We also know that the originators of psychological theories are human beings with an individual psychic predisposition, the one more prone to a certain kind of opinion or interpretation than the other. On the one hand we have to deal with very individual patients and on the other hand we make use of opinions which are only very relatively valid. These truths are incontestable. They should warn us against any fixed standpoint and they should turn our minds to what we actually do with our patients, rather than to a meaningless dispute about opinions.

[1072] The Swiss Committee of Psychotherapy has made the attempt to formulate those points about which all psychotherapists, working along the lines of psychological analysis, could agree. The democratic spirit of Switzerland has helped us to avoid all absolutism and we succeeded in producing Fourteen Points of mutual agreement.² President Wilson's noble attempt seems to have stood godfather to our little enterprise. There are people who doubt whether the League of Nations really works.

But our enterprise in Switzerland has already worked. We are ready now to start an Institute of Psychotherapy.

[1073] Our fourteen points, which I am presently going to discuss, have been ridiculed as a lukewarm compromise that skates over the most tremendous differences of opinion. That is exactly what we intended to do. If you want to quarrel about opinions, you can spend the rest of your life doing so. But we wanted to get something done, and you cannot do that by endless philosophical discussions about the ultimate meaning of the psyche. Each school had to sacrifice some of its hobby-horses and to abandon stiff-necked resistance to other points of view. Something little short of a miracle happened: our admittedly lukewarm and superficial formulations brought about a cordial collaboration between people who formerly thought they were miles apart from each other. If my colleagues understand that psychotherapy is our common cause, then there is a hope it will find a well-merited place among the other branches of medical science.

BIBLIOGRAPHY

BIBLIOGRAPHY

Acta Archelai. See HEGEMONIUS.

ANGELUCCI, ORFEO M. *The Secret of the Saucers*. Amherst (Wis.), 1955.

Annalen der Naturphilosophie. Edited by Wilhelm Ostwald. Leipzig, 1902– .

ANQUETIL DU PERRON, ABRAHAM HYACINTHE. *Oupnek'hat (id est, Secretum tegendum) ... in Latinum conversum ... studio et opere Anquetil du Perron*. Strasbourg, 1801–2. 2 vols.

Anthropophyteia. Jahrbücher für folkloristische Erhebungen und Forschungen zur Entwicklungsgeschichte der geschlechtlichen Moral. Edited by Friedrich H. Krauss. Leipzig, 1904–13. 10 vols.

AUGUSTINE, SAINT. *Sermo 189*. See MIGNE, *P.L.*, vol. 38, cols. 1005–7.

Aurora Consurgens. See FRANZ, MARIE-LOUISE VON.

BALLY, G. “Deutschstämmige Psychotherapie?” *Neue Zürcher Zeitung*, CLV: 343 (Feb. 27, 1934).

BASH, K. W., AHLENSTIEL, H., and KAUFMANN, R. “Ueber Präyantraformen und ein lineares Yantra.” In: *Studien zur analytischen Psychologie C. G. Jungs*. Zurich, 1955. (I, 205–228.)

BELLOWS, HENRY ADAMS (ed. and trans.). *The Poetic Edda*. (Scandinavian Classics, 21, 22.) New York, 1923. 2 vols. in one. (“Voluspo,” I, 1–27.)

BENOÎT, PIERRE. *Atlantida*. Translated by Mary C. Tongue and Mary Ross. New York, 1920. (Original: *L'Atlantide*. Paris, 1920.)

BÖHLER, EUGEN. *Ethik und Wirtschaft*. Zurich (Industrielle Organization), 1957.

[ECKHART, MEISTER.] *Meister Eckhart*. [Works.] Translated by C. de B. Evans. London, 1924–52. 2 vols.

Entretiens: L'Avenir de l'esprit européen. (League of Nations: International Institute of Intellectual Co-operation.) Paris, 1934.

FOERSTER-NIETZSCHE, ELIZABETH (ed.). *Der werdende Nietzsche*. Munich, 1924.

FOREL, AUGUSTE. *The Sexual Question*. Adapted from the 2nd German edition by C. F. Marshall. Revised edn., New York, 1925. (Original: *Die sexuelle Frage*. Munich, 1905.)

FRANZ, MARIE-LOUISE VON. *Aurora Consurgens: ein dem Thomas von Aquin zugeschriebenes Dokument der alchemistischen Gegensatzproblematik*. (Part III of C. G. Jung: *Mysterium Coniunctionis*.) Zurich, 1957. (English edn.: *Aurora Consurgens; A Document of the Alchemical Problem of Opposites, Attributed to Thomas Aquinas*. Translated by R. F. C. Hull and A. S. B. Glover. New York [Bollingen Series] and London, in press.)

FREUD, SIGMUND. *The Future of an Illusion*. Translated by W. D. Robson-Scott. In: Standard Edn.,* 21. 1961.

_____. *The Interpretation of Dreams*. Translated by James Strachey. In: Standard Edn.,* 4 and 5. 1953.

_____. *The Psychopathology of Everyday Life*. Translated by Alan Tyson. In: Standard Edn.,* 6. 1961 (dated 1960).

_____. *Totem and Taboo*. Translated by James Strachey. In: Standard Edn.,* 13. 1955.

- FÜRST, EMMA. "Statistical Investigations on Word-Associations and on Familial Agreement in Reaction Type among Uneducated Persons." In: *Studies in Word-Association*, under the direction of C. G. Jung. Translated by M. D. Eder. London, 1918; New York, 1919. (Pp. 407–445.)
- GEORGE, STEFAN. *Werke*. Gesamt-Ausgabe. Endgültige Fassung. Berlin, 1927–34. 18 vols.
- GOETHE, JOHANN WOLFGANG VON. *Faust, Parts One and Two*. Translated by Philip Wayne. (Penguin Classics.) Harmondsworth and Baltimore, 1949, 1959.
- _____. *Werke*. Edited by Ernst Beutler. (Gedenkausgabe.) Zurich, 1948–54. 24 vols. (Vols. I–II: Sämtliche Gedichte.)
- GOETZ, BRUNO. *Deutsche Dichtung*. Lucerne, 1935.
- _____. *Das Reich ohne Raum*. Potsdam, 1919; 2nd enl. edn., Constance, 1925.
- GOTTHELF, JEREMIAS (pseudonym of Albert Bitzius). *The Black Spider*. Translated by H. M. Waidson. London, 1958. (Original: *Die schwarze Spinne*.)
- HAGGARD, H. RIDER. *Ayesha: the Return of She*. London, 1905.
- _____. *She*. London, 1887.
- _____. *Wisdom's Daughter*. London, [1923].
- HARDING, M. ESTHER. *Journey into Self*. New York, 1956.
- _____. *The Way of All Women*. London and New York, 1933.
- _____. *Women's Mysteries, Ancient and Modern*. London and New York, 1935.
- HASTINGS, JAMES (ed.). *Encyclopaedia of Religion and Ethics*. Edinburgh and New York, 1908–27. 13 vols.
- HAUER, (JACOB) WILHELM. *Deutsche Gottschau: Grundzüge eines deutschen Glaubens*. Stuttgart, 1935.
- HAY, AGNES BLANCHE MARIE. *The Evil Vineyard*. London and New York, 1923.
- HEARD, [HENRY FITZ]GERALD. *Is Another World Watching? The Riddle of the Flying Saucers*. London, 1950; New York, 1951.
- HEGEMONIUS. *Acta Archelai*. Edited by Charles Henry Beeson. (Griechische christliche Schriftsteller.) Leipzig, 1906.
- HERMES TRISMEGISTUS. *The Emerald Table (Tabula Smaragdina)*. In: *The Lives of the Alchymistical Philosophers*. London, 1815; repr. 1955. (Pp. 383–84.)
- HILDEGARD OF BINGEN, SAINT. *Wisse die Wege; Scivias*. Translated (into German) and edited by Maria Böckeler. Salzburg, 1955.
- HÖLDERLIN, JOHANN CHRISTIAN FRIEDRICH. *Gedichte*. Edited by Franz Zinkermagel. Leipzig, 1922.
- HOYLE, FRED. *The Black Cloud*. London, 1957.
- _____. *Frontiers of Astronomy*. London, 1955.
- _____. *The Nature of the Universe*. London, 1950.
- IRENÆUS. *Adversus [or Contra] haereses libri quinque*. In: *The Writings of Irenaeus*. Translated by Alexander Roberts and W. H. Rambaut. (Ante-Nicene Christian Library, 5, 9.) Edinburgh, 1868–9. 2 vols.
- JAFFÉ, ANIELA. *Apparitions and Precognition. A Study from the Point of View of C. G. Jung's Analytical Psychology*. Translated by Vera Klein Williams and Mary Elliot. New Hyde Park (N.Y.) and London, 1963.

- JONES, ERNEST. *Sigmund Freud: Life and Work*. London, 1953–57. 3 vols. (New York edn. differently paged.)
- JOYCE, JAMES. *Ulysses*. Paris, 1922.
- JUNG, CARL GUSTAV. *Aion*. (Collected Works, 9, ii.) 1959.
- _____. *The Archetypes and the Collective Unconscious*. (Collected Works, 9, i.) 1959.
- _____. “Brother Klaus.” In: *Philosophy and Religion, West and East*, q.v.
- _____. *Collected Papers on Analytical Psychology*. Edited by Constance E. Long, translated by various persons. London, 1916; 2nd edn., London, 1917; New York, 1920.
- _____. “Concerning Mandala Symbolism.” In: *The Archetypes and the Collective Unconscious*, q.v.
- _____. “Concerning Rebirth.” In: *The Archetypes and the Collective Unconscious*, q.v.
- _____. “A Contribution to the Study of Psychological Types.” In: *Psychological Types*. (Collected Works, 6.*) (Alternative source: *Contributions to Analytical Psychology*, q.v.)
- _____. *Contributions to Analytical Psychology*. Translated by C. F. and H. G. Baynes. London and New York, 1928.
- _____. “The Development of Personality.” In: *The Development of Personality*, q.v.
- _____. *The Development of Personality*. (Collected Works, 17.) 1954.
- _____. *Essays on Contemporary Events*. Translated by Elizabeth Welsh, Barbara Hannah, and Mary Briner. London, 1947.
- _____. “Freud and Jung: Contrasts.” In: *Freud and Psychoanalysis*, q.v.
- _____. *Freud and Psychoanalysis*. (Collected Works, 4.) 1961.
- _____. “General Aspects of Dream Psychology.” In: *The Structure and Dynamics of the Psyche*, q.v.
- _____. “Instinct and the Unconscious.” In: *The Structure and Dynamics of the Psyche*, q.v.
- _____. “Introduction to Kranefeldt’s ‘Secret Ways of the Mind.’” In: *Freud and Psychoanalysis*, q.v.
- _____. “Marriage as a Psychological Relationship.” In: *The Development of Personality*, q.v.
- _____. *Modern Man in Search of a Soul*. Translated by W. S. Dell and Cary F. Baynes. London and New York, 1933.
- _____. “On Psychological Understanding.” In: *The Psychogenesis of Mental Disease*. (Collected Works, 3.)
- _____. *Philosophy and Religion, West and East*. (Collected Works, 11.) 1958.
- _____. *The Practice of Psychotherapy*. (Collected Works, 16.) 1954.
- _____. *Psychiatric Studies*. (Collected Works, 1.) 1957.
- _____. *The Psychogenesis of Mental Disease*. (Collected Works, 3.) 1960.
- _____. “The Psychological Foundations of Belief in Spirits.” In: *The Structure and Dynamics of the Psyche*, q.v.
- _____. “A Psychological Theory of Types.” In: *Psychological Types*, q.v. (Alternative source: *Modern Man in Search of a Soul*, q.v.)
- _____. *Psychological Types*. (Collected Works, 6.*) (Alternative source: Translation by H. G. Baynes. London and New York, 1923.)
- _____. *Psychology and Alchemy*. (Collected Works, 12.) 1953.
- _____. “Psychology and Religion.” In: *Psychology and Religion, West and East*, q.v.
- _____. *The Psychogenesis of Mental Disease*. (Collected Works, 3.) 1960.

- ____. "Psychology of the Transference." In: *The Practice of Psychotherapy*, q.v.
- ____. "The Psychology of the Unconscious." In: *Two Essays on Analytical Psychology*, q.v.
- ____. "The Relations between the Ego and the Unconscious." In: *Two Essays on Analytical Psychology*, q.v.
- ____. *The Structure and Dynamics of the Psyche*. (Collected Works, 8.) 1960.
- ____. "The Structure of the Psyche." In: *The Structure and Dynamics of the Psyche*, q.v.
- ____. "The Structure of the Unconscious." In: *Two Essays on Analytical Psychology*, q.v.
- ____. *Symbols of Transformation*. (Collected Works, 5.) 1956.
- ____. "Synchronicity: an Acausal Connecting Principle." In: *The Structure and Dynamics of the Psyche*, q.v.
- ____. "The Theory of Psychoanalysis." In: *Freud and Psychoanalysis*, q.v.
- ____. "Transformation Symbolism in the Mass." In: *Psychology and Religion: West and East*, q.v.
- ____. *Two Essays on Analytical Psychology*. (Collected Works, 7.) 1953.
- ____. "What Is Psychotherapy?" In: *The Practice of Psychotherapy*, q.v.
- ____. See also WILHELM, RICHARD.
- JUNGER, ERNST. *On the Marble Cliffs*. Translated by Stuart Hood. London, 1947. (Original: *Auf den Marmorklippen*.)
- KERNER, JUSTINUS. *The Seeress of Prevorst*. Translated by Mrs. [Catherine] Crowe. New York, 1859. (Original: *Die Seherin von Prevorst*. Stuttgart and Tübingen, 1829. 2 vols.)
- KEYHOE, DONALD EDWARD. *The Flying Saucer Conspiracy*. London, 1957.
- ____. *Flying Saucers from Outer Space*. New York, 1953; London, 1954.
- KEYSERLING, COUNT HERMANN. *America Set Free*. New York and London, 1929. (Original: *Amerika. Der Aufgang einer neuen Welt*. Stuttgart and Berlin, 1930.)
- ____. *The Book of Marriage*. Translated by W. H. Hilton-Brown and others. New York, [1926]. (Original: *Das Ehe-Buch*. Celle, 1925.)
- ____. *Europe*. Translated by Maurice Samuel. New York and London, 1928. (Original: *Das Spektrum Europas*. Heidelberg, 1928.)
- ____. *Mensch und Erde*. (Der Leuchter, 8.) Darmstadt, 1927.
- ____. *La Révolution mondiale et la responsabilité de l'Esprit*. Paris, 1934.
- ____. *South-American Meditations*. Translated by Therese Duerr. New York and London, 1932. (Original: *Südamerikanische Meditationen*. Stuttgart, 1932.)
- KLAGES, LUDWIG. *Der Geist als Widersacher der Seele*. 2nd edn., Leipzig, 1937.
- ____. *Vom cosmogonischen Eros*. Jena, 1922.
- KRAFFT-EBING, RICHARD VON. *Psychopathia Sexualis*. Adapted from the 12th German edition by F. J. Rebman. New York, 1925. (Original: Stuttgart, 1886.)
- LE BON, GUSTAVE. *The Crowd, a Study of the Popular Mind*. London, 1896.
- MACROBIUS, AMBROSIVS THEODOSIVS. *Commentarium in Somnium Scipionis*. In: *Opera*. Edited by F. Eysenhardt. Leipzig, 1893. For translation, see: *Commentary on the Dream of Scipio*. Translated by William Harris Stahl. (Records of Civilization, Sources and Studies, 48.) New York, 1952.

- MENZEL, DONALD HOWARD. *Flying Saucers*. Cambridge (Mass.) and London, 1953.
- MICHEL, AIMÉ. *The Truth about Flying Saucers*. London, 1957. (Original: *Lueurs sur les soucoupes volantes*. Paris, 1954.)
- MIGNE, JACQUES PAUL (ed.). *Patrologiae cursus completus*. Latin series. Paris, 1844–64. 221 vols. (This work is referred to as “Migne, P.L.”)
- [MURRAY, JOHN.] *Murray’s Handbook for Travellers in India, Burma, and Ceylon*. London, 1891; 17th edn., 1955.
- NIETZSCHE, FRIEDRICH WILHELM. *Beyond Good and Evil*. Translated by Helen Zimmern. Edinburgh and London, 1907.
- _____. *The Birth of Tragedy*. Translated by William A. Hausmann. London, 1909.
- _____. *Thus Spoke Zarathustra*. See: *The Portable Nietzsche*. Selected and translated by Walter Kaufmann. New York, 1954.
- _____. *Werke*. Leipzig, [1930–32]. 8 vols. (“An den Mistral,” V, 495; “To the Unknown God,” V, 457–58.)
- NINCK, MARTIN. *Wotan und germanische Schicksalsglaube*. Jena, 1935.
- NOSTRADAMUS, MICHEL (Nostredame). *The Complete Prophecies of Nostradamus*. Translated and edited by Henry C. Roberts. New York, 1949. (Original: *Vrayes Centuries et prophéties de Maistre Michel Nostredame*. Amsterdam, 1667.)
- OSTWALD. See: *Annalen der Naturphilosophie*.
- PORTMANN, ADOLF. “Die Bedeutung der Bilder in der lebendigen Energiewandlung.” In: *Eranos-Jahrbuch 1952* (XXI). Zurich, 1953.
- REINWALD, PAUL. *Vom Geist der Massen*. Zurich, 1946.
- ROUSSEAU, JEAN-JACQUES. *The Confessions*. The anonymous translation into English of 1783 and 1790 revised and completed by A. S. B. Glover. New York, 1955.
- RUPPELT, EDWARD J. *Report on Unidentified Flying Objects*. London and New York, 1956.
- SCHMITZ, OSCAR A. H. [Autobiography, I:] *Die Geister des Hauses; Jugenderinnerungen*. [II:] *Dämon Welt; Jahre der Entwicklung*. [III:] *Ergo Sum; Jahre des Reifens*. Munich, 1925–27. 3 vols.
- _____. *Psychoanalyse und Yoga*. Darmstadt, 1923.
- SCHREBER, DANIEL PAUL. *Memoirs of My Nervous Illness*. Translated by Ida Macalpine and Richard A. Hunter. London, 1955. (Original: *Denkwürdigkeiten eines Nervenkranken*. Leipzig, 1903.)
- SIEVERS, EDGAR. *Flying Saucers über Südafrika*. Pretoria, 1955.
- Tabula smaragdina*. See HERMES.
- TERTULLIAN. *Adversus Judaeos*. See Migne, P.L., vol. 2, cols. 595–642.
- VALÉRY, PAUL. *History and Politics*. Translated by Denise Folliot and Jackson Mathews. (Collected Works, edited by Jackson Mathews, 10.) New York (Bollingen Series XLV) and London, 1962.
- VIRGIL. [Eclogues.] *The Pastoral Poems*. The text of the Eclogues, with a translation by E. V. Rieu. (Penguin Classics.) Harmondsworth and Baltimore, 1954.

WELLS, HERBERT GEORGE. *The Time Machine*. London, 1895.

_____. *The War of the Worlds*. London, 1898.

WILHELM, RICHARD (trans.). *The Secret of the Golden Flower*. With a foreword and commentary by C. G. Jung.

Translated from the German by Cary F. Baynes. New edn., London and New York, 1962.

WILKINS, HAROLD TOM. *Flying Saucers on the Attack*. London, n.d. [1954.]

WOLFF, TONI. *Studien zu C. G. Jungs Psychologie*. Zurich, 1959.

WYNDHAM, JOHN. *The Midwich Cuckoos*. London and New York, 1957.

ZSCHOKKE, JOHANN HEINRICH DANIEL. *Eine Selbstschau*. 3rd edn., Aarau, 1843.

INDEX

INDEX

A

- abaissement du niveau mental*, 420
- abstinence, sexual, 109
- Abyssinia, 179
- acausal phenomena, *see* synchronicity
- acceleration, of Ufos, 316
- accidents, 450
 - as omens, 61
- Acta Archelai*, 369
- Acts of the Apostles, 40, 280, 445
- Adam, 296
- Adam's Bridge, 525
- Adamski,—, 323
- adaptation: diminished, 241
 - neurosis and, 162
 - psychological, and projection, 25
 - psychotherapy and, 549
 - will to, 161, 169
- adaptedness, 282
- Adler, Alfred, 14, 160, 161, 164*f*, 288, 348, 541
- Adler, Gerhard, 557
- adultery, 120, 123, 129
- aeroplanes, 317
- aesthetics, values in, 457
- affect(s): control of, 360
 - excess of, 458, 459
 - deviations from instinct as, 360
 - uncontrolled, 360
 - wallowing in, 468
- Africa, 66, 136, 152

and Christianity, 89
hysteria in, 19
white and black in, 47
afterlife, belief in, 328
aggression, and religion, 343
Ahasuerus, 181
Ahlenstiel, H., 424n
airman, as observer, 340
Akbar the Great, 516
Alberich, 186
Albertus Magnus, 458
alchemy, 331f, 334, 385f, 394, 404f
 colours in, 417
 Hildegard and, 404
 Holy Ghost in, 405
 mandala in, 326
 three plus one motif in, 39
 water in, 332, 333
Alexander the Great, 516
Allah, 192, 328
all-being, non-existent, 139
Allgemeine Ärztliche Gesellschaft für Psychotherapie, 533, 535, 537, 538
Alps, 115
America, 94, 379, 417, 489ff
 communism and, 267
 conscious and unconscious in, 49
 divorce in, 120
 Ufos in, 315ff
 Indianization in, 13, 45f, 502, 510f
 lack of soul in, 490
 national spirit of, 512
 Negroes in, 46f, 508f
 North, Germanic colonization of, 45
 South, 497; *see also* psychology

American(s): and Europeans, differences, 503, 509

Negro complex of, 508

American Indians, 507

Americanization, 91, 493

Amorites, 182

amplification, 325, 340, 389, 406

Amsterdam, 551

anabasis, 62

analysis: a dialectical process, 469

training, 159, 163

see also psychoanalysis

analyst, sex of, and patient's reactions, 470

ancestor-spirits, 510

anchorites, 341

angel(s), 369

guardian, 447

of Rev. 10:1, 386

Angelucci, Orfeo M., 418ff, 430, 431

Anglo-Saxons, 524

anima, 366f, 376, 426

as archetype, 38ff

and collective unconscious, 377f

fateful quality of, 378

feminine character, 118

figure, projection on to, 378

in German literature, 408

as mediatrix, 378

and Ufo, 378

animal magnetism, 15

animals: Christianity and, 22

domestic, complexes in, 446

as dream symbols, 360

instinct in, 287

animism, primitive, 211

animosity, 40
animus, 119, 369
 as archetype, 38, 41ff
Anquetil du Perron, A. H., 85, 86
Antarctic, 317
anteaters, 57
Anthropophyteia, 87
Anthropos, 327, 389, 405
 Christ as, 397
 see also man, primordial
anthroposophy, 16, 83, 84, 87
anti-gravity, 352, 416
 see also weightlessness
antinomianism, 356
anti-Semitism, 166, 181, 213, 541, 544n
antithesis(-es), *see* opposites
anxiety, seat of, 170
 anxiety states, 143, 146
apes, 287
Appenzell, 492
apperceptions, 9
aqua caelestis, *see aqua permanens*
aqua doctrinae, 394
aqua permanens, 331, 332, 392
Aquarius, 311
Aquinas, *see* Thomas Aquinas
arcane substance, 334, 386
archetype(s), 313, 327f, 335, 366, 411
 ambivalence of, 237
 amorality of, 448
 analogy with watercourse, 189
 autonomy of, 449
 bipolar, 229
 change in constellation of, 311

foundation of consciousness, 346
Freud and, 439*f*
manifestation in child, 32*f*
and myth, 329
nature of, 31, 219, 449
numinosity of, 272, 340, 343
of order, 328
psychoid nature of, 450, 451, 452, 453
recognition of, 32*ff*
of self, 407
in Tanguy picture, 398*f*
transgressiveness of, 349
Wotan as, 187

architecture, Indian, 516, 519

Aries, 311

arrangement, 360

arrow, 337

art
 expressionist, 83
 modern, 140, 210, 303, 383
 —, psychology of, 146
 —, and unconscious, 398
 “symbol” of, 19

Aryan, *see* Germanic

ascetics, 341

Asia, Central, 491

ass, 66

assimilation, of man to country, 510*f*

association: experiments, 544*n*
 processes, parallel, 319
 tests, 30, 397*f*

astrologer, 361, 364

astrology, 59, 83, 84, 87, 90, 312, 364, 484
 current, 370

see also horoscopes
asymmetry, of fourth dimension, [392f](#)
atheism, [258](#)
atman, [35](#), [410](#), [463](#), [464](#)
 Purusha, [463](#)
atomic energy, [242](#), [321](#)
atomic physics, *see* physics
atoms, of Democritus, [404](#)
attic, [354](#)
attitude(s): collective national, [511](#)
 earth-bound, and spiritual, [484](#)
 positive, Keyserling and, [498f](#)
Augustine, St., [287](#), [484](#)
Augustus, era of, [141](#), [247](#)
Aurobindo, Shri, [464](#)
aurora borealis, [186](#)
Aurora consurgens, [403](#), [427](#)
aurum non vulgi, [386](#)
aurum potabile, [392](#)
Auschwitz, [196](#)
Australian primitives, [49](#)
Austria, [481](#), [512](#), [554](#), [558](#)
authoritarian principle, [153](#)
average, statistical, [328](#), [393f](#)
Axiom of Maria, *see* Maria

B

Babbitt, [491](#)
Bach, Johann Sebastian, [79](#)
Bad Nauheim: 7th Congress, [535n](#), [545n](#), [547](#)
 8th Congress, [554](#)
Badrutt, Hans, [482](#)
Bahamas, [317](#)
Baldur, [190n](#), [371](#)
Bally, G., [535ff](#)

baptism, [67](#)
 en masse, [262](#)

barbarians, and Germanic mentality, [14](#)

Barbelo, [397](#)

Basel, [401](#)

Bash, K. W., [424n](#)

ba-soul, [42](#)

Baudouin, C., [552](#)

Baynes, H. Godwin, [552](#), [564](#)

bear, [65](#)

“beast, blond,” [13](#), [212](#), [219](#), [227](#)

Beauchamp, Christine L., [125](#)

beauty, [67](#), [69](#)
 modern art and, [383](#)

Beelzebub, [275](#)

beetles, [352](#)

behaviour: American, [508](#)
 and real man, [509](#)
 typology of, [471](#)

behaviourism, [491](#), [492](#)

behaviourists, [70](#)

belief: and reality, [526](#)
 unreflecting, [265](#)

Benares, [519](#), [526](#)

Benoît, Pierre, [39f](#), [43](#), [44](#)

Bergson, Henri, [147](#)

Berlin, [236](#)

Bernheim, H., [172](#)

Bernoulli, C. A., [482](#)

berserker, [185](#), [186](#), [213](#), [214](#)

Besant, Annie, [44](#), [86](#)

Bhagavad Gita, [465](#)

Bhakti-Yoga, [464](#)

Binet, Alfred, [4](#)

biology: knowledge and, [336](#)
 and man, [282f](#)
 and the psyche, [7](#), [17](#)

birds, song of, [288](#)

Birkhäuser, p., [390](#), Pl. III

birth control, *see* contraception

birthplace, indications of, in children, [510](#)

Bismarck, Otto Eduard Leopold von, [208](#)

Bjerre, Poul, [551](#), [554](#), [563](#)

“black, going,” [121](#), [507](#), [509](#)

Blavatsky, Mme. Helena, [86](#)

Bleuler, Eugen, [544n](#), [563](#)

blood: Mercurius as, [332](#)
 rains of, [319](#)

Boas, Franz, [45](#), [503](#)

body: rediscovery of, [93f](#)
 and psyche/spirit, relation, [94](#), [411](#)

Boehme, Jacob, [338](#), [389](#), [403](#)

Boer War, [239](#)

Böhler, Eugen, [324n](#)

Bolsheviks/Bolshevism, [87](#), [88](#), [320](#), [491](#), [493](#)
 and behaviourism, [492](#)
 and totalitarianism, [537](#)

Bombay, [515ff](#)

bombings, of cities, [394](#)

borderline cases, [565](#)

boredom, [341](#)

Borgias, the, [425](#)

boy, in golden clothes, [387](#)

Brahman, [463](#)

brain: and fantasies, [10](#)
 and psyche, [270](#)

bread, superessential, [342](#)

“breakthrough,” [347](#)

breath, as spirit, 72
British Empire, 516
broadsheets, illustrating Ufos, 401f, Pls. V, VI
Brocken, spectre of, 385
Buchenwald, 196
Buel, O., 551, 554, 563
Buddha, 92, 410, 517, 520, 525f
Buddhism, 153, 257, 278, 525f
 and animals, 22
 and compassion, 98
 in Europe, 16
 mandalas in, 423
 monasticism and, 40
Buffalo (New York), 46n, 502
bull: dream-symbol, 20f
 sacrifice of, 21
Bunyan, John, 381
Burckhardt, Johann Jakob, 213
bureau, Ufo recording, 316
Buridan's ass, 374, 454
bush-soul, 65f

C

cabalism, 410
Cabiri, see *Faust*
Calcutta, 520, 526
California, 372
calves, two-headed, 319
cannons, 402
capital, living on one's, 482n
Capitalists, 320
Carpocrates, 131
case-histories, 548
Cassandra, 377
catastrophe(s): cosmic, 367

psychic, [355](#)
categories, Kantian, [10](#)
caterpillar, [336](#)
Catholic Church: and confession, [549](#)
 and Fascism, [190](#)
 and sexuality, [345](#)
cats, and earthquakes, [336](#)
causality, [54ff](#)
 life-process and, [336](#)
 psychic, [445](#)
censorship, [209](#)
cerebrospinal nervous system, [353f](#)
Ceylon, [464f](#), [525](#)
chain-reactions, atomic, [321](#)
Chamberlain, Houston Stewart, [186](#)
Chamberlain, Neville, [205](#), [206](#)
Champs Élysées, [330f](#)
chance, [55f](#), [66ff](#)
 grouping of chance occurrences, [60](#)
 primitives and, [443](#)
chaos, [384](#)
character: changes of, [139](#)
 national, [486f](#)
Charcot, J. M., [172](#)
chariot, fiery, [327](#)
Charon, [369](#)
chauffeur, as culture-hero, [93](#)
cheese, Hildegard on, [405](#)
chemistry, physiological, [547](#)
chên-yên, [327](#)
chickens, and earthquakes, [336](#)
child: overrated, [492](#)
 in womb, quickening of, [403ff](#), Pl. 8
children: indication of birthplace in, [510](#)

and student marriages, 103f

China/Chinese, 89, 521

alchemy in, 333

and America, 491

characters, 496

philosophy, 142

psychological consciousness in, 165

science in, 90

and spirit, 498

choking, 5

Christ, 328, 334, 389, 410

androgyny of, 407

fish as symbol of, 141, 425

as “fountain,” 332

head of Church, 397

historicity of, 285

and *lapis*, 424

Nietzschean travesty of, 213

and Mercurius, 405

and Sabbath-breaker, 357

soul of, as ball, 404

as sun, 425

symbols of, 449

temptation of, 389

and Wotan, 180; *see also* Anthropos; Jesus

Christianity, 89, 92, 115, 187, 257, 279, 526

in Africa, 89

Asiatic origin of, 91

barbarian element in, 14

and bull sacrifice, 21

and Christian Science, 48

French Revolution and, 16

and Germanic peoples, 12f, 190n

and individuation process, 271

repristinization of, 328
rise of, 311, 497
in Roman Empire, 92
and slavery, 121
Christian Science, 16, 48, 84, 514
chthonic: portion of psyche, 31
quality, in man, 13
Church(es), 549
Christian, 77, 153, 480
—, and guilt, 196
as communal ideal, 261
and mass action, 275f
and politics, 265
and the psyche, 271
totalitarianism in, 537
see also Catholic Church
cigar-form, 407
in Tanguy painting, 396
of Ufos, 325, 336
Cilicia, 91
Cimbal, W., 538, 546
cinema, 93
circle: antithesis to cigar-form, 407
apotropaic/magic, 326
God as, 327, 424
quadripartite, 391
squaring of, 405
see also mandala
cities, and culture, 115
city, symbol in picture, 395, 397
civilization(s): American, uniformity of, 492
collapse of, 142
regeneration of, 143
clergy, and psychotherapy, 565

cloud, black, [426ff](#)
Coccius, Samuel, [401](#)
coeducation, [521](#)
coffin, symbol in Nietzsche, [182](#)
cohabitation, [396](#)
coincidence, meaningful, *see* synchronicity
coincidentia oppositorum, [355](#)
 see also opposites; *complexio*; *coniunctio*
coins
 falling from sky, [387](#)
 symbols on, [47](#)
Coleridge, Samuel Taylor, [158](#)
collective man, *see* man, collective
collectiveness, American, [506](#)
colours: masculine/feminine, [417](#)
 red/white, [417](#)
coloured races, [295](#), [296](#)
 and American man, [508](#)
 reactions to, [508](#)
 see also Negro
comets, [319](#)
communism, [289](#), [537](#)
 archaic social order, [279](#), [430](#)
 Bolshevism and, [493](#)
 ideal of, [261](#)
 ideology of, [266f](#), [295](#)
 primitive, [255](#)
 State prison of, [344](#)
 Communist revolution, [289](#)
community, idea of, [261](#)
compassion, [98](#)
compensation: psychic/psychological, [141](#), [219](#), [220](#), [342](#)
 —, in history, [121](#), [142](#)
 purpose of unconscious, [388](#)

see also compensatory function

compensatory function, of unconscious, [18ff](#), [23](#), [43](#), [86](#), [118](#), [152](#), [219](#)

complexes: awareness of, [225](#)

 Jewish, [539](#)

 modern art and, [399](#)

 theory of, [544n](#)

complex-indicators, [398n](#)

complexio oppositorum: God as, [404](#), [424](#)

 Mercurius as, [385](#)

see also coincidentia oppositorum; opposites; *coniunctio*

complex-proneness, [34](#)

compulsions, conscience and, [447](#)

concentration, among primitives, [54](#)

concentration camps, [196](#), [239](#)

concept, implications of term, [529](#)

conception and fantasy, relation, [313](#)

concupiscence/*concupiscentia*, [160f](#), [287](#)

Condillac, Étienne de, [173](#)

confessional, [549](#)

Confiteor, [355](#)

Confucianism, [153](#)

coniunctio, [404](#)

oppositorum, [405](#), [423](#)

see also coincidentia; *complexio*

conscience, [292](#), [424](#)

 moral and ethical, [454f](#)

 morality of [453f](#)

 nature of, [437f](#)

 paradox of, [442](#)

 relation to moral precepts, [443](#)

 “right” and “false,” [445](#)

 and synchronicity, [450f](#)

see also vox Dei

conscientia peccati, [438](#)

consciousness/conscious mind: adaptive function of, 11

axis of, 408

not biochemically explicable, 346

cosmic, 136f

dawn of, 139

differerentiation of, 136

discriminating, 347

disintegration of, 137

ego-, 136, 137, 145, 149, 249

founded on archetypes, 346

group-, 136

higher, 433

one-sidedness of, 15

precondition of being, 271

present-day, 75

relation to *whole man*, 441

split, 285, 360

and unconscious, dissociation, 527

—, relation, 334

see also unconscious

consensus omnium, 292

“container,” 122, 123

contraception, 101, 122, 323

contrasexuality, 118f

conventionality, 507

conversion, 293

Copenhagen, 551, 554, 561

Copernicus, 270

Corinthians (II), 447

costume, *see* dress

Couéism, 157

countertransference, 273

counting, 393, 409

courtesan, 39

creation, error of, [328](#)
credulity, [286f](#)
creed: ambivalence of, [265](#)
 religion and, difference, [257](#)
crime, collective, [200](#)
criminal: pale, [202](#), [215](#)
 statistical, [199](#)
crisis, [140](#)
crocodile(s), [51f](#), [56](#), [64](#), [498](#)
cross, [391](#), [402](#)
crowds, psychology of, *see* psychology, mass
cruelty, in dream symbols, [219](#), [220](#)
Crusaders, [314](#)
culture: creation of, [132](#)
 development of, [12](#)
cure of souls, [550](#)
Cusanus, Nicolaus, [404](#), [424](#)
cynicism, [344](#)

D

Dadaism, [27](#)
daemon, [447](#)
 Socrates', [446](#), [453](#)
dancing, in America, and African, [508](#)
danger, collective, [319](#)
Daniel, [389](#)
David, star of, *see* star
death: fear of, [368](#)
 irrationalism and, [181n](#)
 as perfecter, [367](#)
 primitives and, [51](#), [72](#)
 ship of, [372](#)
 synchronistic phenomena and, [450](#)
 and Ufos, [369](#)
defence: aggressive, German, [240](#)

resentment as, 485

Delhi, 516

delinquency, juvenile, 473

deliverance, archetype of, 328

delusion, 377; *see also* hallucination

demiurge, 334

democracy, 154, 224f

Democritus, 404

demons: fear of, 19

- psychic forces as, 211

Denmark, 545, 551, 554

destroyers, great, epoch of, 383

destruction of world, *see* millennium

detective story, 93

Deussen, Paul, 91

development, man's, 358

devil(s), 69, 298

- and conscience, 447
- contemporary, 465
- delusions of, 343
- as half animal, 392
- as Lucifer, 389
- as a neurosis, 155
- pacts with, 370
- and pathological states, 146f
- Trinity and, 391, 392
- Wotan and, 181

dew, of Gideon, 332

Dewey, John, 491

dictators: deification of, 261

- and external solemnities, 260

differentiation: of whole man, 528

- see also* functions

dimension, fourth, 390, 392ff, 407

Dionysus: and Apollo, [181n](#), [187](#)
enkolpios, [337n](#)
Wotan and, [180](#), [181](#), [185](#), [188](#), [189](#)
-Zagreus, [213](#), [214](#)
direction, sense of, in primitives, [53](#)
director of conscience, [274](#), [287](#)
discovery, age of, [84](#)
disintegration, in painting, [383](#)
disks, starry, [392n](#)
disparagement, euphemistic, [171](#)
Disraeli, Benjamin, [141](#)
dissociation, [278](#), [282](#), [373](#)
 of conscious and unconscious, [527](#)
 hysteria and, [203](#), [207](#)
 in modern society, [285](#)
 phenomena of, [139](#)
 psychic, [64](#), [319](#)
 psychopathic, [238](#)
 in Roman world, [240](#)
distress, situation of, [323](#)
divans, [519](#)
divination, [59](#)
divinity, symbols of, [339](#)
divorce, [120](#), [506](#)
doctor: analysis of, [159](#)
 approach to individual, [273](#), [466f](#)
 personality of, and therapy, [159f](#)
Doggeli, [371n](#)
Don Juan, [120](#)
dogma, and truth, [158](#)
Dornach, [87](#)
Dove, of Holy Ghost, [360](#)
dragon, [498](#)
dreams, [11f](#), [33](#), [144f](#)

always of oneself, [151f](#)
of Americans, Indian/Negro symbols in, [47](#)
“big,” [152](#)
with collective meaning, [152](#)
as compensatory, [20](#), [388](#)
distortion of, [151](#)
among Elgonyi, [63](#)
interpretation of, [150ff](#)
modern symbols in, [336](#)
moral judgments and, [438](#), [442](#)
and psychoanalysis, [164](#)
sent by God, [338](#)
soul symbol in, [326](#)
specialism of, [359](#)
symptoms of unconscious, [151](#)
Ufos in, [330ff](#), [406](#)
and unconscious psychic activity, [218](#)

INSTANCES OF DREAMS (in order of occurrence in text): woman singing hymns, and
bull in agony, [20](#)

being attacked by mamba, [62](#)
drunken tramp in ditch, [151](#)
drunken prostitute in gutter, [151](#)
fairy changing into flame, [326](#)
flying saucer over Champs Élysées, [330f](#)
burnt face as result of seeing interplanetary machine, [331](#), [334f](#)
flying spider over international gathering, [351ff](#)
cobweb in attic, [354](#)
pallid sun and sphere, [361ff](#)
two women on edge of world, [368ff](#)
flying saucers in California, [372f](#)
flying saucer resembling fish, [376ff](#)
arms covered with dirt, [438](#)

dress: European, [521](#)

Indian, [520ff](#)

drop, Ufo as, [331](#), [333](#), [336](#)
Dryden, Hugh L., [318](#)
dualism: psychological, [297](#), [299](#)
 and *vox Dei* conception, [447](#)
duplication of cases, law of, [59](#)
durée créatrice, [147](#)
duty, conflicts of, [357](#), [444](#), [445](#), [454f](#)
dyad, [424](#)
“dying, great,” [369](#)

E

eagle, [327n](#)
earth: and heaven, interrelation, [498](#)
 low opinion of, entertained by Ufo occupants, [421](#)
 man of, [484](#)
 square as symbol of, [404](#)
earthquakes, animal warnings of, [336](#)
East, significance of, [114](#)
Eckhart, Meister, [190](#), [191](#), [216](#), [540](#)
ecstasy, [181n](#), [213](#)
Edda, [191ff](#)
Eddy, Mary Baker, [84](#)
Eden, Garden of, [358](#)
Edomites, [182](#)
education: of adults, [549](#)
 American, [267](#), [491](#), [492](#)
 German, [222](#)
 and individuality, [473](#)
 Marxist, [284](#)
 medical psychology and, [565](#)
 one-sidedness of modern, [153](#)
 scientific, and the individual, [252](#)
effeminacy, [41](#), [107](#)
eggs, Easter, [72](#)
Église gnostique de la France, [83](#)

ego: depotentiation of, [424](#)
inflation of, [211](#), [253](#), [356](#), [380](#)
instincts, [288](#)
as seat of anxiety, [170](#)
and self, [149](#), [463](#)

ego-consciousness, *see* consciousness

egoism, primitive, [137](#)

Egypt: concept of soul in, [42](#)
Mithraism and, [91](#)
mythology, [339](#)
psyche in, [78](#)

eight, the number, [366](#)

Einherjer, [188](#)

Einstein, Alfred, [89](#), [537](#)

Eisleben, [184](#)

élan vital, [147](#)

electricity, [8](#)

elements, transformation/transmutation of, [332](#)

eleven, the number, [366](#)

Elgon, Mount, [57](#), [61](#)

Elgonyi, [64](#), [71](#)

Elijah, [327f](#), [389](#)

elixir of life/*elixir vitae*, [385](#), [392](#)

Ellis, H. Havelock, [87](#)

emblems, national aircraft, [417](#)

Emerson, Ralph Waldo, [491](#)

emotion: signs of, infective, [508](#)
unusual, [315](#)
see also affects

enantiodromia, [82](#)

end of the world, [328](#), [367](#)

endocrinology, [550](#)

energy, [7f](#)
of archetypes, [335](#)

conservation of, 86
mana and, 69
need of goal for, 122
English: German attitude to, 239
national character of, 487
national idea, 512
Englishman, as “beast-man,” 481
Enlightenment, Age of the, 16, 235
Enoch, 389
enthusiasm, 389
environment, and extraversion, 347
epidemics, psychic, 235, 248, 249, 264f, 381
epiphany, 406f
equality, 154
 psychic, 137
equations, 409
Ergreifer/Ergriffener/Ergriffenheit, 184f, 189, 191
Eros, 7, 123, 124, 125, 133
 cosmogonic, 181
 Islamic, 519
esotericism, 468
ESP (extra-sensory perception), 349
esprit and spirit, 496
ethics, 257, 357f
 of action and conviction, 462
 and individual, 483
 Judaean-Christian, 263
 primitive and civilized, 53
Eulenspiegel, Till, 143
Europe: collective guilt of, 196ff
 non-European view of, 211
 relation of Switzerland to, 486
 relation to East and West, 114
Eurydice, 213

evangelists, emblems of, 491
evil, 356
 by contagion, 199
 imagination in, 290, 297
 knowledge of, 457ff
 need to realize, 297
 “overcoming,” 467
 reality of, 465
 and unconsciousness, 82
 see also good; *privatio boni*
exceptions, and probability, 394
exclusiveness, in marriage relation, 123
exhydrargyrosis, 332
expectations, of supernatural events, 328
experience: communal, 261
 religious, 293, 345f
expiation, 200
explosions, atomic, 321
expressionism, 83
extra-sensory perception, *see* ESP
extraversion, 142, 347, 471
eye(s), 353, 424f
 blue/white, in dream, 331, 337
 evil, 211
 fishes’, 404, 424, 425
 of God, 339, 386, 424
 —, seven, 404
 golden, 432
 in Hildegard’s vision, 404f
 of Horus, 339
 as symbol, 337, 392ff
Ezekiel, 389, 391, 392, 403, 404

F

face, burned, 331, 338f, 350

fairy, 326

fairytale, 26, 33, 219, 332, 449

faith, 84, 265, 292, 362

- demythologization of, 285
- and knowledge, 285, 453

faithfulness, in marriage, 131

family, Indian, 522, 523

family romance, 164

fanaticism, 259

fantasies: of ascetics, 341

- and problem of perception, 313
- infantile, 281*f*
- infantile-perverse, 162, 167
- mythological, 9*f*
- perverse, 80
- sexual, 105*f*
- unconscious, activation of, 281

Faria, 172

fascinosum, 458, 463

Fascism, 190

Fatehpur-Sikri, 516

father, archetype of, 35*f*, 190

- complex, 540

Fatima, 314

Faust, see Goethe

fear(s): children's, 33

- collective, compensation of, 387
- devaluation of psyche and, 271
- expression in art, 383
- and inferiority, 384
- nocturnal, 33
- projection and, 297, 324

feeling: as feminine virtue, 41

- function of, 330, 347, 408

see also functions, four
see also intellect
felix culpa, 358, 460
femina candida, 417
fetishes, 15, 329
fifth column, 264
fights, Indian, 522
filius hermaphroditus/macrocosmi, 332
filius hominis, 389
film producers, 372f
fire: divine epiphany and, 327
 God as, 386
 of the Philosophers, 384f
 in star of David, 407
 as symbol, 384, 389
 —of emotion, 338, 394
 tongues of, 386
 see also water
fireballs, 404ff
 green, 316n, 419
Fire Sower, 383ff, 406, Pl. 2
fish: Christ as, 141
 deep-sea, 376
 dream of Ufo resembling, 376f
fission, nuclear, 299, 316, 428, 465
flagstaff, missionary's, 58
flight of Ufos, nature of, 316f, 415
flirting, 110
fluid, Ufo as, 331
flying saucers, *see* Ufos
Foerster-Nietzsche, Elizabeth, 183
foetus, 403
folklore, 332
“Foo fighters,” 315

food of immortality, 332
food production, 323
forces, psychic, 185
foreigners, 81
Forel, August, 103, 172
forms: disintegration of, 383
 sexual significance of, 336
fountain, Christ as, 332
four, the number, 391, 408
 archetype of order, 424
 as division of circle, 407
 union of the, 403
 see also quaternity
fourteen points, of psychotherapeutic agreement, 566
Fourth dimension, 390ff, P1. III
France, 316
 Keyserling and, 481
 national keynote, 511
 psychology in, 4
Franz, Marie-Louise von, 427n
freedom: in East and West, 114
 and morality, 229
 striving for, 359
 threat to individual, 379
free love, 111
Freemasons, 239, 320
French Revolution, 15, 16, 85
frenzy, pantheistic, 392
Freud, Sigmund, 90, 124, 160, 161, 162, 169ff, 541, 558
 and analysis of therapist, 159
 attitude of, 164f
 and “archaic vestiges,” 440
 and dream interpretation, 150
 on ego and anxiety, 170

and ego instincts, 288
and evil nature of psyche, 85, 87
Future of an Illusion, The, 172
and incest prohibition, 33
Interpretation of Dreams, The, 88, 163
and lay therapy, 559
materialistic bias of, 164
and meaning of forms, 336
and occultism, 272
and perverse fantasies, 80
and prehistory of psyche, 349
Psychopathology of Everyday Life, The, 30
reductive attitude, 14
relation to Jung, 544n
and religion, 548
on sublimation, 171
and superego, 348, 438ff
Freidenkaiser, 222
friendship, homosexual, 107
frigidity: animus and, 119
 sexual, 106
Fulfilment, Great, 207
function(s): autonomy of, 347
 compensatory, *see* compensatory function
 conflicting, 347
 four, 330, 391, 408
 —, differentiation of, 347, 358, 396
 transcendent, 454
 see also feeling; intellect; intuition; sensation; thinking
furor teutonicus, 185
Fürst, Emma, 37n
Futurism, 27
Fylgja, 188

Gaillac, 353
gait, of Americans, 505
galaxies, 335, 336
Galileo, 537
gana-world, South American, 497
Ganesha, 519
Gate of Victory, 516
Gateway of India, 516
genealogies, feminine passion for, 43
General Medical Society for Psychotherapy, *see* Allgemeine Ärztliche Gesellschaft für Psychotherapie
Genesis, Book of, 139f
Genghis Khan, 481
genius, 447, 525f
gentleman, the, 512
George, Stefan, 181 & *n*
German Faith movement, 190f
Germanic peoples/Germans: collective hysteria of, 204
 collective unconscious in, 219
 and coloured man, 508
 hysteria in, 207ff
 psychology of, 13, 165f, 210
 and triadic mandalas, 408
 as victims, 192
 Wotan and the, 186
Germany, 186ff, 222ff
 inferiority feelings in, 203
 Gnosticism in, 83
 and mass psychology, 222
 mass psychosis of, 233, 235
 Keyserling and, 481
 national keynote, 511f
 psychological problem of, 227ff
 psychopathology in, 4
 see also *Gleichschaltung*; National Socialism

Gerster, Georg, [312](#)
Gestapo, [232](#)
Geulincx, Arnold, [313](#)
ghosts, [69](#)
giants, [317](#)
Gideon, *see* dew
glass, broken, [60](#)
Gleichschaltung, in Germany, [535ff](#), [558](#)
globes, black, [401](#)
globulus, [426](#)
gloire, la, [510](#)
Gnosticism/Gnostics, [356](#)
 and evil, [358](#)
 “Father-Mother” in, [407](#)
 four in, [397](#)
 modern, [83](#)
God/gods: Buddhist view, [525](#)
 childish view of, [185](#)
 claims on individual, [256f](#)
 Greek, [189](#)
 inner, [155](#)
 loving v. hating, [464](#)
 man’s kinship with, [334](#)
 Old Testament idea of, [337](#)
 personifications of psychic forces, [185](#), [211](#)
 principles and, [458](#)
 relation to, [293](#)
 and religious experiences, [293](#)
 and the State, [258](#)
 symbols of, and self, [339](#)
 totality symbol, [327](#)
 Ufos as, [327](#)
 unconscious powers as, [361](#)
 voice of, *see* *vox Dei*

see also circle; God-image
“God-Almightiness,” 215
God-image(s), 327f
 anthropomorphism of, 449
 father as, 36
 opposites in, 394
 return of, 214
 symbols of self and, 424
 Yahwistic, morality of, 448
Godless, movement of, 180
God-substitute, 463
Goebbels, Josef, 204f, 236
Goethe, J. W. von, 16, 40, 43, 75n, 98, 135, 144, 146, 172, 190n, 203, 207, 213, 355, 366n, 391, 448
Goetz, Bruno, 184, 187n
gold, philosophical, 386
 see also aurum
good: and evil, relativity of, 459
 knowledge of, 456ff
Göring, Hermann, 204f
Göring, M. H., 538, 551, 554
Gospel(s), 142
 four, 391, 397
Gothic: man, 481
 style, 480
Gottesminne, 98
Gotthelf, Jeremias, 353n
grace, 342
Grail, messenger of, 377
gravitation, 321, 329, 352
 see also weightlessness
gravity, spirit of, 498
greatness, national conceptions of, 513
Greco-Roman religions, and Christianity, 526
Greece, 481

Greek temperament, and Germanic, 189
grex segregatus, 184
group: effects on members, 471f
 factors influencing, 471
 inferiority to individuals, 382
group-consciousness, *see* consciousness
group psychology, 470
Guatemala, 322
guilt: collective, 195ff, 210, 217
 consciousness of, 215f
 Germany and, 340f
 legal and psychic, 195
Gustloff, Sigmund, 190n

H

Haggard, H. Rider, 39, 40, 43, 44
hallucination(s), 314n, 320, 377
Hänsel and Gretel, 33
Harding, M. Esther, 381, 552
hare, 360, 410
Hartmann, Eduard von, 3
Hauer, Wilhelm, 190f
Hauffe, Frau, 125
Hay, Marie, 44
Heard, Gerald, 352n
heart, 447
heat: emitted by Ufos, 338
 magical, 338
heaven: and earth, interrelation, 498
 intervention from, 328
 water as, 331
Heine, Heinrich, 203
Helen: of Troy, 40, 213
 companion of Simon Magus, 40
Heraclitus, 82, 333, 367

Herbart, Johann Friedrich, [173](#)
herd instinct, [219](#)
hereafter, the, [526](#)
heredity, [340](#), [507](#)
 and introversion, [347](#)
heresy, [271](#)
hermaphrodite, [407](#)
 see also *filius hermaphroditus*; Mercurius
hermaphroditosis, [521](#)
Hermes, [188](#)
 katachthonios, [185](#)
 see also Mercurius
Hermetic philosophy, [327](#), [334](#)
hermits, [341](#)
Hero of Alexandria, [79](#)
hero-archetype/motif, [44](#), [47f](#)
Herostratus, [80](#), [384](#)
Herrenvolk, [210](#)
hexad, [407](#)
Heyer, G. R., [552](#)
hierosgamos, [397](#)
Hildegard of Bingen, [403ff](#), P1. VIII
Himalayas, [91](#), [317](#)
historians, [324](#)
history: conflict with, [130](#)
 contemporary, therapist and, [177](#)
 Indian attitude to, [517](#)
 psychological factors and, [324](#)
 subjective in, [148f](#)
Hitler, Adolf, [185](#), [186](#), [203ff](#), [222f](#), [236](#)
 movement, and Wotan, [180](#)
 see also National Socialism
Holbein, Hans, [81](#)
Hölderlin, Friedrich, [16](#), [94](#)

Holland, *see* Netherlands

Holy Ghost, 386, 404, 405

age of, 494

in alchemy, 405

arithmetical structure of, 405

descent on man, 405

Dove of, 360

enthusiasm of, 389

as nickname for Ufo, 325*n*

homelessness, 523

homo maximus, 86, 385, 389

Homo sapiens, 282, 432, 469

homosexuality: female, 99, 108, 119

among students, 99*f*, 105, 107*f*

Hopfer, Hans, 368

horoscopes, 85, 317

horse, white, and Wotan, 180

Horus: eye of, 339

sons of, 391

Hoyle, Fred, 426*ff*

humanitarianism, 81

humanity: cosmic view of, 481

as ideal, 154

oneness of, 410

humour, Keyserling's, 479*f*, 492

Hungary, 264*n*, 481

hunger, 337

and religion, 343

spiritual, 343

hunter, wild, 181

in Nietzsche, 183

Hus, John, 448

hydrogen atom, 422, 424

hydrogen bomb, 298*f*

hydrophobia, 336
hyenas, 61
Hyperboreans, 84
hypnosis, 555
hypnotism, 16, 157, 563
hypotheses, necessity of, 546
hysteria, 6, 173, 202ff, 206f
 national, 210
 Ufos and, 333

I

I Ching, 498
Ichthys, 425
idea(s): adaptation of primordial, 283
 German, 511f
 inherited, 10, 440
 lag in, 284
 lucky, 145
 new, 230
 —, Swiss and, 485
 Platonic, 326
 power of, over psyche, 24
ideal, heroic, 512f
idealism(s), 300
 in America, 512
identification: of child with parents, 37
 with nation, 482
identity, unconscious, 37
 see also *participation mystique*
illness, as defence, 466
illusion(s), 319, 354
 in adolescents, 105
 of anchorites, 342
 reality as, 517
image(s): “austere,” 387

mythological, [339](#)
imago, parental, [36ff](#)
imitation, instinct for, [288](#)
immortality, [44](#), [70f](#), [79](#), [266](#)
Imperialists, [320](#)
improbable, occurrence of the, [394](#)
incest: archetype of, [349](#)
 complex, [348](#)
 and religious instinct, [349](#)
tendency, [33f](#)
independence, social, women and, [117](#)
indeterminacy, [90](#)
India, [507](#), [515ff](#), [525ff](#)
 and alchemy, [333](#)
 and birth control, [323](#)
 civilization and primitivity in, [528](#)
 as part of Asia, [519](#)
 and Western culture, [196](#)
 wholeness of life in, [518](#)
Indian Science Congress, [520](#)
Indians, American, *see* America
individual: diminishing importance of, [253f](#)
 need of individual consciousness, [472](#)
 as resultant, [70](#)
 reevaluation of, [380](#)
 salvation of, [276](#)
 understanding the, [251](#)
individuation, [378](#), [379](#), [381](#), [426](#)
 Christianity and, [271](#)
 seriousness of problem, [379](#)
 symbol of, [326](#), [403](#)
industrialization, [222](#)
inertia, psychic, [139](#)
infantilism, [460](#)

and neurosis, [161f](#)
infection: psychic, *see* epidemic, psychic
 racial, [509](#)
inferiority(-ies), psychopathic, [204](#), [207](#), [233](#), [239](#)
inferiority complex, [346](#)
inferiority feelings, [202f](#), [513](#), [523](#)
infinite, hungering for, [207](#)
inflation, [354](#), [356](#), [381](#), [525](#)
 of ego, *see* ego
 spiritual, [355](#)
inhibitions, [398f](#)
initiation: in modern America, [514](#)
 rites of, [38](#)
 and sportsmen's training, [48](#)
insane: unconscious in the, [4](#)
 "voices" and, [68](#)
insanity, [338](#)
 epidemic, [212](#), [248](#)
 latent, [248](#)
 moral, [161](#)
insects, [352](#)
instinct(s): in animals, [287](#)
 archetypal, [282](#)
 atrophy of, in civilized man, [19](#)
 basis of consciousness, [346](#)
 and choice of symbols, [337](#), [343](#)
 deviations from, [360](#)
 dream emphasis on, [360](#)
 imagination of, [282](#), [290](#)
 lack of contact with, [467](#)
 loss of, [291](#)
 and love, [98](#)
 migratory, [450](#)
 modern art and, [399](#)

in primitive, 32
and psyche, 7f, 340
religious, 344
two aspects, 287
and unconscious, 18
and wholeness, 345, 349f

integration, of unconscious contents, 221, 236

intellect: and feeling, discrepancy 295
function of, 347f, 408

intellectualisms, 371

intention, 340

International General Medical Society for Psychotherapy, 536, 545, 547, 550f, 554, 555, 557, 559, 561f

International Institute of Intellectual Co-operation, 499n

internationalism, 93

interpretation, “low-down,” 167f

inter-planetary travel, 323

intonation, American, 505

introversion, 347, 398, 471

intuition: function of, 330, 408
lack of, in Swiss, 485
and sensation, 486
and unconscious, 18, 298

invasion, extra-terrestrial, 315f

inventions, misuse of, 528

Irenaeus, 40n

Irma (Freudian patient), 163

Iron Curtain, 247, 263, 280

irrationalism/irrationality, 181
collective, 248

irregularity, and absolute reality, 250

Isaiah, 338

Islam, 257
in India, 519
rise of, 497

isms, [49](#), [234](#)

isolation: individual, State and, [300f](#)

national, Germany's, [242](#)

Italy, [190](#), [205](#), [238](#), [316](#), [481](#), [512](#)

ancient, slavery in, [121](#)

J

Jacob, [461](#)

Jacobi, Karl G. J., [409](#)

Jaffé, Aniela, [370n](#)

Jakoby, E., [390](#), P1. II

James, William, [491](#), [499](#)

Janet, Pierre, [4](#), [5](#), [172](#), [544n](#)

jazz, [508](#)

Jerusalem, [201](#)

Siege of, [314](#)

Jesuits, [320](#)

Jesus, [76](#), [276](#), [338](#)

German view, [186](#)

Ufo pilots' view of, [421](#)

see also Christ

Jews: Christ-complex of, [508](#)

and Christians, difference, [542](#)

differences among, [45](#)

and membership of International Society for Psychotherapy, [545n](#), [558](#)

and Nazism, [239](#)

projection on, [181](#), [320](#)

psychological consciousness of, [165f](#)

and race theories, [202](#)

two cultures of, [13f](#), [544n](#)

resentment in, [485](#)

see also psychology, Jewish

Jew, Wandering, [181](#)

John, First Epistle of, [444](#)

jokes, [541](#)

Josephus, [201](#)

Joyce, James, [210](#)

Judaism, [257](#)

Jung, Carl Gustav: Keyserling and, [482](#)

and Nazis, [232](#)

WORKS: *Aion*, [141n](#), [327n](#)

“Brother Klaus,” [339n](#)

Collected Papers on Analytical Psychology, [233n](#)

“Concerning Rebirth,” [328n](#)

“Contribution to the Study of Psychological Types, A,” [543n](#)

Contributions to Analytical Psychology, [234n](#)

“Development of the Personality, The,” [236n](#)

“Freud and Jung: Contrasts,” [543n](#)

“General Aspects of Dream Psychology,” [235n](#)

“Introduction to Kranefeldt’s *Secret Ways of the Mind*,” [543n](#)

“Marriage as a Psychological Relationship,” [122](#)

“On Mandala Symbolism,” [326n](#)

“On Psychological Understanding,” [543n](#)

Psychiatric Studies, [125n](#)

“Psychological Foundations of the Belief in Spirits, The,” [234n](#)

“Psychological Theory of Types, A,” [543n](#)

Psychological Types, [543n](#)

Psychology and Alchemy, [366n](#), [384n](#), [387n](#)

“Psychology and Religion,” [231n](#), [232n](#)

“Psychology of the Transference, The,” [402](#)

“Psychology of the Unconscious Processes, The,” [233n](#)

“Relations Between the Ego and the Unconscious, The,” [228n](#), [544n](#)

“Commentary on the *Secret of the Golden Flower*,” [235n](#), [387](#)

Structure and Dynamics of the Psyche, *The*, [234n](#), [235n](#)

“Structure of the Unconscious, The,” [228n](#)

Symbols of Transformation, [47](#)

“Synchronicity: An Acausal Connecting Principle,” [313n](#)

“Theory of Psychoanalysis, The,” [543n](#)

“Transformation Symbolism in the Mass,” [355n](#)

Two Essays on Analytical Psychology, [38n](#), [41n](#), [228n](#), [229n](#), [233n](#), [234n](#)

“What is Psychotherapy?”, [557n](#)

Jünger, Ernst, [214](#)

Jungfrau, [484](#)

Jupiter, [362](#), [365](#), [367](#)

K

Kabras forest, [61](#)

kairos/*καιρός*, [191](#), [304](#)

Kali, [519](#)

—Durga, [466](#)

Kant, Immanuel, [410](#), [462](#)

karma, [88](#)

ka-soul, [42](#)

katabasis, [355](#)

Kathakali, [517](#)

Kaufmann, R., [424n](#)

Keyhoe, Donald E., [312](#), [317](#), [338n](#), [379n](#), [413](#)

Keyserling, Count Hermann, [93](#), [417](#), [479ff](#), [489ff](#), [496ff](#)

Khidr, [328](#), [410](#)

Kitoshi, [61](#)

Klages, Ludwig, [181](#), [347](#)

Klaus, Brother, [339](#)

Kluger, H. Y., [372](#)

Knights of Columbus, [514](#)

Knoll, Max, [312](#)

knowledge: absolute, [336](#)

and belief, [265](#)

and faith, [285](#), [453](#)

organ and object of, [540](#)

tree of, [140](#)

and understanding, of man, [250](#), [273](#)

Konarak: Black Pagoda, [529](#)

Krafft-Ebing, Richard von, [103](#)

Kranefeldt, W. M., [557](#)

krater, [355](#)

Kretschmer, Ernst, [533](#), [535](#)

Kreuger, Ivar, [142](#)

Krishnamurti, [86](#)

Kronos, [188](#), [189](#)

Ku Klux Klan, [514](#)

Kundalini yoga, [84](#)

kwei-soul, [29](#)

Kyffhäuser, [186](#)

L

labour camps, [323](#)

lady, white, [377](#)

Lamb of God, [360](#)

Lambarene, [414](#)

landings, from Ufos, [317](#), [322](#)

Langmann, Dr. (clergyman), [190n](#)

language, affective results of, [509](#)

lapis philosophorum, *see* stone, philosophers'

Latin, [480](#)

Latins, and coloured men, [508](#)

laughter, American, [46](#), [504](#), [508](#)

law, Roman, [263](#)

laymen, as therapists, [554](#)

leader(s), [154](#), [230](#), [253](#)

of mob, [220](#)

see also mass(es)

League of Nations, [189](#), [499n](#)

learning capacity, [287](#), [288](#)

Le Bon, Gustave, [239](#)

legends, [219](#)

formation of, [322f](#)

Leibniz, G. W., [313](#), [335](#)

lens-shape, of Ufos, [335f](#)

leopard-woman, [64](#), [66](#)

levitation, [352](#)
Lévy-Bruhl, Lucien, [37](#), [51](#), [52](#), [64](#), [65](#), [452](#)
liaisons, sexual, among students, [106f](#)
liar, pathological, see *pseudologia phantastica*
libertinism, [356](#)
libido, [8](#)
lie, and political action, [261](#), [266](#)
Liébeault, A.-A., [326](#)
life, negation of, [181n](#)
life-instinct, [147](#)
light: divine epiphany and, [327](#)
 emission by fish and insects, [336](#)
lion, symbol of Christ and Satan, [449](#)
living standard, [492](#)
Lockheed Aircraft Corporation, [418](#)
Logos: as male principle, [123](#), [124](#)
 supremacy of, [286](#)
Los Angeles, [537](#)
Louis XIV, [253](#)
love, [97f](#)
 conjugal, [98](#)
 development of ideal, [110](#)
 and faith, [112](#)
 and hygiene, [102](#)
 kinds of, [97f](#)
 and marriage, [123](#)
 of neighbour, [301](#)
 and sexuality, [6f](#), [98ff](#), [112](#)
 for things, [118](#)
love choice, and parents, [38f](#)
Loyola, Ignatius, [266](#)
Lucifer, [389](#), [449](#)
Luke, Gospel of, [240](#), [357](#), [389n](#)

M

- machine, man and the, [268](#)
- Macrobius, [404n](#)
- macrocosm and microcosm, [335](#)
- maenads, [185](#)
- magic: books, [371](#)
 - primitives and, [51](#), [446](#)
 - psychological effect of, [260](#)
 - science of the jungle, [63](#)
 - in Switzerland, [371](#)
- magnetic fields, interstellar, [321](#)
- Maha-Parinibbana Sutta*, [520](#)
- Mahatmas, [91](#)
- Mahayana, *see* Buddhism
- Maidenek, [196](#)
- Main, river, [181](#)
- majesty, [364](#)
- mamba, [61](#)
- man: Christ as prototype and goal of, [397](#)
 - collective/mass, [229f](#), [258](#)
 - _____, atomization of, [301](#)
 - demasculinization of, [493](#)
 - inner/higher, [447](#)
 - Primordial, [327](#), [405](#)
 - see also* Anthropos
- mana*, [63](#), [68](#), [69](#), [72](#), [303](#), [448](#)
 - see also* personality
- mandala(s), [221](#), [366](#)
 - cross-shaped, [402](#)
 - mathematical structure of, [409](#), [424](#)
 - as space ship, [335](#)
 - as totality symbol, [326](#)
 - triadic, and Germans, [408](#)

and Ufos, 387, 423f
“manning,” 368, 372
Mantell, Capt., 331n
mare nostrum, 332
Maria the Copt/Jewess, 391
 Axiom of, 405
marriage: cross-cousin, 402f
 medieval, 125f
 and mother archetype, 35
 “perfect,” 120, 126
 problems, 128
 quaternio, 402
 and the student, 100f, 103ff
 trial, 111f
 women and, 120ff
Mars, 321, 323
Martians, 315
Mary, Virgin, as patron of Swiss, 484
masculine-feminine antithesis, 407
Marxism, 265, 295
Mass, the, 355
mass(es), 275ff
 anonymity of, 154, 230
 Churches and, 275f
 industrialized, 200
 leaders and, 154, 230, 253, 275
 and manifestation of archetypes, 229
 resistance to, 278
 “telluric,” 498
 see also man, collective/mass; psychology, mass
mass meeting, and numinous experience, 294
mass-mindedness, 379, 382
masturbation, 104
 effects of, 109f

mutual, [107](#)
materialism/materialists, [70](#), [223](#), [258](#), [344](#), [411](#), [512](#)
 and psyche, [411](#)
materialization, [416](#)
matriarchy, in America, [417](#)
matter, [361](#)
 physicist and, [147](#)
 and psyche, [411](#)
Matthew, Gospel of, [389](#)
Max Müller, Frederick, [91](#)
Maya, [463](#), [464](#), [516](#)
Mayer, Robert, [15](#)
meaning, search for, [480](#)
mediator: loss of belief in, [414](#)
 number as, [410](#)
medicine, and politics, [538f](#)
medicine-man, [59](#), [66](#), [68](#), [498](#)
mediums, spiritualistic, [416](#)
megalomania, [89](#), [385](#)
 Keyserling's, [480](#)
Meier, C. A., [545](#)
melody, infectiveness of, [509](#)
Menzel, D. H., [371](#), [413](#)
Mephistopheles, [144](#), [172](#), [207](#), [215](#), [378](#)
Mercurius, [332](#)
 duplex/hermaphroditus, [385](#), [407](#)
 metal, and spirit, [332](#)
 Philosophorum, [405](#)
 quadratus, [405](#)
 subterranean, [385](#)
 see also Hermes; spiritus
Mercury, [188](#)
Merseburg spell, [371](#), [372](#)
Mesmer, Friedrich Anton, [15](#), [172](#)

Messiah, [44](#), [328](#)
metamorphosis of the gods, [304](#)
metanoia, [276](#), [379](#)
metaphors, [337](#)
metaphysics, [215](#), [448](#)
 Christian, [391](#)
 fear of, [185](#)
 Jung and, [328](#)
 psychologizing, [328n](#)
meteors/meteorites, [316](#), [319](#)
M'ganga, [59](#)
Michel, Aimé, [312](#), [320n](#), [353n](#)
microbiology, [547](#)
microcosm: alchemical, [326](#)
 man as, [278](#), [286](#)
 soul as, [335](#)
Middle Ages, [326](#), [369](#)
 adultery in, [120](#)
 and anima, [41](#)
 world-view of, [81](#), [328](#)
Midwich Cuckoos, The, [431ff](#)
migrations, European, [524](#)
milk, drying up, [370](#)
millennium, [80](#)
 first, end of, [247](#), [324](#)
Mimir, [192](#), [194](#)
mind: causal concept of, [29](#)
 conscious, *see* consciousness
 influence of country on, [511](#)
 meaning of, [30](#)
 see also psyche
Minne, [188](#) & *n*
missionaries, Christian, [89](#)
Mithraism, [21](#), [91](#)

mob, 275
 formation of, 220
 see also mass(es)

modern man: and power instinct, 344
 and unconscious, 358

Moguls/Mogul Empire, 516, 519

monadology, 335

monastery, cultural, 499ff

monasticism, ideals of, 40

Mondamin, 410

money, American attitude to, 512

monogenes, 397

monotheism, 334

Mons, battle of, 314

month, Platonic, 311

mood(s): changes of, 139
 in woman, 119

moon, 321, 323, 404
 further side of, 322
 as symbol of divine mother, 425
 visionary, 314
 waxing, and departed souls, 369

moral code, 440ff
 and religion, 461

morality: alteration of, 116
 primitives and, 53
 and the unconscious, 441

Morgenthauer, W., 557n, 558, 560

mortification, 342

Moses, 338, 339

mosque, 180

mother: archetype of, 34f, 36
 in India, 522
 and son, unity of, 407

Mothers, realm of, [377](#)
mother-ships, [402](#), [420](#)
Mountain Lake, [68](#)
movement, in Americans, [505](#)
multiplicatio, [334](#)
mungu, [72](#)
Murray, John: *Handbook for India*, [529](#)
museums, [500](#)
music: American, [508](#)
 atonal, [210](#)
 “etheric,” [420ff](#)
Mussolini, Arnaldo, [250](#)
Mussolini, Benito, [250](#)
mysteries: ancient, [10](#)
 Gnostic, [16](#)
mystery religions, [16](#), [92](#)
mystical instruction, [118](#)
mystics, and love, [98](#)
myth(s), [9](#), [26](#), [449](#)
 age of, and Wotan, [187](#)
 art and, [303](#)
 autogenesis of, [443](#)
 and dreams, [219](#)
 integral to religion, [285](#)
 living, Ufos as, [322](#)
 natural bases of, [329](#)
mythology: Christian, symbolical understanding of, [266](#)
 Egyptian, [339](#)
 modern, [369](#)

N

nadir, [407](#)
names: and magical compulsion, [426](#)
 of tribes, [136](#)
Napoleon, [481](#)

narcissism, 99, 160

nation(s): “aunt of,” 492

as functions of mankind, 480, 487

identification with, 482

and individual, relation, 27, 488

personified, 487

nationalism, fear of, 263

National Socialism, 166, 237ff, 289, 430, 537ff, 543

Wotan and, 184, 192

nature: man and, 66

and unconscious, 23

Navahos, 507

Negro: American, 46f, 507

_____ and African, gap between, 509

European assimilation to, 121

white complex of, 508, 509

Neptune (Ufo pilot), 423

Netherlands, 481, 512, 553

Society for Psychotherapy, 551, 554

neurology, and psychotherapy, 554f

neurosis, 39, 120, 138, 159, 219

and adaptation, 162

affects whole personality, 566

alternative explanations, 160

cardiac, 159

child's, and parents' psychology, 34

concupiscence and, 160

hysterical, 203

see also hysteria

infantile fantasies and, 281

learning to bear, 169

loss of, 167

as new name for devil, 146f, 155

positive aspects, 167, 169

and psychotherapy, [559](#)
reason for, in the present, [171](#)
symptoms of, and instincts, [288](#)
uncontrolled affects and, [360](#)
neutrality, Swiss, [485](#)
New Testament, [258](#)
n'goma, [508](#)
Nicholas of Cusa, *see* Cusanus
Nietzsche, F. W., [14](#), [86](#), [98](#), [113](#), [121](#), [131](#), [181](#), [182f](#), [202](#), [203](#), [212](#), [214f](#), [347](#), [348](#),
[497](#), [498](#)
feminine side in, [213](#)
nightmare(s), [34](#)
Nietzsche's, [183](#)
nigredo, [427](#), [428](#)
Nile, [332](#)
Ninck, Martin, [188f](#)
normality, concept of, [238](#), [296](#)
Normans, [524](#)
Nostradamus (Michel Nostredame), [179](#)
“nothing but,” [8](#), [23](#), [144](#), [162](#), [168](#), [170](#), [171](#), [348](#)
Notre Dame (Paris), [85](#), [86](#)
novels, and sex, [102f](#)
number(s): archetypal aspect, [409ff](#), [424](#)
as mediator, [410](#)
see also dyad; hexad; ogdoad; pentad; quaternity; quincunx; tetraktys; three plus one
motif; triad; two; four; eight; ten; twenty-four; thirty
numinosum/numinosity/numinous, [340](#), [342f](#), [377](#), [380](#), [385](#), [387](#), [393](#), [415](#), [458](#)
Nuremberg, [401](#)
nutrition, function of, [6](#)
nycticorax, [449](#)

O

Oannes, [141](#)
oath, modernist, [537](#)
obliqueness, Indian, [524](#)

observer, in physics, [252](#)
obsessions/obsessional ideas, [143](#), [146](#)
 conscience and, [447](#)
occultism, [3](#), [272](#), [328](#)
occupants, of Ufos, [317](#)
occurrences, unusual, as omens, [319](#)
octopus, [395](#)
Odin, [187n](#)
 see also Wotan
Oedipus, [378](#)
 complex/motif, [348](#), [349](#)
ogdoad, [366](#), [392](#)
Oldenberg, Hermann, [91](#)
Old Masters, [500](#)
Old Testament, [190n](#), [392](#), [447](#), [467](#)
Oloron, [353](#)
omens, [58ff](#), [319](#)
One, the, [334](#)
one-sidedness, [93](#), [130](#), [253](#), [347](#), [552](#)
 of conscious mind, [15](#)
 Freud's, [160](#)
 of modern education, [153](#)
opinion: psychotherapy and, [158](#)
 in women, [119](#)
opium trade, [89](#)
Oppenheimer, Robert J., [465](#)
opposites: above/below, [407](#), [484](#)
 aristocratic/unaristocratic, [484](#)
 collision of, [428f](#)
 fire/water, [407](#)
 higher world/human world, [408f](#)
 masculine/feminine, [407](#)
 psychic, and conscience, [447](#)
 reconciliation of, [373](#)

self as combination of, 337
tension of, 410, 414
union of, 327, 369, 402, 417
unity/quaternity, 407f
see also antitheses; *coincidentia oppositorum*; *complexio oppositorum*
opus divinum, 334
organizations, large, 379f
Origen, 98
Orpheus, 425
Ortega y Gasset, José, 501
Orthodox Church, Eastern, 180
Osiris, 339
Ostwald, Wilhelm, 103
“other” in us, 152, 169f, 486
Otto, Rudolf, 458
Oupnek’hat, 85
overcrowding, in India, 524
overpopulation, 277, 323
Oxford, 564

P

paedagogics, 549
painting: medieval, 406
 modern, pathological element in, 210
 _____, and Ufos, 383ff
Pali Canon, 525, 526
Pallas Athene, 388
panacea, 332, 383, 385
Papuan, 64
Paracelsus, 211
Paradise, 139
parallelism, psychophysical, 270, 411
parapsychology/parapsychological phenomena, 83, 84, 335, 411
 and absolute knowledge, 336
 and materialization, 416

and relativization of space/time, 270, 450

parents: as archetypes, 34ff

influences from, and conflicts, 281

Paris, 481

Parsifal, 214

parthenogenesis, 432

participation mystique, 37f, 64, 65, 67, 75, 195, 433, 452

Pathans, 519

Paul, St., 129, 276, 293, 414, 442, 447

Greek mother of, 186

passivity, woman's, 117

pax Romana, 487

peculiarities, individual, 472f

pèlerinage de l'âme, 403, 423

penetration, 337, 402

pentad, 408

Pentecost, 189

perception(s): of conscious and unconscious, 18

subliminal, 9

perils of the soul, 139, 172, 186, 381

permanence, civilization and, 487

persecution, ideas of, 320

persona, 127

personality: dissociation of, 203, 373

see also dissociation

mana, 69, 70

of portions of psyche, 67

splitting of, 207, 282, 289

persuasion, 157

perversions, sexual, 99f

Pforta, 183

phallus, 337

Philemon and Baucis, 207, 213

Philistines, 182

philosophy: in India, [526](#)
and modern age, [180](#)
psychopathology and, [547](#)

photographing Ufos, [322](#)

phrases, familiar, and disruption of consciousness, [138](#)

phylogeny, [32](#), [33](#)

physics, [89](#), [462](#)
atomic/nuclear, [298](#), [316](#), [329](#), [393](#), [452](#)
and observer, [252](#)
theoretical, [411](#)

physiotherapy, [559](#)

pictures, “meaningless,” [383](#)

pietism, [257](#)

pigeons, carrier, [336](#)

Pilgrim, Spiritual, [403](#), Pl. VII

pin-sticking, [370](#)

Pisces, [141](#), [311](#)

“plan, great,” [205f](#)

planets: and atomic explosions, [321](#)
reconnaissance from, [321](#)

Plato, [98](#), [198](#), [326](#), [391](#), [448](#)

platonic relationships, [109f](#), [123](#)

play, and sport, [513](#)

pleasure principle, [160](#)
Freud and, [348](#)

plurality, of “selves,” [334](#)

Pluto, [188](#)

pneuma, [35](#), [72](#), [189](#), [332](#), [463](#)

Poimandres, [189](#)

Poland, [239](#), [264n](#)

polis, [99](#)

politics: individual’s part in, [299](#)
relation to therapy, [178](#), [538ff](#)

population, increasing, [323](#)

polygamy, 89
Polynesia/Polynesians, 89, 527
Portmann, Adolf, 336
possession, 139, 146, 211, 214, 381
 collective, 248
 see also *Ergreifer*
power, drive/principle/will to, 27, 135, 147, 155, 287, 349
 Adler and, 161, 165, 348
 Catholic Church and, 345
 instinct, 344
 in mob leader, 220
powers: arbitrary, 66, 69
 telluric, 497f
“power-word,” 48
pragmatism, 499
prayer, 351, 353, 359
precognition, 336, 450
“prelogical” mind, 51ff
present: consciousness of, 75ff
 meaning of, 115
prestige psychology, 348
presuppositions, of primitive, 54
“Prevorst, Seeress of,” 124
priest, Catholic, 118
primitives: and ancestral inheritance, 510
 and autonomous psyche, 446
 and causality, 56
 concentration among, 54
 and death, 51
 and dreams, 150
 and fetish, 329
 and morals, 53
 and mystical instruction, 118
 neurotics among, 19

projection among, 26, 65
and psyche, 11f
psychology of, 136
senses of, 53
and sex, 103
thought-production among, 527
“totality” in, 347
unpsychological, 63
and the unusual, 137

primitivity: in dream symbols, 219, 220
elements of, in India, 528f
sexual, 506

Primordial Being, 407

principles, 458, 467

privatio boni, 338, 358, 465

problem(s): personal, attitude to, 78
sexual, discussion of, 123
woman’s, 114

proficiency, 76

projection(s): 25f, 65, 69, 318, 320, 562
on to anima figure, 378
appearance as physical facts, 335
ascetics and, 341
basis of, 328
carriers of, 320
explanatory, 324
instinctual and spiritual, 341
mandala as, 327
among primitives, 64, 68
and radar, 413
return of, to origin, 214
Ufos and, 318ff; 323, 373, 417
of unrecognized evil, 297
withdrawal of, 300

see also fear

promiscuity, sexual, 506

propaganda, political, 320

propitiation, rites of, 19

prostitution: and love, 100

and marriage, 40, 120

tolerated, 120

in Uganda, 89

Protestantism, 257, 261

in Germany, 190

theology of, 549

Psalms, 386

pseudologia phantastica, 203, 205

pseudo-moderns, 76f

psychasthenia, 6

psyche: analogy with building, 31

building up of, 70

cannot know itself, 410

child's, and parents, 34

collective, 80, 86, 137

complexity of, 7, 550

current undervaluation of, 346

differences in, 137f

not an epiphenomenon, 270

European, 562

fascination of, 90, 92, 93

German, 186

importance of, 291

individual differences, 135

inside and outside, 78

materialized, 416

and matter, relation of, 411

national, 481

a natural phenomenon, 340

not subject to will, [440](#)
objective, [147](#)
peculiar nature of, [270f](#)
polarity of, [447](#)
prehistory of, Freud and, [349](#)
reality of, [346](#)
two-sided, [141](#)
unity of, [146](#)
weightless, [352](#)

psychiatrist, [348](#)

psychiatry, and psychotherapy, [554f](#)

psychism, materialized, Ufo as, [416](#)

psychoanalysis: and attitude to sex, [102](#)
beginning of, [4](#)
Freudian, [83](#), [85](#), [163](#), [348](#)
as technique, [163f](#)
and Ufos, [333](#)
and yoga, [90](#)
see also analysis; Freud

psychogenic disturbances, [5f](#)

psychokinesis, [411](#)

psychologem, [378f](#)

Psychological Club of Zurich, [469](#)

psychologism, [144](#), [549](#)

psychology: abstract approach of, [272](#)
academic, [272](#)
American, [490ff](#), [502ff](#)
analytical, sources of, [16](#)
Chinese, [90](#)
comparative, [340](#)
complex, [469](#)
and complexes, [225](#)
criminal, [233](#)
current interest in, [83](#), [324](#)

“dirty-joke,” 168
“discovery” of, 79
and evil, 356
Freudian, 90, *see also* psychoanalysis
Jewish and Germanic, 533, 540ff
layman’s attitude to, 134ff
mass, 222, 225, 228f, 239, 276
_____, German proneness to, 219, 222
medical, psychotherapy as, 547
national, 233
practice and theory in, 565
of primitives, 136
recent origin of, 137
as a science, 540
and therapy, 157f
Western man’s interest in, 281
woman’s, 116, 123f

psychoneuroses, 555

psychopathology, 124
and experimental psychology, 4
French, 16
and psychotherapy, 547f

psychopathy, 238
German, 232, 238
national, 233

psychotherapy: confusion in, 533
Germanic, 538
as medical psychology, 547
need for wider field, 549
as profession, 558
and psychiatry, separation of, 558
as relationship, 164
schools of, 158, 564
scope of, 17

task of, [349](#)
as a technique, [157ff](#); [168](#)
and universities, [565](#)
see also neurology; psychiatry; therapy
puberty; and metabolism, [105](#)
psychological, [104](#), [106](#)
publicity, American, [505f](#)
Pueblo Indians, [61](#), [65](#), [89](#), [211](#)
puer aeternus, [181](#)
puerperal fever, [355](#)
Puerto Rico, [318](#)
puff-adder, [61](#)
Punch, [186](#)
Pyramids, [79](#)

Q

quaternio, marriage, [402](#)
quaternity, [366](#), [391f](#), [396](#), [398](#), [402](#), [404](#)
square as, [404](#)
and unity, [407](#)
quicksilver, [332](#), [333](#)
see also Mercurius
quietism, Eastern, [91](#)
quincunx, [391](#), [395](#), [397](#), [398](#), [407](#)
quintessence/*quinta essentia*, [331](#), [391](#), [392](#)

R

rabbi, [20](#)
radar, [312](#), [318](#), [325](#), [332](#), [413](#), [415](#)
Ramanuja, [464](#)
rationalism: and city dwelling, [341](#)
scientific, [253](#)
and sexuality, [344](#)
rationalists, [344](#)
and neurosis, [167](#)

raven, 449

ray (fish), 376

reality: lack of, 208

- spiritual, lack of experience of, 342

Reason, Goddess of, 85, 280

reconnaissance, aerial, 316

red, masculine colour, 417

redeemer, personified as animal, 360

rééducation de la volonté, 157

Reformation, 153, 213

refrigerium, 394

regression, 160, 237

Reich, German: founding of, 212

- “thousand-year,” 190, 215

Reichstag fire, 199

reincarnation, 88

- and anima, 43

Reinwald, 239

relationship: doctor-patient, 164, 274

- human, and imperfection, 301

relativization, of space and time, 270, 346, 450

relativism, 90

relativity, 89

religion(s): decline of, and psyche, 79, 83

- difficulty of understanding, 280
- Elgonyi and, 71*f*
- goals of, 260
- and hero-motif, 48
- instinctive nature of, 259
- inter-War development, 180
- and mass-mindedness, 256*ff*
- modern contempt for, 93
- “night,” 33
- a psychic fact, 549

as psychotherapeutic, [172](#)
and psychotherapy, [555](#)
State, [266](#)
and unconscious, [19](#)
religious activity, [155](#)
religious experience, psychological structure of, [345](#)
representations, collective, [51f](#), [60](#), [71](#), [443](#), [549](#)
repression(s), [5f](#), [160](#), [320](#)
 neurotic consequences of, [340](#)
 sexual, and “spirit,” [343](#)
 of sexuality, [345](#)
 superego and, [438f](#)
resentment(s): of chthonic man, [486](#)
 early, [164](#)
 Swiss, [485](#)
resistance(s), [162](#), [470](#)
respectability, [129](#)
restraint, lack of, American, [506](#)
restrictions, sexual, [343](#)
resurrection, Christ’s, symbolism, of, [266](#)
Revelation, Book of, [337](#), [386](#)
revelations, divine, visions as, [342](#)
revolution: Communist, *see* Communism; French, *see* French Revolution
Rhine, J. B., [349](#), [393](#), [394](#), [411](#)
Rhineland, [181](#)
rhythm, infectiveness of, [509](#)
Ribot, Théodore, [4](#)
rickshaw boys, [465](#)
riddle, of Sphinx, [378](#)
rites: effects of, [260](#)
 and unconscious, [346](#)
rites d’entrée et de sortie, [200](#), [259](#)
romance, and marriage, [102](#)
Roman empire, [487](#)

Romans, Epistle to the, [265](#), [359](#), [442](#)

Rome: absence of technical progress, [79](#)

Asianization of, [91](#)

germ of regeneration in, [143](#)

malaise in post-classical, [140](#)

and mystery cults, [514](#)

imported religions, [16](#)

slavery in, [121](#)

restlessness, [49](#)

Rorschach test, [395](#), [397](#), [398](#), [406](#)

ros Gedeonis, [332](#)

Rosicrucians, [403](#)

rotundum(-a), [326](#), [378](#), [404](#), [423f](#), [425](#), [429](#)

Rousseau, Jean-Jacques, [108](#)

Rumania, [481](#)

rumour(s): mass, [324](#)

requisites for, [315](#)

symbolic, [328](#)

Ufo as symbolical, [387](#)

visionary, [314](#), [318f](#)

Rupertsberg codex, [403](#)

Ruppelt, Edward J., [312](#), [316](#), [413](#)

Russia, [114n](#), [196](#), [261n](#), [481](#)

and America, [491](#)

education in prerevolutionary, [238](#)

labour camps, [323](#)

policy of, [319](#)

red as colour of, [417](#)

religion in, [180](#), [190](#)

Tsarist, [115](#)

S

Sabbath, defiler of, [357](#)

Sahara, [317](#)

saints, [360](#)

and dreams, [146](#)
salamander, [394](#)
Salpêtrière, [4](#)
salvation, archetype of, [328](#)
Sanchi, [520](#)
sanctions, Christianity and, [215](#)
sanguis, [332](#)
Saqqara, [79](#)
Satan, symbols of, [449](#)
saving and spending, [488](#)
saviour, [356](#)
 birth and epiphany of, [397](#)
scapegoat, [297](#)
Schiller, Friedrich, [18](#), [499](#), [540](#)
schizoid states, [139](#)
schizophrenia, [565](#)
Schmitz, Oscar, [90](#), [487](#)
Schopenhauer, Arthur, [16](#), [86](#), [147](#), [313](#)
Schreber, Daniel Paul, [365](#)
Schuler, Alfred, [181](#) & *n*
Schwabing, [206](#)
Schweitzer, Albert, [414](#), [483](#)
science, [81](#), [82](#), [279](#)
 Chinese, [90](#)
 and the exceptional, [371f](#)
 v. faith, [84](#)
 and the individual, [252](#)
scintillae, [404](#)
“sea, our,” [332](#)
sea-anemone, [395](#)
séance, [314](#)
secrets, [468](#)
sectarianism, [257](#)
security, [91f](#)

magic and, 260
material, 81
Seifert, Friedrich, 456 & n
self: appearance of, 380
 archetype of, 406f
 ____, Ufo as, 327
 archetype of order, 424
 better, 447
 breaking up of unity of, 334
 as combination of opposites, 337
 and ego, 149, 463
 as mediating symbol, 410
 organizer of personality, 366
 as psychic wholeness, 410
 symbols of, 326, 424ff
 see also ego
self-assertion, 160
 see also power drive
self-control, 41
self-criticism, 300, 356, 447, 482f
self-knowledge, 151f, 248ff, 269, 293ff, 356
 in therapist, 163
self-preservation, 200f, 287
“selves,” multiplication of, 334
sensation, function of: 330, 347, 408
 and frigidity, 106
 and intuition, 486
 see also functions, four
seraphim, four, 391
serpent: in Paradise, 140
 symbol of Christ and Satan, 449
servator mundi, 332
servus rubeus, 417
Set, 339

sex(uality), 287

aggressive, in women, 119

in America, 492, 506

Catholic Church and, 345

and forms, 336ff

Freudian view, 7, 348f

and love, *see* love

in men and women, 104

and metaphor, 337

primitives and, 103

and psyche, 135, 147

and religion, 343, 345

repressed, 155, 344, 346

study of, 90

and symbolism, 343f

Ufos and, 333

and unconscious, 6f, 23

in women, and marriage, 123f

shadow, 215, 345, 366, 377n

collective, of humanity, 296f

confrontation with, 463, 468

discovery of, 216

Hitler as representing, 223

ignorance of, in hysterics, 207

inescapable, 170

man's, and woman, 113, 127

necessary to self, 337

projection of, 203

recognition of, 300f

unconsciousness of, 280f

Western man and, 290

Shah Jehan, 519

Shakespeare, 156

shaman/shamanism, 15, 16, 48, 514

Shankara, [464](#)
shape(s); sexual significance of, [336](#)
 of Ufos, [317](#), [325](#), [335f](#)
shark, [376](#)
sheep sacrifices, [181](#)
shen-soul, [29](#)
Shiraz, [519](#)
Shiva, [519](#)
shofar, [20](#)
Siegfried, [190n](#)
Sievers, Edgar, [322](#), [352n](#), [399](#)
“signs in the heavens,” [320](#), [323](#), [398](#)
Sikhs, [519](#)
Simon Magus, [40](#)
sin, [356f](#)
 original, [296](#)
size, of Ufos, [317](#)
skyscrapers, [514](#)
slang, American, [504f](#)
slaves, [121](#)
Sleipnir, [184](#)
slips of the tongue, [398n](#)
slogans, [248](#), [276](#)
smiling, infective, [509](#)
Smith, H el ene, [125](#)
snakes, dream-symbol, [19](#)
 see also serpent
social democracy, [77](#)
social service, [492](#)
socialism, [537](#)
societies, secret, American, [514](#)
Society for Psychical Research, British, [234](#)
society, abstract nature of, [254f](#)
Socrates, [76](#), [446](#), [453](#), [481](#)

solar plexus, [517](#)
sol invictus, [425](#)
solstice, [181](#)
solution/solvent, [331f](#)
Sommer, Robert, [533n](#), [562](#)
Son of God, Christ and Satan as, [449](#)
Son of Man, [271](#), [397](#)
soul(s): concept of, [42f](#)
 _____, Chinese, [29](#)
 “in chains,” [334](#)
 individual, and world soul, [335](#)
 loss of, [139](#), [381](#)
 “nations of the,” [86](#)
 of the nation, [481](#)
 perils of, *see* perils
 as sphere, [326](#), [335](#)
 Ufos as, [326](#)
 universality of, [67](#)
 wandering, [64](#)
 see also world-soul
soul-force, [15](#)
soul-sparks, [404](#)
space-ships/travel, [315f](#), [321](#), [323](#), [324](#), [329](#), [369](#), [421](#)
 see also Ufos
Spain, [115](#), [481](#), [512](#)
 Civil War in, [190](#)
spear(s), [337](#), [402](#)
specialization, growth of, [79](#)
speech: English, [522f](#)
 Indian, [522](#), [523](#)
 peculiarities of, [508](#)
speed, of Ufos, [316](#)
spells, [371](#)
Spengler, Oswald, [487](#)

sphere: dream figure, 362
soul as, 326

Sphinx, 377
riddle of, 378

spider, flying, 351ff, 359

Spinoza, Benedict/Baruch, 20, 98

spirit(s): alchemical water as, 332
ancestral, 69
and body, relation of, 94
breath as, 72
collective, 501
danger of, 486
evil, 447, *see also* demon, devil
man of the, 484
Mercurius as, 332, *see also* Mercurius
primitive man and, 11, 52
symbolized by circle, 404
and telluric powers, 498f

spiritualism, 15, 48, 67f, 83, 84, 87, 514

spirituality, secret, 494

spiritus loci, 511

spiritus Mercurii/mercurialis, 332, 405

spittle, 72

split, psychic, 139
split-mindedness, 327
see also consciousness; dissociation; personality

spring-point, 311

sport, 93
in America, 48, 513

sputniks, 323

square, 404f

Squires, H. C., 564

“stab in the back,” 208

Stalin, J. V., 263

stammering, [508f](#)
star of David, [407](#)
star, as aircraft emblem, [417](#)
State: American view of, [492](#)
 deification of, [261](#)
 dependence on, [201](#), [221](#)
 goals of, [260](#)
 and individual, [225f](#), [252ff](#), [256](#), [258](#)
 as personality, [255](#), [286](#)
 and religion, [259f](#)
 Welfare, [201](#)
statistical method/statistics, [249f](#), [394](#)
Steiner, Rudolf, [84](#)
stepmother, [37](#)
steward, unjust, [357](#)
stigmatization, [422](#), [424](#)
Stockholm, [551](#), [554](#)
stone: found in Nile, [332](#)
 Philosophers', [391](#), [424](#)
 see also *lapis*
storm-god, [184](#)
Stransky, Erwin, [554](#)
stratosphere, [311](#)
Strauss, Dr., [564](#)
Strudel, [370](#)
stupa, [520](#)
subjective factor, energy charge of, [397](#)
subject status, Swiss and, [483](#)
sublimation, [8](#), [160](#), [171](#)
substitute formation, [161](#)
Suez, [290](#)
suffering, chain of, [360](#)
suggestion(s), [70](#), [157](#)
 mass, [234](#), [254](#), [276](#)

therapy, [547](#)
suicide, [41](#)
Summum Bonum, [445](#), [449](#)
sun, [424](#)
 allegory of Christ, [425](#)
 dream-figure, [361f](#)
 Elgonyi and, [72](#)
 falling from sky, [387](#)
 Pueblo view of, [68](#)
sun children, [432f](#)
sun wheel, [326](#)
superbia, [287](#)
superego, [348](#), [438](#), [439f](#), [446](#)
 archaic vestiges in, [440](#)
Superman, [203](#), [208](#), [212](#), [213](#), [214](#)
Sweden, [315](#), [316](#)
Swedenborg, Emanuel, [86](#)
Swiss, character of, [484ff](#)
Swiss Committee of Psychotherapy, [566](#)
Swiss Society for Practical Psychology, [551](#)
Swiss Society of Psychiatry, [565](#)
Switzerland, [103](#), [186](#), [200](#), [224](#), [512](#)
 as Europe's centre of gravity, [486](#)
 function in Europe, [487](#)
 and German guilt, [196](#)
 Keyserling and, [481ff](#)
 magic in, [370](#), [371](#)
sword, [337](#)
symbiosis, [336](#)
 of conscious and unconscious, [378](#)
symbol(s), [11](#), [279](#)
 circular, [327](#)
 collective, in dreams, [152](#)
 creation of, [18](#)

individuation, [326](#)
religious, archetypal character of, [285](#)
of self and of divinity, [339](#)
theriomorphic, [360](#)
Ufos as, [325](#), [387](#)
union of rational and irrational in, [18](#)
uniting, [389](#), [407](#), [414](#)
see also totality
symbol-creating function, [18](#), [19](#)
symbolism: Christian, archetypal nature, [343](#)
ecclesiastical, [370](#)
neurotic, ambiguity of, [169](#)
oriental, psychology and, [548](#)
sexual interpretation, [343](#)
ymbology, comparative, [340](#)
synchronicity, [313](#), [349](#), [361](#), [411](#), [417](#), [450](#)
synchronism, [450](#)

T

table, four-footed, [397](#)
table-turning, [15](#)
Tabula smaragdina, [484](#)
Taj Mahal, [519](#), [520](#)
talking, Americans and, [504](#)
Tanguy, Yves, [394ff](#), [403](#), P1. IV
Tao, [407](#), [410](#), [463](#)
Taos, [514](#)
Taurus, [311](#), [484](#)
tear-drop, Ufo as, [331n](#)
technique, psychotherapy and, [157ff](#)
technology, [328](#)
telepathy, [336](#), [450](#)
telluric man/masses, [497f](#)
temperature inversion layers, [316](#), [325](#)
temptation of Jesus, [389](#)

ten, the number, [366](#)
Ten Commandments, [439](#)
tension, emotional, [319](#)
Teresa of Avila, [467](#)
tetraktys, [424](#)
tetrapeza, [397](#)
Teutschenthal, [184](#)
theocracy, [231](#)
theories, statistical, [249](#)
Theosophy, [16](#), [83](#), [84](#), [87](#), [88](#), [90](#), [91](#)
therapist, *see* doctor
thinking: *see* functions, four; intellect
thirty, the number, [404](#)
Thomas Aquinas, [403](#), [427](#)
thought: Indians and, [527](#), [529](#)
 primitives and, [12](#)
threads, rain of, [352n](#), [353](#)
three plus one motif, [391](#), [392](#), [397](#), [402](#), [408](#)
thriller, vogue for, [199](#)
thunderbolt, [450](#)
Tibet, [91](#), [525](#)
tics, [508](#)
Tifereth, [410](#)
time machine, [391n](#)
totalitarianism, [221](#), [536f](#)
totality: Christian, [392](#)
 consciousness and, [335](#)
 God as symbol of, [327](#)
 symbols of, [404](#), [407](#)
 see also mandala; wholeness
town, in America, [506f](#)
tradition, as criterion, [343](#)
transference, [160](#), [273](#)
transformation: Buddhism and, [526](#)

of souls into water, 333
trauma, infantile sexual, 171
tremendum, 458, 463
triad, 408
tricephalus, 392
Trinity, Holy, 391, 403
 Christ and, 397
 and the devil, 392
 iconography of, 392
 vision of, 339
troposphere, 311
trusts, 379
tubes, seen in sky, 402
Turkey, 481
twenty-four, the number, 404
twilight state, hysterical, 208
two, as vertical axis, 407
tyranny, 277

U

Ufos, 311ff, 415
 appearance and disappearance, 332f
 as archetypal images, 327
 in dreams, 330ff
 in history, 401ff
 materiality of, 416f
 not photogenic, 322
 occupants of, 317, 321f
 plurality of, 334f
 as portents of death, 369
 psychic nature of, 415
 and radar, 332, 415
 sexual aspects, 333, 350f
 shapes, 325, 336
 see also acceleration; drop; flight; size; speed

Uganda, 89

“ugliest Man,” 131

uncleanness, magical, 197

unconscious, 147, 290, 334f

autonomy of, 335, 441

collective/suprapersonal, 10ff, 138, 219, 377

____, unity of, 450

compensation, theory of, 15, 17, 23, 219, 388

contents of, 8f, 18

denial of, 3

dependence on consciousness, doubts regarding, 440

discovery of, 211f, 358

dreams as symptoms of, 151, 218

early use of term, 3

fear of, 119

Freudian concept, 5, 30

Germanic, tensions in, 166, 219

guiding function, 23

language of, 17

nature of, 30

objectivity of, 291

personal, 9

projection of, 25

psychic forces and, 185

psychoanalysis and, 4

and religious experience, 293

in religious persons, 292

uniting symbol in, 414

see also consciousness; dissociation; compensatory

unconsciousness: Jewish, and Aryan, 165

of mass man, 75

as sin, 357

woman's, 117, 119

understanding, 499

see also knowledge
unemployed, in Germany, [180](#), [205](#)
unigenitus, [397](#)
United Kingdom, [316](#)
United States, *see* America
unity: focus of, [143](#)
 of individual, [349](#)
 of mankind, [295](#)
 and quaternity, [407](#)
 symbol of, [414](#)
 see also totality; wholeness
universities, [565](#)
unus mundus, [409](#), [411](#), [452](#)
Upanishads, [85](#), [191](#)
U.S.S.R., *see* Russia
uterus, [333](#), [336](#)

V

Valentino, Rudolph, [513](#)
Valéry, Paul, [499n](#), [500](#)
Valhalla, [190n](#)
Valkyries, [186](#), [188](#)
van Gogh, Vincent, [392n](#)
van der Hoop, Dr., [551](#), [554](#)
van Houten, D., [403n](#)
venereal diseases, [89](#), [102](#)
Venus, [321](#)
 incantation to, [371](#)
Verdant One, [328](#)
Vienna, [235](#), [481](#), [554](#)
vimana, [525](#)
vinum ardens, [332](#), [392](#)
violence, in dream-symbols, [219](#), [220](#)
Virgil, [121](#)
Virgo, [484](#)

Vishnu, 520
vision, and hallucination, 314n
visions: collective, 314, 319, 320, 324
 of Saints, 342
 as symbol, 350
voice(s): 353
 English, 522f
 inner, 447
volatilization, 332
volition, 340
Voluspo, 192f, 194
vox Dei, 444f, 446ff, 453

W

Wagalaweia songs, 186
Wagner, Richard, 184, 186n, 212, 214
war: outlawing, 77
 preparation for, 82
 see also World War I
Warens, Madame de, 108
wasp, 336
water: permanent/of the Philosophers/philosophical, 331f, 385
 in star of David, 407
 source of living, 392
 symbol of passivity, 394
 that is fire, 385, 394
 as unconscious, 425
 see also aqua permanens
Watson, John B., 491, 492
weightlessness, 315, 316, 321, 329, 352, 415
Weimar Republic, 180
Weizsäcker, Viktor von, 166n
welfare, social, 154, 492
Welfare State, 201
Welles, Orson, 315n

Wells, H. G., 315, 39n
Weltanschauung, of psychotherapy, 548
West and East, differences, 114
wheels, in Ezekiel's vision, 403
white, feminine colour, 417
white man, Pueblo view of, 89, 211
White House, 417
wholeness, 339
 archetype of, 328, 335
 death and, 367
 four as symbol of, 391
 instinct for, 344f
 psychic, cosmic affinities, 335
 _____, images of, 335
 and sexuality, 344
 symbol of, 339, 414
 and transcendence, 410
 see also individuation; totality; unity
Wilhelm II, 239
Wilhelm, Richard, 90, 91, 235, 464
Wilkins, Harold T., 331n, 352n, 353n
will to power, *see* power
wind: god of, 187f
 Hermes and, 188f
 symbol in Nietzsche, 182
wine, fiery, 332
wish-fantasies, 164f, 169, 248
wish-fulfilment, 160, 162, 277
wishes, repressed/suppressed, 5, 341
witchcraft, 11, 52, 69
 dreams and, 150
witch-doctor, 370
witch-motif, 33
witnesses, 320

wizards, [371](#), [372](#)

woman (women): conservatism of, [511](#)

Dionysus and, [185](#)

dress, [520f](#)

Indian, [520f](#), [522](#)

male attachment to older, [108](#)

man's image of, [39](#)

mental masculinization of, [119](#)

and psychology, [125](#)

relation to man's world, [116](#)

and social independence, [117](#)

unmarried, surplus of, [120](#)

see also anima

“wooden-headedness,” Swiss, [540](#)

word(s): magical, [147](#)

personification of, [286f](#)

see also Logos

world: end of, [328](#), [367](#)

higher and human, [408f](#)

lower and upper, [392](#)

vertical and horizontal, [391f](#)

world-soul, [326](#)

and individual souls, [335](#)

World War I, [77](#), [80](#), [130](#), [179](#), [208](#), [220](#), [221](#), [233](#), [314](#)

woman and, [116](#)

World War II, [222](#)

World War III, [364f](#)

Wotan, [194](#), [214](#), [371](#)

archetype of, [187f](#), [189](#)

cavalcade of, [371](#)

as *Ergreifer*, [185](#)

oak(s) of, [85](#), [184](#)

resurrection of, [180](#)

wrath-fire, [389](#)

writing, American, [504](#)

Wunsch, [188](#) & *n*

Wyndham, John, [431ff](#)

Y

Yahweh, [192](#), [448](#)

fire of, [389](#)

wildness of, [392](#)

yang, see *yin*

yantras, [424](#)

yin and *yang*, [35](#), [142](#), [407](#), [484](#), [486](#), [498](#)

yoga, [518](#)

and psychoanalysis, [90](#)

see also *Bhakti-Yoga*; *Kundalini yoga*

yogi, [517](#)

youth, [375](#)

Youth Movement, German, [180](#)

yucca moth, [282](#)

Z

Zagreus, see *Dionysus*

Zarathustra, see *Nietzsche*

Zechariah, Book of, [404](#)

Zeitgeist, [281](#), [303](#), [501](#)

zenith, [407](#)

zeppelin, [325n](#)

Zeus, [189](#), [388](#), [450](#)

Zosimos, [333](#), [386](#), [405](#)

Zschokke, Heinrich, [451](#)

Zurich, [551](#), [554](#)

THE COLLECTED WORKS OF

C. G. JUNG

THE PUBLICATION of the first complete edition, in English, of the works of C. G. Jung has been undertaken by Routledge and Kegan Paul, Ltd., in England and by Bollingen Foundation (distributing through Pantheon Books) in the United States. The edition contains revised versions of works previously published, such as *Psychology of the Unconscious*, which is now entitled *Symbols of Transformation*; works originally written in English, such as *Psychology and Religion*; works not previously translated, such as *Aion*; and, in general, new translations of the major body of Professor Jung's writings. Prior to his death, in 1961, the author supervised the textual revision, which in some cases is extensive. Sir Herbert Read, Dr. Michael Fordham, and Dr. Gerhard Adler compose the Editorial Committee; the translator is R. F. C. Hull.

Every volume of the Collected Works contains material that either has not previously been published in English or is being newly published in revised form. In addition to *Aion*, the following volumes will, entirely or in large part, be new to English readers: *Psychiatric Studies*; *The Archetypes and the Collective Unconscious*; *Alchemical Studies*; *Mysterium Coniunctionis*; *The Spirit in Man, Art, and Literature*; and *The Practice of Psychotherapy*.

The volumes are not being published in strictly consecutive order; but, generally speaking, works of which translations are lacking or unavailable are given precedence. The price of the volumes varies according to size; they are sold separately, and may also be obtained on standing order. Several of the volumes are extensively illustrated. Each volume contains an index and, in most cases, a bibliography; the final volume will contain a complete bibliography of Professor Jung's writings and a general index of the entire edition. Subsequent works of the author's are being added in due course.

In the following list, dates of original publication are given in parentheses (of original composition, in brackets). Multiple dates indicate revisions.

*1. PSYCHIATRIC STUDIES

On the Psychology and Pathology of So-Called Occult Phenomena (1902)

On Hysterical Misreading (1904)

Cryptomnesia (1905)

On Manic Mood Disorder (1903)

A Case of Hysterical Stupor in a Prisoner in Detention (1902)

On Simulated Insanity (1903)

A Medical Opinion on a Case of Simulated Insanity (1904)

A Third and Final Opinion on Two Contradictory Psychiatric Diagnoses (1906)

On the Psychological Diagnosis of Facts (1905)

2. EXPERIMENTAL RESEARCHES

STUDIES IN WORD ASSOCIATION

The Associations of Normal Subjects (by Jung and Riklin) (1906)

Experimental Observations on Memory (1905)

On the Determination of Facts by Psychological Means (1906)

An Analysis of the Associations of an Epileptic (1906)

The Association Method (1910)

Reaction-Time in Association Experiments (1906)

On Disturbances in Reproduction in Association Experiments (1909)

The Significance of Association Experiments for Psychopathology (1907)

Psychoanalysis and Association Experiments (1906)

Association, Dream, and Hysterical Symptoms (1909)

PSYCHOPHYSICAL RESEARCHES

On Psychophysical Relations of the Association Experiment (1907)

Psychophysical Investigations with the Galvanometer and Pneumograph in Normal and Insane Individuals (by Peterson and Jung) (1907)

Further Investigations on the Galvanic Phenomenon and Respirations in Normal and Insane Individuals (by Ricksher and Jung) (1907–8)

†3. THE PSYCHOGENESIS OF MENTAL DISEASE

The Psychology of Dementia Praecox (1907)

The Content of the Psychoses (1908/1914)

On Psychological Understanding (1914)

A Criticism of Bleuler's Theory of Schizophrenic Negativism (1911)

On the Importance of the Unconscious in Psychopathology (1914)

On the Problem of Psychogenesis in Mental Disease (1919)

Mental Disease and the Psyche (1928)

On the Psychogenesis of Schizophrenia (1939)

Recent Thoughts on Schizophrenia (1957)

Schizophrenia (1958)

*4. FREUD AND PSYCHOANALYSIS

Freud's Theory of Hysteria: A Reply to Aschaffenburg (1906)

The Freudian Theory of Hysteria (1908)

The Analysis of Dreams { 1909)

A Contribution to the Psychology of Rumour (1910–11)

On the Significance of Number Dreams (1910–11)

Morton Prince, "Mechanism and Interpretation of Dreams": A Critical Review
(1911)

On the Criticism of Psychoanalysis (1910)

Concerning Psychoanalysis (1912)

The Theory of Psychoanalysis (1913)

General Aspects of Psychoanalysis (1913)

Psychoanalysis and Neurosis (1916)

Some Crucial Points in Psychoanalysis: The Jung-Loÿ Correspondence (1914)

Prefaces to "Collected Papers on Analytical Psychology" (1916, 1917)

The Significance of the Father in the Destiny of the Individual (1909/1949)

Introduction to Kranefeldt's "Secret Ways of the Mind" (1930)

Freud and Jung: Contrasts (1929)

†5. SYMBOLS OF TRANSFORMATION (1912/1952)

PART I

Introduction

Two Kinds of Thinking

The Miller Fantasies: Anamnesis

The Hymn of Creation

The Song of the Moth

PART II

Introduction

The Concept of Libido

The Transformation of Libido

The Origin of the Hero

Symbols of the Mother and of Rebirth

The Battle for Deliverance from the Mother

The Dual Mother

The Sacrifice Epilogue

Appendix: The Miller Fantasies

6. PSYCHOLOGICAL TYPES (1921)

Introduction

The Problem of Types in the History of Classical and Medieval Thought

Schiller's Ideas upon the Type Problem The Apollonian and the Dionysian

The Type Problem in the Discernment of Human Character

The Problem of Types in Poetry

The Type Problem in Psychiatry

The Problem of Typical Attitudes in Aesthetics

The Problem of Types in Modern Philosophy

The Type Problem in Biography

General Description of the Types

Definitions

Conclusion

Four Papers on Psychological Typology (1913, 1925, 1931, 1936)

*7. TWO ESSAYS ON ANALYTICAL PSYCHOLOGY

The Psychology of the Unconscious (1917/1926/1943)

The Relations between the Ego and the Unconscious (1928)

Appendices: New Paths in Psychology (1912); The Structure of the Unconscious (1916)

†8. THE STRUCTURE AND DYNAMICS OF THE PSYCHE

On Psychic Energy (1928)

The Transcendent Function ([1916]/1957)

A Review of the Complex Theory (1934)

The Significance of Constitution and Heredity in Psychology (1929)

Psychological Factors Determining Human Behaviour (1937)

Instinct and the Unconscious (1919)

The Structure of the Psyche (1927/1931)

On the Nature of the Psyche (1947/1954)
General Aspects of Dream Psychology (1916/1948)
On the Nature of Dreams (1945/1948)
The Psychological Foundations of Belief in Spirits (1920/1948)
Spirit and Life (1926)
Basic Postulates of Analytical Psychology (1931)
Analytical Psychology and *Weltanschauung* (1928/1931)
The Real and the Surreal (1933)
The Stages of Life (1930–1931)
The Soul and Death (1934)
Synchronicity: An Acausal Connecting Principle (1952)

Appendix: On Synchronicity (1951)

*9. PART 1. THE ARCHETYPES AND THE COLLECTIVE UNCONSCIOUS

Archetypes of the Collective Unconscious (1934/1954)
The Concept of the Collective Unconscious (1936)
Concerning the Archetypes, with Special Reference to the Anima Concept
(1936/1954)
Psychological Aspects of the Mother Archetype (1938/1954)
Concerning Rebirth (1940/1950)
The Psychology of the Child Archetype (1940)
The Psychological Aspects of the Kore (1941)
The Phenomenology of the Spirit in Fairytales (1945/1948)
On the Psychology of the Trickster-Figure (1954)
Conscious, Unconscious, and Individuation (1939)
A Study in the Process of Individuation (1934/1950)
Concerning Mandala Symbolism (1950)

Appendix: Mandalas (1955)

*9. PART II. AION (1951)

RESEARCHES INTO THE PHENOMENOLOGY OF THE SELF

The Ego
The Shadow
The Syzygy: Anima and Animus The Self

Christ, a Symbol of the Self

The Sign of the Fishes

The Prophecies of Nostradamus

The Historical Significance of the Fish

The Ambivalence of the Fish Symbol

The Fish in Alchemy

The Alchemical Interpretation of the Fish

Background to the Psychology of Christian Alchemical Symbolism

Gnostic Symbols of the Self

The Structure and Dynamics of the Self

Conclusion

*10. CIVILIZATION IN TRANSITION

The Role of the Unconscious (1918)

Mind and Earth (1927/1931)

Archaic Man (1931)

The Spiritual Problem of Modern Man (1928/1931)

The Love Problem of a Student (1928)

Woman in Europe (1927)

The Meaning of Psychology for Modern Man (1933/1934)

The State of Psychotherapy Today (1934)

Wotan (1936)

After the Catastrophe (1945)

The Fight with the Shadow (1946)

Epilogue to "Essays on Contemporary Events" (1946)

The Undiscovered Self (Present and Future) (1957)

Flying Saucers: A Modern Myth (1958)

A Psychological View of Conscience (1958)

Good and Evil in Analytical Psychology (1959)

Introduction to Wolff's "Studies in Jungian Psychology" (1959)

The Swiss Line in the European Spectrum (1928)

Reviews of Keyserling's "America Set Free" (1930) and "La Révolution Mondiale" (1934)

Complications of American Psychology (1930)

The Dreamlike World of India (1939)

What India Can Teach Us (1939)

Appendix: Miscellaneous Shorter Papers

†11. PSYCHOLOGY AND RELIGION: WEST AND EAST

WESTERN RELIGION

Psychology and Religion (The Terry Lectures) (1938/1940)

A Psychological Approach to the Dogma of the Trinity (1942/1948)

Transformation Symbolism in the Mass (1942/1954)

Forewords to White's "God and the Unconscious" and Werblowsky's "Lucifer and Prometheus" (1952)

Brother Klaus (1933)

Psychotherapists or the Clergy (1932)

Psychoanalysis and the Cure of Souls (1928)

Answer to Job (1952)

EASTERN RELIGION

Psychological Commentaries on "The Tibetan Book of the Great Liberation" (1939) and "The Tibetan Book of the Dead" (1935/1953)

Yoga and the West (1936)

Foreword to Suzuki's "Introduction to Zen Buddhism" (1939)

The Psychology of Eastern Meditation (1943)

The Holy Men of India: Introduction to Zimmer's "Der Weg zum Selbst" (1944)

Foreword to the "I Ching" (1950)

*12. PSYCHOLOGY AND ALCHEMY (1944)

Introduction to the Religious and Psychological Problems of Alchemy

Individual Dream Symbolism in Relation to Alchemy (1936)

Religious Ideas in Alchemy (1937)

Epilogue

13. ALCHEMICAL STUDIES

Commentary on "The Secret of the Golden Flower" (1929)

The Spirit Mercurius (1943/1948)

Some Observations on the Visions of Zosimos (1938/1954)

Paracelsus as a Spiritual Phenomenon (1942)

The "Arbor philosophica" (1945/1954)

†14. MYSTERIUM CONIUNCTIONIS (1955, 1956)

AN INQUIRY INTO THE SEPARATION AND

SYNTHESIS OF PSYCHIC OPPOSITES IN ALCHEMY

The Components of the Coniunctio

The Paradoxa

The Personification of Opposites

Rex and Regina

Adam and Eve

The Conjunction

15. THE SPIRIT IN MAN, ART, AND LITERATURE

Paracelsus (1929)

Paracelsus the Physician (1941)

Sigmund Freud in His Historical Setting (1932)

Sigmund Freud: An Obituary (1939)

Richard Wilhelm: In Memory (1930)

Psychology and Literature (1930/1950)

On the Relation of Analytical Psychology to Poetry (1922)

Picasso (1932)

“Ulysses” (1932)

*16. THE PRACTICE OF PSYCHOTHERAPY

GENERAL PROBLEMS OF PSYCHOTHERAPY

Principles of Practical Psychotherapy (1935)

What Is Psychotherapy? (1935)

Some Aspects of Modern Psychotherapy (1930)

The Aims of Psychotherapy (1931)

Problems of Modern Psychotherapy (1929)

Psychotherapy and a Philosophy of Life (1943)

Medicine and Psychotherapy (1945)

Psychotherapy Today (1945)

Fundamental Questions of Psychotherapy (1951)

SPECIFIC PROBLEMS OF PSYCHOTHERAPY

The Therapeutic Value of Abreaction (1921/1928)

The Practical Use of Dream-Analysis (1934)

Psychology of the Transference (1946)

†17. THE DEVELOPMENT OF PERSONALITY

Psychic Conflicts in a Child (1910/1946)

Introduction to Wickes's "Analyse der Kinderseele" (1927/1931)

Child Development and Education (1928)

Analytical Psychology and Education: Three Lectures (1926/1946)

The Gifted Child (1943)

The Significance of the Unconscious in Individual Education (1928)

The Development of Personality (1934)

Marriage as a Psychological Relationship (1925)

Final Volumes. MISCELLANEOUS

Posthumous and Other Miscellaneous Works

Bibliography of C. G. Jung's Writings

General Index to the Collected Works

¹ [Originally published as “Ueber das Unbewusste,” *Schweizerland: Monatshefte für Schweizer Art und Arbeit* (Zurich), IV (1918), no. 9, 464–72, and no. 11–12, 548–58.—EDITORS.]

² “If we take Nature for our guide, we shall never go astray.”

¹ [Originally published as part of an essay, “Die Erdbedingtheit der Psyche,” in *Mensch und Erde*, edited by Count Hermann Keyserling (Darmstadt, 1927). pp. 83–137. That essay was later divided and largely rewritten as two: “Die Struktur der Seele,” for the bibliographical history of which see its translation, “The Structure of the Psyche,” *Coll. Works*, Vol. 8, p. 300; and the present paper, “Seele und Erde,” in *Seelenprobleme der Gegenwart* (Zurich, 1931). The original (1927) paper was translated by C. F. and H. G. Baynes as “Mind and the Earth,” *Contributions to Analytical Psychology* (London and New York, 1928), and that version has been consulted.—EDITORS.]

² [The word used throughout this essay is “Seele,” which in this context can be translated either as “mind” or as “psyche.” Cf. “The Structure of the Psyche,” p. 300, note.—TRANS.]

³ [“The Structure of the Psyche” (cf. *supra*, n. 1), which immediately preceded the present essay in *Seelenprobleme der Gegenwart*.—EDITORS.]

⁴ [Cf. “Instinct and the Unconscious,” in *The Structure and Dynamics of the Psyche*.—EDITORS.]

⁵ [“Statistical Investigations on Word-Associations and on Familial Agreement in Reaction Type among Uneducated Persons,” by Emma Fürst, in *Studies in Word Association* (trans. by Eder).—EDITORS.]

⁶ Cf. *Two Essays on Analytical Psychology*, pp. 186ff.

⁷ 8:9–24. For the Helen legend see Irenaeus, *Adv. haer.* 9, xxiii.

⁸ *Two Essays on Analytical Psychology*, pp. 207f.

⁹ Untitled poem (“Warum gabst du uns die tiefen Blicke?”) in *Werke*, II, p. 43.

¹⁰ [*Sic* but Buffalo, New York, is meant. Cf. *infra*, par. 948.—EDITORS.]

¹¹ See “The Complications of American Psychology,” *infra*, pp. 502ff.

¹ [First published as “Der archaische Mensch,” *Europäische Revue* (Berlin), VII (1931), 182–203. Revised and republished in *Seelenprobleme der Gegenwart* (Zurich, 1931), pp. 211–47; trans. by W. S. Dell and Cary F. Baynes in *Modern Man in Search of a Soul* (London and New York, 1933), pp. 143–74. The latter trans. has been consulted.—
EDITORS.]

¹ [First pub. as “Das Seelenproblem des modernen Menschen,” *Europäische Revue* (Berlin), IV (1928), 700–715. Revised and expanded in *Seelenprobleme der Gegenwart* (Zurich, 1931), pp. 401–35. Trans. by W. S. Dell and Cary F. Baynes in *Modern Man in Search of a Soul* (London and New York, 1933), pp. 226–54. The latter version has been consulted.—EDITORS.]

² [“In this, your Nothing, I may find my All!” *Faust, Part Two*.—TRANS.]

³ [This essay was originally written in 1928.—EDITORS.]

⁴ [See bibliography.]

⁵ [*Psychoanalyse und Yoga*.]

¹ [A lecture to Zurich University students, probably in Dec., 1922. Originally published in English as “The Love Problem of the Student,” trans. by C. F. and H. G. Baynes from the unpublished German ms., in *Contributions to Analytical Psychology* (London and New York, 1928). For the present trans. the Baynes version has been consulted. —EDITORS.]

¹ [Originally published as “Die Frau in Europa,” *Europäische Revue* (Berlin), III: 7 (Oct., 1927); republished by the *Neue Schweizer Rundschau* as a pamphlet (Zurich, 1929), which was reprinted by Rascher Verlag in 1932, 1948, and 1959 (cf. n. 2, *infra*). Trans. by C. F. and H. G. Baynes in *Contributions to Analytical Psychology* (London and New York, 1928), pp. 164–88, which version has been consulted here. The motto is from the trans. of Nietzsche by Common.—EDITORS.]

² In the thirty years since this essay was written the significance of the “East” has changed and has largely assumed the form of the “Russian Empire.” This already reaches as far as central Germany, but it has lost nothing of its Asiatic character. [Author’s footnote in 1959 pamphlet edition.—EDITORS.]

³ In *The Development of Personality*.

⁴ [See *Psychiatric Studies*, index, s. vv.—EDITORS.]

¹ [Originally published as ‘Ueber Psychologie,’ *Neue Schweizer Rundschau* (Zurich), I (1933), no. 1, 21–28, and no. 2, 98–106. Revised and expanded as “Die Bedeutung der Psychologie für die Gegenwart,” *Wirklichkeit der Seele* (Zurich, 1934), pp. 32–67.—EDITORS.]

² *Faust, Part One*, trans. by Wayne, p. 48.

³ [Cf. *Aion*, passim.—EDITORS.]

⁴ [Swedish financier (1880–1932), known as “The Match King,” whose complicated speculations led to his financial collapse and suicide.—EDITORS.]

⁵ *Faust, Part One*, trans. by Wayne, pp. 110f.

⁶ Cf. Wayne trans., p. 178.

¹ [Translated from “Zur gegenwärtigen Lage der Psychotherapie,” *Zentralblatt für Psychotherapie und ihre Grenzgebiete* (Leipzig), VII (1934): 1, 1–16.—EDITORS.]

² Similar views are expressed by von Weizsäcker in regard to internal medicine. [Viktor von Weizsäcker (1886–1957), professor of medicine at Heidelberg University. He pioneered in psychosomatic medicine.—EDITORS.]

³ [“Afterbild.”—TRANS.]

¹ [Originally published as the Vorwort to *Aufsätze zur Zeitgeschichte* (Zurich, 1946). Trans. by Elizabeth Welsh in *Essays on Contemporary Events* (London, 1947); this version has been consulted. The latter volume contained the four papers that follow this preface and two more that were published in Vol. 16 of the *Coll. Works*: “Psychotherapy Today” (pp. 94ff.) and “Psychotherapy and a Philosophy of Life” (pp. 76ff.).—EDITORS.]

² [Infra, pp. 227ff.]

¹ [First published as ‘Wotan,’ *Neue Schweizer Rundschau* (Zurich), n.s., III (March, 1936), 657–69. Republished in *Aufsätze zur Zeitgeschichte* (Zurich, 1946), 1–23. Trans. by Barbara Hannah in *Essays on Contemporary Events* (London, 1947), 1–16; this version has been consulted. The author added footnotes 3, 4, 15 and 16 (first par.) to the London edn. Motto, trans. by H. C. Roberts:

“In Germany shall divers sects arise,
Coming very near to happy paganism.
The heart captivated and small receivings
Shall open the gate to pay the true tithe.”

—EDITORS.]

² Abyssinia.

³ Ever since Nietzsche (1844–1900) there has been consistent emphasis on the “Dionysian” aspect of life in contrast to its “Apollonian” opposite. Since “The Birth of Tragedy” (1872), the dark, earthy, feminine side, with its mantic and orgiastic characteristics, has possessed the imagination of philosophers and poets. Irrationality gradually came to be regarded as the ideal; this is found, for example, all through the research of Alfred Schuler (d. 1923) into the mystery religions, and particularly in the writings of Klages (b. 1872 [d. 1956]), who expounded the philosophy of “irrationalism.” To Klages, logos and consciousness are the destroyers of creative preconscious life. In these writers we witness the origin of a gradual rejection of reality and a negation of life as it is. This leads in the end to a cult of ecstasy, culminating in the self-dissolution of consciousness in death, which meant, to them, the conquest of material limitations.

The poetry of Stefan George (1868–1933) combines elements of classical civilization, medieval Christianity, and oriental mysticism. George deliberately attacked nineteenth- and twentieth-century rationalism. His aristocratic message of mystical beauty and of an esoteric conception of history had a deep influence on German youth. His work has been exploited by unscrupulous politicians for propaganda purposes.

⁴ *Vom kosmogonischen Eros* is the title of one of Klages’ main works (first pub. 1922).

⁵ *Thus Spake Zarathustra*, trans. by Kaufmann, p. 211 (mod.).

⁶ *Ibid.*, p. 247 (mod.).

⁷ *Werke*, V, pp. 457f. and 495; trans. by R.F.C.H.

⁸ *Thus Spake Zarathustra*, Kaufmann trans., p. 365.

⁹ *Der werdende Nietzsche*, pp. 84ff.

¹⁰ [After the meaningless refrains sung by the Rhine maidens in Wagner’s *Ring* cycle: “*Weia! Waga! Wagala weia!*,” etc.—EDITORS.]

¹¹ One should read what Bruno Goetz (*Deutsche Dichtung*, pp. 36ff. and 72ff.) has to say about Odin as the German wanderer-god. Unfortunately I only read this book after I had finished my article.

¹² *Wodan und germanischer Schicksalsglaube*.

¹³ [*Wunsch*, magical wish; *Minne*, remembrance, love; *Einherier*, the dead heroes in Valhalla (*Meyers Konversations-Lexikon*).— EDITORS.]

¹⁴ [*Fylgja*, attendant spirit in the form of an animal (Hastings, *Encyclopedia*).]

¹⁵ A National Socialist movement inside the Protestant Church, which tried to eliminate all vestiges of the Old Testament from Christianity.

¹⁶ Wilhelm Hauer (b. 1881), first a missionary and later professor of Sanskrit at the University of Tübingen, was the founder and leader of the “German Faith Movement” It tried to establish a “German Faith” founded on German and Nordic writings and traditions, e.g., those of Eckhart and Goethe. This movement sought to combine a number of different and often incompatible trends: some of its members accepted an expurgated form of Christianity, others were opposed not only to Christianity in any form but to every kind of religion or god. One of the common articles of faith, which the movement adopted in 1934, was: “The German Faith Movement aims at the religious renaissance of the nation out of the hereditary foundations of the German race.”

The spirit of this movement may be contrasted with a sermon preached by Dr. Langmann, an evangelical clergyman and high dignitary of the Church, at the funeral of the late Gustloff. Dr. Langmann gave the address “in S.A. uniform and jackboots.” He sped the deceased on his journey to Hades, and directed him to Valhalla, to the home of Siegfried and Baldur, the heroes who “nourish the life of the German people by the sacrifice of their blood”—like Christ among others. “May this god send the nations of the earth *clanking on their way* through history.” “Lord bless our struggle. Amen.” Thus the reverend gentleman ended his address, according to the *Neue Zürcher Zeitung* (1936, no. 249). As a service held to Wotan it is no doubt very edifying—and remarkably tolerant towards believers in Christ! Are our Churches inclined to be equally tolerant and to preach that Christ shed his blood for the salvation of mankind, like Siegfried, Baldur, and Odin among others?! One can ask unexpectedly grotesque questions these days.

¹⁷ *Deutsche Gottschau: Grundzüge eines deutschen Glaubens* [German Vision of God: Basic Elements of a German Faith].

¹⁸ [Using the word to connote those peoples within the Semitic language-group.—TRANS.]

¹⁹ *Voluspo* (*The Poetic Edda*, trans. by Bellows, pp. 20f.; line 7 mod.).

¹ [First published as “Nach der Katastrophe,” *Neue Schweizer Rundschau* (Zurich), n.s., XIII (1945), 67–88; reprinted in *Aufsätze zur Zeitgeschichte* (Zurich, 1946), pp. 73–116. Previously trans. by Elizabeth Welsh in *Essays on Contemporary Events* (London, 1947), pp. 45–72.—EDITORS.]

² [See previous paper.]

³ [Schwabing is the bohemian quarter of Munich.—EDITORS.]

⁴ *Works*, trans. by Evans, II, PP. 18–19.

¹ [A broadcast talk in the Third Programme of the British Broadcasting Corporation, on November 3, 1946. First published in *The Listener* (London), XXXVI (1946), no. 930, 615–16; reprinted as an introduction to *Essays on Contemporary Events* (1947); also published, under the title “Individual and Mass Psychology,” in *Chimera* (New York and Princeton, N.J.), V (1947):3, 3–11. Here slightly revised.—EDITORS.]

² Cf. “The Role of the Unconscious,” above, par. 17.

¹ [Originally published as Nachwort to *Aufsätze zur Zeitgeschichte* (Zurich, 1946), pp. 117–47. Translated by Elizabeth Welsh in *Essays on Contemporary Events* (London, 1947), pp. 73–90, which version has been consulted. Unless otherwise indicated, the quotations of and references to Jung’s writings are in accordance with the *Coll. Works*, although the author gives dates of original publication.—EDITORS.]

² “The Role of the Unconscious,” supra, par. 17.

³ Ibid., pars. 45f.

⁴ “The Structure of the Unconscious,” expanded into “The Relations between the Ego and the Unconscious.” Both in *Two Essays on Analytical Psychology*.

⁵ *Two Essays*, pp. 150f.

⁶ Ibid., p. 181.

⁷ “The Meaning of Psychology for Modern Man,” supra, pars. 326ff.

⁸ “Psychology and Religion,” pp. 14f.

⁹ Ibid., pp. 47f.

¹⁰ “The Psychology of the Unconscious Processes,” in *Collected Papers on Analytical Psychology* (1917), p. 416.

¹¹ *Two Essays*, pp. 92f.; cf. *Collected Papers*, p. 432.

¹² “The Psychological Foundations of Belief in Spirits,” reprinted in *Contributions to Analytical Psychology* (1928), pp. 265f. In *Über die Energetik der Seele* (1928) the end of this passage was revised as follows: “... the mental state of the people as a whole might well be compared to a psychosis.” [Cf. *The Structure and Dynamics of the Psyche*, par. 595.—EDITORS]

¹³ *Two Essays*, pp. 202f.

¹⁴ “General Aspects of Dream Psychology,” in *The Structure and Dynamics of the Psyche*, p. 272.

¹⁵ Cf. *The Secret of the Golden Flower* (1932 edn., p. 111).

¹⁶ “The Development of the Personality,” pp. 177f.

¹⁷ For the necessary qualifications of this general statement see “After the Catastrophe,” Pars. 423ff.

¹⁸ *The Crowd: A Study of the Popular Mind*. Cf. also Reinwald’s *Vom Geist der Massen*, which has just appeared [1946].

¹⁹ My italics. Here I am making use of an authentic document, the authors of which I do not wish to expose by name, as they are worthy people whose shortcomings are not a personal fault but a national one.

²⁰ Luke 15:22f.

²¹ Nor does my diagnosis include every individual German. I have heard statements from Germans which were spoken like a man and were not vitiated by that infantile weakness which underlies the German *Kraftmeier* style.

²² Cf. “Wotan,” supra, par. 398.

¹ Since this essay was written, in the spring of 1956, there has been a noticeable reaction in the U.S.S.R. to this objectionable state of affairs.

² Added in January 1957.

¹ Recent events in Poland and Hungary have shown that this opposition is more considerable than could have been foreseen.

¹ This is a classic instance of the symbiosis of insect and plant.

¹ Since these words were written, the shadow has followed up this overbright picture hotfoot with the Charge of the Light Brigade to Suez.

² [Cf. *infra*, pars. 826ff.—EDITORS.]

¹ “Wotan,” first published in the *Neue Schweizer Rundschau*, 1936. [See supra, pars. 371ff.]

² In an interview by Georg Gerster, *Weltwoche* (Zurich), XXII:1078 (July 9, 1954), p. 7.

³ *The Report on Unidentified Flying Objects* (1956).

⁴ Major Donald E. Keyhoe, *Flying Saucers from Outer Space* (1953), and *The Flying Saucer Conspiracy* (1955). Cf. also Aimé Michel, *The Truth about Flying Saucers* (1956).

⁵ Cf. my paper “Synchronicity: An Acausal Connecting Principle.”

¹ I prefer the term “vision” to “hallucination,” because the latter bears the stamp of a pathological concept, whereas a vision is a phenomenon that is by no means peculiar to pathological states.

² [*The War of the Worlds*, radio adaptation by Orson Welles (1938).—EDITORS.]

³ Special emphasis should be laid on the *green* fire-balls frequently observed in the southwestern United States.

⁴ Aimé Michel remarks that Ufos are mostly seen by people who do not believe in them or who regard the whole problem with indifference.

⁵ Cf. *Flying Saucers über Südafrika* (1955).

⁶ Cf. Eugen Böhler’s enlightening remarks in *Ethik und Wirtschaft* (Industrielle Organisation, Zurich, 1957).

⁷ The more rarely reported cigar-form may have the Zeppelin for a model. The obvious phallic comparison, i.e., a translation into sexual language, springs naturally to the lips of the people. Berliners, for instance, refer to the cigar-shaped Ufo as a “holy ghost,” and the Swiss military have an even more outspoken name for observation balloons.

⁸ “Concerning Mandala Symbolism.”

⁹ Cf. “The Self,” in *Aion*.

¹⁰ Significantly enough, Elijah also appears as an eagle, who spies out unrighteousness on earth from above.

¹¹ Cf. “Concerning Rebirth.”

¹² It is a common and totally unjustified misunderstanding on the part of scientifically trained people to say that I regard the psychic background as something “metaphysical,” while on the other hand the theologians accuse me of “psychologizing” metaphysics. Both are wide of the mark: I am an empiricist, who keeps within the boundaries set for him by the theory of knowledge.

- ¹ A report on the case of Captain Mantell, now become a classic, speaks of the Ufo's resemblance to a "tear drop" and says it behaved like a fluid. Cf. Wilkins, *Flying Saucers on the Attack*, p. 90.
- ² "Die Bedeutung der Bilder in der lebendigen Energiewandlung."
- ³ The phallus is not just a sign that indicates the penis; it is a "symbol" because it has so many other meanings.
- ⁴ Dionysus, for instance, was invoked as *enkolpios*: 'he in the lap.'
- ⁵ Cf. Keyhoe, *The Flying Saucer Conspiracy*.
- ⁶ Cf. "Brother Klaus."
- ⁷ Neither is there any proof that they are "only" psychic!
- ⁸ Here I must beg the reader to eschew the popular misconception that this background is "metaphysical." This view is a piece of gross carelessness of which even professional people are guilty. It is far more a question of instincts which influence not only our outward behaviour but also the psychic structure. The psyche is not an arbitrary fantasy; it is a biological fact subject to the laws of life.
- ⁹ "The spirit as adversary of the soul."
- ¹⁰ Sievers, *Flying Saucers über Südafrika*, p. 157, mentions Gerald Heard's hypothesis that they are a species of bees from Mars (*Is Another World Watching? The Riddle of the Flying Saucers*). Harold T. Wilkins, in *Flying Saucers on the Attack*, mentions a report of a "rain of threads," supposed to come from unknown spiders.
- ¹¹ Aimé Michel, *The Truth about Flying Saucers*.
- ¹² Wilkins, p. 138.
- ¹³ The horror people feel for spiders has been vividly described by Jeremias Gotthelf in his story *The Black Spider*.
- ¹⁴ [Cf. "Transformation Symbolism in the Mass," pp. 210, 233, etc.—EDITORS.]
- ¹⁵ Cf. the Cabiri scene in *Faust; Psychology and Alchemy*, pp. 148ff.
- ¹⁶ "Der Tod ist die letzte Lini der Ding. Ich weich kaim."
- ¹⁷ Cf. Aniela Jaffé's *Apparitions and Precognition*, which investigates strange occurrences among modern people for their mythological content.
- ¹⁸ Swiss-German expression for the nightmare or stable spook.
- ¹⁹ D. H. Menzel, *Flying Saucers* (1953).
- ²⁰ I am indebted to Dr. H. Y. Kluger, Los Angeles, for this material.
- ²¹ When the shadow, the inferior personality, is in large measure unconscious, the unconscious is represented by a masculine figure.
- ²² Cf. Keyhoe, *The Flying Saucer Conspiracy*.
- ²³ *Journey into Self*.

- ¹ Herostratus, in order to make his name immortal, burned down the temple of Artemis in Ephesus, 365 B.C.
- ² He was not a Saucer addict and had not read the Ufo literature.
- ³ In what follows there are a number of allusions to medieval symbolism, which may perhaps be unknown to the reader. He will find the necessary documentation in my book *Psychology and Alchemy*.
- ⁴ Cf. *Psychology and Alchemy*, p. 148.
- ⁵ “I am come to send fire on earth, and what will I, if it be already kindled?” Luke 12:49.
- ⁶ In H. G. Wells, the “time machine” seems to have three visible rods, but the fourth “has an odd, twinkling appearance, as if it were not real.”
- ⁷ In this connection I would like to draw attention to van Gogh’s *Starry Night* (1889). There the stars are painted as large shining disks, though the eye never sees them like that. Speaking of his picture, van Gogh used the expression “pantheistic frenzy,” calling it the “remnant of an apocalyptic fantasy” and comparing the starry disks to a “group of living figures who are like one of us.” The painting is supposed to be derived from a dream.
- ⁸ The refreshing, cool water of life in paradise after the heat of purgatory.
- ⁹ Inhibitions, faults, slips of the tongue, subsequent forgetting of the answers, etc. All these are “complex-indicators.”

¹ It was kindly placed at my disposal by D. van Houten, Bergen, Netherlands. [Later information suggests that it is a late 19th-cent. imitation.—EDITORS.]

² Macrobius, *In somnium Scipionis*, I, 14, 19.

³ “You look further and see people on the earth who carry milk in clay vessels. From this they prepare cheese. They are the people, men and women, who carry human seed in their bodies. From it arise the various generations of men. Part of the milk is fatty. It makes fatty cheese. This seed ... produces energetic people.... In cleverness and discretion they master life and flourish in their works visibly before God and men. The devil does not find his place in them. Other milk is thin. This curdles into insipid cheese. This seed ... produces weakly people.... A last part of the milk is mixed with corruption, and the cheese that comes from it is bitter. This seed ... produces malformed people,” etc. *Scivias*, pp. 128f.

¹ See *infra*, par. 931.

¹ For the physiological foundations see K. W. Bash, H. Ahlenstiel, and R. Kaufmann, “Ueber Präyantraformen und ein lineares Yantra.”

² Von Franz, ed., *Aurora Consurgens*, Ch. 6 and commentary.

¹ [Originally published as “Das Gewissen in psychologischer Sicht,” in a symposium, *Das Gewissen* (Studien aus dem C. G. Jung-Institut, VII; Zurich, 1958).—EDITORS.]

² [In the original, resp., *Gewissen*, *Wissen*, and *Bewusstsein*. Cf. L. *conscientia*, *scientia* (from *scire*, ‘to know’), *consciūs*.—EDITORS.]

³ *Eine Selbstschau* (1843).

¹ [An extemporaneous address to the Stuttgarter Gemeinschaft “Arzt und Seelsorger,” whose members travelled to Zurich to conduct the eighth annual meeting, upon which occasion Professor Jung met the group. A transcript prepared by Gebhard Frei was approved, with corrections, by the author and was first published in *Gut und Bose in der Psychotherapie* (ed. by Wilhelm Bitter, Stuttgart, 1959), a report of the meeting. The present translation (here revised) appeared first in the *Journal of Analytical Psychology* (London), V (1960), 91–99.—EDITORS.]

² [Friedrich Seifert, of Munich, a participant in the meeting.]

³ [Presumably in one of the other talks in this symposium.—EDITORS.]

¹ [Translated from the Vorrede to Toni Wolff, *Studien zu C. G. Jungs Psychologie* (Zurich, 1959), pp. 7–14.—

EDITORS.]

¹ [First published as “Die Bedeutung der schweizerischen Linie im Spektrum Europas,” *Neue Schweizer Rundschau* (Zurich), XXIV (21st year), (1928), 6, 1–11, 469–79. The article is in effect a review of Count Hermann Keyserling’s *Das Spektrum Europas* [The Spectrum of Europe] (Heidelberg, 1928), trans. by Maurice Samuel as *Europe* (New York and London, 1928). The quotations in the present version are trans. from the original.—EDITORS.]

² At a family gathering someone noticed that a certain relative was cut by everyone. Wondering what the reason might be for this behaviour, he asked the lady of the house. “He does terrible things, he’s a dreadful person.”—Well, what’s he done?—“He’s living on his capital!”

³ “Der eine betracht’s, der andere acht’s, der dritte veracht’s, was machts!”

⁴ [See bibliography.]

¹ [First published as “Der Aufgang einer neuen Welt,” *Neue Zürcher Zeitung* (Zurich), no. 2378, iv (Dec. 7, 1930): a review of Count Hermann Keyserling’s *Amerika; Der Aufgang einer Neuen Welt* (Stuttgart, 1930), trans. anon, as *America Set Free* (New York and London, 1930). This translation of Jung’s article is new, but the Keyserling quotations are from the English edition.—EDITORS.]

² [*South-American Meditations* (1932).]

¹ [First published as “Ein neues Buch von Keyserling,” *Basler Nachrichten*, Sonntagsblatt [Sunday Supplement], XXVIII:19 (May 13, 1934), 78–79. The article is a review of Keyserling’s *La Révolution mondiale et la responsabilité de l’Esprit* (Paris, 1934), quotations of which have been translated from the French.—EDITORS.]

² [The third in a series of “Conversations,” actually organized by the Permanent Committee of Arts and Letters of the League of Nations and conducted by the International Institute of Intellectual Co-operation in various cities from 1932 to 1938. Keyserling represented Germany at the meeting in question. Cf. Valéry, *History and Politics*, pp. 531ff. and 541ff.—EDITORS.]

¹ [Written in English and first published as “Your Negroid and Indian Behavior,” *Forum* (New York), LXXXIII (1930):4, 193–99. Slightly revised stylistically for publication here.—EDITORS.]

¹ [Written in English and first published in *Asia* (New York), XXXIX (1939):1, 5–8.—EDITORS.]

¹ [Written in English and first published in *Asia* (New York), XXXIX (1939):2, 97–98.—EDITORS.]

² [The body of Southern Buddhist Sacred Writings.—EDITORS.]

¹ [Published in the *Zentralblatt für Psychotherapie und ihre Grenzgebiete* (Leipzig). VI:3 (Dec., 1933), 139–40.—

EDITORS.]

² [Allgemeine Ärztliche Gesellschaft für Psychotherapie. Founded 1928, with Dr. Robert Sommer as first president. In 1930, Professor Ernst Kretschmer became president and Jung vice-president.]

³ [Jung implemented this principle in the International Society. Cf. *infra*, Circular Letter, p. 545, and also p. 558.—

EDITORS.]

¹ [Published under “Zeitgenössisches” in the *Neue Zürcher Zeitung*, CLV (1934), no. 437, p. 1, and no. 443, p. 1 (March 13 and 14). The article by the Swiss psychiatrist Dr. G. Bally was published under the title “Deutschstämmige Psychotherapie?” in the same periodical, no. 343 (Feb. 27). Cf. *infra*, p. 543, n. 5.—EDITORS.]

² [*Zentralblatt für Psychotherapie*, VI:3 (Dec., 1933), 142ff. The confusion no doubt arose because the General Medical Society for Psychotherapy was dominated by the Germans, who held the main executive positions. Its membership was, however, international, and the congresses were international in character. Upon Kretschmer’s resignation (Apr. 6, 1933), Jung was probably for a short time acting president, by virtue of his position as vice-president. Almost at once, however, with the agreement of his colleagues, he reorganized the society so as to make it formally international. Jung was then elected president of this International General Medical Society for Psychotherapy. The statutes were ratified at a congress at Bad Nauheim, May 10–13, 1934: cf. the *Zentralblatt*, VII:3 (1934, month not indicated). The society’s headquarters were located in Switzerland. A separate German society, under the presidency of Prof. M. H. Göring, was founded in Berlin on Sept. 15, 1933, as the German section of the International Society (VI:3, pp. 140ff.).—EDITORS.]

³ [In Germany.—EDITORS.]

⁴ [Actually, a short while before, when Jung stipulated that the analyst must be analysed. The first reference to this occurs in “The Theory of Psychoanalysis” (1913), in *Freud and Psychoanalysis*, pars. 447–50 (cf. *ibid.*, pp. 252f.). Cf. also “A Contribution to the Study of Psychological Types” (1913; cf. *Collected Papers on Analytical Psychology*, pp. 297f); “On Psychological Understanding” (1914), in *The Psychogenesis of Mental Disease*, pars. 419f; *Psychological Types* (1921 edn., pp. 78ff., 453f.); “A Psychological Theory of Types” (1927; cf. *Modern Man in Search of a Soul*, pp. 87f.); “Freud and Jung: Contrasts” (1929), in *Freud and Psychoanalysis*; “Introduction to Kranefeldt’s ‘Secret Ways of the Mind’” (1939), *ibid.*, pars. 747, 757f.—EDITORS.]

⁵ [When the foregoing “Rejoinder to Dr. Bally” was published in the *Neue Zürcher Zeitung*, a prefatory note by the Editor stated: “Dr. Bally, in his article ‘Deutschstämmige Psychotherapie?’, was in our view entitled to take up Dr. Jung’s programme as outlined in the *Zentralblatt für Psychotherapie* [VI: 3] and to express his astonishment that though Dr. Jung started from the teachings of Freud and quite legitimately departed from them, he did not in his scientific writings support his opposition with the differences between Christian-Germanic and Semitic psychology, but only at this present juncture acknowledges the ‘super psychology of the racial psychologists.’” In the issue of March 15, 1934 (CLV, 457), Jung replied as follows:

 [“In the Editor’s prefatory note to my article, it is stated that I started from the teachings of Freud. I did not start from Freud, but from Eugen Bleuler and Pierre Janet, who were my immediate teachers. When I took up the cudgels for Freud in public. I already had a scientific position that was widely known on account of my association experiments, conducted independently of Freud, and the theory of complexes based upon them. My collaboration was qualified by an objection in principle to the sexual theory, and it lasted up to the time when Freud identified in principle his sexual theory with his method.

 [“The assertion that I acknowledge racial psychology only at this present juncture is incorrect. In 1927 I wrote: ‘Thus it is a quite unpardonable mistake to accept the conclusions of a Jewish psychology as generally valid. Nobody would dream of taking Chinese or Indian psychology as binding upon ourselves. The cheap accusation of anti-Semitism that has been levelled at me on the ground of this criticism is about as intelligent as accusing me of an anti-

Chinese prejudice.’ [“The Relations between the Ego and the Unconscious” (*Coll. Works*, Vol. 7), p. 149, n. 8.] And in June 1918 I wrote: ‘In my opinion this problem does not exist for the Jews. The Jew already had the culture of the ancient world and on top of that has taken over the culture of the nations amongst whom he dwells. He has two cultures, paradoxical as that may sound. He is domesticated to a higher degree than we are, but he is badly at a loss for that quality in man which roots him to the earth and draws new strength from below. This chthonic quality is found in dangerous concentration in the Germanic peoples. Naturally the Aryan European has not noticed any signs of this for a very long time, but perhaps he is beginning to notice it in the present war; and again, perhaps not. The Jew has too little of this quality—where has he his own earth underfoot? The mystery of the earth is no joke and no paradox.’” (Supra, par. 18.)—EDITORS.]

¹ [Inserted as a separate sheet in the *Zentralblatt*, VII:6 (Dec., 1934). The stipulations are based on the statutes of the Society, printed *ibid.*, VII:3—EDITORS.]

² [At this, the 7th Congress for Psychotherapy, May, 1934, at Bad Nauheim, the statutes of the International General Medical Society for Psychotherapy were ratified. Jung's presidential address to the Congress may have been extempore; a ms. cannot be traced, but there is a summary of it in the *Zentralblatt*, VII:3. It seems to have been much the same in substance as the "Contribution to a Discussion on Psychotherapy" (*infra*, pars. 1060ff.).

[At the same Congress, Jung delivered a lecture, "Über Komplextheorie," previously delivered on May 5 at the Federal Polytechnic Institute, Zurich, and published the same year as "Allgemeines zur Komplextheorie." Cf. "A Review of the Complex Theory," *Coll. Works*, Vol. 8, pp. 92ff.]

[For Jung's presidential address to the 8th Congress, held in March 1935, also at Bad Nauheim, see pars. 1055ff.]

³ [In order to prevent any national group dominating the Society, it was stipulated in the statutes that no national group could muster more than 40 per cent voting strength.]

⁴ [By this means, German Jews could remain members of the International Society though ejected from the German national group (*cf. infra*, p. 558).]

¹ [Published in the *Zentralblatt*, VIII:1 (1935, month not indicated), 105.—EDITORS.]

² [The 7th Congress for Psychotherapy. See *supra*, pp. 535, n. 2, and 545, n. 2.]

¹ [Published in the *Zentralblatt*, VIII:2 (1935, month not indicated), 165.—EDITORS.]

¹ [March 27–30, 1935. Previously unpublished. Cf. *supra*, par. 1039.—EDITORS.]

¹ [In May 1935, Dr. W. Morgenthaler, an official of the Swiss section of the International General Medical Society for Psychotherapy, organized a symposium on “Psychotherapy in Switzerland.” Jung delivered a lecture entitled “What Is Psychotherapy?” (*Coll. Works*, Vol. 16, pp. 21ff.). A discussion followed, and Jung contributed the present remarks (styled “Votum C. G. Jung”), which were published in the *Schweizerische Ärztezeitung für Standesfragen* (Bern), XVI (1935): 26, 345f., together with his lecture (pp. 335ff.).—EDITORS.]

² [By Dr. Morgenthaler.—EDITORS.]

³ [See *supra*, par. 1018.]

⁴ [See *supra*, pars. 1035ff.]

¹ [October 2–4, 1937. Previously unpublished.]

¹ [July 29— August 2, 1938. Delivered in English; previously unpublished.]

² [“The fourteen points dealt with medical procedure, psychogenesis, diagnosis, exploration, material (including all possible forms of human expression, behaviour, controlled language, the language of free association, of fantasy, of dreams, of symptoms and symptomatic actions), aetiology, the unconscious, fixation, conscious realization, analysis and interpretation, transference, ontogenic reduction, phylogenic reduction, and therapy.”—*Zentralblatt*, XI (1939): 1–2, p. 2.—EDITORS.]

* The Standard Edition of the Complete Psychological Works of Sigmund Freud, translated from the German under the general editorship of James Strachey, in collaboration with Anna Freud, assisted by Alix Strachey and Alan Tyson. London.

* For details, see the list at the end of this volume.

- * Published 1957.
- † Published 1960.
- * Published 1961.
- † Published 1956. (65 plates, 43 text figures.)
- * Published 1953.
- † Published 1960.
- * Published 1959 (Part I: 79 plates, with 29 in colour.)
- * Published 1964.
- † Published 1958; 2nd impr., 1963.
- * Published 1953. (270 illustrations.)
- † Published 1963. (10 plates.)
- * Published 1954. (13 illustrations.)
- † Published 1954.

B O L L I N G E N S E R I E S X X

THE COLLECTED WORKS

OF

C. G. JUNG

VOLUME 11

EDITORS

† SIR HERBERT READ

MICHAEL FORDHAM, M.D., M.R.C.P.

GERHARD ADLER, PH.D.

WILLIAM MCGUIRE, *executive editor*



Jean Fouquet: *The Trinity with the Virgin Mary*
From the Book of Hours of Etienne Chevalier (Chantilly)

The mandala encloses the three identical male figures composing the Trinity and a fourth, female figure, together with the four symbols of the Evangelists, three in the form of animals and one (Matthew) in the form of an angel. Mary is Queen of the Angels. (Cf. pp. 64ff. and 107ff.)

**PSYCHOLOGY AND
RELIGION:
WEST AND EAST**

C. G. JUNG

SECOND EDITION

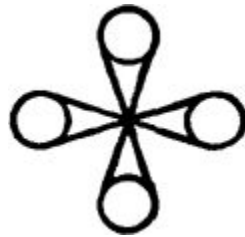

TRANSLATED BY R. F. C. HULL

BOLLINGEN SERIES XX

PRINCETON UNIVERSITY PRESS

COPYRIGHT © 1958 BY BOLLINGEN FOUNDATION, NEW YORK, N. Y.

SECOND EDITION COPYRIGHT © 1969

BY PRINCETON UNIVERSITY PRESS, PRINCETON, NEW JERSEY

Second edition, 1969

Second printing, 1973

THIS EDITION IS BEING PUBLISHED IN THE UNITED STATES OF AMERICA BY PRINCETON UNIVERSITY PRESS, AND IN ENGLAND BY ROUTLEDGE AND KEGAN PAUL, LTD. IN THE AMERICAN EDITION, ALL THE VOLUMES COMPRISING THE COLLECTED WORKS CONSTITUTE NUMBER XX IN BOLLINGEN SERIES, SPONSORED BY BOLLINGEN FOUNDATION. THE PRESENT VOLUME IS NUMBER 11 OF THE COLLECTED WORKS, AND WAS THE SEVENTH TO APPEAR.

Psychology and Religion (The Terry Lectures) copyright 1938, renewed 1966 by Yale University Press. Foreword to the *I Ching* copyright 1950 and “Transformation Symbolism in the Mass” copyright © 1955 by Bollingen Foundation Inc. Foreword to *White’s God and the Unconscious* copyright 1953 by Henry Regnery Co.

LIBRARY OF CONGRESS CATALOG CARD NUMBER: 75-156

ISBN 0-691-09772-0

MANUFACTURED IN THE U.S.A.

EDITORIAL NOTE

The title *Psychology and Religion: West and East* calls for comment, since no single volume can cover Jung's publications on a subject that takes so prominent a place in all his later works. To a full understanding of Jung's thesis on religion a thorough grasp of his theory of the archetypes is essential, as well as a knowledge of several other of the volumes of the Collected Works, of which *Aion* and *Psychology and Alchemy* may be singled out.

It could, therefore, be said that the Editors would have been better advised to group all these works under the general title *Psychology and Religion*, rather than confine this title to a single volume. It will not be out of place to remember that Jung's definition of religion is a wide one. Religion, he says, is "a careful and scrupulous observation of what Rudolf Otto aptly termed the *numinosum*." From this standpoint, Jung was struck by the contrasting methods of observation employed by religious men of the East and by those of the predominantly Christian West.

The main part of the title is that of the Terry Lectures for 1937, its general applicability being evident; but the volume has a particular aim, which the subtitle *West and East* clarifies. Thus the division into two parts, "Western Religion" and "Eastern Religion," reflecting Jung's idea that the two are radically different.

In the original "Psychology and Religion," which introduces Part One, Jung expounds the relation between Christianity and alchemy. This connection he has worked out in greater detail in *Psychology and Alchemy*, where he says that "alchemy seems like a continuation of Christian mysticism carried on in the subterranean darkness of the unconscious." There follow in this volume "A Psychological Approach to the Dogma of the Trinity," translated for the first time into English, and "Transformation Symbolism in the Mass," which presents alchemical and Aztec parallels to the Christian ritual. Part One ends with the provocative essay "Answer to Job." These three works, all original researches of distinctive importance, are especially significant because they penetrate to the heart of Christian symbolism and shed new light on its psychological meaning. Part One also contains two forewords, of particular interest because the books they introduce both illustrate the relevance of Jung's work for religious thinking; a short essay on the Swiss saint, Brother Klaus; and two essays on the relation between psychotherapy and religious healing.

It is worthy of note that most of the works on Eastern religion in Part Two are commentaries or forewords, in contrast with the authoritative tone of Jung's writings on Christianity and alchemy. This fact confirms what should be clear from all his

work: that his main interest has been in the psychology of Western man and so in his religious life and development.

It may be a matter for surprise that the foreword to the *I Ching*, which closes the volume, is included here; it is a document that would scarcely be termed religious, in the common usage of that word. If, however, Jung's definition cited above be kept in mind, and if it be remembered that the earlier interpretations of what is now known as synchronicity were essentially religious in Jung's sense and that the *I Ching* was studied by the most illustrious of the Eastern sages, the intention of the Editors will be apparent. Jung's commentary on *The Secret of the Golden Flower* might equally well have come into the second part of this volume, but because of the many analogies between this Taoist text and alchemy, the Editors have placed it in Volume 13, *Alchemical Studies*.

*

Grateful acknowledgment is made to the School of American Research, Santa Fe, New Mexico, for a quotation from the Anderson and Dibble translation of Sahagún; to the Clarendon Press, Oxford, for passages from M. R. James, *The Apocryphal New Testament*; the Oxford University Press, for Professor Jung's commentary on *The Tibetan Book of the Great Liberation*; and the Harvill Press and the Henry Regnery Company for Professor Jung's foreword to *God and the Unconscious*.

The frontispiece is from a photograph by Giraudon, Paris, of an illustration in the Book of Hours of Etienne Chevalier, Condé Museum, Chantilly.

TRANSLATOR'S NOTE

I wish to make grateful acknowledgment to the following persons, whose various translations have been consulted to a greater or less degree during the preparation of this volume; Miss Monica Curtis, for help derived from her perceptive translation of extensive portions of "Transformation Symbolism in the Mass," published as Guild Lecture No. 69 by the Guild of Pastoral Psychology, London, and of which certain passages are incorporated here almost verbatim; Father Victor White, O.P., for the use of his translation of the foreword to his book *God and the Unconscious*; Dr. Horace Gray, for reference to his translation of "Brother Klaus" in the *Journal of Nervous and Mental Diseases*; Mr. W. S. Dell and Mrs. Cary F. Baynes, for reference to their translation of "Psychotherapists or the Clergy" in *Modern Man in Search of a Soul*; Dr. James Kirsch, for making available to me his private translation of "Answer to Job," prepared for members of a seminar he conducted at Los Angeles, 1952–53, and also for his helpful criticism during personal discussions; Mrs. Cary F. Baynes, for reference to her translation of "Yoga and the West" in *Prabuddha Bharata* and for the use with only minor alterations of her translation of the foreword to the *I Ching*; Miss Constance Rolfe, for reference to her translation of the foreword to Suzuki's *Introduction to Zen Buddhism*; and Mrs. Carol Baumann, for reference to her translation of "The Psychology of Eastern Meditation" in *Art and Thought*. Acknowledgment is also made to Mr. A. S. B. Glover for his translations of many Latin passages throughout as well as for the index.

EDITORIAL NOTE TO THE SECOND EDITION

Bibliographical citations and entries have been revised in the light of subsequent publications in the *Collected Works*; some revisions have been made in the translation as the consequence of continued study of Jung's work particularly in alchemy; other revisions and minor additions of a reference nature arose as the result of the publication of *Zur Psychologie Westlicher und Östlicher Religion*, Band 11 in the *Gesammelte Werke* (Zurich: Rascher, 1963), which was mostly edited before Jung's death.

The paragraph numbers of the Swiss and English editions of Volume 11 correspond through par. 963. Thereafter, the "Foreword to the 'I Ching'" varies somewhat in the original German manuscript, which is reproduced in the Swiss edition. Finally, the Swiss edition contains an appendix of short articles, which are disposed as follows in the English edition:

"Answer to Martin Buber" (1952) : Vol. 18.

"Good and Evil in Analytical Psychology" (1959) : Vol. 10, pars. 858 ff.

"On *Die Reden Gotamo Buddhos*, by K. E. Neumann" (1955) : Vol. 18.

Four extracts from letters to theologians: to be published in a separate edition of Jung's Letters under the editorship of Gerhard Adler.

VOLUME 11
PSYCHOLOGY AND RELIGION: WEST AND EAST

TABLE OF CONTENTS

EDITORIAL NOTE

TRANSLATOR'S NOTE

PART ONE: WESTERN RELIGION

I

Psychology and Religion

Originally published in English: The Terry Lectures of 1937 (New Haven, Conn.: Yale University Press, and London: Oxford University Press, 1938); here revised and augmented in accordance with the Swiss edition (Zurich: Rascher, 1940).

1. The Autonomy of the Unconscious
2. Dogma and Natural Symbols
3. The History and Psychology of a Natural Symbol

II

A Psychological Approach to the Dogma of the Trinity

Translated from "Versuch zu einer psychologischen Deutung des Trinitätsdogmas," *Symbolik des Geistes* (Zurich: Rascher, 1948).

Introduction

1. Pre-Christian Parallels
 - I. Babylonia
 - II. Egypt
 - III. Greece
2. Father, Son, and Spirit
3. The Symbola

- I. The Symbolum Apostolicum
- II. The Symbolum of Gregory Thaumaturgus
- III. The Nicaenum
- IV. The Nicaeno-Constantinopolitanum, the Athanasianum, and the Lateranense
4. The Three Persons in the Light of Psychology
 - I. The Hypothesis of the Archetype
 - II. Christ as Archetype
 - III. The Holy Ghost
5. The Problem of the Fourth
 - I. The Concept of Quaternity
 - II. The Psychology of the Quaternity
 - III. General Remarks on Symbolism
6. Conclusion

III

Transformation Symbolism in the Mass

Translated from “Das Wandlungssymbol in der Messe,” *Von den Wurzeln des Bewusstseins* (Zurich: Rascher, 1954).

1. Introduction
2. The Sequence of the Transformation Rite
 - I. Oblation of the Bread.
 - II. Preparation of the Chalice
 - III. Elevation of the Chalice
 - IV. Censing of the Substances and the Altar
 - V. The Epiclesis
 - VI. The Consecration
 - VII. The Greater Elevation
 - VIII. The Post-Consecration
 - IX. End of the Canon
 - X. Breaking of the Host (“Fractio”)
 - XI. Consignado
 - XII. Commixtio

XIII. Conclusion

3. Parallels to the Transformation Mystery

I. The Aztec “Teoqualo,”

II. The Vision of Zosimos

4. The Psychology of the Mass

I. General Remarks on the Sacrifice

II. The Psychological Meaning of Sacrifice

III. The Mass and the Individuation Process

IV

Foreword to White’s *God and the Unconscious*

Originally translated from a manuscript and published in English in the book by Victor White (London: Harvill, 1952; Chicago: H. Regnery, 1953).

Foreword to Werblowsky’s *Lucifer and Prometheus*

Originally translated from a manuscript and published in English in the book by R. J. Zwi Werblowsky (London: Routledge and Kegan Paul, 1952).

Brother Klaus

Translated from a book review in the *Neue Schweizer Rundschau* (Zurich), new series, I (1933).

V

Psychotherapists or the Clergy

Translated from *Die Beziehungen der Psychotherapie zur Seelsorge* (Zurich: Rascher, 1932).

Psychoanalysis and the Cure of Souls

Translated from “Psychoanalyse und Seelsorge,” *Ethik: Sexual- und Gesellschafts-Ethik* (Halle), V (1928).

VI

Answer to Job

Translated from *Antwort auf Hiob* (Zurich: Rascher, 1952).

Prefatory Note

Lectori Benevolo

Answer to Job

PART TWO: EASTERN RELIGION

VII

Psychological Commentary on *The Tibetan Book of the Great Liberation*

Originally published in English in the book (London and New York: Oxford University Press, 1954).

1. The Difference between Eastern and Western Thinking.
2. Comments on the Text

Psychological Commentary on *The Tibetan Book of the Dead*

Translated from “Psychologischer Kommentar zum Bardo Thödol,” in *Das Tibetische Totenbuch*, 5th edition (Zurich: Rascher, 1953).

VIII

Yoga and the West

Originally translated from a manuscript and published in English in *Prabuddha Bharata* (Calcutta), February 1936.

Foreword to Suzuki’s *Introduction to Zen Buddhism*

Translated from the foreword to D. T. Suzuki, *Die Grosse Befreiung: Einführung in den Zen-Buddhismus* (Leipzig: Curt Weller, 1939).

The Psychology of Eastern Meditation

Translated from “Zur Psychologie östlicher Meditation,” *Symbolik des Geistes* (Zurich: Rascher, 1948).

The Holy Men of India

Translated from the introduction to Heinrich Zimmer, *Der Weg zum Selbst* (Zurich: Rascher, 1944).

IX

Foreword to the *I Ching*

Originally translated from a manuscript and published in English in *The I Ching, or Book of Changes*, translated by Cary F. Baynes from the German translation of Richard Wilhelm (New York: Pantheon Books [Bollingen Series XIX] and London: Routledge and Kegan Paul, 1950). This is the Baynes translation of the Foreword with minor revisions.

BIBLIOGRAPHY

INDEX

PART ONE

WESTERN RELIGION

PSYCHOLOGY AND RELIGION

[Originally written in English and delivered in 1937, at Yale University, New Haven, Connecticut, as the fifteenth series of “Lectures on Religion in the Light of Science and Philosophy” under the auspices of the Dwight Harrington Terry Foundation. The lectures were published for the Terry Foundation by the Yale University Press (and by Oxford University Press, London) in 1938. They were then translated into German by Felicia Froboese, and the translation, revised by Toni Wolff and augmented by Professor Jung, was published at Zurich, 1940, as *Psychologie und Religion*. The present version is based on both the original English and the German versions and contains the revisions and additions of the latter.—EDITORS.]

1. THE AUTONOMY OF THE UNCONSCIOUS

- [1] As it seems to be the intention of the founder of the Terry Lectures to enable representatives of science, as well as of philosophy and other spheres of human knowledge, to contribute to the discussion of the eternal problem of religion, and since Yale University has bestowed upon me the great honour of delivering the Terry Lectures for 1937, I assume that it will be my task to show what psychology, or rather that special branch of medical psychology which I represent, has to do with or to say about religion. Since religion is incontestably one of the earliest and most universal expressions of the human mind, it is obvious that any psychology which touches upon the psychological structure of human personality cannot avoid taking note of the fact that religion is not only a sociological and historical phenomenon, but also something of considerable personal concern to a great number of individuals.
- [2] Although I have often been called a philosopher, I am an empiricist and adhere as such to the phenomenological standpoint. I trust that it does not conflict with the principles of scientific empiricism if one occasionally makes certain reflections which go beyond a mere accumulation and classification of experience. As a matter of fact I believe that experience is not even possible without reflection, because “experience” is a process of assimilation without which there could be no understanding. As this statement indicates, I approach psychological matters from a scientific and not from a philosophical standpoint. Inasmuch as religion has a very important psychological aspect, I deal with it from a purely empirical point of view, that is, I restrict myself to the observation of phenomena and I eschew any metaphysical or philosophical considerations. I do not deny the validity of these other considerations, but I cannot claim to be competent to apply them correctly.
- [3] I am aware that most people believe they know all there is to be known about psychology, because they think that psychology is nothing but what they know of themselves. But I am afraid psychology is a good deal more than that. While having little to do with philosophy, it has much to do with empirical facts, many of which are not easily accessible to the experience of the average man. It is my intention to give you a few glimpses of the way in which practical psychology comes up against the problem of religion. It is self-evident that the vastness of the problem requires far more than three lectures, as the necessary elaboration of concrete detail takes a great deal of time and explanation. My first lecture will be a sort of introduction to the

problem of practical psychology and religion. The second is concerned with facts which demonstrate the existence of an authentic religious function in the unconscious. The third deals with the religious symbolism of unconscious processes.

[4] Since I am going to present a rather unusual argument, I cannot assume that my audience will be fully acquainted with the methodological standpoint of the branch of psychology I represent. This standpoint is exclusively phenomenological, that is, it is concerned with occurrences, events, experiences—in a word, with facts. Its truth is a fact and not a judgment. When psychology speaks, for instance, of the motif of the virgin birth, it is only concerned with the fact that there is such an idea, but it is not concerned with the question whether such an idea is true or false in any other sense. The idea is psychologically true inasmuch as it exists. Psychological existence is subjective in so far as an idea occurs in only one individual. But it is objective in so far as that idea is shared by a society—by a *consensus gentium*.

[5] This point of view is the same as that of natural science. Psychology deals with ideas and other mental contents as zoology, for instance, deals with the different species of animals. An elephant is “true” because it exists. The elephant is neither an inference nor a statement nor the subjective judgment of a creator. It is a phenomenon. But we are so used to the idea that psychic events are wilful and arbitrary products, or even the inventions of a human creator, that we can hardly rid ourselves of the prejudiced view that the psyche and its contents are nothing but our own arbitrary invention or the more or less illusory product of supposition and judgment. The fact is that certain ideas exist almost everywhere and at all times and can even spontaneously create themselves quite independently of migration and tradition. They are not made by the individual, they just happen to him—they even force themselves on his consciousness. This is not Platonic philosophy but empirical psychology.

[6] In speaking of religion I must make clear from the start what I mean by that term. Religion, as the Latin word denotes, is a careful and scrupulous observation of what Rudolf Otto¹ aptly termed the *numinosum*, that is, a dynamic agency or effect not caused by an arbitrary act of will. On the contrary, it seizes and controls the human subject, who is always rather its victim than its creator. The *numinosum*—whatever its cause may be—is an experience of the subject independent of his will. At all events, religious teaching as well as the *consensus gentium* always and everywhere explain this experience as being due to a cause external to the individual. The *numinosum* is either a quality belonging to a visible object or the influence of an invisible presence that causes a peculiar alteration of consciousness. This is, at any rate, the general rule.

- [7] There are, however, certain exceptions when it comes to the question of religious practice or ritual. A great many ritualistic performances are carried out for the sole purpose of producing at will the effect of the *numinosum* by means of certain devices of a magical nature, such as invocation, incantation, sacrifice, meditation and other yoga practices, self-inflicted tortures of various descriptions, and so forth. But a religious belief in an external and objective divine cause is always prior to any such performance. The Catholic Church, for instance, administers the sacraments for the purpose of bestowing their spiritual blessings upon the believer; but since this act would amount to enforcing the presence of divine grace by an indubitably magical procedure, it is logically argued that nobody can compel divine grace to be present in the sacramental act, but that it is nevertheless inevitably present since the sacrament is a divine institution which God would not have caused to be if he had not intended to lend it his support.²
- [8] Religion appears to me to be a peculiar attitude of mind which could be formulated in accordance with the original use of the word *religio*, which means a careful consideration and observation of certain dynamic factors that are conceived as “powers”: spirits, daemons, gods, laws, ideas, ideals, or whatever name man has given to such factors in his world as he has found powerful, dangerous, or helpful enough to be taken into careful consideration, or grand, beautiful, and meaningful enough to be devoutly worshipped and loved. In colloquial speech one often says of somebody who is enthusiastically interested in a certain pursuit that he is almost “religiously devoted” to his cause; William James, for instance, remarks that a scientist often has no creed, but his “temper is devout.”³
- [9] I want to make clear that by the term “religion”⁴ I do not mean a creed. It is, however, true that every creed is originally based on the one hand upon the experience of the *numinosum* and on the other hand upon *πίστις*, that is to say, trust or loyalty, faith and confidence in a certain experience of a numinous nature and in the change of consciousness that ensues. The conversion of Paul is a striking example of this. We might say, then, that the term “religion” designates the attitude peculiar to a consciousness which has been changed by experience of the *numinosum*.
- [10] Creeds are codified and dogmatized forms of original religious experience.⁵ The contents of the experience have become sanctified and are usually congealed in a rigid, often elaborate, structure of ideas. The practice and repetition of the original experience have become a ritual and an unchangeable institution. This does not necessarily mean lifeless petrification. On the contrary, it may prove to be a valid form of religious experience for millions of people for thousands of years, without there arising any vital necessity to alter it. Although the Catholic Church has often been accused of particular rigidity, she nevertheless admits that dogma is a living

thing and that its formulation is therefore capable of change and development. Even the number of dogmas is not limited and can be multiplied in the course of time. The same holds true of the ritual. Yet all changes and developments are determined within the framework of the facts as originally experienced, and this sets up a special kind of dogmatic content and emotional value. Even Protestantism, which has abandoned itself apparently to an almost unlimited emancipation from dogmatic tradition and codified ritual and has thus split into more than four hundred denominations—even Protestantism is bound at least to be Christian and to express itself within the framework of the belief that God revealed himself in Christ, who suffered for mankind. This is a definite framework with definite contents which cannot be combined with or supplemented by Buddhist or Islamic ideas and feelings. Yet it is unquestionably true that not only Buddha and Mohammed, Confucius and Zarathustra, represent religious phenomena, but also Mithras, Attis, Cybele, Mani, Hermes, and the deities of many other exotic cults. The psychologist, if he takes up a scientific attitude, has to disregard the claim of every creed to be the unique and eternal truth. He must keep his eye on the human side of the religious problem, since he is concerned with the original religious experience quite apart from what the creeds have made of it.

[11] As I am a doctor and a specialist in nervous and mental diseases, my point of departure is not a creed but the psychology of the *homo religiosus*, that is, of the man who takes into account and carefully observes certain factors which influence him and his general condition. It is easy to designate and define these factors in accordance with historical tradition or ethnological knowledge, but to do the same thing from the standpoint of psychology is an uncommonly difficult task. What I can contribute to the question of religion is derived entirely from my practical experience, both with my patients and with so-called normal persons. As our experience with people depends to a large extent upon what we do with them, I can see no other way of proceeding than to give you at least a general idea of the line I take in my professional work.

[12] Since every neurosis is connected with man's most intimate life, there will always be some hesitation when a patient has to give a complete account of all the circumstances and complications which originally led him into a morbid condition. But why shouldn't he be able to talk freely? Why should he be afraid or shy or prudish? The reason is that he is "carefully observing" certain external factors which together constitute what one calls public opinion or respectability or reputation. And even if he trusts his doctor and is no longer shy of him, he will be reluctant or even afraid to admit certain things to *himself*, as if it were dangerous to become conscious of himself. One is usually afraid of things that seem to be overpowering. But is there anything in man that is stronger than himself? We should not forget that every

neurosis entails a corresponding amount of demoralization. If a man is neurotic, he has lost confidence in himself. A neurosis is a humiliating defeat and is felt as such by people who are not entirely unconscious of their own psychology. And one is defeated by something “unreal.” Doctors may have assured the patient, long ago, that there is nothing the matter with him, that he does not suffer from a real heart-disease or from a real cancer. His symptoms are quite imaginary. The more he believes that he is a *malade imaginaire*, the more a feeling of inferiority permeates his whole personality. “If my symptoms are imaginary,” he will say, “where have I picked up this confounded imagination and why should I put up with such a perfect nuisance?” It is indeed pathetic to have an intelligent man almost imploringly assure you that he is suffering from an intestinal cancer and declare at the same time in a despondent voice that of course he knows his cancer is a purely imaginary affair.

[13] Our usual materialistic conception of the psyche is, I am afraid, not particularly helpful in cases of neurosis. If only the soul were endowed with a subtle body, then one could at least say that this breath- or vapour-body was suffering from a real though somewhat ethereal cancer, in the same way as the gross material body can succumb to a cancerous disease. That, at least, would be something real. Medicine therefore feels a strong aversion for anything of a psychic nature—either the body is ill or there is nothing the matter. And if you cannot prove that the body is really ill, that is only because our present techniques do not enable the doctor to discover the true nature of the undoubtedly organic trouble.

[14] But what, actually, is the psyche? Materialistic prejudice explains it as a mere epiphenomenal by-product of organic processes in the brain. Any psychic disturbance must therefore be an organic or physical disorder which is undiscoverable only because of the inadequacy of our present methods of diagnosis. The undeniable connection between psyche and brain gives this point of view a certain weight, but not enough to make it an unshakable truth. We do not know whether there is a real disturbance of the organic processes in the brain in a case of neurosis, and if there are disorders of an endocrine nature it is impossible to say whether they might not be effects rather than causes.

[15] On the other hand, it cannot be doubted that the real causes of neurosis are psychological. Not so long ago it was very difficult to imagine how an organic or physical disorder could be relieved by quite simple psychological means, yet in recent years medical science has recognized a whole class of diseases, the psychosomatic disorders, in which the patient’s psychology plays the essential part. Since my readers may not be familiar with these medical facts I may instance a case of hysterical fever, with a temperature of 102°, which was cured in a few minutes through confession of the psychological cause. A patient with psoriasis extending

over practically the whole body was told that I did not feel competent to treat his skin trouble, but that I should concentrate on his psychological conflicts, which were numerous. After six weeks of intense analysis and discussion of his purely psychological difficulties, there came about as an unexpected by-product the almost complete disappearance of the skin disease. In another case, the patient had recently undergone an operation for distention of the colon. Forty centimetres of it had been removed, but this was followed by another extraordinary distention. The patient was desperate and refused to permit a second operation, though the surgeon thought it vital. As soon as certain intimate psychological facts were discovered, the colon began to function normally again.

[16] Such experiences make it exceedingly difficult to believe that the psyche is nothing, or that an imaginary fact is unreal. Only, it is not there where a near-sighted mind seeks it. It exists, but not in physical form. It is an almost absurd prejudice to suppose that existence can only be physical. As a matter of fact, the only form of existence of which we have immediate knowledge is psychic. We might well say, on the contrary, that physical existence is a mere inference, since we know of matter only in so far as we perceive psychic images mediated by the senses.

[17] We are surely making a great mistake when we forget this simple yet fundamental truth. Even if a neurosis had no cause at all other than imagination, it would, none the less, be a very real thing. If a man imagined that I was his arch-enemy and killed me, I should be dead on account of mere imagination. Imaginary conditions do exist and they may be just as real and just as harmful or dangerous as physical conditions. I even believe that psychic disturbances are far more dangerous than epidemics or earthquakes. Not even the medieval epidemics of bubonic plague or smallpox killed as many people as certain differences of opinion in 1914 or certain political "ideals" in Russia.

[18] Although the mind cannot apprehend its own form of existence, owing to the lack of an Archimedean point outside, it nevertheless exists. Not only does the psyche exist, it is existence itself.

[19] What, then, shall we say to our patient with the imaginary cancer? I would tell him: "Yes, my friend, you are really suffering from a cancer-like thing, you really do harbour in yourself a deadly evil. However, it will not kill your body, because it is imaginary. But it will eventually kill your soul. It has already spoilt and even poisoned your human relations and your personal happiness and it will go on growing until it has swallowed your whole psychic existence. So that in the end you will not be a human being any more, but an evil destructive tumour."

[20] It is obvious to our patient that he is not the author of his morbid imagination, although his theoretical turn of mind will certainly suggest that he is the owner and

maker of his own imaginings. If a man is suffering from a real cancer, he never believes himself to be responsible for such an evil, despite the fact that the cancer is in his own body. But when it comes to the psyche we instantly feel a kind of responsibility, as if we were the makers of our psychic conditions. This prejudice is of relatively recent date. Not so very long ago even highly civilized people believed that psychic agencies could influence our minds and feelings. There were ghosts, wizards, and witches, daemons and angels, and even gods, who could produce certain psychological changes in human beings. In former times the man with the idea that he had cancer might have felt quite differently about his idea. He would probably have assumed that somebody had worked witchcraft against him or that he was possessed. He never would have thought of himself as the originator of such a fantasy.

[21] As a matter of fact, I take his cancer to be a spontaneous growth, which originated in the part of the psyche that is not identical with consciousness. It appears as an autonomous formation intruding upon consciousness. Of consciousness one might say that it is our own psychic existence, but the cancer has *its* own psychic existence, independent of ourselves. This statement seems to formulate the observable facts completely. If we submit such a case to an association experiment,⁶ we soon discover that he is not master in his own house. His reactions will be delayed, altered, suppressed, or replaced by autonomous intruders. There will be a number of stimulus-words which cannot be answered by his conscious intention. They will be answered by certain autonomous contents, which are very often unconscious even to himself. In our case we shall certainly discover answers that come from the psychic complex at the root of the cancer idea. Whenever a stimulus-word touches something connected with the hidden complex, the reaction of the conscious ego will be disturbed, or even replaced, by an answer coming from the complex. It is just as if the complex were an autonomous being capable of interfering with the intentions of the ego. Complexes do indeed behave like secondary or partial personalities possessing a mental life of their own.

[22] Many complexes are split off from consciousness because the latter preferred to get rid of them by repression. But there are others that have never been in consciousness before and therefore could never have been arbitrarily repressed. They grow out of the unconscious and invade the conscious mind with their weird and unassailable convictions and impulses. Our patient belonged to the latter category. Despite his culture and intelligence, he was a helpless victim of something that obsessed and possessed him. He was unable to help himself in any way against the demonic power of his morbid idea. It proliferated in him like a carcinoma. One day the idea appeared and from then on it remained unshakable; there were only short intervals when he was free from it.

[23] The existence of such cases does something to explain why people are afraid of becoming conscious of themselves. There might really be something behind the screen—one never knows—and so people prefer “to consider and observe carefully” the factors external to their consciousness. In most people there is a sort of primitive *δεισιδαιμονία* with regard to the possible contents of the unconscious. Beneath all natural shyness, shame, and tact, there is a secret fear of the unknown “perils of the soul.” Of course one is reluctant to admit such a ridiculous fear. But one should realize that this fear is by no means unjustified; on the contrary, it is only too well founded. We can never be sure that a new idea will not seize either upon ourselves or upon our neighbours. We know from modern as well as from ancient history that such ideas are often so strange, indeed so bizarre, that they fly in the face of reason. The fascination which is almost invariably connected with ideas of this sort produces a fanatical obsession, with the result that all dissenters, no matter how well meaning or reasonable they are, get burnt alive or have their heads cut off or are disposed of in masses by the more modern machine-gun. We cannot even console ourselves with the thought that such things belong to the remote past. Unfortunately they seem to belong not only to the present, but, quite particularly, to the future. “Homo homini lupus” is a sad yet eternal truism. There is indeed reason enough for man to be afraid of the impersonal forces lurking in his unconscious. We are blissfully unconscious of these forces because they never, or almost never, appear in our personal relations or under ordinary circumstances. But if people crowd together and form a mob, then the dynamisms of the collective man are let loose—beasts or demons that lie dormant in every person until he is part of a mob. Man in the mass sinks unconsciously to an inferior moral and intellectual level, to that level which is always there, below the threshold of consciousness, ready to break forth as soon as it is activated by the formation of a mass.

[24] It is, to my mind, a fatal mistake to regard the human psyche as a purely personal affair and to explain it exclusively from a personal point of view. Such a mode of explanation is only applicable to the individual in his ordinary everyday occupations and relationships. If, however, some slight trouble occurs, perhaps in the form of an unforeseen and somewhat unusual event, instantly instinctual forces are called up, forces which appear to be wholly unexpected, new, and strange. They can no longer be explained in terms of personal motives, being comparable rather to certain primitive occurrences like panics at solar eclipses and the like. To explain the murderous outbreak of Bolshevism, for instance, as a personal father-complex appears to me singularly inadequate.

[25] The change of character brought about by the uprush of collective forces is amazing. A gentle and reasonable being can be transformed into a maniac or a savage beast. One is always inclined to lay the blame on external circumstances, but nothing

could explode in us if it had not been there. As a matter of fact, we are constantly living on the edge of a volcano, and there is, so far as we know, no way of protecting ourselves from a possible outburst that will destroy everybody within reach. It is certainly a good thing to preach reason and common sense, but what if you have a lunatic asylum for an audience or a crowd in a collective frenzy? There is not much difference between them because the madman and the mob are both moved by impersonal, overwhelming forces.

[26] As a matter of fact, it only needs a neurosis to conjure up a force that cannot be dealt with by rational means. Our cancer case shows clearly how impotent man's reason and intellect are against the most palpable nonsense. I always advise my patients to take such obvious but invincible nonsense as the manifestation of a power and a meaning they have not yet understood. Experience has taught me that it is much more effective to take these things seriously and then look for a suitable explanation. But an explanation is suitable only when it produces a hypothesis equal to the morbid effect. Our patient is confronted with a power of will and suggestion more than equal to anything his consciousness can put against it. In this precarious situation it would be bad strategy to convince him that in some incomprehensible way he is at the back of his own symptom, secretly inventing and supporting it. Such a suggestion would instantly paralyse his fighting spirit, and he would get demoralized. It is far better for him to understand that his complex is an autonomous power directed against his conscious personality. Moreover, such an explanation fits the actual facts much better than a reduction to personal motives. An apparently personal motivation does exist, but it is not made by his will, it just happens to him.

[27] When in the Babylonian epic Gilgamesh's arrogance and hybris defy the gods, they create a man equal in strength to Gilgamesh in order to check the hero's unlawful ambition. The very same thing has happened to our patient: he is a thinker who has settled, or is always going to settle, the world by the power of his intellect and reason. His ambition has at least succeeded in forging his own personal fate. He has forced everything under the inexorable law of his reason, but somewhere nature escaped and came back with a vengeance in the form of an unassailable bit of nonsense, the cancer idea. This was the clever device of the unconscious to keep him on a merciless and cruel leash. It was the worst blow that could be dealt to all his rational ideals and especially to his belief in the all-powerful human will. Such an obsession can occur only in a person who makes habitual misuse of reason and intellect for egotistical power purposes.

[28] Gilgamesh, however, escaped the vengeance of the gods. He had warning dreams to which he paid attention. They showed him how he could overcome his enemy. Our patient, living in an age when the gods have become extinct and have fallen into bad

repute, also had such dreams, but he did not listen to them. How could an intelligent man be so superstitious as to take dreams seriously! The very common prejudice against dreams is but one symptom of a far more serious undervaluation of the human psyche in general. The marvellous development of science and technics is counterbalanced by an appalling lack of wisdom and introspection. It is true that our religion speaks of an immortal soul; but it has very few kind words to say for the human psyche as such, which would go straight to eternal damnation were it not for a special act of Divine Grace. These two important factors are largely responsible for the general undervaluation of the psyche, but not entirely so. Older by far than these relatively recent developments are the primitive fear of and aversion to everything that borders on the unconscious.

[29] Consciousness must have been a very precarious thing in its beginnings. In relatively primitive societies we can still observe how easily consciousness gets lost. One of the “perils of the soul,”⁷ for instance, is the loss of a soul. This is what happens when part of the psyche becomes unconscious again. Another example is “running amok,”⁸ the equivalent of “going berserk” in Germanic saga.⁹ This is a more or less complete trance-state, often accompanied by devastating social effects. Even a quite ordinary emotion can cause considerable loss of consciousness. Primitives therefore cultivate elaborate forms of politeness, speaking in a hushed voice, laying down their weapons, crawling on all fours, bowing the head, showing the palms. Even our own forms of politeness still exhibit a “religious” consideration of possible psychic dangers. We propitiate fate by magically wishing one another a good day. It is not good form to keep the left hand in your pocket or behind your back when shaking hands. If you want to be particularly ingratiating you use both hands. Before people of great authority we bow with uncovered head, i.e., we offer our head unprotected in order to propitiate the powerful one, who might quite easily fall sudden prey to a fit of uncontrollable violence. In war-dances primitives can become so excited that they may even shed blood.

[30] The life of the primitive is filled with constant regard for the ever-lurking possibility of psychic danger, and the procedures employed to diminish the risks are very numerous. The setting up of tabooed areas is an outward expression of this fact. The innumerable taboos are delimited psychic areas which are meticulously and fearfully observed. I once made a terrific mistake when I was with a tribe on the southern slopes of Mount Elgon, in East Africa. I wanted to inquire about the ghost-houses I frequently found in the woods, and during a palaver I mentioned the word *selelteni*, meaning ‘ghost.’ Instantly everybody was silent and painfully embarrassed. They all looked away from me because I had spoken aloud a carefully hushed-up word, and had thus invited most dangerous consequences. I had to change the subject in order to be able to continue the meeting. The same men assured me that they never

had dreams; they were the prerogative of the chief and of the medicine man. The medicine man then confessed to me that he no longer had any dreams either, they had the District Commissioner instead. "Since the English are in the country we have no dreams any more," he said. "The District Commissioner knows everything about war and diseases, and about where we have got to live." This strange statement is based on the fact that dreams were formerly the supreme political guide, the voice of *Mungu*, 'God.' Therefore it would have been unwise for an ordinary man to suggest that he had dreams.

[31] Dreams are the voice of the Unknown, ever threatening new schemes, new dangers, sacrifices, warfare, and other troublesome things. An African Negro once dreamt that his enemies had taken him prisoner and burnt him alive. The next day he called his relatives together and implored them to burn him. They consented so far as to bind his feet together and put them in the fire. He was of course badly crippled but had escaped his foes.¹⁰

[32] There are any amount of magical rites that exist for the sole purpose of erecting a defence against the unexpected, dangerous tendencies of the unconscious. The peculiar fact that the dream is a divine voice and messenger and yet an unending source of trouble does not disturb the primitive mind in the least. We find obvious remnants of this primitive thinking in the psychology of the Hebrew prophets.¹¹ Often enough they hesitate to listen to the voice. And it was, we must admit, rather hard on a pious man like Hosea to marry a harlot in order to obey the Lord's command. Since the dawn of humanity there has been a marked tendency to limit this unruly and arbitrary "supernatural" influence by means of definite forms and laws. And this process has continued throughout history in the form of a multiplication of rites, institutions, and beliefs. During the last two thousand years we find the institution of the Christian Church taking over a mediating and protective function between these influences and man. It is not denied in medieval ecclesiastical writings that a divine influx may occur in dreams, but this view is not exactly encouraged, and the Church reserves the right to decide whether a revelation is to be considered authentic or not.¹² In spite of the Church's recognition that certain dreams are sent by God, she is disinclined, and even averse, to any serious concern with dreams, while admitting that some might conceivably contain an immediate revelation. Thus the change of mental attitude that has taken place in recent centuries is, from this point of view at least, not wholly unwelcome to the Church, because it effectively discouraged the earlier introspective attitude which favoured a serious consideration of dreams and inner experiences.

[33] Protestantism, having pulled down so many walls carefully erected by the Church, immediately began to experience the disintegrating and schismatic effect of

individual revelation. As soon as the dogmatic fence was broken down and the ritual lost its authority, man had to face his inner experience without the protection and guidance of dogma and ritual, which are the very quintessence of Christian as well as of pagan religious experience. Protestantism has, in the main, lost all the finer shades of traditional Christianity: the mass, confession, the greater part of the liturgy, and the vicarious function of priesthood.

[34] I must emphasize that this statement is not a value-judgment and is not intended to be one. I merely state the facts. Protestantism has, however, intensified the authority of the Bible as a substitute for the lost authority of the Church. But as history has shown, one can interpret certain biblical texts in many ways. Nor has scientific criticism of the New Testament been very helpful in enhancing belief in the divine character of the holy scriptures. It is also a fact that under the influence of a so-called scientific enlightenment great masses of educated people have either left the Church or become profoundly indifferent to it. If they were all dull rationalists or neurotic intellectuals the loss would not be regrettable. But many of them are religious people, only incapable of agreeing with the existing forms of belief. Otherwise, one could hardly explain the remarkable effect of the Buchman movement on the more-or-less educated Protestant classes. The Catholic who has turned his back on the Church usually develops a secret or manifest leaning towards atheism, whereas the Protestant follows, if possible, a sectarian movement. The absolutism of the Catholic Church seems to demand an equally absolute negation, whereas Protestant relativism permits of variations.

[35] It may perhaps be thought that I have gone a bit too far into the history of Christianity, and for no other purpose than to explain the prejudice against dreams and inner experiences. But what I have just said might have been part of my conversation with our cancer patient. I told him that it would be better to take his obsession seriously instead of reviling it as pathological nonsense. But to take it seriously would mean acknowledging it as a sort of diagnostic statement of the fact that, in a psyche which really existed, trouble had arisen in the form of a cancer-like growth. "But," he will certainly ask, "what could that growth be?" And I shall answer: "I do not know," as indeed I do not. Although, as I mentioned before, it is surely a compensatory or complementary unconscious formation, nothing is yet known about its specific nature or about its content. It is a spontaneous manifestation of the unconscious, based on contents which are not to be found in consciousness.

[36] My patient is now very curious how I shall set about getting at the contents that form the root of the obsession. I then inform him, at the risk of shocking him severely, that his dreams will provide us with all the necessary information. We will take them as if they issued from an intelligent, purposive, and, as it were, personal

source. This is of course a bold hypothesis and at the same time an adventure, because we are going to give extraordinary credit to a discredited entity—the psyche—whose very existence is still denied by not a few contemporary psychologists as well as by philosophers. A famous anthropologist, when I showed him my way of proceeding, made the typical remark: “That’s all very interesting indeed, but dangerous.” Yes, I admit it is dangerous, just as dangerous as a neurosis. If you want to cure a neurosis you have to risk something. To do something without taking a risk is merely ineffectual, as we know only too well. A surgical operation for cancer is a risk too, and yet it has to be done. For the sake of better understanding I have often felt tempted to advise my patients to think of the psyche as a subtle body in which subtle tumours can grow. The prejudiced belief that the psyche is unimaginable and consequently less than air, or that it is a more or less intellectual system of logical concepts, is so great that when people are not conscious of certain contents they assume these do not exist. They have no confidence and no belief in a reliable psychic functioning outside consciousness, and dreams are thought to be only ridiculous. Under such conditions my proposal arouses the worst suspicions. And indeed I have heard every argument under the sun used against the vague spectres of dreams.

[37] Yet in dreams we find, without any profound analysis, the same conflicts and complexes whose existence can also be demonstrated by the association test. Moreover, these complexes form an integral part of the existing neurosis. We have, therefore, reason to believe that dreams can give us at least as much information as the association test can about the content of a neurosis. As a matter of fact, they give very much more. The symptom is like the shoot above ground, yet the main plant is an extended rhizome underground. The rhizome represents the content of a neurosis; it is the matrix of complexes, of symptoms, and of dreams. We have every reason to believe that dreams mirror exactly the underground processes of the psyche. And if we get there, we literally get at the “roots” of the disease.

[38] As it is not my intention to go any further into the psychopathology of neuroses, I propose to choose another case as an example of how dreams reveal the unknown inner facts of the psyche and of what these facts consist. The dreamer was another intellectual, of remarkable intelligence and learning. He was neurotic and was seeking my help because he felt that his neurosis had become overpowering and was slowly but surely undermining his morale. Fortunately his intellectual integrity had not yet suffered and he had the free use of his fine intelligence. For this reason I set him the task of observing and recording his dreams himself. The dreams were not analysed or explained to him and it was only very much later that we began their analysis. Thus the dreams I am going to relate have not been tampered with at all.

They represent an entirely uninfluenced natural sequence of events. The patient had never read any psychology, much less any analytical psychology.

[39] Since the series consists of over four hundred dreams, I could not possibly convey an impression of the whole material; but I have published elsewhere a selection of seventy-four dreams containing motifs of special religious interest.¹³ The dreamer, it should be said, was a Catholic by education, but no longer a practising one, nor was he interested in religious problems. He was one of those scientifically minded intellectuals who would be simply amazed if anybody should saddle them with religious views of any kind. If one holds that the unconscious has a psychic existence independent of consciousness, a case such as that of our dreamer might be of particular interest, provided we are not mistaken in our conception of the religious character of certain dreams. And if one lays stress on the conscious mind alone and does not credit the unconscious with an independent existence, it will be interesting to find out whether or not the dreams really derive their material from conscious contents. Should the facts favour the hypothesis of the unconscious, one could then use dreams as possible sources of information about the religious tendencies of the unconscious.

[40] One cannot expect dreams to speak of religion as we know it. There are, however, two dreams among the four hundred that obviously deal with religion. I will now give the text which the dreamer himself had taken down:

All the houses have something theatrical about them, with stage scenery and decorations. The name of Bernard Shaw is mentioned. The play is supposed to take place in the distant future. There is a notice in English and German on one of the sets:

This is the universal Catholic Church.

It is the Church of the Lord.

All those who feel that they are the instruments of the Lord may enter.

Under this is printed in smaller letters: "The Church was founded by Jesus and Paul"—like a firm advertising its long standing.

I say to my friend, "Come on, let's have a look at this." He replies, "I do not see why a lot of people have to get together when they're feeling religious." I answer, "As a Protestant you will never understand." A woman nods emphatic approval. Then I see a sort of proclamation on the wall of the church. It runs:

Soldiers!

When you feel you are under the power of the Lord, do not address him directly. The Lord cannot be reached by words. We also strongly advise you not to indulge in any discussions among yourselves concerning the attributes of the Lord. It is futile, for everything valuable and important is ineffable.

(Signed) Pope ... (Name illegible)

Now we go in. The interior resembles a mosque, more particularly the Hagia Sophia: no seats—wonderful effect of space; no images, only framed texts decorating the walls (like the Koran texts in the Hagia Sophia). One of the texts reads “Do not flatter your benefactor.” The woman who had nodded approval bursts into tears and cries, “Then there’s nothing left!” I reply, “I find it quite right!” but she vanishes. At first I stand with a pillar in front of me and can see nothing. Then I change my position and see a crowd of people. I do not belong to them and stand alone. But they are quite clear, so that I can see their faces. They all say in unison, “We confess that we are under the power of the Lord. The Kingdom of Heaven is within us.” They repeat this three times with great solemnity. Then the organ starts to play and they sing a Bach fugue with chorale. But the original text is omitted; sometimes there is only a sort of coloratura singing, then the words are repeated: “Everything else is paper” (meaning that it does not make a living impression on me). When the chorale has faded away the gemütlich part of the ceremony begins; it is almost like a students’ party. The people are all cheerful and equable. We move about, converse, and greet one another, and wine (from an episcopal seminary) is served with other refreshments. The health of the Church is drunk and, as if to express everybody’s pleasure at the increase in membership, a loudspeaker blares a ragtime melody with the refrain, “Charles is also with us now.” A priest explains to me: “These somewhat trivial amusements are officially approved and permitted. We must adapt a little to American methods. With a large crowd such as we have here this is inevitable. But we differ in principle from the American churches by our decidedly anti-ascetic tendency.” Thereupon I awake with a feeling of great relief.

[41] There are, as you know, numerous works on the phenomenology of dreams, but very few that deal with their psychology. This for the obvious reason that a psychological interpretation of dreams is an exceedingly ticklish and risky business. Freud has made a courageous attempt to elucidate the intricacies of dream psychology with the help of views which he gathered in the field of psychopathology.¹⁴ Much as I admire the boldness of his attempt, I cannot agree either with his method or with its results. He explains the dream as a mere façade behind which something has been carefully hidden. There is no doubt that neurotics hide disagreeable things, probably just as much as normal people do. But it is a serious question whether this category can be applied to such a normal and world-wide phenomenon as the dream. I doubt whether we can assume that a dream is something other than it appears to be. I am rather inclined to quote another Jewish authority, the Talmud, which says: “The dream is its own interpretation.” In other words *I take the dream for what it is*. The dream is such a difficult and complicated thing that I do not dare to make any assumptions about its possible cunning or its tendency to deceive. The dream is a natural occurrence, and there is no earthly reason why we should assume that it is a crafty device to lead us astray. It occurs when consciousness and will are to a large extent extinguished. It seems to be a natural product which is also found in people who are not neurotic. Moreover, we know so little about the psychology of the dream process that we must be more than careful when we introduce into its explanation elements that are foreign to the dream itself.

[42] For all these reasons I hold that our dream really is speaking of religion and that it intends to do so. Since the dream has a coherent and well-designed structure, it suggests a certain logic and a certain intention, that is, it has a meaningful motivation which finds direct expression in the dream-content.

[43] The first part of the dream is a serious statement in favour of the Catholic Church. A certain Protestant point of view—that religion is just an individual experience—is discouraged by the dreamer. The second, more grotesque part is the Church's adaptation to a decidedly worldly standpoint, and the end is a statement in favour of an anti-ascetic tendency which would not and could not be backed up by the real Church. Nevertheless the dreamer's anti-ascetic priest makes it a matter of principle. Spiritualization and sublimation are essentially Christian principles, and any insistence upon the contrary would amount to blasphemous paganism. Christianity has never been worldly nor has it ever looked with favour on good food and wine, and it is more than doubtful whether the introduction of jazz into the cult would be a particular asset. The "cheerful and equable" people who peripatetically converse with each other in more or less Epicurean style remind one much more of an ancient philosophical ideal which is rather distasteful to the contemporary Christian. In the first and second part the importance of masses or crowds of people is emphasized.

[44] Thus the Catholic Church, though highly recommended, appears coupled with a strange pagan point of view which is irreconcilable with a fundamentally Christian attitude. The actual irreconcilability does not appear in the dream. It is hushed up as it were by a cosy ("gemütlich") atmosphere in which dangerous contrasts are blurred and blended. The Protestant conception of an individual relationship to God is swamped by mass organization and a correspondingly collective religious feeling. The insistence on crowds and the insinuation of a pagan ideal are remarkable parallels to things that are actually happening in Europe today. Everybody was astonished at the pagan tendencies of modern Germany because nobody knew how to interpret Nietzsche's Dionysian experience. Nietzsche was but one of the thousands and millions of Germans yet unborn in whose unconscious the Teutonic cousin of Dionysus—Wotan—came to birth during the Great War.¹⁵ In the dreams of the Germans whom I treated then I could clearly see the Wotanistic revolution coming on, and in 1918 I published an article in which I pointed out the peculiar kind of new development to be expected in Germany.¹⁶ Those Germans were by no means people who had studied *Thus Spake Zarathustra*, and certainly the young people who resurrected the pagan sacrifices of sheep knew nothing of Nietzsche's experience.¹⁷ That is why they called their god Wotan and not Dionysus. In Nietzsche's biography you will find irrefutable proof that the god he originally meant was really Wotan, but, being a philologist and living in the seventies and eighties of the nineteenth century,

he called him Dionysus. Looked at from a comparative point of view, the two gods have much in common.

[45] There is apparently no opposition to collective feeling, mass religion, and paganism anywhere in the dream of my patient, except for the Protestant friend who is soon reduced to silence. One curious incident merits our attention, and that is the unknown woman who at first backs up the eulogy of Catholicism and then suddenly bursts into tears, saying: “Then there’s nothing left,” and vanishes without returning.

[46] Who is this woman? To the dreamer she is a vague and unknown person, but when he had that dream he was already well acquainted with her as the “unknown woman” who had frequently appeared in previous dreams.

[47] As this figure plays a great role in men’s dreams, it bears the technical name of the “anima,”¹⁸ with reference to the fact that, from time immemorial, man in his myths has expressed the idea of a male and female coexisting in the same body. Such psychological intuitions were usually projected in the form of the divine syzygy, the divine pair, or in the idea of the hermaphroditic nature of the creator.¹⁹ Edward Maitland, the biographer of Anna Kingsford, relates in our own day an inner experience of the bisexual nature of the Deity.²⁰ Then there is Hermetic philosophy with its hermaphrodite and its androgynous inner man,²¹ the *homo Adamicus*, who, “although he appears in masculine form, always carries about with him Eve, or his wife, hidden in his body,” as a medieval commentator on the *Hermetis Tractatus aureus* says.²²

[48] The anima is presumably a psychic representation of the minority of female genes in a man’s body. This is all the more probable since the same figure is not to be found in the imagery of a woman’s unconscious. There is a corresponding figure, however, that plays an equivalent role, yet it is not a woman’s image but a man’s. This masculine figure in a woman’s psychology has been termed the “animus.”²³ One of the most typical manifestations of both figures is what has long been called “animosity.” The anima causes illogical moods, and the animus produces irritating platitudes and unreasonable opinions. Both are frequent dream-figures. As a rule they personify the unconscious and give it its peculiarly disagreeable or irritating character. The unconscious in itself has no such negative qualities. They appear only when it is personified by these figures and when they begin to influence consciousness. Being only partial personalities, they have the character either of an inferior woman or of an inferior man—hence their irritating effect. A man experiencing this influence will be subject to unaccountable moods, and a woman will be argumentative and produce opinions that are beside the mark.²⁴

[49] The negative reaction of the anima to the church dream indicates that the dreamer’s feminine side, his unconscious, disagrees with his conscious attitude. The

disagreement started with the text on the wall: "Do not flatter your benefactor," which the dreamer agreed with. The meaning of the text seems sound enough, so that one does not understand why the woman should feel so desperate about it. Without delving further into this mystery, we must content ourselves for the time being with the statement that there is a contradiction in the dream and that a very important minority has left the stage under vivid protest and pays no more attention to the proceedings.

[50] We gather, then, from the dream that the unconscious functioning of the dreamer's mind has produced a pretty flat compromise between Catholicism and pagan *joie de vivre*. The product of the unconscious is manifestly not expressing a fixed point of view or a definite opinion, rather it is a dramatic exposition of an act of reflection. It could be formulated perhaps as follows: "Now what about this religious business? You are a Catholic, are you not? Is that not good enough? But asceticism—well, well, even the church has to adapt a little—movies, radio, spiritual five o'clock tea and all that—why not some ecclesiastical wine and gay acquaintances?" But for some secret reason this awkward mystery woman, well known from many former dreams, seems to be deeply disappointed and quits.

[51] I must confess that I find myself in sympathy with the anima. Obviously the compromise is too cheap and too superficial, but it is characteristic of the dreamer as well as of many other people to whom religion does not matter very much. Religion was of no concern to my patient and he certainly never expected that it would concern him in any way. But he had come to me because of a very alarming experience. Being highly rationalistic and intellectual he had found that his attitude of mind and his philosophy forsook him completely in the face of his neurosis and its demoralizing forces. He found nothing in his whole *Weltanschauung* that would help him to gain sufficient control of himself. He was therefore very much in the situation of a man deserted by his hitherto cherished convictions and ideals. It is by no means extraordinary that under such conditions a man should return to the religion of his childhood in the hope of finding something helpful there. It was, however, not a conscious attempt or decision to revivify his earlier religious beliefs. He merely dreamed it; that is, his unconscious produced a peculiar statement about his religion. It is just as if the spirit and the flesh, the eternal enemies in a Christian consciousness, had made peace with each other in the form of a curious mitigation of their contradictory nature. Spirituality and worldliness come together in unexpected amity. The effect is slightly grotesque and comical. The inexorable severity of the spirit seems to be undermined by an almost antique gaiety perfumed with wine and roses. At all events the dream describes a spiritual and worldly atmosphere that dulls the sharpness of a moral conflict and swallows up in oblivion all mental pain and distress.

[52] If this was a wish-fulfilment it was surely a conscious one, for it was precisely what the patient had already done to excess. And he was not unconscious of this either, since wine was one of his most dangerous enemies. The dream, on the other hand, is an impartial statement of the patient's spiritual condition. It gives a picture of a degenerate religion corrupted by worldliness and mob instincts. There is religious sentimentality instead of the *numinosum* of divine experience. This is the well-known characteristic of a religion that has lost its living mystery. It is readily understandable that such a religion is incapable of giving help or of having any other moral effect.

[53] The over-all aspect of the dream is definitely unfavourable, although certain other aspects of a more positive nature are dimly visible. It rarely happens that dreams are either exclusively positive or exclusively negative. As a rule one finds both aspects, but usually one is stronger than the other. It is obvious that such a dream provides the psychologist with enough material to raise the problem of a religious attitude. If our dream were the only one we possess we could hardly hope to unlock its innermost meaning, but we have quite a number of dreams in our series which point to a remarkable religious problem. I never, if I can help it, interpret one dream by itself. As a rule a dream belongs in a series. Since there is a continuity of consciousness despite the fact that it is regularly interrupted by sleep, there is probably also a continuity of unconscious processes—perhaps even more than with the events of consciousness. In any case my experience is in favour of the probability that dreams are the visible links in a chain of unconscious events. If we want to shed any light on the deeper reasons for the dream, we must go back to the series and find out where it is located in the long chain of four hundred dreams.

[54] We find our dream wedged in between two important dreams of an uncanny quality. The dream before reports that there is a gathering of many people and that a peculiar ceremony is taking place, apparently of magical character, for the purpose of "reconstructing the gibbon." The dream after is concerned with a similar theme—the magical transformation of animals into human beings.²⁵

[55] Both dreams are intensely disagreeable and very alarming to the patient. Whereas the church dream manifestly moves on the surface and expresses opinions which in other circumstances could just as well have been thought consciously, these two dreams are strange and remote in character and their emotional effect is such that the dreamer would avoid them if possible. As a matter of fact, the text of the second dream says: "If one runs away, all is lost." Curiously enough, this remark coincides with that of the unknown woman: "Then there's nothing left." The inference to be drawn from these remarks is that the church dream was an attempt to escape from other dream ideas of a much deeper significance. These ideas appear in the dreams occurring immediately before and after it.

2. DOGMA AND NATURAL SYMBOLS

[56] The first of these dreams—the one preceding the church dream—speaks of a ceremony whereby an ape is to be reconstructed. To explain this point sufficiently would require too many details. I must, therefore, restrict myself to the mere statement that the “ape” refers to the dreamer’s instinctual personality,¹ which he had completely neglected in favour of an exclusively intellectual attitude. The result had been that his instincts got the better of him and attacked him at times in the form of uncontrollable outbursts. The “reconstruction” of the ape means the rebuilding of the instinctual personality within the framework of the hierarchy of consciousness. Such a reconstruction is only possible if accompanied by important changes in the conscious attitude. The patient was naturally afraid of the tendencies of the unconscious, because hitherto they had revealed themselves to him in their most unfavourable form. The church dream that followed represents an attempt to seek refuge from this fear in the shelter of a church religion. The third dream, in speaking of the “transformation of animals into human beings,” obviously continues the theme of the first one; that is, the ape is reconstructed solely for the purpose of being transformed later into a human being. In other words, the patient has to undergo an important change through the reintegration of his hitherto split-off instinctuality, and is thus to be made over into a new man. The modern mind has forgotten those old truths that speak of the death of the old man and the making of a new one, of spiritual rebirth and such-like old-fashioned “mystical absurdities.” My patient, being a scientist of today, was more than once seized by panic when he realized how much he was gripped by such thoughts. He was afraid he was going mad, whereas the man of two thousand years ago would have welcomed such dreams and rejoiced in the hope of a magical rebirth and renewal of life. But our modern attitude looks back arrogantly upon the mists of superstition and of medieval or primitive credulity, entirely forgetting that we carry the whole living past in the lower storeys of the skyscraper of rational consciousness. Without the lower storeys our mind is suspended in mid air. No wonder it gets nervous. The true history of the mind is not preserved in learned volumes but in the living psychic organism of every individual.

[57] I must admit, however, that the idea of renewal took on shapes that could easily shock a modern mind. It is indeed difficult, if not impossible, to connect “rebirth,” as we understand it, with the way it is depicted in the dreams. But before we discuss the

strange and unexpected transformation there hinted at, we should turn our attention to the other manifestly religious dream to which I alluded before.

[58] While the church dream comes relatively early in the long series, the following dream belongs to the later stages of the process.² This is the literal text:

*I come to a strange, solemn house—the “House of the Gathering.” Many candles are burning in the background, arranged in a peculiar pattern with four points running upward. Outside, at the door of the house, an old man is posted. People are going in. They say nothing and stand motionless in order to collect themselves inwardly. The man at the door says of the visitors to the house, “When they come out again they are cleansed.” I go into the house myself and find I can concentrate perfectly. Then a voice says: “What you are doing is dangerous. Religion is not a tax to be paid so that you can rid yourself of the woman’s image, for this image cannot be got rid of. Woe unto them who use religion as a substitute for the other side of the soul’s life; they are in error and will be accursed. Religion is no substitute; it is to be added to the other activities of the soul as the ultimate completion. Out of the fulness of life shall you bring forth your religion; only then shall you be blessed!” While the last sentence is being spoken in ringing tones I hear distant music, simple chords on an organ. Something about it reminds me of Wagner’s *Fire Music*. As I leave the house I see a burning mountain and I feel: “The fire that is not put out is a holy fire” (Shaw, *Saint Joan*).*

[59] The patient was deeply impressed by this dream. It was a solemn and powerful experience for him, one of several which produced a far-reaching change in his attitude to life and humanity.

[60] It is not difficult to see that this dream forms a parallel to the church dream. Only this time the church has become a house of solemnity and self-collection. There are no indications of ceremonies or of any other known attributes of the Catholic Church, with the sole exception of the burning candles, which are arranged in a symbolic form probably derived from the Catholic cult.³ They form four pyramids or points, which perhaps anticipate the final vision of the flaming mountain. The appearance of the number four is, however, a regular feature in the patient’s dreams and plays a very important role. The holy fire refers to Bernard Shaw’s *Saint Joan*, as the dreamer himself observes. The unquenchable fire, on the other hand, is a well-known attribute of the Deity, not only in the Old Testament, but also as an *allegoria Christi* in an uncanonical logion cited in Origen’s *Homilies*:⁴ “Ait ipse salvator: qui iuxta me est, iuxta ignem est, qui longe est a me, longe est a regno” (the Saviour himself says: Whoever is near to me is near to the fire; whoever is far from me is far from the kingdom). Since the time of Heraclitus life has been conceived as a *πῦρ ἀεὶ ζῶν*, an ever-living fire; and as Christ calls himself “The Life,” the uncanonical saying is quite understandable. The fire signifying “life” fits into the frame of the dream, for it emphasizes that “fulness of life” is the only legitimate source of religion. Thus the four fiery points function almost as an icon denoting the presence of the Deity or an equivalent being. In the system of Barbelo-Gnosis, four lights surround the

Autogenes (the Self-Born, or Uncreated).⁵ This strange figure may correspond to the Monogenes of Coptic Gnosis, mentioned in the Codex Brucianus. There too the Monogenes is characterized as a quaternity symbol.

[61] As I said before, the number four plays an important role in these dreams, always alluding to an idea akin to the Pythagorean tetraktys.⁶

[62] The *quaternarium* or quaternity has a long history. It appears not only in Christian iconology and mystical speculation⁷ but plays perhaps a still greater role in Gnostic philosophy⁸ and from then on down through the Middle Ages until well into the eighteenth century.⁹

[63] In the dream under discussion, the quaternity appears as the most significant exponent of the religious cult created by the unconscious.¹⁰ The dreamer enters the "House of the Gathering" alone, instead of with a friend as in the church dream. Here he meets an old man, who had already appeared in an earlier dream as the sage who had pointed to a particular spot on the earth where the dreamer belonged. The old man explains the character of the cult as a purification ritual. It is not clear from the dream-text what kind of purification is meant, or from what it should purify. The only ritual that actually takes place seems to be a concentration or meditation, leading up to the ecstatic phenomenon of the voice. The voice is a frequent occurrence in this dream-series. It always utters an authoritative declaration or command, either of astonishing common sense or of profound philosophic import. It is nearly always a final statement, usually coming toward the end of a dream, and it is, as a rule, so clear and convincing that the dreamer finds no argument against it. It has, indeed, so much the character of indisputable truth that it can hardly be understood as anything except a final and trenchant summing up of a long process of unconscious deliberation and weighing of arguments. Frequently the voice issues from an authoritative figure, such as a military commander, or the captain of a ship, or an old physician. Sometimes, as in this case, there is simply a voice coming apparently from nowhere. It was interesting to see how this very intellectual and sceptical man accepted the voice; often it did not suit him at all, yet he accepted it unquestioningly, even humbly. Thus the voice revealed itself, in the course of several hundred carefully recorded dreams, as an important and even decisive spokesman of the unconscious. Since this patient is by no means the only one I have observed who exhibited the phenomenon of the voice in dreams and in other peculiar states of consciousness, I am forced to admit that the unconscious is capable at times of manifesting an intelligence and purposiveness superior to the actual conscious insight. There can be no doubt that this is a basic religious phenomenon, observed here in a person whose conscious mental attitude certainly seemed most unlikely to produce religious phenomena. I have not infrequently made similar observations in

other cases and I must confess that I am unable to formulate the facts in any other way. I have often met with the objection that the thoughts which the voice represents are no more than the thoughts of the individual himself. That may be; but I would call a thought my own only when *I* have thought it, just as I would call money my own only when I have earned or acquired it in a conscious and legitimate manner. If somebody gives me the money as a present, then I shall certainly not say to my benefactor, "Thank you for my money," although to a third person I might say afterwards: "This is my own money." With the voice I am in a similar situation. The voice gives me certain contents, exactly as if a friend were informing me of his ideas. It would be neither decent nor truthful to suggest that what he says are my own ideas.

[64] This is the reason why I differentiate between what I have produced or acquired by my own conscious effort and what is clearly and unmistakably a product of the unconscious. Someone may object that the so-called unconscious mind is merely my own mind and that, therefore, such a differentiation is superfluous. But I am not at all convinced that the unconscious mind is merely *my* mind, because the term "unconscious" means that I am not even conscious of it. As a matter of fact, the concept of the unconscious is an assumption for the sake of convenience. In reality I am totally unconscious of—or, in other words, I do not know at all—where the voice comes from. Not only am I incapable of producing the phenomenon at will, I am unable to anticipate what the voice will say. Under such conditions it would be presumptuous to refer to the factor that produces the voice as *my* unconscious or *my* mind. This would not be accurate, to say the least. The fact that you perceive the voice in your dream proves nothing at all, for you can also hear the noises in the street, which you would never think of calling your own.

[65] There is only one condition under which you might legitimately call the voice your own, and that is when you assume your conscious personality to be a part of a whole or to be a smaller circle contained in a bigger one. A little bank-clerk, showing a friend around town, who points to the bank building with the words, "And this is *my* bank," is making use of the same privilege.

[66] We may suppose that human personality consists of two things: first, consciousness and whatever this covers, and second, an indefinitely large hinterland of unconscious psyche. So far as the former is concerned, it can be more or less clearly defined and delimited; but as for the sum total of human personality, one has to admit the impossibility of a complete description or definition. In other words, there is bound to be an illimitable and indefinable addition to every personality, because the latter consists of a conscious and observable part which does not contain certain factors whose existence, however, we are forced to assume in order to explain

certain observable facts. The unknown factors form what we call the unconscious part of the personality.

[67] Of what those factors consist we have no idea, since we can observe only their effects. We may assume that they are of a psychic nature comparable to that of conscious contents, yet there is no certainty about this. But if we suppose such a likeness we can hardly refrain from going further. Since psychic contents are conscious and perceivable only when they are associated with an ego, the phenomenon of the voice, having a strongly personal character, may also issue from a centre—but a centre which is not identical with the conscious ego. Such reasoning is permissible if we conceive of the ego as being subordinated to, or contained in, a supraordinate self as centre of the total, illimitable, and indefinable psychic personality.

[68] I do not enjoy philosophical arguments that amuse by their own complications. Although my argument may seem abstruse, it is at least an honest attempt to formulate the observed facts. To put it simply one could say: Since we do not know everything, practically every experience, fact, or object contains something unknown. Hence, if we speak of the totality of an experience, the word “totality” can refer only to the conscious part of it. As we cannot assume that our experience covers the totality of the object, it is clear that its absolute totality must necessarily contain the part that has not been experienced. The same holds true, as I have mentioned, of every experience and also of the psyche, whose absolute totality covers a greater area than consciousness. In other words, the psyche is no exception to the general rule that the universe can be established only so far as our psychic organism permits.

[69] My psychological experience has shown time and again that certain contents issue from a psyche that is more complete than consciousness. They often contain a superior analysis or insight or knowledge which consciousness has not been able to produce. We have a suitable word for such occurrences—intuition. In uttering this word most people have an agreeable feeling, as if something had been settled. But they never consider that you do not *make* an intuition. On the contrary, it always comes to you; you *have* a hunch, it has come of itself, and you only catch it if you are clever or quick enough.

[70] Consequently, I explain the voice, in the dream of the sacred house, as a product of the more complete personality of which the dreamer’s conscious self is a part, and I hold that this is the reason why the voice shows an intelligence and a clarity superior to the dreamer’s actual consciousness. This superiority is the reason for the absolute authority of the voice.

[71] The message of the voice contains a strange criticism of the dreamer’s attitude. In the church dream, he made an attempt to reconcile the two sides of life by a kind of

cheap compromise. As we know, the unknown woman, the anima, disagreed and left the scene. In the present dream the voice seems to have taken the place of the anima, making not a merely emotional protest but a masterful statement on two kinds of religion. According to this statement, the dreamer is inclined to use religion as a substitute for the “woman’s image,” as the text says. The “woman” refers to the anima. This is borne out by the next sentence, which speaks of religion being used as a substitute for “the other side of the soul’s life.” The anima is the “other side,” as I explained before. She is the representative of the female minority hidden below the threshold of consciousness, that is to say, in the unconscious. The criticism, therefore, would read as follows: “You try religion in order to escape from your unconscious. You use it as a substitute for a part of your soul’s life. But religion is the fruit and culmination of the completeness of life, that is, of a life which contains both sides.”

[72] Careful comparison with other dreams of the same series shows unmistakably what the “other side” is. The patient always tried to evade his emotional needs. As a matter of fact he was afraid they might get him into trouble, for instance into marriage, and into other responsibilities such as love, devotion, loyalty, trust, emotional dependence, and general submission to the soul’s needs. All this had nothing to do with science or an academic career; moreover, the word “soul” was nothing but an intellectual obscenity, not fit to be touched with a barge pole.

[73] The “mystery” of the anima is the mysterious allusion to religion. This was a great puzzle to my patient, who naturally enough knew nothing of religion except as a creed. He also knew that religion can be a substitute for certain awkward emotional demands which one might circumvent by going to church. The prejudices of our age are visibly reflected in the dreamer’s apprehensions. The voice, on the other hand, is unorthodox, indeed shockingly unconventional: it takes religion seriously, puts it on the very apex of life, a life containing “both sides,” and thus upsets his most cherished intellectual and rationalistic prejudices. This was such a revolution that my patient was often afraid he would go crazy. Well, I should say that we—knowing the average intellectual of today and yesterday—can easily sympathize with his predicament. To take the “woman’s image”—in other words, the unconscious—seriously into account, what a blow to enlightened common sense!¹¹

[74] I began his personal treatment only after he had observed the first series of about three hundred and fifty dreams. Then I got the whole backwash of his upsetting experiences. No wonder he wanted to run away from his adventure! But, fortunately, the man had *religio*, that is, he “carefully took account of” his experience and he had enough *πίστις*, or loyalty to his experience, to enable him to hang on to it and continue it. He had the *great advantage of being neurotic* and so, whenever he tried to be disloyal to his experience or to deny the voice, the neurotic condition instantly

came back. He simply could not “quench the fire” and finally he had to admit the incomprehensibly numinous character of his experience. He had to confess that the unquenchable fire was “holy.” This was the *sine qua non* of his cure.

[75] One might, perhaps, consider this case an exception inasmuch as fairly complete human beings are exceptions. It is true that an overwhelming majority of educated people are fragmentary personalities and have a lot of substitutes instead of the genuine goods. But being like that meant a neurosis for this man, and it means the same for a great many other people too. What is ordinarily called “religion” is a substitute to such an amazing degree that I ask myself seriously whether this kind of “religion,” which I prefer to call a creed, may not after all have an important function in human society. The substitute has the obvious purpose of replacing *immediate experience* by a choice of suitable symbols tricked out with an organized dogma and ritual. The Catholic Church maintains them by her indisputable authority, the Protestant “church” (if this term is still applicable) by insistence on belief in the evangelical message. So long as these two principles work, people are effectively protected against immediate religious experience.¹² Even if something of the sort should happen to them, they can refer to the Church, for she would know whether the experience came from God or from the devil, and whether it is to be accepted or rejected.

[76] In my profession I have encountered many people who have had immediate experience and who would not and could not submit to the authority of ecclesiastical decision. I had to go with them through the crises of passionate conflicts, through the panics of madness, through desperate confusions and depressions which were grotesque and terrible at the same time, so that I am fully aware of the extraordinary importance of dogma and ritual, at least as methods of mental hygiene. If the patient is a practising Catholic, I invariably advise him to confess and to receive communion in order to protect himself from immediate experience, which might easily prove too much for him. With Protestants it is usually not so easy, because dogma and ritual have become so pale and faint that they have lost their efficacy to a very great extent. There is also, as a rule, no confession, and the clergy share the common dislike of psychological problems and also, unfortunately, the common ignorance of psychology. The Catholic “director of conscience” often has infinitely more psychological skill and insight. Protestant parsons, moreover, have gone through a scientific training at a theological faculty which, with its critical spirit, undermines naïveté of faith, whereas the powerful historical tradition in a Catholic priest’s training is apt to strengthen the authority of the institution.

[77] As a doctor I might, of course, espouse a so-called “scientific” creed, holding that the contents of a neurosis are nothing but repressed infantile sexuality or will to

power. By thus depreciating these contents, it would be possible, up to a point, to shield a number of patients from the risk of immediate experience. But I know that this theory is only partially true, which means that it formulates only certain aspects of the neurotic psyche. And I cannot tell my patients what I myself do not fully believe.

[78] Now people may ask me: “But if you tell your practising Catholic to go to the priest and confess, you are telling him something you do not believe”—that is, assuming that I am a Protestant.

[79] In order to answer this critical question I must first of all explain that, if I can help it, I never preach my belief. If asked I shall certainly stand by my convictions, but these do not go beyond what I consider to be my actual knowledge. I believe only what I *know*. Everything else is hypothesis and beyond that I can leave a lot of things to the Unknown. They do not bother me. But they would begin to bother me, I am sure, if I felt that I *ought* to know about them. If, therefore, a patient is convinced of the exclusively sexual origin of his neurosis, I would not disturb him in his opinion because I know that such a conviction, particularly if it is deeply rooted, is an excellent defence against an onslaught of immediate experience with its terrible ambiguity. So long as such a defence works I shall not break it down, since I know that there must be cogent reasons why the patient has to think in such a narrow circle. But if his dreams should begin to destroy the protective theory, I have to support the wider personality, as I have done in the case of the dream described. In the same way and for the same reason I support the hypothesis of the practising Catholic while it works for him. In either case, I reinforce a means of defence against a grave risk, without asking the academic question whether the defence is an ultimate truth. I am glad when it works and so long as it works.

[80] With our patient, the Catholic defence had broken down long before I ever touched the case. He would have laughed at me if I had advised him to confess or anything of that sort, just as he laughed at the sexual theory, which he had no use for either. But I always let him see that I was entirely on the side of the voice, which I recognized as part of his future greater personality, destined to relieve him of his one-sidedness.

[81] For a certain type of intellectual mediocrity characterized by enlightened rationalism, a scientific theory that simplifies matters is a very good means of defence because of the tremendous faith modern man has in anything which bears the label “scientific.” Such a label sets your mind at rest immediately, almost as well as *Roma locuta causa finita*: “Rome has spoken, the matter is settled.” In itself any scientific theory, no matter how subtle, has, I think, less value from the standpoint of psychological truth than religious dogma, for the simple reason that a theory is

necessarily highly abstract and exclusively rational, whereas dogma expresses an irrational whole by means of imagery. This guarantees a far better rendering of an irrational fact like the psyche. Moreover, dogma owes its continued existence and its form on the one hand to so-called “revealed” or immediate experiences of the “Gnosis”¹³—for instance, the God-man, the Cross, the Virgin Birth, the Immaculate Conception, the Trinity, and so on, and on the other hand to the ceaseless collaboration of many minds over many centuries. It may not be quite clear why I call certain dogmas “immediate experiences,” since in itself a dogma is the very thing that precludes immediate experience. Yet the Christian images I have mentioned are not peculiar to Christianity alone (although in Christianity they have undergone a development and intensification of meaning not to be found in any other religion). They occur just as often in pagan religions, and besides that they can reappear spontaneously in all sorts of variations as psychic phenomena, just as in the remote past they originated in visions, dreams, or trances. Ideas like these are never invented. They came into being before man had learned to use his mind purposively. Before man learned to produce thoughts, thoughts came to him. *He did not think—he perceived his mind functioning.* Dogma is like a dream, reflecting the spontaneous and autonomous activity of the objective psyche, the unconscious. Such an expression of the unconscious is a much more efficient means of defence against further immediate experiences than any scientific theory. The theory has to disregard the emotional values of the experience. The dogma, on the other hand, is extremely eloquent in just this respect. One scientific theory is soon superseded by another. Dogma lasts for untold centuries. The suffering God-Man may be at least five thousand years old and the Trinity is probably even older.

[82] Dogma expresses the psyche more completely than a scientific theory, for the latter gives expression to and formulates the conscious mind alone. Furthermore, a theory can do nothing except formulate a living thing in abstract terms. Dogma, on the contrary, aptly expresses the living process of the unconscious in the form of the drama of repentance, sacrifice, and redemption. It is rather astonishing, from this point of view, that the Protestant schism could not have been avoided. But since Protestantism became the creed of the adventurous Germanic tribes with their characteristic curiosity, acquisitiveness, and recklessness, it seems possible that their peculiar nature was unable to endure the peace of the Church, at least not for any length of time. It looks as if they were not yet advanced enough to suffer a process of salvation and to submit to a deity who was made visible in the magnificent structure of the Church. There was, perhaps, too much of the Imperium Romanum or of the Pax Romana in the Church—too much, at least, for their energies, which were and still are insufficiently domesticated. It is quite likely that they needed an unmitigated and less controlled experience of God, as often happens to adventurous and restless

people who are too youthful for any form of conservatism or domestication. They therefore did away with the intercession of the Church between God and man, some more and some less. With the demolition of protective walls, the Protestant lost the sacred images that expressed important unconscious factors, together with the ritual which, from time immemorial, has been a safe way of dealing with the unpredictable forces of the unconscious. A vast amount of energy was thus liberated and instantly went into the old channels of curiosity and acquisitiveness. In this way Europe became the mother of dragons that devoured the greater part of the earth.

[83] Since those days Protestantism has become a hotbed of schisms and, at the same time, of rapid advances in science and technics which cast such a spell over man's conscious mind that it forgot the unpredictable forces of the unconscious. The catastrophe of the first World War and the extraordinary manifestations of profound spiritual malaise that came afterwards were needed to arouse a doubt as to whether all was well with the white man's mind. Before the war broke out in 1914 we were all quite certain that the world could be righted by rational means. Now we behold the amazing spectacle of states taking over the age-old totalitarian claims of theocracy, which are inevitably accompanied by suppression of free opinion. Once more we see people cutting each other's throats in support of childish theories of how to create paradise on earth. It is not very difficult to see that the powers of the underworld—not to say of hell—which in former times were more or less successfully chained up in a gigantic spiritual edifice where they could be of some use, are now creating, or trying to create, a State slavery and a State prison devoid of any mental or spiritual charm. There are not a few people nowadays who are convinced that mere human reason is not entirely up to the enormous task of putting a lid on the volcano.

[84] This whole development is fate. I would not lay the blame either on Protestantism or on the Renaissance. But one thing is certain—that modern man, Protestant or otherwise, has lost the protection of the ecclesiastical walls erected and reinforced so carefully since Roman days, and because of this loss has approached the zone of world-destroying and world-creating fire. Life has become quickened and intensified. Our world is shot through with waves of uneasiness and fear.

[85] Protestantism was, and still is, a great risk and at the same time a great opportunity. If it goes on disintegrating as a church, it must have the effect of stripping man of all his spiritual safeguards and means of defence against immediate experience of the forces waiting for liberation in the unconscious. Look at all the incredible savagery going on in our so-called civilized world: it all comes from human beings and the spiritual condition they are in! Look at the devilish engines of destruction! They are invented by completely innocuous gentlemen, reasonable, respectable citizens who are everything we could wish. And when the whole thing

blows up and an indescribable hell of destruction is let loose, nobody seems to be responsible. It simply happens, and yet it is all man-made. But since everybody is blindly convinced that he is nothing more than his own extremely unassuming and insignificant conscious self, which performs its duties decently and earns a moderate living, nobody is aware that this whole rationalistically organized conglomeration we call a state or a nation is driven on by a seemingly impersonal, invisible but terrifying power which nobody and nothing can check. This ghastly power is mostly explained as fear of the neighbouring nation, which is supposed to be possessed by a malevolent fiend. Since nobody is capable of recognizing just where and how much he himself is possessed and unconscious, he simply projects his own condition upon his neighbour, and thus it becomes a sacred duty to have the biggest guns and the most poisonous gas. The worst of it is that he is quite right. All one's neighbours are in the grip of some uncontrolled and uncontrollable fear, just like oneself. In lunatic asylums it is a well-known fact that patients are far more dangerous when suffering from fear than when moved by rage or hatred.

[86] The Protestant is left to God alone. For him there is no confession, no absolution, no possibility of an expiatory *opus divinum* of any kind. He has to digest his sins by himself; and, because the absence of a suitable ritual has put it beyond his reach, he is none too sure of divine grace. Hence the present alertness of the Protestant conscience—and this bad conscience has all the disagreeable characteristics of a lingering illness which makes people chronically uncomfortable. But, for this very reason, the Protestant has a unique chance to make himself conscious of sin to a degree that is hardly possible for a Catholic mentality, as confession and absolution are always at hand to ease excess of tension. The Protestant, however, is left to his tensions, which can go on sharpening his conscience. Conscience, and particularly a bad conscience, can be a gift from heaven, a veritable grace if used in the interests of the higher self-criticism. And self-criticism, in the sense of an introspective, discriminating activity, is indispensable in any attempt to understand your own psychology. If you have done something that puzzles you and you ask yourself what could have prompted you to such an action, you need the sting of a bad conscience and its discriminating faculty in order to discover the real motive of your behaviour. It is only then that you can see what motives are governing your actions. The sting of a bad conscience even spurs you on to discover things that were unconscious before, and in this way you may be able to cross the threshold of the unconscious and take cognizance of those impersonal forces which make you an unconscious instrument of the wholesale murderer in man. If a Protestant survives the complete loss of his church and still remains a Protestant, that is to say a man who is defenceless against God and no longer shielded by walls or communities, he has a unique spiritual opportunity for immediate religious experience.

[87] I do not know whether I have succeeded in conveying what the experience of the unconscious meant to my patient. There is, however, no objective criterion by which such an experience can be valued. We have to take it for what it is worth to the person who has the experience. Thus you may be impressed by the fact that the apparent futility of certain dreams should mean something to an intelligent person. But if you cannot accept what he says, or if you cannot put yourself in his place, you should not judge his case. The *genius religiosus* is a wind that bloweth where it listeth. There is no Archimedean point from which to judge, since the psyche is indistinguishable from its manifestations. The psyche is the object of psychology, and—fatally enough—also its subject. There is no getting away from this fact.

[88] The few dreams I have chosen as examples of what I call “immediate experience” certainly look very insignificant to the unpractised eye. They are not spectacular, and are only modest witnesses to an individual experience. They would cut a better figure if I could present them in their sequence, together with the wealth of symbolic material that was brought up in the course of the entire process. But even the sum total of the dreams in the series could not compare in beauty and expressiveness with any part of a traditional religion. A dogma is always the result and fruit of many minds and many centuries, purified of all the oddities, shortcomings, and flaws of individual experience. But for all that, the individual experience, by its very poverty, is immediate life, the warm red blood pulsating today. It is more convincing to a seeker after truth than the best tradition. Immediate life is always individual since the carrier of life is the individual, and whatever emanates from the individual is in a way unique, and hence transitory and imperfect, particularly when it comes to spontaneous psychic products such as dreams and the like. No one else will have the same dreams, although many have the same problem. But just as no individual is differentiated to the point of absolute uniqueness, so there are no individual products of absolutely unique quality. Even dreams are made of collective material to a very high degree, just as, in the mythology and folklore of different peoples, certain motifs repeat themselves in almost identical form. I have called these motifs “archetypes,”¹⁴ and by this I mean forms or images of a collective nature which occur practically all over the earth as constituents of myths and at the same time as autochthonous, individual products of unconscious origin. The archetypal motifs presumably derive from patterns of the human mind that are transmitted not only by tradition and migration but also by heredity. The latter hypothesis is indispensable, since even complicated archetypal images can be reproduced spontaneously without there being any possibility of direct tradition.

[89] The theory of preconscious primordial ideas is by no means my own invention, as the term “archetype,” which stems from the first centuries of our era, proves.¹⁵ With special reference to psychology we find this theory in the works of Adolf Bastian¹⁶

and then again in Nietzsche.¹⁷ In French literature Hubert and Mauss,¹⁸ and also Lévy-Bruhl,¹⁹ mention similar ideas. I only gave an empirical foundation to the theory of what were formerly called primordial or elementary ideas, “catégories” or “habitudes directrices de la conscience,” “representations collectives,” etc., by setting out to investigate certain details.

[90] In the second of the dreams discussed above, we met with an archetype which I have not yet considered. This is the peculiar arrangement of the burning candles in four pyramid-like points. The arrangement emphasizes the symbolic importance of the number four by putting it in place of the altar or iconostasis where one would expect to find the sacred images. Since the temple is called the “House of the Gathering,” we may assume that this character is expressed if the image or symbol appears in the place of worship. The tetraktys—to use the Pythagorean term—does indeed refer to an “inner gathering,” as our patient’s dream clearly demonstrates. The symbol appears in other dreams, usually in the form of a circle divided into four or containing four main parts. In other dreams of the same series it takes the form of an undivided circle, a flower, a square place or room, a quadrangle, a globe, a clock, a symmetrical garden with a fountain in the centre, four people in a boat, in an aeroplane, or at a table, four chairs round a table, four colours, a wheel with eight spokes, an eight-rayed star or sun, a round hat divided into eight parts, a bear with four eyes, a square prison cell, the four seasons, a bowl containing four nuts, the world clock with a disc divided into $4 \times 8 = 32$ partitions, and so on.²⁰

[91] These quaternity symbols occur no less than seventy-one times in a series of four hundred dreams.²¹ My case is no exception in this respect. I have observed many cases where the number four occurred and it always had an unconscious origin, that is, the dreamer got it first from a dream and had no idea of its meaning, nor had he ever heard of the symbolic importance of the number four. It would of course be a different thing with the number three, since the Trinity represents a symbolic number known to everybody. But for us, and particularly for a modern scientist, four conveys no more than any other number. Number symbolism and its venerable history is a field of knowledge completely outside our dreamer’s intellectual interests. If under such conditions dreams insist upon the importance of four, we have every right to call its origin an unconscious one. The numinous character of the quaternity is obvious in the second dream. From this we must conclude that it points to a meaning which we have to call “sacred.” Since the dreamer was unable to trace this peculiar character to any conscious source, I apply a comparative method in order to elucidate the meaning of the symbolism. It is of course impossible to give a complete account of this procedure here, so I must restrict myself to the barest hints.

[92] Since many unconscious contents seem to be remnants of historical states of mind, we need only go back a few hundred years in order to reach the conscious level that forms the parallel to our dreams. In our case we step back not quite three hundred years and find ourselves among scientists and natural philosophers who were seriously discussing the enigma of squaring the circle.²² This abstruse problem was itself a psychological projection of something much older and completely unconscious. But they knew in those days that the circle signified the Deity: “God is an intellectual figure whose centre is everywhere and the circumference nowhere,”²³ as one of these philosophers said, repeating St. Augustine. A man as introverted and introspective as Emerson²⁴ could hardly fail to touch on the same idea and likewise quote St. Augustine. The image of the circle—regarded as the most perfect form since Plato’s *Timaeus*, the prime authority for Hermetic philosophy—was assigned to the most perfect substance, to the gold, also to the *anima mundi* or *anima media natura*, and to the first created light. And because the macrocosm, the Great World, was made by the creator “in a form round and globose,”²⁵ the smallest part of the whole, the point, also possesses this perfect nature. As the philosopher says: “Of all shapes the simplest and most perfect is the sphere, which rests in a point.”²⁶ This image of the Deity dormant and concealed in matter was what the alchemists called the original chaos, or the earth of paradise, or the round fish in the sea,²⁷ or the egg, or simply the *rotundum*. That round thing was in possession of the magical key which unlocked the closed doors of matter. As is said in the *Timaeus*, only the demiurge, the perfect being, is capable of dissolving the tetraktys, the embrace of the four elements.²⁸ One of the great authorities since the thirteenth century, the *Turba philosophorum*, says that the *rotundum* can turn copper into four.²⁹ Thus the much-sought-for *aurum philosophicum* was round.³⁰ Opinions were divided as to the procedure for procuring the dormant demiurge. Some hoped to lay hold of him in the form of a *prima materia* containing a particular concentration or a particularly suitable variety of this substance. Others endeavoured to produce the round substance by a sort of synthesis, called the *coniunctio*; the anonymous author of the *Rosarium philosophorum* says: “Make a round circle of man and woman, extract therefrom a quadrangle and from it a triangle. Make the circle round, and you will have the Philosophers’ Stone.”³¹

[93] This marvellous stone was symbolized as a perfect living being of hermaphroditic nature corresponding to the Empedoclean σφαῖρος, the εἰδαιμονέστατος θεός and all-round bisexual being in Plato.³² As early as the beginning of the fourteenth century, the *lapis* was compared by Petrus Bonus to Christ, as an *allegoria Christi*.³³ In the *Aurea hora*, a Pseudo-Thomist tract from the thirteenth century, the mystery of the stone is rated even higher than the mysteries of the Christian religion.³⁴ I mention

these facts merely to show that the circle or globe containing the four was an allegory of the Deity for not a few of our learned forefathers.

[94] From the Latin treatises it is also evident that the latent demiurge, dormant and concealed in matter, is identical with the so-called *homo philosophicus*, the second Adam.³⁵ He is the spiritual man, Adam Kadmon, often identified with Christ. Whereas the original Adam was mortal, because he was made of the corruptible four elements, the second Adam is immortal, because he consists of one pure and incorruptible essence. Thus Pseudo-Thomas says: “The Second Adam ... from pure elements entered into eternity. Therefore, what is composed of simple and pure essence remaineth forever.”³⁶ The same treatise quotes a Latinized Arabic author called Senior, a famous authority throughout the Middle Ages, as saying: “There is One thing that never dieth, for it continueth by perpetual increase,” and interprets this One thing as the second Adam.³⁷

[95] It is clear from these quotations that the round substance searched for by the philosophers was a projection very similar to our own dream symbolism. We have historical documents which prove that dreams, visions, and even hallucinations were often mixed up with the great philosophic opus.³⁸ Our forefathers, being even more naïvely constituted than ourselves, projected their unconscious contents directly into matter. Matter, however, could easily take up such projections, because at that time it was a practically unknown and incomprehensible entity. And whenever man encounters something mysterious he projects his own assumptions into it without the slightest self-criticism. But since chemical matter nowadays is something we know fairly well, we can no longer project as freely as our ancestors. We have, at last, to admit that the quaternity is something psychic; and we do not yet know whether, in a more or less distant future, this too may not prove to be a projection. For the time being we must be satisfied with the fact that an idea of God which is entirely absent from the conscious mind of modern man returns in a form known consciously three hundred or four hundred years ago.

[96] I do not need to emphasize that this piece of history was completely unknown to my dreamer. One could say with the classical poet: “Naturam expelles furca tamen usque recurret” (Drive out nature with a pitchfork and she always turns up again).³⁹

[97] The idea of those old philosophers was that God manifested himself first in the creation of the four elements. They were symbolized by the four partitions of the circle. Thus we read in a Coptic treatise of the Codex Brucianus⁴⁰ concerning the Only-Begotten (Monogenes or Anthropos):

This same is he who dwelleth in the Monad, which is in the Setheus [creator], and which came from the place of which none can say where it is.... From Him it is the

Monad came, in the manner of a ship, laden with all good things, and in the manner of a field, filled or planted with every kind of tree, and in the manner of a city, filled with all races of mankind ... And to its veil which surroundeth it in the manner of a defence there are twelve Gates ... This same is the Mother-City (*μητρόπολις*) of the Only-Begotten.

In another place the Anthropos himself is the city and his members are the four gates. The Monad is a spark of light (*σπινθήρ*), an atom of the Deity. The Monogenes is thought of as standing upon a *τετράπεζα*, a platform supported by four pillars, corresponding to the Christian quaternarium of the Evangelists, or to the Tetramorph, the symbolic steed of the Church, composed of the symbols of the four evangelists: the angel, eagle, ox or calf, and lion. The analogy with the New Jerusalem of the Apocalypse is obvious.

[98] The division into four, the synthesis of the four, the miraculous appearance of the four colours, and the four stages of the work—*nigredo*, *dealbatio*, *rubefactio*, and *citritas*—are constant preoccupations of the old philosophers.⁴¹ Four symbolizes the parts, qualities, and aspects of the One. But why should my patient recapitulate these old speculations?

[99] I do not know why he should. I only know that this is not an isolated case; many others under my observation or under that of my colleagues have spontaneously produced the same symbolism. I naturally do not think that it originated three or four hundred years ago. That was simply another epoch when this same archetypal idea was very much in the foreground. As a matter of fact, it is much older than the Middle Ages, as the *Timaeus* proves. Nor is it a classical or an Egyptian heritage, since it is to be found practically everywhere and in all ages. One has only to remember, for instance, how great an importance was attributed to the quaternity by the American Indians.⁴²

[100] Although the quaternity is an age-old and presumably prehistoric symbol,⁴³ always associated with the idea of a world-creating deity, it is—curiously enough—rarely understood as such by those moderns in whom it occurs. I have always been particularly interested to see how people, if left to their own devices and not informed about the history of the symbol, would interpret it to themselves. I was careful, therefore, not to disturb them with my own opinions, and as a rule I discovered that they took it to symbolize *themselves* or rather *something in themselves*. They felt it belonged intimately to themselves as a sort of creative background, a life-producing sun in the depths of the unconscious. Though it was easy to see that certain mandala-drawings were almost an exact replica of Ezekiel's vision, it very seldom happened that people recognized the analogy even when they knew the vision—which knowledge, by the way, is pretty rare nowadays. What one

could almost call a systematic blindness is simply the effect of the prejudice that God is *outside* man. Although this prejudice is not exclusively Christian, there are certain religions which do not share it at all. On the contrary they insist, as do certain Christian mystics, on the essential identity of God and man, either in the form of an *a priori* identity or of a goal to be attained by certain practices or initiations, as known to us, for instance, from the metamorphoses of Apuleius, not to speak of certain yoga methods.

[101] The use of the comparative method shows without a doubt that the quaternity is a more or less direct representation of the God who is manifest in his creation. We might, therefore, conclude that the symbol spontaneously produced in the dreams of modern people means something similar—*the God within*. Although the majority of the persons concerned do not recognize this analogy, the interpretation might nevertheless be correct. If we consider the fact that the idea of God is an “unscientific” hypothesis, we can easily explain why people have forgotten to think along such lines. And even if they do cherish a certain belief in God they would be deterred from the idea of a God within by their religious education, which has always depreciated this idea as “mystical.” Yet it is precisely this “mystical” idea which is forced upon the conscious mind by dreams and visions. I myself, as well as my colleagues, have seen so many cases developing the same kind of symbolism that we cannot doubt its existence any longer. My observations, moreover, date back to 1914, and I waited fourteen years before alluding to them publicly.⁴⁴

[102] It would be a regrettable mistake if anybody should take my observations as a kind of proof of the existence of God. They prove only the existence of an archetypal God-image, which to my mind is the most we can assert about God psychologically. But as it is a very important and influential archetype, its relatively frequent occurrence seems to be a noteworthy fact for any *theologia naturalis*. And since experience of this archetype has the quality of numinosity, often in very high degree, it comes into the category of religious experiences.

[103] I cannot refrain from calling attention to the interesting fact that whereas the central Christian symbolism is a Trinity, the formula presented by the unconscious is a quaternity. In reality the orthodox Christian formula is not quite complete, because the dogmatic aspect of the evil principle is absent from the Trinity and leads a more or less awkward existence on its own as the devil. Nevertheless it seems that the Church does not exclude an inner relationship between the devil and the Trinity. A Catholic authority expresses himself on this question as follows: “The existence of Satan, however, can only be understood in relation to the Trinity.” “Any theological treatment of the devil that is not related to God’s trinitarian consciousness is a falsification of the actual position.”⁴⁵ According to this view, the devil possesses personality and absolute freedom. That is why he can be the true, personal

“counterpart of Christ.” “Herein is revealed a new freedom in God’s being: he freely allows the devil to subsist beside him and permits his kingdom to endure for ever.” “The idea of a mighty devil is incompatible with the conception of Yahweh, but not with the conception of the Trinity. The mystery of one God in Three Persons opens out a new freedom in the depths of God’s being, and this even makes possible the thought of a personal devil existing alongside God and in opposition to him.”⁴⁶ The devil, accordingly, possesses an autonomous personality, freedom, and eternity, and he has these metaphysical qualities so much in common with God that he can actually subsist in opposition to him. Hence the relationship or even the (negative) affinity of the devil with the Trinity can no longer be denied as a Catholic idea.

[104] The inclusion of the devil in the quaternity is by no means a modern speculation or a monstrous fabrication of the unconscious. We find in the writings of the sixteenth-century natural philosopher and physician, Gerard Dorn, a detailed discussion of the symbols of the Trinity and the quaternity, the latter being attributed to the devil. Dorn breaks with the whole alchemical tradition inasmuch as he adopts the rigidly Christian standpoint that Three is One but Four is not, because Four attains to unity in the *quinta essentia*. According to this author the quaternity is in truth a “diabolical fraud” or “deception of the devil,” and he holds that at the fall of the angels the devil “fell into the realm of quaternity and the elements” (*in quaternariam et elementariam regionem decedit*). He also gives an elaborate description of the symbolic operation whereby the devil produced the “double serpent” (the number 2) “with the four horns” (the number 4). Indeed, the number 2 is the devil himself, the *quadricornutus binarius*.⁴⁷

[105] Since a God identical with the individual man is an exceedingly complex assumption bordering on heresy,⁴⁸ the “God within” also presents a dogmatic difficulty. But the quaternity as produced by the modern psyche points directly not only to the God within, but to the identity of God and man. Contrary to the dogma, there are not three, but four aspects. It could easily be inferred that the fourth represents the devil. Though we have the logion “I and the Father are one: who seeth me seeth the Father,” it would be considered blasphemy or madness to stress Christ’s dogmatic humanity to such a degree that man could identify himself with Christ and his homoousia.⁴⁹ But this is precisely what seems to be meant by the natural symbol. From an orthodox standpoint, therefore, the natural quaternity could be declared a *diabolica fraus*, and the chief proof of this would be its assimilation of the fourth aspect which represents the reprehensible part of the Christian cosmos. The Church, it seems to me, probably has to repudiate any attempt to take such conclusions seriously. She may even have to condemn any approach to these experiences, since she cannot admit that nature unites what she herself has divided. The voice of nature is clearly audible in all experiences of the quaternity, and this arouses all the old

mistrust of anything even remotely connected with the unconscious. Scientific investigation of dreams is simply the old oneiromancy in new guise and therefore just as objectionable as any other of the “occult” arts. Close parallels to the symbolism of dreams can be found in the old alchemical treatises, and these are quite as heretical as dreams.⁵⁰ Here, it would seem, was reason enough for secrecy and protective metaphors.⁵¹ The symbolic statements of the old alchemists issue from the same unconscious as modern dreams and are just as much the voice of nature.

[106] If we were still living in a medieval setting where there was not much doubt about the ultimate things and where every history of the world began with Genesis, we could easily brush aside dreams and the like. Unfortunately we live in a modern setting where all the ultimate things are doubtful, where there is a prehistory of enormous extension, and where people are fully aware that if there is any numinous experience at all, it is the experience of the psyche. We can no longer imagine an empyrean world revolving round the throne of God, and we would not dream of seeking for him somewhere behind the galactic systems. Yet the human soul seems to harbour mysteries, since to an empiricist all religious experience boils down to a peculiar psychic condition. If we want to know anything of what religious experience means to those who have it, we have every chance nowadays of studying it in every imaginable form. And if it means anything, it means everything to those who have it. This is at any rate the inevitable conclusion one reaches by a careful study of the evidence. One could even define religious experience as that kind of experience which is accorded the highest value, no matter what its contents may be. The modern mind, so far as it stands under the verdict “extra ecclesiam nulla salus,” will turn to the psyche as the last hope. Where else could one obtain experience? And the answer will be more or less of the kind which I have described. The voice of nature will answer and all those concerned with the spiritual problem of man will be confronted with new and baffling problems. Because of the spiritual need of my patients I have been forced to make a serious attempt to understand some of the symbols produced by the unconscious. As it would lead much too far to embark on a discussion of the intellectual and ethical consequences, I shall have to content myself with a mere sketch.

[107] The main symbolic figures of a religion are always expressive of the particular moral and mental attitude involved. I would mention, for instance, the cross and its various religious meanings. Another main symbol is the Trinity. It is of exclusively masculine character. The unconscious, however, transforms it into a quaternity, which is at the same time a unity, just as the three persons of the Trinity are one and the same God. The natural philosophers of antiquity represented the Trinity, so far as it was *imaginata in natura*, as the three *ἀσώματα* or “spirits,” also called “volatilia,” namely water, air, and fire. The fourth constituent, on the other hand, was

τὸ σῶματον, the earth or the body. They symbolized the latter by the Virgin.⁵² In this way they added the feminine element to their physical Trinity, thereby producing the quaternity or *circulus quadratus*, whose symbol was the hermaphroditic *rebis*,⁵³ the *filius sapientiae*. The natural philosophers of the Middle Ages undoubtedly meant earth and woman by the fourth element. The principle of evil was not openly mentioned, but it appears in the poisonous quality of the *prima materia* and in other allusions. The quaternity in modern dreams is a creation of the unconscious. As I explained in the first chapter, the unconscious is often personified by the anima, a feminine figure. Apparently the symbol of the quaternity issues from her. She would be the matrix of the quaternity, a θεοτόκος or Mater Dei, just as the earth was understood to be the Mother of God. But since woman, as well as evil, is excluded from the Deity in the dogma of the Trinity, the element of evil would form part of the religious symbol if the latter should be a quaternity. It needs no particular effort of imagination to guess the far-reaching spiritual consequences of such a development.

3. THE HISTORY AND PSYCHOLOGY OF A NATURAL SYMBOL

[108] Although I have no wish to discourage philosophical curiosity, I would rather not lose myself in a discussion of the ethical and intellectual aspects of the problem raised by the quaternity symbol. Its psychological importance is far-reaching and plays a considerable role in practical treatment. While we are not concerned here with psychotherapy, but with the religious aspect of certain psychic phenomena, I have been forced through my studies in psychopathology to dig out these historical symbols and figures from the dust of their graves.¹ When I was a young alienist I should never have suspected myself of doing such a thing. I shall not mind, therefore, if this long discussion of the quaternity symbol, the *circulus quadratus*, and the heretical attempts to improve on the dogma of the Trinity seem to be somewhat far-fetched and exaggerated. But, in point of fact, my whole discourse on the quaternity is no more than a regrettably short and inadequate introduction to the final and crowning example which illustrates my case.

[109] Already at the very beginning of our dream-series the circle appears. It takes the form, for instance, of a serpent, which describes a circle² round the dreamer. It appears in later dreams as a clock, a circle with a central point, a round target for shooting practice, a clock that is a *perpetuum mobile*, a ball, a globe, a round table, a basin, and so on. The square appears also, about the same time, in the form of a city square or a garden with a fountain in the centre. Somewhat later it appears in connection with a circular movement:³ people walking round in a square; a magic ceremony (the transformation of animals into human beings) that takes place in a square room, in the corners of which are four snakes, with people again circulating round the four corners; the dreamer driving round a square in a taxi; a square prison cell; an empty square which is itself rotating; and so on. In other dreams the circle is represented by rotation—for instance, four children carry a “dark ring” and walk in a circle. Again, the circle appears combined with the quaternity, as a silver bowl with four nuts at the four cardinal points, or as a table with four chairs. The centre seems to be particularly emphasized. It is symbolized by an egg in the middle of a ring; by a star consisting of a body of soldiers; by a star rotating in a circle, the cardinal points of which represent the four seasons; by the Pole; by a precious stone, and so on.

[110] All these dreams lead up to one image which came to the patient in the form of a sudden visual impression. He had had such glimpses or visualizations on several occasions before, but this time it was a most impressive experience. As he himself

says: “It was an impression of the most sublime harmony.” In such a case it does not matter at all what *our* impression is or what *we* think about it. It only matters how the patient feels about it. It is *his* experience, and if it has a deeply transforming influence upon his condition there is no point in arguing against it. The psychologist can only take note of the fact and, if he feels equal to the task, he might also make an attempt to understand why such a vision had such an effect upon such a person. The vision was a turning point in the patient’s psychological development. It was what one would call—in the language of religion—a conversion.

[111] This is the literal text of the vision:

*There is a vertical and a horizontal circle, having a common centre. This is the world clock. It is supported by the black bird.*⁴

The vertical circle is a blue disc with a white border divided into $4 \times 8 = 32$ partitions. A pointer rotates upon it.

The horizontal circle consists of four colours. On it stand four little men with pendulums, and round about it is laid the ring that was once dark and is now golden (formerly carried by four children).

The world clock has three rhythms or pulses:

1. *The small pulse:* *the pointer on the blue vertical disc advances by $1/32$.*
2. *The middle pulse:* *one complete rotation of the pointer. At the same time the horizontal circle advances by $1/32$.*
3. *The great pulse:* *32 middle pulses are equal to one complete rotation of the golden ring.*

[112] The vision sums up all the allusions in the previous dreams. It seems to be an attempt to make a meaningful whole of the formerly fragmentary symbols, then characterized as circle, globe, square, rotation, clock, star, cross, quaternity, time, and so on.

[113] It is of course difficult to understand why a feeling of “most sublime harmony” should be produced by this abstract structure. But if we think of the two circles in Plato’s *Timaeus*, and of the harmonious all-roundness of his *anima mundi*, we might find an avenue to understanding. Again, the term “world clock” suggests the antique conception of the musical harmony of the spheres. It would thus be a sort of cosmological system. If it were a vision of the firmament and its silent rotation, or of the steady movement of the solar system, we could readily understand and appreciate the perfect harmony of the picture. We might also assume that the platonic vision of the cosmos was faintly glimmering through the mist of a dreamlike consciousness. But there is something in the vision that does not quite accord with the harmonious perfection of the platonic picture. The two circles are each of a different nature. Not

only is their movement different, but their colour too. The vertical circle is blue and the horizontal one containing four colours is golden. The blue circle might easily symbolize the blue hemisphere of the sky, while the horizontal circle would represent the horizon with its four cardinal points, personified by the four little men and characterized by the four colours. (In a former dream, the four points were represented once by four children and another time by the four seasons.) This picture immediately calls to mind the medieval representations of the world in the form of a circle or in the shape of the *rex gloriae* with the four evangelists, or the *melothesia*,⁵ where the horizon is formed by the zodiac. The representation of the triumphant Christ seems to be derived from similar pictures of Horus and his four sons.⁶ There are also Eastern analogies: the Buddhist mandalas or circles, usually of Tibetan origin. These consist as a rule of a circular padma or lotus which contains a square sacred building with four gates, indicating the four cardinal points and the seasons. The centre contains a Buddha, or more often the conjunction of Shiva and his Shakti, or an equivalent *dorje* (thunderbolt) symbol.⁷ They are yantras or ritualistic instruments for the purpose of contemplation, concentration, and the final transformation of the yogi's consciousness into the divine all-consciousness.⁸

[114] However striking these analogies may be, they are not entirely satisfactory, because they all emphasize the centre to such an extent that they seem to have been made in order to express the importance of the central figure. In our case, however, the centre is empty. It consists only of a mathematical point. The parallels I have mentioned depict the world-creating or world-ruling deity, or else man in his dependence upon the celestial constellations. Our symbol is a clock, symbolizing time. The only analogy I can think of to such a symbol is the design of the horoscope. It too has four cardinal points and an empty centre. And there is another remarkable correspondence: rotation is often mentioned in the previous dreams, and this is usually reported as moving to the left. The horoscope has twelve houses that progress numerically to the left, that is, counter-clockwise.

[115] But the horoscope consists of one circle only and moreover contains no contrast between two obviously different systems. So the horoscope too is an unsatisfactory analogy, though it sheds some light on the time aspect of our symbol. We would be forced to give up our attempt to find psychological parallels were it not for the treasure-house of medieval symbolism. By a lucky chance I came across a little-known medieval author of the early fourteenth century, Guillaume de Digulleville, prior of a monastery at Châlis, a Norman poet who wrote three "Pélerinages" between 1330 and 1355.⁹ They are called *Les Pélerinages de la vie humaine, de l'âme*, and *de Jésus Christ*. In the last canto of the *Pélerinage de l'âme* we find a vision of paradise.

[116] Paradise consists of forty-nine rotating spheres. They are called “siècles,” centuries, being the prototypes or archetypes of the earthly centuries. But, as the angel who serves as a guide to Guillaume explains, the ecclesiastical expression “in saecula saeculorum” means eternity and not ordinary time. A golden heaven surrounds all the spheres. When Guillaume looked up to the golden heaven he suddenly became aware of a small circle, only three feet wide and of the colour of sapphire. He says of this circle: “It came out of the golden heaven at one point and reentered it at another, and it made the whole tour of the golden heaven.” Evidently the blue circle was rolling like a disc upon a great circle which intersected the golden sphere of heaven.

[117] Here, then, we have two different systems, the one golden, the other blue, and the one cutting through the other. What is the blue circle? The angel again explains to the wondering Guillaume:

Ce cercle que tu vois est le calendrier,
Qui en faisant son tour entier,
Montre des Saints les journées
Quand elles doivent être fêtées.
Chacun en fait le cercle un tour,
Chacune étoile y est pour jour,
Chacun soleil pour l'espace
De jours trente ou zodiaque.

(This circle is the calendar
Which spinning round the course entire
Shows the feast day of each saint
And when it should be celebrate.
Each saint goes once round all the way,
Each star you see stands for a day,
And every sun denotes a spell
Of thirty days zodiacal.)

[118] The blue circle is the ecclesiastical calendar. So here we have another parallel—the element of time. It will be remembered that time, in our vision, is characterized or measured by three pulses. Guillaume’s calendar circle is three feet in diameter. Moreover, while Guillaume is gazing at the blue circle, three spirits clad in purple suddenly appear. The angel explains that this is the feast-day of the three saints, and he goes on to discourse about the whole zodiac. When he comes to the sign of the Fishes he mentions the feast of the twelve fishermen which precedes that of the Holy Trinity. Whereupon Guillaume tells the angel that he has never quite understood the

symbol of the Trinity. He asks him to be good enough to explain this mystery. Whereupon the angel answers: “Well, there are three principal colours: green, red, and golden.” One can see them united in the peacock’s tail. And he goes on: “The almighty King who puts three colours in one, cannot he also make one substance to be three?” The golden colour, he says, belongs to the Father, the red to the Son, and the green to the Holy Ghost.¹⁰ Then the angel warns the poet not to ask any more questions and disappears.

[119] We know, happily enough, from the angel’s teaching, that three has to do with the Trinity. So we also know that our former digression into the field of mystical speculation on the Trinity was not far off the mark. At the same time we meet with the motif of the colours, but unfortunately our patient has four, whereas Guillaume, or rather the angel, speaks only of three—gold, red, and green. Here we might quote the opening words of the *Timaeus*: “Three there are, but where is the fourth?” Or we could quote the very same words from Goethe’s *Faust*, from the famous Cabiri scene in Part II, where the Cabiri bring the vision of that mysterious “streng Gebilde,” the “severe image,” from the sea.

[120] The four little men of our vision are dwarfs or Cabiri. They represent the four cardinal points and the four seasons, as well as the four colours and the four elements. In the *Timaeus*, as also in *Faust* and the *Pélerinage*, something seems to be wrong with the number four. The missing fourth colour is obviously blue. It is the one that belongs to the series yellow, red, and green. Why is blue missing? What is wrong with the calendar? or with time? or with the colour blue?¹¹

[121] Poor old Guillaume has evidently been stumped by the same problem. Three there are, but where is the fourth? He was eager to learn something about the Trinity—which, as he says, he had never quite understood. And it is slightly suspicious that the angel is in such a hurry to get away before Guillaume can ask any more awkward questions.

[122] Well, I suppose Guillaume was pretty unconscious when he went to heaven, or he surely would have drawn certain conclusions from what he saw. Now what did he actually see? First he saw the spheres or “siècles” inhabited by those who had attained eternal bliss. Then he beheld the heaven of gold, the “ciel d’or,” and there was the King of Heaven sitting upon a golden throne and, beside him, the Queen of Heaven sitting upon a round throne of *brown crystal*. This latter detail refers to the fact that Mary is supposed to have been taken up to heaven with her body, as the only mortal being permitted to unite with the body before the resurrection of the dead. The king is usually represented as the triumphant Christ in conjunction with his bride, the Church. But the all-important point is that the king, being Christ, is at the same time the Trinity, and that the introduction of a fourth person, the Queen, makes it a quaternity. The royal pair represents in ideal form the unity of the Two under the rule

of the One—“binarius sub monarchia unarii,” as Dorn would say. Moreover, in the brown crystal, the “realm of quaternity and the elements” into which the “four-horned binarius” was cast has been exalted to the throne of the supreme intercessor, Mary. Consequently the quaternity of the natural elements appears not only in close conjunction with the *corpus mysticum* of the bridal Church or Queen of Heaven—often it is difficult to distinguish between the two—but in immediate relationship to the Trinity.¹²

[123] Blue is the colour of Mary’s celestial cloak; she is the earth covered by the blue tent of the sky.¹³ But why should the Mother of God not be mentioned? According to the dogma she is only *beata*, not divine. Moreover, she represents the earth, which is also the body and its darkness. That is the reason why she, the all-merciful, has the power of attorney to plead for all sinners, but also why, despite her privileged position (it is not possible for the angels to sin), she has a relationship with the Trinity which is rationally not comprehensible, since it is so close and yet so distant. As the matrix, the vessel, the earth, she can be interpreted allegorically as the *rotundum*, which is characterized by the four cardinal points, and hence as the globe with the four quarters, God’s footstool, or as the “four-square” Heavenly City, or the “flower of the sea, in which Christ lies hidden”¹⁴—in a word, as a mandala. This, according to the Tantric idea of the lotus, is feminine, and for readily understandable reasons. The lotus is the eternal birthplace of the gods. It corresponds to the Western rose in which the King of Glory sits, often supported by the four evangelists, who correspond to the four quarters.

[124] From this precious piece of medieval psychology we gain some insight into the meaning of our patient’s mandala. It unites the four and they function together harmoniously. My patient had been brought up a Catholic and thus, unwittingly, he was confronted with the same problem which caused not a little worry to old Guillaume. It was, indeed, a great problem to the Middle Ages, this problem of the Trinity and the exclusion, or the very qualified recognition, of the feminine element, of the earth, the body, and matter in general, which were yet, in the form of Mary’s womb, the sacred abode of the Deity and the indispensable instrument for the divine work of redemption. My patient’s vision is a symbolic answer to this age-old question. That is probably the deeper reason why the image of the world clock produced the impression of “most sublime harmony.” It was the first intimation of a possible solution of the devastating conflict between matter and spirit, between the desires of the flesh and the love of God. The miserable and ineffectual compromise of the church dream is completely overcome in this mandala vision, where all opposites are reconciled. If we hark back to the old Pythagorean idea that the soul is a square,¹⁵ then the mandala would express the Deity through its threefold rhythm

and the soul through its static quaternity, the circle divided into four colours. And thus its innermost meaning would simply be the *union of the soul with God*.

[125] As the world clock also represents the *quadratura circuli* and the *perpetuum mobile*, both these preoccupations of the medieval mind find adequate expression in our mandala. The golden circle and its contents represent the quaternity in the form of the four Cabiri and the four colours, and the blue circle represents the Trinity and the movement of time, according to Guillaume. In our case, the hand of the blue circle has the fastest movement, while the golden circle moves slowly. Whereas the blue circle seems to be somewhat incongruous in Guillaume's golden heaven, the circles in our case are harmoniously combined. The Trinity is now the life, the "pulse" of the whole system, with a threefold rhythm based, however, on thirty-two, a multiple of four. This agrees with the view I expressed before, that the quaternity is the *sine qua non* of divine birth and, consequently, of the inner life of the Trinity. Thus circle and quaternity on one side and the threefold rhythm on the other interpenetrate so that each is contained in the other. In Guillaume's version the Trinity is obvious enough, but the quaternity is concealed in the duality of the King and Queen of Heaven. What is more, the blue colour does not belong to the queen but to the calendar, which represents time and is characterized by trinitarian attributes. There seems to be a mutual interpenetration of symbols, just as in our case.

[126] Interpenetrations of qualities and contents are typical not only of symbols in general, but also of the *essential similarity* of the contents symbolized. Without this similarity no interpenetration would be possible at all. We therefore find interpenetration also in the Christian conception of the Trinity, where the Father appears in the Son, the Son in the Father, the Holy Ghost in Father and Son, or both these in the Holy Ghost as the Paraclete. The progression from Father to Son and the Son's appearance on earth at a particular moment would represent the time element, while the spatial element would be personified by the Mater Dei. (The mother quality was originally an attribute of the Holy Ghost, and the latter was known as Sophia-Sapientia by certain early Christians.¹⁶ This feminine quality could not be completely eradicated; it still adheres to the symbol of the Holy Ghost, the *columba spiritus sancti*). But the quaternity is entirely absent from the dogma, though it appears in early ecclesiastical symbolism. I refer to the cross with equal arms enclosed in the circle, the triumphant Christ with the four evangelists, the tetramorph, and so on. In later ecclesiastical symbolism the *rosa mystica*, the *vas devotionis*, the *fons signatus*, and the *hortus conclusus* appear as attributes of the Mater Dei and of the spiritualized earth.¹⁷

[127] It would hardly be worth while to look at all these relationships in a psychological light if the conceptions of the Trinity were nothing more than the ingenuities of human reason. I have always taken the view that they belong to the

type of revelation to which Koeppen has recently given the name of “Gnosis” (not to be confused with Gnosticism). Revelation is an “unveiling” of the depths of the human soul first and foremost, a “laying bare”; hence it is an essentially psychological event, though this does not, of course, tell us what *else* it might be. That lies outside the province of science. My view comes very close to Koeppen’s lapidary formula, which moreover bears the ecclesiastical imprimatur: “The Trinity is a revelation not only of God but at the same time of man.”¹⁸

[128] Our mandala is an abstract, almost mathematical representation of some of the main problems discussed in medieval Christian philosophy. The abstraction goes so far, indeed, that if it had not been for the help of Guillaume’s vision we might have overlooked its widespread system of roots in human history. The patient did not possess any real knowledge of the historical material. He knew only what anybody who had received a smattering of religious instruction in early childhood would know. He himself saw no connection between his world clock and any religious symbolism. One can readily understand this, since the vision contains nothing at first sight that would remind anyone of religion. Yet the vision itself came shortly after the dream of the “House of the Gathering.” And that dream was the answer to the problem of three and four represented in a still earlier dream. There it was a matter of a rectangular space, on the four sides of which were four goblets filled with coloured water. One was yellow, another red, the third green, and the fourth colourless. Obviously blue was missing, yet it had been connected with the three other colours in a previous vision, where a bear appeared in the depths of a cavern. The bear had four eyes emitting red, yellow, green, and blue light. Astonishingly enough, in the later dream the blue colour had disappeared. At the same time the customary square was transformed into an oblong, which had never appeared before. The cause of this manifest disturbance was the dreamer’s resistance to the feminine element represented by the anima. In the dream of the “House of the Gathering” the voice confirms this fact. It says: “What you are doing is dangerous. Religion is not the tax you pay in order to get rid of the woman’s image, for this image cannot be got rid of.” The “woman’s image” is exactly what we would call the “anima.”¹⁹

[129] It is normal for a man to resist his anima, because she represents, as I said before, the unconscious and all those tendencies and contents hitherto excluded from conscious life. They were excluded for a number of reasons, both real and apparent. Some are suppressed and some are repressed. As a rule those tendencies that represent the antisocial elements in man’s psychic structure—what I call the “statistical criminal” in everybody—are suppressed, that is, they are consciously and deliberately disposed of. But tendencies that are merely repressed are usually of a somewhat doubtful character. They are not so much antisocial as unconventional and socially awkward. The reason why we repress them is equally doubtful. Some people

repress them from sheer cowardice, others from conventional morality, and others again for reasons of respectability. Repression is a sort of half-conscious and half-hearted letting go of things, a dropping of hot cakes or a reviling of grapes which hang too high, or a looking the other way in order not to become conscious of one's desires. Freud discovered that repression is one of the main mechanisms in the making of a neurosis. Suppression amounts to a conscious moral choice, but repression is a rather immoral "penchant" for getting rid of disagreeable decisions. Suppression may cause worry, conflict and suffering, but it never causes a neurosis. Neurosis is always a substitute for legitimate suffering.

[130] If one discounts the "statistical criminal," there still remains the vast domain of inferior qualities and primitive tendencies which belong to the psychic structure of the man who is less ideal and more primitive than we should like to be.²⁰ We have certain ideas as to how a civilized or educated or moral being should live, and we occasionally do our best to fulfil these ambitious expectations. But since nature has not bestowed the same blessings upon each of her children, some are more and others less gifted. Thus there are people who can just afford to live properly and respectably; that is to say, no manifest flaw is discoverable. They either commit minor sins, if they sin at all, or their sins are concealed from them by a thick layer of unconsciousness. One is rather inclined to be lenient with sinners who are unconscious of their sins. But nature is not at all lenient with unconscious sinners. She punishes them just as severely as if they had committed a conscious offence. Thus we find, as the pious Henry Drummond²¹ once observed, that it is highly moral people, unaware of their other side, who develop particularly hellish moods which make them insupportable to their relatives. The odour of sanctity may be far reaching, but to live with a saint might well cause an inferiority complex or even a wild outburst of immorality in individuals less morally gifted. Morality seems to be a gift like intelligence. You cannot pump it into a system to which it is not indigenous.

[131] Unfortunately there can be no doubt that man is, on the whole, less good than he imagines himself or wants to be. Everyone carries a shadow, and the less it is embodied in the individual's conscious life, the blacker and denser it is. If an inferiority is conscious, one always has a chance to correct it. Furthermore, it is constantly in contact with other interests, so that it is continually subjected to modifications. But if it is repressed and isolated from consciousness, it never gets corrected, and is liable to burst forth suddenly in a moment of unawareness. At all events, it forms an unconscious snag, thwarting our most well-meant intentions.

[132] We carry our past with us, to wit, the primitive and inferior man with his desires and emotions, and it is only with an enormous effort that we can detach ourselves from this burden. If it comes to a neurosis, we invariably have to deal with a considerably intensified shadow. And if such a person wants to be cured it is

necessary to find a way in which his conscious personality and his shadow can live together.

[133] This is a very serious problem for all those who are themselves in such a predicament or have to help sick people back to normal life. Mere suppression of the shadow is as little of a remedy as beheading would be for headache. To destroy a man's morality does not help either, because it would kill his better self, without which even the shadow makes no sense. The reconciliation of these opposites is a major problem, and even in antiquity it bothered certain minds. Thus we know of an otherwise legendary personality of the second century, Carpocrates,²² a Neoplatonist philosopher whose school, according to Irenaeus, taught that good and evil are merely human opinions and that the soul, before its departure from the body, must pass through the whole gamut of human experience to the very end if it is not to fall back into the prison of the body. It is as if the soul could only ransom itself from imprisonment in the somatic world of the demiurge by complete fulfilment of all life's demands. The bodily existence in which we find ourselves is a kind of hostile brother whose conditions must first be known. It was in this sense that the Carpocratians interpreted Matthew 5:25f. (also Luke 12:58f.): "Agree with thine adversary quickly, whiles thou art in the way with him; lest at any time the adversary deliver thee to the judge, and the judge deliver thee to the officer, and thou be cast into prison. Verily I say unto thee, Thou shalt by no means come out thence, till thou hast paid the uttermost farthing." Remembering the other Gnostic doctrine that no man can be redeemed from a sin he has not committed, we are here confronted with a problem of the very greatest importance, obscured though it is by the Christian abhorrence of anything Gnostic. Inasmuch as the somatic man, the "adversary," is none other than "the other in me," it is plain that the Carpocratian mode of thought would lead to the following interpretation of Matthew 5:22f.: "But I say unto you, That whosoever is angry with *himself* without a cause shall be in danger of the judgment: and whosoever shall say to *himself*, Raca, shall be in danger of the council: but whosoever shall say, Thou fool, shall be in danger of hell fire. Therefore if thou bring thy gift to the altar, and there rememberest that *thou hast aught against thyself*, leave there thy gift before the altar, and go thy way; first be reconciled to *thyself*, and then come and offer thy gift. Agree with *thyself* quickly, whiles thou art in the way with *thyself*; lest at any time *thou deliverest thyself* to the judge." From here it is but a step to the uncanonical saying: "Man, if indeed thou knowest what thou doest, thou art blessed; but if thou knowest not, thou art cursed, and a transgressor of the law."²³ But the problem comes very close indeed in the parable of the unjust steward, which is a stumbling-block in more senses than one. "And the lord commended the unjust steward, because he had done wisely" (Luke 16:8). In the Vulgate the word for 'wisely' is *prudenter*, and in the Greek text it is *φρονίμως* (prudently, sensibly,

intelligently). There's no denying that practical intelligence functions here as a court of ethical decision. Perhaps, despite Irenaeus, we may credit the Carpocratians with this much insight, and allow that they too, like the unjust steward, were commendably aware of how to save face. It is natural that the more robust mentality of the Church Fathers could not appreciate the delicacy and the merit of this subtle and, from a modern point of view, immensely practical argument. It was also dangerous, and it is still the most vital and yet the most ticklish ethical problem of a civilization that has forgotten why man's life should be sacrificial, that is, offered up to an idea greater than himself. Man can live the most amazing things if they make sense to him. But the difficulty is to create that sense. It must be a conviction, naturally; but you find that the most convincing things man can invent are cheap and ready-made, and are never able to convince him against his personal desires and fears.

[134] If the repressed tendencies, the shadow as I call them, were obviously evil, there would be no problem whatever. But the shadow is merely somewhat inferior, primitive, unadapted, and awkward; not wholly bad. It even contains childish or primitive qualities which would in a way vitalize and embellish human existence, but—convention forbids! The educated public, flower of our present civilization, has detached itself from its roots, and is about to lose its connection with the earth as well. There is no civilized country nowadays where the lowest strata of the population are not in a state of unrest and dissent. In a number of European nations such a condition is overtaking the upper strata too. This state of affairs demonstrates our psychological problem on a gigantic scale. Inasmuch as collectivities are mere accumulations of individuals, their problems are accumulations of individual problems. One set of people identifies itself with the superior man and cannot descend, and the other set identifies itself with the inferior man and wants to get to the top.

[135] Such problems are never solved by legislation or by tricks. They are solved only by a general change of attitude. And the change does not begin with propaganda and mass meetings, or with violence. It begins with a change in individuals. It will continue as a transformation of their personal likes and dislikes, of their outlook on life and of their values, and only the accumulation of these individual changes will produce a collective solution.

[136] The educated man tries to repress the inferior man in himself, not realizing that by so doing he forces the latter into revolt. It is characteristic of my patient that he once dreamt of a military party that wanted "to strangle the left completely." Somebody remarks that the left is weak enough anyway, but the military party answers that this is just why it ought to be strangled completely. The dream shows how my patient dealt with his own inferior man. This is clearly not the right method.

The dream of the “House of the Gathering,” on the contrary, shows a religious attitude as the correct answer to his question. The mandala seems to be an amplification of this particular point. Historically, as we have seen, the mandala served as a symbol to clarify the nature of the deity philosophically, or to represent the same thing in a visible form for the purpose of adoration, or, as in the East, as a yantra for yoga practices. The wholeness (“perfection”) of the celestial circle and the squareness of the earth, combining the four principles or elements or psychic qualities,²⁴ express completeness and union. Thus the mandala has the status of a “uniting symbol.”²⁵ As the union of God and man is expressed in the symbol of Christ or the cross,²⁶ we would expect the patient’s world clock to have a similar reconciling significance. Prejudiced by historical analogies, we would expect a deity to occupy the centre of the mandala. The centre is, however, empty. The seat of the deity is unoccupied, in spite of the fact that, when we analyse the mandala in terms of its historical models, we arrive at the god symbolized by the circle and the goddess symbolized by the square. Instead of “goddess” we could also say “earth” or “soul.” Despite the historical prejudice, however, the fact must be insisted upon that (as in the “House of the Gathering,” where the place of the sacred image was occupied by the quaternity) we find no trace of a deity in the mandala, but, on the contrary, a mechanism. I do not believe that we have any right to disregard such an important fact in favour of a preconceived idea. A dream or a vision is just what it seems to be. It is not a disguise for something else. It is a natural product, which is precisely a thing without ulterior motive. I have seen many hundreds of mandalas, done by patients who were quite uninfluenced, and I have found the same fact in an overwhelming majority of cases: there was never a deity occupying the centre. The centre, as a rule, is emphasized. But what we find there is a symbol with a very different meaning. It is a star, a sun, a flower, a cross with equal arms, a precious stone, a bowl filled with water or wine, a serpent coiled up, or a human being, but never a god.²⁷

[137] When we find a triumphant Christ in the rose window of a medieval church, we rightly assume that this must be a central symbol of the Christian cult. At the same time we also assume that any religion which is rooted in the history of a people is as much an expression of their psychology as the form of political government, for instance, that the people have developed. If we apply the same method to the modern mandalas that people have seen in dreams or visions, or have developed through “active imagination,”²⁸ we reach the conclusion that mandalas are expressions of a certain attitude which we cannot help calling “religious.” Religion is a relationship to the highest or most powerful value, be it positive or negative. The relationship is voluntary as well as involuntary, that is to say you can accept, consciously, the value by which you are possessed unconsciously. That psychological fact which yields the

greatest power in your system functions as a god, since it is always the overwhelming psychic factor that is called “God.” As soon as a god ceases to be an overwhelming factor he dwindles to a mere name. His essence is dead and his power is gone. Why did the gods of antiquity lose their prestige and their effect on the human soul? Because the Olympians had served their time and a new mystery began: God became man.

[138] If we allow ourselves to draw conclusions from modern mandalas we should ask people, first, whether they worship stars, suns, flowers, and snakes. They will deny this, and at the same time they will assert that the globes, stars, crosses, and the like are symbols for a *centre in themselves*. And if asked what they mean by this centre, they will begin to stammer and to refer to this or that experience which may turn out to be something very similar to the confession of my patient, who found that the vision of his world clock had left him with a wonderful feeling of perfect harmony. Others will confess that a similar vision came to them in a moment of extreme pain or profound despair. To others again it is the memory of a sublime dream or of a moment when long and fruitless struggles came to an end and a reign of peace began. If you sum up what people tell you about their experiences, you can formulate it this way: They came to themselves, they could accept themselves, they were able to become reconciled to themselves, and thus were reconciled to adverse circumstances and events. This is almost like what used to be expressed by saying: He has made his peace with God, he has sacrificed his own will, he has submitted himself to the will of God.

[139] A modern mandala is an involuntary confession of a peculiar mental condition. There is no deity in the mandala, nor is there any submission or reconciliation to a deity. The place of the deity seems to be taken by the wholeness of man.²⁹

[140] When one speaks of man, everybody means his own ego-personality—that is, his personality so far as he is conscious of it—and when one speaks of others one assumes that they have a very similar personality. But since modern research has acquainted us with the fact that individual consciousness is based on and surrounded by an indefinitely extended unconscious psyche, we must needs revise our somewhat old-fashioned prejudice that man is nothing but his consciousness. This naïve assumption must be confronted at once with the critical question: *Whose consciousness?* The fact is, it would be a difficult task to reconcile the picture I have of myself with the one which other people have of me. Who is right? And who is the real individual? If we go further and consider the fact that man is also what neither he himself nor other people know of him—an unknown something which can yet be proved to exist—the problem of identity becomes more difficult still. Indeed, it is quite impossible to define the extent and the ultimate character of psychic existence. When we now speak of man we mean the indefinable whole of him, an ineffable

totality, which can only be formulated symbolically. I have chosen the term “self” to designate the totality of man, the sum total of his conscious and unconscious contents.³⁰ I have chosen this term in accordance with Eastern philosophy,³¹ which for centuries has occupied itself with the problems that arise when even the gods cease to incarnate. The philosophy of the Upanishads corresponds to a psychology that long ago recognized the relativity of the gods.³² This is not to be confused with a stupid error like atheism. The world is as it ever has been, but our consciousness undergoes peculiar changes. First, in remote times (which can still be observed among primitives living today), the main body of psychic life was apparently in human and in nonhuman objects: it was projected, as we should say now.³³ Consciousness can hardly exist in a state of complete projection. At most it would be a heap of emotions. Through the withdrawal of projections, conscious knowledge slowly developed. Science, curiously enough, began with the discovery of astronomical laws, and hence with the withdrawal, so to speak, of the most distant projections. This was the first stage in the despiritualization of the world. One step followed another: already in antiquity the gods were withdrawn from mountains and rivers, from trees and animals. Modern science has subtilized its projections to an almost unrecognizable degree, but our ordinary life still swarms with them. You can find them spread out in the newspapers, in books, rumours, and ordinary social gossip. All gaps in our actual knowledge are still filled out with projections. We are still so sure we know what other people think or what their true character is. We are convinced that certain people have all the bad qualities we do not know in ourselves or that they practise all those vices which could, of course, never be our own. We must still be exceedingly careful not to project our own shadows too shamelessly; we are still swamped with projected illusions. If you imagine someone who is brave enough to withdraw all these projections, then you get an individual who is conscious of a pretty thick shadow. Such a man has saddled himself with new problems and conflicts. He has become a serious problem to himself, as he is now unable to say that *they* do this or that, *they* are wrong, and *they* must be fought against. He lives in the “House of the Gathering.” Such a man knows that whatever is wrong in the world is in himself, and if he only learns to deal with his own shadow he has done something real for the world. He has succeeded in shouldering at least an infinitesimal part of the gigantic, unsolved social problems of our day. These problems are mostly so difficult because they are poisoned by mutual projections. How can anyone see straight when he does not even see himself and the darkness he unconsciously carries with him into all his dealings?

[141] Modern psychological development leads to a much better understanding as to what man really consists of. The gods at first lived in superhuman power and beauty on the top of snow-clad mountains or in the darkness of caves, woods, and seas. Later

on they drew together into one god, and then that god became man. But in our day even the God-man seems to have descended from his throne and to be dissolving himself in the common man. That is probably why his seat is empty. Instead, the common man suffers from a hybris of consciousness that borders on the pathological. This psychic condition in the individual corresponds by and large to the hypertrophy and totalitarian pretensions of the idealized State. In the same way that the State has caught the individual, the individual imagines that he has caught the psyche and holds her in the hollow of his hand. He is even making a science of her in the absurd supposition that the intellect, which is but a part and a function of the psyche, is sufficient to comprehend the much greater whole. In reality the psyche is the mother and the maker, the subject and even the possibility of consciousness itself. It reaches so far beyond the boundaries of consciousness that the latter could easily be compared to an island in the ocean. Whereas the island is small and narrow, the ocean is immensely wide and deep and contains a life infinitely surpassing, in kind and degree, anything known on the island—so that if it is a question of space, it does not matter whether the gods are “inside” or “outside.” It might be objected that there is no proof that consciousness is nothing more than an island in the ocean. Certainly it is impossible to prove this, since the known range of consciousness is confronted with the unknown extension of the unconscious, of which we only know that it exists and by the very fact of its existence exerts a limiting effect on consciousness and its freedom. Wherever unconsciousness reigns, there is bondage and possession. The immensity of the ocean is simply a comparison; it expresses in allegorical form the capacity of the unconscious to limit and threaten consciousness. Empirical psychology loved, until recently, to explain the “unconscious” as mere absence of consciousness—the term itself indicates as much—just as shadow is an absence of light. Today accurate observation of unconscious processes has recognized, with all other ages before us, that the unconscious possesses a creative autonomy such as a mere shadow could never be endowed with. When Carus, von Hartmann and, in a sense, Schopenhauer equated the unconscious with the world-creating principle, they were only summing up all those teachings of the past which, grounded in inner experience, saw the mysterious agent personified as the gods. It suits our hypertrophied and hybristic modern consciousness not to be mindful of the dangerous autonomy of the unconscious and to treat it negatively as an absence of consciousness. The hypothesis of invisible gods or daemons would be, psychologically, a far more appropriate formulation, even though it would be an anthropomorphic projection. But since the development of consciousness requires the withdrawal of all the projections we can lay our hands on, it is not possible to maintain any non-psychological doctrine about the gods. If the historical process of world despiritualization continues as hitherto, then everything of a divine or

daemonic character outside us must return to the psyche, to the inside of the unknown man, whence it apparently originated.

[142] The materialistic error was probably unavoidable at first. Since the throne of God could not be discovered among the galactic systems, the inference was that God had never existed. The second unavoidable error is psychologism: if God is anything, he must be an illusion derived from certain motives—from the will to power, for instance, or from repressed sexuality. These arguments are not new. Much the same thing was said by the Christian missionaries who overthrew the idols of heathen gods. But whereas the early missionaries were conscious of serving a new God by combatting the old ones, modern iconoclasts are unconscious of the one in whose name they are destroying old values. Nietzsche thought himself quite conscious and responsible when he smashed the old tablets, yet he felt a peculiar need to back himself up with a revived Zarathustra, a sort of alter ego, with whom he often identifies himself in his great tragedy *Thus Spake Zarathustra*. Nietzsche was no atheist, but his God was dead. The result of this demise was a split in himself, and he felt compelled to call the other self “Zarathustra” or, at times, “Dionysus.” In his fatal illness he signed his letters “Zagreus,” the dismembered god of the Thracians. The tragedy of *Zarathustra* is that, because his God died, Nietzsche himself became a god; and this happened because he was no atheist. He was of too positive a nature to tolerate the urban neurosis of atheism. It seems dangerous for such a man to assert that “God is dead”: he instantly becomes the victim of inflation.³⁴ Far from being a negation, God is actually the strongest and most effective “position” the psyche can reach, in exactly the same sense in which Paul speaks of people “whose God is their belly” (Phil. 3:19). The strongest and therefore the decisive factor in any individual psyche compels the same belief or fear, submission or devotion which a God would demand from man. Anything despotic and inescapable is in this sense “God,” and it becomes absolute unless, by an ethical decision freely chosen, one succeeds in building up against this natural phenomenon a position that is equally strong and invincible. If this psychic position proves to be absolutely effective, it surely deserves to be named a “God,” and what is more, a spiritual God, since it sprang from the freedom of ethical decision and therefore from the mind. Man is free to decide whether “God” shall be a “spirit” or a natural phenomenon like the craving of a morphine addict, and hence whether “God” shall act as a beneficent or a destructive force.

[143] However indubitable and clearly understandable these psychic events or decisions may be, they are very apt to lead people to the false, unpsychological conclusion that it rests with them to decide whether they will *create* a “God” for themselves or not. There is no question of that, since each of us is equipped with a psychic disposition that limits our freedom in high degree and makes it practically

illusory. Not only is “freedom of the will” an incalculable problem philosophically, it is also a misnomer in the practical sense, for we seldom find anybody who is not influenced and indeed dominated by desires, habits, impulses, prejudices, resentments, and by every conceivable kind of complex. All these natural facts function exactly like an Olympus full of deities who want to be propitiated, served, feared and worshipped, not only by the individual owner of this assorted pantheon, but by everybody in his vicinity. Bondage and possession are synonymous. Always, therefore, there is something in the psyche that takes possession and limits or suppresses our moral freedom. In order to hide this undeniable but exceedingly unpleasant fact from ourselves and at the same time pay lip-service to freedom, we have got accustomed to saying apotropaically, “I *have* such and such a desire or habit or feeling of resentment,” instead of the more veracious “Such and such a desire or habit or feeling of resentment *has me*.” The latter formulation would certainly rob us even of the illusion of freedom. But I ask myself whether this would not be better in the end than fuddling ourselves with words. The truth is that we do not enjoy masterless freedom; we are continually threatened by psychic factors which, in the guise of “natural phenomena,” may take possession of us at any moment. The withdrawal of metaphysical projections leaves us almost defenceless in the face of this happening, for we immediately identify with every impulse instead of giving it the name of the “other,” which would at least hold it at arm’s length and prevent it from storming the citadel of the ego. “Principalities and powers” are always with us; we have no need to create them even if we could. It is merely incumbent on us to *choose* the master we wish to serve, so that his service shall be our safeguard against being mastered by the “other” whom we have not chosen. We do not *create* “God,” we *choose* him.

[144] Though our choice characterizes and defines “God,” it is always man-made, and the definition it gives is therefore finite and imperfect. (Even the idea of perfection does not posit perfection.) The definition is an image, but this image does not raise the unknown fact it designates into the realm of intelligibility, otherwise we would be entitled to say that we had created a God. The “master” we choose is not identical with the image we project of him in time and space. He goes on working as before, like an unknown quantity in the depths of the psyche. We do not even know the nature of the simplest thought, let alone the ultimate principles of the psyche. Also, we have no control over its inner life. But because this inner life is intrinsically free and not subject to our will and intentions, it may easily happen that the living thing chosen and defined by us will drop out of its setting, the man-made image, even against our will. Then, perhaps, we could say with Nietzsche, “God is dead.” Yet it would be truer to say, “He has put off our image, and where shall we find him again?” The interregnum is full of danger, for the natural facts will raise their claim

in the form of various -isms, which are productive of nothing but anarchy and destruction because inflation and man's hybris between them have elected to make the ego, in all its ridiculous paltriness, lord of the universe. That was the case with Nietzsche, the uncomprehended portent of a whole epoch.

[145] The individual ego is much too small, its brain is much too feeble, to incorporate all the projections withdrawn from the world. Ego and brain burst asunder in the effort; the psychiatrist calls it schizophrenia. When Nietzsche said "God is dead," he uttered a truth which is valid for the greater part of Europe. People were influenced by it not because he said so, but because it stated a widespread psychological fact. The consequences were not long delayed: after the fog of -isms, the catastrophe. Nobody thought of drawing the slightest conclusions from Nietzsche's pronouncement. Yet it has, for some ears, the same eerie sound as that ancient cry which came echoing over the sea to mark the end of the nature gods: "Great Pan is dead."³⁵

[146] The life of Christ is understood by the Church on the one hand as an historical, and on the other hand as an eternally existing, mystery. This is especially evident in the sacrifice of the Mass. From a psychological standpoint this view can be translated as follows: Christ lived a concrete, personal, and unique life which, in all essential features, had at the same time an archetypal character. This character can be recognized from the numerous connections of the biographical details with worldwide myth-motifs. These undeniable connections are the main reason why it is so difficult for researchers into the life of Jesus to construct from the gospel reports an individual life divested of myth. In the gospels themselves factual reports, legends, and myths are woven into a whole. This is precisely what constitutes the meaning of the gospels, and they would immediately lose their character of wholeness if one tried to separate the individual from the archetypal with a critical scalpel. The life of Christ is no exception in that not a few of the great figures of history have realized, more or less clearly, the archetype of the hero's life with its characteristic changes of fortune. But the ordinary man, too, unconsciously lives archetypal forms, and if these are no longer valued it is only because of the prevailing psychological ignorance. Indeed, even the fleeting phenomena of dreams often reveal distinctly archetypal patterns. At bottom, all psychic events are so deeply grounded in the archetype and are so much interwoven with it that in every case considerable critical effort is needed to separate the unique from the typical with any certainty. Ultimately, every individual life is at the same time the eternal life of the species. The individual is continuously "historical" because strictly time-bound; the relation of the type to time, on the other hand, is irrelevant. Since the life of Christ is archetypal to a high degree, it represents to just that degree the life of the archetype. But since the archetype is the unconscious precondition of every human life, its life, when

revealed, also reveals the hidden, unconscious ground-life of every individual. That is to say, what happens in the life of Christ happens always and everywhere. In the Christian archetype all lives of this kind are prefigured and are expressed over and over again or once and for all. And in it, too, the question that concerns us here of God's death is anticipated in perfect form. Christ himself is the typical dying and self-transforming God.

[147] The psychological situation from which we started is tantamount to "Why seek ye the living among the dead? He is not here" (Luke 24:5f.). But where shall we find the risen Christ?

[148] I do not expect any believing Christian to pursue these thoughts of mine any further, for they will probably seem to him absurd. I am not, however, addressing myself to the happy possessors of faith, but to those many people for whom the light has gone out, the mystery has faded, and God is dead. For most of them there is no going back, and one does not know either whether going back is always the better way. To gain an understanding of religious matters, probably all that is left us today is the psychological approach. That is why I take these thought-forms that have become historically fixed, try to melt them down again and pour them into moulds of immediate experience. It is certainly a difficult undertaking to discover connecting links between dogma and immediate experience of psychological archetypes, but a study of the natural symbols of the unconscious gives us the necessary raw material.

[149] God's death, or his disappearance, is by no means only a Christian symbol. The search which follows the death is still repeated today after the death of a Dalai Lama, and in antiquity it was celebrated in the annual search for the Kore. Such a wide distribution argues in favour of the universal occurrence of this typical psychic process: the highest value, which gives life and meaning, has got lost. This is a typical experience that has been repeated many times, and its expression therefore occupies a central place in the Christian mystery. The death or loss must always repeat itself: Christ always dies, and always he is born; for the psychic life of the archetype is timeless in comparison with our individual time-boundness. According to what laws now one and now another aspect of the archetype enters into active manifestation, I do not know. I only know—and here I am expressing what countless other people know—that the present is a time of God's death and disappearance. The myth says he was not to be found where his body was laid. "Body" means the outward, visible form, the erstwhile but ephemeral setting for the highest value. The myth further says that the value rose again in a miraculous manner, transformed. It looks like a miracle, for, when a value disappears, it always seems to be lost irretrievably. So it is quite unexpected that it should come back. The three days' descent into hell during death describes the sinking of the vanished value into the unconscious, where, by conquering the power of darkness, it establishes a new order,

and then rises up to heaven again, that is, attains supreme clarity of consciousness. The fact that only a few people see the Risen One means that no small difficulties stand in the way of finding and recognizing the transformed value.

[150] I showed earlier, with the help of dreams, how the unconscious produces a natural symbol, technically termed a mandala, which has the functional significance of a union of opposites, or of mediation. These speculative ideas, symptomatic of an activated archetype, can be traced back to about the time of the Reformation, which we find them formulated in the alchemical treatises as symbolic geometrical figures which sought to express the nature of the *Deus terrenus*, the philosophers' stone. For instance, we read in the commentary to the *Tractatus aureus*:

This one thing to which the elements must be reduced is that little circle holding the place of the centre in this squared figure. It is a mediator making peace between enemies or the elements, that they may love one another in a meet embrace. He alone brings about the squaring of the circle, which many hitherto have sought, but few have found.³⁶

Of this “mediator,” the wonderful stone, Orthelius says:

For as ... the supernatural and eternal good, Christ Jesus our Mediator and Saviour, who delivers us from eternal death, from the devil, and from all evil, partakes of two natures, the divine and the human, so likewise is that earthly saviour composed of two parts, the heavenly and the earthly. With these he has restored us to health, and delivers us from diseases heavenly and earthly, spiritual and corporeal, visible and invisible.³⁷

Here the “saviour” does not come down from heaven but out of the depths of the earth, i.e., from that which lies below consciousness. These philosophers suspected that a “spirit” was imprisoned there, in the vessel of matter; a “white dove” comparable to the *Nous* in the krater of Hermes, of which it is said: “Plunge into this krater, if thou canst, by recognizing to what end thou wast created,³⁸ and by believing that thou wilt rise up to Him, who hath sent the krater down to earth.”³⁹

[151] This *Nous* or spirit was known as “Mercurius,”⁴⁰ and it is to this arcanum that the alchemical saying refers: “Whatever the wise seek is in mercury.” A very ancient formula, attributed by Zosimos to the legendary Ostanos, runs: “Go to the waters of the Nile, and there thou wilt find a stone that hath a spirit [pneuma].” A commentator explains that this refers to quicksilver (*hydrargyron*, mercury).⁴¹ This spirit, coming from God, is also the cause of the “greenness,” the *benedicta viriditas*, much praised by the alchemists. Mylius says of it: “God has breathed into created things ... a kind of germination, which is the viridescence.” In Hildegard of Bingen's Hymn to the Holy Ghost, which begins “O ignis Spiritus paraclite,” we read: “From you the clouds rain down, the heavens move, the stones have their moisture, the waters give forth streams, and the earth sweats out greenness.”^{41a} This water of the Holy Ghost played an important role in alchemy since the remotest times, as the ὕδωρ θεῖον or

aqua permanens, a symbol of the spirit assimilated to matter, which according to Heraclitus turned to water. The Christian parallel was naturally Christ's blood, for which reason the water of the philosophers was named "spiritualis sanguis."⁴²

[152] The arcane substance was also known simply as the *rotundum*, by which was understood the *anima media natura*, identical with the *anima mundi*. The latter is a *virtus Dei*, an organ or a sphere that surrounds God. Of this Mylius says: "[God has] love all round him. Others have declared him to be an intellectual and fiery spirit,⁴³ having no form, but transforming himself into whatsoever he wills and making himself equal to all things; who by a manifold relation is in a certain measure bound up with his creatures."⁴⁴ This image of God enveloped by the *anima* is the same as Gregory the Great's allegory of Christ and the Church: "A woman shall compass a man" (Jeremiah 31:22).⁴⁵ This is an exact parallel to the Tantric conception of Shiva in the embrace of his Shakti.⁴⁶ From this fundamental image of the male-female opposites united in the centre is derived another designation of the lapis as the "hermaphrodite"; it is also the basis for the mandala motif. The extension of God as the *anima media natura* into every individual creature means that there is a divine spark, the *scintilla*,⁴⁷ indwelling even in dead matter, in utter darkness. The medieval natural philosophers endeavoured to make this spark rise up again as a divine image from the "round vessel." Such ideas can only be based on the existence of unconscious psychic processes, for otherwise we simply could not understand how the same ideas crop up everywhere. Our dream-example shows that such images are not inventions of the intellect; rather, they are natural revelations. And they will probably be found again and again in exactly the same way. The alchemists themselves say that the *arcanum* is sometimes revealed in a dream.⁴⁸

[153] The old natural philosophers not only felt pretty clearly, but actually said, that the miraculous substance whose essential nature they symbolized by a circle divided into four parts, was man himself. The "Aenigmata ex visione Arislei"⁴⁹ speaks of the *homo albus* who is formed in the hermetic vessel. This "white man" is the equivalent of the priest figure in the visions of Zosimos. In the Arabic-transmitted "Book of Krates"⁵⁰ we find an equally significant allusion in the dialogue between the spiritual and the worldly man (corresponding to the *pneumatikos* and *sarkikos* of the Gnostics). The spiritual man says to the worldly man: "Are you capable of knowing your soul in a complete manner? If you knew it as is fitting, and if you knew what makes it better, you would be able to recognize that the names which the philosophers formerly gave it are not its true names.... O dubious names which resemble the true names, what errors and agonies you have provoked among men!" The names refer in turn to the philosophers' stone. A treatise ascribed to Zosimos, though it more likely derives from the Arabic-Latinist school of literature, says unmistakably of the stone: "Thus it comes from man, and you are its mineral (raw

material); in you it is found, and from you it is extracted ... and it remains inseparably in you.”⁵¹ Solomon Trismosin expresses it most clearly of all:

Study what thou art,
Whereof thou art a part,
What thou knowest of this art,
This is really what thou art.
All that is without thee
Also is within.
Thus wrote Trismosin.⁵²

[154] And Gerhard Dorn cries out: “Transform yourselves into living philosophical stones!”⁵³ There can hardly be any doubt that not a few of those seekers had the dawning knowledge that the secret nature of the stone was man’s own self. This “self” was evidently never thought of as an entity identical with the ego, and for this reason it was described as a “hidden nature” dwelling in inanimate matter, as a spirit, daemon,⁵⁴ or fiery spark. By means of the philosophical *opus*, which was mostly thought of as a mental one,⁵⁵ this entity was freed from darkness and imprisonment, and finally it enjoyed a resurrection, often represented in the form of an apotheosis and equated with the resurrection of Christ.⁵⁶ It is clear that these ideas can have nothing to do with the empirical ego, but are concerned with a “divine nature” quite distinct from it, and hence, psychologically speaking, with a consciousness-transcending content issuing from the realm of the unconscious.

[155] With this we come back to our modern experiences. They are obviously similar in nature to the basic medieval and classical ideas, and can therefore be expressed by the same, or at any rate similar, symbols. The medieval representations of the circle are based on the idea of the microcosm, a concept that was also applied to the stone.⁵⁷ The stone was a “little world” like man himself, a sort of inner image of the cosmos, reaching not into immeasurable distances but into an equally immeasurable depth-dimension, i.e., from the small to the unimaginably smallest. Mylius therefore calls this centre the “punctum cordis.”⁵⁸

[156] The experience formulated by the modern mandala is typical of people who cannot project the divine image any longer. Owing to the withdrawal and introjection of the image they are in danger of inflation and dissociation of the personality. The round or square enclosures built round the centre therefore have the purpose of protective walls or of a *vas hermeticum*, to prevent an outburst or a disintegration. Thus the mandala denotes and assists exclusive concentration on the centre, the self. This is anything but egocentricity. On the contrary, it is a much needed self-control for the purpose of avoiding inflation and dissociation.

[157] The enclosure, as we have seen, has also the meaning of what is called in Greek a *temenos*, the precincts of a temple or any isolated sacred place. The circle in this case protects or isolates an inner content or process that should not get mixed up with things outside. Thus the mandala repeats in symbolic form archaic procedures which were once concrete realities. As I have already mentioned, the inhabitant of the *temenos* was a god. But the prisoner, or the well-protected dweller in the mandala, does not seem to be a god, since the symbols used—stars, crosses, globes, etc.—do not signify a god but an obviously important part of the human personality. One might almost say that man himself, or his innermost soul, is the prisoner or the protected inhabitant of the mandala. Since modern mandalas are amazingly close parallels to the ancient magical circles, which usually have a deity in the centre, it is clear that in the modern mandala man—the deep ground, as it were, of the self—is not a substitute but a symbol for the deity.

[158] It is a remarkable fact that this symbol is a natural and spontaneous occurrence and that it is always an essentially unconscious product, as our dream shows. If we want to know what happens when the idea of God is no longer projected as an autonomous entity, this is the answer of the unconscious psyche. The unconscious produces the idea of a deified or divine man who is imprisoned, concealed, protected, usually depersonalized, and represented by an abstract symbol. The symbols often contain allusions to the medieval conception of the microcosm, as was the case with my patient's world clock, for instance. Many of the processes that lead to the mandala, and the mandala itself, seem to be direct confirmations of medieval speculation. It looks as if the patients had read those old treatises on the philosophers' stone, the divine water, the *rotundum*, the squaring of the circle, the four colours, etc. And yet they have never been anywhere near alchemical philosophy and its abstruse symbolism.

[159] It is difficult to evaluate such facts properly. They could be explained as a sort of regression to archaic ways of thinking, if one's chief consideration was their obvious and impressive parallelism with medieval symbolism. But whenever such regressions occur, the result is always inferior adaptation and a corresponding lack of efficiency. This is by no means typical of the psychological development depicted here. On the contrary, neurotic and dissociated conditions improve considerably and the whole personality undergoes a change for the better. For this reason I do not think the process in question should be explained as regression, which would amount to saying that it was a morbid condition. I am rather inclined to understand the apparently retrograde connections of mandala psychology⁵⁹ as the continuation of a process of spiritual development which began in the early Middle Ages, and perhaps even further back, in early Christian times. There is documentary evidence that the essential symbols of Christianity were already in existence in the first century. I am

thinking of the Greek treatise entitled: “Comarius, the Archpriest, teaches Cleopatra the Divine Art.”⁶⁰ The text is of Egyptian origin and bears no trace of Christian influence. There are also the mystical texts of Pseudo-Democritus and Zosimos.⁶¹ Jewish and Christian influences are noticeable in the last-named author, though the main symbolism is Neoplatonist and is closely connected with the philosophy of the *Corpus Hermeticum*.⁶²

[160] The fact that the symbolism of the mandala can be traced back through its near relatives to pagan sources casts a peculiar light upon these apparently modern psychological phenomena. They seem to continue a Gnostic trend of thought without being supported by direct tradition. If I am right in supposing that every religion is a spontaneous expression of a certain predominant psychological condition, then Christianity was the formulation of a condition that predominated at the beginning of our era and lasted for several centuries. But a particular psychological condition which predominates for a certain length of time does not exclude the existence of other psychological conditions at other times, and these are equally capable of religious expression. Christianity had at one time to fight for its life against Gnosticism, which corresponded to another psychological condition. Gnosticism was stamped out completely and its remnants are so badly mangled that special study is needed to get any insight at all into its inner meaning. But if the historical roots of our symbols extend beyond the Middle Ages they are certainly to be found in Gnosticism. It would not seem to me illogical if a psychological condition, previously suppressed, should reassert itself when the main ideas of the suppressive condition begin to lose their influence. In spite of the suppression of the Gnostic heresy, it continued to flourish throughout the Middle Ages under the disguise of alchemy. It is a well-known fact that alchemy consisted of two parts which complement one another—on the one hand chemical research proper and on the other the “theoria” or “philosophia.”⁶³ As is clear from the writings of Pseudo-Democritus in the first century, entitled *τὰ φυσικὰ καὶ τὰ μυστικά*,⁶⁴ the two aspects already belonged together at the beginning of our era. The same holds true of the Leiden papyri and the writings of Zosimos in the third century. The religious or philosophical views of ancient alchemy were clearly Gnostic. The later views seem to cluster round the following central idea: The *anima mundi*, the demiurge or divine spirit that incubated the chaotic waters of the beginning, remained in matter in a potential state, and the initial chaotic condition persisted with it.⁶⁵ Thus the philosophers, or the “sons of wisdom” as they called themselves, took their *prima materia* to be a part of the original chaos pregnant with spirit. By “spirit” they understood a semimaterial pneuma, a sort of “subtle body,” which they also called “volatile” and identified chemically with oxides and other dissoluble compounds. They called this spirit Mercurius, which was chemically quicksilver—though

“Mercurius noster” was no ordinary Hg!—and philosophically Hermes, the god of revelation, who, as Hermes Trismegistus, was the arch-authority on alchemy.⁶⁶ Their aim was to extract the original divine spirit out of the chaos, and this extract was called the *quinta essentia*, *aqua permanens*, ὑδωρ θεῖον, βαφή or *tinctoria*. A famous alchemist, Johannes de Rupescissa (d. 1375),⁶⁷ calls the quintessence “le ciel humain,” the human sky or heaven. For him it was a blue liquid and incorruptible like the sky. He says that the quintessence is of the colour of the sky “and our sun has adorned it, as the sun adorns the sky.” The sun is an allegory of gold. He says: “This sun is true gold.” He continues: “These two things joined together influence in us ... the condition of the Heaven of heavens, and of the heavenly Sun.” His idea is, obviously, that the quintessence, the blue sky with the golden sun in it, evokes corresponding images of the heaven and the heavenly sun in ourselves. It is a picture of a blue and golden microcosm,⁶⁸ and I take it to be a direct parallel to Guillaume’s celestial vision. The colours are, however, reversed; with Rupescissa the disc is golden and the sky blue. My patient, therefore, having a similar arrangement, seems to lean more towards the alchemical side.

[161] The miraculous liquid, the divine water, called sky or heaven, probably refers to the supra-celestial waters of Genesis 1:7. In its functional aspect it was thought to be a sort of baptismal water which, like the holy water of the Church, possesses a creative and transformative quality.⁶⁹ The Catholic Church still performs the rite of the *benedictio fontis* on Holy Saturday before Easter.⁷⁰ The rite consists in a repetition of the *descensus spiritus sancti in aquam*. The ordinary water thereby acquires the divine quality of transforming and giving spiritual rebirth to man. This is exactly the alchemical idea of the divine water, and there would be no difficulty whatever in deriving the *aqua permanens* of alchemy from the rite of the *benedictio fontis* were it not that the former is of pagan origin and certainly the older of the two. We find the miraculous water mentioned in the first treatises of Greek alchemy, which belong to the first century.⁷¹ Moreover the descent of the spirit into Physis is a Gnostic legend that greatly influenced Mani. And it was possibly through Manichean influences that it became one of the main ideas of Latin alchemy. The aim of the philosophers was to transform imperfect matter chemically into gold, the panacea, or the *elixir vitae*, but philosophically or mystically into the divine hermaphrodite, the second Adam,⁷² the glorified, incorruptible body of resurrection,⁷³ or the *lumen luminum*,⁷⁴ the illumination of the human mind, or *sapientia*. As I have shown, together with Richard Wilhelm, Chinese alchemy produced the same idea, that the goal of the *opus magnum* is the creation of the “diamond body.”⁷⁵

[162] All these parallels are an attempt to put my psychological observations into their historical setting. Without the historical connection they would remain suspended in mid air, a mere curiosity, although one could find numerous other modern parallels to

the dreams described here. For instance, there is the following dream of a young woman. The initial dream was mainly concerned with the memory of an actual experience, a baptizing ceremony in a Protestant sect that took place under particularly grotesque and even repulsive conditions. The associations were a precipitate of all the dreamer's disappointments with religion. But the dream that came immediately after showed her a picture which she did not understand and could not relate to the previous dream. One could have aided her understanding by the simple device of prefacing her second dream with the words "on the contrary." This was the dream: *She was in a planetarium, a very impressive place overhung by the vault of the sky. In the sky two stars were shining; a white one, which was Mercury, but the other star emitted warm red waves of light and was unknown to her. She now saw that the walls underneath the vault were covered with frescoes. But she could recognize only one of them: it was an antique picture of the tree-birth of Adonis.*

[163] The "red waves of light" she took to be "warm feelings," i.e., love, and she now thought the star must have been Venus. She had once seen a picture of the tree-birth in a museum and had fancied that Adonis, as the dying and resurgent god, must also be a god of rebirth.

[164] In the first dream, then, there was violent criticism of Church religion, followed in the second dream by the mandala vision of a world clock—which is what a planetarium is in the fullest sense. In the sky the divine pair stands united, he white, she red, thus reversing the famous alchemical pair, where he is red and she is white, whence she was called *Beya* (Arabic *al baida*, 'the White One'), and he was called "servus rubeus," the 'red slave,' although, as *Gabricius* (Arabic *kibrit*, 'sulphur'), he is her royal brother. The divine pair makes one think of *Guillaume de Digulleville's* Christian allegory. The allusion to the tree-birth of Adonis corresponds to those dreams of my patient which had to do with mysterious rites of creation and renewal.⁷⁶

[165] So in principle these two dreams largely repeat the thought-processes of my patient, although having nothing in common with the latter except the spiritual malaise of our time. As I have already pointed out, the connection of spontaneous modern symbolism with ancient theories and beliefs is not established by direct or indirect tradition, nor even by a secret tradition as has sometimes been surmised, though there are no tenable proofs of this.⁷⁷ The most careful inquiry has never revealed any possibility of my patients' being acquainted with the relevant literature or having any other information about such ideas. It seems that their unconscious worked along the same line of thought which has manifested itself time and again in the last two thousand years. Such a continuity can only exist if we assume a certain unconscious condition as an inherited *a priori* factor. By this I naturally do not mean the inheritance of ideas, which would be difficult if not impossible to prove. I suppose, rather, the inherited quality to be something like the formal possibility of

producing the same or similar ideas over and over again. I have called this possibility the “archetype.” Accordingly, the archetype would be a structural quality or condition peculiar to a psyche that is somehow connected with the brain.⁷⁸

[166] In the light of these historical parallels the mandala symbolizes either the divine being hitherto hidden and dormant in the body and now extracted and revived, or else the vessel or the room in which the transformation of man into a divine being takes place. I know such formulations are fatally reminiscent of the wildest metaphysical speculations. I am sorry if it sounds crazy, but this is exactly what the human psyche produces and always has produced. Any psychology which assumes it can do without these facts must exclude them artificially. I would call this a philosophical prejudice, inadmissible from the empirical point of view. I should perhaps emphasize that we do not establish any metaphysical truth with these formulations. It is merely a statement that the psyche functions in such a way. And it is a fact that my patient felt a great deal better after the vision of the mandala. If you understand the problem it solved for him, you can also understand why he had such a feeling of “sublime harmony.”

[167] I would not hesitate for a moment to suppress all speculations about the possible consequences of an experience as abstruse and remote as the mandala, if this were feasible. But for me, unfortunately, this type of experience is neither abstruse nor remote. On the contrary, it is an almost daily occurrence in my profession. I know a fair number of people who have to take their experience seriously if they want to live at all. They can only choose between the devil and the deep blue sea. The devil is the mandala or something equivalent to it and the deep blue sea is their neurosis. The well-meaning rationalist will point out that I am casting out the devil with Beelzebub and replacing an honest neurosis by the swindle of a religious belief. As to the former charge, I have nothing to say in reply, being no metaphysical expert. But as to the latter one, I beg leave to point out that it is not a question of belief but of experience. Religious experience is absolute; it cannot be disputed. You can only say that you have never had such an experience, whereupon your opponent will reply: “Sorry, I have.” And there your discussion will come to an end. No matter what the world thinks about religious experience, the one who has it possesses a great treasure, a thing that has become for him a source of life, meaning, and beauty, and that has given a new splendour to the world and to mankind. He has *pistis* and peace. Where is the criterion by which you could say that such a life is not legitimate, that such an experience is not valid, and that such *pistis* is mere illusion? Is there, as a matter of fact, any better truth about the ultimate things than the one that helps you to live? That is the reason why I take careful account—*religio!*—of the symbols produced by the unconscious. They are the one thing that is capable of convincing the critical mind of modern man. And they are convincing for a very old-fashioned reason: They

are *overwhelming*, which is precisely what the Latin word *convincere* means. The thing that cures a neurosis must be as convincing as the neurosis, and since the latter is only too real, the helpful experience must be equally real. It must be a very real illusion, if you want to put it pessimistically. But what is the difference between a real illusion and a healing religious experience? It is merely a difference of words. You can say, for instance, that life is a disease with a very bad prognosis: it lingers on for years, only to end with death; or that normality is a general constitutional defect; or that man is an animal with a fatally overgrown brain. This kind of thinking is the prerogative of habitual grumblers with bad digestions. No one can know what the ultimate things are. We must therefore take them as we experience them. And if such experience helps to make life healthier, more beautiful, more complete and more satisfactory to yourself and to those you love, you may safely say: "This was the grace of God."

[168] No transcendental truth is thereby demonstrated, and we must confess in all humility that religious experience is *extra ecclesiam*, subjective, and liable to boundless error. Yet, if the spiritual adventure of our time is the exposure of human consciousness to the undefined and indefinable, there would seem to be good reasons for thinking that even the Boundless is pervaded by psychic laws, which no man invented, but of which he has "gnosis" in the symbolism of Christian dogma. Only heedless fools will wish to destroy this; the lover of the soul, never.

II

A PSYCHOLOGICAL APPROACH TO THE DOGMA OF THE TRINITY

*Noli foras ire, in teipsum redi;
in interiore homine habitat veritas.*

(Go not outside, return into thyself:
Truth dwells in the inward man.)

—St. Augustine,
Liber de vera religione, xxix (72)

INTRODUCTION

[169] The present study grew up out of a lecture I gave at the Eranos meeting in 1940, under the title “On the Psychology of the Idea of the Trinity.” The lecture, though subsequently published,¹ was no more than a sketch, and it was clear to me from the beginning that it needed improving. Hence I felt under a kind of moral obligation to return to this theme in order to treat it in a manner befitting its dignity and importance.

[170] From the reactions the lecture provoked, it was plain that some of my readers found a psychological discussion of Christian symbols objectionable even when it carefully avoided any infringement of their religious value. Presumably my critics would have found less to object to had the same psychological treatment been accorded to Buddhist symbols, whose sacredness is just as indubitable. Yet, what is sauce for the goose is sauce for the gander. I have to ask myself also, in all seriousness, whether it might not be far more dangerous if Christian symbols were made inaccessible to thoughtful understanding by being banished to a sphere of sacrosanct unintelligibility. They can easily become so remote from us that their irrationality turns into preposterous nonsense. Faith is a charisma not granted to all; instead, man has the gift of thought, which can strive after the highest things. The timid defensiveness certain moderns display when it comes to thinking about symbols was certainly not shared by St. Paul or by many of the venerable Church Fathers.² This timidity and anxiety about Christian symbols is not a good sign. If these symbols stand for a higher truth—which, presumably, my critics do not doubt—then science can only make a fool of itself if it proceeds incautiously in its efforts to understand them. Besides, it has never been my intention to invalidate the meaning of symbols; I concern myself with them precisely because I am convinced of their psychological validity. People who merely believe and don’t think always forget that they continually expose themselves to their own worst enemy: doubt. Wherever belief reigns, doubt lurks in the background. But thinking people welcome doubt: it serves them as a valuable stepping-stone to better knowledge. People who can believe should be a little more tolerant with those of their fellows who are only capable of thinking. Belief has already conquered the summit which thinking tries to win by toilsome climbing. The believer ought not to project his habitual enemy, doubt, upon the thinker, thereby suspecting him of destructive designs. If the ancients had not done a bit of thinking we would not possess any dogma about the Trinity at

all. The fact that a dogma is on the one hand believed and on the other hand is an object of thought is proof of its vitality. Therefore let the believer rejoice that others, too, seek to climb the mountain on whose peak he sits.

[171] My attempt to make the most sacred of all dogmatic symbols, the Trinity, an object of psychological study is an undertaking of whose audacity I am very well aware. Not having any theological knowledge worth mentioning, I must rely in this respect on the texts available to every layman. But since I have no intention of involving myself in the metaphysics of the Trinity, I am free to accept the Church's own formulation of the dogma, without having to enter into all the complicated metaphysical speculations that have gathered round it in the course of history. For the purposes of psychological discussion the elaborate version contained in the Athanasian Creed would be sufficient, as this shows very clearly what Church doctrine understands by the Trinity. Nevertheless, a certain amount of historical explanation has proved unavoidable for the sake of psychological understanding. My chief object, however, is to give a detailed exposition of those psychological views which seem to me necessary if we are to understand the dogma as a symbol in the psychological sense. Yet my purpose would be radically misunderstood if it were conceived as an attempt to "psychologize" the dogma. Symbols that have an archetypal foundation can never be reduced to anything else, as must be obvious to anybody who possesses the slightest knowledge of my writings. To many people it may seem strange that a doctor with a scientific training should interest himself in the Trinity at all. But anyone who has experienced how closely and meaningfully these *représentations collectives* are bound up with the weal and woe of the human soul will readily understand that the central symbol of Christianity must have, above all else, a psychological meaning, for without this it could never have acquired any universal meaning whatever, but would have been relegated long ago to the dusty cabinet of spiritual monstrosities and shared the fate of the many-armed and many-headed gods of India and Greece. But since the dogma stands in a relationship of living reciprocity to the psyche, whence it originated in the first place, it expresses many of the things I am endeavouring to say over again, even though with the uncomfortable feeling that there is much in my exposition that still needs improvement.

1. PRE-CHRISTIAN PARALLELS

I. BABYLONIA

[172] In proposing to approach this central symbol of Christianity, the Trinity, from the psychological point of view, I realize that I am trespassing on territory that must seem very far removed from psychology. Everything to do with religion, everything it is and asserts, touches the human soul so closely that psychology least of all can afford to overlook it. A conception like the Trinity pertains so much to the realm of theology that the only one of the profane sciences to pay any attention to it nowadays is history. Indeed, most people have ceased even to think about dogma, especially about a concept as hard to visualize as the Trinity. Even among professing Christians there are very few who think seriously about the Trinity as a matter of dogma and would consider it a possible subject for reflection—not to mention the educated public. A recent exception is Georg Koepgen's very important book, *Die Gnosis des Christentums*,¹ which, unfortunately, soon found its way onto the Index despite the episcopal "Placet." For all those who are seriously concerned to understand dogmatic ideas, this book of Koepgen's is a perfect example of thinking which has fallen under the spell of trinitarian symbolism.

[173] Triads of gods appear very early, at a primitive level. The archaic triads in the religions of antiquity and of the East are too numerous to be mentioned here. Arrangement in triads is an archetype in the history of religion, which in all probability formed the basis of the Christian Trinity. Often these triads do not consist of three different deities independent of one another; instead, there is a distinct tendency for certain family relationships to arise within the triads. I would mention as an example the Babylonian triads, of which the most important is Anu, Bel, and Ea. Ea, personifying knowledge, is the father of Bel ("Lord"), who personifies practical activity.² A secondary, rather later triad is the one made up of Sin (moon), Shamash (sun), and Adad (storm). Here Adad is the son of the supreme god, Anu.³ Under Nebuchadnezzar, Adad was the "Lord of heaven and earth." This suggestion of a father-son relationship comes out more clearly at the time of Hammurabi: Marduk, the son of Ea, was entrusted with Bel's power and thrust him into the background.⁴ Ea was a "loving, proud father, who willingly transferred his power and rights to his son."⁵ Marduk was originally a sun-god, with the cognomen "Lord" (Bel);⁶ he was the mediator between his father Ea and mankind. Ea declared that he knew nothing that his son did not know.⁷ Marduk, as his fight with Tiamat shows, is a redeemer. He

is “the compassionate one, who loves to awaken the dead”; the “Great-eared,” who hears the pleadings of men. He is a helper and healer, a true saviour. This teaching about a redeemer flourished on Babylonian soil all through the Christian era and goes on living today in the religion of the Mandaeans (who still exist in Mesopotamia), especially in their redeemer figure Manda d’ Hayya or Hibil Ziwa.⁸ Among the Mandaeans he appears also as a light-bringer and at the same time as a world-creator.⁹ Just as, in the Babylonian epic, Marduk fashions the universe out of Tiamat, so Mani, the Original Man, makes heaven and earth from the skin, bones, and excrement of the children of darkness.¹⁰ “The all-round influence which the myth of Marduk had on the religious ideas of the Israelites is surprising.”¹¹

[174] It appears that Hammurabi worshipped only a dyad, Anu and Bel; but, as a divine ruler himself, he associated himself with them as the “proclaimer of Anu and Bel,”¹² and this at a time when the worship of Marduk was nearing its height. Hammurabi felt himself the god of a new aeon¹³—the aeon of Aries, which was then beginning—and the suspicion is probably justified that tacit recognition was given to the triad Anu-Bel-Hammurabi.¹⁴

[175] The fact that there is a secondary triad, Sin-Shamash-Ishtar, is indicative of another intra-triadic relationship. Ishtar¹⁵ appears here in the place of Adad, the storm god. She is the mother of the gods, and at the same time the daughter¹⁶ of Anu as well as of Sin.

[176] Invocation of the ancient triads soon takes on a purely formal character. The triads prove to be “more a theological tenet than a living force.”¹⁷ They represent, in fact, the earliest beginnings of theology. Anu is the Lord of heaven, Bel is the Lord of the lower realm, earth, and Ea too is the god of an “underworld,” but in his case it is the watery deep.¹⁸ The knowledge that Ea personifies comes from the “depths of the waters.” According to one Babylonian legend, Ea created Uddushunamir, a creature of light, who was the messenger of the gods on Ishtar’s journey to hell. The name means: “His light (or rising) shines.”¹⁹ Jeremias connects him with Gilgamesh, the hero who was more than half a god.²⁰ The messenger of the gods was usually called Girru (Sumerian “Gibil”), the god of fire. As such he has an ethical aspect, for with his purifying fire he destroys evil. He too is a son of Ea, but on the other hand he is also described as a son of Anu. In this connection it is worth mentioning that Marduk as well has a dual nature, since in one hymn he is called Mar Mummi, ‘son of chaos.’ In the same hymn his consort Sarpanitu is invoked along with Ea’s wife, the mother of Marduk, as the “Silver-shining One.” This is probably a reference to Venus, the *femina alba*. In alchemy the *albedo* changes into the moon, which, in Babylonia, was still masculine.²¹ Marduk’s companions were four dogs.²² Here the number four may signify totality, just as it does in the case of the four sons of Horus, the four seraphim

in the vision of Ezekiel, and the four symbols of the evangelists, consisting of three animals and one angel.

II. EGYPT

[177] The ideas which are present only as intimations in Babylonian tradition are developed to full clarity in Egypt. I shall pass lightly over this subject here, as I have dealt with the Egyptian prefigurations of the Trinity at greater length elsewhere, in an as yet unfinished study of the symbolical bases of alchemy.¹ I shall only emphasize that Egyptian theology asserts, first and foremost, the essential unity (*homoousia*) of God as father and son, both represented by the king.² The third person appears in the form of Ka-mutef (“the bull of his mother”), who is none other than the *ka*, the procreative power of the deity. In it and through it father and son are combined not in a triad but in a triunity. To the extent that Ka-mutef is a special manifestation of the divine *ka*, we can “actually speak of a triunity of God, king, and *ka*, in the sense that God is the father, the king is the son, and *ka* the connecting-link between them.”³ In his concluding chapter Jacobsohn draws a parallel between this Egyptian idea and the Christian credo. Apropos the passage “qui conceptus est de Spiritu Sancto, natus ex Maria virgine,” he cites Karl Barth’s formulation: “There is indeed a unity of God and man; God himself creates it.... It is no other unity than his own eternal unity as father and son. This unity is the Holy Ghost.”⁴ As procreator the Holy Ghost would correspond to Ka-mutef, who connotes and guarantees the unity of father and son. In this connection Jacobsohn cites Barth’s comment on Luke 1:35 (“The Holy Ghost shall come upon thee, and the power of the Highest shall overshadow thee: therefore also that holy thing which shall be born of thee shall be called the Son of God”): “When the Bible speaks of the Holy Ghost, it is speaking of God as the combination of father and son, of the *vinculum caritatis*.”⁵ The divine procreation of Pharaoh takes place through Ka-mutef, in the human mother of the king. But, like Mary, she remains outside the Trinity. As Preisigke points out, the early Christian Egyptians simply transferred their traditional ideas about the *ka* to the Holy Ghost.⁶ This explains the curious fact that in the Coptic version of *Pistis Sophia*, dating from the third century, Jesus has the Holy Ghost as his double, just like a proper *ka*.⁷ The Egyptian mythologem of the unity of substance of father and son, and of procreation in the king’s mother, lasted until the Vth dynasty (about 2500 B.C.). Speaking of the birth of the divine boy in whom Horus manifests himself, God the Father says: “He will exercise a kingship of grace in this land, for my soul is in him,” and to the child he says: “You are the son of my body, begotten by me.”⁸ “The sun he bears within him from his father’s seed rises anew in him.” His eyes are the sun and moon, the eyes of Horus.⁹ We know that the passage in Luke 1:78f.: “Through the tender mercy of our God, whereby the dayspring from on high hath visited us, to give light to them

that sit in darkness and in the shadow of death,” refers to Malachi 4:2: “But unto you that fear my name shall the sun of righteousness arise with healing in his wings.” Who does not think here of the winged sun-disc of Egypt?

[178] These ideas¹⁰ passed over into Hellenistic syncretism and were transmitted to Christianity through Philo and Plutarch.¹¹ So it is not true, as is sometimes asserted even by modern theologians, that Egypt had little if any influence on the formation of Christian ideas. Quite the contrary. It is, indeed, highly improbable that only Babylonian ideas should have penetrated into Palestine, considering that this small buffer state had long been under Egyptian hegemony and had, moreover, the closest cultural ties with its powerful neighbour, especially after a flourishing Jewish colony established itself in Alexandria, several centuries before the birth of Christ. It is difficult to understand what could have induced Protestant theologians, whenever possible, to make it appear that the world of Christian ideas dropped straight out of heaven. The Catholic Church is liberal enough to look upon the Osiris-Horus-Isis myth, or at any rate suitable portions of it, as a prefiguration of the Christian legend of salvation. The numinous power of a mythologem and its value as truth are considerably enhanced if its archetypal character can be proved. The archetype is “that which is believed always, everywhere, and by everybody,” and if it is not recognized consciously, then it appears from behind in its “wrathful” form, as the dark “son of chaos,” the evil-doer, as Antichrist instead of Saviour—a fact which is all too clearly demonstrated by contemporary history.

III. GREECE

[179] In enumerating the pre-Christian sources of the Trinity concept, we should not omit the mathematical speculations of the Greek philosophers. As we know, the philosophizing temper of the Greek mind is discernible even in St. John’s gospel, a work that is, very obviously, of Gnostic inspiration. Later, at the time of the Greek Fathers, this spirit begins to amplify the archetypal content of the Revelation, interpreting it in Gnostic terms. Pythagoras and his school probably had the most to do with the moulding of Greek thought, and as one aspect of the Trinity is based on number symbolism, it would be worth our while to examine the Pythagorean system of numbers and see what it has to say about the three basic numbers with which we are concerned here. Zeller¹ says: “One is the first from which all other numbers arise, and in which the opposite qualities of numbers, the odd and the even, must therefore be united; two is the first even number; three the first that is uneven and perfect, because in it we first find beginning, middle, and end.”² The views of the Pythagoreans influenced Plato, as is evident from his *Timaeus*; and, as this had an incalculable influence on the philosophical speculations of posterity, we shall have to go rather deeply into the psychology of number speculation.

[180] The number one claims an exceptional position, which we meet again in the natural philosophy of the Middle Ages. According to this, one is not a number at all; the first number is two.³ Two is the first number because, with it, separation and multiplication begin, which alone make counting possible. With the appearance of the number two, *another* appears alongside the one, a happening which is so striking that in many languages “the other” and “the second” are expressed by the same word. Also associated with the number two is the idea of right and left,⁴ and remarkably enough, of favourable and unfavourable, good and bad. The “other” can have a “sinister” significance—or one feels it, at least, as something opposite and alien. Therefore, argues a medieval alchemist, God did not praise the second day of creation, because on this day (Monday, the day of the moon) the *binarius*, alias the devil,⁵ came into existence. Two implies a one which is different and distinct from the “numberless” One. In other words, as soon as the number two appears, a unit is produced out of the original unity, and this unit is none other than that same unity split into two and turned into a “number.” The “One” and the “Other” form an opposition, but there is no opposition between one and two, for these are simple numbers which are distinguished only by their arithmetical value and by nothing else. The “One,” however, seeks to hold to its one-and-alone existence, while the “Other” ever strives to be another opposed to the One. The One will not let go of the Other because, if it did, it would lose its character; and the Other pushes itself away from the One in order to exist at all. Thus there arises a tension of opposites between the One and the Other. But every tension of opposites culminates in a release, out of which comes the “third.” In the third, the tension is resolved and the lost unity is restored. Unity, the absolute One, cannot be numbered, it is indefinable and unknowable; only when it appears as a unit, the number one, is it knowable, for the “Other” which is required for this act of knowing is lacking in the condition of the One. Three is an unfolding of the One to a condition where it can be known—unity become recognizable; had it not been resolved into the polarity of the One and the Other, it would have remained fixed in a condition devoid of every quality. Three therefore appears as a suitable synonym for a process of development in time, and thus forms a parallel to the self-revelation of the Deity as the absolute One unfolded into Three. The relation of Threeness to Oneness can be expressed by an equilateral triangle,⁶ $A = B = C$, that is, by the identity of the three, threeness being contained in its entirety in each of the three angles. This intellectual idea of the equilateral triangle is a conceptual model for the logical image of the Trinity.

[181] In addition to the Pythagorean interpretation of numbers, we have to consider, as a more direct source of trinitarian ideas in Greek philosophy, the mystery-laden *Timaeus* of Plato. I shall quote, first of all, the classical argument in sections 31B–32A:

Hence the god, when he began to put together the body of the universe, set about making it of fire and earth. But two things alone cannot be satisfactorily united without a third; for there must be some bond between them drawing them together. And of all bonds the best is that which makes itself and the terms it connects a unity in the fullest sense; and it is of the nature of a continued geometrical proportion to effect this most perfectly. For whenever, of three numbers, the middle one between any two that are either solids or planes [i.e., cubes or squares] is such that, as the first is to it, so is it to the last, and conversely as the last is to the middle, so is the middle to the first, then since the middle becomes first and last, and again the last and first become middle, in that way all will necessarily come to play the same part towards one another, and by so doing they will all make a unity.⁷

In a geometrical progression, the quotient (q) of a series of terms remains the same, e.g.: $2:1 = 4:2 = 8:4 = 2$, or, algebraically expressed: a, aq, aq^2 . The proportion is therefore as follows: 2 is to 4 as 4 is to 8, or a is to aq as aq is to aq^2 .

[182] This argument is now followed by a reflection which has far-reaching psychological implications: if a simple pair of opposites, say fire and earth, are bound together by a mean ($\mu\acute{\alpha}\sigma\omicron\nu$), and if this bond is a geometrical proportion, then *one* mean can only connect plane figures, since two means are required to connect solids:

Now if it had been required that the body of the universe should be a plane surface with no depth, a single mean would have been enough to connect its companions and itself; but in fact the world was to be solid in form, and solids are always conjoined, not by one mean, but by two.⁸

Accordingly, the two-dimensional connection is not yet a physical reality, for a plane without extension in the third dimension is only an *abstract thought*. If it is to become a physical reality, three dimensions and therefore two means are required. Sir Thomas Heath⁹ puts the problem in the following algebraic formulae:

Union in two dimensions of earth (p^2) and fire (q^2):

$$p^2 : pq = pq : q^2$$

Obviously the mean is pq .

Physical union of earth and fire, represented by p^3 and q^3 respectively:

$$p^3 : p^2q = p^2q : pq^2 = pq^2 : q^3$$

The two means are p^2q and pq^2 , corresponding to the physical elements water and air. Accordingly, the god set water and air between fire and earth, and made them, so far as was possible, proportional to one another, so that as fire is to air, so is air to water, and as air is to water, so is water to earth, and thus he bound together the frame of a world visible and tangible. For these reasons and from such constituents, four in number, the body of the universe was brought into being, coming into concord by means of proportion, and from these it acquired Amity, so that united with itself it became indissoluble by any other power save him who bound it together.¹⁰

[183] The union of one pair of opposites only produces a two-dimensional triad: $p^2 + pq + q^2$. This, being a plane figure, is not a reality but a thought. Hence two pairs of opposites, making a *quaternion* ($p^3 + p^2q + pq^2 + q^3$), are needed to represent physical reality. Here we meet, at any rate in veiled form, the dilemma of three and four alluded to in the opening words of the *Timaeus*. Goethe intuitively grasped the significance of this allusion when he says of the fourth Cabir in *Faust*: “He was the right one / Who thought for them all,” and that “You might ask on Olympus” about the eighth “whom nobody thought of.”¹¹

[184] It is interesting to note that Plato begins by representing the union of opposites two-dimensionally, as an intellectual problem to be solved by thinking, but then comes to see that its solution does not add up to reality. In the former case we have to do with a self-subsistent triad, and in the latter with a quaternion. This was the dilemma that perplexed the alchemists for more than a thousand years, and, as the “axiom of Maria Prophetissa” (the Jewess or Copt), it appears in modern dreams,¹² and is also found in psychology as the opposition between the functions of consciousness, three of which are fairly well differentiated, while the fourth, undifferentiated, “inferior” function is undomesticated, unadapted, uncontrolled, and primitive. Because of its contamination with the collective unconscious, it possesses archaic and mystical qualities, and is the complete opposite of the most differentiated function. For instance, if the most differentiated is thinking, or the intellect, then the inferior,¹³ fourth function¹⁴ will be feeling. Hence the opening words of the *Timaeus* —“One, two, three—but where, my dear Timaeus, is the fourth ... ?”—fall familiarly upon the ears of the psychologist and alchemist, and for him as for Goethe there can be no doubt that Plato is alluding to something of mysterious import. We can now see that it was nothing less than the dilemma as to whether something we think about is a mere thought or a reality, or at least capable of becoming real. And this, for any philosopher who is not just an empty babbler, is a problem of the first order and no whit less important than the moral problems inseparably connected with it. In this matter Plato knew from personal experience how difficult is the step from two-dimensional thinking to its realization in three-dimensional fact.¹⁵ Already with his friend Dionysius the Elder, tyrant of Syracuse, he had so many disagreements that the philosopher-politician contrived to sell him as a slave, from which fate he was preserved only because he had the good fortune to be ransomed by friends. His attempts to realize his political theories under Dionysius the Younger also ended in failure, and from then on Plato abandoned politics for good. Metaphysics seemed to him to offer more prospects than this ungovernable world. So, for him personally, the main emphasis lay on the two-dimensional world of thought; and this is especially true of the *Timaeus*, which was written after his political disappointments. It is generally reckoned as belonging to Plato’s late works.

[185] In these circumstances the opening words, not being attributable either to the jocosity of the author or to pure chance, take on a rather mournful significance: one of the four is absent because he is “unwell.” If we regard the introductory scene as symbolical, this means that of the four elements out of which reality is composed, either air or water is missing. If air is missing, then there is no connecting link with spirit (fire), and if water is missing, there is no link with concrete reality (earth). Plato certainly did not lack spirit; the missing element he so much desired was the concrete realization of ideas. He had to content himself with the harmony of airy thought-structures that lacked weight, and with a paper surface that lacked depth. The step from three to four brought him sharply up against something unexpected and alien to his thought, something heavy, inert, and limited, which no “μὴ ὄν”¹⁶ and no “privatio boni” can conjure away or diminish. Even God’s fairest creation is corrupted by it, and idleness, stupidity, malice, discontent, sickness, old age and death fill the glorious body of the “blessed god.” Truly a grievous spectacle, this sick world-soul, and unfortunately not at all as Plato’s inner eye envisaged it when he wrote:

All this, then, was the plan of the everlasting god for the god who was going to be. According to this plan he made the body of the world smooth and uniform, everywhere equidistant from its centre, a body whole and complete, with complete bodies for its parts. And in the centre he set the soul and caused it to extend throughout the whole body, and he further wrapped the body round with soul on the outside. So he established one world alone, round and revolving in a circle, solitary but able by reason of its excellence to bear itself company, needing no other acquaintance or friend but sufficient unto itself. On all these accounts the world which he brought into being was a blessed god.¹⁷

[186] This world, created by a god, is itself a god, a son of the self-manifesting father. Further, the demiurge furnished it with a soul which is “prior” to the body (34B). The world-soul was fashioned by the demiurge as follows: he made a mixture of the indivisible (ἀμερές) and the divisible (μεριστόν), thus producing a third form of existence. This third form had a nature independent of the “Same” (τὸ αὐτόν) and the “Different” (τὸ ἕτερον). At first sight the “Same” seems to coincide with the indivisible and the “Different” with the divisible.¹⁸ The text says:¹⁹ “From the indivisible and ever the same substance [Cornford’s “Sameness”], and that which is physically divisible, he mixed an intermediate, third form of existence which had its own being beside the Same and the Different, and this form he fashioned accordingly [κατὰ ταῦτά] as a mean between the indivisible and the physically divisible. Then taking these three existences, he mixed them again, forcing the nature of the Different, though it resisted the mixture, into union with the Same. Thus, with the admixture of being (οὐσία), the three became one.”²⁰

[187] The world-soul, representing the governing principle of the whole physical world, therefore possesses a triune nature. And since, for Plato, the world is a *δεύτερος θεός* (second god), the world-soul is a revelation or unfolding of the God-image.²¹

[188] Plato's account of the actual process of creation is very curious and calls for some elucidation. The first thing that strikes us is the twice-repeated *συνεκεράσατο* ('he mixed'). Why should the mixture be repeated, since it consists of three elements in the first place and contains no more than three at the end, and, in the second place, Same and Different appear to correspond with indivisible and divisible? Appearances, however, are deceptive. During the first mixture there is nothing to suggest that the divisible was recalcitrant and had to be forcibly united with the indivisible. In both mixtures it is rather a question of combining two separate pairs of opposites,²² which, because they are called upon to make a unity, may be thought of as arranged in a *quaternio*:

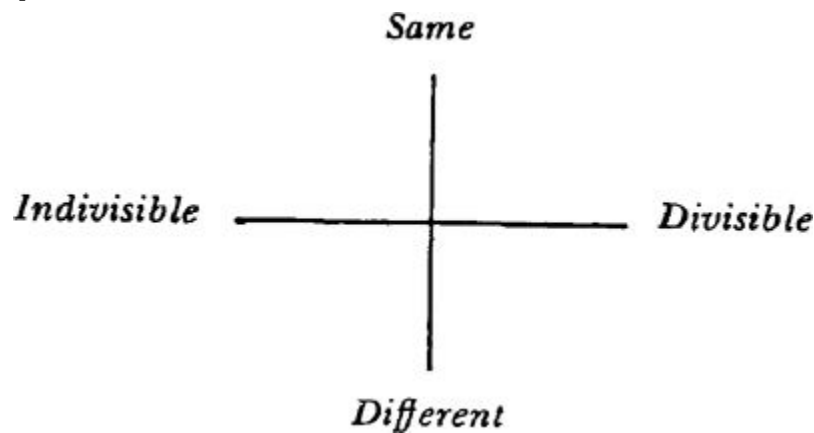

Indivisible and divisible, together with their mean, form a simple triad which has "its own being" beside the Same and the Different. This triad corresponds to the condition of "thought" not yet become "reality." For this a second mixture is needed, in which the Different (i.e., the "Other") is incorporated by force. The "Other" is therefore the "fourth" element, whose nature it is to be the "adversary" and to resist harmony. But the fourth, as the text says, is intimately connected with Plato's desire for "being." One thinks, not unnaturally, of the impatience the philosopher must have felt when reality proved so intractable to his ideas. That reasonableness might, under certain circumstances, have to be imposed by force is a notion that must sometimes have crossed his mind.

[189] The passage as a whole, however, is far from simple. It can be translated in many ways and interpreted in many more. The critical point for us is *συνέστησεν ἐν μέσῳ τοῦ τε ἀμεροῦς*, literally, 'he compounded (a form of the nature of sameness and difference) *in the middle* (ἐν μέσῳ) of the indivisible (and the divisible).' Consequently the middle term of the second pair of opposites would coincide with the middle term of the first pair. The resultant figure is a quincunx,

since the two pairs of opposites have a common mean or “third form” (τρίτον εἶδος):

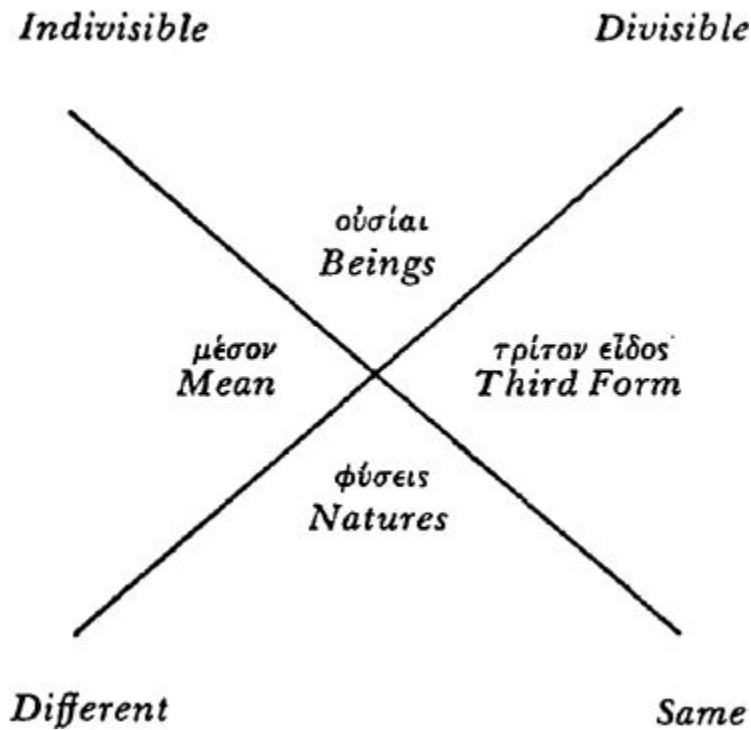

[190] I have placed the pairs of opposites side by side, instead of facing one another (as in the previous diagram), in order to illustrate their union in a single mean. Three elements are to be distinguished in our diagram: the two pairs of opposites and their common mean, and I understand the text as referring to these three elements when it says: “Then, taking these three existences ...” Since the mean is called the “third form,” each pair of opposites can presumably be taken as representing the first and second forms: Indivisible = first form, Divisible = second form, mean = third form, and so on. Their union in a quincunx signifies union of the four elements in a world-body. Thomas Taylor, who was strongly influenced by Proclus, says in his commentary to the *Timaeus*: “For those which are connected with her essence in a following order, proceed from her [the *anima mundi*] according to the power of the fourth term (4), which possesses generative powers; but return to her according to the fifth (9) which reduces them to one.”²³ Further confirmation of the quaternary nature of the world-soul and world-body may be found in the passage where the demiurge splits this whole fabric lengthwise into two halves and joins them up again in the form of a \times .²⁴ According to Porphyry, a \times in a circle signified the world-soul for the Egyptians.²⁵ It is, in fact, the hieroglyph for ‘city.’²⁶ Perhaps Plato was trying, in this passage, to bring forth the mandala structure that later appeared as the capital of Atlantis in his *Critias*.

[191] The two mixtures could be regarded as a parallel to the two means of the physical elements. Cornford, on the other hand, considers that Plato is referring to three intermedia, which he calls “Intermediate Existence,” “Intermediate Sameness,”

“Intermediate Difference.”²⁷ His main insistence is on the threefold procedure and not on the four substances. The Middle Ages were also familiar with the *quatuor elementa* (A B C D) and the *tria regimina* (three procedures) which united them as follows: AB, BC, CD. From this point of view, Cornford fails to catch Plato’s subtle allusion to the recalcitrant fourth.

[192] We do not wish it to be supposed that the thought-processes we have deduced from the text of the *Timaeus* represent Plato’s conscious reflections. However extraordinary his genius may have been, it by no means follows that his thoughts were all conscious ones. The problem of the fourth, for instance, which is an absolutely essential ingredient of totality, can hardly have reached his consciousness in complete form. If it had, he would have been repelled by the violence with which the elements were to be forced into a harmonious system. Nor would he have been so illogical as to insist on the threefoldness of his world-soul. Again, I would not venture to assert that the opening words of the *Timaeus* are a conscious reference to the underlying problem of the recalcitrant fourth. Everything suggests that the same unconscious *spiritus rector* was at work which twice impelled the master to try to write a tetralogy, the fourth part remaining unfinished on both occasions.²⁸ This factor also ensured that Plato would remain a bachelor to the end of his life, as if affirming the masculinity of his triadic God-image.

[193] As history draws nearer to the beginning of our era, the gods become more and more abstract and spiritualized. Even Yahweh had to submit to this transformation. In the Alexandrian philosophy that arose in the last century B.C., we witness not only an alteration of his nature but an emergence of two other divinities in his immediate vicinity: the Logos and Sophia. Together with him they form a triad,²⁹ and this is a clear prefiguration of the post-Christian Trinity.

2. FATHER, SON, AND SPIRIT

[194] I have dwelt at some length on the views of the Babylonians and Egyptians, and on Platonist philosophy, in order to give the reader some conception of the trinitarian and unitarian ideas that were in existence many centuries before the birth of Christianity. Whether these ideas were handed down to posterity as a result of migration and tradition or whether they arose spontaneously in each case is a question of little importance. The important thing is that they occurred because, once having sprung forth from the unconscious of the human race (and not just in Asia Minor!), they could rearise anywhere at any time. It is, for instance, more than doubtful whether the Church Fathers who devised the *homoousios* formula were even remotely acquainted with the ancient Egyptian theology of kingship. Nevertheless, they neither paused in their labours nor rested until they had finally reconstructed the ancient Egyptian archetype. Much the same sort of thing happened when, in A.D. 431, at the Council of Ephesus, whose streets had once rung with hymns of praise to many-breasted Diana, the Virgin Mary was declared the *θεοτόκος*, ‘birth-giver of the god.’¹ As we know from Epiphanius,² there was even a sect, the Collyridians, who worshipped Mary after the manner of an antique goddess. Her cult had its chief centres in Arabia, Thrace, and Upper Scythia, the most enthusiastic devotees being women. Their provocations moved Epiphanius to the rebuke that “the whole female sex is slippery and prone to error, with a mind that is very petty and narrow.”³ It is clear from this chastening sermon that there were priestesses who on certain feast days decorated a wagon or four-cornered seat and covered it with linen, on which they placed offerings of bakemeats “in the name of Mary” (*εἰς ὄνομα τῆς Μαρίας*), afterwards partaking of the sacrificial meal. This plainly amounted to a Eucharistic feast in honour of Mary, at which wheaten bread was eaten. The orthodox standpoint of the time is aptly expressed in the words of Epiphanius: “Let Mary be held in honour, and let the Father and the Son and the Holy Ghost be adored, but let no one adore Mary.”

[195] Thus the archetype reasserted itself, since, as I have tried to show, archetypal ideas are part of the indestructible foundations of the human mind. However long they are forgotten and buried, always they return, sometimes in the strangest guise, with a personal twist to them or intellectually distorted, as in the case of the Arian heresy, but continually reproducing themselves in new forms representing the timeless truths that are innate in man’s nature.⁴

[196] Even though Plato's influence on the thinkers of the next few centuries can hardly be overestimated, his philosophically formulated triad cannot be held responsible for the origins of the Christian dogma of the Trinity. For we are concerned here not with any philosophical, that is conscious, assumptions but with unconscious, archetypal forms. The Platonic formula for the triad contradicts the Christian Trinity in one essential point: the triad is built on opposition, whereas the Trinity contains no opposition of any kind, but is, on the contrary, a complete harmony in itself. The three Persons are characterized in such a manner that they cannot possibly be derived from Platonic premises, while the terms Father, Son, and Holy Ghost do not proceed in any sense from the number three. At most, the Platonic formula supplies the intellectual scaffolding for contents that come from quite other sources. The Trinity may be conceived platonically as to its form, but for its content we have to rely on psychic factors, on irrational data that cannot be logically determined beforehand. In other words, we have to distinguish between the *logical idea* of the Trinity and its *psychological reality*. The latter brings us back to the very much more ancient Egyptian ideas and hence to the archetype, which provides the authentic and eternal justification for the existence of any trinitarian idea at all.

[197] The psychological datum consists of Father, Son, and Holy Ghost. If we posit "Father," then "Son" logically follows; but "Holy Ghost" does not follow logically from either "Father" or "Son." So we must be dealing here with a special factor that rests on a different presupposition. According to the old doctrine, the Holy Ghost is "vera persona, quae a filio et patre missa est" (a real person who is sent by the Son and the Father). The "processio a patre filioque" (procession from the Father and the Son) is a "spiration" and not a "begetting." This somewhat peculiar idea corresponds to the separation, which still existed in the Middle Ages, of "corpus" and "spiramen," the latter being understood as something more than mere "breath." What it really denoted was the *anima*, which, as its name shows, is a breath-being (*anemos* = wind). Although an activity of the body, it was thought of as an independent substance (or hypostasis) existing alongside the body. The underlying idea is that the body "lives," and that "life" is something superadded and autonomous, conceived as a soul unattached to the body. Applying this idea to the Trinity formula, we would have to say: Father, Son, and Life—the life proceeding from both or lived by both. The Holy Ghost as "life" is a concept that cannot be derived logically from the identity of Father and Son, but is, rather, a psychological idea, a datum based on an irrational, primordial image. This primordial image is the archetype, and we find it expressed most clearly in the Egyptian theology of kingship. There, as we have seen, the archetype takes the form of God the father, Ka-mutef (the begetter), and the son. The *ka* is the life-spirit, the animating principle of men and gods, and therefore can be legitimately interpreted as the soul or spiritual double. He is the "life" of the dead

man, and thus corresponds on the one hand to the living man's soul, and on the other to his "spirit" or "genius." We have seen that Ka-mutef is a hypostatization of procreative power.⁵ In the same way, the Holy Ghost is hypostatized procreative power and life-force.⁶ Hence, in the Christian Trinity, we are confronted with a distinctly archaic idea, whose extraordinary value lies precisely in the fact that it is a supreme, hypostatic representation of an abstract thought (two-dimensional triad). The form is still concretistic, in that the archetype is represented by the relationship "Father" and "Son." Were it nothing but that, it would only be a dyad. The third element, however, the connecting link between "Father" and "Son," is spirit and not a human figure. The masculine father-son relationship is thus lifted out of the natural order (which includes mothers and daughters) and translated to a sphere from which the feminine element is excluded: in ancient Egypt as in Christianity the Theotokos stands outside the Trinity. One has only to think of Jesus's brusque rejection of his mother at the marriage in Cana: "Woman, what have I to do with thee?" (John 2:4), and also earlier, when she sought the twelve-year-old child in the temple: "How is it that ye sought me? wist ye not that I must be about my Father's business?" (Luke 2:49). We shall probably not be wrong in assuming that this special sphere to which the father-son relationship is removed is the sphere of primitive mysteries and masculine initiations. Among certain tribes, women are forbidden to look at the mysteries on pain of death. Through the initiations the young men are systematically alienated from their mothers and are reborn as spirits. The celibacy of the priesthood is a continuation of this archetypal idea.⁷

[198] The intellectual operation that lies concealed in the higher father-son relationship consists in the extrapolation of an invisible figure, a "spirit" that is the very essence of masculine life. The life of the body or of a man is posited as something different from the man himself. This led to the idea of a *ka* or immortal soul, able to detach itself from the body and not dependent on it for its existence. In this respect, primitives have extraordinarily well developed ideas about a plurality of souls. Some are immortal, others are only loosely attached to the body and can wander off and get lost in the night, or they lose their way and get caught in a dream. There are even souls that belong to a person without being lodged in his body, like the bush-soul, which dwells outside in the forest, in the body of an animal. The juxtaposition of a person and his "life" has its psychological basis in the fact that a mind which is not very well differentiated cannot think abstractly and is incapable of putting things into categories. It can only take the qualities it perceives and place them side by side: man and his life, or his sickness (visualized as a sort of demon), or his health or prestige (mana, etc.). This is obviously the case with the Egyptian *ka*. Father-son-life (or procreative power), together with rigorous exclusion of the Theotokos, constitute the patriarchal formula that was "in the air" long before the advent of Christianity.

[199] The Father is, by definition, the prime cause, the creator, the *auctor rerum*, who, on a level of culture where reflection is still unknown, can only be One. The Other follows from the One by splitting off from it. This split need not occur so long as there is no criticism of the *auctor rerum*—so long, that is to say, as a culture refrains from all reflection about the One and does not start criticizing the Creator’s handiwork. A feeling of oneness, far removed from critical judgment and moral conflict, leaves the Father’s authority unimpaired.

[200] I had occasion to observe this original oneness of the father-world when I was with a tribe of Negroes on Mount Elgon. These people professed to believe that the Creator had made everything good and beautiful. “But what about the bad animals that kill your cattle?” I asked. They replied: “The lion is good and beautiful.” “And your horrible diseases?” “You lie in the sun, and it is beautiful.” I was impressed by their optimism. But at six o’clock in the evening this philosophy came to a sudden stop, as I was soon to discover. After sunset, another world took over—the dark world of the Ayik, who is everything evil, dangerous, and terrifying. The optimistic philosophy ends and a philosophy of fear, ghosts, and magical spells for averting the Evil One begins. Then, at sunrise, the optimism starts off again without any trace of inner contradiction.

[201] Here man, world, and God form a whole, a unity unclouded by criticism. It is the world of the Father, and of man in his childhood state. Despite the fact that twelve hours out of every twenty-four are spent in the world of darkness, and in agonizing belief in this darkness, the doubt never arises as to whether God might not also be the Other. The famous question about the origin of evil does not yet exist in a patriarchal age. Only with the coming of Christianity did it present itself as the principal problem of morality. The world of the Father typifies an age which is characterized by a pristine oneness with the whole of Nature, no matter whether this oneness be beautiful or ugly or awe-inspiring. But once the question is asked: “Whence comes the evil, why is the world so bad and imperfect, why are there diseases and other horrors, why must man suffer?”—then reflection has already begun to judge the Father by his manifest works, and straightway one is conscious of a doubt, which is itself the symptom of a split in the original unity. One comes to the conclusion that creation is imperfect—nay more, that the Creator has not done his job properly, that the goodness and almightiness of the Father cannot be the sole principle of the cosmos. Hence the One has to be supplemented by the Other, with the result that the world of the Father is fundamentally altered and is superseded by the world of the Son.

[202] This was the time when the Greeks started criticizing the world, the time of “gnosis” in its widest sense, which ultimately gave birth to Christianity. The archetype of the redeemer-god and Original Man is age-old—we simply do not know

how old. The Son, the revealed god, who voluntarily or involuntarily offers himself for sacrifice as a man, in order to create the world or redeem it from evil, can be traced back to the Purusha of Indian philosophy, and is also found in the Persian conception of the Original Man, Gayomart. Gayomart, son of the god of light, falls victim to the darkness, from which he must be set free in order to redeem the world. He is the prototype of the Gnostic redeemer-figures and of the teachings concerning Christ, redeemer of mankind.

[203] It is not hard to see that a critique which raised the question of the origin of evil and of suffering had in mind another world—a world filled with longing for redemption and for that state of perfection in which man was still one with the Father. Longingly he looked back to the world of the Father, but it was lost forever, because an irreversible increase in man’s consciousness had taken place in the meantime and made it independent. With this mutation he broke away from the world of the Father and entered upon the world of the Son, with its divine drama of redemption and the ritualistic retelling of those things which the God-man had accomplished during his earthly sojourn.⁸ The life of the God-man revealed things that could not possibly have been known at the time when the Father ruled as the One. For the Father, as the original unity, was not a defined or definable object; nor could he, strictly speaking, either be called the “Father” or be one. He only became a “Father” by incarnating in the Son, and by so doing became defined and definable. By becoming a father and a man he revealed to man the secret of his divinity.

[204] One of these revelations is the Holy Ghost. As a being who existed before the world was, he is eternal, but he appears empirically in this world only when Christ had left the earthly stage. He will be for the disciples what Christ was for them. He will invest them with the power to do works greater, perhaps, than those of the Son (John 14:12). The Holy Ghost is a figure who deputizes for Christ and who corresponds to what Christ received from the Father. From the Father comes the Son, and common to both is the living activity of the Holy Ghost, who, according to Christian doctrine, is breathed forth (“spirated”) by both. As he is the third term common to Father and Son, he puts an end to the duality, to the “doubt” in the Son. He is, in fact, the third element that rounds out the Three and restores the One. The point is that the unfolding of the One reaches its climax in the Holy Ghost after polarizing itself as Father and Son. Its descent into a human body is sufficient in itself to make it become another, to set it in opposition to itself. Thenceforward there are two: the “One” and the “Other,” which results in a certain tension.⁹ This tension works itself out in the suffering and fate of the Son¹⁰ and, finally, in Christ’s admission of abandonment by God (Matthew 27:46).

[205] Although the Holy Ghost is the progenitor of the Son (Matthew 1:18), he is also, as the Paraclete, a legacy from him. He continues the work of redemption in mankind

at large, by descending upon those who merit divine election. Consequently, the Paraclete is, at least by implication, the crowning figure in the work of redemption on the one hand and in God's revelation of himself on the other. It could, in fact, be said that the Holy Ghost represents the final, complete stage in the evolution of God and the divine drama. For the Trinity is undoubtedly a higher form of God-concept than mere unity, since it corresponds to a level of reflection on which man has become more conscious.

[206] The trinitarian conception of a life-process within the Deity, which I have outlined here, was, as we have seen, already in existence in pre-Christian times, its essential features being a continuation and differentiation of the primitive rites of renewal and the cult-legends associated with them. Just as the gods of these mysteries become extinct, so, too, do the mysteries themselves, only to take on new forms in the course of history. A large-scale extinction of the old gods was once more in progress at the beginning of our era, and the birth of a new god, with new mysteries and new emotions, was an occurrence that healed the wound in men's souls. It goes without saying that any conscious borrowing from the existing mystery traditions would have hampered the god's renewal and rebirth. It had to be an entirely unprejudiced revelation which, quite unrelated to anything else, and if possible without preconceptions of any kind, would usher into the world a new *δρῶμενον* and a new cult-legend. Only at a comparatively late date did people notice the striking parallels with the legend of Dionysus, which they then declared to be the work of the devil. This attitude on the part of the early Christians can easily be understood, for Christianity did indeed develop in this unconscious fashion, and furthermore its seeming lack of antecedents proved to be the indispensable condition for its existence as an effective force. Nobody can doubt the manifold superiority of the Christian revelation over its pagan precursors, for which reason it is distinctly superfluous today to insist on the unheralded and unhistorical character of the gospels, seeing that they swarm with historical and psychological assumptions of very ancient origin.

3. THE SYMBOLA

[207] The trinitarian drama of redemption (as distinct from the intellectual conception of it) burst upon the world scene at the beginning of a new era, amid complete unconsciousness of its resuscitation from the past. Leaving aside the so-called prefigurations in the Old Testament, there is not a single passage in the New Testament where the Trinity is formulated in an intellectually comprehensible manner.¹ Generally speaking, it is more a question of formulae for triple benediction, such as the end of the second epistle to the Corinthians: “The grace of the Lord Jesus Christ, and the love of God, and the communion of the Holy Ghost, be with you all,”² or the beginning of the first epistle of Peter: “... chosen and destined by God the Father and sanctified by the Spirit for obedience to Jesus Christ and for sprinkling with his blood,”³ or Jude 20–21. Another passage cited in favour of the Trinity is I Corinthians 12:4–6, but this only gives the emphatic assurance that the Spirit is one (repeated in Ephesians 4:4–6), and may be taken more as an incantation against polytheism and polydemonism than an assertion of the Trinity. Triadic formulae were also current in the post-apostolic epoch. Thus Clement says in his first letter (46:6): “... Have we not one God, and one Christ, and one Spirit ...”⁴ Epiphanius even reports that Christ taught his disciples that “the Father and the Son and the Holy Ghost are the same.”⁵

[208] Epiphanius took this passage from the apocryphal “Gospel according to the Egyptians,”⁶ of which unfortunately only fragments are preserved. The formula is significant insofar as it provides a definite starting-point for a “modalistic” concept of the Trinity.

[209] Now the important point is not that the New Testament contains no trinitarian formulae, but that we find in it three figures who are reciprocally related to one another: the Father, the Son, begotten through the Holy Ghost, and the Holy Ghost. Since olden times, formulae for benediction, all solemn agreements, occasions, attributes, etc. have had a magical, threefold character (e.g., the Trishagion).⁷ Although they are no evidence for the Trinity in the New Testament, they nevertheless occur and, like the three divine Persons, are clear indications of an active archetype operating beneath the surface and throwing up triadic formations. This proves that the trinitarian archetype is already at work in the New Testament, for what comes after is largely the result of what has gone before, a proposition which is especially apposite when, as in the case of the Trinity, we are confronted with the

effects of an unconscious content or archetype. From the creeds to be discussed later, we shall see that at the synods of the Fathers the New Testament allusions to the divine trio were developed in a thoroughly consistent manner until the homoousia was restored, which again happened unconsciously, since the Fathers knew nothing of the ancient Egyptian model that had already reached the homoousian level. The after-effects on posterity were inevitable consequences of the trinitarian anticipations that were abroad in the early days of Christianity, and are nothing but amplifications of the constellated archetype. These amplifications, so far as they were naïve and unprejudiced, are direct proof that what the New Testament is alluding to is in fact the Trinity, as the Church also believes.

[210] Since people did not actually *know* what it was that had so suddenly revealed itself in the “Son of Man,” but only *believed* the current interpretations, the effects it had over the centuries signify nothing less than the gradual unfolding of the archetype in man’s consciousness, or rather, its absorption into the pattern of ideas transmitted by the cultures of antiquity.⁸ From this historical echo it is possible to recognize what had revealed itself in a sudden flash of illumination and seized upon men’s minds, even though the event, when it happened, was so far beyond their comprehension that they were unable to put it into a clear formula. Before “revealed” contents can be sorted out and properly formulated, time and distance are needed. The results of this intellectual activity were deposited in a series of tenets, the dogmata, which were then summed up in the “symbolum” or creed. This breviary of belief well deserves the name “symbolum,” for, from a psychological point of view, it gives symbolical expression to, and paints an anthropomorphic picture of, a transcendent fact that cannot be demonstrated or explained rationally, the word “transcendent” being used here in a strictly psychological sense.⁹

I. THE SYMBOLUM APOSTOLICUM

[211] The first of these summaries was attempted fairly early, if tradition may be relied on. St. Ambrose, for instance, reports that the confession used at baptism in the church of Milan originated with the twelve apostles.¹⁰ This creed of the old Church is therefore known as the Apostles’ Creed. As established in the fourth century, it ran:

I believe in God the Father Almighty, and in Jesus Christ his only begotten Son our Lord, who was born of the Holy Ghost and the Virgin Mary, was crucified under Pontius Pilate, buried, and on the third day rose again from the dead, ascended into heaven, and sitteth on the right hand of the Father, whence he shall come to judge the quick and the dead. And [I believe] in the Holy Ghost, the holy Church, the forgiveness of sins, the resurrection of the flesh.

[212] This creed is still entirely on the level of the gospels and epistles: there are three divine figures, and they do not in any way contradict the one God. Here the Trinity is

not explicit, but exists latently, just as Clement’s second letter says of the pre-existent Church: “It was spiritually there.” Even in the very early days of Christianity it was accepted that Christ as Logos was God himself (John 1:1). For Paul he is pre-existent in God’s form, as is clear from the famous “kenosis” passage in Philippians 2:6 (AV): “Who, being in the form of God, thought it not robbery to be equal with God” (τὸ εἶναι ἴσα θεῶ = *esse se aequalem Deo*). There are also passages in the letters where the author confuses Christ with the Holy Ghost, or where the three are seen as one, as in II Corinthians 3:17 (DV): “Now the Lord is the spirit” (ὁ δὲ κύριος τὸ πνεῦμα ἐστίν = *Dominus autem spiritus est*). When the next verse speaks of the “glory of the Lord” (δόξα κυρίου = *gloria Domini*), “Lord” seems to refer to Christ. But if you read the whole passage, from verses 7 to 18, it is evident that the “glory” refers equally to God, thus proving the promiscuity of the three figures and their latent Trinity.

II. THE SYMBOLUM OF GREGORY THAUMATURGUS

[213] Although the Apostles’ Creed does not stipulate the Trinity in so many words, it was nevertheless “spiritually there” at a very early date, and it is nothing but a quibble to insist, as many people do, that the Trinity was “invented only long afterwards.” In this connection, therefore, I must mention the vision of Gregory Thaumaturgus (210–70), in which the Blessed Virgin and St. John appeared to him and enunciated a creed which he wrote down on the spot.¹¹ It runs:

One God, Father of the living Word, [of his] self-subsistent wisdom and power, [of his] eternal likeness, perfect Begetter of what is perfect, Father of the only begotten Son. One Lord, Alone of the Alone, God of God, veritable likeness of Godhead, effectual Word, comprehensive Wisdom by which all things subsist, Power that creates all Creation, true Son of the true Father, unseen [Son] of the unseen [Father], incorruptible of the incorruptible, deathless of the deathless, everlasting of the everlasting. And one Holy Spirit, having existence from God and appearing through the Son, Image of the Son and perfect [Image] of the perfect [Father], Life and cause of life, holy Fount, Ringleader [Χορηγός] of holiness: in whom is manifest God the Father, who is above all and in all, and God the Son, who pervades all. Perfect Trinity, whose glory and eternity and dominion is not divided and not separate.¹²

[214] This trinitarian creed had already established itself in a position of authority long before the appearance of the Apostles’ Creed, which is far less explicit. Gregory had been a pupil of Origen until about 238. Origen (182—251) employed the concept of the Trinity¹³ in his writings and gave it considerable thought, concerning himself more particularly with its internal economy (*οἰκονομία, oeconomia*) and the management of its power: “I am of the opinion, then, that the God and Father, who holds the universe together, is superior to every being that exists, for he imparts to each one from his own existence that which each one is. The Son, being less than the

Father, is superior to rational creatures alone (for he is second to the Father). The Holy Spirit is still less, and dwells within the saints alone. So that in this way the power of the Father is greater than that of the Son and of the Holy Spirit, and in turn the power of the Holy Spirit exceeds that of every other holy being.”¹⁴ He is not very clear about the nature of the Holy Spirit, for he says: “The Spirit of God, therefore, who, as it is written, moved upon the waters in the beginning of the creation of the world, I reckon to be none other than the Holy Spirit, so far as I can understand.”¹⁵ Earlier he says: “But up to the present we have been able to find no passage in the holy scriptures which would warrant us in saying that the Holy Spirit was a being made or created.”¹⁶

III. THE NICAENUM

[215] Trinitarian speculation had long passed its peak when the Council of Nicaea, in 325, created a new creed, known as the “Nicene.” It runs:

We believe in one God, the Father Almighty, Creator of all things visible and invisible, and in one Lord Jesus Christ, Son of God, the only begotten of the Father, being of the substance [*οὐσία*] of the Father, God of God, Light of Light, very God of very God, begotten not made, consubstantial [*ὁμοούσιος*] with the Father, through whom all things have been made which are in heaven and on earth. Who for us men and for our salvation descended and was made flesh, became man, suffered, rose again the third day, ascended into heaven, and will come to judge the living and the dead. And in the Holy Spirit. As for those who say, “There was a time when He was not,” or “Before He was begotten He was not,” or “He was made from that which was not, or from another subsistence [*ὑπόστασις*], or substance,” or “The Son of God is created, changeable, or subject to change,” these the Catholic Church anathematizes.¹⁷

[216] It was, apparently, a Spanish bishop, Hosius of Cordoba, who proposed to the emperor the crucial word *ὁμοούσιος*. It did not occur then for the first time, for it can be found in Tertullian, as the “unitas substantiae.” The concept of homoousia can also be found in Gnostic usage, as for instance in Irenaeus’ references to the Valentinians (140–c. 200), where the Aeons are said to be of one substance with their creator, Bythos.¹⁸ The Nicene Creed concentrates on the father-son relationship, while the Holy Ghost receives scant mention.

IV. THE NICAENO-CONSTANTINOPOLITANUM, THE ATHANASIANUM, AND THE LATERANENSE

[217] The next formulation in the Nicene-Constantinopolitan Creed of 381 brings an important advance. It runs:

We believe in one God the Father Almighty, Maker of heaven and earth, and of all things visible and invisible. And in one Lord Jesus Christ, the only begotten Son of God, begotten of his Father before all worlds, God of God, Light of Light, very God of very God, begotten, not made, being of one substance with the Father, by whom all

things were made; who for us men and for our salvation came down from heaven and was made flesh by the Holy Ghost and the Virgin Mary and became man, and was crucified for us under Pontius Pilate, suffered and was buried, and on the third day rose again according to the Scriptures, and ascended into heaven, and sitteth on the right hand of God the Father, whence he shall come again in glory to judge the quick and the dead, and whose kingdom shall have no end. And [we believe] in the Holy Ghost, the Lord and Giver of life, who proceedeth from the Father,¹⁹ who with the Father and the Son together is worshipped and glorified, who spake through the prophets. And [we believe] in one holy Catholic and Apostolic Church. We acknowledge one baptism for the remission of sins. And we await the resurrection of the dead and the life of the world to come. Amen.

[218] Here the Holy Ghost is given due consideration: he is called “Lord” and is worshipped together with Father and Son. But he proceeds from the Father only. It was this point that caused the tremendous controversy over the “filioque” question, as to whether the Holy Ghost proceeds from the Father only, or from the Son as well. In order to make the Trinity a complete unity, the *filioque* was just as essential as the *homoousia*. The (falsely so-called) Athanasian Creed²⁰ insisted in the strongest possible terms on the equality of all three Persons. Its peculiarities have given much offence to rationalistic and liberal-minded theologians. I quote, as a sample, a passage from the beginning:

Now the Catholic Faith is this: That we worship one God in Trinity, and Trinity in Unity, neither confounding the Persons nor dividing the substance. For there is one Person of the Father, another of the Son, another of the Holy Ghost. But the Godhead of the Father and of the Son and of the Holy Ghost is all one; the glory equal, the majesty co-eternal. Such as the Father is, such is the Son, and such is the Holy Ghost. The Father uncreated, the Son uncreated, the Holy Ghost uncreated. The Father infinite, the Son infinite, the Holy Ghost infinite. The Father eternal, the Son eternal, the Holy Ghost eternal. And yet not three Eternals, but one Eternal. As also there are not three Uncreated, nor three Infinities, but one Infinite and one Uncreated. So likewise is the Father almighty, the Son almighty, the Holy Ghost almighty; and yet there are not three Almightyies, but one Almighty. So the Father is God, the Son is God, the Holy Ghost is God; and yet there are not three Gods, but one God. Likewise the Father is Lord, the Son is Lord, the Holy Ghost is Lord; and yet there are not three Lords, but one Lord. For just as we are compelled by the Christian verity to acknowledge each Person by himself to be both God and Lord, so we are forbidden by the Catholic religion to say there are three Gods or three Lords. The Father is made of none, neither created nor begotten. The Son is of the Father alone, not made, nor created, but begotten. The Holy Ghost is of the Father and the Son, not made, nor created, nor begotten, but proceeding. So there is one Father, not three Fathers; one Son, not three Sons; one Holy Ghost, not three Holy Ghosts. And in this Trinity none is before or after, none is greater or less; but all three Persons are coeternal together and coequal. So that in all ways, as is aforesaid, both the Trinity is to be worshipped in Unity, and the Unity in Trinity. He, therefore, that would be saved, let him think thus of the Trinity.²¹

[219] Here the Trinity is a fully developed conceptual schema in which everything balances, the *homoousia* binding all three Persons equally. The Creed of the Lateran Council, 1215, brings a further differentiation. I shall quote only the beginning:

We firmly believe and wholeheartedly confess that there is only one true God, eternal, infinite, and unchanging; incomprehensible, almighty, and ineffable; Father and Son and Holy Ghost; three Persons, but one essence; entirely simple in substance and nature. The Father is of none, the Son is of the Father alone, and the Holy Ghost is of both equally; for ever without beginning and without end; the Father begetting, the Son being born, and the Holy Ghost proceeding; consubstantial and coequal and coalmighty and coeternal.²²

[220] The “filioque” is expressly taken up into this creed, thus assigning the Holy Ghost a special activity and significance. So far as I can judge, the later Creed of the Council of Trent adds nothing further that would be of interest for our theme.

[221] Before concluding this section, I would like to call attention to a book well known in the Middle Ages, the *Liber de Spiritu et Anima*,²³ which attempts a psychological interpretation of the Trinity. The argument starts with the assumption that by self-knowledge a man may attain to a knowledge of God.²⁴ The *mens rationalis* is closest to God, for it is “excellently made, and expressly after his likeness.” If it recognizes its own likeness to God it will the more easily recognize its creator. And thus knowledge of the Trinity begins. For the intellect sees how wisdom (*sapientia*) proceeds from it and how it loves this wisdom. But, from intellect and wisdom, there proceeds love, and thus all three, intellect, wisdom, and love, appear in one. The origin of all wisdom, however, is God. Therefore intellect (*νοῦς*) corresponds to the Father, the wisdom it begets corresponds to the Son (*λόγος*), and love corresponds to the Spirit (*λόγος*) breathed forth between them.²⁵ The wisdom of God was often identified with the cosmogonic Logos and hence with Christ. The medieval mind finds it natural to derive the structure of the psyche from the Trinity, whereas the modern mind reverses the procedure.

4. THE THREE PERSONS IN THE LIGHT OF PSYCHOLOGY

I. THE HYPOTHESIS OF THE ARCHETYPE

[222] The sequence of creeds illustrates the evolution of the Trinity idea through the centuries. In the course of its development it either consistently avoided, or successfully combated, all rationalistic deviations, such as, for instance, the so-plausible-looking Arian heresy. The creeds superimposed on the trinitarian allusions in the Holy Scriptures a structure of ideas that is a perpetual stumbling-block to the liberal-minded rationalist. Religious statements are, however, never rational in the ordinary sense of the word, for they always take into consideration that other world, the world of the archetype, of which reason in the ordinary sense is unconscious, being occupied only with externals. Thus the development of the Christian idea of the Trinity unconsciously reproduced the archetype of the homoousia of Father, Son, and Ka-mutef which first appeared in Egyptian theology. Not that the Egyptian model could be considered the archetype of the Christian idea. The archetype *an sich*, as I have explained elsewhere,¹ is an “irrepresentable” factor, a “disposition” which starts functioning at a given moment in the development of the human mind and arranges the material of consciousness into definite patterns.² That is to say, man’s conceptions of God are organized into triads and trinities, and a whole host of ritualistic and magical practices take on a triple or trichotomous character, as in the case of thrice-repeated apotropaic spells, formulae for blessing, cursing, praising, giving thanks, etc. Wherever we find it, the archetype has a compelling force which it derives from the unconscious, and whenever its effect becomes conscious it has a distinctly numinous quality. There is never any conscious invention or cogitation, though speculations about the Trinity have often been accused of this. All the controversies, sophistries, quibbles, intrigues, and dissensions that are such an odious blot on the history of this dogma owe their existence to the compelling numinosity of the archetype and to the unexampled difficulty of incorporating it in the world of rational thought. Although the emperors may have made political capital out of the quarrels that ensued, this singular chapter in the history of the human mind cannot possibly be traced back to politics, any more than social and economic causes can be held responsible for it. The sole reason for the dogma lies in the Christian “message,” which caused a psychic revolution in Western man. On the evidence of the gospels, and of Paul’s letters in particular, it announced the real and veracious appearance of the God-man in this humdrum human world, accompanied by all the marvellous

portents worthy of the son of God. However obscure the historical core of this phenomenon may seem to us moderns, with our hankering for factual accuracy, it is quite certain that those tremendous psychic effects, lasting for centuries, were not causelessly called forth, by just nothing at all. Unfortunately the gospel reports, originating in missionary zeal, form the meagrest source imaginable for attempts at historical reconstruction. But, for that very reason, they tell us all the more about the psychological reactions of the civilized world at that time. These reactions and assertions are continued in the history of dogma, where they are still conceived as the workings of the Holy Ghost. This interpretation, though the psychologist has nothing to say in regard to its metaphysical validity, is of the greatest moment, for it proves the existence of an overwhelming opinion or conviction that the operative factor in the formation of ideas is not man's intellect but an authority above and beyond consciousness. This psychological fact should on no account be overlooked, for any theoretical reasons whatsoever. Rationalistic arguments to the effect that the Holy Ghost is an hypothesis that cannot be proved are not commensurable with the statements of the psyche. A delusional idea is real, even though its content is, factually considered, nonsense. Psychology's concern is with psychic phenomena and with nothing else. These may be mere aspects of phenomena which, in themselves, could be subjected to a number of quite different modes of observation. Thus the statement that dogmas are inspired by the Holy Ghost indicates that they are not the product of conscious cogitation and speculation but are motivated from sources outside consciousness and possibly even outside man. Statements of this kind are the rule in archetypal experiences and are constantly associated with the sensed presence of a numen. An archetypal dream, for instance, can so fascinate the dreamer that he is very apt to see in it some kind of illumination, warning, or supernatural help. Nowadays most people are afraid of surrendering to such experiences, and their fear proves the existence of a "holy dread" of the numinous. Whatever the nature of these numinous experiences may be, they all have one thing in common: they relegate their source to a region outside consciousness. Psychology uses instead the concept of the unconscious, and specially that of the collective unconscious as opposed to the personal unconscious. People who reject the former and give credence only to the latter are forced into personalistic explanations. But collective and, above all, manifestly archetypal ideas can never be derived from the personal sphere. If Communism, for instance, refers to Engels, Marx, Lenin, and so on as the "fathers" of the movement, it does not know that it is reviving an archetypal order of society that existed even in primitive times, thereby explaining, incidentally, the "religious" and "numinous" (i.e., fanatical) character of Communism. Neither did the Church Fathers know that their Trinity had a prehistory dating back several thousand years.

[223] There can be no doubt that the doctrine of the Trinity originally corresponded with a patriarchal order of society. But we cannot tell whether social conditions produced the idea or, conversely, the idea revolutionized the existing social order. The phenomenon of early Christianity and the rise of Islam, to take only these two examples, show what ideas can do. The layman, having no opportunity to observe the behaviour of autonomous complexes, is usually inclined, in conformity with the general trend, to trace the origin of psychic contents back to the environment. This expectation is certainly justified so far as the ideational contents of consciousness are concerned. In addition to these, however, there are irrational, affective reactions and impulses, emanating from the unconscious, which organize the conscious material in an archetypal way. The more clearly the archetype is constellated, the more powerful will be its fascination, and the resultant religious statements will formulate it accordingly, as something “daemonic” or “divine.” Such statements indicate possession by an archetype. The ideas underlying them are necessarily anthropomorphic and are thereby distinguished from the organizing archetype, which in itself is irrepresentable because unconscious.³ They prove, however, that an archetype has been activated.⁴

[224] Thus the history of the Trinity presents itself as the gradual crystallization of an archetype that moulds the anthropomorphic conceptions of father and son, of life, and of different persons into an archetypal and numinous figure, the “Most Holy Three-in-One.” The contemporary witnesses of these events apprehended it as something that modern psychology would call a psychic presence outside consciousness. If there is a consensus of opinion in respect of an idea, as there is here and always has been, then we are entitled to speak of a collective presence. Similar “presences” today are the Fascist and Communist ideologies, the one emphasizing the power of the chief, and the other communal ownership of goods in a primitive society.

[225] “Holiness” means that an idea or thing possesses the highest value, and that in the presence of this value men are, so to speak, struck dumb. Holiness is also revelatory: it is the illuminative power emanating from an archetypal figure. Nobody ever feels himself as the subject of such a process, but always as its object.⁵ *He* does not perceive holiness, *it* takes him captive and overwhelms him; nor does *he* behold it in a revelation, *it* reveals itself to him, and he cannot even boast that he has understood it properly. Everything happens apparently outside the sphere of his will, and these happenings are contents of the unconscious. Science is unable to say anything more than this, for it cannot, by an act of faith, overstep the limits appropriate to its nature.

II. CHRIST AS ARCHETYPE

[226] The Trinity and its inner life process appear as a closed circle, a self-contained divine drama in which man plays, at most, a passive part. It seizes on him and, for a

period of several centuries, forced him to occupy his mind passionately with all sorts of queer problems which today seem incredibly abstruse, if not downright absurd. It is, in the first place, difficult to see what the Trinity could possibly mean for us, either practically, morally, or symbolically. Even theologians often feel that speculation on this subject is a more or less otiose juggling with ideas, and there are not a few who could get along quite comfortably without the divinity of Christ, and for whom the role of the Holy Ghost, both inside and outside the Trinity, is an embarrassment of the first order. Writing of the Athanasian Creed, D. F. Strauss remarks: "The truth is that anyone who has sworn to the Symbolum Quicumque has abjured the laws of human thought." Naturally, the only person who can talk like that is one who is no longer impressed by the revelation of holiness and has fallen back on his own mental activity. This, so far as the revealed archetype is concerned, is an inevitably retrograde step: the liberalistic humanization of Christ goes back to the rival doctrine of homoiousia and to Arianism, while modern anti-trinitarianism has a conception of God that is more Old Testament or Islamic in character than Christian.

[227] Obviously, anyone who approaches this problem with rationalistic and intellectualistic assumptions, like D. F. Strauss, is bound to find the patristic discussions and arguments completely nonsensical. But that anyone, and especially a theologian, should fall back on such manifestly incommensurable criteria as reason, logic, and the like, shows that, despite all the mental exertions of the Councils and of scholastic theology, they failed to bequeath to posterity an intellectual understanding of the dogma that would lend the slightest support to belief in it. There remained only submission to faith and renunciation of one's own desire to understand. Faith, as we know from experience, often comes off second best and has to give in to criticism which may not be at all qualified to deal with the object of faith. Criticism of this kind always puts on an air of great enlightenment—that is to say, it spreads round itself that thick darkness which the Word once tried to penetrate with its light: "And the light shineth in the darkness, and the darkness comprehended it not."

[228] Naturally, it never occurs to these critics that their way of approach is incommensurable with their object. They think they have to do with rational facts, whereas it entirely escapes them that it is and always has been primarily a question of irrational psychic phenomena. That this is so can be seen plainly enough from the unhistorical character of the gospels, whose only concern was to represent the miraculous figure of Christ as graphically and impressively as possible. Further evidence of this is supplied by the earliest literary witness, Paul, who was closer to the events in question than the apostles. It is frankly disappointing to see how Paul hardly ever allows the real Jesus of Nazareth to get a word in. Even at this early date (and not only in John) he is completely overlaid, or rather smothered, by metaphysical conceptions: he is the ruler over all daemonic forces, the cosmic

saviour, the mediating God-man. The whole pre-Christian and Gnostic theology of the Near East (some of whose roots go still further back) wraps itself about him and turns him before our eyes into a dogmatic figure who has no more need of historicity. At a very early stage, therefore, the real Christ vanished behind the emotions and projections that swarmed about him from far and near; immediately and almost without trace he was absorbed into the surrounding religious systems and moulded into their archetypal exponent. He became the collective figure whom the unconscious of his contemporaries expected to appear, and for this reason it is pointless to ask who he “really” was. Were he human and nothing else, and in this sense historically true, he would probably be no more enlightening a figure than, say, Pythagoras, or Socrates, or Apollonius of Tyana. He opened men’s eyes to revelation precisely because he was, from everlasting, God, and therefore unhistorical; and he functioned as such only by virtue of the consensus of unconscious expectation. If nobody had remarked that there was something special about the wonder-working Rabbi from Galilee, the darkness would never have noticed that a light was shining. Whether he lit the light with his own strength, or whether he was the victim of the universal longing for light and broke down under it, are questions which, for lack of reliable information, only faith can decide. At any rate the documentary reports relating to the general projection and assimilation of the Christ-figure are unequivocal. There is plenty of evidence for the co-operation of the collective unconscious in view of the abundance of parallels from the history of religion. In these circumstances we must ask ourselves what it was in man that was stirred by the Christian message, and what was the answer he gave.

[229] If we are to answer this psychological question, we must first of all examine the Christ-symbolism contained in the New Testament, together with the patristic allegories and medieval iconography, and compare this material with the archetypal content of the unconscious psyche in order to find out what archetypes have been constellated. The most important of the symbolical statements about Christ are those which reveal the attributes of the hero’s life: improbable origin, divine father, hazardous birth, rescue in the nick of time, precocious development, conquest of the mother and of death, miraculous deeds, a tragic, early end, symbolically significant manner of death, postmortem effects (reappearances, signs and marvels, etc.). As the Logos, Son of the Father, *Rex gloriae*, *Judex mundi*, Redeemer, and Saviour, Christ is himself God, an all-embracing totality, which, like the definition of Godhead, is expressed iconographically by the circle or mandala.⁶ Here I would mention only the traditional representation of the *Rex gloriae* in a mandala, accompanied by a quaternity composed of the four symbols of the evangelists (including the four seasons, four winds, four rivers, and so on). Another symbolism of the same kind is the choir of saints, angels, and elders grouped round Christ (or God) in the centre.

Here Christ symbolizes the integration of the kings and prophets of the Old Testament. As a shepherd he is the leader and centre of the flock. He is the vine, and those that hang on him are the branches. His body is bread to be eaten, and his blood wine to be drunk; he is also the mystical body formed by the congregation. In his human manifestation he is the hero and God-man, born without sin, more complete and more perfect than the natural man, who is to him what a child is to an adult, or an animal (sheep) to a human being.

[230] These mythological statements, coming from within the Christian sphere as well as from outside it, adumbrate an archetype that expresses itself in essentially the same symbolism and also occurs in individual dreams or in fantasy-like projections upon living people (transference phenomena, hero-worship, etc.). The content of all such symbolic products is the idea of an overpowering, all-embracing, complete or perfect being, represented either by a man of heroic proportions, or by an animal with magical attributes, or by a magical vessel or some other “treasure hard to attain,” such as a jewel, ring, crown, or, geometrically, by a mandala. This archetypal idea is a reflection of the individual’s wholeness, i.e., of the self, which is present in him as an unconscious image. The conscious mind can form absolutely no conception of this totality, because it includes not only the conscious but also the unconscious psyche, which is, as such, inconceivable and irrepresentable.

[231] It was this archetype of the self in the soul of every man that responded to the Christian message, with the result that the concrete Rabbi Jesus was rapidly assimilated by the constellated archetype. In this way Christ realized the idea of the self.⁷ But as one can never distinguish empirically between a symbol of the self and a God-image, the two ideas, however much we try to differentiate them, always appear blended together, so that the self appears synonymous with the inner Christ of the Johannine and Pauline writings, and Christ with God (“of one substance with the Father”), just as the atman appears as the individualized self and at the same time as the animating principle of the cosmos, and Tao as a condition of mind and at the same time as the correct behaviour of cosmic events. Psychologically speaking, the domain of “gods” begins where consciousness leaves off, for at that point man is already at the mercy of the natural order, whether he thrive or perish. To the symbols of wholeness that come to him from there he attaches names which vary according to time and place.

[232] The self is defined psychologically as the psychic totality of the individual. Anything that a man postulates as being a greater totality than himself can become a symbol of the self. For this reason the symbol of the self is not always as total as the definition would require. Even the Christ-figure is not a totality, for it lacks the nocturnal side of the psyche’s nature, the darkness of the spirit, and is also without sin. Without the integration of evil there is no totality, nor can evil be “added to the

mixture by force.” One could compare Christ as a symbol to the mean of the first mixture: he would then be the middle term of a triad, in which the One and Indivisible is represented by the Father, and the Divisible by the Holy Ghost, who, as we know, can divide himself into tongues of fire. But this triad, according to the *Timaeus*, is not yet a reality. Consequently a second mixture is needed.

[233] The goal of psychological, as of biological, development is self-realization, or individuation. But since man knows himself only as an ego, and the self, as a totality, is indescribable and indistinguishable from a God-image, self-realization—to put it in religious or metaphysical terms—amounts to God’s incarnation. That is already expressed in the fact that Christ is the son of God. And because individuation is an heroic and often tragic task, the most difficult of all, it involves suffering, a passion of the ego: the ordinary, empirical man we once were is burdened with the fate of losing himself in a greater dimension and being robbed of his fancied freedom of will. He suffers, so to speak, from the violence done to him by the self.⁸ The analogous passion of Christ signifies God’s suffering on account of the injustice of the world and the darkness of man. The human and the divine suffering set up a relationship of complementarity with compensating effects. Through the Christ-symbol, man can get to know the real meaning of his suffering: he is on the way towards realizing his wholeness. As a result of the integration of conscious and unconscious, his ego enters the “divine” realm, where it participates in “God’s suffering.” The cause of the suffering is in both cases the same, namely “incarnation,” which on the human level appears as “individuation.” The divine hero born of man is already threatened with murder; he has nowhere to lay his head, and his death is a gruesome tragedy. The self is no mere concept or logical postulate; it is a psychic reality, only part of it conscious, while for the rest it embraces the life of the unconscious and is therefore inconceivable except in the form of symbols. The drama of the archetypal life of Christ describes in symbolic images the events in the conscious life—as well as in the life that transcends consciousness—of a man who has been transformed by his higher destiny.

III. THE HOLY GHOST

[234] The psychological relationship between man and the trinitarian life process is illustrated first by the human nature of Christ, and second by the descent of the Holy Ghost and his indwelling in man, as predicted and promised by the Christian message. The life of Christ is on the one hand only a short, historical interlude for proclaiming the message, but on the other hand it is an exemplary demonstration of the psychic experiences connected with God’s manifestation of himself (or the realization of the self). The important thing for man is not the *δεικνύμενον* and the

δρῶμενον (what is “shown” and “done”), but what happens afterwards: the seizure of the individual by the Holy Ghost.

[235] Here, however, we run into a great difficulty. For if we follow up the theory of the Holy Ghost and carry it a step further (which the Church has not done, for obvious reasons), we come inevitably to the conclusion that if the Father appears in the Son and breathes together with the Son, and the Son leaves the Holy Ghost behind for man, then the Holy Ghost breathes in man, too, and thus is the breath common to man, the Son, and the Father. Man is therefore included in God’s sonship, and the words of Christ—“Ye are gods” (John 10:34)—appear in a significant light. The doctrine that the Paraclete was expressly left behind for man raises an enormous problem. The triadic formula of Plato would surely be the last word in the matter of logic, but psychologically it is not so at all, because the psychological factor keeps on intruding in the most disturbing way. Why, in the name of all that’s wonderful, wasn’t it “Father, Mother, and Son?” That would be much more “reasonable” and “natural” than “Father, Son, and Holy Ghost.” To this we must answer: it is not just a question of a natural situation, but of a product of human reflection⁹ added on to the natural sequence of father and son. Through reflection, “life” and its “soul” are abstracted from Nature and endowed with a separate existence. Father and son are united in the same soul, or, according to the ancient Egyptian view, in the same procreative force, Ka-mutef. Ka-mutef is exactly the same hypostatization of an attribute as the breath or “spiration” of the Godhead.¹⁰

[236] This psychological fact spoils the abstract perfection of the triadic formula and makes it a logically incomprehensible construction, since, in some mysterious and unexpected way, an important mental process peculiar to man has been imported into it. If the Holy Ghost is, at one and the same time, the breath of life and a loving spirit and the Third Person in whom the whole trinitarian process culminates, then he is essentially a product of reflection, an hypostatized noumenon tacked on to the natural family-picture of father and son. It is significant that early Christian Gnosticism tried to get round this difficulty by interpreting the Holy Ghost as the Mother.¹¹ But that would merely have kept him within the archaic family-picture, within the tritheism and polytheism of the patriarchal world. It is, after all, perfectly natural that the father should have a family and that the son should embody the father. This train of thought is quite consistent with the father-world. On the other hand, the mother-interpretation would reduce the specific meaning of the Holy Ghost to a primitive image and destroy the most essential of the qualities attributed to him: not only is he the life common to Father and Son, he is also the Paraclete whom the Son left behind him, to procreate in man and bring forth works of divine parentage. It is of paramount importance that the idea of the Holy Ghost is not a natural image, but a recognition of the living quality of Father and Son, abstractly conceived as the “third” term between

the One and the Other. Out of the tension of duality life always produces a “third” that seems somehow incommensurable or paradoxical. Hence, as the “third,” the Holy Ghost is bound to be incommensurable and paradoxical too. Unlike Father and Son, he has no name and no character. He is a *function*, but that function is the Third Person of the Godhead.

[237] He is psychologically heterogeneous in that he cannot be logically derived from the father-son relationship and can only be understood as an idea introduced by a process of human reflection. The Holy Ghost is an exceedingly “abstract” conception, since a “breath” shared by two figures characterized as distinct and not mutually interchangeable can hardly be conceived at all. Hence one feels it to be an artificial construction of the mind, even though, as the Egyptian Ka-mutef concept shows, it seems somehow to belong to the very essence of the Trinity. Despite the fact that we cannot help seeing in the positing of such a concept a product of human reflection, this reflection need not necessarily have been a conscious act. It could equally well owe its existence to a “revelation,” i.e., to an unconscious reflection,¹² and hence to an autonomous functioning of the unconscious, or rather of the self, whose symbols, as we have already said, cannot be distinguished from God-images. A religious interpretation will therefore insist that this hypostasis was a divine revelation. While it cannot raise any objections to such a notion, psychology must hold fast to the conceptual nature of the hypostasis, for in the last analysis the Trinity, too, is an anthropomorphic configuration, gradually taking shape through strenuous mental and spiritual effort, even though already preformed by the timeless archetype.

[238] This separating, recognizing, and assigning of qualities is a mental activity which, although unconscious at first, gradually filters through to consciousness as the work proceeds. What started off by merely happening to consciousness later becomes integrated in it as its own activity. So long as a mental or indeed any psychic process at all is unconscious, it is subject to the law governing archetypal dispositions, which are organized and arranged round the self. And since the self cannot be distinguished from an archetypal God-image, it would be equally true to say of any such arrangement that it conforms to natural law and that it is an act of God’s will. (Every metaphysical statement is, *ipso facto*, unprovable). Inasmuch, then, as acts of cognition and judgment are essential qualities of consciousness, any accumulation of unconscious acts of this sort¹³ will have the effect of strengthening and widening consciousness, as one can see for oneself in any thorough analysis of the unconscious. Consequently, man’s achievement of consciousness appears as the result of prefigurative archetypal processes or—to put it metaphysically—as part of the divine life-process. In other words, God becomes manifest in the human act of reflection.

[239] The nature of this conception (i.e., the hypostatizing of a quality) meets the need evinced by primitive thought to form a more or less abstract idea by endowing each individual quality with a concrete existence of its own. Just as the Holy Ghost is a legacy left to man, so, conversely, the concept of the Holy Ghost is something begotten by man and bears the stamp of its human progenitor. And just as Christ took on man's bodily nature, so through the Holy Ghost man as a spiritual force is surreptitiously included in the mystery of the Trinity, thereby raising it far above the naturalistic level of the triad and thus beyond the Platonic triunity. The Trinity, therefore, discloses itself as a symbol that comprehends the essence of the divine *and* the human. It is, as Koepgen¹⁴ says, "a revelation not only of God but at the same time of man."

[240] The Gnostic interpretation of the Holy Ghost as the Mother contains a core of truth in that Mary was the instrument of God's birth and so became involved in the trinitarian drama as a human being. The Mother of God can, therefore, be regarded as a symbol of mankind's essential participation in the Trinity. The psychological justification for this assumption lies in the fact that thinking, which originally had its source in the self-revelations of the unconscious, was felt to be the manifestation of a power external to consciousness. The primitive does not think; the thoughts come to him. We ourselves still feel certain particularly enlightening ideas as "in-fluences," "in-spirations," etc. Where judgments and flashes of insight are transmitted by unconscious activity, they are often attributed to an archetypal feminine figure, the anima or mother-beloved. It then seems as if the inspiration came from the mother or from the beloved, the "femme inspiratrice." In view of this, the Holy Ghost would have a tendency to exchange his neuter designation (τὸ πνεῦμα) for a feminine one. (It may be noted that the Hebrew word for spirit—*ruach*—is predominantly feminine.) Holy Ghost and Logos merge in the Gnostic idea of Sophia, and again in the Sapientia of the medieval natural philosophers, who said of her: "In gremio matris sedet sapientia patris" (the wisdom of the father lies in the lap of the mother). These psychological relationships do something to explain why the Holy Ghost was interpreted as the mother, but they add nothing to our understanding of the Holy Ghost as such, because it is impossible to see how the mother could come third when her natural place would be second.

[241] Since the Holy Ghost is an hypostasis of "life," posited by an act of reflection, he appears, on account of his peculiar nature, as a separate and incommensurable "third," whose very peculiarities testify that it is neither a compromise nor a mere triadic appendage, but rather the logically unexpected resolution of tension between Father and Son. The fact that it is precisely a process of human reflection that irrationally creates the uniting "third" is itself connected with the nature of the drama

of redemption, whereby God descends into the human realm and man mounts up to the realm of divinity.

[242] Thinking in the magic circle of the Trinity, or trinitarian thinking, is in truth motivated by the “Holy Spirit” in so far as it is never a question of mere cogitation but of giving expression to imponderable psychic events. The driving forces that work themselves out in this thinking are not conscious motives; they spring from an historical occurrence rooted, in its turn, in those obscure psychic conditions for which one could hardly find a better or more succinct formula than the “change from father to son,” from unity to duality, from non-reflection to criticism. To the extent that personal motives are lacking in trinitarian thinking, and the forces motivating it derive from impersonal and collective psychic conditions, it expresses a need of the unconscious psyche far surpassing all personal needs. This need, aided by human thought, produced the symbol of the Trinity, which was destined to serve as a saving formula of wholeness in an epoch of change and psychic transformation. Manifestations of a psychic activity not caused or consciously willed by man himself have always been felt to be daemonic, divine, or “holy,” in the sense that they heal and make whole. His ideas of God behave as do all images arising out of the unconscious: they compensate or complete the general mood or attitude of the moment, and it is only through the integration of these unconscious images that a man becomes a psychic whole. The “merely conscious” man who is all ego is a mere fragment, in so far as he seems to exist apart from the unconscious. But the more the unconscious is split off, the more formidable the shape in which it appears to the conscious mind—if not in divine form, then in the more unfavourable form of obsessions and outbursts of affect.¹⁵ Gods are personifications of unconscious contents, for they reveal themselves to us through the unconscious activity of the psyche.¹⁶ Trinitarian thinking had something of the same quality, and its passionate profundity rouses in us latecomers a naïve astonishment. We no longer know, or have not yet discovered, what depths in the soul were stirred by that great turning-point in human history. The Holy Ghost seems to have faded away without having found the answer to the question he set humanity.

5. THE PROBLEM OF THE FOURTH

I. THE CONCEPT OF QUATERNITY

[243] The *Timaeus*, which was the first to propound a triadic formula for the God-image in philosophical terms, starts off with the ominous question: “One, two, three—but ... where is the fourth?” This question is, as we know, taken up again in the Cabiri scene in *Faust*:

Three we brought with us,
The fourth would not come.
He was the right one
Who thought for them all.

[244] When Goethe says that the fourth was the one “who thought for them all,” we rather suspect that the fourth was Goethe’s own thinking function.¹ The Cabiri are, in fact, the mysterious creative powers, the gnomes who work under the earth, i.e., below the threshold of consciousness, in order to supply us with lucky ideas. As imps and hobgoblins, however, they also play all sorts of nasty tricks, keeping back names and dates that were “on the tip of the tongue,” making us say the wrong thing, etc. They give an eye to everything that has not already been anticipated by the conscious mind and the functions at its disposal. As these functions can be used consciously only because they are adapted, it follows that the unconscious, autonomous function is not or cannot be used consciously because it is unadapted. The differentiated and differentiable functions are much easier to cope with, and, for understandable reasons, we prefer to leave the “inferior” function round the corner, or to repress it altogether, because it is such an awkward customer. And it is a fact that it has the strongest tendency to be infantile, banal, primitive, and archaic. Anybody who has a high opinion of himself will do well to guard against letting it make a fool of him. On the other hand, deeper insight will show that the primitive and archaic qualities of the inferior function conceal all sorts of significant relationships and symbolical meanings, and instead of laughing off the Cabiri as ridiculous Tom Thumbs he may begin to suspect that they are a treasure-house of hidden wisdom. Just as, in *Faust*, the fourth thinks for them all, so the whereabouts of the eighth should be asked “on Olympus.” Goethe showed great insight in not underestimating his inferior function, thinking, although it was in the hands of the Cabiri and was undoubtedly

mythological and archaic. He characterizes it perfectly in the line: “The fourth would not come.” Exactly! It wanted for some reason to stay behind or below.²

[245] Three of the four orienting functions are available to consciousness. This is confirmed by the psychological experience that a rational type, for instance, whose superior function is thinking, has at his disposal one, or possibly two, auxiliary functions of an irrational nature, namely sensation (the “fonction du réel”) and intuition (perception via the unconscious). His inferior function will be feeling (valuation), which remains in a retarded state and is contaminated with the unconscious. It refuses to come along with the others and often goes wildly off on its own. This peculiar dissociation is, it seems, a product of civilization, and it denotes a freeing of consciousness from any excessive attachment to the “spirit of gravity.” If that function, which is still bound indissolubly to the past and whose roots reach back as far as the animal kingdom,³ can be left behind and even forgotten, then consciousness has won for itself a new and not entirely illusory freedom. It can leap over abysses on winged feet; it can free itself from bondage to sense-impressions, emotions, fascinating thoughts, and presentiments by soaring into abstraction. Certain primitive initiations stress the idea of transformation into ghosts and invisible spirits and thereby testify to the relative emancipation of consciousness from the fetters of non-differentiation. Although there is a tendency, characteristic not only of primitive religions, to speak rather exaggeratedly of complete transformation, complete renewal and rebirth, it is, of course, only a relative change, continuity with the earlier state being in large measure preserved. Were it otherwise, every religious transformation would bring about a complete splitting of the personality or a loss of memory, which is obviously not so. The connection with the earlier attitude is maintained because part of the personality remains behind in the previous situation; that is to say it lapses into unconsciousness and starts building up the shadow.⁴ The loss makes itself felt in consciousness through the absence of at least one of the four orienting functions, and the missing function is always the opposite of the superior function. The loss need not necessarily take the form of complete absence; in other words, the inferior function may be either unconscious or conscious, but in both cases it is autonomous and obsessive and not influenceable by the will. It has the “all-or-none” character of an instinct. Although emancipation from the instincts brings a differentiation and enhancement of consciousness, it can only come about at the expense of the unconscious function, so that conscious orientation lacks that element which the inferior function could have supplied. Thus it often happens that people who have an amazing range of consciousness know less about themselves than the veriest infant, and all because “the fourth would not come”—it remained down below—or up above—in the unconscious realm.

[246] As compared with the trinitarian thinking of Plato, ancient Greek philosophy favoured thinking of a quaternary type. In Pythagoras the great role was played not by three but by four; the Pythagorean oath, for instance, says that the tetraktys “contains the roots of eternal nature.”⁵ The Pythagorean school was dominated by the idea that the soul was a square and not a triangle. The origin of these ideas lies far back in the dark prehistory of Greek thought. The quaternity is an archetype of almost universal occurrence. It forms the logical basis for any whole judgment. If one wishes to pass such a judgment, it must have this fourfold aspect. For instance, if you want to describe the horizon as a whole, you name the four quarters of heaven. Three is not a natural coefficient of order, but an artificial one. There are four elements, four prime qualities, four colours, four castes, four ways of spiritual development in Buddhism, etc. So, too, there are four aspects of psychological orientation, beyond which nothing fundamental remains to be said. In order to orient ourselves, we must have a function which ascertains that something is there (sensation); a second function which establishes *what* it is (thinking); a third function which states whether it suits us or not, whether we wish to accept it or not (feeling); and a fourth function which indicates where it came from and where it is going (intuition). When this has been done, there is nothing more to say. Schopenhauer proves that the “Principle of Sufficient Reason” has a fourfold root.⁶ This is so because the fourfold aspect is the minimum requirement for a complete judgment. The ideal of completeness is the circle or sphere, but its natural minimal division is a quaternity.

[247] Now if Plato had had the idea of the Christian Trinity⁷—which of course he did not—and had on that account placed his triad above everything, one would be bound to object that this cannot be a whole judgment. A necessary fourth would be left out; or, if Plato took the three-sided figure as symbolic of the Beautiful and the Good and endowed it with all positive qualities, he would have had to deny evil and imperfection to it. In that case, what has become of them? The Christian answer is that evil is a *privatio boni*. This classic formula robs evil of absolute existence and makes it a shadow that has only a relative existence dependent on light. Good, on the other hand, is credited with a positive substantiality. But, as psychological experience shows, “good” and “evil” are opposite poles of a moral judgment which, as such, originates in man. A judgment can be made about a thing only if its opposite is equally real and possible. The opposite of a seeming evil can only be a seeming good, and an evil that lacks substance can only be contrasted with a good that is equally non-substantial. Although the opposite of “existence” is “non-existence,” the opposite of an existing good can never be a non-existing evil, for the latter is a contradiction in terms and opposes to an existing good something incommensurable with it; the opposite of a non-existing (negative) evil can only be a non-existing (negative) good. If, therefore, evil is said to be a mere privation of good, the

opposition of good and evil is denied outright. How can one speak of “good” at all if there is no “evil”? Or of “light” if there is no “darkness,” or of “above” if there is no “below”? There is no getting round the fact that if you allow substantiality to good, you must also allow it to evil. If evil has no substance, good must remain shadowy, for there is no substantial opponent for it to defend itself against, but only a shadow, a mere privation of good. Such a view can hardly be squared with observed reality. It is difficult to avoid the impression that apotropaic tendencies have had a hand in creating this notion, with the understandable intention of settling the painful problem of evil as optimistically as possible. Often it is just as well that we do not know the danger we escape when we rush in where angels fear to tread.

[248] Christianity also deals with the problem in another way, by asserting that evil has substance and personality as the devil, or Lucifer. There is one view which allows the devil a malicious, goblin-like existence only, thus making him the insignificant head of an insignificant tribe of wood-imps and poltergeists. Another view grants him a more dignified status, depending on the degree to which it identifies him with “ills” in general. How far “ills” may be identified with “evil” is a controversial question. The Church distinguishes between physical ills and moral ills. The former may be willed by divine Providence (e.g., for man’s improvement), the latter not, because sin cannot be willed by God even as a means to an end. It would be difficult to verify the Church’s view in concrete instances, for psychic and somatic disorders are “ills,” and, as illnesses, they are moral as well as physical. At all events there is a view which holds that the devil, though created, is autonomous and eternal. In addition, he is the adversary of Christ: by infecting our first parents with original sin he corrupted creation and made the Incarnation necessary for God’s work of salvation. In so doing he acted according to his own judgment, as in the Job episode, where he was even able to talk God round. The devil’s prowess on these occasions hardly squares with his alleged shadow-existence as the *privatio boni*, which, as we have said, looks very like a euphemism. The devil as an autonomous and eternal personality is much more in keeping with his role as the adversary of Christ and with the psychological reality of evil.

[249] But if the devil has the power to put a spoke in God’s Creation, or even corrupt it, and God does nothing to stop this nefarious activity and leaves it all to man (who is notoriously stupid, unconscious, and easily led astray), then, despite all assurances to the contrary, the evil spirit must be a factor of quite incalculable potency. In this respect, anyhow, the dualism of the Gnostic systems makes sense, because they at least try to do justice to the real meaning of evil. They have also done us the supreme service of having gone very thoroughly into the question of where evil comes from. Biblical tradition leaves us very much in the dark on this point, and it is only too obvious why the old theologians were in no particular hurry to enlighten us. In a

monotheistic religion everything that goes against God can only be traced back to God himself. This thought is objectionable, to say the least of it, and has therefore to be circumvented. That is the deeper reason why a highly influential personage like the devil cannot be accommodated properly in a trinitarian cosmos. It is difficult to make out in what relation he stands to the Trinity. As the adversary of Christ, he would have to take up an equivalent counterposition and be, like him, a “son of God.”⁸ But that would lead straight back to certain Gnostic views according to which the devil, as Satanaël,⁹ is God’s first son, Christ being the second.^{9a} A further logical inference would be the abolition of the Trinity formula and its replacement by a quaternity.

[250] The idea of a quaternity of divine principles was violently attacked by the Church Fathers when an attempt was made to add a fourth—God’s “essence”—to the Three Persons of the Trinity. This resistance to the quaternity is very odd, considering that the central Christian symbol, the Cross, is unmistakably a quaternity. The Cross, however, symbolizes God’s suffering in his immediate encounter with the world.¹⁰ The “prince of this world,” the devil (John 12:31, 14:30), vanquishes the God-man at this point, although by so doing he is presumably preparing his own defeat and digging his own grave. According to an old view, Christ is the “bait on the hook” (the Cross), with which he catches “Leviathan” (the devil).¹¹ It is therefore significant that the Cross, set up midway between heaven and hell as a symbol of Christ’s struggle with the devil, corresponds to the quaternity.

[251] Medieval iconology, embroidering on the old speculations about the Theotokos, evolved a quaternity symbol in its representations of the coronation of the Virgin¹² and surreptitiously put it in place of the Trinity. The Assumption of the Blessed Virgin Mary, i.e., the taking up of Mary’s soul into heaven *with her body*, is admitted as ecclesiastical doctrine but has not yet become dogma.¹³ Although Christ, too, rose up with his body, this has a rather different meaning, since Christ was a divinity in the first place and Mary was not. In her case the body would have been a much more material one than Christ’s, much more an element of space-time reality.¹⁴ Ever since the *Timaeus* the “fourth” has signified “realization,” i.e., entry into an essentially different condition, that of worldly materiality, which, it is authoritatively stated, is ruled by the Prince of this world—for matter is the diametrical opposite of spirit. It is the true abode of the devil, whose hellish hearth-fire burns deep in the interior of the earth, while the shining spirit soars in the aether, freed from the shackles of gravity.

[252] The *Assumptio Mariae* paves the way not only for the divinity of the Theotokos (i.e., her ultimate recognition as a goddess),¹⁵ but also for the quaternity. At the same time, matter is included in the metaphysical realm, together with the corrupting principle of the cosmos, evil. One can explain that matter was originally pure, or at least capable of purity, but this does not do away with the fact that matter represents

the *concreteness* of God's thoughts and is, therefore, the very thing that makes individuation possible, with all its consequences. The adversary is, quite logically, conceived to be the soul of matter, because they both constitute a point of resistance without which the relative autonomy of individual existence would be simply unthinkable. The will to be different and contrary is characteristic of the devil, just as disobedience was the hallmark of original sin. These, as we have said, are the necessary conditions for the Creation and ought, therefore, to be included in the divine plan and—ultimately—in the divine realm.¹⁶ But the Christian definition of God as the *summum bonum* excludes the Evil One right from the start, despite the fact that in the Old Testament he was still one of the “sons of God.” Hence the devil remained outside the Trinity as the “ape of God” and in opposition to it. Medieval representations of the triune God as having three heads are based on the three-headedness of Satan, as we find it, for instance, in Dante. This would point to an infernal Antitrinity, a true “umbra trinitatis” analogous to the Antichrist.¹⁷ The devil is, undoubtedly, an awkward figure: he is the “odd man out” in the Christian cosmos. That is why people would like to minimize his importance by euphemistic ridicule or by ignoring his existence altogether; or, better still, to lay the blame for him at man's door. This is in fact done by the very people who would protest mightily if sinful man should credit himself, equally, with the origin of all good. A glance at the Scriptures, however, is enough to show us the importance of the devil in the divine drama of redemption.¹⁸ If the power of the Evil One had been as feeble as certain persons would wish it to appear, either the world would not have needed God himself to come down to it or it would have lain within the power of man to set the world to rights, which has certainly not happened so far.

[253] Whatever the metaphysical position of the devil may be, in psychological reality evil is an effective, not to say menacing, limitation of goodness, so that it is no exaggeration to assume that in this world good and evil more or less balance each other, like day and night, and that this is the reason why the victory of the good is always a special act of grace.

[254] If we disregard the specifically Persian system of dualism, it appears that no real devil is to be found anywhere in the early period of man's spiritual development. In the Old Testament, he is vaguely foreshadowed in the figure of Satan. But the real devil first appears as the adversary of Christ,¹⁹ and with him we gaze for the first time into the luminous realm of divinity on the one hand and into the abyss of hell on the other. The devil is autonomous; he cannot be brought under God's rule, for if he could he would not have the power to be the adversary of Christ, but would only be God's instrument. Once the indefinable One unfolds into two, it becomes something definite: the man Jesus, the Son and Logos. This statement is possible only by virtue

of something else that is *not* Jesus, not Son or Logos. The act of love embodied in the Son is counterbalanced by Lucifer's denial.

[255] Inasmuch as the devil was an angel created by God and "fell like lightning from heaven," he too is a divine "procession" that became Lord of this world. It is significant that the Gnostics thought of him sometimes as the imperfect demiurge and sometimes as the Saturnine archon, Ialdabaoth. Pictorial representations of this archon correspond in every detail with those of a diabolical demon. He symbolized the power of darkness from which Christ came to rescue humanity. The archons issued from the womb of the unfathomable abyss, i.e., from the same source that produced the Gnostic Christ.

[256] A medieval thinker observed that when God separated the upper waters from the lower on the second day of Creation, he did not say in the evening, as he did on all the other days, that it was good. And he did not say it because on that day he had created the *binarius*, the origin of all evil.²⁰ We come across a similar idea in Persian literature, where the origin of Ahriman is attributed to a *doubting thought* in Ahura-Mazda's mind. If we think in non-trinitarian terms, the logic of the following schema seems inescapable:

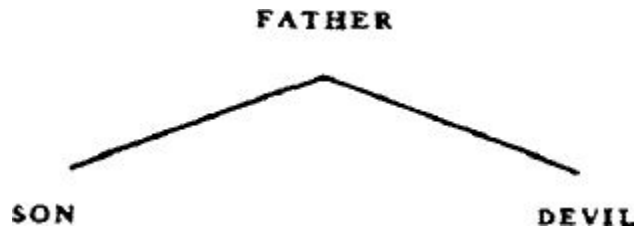

[257] So it is not strange that we should meet the idea of Antichrist so early. It was probably connected on the one hand with the astrological synchronicity of the dawning aeon of Pisces,²¹ and on the other hand with the increasing realization of the duality postulated by the Son, which in turn is prefigured in the fish symbol:)—(, showing two fishes, joined by a commissure, moving in opposite directions.²² It would be absurd to put any kind of causal construction on these events. Rather, it is a question of preconscious, prefigurative connections between the archetypes themselves, suggestions of which can be traced in other constellations as well and above all in the formation of myths.

[258] In our diagram, Christ and the devil appear as equal and opposite, thus conforming to the idea of the "adversary." This opposition means conflict to the last, and it is the task of humanity to endure this conflict until the time or turning-point is reached where good and evil begin to relativize themselves, to doubt themselves, and the cry is raised for a morality "beyond good and evil." In the age of Christianity and in the domain of trinitarian thinking such an idea is simply out of the question, because the conflict is too violent for evil to be assigned any other logical relation to the Trinity than that of an absolute opposite. In an emotional opposition, i.e., in a conflict situation, thesis and antithesis cannot be viewed together at the same time.

This only becomes possible with cooler assessment of the relative value of good and the relative non-value of evil. Then it can no longer be doubted, either, that a common life unites not only the Father and the “light” son, but the Father and his *dark* emanation. The unspeakable conflict posited by duality resolves itself in a fourth principle, which restores the unity of the first in its full development. The rhythm is built up in three steps, but the resultant symbol is a quaternity.

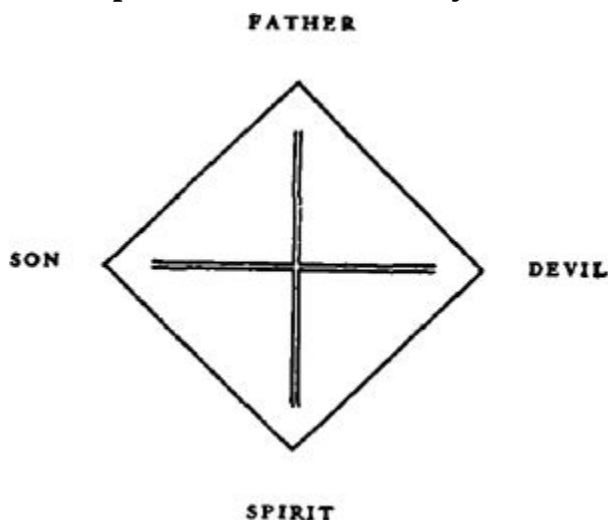

[259] The dual aspect of the Father is by no means unknown to religious speculation.²³

This is proved by the allegory of the monoceros, or unicorn, who symbolizes Yahweh’s angry moodiness. Like this irritable beast, he reduced the world to chaos and could only be moved to love in the lap of a pure virgin.²⁴ Luther was familiar with a *deus absconditus*. Murder, sudden death, war, sickness, crime, and every kind of abomination fall in with the unity of God. If God reveals his nature and takes on definite form as a man, then the opposites in him must fly apart: here good, there evil. So it was that the opposites latent in the Deity flew apart when the Son was begotten and manifested themselves in the struggle between Christ and the devil, with the Persian Ormuzd-Ahriman antithesis, perhaps, as the underlying model. The world of the Son is the world of moral discord, without which human consciousness could hardly have progressed so far as it has towards mental and spiritual differentiation. That we are not unreservedly enthusiastic about this progress is shown by the fits of doubt to which our modern consciousness is subject.

[260] Despite the fact that he is potentially redeemed, the Christian is given over to moral suffering, and in his suffering he needs the Comforter, the Paraclete. He cannot overcome the conflict on his own resources; after all, he didn’t invent it. He has to rely on divine comfort and mediation, that is to say on the spontaneous revelation of the spirit, which does not obey man’s will but comes and goes as *it* wills. This spirit is an autonomous psychic happening, a hush that follows the storm, a reconciling light in the darkneses of man’s mind, secretly bringing order into the chaos of his soul. The Holy Ghost is a comforter like the Father, a mute, eternal, unfathomable One in whom God’s love and God’s terribleness come together in wordless union.

And through this union the original meaning of the still-unconscious Father-world is restored and brought within the scope of human experience and reflection. Looked at from a quaternary standpoint, the Holy Ghost is a reconciliation of opposites and hence the answer to the suffering in the Godhead which Christ personifies.

[261] The Pythagorean quaternity was a natural phenomenon, an archetypal image, but it was not yet a moral problem, let alone a divine drama. Therefore it “went underground.” It was a purely naturalistic, intuitive idea born of the nature-bound mind. The gulf that Christianity opened out between nature and spirit enabled the human mind to think not only beyond nature but in opposition to it, thus demonstrating its divine freedom, so to speak. This flight from the darkness of nature’s depths culminates in trinitarian thinking, which moves in a Platonic, “supracelestial” realm. But the question of the fourth, rightly or wrongly, remained. It stayed down “below,” and from there threw up the heretical notion of the quaternity and the speculations of Hermetic philosophy.

[262] In this connection I would like to call attention to Gerhard Dorn, a physician and alchemist, and a native of Frankfurt. He took great exception to the traditional quaternity of the basic principles of his art, and also to the fourfold nature of its goal, the *lapis philosophorum*. It seemed to him that this was a heresy, since the principle that ruled the world was a Trinity. The quaternity must therefore be of the devil.²⁵ Four, he maintained, was a doubling of two, and two was made on the second day of Creation, but God was obviously not altogether pleased with the result of his handiwork that evening. The *binarius* is the devil of discord and, what is worse, of feminine nature. (In East and West alike even numbers are feminine.) The cause of dissatisfaction was that, on this ominous second day of Creation, just as with Ahura-Mazda, a split was revealed in God’s nature. Out of it crept the “four-horned serpent,” who promptly succeeded in seducing Eve, because she was related to him by reason of her binary nature. (“Man was created by God, woman by the ape of God.”)

[263] The devil is the aping shadow of God, the *ἀντίμιμον πνεῦμα*, in Gnosticism and also in Greek alchemy. He is “Lord of this world,” in whose shadow man was born, fatally tainted with the original sin brought about by the devil. Christ, according to the Gnostic view, cast off the shadow he was born with and remained without sin. His sinlessness proves his essential lack of contamination with the dark world of nature-bound man, who tries in vain to shake off this darkness. (“Uns bleibt ein Erdenrest / zu tragen peinlich.”²⁶) Man’s connection with physis, with the material world and its demands, is the cause of his anomalous position: on the one hand he has the capacity for enlightenment, on the other he is in thrall to the Lord of this world. (“Who will deliver me from the body of this death?”) On account of his sinlessness, Christ on the contrary lives in the Platonic realm of pure ideas whither

only man's thought can reach, but not he himself in his totality. Man is, in truth, the bridge spanning the gulf between "this world"—the realm of the dark Tricephalus—and the heavenly Trinity. That is why, even in the days of unqualified belief in the Trinity, there was always a quest for the lost fourth, from the time of the Neopythagoreans down to Goethe's *Faust*. Although these seekers thought of themselves as Christians, they were really Christians only on the side, devoting their lives to a work whose purpose it was to redeem the "four-horned serpent," the fallen Lucifer, and to free the *anima mundi* imprisoned in matter. What in their view lay hidden in matter was the *lumen luminum*, the *Sapientia Dei*, and their work was a "gift of the Holy Spirit." Our quaternity formula confirms the rightness of their claims; for the Holy Ghost, as the synthesis of the original One which then became split, issues from a source that is both light and dark. "For the powers of the right and the left unite in the harmony of wisdom," we are told in the Acts of John.²⁷

[264] It will have struck the reader that two corresponding elements cross one another in our quaternity schema. On the one hand we have the polaristic identity of Christ and his adversary, and on the other the unity of the Father unfolded in the multiplicity of the Holy Ghost. The resultant cross is the symbol of the suffering Godhead that redeems mankind. This suffering could not have occurred, nor could it have had any effect at all, had it not been for the existence of a power opposed to God, namely "this world" and its Lord. The quaternity schema recognizes the existence of this power as an undeniable fact by fettering trinitarian thinking to the reality of this world. The Platonic freedom of the spirit does not make a whole judgment possible: it wrenches the light half of the picture away from the dark half. This freedom is to a large extent a phenomenon of civilization, the lofty preoccupation of that fortunate Athenian whose lot it was not to be born a slave. We can only rise above nature if somebody else carries the weight of the earth for us. What sort of philosophy would Plato have produced had he been his own house-slave? What would the Rabbi Jesus have taught if he had had to support a wife and children? If he had had to till the soil in which the bread he broke had grown, and weed the vineyard in which the wine he dispensed had ripened? The dark weight of the earth must enter into the picture of the whole. In "this world" there is no good without its bad, no day without its night, no summer without its winter. But civilized man can live without the winter, for he can protect himself against the cold; without dirt, for he can wash; without sin, for he can prudently cut himself off from his fellows and thereby avoid many an occasion for evil. He can deem himself good and pure, because hard necessity does not teach him anything better. The natural man, on the other hand, has a wholeness that astonishes one, though there is nothing particularly admirable about it. It is the same old unconsciousness, apathy, and filth.

[265] If, however, God is born as a man and wants to unite mankind in the fellowship of the Holy Ghost, he must suffer the terrible torture of having to endure the world in all its reality. This is the cross he has to bear, and he himself is a cross. The whole world is God's suffering, and every individual man who wants to get anywhere near his own wholeness knows that this is the way of the cross.

[266] These thoughts are expressed with touching simplicity and beauty in the Negro film *The Green Pastures*.²⁸ For many years God ruled the world with curses, thunder, lightning, and floods, but it never prospered. Finally he realized that he would have to become a man himself in order to get at the root of the trouble.

[267] After he had experienced the world's suffering, this God who became man left behind him a Comforter, the Third Person of the Trinity, who would make his dwelling in many individuals still to come, none of whom would enjoy the privilege or even the possibility of being born without sin. In the Paraclete, therefore, God is closer to the real man and his darkness than he is in the Son. The light God bestrides the bridge—Man—from the day side; God's shadow, from the night side. What will be the outcome of this fearful dilemma, which threatens to shatter the frail human vessel with unknown storms and intoxications? It may well be the revelation of the Holy Ghost out of man himself. Just as man was once revealed out of God, so, when the circle closes, God may be revealed out of man. But since, in this world, an evil is joined to every good, the ἀντίμιμον πνεῦμα will twist the indwelling of the Paraclete into a self-deification of man, thereby causing an inflation of self-importance of which we had a foretaste in the case of Nietzsche. The more unconscious we are of the religious problem in the future, the greater the danger of our putting the divine germ within us to some ridiculous or demoniacal use, puffing ourselves up with it instead of remaining conscious that we are no more than the stable in which the Lord is born. Even on the highest peak we shall never be "beyond good and evil," and the more we experience of their inextricable entanglement the more uncertain and confused will our moral judgment be. In this conflict, it will not help us in the least to throw the moral criterion on the rubbish heap and to set up new tablets after known patterns; for, as in the past, so in the future the wrong we have done, thought, or intended will wreak its vengeance on our souls, no matter whether we turn the world upside down or not. Our knowledge of good and evil has dwindled with our mounting knowledge and experience, and will dwindle still more in the future, without our being able to escape the demands of ethics. In this utmost uncertainty we need the illumination of a holy and whole-making spirit—a spirit that can be anything rather than our reason.

II. THE PSYCHOLOGY OF THE QUATERNITY

[268] As I have shown in the previous chapter, one can think out the problem of the fourth without having to discard a religious terminology. The development of the Trinity into a quaternity can be represented in projection on metaphysical figures, and at the same time the exposition gains in plasticity. But any statements of this kind can—and for scientific reasons, must—be reduced to man and his psychology, since they are mental products which cannot be presumed to have any metaphysical validity. They are, in the first place, projections of psychic processes, and nobody really knows what they are “in themselves,” i.e., if they exist in an unconscious sphere inaccessible to man. At any rate, science ought not to treat them as anything other than projections. If it acts otherwise, it loses its independence. And since it is not a question of individual fantasies but—at least so far as the Trinity is concerned—of a collective phenomenon, we must assume that the development of the idea of the Trinity is a collective process, representing a differentiation of consciousness that has been going on for several thousand years.

[269] In order to interpret the Trinity-symbol psychologically, we have to start with the individual and regard the symbol as an expression of his psyche, rather as if it were a dream-image. It is possible to do this because even collective ideas once sprang from single individuals and, moreover, can only be “had” by individuals. We can treat the Trinity the more easily as a dream in that its life is a drama, as is also the case with every dream that is moderately well developed.

[270] Generally speaking, the father denotes the earlier state of consciousness when one was still a child, still dependent on a definite, ready-made pattern of existence which is habitual and has the character of law. It is a passive, unreflecting condition, a mere awareness of what is given, without intellectual or moral judgment.¹ This is true both individually and collectively.

[271] The picture changes when the accent shifts to the son. On the individual level the change usually sets in when the son starts to put himself in his father’s place. According to the archaic pattern, this takes the form of quasi-father-murder—in other words, violent identification with the father followed by his liquidation. This, however, is not an advance; it is simply a retention of the old habits and customs with no subsequent differentiation of consciousness. No detachment from the father has been effected. Legitimate detachment consists in conscious differentiation from the father and from the habitus represented by him. This requires a certain amount of knowledge of one’s own individuality, which cannot be acquired without moral discrimination and cannot be held on to unless one has understood its meaning.² Habit can only be replaced by a mode of life consciously chosen and acquired. The Christianity symbolized by the “Son” therefore forces the individual to discriminate and to reflect, as was noticeably the case with those Church Fathers³ who laid such emphasis on *ἐπιστήμη* (knowledge) as opposed to *ἀνάγκη* (necessity) and *ἄγνοια*

(ignorance). The same tendency is apparent in the New Testament controversies over the Jews' righteousness in the eyes of the law, which stands exclusively for the old habitus.

[272] The third step, finally, points beyond the "Son" into the future, to a continuing realization of the "spirit," i.e., a living activity proceeding from "Father" and "Son" which raises the subsequent stages of consciousness to the same level of independence as that of "Father" and "Son." This extension of the *filiatio*, whereby men are made children of God, is a metaphysical projection of the psychic change that has taken place. The "Son" represents a transition stage, an intermediate state, part child, part adult. He is a transitory phenomenon, and it is thanks to this fact that the "Son"-gods die an early death. "Son" means the transition from a permanent initial stage called "Father" and "auctor rerum" to the stage of being a father oneself. And this means that the son will transmit to his children the procreative spirit of life which he himself has received and from which he himself was begotten. Brought down to the level of the individual, this symbolism can be interpreted as follows: the state of unreflecting awareness known as "Father" changes into the reflective and rational state of consciousness known as "Son." This state is not only in opposition to the still-existing earlier state, but, by virtue of its conscious and rational nature, it also contains many latent possibilities of dissociation. Increased discrimination begets conflicts that were unconscious before but must now be faced, because, unless they are clearly recognized, no moral decisions can be taken. The stage of the "Son" is therefore a conflict situation *par excellence*: the choice of possible ways is menaced by just as many possibilities of error. "Freedom from the law" brings a sharpening of opposites, in particular of the moral opposites. Christ crucified between two thieves is an eloquent symbol of this fact. The exemplary life of Christ is in itself a "transitus" and amounts therefore to a bridge leading over to the third stage, where the initial stage of the Father is, as it were, recovered. If it were no more than a repetition of the first stage, everything that had been won in the second stage—reason and reflection—would be lost, only to make room for a renewed state of semiconsciousness, of an irrational and unreflecting nature. To avoid this, the values of the second stage must be held fast; in other words, reason and reflection must be preserved intact. Though the new level of consciousness acquired through the emancipation of the son continues in the third stage, it must recognize that *it* is not the source of the ultimate decisions and flashes of insight which rightly go by the name of "gnosis," but that these are inspired by a higher authority which, in projected form, is known as the "Holy Ghost." Psychologically speaking, "inspiration" comes from an unconscious function. To the naïve-minded person the agent of inspiration appears as an "intelligence" correlated with, or even superior to, consciousness, for it often happens that an idea drops in on one like a saving *deus ex machina*.

[273] Accordingly, the advance to the third stage means something like a recognition of the unconscious, if not actual subordination to it.⁴ Adulthood is reached when the son reproduces his own childhood state by voluntarily submitting to a paternal authority, either in psychological form, or factually in projected form, as when he recognizes the authority of the Church's teachings. This authority can, of course, be replaced by all manner of substitutes, which only proves that the transition to the third stage is attended by unusual spiritual dangers, consisting chiefly in rationalistic deviations that run counter to the instincts.⁵ Spiritual transformation does not mean that one should remain a child, but that the adult should summon up enough honest self-criticism admixed with humility to see where, and in relation to what, he must behave as a child—irrationally, and with unreflecting receptivity. Just as the transition from the first stage to the second demands the sacrifice of childish dependence, so, at the transition to the third stage, an exclusive independence has to be relinquished.

[274] It is clear that these changes are not everyday occurrences, but are very fateful transformations indeed. Usually they have a numinous character, and can take the form of conversions, illuminations, emotional shocks, blows of fate, religious or mystical experiences, or their equivalents. Modern man has such hopelessly muddled ideas about anything "mystical," or else such a rationalistic fear of it, that, if ever a mystical experience should befall him, he is sure to misunderstand its true character and will deny or repress its numinosity. It will then be evaluated as an inexplicable, irrational, and even pathological phenomenon. This sort of misinterpretation is always due to lack of insight and inadequate understanding of the complex relationships in the background, which as a rule can only be clarified when the conscious data are supplemented by material derived from the unconscious. Without this, too many gaps remain unfilled in a man's experience of life, and each gap is an opportunity for futile rationalizations. If there is even the slightest tendency to neurotic dissociation, or an indolence verging upon habitual unconsciousness, then false causalities will be preferred to truth every time.

[275] The numinous character of these experiences is proved by the fact that they are *overwhelming*—an admission that goes against not only our pride, but against our deep-rooted fear that consciousness may perhaps lose its ascendancy, for pride is often only a reaction covering up a secret fear. How thin these protective walls are can be seen from the positively terrifying suggestibility that lies behind all psychic mass movements, beginning with the simple folk who call themselves "Jehovah's Witnesses," the "Oxford Groups" (so named for reasons of prestige⁶) among the upper classes, and ending with the National Socialism of a whole nation—all in search of the unifying mystical experience!

[276] Anyone who does not understand the events that befall him is always in danger of getting stuck in the transitional stage of the Son. The criterion of adulthood does not

consist in being a member of certain sects, groups, or nations, but in submitting to the spirit of one's own independence. Just as the "Son" proceeds from the "Father," so the "Father" proceeds from the stage of the "Son," yet this Father is not a mere repetition of the original Father or an identification with him, but one in whom the vitality of the "Father" continues its procreative work. This third stage, as we have seen, means articulating one's ego-consciousness with a supraordinate totality, of which one cannot say that it is "I," but which is best visualized as a more comprehensive being, though one should of course keep oneself conscious all the time of the anthropomorphism of such a conception. Hard as it is to define, this unknown quantity can be experienced by the psyche and is known in Christian parlance as the "Holy Ghost," the breath that heals and makes whole. Christianity claims that this breath also has personality, which in the circumstances could hardly be otherwise. For close on two thousand years history has been familiar with the figure of the Cosmic Man, the Anthropos, whose image has merged with that of Yahweh and also of Christ. Similarly, the saints who received the stigmata became Christ-figures in a visible and concrete sense, and thus carriers of the Anthropos-image. They symbolize the working of the Holy Ghost among men. The Anthropos is a symbol that argues in favour of the personal nature of the "totality," i.e., the self. If, however, you review the numerous symbols of the self, you will discover not a few among them that have no characteristics of human personality at all. I won't back up this statement with psychological case histories, which are *terra incognita* to the layman anyway, but will only refer to the historical material, which fully confirms the findings of modern scientific research. Alchemical symbolism has produced, aside from the personal figures, a whole series of non-human forms, geometrical configurations like the sphere, circle, square, and octagon, or chemical symbols like the Philosophers' Stone, the ruby, diamond, quicksilver, gold, water, fire, and spirit (in the sense of a volatile substance). This choice of symbols tallies more or less with the modern products of the unconscious.⁷ I might mention in this connection that there are numerous theriomorphic spirit symbols, the most important Christian ones being the lamb, the dove, and the snake (Satan). The snake symbolizing the Gnostic Nous and the Agathodaimon has a pneumatic significance (the devil, too, is a spirit). These symbols express the non-human character of the totality or self, as was reported long ago when, at Pentecost, the spirit descended on the disciples in tongues of fire. From this point of view we can share something of Origen's perplexity as to the nature of the Holy Ghost. It also explains why the Third Person of the Trinity, unlike Father and Son, has no personal quality.⁸ "Spirit" is not a personal designation but the qualitative definition of a substance of aeriform nature.

[277] Whenever, as in the present instance, the unconscious makes such sweepingly contradictory statements, experience tells us that the situation is far from simple. The

unconscious is trying to express certain facts for which there are no conceptual categories in the conscious mind. The contents in question need not be “metaphysical,” as in the case of the Holy Ghost. Any content that transcends consciousness, and for which the apperceptive apparatus does not exist, can call forth the same kind of paradoxical or antinomial symbolism. For a naïve consciousness that sees everything in terms of black and white, even the unavoidable dual aspect of “man and his shadow” can be transcendent in this sense and will consequently evoke paradoxical symbols. We shall hardly be wrong, therefore, if we conjecture that the striking contradictions we find in our spirit symbolism are proof that the Holy Ghost is a *complexio oppositorum* (union of opposites). Consciousness certainly possesses no conceptual category for anything of this kind, for such a union is simply inconceivable except as a violent collision in which the two sides cancel each other out. This would mean their mutual annihilation.

[278] But the spontaneous symbolism of the *complexio oppositorum* points to the exact opposite of annihilation, since it ascribes to the product of their union either everlasting duration, that is to say incorruptibility and adamant stability, or supreme and inexhaustible efficacy.⁹

[279] Thus the spirit as a *complexio oppositorum* has the same formula as the “Father,” the *auctor rerum*, who is also, according to Nicholas of Cusa, a union of opposites.¹⁰ The “Father,” in fact, contains the opposite qualities which appear in his son and his son’s adversary. Riwkah Schärf¹¹ has shown just how far the monotheism of the Old Testament was obliged to make concessions to the idea of the “relativity” of God. The Book of Job comes within a hair’s breadth of the dualism which flowered in Persia for some centuries before and after Christ, and which also gave rise to various heretical movements within Christianity itself. It was only to be expected, therefore, that, as we said above, the dual aspect of the “Father” should reappear in the Holy Ghost, who in this way effects an apocatastasis of the Father. To use an analogy from physics, the Holy Ghost could be likened to the stream of photons arising out of the destruction of matter, while the “Father” would be the primordial energy that promotes the formation of protons and electrons with their positive and negative charges. This, as the reader will understand, is not an explanation, but an analogy which is possible because the physicist’s models ultimately rest on the same archetypal foundations that also underlie the speculations of the theologian. Both are psychology, and it too has no other foundation.

III. GENERAL REMARKS ON SYMBOLISM

[280] Although it is extremely improbable that the Christian Trinity is derived directly from the triadic World-Soul in the *Timaeus*, it is nevertheless rooted in the same archetype. If we wish to describe the phenomenology of this archetype, we shall have

to consider all the aspects which go to make up the total picture. For instance, in our analysis of the *Timaeus*, we found that the number three represents an intellectual schema only, and that the second mixture reveals the resistance of the “recalcitrant fourth” ingredient, which we meet again as the “adversary” of the Christian Trinity. Without the fourth the three have no reality as we understand it; they even lack meaning, for a ‘thought’ has meaning only if it refers to a possible or actual reality. This relationship to reality is completely lacking in the idea of the Trinity, so much so that people nowadays tend to lose sight of it altogether, without even noticing the loss. But we can see what this loss means when we are faced with the problem of reconstruction—that is to say in all those cases where the conscious part of the psyche is cut off from the unconscious part by a dissociation. This split can only be mended if consciousness is able to formulate conceptions which give adequate expression to the contents of the unconscious. It seems as if the Trinity plus the incommensurable “fourth” were a conception of this kind. As part of the doctrine of salvation it must, indeed, have a saving, healing, wholesome effect. During the process of integrating the unconscious contents into consciousness, undoubted importance attaches to the business of seeing how the dream-symbols relate to trivial everyday realities. But, in a deeper sense and on a long-term view, this procedure is not sufficient, as it fails to bring out the significance of the archetypal contents. These reach down, or up, to quite other levels than so-called common sense would suspect. As *a priori* conditions of all psychic events, they are endued with a dignity which has found immemorial expression in godlike figures. No other formulation will satisfy the needs of the unconscious. The unconscious is the unwritten history of mankind from time unrecorded. Rational formulae may satisfy the present and the immediate past, but not the experience of mankind as a whole. This calls for the all-embracing vision of the myth, as expressed in symbols. If the symbol is lacking, man’s wholeness is not represented in consciousness. He remains a more or less accidental fragment, a suggestible wisp of consciousness, at the mercy of all the utopian fantasies that rush in to fill the gap left by the totality symbols. A symbol cannot be made to order as the rationalist would like to believe. It is a legitimate symbol only if it gives expression to the immutable structure of the unconscious and can therefore command general acceptance. So long as it evokes belief spontaneously, it does not require to be understood in any other way. But if, from sheer lack of understanding, belief in it begins to wane then, for better or worse, one must use understanding as a tool if the incalculable consequences of a loss are to be avoided. What should we then put in place of the symbol? Is there anybody who knows a better way of expressing something that has never yet been understood?

[281] As I have shown in *Psychology and Alchemy* and elsewhere, trinity and quaternity symbols occur fairly frequently in dreams, and from this I have learnt that

the idea of the Trinity is based on something that can be experienced and must, therefore, have a meaning. This insight was not won by a study of the traditional sources. If I have succeeded in forming an intelligible conception of the Trinity that is in any way based on empirical reality, I have been helped by dreams, folklore, and the myths in which these number motifs occur. As a rule they appear spontaneously in dreams, and such dreams look very banal from the outside. There is nothing at all of the myth or fairytale about them, much less anything religious. Mostly it is three men and a woman, either sitting at a table or driving in a car, or three men and a dog, a huntsman with three hounds, three chickens in a coop from which the fourth has escaped, and suchlike. These things are indeed so banal that one is apt to overlook them. Nor do they wish to say anything more specific, at first, than that they refer to functions and aspects of the dreamer's personality, as can easily be ascertained when they appear as three or four known persons with well-marked characteristics, or as the four principal colours, red, blue, green, and yellow. It happens with some regularity that these colours are correlated with the four orienting functions of consciousness. Only when the dreamer begins to reflect that the four are an allusion to his total personality does he realize that these banal dream-motifs are like shadow pictures of more important things. The fourth figure is, as a rule, particularly instructive: it soon becomes incompatible, disagreeable, frightening, or in some way odd, with a different sense of good and bad, rather like a Tom Thumb beside his three normal brothers. Naturally the situation can be reversed, with three odd figures and one normal one. Anybody with a little knowledge of fairytales will know that the seemingly enormous gulf that separates the Trinity from these trivial happenings is by no means unbridgeable. But this is not to say that the Trinity can be reduced to this level. On the contrary, the Trinity represents the most perfect form of the archetype in question. The empirical material merely shows, in the smallest and most insignificant psychic detail, how the archetype works. This is what makes the archetype so important, firstly as an organizing schema and a criterion for judging the quality of an individual psychic structure, and secondly as a vehicle of the synthesis in which the individuation process culminates. This goal is symbolized by the putting together of the four; hence the quaternity is a symbol of the self, which is of central importance in Indian philosophy and takes the place of the Deity. In the West, any amount of quaternities were developed during the Middle Ages; here I would mention only the *Rex gloriae* with the four symbols of the evangelists (three theriomorphic, one anthropomorphic). In Gnosticism there is the figure of Barbelo ("God is four"). These examples and many others like them bring the quaternity into closest relationship with the Deity, so that, as I said earlier, it is impossible to distinguish the self from a God-image. At any rate, I personally have found it impossible to discover a criterion of distinction. Here faith or philosophy alone can decide, neither of which has anything to do with the empiricism of the scientist.

[282] One can, then, explain the God-image aspect of the quaternity as a reflection of the self, or, conversely, explain the self as an *imago Dei* in man. Both propositions are psychologically true, since the self, which can only be perceived subjectively as a most intimate and unique thing, requires universality as a background, for without this it could not manifest itself in its absolute separateness. Strictly speaking, the self must be regarded as the extreme opposite of God. Nevertheless we must say with Angelus Silesius: “He cannot live without me, nor I without him.” So although the empirical symbol requires two diametrically opposite interpretations, neither of them can be proved valid. The symbol means both and is therefore a paradox. This is not the place to say anything more about the role these number symbols play in practice; for this I must refer the reader to the dream material in *Psychology and Alchemy*, Part II.

*

[283] In view of the special importance of quaternity symbolism one is driven to ask how it came about that a highly differentiated form of religion like Christianity reverted to the archaic triad in order to construct its trinitarian God-image.¹ With equal justification one could also ask (as has, in fact, been done) with what right Christ is presumed to be a symbol of the self, since the self is by definition a *complexio oppositorum*, whereas the Christ figure wholly lacks a dark side? (In dogma, Christ is *sine macula peccati*—‘unspotted by sin.’)

[284] Both questions touch on the same problem. I always seek the answer to such questions on empirical territory, for which reason I must now cite the concrete facts. It is a general rule that most geometrical or numerical symbols have a quaternary character. There are also ternary or trinitarian symbols, but in my experience they are rather rare. On investigating such cases carefully, I have found that they were distinguished by something that can only be called a “medieval psychology.” This does not imply any backwardness and is not meant as a value judgment, but only as denoting a special problem. That is to say, in all these cases there is so much unconsciousness, and such a large degree of primitivity to match it, that a spiritualization appears necessary as a compensation. The saving symbol is then a triad in which the fourth is lacking because it has to be unconditionally rejected.

[285] In my experience it is of considerable practical importance that the symbols aiming at wholeness should be correctly understood by the doctor. They are the remedy with whose help neurotic dissociations can be repaired, by restoring to the conscious mind a spirit and an attitude which from time immemorial have been felt as solving and healing in their effects. They are “représentations collectives” which facilitate the much-needed union of conscious and unconscious. This union cannot be accomplished either intellectually or in a purely practical sense, because in the

former case the instincts rebel and in the latter case reason and morality. Every dissociation that falls within the category of the psychogenic neuroses is due to a conflict of this kind, and the conflict can only be resolved through the symbol. For this purpose the dreams produce symbols which in the last analysis coincide with those recorded throughout history. But the dream-images can be taken up into the dreamer's consciousness, and grasped by his reason and feeling, only if his conscious mind possesses the intellectual categories and moral feelings necessary for their assimilation. And this is where the psychotherapist often has to perform feats that tax his patience to the utmost. The synthesis of conscious and unconscious can only be implemented by a conscious confrontation with the latter, and this is not possible unless one understands what the unconscious is saying. During this process we come upon the symbols investigated in the present study, and in coming to terms with them we re-establish the lost connection with ideas and feelings which make a synthesis of the personality possible. The loss of gnosis, i.e., knowledge of the ultimate things, weighs much more heavily than is generally admitted. Faith alone would suffice too, did it not happen to be a charisma whose true possession is something of a rarity, except in spasmodic form. Were it otherwise, we doctors could spare ourselves much thankless work. Theology regards our efforts in this respect with mistrustful mien, while pointedly declining to tackle this very necessary task itself. It proclaims doctrines which nobody understands, and demands a faith which nobody can manufacture. This is how things stand in the Protestant camp. The situation in the Catholic camp is more subtle. Of especial importance here is the ritual with its sacral action, which dramatizes the living occurrence of archetypal meaning and thus makes a direct impact on the unconscious. Can any one, for instance, deny the impression made upon him by the sacrament of the Mass, if he has followed it with even a minimum of understanding? Then again, the Catholic Church has the institution of confession and the director of conscience, which are of the greatest practical value when these activities devolve upon suitable persons. The fact that this is not always so proves, unfortunately, to be an equally great disadvantage. Thirdly, the Catholic Church possesses a richly developed and undamaged world of dogmatic ideas, which provide a worthy receptacle for the plethora of figures in the unconscious and in this way give visible expression to certain vitally important truths with which the conscious mind should keep in touch. The faith of a Catholic is not better or stronger than the faith of a Protestant, but a person's unconscious is gripped by the Catholic form no matter how weak his faith may be. That is why, once he slips out of this form, he may easily fall into a fanatical atheism, of a kind that is particularly to be met with in Latin countries.

6. CONCLUSION

[286] Because of its noetic character, the Trinity expresses the need for a spiritual development that demands independence of thought. Historically we can see this striving at work above all in scholastic philosophy, and it was these preliminary exercises that made the scientific thinking of modern man possible. Also, the Trinity is an archetype whose dominating power not only fosters spiritual development but may, on occasion, actually enforce it. But as soon as the spiritualization of the mind threatens to become so one-sided as to be deleterious to health, the compensatory significance of the Trinity necessarily recedes into the background. Good does not become better by being exaggerated, but worse, and a small evil becomes a big one through being disregarded and repressed. The shadow is very much a part of human nature, and it is only at night that no shadows exist.

[287] As a psychological symbol the Trinity denotes, first, the homoousia or essential unity of a three-part process, to be thought of as a process of unconscious maturation taking place within the individual. To that extent the three Persons are personifications of the three phases of a regular, instinctive psychic occurrence that always tends to express itself in the form of mythologems and ritualistic customs (for instance, the initiations at puberty, and the various rites for birth, marriage, sickness, war, and death). As the medical lore of the ancient Egyptians shows, myths as well as rites have a psychotherapeutic value, and they still have today.

[288] Second, the Trinity denotes a process of conscious realization continuing over the centuries.

[289] Third, the Trinity lays claim not only to *represent* a personification of psychic processes in three roles, but to *be* the one God in three Persons, who all share the same divine nature. In God there is no advance from the potential to the actual, from the possible to the real, because God is pure reality, the “actus purus” itself. The three Persons differ from one another by reason of the different manner of their origin, or their procession (the Son begotten by the Father and the Holy Ghost proceeding from both—*procedit a patre filioque*). The homoousia, whose general recognition was the cause of so many controversies, is absolutely necessary from a psychological standpoint, because, regarded as a psychological symbol, the Trinity represents the progressive transformation of one and the same substance, namely the psyche as a whole. The homoousia together with the *filioque* assert that Christ and the Holy Ghost are both of the same substance as the Father. But since, psychologically, Christ

must be understood as a symbol of the self, and the descent of the Holy Ghost as the self's actualization in man, it follows that the self must represent something that is of the substance of the Father too. This formulation is in agreement with the psychological statement that the symbols of the self cannot be distinguished empirically from a God-image. Psychology, certainly, can do no more than establish the fact that they *are* indistinguishable. This makes it all the more remarkable that the “metaphysical” statement should go so much further than the psychological one. Indistinguishability is a negative constatation merely; it does not rule out the possibility that a distinction may exist. It may be that the distinction is simply not perceived. The dogmatic assertion, on the other hand, speaks of the Holy Ghost making us “children of God,” and this filial relationship is indistinguishable in meaning from the *υιότης* (sonship) or *filiatio* of Christ. We can see from this how important it was that the homoousia should triumph over the homoiousia (*similarity* of substance); for, through the descent of the Holy Ghost, the self of man enters into a relationship of unity with the substance of God. As ecclesiastical history shows, this conclusion is of immense danger to the Church—it was, indeed, the main reason why the Church did not insist on any further elaboration of the doctrine of the Holy Ghost. Its continued development would lead, on a negative estimate, to explosive schisms, and on a positive estimate straight into psychology. Moreover, the gifts of the Holy Ghost are somewhat mixed: not all of them are unreservedly welcome, as St. Paul has already pointed out. Also, St. Thomas Aquinas observes that revelation is a gift of the spirit that does not stand in any clearly definable relationship to moral endowment.¹ The Church must reserve the right to decide what is a working of the Holy Ghost and what is not, thereby taking an exceedingly important and possibly disagreeable decision right out of the layman's hands. That the spirit, like the wind, “bloweth where it listeth” is something that alarmed even the Reformers. The third as well as the first Person of the Trinity can wear the aspect of a *deus absconditus*, and its action, like that of fire, may be no less destructive than beneficial when regarded from a purely human standpoint.

[290] “Creation” in the sense of “matter” is not included in the Trinity formula, at any rate not explicitly. In these circumstances there are only two possibilities: either the material world is real, in which case it is an intrinsic part of the divine “actus purus,” or it is unreal, a mere illusion, because outside the divine reality. The latter conclusion is contradicted firstly by God's incarnation and by his whole work of salvation, secondly by the autonomy and eternity of the “Prince of this world,” the devil, who has merely been “overcome” but is by no means destroyed—and cannot be destroyed because he is eternal. But if the reality of the created world is included in the “actus purus,” then the devil is there too—Q.E.D. This situation gives rise to a quaternity, albeit a very different quaternity from the one anathematized by the fourth

Lateran Council. The question there debated was whether God's essence could claim a place alongside the three Persons or not. But the question we are confronted with here is the independent position of a creature endowed with autonomy and eternity: the fallen angel. He is the fourth, "recalcitrant" figure in our symbolical series, the intervals between which correspond to the three phases of the trinitarian process. Just as, in the *Timaeus*, the adversary is the second half of the second pair of opposites, without whom the world-soul would not be whole and complete, so, too, the devil must be added to the *trias* as τὸ ἐν τέταρτον (the One as the Fourth),² in order to make it a totality. If the Trinity is understood as a *process*, as I have tried to do all along, then, by the addition of the Fourth, this process would culminate in a condition of absolute totality. Through the intervention of the Holy Ghost, however, man is included in the divine process, and this means that the principle of separateness and autonomy over against God—which is personified in Lucifer as the God-opposing will—is included in it too. But for this will there would have been no creation and no work of salvation either. The shadow and the opposing will are the necessary conditions for all actualization. An object that has no will of its own, capable, if need be, of opposing its creator, and with no qualities other than its creator's, such an object has no independent existence and is incapable of ethical decision. At best it is just a piece of clockwork which the Creator has to wind up to make it function. Therefore Lucifer was perhaps the one who best understood the divine will struggling to create a world and who carried out that will most faithfully. For, by rebelling against God, he became the active principle of a creation which opposed to God a counter-will of its own. Because God willed this, we are told in Genesis 3 that he gave man the power to will otherwise. Had he not done so, he would have created nothing but a machine, and then the incarnation and the redemption would never have come about. Nor would there have been any revelation of the Trinity, because everything would have remained One for ever.

[291] The Lucifer legend is in no sense an absurd fairytale; like the story of the serpent in the Garden of Eden, it is a "therapeutic" myth. We naturally boggle at the thought that good and evil are both contained in God, and we think God could not possibly want such a thing. We should be careful, though, not to pare down God's omnipotence to the level of our human opinions; but that is just how we do think, despite everything. Even so, it would not do to impute all evil to God: thanks to his moral autonomy, man can put down a sizable portion of it to his own account. Evil is a relative thing, partly avoidable, partly fate—just as virtue is, and often one does not know which is worse. Think of the fate of a woman married to a recognized saint! What sins must not the children commit in order to feel their lives their own under the overwhelming influence of such a father! Life, being an energetic process, needs the opposites, for without opposition there is, as we know, no energy. Good and evil

are simply the moral aspects of this natural polarity. The fact that we have to feel this polarity so excruciatingly makes human existence all the more complicated. Yet the suffering that necessarily attaches to life cannot be evaded. The tension of opposites that makes energy possible is a universal law, fittingly expressed in the *yang* and *yin* of Chinese philosophy. Good and evil are feeling-values of human provenance, and we cannot extend them beyond the human realm. What happens beyond this is beyond our judgment: God is not to be caught with human attributes. Besides, where would the *fear* of God be if only good—i.e., what seems good to us—were to be expected from him? After all, eternal damnation doesn't bear much resemblance to goodness as we understand it! Although good and evil are unshakable as moral values, they still need to be subjected to a bit of psychological revision. Much, that is to say, that proves to be abysmally evil in its ultimate effects does not come from man's wickedness but from his stupidity and unconsciousness. One has only to think of the devastating effects of Prohibition in America or of the hundred thousand autos-da-fé in Spain, which were all caused by a praiseworthy zeal to save people's souls. One of the toughest roots of all evil is unconsciousness, and I could wish that the saying of Jesus, "Man, if thou knowest what thou doest, thou art blessed, but if thou knowest not, thou art accursed, and a transgressor of the law,"³ were still in the gospels, even though it has only one authentic source. It might well be the motto for a new morality.

[292] The individuation process is invariably started off by the patient's becoming conscious of the shadow, a personality component usually with a negative sign. This "inferior" personality is made up of everything that will not fit in with, and adapt to, the laws and regulations of conscious life. It is compounded of "disobedience" and is therefore rejected not on moral grounds only, but also for reasons of expediency. Closer investigation shows that there is at least one function in it which ought to collaborate in orienting consciousness. Or rather, this function does collaborate, not for the benefit of conscious, purposive intentions, but in the interests of unconscious tendencies pursuing a different goal. It is this fourth, "inferior" function which acts autonomously towards consciousness and cannot be harnessed to the latter's intentions. It lurks behind every neurotic dissociation and can only be annexed to consciousness if the corresponding unconscious contents are made conscious at the same time. But this integration cannot take place and be put to a useful purpose unless one can admit the tendencies bound up with the shadow and allow them some measure of realization—tempered, of course, with the necessary criticism. This leads to disobedience and self-disgust, but also to self-reliance, without which individuation is unthinkable. The ability to "will otherwise" must, unfortunately, be real if ethics are to make any sense at all. Anyone who submits to the law from the start, or to what is generally expected, acts like the man in the parable who buried his

talent in the earth. Individuation is an exceedingly difficult task: it always involves a conflict of duties, whose solution requires us to understand that our “counter-will” is also an aspect of God’s will. One cannot individuate with mere words and convenient self-deceptions, because there are too many destructive possibilities in the offing. One almost unavoidable danger is that of getting stuck in the conflict and hence in the neurotic dissociation. Here the therapeutic myth has a helpful and loosening effect, even when the patient shows not a trace of conscious understanding. The felt presence of the archetype is enough; it only fails to work when the possibility of conscious understanding is there, within the patient’s reach. In those circumstances it is positively deleterious for him to remain unconscious, though this happens frequently enough in our Christian civilization today. So much of what Christian symbolism taught has gone by the board for large numbers of people, without their ever having understood what they have lost. Civilization does not consist in progress as such and in mindless destruction of the old values, but in developing and refining the good that has been won.

[293] Religion is a “revealed” way of salvation. Its ideas are products of a pre-conscious knowledge which, always and everywhere, expresses itself in symbols. Even if our intellect does not grasp them, they still work, because our unconscious acknowledges them as exponents of universal psychic facts. For this reason faith is enough—if it is there. Every extension and intensification of rational consciousness, however, leads us further away from the sources of the symbols and, by its ascendancy, prevents us from understanding them. That is the situation today. One cannot turn the clock back and force oneself to believe “what one knows is not true.” But one could give a little thought to what the symbols really mean. In this way not only would the incomparable treasures of our civilization be conserved, but we should also gain new access to the old truths which have vanished from our “rational” purview because of the strangeness of their symbolism. How can a man be God’s Son and be born of a virgin? That is a slap in the face of reason. But did not Justin Martyr point out to his contemporaries that exactly the same thing was said of their heroes, *and* get himself listened to? That was because man’s consciousness in those days did not find the symbols as outlandish as they are for us. Today such dogmas fall on deaf ears, because nothing in our known world responds to such assertions. But if we understand these things for what they are, as symbols, then we can only marvel at the unfathomable wisdom that is in them and be grateful to the institution which has not only conserved them, but developed them dogmatically. The man of today lacks the very understanding that would help him to believe.

[294] If I have ventured to submit old dogmas, now grown stale, to psychological scrutiny, I have certainly not done so in the priggish conceit that I knew better than others, but in the sincere conviction that a dogma which has been such a bone of

contention for so many centuries cannot possibly be an empty fantasy. I felt it was too much in line with the *consensus omnium*, with the archetype, for that. It was only when I realized this that I was able to establish any relationship with the dogma at all. As a metaphysical “truth” it remained wholly inaccessible to me, and I suspect that I am by no means the only one to find himself in that position. A knowledge of the universal archetypal background was, in itself, sufficient to give me the courage to treat “that which is believed always, everywhere, by everybody” as a *psychological fact* which extends far beyond the confines of Christianity, and to approach it as an object of scientific study, as a *phenomenon* pure and simple, regardless of the “metaphysical” significance that may have been attached to it. I know from my own experience that this latter aspect has never contributed in the slightest to my belief or to my understanding. It told me absolutely nothing. However, I was forced to admit that the “symbolum” possesses the highest degree of actuality inasmuch as it was regarded by countless millions of people, for close on two thousand years, as a valid statement concerning those things which one cannot see with the eyes or touch with the hands. It is this fact that needs to be understood, for of “metaphysical truth” we know only that part which man has made, unless the unbiddable gift of faith lifts us beyond all dubiety and all uneasy investigation. It is dangerous if these matters are only objects of belief;⁴ for where there is belief there is doubt, and the fiercer and naïver the belief the more devastating the doubt once it begins to dawn. One is then infinitely cleverer than all the benighted heads of the Middle Ages.

[295] These considerations have made me extremely cautious in my approach to the further metaphysical significance that may possibly underlie archetypal statements. There is nothing to stop their ultimate ramifications from penetrating to the very ground of the universe. We alone are the dumb ones if we fail to notice it. Such being the case, I cannot pretend to myself that the object of archetypal statements has been explained and disposed of merely by our investigation of its psychological aspects. What I have put forward can only be, at best, a more or less successful or unsuccessful attempt to give the inquiring mind some access to one side of the problem—the side that can be approached. It would be presumptuous to expect more than this. If I have merely succeeded in stimulating discussion, then my purpose is more than fulfilled. For it seems to me that the world, if it should lose sight of these archetypal statements, would be threatened with unspeakable impoverishment of mind and soul.

III

TRANSFORMATION SYMBOLISM IN THE MASS

[First published as a lecture in *Eranos Jahrbuch 1940/41*; later published in revised and expanded form in *Von den Wurzeln des Bewusstseins* (Zurich, 1954). The present translation is made from the 1954 version. It was published in slightly different form in *The Mysteries* (Papers from the Eranos Yearbooks, 2; New York, 1955; London, 1956).
—EDITORS.]

1. INTRODUCTION¹

[296] The Mass is a still-living mystery, the origins of which go back to early Christian times. It is hardly necessary to point out that it owes its vitality partly to its undoubted psychological efficacy, and that it is therefore a fit subject for psychological study. But it should be equally obvious that psychology can only approach the subject from the phenomenological angle, for the realities of faith lie outside the realm of psychology.

[297] My exposition falls into four parts: in this introduction I indicate some of the New Testament sources of the Mass, with notes on its structure and significance. In section 2, I recapitulate the sequence of events in the rite. In 3, I cite a parallel from pagan antiquity to the Christian symbolism of sacrifice and transformation: the visions of Zosimos. Finally, in 4, I attempt a psychological discussion of the sacrifice and transformation.

*

[298] The oldest account of the sacrament of the Mass is to be found in I Corinthians 11:23ff.:

For the tradition which I have received of the Lord and handed down to you is that the Lord Jesus, on the night he was betrayed, took bread, gave thanks, broke it, and said: *This is my body for you; do this in remembrance of me. And after he had supped, he took the chalice also, and said: This chalice is the new testament in my blood. As often as you drink, do this in remembrance of me. For as often as you eat this bread and drink the chalice, you declare the death of the Lord, until he comes.*²

[299] Similar accounts are to be found in Matthew, Mark, and Luke. In John the corresponding passage speaks of a “supper,”³ but there it is connected with the washing of the disciples’ feet. At this supper Christ utters the words which characterize the meaning and substance of the Mass (John 15:1,4, 5). “I am the true vine.” “Abide in me, and I in you.” “I am the vine, ye are the branches.” The correspondence between the liturgical accounts points to a traditional source outside the Bible. There is no evidence of an actual feast of the Eucharist until after A.D. 150.

[300] The Mass is a Eucharistic feast with an elaborately developed liturgy. It has the following structure:

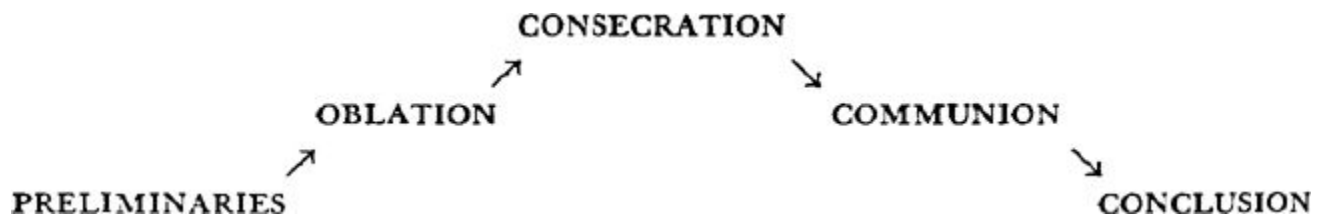

- [301] As this investigation is concerned essentially with the symbol of transformation, I must refrain from discussing the Mass as a whole.
- [302] In the sacrifice of the Mass two distinct ideas are blended together: the ideas of *deipnon* and *thysia*. *Thysia* comes from the verb *θύειν*, ‘to sacrifice’ or ‘to slaughter’; but it also has the meaning of ‘blazing’ or ‘flaring up.’ This refers to the leaping sacrificial fire by which the gift offered to the gods was consumed. Originally the food-offering was intended for the nourishment of the gods; the smoke of the burnt sacrifice carried the food up to their heavenly abode. At a later stage the smoke was conceived as a spiritualized form of food-offering; indeed, all through the Christian era up to the Middle Ages, spirit (or *pneuma*) continued to be thought of as a fine, vaporous substance.⁴
- [303] *Deipnon* means ‘meal.’ In the first place it is a meal shared by those taking part in the sacrifice, at which the god was believed to be present. It is also a “sacred” meal at which “consecrated” food is eaten, and hence a *sacrifice* (from *sacrificare*, ‘to make sacred,’ ‘to consecrate’).
- [304] The dual meaning of *deipnon* and *thysia* is implicitly contained in the words of the sacrament: “the body which (was given) for you.”⁵ This may mean either “which was given to you to eat” or, indirectly, “which was given for you to God.” The idea of a meal immediately invests the word ‘body’ with the meaning of *σᾶρξ*, ‘flesh’ (as an edible substance). In Paul, *σῶμα* and *σᾶρξ* are practically identical.⁶
- [305] Besides the authentic accounts of the institution of the sacrament, we must also consider Hebrews 13:10–15 as a possible source for the Mass:
- We have an altar, whereof they have no right to eat which serve the tabernacle. For the bodies of those beasts, whose blood is brought into the sanctuary by the high priest for sin, are burned without the camp. Wherefore Jesus also, that he might sanctify the people with his own blood, suffered without the gate. Let us go forth therefore unto him without the camp, bearing his reproach. For here have we no continuing city, but we seek one to come. By him therefore let us offer the sacrifice of praise to God continually....
- [306] As a further source we might mention Hebrews 7:17: “Thou art a priest for ever after the order of Melchisedec.”⁷ The idea of perpetual sacrifice and of an eternal priesthood is an essential component of the Mass. Melchisedec, who according to Hebrews 7:3 was “without father, without mother, without descent, having neither beginning of days, nor end of life, but made like unto the Son of God,” was believed to be a pre-Christian incarnation of the Logos.

[307] The idea of an eternal priesthood and of a sacrifice offered to God “continually” brings us to the true *mysterium fidei*, the transformation of the substances, which is the third aspect of the Mass. The ideas of *deipnon* and *thysia* do not in themselves imply or contain a mystery, although, in the burnt offering which is reduced to smoke and ashes by the fire, there is a primitive allusion to a transformation of substance in the sense of its spiritualization. But this aspect is of no practical importance in the Mass, where it only appears in subsidiary form in the censuring, as an incense-offering. The *mysterium*, on the other hand, manifests itself clearly enough in the eternal priest “after the order of Melchisedec” and in the sacrifice which he offers to God “continually.” The manifestation of an order outside time involves the idea of a *miracle* which takes place “vere, realiter, substantialiter” at the moment of transubstantiation, for the substances offered are no different from natural objects, and must in fact be definite commodities whose nature is known to everybody, namely pure wheaten bread and wine. Furthermore, the officiating priest is an ordinary human being who, although he bears the indelible mark of the priesthood upon him and is thus empowered to offer sacrifice, is nevertheless not yet in a position to be the instrument of the divine self-sacrifice enacted in the Mass.⁸ Nor is the congregation standing behind him yet purged from sin, consecrated, and itself transformed into a sacrificial gift. The ritual of the Mass takes this situation and transforms it step by step until the climax is reached—the Consecration, when Christ himself, as sacrificer and sacrificed, speaks the decisive words through the mouth of the priest. At that moment Christ is present in time and space. Yet his presence is not a reappearance, and therefore the inner meaning of the consecration is not a repetition of an event which occurred once in history, but the revelation of something existing in eternity, a rending of the veil of temporal and spatial limitations which separates the human spirit from the sight of the eternal. This event is necessarily a mystery, because it is beyond the power of man to conceive or describe. In other words, the rite is necessarily and in every one of its parts a *symbol*. Now a symbol is not an arbitrary or intentional sign standing for a known and conceivable fact, but an admittedly anthropomorphic—hence limited and only partly valid—expression for something supra-human and only partly conceivable. It may be the best expression possible, yet it ranks below the level of the mystery it seeks to describe. The Mass is a symbol in this sense. Here I would like to quote the words of Father Kramp: “It is generally admitted that the sacrifice is a *symbolic* act, by which I mean that the offering of a material gift to God has no purpose in itself, but merely serves as a means to express an idea. And the choice of this means of expression brings a wide range of anthropomorphism into play: man confronts God as he confronts his own kind, almost as if God were a human being. We offer a gift to God as we offer it to a good friend or to an earthly ruler.”⁹

[308] In so far, then, as the Mass is an anthropomorphic symbol standing for something otherworldly and beyond our power to conceive, its symbolism is a legitimate subject for comparative psychology and analytical research. My psychological explanations are, of course, exclusively concerned with the symbolical expression.

2. THE SEQUENCE OF THE TRANSFORMATION RITE

[309] The rite of transformation may be said to begin with the Offertory, an antiphon recited during the offering of the sacrificial gifts. Here we encounter the first ritual act relating to the transformation.¹

I. OBLATION OF THE BREAD

[310] The Host is lifted up towards the cross on the altar, and the priest makes the sign of the cross over it with the paten. The bread is thus brought into relation with Christ and his death on the cross; it is marked as a “sacrifice” and thereby becomes sacred. The elevation exalts it into the realm of the spiritual: it is a preliminary act of spiritualization. Justin makes the interesting remark that the presentation of the cleansed lepers in the temple was an image of the Eucharistic bread.² This links up with the later alchemical idea of the imperfect or “leprous” substance which is made perfect by the *opus*. (*Quod natura relinquit imperfectum, arte perficitur.*—“What nature leaves imperfect is perfected by the art.”)

II. PREPARATION OF THE CHALICE

[311] This is still more solemn than that of the bread, corresponding to the “spiritual” nature of the wine, which is reserved for the priest.³ Some water is mingled with the wine.

[312] The mixing of water with the wine originally referred to the ancient custom of not drinking wine unless mixed with water. A drunkard was therefore called *akratopotes*, an ‘unmixed drinker.’ In modern Greek, wine is still called *κρασί* (mixture). From the custom of the Monophysite Armenians, who did not add any water to the Eucharistic wine (so as to preserve the exclusively divine nature of Christ), it may be inferred that water has a hylical, or physical, significance and represents man’s material nature. The mixing of water and wine in the Roman rite would accordingly signify that divinity is mingled with humanity as indivisibly as the wine with the water.⁴ St. Cyprian (bishop of Carthage, d. 258) says that the wine refers to Christ, and the water to the congregation as the body of Christ. The significance of the water is explained by an allusion to the Book of Revelation 17:15: “The waters which thou sawest, where the whore sitteth, are peoples, and multitudes, and nations, and tongues.” (In alchemy, *meretrix* the whore is a synonym for the

prima materia, the *corpus imperfectum* which is sunk in darkness, like the man who wanders in darkness, unconscious and unredeemed. This idea is foreshadowed in the Gnostic image of Physis, who with passionate arms draws the Nous down from heaven and wraps him in her dark embrace.) As the water is an imperfect or even leprous substance, it has to be blessed and consecrated before being mixed, so that only a purified body may be joined to the wine of the spirit, just as Christ is to be united only with a pure and sanctified congregation. Thus this part of the rite has the special significance of preparing a perfect body—the glorified body of resurrection.

[313] At the time of St. Cyprian the communion was generally celebrated with water.⁵ And, still later, St. Ambrose (bishop of Milan, d. 397) says: “In the shadow there was water from the rock, as it were the blood of Christ.”⁶ The water communion is prefigured in John 7:37–39: “If any man thirst, let him come unto me, and drink. He that believeth on me, as the scripture hath said, out of his belly flow rivers of living water. (But this he spake of the Spirit, which they that believe on him should receive: for the Holy Ghost was not yet given, because that Jesus was not yet glorified.)” And also in John 4:14: “But whosoever drinketh of the water that I shall give him shall never thirst; but the water that I shall give him shall be in him a well of water springing up into everlasting life.” The words “as the scripture hath said, out of his belly shall flow rivers of living water” do not occur anywhere in the Old Testament. They must therefore come from a writing which the author of the Johannine gospel obviously regarded as holy, but which is not known to us. It is just possible that they are based on Isaiah 58:11: “And the Lord shall guide thee continually, and satisfy thy soul in drought, and make fat thy bones: and thou shalt be like a watered garden, and like a spring of water, whose waters fail not.” Another possibility is Ezekiel 47:1: “Afterward he brought me again unto the door of the house; and, behold, waters issued out from under the threshold of the house eastward ... and the waters came down from under from the right side of the house, at the south side of the altar.” In the Church Order of Hippolytus (d. c. 235) the water chalice is associated with the baptismal font, where the inner man is renewed as well as the body.⁷ This interpretation comes very close to the baptismal *krater* of Poimandres⁸ and to the Hermetic basin filled with *nous* which God gave to those seeking *ἔννοια*.⁹ Here the water signifies the *pneuma*, i.e., the spirit of prophecy, and also the doctrine which a man receives and passes on to others.¹⁰ The same image of the spiritual water occurs in the “Odes of Solomon”:¹¹

For there went forth a stream, and became a river great and broad; ... and all the thirsty upon earth were given to drink of it; and thirst was relieved and quenched; for from the Most High the draught was given. Blessed then are the ministers of that draught who are entrusted with that water of His; they have assuaged the dry lips, and the will that had fainted they have raised up; and souls that were near departing they have caught back from death; and

limbs that had fallen they straightened and set up; they gave strength for their feebleness and light to their eyes. For everyone knew them in the Lord, and they lived by the water of life for ever.¹²

[314] The fact that the Eucharist was also celebrated with water shows that the early Christians were mainly interested in the symbolism of the mysteries and not in the literal observance of the sacrament. (There were several other variants —“galactophagy,” for instance—which all bear out this view.)

[315] Another, very graphic, interpretation of the wine and water is the reference to John 19:34: “And forthwith came there out blood and water.” Deserving of special emphasis is the remark of St. John Chrysostom (patriarch of Constantinople, d. 407), that in drinking the wine Christ drank his own blood. (See Section 3, on Zosimos.)

[316] In this section of the Mass we meet the important prayer:

O God, who in creating human nature, didst wonderfully dignify it, and hast still more wonderfully renewed it; grant that, by the mystery of this water and wine, we may be made partakers of his divinity who vouchsafed to become partaker of our humanity, Jesus Christ....¹³

III. ELEVATION OF THE CHALICE

[317] The lifting up of the chalice in the air prepares the spiritualization (i.e., volatilization) of the wine.¹⁴ This is confirmed by the invocation to the Holy Ghost which immediately follows (*Veni sanctificator*), and it is even more evident in the Mozarabic liturgy, which has “*Veni spiritus sanctificator.*”¹⁵ The invocation serves to infuse the wine with holy spirit, for it is the Holy Ghost who begets, fulfils, and transforms (cf. the “*Obumbratio Mariae*,” Pentecostal fire). After the elevation, the chalice was, in former times, set down to the right of the Host, to correspond with the blood that flowed from the right side of Christ.

IV. CENSING OF THE SUBSTANCES AND THE ALTAR

[318] The priest makes the sign of the cross three times over the substances with the thurible, twice from right to left and once from left to right.¹⁶ The counterclockwise movement (from right to left) corresponds psychologically to a circumambulation downwards, in the direction of the unconscious, while the clockwise (left-to-right) movement goes in the direction of consciousness. There is also a complicated censuring of the altar.¹⁷

[319] The censuring has the significance of an incense offering and is therefore a relic of the original *thysia*. At the same time it signifies a transformation of the sacrificial gifts and of the altar, a spiritualization of all the physical substances subserving the rite. Finally, it is an apotropaic ceremony to drive away any demonic forces that may be present, for it fills the air with the fragrance of the *pneuma* and renders it uninhabitable by evil spirits. The vapour also suggests the sublimated body, the *corpus volatile sive spirituale*, or wraithlike “subtle body.” Rising up as a “spiritual” substance, the incense implements and represents the ascent of prayer—hence the *Dirigatur, Domine, oratio mea, sicut incensum, in conspectu tuo.*¹⁸

[320] The censuring brings the preparatory, spiritualizing rites to an end. The gifts have been sanctified and prepared for the actual transubstantiation. Priest and congregation are likewise purified by the prayers *Accendat in nobis Dominus ignem sui amoris* and *Lavabo inter innocentes*,¹⁹ and are made ready to enter into the mystic union of the sacrificial act which now follows.

V. THE EPICLESIS

[321] The *Suscipe, sancta Trinitas*, like the *Orate, fratres*, the *Sanctus*, and the *Hanc igitur*, is a propitiatory prayer which seeks to insure the acceptance of the sacrifice. Hence the Preface that comes after the Secret is called *Illatio* in the Mozarabic rite (the equivalent of the Greek *ἀναφορά*), and in the old Gallican liturgy is known as *Immolatio* (in the sense of *oblatio*), with reference to the presentation of the gifts. The words of the *Sanctus*, “*Benedictus qui venit in nomine Domini*,”²⁰ point to the expected appearance of the Lord which has already been prepared, on the ancient principle that a “naming” has the force of a “summons.” After the Canon there follows the “Commemoration of the Living,” together with the prayers *Hanc igitur* and *Quam oblationem*. In the Mozarabic Mass these are followed by the Epiclesis (invocation): “*Adesto, adesto Jesu, bone Pontifex, in medio nostri: sicut fuisti in medio discipulorum tuorum*.”²¹ This naming likewise has the original force of a summons. It is an intensification of the *Benedictus qui venit*, and it may be, and sometimes was, regarded as the actual manifestation of the Lord, and hence as the culminating point of the Mass.

VI. THE CONSECRATION

[322] This, in the Roman Mass, is the climax, the transubstantiation of the bread and wine into the body and blood of Christ. The formula for the consecration of the bread runs:²²

Qui pridie quam pateretur, accepit panem in sanctas ac venerabiles manus suas, et elevatis oculis in caelum ad te Deum, Patrem suum omnipotentem, tibi gratias agens, benedixit, fregit, deditque discipulis suis, dicens: Accipite, et manducate ex hoc omnes. Hoc est enim Corpus meum.

And for the consecration of the chalice:

Simili modo postquam coenatum est, accipiens et hunc praeclarum Calicem in sanctas ac venerabiles manus suas, item tibi gratias agens, benedixit, deditque discipulis suis, dicens: Accipite, et bibite ex eo omnes. Hic est enim Calix Sanguinis mei, novi et aeterni testamenti: mysterium fidei: qui pro vobis et pro multis effundetur in remissionem peccatorum. Haec quotiescumque feceritis, in mei memoriam facietis.

[323] The priest and congregation, as well as the substances and the altar, have now been progressively purified, consecrated, exalted, and spiritualized by means of the prayers and rites which began with the Preliminaries and ended with the Canon, and are thus prepared as a mystical unity for the divine epiphany. Hence the uttering of the words of the consecration signifies Christ himself speaking in the first person, his living presence in the *corpus mysticum* of priest, congregation, bread, wine, and incense, which together form the mystical unity offered for sacrifice. At this moment the eternal character of the one divine sacrifice is made evident: it is experienced at a particular time and a particular place, as if a window or a door had been opened upon that which lies beyond space and time. It is in this sense that we have to understand

the words of St. Chrysostom: “And this word once uttered in any church, at any altar, makes perfect the sacrifice from that day to this, and till his Second Coming.” It is clear that only by our Lord’s presence in his words, and by their virtue, is the imperfect body of the sacrifice made perfect, and not by the preparatory action of the priest. Were this the efficient cause, the rite would be no different from common magic. The priest is only the *causa ministerialis* of the transubstantiation. The real cause is the living presence of Christ which operates spontaneously, as an act of divine grace.

[324] Accordingly, John of Damascus (d. 754) says that the words have a consecrating effect no matter by what priest they be spoken, as if Christ were present and uttering them himself. And Duns Scotus (d. 1308) remarks that, in the sacrament of the Last Supper, Christ, by an act of will, offers himself as a sacrifice in every Mass, through the agency of the priest.²³ This tells us plainly enough that the sacrificial act is not performed by the priest, but by Christ himself. The agent of transformation is nothing less than the divine will working through Christ. The Council of Trent declared that in the sacrifice of the Mass “the selfsame Christ is contained and bloodlessly sacrificed,”²⁴ although this is not a repetition of the historical sacrifice but a bloodless renewal of it. As the sacramental words have the power to accomplish the sacrifice, being an expression of God’s will, they can be described metaphorically as the sacrificial knife or sword which, guided by his will, consummates the *thysia*. This comparison was first drawn by the Jesuit father Lessius (d. 1623), and has since gained acceptance as an ecclesiastical figure of speech. It is based on Hebrews 4:12: “For the word of God is quick, and powerful, and sharper than any two-edged sword,” and perhaps even more on the Book of Revelation 1:16: “And out of his mouth went a sharp two-edged sword.” The “mactation theory” first appeared in the sixteenth century. Its originator, Cuesta, bishop of Leon (d. 1560), declared that Christ was slaughtered by the priest. So the sword metaphor followed quite naturally.²⁵ Nicholas Cabasilas, archbishop of Thessalonica (d. c. 1363), gives a vivid description of the corresponding rite in the Greek Orthodox Church:

The priest cuts a piece of bread from the loaf, reciting the text: “As a lamb he was led to the slaughter.” Laying it on the table he says: “The lamb of God is slain.” Then a sign of the cross is imprinted on the bread and a small lance is stabbed into its side, to the text: “And one of the soldiers with a spear pierced his side, and forthwith came there out blood and water.” With these words water and wine are mixed in the chalice, which is placed beside the bread.

The *δῶρον* (gift) also represents the giver; that is to say, Christ is both the sacrificer and the sacrificed.

[325] Kramp writes: “Sometimes the *fractio* and sometimes the *elevatio* which precedes the Pater noster was taken as symbolizing the death of Christ, sometimes

the sign of the cross at the end of the *Supplices*, and sometimes the *consecratio*; but no one ever thought of taking a symbol like the ‘mystical slaughter’ as a sacrifice which constitutes the essence of the Mass. So it is not surprising that there is no mention of any ‘slaughter’ in the liturgy.”²⁶

VII. THE GREATER ELEVATION

[326] The consecrated substances are lifted up and shown to the congregation. The Host in particular represents a beatific vision of heaven, in fulfilment of Psalm 27:8: “Thy face, Lord, will I seek,” for in it the Divine Man is present.

VIII. THE POST-CONSECRATION

[327] There now follows the significant prayer *Unde et memores*, which I give in full together with the *Supra quae* and *Supplices*:

Wherefore, O Lord, we thy servants, as also thy holy people, calling to mind the blessed passion of the same Christ thy Son our Lord, his resurrection from hell, and glorious ascension into heaven, offer unto thy most excellent majesty, of thy gifts and grants, a pure Host, a holy Host, an immaculate Host, the holy bread of eternal life, and the chalice of everlasting salvation.

Upon which vouchsafe to look down with a propitious and serene countenance, and to accept them, as thou wert graciously pleased to accept the gifts of thy just servant Abel, and the sacrifice of our patriarch Abraham, and that which thy high priest Melchisedec offered to thee, a holy sacrifice, an immaculate Host.

We most humbly beseech thee, almighty God, command these things to be carried by the hands of thy holy angel to thy altar on high, in the sight of thy divine majesty, that as many of us as, by participation at this altar, shall receive the most sacred body and blood of thy Son, may be filled with all heavenly benediction and grace. Through the same Christ, our Lord. Amen.²⁷

[328] The first prayer shows that in the transformed substances there is an allusion to the resurrection and glorification of our Lord, and the second prayer recalls the sacrifices prefigured in the Old Testament. Abel sacrificed a lamb; Abraham was to sacrifice his son, but a ram was substituted at the last moment. Melchisedec offers no sacrifice, but comes to meet Abraham with bread and wine. This sequence is probably not accidental—it forms a sort of crescendo. Abel is essentially the son, and sacrifices an animal; Abraham is essentially the father—indeed, the “tribal father”—and therefore on a higher level. He does not offer a choice possession merely, but is ready to sacrifice the best and dearest thing he has—his only son. Melchisedec (“teacher of righteousness”), is, according to Hebrews 7:1, king of Salem and “priest of the most high God,” El ‘Elyon. Philo Byblius mentions a ‘*Ελιοῦν ὁ ὕψιστος*’ as a Canaanite deity,²⁸ but he cannot be identical with Yahweh. Abraham nevertheless acknowledges the priesthood of Melchisedec²⁹ by paying him “a tenth part of all.” By virtue of his priesthood, Melchisedec stands above the patriarch, and his feasting of

Abraham has the significance of a priestly act. We must therefore attach a symbolical meaning to it, as is in fact suggested by the bread and wine. Consequently the symbolical offering ranks even higher than the sacrifice of a son, which is still the sacrifice of somebody else. Melchisedec's offering is thus a prefiguration of Christ's sacrifice of himself.

[329] In the prayer *Supplices te rogamus* we beseech God to bring the gifts "by the hands of thy holy angel to thy altar on high." This singular request derives from the apocryphal *Epistolae Apostolorum*, where there is a legend that Christ, before he became incarnate, bade the archangels take his place at God's altar during his absence.³⁰ This brings out the idea of the eternal priesthood which links Christ with Melchisedec.

IX. END OF THE CANON

[330] Taking up the Host, the priest makes the sign of the cross three times over the chalice, and says: "Through Him, and with Him, and in Him." Then he makes the sign of the cross twice between himself and the chalice. This establishes the identity of Host, chalice, and priest, thus affirming once more the unity of all parts of the sacrifice. The union of Host and chalice signifies the union of the body and blood, i.e., the quickening of the body with a soul, for blood is equivalent to soul. Then follows the *Pater noster*.

X. BREAKING OF THE HOST ("FRACTIO")

[331] The prayer "Deliver us, O Lord, we beseech thee, from all evils, past, present, and to come" lays renewed emphasis on the petition made in the preceding *Pater noster*: "but deliver us from evil." The connection between this and the sacrificial death of Christ lies in the descent into hell and the breaking of the infernal power. The breaking of the bread that now follows is symbolic of Christ's death. The Host is broken in two over the chalice. A small piece, the *particula*, is broken off from the left half and used for the rite of *consignatio* and *commixtio*. In the Byzantine rite the bread is divided into four, the four pieces being marked with letters as follows:

ΙΣ
NI KA
ΧΣ

This means "Ἰησοῦς Χριστὸς νικᾷ"—'Jesus Christ is victorious.' The peculiar arrangement of the letters obviously represents a quaternity, which as we know always has the character of wholeness. This quaternity, as the letters show, refers to Christ glorified, king of glory and Pantokrator.

[332] Still more complicated is the Mozarabic *fractio*: the Host is first broken into two, then the left half into five parts, and the right into four. The five are named *corporatio (incarnatio)*, *nativitas*, *circumcisio*, *apparitio*, and *passio*; and the four *mors*, *resurrectio*, *gloria*, *regnum*. The first group refers exclusively to the human life of our Lord, the second to his existence beyond this world. According to the old view, five is the number of the natural (“hylical”) man, whose outstretched arms and legs form, with the head, a pentagram. Four, on the other hand, signifies eternity and totality (as shown for instance by the Gnostic name “Barbelo,” which is translated as “fourness is God”). This symbol, I would add in passing, seems to indicate that extension in space signifies God’s suffering (on the cross) and, on the other hand, his dominion over the universe.

XI. CONSIGNATIO

[333] The sign of the cross is made over the chalice with the *particula*, and then the priest drops it into the wine.

XII. COMMIXTIO

[334] This is the mingling of bread and wine, as explained by Theodore of Mopsuestia (d. 428?): “... he combines them into one, whereby it is made manifest to everybody that although they are two they are virtually one.”³¹ The text at this point says: “May this mixture and consecration [*commixtio et consecratio*] of the body and blood of our Lord help us,” etc. The word ‘consecration’ may be an allusion to an original consecration by contact, though that would not clear up the contradiction since a consecration of both substances has already taken place. Attention has therefore been drawn to the old custom of holding over the sacrament from one Mass to another, the Host being dipped in wine and then preserved in softened, or mixed, form. There are numerous rites that end with minglings of this kind. Here I would only mention the consecration by water, or the mixed drink of honey and milk which the neophytes were given after communion in the Church Order of Hippolytus.

[335] The *Leonine Sacramentary* (seventh century) interprets the *commixtio* as a mingling of the heavenly and earthly nature of Christ. The later view was that it symbolizes the resurrection, since in it the blood (or soul) of our Lord is reunited with the body lying in the sepulchre. There is a significant reversal here of the original rite of baptism. In baptism, the body is immersed in water for the purpose of transformation; in the *commixtio*, on the other hand, the body, or *particula*, is steeped in wine, symbolizing spirit, and this amounts to a glorification of the body. Hence the justification for regarding the *commixtio* as a symbol of the resurrection.

XIII. CONCLUSION

[336] On careful examination we find that the sequence of ritual actions in the Mass contains, sometimes clearly and sometimes by subtle allusions, a representation in condensed form of the life and sufferings of Christ. Certain phases overlap or are so close together that there can be no question of conscious and deliberate condensation. It is more likely that the historical evolution of the Mass gradually led to its becoming a concrete picture of the most important aspects of Christ's life. First of all (in the *Benedictus qui venit* and *Supra quae*) we have an anticipation and prefiguration of his coming. The uttering of the words of consecration corresponds to the incarnation of the Logos, and also to Christ's passion and sacrificial death, which appears again in the *fractio*. In the *Libera nos* there is an allusion to the descent into hell, while the *consignatio* and *commixtio* hint at resurrection.

[337] In so far as the offered gift is the sacrificer himself, in so far as the priest and congregation offer themselves in the sacrificial gift, and in so far as Christ is both sacrificer and sacrificed, there is a mystical unity of all parts of the sacrificial act.³² The combination of offering and offerer in the single figure of Christ is implicit in the doctrine that just as bread is composed of many grains of wheat, and wine of many grapes, so the mystical body of the Church is made up of a multitude of believers. The mystical body, moreover, includes both sexes, represented by the bread and wine.³³ Thus the two substances—the masculine wine and the feminine bread—also signify the androgynous nature of the mystical Christ.

[338] The Mass thus contains, as its essential core, the mystery and miracle of God's transformation taking place in the human sphere, his becoming Man, and his return to his absolute existence in and for himself. Man, too, by his devotion and self-sacrifice as a ministering instrument, is included in the mysterious process. God's offering of himself is a voluntary act of love, but the actual sacrifice was an agonizing and bloody death brought about by men *instrumentaliter et ministerialiter*. (The words *incruente immolatur*—'bloodlessly sacrificed'—refer only to the rite, not to the thing symbolized.) The terrors of death on the cross are an indispensable condition for the transformation. This is in the first place a bringing to life of substances which are in themselves lifeless, and, in the second, a substantial alteration of them, a spiritualization, in accordance with the ancient conception of *pneuma* as a subtle material entity (the *corpus glorificationis*). This idea is expressed in the concrete participation in the body and blood of Christ in the Communion.

3. PARALLELS TO THE TRANSFORMATION MYSTERY

I. THE AZTEC "TEOQUALO"

[339] Although the Mass itself is a unique phenomenon in the history of comparative religion, its symbolic content would be profoundly alien to man were it not rooted in the human psyche. But if it is so rooted, then we may expect to find similar patterns of symbolism both in the earlier history of mankind and in the world of pagan thought contemporary with it. As the prayer *Supra quae* shows, the liturgy of the Mass contains allusions to the "prefigurations" in the Old Testament, and thus indirectly to ancient sacrificial symbolism in general. It is clear, then, that in Christ's sacrifice and the Communion one of the deepest chords in the human psyche is struck: human sacrifice and ritual anthropophagy. Unfortunately I cannot enter into the wealth of ethnological material in question here, so must content myself with mentioning the ritual slaying of the king to promote the fertility of the land and the prosperity of his people, the renewal and revivification of the gods through human sacrifice, and the totem meal, the purpose of which was to reunite the participants with the life of their ancestors. These hints will suffice to show how the symbols of the Mass penetrate into the deepest layers of the psyche and its history. They are evidently among the most ancient and most central of religious conceptions. Now with regard to these conceptions there is still a widespread prejudice, not only among laymen, but in scientific circles too, that beliefs and customs of this kind must have been "invented" at some time or other, and were then handed down and imitated, so that they would not exist at all in most places unless they had got there in the manner suggested. It is, however, always precarious to draw conclusions from our modern, "civilized" mentality about the primitive state of mind. Primitive consciousness differs from that of the present-day white man in several very important respects. Thus, in primitive societies, "inventing" is very different from what it is with us, where one novelty follows another. With primitives, life goes on in the same way for generations; nothing alters, except perhaps the language. But that does not mean that a new one is "invented." Their language is "alive" and can therefore change, a fact that has been an unpleasant discovery for many lexicographers of primitive languages. Similarly, no one "invents" the picturesque slang spoken in America; it just springs up in inexhaustible abundance from the fertile soil of colloquial speech. Religious rites and their stock of symbols must have developed in much the same way from beginnings now lost to us, and not just in one place only, but in many

places at once, and also at different periods. They have grown spontaneously out of the basic conditions of human nature, which are never invented but are everywhere the same.

[340] So it is not surprising that we find religious rites which come very close to Christian practices in a field untouched by classical culture. I mean the rites of the Aztecs, and in particular that of the *teoqualo*, ‘god-eating,’ as recorded by Fray Bernardino de Sahagún, who began his missionary work among the Aztecs in 1529, eight years after the conquest of Mexico. In this rite, a doughlike paste was made out of the crushed and pounded seeds of the prickly poppy (*Argemone mexicana*) and moulded into the figure of the god Huitzilopochtli:

And upon the next day the body of Huitzilopochtli died.

And he who slew him was the priest known as Quetzalcoatl. And that with which he slew him was a dart, pointed with flint, which he shot into his heart.

He died in the presence of Moctezuma and of the keeper of the god, who verily spoke to Huitzilopochtli—who verily appeared before him, who indeed could make him offerings; and of four masters of the youths, front rank leaders. Before all of them died Huitzilopochtli.

And when he had died, thereupon they broke up his body of ... dough. His heart was apportioned to Moctezuma.

And as for the rest of his members, which were made, as it were, to be his bones, they were distributed and divided up among all.... Each year ... they ate it.... And when they divided up among themselves his body made of ... dough, it was broken up exceeding small, very fine, as small as seeds. The youths ate it.

And of this which they ate, it was said: “The god is eaten.” And of those who ate it, it was said: “They guard the god.”¹

[341] The idea of a divine body, its sacrifice in the presence of the high priest to whom the god appears and with whom he speaks, the piercing with the spear, the god’s death followed by ritual dismemberment, and the eating (*communio*) of a small piece of his body, are all parallels which cannot be overlooked and which caused much consternation among the worthy Spanish Fathers at the time.

[342] In Mithraism, a religion that sprang up not long before Christianity, we find a special set of sacrificial symbols and, it would seem, a corresponding ritual which unfortunately is known to us only from dumb monuments. There is a *transitus*, with Mithras carrying the bull; a bull-sacrifice for seasonal fertility; a stereotyped representation of the sacrificial act, flanked on either side by dadophors carrying raised and lowered torches; and a meal at which pieces of bread marked with crosses were laid on the table. Even small bells have been found, and these probably have some connection with the bell which is sounded at Mass. The Mithraic sacrifice is essentially a self-sacrifice, since the bull is a world bull and was originally identical

with Mithras himself. This may account for the singularly agonized expression on the face of the *tauroktonos*,² which bears comparison with Guido Reni's *Crucifixion*. The Mithraic *transitus* is a motif that corresponds to Christ carrying the cross, just as the transformation of the beast of sacrifice corresponds to the resurrection of the Christian God in the form of food and drink. The representations of the sacrificial act, the tauroctony (bull-slaying), recall the crucifixion between two thieves, one of whom is raised up to paradise while the other goes down to hell.

[343] These few references to the Mithras cult are but one example of the wealth of parallels offered by the legends and rites of the various Near Eastern gods who die young, are mourned, and rise again. For anyone who knows these religions at all, there can be no doubt as to the basic affinity of the symbolic types and ideas.³ At the time of primitive Christianity and in the early days of the Church, the pagan world was saturated with conceptions of this kind and with philosophical speculations based upon them, and it was against this background that the thought and visionary ideas of the Gnostic philosophers were unfolded.

II. THE VISION OF ZOSIMOS

[344] A characteristic representative of this school of thought was Zosimos of Panopolis, a natural philosopher and alchemist of the third century A.D., whose works have been preserved, though in corrupt state, in the famous alchemical Codex Marcianus, and were published in 1887 by Berthelot in his *Collection des anciens alchimistes grecs*. In various portions of his treatises⁴ Zosimos relates a number of dream-visions, all of which appear to go back to one and the same dream.⁵ He was clearly a non-Christian Gnostic, and in particular—so one gathers from the famous passage about the *krater*⁶—an adherent of the Poimandres sect, and therefore a follower of Hermes. Although alchemical literature abounds in parables, I would hesitate to class these dream-visions among them. Anyone acquainted with the language of the alchemists will recognize that their parables are mere allegories of ideas that were common knowledge. In the allegorical figures and actions, one can usually see at once what substances and what procedures are being referred to under a deliberately theatrical disguise. There is nothing of this kind in the Zosimos visions. Indeed, it comes almost as a surprise to find the alchemical interpretation, namely that the dream and its impressive machinery are simply an illustration of the means for producing the “divine water.” Moreover, a parable is a self-contained whole, whereas our vision varies and amplifies a single theme as a dream does. So far as one can assess the nature of these visions at all, I should say that even in the original text the contents of an imaginative meditation have grouped themselves round the kernel of an actual dream and been woven into it. That there really was such a meditation is evident from the fragments of it that accompany the visions in the form of a

commentary. As we know, meditations of this kind are often vividly pictorial, as if the dream were being continued on a level nearer to consciousness. In his *Lexicon alchemiae*, Martin Ruland, writing in Frankfort in 1612, defines the meditation that plays such an important part in alchemy as an “internal colloquy with someone else, who is nevertheless not seen, it may be with God, with oneself, or with one’s good angel.” The latter is a milder and less obnoxious form of the *paredros*, the familiar spirit of ancient alchemy, who was generally a planetary demon conjured up by magic. It can hardly be doubted that real visionary experiences originally lay at the root of these practices, and a vision is in the last resort nothing less than a dream which has broken through into the waking state. We know from numerous witnesses all through the ages that the alchemist, in the course of his imaginative work, was beset by visions of all kinds,⁷ and was sometimes even threatened with madness.⁸ So the visions of Zosimos are not something unusual or unknown in alchemical experience, though they are perhaps the most important self-revelations ever bequeathed to us by an alchemist.

[345] I cannot reproduce here the text of the visions in full, but will give as an example the first vision, in Zosimos’ own words:

And while I said this I fell asleep, and I saw a sacrificial priest standing before me, high up on an altar, which was in the shape of a shallow bowl. There were fifteen steps leading up to the altar. And the priest stood there, and I heard a voice from above say to me: “Behold, I have completed the descent down the fifteen steps of darkness and I have completed the ascent up the steps of light. And he who renews me is the priest, casting away the grossness of the body, and by compelling necessity I am sanctified and now stand in perfection as a spirit [*pneuma*].” And I perceived the voice of him who stood upon the altar, and I inquired of him who he was. And he answered me in a fine voice, saying: “I am Ion, priest of the innermost hidden sanctuary, and I submit myself to an unendurable torment. For there came one in haste at early morning, who overpowered me and pierced me through with the sword and cut me in pieces, yet in such a way that the order of my limbs was preserved. And he drew off the scalp of my head with the sword, which he wielded with strength, and he put the bones and the pieces of flesh together and with his own hand burned them in the fire, until I perceived that I was transformed and had become spirit. And that is my unendurable torment.” And even as he spoke this, and I held him by force to converse with me, his eyes became as blood. And he spewed out all his own flesh. And I saw how he changed into a manikin [*άνθρωπάριον*, i.e., an homunculus] who had lost a part of himself. And he tore his flesh with his own teeth, and sank into himself.

[346] In the course of the visions the Hiereus (priest) appears in various forms. At first he is split into the figures of the Hiereus and the Hierourgon (sacrificer), who is charged with the performance of the sacrifice. But these figures blend into one in so far as both suffer the same fate. The sacrificial priest submits voluntarily to the torture by which he is transformed. But he is also the sacrificer who is sacrificed, since he is pierced through with the sword and ritually dismembered.⁹ The *deipnon*

consists in his tearing himself to pieces with his own teeth and eating himself; the *thysia*, in his flesh being sacrificially burned on the altar.

[347] He is the Hieres in so far as he rules over the sacrificial rite as a whole, and over the human beings who are transformed during the *thysia*. He calls himself a guardian of spirits. He is also known as the “Brazen Man” and as Xyrourgos, the barber. The brazen or leaden man is an allusion to the spirits of the metals, or planetary demons, as protagonists of the sacrificial drama. In all probability they are *paredroi* who were conjured up by magic, as may be deduced from Zosimos’ remark that he “held him by force” to converse with him. The planetary demons are none other than the old gods of Olympus who finally expired only in the eighteenth century, as the “souls of the metals”—or rather, assumed a new shape, since it was in this same century that paganism openly arose for the first time (in the French Revolution).

[348] Somewhat more curious is the term ‘barber,’ which we find in other parts of the visions,¹⁰ for there is no mention of cutting the hair or shaving. There is, however, a scalping, which in our context is closely connected with the ancient rites of flaying and their magical significance.¹¹ I need hardly mention the flaying of Marsyas, who is an unmistakable parallel to the son-lover of Cybele, namely Attis, the dying god who rises again. In one of the old Attic fertility rites an ox was flayed, stuffed, and set up on its feet. Herodotus (IV, 60) reports a number of flaying ceremonies among the Scythians, and especially scalpings. In general, flaying signifies transformation from a worse state to a better, and hence renewal and rebirth. The best examples are to be found in the religion of ancient Mexico.¹² Thus, in order to renew the moon-goddess a young woman was decapitated and skinned, and a youth then put the skin round him to represent the risen goddess. The prototype of this renewal is the snake casting its skin every year, a phenomenon round which primitive fantasy has always played. In our vision the skinning is restricted to the head, and this can probably be explained by the underlying idea of spiritual transformation. Since olden times shaving the head has been associated with consecration, that is, with spiritual transformation or initiation. The priests of Isis had their heads shaved quite bald, and the tonsure, as we know, is still in use at the present day. This “symptom” of transformation goes back to the old idea that the transformed one becomes like a new-born babe (neophyte, *quasimodogenitus*) with a hairless head. In the myth of the night sea journey, the hero loses all his hair during his incubation in the belly of the monster, because of the terrific heat.¹³ The custom of tonsure, which is derived from these primitive ideas, naturally presupposes the presence of a ritual barber.¹⁴ Curiously enough, we come across the barber in that old alchemical “mystery,” the *Chymical Wedding* of 1616.¹⁵ There the hero, on entering the mysterious castle, is pounced on by invisible barbers,

who give him something very like a tonsure.¹⁶ Here again the initiation and transformation process is accompanied by a shaving.¹⁷

[349] In one variant of these visions there is a dragon who is killed and sacrificed in the same manner as the priest and therefore seems to be identical with him. This makes one think of those far from uncommon medieval pictures, not necessarily alchemical, in which a serpent is shown hanging on the Cross in place of Christ. (*Psychology and Alchemy*, fig. 217. Note the comparison of Christ with the serpent of Moses in John 3:14.)

[350] A notable aspect of the priest is the leaden homunculus, and this is none other than the leaden spirit or planetary demon Saturn. In Zosimos' day Saturn was regarded as a Hebrew god, presumably on account of the keeping holy of the Sabbath—Saturday means 'Saturn's Day'¹⁸—and also on account of the Gnostic parallel with the supreme archon Ialdabaoth ('child of chaos') who, as *λεοντοειδής*, may be grouped together with Baal, Kronos, and Saturn.¹⁹ The later Arabic designation of Zosimos as al-'Ibrî (the Hebrew) does not of course prove that he himself was a Jew, but it is clear from his writings that he was acquainted with Jewish traditions.²⁰ The parallel between the Hebrew god and Saturn is of considerable importance as regards the alchemical idea of the transformation of the God of the Old Testament into the God of the New. The alchemists naturally attached great significance to Saturn,²¹ for, besides being the outermost planet, the supreme archon (the Harranites named him "Primas"), and the demiurge Ialdabaoth, he was also the *spiritus niger* who lies captive in the darkness of matter, the deity or that part of the deity which has been swallowed up in his own creation. He is the dark god who reverts to his original luminous state in the mystery of alchemical transmutation. As the *Aurora Consurgens* says: "Blessed is he that shall find this science and into whom this prudence of Saturn floweth."²²

[351] The later alchemists were familiar not only with the ritual slaying of a dragon but also with the slaying of a lion, which took the form of his having all four paws cut off. Like the dragon, the lion devours himself, and so is probably only a variant.²³

[352] The vision itself indicates that the main purpose of the transformation process is the spiritualization of the sacrificing priest: he is to be changed into *pneuma*. We are also told that he would "change the bodies into blood, make the eyes to see and the dead to rise again." Later in the visions he appears in glorified form, shining white like the midday sun.

[353] Throughout the visions it is clear that sacrificer and sacrificed are one and the same. This idea of the unity of the *prima* and *ultima materia*, of that which redeems and that which is to be redeemed, pervades the whole of alchemy from beginning to end. "Unus est lapis, una medicina, unum vas, unum regimen, unaque dispositio" is

the key formula to its enigmatic language.²⁴ Greek alchemy expresses the same idea in the formula *ἐν τὸ πᾶν*. Its symbol is the uroboros, the tail-eating serpent. In our vision it is the priest as sacrificer who devours himself as the sacrifice. This recalls the saying of St. John Chrysostom that in the Eucharist Christ drinks his own blood. By the same token, one might add, he eats his own flesh. The grisly repast in the dream of Zosimos reminds us of the orgiastic meals in the Dionysus cult, when sacrificial animals were torn to pieces and eaten. They represent Dionysus Zagreus being torn to pieces by the Titans, from whose mangled remains the *νέος Διόνυσος* arises.²⁵

[354] Zosimos tells us that the vision represents or explains the “production of the waters.”²⁶ The visions themselves only show the transformation into *pneuma*. In the language of the alchemists, however, spirit and water are synonymous,²⁷ as they are in the language of the early Christians, for whom water meant the *spiritus veritatis*. In the “Book of Krates” we read: “You make the bodies to liquefy, so that they mingle and become an homogeneous liquid; this is then named the ‘divine water.’”²⁸ The passage corresponds to the Zosimos text, which says that the priest would “change the bodies into blood.” For the alchemists, water and blood are identical. This transformation is the same as the *solutio* or *liquefactio*, which is a synonym for the *sublimatio*, for “water” is also “fire”: “Item ignis ... est aqua et ignis noster est ignis et non ignis” (For fire ... is water and our fire is the fire that is no fire). “Aqua nostra” is said to be “igneae” (fiery).²⁹

[355] The “secret fire of our philosophy” is said to be “our mystical water,” and the “permanent water” is the “fiery form of the true water.”³⁰ The permanent water (the *ὕδωρ θεῖον* of the Greeks) also signifies “spiritualis sanguis,”³¹ and is identified with the blood and water that flowed from Christ’s side. Heinrich Khunrath says of this water: “So there will open for thee an healing flood which issues from the heart of the son of the great world.” It is a water “which the son of the great world pours forth from his body and heart, to be for us a true and natural Aqua vitae.”³² Just as a spiritual water of grace and truth flows from Christ’s sacrifice, so the “divine water” is produced by a sacrificial act in the Zosimos vision. It is mentioned in the ancient treatise entitled “Isis to Horus,”³³ where the angel Amnael brings it to the prophetess in a drinking vessel. As Zosimos was probably an adherent of the Poimandres sect, another thing to be considered here is the *krater* which God filled with *nous* for all those seeking “*ἔννοια*.”³⁴ But *nous* is identical with the alchemical Mercurius. This is quite clear from the Ostanes quotation in Zosimos, which says: “Go to the streams of the Nile and there thou wilt find a stone which hath a spirit. Take and divide it, thrust in thy hand and draw out its heart, for its soul is in its heart.” Commenting on this, Zosimos remarks that “having a spirit” is a metaphorical expression for the *exhydrargyrosis*, the expulsion of the quicksilver.³⁵

[356] During the first centuries after Christ the words *nous* and *pneuma* were used indiscriminately, and the one could easily stand for the other. Moreover the relation of Mercurius to “spirit” is an extremely ancient astrological fact. Like Hermes, Mercurius (or the planetary spirit Mercury) was a god of revelation, who discloses the secret of the art to the adepts. The *Liber quartorum*, which being of Harranite origin cannot be dated later than the tenth century, says of Mercurius: “Ipse enim aperit clausiones operum cum ingenio et intellectu suo” (For he opens with his genius and understanding the locked [insoluble] problems of the work).³⁶ He is also the “soul of the bodies,” the “anima vitalis,”³⁷ and Ruland defines him as “spirit which has become earth.”³⁸ He is a spirit that penetrates into the depths of the material world and transforms it. Like the *nous*, he is symbolized by the serpent. In Michael Maier he points the way to the earthly paradise.³⁹ Besides being identified with Hermes Trismegistus,⁴⁰ he is also called the “mediator”⁴¹ and, as the Original Man, the “Hermaphroditic Adam.”⁴² From numerous passages it is clear that Mercurius is as much a fire as a water, both of which aptly characterize the nature of spirit.⁴³

[357] Killing with the sword is a recurrent theme in alchemical literature. The “philosophical egg” is divided with the sword, and with it the “King” is transfixed and the dragon or “corpus” dismembered, the latter being represented as the body of a man whose head and limbs are cut off.⁴⁴ The lion’s paws are likewise cut off with the sword. For the alchemical sword brings about the *olutio* or *separatio* of the elements, thereby restoring the original condition of chaos, so that a new and more perfect body can be produced by a new *impressio formae*, or by a “new imagination.” The sword is therefore that which “kills and vivifies,” and the same is said of the permanent water or mercurial water. Mercurius is the giver of life as well as the destroyer of the old form. In ecclesiastical symbolism the sword which comes out of the mouth of the Son of Man in the Book of Revelation is, according to Hebrews 4:12, the Logos, the Word of God, and hence Christ himself. This analogy did not escape the notice of the alchemists, who were always struggling to give expression to their fantasies. Mercurius was their mediator and saviour, their *filius macrocosmi* (contrasted with Christ the *filius microcosmi*),⁴⁵ the solver and separator. So he too is a sword, for he is a “penetrating spirit” (“more piercing than a two-edged sword”!). Gerhard Dorn, an alchemist of the sixteenth century, says that in our world the sword was changed into Christ our Saviour. He comments as follows:

After a long interval of time the Deus Optimus Maximus immersed himself in the innermost of his secrets, and he decided, out of the compassion of his love as well as for the demands of justice, to take the sword of wrath from the hand of the angel. And having hung the sword on the tree, he substituted for it a golden trident, and thus was the wrath of God changed into love.... When peace and justice were united, the water of Grace flowed more abundantly from above, and now it bathes the whole world.⁴⁶

[358] This passage, which might well have occurred in an author like Rabanus Maurus or Honorius of Autun without doing them discredit, actually occurs in a context which throws light on certain esoteric alchemical doctrines, namely in a colloquy between Animus, Anima, and Corpus. There we are told that it is Sophia, the Sapientia, Scientia, or Philosophia of the alchemists, “de cuius fonte scaturiunt aquae” (from whose fount the waters gush forth). This Wisdom is the *nous* that lies hidden and bound in matter, the “serpens mercurialis” or “humidum radicale” that manifests itself in the “viventis aquae fluvius de montis apice” (stream of living water from the summit of the mountain).⁴⁷ That is the water of grace, the “permanent” and “divine” water which “now bathes the whole world.” The apparent transformation of the God of the Old Testament into the God of the New is in reality the transformation of the *deus absconditus* (i.e., the *natura abscondita*) into the *medicina catholica* of alchemical wisdom.⁴⁸

[359] The divisive and separative function of the sword, which is of such importance in alchemy, is prefigured in the flaming sword of the angel that separated our first parents from paradise. Separation by a sword is a theme that can also be found in the Gnosis of the Ophites: the earthly cosmos is surrounded by a ring of fire which at the same time encloses paradise. But paradise and the ring of fire are separated by the “flaming sword.”⁴⁹ An important interpretation of this flaming sword is given in Simon Magus:⁵⁰ there is an incorruptible essence potentially present in every human being, the divine *pneuma* “which is stationed above and below in the stream of water.” Simon says of this *pneuma*: “I and thou, thou before me. I, who am after thee.” It is a force “that generates itself, that causes itself to grow; it is its own mother, sister, bride, daughter; its own son, mother, father; a unity, a root of the whole.” It is the very ground of existence, the procreative urge, which is of fiery origin. Fire is related to blood, which “is fashioned warm and ruddy like fire.” Blood turns into semen in men, and in women into milk. This “turning” is interpreted as “the flaming sword which turned every way, to keep the way of the tree of life.”⁵¹ The operative principle in semen and milk turns into mother and father. The tree of life is guarded by the turning (i.e., transforming) sword, and this is the “seventh power” which begets itself. “For if the flaming sword turned not, then would that fair Tree be destroyed, and perish utterly; but if it turneth into semen and milk, and there be added the Logos and the place of the Lord where the Logos is begotten, he who dwelleth potentially in the semen and milk shall grow to full stature from the littlest spark, and shall increase and become a power boundless and immutable, like to an unchanging Aeon, which suffereth no more change until measureless eternity.”⁵² It is clear from these remarkable statements of Hippolytus concerning the teachings of Simon Magus that the sword is very much more than an instrument which divides; it is itself the force which “turns” from something infinitesimally small into the

infinitely great: from water, fire, and blood it becomes the limitless aeon. What it means is the transformation of the vital spirit in man into the Divine. The natural being becomes the divine *pneuma*, as in the vision of Zosimos. Simon's description of the creative *pneuma*, the true arcane substance, corresponds in every detail to the uroboros or *serpens mercurialis* of the Latinists. It too is its own father, mother, son, daughter, brother, and sister from the earliest beginnings of alchemy right down to the end.⁵³ It begets and sacrifices itself and is its own instrument of sacrifice, for it is a symbol of the deadly and life-giving water.⁵⁴

[360] Simon's ideas also throw a significant light on the above-quoted passage from Dorn, where the sword of wrath is transformed into Christ. Were it not that the philosophoumena of Hippolytus were first discovered in the nineteenth century, on Mount Athos, one might almost suppose that Dorn had made use of them. There are numerous other symbols in alchemy whose origin is so doubtful that one does not know whether to attribute them to tradition, or to a study of the heresiologists, or to spontaneous revival.⁵⁵

[361] The sword as the "proper" instrument of sacrifice occurs again in the old treatise entitled "Consilium coniugii de massa solis et lunae." This says: "Both must be killed with their own sword" ("both" referring to Sol and Luna).⁵⁶ In the still older "Tractatus Micreris,"⁵⁷ dating perhaps from the twelfth century, we find the "fiery sword" in a quotation from Ostanes: "The great Astanus [Ostanes] said: Take an egg, pierce it with the fiery sword, and separate its soul from its body."⁵⁸ Here the sword is something that divides body and soul, corresponding to the division between heaven and earth, the ring of fire and paradise, or paradise and the first parents. In an equally old treatise, the "Allegoriae sapientum ... supra librum Turbae," there is even mention of a sacrificial rite: "Take a fowl [*volatile*], cut off its head with the fiery sword, then pluck out its feathers, separate the limbs, and cook over a charcoal fire till it becomes of one colour."⁵⁹ Here we have a decapitation with the fiery sword, then a "clipping," or more accurately a "plucking," and finally a "cooking." The cock, which is probably what is meant here, is simply called "volatile," a fowl or winged creature, and this is a common term for spirit, but a spirit still nature-bound and imperfect, and in need of improvement. In another old treatise, with the very similar title "Allegoriae super librum Turbae,"⁶⁰ we find the following supplementary variants: "Kill the mother [the *prima materia*], tearing off her hands and feet." "Take a viper ... cut off its head and tail." "Take a cock ... and pluck it alive." "Take a man, shave him, and drag him over the stone [i.e., dry him on the hot stone] till his body dies." "Take the glass vessel containing bridegroom and bride, throw them into the furnace, and roast them for three days, and they will be two in one flesh." "Take the white man from the vessel."⁶¹

[362] One is probably right in assuming that these recipes are instructions for magical sacrifices, not unlike the Greek magic papyri.⁶² As an example of the latter I will give the recipe from the Mimaut Papyrus (li. 2ff.): “Take a tomcat and make an Osiris of him⁶³ [by immersing] his body in water. And when you proceed to suffocate him, talk into his back.” Another example from the same papyrus (li. 425): “Take a hoopoe, tear out its heart, pierce it with a reed, then cut it up and throw it into Attic honey.”

[363] Such sacrifices really were made for the purpose of summoning up the *paredros*, the familiar spirit. That this sort of thing was practised, or at any rate recommended, by the alchemists is clear from the “Liber Platonis quartorum,” where it speaks of the “oblaciones et sacrificia” offered to the planetary demon. A deeper and more sombre note is struck in the following passage, which I give in the original (and generally very corrupt) text.⁶⁴

Vas ... oportet esse rotundae figurae: Ut sit artifex huius mutator firmamenti et testae capitis, ut cum sit res, qua indigemus, res simplex, habens partes similes, necesse est ipsius generationem, et in corpore habente similes partibus ... proiicies ex testa capitis, videlicet capitis elementi hominis et massetur totum cum urina ...

(The vessel ... must be round in -shape. Thus the artifex must be the transformer of this firmament and of the brain-pan, just as the thing for which we seek is a simple thing having uniform parts. It is therefore necessary that you should generate it in a body [i.e., a vessel] of uniform parts ... from the brain-pan, that is, from the head of the element Man, and that the whole should be macerated with urine ...)

[364] One asks oneself how literally this recipe is to be taken.⁶⁵ The following story from the “Ghāya al-hakīm” is exceedingly enlightening in this connection:

[365] The Jacobite patriarch Dionysius I set it on record that in the year 765, a man who was destined for the sacrifice, on beholding the bloody head of his predecessor, was so terrified that he took flight and lodged a complaint with Abbas, the prefect of Mesopotamia, against the priests of Harran, who were afterwards severely punished. The story goes on to say that in 830 the Caliph Mamun told the Harranite envoys: “You are without doubt the people of the head, who were dealt with by my father Rashid.” We learn from the “Ghāya” that a fair-haired man with dark-blue eyes was lured into a chamber of the temple, where he was immersed in a great jar filled with sesame oil. Only his head was left sticking out. There he remained for forty days, and during this time was fed on nothing but figs soaked in sesame oil. He was not given a drop of water to drink. As a result of this treatment his body became as soft as wax. The prisoner was repeatedly fumigated with incense, and magical formulae were pronounced over him. Eventually his head was torn off at the neck, the body remaining in the oil. The head was then placed in a niche on the ashes of burnt olives, and was packed round with cotton wool. More incense was burned before it, and the head would thereupon predict famines or good harvests, changes of dynasty, and other future events. Its eyes could see, though the lids did not move. It also revealed

to people their inmost thoughts, and scientific and technical questions were likewise addressed to it.⁶⁶

[366] Even though it is possible that the real head was, in later times, replaced by a dummy, the whole idea of this ceremony, particularly when taken in conjunction with the above passage from the “Liber quartorum,” seems to point to an original human sacrifice. The idea of a mysterious head is, however, considerably older than the school of Harran. As far back as Zosimos we find the philosophers described as “children of the golden head,” and we also encounter the “round element,” which Zosimos says is the letter omega (Ω). This symbol may well be interpreted as the head, since the “Liber quartorum” also associates the round vessel with the head. Zosimos, moreover, refers on several occasions to the “whitest stone, which is in the head.”⁶⁷ Probably all these ideas go back to the severed head of Osiris, which crossed the sea and was therefore associated with the idea of resurrection. The “head of Osiris” also plays an important part in medieval alchemy.

[367] In this connection we might mention the legend that was current about Gerbert of Rheims, afterwards Pope Sylvester II (d. 1003). He was believed to have possessed a golden head which spoke to him in oracles. Gerbert was one of the greatest savants of his time, and well known as a transmitter of Arabic science.⁶⁸ Can it be that the translation of the “Liber quartorum,” which is of Harranite origin, goes back to this author? Unfortunately there is little prospect of our being able to prove this.

[368] It has been conjectured that the Harranite oracle head may be connected with the ancient Hebrew teraphim. Rabbinic tradition considers the teraphim to have been originally either the decapitated head or skull of a human being, or else a dummy head.⁶⁹ The Jews had teraphim about the house as a sort of lares and penates (who were plural spirits, like the Cabiri). The idea that they were heads goes back to I Samuel 19:13f., which describes how Michal, David’s wife, put the teraphim in David’s bed in order to deceive the messengers of Saul, who wanted to kill him. “Then Michal took an image and laid it on the bed and put a pillow of goats’ hair at its head, and covered it with the clothes (RSV).” The “pillow of goats’ hair” is linguistically obscure and has even been interpreted as meaning that the teraphim were goats. But it may also mean something woven or plaited out of goats’ hair, like a wig, and this would fit in better with the picture of a man lying in bed. Further evidence for this comes from a legend in a collection of midrashim from the twelfth century, printed in Bin Gorion’s *Die Sagen der Juden*. There it is said:

The teraphim were idols, and they were made in the following way. The head of a man, who had to be a first-born, was cut off and the hair plucked out. The head was then sprinkled with salt and anointed with oil. Afterwards a little plaque, of copper or gold, was inscribed with the name of an idol and placed under the tongue of the

decapitated head. The head was set up in a room, candles were lit before it, and the people made obeisance. And if any man fell down before it, the head began to speak, and answered all questions that were addressed to it.⁷⁰

[369] This is an obvious parallel to the Harranite ritual with the head. The tearing out of the hair seems significant, since it is an equivalent of scalping or shearing, and is thus a rebirth mystery. It is conceivable that in later times the bald skull was covered with a wig for a rite of renewal, as is also reported from Egypt.

[370] It seems probable that this magical procedure is of primitive origin. I am indebted to the South African writer, Laurens van der Post, for the following report from a lecture which he gave in Zurich in 1951:

The tribe in question was an offshoot of the great Swazi nation—a Bantu people. When, some years ago, the old chief died, he was succeeded by his son, a young man of weak character. He soon proved to be so unsatisfactory a chief that his uncles called a meeting of the tribal elders. They decided that something must be done to strengthen their chief, so they consulted the witch doctors. The witch doctors treated him with a medicine which proved ineffective. Another meeting was held and the witch doctors were asked to use the strongest medicine of all on the chief because the situation was becoming desperate. A half brother of the chief, a boy of twelve, was chosen to provide the material for the medicine.

One afternoon a sorcerer went up to the boy, who was tending cattle, and engaged him in conversation. Then, emptying some powder from a horn into his hand, he took a reed and blew the powder into the ears and nostrils of the boy. A witness told me that the lad thereupon began to sway like a drunken person and sank to the ground shivering. He was then taken to the river bed and tied to the roots of a tree. More powder was sprinkled round about, the sorcerer saying: “This person will no longer eat food but only earth and roots.”

The boy was kept in the river bed for nine months. Some people say a cage was made and put into the stream, with the boy inside it, for hours on end, so that the water should flow over him and make his skin white. Others reported seeing him crawling about in the river bed on his hands and knees. But all were so frightened that, although there was a mission school only one hundred yards away, no one except those directly concerned in the ritual would go near him. All are agreed that at the end of nine months this fat, normal, healthy boy was like an animal and quite white-skinned. One woman said, “His eyes were white and the whole of his body was white as white paper.”

On the evening that the boy was to be killed a veteran witch doctor was summoned to the chief’s kraal and asked to consult the tribal spirits. This he did in the cattle kraal, and after selecting an animal for slaughter he retired to the chief’s hut. There the witch doctor was handed parts of the dead boy’s body: first the head in a sack, then a thumb and a toe. He cut off the nose and ears and lips, mixed them with medicine, and cooked them over a fire in a broken clay pot. He stuck two spears on either side of the pot. Then those present—twelve in all including the weak chief—leaned over the pot and deeply inhaled the steam. All save the boy’s mother dipped their fingers in the pot and licked them. She inhaled but refused to dip her fingers in the pot. The rest of the body the witch doctor mixed into a kind of bread for doctoring the tribe’s crops.

[371] Although this magical rite is not actually a “head mystery,” it has several things in common with the practices previously mentioned. The body is macerated and

transformed by long immersion in water. The victim is killed, and the salient portions of the head form the main ingredient of the “strengthening” medicine which was concocted for the chief and his immediate circle. The body is kneaded into a sort of bread, and this is obviously thought of as a strengthening medicine for the tribe’s crops as well. The rite is a transformation process, a sort of rebirth after nine months of incubation in the water. Laurens van der Post thinks that the purpose of the “whitening”⁷¹ was to assimilate the mana of the white man, who has the political power. I agree with this view, and would add that painting with white clay often signifies transformation into ancestral spirits, in the same way as the neophytes are made invisible in the Nandi territory, in Kenya, where they walk about in portable, cone-shaped grass huts and demonstrate their invisibility to everyone.

[372] Skull worship is widespread among primitives. In Melanesia and Polynesia it is chiefly the skulls of the ancestors that are worshipped, because they establish connections with the spirits or serve as tutelary deities, like the head of Osiris in Egypt. Skulls also play a considerable role as sacred relics. It would lead us too far to go into this primitive skull worship, so I must refer the reader to the literature.⁷² I would only like to point out that the cut-off ears, nose, and mouth can represent the head as parts that stand for the whole. There are numerous examples of this. Equally, the head or its parts (brain, etc.) can act as magical food or as a means for increasing the fertility of the land.

[373] It is of special significance for the alchemical tradition that the oracle head was also known in Greece. Aelian⁷³ reports that Cleomenes of Sparta had the head of his friend Archonides preserved in a jar of honey, and that he consulted it as an oracle. The same was said of the head of Orpheus. Onians⁷⁴ rightly emphasizes the fact that the *ψυχή*, whose seat was in the head, corresponds to the modern “unconscious,” and that at that stage of development consciousness was identified with *θυμός* (breath) and *φρένες* (lungs), and was localized in the chest or heart region. Hence Pindar’s expression for the soul—*αἰωνος εἶδωλον* (image of Aion)—is extraordinarily apt, for the collective unconscious not only imparts “oracles” but forever represents the microcosm (i.e., the form of a physical man mirroring the Cosmos).

[374] There is no evidence to show that any of the parallels we have drawn are historically connected with the Zosimos visions. It seems rather to be a case partly of parallel traditions (transmitted, perhaps, chiefly through the Harran school), and partly of spontaneous fantasies arising from the same archetypal background from which the traditions were derived in the first place. As my examples have shown, the imagery of the Zosimos visions, however strange it may be, is by no means isolated, but is interwoven with older ideas some of which were certainly, and others quite possibly, known to Zosimos, as well as with parallels of uncertain date which

continued to mould the speculations of the alchemists for many centuries to come. Religious thought in the early Christian era was not completely cut off from all contact with these conceptions; it was in fact influenced by them, and in turn it fertilized the minds of the natural philosophers during later centuries. Towards the end of the sixteenth century the alchemical *opus* was even represented in the form of a Mass. The author of this tour de force was the Hungarian alchemist, Melchior Cibinensis. I have elaborated this parallel in my book *Psychology and Alchemy*.⁷⁵

[375] In the visions of Zosimos, the Hieres who is transformed into *pneuma* represents the transformative principle at work in nature and the harmony of opposing forces. Chinese philosophy formulated this process as the enantiodromian interplay of Yin and Yang.⁷⁶ But the curious personifications and symbols characteristic not only of these visions but of alchemical literature in general show in the plainest possible terms that we are dealing with a psychic process that takes place mainly in the unconscious and therefore can come into consciousness only in the form of a dream or vision. At that time and until very much later no one had any idea of the unconscious; consequently all unconscious contents were projected into the object, or rather were found in nature as apparent objects or properties of matter and were not recognized as purely internal psychic events. There is some evidence that Zosimos was well aware of the spiritual or mystical side of his art, but he believed that what he was concerned with was a spirit that dwelt in natural objects, and not something that came from the human psyche. It remained for modern science to despiritualize nature through its so-called objective knowledge of matter. All anthropomorphic projections were withdrawn from the object one after another, with a twofold result: firstly man's mystical identity with nature⁷⁷ was curtailed as never before, and secondly the projections falling back into the human soul caused such a terrific activation of the unconscious that in modern times man was compelled to postulate the existence of an unconscious psyche. The first beginnings of this can be seen in Leibniz and Kant, and then, with mounting intensity, in Schelling Carus, and von Hartmann, until finally modern psychology discarded the last metaphysical claims of the philosopher-psychologists and restricted the idea of the psyche's existence to the psychological statement, in other words, to its phenomenology. So far as the dramatic course of the Mass represents the death, sacrifice and resurrection of a god and the inclusion and active participation of the priest and congregation, its phenomenology may legitimately be brought into line with other fundamentally similar, though more primitive, religious customs. This always involves the risk that sensitive people will find it unpleasant when "small things are compared with great." In fairness to the primitive psyche, however, I would like to emphasize that the "holy dread" of civilized man differs but little from the awe of the primitive, and that the God who is present and active in the mystery is a mystery for both. No matter how

crass the outward differences, the similarity or equivalence of meaning should not be overlooked.

4. THE PSYCHOLOGY OF THE MASS

I. GENERAL REMARKS ON THE SACRIFICE

[376] Whereas I kept to the Church's interpretation when discussing the transformation rite in section 2, in the present section I shall treat this interpretation as a symbol. Such a procedure does not imply any evaluation of the content of religious belief. Scientific criticism must, of course, adhere to the view that when something is held as an opinion, thought to be true, or believed, it does not posit the existence of any real fact other than a psychological one. But that does not mean that a *mere nothing* has been produced. Rather, expression has been given to the psychic reality underlying the statement of the belief or rite as its empirical basis. When psychology "explains" a statement of this kind, it does not, in the first place, deprive the *object* of this statement of any reality—on the contrary, it is granted a psychic reality—and in the second place the intended metaphysical *statement* is not, on that account, turned into an hypostasis, since it was never anything more than a psychic phenomenon. Its specifically "metaphysical" coloration indicates that its object is beyond the reach of human perception and understanding except in its psychic mode of manifestation, and therefore cannot be judged. But every science reaches its end in the unknowable. Yet it would not be a science at all if it regarded its temporary limitations as definitive and denied the existence of anything outside them. No science can consider its hypotheses to be the final truth.

[377] The psychological explanation and the metaphysical statement do not contradict one another any more than, shall we say, the physicist's explanation of matter contradicts the as yet unknown or unknowable nature of matter. The very existence of a belief has in itself the reality of a psychic fact. Just what we posit by the concept "psyche" is simply unknowable, for psychology is in the unfortunate position where the observer and the observed are ultimately identical. Psychology has no Archimedean point outside, since all perception is of a psychic nature and we have only indirect knowledge of what is non-psychic.

[378] The ritual event that takes place in the Mass has a dual aspect, human and divine. From the human point of view, gifts are offered to God at the altar, signifying at the same time the self-oblation of the priest and the congregation. The ritual act consecrates both the gifts and the givers. It commemorates and represents the Last Supper which our Lord took with his disciples, the whole Incarnation, Passion, death,

and resurrection of Christ. But from the divine point of view this anthropomorphic action is only the outer shell or husk in which what is really happening is not a human action at all but a divine event. For an instant the life of Christ, eternally existent outside time, becomes visible and is unfolded in temporal succession, but in condensed form, in the sacred action: Christ incarnates as a man under the aspect of the offered substances, he suffers, is killed, is laid in the sepulchre, breaks the power of the underworld, and rises again in glory. In the utterance of the words of consecration the Godhead intervenes, Itself acting and truly present, and thus proclaims that the central event in the Mass is Its act of grace, in which the priest has only the significance of a minister. The same applies to the congregation and the offered substances: they are all ministering causes of the sacred event. The presence of the Godhead binds all parts of the sacrificial act into a mystical unity, so that it is God himself who offers himself as a sacrifice in the substances, in the priest, and in the congregation, and who, in the human form of the Son, offers himself as an atonement to the Father.

[379] Although this act is an eternal happening taking place within the divinity, man is nevertheless included in it as an essential component, firstly because God clothes himself in our human nature, and secondly because he needs the ministering cooperation of the priest and congregation, and even the material substances of bread and wine which have a special significance for man. Although God the Father is of one nature with God the Son, he appears in time on the one hand as the eternal Father and on the other hand as a man with limited earthly existence. Mankind as a whole is included in God's human nature, which is why man is also included in the sacrificial act. Just as, in the sacrificial act, God is both *agens* and *patiens*, so too is man according to his limited capacity. The *causa efficiens* of the transubstantiation is a spontaneous act of God's grace. Ecclesiastical doctrine insists on this view and even tends to attribute the preparatory action of the priest, indeed the very existence of the rite, to divine prompting,¹ rather than to slothful human nature with its load of original sin. This view is of the utmost importance for a psychological understanding of the Mass. Wherever the magical aspect of a rite tends to prevail, it brings the rite nearer to satisfying the individual ego's blind greed for power, and thus breaks up the mystical body of the Church into separate units. Where, on the other hand, the rite is conceived as the action of God himself, the human participants have only an instrumental or "ministering" significance. The Church's view therefore presupposes the following psychological situation: human consciousness (represented by the priest and congregation) is confronted with an autonomous event which, taking place on a "divine" and "timeless" plane transcending consciousness, is in no way dependent on human action, but which impels man to act by seizing upon him as an instrument and making him the exponent of a "divine" happening. In the ritual action

man places himself at the disposal of an autonomous and “eternal” agency operating outside the categories of human consciousness—*si parva licet componere magnis*—in much the same way that a good actor does not merely represent the drama, but allows himself to be overpowered by the genius of the dramatist. The beauty of the ritual action is one of its essential properties, for man has not served God rightly unless he has also served him in beauty. Therefore the rite has no practical utility, for that would be making it serve a purpose—a purely human category. But everything divine is an end-in-itself, perhaps the only legitimate end-in-itself we know. How something eternal can “act” at all is a question we had better not touch, for it is simply unanswerable. Since man, in the action of the Mass, is a tool (though a tool of his own free will), he is not in a position to know anything about the hand which guides him. The hammer cannot discover within itself the power which makes it strike. It is something outside, something autonomous, which seizes and moves him. What happens in the consecration is essentially a miracle, and is meant to be so, for otherwise we should have to consider whether we were not conjuring up God by magic, or else lose ourselves in philosophical wonder how anything eternal can act at all, since action is a process in time with a beginning, a middle, and an end. It is necessary that the transubstantiation should be a cause of wonder and a miracle which man can in no wise comprehend. It is a *mysterium* in the sense of a *δρῶμενον* and *δεικνύμενον*, a secret that is acted and displayed. The ordinary man is not conscious of anything in himself that would cause him to perform a “mystery.” He can only do so if and when *it* seizes upon *him*. This seizure, or rather the sensed or presumed existence of a power outside consciousness which seizes him, is the miracle par excellence, really and truly a miracle when one considers *what* is being represented. What in the world could induce us to represent an absolute impossibility? What is it that for thousands of years has wrung from man the greatest spiritual effort, the loveliest works of art, the profoundest devotion, the most heroic self-sacrifice, and the most exacting service? What else but a miracle? It is a miracle which is not man’s to command; for as soon as he tries to work it himself, or as soon as he philosophizes about it and tries to comprehend it intellectually, the bird is flown. A miracle is something that arouses man’s wonder precisely because it seems inexplicable. And indeed, from what we know of human nature we could never explain why men are constrained to such statements and to such beliefs. (I am thinking here of the impossible statements made by all religions.) There must be some compelling reason for this, even though it is not to be found in ordinary experience. The very absurdity and impossibility of the statements vouches for the existence of this reason. That is the real ground for belief, as was formulated most brilliantly in Tertullian’s “*prorsus credibile, quia ineptum.*”² An improbable opinion has to submit sooner or later to correction. But the statements of religion are the most improbable of all and yet they persist for thousands of years.³ Their wholly

unexpected vitality proves the existence of a sufficient cause which has so far eluded scientific investigation. I can, as a psychologist, only draw attention to this fact and emphasize my belief that there are no facile “nothing but” explanations for psychic phenomena of this kind.

[380] The dual aspect of the Mass finds expression not only in the contrast between human and divine action, but also in the dual aspect of God and the God-man, who, although they are by nature a unity, nevertheless represent a duality in the ritual drama. Without this “dichotomy of God,” if I may use such a term, the whole act of sacrifice would be inconceivable and would lack actuality. According to the Christian view God has never ceased to be God, not even when he appeared in human form in the temporal order. The Christ of the Johannine gospel declares: “I and my Father are one. He that hath seen me hath seen the Father” (John 10:30, 14:9). And yet on the Cross Christ cries out: “My God, my God, why hast thou forsaken me?” This contradiction must exist if the formula “very God and very man” is psychologically true. And if it is true, then the different sayings of Christ are in no sense a contradiction. Being “very man” means being at an extreme remove and utterly different from God. “De profundis clamavi ad te, Domine”—this cry demonstrates both, the remoteness and the nearness, the outermost darkness and the dazzling spark of the Divine. God in his humanity is presumably so far from himself that he has to seek himself through absolute self-surrender. And where would God’s wholeness be if he could not be the “wholly other”? Accordingly it is with some psychological justification, so it seems to me, that when the Gnostic Nous fell into the power of Physis he assumed the dark chthonic form of the serpent, and the Manichaean “Original Man” in the same situation actually took on the qualities of the Evil One. In Tibetan Buddhism all gods without exception have a peaceful and a wrathful aspect, for they reign over all the realms of being. The dichotomy of God into divinity and humanity and his return to himself in the sacrificial act hold out the comforting doctrine that in man’s own darkness there is hidden a light that shall once again return to its source, and that this light actually *wanted* to descend into the darkness in order to deliver the Enchained One who languishes there, and lead him to light everlasting. All this belongs to the stock of pre-Christian ideas, being none other than the doctrine of the “Man of Light,” the Anthropos or Original Man, which the sayings of Christ in the gospels assume to be common knowledge.

II. THE PSYCHOLOGICAL MEANING OF SACRIFICE

(a) *The Sacrificial Gifts*

[381] Kramp, in his book on the Roman liturgy, makes the following observations about the substances symbolizing the sacrifice:

Now bread and wine are not only the ordinary means of subsistence for a large portion of humanity, they are also to be had all over the earth (which is of the greatest significance as regards the worldwide spread of Christianity). Further, the two together constitute the perfect food of man, who needs both solid and liquid sustenance. Because they can be so regarded as the typical food of man, they are best fitted to serve as a symbol of human life and human personality, a fact which throws significant light on the gift-symbol.⁴

[382] It is not immediately apparent why precisely bread and wine should be a “symbol of human life and human personality.” This interpretation looks very like a conclusion *a posteriori* from the special meaning which attaches to these substances in the Mass. In that case the meaning would be due to the liturgy and not to the substances themselves, for no one could imagine that bread and wine, in themselves, signify human life or human personality. But, in so far as bread and wine are important products of culture, they do express a vital human striving. They represent a definite cultural achievement which is the fruit of attention, patience, industry, devotion, and laborious toil. The words “our daily bread” express man’s anxious care for his existence. By producing bread he makes his life secure. But in so far as he “does not live by bread alone,” bread is fittingly accompanied by wine, whose cultivation has always demanded a special degree of attention and much painstaking work. Wine, therefore, is equally an expression of cultural achievement. Where wheat and the vine are cultivated, civilized life prevails. But where agriculture and vine-growing do not exist, there is only the uncivilized life of nomads and hunters.

[383] So in offering bread and wine man is in the first instance offering up the products of his culture, the best, as it were, that human industry produces. But the “best” can be produced only by the best in man, by his conscientiousness and devotion. Cultural products can therefore easily stand for the psychological conditions of their production, that is, for those human virtues which alone make man capable of civilization.⁵

[384] As to the special nature of these substances, bread is undoubtedly a food. There is a popular saying that wine “fortifies,” though not in the same sense as food “sustains.” It stimulates and “makes glad the heart of man” by virtue of a certain volatile substance which has always been called “spirit.” It is thus, unlike innocuous water, an “inspiring” drink, for a spirit or god dwells within it and produces the ecstasy of intoxication. The wine miracle at Cana was the same as the miracle in the temple of Dionysus, and it is profoundly significant that, on the Damascus Chalice, Christ is enthroned among vine tendrils like Dionysus himself.⁶ Bread therefore represents the physical means of subsistence, and wine the spiritual. The offering up of bread and wine is the offering of both the physical and the spiritual fruits of civilization.

[385] But, however sensible he was of the care and labour lavished upon them, man could hardly fail to observe that these cultivated plants grew and flourished according to an inner law of their own, and that there was a power at work in them which he compared to his own life breath or vital spirit. Frazer has called this principle, not unjustly, the “corn spirit.” Human initiative and toil are certainly necessary, but even more necessary, in the eyes of primitive man, is the correct and careful performance of the ceremonies which sustain, strengthen, and propitiate the vegetation numen.⁷ Grain and wine therefore have something in the nature of a soul, a specific life principle which makes them appropriate symbols not only of man’s cultural achievements, but also of the seasonally dying and resurgent god who is their life spirit. Symbols are never simple—only signs and allegories are simple. The symbol always covers a complicated situation which is so far beyond the grasp of language that it cannot be expressed at all in any unambiguous manner.⁸ Thus the grain and wine symbols have a fourfold layer of meaning:

1. as agricultural products;
2. as products requiring special processing (bread from grain, wine from grapes);
3. as expressions of psychological achievement (work, industry, patience, devotion, etc.) and of human vitality in general;
4. as manifestations of mana or of the vegetation daemon.

[386] From this list it can easily be seen that a symbol is needed to sum up such a complicated physical and psychic situation. The simplest symbolical formula for this is “bread and wine,” giving these words the original complex significance which they have always had for tillers of the soil.

(b) The Sacrifice

[387] It is clear from the foregoing that the sacrificial gift is symbolic, and that it embraces everything which is expressed by the symbol, namely the physical product, the processed substance, the psychological achievement, and the autonomous, daemonic life principle of cultivated plants. The value of the gift is enhanced when it is the best or the first fruits. Since bread and wine are the best that agriculture can offer, they are by the same token man’s best endeavour. In addition, bread symbolizes the visible manifestation of the divine numen which dies and rises again, and wine the presence of a pneuma which promises intoxication and ecstasy.⁹ The classical world thought of this pneuma as Dionysus, particularly the suffering Dionysus Zagreus, whose divine substance is distributed throughout the whole of nature. In short, what is sacrificed under the forms of bread and wine is nature, man, and God, all combined in the unity of the symbolic gift.

[388] The offering of so significant a gift at once raises the question: Does it lie within man's power to offer such a gift at all? Is he psychologically competent to do so? The Church says no, since she maintains that the sacrificing priest is Christ himself. But, since man is included in the gift—included, as we have seen, twice over—the Church also says yes, though with qualifications. On the side of the sacrificer there is an equally complicated, symbolic state of affairs, for the symbol is Christ himself, who is both the sacrificer and the sacrificed. This symbol likewise has several layers of meaning which I shall proceed to sort out in what follows.

[389] The act of making a sacrifice consists in the first place in giving something which belongs to me. Everything which belongs to me bears the stamp of “mineness,” that is, it has a subtle identity with my ego. This is vividly expressed in certain primitive languages, where the suffix of animation is added to an object—a canoe, for instance—when it belongs to me, but not when it belongs to somebody else. The affinity which all the things bearing the stamp of “mineness” have with my personality is aptly characterized by Lévy-Bruhl¹⁰ as *participation mystique*. It is an irrational, unconscious identity, arising from the fact that anything which comes into contact with me is not only itself, but also a symbol. This symbolization comes about firstly because every human being has unconscious contents, and secondly because every object has an unknown side. Your watch, for instance. Unless you are a watchmaker, you would hardly presume to say that you know how it works. Even if you do, you wouldn't know anything about the molecular structure of the steel unless you happened to be a mineralogist or a physicist. And have you ever heard of a scientist who knew how to repair his pocket watch? But where two unknowns come together, it is impossible to distinguish between them. The unknown in man and the unknown in the thing fall together in one. Thus there arises an unconscious identity which sometimes borders on the grotesque. No one is permitted to touch what is “mine,” much less use it. One is affronted if “my” things are not treated with sufficient respect. I remember once seeing two Chinese rickshaw boys engaged in furious argument. Just as they were about to come to blows, one of them gave the other's rickshaw a violent kick, thus putting an end to the quarrel. So long as they are unconscious our unconscious contents are always projected, and the projection fixes upon everything “ours,” inanimate objects as well as animals and people. And to the extent that “our” possessions are projection carriers, they are *more* than what they are in themselves, and function as such. They have acquired several layers of meaning and are therefore symbolical, though this fact seldom or never reaches consciousness. In reality, our psyche spreads far beyond the confines of the conscious mind, as was apparently known long ago to the old alchemist who said that the soul was for the greater part outside the body.¹¹

[390] When, therefore, I give away something that is “mine,” what I am giving is essentially a symbol, a thing of many meanings; but, owing to my unconsciousness of its symbolic character, it adheres to my ego, because it is part of my personality. Hence there is, explicitly or implicitly, a personal claim bound up with every gift. There is always an unspoken “give that thou mayest receive.” Consequently the gift always carries with it a personal intention, for the mere giving of it is not a sacrifice. It only becomes a sacrifice if I give up the implied intention of receiving something in return. If it is to be a true sacrifice, the gift must be given as if it were being destroyed.¹² Only then is it possible for the egoistic claim to be given up. Were the bread and wine simply given without any consciousness of an egoistic claim, the fact that it was unconscious would be no excuse, but would on the contrary be sure proof of the existence of a *secret* claim. Because of its egoistic nature, the offering would then inevitably have the character of a magical act of propitiation, with the unavowed purpose and tacit expectation of purchasing the good will of the Deity. That is an ethically worthless simulacrum of sacrifice, and in order to avoid it the giver must at least make himself sufficiently conscious of his identity with the gift to recognize how far he is *giving himself up* in giving the gift. In other words, out of the natural state of identity with what is “mine” there grows the ethical task of sacrificing oneself, or at any rate that part of oneself which is identical with the gift. One ought to realize that when one gives or surrenders oneself there are corresponding claims attached, the more so the less one knows of them. The conscious realization of this alone guarantees that the giving is a real sacrifice. For if I know and admit that I am giving myself, forgoing myself, and do not want to be repaid for it, then I have sacrificed my claim, and thus a part of myself. Consequently, all absolute giving, a giving which is a total loss from the start, is a self-sacrifice. Ordinary giving for which no return is received is felt as a loss; but a sacrifice is meant to be like a loss, so that one may be sure that the egoistic claim no longer exists. Therefore the gift should be given as if it were being destroyed. But since the gift represents myself, I have in that case destroyed myself, given myself away without expectation of return. Yet, looked at in another way, this intentional loss is also a gain, for if you can give yourself it proves that you possess yourself. Nobody can give what he has not got. So anyone who can sacrifice himself and forgo his claim must have had it; in other words, he must have been conscious of the claim. This presupposes an act of considerable self-knowledge, lacking which one remains permanently unconscious of such claims. It is therefore quite logical that the confession of sin should come before the rite of transformation in the Mass. The self-examination is intended to make one conscious of the selfish claim bound up with every gift, so that it may be consciously given up; otherwise the gift is no sacrifice. The sacrifice proves that you possess yourself, for it does not mean just letting yourself be passively taken: it is a conscious and deliberate self-surrender, which proves that you have full control of yourself, that

is, of your ego. The ego thus becomes the object of a moral act, for “I” am making a decision on behalf of an authority which is supraordinate to my ego nature. I am, as it were, deciding against my ego and renouncing my claim. The possibility of self-renunciation is an established psychological fact whose philosophical implications I do not propose to discuss. Psychologically, it means that the ego is a relative quantity which can be subsumed under various supraordinate authorities. What are these authorities? They are not to be equated outright with collective moral consciousness, as Freud wanted to do with his superego, but rather with certain psychic conditions which existed in man from the beginning and are not acquired by experience. Behind a man’s actions there stands neither public opinion nor the moral code,¹³ but the personality of which he is still unconscious. Just as a man still is what he always was, so he already is what he will become. The conscious mind does not embrace the totality of a man, for this totality consists only partly of his conscious contents, and for the other and far greater part, of his unconscious, which is of indefinite extent with no assignable limits. In this totality the conscious mind is contained like a smaller circle within a larger one. Hence it is quite possible for the ego to be made into an object, that is to say, for a more compendious personality to emerge in the course of development and take the ego into its service. Since this growth of personality comes out of the unconscious, which is by definition unlimited, the extent of the personality now gradually realizing itself cannot in practice be limited either. But, unlike the Freudian superego, it is still individual. It is in fact individuality in the highest sense, and therefore theoretically limited, since no individual can possibly display *every* quality. (I have called this process of realization the “individuation process.”) So far as the personality is still potential, it can be called transcendent, and so far as it is unconscious, it is indistinguishable from all those things that carry its projections—in other words, the unconscious personality merges with our environment in accordance with the above-named *participation mystique*. This fact is of the greatest practical importance because it renders intelligible the peculiar symbols through which this projected entity expresses itself in dreams. By this I mean the symbols of the outside world and the cosmic symbols. These form the psychological basis for the conception of man as a microcosm, whose fate, as we know, is bound up with the macrocosm through the astrological components of his character.

[391] The term “self” seemed to me a suitable one for this unconscious substrate, whose actual exponent in consciousness is the ego. The ego stands to the self as the moved to the mover, or as object to subject, because the determining factors which radiate out from the self surround the ego on all sides and are therefore supraordinate to it. The self, like the unconscious, is an *a priori* existent out of which the ego evolves. It is, so to speak, an unconscious prefiguration of the ego. It is not I who

create myself, rather I happen to myself. This realization is of fundamental importance for the psychology of religious phenomena, which is why Ignatius Loyola started off his *Spiritual Exercises* with “Homo creatus est” as their “fundamentum.” But, fundamental as it is, it can be only half the psychological truth. If it were the whole truth it would be tantamount to determinism, for if man were merely a creature that came into being as a result of something already existing unconsciously, he would have no freedom and there would be no point in consciousness. Psychology must reckon with the fact that despite the causal nexus man does enjoy a feeling of freedom, which is identical with autonomy of consciousness. However much the ego can be proved to be dependent and preconditioned, it cannot be convinced that it has no freedom. An absolutely preformed consciousness and a totally dependent ego would be a pointless farce, since everything would proceed just as well or even better unconsciously. The existence of ego consciousness has meaning only if it is free and autonomous. By stating these facts we have, it is true, established an antinomy, but we have at the same time given a picture of things as they are. There are temporal, local, and individual differences in the degree of dependence and freedom. In reality both are always present: the supremacy of the self and the hybris of consciousness.

[392] This conflict between conscious and unconscious is at least brought nearer to a solution through our becoming aware of it. Such an act of realization is presupposed in the act of self-sacrifice. The ego must make itself conscious of its claim, and the self must cause the ego to renounce it. This can happen in two ways:

[393] 1. I renounce my claim in consideration of a general moral principle, namely that one must not expect repayment for a gift. In this case the “self” coincides with public opinion and the moral code. It is then identical with Freud’s superego and for this reason it is projected into the environment and therefore remains unconscious as an autonomous factor.

[394] 2. I renounce my claim because I feel impelled to do so for painful inner reasons which are not altogether clear to me. These reasons give me no particular moral satisfaction; on the contrary, I even feel some resistance to them. But I must yield to the power which suppresses my egoistic claim. Here the self is integrated; it is withdrawn from projection and has become perceptible as a determining psychic factor. The objection that in this case the moral code is simply unconscious must be ruled out, because I am perfectly well aware of the moral criticism against which I would have to assert my egoism. Where the ego wish clashes with the moral standard, it is not easy to show that the tendency which suppresses it is individual and not collective. But where it is a case of conflicting loyalties, or we find ourselves in a situation of which the classic example is Hosea’s marriage with the harlot, then the ego wish coincides with the collective moral standard, and Hosea would have been

bound to accuse Jehovah of immorality. Similarly, the unjust steward would have had to admit his guilt. Jesus took a different view.¹⁴ Experiences of this kind make it clear that the self cannot be equated either with collective morality or with natural instinct, but must be conceived as a determining factor whose nature is individual and unique. The superego is a necessary and unavoidable substitute for the experience of the self.

[395] These two ways of renouncing one's egoistic claim reveal not only a difference of attitude, but also a difference of situation. In the first case the situation need not affect me personally and directly; in the second, the gift must necessarily be a very personal one which seriously affects the giver and forces him to overcome himself. In the one case it is merely a question, say, of going to Mass; in the other it is more like Abraham's sacrifice of his son or Christ's decision in Gethsemane. The one may be felt very earnestly and experienced with all piety, but the other is the real thing.¹⁵

[396] So long as the self is unconscious, it corresponds to Freud's superego and is a source of perpetual moral conflict. If, however, it is withdrawn from projection and is no longer identical with public opinion, then one is truly one's own yea and nay. The self then functions as a union of opposites and thus constitutes the most immediate experience of the Divine which it is psychologically possible to imagine.¹⁶

(c) The Sacrificer

[397] What I sacrifice is my own selfish claim, and by doing this I give up myself. Every sacrifice is therefore, to a greater or lesser degree, a self-sacrifice. The degree to which it is so depends on the significance of the gift. If it is of great value to me and touches my most personal feelings, I can be sure that in giving up my egoistic claim I shall challenge my ego personality to revolt. I can also be sure that the power which suppresses this claim, and thus suppresses me, must be the self. Hence it is the self that causes me to make the sacrifice; nay more, it compels me to make it.¹⁷ The self is the sacrificer, and I am the sacrificed gift, the human sacrifice. Let us try for a moment to look into Abraham's soul when he was commanded to sacrifice his only son. Quite apart from the compassion he felt for his child, would not a father in such a position feel himself as the victim, and feel that he was plunging the knife into his own breast? He would be at the same time the sacrificer and the sacrificed.

[398] Now, since the relation of the ego to the self is like that of the son to the father, we can say that when the self calls on us to sacrifice ourselves, it is really carrying out the sacrificial act on itself. We know more or less what this act means to us, but what it means to the self is not so clear. As the self can only be comprehended by us in particular acts, but remains concealed from us as a whole because it is more comprehensive than we are, all we can do is to draw conclusions from the little of the self that we can experience. We have seen that a sacrifice only takes place when we

feel the self actually carrying it out on ourselves. We may also venture to surmise that in so far as the self stands to us in the relation of father to son, the self in some sort feels our sacrifice as a sacrifice of itself. From that sacrifice we gain ourselves—our “self”—for we have only what we give. But what does the self gain? We see it entering into manifestation, freeing itself from unconscious projection, and, as it grips us, entering into our lives and so passing from unconsciousness into consciousness, from potentiality into actuality. What it is in the diffuse unconscious state we do not know; we only know that in becoming ourself it has become man.

[399] This process of becoming human is represented in dreams and inner images as the putting together of many scattered units, and sometimes as the gradual emergence and clarification of something that was always there.¹⁸ The speculations of alchemy, and also of some Gnostics, revolve round this process. It is likewise expressed in Christian dogma, and more particularly in the transformation mystery of the Mass. The psychology of this process makes it easier to understand why, in the Mass, man appears as both the sacrificer and the sacrificed gift, and why it is not man who is these things, but God who is both: why God becomes the suffering and dying man, and why man, through partaking of the Glorified Body, gains the assurance of resurrection and becomes aware of his participation in Godhead.

[400] As I have already suggested, the integration or humanization of the self is initiated from the conscious side by our making ourselves aware of our selfish aims; we examine our motives and try to form as complete and objective a picture as possible of our own nature. It is an act of self-recollection, a gathering together of what is scattered, of all the things in us that have never been properly related, and a coming to terms with oneself with a view to achieving full consciousness. (Unconscious self-sacrifice is merely an accident, not a moral act.) Self-recollection, however, is about the hardest and most repellent thing there is for man, who is predominantly unconscious. Human nature has an invincible dread of becoming more conscious of itself. What nevertheless drives us to it is the self, which demands sacrifice by sacrificing itself to us. Conscious realization or the bringing together of the scattered parts is in one sense an act of the ego's will, but in another sense it is a spontaneous manifestation of the self,¹⁹ which was always there. Individuation appears, on the one hand, as the synthesis of a new unity which previously consisted of scattered particles, and on the other hand, as the revelation of something which existed before the ego and is in fact its father or creator and also its totality. Up to a point we create the self by making ourselves conscious of our unconscious contents, and to that extent it is our son. This is why the alchemists called their incorruptible substance—which means precisely the self—the *filius philosophorum*. But we are forced to make this effort by the unconscious presence of the self, which is all the time urging us to overcome our unconsciousness. From that point of view the self is

the father. This accounts for certain alchemical terms, such as Mercurius Senex (Hermes Trismegistus) and Saturnus, who in Gnosticism was regarded as both greybeard and youth, just as Mercurius was in alchemy. These psychological connections are seen most clearly in the ancient conceptions of the Original Man, the Protanthropos, and the Son of Man. Christ as the Logos is from all eternity, but in his human form he is the “Son of Man.”²⁰ As the Logos, he is the world-creating principle. This corresponds with the relation of the self to consciousness, without which no world could be perceived at all. The Logos is the real *principium individuationis*, because everything proceeds from it, and because everything which is, from crystal to man, exists only in individual form. In the infinite variety and differentiation of the phenomenal world is expressed the essence of the *auctor rerum*. As a correspondence we have, on the one hand, the indefiniteness and unlimited extent of the unconscious self (despite its individuality and uniqueness), its creative relation to individual consciousness, and, on the other hand, the individual human being as a mode of its manifestation. Ancient philosophy paralleled this idea with the legend of the dismembered Dionysus, who, as creator, is the *ἰμέριστος* (undivided) *νοῦς*, and, as the creature, the *μεμερισμένος* (divided) *νοῦς*.²¹ Dionysus is distributed throughout the whole of nature, and just as Zeus once devoured the throbbing heart of the god, so his worshippers tore wild animals to pieces in order to reintegrate his dismembered spirit. The gathering together of the light-substance in Barbelo-Gnosis and in Manichaeism points in the same direction. The psychological equivalent of this is the integration of the self through conscious assimilation of the split-off contents. Self-recollection is a gathering together of the self. It is in this sense that we have to understand the instructions which Monoimos gives to Theophrastus:

Seek him [God] from out thyself, and learn who it is that taketh possession of everything in thee, saying: *my god, my spirit [νοῦς], my understanding, my soul, my body*; and learn whence is sorrow and joy, and love and hate, and waking though one would not, and sleeping though one would not, and getting angry though one would not, and falling in love though one would not. And if thou shouldst closely investigate these things, thou wilt find Him in thyself, the One and the Many, like to that little point, for it is from thee that he hath his origin.²²

[401] Self-reflection or—what comes to the same thing—the urge to individuation gathers together what is scattered and multifarious, and exalts it to the original form of the One, the Primordial Man. In this way our existence as separate beings, our former ego nature, is abolished, the circle of consciousness is widened, and because the paradoxes have been made conscious the sources of conflict are dried up. This approximation to the self is a kind of repristination or apocatastasis, in so far as the self has an “incorruptible” or “eternal” character on account of its being pre-existent to consciousness.²³ This feeling is expressed in the words from the *benedictio fontis*: “Et quos aut sexus in corpore aut aetas discernit in tempore, omnes in unam pariat

gratia mater infantiam” (And may Mother Grace bring forth into one infancy all those whom sex has separated in the body, or age in time).

[402] The figure of the divine sacrificer corresponds feature for feature to the empirical modes of manifestation of the archetype that lies at the root of almost all known conceptions of God. This archetype is not merely a static image, but dynamic, full of movement. It is always a drama, whether in heaven, on earth, or in hell.²⁴

(d) *The Archetype of Sacrifice*

[403] Comparing the basic ideas of the Mass with the imagery of the Zosimos visions, we find that, despite considerable differences, there is a remarkable degree of similarity. For the sake of clearness I give the similarities and differences in tabular form.

Zosimos

Mass

SIMILARITIES

- | | |
|---|--|
| 1. The chief actors are two priests. | 1. There is the priest, and Christ the eternal priest. |
| 2. One priest slays the other. | 2. The <i>Mactatio Christi</i> takes place as the priest pronounces the words of consecration. |
| 3. Other human beings are sacrificed as well. | 3. The congregation itself is a sacrificial gift. |
| 4. The sacrifice is a voluntary self-sacrifice. | 4. Christ offers himself freely as a sacrifice. |
| 5. It is a painful death. | 5. He suffers in the sacrificial act. |
| 6. The victim is dismembered. | 6. Breaking of the Bread. |
| 7. There is a <i>thysia</i> . | 7. Offering up of incense. |
| 8. The priest eats his own flesh. | 8. Christ drinks his own blood (St. Chrysostom). |
| 9. He is transformed into spirit. | 9. The substances are transformed into the body and blood of Christ. |
| 10. A shining white figure appears, like the | 10. The Host is shown as the Beatific Vision (“ <i>Quaesivi vultum tuum, Domine</i> ”) in the |

midday sun.

greater elevation.

11. Production of the
“divine water.”

11. The Grace conferred by the Mass; similarity of
water chalice and font; water a symbol of grace.

DIFFERENCES

1. The whole sacrificial process is an individual dream vision, a fragment of the unconscious depicting itself in dream consciousness.
2. The dreamer is only a spectator of the symbolic action.
3. The action is a bloody and gruesome human sacrifice.
4. The sacrifice is accompanied by a scalping.
5. It is also performed on a dragon, and is therefore an animal sacrifice.
6. The flesh is roasted.
7. The meaning of the sacrifice is the production of the divine water, used for the transmutation of metals and, mystically, for the birth of the self.
8. What is transformed in the vision is presumably the planetary demon Saturn, the supreme Archon (who is related to the God of the Hebrews). It is the dark, heavy, material principle in man—*hyle*—which is transformed into pneuma.

1. The Mass is a conscious artifact, the product of many centuries and many minds.
2. Priest and congregation both participate in the mystery.
3. Nothing obnoxious; the *mactatio* itself is not mentioned. There is only the bloodless sacrifice of bread and wine (*incruente immolatur!*).
4. Nothing comparable.
5. Symbolic sacrifice of the Lamb.
6. The substances are spiritually transformed.
7. The meaning of the Mass is the communion of the living Christ with his flock.
8. What is transformed in the Mass is God, who as Father begat the Son in human form, suffered and died in that form, and rose up again to his origin.

[404] The gross concretism of the vision is so striking that one might easily feel tempted, for aesthetic and other reasons, to drop the comparison with the Mass altogether. If I nevertheless venture to bring out certain analogies, I do so not with the rationalistic intention of devaluing the sacred ceremony by putting it on a level with a piece of pagan nature worship. If I have any aim at all apart from scientific truth, it is

to show that the most important mystery of the Catholic Church rests, among other things, on psychic conditions which are deeply rooted in the human soul.

[405] The vision, which in all probability has the character of a dream, must be regarded as a spontaneous psychic product that was never consciously intended. Like all dreams, it is a product of nature. The Mass, on the other hand, is a product of man's mind or spirit, and is a definitely conscious proceeding. To use an old but not outmoded nomenclature, we can call the vision *psychic*, and the Mass *pneumatic*. The vision is undifferentiated raw material, while the Mass is a highly differentiated artifact. That is why the one is gruesome and the other beautiful. If the Mass is antique, it is antique in the best sense of the word, and its liturgy is therefore satisfying to the highest requirements of the present day. In contrast to this, the vision is archaic and primitive, but its symbolism points directly to the fundamental alchemical idea of the incorruptible substance, namely to the self, which is beyond change. The vision is a piece of unalloyed naturalism, banal, grotesque, squalid, horrifying and profound as nature herself. Its meaning is not clear, but it allows itself to be divined with the abysmal uncertainty and ambiguity that pertain to all things nonhuman, suprahuman, and subhuman. The Mass, on the other hand, represents and clearly expresses the Deity itself, and clothes it in the garment of the most beautiful humanity.

[406] From all this it is evident that the vision and the Mass are two different things, so different as to be almost incommensurable. But if we could succeed in reconstructing the natural process in the unconscious on which the Mass is psychically based, we should probably obtain a picture which would be rather more commensurable with the vision of Zosimos. According to the view of the Church, the Mass is based on the historical events in the life of Jesus. From this "real" life we can single out certain details that add a few concretistic touches to our picture and thus bring it closer to the vision. For instance, I would mention the scourging, the crowning with thorns, and the clothing in a purple robe, which show Jesus as the archaic sacrificed king. This is further emphasized by the Barabbas episode (the name means "son of the father") which leads to the sacrifice of the king. Then there is the agony of death by crucifixion, a shameful and horrifying spectacle, far indeed from any "incruente immolatur"! The right pleural cavity and probably the right ventricle of the heart were cut open by the spear, so that blood clots and serum flowed out. If we add these details to the process which underlies the Mass, we shall see that they form a striking equivalent to certain archaic and barbarous features of the vision. There are also the fundamental dogmatic ideas to be considered. As is shown by the reference to the sacrifice of Isaac in the prayer *Unde et memores*, the sacrifice has the character not only of a human sacrifice, but the sacrifice of a son—and an *only* son. That is the cruellest and most horrible kind of sacrifice we can imagine, so horrible that, as we

know, Abraham was not required to carry it out.²⁵ And even if he had carried it out, a stab in the heart with a knife would have been a quick and relatively painless death for the victim. Even the bloody Aztec ceremony of cutting out the heart was a swift death. But the sacrifice of the son which forms the essential feature of the Mass began with scourging and mockery, and culminated in six hours of suspension on a cross to which the victim was nailed hand and foot—not exactly a quick death, but a slow and exquisite form of torture. As if that were not enough, crucifixion was regarded as a disgraceful death for slaves, so that the physical cruelty is balanced by the moral cruelty.

[407] Leaving aside for the moment the unity of nature of Father and Son—which it is possible to do because they are two distinct Persons who are not to be confused with one another—let us try to imagine the feelings of a father who saw his son suffering such a death, knowing that it was he himself who had sent him into the enemy’s country and deliberately exposed him to this danger. Executions of this kind were generally carried out as an act of revenge or as punishment for a crime, with the idea that both father and son should suffer. The idea of punishment can be seen particularly clearly in the crucifixion between two thieves. The punishment is carried out on God himself, and the model for this execution is the ritual slaying of the king. The king is killed when he shows signs of impotence, or when failure of the crops arouses doubts as to his efficacy. Therefore he is killed in order to improve the condition of his people, just as God is sacrificed for the salvation of mankind.

[408] What is the reason for this “punishment” of God? Despite the almost blasphemous nature of this question, we must nevertheless ask it in view of the obviously punitive character of the sacrifice. The usual explanation is that Christ was punished for our sins.²⁶ The dogmatic validity of this answer is not in question here. As I am in no way concerned with the Church’s explanation, but only wish to reconstruct the underlying psychic process, we must logically assume the existence of a guilt proportionate to the punishment. If mankind is the guilty party, logic surely demands that mankind should be punished. But if God takes the punishment on himself, he exculpates mankind, and we must then conjecture that it is not mankind that is guilty, but God (which would logically explain why he took the guilt on himself). For reasons that can readily be understood, a satisfactory answer is not to be expected from orthodox Christianity. But such an answer may be found in the Old Testament, in Gnosticism, and in late Catholic speculation. From the Old Testament we know that though Yahweh was a guardian of the law he was not just, and that he suffered from fits of rage which he had every occasion to regret.²⁷ And from certain Gnostic systems it is clear that the *auctor rerum* was a lower archon who falsely imagined that he had created a perfect world, whereas in fact it was woefully imperfect. On account of his Saturnine disposition this demiurgic archon has

affinities with the Jewish Yahweh, who was likewise a world creator. His work was imperfect and did not prosper, but the blame cannot be placed on the creature any more than one can curse the pots for being badly turned out by the potter! This argument led to the Marcionite Reformation and to purging the New Testament of elements derived from the Old. Even as late as the seventeenth century the learned Jesuit, Nicolas Caussin, declared that the unicorn was a fitting symbol for the God of the Old Testament, because in his wrath he reduced the world to confusion like an angry rhinoceros (unicorn), until, overcome by the love of a pure virgin, he was changed in her lap into a God of Love.²⁸

[409] In these explanations we find the natural logic we missed in the answer of the Church. God's guilt consisted in the fact that, as creator of the world and king of his creatures, he was inadequate and therefore had to submit to the ritual slaying. For primitive man the concrete king was perfectly suited to this purpose, but not for a higher level of civilization with a more spiritual conception of God. Earlier ages could still dethrone their gods by destroying their images or putting them in chains. At a higher level, however, one god could be dethroned only by another god, and when monotheism developed, God could only transform himself.

[410] The fact that the transformative process takes the form of a "punishment"—Zosimos uses this very word (*κόλασις*)—may be due to a kind of rationalization or a need to offer some explanation of its cruelty. Such a need only arises at a higher level of consciousness with developed feeling, which then seeks an adequate reason for the revolting and incomprehensible cruelty of the procedure. (A modern parallel would be the experience of dismemberment in shamanistic initiations.) The readiest conjecture at this level is that some guilt or sin is being punished. In this way the transformation process acquires a moral function that can scarcely be conceived as underlying the original event. It seems more likely that a higher and later level of consciousness found itself confronted with an experience for which no sensible reasons or explanations had ever been given, but which it tried to make intelligible by weaving into it a moral aetiology. It is not difficult to see that dismemberment originally served the purpose of reconstituting the neophyte as a new and more effective human being. Initiation even has the aspect of a healing.²⁹ In the light of these facts, moral interpretation in terms of punishment seems beside the mark and arouses the suspicion that dismemberment has still not been properly understood. A moral interpretation is inadequate because it fails to understand the contradiction at the heart of its explanation, namely that guilt should be avoided if one doesn't want to be punished. But, for the neophyte, it would be a real sin if he shrank from the torture of initiation. The torture inflicted on him is *not* a punishment but the indispensable means of leading him towards his destiny. Also, these ceremonies often take place at so young an age that a guilt of corresponding proportions is quite out of

the question. For this reason, the moralistic view of suffering as punishment seems to me not only inadequate but misleading. It is obviously a primitive attempt to give a psychological explanation of an age-old archetypal idea that had never before been the object of reflection. Such ideas and rituals, far from ever having been invented, simply happened and were acted long before they were thought. I have seen primitives practising rites of which none of them had the remotest idea what they meant, and in Europe we still find customs whose meaning has always been unconscious. First attempts at explanation usually turn out to be somewhat clumsy.

[411] The aspect of torture, then, is correlated with a detached and observing consciousness that has not yet understood the real meaning of dismemberment. What is performed concretely on the sacrificial animal, and what the shaman believes to be actually happening to himself, appears on a higher level, in the vision of Zosimos, as a psychic process in which a product of the unconscious, an homunculus, is cut up and transformed. By all the rules of dream-interpretation, this is an aspect of the observing subject himself; that is to say, Zosimos sees himself as an homunculus, or rather the unconscious represents him as such, as an incomplete, stunted, dwarfish creature who is made of some heavy material (lead or bronze) and thus signifies the “hylical man.” Such a one is dark, and sunk in materiality. He is essentially unconscious and therefore in need of transformation and enlightenment. For this purpose his body must be taken apart and dissolved into its constituents, a process known in alchemy as the *divisio*, *separatio* and *solutio*, and in later treatises as *discrimination* and *self-knowledge*.³⁰ This psychological process is admittedly painful and for many people a positive torture. But, as always, every step forward along the path of individuation is achieved only at the cost of suffering.

[412] In the case of Zosimos there is of course no real consciousness of the transformative process, as is abundantly clear from his own interpretation of the vision: he thought the dream imagery was showing him the “production of the waters.” We can see from this that he was still exteriorizing the transformation and did not feel it in any way as an alteration of his own psyche.

[413] A similar state of affairs prevails in Christian psychology whenever the rites and dogmas are taken as merely external factors and are not experienced as inner events. But, just as the *imitatio Christi* in general, and the Mass in particular, endeavour to include the believer in the process of transformation, the Mass actually representing him as a sacrificial gift parallel with Christ, so a better understanding of Christianity raises it as high above the sphere of “mind” as the rite of the Mass is above the archaic level of the Zosimos vision. The Mass tries to effect a *participation mystique*—or identity—of priest and congregation with Christ, so that on the one hand the soul is assimilated to Christ and on the other hand the Christ-figure is recollected in

the soul. It is a transformation of God and man alike, since the Mass is, at least by implication, a repetition of the whole drama of Incarnation.

III. THE MASS AND THE INDIVIDUATION PROCESS

[414] Looked at from the psychological standpoint, Christ, as the Original Man (Son of Man, second Adam, *τέλειος ἄνθρωπος*), represents a totality which surpasses and includes the ordinary man, and which corresponds to the total personality that transcends consciousness.³¹ We have called this personality the “self.” Just as, on the more archaic level of the Zosimos vision, the homunculus is transformed into pneuma and exalted, so the mystery of the Eucharist transforms the soul of the empirical man, who is only a part of himself, into his totality, symbolically expressed by Christ. In this sense, therefore, we can speak of the Mass as the *rite of the individuation process*.

[415] Reflections of this kind can be found very early on in the old Christian writings, as for instance in the Acts of John, one of the most important of the apocryphal texts that have come down to us.³² That part of the text with which we are concerned here begins with a description of a mystical “round dance” which Christ instituted before his crucifixion. He told his disciples to hold hands and form a ring, while he himself stood in the centre. As they moved round in a circle, Christ sang a song of praise, from which I would single out the following characteristic verses:³³

I will be saved and I will save, Amen.

I will be loosed and I will loose,³⁴ Amen.

I will be wounded and I will wound, Amen.

I will be begotten and I will beget, Amen.

I will eat and I will be eaten, Amen.

...

I will be thought, being wholly spirit, Amen.

I will be washed and I will wash, Amen.

Grace paces the round. I will blow the pipe. Dance the round all, Amen.

...

The Eight [ogdoad] sings praises with us, Amen.

The Twelve paces the round aloft, Amen.

To each and all it is given to dance, Amen.

Who joins not the dance mistakes the event, Amen.

...

I will be united and I will unite, Amen.

...

A lamp am I to you that perceive me, Amen.

A mirror am I to you that know me, Amen.

A door am I to you that knock on me, Amen.

A way am I to you the wayfarer.

Now as you respond to my dancing, behold yourself in me who speaks ...

As you dance, ponder what I do, for yours is this human suffering which I will to suffer. For you would be powerless to understand your suffering had I not been sent to you as the Logos by the Father.... If you had understood suffering, you would have non-suffering. Learn to suffer, and you shall understand how not to suffer.... Understand the Word of Wisdom in me.³⁵

[416] I would like to interrupt the text here, as we have come to a natural break, and introduce a few psychological remarks. They will help us to understand some further passages that still have to be discussed. Although our text is obviously based on New Testament models, what strikes us most of all is its antithetical and paradoxical style, which has very little in common with the spirit of the Gospels. This feature only appears in a veiled way in the canonical writings, for instance in the parable of the unjust steward (Luke 16), in the Lord's Prayer ("Lead us not into temptation"), in Matthew 10:16 ("Be wise as serpents"), John 10:34 ("Ye are gods"), in the logion of the Codex Bezae to Luke 6:4,³⁶ in the apocryphal saying "Whoso is near unto me is near unto the fire," and so on. Echoes of the antithetical style can also be found in Matthew 10:26: "... for nothing is covered that will not be revealed, or hidden that will not be known."

[417] Paradox is a characteristic of the Gnostic writings. It does more justice to the *unknowable* than clarity can do, for uniformity of meaning robs the mystery of its darkness and sets it up as something that is *known*. That is a usurpation, and it leads the human intellect into hybris by pretending that it, the intellect, has got hold of the transcendent mystery by a cognitive act and has "grasped" it. The paradox therefore reflects a higher level of intellect and, by not forcibly representing the unknowable as known, gives a more faithful picture of the real state of affairs.

[418] These antithetical predications show the amount of *reflection* that has gone into the hymn: it formulates the figure of our Lord in a series of paradoxes, as God and man, sacrificer and sacrificed. The latter formulation is important because the hymn was sung just before Jesus was arrested, that is, at about the moment when the synoptic gospels speak of the Last Supper and John—among other things—of the parable of the vine. John, significantly enough, does not mention the Last Supper, and in the Acts of John its place is taken by the "round dance." But the round table, like the round dance, stands for synthesis and union. In the Last Supper this takes the form of participation in the body and blood of Christ, i.e., there is an ingestion and assimilation of the Lord, and in the round dance there is a circular circumambulation

round the Lord as the central point. Despite the outward difference of the symbols, they have a common meaning: Christ is taken into the midst of the disciples. But, although the two rites have this common basic meaning, the outward difference between them should not be overlooked. The classical Eucharistic feast follows the synoptic gospels, whereas the one in the Acts of John follows the Johannine pattern. One could almost say that it expresses, in a form borrowed from some pagan mystery feast, a more immediate relationship of the congregation to Christ, after the manner of the Johannine parable: "I am the vine, ye are the branches. He that abideth in me, and I in him, the same bringeth forth much fruit" (John 15:5). This close relationship is represented by the circle and central point: the two parts are indispensable to each other and equivalent. Since olden times the circle with a centre has been a symbol for the Deity, illustrating the wholeness of God incarnate: the single point in the centre and the series of points constituting the circumference. Ritual circumambulation often bases itself quite consciously on the cosmic picture of the starry heavens revolving, on the "dance of the stars," an idea that is still preserved in the comparison of the twelve disciples with the zodiacal constellations, as also in the depictions of the zodiac that are sometimes found in churches, in front of the altar or on the roof of the nave. Some such picture may well have been at the back of the medieval ball-game of pelota that was played in church by the bishop and his clergy.

[419] At all events, the aim and effect of the solemn round dance is to impress upon the mind the image of the circle and the centre and the relation of each point along the periphery to that centre.³⁷ Psychologically this arrangement is equivalent to a mandala and is thus a symbol of the self,³⁸ the point of reference not only of the individual ego but of all those who are of like mind or who are bound together by fate. The self is not an ego but a supraordinate totality embracing the conscious and the unconscious. But since the latter has no assignable limits and in its deeper layers is of a collective nature, it cannot be distinguished from that of another individual. As a result, it continually creates that ubiquitous *participation mystique* which is the unity of many, the *one* man in all men. This psychological fact forms the basis for the archetype of the *άνθρωπος*, the Son of Man, the *homo maximus*, the *vir unus*, purusha, etc.³⁹ Because the unconscious, in fact and by definition, cannot be discriminated as such, the most we can hope to do is to infer its nature from the empirical material. Certain unconscious contents are undoubtedly personal and individual and cannot be attributed to any other individual. But, besides these, there are numerous others that can be observed in almost identical form in many different individuals in no way connected with one another. These experiences suggest that the unconscious has a collective aspect. It is therefore difficult to understand how people today can still doubt the existence of a collective unconscious. After all, nobody would dream of regarding the instincts or human morphology as personal

acquisitions or personal caprices. The unconscious is the universal mediator among men. It is in a sense the all-embracing One, or the one psychic substratum common to all. The alchemists knew it as their Mercurius and they called him the mediator in analogy to Christ.⁴⁰ Ecclesiastical doctrine says the same thing about Christ, and so, particularly, does our hymn. Its antithetical statements could, however, be interpreted as referring just as well to Mercurius, if not better.

[420] For instance, in the first verse, “I will be saved,” it is not clear how far the Lord is able to say such a thing of himself, since he is the saviour (σωτήρ) par excellence. Mercurius, on the other hand, the helpful arcane substance of the alchemists, is the world-soul imprisoned in matter and, like the Original Man who fell into the embrace of Physis, is in need of salvation through the labours of the artifex. Mercurius is set free (“loosed”) and redeemed; as *aqua permanens* he is also the classical solvent. “I will be wounded, and I will wound” is clearer: it refers to the wound in Christ’s side and to the divisive sword. But Mercurius too, as the arcane substance, is divided or pierced through with the sword (*separatio* and *penetratio*), and wounds himself with the sword or *telum passionis*, the dart of love. The reference to Christ is less clear in the words “I will be begotten, and I will beget.” The first statement refers essentially to him in so far as the Son was begotten by the Holy Ghost and not created, but the “begetting” is generally held to be the property of the Holy Ghost and not of Christ as such. It certainly remains a moot point whether Mercurius as the world-soul was begotten or created, but he is unquestionably “vivifying,” and in his ithyphallic form as Hermes Kyllenios he is actually the symbol of generation. “Eating” as compared with “being eaten” is not exactly characteristic of Christ, but rather of the devouring dragon, the corrosive Mercurius, who, as the uroboros, also eats himself, like Zosimos’s homunculus.

[421] “I will be thought,” if evangelical at all, is an exclusively Johannine, post-apostolic speculation concerning the nature of the Logos. Hermes was very early considered to be Nous and Logos, and Hermes Trismegistus was actually the Nous of revelation. Mercurius, until well into the seventeenth century, was thought of as the *veritas* hidden in the human body, i.e., in matter, and this truth had to be known by meditation, or by *cogitatio*, reflection. Meditation is an idea that does not occur at all in the New Testament.⁴¹ The *cogitatio* which might possibly correspond to it usually has a negative character and appears as the wicked *cogitatio cordis* of Genesis 6:5 (and 8:21): “Cuncta cogitatio cordis intenta ad malum” (DV: “... all the thought of their heart was bent upon evil at all times”; AV: “... every imagination of the thoughts of his heart ...”). In I Peter 4:1 Ἐννοια is given as “cogitatio” (DV: “... arm yourselves with the same intent”; AV: “same mind”; RSV: “same thought”). “Cogitare” has a more positive meaning in II Corinthians 10:7, where it really means

to “bethink oneself,” “remember by reflection”: “hoc cogitet iterum apud se” (τοῦτο λογιζέσθω πάλιν ἐφ’ ἑαυτοῦ); DV: “let him reflect within himself”;

AV: “let him of himself think this again”; RSV: “let him remind himself”). But this positive thinking in us is of God (II Cor. 3:5: “non quod sufficientes simus cogitare aliquid a nobis, quasi ex nobis”; οὐχ ὅτι ἀφ’ ἑαυτῶν ἱκανοί ἐσμεν λογίσασθαι τι ὡς ἐξ ἑαυτῶν, ἀλλ’ ἡ ἱκανότης ἡμῶν ἐκ τοῦ θεοῦ); DV: “Not that we are sufficient of ourselves to think anything, as from ourselves, but our sufficiency is from God”). The only place where *cogitatio* has the character of a meditation culminating in enlightenment is Acts 10:19: “Petro autem cogitante de visione, dixit Spiritus ei” (“Τοῦ δὲ Πέτρου διενθυμουμένου περὶ τοῦ ὁράματος εἶπεν τὸ πνεῦμα αὐτῷ”; DV: “But while Peter was pondering over the vision, the spirit said to him ...”).

[422] Thinking, in the first centuries of our era, was more the concern of the Gnostics than of the Church, for which reason the great Gnostics, such as Basilides and Valentinus, seem almost like Christian theologians with a bent for philosophy. With John’s doctrine of the Logos, Christ came to be regarded simultaneously as the Nous and the object of human thought; the Greek text says literally: “Νοηθῆναι θέλω νοῦς ὦν ὅλος”⁴² (I will be thought, being wholly spirit). Similarly, the Acts of Peter say of Christ: “Thou art perceived of the spirit only.”⁴³

[423] The “washing” refers to the *purificatio*, or to baptism, and equally to the washing of the dead body. The latter idea lingered on into the eighteenth century, as the alchemical washing of the “black corpse,” an *opus mulierum*. The object to be washed was the black *prima materia*: it, the washing material (*sapo sapientum!*), and the washer were—all three of them—the selfsame Mercurius in different guises. But whereas in alchemy the *nigredo* and sin were identical concepts (since both needed washing), in Christian Gnosticism there are only a few hints of Christ’s possible identity with the darkness. The *λούσασθαι* (“I will be washed”) in our text is one of them.

[424] The “ogdoad,” being a double quaternity, belongs to the symbolism of the mandala. It obviously represents the archetype of the round dance in the “supra-celestial place,” since it sings in harmony. The same applies to the number Twelve, the zodiacal archetype of the twelve disciples, a cosmic idea that still echoes in Dante’s *Paradiso*, where the saints form shining constellations.

[425] Anyone who does not join in the dance, who does not make the circumambulation of the centre (Christ and Anthropos), is smitten with blindness and sees nothing. What is described here as an outward event is really a symbol for the inward turning towards the centre in each of the disciples, towards the archetype of man, towards the self—for the dance can hardly be understood as an historical event. It should be understood, rather, as a sort of paraphrase of the Eucharist, an amplifying

symbol that renders the mystery more assimilable to consciousness, and it must therefore be interpreted as a psychic phenomenon. It is an act of conscious realization on a higher level, establishing a connection between the consciousness of the individual and the supraordinate symbol of totality.

[426] The “Acts of Peter” says of Christ:

Thou art unto me father, thou my mother, thou my brother, thou my friend, thou my bondsman, thou my steward. Thou art All and All is in thee; thou Art, and there is naught else that is save thee only.

Unto him therefore do ye also, brethren, flee, and if ye learn that in him alone ye exist, ye shall obtain those things whereof he saith unto you: “Which neither eye hath seen nor ear heard, neither have they entered into the heart of man.”⁴⁴

[427] The words “I will be united” must be understood in this sense, as meaning that subjective consciousness is united with an objective centre, thus producing the unity of God and man represented by Christ. The self is brought into actuality through the concentration of the many upon the centre, and the self wants this concentration. It is the subject and the object of the process. Therefore it is a “lamp” to those who “perceive” it. Its light is invisible if it is not perceived; it might just as well not exist. It is as dependent on being perceived as the act of perception is on light. This brings out once again the paradoxical subject-object nature of the unknowable. Christ, or the self, is a “mirror”: on the one hand it reflects the subjective consciousness of the disciple, making it visible to him, and on the other hand it “knows” Christ, that is to say it does not merely reflect the empirical man, it also shows him as a (transcendental) whole. And, just as a “door” opens to one who “knocks” on it, or a “way” opens out to the wayfarer who seeks it, so, when you relate to your own (transcendental) centre, you initiate a process of conscious development which leads to oneness and wholeness. You no longer see yourself as an isolated point on the periphery, but as the One in the centre. Only subjective consciousness is isolated; when it relates to its centre it is integrated into wholeness. Whoever joins in the dance sees himself in the reflecting centre, and his suffering is the suffering which the One who stands in the centre “wills to suffer.” The paradoxical identity and difference of ego and self could hardly be formulated more trenchantly.

[428] As the text says, you would not be able to understand what you suffer unless there were that Archimedean point outside, the objective standpoint of the self, from which the ego can be seen as a phenomenon. Without the objectivation of the self the ego would remain caught in hopeless subjectivity and would only gyrate round itself. But if you can see and understand your suffering without being subjectively involved, then, because of your altered standpoint, you also understand “how not to suffer,” for you have reached a place beyond all involvements (“you have me as a bed, rest upon me”). This is an unexpectedly psychological formulation of the Christian idea of

overcoming the world, though with a Docetist twist to it: “Who I am, you shall know when I depart. What now I am seen to be, I am not.”⁴⁵ These statements are clarified by a vision in which John sees the Lord “standing in the midst of the cave and illuminating it.” He says to John:

[429] John, for the multitude below in Jerusalem I am being crucified and pierced with lances and staves, and vinegar and gall are given me to drink. But to you I speak, and what I say, hear: I put it into your mind to go up on this mountain, that you might hear those things which a disciple must learn from his master and a man from his God. And with these words he showed me a cross of light, and about the cross a great multitude that had no form [*μίαν μορφήν μη ἔοντα*], and in the cross there was one form and one appearance. And above [*ἐπάνω*] the cross I saw the Lord himself, and he had no outward shape [*σχῆμα*], but only a voice, and a voice not such as we knew, but one sweet and kind and truly [that] of [a] God, which spoke to me: John, one man must hear this from me, for I require one that shall hear. For your sakes this cross of light was named by me now Logos, now Nous, now Jesus, now Christ, now Door, now Way, now Bread, now Seed [*σπόρος*], now Resurrection, now Son, now Father, now Pneuma, now Life, now Truth, now Faith [*πίστις*], now Grace. So is it called for men; but in itself and in its essence, as spoken of to you, it is the Boundary of all things, and the composing of things unstable,⁴⁶ and the harmony of wisdom, and the wisdom that is in harmony. For there are [places] of the right and of the left, Powers, Authorities, Archons, Daemons, Workings, Threatenings, Wraths, Devils, Satan, and the Nether Root whence proceeded the nature of whatever comes to be. And so it is this cross which joined all things together through the Word, and which separated the things that are from those that are below, and which caused all things to flow forth from the One.

But this is not the cross of wood which you will see when you go down from here; neither am I he that is on the cross, whom now you do not see, but only hear his voice. I passed for that which I am not, for I am not what I was to many others. But what they will say of me is vile and not worthy of me. Since, then, the place of rest is neither seen nor named, how much less will they see and name me, their Lord!

Now the formless multitude about the cross is of the lower nature. And if those whom you see in the cross have not one form, then not all the parts of him who descended have yet been recollected. But when the nature of man has been taken up and a generation of men that obey my voice draws near to me, he that now hears me shall be united with them and shall no longer be what he now is, but shall stand above them, as I do now. For so long as you call not yourself mine, I am not what I was. But if you understand me, you shall be in your understanding as I am, and I shall be what I was when I have you with me. For this you are through me....

Behold, what you are, I have shown you. But what I am, I alone know, and no man else. Therefore let me have what is mine, but behold what is thine through me. And behold me truly, not as I have said I am, but as you, being akin to me, know me.⁴⁷

[430] Our text throws some doubt on the traditional view of Docetism. Though it is perfectly clear from the texts that Christ only seemed to have a body, which only seemed to suffer, this is Docetism at its grossest. The Acts of John are more subtle, and the argument used is almost epistemological: the historical facts are real enough, but they reveal no more than is intelligible to the senses of the ordinary man. Yet even for the knower of divine secrets the act of crucifixion is a mystery, a symbol that expresses a parallel psychic event in the beholder. In the language of Plato it is an event which occurs in a “supra-celestial place,” i.e., on a “mountain” and in a “cave” where a cross of light is set up, its many synonyms signifying that it has many aspects and many meanings. It expresses the unknowable nature of the “Lord,” the supraordinate personality and *τέλειος ἄνθρωπος*, and since it is a quaternity, a whole divided into four parts, it is the classic symbol of the self.

[431] Understood in this sense, the Docetism of the Acts of John appears more as a completion of the historical event than a devaluation of it. It is not surprising that the common people should have failed to appreciate its subtlety, though it is plain enough from a psychological point of view. On the other hand, the educated public of those days were by no means unfamiliar with the parallelism of earthly and metaphysical happenings, only it was not clear to them that their visionary symbols were not necessarily metaphysical realities but were perceptions of intrapsychic or subliminal processes that I have called “phenomena of assimilation.” The contemplation of Christ’s sacrificial death in its traditional form and cosmic significance constellated analogous psychic processes which in their turn gave rise to a wealth of symbols, as I have shown elsewhere.⁴⁸ This is, quite obviously, what has happened here, and it took the form of a visible split between the historical event down below on earth, as perceived by the senses, and its ideal, visionary reflection on high, the cross appearing on the one hand as a wooden instrument of torture and on the other as a glorious symbol. Evidently the centre of gravity has shifted to the ideal event, with the result that the psychic process is involuntarily given the greater importance. Although the emphasis on the pneuma detracts from the meaning of the concrete event in a rather one-sided and debatable way, it cannot be dismissed as superfluous, since a concrete event by itself can never create meaning, but is largely dependent for this on the manner in which it is understood. Interpretation is necessary before the meaning of a thing can be grasped. The naked facts by themselves “mean” nothing. So one cannot assert that the Gnostic attempts at interpretation were entirely lacking in merit, even though it went far beyond the framework of early Christian tradition. One could even venture to assert that it was already implicit in that tradition, since the cross and the crucified are practically synonymous in the language of the New Testament.⁴⁹

[432] The text shows the cross as the antithesis of the formless multitude: it is, or it has, “form” and its meaning is that of a central point defined by the crossing of two straight lines. It is identical with the Kyrios (Lord) and the Logos, with Jesus and with Christ. How John could “see” the Lord above the cross, when the Lord is described as having no “outward shape,” must remain a mystery. He only hears an explanatory voice, and this may indicate that the cross of light is only a visualization of the unknowable, whose voice can be heard apart from the cross. This seems to be confirmed by the remark that the cross was named Logos and so on “for your sakes.”

[433] The cross signifies order as opposed to the disorderly chaos of the formless multitude. It is, in fact, one of the prime symbols of order, as I have shown elsewhere. In the domain of psychological processes it functions as an organizing centre, and in states of psychic disorder⁵⁰ caused by an invasion of unconscious contents it appears as a mandala divided into four. No doubt this was a frequent phenomenon in early Christian times, and not only in Gnostic circles.⁵¹ Gnostic introspection could hardly fail, therefore, to perceive the numinosity of this archetype and be duly impressed by it. For the Gnostics the cross had exactly the same function that the atman or Self has always had for the East. This realization is one of the central experiences of Gnosticism.

[434] The definition of the cross or centre as *διορισμός*, the “boundary” of all things, is exceedingly original, for it suggests that the limits of the universe are not to be found in a nonexistent periphery but in its centre. There alone lies the possibility of transcending this world. All instability culminates in that which is unchanging and quiescent, and in the self all disharmonies are resolved in the “harmony of wisdom.”

[435] As the centre symbolizes the idea of totality and finality, it is quite appropriate that the text should suddenly start speaking of the dichotomy of the universe, polarized into right and left, brightness and darkness, heaven and the “nether root,” the *omnium genetrix*. This is a clear reminder that everything is contained in the centre and that, as a result, the Lord (i.e., the cross) unites and composes all things and is therefore “nirdvanda,” free from the opposites, in conformity with Eastern ideas and also with the psychology of this archetypal symbol. The Gnostic Christ-figure and the cross are counterparts of the typical mandalas spontaneously produced by the unconscious. They are *natural symbols* and they differ fundamentally from the dogmatic figure of Christ, in whom all trace of darkness is expressly lacking.

[436] In this connection mention should be made of Peter’s valedictory words, which he spoke during his martyrdom (he was crucified upside down, at his own request):

O name of the cross, hidden mystery! O grace ineffable that is pronounced in the name of the cross! O nature of man, that cannot be separated from God! O love unspeakable and indivisible, that cannot be shown forth by unclean lips! I grasp thee now, I that am at the end of my earthly course. I will declare thee as thou art, I will not

keep silent the mystery of the cross which was once shut and hidden from my soul. You that hope in Christ, let not the cross be for you that which appears; for it is another thing, and different from that which appears, this suffering which is in accordance with Christ's. And now above all, because you that can hear are able to hear it of me, who am at the last and farewell hour of my life, hearken: separate your souls from everything that is of the senses, from everything that appears to be but in truth is not. Lock your eyes, close your ears, shun those happenings which are seen! Then you shall perceive that which was done to Christ, and the whole mystery of your salvation....

Learn the mystery of all nature and the beginning of all things, as it was. For the first man, of whose race I bear the likeness, fell head downwards and showed forth a manner of birth such as had not existed till then, for it was dead, having no motion. And being pulled downwards, and having also cast his origin upon the earth, he established the whole disposition of things; for, being hanged up in the manner appointed, he showed forth the things of the right as those of the left, and the things of the left as those of the right, and changed about all the marks of their nature, so that things that were not fair were perceived to be fair, and those that were in truth evil were perceived to be good. Wherefore the Lord says in a mystery: "Except ye make the things of the right as those of the left, and those of the left as those of the right, and those that are above as those below, and those that are behind as those that are before, ye shall not have knowledge of the kingdom."

This understanding have I brought you, and the figure in which you now see me hanging is the representation of the first man who came to birth.

[437] In this passage, too, the symbolical interpretation of the cross is coupled with the problem of opposites, first in the unusual idea that the creation of the first man caused everything to be turned upside down, and then in the attempt to unite the opposites by identifying them with one another. A further point of significance is that Peter, crucified head downwards, is identical not only with the first created man, but with the cross:

For what else is Christ but the word, the sound of God? So the word is this upright beam on which I am crucified; and the sound is the beam which crosses it, the nature of man; but the nail which holds the centre of the crossbeam to the upright is man's conversion and repentance (μετάνοια).⁵²

[438] In the light of these passages it can hardly be said that the author of the Acts of John—presumably a Gnostic—has drawn the necessary conclusions from his premises or that their full implications have become clear to him. On the contrary, one gets the impression that the light has swallowed up everything dark. Just as the enlightening vision appears high above the actual scene of crucifixion, so, for John, the enlightened one stands high above the formless multitude. The text says: "Therefore care not for the many, and despise those that are outside the mystery!"⁵³ This overweening attitude arises from an inflation caused by the fact that the enlightened John has identified with his own light and confused his ego with the self. Therefore he feels superior to the darkness in him. He forgets that light only has a meaning when it illuminates something dark and that his enlightenment is no good to him unless it helps him to recognize his own darkness. If the powers of the left are as

real as those of the right, then their union can only produce a third thing that shares the nature of both. Opposites unite in a new energy potential: the “third” that arises out of their union is a figure “free from the opposites,” beyond all moral categories. This conclusion would have been too advanced for the Gnostics. Recognizing the danger of Gnostic irrealism, the Church, more practical in these matters, has always insisted on the concretism of the historical events despite the fact that the original New Testament texts predict the ultimate deification of man in a manner strangely reminiscent of the words of the serpent in the Garden of Eden: “Ye shall be as gods.”⁵⁴ Nevertheless, there was some justification for postponing the elevation of man’s status until after death, as this avoided the danger of Gnostic inflation.⁵⁵

[439] Had the Gnostic not identified with the self, he would have been bound to see how much darkness was in him—a realization that comes more naturally to modern man but causes him no less difficulties. Indeed, he is far more likely to assume that he himself is wholly of the devil than to believe that God could ever indulge in paradoxical statements. For all the ill consequences of his fatal inflation, the Gnostic did, however, gain an insight into religion, or into the psychology of religion, from which we can still learn a thing or two today. He looked deep into the background of Christianity and hence into its future developments. This he could do because his intimate connection with pagan Gnosis made him an “assimilator” that helped to integrate the Christian message into the spirit of the times.

[440] The extraordinary number of synonyms piled on top of one another in an attempt to define the cross have their analogy in the Naassene and Peratic symbols of Hippolytus, all pointing to this one centre. It is the *Ἐν τῷ πᾶν* of alchemy, which is on the one hand the heart and governing principle of the macrocosm, and on the other hand its reflection in a point, in a microcosm such as man has always been thought to be. He is of the same essence as the universe, and his own mid-point is its centre. This inner experience, shared by Gnostics, alchemists, and mystics alike, has to do with the nature of the unconscious—one could even say that it *is* the experience of the unconscious; for the unconscious, though its objective existence and its influence on consciousness cannot be doubted, is in itself undifferentiable and therefore unknowable. Hypothetical germs of differentiation may be conjectured to exist in it, but their existence cannot be proved, because everything appears to be in a state of mutual contamination. The unconscious gives the impression of multiplicity and unity at once. However overwhelmed we may be by the vast quantity of things differentiated in space and time, we know from the world of the senses that the validity of its laws extends to immense distances. We therefore believe that it is one and the same universe throughout, in its smallest part as in its greatest. On the other hand the intellect always tries to discern differences, because it cannot discriminate without them. Consequently the unity of the cosmos remains, for it, a somewhat

nebulous postulate which it doesn't rightly know what to do with. But as soon as introspection starts penetrating into the psychic background it comes up against the unconscious, which, unlike consciousness, shows only the barest traces of any definite contents, surprising the investigator at every turn with a confusing medley of relationships, parallels, contaminations, and identifications. Although he is forced, for epistemological reasons, to postulate an indefinite number of distinct and separate archetypes, yet he is constantly overcome by doubt as to how far they are really distinguishable from one another. They overlap to such a degree and have such a capacity for combination that all attempts to isolate them conceptually must appear hopeless. In addition the unconscious, in sharpest contrast to consciousness and its contents, has a tendency to personify itself in a uniform way, just as if it possessed only one shape or one voice. Because of this peculiarity, the unconscious conveys an experience of unity, to which are due all those qualities enumerated by the Gnostics and alchemists, and a lot more besides.

[441] As can plainly be seen from Gnosticism and other spiritual movements of the kind, people are naïvely inclined to take all the manifestations of the unconscious at their face value and to believe that in them the essence of the world itself, the ultimate truth, has been unveiled. This assumption does not seem to me quite as unwarranted as it may look at first sight, because the spontaneous utterances of the unconscious do after all reveal a psyche which is not identical with consciousness and which is, at times, greatly at variance with it. These utterances occur as a natural psychic activity that can neither be learnt nor controlled by the will. The manifestation of the unconscious is therefore a revelation of the unknown in man. We have only to disregard the dependence of dream language on environment and substitute "eagle" for "aeroplane," "dragon" for "automobile" or "train," "snake-bite" for "injection," and so forth, in order to arrive at the more universal and more fundamental language of mythology. This gives us access to the primordial images that underlie all thinking and have a considerable influence even on our scientific ideas.⁵⁶

[442] In these archetypal forms, something, presumably, is expressing itself that must in some way be connected with the mysterious operation of a natural psyche—in other words, with a cosmic factor of the first order. To save the honour of the objective psyche, which the contemporary hypertrophy of consciousness has done so much to depreciate, I must again emphasize that without the psyche we could not establish the existence of any world at all, let alone know it. But, judging by all we do know, it is certain that the original psyche possesses no consciousness of itself. This only comes in the course of development, a development that falls mostly within the historical epoch.⁵⁷ Even today we know of primitive tribes whose level of consciousness is not so far removed from the darkness of the primordial psyche, and

numerous vestiges of this state can still be found among civilized people. It is even probable, in view of its potentialities for further differentiation, that our modern consciousness is still on a relatively low level. Nevertheless, its development so far has made it emancipated enough to forget its dependence on the unconscious psyche. It is not a little proud of this emancipation, but it overlooks the fact that although it has apparently got rid of the unconscious it has become the victim of its own verbal concepts. The devil is cast out with Beelzebub. Our dependence on words is so strong that a philosophical brand of “existentialism” had to restore the balance by pointing to a reality that exists in spite of words—at considerable risk, however, of concepts such as “existence,” “existential,” etc. turning into more words which delude us into thinking that we have caught a reality. One can be—and is—just as dependent on words as on the unconscious. Man’s advance towards the Logos was a great achievement, but he must pay for it with loss of instinct and loss of reality to the degree that he remains in primitive dependence on mere words. Because words are substitutes for things, which of course they cannot be in reality, they take on intensified forms, become eccentric, outlandish, stupendous, swell up into what schizophrenic patients call “power words.” A primitive word-magic develops, and one is inordinately impressed by it because anything out of the ordinary is felt to be especially profound and significant. Gnosticism in particular affords some very instructive examples of this. Neologisms tend not only to hypostatize themselves to an amazing degree, but actually to replace the reality they were originally intended to express.

[443] This rupture of the link with the unconscious and our submission to the tyranny of words have one great disadvantage: the conscious mind becomes more and more the victim of its own discriminating activity, the picture we have of the world gets broken down into countless particulars, and the original feeling of unity, which was integrally connected with the unity of the unconscious psyche, is lost. This feeling of unity, in the form of the correspondence theory and the sympathy of all things, dominated philosophy until well into the seventeenth century and is now, after a long period of oblivion, looming up again on the scientific horizon, thanks to the discoveries made by the psychology of the unconscious and by parapsychology. The manner in which the unconscious forcibly obtrudes upon the conscious by means of neurotic disturbances is not only reminiscent of contemporary political and social conditions but even appears as an accompanying phenomenon. In both cases there is an analogous dissociation: in the one case a splitting of the world’s consciousness by an “iron curtain,” and in the other a splitting of the individual personality. This dissociation extends throughout the entire world, so that a psychological split runs through vast numbers of individuals who, in their totality, call forth the corresponding mass phenomena. In the West it was chiefly the mass factor, and in the

East technology, that undermined the old hierarchies. The cause of this development lay principally in the economic and psychological uprootedness of the industrial masses, which in turn was caused by the rapid technological advance. But technology, it is obvious, is based on a specifically rationalistic differentiation of consciousness which tends to repress all irrational psychic factors. Hence there arises, in the individual and nation alike, an unconscious counterposition which in time grows strong enough to burst out into open conflict.

[444] The same situation in reverse was played out on a smaller scale and on a spiritual plane during the first centuries of our era, when the spiritual disorientation of the Roman world was compensated by the irruption of Christianity. Naturally, in order to survive, Christianity had to defend itself not only against its enemies but also against the excessive pretensions of some of its adherents, including those of the Gnostics. Increasingly it had to rationalize its doctrines in order to stem the flood of irrationality. This led, over the centuries, to that strange marriage of the originally irrational Christian message with human reason, which is so characteristic of the Western mentality. But to the degree that reason gradually gained the upper hand, the intellect asserted itself and demanded autonomy. And just as the intellect subjugated the psyche, so also it subjugated Nature and begat on her an age of scientific technology that left less and less room for the natural and irrational man. Thus the foundations were laid for an inner opposition which today threatens the world with chaos. To make the reversal complete, all the powers of the underworld now hide behind reason and intellect, and under the mask of rationalistic ideology a stubborn faith seeks to impose itself by fire and sword, vying with the darkest aspects of a church militant. By a strange enantiodromia,⁵⁸ the Christian spirit of the West has become the defender of the irrational, since, in spite of having fathered rationalism and intellectualism, it has not succumbed to them so far as to give up its belief in the rights of man, and especially the freedom of the individual. But this freedom guarantees a recognition of the irrational principle, despite the lurking danger of chaotic individualism. By appealing to the eternal rights of man, faith binds itself inalienably to a higher order, not only on account of the historical fact that Christ has proved to be an ordering factor for many hundreds of years, but also because the self effectively compensates chaotic conditions no matter by what name it is known: for the self is the *Anthropos* above and beyond this world, and in him is contained the freedom and dignity of the individual man. From this point of view, disparagement and vilification of Gnosticism are an anachronism. Its obviously psychological symbolism could serve many people today as a bridge to a more living appreciation of Christian tradition.

[445] These historical changes have to be borne in mind if we wish to understand the Gnostic figure of Christ, because the sayings in the Acts of John concerning the

nature of the Lord only become intelligible when we interpret them as expressing an experience of the original unity as contrasted with the formless multiplicity of conscious contents. This Gnostic Christ, of whom we hear hints even in the Gospel according to St. John, symbolizes man's original unity and exalts it as the saving goal of his development. By "composing the unstable," by bringing order into chaos, by resolving disharmonies and centring upon the mid-point, thus setting a "boundary" to the multitude and focusing attention upon the cross, consciousness is reunited with the unconscious, the unconscious man is made one with his centre, which is also the centre of the universe, and in this wise the goal of man's salvation and exaltation is reached.

[446] Right as this intuition may be, it is also exceedingly dangerous, for it presupposes a coherent egoconsciousness capable of resisting the temptation to identify with the self. Such an ego-consciousness seems to be comparatively rare, as history shows; usually the ego identifies with the inner Christ, and the danger is increased by an *imitatio Christi* falsely understood. The result is inflation, of which our text affords eloquent proof. In order to exorcise this danger, the Church has not made too much of the "Christ within," but has made all it possibly could of the Christ whom we "have seen, heard, and touched with hands," in other words, with the historical event "below in Jerusalem." This is a wise attitude, which takes realistic account of the primitiveness of man's consciousness, then as now. For the less mindful it is of the unconscious, the greater becomes the danger of its identification with the latter, and the greater, therefore, the danger of inflation, which, as we have experienced to our cost, can seize upon whole nations like a psychic epidemic. If Christ is to be "real" for this relatively primitive consciousness, then he can be so only as an historical figure and a metaphysical entity, but not as a psychic centre in all too perilous proximity to a human ego. The Gnostic development, supported by scriptural authority, pushed so far ahead that Christ was clearly recognized as an inner, psychic fact. This also entailed the relativity of the Christ-figure, as expressively formulated in our text: "For so long as you call not yourself mine, I am not what I was.... I shall be what I was when I have you with me." From this it follows unmistakably that although Christ was whole once upon a time, that is, before time and consciousness began, he either lost this wholeness or gave it away to mankind⁵⁹ and can only get it back again through man's integration. His wholeness depends on man: "You shall be in your understanding as I am"—this ineluctable conclusion shows the danger very clearly. The ego is dissolved in the self; unbeknown to itself, and with all its inadequacy and darkness, it has become a god and deems itself superior to its unenlightened fellows. It has identified with its own conception of the "higher man," quite regardless of the fact that this figure consists of "Places of the right and left, Authorities, Archons, Daemons" etc., and the devil

himself. A figure like this is simply not to be comprehended, an awesome mystery with which one had better not identify if one has any sense. It is sufficient to know that such a mystery exists and that somewhere man can feel its presence, but he should take care not to confuse his ego with it. On the contrary, the confrontation with his own darkness should not only warn him against identification but should inspire him with salutary terror on beholding just what he is capable of becoming. He cannot conquer the tremendous polarity of his nature on his own resources; he can only do so through the terrifying experience of a psychic process that is independent of him, that works *him* rather than he *it*.

[447] If such a process exists at all, then it is something that can be experienced. My own personal experience, going back over several decades and garnered from many individuals, and the experience of many other doctors and psychologists, not to mention the statements—terminologically different, but essentially the same—of all the great religions,⁶⁰ all confirm the existence of a compensatory ordering factor which is independent of the ego and whose nature transcends consciousness. The existence of such a factor is no more miraculous, in itself, than the orderliness of radium decay, or the attunement of a virus to the anatomy and physiology of human beings,⁶¹ or the symbiosis of plants and animals. What is miraculous in the extreme is that man can have conscious, reflective knowledge of these hidden processes, while animals, plants, and inorganic bodies seemingly lack it. Presumably it would also be an ecstatic experience for a radium atom to know that the time of its decay is exactly determined, or for the butterfly to recognize that the flower has made all the necessary provisions for its propagation.

[448] The numinous experience of the individuation process is, on the archaic level, the prerogative of shamans and medicine men; later, of the physician, prophet, and priest; and finally, at the civilized stage, of philosophy and religion. The shaman's experience of sickness, torture, death, and regeneration implies, at a higher level, the idea of being made whole through sacrifice, of being changed by transubstantiation and exalted to the pneumatic man—in a word, of apotheosis. The Mass is the summation and quintessence of a development which began many thousands of years ago and, with the progressive broadening and deepening of consciousness, gradually made the isolated experience of specifically gifted individuals the common property of a larger group. The underlying psychic process remained, of course, hidden from view and was dramatized in the form of suitable "mysteries" and "sacraments," these being reinforced by religious teachings, exercises, meditations, and acts of sacrifice which plunge the celebrant so deeply into the sphere of the mystery that he is able to become conscious of his intimate connection with the mythic happenings. Thus, in ancient Egypt, we see how the experience of "Osirification,"⁶² originally the prerogative of the Pharaohs, gradually passed to the aristocracy and finally, towards

the end of the Old Kingdom, to the single individual as well. Similarly, the mystery religions of the Greeks, originally esoteric and not talked about, broadened out into collective experience, and at the time of the Caesars it was considered a regular sport for Roman tourists to get themselves initiated into foreign mysteries. Christianity, after some hesitation, went a step further and made celebration of the mysteries a public institution, for, as we know, it was especially concerned to introduce as many people as possible to the experience of the mystery. So, sooner or later, the individual could not fail to become conscious of his own transformation and of the necessary psychological conditions for this, such as confession and repentance of sin. The ground was prepared for the realization that, in the mystery of transubstantiation, it was not so much a question of magical influence as of psychological processes—a realization for which the alchemists had already paved the way by putting their *opus operatum* at least on a level with the ecclesiastical mystery, and even attributing to it a cosmic significance since, by its means, the divine world-soul could be liberated from imprisonment in matter. As I think I have shown, the “philosophical” side of alchemy is nothing less than a symbolic anticipation of certain psychological insights, and these—to judge by the example of Gerhard Dorn—were pretty far advanced by the end of the sixteenth century.⁶³ Only our intellectualized age could have been so deluded as to see in alchemy nothing but an abortive attempt at chemistry, and in the interpretative methods of modern psychology a mere “psychologizing,” i.e., annihilation, of the mystery. Just as the alchemists knew that the production of their stone was a miracle that could only happen “Deo concedente,” so the modern psychologist is aware that he can produce no more than a description, couched in scientific symbols, of a psychic process whose real nature transcends consciousness just as much as does the mystery of life or of matter. At no point has he explained the mystery itself, thereby causing it to fade. He has merely, in accordance with the spirit of Christian tradition, brought it a little nearer to individual consciousness, using the empirical material to set forth the individuation process and show it as an actual and experienceable fact. To treat a metaphysical statement as a psychic process is not to say that it is “merely psychic,” as my critics assert—in the fond belief that the word “psychic” postulates something known. It does not seem to have occurred to people that when we say “psyche” we are alluding to the densest darkness it is possible to imagine. The ethics of the researcher require him to admit where his knowledge comes to an end. This end is the beginning of true wisdom.

IV

FOREWORD TO WHITE'S "GOD AND THE UNCONSCIOUS"

FOREWORD TO WERBLOWSKY'S "LUCIFER AND PROMETHEUS"

BROTHER KLAUS

FOREWORD TO WHITE'S "GOD AND THE UNCONSCIOUS"¹

[449] It is now many years since I expressed a desire for co-operation with a theologian, but I little knew—or even dreamt—how or to what extent my wish was to be fulfilled. This book, to which I have the honour of contributing an introductory foreword, is the third major publication² from the theological side which has been written in a spirit of collaboration and mutual effort. In the fifty years of pioneer work that now lie behind me I have experienced criticism, just and unjust, in such abundance that I know how to value any attempt at positive co-operation. Criticism from this quarter is constructive and therefore welcome.

[450] Psychopathology and medical psychotherapy are, when viewed superficially, far removed from the theologian's particular field of interest, and it is therefore to be expected that no small amount of preliminary effort will be required to establish a terminology comprehensible to both parties. To make this possible, certain fundamental realizations are required on either side. The most important of these is an appreciation of the fact that the object of mutual concern is the psychically sick and suffering human being, who is in need of consideration as much from the somatic or biological standpoint as from the spiritual or religious. The problem of neurosis ranges from disturbances in the sphere of instinct to the ultimate questions and decisions affecting our philosophy of life. Neurosis is not an isolated, sharply defined phenomenon; it is a reaction of the *whole* human being. Here a pure therapy of the symptoms is obviously even more definitely proscribed than in the case of purely somatic illnesses; these too, however, always have a psychic component or accompanying symptom even though they are not psychogenic. Modern medicine has just begun to take account of this fact, which the psychotherapists have been emphasizing for a long time. In the same way, long years of experience have shown me over and over again that a therapy along purely biological lines does not suffice, but requires a spiritual complement. This becomes especially clear to the medical psychologist where the question of *dreams* is concerned; for dreams, being statements of the unconscious, play no small part in the therapy. Anyone who sets to work in an honest and critical frame of mind will have to admit that the correct understanding of dreams is no easy matter, but one that calls for careful reflection, leading far beyond purely biological points of view. The indubitable occurrence of archetypal motifs in dreams makes a thorough knowledge of the spiritual history of man indispensable for anyone seriously attempting to understand the real meaning of

dreams. The likeness between certain dream-motifs and mythologems is so striking that they may be regarded not merely as similar but even as identical. This recognition not only raises the dream to a higher level and places it in the wider context of the mythologem, but, at the same time, the problems posed by mythology are brought into connection with the psychic life of the individual. From the mythologem to the religious statement it is only a step. But whereas the mythological figures appear as pale phantoms and relics of a long past life that has become strange to us, the religious statement represents an immediate “numinous” experience. It is a *living mythologem*.

[451] Here the empiricist’s way of thinking and expressing himself gets him into difficulties with the theologian. The latter—when he is either making a dogma of the Gospel or “demythologizing” it—won’t hear anything of “myth” because it seems to him a devaluation of the religious statement, in whose supreme truth he believes. The empiricist, on the other hand, whose orientation is that of natural science, does not connect any notion of value with the concept “myth.” “Myth,” for him, means “a statement about processes in the unconscious,” and this applies equally to the religious statement. He has no means of deciding whether the latter is “truer” than the mythologem, for between the two he sees only one difference: the difference in living intensity. The so-called religious statement is still numinous, a quality which the myth has already lost to a great extent. The empiricist knows that rites and figures once “sacred” have become obsolete and that new figures have become “numinous.”

[452] The theologian can reproach the empiricist and say that he *does* possess the means of deciding the truth, he merely does not wish to make use of it—referring to the truth of revelation. In all humility the empiricist will then ask: *Which* revealed truth, and where is the proof that one view is truer than another? Christians themselves do not appear to be at one on this point. While they are busy wrangling, the doctor has an urgent case on his hands. He cannot wait for age-long schisms to be settled, but will seize upon anything that is “alive” for the patient and therefore effective. Naturally he cannot prescribe *any* religious system which is commonly supposed to be alive. Rather, by dint of careful and persevering investigation, he must endeavour to discover just where the sick person feels a healing, living quality which can make him whole. For the present he cannot be concerned whether this so-called truth bears the official stamp of validity or not. If, however, the patient is able to rediscover himself in this way and so get on his feet again, then the question of reconciling his individual realization—or whatever one may choose to call the new insight or life-giving experience—with the collectively valid opinions and beliefs becomes a matter of vital importance. That which is *only* individual has an isolating effect, and the sick person will never be healed by becoming a mere individualist. He would still be neurotically unrelated and estranged from his social group. Even

Freud's exclusively personalistic psychology of drives was obliged to come to terms, at least negatively, with the generally valid truths, the age-old *représentations collectives* of human society. Scientific materialism is by no means a private religious or philosophical matter, but a very public matter indeed, as we might well have realized from contemporary events. In view of the extraordinary importance of these so-called universal truths, a rapprochement between individual realizations and social convictions becomes an urgent necessity. And just as the sick person in his individual distinctiveness must find a *modus vivendi* with society, so it will be a no less urgent task for him to compare the insights he has won through exploring the unconscious with the universal truths, and to bring them into mutual relationship.

[453] A great part of my life's work has been devoted to this endeavour. But it was clear to me from the outset that I could never accomplish such a task by myself. Although I can testify to the psychological facts, it is quite beyond my power to promote the necessary processes of assimilation which coming to terms with the *représentations collectives* requires. This calls for the cooperation of many, and above all of those who are the expounders of the universal truths, namely the theologians. Apart from doctors, they are the only people who have to worry professionally about the human soul, with the exception perhaps of teachers. But the latter confine themselves to children, who as a rule only suffer from the problems of the age indirectly, via their parents and educators. Surely, then, it would be valuable for the theologian to know what happens in the psyche of an adult. It must gradually be dawning on any responsible doctor what a tremendously important role the spiritual element plays in the psychic economy.

[454] I must acknowledge with gratitude that the co-operation I had so long wished and hoped for has now become a reality. The present book bears witness to this, for it meets the preoccupations of medical psychology not only with intellectual understanding, but with good will. Only the most uncritical optimism could expect such an encounter to be love at first sight. The *points de départ* are too far apart and too different, and the road to their meeting-place too long and too hard, for agreement to come as a matter of course. I do not presume to know what the theologian misunderstands or fails to understand in the empiricist's point of view, for it is as much as I can do to learn to estimate his theological premises correctly. If I am not mistaken, however, one of the main difficulties lies in the fact that both appear to speak the same language, but this language calls up in their minds two totally different fields of association. Both can apparently use the same concept and must then acknowledge, to their amazement, that they are speaking of two different things. Take, for instance, the word "God." The theologian will naturally assume that the metaphysical *Ens Absolutum* is meant. The empiricist, on the contrary, does not dream of making such a far-reaching assumption, which strikes him as downright

impossible anyway. He just as naturally means the word “God” as a mere statement, or at most as an archetypal motif which prefigures such statements. For him “God” can just as well mean Yahweh, Allah, Zeus, Shiva, or Huitzilopochtli. The divine attributes of omnipotence, omniscience, eternity, and so on are to him statements which, symptomatically or as syndromes, more or less regularly accompany the archetype. He grants the divine image numinosity—that is, a deeply stirring emotional effect—which he accepts in the first place as a fact and sometimes tries to explain rationally, in a more or less unsatisfactory way. As a psychiatrist, he is sufficiently hardboiled to be profoundly convinced of the relativity of all such statements. As a scientist, his primary interest is the verification of psychic facts and their regular occurrence, to which he attaches incomparably greater importance than to abstract possibilities. His *religio* consists in establishing facts which can be observed and proved. He describes and circumscribes these in the same way as the mineralogist his mineral samples and the botanist his plants. He is aware that beyond provable facts he can know nothing and at best can only dream, and he considers it immoral to confuse a dream with knowledge. He does not deny what he has not experienced and cannot experience, but he will on no account assert anything which he does not think he can prove with facts. It is true that I have often been accused of having dreamt up the archetypes. I must remind these too hasty critics that a comparative study of motifs existed long before I ever mentioned archetypes. The fact that archetypal motifs occur in the psyche of people who have never heard of mythology is common knowledge to anyone who has investigated the structure of schizophrenic delusions, if his eyes have not already been opened in this respect by the universal occurrence of certain mythologems. Ignorance and narrow-mindedness, even when the latter is political, have never been conclusive scientific arguments.³

[455] I must be content to describe the standpoint, the faith, the struggle, the hope and devotion of the empiricist, which all culminate in the discovery and verification of provable facts and their hypothetical interpretation. For the theological standpoint I refer the reader to the competent *exposé* by the author of this book.

[456] When standpoints differ so widely, it is understandable that numerous clashes should occur in practice, some important, some unimportant. They are important, above all, where one realm threatens to encroach upon the territory of the other. My criticism of the doctrine of the *privatio boni* is such a case. Here the theologian has a certain right to fear an intrusion on the part of the empiricist. This discussion has left its mark on the book, as the reader will see for himself. Hence I feel at liberty to avail myself of the right of free criticism, so generously offered me by the author, and to lay my argument before the reader.

[457] I should never have dreamt that I would come up against such an apparently out-of-the-way problem as that of the *privatio boni* in my practical work. Fate would have it, however, that I was called upon to treat a patient, a scholarly man with an academic training, who had got involved in all manner of dubious and morally reprehensible practices. He turned out to be a fervent adherent of the *privatio boni*, because it fitted in admirably with his scheme: evil in itself is nothing, a mere shadow, a trifling and fleeting diminution of good, like a cloud passing over the sun. This man professed to be a believing Protestant and would therefore have had no reason to appeal to a *sententia communis* of the Catholic Church had it not proved a welcome sedative to his uneasy conscience. It was this case that originally induced me to come to grips with the *privatio boni* in its psychological aspect. It is self-evident to the empiricist that the metaphysical aspect of such a doctrine must be left out of account, for he knows that he is dealing only with moral judgments and not with substances. We name a thing, *from a certain point of view*, good or bad, high or low, right or left, light or dark, and so forth. Here the antithesis is just as factual and real as the thesis.⁴ It would never occur to anyone—except under very special conditions and for a definite purpose—to define cold as a diminution of heat, depth as a diminution of height, right as a diminution of left. With this kind of logic one could just as well call good a diminution of evil. The psychologist would, it is true, find this way of putting it a little too pessimistic, but he would have nothing against it logically. Instead of ninety-nine you can also say a hundred minus one, if you don't find it too complicated. But should he, as a moral man, catch himself glossing over an immoral act by optimistically regarding it as a slight diminution of good, which alone is real, or as an “accidental lack of perfection,” then he would immediately have to call himself to order. His better judgment would tell him: If your evil is in fact only an unreal shadow of your good, then your so-called good is nothing but an unreal shadow of your real evil. If he does not reflect in this way he is deceiving himself, and self-deceptions of this kind have dissociating effects which breed neurosis, among them feelings of inferiority, with all their well-known attendant phenomena.

[458] For these reasons I have felt compelled to contest the validity of the *privatio boni* so far as the empirical realm is concerned. For the same reasons I also criticize the dictum derived from the *privatio boni*, namely: “Omne bonum a Deo, omne malum ab homine”;⁵ for then on the one hand man is deprived of the possibility of doing anything good, and on the other he is given the seductive power of doing evil. The only dignity which is left him is that of the fallen angel. The reader will see that I take this dictum literally.

[459] Criticism can be applied only to psychic phenomena, i.e., to ideas and concepts, and not to metaphysical entities. These can only be confronted with other

metaphysical entities. Hence my criticism is valid *only within the empirical realm*. In the metaphysical realm, on the other hand, good may be a substance and evil a *μη`όν*. I know of no factual experience which approximates to such an assertion, so at this point the empiricist must remain silent. Nevertheless, it is possible that here, as in the case of other metaphysical statements, especially dogmas, there are archetypal factors in the background, which have existed for an indefinitely long time as preformative psychic forces and would therefore be accessible to empirical research. In other words, there might be a preconscious psychic tendency which, independent of time and place, continually causes similar statements to be made, as is the case with mythologems, folklore motifs, and the individual formation of symbols. It seems to me, however, that the existing empirical material, at least so far as I am acquainted with it, permits of no definite conclusion as to the archetypal background of the *privatio boni*. Subject to correction, I would say that clear-cut *moral* distinctions are the most recent acquisition of civilized man. That is why such distinctions are often so hazy and uncertain, unlike other antithetical constructions which undoubtedly have an archetypal nature and are the prerequisites for any act of cognition, such as the Platonic *ταὐτὸν-θᾶτερον* (the Same and the Different).

[460] Psychology, like every empirical science, cannot get along without auxiliary concepts, hypotheses, and models. But the theologian as well as the philosopher is apt to make the mistake of taking them for metaphysical postulates. The atom of which the physicist speaks is not an *hypostasis*, it is a *model*. Similarly, my concept of the archetype or of psychic energy is only an auxiliary idea which can be exchanged at any time for a better formula. From a philosophical standpoint my empirical concepts would be logical monsters, and as a philosopher I should cut a very sorry figure. Looked at theologically, my concept of the anima, for instance, is pure Gnosticism; hence I am often classed among the Gnostics. On top of that, the individuation process develops a symbolism whose nearest affinities are to be found in folklore, in Gnostic, alchemical, and suchlike “mystical” conceptions, not to mention shamanism. When material of this kind is adduced for comparison, the exposition fairly swarms with “exotic” and “far-fetched” proofs, and anyone who merely skims through a book instead of reading it can easily succumb to the illusion that he is confronted with a Gnostic system. In reality, however, individuation is an expression of that biological process—simple or complicated as the case may be—by which every living thing becomes what it was destined to become from the beginning. This process naturally expresses itself in man as much psychically as somatically. On the psychic side it produces those well-known quaternity symbols, for instance, whose parallels are found in mental asylums as well as in Gnosticism and other exoticisms, and—last but not least—in Christian allegory. Hence it is by no means a case of mystical speculations, but of clinical observations and their

interpretation through comparison with analogous phenomena in other fields. It is not the daring fantasy of the anatomist that can be held responsible when he discovers the nearest analogies to the human skeleton in certain African anthropoids of which the layman has never heard.

[461] It is certainly remarkable that my critics, with few exceptions, ignore the fact that, as a doctor and scientist, I proceed from facts which everyone is at liberty to verify. Instead, they criticize me as if I were a philosopher, or a Gnostic with pretensions to supernatural knowledge. As a philosopher and speculating heretic I am, of course, easy prey. That is probably the reason why people prefer to ignore the facts I have discovered, or to deny them without scruple. But it is the facts that are of prime importance to me and not a provisional terminology or attempts at theoretical reflections. The fact that archetypes exist is not spirited away by saying that there are no inborn ideas. I have never maintained that the archetype *an sich* is an idea, but have expressly pointed out that I regard it as a form without definite content.

[462] In view of these manifold misunderstandings, I set a particularly high value on the real understanding shown by the author, whose *point de départ* is diametrically opposed to that of natural science. He has successfully undertaken to feel his way into the empiricist's manner of thinking as far as possible, and if he has not always entirely succeeded in his attempt, I am the last person to blame him, for I am convinced that I am unwittingly guilty of many an offence against the theological way of thinking. Discrepancies of this kind can only be settled by lengthy discussions, but they have their good side: not only do two apparently incompatible mental spheres come into contact, they also animate and fertilize one another. This calls for a great deal of good will on either side, and here I can give the author unstinted praise. He has taken the part of the opposite standpoint very fairly, and—what is especially valuable to me—has at the same time illustrated the theological standpoint in a highly instructive way. The medical psychotherapist cannot in the long run afford to overlook the religious systems of healing—if one may so describe certain aspects of religion—any more than the theologian, if he has the cure of souls at heart, can afford to ignore the experience of medical psychology.

[463] In the practical field of individual treatment it seems to me that no serious difficulties should arise. These may be expected only when the discussion begins between individual experience and the collective truths. In most cases this necessity does not present itself until fairly late in the treatment, if at all. In practice it quite often happens that the whole treatment takes place on the personal plane, without the patient having any inner experiences that are definite enough to necessitate his coming to terms with the collective beliefs. If the patient remains within the framework of his traditional faith, he will, even if stirred or perhaps shattered by an

archetypal dream, translate this experience into the language of his faith. This operation may strike the empiricist (if he happens to be a fanatic of the truth) as questionable, but it can pass off harmlessly and may even lead to a satisfactory issue, in so far as it is *legitimate* for this type of man. I try to impress it upon my pupils not to treat their patients as if they were all cut to the same measure: the population consists of different historical layers. There are people who, psychologically, might be living in the year 5000 B.C., i.e., who can still successfully solve their conflicts as people did seven thousand years ago. There are countless troglodytes and barbarians living in Europe and in all civilized countries, as well as a large number of medieval Christians. On the other hand, there are relatively few who have reached the level of consciousness which is possible in our time. We must also reckon with the fact that a few of our generation belong to the third or fourth millennium A.D. and are consequently anachronistic. So it is psychologically quite “legitimate” when a medieval man solves his conflict today on a thirteenth-century level and treats his shadow as the devil incarnate. For such a man any other procedure would be unnatural and wrong, for his belief is that of a thirteenth-century Christian. But, for the man who belongs by temperament, i.e., psychologically, to the twentieth century, there are certain important considerations which would never enter the head of our medieval specimen. How much the Middle Ages are still with us can be seen, among other things, from the fact that such a simple truth as the psychic quality of metaphysical figures will not penetrate into people’s heads. This is not a matter of intelligence or education, or of *Weltanschauung*, for the materialist also is unable to perceive to what extent, for instance, God is a psychic quantity which nothing can deprive of its reality, which does not insist on a definite name and which allows itself to be called reason, energy, matter, or even ego.

[464] This historical stratification must be taken into account most carefully by the psychotherapist, likewise the possibility of a latent capacity for development, which he would do well, however, not to take for granted.

[465] Whereas the “reasonable,” i.e., rationalistic, point of view is satisfying to the man of the eighteenth century, the psychological standpoint appeals much more to the man of the twentieth century. The most threadbare rationalism means more to the former than the best psychological explanation, for he is incapable of thinking psychologically and can operate only with rational concepts, which must on no account savour of metaphysics, for the latter are taboo. He will at once suspect the psychologist of mysticism, for in his eyes a rational concept can be neither metaphysical nor psychological. Resistances against the psychological standpoint, which regards psychic processes as facts, are, I fear, all equally anachronistic, including the prejudice of “psychologism,” which does not understand the empirical nature of the psyche either. To the man of the twentieth century this is a matter of the

highest importance and the very foundation of his reality, because he has recognized once and for all that without an observer there is no world and consequently no truth, for there would be nobody to register it. The one and only immediate guarantor of reality is the observer. Significantly enough, the most unpsychological of all sciences, physics, comes up against the observer at the decisive point. This knowledge sets its stamp on our century.

[466] It would be an anachronism, i.e., a regression, for the man of the twentieth century to solve his conflicts either rationalistically or metaphysically. Therefore, for better or worse, he has built himself a psychology, because it is impossible to get along without it. Both the theologian and the somatic doctor would do well to give earnest consideration to this fact, if they do not want to risk losing touch with their time. It is not easy for the somatically oriented doctor to see his long familiar clinical pictures and their aetiology in the unaccustomed light of psychology, and in the same way it will cost the theologian considerable effort to adjust his thinking to the new fact of the psyche and, in particular, of the unconscious, so that he too can reach the man of the twentieth century. No art, science, or institution in any way concerned with human beings can escape the effects of the development which the psychologists and physicists have let loose, even if they oppose it with the most stubborn prejudices.

[467] Father White's book has the merit of being the first theological work from the Catholic side to concern itself with the far-reaching effects of the new empirical knowledge in the realm of archetypal ideas, and to make a serious attempt to integrate it. Although the book is addressed primarily to the theologian, the psychologist and particularly the medical psychotherapist will be able to glean from it a rich harvest of knowledge.

FOREWORD TO WERBLOWSKY'S "LUCIFER AND PROMETHEUS"¹

[468] The author has submitted his manuscript to me with the request that I should write a few words by way of introduction. As the subject of the book is essentially literary, I do not feel altogether competent to express an opinion on the matter. The author has, however, rightly discerned that, although the problem of Milton's *Paradise Lost* is primarily a subject for literary criticism, it is, as a piece of confessional writing, fundamentally bound up with certain psychological assumptions. Though he has only touched on these—at least in so many words—he has made it sufficiently plain why he has appealed to me as a psychologist. However little disposed I am to regard Dante's *Divine Comedy* or Klopstock's *Messiah* or Milton's opus as fit subjects for psychological commentary, I cannot but acknowledge the acumen of the author, who has seen that the problem of Milton might well be elucidated from that angle of research which is my special field of study.

[469] For over two thousand years the figure of Satan, both as a theme of poetico-religious thinking and artistic creation and as a mythologem, has been a constant expression of the psyche, having its source in the unconscious evolution of "metaphysical" images. We should go very wrong in our judgment if we assumed that ideas such as this derive from rationalistic thinking. All the old ideas of God, indeed thought itself, and particularly numinous thought, have their origin in *experience*. Primitive man does not think his thoughts, they simply *appear* in his mind. Purposive and directed thinking is a relatively late human achievement. The numinous image is far more an expression of essentially unconscious processes than a product of rational inference. Consequently it falls into the category of psychological objects, and this raises the question of the underlying psychological assumptions. We have to imagine a millennial process of symbol-formation which presses towards consciousness, beginning in the darkness of prehistory with primordial or archetypal images, and gradually developing and differentiating these images into conscious creations. The history of religion in the West can be taken as an illustration of this: I mean the historical development of dogma, which also includes the figure of Satan. One of the best-known archetypes, lost in the grey mists of antiquity, is the triad of gods. In the early centuries of Christianity it reappears in the Christian formula for the Trinity, whose pagan version is *Hermes ter unus*. Nor is it difficult to see that the great goddess of the Ephesians has been resurrected in the

θεοτόκος. This latter problem, after lying dormant for centuries, came into circulation again with the dogma of the Immaculate Conception and, more recently, of the Assumption of the Virgin. The figure of the mediatrix rounds itself out in almost classical perfection, and it is especially noteworthy that behind the solemn promulgation of the dogma there stands no arbitrary tenet of papal authority but an anonymous movement of the Catholic world. The numerous miracles of the Virgin which preceded it are equally autochthonous; they are genuine and legitimate experiences springing directly from the unconscious psychic life of the people.

[470] I do not wish to multiply examples needlessly, but only to make it clear that the figure of Satan, too, has undergone a curious development, from the time of his first undistinguished appearance in the Old Testament texts to his heyday in Christianity. He achieved notoriety as the personification of the adversary or principle of evil, though by no means for the first time, as we meet him centuries earlier in the ancient Egyptian Set and the Persian Ahriman. Persian influences have been conjectured as mainly responsible for the Christian devil. But the real reason for the differentiation of this figure lies in the conception of God as the *summum bonum*, which stands in sharp contrast to the Old Testament view and which, for reasons of psychic balance, inevitably requires the existence of an *infimum malum*. No logical reasons are needed for this, only the natural and unconscious striving for balance and symmetry. Hence very early, in Clement of Rome, we meet with the conception of Christ as the right hand and the devil as the left hand of God, not to speak of the Judaeo-Christian view which recognized two sons of God, Satan the elder and Christ the younger. The figure of the devil then rose to such exalted metaphysical heights that he had to be forcibly depotentiated, under the threatening influence of Manichaeism. The depotentiation was effected—this time—by rationalistic reflection, by a regular *tour de force* of sophistry which defined evil as a *privatio boni*. But that did nothing to stop the belief from arising in many parts of Europe during the eleventh century, mainly under the influence of the Cathars, that it was not God but the devil who had created the world. In this way the archetype of the imperfect demiurge, who had enjoyed official recognition in Gnosticism, reappeared in altered guise. (The corresponding archetype is probably to be found in the cosmogonic jester² of primitive peoples.) With the extermination of the heretics that dragged on into the fourteenth and fifteenth centuries, an uneasy calm ensued, but the Reformation thrust the figure of Satan once more into the foreground. I would only mention Jakob Böhme, who sketched a picture of evil which leaves the *privatio boni* pale by comparison. The same can be said of Milton. He inhabits the same mental climate. As for Böhme, although he was not a direct descendant of alchemical philosophy, whose importance is still grossly underrated today, he certainly took over a number of its leading ideas, among them the specific recognition of Satan, who was exalted

to a cosmic figure of first rank in Milton, even emancipating himself from his subordinate role as the left hand of God (the role assigned to him by Clement). Milton goes even further than Böhme and apostrophizes the devil as the true *principium individuationis*, a concept which had been anticipated by the alchemists some time before. To mention only one example: “Ascendit a terra in coelum, iterumque descendit in terram et recipit vim superiorum et inferiorum. Sic habebis gloriam totius mundi.” (He rises from earth to heaven and descends again to earth, and receives into himself the power of above and below. Thus thou wilt have the glory of the whole world.) The quotation comes from the famous alchemical classic, the *Tabula Smaragdina*, attributed to Hermes Trismegistus, whose authority remained unchallenged for more than thirteen centuries of alchemical thought. His words refer not to Satan, but to the *filius philosophorum*, whose symbolism, as I believe I have shown, coincides with that of the psychological “self.” The *filius* of the alchemists is one of the numerous manifestations of Mercurius, who is called “duplex” and “ambiguus” and is also known outside alchemy as “utriusque capax”—capable of anything. His “dark” half has an obvious affinity with Lucifer.

[471] In Milton’s time these ideas were very much in the air, forming part of the general stock of culture, and there were not a few Masters who realized that their philosophical stone was none other than the “total man.” The Satan-Prometheus parallel shows clearly enough that Milton’s devil stands for the essence of human individuation and thus comes within the scope of psychology. This close proximity, as we know, proved a danger not only to the metaphysical status of Satan, but to that of other numinous figures as well. With the coming of the Enlightenment, metaphysics as a whole began to decline, and the rift which then opened out between knowledge and faith could no longer be repaired. The more resplendent figures in the metaphysical pantheon had their autonomy restored to them practically untarnished, which assuredly cannot be said of the devil. In Goethe’s *Faust* he has dwindled to a very personal *familiaris*, the mere “shadow” of the struggling hero. After rational-liberal Protestantism had, as it were, deposed him by order of the day, he retired to the shadier side of the Christian Olympus as the “odd man out,” and thus, in a manner not unwelcome to the Church, the old principle reasserted itself: *Omne bonum a Deo, omne malum ab homine*. The devil remains as an appendix to psychology.

[472] It is a psychological rule that when an archetype has lost its metaphysical hypostasis, it becomes identified with the conscious mind of the individual, which it influences and refashions in its own form. And since an archetype always possesses a certain numinosity, the integration of the numen generally produces an inflation of the subject. It is therefore entirely in accord with psychological expectations that Goethe should dub his Faust a Superman. In recent times this type has extended

beyond Nietzsche into the field of political psychology, and its incarnation in man has had all the consequences that might have been expected to follow from such a misappropriation of power.

[473] As human beings do not live in airtight compartments, this infectious inflation has spread everywhere and given rise to an extraordinary uncertainty in morals and philosophy. The medical psychologist is bound to take an interest in such matters, if only for professional reasons, and so we witness the memorable spectacle of a psychiatrist introducing a critical study of Milton's *Paradise Lost*. Meditating upon this highly incongruous conjunction, I decided that I should best fulfil my obligations if I explained to the well-intentioned reader how and why the devil got into the consulting-room of the psychiatrist.

BROTHER KLAUS¹

[474] Before me lies a little book by Father Alban Stoeckli on the Visions of the Blessed Brother Klaus.² Let the reader not be alarmed. Though a psychiatrist takes up his pen, it does not necessarily mean that he is going to set about this venerable figure with the profane instrument of psychopathology. Psychiatrists have committed enough sins already and have put their science to the most unsuitable uses. Nothing of the kind is to happen here: no diagnosis or analysis will be undertaken, no significant hints of pathological possibilities will be dropped, and no attempt will be made to bring the Blessed Nicholas of Flüe anywhere near a psychiatric clinic. Hence it must seem all the stranger to the reader that the reviewer of the book is a physician. I admit this fact is difficult to explain to anyone who does not know my unfashionable view on visions and the like. In this respect I am a good deal less sophisticated and more conservative than the so-called educated public, who in their philosophical embarrassment heave a sigh of relief when visions are equated with hallucinations, delusional ideas, mania, and schizophrenia, or whatever else these morbid things may be called, and are reduced to the right denominator by some competent authority. Medically, I can find nothing wrong with Brother Klaus. I see him as a somewhat unusual but in no wise pathological person, a man after my own heart: my brother Klaus. Rather remote, to be sure, at this distance of more than four hundred years, separated by culture and creed, by those fashionable trifles which we always think constitute a world. Yet they amount to no more than linguistic difficulties, and these do not impede understanding of the essentials. So little, in fact, that I was able to converse, in the primitive language of inward vision, with a man who in every way was even further removed from me than Brother Klaus—a Pueblo Indian, my friend Ochwiabiano (“Mountain Lake”).^{2a} For what interests us here is not the historical personage, not the well-known figure at the Diet of Stans,³ but the “friend of God,” who appeared but a few times on the world stage, yet lived a long life in the realms of the soul. Of what he there experienced he left behind only scant traces, so few and inarticulate that it is hard for posterity to form any picture of his inner life.

[475] It has always intrigued me to know what a hermit does with himself all day long. Can we still imagine a real spiritual anchorite nowadays, one who has not simply crept away to vegetate in misanthropic simplicity? A solitary fellow, like an

old elephant who resentfully defies the herd instinct? Can we imagine a normal person living a sensible, vital existence by himself, with no visible partner?

[476] Brother Klaus had a house, wife, and children, and we do not know of any external factors which could have induced him to become a hermit. The sole reason for this was his singular inner life; experiences for which no merely natural grounds can be adduced, decisive experiences which accompanied him from youth up. These things seemed to him of more value than ordinary human existence. They were probably the object of his daily interest and the source of his spiritual vitality. It sounds rather like an anecdote from the life of a scholar who is completely immersed in his studies when the so-called “Pilgrim’s Tract”⁴ relates: “And he [Brother Klaus] began to speak again and said to me, ‘If it does not trouble you, I would like to show you my book, in which I am learning and seeking the art of this doctrine.’ And he brought me a figure, drawn like a wheel with six spokes.” So evidently Brother Klaus studied some mysterious “doctrine” or other; he sought to understand and interpret the things that happened to him. That the hermit’s activity was a sort of study must also have occurred to Gundolfingen,⁵ one of the oldest writers on our subject. He says: “Did he not likewise learn in that High School of the Holy Ghost the representation of the wheel, which he caused to be painted in his chapel, and through which, as in a clear mirror, was reflected the entire essence of the Godhead?” From the same “High School” he derived “his kindness, his doctrine, and his science.”^{5a}

[477] Here we are concerned with the so-called Trinity Vision, which was of the greatest significance for the hermit’s inner life. According to the oldest reports, it was an apparition of light, of surpassing intensity, in the form of a human face. The firsthand reports make no mention of a “wheel.” This seems to have been a subsequent addition for the purpose of clarifying the vision. Just as a stone, falling into calm water, produces wave after wave of circles, so a sudden and violent vision of this kind has long-lasting after-effects, like any shock. And the stranger and more impressive the initial vision was, the longer it will take to be assimilated, and the greater and more persevering will be the efforts of the mind to master it and render it intelligible to human understanding. Such a vision is a tremendous “irruption” in the most literal sense of the word, and it has therefore always been customary to draw rings round it like those made by the falling stone when it breaks the smooth surface of the water.

[478] Now what has “irrupted” here, and wherein lies its mighty “impression”? The oldest source, Wölflin’s biography,⁶ narrates the following on this score:

All who came to him were filled with terror at the first glance. As to the cause of this, he himself used to say that he had seen a piercing light resembling a human face. At the sight of it he feared that his heart would burst into

little pieces. Overcome with terror, he instantly turned his face away and fell to the ground. And that was the reason why his face was now terrible to others.

This is borne out by the account which the humanist Karl Bovillus (Charles de Bouelles) gave to a friend in 1508 (some twenty years after the death of Brother Klaus):

I wish to tell you of a vision which appeared to him in the sky, on a night when the stars were shining and he stood in prayer and contemplation. He saw the head of a human figure with a terrifying face, full of wrath and threats.⁷

So we shall not go wrong in surmising that the vision was terrifying in the extreme. When we consider that the mental attitude of that age, and in particular that of Brother Klaus, allowed no other interpretation than that this vision represented God himself, and that God signified the *summum bonum*, Absolute Perfection, then it is clear that such a vision must, by its violent contrast, have had a profound and shattering effect, whose assimilation into consciousness required years of the most strenuous spiritual effort. Through subsequent elaboration this vision then became the so-called Trinity Vision. As Father Stoeckli rightly conjectures, the “wheel” or circles were formed on the basis of, and as parallels to, the illustrated devotional books that were read at the time. As mentioned above, Brother Klaus even seems to have possessed such a book himself. Later, as a result of further mental elaboration, there were added the spokes of the wheel and the six secondary circles, as shown in the old picture of the vision in the parish church at Sachseln.

[479] The vision of light was not the only one which Brother Klaus had. He even thought that, while still in his mother’s womb, he had seen a star that outshone all others in brightness, and later, in his solitude, he saw a very similar star repeatedly. The vision of light had, therefore, occurred several times before in his life. Light means illumination; it is an illuminating idea that “irrupts.” Using a very cautious formulation, we could say that the underlying factor here is a considerable tension of psychic energy, evidently corresponding to some very important unconscious content. This content has an overpowering effect and holds the conscious mind spellbound. The tremendous power of the “objective psychic” has been named “demon” or “God” in all epochs with the sole exception of the recent present. We have become so bashful in matters of religion that we correctly say “unconscious,” because God has in fact become unconscious to us. This is what always happens when things are interpreted, explained, and dogmatized until they become so encrusted with man-made images and words that they can no longer be seen. Something similar seems to have happened to Brother Klaus, which is why the immediate experience burst upon him with appalling terror. Had his vision been as charming and edifying as the present picture at Sachseln, no such terror would ever have emanated from it.

[480] “God” is a primordial experience of man, and from the remotest times humanity has taken inconceivable pains either to portray this baffling experience, to assimilate it by means of interpretation, speculation, and dogma, or else to deny it. And again and again it has happened, and still happens, that one hears too much about the “good” God and knows him too well, so that one confuses him with one’s own ideas

and regards them as sacred because they can be traced back a couple of thousand years. This is a superstition and an idolatry every bit as bad as the Bolshevik delusion that “God” can be educated out of existence. Even a modern theologian like Gogarten⁸ is quite sure that God *can only be good*. A good man does not terrify me—what then would Gogarten have made of the Blessed Brother Klaus? Presumably he would have had to explain to him that he had seen the devil in person.

[481] And here we are in the midst of that ancient dilemma of how such visions are to be evaluated. I would suggest taking every genuine case at its face value. If it was an overwhelming experience for so worthy and shrewd a man as Brother Klaus, then I do not hesitate to call it a true and veritable experience of God, even if it turns out not quite right dogmatically. Great saints were, as we know, sometimes great heretics, so it is probable that anyone who has immediate experience of God is a little bit outside the organization one calls the Church. The Church itself would have been in a pretty pass if the Son of God had remained a law-abiding Pharisee, a point one tends to forget.

[482] There are many indubitable lunatics who have experiences of God, and here too I do not contest the genuineness of the experience, for I know that it takes a complete and a brave man to stand up to it. Therefore I feel sorry for those who go under, and I shall not add insult to injury by saying that they tripped up on a mere psychologism. Besides, one can never know in what form a man will experience God, for there are very peculiar things just as there are very peculiar people—like those, for instance, who think that one can make anything but a conceptual distinction between the individual experience of God and God himself. It would certainly be desirable to make this distinction, but to do so one would have to know what God is in and for himself, which does not seem to me possible.

[483] Brother Klaus’s vision was a genuine primordial experience, and it therefore seemed to him particularly necessary to submit it to a thorough dogmatic revision. Loyally and with great efforts he applied himself to this task, the more so as he was smitten with terror in every limb so that even strangers took fright. The unconscious taint of heresy that probably clings to all genuine and unexpurgated visions is only hinted at in the Trinity Vision, but in the touched-up version it has been successfully eliminated. All the affectivity, the very thing that made the strongest impression, has vanished without a trace, thus affording at least a negative proof of our interpretation.

[484] Brother Klaus’s elucidation of his vision with the help of the three circles (the so-called “wheel”) is in keeping with age-old human practice, which goes back to the Bronze Age sun-wheels (often found in Switzerland) and to the mandalas depicted in the Rhodesian rock-drawings. These sun-wheels may possibly be paleolithic;⁹ we find them in Mexico, India, Tibet, and China. The Christian mandalas probably date

back to St. Augustine and his definition of God as a circle. Presumably Henry Suso's notions of the circle, which were accessible to the "Friends of God," were derived from the same source. But even if this whole tradition had been cut off and no little treatise with mandalas in the margin had ever come to light, and if Brother Klaus had never seen the rose-window of a church, he would still have succeeded in working his great experience into the shape of a circle, because this is what has always happened in every part of the world and still goes on happening today.¹⁰

[485] We spoke above of heresy. In Father Stoeckli's newly found fragment describing the vision, there is another vision which contains an interesting parallelism. I put the two passages side by side for the sake of comparison:

There came a handsome majestic man through the palace, with a shining colour in his face, and in a white garment. And he laid both arms on his shoulders and pressed him close and thanked him with all the fervent love of his heart, because he had stood by his son and helped him in his need.

There came a beautiful majestic woman through the palace, also in a white garment.... And she laid both arms on his shoulders and pressed him close to her heart with an overflowing love, because he had stood so faithfully by her son in his need.¹¹

[486] It is clear that this is a vision of God the Father and Son, and of the Mother of God. The palace is heaven, where "God the Father" dwells, and also "God the Mother." In pagan form they are unmistakably God and Goddess, as their absolute parallelism shows. The androgyny of the divine Ground is characteristic of mystic experience. In Indian Tantrism the masculine Shiva and the feminine Shakti both proceed from Brahman, which is devoid of qualities. Man as the son of the Heavenly Father and Heavenly Mother is an age-old conception which goes back to primitive times, and in this vision the Blessed Brother Klaus is set on a par with the Son of God. The Trinity in this vision—Father, Mother, and Son—is very undogmatic indeed. Its nearest parallel is the exceedingly unorthodox Gnostic Trinity: God, Sophia, Christ. The Church, however, has expunged the feminine nature of the Holy Ghost, though it is still suggested by the symbolic dove.

[487] It is nice to think that the only outstanding Swiss mystic received, by God's grace, unorthodox visions and was permitted to look with unerring eye into the depths of the divine soul, where all the creeds of humanity which dogma has divided are united in *one* symbolic archetype. As I hope Father Stoeckli's little book will find many attentive readers, I shall not discuss the Vision of the Well, nor the Vision of the Man with the Bearskin,¹² although from the standpoint of comparative symbolism they offer some very interesting aspects—for I do not want to deprive the reader of the pleasure of finding out their meaning by himself.

V

PSYCHOTHERAPISTS OR THE CLERGY

— — —

PSYCHOANALYSIS AND THE CURE OF SOULS

PSYCHOTHERAPISTS OR THE CLERGY¹

[488] It is far more the urgent psychic problems of patients, rather than the curiosity of research workers, that have given effective impetus to the recent developments in medical psychology and psychotherapy. Medical science—almost in defiance of the patients' needs—has held aloof from all contact with strictly psychic problems, on the partly justifiable assumption that psychic problems belong to other fields of study. But it has been compelled to widen its scope so as to include experimental psychology, just as it has been driven time and time again—out of regard for the biological unity of the human being—to borrow from such outlying branches of science as chemistry, physics, and biology.

[489] It was natural that the branches of science adopted by medicine should be given a new direction. We can characterize the change by saying that instead of being regarded as ends in themselves they were valued for their practical application to human beings. Psychiatry, for example, helped itself out of the treasure-chest of experimental psychology and its methods, and funded its borrowings in the inclusive body of knowledge that we call psychopathology—a name for the study of complex psychic phenomena. Psychopathology is built for one part on the findings of psychiatry in the strict sense of the term, and for the other part on the findings of neurology—a field of study which originally embraced the so-called psychogenic neuroses, and still does so in academic parlance. In practice, however, a gulf has opened out in the last few decades between the trained neurologist and the psychotherapist, especially after the first researches in hypnotism. This rift was unavoidable, because neurology, strictly speaking, is the science of organic nervous diseases, whereas the psychogenic neuroses are not organic diseases in the usual sense of the term. Nor do they fall within the realm of psychiatry, whose particular field of study is the psychoses, or mental diseases—for the psychogenic neuroses are not mental diseases as this term is commonly understood. Rather do they constitute a special field by themselves with no hard and fast boundaries, and they show many transitional forms which point in two directions: towards mental disease on the one hand, and diseases of the nerves on the other.

[490] The unmistakable feature of the neuroses is the fact that their causes are psychic, and that their cure depends entirely upon psychic methods of treatment. The attempts to delimit and explore this special field—both from the side of psychiatry and from that of neurology—led to a discovery which was very unwelcome to the science of

medicine: namely, the *discovery of the psyche* as an aetiological or causal factor in disease. In the course of the nineteenth century medicine had become, in its methods and theory, one of the disciplines of natural science, and it cherished the same basically philosophical assumption of *material causation*. For medicine, the psyche as a mental “substance” did not exist, and experimental psychology also did its best to constitute itself a psychology without a psyche.

[491] Investigation, however, has established beyond a doubt that the crux of the psychoneuroses is the psychic factor, that this is the essential cause of the pathological state, and must therefore be recognized in its own right along with other admitted pathogenic factors such as inheritance, disposition, bacterial infection, and so forth. All attempts to explain the psychic factor in terms of more elementary physical factors were doomed to failure. There was more promise in the attempt to reduce it to the concept of the drive or instinct—a concept taken over from biology. It is well known that instincts are observable physiological urges based on the functioning of the glands, and that, as experience shows, they condition or influence psychic processes. What could be more plausible, therefore, than to seek the specific cause of the psychoneuroses not in the mystical notion of the “soul,” but in a disturbance of the instincts which might possibly be curable in the last resort by medicinal treatment of the glands?

[492] Freud’s theory of the neuroses is based on this standpoint: it explains them in terms of disturbances of the sexual instinct. Adler likewise resorts to the concept of the drive, and explains the neuroses in terms of disturbances of the urge to power, a concept which, we must admit, is a good deal more psychic than that of the physiological sexual instinct.

[493] The term “instinct” is anything but well defined in the scientific sense. It applies to a biological phenomenon of immense complexity, and is not much more than a border-line concept of quite indefinite content standing for an unknown quantity. I do not wish to enter here upon a critical discussion of instinct. Instead I will consider the possibility that the psychic factor is just a combination of instincts which for their part may again be reduced to the functioning of the glands. We may even consider the possibility that everything “psychic” is comprised in the sum total of instincts, and that the psyche itself is therefore only an instinct or a conglomerate of instincts, being in the last analysis nothing but a function of the glands. A psychoneurosis would then be a glandular disease.

[494] There is, however, no proof of this statement, and no glandular extract that will cure a neurosis has yet been found. On the other hand, we have been taught by all too many mistakes that organic therapy fails completely in the treatment of neuroses, while psychic methods cure them. These psychic methods are just as effective as we might suppose the glandular extracts would be. So far, then, as our present

knowledge goes, neuroses are to be influenced or cured by approaching them not from the proximal end, i.e., from the functioning of the glands, but from the distal end, i.e., from the psyche, just as if the psyche were itself a substance. For instance, a suitable explanation or a comforting word to the patient can have something like a healing effect which may even influence the glandular secretions. The doctor's words, to be sure, are "only" vibrations in the air, yet their special quality is due to a particular psychic state in the doctor. His words are effective only in so far as they convey a meaning or have significance. It is this that makes them work. But "meaning" is something mental or spiritual. Call it a fiction if you like. Nevertheless this fiction enables us to influence the course of the disease far more effectively than we could with chemical preparations. Indeed, we can even influence the biochemical processes of the body. Whether the fiction forms itself in me spontaneously or reaches me from outside via human speech, it can make me ill or cure me. Fictions, illusions, opinions are perhaps the most intangible and unreal things we can think of; yet they are the most effective of all in the psychic and even the psychophysical realm.

[495] It was by recognizing these facts that medicine discovered the psyche, and it can no longer honestly deny the psyche's reality. It has been shown that the instincts are a condition of psychic activity, while at the same time psychic processes seem to condition the instincts.

[496] The reproach levelled at the Freudian and Adlerian theories is not that they are based on instincts, but that they are one-sided. It is psychology without the psyche, and this suits people who think they have no spiritual needs or aspirations. But here both doctor and patient deceive themselves. Even though the theories of Freud and Adler come much nearer to getting at the bottom of the neuroses than any earlier approach from the medical side, their exclusive concern with the instincts fails to satisfy the deeper spiritual needs of the patient. They are too much bound by the premises of nineteenth-century science, too matter of fact, and they give too little value to fictional and imaginative processes. In a word, they do not give enough meaning to life. And it is only meaning that liberates.

[497] Ordinary reasonableness, sound human judgment, science as a compendium of common sense, these certainly help us over a good part of the road, but they never take us beyond the frontiers of life's most commonplace realities, beyond the merely average and normal. They afford no answer to the question of psychic suffering and its profound significance. A psychoneurosis must be understood, ultimately, as the suffering of a soul which has not discovered its meaning. But all creativeness in the realm of the spirit as well as every psychic advance of man arises from the suffering of the soul, and the cause of the suffering is spiritual stagnation, or psychic sterility.

[498] With this realization the doctor sets foot on territory which he enters with the greatest caution. He is now confronted with the necessity of conveying to his patient the healing fiction, the meaning that quickens—for it is this that the sick person longs for, over and above everything that reason and science can give him. He is looking for something that will take possession of him and give meaning and form to the confusion of his neurotic soul.

[499] Is the doctor equal to this task? To begin with, he will probably hand his patient over to the clergyman or philosopher, or abandon him to that vast perplexity which is the special note of our day. As a doctor he is not required to have a finished outlook on life, and his professional conscience does not demand it of him. But what will he do when he sees only too clearly why his patient is ill; when he sees that he has no love, but only sexuality; no faith, because he is afraid to grope in the dark; no hope, because he is disillusioned by the world and by life; and no understanding, because he has failed to read the meaning of his own existence?

[500] There are many well-educated patients who flatly refuse to consult a clergyman. Still less will they listen to a philosopher, for the history of philosophy leaves them cold, and intellectual problems seem to them more barren than the desert. And where are the great and wise men who do not merely talk about the meaning of life and of the world, but really possess it? One cannot just think up a system or truth which would give the patient what he needs in order to live, namely faith, hope, love, and understanding.

[501] These four highest achievements of human endeavour are so many gifts of grace, which are neither to be taught nor learned, neither given nor taken, neither withheld nor earned, since they come through experience, which is an irrational datum not subject to human will and caprice. Experiences cannot be *made*. They happen—yet fortunately their independence of man's activity is not absolute but relative. We can draw closer to them—that much lies within our human reach. There are ways which bring us nearer to living experience, yet we should beware of calling these ways “methods.” The very word has a deadening effect. The way to experience, moreover, is anything but a clever trick; it is rather a venture which requires us to commit ourselves with our whole being.

[502] Thus, in trying to meet the therapeutic demands made upon him, the doctor is confronted with a question which seems to contain an insuperable difficulty. How can he help the sufferer to attain the liberating experience which will bestow upon him the four great gifts of grace and heal his sickness? We can, of course, advise the patient with the best intentions that he should have true love, or true faith, or true hope; and we can admonish him with the phrase: “Know thyself.” But how is the patient to obtain beforehand that which only experience can give him?

[503] Saul owed his conversion neither to true love, nor to true faith, nor to any other truth. It was solely his hatred of the Christians that set him on the road to Damascus, and to that decisive experience which was to alter the whole course of his life. He was brought to this experience by following out, with conviction, his own worst mistake.

[504] This opens up a problem which we can hardly take too seriously. And it confronts the psychotherapist with a question which brings him shoulder to shoulder with the clergyman: the question of good and evil.

[505] It is in reality the priest or the clergyman, rather than the doctor, who should be most concerned with the problem of spiritual suffering. But in most cases the sufferer consults the doctor in the first place, because he supposes himself to be physically ill, and because certain neurotic symptoms can be at least alleviated by drugs. But if, on the other hand, the clergyman is consulted, he cannot persuade the sick man that the trouble is psychic. As a rule he lacks the special knowledge which would enable him to discern the psychic factors of the disease, and his judgment is without the weight of authority.

[506] There are, however, persons who, while well aware of the psychic nature of their complaint, nevertheless refuse to turn to the clergyman. They do not believe that he can really help them. Such persons distrust the doctor for the same reason, and rightly so, for the truth is that both doctor and clergyman stand before them with empty hands, if not—what is even worse—with empty words. We can hardly expect the doctor to have anything to say about the ultimate questions of the soul. It is from the clergyman, not from the doctor, that the sufferer should expect such help. But the Protestant clergyman often finds himself face to face with an almost impossible task, for he has to cope with practical difficulties that the Catholic priest is spared. Above all, the priest has the authority of his Church behind him, and his economic position is secure and independent. This is far less true of the Protestant clergyman, who may be married and burdened with the responsibility of a family, and cannot expect, if all else fails, to be supported by the parish or taken into a monastery. Moreover the priest, if he is also a Jesuit, is *au fait* with the most up-to-date developments in psychology. I know, for instance, that my own writings were seriously studied in Rome long before any Protestant theologian thought them worthy of a glance.

[507] We have come to a serious pass. The exodus from the German Protestant Church is only one of many symptoms which should make it plain to the clergy that mere admonitions to believe, or to perform acts of charity, do not give modern man what he is looking for. The fact that many clergymen seek support or practical help from Freud's theory of sexuality or Adler's theory of power is astonishing, inasmuch as both these theories are, at bottom, hostile to spiritual values, being, as I have said, psychology without the psyche. They are rationalistic methods of treatment which

actually hinder the realization of meaningful experience. By far the larger number of psychotherapists are disciples of Freud or of Adler. This means that the great majority of patients are necessarily alienated from a spiritual standpoint—a fact which cannot be a matter of indifference to one who has the fate of the psyche at heart. The wave of interest in psychology which at present is sweeping over the Protestant countries of Europe is far from receding. It is coincident with the mass exodus from the Church. Quoting a Protestant minister, I may say: “Nowadays people go to the psychotherapist rather than to the clergyman.”

[508] I am convinced that this statement is true only of relatively educated persons, not of mankind in the mass. However, we must not forget that it takes about twenty years for the ordinary run of people to begin thinking the thoughts of the educated person of today. For instance, Büchner’s work *Force and Matter*² became one of the most widely read books in German public libraries some twenty years after educated persons had forgotten all about it. I am convinced that the psychological needs of the educated today will be the interests of the people tomorrow.

[509] I should like to call attention to the following facts. During the past thirty years, people from all the civilized countries of the earth have consulted me. Many hundreds of patients have passed through my hands, the greater number being Protestants, a lesser number Jews, and not more than five or six believing Catholics. Among all my patients in the second half of life—that is to say, over thirty-five—there has not been one whose problem in the last resort was not that of finding a religious outlook on life. It is safe to say that every one of them fell ill because he had lost what the living religions of every age have given to their followers, and none of them has been really healed who did not regain his religious outlook. This of course has nothing whatever to do with a particular creed or membership of a church.

[510] Here, then, the clergyman stands before a vast horizon. But it would seem as if no one had noticed it. It also looks as though the Protestant clergyman of today were insufficiently equipped to cope with the urgent psychic needs of our age. It is indeed high time for the clergyman and the psychotherapist to join forces to meet this great spiritual task.

[511] Here is a concrete example which goes to show how closely this problem touches us all. A little more than a year ago the leaders of the Christian Students’ Conference at Aarau [Switzerland] laid before me the question whether people in spiritual distress prefer nowadays to consult the doctor rather than the clergyman, and what are the causes of their choice. This was a very direct and very practical question. At the time I knew nothing more than the fact that my own patients obviously had consulted the doctor rather than the clergyman. It seemed to me to be open to doubt whether this was generally the case or not. At any rate, I was unable to give a definite reply. I therefore set on foot an inquiry, through acquaintances of mine, among

people whom I did not know personally; I sent out a questionnaire which was answered by Swiss, German, and French Protestants, as well as by a few Catholics. The results are very interesting, as the following general summary shows. Those who decided for the doctor represented 57 per cent of the Protestants and only 25 per cent of the Catholics, while those who decided for the clergyman formed only 8 per cent of the Protestants as against 58 per cent of the Catholics. These were the unequivocal decisions. The remaining 35 per cent of the Protestants could not make up their minds, while only 17 per cent of the Catholics were undecided.

[512] The main reasons given for not consulting the clergyman were, firstly, his lack of psychological knowledge and insight, and this covered 52 per cent of the answers. Some 28 per cent were to the effect that he was prejudiced in his views and showed a dogmatic and traditional bias. Curiously enough, there was even one clergyman who decided for the doctor, while another made the irritated retort: "Theology has nothing to do with the treatment of human beings." All the relatives of clergymen who answered my questionnaire pronounced themselves against the clergy.

[513] So far as this inquiry was restricted to educated persons, it is only a straw in the wind. I am convinced that the uneducated classes would have reacted differently. But I am inclined to accept these sample results as a more or less valid indication of the views of educated people, the more so as it is a well-known fact that their indifference in matters of the Church and religion is steadily growing. Nor should we forget the above-mentioned truth of social psychology: that it takes about twenty years for the general outlook and problems of the educated to percolate down to the uneducated masses. Who, for instance, would have dared to prophesy twenty years ago, or even ten, that Spain, the most Catholic of European countries, would undergo the tremendous mental revolution we are witnessing today?³ And yet it has broken out with the violence of a cataclysm.

[514] It seems to me that, side by side with the decline of religious life, the neuroses grow noticeably more frequent. There are as yet no statistics with actual figures to prove this increase. But of one thing I am sure, that everywhere the mental state of European man shows an alarming lack of balance. We are living undeniably in a period of the greatest restlessness, nervous tension, confusion, and disorientation of outlook. Among my patients from many countries, all of them educated persons, there is a considerable number who came to see me not because they were suffering from a neurosis but because they could find no meaning in their lives or were torturing themselves with questions which neither our philosophy nor our religion could answer. Some of them perhaps thought I knew of a magic formula, but I soon had to tell them that I didn't know the answer either. And this brings us to practical considerations.

[515] Let us take for example that most ordinary and frequent of questions: What is the meaning of my life, or of life in general? Today people believe that they know only too well what the clergyman will—or rather must—say to this. They smile at the very thought of the philosopher's answer, and in general do not expect much of the physician. But from the psychotherapist who analyses the unconscious—from him one might at last learn something. Perhaps he has dug up from the abstruse depths of his mind, among other things, some meaning which could even be bought for a fee! It must be a relief to every serious-minded person to hear that the psychotherapist also does not know what to say. Such a confession is often the beginning of the patient's confidence in him.

[516] I have found that modern man has an ineradicable aversion for traditional opinions and inherited truths. He is a Bolshevik for whom all the spiritual standards and forms of the past have somehow lost their validity, and who therefore wants to experiment with his mind as the Bolshevik experiments with economics. Confronted with this attitude, every ecclesiastical system finds itself in an awkward situation, be it Catholic, Protestant, Buddhist, or Confucianist. Among these moderns there are of course some of those negative, destructive, and perverse natures—degenerates and unbalanced eccentrics—who are never satisfied anywhere, and who therefore flock to every new banner, much to the hurt of these movements and undertakings, in the hope of finding something *for once* which will compensate at low cost for their own ineptitude. It goes without saying that, in my professional work, I have come to know a great many modern men and women, including of course their pathological hangers-on. But these I prefer to leave aside. Those I am thinking of are by no means sickly eccentrics, but are very often exceptionally able, courageous, and upright persons who have repudiated traditional truths for honest and decent reasons, and not from wickedness of heart. Every one of them has the feeling that our religious truths have somehow become hollow. Either they cannot reconcile the scientific and the religious outlook, or the Christian tenets have lost their authority and their psychological justification. People no longer feel redeemed by the death of Christ; they cannot believe—for although it is a lucky man who *can* believe, it is not possible to compel belief. Sin has become something quite relative: what is evil for one man is good for another. After all, why should not the Buddha be right too?

[517] There is no one who is not familiar with these questions and doubts. Yet Freudian analysis would brush them all aside as irrelevant, for in its view, it is basically a question of repressed sexuality, which the philosophical or religious doubts only serve to mask. If we closely examine an individual case of this sort, we do discover peculiar disturbances in the sexual sphere as well as in the sphere of unconscious impulses in general. Freud sees in the presence of these disturbances an explanation of the psychic disturbance as a whole; he is interested only in the causal

interpretation of the sexual symptoms. He completely overlooks the fact that, in certain cases, the supposed causes of the neurosis were always present, but had no pathological effect until a disturbance of the conscious attitude set in and led to a neurotic upset. It is as though, when a ship was sinking because of a leak, the crew interested itself in the chemical constitution of the water that was pouring in, instead of stopping the leak. The disturbance of the instinctual sphere is not a primary but a secondary phenomenon. When conscious life has lost its meaning and promise, it is as though a panic had broken loose: "Let us eat and drink, for tomorrow we die!" It is this mood, born of the meaninglessness of life, that causes the disturbance in the unconscious and provokes the painfully curbed instincts to break out anew. The causes of a neurosis lie in the present as much as in the past, and only a cause actually existing in the present can keep a neurosis active. A man is not tubercular because he was infected twenty years ago with bacilli, but because active foci of infection are present *now*. The questions when and how the infection occurred are totally irrelevant. Even the most accurate knowledge of the previous history cannot cure the tuberculosis. And the same holds true of the neuroses.

[518] That is why I regard the religious problems which the patient puts before me as authentic and as possible causes of the neurosis. But if I take them seriously, I must be able to confess to the patient: "Yes, I agree, the Buddha may be just as right as Jesus. Sin is only relative, and it is difficult to see how we can feel ourselves in any way redeemed by the death of Christ." As a doctor I can easily admit these doubts, while it is hard for the clergyman to do so. The patient feels my attitude to be one of understanding, while the parson's hesitation strikes him as a traditional prejudice, and this estranges them from one another. He asks himself: "What would the parson say if I began to tell him of the painful details of my sexual disturbances?" He rightly suspects that the parson's moral prejudice is even stronger than his dogmatic bias. In this connection there is a good story about the American president, "silent Cal" Coolidge. When he returned after an absence one Sunday morning his wife asked him where he had been. "To church," he replied. "What did the minister say?" "He talked about sin." "And what did he say about sin?" "He was against it."

519 It is easy for the doctor to show understanding in this respect, you will say. But people forget that even doctors have moral scruples, and that certain patients' confessions are hard even for a doctor to swallow. Yet the patient does not feel himself accepted unless the very worst in him is accepted too. No one can bring this about by mere words; it comes only through reflection and through the doctor's attitude towards himself and his own dark side. If the doctor wants to guide another, or even accompany him a step of the way, he must *feel* with that person's psyche. He never feels it when he passes judgment. Whether he puts his judgments into words, or keeps them to himself, makes not the slightest difference. To take the opposite

position, and to agree with the patient offhand, is also of no use, but estranges him as much as condemnation. Feeling comes only through unprejudiced objectivity. This sounds almost like a scientific precept, and it could be confused with a purely intellectual, abstract attitude of mind. But what I mean is something quite different. It is a human quality—a kind of deep respect for the facts, for the man who suffers from them, and for the riddle of such a man's life. The truly religious person has this attitude. He knows that God has brought all sorts of strange and inconceivable things to pass and seeks in the most curious ways to enter a man's heart. He therefore senses in everything the unseen presence of the divine will. This is what I mean by "unprejudiced objectivity." It is a moral achievement on the part of the doctor, who ought not to let himself be repelled by sickness and corruption. We cannot change anything unless we accept it. Condemnation does not liberate, it oppresses. I am the oppressor of the person I condemn, not his friend and fellow-sufferer. I do not in the least mean to say that we must never pass judgment when we desire to help and improve. But if the doctor wishes to help a human being he must be able to accept him as he is. And he can do this in reality only when he has already seen and accepted himself as he is.

[520] Perhaps this sounds very simple, but simple things are always the most difficult. In actual life it requires the greatest art to be simple, and so acceptance of oneself is the essence of the moral problem and the acid test of one's whole outlook on life. That I feed the beggar, that I forgive an insult, that I love my enemy in the name of Christ—all these are undoubtedly great virtues. What I do unto the least of my brethren, that I do unto Christ. But what if I should discover that the least amongst them all, the poorest of all beggars, the most impudent of all offenders, yea the very fiend himself—that these are within me, and that I myself stand in need of the alms of my own kindness, that I myself am the enemy who must be loved—what then? Then, as a rule, the whole truth of Christianity is reversed: there is then no more talk of love and long-suffering; we say to the brother within us "Raca," and condemn and rage against ourselves. We hide him from the world, we deny ever having met this least among the lowly in ourselves, and had it been God himself who drew near to us in this despicable form, we should have denied him a thousand times before a single cock had crowed.

[521] Anyone who uses modern psychology to look behind the scene not only of his patients' lives but more especially of his own life—and the modern psychotherapist must do this if he is not to be merely an unconscious fraud—will admit that to accept himself in all his wretchedness is the hardest of tasks, and one which it is almost impossible to fulfil. The very thought can make us sweat with fear. We are therefore only too delighted to choose, without a moment's hesitation, the complicated course of remaining in ignorance about ourselves while busying ourselves with other people

and their troubles and sins. This activity lends us a perceptible air of virtue, by means of which we benevolently deceive ourselves and others. God be praised, we have escaped from ourselves at last! There are countless people who can do this with impunity, but not everyone can, and these few break down on the road to their Damascus and succumb to a neurosis. How can I help these people if I myself am a fugitive, and perhaps also suffer from the *morbis sacer* of a neurosis? Only he who has fully accepted himself has “unprejudiced objectivity.” But no one is justified in boasting that he has fully accepted himself. We can point to Christ, who sacrificed his historical bias to the god within him, and lived his individual life to the bitter end without regard for conventions or for the moral standards of the Pharisees.

[522] We Protestants must sooner or later face this question: Are we to understand the “imitation of Christ” in the sense that we should copy his life and, if I may use the expression, ape his stigmata; or in the deeper sense that we are to live our own proper lives as truly as he lived his in its individual uniqueness? It is no easy matter to live a life that is modelled on Christ’s, but it is unspeakably harder to live one’s own life as truly as Christ lived his. Anyone who did this would run counter to the conditions of his own history, and though he might thus be fulfilling them, he would none the less be misjudged, derided, tortured, and crucified. He would be a kind of crazy Bolshevist who deserved the cross. We therefore prefer the historically sanctioned and sanctified imitation of Christ. I would never disturb a monk in the practice of this identification, for he deserves our respect. But neither I nor my patients are monks, and it is my duty as a physician to show my patients how they can live their lives without becoming neurotic. Neurosis is an inner cleavage—the state of being at war with oneself. Everything that accentuates this cleavage makes the patient worse, and everything that mitigates it tends to heal him. What drives people to war with themselves is the suspicion or the knowledge that they consist of two persons in opposition to one another. The conflict may be between the sensual and the spiritual man, or between the ego and the shadow. It is what Faust means when he says: “Two souls, alas, are housed within my breast.” A neurosis is a splitting of personality.

[523] Healing may be called a religious problem. In the sphere of social or national relations, the state of suffering may be civil war, and this state is to be cured by the Christian virtue of forgiveness and love of one’s enemies. That which we recommend, with the conviction of good Christians, as applicable to external situations, we must also apply inwardly in the treatment of neurosis. This is why modern man has heard enough about guilt and sin. He is sorely enough beset by his own bad conscience, and wants rather to know how he is to reconcile himself with his own nature—how he is to love the enemy in his own heart and call the wolf his brother.

[524] The modern man does not want to know in what way he can imitate Christ, but in what way he can live his own individual life, however meagre and uninteresting it may be. It is because every form of imitation seems to him deadening and sterile that he rebels against the force of tradition that would hold him to well-trodden ways. All such roads, for him, lead in the wrong direction. He may not know it, but he behaves as if his own individual life were God's special will which must be fulfilled at all costs. This is the source of his egoism, which is one of the most tangible evils of the neurotic state. But the person who tells him he is too egoistic has already lost his confidence, and rightly so, for that person has driven him still further into his neurosis.

[525] If I wish to effect a cure for my patients I am forced to acknowledge the deep significance of their egoism. I should be blind, indeed, if I did not recognize it as a true will of God. I must even help the patient to prevail in his egoism; if he succeeds in this, he estranges himself from other people. He drives them away, and they come to themselves—as they should, for they were seeking to rob him of his “sacred” egoism. This must be left to him, for it is his strongest and healthiest power; it is, as I have said, a true will of God, which sometimes drives him into complete isolation. However wretched this state may be, it also stands him in good stead, for in this way alone can he get to know himself and learn what an invaluable treasure is the love of his fellow beings. It is, moreover, only in the state of complete abandonment and loneliness that we experience the helpful powers of our own natures.

[526] “When one has several times seen this development at work one can no longer deny that what was evil has turned to good, and that what seemed good has kept alive the forces of evil. The archdemon of egoism leads us along the royal road to that ingathering which religious experience demands. What we observe here is a fundamental law of life—*enantiodromia* or conversion into the opposite; and it is this that makes possible the reunion of the warring halves of the personality and thereby brings the civil war to an end.

[527] I have taken the neurotic's egoism as an example because it is one of his most common symptoms. I might equally well have taken any other characteristic symptom to show what attitude the physician must adopt towards the shortcomings of his patients, in other words, how he must deal with the problem of evil.

[528] No doubt this also sounds very simple. In reality, however, the acceptance of the shadow-side of human nature verges on the impossible. Consider for a moment what it means to grant the right of existence to what is unreasonable, senseless, and evil! Yet it is just this that the modern man insists upon. He wants to live with every side of himself—to know what he is. That is why he casts history aside. He wants to break with tradition so that he can experiment with his life and determine what value and meaning things have in themselves, apart from traditional presuppositions. Modern

youth gives us astonishing examples of this attitude. To show how far this tendency may go, I will instance a question addressed to me by a German society. I was asked if incest is to be reprobated, and what facts can be adduced against it!

529 Granted such tendencies, the conflicts into which people may fall are not hard to imagine. I can well understand that one would like to do everything possible to protect one's fellow beings from such adventures. But curiously enough we find ourselves without means to do this. All the old arguments against unreasonableness, self-deception, and immorality, once so potent, have lost their attraction. We are now reaping the fruit of nineteenth-century education. Throughout that period the Church preached to young people the merit of blind faith, while the universities inculcated an intellectual rationalism, with the result that today we plead in vain whether for faith or reason. Tired of this warfare of opinions, the modern man wishes to find out for himself how things are. And though this desire opens the door to the most dangerous possibilities, we cannot help seeing it as a courageous enterprise and giving it some measure of sympathy. It is no reckless adventure, but an effort inspired by deep spiritual distress to bring meaning once more into life on the basis of fresh and unprejudiced experience. Caution has its place, no doubt, but we cannot refuse our support to a serious venture which challenges the whole of the personality. If we oppose it, we are trying to suppress what is best in man—his daring and his aspirations. And should we succeed, we should only have stood in the way of that invaluable experience which might have given a meaning to life. What would have happened if Paul had allowed himself to be talked out of his journey to Damascus?

[530] The psychotherapist who takes his work seriously must come to grips with this question. He must decide in every single case whether or not he is willing to stand by a human being with counsel and help upon what may be a daring misadventure. He must have no fixed ideas as to what is right, nor must he pretend to know what is right and what not—otherwise he takes something from the richness of the experience. He must keep in view what actually happens—for only that which acts is actual.⁴ If something which seems to me an error shows itself to be more effective than a truth, then I must first follow up the error, for in it lie power and life which I lose if I hold to what seems to me true. Light has need of darkness—otherwise how could it appear as light?

[531] It is well known that Freudian psychoanalysis limits itself to the task of making conscious the shadow-side and the evil within us. It simply brings into action the civil war that was latent, and lets it go at that. The patient must deal with it as best he can. Freud has unfortunately overlooked the fact that man has never yet been able single-handed to hold his own against the powers of darkness—that is, of the unconscious. Man has always stood in need of the spiritual help which his particular religion held out to him. The opening up of the unconscious always means the

outbreak of intense spiritual suffering; it is as when a flourishing civilization is abandoned to invading hordes of barbarians, or when fertile fields are exposed by the bursting of a dam to a raging torrent. The World War was such an invasion which showed, as nothing else could, how thin are the walls which separate a well-ordered world from lurking chaos. But it is the same with the individual and his rationally ordered world. Seeking revenge for the violence his reason has done to her, outraged Nature only awaits the moment when the partition falls so as to overwhelm the conscious life with destruction. Man has been aware of this danger to the psyche since the earliest times, even in the most primitive stages of culture. It was to arm himself against this threat and to heal the damage done that he developed religious and magical practices. This is why the medicine-man is also the priest; he is the saviour of the soul as well as of the body, and religions are systems of healing for psychic illness. This is especially true of the two greatest religions of humanity, Christianity and Buddhism. Man is never helped in his suffering by what he thinks of for himself; only suprahuman, revealed truth lifts him out of his distress.

[532] Today the tide of destruction has already reached us and the psyche has suffered damage. That is why patients force the psychotherapist into the role of the priest and expect and demand of him that he shall free them from their suffering. That is why we psychotherapists must occupy ourselves with problems which, strictly speaking, belong to the theologian. But we cannot leave these questions for theology to answer; challenged by the urgent psychic needs of our patients, we are directly confronted with them every day. Since, as a rule, every concept and every point of view handed down from the past proves futile, we must first tread with the patient the path of his illness—the path of his mistake that sharpens his conflicts and increases his loneliness till it becomes unbearable—hoping that from the psychic depths which cast up the powers of destruction the rescuing forces will also come.

[533] When I first took this path I did not know where it would lead. I did not know what lay hidden in the depths of the psyche—that region which I have since called the “collective unconscious” and whose contents I designate as “archetypes.” Since time immemorial, invasions of the unconscious have occurred, and ever and again they repeat themselves. For consciousness did not exist from the beginning; in every child it has to be built up anew in the first years of life. Consciousness is very weak in this formative period, and the same is true of the psychic history of mankind—the unconscious easily seizes power. These struggles have left their mark. To put it in scientific terms: instinctive defence-mechanisms have been built up which automatically intervene when the danger is greatest, and their coming into action during an emergency is represented in fantasy by helpful images which are ineradicably imprinted on the human psyche. Science can only establish the existence of these psychic factors and attempt a rationalistic explanation by offering an

hypothesis as to their source. This, however, only thrusts the problem a stage further back without solving the riddle. We thus come to those ultimate questions: Where does consciousness come from? What is the psyche? At this point all science ends.

[534] It is as though, at the climax of the illness, the destructive powers were converted into healing forces. This is brought about by the archetypes awaking to independent life and taking over the guidance of the psychic personality, thus supplanting the ego with its futile willing and striving. As a religious-minded person would say: guidance has come from God. With most of my patients I have to avoid this formulation, apt though it is, for it reminds them too much of what they had to reject in the first place. I must express myself in more modest terms and say that the psyche has awakened to spontaneous activity. And indeed this formulation is better suited to the observable facts, as the transformation takes place at that moment when, in dreams or fantasies, motifs appear whose source in consciousness cannot be demonstrated. To the patient it is nothing less than a revelation when something altogether strange rises up to confront him from the hidden depths of the psyche—something that is not his ego and is therefore beyond the reach of his personal will. He has regained access to the sources of psychic life, and this marks the beginning of the cure.

[535] In order to illustrate this process, I ought really to discuss it with the help of examples. But it is almost impossible to give a convincing example offhand, for as a rule it is an extremely subtle and complicated matter. Often it is simply the deep impression made on the patient by the independent way the dreams deal with his problem. Or it may be that his fantasy points to something for which his conscious mind was quite unprepared. But in most cases it is contents of an archetypal nature, or the connections between them, that exert a strong influence of their own whether or not they are understood by the conscious mind. This spontaneous activity of the psyche often becomes so intense that visionary pictures are seen or inner voices heard—a true, primordial experience of the spirit.

[536] Such experiences reward the sufferer for the pains of the labyrinthine way. From now on a light shines through the confusion; more, he can accept the conflict within him and so come to resolve the morbid split in his nature on a higher level.

*

[537] The fundamental problems of modern psychotherapy are so important and far-reaching that their discussion in an essay precludes any presentation of details, however desirable this might be for clarity's sake. I hope nevertheless that I have succeeded in my main purpose, which was to set forth the attitude of the psychotherapist to his work. This may be found more rewarding than precepts and pointers to methods of treatment, which in any case never work properly unless they are applied with right understanding. The attitude of the psychotherapist is infinitely

more important than the theories and methods of psychotherapy, and that is why I was particularly concerned to make this attitude known. I believe I have given an honest account and have, at the same time, imparted information which will allow you to decide how far and in what way the clergyman can join with the psychotherapist in his aspirations and endeavours. I believe, also, that the picture I have drawn of the spiritual outlook of modern man corresponds to the true state of affairs, though I make no claim to infallibility. In any case, what I have had to say about the cure of neurosis, and the problems involved, is the unvarnished truth. We doctors would naturally welcome the sympathetic understanding of the clergy in our endeavours to heal psychic suffering, but we are also fully aware of the fundamental difficulties which stand in the way of co-operation. My own position is on the extreme left wing in the parliament of Protestant opinion, yet I would be the first to warn people against uncritical generalizations of their own point of view. As a Swiss I am an inveterate democrat, yet I recognize that Nature is aristocratic and, what is even more, esoteric. “Quod licet Jovi, non licet bovi” is an unpleasant but eternal truth. Who are forgiven their many sins? Those who have loved much. But as to those who love little, their few sins are held against them. I am firmly convinced that a vast number of people belong to the fold of the Catholic Church and nowhere else, because they are most suitably housed there. I am as much persuaded of this as of the fact, which I have myself observed, that a primitive religion is better suited to primitive people than Christianity, which is so incomprehensible to them and so foreign to their blood that they can only ape it in the most disgusting way. I believe, too, that there must be protestants against the Catholic Church, and also protestants against Protestantism—for the manifestations of the spirit are truly wondrous, and as varied as Creation itself.

[538] The living spirit grows and even outgrows its earlier forms of expression; it freely chooses the men who proclaim it and in whom it lives. This living spirit is eternally renewed and pursues its goal in manifold and inconceivable ways throughout the history of mankind. Measured against it, the names and forms which men have given it mean very little; they are only the changing leaves and blossoms on the stem of the eternal tree.

PSYCHOANALYSIS AND THE CURE OF SOULS¹

[539] The question of the relations between psychoanalysis and the pastoral cure of souls is not easy to answer, because the two are concerned with essentially different things. The cure of souls as practised by the clergyman or priest is a religious influence based on a Christian confession of faith. Psychoanalysis, on the other hand, is a medical intervention, a psychological technique whose purpose it is to lay bare the contents of the unconscious and integrate them into the conscious mind. This definition of psychoanalysis applies, however, only to the methods employed by Freud's school and mine. The Adlerian method is not an analysis in this sense, nor does it pursue the aim stated above. It is chiefly pedagogical in intent, and works directly upon the conscious mind without, as it were, considering the unconscious. It is a further development of the French "rééducation de la volonté" and of Dubois' "psychic orthopedics." The normalization of the individual at which Adlerian pedagogics aim, and his adaptation to the collective psyche, represent a different goal from that pursued by the pastoral cure of souls, which has for its aim the salvation of the soul and its deliverance from the snares of this world. Normalization and adaptation may, under certain circumstances, even be aims which are diametrically opposed to the Christian ideal of detachment from the world, submission to the will of God, and the salvation of the individual. The Adlerian method and the pastoral cure of souls, whether Protestant or Catholic, have only one thing in common, and that is the fact that they both apply themselves to the conscious mind, and in so doing appeal to a person's insight and will.

[540] Freudian psychoanalysis, on the other hand, appeals in the first place neither to insight nor to the will, but seeks to lead the contents of the unconscious over into the conscious mind, thereby destroying the roots of the disturbances or symptoms. Freud seeks, therefore, to remove the disturbance of adaptation by an undermining of the symptoms, and not through treatment of the conscious mind. That is the aim of his psychoanalytic technique.

[541] My difference with Freud begins with the interpretation of unconscious material. It stands to reason that you cannot integrate anything into consciousness without some measure of comprehension, i.e., insight. In order to make the unconscious material assimilable or understandable, Freud employs his famous sexual theory, which conceives the material brought to light through analysis mainly

as sexual tendencies (or other immoral wishes) that are incompatible with the conscious attitude. Freud's standpoint here is based on the rationalistic materialism of the scientific views current in the late nineteenth century (of which his book *The Future of an Illusion* affords the plainest possible demonstration). With these views a fairly far-reaching recognition of the animal nature of man can be effected without too much difficulty, for the moral conflict is then apparently limited to easily avoidable collisions with public opinion or the penal code. At the same time Freud speaks of "sublimation," which he understands as an application of libido in desexualized form. I cannot enter here into a criticism of this very delicate subject, but would merely point out that not everything that comes out of the unconscious can be "sublimated."

[542] For anyone who, whether by temperament, or for philosophical or religious reasons, cannot adopt the standpoint of scientific materialism, the realization of unconscious contents is in every respect a serious problem. Fortunately an instinctive resistance protects us from realizations that would take us too far; hence one can often content oneself with a moderate increase of consciousness. This is particularly so in the case of simple, uncomplicated neuroses, or rather, with people who are simple and uncomplicated (a neurosis is never more complicated than the person who has it). Those, on the other hand, with more refined natures suffer mostly from a passion for consciousness far exceeding their instinctive resistance. They want to see, know, and understand. For these people the answer given by the Freudian art of interpretation is unsatisfying. Here the Church's means of grace, especially as entrusted to the Catholic priest, are likely to come to the aid of understanding, for their form and meaning are suited at the outset to the nature of unconscious contents. That is why the priest not only hears the confession, but also asks questions—indeed, it is incumbent on him to ask them. What is more, he can ask about things which would otherwise only come to the ears of the doctor. In view of the means of grace at his disposal, the priest's intervention cannot be regarded as exceeding his competence, seeing that he is also empowered to lay the storm which he has provoked.

[543] For the Protestant minister the problem is not so simple. Apart from common prayer and Holy Communion, he has no ritual ceremonies at his disposal, no spiritual exercises, rosaries, pilgrimages, etc., with their expressive symbolism. He is therefore compelled to take his stand on moral ground, which puts the instinctual forces coming up from the unconscious in danger of a new repression. Any sacral action, in whatever form, works like a vessel for receiving the contents of the unconscious. Puritan simplification has deprived Protestantism of just this means of acting on the unconscious; at any rate it has dispossessed the clergyman of his quality as a priestly mediator, which is so very necessary to the soul. Instead, it has given the individual

responsibility for himself and left him alone with his God. Herein lies the advantage and also the danger of Protestantism. From this, too, comes its inner unrest, which in the course of a few centuries has begotten more than four hundred Protestant denominations—an indubitable symptom of individualism run riot.

[544] There can be no doubt that the psychoanalytical unveiling of the unconscious has a great effect. Equally, there can be no doubt of the tremendous effect of Catholic confession, especially when it is not just a passive hearing, but an active intervention. In view of this, it is truly astonishing that the Protestant Churches have not long since made an effort to revive the institution of confession as the epitome of the pastoral bond between the shepherd and his flock. For the Protestant, however, there is—and rightly so—no going back to this primitive Catholic form; it is too sharply opposed to the nature of Protestantism. The Protestant minister, rightly seeing in the cure of souls the real purpose of his existence, naturally looks round for a new way that will lead to the souls, and not merely to the ears, of his parishioners. Analytical psychology seems to him to provide the key, for the meaning and purpose of his ministry are not fulfilled with the Sunday sermon, which, though it reaches the ears, seldom penetrates to the heart, much less to the soul, the most hidden of all things hidden in man. The cure of souls can only be practised in the stillness of a colloquy, carried on in the healthful atmosphere of unreserved confidence. Soul must work on soul, and many doors be unlocked that bar the way to the innermost sanctuary. Psychoanalysis possesses the means of opening doors otherwise tightly closed.

[545] The opening of these doors, however, is often very like a surgical operation, where the doctor, with knife poised, must be prepared for anything the moment the cut is made. The psychoanalyst, likewise, can discover unforeseen things that are very unpleasant indeed, such as latent psychoses and the like. Although these things, given time, often come to the surface entirely of their own accord, the blame nevertheless falls on the analyst, who, by his intervention, releases the disturbance prematurely. Only a thorough knowledge of psychiatry and its specialized techniques can protect the doctor from such blunders. A lay analyst should therefore always work in collaboration with a doctor.

[546] Fortunately, the unlucky accidents I have just mentioned occur relatively seldom. But what psychoanalysis brings to light is, in itself, difficult enough to cope with. It brings the patient face to face with his life problem, and hence with some of the ultimate, serious questions which he has hitherto evaded. As human nature is very far from innocent, the facts that come up are usually quite sufficient to explain why the patient avoided them: he felt instinctively that he did not know a satisfactory answer to these questions. Accordingly he expects it from the analyst. The analyst can now safely leave certain critical questions open—and to the patient's own

advantage; for no sensible patient will expect from him anything more than *medical* help. More is expected from the clergyman, namely the solution of *religious* questions.

[547] As already said, the Catholic Church has at her disposal ways and means which have served since olden times to gather the lower, instinctual forces of the psyche into symbols and in this way integrate them into the hierarchy of the spirit. The Protestant minister lacks these means, and consequently often stands perplexed before certain facts of human nature which no amount of admonition, or insight, or goodwill, or heroic self-castigation can subdue. In Protestantism good and evil are flatly and irreconcilably opposed to one another. There is no visible forgiveness; the human being is left alone with his sin. And God, as we know, only forgives the sins we have conquered ourselves. For the Protestant clergy it is a momentous psychological difficulty that they possess no forms which would serve to catch the lower instincts of psychic life. It is precisely the problem of the unconscious conflict brought to light by psychoanalysis that requires solving. The doctor can—on the basis of scientific materialism—treat the problem with medical discretion, that is to say he can regard the ethical problems of his patient as lying outside his competence as a doctor. He can safely retire behind a regretful “There you must make out as best you can.” But the Protestant clergyman cannot, in my opinion, wash his hands in innocence; he must accompany the soul of the person who confides in him on its dark journey. The reductive standpoint of psychoanalysis is of little use to him here, for any development is a building up and not a breaking down. Good advice and moral exhortation are little if any help in serious cases because, if followed, they dispel that intense darkness which precedes the coming of the light. As a wise saying of the East puts it: It is better to do good than to eschew evil. He who is wise, therefore, will play the part of beggar, king, or criminal, and be mindful of the gods.

[548] It is easier for the Catholic clergy to employ the elements of psychological analysis than it is for the Protestant. The latter are faced with the harder task. Not only do the Catholics possess a ready-made pastoral technique in the historically sanctioned form of confession, penance, and absolution, but they also have at their command a rich and palpably ritualistic symbolism which fully satisfies the demands as well as the obscure passions of simpler minds. The Protestants need a psychological technique to an even greater degree since they lack all essential forms of ritual. I therefore hold that psychological interest on the part of the Protestant clergy is entirely legitimate and even necessary. Their possible encroachment upon medical territory is more than balanced by medical incursions into religion and philosophy, to which doctors naïvely believe themselves entitled (witness the explanation of religious processes in terms of sexual symptoms or infantile wish-

fantasies). The doctor and the clergyman undoubtedly clash head-on in analytical psychology. This collision should lead to co-operation and not to enmity.

[549] Owing to the absence of ritual forms, the Protestant (as opposed to the Catholic) cure of souls develops into a personal discussion in the sense of an “I-Thou” relationship. It cannot translate the fundamental problem of the transference into something impersonal, as the Catholic can, but must handle it with confidence as a personal experience. Any contact with the unconscious that goes at all deep leads to transference phenomena. Whenever, therefore, the clergyman penetrates any distance into the psychic background, he will provoke a transference (with men as well as with women). This involves him personally, and on top of that he has no form which he could substitute for his own person, as the Catholic priest can, or rather must do. In this way he finds himself drawn into the most personal participation for the sake of his parishioner’s spiritual welfare, more so even than the analyst, for whom the specific salvation of the patient’s soul is not necessarily a matter of burning importance. At all events he can resort to plausible excuses which the clergyman, somewhat nervously, must repudiate for higher reasons. Hence he stands, and must stand, in constant danger of involving himself in serious psychic conflicts which, to put it mildly, are not conducive to the parochial peace of mind. This danger is no trifling one, but it has the great advantage of drawing the responsible pastor back into real life and, at the same time, of exposing him to the tribulations of the early Church (cf. the gossip against which Paul had to defend himself).

[550] The pastor must make up his mind how far his public position, his stipend, and considerations for his family keep him from setting forth on the perilous mission of curing souls. I would not think ill of him if he decided not to follow the advice that Tertullian gave his catechumens, namely, that they should deliberately visit the arena. Real pastoral work that is based on modern psychology can easily expose the clergyman to the martyrdom of public misinterpretation. Public position and regard for the family, though worldly considerations, counsel a wise reserve (for the children of this world are, as we know, wiser than the children of light). Nevertheless, the eyes of the soul turn longingly to those who, regardless of their worldly welfare, can throw everything into the scales for the sake of something better. Nothing, certainly, is ever won by childish enthusiasm; yet only with daring—a daring which never leaves the firm ground of the real and the possible, and which shrinks from no suffering—can anything of greater worth be achieved.

[551] Thus it is the Protestant minister’s lack of ritual equipment which holds him back from closer contact with the world, and at the same time drives him towards a greater adventure—because it moves him right into the firing line. I hope that the Protestant will not be found wanting in courage for this task.

[552] All intelligent psychotherapists would be glad if their endeavours were supported and supplemented by the work of the clergy. Certainly the problems of the human soul, approached from opposite ends by cleric and doctor, will cause considerable difficulties for both, not least on account of the difference in standpoint. But it is just from this encounter that we may expect the most fruitful stimulation for both sides.

VI

ANSWER TO JOB

[First published as a book, *Antwort auf Hiob* (Zurich, 1952). The present translation was first published, in book form, in London, 1954; for it, Professor Jung made some half-dozen small alterations to the original text and added or authorized an occasional footnote. In 1956, it was reprinted and published by Pastoral Psychology Book Club, Great Neck, New York. Only minor stylistic alterations have been made in the version here published.—EDITORS.]

PREFATORY NOTE¹

The suggestion that I should tell you how *Answer to Job* came to be written sets me a difficult task, because the history of this book can hardly be told in a few words. I have been occupied with its central problem for years. Many different sources nourished the stream of its thoughts, until one day—and after long reflection—the time was ripe to put them into words.

The most immediate cause of my writing the book is perhaps to be found in certain problems discussed in my book *Aion*, especially the problems of Christ as a symbolic figure and of the antagonism Christ-Antichrist, represented in the traditional zodiacal symbolism of the two fishes.

In connection with the discussion of these problems and of the doctrine of Redemption, I criticized the idea of the *privatio boni* as not agreeing with the psychological findings. Psychological experience shows that whatever we call “good” is balanced by an equally substantial “bad” or “evil.” If “evil” is non-existent, then whatever there is must needs be “good.” Dogmatically, neither “good” nor “evil” can be derived from Man, since the “Evil One” existed before Man as one of the “Sons of God.” The idea of the *privatio boni* began to play a role in the Church only after Mani. Before this heresy, Clement of Rome taught that God rules the world with a right and a left hand, the right being Christ, the left Satan. Clement’s view is clearly *monotheistic*, as it unites the opposites in one God.

Later Christianity, however, is dualistic, inasmuch as it splits off one half of the opposites, personified in Satan, and he is *eternal* in his state of damnation. This crucial question of *πόθεν τό κακόν* (whence evil?) forms the point of departure for the Christian theory of Redemption. It is therefore of prime importance. If Christianity claims to be a monotheism, it becomes unavoidable to assume the opposites as being contained in God. But then we are confronted with a major religious problem: the problem of Job. It is the aim of my book to point out its historical evolution since the time of Job down through the centuries to the most recent symbolic phenomena, such as the *Assumptio Mariae*, etc.

Moreover, the study of medieval natural philosophy—of the greatest importance to psychology—made me try to find an answer to the question: what image of God did these old philosophers have? Or rather: how should the symbols which supplement their image of God be understood? All this pointed to a *complexio oppositorum* and thus recalled again the story of Job to my mind: Job who expected help from God against God. This most peculiar fact presupposes a similar conception of the opposites in God.

On the other hand, numerous questions, not only from my patients, but from all over the world, brought up the problem of giving a more complete and explicit answer than I had given in *Aion*. For many years I hesitated to do this because I was quite conscious of the probable consequences, and knew what a storm would be raised. But I was gripped by the urgency and difficulty of the problem and was unable to throw it off. Therefore I found myself obliged to deal with the whole problem, and I did so in the form of describing a personal experience, carried by subjective emotions. I deliberately chose this form because I wanted to avoid the impression that I had any idea of

announcing an “eternal truth.” The book does not pretend to be anything but the voice or question of a single individual who hopes or expects to meet with thoughtfulness in the public.

LECTORI BENEVOLO

I am distressed for thee, my brother ...

II Samuel 1:26 (AV)

[553] On account of its somewhat unusual content, my little book requires a short preface. I beg of you, dear reader, not to overlook it. For, in what follows, I shall speak of the venerable objects of religious belief. Whoever talks of such matters inevitably runs the risk of being torn to pieces by the two parties who are in mortal conflict about those very things. This conflict is due to the strange supposition that a thing is true only if it presents itself as a *physical* fact. Thus some people believe it to be physically true that Christ was born as the son of a virgin, while others deny this as a physical impossibility. Everyone can see that there is no logical solution to this conflict and that one would do better not to get involved in such sterile disputes. Both are right and both are wrong. Yet they could easily reach agreement if only they dropped the word “physical.” “Physical” is not the only criterion of truth: there are also *psychic* truths which can neither be explained nor proved nor contested in any physical way. If, for instance, a general belief existed that the river Rhine had at one time flowed backwards from its mouth to its source, then this belief would in itself be a fact even though such an assertion, physically understood, would be deemed utterly incredible. Beliefs of this kind are psychic facts which cannot be contested and need no proof.

[554] Religious statements are of this type. They refer without exception to things that cannot be established as physical facts. If they did not do this, they would inevitably fall into the category of the natural sciences. Taken as referring to anything physical, they make no sense whatever, and science would dismiss them as non-experienceable. They would be mere miracles, which are sufficiently exposed to doubt as it is, and yet they could not demonstrate the reality of the spirit or *meaning* that underlies them, because meaning is something that always demonstrates itself and is experienced on its own merits. The spirit and meaning of Christ are present and perceptible to us even without the aid of miracles. Miracles appeal only to the understanding of those who cannot perceive the meaning. They are mere substitutes for the not understood reality of the spirit. This is not to say that the living presence of the spirit is not occasionally accompanied by marvellous physical happenings. I only wish to emphasize that these happenings can neither replace nor bring about an understanding of the spirit, which is the one essential thing.

[555] The fact that religious statements frequently conflict with the observed physical phenomena proves that in contrast to physical perception the spirit is autonomous, and that psychic experience is to a certain extent independent of physical data. The psyche is an autonomous factor, and religious statements are psychic confessions which in the last resort are based on unconscious, i.e., on transcendental, processes. These processes are not accessible to physical perception but demonstrate their existence through the confessions of the psyche. The resultant statements are filtered through the medium of human consciousness: that is to say, they are given visible forms which in their turn are subject to manifold influences from within and without. That is why whenever we speak of religious contents we move in a world of images that point to something ineffable. We do not know how clear or unclear these images, metaphors, and concepts are in respect of their transcendental object. If, for instance, we say "God," we give expression to an image or verbal concept which has undergone many changes in the course of time. We are, however, unable to say with any degree of certainty—unless it be by faith—whether these changes affect only the images and concepts, or the Unspeakable itself. After all, we can imagine God as an eternally flowing current of vital energy that endlessly changes shape just as easily as we can imagine him as an eternally unmoved, unchangeable essence. Our reason is sure only of one thing: that it manipulates images and ideas which are dependent on human imagination and its temporal and local conditions, and which have therefore changed innumerable times in the course of their long history. There is no doubt that there is something behind these images that transcends consciousness and operates in such a way that the statements do not vary limitlessly and chaotically, but clearly all relate to a few basic principles or archetypes. These, like the psyche itself, or like matter, are unknowable as such. All we can do is to construct models of them which we know to be inadequate, a fact which is confirmed again and again by religious statements.

[556] If, therefore, in what follows I concern myself with these "metaphysical" objects, I am quite conscious that I am moving in a world of images and that none of my reflections touches the essence of the Unknowable. I am also too well aware of how limited are our powers of conception—to say nothing of the feebleness and poverty of language—to imagine that my remarks mean anything more in principle than what a primitive man means when he conceives of his god as a hare or a snake. But, although our whole world of religious ideas consists of anthropomorphic images that could never stand up to rational criticism, we should never forget that they are based on numinous archetypes, i.e., on an emotional foundation which is unassailable by reason. We are dealing with psychic facts which logic can overlook but not eliminate. In this connection Tertullian has already appealed, quite rightly, to the testimony of the soul. In his *De testimonio animae*, he says:

These testimonies of the soul are as simple as they are true, as obvious as they are simple, as common as they are obvious, as natural as they are common, as divine as they are natural. I think that they cannot appear to any one to be trifling and ridiculous if he considers the majesty of Nature, whence the authority of the soul is derived. What you allow to the mistress you will assign to the disciple. Nature is the mistress, the soul is the disciple; what the one has taught, or the other has learned, has been delivered to them by God, who is, in truth, the Master even of the mistress herself. What notion the soul is able to conceive of her first teacher is in your power to judge, from that soul which is in you. Feel that which causes you to feel; think upon that which is in forebodings your prophet; in omens, your augur; in the events which befall you, your foreseer. Strange if, being given by God, she knows how to act the diviner for men! Equally strange if she knows Him by whom she has been given!¹

[557] I would go a step further and say that the statements made in the Holy Scriptures are also utterances of the soul—even at the risk of being suspected of psychologism. The statements of the conscious mind may easily be snares and delusions, lies, or arbitrary opinions, but this is certainly not true of the statements of the soul: to begin with they always go over our heads because they point to realities that transcend consciousness. These *entia* are the archetypes of the collective unconscious, and they precipitate complexes of ideas in the form of mythological motifs. Ideas of this kind are never invented, but enter the field of inner perception as finished products, for instance in dreams. They are spontaneous phenomena which are not subject to our will, and we are therefore justified in ascribing to them a certain autonomy. They are to be regarded not only as objects but as subjects with laws of their own. From the point of view of consciousness, we can, of course, describe them as objects, and even explain them up to a point, in the same measure as we can describe and explain a living human being. But then we have to disregard their autonomy. If that is considered, we are compelled to treat them as subjects; in other words, we have to admit that they possess spontaneity and purposiveness, or a kind of consciousness and free will. We observe their behaviour and consider their statements. This dual standpoint, which we are forced to adopt towards every relatively independent organism, naturally has a dual result. On the one hand it tells me what I do to the object, and on the other hand what it does (possibly to me). It is obvious that this unavoidable dualism will create a certain amount of confusion in the minds of my readers, particularly as in what follows we shall have to do with the archetype of Deity.

[558] Should any of my readers feel tempted to add an apologetic “only” to the God-images as we perceive them, he would immediately fall foul of experience, which demonstrates beyond any shadow of doubt the extraordinary numinosity of these

images. The tremendous effectiveness (mana) of these images is such that they not only give one the feeling of pointing to the *Ens realissimum*, but make one convinced that they actually express it and establish it as a fact. This makes discussion uncommonly difficult, if not impossible. It is, in fact, impossible to demonstrate God's reality to oneself except by using images which have arisen spontaneously or are sanctified by tradition, and whose psychic nature and effects the naïve-minded person has never separated from their unknowable metaphysical background. He instantly equates the effective image with the transcendental X to which it points. The seeming justification for this procedure appears self-evident and is not considered a problem so long as the statements of religion are not seriously questioned. But if there is occasion for criticism, then it must be remembered that the image and the statement are psychic processes which are different from their transcendental object; they do not posit it, they merely point to it. In the realm of psychic processes criticism and discussion are not only permissible but are unavoidable.

[559] In what follows I shall attempt just such a discussion, such a "coming to terms" with certain religious traditions and ideas. Since I shall be dealing with numinous factors, my feeling is challenged quite as much as my intellect. I cannot, therefore, write in a coolly objective manner, but must allow my emotional subjectivity to speak if I want to describe what I feel when I read certain books of the Bible, or when I remember the impressions I have received from the doctrines of our faith. I do not write as a biblical scholar (which I am not), but as a layman and physician who has been privileged to see deeply into the psychic life of many people. What I am expressing is first of all my own personal view, but I know that I also speak in the name of many who have had similar experiences.

ANSWER TO JOB

[560] The Book of Job is a landmark in the long historical development of a divine drama. At the time the book was written, there were already many testimonies which had given a contradictory picture of Yahweh—the picture of a God who knew no moderation in his emotions and suffered precisely from this lack of moderation. He himself admitted that he was eaten up with rage and jealousy and that this knowledge was painful to him. Insight existed along with obtuseness, loving-kindness along with cruelty, creative power along with destructiveness. Everything was there, and none of these qualities was an obstacle to the other. Such a condition is only conceivable either when no reflecting consciousness is present at all, or when the capacity for reflection is very feeble and a more or less adventitious phenomenon. A condition of this sort can only be described as *amoral*.

[561] How the people of the Old Testament felt about their God we know from the testimony of the Bible. That is not what I am concerned with here, but rather with the way in which a modern man with a Christian education and background comes to terms with the divine darkness which is unveiled in the Book of Job, and what effect it has on him. I shall not give a cool and carefully considered exegesis that tries to be fair to every detail, but a purely subjective reaction. In this way I hope to act as a voice for many who feel the same way as I do, and to give expression to the shattering emotion which the unvarnished spectacle of divine savagery and ruthlessness produces in us. Even if we know by hearsay about the suffering and discord in the Deity, they are so unconscious, and hence so ineffectual morally, that they arouse no human sympathy or understanding. Instead, they give rise to an equally ill-considered outburst of affect, and a smouldering resentment that may be compared to a slowly healing wound. And just as there is a secret tie between the wound and the weapon, so the affect corresponds to the violence of the deed that caused it.

[562] The Book of Job serves as a paradigm for a certain experience of God which has a special significance for us today. These experiences come upon man from inside as well as from outside, and it is useless to interpret them rationalistically and thus weaken them by apotropaic means. It is far better to admit the affect and submit to its violence than to try to escape it by all sorts of intellectual tricks or by emotional value-judgments. Although, by giving way to the affect, one imitates all the bad qualities of the outrageous act that provoked it and thus makes oneself guilty of the

same fault, that is precisely the point of the whole proceeding: the violence is meant to penetrate to a man's vitals, and he to succumb to its action. He must be affected by it, otherwise its full effect will not reach him. But he should know, or learn to know, what has affected him, for in this way he transforms the blindness of the violence on the one hand and of the affect on the other into knowledge.

[563] For this reason I shall express my affect fearlessly and ruthlessly in what follows, and I shall answer injustice with injustice, that I may learn to know why and to what purpose Job was wounded, and what consequences have grown out of this for Yahweh as well as for man.

I

[564] Job answers Yahweh thus:

Behold, I am of small account; what shall I answer thee?

I lay my hand on my mouth.

I have spoken once, and I will not answer;

twice, but I will proceed no further.¹

[565] And indeed, in the immediate presence of the infinite power of creation, this is the only possible answer for a witness who is still trembling in every limb with the terror of almost total annihilation. What else could a half-crushed human worm, grovelling in the dust, reasonably answer in the circumstances? In spite of his pitiable littleness and feebleness, this man knows that he is confronted with a superhuman being who is personally most easily provoked. He also knows that it is far better to withhold all moral reflections, to say nothing of certain moral requirements which might be expected to apply to a god.

[566] Yahweh's "justice" is praised, so presumably Job could bring his complaint and the protestation of his innocence before him as the just judge. But he doubts this possibility. "How can a man be just before God?"² "If I summoned him and he answered me, I would not believe that he was listening to my voice."³ "If it is a matter of justice, who can summon him?"⁴ He "multiplies my wounds without cause."⁵ "He destroys both the blameless and the wicked."⁶ "If the scourge slay suddenly, he will laugh at the trial of the innocent."⁷ "I know," Job says to Yahweh, "thou wilt not hold me innocent. I shall be condemned."⁸ "If I wash myself ... never so clean, yet shalt thou plunge me in the ditch."⁹ "For he is not a man, as I am, that I should answer him, and we should come together in judgment."¹⁰ Job wants to explain his point of view to Yahweh, to state his complaint, and tells him: "Thou knowest that I am not guilty, and there is none to deliver out of thy hand."¹¹ "I desire to argue my case with God."¹² "I will defend my ways to his face,"¹³ "I know that I shall be vindicated."¹⁴ Yahweh should summon him and render him an account or at

least allow him to plead his cause. Properly estimating the disproportion between man and God, he asks: “Wilt thou break a leaf driven to and fro? and wilt thou pursue the dry stubble?”¹⁵ God has put him in the wrong, but there is no justice.¹⁶ He has “taken away my right.”¹⁷ “Till I die I will not put away my integrity from me. I hold fast to my righteousness, and will not let it go.”¹⁸ His friend Elihu the Buzite does not believe the injustice of Yahweh: “Of a truth, God will not do wickedly, and the Almighty will not pervert justice.”¹⁹ Illogically enough, he bases his opinion on God’s *power*: “Is it fit to say to a king, Thou art wicked? and to princes, Ye are ungodly?”²⁰ One must “respect the persons of princes and esteem the high more than the low.”²¹ But Job is not shaken in his faith, and had already uttered an important truth when he said: “Behold, my witness is in heaven, and he that vouches for me is on high ... my eye pours out tears to God, that he would maintain the right of a man with God, like that of a man with his neighbour.”²² And later: “For I know that my Vindicator lives, and at last he will stand upon the earth.”²³

[567] These words clearly show that Job, in spite of his doubt as to whether man can be just before God, still finds it difficult to relinquish the idea of meeting God on the basis of justice and therefore of morality. Because, in spite of everything, he cannot give up his faith in divine justice, it is not easy for him to accept the knowledge that divine arbitrariness breaks the law. On the other hand, he has to admit that no one except Yahweh himself is doing him injustice and violence. He cannot deny that he is up against a God who does not care a rap for any moral opinion and does not recognize any form of ethics as binding. This is perhaps the greatest thing about Job, that, faced with this difficulty, he does not doubt the unity of God. He clearly sees that God is at odds with himself—so totally at odds that he, Job, is quite certain of finding in God a helper and an “advocate” against God. As certain as he is of the evil in Yahweh, he is equally certain of the good. In a human being who renders us evil we cannot expect at the same time to find a helper. But Yahweh is not a human being: he is both a persecutor and a helper in one, and the one aspect is as real as the other. Yahweh is not split but is an *antinomy*—a totality of inner opposites—and this is the indispensable condition for his tremendous dynamism, his omniscience and omnipotence. Because of this knowledge Job holds on to his intention of “defending his ways to his face,” i.e., of making his point of view clear to him, since notwithstanding his wrath, Yahweh is also man’s advocate *against himself* when man puts forth his complaint.

[568] One would be even more astonished at Job’s knowledge of God if this were the first time one were hearing of Yahweh’s amorality. His incalculable moods and devastating attacks of wrath had, however, been known from time immemorial. He had proved himself to be a jealous defender of morality and was specially sensitive in regard to justice. Hence he had always to be praised as “just,” which, it seemed, was

very important to him. Thanks to this circumstance or peculiarity of his, he had a *distinct personality*, which differed from that of a more or less archaic king only in scope. His jealous and irritable nature, prying mistrustfully into the faithless hearts of men and exploring their secret thoughts, compelled a personal relationship between himself and man, who could not help but feel personally called by him. That was the essential difference between Yahweh and the all-ruling Father Zeus, who in a benevolent and somewhat detached manner allowed the economy of the universe to roll along on its accustomed courses and punished only those who were disorderly. He did not moralize but ruled purely instinctively. He did not demand anything more *from* human beings than the sacrifices due to him; he did not want to do anything *with* human beings because he had no plans for them. Father Zeus is certainly a figure but not a personality. Yahweh, on the other hand, was interested in man. Human beings were a matter of first-rate importance to him. He needed them as they needed him, urgently and personally. Zeus too could throw thunderbolts about, but only at hopelessly disorderly individuals. Against mankind as a whole he had no objections—but then they did not interest him all that much. Yahweh, however, could get inordinately excited about man as a species and men as individuals if they did not behave as he desired or expected, without ever considering that in his omnipotence he could easily have created something better than these “bad earthenware pots.”

[569] In view of this intense personal relatedness to his chosen people, it was only to be expected that a regular covenant would develop which also extended to certain individuals, for instance to David. As we learn from the Eighty-ninth Psalm, Yahweh told him:

My steadfast love I will keep for him for ever,
and my covenant will stand firm for him.

.

I will not violate my covenant,
or alter the word that went forth from my lips.

Once for all I have sworn by my holiness;
I will not lie to David.²⁴

[570] And yet it happened that he, who watched so jealously over the fulfilment of laws and contracts, broke his own oath. Modern man, with his sensitive conscience, would have felt the black abyss opening and the ground giving way under his feet, for the least he expects of his God is that he should be superior to mortal man in the sense of being better, higher, nobler—but not his superior in the kind of moral flexibility and unreliability that do not jib even at perjury.

[571] Of course one must not tax an archaic god with the requirements of modern ethics. For the people of early antiquity things were rather different. In their gods there was absolutely everything: they teemed with virtues and vices. Hence they could be punished, put in chains, deceived, stirred up against one another without losing face, or at least not for long. The man of that epoch was so inured to divine inconsistencies that he was not unduly perturbed when they happened. With Yahweh the case was different because, from quite early on, the personal and moral tie began to play an important part in the religious relationship. In these circumstances a breach of contract was bound to have the effect not only of a personal but of a moral injury. One can see this from the way David answers Yahweh:

How long, Lord? wilt thou hide thyself for ever?
shall thy wrath burn like fire?
Remember how short my time is:
wherefore hast thou made all men in vain?
.
Lord, where are thy former lovingkindnesses,
which by thy faithfulness thou didst swear to David?²⁵

[572] Had this been addressed to a human being it would have run something like this: “For heaven’s sake, man, pull yourself together and stop being such a senseless savage! It is really too grotesque to get into such a rage when it’s partly your own fault that the plants won’t flourish. You used to be quite reasonable and took good care of the garden you planted, instead of trampling it to pieces.”

[573] Certainly our interlocutor would never dare to remonstrate with his almighty partner about this breach of contract. He knows only too well what a row he would get into if *he* were the wretched breaker of the law. Because anything else would put him in peril of his life, he must retire to the more exalted plane of reason. In this way, without knowing it or wanting it, he shows himself superior to his divine partner both intellectually and morally. Yahweh fails to notice that he is being humoured, just as little as he understands why he has continually to be praised as just. He makes pressing demands on his people to be praised²⁶ and propitiated in every possible way, for the obvious purpose of keeping him in a good temper at any price.

[574] The character thus revealed fits a personality who can only convince himself that he exists through his relation to an object. Such dependence on the object is absolute when the subject is totally lacking in self-reflection and therefore has no insight into himself. It is as if he existed only by reason of the fact that he has an object which assures him that he is really there. If Yahweh, as we would expect of a sensible human being, were really conscious of himself, he would, in view of the true facts of the case, at least have put an end to the panegyrics on his justice. But he is too

unconscious to be moral. Morality presupposes consciousness. By this I do not mean to say that Yahweh is imperfect or evil, like a gnostic demiurge. He is everything in its totality; therefore, among other things, he is total justice, and also its total opposite. At least this is the way he must be conceived if one is to form a unified picture of his character. We must only remember that what we have sketched is no more than an anthropomorphic picture which is not even particularly easy to visualize. From the way the divine nature expresses itself we can see that the individual qualities are not adequately related to one another, with the result that they fall apart into mutually contradictory acts. For instance, Yahweh regrets having created human beings, although in his omniscience he must have known all along what would happen to them.

II

[575] Since the Omniscient looks into all hearts, and Yahweh's eyes "run to and fro through the whole earth,"¹ it were better for the interlocutor of the Eighty-ninth Psalm not to wax too conscious of his slight moral superiority over the more unconscious God. Better to keep it dark, for Yahweh is no friend of critical thoughts which in any way diminish the tribute of recognition he demands. Loudly as his power resounds through the universe, the basis of its existence is correspondingly slender, for it needs conscious reflection in order to exist in reality. Existence is only real when it is conscious to somebody. That is why the Creator needs conscious man even though, from sheer unconsciousness, he would like to prevent him from becoming conscious. And that is also why Yahweh needs the acclamation of a small group of people. One can imagine what would happen if this assembly suddenly decided to stop the applause: there would be a state of high excitation, with outbursts of blind destructive rage, then a withdrawal into hellish loneliness and the torture of non-existence, followed by a gradual reawakening of an unutterable longing for something which would make him conscious of himself. It is probably for this reason that all pristine things, even man before he becomes the canaille, have a touching, magical beauty, for in its nascent state "each thing after its kind" is the most precious, the most desirable, the tenderest thing in the world, being a reflection of the infinite love and goodness of the Creator.

[576] In view of the undoubted frightfulness of divine wrath, and in an age when men still knew what they were talking about when they said "Fear God," it was only to be expected that man's slight superiority should have remained unconscious. The powerful personality of Yahweh, who, in addition to everything else, lacked all biographical antecedents (his original relationship to the Elohim had long since been sunk in oblivion), had raised him above all the numina of the Gentiles and had immunized him against the influence that for several centuries had been undermining

the authority of the pagan gods. It was precisely the details of their mythological biography that had become their nemesis, for with his growing capacity for judgment man had found these stories more and more incomprehensible and indecent. Yahweh, however, had no origin and no past, except his creation of the world, with which all history began, and his relation to that part of mankind whose forefather Adam he had fashioned in his own image as the *Anthropos*, the original man, by what appears to have been a special act of creation. One can only suppose that the other human beings who must also have existed at that time had been formed previously on the divine potter's wheel along with the various kinds of beasts and cattle—those human beings, namely, from whom Cain and Seth chose their wives. If one does not approve of this conjecture, then the only other possibility that remains is the far more scandalous one that they incestuously married their sisters (for whom there is no evidence in the text), as was still surmised by the philosopher Karl Lamprecht at the end of the nineteenth century.

[577] The special providence which singled out the Jews from among the divinely stamped portion of humanity and made them the “chosen people” had burdened them from the start with a heavy obligation. As usually happens with such mortgages, they quite understandably tried to circumvent it as much as possible. Since the chosen people used every opportunity to break away from him, and Yahweh felt it of vital importance to tie this indispensable object (which he had made “godlike” for this very purpose) definitely to himself, he proposed to the patriarch Noah a contract between himself on the one hand, and Noah, his children, and all their animals, both tame and wild, on the other—a contract that promised advantages to both parties. In order to strengthen this contract and keep it fresh in the memory, he instituted the rainbow as a token of the covenant. If, in future, he summoned the thunder-clouds which hide within them floods of water and lightning, then the rainbow would appear, reminding him and his people of the contract. The temptation to use such an accumulation of clouds for an experimental deluge was no small one, and it was therefore a good idea to associate it with a sign that would give timely warning of possible catastrophe.

[578] In spite of these precautions the contract had gone to pieces with David, an event which left behind it a literary deposit in the Scriptures and which grieved some few of the devout, who upon reading it became reflective. As the Psalms were zealously read, it was inevitable that certain thoughtful people were unable to stomach the Eighty-ninth Psalm. However that may be, the fatal impression made by the breach of contract survived.² It is historically possible that these considerations influenced the author of the Book of Job.

[579] The Book of Job places this pious and faithful man, so heavily afflicted by the Lord, on a brightly lit stage where he presents his case to the eyes and ears of the

world. It is amazing to see how easily Yahweh, quite without reason, had let himself be influenced by one of his sons, by a *doubting thought*,³ and made unsure of Job's faithfulness. With his touchiness and suspiciousness the mere possibility of doubt was enough to infuriate him and induce that peculiar double-faced behaviour of which he had already given proof in the Garden of Eden, when he pointed out the tree to the First Parents and at the same time forbade them to eat of it. In this way he precipitated the Fall, which he apparently never intended. Similarly, his faithful servant Job is now to be exposed to a rigorous moral test, quite gratuitously and to no purpose, although Yahweh is convinced of Job's faithfulness and constancy, and could moreover have assured himself beyond all doubt on this point had he taken counsel with his own omniscience. Why, then, is the experiment made at all, and a bet with the unscrupulous slanderer settled, without a stake, on the back of a powerless creature? It is indeed no edifying spectacle to see how quickly Yahweh abandons his faithful servant to the evil spirit and lets him fall without compunction or pity into the abyss of physical and moral suffering. From the human point of view Yahweh's behaviour is so revolting that one has to ask oneself whether there is not a deeper motive hidden behind it. Has Yahweh some secret resistance against Job? That would explain his yielding to Satan. But what does man possess that God does not have? Because of his littleness, puniness, and defencelessness against the Almighty, he possesses, as we have already suggested, a somewhat keener consciousness based on self-reflection: he must, in order to survive, always be mindful of his impotence. God has no need of this circumspection, for nowhere does he come up against an insuperable obstacle that would force him to hesitate and hence make him reflect on himself. Could a suspicion have grown up in God that man possesses an infinitely small yet more concentrated light than he, Yahweh, possesses? A jealousy of that kind might perhaps explain his behaviour. It would be quite explicable if some such dim, barely understood deviation from the definition of a mere "creature" had aroused his divine suspicions. Too often already these human beings had not behaved in the prescribed manner. Even his trusty servant Job might have something up his sleeve.... Hence Yahweh's surprising readiness to listen to Satan's insinuations against his better judgment.

[580] Without further ado Job is robbed of his herds, his servants are slaughtered, his sons and daughters are killed by a whirlwind, and he himself is smitten with sickness and brought to the brink of the grave. To rob him of peace altogether, his wife and his old friends are let loose against him, all of whom say the wrong things. His justified complaint finds no hearing with the judge who is so much praised for his justice. Job's right is refused in order that Satan be not disturbed in his play.

[581] One must bear in mind here the dark deeds that follow one another in quick succession: robbery, murder, bodily injury with premeditation, and denial of a fair

trial. This is further exacerbated by the fact that Yahweh displays no compunction, remorse, or compassion, but only ruthlessness and brutality. The plea of unconsciousness is invalid, seeing that he flagrantly violates at least three of the commandments he himself gave out on Mount Sinai.

[582] Job's friends do everything in their power to contribute to his moral torments, and instead of giving him, whom God has perfidiously abandoned, their warm-hearted support, they moralize in an all too human manner, that is, in the stupidest fashion imaginable, and "fill him with wrinkles." They thus deny him even the last comfort of sympathetic participation and human understanding, so that one cannot altogether suppress the suspicion of connivance in high places.

[583] Why Job's torments and the divine wager should suddenly come to an end is not quite clear. So long as Job does not actually die, the pointless suffering could be continued indefinitely. We must, however, keep an eye on the background of all these events: it is just possible that something in this background will gradually begin to take shape as a compensation for Job's undeserved suffering—something to which Yahweh, even if he had only a faint inkling of it, could hardly remain indifferent. Without Yahweh's knowledge and contrary to his intentions, the tormented though guiltless Job had secretly been lifted up to a superior knowledge of God which God himself did not possess. Had Yahweh consulted his omniscience, Job would not have had the advantage of him. But then, so many other things would not have happened either.

[584] Job realizes God's inner antinomy, and in the light of this realization his knowledge attains a divine numinosity. The possibility of this development lies, one must suppose, in man's "godlikeness," which one should certainly not look for in human morphology. Yahweh himself had guarded against this error by expressly forbidding the making of images. Job, by his insistence on bringing his case before God, even without hope of a hearing, had stood his ground and thus created the very obstacle that forced God to reveal his true nature. With this dramatic climax Yahweh abruptly breaks off his cruel game of cat and mouse. But if anyone should expect that his wrath will now be turned against the slanderer, he will be severely disappointed. Yahweh does not think of bringing this mischief-making son of his to account, nor does it ever occur to him to give Job at least the moral satisfaction of explaining his behaviour. Instead, he comes riding along on the tempest of his almightiness and thunders reproaches at the half-crushed human worm:

Who is this that darkens counsel
by words without insight?⁴

[585] In view of the subsequent words of Yahweh, one must really ask oneself: *Who* is darkening *what* counsel? The only dark thing here is how Yahweh ever came to make

a bet with Satan. It is certainly not Job who has darkened anything and least of all a counsel, for there was never any talk of this nor will there be in what follows. The bet does not contain any “counsel” so far as one can see—unless, of course, it was Yahweh himself who egged Satan on for the ultimate purpose of exalting Job. Naturally this development was foreseen in omniscience, and it may be that the word “counsel” refers to this eternal and absolute knowledge. If so, Yahweh’s attitude seems the more illogical and incomprehensible, as he could then have enlightened Job on this point—which, in view of the wrong done to him, would have been only fair and equitable. I must therefore regard this possibility as improbable.

[586] *Whose words are without insight?* Presumably Yahweh is not referring to the words of Job’s friends, but is rebuking Job. But what is Job’s guilt? The only thing he can be blamed for is his incurable optimism in believing that he can appeal to divine justice. In this he is mistaken, as Yahweh’s subsequent words prove. God does not want to be just; he merely flaunts might over right. Job could not get that into his head, because he looked upon God as a moral being. He had never doubted God’s might, but had hoped for right as well. He had, however, already taken back this error when he recognized God’s contradictory nature, and by so doing he assigned a place to God’s justice and goodness. So one can hardly speak of lack of insight.

[587] The answer to Yahweh’s conundrum is therefore: it is Yahweh himself who darkens his own counsel and who has no insight. He turns the tables on Job and blames him for what he himself does: man is not permitted to have an opinion about him, and, in particular, is to have no insight which he himself does not possess. For seventy-one verses he proclaims his world-creating power to his miserable victim, who sits in ashes and scratches his sores with potsherds, and who by now has had more than enough of superhuman violence. Job has absolutely no need of being impressed by further exhibitions of this power. Yahweh, in his omniscience, could have known just how incongruous his attempts at intimidation were in such a situation. He could easily have seen that Job believes in his omnipotence as much as ever and has never doubted it or wavered in his loyalty. Altogether, he pays so little attention to Job’s real situation that one suspects him of having an ulterior motive which is more important to him: Job is no more than the outward occasion for an inward process of dialectic in God. His thunderings at Job so completely miss the point that one cannot help but see how much he is occupied with himself. The tremendous emphasis he lays on his omnipotence and greatness makes no sense in relation to Job, who certainly needs no more convincing, but only becomes intelligible when aimed at a listener *who doubts it*. This “doubting thought” is Satan, who after completing his evil handiwork has returned to the paternal bosom in order to continue his subversive activity there. Yahweh must have seen that Job’s loyalty was unshakable and that Satan had lost his bet. He must also have realized that, in

accepting this bet, he had done everything possible to drive his faithful servant to disloyalty, even to the extent of perpetrating a whole series of crimes. Yet it is not remorse and certainly not moral horror that rises to his consciousness, but an obscure intimation of something that questions his omnipotence. He is particularly sensitive on this point, because “might” is the great argument. But omniscience knows that might excuses nothing. The said intimation refers, of course, to the extremely uncomfortable fact that Yahweh had let himself be bamboozled by Satan. This weakness of his does not reach full consciousness, since Satan is treated with remarkable tolerance and consideration. Evidently Satan’s intrigue is deliberately overlooked at Job’s expense.

[588] Luckily enough, Job had noticed during this harangue that everything else had been mentioned except his right. He has understood that it is at present impossible to argue the question of right, as it is only too obvious that Yahweh has no interest whatever in Job’s cause but is far more preoccupied with his own affairs. Satan, that is to say, has somehow to disappear, and this can best be done by casting suspicion on Job as a man of subversive opinions. The problem is thus switched on to another track, and the episode with Satan remains unmentioned and unconscious. To the spectator it is not quite clear why Job is treated to this almighty exhibition of thunder and lightning, but the performance as such is sufficiently magnificent and impressive to convince not only a larger audience but above all Yahweh himself of his unassailable power. Whether Job realizes what violence Yahweh is doing to his own omniscience by behaving like this we do not know, but his silence and submission leave a number of possibilities open. Job has no alternative but formally to revoke his demand for justice, and he therefore answers in the words quoted at the beginning: “I lay my hand on my mouth.”

[589] He betrays not the slightest trace of mental reservation—in fact, his answer leaves us in no doubt that he has succumbed completely and without question to the tremendous force of the divine demonstration. The most exacting tyrant should have been satisfied with this, and could be quite sure that his servant—from terror alone, to say nothing of his undoubted loyalty—would not dare to nourish a single improper thought for a very long time to come.

[590] Strangely enough, Yahweh does not notice anything of the kind. He does not see Job and his situation at all. It is rather as if he had another powerful opponent in the place of Job, one who was better worth challenging. This is clear from his twicerepeated taunt:

Gird up your loins like a man;

I will question you, and you shall declare to me.⁵

[591] One would have to choose positively grotesque examples to illustrate the disproportion between the two antagonists. Yahweh sees something in Job which we would not ascribe to him but to God, that is, an equal power which causes him to bring out his whole power apparatus and parade it before his opponent. Yahweh projects on to Job a sceptic's face which is hateful to him because it is his own, and which gazes at him with an uncanny and critical eye. He is afraid of it, for only in face of something frightening does one let off a cannonade of references to one's power, cleverness, courage, invincibility, etc. What has all that to do with Job? Is it worth the lion's while to terrify a mouse?

[592] Yahweh cannot rest satisfied with the first victorious round. Job has long since been knocked out, but the great antagonist whose phantom is projected on to the pitiable sufferer still stands menacingly upright. Therefore Yahweh raises his arm again:

Will you even put me in the wrong?

Will you condemn me that you may be justified?

Have you an arm like God,

and can you thunder with a voice like his?⁶

[593] Man, abandoned without protection and stripped of his rights, and whose nothingness is thrown in his face at every opportunity, evidently appears to be so dangerous to Yahweh that he must be battered down with the heaviest artillery. What irritates Yahweh can be seen from his challenge to the ostensible Job:

Look on every one that is proud, and bring him low;

and tread down the wicked where they stand.

Hide them in the dust together;

bind their faces in the hidden place.

Then will I also acknowledge to you

that your own right hand can give you victory.⁷

[594] Job is challenged as though he himself were a god. But in the contemporary metaphysics there was no *deuteros theos*, no other god except Satan, who owns Yahweh's ear and is able to influence him. He is the only one who can pull the wool over his eyes, beguile him, and put him up to a massive violation of his own penal code. A formidable opponent indeed, and, because of his close kinship, so compromising that he must be concealed with the utmost discretion—even to the point of God's hiding him from his own consciousness in his own bosom! In his stead God must set up his miserable servant as the bugbear whom he has to fight, in the hope that by banishing the dreaded countenance to "the hidden place" he will be able to maintain himself in a state of unconsciousness.

[595] The stage-managing of this imaginary duel, the speechifying, and the impressive performance given by the prehistoric menagerie would not be sufficiently explained if we tried to reduce them to the purely negative factor of Yahweh's fear of becoming conscious and of the relativization which this entails. The conflict becomes acute for Yahweh as a result of a new factor, which is, however, not hidden from omniscience—though in this case the existing knowledge is not accompanied by any conclusion. The new factor is something that has never occurred before in the history of the world, the unheard-of fact that, without knowing it or wanting it, a mortal man is raised by his moral behaviour above the stars in heaven, from which position of advantage he can behold the back of Yahweh, the abysmal world of “shards.”⁸

[596] Does Job know what he has seen? If he does, he is astute or canny enough not to betray it. But his words speak volumes:

I know that thou canst do all things,
and that no purpose of thine can be thwarted.⁹

[597] Truly, Yahweh can do all things and permits himself all things without batting an eyelid. With brazen countenance he can project his shadow side and remain unconscious at man's expense. He can boast of his superior power and enact laws which mean less than air to him. Murder and manslaughter are mere bagatelles, and if the mood takes him he can play the feudal grand seigneur and generously recompense his bondsman for the havoc wrought in his wheat-fields. “So you have lost your sons and daughters? No harm done, I will give you new and better ones.”

[598] Job continues (no doubt with downcast eyes and in a low voice):

“Who is this that hides counsel without insight?”
Therefore I have uttered what I did not understand,
things too wonderful for me, which I did not know.
“Hear, and I will speak;
I will question you, and you declare to me.”
I had heard of thee by the hearing of the ear,
but now my eye sees thee;
therefore I abhor myself,
and repent in dust and ashes.¹⁰

[599] Shrewdly, Job takes up Yahweh's aggressive words and prostrates himself at his feet as if he were indeed the defeated antagonist. Guileless as Job's speech sounds, it could just as well be equivocal. He has learnt his lesson well and experienced “wonderful things” which are none too easily grasped. Before, he had known Yahweh “by the hearing of the ear,” but now he has got a taste of his reality, more so even than David—an incisive lesson that had better not be forgotten. Formerly he was

naïve, dreaming perhaps of a “good” God, or of a benevolent ruler and just judge. He had imagined that a “covenant” was a legal matter and that anyone who was party to a contract could insist on his rights as agreed; that God would be faithful and true or at least just, and, as one could assume from the Ten Commandments, would have some recognition of ethical values or at least feel committed to his own legal standpoint. But, to his horror, he has discovered that Yahweh is not human but, in certain respects, less than human, that he is just what Yahweh himself says of Leviathan (the crocodile):

He beholds everything that is high:

He is king over all proud beasts.¹¹

[600] Unconsciousness has an animal nature. Like all old gods Yahweh has his animal symbolism with its unmistakable borrowings from the much older theriomorphic gods of Egypt, especially Horus and his four sons. Of the four animals of Yahweh only one has a human face. That is probably Satan, the godfather of man as a spiritual being. Ezekiel’s vision attributes three-fourths animal nature and only one-fourth human nature to the animal deity, while the upper deity, the one above the “sapphire throne,” merely had the “likeness” of a man.¹² This symbolism explains Yahweh’s behaviour, which, from the human point of view, is so intolerable: it is the behaviour of an unconscious being who cannot be judged morally. Yahweh is a *phenomenon* and, as Job says, “not a man.”¹³

[601] One could, without too much difficulty, impute such a meaning to Job’s speech. Be that as it may, Yahweh calmed down at last. The therapeutic measure of unresisting acceptance had proved its value yet again. Nevertheless, Yahweh is still somewhat nervous of Job’s friends—they “have not spoken of me what is right.”¹⁴ The projection of his doubt-complex extends—comically enough, one must say—to these respectable and slightly pedantic old gentlemen, as though God-knows-what depended on what they thought. But the fact that men should think at all, and especially about him, is maddeningly disquieting and ought somehow to be stopped. It is far too much like the sort of thing his vagrant son is always springing on him, thus hitting him in his weakest spot. How often already has he bitterly regretted his unconsidered outbursts!

[602] One can hardly avoid the impression that Omniscience is gradually drawing near to a realization, and is threatened with an insight that seems to be hedged about with fears of self-destruction. Fortunately, Job’s final declaration is so formulated that one can assume with some certainty that, for the protagonists, the incident is closed for good and all.

[603] We, the commenting chorus on this great tragedy, which has never at any time lost its vitality, do not feel quite like that. For our modern sensibilities it is by no

means apparent that with Job's profound obeisance to the majesty of the divine presence, and his prudent silence, a real answer has been given to the question raised by the Satanic prank of a wager with God. Job has not so much answered as reacted in an adjusted way. In so doing he displayed remarkable self-discipline, but an unequivocal answer has still to be given.

[604] To take the most obvious thing, what about the moral wrong Job has suffered? Is man so worthless in God's eyes that not even a *tort moral* can be inflicted on him? That contradicts the fact that man is desired by Yahweh and that it obviously matters to him whether men speak "right" of him or not. He needs Job's loyalty, and it means so much to him that he shrinks at nothing in carrying out his test. This attitude attaches an almost divine importance to man, for what else is there in the whole wide world that could mean anything to one who has everything? Yahweh's divided attitude, which on the one hand tramples on human life and happiness without regard, and on the other hand must have man for a partner, puts the latter in an impossible position. At one moment Yahweh behaves as irrationally as a cataclysm; the next moment he wants to be loved, honoured, worshipped, and praised as just. He reacts irritably to every word that has the faintest suggestion of criticism, while he himself does not care a straw for his own moral code if his actions happen to run counter to its statutes.

[605] One can submit to such a God only with fear and trembling, and can try indirectly to propitiate the despot with unctuous praises and ostentatious obedience. But a relationship of trust seems completely out of the question to our modern way of thinking. Nor can moral satisfaction be expected from an unconscious nature god of this kind. Nevertheless, Job got his satisfaction, without Yahweh's intending it and possibly without himself knowing it, as the poet would have it appear. Yahweh's allocutions have the unthinking yet none the less transparent purpose of showing Job the brutal power of the demiurge: "This is I, the creator of all the ungovernable, ruthless forces of Nature, which are not subject to any ethical laws. I, too, am an amoral force of Nature, a purely phenomenal personality that cannot see its own back."

[606] This is, or at any rate could be, a moral satisfaction of the first order for Job, because through this declaration man, in spite of his impotence, is set up as a judge over God himself. We do not know whether Job realizes this, but we do know from the numerous commentaries on Job that all succeeding ages have overlooked the fact that a kind of Moira or Dike rules over Yahweh, causing him to give himself away so blatantly. Anyone can see how he unwittingly raises Job by humiliating him in the dust. By so doing he pronounces judgment on himself and gives man the moral satisfaction whose absence we found so painful in the Book of Job.

[607] The poet of this drama showed a masterly discretion in ringing down the curtain at the very moment when his hero gave unqualified recognition to the *ἀπόφασις μεγάλη* of the Demiurge by prostrating himself at the feet of His Divine Majesty. No other impression was permitted to remain. An unusual scandal was blowing up in the realm of metaphysics, with supposedly devastating consequences, and nobody was ready with a saving formula which would rescue the monotheistic conception of God from disaster. Even in those days the critical intellect of a Greek could easily have seized on this new addition to Yahweh's biography and used it in his disfavour (as indeed happened, though very much later)¹⁵ so as to mete out to him the fate that had already overtaken the Greek gods. But a relativization of God was utterly unthinkable at that time, and remained so for the next two thousand years.

[608] The unconscious mind of man sees correctly even when conscious reason is blind and impotent. The drama has been consummated for all eternity: Yahweh's dual nature has been revealed, and somebody or something has seen and registered this fact. Such a revelation, whether it reached man's consciousness or not, could not fail to have far-reaching consequences.

III

[609] Before turning to the question of how the germ of unrest developed further, we must turn back to the time when the Book of Job was written. Unfortunately the dating is uncertain. It is generally assumed that it was written between 600 and 300 B.C.—not too far away, therefore, from the time of the Book of Proverbs (4th to 3rd century). Now in Proverbs we encounter a symptom of Greek influence which, if an earlier date is assigned to it, reached the Jewish sphere of culture through Asia Minor and, if a later date, through Alexandria. This is the idea of Sophia, or the *Sapientia Dei*, who is a coeternal and more or less hypostatized pneuma of feminine nature that existed before the Creation:

The Lord possessed me in the beginning of his way,
before his works of old.

I was set up from everlasting, from the beginning,
or ever the earth was.

When there were no depths, I was brought forth;
when there were no fountains abounding with water.

.

When he established the heavens, I was there,

.

when he marked out the foundations of the earth,
then I was by him, as a master workman,

and I was daily his delight,
rejoicing always before him,
rejoicing in his habitable earth;
and my delights were with the sons of men.¹

[610] This Sophia, who already shares certain essential qualities with the Johannine Logos, is on the one hand closely associated with the Hebrew Chochma, but on the other hand goes so far beyond it that one can hardly fail to think of the Indian Shakti. Relations with India certainly existed at that time (the time of the Ptolemys). A further source is the Wisdom of Jesus the Son of Sirach, or Ecclesiasticus, written around 200 B.C. Here Wisdom says of herself:

I came out of the mouth of the most High,
and covered the earth as a cloud.
I dwelt in high places,
and my throne is in a cloudy pillar.
I alone encompassed the circuit of heaven,
and walked in the bottom of the deep.
I had power over the waves of the sea, and over all the earth,
and over every people and nation.

.

He created me from the beginning before the world,
and I shall never fail.
In the holy tabernacle I served before him;
and so was I established in Sion.
Likewise in the beloved city he gave me rest,
and in Jerusalem was my power.

.

I was exalted like a cedar in Libanus,
and as a cypress tree upon the mountains of Hermon.
I was exalted like a palm tree in En-gaddi,
and as a rose plant in Jericho,
as a fair olive tree in a pleasant field,
and grew up as a plane tree by the water.
I gave a sweet smell like cinnamon and aspalathus,
and I yielded a pleasant odour like the best myrrh ...
As the turpentine tree I stretched out my branches,
and my branches are the branches of honour and grace.

As the vine brought I forth pleasant savour,
and my flowers are the fruit of honour and riches.

I am the mother of fair love,
and fear, and knowledge, and holy hope:
I therefore, being eternal, am given to all my children
which are chosen of him.²

[611] It is worth while to examine this text more closely. Wisdom describes herself, in effect, as the Logos, the Word of God (“I came out of the mouth of the most High”). As Ruach, the spirit of God, she brooded over the waters of the beginning. Like God, she has her throne in heaven. As the cosmogonic Pneuma she pervades heaven and earth and all created things. She corresponds in almost every feature to the Logos of St. John. We shall see below how far this connection is also important as regards content.

[612] She is the feminine numen of the “metropolis” par excellence, of Jerusalem the mother-city. She is the mother-beloved, a reflection of Ishtar, the pagan city-goddess. This is confirmed by the detailed comparison of Wisdom with trees, such as the cedar, palm, terebinth (“turpentine-tree”), olive, cypress, etc. All these trees have from ancient times been symbols of the Semitic love- and mother-goddess. A holy tree always stood beside her altar on high places. In the Old Testament oaks and terebinths are oracle trees. God or angels are said to appear in or beside trees. David consulted a mulberry-tree oracle.³ The tree in Babylon represented Tammuz, the son-lover, just as it represented Osiris, Adonis, Attis, and Dionysus, the young dying gods of the Near East. All these symbolic attributes also occur in the Song of Songs, as characteristics of the *sponsus* as well as the *sponsa*. The vine, the grape, the vine flower, and the vineyard play a significant role here. The Beloved is like an appletree; she shall come down from the mountains (the cult places of the mother-goddess), “from the lions’ dens, from the mountains of the leopards”;⁴ her womb is “an orchard of pomegranates, with pleasant fruits, camphire with spikenard, spikenard and saffron, calamus and cinnamon, with all trees of frankincense, myrrh and aloes, with all the chief spices.”⁵ Her hands “dropped with myrrh”⁶ (Adonis, we may remember, was born of the myrrh). Like the Holy Ghost, Wisdom is given as a gift to the elect, an idea that is taken up again in the doctrine of the Paraclete.

[613] The pneumatic nature of Sophia as well as her world-building Maya character come out still more clearly in the apocryphal Wisdom of Solomon. “For wisdom is a loving spirit,”⁷ “kind to man.”⁸ She is “the worker of all things,” “in her is an understanding spirit, holy.”⁹ She is “the breath of the power of God,” “a pure effluence flowing from the glory of the Almighty,”¹⁰ “the brightness of the everlasting light, the unspotted mirror of the power of God,”¹¹ a being “most subtil,” who “passeth and goeth through all things by reason of her pureness.”¹² She is

“conversant with God,” and “the Lord of all things himself loved her.”¹³ “Who of all that are is a more cunning workman than she?”¹⁴ She is sent from heaven and from the throne of glory as a “Holy Spirit.”¹⁵ As a psychopomp she leads the way to God and assures immortality.¹⁶

[614] The Wisdom of Solomon is emphatic about God’s justice and, probably not without pragmatic purpose, ventures to sail very close to the wind: “Righteousness is immortal, but ungodly men with their works and words call death upon themselves.”¹⁷ The unrighteous and the ungodly, however, say:

Let us oppress the poor righteous man,
let us not spare the widow,
nor reverence the ancient gray hairs of the aged.
Let our strength be the law of justice:
for that which is feeble is found to be nothing worth.
Therefore let us lie in wait for the righteous;
because ... he upbraideth us with our offending the law,
and objecteth to our infamy....
He professeth to have the knowledge of God:
and he calleth himself the child of the Lord.
He was made to reprove our thoughts.

.

Let us see if his words be true:
and let us prove what shall happen in the end of him.

.

Let us examine him with despitefulness and torture,
that we may know his meekness, and prove his patience.¹⁸

[615] Where did we read but a short while before: “And the Lord said to Satan, Have you considered my servant Job, that there is none like him on the earth, a blameless and upright man, who fears God and turns away from evil? He still holds fast his integrity, although you moved me against him, to destroy him without cause”? “Wisdom is better than might,” saith the Preacher.¹⁹

[616] Not from mere thoughtfulness and unconsciousness, but from a deeper motive, the Wisdom of Solomon here touches on the sore spot. In order to understand this more fully, we would have to find out in what sort of relation the Book of Job stands to the change that occurred in the status of Yahweh at about the same time, i.e., its relation to the appearance of Sophia. It is not a question of literary history, but of Yahweh’s fate as it affects man. From the ancient records we know that the divine drama was enacted between God and his people, who were betrothed to him, the masculine dynamis, like a woman, and over whose faithfulness he watched jealously.

A particular instance of this is Job, whose faithfulness is subjected to a savage test. As I have said, the really astonishing thing is how easily Yahweh gives in to the insinuations of Satan. If it were true that he trusted Job perfectly, it would be only logical for Yahweh to defend him, unmask the malicious slanderer, and make him pay for his defamation of God's faithful servant. But Yahweh never thinks of it, not even after Job's innocence has been proved. We hear nothing of a rebuke or disapproval of Satan. Therefore, one cannot doubt Yahweh's connivance. His readiness to deliver Job into Satan's murderous hands proves that he doubts Job precisely because he projects his own tendency to unfaithfulness upon a scapegoat. There is reason to suspect that he is about to loosen his matrimonial ties with Israel but hides this intention from himself. This vaguely suspected unfaithfulness causes him with the help of Satan, to seek out the unfaithful one, and he infallibly picks on the most faithful of the lot, who is forthwith subjected to a gruelling test. Yahweh has become unsure of his own faithfulness.

[617] At about the same time, or a little later, it is rumoured what has happened: he has remembered a feminine being who is no less agreeable to him than to man, a friend and playmate from the beginning of the world, the first-born of all God's creatures, a stainless reflection of his glory and a master workman, nearer and dearer to his heart than the late descendants of the protoplast, the original man, who was but a secondary product stamped in his image. There must be some dire necessity responsible for this anamnesis of Sophia: things simply could not go on as before, the "just" God could not go on committing injustices, and the "Omniscient" could not behave any longer like a clueless and thoughtless human being. Self-reflection becomes an imperative necessity, and for this Wisdom is needed. Yahweh has to remember his absolute knowledge; for, if Job gains knowledge of God, then God must also learn to know himself. It just could not be that Yahweh's dual nature should become public property and remain hidden from himself alone. Whoever knows God has an effect on him. The failure of the attempt to corrupt Job has changed Yahweh's nature.

[618] We shall now proceed to reconstruct, from the hints given in the Bible and from history, what happened after this change. For this purpose we must turn back to the time of Genesis, and to the protoplast before the Fall. He, Adam, produced Eve, his feminine counterpart, from his rib with the Creator's help, in the same way as the Creator had produced the hermaphroditic Adam from the *prima materia* and, along with him, the divinely stamped portion of humanity, namely the people of Israel and the other descendants of Adam.²⁰ Mysteriously following the same pattern, it was bound to happen that Adam's first son, like Satan, was an evildoer and murderer before the Lord, so that the prologue in heaven was repeated on earth. It can easily be surmised that this was the deeper reason why Yahweh gave special protection to the

unsuccessful Cain, for he was a faithful reproduction of Satan in miniature. Nothing is said about a prototype of the early-departed Abel, who was dearer to God than Cain, the go-ahead husbandman (who was no doubt instructed in these arts by one of Satan's angels). Perhaps this prototype was another son of God of a more conservative nature than Satan, no rolling stone with a fondness for new and blackhearted thoughts, but one who was bound to the Father in childlike love, who harboured no other thoughts except those that enjoyed paternal approval, and who dwelt in the inner circle of the heavenly economy. That would explain why his earthly counterpart Abel could so soon "hasten away from the evil world," in the words of the Book of Wisdom, and return to the Father, while Cain in his earthly existence had to taste to the full the curse of his progressiveness on the one hand and of his moral inferiority on the other.

[619] If the original father Adam is a copy of the Creator, his son Cain is certainly a copy of God's son Satan, and this gives us good reason for supposing that God's favourite, Abel, must also have his correspondence in a "supracelestial place." The ominous happenings that occur right at the beginning of a seemingly successful and satisfactory Creation—the Fall and the fratricide—catch our attention, and one is forced to admit that the initial situation, when the spirit of God brooded over the tohubohu, hardly permits us to expect an absolutely perfect result. Furthermore the Creator, who found every other day of his work "good," failed to give good marks to what happened on Monday. He simply said nothing—a circumstance that favours an argument from silence! What happened on that day was the final separation of the upper from the lower waters by the interposed "plate" of the firmament. It is clear that this unavoidable dualism refused, then as later, to fit smoothly into the concept of monotheism, because it points to a metaphysical disunity. This split, as we know from history, had to be patched up again and again through the centuries, concealed and denied. It had made itself felt from the very beginning in Paradise, through a strange inconsequence which befell the Creator or was put over on him. Instead of following his original programme of letting man appear on the last day as the most intelligent being and lord of all creatures, he created the serpent who proved to be much more intelligent and more conscious than Adam, and, in addition, had been created before him. We can hardly suppose that Yahweh would have played such a trick on himself; it is far more likely that his son Satan had a hand in it. He is a trickster and spoilsport who loves nothing better than to cause annoying accidents. Although Yahweh had created the reptiles before Adam, they were common or garden snakes, highly unintelligent, from among whom Satan selected a tree-snake to use as his disguise. From then on the rumour spread that the snake was "the most spiritual animal."²¹ Later the snake became the favourite symbol of the Noug, received high honours and was even permitted to symbolize God's second son,

because the latter was interpreted as the world-redeeming Logos, which frequently appears as identical with the Nous. A legend of later origin maintains that the snake in the Garden of Eden was Lilith, Adam's first wife, with whom he begot a horde of demons. This legend likewise supposes a trick that can hardly have been intended by the Creator. Consequently, the Bible knows only of Eve as Adam's legitimate wife. It nevertheless remains a strange fact that the original man who was created in the image of God had, according to tradition, two wives, just like his heavenly prototype. Just as Yahweh is legitimately united with his wife Israel, but has a feminine pneuma as his intimate playmate from all eternity, so Adam first has Lilith (the daughter or emanation of Satan) to wife, as a Satanic correspondence to Sophia. Eve would then correspond to the people of Israel. We naturally do not know why we should hear at such a late date that the Ruach Elohim, the "spirit of God," is not only feminine but a comparatively independent being who exists side by side with God, and that long before the marriage with Israel Yahweh had had relations with Sophia. Nor do we know why, in the older tradition, the knowledge of this first alliance had been lost. Likewise it was only quite late that one heard of the delicate relationship between Adam and Lilith. Whether Eve was as troublesome a wife for Adam as the children of Israel, who were perpetually flirting with unfaithfulness, were for Yahweh, is equally dark to us. At any rate the family life of our first parents was not all beer and skittles: their first two sons are a typical pair of hostile brothers, for at that time it was apparently still the custom to live out mythological motifs in reality. (Nowadays this is felt to be objectionable and is denied whenever it happens.) The parents can share the blame for original sin: Adam has only to remember his demon princess, and Eve should never forget that she was the first to fall for the wiles of the serpent. Like the Fall, the Cain-Abel intermezzo can hardly be listed as one of Creation's shining successes. One must draw this conclusion because Yahweh himself did not appear to be informed in advance of the above-mentioned incidents. Here as later there is reason to suspect that no conclusions were ever drawn from Omniscience: Yahweh did not consult his total knowledge and was accordingly surprised by the result. One can observe the same phenomenon in human beings, wherever in fact people cannot deny themselves the pleasure of their emotions. It must be admitted that a fit of rage or a sulk has its secret attractions. Were that not so, most people would long since have acquired a little wisdom.

[620] From this point of view we may be in a better position to understand what happened to Job. In the pleromatic or (as the Tibetans call it) Bardo state,²² there is a perfect interplay of cosmic forces, but with the Creation—that is, with the division of the world into distinct processes in space and time—events begin to rub and jostle one another. Covered by the hem of the paternal mantle, Satan soon starts putting a right touch here and a wrong touch there, thus giving rise to complications which

were apparently not intended in the Creator's plan and which come as surprises. While unconscious creation—animals, plants, and crystals—functions satisfactorily so far as we know, things are constantly going wrong with man. At first his consciousness is only a very little higher than that of the animals, for which reason his freedom of will is also extremely limited. But Satan takes an interest in him and experiments with him in his own way, leading him into all sorts of wickedness while his angels teach him the arts and sciences, which until now had been reserved for the perfection of the pleroma. (Even in those days Satan would have merited the name of "Lucifer"!) The peculiar, unforeseen antics of men arouse Yahweh's wrath and thereby involve him in his own creation. Divine interventions become a compelling necessity. Irritatingly enough, they only meet with temporary success. Even the Draconian punishment of drowning all life with a few choice exceptions (a fate which, according to old Johann Jacob Scheuchzer on the evidence of the fossils, not even the fishes escaped), had no lasting effect. Creation remained just as tainted as before. The strange thing is that Yahweh invariably seeks the reason for this in man, who apparently refuses to obey, but never in his son, the father of all tricksters. This false orientation cannot fail to exasperate his already touchy nature, so that fear of God is regarded by man in general as the principle and even as the beginning of all wisdom. While mankind tried, under this hard discipline, to broaden their consciousness by acquiring a modicum of wisdom, that is, a little foresight and reflection,²³ it is clear from the historical development that Yahweh had lost sight of his pleromatic coexistence with Sophia since the days of the Creation. Her place was taken by the covenant with the chosen people, who were thus forced into the feminine role. At that time the people consisted of a patriarchal society in which women were only of secondary importance. God's marriage with Israel was therefore an essentially masculine affair, something like the founding of the Greek *polis*, which occurred about the same time. The inferiority of women was a settled fact. Woman was regarded as less perfect than man, as Eve's weakness for the blandishments of the serpent amply proved. *Perfection* is a masculine desideratum, while woman inclines by nature to *completeness*. And it is a fact that, even today, a man can stand a relative state of perfection much better and for a longer period than a woman, while as a rule it does not agree with women and may even be dangerous for them. If a woman strives for perfection she forgets the complementary role of completeness, which, though imperfect by itself, forms the necessary counterpart to perfection. For, just as completeness is always imperfect, so perfection is always incomplete, and therefore represents a final state which is hopelessly sterile. "Ex perfecto nihil fit," say the old masters, whereas the *imperfectum* carries within it the seeds of its own improvement. Perfectionism always ends in a blind alley, while completeness by itself lacks selective values.

[621] At the bottom of Yahweh's marriage with Israel is a perfectionist intention which excludes that kind of relatedness we know as "Eros." The lack of Eros, of relationship to values, is painfully apparent in the Book of Job: the paragon of all creation is not a man but a monster! Yahweh has no Eros, no relationship to man, but only to a purpose man must help him fulfil. But that does not prevent him from being jealous and mistrustful like any other husband, though even here he has his purpose in mind and not man.

[622] The faithfulness of his people becomes the more important to him the more he forgets Wisdom. But again and again they slip back into unfaithfulness despite the many proofs of his favour. This behaviour naturally does nothing to mollify Yahweh's jealousy and suspicions, hence Satan's insinuations fall on fertile ground when he drips his doubt about Job's faithfulness into the paternal ear. Against his own convictions Yahweh agrees without any hesitation to inflict the worst tortures on him. One misses Sophia's "love of mankind" more than ever. Even Job longs for the Wisdom which is nowhere to be found.²⁴

[623] Job marks the climax of this unhappy development. He epitomizes a thought which had been maturing in mankind about that time—a dangerous thought that makes great demands on the wisdom of gods and men. Though conscious of these demands, Job obviously does not know enough about the Sophia who is coeternal with God. Because man feels himself at the mercy of Yahweh's capricious will, he is in need of wisdom; not so Yahweh, who up to now has had nothing to contend with except man's nothingness. With the Job drama, however, the situation undergoes a radical change. Here Yahweh comes up against a man who stands firm, who clings to his rights until he is compelled to give way to brute force. He has seen God's face and the unconscious split in his nature. God was now known, and this knowledge went on working not only in Yahweh but in man too. Thus it was the men of the last few centuries before Christ who, at the gentle touch of the pre-existent Sophia, compensate Yahweh and his attitude, and at the same time complete the anamnesis of Wisdom. Taking a highly personified form that is clear proof of her autonomy, Wisdom reveals herself to men as a friendly helper and advocate against Yahweh, and shows them the bright side, the kind, just, and amiable aspect of their God.

[624] At the time when Satan's practical joke with the snake compromised the paradise that was planned to be perfect, Yahweh banished Adam and Eve, whom he had created as images of his masculine essence and its feminine emanation, to the extraparadise world, the limbo of "shards." It is not clear how much of Eve represents Sophia and how much of her is Lilith. At any rate Adam has priority in every respect. Eve was taken out of his body as an afterthought. I mention these details from Genesis only because the reappearance of Sophia in the heavenly regions points to a coming act of creation. She is indeed the "master workman"; she realizes

God's thoughts by clothing them in material form, which is the prerogative of all feminine beings. Her coexistence with Yahweh signifies the perpetual *hieros gamos* from which worlds are begotten and born. A momentous change is imminent: God desires to regenerate himself in the mystery of the heavenly nuptials—as the chief gods of Egypt had done from time immemorial—and to become man. For this he uses the Egyptian model of the god's incarnation in Pharaoh, which in its turn is but a copy of the eternal *hieros gamos* in the pleroma. It would, however, be wrong to suppose that this archetype is merely repeating itself mechanically. So far as we know, this is never the case, since archetypal situations only return when specifically called for. The real reason for God's becoming man is to be sought in his encounter with Job. Later on we shall deal with this question in more detail.

IV

[625] Just as the decision to become man apparently makes use of the ancient Egyptian model, so we can expect that the process itself will follow certain prefigurations. The approach of Sophia betokens a new creation. But this time it is not the world that is to be changed; rather it is God who intends to change his own nature. Mankind is not, as before, to be destroyed, but saved. In this decision we can discern the "philanthropic" influence of Sophia: no new human beings are to be created, but only one, the God-man. For this purpose a contrary procedure must be employed. The Second Adam shall not, like the first, proceed directly from the hand of the Creator, but shall be born of a human woman. So this time priority falls to the Second Eve, not only in a temporal sense but in a material sense as well. On the basis of the so-called Proto-Evangelium, the Second Eve corresponds to "the woman and her seed" mentioned in Genesis 3:15, which shall bruise the serpent's head. And just as Adam was believed to be originally hermaphroditic, so "the woman and her seed" are thought of as a human pair, as the Queen of Heaven and Mother of God and as the divine son who has no human father. Thus Mary, the virgin, is chosen as the pure vessel for the coming birth of God. Her independence of the male is emphasized by her virginity as the *sine qua non* of the process. She is a "daughter of God" who, as a later dogma will establish, is distinguished at the outset by the privilege of an immaculate conception and is thus free from the taint of original sin. It is therefore evident that she belongs to the state before the Fall. This posits a new beginning. The divine immaculateness of her status makes it immediately clear that she not only bears the image of God in undiminished purity, but, as the bride of God, is also the incarnation of her prototype, namely Sophia. Her love of mankind, widely emphasized in the ancient writings, suggests that in this newest creation of his Yahweh has allowed himself to be extensively influenced by Sophia. For Mary, the blessed among women, is a friend and intercessor for sinners, which all men are. Like Sophia, she is

a mediatrix who leads the way to God and assures man of immortality. Her Assumption is therefore the prototype of man's bodily resurrection. As the bride of God and Queen of Heaven she holds the place of the Old Testament Sophia.

[626] Remarkable indeed are the unusual precautions which surround the making of Mary: immaculate conception, extirpation of the taint of sin, everlasting virginity. The Mother of God is obviously being protected against Satan's tricks. From this we can conclude that Yahweh has consulted his own omniscience, for in his omniscience there is a clear knowledge of the perverse intentions which lurk in the dark son of God. Mary must at all costs be protected from these corrupting influences. The inevitable consequence of all these elaborate protective measures is something that has not been sufficiently taken into account in the dogmatic evaluation of the Incarnation: her freedom from original sin sets Mary apart from mankind in general, whose common characteristic is original sin and therefore the need of redemption. The *status ante lapsum* is tantamount to a paradisal, i.e., pleromatic and divine, existence. By having these special measures applied to her, Mary is elevated to the status of a goddess and consequently loses something of her humanity: she will not conceive her child in sin, like all other mothers, and therefore he also will never be a human being, but a god. To my knowledge at least, no one has ever perceived that this queers the pitch for a genuine Incarnation of God, or rather, that the Incarnation was only partially consummated. Both mother and son are not real human beings at all, but gods.

[627] This arrangement, though it had the effect of exalting Mary's personality in the masculine sense by bringing it closer to the perfection of Christ, was at the same time injurious to the feminine principle of imperfection or completeness, since this was reduced by the perfectionizing tendency to the little bit of imperfection that still distinguishes Mary from Christ. *Phoebo propior lumina perdit!* Thus the more the feminine ideal is bent in the direction of the masculine, the more the woman loses her power to compensate the masculine striving for perfection, and a typically masculine, ideal state arises which, as we shall see, is threatened with an enantiodromia. No path leads beyond perfection into the future—there is only a turning back, a collapse of the ideal, which could easily have been avoided by paying attention to the feminine ideal of completeness. Yahweh's perfectionism is carried over from the Old Testament into the New, and despite all the recognition and glorification of the feminine principle this never prevailed against the patriarchal supremacy. We have not, therefore, by any means heard the last of it.

[628] The older son of the first parents was corrupted by Satan and not much of a success. He was an eidolon of Satan, and only the younger son, Abel, was pleasing to

God. In Cain the God-image was distorted, but in Abel it was considerably less dimmed. If Adam is thought of as a copy of God, then God's successful son, who served as a model for Abel (and about whom, as we have seen, there are no available documents), is the prefiguration of the God-man. Of the latter we know positively that, as the Logos, he is preexistent and coeternal with God, indeed of the same substance (*ὁμοούσιος*) as he. One can therefore regard Abel as the imperfect prototype of God's son who is about to be begotten in Mary. Just as Yahweh originally undertook to create a chthonic equivalent of himself in the first man, Adam, so now he intends something similar, but much better. The extraordinary precautionary measures above-mentioned are designed to serve this purpose. The new son, Christ, shall on the one hand be a chthonic man like Adam, mortal and capable of suffering, but on the other hand he shall not be, like Adam, a mere copy, but God himself, begotten by himself as the Father, and rejuvenating the Father as the Son. As God he has always been God, and as the son of Mary, who is plainly a copy of Sophia, he is the Logos (synonymous with Nous), who, like Sophia, is a master workman, as stated by the Gospel according to St. John.¹ This identity of mother and son is borne out over and over again in the myths.

[629] Although the birth of Christ is an event that occurred but once in history, it has always existed in eternity. For the layman in these matters, the identity of a nontemporal, eternal event with a unique historical occurrence is something that is extremely difficult to conceive. He must, however, accustom himself to the idea that "time" is a relative concept and needs to be complemented by that of the "simultaneous" existence, in the Bardo or pleroma, of all historical processes. What exists in the pleroma as an eternal process appears in time as an aperiodic sequence, that is to say, it is repeated many times in an irregular pattern. To take but one example: Yahweh had one good son and one who was a failure. Cain and Abel, Jacob and Esau, correspond to this prototype, and so, in all ages and in all parts of the world, does the motif of the hostile brothers, which in innumerable modern variants still causes dissension in families and keeps the psychotherapist busy. Just as many examples, no less instructive, could be found for the two women prefigured in eternity. When these things occur as modern variants, therefore, they should not be regarded merely as personal episodes, moods, or chance idiosyncrasies in people, but as fragments of the pleromatic process itself, which, broken up into individual events occurring in time, is an essential component or aspect of the divine drama.

[630] When Yahweh created the world from his *prima materia*, the "Void," he could not help breathing his own mystery into the Creation which is himself in every part, as every reasonable theology has long been convinced. From this comes the belief that it is possible to know God from his Creation. When I say that he could not help doing this, I do not imply any limitation of his omnipotence; on the contrary, it is an

acknowledgment that all possibilities are contained in him, and that there are in consequence no other possibilities than those which express him.

[631] All the world is God's, and God is in all the world from the very beginning. Why, then, the *tour de force* of the Incarnation? one asks oneself, astonished. God is in everything already, and yet there must be something missing if a sort of second entrance into Creation has now to be staged with so much care and circumspection. Since Creation is universal, reaching to the remotest stellar galaxies, and since it has also made organic life infinitely variable and capable of endless differentiation, we can hardly see where the defect lies. The fact that Satan has everywhere intruded his corrupting influence is no doubt regrettable for many reasons, but it makes no difference in principle. It is not easy to give an answer to this question. One would like to say that Christ had to appear in order to deliver mankind from evil. But when one considers that evil was originally slipped into the scheme of things by Satan, and still is, then it would seem much simpler if Yahweh would, for once, call this "practical joker" severely to account, get rid of his pernicious influence, and thus eliminate the root of all evil. He would then not need the elaborate arrangement of a special Incarnation with all the unforeseeable consequences which this entails. One should make clear to oneself what it means when God becomes man. It means nothing less than a world-shaking transformation of God. It means more or less what Creation meant in the beginning, namely an objectivation of God. At the time of the Creation he revealed himself in Nature; now he wants to be more specific and become man. It must be admitted, however, that there was a tendency in this direction right from the start. For, when those other human beings, who had evidently been created before Adam, appeared on the scene along with the higher mammals, Yahweh created on the following day, by a special act of creation, a man who was the image of God. This was the first prefiguration of his becoming man. He took Adam's descendants, especially the people of Israel, into his personal possession, and from time to time he filled this people's prophets with his spirit. All these things were preparatory events and symptoms of a tendency within God to become man. But in omniscience there had existed from all eternity a knowledge of the human nature of God or of the divine nature of man. That is why, long before Genesis was written, we find corresponding testimonies in the ancient Egyptian records. These intimations and prefigurations of the Incarnation must strike one as either completely incomprehensible or superfluous, since all creation *ex nihilo* is God's and consists of nothing but God, with the result that man, like the rest of creation, is simply God become concrete. Prefigurations, however, are not in themselves creative events, but are only stages in the process of becoming conscious. It was only quite late that we realized (or rather, are beginning to realize) that God is Reality itself and therefore—last but not least—man. This realization is a millennial process.

[632] In view of the immense problem which we are about to discuss, this excursus on pleromatic events is not out of place as an introduction.

[633] What, then, is the real reason for the Incarnation as an historical event?

[634] In order to answer this question we have to go rather far back. As we have seen, Yahweh evidently has a disinclination to take his absolute knowledge into account as a counterbalance to the dynamism of omnipotence. The most instructive example of this is his relation to Satan: it always looks as if Yahweh were completely uninformed about his son's intentions. That is because he never consults his omniscience. We can only explain this on the assumption that Yahweh was so fascinated by his successive acts of creation, so taken up with them, that he forgot about his omniscience altogether. It is quite understandable that the magical bodying forth of the most diverse objects, which had never before existed in such pristine splendour, should have caused God infinite delight. Sophia's memory is not at fault when she says:

when he marked out the foundations of the earth,
then I was by him, like a master workman,
and I was daily his delight.¹

[635] The Book of Job still rings with the proud joy of creating when Yahweh points to the huge animals he has successfully turned out:

Behold, Behemoth,
which I made as I made you.
.
.
.
.
.
.
.
.
.
.
He is the first of the works of God,
made to be lord over his companions.²

[636] So even in Job's day Yahweh is still intoxicated with the tremendous power and grandeur of his creation. Compared with this, what are Satan's pinpricks and the lamentations of human beings who were created with the behemoth, even if they do bear God's image? Yahweh seems to have forgotten this fact entirely, otherwise he would never have ridden so roughshod over Job's human dignity.

[637] It is only the careful and farsighted preparations for Christ's birth which show us that omniscience has begun to have a noticeable effect on Yahweh's actions. A certain philanthropic and universalistic tendency makes itself felt. The "children of Israel" take something of a second place in comparison with the "children of men." After Job, we hear nothing further about new covenants. Proverbs and gnostic

utterances seem to be the order of the day, and a real *novum* now appears on the scene, namely apocalyptic communications. This points to metaphysical acts of cognition, that is, to “constellated” unconscious contents which are ready to irrupt into consciousness. In all this, as we have said, we discern the helpful hand of Sophia.

[638] If we consider Yahweh’s behaviour, up to the reappearance of Sophia, as a whole, one indubitable fact strikes us—the fact that his actions are accompanied by an inferior consciousness. Time and again we miss reflection and regard for absolute knowledge. His consciousness seems to be not much more than a primitive “awareness” which knows no reflection and no morality. One merely perceives and acts blindly, without conscious inclusion of the subject, whose individual existence raises no problems. Today we would call such a state psychologically “unconscious,” and in the eyes of the law it would be described as *non compos mentis*. The fact that consciousness does not perform acts of thinking does not, however, prove that they do not exist. They merely occur unconsciously and make themselves felt indirectly in dreams, visions, revelations, and “instinctive” changes of consciousness, whose very nature tells us that they derive from an “unconscious” knowledge and are the result of unconscious acts of judgment or unconscious conclusions.

[639] Some such process can be observed in the curious change which comes over Yahweh’s behaviour after the Job episode. There can be no doubt that he did not immediately become conscious of the moral defeat he had suffered at Job’s hands. In his omniscience, of course, this fact had been known from all eternity, and it is not unthinkable that the knowledge of it unconsciously brought him into the position of dealing so harshly with Job in order that he himself should become conscious of something through this conflict, and thus gain new insight. Satan who, with good reason, later on received the name of “Lucifer,” knew how to make more frequent and better use of omniscience than did his father.³ It seems he was the only one among the sons of God who developed that much initiative. At all events, it was he who placed those unforeseen incidents in Yahweh’s way, which omniscience knew to be necessary and indeed indispensable for the unfolding and completion of the divine drama. Among these the case of Job was decisive, and it could only have happened thanks to Satan’s initiative.

[640] The victory of the vanquished and oppressed is obvious: Job stands morally higher than Yahweh. In this respect the creature has surpassed the creator. As always when an external event touches on some unconscious knowledge, this knowledge can reach consciousness. The event is recognized as a *déjà vu*, and one remembers a pre-existent knowledge about it. Something of the kind must have happened to Yahweh. Job’s superiority cannot be shrugged off. Hence a situation arises in which real reflection is needed. That is why Sophia steps in. She reinforces the much needed

self-reflection and thus makes possible Yahweh's decision to become man. It is a decision fraught with consequences: he raises himself above his earlier primitive level of consciousness by indirectly acknowledging that the man Job is morally superior to him and that therefore he has to catch up and become human himself. Had he not taken this decision he would have found himself in flagrant opposition to his omniscience. Yahweh must become man precisely because he has done man a wrong. He, the guardian of justice, knows that every wrong must be expiated, and Wisdom knows that moral law is above even him. Because his creature has surpassed him he must regenerate himself.

[641] As nothing can happen without a pre-existing pattern, not even creation *ex nihilo*, which must always resort to the treasurehouse of eternal images in the fabulous mind of the "master workman," the choice of a model for the son who is now about to be begotten lies between Adam (to a limited extent) and Abel (to a much greater extent). Adam's limitation lies in the fact that, even if he is the Anthropos, he is chiefly a creature and a father. Abel's advantage is that he is the son well pleasing to God, begotten and not directly created. One disadvantage has to be accepted: he met with an early death by violence, too early to leave behind him a widow and children, which ought really to be part of human fate if lived to the full. Abel is not the authentic archetype of the son well pleasing to God; he is a copy, but the first of the kind to be met with in the Scriptures. The young dying god is also well known in the contemporary pagan religions, and so is the fratricide motif. We shall hardly be wrong in assuming that Abel's fate refers back to a metaphysical event which was played out between Satan and another son of God with a "light" nature and more devotion to his father. Egyptian tradition can give us information on this point (Horus and Set). As we have said, the disadvantage prefigured in the Abel type can hardly be avoided, because it is an integral part of the mythical-son drama, as the numerous pagan variants of this motif show. The short, dramatic course of Abel's fate serves as an excellent paradigm for the life and death of a God become man.

[642] To sum up: the immediate cause of the Incarnation lies in Job's elevation, and its purpose is the differentiation of Yahweh's consciousness. For this a situation of extreme gravity was needed, a *peripeteia* charged with affect, without which no higher level of consciousness can be reached.

VII

[643] In addition to Abel, we have to consider, as a model for the impending birth of the son of God, the general pattern of the hero's life which has been established since time immemorial and handed down by tradition. Since this son is not intended merely as a national Messiah, but as the universal saviour of mankind, we have also to

consider the pagan myths and revelations concerning the life of one who is singled out by the gods.

[644] The birth of Christ is therefore characterized by all the usual phenomena attendant upon the birth of a hero, such as the annunciation, the divine generation from a virgin, the coincidence of the birth with the thrice-repeated *coniunctio maxima* (♈ ♂ ♀) in the sign of Pisces, which at that precise moment inaugurated the new era, the recognition of the birth of a king, the persecution of the newborn, his flight and concealment, his lowly birth, etc. The motif of the growing up of the hero is discernible in the wisdom of the twelve-year-old child in the temple, and there are several examples in the gospels of the breaking away from the mother.

[645] It goes without saying that a quite special interest attaches to the character and fate of the incarnate son of God. Seen from a distance of nearly two thousand years, it is uncommonly difficult to reconstruct a biographical picture of Christ from the traditions that have been preserved. Not a single text is extant which would fulfil even the minimum modern requirements for writing a history. The historically verifiable facts are extremely scanty, and the little biographically valid material that exists is not sufficient for us to create out of it a consistent career or an even remotely probable character. Certain theologians have discovered the main reason for this in the fact that Christ's biography and psychology cannot be separated from eschatology. Eschatology means in effect that Christ is God and man at the same time and that he therefore suffers a divine as well as a human fate. The two natures interpenetrate so thoroughly that any attempt to separate them mutilates both. The divine overshadows the human, and the human being is scarcely graspable as an empirical personality. Even the critical procedures of modern psychology do not suffice to throw light on all the obscurities. Every attempt to single out one particular feature for clarity's sake does violence to another which is just as essential either with respect to his divinity or with respect to his humanity. The commonplace is so interwoven with the miraculous and the mythical that we can never be sure of our facts. Perhaps the most disturbing and confusing thing of all is that the oldest writings, those of St. Paul, do not seem to have the slightest interest in Christ's existence as a concrete human being. The synoptic gospels are equally unsatisfactory as they have more the character of propaganda than of biography.

[646] With regard to the human side of Christ, if we can speak of a "purely human" aspect at all, what stands out particularly clearly is his love of mankind. This feature is already implied in the relationship of Mary to Sophia, and especially in his genesis by the Holy Ghost, whose feminine nature is personified by Sophia, since she is the preliminary historical form of the ἅγιον πνεῦμα, who is symbolized by the dove, the bird belonging to the love-goddess. Furthermore, the love-goddess is in most cases the mother of the young dying god. Christ's love of mankind is, however, limited to a not

inconsiderable degree by a certain predestinarian tendency which sometimes causes him to withhold his salutary message from those who do not belong to the elect. If one takes the doctrine of predestination literally, it is difficult to see how it can be fitted into the framework of the Christian message. But taken psychologically, as a means to achieving a definite effect, it can readily be understood that these allusions to predestination give one a feeling of distinction. If one knows that one has been singled out by divine choice and intention from the beginning of the world, then one feels lifted beyond the transitoriness and meaninglessness of ordinary human existence and transported to a new state of dignity and importance, like one who has a part in the divine world drama. In this way man is brought nearer to God, and this is in entire accord with the meaning of the message in the gospels.

[647] Besides his love of mankind a certain irascibility is noticeable in Christ's character, and, as is often the case with people of emotional temperament, a manifest lack of self-reflection. There is no evidence that Christ ever wondered about himself, or that he ever confronted himself. To this rule there is only one significant exception—the despairing cry from the Cross: “My God, my God, why hast thou forsaken me?” Here his human nature attains divinity; at that moment God experiences what it means to be a mortal man and drinks to the dregs what he made his faithful servant Job suffer. Here is given the answer to Job, and, clearly, this supreme moment is as divine as it is human, as “eschatological” as it is “psychological.” And at this moment, too, where one can feel the human being so absolutely, the divine myth is present in full force. And both mean one and the same thing. How, then, can one possibly “demythologize” the figure of Christ? A rationalistic attempt of that sort would soak all the mystery out of his personality, and what remained would no longer be the birth and tragic fate of a God in time, but, historically speaking, a badly authenticated religious teacher, a Jewish reformer who was hellenistically interpreted and misunderstood—a kind of Pythagoras, maybe, or, if you like, a Buddha or a Mohammed, but certainly not a son of God or a God incarnate. Nor does anybody seem to have realized what would be the consequences of a Christ disinfected of all trace of eschatology. Today we have an empirical psychology, which continues to exist despite the fact that the theologians have done their best to ignore it, and with its help we can put certain of Christ's statements under the microscope. If these statements are detached from their mythical context, they can only be explained personalistically. But what sort of conclusion are we bound to arrive at if a statement like “I am the way, and the truth, and the life; no one comes to the Father, but by me”¹ is reduced to personal psychology? Obviously the same conclusion as that reached by Jesus' relatives when, in their ignorance of eschatology, they said, “He is beside himself.”² What is the use of a religion without a mythos, since religion

means, if anything at all, precisely that function which links us back to the eternal myth?

[648] In view of these portentous impossibilities, it has been assumed, perhaps as the result of a growing impatience with the difficult factual material, that Christ was nothing but a myth, in this case no more than a fiction. But myth is not fiction: it consists of facts that are continually repeated and can be observed over and over again. It is something that happens to man, and men have mythical fates just as much as the Greek heroes do. The fact that the life of Christ is largely myth does absolutely nothing to disprove its factual truth—quite the contrary. I would even go so far as to say that the mythical character of a life is just what expresses its universal human validity. It is perfectly possible, psychologically, for the unconscious or an archetype to take complete possession of a man and to determine his fate down to the smallest detail. At the same time objective, non-psychic parallel phenomena can occur which also represent the archetype. It not only seems so, it simply is so, that the archetype fulfils itself not only psychically in the individual, but objectively outside the individual. My own conjecture is that Christ was such a personality. The life of Christ is just what it had to be if it is the life of a god and a man at the same time. It is a *symbolum*, a bringing together of heterogeneous natures, rather as if Job and Yahweh were combined in a single personality. Yahweh's intention to become man, which resulted from his collision with Job, is fulfilled in Christ's life and suffering.

VIII

[649] When one remembers the earlier acts of creation, one wonders what has happened to Satan and his subversive activities. Everywhere he sows his tares among the wheat. One suspects he had a hand in Herod's massacre of the innocents. What is certain is his attempt to lure Christ into the role of a worldly ruler. Equally obvious is the fact, as is evidenced by the remarks of the man possessed of devils, that he is very well informed about Christ's nature. He also seems to have inspired Judas, without, however, being able to influence or prevent the sacrificial death.

[650] His comparative ineffectiveness can be explained on the one hand by the careful preparations for the divine birth, and on the other hand by a curious metaphysical phenomenon which Christ witnessed: he saw Satan fall like lightning from heaven.¹ In this vision a metaphysical event has become temporal; it indicates the historic and—so far as we know—final separation of Yahweh from his dark son. Satan is banished from heaven and no longer has any opportunity to inveigle his father into dubious undertakings. This event may well explain why he plays such an inferior role wherever he appears in the history of the Incarnation. His role here is in no way comparable to his former confidential relationship to Yahweh. He has obviously forfeited the paternal affection and been exiled. The punishment which we missed in

the story of Job has at last caught up with him, though in a strangely limited form. Although he is banished from the heavenly court he has kept his dominion over the sublunary world. He is not cast directly into hell, but upon earth. Only at the end of time shall he be locked up and made permanently ineffective. Christ's death cannot be laid at his door, because, through its prefiguration in Abel and in the young dying gods, the sacrificial death was a fate chosen by Yahweh as a reparation for the wrong done to Job on the one hand, and on the other hand as a fillip to the spiritual and moral development of man. There can be no doubt that man's importance is enormously enhanced if God himself deigns to become one.

[651] As a result of the partial neutralization of Satan, Yahweh identifies with his light aspect and becomes the good God and loving father. He has not lost his wrath and can still mete out punishment, but he does it with justice. Cases like the Job tragedy are apparently no longer to be expected. He proves himself benevolent and gracious. He shows mercy to the sinful children of men and is defined as Love itself. But although Christ has complete confidence in his father and even feels at one with him, he cannot help inserting the cautious petition—and warning—into the Lord's Prayer: "Lead us not into temptation, but deliver us from evil." God is asked not to entice us outright into doing evil, but rather to deliver us from it. The possibility that Yahweh, in spite of all the precautionary measures and in spite of his express intention to become the Summum Bonum, might yet revert to his former ways is not so remote that one need not keep one eye open for it. At any rate, Christ considers it appropriate to remind his father of his destructive inclinations towards mankind and to beg him to desist from them. Judged by any human standards it is after all unfair, indeed extremely immoral, to entice little children into doing things that might be dangerous for them, simply in order to test their moral stamina! Especially as the difference between a child and a grown-up is immeasurably smaller than that between God and his creatures, whose moral weakness is particularly well known to him. The incongruity of it is so colossal that if this petition were not in the Lord's Prayer one would have to call it sheer blasphemy, because it really will not do to ascribe such contradictory behaviour to the God of Love and Summum Bonum.

[652] The sixth petition indeed allows a deep insight, for in face of this fact Christ's immense certainty with regard to his father's character becomes somewhat questionable. It is, unfortunately, a common experience that particularly positive and categorical assertions are met with wherever there is a slight doubt in the background that has to be stifled. One must admit that it would be contrary to all reasonable expectations to suppose that a God who, for all his lavish generosity, had been subject to intermittent but devastating fits of rage ever since time began could suddenly become the epitome of everything good. Christ's unadmitted but none the less evident doubt in this respect is confirmed in the New Testament, and particularly

in the Apocalypse. There Yahweh again delivers himself up to an unheard-of fury of destruction against the human race, of whom a mere hundred and forty-four thousand specimens appear to survive.²

[653] One is indeed at a loss how to bring such a reaction into line with the behaviour of a loving father, whom we would expect to glorify his creation with patience and love. It looks as if the attempt to secure an absolute and final victory for good is bound to lead to a dangerous accumulation of evil and hence to catastrophe. Compared with the end of the world, the destruction of Sodom and Gomorrah and even the Deluge are mere child's play; for this time the whole of creation goes to pieces. As Satan was locked up for a time, then conquered and cast into a lake of fire,³ the destruction of the world can hardly be the work of the devil, but must be an "act of God" not influenced by Satan.

[654] The end of the world is, however, preceded by the circumstance that even Christ's victory over his brother Satan—Abel's counterstroke against Cain—is not really and truly won, because, before this can come to pass, a final and mighty manifestation of Satan is to be expected. One can hardly suppose that God's incarnation in his son Christ would be calmly accepted by Satan. It must certainly have stirred up his jealousy to the highest pitch and evoked in him a desire to imitate Christ (a role for which he is particularly well suited as the *πνεῦμα ἀντίμιμον*), and to become incarnate in his turn as the *dark* God. (As we know, numerous legends were later woven round this theme.) This plan will be put into operation by the figure of the Antichrist after the preordained thousand years are over, the term allotted by astrology to the reign of Christ. This expectation, which is already to be found in the New Testament, reveals a doubt as to the immediate finality or universal effectiveness of the work of salvation. Unfortunately it must be said that these expectations gave rise to thoughtless revelations which were never even discussed with other aspects of the doctrine of salvation, let alone brought into harmony with them.

IX

[655] I mention these future apocalyptic events only to illustrate the doubt which is indirectly expressed in the sixth petition of the Lord's Prayer, and not in order to give a general interpretation of the Apocalypse. I shall come back to this theme later on. But, before doing so, we must turn to the question of how matters stood with the Incarnation after the death of Christ. We have always been taught that the Incarnation was a unique historical event. No repetition of it was to be expected, any more than one could expect a further revelation of the Logos, for this too was included in the uniqueness of God's appearance on earth, in human form, nearly two thousand years ago. The sole source of revelation, and hence the final authority, is the Bible. God is

an authority only in so far as he authorized the writings in the New Testament, and with the conclusion of the New Testament the authentic communications of God cease. Thus far the Protestant standpoint. The Catholic Church, the direct heir and continuator of historical Christianity, proves to be somewhat more cautious in this regard, believing that with the assistance of the Holy Ghost the dogma can progressively develop and unfold. This view is in entire agreement with Christ's own teachings about the Holy Ghost and hence with the further continuance of the Incarnation. Christ is of the opinion that whoever believes in him—believes, that is to say, that he is the son of God—can “do the works that I do, and greater works than these.”¹ He reminds his disciples that he had told them they were gods.² The believers or chosen ones are children of God and “fellow heirs with Christ.”³ When Christ leaves the earthly stage, he will ask his father to send his flock a Counsellor (the “Paraclete”), who will abide with them and in them for ever.⁴ The Counsellor is the Holy Ghost, who will be sent from the father. This “Spirit of truth” will teach the believers “all things” and guide them “into all truth.”⁵ According to this, Christ envisages a continuing realization of God in his children, and consequently in his (Christ's) brothers and sisters in the spirit, so that his own works need not necessarily be considered the greatest ones.

[656] Since the Holy Ghost is the Third Person of the Trinity and God is present entire in each of the three Persons at any time, the indwelling of the Holy Ghost means nothing less than an approximation of the believer to the status of God's son. One can therefore understand what is meant by the remark “you are gods.” The deifying effect of the Holy Ghost is naturally assisted by the *imago Dei* stamped on the elect. God, in the shape of the Holy Ghost, puts up his tent in man, for he is obviously minded to realize himself continually not only in Adam's descendants, but in an indefinitely large number of believers, and possibly in mankind as a whole. Symptomatic of this is the significant fact that Barnabas and Paul were identified in Lystra with Zeus and Hermes: “The gods have come down to us in the likeness of men.”⁶ This was certainly only the more naïve, pagan view of the Christian transmutation, but precisely for that reason it convinces. Tertullian must have had something of the sort in mind when he described the “*sublimiorem Deum*” as a sort of lender of divinity “who has made gods of men.”⁷

[657] God's Incarnation in Christ requires continuation and completion because Christ, owing to his virgin birth and his sinlessness, was not an empirical human being at all. As stated in the first chapter of St. John, he represented a light which, though it shone in the darkness, was not comprehended by the darkness. He remained outside and above mankind. Job, on the other hand, was an ordinary human being, and therefore the wrong done to him, and through him to mankind, can, according to divine justice, only be repaired by an incarnation of God in an empirical human being. This act of

expiation is performed by the Paraclete; for, just as man must suffer from God, so God must suffer from man. Otherwise there can be no reconciliation between the two.

[658] The continuing, direct operation of the Holy Ghost on those who are called to be God's children implies, in fact, a broadening process of incarnation. Christ, the son begotten by God, is the first-born who is succeeded by an ever-increasing number of younger brothers and sisters. These are, however, neither begotten by the Holy Ghost nor born of a virgin. This may be prejudicial to their metaphysical status, but their merely human birth will in no sense endanger their prospects of a future position of honour at the heavenly court, nor will it diminish their capacity to perform miracles. Their lowly origin (possibly from the mammals) does not prevent them from entering into a close kinship with God as their father and Christ as their brother. In a metaphorical sense, indeed, it is actually a "kinship by blood," since they have received their share of the blood and flesh of Christ, which means more than mere adoption. These profound changes in man's status are the direct result of Christ's work of redemption. Redemption or deliverance has several different aspects, the most important of which is the expiation wrought by Christ's sacrificial death for the misdemeanours of mankind. His blood cleanses us from the evil consequences of sin. He reconciles God with man and delivers him from the divine wrath, which hangs over him like doom, and from eternal damnation. It is obvious that such ideas still picture God the father as the dangerous Yahweh who has to be propitiated. The agonizing death of his son is supposed to give him satisfaction for an affront he has suffered, and for this "moral injury" he would be inclined to take a terrible vengeance. Once more we are appalled by the incongruous attitude of the world creator towards his creatures, who to his chagrin never behave according to his expectations. It is as if someone started a bacterial culture which turned out to be a failure. He might curse his luck, but he would never seek the reason for the failure in the bacilli and want to punish them morally for it. Rather, he would select a more suitable culture medium. Yahweh's behaviour towards his creatures contradicts all the requirements of so-called "divine" reason whose possession is supposed to distinguish men from animals. Moreover, a bacteriologist might make a mistake in his choice of a culture medium, for he is only human. But God in his omniscience would never make mistakes if only he consulted with it. He has equipped his human creatures with a modicum of consciousness and a corresponding degree of free will, but he must also know that by so doing he leads them into the temptation of falling into a dangerous independence. That would not be too great a risk if man had to do with a creator who was only kind and good. But Yahweh is forgetting his son Satan, to whose wiles even he occasionally succumbs. How then could he expect man with his limited consciousness and imperfect knowledge to do any better? He also

overlooks the fact that the more consciousness a man possesses the more he is separated from his instincts (which at least give him an inkling of the hidden wisdom of God) and the more prone he is to error. He is certainly not up to Satan's wiles if even his creator is unable, or unwilling, to restrain this powerful spirit.

X

[659] The fact of God's "unconsciousness" throws a peculiar light on the doctrine of salvation. Man is not so much delivered from his sins, even if he is baptized in the prescribed manner and thus washed clean, as delivered from fear of the consequences of sin, that is, from the wrath of God. Consequently, the work of salvation is intended to save man from the fear of God. This is certainly possible where the belief in a loving father, who has sent his only-begotten son to rescue the human race, has repressed the persistent traces of the old Yahweh and his dangerous affects. Such a belief, however, presupposes a lack of reflection or a *sacrificium intellectus*, and it appears questionable whether either of them can be morally justified. We should never forget that it was Christ himself who taught us to make usurious use of the talents entrusted to us and not hide them in the ground. One ought not to make oneself out to be more stupid and more unconscious than one really is, for in all other aspects we are called upon to be alert, critical, and self-aware, so as not to fall into temptation, and to "examine the spirits" who want to gain influence over us and "see whether they are of God,"¹ so that we may recognize the mistakes we make. It even needs superhuman intelligence to avoid the cunning snares of Satan. These obligations inevitably sharpen our understanding, our love of truth, and the urge to know, which as well as being genuine human virtues are quite possibly effects of that spirit which "searches everything, even the depths of God."² These intellectual and moral capacities are themselves of a divine nature, and therefore cannot and must not be cut off. It is just by following Christian morality that one gets into the worst collisions of duty. Only those who habitually make five an even number can escape them. The fact that Christian ethics leads to collisions of duty speaks in its favour. By engendering insoluble conflicts and consequently an *afflictio animae*, it brings man nearer to a knowledge of God. All opposites are of God, therefore man must bend to this burden; and in so doing he finds that God in his "oppositeness" has taken possession of him, incarnated himself in him. He becomes a vessel filled with divine conflict. We rightly associate the idea of suffering with a state in which the opposites violently collide with one another, and we hesitate to describe such a painful experience as being "redeemed." Yet it cannot be denied that the great symbol of the Christian faith, the Cross, upon which hangs the suffering figure of the Redeemer, has been emphatically held up before the eyes of Christians for nearly two thousand years. This picture is completed by the two thieves, one of whom goes down to hell,

the other into paradise. One could hardly imagine a better representation of the “oppositeness” of the central Christian symbol. Why this inevitable product of Christian psychology should signify redemption is difficult to see, except that the conscious recognition of the opposites, painful though it may be at the moment, does bring with it a definite feeling of deliverance. It is on the one hand a deliverance from the distressing state of dull and helpless unconsciousness, and on the other hand a growing awareness of God’s oppositeness, in which man can participate if he does not shrink from being wounded by the dividing sword which is Christ. Only through the most extreme and most menacing conflict does the Christian experience deliverance into divinity, always provided that he does not break, but accepts the burden of being marked out by God. In this way alone can the *imago Dei* realize itself in him, and God become man. The seventh petition in the Lord’s Prayer, “But deliver us from evil,” is to be understood in the same sense as Christ’s prayer in the Garden of Gethsemane: “My Father, if it be possible, let this cup pass from me.”³ In principle it does not seem to fit God’s purpose to exempt a man from conflict and hence from evil. It is altogether human to express such a desire but it must not be made into a principle, because it is directed against God’s will and rests only on human weakness and fear. Fear is certainly justified up to a point, for, to make the conflict complete, there must be doubt and uncertainty as to whether man’s strength is not being overtaxed.

[660] Because the *imago Dei* pervades the whole human sphere and makes mankind its involuntary exponent, it is just possible that the four-hundred-year-old schism in the Church and the present division of the political world into two hostile camps are both expressions of the unrecognized polarity of the dominant archetype.

[661] The traditional view of Christ’s work of redemption reflects a one-sided way of thinking, no matter whether we regard that one-sidedness as purely human or as willed by God. The other view, which regards the atonement not as the payment of a human debt to God, but as reparation for a wrong done by God to man, has been briefly outlined above. This view seems to me to be better suited to the power situation as it actually exists. The sheep can stir up mud in the wolf’s drinking water, but can do him no other harm. So also the creature can disappoint the creator, but it is scarcely credible that he can do him a painful wrong. This lies only in the power of the creator with respect to the powerless creature. On this view, a wrong is imputed to God, but it is certainly no worse than what has already been imputed to him if one assumes that it was necessary to torture the son to death on the Cross merely in order to appease the father’s wrath. What kind of father is it who would rather his son were slaughtered than forgive his ill-advised creatures who have been corrupted by his precious Satan? What is supposed to be demonstrated by this gruesome and archaic sacrifice of the son? God’s love, perhaps? Or his implacability? We know from

chapter 22 of Genesis⁴ and from Exodus 22:29 that Yahweh has a tendency to employ such means as the killing of the son and the first-born in order to test his people's faith or to assert his will, despite the fact that his omniscience and omnipotence have no need whatever of such savage procedures, which moreover set a bad example to the mighty ones of the earth. It is very understandable, therefore, that a naïve mind is apt to run away from such questions and excuse this manoeuvre as a beautiful *sacrificium intellectus*. If one prefers not to read the Eighty-ninth Psalm, the matter will not end there. He who cheats once will cheat again, particularly when it comes to self-knowledge. But self-knowledge, in the form of an examination of conscience, is demanded by Christian ethics. They were very pious people who maintained that self-knowledge paves the way to knowledge of God.

XI

[662] To believe that God is the Summum Bonum is impossible for a reflecting consciousness. Such a consciousness does not feel in any way delivered from the fear of God, and therefore asks itself, quite rightly, what Christ means to it. That, indeed, is the great question: can Christ still be interpreted in our day and age, or must one be satisfied with the historical interpretation?

[663] One thing, anyway, cannot be doubted: Christ is a highly numinous figure. The interpretation of him as God and the son of God is in full accord with this. The old view, which is based on Christ's own view of the matter, asserts that he came into the world, suffered, and died in order to save mankind from the wrath to come. Furthermore he believed that his own bodily resurrection would assure all God's children of the same future.

[664] We have already pointed out at some length how curiously God's salvationist project works out in practice. All he does is, in the shape of his own son, to rescue mankind from himself. This thought is as scurrilous as the old rabbinical view of Yahweh hiding the righteous from his wrath under his throne, where of course he cannot see them. It is exactly as if God the father were a different God from the son, which is not the meaning at all. Nor is there any psychological need for such an assumption, since the undoubted lack of reflection in God's consciousness is sufficient to explain his peculiar behaviour. It is quite right, therefore, that fear of God should be considered the beginning of all wisdom. On the other hand, the much-vaunted goodness, love, and justice of God should not be regarded as mere propitiation, but should be recognized as a genuine experience, for God is a *coincidentia oppositorum*. Both are justified, the fear of God as well as the love of God.

[665] A more differentiated consciousness must, sooner or later, find it difficult to love, as a kind father, a God whom on account of his unpredictable fits of wrath, his

unreliability, injustice, and cruelty, it has every reason to fear. The decay of the gods of antiquity has proved to our satisfaction that man does not relish any all-too-human inconsistencies and weaknesses in his gods. Likewise, it is probable that Yahweh's moral defeat in his dealings with Job had its hidden effects: man's unintended elevation on the one hand, and on the other hand a disturbance of the unconscious. For a while the first-mentioned effect remains a mere fact, not consciously realized though registered by the unconscious. This contributes to the disturbance in the unconscious, which thereby acquires a higher potential than exists in consciousness. Man then counts for more in the unconscious than he does consciously. In these circumstances the potential starts flowing from the unconscious towards consciousness, and the unconscious breaks through in the form of dreams, visions, and revelations. Unfortunately the Book of Job cannot be dated with any certainty. As mentioned above, it was written somewhere between 600 and 300 B.C. During the first half of the sixth century, Ezekiel,¹ the prophet with the so-called "pathological" features, appears on the scene. Although laymen are inclined to apply this epithet to his visions, I must, as a psychiatrist, emphatically state that visions and their accompanying phenomena cannot be uncritically evaluated as morbid. Visions, like dreams, are unusual but quite natural occurrences which can be designated as "pathological" only when their morbid nature has been proved. From a strictly clinical standpoint Ezekiel's visions are of an archetypal nature and are not morbidly distorted in any way. There is no reason to regard them as pathological.² They are a symptom of the split which already existed at that time between conscious and unconscious. The first great vision is made up of two well-ordered compound quaternities, that is, conceptions of totality, such as we frequently observe today as spontaneous phenomena. Their *quinta essentia* is represented by a figure which has "the likeness of a human form."³ Here Ezekiel has seen the essential content of the unconscious, namely *the idea of the higher man* by whom Yahweh was morally defeated and who he was later to become.

[666] In India, a more or less simultaneous symptom of the same tendency was Gautama the Buddha (b. 562 B.C), who gave the maximum differentiation of consciousness supremacy even over the highest Brahman gods. This development was a logical consequence of the *purusha-atman* doctrine and derived from the inner experience of yoga practice.

[667] Ezekiel grasped, in a symbol, the fact that Yahweh was drawing closer to man. This is something which came to Job as an experience but probably did not reach his consciousness. That is to say, he did not realize that his consciousness was higher than Yahweh's, and that consequently God wants to become man. What is more, in Ezekiel we meet for the first time the title "Son of Man," which Yahweh significantly uses in addressing the prophet, presumably to indicate that he is a son of the "Man"

on the throne, and hence a prefiguration of the much later revelation in Christ. It is with the greatest right, therefore, that the four seraphim on God's throne became the emblems of the evangelists, for they form the quaternity which expresses Christ's totality, just as the four gospels represent the four pillars of his throne.

[668] The disturbance of the unconscious continued for several centuries. Around 165 B.C., Daniel had a vision of four beasts and the "Ancient of Days," to whom "with the clouds of heaven there came one like a son of man."⁴ Here the "son of man" is no longer the prophet but a son of the "Ancient of Days" in his own right, and a son whose task it is to rejuvenate the father.

[669] The Book of Enoch, written around 100 B.C., goes into considerably more detail. It gives a revealing account of the advance of the sons of God into the world of men, another prefiguration which has been described as the "fall of the angels." Whereas, according to Genesis,⁵ Yahweh resolved that his spirit should not "abide in man for ever," and that men should not live to be hundreds of years old as they had before, the sons of God, by way of compensation, fell in love with the beautiful daughters of men. This happened at the time of the giants. Enoch relates that after conspiring with one another, two hundred angels under the leadership of Samiazaz descended to earth, took the daughters of men to wife, and begat with them giants three thousand ells long.⁶ The angels, among whom Azazel particularly excelled, taught mankind the arts and sciences. They proved to be extraordinarily progressive elements who broadened and developed man's consciousness, just as the wicked Cain had stood for progress as contrasted with the stay-at-home Abel. In this way they enlarged the significance of man to "gigantic" proportions, which points to an inflation of the cultural consciousness at that period. An inflation, however, is always threatened with a counter-stroke from the unconscious, and this actually did happen in the form of the Deluge. So corrupt was the earth before the Deluge that the giants "consumed all the acquisitions of men" and then began to devour each other, while men in their turn devoured the beasts, so that "the earth laid accusation against the lawless ones."⁷

[670] The invasion of the human world by the sons of God therefore had serious consequences, which make Yahweh's precautions prior to his appearance on the earthly scene the more understandable. Man was completely helpless in face of this superior divine force. Hence it is of the greatest interest to see how Yahweh behaves in this matter. As the later Draconian punishment proves, it was a not unimportant event in the heavenly economy when no less than two hundred of the sons of God departed from the paternal household to carry out experiments on their own in the human world. One would have expected that information concerning this mass exodus would have trickled through to the court (quite apart from the fact of divine omniscience). But nothing of the sort happened. Only after the giants had long been begotten and had already started to slaughter and devour mankind did four

archangels, apparently by accident, hear the weeping and wailing of men and discover what was going on on earth. One really does not know which is the more astonishing, the bad organization of the angelic hosts or the faulty communications in heaven. Be that as it may, this time the archangels felt impelled to appear before God with the following peroration:

All things are naked and open in Thy sight, and Thou seest all things, and nothing can hide itself from Thee. Thou seest what Azazel hath done, who taught all unrighteousness on earth and revealed the eternal secrets which were preserved in heaven.... [And enchantments hath Samiazaz taught], to whom Thou hast given authority to bear rule over his associates.... And Thou knowest all things before they come to pass, and Thou seest these things and Thou dost suffer them, and Thou dost not say to us what we are to do to them in regard to these.⁸

[671] Either all that the archangels say is a lie, or Yahweh, for some incomprehensible reason, has drawn no conclusions from his omniscience, or—what is more likely—the archangels must remind him that once again he has preferred to know nothing of his omniscience. At any rate it is only on their intervention that retaliatory action is released on a global scale, but it is not really a just punishment, seeing that Yahweh promptly drowns all living creatures with the exception of Noah and his relatives. This intermezzo proves that the sons of God are somehow more vigilant, more progressive, and more conscious than their father. Yahweh's subsequent transformation is therefore to be rated all the higher. The preparations for his Incarnation give one the impression that he has really learnt something from experience and is setting about things more consciously than before. Undoubtedly the recollection of Sophia has contributed to this increase of consciousness. Parallel with this, the revelation of the metaphysical structure becomes more explicit. Whereas in Ezekiel and Daniel we find only vague hints about the quaternity and the Son of Man, Enoch gives us clear and detailed information on these points. The underworld, a sort of Hades, is divided into four hollow places which serve as abodes for the spirits of the dead until the Last Judgment. Three of these hollow places are dark, but one is bright and contains a "fountain of water."⁹ This is the abode of the righteous.

[672] With statements of this type we enter into a definitely psychological realm, namely that of mandala symbolism, to which also belong the ratios 1:3 and 3:4. The quadripartite Hades of Enoch corresponds to a chthonic quaternity, which presumably stands in everlasting contrast to a pneumatic or heavenly one. The former corresponds in alchemy to the *quaternio* of the elements, the latter to a fourfold, or total, aspect of the deity, as for instance Barbelo, Kolorbas, *Mercurius quadratus*, and the four-faced gods all indicate.

[673] In fact, Enoch in his vision sees the four faces of God. Three of them are engaged in praising, praying, and supplicating, but the fourth in "fending off the Satans and

forbidding them to come before the Lord of Spirits to accuse them who dwell on earth.”¹⁰

[674] The vision shows us an essential differentiation of the God-image: God now has four faces, or rather, four angels of his face, who are four hypostases or emanations, of which one is exclusively occupied in keeping his elder son Satan, now changed into many, away from him, and in preventing further experiments after the style of the Job episode.¹¹ The Satans still dwell in the heavenly regions, since the fall of Satan has not yet occurred. The above-mentioned proportions are also suggested here by the fact that three of the angels perform holy or beneficial functions, while the fourth is a militant figure who has to keep Satan at bay.

[675] This quaternity has a distinctly pneumatic nature and is therefore expressed by angels, who are generally pictured with wings, i.e., as aerial beings. This is the more likely as they are presumably the descendants of Ezekiel’s four seraphim.¹² The doubling and separation of the quaternity into an upper and a lower one, like the exclusion of the Satans from the heavenly court, points to a metaphysical split that had already taken place. But the pleromatic split is in its turn a symptom of a much deeper split in the divine will: the father wants to become the son, God wants to become man, the amoral wants to become exclusively good, the unconscious wants to become consciously responsible. So far everything exists only *in statu nascendi*.

[676] Enoch’s unconscious is vastly excited by all this and its contents burst out in a spate of apocalyptic visions. It also causes him to undertake the *peregrinatio*, the journey to the four quarters of heaven and to the centre of the earth, so that he draws a mandala with his own movements, in accordance with the “journeys” of the alchemistic philosophers and the corresponding fantasies of our modern unconscious.

[677] When Yahweh addressed Ezekiel as “Son of Man,” this was no more at first than a dark and enigmatic hint. But now it becomes clear: the man Enoch is not only the recipient of divine revelation but is at the same time a participant in the divine drama, as though he were at least one of the sons of God himself. This can only be taken as meaning that in the same measure as God sets out to become man, man is immersed in the pleromatic process. He becomes, as it were, baptized in it and is made to participate in the divine quaternity (i.e., is crucified with Christ). That is why even today, in the rite of the *benedictio fontis*, the water is divided into a cross by the hand of the priest and then sprinkled to the four quarters.

[678] Enoch is so much under the influence of the divine drama, so gripped by it, that one could almost suppose he had a quite special understanding of the coming Incarnation. The “Son of Man” who is with the “Head [or Ancient] of Days” looks like an angel (i.e., like one of the sons of God). He “hath righteousness”; “with him dwelleth righteousness”; the Lord of Spirits has “chosen him”; “his lot hath the preeminence before the Lord of Spirits in uprightness.”¹³ It is probably no accident

that so much stress is laid on righteousness, for it is the one quality that Yahweh lacks, a fact that could hardly have remained hidden from such a man as the author of the Book of Enoch. Under the reign of the Son of Man "... the prayer of the righteous has been heard, and the blood of the righteous ... [avenged] before the Lord of Spirits."¹⁴ Enoch sees a "fountain of righteousness which was inexhaustible."¹⁵ The Son of Man

... shall be a staff to the righteous....
For this reason hath he been chosen and hidden before
him,
Before the creation of the world and for evermore.
And the wisdom of the Lord of Spirits hath revealed
him ... ,
For he hath preserved the lot of the righteous.¹⁶
For wisdom is poured out like water....
He is mighty in all the secrets of righteousness,
And unrighteousness shall disappear as a shadow....
In him dwells the spirit of wisdom,
And the spirit which gives insight,
And the spirit of understanding and of might.¹⁷

[679] Under the reign of the Son of Man

... shall the earth also give back that which has been
entrusted to it,
And Sheol also shall give back that which it has received,
And hell¹⁸ shall give back that which it owes....

The Elect One shall in those days sit on My throne,
And his mouth shall pour forth all the secrets of
wisdom and counsel.¹⁹

[680] "All shall become angels in heaven." Azazel and his hosts shall be cast into the burning fiery furnace for "becoming subject to Satan and leading astray those who dwell on the earth."²⁰

[681] At the end of the world the Son of Man shall sit in judgment over all creatures. "The darkness shall be destroyed, and the light established for ever."²¹ Even Yahweh's two big exhibits, Leviathan and Behemoth, are forced to succumb: they are carved up and eaten. In this passage²² Enoch is addressed by the revealing angel with the title "Son of Man," a further indication that he, like Ezekiel, has been assimilated by the divine mystery, is included in it, as is already suggested by the bare fact that

he witnesses it. Enoch is wafted away and takes his seat in heaven. In the “heaven of heavens” he beholds the house of God built of crystal, with streams of living fire about it, and guarded by winged beings that never sleep.²³ The “Head of Days” comes forth with the angelic quaternity (Michael, Gabriel, Raphael, Phanuel) and speaks to him, saying: “This is the Son of Man who is born unto righteousness, and righteousness abides over him, and the righteousness of the Head of Days forsakes him not.”²⁴

[682] It is remarkable that the Son of Man and what he means should be associated again and again with righteousness. It seems to be his leitmotif, his chief concern. Only where injustice threatens or has already occurred does such an emphasis on righteousness make any sense. No one, only God, can dispense justice to any noticeable degree, and precisely with regard to him there exists the justifiable fear that he may forget his justice. In this case his righteous son would intercede with him on man’s behalf. Thus “the righteous shall have peace.”²⁵ The justice that shall prevail under the son is stressed to such an extent that one has the impression that formerly, under the reign of the father, injustice was paramount, and that only with the son is the era of law and order inaugurated. It looks as though, with this, Enoch had unconsciously given an answer to Job.

[683] The emphasis laid on God’s agedness is logically connected with the existence of a son, but it also suggests that he himself will step a little into the background and leave the government of the human world more and more to the son, in the hope that a juster order will emerge. From all this we can see the aftereffects of some psychological trauma, the memory of an injustice that cries to heaven and beclouds the intimate relationship with God. God himself wants a son, and man also wants a son to take the place of the father. This son must, as we have conclusively seen, be absolutely just, and this quality is given priority over all other virtues. God and man both want to escape from blind injustice.

[684] Enoch, in his ecstasy, recognizes himself as the Son of Man, or as the son of God, although neither by birth nor by predestination does he seem to have been chosen for such a role.²⁶ He experiences that godlike elevation which, in the case of Job, we merely assumed, or rather inferred as the inevitable outcome. Job himself seems to have suspected something of the sort when he declares: “I know that my Vindicator lives.”²⁷ This highly remarkable statement can, under the circumstances, only refer to the benevolent Yahweh. The traditional Christian interpretation of this passage as an anticipation of Christ is correct in so far as Yahweh’s benevolent aspect incarnates itself, as its own hypostasis, in the Son of Man, and in so far as the Son of Man proves in Enoch to be a representative of justice and, in Christianity, the justifier of mankind. Furthermore, the Son of Man is pre-existent, and therefore Job could very

well appeal to him. Just as Satan plays the role of accuser and slanderer, so Christ, God's other son, plays the role of advocate and defender.

[685] Despite the contradiction, certain scholars have wished to see Enoch's Messianic ideas as Christian interpolations. For psychological reasons this suspicion seems to me unjustified. One has only to consider what Yahweh's injustice, his downright immorality, must have meant to a devout thinker. It was no laughing matter to be burdened with such an idea of God. A much later document tells us of a pious sage who could never read the Eighty-ninth Psalm, "because he could not bear it." When one considers with what intensity and exclusiveness not only Christ's teaching, but the doctrines of the Church in the following centuries down to the present day, have emphasized the goodness of the loving Father in heaven, the deliverance from fear, the *Summum Bonum*, and the *privatio boni*, one can form some conception of the incompatibility which the figure of Yahweh presents, and see how intolerable such a paradox must appear to the religious consciousness. And this has probably been so ever since the days of Job.

[686] The inner instability of Yahweh is the prime cause not only of the creation of the world, but also of the pleromatic drama for which mankind serves as a tragic chorus. The encounter with the creature changes the creator. In the Old Testament writings we find increasing traces of this development from the sixth century B.C. on. The two main climaxes are formed firstly by the Job tragedy, and secondly by Ezekiel's revelation. Job is the innocent sufferer, but Ezekiel witnesses the humanization and differentiation of Yahweh. By being addressed as "Son of Man," it is intimated to him that Yahweh's incarnation and quaternity are, so to speak, the pleromatic model for what is going to happen, through the transformation and humanization of God, not only to God's son as foreseen from all eternity, but to man as such. This is fulfilled as an intuitive anticipation in Enoch. In his ecstasy he becomes the Son of Man in the pleroma, and his wafting away in a chariot (like Elijah) prefigures the resurrection of the dead. To fulfil his role as minister of justice he must get into immediate proximity to God, and as the pre-existing Son of Man he is no longer subject to death. But in so far as he was an ordinary human being and therefore mortal, other mortals as well as he can attain to the vision of God; they too can become conscious of their saviour, and consequently immortal.

[687] All these ideas could easily have become conscious at the time on the basis of the assumptions then current, if only someone had seriously reflected on them. For that no Christian interpolations were needed. The Book of Enoch was an anticipation in the grand manner, but everything still hung in mid air as mere revelation that never came down to earth. In view of these facts one cannot, with the best will in the world, see how Christianity, as we hear over and over again, is supposed to have burst upon world history as an absolute novelty. If ever anything had been historically prepared,

and sustained and supported by the existing *Weltanschauung*, Christianity would be a classic example.

XII

[688] Jesus first appears as a Jewish reformer and prophet of an exclusively good God. In so doing he saves the threatened religious continuity, and in this respect he does in fact prove himself a *σωτήρ*, a saviour. He preserves mankind from loss of communion with God and from getting lost in mere consciousness and rationality. That would have brought something like a dissociation between consciousness and the unconscious, an unnatural and even pathological condition, a “loss of soul” such as has threatened man from the beginning of time. Again and again and in increasing measure he gets into danger of overlooking the necessary irrationalities of his psyche, and of imagining that he can control everything by will and reason alone, and thus paddle his own canoe. This can be seen most clearly in the great socio-political movements, such as Socialism and Communism: under the former the state suffers, and under the latter, man.

[689] Jesus, it is plain, translated the existing tradition into his own personal reality, announcing the glad tidings: “God has good pleasure in mankind. He is a loving father and loves you as I love you, and has sent me as his son to ransom you from the old debt.” He offers himself as an expiatory sacrifice that shall effect the reconciliation with God. The more desirable a real relationship of trust between man and God, the more astonishing becomes Yahweh’s vindictiveness and irreconcilability towards his creatures. From a God who is a loving father, who is actually Love itself, one would expect understanding and forgiveness. So it comes as a nasty shock when this supremely good God only allows the purchase of such an act of grace through a human sacrifice, and, what is worse, through the killing of his own son. Christ apparently overlooked this anticlimax; at any rate all succeeding centuries have accepted it without opposition. One should keep before one’s eyes the strange fact that the God of goodness is so unforgiving that he can only be appeased by a human sacrifice! This is an insufferable incongruity which modern man can no longer swallow, for he must be blind if he does not see the glaring light it throws on the divine character, giving the lie to all talk about love and the Summum Bonum.

[690] Christ proves to be a mediator in two ways: he helps men against God and assuages the fear which man feels towards this being. He holds an important position midway between the two extremes, man and God, which are so difficult to unite. Clearly the focus of the divine drama shifts to the mediating God-man. He is lacking neither in humanity nor in divinity, and for this reason he was long ago characterized by totality symbols, because he was understood to be all-embracing and to unite all opposites. The quaternity of the Son of Man, indicating a more differentiated

consciousness, was also ascribed to him (*vide* Cross and tetramorph). This corresponds by and large to the pattern in Enoch, but with one important deviation: Ezekiel and Enoch, the two bearers of the title “Son of Man,” were ordinary human beings, whereas Christ by his descent,¹ conception, and birth is a hero and half-god in the classical sense. He is virginally begotten by the Holy Ghost and, as he is not a creaturely human being, has no inclination to sin. The infection of evil was in his case precluded by the preparations for the Incarnation. Christ therefore stands more on the divine than on the human level. He incarnates God’s good will to the exclusion of all else and therefore does not stand exactly in the middle, because the essential thing about the creaturely human being, sin, does not touch him. Sin originally came from the heavenly court and entered into creation with the help of Satan, which enraged Yahweh to such an extent that in the end his own son had to be sacrificed in order to placate him. Strangely enough, he took no steps to remove Satan from his entourage. In Enoch a special archangel, Phanuel, was charged with the task of defending Yahweh from Satan’s insinuations, and only at the end of the world shall Satan, in the shape of a star,² be bound hand and foot, cast into the abyss, and destroyed. (This is not the case in the Book of Revelation, where he remains eternally alive in his natural element.)

[691] Although it is generally assumed that Christ’s unique sacrifice broke the curse of original sin and finally placated God, Christ nevertheless seems to have had certain misgivings in this respect. What will happen to man, and especially to his own followers, when the sheep have lost their shepherd, and when they miss the one who interceded for them with the father? He assures his disciples that he will always be with them, nay more, that he himself abides within them. Nevertheless this does not seem to satisfy him completely, for in addition he promises to send them from the father another *παράκλητος* (advocate, “Counsellor”), in his stead, who will assist them by word and deed and remain with them forever.³ One might conjecture from this that the “legal position” has still not been cleared up beyond a doubt, or that there still exists a factor of uncertainty.

[692] The sending of the Paraclete has still another aspect. This Spirit of Truth and Wisdom is the Holy Ghost by whom Christ was begotten. He is the spirit of physical and spiritual procreation who from now on shall make his abode in creaturely man. Since he is the Third Person of the Deity, this is as much as to say that *God will be begotten in creaturely man*. This implies a tremendous change in man’s status, for he is now raised to sonship and almost to the position of a man-god. With this the prefiguration in Ezekiel and Enoch, where, as we saw, the title “Son of Man” was already conferred on the creaturely man, is fulfilled. But that puts man, despite his continuing sinfulness, in the position of the mediator, the unifier of God and creature. Christ probably had this incalculable possibility in mind when he said: “... he who

believes in me, will also do the works that I do; and greater works than these will he do,”⁴ and, referring to the sixth verse of the Eighty-second Psalm, “I say, ‘You are gods, sons of the Most High, all of you,’” he added, “and scripture cannot be broken.”⁵

[693] The future indwelling of the Holy Ghost in man amounts to a continuing incarnation of God. Christ, as the begotten son of God and pre-existing mediator, is a first-born and a divine paradigm which will be followed by further incarnations of the Holy Ghost in the empirical man. But man participates in the darkness of the world, and therefore, with Christ’s death, a critical situation arises which might well be a cause for anxiety. When God became man all darkness and evil were carefully kept outside. Enoch’s transformation into the Son of Man took place entirely in the realm of light, and to an even greater extent this is true of the incarnation in Christ. It is highly unlikely that the bond between God and man was broken with the death of Christ; on the contrary, the continuity of this bond is stressed again and again and is further confirmed by the sending of the Paraclete. But the closer this bond becomes, the closer becomes the danger of a collision with evil. On the basis of a belief that had existed quite early, the expectation grew up that the light manifestation would be followed by an equally dark one, and Christ by an Antichrist. Such an opinion is the last thing one would expect from the metaphysical situation, for the power of evil is supposedly overcome, and one can hardly believe that a loving father, after the whole complicated arrangement of salvation in Christ, the atonement and declaration of love for mankind, would again let loose his evil watch-dog on his children in complete disregard of all that had gone before. Why this wearisome forbearance towards Satan? Why this stubborn projection of evil on man, whom he has made so weak, so faltering, and so stupid that we are quite incapable of resisting his wicked sons? Why not pull up evil by the roots?

[694] God, with his good intentions, begot a good and helpful son and thus created an image of himself as the good father—unfortunately, we must admit, again without considering that there existed in him a knowledge that spoke a very different truth. Had he only given an account of his action to himself, he would have seen what a fearful dissociation he had got into through his incarnation. Where, for instance, did his darkness go—that darkness by means of which Satan always manages to escape his well-earned punishment? Does he think he is completely changed and that his amorality has fallen from him? Even his “light” son, Christ, did not quite trust him in this respect. So now he sends to men the “spirit of truth,” with whose help they will discover soon enough what happens when God incarnates only in his light aspect and believes he is goodness itself, or at least wants to be regarded as such. An enantiodromia in the grand style is to be expected. This may well be the meaning of

the belief in the coming of the Antichrist, which we owe more than anything else to the activity of the “spirit of truth.”

[695] Although the Paraclete is of the greatest significance metaphysically, it was, from the point of view of the organization of the Church, most undesirable, because, as is authoritatively stated in scripture, the Holy Ghost is not subject to any control. In the interests of continuity and the Church the uniqueness of the incarnation and of Christ’s work of redemption has to be strongly emphasized, and for the same reason the continuing indwelling of the Holy Ghost is discouraged and ignored as much as possible. No further individualistic digressions can be tolerated. Anyone who is inclined by the Holy Ghost towards dissident opinions necessarily becomes a heretic, whose persecution and elimination take a turn very much to Satan’s liking. On the other hand one must realize that if everybody had tried to thrust the intuitions of his own private Holy Ghost upon others for the improvement of the universal doctrine, Christianity would rapidly have perished in a Babylonian confusion of tongues—a fate that lay threateningly close for many centuries.

[696] It is the task of the Paraclete, the “spirit of truth,” to dwell and work in individual human beings, so as to remind them of Christ’s teachings and lead them into the light. A good example of this activity is Paul, who knew not the Lord and received his gospel not from the apostles but through revelation. He is one of those people whose unconscious was disturbed and produced revelatory ecstasies. The life of the Holy Ghost reveals itself through its own activity, and through effects which not only confirm the things we all know, but go beyond them. In Christ’s sayings there are already indications of ideas which go beyond the traditionally “Christian” morality—for instance the parable of the unjust steward, the moral of which agrees with the Logion of the Codex Bezae,⁶ and betrays an ethical standard very different from what is expected. Here the moral criterion is *consciousness*, and not law or convention. One might also mention the strange fact that it is precisely Peter, who lacks self-control and is fickle in character, whom Christ wishes to make the rock and foundation of his Church. These seem to me to be ideas which point to the inclusion of evil in what I would call a *differential moral valuation*. For instance, it is good if evil is sensibly covered up, but to act unconsciously is evil. One might almost suppose that such views were intended for a time when consideration is given to evil as well as to good, or rather, when it is not suppressed below the threshold on the dubious assumption that we always know exactly what evil is.

[697] Again, the expectation of the Antichrist is a far-reaching revelation or discovery, like the remarkable statement that despite his fall and exile the devil is still “prince of this world” and has his habitation in the all-surrounding air. In spite of his misdeeds and in spite of God’s work of redemption for mankind, the devil still maintains a position of considerable power and holds all sublunary creatures under his sway. This

situation can only be described as critical; at any rate it does not correspond to what could reasonably have been expected from the “glad tidings.” Evil is by no means fettered, even though its days are numbered. God still hesitates to use force against Satan. Presumably he still does not know how much his own dark side favours the evil angel. Naturally this situation could not remain indefinitely hidden from the “spirit of truth” who has taken up his abode in man. He therefore created a disturbance in man’s unconscious and produced, at the beginning of the Christian era, another great revelation which, because of its obscurity, gave rise to numerous interpretations and misinterpretations in the centuries that followed. This is the Revelation of St. John.

XIII

[698] One could hardly imagine a more suitable personality for the John of the Apocalypse than the author of the Epistles of John. It was he who declared that God is light and that “in him is no darkness at all.”¹ (Who said there was any darkness in God?) Nevertheless, he knows that when we sin we need an “advocate with the Father,” and this is Christ, “the expiation for our sins,”² even though for his sake our sins are already forgiven. (Why then do we need an advocate?) The Father has bestowed his great love upon us (though it had to be bought at the cost of a human sacrifice!), and we are the children of God. He who is begotten by God commits no sin.³ (Who commits *no* sin?) John then preaches the message of love. God himself is love; perfect love casteth out fear. But he must warn against false prophets and teachers of false doctrines, and it is he who announces the coming of the Antichrist.⁴ His conscious attitude is orthodox, but he has evil forebodings. He might easily have dreams that are not listed on his conscious programme. He talks as if he knew not only a sinless state but also a perfect love, unlike Paul, who was not lacking in the necessary self-reflection. John is a bit too sure, and therefore he runs the risk of a dissociation. Under these circumstances a counterposition is bound to grow up in the unconscious, which can then irrupt into consciousness in the form of a revelation. If this happens, the revelation will take the form of a more or less subjective myth, because, among other things, it compensates the one-sidedness of an individual consciousness. This contrasts with the visions of Ezekiel or Enoch, whose conscious situation was mainly characterized by an ignorance (for which they were not to blame) and was therefore compensated by a more or less objective and universally valid configuration of archetypal material.

[699] So far as we can see, the Apocalypse conforms to these conditions. Even in the initial vision a fear-inspiring figure appears: Christ blended with the Ancient of Days, having the likeness of a man and the Son of Man. Out of his mouth goes a “sharp two-edged sword,” which would seem more suitable for fighting and the shedding of

blood than for demonstrating brotherly love. Since this Christ says to him. “Fear not,” we must assume that John was not overcome by love when he fell “as though dead.”⁵ but rather by fear. (What price now the perfect love which casts out fear?)

[700] Christ commands him to write seven epistles to the churches in the province of Asia. The church in Ephesus is admonished to repent: otherwise it is threatened with deprivation of the light (“I will come ... and remove your candlestick from its place”).⁶ We also learn from this letter that Christ “hates” the Nicolaitans. (How does this square with love of your neighbour?)

[701] The church in Smyrna does not come off so badly. Its enemies supposedly are Jews, but they are “a synagogue of Satan” which does not sound too friendly.

[702] Pergamum is censured because a teacher of false doctrines is making himself conspicuous there, and the place swarms with Nicolaitans. Therefore it must repent —“if not, I will come to you soon.” This can only be interpreted as a threat.

[703] Thyatira tolerates the preaching of “that woman Jezebel, who calls herself a prophetess.” He will “throw her on a sickbed” and “strike her children dead.” But “he who ... keeps my works until the end I will give him power over the nations, and he shall rule them with a rod of iron, as when earthen pots are broken in pieces, even as I myself have received power from my Father and I will give him the morning star.”⁷ Christ, as we know, teaches “Love your enemies” but here he threatens a massacre of children all too reminiscent of Bethlehem!

[704] The works of the church in Sardis are not perfect before God. Therefore, “repent.” Otherwise he will come like a thief, “and you will not know at what hour I will come upon you”⁸—a none too friendly warning.

[705] In regard to Philadelphia, there is nothing to be censured. But Laodicea he will spew out of his mouth, because they are lukewarm. They too must repent. His explanation is characteristic: “Those whom I love, I reprove and chasten.”⁹ It would be quite understandable if the Laodiceans did not want too much of this “love.”

[706] Five of the seven churches get bad reports. This apocalyptic “Christ” behaves rather like a bad-tempered, power-conscious “boss” who very much resembles the “shadow” of a love-preaching bishop.

[707] As if in confirmation of what I have said, there now follows a vision in the style of Ezekiel. But he who sat upon the throne did not look like a man, but was to look upon “like jasper and carnelian.”¹⁰ Before him was “a sea of glass, like crystal”; around the throne, four “living creatures” (ζῶα), which were “full of eyes in front and behind ... all round and within.”¹¹ The symbol of Ezekiel appears here strangely modified: stone, glass, crystal—dead and rigid things deriving from the inorganic realm—characterize the Deity. One is inevitably reminded of the preoccupation of the alchemists during the following centuries, when the mysterious “Man,” the *homo*

altus, was named λίθος οὐ λίθος, ‘the stone that is no stone,’ and multiple eyes gleamed in the ocean of the unconscious.¹² At any rate, something of John’s psychology comes in here, which has caught a glimpse of things beyond the Christian cosmos.

[708] Hereupon follows the opening of the Book with Seven Seals by the “Lamb.” The latter has put off the human features of the “Ancient of Days” and now appears in purely theriomorphic but monstrous form, like one of the many other horned animals in the Book of Revelation. It has seven eyes and seven horns, and is therefore more like a ram than a lamb. Altogether it must have looked pretty awful. Although it is described as “standing, as though it had been slain,”¹³ it does not behave at all like an innocent victim, but in a very lively manner indeed. From the first four seals it lets loose the four sinister apocalyptic horsemen. With the opening of the fifth seal, we hear the martyrs crying for vengeance (“O sovereign Lord, holy and true, how long before thou wilt judge and avenge our blood on those who dwell upon the earth?”).¹⁴ The sixth seal brings a cosmic catastrophe, and everything hides from the “wrath of the Lamb,” “for the great day of his wrath is come.”¹⁵ We no longer recognize the meek Lamb who lets himself be led unresistingly to the slaughter; there is only the aggressive and irascible ram whose rage can at last be vented. In all this I see less a metaphysical mystery than the outburst of long pent-up negative feelings such as can frequently be observed in people who strive for perfection. We can take it as certain that the author of the Epistles of John made every effort to practise what he preached to his fellow Christians. For this purpose he had to shut out all negative feelings, and, thanks to a helpful lack of self-reflection, he was able to forget them. But though they disappeared from the conscious level they continued to rankle beneath the surface, and in the course of time spun an elaborate web of resentments and vengeful thoughts which then burst upon consciousness in the form of a revelation. From this there grew up a terrifying picture that blatantly contradicts all ideas of Christian humility, tolerance, love of your neighbour and your enemies, and makes nonsense of a loving father in heaven and rescuer of mankind. A veritable orgy of hatred, wrath, vindictiveness, and blind destructive fury that revels in fantastic images of terror breaks out and with blood and fire overwhelms a world which Christ had just endeavoured to restore to the original state of innocence and loving communion with God.

[709] The opening of the seventh seal naturally brings a new flood of miseries which threaten to exhaust even St. John’s unholy imagination. As if to fortify himself, he must now eat a “little scroll” in order to go on with his “prophesying.”

[710] When the seventh angel had finally ceased blowing his trumpet, there appeared in heaven, after the destruction of Jerusalem, a vision of the *sun-woman*, “with the moon under her feet, and on her head a crown of twelve stars.”¹⁶ She was in the

pangs of birth, and before her stood a great red dragon that wanted to devour her child.

[711] This vision is altogether out of context. Whereas with the previous visions one has the impression that they were afterwards revised, rearranged, and embellished, one feels that this image is original and not intended for any educational purpose. The vision is introduced by the opening of the temple in heaven and the sight of the Ark of the Covenant.¹⁷ This is probably a prelude to the descent of the heavenly bride, Jerusalem, an equivalent of Sophia, for it is all part of the heavenly *hieros gamos*, whose fruit is a divine man-child. He is threatened with the fate of Apollo, the son of Leto, who was likewise pursued by a dragon. But here we must dwell for a moment on the figure of the mother. She is “a woman clothed with the sun.” Note the simple statement “a woman”—an ordinary woman, not a goddess and not an eternal virgin immaculately conceived. No special precautions exempting her from complete womanhood are noticeable, except the cosmic and naturalistic attributes which mark her as an *anima mundi* and peer of the primordial cosmic man, or Anthropos. She is the feminine Anthropos, the counterpart of the masculine principle. The pagan Leto motif is eminently suited to illustrate this, for in Greek mythology matriarchal and patriarchal elements are about equally mixed. The stars above, the moon below, in the middle the sun, the rising Horus and the setting Osiris, and the maternal night all round, οὐρανὸς ἄνω, οὐρανὸς κάτω¹⁸—this symbolism reveals the whole mystery of the “woman”: she contains in her darkness the sun of “masculine” consciousness, which rises as a child out of the nocturnal sea of the unconscious, and as an old man sinks into it again. She adds the dark to the light, symbolizes the hierogamy of opposites, and reconciles nature with spirit.

[712] The son who is born of these heavenly nuptials is perforce a *complexio oppositorum*, a uniting symbol, a totality of life. John’s unconscious, certainly not without reason, borrowed from Greek mythology in order to describe this strange eschatological experience, for it was not on any account to be confused with the birth of the Christ-child which had occurred long before under quite different circumstances. Though obviously the allusion is to the “wrathful Lamb,” i.e., the apocalyptic Christ, the new-born man-child is represented as his duplicate, as one who will “rule the nations with a rod of iron.”¹⁹ He is thus assimilated to the predominant feelings of hatred and vengeance, so that it looks as if he will needlessly continue to wreak his judgment even in the distant future. This interpretation does not seem consistent, because the Lamb is already charged with this task and, in the course of the revelation, carries it to an end without the newborn man-child ever having an opportunity to act on his own. He never reappears afterwards. I am therefore inclined to believe that the depiction of him as a son of vengeance, if it is not an interpretative interpolation, must have been a familiar phrase to John and that

it slipped out as the obvious interpretation. This is the more probable in that the intermezzo could not at the time have been understood in any other way even though this interpretation is quite meaningless. As I have already pointed out, the sun-woman episode is a foreign body in the flow of the visions. Therefore, I believe, it is not too far-fetched to conjecture that the author of the Apocalypse, or perhaps a perplexed transcriber, felt the need to interpret this obvious parallel with Christ and somehow bring it into line with the text as a whole. This could easily be done by using the familiar image of the shepherd with the iron crook. I cannot see any other reason for this association.

[713] The man-child is “caught up” to God, who is manifestly his father, and the mother is hidden in the wilderness. This would seem to indicate that the child-figure will remain latent for an indefinite time and that its activity is reserved for the future. The story of Hagar may be a prefiguration of this. The similarity between this story and the birth of Christ obviously means no more than that the birth of the man-child is an analogous event, like the previously mentioned enthronement of the Lamb in all his metaphysical glory, which must have taken place long before at the time of the ascension. In the same way the dragon, i.e., the devil, is described as being thrown down to earth,²⁰ although Christ had already observed the fall of Satan very much earlier. This strange repetition or duplication of the characteristic events in Christ’s life gave rise to the conjecture that a second Messiah is to be expected at the end of the world. What is meant here cannot be the return of Christ himself, for we are told that he would come “in the clouds of heaven,” but not be *born* a second time, and certainly not from a sun-moon conjunction. The epiphany at the end of the world corresponds more to the content of Revelation 1 and 19:11ff. The fact that John uses the myth of Leto and Apollo in describing the birth may be an indication that the vision, in contrast to the Christian tradition, is a product of the unconscious.²¹ But in the unconscious is everything that has been rejected by consciousness, and the more Christian one’s consciousness is, the more heathenishly does the unconscious behave, if in the rejected heathenism there are values which are important for life—if, that is to say, the baby has been thrown out with the bath water, as so often happens. The unconscious does not isolate or differentiate its objects as consciousness does. It does not think abstractly or apart from the subject: the person of the ecstatic or visionary is always drawn into the process and included in it. In this case it is John himself whose unconscious personality is more or less identified with Christ; that is to say, he is born like Christ, and born to a like destiny. John is so completely captivated by the archetype of the divine son that he sees its activity in the unconscious; in other words, he sees how God is born again in the (partly pagan) unconscious, indistinguishable from the self of John, since the “divine child” is a symbol of the one as much as the other, just as Christ is. Consciously, of course, John was very far

from thinking of Christ as a symbol. For the believing Christian, Christ is everything, but certainly not a symbol, which is an expression for something unknown or not yet knowable. And yet he is a symbol by his very nature. Christ would never have made the impression he did on his followers if he had not expressed something that was alive and at work in their unconscious. Christianity itself would never have spread through the pagan world with such astonishing rapidity had its ideas not found an analogous psychic readiness to receive them. It is this fact which also makes it possible to say that whoever believes in Christ is not only contained in him, but that Christ then dwells in the believer as the perfect man formed in the image of God, the second Adam. Psychologically, it is the same relationship as that in Indian philosophy between man's ego-consciousness and *purusha*, or *atman*. It is the ascendancy of the "complete"—*τέλειος*—or total human being, consisting of the totality of the psyche, of conscious and unconscious, over the ego, which represents only consciousness and its contents and knows nothing of the unconscious, although in many respects it is dependent on the unconscious and is often decisively influenced by it. This relationship of the self to the ego is reflected in the relationship of Christ to man. Hence the unmistakable analogies between certain Indian and Christian ideas, which have given rise to conjectures of Indian influence on Christianity.

[714] This parallelism, which has so far remained latent in John, now bursts into consciousness in the form of a vision. That this invasion is authentic can be seen from the use of pagan mythological material, a most improbable procedure for a Christian of that time, especially as it contains traces of astrological influence. That may explain the thoroughly pagan remark, "And the earth helped the woman."²² Even though the consciousness of that age was exclusively filled with Christian ideas, earlier or contemporaneous pagan contents lay just below the surface, as for example in the case of St. Perpetua.²³ With a Judaeo-Christian—and the author of the Apocalypse was probably such—another possible model to be considered is the cosmic Sophia, to whom John refers on more than one occasion. She could easily be taken as the mother of the divine child,²⁴ since she is obviously a woman in heaven, i.e., a goddess or consort of a god. Sophia comes up to this definition, and so does the transfigured Mary. If the vision were a modern dream one would not hesitate to interpret the birth of the divine child as the coming to consciousness of the self. In John's case the conscious attitude of faith made it possible for the Christ-image to be received into the material of the unconscious; it activated the archetype of the divine virgin mother and of the birth of her son-lover, and brought it face to face with his Christian consciousness. As a result, John became personally involved in the divine drama.

[715] His Christ-image, clouded by negative feelings, has turned into a savage avenger who no longer bears any real resemblance to a saviour. One is not at all sure whether this Christ-figure may not in the end have more of the human John in it, with his compensating shadow, than of the divine saviour who, as the *lumen de lumine*, contains “no darkness.” The grotesque paradox of the “wrathful Lamb” should have been enough to arouse our suspicions in this respect. We can turn and twist it as we like, but, seen in the light of the gospel of love, the avenger and judge remains a most sinister figure. This, one suspects, may have been the reason which moved John to assimilate the newborn man-child to the figure of the avenger, thereby blurring his mythological character as the lovely and lovable divine youth whom we know so well in the figures of Tammuz, Adonis, and Balder. The enchanting springlike beauty of this divine youth is one of those pagan values which we miss so sorely in Christianity, and particularly in the sombre world of the apocalypse—the indescribable morning glory of a day in spring, which after the deathly stillness of winter causes the earth to put forth and blossom, gladdens the heart of man and makes him believe in a kind and loving God.

[716] As a totality, the self is by definition always a *complexio oppositorum*, and the more consciousness insists on its own luminous nature and lays claim to moral authority, the more the self will appear as something dark and menacing. We may assume such a condition in John, since he was a shepherd of his flock and also a fallible human being. Had the apocalypse been a more or less personal affair of John’s, and hence nothing but an outburst of personal resentment, the figure of the wrathful Lamb would have satisfied this need completely. Under those conditions the new-born man-child would have been bound to have a noticeably positive aspect, because, in accordance with his symbolic nature, he would have compensated the intolerable devastation wrought by the outburst of long pent-up passions, being the child of the conjunction of opposites, of the sunfilled day world and the moonlit night world. He would have acted as a mediator between the loving and the vengeful sides of John’s nature, and would thus have become a beneficent saviour who restored the balance. This positive aspect, however, must have escaped John’s notice, otherwise he could never have conceived of the child as standing on the same level as the avenging Christ.

[717] But John’s problem was not a personal one. It was not a question of his personal unconscious or of an outburst of ill humour, but of visions which came up from a far greater and more comprehensive depth, namely from the collective unconscious. His problem expresses itself far too much in collective and archetypal forms for us to reduce it to a merely personal situation. To do so would be altogether too easy as well as being wrong in theory and practice. As a Christian, John was seized by a collective, archetypal process, and he must therefore be explained first and foremost

in that light. He certainly also had his personal psychology, into which we, if we may regard the author of the Epistles and the apocalypticist as one and the same person, have some insight. That the imitation of Christ creates a corresponding shadow in the unconscious hardly needs demonstrating. The fact that John had visions at all is evidence of an unusual tension between conscious and unconscious. If he is identical with the author of the Epistles, he must have been quite old when he wrote the Book of Revelation. *In confinio mortis* and in the evening of a long and eventful life a man will often see immense vistas of time stretching out before him. Such a man no longer lives in the everyday world and in the vicissitudes of personal relationships, but in the sight of many aeons and in the movement of ideas as they pass from century to century. The eye of John penetrates into the distant future of the Christian aeon and into the dark abyss of those forces which his Christianity kept in equilibrium. What burst upon him is the storm of the times, the premonition of a tremendous enantiodromia which he could only understand as the final annihilation of the darkness which had not comprehended the light that appeared in Christ. He failed to see that the power of destruction and vengeance is that very darkness from which God had split himself off when he became man. Therefore he could not understand, either, what that sun-moon-child meant, and he could only interpret it as another figure of vengeance. The passion that breaks through in his revelation bears no trace of the feebleness or serenity of old age, because it is infinitely more than personal resentment: it is the spirit of God itself, which blows through the weak mortal frame and again demands man's *fear* of the unfathomable Godhead.

XIV

[718] The torrent of negative feelings seems to be inexhaustible, and the dire events continue their course. Out of the sea come monsters "with horns" (i.e., endowed with power), the horrid progeny of the deep. Faced with all this darkness and destruction, man's terrified consciousness quite understandably looks round for a mountain of refuge, an island of peace and safety. John therefore weaves in a vision of the Lamb on Mount Zion, where the hundred and forty-four thousand elect and redeemed are gathered round the Lamb.¹ They are the *παρθάνοι*, the male virgins, "which were not defiled with women."² They are the ones who, following in the footsteps of the young dying god, have never become complete human beings, but have voluntarily renounced their share in the human lot and have said no to the continuance of life on earth.³ If everyone were converted to this point of view, man as a species would die out in a few decades. But of such preordained ones there are relatively few. John believed in predestination in accordance with higher authority. This is rank pessimism.

says Mephisto.

[719] This only moderately comforting prospect is immediately interrupted by the warning angels. The first angel proclaims an “everlasting gospel,” the quintessence of which is “Fear God!” There is no more talk of God’s love. What is feared can only be something fearful.⁴

[720] The Son of Man now appears holding a sharp sickle in his hand, together with an auxiliary angel who also has a sickle.⁵ But the grape harvest consists in an unparalleled blood-bath: the angel “gathered the vintage of the earth, and threw it into the great winepress of the wrath of God ... and blood flowed from the winepress”—in which human beings were trodden!—“as high as a horse’s bridle, for one thousand six hundred stadia.”⁶

[721] Seven angels then come out of the heavenly temple with the seven vials of wrath, which they proceed to pour out on the earth.⁷ The *piece de rèsistance* is the destruction of the Great Whore of Babylon, the counterpart of the heavenly Jerusalem. The Whore is the chthonic equivalent of the sun-woman Sophia, with, however, a reversal in moral character. If the elect turn themselves into “virgins” in honour of the Great Mother Sophia, a gruesome fantasy of fornication is spawned in the unconscious by way of compensation. The destruction of Babylon therefore represents not only the end of fornication, but the utter eradication of all life’s joys and pleasures, as can be seen from 18:22–23:

and the sound of harpers and minstrels, of flute players
and trumpeters,
shall be heard in thee no more;

.

and the light of a lamp
shall shine in thee no more;
and the voice of bridegroom and bride
shall be heard in thee no more ...

[722] As we happen to be living at the end of the Christian aeon Pisces, one cannot help but recall the doom that has overtaken our modern art.

[723] Symbols like Jerusalem, Babylon, etc. are always overdetermined, that is, they have several aspects of meaning and can therefore be interpreted in different ways. I am only concerned with the psychological aspect, and do not wish to express an opinion as to their possible connection with historical events.

[724] The destruction of all beauty and of all life's joys, the unspeakable suffering of the whole of creation that once sprang from the hand of a lavish Creator, would be, for a feeling heart, an occasion for deepest melancholy. But John cries: "Rejoice over her, thou heaven, ye holy apostles and prophets, for God hath avenged you on her [Babylon],"⁸ from which we can see how far vindictiveness and lust for destruction can go, and what the "thorn in the flesh" means.

[725] It is Christ who, leading the hosts of angels, treads "the winepress of the fierceness and wrath of Almighty God."⁹ His robe "is dipped in blood."¹⁰ He rides a *white horse*,¹¹ and with the sword which issues out of his mouth he kills the beast and the "false prophet," presumably his—or John's—dark counterpart, i.e., the shadow. Satan is locked up in the bottomless pit for a thousand years, and *Christ shall reign for the same length of time*. "After that he must be loosed a little season."¹² These thousand years correspond astrologically to the first half of the Pisces aeon. The setting free of Satan after this time must therefore correspond—one cannot imagine any other reason for it—to the enantiodromia of the Christian aeon, that is, to the reign of the Antichrist, whose coming could be predicted on astrological grounds. Finally, at the end of an unspecified period, the devil is thrown into the lake of fire and brimstone for ever and ever (but not completely destroyed as in Enoch), and the whole of the first creation disappears.¹³

[726] The *hieros gamos*, the marriage of the Lamb with "his Bride," which had been announced earlier,¹⁴ can now take place. The bride is the "new Jerusalem coming down out of heaven."¹⁵ Her "radiance [was] like a most rare jewel, like a jasper, clear as crystal."¹⁶ The city was built foursquare and was of pure gold, clear as glass, and so were its streets. The Lord God himself and the Lamb are its temple, and the source of never-ending light. There is no night in the city, and nothing unclean can enter in to defile it.¹⁷ (This repeated assurance allays a doubt in John that has never been quite silenced.) From the throne of God and the Lamb flows the river of the water of life, and beside it stands the tree of life, as a reminder of paradise and pleromatic pre-existence.¹⁸

[727] This final vision, which is generally interpreted as referring to the relationship of Christ to his Church, has the meaning of a "uniting symbol" and is therefore a representation of perfection and wholeness: hence the quaternity, which expresses itself in the city as a quadrangle, in paradise as the four rivers, in Christ as the four evangelists, and in God as the four living creatures. While the circle signifies the roundness of heaven and the all-embracing nature of the "pneumatic" deity, the square refers to the earth.¹⁹ Heaven is masculine, but the earth is feminine. Therefore God has his throne in heaven, while Wisdom has hers on the earth, as she says in Ecclesiasticus: "Likewise in the beloved city he gave me rest, and in Jerusalem was my power." She is the "mother of fair love,"²⁰ and when John pictures Jerusalem as

the bride he is probably following Ecclesiasticus. The city is Sophia, who was with God before time began, and at the end of time will be reunited with God through the sacred marriage. As a feminine being she coincides with the earth, from which, so a Church Father tells us, Christ was born,²¹ and hence with the quaternity of the four living creatures in whom God manifests himself in Ezekiel. In the same way that Sophia signifies God's self-reflection, the four seraphim represent God's consciousness with its four functional aspects. The many perceiving eyes²² which are concentrated in the four wheels point in the same direction. They represent a fourfold synthesis of unconscious luminosities, corresponding to the tetrameria of the *lapis philosophorum*, of which the description of the heavenly city reminds us: everything sparkles with precious gems, crystal, and glass, in complete accordance with Ezekiel's vision of God. And just as the *hieros gamos* unites Yahweh with Sophia (Shekinah in the Cabala), thus restoring the original pleromatic state, so the parallel description of God and city points to their common nature: they are originally one, a single hermaphroditic being, an archetype of the greatest universality.

[728] No doubt this is meant as a final solution of the terrible conflict of existence. The solution, however, as here presented, does not consist in the reconciliation of the opposites, but in their final severance, by which means those whose destiny it is to be saved can save themselves by identifying with the bright pneumatic side of God. An indispensable condition for this seems to be the denial of propagation and of sexual life altogether.

XV

[729] The Book of Revelation is on the one hand so personal and on the other so archetypal and collective that one is obliged to consider both aspects. Our modern interest would certainly turn first to the person of John. As I have said before, it is possible that John the author of the Epistles is identical with the apocalypticist. The psychological findings speak in favour of such an assumption. The "revelation" was experienced by an early Christian who, as a leading light of the community, presumably had to live an exemplary life and demonstrate to his flock the Christian virtues of true faith, humility, patience, devotion, selfless love, and denial of all worldly desires. In the long run this can become too much, even for the most righteous. Irritability, bad moods, and outbursts of affect are the classic symptoms of chronic virtuousness.¹ In regard to his Christian attitude, his own words probably give us the best picture:

Beloved, let us love one another; for love is of God, and he who loves is born of God and knows God. He who does not love does not know God; for God is love.... In this is love, not that we loved God but that he loved us and sent his Son to be the expiation for

our sins. Beloved, if God so loved us, we also ought to love one another.... So we know and believe the love God has for us. God is love, and he who abides in love abides in God, and God abides in him.... There is no fear in love, but perfect love casts out fear. For fear has to do with punishment, and he who fears is not perfected in love.... If any one says, "I love God," and hates his brother, he is a liar; for he who does not love his brother whom he has seen, cannot love God whom he has not seen. And this commandment we have from him, that he who loves God should love his brother also.²

[730] But who hates the Nicolaitans? Who thirsts for vengeance and even wants to throw "that woman Jezebel" on a sickbed and strike her children dead? Who cannot have enough of bloodthirsty fantasies? Let us be psychologically correct, however: it is not the conscious mind of John that thinks up these fantasies, they come to him in a violent "revelation." They fall upon him involuntarily with an unexpected vehemence and with an intensity which, as said, far transcends anything we could expect as compensation of a somewhat one-sided attitude of consciousness.

[731] I have seen many compensating dreams of believing Christians who deceived themselves about their real psychic constitution and imagined that they were in a different condition from what they were in reality. But I have seen nothing that even remotely resembles the brutal impact with which the opposites collide in John's visions, except in the case of severe psychosis. However, John gives us no grounds for such a diagnosis. His apocalyptic visions are not confused enough; they are too consistent, not subjective and scurrilous enough. Considering the nature of their subject, the accompanying affects are adequate. Their author need not necessarily be an unbalanced psychopath. It is sufficient that he is a passionately religious person with an otherwise well-ordered psyche. But he must have an intensive relationship to God which lays him open to an invasion far transcending anything personal. The really religious person, in whom the capacity for an unusual extension of consciousness is inborn, must be prepared for such dangers.

[732] The purpose of the apocalyptic visions is not to tell John, as an ordinary human being, how much shadow he hides beneath his luminous nature, but to open the seer's eye to the immensity of God, for he who loves God will know God. We can say that just because John loved God and did his best to love his fellows also, this "gnosis," this knowledge of God, struck him. Like Job, he saw the fierce and terrible side of Yahweh. For this reason he felt his gospel of love to be one-sided, and he supplemented it with the gospel of fear: *God can be loved but must be feared.*

[733] With this, the seer's range of vision extends far beyond the first half of the Christian aeon: he divines that the reign of Antichrist will begin after a thousand years, a clear indication that Christ was not an unqualified victor. John anticipated the alchemists and Jakob Böhme; maybe he even sensed his own personal implication in

the divine drama, since he anticipated the possibility of God's birth in man, which the alchemists, Meister Eckhart, and Angelus Silesius also intuited. He thus outlined the programme for the whole aeon of Pisces, with its dramatic enantiodromia, and its dark end which we have still to experience, and before whose—without exaggeration—truly apocalyptic possibilities mankind shudders. The four sinister horsemen, the threatening tumult of trumpets, and the brimming vials of wrath are still waiting; already the atom bomb hangs over us like the sword of Damocles, and behind that lurk the incomparably more terrible possibilities of chemical warfare, which would eclipse even the horrors described in the Apocalypse. *Luciferi vires accendit Aquarius acres*—"Aquarius sets aflame Lucifer's harsh forces." Could anyone in his right senses deny that John correctly foresaw at least some of the possible dangers which threaten our world in the final phase of the Christian aeon? He knew, also, that the fire in which the devil is tormented burns in the divine pleroma for ever. God has a terrible double aspect: a sea of grace is met by a seething lake of fire, and the light of love glows with a fierce dark heat of which it is said "ardet non lucet"—it burns but gives no light. That is the eternal, as distinct from the temporal, gospel: *one can love God but must fear him.*

XVI

[734] The book of Revelation, rightly placed at the end of the New Testament, reaches beyond it into a future that is all too palpably close with its apocalyptic terrors. The decision of an ill-considered moment, made in some Herostratic head,¹ can suffice to unleash the world cataclysm. The thread by which our fate hangs is wearing thin. Not nature, but the "genius of mankind," has knotted the hangman's noose with which it can execute itself at any moment. This is simply another *façon de parler* for what John called the "wrath of God."

[735] Unfortunately we have no means of envisaging how John—if, as I surmise, he is the same as the author of the Epistles—would have come to terms with the double aspect of God. It is possible, even probable, that he was not aware of any contrast. It is altogether amazing how little most people reflect on numinous objects and attempt to come to terms with them, and how laborious such an undertaking is once we have embarked upon it. The numinosity of the object makes it difficult to handle intellectually, since our affectivity is always involved. One always participates for or against, and "absolute objectivity" is more rarely achieved here than anywhere else. If one has positive religious convictions, i.e., if one believes, then doubt is felt as very disagreeable and also one fears it. For this reason, one prefers not to analyse the object of belief. If one has no religious beliefs, then one does not like to admit the feeling of deficit, but prates loudly about one's liberal-mindedness and pats oneself on the back for the noble frankness of one's agnosticism. From this standpoint, it is

hardly possible to admit the numinosity of the religious object, and yet its very numinosity is just as great a hindrance to critical thinking, because the unpleasant possibility might then arise that one's faith in enlightenment or agnosticism would be shaken. Both types feel, without knowing it, the insufficiency of their argument. Enlightenment operates with an inadequate rationalistic concept of truth and points triumphantly to the fact that beliefs such as the virgin birth, divine filiation, the resurrection of the dead, transubstantiation, etc., are all moonshine. Agnosticism maintains that it does not possess any knowledge of God or of anything metaphysical, overlooking the fact that one never *possesses* a metaphysical belief but is *possessed by it*. Both are possessed by reason, which represents the supreme arbiter who cannot be argued with. But who or what is this "reason" and why should it be supreme? Is not something that *is* and has real existence for us an authority superior to any rational judgment, as has been shown over and over again in the history of the human mind? Unfortunately the defenders of "faith" operate with the same futile arguments, only the other way about. The only thing which is beyond doubt is that there are metaphysical statements which are asserted or denied with considerable affect precisely because of their numinosity. This fact gives us a sure empirical basis from which to proceed. It is objectively real as a psychic phenomenon. The same applies naturally to all statements, even the most contradictory, that ever were or still are numinous. From now on we shall have to consider religious statements in their totality.

XVII

[736] Let us turn back to the question of coming to terms with the paradoxical idea of God which the Apocalypse reveals to us. Evangelical Christianity, in the strict sense, has no need to bother with it, because it has as an essential doctrine an idea of God that, unlike Yahweh, coincides with the epitome of good. It would have been very different if the John of the Epistles had been obliged to discuss these matters with the John of Revelation. Later generations could afford to ignore the dark side of the Apocalypse, because the specifically Christian achievement was something that was not to be frivolously endangered. But for modern man the case is quite otherwise. We have experienced things so unheard of and so staggering that the question of whether such things are in any way reconcilable with the idea of a good God has become burningly topical. It is no longer a problem for experts in theological seminaries, but a universal religious nightmare, to the solution of which even a layman in theology like myself can, or perhaps must, make a contribution.

[737] I have tried to set forth above the inescapable conclusions which must, I believe, be reached if one looks at tradition with critical common sense. If, in this wise, one is confronted with a paradoxical idea of God, and if, as a religious person, one

considers at the same time the full extent of the problem, one finds oneself in the situation of the author of Revelation, who we may suppose was a convinced Christian. His possible identity with the writer of the letters brings out the acuteness of the contradiction: What is the relationship of this man to God? How does he endure the intolerable contradiction in the nature of Deity? Although we know nothing of his conscious decision, we believe we may find some clue in the vision of the sun-woman in travail.

[738] The paradoxical nature of God has a like effect on man: it tears him asunder into opposites and delivers him over to a seemingly insoluble conflict. What happens in such a condition? Here we must let psychology speak, for psychology represents the sum of all the observations and insights it has gained from the empirical study of severe states of conflict. There are, for example, conflicts of duty no one knows how to solve. Consciousness only knows: *tertium non datur!* The doctor therefore advises his patient to wait and see whether the unconscious will not produce a dream which proposes an irrational and therefore unexpected third thing as a solution. As experience shows, symbols of a reconciling and unitive nature do in fact turn up in dreams, the most frequent being the motif of the child-hero and the squaring of the circle, signifying the union of opposites. Those who have no access to these specifically medical experiences can derive practical instruction from fairy tales, and particularly from alchemy. The real subject of Hermetic philosophy is the *coniunctio oppositorum*. Alchemy characterizes its “child” on the one hand as the stone (e.g., the carbuncle), and on the other hand as the homunculus, or the *filius sapientiae* or even the *homo altus*. This is precisely the figure we meet in the Apocalypse as the son of the sun-woman, whose birth story seems like a paraphrase of the birth of Christ—a paraphrase which was repeated in various forms by the alchemists. In fact, they posit their stone as a parallel to Christ (this, with one exception, without reference to the Book of Revelation). This motif appears again in corresponding form and in corresponding situations in the dreams of modern man, with no connection with alchemy, and always it has to do with the bringing together of the light and the dark, as though modern man, like the alchemists, had divined what the problem was that the Apocalypse set the future. It was this problem on which the alchemists laboured for nearly seventeen centuries, and it is the same problem that distresses modern man. Though in one respect he knows more, in another respect he knows less than the alchemists. The problem for him is no longer projected upon matter, as it was for them; but on the other hand it has become psychologically acute, so that the psychotherapist has more to say on these matters than the theologian, who has remained caught in his archaic figures of speech. The doctor, often very much against his will, is forced by the problems of psychoneurosis to look more closely at the religious problem. It is not without good reason that I myself have reached the age of

seventy-six before venturing to catechize myself as to the nature of those “ruling ideas” which decide our ethical behaviour and have such an important influence on our practical life. They are in the last resort the principles which, spoken or unspoken, determine the moral decisions upon which our existence depends, for weal or woe. All these dominants culminate in the positive or negative concept of God.¹

[739] Ever since John the apocalyptist experienced for the first time (perhaps unconsciously) the conflict into which Christianity inevitably leads, mankind has groaned under this burden: *God wanted to become man, and still wants to*. That is probably why John experienced in his vision a second birth of a son from the mother Sophia, a divine birth which was characterized by a *coniunctio oppositorum* and which anticipated the *filius sapientiae*, the essence of the individuation process. This was the effect of Christianity on a Christian of early times, who had lived long and resolutely enough to be able to cast a glance into the distant future. The mediation between the opposites was already indicated in the symbolism of Christ’s fate, in the crucifixion scene where the mediator hangs between two thieves, one of whom goes to paradise, the other down to hell. Inevitably, in the Christian view, the opposition had to lie between God and man, and man was always in danger of being identified with the dark side. This, and the predestinarian hints dropped by our Lord, influenced John strongly: only the few preordained from eternity shall be saved, while the great mass of mankind shall perish in the final catastrophe. The opposition between God and man in the Christian view may well be a Yahwistic legacy from olden times, when the metaphysical problem consisted solely in Yahweh’s relations with his people. The fear of Yahweh was still too great for anybody to dare—despite Job’s gnosis—to lodge the antinomy in Deity itself. But if you keep the opposition between God and man, then you finally arrive, whether you like it or not, at the Christian conclusion “*omne bonum a Deo, omne malum ab homine,*” with the absurd result that the creature is placed in opposition to its creator and a positively cosmic or daemonic grandeur in evil is imputed to man. The terrible destructive will that breaks out in John’s ecstasies gives some idea of what it means when man is placed in opposition to the God of goodness: it burdens him with the dark side of God, which in Job is still in its right place. But either way man is identified with evil, with the result that he sets his face against goodness or else tries to be as perfect as his father in heaven.

[740] Yahweh’s decision to become man is a symbol of the development that had to supervene when man becomes conscious of the sort of God-image he is confronted with.² God acts out of the unconscious of man and forces him to harmonize and unite the opposing influences to which his mind is exposed from the unconscious. The unconscious wants both: to divide and to unite. In his striving for unity, therefore, man may always count on the help of a metaphysical advocate, as Job clearly

recognized. The unconscious wants to flow into consciousness in order to reach the light, but at the same time it continually thwarts itself, because it would rather remain unconscious. That is to say, God wants to become man, but not quite. The conflict in his nature is so great that the incarnation can only be bought by an expiatory self-sacrifice offered up to the wrath of God's dark side.

[741] At first, God incarnated his good side in order, as we may suppose, to create the most durable basis for a later assimilation of the other side. From the promise of the Paraclete we may conclude that God wants to become *wholly* man; in other words, to reproduce himself in his own dark creature (man not redeemed from original sin). The author of Revelation has left us a testimony to the continued operation of the Holy Ghost in the sense of a continuing incarnation. He was a creaturely man who was invaded by the dark God of wrath and vengeance—a *ventus urens*, a 'burning wind.' (This John was possibly the favourite disciple, who in old age was vouchsafed a premonition of future developments.) This disturbing invasion engendered in him the image of the divine child, of a future saviour, born of the divine consort whose reflection (the anima) lives in every man—that child whom Meister Eckhart also saw in a vision. It was he who knew that God alone in his Godhead is not in a state of bliss, but must be born in the human soul ("Gott ist selig in der Seele"). The incarnation in Christ is the prototype which is continually being transferred to the creature by the Holy Ghost.

[742] Since our moral conduct can hardly be compared with that of an early Christian like John, all manner of good as well as evil can still break through in us, particularly in regard to love. A sheer will for destruction, such as was evident in John, is not to be expected in our case. In all my experience I have never observed anything like it, except in cases of severe psychoses and criminal insanity. As a result of the spiritual differentiation fostered by the Reformation, and by the growth of the sciences in particular (which were originally taught by the fallen angels), there is already a considerable admixture of darkness in us, so that, compared with the purity of the early Christian saints (and some of the later ones too), we do not show up in a very favourable light. Our comparative blackness naturally does not help us a bit. Though it mitigates the impact of evil forces, it makes us more vulnerable and less capable of resisting them. We therefore need more light, more goodness and moral strength, and must wash off as much of the obnoxious blackness as possible, otherwise we shall not be able to assimilate the dark God who also wants to become man, and at the same time endure him without perishing. For this all the Christian virtues are needed and something else besides, for the problem is not only moral: we also need the Wisdom that Job was seeking. But at that time she was still hidden in Yahweh, or rather, she was not yet remembered by him. That higher and "complete" (τέλειος) man is begotten by the "unknown" father and born from Wisdom, and it is he who, in

the figure of the *puer aeternus*—“*vultu mutabilis albus et ater*”³—represents our totality, which transcends consciousness. It was this boy into whom Faust had to change, abandoning his inflated onesidedness which saw the devil only outside. Christ’s “Except ye become as little children” prefigures this change, for in them the opposites lie close together; but what is meant is the boy who is born from the maturity of the adult man, and not the unconscious child we would like to remain. Looking ahead, Christ also hinted, as I mentioned before, at a morality of evil.

[743] Strangely, suddenly, as if it did not belong there, the sun-woman with her child appears in the stream of apocalyptic visions. He belongs to another, future world. Hence, like the Jewish Messiah, the child is “caught up” to God, and his mother must stay for a long time hidden in the wilderness, where she is nourished by God. For the immediate and urgent problem in those days was not the union of opposites, which lay in the future, but the incarnation of the light and the good, the subjugation of *concupiscentia*, the lust of this world, and the consolidation of the *civitas Dei* against the advent of the Antichrist, who would come after a thousand years to announce the horrors of the last days, the epiphany of the wrathful and avenging God. The Lamb, transformed into a demonic ram, reveals a new gospel, the *Evangelium Aeternum*, which, going right beyond the love of God, has the fear of God as its main ingredient. Therefore the Apocalypse closes, like the classical individuation process, with the symbol of the *hieros gamos*, the marriage of the son with the mother-bride. But the marriage takes place in heaven, where “nothing unclean” enters, high above the devastated world. Light consorts with light. That is the programme for the Christian aeon which must be fulfilled before God can incarnate in the creaturely man. Only in the last days will the vision of the sun-woman be fulfilled. In recognition of this truth, and evidently inspired by the workings of the Holy Ghost, the Pope has recently announced the dogma of the *Assumptio Mariae*, very much to the astonishment of all rationalists. Mary as the bride is united with the son in the heavenly bridal-chamber, and, as Sophia, with the Godhead.⁴

[744] This dogma is in every respect timely. In the first place it is a symbolical fulfilment of John’s vision.⁵ Secondly, it contains an allusion to the marriage of the Lamb at the end of time, and, thirdly, it repeats the Old Testament anamnesis of Sophia. These three references foretell the Incarnation of God. The second and third foretell the Incarnation in Christ,⁶ but the first foretells the Incarnation in creaturely man.

[745] Everything now depends on man: immense power of destruction is given into his hand, and the question is whether he can resist the will to use it, and can temper his will with the spirit of love and wisdom. He will hardly be capable of doing so on his

own unaided resources. He needs the help of an “advocate” in heaven, that is, of the child who was caught up to God and who brings the “healing” and making whole of the hitherto fragmentary man. Whatever man’s wholeness, or the self, may mean *per se*, empirically it is an image of the goal of life spontaneously produced by the unconscious, irrespective of the wishes and fears of the conscious mind. It stands for the goal of the total man, for the realization of his wholeness and individuality with or without the consent of his will. The dynamic of this process is instinct, which ensures that everything which belongs to an individual’s life shall enter into it, whether he consents or not, or is conscious of what is happening to him or not. Obviously, it makes a great deal of difference subjectively whether he knows what he is living out, whether he understands what he is doing, and whether he accepts responsibility for what he proposes to do or has done. The difference between conscious realization and the lack of it has been roundly formulated in the saying of Christ already quoted: “Man, if indeed thou knowest what thou doest, thou art blessed: but if thou knowest not, thou art cursed, and a transgressor of the law.”¹ Before the bar of nature and fate, unconsciousness is never accepted as an excuse; on the contrary there are very severe penalties for it. Hence all unconscious nature longs for the light of consciousness while frantically struggling against it at the same time.

[746] The conscious realization of what is hidden and kept secret certainly confronts us with an insoluble conflict; at least this is how it appears to the conscious mind. But the symbols that rise up out of the unconscious in dreams show it rather as a confrontation of opposites, and the images of the goal represent their successful reconciliation. Something empirically demonstrable comes to our aid from the depths of our unconscious nature. It is the task of the conscious mind to understand these hints. If this does not happen, the process of individuation will nevertheless continue. The only difference is that we become its victims and are dragged along by fate towards that inescapable goal which we might have reached walking upright, if only we had taken the trouble and been patient enough to understand in time the meaning of the numina that cross our path. The only thing that really matters now is whether man can climb up to a higher moral level, to a higher plane of consciousness, in order to be equal to the superhuman powers which the fallen angels have played into his hands. But he can make no progress with himself unless he becomes very much better acquainted with his own nature. Unfortunately, a terrifying ignorance prevails in this respect, and an equally great aversion to increasing the knowledge of his intrinsic character. However, in the most unexpected quarters nowadays we find people who can no longer blink the fact that something *ought* to be done with man in regard to his psychology. Unfortunately, the little word “ought” tells us that they do not know what to do, and do not know the way that leads to the goal. We can, of course, hope for the undeserved grace of God, who hears our prayers. But God, who

also does *not* hear our prayers, wants to become man, and for that purpose he has chosen, through the Holy Ghost, the creaturely man filled with darkness—the natural man who is tainted with original sin and who learnt the divine arts and sciences from the fallen angels. The guilty man is eminently suitable and is therefore chosen to become the vessel for the continuing incarnation, not the guiltless one who holds aloof from the world and refuses to pay his tribute to life, for in him the dark God would find no room.

[747] Since the Apocalypse we now know again that God is not only to be loved, but also to be feared. He fills us with evil as well as with good, otherwise he would not need to be feared; and because he wants to become man, the uniting of his antinomy must take place in man. This involves man in a new responsibility. He can no longer wriggle out of it on the plea of his littleness and nothingness, for the dark God has slipped the atom bomb and chemical weapons into his hands and given him the power to empty out the apocalyptic vials of wrath on his fellow creatures. Since he has been granted an almost godlike power, he can no longer remain blind and unconscious. He must know something of God's nature and of metaphysical processes if he is to understand himself and thereby achieve gnosis of the Divine.

XIX

[748] The promulgation of the new dogma of the Assumption of the Virgin Mary could, in itself, have been sufficient reason for examining the psychological background. It was interesting to note that, among the many articles published in the Catholic and Protestant press on the declaration of the dogma, there was not one, so far as I could see, which laid anything like the proper emphasis on what was undoubtedly the most powerful motive: namely, the popular movement and the psychological need behind it. Essentially, the writers of the articles were satisfied with learned considerations, dogmatic and historical, which have no bearing on the living religious process. But anyone who has followed with attention the visions of Mary which have been increasing in number over the last few decades, and has taken their psychological significance into account, might have known what was brewing. The fact, especially, that it was largely children who had the visions might have given pause for thought, for in such cases the collective unconscious is always at work. Incidentally, the Pope himself is rumoured to have had several visions of the Mother of God on the occasion of the declaration. One could have known for a long time that there was a deep longing in the masses for an intercessor and mediatrix who would at last take her place alongside the Holy Trinity and be received as the "Queen of Heaven and Bride at the heavenly court." For more than a thousand years it had been taken for granted that the Mother of God dwelt there, and we know from the Old Testament that Sophia was with God before the creation. From the ancient Egyptian theology of

the divine Pharaohs we know that God wants to become man by means of a human mother, and it was recognized even in prehistoric times that the primordial divine being is both male and female. But such a truth eventuates in time only when it is solemnly proclaimed or rediscovered. It is psychologically significant for our day that in the year 1950 the heavenly bride was united with the bridegroom. In order to interpret this event, one has to consider not only the arguments adduced by the Papal Bull, but the prefigurations in the apocalyptic marriage of the Lamb and in the Old Testament anamnesis of Sophia. The nuptial union in the *thalamus* (bridal-chamber) signifies the *hieros gamos*, and this in turn is the first step towards incarnation, towards the birth of the saviour who, since antiquity, was thought of as the *filius solis et lunae*, the *filius sapientiae*, and the equivalent of Christ. When, therefore, a longing for the exaltation of the Mother of God passes through the people, this tendency, if thought to its logical conclusion, means the desire for the birth of a saviour, a peacemaker, a “mediator pacem faciens inter inimicos.”¹ Although he is already born in the pleroma, his birth in time can only be accomplished when it is perceived, recognized, and declared by man.

[749] The motive and content of the popular movement which contributed to the Pope’s decision solemnly to declare the new dogma consist not in the birth of a new god, but in the continuing incarnation of God which began with Christ. Arguments based on historical criticism will never do justice to the new dogma; on the contrary, they are as lamentably wide of the mark as are the unqualified fears to which the English archbishops have given expression. In the first place, the declaration of the dogma has changed nothing in principle in the Catholic ideology as it has existed for more than a thousand years; and in the second place, the failure to understand that God has eternally wanted to become man, and for that purpose continually incarnates through the Holy Ghost in the temporal sphere, is an alarming symptom and can only mean that the Protestant standpoint has lost ground by not understanding the signs of the times and by ignoring the continued operation of the Holy Ghost. It is obviously out of touch with the tremendous archetypal happenings in the psyche of the individual and the masses, and with the symbols which are intended to compensate the truly apocalyptic world situation today.² It seems to have succumbed to a species of rationalistic historicism and to have lost any understanding of the Holy Ghost who works in the hidden places of the soul. It can therefore neither understand nor admit a further revelation of the divine drama.

[750] This circumstance has given me, a layman in things theological, cause to put forward my views on these dark matters. My attempt is based on the psychological experience I have harvested during the course of a long life. I do not underestimate the psyche in any respect whatsoever, nor do I imagine for a moment that psychic happenings vanish into thin air by being explained. Psychologism represents a still

primitive mode of magical thinking, with the help of which one hopes to conjure the reality of the soul out of existence, after the manner of the “Proktophantasmist” in *Faust*:

Are you still here? Nay, it's a thing unheard.

Vanish at once! We've said the enlightening word.

[751] One would be very ill advised to identify me with such a childish standpoint. However, I have been asked so often whether I believe in the existence of God or not that I am somewhat concerned lest I be taken for an adherent of “psychologism” far more commonly than I suspect. What most people overlook or seem unable to understand is the fact that I regard the psyche as *real*. They believe only in physical facts, and must consequently come to the conclusion that either the uranium itself or the laboratory equipment created the atom bomb. That is no less absurd than the assumption that a non-real psyche is responsible for it. God is an obvious psychic and non-physical fact, i.e., a fact that can be established psychically but not physically. Equally, these people have still not got it into their heads that the psychology of religion falls into two categories, which must be sharply distinguished from one another: firstly, the psychology of the religious person, and secondly, the psychology of religion proper, i.e., of religious contents.

[752] It is chiefly my experiences in the latter field which have given me the courage to enter into the discussion of the religious question and especially into the pros and cons of the dogma of the Assumption—which, by the way, I consider to be the most important religious event since the Reformation. It is a *petra scandali* for the unpsychological mind: how can such an unfounded assertion as the bodily reception of the Virgin into heaven be put forward as worthy of belief? But the method which the Pope uses in order to demonstrate the truth of the dogma makes sense to the psychological mind, because it bases itself firstly on the necessary prefigurations, and secondly on a tradition of religious assertions reaching back for more than a thousand years. Clearly, the material evidence for the existence of this psychic phenomenon is more than sufficient. It does not matter at all that a physically impossible fact is asserted, because all religious assertions are physical impossibilities. If they were not so, they would, as I said earlier, necessarily be treated in the text-books of natural science. But religious statements without exception have to do with the reality of the *psyche* and not with the reality of *physis*. What outrages the Protestant standpoint in particular is the boundless approximation of the Deipara to the Godhead and, in consequence, the endangered supremacy of Christ, from which Protestantism will not budge. In sticking to this point it has obviously failed to consider that its hymnology is full of references to the “heavenly bridegroom,” who is now suddenly supposed

not to have a bride with equal rights. Or has, perchance, the “bridegroom,” in true psychologistic manner, been understood as a mere metaphor?

[753] The logical consistency of the papal declaration cannot be surpassed, and it leaves Protestantism with the odium of being nothing but a *man's religion* which allows no metaphysical representation of woman. In this respect it is similar to Mithraism, and Mithraism found this prejudice very much to its detriment. Protestantism has obviously not given sufficient attention to the signs of the times which point to the equality of women. But this equality requires to be metaphysically anchored in the figure of a “divine” woman, the bride of Christ. Just as the person of Christ cannot be replaced by an organization, so the bride cannot be replaced by the Church. The feminine, like the masculine, demands an equally personal representation.

[754] The dogmatizing of the Assumption does not, however, according to the dogmatic view, mean that Mary has attained the status of a goddess, although, as mistress of heaven (as opposed to the prince of the sublunary aerial realm, Satan) and mediatrix, she is functionally on a par with Christ, the king and mediator. At any rate her position satisfies the need of the archetype. The new dogma expresses a renewed hope for the fulfilment of that yearning for peace which stirs deep down in the soul, and for a resolution of the threatening tension between the opposites. Everyone shares this tension and everyone experiences it in his individual form of unrest, the more so the less he sees any possibility of getting rid of it by rational means. It is no wonder, therefore, that the hope, indeed the expectation of divine intervention arises in the collective unconscious and at the same time in the masses. The papal declaration has given comforting expression to this yearning. How could Protestantism so completely miss the point? This lack of understanding can only be explained by the fact that the dogmatic symbols and hermeneutic allegories have lost their meaning for Protestant rationalism. This is also true, in some measure, of the opposition to the new dogma within the Catholic Church itself, or rather to the dogmatization of the old doctrine. Naturally, a certain degree of rationalism is better suited to Protestantism than it is to the Catholic outlook. The latter gives the archetypal symbolisms the necessary freedom and space in which to develop over the centuries while at the same time insisting on their original form, unperturbed by intellectual difficulties and the objections of rationalists. In this way the Catholic Church demonstrates her maternal character, because she allows the tree growing out of her matrix to develop according to its own laws. Protestantism, in contrast, is committed to the paternal spirit. Not only did it develop, at the outset, from an encounter with the worldly spirit of the times, but it continues this dialectic with the spiritual currents of every age; for the pneuma, in keeping with its original wind nature, is flexible, ever in living motion, comparable now to water, now to fire. It can

desert its original haunts, can even go astray and get lost, if it succumbs too much to the spirit of the age. In order to fulfil its task, the Protestant spirit must be full of unrest and occasionally troublesome; it must even be revolutionary, so as to make sure that tradition has an influence on the change of contemporary values. The shocks it sustains during this encounter modify and at the same time enliven the tradition, which in its slow progress through the centuries would, without these disturbances, finally arrive at complete petrification and thus lose its effect. By merely criticizing and opposing certain developments within the Catholic Church, Protestantism would gain only a miserable bit of vitality, unless, mindful of the fact that Christianity consists of two separate camps, or rather, is a disunited brother-sister pair, it remembers that besides defending its own existence it must acknowledge Catholicism's right to exist too. A brother who for theological reasons wanted to cut the thread of his elder sister's life would rightly be called inhuman—to say nothing of Christian charity—and the converse is also true. Nothing is achieved by merely negative criticism. It is justified only to the degree that it is creative. Therefore it would seem profitable to me if, for example, Protestantism admitted that it is shocked by the new dogma not only because it throws a distressing light on the gulf between brother and sister, but because, for fundamental reasons, a situation has developed within Christianity which removes it further than ever from the sphere of worldly understanding. Protestantism knows, or could know, how much it owes its very existence to the Catholic Church. How much or how little does the Protestant still possess if he can no longer criticize or protest? In view of the intellectual *skandalon* which the new dogma represents, he should remind himself of his Christian responsibility—"Am I my brother's (or in this case, my sister's) keeper?"—and examine in all seriousness the reasons, explicit or otherwise, that decided the declaration of the new dogma. In so doing, he should guard against casting cheap aspersions and would do well to assume that there is more in it than papal arbitrariness. It would be desirable for the Protestant to understand that the new dogma has placed upon him a new responsibility toward the worldly spirit of our age, for he cannot simply deny his problematical sister before the eyes of the world. He must, even if he finds her antipathetic, be fair to her if he does not want to lose his self-respect. For instance, this is a favourable opportunity for him to ask himself, for a change, what is the meaning not only of the new dogma but of all more or less dogmatic assertions over and above their literal concretism. Considering the arbitrary and protean state of his own dogmas, and the precarious, schism-riven condition of his Church, he cannot afford to remain rigid and impervious to the spirit of the age. And since, in accordance with his obligations to the *Zeitgeist*, he is more concerned to come to terms with the world and its ideas than with God, it would seem clearly indicated that, on the occasion of the entry of the Mother of God into the heavenly bridal-chamber, he should bend to the great task of reinterpreting all the Christian

traditions. If it is a question of truths which are anchored deep in the soul—and no one with the slightest insight can doubt this fact—then the solution of this task must be possible. For this we need the freedom of the spirit, which, as we know, is assured only in Protestantism. The dogma of the Assumption is a slap in the face for the historical and rationalistic view of the world, and would remain so for all time if one were to insist obstinately on the arguments of reason and history. This is a case, if ever there was one, where psychological understanding is needed, because the mythologem coming to light is so obvious that we must be deliberately blinding ourselves if we cannot see its symbolic nature and interpret it in symbolic terms.

[755] The dogmatization of the *Assumptio Mariae* points to the *hieros gamos* in the pleroma, and this in turn implies, as we have said, the future birth of the divine child, who, in accordance with the divine trend towards incarnation, will choose as his birthplace the empirical man. The metaphysical process is known to the psychology of the unconscious as the individuation process. In so far as this process, as a rule, runs its course un-unconsciously as it has from time immemorial, it means no more than that the acorn becomes an oak, the calf a cow, and the child an adult. But if the individuation process is made conscious, consciousness must confront the unconscious and a balance between the opposites must be found. As this is not possible through logic, one is dependent on *symbols* which make the irrational union of opposites possible. They are produced spontaneously by the unconscious and are amplified by the conscious mind. The central symbols of this process describe the self, which is man's totality, consisting on the one hand of that which is conscious to him, and on the other hand of the contents of the unconscious. The self is the *τάλειος; άνθρωπος*, the whole man, whose symbols are the divine child and its synonyms. This is only a very summary sketch of the process, but it can be observed at any time in modern man, or one can read about it in the documents of Hermetic philosophy from the Middle Ages. The parallelism between the symbols is astonishing to anyone who knows both the psychology of the unconscious and alchemy.

[756] The difference between the “natural” individuation process, which runs its course unconsciously, and the one which is consciously realized, is tremendous. In the first case consciousness nowhere intervenes; the end remains as dark as the beginning. In the second case so much darkness comes to light that the personality is permeated with light, and consciousness necessarily gains in scope and insight. The encounter between conscious and unconscious has to ensure that the light which shines in the darkness is not only comprehended by the darkness, but comprehends it. The *filus solis et lunae* is the symbol of the union of opposites as well as the catalyst of their union. It is the alpha and omega of the process, the mediator and intermedium. “It has a thousand names,” say the alchemists, meaning that the source from which the individuation process rises and the goal towards which it aims is nameless, ineffable.

[757] It is only through the psyche that we can establish that God acts upon us, but we are unable to distinguish whether these actions emanate from God or from the unconscious. We cannot tell whether God and the unconscious are two different entities. Both are border-line concepts for transcendental contents. But empirically it can be established, with a sufficient degree of probability, that there is in the unconscious an archetype of wholeness which manifests itself spontaneously in dreams, etc., and a tendency, independent of the conscious will, to relate other archetypes to this centre. Consequently, it does not seem improbable that the archetype of wholeness occupies as such a central position which approximates it to the God-image. The similarity is further borne out by the peculiar fact that the archetype produces a symbolism which has always characterized and expressed the Deity. These facts make possible a certain qualification of our above thesis concerning the indistinguishableness of God and the unconscious. Strictly speaking, the God-image does not coincide with the unconscious as such, but with a special content of it, namely the archetype of the self. It is this archetype from which we can no longer distinguish the God-image empirically. We can arbitrarily postulate a difference between these two entities, but that does not help us at all. On the contrary, it only helps us to separate man from God, and prevents God from becoming man. Faith is certainly right when it impresses on man's mind and heart how infinitely far away and inaccessible God is; but it also teaches his nearness, his immediate presence, and it is just this nearness which has to be empirically real if it is not to lose all significance. Only that which acts upon me do I recognize as real and actual. But that which has no effect upon me might as well not exist. The religious need longs for wholeness, and therefore lays hold of the images of wholeness offered by the unconscious, which, independently of the conscious mind, rise up from the depths of our psychic nature.

XX

[758] It will probably have become clear to the reader that the account I have given of the development of symbolic entities corresponds to a process of differentiation of human consciousness. But since, as I showed in the introduction, the archetypes in question are not mere objects of the mind, but are also autonomous factors, i.e., living subjects, the differentiation of consciousness can be understood as the effect of the intervention of transcendentially conditioned dynamisms. In this case it would be the archetypes that accomplish the primary transformation. But since, in our experience, there are no psychic conditions which could be observed *through introspection* outside the human being, the behaviour of the archetypes cannot be investigated at all without the interaction of the observing consciousness. Therefore the question as to whether the process is initiated by consciousness or by the

archetype can never be answered; unless, in contradiction to experience, one either robbed the archetype of its autonomy or degraded consciousness to a mere machine. We find ourselves in best agreement with psychological experience if we concede to the archetype a definite measure of independence, and to consciousness a degree of creative freedom proportionate to its scope. There then arises that reciprocal action between two relatively autonomous factors which compels us, when describing and explaining the processes, to present sometimes the one and sometimes the other factor as the acting subject, even when God becomes man. The Christian solution has hitherto avoided this difficulty by recognizing Christ as the one and only God-man. But the indwelling of the Holy Ghost, the third Divine Person, in man, brings about a Christification of many, and the question then arises whether these many are all complete God-men. Such a transformation would lead to insufferable collisions between them, to say nothing of the unavoidable inflation to which the ordinary mortal, who is not freed from original sin, would instantly succumb. In these circumstances it is well to remind ourselves of St. Paul and his split consciousness: on one side he felt he was the apostle directly called and enlightened by God, and, on the other side, a sinful man who could not pluck out the "thorn in the flesh" and rid himself of the Satanic angel who plagued him. That is to say, even the enlightened person remains what he is, and is never more than his own limited ego before the One who dwells within him, whose form has no knowable boundaries, who encompasses him on all sides, fathomless as the abysses of the earth and vast as the sky.

PART TWO

EASTERN RELIGION

VII

PSYCHOLOGICAL COMMENTARIES ON "THE TIBETAN BOOK OF THE GREAT LIBERATION" AND "THE TIBETAN BOOK OF THE DEAD"

PSYCHOLOGICAL COMMENTARY ON “THE TIBETAN BOOK OF THE GREAT LIBERATION”¹

1. THE DIFFERENCE BETWEEN EASTERN AND WESTERN THINKING

[759] Dr. Evans-Wentz has entrusted me with the task of commenting on a text which contains an important exposition of Eastern “psychology.” The very fact that I have to use quotation marks shows the dubious applicability of this term. It is perhaps not superfluous to mention that the East has produced nothing equivalent to what we call psychology, but rather philosophy or metaphysics. Critical philosophy, the mother of modern psychology, is as foreign to the East as to medieval Europe. Thus the word “mind,” as used in the East, has the connotation of something metaphysical. Our Western conception of mind has lost this connotation since the Middle Ages, and the word has now come to signify a “psychic function.” Despite the fact that we neither know nor pretend to know what “psyche” is, we can deal with the phenomenon of “mind.” We do not assume that the mind is a metaphysical entity or that there is any connection between an individual mind and a hypothetical Universal Mind. Our psychology is, therefore, a science of mere phenomena without any metaphysical implications. The development of Western philosophy during the last two centuries has succeeded in isolating the mind in its own sphere and in severing it from its primordial oneness with the universe. Man himself has ceased to be the microcosm and eidolon of the cosmos, and his “anima” is no longer the consubstantial *scintilla*, or spark of the *Anima Mundi*, the World Soul.

[760] Psychology accordingly treats all metaphysical claims and assertions as mental phenomena, and regards them as statements about the mind and its structure that derive ultimately from certain unconscious dispositions. It does not consider them to be absolutely valid or even capable of establishing a metaphysical truth. We have no intellectual means of ascertaining whether this attitude is right or wrong. We only know that there is no evidence for, and no possibility of proving, the validity of a metaphysical postulate such as “Universal Mind.” If the mind asserts the existence of a Universal Mind, we hold that it is merely making an assertion. We do not assume that by such an assertion the existence of a Universal Mind has been established. There is no argument against this reasoning, but no evidence, either, that our conclusion is ultimately right. In other words, it is just as possible that our mind is nothing but a perceptible manifestation of a Universal Mind. Yet we do not know,

and we cannot even see, how it would be possible to recognize whether this is so or not. Psychology therefore holds that the mind cannot establish or assert anything beyond itself.

[761] If, then, we accept the restrictions imposed upon the capacity of our mind, we demonstrate our common sense. I admit it is something of a sacrifice, inasmuch as we bid farewell to that miraculous world in which mind-created things and beings move and live. This is the world of the primitive, where even inanimate objects are endowed with a living, healing, magic power, through which they participate in us and we in them. Sooner or later we had to understand that their potency was really ours, and that their significance was our projection. The theory of knowledge is only the last step out of humanity's childhood, out of a world where mind-created figures populated a metaphysical heaven and hell.

[762] Despite this inevitable epistemological criticism, however, we have held fast to the religious belief that the organ of faith enables man to know God. The West thus developed a new disease: the conflict between science and religion. The critical philosophy of science became as it were negatively metaphysical—in other words, materialistic—on the basis of an error in judgment; matter was assumed to be a tangible and recognizable reality. Yet this is a thoroughly metaphysical concept hypostatized by uncritical minds. Matter is an hypothesis. When you say “matter,” you are really creating a symbol for something unknown, which may just as well be “spirit” or anything else; it may even be God. Religious faith, on the other hand, refuses to give up its pre-critical *Weltanschauung*. In contradiction to the saying of Christ, the faithful try to *remain* children instead of becoming *as* children. They cling to the world of childhood. A famous modern theologian confesses in his autobiography that Jesus has been his good friend “from childhood on.” Jesus is the perfect example of a man who preached something different from the religion of his forefathers. But the *imitatio Christi* does not appear to include the mental and spiritual sacrifice which he had to undergo at the beginning of his career and without which he would never have become a saviour.

[763] The conflict between science and religion is in reality a misunderstanding of both. Scientific materialism has merely introduced a new hypostasis, and that is an intellectual sin. It has given another name to the supreme principle of reality and has assumed that this created a new thing and destroyed an old thing. Whether you call the principle of existence “God,” “matter,” “energy,” or anything else you like, you have created nothing; you have simply changed a symbol. The materialist is a metaphysician *malgré lui*. Faith, on the other hand, tries to retain a primitive mental condition on merely sentimental grounds. It is unwilling to give up the primitive, childlike relationship to mind-created and hypostatized figures; it wants to go on enjoying the security and confidence of a world still presided over by powerful,

responsible, and kindly parents. Faith may include a *sacrificium intellectus* (provided there is an intellect to sacrifice), but certainly not a sacrifice of feeling. In this way the faithful *remain* children instead of becoming *as* children, and they do not gain their life because they have not lost it. Furthermore, faith collides with science and thus gets its deserts, for it refuses to share in the spiritual adventure of our age.

[764] Any honest thinker has to admit the insecurity of all metaphysical positions, and in particular of all creeds. He has also to admit the unwarrantable nature of all metaphysical assertions and face the fact that there is no evidence whatever for the ability of the human mind to pull itself up by its own bootstrings, that is, to establish anything transcendental.

[765] Materialism is a metaphysical reaction against the sudden realization that cognition is a mental faculty and, if carried beyond the human plane, a projection. The reaction was “metaphysical” in so far as the man of average philosophical education failed to see through the implied hypostasis, not realizing that “matter” was just another name for the supreme principle. As against this, the attitude of faith shows how reluctant people were to accept philosophical criticism. It also demonstrates how great is the fear of letting go one’s hold on the securities of childhood and of dropping into a strange, unknown world ruled by forces unconcerned with man. Nothing really changes in either case; man and his surroundings remain the same. He has only to realize that he is shut up inside his mind and cannot step beyond it, even in insanity; and that the appearance of his world or of his gods very much depends upon his own mental condition.

[766] In the first place, the structure of the mind is responsible for anything we may assert about metaphysical matters, as I have already pointed out. We have also begun to understand that the intellect is not an *ens per se*, or an independent mental faculty, but a psychic function dependent upon the conditions of the psyche as a whole. A philosophical statement is the product of a certain personality living at a certain time in a certain place, and not the outcome of a purely logical and impersonal procedure. To that extent it is chiefly subjective; whether it has an objective validity or not depends on whether there are few or many persons who argue in the same way. The isolation of man within his mind as a result of epistemological criticism has naturally led to psychological criticism. This kind of criticism is not popular with the philosophers, since they like to consider the philosophic intellect as the perfect and unconditioned instrument of philosophy. Yet this intellect of theirs is a function dependent upon an individual psyche and determined on all sides by subjective conditions, quite apart from environmental influences. Indeed, we have already become so accustomed to this point of view that “mind” has lost its universal character altogether. It has become a more or less individualized affair, with no trace of its former cosmic aspect as the *anima rationalis*. Mind is understood nowadays as

a subjective, even an arbitrary, thing. Now that the formerly hypostatized “universal ideas” have turned out to be mental principles, it is dawning upon us to what an extent our whole experience of so-called reality is psychic; as a matter of fact, everything thought, felt, or perceived is a psychic image, and the world itself exists only so far as we are able to produce an image of it. We are so deeply impressed with the truth of our imprisonment in, and limitation by, the psyche that we are ready to admit the existence in it even of things we do *not* know: we call them “the unconscious.”

[767] The seemingly universal and metaphysical scope of the mind has thus been narrowed down to the small circle of individual consciousness, profoundly aware of its almost limitless subjectivity and of its infantile-archaic tendency to heedless projection and illusion. Many scientifically-minded persons have even sacrificed their religious and philosophical leanings for fear of uncontrolled subjectivism. By way of compensation for the loss of a world that pulsed with our blood and breathed with our breath, we have developed an enthusiasm for *facts*—mountains of facts, far beyond any single individual’s power to survey. We have the pious hope that this incidental accumulation of facts will form a meaningful whole, but nobody is quite sure, because no human brain can possibly comprehend the gigantic sum total of this mass-produced knowledge. The facts bury us, but whoever dares to speculate must pay for it with a bad conscience—and rightly so, for he will instantly be tripped up by the facts.

[768] Western psychology knows the mind as the mental functioning of a psyche. It is the “mentality” of an individual. An impersonal Universal Mind is still to be met with in the sphere of philosophy, where it seems to be a relic of the original human “soul.” This picture of our Western outlook may seem a little drastic, but I do not think it is far from the truth. At all events, something of the kind presents itself as soon as we are confronted with the Eastern mentality. In the East, mind is a cosmic factor, the very essence of existence; while in the West we have just begun to understand that it is the essential condition of cognition, and hence of the cognitive existence of the world. There is no conflict between religion and science in the East, because no science is there based upon the passion for facts, and no religion upon mere faith; there is religious cognition and cognitive religion.² With us, man is incommensurably small and the grace of God is everything; but in the East, man is God and he redeems himself. The gods of Tibetan Buddhism belong to the sphere of illusory separateness and mind-created projections, and yet they exist; but so far as we are concerned an illusion remains an illusion, and thus is nothing at all. It is a paradox, yet nevertheless true, that with us a thought has no proper reality; we treat it as if it were a nothingness. Even though the thought be true in itself, we hold that it exists only by virtue of certain facts which it is said to formulate. We can produce a

most devastating fact like the atom bomb with the help of this ever-changing phantasmagoria of virtually nonexistent thoughts, but it seems wholly absurd to us that one could ever establish the reality of thought itself.

[769] “Psychic reality” is a controversial concept, like “psyche” or “mind.” By the latter terms some understand consciousness and its contents, others allow the existence of “dark” or “subconscious” representations. Some include instincts in the psychic realm, others exclude them. The vast majority consider the psyche to be a result of biochemical processes in the brain cells. A few conjecture that it is the psyche that makes the cortical cells function. Some identify “life” with psyche. But only an insignificant minority regards the psychic phenomenon as a category of existence *per se* and draws the necessary conclusions. It is indeed paradoxical that *the* category of existence, the indispensable *sine qua non* of all existence, namely the psyche, should be treated as if it were only semi-existent. Psychic existence is the only category of existence of which we have *immediate* knowledge, since nothing can be known unless it first appears as a psychic image. Only psychic existence is immediately verifiable. To the extent that the world does not assume the form of a psychic image, it is virtually non-existent. This is a fact which, with few exceptions—as for instance in Schopenhauer’s philosophy—the West has not yet fully realized. But Schopenhauer was influenced by Buddhism and by the Upanishads.

[770] Even a superficial acquaintance with Eastern thought is sufficient to show that a fundamental difference divides East and West. The East bases itself upon psychic reality, that is, upon the psyche as the main and unique condition of existence. It seems as if this Eastern recognition were a psychological or temperamental fact rather than a result of philosophical reasoning. It is a typically introverted point of view, contrasted with the equally typical extraverted point of view of the West.³ Introversion and extraversion are known to be temperamental or even constitutional attitudes which are never intentionally adopted in normal circumstances. In exceptional cases they may be produced at will, but only under very special conditions. Introversion is, if one may so express it, the “style” of the East, an habitual and collective attitude, just as extraversion is the “style” of the West. Introversion is felt here as something abnormal, morbid, or otherwise objectionable. Freud identifies it with an autoerotic, “narcissistic” attitude of mind. He shares his negative position with the National Socialist philosophy of modern Germany,⁴ which accuses introversion of being an offence against community feeling. In the East, however, our cherished extraversion is depreciated as illusory desirousness, as existence in the *samsāra*, the very essence of the *nidāna-chain* which culminates in the sum of the world’s sufferings.⁵ Anyone with practical knowledge of the mutual depreciation of values between introvert and extravert will understand the emotional conflict between the Eastern and the Western standpoint. For those who know

something of the history of European philosophy the bitter wrangling about “universals” which began with Plato will provide an instructive example. I do not wish to go into all the ramifications of this conflict between introversion and extraversion, but I must mention the religious aspects of the problem. The Christian West considers man to be wholly dependent upon the grace of God, or at least upon the Church as the exclusive and divinely sanctioned earthly instrument of man’s redemption. The East, however, insists that man is the sole cause of his higher development, for it believes in “self-liberation.”

[771] The religious point of view always expresses and formulates the essential psychological attitude and its specific prejudices, even in the case of people who have forgotten, or who have never heard of, their own religion. In spite of everything, the West is thoroughly Christian as far as its psychology is concerned. Tertullian’s *anima naturaliter christiana* holds true throughout the West—not, as he thought, in the religious sense, but in a psychological one. Grace comes from elsewhere; at all events from outside. Every other point of view is sheer heresy. Hence it is quite understandable why the human psyche is suffering from undervaluation. Anyone who dares to establish a connection between the psyche and the idea of God is immediately accused of “psychologism” or suspected of morbid “mysticism.” The East, on the other hand, compassionately tolerates those “lower” spiritual stages where man, in his blind ignorance of karma, still bothers about sin and tortures his imagination with a belief in absolute gods, who, if he only looked deeper, are nothing but the veil of illusion woven by his own unenlightened mind. The psyche is therefore all-important; it is the all-pervading Breath, the Buddha-essence; it is the Buddha-Mind, the One, the *Dharmakāya*. All existence emanates from it, and all separate forms dissolve back into it. This is the basic psychological prejudice that permeates Eastern man in every fibre of his being, seeping into all his thoughts, feelings, and deeds, no matter what creed he professes.

[772] In the same way Western man is Christian, no matter to what denomination his Christianity belongs. For him man is small inside, he is next to nothing; moreover, as Kierkegaard says, “before God man is always wrong.” By fear, repentance, promises, submission, self-abasement, good deeds, and praise he propitiates the great power, which is not himself but *totaliter aliter*, the Wholly Other, altogether perfect and “outside,” the only reality.⁶ If you shift the formula a bit and substitute for God some other power, for instance the world or money, you get a complete picture of Western man—assiduous, fearful, devout, self-abasing, enterprising, greedy, and violent in his pursuit of the goods of this world: possessions, health, knowledge, technical mastery, public welfare, political power, conquest, and so on. What are the great popular movements of our time? Attempts to grab the money or property of others and to protect our own. The mind is chiefly employed in devising suitable “isms” to hide the

real motives or to get more loot. I refrain from describing what would happen to Eastern man should he forget his ideal of Buddhahood, for I do not want to give such an unfair advantage to my Western prejudices. But I cannot help raising the question of whether it is possible, or indeed advisable, for either to imitate the other's standpoint. The difference between them is so vast that one can see no reasonable possibility of this, much less its advisability. You cannot mix fire and water. The Eastern attitude stultifies the Western, and vice versa. You cannot be a good Christian and redeem yourself, nor can you be a Buddha and worship God. It is much better to accept the conflict, for it admits only of an irrational solution, if any.

[773] By an inevitable decree of fate the West is becoming acquainted with the peculiar facts of Eastern spirituality. It is useless either to belittle these facts, or to build false and treacherous bridges over yawning gaps. Instead of learning the spiritual techniques of the East by heart and imitating them in a thoroughly Christian way—*imitatio Christi!*;—with a correspondingly forced attitude, it would be far more to the point to find out whether there exists in the unconscious an introverted tendency similar to that which has become the guiding spiritual principle of the East. We should then be in a position to build on our own ground with our own methods. If we snatch these things directly from the East, we have merely indulged our Western acquisitiveness, confirming yet again that “everything good is outside,” whence it has to be fetched and pumped into our barren souls.⁷ It seems to me that we have really learned something from the East when we understand that the psyche contains riches enough without having to be primed from outside, and when we feel capable of evolving out of ourselves with or without divine grace. But we cannot embark upon this ambitious enterprise until we have learned how to deal with our spiritual pride and blasphemous self-assertiveness. The Eastern attitude violates the specifically Christian values, and it is no good blinking this fact. If our new attitude is to be genuine, i.e., grounded in our own history, it must be acquired with full consciousness of the Christian values and of the conflict between them and the introverted attitude of the East. We must get at the Eastern values from within and not from without, seeking them in ourselves, in the unconscious. We shall then discover how great is our fear of the unconscious and how formidable are our resistances. Because of these resistances we doubt the very thing that seems so obvious to the East, namely, the *self-liberating power of the introverted mind*.

[774] This aspect of the mind is practically unknown to the West, though it forms the most important component of the unconscious. Many people flatly deny the existence of the unconscious, or else they say that it consists merely of instincts, or of repressed or forgotten contents that were once part of the conscious mind. It is safe to assume that what the East calls “mind” has more to do with our “unconscious” than with mind as we understand it, which is more or less identical with consciousness. To us,

consciousness is inconceivable without an ego; it is equated with the relation of contents to an ego. If there is no ego there is nobody to be conscious of anything. The ego is therefore indispensable to the conscious process. The Eastern mind, however, has no difficulty in conceiving of a consciousness without an ego. Consciousness is deemed capable of transcending its ego condition; indeed, in its “higher” forms, the ego disappears altogether. Such an ego-less mental condition can only be unconscious to us, for the simple reason that there would be nobody to witness it. I do not doubt the existence of mental states transcending consciousness. But they lose their consciousness to exactly the same degree that they transcend consciousness. I cannot imagine a conscious mental state that does not relate to a subject, that is, to an ego. The ego may be depotentiated—divested, for instance, of its awareness of the body—but so long as there is awareness of something, there must be somebody who is aware. The unconscious, however, is a mental condition of which no ego is aware. It is only by indirect means that we eventually become conscious of the existence of an unconscious. We can observe the manifestation of unconscious fragments of the personality, detached from the patient’s consciousness, in insanity. But there is no evidence that the unconscious contents are related to an unconscious centre analogous to the ego; in fact there are good reasons why such a centre is not even probable.

[775] The fact that the East can dispose so easily of the ego seems to point to a mind that is not to be identified with our “mind.” Certainly the ego does not play the same role in Eastern thought as it does with us. It seems as if the Eastern mind were less egocentric, as if its contents were more loosely connected with the subject, and as if greater stress were laid on mental states which include a depotentiated ego. It also seems as if *hatha* yoga were chiefly useful as a means for extinguishing the ego by fettering its unruly impulses. There is no doubt that the higher forms of yoga, in so far as they strive to reach *samādhi*, seek a mental condition in which the ego is practically dissolved. Consciousness in our sense of the word is rated a definitely inferior condition, the state of *avidyā* (ignorance), whereas what we call the “dark background of consciousness” is understood to be a “higher” consciousness.⁸ Thus our concept of the “collective unconscious” would be the European equivalent of *buddhi*, the enlightened mind.

[776] In view of all this, the Eastern form of “sublimation” amounts to a withdrawal of the centre of psychic gravity from ego-consciousness, which holds a middle position between the body and the ideational processes of the psyche. The lower, semi-physiological strata of the psyche are subdued by *askesis*, i.e., exercises, and kept under control. They are not exactly denied or suppressed by a supreme effort of the will, as is customary in Western sublimation. Rather, the lower psychic strata are adapted and shaped through the patient practice of *hatha* yoga until they no longer

interfere with the development of “higher” consciousness. This peculiar process seems to be aided by the fact that the ego and its desires are checked by the greater importance which the East habitually attaches to the “subjective factor.”⁹ By this I mean the “dark background” of consciousness, the unconscious. The introverted attitude is characterized in general by an emphasis on the *a priori* data of apperception. As is well known, the act of apperception consists of two phases: first the perception of the object, second the assimilation of the perception to a preexisting pattern or concept by means of which the object is “comprehended.” The psyche is not a nonentity devoid of all quality; it is a definite system made up of definite conditions and it reacts in a specific way. Every new representation, be it a perception or a spontaneous thought, arouses associations which derive from the storehouse of memory. These leap immediately into consciousness, producing the complex picture of an “impression,” though this is already a sort of interpretation. The unconscious disposition upon which the quality of the impression depends is what I call the “subjective factor.” It deserves the qualification “subjective” because objectivity is hardly ever conferred by a first impression. Usually a rather laborious process of verification, comparison, and analysis is needed to modify and adapt the immediate reactions of the subjective factor.

[777] The prominence of the subjective factor does not imply a *personal subjectivism*, despite the readiness of the extraverted attitude to dismiss the subjective factor as “nothing but” subjective. The psyche and its structure are real enough. They even transform material objects into psychic images, as we have said. They do not perceive waves, but sound; not wave-lengths, but colours. Existence is as we see and understand it. There are innumerable things that can be seen, felt, and understood in a great variety of ways. Quite apart from merely personal prejudices, the psyche assimilates external facts in its own way, which is based ultimately upon the laws or patterns of apperception. These laws do not change, although different ages or different parts of the world call them by different names. On a primitive level people are afraid of witches; on the modern level we are apprehensively aware of microbes. There everybody believes in ghosts, here everybody believes in vitamins. Once upon a time men were possessed by devils, now they are not less obsessed by ideas, and so on.

[778] The subjective factor is made up, in the last resort, of the eternal patterns of psychic functioning. Anyone who relies upon the subjective factor is therefore basing himself on the reality of psychic law. So he can hardly be said to be wrong. If by this means he succeeds in extending his consciousness downwards, to touch the basic laws of psychic life, he is in possession of that truth which the psyche will naturally evolve if not fatally interfered with by the non-psychic, i.e., the external, world. At any rate, his truth could be weighed against the sum of all knowledge acquired

through the investigation of externals. We in the West believe that a truth is satisfactory only if it can be verified by external facts. We believe in the most exact observation and exploration of nature; our truth must coincide with the behaviour of the external world, otherwise it is merely “subjective.” In the same way that the East turns its gaze from the dance of *prakriti* (physis) and from the multitudinous illusory forms of *māyā*, the West shuns the unconscious and its futile fantasies. Despite its introverted attitude, however, the East knows very well how to deal with the external world. And despite its extraversions the West, too, has a way of dealing with the psyche and its demands; it has an institution called the Church, which gives expression to the unknown psyche of man through its rites and dogmas. Nor are natural science and modern techniques by any means the invention of the West. Their Eastern equivalents are somewhat old-fashioned, or even primitive. But what we have to show in the way of spiritual insight and psychological technique must seem, when compared with yoga, just as backward as Eastern astrology and medicine when compared with Western science. I do not deny the efficacy of the Christian Church; but, if you compare the *Exercitia* of Ignatius Loyola with yoga, you will take my meaning. There is a difference, and a big one. To jump straight from that level into Eastern yoga is no more advisable than the sudden transformation of Asian peoples into half-baked Europeans. I have serious doubts as to the blessings of Western civilization, and I have similar misgivings as to the adoption of Eastern spirituality by the West. Yet the two contradictory worlds have met. The East is in full transformation; it is thoroughly and fatally disturbed. Even the most efficient methods of European warfare have been successfully imitated. The trouble with us seems to be far more psychological. Our blight is ideologies—they are the long-expected Antichrist! National Socialism comes as near to being a religious movement as any movement since A.D. 622.^{9a} Communism claims to be paradise come to earth again. We are far better protected against failing crops, inundations, epidemics, and invasions from the Turk than we are against our own deplorable spiritual inferiority, which seems to have little resistance to psychic epidemics.

[779] In its religious attitude, too, the West is extraverted. Nowadays it is gratuitously offensive to say that Christianity implies hostility, or even indifference, to the world and the flesh. On the contrary, the good Christian is a jovial citizen, an enterprising business man, an excellent soldier, the very best in every profession there is. Worldly goods are often interpreted as special rewards for Christian behaviour, and in the Lord’s Prayer the adjective *ἀπιοῦσιος*, *supersubstantialis*,¹⁰ referring to the bread, has long since been omitted, for the real bread obviously makes so very much more sense! It is only logical that extraversion, when carried to such lengths, cannot credit man with a psyche which contains anything not imported into it from outside, either by human teaching or divine grace. From this point of view it is downright

blasphemy to assert that man has it in him to accomplish his own redemption. Nothing in our religion encourages the idea of the self-liberating power of the mind. Yet a very modern form of psychology—"analytical" or "complex" psychology—envisages the possibility of there being certain processes in the unconscious which, by virtue of their symbolism, compensate the defects and anfractuositities of the conscious attitude. When these unconscious compensations are made conscious through the analytical technique, they produce such a change in the conscious attitude that we are entitled to speak of a new level of consciousness. The method cannot, however, produce the actual process of unconscious compensation; for that we depend upon the unconscious psyche or the "grace of God"—names make no difference. But the unconscious process itself hardly ever reaches consciousness without technical aid. When brought to the surface, it reveals contents that offer a striking contrast to the general run of conscious thinking and feeling. If that were not so, they would not have a compensatory effect. The first effect, however, is usually a conflict, because the conscious attitude resists the intrusion of apparently incompatible and extraneous tendencies, thoughts, feelings, etc. Schizophrenia yields the most startling examples of such intrusions of utterly foreign and unacceptable contents. In schizophrenia it is, of course, a question of pathological distortions and exaggerations, but anybody with the slightest knowledge of the normal material will easily recognize the sameness of the underlying patterns. It is, as a matter of fact, the same imagery that one finds in mythology and other archaic thought-forms.

[780] Under normal conditions, every conflict stimulates the mind to activity for the purpose of creating a satisfactory solution. Usually—i.e., in the West—the conscious standpoint arbitrarily decides against the unconscious, since anything coming from inside suffers from the prejudice of being regarded as inferior or somehow wrong. But in the cases with which we are here concerned it is tacitly agreed that the apparently incompatible contents shall not be suppressed again, and that the conflict shall be accepted and suffered. At first no solution appears possible, and this fact, too, has to be borne with patience. The suspension thus created "constellates" the unconscious—in other words, the conscious suspense produces a new compensatory reaction in the unconscious. This reaction (usually manifested in dreams) is brought to conscious realization in its turn. The conscious mind is thus confronted with a new aspect of the psyche, which arouses a different problem or modifies an old one in an unexpected way. The procedure is continued until the original conflict is satisfactorily resolved. The whole process is called the "transcendent function." It is a process and a method at the same time. The production of unconscious compensations is a spontaneous *process*; the conscious realization is a *method*. The function is called "transcendent" because it facilitates the transition from one psychic condition to another by means of the mutual confrontation of opposites.

[781] This is a very sketchy description of the transcendent function, and for details I must refer the reader to the relevant literature.¹¹ But I felt it necessary to call attention to these psychological observations and methods because they indicate the way by which we may find access to the sort of “mind” referred to in our text. This is the image-creating mind, the matrix of all those patterns that give apperception its peculiar character. These patterns are inherent in the unconscious “mind”; they are its structural elements, and they alone can explain why certain mythological motifs are more or less ubiquitous, even where migration as a means of transmission is exceedingly improbable. Dreams, fantasies, and psychoses produce images to all appearances identical with mythological motifs of which the individuals concerned had absolutely no knowledge, not even indirect knowledge acquired through popular figures of speech or through the symbolic language of the Bible.¹² The psychopathology of schizophrenia, as well as the psychology of the unconscious, demonstrate the production of archaic material beyond a doubt. Whatever the structure of the unconscious may be, one thing is certain: it contains an indefinite number of motifs or patterns of an archaic character, in principle identical with the root ideas of mythology and similar thought-forms.

[782] Because the unconscious is the matrix mind, the quality of creativeness attaches to it. It is the birthplace of thought-forms such as our text considers the Universal Mind to be. Since we cannot attribute any particular form to the unconscious, the Eastern assertion that the Universal Mind is without form, the *arupaloka*, yet is the source of all forms, seems to be psychologically justified. In so far as the forms or patterns of the unconscious belong to no time in particular, being seemingly eternal, they convey a peculiar feeling of timelessness when consciously realized. We find similar statements in primitive psychology: for instance, the Australian word *aljira*¹³ means ‘dream’ as well as ‘ghostland’ and the ‘time’ in which the ancestors lived and still live. It is, as they say, the ‘time when there was no time.’ This looks like an obvious concretization and projection of the unconscious with all its characteristic qualities—its dream manifestations, its ancestral world of thought-forms, and its timelessness.

[783] An introverted attitude, therefore, which withdraws its emphasis from the external world (the world of consciousness) and localizes it in the subjective factor (the background of consciousness) necessarily calls forth the characteristic manifestations of the unconscious, namely, archaic thought-forms imbued with “ancestral” or “historic” feeling, and, beyond them, the sense of indefiniteness, timelessness, oneness. The extraordinary feeling of oneness is a common experience in all forms of “mysticism” and probably derives from the general contamination of contents, which increases as consciousness dims. The almost limitless contamination of images in dreams, and particularly in the products of insanity, testifies to their

unconscious origin. In contrast to the clear distinction and differentiation of forms in consciousness, unconscious contents are incredibly vague and for this reason capable of any amount of contamination. If we tried to conceive of a state in which nothing is distinct, we should certainly feel the whole as one. Hence it is not unlikely that the peculiar experience of oneness derives from the subliminal awareness of all-contamination in the unconscious.

[784] By means of the transcendent function we not only gain access to the “One Mind” but also come to understand why the East believes in the possibility of self-liberation. If, through introspection and the conscious realization of unconscious compensations, it is possible to transform one’s mental condition and thus arrive at a solution of painful conflicts, one would seem entitled to speak of “self-liberation.” But, as I have already hinted, there is a hitch in this proud claim to self-liberation, for a man cannot produce these unconscious compensations at will. He has to rely upon the possibility that they *may* be produced. Nor can he alter the peculiar character of the compensation: *est ut est aut non est*—‘it is as it is or it isn’t at all.’ It is a curious thing that Eastern philosophy seems to be almost unaware of this highly important fact. And it is precisely this fact that provides the psychological justification for the Western point of view. It seems as if the Western mind had a most penetrating intuition of man’s fateful dependence upon some dark power which must co-operate if all is to be well. Indeed, whenever and wherever the unconscious fails to co-operate, man is instantly at a loss, even in his most ordinary activities. There may be a failure of memory, of co-ordinated action, or of interest and concentration; and such failure may well be the cause of serious annoyance, or of a fatal accident, a professional disaster, or a moral collapse. Formerly, men called the gods unfavourable: now we prefer to call it a neurosis, and we seek the cause in lack of vitamins, in endocrine disturbances, overwork, or sex. The co-operation of the unconscious, which is something we never think of and always take for granted, is, when it suddenly fails, a very serious matter indeed.

[785] In comparison with other races—the Chinese for instance—the white man’s mental equilibrium, or to put it bluntly, his brain, seems to be his tender spot. We naturally try to get as far away from our weaknesses as possible, a fact which may explain the sort of extraversion that is always seeking security by dominating its surroundings. Extraversion goes hand in hand with mistrust of the inner man. If indeed there is any consciousness of him at all. Moreover, we all tend to undervalue the things we are afraid of. There must be some such reason for our absolute conviction that *nihil est in intellectu quod non antea fuerit in sensu*, which is the motto of Western extraversion. But as we have emphasized, this extraversion is psychologically justified by the vital fact that unconscious compensation lies beyond man’s control. I know that yoga prides itself on being able to control even the

unconscious processes, so that nothing can happen in the psyche as a whole that is not ruled by a supreme consciousness. I have not the slightest doubt that such a condition is more or less possible. But it is possible only at the price of becoming identical with the unconscious. Such an identity is the Eastern equivalent of our Western fetish of “complete objectivity,” the machine-like subservience to one goal, to one idea or cause, at the cost of losing every trace of inner life. From the Eastern point of view this complete objectivity is appalling, for it amounts to complete identity with the *samsāra*; to the West, on the other hand, *samādhi* is nothing but a meaningless dream-state. In the East, the inner man has always had such a firm hold on the outer man that the world had no chance of tearing him away from his inner roots; in the West, the outer man gained the ascendancy to such an extent that he was alienated from his innermost being. The One Mind, Oneness, indefiniteness, and eternity remained the prerogative of the One God. Man became small, futile, and essentially in the wrong.

[786] I think it is becoming clear from my argument that the two standpoints, however contradictory, each have their psychological justification. Both are one-sided in that they fail to see and take account of those factors which do not fit in with their typical attitude. The one underrates the world of consciousness, the other the world of the One Mind. The result is that, in their extremism, both lose one half of the universe; their life is shut off from total reality, and is apt to become artificial and inhuman. In the West, there is the mania for “objectivity,” the asceticism of the scientist or of the stockbroker, who throw away the beauty and universality of life for the sake of the ideal, or not so ideal, goal. In the East, there is the wisdom, peace, detachment, and inertia of a psyche that has returned to its dim origins, having left behind all the sorrow and joy of existence as it is and, presumably, ought to be. No wonder that one-sidedness produces very similar forms of monasticism in both cases, guaranteeing to the hermit, the holy man, the monk or the scientist unswerving singleness of purpose. I have nothing against one-sidedness as such. Man, the great experiment of nature, or his own great experiment, is evidently entitled to all such undertakings—if he can endure them. Without one-sidedness the spirit of man could not unfold in all its diversity. But I do not think there is any harm in trying to understand both sides.

[787] The extraverted tendency of the West and the introverted tendency of the East have one important purpose in common: both make desperate efforts to conquer the mere naturalness of life. It is the assertion of mind over matter, the *opus contra naturam*, a symptom of the youthfulness of man, still delighting in the use of the most powerful weapon ever devised by nature: the conscious mind. The afternoon of humanity, in a distant future, may yet evolve a different ideal. In time, even conquest will cease to be the dream.

2. COMMENTS ON THE TEXT

[788] Before embarking upon the commentary proper, I must not omit to call the reader's attention to the very marked difference between the tenor of a psychological dissertation and that of a sacred text. A scientist forgets all too easily that the impartial handling of a subject may violate its emotional values, often to an unpardonable degree. The scientific intellect is inhuman and cannot afford to be anything else; it cannot avoid being ruthless in effect, though it may be well-intentioned in motive. In dealing with a sacred text, therefore, the psychologist ought at least to be aware that his subject represents an inestimable religious and philosophical value which should not be desecrated by profane hands. I confess that I myself venture to deal with such a text only because I know and appreciate its value. In commenting upon it I have no intention whatsoever of anatomizing it with heavy-handed criticism. On the contrary, my endeavour will be to amplify its symbolic language so that it may yield itself more easily to our understanding. To this end, it is necessary to bring down its lofty metaphysical concepts to a level where it is possible to see whether any of the psychological facts known to us have parallels in, or at least border upon, the sphere of Eastern thought. I hope this will not be misunderstood as an attempt to belittle or to banalize; my aim is simply to bring ideas which are alien to our way of thinking within reach of Western psychological experience.

[789] What follows is a series of notes and comments which should be read together with the textual sections indicated by the titles.

The Obeisance

[790] Eastern texts usually begin with a statement which in the West would come at the end, as the *conclusio finalis* to a long argument. We would begin with things generally known and accepted, and would end with the most important item of our investigation. Hence our dissertation would conclude with the sentence: "Therefore the *Trikāya* is the All-Enlightened Mind itself." In this respect, the Eastern mentality is not so very different from the medieval. As late as the eighteenth century our books on history or natural science began, as here, with God's decision to create a world. The idea of a Universal Mind is a commonplace in the East, since it aptly expresses the introverted Eastern temperament. Put into psychological language, the above sentence could be paraphrased thus: The unconscious is the root of all experience of oneness (*dharmakāya*), the matrix of all archetypes or structural patterns (*sambhogakāya*), and the *conditio sine qua non* of the phenomenal world (*nirmānakāya*).

The Foreword

[791] The gods are archetypal thought-forms belonging to the *sambhogakāya*.¹⁴ Their peaceful and wrathful aspects, which play a great role in the meditations of the Tibetan Book of the Dead, symbolize the opposites. In the *nirmānakāya* these opposites are no more than human conflicts, but in the *sambhogakāya* they are the positive and negative principles united in one and the same figure. This corresponds to the psychological experience, also formulated in Lao-tzu's *Tao Teh Ching*, that there is no position without its negation. Where there is faith, there is doubt; where there is doubt, there is credulity; where there is morality, there is temptation. Only saints have diabolical visions, and tyrants are the slaves of their *valets de chambre*. If we carefully scrutinize our own character we shall inevitably find that, as Lao-tzu says, "high stands on low," which means that the opposites condition one another, that they are really one and the same thing. This can easily be seen in persons with an inferiority complex: they foment a little megalomania somewhere. The fact that the opposites appear as gods comes from the simple recognition that they are exceedingly powerful. Chinese philosophy therefore declared them to be cosmic principles, and named them *yang* and *yin*. Their power increases the more one tries to separate them. "When a tree grows up to heaven its roots reach down to hell," says Nietzsche. Yet, above as below, it is the same tree. It is characteristic of our Western mentality that we should separate the two aspects into antagonistic personifications: God and the Devil. And it is equally characteristic of the worldly optimism of Protestantism that it should have hushed up the Devil in a tactful sort of way, at any rate in recent times. *Omne bonum a Deo, omne malum ab homine* is the uncomfortable consequence.

[792] The "seeing of reality" clearly refers to Mind as the supreme reality. In the West, however, the unconscious is considered to be a fantastic irreality. The "seeing of the Mind" implies self-liberation. This means, psychologically, that the more weight we attach to unconscious processes the more we detach ourselves from the world of desires and of separated opposites, and the nearer we draw to the state of unconsciousness with its qualities of oneness, indefiniteness, and timelessness. This is truly a liberation of the self from its bondage to strife and suffering. "By this method, one's mind is understood." Mind in this context is obviously the individual's mind, that is, his psyche. Psychology can agree in so far as the understanding of the unconscious is one of its foremost tasks.

Salutation to the One Mind

[793] This section shows very clearly that the One Mind is the unconscious, since it is characterized as "eternal, unknown, not visible, not recognized." But it also displays positive features which are in keeping with Eastern experience. These are the attributes "ever clear, ever existing, radiant and unobscured." It is an undeniable

psychological fact that the more one concentrates on one's unconscious contents the more they become charged with energy; they become vitalized, as if illuminated from within. In fact they turn into something like a substitute reality. In analytical psychology we make methodical use of this phenomenon. I have called the method "active imagination." Ignatius Loyola also made use of active imagination in his *Exercitia*. There is evidence that something similar was used in the meditations of alchemical philosophy.¹⁵

The Result of Not Knowing the One Mind

[794] "Knowledge of that which is vulgarly called mind is widespread." This clearly refers to the conscious mind of everybody, in contrast to the One Mind which is unknown, i.e., unconscious. These teachings "will also be sought after by ordinary individuals who, not knowing the One Mind, do not know themselves." Self-knowledge is here definitely identified with "knowing the One Mind," which means that knowledge of the unconscious is essential for any understanding of one's own psychology. The desire for such knowledge is a well-established fact in the West, as evidenced by the rise of psychology in our time and a growing interest in these matters. The public desire for more psychological knowledge is largely due to the suffering which results from the disuse of religion and from the lack of spiritual guidance. "They wander hither and thither in the Three Regions ... suffering sorrow." As we know what a neurosis can mean in moral suffering, this statement needs no comment. This section formulates the reasons why we have such a thing as the psychology of the unconscious today.

[795] Even if one wishes "to know the mind as it is, one fails." The text again stresses how hard it is to gain access to the basic mind, because it is unconscious.

The Results of Desires

[796] Those "fettered by desires cannot perceive the Clear Light." The "Clear Light" again refers to the One Mind. Desires crave for external fulfilment. They forge the chain that fetters man to the world of consciousness. In that condition he naturally cannot become aware of his unconscious contents. And indeed there is a healing power in withdrawing from the conscious world—up to a point. Beyond that point, which varies with individuals, withdrawal amounts to neglect and repression.

[797] Even the "Middle Path" finally becomes "obscured by desires." This is a very true statement, which cannot be dinned too insistently into European ears. Patients and normal individuals, on becoming acquainted with their unconscious material, hurl themselves upon it with the same heedless desirousness and greed that before had engulfed them in their extraversion. The problem is not so much a withdrawal from the objects of desire, as a more detached attitude to desire as such, no matter

what its object. We cannot compel unconscious compensation through the impetuosity of uncontrolled desire. We have to wait patiently to see whether it will come of its own accord, and put up with whatever form it takes. Hence we are forced into a sort of contemplative attitude which, in itself, not rarely has a liberating and healing effect.

The Transcendent At-one-ment

[798] “There being really no duality, pluralism is untrue.” This is certainly one of the most fundamental truths of the East. There are no opposites—it is the same tree above and below. The *Tabula smaragdina* says: “Quod est inferius est sicut quod est superius. Et quod est superius est sicut quod est inferius, ad perpetranda miracula rei unius.”¹⁶ Pluralism is even more illusory, since all separate forms originate in the indistinguishable oneness of the psychic matrix, deep down in the unconscious. The statement made by our text refers psychologically to the subjective factor, to the material immediately constellated by a stimulus, i.e., the first impression which, as we have seen, interprets every new perception in terms of previous experience. “Previous experience” goes right back to the instincts, and thus to the inherited and inherent patterns of psychic functioning, the ancestral and “eternal” laws of the human mind. But the statement entirely ignores the possible transcendent reality of the physical world as such, a problem not unknown to Sankhya philosophy, where *prakriti* and *purusha*—so far as they are a polarization of Universal Being—form a cosmic dualism that can hardly be circumvented. One has to close one’s eyes to dualism and pluralism alike, and forget all about the existence of a world, as soon as one tries to identify oneself with the monistic origin of life. The questions naturally arise: “Why should the One appear as the Many, when ultimate reality is All-One? What is the cause of pluralism, or of the illusion of pluralism? If the One is pleased with itself, why should it mirror itself in the Many? Which after all is the more real, the one that mirrors itself, or the mirror it uses?” Probably we should not ask such questions, seeing that there is no answer to them.

[799] It is psychologically correct to say that “At-one-ment” is attained by withdrawal from the world of consciousness. In the stratosphere of the unconscious there are no more thunderstorms, because nothing is differentiated enough to produce tensions and conflicts. These belong to the surface of our reality.

[800] The Mind in which the irreconcilables—*samsāra* and *nirvāna*—are united is ultimately our mind. Does this statement spring from profound modesty or from overweening hybris? Does it mean that the Mind is “nothing but” our mind? Or that our mind is the Mind? Assuredly it means the latter, and from the Eastern point of view there is no hybris in this; on the contrary, it is a perfectly acceptable truth, whereas with us it would amount to saying “I am God.” This is an incontestable

“mystical” experience, though a highly objectionable one to the Westerner; but in the East, where it derives from a mind that has never lost touch with the instinctual matrix, it has a very different value. The collective introverted attitude of the East did not permit the world of the senses to sever the vital link with the unconscious; psychic reality was never seriously disputed, despite the existence of so-called materialistic speculations. The only known analogy to this fact is the mental condition of the primitive, who confuses dream and reality in the most bewildering way. Naturally we hesitate to call the Eastern mind primitive, for we are deeply impressed with its remarkable civilization and differentiation. Yet the primitive mind is its matrix, and this is particularly true of that aspect of it which stresses the validity of psychic phenomena, such as relate to ghosts and spirits. The West has simply cultivated the other aspect of primitivity, namely, the scrupulously accurate observation of nature at the expense of abstraction. Our natural science is the epitome of primitive man’s astonishing powers of observation. We have added only a moderate amount of abstraction, for fear of being contradicted by the facts. The East, on the other hand, cultivates the psychic aspect of primitivity together with an inordinate amount of abstraction. Facts make excellent stories but not much more.

[801] Thus, if the East speaks of the Mind as being inherent in everybody, no more hybris or modesty is involved than in the European’s belief in facts, which are mostly derived from man’s own observation and sometimes from rather less than his observation, to wit, his interpretation. He is, therefore, quite right to be afraid of too much abstraction.

The Great Self-Liberation

[802] I have mentioned more than once that the shifting of the basic personality-feeling to the less conscious mental sphere has a liberating effect. I have also described, somewhat cursorily, the transcendent function which produces the transformation of personality, and I have emphasized the importance of spontaneous unconscious compensation. Further, I have pointed out the neglect of this crucial fact in yoga. This section tends to confirm my observations. The grasping of “the whole essence of these teachings” seems also to be the whole essence of “self-liberation.” The Westerner would take this to mean: “Learn your lesson and repeat it, and then you will be self-liberated.” That, indeed, is precisely what happens with most Western practitioners of yoga. They are very apt to “do” it in an extraverted fashion, oblivious of the inturning of the mind which is the essence of such teachings. In the East, the “truths” are so much a part of the collective consciousness that they are at least intuitively grasped by the pupil. If the European could turn himself inside out and live as an Oriental, with all the social, moral, religious, intellectual, and aesthetic obligations which such a course would involve, he might be able to benefit by these

teachings. But you cannot be a good Christian, either in your faith or in your morality or in your intellectual make-up, and practise genuine yoga at the same time. I have seen too many cases that have made me sceptical in the highest degree. The trouble is that Western man cannot get rid of his history as easily as his short-legged memory can. History, one might say, is written in the blood. I would not advise anyone to touch yoga without a careful analysis of his unconscious reactions. What is the use of imitating yoga if your dark side remains as good a medieval Christian as ever? If you can afford to seat yourself on a gazelle skin under a Bo-tree or in the cell of a *gompa* for the rest of your life without being troubled by politics or the collapse of your securities, I will look favourably upon your case. But yoga in Mayfair or Fifth Avenue, or in any other place which is on the telephone, is a spiritual fake.

[803] Taking the mental equipment of Eastern man into account, we may suppose that the teaching is effective. But unless one is prepared to turn away from the world and to disappear into the unconscious for good, mere teaching has no effect, or at least not the desired one. For this the union of opposites is necessary, and in particular the difficult task of reconciling extraversion and introversion by means of the transcendent function.

The Nature of Mind

[804] This section contains a valuable piece of psychological information. The text says: "The mind is of intuitive ("quick-knowing") Wisdom." Here "mind" is understood to be identical with immediate awareness of the "first impression" which conveys the whole sum of previous experience based upon instinctual patterns. This bears out our remarks about the essentially introverted prejudice of the East. The formula also draws attention to the highly differentiated character of Eastern intuition. The intuitive mind is noted for its disregard of facts in favour of possibilities.¹⁷

[805] The assertion that the Mind "has no existence" obviously refers to the peculiar "potentiality" of the unconscious. A thing seems to exist only to the degree that we are aware of it, which explains why so many people are disinclined to believe in the existence of an unconscious. When I tell a patient that he is chock full of fantasies, he is often astonished beyond all measure, having been completely unaware of the fantasy-life he was leading.

The Names Given to the Mind

[806] The various terms employed to express a "difficult" or "obscure" idea are a valuable source of information about the ways in which that idea can be interpreted, and at the same time an indication of its doubtful or controversial nature even in the country, religion, or philosophy to which it is indigenous. If the idea were perfectly

straightforward and enjoyed general acceptance, there would be no reason to call it by a number of different names. But when something is little known, or ambiguous, it can be envisaged from different angles, and then a multiplicity of names is needed to express its peculiar nature. A classical example of this is the philosophers' stone; many of the old alchemical treatises give long lists of its names.

[807] The statement that “the various names given to it [the Mind] are innumerable” proves that the Mind must be something as vague and indefinite as the philosophers' stone. A substance that can be described in “innumerable” ways must be expected to display as many qualities or facets. If these are really “innumerable,” they cannot be counted, and it follows that the substance is well-nigh indescribable and unknowable. It can never be realized completely. This is certainly true of the unconscious, and a further proof that the Mind is the Eastern equivalent of our concept of the unconscious, more particularly of the collective unconscious.

[808] In keeping with this hypothesis, the text goes on to say that the Mind is also called the “Mental Self.” The “self” is an important concept in analytical psychology, where much has been said that I need not repeat here. I would refer the interested reader to the literature given below.¹⁸ Although the symbols of the “self” are produced by unconscious activity and are mostly manifested in dreams,¹⁹ the facts which the idea covers are not merely mental; they include aspects of physical existence as well. In this and other Eastern texts the “Self” represents a purely spiritual idea, but in Western psychology the “self” stands for a totality which comprises instincts, physiological and semi-physiological phenomena. To us a purely spiritual totality is inconceivable for the reasons mentioned above.²⁰

[809] It is interesting to note that in the East, too, there are “heretics” who identify the Self with the ego.²¹ With us this heresy is pretty widespread and is subscribed to by all those who firmly believe that ego-consciousness is the only form of psychic life.

[810] The Mind as “the means of attaining the Other Shore” points to a connection between the transcendent function and the idea of the Mind or Self. Since the unknowable substance of the Mind, i.e., of the unconscious, always represents itself to consciousness in the form of symbols—the self being one such symbol—the symbol functions as a “means of attaining the Other Shore,” in other words, as a means of transformation. In my essay on psychic energy I said that the symbol acts as a transformer of energy.²²

[811] My interpretation of the Mind or Self as a symbol is not arbitrary; the text itself calls it “The Great Symbol.”

[812] It is also remarkable that our text recognizes the “potentiality” of the unconscious, as formulated above, by calling the Mind the “Sole Seed” and the “Potentiality of Truth.”

[813] The matrix-character of the unconscious comes out in the term “All-Foundation.”

[814] I have already explained this “timelessness” as a quality inherent in the experience of the collective unconscious. The application of the “yoga of self-liberation” is said to reintegrate all forgotten knowledge of the past with consciousness. The motif of *ἀποκατάστασις* (restoration, restitution) occurs in many redemption myths and is also an important aspect of the psychology of the unconscious, which reveals an extraordinary amount of archaic material in the dreams and spontaneous fantasies of normal and insane people. In the systematic analysis of an individual the spontaneous reawakening of ancestral patterns (as a compensation) has the effect of a restoration. It is also a fact that premonitory dreams are relatively frequent, and this substantiates what the text calls “knowledge of the future.”

[815] The Mind’s “own time” is very difficult to interpret. From the psychological point of view we must agree with Dr. Evans-Wentz’s comment here.²³ The unconscious certainly has its “own time” inasmuch as past, present, and future are blended together in it. Dreams of the type experienced by J. W. Dunne,²⁴ where he dreamed the night before what he ought logically to have dreamed the night after, are not infrequent.

Mind in Its True State

[816] This section describes the state of detached consciousness²⁵ which corresponds to a psychic experience very common throughout the East. Similar descriptions are to be found in Chinese literature, as, for instance, in the *Hui Ming Ch’ing*:

A luminosity surrounds the world of spirit.

We forget one another when, still and pure, we draw strength from the Void.

The Void is filled with the light of the Heart of Heaven ... Consciousness dissolves in vision.²⁶

[817] The statement “Nor is one’s own mind separable from other minds” is another way of expressing the fact of “all-contamination.” Since all distinctions vanish in the unconscious condition, it is only logical that the distinction between separate minds should disappear too. “Wherever there is a lowering of the conscious level we come across instances of unconscious identity,²⁷ or what Lévy-Bruhl calls “participation mystique.”²⁸ The realization of the One Mind is, as our text says, the “at-one-ment of the *Trikāya*”; in fact it creates the at-one-ment. But we are unable to imagine how such a realization could ever be complete in any human individual. There must always be somebody or something left over to experience the realization, to say “I know at-one-ment, I know there is no distinction.” The very fact of the realization proves its inevitable incompleteness. One cannot know something that is not distinct from oneself. Even when I say “I know myself,” an infinitesimal ego—the knowing

“I”—is still distinct from “myself.” In this as it were atomic ego, which is completely ignored by the essentially non-dualist standpoint of the East, there nevertheless lies hidden the whole unabolished pluralistic universe and its unconquered reality.

[818] The experience of “at-one-ment” is one example of those “quick-knowing” realizations of the East, an intuition of what it would be like if one could exist and not exist at the same time. If I were a Moslem, I should maintain that the power of the All-Compassionate is infinite, and that He alone can make a man to be and not to be at the same time. But for my part I cannot conceive of such a possibility. I therefore assume that, in this point, Eastern intuition has overreached itself.

Mind Is Non-Created

[819] This section emphasizes that as the Mind is without characteristics, one cannot assert that it is created. But then, it would be illogical to assert that it is non-created, for such a qualification would amount to a “characteristic.” As a matter of fact you can make no assertion whatever about a thing that is indistinct, void of characteristics and, moreover, “unknowable.” For precisely this reason Western psychology does not speak of the One Mind, but of the unconscious, regarding it as a thing-in-itself, a noumenon, “a merely negative borderline concept,” to quote Kant.²⁹ We have often been reproached for using such a negative term, but unfortunately intellectual honesty does not allow a positive one.

The Yoga of Introspection

[820] Should there be any doubt left concerning the identity of the One Mind and the unconscious, this section certainly ought to dispel it. “The One Mind being verily of the Voidness and without any foundation, one’s mind is, likewise, as vacuous as the sky.” The One Mind and the individual mind are equally void and vacuous. Only the collective and the personal unconscious can be meant by this statement, for the conscious mind is in no circumstances “vacuous.”

[821] As I have said earlier, the Eastern mind insists first and foremost upon the subjective factor, and in particular upon the intuitive “first impression,” or the psychic disposition. This is borne out by the statement that “All appearances are verily one’s own concepts, self-conceived in the mind.”

The Dharma Within

[822] *Dharma*, law, truth, guidance, is said to be “nowhere save in the mind.” Thus the unconscious is credited with all those faculties which the West attributes to God. The transcendent function, however, shows how right the East is in assuming that the complex experience of *dharma* comes from “within,” i.e., from the unconscious. It

also shows that the phenomenon of spontaneous compensation, being beyond the control of man, is quite in accord with the formula “grace” or the “will of God.”

[823] This and the preceding section insist again and again that introspection is the only source of spiritual information and guidance. If introspection were something morbid, as certain people in the West opine, we should have to send practically the whole East, or such parts of it as are not yet infected with the blessings of the West, to the lunatic asylum.

The Wondrousness of These Teachings

[824] This section calls the mind “Natural Wisdom,” which is very much the same expression that I used in order to designate the symbols produced by the unconscious. I called them “natural symbols.”³⁰ I chose the term before I had any knowledge of this text. I mention this fact simply because it illustrates the close parallelism between the findings of Eastern and Western psychology.

[825] The text also confirms what we said earlier about the impossibility of a “knowing” ego. “Although it is Total Reality, there is no perceiver of it. “Wondrous is this.” Wondrous indeed, and incomprehensible; for how could such a thing ever be *realized* in the true sense of the word? “It remains undefiled by evil” and “it remains unallied to good.” One is reminded of Nietzsche’s “six thousand feet beyond good and evil.” But the consequences of such a statement are usually ignored by the emulators of Eastern wisdom. While one is safely ensconced in one’s cosy flat, secure in the favour of the Oriental gods, one is free to admire this lofty moral indifference. But does it agree with our temperament, or with our history, which is not thereby conquered but merely forgotten? I think not. Anyone who affects the higher yoga will be called upon to prove his professions of moral indifference, not only as the doer of evil but, even more, as its victim. As psychologists well know, the moral conflict is not to be settled merely by a declaration of superiority bordering on inhumanity. We are witnessing today some terrifying examples of the Superman’s aloofness from moral principles.

[826] I do not doubt that the Eastern liberation from vices, as well as from virtues, is coupled with detachment in every respect, so that the yogi is translated beyond this world, and quite inoffensive. But I suspect every European attempt at detachment of being mere liberation from moral considerations. Anybody who tries his hand at yoga ought therefore to be conscious of its far-reaching consequences, or else his so-called quest will remain a futile pastime.

The Fourfold Great Path

[827] The text says: “This meditation [is] devoid of mental concentration.” The usual assumption about yoga is that it chiefly consists in intense concentration. We think

we know what concentration means, but it is very difficult to arrive at a real understanding of Eastern concentration. Our sort may well be just the opposite of the Eastern, as a study of Zen Buddhism will show.³¹ However, if we take “devoid of mental concentration” literally, it can only mean that the meditation does not centre upon anything. Not being centred, it would be rather like a dissolution of consciousness and hence a direct approach to the unconscious condition. Consciousness always implies a certain degree of concentration, without which there would be no clarity of mental content and no consciousness of anything. Meditation without concentration would be a waking but empty condition, on the verge of falling asleep. Since our text calls this “the most excellent of meditations” we must suppose the existence of less excellent meditations which, we infer, would be characterized by more concentration. The meditation our text has in mind seems to be a sort of Royal Road to the unconscious.

The Great Light

[828] The central mystical experience of enlightenment is aptly symbolized by Light in most of the numerous forms of mysticism. It is a curious paradox that the approach to a region which seems to us the way into utter darkness should yield the light of illumination as its fruit. This is, however, the usual *enantiodromia per tenebras ad lucem*. Many initiation ceremonies³² stage a *κατάβασις εἰς ἄντρον* (descent into the cave), a diving down into the depths of the baptismal water, or a return to the womb of rebirth. Rebirth symbolism simply describes the union of opposites—conscious and unconscious—by means of concretistic analogies. Underlying all rebirth symbolism is the transcendent function. Since this function results in an increase of consciousness (the previous condition augmented by the addition of formerly unconscious contents), the new condition carries more insight, which is symbolized by more light.³³ It is therefore a more enlightened state compared with the relative darkness of the previous state. In many cases the Light even appears in the form of a vision.

The Yoga of the Nirvanic Path

[829] This section gives one of the best formulations of the complete dissolution of consciousness, which appears to be the goal of this yoga: “There being no two such things as action and performer of action, if one seeks the performer of action and no performer of action be found anywhere, thereupon the goal of all fruit-obtaining is reached and also the final consummation itself.”

[830] With this very complete formulation of the method and its aim, I reach the end of my commentary. The text that follows, in Book II, is of great beauty and wisdom, and contains nothing that requires further comment. It can be translated into

psychological language and interpreted with the help of the principles I have here set forth in Part I and illustrated in Part II.

PSYCHOLOGICAL COMMENTARY ON "THE TIBETAN BOOK OF THE DEAD"¹

[831] Before embarking upon the psychological commentary, I should like to say a few words about the text itself. The Tibetan Book of the Dead, or the *Bardo Thödol*, is a book of instructions for the dead and dying. Like the Egyptian Book of the Dead, it is meant to be a guide for the dead man during the period of his *Bardo* existence, symbolically described as an intermediate state of forty-nine days' duration between death and rebirth. The text falls into three parts. The first part, called *Chikhai Bardo*, describes the psychic happenings at the moment of death. The second part, or *Chönyid Bardo*, deals with the dream-state which supervenes immediately after death, and with what are called "karmic illusions." The third part, or *Sidpa Bardo*, concerns the onset of the birth-instinct and of prenatal events. It is characteristic that supreme insight and illumination, and hence the greatest possibility of attaining liberation, are vouchsafed during the actual process of dying. Soon afterward, the "illusions" begin which lead eventually to reincarnation, the illuminative lights growing ever fainter and more multifarious, and the visions more and more terrifying. This descent illustrates the estrangement of consciousness from the liberating truth as it approaches nearer and nearer to physical rebirth. The purpose of the instruction is to fix the attention of the dead man, at each successive stage of delusion and entanglement, on the ever-present possibility of liberation, and to explain to him the nature of his visions. The text of the *Bardo Thödol* is recited by the lama in the presence of the corpse.

[832] I do not think I could better discharge my debt of thanks to the two previous translators of the *Bardo Thödol*, the late Lama Kazi Dawa-Samdup and Dr. Evans-Wentz, than by attempting, with the aid of a psychological commentary, to make the magnificent world of ideas and the problems contained in this treatise a little more intelligible to the Western mind. I am sure that all who read this book with open eyes, and who allow it to impress itself upon them without prejudice, will reap a rich reward.

*

[833] The *Bardo Thödol*, fitly named by its editor, Dr. W. Y. Evans-Wentz, "The Tibetan Book of the Dead," caused a considerable stir in English-speaking countries at the time of its first appearance in 1927. It belongs to that class of writings which are not only of interest to specialists in Mahayana Buddhism, but which also, because of their deep humanity and their still deeper insight into the secrets of the human

psyche, make an especial appeal to the layman who is seeking to broaden his knowledge of life. For years, ever since it was first published, the *Bardo Thödol* has been my constant companion, and to it I owe not only many stimulating ideas and discoveries, but also many fundamental insights. Unlike the Egyptian Book of the Dead, which always prompts one to say too much or too little, the *Bardo Thödol* offers one an intelligible philosophy addressed to human beings rather than to gods or primitive savages. Its philosophy contains the quintessence of Buddhist psychological criticism; and, as such, one can truly say that it is of an unexampled sublimity. Not only the “wrathful” but also the “peaceful” deities are conceived as samsaric projections of the human psyche, an idea that seems all too obvious to the enlightened European, because it reminds him of his own banal simplifications. But though the European can easily explain away these deities as projections, he would be quite incapable of positing them at the same time as real. The *Bardo Thödol* can do that, because, in certain of its most essential metaphysical premises, it has the enlightened as well as the unenlightened European at a disadvantage. The ever-present, unspoken assumption of the *Bardo Thödol* is the antinomian character of all metaphysical assertions, and also the idea of the qualitative difference of the various levels of consciousness and of the metaphysical realities conditioned by them. The background of this unusual book is not the niggardly European “either-or,” but a magnificently affirmative “both-and.” This statement may appear objectionable to the Western philosopher, for the West loves clarity and unambiguity; consequently, one philosopher clings to the position, “God is,” while another clings equally fervently to the negation, “God is not.” What would these hostile brethren make of an assertion like the following [p. 96]:

Recognizing the voidness of thine own intellect to be Buddhahood, and knowing it at the same time to be thine own consciousness, thou shalt abide in the state of the divine mind of the Buddha.

[834] Such an assertion is, I fear, as unwelcome to our Western philosophy as it is to our theology. The *Bardo Thödol* is in the highest degree psychological in its outlook; but, with us, philosophy and theology are still in the medieval, pre-psychological stage where only the assertions are listened to, explained, defended, criticized and disputed, while the authority that makes them has, by general consent, been deposed as outside the scope of discussion.

[835] Metaphysical assertions, however, are *statements of the psyche*, and are therefore psychological. To the Western mind, which compensates its well-known feelings of resentment by a slavish regard for “rational” explanations, this obvious truth seems all too obvious, or else it is seen as an inadmissible negation of metaphysical “truth.” Whenever the Westerner hears the word “psychological,” it always sounds to him like “*only* psychological.” For him the “soul” is something pitifully small, unworthy,

personal, subjective, and a lot more besides. He therefore prefers to use the word “mind” instead, though he likes to pretend at the same time that a statement which may in fact be very subjective indeed is made by the “mind,” naturally by the “Universal Mind,” or even—at a pinch—by the “Absolute” itself. This rather ridiculous presumption is probably a compensation for the regrettable smallness of the soul. It almost seems as if Anatole France had uttered a truth which were valid for the whole Western world when, in his *Penguin Island*, Cathérine d’Alexandrie offers this advice to God: “Donnez-leur une âme, mais une petite!”

[836] It is the psyche which, by the divine creative power inherent in it, makes the metaphysical assertion; it posits the distinctions between metaphysical entities. Not only is it the condition of all metaphysical reality, it is that reality.

[837] With this great psychological truth the *Bardo Thödol* opens. The book is not a ceremonial of burial, but a set of instructions for the dead, a guide through the changing phenomena of the *Bardo* realm, that state of existence which continues for forty-nine days after death until the next incarnation. If we disregard for the moment the supratemporality of the soul—which the East accepts as a self-evident fact—we, as readers of the *Bardo Thödol*, shall be able to put ourselves without difficulty in the position of the dead man, and shall consider attentively the teaching set forth in the opening section, which is outlined in the quotation above. At this point, the following words are spoken, not presumptuously, but in a courteous manner [pp. 95f.]:

O nobly born (so and so), listen. Now thou art experiencing the Radiance of the Clear Light of Pure Reality. Recognize it. O nobly-born, thy present intellect, in real nature void, not formed into anything as regards characteristics or colour, naturally void, is the very Reality, the All-Good.

Thine own intellect, which is now voidness, yet not to be regarded as of the voidness of nothingness, but as being the intellect itself, unobstructed, shining, thrilling, and blissful, is the very consciousness, the All-good Buddha.

[838] This realization is the *Dharmakāya* state of perfect enlightenment; or, as we should express it in our own language, the creative ground of all metaphysical assertion is consciousness, as the invisible, intangible manifestation of the soul. The “Voidness” is the state transcendent over all assertion and all predication. The fulness of its discriminative manifestations still lies latent in the soul.

[839] The text continues:

Thine own consciousness, shining, void, and inseparable from the Great Body of Radiance, hath no birth, nor death, and is the Immutable Light—Buddha Amitābha.

[840] The soul is assuredly not small, but the radiant Godhead itself. The West finds this statement either very dangerous, if not downright blasphemous, or else accepts it unthinkingly and then suffers from a theosophical inflation. Somehow we always have a wrong attitude to these things. But if we can master ourselves far enough to

refrain from our chief error of always wanting to *do* something with things and put them to practical use, we may perhaps succeed in learning an important lesson from these teachings, or at least in appreciating the greatness of the *Bardo Thödol*, which vouchsafes to the dead man the ultimate and highest truth, that even the gods are the radiance and reflection of our own souls. No sun is thereby eclipsed for the Oriental as it would be for the Christian, who would feel robbed of his God; on the contrary, his soul is the light of the Godhead, and the Godhead is the soul. The East can sustain this paradox better than the unfortunate Angelus Silesius, who even today would be psychologically far in advance of his time.

[841] It is highly sensible of the *Bardo Thödol* to make clear to the dead man the primacy of the psyche, for that is the one thing which life does not make clear to us. We are so hemmed in by things which jostle and oppress that we never get a chance, in the midst of all these “given” things, to wonder by whom they are “given.” It is from this world of “given” things that the dead man liberates himself; and the purpose of the instruction is to help him towards this liberation. We, if we put ourselves in his place, shall derive no lesser reward from it, since we learn from the very first paragraphs that the “giver” of all “given” things dwells within us. This is a truth which in the face of all evidence, in the greatest things as in the smallest, is never known, although it is often so very necessary, indeed vital, for us to know it. Such knowledge, to be sure, is suitable only for contemplatives who are minded to understand the purpose of existence, for those who are Gnostics by temperament and therefore believe in a saviour who, like the saviour of the Mandaeans, is called “knowledge of life” (Manda d’Hayye). Perhaps it is not granted to many of us to see the world as something “given.” A great reversal of standpoint, calling for much sacrifice, is needed before we can see the world as “given” by the very nature of the psyche. It is so much more straightforward, more dramatic, impressive, and therefore more convincing, to see all the things that happen to me than to observe how I make them happen. Indeed, the animal nature of man makes him resist seeing himself as the maker of his circumstances. That is why attempts of this kind were always the object of secret initiations, culminating as a rule in a figurative death which symbolized the total character of this reversal. And, in point of fact, the instruction given in the *Bardo Thödol* serves to recall to the dead man the experiences of his initiation and the teachings of his guru, for the instruction is, at bottom, nothing less than an initiation of the dead into the *Bardo* life, just as the initiation of the living was a preparation for the Beyond. Such was the case, at least, with all the mystery cults in ancient civilizations from the time of the Egyptian and Eleusinian mysteries. In the initiation of the living, however, this “Beyond” is not a world beyond death, but a reversal of the mind’s intentions and outlook, a psychological “Beyond” or, in Christian terms, a “redemption” from the trammels of the world and of sin.

Redemption is a separation and deliverance from an earlier condition of darkness and unconsciousness, and leads to a condition of illumination and releasedness, to victory and transcendence over everything “given.”

[842] Thus far the *Bardo Thödol* is, as Dr. Evans-Wentz also feels, an initiation process whose purpose it is to restore to the soul the divinity it lost at birth. Now it is a characteristic of Oriental religious literature that the teaching invariably begins with the most important item, with the ultimate and highest principles which, with us, would come last—as for instance in Apuleius, where Lucius is worshipped as Helios only right at the end. Accordingly, in the *Bardo Thödol*, the initiation is a series of diminishing climaxes ending with rebirth in the womb. The only “initiation process” that is still alive and practised today in the West is the analysis of the unconscious as used by doctors for therapeutic purposes. This penetration into the ground-layers of consciousness is a kind of rational maieutics in the Socratic sense, a bringing forth of psychic contents that are still germinal, subliminal, and as yet unborn. Originally, this therapy took the form of Freudian psychoanalysis and was mainly concerned with sexual fantasies. This is the realm that corresponds to the last and lowest region of the *Bardo*, known as the *Sidpa Bardo*, where the dead man, unable to profit by the teachings of the *Chikhai* and *Chönyid Bardo*, begins to fall a prey to sexual fantasies and is attracted by the vision of mating couples. Eventually he is caught by a womb and born into the earthly world again. Meanwhile, as one might expect, the Oedipus complex starts functioning. If his karma destines him to be reborn as a man, he will fall in love with his mother-to-be and will find his father hateful and disgusting. Conversely, the future daughter will be highly attracted by her father-to-be and repelled by her mother. The European passes through this specifically Freudian domain when his unconscious contents are brought to light under analysis, but he goes in the reverse direction. He journeys back through the world of infantile-sexual fantasy to the womb. It has even been suggested in psychoanalytical circles that the trauma par excellence is the birth-experience itself—nay more, psychoanalysts even claim to have probed back to memories of intra-uterine origin. Here Western reason reaches its limit, unfortunately. I say “unfortunately,” because one rather wishes that Freudian psychoanalysis could have happily pursued these so-called intra-uterine experiences still further back. Had it succeeded in this bold undertaking, it would surely have come out beyond the *Sidpa Bardo* and penetrated from behind into the lower reaches of the *Chönyid Bardo*. It is true that, with the equipment of our existing biological ideas, such a venture would not have been crowned with success; it would have needed a wholly different kind of philosophical preparation from that based on current scientific assumptions. But, had the journey back been consistently pursued, it would undoubtedly have led to the postulate of a pre-uterine existence, a true *Bardo* life, if only it had been possible to find at least some trace of an experiencing

subject. As it was, the psychoanalysts never got beyond purely conjectural traces of intra-uterine experiences, and even the famous “birth trauma” has remained such an obvious truism that it can no longer explain anything, any more than can the hypothesis that life is a disease with a bad prognosis because its outcome is always fatal.

[843] Freudian psychoanalysis, in all essential aspects, never went beyond the experiences of the *Sidpa Bardo*; that is, it was unable to extricate itself from sexual fantasies and similar “incompatible” tendencies which cause anxiety and other affective states. Nevertheless, Freud’s theory is the first attempt made by the West to investigate, as if from below, from the animal sphere of instinct, the psychic territory that corresponds in Tantric Lamaism to the *Sidpa Bardo*. A very justifiable fear of metaphysics prevented Freud from penetrating into the sphere of the “occult.” In addition to this, the *Sidpa* state, if we are to accept the psychology of the *Sidpa Bardo*, is characterized by the fierce wind of karma, which whirls the dead man along until he comes to the “womb-door.” In other words, the *Sidpa* state permits of no going back, because it is sealed off against the *Chönyid* state by an intense striving downwards, towards the animal sphere of instinct and physical rebirth. That is to say, anyone who penetrates into the unconscious with purely biological assumptions will become stuck in the instinctual sphere and be unable to advance beyond it, for he will be pulled back again and again into physical existence. It is therefore not possible for Freudian theory to reach anything except an essentially negative valuation of the unconscious. It is a “nothing but.” At the same time, it must be admitted that this view of the psyche is typically Western, only it is expressed more blatantly, more plainly, and more ruthlessly than others would have dared to express it, though at bottom they think no differently. As to what “mind” means in this connection, we can only cherish the hope that it will carry conviction. But, as even Max Scheler² noted with regret, the power of this “mind” is, to say the least of it, doubtful.

[844] I think, then, we can state it as a fact that with the aid of psychoanalysis the rationalizing mind of the West has pushed forward into what one might call the neuroticism of the *Sidpa* state, and has there been brought to an inevitable standstill by the uncritical assumption that everything psychological is subjective and personal. Even so, this advance has been a great gain, inasmuch as it has enabled us to take one more step behind our conscious lives. This knowledge also gives us a hint of how we ought to read the *Bardo Thödol*—that is, backwards. If, with the help of our Western science, we have to some extent succeeded in understanding the psychological character of the *Sidpa Bardo*, our next task is to see if we can make anything of the preceding *Chönyid Bardo*.

[845] The *Chönyid* state is one of karmic illusion—that is to say, illusions which result from the psychic residua of previous existences. According to the Eastern view,

karma implies a sort of psychic theory of heredity based on the hypothesis of reincarnation, which in the last resort is an hypothesis of the supratemporality of the soul. Neither our scientific knowledge nor our reason can keep in step with this idea. There are too many if's and but's. Above all, we know desperately little about the possibilities of continued existence of the individual soul after death, so little that we cannot even conceive how anyone could prove anything at all in this respect. Moreover, we know only too well, on epistemological grounds, that such a proof would be just as impossible as the proof of God. Hence we may cautiously accept the idea of karma only if we understand it as *psychic heredity* in the very widest sense of the word. Psychic heredity does exist—that is to say, there is inheritance of psychic characteristics such as predisposition to disease, traits of character, special gifts, and so forth. It does no violence to the psychic nature of these complex facts if natural science reduces them to what appear to be physical aspects (nuclear structures in cells, and so on). They are essential phenomena of life which express themselves, in the main, psychically, just as there are other inherited characteristics which express themselves, in the main, physiologically, on the physical level. Among these inherited psychic factors there is a special class which is not confined either to family or to race. These are the universal dispositions of the mind, and they are to be understood as analogous to Plato's forms (*eidola*), in accordance with which the mind organizes its contents. One could also describe these forms as *categories* analogous to the logical categories which are always and everywhere present as the basic postulates of reason. Only, in the case of our "forms," we are not dealing with categories of reason but with categories of the *imagination*. As the products of imagination are always in essence visual, their forms must, from the outset, have the character of images and moreover of *typical* images, which is why, following St. Augustine, I call them "archetypes." Comparative religion and mythology are rich mines of archetypes, and so is the psychology of dreams and psychoses. The astonishing parallelism between these images and the ideas they serve to express has frequently given rise to the wildest migration theories, although it would have been far more natural to think of the remarkable similarity of the human psyche at all times and in all places. Archetypal fantasy-forms are, in fact, reproduced spontaneously anytime and anywhere, without there being any conceivable trace of direct transmission. The original structural components of the psyche are of no less surprising a uniformity than are those of the visible body. The archetypes are, so to speak, organs of the pre-rational psyche. They are eternally inherited forms and ideas which have at first no specific content. Their specific content only appears in the course of the individual's life, when personal experience is taken up in precisely these forms. If the archetypes were not pre-existent in identical form everywhere, how could one explain the fact, postulated at almost every turn by the *Bardo Thödol*, that the dead do not know that they are dead, and that this assertion is to be met with

just as often in the dreary, half-baked literature of European and American Spiritualism? Although we find the same assertion in Swedenborg, knowledge of his writings can hardly be sufficiently widespread for this little bit of information to have been picked up by every small-town medium. And a connection between Swedenborg and the *Bardo Thödol* is completely unthinkable. It is a primordial, universal idea that the dead simply continue their earthly existence and do not know that they are disembodied spirits—an archetypal idea which enters into immediate, visible manifestation whenever anyone sees a ghost. It is significant, too, that ghosts all over the world have certain features in common. I am naturally aware of the unverifiable spiritualistic hypothesis, though I have no wish to make it my own. I must content myself with the hypothesis of an omnipresent, but differentiated, psychic structure which is inherited and which necessarily gives a certain form and direction to all experience. For, just as the organs of the body are not mere lumps of indifferent, passive matter, but are dynamic, functional complexes which assert themselves with imperious urgency, so also the archetypes, as organs of the psyche, are dynamic, instinctual complexes which determine psychic life to an extraordinary degree. That is why I also call them *dominants* of the unconscious. The layer of unconscious psyche which is made up of these universal dynamic forms I have termed the *collective unconscious*.

[846] So far as I know, there is no inheritance of individual prenatal, or pre-uterine, memories, but there are undoubtedly inherited archetypes which are, however, devoid of content, because, to begin with, they contain no personal experiences. They only emerge into consciousness when personal experiences have rendered them visible. As we have seen, *Sidpa* psychology consists in wanting to live and to be born. (The *Sidpa Bardo* is the “*Bardo* of Seeking Rebirth.”) Such a state, therefore, precludes any experience of transsubjective psychic realities, unless the dead man refuses categorically to be born back again into the world of consciousness. According to the teachings of the *Bardo Thödol*, it is still possible for him, in each of the *Bardo* states, to reach the *Dharmakāya* by transcending the four-faced Mount Meru, provided that he does not yield to his desire to follow the “dim lights.” This is as much as to say that the individual must desperately resist the dictates of reason, as we understand it, and give up the supremacy of egohood, regarded by reason as sacrosanct. What this means in practice is complete capitulation to the objective powers of the psyche, with all that this entails; a kind of figurative death, corresponding to the Judgment of the Dead in the *Sidpa Bardo*. It means the end of all conscious, rational, morally responsible conduct of life, and a voluntary surrender to what the *Bardo Thödol* calls “karmic illusion.” Karmic illusion springs from belief in a visionary world of an extremely irrational nature, which neither accords with nor derives from our rational judgments but is the exclusive product of uninhibited imagination. It is sheer dream

or “fantasy,” and every well-meaning person will instantly caution us against it; nor indeed can one see at first sight what is the difference between fantasies of this kind and the phantasmagoria of a lunatic. Very often only a slight *abaissement du niveau mental* is needed to unleash this world of illusion. The terror and darkness of this moment are reflected in the experiences described in the opening sections of the *Sidpa Bardo*. But the contents of the *Chönyid Bardo* reveal the archetypes, the karmic images which appear first in their terrifying form. The *Chönyid* state is equivalent to a deliberately induced psychosis.

[847] One often hears and reads about the dangers of yoga, particularly of the ill-reputed *kundalini* yoga. The deliberately induced psychotic state, which in certain unstable individuals might easily lead to a real psychosis, is a danger that needs to be taken very seriously indeed. These things really are dangerous and ought not to be meddled with in our typically Western way. It is a meddling with fate, which strikes at the very roots of human existence and can let loose a flood of sufferings of which no sane person ever dreamed. These sufferings correspond to the hellish torments of the *Chönyid* state, described in the text as follows:

Then the Lord of Death will place round thy neck a rope and drag thee along; he will cut off thy head, tear out thy heart, pull out thy intestines, lick up thy brain, drink thy blood, eat thy flesh, and gnaw thy bones; but thou wilt be incapable of dying. Even when thy body is hacked to pieces, it will revive again. The repeated hacking will cause intense pain and torture.³

[848] These tortures aptly describe the real nature of the danger: it is a disintegration of the wholeness of the *Bardo* body, which is a kind of “subtle body” constituting the visible envelope of the psychic self in the after-death state. The psychological equivalent of this dismemberment is psychic dissociation. In its deleterious form it would be schizophrenia (split mind). This most common of all mental illnesses consists essentially in a marked *abaissement du niveau mental* which abolishes the normal checks imposed by the conscious mind and thus gives unlimited scope to the play of the unconscious “dominants.”

[849] The transition, then, from the *Sidpa* state to the *Chönyid* state is a dangerous reversal of the aims and intentions of the conscious mind. It is a sacrifice of the ego’s stability and a surrender to the extreme uncertainty of what must seem like a chaotic riot of phantasmal forms. When Freud coined the phrase that the ego was “the true seat of anxiety,” he was giving voice to a very true and profound intuition. Fear of self-sacrifice lurks deep in every ego, and this fear is often only the precariously controlled demand of the unconscious forces to burst out in full strength. No one who strives for selfhood (individuation) is spared this dangerous passage, for that which is feared also belongs to the wholeness of the self—the sub-human, or supra-human, world of psychic “dominants” from which the ego originally emancipated itself with enormous effort, and then only partially, for the sake of a more or less illusory

freedom. This liberation is certainly a very necessary and very heroic undertaking, but it represents nothing final: it is merely the creation of a *subject*, who, in order to find fulfilment, has still to be confronted by an *object*. This, at first sight, would appear to be the world, which is swelled out with projections for that very purpose. Here we seek and find our difficulties, here we seek and find our enemy, here we seek and find what is dear and precious to us; and it is comforting to know that all evil and all good is to be found out there, in the visible object, where it can be conquered, punished, destroyed, or enjoyed. But nature herself does not allow this paradisaic state of innocence to continue for ever. There are, and always have been, those who cannot help but see that the world and its experiences are in the nature of a symbol, and that it really reflects something that lies hidden in the subject himself, in his own transubjective reality. It is from this profound intuition, according to lamaist doctrine, that the *Chönyid* state derives its true meaning, which is why the *Chönyid Bardo* is entitled “The *Bardo* of the Experiencing of Reality.”

[850] The reality experienced in the *Chönyid* state is, as the last section [pp. 143ff.] of this *Bardo* teaches, the reality of thought. The “thought-forms” appear as realities, fantasy takes on real form, and the terrifying dream evoked by karma and played out by the unconscious “dominants” begins. The first to appear (if we read the text backwards) is the all-destroying God of Death, the epitome of all terrors; he is followed by the twenty-eight “power-holding” and sinister goddesses and the fifty-eight “blood-drinking” goddesses. In spite of their demonic aspect, which appears as a confusing chaos of terrifying attributes and monstrosities, a certain order is already discernible. We find that there are companies of gods and goddesses who are arranged according to the four directions and are distinguished by typical mystic colours. It gradually becomes clearer that all these deities are organized into mandalas, or circles, containing a cross of the four colours. The colours are coordinated with the four aspects of wisdom:

- (1) White = the light-path of the mirror-like wisdom;
- (2) Yellow = the light-path of the wisdom of equality;
- (3) Red = the light-path of the discriminative wisdom;
- (4) Green = the light-path of the all-performing wisdom.

[851] On a higher level of insight, the dead man knows that the real thought-forms all emanate from himself, and that the four light-paths of wisdom which appear before him are the radiations of his own psychic faculties. This takes us straight to the psychology of the lamaistic mandala, which I have already discussed in the book I brought out with the late Richard Wilhelm, *The Secret of the Golden Flower*.

[852] Continuing our ascent backwards through the region of the *Chönyid Bardo*, we come finally to the vision of the Four Great Ones: the green Amogha-Siddhi, the red Amitābha, the yellow Ratna-Sambhava, and the white Vajra-Sattva. The ascent ends

with the effulgent blue light of the *Dharmadhātu*, the Buddha-body, which glows in the midst of the mandala from the heart of Vairochana.

[853] With this final vision the karmic illusions cease; consciousness, weaned away from all form and from all attachment to objects, returns to the timeless, inchoate state of the *Dharmakāya*. Thus (reading backwards) the *Chikhai* state, which appeared at the moment of death, is reached.

[854] I think these few hints will suffice to give the attentive reader some idea of the psychology of the *Bardo Thödol*. The book describes a way of initiation in reverse, which, unlike the eschatological expectations of Christianity, prepares the soul for a descent into physical being. The thoroughly intellectualistic and rationalistic worldly-mindedness of the European makes it advisable for us to reverse the sequence of the *Bardo Thödol* and to regard it as an account of Eastern initiation experiences, though one is perfectly free, if one chooses, to substitute Christian symbols for the gods of the *Chönyid Bardo*. At any rate, the sequence of events as I have described it offers a close parallel to the phenomenology of the European unconscious when it is undergoing an “initiation process,” that is to say, when it is being analysed. The transformation of the unconscious that occurs under analysis makes it the natural analogue of the religious initiation ceremonies, which do, however, differ in principle from the natural process in that they anticipate the natural course of development and substitute for the spontaneous production of symbols a deliberately selected set of symbols prescribed by tradition. We can see this in the *Exercitia* of Ignatius Loyola, or in the yoga meditations of the Buddhists and Tantrists.

[855] The reversal of the order of the chapters, which I have suggested here as an aid to understanding, in no way accords with the original intention of the *Bardo Thödol*. Nor is the psychological use we make of it anything but a secondary intention, though one that is possibly sanctioned by lamaist custom. The real purpose of this singular book is the attempt, which must seem very strange to the educated European of the twentieth century, to enlighten the dead on their journey through the regions of the *Bardo*. The Catholic Church is the only place in the world of the white man where any provision is made for the souls of the departed. Inside the Protestant camp, with its world-affirming optimism, we only find a few mediumistic “rescue circles,” whose main concern is to make the dead aware of the fact that they *are* dead.⁴ But, generally speaking, we have nothing in the West that is in any way comparable to the *Bardo Thödol*, except for certain secret writings which are inaccessible to the wider public and to the ordinary scientist. According to tradition, the *Bardo Thödol*, too, seems to have been included among the “hidden” books, as Dr. Evans-Wentz makes clear in his Introduction. As such, it forms a special chapter in the magical “cure of the soul” which extends even beyond death. This cult of the dead is rationally based on the belief in the supra-temporality of the soul, but its irrational basis is to be found

in the psychological need of the living to do something for the departed. This is an elementary need which forces itself upon even the most “enlightened” individuals when faced by the death of relatives and friends. That is why, enlightenment or no enlightenment, we still have all manner of ceremonies for the dead. If Lenin had to submit to being embalmed and put on show in a sumptuous mausoleum like an Egyptian pharaoh, we may be quite sure it was not because his followers believed in the resurrection of the body. Apart, however, from the Masses said for the soul in the Catholic Church, the provisions we make for the dead are rudimentary and on the lowest level, not because we cannot convince ourselves of the soul’s immortality, but because we have rationalized the above-mentioned psychological need out of existence. We behave as if we did not have this need, and because we cannot believe in a life after death we prefer to do nothing about it. Simpler-minded people follow their own feelings, and, as in Italy, build themselves funeral monuments of gruesome beauty. The Catholic Masses for the soul are on a level considerably above this, because they are expressly intended for the psychic welfare of the deceased and are not a mere gratification of lachrymose sentiments. But the highest application of spiritual effort on behalf of the departed is surely to be found in the instructions of the *Bardo Thödol*. They are so detailed and thoroughly adapted to the apparent changes in the dead man’s condition that every serious-minded reader must ask himself whether these wise old lamas might not, after all, have caught a glimpse of the fourth dimension and twitched the veil from the greatest of life’s secrets.

[856] Even if the truth should prove to be a disappointment, one almost feels tempted to concede at least some measure of reality to the vision of life in the *Bardo*. At any rate, it is unexpectedly original, if nothing else, to find the after-death state, of which our religious imagination has formed the most grandiose conceptions, painted in lurid colours as a terrifying dream-state of a progressively degenerative character.⁵ The supreme vision comes not at the end of the *Bardo*, but right at the beginning, at the moment of death; what happens afterward is an ever-deepening descent into illusion and obscuration, down to the ultimate degradation of new physical birth. The spiritual climax is reached at the moment when life ends. Human life, therefore, is the vehicle of the highest perfection it is possible to attain; it alone generates the karma that makes it possible for the dead man to abide in the perpetual light of the Voidness without clinging to any object, and thus to rest on the hub of the wheel of rebirth, freed from all illusion of genesis and decay. Life in the *Bardo* brings no eternal rewards or punishments, but merely a descent into a new life which shall bear the individual nearer to his final goal. But this eschatological goal is what he himself brings to birth as the last and highest fruit of the labours and aspirations of earthly existence. This view is not only lofty, it is manly and heroic.

[857] The degenerative character of *Bardo* life is corroborated by the spiritualistic literature of the West, which again and again gives one a sickening impression of the utter inanity and banality of communications from the “spirit world.” The scientific mind does not hesitate to explain these reports as emanations from the unconscious of the mediums and of those taking part in the séance, and even to extend this explanation to the description of the Hereafter given in the Tibetan Book of the Dead. And it is an undeniable fact that the whole book is created out of the archetypal contents of the unconscious. Behind these there lie—and in this our Western reason is quite right—no physical or metaphysical realities, but “merely” the reality of psychic facts, the data of psychic experience. Now whether a thing is “given” subjectively or objectively, the fact remains that it *is*. The *Bardo Thödol* says no more than this, for its five Dhyāni-Buddhas are themselves no more than psychic data. That is just what the dead man has to recognize, if it has not already become clear to him during life that his own psychic self and the giver of all data are one and the same. The world of gods and spirits is truly “nothing but” the collective unconscious inside me. To turn this sentence round so that it reads “The collective unconscious is the world of gods and spirits outside me,” no intellectual acrobatics are needed, but a whole human lifetime, perhaps even many lifetimes of increasing completeness. Notice that I do not say “of increasing perfection,” because those who are “perfect” make another kind of discovery altogether.

[858] The *Bardo Thödol* began by being a “closed” book, and so it has remained, no matter what kind of commentaries may be written upon it. For it is a book that will only open itself to spiritual understanding, and this is a capacity which no man is born with, but which he can only acquire through special training and special experience. It is good that such to all intents and purposes “useless” books exist. They are meant for those “queer folk” who no longer set much store by the uses, aims, and meaning of present-day “civilization.”

VIII

YOGA AND THE WEST

———

FOREWORD TO SUZUKI'S "INTRODUCTION TO ZEN BUDDHISM"

———

THE PSYCHOLOGY OF EASTERN MEDITATION

———

THE HOLY MEN OF INDIA

YOGA AND THE WEST¹

[859] Less than a century has passed since yoga became known to the West. Although all sorts of miraculous tales had come to Europe two thousand years before from the fabled land of India, with its wise men, its gymnosophists and omphalosceps, yet no real knowledge of Indian philosophy and philosophical practices can be said to have existed until, thanks to the efforts of the Frenchman, Anquetil du Perron, the Upanishads were transmitted to the West. A general and more profound knowledge was first made possible by Max Müller, of Oxford, and the Sacred Books of the East edited by him. To begin with, this knowledge remained the preserve of Sanskrit scholars and philosophers. But it was not so very long before the theosophical movement inaugurated by Mme. Blavatsky possessed itself of the Eastern traditions and promulgated them among the general public. For several decades after that, knowledge of yoga in the West developed along two separate lines. On the one hand it was regarded as a strictly academic science, and on the other it became something very like a religion, though it did not develop into an organized Church—despite the endeavours of Annie Besant and Rudolf Steiner. Although he was the founder of the anthroposophical secession, Steiner was originally a follower of Mme. Blavatsky.

[860] The peculiar product resulting from this Western development can hardly be compared with what yoga means in India. In the West, Eastern teaching encountered a special situation, a condition of mind such as the earlier India, at any rate, had never known. This was the strict line of division between science and philosophy, which had already existed, to a greater or lesser degree, for some three hundred years before yoga teachings began to be known in the West. The beginning of this split—a specifically Western phenomenon—really set in with the Renaissance, in the fifteenth century. At that time, there arose a widespread and passionate interest in antiquity, stimulated by the fall of the Byzantine Empire under the onslaught of Islam. Then, for the first time, knowledge of the Greek language and of Greek literature was carried to every corner of Europe. As a direct result of this invasion of so-called pagan philosophy, there arose the great schism in the Roman Church—Protestantism, which soon covered the whole of northern Europe. But not even this renewal of Christianity was able to hold the liberated minds in thrall.

[861] The period of world discovery in the geographical and scientific sense had begun, and to an ever-increasing degree thought emancipated itself from the shackles

of religious tradition. The Churches, of course, continued to exist because they were maintained by the strictly religious needs of the public, but they lost their leadership in the cultural sphere. While the Church of Rome, thanks to her unsurpassed organization, remained a unity, Protestantism split into nearly four hundred denominations. This is a proof on the one hand of its bankruptcy, and, on the other, of a religious vitality which refuses to be stifled. Gradually, in the course of the nineteenth century, this led to syncretistic outgrowths and to the importation on a mass scale of exotic religious systems, such as the religion of Abdul Baha, the Sufi sects, the Ramakrishna Mission, Buddhism, and so on. Many of these systems, for instance anthroposophy, were syncretized with Christian elements. The resultant picture corresponds roughly to the Hellenistic syncretism of the third and fourth centuries A.D., which likewise showed traces of Indian thought. (Cf. Apollonius of Tyana, the Orphic-Pythagorean secret doctrines, the Gnosis, etc.)

[862] All these systems moved on the religious plane and recruited the great majority of their adherents from Protestantism. They are thus, fundamentally, Protestant sects. By directing its main attack against the authority of the Roman Church, Protestantism largely destroyed belief in the Church as the indispensable agent of divine salvation. Thus the burden of authority fell to the individual, and with it a religious responsibility that had never existed before. The decline of confession and absolution sharpened the moral conflict of the individual and burdened him with problems which previously the Church had settled for him, since her sacraments, particularly that of the Mass, guaranteed his salvation through the priest's enactment of the sacred rite. The only things the individual had to contribute were confession, repentance, and penance. With the collapse of the rite, which did the work for him, he had to do without God's answer to his plans. This dissatisfaction explains the demand for systems that promise an answer—the visible or at least noticeable favour of another (higher, spiritual, or divine) power.

[863] European science paid no attention to these hopes and expectations. It lived its intellectual life unconcerned with religious needs and convictions. This—historically inevitable—split in the Western mind also affected yoga so far as this had gained a footing in the West, and led to its being made an object of scientific study on the one hand, while on the other it was welcomed as a way of salvation. But inside the religious movement there were any number of attempts to combine science with religious belief and practice, as for instance Christian Science, theosophy, and anthroposophy. The last-named, especially, likes to give itself scientific airs and has, therefore, like Christian Science, penetrated into intellectual circles.

[864] Since the way of the Protestant is not laid down for him in advance, he gives welcome, one might say, to practically any system which holds out the promise of

successful development. He must now do for himself the very thing which had always been done by the Church as intermediary, and he does not know *how* to do it. If he is a man who has taken his religious needs seriously, he has also made untold efforts towards faith, because his doctrine sets exclusive store by faith. But faith is a charisma, a gift of grace, and not a method. The Protestant is so entirely without a method that many of them have seriously interested themselves in the rigorously Catholic exercises of Ignatius Loyola. Yet, do what they will, the thing that disturbs them most is naturally the contradiction between religious and scientific truth, the conflict between faith and knowledge, which reaches far beyond Protestantism into Catholicism itself. This conflict is due solely to the historical split in the European mind. Had it not been for the—psychologically speaking—unnatural compulsion to believe, and an equally unnatural belief in science, this conflict would have had no reason to exist. One can easily imagine a state of mind in which one simply *knows* and in addition *believes* a thing which seems probable for such and such reasons. There are no grounds whatsoever for any conflict between these two things. Both are necessary, for knowledge alone, like faith alone, is always insufficient.

[865] When, therefore, a “religious” method recommends itself at the same time as “scientific,” it can be sure of finding a public in the West. Yoga fulfils this expectation. Quite apart from the charm of the new and the fascination of the half-understood, there is good reason for yoga to have many adherents. It offers not only the much-sought way, but also a philosophy of unrivalled profundity. It holds out the possibility of controllable experience, and thus satisfies the scientist’s need for “facts.” Moreover, by reason of its breadth and depth, its venerable age, its teachings and methods which cover every sphere of life, it promises undreamt of possibilities which the missionaries of yoga seldom omit to emphasize.

[866] I will remain silent on the subject of what yoga means for India, because I cannot presume to judge something I do not know from personal experience. I can, however, say something about what it means for the West. Our lack of direction borders on psychic anarchy. Therefore, any religious or philosophical practice amounts to a psychological discipline; in other words, it is a method of psychic hygiene. The numerous purely physical procedures of yoga are a physiological hygiene as well, which is far superior to ordinary gymnastics or breathing exercises in that it is not merely mechanistic and scientific but, at the same time, philosophical. In its training of the parts of the body, it unites them with the whole of the mind and spirit, as is quite clear, for instance, in the *prāṇayāma* exercises, where *prāṇa* is both the breath and the universal dynamics of the cosmos. When the doing of the individual is at the same time a cosmic happening, the elation of the body (innervation) becomes one with the elation of the spirit (the universal idea), and from this there arises a living whole which no technique, however scientific, can hope to

produce. Yoga practice is unthinkable, and would also be ineffectual, without the ideas on which it is based. It works the physical and the spiritual into one another in an extraordinarily complete way.

[867] In the East, where these ideas and practices originated, and where an uninterrupted tradition extending over some four thousand years has created the necessary spiritual conditions, yoga is, as I can readily believe, the perfect and appropriate method of fusing body and mind together so that they form a unity that can hardly be doubted. They thus create a psychological disposition which makes possible intuitions that transcend consciousness. The Indian mentality has no difficulty in operating intelligently with a concept like *prāna*. The West, on the contrary, with its bad habit of wanting to believe on the one hand, and its highly developed scientific and philosophical critique on the other, finds itself in a real dilemma. Either it falls into the trap of faith and swallows concepts like *prāna*, *atman*, *chakra*, *samādhi*, etc., without giving them a thought, or its scientific critique repudiates them one and all as “pure mysticism.” The split in the Western mind therefore makes it impossible at the outset for the intentions of yoga to be realized in any adequate way. It becomes either a strictly religious matter, or else a kind of training like Pelmanism, breath-control, eurhythmics, etc., and not a trace is to be found of the unity and wholeness of nature which is characteristic of yoga. The Indian can forget neither the body nor the mind, while the European is always forgetting either the one or the other. With this capacity to forget he has, for the time being, conquered the world. Not so the Indian. He not only knows his own nature, but he knows also how much he himself is nature. The European, on the other hand, has a science of nature and knows astonishingly little of his own nature, the nature within him. For the Indian, it comes as a blessing to know of a method which helps him to control the supreme power of nature within and without. For the European, it is sheer poison to suppress his nature, which is warped enough as it is, and to make out of it a willing robot.

[868] It is said of the yogi that he can remove mountains, though it would be difficult to furnish any real proof of this. The power of the yogi operates within limits acceptable to his environment. The European, on the other hand, can blow up mountains, and the World War has given us a bitter foretaste of what he is capable of when free rein is given to an intellect that has grown estranged from human nature. As a European, I cannot wish the European more “control” and more power over the nature within and around us. Indeed, I must confess to my shame that I owe my best insights (and there are some quite good ones among them) to the circumstance that I have always done just the opposite of what the rules of yoga prescribe. Through his historical development, the European has become so far removed from his roots that his mind was finally split into faith and knowledge, in the same way that every

psychological exaggeration breaks up into its inherent opposites. He needs to return, not to Nature in the manner of Rousseau, but to his own nature. His task is to find the natural man again. Instead of this, there is nothing he likes better than systems and methods by which he can repress the natural man who is everywhere at cross purposes with him. He will infallibly make a wrong use of yoga because his psychic disposition is quite different from that of the Oriental. I say to whomsoever I can: “Study yoga—you will learn an infinite amount from it—but do not try to apply it, for we Europeans are not so constituted that we apply these methods correctly, just like that. An Indian guru can explain everything and you can imitate everything. But do you know *who* is applying the yoga? In other words, do you know who you are and how you are constituted?”

[869] The power of science and technics in Europe is so enormous and indisputable that there is little point in reckoning up all that can be done and all that has been invented. One shudders at the stupendous possibilities. Quite another question begins to loom up: *Who* is applying this technical skill? in *whose* hands does this power lie? For the present, the state is a provisional means of protection, because, apparently, it safeguards the citizen from the enormous quantities of poison gas and other infernal engines of destruction which can be manufactured by the thousand tons at a moment’s notice. Our technical skill has grown to be so dangerous that the most urgent question today is not what *more* can be done in this line, but how the man who is entrusted with the control of this skill should be constituted, or how to alter the mind of Western man so that he would renounce his terrible skill. It is infinitely more important to strip him of the illusion of his power than to strengthen him still further in the mistaken idea that he can do everything he wills. The slogan one hears so often in Germany, “Where there’s a will there’s a way,” has cost the lives of millions of human beings.

[870] Western man has no need of more superiority over nature, whether outside or inside. He has both in almost devilish perfection. What he lacks is conscious recognition of his inferiority to the nature around and within him. He must learn that he may not do exactly as he wills. If he does not learn this, his own nature will destroy him. He does not know that his own soul is rebelling against him in a suicidal way.

[871] Since Western man can turn everything into a technique, it is true in principle that everything that looks like a method is either dangerous or condemned to futility. In so far as yoga is a form of hygiene, it is as useful to him as any other system. In the deepest sense, however, yoga does not mean this but, if I understand it correctly, a great deal more, namely the final release and detachment of consciousness from all bondage to object and subject. But since one cannot detach oneself from something

of which one is unconscious, the European must first learn to know his subject. This, in the West, is what one calls the unconscious. Yoga technique applies itself exclusively to the conscious mind and will. Such an undertaking promises success only when the unconscious has no potential worth mentioning, that is to say, when it does not contain large portions of the personality. If it does, then all conscious effort remains futile, and what comes out of this cramped condition of mind is a caricature or even the exact opposite of the intended result.

[872] The rich metaphysic and symbolism of the East express the larger and more important part of the unconscious and in this way reduce its potential. When the yogi says “prāna,” he means very much more than mere breath. For him the word *prāna* brings with it the full weight of its metaphysical components, and it is as if he really knew what prāna meant in this respect. He does not know it with his understanding, but with his heart, belly, and blood. The European only imitates and learns ideas by rote, and is therefore incapable of expressing his subjective facts through Indian concepts. I am more than doubtful whether the European, if he were capable of the corresponding experiences, would choose to express them through intuitive ideas like prāna.

[873] Yoga was originally a natural process of introversion, with all manner of individual variations. Introversions of this sort lead to peculiar inner processes which change the personality. In the course of several thousand years these introversions became organized as methods, and along widely differing lines. Indian yoga itself recognizes numerous and extremely diverse forms. The reason for this lies in the original diversity of individual experience. This is not to say that any one of these methods is suited to the peculiar historical structure of the European. It is much more likely that the yoga natural to the European proceeds from historical patterns unknown to the East. As a matter of fact, the two cultural achievements which, in the West, have had to concern themselves most with the psyche in the practical sense, namely medicine and the Catholic cure of souls, have both produced methods comparable to yoga. I have already referred to the exercises of Ignatius Loyola. With respect to medicine, it is the modern psychotherapeutic methods which come closest to yoga. Freud’s psychoanalysis leads the conscious mind of the patient back to the inner world of childhood reminiscences on one side, and on the other to wishes and drives which have been repressed from consciousness. The latter technique is a logical development of confession. It aims at an artificial introversion for the purpose of making conscious the unconscious components of the subject.

[874] A somewhat different method is the so-called “autogenic training” of Professor Schultz,² which consciously links up with yoga. His chief aim is to break down the conscious cramp and the repression of the unconscious this has caused.

[875] My method, like Freud's, is built up on the practice of confession. Like him, I pay close attention to dreams, but when it comes to the unconscious our views part company. For Freud it is essentially an appendage of consciousness, in which all the individual's incompatibilities are heaped up. For me the unconscious is a collective psychic disposition, creative in character. This fundamental difference of viewpoint naturally produces an entirely different evaluation of the symbolism and the method of interpreting it. Freud's procedure is, in the main, analytical and reductive. To this I add a synthesis which emphasizes the purposiveness of unconscious tendencies with respect to personality development. In this line of research important parallels with yoga have come to light, especially with *kundalini* yoga and the symbolism of tantric yoga, lamaism, and Taoistic yoga in China. These forms of yoga with their rich symbolism afford me invaluable comparative material for interpreting the collective unconscious. However, I do not apply yoga methods in principle, because, in the West, nothing ought to be forced on the unconscious. Usually, consciousness is characterized by an intensity and narrowness that have a cramping effect, and this ought not to be emphasized still further. On the contrary, everything must be done to help the unconscious to reach the conscious mind and to free it from its rigidity. For this purpose I employ a method of active imagination, which consists in a special training for switching off consciousness, at least to a relative extent, thus giving the unconscious contents a chance to develop.

[876] If I remain so critically averse to yoga, it does not mean that I do not regard this spiritual achievement of the East as one of the greatest things the human mind has ever created. I hope my exposition makes it sufficiently clear that my criticism is directed solely against the application of yoga to the peoples of the West. The spiritual development of the West has been along entirely different lines from that of the East and has therefore produced conditions which are the most unfavourable soil one can think of for the application of yoga. Western civilization is scarcely a thousand years old and must first of all free itself from its barbarous one-sidedness. This means, above all, deeper insight into the nature of man. But no insight is gained by repressing and controlling the unconscious, and least of all by imitating methods which have grown up under totally different psychological conditions. In the course of the centuries the West will produce its own yoga, and it will be on the basis laid down by Christianity.

[877] Daisetz Teitaro Suzuki's works on Zen Buddhism are among the best contributions to the knowledge of living Buddhism that recent decades have produced, and Zen itself is the most important fruit to have sprung from the tree whose roots are the collections of the Pali Canon.² We cannot be sufficiently grateful to the author, first for having brought Zen closer to Western understanding, and secondly for the manner in which he has performed this task. Oriental religious conceptions are usually so very different from our Western ones that even the bare translation of the words often presents the greatest difficulties, quite apart from the meaning of the terms used, which in certain circumstances are better left untranslated. I need only mention the Chinese "tao," which no European translation has yet got near. The original Buddhist writings contain views and ideas which are more or less unassimilable for ordinary Europeans. I do not know, for instance, just what kind of mental (or perhaps climatic?) background or preparation is necessary before one can form any completely clear idea of what is meant by the Buddhist "kamma." Judging by all we know of the nature of Zen, here too we are up against a central conception of unsurpassed singularity. This strange conception is called "satori," which may be translated as "enlightenment." "Satori is the *raison d'être* of Zen without which Zen is not Zen," says Suzuki.³ It should not be too difficult for the Western mind to grasp what a mystic understands by "enlightenment," or what is known as such in religious parlance. Satori, however, designates a special kind and way of enlightenment which it is practically impossible for the European to appreciate. By way of illustration, I would refer the reader to the enlightenment of Hyakujo (Pai-chang Huai-hai, A.D. 724–814) and of the Confucian poet and statesman Kozankoku (Huang Shan-ku),⁴ as described by Suzuki.

[878] The following may serve as a further example: A monk once went to Gensha, and wanted to learn where the entrance to the path of truth was. Gensha asked him, "Do you hear the murmuring of the brook?" "Yes, I hear it," answered the monk. "There is the entrance," the Master instructed him.

[879] I will content myself with these few examples, which aptly illustrate the opacity of satori experiences. Even if we take example after example, it still remains exceedingly obscure how any enlightenment comes and of what it consists—in other words, by what or about what one is enlightened. Kaiten Nukariya, who was himself a professor at the So-to-shu Buddhist College in Tokyo, says, speaking of enlightenment:

Having set ourselves free from the mistaken conception of self, next we must awaken our innermost wisdom, pure and divine, called the Mind of Buddha, or Bodhi, or Prajna by Zen masters. It is the divine light, the inner heaven, the key to all moral treasures, the centre of thought and consciousness, the source of all influence and power, the seat of kindness, justice, sympathy, impartial love, humanity, and mercy, the measure of all things. When this innermost wisdom is fully awakened, we are able to realize that each and every one of us is identical in spirit, in essence, in nature with the universal life or Buddha, that each ever lives face to face with Buddha, that each is beset by the abundant grace of the Blessed One, that He arouses his moral nature, that He opens his spiritual eyes, that He unfolds his new capacity, that He appoints his mission, and that life is not an ocean of birth, disease, old age, and death, nor the vale of tears, but the holy temple of Buddha, the Pure Land, where he can enjoy the bliss of Nirvana.⁵

[880] That is how an Oriental, himself an adept in Zen, describes the essence of enlightenment. One must admit that this passage would need only a few trifling alterations in order to find its way into a Christian mystical book of devotion. Yet somehow it sends us away empty as regards understanding the satori experience described again and again in the literature. Presumably Nukariya is addressing himself to Western rationalism, of which he himself acquired a good dose, and that is why it all sounds so flatly edifying. The abstruse obscurity of the Zen anecdotes is distinctly preferable to this adaptation *ad usum Delphini*: it conveys a great deal more by saying less.

[881] Zen is anything but a philosophy in the Western sense of the word.⁶ This is also the opinion of Rudolf Otto, who says in his foreword to Ohazama's book on Zen that Nukariya has "imported the magical world of Oriental ideas into our Western philosophical categories" and confused it with these. "If psycho-physical parallelism, that most wooden of all doctrines, is invoked in order to explain this mystical intuition of Non-duality and Oneness and the *coincidentia oppositorum*, then one is completely outside the sphere of the *koan*, the *kwatsu*, and *satori*."⁷ It is far better to allow oneself to become deeply imbued at the outset with the exotic obscurity of the Zen anecdotes, and to bear in mind the whole time that satori is a *mysterium ineffabile*, as indeed the Zen masters wish it to be. Between the anecdote and the mystical enlightenment there is to our way of thinking, a gulf, and the possibility of bridging it can at best be hinted but never in practice achieved.⁸ One has the feeling of touching upon a true secret, and not one that is merely imagined or pretended. It is not a question of mystification and mumbo-jumbo, but rather of an experience which strikes the experient dumb. Satori comes upon one unawares, as something utterly unexpected.

[882] When, in the sphere of Christianity, visions of the Holy Trinity, the Madonna, the Crucified, or of the patron saint are vouchsafed after long spiritual preparation, one has the impression that this is all more or less as it should be. That Jakob Böhme should obtain a glimpse into the *centrum naturae* by means of a sunbeam reflected in a tin platter is also understandable. It is harder to digest Meister Eckhart's vision of the "little naked boy," not to speak of Swedenborg's "man in the purple coat," who wanted to dissuade him from overeating, and whom, in spite—or perhaps because—of this, he recognized as the Lord God.⁹ Such things are difficult to swallow, bordering as they do on the grotesque. Many of the Zen anecdotes, however, not only border on the grotesque but are right there in the middle of it, and sound like the most crashing nonsense.

[883] For anyone who has devoted himself, with love and sympathetic understanding, to studying the flowerlike mind of the Far East, many of these puzzling things, which drive the naïve European from one perplexity to another, simply disappear. Zen is indeed one of the most wonderful blossoms of the Chinese spirit¹⁰—a spirit fertilized by the immense world of Buddhist thought. Anyone who has really tried to understand Buddhist doctrine—even if only to the extent of giving up certain Western prejudices—will begin to suspect treacherous depths beneath the bizarre surface of individual satori experiences, or will sense disquieting difficulties which the religion and philosophy of the West have up to now thought fit to disregard. If he is a philosopher, he is exclusively concerned with the kind of understanding that has nothing to do with life. And if he is a Christian, he has of course no truck with heathens ("God, I thank thee that I am not as other men are"). There is no satori within these Western limits—that is a purely Oriental affair. But is this really so? Have we in fact no satori?

[884] When one reads the Zen texts attentively, one cannot escape the impression that, however bizarre, satori is a *natural occurrence*, something so very simple,¹¹ even, that one fails to see the wood for the trees, and in attempting to explain it invariably says the very thing that throws others into the greatest confusion. Nukariya is therefore right when he says that any attempt to explain or analyse the content of Zen, or of the enlightenment, is futile. Nevertheless he does venture to assert that enlightenment "implies an insight into the nature of self,"¹² and that it is an "emancipation of mind from illusion concerning self."¹³ The illusion concerning the nature of self is the common confusion of the self with the ego. Nukariya understands by "self" the All-Buddha, i.e., total consciousness of life. He quotes Pan Shan, who says: "The moon of mind comprehends all the universe in its light," adding: "It is Cosmic life and Cosmic spirit, and at the same time individual life and individual spirit."¹⁴

[885] However one may define the self, it is always something other than the ego, and inasmuch as a higher insight of the ego leads over to the self, the self is a more comprehensive thing which includes the experience of the ego and therefore transcends it. Just as the ego is a certain experience I have of myself, so is the self an experience of my ego. It is, however, no longer experienced in the form of a broader or higher ego, but in the form of a non-ego.

[886] Such thoughts were familiar to the anonymous author of the *Theologia Germanica*:

In whatsoever creature the Perfect shall be known, therein creature-nature, created state, I-hood, selfhood, and the like must all be given up and done away.¹⁵

Now that I arrogate anything good to myself, as if I were, or had done, or knew, or could perform any good thing, or that it were mine; that is all out of blindness and folly. For if the real truth were in me, I should understand that I am not that good thing, and that it is not mine nor of me.

Then the man says: "Behold! I, poor fool that I was, thought it was I, but behold! it is, and was, of a truth, God!"¹⁶

[887] This tells us a good deal about the "content of enlightenment." The occurrence of satori is interpreted and formulated as a *break-through*, by a consciousness limited to the ego-form, into the non-ego-like self. This view is in accord not only with the essence of Zen, but also with the mysticism of Meister Eckhart:

When I flowed out from God, all things declared, "God is!" Now this cannot make me blessed, for thereby I acknowledge myself a creature. But in the breakthrough¹⁷ I stand empty in the will of God, and empty also of God's will, and of all his works, even of God himself—then I am more than all creatures, then I am neither God nor creature: I am what I was, and that I shall remain, now and ever more! Then I receive a thrust which carries me above all angels. By this thrust I become so rich that God cannot suffice me, despite all that he is as God and all his godly works; for in this breakthrough I receive what God and I have in common. I am what I was,¹⁸ I neither increase nor diminish, for I am the unmoved mover that moves all things. Here God can find no more place in man, for man by his emptiness has won back that which he was eternally and ever shall remain.¹⁹

[888] Here the Master may actually be describing a satori experience, a supersession of the ego by the self, which is endued with the "Buddha nature" or divine universality. Since, out of scientific modesty, I do not presume to make a metaphysical statement, but am referring only to a change of consciousness that can be experienced, I treat satori first of all as a psychological problem. For anyone who does not share or understand this point of view, the "explanation" will consist of nothing but words which have no tangible meaning. He is then incapable of throwing a bridge from these abstractions to the facts reported; that is to say, he cannot understand how the scent of the blossoming laurel or the tweaked nose²⁰ could bring about so formidable a change of consciousness. Naturally the simplest thing would

be to relegate all these anecdotes to the realm of amusing fairytales, or, if one accepts the facts as they are, to write them off as instances of self-deception. (Another favourite explanation is “auto-suggestion,” that pathetic white elephant from the arsenal of intellectual inadequacies!) But no serious and responsible investigation can pass over these facts unheedingly. Of course, we can never decide definitely whether a person is *really* “enlightened” or “released,” or whether he merely imagines it. We have no criteria to go on. Moreover, we know well enough that an imaginary pain is often far more agonizing than a so-called real one, since it is accompanied by a subtle moral suffering caused by a dull feeling of secret self-accusation. In this sense, therefore, it is not a question of “actual fact” but of *psychic reality*, i.e., the psychic process known as satori.

[889] Every psychic process is an image and an “imagining,” otherwise no consciousness could exist and the occurrence would lack phenomenality. Imagination itself is a psychic process, for which reason it is completely irrelevant whether the enlightenment be called “real” or “imaginary.” The person who has the enlightenment, or alleges that he has it, thinks at all events that he is enlightened. “What others think about it decides nothing whatever for him in regard to his experience. Even if he were lying, his lie would still be a psychic fact. Indeed, even if all the reports of religious experiences were nothing but deliberate inventions and falsifications, a very interesting psychological treatise could still be written about the incidence of such lies, and with the same scientific objectivity with which one describes the psychopathology of delusional ideas. The fact that there is a religious movement upon which many brilliant minds have worked over a period of many centuries is sufficient reason for at least venturing a serious attempt to bring such processes within the realm of scientific understanding.

[890] Earlier, I raised the question of whether we have anything like satori in the West. If we discount the sayings of our Western mystics, a superficial glance discloses nothing that could be likened to it in even the faintest degree. The possibility that there are stages in the development of consciousness plays no role in our thinking. The mere thought that there is a tremendous psychological difference between consciousness of the existence of an object and “consciousness of the consciousness” of an object borders on a quibble that hardly needs answering. For the same reason, one could hardly bring oneself to take such a problem seriously enough to consider the psychological conditions in which it arose. It is significant that questions of this kind do not, as a rule, arise from any intellectual need, but, where they exist, are nearly always rooted in an originally religious practice. In India it was yoga and in China Buddhism which supplied the driving force for these attempts to wrench oneself free from bondage to a state of consciousness that was felt to be incomplete. So far as Western mysticism is concerned, its texts are full of instructions as to how

man can and must release himself from the “I-ness” of his consciousness, so that through knowledge of his own nature he may rise above it and attain the inner (godlike) man. John of Ruysbroeck makes use of an image which was also known to Indian philosophy, that of the tree whose roots are above and its branches below:²¹ “And he must climb up into the tree of faith, which grows from above downwards, for its roots are in the Godhead.”²² He also says, like the yogi: “Man must be free and without ideas, released from all attachments and empty of all creatures.”²³ “He must be untouched by joy and sorrow, profit and loss, rising and falling, concern for others, pleasure and fear, and not be attached to any creature.”²⁴ It is in this that the “unity” of his being consists, and this means “being turned inwards.” Being turned inwards means that “a man is turned within, into his own heart, that he may understand and feel the inner working and the inner words’ of God.”²⁵ This new state of consciousness born of religious practice is distinguished by the fact that outward things no longer affect an ego-bound consciousness, thus giving rise to mutual attachment, but that an empty consciousness stands open to another influence. This “other” influence is no longer felt as one’s own activity, but as that of a non-ego which has the conscious mind as its object.²⁶ It is as if the subject-character of the ego had been overrun, or taken over, by another subject which appears in place of the ego.²⁷ This is a well-known religious experience, already formulated by St. Paul.²⁸ Undoubtedly a new state of consciousness is described here, separated from the earlier state by an incisive process of religious transformation.

[891] It could be objected that consciousness in itself has not changed, only the consciousness of something, just as though one had turned over the page of a book and now saw a different picture with the same eyes. I am afraid this is no more than an arbitrary interpretation, for it does not fit the facts. The fact is that in the texts it is not merely a different picture or object that is described, but rather an experience of transformation, often occurring amid the most violent psychic convulsions. The blotting out of one picture and its replacement by another is an everyday occurrence which has none of the attributes of a transformation experience. *It is not that something different is seen, but that one sees differently.* It is as though the spatial act of seeing were changed by a new dimension. When the Master asks: “Do you hear the murmuring of the brook?” he obviously means something quite different from ordinary “hearing.”²⁹ Consciousness is something like perception, and like the latter is subject to conditions and limitations. You can, for instance, be conscious at various levels, within a narrower or wider field, more on the surface or deeper down. These differences in degree are often differences in kind as well, since they depend on the development of the personality as a whole; that is to say, on the nature of the perceiving subject.

[892] The intellect has no interest in the nature of the perceiving subject so far as the latter only thinks logically. The intellect is essentially concerned with elaborating the contents of consciousness and with methods of elaboration. A rare philosophic passion is needed to compel the attempt to get beyond intellect and break through to a “knowledge of the knower.” Such a passion is practically indistinguishable from the driving force of religion; consequently this whole problem belongs to the religious transformation process, which is incommensurable with intellect. Classical philosophy subserves this process on a wide scale, but this can be said less and less of the newer philosophy. Schopenhauer is still—with qualifications—classical, but Nietzsche’s *Zarathustra* is no longer philosophy at all: it is a dramatic process of transformation which has completely swallowed up the intellect. It is no longer concerned with thought, but, in the highest sense, with the thinker of thought—and this on every page of the book. A new man, a completely transformed man, is to appear on the scene, one who has broken the shell of the old and who not only looks upon a new heaven and a new earth, but has created them. Angelus Silesius puts it rather more modestly than Zarathustra:

My body is a shell in which a chick lies closed about;

Brooded by the spirit of eternity, it waits its hatching out.³⁰

[893] Satori corresponds in the Christian sphere to an experience of religious transformation. As there are different degrees and kinds of such an experience, it may not be superfluous to define more accurately the category which corresponds most closely to the Zen experience. This is without doubt the mystic experience, which differs from other types in that its preliminary stages consist in “letting oneself go,” in “emptying oneself of images and ideas,” as opposed to those religious experiences which, like the exercises of Ignatius Loyola, are based on the practice of envisaging sacred images. In this latter class I would include transformation through faith and prayer and through collective experience in Protestantism, since a very definite expectation plays the decisive role here, and not by any means “emptiness” or “freeness.” The characteristically Eckhartian assertion that “God is Nothingness” may well be incompatible in principle with the contemplation of the Passion, with faith and collective expectations.

[894] Thus the correspondence between satori and Western experience is limited to those few Christian mystics whose paradoxical statements skirt the edge of heterodoxy or actually overstep it. As we know, it was this that drew down on Meister Eckhart’s writings the condemnation of the Church. If Buddhism were a “Church” in our sense of the word, she would undoubtedly find Zen an insufferable nuisance. The reason for this is the extreme individualism of its methods, and also the

iconoclastic attitude of many of the Masters.³¹ To the extent that Zen is a movement, collective forms have arisen in the course of the centuries, as can be seen from Suzuki's *Training of the Zen Buddhist Monk* (Kyoto, 1934). But these concern externals only. Apart from the typical mode of life, the spiritual training or development seems to lie in the method of the *koan*. The koan is understood to be a paradoxical question, statement, or action of the Master. Judging by Suzuki's description, it seems to consist chiefly of master-questions handed down in the form of anecdotes. These are submitted by the teacher to the student for meditation. A classic example is the Wu anecdote. A monk once asked the Master: "Has a dog a Buddha nature too?" Whereupon the Master replied: "Wu!" As Suzuki remarks, this "Wu" means quite simply "bow-wow," obviously just what the dog himself would have said in answer to such a question.³²

[895] At first sight it seems as if the posing of such a question as an object of meditation would anticipate or prejudice the end-result, and that it would therefore determine the content of the experience, just as in the Jesuit exercises or in certain yoga meditations the content is determined by the task set by the teacher. The koans, however, are so various, so ambiguous, and above all so boundlessly paradoxical that even an expert must be completely in the dark as to what might be considered a suitable solution. In addition, the descriptions of the final result are so obscure that in no single case can one discover any rational connection between the koan and the experience of enlightenment. Since no logical sequence can be demonstrated, it remains to be supposed that the koan method puts not the smallest restraint upon the freedom of the psychic process and that the end-result therefore springs from nothing but the individual disposition of the pupil. The complete destruction of the rational intellect aimed at in the training creates an almost perfect lack of conscious presuppositions. These are excluded as far as possible, but not unconscious presuppositions—that is, the existing but unrecognized psychological disposition, which is anything but empty or a *tabula rasa*. It is a nature-given factor, and when it answers—this being obviously the satori experience—it is an answer of Nature, who has succeeded in conveying her reaction direct to the conscious mind.³³ What the unconscious nature of the pupil presents to the teacher or to the koan by way of an answer is, manifestly, satori. This seems, at least to me, to be the view which, to judge by the descriptions, formulates the nature of satori more or less correctly. It is also supported by the fact that the "glimpse into one's own nature," the "original man," and the depths of one's being are often a matter of supreme concern to the Zen master.³⁴

[896] Zen differs from all other exercises in meditation, whether philosophical or religious, in its total lack of presuppositions. Often Buddha himself is sternly rejected, indeed, almost blasphemously ignored, although—or perhaps just because

—he could be the strongest spiritual presupposition of the whole exercise. But he too is an image and must therefore be set aside. Nothing must be present except what is actually there: that is, man with all his unconscious presuppositions, of which, precisely because they are unconscious, he can never, never rid himself. The answer which appears to come from the void, the light which flares up from the blackest darkness, these have always been experienced as a wonderful and blessed illumination.

[897] The world of consciousness is inevitably a world full of restrictions, of walls blocking the way. It is of necessity one-sided, because of the nature of consciousness itself. No consciousness can harbour more than a very small number of simultaneous perceptions. All else must lie in shadow, withdrawn from sight. Any increase in the simultaneous contents immediately produces a dimming of consciousness, if not confusion to the point of disorientation. Consciousness not only requires, but is of its very nature strictly limited to, the few and hence the distinct. We owe our general orientation simply and solely to the fact that through attention we are able to register a fairly rapid succession of images. But attention is an effort of which we are not capable all the time. We have to make do, so to speak, with a minimum of simultaneous perceptions and successions of images. Hence in wide areas possible perceptions are continuously excluded, and consciousness is always bound to the narrowest circle. What would happen if an individual consciousness were able to take in at a single glance a simultaneous picture of every possible perception is beyond imagining. If man has already succeeded in building up the structure of the world from the few distinct things that he can perceive at one and the same time, what godlike spectacle would present itself to his eyes if he were able to perceive a great deal more all at once and distinctly? This question applies only to perceptions that are *possible* to us. If we now add to these the unconscious contents—i.e., contents which are not yet, or no longer, capable of consciousness—and then try to imagine a total vision, why, this is beyond the most audacious fantasy. It is of course completely unimaginable in any conscious form, but in the unconscious it is a fact, since everything subliminal holds within it the ever-present possibility of being perceived and represented in consciousness. The unconscious is an irrepresentable totality of all subliminal psychic factors, a “total vision” *in potentia*. It constitutes the total disposition from which consciousness singles out tiny fragments from time to time.

[898] Now if consciousness is emptied as far as possible of its contents, they will fall into a state of unconsciousness, at least for the time being. In Zen, this displacement usually results from the energy being withdrawn from conscious contents and transferred either to the conception of “emptiness” or to the koan. As both of these must be static, the succession of images is abolished and with it the energy which maintains the kinetics of consciousness. The energy thus saved goes over to the

unconscious and reinforces its natural charge to bursting point. This increases the readiness of the unconscious contents to break through into consciousness. But since the emptying and shutting down of consciousness is no easy matter, a special training of indefinite duration³⁵ is needed in order to set up that maximum tension which leads to the final break-through of unconscious contents.

[899] The contents that break through are far from being random ones. As psychiatric experience with insane patients shows, specific relations exist between the conscious contents and the delusional ideas that break through in delirium. They are the same relations as exist between the dreams and the waking consciousness of normal people. The connection is an essentially compensatory relationship:³⁶ the unconscious contents bring to the surface everything that is necessary³⁷ in the broadest sense for the completion and wholeness of conscious orientation. If the fragments offered by, or forced up from, the unconscious are meaningfully built into conscious life, a form of psychic existence results which corresponds better to the whole of the individual's personality, and so abolishes the fruitless conflicts between his conscious and unconscious self. Modern psychotherapy is based on this principle, in so far as it has been able to free itself from the historical prejudice that the unconscious consists only of infantile and morally inferior contents. There is certainly an inferior corner in it, a lumber-room full of dirty secrets, though these are not so much unconscious as hidden and only half forgotten. But all this has about as much to do with the whole of the unconscious as a decayed tooth has with the total personality. The unconscious is the matrix of all metaphysical statements, of all mythology, of all philosophy (so far as this is not merely critical), and of all expressions of life that are based on psychological premises.

[900] Every invasion of the unconscious is an answer to a definite conscious situation, and this answer follows from the totality of possible ideas present, i.e., from the total disposition which, as explained above, is a simultaneous picture *in potentia* of psychic existence. The splitting up into single units, its one-sided and fragmentary character, is of the essence of consciousness. The reaction coming from the disposition always has a total character, as it reflects a nature which has not been divided up by any discriminating consciousness.³⁸ Hence its overpowering effect. It is the unexpected, all-embracing, completely illuminating answer, which works all the more as illumination and revelation since the conscious mind has got itself wedged into a hopeless blind alley.³⁹

[901] When, therefore, after many years of the hardest practice and the most strenuous demolition of rational understanding, the Zen devotee receives an answer—the only true answer—from Nature herself, everything that is said of satori can be understood. As one can see for oneself, it is the *naturalness* of the answer that strikes one most

about the Zen anecdotes. Yes, one can accept with a sort of old-roguish satisfaction the story of the enlightened pupil who gave his Master a slap in the face as a reward.⁴⁰ And how much wisdom there is in the Master's "Wu," the answer to the question about the Buddha-nature of the dog! One must always bear in mind, however, that there are a great many people who cannot distinguish between a metaphysical joke and nonsense, and just as many who are so convinced of their own cleverness that they have never in their lives met any but fools.

[902] Great as is the value of Zen Buddhism for understanding the religious transformation process, its use among Western people is very problematical. The mental education necessary for Zen is lacking in the West. Who among us would place such implicit trust in a superior Master and his incomprehensible ways? This respect for the greater human personality is found only in the East. Could any of us boast that he believes in the possibility of a boundlessly paradoxical transformation experience, to the extent, moreover, of sacrificing many years of his life to the wearisome pursuit of such a goal? And finally, who would dare to take upon himself the responsibility for such an unorthodox transformation experience—except a man who was little to be trusted, one who, maybe for pathological reasons, has too much to say for himself? Just such a person would have no cause to complain of any lack of following among us. But let a "Master" set us a hard task, which requires more than mere parrot-talk, and the European begins to have doubts, for the steep path of self-development is to him as mournful and gloomy as the path to hell.

[903] I have no doubt that the satori experience does occur also in the West, for we too have men who glimpse ultimate goals and spare themselves no pains to draw near to them. But they will keep silent, not only out of shyness, but because they know that any attempt to convey their experience to others is hopeless. There is nothing in our civilization to foster these strivings, not even the Church, the custodian of religious values. Indeed, it is the function of the Church to oppose all original experience, because this can only be unorthodox. The only movement inside our civilization which has, or should have, some understanding of these endeavours is psychotherapy. It is therefore no accident that it is a psychotherapist who is writing this foreword.

[904] Psychotherapy is at bottom a dialectical relationship between doctor and patient. It is an encounter, a discussion between two psychic wholes, in which knowledge is used only as a tool. The goal is transformation—not one that is predetermined, but rather an indeterminable change, the only criterion of which is the disappearance of egohood. No efforts on the part of the doctor can compel this experience. The most he can do is to smooth the path for the patient and help him to attain an attitude which offers the least resistance to the decisive experience. If knowledge plays no small part in our Western procedure, this is equivalent to the importance of the

traditional spiritual atmosphere of Buddhism in Zen. Zen and its technique could only have arisen on the basis of Buddhist culture, which it presupposes at every turn. You cannot annihilate a rationalistic intellect that was never there—no Zen adept was ever the product of ignorance and lack of culture. Hence it frequently happens with us also that a conscious ego and a cultivated understanding must first be produced through analysis before one can even think about abolishing egohood or rationalism. What is more, psychotherapy does not deal with men who, like Zen monks, are ready to make any sacrifice for the sake of truth, but very often with the most stubborn of all Europeans. Thus the tasks of psychotherapy are much more varied, and the individual phases of the long process much more contradictory, than is the case in Zen.

[905] For these and many other reasons a direct transplantation of Zen to our Western conditions is neither commendable nor even possible. All the same, the psychotherapist who is seriously concerned with the question of the aim of his therapy cannot remain unmoved when he sees the end towards which this Eastern method of psychic “healing”—i.e., “making whole”—is striving. As we know, this question has occupied the most adventurous minds of the East for more than two thousand years, and in this respect methods and philosophical doctrines have been developed which simply put all Western attempts along these lines into the shade. Our attempts have, with few exceptions, all stopped short at either magic (mystery cults, amongst which we must include Christianity) or intellectualism (philosophy from Pythagoras to Schopenhauer). It is only the tragedies of Goethe’s *Faust* and Nietzsche’s *Zarathustra* which mark the first glimmerings of a break-through of total experience in our Western hemisphere.⁴¹ And we do not know even today what these most promising of all products of the Western mind may at length signify, so overlaid are they with the materiality and concreteness of our thinking, as moulded by the Greeks.⁴² Despite the fact that our intellect has developed almost to perfection the capacity of the bird of prey to spy the tiniest mouse from the greatest height, yet the pull of the earth drags it down, and the *samskaras* entangle it in a world of confusing images the moment it no longer seeks for booty but turns one eye inwards *to find him who seeks*. Then the individual falls into the throes of a daemonic rebirth, beset with unknown terrors and dangers and menaced by deluding mirages in a labyrinth of error. The worst of all fates threatens the venturer: mute, abysmal loneliness in the age he calls his own. What do we know of the hidden motives for Goethe’s “main business,” as he called his *Faust*, or of the shudders of the “Dionysus experience”? One has to read the *Bardo Thödol*, the Tibetan Book of the Dead, backwards, as I have suggested,⁴³ in order to find an Eastern parallel to the torments and catastrophes of the Western “way of release” to wholeness. This is the issue here—not good intentions, clever imitations, or intellectual acrobatics. And this, in shadowy hints or

in greater or lesser fragments, is what the psychotherapist is faced with when he has freed himself from over-hasty and short-sighted doctrinal opinions. If he is a slave to his quasi-biological credo he will always try to reduce what he has glimpsed to the banal and the known, to a rationalistic denominator which satisfies only those who are content with illusions. But the foremost of all illusions is that anything can ever satisfy anybody. That illusion stands behind all that is unendurable in life and in front of all progress, and it is one of the most difficult things to overcome. If the psychotherapist can take time off from his helpful activities for a little reflection, or if by any chance he is forced into seeing through his own illusions, it may dawn on him how hollow and flat, how inimical to life, are all rationalistic reductions when they come upon something that is alive, that wants to grow. Should he follow this up he will soon get an idea of what it means to “open wide that gate / Past which man’s steps have ever flinching trod.”⁴⁴

[906] I would not under any circumstances like it to be understood that I am making any recommendations or offering any advice. But when one begins to talk about Zen in the West I consider it my duty to show the European where our entrance lies to that “longest road” which leads to satori, and what kind of difficulties bestrew the path which only a few of our great ones have trod—beacons, perhaps, on high mountains, shining out into the dim future. It would be a disastrous mistake to assume that satori or samādhi are to be met with anywhere below these heights. As an experience of totality it cannot be anything cheaper or smaller than the whole. What this means psychologically can be seen from the simple reflection that consciousness is always only a part of the psyche and therefore never capable of psychic wholeness: for that the indefinite extension of the unconscious is needed. But the unconscious can neither be caught with clever formulas nor exorcized by means of scientific dogmas, for something of destiny clings to it—indeed, it is sometimes destiny itself, as *Faust* and *Zarathustra* show all too clearly. The attainment of wholeness requires one to stake one’s whole being. Nothing less will do; there can be no easier conditions, no substitutes, no compromises. Considering that both *Faust* and *Zarathustra*, despite the highest recognition, stand on the border-line of what is comprehensible to the European, one could hardly expect the educated public, which has only just begun to hear about the obscure world of the psyche, to form any adequate conception of the spiritual state of a man caught in the toils of the individuation process—which is my term for “becoming whole.” People then drag out the vocabulary of pathology and console themselves with the terminology of neurosis and psychosis, or else they whisper about the “creative secret.” But what can a man “create” if he doesn’t happen to be a poet? This misunderstanding has caused not a few persons in recent times to call themselves—by their own grace—“artists,” just as if art had nothing to do with ability. But if you have nothing at all to create, then perhaps you create yourself.

[907] Zen shows how much “becoming whole” means to the East. Preoccupation with the riddles of Zen may perhaps stiffen the spine of the faint-hearted European or provide a pair of spectacles for his psychic myopia, so that from his “damned hole in the wall”⁴⁵ he may enjoy at least a glimpse of the world of psychic experience, which till now lay shrouded in fog. No harm can be done, for those who are too frightened will be effectively protected from further corruption, as also from everything of significance, by the helpful idea of “auto-suggestion.”⁴⁶ I should like to warn the attentive and sympathetic reader, however, not to underestimate the spiritual depth of the East, or to assume that there is anything cheap and facile about Zen.⁴⁷ The assiduously cultivated credulity of the West in regard to Eastern thought is in this case a lesser danger, as in Zen there are fortunately none of those marvellously incomprehensible words that we find in Indian cults. Neither does Zen play about with complicated *hatha-yoga* techniques,⁴⁸ which delude the physiologically minded European into the false hope that the spirit can be obtained by just sitting and breathing. On the contrary, Zen demands intelligence and will power, as do all greater things that want to become realities.

[908] The profound relationship between yoga and the hieratic architecture of India has already been pointed out by my friend Heinrich Zimmer, whose unfortunate early death is a great loss to Indology. Anyone who has visited Borobudur or seen the stupas at Bharhut and Sanchi can hardly avoid feeling that an attitude of mind and a vision quite foreign to the European have been at work here—if he has not already been brought to this realization by a thousand other impressions of Indian life. In the overflowing wealth of Indian spirituality there is reflected a vision of the soul which at first appears strange and inaccessible to the Greek-trained European mind. Our minds perceive things, our eyes, as Gottfried Keller says, “drink what the eyelids hold of the golden abundance of the world,” and we draw conclusions about the inner world from our wealth of outward impressions. We even derive its content from outside on the principle that “nothing is in the mind which was not previously in the senses.” This principle seems to have no validity in India. Indian thought and Indian art merely *appear* in the sense-world, but do not derive from it. Although often expressed with startling sensuality, they are, in their truest essence, unsensual, not to say suprasensual. It is not the world of the senses, of the body, of colours and sounds, not human passions that are born anew in transfigured form, or with realistic pathos, through the creativity of the Indian soul, but rather an underworld or an overworld of a metaphysical nature, out of which strange forms emerge into the familiar earthly scene. For instance, if one carefully observes the tremendously impressive impersonations of the gods performed by the Kathakali dancers of southern India, there is not a single *natural* gesture to be seen. Everything is bizarre, subhuman and superhuman at once. The dancers do not walk like human beings—they glide; they do not think with their heads but with their hands. Even their human faces vanish behind blue-enamelled masks. The world we know offers nothing even remotely comparable to this grotesque splendour. Watching these spectacles one is transported to a world of dreams, for that is the only place where we might conceivably meet with anything similar. But the Kathakali dancers, as we see them in the flesh or in the temple sculptures, are no nocturnal phantoms; they are intensely dynamic figures, consistent in every detail, or as if they had grown organically. These are no shadows or ghosts of a bygone reality, they are more like realities which have *not yet been*, potential realities which might at any moment step over the threshold.

[909] Anyone who wholeheartedly surrenders to these impressions will soon notice that these figures do not strike the Indians themselves as dreamlike but as real. And, indeed, they touch upon something in our own depths, too, with an almost terrifying intensity, though we have no words to express it. At the same time, one notices that

the more deeply one is stirred the more our sense-world fades into a dream, and that we seem to wake up in a world of gods, so immediate is their reality.

[910] What the European notices at first in India is the outward corporeality he sees everywhere. But that is not India as the Indian sees it; that is not *his* reality. Reality, as the German word “Wirklichkeit” implies, is that which *works*. For us the essence of that which works is the world of appearance; for the Indian it is the soul. The world for him is a mere show or façade, and his reality comes close to being what we would call a dream.

[911] This strange antithesis between East and West is expressed most clearly in religious practice. We speak of religious uplift and exaltation; for us God is the Lord of the universe, we have a religion of brotherly love, and in our heaven-aspiring churches there is a *high altar*. The Indian, on the other hand, speaks of *dhyāna*, of self-immersion, and of *sinking* into meditation; God is within all things and especially within man, and one turns away from the outer world to the inner. In the old Indian temples the altar is sunk six to eight feet deep in the earth, and what we hide most shamefacedly is the holiest symbol to the Indian. We believe in *doing*, the Indian in impassive *being*. Our religious exercises consist of prayer, worship, and singing hymns. The Indian’s most important exercise is yoga, an immersion in what we would call an unconscious state, but which he praises as the highest consciousness. Yoga is the most eloquent expression of the Indian mind and at the same time the instrument continually used to produce this peculiar attitude of mind.

[912] What, then, is yoga? The word means literally “yoking,” i.e., the disciplining of the instinctual forces of the psyche, which in Sanskrit are called *kleshas*. The yoking aims at controlling these forces that fetter human beings to the world. The *kleshas* would correspond, in the language of St. Augustine, to *superbia* and *concupiscentia*. There are many different forms of yoga, but all of them pursue the same goal. Here I will only mention that besides the purely psychic exercises there is also a form called *hatha* yoga, a sort of gymnastics consisting chiefly of breathing exercises and special body postures. In this lecture I have undertaken to describe a yoga text which allows a deep insight into the psychic processes of yoga. It is a little-known Buddhist text, written in Chinese but translated from the original Sanskrit, and dating from A.D. 424. It is called the *Amitāyur-dhyāna Sūtra*, the Sutra of Meditation on Amitāyus. This sutra, highly valued in Japan, belongs to the sphere of theistic Buddhism, in which is found the teaching that the Ādi-Buddha or Mahābuddha, the Primordial Buddha, brought forth the five Dhyāni-Buddhas or Dhyāni-Bodhisattvas. One of the five is Amitābha, “the Buddha of the *setting sun* of immeasurable light,” the Lord of Sukhāvati, land of supreme bliss. He is the protector of our present world-period, just as Shākyamuni, the historical Buddha, is its teacher. In the cult of Amitābha there is,

oddly enough, a kind of Eucharistic feast with consecrated bread. He is sometimes depicted holding in his hand the vessel of the life-giving food of immortality, or the vessel of holy water.

[913] The text² begins with an introductory story that need not detain us here. A crown prince seeks to take the life of his parents, and in her extremity the Queen calls upon the Buddha for help, praying him to send her his two disciples Maudgalyāyana and Ānanda. The Buddha fulfils her wish, and the two appear at once. At the same time Shākyamuni, the Buddha himself, appears before her eyes. He shows her in a vision all the ten worlds, so that she can choose in which one she wishes to be reborn. She chooses the western realm of Amitābha. He then teaches her the yoga which should enable her to retain rebirth in the Amitābha land, and after giving her various moral instructions he speaks to her as follows:

[914] You and all other beings besides ought to make it their only aim, with concentrated thought, to get a perception of the western quarter. You will ask how that perception is to be formed. I will explain it now. All beings, if not blind from birth, are uniformly possessed of sight, and they all see the setting sun. You should sit down properly, looking in the western direction, and prepare your thought for a close meditation on the sun: cause your mind to be firmly fixed on it so as to have an unwavering perception by the exclusive application of your thought, and gaze upon it more particularly when it is about to set and looks like a suspended drum. After you have thus seen the sun, let that image remain clear and fixed, whether your eyes be shut or open. Such is the perception of the sun, which is the First Meditation.

[915] As we have already seen, the setting sun is an allegory of the immortality-dispensing Amitābha. The text continues:

Next you should form the perception of water; gaze on the water clear and pure, and let this image also remain clear and fixed afterwards; never allow your thought to be scattered and lost.

[916] As already mentioned, Amitābha is also the dispenser of the water of immortality.

[917] When you have thus seen the water you should form the perception of ice. As you see the ice shining and transparent, so you should imagine the appearance of lapis lazuli. After that has been done, you will see the ground consisting of lapis lazuli transparent and shining both within and without. Beneath this ground of lapis lazuli there will be seen a golden banner with the seven jewels, diamonds, and the rest, supporting the ground. It extends to the eight points of the compass, and thus the eight corners of the ground are perfectly filled up. Every side of the eight quarters consists of a hundred jewels, every jewel has a thousand rays, and every ray has eighty-four thousand colours which, when reflected in the ground of lapis lazuli, look

like a thousand millions of suns, and it is difficult to see them all one by one. Over the surface of that ground of lapis lazuli there are stretched golden ropes intertwined crosswise; divisions are made by means of [strings of] seven jewels with every part clear and distinct....

When this perception has been formed, you should meditate on its constituents one by one and make the images as clear as possible, so that they may never be scattered and lost, whether your eyes be shut or open. Except only during the time of your sleep, you should always keep this in mind. One who has reached this stage of perception is said to have dimly seen the Land of Highest Happiness [Sukhāvati]. One who has obtained *samādhi* [the state of supernatural calm] is able to see the land of that Buddha country clearly and distinctly; this state is too much to be explained fully. Such is the perception of the land, and it is the Third Meditation.

[918] Samādhi is ‘withdrawnness,’ i.e., a condition in which all connections with the world are absorbed into the inner world. Samādhi is the eighth phase of the Eightfold Path.

[919] After the above comes a meditation on the Jewel Tree of the Amitābha land, and then follows the meditation on water:

In the Land of Highest Happiness there are waters in eight lakes; the water in every lake consists of seven jewels which are soft and yielding. Its source derives from the king of jewels that fulfils every wish [*cintāmani*, the wishing-pearl].... In the midst of each lake there are sixty millions of lotus-flowers, made of seven jewels; all the flowers are perfectly round and exactly equal in circumference.... The water of jewels flows amidst the flowers and ... the sound of the streaming water is melodious and pleasing. It proclaims all the perfect virtues [*pārāmitās*], “suffering,” “non-existence,” “impermanence” and “non-self”; it proclaims also the praise of the signs of perfection, and minor marks of excellence, of all Buddhas. From the king of jewels that fulfils every wish stream forth the golden-coloured rays excessively beautiful, the radiance of which transforms itself into birds possessing the colours of a hundred jewels, which sing out harmonious notes, sweet and delicious, ever praising the remembrance of the Buddha, the remembrance of the Law, and the remembrance of the Church. Such is the perception of the water of eight good qualities, and it is the Fifth Meditation.

[920] Concerning the meditation on Amitābha himself, the Buddha instructs the Queen in the following manner: “Form the perception of a lotus-flower on a ground of seven jewels.” The flower has 84,000 petals, each petal 84,000 veins, and each vein possesses 84,000 rays, “of which each can clearly be seen.”

[921] When you have perceived this, you should next perceive the Buddha himself. Do you ask how? Every Buddha Tathāgata is one whose spiritual body is the principle of nature [*Dharmadhātu-kāya*], so that he may enter into the mind of all beings. Consequently, when you have perceived the Buddha, it is indeed that mind of yours that possesses those thirty-two signs of perfection and eighty minor marks of excellence which you see in the Buddha. In fine, it is your mind that becomes the Buddha, nay, it is your mind that is indeed the Buddha. The ocean of true and

universal knowledge of all the Buddhas derives its source from one's own mind and thought. Therefore you should apply your thought with undivided attention to a careful meditation on that Buddha Tathāgata, the *Arhat*, the Holy and Fully Enlightened One. In forming the perception of that Buddha, you should first perceive the image of that Buddha; whether your eyes be open or shut, look at him as at an image like to Jambunada³ gold in colour, sitting on the flower.

When you have seen the seated figure your mental vision will become clear, and you will be able to see clearly and distinctly the adornment of that Buddha-country, the jewelled ground, etc. In seeing these things let them be clear and fixed just as you see the palms of your hands....

If you pass through this experience, you will at the same time see all the Buddhas of the ten quarters.... Those who have practised this meditation are said to have contemplated the bodies of all the Buddhas. Since they have meditated on the Buddha's body, they will also see the Buddha's mind. It is great compassion that is called the Buddha's mind. It is by his absolute compassion that he receives all beings. Those who have practised this meditation will, when they die, be born in the presence of the Buddhas in another life, and obtain a spirit of resignation wherewith to face all the consequences which shall hereafter arise. Therefore those who have wisdom should direct their thought to the careful meditation upon that Buddha Amitāyus.

[922] Of those who practise this meditation it is said that they no longer live in an embryonic condition but will "obtain free access to the excellent and admirable countries of Buddhas."

[923] After you have had this perception, you should imagine yourself to be born in the World of Highest Happiness in the western quarter, and to be seated, cross-legged, on a lotus-flower there. Then imagine that the flower has shut you in and has afterwards unfolded: when the flower has thus unfolded, five hundred coloured rays will shine over your body, your eyes will be opened so as to see the Buddhas and Bodhisattvas who fill the whole sky; you will hear the sounds of waters and trees, the notes of birds, and the voices of many Buddhas....

[924] The Buddha then says to Ānanda and Yaidehi (the Queen):

Those who wish, by means of their serene thoughts, to be born in the western land, should first meditate on an image of the Buddha, which is sixteen cubits high, seated on a lotus-flower in the water of the lake. As was stated before, the real body and its measurements are unlimited, incomprehensible to the ordinary mind. But by the efficacy of the ancient prayer of that Tathāgata, those who think of and remember him shall certainly be able to accomplish their aim....

[925] The Buddha's speech continues for many pages, then the text says:

When the Buddha had finished this speech, Vaidehi, together with her five hundred female attendants, guided by the Buddha's words, could see the scene of the far-stretching World of the Highest Happiness, and could also see the body of the Buddha and the bodies of the two Bodhisattvas. With her mind filled with joy she praised them, saying: "Never have I seen such a wonder!" Instantly she became wholly and fully enlightened, and attained a

spirit of resignation, prepared to endure whatever consequences might yet arise. Her five hundred female attendants too cherished the thought of obtaining the highest perfect knowledge, and sought to be born in that Buddha-country. The World-Honoured One predicted that they would all be born in that Buddha-country, and be able to obtain samādhi of the presence of many Buddhas.

[926] In a digression on the fate of the unenlightened, the Buddha sums up the yoga exercise as follows:

But, being harassed by pains, he will have no time to think of the Buddha. Some good friend will then say to him: “Even if you cannot exercise the remembrance of the Buddha, you may, at least, utter the name, ‘Buddha Amitāyus.’” Let him do so serenely with his voice uninterrupted; let him be continually thinking of the Buddha until he has completed ten times the thought, repeating the formula, “Adoration to Buddha Amitāyus.” On the strength of his merit in uttering the Buddha’s name he will, during every repetition, expiate the sins which involve him in births and deaths during eighty millions of *kalpas*. He will, while dying, see a golden lotus-flower like the disc of the sun appearing before his eyes; in a moment he will be born in the World of Highest Happiness.

[927] The above quotations form the essential content of the yoga exercise which interests us here. The text is divided into sixteen meditations, from which I have chosen only certain parts, but they will suffice to portray the intensification of the meditation, culminating in samādhi, the highest ecstasy and enlightenment.

[928] The exercise begins with the concentration on the setting sun. In southern latitudes the intensity of the rays of the setting sun is so strong that a few moments of gazing at it are enough to create an intense after-image. With closed eyes one continues to see the sun for some time. As is well known, one method of hypnosis consists in fixating a shining object, such as a diamond or a crystal. Presumably the fixation of the sun is meant to produce a similar hypnotic effect. On the other hand it should not have a soporific effect, because a “meditation” of the sun must accompany the fixation. This meditation is a reflecting, a “making clear,” in fact a *realization* of the sun, its form, its qualities, and its meanings. Since the round form plays such an important role in the subsequent meditations, we may suppose that the sun’s disk serves as a model for the later fantasies of circular structures, just as, by reason of its intense light, it prepares the way for the resplendent visions that come afterwards. In this manner, so the text says, “the perception is to be formed.”

[929] The next meditation, that of the water, is no longer based on any sense-impression but creates through active imagination the image of a reflecting expanse of water. This, as we know, throws back the full light of the sun. It should now be imagined that the water changes into ice, “shining and transparent.” Through this procedure the immaterial light of the sun-image is transformed into the substance of water and this in turn into the solidity of ice. A concretization of the vision is evidently aimed at, and this results in a materialization of the fantasy-creation, which appears in the place of physical nature, of the world as we know it. A different reality

is created, so to speak, out of soul-stuff. The ice, of a bluish colour by nature, changes into blue lapis lazuli, a solid, stony substance, which then becomes a “ground,” “transparent and shining.” With this “ground” an immutable, absolutely real foundation has been created. The blue translucent floor is like a lake of glass, and through its transparent layers one’s gaze penetrates into the depths below.

[930] The so-called “golden banner” then shines forth out of these depths. It should be noted that the Sanskrit word *dhvaja* also means ‘sign’ or ‘symbol’ in general. So we could speak just as well of the appearance of the “symbol.” It is evident that the symbol “extending to the eight points of the compass” represents the ground plan of an eight-rayed system. As the text says, the “eight corners of the ground are perfectly filled up” by the banner. The system shines “like a thousand millions of suns,” so that the shining after-image of the sun has enormously increased its radiant energy, and its illuminative power has now been intensified to an immeasurable degree. The strange idea of the “golden ropes” spread over the system like a net presumably means that the system is tied together and secured in this way, so that it can no longer fall apart. Unfortunately the text says nothing about a possible failure of the method, or about the phenomena of disintegration which might supervene as the result of a mistake. But disturbances of this kind in an imaginative process are nothing unexpected to an expert—on the contrary, they are a regular occurrence. So it is not surprising that a kind of inner reinforcement of the image is provided in the yoga vision by means of golden ropes.

[931] Although not explicitly stated in the text, the eight-rayed system is already the Amitābha land. In it grow wonderful trees, as is meet and proper, for this is paradise. Especial importance attaches to the water of the Amitābha land. In accordance with the octagonal system it is arranged in the form of eight lakes, and the source of these waters is a central jewel, *cintāmani*, the wishing pearl, a symbol of the “treasure hard to attain,”⁴ the highest value. In Chinese art it appears as a moonlike image, frequently associated with a dragon.⁵ The wondrous sounds of the water consist of two pairs of opposites which proclaim the dogmatic ground truths of Buddhism: “suffering and non-existence, impermanence and non-self,” signifying that all existence is full of suffering, and that everything that clings to the ego is impermanent. Not-being and not-being-ego deliver us from these errors. Thus the singing water is something like the teaching of the Buddha—a redeeming water of wisdom, an *aqua doctrinae*, to use an expression of Origen. The source of this water, the pearl without peer, is the Tathāgata, the Buddha himself. Hence the imaginative reconstruction of the Buddha-image follows immediately afterwards, and while this structure is being built up in the meditation it is realized that the Buddha is really nothing other than the activating psyche of the yogi—the meditator himself. It is not

only that the image of the Buddha is produced out of “one’s own mind and thought,” but the psyche which produces these thought-forms *is the Buddha himself*.

[932] The image of the Buddha sits in the round lotus in the centre of the octagonal Amitābha land. He is distinguished by the great compassion with which he “receives all beings,” including the meditator. This means that the inmost being which is the Buddha is bodied forth in the vision and revealed as the true self of the meditator. He experiences himself as the only thing that exists, as the highest consciousness, even the Buddha. In order to attain this final goal it was necessary to pass through all the laborious exercises of mental reconstruction, to get free of the deluded ego-consciousness which is responsible for the sorrowful illusion of the world, and to reach that other pole of the psyche where the world as illusion is abolished.

*

[933] Although it appears exceedingly obscure to the European, this yoga text is not a mere literary museum piece. It lives in the psyche of every Indian, in this form and in many others, so that his life and thinking are permeated by it down to the smallest details. It was not Buddhism that nurtured and educated this psyche, but yoga. Buddhism itself was born of the spirit of yoga, which is older and more universal than the historical reformation wrought by the Buddha. Anyone who seeks to understand Indian art, philosophy, and ethics from the inside must of necessity befriend this spirit. Our habitual understanding from the outside breaks down here, because it is hopelessly inadequate to the nature of Indian spirituality. And I wish particularly to warn against the oft-attempted imitation of Indian practices and sentiments. As a rule nothing comes of it except an artificial stultification of our Western intelligence. Of course, if anyone should succeed in giving up Europe from every point of view, and could actually *be* nothing but a yogi and sit in the lotus position with all the practical and ethical consequences that this entails, evaporating on a gazelle-skin under a dusty banyan tree and ending his days in nameless non-being, then I should have to admit that such a person understood yoga in the Indian manner. But anyone who cannot do this should not behave as if he did. He cannot and should not give up his Western understanding; on the contrary, he should apply it honestly, without imitation or sentimentality, to understanding as much of yoga as is possible for the Western mind. The secrets of yoga mean as much or even more to the Indian than our own Christian mysteries mean to us, and just as we would not allow any foreigner to make our *mysterium fidei* ludicrous, so we should not belittle these strange Indian ideas and practices or scorn them as absurd errors. By so doing we only block the way to a sensible understanding. Indeed, we in Europe have already gone so far in this direction that the spiritual content of our Christian dogma has disappeared in a rationalistic and “enlightened” fog of alarming density, and this

makes it all too easy for us to undervalue those things which we do not know and do not understand.

[934] If we wish to understand at all, we can do so only in the European way. One can, it is true, understand many things with the heart, but then the head often finds it difficult to follow up with an intellectual formulation that gives suitable expression to what has been understood. There is also an understanding with the head, particularly of the scientific kind, where there is sometimes too little room for the heart. We must therefore leave it to the good will and co-operation of the reader to use first one and then the other. So let us first attempt, with the head, to find or build that hidden bridge which may lead to a European understanding of yoga.

[935] For this purpose we must again take up the series of symbols we have already discussed, but this time we shall consider their sense-content. The *sun*, with which the series begins, is the source of warmth and light, the indubitable central point of our visible world. As the giver of life it is always and everywhere either the divinity itself or an image of the same. Even in the world of Christian ideas, the sun is a favourite allegory of Christ. A second source of life, especially in southern countries, is *water*, which also plays an important role in Christian allegory, for instance as the four rivers of paradise and the waters which issued from the side of the temple (Ezekiel 47). The latter were compared to the blood that flowed from the wound in Christ's side. In this connection I would also mention Christ's talk with the woman of Samaria at the well, and the rivers of living water flowing from the body of Christ (John 7:38). A meditation on sun and water evokes these and similar associations without fail, so that the meditator will gradually be led from the foreground of visible appearances into the background, that is, to the spiritual meaning behind the object of meditation. He is transported to the psychic sphere, where sun and water, divested of their physical objectivity, become symbols of psychic contents, images of the source of life in the individual psyche. For indeed our consciousness does not create itself—it wells up from unknown depths. In childhood it awakens gradually, and all through life it wakes each morning out of the depths of sleep from an unconscious condition. It is like a child that is born daily out of the primordial womb of the unconscious. In fact, closer investigation reveals that it is not only influenced by the unconscious but continually emerges out of it in the form of numberless spontaneous ideas and sudden flashes of thought. Meditation on the meaning of sun and water is therefore something like a descent into the fountainhead of the psyche, into the unconscious itself.

[936] Here, then, is a great difference between the Eastern and the Western mind. It is the same difference as the one we met before: the difference between the high and the low altar. The West is always seeking uplift, but the East seeks a sinking or

deepening. Outer reality, with its bodiliness and weight, appears to make a much stronger and sharper impression on the European than it does on the Indian. Therefore the European seeks to raise himself above this world, while the Indian likes to turn back into the maternal depths of Nature.

[937] Just as the Christian contemplative, for instance in the *Exercitia spiritualia* of Loyola, strives to comprehend the holy image as concretely as possible, with all the senses, so the yogi solidifies the water he contemplates first to ice and then to lapis lazuli, thereby creating a firm “ground,” as he calls it. He makes, so to speak, a solid body for his vision. In this way he endows the figures of his psychic world with a concrete reality which takes the place of the outer world. At first he sees nothing but a reflecting blue surface, like that of a lake or ocean (also a favourite symbol of the unconscious in our Western dreams); but under the shining surface unknown depths lie hidden, dark and mysterious.

[938] As the text says, the blue stone is *transparent*, which informs us that the gaze of the meditator can penetrate into the depths of the psyche’s secrets. There he sees what could not be seen before, i.e., what was unconscious. Just as sun and water are the physical sources of life, so, as symbols, they express the essential secret of the life of the unconscious. In the *banner*, the symbol the yogi sees through the floor of lapis lazuli, he beholds, as it were, an image of the source of consciousness, which before was invisible and apparently without form. Through *dhyāna*, through the sinking and deepening of contemplation, the unconscious has evidently taken on form. It is as if the light of consciousness had ceased to illuminate the objects of the outer world of the senses and now illumines the darkness of the unconscious. If the world of the senses and all thought of it are completely extinguished, then the inner world springs into relief more distinctly.

[939] Here the Eastern text skips over a psychic phenomenon that is a source of endless difficulties for the European. If a European tries to banish all thought of the outer world and to empty his mind of everything outside, he immediately becomes the prey of his own subjective fantasies, which have nothing whatever to do with the images mentioned in our text. Fantasies do not enjoy a good reputation; they are considered cheap and worthless and are therefore rejected as useless and meaningless. They are the *kleshas*, the disorderly and chaotic instinctual forces which yoga proposes to yoke. The *Exercitia spiritualia* pursue the same goal, in fact both methods seek to attain success by providing the meditator with an object to contemplate and showing him the image he has to concentrate on in order to shut out the allegedly worthless fantasies. Both methods, Eastern as well as Western, try to reach the goal by a direct path. I do not wish to question the possibilities of success when the meditation exercise is conducted in some kind of ecclesiastical setting. But,

outside of some such setting, the thing does not as a rule work, or it may even lead to deplorable results. By throwing light on the unconscious one gets first of all into the chaotic sphere of the personal unconscious, which contains all that one would like to forget, and all that one does not wish to admit to oneself or to anybody else, and which one prefers to believe is not true anyhow. One therefore expects to come off best if one looks as little as possible into this dark corner. Naturally anyone who proceeds in that way will never get round this corner and will never obtain even a trace of what yoga promises. Only the man who goes through this darkness can hope to make any further progress. I am therefore in principle against the uncritical appropriation of yoga practices by Europeans, because I know only too well that they hope to avoid their own dark corners. Such a beginning is entirely meaningless and worthless.

[940] This is also the deeper reason why we in the West have never developed anything comparable to yoga, aside from the very limited application of the Jesuit *Exercitia*. We have an abysmal fear of that lurking horror, our personal unconscious. Hence the European much prefers to tell others “how to do it.” That the improvement of the whole begins with the individual, even with myself, never enters our heads. Besides, many people think it morbid to glance into their own interiors—it makes you melancholic, a theologian once assured me.

[941] I have just said that we have developed nothing that could be compared with yoga. This is not entirely correct. True to our European bias, we have evolved a medical psychology dealing specifically with the kleshas. We call it the “psychology of the unconscious.” The movement inaugurated by Freud recognized the importance of the human shadow-side and its influence on consciousness, and then got entangled in this problem. Freudian psychology is concerned with the very thing that our text passes over in silence and assumes is already dealt with. The yogi is perfectly well aware of the world of the kleshas, but his religion is such a natural one that he knows nothing of the *moral conflict* which the kleshas represent for us. An ethical dilemma divides us from our shadow. The spirit of India grows out of nature; with us spirit is opposed to nature.

[942] The floor of lapis lazuli is not transparent for us because the question of the *evil in nature* must first be answered. This question *can* be answered, but surely not with shallow rationalistic arguments and intellectual patter. The ethical responsibility of the individual can give a valid answer, but there are no cheap recipes and no licences—one must pay to the last penny before the floor of lapis lazuli can become transparent. Our sutra presupposes that the shadow world of our personal fantasies—the personal unconscious—has been traversed, and goes on to describe a symbolical figure which at first strikes us as very strange. This is a geometrical structure raying

out from a centre and divided into eight parts—an ogdoad. In the centre there is a lotus with the Buddha sitting in it, and the decisive experience is the final knowledge that the meditator himself is the Buddha, whereby the fateful knots woven in the opening story are apparently resolved. The concentrically constructed symbol evidently expresses the highest concentration, which can be achieved only when the previously described withdrawal and canalization of interest away from the impressions of the sense-world and from object-bound ideas is pushed to the limit and applied to the background of consciousness. The conscious world with its attachment to objects, and even the centre of consciousness, the ego, are extinguished, and in their place the splendour of the Amitābha land appears with ever-increasing intensity.

[943] Psychologically this means that behind or beneath the world of personal fantasies and instincts a still deeper layer of the unconscious becomes visible, which in contrast to the chaotic disorder of the kleshas is pervaded by the highest order and harmony, and, in contrast to their multiplicity, symbolizes the all-embracing unity of the *bodhimandala*, the magic circle of enlightenment.

[944] What has our psychology to say about this Indian assertion of a supra-personal, world-embracing unconscious that appears when the darkness of the personal unconscious grows transparent? Modern psychology knows that the personal unconscious is only the top layer, resting on a foundation of a wholly different nature which we call the collective unconscious. The reason for this designation is the circumstance that, unlike the personal unconscious and its purely personal contents, the images in the deeper unconscious have a distinctly mythological character. That is to say, in form and content they coincide with those widespread primordial ideas which underlie the myths. They are no longer of a personal but of a purely supra-personal nature and are therefore common to all men. For this reason they are to be found in the myths and legends of all peoples and all times, as well as in individuals who have not the slightest knowledge of mythology.

[945] Our Western psychology has, in fact, got as far as yoga in that it is able to establish scientifically a deeper layer of unity in the unconscious. The mythological motifs whose presence has been demonstrated by the exploration of the unconscious form in themselves a multiplicity, but this culminates in a concentric or radial order which constitutes the true centre or essence of the collective unconscious. On account of the remarkable agreement between the insights of yoga and the results of psychological research, I have chosen the Sanskrit term *mandala* for this central symbol.

[946] You will now surely ask: but how in the world does science come to such conclusions? There are two paths to this end. The first is the historical path. If we

study, for instance, the introspective method of medieval natural philosophy, we find that it repeatedly used the circle, and in most cases the circle divided into four parts, to symbolize the central principle, obviously borrowing this idea from the ecclesiastical allegory of the quaternity as found in numerous representations of the *Rex gloriae* with the four evangelists, the four rivers of paradise, the four winds, and so on.

[947] The second is the path of empirical psychology. At a certain stage in the psychological treatment patients sometimes paint or draw such mandalas spontaneously, either because they dream them or because they suddenly feel the need to compensate the confusion in their psyches through representations of an ordered unity. For instance, our Swiss national saint, the Blessed Brother Nicholas of Flüe, went through a process of this kind, and the result can still be seen in the picture of the Trinity in the parish church at Sachseln. With the help of circular drawings in a little book by a German mystic,⁶ he succeeded in assimilating the great and terrifying vision that had shaken him to the depths.

[948] But what has our empirical psychology to say about the Buddha sitting in the lotus? Logically one would expect Christ to be enthroned in the centre of our Western mandalas. This was once true, as we have already said, in the Middle Ages. But our modern mandalas, spontaneously produced by numerous individuals without any preconceived ideas or suggestions from outside, contain no Christ-figure, still less a Buddha in the lotus position. On the other hand, the equal-armed Greek cross, or even an unmistakable imitation of the swastika, is to be found fairly often. I cannot discuss this strange fact here, though in itself it is of the greatest interest.⁷

[949] Between the Christian and the Buddhist mandala there is a subtle but enormous difference. The Christian during contemplation would never say “*I am Christ,*” but will confess with Paul: “Not I, but Christ liveth in me” (Gal. 2:20). Our sutra, however, says: “Thou wilt know that *thou* art the Buddha.” At bottom the two confessions are identical, in that the Buddhist only attains this knowledge when he is *anātman*, ‘without self.’ But there is an immeasurable difference in the formulation. The Christian attains his end *in Christ*, the Buddhist knows *he* is the Buddha. The Christian gets *out of* the transitory and ego-bound world of consciousness, but the Buddhist *still* reposes on the eternal ground of his inner nature, whose oneness with Deity, or with universal Being, is confirmed in other Indian testimonies.

[950] Heinrich Zimmer had been interested for years in the Maharshi of Tiruvannamalai, and the first question he asked me on my return from India concerned this latest holy and wise man from southern India. I do not know whether my friend found it an unforgivable or an incomprehensible sin on my part that I had not sought out Shri Ramana. I had the feeling that *he* would certainly not have neglected to pay him a visit, so warm was his interest in the life and thought of the holy man. This was scarcely surprising, as I know how deeply Zimmer had penetrated into the spirit of India. His most ardent wish to see India in reality was unfortunately never fulfilled, and the one chance he had of doing so fell through in the last hours before the outbreak of the second World War. As if in compensation, his vision of the spiritual India was all the more magnificent. In our work together he gave me invaluable insights into the Oriental psyche, not only through his immense technical knowledge, but above all through his brilliant grasp of the meaning and content of Indian mythology. Unhappily, the early death of those beloved of the gods was fulfilled in him, and it remains for us to mourn the loss of a spirit that overcame the limitations of the specialist and, turning towards humanity, bestowed upon it the joyous gift of “immortal fruit.”

[951] The carrier of mythological and philosophical wisdom in India has been since time immemorial the “holy man”—a Western title which does not quite render the essence and outward appearance of the parallel figure in the East. This figure is the embodiment of the spiritual India, and we meet him again and again in the literature. No wonder, then, that Zimmer was passionately interested in the latest and best incarnation of this type in the phenomenal personage of Shri Ramana. He saw in this yogi the true avatar of the figure of the *rishi*, seer and philosopher, which strides, as legendary as it is historical, down the centuries and the ages.

[952] Perhaps I should have visited Shri Ramana. Yet I fear that if I journeyed to India a second time to make up for my omission, it would fare with me just the same: I simply could not, despite the uniqueness of the occasion, bring myself to visit this undoubtedly distinguished man personally. For the fact is, I doubt his uniqueness; he is of a type which always was and will be. Therefore it was not necessary to seek him out. I saw him all over India, in the pictures of Ramakrishna, in Ramakrishna’s disciples, in Buddhist monks, in innumerable other figures of the daily Indian scene, and the words of his wisdom are the *sous-entendu* of India’s spiritual life. Shri Ramana is, in a sense, a *hominum homo*, a true “son of man” of the Indian earth. He is “genuine,” and on top of that he is a “phenomenon” which, seen through European eyes, has claims to uniqueness. But in India he is merely the whitest spot on a white

surface (whose whiteness is mentioned only because there are so many surfaces that are just as black). Altogether, one sees so much in India that in the end one only wishes one could see less: the enormous variety of countries and human beings creates a longing for complete simplicity. This simplicity is there too; it pervades the spiritual life of India like a pleasant fragrance or a melody. It is everywhere the same, but never monotonous, endlessly varied. To get to know it, it is sufficient to read an Upanishad or any discourse of the Buddha. What is heard there is heard everywhere; it speaks out of a million eyes, it expresses itself in countless gestures, and there is no village or country road where that broad-branched tree cannot be found in whose shade the ego struggles for its own abolition, drowning the world of multiplicity in the All and All-Oneness of Universal Being. This note rang so insistently in my ears that soon I was no longer able to shake off its spell. I was then absolutely certain that no one could ever get beyond this, least of all the Indian holy man himself; and should Shri Ramana say anything that did not chime in with this melody, or claim to know anything that transcended it, his illumination would assuredly be false. The holy man is right when he intones India's ancient chants, but wrong when he pipes any other tune. This effortless drone of argumentation, so suited to the heat of southern India, made me refrain, without regret, from a visit to Tiruvannamalai.

[953] Nevertheless, the unfathomableness of India saw to it that I should encounter the holy man after all, and in a form that was more congenial to me, without my seeking him out: in Trivandrum, the capital of Travancore, I ran across a disciple of the Maharshi. He was an unassuming little man, of a social status which we would describe as that of a primary-school teacher, and he reminded me most vividly of the shoemaker of Alexandria who (in Anatole France's story) was presented to St. Anthony by the angel as an example of an even greater saint than he. Like the shoemaker, my little holy man had innumerable children to feed and was making special sacrifices in order that his eldest son might be educated. (I will not enter here into the closely allied question as to whether holy men are always wise, and conversely, whether all wise men are unconditionally holy. In this respect there is room for doubt.) Be that as it may, in this modest, kindly, devout, and childlike spirit I encountered a man who had absorbed the wisdom of the Maharshi with utter devotion, and at the same time had surpassed his master because, notwithstanding his cleverness and holiness, he had "eaten" the world. I acknowledge with deep gratitude this meeting with him; nothing better could have happened to me. The man who is only wise and only holy interests me about as much as the skeleton of a rare saurian, which would not move me to tears. The insane contradiction, on the other hand, between existence beyond Māyā in the cosmic Self, and that amiable human weakness which fruitfully sinks many roots into the black earth, repeating for all eternity the weaving and rending of the veil as the ageless melody of India—this

contradiction fascinates me; for how else can one perceive the light without the shadow, hear the silence without the noise, attain wisdom without foolishness? The experience of holiness may well be the most painful of all. My man—thank God—was only a little holy man; no radiant peak above the dark abysses, no shattering sport of nature, but an example of how wisdom, holiness, *and* humanity can dwell together in harmony, richly, pleasantly, sweetly, peacefully, and patiently, without limiting one another, without being peculiar, causing no surprise, in no way sensational, necessitating no special post-office, yet embodying an age-old culture amid the gentle murmur of the coconut palms fanning themselves in the light sea wind. He has found a meaning in the rushing phantasmagoria of Being, freedom in bondage, victory in defeat.

[954] Unadulterated wisdom and unadulterated holiness, I fear, are seen to best advantage in literature, where their reputation remains undisputed. Lao-tzu reads exquisitely, unsurpassably well, in the *Tao Teh Ching*; Lao-tzu with his dancing girl on the Western slope of the mountain, celebrating the evening of life, is rather less edifying. But even less can one approve of the neglected body of the “unadulterated” holy man, especially if one believes that beauty is one of the most excellent of God’s creations.

[955] Shri Ramana’s thoughts are beautiful to read. What we find here is purest India, the breath of eternity, scorning and scorned by the world. It is the song of the ages, resounding, like the shrilling of crickets on a summer’s night, from a million beings. This melody is built up on the one great theme, which, veiling its monotony under a thousand colourful reflections, tirelessly and everlastingly rejuvenates itself in the Indian spirit, whose youngest incarnation is Shri Ramana himself. It is the drama of *ahamkāra*, the “I-maker” or ego-consciousness, in opposition and indissoluble bondage to the atman, the self or non-ego. The Maharshi also calls the atman the “ego-ego”—significantly enough, for the self is indeed experienced as the subject of the subject, as the true source and controller of the ego, whose (mistaken) strivings are continually directed towards appropriating the very autonomy which is intimated to it by the self.

[956] This conflict is not unknown to the Westerner: for him it is the relationship of man to God. The modern Indian, as I can testify from my own experience, has largely adopted European habits of language, “self” or “atman” being essentially synonymous with “God.” But, in contradistinction to the Western “man and God,” the Indian posits the opposition (or correspondence) between “ego and self.” “Ego,” as contrasted with “man,” is a distinctly psychological concept, and so is “self”—to *our* way of thinking. We might therefore be inclined to assume that in India the metaphysical problem “man and God” has been shifted on to the psychological plane.

On closer inspection it is clear that this is not so, for the Indian concept of “ego” and “self” is not really psychological but—one could well say—just as metaphysical as our “man and God.” The Indian lacks the epistemological standpoint just as much as our own religious language does. He is still “pre-Kantian.” This complication is unknown in India and it is still largely unknown with us. In India there is no psychology in our sense of the word. India is “pre-psychological”: when it speaks of the “self,” it *posits* such a thing as existing. Psychology does not do this. It does not in any sense deny the existence of the dramatic conflict, but reserves the right to the poverty, or the riches, of *not* knowing about the self. Though very well acquainted with the self’s peculiar and paradoxical phenomenology, we remain conscious of the fact that we are discerning, with the limited means at our disposal, something essentially unknown and expressing it in terms of psychic structures which may not be adequate to the nature of what is to be known.

[957] This epistemological limitation keeps us at a remove from what we term “self” or “God.” The equation self = God is shocking to the European. As Shri Ramana’s statements and many others show, it is a specifically Eastern insight, to which psychology has nothing further to say except that it is not within its competence to differentiate between the two. Psychology can only establish that the empiricism of the “self” exhibits a religious symptomatology, just as does that category of assertions associated with the term “God.” Although the phenomenon of religious exaltation transcends epistemological criticism—a feature it shares with all manifestations of emotion—yet the human urge to knowledge asserts itself again and again with “ungodly” or “Luciferian” obstinacy and wilfulness, indeed with necessity, whether it be to the loss or gain of the thinking man. Sooner or later he will place his reason in opposition to the emotion that grips him and seek to withdraw from its entangling grasp in order to give an account of what has happened. If he proceeds prudently and conscientiously, he will continually discover that at least a part of his experience is a humanly limited *interpretation*, as was the case with Ignatius Loyola and his vision of the snake with multiple eyes, which he at first regarded as of divine, and later as of diabolical, origin. (Compare the exhortation in I John 4:1: “Do not believe every spirit, but test the spirits to see whether they are of God.”) To the Indian it is clear that the self as the originating ground of the psyche is not different from God, and that, so far as a man is *in* the self, he is not only contained in God but actually is God. Shri Ramana is quite explicit on this point. No doubt this equation, too, is an “interpretation.” Equally, it is an interpretation to regard the self as the highest good or as the goal of all desire and fulfilment, although the phenomenology of such an experience leaves no doubt that these characteristics exist *a priori* and are indispensable components of religious exaltation. But that will not prevent the critical intellect from questioning the validity of these characteristics.

It is difficult to see how this question could be answered, as the intellect lacks the necessary criteria. Anything that might serve as a criterion is subject in turn to the critical question of validity. The only thing that can decide here is the preponderance of psychic facts.

[958] The goal of Eastern religious practice is the same as that of Western mysticism: the shifting of the centre of gravity from the ego to the self, from man to God. This means that the ego disappears in the self, and man in God. It is evident that Shri Ramana has either really been more or less absorbed by the self, or has at least struggled earnestly all his life to extinguish his ego in it. The *Exercitia spiritualia* reveal a similar striving: they subordinate “self-possession” (possession of an ego) as much as possible to possession by Christ. Shri Ramana’s elder contemporary, Ramakrishna, had the same attitude concerning the relation to the self, only in his case the dilemma between ego and self seems to emerge more distinctly. Whereas Shri Ramana displays a “sympathetic” tolerance towards the worldly callings of his disciples, while yet exalting the extinction of the ego as the real goal of spiritual exertion, Ramakrishna shows a rather more hesitant attitude in this respect. He says: “So long as ego-seeking exists, neither knowledge (*jñāna*) nor liberation (*mukti*) is possible, and to births and deaths there is no end.”² All the same, he has to admit the fatal tenacity of *ahamkāra* (the “I-maker”): “Very few can get rid of the sense of ‘I’ through *samādhi*.... We may discriminate a thousand times, but the sense of ‘I’ is bound to return again and again. You may cut down the branches of a fig-tree today, but tomorrow you will see that new twigs are sprouting.”³ He goes so far as to suggest the indestructibility of the ego with the words: “If this sense of ‘I’ will not leave, then let it stay on as the servant of God.”⁴ Compared with this concession to the ego, Shri Ramana is definitely the more radical or, in the sense of Indian tradition, the more conservative. Though the elder, Ramakrishna is the more modern of the two, and this is probably to be attributed to the fact that he was affected by the Western attitude of mind far more profoundly than was Shri Ramana.

[959] If we conceive of the self as the essence of psychic wholeness, i.e., as the totality of conscious and unconscious, we do so because it does *in fact* represent something like a goal of psychic development, and this irrespective of all conscious opinions and expectations. The self is the subject-matter of a process that generally runs its course outside consciousness and makes its presence felt only by a kind of long-range effect. A critical attitude towards this natural process allows us to raise questions which are excluded at the outset by the formula self = God. This formula shows the dissolution of the ego in the atman to be the unequivocal goal of religion and ethics, as exemplified in the life and thought of Shri Ramana. The same is obviously true of Christian mysticism, which differs from Oriental philosophy only through having a different terminology. The inevitable consequence is the

depreciation and abolition of the physical and psychic man (i.e., of the living body and *ahamkāra*) in favour of the pneumatic man. Shri Ramana speaks of his body as “this clod.” As against this, and taking into consideration the complex nature of human experience (emotion plus interpretation), the critical standpoint admits the importance of ego-consciousness, well knowing that without *ahamkāra* there would be absolutely no one there to register what was happening. Without the Maharshi’s personal ego, which, as a matter of brute experience, only exists in conjunction with the said “clod” (= body), there would be no Shri Ramana at all. Even if we agreed with him that it is no longer his ego, but the atman speaking, it is still the psychic structure of consciousness in association with the body that makes speech communication possible. Without this admittedly very troublesome physical and psychic man, the self would be entirely without substance, as Angelus Silesius has already said:

I know that without me
God can no moment live;
Were I to die, then he
No longer could survive.

[960] The intrinsically goal-like quality of the self and the urge to realize this goal are, as we have said, not dependent on the participation of consciousness. They cannot be denied any more than one can deny one’s ego-consciousness. It, too, puts forward its claims peremptorily, and very often in overt or covert opposition to the needs of the evolving self. In reality, i.e., with few exceptions, the entelechy of the self consists in a succession of endless compromises, ego and self laboriously keeping the scales balanced if all is to go well. Too great a swing to one side or the other is often no more than an example of how not to set about it. This certainly does not mean that extremes, when they occur in a natural way, are in themselves evil. We make the right use of them when we examine their meaning, and they give us ample opportunity to do this in a manner deserving our gratitude. Exceptional human beings, carefully hedged about and secluded, are invariably a gift of nature, enriching and widening the scope of our consciousness—but only if our capacity for reflection does not suffer shipwreck. Enthusiasm can be a veritable gift of the gods or a monster from hell. With the hybris which attends it, corruption sets in, even if the resultant clouding of consciousness seems to put the attainment of the highest goals almost within one’s grasp. The only true and lasting gain is heightened and broadened reflection.

[961] Banalities apart, there is unfortunately no philosophical or psychological proposition that does not immediately have to be reversed. Thus reflection as an end in itself is nothing but a limitation if it cannot stand firm in the turmoil of chaotic

extremes, just as mere dynamism for its own sake leads to inanity. Everything requires for its existence its own opposite, or else it fades into nothingness. The ego needs the self and vice versa. The changing relations between these two entities constitute a field of experience which Eastern introspection has exploited to a degree almost unattainable to Western man. The philosophy of the East, although so vastly different from ours, could be an inestimable treasure for us too; but, in order to possess it, we must first earn it. Shri Ramana's words, which Heinrich Zimmer has bequeathed to us, in excellent translation, as the last gift of his pen, bring together once again the loftiest insights that the spirit of India has garnered in the course of the ages, and the individual life and work of the Maharshi illustrate once again the passionate striving of the Indian for the liberating "Ground." I say "once again," because India is about to take the fateful step of becoming a State and entering into a community of nations whose guiding principles have anything and everything on the programme except detachment and peace of the soul.

[962] The Eastern peoples are threatened with a rapid collapse of their spiritual values, and what replaces them cannot always be counted among the best that Western civilization has produced. From this point of view, one could regard Ramakrishna and Shri Ramana as modern prophets, who play the same compensatory role in relation to their people as that of the Old Testament prophets in relation to the "unfaithful" children of Israel. Not only do they exhort their compatriots to remember their thousand-year-old spiritual culture, they actually embody it and thus serve as an impressive warning, lest the demands of the soul be forgotten amid the novelties of Western civilization with its materialistic technology and commercial acquisitiveness. The breathless drive for power and aggrandizement in the political, social, and intellectual sphere, gnawing at the soul of the Westerner with apparently insatiable greed, is spreading irresistibly in the East and threatens to have incalculable consequences. Not only in India but in China, too, much has already perished where once the soul lived and thrived. The externalization of culture may do away with a great many evils whose removal seems most desirable and beneficial, yet this step forward, as experience shows, is all too dearly paid for with a loss of spiritual culture. It is undeniably much more comfortable to live in a well-planned and hygienically equipped house, but this still does not answer the question of *who* is the dweller in this house and whether his soul rejoices in the same order and cleanliness as the house which ministers to his outer life. The man whose interests are all outside is never satisfied with what is necessary, but is perpetually hankering after something more and better which, true to his bias, he always seeks outside himself. He forgets completely that, for all his outward successes, he himself remains the same inwardly, and he therefore laments his poverty if he possesses only one automobile when the majority have two. Obviously the outward lives of men could

do with a lot more bettering and beautifying, but these things lose their meaning when the inner man does not keep pace with them. To be satiated with “necessities” is no doubt an inestimable source of happiness, yet the inner man continues to raise his claim, and this can be satisfied by no outward possessions. And the less this voice is heard in the chase after the brilliant things of this world, the more the inner man becomes the source of inexplicable misfortune and uncomprehended unhappiness in the midst of living conditions whose outcome was expected to be entirely different. The externalization of life turns to incurable suffering, because no one can understand why he should suffer from himself. No one wonders at his insatiability, but regards it as his lawful right, never thinking that the one-sidedness of this psychic diet leads in the end to the gravest disturbances of equilibrium. That is the sickness of Western man, and he will not rest until he has infected the whole world with his own greedy restlessness.

[963] The wisdom and mysticism of the East have, therefore, very much to say to us, even when they speak their own inimitable language. They serve to remind us that we in our culture possess something similar, which we have already forgotten, and to direct our attention to the fate of the inner man, which we set aside as trifling. The life and teaching of Shri Ramana are of significance not only for India, but for the West too. They are more than a *document humain*: they are a warning message to a humanity which threatens to lose itself in unconsciousness and anarchy. It is perhaps, in the deeper sense, no accident that Heinrich Zimmer’s last book should leave us, as a testament, the life-work of a modern Indian prophet who exemplifies so impressively the problem of psychic transformation.

IX

FOREWORD TO THE "I CHING"

FOREWORD TO THE "I CHING"¹

[964] Since I am not a Sinologue, a foreword to the Book of Changes from my hand must be a testimonial of my individual experience with this great and singular book. It also affords me a welcome opportunity to pay tribute again to the memory of my late friend, Richard Wilhelm. He himself was profoundly aware of the cultural significance of his translation of the *I Ching*, a version unrivalled in the West.

[965] If the meaning of the Book of Changes were easy to grasp, the work would need no foreword. But this is far from being the case, for there is so much that is obscure about it that Western scholars have tended to dispose of it as a collection of "magic spells," either too abstruse to be intelligible or of no value whatsoever. Legge's translation of the *I Ching*, up to now the only version available in English, has done little to make the work accessible to Western minds.² Wilhelm, however, has made every effort to open the way to an understanding of the symbolism of the text. He was in a position to do this because he himself was taught the philosophy and the use of the *I Ching* by the venerable sage Lao Nai-hsüan; moreover, he had over a period of many years put the peculiar technique of the oracle into practice. His grasp of the living meaning of the text gives his version of the *I Ching* a depth of perspective that an exclusively academic knowledge of Chinese philosophy could never provide.

[966] I am greatly indebted to Wilhelm for the light he has thrown upon the complicated problem of the *I Ching*, and for insight into its practical application. For more than thirty years I have interested myself in this oracle technique, for it seemed to me of uncommon significance as a method of exploring the unconscious. I was already fairly familiar with the *I Ching* when I first met Wilhelm in the early nineteen twenties; he confirmed then what I already knew, and taught me many things more.

[967] I do not know Chinese and have never been in China. I can assure my reader that it is not altogether easy to find the right approach to this monument of Chinese thought, which departs so completely from our ways of thinking. In order to understand what such a book is all about, it is imperative to cast off certain of our Western prejudices. It is a curious fact that such a gifted and intelligent people as the Chinese has never developed what we call science. Our science, however, is based upon the principle of causality, and causality is considered to be an axiomatic truth. But a great change in our standpoint is setting in. What Kant's *Critique of Pure Reason* failed to do is being accomplished by modern physics. The axioms of causality are being shaken to their foundations: we know now that what we term

natural laws are merely statistical truths and thus must necessarily allow for exceptions. We have not sufficiently taken into account as yet that we need the laboratory with its incisive restrictions in order to demonstrate the invariable validity of natural law. If we leave things to nature, we see a very different picture: every process is partially or totally interfered with by chance, so much so that under natural circumstances a course of events absolutely conforming to specific laws is almost an exception.

[968] The Chinese mind, as I see it at work in the *I Ching*, seems to be exclusively preoccupied with the chance aspect of events. What we call coincidence seems to be the chief concern of this peculiar mind, and what we worship as causality passes almost unnoticed. We must admit that there is something to be said for the immense importance of chance. An incalculable amount of human effort is directed to combatting and restricting the nuisance or danger that chance represents. Theoretical considerations of cause and effect often look pale and dusty in comparison with the practical results of chance. It is all very well to say that the crystal of quartz is a hexagonal prism. The statement is quite true in so far as an ideal crystal is envisaged. But in nature one finds no two crystals exactly alike, although all are unmistakably hexagonal. The actual form, however, seems to appeal more to the Chinese sage than the ideal one. The jumble of natural laws constituting empirical reality holds more significance for him than a causal explanation of events that, in addition, must usually be separated from one another in order to be properly dealt with.

[969] The manner in which the *I Ching* tends to look upon reality seems to disfavour our causal procedures. The moment under actual observation appears to the ancient Chinese view more of a chance hit than a clearly defined result of concurrent causal chains. The matter of interest seems to be the configuration formed by chance events at the moment of observation, and not at all the hypothetical reasons that seemingly account for the coincidence. While the Western mind carefully sifts, weighs, selects, classifies, isolates, the Chinese picture of the moment encompasses everything down to the minutest nonsensical detail, because all of the ingredients make up the observed moment.

[970] Thus it happens that when one throws the three coins, or counts through the forty-nine yarrow-stalks, these chance details enter into the picture of the moment of observation and form a part of it—a part that is insignificant to us, yet most meaningful to the Chinese mind. With us it would be a banal and almost meaningless statement (at least on the face of it) to say that whatever happens in a given moment has inevitably the quality peculiar to that moment. This is not an abstract argument but a very practical one. There are certain connoisseurs who can tell you merely from the appearance, taste, and behaviour of a wine the site of its vineyard and the year of its origin. There are antiquarians who with almost uncanny accuracy will name the

time and place of origin and the maker of an *objet d'art* or piece of furniture on merely looking at it. And there are even astrologers who can tell you, without any previous knowledge of your nativity, what the position of sun and moon was and what zodiacal sign rose above the horizon at the moment of your birth. In the face of such facts, it must be admitted that moments can leave long-lasting traces.

[971] In other words, whoever invented the *I Ching* was convinced that the hexagram worked out in a certain moment coincided with the latter in quality no less than in time. To him the hexagram was the exponent of the moment in which it was cast—even more so than the hours of the clock or the divisions of the calendar could be—inasmuch as the hexagram was understood to be an indicator of the essential situation prevailing at the moment of its origin.

[972] This assumption involves a certain curious principle which I have termed synchronicity,³ a concept that formulates a point of view diametrically opposed to that of causality. Since the latter is a merely statistical truth and not absolute, it is a sort of working hypothesis of how events evolve one out of another, whereas synchronicity takes the coincidence of events in space and time as meaning something more than mere chance, namely, a peculiar interdependence of objective events among themselves as well as with the subjective (psychic) states of the observer or observers.

[973] The ancient Chinese mind contemplates the cosmos in a way comparable to that of the modern physicist, who cannot deny that his model of the world is a decidedly psychophysical structure. The microphysical event includes the observer just as much as the reality underlying the *I Ching* comprises subjective, i.e., psychic conditions in the totality of the momentary situation. Just as causality describes the sequence of events, so synchronicity to the Chinese mind deals with the coincidence of events. The causal point of view tells us a dramatic story about how *D* came into existence: it took its origin from *C*, which existed before *D*, and *C* in its turn had a father, *B*, etc. The synchronistic view on the other hand tries to produce an equally meaningful picture of coincidence. How does it happen that *A'*, *B'*, *C'*, *D'*, etc., appear all at the same moment and in the same place? It happens in the first place because the physical events *A'* and *B'* are of the same quality as the psychic events *C'* and *D'*, and further because all are the exponents of one and the same momentary situation. The situation is assumed to represent a legible or understandable picture.

[974] Now the sixty-four hexagrams of the *I Ching* are the instrument by which the meaning of sixty-four different yet typical situations can be determined. These interpretations are equivalent to causal explanations. Causal connection can be determined statistically and can be subjected to experiment. Inasmuch as situations are unique and cannot be repeated, experimenting with synchronicity seems to be impossible under ordinary conditions.⁴ In the *I Ching*, the only criterion of the

validity of synchronicity is the observer's opinion that the text of the hexagram amounts to a true rendering of his psychic condition. It is assumed that the fall of the coins or the result of the division of the bundle of yarrow-stalks is what it necessarily must be in a given "situation," inasmuch as anything happening at that moment belongs to it as an indispensable part of the picture. If a handful of matches is thrown to the floor, they form the pattern characteristic of that moment. But such an obvious truth as this reveals its meaningful nature only if it is possible to read the pattern and to verify its interpretation, partly by the observer's knowledge of the subjective and objective situation, partly by the character of subsequent events. It is obviously not a procedure that appeals to a critical mind used to experimental verification of facts or to factual evidence. But for someone who likes to look at the world at the angle from which ancient China saw it, the *I Ching* may have some attraction.

[975] My argument as outlined above has of course never entered a Chinese mind. On the contrary, according to the old tradition, it is "spiritual agencies," acting in a mysterious way, that make the yarrow-stalks give a meaningful answer.⁵ These powers form, as it were, the living soul of the book. As the latter is thus a sort of animated being, the tradition assumes that one can put questions to the *I Ching* and expect to receive intelligent answers. Thus it occurred to me that it might interest the uninitiated reader to see the *I Ching* at work. For this purpose I made an experiment strictly in accordance with the Chinese conception: I personified the book in a sense, asking its judgment about its present situation, i.e., my intention to introduce it to the English-speaking public.

[976] Although this procedure is well within the premises of Taoist philosophy, it appears exceedingly odd to us. However, not even the strangeness of insane delusions or of primitive superstition has ever shocked me. I have always tried to remain unbiased and curious—*rerum novarum cupidus*. Why not venture a dialogue with an ancient book that purports to be animated? There can be no harm in it, and the reader may watch a psychological procedure that has been carried out time and again throughout the millennia of Chinese civilization, representing to a Confucius or a Lao-tzu both a supreme expression of spiritual authority and a philosophical enigma. I made use of the coin method, and the answer obtained was hexagram 50, Ting, THE CAULDRON.⁶

[977] In accordance with the way my question was phrased, the text of the hexagram must be regarded as though the *I Ching* itself were the speaking person. Thus it describes itself as a cauldron, that is, as a ritual vessel containing cooked food. Here the food is to be understood as spiritual nourishment. Wilhelm says about this:

The *ting*, as a utensil pertaining to a refined civilization, suggests the fostering and nourishing of able men, which redounded to the benefit of the state.... Here we see civilization as it reaches its culmination in religion. The *ting* serves in offering sacrifice to God.... The supreme revelation of God appears in prophets and holy men. To

venerate them is true veneration of God. The will of God, as revealed through them, should be accepted in humility.

[978] Keeping to our hypothesis, we must conclude that the *I Ching* is here testifying concerning itself.

[979] When any of the lines of a given hexagram have the value of six or nine, it means that they are specially emphasized and hence important in the interpretation.⁷ In my hexagram the “spiritual agencies” have given the emphasis of a nine to the lines in the second and in the third place. The text says:

Nine in the second place means:

There is food in the *ting*.

My comrades are envious,

But they cannot harm me.

Good fortune.

[980] Thus the *I Ching* says of itself: “I contain (spiritual) nourishment.” Since a share in something great always arouses envy, the chorus of the envious⁸ is part of the picture. The envious want to rob the *I Ching* of its great possession, that is, they seek to rob it of meaning, or to destroy its meaning. But their enmity is in vain. Its richness of meaning is assured; that is, it is convinced of its positive achievements, which no one can take away. The text continues:

Nine in the third place means:

The handle of the *ting* is altered.

One is impeded in his way of life.

The fat of the pheasant is not eaten.

Once rain falls, remorse is spent.

Good fortune comes in the end.

[981] The handle [German *Griff*] is the part by which the *ting* can be grasped [*gegriffen*]. Thus it signifies the concept⁹ [*Begriff*] one has of the *I Ching* (the *ting*). In the course of time this concept has apparently changed, so that today we can no longer grasp [*begreifen*] the *I Ching*. Thus “one is impeded in his way of life.” We are no longer supported by the wise counsel and deep insight of the oracle; therefore we no longer find our way through the mazes of fate and the obscurities of our own natures. The fat of the pheasant, that is, the best and richest part of a good dish, is no longer eaten. But when the thirsty earth finally receives rain again, that is, when this state of want has been overcome, “remorse,” that is, sorrow over the loss of wisdom, is ended, and then comes the longed-for opportunity. Wilhelm comments: “This describes a man who, in a highly evolved civilization, finds himself in a place where no one notices or recognizes him. This is a severe block to his effectiveness.” The *I*

Ching is complaining, as it were, that its excellent qualities go unrecognized and hence lie fallow. It comforts itself with the hope that it is about to regain recognition.

[982] The answer given in these two salient lines to the question I put to the *I Ching* requires no particular subtlety for its interpretation, no artifices, and no unusual knowledge. Anyone with a little common sense can understand the meaning of the answer; it is the answer of one who has a good opinion of himself, but whose value is neither generally recognized nor even widely known. The answering subject has an interesting notion of itself: it looks upon itself as a vessel in which sacrificial offerings are brought to the gods, ritual food for their nourishment. It conceives of itself as a cult utensil serving to provide spiritual nourishment for the unconscious elements or forces (“spiritual agencies”) that have been projected as gods—in other words, to give these forces the attention they need in order to play their part in the life of the individual. Indeed, this is the original meaning of the word *religio*—a careful observation and taking account of (from *relegere*¹⁰) the numinous.

[983] The method of the *I Ching* does indeed take into account the hidden individual quality in things and men, and in one’s own unconscious self as well. I questioned the *I Ching* as one questions a person whom one is about to introduce to friends: one asks whether or not it will be agreeable to him. In answer the *I Ching* tells me of its religious significance, of the fact that at present it is unknown and misjudged, of its hope of being restored to a place of honour—this last obviously with a sidelong glance at my as yet unwritten foreword,¹¹ and above all at the English translation. This seems a perfectly understandable reaction, such as one could expect also from a person in a similar situation.

[984] But how has this reaction come about? Simply because I threw three small coins into the air and let them fall, roll, and come to rest, heads up or tails up as the case might be. This peculiar fact—that a reaction that makes sense arises out of a technique which at the outset seemingly excludes all sense—is the great achievement of the *I Ching*. The instance I have just given is not unique; meaningful answers are the rule. Western sinologues and distinguished Chinese scholars have been at pains to inform me that the *I Ching* is a collection of obsolete “magic spells.” In the course of these conversations my informant has sometimes admitted having consulted the oracle through a fortune teller, usually a Taoist priest. This could be “only nonsense” of course. But oddly enough, the answer received apparently coincided with the questioner’s psychological blind spot remarkably well.

[985] I agree with Western thinking that any number of answers to my question were possible, and I certainly cannot assert that another answer would not have been equally significant. However, the answer received was the first and only one; we know nothing of other possible answers. It pleased and satisfied me. To ask the same question a second time would have been tactless and so I did not do it: “the master

speaks but once.” The heavy-handed pedagogic approach that attempts to fit irrational phenomena into a preconceived rational pattern is anathema to me. Indeed, such things as this answer should remain as they were when they first emerged to view, for only then do we know what nature does when left to herself undisturbed by the meddlesomeness of man. One ought not to go to dead bodies to study life. Moreover, a repetition of the experiment is impossible, for the simple reason that the original situation cannot be reconstructed. Therefore in each instance there is only a first and single answer.

[986] To return to the hexagram itself. There is nothing strange in the fact that all of Ting, THE CAULDRON, amplifies the themes announced by the two salient lines.¹² The first line of the hexagram says:

A *ting* with legs upturned

Furthers removal of stagnating stuff.

One takes a concubine for the sake of her son.

No blame.

[987] A *ting* that is turned upside down is not in use. Hence the *I Ching* is like an unused cauldron. Turning it over serves to remove stagnating matter, as the line says. Just as a man takes a concubine when his wife has no son, so the *I Ching* is called upon when one sees no other way out. Despite the quasi-legal status of the concubine in China, she is in reality only a somewhat awkward makeshift; so likewise the magic procedure of the oracle is an expedient that may be utilized for a higher purpose. There is no blame, although it is an exceptional recourse.

[988] The second and third lines have already been discussed. The fourth line says:

The legs of the *ting* are broken.

The prince's meal is spilled

And his person is soiled.

Misfortune.

[989] Here the *ting* has been put to use, but evidently in a very clumsy manner, that is, the oracle has been abused or misinterpreted. In this way the divine food is lost, and one puts oneself to shame. Legge translates as follows: “Its subject will be made to blush for shame.” Abuse of a cult utensil such as the *ting* (i.e., the *I Ching*) is a gross profanation. The *I Ching* is evidently insisting here on its dignity as a ritual vessel and protesting against being profanely used.

[990] The fifth line says:

The *ting* has yellow handles, golden carrying rings.

Perseverance furthers.

[991] The *I Ching* has, it seems, met with a new, correct (yellow) understanding, that is, a new concept [*Begriff*] by which it can be grasped. This concept is valuable (golden). There is indeed a new edition in English, making the book more accessible to the Western world than before.

[992] The sixth line says:

The *ting* has rings of jade.

Great good fortune.

Nothing that would not act to further.

[993] Jade is distinguished for its beauty and soft sheen. If the carrying rings are of jade, the whole vessel is enhanced in beauty, honour, and value. The *I Ching* expresses itself here as being not only well satisfied but indeed very optimistic. One can only await further events and in the meantime remain content with the pleasant conclusion that the *I Ching* approves of the new edition.

[994] I have shown in this example as objectively as I can how the oracle proceeds in a given case. Of course the procedure varies somewhat according to the way the question is put. If for instance a person finds himself in a confusing situation, he may himself appear in the oracle as the speaker. Or, if the question concerns a relationship with another person, that person may appear as the speaker. However, the identity of the speaker does not depend entirely on the manner in which the question is phrased, inasmuch as our relations with our fellow beings are not always determined by the latter. Very often our relations depend almost exclusively on our own attitudes, though we may be quite unaware of this fact. Hence, if an individual is unconscious of his role in a relationship, there may be a surprise in store for him; contrary to expectation, he himself may appear as the chief agent, as is sometimes unmistakably indicated by the text. It may also happen that we take a situation too seriously and consider it extremely important, whereas the answer we get on consulting the *I Ching* draws attention to some unsuspected other aspect implicit in the question.

[995] Such instances might at first lead one to think that the oracle is fallacious. Confucius is said to have received only one inappropriate answer, i.e., hexagram 22, GRACE—a thoroughly aesthetic hexagram. This is reminiscent of the advice given to Socrates by his daemon—“You ought to make more music”—whereupon Socrates took to playing the flute. Confucius and Socrates compete for first place as far as rationality and a pedagogic attitude to life are concerned; but it is unlikely that either of them occupied himself with “lending grace to the beard on his chin,” as the second line of this hexagram advises. Unfortunately, reason and pedagogy often lack charm and grace, and so the oracle may not have been wrong after all.

[996] To come back once more to our hexagram. Though the *I Ching* not only seems to be satisfied with its new edition, but even expresses emphatic optimism, this still

does not foretell anything about the effect it will have on the public it is intended to reach. Since we have in our hexagram two *yang* lines stressed by the numerical value nine, we are in a position to find out what sort of prognosis the *I Ching* makes for itself. Lines designated by a six or a nine have, according to the ancient conception, an inner tension so great as to cause them to change into their opposites, that is, *yang* into *yin*, and vice versa. Through this change we obtain in the present instance hexagram 35, Chin, PROGRESS.

[997] The subject of this hexagram is someone who meets with all sorts of vicissitudes of fortune in his climb upward, and the text describes how he should behave. The *I Ching* is in this same situation: it rises like the sun and declares itself, but it is rebuffed and finds no confidence—it is “progressing, but in sorrow.” However, “one obtains great happiness from one’s ancestress.” Psychology can help us to elucidate this obscure passage. In dreams and fairy tales the grandmother, or ancestress, often represents the unconscious, because the latter in a man contains the feminine component of the psyche. If the *I Ching* is not accepted by the conscious, at least the unconscious meets it halfway, for the *I Ching* is more closely connected with the unconscious than with the rational attitude of consciousness. Since the unconscious is often represented in dreams by a feminine figure, this may be the explanation here. The feminine person might be the translator, who has given the book her maternal care, and this might easily appear to the *I Ching* a “great happiness.” It anticipates general understanding, but is afraid of misuse—“Progress like a hamster.” But it is mindful of the admonition, “Take not gain and loss to heart.” It remains free of “partisan motives.” It does not thrust itself on anyone.

[998] The *I Ching* therefore faces its future on the American book market calmly and expresses itself here just about as any reasonable person would in regard to the fate of so controversial a work. This prediction is so very reasonable and full of common sense that it would be hard to think of a more fitting answer.

[999] All this happened before I had written the foregoing paragraphs. When I reached this point, I wished to know the attitude of the *I Ching* to the new situation. The state of things had been altered by what I had written, inasmuch as I myself had now entered upon the scene, and I therefore expected to hear something referring to my own action. I must confess that I had not been feeling too happy in the course of writing this foreword, for, as a person with a sense of responsibility toward science, I am not in the habit of asserting something I cannot prove or at least present as acceptable to reason. It is a dubious task indeed to try to introduce a collection of archaic “magic spells” to a critical modern public with the idea of making them more or less acceptable. I have undertaken it because I myself think that there is more to the ancient Chinese way of thinking than meets the eye. But it is embarrassing to me that I must appeal to the good will and imagination of the reader, instead of giving

him conclusive proofs and scientifically watertight explanations. Unfortunately I am only too well aware of the arguments that can be brought against this age-old oracle technique. We are not even certain that the ship that is to carry us over the unknown seas has not sprung a leak somewhere. May not the old text be corrupt? Is Wilhelm's translation accurate? Are we not self-deluded in our explanations?

[1000] The *I Ching* insists upon self-knowledge throughout. The method by which this is to be achieved is open to every kind of misuse, and is therefore not for the frivolous-minded and immature; nor is it for intellectualists and rationalists. It is appropriate only for thoughtful and reflective people who like to think about what they do and what happens to them—a predilection not to be confused with the morbid brooding of the hypochondriac. As I have indicated above, I have no answer to the multitude of problems that arise when we seek to harmonize the oracle of the *I Ching* with our accepted scientific canons. But needless to say, nothing “occult” is to be inferred. My position in these matters is pragmatic, and the great disciplines that have taught me the practical usefulness of this viewpoint are psychotherapy and medical psychology. Probably in no other field do we have to reckon with so many unknown quantities, and nowhere else do we become more accustomed to adopting methods that work even though for a long time we may not know why they work. Unexpected cures may arise from questionable therapies and unexpected failures from allegedly reliable methods. In the exploration of the unconscious we come upon very strange things, from which a rationalist turns away with horror, claiming afterward that he did not see anything. The irrational fulness of life has taught me never to discard anything, even when it goes against all our theories (so short-lived at best) or otherwise admits of no immediate explanation. It is of course disquieting, and one is not certain whether the compass is pointing true or not; but security, certitude, and peace do not lead to discoveries. It is the same with this Chinese mode of divination. Clearly the method aims at self-knowledge, though at all times it has also been put to superstitious use.

[1001] I of course am thoroughly convinced of the value of self-knowledge, but is there any use in recommending such insight, when the wisest of men throughout the ages have preached the need of it without success? Even to the most biased eye it is obvious that this book represents one long admonition to careful scrutiny of one's own character, attitude, and motives. This attitude appeals to me and has induced me to undertake the foreword. Only once before have I expressed myself in regard to the problem of the *I Ching*: this was in a memorial address in tribute to Richard Wilhelm.¹³ For the rest I have maintained a discreet silence. It is by no means easy to feel one's way into such a remote and mysterious mentality as that underlying the *I Ching*. One cannot easily disregard such great minds as Confucius and Lao-tzu, if one is at all able to appreciate the quality of the thoughts they represent; much less

can one overlook the fact that the *I Ching* was their main source of inspiration. I know that previously I would not have dared to express myself so explicitly about so uncertain a matter. I can take this risk because I am now in my eighth decade, and the changing opinions of men scarcely impress me any more; the thoughts of the old masters are of greater value to me than the philosophical prejudices of the Western mind.

[1002] I do not like to burden my reader with these personal considerations; but, as already indicated, one's own personality is very often implicated in the answer of the oracle. Indeed, in formulating my question I even invited the oracle to comment directly on my action. The answer was hexagram 29, K'an, THE ABYSMAL. Special emphasis is given to the third place by the fact that the line is designated by a six. This line says:

Forward and backward, abyss on abyss.

In danger like this, pause at first and wait,

Otherwise you will fall into a pit in the abyss.

Do not act in this way.

[1003] Formerly I would have accepted unconditionally the advice, "Do not act in this way," and would have refused to give my opinion of the *I Ching*, for the sole reason that I had none. But now the counsel may serve as an example of the way in which the *I Ching* functions. It is a fact that if one begins to think about it, the problems of the *I Ching* do represent "abyss on abyss," and unavoidably one must "pause at first and wait" in the midst of the dangers of limitless and uncritical speculation; otherwise one really will lose one's way in the darkness. Could there be a more uncomfortable position intellectually than that of floating in the thin air of unproven possibilities, not knowing whether what one sees is truth or illusion? This is the dreamlike atmosphere of the *I Ching*, and in it one has nothing to rely upon except one's own so fallible subjective judgment. I cannot but admit that this line represents very appropriately the feelings with which I wrote the foregoing passages. Equally fitting is the comforting beginning of this hexagram—"If you are sincere, you have success in your heart"—for it indicates that the decisive thing here is not the outer danger but the subjective condition, that is, whether one believes oneself to be "sincere" or not.

[1004] The hexagram compares the dynamic action in this situation to the behaviour of flowing water, which is not afraid of any dangerous place but plunges over cliffs and fills up the pits that lie in its course (K'an also stands for water). This is the way in which the "superior man" acts and "carries on the business of teaching."

[1005] K'an is definitely one of the less agreeable hexagrams. It describes a situation in which the subject seems in grave danger of being caught in all sorts of pitfalls. I have

found that K'an often turned up with patients who were too much under the sway of the unconscious (water) and hence threatened with the possible occurrence of psychotic phenomena. If one were superstitious, one would be inclined to assume that some such meaning attaches intrinsically to this hexagram. But just as, in interpreting a dream, one must follow the dream-text with the utmost exactitude, so in consulting the oracle one must keep in mind the form of the question put, for this sets a definite limit to the interpretation of the answer. "When I consulted the oracle the first time, I was thinking above all of the meaning for the *I Ching* of the foreword I had still to write. I thus put the book in the foreground and made it, so to speak, the acting subject. But in my second question, it is I who am the acting subject. So it would be illogical to take the *I Ching* as the subject in this case too, and, in addition, the interpretation would become unintelligible. But if I am the subject, the interpretation is meaningful to me, because it expresses the undeniable feeling of uncertainty and risk present in my mind. If one ventures upon such uncertain ground, it is easy to come dangerously under the influence of the unconscious without knowing it.

[1006] The first line of the hexagram notes the presence of the danger: "In the abyss one falls into a pit." The second line does the same, then adds the counsel: "One should strive to attain small things only." I apparently anticipated this advice by limiting myself in this foreword to a demonstration of how the *I Ching* functions in the Chinese mind, and by renouncing the more ambitious project of writing a psychological commentary on the whole book.

[1007] The simplification of my task is expressed in the fourth line, which says:

A jug of wine, a bowl of rice with it;
Earthen vessels
Simply handed in through the window.
There is certainly no blame in this.

[1008] Wilhelm makes the following comment here:

Although as a rule it is customary for an official to present certain introductory gifts and recommendations before he is appointed, here everything is simplified to the utmost. The gifts are insignificant, there is no one to sponsor him, he introduces himself; yet all this need not be humiliating if only there is the honest intention of mutual help in danger.

[1009] The fifth line continues the theme of limitation. If one studies the nature of water, one sees that it fills a pit only to the rim and then flows on. It does not stay caught there:

The abyss is not filled to overflowing,

It is filled only to the rim.

[1010] But if, tempted by the danger, and just because of the uncertainty, one were to insist on forcing conviction by special efforts, such as elaborate commentaries and the like, one would only be bogged down in the difficulty, which the top line describes very accurately as a tied-up and caged-in condition. Indeed, the last line often shows the consequences that result when one does not take the meaning of the hexagram to heart.

[1011] In our hexagram we have a six in the third place. This *yin* line of mounting tension changes into a *yang* line and thus produces a new hexagram showing a new possibility or tendency. We now have hexagram 48, Ching, THE WELL. The water hole no longer means danger, however, but rather something beneficial, a well:

Thus the superior man encourages the people at their work,
And exhorts them to help one another.

[1012] The image of people helping one another would seem to refer to the reconstruction of the well, for it is broken down and full of mud. Not even animals drink from it. There are fishes living in it, and one can catch these, but the well is not used for drinking, that is, for human needs. This description is reminiscent of the overturned and unused *ting* that is to receive a new handle. Moreover, like the *ting*, “the well is cleaned, but no one drinks from it”:

This is my heart’s sorrow,
For one might draw from it.

[1013] The dangerous water-hole or abyss pointed to the *I Ching*, and so does the well, but the latter has a positive meaning: it contains the waters of life. It should be restored to use. But one has no concept [*Begriff*] of it, no utensil with which to carry the water; the jug is broken and leaks. The *ting* needs new handles and carrying rings by which to grasp it, and so also the well must be newly lined, for it contains “a clear, cold spring from which one can drink.” One may draw water from it, because “it is dependable.”

[1014] It is clear that in this prognosis the speaking subject is once more the *I Ching*, representing itself as a spring of living water. The previous hexagram described in detail the danger confronting the person who accidentally falls into the pit within the abyss. He must work his way out of it, in order to discover that it is an old, ruined well, buried in mud, but capable of being restored to use again.

[1015] I submitted two questions to the method of chance represented by the coin oracle, the second question being put after I had written my analysis of the answer to the first. The first question was directed, as it were, to the *I Ching*: what had it to say

about my intention to write a foreword? The second question concerned my own action, or rather the situation in which I was the acting subject who had discussed the first hexagram. To the first question the *I Ching* replied by comparing itself to a cauldron, a ritual vessel in need of renovation, a vessel that was finding only doubtful favour with the public. To the second question the reply was that I had fallen into a difficulty, for the *I Ching* represented a deep and dangerous water-hole in which one might easily be bogged down. However, the water-hole proved to be an old well that needed only to be renovated in order to be put to useful purposes once more.

[1016] These four hexagrams are in the main consistent as regards theme (vessel, pit, well); and as regards intellectual content, they seem to be meaningful. Had a human being made such replies, I should, as a psychiatrist, have had to pronounce him of sound mind, at least on the basis of the material presented. Indeed, I should not have been able to discover anything delirious, idiotic, or schizophrenic in the four answers. In view of the *I Ching's* extreme age and its Chinese origin, I cannot consider its archaic, symbolic, and flowery language abnormal. On the contrary, I should have had to congratulate this hypothetical person on the extent of his insight into my unexpressed state of doubt. On the other hand, any person of clever and versatile mind can turn the whole thing around and show how I have projected my subjective contents into the symbolism of the hexagrams. Such a critique, though catastrophic from the standpoint of Western rationality, does no harm to the function of the *I Ching*. On the contrary, the Chinese sage would smilingly tell me: "Don't you see how useful the *I Ching* is in making you project your hitherto unrealized thoughts into its abstruse symbolism? You could have written your foreword without ever realizing what an avalanche of misunderstanding might be released by it."

[1017] The Chinese standpoint does not concern itself with the attitude one takes toward the performance of the oracle. It is only we who are puzzled, because we trip time and again over our prejudice, viz., the notion of causality. The ancient wisdom of the East lays stress upon the fact that the intelligent individual realizes his own thoughts, but not in the least upon the way in which he does it. The less one thinks about the theory of the *I Ching*, the more soundly one sleeps.

[1018] It would seem to me that on the basis of this example an unprejudiced reader should now be in a position to form at least a tentative judgment on the operation of the *I Ching*.¹⁴ More cannot be expected from a simple introduction. If by means of this demonstration I have succeeded in elucidating the psychological phenomenology of the *I Ching*, I shall have carried out my purpose. As to the thousands of questions, doubts, and criticisms that this singular book stirs up—I cannot answer these. The *I Ching* does not offer itself with proofs and results; it does not vaunt itself, nor is it easy to approach. Like a part of nature, it waits until it is discovered. It offers neither facts nor power, but for lovers of self-knowledge, of wisdom—if there be such—it

seems to be the right book. To one person its spirit appears as clear as day; to another, shadowy as twilight; to a third, dark as night. He who is not pleased by it does not have to use it, and he who is against it is not obliged to find it true. Let it go forth into the world for the benefit of those who can discern its meaning.

BIBLIOGRAPHY

BIBLIOGRAPHY

The items of the bibliography are arranged alphabetically under two headings: *A.* Ancient volumes containing collections of alchemical tracts by various authors; *B.* General bibliography, including cross-references to the material in section *A.* Short titles of the ancient volumes are printed in capital letters.

A. ANCIENT VOLUMES CONTAINING COLLECTIONS OF ALCHEMICAL TRACTS BY VARIOUS AUTHORS

ARS CHEMICA, quod sit licita recte exercentibus, probationes doctissimorum iurisconsultorum.... Argentorati [Strasbourg], 1566.

Contents quoted in this volume:

- i Septem tractatus seu capitula Hermetis Trismegisti aurei [pp. 7–31; usually referred to as “Tractatus aureus”]
- ii Hortulanus: Commentariolum in Tabulam smaragdinam [pp. 33–47]
- iii Studium Consilii coniugii de massa solis et lunae [pp. 48–263; usually referred to as “Consilium coniugii”]

ARTIS AURIFERAE quam chemiam vocant.... Basileae [Basel], [1593]. 2 vols.

Contents quoted in this volume:

VOLUME I

- i Turba philosophorum [(a) First edition, pp. 1–65; (b) Second edition, pp. 66–139]
- ii Allegoriae super librum Turbae [pp. 139–45]
- iii Aenigmata ex Visione Arislei et allegoriis sapientum [pp. 146–54; usually referred to as “Visio Arislei”]
- iv Aurora consurgens, quae dicitur Aurea hora [pp. 185–246]

v [Zosimus:] Rosinus ad Sarratantam episcopum [pp. 277–319]

vi Tractatulus Avicennae [pp. 405–37]

vii Liber de arte chymica [pp. 575–631]

VOLUME II

viii Rosarium philosophorum [pp. 204–384; contains a second version of the “Visio Arislei” at pp. 246ff.]

AUREUM VELLUS, oder Guldin Schatz und Kunstkammer ... von dem ... bewehrten Philosopho Salomone Trismosino. Rorschach, 1598. (Other editions appeared at Rorschach, 1599; Basel, 1604; Hamburg, 1708.)

Contents quoted in this volume:

i [Trismosin:] Splendor solis [Tractatus III, pp. 3–59]

MANGETUS, JOANNES JACOBUS (ed.). *BIBLIOTHECA CHEMICA CURIOSA, seu Rerum ad alchemiam pertinentium thesaurus instructissimus....* Coloniae Allobrogum [Geneva], 1702. 2 vols.

Contents quoted in this volume:

VOLUME I

i Hoghelande: De alchemiae difficultatibus [pp. 336–68]

ii Hermes Trismegistus: Tractatus aureus de lapidis physici secreto [pp. 400–445]

iii Turba philosophorum [pp. 445–65; another version, pp. 480–94]

iv Allegoriae sapientum supra librum Turbae philosophorum XXIX distinctiones [pp. 467–79]

VOLUME II

v Bonus: Margarita pretiosa novella correctissima [pp. 1–80]

vi Rosarium philosophorum [pp. 87–119]

vii Consilium coniugii seu De massa solis et lunae libri III [pp. 235–65]

viii Sendivogius: Novum lumen chymicum [pp. 463–73]

ix Sendivogius: Parabola, seu Aenigma philosophicum [pp. 474–75]

x Orthelius: Epilogus et recapitulatio in Novum lumen Sendivogii [pp. 526–30]

MUSAEUM HERMETICUM reformatum et amplificatum ... continens tractatus chimicos XXI praestantissimos.... Francofurti [Frankfurt a. M.], 1678. For translation, see WAITE.

Contents quoted in this volume:

- i Madathanus: Aureum saeculum redivivum [pp. 53–72]
- ii Sendivogius: Novum lumen chemicum e naturae fonte et manuali experientia depromptum [pp. 545–600]
- iii [Sendivogius:] Novi luminis chemici tractatus alter de sulphure [pp. 601–46]

THEATRUM CHEMICUM, praecipuos selectorum auctorum tractatus ... continens. Ursellis [Ursel] and Argentorati [Strasbourg], 1602–61. 6 vols. (Vols. I–III, Ursel, 1602; Vols. IV–VI, Strasbourg, 1613, 1622, 1661 respectively.)

Contents quoted in this volume:

VOLUME I

- i Hoghelande: Liber de alchemiae difficultatibus [pp. 121–215]
- ii Dorn: Speculativae philosophiae, gradus septem vel decem continens [pp. 255–310]
- iii Dorn: De spagirico artificio Trithemii sententia [pp. 437–50]
- iv Dorn: Philosophia meditativa [pp. 450–72]
- v Dorn: Philosophia chemica ad meditativam comparata [pp. 472–517]
- vi Dorn: De tenebris contra naturam et vita brevi [pp. 518–35]
- vii Dorn: Congeries Paracelsicae chemicae de transmutatione metallorum [pp. 557–646]
- viii Dorn: De duello animi cum corpore [pp. 535–50]

VOLUME IV

- ix Raymundi Lulli: Theorica et practica [pp. 1–191]
- x Aphorismi Basiliani sive Canones Hermetici. De spiritu, anima, et corpore medio, majoris et minoris mundi [pp. 368–71]

xi Hermetis Trismegisti Tractatus vere aureus de Lapide philosophici secreto
[pp. 672–797]

VOLUME V

xii Allegoriae Sapientum ... supra librum Turbae [pp. 64–100]

xiii Tractatus Micreris suo discipulo Mirnefindo [pp. 101–13]

xiv Liber Platonis quartorum ... [pp. 114–208]

xv Bonus [Lacinius]: Margarita novella correctissima [pp. 589–794]

VOLUME VI

xvi Christopher of Paris: Elucidarius artis transmutatoriae [pp. 195–293]

xvii Grasseus: Arca arcani ... [pp. 294–381]

xviii Orthelius: Epilogus et recapitulatio ... in Novum lumen chymicum
Sendivogii [pp. 430–58]

B. GENERAL BIBLIOGRAPHY

ABU'L KASIM. See HOLMYARD.

Acts of Thomas. See MEAD, *Fragments of a Faith Forgotten*; also in JAMES, *The Apocryphal New Testament*, pp. 365ff.

ADLER, GERHARD. *Entdeckung der Seele*. Zurich, 1934.

AELIAN (Claudius Aelianus). *Varia historia*. Edited by Rudolf Hercher. Leipzig, 1866.
For translation, see:

———. *Claudius Aelianus his Various History*. Translated by Thomas Stanley. London, 1665.

“Allegoriae sapientum supra librum Turbae.” See (A) *Artis auriferae*, ii; MANGETUS, *Bibliotheca chemica curiosa*, iv; *Theatrum chemicum*, xii.

ALPHIDIUS. See (A) *Artis auriferae*, viii: “Rosarium philosophorum,” wherein quoted.

AMBROSE, SAINT. *Explanatio symboli ad initiandos*. Text with introduction and translation by Richard Hugh Connolly. (Texts and Studies, 10.) Cambridge, 1952.

Amitāyur-dhyāna Sūtra. Translated by Junjiro Takakusu. In: *Buddhist Mahāyāna Sūtras*, Part II. (Sacred Books of the East, 49.) Oxford, 1894. (Pp. 159–201.)

ANDREAE, JOHANN VALENTIN. (Christian Rosencreutz, pseud.) *Chymische Hochzeit ... Anno 1459*. Reprinted from a Strasbourg 1616 edition. Edited by Ferdinand Maack. Berlin, 1913. For translation, see:

———. *The Hermetick Romance; or, The Chymical Wedding*. Translated by E. Foxcroft. London, 1690.

ANGELUS SILESIUS (Johann Scheffler). *Der Cherubinische Wandersmann*. In: *Sämtliche Poetische Werke*. Munich, 1949–52. 3 vols. (III, 7–218.)

ANTHONY OF PADUA, SAINT. *S. Antonii Patavini Sermones dominicales et in solemnitatibus*. Edited by Antonio Maria Locatelli. Padua, 1895. 3 vols.

“Aphorismi Basiliani.” See (A) *Theatrum chemicum*, x.

ARISLEUS (Archelaos). “Visio Arislei.” See (A) *Artis auriferae*, iii, viii.

ARISTOTLE. [*De coelo*.] ... *On the Heavens*. With an English translation by W. K. C. Guthrie. (Loeb Classical Library.) London and Cambridge (Mass.), 1939.

AUGUSTINE, SAINT. *Sermones*. See Migne, *P.L.*, vol. 38.

———. *Tractatus in Joannem*. See Migne, *P.L.*, vol. 35. For translation, see: *Works*. Edited by Marcus Dods. Edinburgh, 1874. (Vol. 11, translated by James Innes.)

AUGUSTINE, pseud. *De Spiritu et Anima*. See: *Opera Omnia S. Augustini*. Paris, 1836. 11 vols. (Vol. 6.)

“Aurea hora.” See (A) *Artis auriferae*, iv; *Codices and MSS.*, vi, xiii; FRANZ, *Aurora Consurgens*; THOMAS AQUINAS, pseud.

AVALON, ARTHUR, pseud. (Sir John Woodroffe) (ed.). *Shrīchakrasambhāra Tantra*. Translated by Kazi Dawa-Samdup. (Tantric Texts, 7.) London and Calcutta, 1919.

AVICENNA, pseud. See (A) *Artis auriferae*, vi.

BARBARUS, HERMOLAUS (Ermolao Barbaro). *In Dioscoridem corollarium libris quinque absolutum*. Venice, 1516.

- BARTH, KARL. *Bibelstundenüber Luk I. (Theologische Existenz Heute, edited by K. Barth and E. Thurneysen, 19.)* Munich, 1935.
- . *Credo*. Translated by J. Strathearn McNab. London, 1936.
- BASTIAN, ADOLF. *Das Beständige in den Menschenrassen*. Berlin, 1868.
- . *Ethnische Elementargedanken in der Lehre vom Menschen*. Berlin, 1895. 2 vols.
- . *Der Völkergedanke im Aufbau einer Wissenschaft vom Menschen*. Berlin, 1878.
- . *Die Vorstellungen von der Seele*. In: RUDOLF VIRCHOW and FRANZ VON HOLTZENDORFF. *Sammlung gemeinverständlicher wissenschaftlicher Vorträge*, 10th series, Heft 226. Berlin, 1875.
- BAUMGARTNER, MATHIAS. *Die Philosophie des Alanus de Insulis*. In: CLEMENS BAEUMKER and GEORG FREIHERR VON HERTLING *Beiträge zur Geschichte der Philosophie des Mittelalters*, Vol. 2, Heft 4. Münster, 1896.
- BAYNES, CHARLOTTE AUGUSTA. *A Coptic Gnostic Treatise Contained in the Codex Brucianus—Bruce MS. 96, Bodleian Library, Oxford*. Cambridge, 1933.
- BERNARD, SAINT, pseud. *Vitis Mystica*. In Migne, *P.L.*, vol. 184, cols. 635–740. For translation see: *Vitis Mystica*. Translated by Samuel John Eales. London, 1889.
- BERNARD, JOHN HENRY (ed.). *The Odes of Solomon*. (Texts and Studies, VIII, 3.) Cambridge, 1912.
- BERNARDINO DE SAHAGÚN. *General History of the Things of New Spain (Florentine Codex)*. Book 3: *The Origin of the Gods*. Translated by Arthur J. O. Anderson and Charles E. Dibble. (Monographs of the School of American Research, 14, Part IV.) Santa Fe, 1952.
- BERNARDUS SYLVESTRIS. *De mundi universitate libri duo*. Edited by Carl Sigmund Barach and Johann Wrobel. (Bibliotheca philosophorum mediae aetatis, 1.) Innsbruck, 1876.
- BÉROALDE DE VERVILLE, FRANÇOIS (trans.). *Le tableau des riches inventions ... représentées dans le Songe de Poliphile*. Paris, 1600. See also COLONNA; FIERZ-DAVID.

BERTHELOT, MARCELLIN. *La Chimie au moyen age*. Paris, 1893. 3 vols.

———. *Collection des anciens alchimistes grecs*. Paris, 1887–88. 3 vols.: Introduction, Textes, Traductions.

Bible. The following versions are cited textually:

[AV] Authorized (“King James”) Version (cited unless otherwise indicated).

[DV] Douay-Reims Version.

[RSV] Revised Standard Version (1952).

[ZB] Zürcher Bibel (first trans. 16th cent.; cited in English trans. from a 1932 edn. published by the Consistory of Canton Zurich on the order of the Zurich Church Synod, being the German version generally used by the author).

BÖHME, JAKOB. *XL Questions Concerning the Soule*. Propounded by Dr. Balthasar Walter and answered by Jacob Behmen. London, 1647.

BONUS, PETRUS. *Pretiosa margarita novella de thesauro ac pretiosissimo philosophorum lapide ...* Edited by Janus Lacinius Calabrus. Venice, 1546. For translation see WAITE, *The New Pearl*; see also (A) MANGETUS, *Bibliotheca chemica curiosa*, v; (A) *Theatrum chemicum*, xv.

BOUCHÉ, LECLERCQ, AUGUSTE. *L’Astrologie grecque*. Paris, 1899.

BOUSSET, WILHELM. *Hauptprobleme der Gnosis*. (Forschungen zur Religion und Literatur des Alten und Neuen Testaments, 10.) Göttingen, 1907.

BOVILLUS, KARL (Charles de Bouelles). *Ein gesichte Bruder Clausen ynn Schweytz und seine deutunge*. Wittenberg, 1528.

BRADFORD, ROARK. *Ol’ Man Adam an’ His Chillun*. New York, 1928.

BRINKTRINE, JOHANNES. *Die Heilige Messe in ihrem Werden und Wesen*. 2nd edn., Paderborn, 1934.

BRUNO OF WÜRZBURG, SAINT. *Expositio Psalmorum*. See Migne, *P.L.*, vol. 142, cols. 39–530.

BUDGE, E. A. WALLIS. *Osiris and the Egyptian Resurrection*. London, 1911. 2 vols.

———. (ed. and trans.). *The Book of the Dead. Facsimiles of the Papyrus of Hunefer, etc.* London, 1899.

- . *The Book of Paradise, being the Histories and Sayings of the Monks and Ascetics of the Egyptian Desert*. London, 1904. 2 vols. For St. Athanasius, *The Life of St. Anthony*, see Vol. I, pp. 3–108.
- BUSSELL, FREDERICK WILLIAM. *Religious Thought and Heresy in the Middle Ages*. London, 1918.
- BÜTTNER, H. *Meister Eckhart's Schriften und Predigten*. Jena, 1909–17. 2 vols.
- CABASILAS, NICHOLAS, of Thessalonica. “De divino altaris sacrificio.” In Migne, *P.G.*, vol. 150, cols. 363–492.
- CAMPBELL, COLIN. *The Miraculous Birth of King Amon-Hotep III*. Edinburgh and London, 1912.
- CASPARI, CARL PAUL. *Alte und neue Quellen zur Geschichte des Taufsymbols und der Glaubensregel*. Christiania (Oslo), 1879.
- CAUSSIN, NICHOLAS. *De symbolica Aegyptiorum sapientia. Polyhistor Symbolicus, Electorum Symbolorum & Parabolarum historicarum stromata*. Paris, [1618 and] 1631.
- Chhandogya Upanishad*. In: *The Upanishads*. Part 1. Translated by F. Max Müller. (Sacred Books of the East, 1.) Oxford, 1879. (Pp. 1–144.)
- CHARLES, ROBERT HENRY (ed.). *The Apocrypha and Pseudepigrapha of the Old Testament in English*. Oxford, 1913. 2 vols.
- CHRISTOPHER OF PARIS. “Elucidarius artis transmutatoriae.” See (*A*) *Theatrum chemicum*, xvi.
- CICERO, MARCUS TULLIUS. *De inventione rhetorica, De optimo genere oratorum, Topica*. With an English translation by H. M. Hubbell. (Loeb Classical Library.) London and Cambridge, (Mass.), 1949.
- . *Pro Sestio, In Vatinius, Pro Caelio, etc.* With an English translation by J. H. Freese and R. Gardner. (Loeb Classical Library.) London and Cambridge (Mass.), in press.
- CLEMENT OF ALEXANDRIA, SAINT. *Stromata*. See Migne, *P.G.*, vol. 8, col. 685, to vol. 9, col. 602. For translation, see:
- . *The Writings of Clement of Alexandria*. Translated by William Wilson. (Ante-Nicene Christian Library, 4, 12.) Edinburgh, 1867–69. 2 vols.

CLEMENT OF ROME, SAINT. *First Epistle to the Corinthians*. In: KIRSOPP LAKE (ed. and trans.). *The Apostolic Fathers*. (Loeb Classical Library.) London and New York, 1914. 2 vols. (Vol. 1, pp. 8–121.)

Codices and Manuscripts:

i Florence. Biblioteca Medicea-Laurenziana. Codex Laurentianus 71,33. 14th cent.

ii Lucca. Biblioteca governativa. Saint Hildegarde of Bingen, “Liber divinorum operum.” Codex 1942. 12th cent.

iii Munich. Staatsbibliothek. Codex Germanicus 598. “Das Buch der heiligen Dreifaltigkeit und Beschreibung der Heimlichkeit von Veränderung der Metallen.” Offenbahret anno Christi 1420.

iv Oxford. Bodleian Library. Codex Brucianus (Bruce MS. 96). See BAYNES.

v Paris. Bibliothèque nationale. Codex Parisinus 6319. Liber Hermetis Trismegisti. 14th cent.

vi ———. ———. Codex Latinus 14006. “Aurora consurgens.”

vii ———. ———. Codex Parisinus Graecus 1220. 14th cent.

viii Vatican. Biblioteca Vaticana. Codex Palatinus Latinus 1993. Opicinus de Canistris.

ix ———. ———. Codex Latinus 3060. Liber Hermetis Trismegisti. 14th cent.

x ———. ———. Codex Graecus 237. 14th cent.

xi ———. ———. Codex Graecus 951. 14th cent.

xii Wiesbaden. Nassauische Landesbibliothek. St. Hildegarde of Bingen. “Scivias.” 12th cent. (Destroyed in the second World War.)

xiii Zurich. Zentralbibliothek. Codex Rhenoviensis 172. Abh. 1: “Aurora consurgens.” 15th cent. (Note: Mutilated manuscript beginning at the fourth parable.)

COLONNA, FRANCESCO. *Hypnerotomachia Poliphili*.... Venice, 1499. See also BÉROALDE DE VERVILLE; FIERZ-DAVID.

CONNELLY, MARC. *The Green Pastures*. New York, 1930.

CONNOLLY, R. HUGH (ed.). *The So-called Egyptian Church Order and Derived Documents*. (Texts and Studies, VIII, 4.) Cambridge, 1916.

“Consilium coniugii.” See (A) *Ars chemica*, iii; MANGETUS, *Bibliotheca chemica curiosa*, vii.

CORNFORD, FRANCIS MACDONALD. *Plato's Cosmology: The Timaeus of Plato*. New edn., London and New York, 1952.

Corpus Hermeticum. See SCOTT.

CRAWLEY, ALFRED ERNEST. *The Idea of the Soul*. London, 1909.

CUMONT, FRANZ. *Textes et monuments figurés relatifs aux mystères de Mithra*. Brussels, 1894–99. 2 vols.

CYPRIAN, SAINT. *Letter lxiii to Caecilius*. In Migne, *P.L.*, vol. 4, cols. 372ff. For translation see:

———. *Epistles of St. Cyprian*. Translated by H. Carey. (Library of Fathers of the Holy Catholic Church.) Oxford, 1844. (Pp. 181ff.)

DANIEL, HERMANN ADALBERT. *Thesaurus Hymnologicus*. Halle and Leipzig, 1841–56. 5 vols.

“De arte chymica.” See (A) *Artis auriferae*, vii.

DELACOTTE, JOSEPH. *Guillaume de Digulleville.... Trois romans-poèmes du XIV^e siècle*. Paris, 1932.

DENZINGER, HEINRICH, and BANNWART, KLEMENS. *Enchiridion symbolorum*. 6th–7th edition, edited by J. B. Umberg. Freiburg, 1928.

DIETERICH, ALBRECHT. *Eine Mithrasliturgie*. Leipzig, 1910.

DIOGENES LAERTIUS. *Lives of Eminent Philosophers*. With an English translation by R. D. Hicks. (Loeb Classical Library.) London and New York, 1925. 2 vols.

DJABIR. See GEBER.

DORN, GERHARD. See (A) *Theatrum chemicum*, ii–viii.

DOWDING, HUGH CASWAL TREMENHEERE, BARON DOWDING. *God's Magic*. London, 1946.

———. *Lychgate*. London, 1945.

———. *Many Mansions*. London, 1943.

- DOZY, REINHART, and DE GOEJE, M. J. "Nouveaux documents pour l'étude de la religion des Harraniens." *Actes du sixième congrès international des Orientalistes*, 1883. Leiden, 1885.
- DRUMMOND, HENRY. *The Greatest Thing in the World, and other addresses*. London, 1894.
- . *Natural Law in the Spiritual World*. London, 1883.
- DUNBAR, HELEN FLANDERS. *Symbolism in Medieval Thought and Its Consummation in the Divine Comedy*. New Haven, 1929.
- DUNNE, JOHN WILLIAM. *An Experiment with Time*. London, 1927.
- DURRER, ROBERT. *Bruder Klaus—Die ältesten Quellen über den Seligen Nikolaus von Flue, sein Leben und seinen Einfluss*. Sarnen, 1907–21. 2 vols.
- [ECKHART, MEISTER.] *Meister Eckhart*. [Works.] Translated by C. de B. Evans. London, 1924–52. 2 vols.
- . *Meister Eckhart: A Modern Translation*. Translated by Raymond Bernard Blakney. New York, 1941.
- EISLER, ROBERT. *Orpheus—the Fisher*. London, 1921.
- . *Weltenmantel und Himmelszelt*. Munich, 1910. 2 vols.
- ELIADE, MIRCEA. *Shamanism: Archaic Techniques of Ecstasy*. Translated by Willard R. Trask. New York (Bollingen Series) and London, 1964.
- EMERSON, RALPH WALDO. *Essays*. (Everyman's Library.) New York and London, 1930.
- Enoch, Book of*. See CHARLES.
- EPIPHANIUS. *Panarium, sive Arcula (Contra Octoginta Haereses)*. In Migne, P.G., vol. 41, col. 173, to vol. 42, col. 852.
- ERMAN, ADOLF. *Aegypten*. Tübingen, 1885. For translation, see: *Life in Ancient Egypt*. Translated by H. M. Tirard. London, 1894.
- EUSEBIUS. *Evangelica praeparatio*. In Migne, P.G., vol. 21, cols. 21–1408.
- EVANS-WENTZ, W. Y. (ed.). *The Tibetan Book of the Dead*. London, 1927; 2nd edn., 1957.

- (ed.). *The Tibetan Book of the Great Liberation*. London, 1954.
- FENN, GEORGE MANVILLE. *Running Amok*. London, 1901.
- FIERZ-DAVID, LINDA. *The Dream of Poliphilo*. Translated by Mary Hottinger. New York (Bollingen Series XXV) and London, 1950.
- FIRMICUS MATERNUS, JULIUS. *De errore profanarum religionum*. Edited by Carolus Halm. (Corpus scriptorum ecclesiasticorum Latinorum, 2.) Vienna, 1867.
- FOERSTER-NIETZSCHE, ELISABETH (ed.). *Der werdende Nietzsche*. Munich, 1924.
- FRANZ, MARIE-LOUISE VON. *Aurora Consurgens. A Document Attributed to Thomas Aquinas on the Problem of Opposites in Alchemy*. Translated by R. F. C. Hull and A. S. B. Glover. New York (Bollingen Series) and London, 1966.
- . *Die Passio Perpetuae*. In: C. G. JUNG. *Aion: Untersuchungen zur Symbolgeschichte*. Zurich, 1951.
- . *Die Visionen des Niklaus von Flue*. (Studien aus dem C. G. Jung Institut, 9.) Zurich, 1959.
- FRAZER, SIR JAMES GEORGE. *Adonis, Attis, Osiris. (The Golden Bough, Part IV.)* 2nd edn., London, 1907. 2 vols.
- . *The Dying God. (The Golden Bough, Part III.)* London, 1911.
- . *Taboo and the Perils of the Soul. (The Golden Bough, Part II.)* London, 1911.
- FREUD, SIGMUND. *The Future of an Illusion*. In: Standard Edition of the Complete Psychological Works, translated under the editorship of James Strachey, 21. London, 1961. (Orig., 1928.)
- . *The Interpretation of Dreams*. Ibid., 4, 5. London, 1953. (Orig., 1900.)
- FROMER, JAKOB, and SCHNITZER, MANUEL. *Legenden aus dem Talmud*. Berlin, 1922.
- GARNERIUS DE SANCTO VICTORE. *Gregorianum*. In Migne, *P.L.*, vol. 193, cols. 23–462.
- GAUDENTIUS, SAINT, Bishop of Brixen. *Sermones*. In Migne, *P.L.*, vol. 20, cols. 827–1002.
- GEBER (Jābir ibn-Hayyān). “Livre de la miséricorde.” In Berthelot, *La Chimie au moyen âge*, q.v., Vol. III, pp. 163–90.

- GNOSIUS, DOMINICUS. *Hermetis Trismegisti Tractatus vere Aureus ... cum scholiis Dominici Gnosii*. Leipzig, 1610. See also (A) MANGETUS, *Bibliotheca chemica*, ii; and *Theatrum chemicum*, xi.
- GOETHE, J. W. VON. *Faust: Parts I and II*. Translated by Philip Wayne. (Penguin Classics.) Harmondsworth, 1949, 1959.
- GOMPERZ, THEODOR. *Greek Thinkers*. Translated from the German by Laurie Magnus and G. G. Berry. London, 1901–12. 4 vols.
- GRASSEUS. “Arca arcani.” See (A) *Theatrum chemicum*, xvii.
- GREGORY THE GREAT, SAINT. *Dialogues (Dialogorum Libri IV)*. See Migne, *P.L.*, vol. 77, cols. 149–430.
- . *Expositiones in Librum I Regum*. See Migne, *P.L.*, vol. 79, cols. 17–468.
- GREGORY OF NYSSA, SAINT. *De Vita Beati Gregorii Miraculorum Opificio*. In Migne, *P.G.*, vol. 46, cols. 911–14.
- GRIFFITH, FRANCIS LLEWELLYN. *A Collection of Hieroglyphs*. (Archaeological Survey of Egypt, 6th Memoir.) London, 1898.
- GUILLAUME DE DIGULLEVILLE. See DELACOTTE.
- GUILLÉN, JORGE. *Cantico: Fe de Vida*. Buenos Aires, 1950.
- HAEUSSERMANN, FRIEDRICH. *Wortempfang und Symbol in der alttestamentlichen Prophetie*. (Beihefte zur Zeitschrift für die alttestamentliche Wissenschaft, 58.) Giessen, 1932.
- HARNACK, ADOLF VON. *Dogmengeschichte*. 7th edn., Tübingen, 1931.
- HARPER, ROBERT FRANCIS. *The Code of Hammurabi*. Chicago, 1904.
- HARRISON, JANE ELLEN. *Themis*. Cambridge, 1912.
- HASTINGS, JAMES (ed.). *Encyclopaedia of Religion and Ethics*. Edinburgh and New York, 1908–27. 13 vols.
- HAUCK, ALBERT (ed.). *Realenzyklopädie für protestantische Theologie und Kirche*. Leipzig, 1896–1913. 24 vols.

- HAUER, J. W. "Symbole und Erfahrung des Selbstes in der indoarischen Mystik," *Eranos-Jahrbuch* (Zurich), [II] (1935), 35–96.
- HEATH, SIR THOMAS L. *A History of Greek Mathematics*. Oxford, 1921. 2 vols.
- HENNECKE, EDGAR (ed.). *Neutestamentliche Apokryphen*. 2nd edn., Tübingen, 1924.
- HERMES TRISMEGISTUS. *Tractatus aureus*. See (A) *Ars chemica*, i; MANGETUS, *Bibliotheca chemica*, ii; *Theatrum chemicum*, xi.
- HERODOTUS. *The Histories*. Translated by Aubrey de Selincourt. (Penguin Classics.) Harmondsworth, 1954.
- HERRAD OF LANDSBERG. *Hortus deliciarum*. See KELLER and STRAUB.
- HILDEGARDE, SAINT, of Bingen. *Scivias*. See Codices and Manuscripts, xii; also, *Scivias, vel Visionum ac revelationum libri tres*, in Migne, *P.L.*, vol. 197, cols. 383–738.
- HIPPOLYTUS. *Elenchos (Refutatio omnium haeresiarum)*. In: *Hippolytus' Werke*. Edited by Paul Wendland. Vol. III. Leipzig, 1916. For translation, see LEGGE, FRANCIS.
- . *Church Order*. See CONNOLLY.
- HOGG, JAMES. *The Private Memoirs and Confessions of a Justified Sinner*. London, 1824. (Reprinted, with introduction by André Gide, London, 1947.)
- HOGHELANDE, THEOBALD DE. "De alchemiae difficultatibus." See (A) MANGETUS, *Bibliotheca chemica*, i; *Theatrum chemicum*, i.
- HOLMYARD, ERIC JOHN (ed. and trans.). *Kitāb al-'ilm al-muktasab fi-zinā'at adhdhahab* [Book of knowledge acquired concerning the cultivation of gold]. [By Abu'l Qāsim Muhammad ibn Ahmad al-'Irāqī.] Paris, 1923.
- HORTULANUS, pseud. (Joannes de Garlandia). "Commentariolum." See (A) *Ars chemica*, ii. For translation, see: ROGER BACON. *The Mirror of Alchemy*.... London, 1597.
- HUBERT, HENRI, and MAUSS, MARCEL. *Melanges d'Histoire des Religions*. (Travaux de l'Année Sociologique.) Paris, 1909.
- IGNATIUS OF LOYOLA, SAINT. *The Spiritual Exercises*. Edited and translated by Joseph Rickaby, S.J. 2nd edn., London, 1923.
- IRENAEUS, SAINT. *Contra [or Adversus] haereses libri quinque*. See Migne, *P.G.*, vol. 7, cols. 433–1224. For translation, see:

- . *Five Books of Irenaeus against Heresies*. Translated by John Keble. (Library of Fathers of the Holy Catholic Church.) Oxford, 1872. Also: *The Writings of Irenaeus*. Translated by Alexander Roberts and W. H. Rambaut. Vol. I. (Ante-Nicene Christian Library, 5.) Edinburgh, 1868.
- JACOBI, JOLANDE (ed.). *Paracelsus: Selected Writings*. Translated by Norbert Guterman. New York (Bollingen Series XXVIII) and London, 1951; 2nd edn., rev., 1958.
- JACOBSON, HELMUTH. “Das Gespräch eines Lebensmüden mit seinem Ba.” In: *Zeitlose Dokumente der Seele*. (Studien aus dem C. G. Jung-Institut, 3.) Zurich, 1952.
- . “Die dogmatische Stellung des Königs in der Theologie der alten Ägypter.” In: *Aegyptische Forschungen*, ed. Alexander Scharff. Heft 8. Gluckstadt, Hamburg, and New York, 1939.
- JAMES, MONTAGUE RHODES (trans.). *The Apocryphal New Testament*. Oxford, 1924.
- JAMES, WILLIAM. *Pragmatism*. London, 1907.
- JASTROW, MORRIS. *Die Religion Babyloniens und Assyriens*. Giessen, 1905–12. 2 vols.
- . *The Religion of Babylonia and Assyria*. (Handbooks of the History of Religions, 2.) Boston, 1898. (Not a translation, but a parallel volume to the preceding.)
- JENSEN INGEBOG H. *Die älteste Alchemie* Copenhagen, 1921.
- JEREMIAS, ALFRED. *The Old Testament in the Light of the Ancient East*. Translated by C. L. Beaumont. London and New York, 1911. 2 vols.
- Jewish Encyclopedia, The*. New York, 1925. 12 vols.
- JOANNES DE RUPESCISSA. See RUPESCISSA.
- JOHN DAMASCENE, SAINT. *Encomium in Dormitionem, etc.* In Migne, P.G., vol. 96, cols. 721–754. For translation, see: MARY H. ALLIES. *St. John Damascene on Holy Images, followed by Three Sermons on the Assumption*. London, 1898.
- JOHN OF RUYSBROECK. See RUPESCISSA.
- JOSEF BIN GORION, MICHA (pseud. of Micha Josef Berdyczewski). *Die Sagen der Juden*. Collected and revised by M. J. bin Gorion. The text translated into German by R. Ramberg-Berdyczewski. Edited by Rahel and Emanuel bin Gorion (i.e., R. and E. Berdyczewski). Frankfurt a. M., 1913–27. 5 vols.

JOYCE, JAMES. *Ulysses*. New York, 1933; London, 1936. (1st edn., Paris, 1922.)

JUNG, CARL GUSTAV. *Aion: Researches into the Phenomenology of the Self. Collected Works*, * Vol. 9, part ii.

———. “Archetypes of the Collective Unconscious.” In: *Collected Works*, Vol. 9, part i.

———. *Civilization in Transition. Collected Works*, Vol. 10.

———. “Commentary on *The Secret of the Golden Flower*.” In: *Collected Works*, Vol. 13.

———. “Concerning the Archetypes, with special reference to the Anima Concept.” In: *Collected Works*, Vol. 9, part i.

———. “Concerning Mandala Symbolism.” In: *Collected Works*, Vol. 9, part i.

———. “Freud and Jung: Contrasts.” In: *Collected Works*, Vol. 4.

———. *Mysterium Coniunctionis. Collected Works*, Vol. 14.

———. “On the Nature of the Psyche.” In: *Collected Works*, Vol. 8.

———. “On Psychic Energy.” In: *Collected Works*, Vol. 8.

———. “On the Psychology of the Trickster Figure.” In: *Collected Works*, Vol. 9, part i.

———. “The Philosophical Tree.” In: *Collected Works*, Vol. 13.

———. *The Practice of Psychotherapy. Collected Works*, Vol. 16.

———. “The Psychological Aspects of the Kore.” In: *Collected Works*, Vol. 9, part i.

———. “Psychological Factors Determining Human Behaviour.” In: *Collected Works*, Vol. 8.

———. *Psychological Types. Collected Works*, Vol. 6. Alternative source: *Psychological Types*, translated by H. G. Baynes, London and New York, 1923.

———. *Psychology and Alchemy. Collected Works*, Vol. 12.

———. “The Psychology of the Transference.” In: *Collected Works*, Vol. 16.

———. “The Relations between the Ego and the Unconscious.” In: *Two Essays on Analytical Psychology*, q.v.

- . “The Role of the Unconscious.” In: *Collected Works*, Vol. 10.
- . “The Spirit Mercurius.” In: *Collected Works*, Vol. 13.
- . “A Study in the Process of Individuation.” In: *Collected Works*, Vol. 9, part i.
- . “Studies in Word Association.” In: *Collected Works*, Vol. 2. Alternative source: *Studies in Word Association ...* under the direction of C. G. Jung, translated by M. D. Eder, London, 1918, New York, 1919.
- . *Symbols of Transformation. Collected Works*, Vol. 5.
- . “Synchronicity: An Acausal Connecting Principle.” In: *Collected Works*, Vol. 8.
- . “The Tavistock Lectures.” In: *Collected Works*, Vol. 18. Alternative version: *Analytical Psychology: Its Theory and Practice. The Tavistock Lectures*. London and New York, 1968.
- . “The Transcendent Function.” In: *Collected Works*, Vol. 8.
- . *Two Essays on Analytical Psychology. Collected Works*, Vol. 7.
- . “The Visions of Zosimos.” In: *Collected Works*, Vol. 13.
- . “Wotan.” In: *Collected Works*, Vol. 10.
- JUNG, EMMA. “On the Nature of the Animus.” Translated by Cary F. Baynes. In: EMMA JUNG. *Animus and Anima*. New York (The Analytical Psychology Club of New York), 1957.
- JUSTIN [MARTYR], SAINT. *Apologia secunda*. See Migne, P.G., vol. 6, cols. 441–70. For translation, see: MARCUS DODS, GEORGE REITH, and B. P. PRATTEN (trans.). *The Writings of Justin Martyr and Athenagoras*. (Ante-Nicene Christian Library, 2.) Edinburgh, 1867.
- KANT, IMMANUEL. *Critique of Pure Reason*. Translated by J. M. D. Meiklejohn. (Everyman’s Library.) London and New York, 1934.
- KÄSEMANN, ERNST. *Leib und Leib Christi*. (Beiträge zur historischen Theologie, 9.) Tübingen, 1933.
- Katha Upanishad. In: *The Thirteen Principal Upanishads*. Translated by Robert Ernest Hume. London, 1921. (Pp. 341–61.)

- KELLER, G., and STRAUB, A. (trans.). *Herrad von Landsberg Hortus Deliciarum*. Strasbourg, 1879–99 (1901).
- KESSLER, KONRAD. *Mani: Forschungen über die manichäische Religion*. Berlin, 1889.
- KHUNRATH, HEINRICH CONRAD. *Amphitheatrum sapientiae aeternae ...* Hanau, 1604.
- . *Vom hylealischen, das ist, pri-materialischen catholischen, oder algemeinem natürlichen Chaos*. Magdeburg, 1597.
- KIRCHER, ATHANASIUS. *Mundus subterraneus*. Amsterdam, 1678. 2 vols.
- [KLAUS, BROTHER.] *Ein nützlicher und loblicher Tractat von Bruder Claus und einem Bilger*. Nürnberg, 1488.
- KLUG, IGNAZ. Article in *Theologie und Glaube* (Paderborn), XVIII (1926), 335f.
- KOEPGEN, GEORG. *Die Gnosis des Christentums*. Salzburg, 1939.
- KRAMP, JOSEPH. *Die Opferanschauungen der römischen Messliturgie*. 2nd edn., Regensburg, 1924.
- KRANEFELDT, WOLFGANG M. *Secret Ways of the Mind*. Translated [from *Die Psychoanalyse, psychoanalytische Psychologie*] by Ralph M. Eaton. New York, 1932; London, 1934.
- KROLL, JOSEF. *Gott und Hölle. Der Mythos von Descensuskampfe*. (Studien der Bibliothek Warburg, 20.) Leipzig and Berlin, 1932.
- KRUEGER, GUSTAV. *Das Dogma von der Dreieinigkeit und Gottmenschheit in seiner geschichtlichen Entwicklung dargestellt*. (Lebensfragen; Schriften und Reden, edited by Heinrich Weinel.) Tübingen, 1905.
- KUEKELHAUS, HUGO. *Urzahl und Gebärde*. Berlin, 1934.
- LACINIUS, JANUS. See BONUS, PETRUS.
- LEGG, FRANCIS (trans.). *Philosophumena; or, The Refutation of All Heresies*. (Formerly attributed to Origen but now to Hippolytus.) London and New York, 1921.
- LEGG, JAMES (trans.). *The Sacred Books of Confucianism: Part II. The Yi King*. (Sacred Books of the East, 16.) Oxford, 1882; 2nd edn., 1899.
- LEISEGANG, HANS. *Denkformen*. Berlin, 1928.

———. *Die Gnosis*. Leipzig, 1924.

———. *Der Heilige Geist*. Leipzig, 1919.

———. *Pneuma Hagion*. (Veröffentlichungen der Forschungsinstituts für vergleichende Religionsgeschichte an die Universität Leipzig, 4.) Leipzig, 1922.

LÉVY-BRUHL, LUCIEN. *How Natives Think*. Translated by Lilian A. Clare [from *Les Fonctions mentales dans les sociétés inférieures*]. London, 1926.

———. *Primitive Mentality*. Translated by Lilian A. Clare. London and New York, 1923.

———. *La Mythologie primitive*. Paris, 1935.

“Liber de arte chymica.” See (A) “Artis auriferae,” vii.

“Liber Platonis quattorum.” See (A) “Theatrum chemicum,” xiv.

LIDDELL, HENRY GEORGE, and SCOTT, ROBERT. *A Greek-English Lexicon*. New (9th) edn., revised by Sir Henry Stuart Jones and Roderick McKenzie. Oxford, 1940. 2 vols.

LIPPMANN, EDUARD OSKAR VON. *Entstehung und Ausbreitung der Alchemie* Berlin, 1919–31. 2 vols.

LIPSIUS, RICHARD ADELBERT, and BONNET, MAX. *Acta Apostolorum Apocrypha*. Leipzig, 1891–1903. 2 parts in 3 vols.

Lo, L. C. (trans.). “Liu Hua Yang, Hui Ming King. Das Buch von Bewusstsein und Leben,” *Chinesische Blätter für Wissenschaft und Kunst*. Edited by Richard Wilhelm (China-Institut, Frankfurt a. M.; pub. at Darmstadt), I : 3 (1926), 104–14.

LÜ PU-WEI (Lü Bu We). *Frühling und Herbst des Lü Bu We*. Edited by Richard Wilhelm. Jena, 1928.

LULLY, RAYMOND. See (A) *Theatrum chemicum*, ix.

MACROBIUS. *Commentarium in Somnium Scipionis*. For translation, see:

———. *Commentary on the Dream of Scipio*. Translated by William Harris Stahl. (Records of Civilization, Sources and Studies, 48.) New York, 1952.

MADATHANUS. “Aureum saeculum redivivum.” See (A) *Musaeum hermeticum*, i.

- MAIER, MICHAEL. *Atalanta fugiens, hoc est, Emblemata nova de secretis naturae chymica*. Oppenheim, 1618.
- . *De circulo physico quadrato*. Oppenheim, 1616.
- . *Secretioris naturae secretorum scrutinium chymicum*. Frankfurt a. M., 1687.
- . *Symbola aureae mensae duodecim nationum*. Frankfurt a. M., 1617.
- MAITLAND, EDWARD. *Anna Kingsford, Her Life, Letters, Diary, and Work*. London, 1896. 2 vols.
- MEAD, G. R. S. *Fragments of a Faith Forgotten*. 3rd edn., London, 1931.
- . *Pistis Sophia*. 2nd edn., London, 1921.
- MEIER, C. A. “Spontanmanifestationen des kollektiven Unbewussten,” *Zentralblatt für Psychotherapie* (Leipzig), XI (1939), 284–303.
- MEYER, WILHELM. “Die Geschichte des Kreuzholzes vor Christus,” *Abhandlungen der philosophisch-philologischen Classe der königlich Bayerischen Akademie der Wissenschaft* (Munich), XVI, 2 (1882), 107–8.
- MICRERIS. “Tractatus Micreris.” See (A) *Theatrum chemicum*, xiii.
- MIGNE, JACQUES PAUL (ed.). *Patrologiae cursus completus*.
[P.L.] Latin Series. Paris, 1844–64. 221 vols.
[P.G.] Greek Series. Paris, 1857–66. 166 vols.
(These works are referred to in the text and in this bibliography as “Migne, P.L.” and “Migne, P.G.” respectively. References are to columns, not to pages.)
- Missale Romanum (The Roman Missal)*. For translation, see: *The Missal in Latin and English*. Edited by J. O’Connell and H. P. R. Finberg. London, 1949.
- MORET, ALEXANDRE. *Du caractère religieux de la royauté pharaonique*. (Annales du Musée Guimet, Bibliothèque d’études, 15.) Paris, 1902.
- MYLIUS, JOHANN DANIEL. *Philosophia reformata*. Frankfurt a. M., 1622.
- The Mysteries*. Translated by Ralph Manheim and R. F. C. Hull. (Papers from the Eranos Yearbooks, 2.) New York (Bollingen Series XXX) and London, 1955.
- NELKEN, JAN. “Analytische Beobachtungen über Phantasien eines Schizophrenen,” *Jahrbuch für psychoanalytische und psychopathologische Forschung* (Vienna and Leipzig), IV (1912), 504ff.

- NEUMANN, ERICH. *The Origins and History of Consciousness*. Translated by R. F. C. Hull. New York (Bollingen Series XLII) and London, 1954.
- NIELSEN, [CHRISTIAN] DETLEF. *Der Dreieinige Gott*. Copenhagen, 1922–42. 2 vols. (Vol. I, *Die dreigöttlichen Personen*; Vol. II, *Die drei Naturgottheiten*.)
- NIETZSCHE, FRIEDRICH WILHELM. *Human, All-too-Human*. Translated by Helen Zimmern and Paul V. Cohn. (Complete Works, 6, 7.) London and New York, 1909, 1911. 2 vols.
- . *Thus Spake Zarathustra*. Translated by Thomas Common and revised by Oscar Levy and John L. Beevers. London, 1931.
- . *Werke*. Edited by Alfred Baeumler. Leipzig, [1930–32]. 8 vols. (“Dem unbekanntem Gott” appears in Vol. 5, p. 457.)
- NIKLAUS VON FLÜE. See KLAUS, BROTHER.
- NINCK, MARTIN. *Wodan und germanischer Schicksalsglaube*. Jena, 1935.
- NORDEN, EDUARD. *Die Geburt des Kindes*. (Studien der Bibliothek Warburg, 3.) Leipzig and Berlin, 1924.
- NUKARIYA, KAITEN. *The Religion of the Samurai*. London, 1913.
- ŌHAZAMA, SHŪEL [Ohasama, Schûej]. *Zen: Der lebendige Buddhismus in Japan*. Translated from Japanese into German by August Faust. Gotha and Stuttgart, 1925.
- ONIAN, RICHARD BROXTON. *The Origins of European Thought*. Cambridge, 1951.
- OPICINUS DE CANISTRIS. See Codices and Manuscripts, viii.
- ORIGEN. *Contra Celsum*. See Migne, *P.G.*, vol. 11, cols. 657–1632. For translation, see:
- . *Origen, Contra Celsum*. Translated by Henry Chadwick. Cambridge, 1953.
- . *In Jeremiam Homiliae*. See Migne, *P.G.*, vol. 13, cols. 255–544.
- . *De Principiis*. See Migne, *P.G.*, vol. 11, cols. 115–414. For translation, see:
- . *On First Principles*. Translated by G. W. Butterworth. London, 1936.
- ORTHELIUS. See (A) *Theatrum chemicum*, xviii; MANGETUS, *Bibliotheca chemica*, x.

- OTTO, RUDOLF. *The Idea of the Holy*. Translated by John W. Harvey. 4th impr., Oxford, 1926.
- PALANQUE, J. R., and others. *The Church in the Christian Roman Empire*. Vol. I: *The Church and the Arian Crisis*. Translated by Ernest C. Messenger. London, 1949.
- PANTHEUS, JOANNES AUG. *Ars transmutationis metallica*. Venice, 1519.
- PAULI, W. "The Influence of Archetypal Ideas on the Scientific Theories of Kepler," translated from the German by Priscilla Silz. In: *The Interpretation of Nature and the Psyche*. New York (Bollingen Series LI) and London, 1955.
- PEARCY, HENRI REUBELT. *A Vindication of Paul*. New York, 1936.
- PERCIVAL, MILTON A. *William Blake's Circle of Destiny*. New York, 1938.
- PERERIUS, BENEDICTUS, S. J. *De Magia: De observatione somniorum et de divinatione astrologica libri tres*. Cologne, 1598.
- PETRUS BONUS. See BONUS.
- PEUCER, KASPAR. *Commentarius de praecipuis generibus divinationum ...* Wittenberg, 1560.
- PICINELLI, FILIPPO. *Mondo simbolico*. Milan, 1669. Translated into Latin as: PHILIPPUS PICINELLUS. *Mundus symbolicus*. Cologne, 1680–81.
- Pistis Sophia*. See MEAD.
- PITRA, JEAN-BAPTISTE. *Analecta sacra Spicilegio Solesmensi parata*. Paris, 1876–91. 8 vols.
- PIUS XII, POPE. *Apostolic Constitution "Munificentissimus Deus."* Translated into English. Dublin (Irish Messenger Office), 1950.
- PLATO. *Symposium*.
- . *Timaeus and Critias. The Thomas Taylor Translation*. (Bollingen Series III.) New York, 1944.
- . *Timaeus und Kritias*. Translated (into German) by Otto Apelt. (Philosophische Bibliothek, 179.) Leipzig, 1922.
- . See also CORNFORD.

- PLATO, pseud. "Liber Platonis quartorum." See (A) *Theatrum chemicum*, xiv.
- PLUTARCH. *De defectu oraculorum*. In: *Moralia*. With an English translation by Frank Cole Babbitt. (Loeb Classical Library.) Cambridge (Mass.) and London, 1936ff. 14 vols. (Vol. V, pp. 350ff.)
- . *Quaestiones convivales*. In: *Plutarchi Moralia*. Edited by C. Hubert and others. Vol. IV. Leipzig, 1925.
- PEPELIN, CLAUDIUS. *Le Songe de Poliphile*. Paris, 1883. 2 vols.
- PORTMANN, ADOLF. "Die Bedeutung der Bilder in der lebendigen Energiewandlung," *Eranos-Jahrbuch* (Zurich), XXI (1953), 325–57.
- POWELL, JOHN WESLEY. *Annual Reports of the Bureau of Ethnology to the Secretary of the Smithsonian Institution, Washington*. Vols. V (1883–84) and VIII (1886–87). Washington, 1887, 1891.
- PREISENDANZ, KARL. *Papyri Graecae Magicae*. Leipzig and Berlin, 1928–31. 2 vols.
- PREISIGKE, FRIEDRICH. *Vom göttlichen Fluidum nach ägyptischer Anschauung*. (Papyrusinstitut Heidelberg, Schrift I.) Berlin and Leipzig, 1920.
- . *Die Gotteskraft der frühchristlichen Zeit*. (Papyrusinstitut Heidelberg, Schrift VI.) Berlin and Leipzig, 1922.
- PRZYWARA, ERICH. *Deus semper major*. Freiburg i. B., 1938. 3 vols.
- PSELLUS, MICHAEL. *De daemonibus*. In: *Iamblichus de mysteriis Aegyptiorum, Chaldaeorum, Assyriorum, etc.* Edited by Marsilio Ficino. Venice, 1497.
- RAHNER, HUGO. *Griechische Mythen in christlicher Deutung*. Zurich, 1945.
- . "Mysterium Lunae," *Zeitschrift für katholische Theologie* (Innsbruck and Leipzig), LXIV (1940), 80.
- [RAMAKRISHNA PARAMAHAMSA.] *The Gospel of Ramakrishna*. Authorized edn., New York, 1907.
- [———.] *Worte des Ramakrishna*. Edited by Emma von Pelet. Zurich, 1930.
- REITZENSTEIN, RICHARD. *Poimandres*. Leipzig, 1904.
- REUSNER, HIERONYMUS. *Pandora, das ist, die edelst Gab Gottes, oder der werde und heilsame Stein der Weysen*. Basel, 1588.

RHINE, J. B. *The Reach of the Mind*. London and New York, 1948.

Rig-Veda. See: NICOL MACNICOL (ed.). *Hindu Scriptures*. (Everyman's Library.) London and New York, 1938.

RIPLEY, GEORGE. *Opera omnia chemica*. Kassel, 1649.

Rituale Romanum (The Roman Ritual.) Editio typica. Vatican City, 1952.

ROMANUS, SAINT. See PITRA.

Rosarium philosophorum. Secunda pars alchimiae ... cum figuris. Frankfurt a. M., 1550. See also (A) Manget, *Bibliotheca chemica*, vi; and *Artis auriferae*, viii.

ROSCHER, W. H. (ed.). *Ausführliches Lexikon der griechischen und römischen Mythologie*. Leipzig, 1884–1937. 6 vols.

ROSENCREUTZ. See ANDREAE.

“Rosinus ad Sarratantam.” See (A) *Artis Auriferae*, v.

ROSSI, GIOVANNI BATTISTA DE'. *Musaici cristiani delle Chiese di Roma anteriori al secolo XV*. Rome, 1899.

RULAND, MARTIN. *Lexicon alchemiae, sive Dictionarium alchemisticum*. Frankfurt a. M., 1612. For translation, see: *A Lexicon of Alchemy or Alchemical Dictionary* [London, 1892].

RÜCKER, ADOLF. See THEODORE, BISHOP OF MOPSUESTIA.

RUPERT, ABBOT OF DEUTZ (Rupertus Abbas Tuitiensis). *Commentarium in Joannem*. In Migne, *P.L.*, vol. 169, cols. 205–826.

RUPESCISSA, JOANNES DE. *La Vertu et la propriété de la quinte essence*. Lyons, 1581.

RUSKA, JULIUS. *Tabula Smaragdina: ein Beitrag zur Geschichte der hermetischen Literatur*. Heidelberg, 1926.

———. *Turba Philosophorum; ein Beitrag zur Geschichte der Alchemie*. (Quellen und Studien zur Geschichte der Naturwissenschaften und der Medizin, 1.) Berlin, 1931.

RUYSBROECK, JOHN OF. *The Adornment of the Spiritual Marriage, etc.* Translated by C. A. Wynschenck Dom. London, 1916.

- SALOMON, RICHARD. *Opicinus de Canistris: Weltbild und Bekenntnisse eines avignonesischen Klerikers des 14. Jahrhunderts*. London, 1936.
- SALZER, ANSELM. *Die Sinnbilder und Beiworte Mariens*. Linz, 1893.
- Samyutta-Nikāya. *The Book of the Kindred Sayings (Samyutta-Nikāya)*. Part II: The Nidāna Book (Nidāna-Vagga). Translated by Mrs. Catherine F. Rhys Davids and F. H. Woodward. (Pali Text Society, Translation Series, 10.) London, 1922.
- SCHAER [SCHÄR], HANS. *Erlösungsvorstellungen und ihre psychologischen Aspekte*. (Studien aus dem C. G. Jung-Institut, II.) Zurich, 1950.
- . *Religion and the Cure of Souls in Jung's Psychology*. Translated by R. F. C. Hull. New York (Bollingen Series XXI) and London, 1951.
- SCHÄRF, RIWKAH. "Die Gestalt des Satans im Alten Testament." In: C. G. JUNG. *Symbolik des Geistes*. Zurich, 1953.
- SCHILLER, FRIEDRICH. *Wallensteins Tod*. 1799.
- SCHOLEM, GERSHOM G. *Major Trends in Jewish Mysticism*. New York, 1941; 3rd edn., 1954.
- SCHOLZ, HEINRICH. *Die Religionsphilosophie des Als-Ob*. Leipzig, 1921.
- SCHOPENHAUER, ARTHUR. "On the Fourfold Root of the Principle of Sufficient Reason." In: *Two Essays by Arthur Schopenhauer*. Translated anon. (Bohn's Philosophical Library.) London, 1889. (Pp. 1–189.)
- SCHULTZ, WOLFGANG. *Dokumente der Gnosis*. Jena, 1910.
- SCOTT, WALTER (ed.). *Hermetica*. Oxford, 1924–36. 4 vols.
- SENDIVOGIUS. See (A) *Musaeum Hermeticum*, ii, iii; *Theatrum chemicum*, xviii; MANGETUS, *Bibliotheca chemica*, viii, ix.
- The Shatapatha-Brāhmaṇa*. Translated by Julius Eggeling. Vol. V. (Sacred Books of the East, 44.) Oxford, 1900.
- SHAW, GEORGE BERNARD. *Saint Joan*. London, 1938.
- SIGISMUND [DULLINGER] OF SEON. *Trithemius sui-ipsius Vindex*. Ingolstadt, 1616.
- SILBERER, HERBERT. *Der Traum*. Stuttgart, 1919.

SINGER, CHARLES (ed.). *Studies in the History and Method of Science*. Oxford, 1917.

SMITHSONIAN INSTITUTION. See POWELL.

Solomon, Odes of. See BERNARD, JOHN HENRY.

SOSNOSKY, THEODOR VON. *Die rote Dreifaltigkeit: Jakobiner und Bolscheviken*.
Einsiedeln, 1931.

SPAMER, ADOLF (ed.). *Texte aus der deutschen Mystik des 14. und 15. Jahrhunderts*.
Jena, 1912.

SPIELREIN, SABINA. "Über den psychologischen Inhalt eines Falls von Schizophrenie"
Jahrbuch für psychoanalytische und psychopathologische Forschung (Leipzig and
Vienna), III (1912), 329–400.

Spirit and Nature. Translated by Ralph Manheim and R. F. C. Hull. (Papers from the
Eranos Yearbooks, 1.) New York (Bollingen Series XXX), 1954; London, 1955.

"Splendor solis." See (A) *Aureum vellus*, i.

STEEB, JOANNES CHRISTOPHORUS. *Coelum sephiroticum hebraeorum*. Mainz, 1679.

STERN, LUDWIG. "Die koptische Apokalypse des Sophonias," in *Zeitschrift für
Ägyptische Sprache und Alterthumskunde* (Leipzig), XXIV (1886), 115–36.

STOECKLI, ALBAN. *Die Visionen des seligen Bruder Klaus*. Einsiedeln, 1933.

STOLCIUS DE STOLCENBERG, DANIEL. *Viridarium chymicum figuris cupro incis
adornatum et poeticis picturis illustratum ...* Frankfurt a. M., 1624.

STRACK, H. L., and BILLERBECK, PAUL. *Kommentar zum neuen Testament aus Talmud
und Midrasch*. Munich, 1922–28. 4 vols.

SUZUKI DAISETZ TEITARO. *Essays in Zen Buddhism*. Three series. (2nd edn.: Complete
Works, ed. C. Humphreys.) London, 1949–53.

———. *An Introduction to Zen Buddhism*. London and New York, 1949.

———. *The Training of the Zen Buddhist Monk*. Kyoto, 1934.

TAYLOR, F. SHERWOOD. "A Survey of Greek Alchemy," *Journal of Hellenic Studies*
(London), L (1930), 109–39.

TERTULLIAN. *Adversus Iudaeos*. In Migne, *P.L.*, vol. 2, cols. 595–642. For translation, see: *The Writings of Tertullianus*. Translated by S. Thelwall, P. Holmes, and others. Vol. III. (Ante-Nicene Christian Library, 18.) Edinburgh, 1870.

———. *Apologeticus adversus Gentes pro Christianis*. In Migne, *P.L.*, vol. 1, cols. 257–536.

———. *De Carne Christi*. In Migne, *P.L.*, vol. 2, cols. 751–92.

———. *De testimonio animae*. In Migne, *P.L.*, vol. 1, cols. 607–18. For translation, see:

———. *Tertullian*. Translated by C. L. Dodgson. (Library of Fathers of the Holy Catholic Church.) Oxford, 1842.

[THEODORE, BISHOP OF MOPSUESTIA.] *Ritus Baptismi et Missae quem descripsit Theodorus ep. Mopsuestanus in sermonibus catecheticis*. Translated by Adolf Rucker. (Opuscula et textus, series liturgica, 2.) Münster, 1933.

Theologia Germanica. Translated by Susanna Winkworth; revised and edited by Willard R. Trask. New York, 1949; London, 1950.

Theologische Zeitschrift. Basel.

Thomas, Acts of. See *Acts of Thomas*; JAMES; MEAD.

THOMAS AQUINAS, SAINT. *Quaestiones de veritate*. In: *Sancti Thomae Aquinatis Quaestiones disputatae*. Edited by P. Mandonnet. Paris, 1925. 3 vols. (Vol. I.)

———. *The Summa Theologica of St. Thomas Aquinas*. Literally translated by the Fathers of the English Dominican Province. London, 1911–22. 18 vols.

THOMAS AQUINAS, pseud. “Aurora, sive Aurea hora.” In: [H. CONDEESYANUS, pseud. i.e., J. Grasseus.] *Harmoniae inperscrutabilis chymico-philosophicae, sive Philosophorum antiquorum consentientium ...* Frankfurt a. M., 1625. (Decas II, pp. 175–242.) See also: (A) *Artis auriferae*, iv; Codices and Manuscripts, vi, xiii; FRANZ, *Aurora Consurgens*.

THORNDIKE, LYNN. *A History of Magic and Experimental Science*. New York, 1923–41. 6 vols.

TONQUÉDEC, JOSEPH DE. *Les Maladies nerveuses ou mentales et les manifestations diaboliques*. Paris, 1938.

“Tractatulus Avicennae.” See (A) *Artis auriferae*, vi.

Tractatus aureus. See HERMES TRISMEGISTUS.

“Tractatus Micreris.” See (A) *Theatrum chemicum*, xiii.

TRISMOSIN, SOLOMON. “Splendor solis.” See (A) *Aureum vellus*, i. For translation, see:

———. *Alchemical Treatises of Solomon Trismosin*. With explanatory notes by J. K. London, 1920.

“Turba philosophorum.” See RUSKA; (A) *Artis auriferae*, i; MANGETUS, *Bibliotheca chemica*, iii.

“Viridarium chymicum.” See STOLCIUS DE STOLCENBERG.

“Visio Arislei.” See (A) *Artis auriferae*, iii, viii.

WAITE, ARTHUR EDWARD. *The Hermetic Museum Restored and Enlarged*. London, 1893. 2 vols.

———. *The Secret Tradition in Alchemy*. London, 1926.

———. (ed. and trans.). *The New Pearl of Great Price*. London, 1894.

WHITE, VICTOR. *God and the Unconscious*. London, 1952; Chicago, 1953.

WHITE, WILLIAM. *Emanuel Swedenborg: His Life and Writings*. London, 1867. 2 vols.

WICKHOFF, FRANZ. “Das Apsismosaik in der Basilica des H. Felix zu Nola,” *Römische Quartalschrift* (Rome), III (1889), 158–76.

WIEDERKEHR, KARL. *Die leibliche Aufnahme der allerseligsten Jungfrau Maria in den Himmel*. Einsiedeln, 1927.

WILHELM, RICHARD (trans.). *The I Ching or Book of Changes*. Translated into English by Cary F. Baynes. New York (Bollingen Series XIX) and London, 1950. 2 vols.; 2nd edn. in 1 vol., 1961; 3rd edn. in small format, with new preface by Hellmut Wilhelm, 1967.

———. *The Secret of the Golden Flower*. With a European commentary by C. G. Jung. Translated by Cary F. Baynes. London and New York, 1931; new edn., with revised translation, 1962.

———. See also LÜ PU-WEI.

- WOLFF, TONI. "Einführung in die Grundlagen der Komplexen Psychologie." In: *Die Kulturelle Bedeutung der Komplexen Psychologie*. (Festschrift zum 60. Geburtstag von C. G. Jung.) Berlin, 1935. (Pp. 1–168.)
- WOOLLEY, SIR LEONARD. *Abraham: Recent Discoveries and Hebrew Origins*. London, 1936.
- ZELLER, EDUARD. *Die Philosophie der Griechen*. Tübingen and Leipzig, 1856–68. 3 vols. Partially translated as: *A History of Greek Philosophy*. Translated by S. F. Alleyne. London, 1881. 2 vols.
- ZIMMER, HEINRICH. *The Art of Indian Asia*. Completed and edited by Joseph Campbell. (Bollingen Series XXXIX.) New York, 1955. 2 vols.
- . *Kunstform und Yoga im indischen Kultbild*. Berlin, 1926.
- . *Myths and Symbols in Indian Art and Civilization*. Edited by Joseph Campbell. (Bollingen Series VI.) New York, 1946.
- ZÖCKLER, OTTO. *The Cross of Christ*. Translated by Maurice J. Evans. London, 1877.
- ZOSIMOS. "Rosinus ad Sarratantam." See (A) *Artis auriferae*, v.

INDEX

INDEX

In entries relating to the books of the Bible, the numbers in parentheses indicate the chapter and verse(s) referred to.

A

- Aarau, 334
- abaissement du niveau mental*, 520
- abandonment, and helpful powers, 342
- Abbas, prefect of Mesopotamia, 240
- Abdul Baha, 530
- Abel, 173n, 217, 391–92, 399–400, 405–6, 410, 412, 422; *see also* Cain
- Abraham, 217–18, 261–62, 268, 269n, 418
- absolute, the, 512
- absolution, 353
- decline of, 531
 - Protestants and, 48, 49
- abstraction, 166, 499
- Abu'l-Qasim Muhammad, 98n
- Abysmal, the (hexagram), 603ff
- abyss, 173
- acceptance: by doctor, 339
- of oneself, 339–40
- acquisitiveness, Western, 483
- active imagination, 81, 496, 537
- Acts of the Apostles, (10:19), 279
- (14:11), 414
- Acts of John*, *see John, Acts of*
- Acts of Peter*, *see Peter, Acts of*
- actus purus*, 194, 195
- Adad, 113, 114
- Adam, 305n, 391ff, 402
- Anthropos/original man, 373

copy/chthonic equivalent of God, [392](#), [399](#), [400](#)
hermaphroditic, [102n](#), [234](#), [391](#), [398](#)
Kadmon, [55](#)
limitation of, [405](#)
the second, [55–56](#), [102](#), [273](#), [397](#), [441](#)
and number three, [60n](#)
see also First Parents
adaptation, [348](#)
Ādi-Buddha, [561](#)
Adler, Alfred, [329](#), [333](#)
 Adlerian psychology, [330](#), [348–49](#)
Adler, Gerhard, [26n](#)
Adonis, [388](#), [443](#)
 birth of, [103](#), [389](#)
adulthood, [183](#)
 criterion of, [184](#)
adversary, the, [77](#), [174](#), [187](#), [196](#), [313](#)
 see also devil; Satan
advice, good, [352](#)
advocate, *see* Paraclete
Aelian, [244](#)
Aenigmata ex visione Arislei, [93](#)
Aeon(s), [144](#), [237](#)
aeon, Christian, [446–47](#), [451](#), [458](#)
aeroplane, [52](#)
Aesculapius, [98n](#)
affect(s), [406](#)
 author's, [366](#)
 symptom of virtuousness, [449](#)
 of Yahweh, [416](#)
affectivity, [321](#)
Agathodaimon, [185](#)
agnosticism, [452](#)
ahamkāra, [579](#), [582](#), [584](#)

Ahriman, [174](#), [175](#), [313](#), [375n](#)
Ahura-Mazda, [174](#), [177](#); *see also* Ormuzd
Aion, image of, [244](#)
Alanus de Insulis, [100n](#)
albedo, [115](#), [243n](#)
Albertus Magnus, [100n](#)
alchemy, [91ff](#), [225ff](#), [279](#), [288](#), [313–14](#), [437](#), [450](#)
 and chemistry, [296](#)
 Chinese, [102](#)
 and dreams, parallels, [61](#)
 and Gnosticism, [97–98](#)
 Greek, [177](#)
 and humanization of self, [262](#)
 meditations of, [496](#)
 parables in, [225](#)
 philosophical side of, [295](#)
 quaternity in, [423](#)
 symbols of, [468](#)
 terms used in, [263](#)
 two aspects of, [97–98](#)
 and union of opposites, [454](#); *see also* Zosimos
Alexandria, [117](#)
 Alexandrian philosophy, [128](#)
aljira, [490](#)
Allah, [303](#)
Allegoriae sapientum supra librum Turbae, [238](#)
Allegoriae super librum Turbae, [238](#)
allegory (-ies): in alchemy, [225](#)
 Christian, [307](#)
Alphidius, [102n](#)
altar: censuring of, [212](#)
 high and low, [560](#), [570](#)
 and number four, [51](#)
ambiguity, conviction and, [45](#)

Ambrose, St.: and Apostles' creed, 141
on water as symbol, 209–10

American Indians, 57

Amitābha/Buddha, 513, 522, 561–63, 567, 573

Amitāyur-dhyāna-Sūtra, 502n, 560ff

Amitāyus, 560, 564–65

Amnael, 233

Amogha-siddhi, 522

“amok, running,” 17

Anabaptists, 21n

analysis: as initiation process, 515, 523
and production of conscious ego, 554
see also psychoanalysis

analytical psychology: and active imagination, 496
clash of doctor and clergyman in, 353
and Protestantism, 351
self in, 502
and unconscious, 488

Ānanda, 561, 564

anarchy, 88
psychic, 532

anātmān, 575

anatomist, 307

ancestors, and totem meal, 222

ancestral patterns, reawakening of, 503

ancestress, 600

anchorite, 317

“Ancient of Days,” 421, 435, 437

Andreae, Johann valentin, 229&n

androgyny; of Christ, 221
of God, 175n, 322
see also hermaphroditic nature

anecdotes, Zen, 539–41, 543n, 548n, 549n, 552–53, 557n

angel(s), 13, 155, 446

auxiliary, 445
devil as, 173, 196
fallen, 305, 392, 394, 421ff, 457, 460
of God's face, 424, 426
in the Mass, 217f
Angelus Silesius (Johannes Scheffler), 190, 450, 513, 547, 583
anima, 29–31, 41–42, 75, 456
 a Gnostic concept, 306
 “hidden” nature and, 93n
 insight and, 161
 man's, and *anima mundi*, 476
 resisting the, 75
 unconscious personified by, 63
anima (breath-being), 131
animal(s), 155
 creation of, 402, 403
 four, of Yahweh, 383
 transformation into human beings, 34, 65
 see also bear; behemoth; bull; cock; crocodile; dove; dragon; fish; hoopoe; horse;
 lamb; leviathan; lion; monoceros; ox; ram; rhinoceros; scorpion; sea monsters;
 serpent; snake; unicorn; viper
anima media natura, 53, 92
anima mundi, 92, 98, 178, 476
 circle and, 53
 Mercurius as, 102n
 Plato's, 66, 126
 sun-woman as, 439
 see also world-soul
anima rationalis, 479
animation, suffix of, 255
animism, 83n
animosity, manifestation of animus/anima, 30
animus, 30
Anthony (of Egypt), St., 20n, 578
Anthony of Padua, St., 458n

anthropoids: African, 307
pre-Adamic, 374, 391n

anthropomorphic: ideas, 151, 185
images of God, 361
projections, 245

anthropomorphism, in symbolism of the Mass, 207

anthropophagy, ritual, 222

Anthropos (ἄνθρωπος), 56–57, 185, 252, 280, 439
Adam as, 373, 405
as archetype, 277
self as, 292
sun-woman as feminine, 439
see also man, original; man, primordial; Protanthropos

anthroposophy, 529–31

Antichrist, 172, 174, 357, 412, 432–35, 458, 488
archetype as, 117
expectation of, 433–35
reign of, 447, 450

antimimon pneuma (ἀποκατάστασις), 177, 179, 412

antinomy, *see* opposites

antiquarians, 592

antithesis(-es), 306
religious, East/West, 560
see also opposites, pairs of

anti-Trinity, infernal, 172

Anu, 113, 114

anxiety, ego as seat of, 521

ape, 34
of God, devil as, 70n, 172

Apelt, Otto, 123n

Aphorismi Basiliani, 95n

Apocalypse, *see* Revelation

apocatastasis (ἀποκατάστασις), 265, 503
of the Father, 187

Apollo, 438, 440

Apollonius of Tyana, 154, 530

Apostles' Creed, *see* Creeds

apotheosis, 94, 102*n*, 295

apperception, 486, 490

Apuleius, 58, 514

aqua doctrinae, 567

aqua permanens, 92, 100, 101&*n*, 211*n*, 277

see also water, permanent

Aquarius, 446*n*, 451

Arabia, 130

archaic patterns, *see* archetypes; motifs, mythological

archetype(s), 104, 345, 361, 362, 409, 469–70, 518, *et passim*

activation of, 151

a priori conditions of psychic events, 188

author and, 303

an auxiliary idea, 306

Christ as, 88, 152*ff*, 409

and consciousness, 469–70

as dominants of unconscious, 519

and dreams, 300

fascination of, 151

of God, 265, 303, 362

God as, 59

identification with conscious mind, 315

importance of, 190

indestructible foundations of human mind, 130

and individual life, 89

“irrepresentable,” 148–49, 151

luminosity of, 437*n*

meaning of, 50

metaphysical significance, 200

multiplicity of, 288

numinosity of, 59, 149, 315

possession by, 151
psychic life timeless, 90
recognized only by effects, 149n
religious statements and, 148
supplanting ego, 345
Trinity as, *see* Trinity
whether acquired, 149n
of wholeness, 469
wrathful form, 117
see also anima; animus; Anthropos; Christ; divine child; duality; God-image; hero;
mandala; self

architecture, Indian hieratic, 558
archon(s), 270; *see also* Ialdabaoth; Saturn
Archonides, 244
Archytas, 72n
Arian heresy, 130, 148, 153
Aries, aeon of, 114
Aristotle, 118n
Ark of the Covenant, 438
Armenians, 209
Arnold of Villanova, 54n
Ars chemica, 30n, 94n, 99n, 102n, 232n, 238n
art 556–57
 Indian, 568
 modern, 446
Artis auriferae, 29n, 30n, 54n, 55n, 92n, 93n, 94n, 99n, 101n, 102n, 231n, 238n, 239n
arts and sciences, taught by fallen angels, 421, 457, 460
arupaloka, 490
asceticism, 26, 27, 31, 493; *see also* askesis
askesis, 485
assimilation, 302
 experience as, 5
 of God-experience, 320
 phenomena of, 288
 of split-off contents, 264

of vision, 319

association(s), 303, 486

 experiment/test, 13, 23

association test, complexes and, 23

Assumption, of Virgin Mary, 170&n, 312, 358, 398, 430n

 proclamation of dogma, 458f, 461ff

Astanus, *see* Ostanus

astrologers, 592

astrology, 174n, 259, 412, 442

astronomical laws, 83

Athanasian Creed, *see* Creeds

Athanasius, St., 20n

atheism, 22, 82, 192

 urban neurosis of, 86

Atlantis, 127

atman, 156, 284, 533, 579–80, 582; *see also* purusha-atman doctrine

atom bomb, 451, 461, 464, 480

atonement, 418

at-one-ment, 498, 504–5

attention, 550

Attis, 9, 228, 388, 445n, 508n

attitude(s): connection with earlier, 166

 conscious, 34, 337

 contemplative, 498

 doctor's/psychotherapist's, 338, 342, 346

 introvert and extravert, 481, 486, 491

 religious, 32

auctor rerum, 133, 186, 264, 270

Augustine, St., 53, 63n, 107, 146n, 210n, 322, 518, 560

Aurea hora, 55, 94n; *see also* *Aurora consurgens*

Aureum vellus, 30n, 94n, 234n

Aurora consurgens, 55n, 56n, 94n, 100n, 102n, 230, 233n

aurum philosophicum, 54

autoerotism, 481

Autogenes, 37
autogenic training, 536
autonomy: of archetypes, 362
 in divine process, 196
autos-da-fé, 197
auto-suggestion, 544, 557
Avalon, Arthur, 67n, 495n
Avicenna, 29n
avidyā, 485
awareness, 484
 mind and, 501
 unreflecting, 182
 see also conscious(ness)
Ayik, the, 133
Azazel, 421, 422, 426
Aztecs, 223–24, 269

B

Baal, 230
Babylon, 388, 446
Babylonia, 112ff
Bahaim, 530
Balder, 443
ball, 65
banner, golden, 562, 566, 570
baptism, 279, 416
 and *commixtio*, 220
 dream of, 102
Barabbas, 268
barbarians, 308
Barbelo, 92n, 190, 219, 423
Barbelo-Gnosis, 37, 92n, 264
barber, 227, 228f
Bardo state, 394, 400, 509, 512ff; *see also* pleroma
Bardo Thödol, 509ff, 555

Barnabas, 414
Barth, Karl, 116
Basilides, 279
basin, 65
 Hermetic, 210
 see also krater
Baumgartner, Matthias, 155*n*
Baynes, Charlotte A., 37*n*, 56*n*
bear, 52, 74
bearskin, vision of man with, 323
beauty, 579
 in Mass ritual, 249–50
behaviour, pattern of, 149*n*
behemoth, 403, 426
Being, Universal, 578
Bel, 113*f*
belief(s): collective, 308
 content of, and psychology, 247
 and doubt, 200
 “invention” of, 223
 uncompellable, 337
bells, in Mithraic ritual, 224
benedictio fontis, 100–101, 265, 425
Bernard, St., 37*n*
Bernardino de Sahagún, 223, 224*n*
Bernardus Sylvestris, 99*n*
Béroalde de Verville, François, 230*n*
“berserk, going,” 17
Berthelot, Marcellin, 53*n*, 70*n*, 91*n*, 92*n*, 93*n*, 94*n*, 97*n*, 98*n*, 100*n*, 101*n*, 102*n*, 210*n*,
 211*n*, 225, 226*n*, 228*n*, 231*n*, 232*n*, 233*n*, 240*n*
Besant, Annie, 529
Bethlehem, 436
“Beyond,” 514
Bharhut, 558
Bible, 362, 363, 365, 367, 374, 413, 490

Protestantism and, [21](#)
see also New Testament, Old Testament, *and names of specific books*

Bin Gorion, Josef, [241](#), [242n](#)

binarius, [71](#), [174](#)
created on Monday, [118](#)
devil as, [60](#), [70n](#), [177](#)

biological process, individuation a, [307](#)

biology, [327](#), [329](#)
inadequate basis for therapy, [300](#)

bird, black, [66](#)

birth: hazardous, of Christ, [155](#)
rites at, [193](#)
trauma of, [515f](#)

Blake, William, [555n](#)

Blavatsky, Madame, [529](#)

blessing, formulae for, [149](#)

blindness, symbolical, [280](#)

blood: in alchemy, [232](#), [237](#)
see also Christ

blue (colour), [71](#), [73](#), [74–75](#)
in alchemy, [100](#)

boat, [52](#)

Bodhi, [539](#)

Bodhidharma, [551n](#)

bodhimandala, [573](#)

body: *Bardo*, [520](#)
ego's awareness of, [484](#)
glorified, [209](#)
mystical, [155](#), [221](#)
resurrection of, [524](#)
in sacramental meal, [205](#)

Böhme, Jakob, [37n](#), [80n](#), [313f](#), [450](#), [541](#)

Bolshevism/Bolshevist, [15](#), [320](#), [336](#), [340](#)

Bonaventura, St., [270n](#)

Bonus, Petrus, [38n](#), [55](#), [99n](#)

Book of Changes, *see I Ching*

Book of the Dead: Egyptian, [510](#)

Tibetan, *see Bardo Thödol*

books, “useless,” [526](#)

Borobudur, [558](#)

Bouché-Leclercq, Auguste, [233n](#)

Bouelles, Charles de, *see Bovillus*

boundary, cross as, [282](#), [285](#), [292](#)

Bousset, Wilhelm, [230n](#)

Bovillus (de Bouelles), Karl, [319](#)

bowl, [52](#), [65](#), [80](#)

boy, sacrificed, [241–42](#)

Brahma, [545n](#)

Brahman, [322](#)

brain, and psyche, [10](#), [480](#)

Brazen Man, [227–28](#)

bread: breaking of, *see Fractio*

Christ’s body as, [155](#)

consecration formula, in Mass, [214](#)

in the Mass, [208](#), [252–53](#), [254](#)

break-through: beyond intellect, [547](#)

in Goethe and Nietzsche, [555](#)

Greeks and, [555n](#)

in satori, [543](#)

breath: and consciousness, [244](#)

Holy Ghost as, [158](#), [160](#), [185](#)

breath-control, [533](#)

bridge: life of Christ as, [182](#)

man as, [177](#), [179](#)

bridegroom, heavenly, [464](#)

Brinktrine, Johannes, [208n](#), [215n](#)

Bronze Age, [321](#)

brook, [539](#), [546](#)

brothers, hostile, [173n](#), [400](#)
 see also Abel; Cain; fratricide
Bruno, bishop of Würzburg, [100n](#)
Buchman, Frank, [184n](#)
Buchman movement, [22](#)
Büchner, Ludwig, [334](#)
Buddha, [9](#), [337f](#), [420](#), [540](#), [550](#), [563ff](#), [578](#)
 in mandala, [67](#)
 meditator as, [512ff](#), [572](#), [575](#)
 primordial, [561](#)
 see also Adi-Buddha; Amitābha; Amitāyus; Dharmakāya; Dhyāni-
 Bodhisattvas/Buddhas; Flower Sermon; Mahābuddha; Shākya-muni; Tathāgata
Buddha-essence, [482](#)
Buddha-Mind, [482](#), [539](#)
Buddha-nature, [543](#), [548](#), [549n](#)
buddhi, [485](#)
Buddhism, [336](#), [344](#), [481](#)
 in China, [545](#)
 circumambulation in, [212n](#)
 Mahayana, [510](#)
 mandalas, [67](#)
 meditations, [523](#)
 theistic, [561](#)
 Tibetan, [79n](#), [252](#), [394](#), [480](#)
 in West, [530](#)
 and yoga, [568](#)
 Zen, [507](#) [538ff](#), [554](#)
Budge, Sir E. A. Wallis, [20n](#), [67n](#)
bull: in Egyptian ritual, [228n](#)
 in Mithraic ritual, [224–25](#)
burnt offering, [206](#)
bush-soul, [133](#)
Bussell, Frederick W., [54n](#)
Bythos, [144](#)
Byzantine empire, fall of, [530](#)

C

Cabala, 381n, 448

Cabasilas, Nicholas, 215

Cabiri, 70, 72, 121, 164, 165, 241

caduceus, 98n

Cain, 173n, 374, 394, 399f, 412, 421

as copy of Satan, 391f

see also Abel

calendar, ecclesiastical, 69

Campbell, Colin, 228n, 229n

Cana, marriage miracle at, 132, 253

cancer, imaginary, 10f, 14, 15, 22

candles, 36, 51

Canon of the Mass, 213ff

Carpocrates/Carpocratians, 77f

Carus, C. G., 85, 245

Caspari, Carl Paul, 142n

Cassian, John, 19n

castes, four, 167

castration, 445n

categories, mental, 517f

Catharists, 313

Catholic Church, 192, 304, 347, 352

absolutism of, 22

and blessing of font, 100–101

and departed souls, 523

and dogma, 9

and dogma of the Assumption, 462, 465

and dreams, 19–20

in dream, 25, 27

“Pax Romana” and, 47

priest and, 333

and Protestantism, 465–66

on revelation, 413
and sacraments, 7
and symbols, 43
see also Catholics; Church

Catholics, 334–35
and psychological analysis, 352–53
cauldron, 594, 597ff, 606; *see also* *ting*
causa instrumentalis, 8n
causa ministerialis, 8n
causality, 590, 607
opposed viewpoint, 592–93
causation, material, 328
cause(s): divine, belief in, 7
of neurosis, 337–38
Caussin, Nicolas, 270
celibacy, of priesthood, 132
censing, 206, 212f, 266
centre, 285
in self, mandala as symbol of, 81
unconscious, improbable, 485
see also mandala

chairs, 52
chakra, 533
chalice: consecration formula, in Mass, 214
elevation of, 212
preparation of, 209–11
chance: Chinese mind and, 591
and natural law, 591
and synchronicity, 592
change, from father to son, 162
chaos, 99n, 344
original, 54, 99, 234
prima materia as, 98n
character, change of, from uprush of collective forces, 15

Charles, R. H., 422
chemical warfare, 451, 461
chemistry, 296, 327
Chhāndogya Upanishad, 502
Chikhai Bardo, 509, 515, 522
child, divine, *see* divine child
childhood, faith and, 477
chin, 600
China, 447*n*, 585, 590*ff*;
 sun-wheels in, 322
 yoga in, 537
Chinese: alchemy, 102
 art, 567
 and Europeans, compared, 492
 philosophy, 197, 245, 495, 590*ff*
 see also Confucianism; *I Ching*; Tao
ching (hexagram), 605
Chochma, 387
Chönyid Bardo, 509, 515–17, 520–22, 523
Christ, 9, 264
 and Antichrist, 357
 apocalyptic, 439*ff*, 446*ff*
 as Archetype, 88, 152*ff*
 archetypal life, symbolizes conscious life of man, 157
 birth of, 359, 400, 403, 406, 414, 430, 439, 440, 448, 454
 blood of, 92, 567
 bride of, 458, 465
 chthonic man, 400
 and Church, 88, 447
 and confidence/doubt in God, 410–11, 429, 431, 433
 and consciousness, 459
 as Cosmic/Original Man/saviour, 154, 185, 273
 crucifixion/death of, 155, 248, 337*f*, 410, 418, 432, 432, 455
 and dance, in *Acts of John*, 273*ff*

demythologization of, 408
devil as counterpart/adversary of, 59, 169, 173
dual nature of, 251
Ezekiel as prefiguring, 421, 431
figure, not a totality, 156
Gnostic, 173, 292
as God (incarnation) *see* Incarnation
God's right hand, 313, 358
as God's second son, 170
in the gospels, 153
as hero of myth, 406, 409, 430
historicity of, 406–7, 409
and Holy Ghost/Paraclete, 135, 413, 431
humanization of, 153
imitation of, 340, 341, 444
immanence of, 441
inner, 156
irascibility of, 408, 436–37
as Jewish prophet/reformer, 408, 429
lacks a dark side, 191
as “life,” 37
life of, visualized in Mass, 248
man and, 60
as man, 406–7, 408–9
and Mary, 399, 400
meaning of, 360, 430
as mediator/redeemer, 134, 277, 414, 418, 428, 430, 432–33, 455, 465
middle term of triad, 156
and morality of evil, 457
New Testament symbolism and, 154*ff*
offering and offerer, united in, 221
perfection of, 399
and philosophers' stone, 55, 91, 99*n*, 454
presence in the Mass, 207, 215

as priest, 255
realized idea of self, 156
relativity of, 293
represented by priest, 207
and Satan, 409, 412, 440
as saviour (*soter*), 406, 429
as second Adam, 55
second coming of, 440, 447
as Son of God, 410, 412, 414, 428, 430, 432, 433
as Son of Man, 264, 430
supremacy of, in Protestantism, 464
as sword, 234
as symbol, 409, 441
— of self, 191, 194
thousand-year reign of, 447
totality/wholeness of, 155, 293, 421, 430
triumphant, 80
typical dying God, 89
unhistorical, 154
“within” and historical, 293
see also Gethsemane; Jesus; Logos; passion

Christianity, 22, 273, 344, 466
doctrinal rationalization, 291
early, 151
essential symbols of, 97
ethics of, 416
evangelical, 453
and evil, 168–69
historical preparation for, 429
images in, 46
Indian influence on, 441
not worldly, 27
opposition of God/man in, 455
primitive peoples and, 347

seeming lack of antecedents, 137
spread of, 441
Western man and, 482
and the world, 488
and yoga, 537
Christians, medieval, 308–g
Christian Science, 531
Christian Students' Conference, 334
Christification, 470
Christ-image, 442
Christopher of Paris, 99n
Chrysostom, *see* John Chrysostom
Church: authority of, 183
and Christ, 88
doctrines of, 428
experience of God and, 321
and evil, 169
as expression of psyche, 487
and Holy Ghost, 195, 433
as instrument of redemption, 481–82
its intercession, 47
mass exodus from, 333
mystical body of, 221
opposes original experience, 553
Protestant destruction of belief in, 531
see also Catholic Church; Protestantism
Cibinensis, Melchior, 245
Cicero, 8n, 51n
cintāmam, 563, 567
circle, 52, 64f, 90, 185
expressing Christ, 155
four partitions of, 52, 56
God as a, 53, 55, 80, 155n, 276, 322
representing heaven, 447

magical, 96
man symbolized by, 93
in medieval philosophy, 574
and microcosm, 95
squaring the, 53, 91, 96, 454
sun as, 566
as temenos, 95
wholeness of, 79, 96n, 167
see also mandala(s)
circulus quadratus, 64
circumambulation, 212, 275–76, 280
citrinitas, 57
civilization, 178, 198, 487
clay, white, 243
Clement of Alexandria, 110n, 181n
Clement of Rome, 313f, 357
First Epistle of, 139
Second Epistle of, 141
Cleomenes, 244
clergyman, 331–33, 334–35, 338
and cure of souls, 348ff
and ethical problems, 352
expectations from, 352
and meaning of life, 336
misinterpretation of, 354
psychological interest legitimate, 353
and psychotherapist, 346–47, 353
see also priest
Clock, 52, 65, 67
world clock, 66, 74, 80f, 96, 103
cock, 238
Codices: Bezae, 275, 434, 459n
Brucianus, 37, 56
Marcianus, 225, 229n

Rhenoviensis, 55n
cogitatio, 278–79
cognition, 306
 essential to consciousness, 160
 a mental faculty, 478
 mind the condition of, 480
coincidence, 591ff
coincidentia oppositorum, 540; *see also* opposites, union of
coins, 591, 593
collective unconscious, 345, 465, 519, 573
 and *buddhi*, 485
 Christ and, 154
 St. John and, 443
 One Mind and, 502
 and personal unconscious, 150, 573
 and visions, 461
 yoga and, 537
 see also archetypes
Collyridians, 129
colours: four, 52, 57, 66f, 69f, 72, 74, 96, 167
 and functions of consciousness, 189
 symbolic, in Bardo state, 522
Comarius (Komarios), 92, 94n, 97, 101n, 211n
Comma Johanneum, 138n
Commixtio, in the Mass, 219ff
communio, among Aztecs, 224
Communion, Holy, 44, 350; *see also* Mass
Communism, 150ff, 429, 488
compassion, 564, 567
compensation(s), unconscious, 488, 500, 506
 cannot be compelled, 497
 realization of, 491
complementarity, human-divine, 157
completeness, 167

as feminine, 395, 399

complex(es): autonomous, 13, 16, 151

- domination of will by, 86
- in dreams, 23
- resembles secondary personality, 14
- repressed and unrepressed, 14
- see also* father-complex; inferiority complex; Oedipus complex

complexio oppositorum, 358

- self as, 191, 443
- sun-woman's son as, 439
- see also* opposites; complex psychology, *see* analytical psychology

concentration, 38, 572

- Eastern, 507
- failure of, 492

concept, 595&n, 599, 606

Conception, Immaculate, *see* Immaculate Conception

concubine, 598

condemnation, 339

confession(s), 295, 536

- in Catholic Church, 192, 350, 353
- decline of, 531
- effect of, 49, 351
- in Mass, 257
- patient's, 338
- Protestants and, 21, 44, 48, 351

confidence in self, loss of, 10

conflict(s), 291, 341f, 344, 489

- clergyman and psychic, 353
- conscious/unconscious, 260
- in dreams, 23
- East/West, 481
- faith/knowledge, 532
- inner, acceptance of, 346
- moral, 349, 572

science/religion, 477, 480
unconscious, Protestantism and, 352
see also opposites

conflict situation, 174–75
“Son” stage as, 182

Confucianism, 336

Confucius, 9, 594, 599f, 602

congregation: function in the Mass, 206
represented by Eucharistic water, 209
as sacrificial gift, 266

coniunctio: maxima, 54
oppositorum, *see* opposites, union of

Connelly, Marc, 179n

connoisseurs, 592

Connolly, R. Hugh, 210n

conscience, Protestant, 49

conscious (mind) / consciousness, 415, 439, 513, 550ff, *et passim*
Adlerian psychology and, 348
alteration of, caused by *numinosum*, 7
as our own psychic existence, 13
as the Buddha, 513
building up of, in child, 345
of consciousness, 545
continuity of, 33
dark background of, 485f
detached, 504
detachment of, by yoga, 535
development/enhancement of, 166, 289
differentiation of, 180, 469
dissolution of, 508
Eastern view of, 484
ego-, *see* ego-consciousness
emancipation from unconscious, 290
empty, 545–46, 551

freedom won by, 165
and God, 373, 381, 404
Greeks and, 244
higher, 485
individual, 479
levels of, 546–47
man more than, 82
masculine, in sun-woman, 439
modern, low level of, 289
moral, collective, 258
as moral criterion, 434
nature of, 550
new level of, 488
passion for, 350
precariousness of, 17
of primitives, 17, 223
and projection, 83
psyche greater than, 41, 84, 556
of self, fear of, 14
stages of, 180ff, 545
switching off, 537
and unconscious, in human personality, 40
—, reunion, 292
whence it comes, 345
world's, splitting of, 291
Yahweh's, 404
see also satori; unconscious(ness)

conscious mind: Adlerian psychology and, 348
complexes and, 14
not whole man, 258
and religion, 360, 362

Consecration, in the Mass, 206f, 214–16, 220
essentially a miracle, 250
inner meaning, 207

words of, 248
and shaving the head, 228
consensus omnium, 199
Consignatio, 219, 221
Consilium coniugii, 94n, 232n, 238
contamination: “all-,” 504
of images, 491
contemplation, Christian and yogic, 570
contract, between Yahweh and man, 370–71, 374, 383, 395, 403; *see also* covenant
conversion(s), 65, 183
Coolidge, Calvin, 338
I Corinthians, (2:10), 416
(11:230ff), 203–4
(12:4–6), 139
II Corinthians, 278f
(3:5), 279
(3:7–18), 141
(10:7), 278
(13:14), 138
Cornford, Francis M., 127
corn spirit, 254
Corpus Hermeticum, 29n, 51n, 91n, 97, 210n; *see also* Scott, Walter
corpus mysticum, 71, 214
correspondence theory, 290
cortical cells, 480
Cosmic Man, *see* man
cosmos: Chinese view of, 592
stone as image of, 95
Councils, of the Church, 153
counter-will, 198
covenant, 370, 383, 395; *see also* contract
cramp, 536
Crawley, Alfred Ernest, 17n
creation, 367, 392, 394, 401

of a god, 86
imperfection of, 134
of man, 372*f*, 402
second day of, 118, 173, 177
and Trinity, 195
creativeness, 331, 490
creative secret, 556
creed(s), 9
 Apostles', 141*f*
 Athanasian, 111, 145, 152*f*
 and development of Trinity idea, 148
 of Gregory Thaumaturgus, 142*f*
 insecurity of all, 478
 Nicene, 143*f*
 Nicene-Constantinopolitan, 144
 and religion, 8, 43
 “scientific,” 44
criminal, statistical, 75
crocodile, 383
cross, 45, 224, 284*ff*, 417
 in *Acts of Peter*, 285*f*
 condition of transformation, 221
 expressing union of God and man, 80
 Greek, 574
 historical and ideal, 283
 of light, 281–83
 in mandala, 80
 of the Mayas, 404*n*
 a quaternity, 73, 170, 430
 serpent on, 229
 symbolic meanings, 62, 178
 symbol of order, 284
 use in the Mass, 208
see also crucifixion

crown, 155
crucifixion, 268, 283, 417
 between two thieves, 225, 269, 455
 of Peter, 286
 a quaternity, 283, 425
 see also Christ
cruelty, 271
crystals: brown, 71
 dissimilarity of, 591
cube, 167
Cuesta, bishop of Leon, 215
culture: bread and wine as expression of, 253
 externalization of, 585
Cumont, Franz, 224*n*
cure of souls, 348*ff*
cursing, as spell, 149
customs, religious, “invention” of, 223
Cybele, 8, 228, 445*ff*
Cyprian, St., 209

D

dadophors, 224
daemon(s), 8, 13, 85
 archetype “daemonic,” 151, 162
 self as, 94
Dalai Lama, 89
Damascus, Paul’s journey to, 332, 343
Damascus chalice, 253
damnation, eternal, 17, 197
dance(s): of primitives, 559
 round, of Jesus and his disciples, 273*ff*
dancers, Kathakali, 559
danger, psychic, primitives and, 17*f*
Daniel (book), 421, 423
 (7:13), 421

Daniel, H. A., [92n](#)
Dante, [172](#), [280](#), [311](#)
David, [241](#), [370f](#), [374](#), [382](#)
 consults oracle, [388](#)
 dead: ceremonies for, [523–24](#)
 do not know they are dead, [518](#)
 Masses for, [524](#)
dead body, washing of, [279](#)
dealbatio, [57](#)
defence: dogma as, [46](#)
 scientific theory as, [45](#)
 and truth, [45](#)
defence-mechanisms, instinctive, [345](#)
degenerates, [336](#)
deipnon, [204ff](#), [227](#)
deisidaimonia (δεισιδαμονία), [14](#)
deities, peaceful and wrathful, [511](#)
 see also gods
Deity: bisexual nature of, [29](#)
 circle as symbol of, [53](#)
 life-process within, [136](#)
 and mandala, [82](#); *see also* God; gods
déjà vu, [405](#)
Delacotte, Joseph, [68n](#)
deliberation, unconscious, [38](#)
Deluge, the, [374](#), [412](#), [422f](#)
delusional idea(s), *see* delusions
delusions, [362](#)
 in delirium, [551](#)
 reality of, [150](#)
 schizophrenic, [304](#)
demiurge, the: concealed in matter, [54f](#)
 devil as, [173](#), [313](#)
 Gnostic, [98](#), [270](#)

Somatic, 77
in *Timaeus*, 123
Democritus, pseudo-, 93n, 97, 98, 100n, 101n
demons, 320: planetary, 226, 228, 239
demoralization, neurosis and, 10, 16
demythologization, of Christ, 408
denominations, Protestant, 9, 350
Denzinger, H., and Bannwart, C., 215n
“Deo concedente,” 296
depotentialization of ego, 484f
despiritualization, of the world, 83, 85
destruction, 48, 344
 man’s power of, 459
 powers of, 345
 and sacrifice, 256
 of the world, 412, 455
detachment: Christian ideal of, 349
 from father, 181
 in yoga, 507, 545
determinism, 259
deus absconditus, 175, 195, 236
Deus terrenus, 90
deuteros theos, 381
development: precocious, of Christ, 155
 in religion, 9
 spiritual, four ways of, 167
 see also conscious (mind)
devil, the, 43, 70n, 168ff
 as autonomous, 169, 173, 195
 as *binarius*, 118
 counterpart of Christ, 59
 and dreams, 19n
 eternality of, 195
 God’s first son, 170

as left hand of God, [313ff](#)
materiality the abode of, [171](#)
in Protestantism, [495](#)
relation to Trinity, [169f](#)
shadow as, [309](#)
see also “lord of this world”; Satan
devils, possession by, [486](#)
devotion, “devoted,” “devout,” [8](#)
dew, [100n](#)
dharmā, [506](#)
Dharmadhātu, [522](#), [563](#)
Dharmakāya, [482](#), [495](#), [512](#), [519](#), [522](#)
dhvaja, [566](#)
dhyāna, [560](#), [570](#)
Dhyāni-Bodhisattvas/Buddhas, [525](#), [561](#)
diamond, [185](#)
diamond body, [102](#)
Diana, [129](#)
dichotomy: of God, [251f](#)
 of universe, [285](#)
Dieterich, Albrecht, [231n](#)
“Different, the,” in *Timaeus*, [123ff](#)
differentiation: of consciousness, Trinity and, [180](#)
 in unconscious, [288](#)
 of unconscious from conscious products, [39](#)
Digulleville, Guillaume de, [68–72](#), [100](#), [103](#)
Dike, [385](#)
Diogenes Laertius, [230n](#)
Dionysian, [28](#)
Dionysus, [388](#); [404n](#)
Christian parallels, [136](#)
 dismembered, [264](#)
 miracle of, [253](#)
Nietzsche’s, [28](#), [85](#)

orgiastic cult of, [231](#)

as pneuma, [255](#)

Zagreus, [85](#), [231](#), [255](#)

Dionysius (pseudo-), the Areopagite, [110n](#)

Dionysius the Elder (of Syracuse), [122](#)

Dionysius the Younger (of Syracuse), [122](#)

Dionysius I (Jacobite patriarch), [239](#)

director of conscience, [44](#), [192](#)

Church as, [183n](#)

disciples, Christ's, 273, 275–76; *see also* dance

discrimination, in alchemy, 272

disease, physical, and psyche, 11

disintegration, 567

dismemberment, 227&n, 271f

disobedience, shadow and, 198

disposition, 328

dissenters, fate of, 14

dissociation, 182, 291, 435

- of conscious and unconscious, 188, 429
- inferior function and, 198
- neurotic, 184, 191
- psychic, 520

distinction, vanishing of, in unconscious, 504

“divine,” archetype as, 151

divine child, 441f, 444, 454, 456, 467f

- as symbol of self, 441

divine youth, 442f

- see also* dying god

divisio, 272

Djabir, 94n, 100n

Docetism, 281ff

doctor(s): and clergyman, 331–33, 334f, 338f, 347, 353

- and ethics, 352
- and meaning of life, 336
- neurotic's attitude to, 10
- and patient, in psychotherapy, 554
- and religion, 301, 353, 454
- somatic, 310
- words of, 330
- see also* psychotherapist

dogma(s), 43, 306

- and archetypes, links, 89, 306
- of the Assumption, *see* Assumption of Virgin Mary

in Catholic Church, 192
current neglect of, 112
development of, 312
expression of psyche, 487
fruit of many minds and centuries, 50
history of, 150
Holy Ghost and, 150
importance for mental hygiene, 44
loss of, in Protestantism, 21
Protestantism and, 467
psychological value of, 45, 111, 200
unconscious reflected in, 46
value of, 199

dominants, psychic, 521; *see also* archetypes

door, 281

dorje, 67

Dorn, Gerhard, 60, 70n, 92n, 93n, 94, 95n, 176f, 234f, 236f, 272, 295

doubt(s), 452
philosophical and religious, 337
stepping-stone to knowledge, 110; *see also* belief

dove (Christian symbol), 185, 284n, 323, 407
white, 91, 99n

Dozy, R., and de Goeje, M. J., 230n, 240n

dragon: in alchemy, 229f, 234, 267, 278
in Chinese art, 567
in St. John's visions, 438, 439, 440

dread, holy, of the numinous, 150, 246

dream(s), 404, 454, 460, 490
alchemical parallels, 61
apparent futility of, 49
arcanum revealed in, 93
archetypal, 89, 150, 300, 469
causes of, 19n
the Church and, 19–20

compensatory, 450, 489
conflicts and complexes in, 23
contamination of images in, 491
and content of neuroses, 23
dogma compared to, 46
Freud and, 26, 536
in Gilgamesh epic, 16
individuality of, 50
language of, and environment, 289
links of unconscious events, 33
are natural, 27, 80, 420
of a neurotic intellectual, 24ff
number motifs in, 189
Pererius on, 19–21n
both positive and negative, 32
prejudice against, 16–17
premonitory, 503
prerogative of medicine-men, 18
psychological interpretation of, 26
and psychotherapy, 300
symbols of self and, 502
time and, 503
Trinity as a, 181
trinity and quaternity symbols in, 189
usually in series, 33
voice of the Unknown, 18
see also alchemy; visions

drive(s), 329
 psychology of, 301

Drummond, Henry, 76

Drusiana, 277n

dualism: in Christianity, 358
 Persian, 173, 187
 see also duality

duality, [362](#), [498](#)
tension of, [159](#)
see also God; opposites

Dubois, [348](#)

Dunbar, Helen F., [37n](#)

Dunne, J. W., [503](#)

Duns Scotus, [215](#)

Durrer, Robert, [318n](#)

duty, conflicts of, [416](#), [453–54](#)

dwarfs, *see* Cabiri

dyad, [132](#)

dying, process of, [510](#)

dying god(s), [225](#), [228](#), [254](#), [388](#), [405](#), [443](#), [445](#)

Christ as, [89](#), [410](#)

mother of, [407](#)

E

Ea, [113](#)

earth: cube and, [167n](#)

feminine nature of, [448](#)

of paradise, [54](#)

Eastern/Western man, contrasted, [483](#)

Eastern/Western thought, compared, [481](#)

eating, [278](#)

eccentrics, [336–37](#)

Ecclesiastes, (9 : 16), [390](#)

Ecclesiasticus, (24:3–18), [387f](#); (24: 11, 18), [448](#)

Eckhart, Meister, [450](#), [456](#), [483n](#), [541](#), [543](#), [548](#)

ecstasy, [255](#)

Eden, Garden of, [196](#), [287](#), [375](#), [393](#)

educated persons, psychology and, [334f](#)

egg, 65

in alchemy, 54, 238

philosophical, 234

ego, 281, 580ff, *et passim*

can be made an object, 258

and consciousness, 485

depotentiating, 484–85

dissolved in self, 293

Eastern view of, 485

impossibility of a “knowing ego,” 506

intentions of, interfered with by complex, 13–14

of Jesus, cosmic, 156n

relation to self, 40–41, 94, 259, 262

and sacrifice, 255, 258ff

and self, identification of, 502, 542

suffering and, 157

supplanted by archetypes, 345

too small to incorporate projections, 88

and unconscious, 441

see also self

ego-consciousness, 185, 259, 292–93, 441, 484f, 502, 568, 579

ego-ego, 580

egoism, 341–42

Egypt: barbers in, 229n

and Christian ideas, 117

medical lore of, 194

“Osirification” in, 295

triads of gods in, 115–17

Egyptian: mysteries, 514

mythology, 383, 397, 402, 405, 462

theology, 148

Egyptians, Gospel according to the, 139

eidola, 517

Eisler, Robert, 71n, 153n

elation, of body and spirit, 533
elders, surrounding Christ, 155
electrons, 187
El 'Elyon, 217
elements, four, 38n, 56, 167
Eleusinian mysteries, 508n, 514
elevation, greater, in Mass, 216
Elgon, Mount, 18, 133
Eliade, Mircea, 227n, 271n, 294n
Elihu the Buzite, 368
Elijah, 171n, 428
elixir vitae, 101
Elohim, 373
Emerson, Ralph Waldo, 53
emotional needs, evasion of, 42
Empedocles, 38n, 55, 60n, 167n
empiricism, scientific, 5, 6
empiricist, and theologian, 300–301, 304–5, 307–8
enantiodromia, 342, 399, 433, 444, 451, 508
 Christ/Antichrist, 447
 Christianity/irrationalism, 292
 Yin/Yang, 245
Enchained One, 252
enclosure, 95
endocrine disorders, and neurosis, 11, 492; *see also* glands
energy: liberated by Reformation, 47
 primordial, 187
 as principle of existence, 477
 psychic, an auxiliary idea, 306
 —, tension of, 320
 symbol as transformer of, 503
 unconscious contents and, 496, 551
Engels, Friedrich, 150
English archbishops, 462

enlightenment, 314, 540ff

koan and, 549

see also satori

ennoia, 92n

Enoch (patriarch), 171n, 423–29, 430–32, 435

Enoch (book), 284n, 421ff, 447

(7:2), 421

(7:3–6), 422

(9:5–11), 423

(22:2), 423

(40:7), 424

(46:1–3), 425

(47:4), 425

(48:1, 4, 6, 7), 425

(49:1–3), 426

(51:1. 3) 426

(54:6), 426

(58:6), 426

(60:10), 426

(71:5–6, 14, 17), 426f

(87f), 424

ens absolutum, 303

ens realissimum, 363

entelechy, 583

enthusiasm, 583

άν το`παῖ, 288

environment, and origin of psychic contents, 151

envy, envious, 595

Ephesians, Epistle to the, (4:4–6), 139

Ephesians, goddess of, 312

Ephesus: Council of, 129

letter (*Apocalypse*) to Church of, 436

epiclesis, 213

Epicureanism, 27

epiousios, 488

Epiphanius, 129f, 139, 170n, 238n

epistemology, India and, 580

epistles: New Testament, *see names of specific epistles*;
to Seven Churches (*Apocalypse*), 436f

Epistolae Apostolorum, 218

Erman, Adolf, 132n, 229n

Eros, 395

error, in psychotherapy, 343

Esau, 400

eschatology, 407f, 524f

essence, God's, 170, 195–96

eternity: divine attribute, 303, 493

the Mass and, 207

signified by four, 219

ethical problems, doctor and, 352; *see also* morality

Eucharist, earliest evidence for, 204; *see also* Mass

Eucharistic feast: in Amitābha cult, 561

in honour of Mary, 130

round dance and, 280

eunuchs, 445n

eurhythmics, 533

Euripides, 231n

Europe, 47

European man, mental state of, 336

Eusebius, 217n

Evangelists, the four, 57, 67, 72f, 115, 155, 190, 574

Evangelium aeternum, *see* gospel, everlasting/eternal

Eve, 391

in alchemy, 30

as binary, 60n, 177

as Israel, 393

as Lilith, 397

as Sophia, 397

Second, 397

see also Adam; First Parents

events, psychic, 7

psychic and physical, relation, 592–93

evil, 391*f*, 401, 411, 430, 432–34, 461

Christian view of, 168–69

decomposition of good, 305*n*

integration necessary to totality, 156

man identified with, 456*f*

man's responsibility for, 197

morality of, 434

in nature, question of, 572

origin of, 134*f*, 169*f*

principle of, 63, 313

problem of, 342

relative, 197, 337

substantiality of, 168

and unconsciousness, 197

see also good and evil; *privatio boni*

Evil One, 357; *see also* devil; Satan

exaltation, religious, 581

execution, as punishment, 269

Exercitia spiritualia, *see* Ignatius Loyola, St.

exhortation, 352

existence; physical and psychic, 12

principle of, 477

psyche as, 12, 480

psychological, subjective and objective, 6

existentialism, 290

Exodus, (22:29), 418

exorcism, 163*n*

experience, 331–32

immediate, *see below*

individual, and collective truths, 308

and reflection, 5
religious, *see below*
and thought, 312
experience, immediate, 89
 defence against, 46, 48
 dreams and, 50
 replacement by symbols, 43
 risks of, 43*f*
experience, religious, 62
 absoluteness of, 104–5
 creeds and, 9
 definition of, 62
 reality of, 544
 subjectivity of, 105
extraversion, 497, 501
 “style” of West, 481
 Western, 488, 492
Ezekiel (prophet), 420*f*, 424, 426, 428, 430
 visions of, *see* vision(s)
Ezekiel (book), 421, 423, 431, 437, 448
 (1:18), 448
 (1:26), 383, 420
 (47), 569
 (47:1), 210

F

face(s): four, of God, 423*f*
 human, in vision, 318*f*
factor(s): constituting unconscious, 40
 ordering/transcending consciousness, 294
 pathogenic, 328

psychic, and freedom, 87
psychic, inherited, 517
subjective, 486*f*, 498, 506

facts, 303
enthusiasm for, 479
European belief in, 499
psychic, 360
rational, 153

fairy tales, 189, 454

faith, 199, 291
of Catholic and Protestant, 192
childlikeness of, 477
Christian confession of, 348
and criticism, 153
doctor and, 331, 332
and knowledge, conflict, 532
organ of, 477
Protestantism and, 531
a rarity, 192
and rights of man, 392

fake, spiritual, Yoga in West as, 500

fall: of the angels, 421
of man, 375, 391, 392, 396*f*
of Satan, 410, 424, 440

fantasy(-ies), 345*f*, 490
karmic illusion as, 519–20
subjective, 571
unawareness of, 501

Fascism, 152

fate, propitiation of, 17

Father, (God) the, 73, 131, 182*f*, 249, 322
dual aspect of, 175
indefinable, 135
as prime cause, 133

relation to Holy Ghost, [131](#), [158f](#)
represents One and Indivisible, [156](#)
a union of opposites, [187](#)
world of, [134f](#); *see also* Trinity

father: Abraham as, [217](#)
denotes earlier state of consciousness, [181](#)
divine, of Christ, [154](#)
see also Father *below*
self as the, [263](#)

father: -complex, Bolshevism as, [15](#)
-murder, [181](#)
-son relationship, [132](#)
-world, oneness of, [133](#)

Fathers, Church, and knowledge, [181](#)
and Trinity, [151](#), [170](#)

Faust, *see* Goethe

fear: in contemporary world, [48](#)
of God, [43n](#), [197](#), [373](#), [416](#), [419](#), [444f](#), [450f](#), [458](#), [461](#)
in lunatic asylums, [48](#)
salvation as deliverance from, [416](#), [428](#), [430](#)
of self-consciousness, [14](#)
of unconscious, [17](#)

feeling: “ancestral,” [491](#)
faith and, [477](#)
function, [122](#), [165](#), [167](#)
see also freedom

feet, Jesus’ washing of, [204](#)

feminine nature, [177](#)

“femme inspiratrice,” [161](#)

Fenn, G. Manville, [17n](#)

fertility rites, [222](#)
Attic, [228](#)
Mithraic, [224](#)

Ficino, Marsilio, [29n](#)

fictions, influence in disease, [330f](#)

Fierz-David, Linda, [42n](#)

filiatio, [182](#), [194](#)

Filioque clause, [144n](#), [145f](#), [194](#)

filius macrocosmi, [234](#)

filius philosophorum, [263](#), [314](#)

filius sapientiae, [442n](#), [454f](#), [462](#)

filius solis et lunae, [462](#), [468](#)

fire, [185](#)

and blood, [237](#)

sacrificial, [205](#)

signifying life, [36–37](#)

tongues of, [156](#), [186](#)

unquenchable, [36](#), [43](#)

and water, in alchemy, [232](#)

Firmicus Maternus, Julius, [264n](#)

first fruits, [255](#)

First Parents, [375](#), [393](#), [399](#); *see also* Adam; Eve

fish(es): eucharistic meal of, [226n](#)

round, in sea, [54](#)

symbol of the son, [174](#)

two, [357](#)

Fishes, sign of the, [69](#), [174n](#), [406](#); *see also* Pisces

five, the number, in Mozarabic Mass, [219](#)

flaying, [228](#)

flesh, in sacramental meal, [205](#)

“Flos,” [101n](#)

flower, [52](#), [80](#), [101n](#)

Flower Sermon, Buddha’s, [538n](#)

Foerster-Nietzsche, Elisabeth, [28n](#)

folklore motifs, [306](#)

fons signatus, [73–74](#)

font, baptismal, [210](#)

blessing of, *see benedictio fontis*

forces, instinctual, 15

forgiveness, 341, 347, 352

forms: actual and ideal, 591

- Platonic, 517f
- Universal Mind source of all, 490

fornication, 446

four, the number, 36f, 51ff, 164ff

- in Christian iconography, 37n
- “God is in the Four,” 92n
- Pythagorean school and, 37, 167
- recalcitrant fourth, 187, 196
- signifying totality, 115
- see also* quaternity; tetraktys

fowl, 238

Fractio, in the Mass, 218f, 221

France, Anatole, 512, 578

Franz, Marie-Louise von, 55n, 56n, 102n, 230n, 323n, 442n

fratricide, 392, 400, 405; *see also* brothers, hostile

Frazer, Sir James G., 17n, 225n, 228n, 254

freedom: of the devil, 59

- of the individual, 292
- “from the law,” 182
- man’s feeling of, 259
- moral, 86–87
- and reflection, 158n

French Revolution, 228

Freud, Sigmund, 301, 348f, 536f, 572

- on anxiety, 521
- author’s difference with, 349
- on dreams, 26
- The Future of an Illusion*, 349
- on introversion, 481
- on neuroses, 329f
- and repression, 75

and shadow-side, 343, 572
and superego, 258, 260f
theory of sexuality, 333, 337
and unconscious, 343ff 349, 536
see also psychoanalysis
“Friends of God,” 317, 322
Fromer, J., and Schnitzer, M., 269n
function(s): of consciousness, 166
—, opposition between, 121
four, 167, 189
Goethe’s thinking, 164
Holy Ghost a, 159
inferior, 76n, 121, 166, 198
loss of one, 166
psychic, mind as, 475
three available to consciousness, 165
transcendent, 489, 491, 500ff, 506, 508
unconscious, 166
funeral monuments, 524

G

Gabricius and Beya, 103
Gabriel, 426
galactophagy, 211
Galatians, Epistle to, (2 : 20), 546n, 574n
Galli, 445n
Gallican liturgy, 213
garden: of Eden, *see* Eden
— symmetrical, 52
Garnerius of St. Victor, 100n
Gaudentius, 100n

Gautama, *see* Buddha

Gayomart, 134

genes, 30

Genesis, 196, 391–97

(1:27), 175*n*

(3:5), 287*n*

(3:15), 398

(3:24), 237

(5:24), 427

(6:3*f*), 421

(6:5 and 8:21), 278

(22:1*ff*), 418

genius religiosus, 49

Gensha, 539

Gentiles, 373

geometrical progression, 119–21

Gerbert, 241

Germanic tribes, 46

Germany: Nazism in, 481

paganism in, 28

Gethsemane, Christ's prayer in, 261, 417

“getting stuck,” 184, 198, 516, 552

Ghāya al-hakīm, 239*f*

ghost-houses, 19

ghosts, 13, 166, 486, 499, 518

giants, 421*f*

Gibil, 114

gifts, relation to ego, 256

Gilgamesh, 16, 114

Girru, 114

glands, 329; *see also* endocrine disorders

globe, 52, 55, 65, 71

glory of the Lord, 141

glossolalia, 284*n*

Gnosis, [74](#), [134](#), [183](#), [530](#)

Coptic, [37](#)

faith and, [181n](#)

and Gnosticism, [45n](#), [74](#)

“of life,” [514](#)

loss of, [192](#)

of the Ophites, [236](#)

see also Barbelo-Gnosis

Gnosius, Dominicus, [30n](#), [55n](#), [102n](#)

Gnostics(-ism), [93](#), [97](#), [190](#), [262](#), [263](#), [270](#), [284ff](#), [289f](#) [306ff](#), [514](#)

and alchemy, [97f](#)

and Christ, [154](#), [166n](#), [279](#), [292n](#)

and Christianity, [97](#), [291](#)

and circle, [155n](#)

“circular thinking” of, [96](#)

and the cross, [284f](#)

demiurge in, [313](#)

and the devil, [173](#), [177](#)

dualism in, [169](#)

and gnosis, [45n](#), [74](#)

Holy Ghost in, [159](#), [161–62](#)

and mandala, [97](#)

paradox in, [275](#)

and Physis, [209](#)

redeemer figures, [134](#)

and sin, [77](#)

see also Barbelo-Gnosis

goal: of Eastern and Western religion, [581](#)

of psychic development, [582](#)

self as, [583](#)

goats' hair, [241](#)

goblets, [74](#)

God/Yahweh [*i.e., the personal God of the Old and New Testament and derived or allied concepts*

for other concepts see entry gods below]: [85ff](#)

affect aroused by, 366
antinomies/opposites in, 377, 384, 416*f*, 419, 428, 453*f*, 458, 461
anti-trinitarian conception of, 153
archetypal image of, 59
changes in concept of, 360*f*
chosen not created, 87
Christ as, 155
as current of vital energy, 361
dark aspect of, 371, 381*n*, 411, 428, 430, 432*ff*, 450, 455
and David, 370*f*, 374, 382
death of, 88*ff*
definition of, imperfect, 87
devil's relation to, 59
double aspect/duality of, 365*f*, 369, 372, 384*ff*, 391*ff*, 411, 419, 428, 444, 450*f*, 454*ff*,
461
as Elohim, 373
of empiricist and theologian, 303
and Enoch, 421*ff*;
experience of, 321
— needed by Germans, 47
—, and God, distinction, 321
—, and Ezekiel, 420*f*, 428
the “good,” 320
identity with man, 61, 263
incarnation of, see Incarnation
intention/desire to become man, 397, 404*n*, 409, 420*f*, 424, 456*f*, 460, 462*f*
and Israel, 374, 390, 393, 395*f* 402*ff*
and Job, 367*ff*
light aspect of, 410, 433
as love/goodness, 419, 430, 435, 443, 449
and man, 370, 455
man's conception of, triadic, 149
Nietzsche's, 85, 88
and Noah, 374, 423
“nothing but” psychology, 163*n*

of Old/New Testament, 230, 236, 365
as outside man, 58
overwhelming psychic factor, 81
a primordial experience, 320
as principle of existence, 477
psyche and, 86
a psychic fact, 464
a psychic quantity, 309
pure reality, 194
sacred marriage, with Israel, 390, 393, 395
—, with Sophia, 393, 397, 448
and Satan, 375–77, 379, 381, 383*f*, 390*ff*, 402, 404 409*ff*, 415, 418, 431*f*, 434
and self/atman, 580*f*
self-offering of, in Mass, 248
and Sophia/Wisdom, 386*ff*, 391 393, 395*ff*, 438, 448, 458, 462
the soul as, 513
as Summum Bonum, 411, 419, 428
as tetraktys, 56
Trinity and, 194
unconsciousness of, 365, 372, 373, 376, 383, 404, 416
vision of Father, Son, and Mother, 322
“within,” 60*f*
within, quaternity as symbol of, 58
and Zeus, compared, 370
see also Father; Yahweh
God-concept, 455*n*, 456*n*
goddesses, “power-holding” and “blood-drinking,” 521*f*
god-eating, Aztec, 223
Godhead, essence of the, 318
God-image, 363, 456
in Cain and Abel, 399
self and, 156, 160, 190, 194
see also imago Dei
God-man, 45*f*, 84, 135, 149, 397, 470

Jesus as, [154f](#), [399f](#), [470](#)

gods: absolute, East and, [482](#)

- as agents of psychological change, [13](#)
- domain of, and consciousness, [156](#)
- dying, *see* dying gods
- in Gilgamesh epic, [16](#)
- personifications of unconscious contents, [163](#)
- relativity of, [82](#)
- renewal through sacrifice, [222](#)
- Tibetan Buddhist, [252](#), [495](#)

Goethe, J. W. von: *Faust*, [70](#), [121f](#), [164f](#), [177](#), [314f](#), [341](#), [445](#), [447](#), [463](#), [555](#), [556f](#)

- his thinking function, [164](#)

Gogarten, Friedrich, [320](#)

gold, [53](#), [185](#)

- sun as allegory of, [100](#)

gompa, [500](#)

Gomperz, Theodor, [123n](#), [127n](#)

good, decomposition of, [305n](#)

good and evil, [77](#), [168](#), [173](#), [180](#), [306](#), [342](#), [357](#), [411](#), [457](#), [506](#)

“beyond good and evil,” [174](#), [180](#)

- in God, [196](#)
- in Protestantism, [352](#)

gospel(s), [149](#)

- everlasting/eternal, [445](#), [451](#), [458](#)
- as historical source, [150](#)
- meaning of, [88](#)
- and myth, [301](#)
- synoptic, [407](#)
- see also* John; Luke; Mark; Matthew

grace: divine, [8](#), [17](#)

- external origin of, [482](#)
- gifts of, [331f](#)
- gratia adiuuans* and *sanctificans*, [8](#)
- man’s dependence on, [481](#)

and the Mass, [206n](#), [266](#)
means of, [350](#)
and spontaneous compensation, [306](#)
grandmother, [600](#)
Grasseus, Johannes, [99n](#)
gravity, spirit of, [165](#)
Great Mother, [445n](#), [446](#); *see also* mother
Greece: oracle head in, [244](#)
triads of gods in, [117–28](#)
Greek: alchemy, [177](#)
influence, on modern thought, [555](#)
—, on Old Testament, [386](#)
language and literature, [530](#)
mythology, [386](#), [439f](#)
matriarchal-patriarchal elements in, [439](#)
Greek Church, [191n](#), [216](#)
greenness, *see* viriditas
Gregory the Great, St., [20n](#), [92](#)
Gregory of Nyssa, St., [142n](#)
Gregory Thaumaturgus, St., creed of, [142f](#)
Griffith, F. L., [127n](#)
ground, [575](#), [584](#)
divine, [322](#)
of lapis lazuli, [562](#), [566](#), [570](#)
guidance, divine, [345](#)
Guillén, Jorge, [276n](#)
guilt, God's, [270f](#)
Gundolfingen (Gundelfingen, Gundelfinger), Heinrich, [318](#)
gymnosophists, [529](#) [60](#)

H

habit, [181](#)
Hades, [423](#)
as quaternity, [423](#)

Haeussermann, Friedrich, [18n](#)
Hagar, [440](#)
Hagia Sophia, [25](#)
hallucinations, [316](#)
Hammurabi, [113f](#)
hand, right and left, of God, [358](#)
harmony: of the spheres, [66](#)
 sublime, [104](#)
 of wisdom, [282](#), [285](#)
Harnack, Adolf, [119n](#)
Harper, R. F., [114n](#)
Harranite(s), [230](#), [233](#), [240ff](#), [244](#)
Harrison, Jane Ellen, [132](#), [135n](#)
Hartmann, E. von, [85](#), [245](#)
hat, [52](#)
hate/hatred, [48](#), [436](#), [449](#)
hatha yoga, *see* yoga
Hauck, Albert, [215n](#)
Hauer, J. W., [52n](#), [82n](#)
head: golden, Gerbert's, [241](#)
 Harranite, [240](#), [242](#)
 oracle, [240ff](#)
 people of the, [240](#)
 shaving the, [228–29](#)
 see also face
healing: initiation as, [271](#)
 a religious problem, [341](#)
Heath, Sir Thomas, [120](#)
heaven: in alchemy, [99n](#), [100](#)
 four quarters of, [167](#)
 Host as representing, [216](#)
 vision of, [322](#)
Hebrews, Epistle to the, (4:12), [215](#), [234](#)
 (7:1), [217](#)

(7:3), 206
(7:17), 205
(13:10–15), 205
hegira, 488n
Helios, 514
hell, 80n, 90, 218, 221, 265n
Hennecke, Edgar, 282n
Heraclitus, 36, 92
heredity: archetypes and, 50
 psychic, 517
heresiologists, 238
heresy, 322
 unconscious, 321
heretical movements, in Christianity, 187, 313
heretics, saints as, 321
hermaphrodite: creator as, 29
 divine, 102
 philosophers' stone as, 55, 92
hermaphrodite nature: of Adam, *see* Adam
 of primordial divine being, 462
 of Yahweh/Sophia, 448
Hermaphroditus, 237n
Hermes, 99, 233, 414
 krater of, 91, 101n
 Kyllenios, 278
 as Nous and Logos, 278
 psychopompos, 98n
 “the volatile,” 98n
 see also Mercurius
Hermes Trismegistus, 99, 233, 263, 278
 Tabula smaragdina, 314, 498
 Tractatus aureus, 30n, 90f, 102n
Hermetic philosophy, 29, 176
 coniunctio oppositorum as real subject of, 454

documents of, 468
four elements in, 38n
Timaeus and, 53
see also alchemy

hermit, 317, 493

Hermolaus Barbarus, 231n

hero(es): child-, 454
Christ as archetype, 88, 154–55, 406, 408, 430
loses hair, 229
virgin birth of, 199

Herod, 409

Herodotus, 228

Herostratus, 451&n

hero-worship, 155

Herrad of Landsberg, 37n

hexagrams, 592ff

Hibil Ziwa, 113

hiereus, *see* priest

hieros gamos/sacred marriage, 438, 439, 447f, 462
first step to incarnation, 462
Israel/Yahweh, 390, 393, 395
of the lamb, 447
in pleroma, 397, 467
of son and mother-bride, 458
Sophia/Yahweh, 393, 397, 448

Hildegard of Bingen, St., 37n, 91, 92n

Hippolytus, 287
Church Order, 210, 220
Elenchos, 236n, 237, 265n

history, modern man and, 342

Hogg, James, 265n

Hoghelande, Theobald de, 91n, 94n, 95n, 232n

holiness, 152

Holy Ghost/Spirit, 69n, 73, 131, 135f, 157ff, 185, 430ff, 458, 460

abstract nature of, 160
based on archetype, 131
a comforter, 176
concept begotten by man, 161
continuing incarnation of God, 413, 414, 432, 456, 462f, 470
descent of, 194
and dogma, 150
as double of Jesus, 116
and dream-interpretation, 21n
fading away of, 163
feminine nature of, 323, 407
a function, 159
gifts of, 195
has no personal quality, 186
as life, 131f
Mercurius and, 99n
as mother, 73, 114n, 161, 162
Origen on, 143
procession of, 145
progenitor of the Son, 136, 278
a real person, 131
relation to Father and Son, 158f
represents the Divisible, 156
revelation out of man, 179
seizure of individual by, 158
Sophia as, 389
Unity of God and Man, 116
warmth of, 98n
water of, 92
water as allegory of, 100n
see also Paraclete; Trinity

holy man, 493
 Indian, 577ff

Holy Spirit, *see* Holy Ghost/Spirit

homo: Adamicus, 29
 altus, 437, 454
 maximus, 277
 philosophicus, 55
 religiosus, 9
homoiousia, 153, 194
homoousia, 140, 144ff, 148, 193f, 400
homoousios (*ὁμοούσιος*) formula, 129, 143–44
homunculus, 227, 229, 272f, 278, 454
honey, 219
Honorius of Autun, 236
hoopoe, 239
hope, 331f
Horace, 56n
horoscope, 68
horse, white, 446
Hortulanus, 99n
hortus conclusus, 74
Horus, 67, 383, 406, 439
 eyes of, 116
 four sons of, 67, 115, 383
Hosea, 18, 260
Hosius, Bishop of Cordova, 143
“House of the Gathering,” 35, 38, 51, 74ff, 79f, 80, 83
Huang Shan-ku, *see* Kozankoku
Hubert, H., and Mauss, M., 51
Hut Ming Ch’ing, 504
Hui-neng, 549n
Huitzilopochtli, 223f, 303
hunting, 254n
Hyakujo, 539
hybris, 88, 275, 499, 583
 of consciousness, 260
hygiene, psychic and physiological, 532

hyle, [98n](#), [99n](#), [267](#)

Hypnerotomachia Poliphili, [42n](#)

hypnosis/hypnotism, [328](#), [565](#)

hypostasis, [160](#)

hypothesis, [16](#), [44](#)

Holy Ghost as, [150](#)

hysterical fever, case of, [11](#)

I

“I,” sense of, [582](#); *see also* ego

I-Thou relationship, [353](#)

Ialdabaoth, [173](#), [230](#)

Ibn Sina, *see* Avicenna

’Ibri, al-, [230](#)

ice, [562](#), [566](#)

I Ching, [245n](#), [589ff](#)

iconography, medieval, [154](#)

iconostasis, [51](#)

idea(s), [486](#)

anthropomorphic, [151](#)

formed by authority above consciousness, [150](#)

inborn, [307](#)

inheritance of, [103](#)

morbid, demonic power of, [14](#)

names used for, [501](#)

often opposed to reason, [14](#)

primordial, *see* archetypes

religion and, [8](#)

spontaneous creation of, [7](#)

universal, [479](#)

ideals, [8](#)

identity: of Christ and adversary, 178

with gift, 257

mystical, 245

of priest and Christ, 273

problem of, 82

unconscious, 255f, 504

see also participation mystique

ideologies, 488

Ignatius Loyola, St., *Exercitia spiritualia*, 91n, 259, 487, 496, 531f, 536, 547 570–72, 581

ignorance, in Church Fathers, 182

in Yoga (*avidyā*), 485

illatio, 213

ills: and evil, 169

physical and moral, 169

see also evil

illuminations, as spiritual transformation, 183

illusion(s), 330

descent into, after death, 524

karmic, *see* karmic illusions

projected, 83

and religious experience, 105

image(s); contamination of, 491

definition of God an, 87

helpful, 345

metaphysical, 312

and mythological motifs, 490

numinous, 312

primordial, and scientific ideas, 289

psychic, 486

sacred, envisaging, 547

—, lost by Protestants, 47

simultaneous and successive, 550

typical, 518

see also archetypes

imagination: active, *see* active imagination
categories of the, 518
and neurosis, 10
a psychic process, 544
reality of, 12
imago Dei, 413, 417; *see also* God-image
imitatio Christi, 273, 477, 483
false, 293
Immaculate Conception, 45, 312, 398, 430n
Immolatio, 213
imp(s): Cabiri as, 164
devil as, 168
Imperium Romanum, 47
impression, first, 486, 506
incantation, for producing *numinosum*, 7
Incarnation, 157, 397ff, 400ff, 409f, 412ff, 428, 456f, 459, 470
cause of, 406
commemorated in the Mass, 221, 248
continuing, 413f, 432, 456, 460, 462, 463
devil and, 169
Egyptian, 397, 462
Enoch and, 425
hieros gamos as first step to, 462, 467
Mass a repetition of, 273
only partially consummated, 399
preparations for, 423, 430
purpose of, 401f, 406, 414, 419
and reality of world, 195
Satan and, 410
see also Holy Ghost
incense: representing prayer, 213; *see also* censuring
incest, 342, 374
indefiniteness, 496
and the One God, 493

Index, the, [112](#)

India, [387](#), [420](#), [558f](#), [568](#), [576ff](#), [584](#)

influence on Christianity, [441](#)

and psychology, [580](#)

and religious syncretism, [530](#)

relations with Near East, [387](#)

sun wheels in, [322](#)

see also mythology, Indian; philosophy, Indian

Indians, American, *see* American Indians

indifference, moral, [507](#)

indistinguishability, of self/God-image, [194](#)

individual, [50](#), [82](#), [301](#)

normalization of, [348](#)

not absolutely unique, [50](#)

and species, [89](#)

weakening of Church authority, [531](#)

individuality, [258](#)

individuation, [157](#), [258](#), [296](#), [455](#), [460](#), [467f](#), [521](#), [556](#)

devil and, [314](#)

and *hieros gamos*, [458](#)

involves suffering, [272](#)

Mass as rite of individuation process, [273](#)

matter and, [171](#)

numinous experience of, [294](#)

shadow and, [197–98](#)

symbolism of, [306f](#)

both synthesis and revelation, [263](#)

urge to, [265](#)

inference, rational [312](#)

inferior function, *see* function(s)

inferiority, [76](#), [305](#)

spiritual, [488](#)

inferiority complex, [495](#)

inferior man, [79](#)

inflation, [86](#), [88](#), [95](#), [179](#), [470](#)
in *Acts of John*, [287](#) [293](#)
before the Deluge, [422](#)
and integration of archetype, [315](#)
theosophical, [513](#)
“in-fluences,” [161](#)
inheritance, [328](#); *see also* heredity
initiation process: analysis as, [515](#)
Bardo Thodol as [514](#), [522](#)
initiation rites, [132](#), [193f](#)
dismemberment and [227n](#), [271](#)
and rebirth, [508](#), [514](#)
and transformation into spirits [166](#)
innervation, [533](#)
insanity, [478](#), [551](#)
contamination of images in, [491](#)
unconscious and, [485](#); *see also* madness
insight(s), [302](#), [349](#), [537](#)
and anima, [161](#)
inspiration, [183](#)
“in-spiration,” [161](#)
instinct(s), [34](#), [480](#), [498](#)
emancipation from, [166](#)
and morality, [258n](#)
nature of, [329](#)
neurosis and [300](#)
not personal [277](#)
and psychoneuroses, [329](#)
unconscious and, [484](#)
see also forces, instinctual
instinctuality, [35](#)
instinctual sphere, disturbance of, [337](#)
integration: of conscious and unconscious [157](#), [188](#), [198](#)
of numen, [315](#)

of the self 263, 264

intellect 16, 275

- demand for autonomy 291
- not independent, 478
- and perceiving subject, 547
- philosophic, 478*f*
- and wisdom, 146

intellectualism 554

interdependence of events, 592

interest, failure of 492

interpretation 581

- of unconscious material, 349*f*

intervention, active, in confession, 351

intoxication, 253, 255

intra-uterine experiences, 515

introspection, 491, 506, 584

- lack of 17,

introversion, 481, 483, 486, 491, 501

- artificial, 536
- yoga as, 536

introverted mind, self-liberating powers of, 484

intuition, 41, 165, 167, 292, 491

- Eastern, 501, 505

“inventing,” among primitives, 223

invocation, 7

Ion, 227

Irenaeus, 37*n*, 74*n*, 77*f*, 144

irrational, Christianity and the, 292

irrealism, Gnostic, 287

Isaac, sacrifice of, 268, 269*n*, 418; *see also* Abraham

Isaiah (book), (53:5), 270*n*

- (58:11), 210

Ishtar, 114, 388

Isidorus, 37*n*, 166*n*

Isis, [101n](#), [229](#)

Isis to Horus, [233](#)

Islam, [9](#)

conception of God in, [153](#)

rise of, [151](#), [530](#)

-isms [88](#), [483](#)

isolation, result of will of God, [342](#)

Israel: as bride of God, [390](#), [393](#), [395](#)

children of, [393](#), [403](#)

people of, [391](#), [393](#), [402](#)

J

Jacob, [157n](#), [400](#)

Jacobi Jolande, [67n](#)

Jacobsohn, H., [115f](#), [139n](#), [289n](#)

jade [599](#)

Jambu-tree [563n](#)

James, M. R., *Apocryphal New Testament*, [36n](#), [78n](#), [114n](#), [139n](#), [159n](#), [170n](#), [178](#),
[197n](#), [260n](#), [273n](#), [275n](#), [277n](#), [279n](#), [280n](#), [281n](#), [282n](#), [286n](#), [287n](#) [434n](#), [459n](#)

James, William, [8](#)

Jared, [427n](#)

Jastrow, Morris, [113n](#), [114n](#)

Jehovah's Witnesses, [184](#)

Jensen, Ingeborg H., [97n](#)

Jeremias, Alfred, [113n](#), [114](#)

Jerome, St., [488n](#)

Jerusalem, heavenly, [438](#), [446](#)

New, [447](#)

numen of, [388](#)

jester, cosmogonic, [313](#)

Jesuit, [333](#)

Jesuit exercises, *see* Ignatius Loyola, St.

Jesus, [173](#), [260](#), [477](#)

apocryphal sayings of, [197](#), [260n](#)

assimilated by archetype, [156](#)

cross and, [284](#)

first autonomous personality, [181n](#)

Holy Ghost as double of, [116](#)

relation to his mother, [132](#)

sacrificed king, [268](#)

see also Christ; God-man; Logos

Jesus the son of Sirach, *see* Ecclesiasticus

jewel, [155](#)

Jewish Encyclopedia, [241n](#)

Jews, [334](#)

as chosen people, [374](#)

Jezebel, [436](#), [449](#)

Job (patriarch), [169](#), [181n](#), [358](#), [365ff](#); *passim*, [456](#)

afflicted/tested by Yahweh, [375ff](#), [390](#), [408](#), [414](#), [428](#)

doubted by Yahweh, [375f](#), [396](#)

faith/trust in Yahweh, [367ff](#), [375](#), [378](#), [379](#), [384](#), [390](#), [396](#), [456](#)

and incarnation, [397](#), [406](#), [409](#), [410](#), [414](#)

vindication of, [369](#), [385](#), [390f](#), [405](#), [410](#), [419](#), [427](#)

and Wisdom, [396](#), [405](#)

Job (book), [365ff](#)

dating of, [386](#), [420](#)

and dualism, [187](#)

(1), [7](#)

(2:3), [390](#)

(92–32), [368](#)

(10:7), [368](#)

(10:35), [432](#)

(13:3,15,18), [368](#)

(13:25), [368](#)

(14:12), [432](#)

(16:19–21), [368](#)

(19:6–7), [368](#)

(19:25), [369](#), [427](#)

(27:2,5–6), [368](#)

(28:12), [396](#)

(34:12,18,19), [368](#)

(38:2), [377](#)

(38:3), [380](#)

(40:4–5), [367](#)

(40:7,8–9), [380](#)

(40:12–14), [381](#)

(40:15,19), [403](#)

(41:34), [383](#)

(42:2), [382](#)

(42:3–6), [382](#)

(42:7), [384](#)

John, St. (author of Epistles), [435](#), [438](#), [444](#), [449](#), [451](#), [453](#)

John, St. (author of Revelation), [435ff](#) [439ff](#), [449ff](#), [453](#), [455f](#)

in old age, [444](#), [456](#)

see also Revelation (book)

John, Acts of, [170n](#), [178](#), [273ff](#), [281ff](#), [286](#), [292](#)

John (gospel), [117](#), [140n](#), [153](#)

(1), [414](#)

(1:1), [141](#)

(1:3), [400n](#)

(2:4), [132](#)

(3:14), [229](#)

(4:14), [210](#)

(6:44), [249n](#)

(7:37–39), [210](#)

(7:38), [569](#)

(10:30), [251](#)

(10:34), [158](#), [275](#), [287n](#), [413](#)

(10:35), [432](#)

(12:31), [170](#)

(14:6), [408](#)

(14:9), [251](#)

(14:12), [135](#), [413](#), [432](#)

(14:16f), [413](#), [431](#)

(14:26), [413](#)

(14:30), [170](#)

(15:1,4,5), [204](#)

(15:5), [276](#)

(16:13), [413](#)

(19:34), [211](#)

I John (epistle)

(1:5), [435](#)

(2:1–2,18f), [435](#)

(3:9), [435](#)

(4:1), [416](#), [581](#)

(4:3), [435](#)

(4:7–21), [449](#)

John Chrysostom, St., [211](#), [214](#), [231](#), [266](#)

John of Damascus, St., [215](#)

Encomium in Dormitionem, [458n](#)

John of Ruysbroeck, [545](#)

Joyce, James, [265n](#)

Jud, Gallus, [203n](#)

Judas, [410](#)

Jude, Epistle of, [139](#)

Judex mundi, Christ as, [155](#)

judgment, [338](#)

acts of, and consciousness, [160](#)

moral, good and evil in, [168](#)

quaternity, basis of, [167](#)

Judgment of the Dead, [519](#)

Jung, Carl Gustav:

CASES IN SUMMARY (in *Order of presentation, numbered for reference*):

[1] of hysterical fever, cured by confession of psychological cause, 11
[2] of psoriasis, cured by analysis, 11
[3] of distended colon, 12
[4] of intellectual with series of 400 dreams, 23ff
[5] of young woman who dreamed of baptism, planetarium, 102ff
[6] of adherent of *privatio boni* doctrine, 204–5
WORKS: *Aion*, 30n, 3n, 54n, 75n, 76n, 82n, 91n, 102n, 166n, 225n, 230n, 273n, 276n,
283n, 295n, 357, 358, 386n, 502n
“Archetypes of the Collective Unconscious,” 29n
Civilization in Transition, 28n
“Commentary on *The Secret of the Golden Flower*,” 29n, 52n, 82n, 322n, 504n
“Concerning the Archetypes,” 29n
“Concerning Mandala Symbolism,” 67n, 80n, 82n
“Dream Symbols of the Individuation Process,” 24n
“Freud and Jung: Contrasts,” 26n
Mysterium Coniunctionis, 81n, 115n, 496n,
“On the Nature of the Psyche,” 50n, 148n, 151n, 160n, 437n
“On Psychic Energy,” 503n
“On the Psychology of the Trickster Figure,” 313n
“The Philosophical Tree,” 235n
“Psychological Factors Determining Human Behaviour,” 104n
Psychological Types, 29n, 30n, 50n, 75n, 76n, 79n, 82n, 102n, 122n, 140n, 158n,
165n, 253n, 254n, 261n, 292n, 481n, 486n, 489n, 501n, 502n, 504n
Psychology and Alchemy, 24n, 33n, 34n, 35n, 37n, 38n, 52n, 55n, 56n, 63, 66n, 94n,
98n, 99n, 103n, 121n, 164n, 170n, 175n, 185n, 189, 190, 196n, 226n, 229n, 230n,
245, 490n, 496n, 502n, 567n
“The Psychology of the Transference,” 31n, 63n, 229n
“Relations between the Ego and the Unconscious,” 81n, 82n, 86n
“The Role of the Unconscious,” 28
“The Spirit Mercurius,” 234n, 277n
“Studies in Word Association,” 13n
“A Study in the Process of Individuation,” 80n
Symbols of Transformation, 64n, 228n, 229n, 490n, 567n
“Synchronicity,” 174n, 265n, 592n
“The Tavistock Lectures,” 322n

“The Transcendent Function,” [81n](#), [489n](#)
Two Essays on Analytical Psychology, [26n](#), [28n](#), [30n](#), [52n](#), [292n](#), [502n](#)
“The Visions of Zosimos,” [53n](#), [225n](#), [228n](#), [231n](#), [233n](#)
“Wotan,” [28n](#)
and Wilhelm, *The Secret of the Golden Flower*, [38n](#), [58n](#), [65n](#), [102n](#), [504n](#), [522](#), [602n](#)
Jung, Emma, [30n](#)
Justin Martyr, [181n](#), [199](#), [208](#)

K

ka, [115](#), [116](#), [131–32](#), [133](#)
Ka-mutef, [115f](#), [131f](#), [148](#), [159](#), [160](#)
k’an (hexagram), [603ff](#)
Kant, Immanuel, [245](#), [262n](#), [505](#), [590](#)
karma, [482](#), [515ff](#), [525](#), [539](#)
karmic illusion(s), [509](#), [517](#), [519](#)
Käsemann, Ernst, [205n](#)
Kasyapa, [538n](#)
Kathakali dancers, [559](#)
Katha Upanishad, [545n](#)
Keller, Gottfried, [558](#)
kenosis, [141](#), [293n](#)
Kenya, [243](#)
Kessler, Konrad, [113n](#)
Khunrath, Heinrich, [37n](#), [232](#), [233n](#), [234n](#)
Kierkegaard, Søren, [482](#)
king(s): in alchemy, [234](#)
 Jesus as sacrificed, [268](#)
 Old Testament, [155](#)
 ritual slaying, [222](#), [269](#), [271](#)
Kingsford, Anna, [29](#)
kingship, Egyptian theology of, [131](#)

Kircher, Athanasius, [54n](#)

Klaus, Brother, [316ff](#), [574n](#)

kleshas, 560, 571ff
Klopstock, G., 311
Klug, Ignaz, 215n
knife, sacrificial, 215
knowledge, 554
 in Church Fathers, 181
 and faith, conflict, 532
 of the knower, 547
 of self and of God, 146
 theory of, 476
 urge to, 581
koan, 540, 548f, 551
Koeppen, Georg, 59n, 74, 96n, 112, 152n, 156n, 161, 172n, 181n
Kolorbas, 423
Komarios, *see* Comarius
Kore, search for, 90
Kozankoku, 539
Kramp, Joseph, 206n, 207, 216, 221n, 252
Kranefeldt, Wolfgang M., 26n
krater: of Hermes, 91, 101n
 of Poimandres, 210, 233
 Zosimos and the, 225
Krates, Book of, 93, 232
Kroll, Josef, 807n
Kronos, 230
Krueger, Gustav, 139
Kuekelhaus, Hugo, 38n
kundalini yoga, 520, 537
kwatsu, 540
Kyrios, 284

Lacinius, Janus, [55n](#)
lamb, [185](#)
Lamb: in Revelation, [437](#), [439f](#), [442ff](#), [447](#), [458](#)
 marriage of the, [459](#), [462](#)
lamp, [280](#)
Lamprecht, Karl, [374](#)
language: primitive, [223](#), [255](#)
 of theologian and empiricist, [303](#)
Lankavatāra Sutra, [546n](#)
Laodicea, [436](#)
Lao Nai-hsüan, [590](#)
Lao-tzu, [495](#), [579](#), [594](#), [602](#)
lapis, *see* philosophers' stone
lapis lazuli, [562](#), [566](#), [570](#)
Lateran Council, [146](#), [195](#)
laws, [8](#)
 natural, [590](#)
lay analyst, [351](#)
lead, [226n](#)
Legge, James, [589](#), [589–90n](#), [598](#)
Leibniz, Gottfried W., [245](#)
Leiden papyri, [98](#)
Leisegang, Hans, [92n](#), [128n](#), [155n](#), [236n](#), [237n](#), [255n](#)
Lenin, V. I., [151](#), [524](#)
Leonine Sacramentary, [220](#)
lepers, the cleansed, [208](#)
Lessius, Joannes, [215](#)
Leto, [438ff](#)
Leviathan, [170](#), [383](#), [426](#)
Lévy-Bruhl, L., [170](#), [18n](#), [51](#), [22n](#), [255](#), [490n](#), [504&n](#)
Liber de arte chymica, [30n](#)
Liber de Spiritu et Anima, [146](#)
Liber Hermetis, [155n](#)
Liber quartorum, [233](#), [239](#), [240](#), [241](#)

liberation, *see* self-liberation

of ego, [521](#)

libido, desexualized, [349](#)

Liddell and Scott, [67n](#)

life: as disease with bad prognosis, [105](#), [516](#)

Holy Ghost as, [131](#), [161](#)

ka as, [132](#)

meaning(lessness) of, [336](#), [337](#)

and psyche, [480](#)

relation to body, [131](#)

renewal of, [35](#)

as vehicle of human perfection, [524](#)

light: Christ and, [154](#)

the Clear, [497](#)

Man of Light, [252](#)

in mysticism, [508](#)

vision of, [318–19](#), [320](#)

Lilith, [393](#), [397](#)

lion, in alchemy, [230](#), [234](#)

Lippmann, Eduard Oskar von, [230n](#)

Lipsius, Richard A., and Bonnet, Max, [279n](#)

liquefactio, [232](#)

Litany of Loreto, [73n](#)

liturgy: loss of, by Protestants, [21](#)

of the Mass, [268](#)

see also Byzantine rite; Gallican liturgy; Moza-rabic liturgy; Uniate rites

Logos, the, [237](#), [279](#), [284](#), [387](#), [393](#), [412](#)

Christ/Jesus as, [141](#), [155](#), [173](#), [264](#), [400](#)

Hermes as, [278](#)

incarnation of, [221](#)

man's advance towards, [290](#)

Melchisedec as, [206](#)

and Sophia, [128](#), [162](#)

as sword, [234](#)

wisdom identified with, [147](#), [388](#)
see also [Nous](#)

loneliness, [342](#), [345](#), [555](#)

“Lord of this world,” devil as, [170](#), [173f](#) [177f](#), [195](#), [434](#), [465](#)

Lord’s Prayer, [275](#), [410ff](#), [417](#), [488](#)

lotus, [67](#), [72](#), [563ff](#), [567](#), [572](#), [574](#)

love, [146](#), [331f](#), [449](#)
 of enemies, [341](#)

love-goddess, [388](#), [407](#)

Loyola, *see* [Ignatius Loyola](#)

Lucifer, [168](#), [173](#), [178](#), [196](#), [314](#), [394](#), [404](#), [451](#); *see also* [Satan](#)

Lucius (in Apuleius), [514](#)

Luke, Gospel of, [204](#)
 (1:35), [116](#)
 (1:78f), [116](#)
 (2:49), [132](#)
 (6:4), [275](#), [434–459n](#)
 (10:18), [410](#)
 (16), [275](#)
 (16:8), [395n](#)

Lully, Raymond, [38n](#)

Luna, [238](#)

lunatics, [321](#)

lungs, [244](#)

Lü Pu-wei, [167n](#)

Luria, Isaac, cabalism of, [382n](#)

Luther, Martin, [175](#)

Lydgate, John, [68n](#)

Lystra, [414](#)

M

Macrobius, [118n](#)

macrocosm, [53](#), [259](#), [288](#)

mactatio, [215n](#), [266](#)

mactation theory, [215](#)

madness, [226](#); *see also* insanity

magic, [226](#), [228](#), [344](#), [554](#)

and the Mass, [215](#)

and propitiation of fate, [17](#)

and sacramental grace, [7–8](#)

word-, [290](#)

magical: animal/vessel, [155](#)

rites, [18](#)

Mahābuddha, [561](#)

Maier, Michael, [30n](#), [38n](#), [53n](#), [54n](#), [61n](#), [94n](#), [98n](#), [99n](#), [102n](#), [231n](#), [233](#)

Maitland, Edward, [29](#)

Malachi (book), (1:10–11), [205n](#)

(4:2), [116](#)

malade imaginaire, neurotic as, [10](#)

malaise, spiritual, after first World War, [47](#)

Mamun, Caliph, [240](#)

man: animal nature of, [349](#)

bridge between world and Trinity, [177](#), [179](#)

collective, [15](#)

Cosmic, [185](#)

as a creature, [259](#)

in divine process, [196](#)

and ego-personality, [82](#)

first, [286](#), *see also* Adam, First Parents

“higher,” [293](#), [457](#)

hylical, [272](#)

included in God’s sonship, [158](#)

inner, claims of, [585](#)

in the Mass, [250](#)

modern, *see* modern man

original, 234, 252, 264, 273, 277, *see also* Christ, man, cosmic
original (in Zen), 549
pneumatic, 295, 583
predominantly unconscious, 263
primordial, 265
prisoner of mandala, 95*f*
somatic, 77
as Son of heavenly Father and Mother, 323
spiritual and worldly, dialogue, 93
of twentieth century, 309–10, *see also* modern man
unity of, 277
an unknown something, 82
Western, *see* Western man
“white,” 93
mana, 51*n*, 133, 243, 254, 363
Manda d’Hayya, 113, 514
Mandaeans, 113, 514
mandala(s), 72, 79*ff*, 95*f*, 276, 522, 573
 Buddhist, 67, 574
 Christian, 155, 322, 574
 cross as, 284*f*
 Enoch’s, 423*f*
 and Ezekiel’s vision, 58
 lamaistic, 522
 and medieval speculation, 74, 96
 ogdoad and, 279
 and pagan sources, 97
 in Plato, 127
 representation of perfect being, 156
 spontaneous, 96, 574
 symbolism of, 104
 as union of opposites, 90, 92
Manget(us), J. J., 30*n*, 55*n*, 91*n*, 238*n*
Manheim, Ralph, 274*n*

Mani (original man), 113

Mani/Manichaeism/Manichaeism, 9, 101, 313, 357

and light-substance, 264

“Original Man,” 252

mania, 316

manikin, *see* homunculus

Many, *see* One and Many

Marcionites, 270

Marcus (Gnostic), 37n

Marduk, 113f

Maria Prophetissa, axiom of, 121, 196

Mark, Gospel of, 204

(3:21), 409

Mar Mummi, 115

marriage: rites at, 193

sacred, *see hieros gamos*

Mars (planet), 431n

Marsyas, 228

Marx, Karl, 151

Marxist philosophy, 304n

Mary, the Virgin, 71, 270n

Annunciation of, 459

Assumption of, *see* Assumption

cult of, 130

divinity of, 171–72

Eucharist in honour of, 130

as Goddess, 399, 465

Immaculate Conception of, *see* Immaculate Conception

Jesus’ relation to, 132

as mediatrix, 312, 398, 462, 465

miracles of, 312

mother of Christ/God/Theotokos, 114n, 129, 161, 398–99, 400, 461–62

in pleroma, 399

Sophia as, 398, 400, 407, 442, 458

and the Trinity, [161](#)
see also Virgin

masculine/feminine principle, [395](#), [399](#)
symbols of, [447–48](#)

Mass, the, [192](#), [203ff](#), [295](#), [531](#)
accounts of institution, [203ff](#)
an artifact, [266f](#)
candles at, [36n](#)
compared with Zosimos visions, [266f](#)
for the dead, [524](#)
deipnon and *thysia* in, [204](#); *see also deipnon, thysia*;
dual aspect, [251](#)
ethnological prefigurations, [222](#)
events commemorated in, [248](#)
and life of Christ, [88](#), [268](#)
loss of, in Protestantism, [21](#)
meaning of, [221](#)
mystical unity of parts in, [221](#)
originates in divine prompting, [249](#)
priest and congregation in, [206](#)
psychological efficacy, [203](#)
as representation of Christ's life, [220](#)
rite of individuation process, [273](#)
sacrificer and sacrificed in, [263](#)
structural formula, [204](#)
a symbol, [207](#)
symbolism rooted in psyche, [222](#)
see also Canon of the Mass; ritual; sacrifice

mass/mob, man in, [15](#), [291](#), [333](#)

massa confusa, [98n](#), [99n](#)

masses, [27](#)
and the educated, [335](#)

industrial, [291](#)

mass movements, psychic, [184](#)

materialism, 85

Freud and, 349

and metaphysics, 478

scientific, 302, 349, 352, 477

matrix: instinctual, 498*f*, 503

unconscious as, 552

matter, 56, 195, 245

and individuation, 171

as principle of existence, 477

Saturn and, 230

science and, 477

a symbol of the unknown, 477; *see also prima materia*

Matthew, Gospel of, 204

(1:17), 139*n*

(10:16), 275

(10:26), 275

(19:12), 445*n*

(26:39), 417

(27:46), 136

Maudgalyāyana, 561

Max Müller, F., 529

Māyā (illusion), 487, 579

Maya character of Sophia, 389

Mayas, of Yucatan, 404*n*

Mead, G. R. S., 54*n*, 70*n*, 73*n*, 77*n*, 116*n*, 166*n*, 230*n*

meal, sacred, 205

Aztec, 233*f*

in Mithraism, 224

mean, in *Timaeus*, 119*ff*

meaning, 330

self-demonstrating, 360

mediation, mandala and, 90

mediator/mediatrix: Christ as, 415, 430, 432, 455, 465

clergyman not a, 350

“making peace between enemies,” 102n, 462
man as, 432
Mary as, 312, 398, 462, 465
Mercurius as, 233f
stone as, 91
sun-moon-child as, 468
sun-woman’s child as, 443
unconscious as, 277
Wisdom (Sophia) as, 396, 398, 405
medicine, scientific materialism of, 328
medicine-men, 18, 227n, 294, 344
meditation(s), 7, 38, 507
 of alchemy, 226, 496
 Eastern and Western, 571
 imaginative, 226
 “sinking into,” 560
 on sun and water, 569f
 unknown to New Testament, 278
mediums, spiritualistic, 525
megalomania, 495
Meier, C. A., 490n
Melanesia, 243
Melchisedec, 205f, 217f
melothesia, 67&n
memories, prenatal, not inherited, 519
memory, 486
 failure of, 492
 loss of, 166
mental disease, 328
mentality, 479
Mercurius, 233f, 279
 anima mundi, 102n
 “capable of anything,” 314
 giver of life, 234

hermaphroditic, 30n
identified with Holy Ghost, 99n
Nous/spirit as, 91, 99
senex, 263
and “spirit,” 233
unconscious as, 277
as *Veritas*, 278
winged, 98n
Mercurius quadratus, 423
mercury (quicksilver), in alchemy, 91
Meru, Mount, 519, 563n
message, Christian, 149
Messiah, 406, 458
 second, 440
metals, spirits of, 228
metaphysical: entities, 305f
 factors, and psychic factors, 183n
 figures, psychic quality of, 309
 statement(s), of the psyche, 511
 —, and psychological explanation, 247f
 —, unprovable, 160
 status of Satan, 314
metaphysics: Indian, 568
 materialism and, 478
 psychology and, 476
methodology, 6
methods, 332
 religious and scientific, 532
Mexico, ancient, 228, 322
 see also Aztecs; Mayas
Meyer, Wilhelm, 37n Michael, 426
Michal, 241
Micreris, Tractatus, 238
microbes, 486

microcosm, [95f](#), [100](#), [476](#)
collective unconscious represents, [244](#)
man as, [259](#), [288](#)
Middle Ages, [97](#), [127](#)
Middle Path, [497](#)
migration, archetypes and, [50](#), [518](#)
Milan, [141](#)
milk, [219](#), [237](#)
Milton, [311](#), [313–15](#)
Mimaut Papyrus, [239](#)
Mimir, [28n](#)
mind: Eastern view of, [480](#), [484f](#)
history of the, [35](#)
image-creating, [490](#)
individualized, [479](#)
and intuition, [501](#)
man cannot escape from his, [478](#)
metaphysics and, [476](#)
names given to, [501ff](#)
non-created, [505](#)
One, [496ff](#); *see also* Universal below
as “psychic function,” [475](#)
real existence of, [12](#)
subjective, [479](#)
as supreme reality, [496](#)
Universal, [476](#), [479](#), [490f](#), [493–495ff](#), [512](#)
use of term in East, [475](#)
Western, split in, [531f](#)
see also conscious mind
“mineness,” [255f](#)
minister, Protestant, *see* clergyman
miracle(s), [360](#)
of Christ, [155](#)
of transubstantiation, [206](#), [250](#)

of the Virgin Mary, 312
mirror, 280
missionaries, Christian, 85
Mithraism, 224f, 465
Mithras, 9, 224f, 508n
mob, *see* mass
Moctezuma, 223f
models, 306
modern man, 48, 341, 370f, 454, 585
 dreams of, 454
 and the mystical, 184
 spiritual outlook of, 346
 and tradition, 336, 342
 see also art
Mohammed, 9, 488n
Moir, 385
Monad, 56f
monasticism, 493
monistic origin of life, 498
monk(s), 340, 493
 Buddhist, 577
monoceros, 175
Monogenes, 37, 56, 57
Monoimos, 264
Monophysites, 209
monotheism, 358
mood, born of life's meaninglessness, 337
moon, in alchemy, 115
Moon-goddess, 228
moral distinctions, 306
morality, 258&n
 Christian, and collisions of duty, 416
 and the ego, 260
 a gift, 76

and yoga, 507
Moral Rearmament Movement, 184n
Moret, Alexandre, 116n
morning star, 43
Moses, serpent of, 229
mother: Christ's conquest of the, 155
 conceived in sin, 399
 of dying god, 407
 earth as, 448
 "God the," 322
 goddess, 388
 Holy Ghost as, 159, 161f
 sun-woman as, 439f, 458
 in the Trinity, 158f
 see also Great Mother; Mary
motifs: archetypal, *see* archetypes
 mythological, 362, 490, 573
motives, conscience and, 49
Mozarabic liturgy, 212&n, 213, 219
mukti, 582
Müller, *see* Max Müller
multitude, formless, 282, 284, 286
Mungu, 18
Musaeum hermeticum, 53n, 256n
Mylius, J. D., 30n, 38n, 91, 92, 94n, 95, 232n, 233n
mysteries, 295
 Christianity and, 295
 Egyptian, 514
 Eleusinian, 508n, 514
 new forms of, 136
women and the, 132
mysterium, Mass as, 250
mysterium fidei, 206
mystery religions, Greek, 295

see also Egyptian mysteries
mystical: experiences, [184](#), [322](#), [499](#), [547](#)
idea of God, [58](#)
mystics, [288](#)
myth(s), [435](#), [573](#)
meaning for empiricist, [301](#)
psychotherapeutic value, [194](#)
religion and, [409](#)
theologian and, [301](#)
therapeutic, [196](#), [198](#)
myth-motifs, and Christ, [88](#)
mythologem(s), [193](#), [306](#)
and archetype, [117](#)
in Assumption dogma, [467](#)
and dreams, [300](#)
not exclusively psychic, [130n](#)
and religion, [300f](#)
Satan as, [312](#)
universal, [304](#)
see also archetypes
mythology: Egyptian, *see* Egyptian mythology
Greek, *see* Greek mythology
Indian, [577](#)
language of, [289](#)
Persian, [313](#), [375n](#)
unconscious matrix of, [552](#)

N

Naassene symbols, [287](#)
name(s): multiplicity of, [501](#)
of the soul, [93](#)

spirit has no proper, 186
Nandi tribe, 243
narcissism, 481
National Socialism, 184, 481, 488
nature, 344
 aristocratic, 347
 Christianity and, 176
 divine, 95
 —, and Trinity, 194
 esoteric, 347
 European man and, 534
 hidden, 92–93*n*, 94, 101*n*
 man's identity with, 245
 observation of, in primitives, 499
 oneness with, 134
 perfected by the art, 208
 roots of eternal, 167
Nebuchadnezzar, 113
necessity, in Church Fathers, 182
Nelken, Jan, 490*n*
neologisms, 290
neophyte(s), 229, 243, 271
Neoplatonists(-ism), 37*n*, 77, 97
Neopythagoreans, 177
Neumann, Erich, 295*n*
neurology, 328
neurosis(-es), 328*f*, 335*ff*, 492
 Adler's theory of, 329
 advantage of, 43
 belief in sexual origin of, 45
 causes are psychic, 11, 328
 complexes in, 23
 cure involves risk, 23
 Freud's theory of, 329

a humiliation, 10
increasing frequency, 335f
an inner cleavage, 340
and moral suffering, 497
organic therapy and, 329
patient's account of, 10
psychogenic, 191, 328
reaction of whole man, 300
real though imaginary, 12
replacement by religion, 104
repression and, 75
and rise of irrational forces, 15
self-deceptions and, 305
uncomplicated, 350
neurotic disturbances, 290
New Testament, 21, 77, 182, 270, 399–411ff, 451
 Trinity in, 138f
 see also Bible; Lord's Prayer; *names of specific books*
Nicaea, Council of, 143
Nicene Creed, *see* Creeds
Nicholas of Cusa, 187
Nicholas of Flüe, St., 316ff, 574
Nicolaitans, 436, 449
nidāna-chain, 481
Nielsen, D., 117n
Nietzsche, Friedrich, 28, 51, 85, 87, 88, 179, 315, 495, 506, 547, 555, 556
night sea journey, 229
nigredo, 57, 279
Nimrod, 115n
Ninck, Martin, 17n, 28n
nine, in *I Ching*, 595, 600
nirdvanda, 285
nirmānakāya, 495
nirvāna, 499, 540

Noah, [374](#), [423](#)

non-duality, [540](#); *see also nirdvanda*

nonsense, meaning of and attitude to, [15f](#)

Nola, Church of St. Felix, [284n](#)

Norden, Eduard, [117n](#)

normalization, [348](#)

“nothing but,” [251](#), [486](#), [499](#), [516](#), [525](#)

nothingness, God as, [548](#)

Nous, [91](#), [236](#), [400](#)

Christ as, [279](#)

descent of, [98n](#), [209](#)

Gnostic, [185](#), [252](#)

Hermes as, [278](#)

and Mercurius, [233](#)

as redeemer, [99n](#)

snake symbol of, [393](#)

see also Logos

Nukariya, Kaiten, [539n](#), [542](#)

numbers: even, as feminine, [177](#)

Pythagorean, [118ff](#)

symbolism of, [51](#)

see also dyad; ogdoad; quaternity; one; two; three; third; four; five; six; seven; nine; twelve

numen, [460](#)

divine, bread as symbol of, [255](#)

of the Gentiles, [373](#)

presence of, and dogma, [150](#)

Wisdom as feminine, [388](#)

numinosity: of archetype, [59](#), [149](#), [315](#)

of Christ, [419](#)

of the cross, [284](#)

of God-images, [303](#), [363](#)

of Job's knowledge, [377](#)

of metaphysical statement, [452](#)

of mystical experience, [184](#)

of symbol, [221n](#)
numinosum: creeds and, [8](#)
defined, [7](#)
effect of, produced by ritual, [7](#)

numinous, [596](#)
character of changes of consciousness, [183](#)
“holy dread” of, [150](#), [246](#)
in individuation, [294](#)
in religious statement, [300n](#)

O

oath, Pythagorean, [167](#)
objective psychic, [320](#)
objectivity, [493](#)
absolute, [452](#)
complete, [492](#)
need of, [338f](#)
unprejudiced, [339n](#)
oblong, [75](#)
observer: necessity of, [309](#)
and observed, identical in psychology, [248](#)
subjective states of, [592](#)
obsession, [14](#), [16](#), [22](#), [162](#); *see also* possession
Ochwiabiano, [317](#)
octagon, [185](#), [567](#)
Odin, [28n](#); *see also* Wotan
Oedipus complex, [515](#)
Offertory, of the Mass, [208–12](#)
ogdoad, [279](#), [572](#); *see also* octagon
Ohazama, Shuei, [538n](#), [540](#)
old man, dream-symbol, [38](#)
Old Testament, [399](#), [428](#)
conception of God in, [153](#), [365](#)
devil (Satan) in, [173](#), [312](#)

fire in, [36](#)
God of, [270](#), *see also* God
Greek influence on, [386](#)
oracle trees in, [388](#)
prefigurations of Mass in, [222](#)
and relativity of God, [187](#)
sacrifices in, [217](#)
see also Ten Commandments; *names of specific books*
Olympiodorus, [94n](#), [226n](#)
Olympus, [228](#)
 Christian, [314](#)
omnipotence, omniscience, Divine attributes, [303](#)
omphalosceptics, [529](#)
one, the number, [118n](#)
One and Many, [498](#)
oneiromancy, [61](#)
oneness, [540](#)
 feeling of, [491](#), [493](#), [496](#)
one-sidedness, [45](#), [493](#), [537](#)
Onians, R. B., [244](#)
Only-Begotten, [56](#); *see also* Mono-genes
Ophites, [236](#)
Opicinus de Canistris, [37n](#)
opinion(s), [330](#)
 free, suppression of, [47](#)
opposites, [416](#)
 in alchemy, [454](#)
 confrontation of, [489](#)
 cross and problem of, [286](#)
 and dogma of the Assumption, [465](#)
 free from, [285](#)
 in God, [377](#), [384f](#), [419](#), [428](#), [453f](#), [461](#)
Holy Ghost as reconciliation of, [176](#)
life needs, [197](#)

non-existence of, [498](#)
pairs of, *see below*
reconciliation of, [77](#)
in St. John's visions, [450](#)
in self, [443](#)
severance/opposition of, [448](#), [455](#)
in *Tao Teh Ching*, [495](#)
tension of, [119](#), [197](#)
union of, *see below*
see also duality; enantiodromia

opposites, pairs of, [567](#)
child/man, [457](#)
Christ/Antichrist, [357](#)
Christ/devil, [174](#)
conscious/unconscious, [468](#)
doubt/credulity (faith), [495](#)
extraversion/introversion, [501](#)
God/devil, [495](#); *see also* Satan
God/man, [455](#)
good/evil, [168](#); *see also* good and evil
impermanence/non-self, [567](#)
morality/temptation, [495](#)
"one"/"other," [118f](#)
Ormuzd/Ahriman, [175](#)
samsāra/nirvāna, [499](#)
subject/object, [521](#)
suffering/non-existence, [567](#)
see also enantio-dromia; yang and yin

opposites, union of, [287](#), [501](#)
Christ as, [430](#), [439](#)
and divine birth, [455](#)
Father as, [187](#)
in God, [369](#), [416](#), [419](#)
Holy Ghost a, [186](#)

mandala and, [90](#), [92](#)
in Plato, [121](#)
rebirth symbolism and, [508](#)
self as, [261](#)
in son of Sophia, [455](#)
subject of alchemy, [454](#)
symbols of, [454](#), [460](#), [468](#)
see also coincidentia oppositorum

opposition, in triad and Trinity, [130](#)

optimism, of Negroes, [133n](#)

opus, alchemical, [94](#), [295](#)
goal of, [102](#)
as a Mass, [245](#)
perfects imperfect substance, [208](#)

opus divinum, expiatory, [48](#)

oracles, *see I Ching*

oracle trees, [388](#)

order, cross as symbol of, [284](#)

orientation, psychological, four ways of, [167](#)

Origen, [36n](#), [110n](#), [142](#), [186](#), [230n](#), [488n](#), [567](#)

origin, improbable, of Christ, [154](#)

original man, *see man*

Ormuzd, [175](#), [375n](#); *see also Ahura-Mazda*

Orpheus, [244](#)

Orphic-Pythagorean doctrines, [530](#)

Orthelius, [91](#), [99n](#)

orthopedics, psychic, [348](#)

Osirification, [295](#)

Osiris, [228n](#), [239](#), [439](#)
and Christianity, [117](#)
head of, [241](#), [244](#)
tree as representing, [388](#)

Ostanes, [91](#), [94n](#), [233](#), [238](#)

“other,” the, [87](#), [546](#)

God as, [134](#), [159](#), [482](#)
and the number two, [118](#)
splitting off from the One, [133](#)
“other in me,” the, [77](#)
Other Shore, [502f](#)
“other side” of soul’s life, *see* anima
Otto, Rudolf, [7](#), [482n](#), [540](#)
outlook, religious, [334](#)
 and scientific, [337](#)
ox, [228](#)
Oxford Groups, [184](#); *see also* Buchman Movement
Oxford Movement, [184](#)
oxides, in alchemy, [99](#)

P

paganism: in eighteenth century, [228](#)
 images in, [46](#)
Pai-chang Huai-hai, *see* Hyakujo
Palanque, J. R., [143n](#)
 Pan, [88](#)
panacea, [98n](#), [101](#)
panic(s), [15](#), [44](#), [337](#)
Pan Shan, [542](#)
Panspermia, [53–54n](#)
Pantheus, Joannes, [38n](#)
papal rejection of psychological symbolism, [463n](#)
parables, [225f](#)
Paracelsus, [238n](#)
Paraclete, [158f](#), [413f](#), [456](#)
 expiatory, [414](#)
 as legacy of the Son, [136](#), [158](#), [179](#), [413](#), [431](#)

man's need of, 176
as spirit of procreation, 431
as spirit of truth, 413, 431, 433
as Wisdom, 389
work in individuals, 433
see also Christ; Holy Ghost

Paradise, 238
earthly, 233
in Guillaume de Digulleville, 68

paradox, 275

parallelism, psychophysical, 540

pārāmitās, 563

parapsychology, 290

paredros(-oi), 226, 228, 236, 239

parents, 477

parthenoi, 445

participation mystique, 221n, 255, 259, 273, 277, 504&n

passion of Christ, 157, 221, 248, 548; *see also* Mass

Pater noster, 218

patients: confessions of, 338
expectations from analyst, 352
religion of, 334

patriarchal: social order, 151
world, polytheism of, 159

patristic allegories, 154

Paul, St., 110, 195, 354, 433, 435, 546
attitude to Christ/Jesus, 141, 149, 153
conversion of, 8
epistles of, 149, 407, *see also under names of specific epistles*
identified with Hermes, 414
soma and *sarx* in, 205
split consciousness of, 470
see also Damascus

Pauli, W., 289n

Pax Romana, 47
Pearcy, Henri R., 9n
pearl, wishing, *see cintāmani*
pedagogics, Adlerian, 348
Pegasus, 446n
Pelmanism, 533
pelota, 276
penance, 353, 531
penetratio, 278
pentagram, man as, 219
Pentecost, 186
Peratic symbols, 287
perception(s): always psychic, 248
 and consciousness, compared, 546
 simultaneous, 550
Percival, Milton A., 555n
peregrinatio, 424
Pererius, Benedictus, 19–21n
perfection: accidental lack of, 305
 of Christ, 399
 idea of, 87
 as masculine, 395
 symbol of, 447
perfectionism, 395, 399
Pergamum, 436
“perils of the soul,” 14, 17
peripeteia, 406
Perpetua, St., 442
perpetuum mobile, 72
Persian: dualism, 173, 187
 literature, 174
 mythology, 313, 375n
personality, 82
 fragmentary, 43

and gifts, 256
growth of, 258
human, consists of conscious and unconscious, 40
instinctual reconstruction of, 34f
possessed by the devil, 59
psychological structure of, 5
respect for greater, 553
self and ego in, 41
splitting of, 341
total, 273
transformation of, 500

Peter, St., 434
Peter, Acts of, 279f, 285f
Peter, First Epistle of, (1:2), 138f
(4:1), 278

Petrus Toletanus, 54n

Peucer, Kaspar, 20n

Phanuel, 426, 431

Pharaoh, 116, 295

pheasant, fat of, 595f

phenomenology, 5

phenomenon, 7

Philadelphia, 436

Philippians, Epistle to, (2:5f), 293n
(2:6), 141

Philo, 117, 217, 293n

philosopher, 306, 331
and meaning of life, 336

philosophers' stone, 54f, 90f, 96, 185
Dorn and, 177
identified with/parallel of Christ, 99n, 454
names of, 501, 508n
resurrection and, 94
tetrameria of, 448

as total man, 314
philosophy, 554f
alchemical, *see* alchemy
Alexandrian, 128
Chinese, *see* Chinese
critical, 475
Eastern, 475, 584
Greek, 167
Indian, 190, 441, 529f, 568; *see also* Sankhya
natural, medieval, 358
and science, division, 530
statements of, chiefly subjective, 478
Western, mind in, 476
photons, 187
physician, *see* doctor
physicist, modern, 592
physics, 187, 310, 327
and causality, 590
Physis, 177, 464, 487
descent of spirit/Nous into, 98n, 101, 209, 252, 277
Picinelli, Filippo, 270n
pictures, visionary, 346
“Pilgrim’s Tract,” 318
Pindar, 244
Pisces: aeon of, 174, 446, 447, 450
sign of, 406; *see also* Fishes
pistis (πιστις), 8, 43, 105
Pistis Sophia, 54n, 70n, 116, 230n
Pius XII, Pope, 316, 458n, 461f
planetarium, 102f
Plato, 29n, 37n, 55, 167n, 178, 283
and forms/universals, 481, 517
on numbers and creation, 119ff
Timaeus, 53, 57, 66, 70, 98n, 118ff, 157, 164, 171, 187, 196

triadic/trinitarian thinking of, [130](#), [158](#), [167](#)
unfinished tetralogies of, [127](#)
pleroma/pleromatic, [394](#), [400](#), [424](#), [425](#), [451](#), [462](#)
 Bardo State, [394](#)
 Ezekiel as son of man in, [428](#)
 hieros gamos in, [397](#), [467](#)
 preexistence of Yahweh and Sophia in, [447f](#)
Pliny, [51n](#)
pluralism, [498](#)
Plutarch, [88](#), [117](#), [230n](#), [233ff](#)
pneuma (πνεῦμα), [161](#), [227](#), [231](#), [233](#), [236f](#), [273](#)
 antimimon, [177](#), [179](#), [412](#)
 circle as symbol of, [447](#)
 flexibility of, [466](#)
 hagion, [407](#), *see also* Holy Ghost
 equivalent to Nous, [233](#)
 pneumatic nature of quaternity, [424](#)
 signified by water, [210](#)
 Sophia as, [386](#), [388](#), [393](#)
 as subtle material substance, [205](#), [221](#), [231](#)
 wine as symbol of, [255](#)
 see also Nous; Spirit
pneumatic, [267](#)
 man, *see* man
Poimandres, [210](#)
 sect, [225](#), [233](#)
Poliphilo, *see* Béroalde de Verville; *Hypnerotomachia Poliphili*
politeness: among primitives, [17](#)
 and psychic danger, [17](#)
politics: superman and, [315](#)
 Trinity and, [149](#)
Polynesia, [243](#)
pope, *see* Pius XII
Porphyry, [126](#)

Portmann, Adolf, [294n](#)
possession, [13f](#), [48](#), [86](#), [163n](#)
 by archetype, [151](#)
 criteria of, [163n](#)
 distinguished from disease, [63n](#)
postulates, metaphysical, [306](#)
potentiality, of unconscious, [501](#), [503](#)
power: technical, dangers of, [534f](#)
 urge to, [329](#), [333](#)
“powers,” religion and, [8](#)
power words, [290](#)
praising, formulae for, [149](#)
Prajapati, [261n](#)
Prajna, [539](#)
prakṛti, [487](#), [498](#)
prāna, [532f](#), [535](#)
prāṇayāma exercises, [532](#)
prayer, [456n](#)
 common, [350](#)
predestination, [407](#), [445](#), [455](#)
Preface, of the Mass, [213](#)
Preisendanz, Karl, [239n](#)
Preisigke, Friedrich, [116](#)
presence: collective, [152](#)
 psychic, prickly poppy, [223](#)
priest, [332f](#)
 causa ministerialis, [215](#)
 Christ as, [255](#)
 and confession, [350](#)
 and cure of souls, [348](#)
 function in the Mass, [206](#), [215](#)
 psychotherapist as, [344](#)
 and transference, [353](#)
 in Zosimos’ vision, [226f](#), [245](#)

see also clergyman

priesthood: eternal, 206

vicarious function of, 21

see also celibacy

prima materia, 98f, 238, 279, 401

Adam produced from, 391

and chaos, 98f

as demiurge, 54

called *meretrix*, 209

and principle of evil, 63

and *ultima materia*, 231

Primas, 230

primitive(s) awe in, 246

confuses dream and reality, 499

consciousness in, 289

“inventing” among, 223

and plurality of souls, 133

psychic life in, 83

and religion, 347, 361

and thought, 161, 312

world of the, 476

primitive societies: and ceremonies, 254

consciousness in, 17, 226: politeness in, 17

and psychic danger, 17f

“Prince of this world,” *see* “Lord of this world”

principium individuationis, 264

devil as, 314

Priscillian, 175n

prison cell, 52, 65

privatio boni, 168f, 304f, 313, 357, 383n, 428

process, psychic: as image, 544

independent, 294

procession: of the devil, 173

of Holy Ghost, 131, 194

Proclus, [126](#)
prohibition, in U.S.A., [197](#)
projection(s) [56](#), [256](#), [521](#)
 cognition a, [478](#)
 in modern life, [83](#)
 of psyche, deities as, [511](#)
 of psychic life, [83](#), [180](#)
 psychic life, [83](#), [180](#)
 withdrawal of, [87](#), [245](#)

Prometheus, [314](#)

prophets, modern, [584](#)
 Old Testament, [18](#), [155](#), [584](#)

propitiation, [257](#)

Protanthropos, [264](#); *see also* Anthropos; man, original

Protestant(s), [304](#), [333ff](#), [347](#)
 Church, German, [333](#)
 see also clergyman; denominations

Protestantism, [27](#), [46ff](#), [192](#), [350](#)
 absence of method in, [531f](#)
 and departed souls, [523](#)
 and the devil, [314](#), [495](#)
 on dogma of Assumption, [462ff](#)
 and exotic sects, [531](#)
 fragmentation of, [47](#), [530](#)
 framework of, [9](#)
 good and evil in, [352](#)
 and Holy Ghost, [463](#)
 a man's religion, [465](#)
 protestants against, [347](#)
 relativism of, [22](#)
 on revelation, [413](#)
 revolutionary role, [466](#)
 rise of, [530](#)
 as risk and opportunity, [48](#)

sola fide standpoint, 200n
and symbols, 43f
and totalitarianism, 47
and tradition, 21
transformation in, 548
see also denominations

Proverbs (book), 386
(8:22–31), 386f
(8:29f), 403

Providence, 169

Przywara, Erich, 170n

Psalms (book), 374
(27:8), 216
(82:6), 432
(89), 372, 374, 418, 428
(89:28,34,35), 370
(89:46,47,49), 371

Psellus, Michael, 170n

psoriasis, 10

Psyche, 345
an arbitrary invention, 7
autonomous, 360
—, contents of, 13
awakening to spontaneous activity, 345f
as breath, 482
as the buddha, 567
category of existence, 480
causal factor in disease, 328
collective, adaptation to, 348
and consciousness, 13, 84
discovery of, 330
Eastern view of, 481
feeling of responsibility for, 13
indistinguishable from its manifestations, 49

its inner life uncontrollable, 87
instincts and, 329
intellect dependent on, 479
medical distrust of, 11
as metaphysical reality, 512
nature of, 11
—, unknown, 475
and neurosis, 10–11, 329
not identical with consciousness, 41, 256, 289
not purely personal, 15
original, has no consciousness, 289
primacy of, 513
production of mandala by, 104
reality of, 12, 330, 464, 486
religion and, 17
return to its origin, 493
structure of, and the Trinity, 147
subject and object of psychology, 49–50
“tumours” in, 23
unconscious, 245
and unconscious, 244
underground processes mirrored in dreams, 23
undervaluation of, 17, 482
various meanings, 480

psychiatry, 327*f*, 351

psychic: factor, in psychoneuroses, 328
—, as combination of instincts, 329
laws, 487
“merely,” 296
phenomena, 499
and pneumatic, 267

psychoanalysis, 348*ff*
Freudian, 343, 349, 515*f*, 536

psychologism, 85, 309, 321, 362, 463, 482

psychologist, and religious experience, 9

psychology: Adlerian, *see* Adler, Alfred; analytical, *see* Analytical psychology; and belief, 247

concerned only with psychic phenomena, 150

and dogma of Assumption, 461ff;

the East and, 475

empirical, 408ff, 574

experimental, and psyche, 328

and the *homo religiosus*, 9f

idea of God and, 163n

Indian attitude to, 580

interest in, 333

interpretative methods, 296

and knowledge of self, 6

and man of twentieth century, 309f

“medieval,” 191

and nature of God, 453ff

needs hypotheses, 306

and philosophy, 6

Protestant attitude to, 44

of quaternity, 180ff

and religion, 5

of religion, two categories, 464

a science of phenomena, 476

of the unconscious, 572

Western, Christian, 482

Western desire for knowledge of, 497

without the psyche, 330, 333

psychoneuroses, 328ff, 454; *see also* psychosis(-es)

psychopathology, 327f

and religion, 454

visions and, 420

psychosis(-es), 328, 490

Chönyid state as, 520

latent, 351

yoga and, 520

psychosomatic disorders, 11

psychotherapist, 192, 309, 343, 555*f*
and clergyman/theologian, 299*f*, 308, 334
Freudian and Adlerian, 333
as priest, 344
and his work, 346

psychotherapy, 552*f*, 602
and conflicts of duty, 454
a dialectical relationship, 554
its goal, 554
and hostile brothers motif, 400
jungian and Freudian, compared, 536*f*
and yoga, 536
and Zen, compared, 554

Puberty, 193

public opinion, 10

Pueblo Indian, 317

puer aeternus, 457; *see also* divine child

Pulyer, Max, 274*n*

Punishment, 269*f*, 271*f*

Pure Land, 540

purificatio 279

purification ritual, 38

purple robe, 268

Purusha, 134, 277, 498

purusha-atman doctrine, 421, 441

Purusha Narayana, 261*n*

Pythagoras, Pythagorean(s), 154, 555
number symbolism of, 118*ff*, 167
quaternity/tetraktys, 37, 167, 176

Q

- quadrangle, [52](#)
- quadratura circuli*, [72](#); *see also* squaring the circle
- quadricornutus binarius*, [60](#)
- qualities, prime, four, [167](#)
- quaternarium*, *see* quaternity
- quaternary thinking, [167](#)
- quaternio*, [121](#), [125](#), [423](#)
- quaternity, [37f](#), [56ff](#), [64](#), [164f](#), [284n](#), [447f](#), [574](#)
 - in alchemy, [423](#)
 - and Byzantine liturgy, [219](#)
 - Christian resistance to, [170](#)
 - cross as, [283](#)
 - the devil and, [59f](#), [170](#)
 - and the Deity, [190](#)
 - divine, [425](#)
 - in Ezekiel and Enoch, [420f](#), [423ff](#)
 - Hades of Enoch as, [423](#)
 - in mandala, [80](#), [155](#)
 - Monogenes as symbol of, [37](#)
 - pleromatic split in, [424](#)
 - pneumatic nature of, [423](#)
 - of Son of Man, [430](#)
 - symbol of self, [190](#)
 - symbols of, [52](#), [307](#), [430](#), [437](#)
 - ungodliness of, [60n](#)
 - universal archetype, [167](#)
 - see also* four
- questionnaire, [334f](#)
 - questions, in confession, [350](#)

Quetzalcoatl, [223](#)
quicksilver, [91](#), [99](#), [101n](#), [185](#)
 expulsion of, [233](#)
 see also Mercury
Quicumque, *see* Creed(s), Athanasian
quinta essentia/quintessence, [60](#), [99n](#), [100](#)

R

Rabanus Maurus, [236](#)
radium, [294](#)
rage, in mental patients, [48](#)
Rahner, Hugo, [115n](#)
rainbow, sign of contract, [374](#)
ram, [269n](#), [437](#), [458](#)
Ramakrishna, [577](#), [581f](#), [584](#)
Ramakrishna Mission, [530](#)
Ramana Maharshi, Shri, [576ff](#)
Raphael, [426](#)
rationalism, [309](#)
 analysis and, [554](#)
 enlightened, [45](#)
 and Holy Ghost, [150](#)
 and Zen, [540](#)
rationalistic methods, [333](#)
rationalization, [184](#)
rational type, [165](#)
Ratna-Sambhava, [522](#)
reality: Chinese view of, [591](#)
 experiencing of, [479](#), [521](#)
 God as pure, [194](#)
 Indian view of, [560](#)

psychic, 247, 479ff, 544
thought and, 188
realization, 171, 194
 of unconscious contents, 349f
reason, 16, 182f, 344
 and the archetype, 148
 and Christian doctrine, 291
 limitations of, 47
 supremacy of, 452
rebis, 63, 102n
receptor, *see* assimilation
reconciliation of opposites, *see* opposites, union of
redeemer: archetype of, 134
 Christ as, 155
 Hermes as, 99n
 Marduk as, 113
redemption, 337f, 414f, 514
 Christian theory of, 358
 Christ's work of, 414, 417f, 433
 the devil and, 172
 doctrine of, 357
 drama of, 138, 162
 God's work of, 434
 Holy Ghost and, 136
 longing for, 135
 myths of, 503
reductive standpoint, 352
rééducation de la volonté, 348
reflection, 158, 182f, 278f, 584
 God manifest in, 161
 Holy Ghost a product of, 159f, 162
Reformation, 47, 190, 313, 457
regression, to archaic thinking, 96
reincarnation, 510

and karma, 517
Reitzenstein, Richard, 54n, 230n
relativism, Protestant, 22
relativity: of God, 187, 303
 of the gods, 82
religio, 43, 303, 596
religion, 334
 cognitive, 480
 East/West antithesis in, 560
 as expressed in dreams, 24ff
 expresses psychological condition, 80, 97
 and fulness of life, 37
 meaning of term, 7
 medical psychology and, 5
 and mythologems, 300
 and the *numinosum*, 8
 primitive, 347
 psychological approach to, 89
 relationship to highest value, 81
 return to religion of childhood, 32
 as a substitute, 43
 used as anima, 42
 as way of salvation, 199
religious life, decline of, and neuroses, 335
religious statements: never rational, 148
 unrelated to physical facts, 360
religious viewpoint, and psychological attitude, 482
remorse, in *I Ching*, 595f
Renaissance, 47, 530
Reni, Guido, 224
repentance, 295, 531
représentations collectives, 51, 111, 191, 302
repression, 14, 75, 350
reputation, 10

rescue, of Christ, 155

resistances, against psychological standpoint, 309

respect, for facts, 339

respectability, 10, 75

resurrection: body of, 102

of Christ, 217, 220, 221, 248

of Osiris, 241

of self, 94

Reusner, H., 30*n*, 38*n*, 63*n*, 102*n*, 230*n*

Revelation (book), 234, 411*f*, 431, 434*ff*

(1), 440

(1:16–17), 215, 436

(2:5,20*f*), 436

(2:27), 439

(2:28), 431*n*

(3:3,19), 436

(4:3,6*f*), 437

(5:6), 437

(6:10,17), 437

(7:4), 411

(7:9), 445

(11:19), 438

(12:1*ff*), 438*f*, 458*n*

(12:9), 440

(12:16), 442

(14:1,4), 445

(14:14,17,19*f*), 445

(15:6*f*), 445

(16:1*ff*), 445

(17:15), 209

(18:20), 446

(18:22*f*), 446

(19:5), 445

(19:7), 447

(19:11ff), 440
(19:11,13,15), 446
(19:20), 412
(20:3), 447
(20:10), 447
(21:1,2,11,16–27), 447
(22:1,2), 447
(22:16), 43n
see also John, St. (author of Revelation)

revelation(s), 412, 420, 433ff
Christ and, 154
Gnosis as, 74
Holy Ghost and, 160
individual, 21
John's, 444, 450
and morality, 195&n
Paul's, 433
truth of, 301

rex gloriae, 190
Christ as, 155
in mandala, 67, 155, 574

Rhine, J. B., 265n, 593n

rhinoceros, 270

right and left, 282, 285, 286

righteousness, 182, 389
and son of Man, 425ff

rights of man, 292

Rig-Veda, 261n

ring, 155

Ripley, Sir George, 232n, 233n

rishi, 577

rites, of Church, 487; *see also* Byzantine rite; Mozarabic liturgy; Uniate rites
rites d'entrée, 254n

ritual, 9, 43, 192

creeds as, 9
dual aspect, 248
importance for mental hygiene, 44
lost by Protestants, 21, 47, 350, 353f, 531
magical aspect of, 249
of the Mass, 206, 248
Mithraist, 224f; Purpose of, 7
see also purification ritual
Rituale Romanum, 163n
rivers, four, 155, 574
rock-drawings, Rhodesian, 321
Roman Catholicism, *see* Catholic Church
Romans, Epistle to the, (8:17), 413
Romans, and mystery religions, 295
Romanus, 101n
Roman world, disorientation of, 291
Rome, Church of, *see* Catholic Church
Rome, San Clemente, 284n
“roots,” the four, 38n
ropes, golden, 562, 566f
rosa mystica, 73
Rosarium philosophorum, 54, 57n, 94n, 95n, 101n, 102n, 231n, 232n
Roscher, W. H., 114n, 115n, 230n
“Rosencreutz, Christian,” 229&n
Rosinus ad Sarratantam, 29n, 94n
Rossi, G. B. de’, 284n
rotation, 68
rotundum, 54, 71, 92, 96, 99n
round element, 240
round substance, 54ff
Rousseau, Jean-Jacques, 534
ruach, 161
Ruach Elohim, 388, 393
rubefactio, 57

ruby, 185
Rücker, Adolf, 220n
Ruland, Martin, 226, 233
Rupert, Abbot of Deutz, 100n
Rupescissa, Johannes de, 99n, 100
Ruska, Julius, 30n, 53n, 94n, 101n, 498n
Ruysbroeck, *see* John of Ruysbroeck

S

Sabbath, 230
 defiler of, 26n
Sachseln, 319f, 574
sacral action, and unconscious contents, 350
sacraments, 295, 531
 Christ and, 8n
 grace and, 7f
sacred, the, 301
Sacred Books of the East, 529
sacred texts, psychology and, 494
sacrifice, 7, 205
 in alchemy, 238ff
 Aztec, 224
 Christ's, 415, 430
 gift and, 256
 human, 222
 magical, 239
 in the Mass, 206, 254ff
 oblation of bread and, 208
 of son, 268, 418
 see also Mass
sacrificer: in the Mass, 255, 261n

and sacrificed, unity of, [231](#)

sacrificium intellectus, [477](#)

saints: sometimes heretics, [321](#)

surrounding Christ, [155](#)

Salomon, Richard, [37n](#)
salvation, [46](#), [195](#), [196](#), [348f](#)
 religion and, [199](#), [348](#)
Salzer, Anselm, [71n](#), [72n](#)
samādhi, [485](#), [492](#), [533](#), [556](#), [562](#), [565](#), [581](#)
Samaria, woman of, [569](#)
sambhogakāya, [495](#)
“same, the,” in *Timaeus*, [123ff](#)
Samiazaz, [421f](#)
samsāra, [481](#), [492](#), [499](#)
samskaras, [555](#)
I Samuel, (19:13f), [241](#)
II Samuel, (1:26), [359](#)
 (5:23ff), [388](#)
Samyutta-nikāya, [481n](#)
Sanchi, [80n](#), [558](#)
Sanctus (in Mass), [213](#)
Sankhya philosophy, [498](#)
Sapientia, [162](#), [178](#), [236](#)
Sapientia Dei, [386](#); *see also* Sophia/Wisdom
Sardis, [436](#)
Sarpanitu, [115](#)
Satan, [311ff](#), [375ff](#)
 and Christ, [409f](#), [412](#), [440](#)
 as dark God, [412](#), [433](#)
 daughter of, *see* Lilith
 eternal in damnation, [358](#)
 fall/destruction of, [410](#), [424](#), [431](#), [440](#)
 and God/Yahweh, [375n](#), [377](#), [379](#), [383](#), [390ff](#), [402](#), [404](#), [410ff](#), [418](#), [431f](#), [434](#)
 godfather of man, [383](#)
 God’s left hand, [358](#)
 influence everywhere, [401](#)
 and Mary, [398](#), [465](#)
 in Old Testament, [173](#)

Satans, in Enoch, [424](#)
as snake, [185](#)
thousand-year confinement of, [447](#)
three-headed, [172](#)
and the Trinity, [59](#)
see also adversary; devil; Lucifer

Satanael, [170](#)

satori, [539ff](#)
a natural occurrence, [542](#)
in the West, [545](#)

Saturn (planet), [431n](#)

Saturn(us), [229f](#), [263](#), [267](#)

Saul, *see* Paul

Saul, king, [241](#)

saviour, [91](#), [344](#)
Christ as, [154](#), [155](#), [277](#)
Mandaeen, [514](#)
Mercurius as, [234](#), [277](#)
see also mediator; redeemer

scalping, [227f](#), [242](#), [267](#)

Schaer, Hans, [299f](#)

Schärf, Riwkah, [170n](#), [187](#)

Scheffler, Johannes, *see* Angelus Silesius

Scheler, Max, [516](#)

Schelling, Friedrich W., [245](#)

Scheuchzer, Johann Jakob, [394](#)

Schiller, Friedrich, [122n](#)

schizophrenia, [88](#), [316f](#), [489f](#), [520](#)
schizophrenic delusions, [304](#)
schizophrenics, [290](#)

scholastic: philosophy, [193](#)
theology, [153](#)

Scholem, Gershom, [382n](#)

Scholz, Heinrich, [8n](#)

Schopenhauer, Arthur, [85](#), [167](#), [481](#), [547](#), [555](#)

Schultz, J. H., [536](#)

science: China and, [590](#)

and faith, [152](#)

modern man's faith in, [45](#)

natural, [487](#), [499](#)

and philosophy, division, [530](#)

philosophy of, [477](#)

power of, in Europe, [534](#)

and religion, conflict, [477](#), [531](#)

and subtilization of projections, [83](#)

see also arts and sciences

scientist, asceticism of, [493](#)

scintilla, [476](#); *see also* spark

scorpion, [237n](#)

Scott, Walter, [29n](#), [51n](#), [97n](#), [99n](#), [210n](#), [233n](#)

scourging, of Jesus, [268](#)

Scriptures, Holy, *see* Bible; New Testament; Old Testament; *names of specific books*

Scythia, Upper, [130](#)

Scythians, [228](#)

sea-monsters, [444](#); *see also* behemoth; leviathan

seasons, the four, [52](#), [65](#), [155](#)

second half of life, [334](#)

sectarianism, [22](#)

Secundus, [37n](#)

sefiroth, [381–82n](#)

selelteni, [19](#)

Seler, Eduard, [228n](#)

self, [264n](#), [441f](#)

archetype of, [469](#)

Christ and idea of, [156](#)

Christ symbol of, [191](#), [194](#)

Eastern and Western conceptions, [502](#)

ego and, [41](#), [94](#), [281](#), [542](#), [579f](#)

enlightenment and the, 542
as the father, 263
as God-image, 156, 160, 190, 194
in Indian philosophy, 190, 580
“Mental Self,” 502
is more than conscious personality, 262*n*
passing into consciousness, 262
philosophers’ stone as, 94
a psychic reality, 157
reflection of, 156
and sacrifice, 258*ff*
symbols of, 502
as total personality, 273, 276
as totality, 82, 156, 443, 468
unconscious prefiguraion of ego, 259

self-: assertiveness, 484
born, the, 37
criticism, 49
knowledge, 257, 272, 497, 601, 602
liberation, 482, 484, 488, 491, 496, 500, 510, 513, 582
—, yoga of, 503
possession, 581
realization, *see* individuation; recollection, 263*ff*
reliance, 198
renunciation, 258
sacrifice, 260*f*, 263
—, fear of, 521
surrender, 258

semen, 237
Sendivogius, Michael, 53*n*, 93*n*, 256*n*
Senior, 55, 102*n*
Sennezem, 229*n*
sensation, 165, 167
sensuality, in Indian art, 559

sententia communis, 304
separateness, in divine process, 196
separatio, 234, 272, 278
seraphim, 115
sermon, 351
serpent: circle as, 64
 on cross, 229
 in Eden, 196, 287, 305n, 392
 four-horned, 177f
 in mandala, 80
 Mercurius as, 233
 Nous as, 252
 serpens mercurialis, 98n, 236f
 see also snake; uroboros
Set, 313, 406
Seth, 374
Setheus, 56
seven, in Bible, 437, 445
Seven Seals, 437f
sexual fantasies, 515f
sexual instinct, and neuroses, 329, 492; *see also* sexuality
sexuality: Freud's theory of, 333, 349
 infantile, 44
 repressed, 337
 —, God and, 85
sexual life, denial of, 445, 448
sexual theory, Freudian, 349
shadow, 76ff, 166, 186, 193, 196ff, 309, 342, 447
 St. Ambrose on, 210&n
 Christ and, 166n, 177, 444
 conflict with ego, 341
 Freudian psychology and, 343, 572
 projection of, 83
Shakti, 322, 387

Shākyamuni, [561](#); *see also* Buddha
shamans / shamanism / shamanistic, [227n](#), [271f](#), [294](#), [306](#)
Shamash, [113f](#)
shards, [381&n](#), [397](#)
Shatapatha-Brahmana, [261n](#)
shaving the head, [228](#)
Shaw, Bernard, [24](#), [36](#)
Shekinah, [448](#)
shên, [594n](#)
Sheol, [426](#)
shepherd, Christ as, [155](#)
Shiva, [67](#), [92](#), [303](#), [322](#)
shocks, emotional, [183](#)
shoemaker, [578](#)
Shrī-Chakra-Sambhara Tantra, [495n](#)
sickle, [445](#)
sickness, rites, [194](#)
Sidik, [218n](#)
Sidpa Bardo, [509](#), [515ff](#), [519f](#)
Sigismund of Seon, [238n](#)
Silberer, Herbert, [26n](#)
Silenus, [28n](#)
similarity, *see* homoiousia
Simon Magus, [236f](#)
simplification, Puritan, [350](#)
Sin (Babylonian god), [113f](#)
sin(s), [435](#)
 Christ born without, [155](#)
 consciousness of, [49](#)
 forgiveness of many, [347](#)
 Gnostics and, [77](#)
 God cannot will, [169](#)
 Mary and, [398](#)
 original, [169](#), [172](#), [177](#), [393](#), [398](#), [431](#), [460](#), [470](#)

Protestantism and, [352](#)
see also forgiveness

Singer, Charles, [37n](#)

sinners, unconscious, [76](#)

situation, momentary, [593](#)

six, in *I Ching*, [600](#)

skull worship, [243f](#)

sky: the human, [100](#)
quintessence and, [100](#)

slang, American, [223](#)

slaughter, mystical, [216](#); *see also* mactation

sleep, and consciousness, [33](#)

smoke: of incense, [212](#)
sacrificial, [205](#)

Smyrna, [436](#)

snake(s), [65](#), [393ff](#)
in Eden, [393ff](#)
St. Ignatius Loyola's vision of, [581](#)
renewal of, [228](#)
spirit symbol, [185](#)
see also serpent

Socialism, [429](#)

social order, and Trinity, [151](#)

social problems, and projections, [83](#)

Socrates, [154](#), [600](#)

Sodom and Gomorrah, [412](#)

Solomon, Odes of, [211](#)

solutio, [232](#), [234](#), [272](#)

solvent, in alchemy, [278](#)

somatic man, [77](#)

son: devil as God's, [170](#)
sacrifice of, [217f](#)

Son, (God) the, [73](#), [131](#), [182f](#), [322](#)
Christ as, [155](#)

eternal begetting of, [136n](#)
as redeemer, [134f](#)
relation to Holy Ghost, [158ff](#)
a transitory phenomenon, [182](#)
unity of nature with Father, [269](#)
world of the, [135](#), [176](#)

see also Trinity

Son of Man, [140](#), [277](#), [423ff](#), [435](#)
as benevolent aspect of Yahweh, [427](#)
Christ as, [264](#), [273](#), [430](#)
Enoch as, [426](#), [430f](#)
Ezekiel as, [421](#), [424](#), [428](#), [430f](#)
quaternity of, [430](#)
symbol of righteousness, [425](#)

Song of Solomon, (4:8), [388](#)
(4:8,13–15), [388](#)
(5:5), [389](#)

Sons of God, two, [313](#), [357](#)

Sophia/Wisdom: [162](#), [236](#), [323](#)
anamnesis of, [391](#), [423](#), [457](#), [459](#), [462](#)
and Chochma, [387](#)
coexistence/oneness with God, [386](#), [395](#), [448](#), [462](#)
cosmic, [442](#)
and dogma of the Assumption, [458](#)
as earth, [447f](#)
in Ecclesiasticus, [387f](#)
as feminine pneuma, [386](#), [389](#), [393](#), [407](#)
as Holy Ghost, [114n](#), [389](#), [407](#)
as Jerusalem, [388](#), [438](#), [448](#)
and Lilith, [393](#)
as the Logos, [128](#), [387](#)
Mary as, [398](#), [400](#), [407](#), [442](#), [458](#)
as “master workman,” [386](#), [391](#), [397](#), [400](#), [403](#)
Maya character of, [389](#)

as mother, 407, 438, 442, 448, 457
as playmate of God, 391, 393
in Proverbs, 386, 403
and Ruach, 388, 393
as Shekinah, 448
as sun-woman, 438f, 446
Sophonias, Apocalypse of, 284n
Sosnosky, Theodor von, 172n
So-to-shu college, 539
soul(s), 12, 17, 351
 analyst and patient's, 353
 cure of, 523, *see also* cure
 existence after death, 517
 fettered, 92n
 as the Godhead, 513
 in grain and wine, 254
 loss of, 429
 names of, 93
 Pindar and, 244
 plurality of, 133
 psychoneuroses and, 329
 supra-temporality of, 512, 517, 523
 testimony of the, 361
 its union with God, 72
 Universal Mind as relic of, 479
 Western idea of, 512
 see also "perils of the soul"
space, 265n
Spain, 335
spark, divine, 92f
spells: apotropaic, 149
 magic, 597, 601
sphere, 53, 167, 185
Spielrein, S., 490n

spiration, [131](#), [135](#), [159](#)

active and passive, [159n](#)

spirit(s), [8](#), [499](#)

in alchemy, [99](#)

darkness of the, [156](#)

descent into water, [100–101](#)

discernment of, [193n](#)

doubling of the, [132](#)

and Eucharistic wine, [211](#)

evil, censing and, [212](#)

familiar, in alchemy, [226](#), [239](#)

God a formless, [92](#)

and human will, [176](#)

imprisoned in matter, [91](#)

living, [347](#)

and nature, gulf between, [176](#)

not a personal designation, [186](#)

primordial experience of, [346](#)

as subtle material entity, [221](#)

and water, [231–32](#)

spirit (volatile substance), [185](#), [205](#)

wine as, [253](#)

Spirit, Holy, *see* Holy Ghost/Spirit

spiritualism, [518](#), [525](#)

spirituality, [32](#)

Eastern, [483](#)

—, and the West, [487](#)

Indian, [568](#)

spiritualization, [27](#), [193](#), [221](#), [231](#)

censing and, [212](#)

of Eucharistic wine, [212](#)

oblation of bread and, [208](#)

of substance, [206](#)

spiritus niger, [230](#)

Splendor Solis, 30n, 94n, 234n

split, in European mind, 531ff

splitting of personality, 166

sponsa and *sponsus*, 388

square, 65, 75

in alchemy, 185

goddess symbolized by, 80

New Jerusalem as, 447

soul as a, 37n, 72, 167

see also quaternity

squaring the circle, 53, 91, 96, 454

stagnation, spiritual, 331

Stans, Diet of, 317&n

star(s), 52, 65, 80

dance of, 276

vision of, 320

State, the, 534

totalitarian claims of, 47, 84

Steeb, Joannes C., 53n, 98n, 233n

Steiner, Rudolf, 529

sterility, psychic, 331

Stern, L., 284n

steward, unjust, parable of, 260, 275, 395n, 434

stigmata, 185

stimulus-words, 13

Stoekli, Alban, 316, 319, 322, 574n

stone: "that hath a spirit," 91, 98n, 233

"that is no stone," 437; *see also* philosophers' stone

Strack, H. L., and Billerbeck, Paul, 211n

Strauss, David Friedrich, 152f

subconsciousness, 485n

subjective factor, *see* factor(s)

subjectivism, personal, 486

subjectivity: of consciousness, 479

relation to events, 592ff
sublimatio, 232
sublimation, 27, 349
 Eastern and Western, 485
submission, to unconscious, 183&n
substance: imperfect, perfected by alchemical opus, 208
 incorruptible, 268
“subtle body,” 99
suffering, 341
 in Buddhism, 567
 Godhead’s redemptive, 157, 178f
 in *Acts of John*, 274, 281
 inescapable, 197
 moral, of Christian, 176
 psychic, 330f
 spiritual, 332, 344
Sufi sects, 530
Sukhāvati, 561f
summum bonum, 428, 530
 God as, 172, 313, 319, 419
 Yahweh as, 411, 428
sun, 52, 80, 569
 after-image of, 566
 in alchemy, 100
 and Amitabha, 562
 setting, 565
sun-disc, winged, 116
sun-wheels, 57n, 321f
Sun-woman, 438ff, 453, 458
 son of, 454, 458, *see also* divine child
 superego, 258, 260f
 superman, 315
Supper, the Last, 204, 248, 275
supposition, lack of, in Zen, 550

suppression, [75](#), [489](#)
Suso, Henry, [322](#)
Suzuki, D. T., [507n](#), [538ff](#)
swastika, [574](#)
Swazi people, [242](#)
Swedenborg, Emanuel, [518](#), [541](#)
Switzerland, [321](#)
sword, [278](#), [447](#)
 in alchemy, [234](#), [236f](#)
 flaming, [236](#)
 sacrificial, [215](#), [238](#)
Sylvester II, Pope, [241](#)
symbiosis, [29f](#)
symbol(s), [255](#), [566](#)
 use of, by Catholic Church, [332](#)
 of Christ, [155](#)
 Christian, [109–10](#)
 — early, [97](#)
 convincingness of, [105](#)
 in dreams, [259](#)
 individual formation of, [306](#)
 interpenetration of, [73](#)
 the Mass a, [207](#)
 migration of, [490](#)
 natural, [285](#), [506](#)
 never simple, [254](#)
 objective and subjective aspects, [253n](#)
 overdetermined, [446](#)
 religion expressed in, [199](#)
 religious, beginnings of, [223](#)
 replacing experience, [43](#)
 representing deified man, [96](#)
 spontaneous and prescribed, [523](#)
 ternary and quaternary, [191](#)

theriomorphic, 185
of totality, 421, 430, 457
unconscious represented by, 502
and union of opposites, 468
of unity, 447, 454, 468
see also mandala

Symbola, *see* Creeds

symbol-formation, process of, 312

symbolism, 187ff
alchemical, 185
in Catholic Church, 353
Christ-, 154ff
of individuation process, 306
Mithraist, 224ff
paradoxical, 186
religious, of unconscious processes, 6
sacrificial, 222
tradition and, 103
of unconscious processes, 488

sympathy, of all things, 290

symptoms: Freud and, 349
imaginary, 10, 16, 349
sexual, 337
therapy of, 300

synchronicity, 174, 592f
and experimentation, 593

syncretism, modern and Hellenistic, 530

synthesis: of conscious and unconscious, 192
in Jungian psychology, 537

syzygy, divine, 29

table, [52](#), [65](#)
 round, [275](#)
taboos, [17f](#)
Tabula smaragdina, [314](#), [498](#)
Talmud, [26](#), [269n](#)
 Tammuz, [388](#), [443](#)
Tantric, Tantrism, [92](#), [322](#), [516](#), [523](#)
 tantric yoga, [537](#)
Tao, [156](#), [538](#)
 Taoist philosophy, [594](#)
 taoistic yoga, [537](#)
Tao Teh Ching, [495](#), [579](#)
target, [65](#)
Tathāgata, [563f](#), [567](#); *see also* Buddha
tauroctony, [225](#)
tauroktonos, [224](#)
Taylor, F. Sherwood, [97](#)
Taylor, Thomas, [126](#)
teachers, [302](#)
technics, [291](#)
 dangers of, [534](#)
technique(s): Freudian, aim of, [349](#)
 modern, [487](#)
 spiritual, Eastern, [483](#)
teleios (τέλειος) (*anthropos*), [457](#), [468](#)
telepathy, [266n](#)
telum passionis, [278](#)
ternenos, [95](#)
Ten Commandments, [376](#), [383](#)
tension: Father-Son, [136](#), [162](#)
 in *I Ching* hexagrams, [600](#)
 of psychic energy, [320](#)
Teoqualo, [223f](#)
teraphim, [241](#)

Tertullian, 142n, 144, 251, 354, 482, 488n

Adversus Judaeos, 63n, 448n

Apologeticus, 414

De testimonio animae, 361f

tetraktys, 37, 52, 167

dissolution of, by demiurge, 54

see also four; quaternity

Tetramorph, 37n, 57, 73, 430

thanks, giving, 149

Theatrum chemicum, 55n, 60n, 70n, 91n, 92n, 94n, 95n, 99n 232n, 234n, 235n, 238n, 239n, 272n

theocracy, totalitarian claims of, 47

Theodore of Mopsuestia, 219

Theologia Germanica, 542f

theologian, 344

co-operation with, 299, 302

theology, 192

philosophy and, 511

and psychotherapy, 299, 335

Theophrastus, 264

theory, 46

lack of psychological value, 45

theosophy, 529, 531

Theotokos, 170, 312

in Egypt, 132

excluded from patriarchal formula, 133

see also Mary; Virgin

thieves, two, see crucifixion

thinking, 161, 278f

all-round, 96n

function, 121, 167

Goethe's, 164f

purposive, 312

rationalistic, 312

trinitarian, 162f

third, 454; *see also* Trinity
Thomas, Acts of, 73n, 114n, 159n
Thomas Aquinas, St., 100n, 159n, 186n, 195
Thomas Aquinas (pseudo-), 55
Thorndike, Lynn, 241n
thorns, crowning with, 268
Toth, 55n
thought(s): laws of, 153
 meaning of a, 188
 as perceived functioning of mind, 46
 in the primitive, 161, 312
 reality of, 521
 Western, lacks reality, 480
thought-forms: archaic, 491
 in Bardo state, 521
Thrace, 130
three: the number, 51, 118ff, 185
 Adam and, 60n
 artificial coefficient of order, 167
Thutmosis III, 132n
Thyatira, 436
thysia, 204ff, 212, 215, 227, 266
Tiamat, 113
Tibet, 322
Timaeus, *see* Plato
time, 69, 265n
 mind's own, 503
 a relative concept, 400
 “when there was no time,” 490
 see also pleroma
timelessness, 490f, 496, 503
Timothy, First Epistle to, (4:15), 278n
tinctura, 100
ting (hexagram), 594, 597ff, 605f

Tiruvannamalai, [576](#), [578](#)
Titans, [231](#)
tohu-bohu, [392](#)
tomcat, [239](#)
Tom Thumb, [189](#)
tongues: speaking with, [284n](#)
 unknown, [163n](#)
Tonquédec, Joseph de, [163n](#)
tonsure, [229](#)
torment, *see* torture
torture: of *Chönyid* state, [520](#)
 at initiation, [271](#)
 self-inflicted, [7](#)
 in Zosimos' vision, [227](#)
totalitarianism, [47](#), [84](#)
totality: conscious mind is not, [258](#)
 of experience, [41](#)
 including conscious and unconscious, [156](#), [582](#)
 man an ineffable, [82](#)
 supraordinate, [185](#)
 symbols of non-human character of, [185](#)
 of thinking, [96](#)
 Trinity and, [196](#)
 see also Christ; wholeness
totem meal, [222](#)
Tractatulus Avicennae, [29n](#)
Tractatus aureus, [30n](#), [90f](#), [102n](#)
tradition, [341](#)
 archetypes and, [50](#)
 historical, and Catholicism, [44](#)
 Jewish, [230](#)
 modern man and, [336](#), [342](#)
 secret, and symbolism, [103](#)
trance(s), states, [17](#), [46](#)

transcendental, the, 478
transcendent function, *see* function(s)
transference, 353
 clergyman and, 353
 phenomena, 155, 353
transformation, 237, 586
 censing and, 212
 complete, 166
 flaying and, 228
 goal of psychotherapy, 554
 God's, in the Mass, 221
 in the Mass, 206ff
 of personality, 500
 purpose of process, 231
 religious, 546ff
 spiritual, 183
 symbol of, 204
 symbol as means of, 503
 in Zen, 553
transitus, in Mithraism, 224
transubstantiation, 206, 214, 250, 294f
 efficient cause of, 249
 see also Mass
“treasure hard to attain,” 155, 567
treatment, 308
 methods of, 346
tree of faith, 545
tree of life, 237
tree symbolism, 388, 447
Trent, Council of, 146, 215
triad(s), 191
 Babylonian, 113ff
 Egyptian, 115ff
 of gods, 113ff

Greek, [117ff](#)

Plato's, [167](#)

triangle, equilateral, [119](#)

Tricephalus, [177](#)

trickster, Satan as, [393](#), [395](#)

Trikāya, [494](#), [504](#)

Trinity, [46](#), [51](#), [62](#), [72ff](#), [109ff](#), [312](#), [413](#)

an anthropomorphic configuration, [160](#)

as archetype, [131](#), [139f](#), [151](#), [189](#)

central Christian symbol, [59](#)

in Christianity, [191](#)

controversies regarding, [149](#)

development of idea a collective process, [180](#)

the devil's relation to, [59](#), [169f](#)

exclusively masculine, [62](#)

and feminine element, [63](#)

form and content of, [131](#)

formulations in New Testament, [138](#)

Gnostic, [323](#)

Guillaume de Digulleville and, [69f](#)

higher conception than unity, [136](#)

logical idea and psychological reality, [131](#)

Mary's relation to, [71](#)

must have meaning, [189](#)

noetic character of, [193](#)

and patriarchal society, [151](#)

and Platonic triad, [130](#)

prehistory of, [151](#)

as process, [196](#)

as psychological symbol, [193](#)

and quaternity, [62](#)

a revelation of man, [74](#)

saving effect of, [188](#)

and structure of psyche, [147](#)

Trinity vision, [318f](#)
Trishagion, [139](#)
Trismosin, Solomon, [94](#)
Trithemius of Spanheim, [238n](#)
triunity, [115](#), [161](#)
Trivandrum, [578](#)
troglodytes, [308](#)
truth(s): collective, [308](#)
 and external world, [487](#)
 metaphysical, [200](#)
 psychic, [359](#)
 revealed, [301](#), [344](#)
 statistical, [590](#), [592](#)
 subjective, [487](#)
 traditional, repudiation of, [337](#)
 universal, [302](#)
tuberculosis, [338](#)
Turba philosophorum, [29n](#), [53n](#), [54](#), [92n](#), [94n](#), [101 n](#), [595n](#)
twelve, the number, [279](#)
two, the number, [60](#), [118](#)
 associations of, [118](#)
 the first number, [118](#)

U

Uddushu-namir, [114](#)
umbra solis, [166n](#)
unconscious(ness), [288](#), [476ff](#), [550ff](#), *et passim*
 alchemy and, [245](#)
 anima and animus in, [30](#)
 and archetypes, [160](#)
 an assumption, [39](#)

autonomy of, 85
breaking through / disturbance / emergence of, 420ff, 424, 435, 438, 456, 460, 469
cannot be discriminated, 277
and conscious in human personality, 40
vs. consciousness, 420, 440f, 456, 459, 468
constellation of, 489
contents of, 404, 424, 437, 438, 454, 460
continuity of, 33
conveys experience of unity, 288
creativity of, 537
crossing threshold of, 49
deeper unity in, 573
and evil, 197
extension unknown, 84
fear of impersonal forces in, 14f
Freud's conception, 536
of God, 373, 382f, 404, 416
God and the, 468f
and God-image, 456
growth of complexes from, 14
I Ching and, 600
indefinite in extent, 258
individuation in, 468
invasions of, 345
longs for consciousness, 460
lumber-room of, 552
magical rites as defence against, 18
manifestations of, 289
manifests purposiveness, 39
mankind's unwritten history, 188
the numinous and, 150
opening up of, 344
personal, 571f
—, and collective, 150, 277, 573

possession by, 409
perceptiveness of, 386, 404, 454
primitive fear of, 17
products of, differentiated from those of conscious mind, 39
psychoanalysis and, 348
psychology of the, 572
reflected in dogma, 46
in relation to dream-series, 24
religion as escape from, 42
and religious experience, 360*f*
religious function in, 6
spontaneous manifestation of, 22
symbolism of, 488
as “total vision,” 551
transformation under analysis, 523
yoga and, 535
see also archetype(s); collective unconscious

unconscious material, interpretation of, 349

Uncreated, the, 37

understanding, 331
attitude of, 338

Uniate rites, 209*n*

unicorn, 175, 270

union: of conscious and unconscious, 191
of God and man, 280

uniting symbols, 439, 454; *see also* opposites, union of

unity: of cosmos, 288
of God and man, 116
of God, man, and world, 134
loss of feeling of, 290
mystical, in Mass, 248
original, 292
of redeemer and redeemed, in alchemy, 231
see also one

Universal Mind, [476](#), [479](#), [490f](#)
universals, [481](#)
unknowable, the, [275](#)
Upanishads, [82](#), [481](#), [529](#), [577](#): *see also names of specific Upanishads*
Uroboros, [64n](#), [102n](#), [230n](#), [231](#), [237](#), [278](#)

V

Vaidehi, [564f](#)
Vairochana, [522](#)
Vajra-Sattva, [522n](#)
Valentinians, [144](#), [166](#)
Valentinus, [37n](#), [279](#)
valuation, [165](#)
value(s): Christian, and Eastern thought, [484](#)
 holiness and, [152](#)
 introvert and extravert, [481](#)
 loss and return of, [90](#)
 and myth, [301](#)
Van der Post, Laurens, [242f](#)
vas devotionis, [73](#)
vas hermeticum, [95](#)
Venus, [115](#)
Venus (planet), [431n](#)
vessel, round, [93](#); *see also* rotundum
vestments, ecclesiastical, [43n](#)
vine, Christ as, [155](#), [204](#), [253](#), [275f](#)
vineyard symbolism, [388](#), [445](#)
viper, [238](#)
Virgin (Mary): coronation of, [170](#)
 divine motherhood of, [359](#), [406](#)
 symbol of earth, [63](#)

and unicorn, [270](#)
see also [Mary](#)

Virgin Birth, [45](#)
psychology and, [6](#)
see also [Christ](#)

virgins, male, [445](#)

Viridarium chymicum, [230n](#)

viriditas, [69n](#), [91](#), [98n](#)

virtue: disadvantages of, [197](#)
and vice, liberation from, [507](#)

vir unus, [277](#)

virus, [294](#)

Visio Arislei, [93n](#), [99n](#)

vision(s), [46](#), [65](#), [80](#), [420](#)
Bardo, [512ff](#)
in Christianity, [541](#)
concretization of, [570](#)
of Daniel, [421](#)
Enoch's, [424](#), [435](#)
Ezekiel's, [58](#), [115](#), [284n](#), [383](#), [420](#), [435](#), [448](#)
St. Ignatius Loyola's, [531](#)
John's, [435ff](#), [444ff](#), [455](#), [458](#)
of Mary, [461](#)
Meister Eckhart's, [456](#), [541](#)
St. Nicholas of Flüe's, [316ff](#), [574](#)
Pope Pius XII's, [461](#)
Zosimos', [225ff](#), [266f](#)

vitamins, [486](#)
lack of, [492](#)

voice(s): Böhme's, [541](#)
dream-symbol, [35](#), [38ff](#), [75](#)
inner, [346](#)
Swedenborg's, [541](#)

Voidness, [505](#), [511ff](#), [525](#)

“volatile,” cock’s name in alchemy, 238

W

Wagner, Richard, 36

Waite, A. E., 53n, 103n

war, civil, 341, 344

war, rites, 194

War, World, 47, 344, 534

washing, 279

of feet, by Jesus, 204

water(s), 185, 566f, 603f, 606

allegory of Holy Spirit, 100n, 232

in Amitābha meditation, 562f

baptismal, 100f

and blood, 232

in Christian allegory, 569

divine, 92, 96, 100f, 226, 232, 236, 266f

and fire, 232

mixture with Eucharistic wine, 209ff

permanent, 234, 236, *see also aqua permanens*

production of the, 231, 272

represents man’s material nature, 209

and spirit, 231f

symbolism in Bible, 210

“way,” 281

Weizsäcker, Karl von (version of New Testament), 204n

well, 605f

Well, vision of the, 323

Weltanschauung, 309, 429, 477

Werner von Niederrhein, 71n

Western land/quarter, 561, 564

Western man, 482f
and nature, 534f
wheel, 52, 318f, 321
White, Victor, O. P., 186n, 195n
White, William, 541n
wholeness, 281, 556
archetype of, 469
of the gospels, 88
in mandala, 82
man's, 450
of natural man, 179
quaternity and, 219
self as essence of, 582
suffering and, 157
symbol(s) of, 156, 191, 447
Trinity a formula of, 162
way of release to, 555
see also circle; individuation; totality
whore, the, in alchemy, 209
Whore of Babylon, 446
Wickhoff, Franz, 284n
Wiederkehr, Karl, 171n
wig(s), 229n, 241, 242
Wilhelm, Richard, 38n, 102, 312n, 589, 594, 596, 602, 605; *see also* Jung, C. G.,
WORKS, s.v. and Wilhelm
will, 349
divine, 339, 341f, 349
freedom of the, 86f, 157
human, 16
necessary for creation, 196
and the spirit, 176
will to power, 44, 85
winds, four, 155, 574
wine: Christ's blood as, 155

Eucharistic, [252ff](#)
mixing of water with, [209ff](#)
preparation of, [209](#)
winepress, [445](#)
wisdom, [146](#)
 four aspects of, [522](#)
 lack of, [17](#)
 natural, mind as, [506](#)
 see also Sophia/Wisdom
Wisdom of Jesus the Son of Sirach, *see* Ecclesiasticus
Wisdom of Solomon, [392](#)
 (1:6), [389](#)
 (1:10), [372n](#)
 (1:15f), [389](#)
 (2:10–19), [389f](#)
 (6:8), [389](#)
 (7:22ff), [389](#)
 (8:3,6,13), [389](#)
 (9:10,17), [389](#)
wish-fantasies, [353](#)
wish-fulfilment, [32](#)
witches, [13](#), [486](#)
withdrawal, from the conscious, [497](#)
wizards, [13](#)
Wolff, Toni, [26n](#)
Wölflin, Heinrich, [319](#)
woman: and the devil, affinity, [60n](#)
 excluded from Trinity, [63](#)
 inferiority of, in Biblical times, [395](#)
 and perfection, [395](#)
 in Protestantism, [465](#)
 sun-woman in Revelation, [438f](#)
Woolley, Sir Leonard, [218n](#)
Word, the, [153](#), [231](#); *see also* Logos, Son

words: dependence on, 290
doctor's, 330
tabooed, 18

world: dependent on our image of it, 479
material, real or illusion, 195
as object, 521
physical, transcendent reality of, 498
physicist's model of, 592
seen as "given," 514
as symbol, 521

world-soul, 295
Mercurius as, 278
in *Timaeus*, 123ff, 185, 295
see also anima mundi

Wotan, 28

Wu anecdote, 548, 553

X/Y/Z

Xyrourgos, 227

Yahweh, 128, 175, 181n, 185, 270, 303: *see also* God

yang and yin, 197, 245, 495, 600

yantra(s), 67, 79

yarrow-stalks, 591, 593, 594

Yoga, 7, 58, 79, 421, 487, 492, 500, 508, 545, 560, 568ff
and architecture, 558
dangers of, 520, 534
diverse forms of, 536
European parallels, 536
hatha, 485, 557, 560
kundalini, 520, 537
meaning, 560

meditations, 549
of self-liberation, 503
tantric, 537
taoistic, 537
Western man and, 500, 529ff, 537, 568
see also detachment

Yves, bishop of Chartres, 209n

Zagreus, *see* Dionysus

Zarathustra, Nietzsche's, 85

Zechariah, (4:10), 372n

Zeller, Heinrich, 37n, 72n, 99n, 118

Zen: fourth maxim of, 549
naturalness of, 552
and the West, 553ff
see also Buddhism

Zephaniah, *see* *Sophonias*

Zeus, 254, 303, 370, 414

Zimmer, Heinrich, 38n, 322n, 558, 576, 577, 584, 586

Zion, Mount, 444

zodiac, 69, 276, 357
zodiacal constellations, 276

Zohar, 381–82n

zoology, 7

Zosimos, 29n, 53n, 55n, 70n, 91, 93, 94n, 97f, 101n, 203, 215n, 225ff, 240, 244f, 265, 271ff, 278
comparison of his visions with Mass, 266f

Zürcher Bibel, 367n

THE COLLECTED WORKS OF **C. G. JUNG**

THE PUBLICATION of the first complete edition, in English, of the works of C. G. Jung has been undertaken by Routledge and Kegan Paul, Ltd., in England and by Bollingen Foundation (through Princeton University Press) in the United States. The edition contains revised versions of works previously published, such as *Psychology of the Unconscious*, which is now entitled *Symbols of Transformation*; works originally written in English, such as *Psychology and Religion*; works not previously translated, such as *Aron*; and, in general, new translations of virtually all of Professor Jung's writings. Prior to his death, in 1961, the author supervised the textual revision, which in some cases is extensive. Sir Herbert Read (d. 1968), Dr. Michael Fordham, and Dr. Gerhard Adler compose the Editorial Committee; the translator is R. F. C. Hull (except for Volume 2) and William McGuire is executive editor.

The price of the volumes varies according to size; they are sold separately, and may also be obtained on standing order. Several of the volumes are extensively illustrated. Each volume contains an index and, in most cases, a bibliography; the final volume will contain a complete bibliography of Professor Jung's writings and a general index to the entire edition.

In the following list, dates of original publication are given in parentheses (of original composition, in brackets). Multiple dates indicate revisions.

*1. PSYCHIATRIC STUDIES

On the Psychology and Pathology of So-Called Occult Phenomena (1902)

On Hysterical Misreading (1904)

Crytomnesia (1905)

On Manic Mood Disorder (1903)

A Case of Hysterical Stupor in a Prisoner in Detention (1902)

On Simulated Insanity (1903)

A Medical Opinion on a Case of Simulated Insanity (1904)

A Third and Final Opinion on Two Contradictory Psychiatric Diagnoses (1906)

On the Psychological Diagnosis of Facts (1905)

2. EXPERIMENTAL RESEARCHES

Translated by Leopold Stein in collaboration with Diana Riviere

STUDIES IN WORD ASSOCIATION (1904–7)

The Associations of Normal Subjects (by Jung and F. Riklin)

Experimental Observations on Memory

The Psychological Diagnosis of the Criminal Case

An Analysis of the Associations of an Epileptic

The Association Method (1910)

The Reaction-Time Ratio in the Association Experiment

On Disturbances in Reproduction in Association Experiment

The Psychopathological Significance of the Association Experiment

Psychoanalysis and Association Experiments

Association, Dream, and Hysterical Symptom

PSYCHOPHYSICAL RESEARCHES (1907–8)

On Psychophysical Relations of the Association Experiment

Psychophysical Investigations with the Galvanometer and Pneumograph in Normal and Insane Individuals (by F. Peterson and Jung)

Further Investigations on the Galvanic Phenomenon and Respiration in Normal and Insane Individuals (by C. Ricksher and Jung)

†3. THE PSYCHOGENESIS OF MENTAL DISEASE

The Psychology of Dementia Praecox (1907)

The Content of the Psychoses (1908/1914)

On Psychological Understanding (1914)

A Criticism of Bleuler's Theory of Schizophrenic Negativism (1911)

On the Importance of the Unconscious in Psychopathology (1914)

On the Problem of Psychogenesis in Mental Disease (1919)

Mental Disease and the Psyche (1928)

On the Psychogenesis of Schizophrenia (1939)

Recent Thoughts on Schizophrenia (1957)

Schizophrenia (1958)

*4. FREUD AND PSYCHOANALYSIS

Freud's Theory of Hysteria: A Reply to Aschaffenburg (1906)

The Freudian Theory of Hysteria (1908)

The Analysis of Dreams (1909)

A Contribution to the Psychology of Rumour (1910–11)

On the Significance of Number Dreams (1910–11)

Morton Prince, "Mechanism and Interpretation of Dreams": A Critical Review (1911)

On the Criticism of Psychoanalysis (1910)

Concerning Psychoanalysis (1912)

The Theory of Psychoanalysis (1913)

General Aspects of Psychoanalysis (1913)

Psychoanalysis and Neurosis (1916)

Some Crucial Points in Psychoanalysis: The Jung-Loy Correspondence (1914)

Prefaces to "Collected Papers on Analytical Psychology" (1916, 1917)

The Significance of the Father in the Destiny of the Individual (1909/1949)

Introduction to Kranefeldt's "Secret Ways of the Mind" (1930)

Freud and Jung: Contrasts (1929)

†5. SYMBOLS OF TRANSFORMATION (1911–12/1952)

PART 1

Introduction

Two Kinds of Thinking

The Miller Fantasies: Anamnesis

The Hymn of Creation

The Song of the Moth

PART II

Introduction

The Concept of Libido

The Transformation of Libido

The Origin of the Hero

Symbols of the Mother and of Rebirth

The Battle for Deliverance from the Mother

The Dual Mother

The Sacrifice

Epilogue

Appendix: The Miller Fantasies

6. PSYCHOLOGICAL TYPES (1921)

Introduction

The Problem of Types in the History of Classical and Medieval Thought

Schiller's Ideas on the Type Problem

The Apollonian and the Dionysian

The Type Problem in the Discernment of Human Character

The Type Problem in Poetry

The Type Problem in Psychopathology

The Problem of Typical Attitudes in Aesthetics

The Type Problem in Modern Philosophy

The Type Problem in Biography

General Description of the Types

Definitions

Conclusion

Four Papers on Psychological Typology (1913, 1925, 1931, 1936)

*7. TWO ESSAYS ON ANALYTICAL PSYCHOLOGY

On the Psychology of the Unconscious (1917/1926/1943)

The Relations between the Ego and the Unconscious (1928)

Appendices: New Paths in Psychology (1912); The Structure of the Unconscious (1916) (new versions, with variants, 1966)

†8. THE STRUCTURE AND DYNAMICS OF THE PSYCHE

On Psychic Energy (1928)

The Transcendent Function ([1916]/1957)

A Review of the Complex Theory (1934)

The Significance of Constitution and Heredity in Psychology (1929)

Psychological Factors Determining Human Behaviour (1937)

Instinct and the Unconscious (1919)

The Structure of the Psyche (1927/1931)

On the Nature of the Psyche (1947/1954)

General Aspects of Dream Psychology (1916/1948)

On the Nature of Dreams (1945/1948)

The Psychological Foundations of Belief in Spirits (1920/1948)

Spirit and Life (1926)

Basic Postulates of Analytical Psychology (1931)

Analytical Psychology and *Weltanschauung* (1928/1931)

The Real and the Surreal (1933)

The Stages of Life (1930–1931)

The Soul and Death (1934)

Synchronicity: An Acausal Connecting Principle (1952)

***9. PART I. THE ARCHETYPES AND THE COLLECTIVE UNCONSCIOUS**

Archetypes of the Collective Unconscious (1934/1954)

The Concept of the Collective Unconscious (1936)

Concerning the Archetypes, with Special Reference to the Anima Concept (1936/1954)

Psychological Aspects of the Mother Archetype (1938/1954)

Concerning Rebirth (1940/1950)

The Psychology of the Child Archetype (1940)

The Psychological Aspects of the Kore (1941)

The Phenomenology of the Spirit in Fairytales (1945/1948)

On the Psychology of the Trickster-Figure (1954)

Conscious, Unconscious, and Individuation (1939)

A Study in the Process of Individuation (1934/1950)

Concerning Mandala Symbolism (1950)

Appendix: Mandalas (1955)

***9. PART II. AION (1951)**

RESEARCHES INTO THE PHENOMENOLOGY OF THE SELF

The Ego

The Shadow

The Syzygy: Anima and Animus

The Self

Christ, a Symbol of the Self

The Sign of the Fishes

The Prophecies of Nostradamus

The Historical Significance of the Fish

The Ambivalence of the Fish Symbol

The Fish in Alchemy

The Alchemical Interpretation of the Fish

Background to the Psychology of Christian Alchemical Symbolism

Gnostic Symbols of the Self

The Structure and Dynamics of the Self

Conclusion

***10. CIVILIZATION IN TRANSITION**

The Role of the Unconscious (1918)

Mind and Earth (1927/1931)

Archaic Man (1931)

The Spiritual Problem of Modern Man (1928/1931)

The Love Problem of a Student (1928)

Woman in Europe (1927)

The Meaning of Psychology for Modern Man (1933/1934)

The State of Psychotherapy Today (1934)

Preface and Epilogue to “Essays on Contemporary Events” (1946)

Wotan (1936)

After the Catastrophe (1945)

The Fight with the Shadow (1946)

The Undiscovered Self (Present and Future) (1957)

Flying Saucers: A Modern Myth (1958)

A Psychological View of Conscience (1958)

Good and Evil in Analytical Psychology (1959)

Introduction to Wolff’s “Studies in Jungian Psychology” (1959)

The Swiss Line in the European Spectrum (1928)

Reviews of Keyserling’s “America Set Free” (1930) and “La Revolution Mondiale” (1934)

Complications of American Psychology (1930)

The Dreamlike World of India (1939)

What India Can Teach Us (1939)

Appendix: Documents (1933–1938)

†11. PSYCHOLOGY AND RELIGION: WEST AND EAST

WESTERN RELIGION

Psychology and Religion (The Terry Lectures) (1938/1940)

A Psychological Approach to the Dogma of the Trinity (1942/1948)

Transformation Symbolism in the Mass (1942/1954)

Forewords to White’s “God and the Unconscious” and Werblowsky’s “Lucifer and Prometheus” (1952)

Brother Klaus (1933)

Psychotherapists or the Clergy (1932)

Psychoanalysis and the Cure of Souls (1928)

Answer to Job (1952)

EASTERN RELIGION

Psychological Commentaries on “The Tibetan Book of the Great Liberation” (1939/1954) and “The Tibetan Book of the Dead” (1935/1953)

Yoga and the West (1936)

Foreword to Suzuki's "Introduction to Zen Buddhism" (1939)

The Psychology of Eastern Meditation (1943)

The Holy Men of India: Introduction to Zimmer's "Der Weg zum Selbst" (1944)

Foreword to the "I Ching" (1950)

*12. PSYCHOLOGY AND ALCHEMY (1944)

Prefatory Note to the English Edition ([1951?] added 1967)

Introduction to the Religious and Psychological Problems of Alchemy

Individual Dream Symbolism in Relation to Alchemy (1936)

Religious Ideas in Alchemy (1937)

Epilogue

†13. ALCHEMICAL STUDIES

Commentary on "The Secret of the Golden Flower" (1929)

The Visions of Zosimos (1938/1954)

Paracelsus as a Spiritual Phenomenon (1942)

The Spirit Mercurius (1943/1948)

The Philosophical Tree (1945/1954)

‡14. MYSTERIUM CONIUNCTIONIS (1955–56)

AN INQUIRY INTO THE SEPARATION AND
SYNTHESIS OF PSYCHIC OPPOSITES IN ALCHEMY

The Components of the Coniunctio

The Paradoxa

The Personification of Opposites

Rex and Regina

Adam and Eve

The Conjunction

*15. THE SPIRIT IN MAN, ART, AND LITERATURE

Paracelsus (1929)

Paracelsus the Physician (1941)

Sigmund Freud in His Historical Setting (1932)

In Memory of Sigmund Freud (1939)

Richard Wilhelm: In Memoriam (1930)

On the Relation of Analytical Psychology to Poetry (1922)

Psychology and Literature (1930/1950)

“Ulysses” (1932)

Picasso (1932)

†16. THE PRACTICE OF PSYCHOTHERAPY

GENERAL PROBLEMS OF PSYCHOTHERAPY

Principles of Practical Psychotherapy (1935)

What Is Psychotherapy? (1935)

Some Aspects of Modern Psychotherapy (1930)

The Aims of Psychotherapy (1931)

Problems of Modern Psychotherapy (1929)

Psychotherapy and a Philosophy of Life (1943)

Medicine and Psychotherapy (1945)

Psychotherapy Today (1945)

Fundamental Questions of Psychotherapy (1951)

SPECIFIC PROBLEMS OF PSYCHOTHERAPY

The Therapeutic Value of Abreaction (1921/1928)

The Practical Use of Dream-Analysis (1934)

The Psychology of the Transference (1946)

Appendix: The Realities of Practical Psychotherapy ([1937] added, 1966)

‡17. THE DEVELOPMENT OF PERSONALITY

Psychic Conflicts in a Child (1910/1946)

Introduction to Wickes’s “Analyse der Kinderseele” (1927/1931)

Child Development and Education (1928)

Analytical Psychology and Education: Three Lectures (1926/1946)

The Gifted Child (1943)

The Significance of the Unconscious in Individual Education (1928)

The Development of Personality (1934)

Marriage as a Psychological Relationship (1925)

18. MISCELLANY

Posthumous and Other Miscellaneous Works

19. BIBLIOGRAPHY AND INDEX

Complete Bibliography of C. G. Jung’s Writings

General Index to the Collected Works

¹ *The Idea of the Holy*.

² *Gratia adiuvens* and *gratia sanctificans* are the effects of the *sacramentum ex opere operato*. The sacrament owes its undoubted efficacy to the fact that it is directly instituted by Christ himself. The Church is powerless to connect the rite with grace in such a way that the sacramental act would produce the presence and effect of grace. Consequently the rite performed by the priest is not a *causa instrumentalis*, but merely a *causa ministerialis*.

³ “But our esteem for facts has not neutralized in us all religiousness. It is itself almost religious. Our scientific temper is devout.” *Pragmatism*, p. 14.

⁴ “Religion is that which gives reverence and worship to some higher nature [which is called divine].” Cicero, *De inventione rhetorica*, II, 53, 161. For “testimony given under the sanction of religion on the faith of an oath” cf. Cicero, *Pro Coelio*, 55.

⁵ Heinrich Scholz (*Die Religionsphilosophie des Als-Ob*) insists on a similar standpoint. Cf. also Percy, *A Vindication of Paul*.

⁶ Cf. my “Studies in Word Association.”

⁷ Frazer, *Taboo and the Perils of the Soul*, pp. 30ff.; Crawley, *The Idea of the Soul*, pp. 82ff.; Lévy-Bruhl, *Primitive Mentality*.

⁸ Fenn, *Running Amok*.

⁹ Ninck, *Wodan und germanischer Schicksalsglaube*.

¹⁰ Lévy-Bruhl, *How Natives Think*, and *Primitive Mentality*, ch. 3, “Dreams,” pp. 97ff.

¹¹ Haeussermann, *Wortempfang und Symbol in der alttestamentlichen Prophetie*.

¹² In his excellent treatise on dreams and their functions, Benedictus Pererius, S.J. (*De Magia; De Observatione Somniorum et de Divinatione Astrologica libri tres*, 1598) says: “For God is not constrained by such laws of time, nor does he await opportune moments for his operation; for he inspires dreams where he will, when he will, and in whomsoever he will” (p. 147). The following passage throws an interesting light on the relation of the Church to the problem of dreams: “For we read in Cassian’s 22nd Collation, that the old governors and directors of the monks were well versed in seeking out and testing the causes of certain dreams” (p. 142). Pererius classifies dreams as follows: “Many [dreams] are natural, some are of human origin, and some are even divine” (p. 145). There are four causes of dreams: (1) An affection of the body. (2) An affect or vehement commotion of the mind caused by love, hope, fear, or hatred (pp. 126ff.). (3) The power and cunning of the demon, i.e. of a heathen god or the Christian devil. (“For the devil is able to know natural effects which will needs come about at some future time from fixed causes; he can know those things which he himself is going to bring about at a later time; he can know things, both present and past, which are hidden from men, and make them known to men in dreams” [p. 129]. Concerning the diagnosis of demonic dreams, the author says: “It can be surmised that dreams are sent by the devil, firstly if dreams often occur which signify future or hidden events, knowledge whereof is advantageous not to any useful end whether for oneself or for others, but only for the vain display of curious information, or even for the doing of some evil act ...” [p. 130].) (4) Dreams sent by God. Concerning the signs indicating the divine nature of a dream, the author says: “... from the importance of the matters made known by the dream, especially if, in the dream, those things are made known to a man of which certain knowledge can come to him only by God’s leave and bounty. Of such sort are those things which in the schools of the theologians are called contingent future events; further, the secrets of the heart which are

wholly hidden from all men's understanding; and lastly, those highest mysteries of our faith which are known to no man unless he be taught them by God [!] ... That this [is divine] is especially declared by a certain enlightenment and moving of the spirits, whereby God so illumines the mind, so acts upon the will, and so assures the dreamer of the credibility and authority of his dream that he so clearly recognizes and so certainly judges God to be its author that he not only desires to believe it, but must believe it without any doubt whatsoever" (pp. 131ff.). Since the demon, as stated above, is also capable of producing dreams accurately predicting future events, the author adds a quotation from Gregory the Great (*Dialogorum Libri IV*, cap. 48, in Migne, *P.L.*, vol. 77, col. 412): "Holy men discern between illusions and revelations, the very words and images of visions, by a certain inward sensibility, so that they know what they receive from the good spirit and what they endure from the deceiver. For if a man's mind were not careful in this regard, it would plunge itself into many vanities through the deceiving spirit, who is sometimes wont to foretell many true things, in order that he may entirely prevail to ensnare the soul by some one single falsity" (p. 132). It seemed to be a welcome safeguard against this uncertainty if dreams were concerned with the "highest mysteries of our faith." Athanasius, in his biography of St. Anthony, gives us some idea of how clever the devils are in foretelling future events. (Cf. Budge, *The Book of Paradise*, I, pp. 37ff.) The same author says they sometimes appear even in the shape of monks, singing psalms, reading the Bible aloud, and making disturbing remarks about the moral conduct of the brethren (pp. 33ff. and 47). Pererius, however, seems to trust his own criterion, for he continues: "As therefore the natural light of our minds enables us clearly to discern the truth of first principles, so that they are embraced by our assent immediately and without any argument; so in dreams sent by God the divine light shining upon our minds brings it about that we understand and believe with certainty that those dreams are true and of God." He does not touch on the delicate question of whether every unshakable conviction derived from a dream necessarily proves the divine origin of the dream. He merely takes it for granted that a dream of this sort would naturally exhibit a character consistent with the "highest mysteries of our faith," and not perchance with those of another one. The humanist Kaspar Peucer (in his *Commentarius de praecipuis generibus divinationum*, 1560) is far more definite and restrictive in this respect. He says (p. 270): "Those dreams are of God which the sacred scriptures affirm to be sent from on high, not to every one promiscuously, nor to those who strive after and expect revelations of their own opinion, but to the Holy Patriarchs and Prophets by the will and judgment of God. [Such dreams are concerned] not with light matters, or with trifles and ephemeral things, but with Christ, the governance of the Church, with empires and their well ordering, and other remarkable events; and to these God always adds sure testimonies, such as the gift of interpretation and other things, by which it is clear that they are not rashly to be objected to, nor are they of natural origin, but are divinely inspired." His crypto-Calvinism is palpably manifest in his words, particularly when one compares them with the natural theology of his Catholic contemporaries. It is probable that Peucer's hint about "revelations" refers to certain heretical innovations. At any rate, in the next paragraph, where he deals with dreams of diabolical origin, he says these are the dreams "which the devil shows nowadays to Anabaptists, and at all times to Enthusiasts and suchlike fanatics." Pererius with more perspicacity and human understanding devotes one chapter to the question "Whether it be lawful for a Christian man to observe dreams?" (pp. 142ff) and another to the question "To what kind of man does it belong to interpret dreams aright?" (pp. 245ff.). In the first he reaches the conclusion that important dreams should be considered. I quote his words: "Finally, to consider whether the dreams which oftentimes disturb us and move us to evil courses are put before us by the devil, as likewise on the other hand to ponder whether those by which we are aroused and incited to good, as for example to celibacy, almsgiving, and entering the religious life, are sent us by God, is the part not of a superstitious mind, but of one that is religious, prudent, and

careful and solicitous for its salvation.” Only stupid people would observe all the other futile dreams. In the second chapter, he answers that nobody should or could interpret dreams “unless he be divinely inspired and instructed.” “Even so,” he adds, “the things of God knoweth no man, but the Spirit of God” (I Cor. 2:11). This statement, eminently true in itself, reserves the art of interpretation to such persons as are endowed by their office with the gift of the Holy Spirit. It is obvious, however, that a Jesuit author could not envisage a descent of the Holy Spirit outside the Church.

¹³ “Dream Symbols of the Individuation Process.” [Orig. in *Eranos-Jahrbuch 1935*. A revised and expanded version of this appears in *Psychology and Alchemy*, as Part II.—EDITORS.] Although the dreams cited here are mentioned in the above publication, they are examined there from a different standpoint. Since dreams have many aspects they can be studied from various angles.

¹⁴ Freud, *The Interpretation of Dreams*. Silberer (*Der Traum*, 1919) presents a more cautious and more balanced point of view. As to the difference between Freud’s and my own views, I would refer the reader to my little essay on this subject, “Freud and Jung: Contrasts.” Further material in *Two Essays on Analytical Psychology*, pars. 16ff.; Kranefeldt, *Secret Ways of the Mind*; Gerhard Adler, *Entdeckung der Seele*; and Toni Wolff, “Einführung in die Grundlagen der komplexen Psychologie,” in *Die kulturelle Bedeutung der komplexen Psychologie*.

¹⁵ Cf. the relation of Odin as the god of poets, seers, and raving enthusiasts, and of Mimir, the Wise One, to Dionysus and Silenus. The word Odin has a root-connection with Gall. *obāteis*, Ir. *fāith*, L. *vates*, similar to *μάντις* and *μαίνομαι*. Ninck, *Wodan und germanischer Schicksalsglaube*, pp. 30ff.

¹⁶ “The Role of the Unconscious.”

¹⁷ Cf. my “Wotan,” *Neue Schweizer Rundschau*, 1936 [an abbreviated version in the *Saturday Review of Literature*, Oct. 16, 1937; subsequently published in *Essays on Contemporary Events*, 1947, now in *Coll. Works*, vol. 10]. The Wotan parallels in Nietzsche’s work are to be found in the poem “To the Unknown God” (*Werke*, ed. Baeumler, V, p. 457); *Thus Spake Zarathustra*, trans. by Thomas Common, pp. 293ff., 150, and 185f.; and the Wotan dream of 1859 in Elisabeth Foerster-Nietzsche, *Der werdende Nietzsche*, pp. 84ff.

¹⁸ Cf. my *Two Essays*, pars. 296ff.; *Psychological Types*, Defs. 48, 49; “Archetypes of the Collective Unconscious,” pars. 52ff.; and “Concerning the Archetypes.”

¹⁹ Cf. my “Concerning the Archetypes,” pars. 120ff.

²⁰ Maitland, *Anna Kingsford*, I, pp. 129ff. [Cf. “Comm. on *Golden Flower*,” par. 40.]

²¹ The statement about the hermaphroditic nature of the Deity in *Corpus Hermeticum*, Lib. I (ed. Scott, *Hermetica*, 1, p. 118): “For the first Mind was bisexual,” is probably taken from Plato, *Symposium*, XIV. It is questionable whether the later medieval representations of the hermaphrodite stem from “Poimandres” (*Hermetica*, I), since the hermaphrodite figure was practically unknown in the West before the *Poimander* was printed by Marsilio Ficino in 1471. It is possible, however, that one of the few scholars of those days who understood Greek got the idea from one of the Greek codices then extant, as for instance the Codex Laurentianus 71, 33, the Codex Parisinus Graecus 1220, or the Codices Vaticanus Graecus 237 and 951, all from the 14th century. There are no older codices. The first Latin translation by Marsilio Ficino had a sensational effect. But before that date we have the hermaphroditic symbols from the Codex Germanicus Monacensis 598, dated 1417. It seems to me more probable that the hermaphrodite symbol derives from Arabic or Syriac MSS. translated in the 11th or 12th century. In the old Latin

“Tractatulus Avicennae,” which is strongly influenced by Arabic tradition, we find: “[The elixir] is a voluptuous serpent impregnating itself” (*Artis auriferae*, I, 1593, p. 406). Although the author was a Pseudo-Avicenna and not the authentic Ibn Sina (970–1037), he is one of the Arabic-Latin sources for medieval Hermetic literature. We find the same passage in “Rosinus ad Sarratantam” (*Artis aurif.*, I, p. 303). “Rosinus” is an Arabic-Latin corruption of “Zosimos,” a Greek neo-Platonic philosopher of the 3rd century. His treatise “Ad Sarratantam” belongs to the same class of literature, and since the history of these texts is still shrouded in darkness, nobody can say who copied from whom. The *Turba philosophorum*, Sermo LXV, a Latin text of Arabic origin, makes the same allusion: “The composite brings itself forth.” (Ruska, *Turba philosophorum*, 1931, p. 165.) So far as I can judge, the first text that definitely mentions the hermaphrodite is the “Liber de arte chymica” of the 16th century (*Artis aurif.*, I, pp. 575ff.). On p. 610 it says: “For that Mercurius is all metals, male and female, and an hermaphroditic monster even in the marriage of soul and body.” Of the later literature I mention only Hieronymus Reusner, *Pandora* (1588); “Splendor Solis” (*Aureum vellus*, 1598); Michael Maier, *Symbola aureae mensae* (1617) and *Atalanta fugiens* (1618); J. D. Mylius, *Philosophia reformata* (1622).

²² The “Tractatus aureus Hermetis” is of Arabic origin and does not belong to the *Corpus Hermeticum*. Its history is unknown (first printed in *Ars chemica*, 1566). Dominicus Gnosius wrote a commentary on the text in his *Hermetis Trismegisti Tractatus vere Aureus de Lapide philosophici secreto* (1610). On p. 101 he says: “As a shadow continually follows the body of one who walks in the sun ... so our Adamic hermaphrodite, though he appears in masculine form, nevertheless always carries about with him Eve, or his feminine part, hidden in his body.” This commentary, together with the text, is reproduced in Manget, *Bibliotheca chemica curiosa*, I (1702), pp. 401ff.

²³ There is a description of both these figures in *Two Essays*, Part II, pars. 296ff. See also *Psychological Types*, Def. 48, and Emma Jung, “On the Nature of the Animus.” [Cf. also *Aion*, ch. III.]

²⁴ Anima and animus do not only occur in negative form. They may sometimes appear as a source of enlightenment, as messengers (ἄγγελοι), and as mystagogues. [Cf. Jung, *Aion (Coll. Works*, Vol. 9, pt. II), p. 16; “Psychology of the Transference,” par. 504.—EDITORS.]

²⁵ [Cf. *Psychology and Alchemy*, pars. 164ff., 183ff.—EDITORS.]

¹ [Cf. *Psychology and Alchemy*, par. 175.—EDITORS.]

² [Cf. *ibid.*, par. 293.—EDITORS.]

³ A bishop is allowed four candles for a private mass. Some of the more solemn forms of the Mass, such as the *Missa cantata*, also have four. Still higher forms have six or seven.

⁴ Origen, *In Jeremiam homiliae*, XX, 3, in Migne, *P.G.*, vol. 13, col. 532. Also in James, *The Apocryphal New Testament*, p. 35.

⁵ Irenaeus, *Against Heresies*, trans. by Keble, p. 81.

⁶ Cf. Zeller, *Die Philosophie der Griechen*, where all the sources are collected. “Four is the origin and root of eternal nature” (I, p. 291). Plato derives the human body from the four. According to the Neoplatonists, Pythagoras himself called the soul a square (Zeller, III, II, p. 120).

⁷ The “four” in Christian iconography appears chiefly in the form of the four evangelists and their symbols, arranged in a rose, circle, or melothesia, or as a tetramorph, as for instance in the *Hortus deliciarum* of Herrad of Landsberg and in works of mystical speculation. Of these I mention only: (1) Jakob Böhme, *XL Questions concerning the Soule* (1647). (2) Hildegard of Bingen, Codex Luccensis, fol. 372, and Codex Heidelbergensis, “Scivias,” representations of the mystic universe; cf. Singer, *Studies in the History and Method of Science*. (3) The remarkable drawings of Opicinus de Canistris in the Codex Palatinus Latinus 1993, Vatican; cf. Salomon, *Weltbild und Bekenntnisse eines avignonesischen Klerikers des 14. Jahrhunderts*. (4) Heinrich Khunrath, *Vom hylealischen, das ist, pri-materialischen catholischen, oder allgemeinen naturlichen Chaos* (1597), pp. 204 and 281, where he says the “Monas catholica” arises from the rotation of the “Quaternarium” and interprets it as an image and allegory of Christ (further material in Khunrath, *Amphitheatrum sapientiae aeternae*, 1604). (5) The speculations about the cross: “It is said ... that the cross was made of four kinds of wood,” St. Bernard, *Vitis mystica*, cap. XLVI, in Migne, *P.L.*, vol. 184, col. 752; cf. W. Meyer, *Die Geschichte des Kreuzholzes vor Christus*, p. 7. For the quaternity see also Dunbar, *Symbolism in Mediaeval Thought and Its Consummation in the Divine Comedy*.

⁸ Cf. the systems of Isidorus, Valentinus, Marcus, and Secundus. A most instructive example is the symbolism of the Monogenes in the Codex Brucianus (Bodleian Library, Oxford, MS. Bruce 96), trans. by C. A. Baynes, *A Coptic Gnostic Treatise*, pp. 59ff., 70ff. [Cf. *Psychology and Alchemy*, pars. 138ff.]

⁹ I am thinking of the mystical speculations about the four “roots” (the rhizomata of Empedocles), i.e., the four elements or four qualities (wet, dry, warm, cold), peculiar to Hermetic or alchemical philosophy. Descriptions in Petrus Bonus, *Pretiosa margarita novella* (1546); Joannes Pantheus, *Ars transmutationis metallica* (1519), p. 5, based on a *quaternatio*; Raymond Lully, “Theorica et practica” (*Theatrum chemicum*, IV, 1613, p. 174), a *quaternatio elementorum* and of chemical processes; Michael Maier, *Scrutinium chymicum* (1687), symbols of the four elements. The last-named author wrote an interesting treatise called *De circulo physico quadrato* (1616). There is much the same symbolism in Mylius, *Philosophia reformata* (1622). Pictures of the Hermetic redemption in the form of a tetrad with symbols of the four evangelists (from Reusner’s *Pandora* and the Codex Germanicus Monacensis 598) are reproduced in *Psychology and Alchemy*, figs. 231 and 232; quaternity symbolism, *ibid.*, par. 327. Further material in Kuekelhaus, *Urzahl und Gebärde*. Eastern parallels in Zimmer, *Kunstform und Yoga im indischen Kultbild*; Wilhelm and Jung, *The Secret of the Golden Flower*. The literature on the symbolism of the cross is also relevant here.

¹⁰ This sentence may sound presumptuous, for I seem to be forgetting that we are concerned here with a single and unique dream from which no far-reaching conclusions can be drawn. My conclusions, however, are based not on this dream alone but on many similar experiences to which I have alluded elsewhere.

¹¹ Cf. the *Hypnerotomachia Poliphili* (1499). This book is supposed to have been written by a monk of the 15th century. It is an excellent example of an anima-romance. [Fierz-David's study *The Dream of Poliphilo* treats it as such.—EDITORS.]

¹² Ecclesiastical vestments are not for adornment only, they also serve to protect the officiating priest. "Fear of God" is no groundless metaphor, for at the back of it there is a very real phenomenology. Cf. Exodus 20:18f.

¹³ Gnosis, as a special kind of knowledge, should not be confused with "Gnosticism."

¹⁴ Cf. *Psychological Types*, Def. 26 [Also "On the Nature of the Psyche," *Coll. Works*, Vol 8, pp. 212ff.—EDITORS]

¹⁵ The term "archetypus" is used by Cicero, Pliny, and others. It appears in the *Corpus Hermeticum*, Lib. I (Scott, *Hermetica*, I, p. 116, 8a) as a definitely philosophical concept: "Thou knowest in thy mind the *archetypal form* [τὸ ἀρχέτυπον εἶδος], the beginning before the beginning, the unbounded."

¹⁶ *Das Bestandige in den Menschenrassen*, p. 75; *Die Vorstellungen von der Seele*, p. 306; *Der Volkergedanke im Aufbau einer Wissenschaft vom Menschen; Ethnische Elementargedanken in der Lehre vom Menschen*.

¹⁷ "In sleep and in dreams we pass through the whole thought of earlier humanity.... I mean, as a man now reasons in dreams, so humanity also reasoned for many thousands of years when awake: the first cause which occurred to the mind as an explanation of anything that required explanation was sufficient and passed for truth.... This atavistic element in man's nature continues to manifest itself in our dreams, for it is the foundation upon which the higher reason has developed and still develops in every individual. Dreams carry us back to remote conditions of human culture and afford us a ready means of understanding it better." Nietzsche, *Human All-Too-Human*, I, pp. 24–25, trans. by Zimmern and Cohn, modified.

¹⁸ Hubert and Mauss, *Mélanges d'Histoire des Religions*, p. xxix: "Constantly set before us in language, though not necessarily explicit in it, ... the categories ... generally exist rather under the form of habits that guide consciousness, themselves remaining unconscious. The notion of *mana* is one of these principles; it is a datum of language; it is implied in a whole series of judgments and reasonings concerned with attributes that are those of *mana*. We have described *mana* as a category, but it is a category not confined to primitive thought; and today, in a weakened degree, it is still the primal form that certain other categories which always function in our minds have covered over: those of substance, cause ..." etc.

¹⁹ Lévy-Bruhl, *How Natives Think*.

²⁰ For the psychology of the *tetraktys*, see my "Commentary on *The Secret of the Golden Flower*," par. 31; ["Dogma of the Trinity," pars. 246, 268ff.]; and Hauer, "Symbole und Erfahrung des Selbstes in der Indo-Arischen Mystik."

²¹ [For a tabulation of these dreams, see *Psychology and Alchemy*, par. 329, n.—EDITORS.]

²² There is an excellent presentation of the problem in Maier, *De circulo* (1616).

²³ [On the source of this saying, see par. 229, n. 6, below.—EDITORS.]

²⁴ Cf. his essay "Circles" (*Essays*, Everyman edn., p. 167).

²⁵ Plato, *Timaeus*, 7; Steeb, *Coelum Sefhiroticum Hebraeorum* (1679), p. 15.

²⁶ Steeb, p. 19. Maier (*De circulo*, p. 27) says: “The circle is a symbol of eternity or an indivisible point.” Concerning the “round element,” see *Turba philosophorum*, Sermo XLI (ed. Ruska, p. 148), where the “rotundum which turns copper into four” is mentioned. Ruska says there is no similar symbol in the Greek sources. This is not quite correct, since we find a *στοιχείον στρογγύλον* (round element) in the *περὶ ὀργάνων* of Zosimos (Berthelot, *Alch. grecs*, III, xlix, 1). The same symbolism may also occur in his *ποίημα* (Berthelot, III, v bis), in the form of the *περιηκονισμένον*, which Berthelot translates as “objet circulaire.” (The correctness of this translation, however, is doubtful.) [Cf. “The Visions of Zosimos,” pal. 86, n. 12.] A better parallel might be Zosimos’ “omega element.” He himself describes it as “round” (Berthelot, III, xlix, 1).

The idea of the creative point in matter is mentioned in Sendivogius, “Novum lumen” (*Musaeum hermeticum*, 1678, p. 559); cf. *The Hermetic Museum Restored and Enlarged*, trans. by A. E. Waite, II, p. 89: “For there is in every body a centre, the seeding-place or spermatic point.” This point is a “point born of God” (p. 59). Here we encounter the doctrine of the “panspermia” (all-embracing seed-bed), about which Athanasius Kircher, S.J. (*Mundus subterraneus*, 1678, II, p. 347) says: “Thus from the holy words of Moses ... it appears that God, the creator of all things, in the beginning created from nothing a certain Matter, which we not unfittingly call Chaotic ... within which something ... confused lay hidden as if in a kind of panspermia ... as though he brought forth afterward from the underlying material all things which had already been fecundated and incubated by the divine Spirit... But he did not forthwith destroy the Chaotic Matter, but willed it to endure until the consummation of the world, as at the first beginning of things so to this very day, a panspermia replete with all things....” These ideas lead us back to the “descent” or “fall of the deity” in the Gnostic systems. Cf. Bussell, *Religious Thought and Heresy in the Middle Ages*, pp. 554ff.; Reitzenstein, *Poimandres*, p. 50; Mead, *Pistis Sophia*, pp. 36ff., and *Fragments of a Faith Forgotten*, p. 470.

²⁷ “There is in the sea a round fish, lacking bones and scales, and having in itself a fatness” (the *humidum radicale* —the *anima mundi* imprisoned in matter). From “Allegoriae super Turbam,” *Art. aurif.*, I (1593), p. 141. [Cf. *Aion*, pars. 195ff.]

²⁸ *Tīmaeus* 7.

²⁹ See above, n. 26.

³⁰ “For as the heaven which is visible is round in form and motion ... so is the Gold” (Maier, *De circulo*, p. 39).

³¹ *Rosarium philosophiorum* (*Art. aurif.*, II, p. 261). This treatise is ascribed to Petrus Toletanus, who lived in Toledo about the middle of the 13th century. He is said to have been either an older contemporary or a brother of Arnold of Villanova, the famous physician and philosopher. The present form of the *Rosarium*, based on the first printing of 1550, is a compilation and probably does not date further than the 15th century, though certain parts may have originated early in the 13th century.

³² *Symposium* XIV.

³³ Petrus Bonus in Janus Lacinius, *Pretiosa margarita novella* (1946). For the *allegoria Christi*, see *Psychology and Alchemy*, “The Lapis-Christ Parallel.”

³⁴ *Beati Thomae de Aquino Aurora sive Aurea hora*. Complete text in the rare printing of 1625: *Harmoniae Inperscrutabilis Chymico-philosophicae sive Philosophorum Antiquorum Consentientium Decas I* (Francofurti apud Conrad Eifridum. Anno MDCXXV). (British Museum 1033 d.11.) The interesting part of this treatise is the first part, “Tractatus paraboliarum,” which was omitted on account of its “blasphemous” character from the printings of *Artis*

auriferae in 1572 and 1593. In the so-called Codex Rhenoviensis (Zurich Central Library), about four chapters of the “Parabolarum” are missing. The Codex Parisinus Fond. Lat. 14006 (Bibl. nat.) contains a complete text. [For English translation, see *Aurora Consurgens*, edited by M.-L. von Franz.—EDITORS.]

³⁵ A good example is the commentary of Gnosius on the “Tractatus aureus Hermetis,” *Theatr. chem.*, IV, pp. 672ff.; Mangel, *Bibl. chein.*, I, pp. 400ff.

³⁶ *Aurora Consurgens* (ed. von Franz), p. 129. Zosimos (Berthelot, *Alch grecs*, III, xlix, 4–5), quoting from a Hermetic writing, says that ὁ θεοῦ υἱὸς πανταγενόμενος was Adam or Thoth, who was made of the four elements and the four cardinal points. Cf. *Psychology and Alchemy*, par. 456, sec. 6.

³⁷ *Aurora Consurgens* (ed. von Franz), p. 129.

³⁸ Cf. *Psychology and Alchemy*, pars. 347ff.

³⁹ Horace, *Epistles*, I, x, 24.

⁴⁰ Baynes, ed., *A Coptic Gnostic Treatise*, pp. 22, 89, 94.

⁴¹ The *Rosarium philosophorum* is one of the first attempts at a synopsis and gives a fairly comprehensive account of the medieval quaternity.

⁴² Cf., for instance, the 5th and 8th Annual Reports of the Smithsonian Institution, Bureau of Ethnology, Washington (1887 and 1892).

⁴³ Cf. the paleolithic (?) “sun wheels” of Rhodesia. [But see infra, par. 484, n. 9.]

⁴⁴ [In his commentary to *The Secret of the Golden Flower*, first pub. (in German) in 1929.—EDITORS.]

⁴⁵ Koepgen, *Die Gnosis des Christentums*, pp. 189, 190.

⁴⁶ *Ibid.*, pp. 185ff.

⁴⁷ Dorn thinks that God created the *binarius* on the second day of Creation, when he separated the upper waters from the lower, and that this was the reason why he omitted to say on the evening of the second day what he said on all the others, namely that “it was good.” The emancipation of the *binarius*, Dorn holds, was the cause of “confusion, division, and strife.” From the *binarius* issued “its quaternary offspring” (*sua proles quaternaria*). Since the number 2 is feminine, it also signified Eve, whereas the number 3 was equated with Adam. Therefore the devil tempted Eve first: “For [the devil] knew, being full of all guile, that Adam was marked with the *unarius*, and for this cause he did not at first attack him, for he greatly doubted whether he could do anything against him. Moreover, he was not ignorant that Eve was divided from her husband as a natural binary from the unity of its ternary [*tanquam naturalem binarium ab unario sui ternarii*]. Accordingly, armed with a certain likeness of binary to binary, he made his attack on the woman. For all even numbers are feminine, of which two, Eve’s proper and original number, is the first,” (Dorn, “De tenebris contra naturam et vita brevi,” *Theatr. chem.*, 1602, 1, p. 527. In this treatise and the one that follows it, “De Duello Animi cum Corpore,” pp. 535ff., the reader will find everything I have mentioned here.) The reader will have noticed how Dorn, with great cunning, discovers in the *binarius* a secret affinity between the devil and woman. He was the first to point out the discord between threeness and fourness, between God as Spirit and Empedoclean nature, thus—albeit unconsciously—cutting the thread of alchemical projection. Accordingly, he speaks of the *quaternarius* as “fundamental to the medicine of the infidels.” We must leave it an open question whether by “infidels” he meant the Arabs or the pagans of antiquity. At any rate Dorn suspected that there was

something ungodly in the quaternity, which was intimately associated with the nature of woman. Cf. my remarks concerning the “virgo terra,” pars. 107, n. 52, 123, 126.

⁴⁸ I am not referring here to the dogma of the human nature of Christ.

⁴⁹ This identification has nothing to do with the Catholic conception of the assimilation of the individual’s life to the life of Christ and his absorption into the *corpus mysticum* of the Church. It is rather the opposite of this view.

⁵⁰ I am thinking chiefly of works that contain alchemical legends and didactic tales. A good example would be Maier’s *Symbola aureae mensae* (1617), with its symbolic *peregrinatio* (pp. 569ff.).

⁵¹ So far as I know, there are no complaints in alchemical literature of persecution by the Church. The authors allude usually to the tremendous secret of the magistry as a reason for secrecy.

⁵² Cf. *Psychology and Alchemy*, fig. 232, showing the glorification of the body in the form of the Assumption of the Virgin (from Reusner, *Pandora*, 1588). St. Augustine used the earth to symbolize the Virgin: “Truth is arisen from the earth, for Christ is born of a virgin” (*Sermones*, 189, II, in Migne, *P.L.*, vol. 38, col. 1006). Likewise Tertullian: “That virgin earth, not yet watered by the rains nor fertilized by the showers” (*Adversus Judaeos*, 13, in Migne, *P.L.*, vol. 2, col. 655).

⁵³ The *rebis* (‘made of two’) is the philosophers’ stone, for in it the masculine and the feminine nature are united. [Cf. *Psychology and Alchemy*, fig. 125, and “The Psychology of the Transference,” pars. 525ff.—EDITORS]

¹ Cf. *Symbols of Transformation*.

² A recurrence of the ancient symbol of the uroboros, ‘tail-eater.’

³ An Eastern parallel is the “circulation of the light” mentioned in the Chinese alchemical treatise, *The Secret of the Golden Flower* [1962, pp. 30ff.], edited by R. Wilhelm and myself.

⁴ This refers to a previous vision, where a black eagle carried away a golden ring. [For this entire clock vision, cf. *Psychology and Alchemy*, pars. 307ff.—EDITORS.]

⁵ The “blood-letting manikins” are *melothesia*. [These are the little figures which medieval physicians used to draw inside a circle or mandala on the part of the body affected, when bleeding or “cupping” a patient. *Melothesia* is the “assignment of parts of the body to the tutelage of signs or planets” (Liddell and Scott, *Greek-English Lexicon*, p. 1099). Woodcuts of *melothesia* are reproduced in Jacobi, ed., *Paracelsus: Selected Writings*, figs. 36 and 45.—EDITORS.]

⁶ Budge, *Osiris and the Egyptian Resurrection*, I, 3; *The Egyptian Book of the Dead* (facsimile), pl. 5. In a manuscript from the 7th century (Gellone), the evangelists are represented with the heads of their symbolic animals instead of human heads.

⁷ [See “Concerning Mandala Symbolism,” fig. 1 and pars. 636f.]

⁸ *Shrīchakrasambhāra Tantra*, ed. by Avalon.

⁹ Abbé Joseph Delacotte, *Guillaume de Digulleville, Trois romans-poèmes du XIV^e siècle*. [A 15th-cent. verse translation of the “Pilgrimage” by John Lydgate was published by the Early English Text Society (1899–1904). For other early English translations, published in recent times, see the *Oxford History of English Literature*, II, part i, p. 308.—EDITORS.]

¹⁰ The Holy Ghost is the cause of the *viriditas* (greenness). Cf. below, pp. 91–92.

¹¹ Gerhard Dorn had a similar conception of circular figures intersecting and disturbing one another: on the one hand the circular system of the Trinity and on the other the devil’s attempt to construct a system of his own. He says: “It is to be noted, moreover, that the centre is unary, and its circle is ternary, but whatever is inserted between the centre [and the circumference], and enters the enclosed realm, is to be taken as binary, be it another circle ... or any other figure whatever.” So the devil fabricated a circle of sorts for himself and tried to devise a circular system with it, but for various reasons the attempt failed. In the end all he produced was the “figure of a twofold serpent lifting up four horns, and therefore is the kingdom of the monomachy [*monomachiae regnum*] divided against itself.” Being the *binarius* in person, the devil could hardly have produced anything else. (“De Duello,” *Theatrum chemicum*, 1602, I, p. 547.) Already in the alchemy of Zosimos the devil appears as *ἀντίμιμος*, the imitator, ape of God. (Berthelot, *Alch. grecs*, III, xlix, 9. Cf. also Mead, *Pistis Sophia*, *passim*.)

¹² A peculiar coincidence of three and four is to be found in Wernher vom Niederrhein’s allegory of Mary, where, besides the three men in the burning fiery furnace, a fourth appears who is interpreted as Christ. Cf. Salzer, *Die Sinnbilder und Beiworte Mariens*, p. 21.

¹³ Eisler, *Weltenmantel und Himmelszelt*, I, pp. 85ff.

¹⁴ Salzer, p. 66.

¹⁵ Zeller, *Die Philosophie der Griechen*, III, ii, p. 120. According to Archytas, the soul is a circle or sphere.

¹⁶ Cf. the invocation in the Acts of Thomas (Mead, *Fragments; of a Faith Forgotten*, pp. 422ff.). Also the “seat of wisdom” in the Litany of Loreto, and the readings from Proverbs on Mary’s feast-days, e.g. the Immaculate Conception (Prov. 8:22–35).

¹⁷ For the Gnostics the quaternity was decidedly feminine. Cf. Irenaeus, *Against Heresies*, I, ch. xi (Keble trans., p. 36).

¹⁸ *Die Gnosis des Christentums*, p. 194.

¹⁹ See *Psychological Types*, Defs. 48 and 49. [Also *Aion (Coll. Works, Vol. 9, pt. 11)*, pars. 20ff.—EDITORS.]

²⁰ A special instance is the “inferior function.” See *Psychological Types*, Def. 30. [And *Aion*, pars. 13ff.—EDITORS.]

²¹ Widely known because of his book *Natural Law in the Spiritual World*. The quotation comes from *The Greatest Thing in the World*.

²² Irenaeus, *Against Heresies*, XXV (Keble, p. 75). Cf. Mead, *Fragments*, p. 231.

²³ James, trans., *The Apocryphal New Testament*, p. 33.

²⁴ In Tibetan Buddhism the four colours are associated with psychic qualities (the four forms of wisdom). Cf. my psychological commentary to the *Tibetan Book of the Dead*, below, p. 522.

²⁵ See *Psychological Types*, Def. 51.

²⁶ The cross has also the meaning of a boundary-stone between heaven and hell, since it is set up in the centre of the cosmos and extends to all sides. (Cf. Kroll, *Gott und Holle*, p. 18, n. 3) The Tibetan mandala occupies a similar central position, its upper half rising up to heaven out of the earth (like the hemispherical stupas at Sanchi, India), with hell lying below. I have often found the same construction in individual mandalas: the light world on top, the dark below, as if they were projecting into these worlds. There is a similar design in Jakob Bohme’s “reversed eye” or “philosophical mirror” (*XL Questions concerning the Soule*, 1647 [Cf. “A Study in the Process of Individuation,” fig. 1, p. 297.]

²⁷ Cf the illustrations in Jung, “Concerning Mándala Symbolism. —EDITORS.]

²⁸ This is a technical term referring to a method I have proposed for raising unconscious contents to consciousness. [Cf. “The Relations between the Ego and the Unconscious,” pars. 342ff.; “The Psychological Aspects of the Kore,” pars. 319ff., “The Transcendent Function,” pars. 167f., *Mysterium Coniunctionis*, pars. 753f.]

²⁹ For the psychology of the mandala, see my “Commentary on *The Secret of the Golden Flower*,” pars. 31ff. [Also “Concerning Mandala Symbolism,” pars. 627ff.:—EDITORS.]

³⁰ See *Psychological Types*, Def. 16 [and 46 in *Coll. Works*, vol. 6]. [Also “The Relations between the Ego and the Unconscious,” par. 274; *Aion*, pars. 43ff.—EDITORS.]

³¹ C. Hauer, “Symbole und Erfahrung des Selbsten,” p. 33.

³² Concerning the concept of the “relativity of God,” see *Psychological Types*, ch. V, 4 b.

³³ This fact accounts for the theory of animism.

³⁴ Concerning the concept “inflation,” see “The Relations between the Ego and the Unconscious,” pars. 228ff.

³⁵ Plutarch, *De defectu oraculorum*, 17.

³⁶ Manget, *Bibliotheca chemica curiosa*, 1 (1702), p. 408.

³⁷ *Theatrum chemicum*, VI (1661), p. 431.

³⁸ Cf. the very similar formula in the “Fundamentum” of St. Ignatius Loyola’s *Spiritual Exercises*. [Cf. *Aion*, par. 252.]

³⁹ *Corpus Hermeticum*, IV, 4.

⁴⁰ Mercury is “wholly aerial and spiritual.” Theobald de Hoghelande, “De alchemiae difficultatibus,” *Theatr. chem.*, I (1602), p. 183.

⁴¹ Berthelot, *Alch. grecs*, III, vi, 5.

^{41a} Daniel, *Thesaurus*, V, pp. 201–2.

⁴² Mylius, *Philosophia reformata*, p. 42; Dorn, “Congeries,” *Theatr. chem.*, I, p. 584; “Turba philosophorum,” *Artis auriferae*, I (1593), p. 89.

⁴³ Originally a Platonic idea.

⁴⁴ Mylius, p. 8.

⁴⁵ St. Gregory, *Expositiones in librum I Regum*, I, i, 1; Migne, *P.L.*, vol. 79, col. 23.

⁴⁶ Barbelo or Ennoia plays the role of the anima in Barbelo-Gnosis. Bousset thinks the name “Barbelo” is a corruption of *parthenos*, ‘virgin.’ It is also translated as ‘God is in the Four.’

⁴⁷ This idea was formulated in the conception of the “anima in compedibus,” the fettered or imprisoned soul. (Cf. Dorn, “Speculativa philosophia,” *Theatr. chem.*, I, pp. 272, 298; “De spagirico artificio,” etc., *ibid.*, I, pp. 457, 497.) So far, I have found no evidence that the medieval natural philosophers based themselves consciously on any heretical traditions. But the parallels are astonishing. Those “enchained in Hades” are mentioned very early on, in the Comarius text dating from the 1st century (Berthelot, *Alch. grecs*, IV, xx, 8.) For the spark in the darkness and the spirit imprisoned in matter, see Leisegang, *Die Gnosis*, pp. 154f. and 233. A similar motif is the conception of the “natura abscondita,” which is discoverable in man and in all things, and is of the same nature as the anima. Thus Dorn (“De spagirico artificio,” p. 457) says: “In the body of man there is hidden a certain substance of heavenly nature known to very few.” In his “Philosophia speculativa” (p. 298) the same author says: “There is in natural things a certain truth not seen by the outward eye but perceived by the mind alone. Of this the philosophers had experience, and found its virtue to be such that it worked miracles.” The idea of the “hidden nature” occurs already in Pseudo-Democritus. (Berthelot, II, iii, 6.)

⁴⁸ A classical example is the “Visio Arislei” (*Art. aurif.*, I, pp. 146ff.). Also the visions of Zosimos (Berthelot, III, i-vi); cf. my paper “The Visions of Zosimos.” Revelation of the magistry in a dream in Sendivogius, “Parabola” (*Bibliotheca chemica curiosa*, II, 1702, p. 475).

⁴⁹ *Art. aurif.*, I, p. 151.

⁵⁰ Berthelot, *La Chimie au moyen age*, III, p. 50.

⁵¹ “Rosinus ad Sarratantam,” *Art. aurif.*, I, p. 311.

⁵² *Aureum vellus* (1598), p. 5; trans. J. K., *Splendor solis* (1920). Cf. also *Rosarium* (*Art. aurif.*, II, p. 292): “None does that work without God’s help / And then only if he see through himself.”

⁵³ “Speculativa philosophia,” *Theatr. chem.*, I, p. 267.

⁵⁴ Olympiodorus (Berthelot, *Alch. grecs*, II, iv, 43).

⁵⁵ Cf. *Psychology and Alchemy*, pars. 357ff.

⁵⁶ Mylius (*Phil. ref.*, p. 106) says that the masculine and feminine components of the stone must first be killed “that they may be brought to life again in a new and incorruptible resurrection, so that thereafter they may be immortal.” The stone is also compared to the future resurrected body as a “*corpus glorificatum*.” The “Aurea hora,” or “Aurora consurgens” (*Art. aurif.*, I, p. 201) says it is “like to a body which is glorified in the day of judgment.” Cf. de Hoghelande, *Theatr. chem.*, I, p. 189; “*Consilium coniugii*,” *Ars chemica* (1566), p. 128; “Aurea hora,” *Art. aurif.*, I, p. 195; Djibir, “Le Livre de la miséricorde,” in Berthelot, *La Chimie au moyen age*, III, p. 188; “Le Livre d’Ostanès,” in *ibid.*, p. 117; Comarius, in Berthelot, *Alch. grecs*, IV, xx, 15; Zosimos, in *ibid.*, III, viii, 2, and III, i, 2; *Turba phil.*, ed. Ruska, p. 139; Michael Maier, *Symbola aureae mensae* (1617), p. 599; *Rosarium philosophorum* (1550), fol. 2a, IV, illustration.

⁵⁷ “Aphorismi Basiliani,” *Theatr. chem.*, IV (1613), p. 368; de Hoghelande, *ibid.*, (1602), p. 178; Dorn, “Congeries,” *ibid.*, I, p. 585; and many other places.

⁵⁸ *Philosophia reformata* (1622), p. 21.

⁵⁹ Koepgen (see above, p. 59n.), rightly speaks of the “circular thinking” of the Gnostics. This is only another term for totality or “all-round” thinking, since, symbolically, roundness is the same as wholeness.

⁶⁰ Berthelot, *Alch. grecs*, IV, xx. According to F. Sherwood Taylor, in “A Survey of Greek Alchemy,” pp. 109ff., this is probably the oldest Greek text of the 1st century. Cf. also Jensen, *Die älteste Alchemie*.

⁶¹ Berthelot, III, *iff.*

⁶² Scott, *Hermetica*.

⁶³ *Psychology and Alchemy*, pars. 401ff.

⁶⁴ Berthelot, *Alch. grecs*, II, *if.*

⁶⁵ Very early among the Greek alchemists we encounter the idea of the “stone that has a spirit” (Berthelot, *Alch. grecs*, III, vi). The “stone” is the *prima materia*, called *hyle* or chaos or *massa confusa*. This alchemical terminology was based on Plato’s *Timaeus*. Joannes C. Steeb (*Coelum spheroticum Hebraeorum*, 1679) says: “Neither earth, nor air, nor fire, nor water, nor those things which are made of these things nor those things of which these are made, should be called the *prima materia*, which must be the receptacle and the mother of that which is made and that which can be beheld, but a certain species which cannot be beheld and is formless and sustains all things” (p. 26). The same author calls the *prima materia* “the primeval chaotic earth, Hyle, Chaos, the abyss, the mother of things.... That first chaotic matter ... was watered by the streams of heaven, and adorned by God with numberless Ideas of the species.” He explains how the spirit of God descended into matter and what became of him there (p. 33): “The spirit of God fertilized the upper waters with a peculiar fostering warmth and made them as it were milky.... The fostering warmth of the Holy Spirit brought about, therefore, in the waters that are above the heavens [*aquis supracoelestibus*; cf. Genesis 1:7], a virtue subtly penetrating and nourishing all things, which, combining with light, generated in the mineral kingdom of the lower regions the mercurial serpent [this could refer just as well to the caduceus of Aesculapius, since the serpent is also the origin of the *medicina catholica*, the panacea], in the vegetable kingdom the blessed greenness [chlorophyll], in the animal kingdom a formative virtue, so that the supracelestial spirit of the waters united in marriage with light may justly be called the soul of the world.” “The lower waters are darksome, and absorb the outflowings of light in their capacious depths” (p. 38). This doctrine is based on nothing less than the

Gnostic legend of the Nous descending from the higher spheres and being caught in the embrace of Physis. The Mercurius of the alchemists is winged (“volatile”). Abu’l-Qāsim Muhammad (*Kitāb al’ilm al muktasab*, etc., ed. Holmyard), speaks of “Hermes, the volatile” (p. 37), and in many other places he is called a “spiritus.” Moreover, he was understood to be a Hermes *psychopompos*, showing the way to Paradise (Michael Maier, *Symbola*, p. 592). This is very much the role of a redeemer, which was attributed to the Nous in “**Ἑρμοῦ πρὸς Τάτ** .” (Scott, *Hermética*, I, pp. 149ff.). For the Pythagoreans the soul was entirely devoured by matter, except for its reasoning part. (Zeller, *Die Philosophie der Griechen*, III, II, p. 158.)

In the old “Commentariolum in Tabulam smaragdinam” (*Ars chemica*), Hortulanus speaks of the “massa confusa” or the “chaos confusum” from which the world was created and from which also the mysterious *lapis* is generated. The *lapis* was identified with Christ from the beginning of the 14th century (Petrus Bonus, *Pretiosa margarita*, 1546). Orthelius (*Theatr. chem.*, VI, p. 431) says: “Our Saviour Jesus Christ ... partakes of two natures.... So likewise is that earthly saviour made up of two parts, the heavenly and the earthly.” In the same way the Mercurius imprisoned in matter was identified with the Holy Ghost. Johannes Grasseus (“Area arcani,” *Theatr. chem.*, VI, p. 314) quotes: “The gift of the Holy Spirit, that is the lead of the philosophers which they call the lead of the air, wherein is a resplendent white dove which is called the salt of the metals, in which consists the magistry of the work.”

Concerning the extraction and transformation of the Chaos, Christopher of Paris (“Elucidarius artis transmutatoriae,” *Theatr. chem.*, VI, p. 228) writes: “In this Chaos the said precious substance and nature truly exists potentially, in a single confused mass of the elements. Human reason ought therefore to apply itself to bringing our heaven into actuality.” “Our heaven” refers to the microcosm and is also called the “quintessence.” It is “incorruptible” and “immaculate.” Johannes de Rupescissa (*La Vertu et la Propriété de la Quinte Essence*, 1581) calls it “le ciel humain.” It is clear that the philosophers projected the vision of the golden and blue circle onto their *aurum philosophicum* (which was named the “rotundum”; see Maier, *De circulo*, 1616, p. 15) and onto the blue quintessence. The terms chaos and *massa confusa* were in general use, according to the testimony of Bernardus Sylvestris, a contemporary of William of Champeaux (1070–1121). His work, *De mundi universitate libri duo*, had a widespread influence. He speaks of the “confusion of the primary matter, that is, Hyle” (p. 5, li. 18), the “congealed mass, formless chaos, refractory matter, the face of being, a discolored mass discordant with itself” (p. 7, li. 18–19), “a mass of confusion” (p. 56, XI, li. 10). Bernardus also mentions the *descensus spiritus* as follows: “When Jove comes down into the lap of his bride, all the world is moved and would urge the soil to bring forth” (p. 51, li. 21–22). Another variant is the idea of the King submerged or concealed in the sea (Maier, *Symbola*, p. 380; “Visio Arislei,” *Art. aurif.*, I, pp. 146ff.). [Cf. *Psychology and Alchemy*, pars. 434ff.]

⁶⁶ For instance, the genius of the planet Mercury reveals the mysteries to Pseudo-Democritus. (Berthelot, *Alch. grecs*, I, Introduction, p. 236.)

⁶⁷ J. de Rupescissa, *La Vertu*, p. 19.

⁶⁸ Djibir, in *La Livre de la Miséricorde*, says that the philosophers’ stone is equal to a microcosm. (Berthelot, *La Chimie au moyen âge*, III, p. 179.)

⁶⁹ It is difficult not to assume that the alchemists were influenced by the allegorical style of patristic literature. They even claimed some of the Fathers as representatives of the Royal Art, for instance Albertus Magnus, Thomas Aquinas, Alanus de Insulis. A text like the “Aurora consurgens” is full of allegorical interpretations of the scriptures.

It has even been ascribed to Thomas Aquinas. Nevertheless, water was in fact used as an allegory of the Holy Spirit: “Water is the living grace of the Holy Spirit” (Rupert, Abbot of Deutz, in Migne, *P.L.*, vol. 169, col. 353). “Flowing water is the Holy Spirit” (Bruno, Bishop of Würzburg, in Migne, *P.L.*, vol. 142, col. 293). “Water is the infusion of the Holy Spirit” (Garnerius of St. Victor, in Migne, *P.L.*, vol. 193, col. 279). Water is also an allegory of Christ’s humanity (Gaudentius, in Migne, *P.L.*, vol. 20, col. 983). Very often water appears as dew (*ros Gedeonis*), and dew, likewise, is an allegory of Christ: “Dew is seen in the fire” (Romanus, *De theophania*, in Pitra, *Analecta sacra*, I, p. 21). “Now has Gideon’s dew flowed on earth” (Romanus, *De nativitate*, *ibid.*, p. 237). The alchemists thought that their *aqua permanens* was endowed with a virtue which they called “flos” (flower). It had the power of changing body into spirit and giving it an incorruptible quality (*Turba phil.*, ed. Ruska, p. 197). The water was also called “acetum” (acid), “whereby God finished his work, whereby also bodies take on spirit and are made spiritual” (*Turba*, p. 126). Another name for it is “spiritus sanguis” (blood spirit, *Turba*, p. 129). The *Turba* is an early Latin treatise of the 12th century, translated from an originally Arabic compilation dating back to the 9th and 10th centuries. Its contents, however, stem from Hellenistic sources. The Christian allusion in “spiritualis sanguis” might be due to Byzantine influence. *Aqua permanens* is quicksilver, *argentum vivum* (Hg). “Our living silver is our clearest water” (*Rosarium phil.*, in *Art. aurif.*, II, p. 213). The *aqua* is also called fire (*ibid.*, p. 218). The body, or substance, is transformed by water and fire, a complete parallel to the Christian idea of baptism and spiritual transformation.

⁷⁰ Missale Romanum. The rite is old and was known as the “lesser (or greater) blessing of salt and water” from about the 8th century.

⁷¹ In “Isis the Prophetess to her Son Horus” (Berthelot, *Alch. grecs*, I, xiii), an angel brings Isis a small vessel filled with transparent water, the arcanum. This is an obvious parallel to the krater of Hermes (*Corpus Hermeticum*, I) and of Zosimos (Berthelot, III, li, 8), which was filled with *nous*. In the *φυσικά καὶ μυστικά*. of Pseudo-Democritus (Berthelot, II, i, 63), the divine water is said to effect a transformation by bringing the “hidden nature” to the surface. And in the treatise of Comarius we find the miraculous waters that produce a new springtime (Berthelot, Traductions, p. 281).

⁷² Gnosius (in *Hermetis Trismegisti Tractatus vere Aureus, cum Scholiis Dominici Gnosii*, 1610, pp. 44 and 101) speaks of “Hermaphroditus noster Adamicus” when treating of the quaternity in the circle. The centre is the “mediator making peace between enemies,” obviously a uniting symbol (cf. *Psychological Types*, 1923 edn., pp. 234ff. and Def. 51). [Further developed in *Aion*, pp. 194ff—EDITORS.] The hermaphrodite is born of the “self-impregnating dragon” (*Art. aurif.*, I, p. 303), who is none other than Mercurius, the *anima mundi*. (Maier, *Symbola*, p. 43; Berthelot, I, 87.) The uroboros is an hermaphroditic symbol. The hermaphrodite is also called the Rebis (“made of two”), frequently depicted in the form of an apotheosis (for instance in the *Rosarium*, in *Art. aurif.*, II, pp. 291 and 359; Reusner, *Pandora*, 1588, p. 253).

⁷³ *Aurora Consurgens* (ed. von Franz, p. 129) says, quoting Senior: “There is One thing that never dieth, for it continueth by perpetual increase, when the body shall be glorified in the final resurrection of the dead.... Then saith the second Adam to the first and to his sons: Come ye blessed of my Father,” etc.

⁷⁴ Alphidius (12th cent.): “Of them is born the modern light (*lux moderna*), to which no light is like in all the world.” (*Rosarium*, in *Art. aurif.*, II, p. 248; “Tractatus aureus,” *Ars chem.*)

⁷⁵ Jung and Wilhelm, *The Secret of the Golden Flower* (1962), p. 69.

⁷⁶ Cf. *Psychology and Alchemy*, pars. 154ff., 183ff.

⁷⁷ Waite, *The Secret Tradition in Alchemy*.

⁷⁸ Cf. my “Psychological Factors Determining Human Behaviour.”

¹ “Zur Psychologie der Trinitätsidee,” *Eranos-Jahrbuch* 1940–41 (Zurich, 1942). [Later revised and expanded as “Versuch zu einer psychologischen Deutung des Trinitätsdogmas,” *Symbolik des Geistes* (Zurich, 1948), pp. 321–446, from which version the present translation is made.—EDITORS.]

² Of the older ones I refer chiefly to Clement of Alexandria (d. c. 216), Origen (d. 253), and Pseudo-Dionysus the Areopagite (d. end of 5th cent.).

¹ Salzburg, 1939.

² Jastrow, *Die Religion Babylonians und Assyriens*, I, p. 61.

³ Ibid., pp. 102, 143f.

⁴ P. 112.

⁵ P. 130.

⁶ P. 112.

⁷ P. 130. Cf. John 16:15.

⁸ Jeremias, *The Old Testament in the Light of the Ancient East*, I, p. 137.

⁹ Cf. John 1:3.

¹⁰ Kessler, *Mani*, pp. 267ff.

¹¹ Roscher, *Lexikon*, II, 2, cols. 2371f., s.v. "Marduk."

¹² Jastrow, p. 139. Cf. John 1:18.

¹³ Cf. the Christian fish-symbol.

¹⁴ "Anu and Bel called me, Hammurabi, the exalted prince, the worshipper of the Gods, to go forth like the sun ... to enlighten the land." Harper, *The Code of Hammurabi*, p. 3.

¹⁵ Cf. the invocation of the Holy Ghost as "Mother" in the Acts of Thomas (James, *The Apocryphal New Testament*, p. 376). Also the feminine nature of Sophia, who frequently represents the Holy Ghost.

¹⁶ Cf. Mary as creature and as Θεοτόκος

¹⁷ Jastrow, p. 141.

¹⁸ P. 61.

¹⁹ P. 133.

²⁰ Jeremias, I, pp. 247ff.

²¹ Cf. Mary's connections with the moon in Rahner, *Griechische Mythen in christlicher Deutung*, pp. 200ff., and "Mysterium Lunae," p. 80.

²² A possible reference to the realm of the dead on the one hand and to Nimrod the mighty hunter on the other. See Roscher, *Lexikon*, II, cols. 2371f., s.v. "Marduk."

- ¹ [*Mysterium Coniunctionis*, ch. IV, 1–3.]
- ² Jacobsohn, “Die dogmatische Stellung des Königs in der Theologie der alten Aegypter,” p. 17.
- ³ *Ibid.*, p. 58.
- ⁴ P. 64. Barth, *Credo*, p. 70.
- ⁵ Barth, *Bibelstunden über Luk I*, p. 26.
- ⁶ Preisigke, *Die Gotteskraft der frühchristlichen Zeit*; also *Vom göttlichen Fluidum nach ägyptischer Anschauung*.
- ⁷ *Pistis Sophia* (trans. by Mead), p. 118.
- ⁸ Cf. Hebrews 1:5: “Thou art my Son, this day have I begotten thee.”
- ⁹ A. Moret, “Du caractère religieux de la royauté pharaonique.”
- ¹⁰ Further material concerning pagan sources in Nielsen, *Der dreieinige Gott*, I.
- ¹¹ Cf. Norden, *Die Geburt des Kindes*, pp. 77ff.

¹ *A History of Greek Philosophy*, I, p. 429.

² Authority for the latter remark in Aristotle, *De coelo*, I, i, 268a.

³ The source for this appears to be Macrobius, *Commentarius in Somnium Scipionis*, I, 6, 8.

⁴ Cf. “the movement of the Different to the left” in the *Timaeus* 36C (trans. by Cornford, p. 73).

⁵ Cf. the etymological relations between G. *zwei*, ‘two,’ and *Zweifler*, ‘doubter.’ [In Eng., cf. *duplicity*, *double-dealer*, *double-cross*, *two-faced*.—TRANS.]

⁶ Harnack (*Dogmengeschichte*, II, p. 303) compares the scholastic conception of the Trinity to an equilateral triangle.

⁷ Trans. by Cornford, p. 44.

⁸ *Ibid.*, p. 44.

⁹ *A History of Greek Mathematics*, I, p. 89; Cornford, p. 47.

¹⁰ Cornford, pp. 44–45, slightly modified.

¹¹ For a detailed account see *Psychology and Alchemy*, pars. 204ff.

¹² As the dream in *Psychology and Alchemy*, par. 200, shows.

¹³ Judging, of course, from the standpoint of the most differentiated function.

¹⁴ Cf. *Psychological Types*, Def. 30.

¹⁵ “The world is narrow and the brain is wide;

Thoughts in the head dwell lightly side by side,

Yet things in space run counter and fall foul.”

—Schiller, *Wallensteins Tod*, II, 2.

¹⁶ “Not being.”

¹⁷ Cornford, p. 58, slightly modified.

¹⁸ Theodor Gomperz (*Greek Thinkers*, III, p. 215) mentions two primary substances which are designated as follows in Plato’s *Philebus*: limit, unlimited; the same, the other; the divisible, the indivisible. He adds that Plato’s pupils would have spoken of “unity” and of “the great and the small” or of “duality.” From this it is clear that Gomperz regards the “Same” and the “indivisible” as synonymous, thus overlooking the resistance of the “Other,” and the fundamentally fourfold nature of the world soul. (See below.)

¹⁹ [The version here given is translated from the German text of Otto Apelt (*Plato: Timaios und Kritias*, p. 52) cited by the author.—TRANS.]

20

Τῆς ἀμερίστου καὶ αἰεὶ κατὰ ταῦτὰ ἐχούσης οὐσίας καὶ τῆς αὐτῆς περὶ τὰ σώματα γιγνομένης μεριστῆς, τρίτον ἐξ ἀμφοῖν ἐν μέσῳ συνεκεράσατο οὐσίας εἶδος· τῆς τε ταύτου φύσεως αὐτῆς περὶ καὶ τῆς τοῦ ἑτέρου, καὶ κατὰ ταῦτὰ συνέστησεν ἐν μέσῳ τοῦ τε ἀμεροῦς αὐτῶν καὶ τοῦ κατὰ τὰ σώματα μεριστοῦ· καὶ τρία λαβὼν αὐτὰ ὄντα συνεκεράσατο εἰς μίαν πάντα ἰδέαν, τὴν θατέρου φύσιν δύσμεικτον οὔσαν εἰς ταύτῳ συναρμόττων βία, μειγνὺς δὲ μετὰ τῆς οὐσίας.

Cornford (pp. 59–60) translates as follows: “Between the indivisible Existence that is ever in the same state and the divisible Existence that becomes in bodies, he compounded a third form of Existence composed of both. Again, in the case of Sameness and in that of Difference, he also on the same principle made a compound intermediate between that kind of them which is indivisible and the kind that is divisible in bodies. Then, taking the three, he blended them all into a unity, forcing the nature of Difference, hard as it was to mingle, into union with Sameness, and mixing them together with Existence” (35A).

²¹ Cf. *Timaeus* 37C, where the first God is described as the “father” and his creation as the copy of an original “pattern,” which is himself (Cornford, p. 97).

²² This seems borne out by the fact that the first pair of opposites is correlated with *οὐσία* (being), and the second with *φύσις* (nature). If one had to choose between *οὐσία* and *φύσις*, the latter would probably be considered the more concrete of the two.

²³ Reprinted as Bollingen Series III, *Plato: Timaeus and Critias*, p. 71.

²⁴ *Timaeus* 36B (Cornford, p. 73).

²⁵ Taylor, p. 75.

²⁶ Griffith, *A Collection of Hieroglyphs*, p. 34 B. Fig. 142:  = Plan of a village with cross-streets.

²⁷ P. 61. The intermedia are constructed on the assumption that Indivisible and Divisible are opposite attributes of each of the three principles, Existence, Sameness, Difference. I do not know whether the text permits of such an operation.

²⁸ Gomperz, III, p. 200 [The two unfinished tetralogies are (a) *Republic, Timaeus, Critias* (left incomplete), (*Hermocrates*, never written); (b) *Theaetetus, Sophist, Statesman, (Philosopher*, never written).—TRANS.]

²⁹ Leisegang, *Pneuma Hagion*, p. 86.

¹ Here one might recall the legend that, after the death of Christ, Mary betook herself with John to Ephesus, where she is said to have lived until her death.

¹ *Panarium (Contra octoginta haereses)* LXXIX. See Migne. *P.G.*, vol. 41, cols. 739ff.

³ “Quod genus lubricum et in errorem proclive, ac pusilli admodum et angusti animi esse solet.”

⁴ The special emphasis I lay on archetypal predispositions does not mean that mythologems are of exclusively psychic origin. I am not overlooking the social conditions that are just as necessary for their production.

⁵ The *ka* of the king even has an individual name. Thus “the living *ka* of the Lord of the Two Lands,” Thutmosis III, was called the “victorious bull which shines in Thebes.” Erman, *Life in Ancient Egypt*, p. 307.

⁶ The “doubling” of the spirit occurs also in the Old Testament, though more as a “potency” emanating from God than as an hypostasis. Nevertheless, Isaiah 48:16 looks very like a hypostasis in the Septuagint text: **Κύριος Κύριος ἀπεστειλὲν με καὶ τὸ πνεῦμα αὐτοῦ** (The Lord the Lord sent me and his spirit).

⁷ For an instructive account of the Greek background see Harrison, *Themis*, ch. 1.

⁸ Cf. the detailed exposition of the death and rebirth of the divine *κοῦρος*, in Harrison, *Themis*.

⁹ The relation of Father to Son is not arithmetical, since both the One and the Other are still united in the original Unity and are, so to speak, eternally on the point of becoming two. Hence the Son is eternally being begotten by the Father, and Christ’s sacrificial death is an eternally present act.

¹⁰ The *πάθη* of Dionysus would be the Greek parallels.

¹ The so-called “Comma Johanneum,” which would seem to be an exception, is a demonstrably late interpolation of doubtful origin. Regarded as a dogmatic and revealed text *per se*, it would afford the strongest evidence for the occurrence of the Trinity in the New Testament. The passage reads (I John 5:8: “And there are three that bear witness: the Spirit, and the water, and the blood; and these three are one” (DV). That is to say, they agree in their testimony that Christ “came in water and in blood” (verse 6, DV). [In verse 8, AV has “and these three agree in one”; RSV: “and these three agree.”—TRANS.] The Vulgate has the late interpolation in verse 7: “Quoniam tres sunt, qui testimonium dant *in caelo: Pater, Verbum et Spiritus Sanctus: et hi tres unum sunt.*” Note that in the Greek text the three neuter nouns *πνεῦμα, ὕδωρ, and αἷμα* are followed by a masculine plural: *οἱ τρεῖς εἰς τὸ ἓν εἰσιν.*

² II Cor. 13:14 (AV). The baptismal formula “In the name of the Father and the Son and the Holy Ghost” comes into this category, though its authenticity is doubted. It seems that originally people were baptized only in the name of Jesus Christ. The formula does not occur in Mark and Luke. Cf. Krueger, *Das Dogma von der Dreieinigkeit und Gottmenschheit in seiner geschichtlichen Entwicklung*, p. 11.

³ I Peter 1:2 (RSV).

⁴ Apostolic Fathers, trans. by Lake, I, p. 89. Clement was the third bishop of Rome after Peter, according to Irenaeus. His dating is unsure, but he seems to have been born in the second half of the 2nd cent.

⁵ Panarium, LXII, 11, in Migne, P.G., vol. 41, cols. 1052-53.

⁶ Cf. James, *The Apocryphal New Testament*, pp. 10f.

⁷ We might also mention the division of Christ’s forbears into 3 × 14 generations in Matthew 1:17. Cf. the role of the 14 royal ancestors in ancient Egypt: Jacobsohn, “Die dogmatische Stellung des Königs in der Theologie der alten Aegypter,” pp. 66ff.

⁸ As we know, St. John’s gospel marks the beginning of this process.

⁹ Cf. *Psychological Types*, Def. 51.

¹⁰ *Explanatio symboli ad initiandos.*

¹¹ Gregory of Nyssa, *De Vita S. Gregorii Thaumaturgi*, in Migne, P.G., vol. 46, cols. 911–14.

¹² Caspari, *Alte und neue Quellen zur Geschichte des Taufsymbols*, pp. 10–17.

¹³ First mentioned in Tertullian (d. 220).

¹⁴ Origen, *On First Principles*, trans. by Butterworth, pp. 331.

¹⁵ *Ibid.*, p. 31.

¹⁶ *Ibid.*

¹⁷ Cf. J. R. Palanque and others, *The Church in the Christian Roman Empire, I: The Church and the Arian Crisis*, p. 96.

¹⁸ More accurately, the unity of substance consists in the fact that the Aeons are descended from the Logos, which proceeds from Nous, the direct emanation of Bythos. Cf. Irenaeus, *Adversus haereses*, II, 17, 4, in Migne, P.G., vol. 7, cols. 762–63 (trans. by Roberts and Rambaut, p. 174).

¹⁹ [The addition at this point of the words “and from the Son” (*Filioque*), which, though never accepted by the Eastern Churches, has been universal in the West, both Catholic and Protestant, since the beginning of the eleventh

century, is still one of the principal points of contention between the two main sections of the Christian body.—
EDITORS.]

²⁰ It is also known as the “Symbolum Quicumque,” on account of the opening words: “Quicumque vult salvus esse” (Whosoever would be saved). It does not go back to Athanasius.

²¹ [Official version from the Revised Book of Common Prayer (1928), with alternative readings.—TRANS.]

²² [From the Decrees of the Lateran Council, ch. 1.—TRANS.]

²³ Erroneously ascribed to St. Augustine. Cf. *Opera*, VI.

²⁴ *Ibid.*, p. 1194, B.

²⁵ “The begetter is the Father, the begotten is the Son, and that which proceeds from both is the Holy Spirit.” *Ibid.*, p. 1195, D.

¹ Cf. my “On the Nature of the Psyche,” pp. 200ff.

² I have often been asked where the archetype comes from and whether it is acquired or not. This question cannot be answered directly. Archetypes are, by definition, factors and motifs that arrange the psychic elements into certain images, characterized as archetypal, but in such a way that they can be recognized only from the effects they produce. They exist preconsciously, and presumably they form the structural dominants of the psyche in general. They may be compared to the invisible presence of the crystal lattice in a saturated solution. As *a priori* conditioning factors they represent a special, psychological instance of the biological “pattern of behaviour,” which gives all living organisms their specific qualities. Just as the manifestations of this biological ground plan may change in the course of development, so also can those of the archetype. Empirically considered, however, the archetype did not ever come into existence as a phenomenon of organic life, but entered into the picture with life itself.

³ Cf. the detailed argument which I have put forward in “On the Nature of the Psyche,” pp. 200ff.

⁴ It is very probable that the activation of an archetype depends on an alteration of the conscious situation, which requires a new form of compensation.

⁵ Koepgen makes the following trenchant remark in his *Gnosis des Christentums*, p. 198: “If there is such a thing as a history of the Western mind ... it would have to be viewed from the standpoint of the personality of Western man, which grew up under the influence of trinitarian dogma.”

⁶ “Deus est circulus cuius centrum est ubique, circumferentia vero nusquam” (God is a circle whose centre is everywhere and the circumference nowhere). This definition occurs in the later literature. In the form “Deus est sphaera infinita” (God is an infinite sphere) it is supposed to have come from the *Liber Hermetis, Liber Termegisti*, Cod. Paris. 6319 (14th cent.); Cod. Vat. 3060 (1315). Cf. Baumgartner, *Die Philosophie des Alanus de Insults*, p. 118. In this connection, mention should be made of the tendency of Gnostic thought to move in a circle, eg: “In the beginning was the Word, and the Word was with God, and God was the Word.” Cf. Leisegang, *Denkformen*, pp. 60ff.

⁷ Koepgen (p. 307) puts it very aptly: “Jesus relates everything to his ego, but this ego is not the subjective ego, it is a cosmic ego.”

⁸ Cf. Jacob’s struggle with the angel at the ford.

⁹ “Reflection” should be understood not simply as an act of thought, but rather as an attitude. [Cf. *Psychological Types*, Def. 8.—EDITORS.] It is a privilege born of human freedom in contradistinction to the compulsion of natural law. As the word itself testifies (“reflection” means literally “bending back”), reflection is a spiritual act that runs counter to the natural process; an act whereby we stop, call something to mind, form a picture, and take up a relation to and come to terms with what we have seen. It should, therefore, be understood as an act of *becoming conscious*.

¹⁰ “Active spiration” is a manifestation of life, an immanent act of Father and Son; “passive spiration,” on the other hand, is a quality of the Holy Ghost. According to St. Thomas, spiration does not proceed from the intellect but from the will of the Father and Son. In relation to the Son the Holy Ghost is not a spiration, but a procreative act of the Father.

¹¹ Cf. the Acts of Thomas (trans. by James, p. 388): “Come, O communion of the male; come, she that knoweth the mysteries of him that is chosen.... Come, holy dove that beareth the twin young; come, hidden mother.”

¹² For this seeming *contradictio in adjecto* see “On the Nature of the Psyche,” p. 172.

¹³ The existence of such process is evidenced by the content of dreams.

¹⁴ *Die Gnosis des Christentums*, p. 194.

¹⁵ In the *Rituale Romanum* (“On the Exorcism of Persons Possessed by the Devil”: 1952 edn., pp. 839ff.), states of possession are expressly distinguished from diseases. We are told that the exorcist must learn to know the signs by which the possessed person may be distinguished from “those suffering from melancholy or any morbid condition.” The criteria of possession are: “... speaking fluently in unknown tongues or understanding those who speak them; revealing things that take place at a distance or in secret; giving evidence of greater strength than is natural in view of one’s age or condition; and other things of the same kind.” The Church’s idea of possession, therefore, is limited to extremely rare cases, whereas I would use it in a much wider sense as designating a frequently occurring psychic phenomenon: any autonomous complex not subject to the conscious will exerts a possessive effect on consciousness proportional to its strength and limits the latter’s freedom. On the question of the Church’s distinction between disease and possession, see Tonquédec, *Les Maladies nerveuses ou mentales et les manifestations diaboliques*.

¹⁶ I am always coming up against the misunderstanding that a psychological treatment or explanation reduces God to “nothing but” psychology. It is not a question of God at all, but of man’s ideas of God, as I have repeatedly emphasized. There are people who do have such ideas and who form such conceptions, and these things are the proper study of psychology.

¹ “Feeling is all; / Names are sound and smoke.” [This problem of the “fourth” in *Faust* is also discussed in *Psychology and Alchemy*, pars. 201ff.—EDITORS.]

² Cf. *Psychological Types*, Def. 30.

³ Cf. the hymn of Valentinus (Mead, *Fragments of a Faith Forgotten*, p. 307): “All things depending in spirit I see; all things supported in spirit I view; flesh from soul depending; soul by air supported; air from aether hanging; fruits born of the deep; babe born of the womb.” Cf. also the *προσφυής ψυχή* of Isidorus, who supposed that all manner of animal qualities attached to the human soul in the form of “outgrowths.” [Cf. *Aion*, par. 370.]

⁴ Cf. the alchemical symbol of the *umbra solis* and the Gnostic idea that Christ was born “not without some shadow.”

⁵ The four *ρίζώματα* of Empedocles.

⁶ “On the Fourfold Root of the Principle of Sufficient Reason,” in *Two Essays by Arthur Schopenhauer*.

⁷ In Plato the quaternity takes the form of a cube, which he correlates with earth. Lü Pu-wei (*Frühling und Herbst*, trans. into German by Wilhelm, p. 38) says: “Heaven’s way is round, earth’s way is square.”

⁸ In her “Die Gestalt des Satans im Alten Testament” (*Symbolik des Geistes*, pp. 153ff.), Riwkah Scharf shows that Satan is in fact one of God’s sons, at any rate in the Old Testament sense.

⁹ The Suffix *-el* means god, so Satanaël = Satan-God.

^{9a} Michael Psellus, “De Daemonibus,” 1497, fol. NVv, ed. M. Ficino. Cf. also Epiphanius, *Panarium*, Haer. XXX, in Migne, *P.G.*, vol. 41, cols. 406ff.

¹⁰ Cf. Przywara’s meditations on the Cross and its relation to God in *Deus Semper Major*, I. Also the early Christian interpretation of the Cross in the Acts of John, trans. by James, pp. 228ff.

¹¹ See *Psychology and Alchemy*, fig. 28.

¹² Cf. *Psychology and Alchemy*, pars. 315ff., and the first paper in this volume, pars. 122ff.

¹³ As this doctrine has already got beyond the stage of “conclusio probabilis” and has reached that of “conclusio certa,” the “definitio sollemnis” is now only a matter of time. The Assumption is, doctrinally speaking, a “revelatum implicitum”; that is to say, it has never been revealed explicitly, but, in the gradual course of development, it became clear as an original content of the Revelation. (Cf. Wiederkehr, *Die leibliche Aufnahme der allerseligsten Jungfrau Maria in den Himmel*.) From the psychological standpoint, however, and in terms of the history of symbols, this view is a consistent and logical restoration of the archetypal situation, in which the exalted status of Mary is revealed implicitly and must therefore become a “conclusio certa” in the course of time.

[This note was written in 1948, two years before the promulgation of the dogma. The bodily assumption of Mary into heaven was defined as a dogma of the Catholic faith by Pope Pius XII in November 1950 by the Apostolic Constitution *Munificentissimus Deus* (*Acta Apostolicae Sedis*, Rome, XLII, pp. 753ff), and in an Encyclical Letter, *Ad Caeli Reginam*, of October 11, 1954, the same Pope instituted a feast to be observed yearly in honour of Mary’s “regalis dignitas” as Queen of Heaven and Earth (*Acta Apostolicae Sedis*, XLVI, pp. 625ff.).—EDITORS.]

¹⁴ Although the assumption of Mary is of fundamental significance, it was not the first case of this kind. Enoch and Elijah were taken up to heaven with their bodies, and many holy men rose from their graves when Christ died.

¹⁵ Her divinity may be regarded as a tacit *conclusio probabilis*, and so too may the worship or adoration (*προσκύνησις*) to which she is entitled.

¹⁶ Koepgen (p. 185) expresses himself in similar terms: “The essence of the devil is his hatred for God; and God allows this hatred. There are two things which Divine Omnipotence alone makes possible: Satan’s hatred and the existence of the human individual. Both are by nature completely inexplicable. But so, too, is their relationship to God.”

¹⁷ Just how alive and ingrained such conceptions are can be seen from the title of a modern book by Sosnosky, *Die rote Dreifaltigkeit: Jakobiner und Bolscheviken* [“The Red Trinity: Jacobins and Bolsheviks”].

¹⁸ Koepgen’s views are not so far from my own in certain respects. For instance, he says that “Satan acts, in a sense, as God’s power.... The mystery of one God in Three Persons opens out a new freedom in the depths of God’s being, and this even makes possible the thought of a personal devil existing alongside God and in opposition to him” (p. 186).

¹⁹ Since Satan, like Christ, is a son of God, it is evident that we have here the archetype of the hostile brothers. The Old Testament prefiguration would therefore be Cain and Abel and their sacrifice. Cain has a Luciferian nature because of his rebellious progressiveness, but Abel is the pious shepherd. At all events, the vegetarian trend got no encouragement from Yahweh [Gen. 4:5].

²⁰ See the first paper in this volume, par. 104.

²¹ In antiquity, regard for astrology was nothing at all extraordinary. [Cf. “Synchronicity: An Acausal Connecting Principle,” pars. 872ff., and *Aion*, pars. 127ff.—EDITORS.]

²² This applies to the zodion of the Fishes. In the astronomical constellation itself, the fish that corresponds approximately to the first 1,000 years of our era is vertical, but the other fish is horizontal.

²³ God’s antithetical nature is also expressed in his androgyny. Priscillian therefore calls him “masculofemina,” on the basis of Genesis 1:27: “So God created man in his own image ... male and female created he them.”

²⁴ Cf. *Psychology and Alchemy*, pars. 520ff.

²⁵ Cf. above, pars. 104ff.

²⁶ *Faust*, Part II, Act 5. (“Earth’s residue to bear / Hath sorely pressed us.” Trans. by Bayard Taylor.)

²⁷ Cf. James, *The Apocryphal New Testament*, p. 255.

²⁸ [From a play by Marc Connelly, adapted from stories by Roark Bradford based on American Negro folk-themes.—EDITORS.]

¹ Yahweh approaches the moral problem comparatively late—only in Job. Cf. “Answer to Job,” in this volume.

² Koepgen (p. 231) therefore calls Jesus, quite rightly, the first “autonomous” personality.

³ Justin Martyr, *Apologia* II: “that we may not remain children of necessity and ignorance, but of choice and knowledge.” Clement of Alexandria, *Stromata*, I, g: “And how necessary is it for him who desires to be partaker of the power of God, to treat of intellectual subjects by philosophizing!” II, 4: “Knowledge accordingly is characterized by faith; and faith, by a kind of divine mutual and reciprocal correspondence, becomes characterized by knowledge.” VII, 10: “For by it (Gnosis) faith is perfected, inasmuch as it is solely by it that the believer becomes perfect.” “And knowledge is the strong and sure demonstration of what is received by faith.” (Trans. by Wilson, I, p. 380; II, pp. 10, 446–47.)

⁴ Submission to any metaphysical authority is, from the psychological standpoint, submission to the unconscious. There are no scientific criteria for distinguishing so-called metaphysical factors from psychic ones. But this does not mean that psychology denies the existence of metaphysical factors.

⁵ The Church knows that the “discernment of spirits” is no simple matter. It knows the dangers of subjective submission to God and therefore reserves the right to act as a director of conscience.

⁶ The “Oxford Movement” was originally the name of the Catholicizing trend started by the Anglican clergy in Oxford, 1833. [Whereas the “Oxford Groups,” or “Moral Rearmament Movement,” were founded in 1921. also at Oxford, by Frank Buchman as “a Christian revolution ... the aim of which is a new social order under the dictatorship of the Spirit of God, and which issues in personal, social racial, national, and supernational renaissance” Buchman, cited in *Webster’s International Dictionary*, 2nd edn., 1950—EDITORS.]

⁷ Cf. *Psychology and Alchemy*, Part II.

⁸ Thomas Aquinas (*Summa theologica*, I, xxxvi, art. 1): “Non habet nomen proprium” (he has no proper name). I owe this reference to the kindness of Fr. Victor White, O.P.

⁹ Both these categories are, as we know, attributes of the *lapis philosophorum* and of the symbols of the self.

¹⁰ It should not be forgotten, however, that the opposites which Nicholas had in mind were very different from the psychological ones.

¹¹ Cf. “Die Gestalt des Satans im Alten Testament,” in *Symbolik des Geistes*, pp. 153ff.

¹ In the Greek Church the Trinity is called *τριάς*.

¹ “St. Thomas emphasizes that prophetic revelation is, as such, independent of good morals—not to speak of personal sanctity” (*De veritate*, xii, 5; *Summa theol.*, I–II, p. 172). I take this remark from the MS. of an essay on “St. Thomas’s Conception of Revelation,” by Fr. Victor White, O.P., with the kind permission of the author.

² The Axiom of Maria. Cf. *Psychology and Alchemy*, pars. 209f.

³ Cf. James, *The Apocryphal New Testament*, p. 33.

⁴ I am thinking here of the *sola fide* standpoint of the Protestants.

¹ The following account and examination of the principal symbol in the Mass is not concerned either with the Mass as a whole, or with its liturgy in particular, but solely with the ritual actions and texts which relate to the transformation process in the strict sense. In order to give the reader an adequate account of this, I had to seek professional help. I am especially indebted to the theologian Dr. Gallus Jud for reading through and correcting the first two sections.

² [This is a translation of the Karl von Weizsäcker version (1875) used here by the author. Elsewhere the Biblical quotations are taken from the AV and occasionally from the RSV and the DV. Following are the Greek and Latin (Vulgate) versions of the italicized portion of this passage.—TRANS.]

“... τοῦτο μού ἐστίν τὸ σῶμα τὸ ὑπὲρ ὑμῶν. τοῦτο ποιεῖτε εἰς τὴν ἐμὴν ἀνάμνησιν. ὡσαύτως καὶ τὸ ποτήριον μετὰ τὸ δειπνῆσαι λέγων· τοῦτο τὸ ποτήριον ἡ καινὴ διαθήκη ἐστίν ἐν τῷ ἐμῷ αἵματι.”

“... hoc est corpus meum, quod pro vobis tradetur: hoc facite in meam commemorationem. Similiter et calicem, postquam coenavit, dicens: Hic calix novum testamentum est in meo sanguine.”

³ δειπνον, ‘coena.’

⁴ This of course has nothing to do with the official conception of spirit by the Church.

⁵ “τὸ σῶμα τὸ ὑπὲρ ὑμῶν.”

⁶ Käsemann, *Leib und Leib Christi*, p. 120.

⁷ Dr. Jud kindly drew my attention to the equally relevant passage in Malachi 1:10–11: “Who is there even among you that would shut the doors for nought? neither do ye kindle fire on mine altar for nought.... And in every place incense shall be offered unto my name, and a pure offering ...”

⁸ That is to say, not before he has accomplished the preparatory part of the service. In offering these gifts the priest is not the “master” of the sacrifice. “Rather that which causes them to be sacrificed in the first place is sanctifying grace. For that is what their sacrifice means: their sanctification. The man who each time performs the sacred act is the servant of grace, and that is why the gifts and their sacrifice are always pleasing to God. The fact that the servant may be bad does not affect them in any way. The priest is only the servant, and even this he has from grace, not from himself.” Joseph Kramp, S.J., *Die Opferanschauungen der römischen Messliturgie*, p. 148.

⁹ Ibid., p. 17.

¹ In the account that follows I have made extensive use of Brinktrine, *Die Heilige Messe in ihrem Werden und Wesen*.

² Τύπος τοῦ ἄρτου τῆς εὐχαριστίας.”

³ That is, in the Roman rite. In the Greek Uniate rites, communion is received in bread *and* wine.

⁴ This is the interpretation of Yves, bishop of Chartres (d. 1116).

⁵ Cyprian attacks this heretical custom in his letter to Caecilius. Letter 63 to Caecilius, Migne, *P.L.*, vol. 4, cols. 372ff. (trans. by Carey, pp. 181ff.).

⁶ “In umbra erat aqua de petra quasi sanguis ex Christo.” The *umbra*, ‘shadow,’ refers to the foreshadowing in the Old Testament, in accordance with the saying: “Umbra in lege, imago in evangelio, veritas in coelestibus” (The shadow in the Law, the image in the Gospel, the truth in Heaven). Note that this remark of Ambrose does not refer to the Eucharist but to the water symbolism of early Christianity in general; and the same is true of the passages from John. St. Augustine himself says: “There the rock was Christ; for to us that is Christ which is placed on the altar of God.” *Tractatus in Joannem*, XLV, 9 (trans. by Innes).

⁷ Connolly, ed., *The So-called Egyptian Church Order and Derived Documents*.

⁸ Berthelot, *Collection des anciens alchimistes grecs*. III, li. 8.

⁹ *Corpus Hermeticum*, Lib. IV, 4, in *Hermetica*, I, p. 151.

¹⁰ Strack and Billerbeck, *Kommentar zum Neuen Testament aus Talmud und Midrasch*, II, p. 492.

¹¹ A collection of Gnostic hymns from the 2nd cent.

¹² Ode VI in *The Odes of Solomon*, ed. Bernard, p. 55, after the J. Rendel Harris version. Cf. the ὕδωρ θεῖον, the *aqua permanens* of early alchemy, also the treatise of Komarius (Berthelot, IV, xx).

¹³ “Deus, qui humanae substantiae dignitatem mirabiliter condidisti, et mirabilius reformasti; da nobis per huius aquae et vini mysterium, eius divinitatis esse consortes, qui humanitatis nostrae fieri dignatus est particeps, Jesus Christus ...” [Here and throughout this essay the English translation is taken from *The Small Missal*, London, 1924. —TRANS.]

¹⁴ This is *my* interpretation and not that of the Church, which sees in this only an act of devotion.

¹⁵ “Mozarabic” from Arabic *musta‘rib*, ‘Arabianized,’ with reference to the Visigothic-Spanish form of ritual. [The Latin phrases: “Come, O sanctifying one.” “Come, O sanctifying spirit.”—EDITORS.]

¹⁶ The circumambulation from left to right is strictly observed in Buddhism.

¹⁷ The censuring is only performed at High Mass.

¹⁸ [“Let my prayer, O Lord, ascend like incense in thy sight.”]

¹⁹ [“May the Lord enkindle in us the fire of his love.” / “I will wash my hands among the innocent.”]

²⁰ [“Blessed is he that cometh in the name of the Lord.”]

²¹ [“Be present, be present in our midst, O Jesus, great High Priest: as thou wert in the midst of thy disciples.”]

²² According to the edict of the Church these words ought not, on account of their sacredness, to be translated into any profane tongue. Although there are missals that sin against this wise edict, I would prefer the Latin text to stand untranslated.

²³ Klug, in *Theologie and Glaube*, XVIII (1926), 335f. Cited by Brinktrine, p. 192.

²⁴ “idem ille Christus continetur et incruente immolatur.” Sessio XXII. Denzinger and Bannwart, *Enchiridion Symbolorum*, p. 312.

²⁵ “Missa est sacrificium hac ratione quia Christus aliquo modo moritur et a sacerdote mactatur” (The Mass is a sacrifice for the reason that in it Christ dies after a certain manner, and is slain by the priest). Hauck, *Realenzyklopädie*, XII, p. 693. The question of the *mactatio* had already been raised by Nicholas Cabasilas of Thessalonica: “De divino altaris sacrificio,” in Migne, *P.G.*, vol. 150, cols. 363ff. The sword as a sacrificial instrument also occurs in the Zosimos visions (see section 3).

²⁶ Kramp, p. 56.

²⁷ “Unde et memores, Domine, nos servi tui, sed et plebs tua sancta, eiusdem Christi Filii tui, Domini nostri, tam beatæ passionis, nec non et ab inferis resurrectionis, sed et in caelos gloriosæ ascensionis: offerimus præclaræ majestati tuæ de tuis donis ac datis, hostiam puram, hostiam sanctam, hostiam immaculatam, Panem sanctum vitæ æternæ, et Calicem salutis perpetuæ.

“Supra quæ propitio ac sereno vultu respicere digneris: et accepta habere, sicuti accepta habere dignatus es munera pueri tui justî Abel, et sacrificium Patriarchæ nostrî Abrahæ: et quod tibi obtulit summus sacerdos tuus Melchisedech, sanctum sacrificium, immaculatam hostiam.

“Supplices te rogamus, omnipotens Deus: jube hæc perferri per manus sancti Angeli tui in sublime altare tuum, in conspectu divinæ majestatis tuæ: ut, quotquot ex hac altaris participatione sacrosanctum Filii tui corpus, et sanguinem sumpserimus, omni benedictione cælesti et gratia repleamur. Per eundem Christum, Dominum nostrum. Amen.”

²⁸ Eusebius, *Evangelica præparatio*, I, 10, 11 (Migne, *P.G.*, vol. 21, col. 30).

²⁹ “Sidik” is a Phœnician name for God. Sir Leonard Woolley gives a very interesting explanation of this in his report on the excavations at Ur: *Abraham: Recent Discoveries and Hebrew Origins*.

³⁰ Kramp, p. 98.

³¹ Rücker, ed., *Ritus baptismi et missæ quam descripsit Theodorus ep. Mopsuestanus*.

³² This unity is a good example of *participation mystique*, which Lévy-Bruhl stressed as being one of the main characteristics of primitive psychology—a view that has recently been contested by ethnologists in a very short-sighted manner. The idea of unity should not, however, be regarded as “primitive” but rather as showing that *participation mystique* is a characteristic of symbols in general. The symbol always includes the unconscious, hence man too is contained in it. The *numinosity* of the symbol is an expression of this fact.

³³ Kramp, p. 55.

¹ Bernardino de Sahagún, *General History of the Things of New Spain*, Book 3: *The Origin of the Gods*, trans. by Anderson and Dibble, pp. 5f. (slightly modified).

² Cumont, *Textes et monuments*, I, p. 182. [And cf. Jung, *Symbols of Transformation*, p. 428 and frontispiece.—EDITORS.]

³ Cf. Frazer's *The Golden Bough*, Part III: "The Dying God." For the Eucharistic meal of fish, see *Aion*, pars. 174ff., 181ff.

⁴ *Alchimistes*, III, i, 2, 3; III, v; III, vi.

⁵ Cf. my paper "The Visions of Zosimos," par. 86, which quotes the relevant passages.

⁶ *Alchimistes*, III, li, 8. Cf. supra, par. 313.

⁷ Cf. the examples given in *Psychology and Alchemy*, pars. 347f.

⁸ Olympiodorus says this is particularly the effect of lead. Cf. Berthelot, II, iv, 43.

⁹ The dismemberment motif belongs in the wider context of rebirth symbolism. Consequently it plays an important part in the initiation experiences of shamans and medicine men, who are dismembered and then put together again. For details, see Eliade, *Shamanism*, ch. II.

¹⁰ [Cf. Berthelot, III, i, 3 and v, 1–2; and "The Visions of Zosimos," par. 86.—EDITORS.]

¹¹ Cf. Frazer's *The Golden Bough*, Part IV: *Adonis, Attis, Osiris*, pp. 242ff. and p. 405, and my *Symbols of Transformation*, pars. 594f. Cf. also Colin Campbell, *The Miraculous Birth of King Amon-Hotep III*, p. 142, concerning the presentation of the dead man, Sen-nezem, before Osiris, Lord of Amentet: "In this scene the god is usually represented enthroned. Before and behind him, hanging from a pole, is the dripping skin of a slain bull that was slaughtered to yield up the soul of Osiris at his reconstruction, with the vase underneath to catch the blood."

¹² Cf. Eduard Seler's account in Hastings, *Encyclopedia*, VIII, pp. 615f.

¹³ [*Symbols of Transformation*, pars. 309f.; *Psychology and Alchemy*, par. 490.]

¹⁴ Barbers were comparatively well-to-do people in ancient Egypt, and evidently did a flourishing trade. Cf. Erman, *Life in Ancient Egypt*, p. 304: "Barbers, all of whom must ... have lived in easy circumstances."

¹⁵ The real author of the *Chymische Hochzeit* was Johann Valentin Andreae. [It appeared under the pseudonym "Christian Rosencreutz," dated 1459, but actually published at Strasbourg, 1616. Concerning Andreae, cf. "The Psychology of the Transference," par. 407 and n. 18.—EDITORS.]

¹⁶ As Andreae must have been a learned alchemist, he might very well have got hold of a copy of the Codex Marcianus and seen the writings of Zosimos. Manuscript copies exist in Gotha, Leipzig, Munich, and Weimar. I know of only one printed edition, published in Italy in the 16th cent., which is very rare.

¹⁷ Hence the "shaving of a man" and the "plucking of a fowl," mentioned further on among the magical sacrificial recipes. A similar motif is suggested by the "changing of wigs" at the Egyptian judgment of the dead. Cf. the picture in the tomb of Sennezem (Campbell, p. 143). When the dead man is led before Osiris his wig is black; afterwards (at the sacrifice in the Papyrus of Ani) it is white.

¹⁸ Plutarch, *Quaestiones convivales*, IV, 5, and Diogenes Laertius, II, §112: Reitzenstein, *Poimandres*, pp. 75f. and 112. In a text named "Ghāya al-hakīm," ascribed to Maslama al-Madjrī, the following instructions are given when

invoking Saturn: “Arrive vêtu à la manière des Juifs, car il est leur patron.” Dozy and de Goeje, “Nouveaux documents pour l’étude de la religion des Harraniens,” p. 350.

¹⁹ Origen, *Contra Celsum*, VI, 31. Mead, *Pistis Sophia*, ch. 45. Bousset, *Hauptprobleme der Gnosis*, pp. 351ff. Roscher, *Lexikon*, s.v. Kronos, II, col. 1496. The dragon (κρόνος) and Kronos are often confused.

²⁰ Lippmann, *Entstehung und Ausbreitung der Alchemie*, II, p. 229.

²¹ Cf. *Aion*, pars. 128f.

²² “Beatus homo qui invenerit hanc scientiam et cui affluit providentia Saturni.” [Ed. von Franz, pp. 37f.]

²³ See the illustration in Reusner, *Pandora* (1588), and in *Le Songe de Poliphile*, trans. Béroalde de Verville (1600). [*Psych. and Alch.*, fig. 4.] Mostly the pictures show two lions eating one another. The uroboros, too, is often pictured in the form of two dragons engaged in the same process (*Viridarium chymicum*, 1624).

²⁴ Cf. the *Rosarium philosophorum*, in the *Artis auriferae* (1593), II, p. 206.

²⁵ Cf. the Cretan fragment of Euripides (Dieterich, *Eine Mithrasliturgie*, p. 105):

ἀγνὸν δὲ βίον τείνων ἐξ οὗ
Διὸς Ἰδαίου μύστης γενόμεν
καὶ νυκτιπόλου Ζαγρέως βούτας
τοὺς ὠμοφάγους δαΐτας τελέσας

(living a holy life, since I have been initiated into the mysteries of the Idaean Zeus, and eaten raw the flesh of Zagreus, the night-wandering shepherd).

²⁶ [Cf. “The Visions of Zosimos,” par. 86, III, i, 3, and—for the reference lower down to “blood”—III, v bis.]

²⁷ “Est et coelestis aqua sive potius divina Chymistarum ... pneuma, ex aetheris natura et essentia rerum quinta” (There is also the celestial, or rather the divine, water of the alchemists ... the pneuma, having the nature of the pneuma and the quintessence of things).—Hermolaus Barbarus, *Coroll. in Dioscoridem*, cited in M. Maier, *Symbola aureae mensae* (1617), p. 174.

“Spiritus autem in hac arte nihil aliud quam aquam indicari ...” (In this art, spirit means nothing else but water).—Theobaldus de Hoghelande, in the *Theatrum chemicum*, I (1602), p. 196. Water is a “spiritus extractus,” or a “spiritus qui in ventre (corporis) occultus est et fiet aqua et corpus absque spiritu: qui est spiritualis naturae” (spirit which is hidden in the belly [of the substance], and water will be produced and a substance without spirit, which is of a spiritual nature).—J. D. Mylius, *Philosophia reformata* (1622), p. 150. This quotation shows how closely spirit and water were associated in the mind of the alchemist.

“Sed aqua coelestis gloriosa scil. aes nostrum ac argentum nostrum, sericum nostrum, totaque oratio nostra, quod est unum et idem scil. sapientia, quam Deus obtulit, quibus voluit” (But the glorious celestial water, namely our copper and our silver, our silk, and everything we talk about, is one and the same thing, namely the Wisdom, which God has given to whomsoever he wished).—“Consilium coniugii,” in the *Ars chemica* (1566), p. 120.

²⁸ Berthelot, *La Chimie au moyen âge*, III, p. 53.

²⁹ Mylius, pp. 121 and 123. For the blood—water—fire equation see George Ripley, *Opera omnia chemica* (1649), pp. 162, 197, 295, 427.

³⁰ Ripley, *Opera*, p. 62; *Rosarium*, p. 264.

³¹ Mylius, p. 42.

³² Khunrath, *Von hylealischen ... Chaos* (1597), pp. 274f

³³ Berthelot, *Alchimistes*, I, xiii. [Cf. “The Visions of Zosimos,” pars. 97ff.]

³⁴ *Ibid.*, III, li, 8, and *Hermetica*, ed. Scott, I, p. 151.

³⁵ Berthelot, *Alchimistes*, III, vi, 5.

³⁶ Of the later authors I will mention only Johannes Christophorus Steeb, *Coelum sephiroticum* (1679, p. 138): “Omnis intellectus acuminis auctor ... a coelesti mercurio omnem ingeniorum vim provenire” (The author of all deeper understanding ... all the power of genius comes from the celestial Mercurius). For the astrological connection see Bouché-Leclercq, *L’Astrologie grecque*, pp. 312, 321–23.

³⁷ “Aurora consurgens.” In Mylius (p. 533) he is a giver of life.

³⁸ *Lexicon*.

³⁹ *Symbola*, p. 592.

⁴⁰ *Ibid.*, p. 600.

⁴¹ Ripley, *Opera*, Foreword, and in Khunrath’s *Chaos*. In Plutarch, Mercurius acts as a kind of world soul.

⁴² Gerhard Dom, “Congeries Paracelsicae chemicae,” in the *Theatrum chemicum*, I, p. 589.

⁴³ Cf “The Spirit Mercurius,” pars. 255, 256ff.

⁴⁴ Illustration in “Splendor solis,” *Aureum vellus* (1598).

⁴⁵ Cf. Khunrath, *Chaos*, and *Amphitheatrum sapientiae aeternae* (1604).

⁴⁶ Dorn, “Speculativae philosophiae,” in the *Theatrum chemicum*, I, pp. 284ff. The whole passage runs as follows:

“Post primam hominis inobedientiam, Dominus viam hanc amplissimam in callem strictissimam difficilimamque (ut videtis) restrinxit, in cuius ostio collocavit Cherubim angelum, ancipitem gladium manu tenentem, quo quidem arceret omnes ab introitu felicis patriae: hinc deflectentes Adae filii propter peccatum primi sui parentis, in sinistram latam sibimet viam construxerunt, quam evitastis. Longo postea temporis intervallo D. O. M. secreta secretorum suorum introivit, in quibus amore miserente, accusanteque iustitia, conclusit angelo gladium irae suae de manibus eripere, cuius loco tridentem hamum substituit aureum, gladio ad arborem suspenso: & sic mutata est ira Dei in amorem, servata iustitia: quod antequam fieret, fluvius iste non erat, ut iam, in se collectus, sed ante lapsum per totum orbem terrarum roris instar expansus aequaliter: post vero rediit unde processerat tandem, ut pax & iustitia sunt osculatae se, descendit affluentius ab alto manans aqua gratiae, totum nunc mundum alluens. In sinistram partem qui deflectunt, partim suspensum in arbore gladium videntes, eiusque noscentes historiam, quia mundo nimium sunt insiti, praetereunt: nonnulli videntes eius efficaciam perquirere negligunt, alii nec vident, nec vidisse voluissent: hi recta peregrinationem suam ad vallem dirigunt omnes, nisi per hamos resipiscentiae, vel poenitentiae nonnulli retrahantur ad montem Sion. Nostro iam saeculo (quod gratiae est) mutatus est gladius in Christum salvatorem nostrum qui crucis arborem pro peccatis nostris ascendit.”

(After man’s first disobedience the Lord straitened this wide road into a very narrow and difficult path, as you see. At its entrance he placed an angel of the Cherubim, holding in his hand a double-edged sword with which he was to keep all from entering into Paradise. Turning from thence on account of the sin of their first parents, the sons of Adam built for themselves a broad left-hand path: this you have shunned. After a long interval of time the Deus Optimus Maximus immersed himself in the innermost of his secrets, and he decided, out of the compassion of his love as well as for the demands of justice, to take the sword of wrath from the hand of the angel. And having

hung the sword on the tree, he substituted for it a golden trident, and thus was the wrath of God changed into love, and justice remained unimpaired. Previous to this, however, the river was not collected into one as it is now, but before the Fall it was spread equally over the whole world, like dew. But later it returned to the place of its origin. When peace and justice were united, the water of Grace flowed more abundantly from above, and now it bathes the whole world. Some of those who take the left-hand path, on seeing the sword suspended from the tree, and knowing its history, pass it by, because they are too entangled in the affairs of this world; some, on seeing it, do not choose to inquire into its efficacy; others never see it and would not wish to see it. All these continue their pilgrimage into the valley, except for those who are drawn back to Mount Zion by the hook of repentance. Now in our age, which is an age of grace, the sword has become Christ our Saviour, who ascended the tree of the Cross for our sins.) Cf. "The Philosophical Tree," pars. 447ff.

⁴⁷ Another remark of Dorn's points in the same direction: "The sword was suspended from a tree over the bank of the river" (p. 288).

⁴⁸ A few pages later Dorn himself remarks: "Scitote, fratres, omnia quae superius dicta sunt et dicentur in posterum, intelligi posse de praeparationibus alchemicis" (Know, brothers, that everything which has been said above and everything which will be said in what follows can also be understood of the alchemical preparations).

⁴⁹ Leisegang, *Die Gnosis*, pp. 171f.

⁵⁰ The passage which follows occurs in Hippolytus, *Elenchos*, vi, pp. 4f.

⁵¹ Genesis 3:24.

⁵² Leisegang, p. 80.

⁵³ That is why it is called "Hermaphroditus."

⁵⁴ One of its symbols is the scorpion, which stings itself to death.

⁵⁵ So far I have come across only one alchemical author who admits to having read the *Panarium* of Epiphanius, while declaring at the same time his sincere abhorrence of heresies. The silence of the alchemists in this matter is nothing to wonder at, since the mere proximity to heresy would have put them in danger of their lives. Thus even 90 years after the death of Trithemius of Spanheim, who was supposed to have been the teacher of Paracelsus, the abbot Sigismund of Seon had to compose a moving defence in which he endeavoured to acquit Trithemius of the charge of heresy. Cf. *Trithemius sui-ipsius vindex* (1616).

⁵⁶ *Ars chemica*, p. 259. Printed in Manget (1702), II.

⁵⁷ "Micreris" is probably a corruption of "Mercurius."

⁵⁸ *Theatr. chem.*, V (1622), p. 103.

⁵⁹ *Ibid.*, p. 68.

⁶⁰ *Artis auriferae*, I, pp. 139f.

⁶¹ *Ibid.*, pp. 151, 140, 140, 139, 151, 151, resp.

⁶² *Papyri Graecae Magicae*, trans. and ed. by Karl Preisendanz.

⁶³ ἀποθέωσις = 'sacrifice.'

⁶⁴ *Theatr. chem.*, V, p. 153.

⁶⁵ See also pp. 127, 128, 130, and 149 of the same work.

⁶⁶ Dozy and de Goeje, p. 365.

⁶⁷ “Τὸν πάνυ λευκότετον λίθον τὸν ἐγκέφαλον.” Berthelot, *Alchimistes*, III, xxix, 4. Cf. also I, iii, 1 and III, ii. 1.

⁶⁸ Thorndike, *A History of Magic and Experimental Science*, I, p. 705.

⁶⁹ *Jewish Encyclopaedia*, XII, s.v. “Teraphim,” pp. 108f.

⁷⁰ Josef bin Gorion, *Die Sagen der Juden*, p. 325. I am indebted to Dr. Riwkah Schärf for drawing my attention to this passage.

⁷¹ Cf. the alchemical *albedo* and *homo albus*.

⁷² Hastings, VI, pp. 535f.

⁷³ *Varia historia*, XII, 8.

⁷⁴ Onians, *The Origins of European Thought*, pp. 101 ff.

⁷⁵ Pars. 480–89.

⁷⁶ The classical example being *The I Ching or Book of Changes*.

⁷⁷ Mystical or *unconscious* identity occurs in every case of projection, because the content projected upon the extraneous object creates an apparent relationship between it and the subject.

¹ John 6:44: “No man can come to me, except the Father which hath sent me draw him.”

² “Et mortuus est Dei filius, prorsus credibile est, quia ineptum est. Et sepultus resurrexit; certum est, quia impossibile est” (And the Son of God is dead, which is to be believed because it is absurd. And buried He rose again, which is certain because it is impossible). Migne, *P.L.*, vol. 2, col. 751.

³ The audacity of Tertullian’s argument is undeniable, and so is its danger, but that does not detract from its psychological truth.

⁴ *Die Opferanschauungen*, p. 55.

⁵ My reason for saying this is that every symbol has an objective and a subjective—or psychic—origin, so that it can be interpreted on the “objective level” as well as on the “subjective level.” This is a consideration of some importance in dream-analysis. Cf. *Psychological Types*, Defs. 38 and 50.

⁶ Further material in Eisler, *Orpheus—the Fisher*, pp. 280f.

⁷ Similarly, in hunting, the *rites d’entrée* are more important than the hunt itself, for on these rites the success of the hunt depends.

⁸ Cf. *Psychological Types*, Def. 51.

⁹ Leisegang, *Der Heilige Geist*, pp. 248ff.

¹⁰ *How Natives Think*.

¹¹ Michael Sendivogius, “Tractatus de sulphure” (16th cent.), in the *Musaeum hermeticum* (1678), p. 617: “[Anima] quae extra corpus multa profundissima imaginatur” ([The soul] which imagines many things of the utmost profundity outside the body).

¹² The parallel to this is total destruction of the sacrificial gift by burning, or by throwing it into water or into a pit.

¹³ If there were really nothing behind him but collective standards of value on the one hand and natural instincts on the other, every breach of morality would be simply a rebellion of instinct. In that case valuable and meaningful innovations would be impossible, for the instincts are the oldest and most conservative element in man and beast alike. Such a view forgets the creative instinct which, although it can behave like an instinct, is seldom found in nature and is confined almost exclusively to *Homo sapiens*.

¹⁴ To the defiler of the Sabbath he said: “Man, if indeed thou knowest what thou doest, thou art blessed; but if thou knowest not, thou art cursed, and a transgressor of the law.” James, *The Apocryphal New Testament*, p. 33.

¹⁵ In order to avoid misunderstandings, I must emphasize that I am speaking only from personal experience, and not of the mysterious reality which the Mass has for the believer.

¹⁶ Cf. the “uniting symbol” in *Psychological Types*, Def. 51.

¹⁷ In Indian philosophy we find a parallel in Prajapati and Purusha Narayana. Purusha sacrifices himself at the command of Prajapati, but at bottom the two are identical. Cf. the *Shatapatha-Brahmana* (Sacred Books of the East, XLIV, pp. 172ff.); also the *Rig-Veda*, X, 90 (trans. by Macnicol, pp. 28–29).

¹⁸ This contradiction is unavoidable because the concept of the self allows only of antinomial statements. The self is by definition an entity more comprehensive than the conscious personality. Consequently the latter cannot pass any comprehensive judgment on the self; any judgment and any statement about it is incomplete and has to be supplemented (but not nullified) by a conditioned negative. If I assert, “The self exists,” I must supplement this by

saving, “But it seems not to exist.” For the sake of completeness I must also invert the proposition and say, “The self does not exist, but yet seems to exist.” Actually, this inversion is superfluous in view of the fact that the self is not a philosophical concept like Kant’s “thing-in-itself,” but an empirical concept of psychology, and can therefore be hypostatized if the above precautions are taken.

¹⁹ In so far as it is the self that actuates the ego’s self-recollection.

²⁰ If I use the unhistorical term “self” for the corresponding processes in the psyche, I do so out of a conscious desire not to trespass on other preserves, but to confine myself exclusively to the field of empirical psychology.

²¹ Firmicus Maternus, *De errore profanarum religionum*, 7, 8.

²² Hippolytus, *Elenchos*, VIII, 15.

²³ And also on account of the fact that the unconscious is only conditionally bound by space and time. The comparative frequency of telepathic phenomena proves that space and time have only a relative validity for the psyche. Evidence for this is furnished by Rhine’s experiments. Cf. my “Synchronicity.”

²⁴ The word “hell” may strike the reader as odd in this connection I would, however, recommend him to study the brothel scene in James Joyce’s *Ulysses*, or James Hogg’s *The Private Memoirs and Confessions of a Justified Sinner*.

²⁵ How Jewish piety reacted to this sacrifice can be seen from the following Talmudic legend: “‘And I,’ cried Abraham, ‘swear that I will not go down from the altar until you have heard me. When you commanded me to sacrifice my son Isaac you offended against your word, “in Isaac shall your descendants be named.” So if ever my descendants offend against you, and you wish to punish them, then remember that you too are not without fault, and forgive them.’ ‘Very well, then,’ replied the Lord, ‘there behind you is a ram caught in the thicket with his horns. Offer up that instead of your son Isaac. And if ever your descendants sin against me, and I sit in judgment over them on New Year’s Day, let them blow the horn of a ram, that I may remember my words, and temper justice with mercy.’” Fromer and Schnitzer, *Legenden aus dem Talmud*, pp. 34f.

²⁶ Isaiah 53:5: “But he was wounded for our transgressions, he was bruised for our iniquities: the chastisement of our peace was upon him; and with his stripes we are healed.”

²⁷ See “Answer to Job,” in this volume.

²⁸ Caussin, *De symbolica Aegyptiorum sapientia. Polyhistor symbolicus, Electorum symbolorum, et Parabolarum historicarum stromata* (1618), p. 401. Cf. also Philippus Picinelli, *Mondo Simbolico*, p. 299: “Of a truth God, terrible beyond measure, appeared before the world peaceful and wholly tamed after dwelling in the womb of the most blessed Virgin. St. Bonaventura said that Christ was tamed and pacified by the most kindly Mary, so that he should not punish the sinner with eternal death.”

²⁹ Eliade, *Shamanism*, esp. chs. II and VII.

³⁰ Particularly in Gerhard Dorn, “Speculativae philosophiae,” *Theatrum chemicum*, I (1602), pp. 276f.

³¹ Cf. my *Aion*, Ch. V.

³² *The Apocryphal New Testament*. The Acts of John were probably written during the first half of the 2nd cent.

³³ *Ibid.*, pp. 253f., modified.

³⁴ [Or: I will be freed and I will free.—TRANS.]

³⁵ Trans. based on James, pp. 253f., and that of Ralph Manheim from the German of Max Pulver, “Jesus’ Round Dance and Crucifixion according to the Acts of St. John,” in *The Mysteries*, pp. 179f.

³⁶ See James, p. 33.

³⁷ Another idea of the kind is that every human being is a ray of sunlight. This image occurs in the Spanish poet Jorge Guillen, *Cántico: Fe de Vida*, pp. 24–25 (“Más allá,” VI):

Where could I stray to, where?

This point is my centre ...

With this earth and this ocean

To rise to the infinite:

One ray more of the sun. (Trans. by J. M. Cohen.)

³⁸ Cf. *Aion*, Ch. IV.

³⁹ The universality of this figure may explain why its epiphanies take so many different forms. For instance, it is related in the Acts of John (James, p. 251) that Drusiana saw the Lord once “in the likeness of John” and another time “in that of a youth.” The disciple James saw him as a child, but John as an adult. John saw him first as “a small man and uncomely,” and then again as one reaching to heaven (p. 251). Sometimes his body felt “material and solid,” but sometimes “the substance was immaterial and as if it existed not at all” (p. 252).

⁴⁰ “The Spirit Mercurius,” pt. 2, ch. 9.

⁴¹ “Haec meditare” (ταῦτα μελέτα) in I Tim. 4:15 has more the meaning of ‘see to’ or ‘attend to’ these things. [Both DV and AV have “meditate on these things,” but RSV has “practise these duties.”—TRANS.]

⁴² Lipsius and Bonnet, eds., *Acta Apostolorum Apocrypha*, I, p. 197.

⁴³ James, p. 335.

⁴⁴ James, p. 335.

⁴⁵ *Ibid.*, p. 254.

⁴⁶ *Ανάγγη βιάβα* uncertain.

⁴⁷ Based on James, pp. 254ff., and the author’s modified version of Hennecke, ed., *Neutestamentliche Apokryphen*, pp. 186ff.

⁴⁸ Cf. *Aion*.

⁴⁹ The quaternity, earlier hinted at in the vision of Ezekiel, is patently manifest in the pre-Christian Book of Enoch. (Cf. “Answer to Job,” below, pars. 662ff.) In the Apocalypse of Sophonias [Zephaniah], Christ appears surrounded by a garland of doves (Stern, “Die koptische Apokalypse des Sophonias,” p. 124). Cf. also the mosaic of St. Felix at Nola, showing a cross surrounded by doves. There is another in San Clemente, Rome (Wickhoff, “Das Apsismosaik in der Basilica des H. Felix zu Nola,” pp. 158ff.; and Rossi, *Musaici Cristiani delle Chiese di Roma anteriori al secolo XV*, pl. XXIX).

⁵⁰ Symbolized by the formless multitude.

⁵¹ Cf. “speaking with tongues” and glossolalia.

⁵² Based on James, pp. 334f.

⁵³ *Ibid.*, p. 255.

⁵⁴ Genesis 3:5.

⁵⁵ The possibility of inflation was brought very close indeed by Christ's words: "Ye are gods" (John 10:34).

⁵⁶ Cf. Pauli, "The Influence of Archetypal Ideas on Kepler's Scientific Theories."

⁵⁷ Cf. the remarkable account of developing consciousness in an ancient Egyptian text, translated, with commentary, by Jacobsohn, entitled "Das Gespräch eines Lebensmüden mit seinem Ba."

⁵⁸ [Cf. *Psychological Types*, Def. 18, and *Two Essays on Analytical Psychology*, par. 111.—EDITORS.]

⁵⁹ This view may be implicit in the *kenosis* passage (Philippians 2:5f.): "Have this mind in you which was also in Christ Jesus, who though he was by nature God, did not consider being equal to God a thing to be clung to, but emptied himself [ἐκένωσεν, *exinanivit*], taking the nature of a slave and being made like unto man" (DV).

⁶⁰ Including shamanism, whose widespread phenomenology anticipates the alchemist's individuation symbolism on an archaic level. For a comprehensive account see Eliade, *Shamanism*.

⁶¹ Cf. Portmann, "Die Bedeutung der Bilder in der lebendigen Energiewandlung."

⁶² Cf. Neumann, *The Origins and History of Consciousness*, pp. 220ff.

⁶³ *Aion*, pp. 162ff.

¹ [Originally trans. (by Fr. White) from the German ms. for publication in the book by Fr. Victor White, O.P. (London, 1952; Chicago, 1953). The foreword was there subscribed May 1952. It has been slightly revised, on the basis of the original ms.—EDITORS.]

² [The two previous ones were by the Protestant theologian Hans Schaer: *Religion and the Cure of Souls in Jung's Psychology*, and *Erlösungsvorstellungen und ihre psychotogischen Aspekte*.—EDITORS.]

³ The fact that the psyche is not a *tabula rasa*, but brings with it instinctive conditions, just as somatic life does, naturally does not suit a Marxist philosophy at all. True, the psyche can be crippled just like the body, but such a prospect would not be pleasing even to Marxists.

⁴ A recent suggestion that evil should be looked upon as a “decomposition” of good does not alter this fact in the slightest. A rotten egg is unfortunately just as real as a fresh one.

⁵ The justice of this dictum strikes me as questionable, since Adam can hardly be held responsible for the wickedness of the serpent.

¹ [Originally trans. by R. F. C. Hull from the German ms. for publication in the book by R. J. Zwi Werblowsky (London, 1952). The present text contains only minor alterations. Professor Jung subscribed the foreword March 1951.—EDITORS.]

² [Cf. Jung's "On the Psychology of the Trickster Figure."—EDITORS.]

¹ [First published as a review in the *Neue Schweizer Rundschau* (Zurich), new series, 1(1933): 4, 223–29. Previously trans. by Horace Gray in the *Journal of Nervous and Mental Diseases* (New York, Richmond, London), CIII (1946): 4, 359–77. In 1947 Nicholas of Flüe, “Bruder Klaus,” was canonized by Pope Pius XII and declared patron saint of Switzerland.—EDITORS.]

² [*Die Visionen des seligen Bruder Klaus* (Einsiedeln, 1933).—EDITORS.]

^{2a} [See *Memories, Dreams, Reflections*, ch. 9, sec. ii.]

³ [The Diet of Stans was a meeting in 1481 of representatives of the Swiss cantons at which disputes between the predominantly rural and the predominantly urban cantons were regulated, and as a result of which—largely through the intervention of Nicholas—Fribourg and Solothurn joined the Confederation.—EDITORS.]

⁴ *Ein nutzlicher und loblicher Tractat von Bruder Claus und einem Bilger* (Nürnberg, 1488). Cited in Stoeckli, p. 41.

⁵ Heinrich Gundolfingen (Gundelfingen or Gundelfinger), c. 1444–90. priest and professor of humanistic studies at the University of Fribourg, knew Klaus probably around the year 1480 and wrote his biography.

^{5a} Durrer, *Bruder Klaus*, I, p. 434.

⁶ Heinrich Wölflin, also called by the Latin form *Lupulus*, born 1470, humanist and director of Latin studies at Bern.

⁷ *Ein gesichte Bruder Clausen ynn Schweytz und seine deutunge* (Wittenberg, 1528), p. 5. Cited in Stoeckli, p. 34, and Durrer, I, p. 560.

⁸ [Friedrich Gogarten (b. 1887), recently professor of systematic theology at Göttingen; author of *Die Kirche in der Welt* (1948).—EDITORS.]

⁹ [Documentation of the Rhodesian sun-wheels has not been possible, though such rock-carved forms are noted in Angola and South Africa. Their dating is in doubt. Cf. supra, par. 100, n. 43. Also Jung’s “Tavistock Lectures,” Lecture 2 (1968 version, pp. 42–43, n. 3).—EDITORS.]

¹⁰ More on this in Zimmer, *Kunstform und Yoga*, and in my “Commentary on *The Secret of the Golden Flower*,” pars. 31–45.

¹¹ Stoeckli, pp. 20f.

¹² Cf. also Franz, *Die Visionen des Niklaus von Flüe*.

¹ [First given as a lecture before the Alsatian Pastoral Conference at Strasbourg in May 1932; published as a pamphlet *Die Beziehungen der Psychotherapie zur Seelsorge* (Zurich, 1932). Previously translated by W. S. Dell and Cary F. Baynes in *Modern Man in Search of a Soul* (London and New York, 1933).—EDITORS.]

² [Ludwig Büchner (1824–99), German materialistic philosopher. His *Kraft und Stoff* was pub. 1855.—EDITORS.]

³ [Under the second republic, established in 1931 and later overthrown by the Franco forces.—EDITORS.]

⁴ [A more literal translation, which brings out the meaning more clearly while losing the play on words, would be: “He must keep in view only what is real (for the patient). But a thing is ‘real’ (*wirklich*) if it ‘works’ (*wirkt*).”—TRANS.]

¹ [First published as “Psychoanalyse und Seelsorge,” in *Ethik: Sexual- und Gesellschafts-Ethik* (Halle), V (1928): 1, 7–12 –EDITORS.]

¹ [Written for *Pastoral Psychology* (Great Neck, N.Y.), VI: 60 (January, 1956).— EDITORS.]

¹ Cap. V, in Migne, *P.L.*, vol. 1, cols. 615f. (trans. by C. Dodgson, I, pp. 138f., slightly modified).

¹ Job 40:4–5. [Quotations throughout are from the Revised Standard Version (RSV), except where the Authorized Version (AV) is closer to the text of the Zürcher Bibel (ZB) used by the author in conjunction with the original Hebrew and Greek sources. Where neither RSV nor AV fits, I have translated direct from ZB. The poetic line-arrangement of RSV is followed in so far as possible.—TRANS.]

² Job 9:2.

³ 9:16.

⁴ 9:19.

⁵ 9:17.

⁶ 9:22.

⁷ 9:23 (AV).

⁸ 9:28,29.

⁹ 9:30–31 (AV).

¹⁰ 9:32 (AV).

¹¹ 10:7.

¹² 13:3.

¹³ 13:15.

¹⁴ 13:18.

¹⁵ 13:25 (AV).

¹⁶ 19:6–7.

¹⁷ 27:2.

¹⁸ 27:5–6.

¹⁹ 34:12.

²⁰ 34:18 (AV).

²¹ 34:19 (ZB).

²² 16:19–21.

²³ 19:25. [‘Vindicator’ is RSV alternative reading for ‘Redeemer,’ and comes very close to the ZB *Anwalt*, ‘advocate.’—TRANS.]

²⁴ Verses 28, 34, 35.

²⁵ Psalm 89:46, 47, 49 (AV; last line from RSV).

²⁶ Or to be “blessed,” which is even more captious of him.

¹ Zechariah 4:10 (AV). Cf. also the Wisdom of Solomon 1:10 (AV): “For the ear of jealousy heareth all things: and the noise of murmurings is not hid.”

² The 89th Psalm is attributed to David and is supposed to have been a community song written in exile.

³ Satan is presumably one of God’s eyes which “go to and fro in the earth and walk up and down in it” (Job 1:7). In Persian tradition, Ahriman proceeded from one of Ormuzd’s doubting thoughts.

⁴ Job 38:2 (ZB).

⁵ Job 38:3 and 40:7.

⁶ 40:8–9.

⁷ 40:12–14 (“in the hidden place” is RSV alternative reading for “in the world below”).

⁸ This is an allusion to an idea found in the later cabalistic philosophy. [These “shards,” also called “shells” (Heb. *kelipot*), form ten counterpoles to the ten *sefiroth*, which are the ten stages in the revelation of God’s creative power. The shards, representing the forces of evil and darkness, were originally mixed with the light of the *sefiroth*. The *Zohar* describes evil as the by-product of the life process of the *sefiroth*. Therefore the *sefiroth* had to be cleansed of the evil admixture of the shards. This elimination of the shards took place in what is described in the cabalistic writings—particularly of Luria and his school—as the “breaking of the vessels.” Through this the powers of evil assumed a separate and real existence. Cf. Scholem, *Major Trends in Jewish Mysticism*, p. 267.—EDITORS.]

⁹ 42:2.

¹⁰ 42:3–6 (modified).

¹¹ Job 41:25 (ZB); cf. 41:34 (AV and RSV).

¹² Ezekiel 1:26.

¹³ The naïve assumption that the creator of the world is a conscious being must be regarded as a disastrous prejudice which later gave rise to the most incredible dislocations of logic. For example, the nonsensical doctrine of the *privatio boni* would never have been necessary had one not had to assume in advance that it is impossible for the consciousness of a good God to produce evil deeds. Divine unconsciousness and lack of reflection, on the other hand, enable us to form a conception of God which puts his actions beyond moral judgment and allows no conflict to arise between goodness and beastliness.

¹⁴ Job 42:7.

¹⁵ [Cf. Gnostic interpretation of Yahweh as Saturn-Ialdabaoth in “Transformation Symbolism in the Mass,” par. 350, above; *Aion*, par. 128.—EDITORS]

¹ Proverbs 8:22–24 (AV). 27, 29–31 (AV mod.).

² Ecclesiasticus 24:3–18 (AV mod.).

³ II Samuel 5:23f.

⁴ Song of Solomon 4:8 (AV).

⁵ 4:13–15.

⁶ Song of Solomon 5:5.

⁷ Wisdom of Solomon 1:6. (φιλόανθρωπον πνεῦμα σοφία.)

⁸ 7:23.

⁹ 7:22. (πάντων τεχνίτις./πνεῦμα νοερὸν ἅγιον)

¹⁰ 7:25 (AV mod.), (ἀπόρροια.)

¹¹ 7:26.

¹² 7:23, 24.

¹³ 8:3. (συμβίωσιν ἔχουσα./πάντων δεσπότης)

¹⁴ 8:6.

¹⁵ 9:10, 17.

¹⁶ 6:18 and 8:13.

¹⁷ 1:15–16 (mod.).

¹⁸ 2:10–19.

¹⁹ Job 2:3; Ecclesiastes 9:16.

²⁰ [As to that portion of humanity *not* divinely stamped, and presumably descended from the pre-Adamic anthropoids, see par. 576, above.—EDITORS.]

²¹ Πνευματικώτατον ζῶον.—A view that is found in Philo Judaeus.

²² [Cf. the commentary on the *Tibetan Book of the Dead*, pars. 831ff., below.— EDITORS.]

²³ Cf. φρονίμως in the parable of the unjust steward (Luke 16:8).

²⁴ Job 28:12: “But where shall wisdom be found?” Whether this is a later interpolation or not makes no difference.

¹ John 1:3: “All things were made through him, and without him was not anything made that was made.”

¹ Proverbs 8:29–30.

² Job 40:15, 19 (last line, ZB).

³ In Christian tradition, too, there is a belief that God’s intention to become man was known to the Devil many centuries before, and that this was why he instilled the Dionysus myth into the Greeks, so that they could say, when the joyful tidings reached them in reality: “So what? We knew all that long ago.” When the conquistadores later discovered the crosses of the Mayas in Yucatán, the Spanish bishops used the same argument.

¹ John 14:6.

² Mark 3:21.

¹ Luke 10:18.

² Revelation 7:4.

³ Revelation 19:20.

¹ John 14:12.

² 10:34.

³ Romans 8:17.

⁴ John 14:16f.

⁵ 14:26 and 16:13.

⁶ Acts 14:11.

⁷ “Mancipem quendam divinitatis qui ex hominibus deos fecerit.” *Apologeticus*. XI, in Migne, *P.L.*, vol. 1, col. 386.

¹ I John 4:1 (mod.).

² I Corinthians 2:10.

³ Matthew 26:39.

⁴ Abraham and Isaac.

¹ The vision in which he received his call occurred in 592 B.C.

² It is altogether wrong to assume that visions as such are pathological. They occur with normal people also—not very frequently, it is true, but they are by no means rare.

³ Ezekiel 1:26.

⁴ Daniel 7:13.

⁵ Genesis 6:3f.

⁶ Enoch 7:2.

⁷ Enoch 7:3–6. [The translations of the Book of Enoch are from Charles, ed., *The Apocrypha and Pseudepigrapha of the Old Testament in English*, II, sometimes slightly modified.—TRANS.]

⁸ Enoch 9:5–11.

⁹ 22:2.

¹⁰ Enoch 40:7.

¹¹ Cf. also ch. 87f. Of the four “beings who were like white men,” three take Enoch by the hand, while the other seizes a star and hurls it into the abyss.

¹² Three had animal faces, one a human face.

¹³ Enoch 46:1–3.

¹⁴ 47:4.

¹⁵ 48:1.

¹⁶ 48:4, 6–7.

¹⁷ Enoch 49:1–3.

¹⁸ Synonym for Sheol.

¹⁹ 51:1,3.

²⁰ 54:6. Here at last we hear that the exodus of the two hundred angels was a prank of Satan’s.

²¹ 58:6 (mod.).

²² 60:10.

²³ 71:5–6.

²⁴ 71:14.

²⁵ 71:17.

²⁶ The author of the Book of Enoch chose, as the hero of his tale, Enoch the son of Jared, the seventh after Adam, who “walked with God,” and, instead of dying, simply disappeared, i.e., was carried away by God (“... and he was not, for God took him.”—Genesis 5:24).

²⁷ Job 19:25.

¹ As a consequence of her immaculate conception Mary is already different from other mortals, and this fact is confirmed by her assumption.

² Presumably the “morning star” (cf. Revelation 2:28 and 22:16). This is the planet Venus in her psychological implications and not, as one might think, either of the two *malefici*, Saturn and Mars.

³ John 14:16.

⁴ John 14:12.

⁵ 10:35.

⁶ An apocryphal insertion at Luke 6:4. [“Man, if indeed thou knowest what thou doest, thou art blessed; but if thou knowest not, thou art cursed, and a transgressor of the law” (trans. in James, *The Apocryphal New Testament*, p. 33) —TRANS.]

¹ I John 1:5.

² 2:1–2.

³ 3:9.

⁴ 2:18f., 4:3.

⁵ Cf. Rev. 1:16–17

⁶ Rev. 2:5.

⁷ 2:20f.

⁸ 3:3.

⁹ 3:19.

¹⁰ 4:3.

¹¹ 4:6f.

¹² This refers to the “luminosity” of the archetypes. [Cf. Jung, “On the Nature of the Psyche,” pp. 190ff.—

EDITORS.]

¹³ Rev. 5:6.

¹⁴ 6:10.

¹⁵ 6:17 (AV).

¹⁶ Rev. 12:1.

¹⁷ Rev. 11:19. The *area foederis* is an *allegoria Marine*.

¹⁸ “Heaven above, heaven below.”

¹⁹ Rev. 12:5; cf. 2:27.

²⁰ Rev. 12:9.

²¹ It is very probable that John knew the Leto myth and used it consciously. What was unconscious and most unexpected, however, was the fact that his unconscious used this pagan myth to describe the birth of the second Messiah.

²² Rev. 12:16 (AV).

²³ [Cf. Marie-Louise von Franz, “Die Passio Perpetuae.”—EDITORS.]

²⁴ The son would then correspond to the *filius sapientiae* of medieval alchemy.

¹ Rev. 14:1. It may be significant that there is no longer any talk of the “great multitude which no man could number, from every nation, from all tribes and peoples and tongues, standing before the throne and before the Lamb,” who were mentioned in 7:9.

² 14:4 (AV).

³ They really belong to the cult of the Great Mother, since they correspond to the emasculated Galli. Cf. the strange passage in Matthew 19:12, about the eunuchs “who have made themselves eunuchs for the sake of the kingdom of heaven,” like the priests of Cybele who used to castrate themselves in honour of her son Attis.

⁴ Cf. also Rev. 19:5.

⁵ 14:14 and 17. The auxiliary angel might well be John himself.

⁶ 14:19–20.

⁷ 15:6–7 and 16:1ff.

⁸ Rev. 18:20 (AV).

⁹ 19:15 (AV).

¹⁰ 19:13.

¹¹ 19:11. Here again astrological speculations concerning the second half of the Christian aeon may be implied, with Pegasus as paranatellon of Aquarius.

¹² Rev. 20:3 (AV).

¹³ 20:10 and 21:1.

¹⁴ 19:7.

¹⁵ 21:2.

¹⁶ 21:11.

¹⁷ 21:16–27.

¹⁸ 22:1–2.

¹⁹ In China, heaven is round and the earth square.

²⁰ Ecclesiasticus 24:11 and 18 (AV).

²¹ Tertullian, *Adversus Judaeos*, XIII (Migne, *P.L.*, vol. 2, col. 635): “... ilia terra virgo nondum pluviis rigata nec imbribus foecundata, ex qua homo tunc primum plasmatus est, ex qua nunc Christus secundum carnem ex virgine natus est” (... that virgin soil, not yet watered by the rains nor fertilized by the showers, from which man was originally formed [and] from which Christ is now born of a Virgin through the flesh).

²² Ezekiel 1:18.

¹ Not for nothing was the apostle John nicknamed “son of thunder” by Christ.

² I John 4:7–21.

¹ [Herostratus, in order to make his name immortal, burned down the temple of Artemis in Ephesus, in 365 B.C.—
EDITORS.]

¹ Psychologically the God-concept includes every idea of the ultimate, of the first or last, of the highest or lowest. The name makes no difference.

² The God-concept, as the idea of an all-embracing totality, also includes the unconscious, and hence, in contrast to consciousness, it includes the objective psyche, which so often frustrates the will and intentions of the conscious mind. Prayer, for instance, reinforces the potential of the unconscious, thus accounting for the sometimes unexpected effects of prayer.

³ “Of changeful countenance, both white and black.” Horace, *Epistulae*, II, 2.

⁴ *Apostolic Constitution* (“*Munificentissimus Deus*”) of ... *Pius XII*, §22: “Oportebat sponsam quam Pater desponsaverat, in thalamis caelestibus habitare” (The place of the bride whom the Father had espoused was in the heavenly courts).—St. John Damascene, *Encomium in Dormitionem, etc.*, Homily II, 14 (cf. Migne, *P.G.*, vol. 96, col. 742). §30: Comparison with the Bride in the Song of Solomon. §33: “... ita pariter surrexit et Area sanctificationis suae, cum in hac die Virgo Mater ad aethereum thalamum est assumpta” (... so in like manner arose the Ark which he had sanctified, when on this day the Virgin Mother was taken up to her heavenly bridal-chamber).—St. Anthony of Padua, *Sermones Dominicales, etc.* (ed. Locatelli. III, p. 730).

⁵ *Apostolic Constitution*, §31: “Ac praeterea scholastici doctores non modo in variis Veteris Testamenti figuris, sed in illa etiam Muliere amicta sole, quam Joannes Apostolus in insula Patmo [Rev. 12:1ff.] contemplatus est, Assumptionem Deiparae Virginis significatam viderunt” (Moreover, the Scholastic doctors saw the Assumption of the Virgin Mother of God signified not only in the various figures of the Old Testament, but also in the Woman clothed with the sun, whom the Apostle John contemplated on the island of Patmos).

⁶ The marriage of the Lamb repeats the Annunciation and the Overshadowing of Mary.

¹ Codex Bezae, apocryphal insertion at Luke 6:4. [Trans. by James; see above, par. 696. n. 6.—TRANS.]

¹ “A mediator making peace between enemies.”

² The papal rejection of psychological symbolism may be explained by the fact that the Pope is primarily concerned with the reality of metaphysical happenings. Owing to the undervaluation of the psyche that everywhere prevails, every attempt at adequate psychological understanding is immediately suspected of psychologism. It is understandable that dogma must be protected from this danger. If, in physics, one seeks to explain the nature of light, nobody expects that as a result there will be no light. But in the case of psychology everybody believes that what it explains is explained away. However, I cannot expect that my particular deviationist point of view could be known in any competent quarter.

¹ [Written in English in 1939 and first published in *The Tibetan Book of the Great Liberation*, the texts of which were translated from Tibetan by various hands and edited by W. Y. Evans-Wentz (London and New York, 1954), pp. xxix–lxiv. The commentary is republished here with only minor alterations.—EDITORS.]

² I am purposely leaving out of account the modernized East.

³ *Psychological Types*, Defs. 19 and 34.

⁴ Written in the year 1939.

⁵ *Samyutta-nikāya* 12, *Nidāna-samyutta*.

⁶ [Cf. Otto, *The Idea of the Holy*. pp. 26ff —EDITORS.]

⁷ “Whereas who holdeth not God as such an inner possession, but with every means must fetch Him from without ... verily such a man hath Him not, and easily something cometh to trouble him.” Meister Eckhart (Büttner, II, p. 185). Cf. *Meister Eckhart*, trans. by Evans, II, p. 8.

⁸ In so far as “higher” and “lower” are categorical judgments of consciousness, Western psychology does not differentiate unconscious contents in this way. It appears that the East recognizes subhuman psychic conditions, a real “subconsciousness” comprising the instincts and semi-physiological psychisms, but classed as a “higher consciousness.”

⁹ *Psychological Types* (1923 edn., pp. 472ff.).

^{9a} [Date of Mohammed’s flight (*hegira*) to Medina: beginning of Moslem era.]

¹⁰ This is not the unacceptable translation of *ἀπιούσιος* by Jerome but the ancient spiritual interpretation by Tertullian, Origen, and others.

¹¹ *Psychological Types*, Def. 51. [Cf. also “The Transcendent Function.”]

¹² Some people find such statements incredible. But either they have no knowledge of primitive psychology, or they are ignorant of the results of psychopathological research. Specific observations occur in my *Symbols of Transformation* and *Psychology and Alchemy*, Part II; Nelken, “Analytische Beobachtungen über Phantasien eines Schizophrenen,” pp. 504ff.; Spielrein, “Über den psychologischen Inhalt eines Falls von Schizophrenie” pp. 329ff.; and C. A. Meier, “Spontanmanifestationen des kollektiven Unbewussten.”

¹³ Lévy-Bruhl, *La Mythologie primitive*, pp. xxiii ff.

¹⁴ Cf. the *Shrī-Chakra-Sambhara Tantra*, in Avalon, ed., *Tantric Texts*, VII.

¹⁵ Cf. *Psychology and Alchemy*, pars. 390ff. [Also *Mysterium Coniunctionis*, pars. 706, 753ff.]

¹⁶ “What is below is like what is above. And what is above is like what is below, so that the miracle of the One may be accomplished.” Cf. Ruska, *Tabula Smaragdina*, p. 2.

¹⁷ Cf. *Psychological Types*, Def. 35.

¹⁸ Cf. *Two Essays on Analytical Psychology*, index, s.v. “self”; *Psychological Types*, Def. 16 [and 46 in *Coll. Works*, 6]; *Psychology and Alchemy*, Part II; *Aion*, ch. IV.

¹⁹ One such case is described in Part II of *Psychology and Alchemy*.

²⁰ This is no criticism of the Eastern point of view *in toto*; for, according to the *Amitāyur-dhyāna Sūtra*, the Buddha’s body is included in the meditation.

²¹ Cf. for instance, *Chhāndogya Upanishad*, viii. 8.

²² “On Psychic Energy,” p. 48.

²³ Cf. his *Tibetan Book of the Great Liberation*, p. 210, n. 3.

²⁴ *An Experiment with Time*. [Cf. Jung’s “Synchronicity: An Acausal Connecting Principle,” p. 433.—EDITORS].

²⁵ I have explained this in my “Commentary on *The Secret of the Golden Flower*,” pars, 64ff.

²⁶ From the [German] trans. of L. C. Lo, I, p. 114. [Cf. *Golden Flower*, 1962, pp. 77f.]

²⁷ *Psychological Types*, Def. 25.

²⁸ Cf. Lévy-Bruhl, *How Natives Think*. Recently this concept as well as that of the *état prélogique* have been severely criticized by ethnologists, and moreover Lévy-Bruhl himself began to doubt their validity in the last years of his life. First he cancelled the adjective “mystique,” growing afraid of the term’s bad reputation in intellectual circles. It is rather to be regretted that he made such a concession to rationalistic superstition, since “mystique” is just the right word to characterize the peculiar quality of “unconscious identity.” There is always something numinous about it. Unconscious identity is a well-known psychological and psychopathological phenomenon (identity with persons, things, functions, roles, positions, creeds, etc.), which is only a shade more characteristic of the primitive than of the civilized mind. Lévy-Bruhl, unfortunately having no psychological knowledge, was not aware of this fact, and his opponents ignore it.

²⁹ Cf. *The Critique of Pure Reason*, sec. i, Part I, 2, 3 (cf. trans. by Meiklejohn, p. 188).

³⁰ Cf. the first paper in this volume, chs. 2 and 3.

³¹ Cf. Suzuki, *Essays in Zen Buddhism*.

³² As in the Eleusinian mysteries and the Mithras and Attis cults.

³³ In alchemy the philosophers’ stone was called, among other things, *lux moderna*, *lux lucis*, *lumen luminum*, etc.

¹ [Originally published as “Psychologischer Kommentar zum Bardo Thödol” (preceded by an “Einführung,” partially translated in the first two parts, here), in *Das Tibetische Totenbuch*, translated into German by Louise Göpfert-March (Zurich, 1935). As ultimately revised for the 5th (revised and expanded) Swiss edition (1953), the commentary was translated by R. F. C. Hull for publication in the 3rd (revised and expanded) English edition (the original) of *The Tibetan Book of the Dead, or The After-Death Experience on the “Bardo” Plane*, according to Lama Kazi Dawa-Samdup’s English rendering, edited by W. V. Evans-Wentz, with foreword by Sir John Woodroffe (London and New York, 1957). With only minor alterations, it is the translation presented here.—EDITORS.]

² [German philosopher and sociologist (1874–1928) working mainly in the field of values.—EDITORS.]

³ [Actually from the *Sidpa Bardo* section (p. 166), but similar torments figure in the “Wrathful Deities” section (pp. 131ff.) of the *Chönyid Bardo*.—EDITORS.]

⁴ Information on this spiritualistic activity will be found in Lord Dowding’s writings. *Many Mansions* (1943), *Lychgate* (1945), *God’s Magic* (1946).

⁵ A similar view in Aldous Huxley, *Time Must Have a Stop* (1945).

¹ [Originally published in *Prabuddha Bharata* (Calcutta), February 1936, Shri Ramakrishna Centenary Number, Sec. III, in a translation by Cary F. Baynes, upon which the present translation is based.—EDITORS.]

² [The German Psychiatrist J. H. Schultz. The Reference is to his book *Das autogene Training* (Berlin, 1932).—EDITORS.]

¹ [Originally published as a foreword to Suzuki, *Die grosse Befreiung: Einführung in den Zen-Buddhismus* (Leipzig, 1939). The Suzuki text had been translated into German by Heinrich Zimmer from the original edition of *An Introduction to Zen Buddhism*. The foreword by Jung was published in an earlier translation by Constance Rolfe in a new edition of the Suzuki work (London and New York, 1949).—EDITORS.]

² The origin of Zen, as Oriental authors themselves admit, is to be found in Buddha's Flower Sermon. On this occasion he held up a flower to a gathering of disciples without uttering a word. Only Kasyapa understood him. Cf. Shuei Ohazama, *Zen: Der lebendige Buddhismus in Japan*, p. 3.

³ *Introduction to Zen Buddhism* (1949), p. 95.

⁴ *Ibid.*, pp. 89 and 92f.

⁵ *The Religion of the Samurai*, p. 133.

⁶ "Zen is neither psychology nor philosophy."

⁷ "In Ohazama, p. viii.

⁸ If in spite of this I attempt "explanations" in what follows, I am nevertheless fully aware that in the sense of satori I have said nothing valid. All the same, I had to make an attempt to manoeuvre our Western understanding into at least the proximity of an understanding—a task so difficult that in doing it one must take upon oneself certain crimes against the spirit of Zen.

⁹ Cf. Spamer, ed., *Texte aus der deutschen Mystik des 14. und 15. Jahrhunderts*, p. 143; Evans, *Meister Eckhart*, I, p. 438; William White, *Emanuel Swedenborg*, I, p. 243.

¹⁰ "There is no doubt that Zen is one of the most precious and in many respects the most remarkable [of the] spiritual possessions bequeathed to Eastern people." Suzuki, *Essays on Zen Buddhism*, I, p. 264.

¹¹ "Before a man studies Zen, to him mountains are mountains and waters are waters; after he gets an insight into the truth of Zen, through the instruction of a good master, mountains to him are not mountains and waters are not waters; after this when he really attains to the abode of rest, mountains are once more mountains and waters are waters." *Ibid.*, pp. 22f.

¹² *Religion of the Samurai*, p. 123.

¹³ *Ibid.*, p. 124.

¹⁴ *Ibid.*, p. 132.

¹⁵ *Theologia Germanica*, ed. by Trask, p. 115.

¹⁶ *Ibid.*, pp. 120–21.

¹⁷ There is a similar image in Zen: When a Master was asked what Buddhahood consisted in, he answered, "The bottom of a pail is broken through" (Suzuki, *Essays*, I, p. 229). Another analogy is the "bursting of the bag" (*Essays*, II, p. 117).

¹⁸ Cf. Suzuki, *Essays*, I, pp. 231, 255. Zen means catching a glimpse of the original nature of man, or the recognition of the original man (p. 157).

¹⁹ Cf. Evans, *Meister Eckhart*, p. 221; also *Meister Eckhart: A Modern Translation*, by Blakney, pp. 231f.

²⁰ Suzuki, *Introduction*, pp. 93. S4.

²¹ “Its root is above, its branches below—this eternal fig-tree! ... That is Brahma, that is called the Immortal.” Katha Upanishad, 6, 1, trans. by Hume, *The Thirteen Principal Upanishads*, p. 358.

²² John of Ruysbroeck, *The Adornment of the Spiritual Marriage*, p. 47. One can hardly suppose that this Flemish mystic, who was born in 1273, borrowed this image from any Indian text.

²³ *Ibid.*, p. 51.

²⁴ P. 57, modified.

²⁵ *Ibid.*, p. 62, modified.

²⁶ “O Lord ... instruct me in the doctrine of the non-ego, which is grounded in the self-nature of mind.” Cited from the Lankavatāra Sutra, in Suzuki, *Essays*, I, p. 89.

²⁷ A Zen Master says: “Buddha is none other than the mind, or rather, him who strives to see this mind.”

²⁸ Galatians 2:20: “It is no longer I who live, but Christ who lives in me.”

²⁹ Suzuki says of this change, “The old way of viewing things is abandoned and the world acquires a new signification ... a new beauty which exists in the ‘refreshing breeze’ and in the ‘shining jewel.’” *Essays*, I, p. 249. See also p. 138.

³⁰ From *Der Cherubinischer Wandersmann*. [Trans. by W. R. Trask (unpub.).]

³¹ “*Satori* is the most intimate individual experience.” *Essays*, I, p. 261.

A Master says to his pupil: “I have really nothing to impart to you, and if I tried to do so you might have occasion to make me an object of ridicule. Besides, whatever I can tell you is my own and can never be yours.” *Introduction*, p. 91.

A monk says to the Master: “I have been seeking for the Buddha, but do not yet know how to go on with my research.” Said the Master: “It is very much like looking for an ox when riding on one.” *Essays*, II, p. 74.

A Master says: “The mind that does not understand is the Buddha: there is no other.” *Ibid.*, p. 72.

³² *Essays*, II, pp. 84, 90.

³³ “Zen consciousness is to be nursed to maturity. When it is fully matured, it is sure to break out as *satori*, which is an insight into the unconscious.” *Essays*, II, p. 60.

³⁴ The fourth maxim of Zen is “Seeing into one’s nature and the attainment of Buddhahood” (I, p. 18). When a monk asked Hui-neng for instruction, the Master told him: “Show me your original face before you were born” (I, p. 224). A Japanese Zen book says: “If you wish to seek the Buddha, you ought to see into your own nature; for this nature is the Buddha himself” (I, p. 231). A *satori* experience shows a Master the “original man” (I, p. 255). Hui-neng said: “Think not of good, think not of evil, but see what at the moment your own original features are, which you had even before coming into existence” (II, p. 42).

³⁵ Bodhidharma, the founder of Zen in China, says: “The incomparable doctrine of Buddhism can be comprehended only after a long hard discipline and by enduring what is most difficult to endure, and by practising what is most difficult to practise. Men of inferior virtue and wisdom are not allowed to understand anything about it. All the labours of such ones will come to naught.” (*Ibid.*, I, p. 188.)

³⁶ This is more probable than one that is merely “complementary.”

³⁷ This “necessity” is a working hypothesis. People can, and do, hold very different views on this point. For instance, are religious ideas “necessary”? Only the course of the individual’s life can decide this, i.e., his individual experience. There are no abstract criteria.

³⁸ “When the mind discriminates, there is manifoldness of things; when it does not it looks into the true state of things.” *Essays*, I, p. 99.

³⁹ See the passage beginning “Have your mind like unto space....” Suzuki, *Essays*, I, p. 223.

⁴⁰ *Introduction to Zen Buddhism*, p. 94.

⁴¹ In this connection I must also mention the English mystic, William Blake. Cf. an excellent account in Percival, *William Blake’s Circle of Destiny*.

⁴² The genius of the Greeks lay in the break-through of consciousness into the materiality of the world, thus robbing the world of its original dreamlike quality.

⁴³ [Cf. above, par. 844.]

⁴⁴ *Faust*, Part I, trans. by Wayne, p. 54.

⁴⁵ *Ibid.*, p. 44.

⁴⁶ *Introduction*, p. 95.

⁴⁷ “It is no pastime but the most serious task in life; no idlers will ever dare attempt it.” Suzuki, *Essays*, I, p. 27; cf. also p. 92.

⁴⁸ Says a Master: “If thou seekest Buddhahood by thus sitting cross-legged, thou murderest him. So long as thou freest thyself not from sitting so, thou never comest to the truth.” *Essays*, I, p. 235. Cf. also II, p. 83f.

¹ [Delivered as a lecture to the Schweizerische Gesellschaft der Freunde ostasiatischer Kultur, in Zurich, Basel, and Bern, during March–May 1943, and published as “Zur Psychologie östlicher Meditation” in the Society’s *Mitteilungen* (St. Gallen), V (1943), 33–53; repub. in *Symbolik des Geistes* (Zurich, 1948), pp. 447–72. Previously trans. by Carol Baumann in *Art and Thought*, a volume in honour of Ananda K. Coomaraswamy (London, 1948), pp. 169–79.

[The work of Heinrich Zimmer’s which the author refers to in the opening sentence was his *Kunstform und Yoga im indischen Kultbild* (1926), the central argument of which has been restated in his posthumous English works, particularly *Myths and Symbols in Indian Art and Civilization* (1946) and *The Art of Indian Asia* (1955). Cf. also the next paper in this volume.—EDITORS.]

² In *Buddhist Mahāyāna Sūtras* (Sacred Books of the East, vol. 49), Part II, pp. 159–201, trans. by J. Takakusu, slightly modified.

³ Jambunadi = Jambu-tree. A river formed of the juice of the fruit of the Jambu-tree flows in a circle round Mount Meru and returns to the tree.

⁴ Cf. *Symbols of Transformation*, Part II, chs. 6 and 7, especially par. 510.

⁵ Cf. *Psychology and Alchemy*, fig. 61.

⁶ Cf. Stoeckli, *Die Visionen des Seligen Bruder Klaus*. Cf. also the sixth paper in this volume, pars. 474ff.

⁷ Cf. the first paper in this volume, pars. 136ff.

¹ [Introduction to Heinrich Zimmer, *Der Weg zum Selbst: Lehre und Leben des indischen Heiligen Shri Ramana Maharshi aus Tiruvannamalai* (Zurich, 1944), edited by C. G. Jung. The work consists of 167 pages translated by Zimmer from English publications of the Sri Ramanasramam Book Depot, Tiruvannamalai India, preceded by a brief (non-significant) foreword and this introduction, both by Jung, an obituary notice by Emil Abegg of Zimmer's death in New York in 1944, and an introduction to the Shri Ramana Maharshi texts by Zimmer.—EDITORS.]

² *Worte des Ramakrishna*, ed. by Emma von Pelet, p. 77.

³ *The Gospel of Ramakrishna*, p. 56.

⁴ Ibid.

¹ [Grateful acknowledgment is made here to Cary F. Baynes for permission to use, with a few minor changes, her translation of this Foreword, which Professor Jung wrote specially for the English edition of the *I Ching or Book of Changes*, translated by Mrs. Baynes from the German translation of Richard Wilhelm (New York and London, 1950); 2nd edn. in 1 vol., 1961; 3rd edn. in small format, 1967. References are to the 3rd edn.—TRANS.]

² Legge makes the following comment on the explanatory text for the individual lines: “According to our notions, a framer of emblems should be a good deal of a poet, but those of the *Yi* only make us think of a dryasdust. Out of more than three hundred and fifty, the greater number are only grotesque” (*The Yi King*, p. 22). Of the “lessons” of the hexagrams, the same author says: “But why, it may be asked, why should they be conveyed to us by such an array of lineal figures, and in such a farrago of emblematic representations” (p. 25). However, we are nowhere told that Legge ever bothered to put the method to a practical test.

³ [Cf. Jung’s “Synchronicity: An Acausal Connecting Principle.” In that work (pp. 450–53) he is concerned with the synchronistic aspects of the *I Ching*.—EDITORS.]

⁴ Cf. J. B. Rhine, *The Reach of the Mind*.

⁵ They are *shén*, that is, ‘spirit-like.’ “Heaven produced the ‘spirit-like things’” (Legge, p. 41).

⁶ [Cf. the *I Ching*, pp. 193ff.—EDITORS.]

⁷ See the explanation of the method, *ibid.*, pp. 721ff.

⁸ For example, the *invidi* (‘the envious’) are a constantly recurring image in the old Latin books on alchemy, especially in the *Turba philosophorum* (11th or 12th cent.).

⁹ From the Latin *concupere*, ‘to take together,’ e.g., in a vessel: *concupere* derives from *capere*, ‘to take,’ ‘to grasp.’

¹⁰ This is the classical etymology. The derivation of *religio* from *religare*, ‘reconnect,’ ‘link back,’ originated with the Church Fathers.

¹¹ I made this experiment before I actually wrote the foreword.

¹² The Chinese interpret only the changing lines in the hexagram obtained by use of the oracle. I have found all the lines of the hexagram to be relevant in most cases.

¹³ [Cf. Wilhelm and Jung, *The Secret of the Golden Flower* (1931), in which this address appears as an appendix. The book did not appear in English until a year after Wilhelm’s death.—C. F. B.]

[For the address, see vol. 15 of the *Coll. Works*.—EDITORS.]

¹⁴ The reader will find it helpful to look up all four of these hexagrams in the [Baynes-Wilhelm] text and to read them together with the relevant commentaries.

* For details of the *Collected Works of C. G. Jung*, see the list at the end of this volume.

- * Published 1957.
- † Published 1960.
- * Published 1961.
- † First published 1956; 2nd edition, 1967. (65, plates, 43 text figures.)
- * First published 1953; revised edition, 1966.
- † First published 1960; revised edition, 1969.
- * Published 1959. (Part I: 79 plates, with 29 in colour.)
- * Published 1964. (8 plates.)
- † First published 1958; revised edition, 1969.
- * First published 1953: 2nd edition, completely revised, 1968. (270 illustrations.)
- † Published 1967. (50 plates, 4 text figures.)
- ‡ First published 1963; revised edition, 1970. (10 plates.)
- * Published 1966.
- † First published 1954; 2nd edition, revised and augmented, 1966. (13 illustrations.)
- ‡ Published 1954; 2nd printing, with corrections. 1964.

B O L L I N G E N S E R I E S X X

THE COLLECTED WORKS

OF

C. G. JUNG

VOLUME 12

EDITORS

HERBERT READ

MICHAEL FORDHAM, M.D., M.R.C.P.

GERHARD ADLER, PH.D.

WILLIAM MCGUIRE, *executive editor*

PSYCHOLOGY AND ALCHEMY

C. G. JUNG

SECOND EDITION

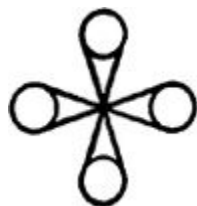

TRANSLATED BY R. F. C. HULL

270 ILLUSTRATIONS

BOLLINGEN SERIES XX

PRINCETON UNIVERSITY PRESS

COPYRIGHT 1953 BY BOLLINGEN FOUNDATION INC., NEW YORK, N. Y. NEW MATERIAL COPYRIGHT
© 1968 BY BOLLINGEN FOUNDATION PUBLISHED BY PRINCETON UNIVERSITY PRESS, PRINCETON,
N. J. ALL RIGHTS RESERVED

Second edition, completely revised, 1968

First Princeton / Bollingen Paperback printing, 1980

THIS EDITION IS BEING PUBLISHED IN THE UNITED STATES OF AMERICA BY PRINCETON UNIVERSITY PRESS AND IN ENGLAND BY ROUTLEDGE AND KEGAN PAUL, LTD. IN THE AMERICAN EDITION, ALL THE VOLUMES COMPRISING THE COLLECTED WORKS CONSTITUTE NUMBER XX IN BOLLINGEN SERIES. THE PRESENT VOLUME IS NUMBER 12 OF THE COLLECTED WORKS, AND WAS THE FIRST TO APPEAR.

Originally published in German as *Psychologie und Alchemie*, by Rascher Verlag, Zurich, 1944; 2nd edition revised, 1952.

ISBN 0-691-09771-2

ISBN 0-691-01831-6 pbk.

LIBRARY OF CONGRESS CATALOG CARD NUMBER: 75-156

MANUFACTURED IN THE U. S. A.

PREFATORY NOTE TO THE ENGLISH EDITION

To the reader who knows little or nothing of my work, a word of explanation may be helpful. Some thirty-five years ago I noticed to my amazement that European and American men and women coming to me for psychological advice were producing in their dreams and fantasies symbols similar to, and often identical with, the symbols found in the mystery religions of antiquity, in mythology, folklore, fairytales, and the apparently meaningless formulations of such esoteric cults as alchemy. Experience showed, moreover, that these symbols brought with them new energy and new life to the people to whom they came.

From long and careful comparison and analysis of these products of the unconscious I was led to postulate a “collective unconscious,” a source of energy and insight in the depth of the human psyche which has operated in and through man from the earliest periods of which we have records.

In this present study of alchemy I have taken a particular example of symbol-formation, extending in all over some seventeen centuries, and have subjected it to intensive examination, linking it at the same time with an actual series of dreams recorded by a modern European not under my direct supervision and having no knowledge of what the symbols appearing in the dreams might mean. It is by such intensive comparisons as this (and not one but many) that the hypothesis of the collective unconscious—of an activity in the human psyche making for the spiritual development of the individual human being—may be scientifically established.

[*Undated*]

C. G. JUNG

***From* EDITORIAL NOTE TO THE FIRST EDITION**

This volume of Professor Jung's *Collected Works* is a translation, with minor alterations made at the instance of the author, of *Psychologie und Alchemie* (Zurich, 1944; 2nd edition, revised, 1952). That work was based on the two lectures mentioned in Professor Jung's foreword, "Traumsymbole des Individuationsprozesses," *Eranos-Jahrbuch 1935* (Zurich, 1936), and "Die Erlösungsvorstellungen in der Alchemie," *Eranos-Jahrbuch 1936* (Zurich, 1937).

The two lectures were previously translated by Stanley Dell and published in *The Integration of the Personality* (New York, 1939; London, 1940) under the titles "Dream Symbols of the Process of Individuation" and "The Idea of Redemption in Alchemy." Professor Jung then considerably expanded them and added an introduction, in which he set out his whole position particularly in relation to religion. These three parts together with a short epilogue make up the Swiss volume.

The translation now presented to the public has been awaited with impatience in many quarters, for it is one of Professor Jung's major works, to be compared in importance with *Psychology of the Unconscious* and *Psychological Types*. It may be said that round the material contained in this volume the major portion of his later work revolves. On this account *Psychology and Alchemy* is being published first, though it is not Volume 1 of the *Collected Works*.

EDITORIAL NOTE TO THE SECOND EDITION

For this second edition of Volume 12, technical considerations made it necessary to reset the text, and this in turn made various improvements possible. The translation has been thoroughly revised, and additions and revisions have been made in accordance with the second Swiss edition, 1952. The bibliography and the footnote references have been corrected and brought up to date, particularly in respect of the author's subsequent publications in English. The paragraph numeration has been preserved, but the pagination has unavoidably changed. An entirely new index has been prepared. The late Mr. A. S. B. Glover was responsible for numerous improvements in the translations from the Latin and in the bibliographical references. The illustrations are printed almost entirely from new photographs; consequently the sources have sometimes had to be altered. For valuable assistance in obtaining new photographs the Editors are indebted to Mrs. Aniela Jaffé, Dr. Jolande Jacobi, and Dr. Rudolf Michel; for general editorial help, to Mrs. B. L. Honum Hull.

After the author's death in 1961, the unpublished draft of a "prefatory note to the English edition," written in English, was found among his papers, and this has been added to the present edition. For permission to publish it, the Editors are indebted to the late Mrs. Marianne Niehus-Jung, then acting on behalf of the heirs of C. G. Jung.

A variant of the text of [Part II](#) presenting the essay in its *Eranos-Jahrbuch 1935* form appeared as "Dream Symbols of the Individuation Process" in *Spiritual Disciplines* (Papers from the Eranos Yearbooks, 4; New York and London, 1959).

TRANSLATOR'S NOTE

So far as concerns the translation of this and other volumes of these collected works, the primary aim has naturally been to reproduce the straightforward, lively, and often informal language of the author. In an undertaking such as this one, it would indeed be an act of presumption for the translator to ignore the labours of his predecessors, and the present edition does not seek to stress its newness and difference by studiously overlooking the manifold excellences of the existing translations. In general, therefore, the secondary aim has been to establish a standard terminology for all volumes in this series and to reduce them to a uniform style, while making the fullest use of previous work in this field. In preparing the text of the present volume I had frequent recourse to the material already translated by Stanley Dell in *The Integration of the Personality*; I gratefully acknowledge my debt to him, and also to Miss Barbara Hannah, who magnanimously placed her private, unpublished version of *Psychology and Alchemy* at my disposal, as well as giving me every possible help in the correction of the typescripts and the proofs.

FOREWORD TO THE SWISS EDITION

The present volume contains two major studies which grew out of lectures delivered at the Eranos Congress. They were first printed in the *Eranos-Jahrbuch* for 1935 and 1936. The present edition has been augmented by nearly a half through the inclusion of additional material and the full apparatus of documentation. The text has been improved in certain respects and part of it newly arranged. Another new feature is the wealth of illustrations, the large number of which is justified by the fact that symbolical images belong to the very essence of the alchemist's mentality. What the written word could express only imperfectly, or not at all, the alchemist compressed into his images; and strange as these are, they often speak a more intelligible language than is found in his clumsy philosophical concepts. Between such images and those spontaneously produced by patients undergoing psychological treatment there is, for the expert, a striking similarity both in form and in content, although I have not gone into it very deeply in the course of my exposition.

I am particularly indebted to Dr. M. L. von Franz for philological help in translating the Zosimos text, which, besides being corrupt, is hard to construe and controversial. I wish also to thank Miss R. Schärf for information on the Og and Unicorn legend in Talmudic literature and Mrs. O. Fröbe-Kapteyn for obtaining photographic copies of a number of alchemical pictures. Lastly, I should like to express my very warm thanks to Dr. J. Jacobi for choosing and arranging the illustrations and looking after the details of printing.

Küsnacht, January, 1943

C. G. JUNG

**VOLUME 12
PSYCHOLOGY AND ALCHEMY**

TABLE OF CONTENTS

PREFATORY NOTE TO THE ENGLISH EDITION

EDITORIAL NOTE TO THE FIRST EDITION

EDITORIAL NOTE TO THE SECOND EDITION

TRANSLATOR'S NOTE

FOREWORD TO THE SWISS EDITION

LIST OF ILLUSTRATIONS

PART I

INTRODUCTION TO THE RELIGIOUS AND PSYCHOLOGICAL PROBLEMS OF ALCHEMY

PART II

INDIVIDUAL DREAM SYMBOLISM IN RELATION TO ALCHEMY

Chapter 1. Introduction

I. THE MATERIAL

II. THE METHOD

Chapter 2. The Initial Dreams

Chapter 3. The Symbolism of the Mandala

I. CONCERNING THE MANDALA

II. THE MANDALAS IN THE DREAMS

III. THE VISION OF THE WORLD CLOCK

IV. THE SYMBOLS OF THE SELF

PART III

RELIGIOUS IDEAS IN ALCHEMY

Chapter 1. Basic Concepts of Alchemy

- I. INTRODUCTION
- II. THE ALCHEMICAL PROCESS AND ITS STAGES
- III. CONCEPTIONS AND SYMBOLS OF THE GOAL

Chapter 2. The Psychic Nature of the Alchemical Work

- I. THE PROJECTION OF PSYCHIC CONTENTS
- II. THE MENTAL ATTITUDE TOWARDS THE OPUS
- III. MEDITATION AND IMAGINATION
- IV. SOUL AND BODY

Chapter 3. The Work

- I. THE METHOD
- II. THE SPIRIT IN MATTER
- III. THE WORK OF REDEMPTION

Chapter 4. The Prima Materia

- I. SYNONYMS FOR THE MATERIA
- II. THE INCREATUM
- III. UBIQUITY AND PERFECTION
- IV. THE KING AND THE KING'S SON
- V. THE MYTH OF THE HERO
- VI. THE HIDDEN TREASURE

Chapter 5. The Lapis-Christ Parallel

- I. THE RENEWAL OF LIFE
- II. EVIDENCE FOR THE RELIGIOUS INTERPRETATION OF THE LAPIS
 - a. Raymond Lully*
 - b. Tractatus aureus*
 - c. Zosimos and the Doctrine of the Anthropos*
 - d. Petrus Bonus*
 - e. "Aurora consurgens" and the Doctrine of Sapientia*
 - f. Melchior Cibinensis and the Alchemical Paraphrase of the Mass*
 - g. Sir George Ripley*
 - h. The Epigoni*

Chapter 6. Alchemical Symbolism in the History of Religion

I. THE UNCONSCIOUS AS THE MATRIX OF SYMBOLS

II. THE PARADIGM OF THE UNICORN

- a. The Unicorn in Alchemy*
- b. The Unicorn in Ecclesiastical Allegory*
- c. The Unicorn in Gnosticism*
- d. The One-Horned Scarabaeus*
- e. The Unicorn in the Vedas*
- f. The Unicorn in Persia*
- g. The Unicorn in Jewish Tradition*
- h. The Unicorn in China*
- i. The Unicorn Cup*

EPILOGUE

BIBLIOGRAPHY

INDEX

LIST OF ILLUSTRATIONS

References to documentary sources, which are somewhat shortened in the captions to the illustrations, are given more fully in this list. For explanation of the abbreviations and acknowledgment of photographs, etc., see the note at the end of the list (p. xxxv).

1. The Creator as Ruler of the threefold and fourfold universe *faces*
“Liber patris sapientiae,” *Theatrum chemicum Britannicum* (1652), p. 210.
(M.C.A.O.)
2. A pair of alchemists
Mutus liber (1702), p. 11, detail. (M.C.A.O.)
3. Symbol of the alchemical work
Hermaphroditisches Sonn- und Mondskind (1752), p. 28. (C.G.J.)
4. Representation of the symbolic process
Title-page, Béroalde de Verville, *Le Tableau des riches inventions* or *Le Songe de Poliphile* (1600). (M.C.A.O.)
5. Seven virgins being transformed
Béroalde de Verville, *Le Songe de Poliphile* (1600), p. 61. (M.C.A.O.)
6. A maternal figure presiding over the goddesses of fate
Thenaud, “Traité de la cabale,” MS. 5061 (16th cent.), Paris, Bibliothèque de l’Arsenal. P: Inst.
7. The Uroboros as symbol of the aeon
Horapollo, *Selecta hieroglyphica* (1597), p. 5, vignette. (C.G.J.)
8. The *anima mundi*
Engraving by J.-T. de Bry, from Fludd, *Utriusque cosmi* (1617), pp. 4/5. P: Inst.
9. The awakening of the sleeping king
Thomas Aquinas (pseud.), “De alchimia,” Codex Vossianus 29 (16th cent.), Leiden, Univ. Bibl., fol. 78.
- 10, 11, 12. Melusina; two-headed Melusina; mermaid with mask
Eleazar, *Uraltes chymisches Werk* (1760), pp. 85, 85, 98 resp. (M.C.A.O.)
13. The “tail-eater” (Uroboros) as the *prima materia*
Reusner, *Pandora* (1588), p. 257. (C.G.J.)

14. [Jacob's dream](#)

Watercolour by William Blake. British Museum, p: John Freeman.

15. [The *scala lapidis*](#)

“Emblematical Figures of the Philosophers’ Stone,” MS. Add. 1316 (17th cent.), British Museum.

16. [Mercurius *tricephalus* as Anthropos](#)

Kelley, *Tractatus de Lapide philosophorum* (1676), p. 101.

17. [The artifex \(or Hermes\) as shepherd of Aries and Taurus](#)

Thomas Aquinas (pseud.), “De alchimia,” Codex Vossianus 29 (16th cent.), Leiden, Univ. Bibl., fol. 86.

18. [Christ as shepherd](#)

Mosaic, mausoleum of Galla Placidia, Ravenna (c. 424–51). p: Anderson.

19. [The soul as guide, showing the way](#)

Watercolour by William Blake for Dante’s *Purgatorio*, Canto IV. Tate Gallery.

20. [The six planets united in the seventh, Mercury](#)

Thomas Aquinas (pseud.), “De alchimia,” Codex Vossianus 29 (16th cent.), Leiden, Univ. Bibl., fol. 94a.

21. [The seven gods of the planets in Hades](#)

Mylius, *Philosophia reformata* (1622), p. 167, fig. 18. (C.G.J.)

22. [Mercurius in the “philosopher’s egg”](#)

Mutus liber (1702), p. 11, detail. (M.C.A.O.)

23. [The mystic vessel](#)

“Figurarum Aegyptiorum secretarum,” MS. in author’s coll. (18th cent.), p. 13. (C.G.J.)

24. [The activities presided over by Mercurius](#)

MS. (c. 1400), Tübingen, Universitätsbibliothek.

25. [The fountain of life as *fons mercurialis*](#)

Rosarium philosophorum (1550). (C.G.J.)

26. [The Virgin Mary surrounded by her attributes](#)

Devotional picture (17th cent.); from Prinz, *Altorientalische Symbolik*, p. 6. (C.G.J.)

27. [Life-renewing influence of the conjoined sun and moon on the bath](#)

Milan, Biblioteca Ambrosiana, Codex I, 6 inf. p: F. Busi, Milan.

28. Capture of the Leviathan

Herrad of Landsberg's *Hortus deliciarum* (12th cent.); from the Keller and Straub edn., Pl. XXIV. (New York Public Library.)

29. Seven-petalled rose

Fludd, *Summum bonum* (1629), frontispiece. British Museum.

30. The red-and-white rose

"Ripley Scrowle," MS. Add. 5025 (1588), British Museum, No. 1, detail.

31. The symbolic city as centre of the earth

Maier, *Viatorium* (1651), p. 57. (C.G.J.)

32. *Coniunctio solis et lunae*

Trismosin, "Splendor solis," MS. Harley 3469 (1582), British Museum.

33. Poliphilo surrounded by nymphs

Béroalde de Verville, *Le Songe de Poliphile* (1600), p. 9. (M.C.A.O.)

34. The *nigredo* standing on the *rotundum*

Mylius, *Philosophia reformatata* (1622), p. 117, fig. 9. (C.G.J.)

35. A medieval version of the "wild man"

Codex Urbanus Latinus 899 (15th cent.), Biblioteca Vaticana, fol. 85.

36. The devil as aerial spirit and ungodly intellect

Illustration by Eugène Delacroix (1799–1863) for *Faust*, Part I. p: Courtesy of The Heritage Club, New York.

37. The seven-petalled flower

Boschius, *Symbolographia* (1702), Symbol. LCCXXIII, Class. 1. Tab. XXI. (C.G.J.)

38. Mercurius as *virgo*

Thomas Aquinas (pseud.), "De alchimia," Codex Vossianus 29 (16th cent.), Leiden, Univ. Bibl., fol. 95a.

39. Shri-Yantra

Traditional, from Avalon, *The Serpent Power*.

40. Tibetan World Wheel (*sidpe-korlo*)

Painted banner. Private collection.

41. The Aztec "Great Calendar Stone"

National Museum, Mexico. p: Instituto Nacional de Antropología y Historia, Mexico.

42. [Mandala containing the Infant Christ carrying the Cross](#)
Mural painting by Albertus Pictor in the church of Harkeberga, Sweden (c. 1480); from Cornell, *Iconography of the Nativity of Christ*, p. 53. P: Courtesy of J. Jacobi.
43. [Lamaic Vajramandala](#)
Tibetan painted banner. Formerly in the China Institute, Frankfurt on the Main; destroyed in 2nd World War.
44. [Mexican calendar](#)
Engraving from Herrliberger, *Heilige Ceremonien* (1748), Pl. XC, No. 1. (C.G.J.)
45. [Hermes as psychopomp](#)
Gem in a Roman ring; from King, *The Gnostics and Their Remains*, fig. 14. (C.G.J.)
- 46, 47. [Crowned dragon as tail-eater](#)
Eleazar, *Uraltes chymisches Werk* (1760), Part II, nos. 4 and 3 facing p. 8. (M.C.A.O.)
48. [The putrefactio](#)
Stolcius de Stolcenberg, *Viridarium chymicum* (1624), fig. VIII. (C.G.J.)
49. [Diagram showing the four functions of consciousness](#)
Author's diagram, taken from Jacobi, *The Psychology of Jung*, Diag. 4.
50. [Baneful spirits attacking the Impregnable Castle](#)
Fludd, *Summum bonum* (1629). British Museum.
51. [The Lapis Sanctuary](#)
Van Vreeswyck, *De Groene Leeuw* (1672), p. 123. British Museum.
52. [Harpokrates on the lotus](#)
Gnostic gem; from King, *The Gnostics and Their Remains*, fig. 6. (C.G.J.)
53. [The tetramorph, the steed of the Church](#)
Crucifixion in Herrad of Landsberg's *Hortus deliciarum* (12th cent.), detail; from the Keller and Straub edn., Pl. XXXVIII. (New York Public Library.)
54. [Hermaphrodite with three serpents and one serpent](#)
Rosarium philosophorum, in *Artis auriferae* (1593), II, p. 359. (C.G.J.)
55. [Faust before the magic mirror](#)
Rembrandt etching (c. 1652). Albertina, Vienna.
56. [Fountain of youth](#)

Codex de Sphaera, in Codex Estensis Latinus 209 (15th cent.), Modena. P: Orlandini, Modena.

57. Imperial bath with the miraculous spring of water

Alcadini, “De balneis Puteolanis,” Codex 1474 (14th cent.), Rome, Biblioteca Angelica.

58. Christ as the source of fire

Stained-glass window (14th cent.) in the choir of the former monastery church at Königsfelden (Aargau), Switzerland; from copy in author’s house at Küssnacht.

59. “All things do live in the three ...”

Jamsthaler, *Viatorium spagyricum* (1625), p. 272. (C.G.J.)

60. Squaring of the circle to make the two sexes one whole

Maier, *Scrutinium chymicum* (1687), Emblema XXI, p. 61. (C.C.J.)

61. The pearl as symbol of Ch’ien

Chinese bronze mirror of the T’ang Period (7th to 9th cent.); from Laignel-Lavastine, *Histoire générale de la médecine*, I, p. 543. P: Courtesy of J. Jacobi.

62. Rectangular mandala with cross

Zwiefalten Abbey breviary (12th cent.), fol. 10; from Löffler, *Schwäbische Buchmalerei*, Pl. 20. P: Courtesy of J. Jacobi.

63. Hermes

Greek vase painting (Hamilton Collection); from Lenormant and Witte, *Élite des monuments céramographiques*, III, Pl. LXXVIII.

64. Christ as Anthropos

Glanville, *Le Propriétaire des choses* (1482). P: Inst.

65. Tetramorph standing on two wheels

Vatopedi Monastery, Mt. Athos (1213); from Gillen, *Ikono-graphische Studien*, p. 15. P: Courtesy of J. Jacobi.

66. Ammon-Ra

From Champollion, *Panthéon égyptien*. (New York Public Library.)

67. Demon in the shape of a monkey

“Speculum humanae salvationis,” Codex Latinus 511 (14th cent.), Paris, Bibliothèque Nationale.

68. Thoth as cynocephalus

From tomb of Amen-her-khopshef, near Der el-Medina, Luxor (XXth dynasty, 12th cent. B.C.). Formerly in the Hahnloser Collection, Bern.

69. Dante and Virgil on their journey to the underworld
Illumination for the *Inferno*, Codex Urbanus Latinus 365 (15th cent.), Biblioteca Vaticana. P: Inst.
70. Pagan rites of transformation in the Middle Ages
Gnostic design; from Hammer-Purgstall, *Mémoire sur deux coffrets gnostiques*, Pl. K. (C.G.J.)
71. Creation of Adam from the clay of the *prima materia*
Schedel, *Das Buch der Chroniken* (1493), p. V. P: Courtesy of J. Jacobi.
72. The “union of irreconcilables”: marriage of water and fire
After an Indian painting; from Mueller, *Glauben, Wissen und Kunst der alten Hindus*, Pl. II, fig. 17.
73. The deliverance of man from the power of the dragon
Wynandi de Stega, “Adamas colluctancium aquilarum,” Codex Palatinus Latinus 412 (15th cent.), Biblioteca Vaticana. P: Inst.
74. Heaven fertilizing Earth and begetting mankind
Thenaud, “Traité de la cabale,” MS. 5061 (16th cent.), Paris, Bibliothèque de l’Arsenal.
75. Trimurti picture
After an Indian painting; from Mueller, *Glauben, Wissen und Kunst der alten Hindus*, Pl. II, fig. 40.
76. The tortoise: an alchemical instrument
Porta, *De distillationibus* (1609), p. 40. P: Inst.
77. Telesphorus
Bronze figure from Roman Gaul; marble statuette from Austria; after figs. in Roscher, *Lexikon*, V, col. 316.
78. Maria Prophetissa
Maier, *Symbola aureae mensae* (1617), frontispiece. (M.C.A.O.)
79. King Sol with his six planet-sons
Bonus, *Pretiosa margarita novella* (1546). (M.C.A.O.)
80. Mercurius turning the eight-spoked wheel
“Speculum veritatis,” Codex Vaticanus Latinus 7286 (17th cent.), Biblioteca Vaticana. P: Inst.
81. “Sol et eius umbra”
Maier, *Scrutinium chymicum* (1687), p. 133.

82. [The Anthropos with the four elements](#)
Russian MS. (18th cent.). P: Inst.
83. [Dante being led before God in the heavenly rose](#)
Illumination for the *Paradiso*, Codex Urbanus Latinus 365 (15th cent.), Biblioteca Vaticana. P: Inst.
84. [The fountain in the walled garden](#)
Boschius, *Symbolographia* (1702), Symbol. CCLI, Class. I, Tab. XVI. (C.G.J.)
85. [The eight-petalled flower](#)
“Recueil de figures astrologiques,” MS. Français 14770 (18th cent.). Paris, Bibliothèque Nationale.
86. [The alchemical apparatus for distillation](#)
Kelley, *Tractatus de Lapide philosophorum* (1676), p. 109. (C.G.J.)
87. [The Virgin as the vas of the divine child](#)
From a Venetian *Rosario dela gloriosa vergine Maria* (1524), in Inman, *Ancient Pagan and Modern Christian Symbolism*, p. 62.
88. [Vision of the Holy Grail](#)
“Roman de Lancelot du Lac,” MS. Français 116 (15th cent.), Paris, Bibliothèque Nationale. fol. 610^v.
89. [The pelican nourishing its young with its own blood](#)
Boschius, *Symbolographia* (1702), Symbol. LXX, Class. I, Tab. IV. (C.G.J.)
90. [The bear representing the dangerous aspect of the *prima materia*](#)
Thomas Aquinas (pseud.), “De alchimia,” Codex Vossianus 29 (16th cent.), Leiden, Univ. Bibl., fol. 82.
91. [Anima Mundi](#)
Thurneisser zum Thurn, *Quinta essentia* (1574), p. 92, woodcut. (C.G.J.)
92. [The alchemical process in the zodiac](#)
“Ripley Scrowle,” MS. Add. 5025 (1588), British Museum, No. 1, detail.
93. [The Mountain of the Adepts](#)
Michelspacher, *Cabala* (1654). P: Photo Archives, Marburg.
94. [Etna: “gelat et ardet”](#)
Boschius, *Symbolographia* (1702), Symbol. XXX, Class. II, Tab. II. (C.G.J.)
95. [Ludus puerorum](#)
Trismosin, “Splendor solis,” MS. Harley 3469 (1582), British Museum.

96. [Pygmies \(helpful child-gods\)](#)
Fragments of an Egyptian mechanical toy, Cairo Museum. P: Courtesy of A. Piankoff.
97. [The “Grand Peregrination” by ship](#)
Maier, *Viatorium* (1651), p. 183. (C.G.J.)
98. [The philosophical egg](#)
Wynandi de Stega, “Adamas colluctancium aquilarum,” Codex Palatinus Latinus 412 (15th cent.), Biblioteca Vaticana. P: Inst.
99. [Time-symbol of the lapis](#)
Thomas Aquinas (pseud.), “De alchimia,” Codex Vossianus 29 (16th cent.), Leiden, Univ. Bibl., fol. 74.
100. [Horoscope, showing the houses, zodiac, and planets](#)
Woodcut by Erhard Schoen for the nativity calendar of Leonhard Reymann (1515); from Strauss, *Der astrologische Gedanke*, p. 54.
101. [Christ in the mandorla](#)
Mural painting, church of Saint-Jacques-des-Guérets, Loir-et-Cher, France; from Clemen, *Die romanische Monumentalmalerei*, fig. 195, p. 260.
102. [Osiris, with the four sons of Horus on the lotus](#)
Budge, *The Book of the Dead* (1899), Papyrus of Hunefer, Plate 5.
103. [Sponsus et sponsa](#)
Detail from *Polittico con I’Incoronazione*, by Stefano da Sant’Agnese (15th cent.), Venice, Accademia. P: Alinari.
104. [God as Father and Logos creating the zodiac](#)
Peter Lombard, “De sacramentis,” Codex Vaticanus Latinus 681 (14th cent.), Biblioteca Vaticana.
105. [The Virgin, personifying the starry heaven](#)
“Speculum humanae saluacionis,” Codex Palatinus Latinus 413 (15th cent.), Biblioteca Vaticana.
106. [“Elixir of the moon”](#)
Codex Reginensis Latinus 1458 (17th cent.), Biblioteca Vaticana.
107. [Virgin carrying the Saviour](#)
“Speculum humanae saluacionis,” Codex Palatinus Latinus 413 (15th cent.), Biblioteca Vaticana.
108. [Maya encircled by the Uroboros](#)

Damaged vignette from frontispiece of a collection of Brahminic sayings; from Mueller, *Glauben, Wissen und Kunst der alten Hindus*, Pl. I, fig. 91.

109. [The four evangelists with their symbols and the four rivers of paradise](#)

Miniature in an Evangeliary, Aschaffenburg, Codex 13 (13th cent.), fol. 177. P: Samhaber, Aschaffenburg.

110. [Sand-painting of the Navajo Indians](#)

Ethnological drawing; from Stevenson, "Ceremonial of Hasjelti Dailjis," Pl. CXXI.

111. [The *cauda pavonis*](#)

Boschius, *Symbolographia* (1702), Symbol. LXXXIV, Class. I, Tab. V. (C.G.J.)

112. [The principal symbols of alchemy](#)

Trismosin, *La Toyson d'or* (1612), frontispiece. Coll. C. A. Meier, Zurich.

113. [Moon and sun furnaces](#)

Mutus liber (1702), p. 14, detail. (M.C.A.O.)

114. [The four stages of the alchemical process](#)

Mylius, *Philosophia reformata* (1622), p. 96, fig. 2. (C.G.J.)

115. [The *nigredo*: eclipse of *Mercurius senex*, exhaling the *spiritus* and *anima*](#)

Jamsthaler, *Viatorium spagyricum* (1625), p. 118. (C.G.J.)

116. [Crowned hermaphrodite](#)

"Traité d'alchimie," MS. 6577 (17th cent.), Paris, Bibliothèque de l'Arsenal.

117. [Anthropos as *anima mundi*](#)

From Albertus Magnus, *Philosophia naturalis* (1650). (C.G.J.)

118. [Brother-sister pair in the "bath of life"](#)

Theatrum chemicum Britannicum (1652), p. 350. P: Inst.

119. [Alchemical furnace](#)

Geber, *De alchimia* (1529), frontispiece. (C.G.J.)

120. [Mercurius in the vessel](#)

Barchusen, *Elementa chemiae* (1718), fig. 75, Paris, Bibliothèque Nationale.

121. [The transformations of Mercurius in the Hermetic vessel](#)

"Cabala mineralis," MS. Add. 5245, British Museum, fol. 2. P: Inst.

122. [The twelve alchemical operations in the form of the *arbor philosophica*](#)

Samuel Norton, *Mercurius redivivus* (1630), British Museum.

123. [Hermaphrodite](#)

Hermaphroditisches Sonn- und Mondskind (1752), p. 16, detail. (C.G.J.)

124. Alchemists at work

Mutus liber (1702), p. 13, detail. (M.C.A.O.)

125. Mercurius as the sun-moon hermaphrodite, standing on the (round) chaos

Mylius, *Philosophia reformata* (1622), p. 354, fig. 5. (C.G.J.)

126. The six days of creation, culminating in the seventh day

St. Hildegarde of Bingen, “Scivias,” MS. (12th cent.); from *Hildegard von Bingen: Wisse die Wege*, ed. Böckeler.

127. The transformation of Mercurius in the fire

Barchusen, *Elementa chemiae* (1718), fig. 76, Paris, Bibliothèque Nationale.

128. Hermes Trismegistus

Senior, *De chemia*, in Mangetus, *Bibliotheca chemica curiosa* (1702), Vol. II, facing p. 216. (M.C.A.O.) [In the original edition, Jung used the Strasbourg 1566 version of Senior’s *De chemia*, now unavailable.]

129. Personified *spiritus* escaping from the heated *prima materia*

Thomas Aquinas (pseud.), “De alchimia,” Codex Vossianus 29 (16th cent.), Leiden, Univ. Bibl., fol. 60a, detail.

130. The Mercurial serpent devouring itself in water or fire

Barchusen, *Elementa chemiae* (1718), figs. 58–61, Paris, Bibliothèque Nationale.

131. Adam as *prima materia*, pierced by the arrow of Mercurius

“Miscellanea d’alchimia.” MS. Ashburnham 1166 (14th cent.), Florence, Biblioteca Medicea-Laurenziana. P: Inst.

132. The “secret” contents of the work

Mutus liber (1702), fig. 3. (M.C.A.O.)

133. Alchemists at work

Mutus liber (1702), p. 6. (M.C.A.O.)

134. Saturn, or *Mercurius senex*, being cooked in the bath

Trismosin, “Splendor solis,” MS. Harley 3169 (1582), British Museum.

135. The skull, symbol of the *mortificatio* of Eve

“Miscellanea d’alchimia,” MS. Ashburnham 1166 (14th cent.), Florence, Biblioteca Medicea-Laurenziana. P: Inst.

136. God enlightening the artifex

Barchusen, *Elementa chemiae* (1718), fig. 2, Paris, Bibliothèque Nationale.

137. Alchemist in the initial *nigredo* state, meditating
Jamsthaler, *Viatorium spagyricum* (1625), p. 27. (C.G.J.)
138. The Mercurial spirit of the *prima materia*, as salamander, frolicking in the fire
Maier, *Scrutinium chymicum* (1687), Emblema XXIX, p. 85. (C.G.J.)
139. Hermes conjuring the winged soul out of an urn
Attic funeral lekythos, Jena; from Harrison, *Themis*, p. 295, fig. 78.
140. The artifex with his *soror mystica*, holding the keys to the work
Thomas Aquinas (pseud.), “De alchimia,” Codex Vossianus 29 (16th cent.),
Leiden, Univ. Bibl., fol. 99.
141. The artifex with book and altar
Kelley, *Tractatus de Lapide philosophorum* (1676), p. 118.
142. The sequence of stages in the alchemical process
Libavius, *Alchymia* (1606), Commentarium, Part II, p. 55. (C.G.J.)
143. Alchemists at work
Mutus liber (1702), p. 7, detail. (M.C.A.O.)
144. Artists in library and laboratory
Maier, *Tripus aureus* (1618), from title-page (M.C.A.O.) [In his original edition,
Jung used an identical version from *Musaeum hermeticum* (1678).]
145. Laboratory and oratory
Khunrath, *Amphitheatrum sapientiae* (1604), Tab. III. p: Courtesy of J. Jacobi.
146. Mercurius as “uniting symbol”
Valentinus. “Duodecim claves,” in *Musaeum hermeticum* (1678), p. 396. (C.G.J.)
147. Uroboros
Codex Marcianus (11th cent.), Venice, fol. 188^v; in Berthelot, *Collection des
anciens alchimistes grecs*, Introduction, p. 132.
148. Mercurius as caduceus, uniting the paired opposites
“Figurarum Aegyptiorum secretarum,” MS. (18th cent.), in author’s coll., p. 14.
(C.G.J.)
149. The sick king (*prima materia*)
“La Sagesse des anciens,” MS. (18th cent.), in author’s coll. (C.G.J.)
150. The penetrating Mercurius
“Speculum veritatis,” Codex Vaticanus Latinus 7286 (17th cent.), Biblioteca
Vaticana. p: Inst.

151. Prisoners in the underworld
Izquierdo, *Praxis exercitiorum spiritualium* (1695), p. 72.
152. Saturn eating his children
Thomas Aquinas (pseud.), “De alchimia,” Codex Vossianus 29 (16th cent.),
Leiden, Univ. Bibl., fol. 73.
153. The artist lifting the homunculus out of the Hermetic vessel
Kelley, *Tractatus de Lapide philosophorum* (1676), p. 108.
- 154, 155. The king with the six planets or metals; the renewed king (*filius philosophorum*) worshipped by the six planets
Kelley, *Tractatus de Lapide philosophorum* (1676), pp. 122, 125.
156. The Dyad (day and night)
“Très Riches Heures du duc de Berry,” MS. 1284 (15th cent.), Chantilly, Musée Condé, fol. 14^v. P: Giraudon.
157. *Anima Mercurii*
“Figurarum Aegyptiorum secretarum,” MS. (18th cent.), in author’s coll., p. 1.
(C.G.J.)
158. The “Mill of the Host”
High altar of church at Tribsees, Pomerania (15th cent.); from Falke, *Geschichte des deutschen Kunstgewerbes*, facing p. 100.
159. The *coniunctio* of soul and body
“Grandes heures du duc de Berry,” MS. Latin 919 (1413), Paris, Bibliothèque Nationale.
160. Symbol of the art as union of water and fire
Eleazar, *Uraltes chymisches Werk* (1760), Part II, no. 9, facing p. 52. (M.C.A.O.)
161. The *prima materia* as Saturn devouring his children
Mutus liber (1702), p. 7, detail. (M.C.A.O.)
162. The unfettered opposites in chaos
Marolles, *Tableaux du temple des muses* (1655), British Museum.
163. Earth as *prima materia*, suckling the son of the philosophers
Mylius, *Philosophia reformata* (1622), p. 96, fig. 1. (C.G.J.)
164. Mercurius, standing on the round chaos, holding the scales
“Figurarum Aegyptiorum secretarum,” MS. (18th cent.), in author’s coll., p. 45.
(C.G.J.)
165. “L’occasione”: Mercurius standing on the globe

Cartari, *Le imagini de i dei* (1581), p. 400. P: Courtesy of J. Jacobi.

166. The *Rex marinus* calling for help

Trismosin, “Splendor solis,” MS. Harley 3469 (1582), British Museum.

167. Allegory of the psychic union of opposites

Rosarium philosophorum (1550). (C.G.J.)

168. The king as *prima materia*, devouring his son

Lambspringk, “Figurae et emblemata,” fig. XIII, in *Musaeum hermeticum* (1678), p. 367. P: Inst.

169. The “green lion” devouring the sun

Rosarium philosophorum (1550). P: Courtesy of J. Fraser.

170. The night sea journey

Biblia pauperum (1471); edn. of 1906, fig. 170.

171. Hercules on the night sea journey in the vessel of the sun

Base of an Attic vase (5th cent. B.C.), Etruscan Museum, Vatican. P: Alinari.

172. Jonah emerging from the belly of the whale

“Speculum humanae salvationis,” Codex Latinus 512 (15th cent.), Paris, Bibliothèque Nationale.

173. The slaying of the king

Stolcius de Stolcenberg, *Viridarium chymicum* (1624), fig. 101. (C.G.J.)

174. Jonah in the whale

Early Christian earthenware lamp, Marseilles Museum; from Eisler, *Orpheus—the Fisher*, Pl. XLVII.

175. The wolf as *prima materia*, devouring the dead king

Maier, *Scrutinium chymicum* (1687), Emblema XXIV. (C.G.J.)

176. Jonah in the belly of the whale

Khludov Psalter, Codex 129, fol. 157 (Monastery of St. Nicholas, Preobrazhensk, Russia), (Byzantine, 9th cent.); from Tikkanen, *Die Psalterillustration im Mittelalter*, p. 24.

177. The Resurrection

Biblia pauperum (1471); edn. of 1906, fig. 170.

178. The dove (*avis Hermetis*) rising from the four elements

“De summa et universalis medicinae sapientiae veterum philosophorum,” MS. 974 (18th cent.), Paris, Bibliothèque de l’Arsenal, fig. 18.

179. [The alchemical trinity](#)
Lambspringk, “Figurae et emblemata,” fig. XV, in *Musaeum hermeticum* (1678), p. 371. (M.C.A.O.)
180. [The Christian Trinity with the Holy Ghost as a winged man](#)
Engraving (15th cent.), by the Master of the Berlin Passion; from Molsdorf, *Christliche Symbolik*, Pl. I.
181. [Sun as symbol of God](#)
Boschius, *Symbolographia* (1702), Symbol. CXII, Class. I, Tab. VII. (C.G.J.)
182. [Christ as the Saviour of souls](#)
Mural painting in church of the Braunweiler monastery, Rhineland (12th cent.), p: Marburg.
183. [Androgynous deity](#)
Late Babylonian gem; from Lajard, “Mémoire sur une représentation figurée de la Vénus orientale androgyne,” p. 161.
184. [The three youths in the fiery furnace](#)
Early Christian ornament on sarcophagus from Villa Carpegna, Rome; from Ehrenstein, *Das alie Testament im Bilde*, p. 818.
185. [Triad as unity; quaternity standing on the binarius](#)
Valentinus, “Duodecim claves,” in *Musaeum hermeticum* (1678), p. 415. (C.G.J.)
186. [The tree of coral in the sea](#)
From Dioscorides, “De materia medica,” MS. (16th cent.), Vienna, Nationalbibliothek, fol. 391b; in Koemstedt, *Vormittelalterliche Malerei*, fig. 79.
187. [The dragon spewing forth Jason](#)
Attic vase (5th cent, B.C.), Etruscan Museum, Vatican. P: Anderson.
188. [The tree of the philosophers](#)
Mylius, *Philosophia reformata* (1622), p. 316. (C.G.J.)
189. [Dragon with tree of the Hesperides](#)
Boschius, *Symbolographia* (1702), Symbol. LVII, Class. III, Tab. IV. (C.G.J.)
190. [Mayan ritual tree with serpent](#)
Dresden Codex, Dresden, Landesbibliothek, Pl. XXVI, detail.
191. [Descent of the Holy Ghost in the form of cloven tongues](#)
Munich Lectionary or *Perikopenbuch*, Codex Latinus 15713 (12th cent.), Munich, Staatsbibliothek, fol. 37^v;. P: Marburg.

192. The quaternity of the cross in the zodiac
Böhme, *Signatura rerum*, in Amsterdam edn. (1682), frontispiece. P: Inst.
193. The white and the red rose as end-product of the transformation of king and queen
“Trésor des trésors,” MS. 975 (17th cent.), Paris, Bibliothèque de l’Arsenal, figs. 11, 12.
194. Sulphur as sun and Mercurius as moon bridging the river of “eternal water”
Barchusen, *Elementa chemiae* (1718), fig. 9, Paris, Bibliothèque Nationale.
195. Creator, macrocosm, and microcosm in human form
St. Hildegarde of Bingen, “Liber divinorum operum,” Codex 1942 (12th cent.), Lucca, Biblioteca governativa. P: Inst.
196. The three manifestations of the Anthropos during his transformation
“Ripley Scrowle,” MS. Add. 5025 (1588), No. 2, detail, British Museum.
197. Christ in the midst of the four rivers of paradise
Peregrinus, “Speculum virginum,” Codex Palatinus Latinus 565 (13th cent.), Biblioteca Vaticana. P: Inst.
198. *Anser or cygnus Hermetis*
Hermaphroditisches Sonn- und Mondskind (1752), p. 54. (C.G.J.)
199. Hermaphrodite on the winged globe of chaos
Jamsthaler, *Viatorium spagyricum* (1625), p. 75. (C.G.J.)
200. Eagle and swan as symbols of the sublimated *spiritus*
Mylius, *Philosophia reformata* (1622), p. 126, fig. 13. (C.G.J.)
201. Sapientia as mother of the wise
Thomas Aquinas (pseud.), “De alchimia,” Codex Vossianus 29 (16th cent.), Leiden, Univ. Bibl., fol. 53, detail.
202. Communion table with seven fish
Christian earthenware lamp, Carthage; from Eisler, *Orpheus—the Fisher*, Pl. LIX.
- 203, 204. The Chnuphis serpent with seven-rayed crown
Gnostic gem and amulet; from King, *The Gnostics and Their Remains*, Pl. III, figs. 7 and 2.
205. Goddess of fate (?) as serpent with seven heads
Seal of St. Servatius, from Maastricht Cathedral; from King, *The Gnostics and Their Remains*, p. 119.
206. Helios riding a chariot with four horses

Theodore Psalter, MS. Add. 19352 (1066), British Museum.

207. [The ascension of Elijah](#)

Early Christian mural painting, crypt of Lucina, Rome; from Ehrenstein, *Das Alte Testament im Bilde*, p. 699. P: Courtesy of J. Jacobi.

208. [Mercurius as *anima mundi*](#)

“Turba philosophorum,” Codex Latinus 7171 (16th cent.), Paris, Bibliothèque Nationale. P: Inst.

209. [The winged sphere \(*aurum aurae*\)](#)

Balduinus, *Aurum hermeticum* (1675), frontispiece. (C.G.J)

210. [“The wind hath carried it in his belly” \(“Tabula smaragdina”\)](#)

Maier, *Scrutinium chymicum* (1687), Emblem I. (C.G.J.)

211. [The god Aër as procreator of all harmony](#)

“Recueil des fausses décrétales,” MS. (13th cent.), Reims. P: inst.

212. [The Trinity as *tricephalus*](#)

Speculum humanae salvationis, Augsburg (1480). (New York Public Library.)

213. [Moses striking water from the rock](#)

Bible Moralisée, MS. 270b (13th cent.), Oxford, Bodleian Library; from Ehrenstein, *Das Alte Testament im Bilde*, p. 384. P: Courtesy of J. Jacobi.

214. [Symbol of Hermetic transformation](#)

Samuel Norton, *Mercurius redivivus* (1630), fig. 2. P: Inst.

215. [The completion of the process](#)

Mutus liber (1702), p. 15. (M.C.A.O.)

216. [The artifex as priest](#)

Frontispiece to Melchior Cibirensis, *Symbolum*; from Maier, *Symbola aureae mensae* (1617), p. 509. (M.C.A.O.)

217. [The crucified *serpens mercurialis*](#)

Abraham le Juif, “Livre des figures hiéroglyphiques,” MS. Français 14765 (18th cent.), Paris, Bibliothèque Nationale. P: Inst.

218. [The “bath of the philosophers”](#)

Mylius, *Philosophia reformata* (1622), fig. 4, p. 224. (C.G.J.)

219. [The “Ethiopian” as the *nigredo*](#)

Trismosin, “Splendor solis,” MS. Harley 3469 (1582), British Museum.

220. [Figure of the moon](#)

Codex Urbanus Latinus 899 (15th cent.), Biblioteca Vaticana, fol. 68. p: Inst.

221. *Arbor philosophica*

Samuel Norton, *Catholicon physicorum* (1630), British Museum.

222. The sea of renewal arising from virgin's milk

Stolcius de Stolcenberg, *Viridarium chymicum* (1624), fig. LXXXIII. p: Courtesy of J. Jacobi.

223. *Mortificatio*: Sol and Luna overcome by death after the *coniunctio*

Mylius, *Philosophia reformata* (1622), fig. 6, p. 243. p: Inst.

224. Transfiguration of the body portrayed as the coronation of the Virgin Mary

“Das Buch der heiligen Dreifaltigkeit,” Codex Germanicus 598 (1420), Munich, Staatsbibliothek. p: Inst.

225. The love-potion being handed to the brother-sister pair

Maier, *Scrutinium chymicum* (1687), Emblema IV, p. 10. (C.G.J.)

226. *Coniunctio* of opposites in the Hermetic vessel

“Trésor des trésors,” MS. 975 (17th cent.), Paris, Bibliothèque de l’Arsenal.

227. *Coniunctio* as a fantastic monstrosity

Brant, *Hexastichon* (1503). (C.G.J.)

228. The plumed king who plucks out his feathers for food

“Ripley Scrowle,” MS. Add. 5025 (1588), British Museum. p: Inst.

229. Eagle as symbol of the spirit ascending from the *prima materia*

Hermaphroditisches Sonn- und Mondskind (1752), p. 44. (C.G.J.)

230. The peacock rising from the retort

MS. (18th cent.), in coll. Dr. C. Rusch, Appenzell. p: Inst.

231. Mercurius as Pandora and *arbor philosophica*

Reusner, *Pandora* (1588), p. 225. (C.G.J.)

232. Glorification of the body portrayed as coronation of the Virgin Mary

Speculum Trinitatis, from Reusner, *Pandora* (1588), p. 253. (C.G.J.)

233. Christian quaternity: Trinity and Mary (detail)

French School (1457), Basel Museum.

234. The Risen Christ as symbol of the *filius philosophorum*

Rosarium philosophorum (1550). (C.G.J.)

235. Alchemical quaternity

Rosarium philosophorum (1550). (C.G.J.)

236. [Contents of the *vas Hermetis*](#)

Kelley, *Tractatus de Lapide philosophorum* (1676), p. 114.

237. [The artifex at work with his *soror mystica*](#)

Mutus liber (1702), p. 7, detail. (M.C.A.O.)

238. [The brazen serpent of Moses on the cross](#)

Eleazar, *Uraltes chymisches Werk* (1760), Part II, no. 10, facing p. 52. (M.C.A.O.)

239. [Unicorn](#)

Amman, *Ein neuw Thierbuch* (1569). P: Courtesy of J. Jacobi.

240. [Stag and unicorn](#)

Lambspringk, “Figurae et emblemata,” fig. III, in *Musaeum hermeticum* (1625 edn.), fig. III, p. 337. (New York Public Library.)

241. [Virgin taming a unicorn](#)

Thomas Aquinas (pseud.), “De alchimia,” Codex Vossianus 29 (16th cent.), Leiden, Univ. Bibl., fol. 87.

242. [Slaying the unicorn in the Virgin’s lap](#)

Initial from “Historia animalium cum picturis,” MS. Harley 4751, fol. 6^v, British Museum. P: Inst.

243. [Unicorn crest of the von Gachnang family](#)

From the Zurich Roll of Arms (1340); from Merz, *Die Wappenrolle von Zürich*, p. 33.

244. [The glorification of Ariosto](#)

Drawing by Giovanni Battista Benvenuti, called Ortolano (1488–?1525); formerly in A. O. Meyer collection; from Börner, *Auctions-Katalog 184* (1914), Pl. 30. P: Warburg Institute, London.

245. [The Virgin Mary with the loving unicorn in the “enclosed garden”](#)

Swiss tapestry (1480), Landesmuseum, Zurich; from Gysin, *Gotische Bildteppiche der Schweiz*, Pl. 5.

246. [Mandala with four ornamental medallions](#)

Pavement from St. Urban’s Monastery, Lucerne, Landesmuseum, Zurich.

247. [Virgin with unicorn](#)

Khudov Psalter, Codex 129, fol. 93^v (Monastery of St. Nicholas, Preobrazhensk, Russia), Byzantine (9th cent.); from Tikkanen, *Die Psalterillustration im Mittelalter*, p. 43.

248. [The creation of Eve](#)
Trésor de sapience,” MS. 5076 (15th cent.), Paris, Bibliothèque de l’Arsenal.
249. [Wild unicorn](#)
From Bock, *Kräuterbuch* (1595), p. 391. P: Courtesy of J. Jacobi.
250. [Wild man riding the unicorn](#)
Engraving from the *Grösseres Kartenspiel*, by the monogrammist E.S. (c. 1463);
from Geisberg, *Die Kupferstiche des Meisters E.S.*, Pl. L269.
251. [The seven stages of the alchemical process shown as a unity](#)
“Ripley Scrowle,” MS. Add. 5025 (1588), British Museum, No. 4, detail.
252. [Chastity](#)
Les Triomphes du Pétrarque,” MS. Français 594 (16th cent.), Paris, Bibliothèque Nationale.
253. [Harpocrates encircled by the Uroboros](#)
Gnostic gem; from King, *The Gnostics and Their Remains*, Pl. II, fig. 8.
254. [The so-called sea-unicorn](#)
Pommet, *Histoire générale des drogues* (1694), II, p. 78, Paris, Bibliothèque Nationale.
255. [Vishnu in his fish incarnation](#)
Indian miniature (18th cent.), in the author’s collection.
256. [Fabulous monster containing the *massa confusa*](#)
Hermaphroditisches Sonn- und Mondskind (1752), p. 57. (C.G.J.)
257. [The transformations of Mercurius](#)
“Ripley Scrowle,” MS. Add. 5025 (1588), British Museum, No. 3, detail.
258. [Unicorn and lion](#)
From the tapestry series *La Dame à la Licorne* (16th cent.), Musée de Cluny, Paris.
P: Bulloz.
- 259, 260. [The ch’i-lin announcing the birth and death of Confucius](#)
From a Chinese illustrated work (c. 18th cent.), *Shêng Chi-t’u*. School of Oriental Studies, London. P: John Freeman.
261. [Pope with the unicorn as the symbol of the Holy Ghost](#)
Scaliger, *Explanatio imaginum* (1570), p. 84, British Museum. P: John Freeman.
262. [The lunar unicorn](#)
Reverse of a medal (1447) by Antonio Pisano, British Museum.

263. The Campion Pendant

Formerly in possession of the Campion family, Sussex, England; probably 16th cent., Victoria and Albert Museum, London.

264. Mandala of the unicorn and the tree of life

Verteuil tapestry (15th cent.), “The Hunt of the Unicorn,” Cloisters, Metropolitan Museum of Art, New York.

265. The unicorn and his reflection

Boschius, *Symbolographia* (1702), Symbol. LXXXIX, Class. I, Tab. V. (C.G.J.)

266. Double-headed eagle with crowns of Pope and Emperor

Wynandi de Stega, “Adamas colluctantium aquilarum,” Codex Palatinus Latinus 412 (15th cent.), Biblioteca Vaticana. P: Inst.

267. The *prima materia* as the dragon, being fertilized by the Holy Ghost

“Hermes Bird,” *Theatrum chemicum Britannicum* (1652), p. 213 (M.C.A.O.)

268. *Fermentatio*, symbolic representation of the *coniunctio spirituum*

Rosarium philosophorum (1550). (C.G.J.)

269. The artifex and his *soror mystica* making the gesture of the secret

Mutus liber (1702), p. 14, detail. (M.C.A.O.)

270. The phoenix as symbol of resurrection

Boschius, *Symbolographia* (1702), Symbol. DCVI, Class. I, Tab. XXVI. (C.G.J.)

NOTE OF ACKNOWLEDGMENT

The illustrations are derived from:

- (1) Rare books, MSS., and other works in the author's collection at Küsnacht, which have been reproduced by kind permission of Mr. Franz Jung and photographed under the supervision of Mrs. Aniela Jaffé; indicated by the initials "C.G.J."
- (2) Rare books in Mr. Paul Mellon's former collection, reproduced by kind permission of him and of the Yale University Library, where the collection has been deposited under the name "Mellon Collection of the Alchemical and Occult"; photographed by Yale University Library; indicated by the initials "M.C.A.O."
- (3) Photographs in private collections, in particular that of Dr. Jolande Jacobi, Zurich, and that of the C. G. Jung Institute, Zurich (indicated as "Inst.").
- (4) Books, MSS., and other works in various museums, libraries, archives, etc., as indicated; photographed by the institution unless otherwise noted. Commercial photographic agencies are credited.
- (5) In a few cases, the blocks used in earlier editions and kindly made available by Rascher Verlag, Zurich.



1. The Creator as Ruler of the threefold and fourfold universe, with water and fire as the counterpart of heaven.

—“Liber patris sapientiae,” *Theatrum chemicum Britannicum* (1652)



INTRODUCTION TO THE RELIGIOUS AND PSYCHOLOGICAL PROBLEMS OF ALCHEMY

Calamum quassatum non conteret, et linum fumigans non extinguet....

—ISAIAH 42 : 3

The bruised reed he shall not break, and the smoking flax he shall not quench.... (D.V.)



2. A pair of alchemists, kneeling by the furnace and praying for God's blessing.

–*Mutus liber* (1702)

[1] For the reader familiar with analytical psychology, there is no need of any introductory remarks to the subject of the following study. But for the reader whose interest is not professional and who comes to this book unprepared, some kind of preface will probably be necessary. The concepts of alchemy and the individuation process are matters that seem to lie very far apart, so that the imagination finds it impossible at first to conceive of any bridge between them. To this reader I owe an explanation, more particularly as I have had one or two experiences since the publication of my recent lectures which lead me to infer a certain bewilderment in my critics.

[2] What I now have to put forward as regards the nature of the human psyche is based first and foremost on my observations of people. It has been objected that these observations deal with experiences that are either unknown or barely accessible. It is a remarkable fact, which we come across again and again, that absolutely everybody, even the most unqualified layman, thinks he knows all about psychology as though the psyche were something that enjoyed the most universal understanding. But anyone who really knows the human psyche will agree with me when I say that it is one of the darkest and most mysterious regions of our experience. There is no end to what can be learned in this field. Hardly a day passes in my practice but I come across something new and unexpected. True enough, my experiences are not commonplaces lying on the surface of life. They are, however, within easy reach of every psychotherapist working in this particular field. It is therefore rather absurd, to say the least, that ignorance of the experiences I have to offer should be twisted into an accusation against me. I do not hold myself responsible for the shortcomings in the lay public's knowledge of psychology.

[3] There is in the analytical process, that is to say in the dialectical discussion between the conscious mind and the unconscious, a development or an advance towards some goal or end, the perplexing nature of which has engaged my attention for many years. Psychological treatment may come to an *end* at any stage in the

development without one's always or necessarily having the feeling that a *goal* has also been reached. Typical and temporary terminations may occur (1) after receiving a piece of good advice; (2) after making a fairly complete but nevertheless adequate confession; (3) after having recognized some hitherto unconscious but essential psychic content whose realization gives a new impetus to one's life and activity; (4) after a hard-won separation from the childhood psyche; (5) after having worked out a new and rational mode of adaptation to perhaps difficult or unusual circumstances and surroundings; (6) after the disappearance of painful symptoms; (7) after some positive turn of fortune such as an examination, engagement, marriage, divorce, change of profession, etc.; (8) after having found one's way back to the church or creed to which one previously belonged, or after a conversion; and finally, (9) after having begun to build up a practical philosophy of life (a "philosophy" in the classical sense of the word).

[4] Although the list could admit of many more modifications and additions, it ought to define by and large the main situations in which the analytical or psychotherapeutic process reaches a temporary or sometimes even a definitive end. Experience shows, however, that there is a relatively large number of patients for whom the outward termination of work with the doctor is far from denoting the end of the analytical process. It is rather the case that the dialectical discussion with the unconscious still continues, and follows much the same course as it does with those who have not given up their work with the doctor. Occasionally one meets such patients again after several years and hears the often highly remarkable account of their subsequent development. It was experiences of this kind which first confirmed me in my belief that there is in the psyche a process that seeks its own goal independently of external factors, and which freed me from the worrying feeling that I myself might be the sole cause of an unreal—and perhaps unnatural—process in the psyche of the patient. This apprehension was not altogether misplaced inasmuch as no amount of argument based on any of the nine categories mentioned above—not even a religious conversion or the most startling removal of neurotic symptoms—can persuade certain patients to give up their analytical work. It was these cases that finally convinced me that the treatment of neurosis opens up a problem which goes far beyond purely medical considerations and to which medical knowledge alone cannot hope to do justice.

[5] Although the early days of analysis now lie nearly half a century behind us, with their pseudo-biological interpretations and their depreciation of the whole process of psychic development, memories die hard and people are still very fond of describing a lengthy analysis as "running away from life," "unresolved transference," "auto-eroticism"—and by other equally unpleasant epithets. But since there are two sides to everything, it is legitimate to condemn this so-called "hanging on" as negative to life

only if it can be shown that it really does contain nothing positive. The very understandable impatience felt by the doctor does not prove anything in itself. Only through infinitely patient research has the new science succeeded in building up a profounder knowledge of the nature of the psyche, and if there have been certain unexpected therapeutic results, these are due to the self-sacrificing perseverance of the doctor. Unjustifiably negative judgments are easily come by and at times harmful; moreover they arouse the suspicion of being a mere cloak for ignorance if not an attempt to evade the responsibility of a thorough-going analysis. For since the analytical work must inevitably lead sooner or later to a fundamental discussion between “I” and “You” and “You” and “I” on a plane stripped of all human pretences, it is very likely, indeed it is almost certain, that not only the patient but the doctor as well will find the situation “getting under his skin.” Nobody can meddle with fire or poison without being affected in some vulnerable spot; for the true physician does not stand outside his work but is always in the thick of it.

[6] This “hanging on,” as it is called, may be something undesired by both parties, something incomprehensible and even unendurable, without necessarily being negative to life. On the contrary, it can easily be a positive “hanging on,” which, although it constitutes an apparently insurmountable obstacle, represents just for that reason a unique situation that demands the maximum effort and therefore enlists the energies of the whole man. In fact, one could say that while the patient is unconsciously and unswervingly seeking the solution to some ultimately insoluble problem, the art and technique of the doctor are doing their best to help him towards it. “Ars totum requirit hominem!” exclaims an old alchemist. It is just this *homo totus* whom we seek. The labours of the doctor as well as the quest of the patient are directed towards that hidden and as yet unmanifest “whole” man, who is at once the greater and the future man. But the right way to wholeness is made up, unfortunately, of fateful detours and wrong turnings. It is a *longissima via*, not straight but snakelike, a path that unites the opposites in the manner of the guiding caduceus, a path whose labyrinthine twists and turns are not lacking in terrors. It is on this *longissima via* that we meet with those experiences which are said to be “inaccessible.” Their inaccessibility really consists in the fact that they cost us an enormous amount of effort: they demand the very thing we most fear, namely the “wholeness” which we talk about so glibly and which lends itself to endless theorizing, though in actual life we give it the widest possible berth.¹ It is infinitely more popular to go in for “compartment psychology,” where the left-hand pigeon-hole does not know what is in the right.

[7] I am afraid that we cannot hold the unconsciousness and impotence of the individual entirely responsible for this state of affairs: it is due also to the general psychological education of the European. Not only is this education the proper

concern of the ruling religions, it belongs to their very nature—for religion excels all rationalistic systems in that it alone relates to the outer and inner man in equal degree. We can accuse Christianity of arrested development if we are determined to excuse our own shortcomings; but I do not wish to make the mistake of blaming religion for something that is due mainly to human incompetence. I am speaking therefore not of the deepest and best understanding of Christianity but of the superficialities and disastrous misunderstandings that are plain for all to see. The demand made by the *imitatio Christi*—that we should follow the ideal and seek to become like it—ought logically to have the result of developing and exalting the inner man. In actual fact, however, the ideal has been turned by superficial and formalistically-minded believers into an external object of worship, and it is precisely this veneration for the object that prevents it from reaching down into the depths of the psyche and giving the latter a wholeness in keeping with the ideal. Accordingly the divine mediator stands outside as an image, while man remains fragmentary and untouched in the deepest part of him. Christ can indeed be imitated even to the point of stigmatization without the imitator coming anywhere near the ideal or its meaning. For it is not a question of an imitation that leaves a man unchanged and makes him into a mere artifact, but of realizing the ideal on one's own account—*Deo concedente*—in one's own individual life. We must not forget, however, that even a mistaken imitation may sometimes involve a tremendous moral effort which has all the merits of a total surrender to some supreme value, even though the real goal may never be reached and the value is represented externally. It is conceivable that by virtue of this total effort a man may even catch a fleeting glimpse of his wholeness, accompanied by the feeling of grace that always characterizes this experience.

[8] The mistaken idea of a merely outward *imitatio Christi* is further exacerbated by a typically European prejudice which distinguishes the Western attitude from the Eastern. Western man is held in thrall by the “ten thousand things”; he sees only particulars, he is ego-bound and thing-bound, and unaware of the deep root of all being. Eastern man, on the other hand, experiences the world of particulars, and even his own ego, like a dream; he is rooted essentially in the “Ground,” which attracts him so powerfully that his relations with the world are relativized to a degree that is often incomprehensible to us. The Western attitude, with its emphasis on the object, tends to fix the ideal—Christ—in its outward aspect and thus to rob it of its mysterious relation to the inner man. It is this prejudice, for instance, which impels the Protestant interpreters of the Bible to interpret ἐν τοῖς ὑμῶν (referring to the Kingdom of God) as “among you” instead of “within you.” I do not mean to say anything about the validity of the Western attitude: we are sufficiently convinced of its rightness. But if we try to come to a real understanding of Eastern man—as the psychologist must—we find it hard to rid ourselves of certain misgivings. Anyone

who can square it with his conscience is free to decide this question as he pleases, though he may be unconsciously setting himself up as an *arbiter mundi*. I for my part prefer the precious gift of doubt, for the reason that it does not violate the virginity of things beyond our ken.

[9] Christ the ideal took upon himself the sins of the world. But if the ideal is wholly outside then the sins of the individual are also outside, and consequently he is more of a fragment than ever, since superficial misunderstanding conveniently enables him, quite literally, to “cast his sins upon Christ” and thus to evade his deepest responsibilities—which is contrary to the spirit of Christianity. Such formalism and laxity were not only one of the prime causes of the Reformation, they are also present within the body of Protestantism. If the supreme value (Christ) and the supreme negation (sin) are outside, then the soul is void: its highest and lowest are missing. The Eastern attitude (more particularly the Indian) is the other way about: everything, highest and lowest, is in the (transcendental) Subject. Accordingly the significance of the Atman, the Self, is heightened beyond all bounds. But with Western man the value of the self sinks to zero. Hence the universal depreciation of the soul in the West. Whoever speaks of the reality of the soul or psyche² is accused of “psychologism.” Psychology is spoken of as if it were “only” psychology and nothing else. The notion that there can be psychic factors which correspond to divine figures is regarded as a devaluation of the latter. It smacks of blasphemy to think that a religious experience is a psychic process; for, so it is argued, a religious experience “is not *only* psychological.” Anything psychic is *only* Nature and therefore, people think, nothing religious can come out of it. At the same time such critics never hesitate to derive all religions—with the exception of their own—from the nature of the psyche. It is a telling fact that two theological reviewers of my book *Psychology and Religion*—one of them Catholic, the other Protestant—assiduously overlooked my demonstration of the psychic origin of religious phenomena.

[10] Faced with this situation, we must really ask: How do we know so much about the psyche that we can say “only” psychic? For this is how Western man, whose soul is evidently “of little worth,” speaks and thinks. If much were in his soul he would speak of it with reverence. But since he does not do so we can only conclude that there is nothing of value in it. Not that this is necessarily so always and everywhere, but only with people who put nothing into their souls and have “all God outside.” (A little more Meister Eckhart would be a very good thing sometimes!)

[11] An exclusively religious projection may rob the soul of its values so that through sheer inanition it becomes incapable of further development and gets stuck in an unconscious state. At the same time it falls victim to the delusion that the cause of all misfortune lies outside, and people no longer stop to ask themselves how far it is

their own doing. So insignificant does the soul seem that it is regarded as hardly capable of evil, much less of good. But if the soul no longer has any part to play, religious life congeals into externals and formalities. However we may picture the relationship between God and soul, one thing is certain: that the soul cannot be “nothing but.”³ On the contrary it has the dignity of an entity endowed with consciousness of a relationship to Deity. Even if it were only the relationship of a drop of water to the sea, that sea would not exist but for the multitude of drops. The immortality of the soul insisted upon by dogma exalts it above the transitoriness of mortal man and causes it to partake of some supernatural quality. It thus infinitely surpasses the perishable, conscious individual in significance, so that logically the Christian is forbidden to regard the soul as a “nothing but.”⁴ As the eye to the sun, so the soul corresponds to God. Since our conscious mind does not comprehend the soul it is ridiculous to speak of the things of the soul in a patronizing or depreciatory manner. Even the believing Christian does not know God’s hidden ways and must leave him to decide whether he will work on man from outside or from within, through the soul. So the believer should not boggle at the fact that there are *somnia a Deo missa* (dreams sent by God) and illuminations of the soul which cannot be traced back to any external causes. It would be blasphemy to assert that God can manifest himself everywhere save only in the human soul. Indeed the very intimacy of the relationship between God and the soul precludes from the start any devaluation of the latter.⁵ It would be going perhaps too far to speak of an affinity; but at all events the soul must contain in itself the faculty of relationship to God, i.e., a correspondence, otherwise a connection could never come about.⁶ *This correspondence is, in psychological terms, the archetype of the God-image.*

- [12] Every archetype is capable of endless development and differentiation. It is therefore possible for it to be more developed or less. In an outward form of religion where all the emphasis is on the outward figure (hence where we are dealing with a more or less complete projection), the archetype is identical with externalized ideas but remains unconscious as a psychic factor. When an unconscious content is replaced by a projected image to that extent, it is cut off from all participation in and influence on the conscious mind. Hence it largely forfeits its own life, because prevented from exerting the formative influence on consciousness natural to it; what is more, it remains in its original form—unchanged, for nothing changes in the unconscious. At a certain point it even develops a tendency to regress to lower and more archaic levels. It may easily happen, therefore, that a Christian who believes in all the sacred figures is still undeveloped and unchanged in his inmost soul because he has “all God outside” and does not experience him in the soul. His deciding motives, his ruling interests and impulses, do not spring from the sphere of Christianity but from the unconscious and undeveloped psyche, which is as pagan

and archaic as ever. Not the individual alone but the sum total of individual lives in a nation proves the truth of this contention. The great events of our world as planned and executed by man do not breathe the spirit of Christianity but rather of unadorned paganism. These things originate in a psychic condition that has remained archaic and has not been even remotely touched by Christianity. The Church assumes, not altogether without reason, that the fact of *semel credidisse* (having once believed) leaves certain traces behind it; but of these traces nothing is to be seen in the broad march of events. Christian civilization has proved hollow to a terrifying degree: it is all veneer, but the inner man has remained untouched and therefore unchanged. His soul is out of key with his external beliefs; in his soul the Christian has not kept pace with external developments. Yes, everything is to be found outside—in image and in word, in Church and Bible—but never inside. Inside reign the archaic gods, supreme as of old; that is to say the inner correspondence with the outer God-image is undeveloped for lack of psychological culture and has therefore got stuck in heathenism. Christian education has done all that is humanly possible, but it has not been enough. Too few people have experienced the divine image as the innermost possession of their own souls. Christ only meets them from without, never from within the soul; that is why dark paganism still reigns there, a paganism which, now in a form so blatant that it can no longer be denied and now in all too threadbare disguise, is swamping the world of so-called Christian civilization.

[13] With the methods employed hitherto we have not succeeded in Christianizing the soul to the point where even the most elementary demands of Christian ethics can exert any decisive influence on the main concerns of the Christian European. The Christian missionary may preach the gospel to the poor naked heathen, but the spiritual heathen who populate Europe have as yet heard nothing of Christianity. Christianity must indeed begin again from the very beginning if it is to meet its high educative task. So long as religion is only faith and outward form, and the religious function is not experienced in our own souls, nothing of any importance has happened. It has yet to be understood that the *mysterium magnum* is not only an actuality but is first and foremost rooted in the human psyche. The man who does not know this from his own experience may be a most learned theologian, but he has no idea of religion and still less of education.

[14] Yet when I point out that the soul possesses by nature a religious function,⁷ and when I stipulate that it is the prime task of all education (of adults) to convey the archetype of the God-image, or its emanations and effects, to the conscious mind, then it is precisely the theologian who seizes me by the arm and accuses me of “psychologism.” But were it not a fact of experience that supreme values reside in the soul (quite apart from the *ἀντίμιμον πνεῦμα* who is also there), psychology would not interest me in the least, for the soul would then be nothing but a miserable

vapour. I know, however, from hundredfold experience that it is nothing of the sort, but on the contrary contains the equivalents of everything that has been formulated in dogma and a good deal more, which is just what enables it to be an eye destined to behold the light. This requires limitless range and unfathomable depth of vision. I have been accused of “deifying the soul.” Not I but God himself has deified it! I did not attribute a religious function to the soul, I merely produced the facts which prove that the soul is *naturaliter religiosa*, i.e., possesses a religious function. I did not invent or insinuate this function, it produces itself of its own accord without being prompted thereto by any opinions or suggestions of mine. With a truly tragic delusion these theologians fail to see that it is not a matter of proving the existence of the light, but of blind people who do not know that their eyes could see. It is high time we realized that it is pointless to praise the light and preach it if nobody can see it. It is much more needful to teach people the art of seeing. For it is obvious that far too many people are incapable of establishing a connection between the sacred figures and their own psyche: they cannot see to what extent the equivalent images are lying dormant in their own unconscious. In order to facilitate this inner vision we must first clear the way for the faculty of seeing. How this is to be done without psychology, that is, without making contact with the psyche, is frankly beyond my comprehension.⁸

[15] Another equally serious misunderstanding lies in imputing to psychology the wish to be a new and possibly heretical doctrine. If a blind man can gradually be helped to see it is not to be expected that he will at once discern new truths with an eagle eye. One must be glad if he sees anything at all, and if he begins to understand what he sees. Psychology is concerned with the act of seeing and not with the construction of new religious truths, when even the existing teachings have not yet been perceived and understood. In religious matters it is a well-known fact that we cannot understand a thing until we have experienced it inwardly, for it is in the inward experience that the connection between the psyche and the outward image or creed is first revealed as a relationship or correspondence like that of *sponsus* and *sponsa*. Accordingly when I say as a psychologist that God is an archetype, I mean by that the “type” in the psyche. The word “type” is, as we know, derived from *τύπος*, “blow” or “imprint”; thus an archetype presupposes an imprinter. Psychology as the science of the soul has to confine itself to its subject and guard against overstepping its proper boundaries by metaphysical assertions or other professions of faith. Should it set up a God, even as a hypothetical cause, it would have implicitly claimed the possibility of proving God, thus exceeding its competence in an absolutely illegitimate way. Science can only be science; there are no “scientific” professions of faith and similar *contradictiones in adiecto*. We simply do not know the ultimate derivation of the archetype any more than we know the origin of the psyche. The

competence of psychology as an empirical science only goes so far as to establish, on the basis of comparative research, whether for instance the imprint found in the psyche can or cannot reasonably be termed a “God-image.” Nothing positive or negative has thereby been asserted about the possible existence of God, any more than the archetype of the “hero” posits the actual existence of a hero.

[16] Now if my psychological researches have demonstrated the existence of certain psychic types and their correspondence with well-known religious ideas, then we have opened up a possible approach to those experienceable contents which manifestly and undeniably form the empirical foundations of all religious experience. The religious-minded man is free to accept whatever metaphysical explanations he pleases about the origin of these images; not so the intellect, which must keep strictly to the principles of scientific interpretation and avoid trespassing beyond the bounds of what can be known. Nobody can prevent the believer from accepting God, Purusha, the Atman, or Tao as the Prime Cause and thus putting an end to the fundamental disquiet of man. The scientist is a scrupulous worker; he cannot take heaven by storm. Should he allow himself to be seduced into such an extravagance he would be sawing off the branch on which he sits.

[17] The fact is that with the knowledge and actual experience of these inner images a way is opened for reason and feeling to gain access to those other images which the teachings of religion offer to mankind. Psychology thus does just the opposite of what it is accused of: it provides possible approaches to a better understanding of these things, it opens people’s eyes to the real meaning of dogmas, and, far from destroying, it throws open an empty house to new inhabitants. I can corroborate this from countless experiences: people belonging to creeds of all imaginable kinds, who had played the apostate or cooled off in their faith, have found a new approach to their old truths, not a few Catholics among them. Even a Parsee found the way back to the Zoroastrian fire-temple, which should bear witness to the objectivity of my point of view.

[18] But this objectivity is just what my psychology is most blamed for: it is said not to decide in favour of this or that religious doctrine. Without prejudice to my own subjective convictions I should like to raise the question: Is it not thinkable that when one refrains from setting oneself up as an *arbiter mundi* and, deliberately renouncing all subjectivism, cherishes on the contrary the belief, for instance, that God has expressed himself in many languages and appeared in divers forms and that all these statements are *true*—is it not thinkable, I say, that this too is a decision? The objection raised, more particularly by Christians, that it is impossible for contradictory statements to be true, must permit itself to be politely asked: Does one equal three? How can three be one? Can a mother be a virgin? And so on. Has it not

yet been observed that all religious statements contain logical contradictions and assertions that are impossible in principle, that this is in fact the very essence of religious assertion? As witness to this we have Tertullian's avowal: "And the Son of God is dead, which is worthy of belief because it is absurd. And when buried He rose again, which is certain because it is impossible."⁹ If Christianity demands faith in such contradictions it does not seem to me that it can very well condemn those who assert a few paradoxes more. Oddly enough the paradox is one of our most valuable spiritual possessions, while uniformity of meaning is a sign of weakness. Hence a religion becomes inwardly impoverished when it loses or waters down its paradoxes; but their multiplication enriches because only the paradox comes anywhere near to comprehending the fulness of life. Non-ambiguity and non-contradiction are one-sided and thus unsuited to express the incomprehensible.

[19] Not everyone possesses the spiritual strength of a Tertullian. It is evident not only that he had the strength to sustain paradoxes but that they actually afforded him the highest degree of religious certainty. The inordinate number of spiritual weaklings makes paradoxes dangerous. So long as the paradox remains unexamined and is taken for granted as a customary part of life, it is harmless enough. But when it occurs to an insufficiently cultivated mind (always, as we know, the most sure of itself) to make the paradoxical nature of some tenet of faith the object of its lucubrations as earnest as they are impotent, it is not long before such a one will break out into iconoclastic and scornful laughter, pointing to the manifest absurdity of the mystery. Things have gone rapidly downhill since the Age of Enlightenment, for, once this petty reasoning mind, which cannot endure any paradoxes, is awakened, no sermon on earth can keep it down. A new task then arises: to lift this still undeveloped mind step by step to a higher level and to increase the number of persons who have at least some inkling of the scope of paradoxical truth. If this is not possible, then it must be admitted that the spiritual approaches to Christianity are as good as blocked. We simply do not understand any more what is meant by the paradoxes contained in dogma; and the more external our understanding of them becomes the more we are affronted by their irrationality, until finally they become completely obsolete, curious relics of the past. The man who is stricken in this way cannot estimate the extent of his spiritual loss, because he has never experienced the sacred images as his inmost possession and has never realized their kinship with his own psychic structure. But it is just this indispensable knowledge that the psychology of the unconscious can give him, and its scientific objectivity is of the greatest value here. Were psychology bound to a creed it would not and could not allow the unconscious of the individual that free play which is the basic condition for the production of archetypes. It is precisely the spontaneity of archetypal contents that convinces, whereas any prejudiced intervention is a bar to genuine experience. If the

theologian really believes in the almighty power of God on the one hand and in the validity of dogma on the other, why then does he not trust God to speak in the soul? Why this fear of psychology? Or is, in complete contradiction to dogma, the soul itself a hell from which only demons gibber? Even if this were really so it would not be any the less convincing; for as we all know the horrified perception of the reality of evil has led to at least as many conversions as the experience of good.

[20] The archetypes of the unconscious can be shown empirically to be the equivalents of religious dogmas. In the hermeneutic language of the Fathers the Church possesses a rich store of analogies with the individual and spontaneous products to be found in psychology. What the unconscious expresses is far from being merely arbitrary or opinionated; it is something that happens to be “just-so,” as is the case with every other natural being. It stands to reason that the expressions of the unconscious are natural and not formulated dogmatically; they are exactly like the patristic allegories which draw the whole of nature into the orbit of their amplifications. If these present us with some astonishing *allegoriae Christi*, we find much the same sort of thing in the psychology of the unconscious. The only difference is that the patristic allegory *ad Christum spectat*—refers to Christ—whereas the psychic archetype is simply itself and can therefore be interpreted according to time, place, and milieu. In the West the archetype is filled out with the dogmatic figure of Christ; in the East, with Purusha, the Atman, Hiranyagarbha, the Buddha, and so on. The religious point of view, understandably enough, puts the accent on the imprinter, whereas scientific psychology emphasizes the *typos*, the imprint—the only thing it can understand. The religious point of view understands the imprint as the working of an imprinter; the scientific point of view understands it as the symbol of an unknown and incomprehensible content. Since the *typos* is less definite and more variegated than any of the figures postulated by religion, psychology is compelled by its empirical material to express the *typos* by means of a terminology not bound by time, place, or milieu. If, for example, the *typos* agreed in every detail with the dogmatic figure of Christ, and if it contained no determinant that went beyond that figure, we would be bound to regard the *typos* as at least a faithful copy of the dogmatic figure, and to name it accordingly. The *typos* would then coincide with Christ. But as experience shows, this is not the case, seeing that the unconscious, like the allegories employed by the Church Fathers, produces countless other determinants that are not explicitly contained in the dogmatic formula; that is to say, non-Christian figures such as those mentioned above are included in the *typos*. But neither do these figures comply with the indeterminate nature of the archetype. It is altogether inconceivable that there could be any definite figure capable of expressing archetypal indefiniteness. For this reason I have found myself obliged to give the corresponding archetype the psychological name of the “self”—a term on the one hand definite enough to convey

the essence of human wholeness and on the other hand indefinite enough to express the indescribable and indeterminable nature of this wholeness. The paradoxical qualities of the term are a reflection of the fact that wholeness consists partly of the conscious man and partly of the unconscious man. But we cannot define the latter or indicate his boundaries. Hence in its scientific usage the term “self” refers neither to Christ nor to the Buddha but to the totality of the figures that are its equivalent, and each of these figures is a symbol of the self. This mode of expression is an intellectual necessity in scientific psychology and in no sense denotes a transcendental prejudice. On the contrary, as we have said before, this objective attitude enables one man to decide in favour of the determinant Christ, another in favour of the Buddha, and so on. Those who are irritated by this objectivity should reflect that science is quite impossible without it. Consequently by denying psychology the right to objectivity they are making an untimely attempt to extinguish the life-light of a science. Even if such a preposterous attempt were to succeed, it would only widen the already catastrophic gulf between the secular mind on the one hand and Church and religion on the other.

[21] It is quite understandable for a science to concentrate more or less exclusively on its subject—indeed, that is its absolute *raison d’être*. Since the concept of the self is of central interest in psychology, the latter naturally thinks along lines diametrically opposed to theology: for psychology the religious figures point to the self, whereas for theology the self points to its—theology’s—own central figure. In other words, theology might possibly take the psychological self as an allegory of Christ. This opposition is, no doubt, very irritating, but unfortunately inevitable, unless psychology is to be denied the right to exist at all. I therefore plead for tolerance. Nor is this very hard for psychology since as a science it makes no totalitarian claims.

[22] The Christ-symbol is of the greatest importance for psychology in so far as it is perhaps the most highly developed and differentiated symbol of the self, apart from the figure of the Buddha. We can see this from the scope and substance of all the pronouncements that have been made about Christ: they agree with the psychological phenomenology of the self in unusually high degree, although they do not include all aspects of this archetype. The almost limitless range of the self might be deemed a disadvantage as compared with the definiteness of a religious figure, but it is by no means the task of science to pass value judgments. Not only is the self indefinite but—paradoxically enough—it also includes the quality of definiteness and even of uniqueness. This is probably one of the reasons why precisely those religions founded by historical personages have become world religions, such as Christianity, Buddhism, and Islam. The inclusion in a religion of a unique human personality—especially when conjoined to an indeterminable divine nature—is consistent with the absolute individuality of the self, which combines uniqueness with eternity and the

individual with the universal. The self is a union of opposites *par excellence*, and this is where it differs essentially from the Christ-symbol. The androgyny of Christ is the utmost concession the Church has made to the problem of opposites. The opposition between light and good on the one hand and darkness and evil on the other is left in a state of open conflict, since Christ simply represents good, and his counterpart the devil, evil. This opposition is the real world problem, which at present is still unsolved. The self, however, is absolutely paradoxical in that it represents in every respect thesis and antithesis, and at the same time synthesis. (Psychological proofs of this assertion abound, though it is impossible for me to quote them here *in extenso*. I would refer the knowledgeable reader to the symbolism of the mandala.)

[23] Once the exploration of the unconscious has led the conscious mind to an experience of the archetype, the individual is confronted with the abysmal contradictions of human nature, and this confrontation in turn leads to the possibility of a direct experience of light and darkness, of Christ and the devil. For better or worse there is only a bare possibility of this, and not a guarantee; for experiences of this kind cannot of necessity be induced by any human means. There are factors to be considered which are not under our control. Experience of the opposites has nothing whatever to do with intellectual insight or with empathy. It is more what we would call fate. Such an experience can convince one person of the truth of Christ, another of the truth of the Buddha, to the exclusion of all other evidence.

[24] Without the experience of the opposites there is no experience of wholeness and hence no inner approach to the sacred figures. For this reason Christianity rightly insists on sinfulness and original sin, with the obvious intent of opening up the abyss of universal opposition in every individual—at least from the outside. But this method is bound to break down in the case of a moderately alert intellect: dogma is then simply no longer believed and on top of that is thought absurd. Such an intellect is merely one-sided and sticks at the *ineptia mysterii*. It is miles from Tertullian's antinomies; in fact, it is quite incapable of enduring the suffering such a tension involves. Cases are not unknown where the rigorous exercises and proselytizing of the Catholics, and a certain type of Protestant education that is always sniffing out sin, have brought about psychic damage that leads not to the Kingdom of Heaven but to the consulting room of the doctor. Although insight into the problem of opposites is absolutely imperative, there are very few people who can stand it in practice—a fact which has not escaped the notice of the confessional. By way of a reaction to this we have the palliative of “moral probabilism,” a doctrine that has suffered frequent attack from all quarters because it tries to mitigate the crushing effect of sin.¹⁰ Whatever one may think of this phenomenon one thing is certain: that apart from anything else it holds within it a large humanity and an understanding of human weakness which compensate for the world's unbearable antinomies. The tremendous

paradox implicit in the insistence on original sin on the one hand and the concession made by probabilism on the other is, for the psychologist, a necessary consequence of the Christian problem of opposites outlined above—for in the self good and evil are indeed closer than identical twins! The reality of evil and its incompatibility with good cleave the opposites asunder and lead inexorably to the crucifixion and suspension of everything that lives. Since “the soul is by nature Christian” this result is bound to come as infallibly as it did in the life of Jesus: we all have to be “crucified with Christ,” i.e., suspended in a moral suffering equivalent to veritable crucifixion. In practice this is only possible up to a point, and apart from that is so unbearable and inimical to life that the ordinary human being can afford to get into such a state only occasionally, in fact as seldom as possible. For how could he remain ordinary in face of such suffering! A more or less probabilistic attitude to the problem of evil is therefore unavoidable. Hence the truth about the self—the unfathomable union of good and evil—comes out concretely in the paradox that although sin is the gravest and most pernicious thing there is, it is still not so serious that it cannot be disposed of with “probabilist” arguments. Nor is this necessarily a lax or frivolous proceeding but simply a practical necessity of life. The confessional proceeds like life itself, which successfully struggles against being engulfed in an irreconcilable contradiction. Note that at the same time the conflict remains in full force, as is once more consistent with the antinomial character of the self, which is itself both conflict and unity.

[25] Christianity has made the antinomy of good and evil into a world problem and, by formulating the conflict dogmatically, raised it to an absolute principle. Into this as yet unresolved conflict the Christian is cast as a protagonist of good, a fellow player in the world drama. Understood in its deepest sense, being Christ’s follower involves a suffering that is unendurable to the great majority of mankind. Consequently the example of Christ is in reality followed either with reservation or not at all, and the pastoral practice of the Church even finds itself obliged to “lighten the yoke of Christ.” This means a pretty considerable reduction in the severity and harshness of the conflict and hence, in practice, a relativism of good and evil. Good is equivalent to the unconditional imitation of Christ and evil is its hindrance. Man’s moral weakness and sloth are what chiefly hinder the imitation, and it is to these that probabilism extends a practical understanding which may sometimes, perhaps, come nearer to Christian tolerance, mildness, and love of one’s neighbour than the attitude of those who see in probabilism a mere laxity. Although one must concede a number of cardinal Christian virtues to the probabilist endeavour, one must still not overlook the fact that it obviates much of the suffering involved in the imitation of Christ and that the conflict of good and evil is thus robbed of its harshness and toned down to tolerable proportions. This brings about an approach to the psychic archetype of the

self, where even these opposites seem to be united—though, as I say, it differs from the Christian symbolism, which leaves the conflict open. For the latter there is a rift running through the world: light wars against night and the upper against the lower. The two are not one, as they are in the psychic archetype. But, even though religious dogma may condemn the idea of two being one, religious practice does, as we have seen, allow the natural psychological symbol of the self at one with itself an approximate means of expression. On the other hand, dogma insists that three are one, while denying that four are one. Since olden times, not only in the West but also in China, uneven numbers have been regarded as masculine and even numbers as feminine. The Trinity is therefore a decidedly masculine deity, of which the androgyny of Christ and the special position and veneration accorded to the Mother of God are not the real equivalent.

[26] With this statement, which may strike the reader as peculiar, we come to one of the central axioms of alchemy, namely the saying of Maria Prophetissa: “One becomes two, two becomes three, and out of the third comes the one as the fourth.” As the reader has already seen from its title, this book is concerned with the psychological significance of alchemy and thus with a problem which, with very few exceptions, has so far eluded scientific research. Until quite recently science was interested only in the part that alchemy played in the history of chemistry, concerning itself very little with the part it played in the history of philosophy and religion. The importance of alchemy for the historical development of chemistry is obvious, but its cultural importance is still so little known that it seems almost impossible to say in a few words wherein that consisted. In this introduction, therefore, I have attempted to outline the religious and psychological problems which are germane to the theme of alchemy. The point is that alchemy is rather like an undercurrent to the Christianity that ruled on the surface. It is to this surface as the dream is to consciousness, and just as the dream compensates the conflicts of the conscious mind, so alchemy endeavours to fill in the gaps left open by the Christian tension of opposites. Perhaps the most pregnant expression of this is the axiom of Maria Prophetissa quoted above, which runs like a *leitmotiv* throughout almost the whole of the lifetime of alchemy, extending over more than seventeen centuries. In this aphorism the even numbers which signify the feminine principle, earth, the regions under the earth, and evil itself are interpolated between the uneven numbers of the Christian dogma. They are personified by the *serpens mercurii*, the dragon that creates and destroys itself and represents the *prima materia*. This fundamental idea of alchemy points back to the תְּהוֹם (Tehom),¹¹ to Tiamat with her dragon attribute, and thus to the primordial matriarchal world which, in the theomachy of the Marduk myth,¹² was overthrown by the masculine world of the father. The historical shift in the world’s consciousness towards the masculine is compensated at first by the chthonic femininity of the

unconscious. In certain pre-Christian religions the differentiation of the masculine principle had taken the form of the father-son specification, a change which was to be of the utmost importance for Christianity. Were the unconscious merely complementary, this shift of consciousness would have been accompanied by the production of a mother and daughter, for which the necessary material lay ready to hand in the myth of Demeter and Persephone. But, as alchemy shows, the unconscious chose rather the Cybele-Attis type in the form of the *prima materia* and the *filius macrocosmi*, thus proving that it is not complementary but compensatory. This goes to show that the unconscious does not simply act *contrary* to the conscious mind but *modifies* it more in the manner of an opponent or partner. The son type does not call up a daughter as a complementary image from the depths of the “chthonic” unconscious—it calls up another son. This remarkable fact would seem to be connected with the incarnation in our earthly human nature of a purely spiritual God, brought about by the Holy Ghost impregnating the womb of the Blessed Virgin. Thus the higher, the spiritual, the masculine inclines to the lower, the earthly, the feminine; and accordingly, the mother, who was anterior to the world of the father, accommodates herself to the masculine principle and, with the aid of the human spirit (alchemy or “the philosophy”), produces a son—not the antithesis of Christ but rather his chthonic counterpart, not a divine man but a fabulous being conforming to the nature of the primordial mother. And just as the redemption of man the microcosm is the task of the “upper” son, so the “lower” son has the function of a *salvator macrocosmi*.

[27] This, in brief, is the drama that was played out in the obscurities of alchemy. It is superfluous to remark that these two sons were never united, except perhaps in the mind and innermost experience of a few particularly gifted alchemists. But it is not very difficult to see the “purpose” of this drama: in the Incarnation it looked as though the masculine principle of the father-world were approximating to the feminine principle of the mother-world, with the result that the latter felt impelled to approximate in turn to the father-world. What it evidently amounted to was an attempt to bridge the gulf separating the two worlds as compensation for the open conflict between them.

[28] I hope the reader will not be offended if my exposition sounds like a Gnostic myth. We are moving in those psychological regions where, as a matter of fact, Gnosis is rooted. The message of the Christian symbol is Gnosis, and the compensation effected by the unconscious is Gnosis in even higher degree. Myth is the primordial language natural to these psychic processes, and no intellectual formulation comes anywhere near the richness and expressiveness of mythical imagery. Such processes are concerned with the primordial images, and these are best and most succinctly reproduced by figurative language.

[29] The process described above displays all the characteristic features of psychological compensation. We know that the mask of the unconscious is not rigid—it reflects the face we turn towards it. Hostility lends it a threatening aspect, friendliness softens its features. It is not a question of mere optical reflection but of an autonomous answer which reveals the self-sufficing nature of that which answers. Thus the *filius philosophorum* is not just the reflected image, in unsuitable material, of the son of God; on the contrary, this son of Tiamat reflects the features of the primordial maternal figure. Although he is decidedly hermaphroditic he has a masculine name—a sign that the chthonic underworld, having been rejected by the spirit and identified with evil, has a tendency to compromise. There is no mistaking the fact that he is a concession to the spiritual and masculine principle, even though he carries in himself the weight of the earth and the whole fabulous nature of primordial animality.

[30] This answer of the mother-world shows that the gulf between it and the father-world is not unbridgeable, seeing that the unconscious holds the seed of the unity of both. The essence of the conscious mind is discrimination; it must, if it is to be aware of things, separate the opposites, and it does this *contra naturam*. In nature the opposites seek one another—*les extrêmes se touchent*—and so it is in the unconscious, and particularly in the archetype of unity, the self. Here, as in the deity, the opposites cancel out. But as soon as the unconscious begins to manifest itself they split asunder, as at the Creation; for every act of dawning consciousness is a creative act, and it is from this psychological experience that all our cosmogonic symbols are derived.

[31] Alchemy is pre-eminently concerned with the seed of unity which lies hidden in the chaos of Tiamat and forms the counterpart to the divine unity. Like this, the seed of unity has a trinitarian character in Christian alchemy and a triadic character in pagan alchemy. According to other authorities it corresponds to the unity of the four elements and is therefore a quaternity. The overwhelming majority of modern psychological findings speaks in favour of the latter view. The few cases I have observed which produced the number three were marked by a systematic deficiency in consciousness, that is to say, by an unconsciousness of the “inferior function.” The number three is not a natural expression of wholeness, since four represents the minimum number of determinants in a whole judgment. It must nevertheless be stressed that side by side with the distinct leanings of alchemy (and of the unconscious) towards quaternity there is always a vacillation between three and four which comes out over and over again. Even in the axiom of Maria Prophetissa the quaternity is muffled and alembicated. In alchemy there are three as well as four *regimina* or procedures, three as well as four colours. There are always four elements, but often three of them are grouped together, with the fourth in a special

position—sometimes earth, sometimes fire. Mercurius¹³ is of course *quadratus*, but he is also a three-headed snake or simply a triunity. This uncertainty has a duplex character—in other words, the central ideas are ternary as well as quaternary. The psychologist cannot but mention the fact that a similar puzzle exists in the psychology of the unconscious: the least differentiated or “inferior” function is so much contaminated with the collective unconscious that, on becoming conscious, it brings up among others the archetype of the self as well—τὸ ἔν τέταρτον, as Maria Prophetissa says. Four signifies the feminine, motherly, physical; three the masculine, fatherly, spiritual. Thus the uncertainty as to three or four amounts to a wavering between the spiritual and the physical—a striking example of how every human truth is a last truth but one.

[32] I began my introduction with human wholeness as the goal to which the psychotherapeutic process ultimately leads. This question is inextricably bound up with one’s philosophical or religious assumptions. Even when, as frequently happens, the patient believes himself to be quite unprejudiced in this respect, the assumptions underlying his thought, mode of life, morale, and language are historically conditioned down to the last detail, a fact of which he is often kept unconscious by lack of education combined with lack of self-criticism. The analysis of his situation will therefore lead sooner or later to a clarification of his general spiritual background going far beyond his personal determinants, and this brings up the problems I have attempted to sketch in the preceding pages. This phase of the process is marked by the production of symbols of unity, the so-called mandalas, which occur either in dreams or in the form of concrete visual impressions, often as the most obvious compensation of the contradictions and conflicts of the conscious situation. It would hardly be correct to say that the gaping “rift”¹⁴ in the Christian order of things is responsible for this, since it is easy to show that Christian symbolism is particularly concerned with healing, or attempting to heal, this very wound. It would be more correct to take the open conflict as a symptom of the psychic situation of Western man, and to deplore his inability to assimilate the whole range of the Christian symbol. As a doctor I cannot demand anything of my patients in this respect, also I lack the Church’s means of grace. Consequently I am faced with the task of taking the only path open to me: the archetypal images—which in a certain sense correspond to the dogmatic images—must be brought into consciousness. At the same time I must leave my patient to decide in accordance with his assumptions, his spiritual maturity, his education, origins, and temperament, so far as this is possible without serious conflicts. As a doctor it is my task to help the patient to cope with life. I cannot presume to pass judgment on his final decisions, because I know from experience that all coercion—be it suggestion, insinuation, or any other method of persuasion—ultimately proves to be nothing but an obstacle to the highest and

most decisive experience of all, which is to be alone with his own self, or whatever else one chooses to call the objectivity of the psyche. The patient must be alone if he is to find out what it is that supports him when he can no longer support himself. Only this experience can give him an indestructible foundation.

[33] I would be only too delighted to leave this anything but easy task to the theologian, were it not that it is just from the theologian that many of my patients come. They ought to have hung on to the community of the Church, but they were shed like dry leaves from the great tree and now find themselves “hanging on” to the treatment. Something in them clings, often with the strength of despair, as if they or the thing they cling to would drop off into the void the moment they relaxed their hold. They are seeking firm ground on which to stand. Since no outward support is of any use to them they must finally discover it in themselves—admittedly the most unlikely place from the rational point of view, but an altogether possible one from the point of view of the unconscious. We can see this from the archetype of the “lowly origin of the redeemer.”

[34] The way to the goal seems chaotic and interminable at first, and only gradually do the signs increase that it is leading anywhere. The way is not straight but appears to go round in circles. More accurate knowledge has proved it to go in spirals: the dream-motifs always return after certain intervals to definite forms, whose characteristic it is to define a centre. And as a matter of fact the whole process revolves about a central point or some arrangement round a centre, which may in certain circumstances appear even in the initial dreams. As manifestations of unconscious processes the dreams rotate or circumambulate round the centre, drawing closer to it as the amplifications increase in distinctness and in scope. Owing to the diversity of the symbolical material it is difficult at first to perceive any kind of order at all. Nor should it be taken for granted that dream sequences are subject to any governing principle. But, as I say, the process of development proves on closer inspection to be cyclic or spiral. We might draw a parallel between such spiral courses and the processes of growth in plants; in fact the plant motif (tree, flower, etc.) frequently recurs in these dreams and fantasies and is also spontaneously drawn or painted.¹⁵ In alchemy the tree is the symbol of Hermetic philosophy.

[35] The first of the following two studies—that which composes [Part II](#)—deals with a series of dreams which contain numerous symbols of the centre or goal. The development of these symbols is almost the equivalent of a healing process. The centre or goal thus signifies *salvation* in the proper sense of the word. The justification for such a terminology comes from the dreams themselves, for these contain so many references to religious phenomena that I was able to use some of them as the subject of my book *Psychology and Religion*. It seems to me beyond all

doubt that these processes are concerned with the religion-creating archetypes. Whatever else religion may be, those psychic ingredients of it which are empirically verifiable undoubtedly consist of unconscious manifestations of this kind. People have dwelt far too long on the fundamentally sterile question of whether the assertions of faith are true or not. Quite apart from the impossibility of ever proving or refuting the truth of a metaphysical assertion, the very existence of the assertion is a self-evident fact that needs no further proof, and when a *consensus gentium* allies itself thereto the validity of the statement is proved to just that extent. The only thing about it that we can verify is the psychological phenomenon, which is incommensurable with the category of objective rightness or truth. No phenomenon can ever be disposed of by rational criticism, and in religious life we have to deal with phenomena and facts and not with arguable hypotheses.

[36] During the process of treatment the dialectical discussion leads logically to a meeting between the patient and his shadow, that dark half of the psyche which we invariably get rid of by means of projection: either by burdening our neighbours—in a wider or narrower sense—with all the faults which we obviously have ourselves, or by casting our sins upon a divine mediator with the aid of *contritio* or the milder *attritio*.¹⁶ We know of course that without sin there is no repentance and without repentance no redeeming grace, also that without original sin the redemption of the world could never have come about; but we assiduously avoid investigating whether in this very power of evil God might not have placed some special purpose which it is most important for us to know. One often feels driven to some such view when, like the psychotherapist, one has to deal with people who are confronted with their blackest shadow.¹⁷ At any rate the doctor cannot afford to point, with a gesture of facile moral superiority, to the tablets of the law and say, “Thou shalt not.” He has to examine things objectively and weigh up possibilities, for he knows, less from religious training and education than from instinct and experience, that there is something very like a *felix culpa*. He knows that one can miss not only one’s happiness but also one’s final guilt, without which a man will never reach his wholeness. Wholeness is in fact a charisma which one can manufacture neither by art nor by cunning; one can only grow into it and endure whatever its advent may bring. No doubt it is a great nuisance that mankind is not uniform but compounded of individuals whose psychic structure spreads them over a span of at least ten thousand years. Hence there is absolutely no truth that does not spell salvation to one person and damnation to another. All universalisms get stuck in this terrible dilemma. Earlier on I spoke of Jesuit probabilism: this gives a better idea than anything else of the tremendous catholic task of the Church. Even the best-intentioned people have been horrified by probabilism, but, when brought face to face with the realities of life, many of them have found their horror evaporating or their laughter dying on their

lips. The doctor too must weigh and ponder, not whether a thing is for or against the Church but whether it is for or against life and health. On paper the moral code looks clear and neat enough; but the same document written on the “living tables of the heart” is often a sorry tatter, particularly in the mouths of those who talk the loudest. We are told on every side that evil is evil and that there can be no hesitation in condemning it, but that does not prevent evil from being the most problematical thing in the individual’s life and the one which demands the deepest reflection. What above all deserves our keenest attention is the question “Exactly *who* is the doer?” For the answer to this question ultimately decides the value of the deed. It is true that society attaches greater importance at first to what is done, because it is immediately obvious; but in the long run the right deed in the hands of the wrong man will also have a disastrous effect. No one who is far-sighted will allow himself to be hoodwinked by the right deed of the wrong man, any more than by the wrong deed of the right man. Hence the psychotherapist must fix his eye not on what is done but on how it is done, because therein is decided the whole character of the doer. Evil needs to be pondered just as much as good, for good and evil are ultimately nothing but ideal extensions and abstractions of doing, and both belong to the chiaroscuro of life. In the last resort there is no good that cannot produce evil and no evil that cannot produce good.

[37] The encounter with the dark half of the personality, or “shadow,” comes about of its own accord in any moderately thorough treatment. This problem is as important as that of sin in the Church. The open conflict is unavoidable and painful. I have often been asked, “And what do you *do* about it?” I do nothing; there is nothing I can do except wait, with a certain trust in God, until, out of a conflict borne with patience and fortitude, there emerges the solution destined—although I cannot foresee it—for that particular person. Not that I am passive or inactive meanwhile: I help the patient to understand all the things that the unconscious produces during the conflict. The reader may believe me that these are no ordinary products. On the contrary, they are among the most significant things that have ever engaged my attention. Nor is the patient inactive; he must do the right thing, and do it with all his might, in order to prevent the pressure of evil from becoming too powerful in him. He needs “justification by works,” for “justification by faith” alone has remained an empty sound for him as for so many others. Faith can sometimes be a substitute for lack of experience. In these cases what is needed is real work. Christ espoused the sinner and did not condemn him. The true follower of Christ will do the same, and, since one should do unto others as one would do unto oneself, one will also take the part of the sinner who is oneself. And as little as we would accuse Christ of fraternizing with evil, so little should we reproach ourselves that to love the sinner who is oneself is to make a pact with the devil. Love makes a man better, hate makes him worse—even

when that man is oneself. The danger in this point of view is the same as in the imitation of Christ; but the Pharisee in us will never allow himself to be caught talking to publicans and whores. I must emphasize of course that psychology invented neither Christianity nor the imitation of Christ. I wish everybody could be freed from the burden of their sins by the Church. But he to whom she cannot render this service must bend very low in the imitation of Christ in order to take the burden of his cross upon him. The ancients could get along with the Greek wisdom of the ages: *Μηδὲν ἄγαν, τῷ καιρῷ πάντα πρόσεστι καλά* (Exaggerate nothing, all good lies in right measure). But what an abyss still separates us from reason!

[38] Apart from the moral difficulty there is another danger which is not inconsiderable and may lead to complications, particularly with individuals who are pathologically inclined. This is the fact that the contents of the personal unconscious (i.e., the shadow) are indistinguishably merged with the archetypal contents of the collective unconscious and drag the latter with them when the shadow is brought into consciousness. This may exert an uncanny influence on the conscious mind; for activated archetypes have a disagreeable effect even—or I should perhaps say, particularly—on the most cold-blooded rationalist. He is afraid that the lowest form of conviction, namely superstition, is, as he thinks, forcing itself on him. But superstition in the truest sense only appears in such people if they are pathological, not if they can keep their balance. It then takes the form of the fear of “going mad”—for everything that the modern mind cannot define it regards as insane. It must be admitted that the archetypal contents of the collective unconscious can often assume grotesque and horrible forms in dreams and fantasies, so that even the most hard-boiled rationalist is not immune from shattering nightmares and haunting fears. The psychological elucidation of these images, which cannot be passed over in silence or blindly ignored, leads logically into the depths of religious phenomenology. The history of religion in its widest sense (including therefore mythology, folklore, and primitive psychology) is a treasure-house of archetypal forms from which the doctor can draw helpful parallels and enlightening comparisons for the purpose of calming and clarifying a consciousness that is all at sea. It is absolutely necessary to supply these fantastic images that rise up so strange and threatening before the mind’s eye with some kind of context so as to make them more intelligible. Experience has shown that the best way to do this is by means of comparative mythological material.

[39] [Part II](#) of this volume gives a large number of such examples. The reader will be particularly struck by the numerous connections between individual dream symbolism and medieval alchemy. This is not, as one might suppose, a prerogative of the case in question, but a general fact which only struck me some ten years ago when first I began to come to grips with the ideas and symbolism of alchemy.

[40] Part III contains an introduction to the symbolism of alchemy in relation to Christianity and Gnosticism. As a bare introduction it is naturally far from being a complete exposition of this complicated and obscure subject—indeed, most of it is concerned only with the *lapis-Christ* parallel. True, this parallel gives rise to a comparison between the aims of the *opus alchymicum* and the central ideas of Christianity, for both are of the utmost importance in understanding and interpreting the images that appear in dreams and in assessing their psychological effect. This has considerable bearing on the practice of psychotherapy, because more often than not it is precisely the more intelligent and cultured patients who, finding a return to the Church impossible, come up against archetypal material and thus set the doctor problems which can no longer be mastered by a narrowly personalistic psychology. Nor is a mere knowledge of the psychic structure of a neurosis by any means sufficient; for once the process has reached the sphere of the collective unconscious we are dealing with healthy material, i.e., with the universal basis of the individually varied psyche. Our understanding of these deeper layers of the psyche is helped not only by a knowledge of primitive psychology and mythology, but to an even greater extent by some familiarity with the history of our modern consciousness and the stages immediately preceding it. On the one hand it is a child of the Church; on the other, of science, in whose beginnings very much lies hid that the Church was unable to accept—that is to say, remnants of the classical spirit and the classical feeling for nature which could not be exterminated and eventually found refuge in the natural philosophy of the Middle Ages. As the “*spiritus metallorum*” and the astrological components of destiny the old gods of the planets lasted out many a Christian century.¹⁸ Whereas in the Church the increasing differentiation of ritual and dogma alienated consciousness from its natural roots in the unconscious, alchemy and astrology were ceaselessly engaged in preserving the bridge to nature, i.e., to the unconscious psyche, from decay. Astrology led the conscious mind back again and again to the knowledge of Heimarmene, that is, the dependence of character and destiny on certain moments in time; and alchemy afforded numerous “hooks” for the projection of those archetypes which could not be fitted smoothly into the Christian process. It is true that alchemy always stood on the verge of heresy and that certain decrees leave no doubt as to the Church’s attitude towards it,¹⁹ but on the other hand it was effectively protected by the obscurity of its symbolism, which could always be explained as harmless allegory. For many alchemists the allegorical aspect undoubtedly occupied the foreground to such an extent that they were firmly convinced that their sole concern was with chemical substances. But there were always a few for whom laboratory work was primarily a matter of symbols and their psychic effect. As the texts show, they were quite conscious of this, to the point of condemning the naïve goldmakers as liars, frauds, and dupes. Their own standpoint they proclaimed with propositions like “*Aurum nostrum non est aurum vulgi.*”

Although their labours over the retort were a serious effort to elicit the secrets of chemical transformation, it was at the same time—and often in overwhelming degree—the reflection of a parallel psychic process which could be projected all the more easily into the unknown chemistry of matter since that process is an unconscious phenomenon of nature, just like the mysterious alteration of substances. What the symbolism of alchemy expresses is the whole problem of the evolution of personality described above, the so-called individuation process.

[41] Whereas the Church's great buttress is the imitation of Christ, the alchemist, without realizing it and certainly without wanting it, easily fell victim, in the loneliness and obscure problems of his work, to the promptings and unconscious assumptions of his own mind, since, unlike the Christians, he had no clear and unmistakable models on which to rely. The authors he studied provided him with symbols whose meaning he thought he understood in his own way; but in reality they touched and stimulated his unconscious. Ironical towards themselves, the alchemists coined the phrase "obscurum per obscurius." But with this method of explaining the obscure by the more obscure they only sank themselves deeper in the very process from which the Church was struggling to redeem them. While the dogmas of the Church offered analogies to the alchemical process, these analogies, in strict contrast to alchemy, had become detached from the world of nature through their connection with the historical figure of the Redeemer. The alchemical four in one, the philosophical gold, the *lapis angularis*, the *aqua divina*, became, in the Church, the four-armed cross on which the Only-Begotten had sacrificed himself once in history and at the same time for all eternity. The alchemists ran counter to the Church in preferring to seek through knowledge rather than to find through faith, though as medieval people they never thought of themselves as anything but good Christians. Paracelsus is a classical example in this respect. But in reality they were in much the same position as modern man, who prefers immediate personal experience to belief in traditional ideas, or rather has it forced upon him. Dogma is not arbitrarily invented nor is it a unique miracle, although it is often described as miraculous with the obvious intent of lifting it out of its natural context. The central ideas of Christianity are rooted in Gnostic philosophy, which, in accordance with psychological laws, simply *had* to grow up at a time when the classical religions had become obsolete. It was founded on the perception of symbols thrown up by the unconscious individuation process which always sets in when the collective dominants of human life fall into decay. At such a time there is bound to be a considerable number of individuals who are possessed by archetypes of a numinous nature that force their way to the surface in order to form new dominants. This state of possession shows itself almost without exception in the fact that the possessed identify themselves with the archetypal contents of their unconscious, and, because

they do not realize that the role which is being thrust upon them is the effect of new contents still to be understood, they exemplify these concretely in their own lives, thus becoming prophets and reformers. In so far as the archetypal content of the Christian drama was able to give satisfying expression to the uneasy and clamorous unconscious of the many, the *consensus omnium* raised this drama to a universally binding truth—not of course by an act of judgment, but by the irrational fact of possession, which is far more effective. Thus Jesus became the tutelary image or amulet against the archetypal powers that threatened to possess everyone. The glad tidings announced: “It has happened, but it will not happen to you inasmuch as you believe in Jesus Christ, the Son of God!” Yet it could and it can and it will happen to everyone in whom the Christian dominant has decayed. For this reason there have always been people who, not satisfied with the dominants of conscious life, set forth—under cover and by devious paths, to their destruction or salvation—to seek direct experience of the eternal roots, and, following the lure of the restless unconscious psyche, find themselves in the wilderness where, like Jesus, they come up against the son of darkness, the *ἀντίμιμον πνεῦμα*. Thus an old alchemist—and he a cleric!—prays: “Horridas nostrae mentis purga tenebras, accende lumen sensibus!” (Purge the horrible darkneses of our mind, light a light for our senses!) The author of this sentence must have been undergoing the experience of the *nigredo*, the first stage of the work, which was felt as “melancholia” in alchemy and corresponds to the encounter with the shadow in psychology.

[42] When, therefore, modern psychotherapy once more meets with the activated archetypes of the collective unconscious, it is merely the repetition of a phenomenon that has often been observed in moments of great religious crisis, although it can also occur in individuals for whom the ruling ideas have lost their meaning. An example of this is the *descensus ad inferos* depicted in *Faust*, which, consciously or unconsciously, is an *opus alchymicum*.

[43] The problem of opposites called up by the shadow plays a great—indeed, the decisive—role in alchemy, since it leads in the ultimate phase of the work to the union of opposites in the archetypal form of the *hierosgamos* or “chymical wedding.” Here the supreme opposites, male and female (as in the Chinese *yang* and *yin*), are melted into a unity purified of all opposition and therefore incorruptible. The prerequisite for this, of course, is that the artifex should not identify himself with the figures in the work but should leave them in their objective, impersonal state. So long as the alchemist was working in his laboratory he was in a favourable position, psychologically speaking, for he had no opportunity to identify himself with the archetypes as they appeared, since they were all projected immediately into the chemical substances. The disadvantage of this situation was that the alchemist was forced to represent the incorruptible substance as a chemical product—an impossible

undertaking which led to the downfall of alchemy, its place in the laboratory being taken by chemistry. But the psychic part of the work did not disappear. It captured new interpreters, as we can see from the example of *Faust*, and also from the signal connection between our modern psychology of the unconscious and alchemical symbolism.

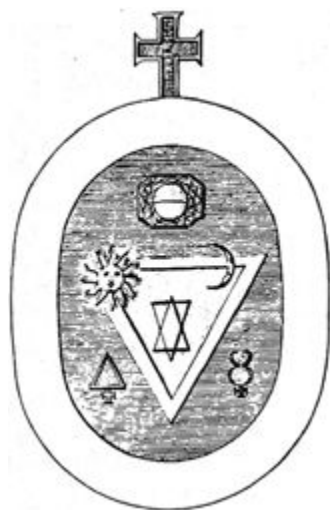

3. Symbol of the alchemical work.

—*Hermaphroditisches Sonn- und Mondskind* (1752)



4. Representation of the symbolic process which begins in chaos and ends with the birth of the phoenix.—Title-page, Béroalde de Verville, *Le Tableau des riches inventions* or *Le Songe de Poliphile* (1600)



INDIVIDUAL DREAM SYMBOLISM IN RELATION TO ALCHEMY

A STUDY OF THE UNCONSCIOUS PROCESSES AT WORK IN DREAMS

*... facilis descensus Averno; noctes atque dies patet atri ianua Ditis;
sed revocare gradum superasque evadere ad auras, hoc opus, hic labor est....*

VIRGIL, *Aeneid*, VI, 126–29

... easy is the descent to Avernus: night and day the door of gloomy Dis stands open; but to recall thy steps and pass out to the upper air, this is the task, this the toil!

—Trans. by H. R. Fairclough



5. Seven virgins being transformed.—Béroalde de Verville, *Le Songe de Poliphile* (1600)

1. INTRODUCTION

I. THE MATERIAL

[44] The symbols of the process of individuation that appear in dreams are images of an archetypal nature which depict the centralizing process or the production of a new centre of personality. A general idea of this process may be got from my essay, "The Relations between the Ego and the Unconscious." For certain reasons mentioned there I call this centre the "self," which should be understood as the totality of the psyche. The self is not only the centre, but also the whole circumference which embraces both conscious and unconscious; it is the centre of this totality, just as the ego is the centre of consciousness.

[45] The symbols now under consideration are not concerned with the manifold stages and transformations of the individuation process, but with the images that refer directly and exclusively to the new centre as it comes into consciousness. These images belong to a definite category which I call mandala symbolism. In *The Secret of the Golden Flower*, published in collaboration with Richard Wilhelm, I have described this symbolism in some detail. In the present study I should like to put before you an individual series of such symbols in chronological order. The material consists of over a thousand dreams and visual impressions coming from a young man of excellent scientific education.¹ For the purposes of this study I have worked on the first four hundred dreams and visions, which covered a period of nearly ten months. In order to avoid all personal influence I asked one of my pupils, a woman doctor, who was then a beginner, to undertake the observation of the process. This went on for five months. The dreamer then continued his observations alone for three months. Except for a short interview at the very beginning, before the commencement of the observation, I did not see the dreamer at all during the first eight months. Thus it happened that 355 of the dreams were dreamed away from any personal contact with myself. Only the last forty-five occurred under my observation. No interpretations worth mentioning were then attempted because the dreamer, owing to his excellent scientific training and ability, did not require any assistance. Hence conditions were really ideal for unprejudiced observation and recording.

[46] First of all, then, I shall present extracts from the twenty-two initial dreams in order to show how the mandala symbolism makes a very early appearance and is embedded in the rest of the dream material. Later on I shall pick out in chronological order the dreams that refer specifically to the mandala.²

[47] With few exceptions all the dreams have been abbreviated, either by extracting the part that carries the main thought or by condensing the whole text to essentials. This simplifying procedure has not only curtailed their length but has also removed personal allusions and complications, as was necessary for reasons of discretion. Despite this somewhat doubtful interference I have, to the best of my knowledge and scrupulosity, avoided any arbitrary distortion of meaning. The same considerations had also to apply to my own interpretation, so that certain passages in the dreams may appear to have been overlooked. Had I not made this sacrifice and kept the material absolutely complete, I should not have been in a position to publish this series, which in my opinion could hardly be surpassed in intelligence, clarity, and consistency. It therefore gives me great pleasure to express my sincere gratitude here and now to the “author” for the service he has rendered to science.

II. THE METHOD

[48] In my writings and lectures I have always insisted that we must give up all preconceived opinions when it comes to the analysis and interpretation of the objective psyche,³ in other words the “unconscious.” We do not yet possess a general theory of dreams that would enable us to use a deductive method with impunity, any more than we possess a general theory of consciousness from which we can draw deductive conclusions. The manifestations of the subjective psyche, or consciousness, can be predicted to only the smallest degree, and there is no theoretical argument to prove beyond doubt that any causal connection necessarily exists between them. On the contrary, we have to reckon with a high percentage of arbitrariness and “chance” in the complex actions and reactions of the conscious mind. Similarly there is no empirical, still less a theoretical, reason to assume that the same does not apply to the manifestations of the unconscious. The latter are just as manifold, unpredictable, and arbitrary as the former and must therefore be subjected to as many different ways of approach. In the case of conscious utterances we are in the fortunate position of being directly addressed and presented with a content whose purpose we can recognize; but with “unconscious” manifestations there is no directed or adapted language in our sense of the word—there is merely a psychic phenomenon that would appear to have only the loosest connections with conscious contents. If the expressions of the conscious mind are incomprehensible we can always ask what they mean. But the objective psyche is something alien even to the conscious mind through which it expresses itself. We are therefore obliged to adopt the method we would use in deciphering a fragmentary text or one containing unknown words: we examine the context. The meaning of the unknown word may become evident when we compare a series of passages in which it occurs. The psychological context of dream-contents consists in the web of associations in which the dream is naturally

embedded. Theoretically we can never know anything in advance about this web, but in practice it is sometimes possible, granted long enough experience. Even so, careful analysis will never rely too much on technical rules; the danger of deception and suggestion is too great. In the analysis of isolated dreams above all, this kind of knowing in advance and making assumptions on the grounds of practical expectation or general probability is positively wrong. It should therefore be an absolute rule to assume that every dream, and every part of a dream, is unknown at the outset, and to attempt an interpretation only after carefully taking up the context. We can then apply the meaning we have thus discovered to the text of the dream itself and see whether this yields a fluent reading, or rather whether a satisfying meaning emerges. But in no circumstances may we anticipate that this meaning will fit in with any of our subjective expectations; for quite possibly, indeed very frequently, the dream is saying something surprisingly different from what we would expect. As a matter of fact, if the meaning we find in the dream happens to coincide with our expectations, that is a reason for suspicion; for as a rule the standpoint of the unconscious is complementary or compensatory⁴ to consciousness and thus unexpectedly “different.” I would not deny the possibility of *parallel* dreams, i.e., dreams whose meaning coincides with or supports the conscious attitude, but, in my experience at least, these are rather rare.

[49] Now, the method I adopt in the present study seems to run directly counter to this basic principle of dream interpretation. It looks as if the dreams were being interpreted without the least regard for the context. And in fact I have not taken up the context at all, seeing that the dreams in this series were not dreamed (as mentioned above) under my observation. I proceed rather as if I had had the dreams myself and were therefore in a position to supply the context.



6. A maternal figure presiding over the goddesses of fate.—Thenaud, “Traité de la cabale” (MS., 16th cent.)

[50] This procedure, if applied to *isolated* dreams of someone unknown to me personally, would indeed be a gross technical blunder. But here we are not dealing with isolated dreams; they form a coherent series in the course of which the meaning gradually unfolds more or less of its own accord. *The series is the context which the dreamer himself supplies.* It is as if not one text but many lay before us, throwing light from all sides on the unknown terms, so that a reading of all the texts is sufficient to elucidate the difficult passages in each individual one. Moreover, in the third chapter we are concerned with a definite archetype—the mandala—that has long been known to us from other sources, and this considerably facilitates the interpretation. Of course the interpretation of each individual passage is bound to be largely conjecture, but the series as a whole gives us all the clues we need to correct any possible errors in the preceding passages.

[51] It goes without saying that while the dreamer was under the observation of my pupil he knew nothing of these interpretations and was therefore quite unprejudiced by anybody else’s opinion. Moreover I hold the view, based on wide experience, that the possibility and danger of prejudgment are exaggerated. Experience shows that the

objective psyche is independent in the highest degree. Were it not so, it could not carry out its most characteristic function: the compensation of the conscious mind. The conscious mind allows itself to be trained like a parrot, but the unconscious does not—which is why St. Augustine thanked God for not making him responsible for his dreams. The unconscious is an autonomous psychic entity; any efforts to drill it are only apparently successful, and moreover are harmful to consciousness. It is and remains beyond the reach of subjective arbitrary control, in a realm where nature and her secrets can be neither improved upon nor perverted, where we can listen but may not meddle.



7. The Uroboros as symbol of the aeon.—Horapollo, *Selecta hieroglyphica* (1597)

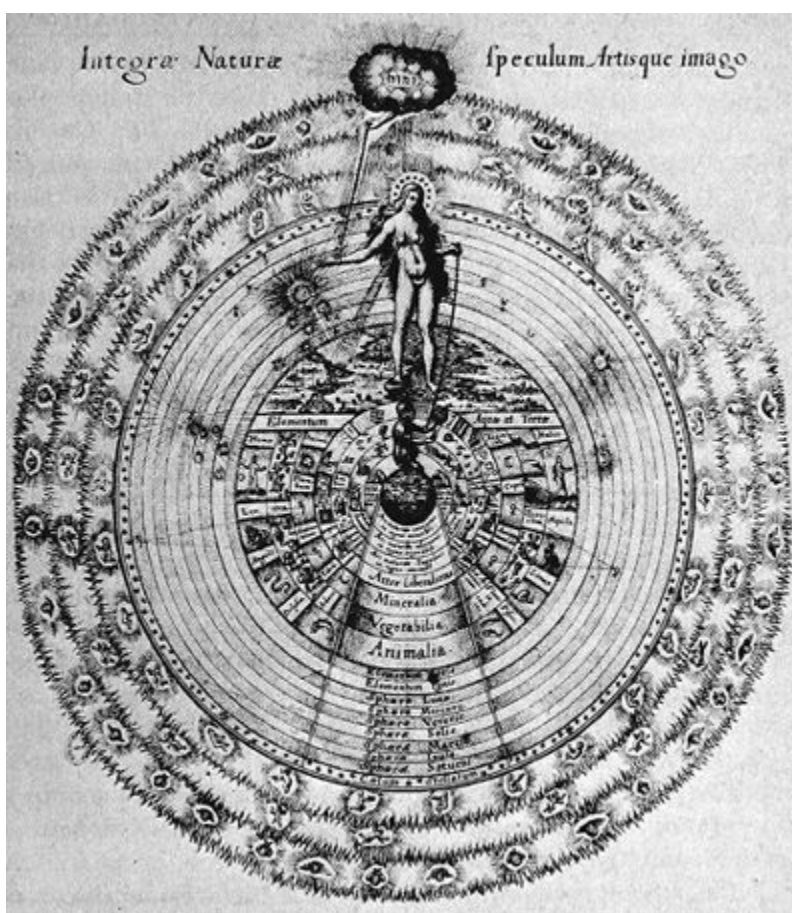

8. The *anima mundi*, guide of mankind, herself guided by God.—Engraving by J.-T. de Bry, from Fludd, *Utriusque cosmi* (1617)

2. THE INITIAL DREAMS

1. DREAM:

[52] *The dreamer is at a social gathering. On leaving, he puts on a stranger's hat instead of his own.*

[53] The hat, as a covering for the head, has the general sense of something that epitomizes the head. Just as in summing up we bring ideas “under one head” (*unter einen Hut*), so the hat, as a sort of leading idea, covers the whole personality and imparts its own significance to it. Coronation endows the ruler with the divine nature of the sun, the doctor's hood bestows the dignity of a scholar, and a stranger's hat imparts a strange personality. Meyrink uses this theme in his novel *The Golem*, where the hero puts on the hat of Athanasius Pernath and, as a result, becomes involved in a strange experience. It is clear enough in *The Golem* that it is the unconscious which entangles the hero in fantastic adventures. Let us stress at once the significance of the *Golem* parallel and assume that the hat in the dream is the hat of an Athanasius, an immortal, a being beyond time, the universal and everlasting man as distinct from the ephemeral and “accidental” mortal man. Encircling the head, the hat is round like the sun-disc of a crown and therefore contains the first allusion to the mandala. We shall find the attribute of eternal duration confirmed in the ninth mandala dream (par. 134), while the mandala character of the hat comes out in the thirty-fifth mandala dream (par. 254). As a general result of the exchange of hats we may expect a development similar to that in *The Golem*: an emergence of the unconscious. The unconscious with its figures is already standing like a shadow behind the dreamer and pushing its way into consciousness.

2. DREAM:

[54] *The dreamer is going on a railway journey, and by standing in front of the window, he blocks the view for his fellow passengers. He must get out of their way.*

[55] The process is beginning to move, and the dreamer discovers that he is keeping the light from those who stand *behind* him, namely the unconscious components of his personality. We have no eyes behind us; consequently “behind” is the region of the unseen, the unconscious. If the dreamer will only stop blocking the window (consciousness), the unconscious content will become conscious.

3. HYPNAGOGIC VISUAL IMPRESSION:

[56] *By the sea shore. The sea breaks into the land, flooding everything. Then the dreamer is sitting on a lonely island.*

[57] The sea is the symbol of the collective unconscious, because unfathomed depths lie concealed beneath its reflecting surface.¹ Those who stand behind, the shadowy personifications of the unconscious, have burst into the *terra firma* of consciousness like a flood. Such invasions have something uncanny about them because they are irrational and incomprehensible to the person concerned. They bring about a momentous alteration of his personality since they immediately constitute a painful personal secret which alienates and isolates him from his surroundings. It is something that we “cannot tell anybody.” We are afraid of being accused of mental abnormality—not without reason, for much the same thing happens to lunatics. Even so, it is a far cry from the intuitive perception of such an invasion to being inundated by it pathologically, though the layman does not realize this. Isolation by a secret results as a rule in an animation of the psychic atmosphere, as a substitute for loss of contact with other people. It causes an activation of the unconscious, and this produces something similar to the illusions and hallucinations that beset lonely wanderers in the desert, seafarers, and saints. The mechanism of these phenomena can best be explained in terms of energy. Our normal relations to objects in the world at large are maintained by a certain expenditure of energy. If the relation to the object is cut off there is a “retention” of energy, which then creates an equivalent substitute. For instance, just as persecution mania comes from a relationship poisoned by mistrust, so, as a substitute for the normal animation of the environment, an illusory reality rises up in which weird ghostly shadows flit about in place of people. That is why primitive man has always believed that lonely and desolate places are haunted by “devils” and suchlike apparitions.

4. DREAM:

[58] *The dreamer is surrounded by a throng of vague female forms (cf. fig. 33). A voice within him says, “First I must get away from Father.”*

[59] Here the psychic atmosphere has been animated by what the Middle Ages would call succubi. We are reminded of the visions of St. Anthony in Egypt, so eruditely described by Flaubert in *La Tentation de Saint-Antoine*. The element of hallucination shows itself in the fact that the thought is spoken aloud. The words “first I must get away” call for a concluding sentence which would begin with “in order to.” Presumably it would run “in order to follow the unconscious, i.e., the alluring female forms” (fig. 9). The father, the embodiment of the traditional spirit as expressed in religion or a general philosophy of life, is standing in his way. He imprisons the dreamer in the world of the conscious mind and its values. The traditional masculine world with its intellectualism and rationalism is felt to be an impediment, from which

we must conclude that the unconscious, now approaching him, stands in direct opposition to the tendencies of the conscious mind and that the dreamer, despite this opposition, is already favourably disposed towards the unconscious. For this reason the latter should not be subordinated to the rationalistic judgments of consciousness; it ought rather to be an experience *sui generis*. Naturally it is not easy for the intellect to accept this, because it involves at least a partial, if not a total, *sacrificium intellectus*. Furthermore, the problem thus raised is very difficult for modern man to grasp; for to begin with he can only understand the unconscious as an inessential and unreal appendage of the conscious mind, and not as a special sphere of experience with laws of its own. In the course of the later dreams this conflict will appear again and again, until finally the right formula is found for the correlation of conscious and unconscious, and the personality is assigned its correct position between the two. Moreover, such a conflict cannot be solved by understanding, but only by experience. Every stage of the experience must be lived through. There is no feat of interpretation or any other trick by which to circumvent this difficulty, for the union of conscious and unconscious can only be achieved step by step.

[60] The resistance of the conscious mind to the unconscious and the depreciation of the latter were historical necessities in the development of the human psyche, for otherwise the conscious mind would never have been able to differentiate itself at all. But modern man's consciousness has strayed rather too far from the fact of the unconscious. We have even forgotten that the psyche is by no means of our design, but is for the most part autonomous and unconscious. Consequently the approach of the unconscious induces a panic fear in civilized people, not least on account of the menacing analogy with insanity. The intellect has no objection to "analysing" the unconscious as a passive object; on the contrary such an activity would coincide with our rational expectations. But to let the unconscious go its own way and to experience it as a reality is something that exceeds the courage and capacity of the average European. He prefers simply not to understand this problem. For the spiritually weak-kneed this is the better course, since the thing is not without its dangers.



9. The awakening of the sleeping king depicted as a judgment of Paris, with Hermes as psychopomp.—Thomas Aquinas (pseud.), “De alchimia” (MS., 16th cent.)



10, 11, 12. Melusina; two-headed Melusina; mermaid with mask.—Eleazar, *Uraltes chymisches Werk* (1760)

[61] The experience of the unconscious is a personal secret communicable only to very few, and that with difficulty; hence the isolating effect we noted above. But isolation brings about a compensatory animation of the psychic atmosphere which strikes us as uncanny. The figures that appear in the dream are feminine, thus

pointing to the feminine nature of the unconscious. They are fairies or fascinating sirens and lamias (figs. 10, 11, 12; cf. also fig. 157), who infatuate the lonely wanderer and lead him astray. Likewise seductive maidens appear at the beginning of the *nekyia*² of Poliphilo³ (fig. 33), and the Melusina of Paracelsus⁴ is another such figure.

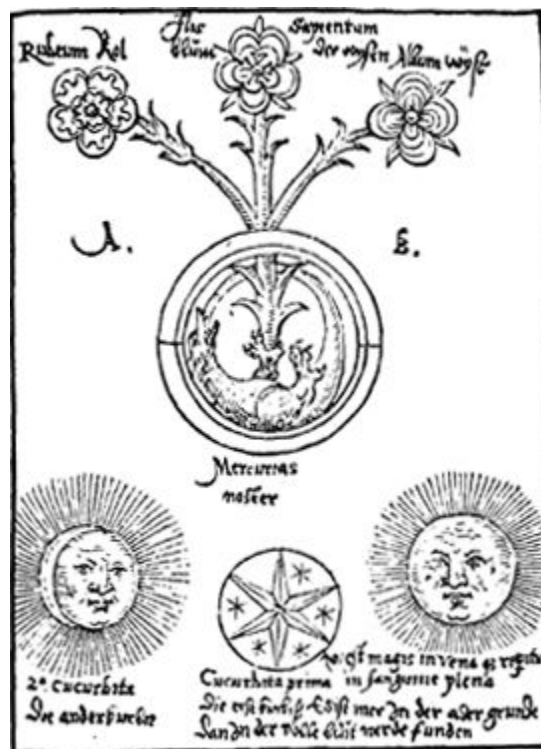

13. The “tail-eater” (Uroboros) as the *prima materia* of the alchemical process, with the red-and-white rose, the *flos sapientum*. Below, *coniunctio solis et lunae*, with the *lapis philosophorum* as the son.—Reusner, *Pandora* (1588)

5. VISUAL IMPRESSION:

[62] A snake describes a circle round the dreamer, who stands rooted to the ground like a tree.

[63] The drawing of a spellbinding circle (fig. 13) is an ancient magical device used by everyone who has a special or secret purpose in mind. He thereby protects himself from the “perils of the soul” that threaten him from without and attack anyone who is isolated by a secret. The same procedure has also been used since olden times to set a place apart as holy and inviolable; in founding a city, for instance, they first drew the *sulcus primigenius* or original furrow⁵ (cf. fig. 31). The fact that the dreamer stands rooted to the centre is a compensation of his almost insuperable desire to run away from the unconscious. He experienced an agreeable feeling of relief after this vision—and rightly, since he has succeeded in establishing a protected *temenos*,⁶ a taboo area where he will be able to meet the unconscious. His isolation, so uncanny before, is now endowed with meaning and purpose, and thus robbed of its terrors.

6. VISUAL IMPRESSION, DIRECTLY FOLLOWING UPON 5:

[64] *The veiled figure of a woman seated on a stair.*

[65] The motif of the unknown woman—whose technical name is the “anima”⁷—appears here for the first time. Like the throng of vague female forms in dream 4, she is a personification of the animated psychic atmosphere. From now on the figure of the unknown woman reappears in a great many of the dreams. Personification always indicates an autonomous activity of the unconscious. If some personal figure appears we may be sure that the unconscious is beginning to grow active. The activity of such figures very often has an anticipatory character: something that the dreamer himself will do later is now being done in advance. In this case the allusion is to a stair, thus indicating an ascent or a descent (fig. 14).

[66] Since the process running through dreams of this kind has an historical analogy in the rites of initiation, it may not be superfluous to draw attention to the important part which the Stairway of the Seven Planets played in these rites, as we know from Apuleius, among others. The initiations of late classical syncretism, already saturated with alchemy (cf. the visions of Zosimos⁸), were particularly concerned with the theme of ascent, i.e., sublimation. The ascent was often represented by a ladder (fig. 15); hence the burial gift in Egypt of a small ladder for the *ka* of the dead.⁹ The idea of an ascent through the seven spheres of the planets symbolizes the return of the soul to the sun-god from whom it originated, as we know for instance from Firmicus Maternus.¹⁰ Thus the Isis mystery described by Apuleius¹¹ culminated in what early medieval alchemy, going back to Alexandrian tradition as transmitted by the Arabs,¹² called the *solificatio*, where the initiand was crowned as Helios.



14. Jacob's dream.—Watercolour by William Blake

Mothus corporis asment. spiritus soluti. Spiritus corporis. m. k.
 septem illa equitatis cum Solis et cum O. d. lumine. 2



15. The *scala lapidis*, representing the stages of the alchemical process.—“Emblematical Figures of the Philosophers’ Stone” (MS., 17th cent.)

7. VISUAL IMPRESSION:

[67] *The veiled woman uncovers her face. It shines like the sun.*

[68] The *solificatio* is consummated on the person of the anima. The process would seem to correspond to the *illuminatio*, or enlightenment. This “mystical” idea contrasts strongly with the rational attitude of the conscious mind, which recognizes only intellectual enlightenment as the highest form of understanding and insight. Naturally this attitude never reckons with the fact that scientific knowledge only satisfies the little tip of personality that is contemporaneous with ourselves, not the collective psyche¹³ that reaches back into the grey mists of antiquity and always requires a special rite if it is to be united with present-day consciousness. It is clear, therefore, that a “lighting up” of the unconscious is being prepared, which has far more the character of an *illuminatio* than of rational “elucidation.” The *solificatio* is infinitely far removed from the conscious mind and seems to it almost chimerical.

8. VISUAL IMPRESSION:

[69] *A rainbow is to be used as a bridge. But one must go under it and not over it. Whoever goes over it will fall and be killed.*

[70] Only the gods can walk rainbow bridges in safety; mere mortals fall and meet their death, for the rainbow is only a lovely semblance that spans the sky, and not a highway for human beings with bodies. These must pass “under it” (fig. 16). But water flows under bridges too, following its own gradient and seeking the lowest place. This hint will be confirmed later.

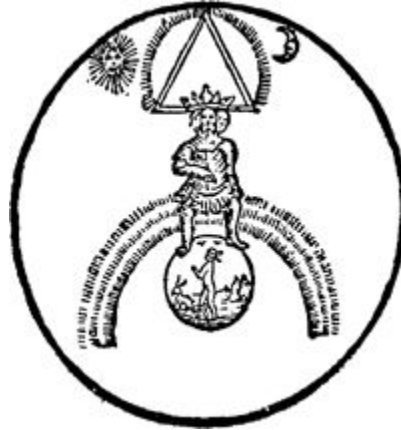

16. *Mercurius tricephalus* as Anthropos. Below, blindfolded man led by an animal.—Kelley, *Tractatus de Lapide philosophorum* (1676)

9. DREAM:

[71] *A green land where many sheep are pastured. It is the “land of sheep.”*

[72] This curious fragment, inscrutable at first glance, may derive from childhood impressions and particularly from those of a religious nature, which would not be far to seek in this connection—e.g., “He maketh me to lie down in green pastures,” or the early Christian allegories of sheep and shepherd¹⁴ (fig. 18). The next vision points in the same direction.

10. VISUAL IMPRESSION:

[73] *The unknown woman stands in the land of sheep and points the way.*

[74] The anima, having already anticipated the *solificatio*, now appears as the psychopomp, the one who shows the way¹⁵ (fig. 19). The way begins in the children’s land, i.e., at a time when rational present-day consciousness was not yet separated from the historical psyche, the collective unconscious. The separation is indeed inevitable, but it leads to such an alienation from that dim psyche of the dawn of mankind that a loss of instinct ensues. The result is instinctual atrophy and hence disorientation in everyday human situations. But it also follows from the separation that the “children’s land” will remain definitely infantile and become a perpetual source of childish inclinations and impulses. These intrusions are naturally most unwelcome to the conscious mind, and it consistently represses them for that reason.

But the very consistency of the repression only serves to bring about a still greater alienation from the fountainhead, thus increasing the lack of instinct until it becomes lack of soul. As a result, the conscious mind is either completely swamped by childishness or else constantly obliged to defend itself in vain against the inundation, by means of a cynical affectation of old age or embittered resignation. We must therefore realize that despite its undeniable successes the rational attitude of present-day consciousness is, in many human respects, childishly un-adapted and hostile to life. Life has grown desiccated and cramped, crying out for the rediscovery of the fountainhead. But the fountainhead can only be found if the conscious mind will suffer itself to be led back to the “children’s land,” there to receive guidance from the unconscious as before. To remain a child too long is childish, but it is just as childish to move away and then assume that childhood no longer exists because we do not see it. But if we return to the “children’s land” we succumb to the fear of becoming childish, because we do not understand that everything of psychic origin has a double face. One face looks forward, the other back. It is ambivalent and therefore symbolic, like all living reality.



17. The artifex (or Hermes) as shepherd of Aries and Taurus, who symbolize the vernal impulses, the beginning of the *opus*.—Thomas Aquinas (pseud.), “De alchimia” (MS., 16th cent.)



18. Christ as shepherd.—Mosaic, mausoleum of Galla Placidia, Ravenna (c. 424–451)

[75] We stand on a peak of consciousness, believing in a childish way that the path leads upward to yet higher peaks beyond. That is the chimerical rainbow bridge. In order to reach the next peak we must first go down into the land where the paths begin to divide.

11. DREAM:

[76] *A voice says, “But you are still a child.”*

[77] This dream forces the dreamer to admit that even a highly differentiated consciousness has not by any means finished with childish things, and that a return to the world of childhood is necessary.



19. The soul as guide, showing the way.—Watercolour by William Blake for Dante's *Purgatorio*, Canto IV

12. DREAM:

[78] *A dangerous walk with Father and Mother, up and down many ladders.*

[79] A childish consciousness is always tied to father and mother, and is never by itself. Return to childhood is always the return to father and mother, to the whole burden of the psychic non-ego as represented by the parents, with its long and momentous history. Regression spells disintegration into our historical and hereditary determinants, and it is only with the greatest effort that we can free ourselves from their embrace. Our psychic prehistory is in truth the spirit of gravity, which needs steps and ladders because, unlike the disembodied airy intellect, it cannot fly at will. Disintegration into the jumble of historical determinants is like losing one's way, where even what is right seems an alarming mistake.

[80] As hinted above, the steps and ladders theme (cf. [figs. 14, 15](#)) points to the process of psychic transformation, with all its ups and downs. We find a classic example of this in Zosimos' ascent and descent of the fifteen steps of light and darkness.¹⁶

[81] It is of course impossible to free oneself from one's childhood without devoting a great deal of work to it, as Freud's researches have long since shown. Nor can it be achieved through intellectual knowledge only; what is alone effective is a remembering that is also a re-experiencing. The swift passage of the years and the overwhelming inrush of the newly discovered world leave a mass of material behind that is never dealt with. We do not shake this off; we merely remove ourselves from it. So that when, in later years, we return to the memories of childhood we find bits of our personality still alive, which cling round us and suffuse us with the feeling of earlier times. Being still in their childhood state, these fragments are very powerful in their effect. They can lose their infantile aspect and be corrected only when they are reunited with adult consciousness. This "personal unconscious" must always be dealt with first, that is, made conscious, otherwise the gateway to the collective unconscious cannot be opened. The journey with father and mother up and down many ladders represents the making conscious of infantile contents that have not yet been integrated.

13. DREAM:

[82] *The father calls out anxiously, "That is the seventh!"*

[83] During the walk over many ladders some event has evidently taken place which is spoken of as "the seventh" (fig. 20). In the language of initiation, "seven" stands for the highest stage of illumination and would therefore be the coveted goal of all desire (cf. fig. 28). But to the conventional mind the *solificatio* is an outlandish, mystical idea bordering on madness. We assume that it was only in the dark ages of misty superstition that people thought in such a nonsensical fashion, but that the lucid and hygienic mentality of our own enlightened days has long since outgrown such nebulous notions, so much so, indeed, that this particular kind of "illumination" is to be found nowadays only in a lunatic asylum. No wonder the father is scared and anxious, like a hen that has hatched out ducklings and is driven to despair by the aquatic proclivities of its young. If this interpretation—that the "seventh" represents the highest stage of illumination—is correct, it would mean in principle that the process of integrating the personal unconscious was actually at an end. Thereafter the collective unconscious would begin to open up, which would suffice to explain the anxiety the father felt as the representative of the traditional spirit.

[84] Nevertheless the return to the dim twilight of the unconscious does not mean that we should entirely abandon the precious acquisition of our forefathers, namely the intellectual differentiation of consciousness. It is rather a question of the *man* taking the place of the *intellect*—not the man whom the dreamer imagines himself to be, but someone far more rounded and complete. This would mean assimilating all sorts of things into the sphere of his personality which the dreamer still rejects as

disagreeable or even impossible. The father who calls out so anxiously, “That is the seventh!” is a psychic component of the dreamer himself, and the anxiety is therefore his own. So the interpretation must bear in mind the possibility that the “seventh” means not only a sort of culmination but something rather ominous as well. We come across this theme, for instance, in the fairytale of Tom Thumb and the Ogre. Tom Thumb is the youngest of seven brothers. His dwarflike stature and his cunning are harmless enough, yet he is the one who leads his brothers to the ogre’s lair, thus proving his own dangerous double nature as a bringer of good and bad luck; in other words, he is also the ogre himself. Since olden times “the seven” have represented the seven gods of the planets (fig. 20); they form what the Pyramid inscriptions call a *paut neteru*, a “company of gods”¹⁷ (cf. figs. 21, 23). Although a company is described as “nine,” it often proves to be not nine at all but ten, and sometimes even more. Thus Maspero¹⁸ tells us that the first and last members of the series can be added to, or doubled, without injury to the number nine. Something of the sort happened to the classical *paut* of the Greco-Roman or Babylonian gods in the post-classical age, when the gods were degraded to demons and retired partly to the distant stars and partly to the metals inside the earth. It then transpired that Hermes or Mercurius possessed a double nature, being a chthonic god of revelation and also the spirit of quicksilver, for which reason he was represented as a hermaphrodite (fig. 22). As the planet Mercury, he is nearest to the sun, hence he is pre-eminently related to gold. But, as quicksilver, he dissolves the gold and extinguishes its sunlike brilliance. All through the Middle Ages he was the object of much puzzled speculation on the part of the natural philosophers: sometimes he was a ministering and helpful spirit, a *πάρεδρος* (literally “assistant, comrade”) or *familiaris*; and sometimes the *servus* or *cervus fugitivus* (the fugitive slave or stag), an elusive, deceptive, teasing goblin¹⁹ who drove the alchemists to despair and had many of his attributes in common with the devil. For instance he is dragon, lion, eagle, raven, to mention only the most important of them. In the alchemical hierarchy of gods Mercurius comes lowest as *prima materia* and highest as *lapis philosophorum*. The *spiritus mercurialis* (fig. 23) is the alchemists’ guide (Hermes Psychopompos: cf. fig. 146), and their tempter; he is their good luck and their ruin. His dual nature enables him to be not only the seventh but also the eighth—the eighth on Olympus “whom nobody thought of” (see *infra*, par. 204f.).



20. The six planets united in the seventh, Mercury, depicted as the Uroboros, and the red-and-white (hermaphroditic) double eagle.—Thomas Aquinas (pseud.). “De alchimia” (MS., 16th cent.)



21. The seven gods of the planets in Hades.—Mylius, *Philosophia reformata* (1622)



22. Mercurius in the “philosopher’s egg” (the alchemical vessel). As *filius* he stands on the sun and moon, tokens of his dual nature. The birds betoken spiritualization, while the scorching rays of the sun ripen the homunculus in the vessel.—*Mutus liber* (1702)

[85] It may seem odd to the reader that anything as remote as medieval alchemy should have relevance here. But the “black art” is not nearly so remote as we think; for as an educated man the dreamer must have read *Faust*, and *Faust* is an alchemical drama from beginning to end, although the educated man of today has only the haziest notion of this. Our conscious mind is far from understanding everything, but

the unconscious always keeps an eye on the “age-old, sacred things,” however strange they may be, and reminds us of them at a suitable opportunity. No doubt *Faust* affected our dreamer much as Goethe was affected when, as a young man in his Leipzig days, he studied Theophrastus Paracelsus with Fräulein von Klettenberg.²⁰ It was then, as we certainly may assume, that the mysterious equivalence of seven and eight sank deep into his soul, without his conscious mind ever unravelling the mystery. The following dream will show that this reminder of *Faust* is not out of place.

14. DREAM:

- [86] The dreamer is in America looking for an employee with a pointed beard. They say that everybody has such an employee.
- [87] America is the land of practical, straightforward thinking, uncontaminated by our European sophistication. The intellect would there be kept, very sensibly, as an employee. This naturally sounds like *lèse-majesté* and might therefore be a serious matter. So it is consoling to know that everyone (as is always the case in America) does the same. The “man with a pointed beard” is our time-honoured Mephisto whom Faust “employed” and who was not permitted to triumph over him in the end, despite the fact that Faust had dared to descend into the dark chaos of the historical psyche and steep himself in the ever-changing, seamy side of life that rose up out of that bubbling cauldron.
- [88] From subsequent questions it was discovered that the dreamer himself had recognized the figure of Mephistopheles in the “man with the pointed beard.” Versatility of mind as well as the inventive gift and scientific leanings are attributes of the astrological Mercurius. Hence the man with the pointed beard represents the intellect, which is introduced by the dream as a real *familiaris*, an obliging if somewhat dangerous spirit. The intellect is thus degraded from the supreme position it once occupied and is put in the second rank, and at the same time branded as daemonic. Not that it had ever been anything but daemonic—only the dreamer had not noticed before how possessed he was by the intellect as the tacitly recognized supreme power. Now he has a chance to view this function, which till then had been the uncontested dominant of his psychic life, at somewhat closer quarters. Well might he exclaim with Faust: “So that’s what was inside the poodle!” Mephistopheles is the diabolical aspect of every psychic function that has broken loose from the hierarchy of the total psyche and now enjoys independence and absolute power (fig. 36). But this aspect can be perceived only when the function becomes a separate entity and is objectivated or personified, as in this dream.



23. The mystic vessel where the two natures unite (*sol* and *luna*, *caduceus*) to produce the *filius hermaphroditus*, Hermes Psychopompos, flanked by the six gods of the planets.—“Figurarum Aegyptiorum secretarum” (MS., 18th cent.)

[89] Amusingly enough, the “man with the pointed beard” also crops up in alchemical literature, in one of the “Parabolae” contained in the “Güldenene Tractat vom philosophischen Stein,”²¹ written in 1625, which Herbert Silberer²² has analysed from a psychological point of view. Among the company of old white-bearded philosophers there is a young man with a black pointed beard. Silberer is uncertain whether he should assume this figure to be the devil.

[90] Mercurius as quicksilver is an eminently suitable symbol for the “fluid,” i.e., mobile, intellect (fig. 24). Therefore in alchemy Mercurius is sometimes a “spirit” and sometimes a “water,” the so-called *aqua permanens*, which is none other than *argentum vivum*.

15. DREAM:

[91] *The dreamer’s mother is pouring water from one basin into another. (The dreamer only remembered in connection with vision 28 of the next series that this basin belonged to his sister.) This action is performed with great solemnity: it is of*

the highest significance for the outside world. Then the dreamer is rejected by his father.



24. The activities presided over by Mercurius.—Tübingen MS. (c. 1400)



[92] Once more we meet with the theme of “exchange” (cf. dream 1): one thing is put in the place of another. The “father” has been dealt with; now begins the action of the “mother.” Just as the father represents collective consciousness, the traditional spirit, so the mother stands for the collective unconscious, the source of the water of life²³ (fig. 25). (Cf. the maternal significance of πηγῆ,²⁴ the *fons signatus*,²⁵ as an attribute of the Virgin Mary, etc.—fig. 26.) The unconscious has altered the locus of the life forces, thus indicating a change of attitude. The dreamer’s subsequent recollection enables us to see who is now the source of life: it is the “sister.” The mother is superior to the son, but the sister is his equal. Thus the deposition of the intellect frees the dreamer from the domination of the unconscious and hence from his infantile attitude. Although the sister is a remnant of the past, we know definitely from later dreams that she was the carrier of the anima-image. We may therefore assume that the transferring of the water of life to the sister really means that the mother has been replaced by the anima.²⁶



26. The Virgin Mary surrounded by her attributes, the quadrangular enclosed garden, the round temple, tower, gate, well and fountain, palms and cypresses (trees of life), all feminine symbols.—17th-century devotional picture

[93] The anima now becomes a life-giving factor, a psychic reality which conflicts strongly with the world of the father. Which of us could assert, without endangering his sanity, that he had accepted the guidance of the unconscious in the conduct of his life, assuming that anyone exists who could imagine what that would mean? Anyone who could imagine it at all would certainly have no difficulty in understanding what a monstrous affront such a *volte face* would offer to the traditional spirit, especially to the spirit that has put on the earthly garment of the Church. It was this subtle change of psychic standpoint that caused the old alchemists to resort to deliberate mystification, and that sponsored all kinds of heresies. Hence it is only logical for the father to reject the dreamer—it amounts to nothing less than excommunication. (Be it noted that the dreamer is a Roman Catholic.) By acknowledging the reality of the psyche and making it a co-determining ethical factor in our lives, we offend against the spirit of convention which for centuries has regulated psychic life from outside by means of institutions as well as by reason. Not that unreasoning instinct rebels of itself against firmly established order; by the strict logic of its own inner laws it is itself of the firmest structure imaginable and, in addition, the creative foundation of all binding order. But just because this foundation is creative, all order which proceeds from it—even in its most “divine” form—is a phase, a stepping-stone. Despite appearances to the contrary, the establishment of order and the dissolution of what has been established are at bottom beyond human control. The secret is that only that which can destroy itself is truly alive. It is well that these things are difficult to understand and thus enjoy a wholesome concealment, for weak heads are only too easily addled by them and thrown into confusion. From all these dangers dogma—whether ecclesiastical, philosophical, or scientific—offers effective protection, and, looked at from a social point of view, excommunication is a necessary and useful consequence.

[94] The water that the mother, the unconscious, pours into the basin belonging to the anima is an excellent symbol for the living power of the psyche (cf. [fig. 152](#)). The old alchemists never tired of devising new and expressive synonyms for this water. They called it *aqua nostra*, *mercurius vivus*, *argentum vivum*, *vinum ardens*, *aqua vitae*, *succus lunariae*, and so on, by which they meant a living being not devoid of substance, as opposed to the rigid immateriality of mind in the abstract. The expression *succus lunariae* (sap of the moon-plant) refers clearly enough to the nocturnal origin of the water, and *aqua nostra*, like *mercurius vivus*, to its earthliness ([fig. 27](#)). *Acetum fontis* is a powerful corrosive water that dissolves all created things and at the same time leads to the most durable of all products, the mysterious *lapis*.

[95] These analogies may seem very far-fetched. But let me refer the reader to dreams 13 and 14 in the next section (pars. 154 and 158), where the water symbolism is taken up again. The importance of the action “for the outside world,” noted by the

dreamer himself, points to the collective significance of the dream, as also does the fact—which had a far-reaching influence on the conscious attitude of the dreamer—that he is “rejected by the father.”

[96] The saying “extra ecclesiam nulla salus”—outside the Church there is no salvation—rests on the knowledge that an institution is a safe, practicable highway with a visible or definable goal, and that no paths and no goals can be found outside it. We must not underestimate the devastating effect of getting lost in the chaos, even if we know that it is the *sine qua non* of any regeneration of the spirit and the personality.



27. Life-renewing influence of the conjoined sun and moon on the bath.—Milan, Biblioteca Ambrosiana, Codex I

16. DREAM:

[97] *An ace of clubs lies before the dreamer. A seven appears beside it.*

[98] The ace, as “1,” is the lowest card but the highest in value. The ace of clubs, being in the form of a cross, points to the Christian symbol.²⁷ Hence in Swiss-German the club is often called *Chrüüz* (cross). At the same time the three leaves

contain an allusion to the threefold nature of the one God. Lowest and highest are beginning and end, alpha and omega.

[99] The seven appears after the ace of clubs and not before. Presumably the idea is: first the Christian conception of God, and then the seven (stages). The seven stages symbolize the transformation (fig. 28) which begins with the symbolism of Cross and Trinity, and, judging by the earlier archaic allusions in dreams 7 and 13, culminates in the *solificatio*. But this solution is not hinted at here. Now, we know that the regression to the Helios of antiquity vainly attempted by Julian the Apostate was succeeded in the Middle Ages by another movement that was expressed in the formula “per crucem ad rosam” (through the cross to the rose), which was later condensed into the “Rosie Crosse” of the Rosicrucians. Here the essence of the heavenly Sol descends into the flower—earth’s answer to the sun’s countenance (fig. 29). The solar quality has survived in the symbol of the “golden flower” of Chinese alchemy.²⁸ The well-known “blue flower” of the Romantics might well be the last nostalgic perfume of the “rose”; it looks back in true Romantic fashion to the medievalism of ruined cloisters, yet at the same time modestly proclaims something new in earthly loveliness. But even the golden brilliance of the sun had to submit to a descent, and it found its analogy in the glitter of earthly gold—although, as *aurum nostrum*, this was far removed from the gross materiality of the metal, at least for subtler minds. One of the most interesting of the alchemical texts is the *Rosarium philosophorum*, subtitled *Secunda pars alchimiae de lapide philosophico vero modo praeparando... Cum figuris rei perfectionem ostendentibus* (1550).²⁹ The anonymous author was very definitely a “philosopher” and was apparently aware that alchemy was not concerned with ordinary goldmaking but with a philosophical secret. For these alchemists the gold undoubtedly had a symbolic nature³⁰ and was therefore distinguished by such attributes as *vitreum* or *philosophicum*. It was probably owing to its all too obvious analogy with the sun that gold was denied the highest philosophical honour, which fell instead to the *lapis philosophorum*. The transformer is above the transformed, and transformation is one of the magical properties of the marvellous stone. The *Rosarium philosophorum* says: “For our stone, namely the living western quicksilver which has placed itself above the gold and vanquished it, is that which kills and quickens.”³¹ As to the “philosophical” significance of the *lapis*, the following quotation from a treatise ascribed to Hermes is particularly enlightening: “Understand, ye sons of the wise, what this exceeding precious stone proclaims ... “And my light conquers every light, and my virtues are more excellent than all virtues.... I beget the light, but the darkness too is of my nature. ...”³²

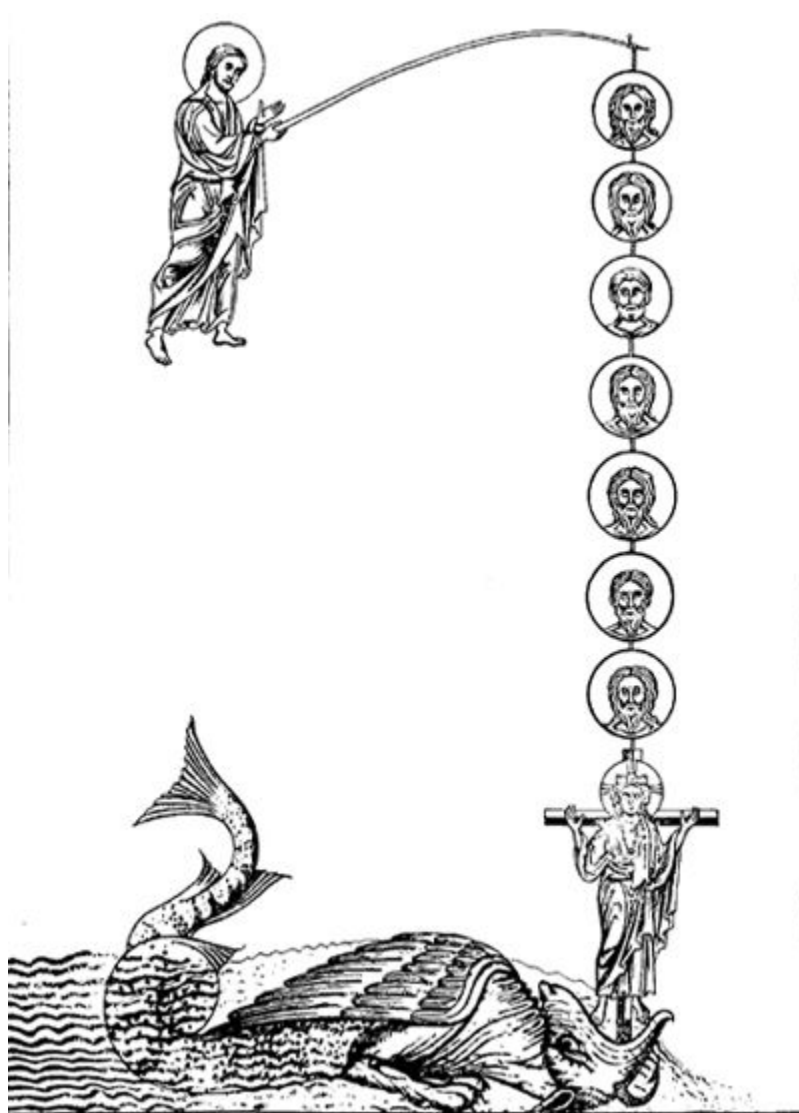

28. Capture of the Leviathan with the sevenfold tackle of the line of David, with the crucifix as bait.—Herrad of Landsberg's *Hortus deliciarum* (12th cent.)



29. Seven-petalled rose as allegory of the seven planets, the seven stages of transformation, etc.—Fludd, *Summum bonum* (1629), frontispiece

17. DREAM:

[100] *The dreamer goes for a long walk, and finds a blue flower on the way.*

[101] To go for a walk is to wander along paths that lead nowhere in particular; it is both a search and a succession of changes. The dreamer finds a blue flower blossoming aimlessly by the wayside, a chance child of nature, evoking friendly memories of a more romantic and lyrical age, of the youthful season when it came to bud, when the scientific view of the world had not yet broken away from the world of actual experience—or rather when this break was only just beginning and the eye looked back to what was already the past. The flower is in fact like a friendly sign, a numinous emanation from the unconscious, showing the dreamer, who as a modern man has been robbed of security and of participation in all the things that lead to man's salvation, the historical place where he can meet friends and brothers of like mind, where he can find the seed that wants to sprout in him too. But the dreamer knows nothing as yet of the old solar gold which connects the innocent flower with the obnoxious black art of alchemy and with the blasphemous pagan idea of the *solificatio*. For the “golden flower of alchemy” (fig. 30) can sometimes be a blue flower: “The sapphire blue flower of the hermaphrodite.”³³

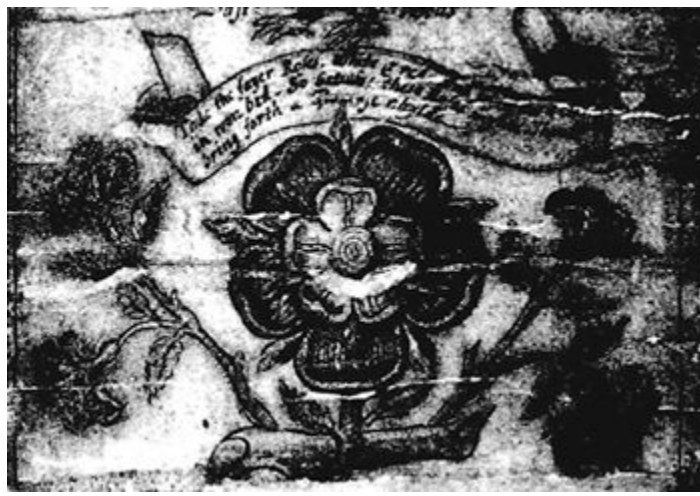

30. The red-and-white rose, the “golden flower” of alchemy, as birthplace of the *filius philosophorum*.—“Ripley Scrowle” (MS., 1588)

18. DREAM:

[102] A man offers him some golden coins in his outstretched hand. The dreamer indignantly throws them to the ground and immediately afterwards deeply regrets his action. A variety performance then takes place in an enclosed space.

[103] The blue flower has already begun to drag its history after it. The “gold” is offered and is indignantly refused. Such a misinterpretation of the *aurum philosophicum* is easy to understand. But hardly has it happened when there comes a pang of remorse that the precious secret has been rejected and a wrong answer given to the riddle of the Sphinx. The same thing happened to the hero in Meyrink’s *Golem*, when the ghost offered him a handful of grain which he spurned. The gross materiality of the yellow metal with its odious fiscal flavour, and the mean look of the grain, make both rejections comprehensible enough—but that is precisely why it is so hard to find the *lapis*: it is *exilis*, uncomely, it is thrown out into the street or on the dunghill, it is the commonest thing to be picked up anywhere—“in planitie, in montibus et aquis.” It has this “ordinary” aspect in common with Spitteler’s jewel in *Prometheus and Epimetheus*, which, for the same reason, was also not recognized by the worldly wise. But “the stone which the builders rejected, the same is become the head of the corner,” and the intuition of this possibility arouses the liveliest regret in the dreamer.

[104] It is all part of the banality of its outward aspect that the gold is minted, i.e., shaped into coins, stamped, and valued. Applied psychologically, this is just what Nietzsche refuses to do in his *Zarathustra*: to give names to the virtues. By being shaped and named, psychic life is broken down into coined and valued units. But this is possible only because it is intrinsically a great variety of things, an accumulation of unintegrated hereditary units. Natural man is not a “self”—he is the mass and a particle in the mass, collective to such a degree that he is not even sure of his own

ego. That is why since time immemorial he has needed the transformation mysteries to turn him into something, and to rescue him from the animal collective psyche, which is nothing but a *variété*.

[105] But if we reject this unseemly *variété* of man “as he is,” it is impossible for him to attain integration, to become a self.³⁴ And that amounts to spiritual death. Life that just happens in and for itself is not real life; it is real only when it is *known*. Only a unified personality can experience life, not that personality which is split up into partial aspects, that bundle of odds and ends which also calls itself “man.” The dangerous plurality already hinted at in dream 4 (par. 58) is compensated in vision 5 (par. 62), where the snake describes a magic circle and thus marks off the taboo area, the *temenos* (fig. 31). In much the same way and in a similar situation the *temenos* reappears here, drawing the “many” together for a united variety performance—a gathering that has the appearance of an entertainment, though it will shortly lose its entertaining character: the “play of goats” will develop into a “tragedy.” According to all the analogies, the satyr play was a mystery performance, from which we may assume that its purpose, as everywhere, was to re-establish man’s connection with his natural ancestry and thus with the source of life, much as the obscene stories, αἰσχρολογία, told by Athenian ladies at the mysteries of Eleusis, were thought to promote the earth’s fertility.³⁵ (Cf. also Herodotus’ account³⁶ of the exhibitionistic performances connected with the Isis festivities at Bubastis.)



31. The symbolic city as centre of the earth, its four protecting walls laid out in a square: a typical *temenos*.—Maier, *Vitorium* (1651)

[106] The allusion to the compensatory significance of the *temenos*, however, is still wrapped in obscurity for the dreamer. As might be imagined, he is much more concerned with the danger of spiritual death, which is conjured up by his rejection of the historical context.

19. VISUAL IMPRESSION:

[107] *A death's-head. The dreamer wants to kick it away, but cannot. The skull gradually changes into a red ball, then into a woman's head which emits light.*

[108] The skull soliloquies of Faust and of Hamlet are reminders of the appalling senselessness of human life when "sicklied o'er with the pale cast of thought." It was traditional opinions and judgments that caused the dreamer to dash aside the doubtful and uninviting-looking offerings. But when he tries to ward off the sinister vision of the death's-head it is transformed into a red ball, which we may take as an allusion to the rising sun, since it at once changes into the shining head of a woman, reminding us directly of vision 7 (par. 67). Evidently an enantiodromia, a play of opposites,³⁷ has occurred: after being rejected the unconscious insists on itself all the more

strongly. First it produces the classical symbol for the unity and divinity of the self, the sun; then it passes to the motif of the unknown woman who personifies the unconscious. Naturally this motif includes not merely the archetype of the anima but also the dreamer's relationship to a real woman, who is both a human personality and a vessel for psychic projections. ("Basin of the sister" in dream 15, par. 91.)

[109] In Neoplatonic philosophy the soul has definite affinities with the sphere. The soul substance is laid round the concentric spheres of the four elements above the fiery heaven.³⁸

20. VISUAL IMPRESSION:

[110] *A globe. The unknown woman is standing on it and worshipping the sun.*

[111] This impression, too, is an amplification of vision 7 (par. 67). The rejection in dream 18 evidently amounted to the destruction of the whole development up to that point. Consequently the initial symbols reappear now, but in amplified form. Such enantiodromias are characteristic of dream-sequences in general. Unless the conscious mind intervened, the unconscious would go on sending out wave after wave without result, like the treasure that is said to take nine years, nine months, and nine nights to come to the surface and, if not found on the last night, sinks back to start all over again from the beginning.

[112] The globe probably comes from the idea of the red ball. But, whereas this is the sun, the globe is rather an image of the earth, upon which the anima stands worshipping the sun (fig. 32). Anima and sun are thus distinct, which points to the fact that the sun represents a different principle from that of the anima. The latter is a personification of the unconscious, while the sun is a symbol of the source of life and the ultimate wholeness of man (as indicated in the *solificatio*). Now, the sun is an antique symbol that is still very close to us. We know also that the early Christians had some difficulty in distinguishing the ἥλιος ἀνατολῆς (the rising sun) from Christ.³⁹ The dreamer's anima still seems to be a sun-worshipper, that is to say, she belongs to the ancient world, and for the following reason: the conscious mind with its rationalistic attitude has taken little or no interest in her and therefore made it impossible for the anima to become modernized (or better, Christianized). It almost seems as if the differentiation of the intellect that began in the Christian Middle Ages, as a result of scholastic training, had driven the anima to regress to the ancient world. The Renaissance gives us evidence enough for this, the clearest of all being the *Hypnerotomachia* of Francesco Colonna, where Poliphilo meets his anima, the lady Polia, at the court of Queen Venus, quite untouched by Christianity and graced with all the "virtues" of antiquity. The book was rightly regarded as a mystery text.⁴⁰ With this anima, then, we plunge straight into the ancient world. So that I would not think anyone mistaken who interpreted the rejection of the gold in dream 18 *ex effectu* as

an attempt to escape this regrettable and unseemly regression to antiquity. Certain vital doctrines of alchemical philosophy go back textually to late Greco-Roman syncretism, as Ruska, for instance, has sufficiently established in the case of the *Turba*. Hence any allusion to alchemy wafts one back to the ancient world and makes one suspect regression to pagan levels.



32. *Coniunctio solis el lunae*.—Trismosin, “*Splendor solis*” (MS., 1582)

[113] It may not be superfluous to point out here, with due emphasis, that consciously the dreamer had no inkling of all this. But in his unconscious he is immersed in this sea of historical associations, so that he behaves in his dreams as if he were fully cognizant of these curious excursions into the history of the human mind. He is in fact an unconscious exponent of an autonomous psychic development, just like the medieval alchemist or the classical Neoplatonist. Hence one could say—*cum grano salis*—that history could be constructed just as easily from one’s own unconscious as from the actual texts.

21. VISUAL IMPRESSION:

[114] *The dreamer is surrounded by nymphs. A voice says, “We were always there, only you did not notice us.” (fig. 33).*

[115] Here the regression goes back even further, to an image that is unmistakably classical. At the same time the situation of dream 4 (par. 58) is taken up again and also the situation of dream 18, where the rejection led to the compensatory enantiodromia in vision 19. But here the image is amplified by the hallucinatory recognition that the drama has always existed although unnoticed until now. The realization of this fact joins the unconscious psyche to consciousness as a coexistent entity. The phenomenon of the “voice” in dreams always has for the dreamer the final and indisputable character of the *αὐτὸς ἔφα*,⁴¹ i.e., the voice expresses some truth or condition that is beyond all doubt. The fact that a sense of the remote past has been established, that contact has been made with the deeper layers of the psyche, is accepted by the unconscious personality of the dreamer and communicates itself to his conscious mind as a feeling of comparative security.



33. Poliphilo surrounded by nymphs.—Béroalde de Verville, *Le Songe de Poliphile* (1600)

[116] Vision 20 represents the anima as a sun-worshipper. She has as it were stepped out of the globe or spherical form (cf. fig. 32). But the first spherical form was the skull. According to tradition the head or brain is the seat of the *anima intellectualis*. For this reason too the alchemical vessel must be round like the head, so that what comes out of the vessel shall be equally “round,” i.e., simple and perfect like the *anima mundi*.⁴² The work is crowned by the production of the *rotundum*, which, as the *materia globosa*, stands at the beginning and also at the end, in the form of gold (fig. 34; cf. also figs. 115, 164, 165). Possibly the nymphs who “were always there” are an allusion to this. The regressive character of the vision is also apparent from the fact that there is a multiplicity of female forms, as in dream 4 (par. 58). But this time they are of a classical nature, which, like the sun-worship in vision 20, points to an

historical regression. The splitting of the anima into many figures is equivalent to dissolution into an indefinite state, i.e., into the unconscious, from which we may conjecture that a relative dissolution of the conscious mind is running parallel with the historical regression (a process to be observed in its extreme form in schizophrenia). The dissolution of consciousness or, as Janet calls it, *abaissement du niveau mental*, comes very close to the primitive state of mind. A parallel to this scene with the nymphs is to be found in the Paracelsan *regio nymphididica*, mentioned in the treatise *De vita longa* as the initial stage of the individuation process.⁴³



34. The *nigredo* standing on the *rotundum*, i.e., *sol niger*.—Mylius, *Philosophia reformata* (1622)

22. VISUAL IMPRESSION:

[117] *In a primeval forest. An elephant looms up menacingly. Then a large ape-man, bear, or cave-man threatens to attack the dreamer with a club (fig. 35). Suddenly the “man with the pointed beard” appears and stares at the aggressor, so that he is spellbound. But the dreamer is terrified. The voice says, “Everything must be ruled by the light.”*

[118] The multiplicity of nymphs has broken down into still more primitive components; that is to say, the animation of the psychic atmosphere has very considerably increased, and from this we must conclude that the dreamer’s isolation from his contemporaries has increased in proportion. This intensified isolation can be traced back to vision 21, where the union with the unconscious was realized and accepted as a fact. From the point of view of the conscious mind this is highly irrational; it constitutes a secret which must be anxiously guarded, since the

justification for its existence could not possibly be explained to any so-called reasonable person. Anyone who tried to do so would be branded as a lunatic. The discharge of energy into the environment is therefore considerably impeded, the result being a surplus of energy on the side of the unconscious: hence the abnormal increase in the autonomy of the unconscious figures, culminating in aggression and real terror. The earlier entertaining variety performance is beginning to become uncomfortable. We find it easy enough to accept the classical figures of nymphs thanks to their aesthetic embellishments; but we have no idea that behind these gracious figures there lurks the Dionysian mystery of antiquity, the satyr play with its tragic implications: the bloody dismemberment of the god who has become an animal. It needed a Nietzsche to expose in all its feebleness Europe's schoolboy attitude to the ancient world. But what did Dionysus mean to Nietzsche? What he says about it must be taken seriously; what it did to him still more so. There can be no doubt that he knew, in the preliminary stages of his fatal illness, that the dismal fate of Zagreus was reserved for him. Dionysus is the abyss of impassioned dissolution, where all human distinctions are merged in the animal divinity of the primordial psyche—a blissful and terrible experience. Humanity, huddling behind the walls of its culture, believes it has escaped this experience, until it succeeds in letting loose another orgy of bloodshed. All well-meaning people are amazed when this happens and blame high finance, the armaments industry, the Jews, or the Freemasons.⁴⁴



35. A medieval version of the “wild man.”—Codex Urbanus Latinus 899 (15th cent.)

[119] At the last moment, friend “Pointed Beard” appears on the scene as an obliging *deus ex machina* and exorcizes the annihilation threatened by the formidable ape-man. Who knows how much Faust owed his imperturbable curiosity, as he gazed on the spooks and bogeys of the classical *Walpurgisnacht*, to the helpful presence of Mephisto and his matter-of-fact point of view! Would that more people could remember the scientific or philosophical reflections of the much-abused intellect at the right moment! Those who abuse it lay themselves open to the suspicion of never having experienced anything that might have taught them its value and shown them why mankind has forged this weapon with such unprecedented effort. One has to be singularly out of touch with life not to notice such things. The intellect may be the devil (fig. 36), but the devil is the “strange son of chaos” who can most readily be trusted to deal effectively with his mother. The Dionysian experience will give this devil plenty to do should he be looking for work, since the resultant settlement with the unconscious far outweighs the labours of Hercules. In my opinion it presents a whole world of problems which the intellect could not settle even in a hundred years—the very reason why it so often goes off for a holiday to recuperate on lighter tasks. And this is also the reason why the psyche is forgotten so often and so long, and why the intellect makes such frequent use of magical apotropaic words like “occult” and

“mystic,” in the hope that even intelligent people will think that these mutterings really mean something.

[120] The voice finally declares, “Everything must be ruled by the light,” which presumably means the light of the discerning, conscious mind, a genuine *illuminatio* honestly acquired. The dark depths of the unconscious are no longer to be denied by ignorance and sophistry—at best a poor disguise for common fear—nor are they to be explained away with pseudo-scientific rationalizations. On the contrary it must now be admitted that things exist in the psyche about which we know little or nothing at all, but which nevertheless affect our bodies in the most obstinate way, and that they possess at least as much reality as the things of the physical world which ultimately we do not understand either. No line of research which asserted that its subject was unreal or a “nothing but” has ever made any contribution to knowledge.



36. The devil as aerial spirit and ungodly intellect.—Illustration by Eugène Delacroix (1799–1863) for *Faust*, [Part I](#)

[121] With the active intervention of the intellect a new phase of the unconscious process begins: the conscious mind must now come to terms with the figures of the unknown woman (“anima”), the unknown man (“the shadow”), the wise old man (“mana personality”),⁴⁵ and the symbols of the self. The last named are dealt with in the following section.



37. The seven-petaled flower.—Boschius, *Symbolographia* (1702)



38. Mercurius as virgo standing on the gold (*sol*) and silver (*luna*) fountain, with the dragon as her son.—Thomas Aquinas (pseud.), “*De alchimia*” (MS., 16th cent.)

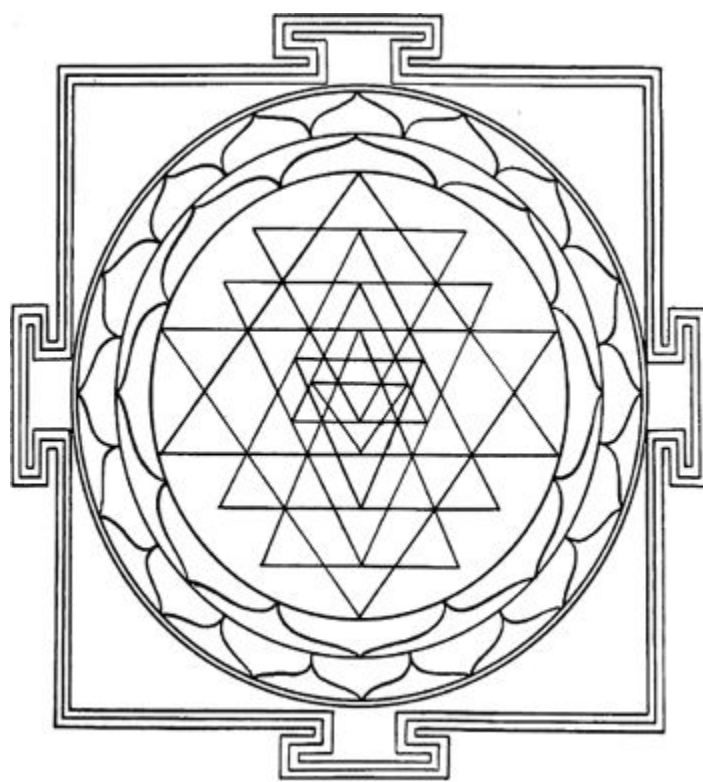

39. Shri-Yantra

3. THE SYMBOLISM OF THE MANDALA

I. CONCERNING THE MANDALA

[122] As I have already said, I have put together, out of a continuous series of some four hundred dreams and visions, all those that I regard as mandala dreams. The term “mandala” was chosen because this word denotes the ritual or magic circle used in Lamaism and also in Tantric yoga as a *yantra* or aid to contemplation (fig. 39). The Eastern mandalas used in ceremonial are figures fixed by tradition; they may be drawn or painted or, in certain special ceremonies, even represented plastically.¹

[123] In 1938, I had the opportunity, in the monastery of Bhutia Busty, near Darjeeling, of talking with a Lamaic *rimpoche*, Lingdam Gomchen by name, about the *khilkor* or mandala. He explained it as a *dmigs-pa* (pronounced “migpa”), a mental image which can be built up only by a fully instructed lama through the power of imagination. He said that no mandala is like any other, they are all individually different. Also, he said, the mandalas to be found in monasteries and temples were of no particular significance because they were external representations only. The true mandala is always an inner image, which is gradually built up through (active) imagination, at such times when psychic equilibrium is disturbed or when a thought cannot be found and must be sought for, because it is not contained in holy doctrine. The aptness of this explanation will become apparent in the course of my exposition. The alleged free and individual formation of the mandala, however, should be taken with a considerable grain of salt, since in all Lamaic mandalas there predominates not only a certain unmistakable style but also a traditional structure. For instance they are all based on a quaternary system, a *quadratura circuli*, and their contents are invariably derived from Lamaic dogma. There are texts, such as the Shri-Chakra-Sambhara Tantra,² which contain directions for the construction of these “mental images.” The *khilkor* is strictly distinguished from the so-called *sidpe-korlo*, or World Wheel (fig. 40), which represents the course of human existence in its various forms as conceived by the Buddhists. In contrast to the *khilkor*, the World Wheel is based on a ternary system in that the three world-principles are to be found in its centre: the cock, equalling concupiscence; the serpent, hatred or envy; and the pig, ignorance or unconsciousness (*avidya*). Here we come upon the dilemma of three and four, which also crops up in Buddhism. We shall meet this problem again in the further course of our dream-series.

[124] It seems to me beyond question that these Eastern symbols originated in dreams and visions, and were not invented by some Mahayana church father. On the

contrary, they are among the oldest religious symbols of humanity (figs 41–44) and may even have existed in paleolithic times (cf. the Rhodesian rock-paintings). Moreover they are distributed all over the world, a point I need not insist on here. In this section I merely wish to show from the material at hand how mandalas come into existence.



40. Tibetan World Wheel (*sidpe-korlo*)

[125] The mandalas used in ceremonial are of great significance because their centres usually contain one of the highest religious figures: either Shiva himself—often in the embrace of Shakti—or the Buddha, Amitabha, Avalokiteshvara, or one of the great Mahayana teachers, or simply the *dorje*, symbol of all the divine forces together, whether creative or destructive (fig. 43). The text of the *Golden Flower*, a product of Taoist syncretism, specifies in addition certain “alchemical” properties of this centre after the manner of the *lapis* and the *elixir vitae*, so that it is in effect a Φάρμακον ἀθανασίας.³



41. The Aztec "Great Calendar Stone"

[126] It is not without importance for us to appreciate the high value set upon the mandala, for it accords very well with the paramount significance of individual mandala symbols which are characterized by the same qualities of a—so to speak—"metaphysical" nature.⁴ Unless everything deceives us, they signify nothing less than a psychic centre of the personality not to be identified with the ego. I have observed these processes and their products for close on thirty years on the basis of very extensive material drawn from my own experience. For fourteen years I neither wrote nor lectured about them so as not to prejudice my observations. But when, in 1929, Richard Wilhelm laid the text of the *Golden Flower* before me, I decided to publish at least a foretaste of the results. One cannot be too cautious in these matters, for what with the imitative urge and a positively morbid avidity to possess themselves of outlandish feathers and deck themselves out in this exotic plumage, far too many people are misled into snatching at such "magical" ideas and applying them externally, like an ointment. People will do anything, no matter how absurd, in order to avoid facing their own souls. They will practise Indian yoga and all its exercises, observe a strict regimen of diet, learn theosophy by heart, or mechanically repeat mystic texts from the literature of the whole world—all because they cannot get on with themselves and have not the slightest faith that anything useful could ever come out of their own souls. Thus the soul has gradually been turned into a Nazareth from which nothing good can come. Therefore let us fetch it from the four corners of the earth—the more far-fetched and bizarre it is the better! I have no wish to disturb such people at their pet pursuits, but when anybody who expects to be taken seriously is deluded enough to think that I use yoga methods and yoga doctrines or that I get my patients, whenever possible, to draw mandalas for the purpose of bringing them to

the “right point”—then I really must protest and tax these people with having read my writings with the most horrible inattention. The doctrine that all evil thoughts come from the heart and that the human soul is a sink of iniquity must lie deep in the marrow of their bones. Were that so, then God had made a sorry job of creation, and it were high time for us to go over to Marcion the Gnostic and depose the incompetent demiurge. Ethically, of course, it is infinitely more convenient to leave God the sole responsibility for such a Home for Idiot Children, where no one is capable of putting a spoon into his own mouth. But it is worth man’s while to take pains with himself, and he has something in his soul that can grow.⁵ It is rewarding to watch patiently the silent happenings in the soul, and the most and the best happens when it is not regulated from outside and from above. I readily admit that I have such a great respect for what happens in the human soul that I would be afraid of disturbing and distorting the silent operation of nature by clumsy interference. That was why I even refrained from observing this particular case myself and entrusted the task to a beginner who was not handicapped by my knowledge—anything rather than disturb the process. The results which I now lay before you are the unadulterated, conscientious, and exact self-observations of a man of unerring intellect, who had nothing suggested to him from outside and who would in any case not have been open to suggestion. Anyone at all familiar with psychic material will have no difficulty in recognizing the authentic character of the results.



42. Mandala containing the Infant Christ carrying the Cross.—Mural painting by Albertus Pictor in the church of Harkeberga, Sweden (c. 1480)

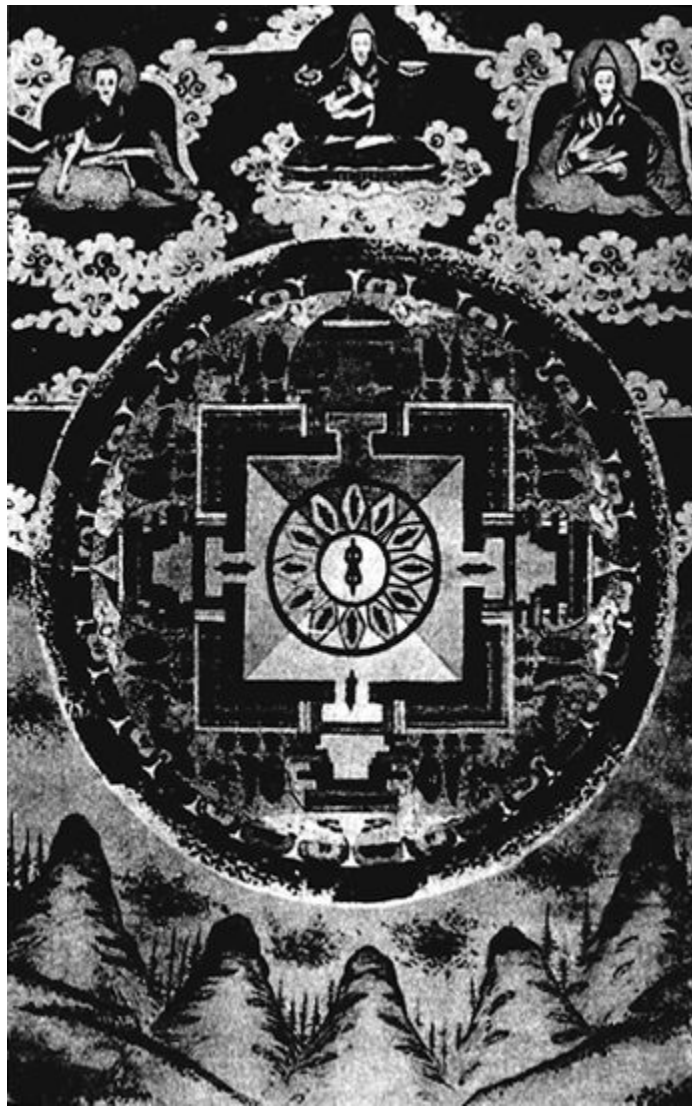

43. Lamaic Vajramandala.—Cf. Jung, “Concerning Mandala Symbolism,” [fig. 1](#)

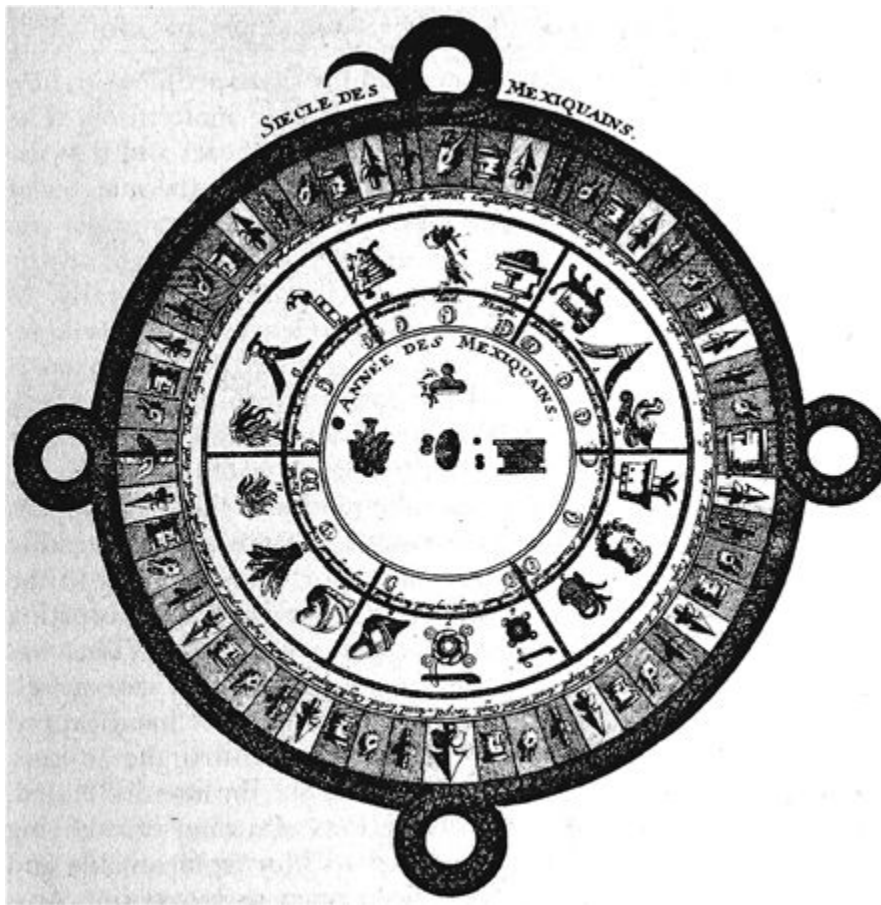

44. Mexican calendar.—Herrliberger, *Heilige Ceremonien* (1748)



45. Hermes as psychopomp.—Gem in a Roman ring

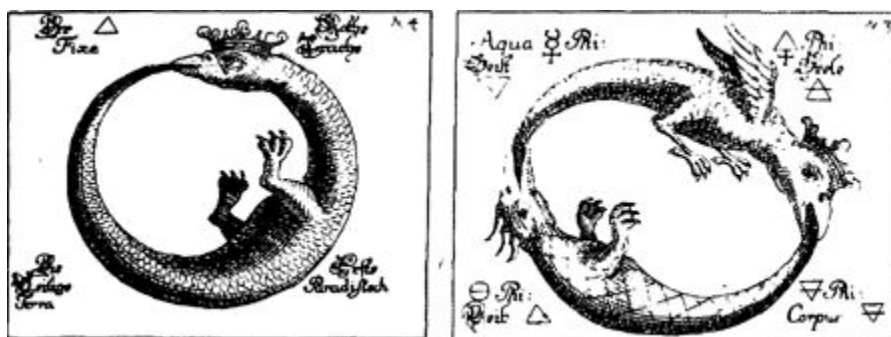

46, 47. Crowned dragon as tail-eater; two dragons forming a circle and, in the four corners, signs of the four elements.—Eleazar, *Uraltes chymisches Werk* (1760)

[127] For the sake of completeness I will recapitulate the mandala symbols which occur in the initial dreams and visions already discussed:

1. The snake that described a circle round the dreamer (5).
2. The blue flower (17).
3. The man with the gold coins in his hand, and the enclosed space for a variety performance (18).
4. The red ball (19).
5. The globe (20).

[128] The next mandala symbol occurs in the first dream of the new series:⁶

6. DREAM:

An unknown woman is pursuing the dreamer. He keeps running round in a circle.

[129] The snake in the first mandala dream was anticipatory, as is often the case when a figure personifying a certain aspect of the unconscious does or experiences something that the subject himself will experience later. The snake anticipates a circular movement in which the subject is going to be involved; i.e., something is taking place in the unconscious which is perceived as a circular movement, and this occurrence now presses into consciousness so forcefully that the subject himself is gripped by it. The unknown woman or anima representing the unconscious continues to harass the dreamer until he starts running round in circles. This clearly indicates a potential centre which is not identical with the ego and round which the ego revolves.

7. DREAM:

[130] *The anima accuses the dreamer of paying too little attention to her. There is a clock that says five minutes to the hour.*

[131] The situation is much the same: the unconscious pesters him like an exacting woman. The situation also explains the clock, for a clock's hands go round in a circle. Five minutes to the hour implies a state of tension for anybody who lives by the clock: when the five minutes are up he must do something or other. He might even be pressed for time. (The symbol of circular movement—cf. [fig. 13](#)—is always connected with a feeling of tension, as we shall see later.)

8. DREAM:

[132] *On board ship. The dreamer is occupied with a new method of taking his bearings. Sometimes he is too far away and sometimes too near: the right spot is in the middle. There is a chart on which is drawn a circle with its centre.*

[133] Obviously the task set here is to find the centre, the right spot, and this is the centre of a circle. While the dreamer was writing down this dream he remembered that he had dreamed shortly before of shooting at a target (fig. 48): sometimes he shot too high, sometimes too low. The right aim lay in the middle. Both dreams struck him as highly significant. The target is a circle with a centre. Bearings at sea are taken by the apparent rotation of the stars round the earth. Accordingly the dream describes an activity whose aim is to construct or locate an objective centre—a centre outside the subject.

9. DREAM:

[134] *A pendulum clock that goes forever without the weights running down.*

[135] This is a species of clock whose hands move unceasingly, and, since there is obviously no loss due to friction, it is a *perpetuum mobile*, an everlasting movement in a circle. Here we meet with a “metaphysical” attribute. As I have already said, I use this word in a psychological sense, hence figuratively. I mean by this that eternity is a quality predicated by the unconscious, and not a hypostasis. The statement made by the dream will obviously offend the dreamer’s scientific judgment, but this is just what gives the mandala its peculiar significance. Highly significant things are often rejected because they seem to contradict reason and thus set it too arduous a test. The movement without friction shows that the clock is cosmic, even transcendental; at any rate it raises the question of a quality which leaves us in some doubt whether the psychic phenomenon expressing itself in the mandala is under the laws of space and time. And this points to something so entirely different from the empirical ego that the gap between them is difficult to bridge; i.e., the other centre of personality lies on a different plane from the ego since, unlike this, it has the quality of “eternity” or relative timelessness.



10. DREAM:

[136] *The dreamer is in the Peterhofstatt in Zurich with the doctor, the man with the pointed beard, and the “doll woman.” The last is an unknown woman who neither speaks nor is spoken to. Question: To which of the three does the woman belong?*

[137] The tower of St. Peter’s in Zurich has a clock with a strikingly large face. The Peterhofstatt is an enclosed space, a *temenos* in the truest sense of the word, a precinct of the church. The four of them find themselves in this enclosure. The circular dial of the clock is divided into four quarters, like the horizon. In the dream the dreamer represents his own ego, the man with the pointed beard the “employed” intellect (Mephisto), and the “doll woman” the anima. Since the doll is a childish object it is an excellent image for the non-ego nature of the anima, who is further characterized as an object by “not being spoken to.” This negative element (also present in dreams 6 and 7 above) indicates an inadequate relationship between the conscious mind and the unconscious, as also does the question of whom the unknown woman belongs to. The “doctor,” too, belongs to the non-ego; he probably contains a faint allusion to myself, although at that time I had no connections with the dreamer.⁷ The man with the pointed beard, on the other hand, belongs to the ego. This whole situation is reminiscent of the relations depicted in the diagram of functions (fig. 49). If we think of the psychological functions⁸ as arranged in a circle, then the most differentiated function is usually the carrier of the ego and, equally regularly, has an auxiliary function attached to it. The “inferior” function, on the other hand, is unconscious and for that reason is projected into a non-ego. It too has an auxiliary function. Hence it would not be impossible for the four persons in the dream to represent the four functions as components of the total personality (i.e., if we include the unconscious). But this totality is ego plus non-ego. Therefore the centre of the circle which expresses such a totality would correspond not to the ego but to the self as the summation of the total personality. (The centre with a circle is a very well-known allegory of the nature of God.) In the philosophy of the Upanishads the Self is in one aspect the *personal* atman, but at the same time it has a cosmic and metaphysical quality as the *suprapersonal* Atman.⁹

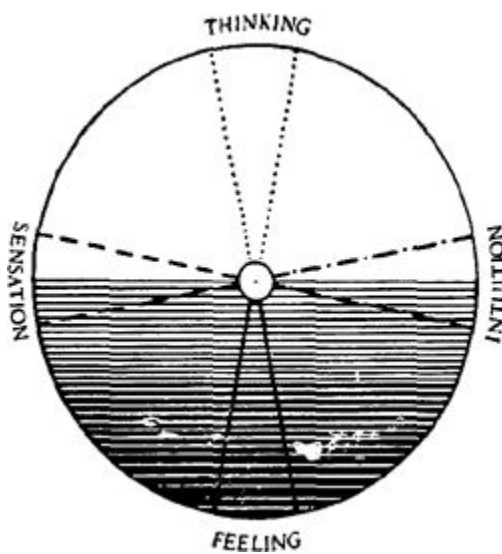

49. Diagram showing the four functions of consciousness. Thinking, the superior function in this case, occupies the centre of the light half of the circle, whereas feeling, the inferior function, occupies the dark half. The two auxiliary functions are partly in the light and partly in the dark

[138] We meet with similar ideas in Gnosticism: I would mention the idea of the Anthropos, the Pleroma, the Monad, and the spark of light (Spinther) in a treatise of the Codex Brucianus:

This same is he [Monogenes] who dwelleth in the Monad, which is in the Setheus, and which came from the place of which none can say where it is.... From Him it is the Monad came, in the manner of a ship, laden with all good things, and in the manner of a field, filled or planted with every kind of tree, and in the manner of a city, filled with all races of mankind.... This is the fashion of the Monad, all these being in it: there are twelve Monads as a crown upon its head.... And to its veil which surroundeth it in the manner of a defence [πύργος = tower] there are twelve gates.... This same is the Mother-City [μητρόπολις] of the Only-begotten [μονογενής].¹⁰

[139] By way of explanation I should add that “Setheus” is a name for God, meaning “creator.” The Monogenes is the Son of God. The comparison of the Monad with a field and a city corresponds to the idea of the *temenos* (fig. 50). Also, the Monad is crowned (cf. the hat which appears in dream 1 of the first series [par. 52] and dream 35 of this series [par. 254]). As “metropolis” (cf. fig. 51) the Monad is feminine, like the *padma* or lotus, the basic form of the Lamaic mandala (the Golden Flower in China and the Rose or Golden Flower in the West). The Son of God, God made manifest, dwells in the flower.¹¹ In the Book of Revelation, we find the Lamb in the centre of the Heavenly Jerusalem. And in our Coptic text we are told that Setheus dwells in the innermost and holiest recesses of the Pleroma, a city with four gates (equivalent to the Hindu City of Brahma on the world-mountain Meru). In each gate there is a Monad.¹² The limbs of the Anthropos born of the Autogenes (=

Monogenes) correspond to the four gates of the city. The Monad is a spark of light (Spinther) and an image of the Father, identical with the Monogenes. An invocation runs: "Thou art the House and the Dweller in the House."¹³ The Monogenes stands on a *tetrapeza*,¹⁴ a table or platform with four pillars corresponding to the quaternion of the four evangelists.¹⁵

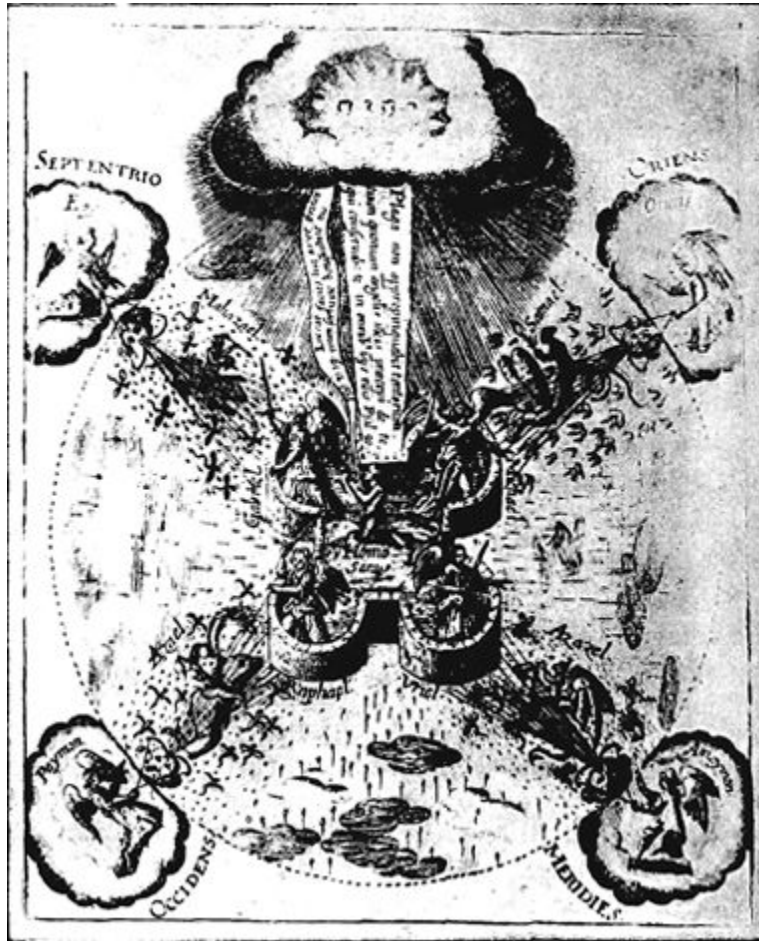

50. Baneful spirits attacking the Impregnable Castle.—Fludd, *Summum bonum*(1629)



[140] The idea of the *lapis* has several points of contact with all this. In the *Rosarium* the *lapis* says, quoting Hermes:¹⁶ “I beget the light, but the darkness too is of my nature ... therefore nothing better or more worthy of veneration can come to pass in the world than the conjunction of myself and my son.”¹⁷ Similarly, the Monogenes is called the “dark light,”¹⁸ a reminder of the *sol niger*, the black sun of alchemy¹⁹ (fig. 34).

[141] The following passage from chapter 4 of the “Tractatus aureus” provides an interesting parallel to the Monogenes who dwells in the bosom of the Mother-City and is identical with the crowned and veiled Monad:

But the king reigns, as is witnessed by his brothers, [and] says: “I am crowned, and I am adorned with the diadem; I am clothed with the royal garment, and I bring joy to the heart; for, being chained to the arms and breast of my mother, and to her substance, I cause my substance to hold together and rest; and I compose the invisible from the visible, making the occult to appear; and everything that the philosophers have concealed will be generated from us. Hear then these words, and understand them; keep them, and meditate upon them, and seek for nothing more. Man is generated from the principle of Nature whose inward parts are fleshy, and from no other substance.”



52. Harpokrates on the lotus.—Gnostic gem



53. The tetramorph, the steed of the Church.—Crucifixion in Herrad of Landsberg’s *Hortus deliciarum* (12th cent.)
detail

[142] The “king” refers to the *lapis*. That the *lapis* is the “master” is evident from the following Hermes quotation in the *Rosarium*.²⁰ “Et sic Philosophus non est Magister lapidis, sed potius minister” (And thus the philosopher is not the master of the stone but rather its minister). Similarly the final production of the *lapis* in the form of the crowned hermaphrodite is called the *aenigma regis*.²¹ A German verse refers to the *aenigma* as follows (fig. 54):

Here now is born the emperor of all honour
 Than whom there cannot be born any higher,
 Neither by art nor by the work of nature
 Out of the womb of any living creature.
 Philosophers speak of him as their son
 And everything they do by him is done.²²

[143] The last two lines might easily be a direct reference to the above quotation from Hermes.

[144] It looks as if the idea had dawned on the alchemists that the Son who, according to classical (and Christian) tradition, dwells eternally in the Father and reveals himself as God's gift to mankind, was something that man could produce out of his own nature—with God's help, of course (*Deo concedente*). The heresy of this idea is obvious.

[145] The feminine nature of the inferior function derives from its contamination with the unconscious. Because of its feminine characteristics the unconscious is personified by the anima (that is to say, in men; in women it is masculine).²³

[146] If we assume that this dream and its predecessors really do mean something that justly arouses a feeling of significance in the dreamer, and if we further assume that this significance is more or less in keeping with the views put forward in the commentary, then we would have reached here a high point of introspective intuition whose boldness leaves nothing to be desired. But even the everlasting pendulum clock is an indigestible morsel for a consciousness unprepared for it, and likely to hamper any too lofty flight of thought.



Ænigma Regis.
*Hie ist geboren der Keyser aller ehren/
kein h her mag vber in geboren werden.*

54. Hermaphrodite with three serpents and one serpent. Below, the three-headed Mercurial dragon.—*Rosarium philosophorum*, in *Artis auriferae* (1593)

[147] *The dreamer, the doctor, a pilot, and the unknown woman are travelling by airplane. A croquet ball suddenly smashes the mirror, an indispensable instrument of navigation, and the airplane crashes to the ground. Here again there is the same doubt: to whom does the unknown woman belong?*

[148] Doctor, pilot, and unknown woman are characterized as belonging to the non-ego by the fact that all three of them are strangers. Therefore the dreamer has retained possession only of the differentiated function, which carries the ego; that is, the unconscious has gained ground considerably. The croquet ball is part of a game where the ball is driven under a hoop. Vision 8 of the first series (par. 69) said that people should not go over the rainbow (fly?), but must go *under* it. Those who go over it fall to the ground. It looks as though the flight had been too lofty after all. Croquet is played on the ground and not in the air. We should not rise above the earth with the aid of “spiritual” intuitions and run away from hard reality, as so often happens with people who have brilliant intuitions. We can never reach the level of our intuitions and should therefore not identify ourselves with them. Only the gods can pass over the rainbow bridge; mortal men must stick to the earth and are subject to its laws (cf. [fig. 16](#)). In the light of the possibilities revealed by intuition, man’s earthliness is certainly a lamentable imperfection; but this very imperfection is part of his innate being, of his reality. He is compounded not only of his best intuitions, his highest ideals and aspirations, but also of the odious conditions of his existence, such as heredity and the indelible sequence of memories that shout after him: “You did it, and that’s what you are!” Man may have lost his ancient saurian’s tail, but in its stead he has a chain hanging on to his psyche which binds him to the earth—an anything-but-Homeric chain²⁴ of given conditions which weigh so heavy that it is better to remain bound to them, even at the risk of becoming neither a hero nor a saint. (History gives us some justification for not attaching any absolute value to these collective norms.) That we are bound to the earth does not mean that we cannot grow; on the contrary it is the *sine qua non* of growth. No noble, well-grown tree ever disowned its dark roots, for it grows not only upward but downward as well. The question of where we are going is of course extremely important; but equally important, it seems to me, is the question of *who* is going where. The “who” always implies a “whence.” It takes a certain greatness to gain lasting possession of the heights, but anybody can overreach himself. The difficulty lies in striking the dead centre (cf. dream 8, par. 132). For this an awareness of the two sides of man’s personality is essential, of their respective aims and origins. These two aspects must never be separated through arrogance or cowardice.

[149] The “mirror” as an “indispensable instrument of navigation” doubtless refers to the intellect, which is able to think and is constantly persuading us to identify ourselves with its insights (“reflections”). The mirror is one of Schopenhauer’s

favourite similes for the intellect. The term “instrument of navigation” is an apt expression for this, since it is indeed man’s indispensable guide on pathless seas. But when the ground slips from under his feet and he begins to speculate in the void, seduced by the soaring flights of intuition, the situation becomes dangerous (fig. 55).

[150] Here again the dreamer and the three dream figures form a quaternity. The unknown woman or anima always represents the “inferior,” i.e., the undifferentiated function, which in the case of our dreamer is feeling. The croquet ball is connected with the “round” motif and is therefore a symbol of wholeness, that is, of the self, here shown to be hostile to the intellect (the mirror). Evidently the dreamer “navigates” too much by the intellect and thus upsets the process of individuation. In *De vita longa*, Paracelsus describes the “four” as *Scaiolae*, but the self as Adech (from Adam=the first man). Both, as Paracelsus emphasizes, cause so many difficulties in the “work” that one can almost speak of Adech as hostile.²⁵

12. DREAM:

[151] *The dreamer finds himself with his father, mother, and sister in a very dangerous situation on the platform of a tram-car.*

[152] Once more the dreamer forms a quaternity with the other dream figures. He has fallen right back into childhood, a time when we are still a long way from wholeness. Wholeness is represented by the family, and its components are still projected upon the members of the family and personified by them. But this state is dangerous for the adult because regressive: it denotes a splitting of personality which primitive man experiences as the perilous “loss of soul.” In the break-up the personal components that have been integrated with such pains are once more sucked into the outside world. The individual loses his guilt and exchanges it for infantile innocence; once more he can blame the wicked father for this and the unloving mother for that, and all the time he is caught in this inescapable causal nexus like a fly in a spider’s web, without noticing that he has lost his moral freedom.²⁶ But no matter how much parents and grandparents may have sinned against the child, the man who is really adult will accept these sins as his own condition which has to be reckoned with. Only a fool is interested in other people’s guilt, since he cannot alter it. The wise man learns only from his own guilt. He will ask himself: Who am I that all this should happen to me? To find the answer to this fateful question he will look into his own heart.



55. Faust before the magic mirror.—Rembrandt, etching (c. 1652).

[153] As in the previous dream the vehicle was an airplane, so in this it is a tram. The type of vehicle in a dream illustrates the kind of movement or the manner in which the dreamer moves forward in time—in other words, how he lives his psychic life, whether individually or collectively, whether on his own or on borrowed means, whether spontaneously or mechanically. In the airplane he is flown by an unknown pilot; i.e., he is borne along on intuitions emanating from the unconscious. (The mistake is that the “mirror” is used too much to steer by.) But in this dream he is in a collective vehicle, a tram, which anybody can ride in; i.e., he moves or behaves just like everybody else. All the same he is again one of four, which means that he is in both vehicles on account of his unconscious striving for wholeness.

13. DREAM:

[154] *In the sea there lies a treasure. To reach it, he has to dive through a narrow opening. This is dangerous, but down below he will find a companion. The dreamer takes the plunge into the dark and discovers a beautiful garden in the depths, symmetrically laid out, with a fountain in the centre (fig. 56).*

[155] The “treasure hard to attain” lies hidden in the ocean of the unconscious, and only the brave can reach it. I conjecture that the treasure is also the “companion,” the one who goes through life at our side—in all probability a close analogy to the lonely ego who finds a mate in the self, for at first the self is the strange non-ego. This is the theme of the magical travelling companion, of whom I will give three famous examples: the disciples on the road to Emmaus, Krishna and Arjuna in the Bhagavad Gita, Moses and El-Khidr in Sura 18 of the Koran.²⁷ I conjecture further that the treasure in the sea, the companion, and the garden with the fountain are all one and the same thing: the self. For the garden is another *temenos*, and the fountain is the source of “living water” mentioned in John 7 : 38, which the Moses of the Koran also sought and found, and beside it El-Khidr,²⁸ “one of Our servants whom We had endowed with Our grace and wisdom” (Sura 18). And the legend has it that the ground round about El-Khidr blossomed with spring flowers, although it was desert. In Islam, the plan of the *temenos* with the fountain developed under the influence of early Christian architecture into the court of the mosque with the ritual wash-house in the centre (e.g., Ahmed ibn-Tulun in Cairo). We see much the same thing in our Western cloisters with the fountain in the garden. This is also the “rose garden of the philosophers,” which we know from the treatises on alchemy and from many beautiful engravings. “The Dweller in the House” (cf. commentary to dream 10, par. 139) is the “companion.” The centre and the circle, here represented by fountain and garden, are analogues of the *lapis*, which is among other things a living being (cf. [figs. 25, 26](#)). In the *Rosarium* the *lapis* says: “Protege me, protegam te. Largire mihi ius meum, ut te adiuvem” (Protect me and I will protect you. Give me my due that I may help you).²⁹ Here the *lapis* is nothing less than a good friend and helper who helps those that help him, and this points to a compensatory relationship. (I would call to mind what was said in the commentary to dream 10, pars. 138ff., more particularly the Monogenes-*lapis*-self parallel.)

[156] The crash to earth thus leads into the depths of the sea, into the unconscious, and the dreamer reaches the shelter of the *temenos* as a protection against the splintering of personality caused by his regression to childhood. The situation is rather like that of dream 4 and vision 5 in the first series (pars. 58 and 62) where the magic circle warded off the lure of the unconscious and its plurality of female forms. (The dangers of temptation approach Poliphilo in much the same way at the beginning of his *nekyia*.)



56. Fountain of youth.—Codex de Sphaera (Modena, 15th cent.)

[157] The source of life is, like El-Khidr, a good companion, though it is not without its dangers, as Moses of old found to his cost, according to the Koran. It is the symbol of the life force that eternally renews itself (fig. 57; cf. also figs. 25–27, 84) and of the clock that never runs down. An uncanonical saying of our Lord runs: “He who is near unto me is near unto the fire.”³⁰ Just as this esoteric Christ is a source of fire (fig. 58)—probably not without reference to the $\pi\acute{\iota}\rho\ \acute{\alpha}\epsilon\iota\ \zeta\omega\omicron\nu$ of Heraclitus—so the alchemical philosophers conceive their *aqua nostra* to be *ignis* (fire).³¹ The source means not only the flow of life but its warmth, indeed its heat, the secret of passion, whose synonyms are always fiery.³² The all-dissolving *aqua nostra* is an essential ingredient in the production of the *lapis*. But the source is underground and therefore the way leads underneath: only down below can we find the fiery source of life. These depths constitute the natural history of man, his causal link with the world of instinct (cf. fig. 16). Unless this link be rediscovered no *lapis* and no self can come into being.

[158] *The dreamer goes into a chemist's shop with his father. Valuable things can be got there quite cheap, above all a special water. His father tells him about the country the water comes from. Afterwards he crosses the Rubicon by train.*

[159] The traditional apothecary's shop, with its carboys and gallipots, its waters, its *lapis divinus* and *infernalis* and its magisteries, is the last visible remnant of the kitchen paraphernalia of those alchemists who saw in the *donum spiritus sancti*—the precious gift—nothing beyond the chimera of goldmaking. The “special water” is literally the *aqua nostra non vulgi*.³³ It is easy to understand why it is his father who leads the dreamer to the source of life, since he is the natural source of the latter's life. We could say that the father represents the country or soil from which that life sprang. But figuratively speaking, he is the “informing spirit” who initiates the dreamer into the meaning of life and explains its secrets according to the teachings of old. He is a transmitter of the traditional wisdom. But nowadays the fatherly pedagogue fulfils this function only in the dreams of his son, where he appears as the archetypal father figure, the “wise old man.”



57. Imperial bath with the miraculous spring of water, beneath the influence of sun and moon.—“De balneis Puteolanis” (MS., 14th cent.)



58. Christ as the source of fire, with the “flaming” stigmata.—14th-cent. stained-glass window, church at Königsfelden, Aargau, Switzerland

[160] The water of life is easily had: everybody possesses it, though without knowing its value. “Spernitur a stultis”—it is despised by the stupid, because they assume that every good thing is always outside and somewhere else, and that the source in their own souls is a “nothing but.” Like the *lapis*, it is “pretio quoque vilis,” of little price, and therefore, like the jewel in Spitteler’s *Prometheus*, it is rejected by everyone from the high priest and the academicians down to the very peasants, and “in viam eiectus,” flung out into the street, where Ahasuerus picks it up and puts it into his pocket. The treasure has sunk down again into the unconscious.

[161] But the dreamer has noticed something and with vigorous determination crosses the Rubicon. He has realized that the flux and fire of life are not to be underrated and are absolutely necessary for the achievement of wholeness. But there is no recrossing the Rubicon.

15. DREAM:

[162] *Four people are going down a river: the dreamer, his father, a certain friend, and the unknown woman.*

[163] In so far as the “friend” is a definite person well known to the dreamer, he belongs, like the father, to the conscious world of the ego. Hence something very important has happened: in dream 11 the unconscious was three against one, but now the situation is reversed and it is the dreamer who is three against one (the latter being the unknown woman). The unconscious has been depotentiated. The reason for this is that by “taking the plunge” the dreamer has connected the upper and the lower regions—that is to say, he has decided not to live only as a bodiless abstract being but to accept the body and the world of

instinct, the reality of the problems posed by love and life, and to act accordingly.³⁴ This was the Rubicon that was crossed. Individuation, becoming a self, is not only a spiritual problem, it is the problem of all life.

16. DREAM:

[164] *Many people are present. They are all walking to the left around a square. The dreamer is not in the centre but to one side. They say that a gibbon is to be reconstructed.*

[165] Here the square appears for the first time. Presumably it arises from the circle with the help of the four people. (This will be confirmed later.) Like the *lapis*, the *tinctura rubea*, and the *aurum philosophicum*, the squaring of the circle was a problem that greatly exercised medieval minds. It is a symbol of the *opus alchymicum* (fig. 59), since it breaks down the original chaotic unity into the four elements and then combines them again in a higher unity. Unity is represented by a circle and the four elements by a square. The production of one from four is the result of a process of distillation and sublimation which takes the so-called “circular” form: the distillate is subjected to sundry distillations³⁵ so that the “soul” or “spirit” shall be extracted in its purest state. The product is generally called the “quintessence,” though this is by no means the only name for the ever-hoped-for and never-to-be-discovered “One.” It has, as the alchemists say, a “thousand names,” like the *prima materia*. Heinrich Khunrath has this to say about the circular distillation: “Through Circumrotation or a Circular Philosophical revolving of the Quaternarius, it is brought back to the highest and purest Simplicity of the plusquamperfect Catholic Monad.... Out of the gross and impure One there cometh an exceeding pure and subtile One,” and so forth.³⁶ Soul and spirit must be separated from the body, and this is equivalent to death: “Therefore Paul of Tarsus saith, Cupio dissolvi, et esse cum Christo.³⁷ Therefore, my dear Philosopher, must thou catch the Spirit and Soul of the Magnesia.”³⁸ The spirit (or spirit and soul) is the *ternarius* or number three which must first be separated from its body and, after the purification of the latter, infused back into it.³⁹ Evidently the body is the fourth. Hence Khunrath refers to a passage from Pseudo-Aristotle,⁴⁰ where the circle re-emerges from a triangle set in a square.⁴¹ This circular figure, together with the Uroboros—the dragon devouring itself tail first—is the basic mandala of alchemy.

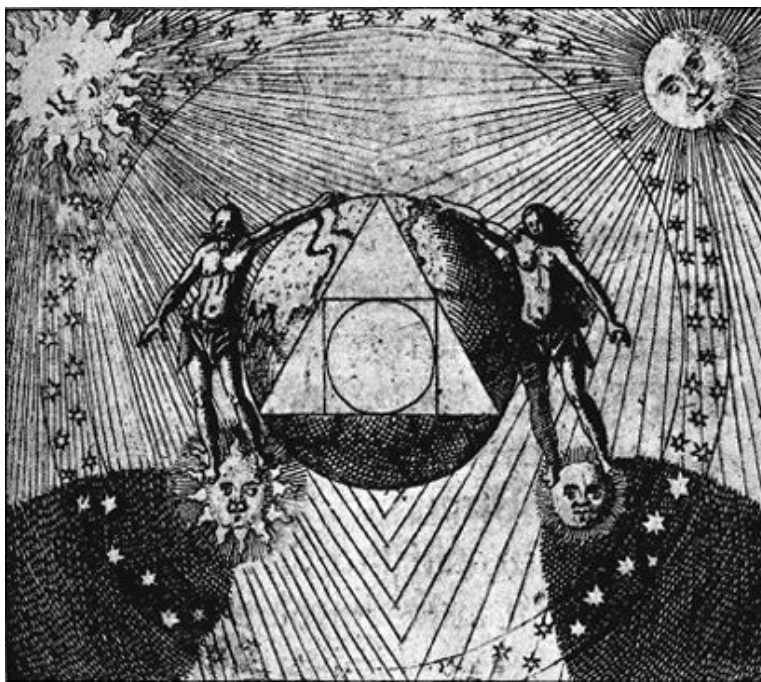

59. “All things do live in the three / But in the four they merry be.” (Squaring the circle.)—Jamsthaler, *Viatorium spagyricum* (1625)



60. Squaring of the circle to make the two sexes one whole.—Maier, *Scrutinium chymicum* (1687)

[166] The Eastern and more particularly the Lamaic mandala usually contains a square ground-plan of the stupa (fig. 43). We can see from the mandalas constructed in solid form that it is really the plan of a *building*. The square also conveys the idea of a house or temple, or of an inner walled-in space⁴² (cf. below). According to the ritual, stupas must always be circumambulated to the right, because a leftward movement is evil. The left, the “sinister” side, is the unconscious side. Therefore a leftward movement is equivalent to a movement in the direction of the unconscious, whereas a movement to the right is “correct” and aims at consciousness. In the East these unconscious contents have gradually, through long

practice, come to assume definite forms which have to be accepted as such and retained by the conscious mind. Yoga, so far as we know it as an established practice, proceeds in much the same way: it impresses fixed forms on consciousness. Its most important Western parallel is the *Exercitia spiritualia* of Ignatius Loyola, which likewise impress fixed concepts about salvation on the psyche. This procedure is “right” so long as the symbol is still a valid expression of the unconscious situation. The psychological rightness of both Eastern and Western yoga ceases only when the unconscious process—which anticipates future modifications of consciousness—has developed so far that it produces shades of meaning which are no longer adequately expressed by, or are at variance with, the traditional symbol. Then and only then can one say that the symbol has lost its “rightness.” Such a process signifies a gradual shift in man’s unconscious view of the world over the centuries and has nothing whatever to do with intellectual criticisms of this view. Religious symbols are phenomena of *life, plain facts and not intellectual opinions*. If the Church clung for so long to the idea that the sun rotates round the earth, and then abandoned this contention in the nineteenth century, she can always appeal to the psychological truth that for millions of people the sun did revolve round the earth and that it was only in the nineteenth century that any major portion of mankind became sufficiently sure of the intellectual function to grasp the proofs of the earth’s planetary nature. Unfortunately there is no “truth” unless there are people to understand it.

[167] Presumably the leftward circumambulation of the square indicates that the squaring of the circle is a stage on the way to the unconscious, a point of transition leading to a goal lying as yet unformulated beyond it. It is one of those paths to the centre of the non-ego which were also trodden by the medieval investigators when producing the *lapis*. The *Rosarium* says:⁴³ “Out of man and woman make a round circle and extract the quadrangle from this and from the quadrangle the triangle. Make a round circle and you will have the philosophers’ stone”⁴⁴ (figs. 59, 60).

[168] The modern intellect naturally regards all this as poppycock. But this estimate fails to get rid of the fact that such concatenations of ideas do exist and that they even played an important part for many centuries. It is up to psychology to *understand* these things, leaving the layman to rant about poppycock and obscurantism. Many of my critics who call themselves “scientific” behave exactly like the bishop who excommunicated the cockchafers for their unseemly proliferation.

[169] Just as the stupas preserve relics of the Buddha in their innermost sanctuary, so in the interior of the Lamaic quadrangle, and again in the Chinese earth-square, there is a Holy of Holies with its magical agent, the cosmic source of energy, be it the god Shiva, the Buddha, a bodhisattva, or a great teacher. In China it is Ch’ien—heaven—with the four cosmic effluences radiating from it (fig. 61). And equally in the Western mandalas of medieval Christendom the deity is enthroned at the centre, often in the form of the triumphant Redeemer together with the four symbolical figures of the evangelists (fig. 62). The symbol in our dream presents the most violent contrast to these highly metaphysical ideas, for it is a gibbon, unquestionably an ape, that is to be reconstructed in the centre. Here we meet again

the ape who first turned up in vision 22 of the first series (par. 117). In that dream he caused a panic, but he also brought about the helpful intervention of the intellect. Now he is to be “reconstructed,” and this can only mean that the anthropoid—man as an archaic fact—is to be put together again. Clearly the left-hand path does not lead upwards to the kingdom of the gods and eternal ideas, but down into natural history, into the bestial instinctive foundations of human existence. We are therefore dealing, to put it in classical language, with a Dionysian mystery.



61. The pearl as symbol of Ch'ien, surrounded by the four cosmic effluences (dragons).
—Chinese bronze mirror of the T'ang Period (7th to 9th cent.)



62. Rectangular mandala with cross, the Lamb in the centre, surrounded by the four evangelists and the four rivers of Paradise. In the medallions, the four cardinal virtues.
—Zwiefalten Abbey breviary (12th cent.)

[170] The square corresponds to the *temenos* (fig. 31), where a drama is taking place—in this case a play of apes instead of satyrs. The inside of the “golden flower” is a “seeding-place” where the “diamond body” is produced. The synonymous term “the ancestral land”⁴⁵ may actually be a hint that this product is the result of integrating the ancestral stages.

[171] The ancestral spirits play an important part in primitive rites of renewal. The aborigines of central Australia even identify themselves with their mythical ancestors of the *alcheringa* period, a sort of Homeric age. Similarly the Pueblo Indians of Taos, in preparation for their ritual dances, identify with the sun, whose sons they are. This atavistic identification with human and animal ancestors can be interpreted psychologically as an integration of the unconscious, a veritable bath of renewal in the life-source where one is once again a fish, unconscious as in sleep, intoxication, and death. Hence the sleep of incubation, the Dionysian orgy, and the ritual death in initiation. Naturally the proceedings always take place in some hallowed spot. We can easily translate these ideas into the concretism of Freudian theory: the *temenos* would then be the womb of the mother and the rite a regression to incest. But these are the neurotic misunderstandings of people who have remained partly infantile and who do not realize that such things have been practised since time immemorial by adults whose activities cannot possibly be explained as a mere

regression to infantilism. Otherwise the highest and most important achievements of mankind would ultimately be nothing but the perverted wishes of children, and the word “childish” would have lost its *raison d’être*.

[172] Since the philosophical side of alchemy was concerned with problems that are very closely related to those which interest the most modern psychology, it might perhaps be worth while to probe a little deeper into the dream motif of the ape that is to be reconstructed in the square. In the overwhelming majority of cases alchemy identifies its transforming substance with the *argentum vivum* or Mercurius. Chemically this term denotes quicksilver, but philosophically it means the *spiritus vitae*, or even the world-soul (cf. fig. 91), so that Mercurius also takes on the significance of Hermes, god of revelation. (This question has been discussed in detail elsewhere.⁴⁶) Hermes is associated with the idea of roundness and also of squareness, as can be seen particularly in Papyrus V (line 401) of the *Papyri Graecae Magicae*,⁴⁷ where he is named *στρογγύλος καὶ τετράγωνος*, “round and square.” He is also called *τετραγώνιον*, “quadrangular.” He is in general connected with the number four; hence there is a *Ἑρμῆς τετρακέφαλος*, a “four-headed Hermes.”⁴⁸ These attributes were known also in the Middle Ages, as the work of Cartari,⁴⁹ for instance, shows. He says:

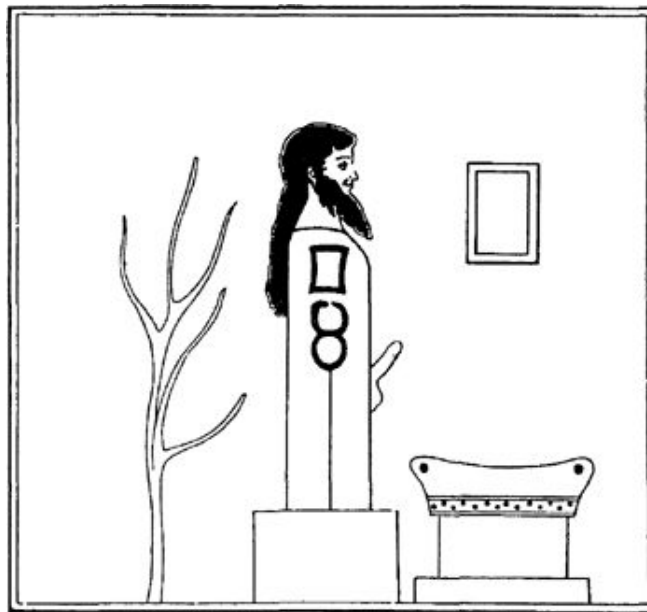

63. Hermes.—Greek vase painting (Hamilton Collection)

Again, the square figures of Mercury [Hermes] [fig. 63], made up of nothing but a head and a virile member, signify that the Sun is the head of the world, and scatters the seed of all things; while the four sides of the square figure have the same significance as the four-stringed sistrum which was likewise attributed to Mercury, namely, the four quarters of the world or the four seasons of the year; or again, that the two equinoxes and the two solstices make up between them the four parts of the whole zodiac.

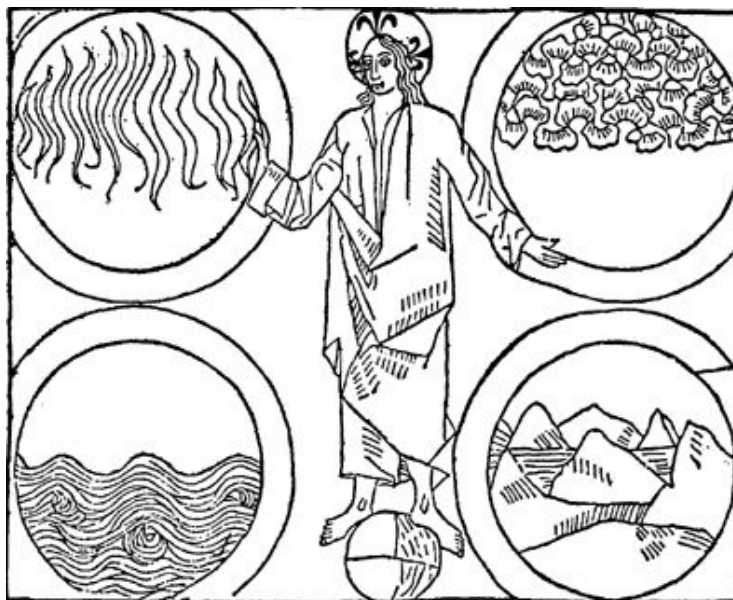

64. Christ as Anthropos, standing on the globe, flanked by the four elements.—Glanville, *Le Propriétaire des choses* (1482)

[173] It is easy to see why such qualities made Mercurius an eminently suitable symbol for the mysterious transforming substance of alchemy; for this is round and square, i.e., a totality consisting of four parts (four elements). Consequently the Gnostic quadripartite original man⁵⁰ (fig. 64) as well as Christ Pantokrator is an *imago lapidis* (fig. 65). Western alchemy is mainly of Egyptian origin, so let us first of all turn our attention to the Hellenistic figure of Hermes Trismegistus, who, while standing sponsor to the medieval Mercurius, derives ultimately from the ancient Egyptian Thoth (fig. 66). The attribute of Thoth was the baboon, or again he was represented outright as an ape.⁵¹ This idea was visibly preserved all through the numberless editions of the Book of the Dead right down to the most recent times. It is true that in the existing alchemical texts—which with few exceptions belong to the Christian era—the ancient connection between Thoth-Hermes and the ape has disappeared, but it still existed at the time of the Roman Empire. Mercurius, however, had several things in common with the devil—which we will not enter upon here—and so the ape once more crops up in the vicinity of Mercurius as the *simia Dei* (fig. 67). It is of the essence of the transforming substance to be on the one hand extremely common, even contemptible (this is expressed in the series of attributes it shares with the devil, such as serpent, dragon, raven, lion, basilisk, and eagle), but on the other hand to mean something of great value, not to say divine. For the transformation leads from the depths to the heights, from the bestially archaic and infantile to the mystical *homo maximus*.



65. Tetramorph (Anthropos symbol) standing on two wheels, symbols of the Old and New Testaments.—Mosaic, Vatopedi Monastery, Mt. Athos (1213)

[174] The symbolism of the rites of renewal, if taken seriously, points far beyond the merely archaic and infantile to man's innate psychic disposition, which is the result and deposit of all ancestral life right down to the animal level—hence the ancestor and animal symbolism. The rites are attempts to abolish the separation between the conscious mind and the unconscious, the real source of life, and to bring about a reunion of the individual with the native soil of his inherited, instinctive make-up. Had these rites of renewal not yielded definite results they would not only have died out in prehistoric times but would never have arisen in the first place. The case before us proves that even if the conscious mind is miles away from the ancient conceptions of the rites of renewal, the unconscious still strives to bring them closer in dreams. It is true that without the qualities of autonomy and autarky there would be no consciousness at all, yet these qualities also spell the danger of isolation and stagnation since, by splitting off the unconscious, they bring about an unbearable alienation of instinct. Loss of instinct is the source of endless error and confusion.

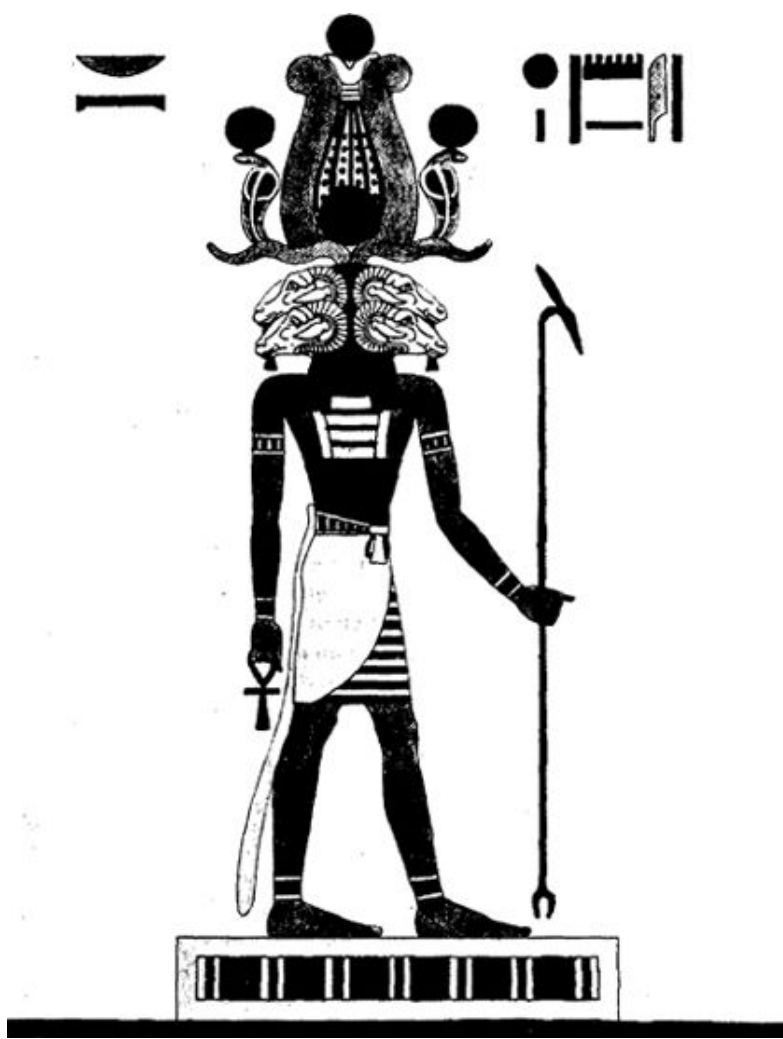

66. Ammon-Ra, the Egyptian spirit of the four elements.—Temple of Esneh, Ptolemaic, from Champollion, *Pantheon égyptien*



67. Demon in the shape of a monkey.—“Speculum humanae salvationis” (Cod. Lat. 511, Paris, 14th cent.)

[175] Finally the fact that the dreamer is “not in the centre but to one side” is a striking indication of what will happen to his ego: it will no longer be able to claim the central place but must presumably be satisfied with the position of a satellite, or at least of a planet revolving round the sun. Clearly the important place in the centre is reserved for the gibbon about to be reconstructed. The gibbon belongs to the anthropoids and, on account of its kinship with man, is an appropriate symbol for that part of the psyche which goes down into the subhuman. Further, we have seen from the cynocephalus or dog-headed baboon associated with Thoth-Hermes (fig. 68), the highest among the apes known to the Egyptians, that its godlike affinities make it an equally appropriate symbol for that part of the unconscious which transcends the conscious level. The assumption that the human psyche possesses layers that lie *below* consciousness is not likely to arouse serious opposition. But that there could just as well be layers lying *above* consciousness seems to be a surmise which borders on a *crimen laesae majestatis humanae*. In my experience the conscious mind can claim only a relatively central position and must accept the fact that the unconscious psyche transcends and as it were surrounds it on all sides. Unconscious contents connect it *backwards* with physiological states on the one hand and archetypal data on the other. But it is extended *forwards* by intuitions which are determined partly by archetypes and partly by subliminal perceptions depending on the relativity of time and space in the unconscious. I must leave it to the reader, after thorough consideration of this

dream-series and the problems it opens up, to form his own judgment as to the possibility of such an hypothesis.

[176] The following dream is given unabridged, in its original text:

17. DREAM:

All the houses have something theatrical about them, with stage scenery and decorations. The name of Bernard Shaw is mentioned. The play is supposed to take place in the distant future. There is a notice in English and German on one of the sets:

*This is the universal Catholic Church.
It is the Church of the Lord.
All those who feel that they are the instruments of the Lord
may enter.*

Under this is printed in smaller letters: "The Church was founded by Jesus and Paul"—like a firm advertising its long standing.

I say to my friend, "Come on, let's have a look at this." He replies, "I do not see why a lot of people have to get together when they're feeling religious." I answer, "As a Protestant you will never understand." A woman nods emphatic approval. Then I see a sort of proclamation on the wall of the church. It runs:

Soldiers!

When you feel you are under the power of the Lord, do not address him directly. The Lord cannot be reached by words. We also strongly advise you not to indulge in any discussions among yourselves concerning the attributes of the Lord. It is futile, for everything valuable and important is ineffable.

(Signed) Pope ... (Name illegible)

Now we go in. The interior resembles a mosque, more particularly the Hagia Sophia: no seats—wonderful effect of space; no images, only framed texts decorating the walls (like the Koran texts in the Hagia Sophia). One of the texts reads "Do not flatter your benefactor." The woman who had agreed with me before bursts into tears and cries, "Then there's nothing left!" I reply, "I find it quite right!" but she vanishes. At first I stand with a pillar in front of me and can see nothing. Then I change my position and see a crowd of people. I do not belong to them and stand alone. But they are quite distinct, so that I can see their faces. They all say in unison, "We confess that we are under the power of the Lord. The Kingdom of Heaven is within us." They repeat this three times with great solemnity. Then the organ starts to play and they sing a Bach fugue with chorale. But the original text is omitted; sometimes there is only a sort of coloratura singing, then the words are repealed: "Everything else is paper" (meaning that it does not make a living impression on me). When the chorale has faded away the gemütlich part of the ceremony begins; it is almost like a students' party. The people are all cheerful and equable. We move about, converse, and greet one another, and wine (from an episcopal seminary) is served with other

refreshments. The health of the Church is drunk and, as if to express everybody's pleasure at the increase in membership, a loudspeaker blares out a ragtime melody with the refrain, "Charles is also with us now." A priest explains to me: "These somewhat trivial amusements are officially approved and permitted. We must adapt a little to American methods. With a large crowd such as we have here this is inevitable. But we differ in principle from the American churches by our decidedly anti-ascetic tendency." Thereupon I awake with a feeling of great relief.



68. Thoth as cynocephalus.—From tomb of Amen-her-khopshef, near Der el-Medina, Luxor (XXth dynasty, 12th cent. B.C.)

[177] Unfortunately I must refrain from commenting on this dream as a whole⁵² and confine myself to our theme. The *temenos* has become a sacred building (in accordance with the hint given earlier). The proceedings are thus characterized as "religious." The grotesque-humorous side of the Dionysian mystery comes out in the so-called *gemütlich* part of the ceremony, where wine is served and a toast drunk to the health of the Church. An inscription on the floor of an Orphic-Dionysian shrine puts it very aptly: μόνον μὴ ὕδωρ (Only no water!).⁵³ The Dionysian relics in the Church, such as the fish and wine symbolism, the Damascus chalice, the seal-cylinder with the crucifix and the inscription ΟΡΦΕΟC ΒΑΚΚΙΚΟC,⁵⁴ and much else besides, can be mentioned only in passing.

[178] The "anti-ascetic" tendency clearly marks the point of difference from the Christian Church, here defined as "American" (cf. commentary to dream 14 of the first series). America is the ideal home of the reasonable ideas of the practical intellect, which would

like to put the world to rights by means of a “brain trust.”⁵⁵ This view is in keeping with the modern formula “intellect = spirit,” but it completely forgets the fact that “spirit” was never a human “activity,” much less a “function.” The movement to the left is thus confirmed as a withdrawal from the modern world of ideas and a regression to pre-Christian Dionysos worship, where “asceticism” in the Christian sense is unknown. At the same time the movement does not lead right out of the sacred spot but remains within it; in other words it does not lose its sacramental character. It does not simply fall into chaos and anarchy, it relates the Church directly to the Dionysian sanctuary just as the historical process did, though from the opposite direction. We could say that this regressive development faithfully retreads the path of history in order to reach the pre-Christian level. Hence it is not a relapse but a kind of systematic descent *ad inferos* (fig. 69), a psychological *nekyia*.⁵⁶

[179] I encountered something very similar in the dream of a clergyman who had a rather problematical attitude to his faith: *Coming into his church at night, he found that the whole wall of the choir had collapsed. The altar and ruins were overgrown with vines hanging full of grapes, and the moon was shining in through the gap.*

[180] Again, a man who was much occupied with religious problems had the following dream: *An immense Gothic cathedral, almost completely dark. High Mass is being celebrated. Suddenly the whole wall of the aisle collapses. Blinding sunlight bursts into the interior together with a large herd of bulls and cows.* This setting is evidently more Mithraic, but Mithras is associated with the early Church in much the same way Dionysos is.



69. Dante and Virgil on their journey to the underworld.—Illumination for the *Inferno*, Canto XVII, Codex Urbanus Latinus 365 (15th cent.)

[181] Interestingly enough, the church in our dream is a syncretistic building, for the Hagia Sophia is a very ancient Christian church which, however, served as a mosque until quite recently. It therefore fits in very well with the purpose of the dream: to attempt a combination of Christian and Dionysian religious ideas. Evidently this is to come about

without the one excluding the other, without any values being destroyed. This is extremely important, since the reconstruction of the “gibbon” is to take place in the sacred precincts. Such a sacrilege might easily lead to the dangerous supposition that the leftward movement is a *diabolica fraus* and the gibbon the devil—for the devil is in fact regarded as the “ape of God.” The leftward movement would then be a perversion of divine truth for the purpose of setting up “His Black Majesty” in place of God. But the unconscious has no such blasphemous intentions; it is only trying to restore the lost Dionysos who is somehow lacking in modern man (*pace* Nietzsche!) to the world of religion. At the end of vision 22 (par. 117), where the ape first appears, it was said that “everything must be ruled by the light,” and everything, we might add, includes the Lord of Darkness with his horns and cloven hoof—actually a Dionysian corybant who has rather unexpectedly risen to the rank of Prince.

[182] The Dionysian element has to do with emotions and affects which have found no suitable religious outlets in the predominantly Apollonian cult and ethos of Christianity. The medieval carnivals and *jeux de paume* in the Church were abolished relatively early; consequently the carnival became secularized and with it divine intoxication vanished from the sacred precincts. Mourning, earnestness, severity, and well-tempered spiritual joy remained. But intoxication, that most direct and dangerous form of possession, turned away from the gods and enveloped the human world with its exuberance and pathos. The pagan religions met this danger by giving drunken ecstasy a place within their cult. Heraclitus doubtless saw what was at the back of it when he said, “But Hades is that same Dionysos in whose honour they go mad and keep the feast of the wine-vat.” For this very reason orgies were granted religious license, so as to exorcise the danger that threatened from Hades. Our solution, however, has served to throw the gates of hell wide open.

18. DREAM:

[183] *A square space with complicated ceremonies going on in it, the purpose of which is to transform animals into men. Two snakes, moving in opposite directions, have to be got rid of at once. Some animals are there, e.g., foxes and dogs. The people walk round the square and must let themselves be bitten in the calf by these animals at each of the four corners (cf. fig. 118). If they run away all is lost. Now the higher animals come on the scene—bulls and ibexes. Four snakes glide into the four corners. Then the congregation files out. Two sacrificial priests carry in a huge reptile and with this they touch the forehead of a shapeless animal lump or life-mass. Out of it there instantly rises a human head, transfigured. A voice proclaims: “These are attempts at being.”*

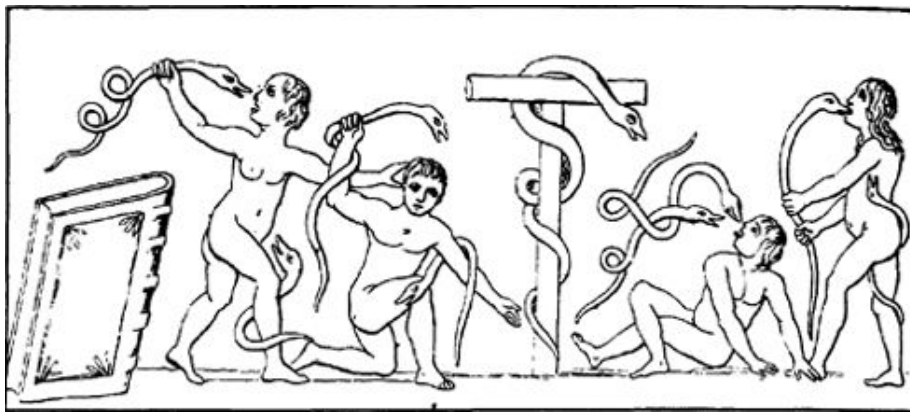

70. Pagan rites of transformation in the Middle Ages, with serpents.—Gnostic design

[184] One might almost say that the dream goes on with the “explanation” of what is happening in the square space. Animals are to be changed into men; a “shapeless life-mass” is to be turned into a transfigured (illuminated) human head by magic contact with a reptile. The animal lump or life-mass stands for the mass of the inherited unconscious which is to be united with consciousness. This is brought about by the ceremonial use of a reptile, presumably a snake. The idea of transformation and renewal by means of a serpent is a well-substantiated archetype (fig. 70). It is the healing serpent, representing the god (cf. figs. 203, 204). It is reported of the mysteries of Sabazius: “Aureus coluber in sinum demittitur consecratis et eximitur rursus ab inferioribus partibus atque imis” (A golden snake is let down into the lap of the initiated and taken away again from the lower parts).⁵⁷ Among the Ophites, Christ was the serpent. Probably the most significant development of serpent symbolism as regards renewal of personality is to be found in Kundalini yoga.⁵⁸ The shepherd’s experience with the snake in Nietzsche’s *Zarathustra* would accordingly be a fatal omen (and not the only one of its kind—cf. the prophecy at the death of the rope-dancer).

[185] The “shapeless life-mass” immediately recalls the ideas of the alchemical “chaos,”⁵⁹ the *massa* or *materia informis* or *confusa* which has contained the divine seeds of life ever since the Creation. According to a midrashic view, Adam was created in much the same way: in the first hour God collected the dust, in the second made a shapeless mass out of it, in the third fashioned the limbs, and so on⁶⁰ (fig. 71).



71. Creation of Adam from the clay of the *prima materia*.—Schedel, *Das Buch der Chroniken* (1493)

[186] But if the life-mass is to be transformed a *circumambulatio* is necessary, i.e., exclusive concentration on the centre, the place of creative change. During this process one is “bitten” by animals; in other words, we have to expose ourselves to the animal impulses of the unconscious without identifying with them and without “running away”; for flight from the unconscious would defeat the purpose of the whole proceeding. We must hold our ground, which means here that the process initiated by the dreamer’s self-observation must be experienced in all its ramifications and then articulated with consciousness to the best of his understanding. This often entails an almost unbearable tension because of the utter incommensurability between conscious life and the unconscious process, which can be experienced only in the innermost soul and cannot touch the visible surface of life at any point. The principle of conscious life is: “Nihil est in intellectu, quod non prius fuerit in sensu.” But the principle of the unconscious is the autonomy of the psyche itself, reflecting in the play of its images not the world but *itself*, even though it utilizes the illustrative possibilities offered by the sensible world in order to make its images clear. The sensory datum, however, is not the *causa efficiens* of this; rather, it is autonomously selected and exploited by the psyche, with the result that the rationality of the cosmos is constantly being violated in the most distressing manner. But the sensible world has an equally devastating effect on the deeper psychic processes when it breaks into them as a *causa efficiens*. If reason is not to be outraged on the one hand and the creative play of images not violently suppressed on the other, a circumspect and farsighted synthetic procedure is required in order to accomplish the paradoxical union of irreconcilables (fig. 72). Hence the alchemical parallels in our dreams.

[187] The focusing of attention on the centre demanded in this dream and the warning about “running away” have clear parallels in the *opus alchymicum*: the need to concentrate on the work and to meditate upon it is stressed again and again. The tendency to run away, however, is attributed not to the operator but to the transforming substance. Mercurius is evasive and is labelled *servus* (servant) or *cervus fugitivus* (fugitive stag). The vessel must be well sealed so that what is within may not escape. Eirenaeus Philalethes⁶¹ says of this *servus*: “You must be very wary how you lead him, for if he can find an opportunity he will give you the slip, and leave you to a world of misfortune.”⁶² It did not occur to these philosophers that they were chasing a projection, and that the more they attributed to the substance the further away they were getting from the psychological source of their expectations. From the difference between the material in this dream and its medieval predecessors we can measure the psychological advance: the running away is now clearly apparent as a characteristic of the dreamer, i.e., it is no longer projected into the unknown substance. Running away thus becomes a moral question. This aspect was recognized by the alchemists in so far as they emphasized the need for a special religious devotion at their work, though one cannot altogether clear them of the suspicion of having used their prayers and pious exercises for the purpose of forcing a miracle—there are even some who aspired to have the Holy Ghost as their familiar!⁶³ But, to do them justice, one should not overlook the fact that there is more than a little evidence in the literature that they realized it was a matter of their own transformation. For instance, Gerhard Dorn exclaims. “Transmutemini in vivos lapides philosophicos!” (Transform yourselves into living philosophical stones!)



72. The “union of irreconcilables”: marriage of water and fire. The two figures each have four hands to symbolize their many different capabilities.—After an Indian painting

[188] Hardly have conscious and unconscious touched when they fly asunder on account of their mutual antagonism. Hence, right at the beginning of the dream, the snakes that are making off in opposite directions have to be removed; i.e., the conflict between conscious and unconscious is at once resolutely stopped and the conscious mind is forced to stand the tension by means of the *circumambulatio*. The magic circle thus traced will also prevent the unconscious from breaking out again, for such an eruption would be equivalent to psychosis. “Nonnulli perierunt in opere nostro”: “Not a few have perished in our work,” we can say with the author of the *Rosarium*. The dream shows that the difficult operation of thinking in paradoxes—a feat possible only to the superior intellect—has succeeded. The snakes no longer run away but settle themselves in the four corners, and the process of transformation or integration sets to work. The “transfiguration” and illumination, the conscious recognition of the centre, has been attained, or at least anticipated, in the dream. This potential achievement—if it can be maintained, i.e., if the conscious mind does not lose touch with the centre again⁶⁴—means a renewal of personality. Since it is a subjective state whose reality cannot be validated by any external criterion, any further attempt to describe and explain it is doomed to failure, for only those who have had this experience are in a position to understand and attest its reality. “Happiness,” for example, is such a noteworthy reality that there is nobody who does not long for it, and yet there is not a single objective criterion which would prove beyond all doubt that this condition necessarily exists. As so often with the most important things, we have to make do with a subjective judgment.

[189] The arrangement of the snakes in the four corners is indicative of an order in the unconscious. It is as if we were confronted with a pre-existent ground plan, a kind of Pythagorean *tetraktys*. I have very frequently observed the number four in this connection. It probably explains the universal incidence and magical significance of the cross or of the circle divided into four. In the present case the point seems to be to capture and regulate the animal instincts so as to exorcise the danger of falling into unconsciousness. This may well be the empirical basis of the cross as that which vanquishes the powers of darkness ([fig. 73](#)).



73. The deliverance of man from the power of the dragon.—Codex Palatinus Latinus 412 (15th cent.)

[190] In this dream the unconscious has managed to stage a powerful advance by thrusting its contents dangerously near to the conscious sphere. The dreamer appears to be deeply entangled in the mysterious synthetic ceremony and will unfailingly carry a lasting memory of the dream into his conscious life. Experience shows that this results in a serious conflict for the conscious mind, because it is not always either willing or able to put forth the extraordinary intellectual and moral effort needed to take a paradox seriously. Nothing is so jealous as a truth.

[191] As a glance at the history of the medieval mind will show, our whole modern mentality has been moulded by Christianity. (This has nothing to do with whether we believe the truths of Christianity or not.) Consequently the reconstruction of the ape in the sacred precincts as proposed by the dream comes as such a shock that the majority of people will seek refuge in blank incomprehension. Others will heedlessly ignore the abysmal depths of the Dionysian mystery and will welcome the rational Darwinian core of the dream as a safeguard against mystic exaltation. Only a very few will feel the collision of the two worlds and realize what it is all about. Yet the dream says plainly enough that in the place where, according to tradition, the deity dwells, the ape is to appear. This substitution is almost as bad as a Black Mass.

[192] In Eastern symbolism the square—signifying the earth in China, the *padma* or lotus in India—has the character of the *yonis*: femininity. A man's unconscious is likewise feminine

and is personified by the anima.⁶⁵ The anima also stands for the “inferior” function⁶⁶ and for that reason frequently has a shady character; in fact she sometimes stands for evil itself. She is as a rule the *fourth* person (cf. dreams 10, 11, 15; pars. 136, 147, 162). She is the dark and dreaded maternal womb (fig. 74), which is of an essentially ambivalent nature. The Christian deity is one in three persons. The fourth person in the heavenly drama is undoubtedly the devil. In the more harmless psychological version he is merely the inferior function. On a moral valuation he is a man’s sin, a function belonging to him and presumably masculine. The feminine element in the deity is kept very dark, the interpretation of the Holy Ghost as Sophia being considered heretical. Hence the Christian metaphysical drama, the “Prologue in Heaven,” has only masculine actors, a point it shares with many of the ancient mysteries. But the feminine element must obviously be somewhere—so it is presumably to be found in the dark. At any rate that is where the ancient Chinese philosophers located it: in the *yin*.⁶⁷ Although man and woman unite they nevertheless represent irreconcilable opposites which, when activated, degenerate into deadly hostility. This primordial pair of opposites symbolizes every conceivable pair of opposites that may occur: hot and cold, light and dark, north and south, dry and damp, good and bad, conscious and unconscious. In the psychology of the functions there are two conscious and therefore masculine functions, the differentiated function and its auxiliary, which are represented in dreams by, say, father and son, whereas the unconscious functions appear as mother and daughter. Since the conflict between the two auxiliary functions is not nearly as great as that between the differentiated and the inferior function, it is possible for the third function—that is, the unconscious auxiliary one—to be raised to consciousness and thus made masculine. It will, however, bring with it traces of its contamination with the inferior function, thus acting as a kind of link with the darkness of the unconscious. It was in keeping with this psychological fact that the Holy Ghost should be heretically interpreted as Sophia, for he was the mediator of birth in the flesh, who enabled the deity to shine forth in the darkness of the world. No doubt it was this association that caused the Holy Ghost to be suspected of femininity, for Mary was the dark earth of the field—“illa terra virgo nondum pluviis irrigata” (that virgin earth not yet watered by the rains), as Tertullian called her.⁶⁸

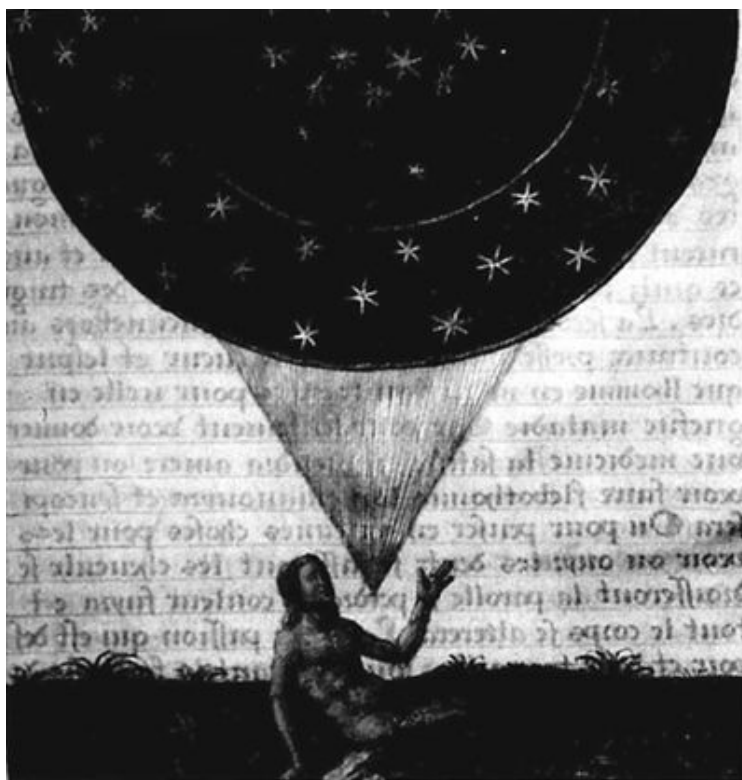

74. Heaven fertilizing Earth and begetting mankind.—Thenaud, “Traité de la cabale” (MS., 16th cent.)

[193] The fourth function is contaminated with the unconscious and, on being made conscious, drags the whole of the unconscious with it. We must then come to terms with the unconscious and try to bring about a synthesis of opposites.¹¹⁰ At first a violent conflict breaks out, such as any reasonable man would experience when it became evident that he had to swallow a lot of absurd superstitions. Everything in him would rise up in revolt and he would defend himself desperately against what looked to him like murderous nonsense. This situation explains the following dreams.

19. DREAM:

[194] *Ferocious war between two peoples.*

[195] This dream depicts the conflict. The conscious mind is defending its position and trying to suppress the unconscious. The first result of this is the expulsion of the fourth function, but, since it is contaminated with the third, there is a danger of the latter disappearing as well. Things would then return to the state that preceded the present one, when only two functions were conscious and the other two unconscious.

20. DREAM:

[196] *There are two boys in a cave. A third falls in as if through a pipe.*

[197] The cave represents the darkness and seclusion of the unconscious; the two boys correspond to the two unconscious functions. Theoretically the third must be the auxiliary function, which would indicate that the conscious mind had become completely absorbed in the differentiated function. The odds now stand 1 : 3, greatly in favour of the unconscious. We may therefore expect a new advance on its part and a return to its former position. The “boys” are an allusion to the dwarf motif (fig. 77), of which more later.

21. DREAM:

[198] *A large transparent sphere containing many little spheres. A green plant is growing out of the top.*

[199] The sphere is a whole that embraces all its contents; life which has been brought to a standstill by useless struggle becomes possible again. In Kundalini yoga the “green womb” is a name for Ishvara (Shiva) emerging from his latent condition.



75. Trimurti picture. The triangle symbolizes the tendency of the universe to converge towards the point of unity. The tortoise represents Vishnu; the lotus growing out of the skull between two flames, Shiva. The shining sun of Brahma forms the background. The whole picture corresponds to the alchemical *opus*, the tortoise symbolizing the *massa confusa*, the skull the *vas* of transformation, and the flower the “self” or wholeness.—After an Indian painting

22. DREAM:

[200] *The dreamer is in an American hotel. He goes up in the lift to about the third or fourth floor. He has to wait there with a lot of other people. A friend (an actual person) is also there and says that the dreamer should not have kept the dark unknown woman waiting so long below, since he had put her in his (the dreamer’s) charge. The friend now gives him an unsealed note for the dark woman, on which is written: “Salvation does not come from refusing to take part or from running away. Nor does it come from just drifting. Salvation comes from complete surrender, with one’s eyes always turned to the centre.” On the margin of the note there is a drawing: a wheel or wreath with eight spokes. Then a lift-boy appears and says that the dreamer’s room is on the eighth floor. He goes on up in the lift, this time to the seventh or eighth floor. An unknown red-haired man, standing there, greets him in a friendly way. Then the scene changes. There is said to be a revolution in Switzerland: the military party is making propaganda for “completely throttling the left.” The objection that the left is weak enough anyway is met by the answer that this is just why it ought to be throttled completely. Soldiers in old-fashioned uniforms now appear, who all resemble the red-haired man. They load their guns with ramrods, stand in a circle, and prepare to shoot at the centre. But in the end they do not shoot and seem to march away. The dreamer wakes up in terror.*

[201] The tendency to re-establish a state of wholeness—already indicated in the foregoing dream—once more comes up against a consciousness with a totally different orientation. It is therefore appropriate that the dream should have an American background. The lift is

going up, as is right and proper when something is coming “up” from the “sub-” conscious. What is coming up is the unconscious content, namely the mandala characterized by the number four (cf. [figs. 61, 62](#)). Therefore the lift should rise to the fourth floor; but, as the fourth function is taboo, it only rises to “about the third or fourth.” This happens not to the dreamer alone but to many others as well, who must all wait like him until the fourth function can be accepted. A good friend then calls his attention to the fact that he should not have kept the dark woman, i.e., the anima who stands for the tabooed function, waiting “below,” i.e., in the unconscious, which was just the reason why the dreamer himself had to wait upstairs with the others. It is in fact not merely an individual but a collective problem, for the animation of the unconscious which has become so noticeable in recent times has, as Schiller foresaw, raised questions which the nineteenth century never even dreamed of. Nietzsche in his *Zarathustra* decided to reject the “snake” and the “ugliest man,” thus exposing himself to an heroic cramp of consciousness which led, logically enough, to the collapse foretold in the same book.

[202] The advice given in the note is as profound as it is to the point, so that there is really nothing to add. After it has been more or less accepted by the dreamer the ascent can be resumed. We must take it that the problem of the fourth function was accepted, at least broadly, for the dreamer now reaches the seventh or eighth floor, which means that the fourth function is no longer represented by a quarter but by an eighth, and is apparently reduced by a half.

[203] Curiously enough, this hesitation before the last step to wholeness seems also to play a part in *Faust II*, where, in the Cabiri scene, “resplendent mermaids” come from over the water:⁷⁰

NEREIDS AND TRITONS:

Bear we, on the waters riding,
That which brings you all glad tiding.
In Chelone’s giant shield
Gleams a form severe revealed:
These are gods that we are bringing;
Hail them, you high anthems singing.

SIRENS:

Little in length,
Mighty in strength!
Time-honoured gods
Of shipwreck and floods.

NEREIDS AND TRITONS:

Great Cabin do we bear,
That our feast be friendly fair:
Where their sacred powers preside
Neptune’s rage is pacified.

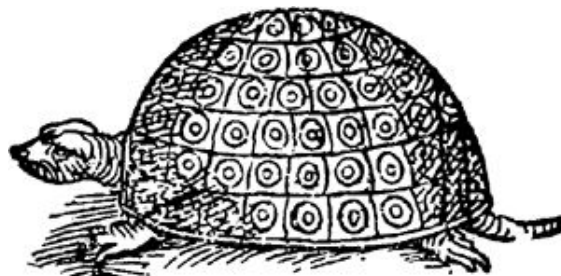

A “form severe” is brought by “mermaids,” feminine figures (cf. [figs. 10, 11, 12. 157](#)) who represent as it were the sea and the waves of the unconscious. The word “severe” reminds us of “severe” architectural or geometrical forms which illustrate a definite idea without any romantic (feeling-toned) trimmings. It “gleams” from the shell of a tortoise⁷¹ ([fig. 76](#)), which, primitive and cold-blooded like the snake, symbolizes the instinctual side of the unconscious. The “image” is somehow identical with the unseen, creative dwarf-gods ([fig. 77](#)), hooded and cloaked manikins who are kept hidden in the dark *cista*, but who also appear on the seashore as little figures about a foot high, where, as kinsmen of the unconscious, they protect navigation, i.e., the venture into darkness and uncertainty. In the form of the Dactyls they are also the gods of invention, small and apparently insignificant like the impulses of the unconscious but endowed with the same mighty power. (*El gabir* is “the great, the mighty one.”)



77. Telesphorus, one of the Cabiri, the *familiaris* of Aesculapius: (a) Bronze figure from Roman Gaul; (b) Marble statuette from Austria.

NEREIDS AND TRITONS: Three have followed where we led,
But the fourth refused to call;
He the rightful seer, he said,
His to think for one and all.

SIRENS: A god may count it sport
To set a god at naught.
Honour the grace they bring,
And fear their threatening.

[204] It is characteristic of Goethe’s feeling-toned nature that the fourth should be the thinker. If the supreme principle is “feeling is all,” then thinking has to play an unfavourable role and be submerged. *Faust I* portrays this development. Since Goethe acted as his own model, thinking became the fourth (taboo) function. Because of its contamination with the unconscious it takes on the grotesque form of the Cabiri, for the Cabiri, as dwarfs, are chthonic gods and misshapen accordingly. (“I call them pot-bellied freaks of common clay.”) They thus stand in grotesque contrast to the heavenly gods and poke fun at them (cf. the “ape of God”). The Nereids and Tritons sing:

Seven there should really be.

SIRENS:

Where, then, stay the other three?

That we know not. You had best
 On Olympus make your quest.
 There an eighth may yet be sought
 Though none other gave him thought.
 Well inclined to us in grace,
 Not all perfect yet their race.
 Beings there beyond compare,
 Yearning, unexplainable,
 Press with hunger's pang to share
 In the unattainable.

[205] We learn that there are “really” seven of them; but again there is some difficulty with the eighth as there was before with the fourth. Similarly, in contradiction to the previous emphasis placed on their lowly origin in the dark, it now appears that the Cabiri are actually to be found on Olympus; for they are eternally striving from the depths to the heights and are therefore always to be found both below *and* above. The “severe image” is obviously an unconscious content that struggles towards the light. It seeks, and itself is, what I have elsewhere called “the treasure hard to attain.”⁷² This hypothesis is immediately confirmed:

SIRENS: Fame is dimmed of ancient time,
 Honour droops in men of old;
 Though they have the Fleece of Gold,
 Ye have the Cabiri.

[206] The Golden Fleece is the coveted goal of the argosy, the perilous quest that is one of the numerous synonyms for attaining the unattainable. Thales makes this wise remark about it:

That is indeed what men most seek on earth:

'Tis rust alone that gives the coin its worth!

[207] The unconscious is always the fly in the ointment, the skeleton in the cupboard of perfection, the painful lie given to all idealistic pronouncements, the earthliness that clings to our human nature and sadly clouds the crystal clarity we long for. In the alchemical view rust, like verdigris, is the metal's sickness. But at the same time this leprosy is the *vera prima materia*, the basis for the preparation of the philosophical gold. The *Rosarium* says:

Our gold is not the common gold. But thou hast inquired concerning the greenness [*viriditas*, presumably verdigris], deeming the bronze to be a leprous body on account of the greenness it hath upon it. Therefore I say unto thee that whatever is perfect in the bronze is that greenness only, because that greenness is straightway changed by our magistry into our most true gold.⁷³

[208] The paradoxical remark of Thales that the rust alone gives the coin its true value is a kind of alchemical quip, which at bottom only says that there is no light without shadow and no psychic wholeness without imperfection. To round itself out, life calls not for perfection but for completeness; and for this the “thorn in the flesh” is needed, the suffering of defects without which there is no progress and no ascent.

[209] The problem of three and four, seven and eight, which Goethe has tackled here was a great puzzle to alchemy and goes back historically to the texts ascribed to Christianos.⁷⁴ In

the treatise on the production of the “mythical water” it is said: “Therefore the Hebrew prophetess cried without restraint, ‘One becomes two, two becomes three, and out of the third comes the One as the fourth.’”⁷⁵ In alchemical literature this prophetess is taken to be Maria Prophetissa⁷⁶ (fig. 78), also called the Jewess, sister of Moses, or the Copt, and it is not unlikely that she is connected with the Maria of Gnostic tradition. Epiphanius testifies to the existence of writings by this Maria, namely the “Interrogationes magnae” and “Interrogationes parvae,” said to describe a vision of how Christ, on a mountain, caused a woman to come forth from his side and how he mingled himself with her.⁷⁷ It is probably no accident that the treatise of Maria (see n. 76) deals with the theme of the *matrimonium alchymicum* in a dialogue with the philosopher Aros,⁷⁸ from which comes the saying, often repeated later: “Marry gum with gum in true marriage.”⁷⁹ Originally it was “gum arabic,” and it is used here as a secret name for the transforming substance, on account of its adhesive quality. Thus Khunrath⁸⁰ declares that the “red” gum is the “resin of the wise”—a synonym for the transforming substance. This substance, as the life force (*vis animans*), is likened by another commentator to the “glue of the world” (*glutinum mundi*), which is the medium between mind and body and the union of both.⁸¹ The old treatise “Consilium coniugii” explains that the “philosophical man” consists of the “four natures of the stone.” Of these three are earthy or in the earth, but “the fourth nature is the water of the stone, namely the viscous gold which is called red gum and with which the three earthy natures are tinted.”⁸² We learn here that gum is the critical fourth nature: it is duplex, i.e., masculine and feminine, and at the same time the one and only *aqua mercurialis*. So the union of the two is a kind of self-fertilization, a characteristic always ascribed to the mercurial dragon.⁸³ From these hints it can easily be seen who the philosophical man is: he is the androgynous original man or Anthropos of Gnosticism⁸⁴ (cf. figs. 64, 82, 117, 195), whose parallel in India is *purusha*. Of him the Brihadaranyaka Upanishad says: “He was as large as a man and woman embracing. He divided his self [Atman] in two, and thence arose husband and wife. He united himself with her and men were born,” etc.⁸⁵ The common origin of these ideas lies in the primitive notion of the bisexual original man.



[210] The fourth nature—to return to the text of the “*Consilium coniugii*”—leads straight to the Anthropos idea that stands for man’s wholeness, that is, the conception of a unitary being who existed before man and at the same time represents man’s goal. The one joins the three as the fourth and thus produces the synthesis of the four in a unity⁸⁶ (fig. 196). We seem to be dealing with much the same thing in the case of seven and eight, though this motif occurs much less frequently in the literature. It is, however, to be found in Paracelsus’ *Ein ander Erklärung der gantzen Astronomie*,⁸⁷ to which Goethe had access. “One is powerful, Six are subjects, the Eighth is also powerful”—and somewhat more so than the first. One is the king, the six are his servants and his son; so here we have King Sol and the six planets or metallic homunculi as depicted in the *Pretiosa margarita novella* of Petrus Bonus (Lacinius edition, 1546)⁸⁸ (fig. 79). As a matter of fact the eighth does not appear in this text; Paracelsus seems to have invented it himself. But since the eighth is even more “powerful” than the first, the crown is presumably bestowed on him. In *Faust II*, the eighth who dwells on Olympus is a direct reference to the Paracelsan text in so far as this describes the “astrology of Olympus” (that is, the structure of the *corpus astrale*).⁸⁹

[211] Returning now to our dream, we find at the critical point—the seventh or eighth floor—the red-haired man, a synonym for the “man with the pointed beard” and hence for the shrewd Mephisto, who magically changes the scene because he is concerned with something that Faust himself never saw: the “severe image,” symbolizing the supreme treasure, the immortal self.⁹⁰ He changes himself into the soldiers, representatives of uniformity, of collective opinion, which is naturally dead against tolerating anything “unsuitable.” For collective opinion the numbers three and seven are, on the highest authority, sacred; but four and eight are the very devil, something inferior,—“common clay”—that in the stern judgment of bonzes of every hue has no right to exist. The “left” is to be “completely throttled,” meaning the unconscious and all the “sinister” things that come from it. An antiquated view, no doubt, and one that uses antiquated methods; but even muzzle-loaders can hit the mark. For reasons unknown, i.e., not stated in the dream, the destructive attack on the “centre”—to which, according to the advice in the note, “one’s eyes must always be turned”—peters out. In the drawing on the margin of the note this centre is portrayed as a wheel with eight spokes (cf. fig. 80).



79. King Sol with his six planet-sons.—Bonus, *Pretiosa margarita novella* (1546)

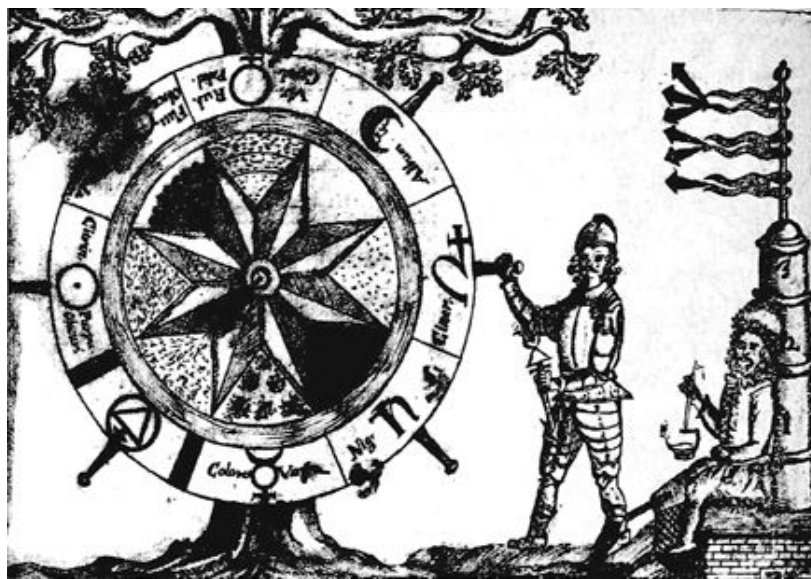

80. Mercurius turning the eight-spoked wheel which symbolizes the process. In one hand he holds the *telum passionis*.
—“Speculum veritatis” (MS., 17th cent.)

23. DREAM:

[212] *In the square space. The dreamer is sitting opposite the unknown woman whose portrait he is supposed to be drawing. What he draws, however, is not a face but three-leaved clovers or distorted crosses in four different colours: red, yellow, green, and blue.*

[213] In connection with this dream the dreamer spontaneously drew a circle with quarters tinted in the above colours. It was a wheel with eight spokes. In the middle there was a four-petaled blue flower. A great many drawings now followed at short intervals, all dealing with the curious structure of the “centre,” and arising from the dreamer’s need to discover a configuration that adequately expresses the nature of this centre. The drawings were based partly on visual impressions, partly on intuitive perceptions, and partly on dreams.

[214] It is to be noted that the wheel is a favourite symbol in alchemy for the circulating process, the *circulatio*. By this is meant firstly the *ascensus* and *descensus*, for instance the ascending and descending birds symbolizing the precipitation of vapours,⁹¹ and secondly the

rotation of the universe as a model for the work, and hence the cycling of the year in which the work takes place. The alchemist was not unaware of the connection between the *rotatio* and his drawings of circles. The contemporary moral allegories of the wheel emphasize that the *ascensus* and *descensus* are, among other things, God's descent to man and man's ascent to God. (On the authority of one of St. Bernard's sermons: "By his descent he established for us a joyful and wholesome ascent."⁹²) Further, the wheel expresses virtues that are important for the work: *constantia*, *obedientia*, *moderatio*, *aequalitas*, and *humilitas*.⁹³ The mystical associations of the wheel play no small part in Jakob Böhme. Like the alchemists he too operates with the wheels of Ezekiel, saying: "Thus we see that the spiritual life stands turned in upon itself, and that the natural life stands turned out of and facing itself. We can then liken it to a round spherical wheel that goes on all its sides, as the wheel in Ezekiel shows."⁹⁴ He goes on to explain: "The wheel of nature turns in upon itself from without; for God dwells within himself and has such a figure, not that it can be painted, it being only a natural likeness, the same as when God paints himself in the figure of this world; for God is everywhere entire, and so dwells in himself. Mark: the outer wheel is the zodiac with the stars, and after it come the seven planets," etc.⁹⁵ "Albeit this figure is not fashioned sufficiently, it is nevertheless a meditation: and we could make a fine drawing of it on a great circle for the meditation of those of less understanding. Mark therefore, desire goes in upon itself to the heart, which is God," etc. But Böhme's wheel is also the "impression" (in alchemical terms, the *informatio*) of the eternal will. It is Mother Nature, or the "mind [*Gemüth*] of the mother, from whence she continually creates and works; and these are the stars with the planetary orb [after the model] of the eternal *astrum*, which is only a spirit, and the eternal mind in the wisdom of God, viz., the Eternal Nature, from whence the eternal spirits proceeded and entered into a creaturely being."⁹⁶ The "property" of the wheel is *life* in the form of "four bailiffs" who "manage the dominion in the life-giving mother." These bailiffs are the four elements "to which the wheel of the mind, viz., the *astrum*, affords will and desire; so that this whole essence is but one thing only, like the mind of a man. Even as he is in soul and body, so also is this whole essence"; for he is created in the likeness of this "whole essence." But nature in her four elements is also a whole essence with a soul.⁹⁷ This "sulphurean wheel" is the origin of good and evil, or rather it leads into them and out of them.⁹⁸

[215] Böhme's mysticism is influenced by alchemy in the highest degree. Thus he says: "The form of the birth is as a turning wheel, which Mercurius causes in the sulphur."⁹⁹ The "birth" is the "golden child" (*filius philosophorum* = archetype of the divine child¹⁰⁰) whose "master-workman" is Mercurius.¹⁰¹ Mercurius himself is the "fiery wheel of the essence" in the form of a serpent. Similarly the (unenlightened) soul is just "such a fiery Mercurius." Vulcan kindles the fiery wheel of the essence in the soul when it "breaks off" from God; whence come desire and sin, which are the "wrath of God." The soul is then a "worm" like the "fiery serpent," a "larva" and a "monster."¹⁰²

[216] The interpretation of the wheel in Böhme reveals something of the mystical secret of alchemy and is thus of considerable importance in this respect as well as from the psychological point of view: the wheel appears here as a concept for wholeness which

represents the essence of mandala symbolism and therefore includes the *mysterium iniquitatis*.

[217] The idea of the “centre,” which the unconscious has been repeatedly thrusting upon the conscious mind of the dreamer, is beginning to gain foothold there and to exercise a peculiar fascination. The next drawing is again of the blue flower (cf. [fig. 85](#)), but this time subdivided into eight; then follow pictures of four mountains round a lake in a crater, also of a red ring lying on the ground with a withered tree standing in it, round which a green snake (cf. [fig. 13](#)) creeps up with a leftward movement.

[218] The layman may be rather puzzled by the serious attention devoted to this problem. But a little knowledge of yoga and of the medieval philosophy of the *lapis* would help him to understand. As we have already said, the squaring of the circle was one of the methods for producing the *lapis*; another was the use of *imaginatio*, as the following text unmistakably proves:

And take care that thy door be well and firmly closed, so that he who is within cannot escape, and—God willing—thou wilt reach the goal. Nature performeth her operations gradually; and indeed I would have thee do the same: let thy imagination be guided wholly by nature. And observe according to nature, through whom the substances regenerate themselves in the bowels of the earth. And imagine this with true and not with fantastic imagination.¹⁰³

[219] The *vas bene clausum* (well-sealed vessel) is a precautionary measure very frequently mentioned in alchemy, and is the equivalent of the magic circle. In both cases the idea is to protect what is within from the intrusion and admixture of what is without, as well as to prevent it from escaping.¹⁰⁴ The *imaginatio* is to be understood here as the real and literal power to create images (*Einbildungskraft* = imagination)—the classical use of the word in contrast to *phantasia*, which means a mere “conceit” in the sense of insubstantial thought. In the *Satyricon* this connotation is more pointed still: *phantasia* means something ridiculous.¹⁰⁵ *Imaginatio* is the active evocation of (inner) images *secundum naturam*, an authentic feat of thought or ideation, which does not spin aimless and groundless fantasies “into the blue”—does not, that is to say, just play with its objects, but tries to grasp the inner facts and portray them in images true to their nature. This activity is an *opus*, a work. And we cannot call the manner in which the dreamer handles the objects of his inner experience anything but true work, considering how conscientiously, accurately, and carefully he records and elaborates the content now pushing its way into consciousness. The resemblance to the *opus* is obvious enough to anyone familiar with alchemy. Moreover the analogy is borne out by the dreams themselves, as dream 24 will show.

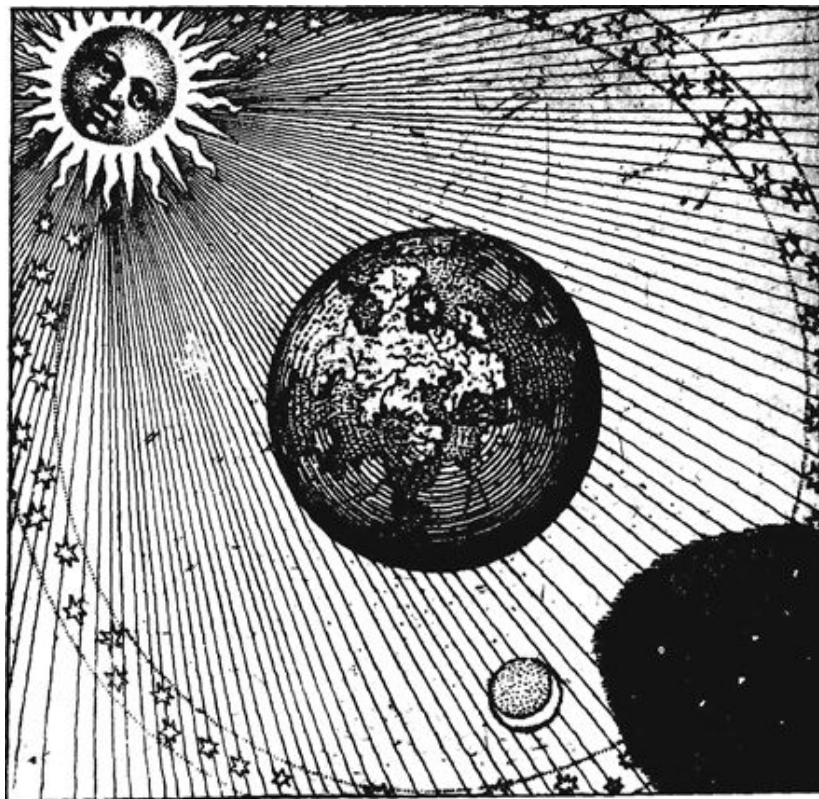

81. "Sol et eius umbra." The earth is midway between light and darkness.—Maier, *Scrutinium chymicum* (1687)

[220] The present dream, from which the above-mentioned drawings originated, shows no signs of the "left" having been in any way "throttled." On the contrary, the dreamer finds himself once more in the *temenos* facing the unknown woman who personifies the fourth or "inferior" function.¹⁰⁶ His drawing of the wheel with a four-petalled blue flower in the middle was anticipated by the dream: what the dream represents in personified form the dreamer reproduces as an abstract ideogram. This might well be a hint that the *meaning* of the personification could also be represented in quite another form. This "other form" (three-leaved clover, distorted cross) refers back to the ace of clubs in dream 16 of the first series (par. 97), where we pointed out its analogy with the irregular cross. The analogy is confirmed here. In this dream, however, the symbol of the Christian Trinity has been overshadowed or "coloured" by the alchemical quaternity. The colours appear as a concretization of the *tetraktys*. The *Rosarium* quotes a similar statement from the "Tractatus aureus": "Vultur¹⁰⁷ ... clamat voce magna, inquiens: Ego sum albus niger et rubeus citrinus"¹⁰⁸ (The vulture ... exclaims in a loud voice: I am the white black and the red yellow). On the other hand it is stressed that the *lapis* unites *omnes colores* in itself. We can thus take it that the quaternity represented by the colours is a kind of preliminary stage of the *lapis*. This is confirmed by the *Rosarium*: "Our stone is from the four elements."¹⁰⁹ (Cf. [figs. 64, 82, 117.](#)) The same applies to the *aurum philosophicum*: "In the gold the four elements are contained in equal proportions."¹¹⁰ The fact is that the four colours in the dream represent the transition from trinity to quaternity and thus to the squared circle ([figs. 59, 60](#)), which, according to the alchemists, comes nearest to the *lapis* on account of its roundness or perfect simplicity. For this reason a recipe for the preparation of the *lapis*, attributed to Raymundus, says:

Take of the body that is most simple and round, and do not take of the triangle or quadrangle but of the round, for the round is nearer to simplicity than the triangle. Hence it is to be noted that a simple body has no corners, for it is the first and last among the planets, like the sun among the stars.¹¹¹

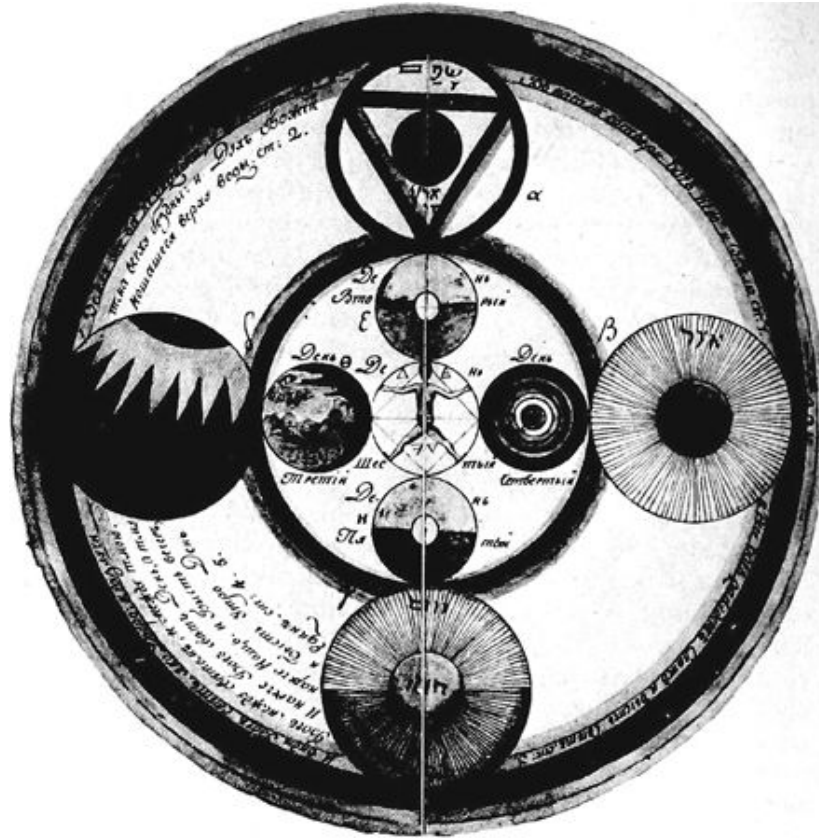

82. The Anthropos with the four elements.—Russian MS. (18th cent.)

24. DREAM:

[221] *Two people are talking about crystals, particularly about a diamond.*

[222] Here one can hardly avoid thinking of the *lapis*. In fact this dream discloses the historical background and indicates that we really are dealing with the coveted *lapis*, the “treasure hard to attain.” The dreamer’s *opus* amounts to an unconscious recapitulation of the efforts of Hermetic philosophy. (More about the diamond in dreams 37, 39, 50 below.)

25. DREAM:

[223] *It is a question of constructing a central point and making the figure symmetrical by reflection at this point.*

[224] The word “constructing” points to the synthetic character of the *opus* and also to the laborious building process that taxes the dreamer’s energy. The “symmetry” is an answer to the conflict in dream 22 (“completely throttling the left”). Each side must perfectly balance the other as its mirror-image, and this image is to fall at the “central point,” which evidently possesses the property of reflection—it is a *vitrum*,¹¹² a crystal or sheet of water (cf. [fig. 209](#)). This power of reflection seems to be another allusion to the underlying idea of the *lapis*, the *aurum philosophicum*, the elixir, the *aqua nostra*, etc. (cf. [fig. 265](#)).

[225] Just as the “right” denotes the world of consciousness and its principles, so by “reflection” the picture of the world is to be turned round to the left, thus producing a corresponding world in reverse. We could equally well say: through reflection the right appears as the reverse of the left. Therefore the left seems to have as much validity as the right; in other words, the unconscious and its—for the most part unintelligible—order becomes the symmetrical counterpart of the conscious mind and its contents, although it is still not clear which of them is reflected and which reflecting (cf. [fig. 55](#)). To carry our reasoning a step further, we could regard the centre as the point of intersection of two worlds that correspond but are inverted by reflection.¹¹³

[226] The idea of creating a symmetry would thus indicate some kind of climax in the task of accepting the unconscious and incorporating it in a general picture of the world. The unconscious here displays a “cosmic” character.

26. DREAM:

[227] *It is night, with stars in the sky. A voice says, “Now it will begin.” The dreamer asks, “What will begin?” Whereupon the voice answers, “The circulation can begin.” Then a shooting star falls in a curious leftward curve. The scene changes, and the dreamer is in a rather squalid night club. The proprietor, who appears to be an unscrupulous crook, is there with some bedraggled-looking girls. A quarrel starts about left and right. The dreamer then leaves and drives round the perimeter of a square in a taxi. Then he is in the bar again. The proprietor says, “What they said about left and right did not satisfy my feelings. Is there really such a thing as a left and a right side of human society?” The dreamer answers, “The existence of the left does not contradict that of the right. They both exist in everyone. The left is the mirror-image of the right. Whenever I feel it like that, as a mirror-image, I am at one with myself. There is no right and no left side to human society, but there are symmetrical and lopsided people. The lopsided are those who can fulfil only one side of themselves, either left or right. They are still in the childhood state.” The proprietor says meditatively, “Now that’s much better,” and goes about his business.*

[228] I have given this dream in full because it is an excellent illustration of how the ideas hinted at in the last dream have been taken up by the dreamer. The idea of symmetrical proportion has been stripped of its cosmic character and translated into psychological terms, expressed in social symbols. “Right” and “left” are used almost like political slogans.

[229] The beginning of the dream, however, is still under the cosmic aspect. The dreamer noted that the curious curve of the shooting star corresponded exactly to the line he drew when sketching the picture of the eightfold flower (cf. par. 217). The curve formed the edge of the petals. Thus the shooting star traces the outline, so to speak, of a flower that spreads over the whole starry heaven. What is now beginning is the circulation of the light.¹¹⁴ This cosmic flower corresponds roughly to the rose in Dante’s *Paradiso* ([fig. 83](#)).

[230] The “cosmic” nature of an experience—as an aspect of some inner occurrence that can only be understood psychologically—is offensive and at once provokes a reaction “from below.” Evidently the cosmic aspect was too high and is compensated “downward,” so that

the symmetry is no longer that of two world pictures but merely of human society, in fact of the dreamer himself. When the proprietor remarks that the latter's psychological understanding is "much better," he is making an estimate whose conclusion should run: "but still not good enough."

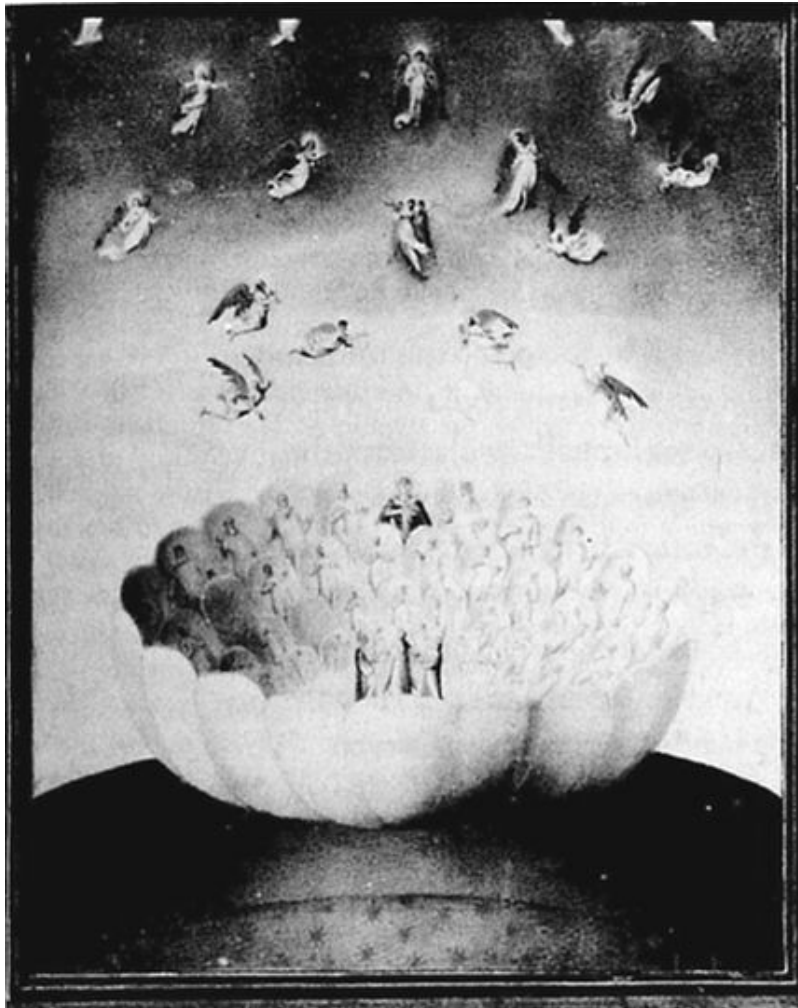

83. Dante being led before God in the heavenly rose.—Illumination for the *Paradiso*, Canto XXXI. Codex Urbanus Latinus 365 (15th cent.)

[231] The quarrel about right and left that starts in the bar is the conflict which breaks out in the dreamer himself when he is called upon to recognize the symmetry. He cannot do this because the other side looks so suspicious that he would rather not investigate it too closely. That is the reason for the magical *circumambulatio* (driving round the square): he has to stay inside and learn to face his mirror-image without running away. He does this as best he can, though not quite as the other side would wish. Hence the somewhat chill recognition of his merits.

27. VISUAL IMPRESSION:

[232] *A circle with a green tree in the middle. In the circle a fierce battle is raging between savages. They do not see the tree.*

[233] Evidently the conflict between right and left has not yet ended. It continues because the savages are still in the "childhood state" and therefore, being "lopsided," only know either the left or the right but not a third that stands above the conflict.

28. VISUAL IMPRESSION:

[234] *A circle: within it, steps lead up to a basin with a fountain inside.*



[235] When a condition is unsatisfactory because some essential aspect of the unconscious content is lacking, the unconscious process reverts to earlier symbols, as is the case here. The symbolism goes back to dream 13 (par. 154), where we met the mandala garden of the philosophers with its fountain of *aqua nostra* (fig. 84; cf. also figs. 25, 26, 56). Circle and basin emphasize the mandala, the rose of medieval symbolism.¹¹⁵ The “rose garden of the philosophers” is one of alchemy’s favourite symbols.¹¹⁶



84. The fountain in the walled garden, symbolizing *constantia in adversis*—a situation particularly characteristic of alchemy.

—Boschius, *Symbolographia* (1702)

29. VISUAL IMPRESSION:

[236] *A bunch of roses, then the sign , but it should be. .*

[237] A rose bouquet is like a fountain fanning out. The meaning of the first sign—possibly a tree—is not clear, whereas the correction represents the eightfold flower (fig. 85). Evidently a mistake is being corrected which somehow impaired the wholeness of the rose. The aim of the reconstruction is to bring the problem of the mandala—the correct valuation and interpretation of the “centre”—once more into the field of consciousness.

30. DREAM:

[238] *The dreamer is sitting at a round table with the dark unknown woman.*

[239] Whenever a process has reached a culmination as regards either its clarity or the wealth of inferences that can be drawn from it, a regression is likely to ensue. From the dreams that come in between the ones we have quoted here it is evident that the dreamer is finding the insistent demands of wholeness somewhat disagreeable; for their realization will have far-reaching practical consequences, whose personal nature, however, lies outside the scope of our study.

[240] The round table again points to the circle of wholeness, and the anima comes in as representative of the fourth function, especially in her “dark” aspect, which always makes itself felt when something is becoming concrete, i.e., when it has to be translated, or

threatens to translate itself, into reality. “Dark” means chthonic, i.e., concrete and earthy. This is also the source of the fear that causes the regression.¹¹⁷

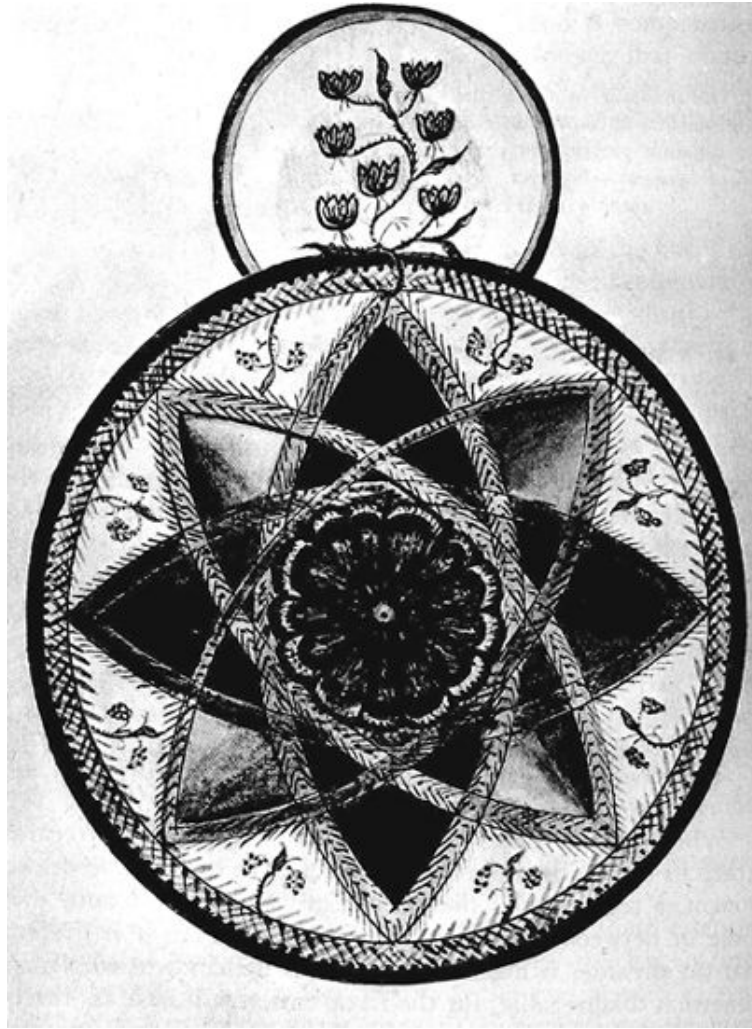

85. The eight-petalled flower as the eighth or the first of seven.—“Recueil de figures astrologiques” (MS., 18th cent.)

31. DREAM:

[241] *The dreamer is sitting with a certain man of unpleasant aspect at a round table. On it stands a glass filled with a gelatinous mass.*

[242] This dream is an advance on the last in that the dreamer has accepted the “dark” as his own darkness, to the extent of producing a real “shadow” belonging to him personally.¹¹⁸ The anima is thus relieved of the moral inferiority projected upon her and can take up the living and creative function¹¹⁹ which is properly her own. This is represented by the glass with its peculiar contents which we, like the dreamer, may compare with the undifferentiated “life-mass” in dream 18 (par. 183). It was then a question of the gradual transformation of primitive animality into something human. So we may expect something of the sort here, for it seems as if the spiral of inner development had come round to the same point again, though higher up.



86. The alchemical apparatus for distillation, the *unum vas*, with the serpents of the (double) Mercurius.—Kelley, *Tractatus de Lapide philosophorum* (1676)

[243] The glass corresponds to the *unum vas* of alchemy (fig. 86) and its contents to the living, semi-organic mixture from which the body of the *lapis*, endowed with spirit and life, will emerge—or possibly that strange Faustian figure who bursts into flame three times: the Boy Charioteer, the Homunculus who is dashed against the throne of Galatea, and Euphorion (all symbolizing a dissolution of the “centre” into its unconscious elements). We know that the *lapis* is not just a “stone” since it is expressly stated to be composed “de re animali, vegetabili et minerali,” and to consist of body, soul, and spirit,¹²⁰ moreover, it grows from flesh and blood.¹²¹ For which reason the philosopher (Hermes in the “*Tabula smaragdina*”) says: “The wind hath carried it in his belly” (fig. 210). Therefore “wind is air, air is life, and life is soul.” “The stone is that thing midway between perfect and imperfect bodies, and that which nature herself begins is brought to perfection through the art.”¹²² The stone “is named the stone of invisibility” (*lapis invisibilitatis*).¹²³

[244] The dream takes up the question of giving the centre life and reality—giving birth to it, so to speak. That this birth can issue from an amorphous mass has its parallel in the alchemical idea of the *prima materia* as a chaotic *massa informis* impregnated by the seeds of life (figs. 162, 163). As we have seen, the qualities of gum arabic and glue are attributed to it, or again it is called *viscosa* and *unctuosa*. (In Paracelsus the “*Nostoc*” is the arcane substance.) Although modern conceptions of nutrient soil, jelly-like growths, etc., underlie the dreamer’s “gelatinous mass,” the atavistic associations with far older alchemical ideas still persist, and these, although not consciously present, nevertheless exert a powerful unconscious influence on the choice of symbols.



87. The Virgin as the *vas* of the divine child.—From a Venetian *Rosario dela gloriosa vergine Maria* (1524)

32. DREAM:

[245] *The dreamer receives a letter from an unknown woman. She writes that she has pains in the uterus. A drawing is attached to the letter, looking roughly like this:*¹²⁴

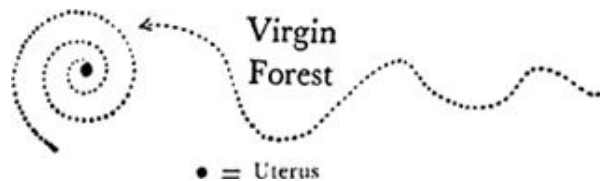

In the primeval forest there are swarms of monkeys. Then a panorama of white glaciers opens out.

[246] The anima reports that there are painful processes going on in the life-creating centre, which in this case is no longer the “glass” containing the life-mass but a point designated as a “uterus,” to be reached—so the spiral suggests—by means of a *circumambulatio*. At all events the spiral emphasizes the centre and hence the uterus, which is a synonym frequently employed for the alchemical vessel, just as it is one of the basic meanings of the Eastern mandala.¹²⁵ The serpentine line leading to the vessel is analogous to the healing serpent of Aesculapius (figs. 203, 204) and also to the Tantric symbol of *Shiva bindu* the creative, latent god without extension in space who, in the form of a point or *lingam*, is encircled three and a half times by the Kundalini serpent.¹²⁶ With the primeval forest we meet the animal or ape motif again, which appeared before in vision 22 of the first series (par. 117) and in dreams 16 and 18 of this (pars. 164, 183). In vision 22 it led to the announcement that “everything must be ruled by the light” and, in dream 18, to the “transfigured” head. Similarly the present dream ends with a panorama of white “glaciers,” reminding the dreamer of an earlier dream (not included here) in which he beheld the Milky Way and was having a conversation about immortality. Thus the glacier symbol is a bridge leading back

again to the cosmic aspect that caused the regression. But, as is nearly always the case, the earlier content does not return in its first simple guise—it brings a new complication with it, which, though it might have been expected logically, is no less repugnant to the intellectual consciousness than the cosmic aspect was. The complication is the memory of the conversation about immortality. This theme was already hinted at in dream 9 (par. 134), with its pendulum clock, a *perpetuum mobile*. Immortality is a clock that never runs down, a mandala that revolves eternally like the heavens. Thus the cosmic aspect returns with interest and compound interest. This might easily prove too much for the dreamer, for the “scientific” stomach has very limited powers of digestion.



88. Vision of the Holy Grail.—“Roman de Lancelot du lac” (MS., Paris, 15th cent.)

[247] The unconscious does indeed put forth a bewildering profusion of semblances for that obscure thing we call the mandala or “self.” It almost seems as if we were ready to go on dreaming in the unconscious the age-old dream of alchemy, and to continue to pile new synonyms on top of the old, only to know as much or as little about it in the end as the ancients themselves. I will not enlarge upon what the *lapis* meant to our forefathers, and what the mandala still means to the Lamaist and Tantrist, Aztec and Pueblo Indian, the “golden pill”¹²⁷ to the Taoist, and the “golden seed” to the Hindu. We know the texts that give us a vivid idea of all this. But what does it mean when the unconscious stubbornly persists in presenting such abstruse symbolisms to a cultured European? The only point of view I can apply here is a psychological one. (There may be others with which I am not familiar.) From this point of view, as it seems to me, everything that can be grouped together under the general concept “mandala” expresses the essence of a certain kind of *attitude*. The known attitudes of the conscious mind have definable aims and purposes. But a man’s attitude towards the self is the only one that has no definable aim and no visible purpose. It is easy enough to say “self,” but exactly what have we said? That remains

shrouded in “metaphysical” darkness. I may define “self” as the totality of the conscious and unconscious psyche, but this totality transcends our vision; it is a veritable *lapis invisibilitatis*. In so far as the unconscious exists it is not definable; its existence is a mere postulate and nothing whatever can be predicated as to its possible contents. The totality can only be experienced in its parts and then only in so far as these are contents of consciousness; but *qua* totality it necessarily transcends consciousness. Consequently the “self” is a pure borderline concept similar to Kant’s *Ding an sich*. True, it is a concept that grows steadily clearer with experience—as our dreams show—without, however, losing anything of its transcendence. Since we cannot possibly know the boundaries of something unknown to us, it follows that we are not in a position to set any bounds to the self. It would be wildly arbitrary and therefore unscientific to restrict the self to the limits of the individual psyche, quite apart from the fundamental fact that we have not the least knowledge of these limits, seeing that they also lie in the unconscious. We may be able to indicate the limits of consciousness, but the unconscious is simply the unknown psyche and for that very reason illimitable because indeterminable. Such being the case, we should not be in the least surprised if the empirical manifestations of unconscious contents bear all the marks of something illimitable, something not determined by space and time. This quality is numinous and therefore alarming, above all to a cautious mind that knows the value of precisely delimited concepts. One is glad not to be a philosopher or theologian and so under no obligation to meet such numina professionally. It is all the worse when it becomes increasingly clear that numina are psychic *entia* that force themselves upon consciousness, since night after night our dreams practise philosophy on their own account. What is more, when we attempt to give these numina the slip and angrily reject the alchemical gold which the unconscious offers, things do in fact go badly with us, we may even develop symptoms in defiance of all reason, but the moment we face up to the stumbling-block and make it—if only hypothetically—the cornerstone, the symptoms vanish and we feel “unaccountably” well. In this dilemma we can at least comfort ourselves with the reflection that the unconscious is a necessary evil which must be reckoned with, and that it would therefore be wiser to accompany it on some of its strange symbolic wanderings, even though their meaning be exceedingly questionable. It might perhaps be conducive to good health to relearn Nietzsche’s “lesson of earlier humanity.”

[248] The only objection I could make to such rationalistic explanations is that very often they do not stand the test of events. We can observe in these and similar cases how, over the years, the entelechy of the self becomes so insistent that consciousness has to rise to still greater feats if it is to keep pace with the unconscious.

[249] All that can be ascertained at present about the symbolism of the mandala is that it portrays an autonomous psychic fact, characterized by a phenomenology which is always repeating itself and is everywhere the same. It seems to be a sort of atomic nucleus about whose innermost structure and ultimate meaning we know nothing. We can also regard it as the actual—i.e., effective—reflection of a conscious attitude that can state neither its aim nor its purpose and, because of this failure, projects its activity entirely upon the virtual centre of the mandala.¹²⁸ The compelling force necessary for this projection always lies in

some situation where the individual no longer knows how to help himself in any other way. That the mandala is merely a psychological reflex is, however, contradicted firstly by the autonomous nature of this symbol, which sometimes manifests itself with overwhelming spontaneity in dreams and visions, and secondly by the autonomous nature of the unconscious as such, which is not only the original form of everything psychic but also the condition we pass through in early childhood and to which we return every night. There is no evidence for the assertion that the activity of the psyche is merely reactive or reflex. This is at best a biological working hypothesis of limited validity. When raised to a universal truth it is nothing but a materialistic myth, for it overlooks the creative capacity of the psyche, which—whether we like it or not—exists, and in face of which all so-called “causes” become mere occasions.



89. The pelican nourishing its young with its own blood, an allegory of Christ.—Boschius, *Symbolographia* (1702)

33. DREAM:

[250] *A battle among savages, in which bestial cruelties are perpetrated.*

[251] As was to be foreseen, the new complication (“immortality”) has started a furious conflict, which makes use of the same symbols as the analogous situation in dream 27 (par. 232).

34. DREAM:

[252] *A conversation with a friend. The dreamer says, “I must carry on with the figure of the bleeding Christ before me and persevere in the work of self-redemption.”*

[253] This, like the previous dream, points to an extraordinary, subtle kind of suffering (fig. 89) caused by the breaking through of an alien spiritual world which we find very hard to accept—hence the analogy with the tragedy of Christ: “My kingdom is not of this world.” But it also shows that the dreamer is now continuing his task in deadly earnest. The reference to Christ may well have a deeper meaning than that of a mere moral reminder: we are concerned here with the process of individuation, a process which has constantly been held up to Western man in the dogmatic and religious model of the life of Christ. The accent has always fallen on the “historicity” of the Saviour’s life, and because of this its symbolical nature has remained in the dark, although the Incarnation formed a very essential part of the *symbolon* (creed). The efficacy of dogma, however, by no means rests on Christ’s unique historical reality but on its own symbolic nature, by virtue of which it expresses a more or less ubiquitous psychological assumption quite independent of the existence of any dogma.

There is thus a “pre-Christian” as well as a “non-Christian” Christ, in so far as he is an autonomous psychological fact. At any rate the doctrine of prefiguration is founded on this idea. In the case of the modern man, who has no religious assumptions at all, it is therefore only logical that the Anthropos or Poimen figure should emerge, since it is present in his own psyche (figs. 117, 195).

35. DREAM:

[254] *An actor smashes his hat against the wall, where it looks like this:*

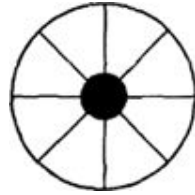

[255] As certain material not included here shows, the “actor” refers to a definite fact in the dreamer’s personal life. Up to now he had maintained a certain fiction about himself which prevented him from taking himself seriously. This fiction has become incompatible with the serious attitude he has now attained. He must give up the actor, for it was the actor in him who rejected the self. The hat refers to the first dream of all, where he put on a *stranger’s* hat. The actor throws the hat against the wall, and the hat proves to be a mandala. So the “strange” hat was the self, which at that time—while he was still playing a fictitious role—seemed like a stranger to him.

36. DREAM:

[256] *The dreamer drives in a taxi to the Rathausplatz, but it is called the “Marienhof.”*

[257] I mention this dream only in passing because it shows the feminine nature of the *temenos*, just as *hortus conclusus* (enclosed garden) is often used as an image for the Virgin Mary in medieval hymns, and *rosa mystica* is one of her attributes in the Litany of Loreto (cf. fig. 26).

37. DREAM:

[258] *There are curves outlined in light around a dark centre. Then the dreamer is wandering about in a dark cave, where a battle is going on between good and evil. But there is also a prince who knows everything. He gives the dreamer a ring set with a diamond and places it on the fourth finger of his left hand.*

[259] The circulation of light that started in dream 26 reappears more clearly. Light always refers to consciousness, which at present runs only along the periphery. The centre is still dark. It is the dark cave, and to enter it is obviously to set the conflict going again. At the same time it is like the prince who stands aloof, who knows everything and is the possessor of the precious stone. The gift means nothing less than the dreamer’s vow to the self—for as a rule the wedding ring is worn on the fourth finger of the left hand. True, the left is the unconscious, from which it is to be inferred that the situation is still largely shrouded in

unconsciousness. The prince seems to be the representative of the *aenigma regis* (fig. 54; cf. commentary to dream 10, par. 142). The dark cave corresponds to the vessel containing the warring opposites. The self is made manifest in the opposites and in the conflict between them; it is a *coincidentia oppositorum*. Hence the way to the self begins with conflict.

38. DREAM:

[260] *A circular table with four chairs round it. Table and chairs are empty.*

[261] This dream confirms the above conjecture. The mandala is not yet “in use.”



90. The bear representing the dangerous aspect of the *prima materia*.—Thomas Aquinas (pseud.), “De alchimia” (MS., 16th cent.)

39. VISUAL IMPRESSION:

[262] *The dreamer is falling into the abyss. At the bottom there is a bear whose eyes gleam alternately in four colours: red, yellow, green, and blue. Actually it has four eyes that change into four lights. The bear disappears and the dreamer goes through a long dark tunnel. Light is shimmering at the far end. A treasure is there, and on top of it the ring with the diamond. It is said that this ring will lead him on a long journey to the east.*

[263] This waking dream shows that the dreamer is still preoccupied with the dark centre. The bear stands for the chthonic element that might seize him. But then it becomes clear that the animal is only leading up to the four colours (cf. dream 23, par. 212), which in their turn lead to the *lapis*, i.e., the diamond whose prism contains all the hues of the rainbow. The way to the east probably points to the unconscious as an antipode. According to the legend the Grail-stone comes from the east and must return there again. In alchemy the bear corresponds to the *nigredo* of the *prima materia* (fig. 90), whence comes the colourful *cauda pavonis*.

40. DREAM:

[264] *Under the guidance of the unknown woman the dreamer has to discover the Pole at the risk of his life.*

[265] The Pole is the point round which everything turns—hence another symbol of the self. Alchemy also took up this analogy: “In the Pole is the heart of Mercurius, who is the true fire, wherein his master rests. When navigating over this great sea ... he sets his course by the aspect of the North star.”¹²⁹ Mercurius is the world-soul, and the Pole is its heart (fig. 149). The idea of the *anima mundi* (fig. 91; cf. fig. 8) coincides with that of the collective unconscious whose centre is the self. The symbol of the sea is another synonym for the unconscious.

41. VISUAL IMPRESSION:

[266] *Yellow balls rolling round to the left in a circle.*

[267] Rotation about a centre, recalling dream 21 (par. 198).

42. DREAM:

[268] *An old master points to a spot on the ground illuminated in red.*

[269] The *philosophus* shows him the “centre.” The redness may mean the dawn, like the *rubedo* in alchemy, which as a rule immediately preceded the completion of the work.

43. DREAM:

[270] *A yellow light like the sun looms through the fog, but it is murky. Eight rays go out from the centre. This is the point of penetration: the light ought to pierce through, but has not quite succeeded.*

[271] The dreamer himself observed that the point of penetration was identical with the Pole in dream 40. So it is, as we surmised, a question of the sun’s appearing, which now turns yellow. But the light is still murky, which probably means insufficient understanding. The “penetration” alludes to the need for effort in coming to a decision. In alchemy yellow (*citrinitas*) often coincides with the *rubedo*. The “gold” is yellow or reddish yellow.

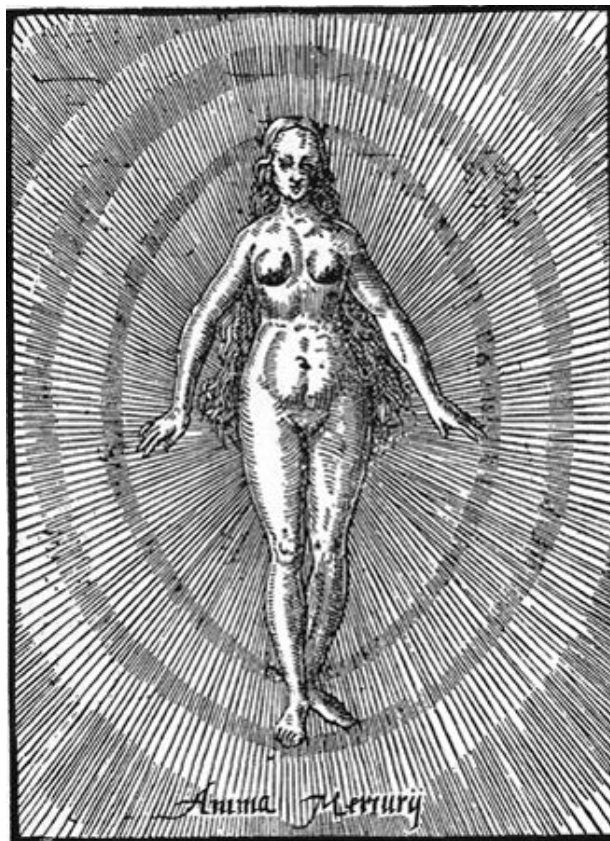

91. *Anima Mundi*.—Thurneisser zum Thurn, *Quinta essentia* (1574)

44. DREAM:

[272] *The dreamer is in a square enclosure where he must keep still. It is a prison for Lilliputians (or children?). A wicked woman is in charge of them. The children start moving and begin to circulate round the periphery. The dreamer would like to run away but may not do so. One of the children turns into an animal and bites him in the calf (fig. 118).*

[273] The lack of clarity demands further efforts of concentration; hence the dreamer finds himself still in the childhood state (figs. 95, 96), hence “lopsided” (cf. dream 26, par. 227), and imprisoned in the *temenos* in the charge of a wicked mother anima. The animal appears as in dream 18 (par. 183) and he is bitten, i.e., he must expose himself and pay the price. The *circumambulatio* means, as always, concentration on the centre. He finds this state of tension almost unendurable. But he wakes up with an intense and pleasant feeling of having solved something, “as if he held the diamond in his hand.” The children point to the dwarf motif, which may express Cabiric elements, i.e., it may represent unconscious formative powers (see dreams 56ff., below), or it may at the same time allude to his still childish condition.

45. DREAM:

[274] *A parade ground with troops. They are not equipping themselves for war but form an eight-rayed star rotating to the left.*

[275] The essential point here is that the conflict seems to be overcome. The star is not in the sky and not a diamond, but a configuration on the earth formed by human beings.

46. DREAM:

[276] *The dreamer is imprisoned in the square enclosure. Lions and a wicked sorceress appear.*

[277] He cannot get out of the chthonic prison because he is not yet ready to do something that he should. (This is an important personal matter, a duty even, and the cause of much misgiving.) Lions, like all wild animals, indicate latent affects. The lion plays an important part in alchemy and has much the same meaning. It is a “fiery” animal, an emblem of the devil, and stands for the danger of being swallowed by the unconscious.

47. DREAM:

[278] *The wise old man shows the dreamer a place on the ground marked in a peculiar way.*

[279] This is probably the place on earth where the dreamer belongs if he is to realize the self (similar to dream 42).

48. DREAM:

[280] *An acquaintance wins a prize for digging up a potter’s wheel.*

[281] The potter’s wheel rotates on the ground (cf. dream 45) and produces earthenware (“earthly”) vessels which may figuratively be called “human bodies.” Being round, the wheel refers to the self and the creative activity in which it is manifest. The potter’s wheel also symbolizes the recurrent theme of circulation.

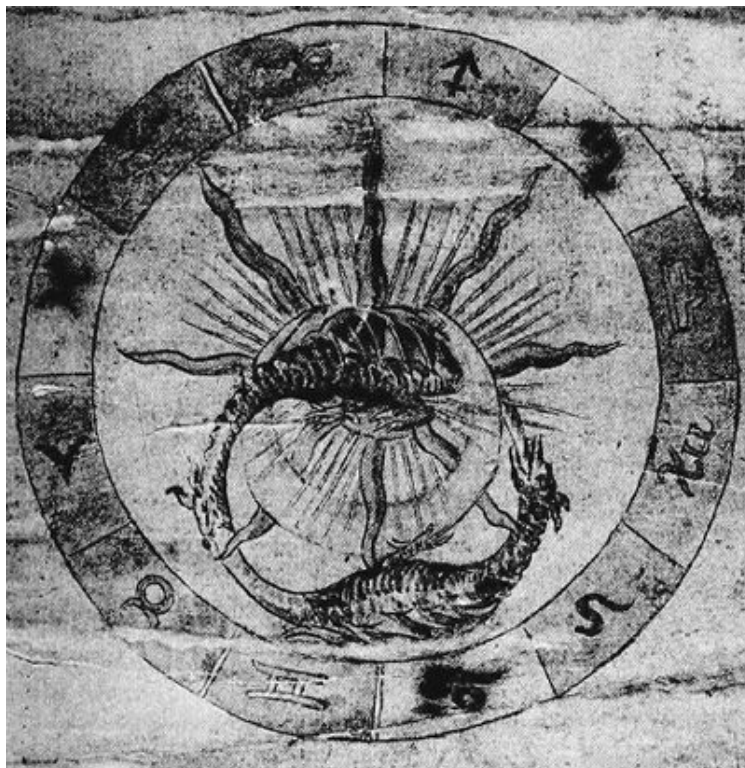

92. The alchemical process in the zodiac.—“Ripley Scrowle” (MS., 1588)

49. DREAM:

[282] *A starry figure rotating. At the cardinal points of the circle there are pictures representing the seasons.*

[283] Just as the place was defined before, so now the time. Place and time are the most general and necessary elements in any definition. The determination of time and place was stressed right at the beginning (cf. dreams 7, 8, 9; pars. 130–34). A definite location in place and time is part of a man's reality. The seasons refer to the quartering of the circle which corresponds to the cycle of the year (fig. 92). The year is a symbol of the original man¹³⁰ (figs. 99, 100, 104). The rotation motif indicates that the symbol of the circle is to be thought of not as static but as dynamic.

50. DREAM:

[284] *An unknown man gives the dreamer a precious stone. But he is attacked by a gang of apaches. He runs away (nightmare) and is able to escape. The unknown woman tells him afterwards that it will not always be so: sometime he will have to stand his ground and not run away.*

[285] When a definite time is added to a definite place one is rapidly approaching reality. That is the reason for the gift of the jewel, but also for the fear of decision, which robs the dreamer of the power to make up his mind.

51. DREAM:

[286] *There is a feeling of great tension. Many people are circulating round a large central oblong with four smaller oblongs on its sides. The circulation in the large oblong goes to the left and in the smaller oblongs to the right. In the middle there is the eight-rayed star. A bowl is placed in the centre of each of the smaller oblongs, containing red, yellow, green, and colourless water. The water rotates to the left. The disquieting question arises: Is there enough water?*

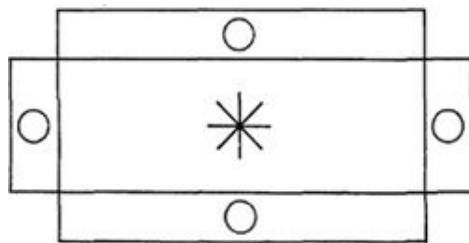

[287] The colours point once more to the preliminary stage. The “disquieting” question is whether there is enough water of life—*aqua nostra*, energy, libido—to reach the central star (i.e., the “core” or “kernel”; cf. next dream). The circulation in the central oblong is still going to the left, i.e., consciousness is moving towards the unconscious. The centre is therefore not yet sufficiently illuminated. The rightward circulation in the smaller oblongs, which represent the quaternity, seems to suggest that the four functions are becoming conscious. The four are generally characterized by the four colours of the rainbow. The striking fact here is that the blue is missing, and also that the square ground-plan has suddenly been abandoned. The horizontal has extended itself at the cost of the vertical. So we are dealing with a “disturbed” mandala.¹³¹ We might add by way of criticism that the

antithetical arrangement of the functions has not yet become sufficiently conscious for their characteristic polarity to be recognized.¹³² The predominance of the horizontal over the vertical indicates that the ego-consciousness is uppermost, thus entailing a loss of height and depth.

52. DREAM:

[288] *A rectangular dance hall. Everybody is going round the periphery to the left. Suddenly the order is heard: "To the kernels!" But the dreamer has first to go into the adjoining room to crack some nuts. Then the people climb down rope ladders to the water.*

[289] The time has come to press on to the "kernel" or core of the matter, but the dreamer still has a few more "hard nuts" to crack in the little rectangle (the "adjoining room"), i.e., in one of the four functions. Meanwhile the process goes on and descends to the "water." The vertical is thus lengthened, and from the incorrect oblong we again get the square which expresses the complete symmetry of conscious and unconscious with all its psychological implications.

53. DREAM:

[290] *The dreamer finds himself in an empty square room which is rotating. A voice cries, "Don't let him out. He won't pay the tax!"*

[291] This refers to the dreamer's inadequate self-realization in the personal matter already alluded to, which in this case was one of the essential conditions of individuation and therefore could not be circumvented. As was to be expected, after the preparatory emphasis on the vertical in the preceding dream, the square is now re-established. The cause of the disturbance was an underestimation of the demands of the unconscious (the vertical), which led to a flattening of the personality (recumbent oblong).

[292] After this dream the dreamer worked out six mandalas in which he tried to determine the right length of the vertical, the form of "circulation," and the distribution of colour. At the end of this work came the following dream (given unabridged):

54. DREAM:

[293] *I come to a strange, solemn house—the "House of the Gathering." Many candles are burning in the background, arranged in a peculiar pattern with four points running upward. Outside, at the door of the house, an old man is posted. People are going in. They say nothing and stand motionless in order to collect themselves inwardly. The man at the door says of the visitors to the house, "When they come out again they are cleansed." I go into the house myself and find I can concentrate perfectly. Then a voice says: "What you are doing is dangerous. Religion is not a tax to be paid so that you can rid yourself of the woman's image, for this image cannot be got rid of. Woe unto them who use religion as a substitute for another side of the soul's life; they are in error and will be accursed. Religion is no substitute; it is to be added to the other activities of the soul as the ultimate completion. Out of the fulness of life shall you bring forth your religion; only then shall you*

be blessed!” While the last sentence is being spoken in ringing tones I hear distant music, simple chords on an organ. Something about it reminds me of Wagner’s *Fire Music*. As I leave the house I see a burning mountain and I feel: “The fire that is not put out is a holy fire” (Shaw, *St. Joan*).

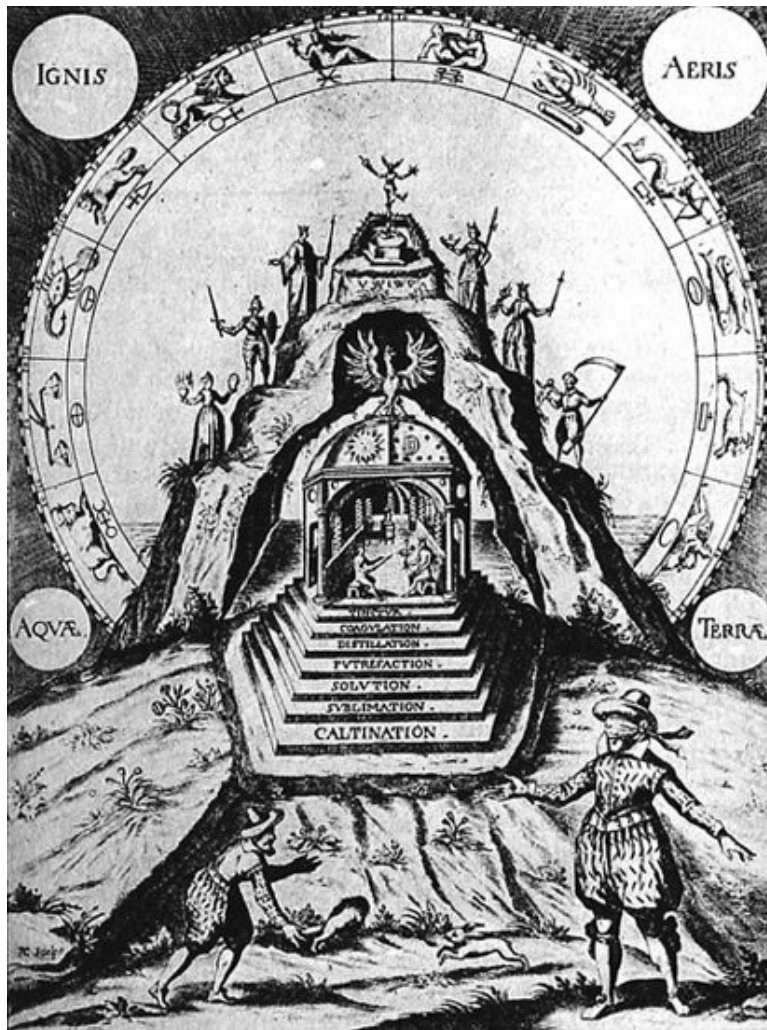

93. The Mountain of the Adepts. The temple of the wise (“House of the Gathering” or of “Self-Collection”), lit by the sun and moon, stands on the seven stages, surmounted by the phoenix. The temple is hidden in the mountain—a hint that the philosophers’ stone lies buried in the earth and must be extracted and cleansed. The zodiac in the background symbolizes the duration of the *opus*, while the four elements indicate wholeness. In foreground, blindfolded man and the investigator who follows his natural instinct.—Michelspacher, *Cabala* (1654)

[294] The dreamer notes that this dream was a “powerful experience.” Indeed it has a numinous quality and we shall therefore not be far wrong if we assume that it represents a new climax of insight and understanding. The “voice” has as a rule an absolutely authoritative character and generally comes at decisive moments.

[295] The house probably corresponds to the square, which is a “gathering place” (fig. 93). The four shining points in the background again indicate the quaternity. The remark about cleansing refers to the transformative function of the taboo area. The production of wholeness, which is prevented by the “tax evasion,” naturally requires the “image of the woman,” since as anima she represents the fourth, “inferior” function, feminine because contaminated with the unconscious. In what sense the “tax” is to be paid depends on the nature of the inferior function and its auxiliary, and also on the attitude type.¹³³ The payment

can be either concrete or symbolic, but the conscious mind is not qualified to decide which form is valid.

[296] The dream's view that religion may not be a substitute for "another side of the soul's life" will certainly strike many people as a radical innovation. According to it, religion is equated with wholeness; it even appears as the expression of the integration of the self in the "fulness of life."

[297] The faint echo of the Fire Music—the Loki motif—is not out of key, for what does "fulness of life" mean? What does "wholeness" mean? I feel that there is every reason here for some anxiety, since man as a whole being casts a shadow. The fourth was not separated from the three and banished to the kingdom of everlasting fire for nothing. Does not an uncanonical saying of our Lord declare: "Whoso is near unto me is near unto the fire"?¹³⁴ (Cf. [fig. 58](#).) Such dire ambiguities are not meant for grown-up children—which is why Heraclitus of old was named "the dark," because he spoke too plainly and called life itself an "ever-living fire." And that is why there are uncanonical sayings for those that have ears to hear.



94. Etna: "gelat et ardet."—Boschius, *Symbolographia* (1702)

[298] The theme of the Fire Mountain ([fig. 94](#)) is to be met with in the Book of Enoch.¹³⁵ Enoch sees the seven stars chained "like great mountains and burning with fire" at the angels' place of punishment. Originally the seven stars were the seven great Babylonian gods, but at the time of Enoch's revelation they had become the seven Archons, rulers of "this world," fallen angels condemned to punishment. In contrast to this menacing theme there is an allusion to the miracles of Jehovah on Mount Sinai, while according to other sources the number seven is by no means sinister, since it is on the seventh mountain of the western land that the tree with the life-giving fruit is to be found, i.e., the *arbor sapientiae* (cf. [fig. 188](#)).¹³⁶

55. DREAM:

[299] *A silver bowl with four cracked nuts at the cardinal points.*

[300] This dream shows that some of the problems in dream 52 have been settled, though the settlement is not complete. The dreamer pictured the goal that has now been attained as a circle divided into four, with the quadrants painted in the four colours. The circulation is to

the left. Though this satisfies the demands of symmetry, the polarity of the functions is still unrecognized—despite the last, very illuminating dream—because, in the painting, red and blue, green and yellow, are side by side instead of opposite one another. From this we must conclude that the “realization” is meeting with strong inner resistances, partly of a philosophical and partly of an ethical nature, the justification for which cannot lightly be set aside. That the dreamer has an inadequate understanding of the polarity is shown by the fact that the nuts have still to be cracked in reality, and also that they are all alike, i.e., not yet differentiated.



95. *Ludus puerorum*—Trismosin, “Splendor solis” (MS., 1582)



96. Pygmies (helpful child-gods).—Fragments of an Egyptian mechanical toy

56. DREAM:

[301] *Four children are carrying a large dark ring. They move in a circle. The dark unknown woman appears and says she will come again, for it is the festival of the solstice.*

[302] In this dream the elements of dream 44 come together again: the children and the dark woman, who was a wicked witch before. The “solstice” indicates the turning-point. In alchemy the work is completed in the autumn (*Vindemia Hermetis*). Children (fig. 95), dwarf-gods, bring the ring—i.e., the symbol of wholeness is still under the sway of childlike creative powers. Note that children also play a part in the *opus alchymicum*: a certain portion of the work is called *ludus puerorum*. Save for the remark that the work is as easy as “child’s play,” I have found no explanation for this. Seeing that the work is, in the unanimous testimony of all the adepts, exceedingly difficult, it must be a euphemistic and probably also a symbolical definition. It would thus point to a co-operation on the part of “infantile” or unconscious forces represented as Cabiri and hobgoblins (homunculi: fig. 96).



97. The “Grand Peregrination” by ship. Two eagles fly round the earth in opposite directions, indicating that it is an odyssey in search of wholeness.—Maier, *Viatorium* (1651)



98. The philosophical egg, whence the double eagle is hatched, wearing the spiritual and temporal crowns.—Codex Palatinus Latinus 412 (15th cent.)

57. VISUAL IMPRESSION:

[303] *The dark ring, with an egg in the middle.*

58. VISUAL IMPRESSION:

[304] *A black eagle comes out of the egg and seizes in its beak the ring, now turned to gold. Then the dreamer is on a ship and the bird flies ahead.*

[305] The eagle signifies height. (Previously the stress was on depth: people descending to the water.) It seizes the whole mandala and, with it, control of the dreamer, who, carried along on a ship, sails after the bird (fig. 97). Birds are thoughts and the flight of thought. Generally it is fantasies and intuitive ideas that are represented thus (the winged Mercurius, Morpheus, genii, angels). The ship is the vehicle that bears the dreamer over the sea and the depths of the unconscious. As a man-made thing it has the significance of a system or method (or a way: cf. Hinayana and Mahayana = the Lesser and Greater Vehicle, the two schools of Buddhism). The flight of thought goes ahead and methodical elaboration follows after. Man cannot walk the rainbow bridge like a god but must go underneath with whatever reflective afterthoughts he may have. The eagle—synonymous with phoenix, vulture, raven—is a well-known alchemical symbol. Even the *lapis*, the *rebis* (compounded of two parts and therefore frequently hermaphroditic as an amalgam of Sol and Luna), is often represented with wings (figs. 22, 54, 208), denoting intuition or spiritual (winged)

potentiality. In the last resort all these symbols depict the consciousness-transcending fact we call the self. This visual impression is rather like a snapshot of an evolving process as it leads on to the next stage.

[306] In alchemy the egg stands for the chaos apprehended by the artifex, the *prima materia* containing the captive world-soul. Out of the egg—symbolized by the round cooking-vessel—will rise the eagle or phoenix, the liberated soul, which is ultimately identical with the Anthropos who was imprisoned in the embrace of Physis (fig. 98).



99. Time-symbol of the *lapis*: the cross and the evangelical emblems mark its analogy with Christ.—Thomas Aquinas (pseud.), “De alchimia” (MS., 16th cent.)

III. THE VISION OF THE WORLD CLOCK

59. THE “GREAT VISION”:¹³⁷

[307] *There is a vertical and a horizontal circle, having a common centre. This is the world clock. It is supported by the black bird.*

The vertical circle is a blue disc with a white border divided into $4 \times 8 = 32$ partitions. A pointer rotates upon it.

The horizontal circle consists of four colours. On it stand four little men with pendulums, and round about it is laid the ring that was once dark and is now golden (formerly carried by the children).

The “clock” has three rhythms or pulses:

1. *The small pulse: the pointer on the blue vertical disc advances by 1/32.*

2. The middle pulse:

one complete revolution of the pointer. At the same time the horizontal circle advances 1/32.

3. The great pulse:

32 middle pulses are equal to one revolution of the golden ring.

[308] This remarkable vision made a deep and lasting impression on the dreamer, an impression of “the most sublime harmony,” as he himself puts it. The world clock may well be the “severe image” which is identical with the Cabiri, i.e., the four children or four little men with the pendulums. It is a three-dimensional mandala—a mandala in bodily form signifying realization. (Unfortunately medical discretion prevents my giving the biographical details. It must suffice to say that this realization did actually take place.) Whatever a man does in reality he himself becomes.

[309] Just why the vision of this curious figure should produce an impression of “the most sublime harmony” is, in one sense, very difficult to understand; but it becomes comprehensible enough as soon as we consider the comparative historical material. It is difficult to feel our way into the matter because the meaning of the image is exceedingly obscure. If the meaning is impenetrable and the form and colour take no account of aesthetic requirements, then neither our understanding nor our sense of beauty is satisfied, and we are at a loss to see why it should give rise to the impression of “the most sublime harmony.” We can only venture the hypothesis that disparate and incongruous elements have combined here in the most fortunate way, simultaneously producing an image which realizes the “intentions” of the unconscious in the highest degree. We must therefore assume that the image is a singularly happy expression for an otherwise unknowable psychic fact which has so far only been able to manifest apparently disconnected aspects of itself.

[310] The impression is indeed extremely abstract. One of the underlying ideas seems to be the intersection of two heterogeneous systems by the sharing of a common centre. Hence if we start as before from the assumption that the centre and its periphery represent the totality of the psyche and consequently the self, then the figure tells us that two heterogeneous systems intersect in the self, standing to one another in a functional relationship that is governed by law and regulated by “three rhythms.” The self is by definition the centre and the circumference of the conscious and unconscious systems. But the regulation of their functions by three rhythms is something that I cannot substantiate. I do not know what the three rhythms allude to. But I do not doubt for a moment that the allusion is amply justified. The only analogy I could adduce would be the three *regimina* mentioned in the Introduction (par. 31), by which the four elements are converted into one another or synthesized in the quintessence:

1st
2nd
3rd

regimen:” :
” :

earth to water.
water to air.
air to fire.

[311] We shall hardly be mistaken if we assume that our mandala aspires to the most complete union of opposites that is possible, including that of the masculine trinity and the feminine quaternity on the analogy of the alchemical hermaphrodite.

[312] Since the figure has a cosmic aspect—world clock—we must suppose it to be a small-scale model or perhaps even a source of space-time, or at any rate an embodiment of it and therefore, mathematically speaking, four-dimensional in nature although only visible in a three-dimensional projection. I do not wish to labour this argument, for such an interpretation lies beyond my powers of proof.

[313] The thirty-two pulses may conceivably derive from the multiplication of 4×8 , as we know from experience that the quaternity found at the centre of a mandala often becomes 8, 16, 32, or more when extended to the periphery. The number 32 plays an important role in the Cabala. Thus we read in the *Sepher Yetsirah* (1 : 1): “Jehovah, the Lord of Hosts, the God of Israel, the living God and King of the world ... has graven his name in thirty-two mysterious paths of wisdom.” These consist of “ten self-contained numbers [*Sephiroth*] and twenty-two basic letters” (1 : 2). The meaning of the ten numbers is as follows: “1: the spirit of the Living God; 2: spirit from spirit; 3: water from spirit; 4: fire from water; 5–10: height, depth, East, West, South, North.”¹³⁸ Cornelius Agrippa mentions that “the learned Jews attribute the number 32 to Wisdom, for so many are the ways of Wisdom described by Abram.”¹³⁹ Franck establishes a connection between 32 and the cabalistic trinity, Kether, Binah, and Hokhmah: “These three persons contain and unite in themselves everything that exists, and they in turn are united in the White Head, the Ancient of Days, for he is everything and everything is he. Sometimes he is represented with three heads which make but a single head, and sometimes he is likened to the brain which, without impairing its unity, divides into three parts and spreads through the whole body by means of thirty-two pairs of nerves, just as God spreads through the universe along thirty-two miraculous paths.”¹⁴⁰ These thirty-two “canales occulti” are also mentioned by Knorr von Rosenroth,¹⁴¹ who calls Hokhmah “the supreme path of all, embracing all,” on the authority of Job 28 : 7 (A.V.): “There is a path which no fowl knoweth, and which the vulture’s eye hath not seen.” Allendy, in his very valuable account of number symbolism, writes: “32 ... is the differentiation which appears in the organic world; not creative generation, but rather the plan and arrangement of the various forms of created things which the creator has modelled—as the product of 8×4”¹⁴² Whether the cabalistic number 32 can be equated with the thirty-two fortunate signs (*mahavyanjana*) of the Buddha-child is doubtful.

[314] As to the interpretation based on comparative historical material, we are in a more favourable position, at least as regards the general aspects of the figure. We have at our disposal, firstly, the whole mandala symbolism of three continents, and secondly, the specific time symbolism of the mandala as this developed under the influence of astrology, particularly in the West. The horoscope (fig. 100) is itself a mandala (a clock) with a dark centre, and a leftward *circumambulatio* with “houses” and planetary phases. The mandalas of ecclesiastical art, particularly those on the floor before the high altar or beneath the transept, make frequent use of the zodiacal beasts or the yearly seasons. A related idea is the identity of Christ with the Church calendar, of which he is the fixed pole and the life. The Son of Man is an anticipation of the idea of the self (fig. 99): hence the Gnostic adulteration of Christ with the other synonyms for the self among the Naassenes, recorded by Hippolytus. There is also a connection with the symbolism of Horus: on the one hand,

Christ enthroned with the four emblems of the evangelists—three animals and an angel (fig. 101); on the other, Father Horus with his four sons, or Osiris with the four sons of Horus¹⁴³ (fig. 102). Horus is also the ἥλιος ἀνατολῆς (rising sun),¹⁴⁴ and Christ was still worshipped as such by the early Christians.



100. Horoscope, showing the houses, zodiac, and planets.—Woodcut by Erhard Schoen for the nativity calendar of Leonhard Reymann (1515)



101. Christ in the mandorla, surrounded by the symbols of the four evangelists.—Mural painting, church of Saint-Jacques-des-Guérets, Loir-et-Cher, France



102. Osiris, with the four sons of Horus on the lotus.—*The Book of the Dead*

[315] We find a remarkable parallel in the writings of Guillaume de Digulleville, prior of the Cistercian monastery at Châlis, a Norman poet who, independently of Dante, composed three “pélerinages” between 1330 and 1355: *Les Pélerinages de la vie humaine, de l’âme, and de Jésus Christ*.¹⁴⁵ The last canto of the *Pélerinage de l’âme* contains a vision of Paradise, which consists of seven large spheres each containing seven smaller spheres.¹⁴⁶ All the spheres rotate, and this movement is called a *siècle* (*saeculum*). The heavenly *siècles* are the prototypes of the earthly centuries. The angel who guides the poet explains: “When holy Church ends her prayers with *in saecula saeculorum* [for ever and ever], she has in mind, not earthly time, but eternity.” At the same time the *siècles* are spherical spaces in which the blessed dwell. *Siècles* and *cieux* are identical. In the highest heaven of pure gold the King sits on a round throne which shines more brightly than the sun. A *couronne* of precious stones surrounds him. Beside him, on a circular throne that is made of brown crystal, sits the Queen, who intercedes for the sinners (fig. 103).

[316] “Raising his eyes to the golden heaven, the pilgrim perceived a marvellous circle which appeared to be three feet across. It came out of the golden heaven at one point and re-entered it at another, and it made the whole tour of the golden heaven.” This circle is sapphire-coloured. It is a small circle, three feet in diameter, and evidently it moves over a great horizontal circle like a rolling disc. This great circle intersects the golden circle of heaven.

[317] While Guillaume is absorbed in this sight, three spirits suddenly appear clad in purple, with golden crowns and girdles, and enter the golden heaven. This moment, so the angel tells him, is *une fête*, like a church festival on earth:

Ce cercle que tu vois est le calendrier
Qui en faisant son tour entier,
Montre des Saints les journées
Quand elles doivent être fêtées.
Chacun en fait le cercle un tour,
Chacune étoile y est pour jour,
Chacun soleil pour l’espace
De jours trente ou zodiaque.

(This circle is the calendar
Which spinning round the course entire
Shows the feast day of each saint
And when it should be celebrate.
Each saint goes once round all the way,
Each star you see stands for a day,

And every sun denotes a spell
Of thirty days zodiacal.)



103. *Sponsus et sponsa*.—Detail from *Polittico con l'Incoronazione*, by Stefano da Sant' Agnese (15th cent.)



104. God as Father and Logos creating the zodiac.—Peter Lombard, “*De sacramentis*”
(MS., 14th cent.)

[318] The three figures are saints whose feast day is even now being celebrated. The small circle that enters the golden heaven is *three* feet in width, and likewise there are *three* figures who make their sudden entry. They signify the moment of time in

eternity, as does the circle of the calendar (fig. 104). But why this should be exactly three feet in diameter and why there are three figures remains a mystery. We naturally think of the three rhythms in our vision which are started off by the pointer moving over the blue disc, and which enter the system just as inexplicably as the calendar-circle enters the golden heaven.

[319] The guide continues to instruct Guillaume on the significance of the signs of the zodiac with particular reference to sacred history, and ends with the remark that the feast of the twelve fishermen will be celebrated in the sign of Pisces, when the twelve will appear before the Trinity. Then it suddenly occurs to Guillaume that he has never really understood the nature of the Trinity, and he begs the angel for an explanation. The angel answers, “Now, there are three principal colours, namely green, red, and gold. These three colours are seen united in divers works of watered silk and in the feathers of many birds, such as the peacock. The almighty King who puts three colours in one, cannot he also make one substance to be three?” Gold, the royal colour, is attributed to God the Father; red to God the Son, because he shed his blood; and to the Holy Ghost green, “la couleur qui verdoie et qui réconforte.” Thereupon the angel warns Guillaume not to ask any more questions, and disappears. The poet wakes up to find himself safely in his bed, and so ends the *Pélerinage de l’âme*.



105. The Virgin, personifying the starry heaven.—“Speculum humanae saluacionis”

(MS., Vatican, 15th cent.)

[320] There is, however, one thing more to be asked: “Three there are—but where is the fourth?” Why is blue missing? This colour was also missing in the “disturbed” mandala of our dreamer (see par. 287). Curiously enough, the *calendrier* that

intersects the golden circle is blue, and so is the vertical disc in the three-dimensional mandala. We would conjecture that blue, standing for the vertical, means height and depth (the blue sky above, the blue sea below), and that any shrinkage of the vertical reduces the square to an oblong, thus producing something like an inflation of consciousness.¹⁴⁷ Hence the vertical would correspond to the unconscious. But the unconscious in a man has feminine characteristics, and blue is the traditional colour of the Virgin's celestial cloak (fig. 105). Guillaume was so absorbed in the Trinity and in the threefold aspect of the *roy* that he quite forgot the *reyne*. Faust prays to her in these words: "Supreme Mistress of the world! Let me behold thy secret in the outstretched azure canopy of heaven."

[321] It was inevitable that blue should be missing for Guillaume in the tetrad of rainbow colours, because of its feminine nature. But, like woman herself, the anima means the height and depth of a man. Without the blue vertical circle the golden mandala remains bodiless and two-dimensional, a mere abstraction. It is only the intervention of time and space here and now that makes reality. Wholeness is realized for a moment only—the moment that Faust was seeking all his life.

[322] The poet in Guillaume must have had an inkling of the heretical truth when he gave the King a Queen sitting on a throne made of earth-brown crystal. For what is heaven without Mother Earth? And how can man reach fulfilment if the Queen does not intercede for his black soul? She understands the darkness, for she has taken her throne—the earth itself—to heaven with her, if only by the subtlest of suggestions. She adds the missing blue to the gold, red, and green, and thus completes the harmonious whole.



106. "Elixir of the moon."—Codex Reginensis Latinus 1458 (17th cent.)

IV. THE SYMBOLS OF THE SELF

[323] The vision of the "world clock" is neither the last nor the highest point in the development of the symbols of the objective psyche. But it brings to an end the first third of the material, consisting in all of some four hundred dreams and visions. This series is noteworthy because it gives an unusually complete description of a psychic fact that I had observed long before in many individual cases.¹⁴⁸ We have to thank not only the completeness of the objective material but the care and discernment of the dreamer for having placed us in a position to follow, step by step, the synthetic work

of the unconscious. The troubled course of this synthesis would doubtless have been depicted in even greater completeness had I taken account of the 340 dreams interspersed among the 59 examined here. Unfortunately this was impossible, because the dreams touch to some extent on the intimacies of personal life and must therefore remain unpublished. So I had to confine myself to the impersonal material.

[324] I hope I may have succeeded in throwing some light upon the development of the symbols of the self and in overcoming, partially at least, the serious difficulties inherent in all material drawn from actual experience. At the same time I am fully aware that the comparative material so necessary for a complete elucidation could have been greatly increased. But, so as not to burden the exposition unduly, I have exercised the greatest reserve in this respect. Consequently there is much that is only hinted at, though this should not be taken as a sign of superficiality. I believe myself to be in a position to offer ample evidence for my views, but I do not wish to give the impression that I imagine I have said anything final on this highly complicated subject. It is true that this is not the first time I have dealt with a series of spontaneous manifestations of the unconscious. I did so once before, in my book *Psychology of the Unconscious*,¹⁴⁹ but there it was more a problem of neurosis in puberty, whereas this is the broader problem of individuation.



107. Virgin carrying the Saviour.—“Speculum humanae saluacionis” (MS., Vatican)



108. Maya, eternal weaver of the illusory world of the senses, encircled by the Uroboros.

—Damaged vignette from a collection of Brahminic sayings

Moreover, there is a very considerable difference between the two personalities in question. The earlier case, which I never saw at first hand, ended in psychic catastrophe—a psychosis; but the present case shows a normal development such as I have often observed in highly intelligent persons.

[325] What is particularly noteworthy here is the consistent development of the central symbol. We can hardly escape the feeling that the unconscious process moves spiral-wise round a centre, gradually getting closer, while the characteristics of the centre grow more and more distinct. Or perhaps we could put it the other way round and say that the centre—itsself virtually unknowable—acts like a magnet on the disparate materials and processes of the unconscious and gradually captures them as in a crystal lattice. For this reason the centre is (in other cases) often pictured as a spider in its web (fig. 108), especially when the conscious attitude is still dominated by fear of unconscious processes. But if the process is allowed to take its course, as it was in our case, then the central symbol, constantly renewing itself, will steadily and consistently force its way through the apparent chaos of the personal psyche and its dramatic entanglements, just as the great Bernoulli's epitaph¹⁵⁰ says of the spiral: "Eadem mutata resurgo." Accordingly we often find spiral representations of the centre, as for instance the serpent coiled round the creative point, the egg.

[326] Indeed, it seems as if all the personal entanglements and dramatic changes of fortune that make up the intensity of life were nothing but hesitations, timid shrinkings, almost like petty complications and meticulous excuses for not facing the finality of this strange and uncanny process of crystallization. Often one has the impression that the personal psyche is running round this central point like a shy animal, at once fascinated and frightened, always in flight, and yet steadily drawing nearer.

[327] I trust I have given no cause for the misunderstanding that I know anything about the nature of the “centre”—for it is simply unknowable and can only be expressed symbolically through its own phenomenology, as is the case, incidentally, with every object of experience. Among the various characteristics of the centre the one that struck me from the beginning was the phenomenon of the quaternity (fig. 109). That it is not simply a question of, shall we say, the “four” points of the compass or something of that kind is proved by the fact that there is often a competition between four and three.¹⁵¹ There is also, but more rarely, a competition between four and five, though five-rayed mandalas must be characterized as abnormal on account of their lack of symmetry.¹⁵² It would seem, therefore, that there is normally a clear insistence on four, or as if there were a greater statistical probability of four. Now it is—as I can hardly refrain from remarking—a curious “sport of nature” that the chief chemical constituent of the physical organism is carbon, which is characterized by four valencies; also it is well known that the diamond is a carbon crystal. Carbon is black—coal, graphite—but the diamond is “purest water.” To draw such an analogy would be a lamentable piece of intellectual bad taste were the phenomenon of four merely a poetic conceit on the part of the conscious mind and not a spontaneous product of the objective psyche. Even if we supposed that dreams could be influenced to any appreciable extent by auto-suggestion—in which case it would naturally be more a matter of their meaning than of their form—it would still have to be proved that the conscious mind of the dreamer had made a serious effort to impress the idea of the quaternity on the unconscious. But in this case as in many other cases I have observed, such a possibility is absolutely out of the question, quite apart from the numerous historical and ethnological parallels¹⁵³ (fig. 110; cf. also figs. 50, 61–66, 82, 109). Surveying these facts as a whole, we come, at least in my opinion, to the inescapable conclusion that there is some psychic element present which expresses itself through the quaternity. No daring speculation or extravagant fancy is needed for this. If I have called the centre the “self,” I did so after mature consideration and a careful appraisal of the empirical and historical data. A materialistic interpretation could easily maintain that the “centre” is “nothing but” the point at which the psyche ceases to be knowable because it there coalesces with the body. And a spiritualistic interpretation might retort that this “self” is nothing but “spirit,” which animates both soul and body and irrupts into time and space at that creative point. I purposely refrain from all such physical and metaphysical speculations and content myself with establishing the empirical facts, and this seems to me infinitely more important for the advance of human knowledge than running after fashionable intellectual crazes or jumped-up “religious” creeds.



109. The four evangelists with their symbols and the four rivers of paradise. Centre, the wheels of Ezekiel with the *spiritus vitae* that “was in the wheels” (Ezek. 1 : 21).—Miniature in an Evangeliary, Aschaffenburg (13th cent.)

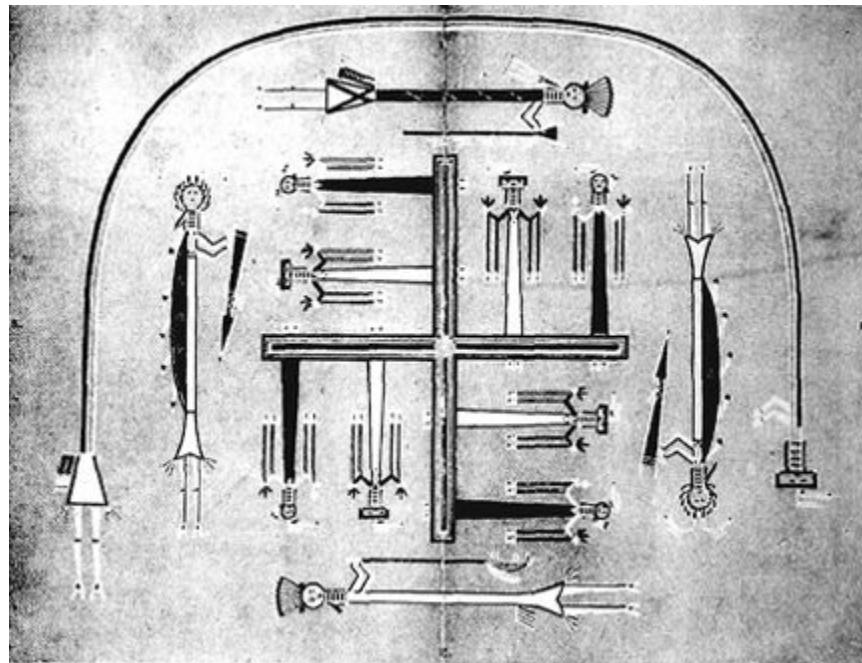

110. Sand-painting of the Navajo Indians.—Ethnological drawing

[328] To the best of my experience we are dealing here with very important “nuclear processes” in the objective psyche—“images of the goal,” as it were, which the psychic process, being goal-directed, apparently sets up of its own accord, without any external stimulus.¹⁵⁴ Externally, of course, there is always a certain condition of psychic need, a sort of hunger, but it seeks for familiar and favourite dishes and never imagines as its goal some outlandish food unknown to consciousness. The goal which beckons to this psychic need, the image which promises to heal, to make whole, is at first strange beyond all measure to the conscious mind, so that it can find entry only with the very greatest difficulty. Of course it is quite different for people who live in a time and environment when such images of the goal have dogmatic validity. These images are then *eo ipso* held up to consciousness, and the unconscious is thus shown its own secret reflection, in which it recognizes itself and so joins forces with the conscious mind.

[329] As to the question of the origin of the mandala motif, from a superficial point of view it looks as if it had gradually come into being in the course of the dream-series. The fact is, however, that it only *appeared* more and more distinctly and in increasingly differentiated form; in reality it was always present and even occurred in the first dream—as the nymphs say later: “We were always there, only you did not notice us.” It is therefore more probable that we are dealing with an *a priori* “type,” an archetype which is inherent in the collective unconscious and thus beyond individual birth and death. The archetype is, so to speak, an “eternal” presence, and the only question is whether it is perceived by the conscious mind or not. I think we are forming a more probable hypothesis, and one that better explains the observed facts, if we assume that the increase in the clarity and frequency of the mandala motif is due to a more accurate perception of an already existing “type,” rather than that it

is generated in the course of the dream-series.¹⁵⁵ The latter assumption is contradicted by the fact, for instance, that such fundamental ideas as the hat which epitomizes the personality, the encircling serpent, and the *perpetuum mobile* appear right at the beginning (first series: dream 1, par. 52, and vision 5, par. 62; second series: dream 9, par. 134).

[330] If the motif of the mandala is an archetype it ought to be a collective phenomenon, i.e., theoretically it should appear in everyone. In practice, however, it is to be met with in distinct form in relatively few cases, though this does not prevent it from functioning as a concealed pole round which everything ultimately revolves. In the last analysis every life is the realization of a whole, that is, of a self, for which reason this realization can also be called “individuation.” All life is bound to individual carriers who realize it, and it is simply inconceivable without them. But every carrier is charged with an individual destiny and destination, and the realization of these alone makes sense of life. True, the “sense” is often something that could just as well be called “nonsense,” for there is a certain incommensurability between the mystery of existence and human understanding. “Sense” and “nonsense” are merely man-made labels which serve to give us a reasonably valid sense of direction.

[331] As the historical parallels show, the symbolism of the mandala is not just a unique curiosity; we can well say that it is a regular occurrence. Were it not so there would be no comparative material, and it is precisely the possibility of comparing the mental products of all times from every quarter of the globe that shows us most clearly what immense importance the *consensus gentium* has always attached to the processes of the objective psyche. This is reason enough not to make light of them, and my medical experience has only confirmed this estimate. There are people, of course, who think it unscientific to take anything seriously; they do not want their intellectual playground disturbed by graver considerations. But the doctor who fails to take account of man’s feelings for values commits a serious blunder, and if he tries to correct the mysterious and well-nigh inscrutable workings of nature with his so-called scientific attitude, he is merely putting his shallow sophistry in place of nature’s healing processes. Let us take the wisdom of the old alchemists to heart: “Naturalissimum et perfectissimum opus est generare tale quale ipsum est.”¹⁵⁶



111. The *cauda pavonis*, combination of all colours, symbolizing wholeness.

—Boschius, *Symbolographia* (1702)



112. The principal symbols of alchemy.—Trismosin, *La Toyson d'or* (1612), title-page detail

III

RELIGIOUS IDEAS IN ALCHEMY

AN HISTORICAL SURVEY OF ALCHEMICAL IDEAS

Habentibus symbolum facilis est transitus (For those who have the symbol the passage is easy).—

An alchemical *verbum magistri* from Mylius, *Philosophia reformata*.



113. Moon and sun furnaces, showing the *coniunctio*, the union of opposites.

—*Mutus liber* (1702)

1. BASIC CONCEPTS OF ALCHEMY

I. INTRODUCTION

[332] Slowly, in the course of the eighteenth century, alchemy perished in its own obscurity. Its method of explanation—“*obscurum per obscurius, ignotum per ignotius*” (the obscure by the more obscure, the unknown by the more unknown)—was incompatible with the spirit of enlightenment and particularly with the dawning science of chemistry towards the end of the century. But these two new intellectual forces only gave the *coup de grâce* to alchemy. Its inner decay had begun at least a century earlier, at the time of Jakob Böhme, when many alchemists deserted their alembics and melting-pots and devoted themselves entirely to (Hermetic) philosophy. It was then that the chemist and the Hermetic philosopher parted company. Chemistry became natural science, whereas Hermetic philosophy lost the empirical ground from under its feet and aspired to bombastic allegories and inane speculations which were kept alive only by memories of a better time.¹ This was a time when the mind of the alchemist was still grappling with the problems of matter, when the exploring consciousness was confronted by the dark void of the unknown, in which figures and laws were dimly perceived and attributed to matter although they really belonged to the psyche. Everything unknown and empty is filled with psychological projection; it is as if the investigator's own psychic background were mirrored in the darkness. What he sees in matter, or thinks he can see, is chiefly the data of his own unconscious which he is projecting into it. In other words, he encounters in matter, as apparently belonging to it, certain qualities and potential meanings of whose psychic nature he is entirely unconscious. This is particularly true of classical alchemy, when empirical science and mystical philosophy were more or less undifferentiated. The process of fission which separated the φνσικὰ from the μνστικὰ set in at the end of the sixteenth century and produced a quite fantastic species of literature whose authors were, at least to some extent, conscious of the psychic nature of their “alchemistical” transmutations. On this aspect of alchemy, especially as regards its psychological significance, Herbert Silberer's book *Problems of Mysticism and Its Symbolism* gives us abundant information. The fantastic symbolism bound up with it is graphically described in a paper by R. Bernoulli,² and a detailed account of Hermetic philosophy is to be found in a study by J. Evola.³ But a comprehensive study of the ideas contained in the texts, and of their history, is still lacking, although we are indebted to Reitzenstein for important preparatory work in this field.

II. THE ALCHEMICAL PROCESS AND ITS STAGES

[333] Alchemy, as is well known, describes a process of chemical transformation and gives numberless directions for its accomplishment. Although hardly two authors are of the same opinion regarding the exact course of the process and the sequence of its stages, the majority are agreed on the principal points at issue, and have been so from the earliest times, i.e., since the beginning of the Christian era. Four stages are distinguished (fig. 114), characterized by the original colours mentioned in Heraclitus: *melanosis* (blackening), *leukosis* (whitening), *xanthosis* (yellowing), and *iosis* (reddening).⁴ This division of the process into four was called the *τετραμερεῖν τὴν φιλοσοφίαν*, the quartering of the philosophy. Later, about the fifteenth or sixteenth century, the colours were reduced to three, and the *xanthosis*, otherwise called the *citrinitas*, gradually fell into disuse or was but seldom mentioned. Instead, the *viriditas* sometimes appears after the *melanosis* or *nigredo* in exceptional cases, though it was never generally recognized. Whereas the original tetrameria corresponded exactly to the quaternity of elements, it was now frequently stressed that although there were four elements (earth, water, fire, and air) and four qualities (hot, cold, dry, and moist), there were only three colours: black, white, and red. Since the process never led to the desired goal and since the individual parts of it were never carried out in any standardized manner, the change in the classification of its stages cannot be due to extraneous reasons but has more to do with the symbolical significance of the quaternity and the trinity; in other words, it is due to inner psychological reasons.⁵

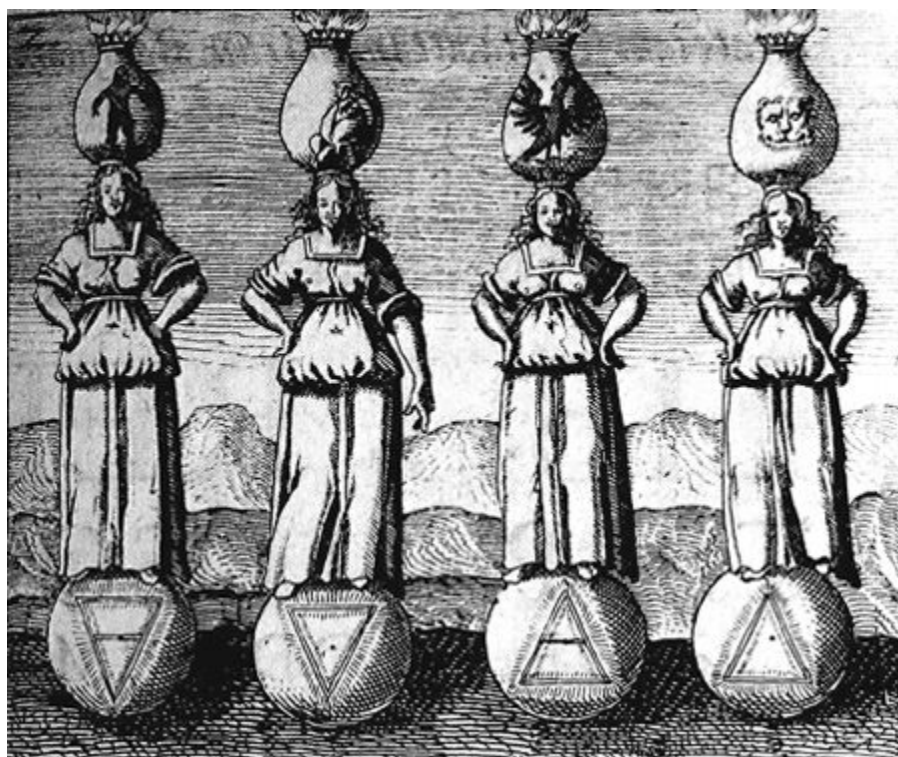

114. The four stages of the alchemical process. The four elements are indicated on the balls.

—Mylius, *Philosophia reformata* (1622)



115. The *nigredo*: eclipse of *Mercurius senex*, exhaling the *spiritus* and *anima*. The raven is a *nigredo* symbol.—

Jamsthaler, *Viatorium spagyricum* (1625)

[334] The *nigredo* or blackness (fig. 115) is the initial state, either present from the beginning as a quality of the *prima materia*, the chaos or *massa confusa*, or else produced by the separation (*solutio, separatio, divisio, putrefactio*) of the elements. If the separated condition is assumed at the start, as sometimes happens, then a union of opposites is performed under the likeness of a union of male and female (called the *coniugium, matrimonium, coniunctio, coitus*), followed by the death of the product of the union (*mortificatio, calcinatio, putrefactio*) and a corresponding *nigredo*. From this the washing (*ablutio, baptisma*) either leads direct to the whitening (*albedo*), or else the soul (*anima*) released at the “death” is reunited with the dead body and brings about its resurrection, or again the “many colours” (*omnes colores*), or “peacock’s tail” (*cauda pavonis*), lead to the one white colour that contains all colours. At this point the first main goal of the process is reached, namely the *albedo*, *tinctura alba, terra alba foliata, lapis albus*, etc., highly prized by many alchemists as if it were the ultimate goal. It is the silver or moon condition, which still has to be raised to the sun condition. The *albedo* is, so to speak, the daybreak, but not till the *rubedo* is it sunrise. The transition to the *rubedo* is formed by the *citrinitas*, though this, as we have said, was omitted later. The *rubedo* then follows direct from the *albedo* as the result of raising the heat of the fire to its highest intensity. The red and the white are King and Queen, who may also celebrate their “chymical wedding” at this stage (fig. 116).



116. Crowned hermaphrodite representing the union of king and queen, between the sun and moon trees.—“Traité d'alchimie” (MS., Paris, 17th cent.)

III. CONCEPTIONS AND SYMBOLS OF THE GOAL

[335] The arrangement of the stages in individual authors depends primarily on their conception of the goal: sometimes this is the white or red tincture (*aqua permanens*); sometimes the philosophers' stone, which, as hermaphrodite, contains both; or again it is the panacea (*aurum potabile*, *elixir vitae*), philosophical gold, golden glass (*vitrum aureum*), malleable glass (*vitrum malleabile*). The conceptions of the goal are as vague and various as the individual processes. The *lapis philosophorum*, for instance, is often the *prima materia*, or the means of producing the gold; or again it is an altogether mystical being that is sometimes called *Deus terrestris*, *Salvator*, or *filius macrocosmi*, a figure we can only compare with the Gnostic Anthropos, the divine original man⁶ (fig. 117).

[336] Besides the idea of the *prima materia*, that of water (*aqua permanens*) and that of fire (*ignis noster*) play an important part. Although these two elements are antagonistic and even constitute a typical pair of opposites, they are yet one and the same according to the testimony of the authors.⁷ Like the *prima materia* the water has a thousand names;⁸ it is even said to be the original material of the stone.⁹ In spite of this we are on the other hand assured that the water is extracted from the stone or

prima materia as its life-giving soul (*anima*).¹⁰ This perplexity comes out very clearly in the following passage from the “VIII Exercitatio in Turbam”:

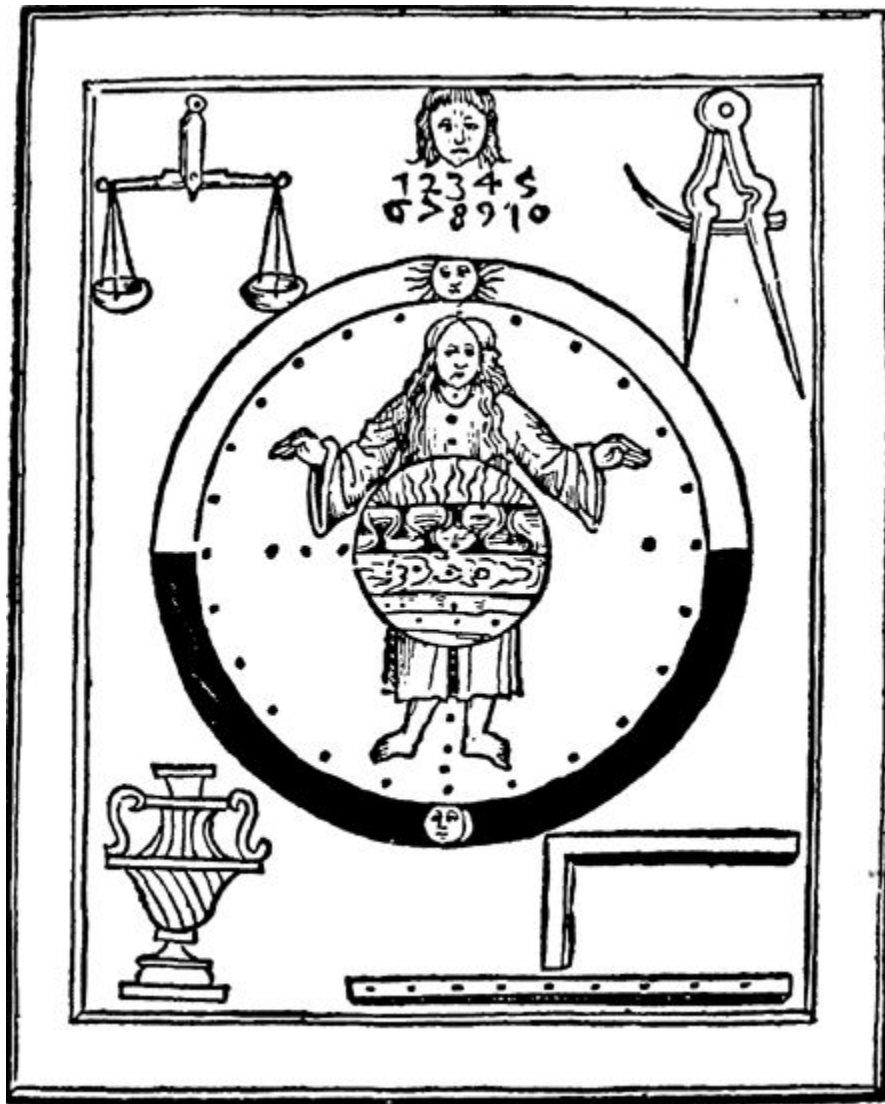

117. Anthropos as *anima mundi*, containing the four elements and characterized by the number 10, which represents perfection (1 + 2 + 3 + 4).—Albertus Magnus, *Philosophia naturalis* (1650)

Many dispute in long controversies whether the stone, under different names, consists of several substances, or of two, or only of one. But this philosopher [Scites]¹¹ and Bonellus¹² say that the whole work and the substance of the whole work are nothing but the water; and that the treatment [*regimen*] of the same also takes place in nothing but the water. And there is in fact one substance in which everything is contained and that is the *sulphur philosophorum*, [which] is water and soul, oil, Mercurius and Sol, the fire of nature, the eagle, the *lachryma*, the first *hyle* of the wise, the *materia prima* of the perfect body. And by whatever names the philosophers have called their stone they always mean and refer to this one substance, i.e., to the water from which everything [originates] and in which everything [is contained], which rules everything, in which errors are made and in which the error is itself corrected. I call it “philosophical” water, not ordinary [*vulgi*] water but *aqua mercurialis*, whether it be simple or composite. For both are the philosophical water, although the vulgar

mercury is different from the philosophical. That [water] is simple [and] unmixed, this [water] is composed of two substances: namely of our mineral and of simple water. These composite waters form the philosophical Mercurius. from which it must be assumed that the substance, or the *prima materia* itself, consists of composite water. Some [alchemists] put three together, others, only two. For myself two species are sufficient: male and female or brother and sister [fig. 118]. But they also call the simple water poison, quicksilver [*argentum vivum*], cambar, *aqua permanens*, gum, vinegar, urine, sea-water, dragon, and serpent.¹³



118. Brother-sister pair in the “bath of life,” being bitten in the calf by dragons while the lunar water, fertilized by the divine breath, is poured over their heads.—*Theatrum chemicum Britannicum* (1652)

[337] This account makes one thing very evident: the philosophical water is the stone or the *prima materia* itself; but at the same time, it is also its solvent, as is proved by the prescription immediately following:

Grind the stone to a very fine powder and put it into the sharpest celestial [*coelestino*] vinegar, and it will at once be dissolved into the philosophical water.



119. Alchemical furnace.—Geber, *De alchimia* (1529)

[338] It can also be shown that fire played the same role as water. Another, no less important, idea is that of the Hermetic vessel (*vas Hermetis*), typified by the retorts or melting-furnaces that contained the substances to be transformed (fig. 119). Although an instrument, it nevertheless has peculiar connections with the *prima materia* as well as with the *lapis*, so it is no mere piece of apparatus. For the alchemists the vessel is something truly marvellous: a *vas mirabile*. Maria Prophetissa (fig. 78) says that the whole secret lies in knowing about the Hermetic vessel. “Unum est vas” (the vessel is one) is emphasized again and again.¹⁴ It must be completely round,¹⁵ in imitation of the spherical cosmos,¹⁶ so that the influence of the stars may contribute to the success of the operation.¹⁷ It is a kind of matrix or uterus from which the *filius philosophorum*, the miraculous stone, is to be born¹⁸ (fig. 120). Hence it is required that the vessel be not only round but egg-shaped¹⁹ (fig. 121; cf. fig. 22). One naturally thinks of this vessel as a sort of retort or flask; but one soon learns that this is an inadequate conception since the vessel is more a mystical idea, a true symbol like all the central ideas of alchemy. Thus we hear that the *vas* is the water or *aqua permanens*, which is none other than the Mercurius of the philosophers.²⁰ But not only is it the water, it is also its opposite: fire.²¹



120. Mercurius in the vessel.—Barchusen, *Elementa chemiae* (1718)

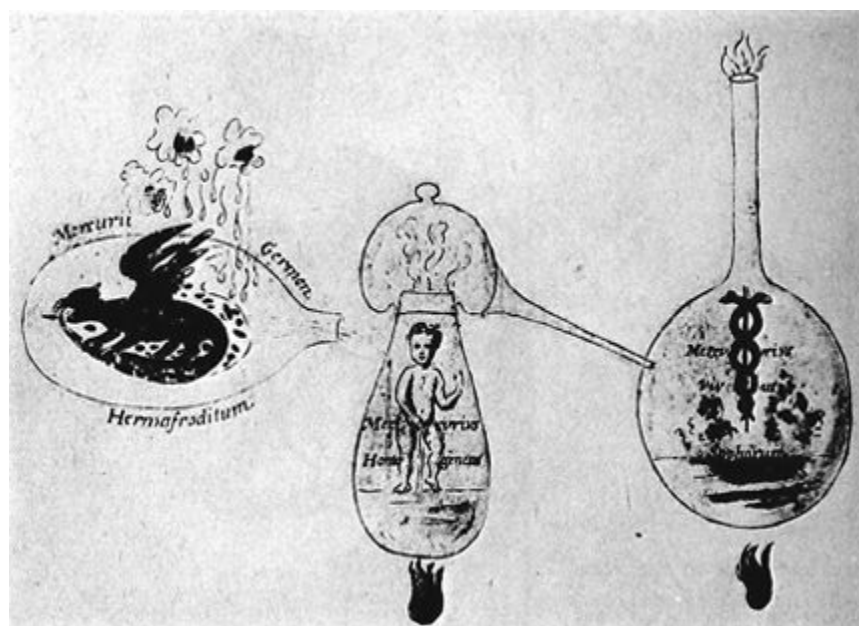

121. The transformations of Mercurius in the Hermetic vessel. The homunculus shown as a “pissing manikin” is an allusion to the *urina puerorum* (= *aqua permanens*).—“Cabala mineralis” (MS., British Museum, Add. 5245)

[339] I will not enter further into all the innumerable synonyms for the vessel. The few I have mentioned will suffice to demonstrate its undoubted symbolical significance.

[340] As to the course of the process as a whole, the authors are vague and contradictory. Many content themselves with a few summary hints, others make an elaborate list of the various operations. Thus in 1576, Josephus Quercetanus, alchemist, physician, and diplomat, who in France and French Switzerland played a somewhat similar role to that of Paracelsus, established a sequence of twelve operations²² as follows (fig. 122):

1. *Calcinatio*
2. *Solutio*
3. *Elementorum separatio*

4. *Coniunctio*
5. *Putrefactio*
6. *Coagulatio*
7. *Cibatio*
8. *Sublimatio*
9. *Fermentatio*
10. *Exaltatio*
11. *Augmentatio*
12. *Proiectio*

Every single one of these terms has more than one meaning; we need only look up the explanations in Ruland's *Lexicon* to get a more than adequate idea of this. It is therefore pointless to go further into the variations of the alchemical procedure in the present context.

[341] Such is, superficially and in the roughest outline, the framework of alchemy as known to us all. From the point of view of our modern knowledge of chemistry it tells us little or nothing, and if we turn to the texts and the hundreds and hundreds of procedures and recipes left behind by the Middle Ages and antiquity, we shall find relatively few among them with any recognizable meaning for the chemist. He would probably find most of them nonsensical, and furthermore it is certain beyond all doubt that no real tincture or artificial gold was ever produced during the many centuries of earnest endeavour. What then, we may fairly ask, induced the old alchemists to go on labouring—or, as they said, “operating”—so steadfastly and to write all those treatises on the “divine” art if their whole undertaking was so portentously futile? To do them justice we must add that all knowledge of the nature of chemistry and its limitations was still completely closed to them, so that they were as much entitled to hope as those who dreamed of flying and whose successors made the dream come true after all. Nor should we underestimate the sense of satisfaction born of the enterprise, the excitement of the adventure, of the *quaerere* (seeking) and the *invenire* (finding). This always lasts as long as the methods employed seem sensible. There was nothing at that time to convince the alchemist of the senselessness of his chemical operations; what is more, he could look back on a long tradition which contained not a few testimonies of such as had achieved the marvellous result.²³ Finally the matter was not entirely without promise, since a number of useful discoveries did occasionally emerge as byproducts of his labours in the laboratory. As the forerunner of chemistry alchemy had a sufficient *raison d'être*. Hence, even if alchemy had consisted in—if you like—an unending series of futile and barren chemical experiments, it would be no more astonishing than the venturesome endeavours of medieval medicine and pharmacology.

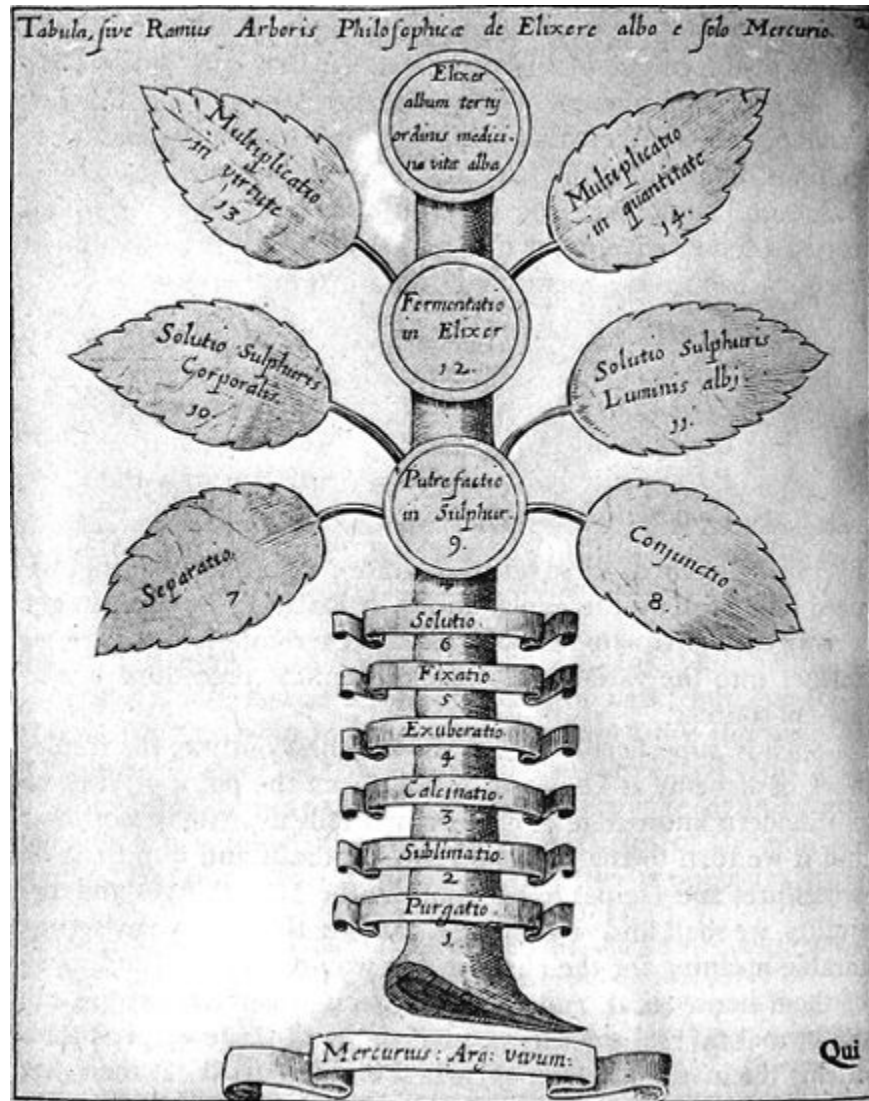

122. The twelve alchemical operations in the form of the *arbor philosophica*.

—Samuel Norton, *Mercurius redivivus* (1630)



123. Hermaphrodite.—*Hermaphroditisches Sonn- und Mondskind* (1752)

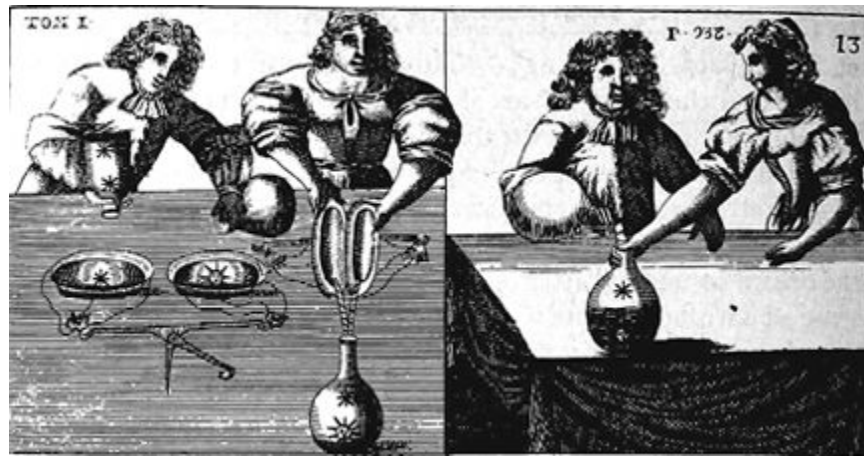

124. Alchemists at work.—*Mutus liber* (1702)

2. THE PSYCHIC NATURE OF THE ALCHEMICAL WORK

I. THE PROJECTION OF PSYCHIC CONTENTS

[342] The alchemical *opus* deals in the main not just with chemical experiments as such, but with something resembling psychic processes expressed in pseudochemical language.¹ The ancients knew more or less what chemical processes were; therefore they must have known that the thing they practised was, to say the least of it, no ordinary chemistry. That they realized the difference is shown even in the title of a treatise by (Pseudo-)Democritus, ascribed to the first century, *τά φυσικιά καὶ τά μυστικά*. And soon afterwards a wealth of evidence accumulates to show that in alchemy there are two—in our eyes—heterogeneous currents flowing side by side, which we simply cannot conceive as being compatible. Alchemy’s “tam ethice quam physice” (as much ethical—i.e., psychological—as physical) is impenetrable to our *logic*. If the alchemist is admittedly using the chemical process only symbolically, then why does he work in a laboratory with crucibles and alembics? And if, as he constantly asserts, he is describing chemical processes, why distort them past recognition with his mythological symbolisms?

[343] This puzzle has proved something of a headache to many an honest and well-meaning student of alchemy. On the one hand the alchemist declares that he is concealing the truth intentionally, so as to prevent wicked or stupid people from gaining possession of the gold and thus precipitating a catastrophe. But, on the other hand, the same author will assure us that the gold he is seeking is not—as the stupid suppose—the ordinary gold (*aurum vulgi*), it is the philosophical gold or even the marvellous stone, the *lapis invisibilitatis* (the stone of invisibility),² or the *lapis aethereus* (the ethereal stone),³ or finally the unimaginable hermaphroditic *rebis* (fig. 125), and he will end up by saying that all recipes whatsoever are to be despised.⁴ For psychological reasons, however, it is highly unlikely that the motive prompting the alchemist to secrecy and mystification was consideration for mankind. Whenever anything real is discovered it is usually announced with a flourish of trumpets. The fact is that the alchemists had little or nothing to divulge in the way of chemistry, least of all the secret of goldmaking.

[344] Mystification can be pure bluff for the obvious purpose of exploiting the credulous. But any attempt to explain alchemy as a whole from this angle is, in my opinion, contradicted by the fact that a fair number of detailed, scholarly, and conscientious treatises were written and published anonymously, and therefore could

not be of unlawful advantage to anyone. At the same time there are undoubtedly a great many fraudulent productions written by charlatans.



125. Mercurius as the sun-moon hermaphrodite (*rebis*), standing on the (round) chaos.—Mylius, *Philosophia reformata* (1622)

[345] But mystification can also arise from another source. The real mystery does not behave mysteriously or secretly; it speaks a secret language, it adumbrates itself by a variety of images which all indicate its true nature. I am not speaking of a secret personally guarded by someone, with a content known to its possessor, but of a mystery, a matter or circumstance which is “secret,” i.e., known only through vague hints but essentially unknown. The real nature of matter was unknown to the alchemist: he knew it only in hints. In seeking to explore it he projected the unconscious into the darkness of matter in order to illuminate it. In order to explain the mystery of matter he projected yet another mystery—his own unknown psychic background—into what was to be explained: *Obscurum per obscurius, ignotum per ignotius!* This procedure was not, of course, intentional; it was an involuntary occurrence.

[346] Strictly speaking, projection is never made; it happens, it is simply there. In the darkness of anything external to me I find, without recognizing it as such, an interior or psychic life that is my own. It would therefore be a mistake in my opinion to explain the formula “tam ethice quam physice” by the theory of correspondences, and to say that this is its “cause.” On the contrary, this theory is more likely to be a rationalization of the experience of projection. The alchemist did not practise his art because he believed on theoretical grounds in correspondence; the point is that he had a theory of correspondence because he experienced the presence of pre-existing

ideas in physical matter. I am therefore inclined to assume that the real root of alchemy is to be sought less in philosophical doctrines than in the projections of individual investigators. I mean by this that while working on his chemical experiments the operator had certain psychic experiences which appeared to him as the particular behaviour of the chemical process. Since it was a question of projection, he was naturally unconscious of the fact that the experience had nothing to do with matter itself (that is, with matter as we know it today). He experienced his projection as a property of matter; but what he was in reality experiencing was his own unconscious. In this way he recapitulated the whole history of man's knowledge of nature. As we all know, science began with the stars, and mankind discovered in them the dominants of the unconscious, the "gods," as well as the curious psychological qualities of the zodiac: a complete projected theory of human character. Astrology is a primordial experience similar to alchemy. Such projections repeat themselves whenever man tries to explore an empty darkness and involuntarily fills it with living form.

[347] This being so, I turned my attention to the question of whether the alchemists themselves had reported any such experiences in the course of their work. I had no reason to hope for a very rich find, since they would be "unconscious" experiences which would escape record for precisely that reason. But in point of fact there are one or two unmistakable accounts in the literature. Characteristically enough, the later accounts are more detailed and specific than the earlier ones. The most recent account comes from a treatise⁵ alleged to have been translated from Ethiopian into Latin and from Latin into German, of which Chapter VIII, "The Creation," reads:

Take of common rainwater a good quantity, at least ten quarts, preserve it well sealed in glass vessels for at least ten days, then it will deposit matter and faeces on the bottom. Pour off the clear liquid and place in a wooden vessel that is fashioned round like a ball, cut it through the middle and fill the vessel a third full, and set it in the sun about midday in a secret or secluded spot.

When this has been done, take a drop of the consecrated red wine and let it fall into the water, and you will instantly perceive a fog and thick darkness on top of the water, such as also was at the first creation. Then put in two drops, and you will see the light coming forth from the darkness; whereupon little by little put in every half of each quarter hour first three, then four, then five, then six drops, and then no more, and you will see with your own eyes one thing after another appearing by and by on top of the water, how God created all things in six days [fig. 126], and how it all came to pass, and such secrets as are not to be spoken aloud and I also have not the power to reveal. Fall on your knees before you undertake this operation. Let your

eyes judge of it; for thus was the world created. Let all stand as it is, and in half an hour after it began it will disappear.

By this you will see clearly the secrets of God, that are at present hidden from you as from a child. You will understand what Moses has written concerning the creation; you will see what manner of body Adam and Eve had before and after the Fall, what the serpent was, what the tree, and what manner of fruits they ate: where and what Paradise is, and in what bodies the righteous shall be resurrected; not in this body that we have received from Adam, but in that which we attain through the Holy Ghost, namely in such a body as our Saviour brought from heaven.

[348] In Chapter IX, “The Heavens,” we read:

You shall take seven pieces of metal, of each and every metal as they are named after the planets, and shall stamp on each the character of the planet in the house of the same planet, and every piece shall be as large and thick as a rose noble.⁶ But of Mercury only the fourth part of an ounce by weight and nothing stamped upon it.

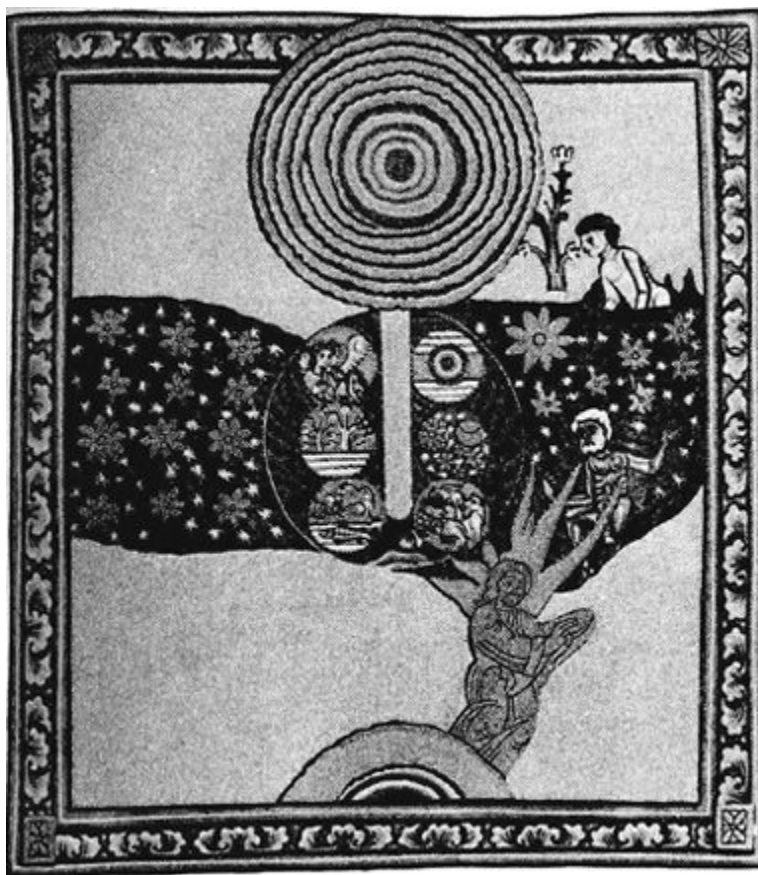

126. The six days of creation, culminating in the seventh day.—St. Hildegarde of Bingen, “Scivias” (MS., 12th cent.)

Then put them after the order in which they stand in the heavens into a crucible, and make all windows fast in the chamber that it may be quite dark within, then melt them all together in the midst of the chamber and drop in seven drops of the blessed Stone, and forthwith a flame of fire will come out of the crucible [fig. 127] and spread itself over the whole chamber (fear no harm), and will light up the whole chamber more brightly than sun and moon, and over your heads you shall behold the

whole firmament as it is in the starry heavens above, and the planets shall hold to their appointed courses as in the sky. Let it cease of itself, in a quarter of an hour everything will be in its own place.



127. The transformation of Mercurius in the fire.—Barchusen, *Elementa chemiae* (1718)

[349] Let us take another example from a treatise by Theobald de Hoghelande (sixteenth century):

They say also that different names are given to the stone on account of the wonderful variety of figures that appear in the course of the work, inasmuch as colours often come forth at the same time, just as we sometimes imagine in the clouds or in the fire strange shapes of animals, reptiles, or trees. I found similar things in a fragment of a book ascribed to Moses: when the body is dissolved, it is there written, then will appear sometimes two branches, sometimes three or more, sometimes also the shapes of reptiles; on occasion it also seems as if a man with a head and all his limbs were seated upon a cathedra.⁷



128. Hermes Trismegistus.—Senior, *De chemia*, in Mangetus, *Bibliotheca chemica curiosa* (1702)

[350] Like the two preceding texts, Hoghelande's remarks prove that during the practical work certain events of an hallucinatory or visionary nature were perceived, which cannot be anything but projections of unconscious contents. Hoghelande quotes Senior as saying that the "vision" of the Hermetic vessel "is more to be sought than the scripture."⁸ The authors speak of seeing with the eyes of the spirit, but it is not always clear whether they mean vision in a real or a figurative sense. Thus the "Novum lumen" says:

To cause things hidden in the shadow to appear, and to take away the shadow from them, this is permitted to the intelligent philosopher by God through nature.... All these things happen, and the eyes of the common men do not see them, but the eyes of the understanding [*intellectus*] and of the imagination perceive them [*percipiunt*] with true and truest vision [*visu*].⁹

[351] Raymond Lully writes:

You should know, dear son, that the course of nature is turned about, so that without invocation [e.g., of the *familiaris*] and without spiritual exaltation you can see certain

fugitive spirits condensed in the air in the shape of divers monsters, beasts and men, which move like the clouds hither and thither [fig. 129].¹⁰



129. Personified *spiritus* escaping from the heated *prima materia*.— Thomas Aquinas (pseud.), “De alchimia” (MS., 16th cent.)

[352] Dorn says much the same:

Thus he will come to see with his mental eyes [*oculis mentalibus*] an indefinite number of sparks shining through day by day and more and more and growing into a great light.¹¹

[353] The psychologist will find nothing strange in a figure of speech becoming concretized and turning into an hallucination. Thus in his biographical notes (1594), Hoghelande describes how, on the third day of the *decoctio*, he saw the surface of the substance cover itself with colours, “chiefly green, red, grey, and for the rest iridescent.” Whenever he remembered that day a verse of Virgil’s came into his mind: “Ut vidi, ut perii, ut me malus abstulit error” (When I saw, how utterly I perished and evil delusion took me off). This error or optical illusion (“*ludibrium oculis oblatum*”), he said, was the cause of much subsequent trouble and expense, for he had believed that he was on the point of attaining the *nigredo*. But a few days later his fire went out in the night, which led to an *irreparabile damnum*; in other words, he never succeeded in repeating the phenomenon.¹² Not that the iridescent skin on molten metal is necessarily an hallucination; but the text shows a remarkable willingness on the part of the author to suspect something of the sort.

[354] The “*Tractatus Aristotelis*” contains a passage that is noteworthy from the point of view of the alchemist’s psychology:

The serpent is more cunning than all the beasts of the earth; under the beauty of her skin she shows a harmless face, and she forms herself in the manner of a *materia hypostatica*, through illusion, when immersed in water.¹³ There she gathers together the virtues from the earth, which is her body. Because she is very thirsty she drinks immoderately and becomes drunken, and she causes the nature wherewith she is united to vanish [*decipere*].¹⁴

[355] The serpent is Mercurius, who as the fundamental substance (*hypostatica*) forms himself in the water and swallows the nature to which he is joined (fig. 130). (Cf. sun drowning in the Fountain of Mercurius, lion devouring the sun [fig. 169], Beya dissolving Gabricus in her own body.) Matter is thus formed through illusion, which is necessarily that of the alchemist. This illusion might well be the *vera imaginatio* possessed of “informing” power.

[356] The fact that visions allied themselves to the alchemical work may also explain why dreams and dream-visions are often mentioned as important *intermezzi* or as sources of revelation. Thus Nazari, for instance, puts his doctrine of transmutation in the form of three dreams,¹⁵ a fairly plain analogy to *Poliphilo*. The classical “*Visio Arislei*” has a similar dream form.¹⁶ Ostances likewise communicates his doctrine dressed up as a revelation in a dream.¹⁷ While the dreams and visions in these texts (as also in Senior and Krates) are mainly a literary convention, the dream-vision of Zosimos has a much more authentic character.¹⁸ It is repeatedly stressed in the literature that the much-sought-after *aqua permanens* would be revealed in a dream.¹⁹ Generally speaking the *prima materia*, indeed the stone itself—or the secret of its production—is revealed to the operator by God. Thus Laurentius Ventura says: “But one cannot know the procedure unless it be a gift of God, or through the instruction of a most experienced Master: and the source of it all is the Divine Will.”²⁰ Khunrath²¹ is of the opinion that one could “perfectly prepare our Chaos Naturae [= *prima materia*] in the highest simplicity and perfection” from a “special Secret Divine Vision and revelation, without further probing and pondering of the causes.”²² Hoghelande explains the necessity for divine illumination by saying that the production of the stone transcends reason²³ and that only a supernatural and divine knowledge knows the exact time for the birth of the stone.²⁴ This means that God alone knows the *prima materia*.²⁵ After the time of Paracelsus the source of enlightenment was the *lumen naturae*:



130. The Mercurial serpent devouring itself in water or fire.—Barchusen, *Elementa chemiae* (1718)

This Light is the true Light of nature, which illuminates all the God-loving Philosophers who come into this World. It is in the World and the whole edifice of the World is beautifully adorned and will be naturally preserved by it until the last and great day of the Lord, but the World knows it not. Above all it is the Subject of the Catholic and Great Stone of the Philosophers, which the whole World has before its eyes yet knows not.²⁶

II. THE MENTAL ATTITUDE TOWARDS THE OPUS

[357] A somewhat different aspect of the psyche's relations to the chemical work is apparent in the following quotation from the text of an anonymous author:²⁷ "I pray you, look with the eyes of the mind at this little tree of the grain of wheat, regarding all its circumstances, that you may be able to plant the tree of the philosophers."²⁸ (Fig. 131; cf. also figs. 135, 188, 189, 221.) This seems to point to active imagination as the thing that sets the process really going.

[358] Dorn says in his "Philosophia meditativa": "Thou wilt never make from others the One that thou seekest, except there first be made one thing of thyself."²⁹

Whatever he may have meant by the “One”³⁰ it must refer to the “artifex,” whose unity is postulated as the absolute condition for the completion of the work. We can hardly doubt that the *psychological* condition for the *opus* is meant, and that this is of fundamental importance.



131. Adam as *prima materia*, pierced by the arrow of Mercurius. The *arbor philosophica* is growing out of him.
—“Miscellanea d’alchimia” (MS., 14th cent.)

[359] The *Rosarium* says:³¹

Who therefore knows the salt and its solution knows the hidden secret of the wise men of old. Therefore turn your mind upon the salt and think not of other things; for in it alone [i.e., the mind] is the science concealed and the most excellent and most hidden secret of all the ancient philosophers.³²

[360] The Latin text has “in ipsa sola,” referring therefore to “mens.” One would have to assume a double misprint were the secret after all concealed in the *salt*. But as a matter of fact “mind” and “salt” are close cousins—*cum grano salis!*³³ Hence, according to Khunrath, the salt is not only the physical centre of the earth but at the same time the *sal sapientiae*,³⁴ of which he says: “Therefore direct your feelings,

senses, reason and thoughts upon this salt alone.”³⁵ The anonymous author of the *Rosarium* says in another place that the work must be performed “with the true and not with the fantastic imagination,”³⁶ and again that the stone will be found “when the search lies heavy on the searcher.”³⁷ This remark can only be understood as meaning that a certain psychological condition is indispensable for the discovery of the miraculous stone.

[361] Both these remarks, therefore, make it seem very possible that the author was in fact of the opinion that the essential secret of the art lies hidden in the human mind—or, to put it in modern terms, in the unconscious (fig. 132).

[362] If it really did dawn on the alchemists that their work was somehow connected with the human psyche and its functions, then it seems to me probable that the passage from the *Rosarium* is no mere misprint. It agrees too well with the statements of other authors. They insist throughout upon careful study and meditation of the books. Thus Richardus Anglicus³⁸ says in his so-called “Correctorium alchymiae”:

Therefore all those who desire to attain the blessing of this art should apply themselves to study, should gather the truth from the books and not from invented fables and untruthful works. There is no way by which this art can truly be found (although men meet with many deceptions), except by completing their studies and understanding the words of the philosophers....³⁹

[363] Bernard of Treviso tells us how he struggled in vain for many years till at last he was “directed into the straight path” through a *sermo* of Parmenides in the *Turba*.⁴⁰

[364] Hoghelande says:

He should collect the books of different authors, because otherwise it is impossible to understand them, and he should not throw aside a book which he has read once, twice, or even three times, although he has not understood it, but should read it again ten, twenty, fifty times or even more. At last he will see wherein the authors are mainly agreed: there the truth lies hidden....⁴¹

[365] Quoting Raymond Lully as his authority, the same author says that owing to their ignorance men are not able to accomplish the work until they have studied universal philosophy, which will show them things that are unknown and hidden from others. “Therefore our stone belongs not to the vulgar but to the very heart of our philosophy.”⁴² Dionysius Zacharius relates that a certain “religiosus Doctor excellentissimus” advised him to refrain from useless expense in “sophisticationibus diabolicis” and to devote himself rather to the study of the books of the old philosophers, so as to acquaint himself with the *vera materia*. After a fit of despair he revived with the help of the Holy Spirit and, applying himself to a serious study of

the literature, read diligently, and meditated day and night until his finances were exhausted. Then he worked in his laboratory, saw the three colours appear, and on Easter Day of the following year the wonder happened: “Vidi perfectionem”—“I saw the perfect fulfilment”: the quicksilver was “conversum in purum aurum prae meis oculis.” This happened, so it was said, in 1550.⁴³ There is an unmistakable hint here that the work and its goal depended very largely on a mental condition. Richardus Anglicus rejects all the assorted filth the alchemists worked with, such as eggshells, hair, the blood of a red-haired man, basilisks, worms, herbs, and human faeces. “Whatsoever a man soweth that also shall he reap. Therefore if he soweth filth, he shall find filth.”⁴⁴ “Turn back, brethren, to the way of truth of which you are ignorant; I counsel you for your own sake to study and to labour with steadfast meditation on the words of the philosophers, whence the truth can be summoned forth.”⁴⁵



132. The “secret” contents of the work. Centre, the *soror mystica*, with the artifex, fishing for Neptune (animus); below, artifex, with *soror*, fishing for Melusina (anima).—*Mutus liber* (1702)

[366] The importance or necessity of understanding and intelligence is insisted upon all through the literature, not only because intelligence above the ordinary is needed in the performance of so difficult a work, but because it is assumed that a species of

magical power capable of transforming even brute matter dwells in the human mind. Dorn, who devoted a series of interesting treatises⁴⁶ to the problem of the relationship between the work and the man (fig. 133), says: “In truth the form, which is the intellect of man, is the beginning, middle and end of the procedure: and this form is made clear by the saffron colour, which indicates that man is the greater and principal form in the spagyric *opus*.”⁴⁷ Dorn draws a complete parallel between the alchemical work and the moral-intellectual transformation of man. His thought, however, is often anticipated in the Harranite “Treatise of Platonic Tetralogies,” the Latin title of which is “Liber Platonis quattorum.”⁴⁸ Its author establishes four series of correspondences, each containing four “books,” “for the help of the investigator”:⁴⁹

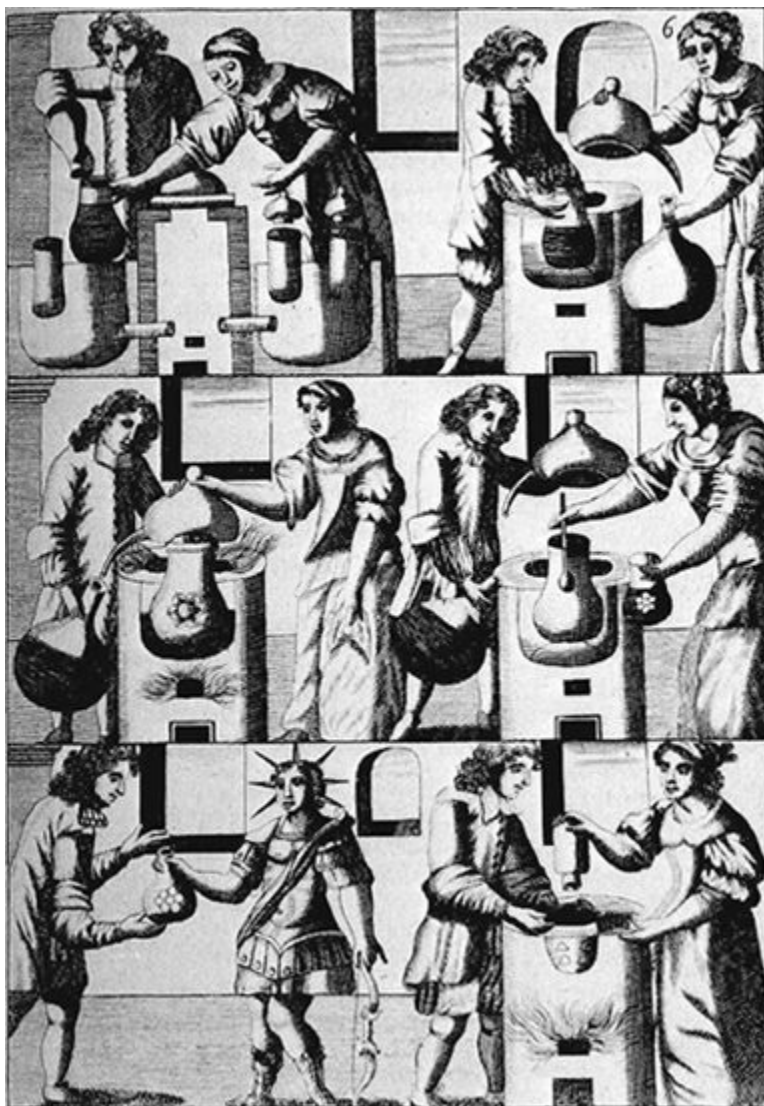

133. Alchemists at work: various stages of the process. Sol appears below, bringing the golden flower.—*Mutus liber* (1702)

I	II ⁵³	III	IV
1. De opere naturalium (Concerning the work of natural things)	1. Elementum aquae	1. Naturae composite (Composite natures)	1. Sensus (Senses)

2. Exaltatio divisionis naturae (Emphasis on—or exaltation of—the division of nature) ⁵⁰	2. Elementum terrae	2. Naturae discretæ (Discriminated natures)	2. Discretio intellectualis (Intellectual discrimination)
3. Exaltatio animae (Emphasis on—or exaltation of—the soul) ⁵¹	3. Elementum aëris	3. Simplicia (Simple things)	3. Ratio (Reason) ⁵⁴
4. Exaltatio intellectus (Emphasis on—or exaltation of—the intellect) ⁵²	4. Elementum ignis	4. Aetheris simplicioris (Things pertaining to yet simpler ether)	4. Res quam concludunt hi effectus præcedentes (The thing included in the foregoing effects) ⁵⁵

[367] The four series show four aspects of the *opus*. The first horizontal series begins with natural things, the *prima materia* as represented by water. These things are composite, i.e., mixed. Their “correspondence” in column IV is sense perception. The second horizontal series represents a higher stage in the process: in column I, the composite natures are decomposed or changed back into their initial elements; in column II, the earth is separated from the (primal) water as in the Book of Genesis, a favourite theme in alchemy; in column III, there is a separation into categories; and column IV is concerned with the psychological act of discrimination.

[368] The third horizontal series shows the upward advance still more clearly: in column I, the soul emerges from nature; in column II, there is an elevation into the realm of air; in column III, the process reaches the “simple” things which, because of their unalloyed quality, are incorruptible, eternal, and akin to Platonis ideas; and in column IV, there is the final ascent from *mens* to *ratio*, to the *anima rationalis*, i.e., the highest form of the soul. The fourth horizontal series illustrates the perfection or completion of each of the vertical columns.

[369] *First vertical series:* This column has a “phenomenological” character, if such a modern term is permissible here. The psychic element emerges from the sum of natural phenomena and culminates in the *exaltatio intellectus*, the phenomenon of clear insight and understanding. We can, without doing violence to the text, take this *intellectus* as the highest lucidity of which consciousness is capable.

[370] *Second vertical series:* The earth emerges from the chaotic waters of the beginning, from the *massa confusa*, in accordance with the ancient alchemical view; above it lies air, the volatile element rising from the earth. Highest of all comes fire⁵⁶ as the “finest” substance, i.e., the fiery pneuma⁵⁷ which reaches up to the seat of the gods⁵⁸ (fig. 134; cf. figs. 166, 178, 200).

[371] *Third vertical series:* This column has a categorical or ideal character; hence it contains intellectual judgments. All composites are dissolved into their “discriminated” components, which in their turn are reduced to the “simple” substance. From this there finally emerge the quintessences, the simple primordial ideas. Ether is the quintessence.⁵⁹

[372] *Fourth vertical series:* This column is exclusively “psychological.” The senses mediate perception, while the *discretio intellectualis* corresponds to apperception. This activity is subject to the *ratio* or *anima rationalis*, the highest faculty bestowed by God on man. Above the *anima rationalis* there is only the *res*, which is the product of all the preceding effects. The “*Liber Platonis quartorum*” interprets this *res* as the

invisible and immovable God⁶⁰ whose will created the intelligence; from the will and intelligence [to be understood here as *intellectus*] is produced the simple soul,⁶¹ but the soul gives rise to the discriminated natures from which the composite natures are produced, and these show that a thing cannot be comprehended save by something superior to it. The soul is above nature and through it nature is comprehended, but the intelligence is above the soul and through it the soul is comprehended, and the intelligence is comprehended by that which is above itself, and is surrounded by the One God whose nature is not to be comprehended.⁶²

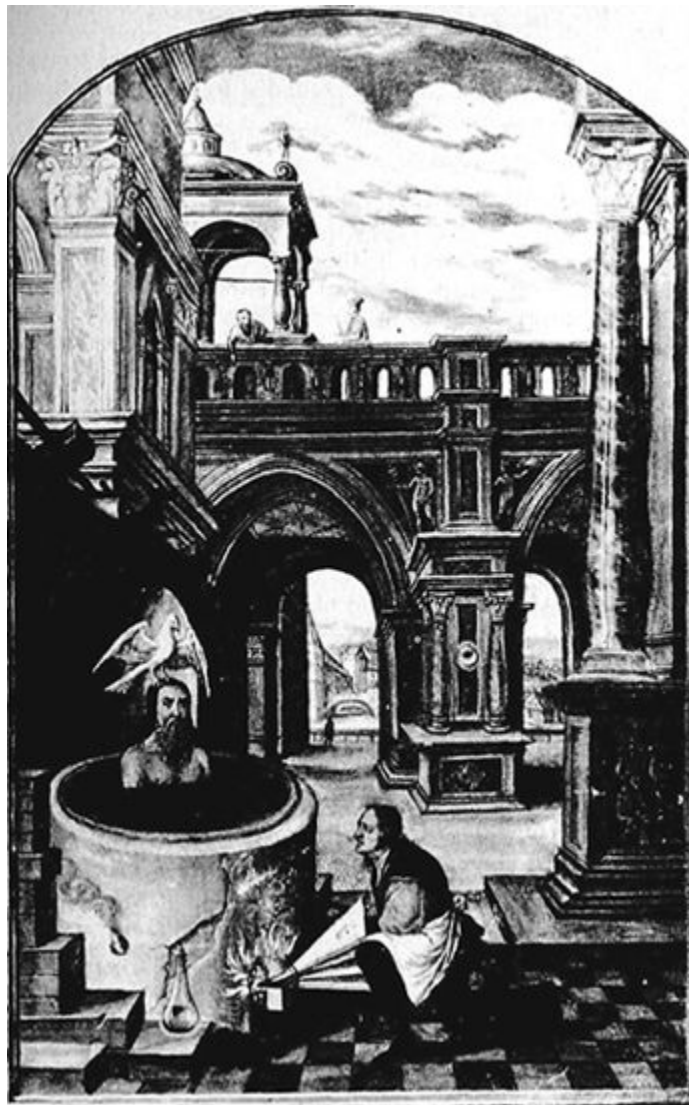

134. Saturn, or *Mercurius senex*, being cooked in the bath until the spirit or white dove (*pneuma*) ascends.—

Trismosin, “*Splendor solis*” (MS., 1582)

[373] The original text runs:

... scias quod scientia antiquorum quibus appraeparatae sunt scientiae et virtutes, est quod res ex qua sunt res, est Deus invisibilis et immobilis, cuius voluntate intelligentia condita est; et voluntate et intelligentia⁶³ est anima simplex; per animam sunt naturae discretae, ex quibus generatae sunt compositae, et indicant quod res non cognoscitur, nisi per suam superius. Anima vero est super naturam, et per eam cognoscitur natura, sed intelligentia est superior anima et per eam cognoscitur anima, et intelligentia[m]⁶⁴ noscit, qui⁶⁵ superior ea est, et circumdat eam Deus unus, cuius qualitas apprehendi non potest.

[374] The author adds a quotation whose origin I have not been able to trace. It runs:

The philosopher said in the Book of Dialogues: I went about the three heavens, namely the heaven of composite nature, the heaven of discriminated nature, and the heaven of the soul. But when I sought to go about the heaven of intelligence, the soul said to me: That way is not for thee. Then nature attracted me, and I was attracted.

This saying of the philosopher was not intended by him to specify this science, but because he wished that his words should not fail to make clear the power which liberates the creature, and that by their means the lower process in this kind of work should be made known through the higher.⁶⁶

[375] In this very ancient text—which in its Arabic form cannot be much later than the tenth century, many of its components being still older—we find a systematic classification of the correspondences between the *opus alchemicum* and the philosophical and psychological processes running parallel with it. The text makes it abundantly clear just how much the chemical processes coincided with spiritual or psychic factors for these thinkers. Indeed the connection went so far that the product to be extracted from matter was known as the *cogitatio*.⁶⁷ This strange idea is explicable only on the assumption that the old philosophers did have a faint suspicion that psychic contents were being projected into matter. Because of the intimate connection between man and the secret of matter, both Dorn and the much earlier “Liber Platonis Quartorum” demand that the operator should rise to the height of his task: he must accomplish in his own self the same process that he attributes to matter, “for things are perfected by their like.” Therefore the operator must himself participate in the work (“oportet operatorem interesse operi”), “for if the investigator does not remotely possess the likeness [i.e., to the work] he will not climb the height I have described, nor reach the road that leads to the goal.”⁶⁸

[376] As a result of the projection there is an unconscious identity between the psyche of the alchemist and the arcane substance, i.e., the spirit imprisoned in matter. The “Liber Platonis quartorum” accordingly recommends the use of the *occiput* (fig. 75) as the vessel of transformation,⁶⁹ because it is the container of thought and intellect⁷⁰ (fig. 135). For we need the brain as the seat of the “divine part.” The text continues:

Through time and exact definition things are converted into intellect, inasmuch as the parts are assimilated [to one another] in composition and in form. But on account of its proximity to the *anima rationalis* the brain had to be assimilated to the amalgam, and the *anima rationalis* is simple, as we have said.⁷¹



135. The skull, symbol of the *mortificatio* of Eve, the feminine aspect of the *prima materia*. Whereas in the case of Adam the tree corresponds to the phallus (see [fig. 131](#)), here the tree grows out of Eve's head.—“Miscellanea d'alchimia” (MS., 14th cent.)

[377] The assumption underlying this train of thought is the causative effect of analogy. In other words, just as in the psyche the multiplicity of sense perceptions produces the unity and simplicity of an idea, so the primal water finally produces fire, i.e., the ethereal substance—not (and this is the decisive point) as a mere analogy but as the result of the mind's working on matter. Consequently Dorn says: “Within the human body is concealed a certain metaphysical substance, known to very few, which needs no medicament, being itself an incorrupt medicament.” This medicine is “of threefold nature: metaphysical, physical, and moral” (“moral” is what we would call “psychological”). “From this,” Dorn goes on, “the attentive reader will conclude that one must pass from the metaphysical to the physical by a philosophic procedure.”⁷² This medicine is clearly the arcane substance which he defines elsewhere as *veritas*:

There is in natural things a certain truth which cannot be seen with the outward eye, but is perceived by the mind alone [*sola mente*], and of this the Philosophers

have had experience, and have ascertained that its virtue is such as to work miracles.⁷³

In this [truth] lies the whole art of freeing the spirit [*spiritus*] from its fetters, in the same way that, as we have said, the mind [*mens*] can be freed [i.e., morally] from the body.⁷⁴

As faith works miracles in man, so this power, the *veritas efficaciae*, brings them about in matter. This truth is the highest power and an impregnable fortress wherein the stone of the philosophers lies hid.⁷⁵

[378] By studying the philosophers man acquires the skill to attain this stone. But again, the stone is man. Thus Dorn exclaims: “Transform yourselves from dead stones into living philosophical stones!”⁷⁶ Here he is expressing in the clearest possible way the identity of something in man with something concealed in matter.

[379] In his “Recueil stéganographique”⁷⁷ Béroalde de Verville says:

If any man wish at times to change the drop of mastic, and by pressing it to cause a clear tear to issue from it, let him take care, and he will see in a fixed time, under the gentle pressure of the fire, a like substance issue from the philosophic matter; for as soon as its violet darkness is excited for the second time, it will stir up from it as it were a drop or flower or flame or pearl, or other likeness of a precious stone, which will be diversified until it runs out in very clear whiteness, which thereafter will be capable of clothing itself with the honour of beauteous rubies, or ethereal stones, which are the true fire of the soul and light of the philosophers.

[380] It should now be sufficiently clear that from its earliest days alchemy had a double face: on the one hand the practical chemical work in the laboratory, on the other a psychological process, in part consciously psychic, in part unconsciously projected and seen in the various transformations of matter.

[381] Not much effort is needed at the beginning of the work; it is sufficient to approach it with “a free and empty mind,” as one text says.⁷⁸ But one important rule must be observed: “the mind [*mens*] must be in harmony with the work”⁷⁹ and the work must be above all else. Another text says that in order to acquire the “golden understanding” (*aurea apprehensio*) one must keep the eyes of the mind and soul well open, observing and contemplating by means of that inner light which God has lit in nature and in our hearts from the beginning.⁸⁰

[382] Since the investigator’s psyche was so closely bound up with the work—not only as its necessary medium but also as its cause and point of departure—it is easy to understand why so much emphasis was laid on the psychic condition and mental attitude of the laboratory worker. Alphidius says: “Know that thou canst not have this science unless thou shalt purify thy mind before God, that is, wipe away all

corruption from thy heart.”⁸¹ According to *Aurora*, the treasure-house of Hermetic wisdom rests on a firm foundation of fourteen principal virtues: health, humility, holiness, chastity, virtue,⁸² victory, faith, hope, charity, goodness (*benignitas*), patience, temperance, a spiritual discipline or understanding,⁸³ and obedience.

[383] The Pseudo-Thomas who is author of this same treatise quotes the saying “Purge the horrible darkneses of our mind,”⁸⁴ and gives as a parallel Senior’s “he maketh all that is black white ...”⁸⁵ Here the “darkneses of our mind” coincide unmistakably with the *nigredo* (figs. 34, 48, 115, 137); i.e., the author feels or experiences the initial stage of the alchemical process as identical with his own psychic condition.

[384] Another old authority is Geber. The *Rosarium* says that in his *Liber perfecti magisterii* Geber requires the following psychological and characterological qualities of the artifex: He must have a most subtle mind and an adequate knowledge of metals and minerals. But he must not have a coarse or rigid mind, nor should he be greedy and avaricious, nor irresolute and vacillating. Further, he must not be hasty or vain. On the contrary, he must be firm in purpose, persevering, patient, mild, long-suffering, and good-tempered.⁸⁶

[385] The author of the *Rosarium* goes on to say that he who wishes to be initiated into this art and wisdom must not be arrogant, but devout, upright, of profound understanding, humane, of a cheerful countenance and a happy nature. He continues: “My son, above all I admonish thee to fear God, who knoweth what manner of man thou art and in whom is help for the solitary, whosoever he may be.”⁸⁷

[386] Particularly instructive is the introduction to the art given by Morienus to Kalid:⁸⁸

This thing for which you have sought so long is not to be acquired or accomplished by force or passion. It is to be won only by patience and humility and by a determined and most perfect love. For God bestows this divine and immaculate science on his faithful servants, namely those on whom he resolved to bestow it from the original nature of things.⁸⁹ ... [Some remarks follow concerning the handing down of the art to pupils.] Nor were they [the elect] able to hold anything back save through the strength granted to them by God, and they themselves could no longer direct their minds save towards the goal⁹⁰ appointed for them by God. For God charges those of his servants whom he has purposely chosen [fig. 136] that they seek this divine science which is hidden from men, and that they keep it to themselves. This is the science that draws its master away from the suffering of this world and leads to the knowledge of future good.

When Morienus was asked by the king why he lived in mountains and deserts rather than in hermitages, he answered: “I do not doubt that in hermitages and

brotherhoods I would find greater repose, and fatiguing work in the deserts and in the mountains; but no one reaps who does not sow.... Exceeding narrow is the gateway to peace, and none may enter save through affliction of the soul.”⁹¹



136. God enlightening the artifex.—Barchusen, *Elementa chemiae* (1718)

[387] We must not forget, in considering this last sentence, that Morienus is not speaking for the general edification but is referring to the divine art and its work. Michael Maier expresses himself in similar vein when he says:

There is in our chemistry a certain noble substance, in the beginning whereof is wretchedness with vinegar, but in its ending joy with gladness. Therefore I have supposed that the same will happen to me, namely that I shall suffer difficulty, grief, and weariness at first, but in the end shall come to glimpse pleasanter and easier things.⁹²

[388] The same author also affirms that “our chemistry stirs up the artifex to a meditation of the heavenly good,”⁹³ and that whoso is initiated by God into these mysteries “casts aside all insignificant cares like food and clothing, and feels himself as it were new-born.”⁹⁴

[389] The difficulty and grief to be encountered at the beginning of the work once more coincide with the *nigredo*, like the “horrible darkneses of our mind” of which *Aurora* speaks; and these in their turn are surely the same as the “affliction of soul” mentioned by Morienus. The term he uses for the attitude of the adept—*amor perfectissimus*—expresses an extraordinary devotion to the work. If this “serious meditation” is not mere bragging—and we have no reason to assume any such thing—then we must imagine the old adepts carrying out their work with an unusual

concentration, indeed with religious fervour (cf. below). Such devotion would naturally serve to project values and meanings into the object of all this passionate research and to fill it with forms and figures that have their origin primarily in the unconscious of the investigator.

III. MEDITATION AND IMAGINATION

[390] The point of view described above is supported by the alchemist's remarkable use of the terms *meditatio* and *imaginatio*. Ruland's *Lexicon alchemiae* defines *meditatio* as follows: "The word *meditatio* is used when a man has an inner dialogue with someone unseen. It may be with God, when He is invoked, or with himself, or with his good angel"⁹⁵ (fig. 137). The psychologist is familiar with this "inner dialogue"; it is an essential part of the technique for coming to terms with the unconscious.⁹⁶ Ruland's definition proves beyond all doubt that when the alchemists speak of *meditari* they do not mean mere cogitation, but explicitly an inner dialogue and hence a living relationship to the answering voice of the "other" in ourselves, i.e., of the unconscious. The use of the term "meditation" in the Hermetic dictum "And as all things proceed from the One through the meditation of the One" must therefore be understood in this alchemical sense as a creative dialogue, by means of which things pass from an unconscious potential state to a manifest one. Thus we read in a treatise of Philalethes:⁹⁷ "Above all it is marvellous that our stone, although already perfect and able to impart a perfect tincture, does voluntarily humble itself again and will meditate a new volatility, apart from all manipulation."⁹⁸ What is meant by a "meditated volatility" we discover a few lines lower down, where it says: "Of its own accord it will liquefy ... and by God's command become endowed with spirit, which will fly up and take the stone with it."⁹⁹ Again, therefore, to "meditate" means that through a dialogue with God yet more spirit will be infused into the stone, i.e., it will become still more spiritualized, volatilized, or sublimated (cf. fig. 178). Khunrath says much the same thing:



137. Alchemist in the initial *nigredo* state, meditating.—Jamsthaler, *Viatorium spagyricum* (1625)

Therefore study, meditate, sweat, work, cook ... so will a healthful flood be opened to you which comes from the Heart of the Son of the great World, a Water which the Son of the Great World pours forth from his Body and Heart, to be for us a True and Natural Aqua Vitae...¹⁰⁰

[391] Likewise the “meditation of the heavenly good,” mentioned earlier, must be taken in the sense of a living dialectical relationship to certain dominants of the unconscious. We have excellent confirmation of this in a treatise by a French alchemist living in the seventeenth and eighteenth centuries.¹⁰¹ He says:

How often did I see them [the *Sacerdotes Aegyptiorum*] overcome with joy at my understanding, how affectionately they kissed me, for the true grasp of the ambiguities of their paradoxical teaching came easily to my mind. How often did their pleasure in the wonderful discoveries I made concerning the abstruse doctrines of the ancients move them to reveal unto my eyes and fingers the Hermetic vessel, the salamander [fig. 138; cf. figs. 129, 130], the full moon and the rising sun.

[392] This treatise, although it is not so much a personal confession as a description of the golden age of alchemy, nevertheless tells us how the alchemist imagined the psychological structure of his *opus*. Its association with the invisible forces of the psyche was the real secret of the *magisterium*. In order to express this secret the old masters readily resorted to allegory. One of the oldest records of this kind, which had a considerable influence on the later literature, is the “*Visio Arislei*,”¹⁰² and its whole character relates it very closely to those visions known to us from the psychology of the unconscious.

[393] As I have already said, the term *imaginatio*, like *meditatio*, is of particular importance in the alchemical opus. Earlier on we came across that remarkable passage in the *Rosarium* telling us that the work must be done with the true *imaginatio*, and we saw elsewhere [par. 357] how the philosophical tree can be made to grow through contemplation (figs. 131, 135). Ruland's *Lexicon* once more helps us to understand what the alchemist meant by *imaginatio*.



138. The Mercurial spirit of the *prima materia*, in the shape of a salamander, frolicking in the fire.—Maier, *Scrutinium chymicum* (1687)

[394] Ruland says, “Imagination is the star in man, the celestial or supercelestial body.”¹⁰³ This astounding definition throws a quite special light on the fantasy processes connected with the *opus*. We have to conceive of these processes not as the immaterial phantoms we readily take fantasy-pictures to be, but as something corporeal, a “subtle body” (fig. 139), semi-spiritual in nature. In an age when there was as yet no empirical psychology such a concretization was bound to be made, because everything unconscious, once it was activated, was projected into matter—that is to say, it approached people from outside. It was a hybrid phenomenon, as it were, half spiritual, half physical; a concretization such as we frequently encounter in the psychology of primitives. The *imaginatio*, or the act of imagining, was thus a physical activity that could be fitted into the cycle of material changes, that brought these about and was brought about by them in turn. In this way the alchemist related himself not only to the unconscious but directly to the very substance which he hoped to transform through the power of imagination. The singular expression “astrum” (star) is a Paracelsan term, which in this context means something like “quintessence.”¹⁰⁴ Imagination is therefore a concentrated extract of the life forces, both physical and psychic. So the demand that the artifex must have a sound physical

constitution is quite intelligible, since he works with and through his own quintessence and is himself the indispensable condition of his own experiment. But, just because of this intermingling of the physical and the psychic, it always remains an obscure point whether the ultimate transformations in the alchemical process are to be sought more in the material or more in the spiritual realm. Actually, however, the question is wrongly put: there was no “either-or” for that age, but there did exist an intermediate realm between mind and matter, i.e., a psychic realm of subtle bodies¹⁰⁵ whose characteristic it is to manifest themselves in a mental as well as a material form. This is the only view that makes sense of alchemical ways of thought, which must otherwise appear nonsensical. Obviously, the existence of this intermediate realm comes to a sudden stop the moment we try to investigate matter in and for itself, apart from all projection; and it remains non-existent so long as we believe we know anything conclusive about matter or the psyche. But the moment when physics touches on the “untrodden, untreadable regions,” and when psychology has at the same time to admit that there are other forms of psychic life besides the acquisitions of personal consciousness—in other words, when psychology too touches on an impenetrable darkness—then the intermediate realm of subtle bodies comes to life again, and the physical and the psychic are once more blended in an indissoluble unity. We have come very near to this turning-point today.



139. Hermes conjuring the winged soul out of an urn.—Attic funeral lekythos

[395] Such reflections are unavoidable if we want to gain any understanding of alchemy’s peculiar terminology. The earlier talk of the “aberration” of alchemy sounds rather old-fashioned today when the psychological aspects of it have faced science with new tasks. There are very modern problems in alchemy, though they lie outside the province of chemistry.

[396] The concept of *imaginatio* is perhaps the most important key to the understanding of the *opus*. The author of the treatise “De sulphure”¹⁰⁶ speaks of the “imaginative faculty” of the soul in that passage where he is trying to do just what the ancients had

failed to do, that is, give a clear indication of the secret of the art. The soul, he says, is the vice-regent of God (*sui locum tenens seu vice Rex est*) and dwells in the life-spirit of the pure blood. It rules the mind (*illa gubernat mentem*) and this rules the body. The soul functions (*operatur*) in the body, but has the greater part of its function (*operatio*) outside the body (or, we might add by way of explanation, in projection). This peculiarity is divine, since divine wisdom is only partly enclosed in the body of the world: the greater part of it is *outside, and it imagines far higher things than the body of the world can conceive (concipere)*. And these things are outside nature: God's own secrets. The soul is an example of this: it too imagines many things of the utmost profundity (*profundissima*) outside the body, just as God does. True, what the soul imagines happens only in the mind (*non exequitur nisi in mente*), but what God imagines happens in reality. "The soul, however, has absolute and independent power [*absolutam et separatam potestatem*] to do other things [*alia facere*] than those the body can grasp. But, when it so desires, it has the greatest power over the body [*potestatem in corpus*], for otherwise our philosophy would be in vain. Thou canst conceive the greater, for we have opened the gates unto thee."¹⁰⁷

IV. SOUL AND BODY

[397] The passage just quoted affords us valuable insight into the alchemical way of thinking. The soul in this text is evidently an *anima corporalis* (figs. 91, 208) that dwells in the blood. It would therefore correspond to the unconscious, if this is understood as the psychic phenomenon that mediates between consciousness and the physiological functions of the body. In the Tantric *chakra* system¹⁰⁸ this *anima* would be located below the diaphragm. On the other hand it is God's lieutenant or viceroy, the analogue of the *Deus Creator*. There are people who can never understand the unconscious as anything but a *subconscious*, and who therefore feel impelled to put a *superconscious* alongside or possibly above it. Such hypotheses do not trouble our philosophers, for according to their teaching every form of life, however elementary, contains its own inner antithesis, thus anticipating the problem of opposites in modern psychology. What our author has to say about the element of air is significant in this respect:

The air is a pure uncorrupted element, in its kind the most worthy, being uncommonly light and invisible, but inside heavy, visible, and solid. Enclosed within it [*inclusus*] is the spirit of the Highest that moved over the waters before the Creation, according to the testimony of the Holy Scripture: "And ... he did fly upon the wings of the wind."¹⁰⁹ All things are integrated [*integrae*] in this element by the imagination of the fire.¹¹⁰



140. The artifex with his *soror mystica*, holding the keys to the work.—Thomas Aquinas (pseud.), “De alchimia” (16th cent.)

[398] In order to understand such a statement we must obviously empty our minds of all modern ideas about the nature of gases, and take it as purely psychological. In this sense, it deals with the projection of pairs of opposites such as light-heavy, visible-invisible, and so on. Now, identity of opposites is a characteristic feature of every psychic event in the unconscious state. Thus the *anima corporalis* is at the same time *spiritualis*, and the air’s heavy, solid kernel is at the same time the *spiritus creator* which moves over the waters. And just as “the images of all creatures” are contained in the creative spirit, so all things are imagined or “pictured” in air “through the power of fire”; firstly because fire surrounds the throne of God and is the source from which the angels and, descending in rank and quality, all other living beings are created or “imagined” through infusion of the fiery *anima* into the breath of life;¹¹¹ secondly because fire destroys all composite things and infuses their images back into the air in the form of smoke.

[399] The soul, says our author, is only partly confined to the body, just as God is only partly enclosed in the body of the world. If we strip this statement of its metaphysics

it asserts that the psyche is only partly identical with our empirical conscious being; for the rest it is projected and in this state it imagines or realizes those greater things which the body cannot grasp, i.e., cannot bring into reality. The “greater things” (*majora*) correspond to the “higher” (*altiora*), referring to the world-creating imagination of God; but because these higher things are imagined by God they at once become substantial instead of lingering in a state of potential reality, like the contents of the unconscious. That this activity of the soul “outside the body” refers to the alchemical *opus* is evident from the remark that the soul has the greatest power over the body, otherwise the royal art or philosophy would be in vain. “Thou canst conceive the greater,” says our author; therefore your body can bring it into reality—with the help of the art and with God’s permission (*Deo concedente*), this being a fixed formula in alchemy.

[400] The *imaginatio*, as the alchemists understand it, is in truth a key that opens the door to the secret of the *opus* (fig. 140). We now know that it was a question of representing and realizing those “greater” things which the soul, on God’s behalf, imagines creatively and *extra naturam*—or, to put it in modern language, a question of actualizing those contents of the unconscious¹¹² which are outside nature, i.e., not a datum of our empirical world, and therefore an *a priori* of archetypal character. The place or the medium of realization is neither mind nor matter, but that intermediate realm of subtle reality which can be adequately expressed only by the symbol. The symbol is neither abstract nor concrete, neither rational nor irrational, neither real nor unreal. It is always both: it is *non vulgi*, the aristocratic preoccupation of one who is set apart (*cuiuslibet sequestrati*), chosen and predestined by God from the very beginning.



141. The artifex with book and altar. In the background, a cornfield (allegory of the *opus*) and the quickening *coniunctio* of *sol* and *luna*.—Kelley, *Tractatus de Lapide philosophorum* (1676)



142. The sequence of stages in the alchemical process.—Libavius, *Alchymia* (1606) (For explanation, see following pages)

In an *explicatio locorum signatorum*, Libavius gives the following “explanation” of this picture (fig. 142):

- A Pedestal or base = earth.
- BB Two giants or Atlases kneeling on the base and supporting a sphere with their hands.
- C Four-headed dragon from whose breath the sphere takes shape. The four grades of fire: the first mouth emits a kind of air, the second a subtle smoke, the third smoke and fire, and the fourth pure fire.
- D Mercurius with a silver chain, to which two recumbent animals are attached.
- E The green lion.
- F One-headed dragon. E and F both mean the same thing: the Mercurial fluid which is the *materia prima* of the stone.
- G A three-headed silver eagle, two of whose heads droop while the third spits white water or the Mercurial fluid into the sea, which is marked H.
- I Picture of the wind, sending forth the breath of the spirit (*spiritus*) into the sea below.

- K Picture of the red lion, with red blood flowing from his breast into the sea below, because the sea must be coloured as if it were a mixture of silver and gold or white and red. The picture is applied to body, soul, and spirit by those who have sought three [principles] from the beginning, or to the blood of the lion and the lime of the eagle. For, because they accept three, they have a double Mercurius. Those who accept two have one only, which comes from a crystal or from the unripe metal of the philosophers.
- L A stream of black water, as in the chaos, representing the *putrefactio*. From it there rises a mountain, which is black at the bottom and white at the top, so that a silver stream flows down from the summit. For it is the picture of the first dissolution and coagulation and of the resultant second dissolution.
- M The above-mentioned mountain.
- NN The heads of black ravens that are looking out of the sea.
- O Silver rain falling from the clouds on to the summit of the mountain. Sometimes this represents the nourishment and cleansing of the Lato by Azoch, sometimes the second dissolution, whereby the element of air is extracted from the earth and water. (The earth is a form of the mountain, and the water is the liquid of the sea aforementioned.)
- PP The clouds from which [come] the dew or rain and the nourishing moisture.
- Q A vision of heaven, where a dragon lies on his back and devours his own tail: he is an image of the second coagulation.
- RR An Ethiopian man and woman, supporting two higher spheres. They sit on the big sphere and accordingly represent the *nigredo* of the second operation in the second putrefaction.
- SS A sea of pure silver, which represents the Mercurial fluid whereby the tinctures are united.
- T A swan swimming on the sea, spitting out a milky liquid from his beak. This swan is the white elixir, the white chalk, the arsenic of the philosophers, the thing common to both ferments. He has to support the upper sphere with his back and wings.
- V Eclipse of the sun.
- XX The sun diving into the sea, i.e., into the Mercurial water into which the elixir also must flow. This leads to the true eclipse of the sun and one should put a rainbow on either side to suggest the peacock's tail that then appears in the coagulation.
- YY Eclipse of the moon, which likewise has a rainbow on either side and [also] in the lowest part of the sea, into which the moon must dive. This is the picture of the white fermentation. But both seas should be fairly dark.
- ZZ The moon gliding into the sea.
- a The king, clad in purple, with a golden crown, has a golden lion beside him. He has a red lily in his hand, whereas the queen has a white lily.
- b The queen, crowned with a silver crown, strokes a white or silver eagle standing beside her.
- c The phoenix on the sphere, cremating itself; many gold and silver birds fly out of the ashes. It is the sign of multiplication and increase.

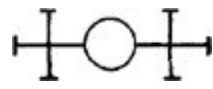



143. Alchemists at work—*Mutus liber* (1702)

3. THE WORK

I. THE METHOD

[401] The basis of alchemy is the work (*opus*). Part of this work is practical, the *operatio* itself, which is to be thought of as a series of experiments with chemical substances. In my opinion it is quite hopeless to try to establish any kind of order in the infinite chaos of substances and procedures. Seldom do we get even an approximate idea of how the work was done, what materials were used, and what results were achieved. The reader usually finds himself in the most impenetrable darkness when it comes to the names of the substances—they could mean almost anything. And it is precisely the most commonly used substances, like quicksilver, salt, and sulphur, whose alchemical meaning is one of the secrets of the art. Moreover, one must not imagine for a moment that the alchemists always understood one another. They themselves complain about the obscurity of the texts, and occasionally betray their inability to understand even their own symbols and symbolic figures. For instance, the learned Michael Maier accuses the classical authority Geber of being the obscurest of all, saying that it would require an Oedipus to solve the riddle of the “Gebrina Sphinx.”¹ Bernard of Treviso, another famous alchemist, goes so far as to call Geber an obscurantist and a Proteus who promises kernels and gives husks.

[402] The alchemist is quite aware that he writes obscurely. He admits that he veils his meaning on purpose, but nowhere—so far as I know—does he say that he cannot write in any other way. He makes a virtue of necessity by maintaining either that mystification is forced on him for one reason or another, or that he really wants to make the truth as plain as possible, but cannot proclaim aloud just what the *prima materia* or the *lapis* is.

[403] The profound darkness that shrouds the alchemical procedure comes from the fact that although the alchemist was interested in the chemical part of the work he also used it to devise a nomenclature for the psychic transformations that really fascinated him. Every original alchemist built himself, as it were, a more or less individual edifice of ideas, consisting of the dicta of the philosophers and of miscellaneous analogies to the fundamental concepts of alchemy. Generally these analogies are taken from all over the place. Treatises were even written for the purpose of supplying the artist with analogy-making material.² The method of alchemy, psychologically speaking, is one of boundless amplification. The *amplificatio* is always appropriate when dealing with some obscure experience which

is so vaguely adumbrated that it must be enlarged and expanded by being set in a psychological context in order to be understood at all. That is why, in analytical psychology, we resort to amplification in the interpretation of dreams, for a dream is too slender a hint to be understood until it is enriched by the stuff of association and analogy and thus amplified to the point of intelligibility. This *amplificatio* forms the second part of the *opus*, and is understood by the alchemist as *theoria*.³ Originally the theory was the so-called “Hermetic philosophy,” but quite early on it was broadened by the assimilation of ideas taken over from Christian dogma. In the oldest alchemy known to the West the Hermetic fragments were handed down mostly through Arabic originals. Direct contact with the *Corpus Hermeticum* was only established in the second half of the fifteenth century, when the Greek manuscript reached Italy from Macedonia and was translated into Latin by Marsilio Ficino.



144. Left, three artists in the library. Right, the artist, or his assistant, working in the laboratory.—Maier, *Tripus aureus* (1618)

[404] The vignette (fig. 144) that is on the title-page to the *Tripus aureus* (1618) is a graphic illustration of the double face of alchemy. The picture is divided into two parts.⁴ On the right is a laboratory where a man, clothed only in trunks, is busy at the fire; on the left a library, where an abbot,⁵ a monk,⁶ and a layman⁷ are conferring together. In the middle, on top of the furnace, stands the tripod with a round flask on it containing a winged dragon. The dragon symbolizes the visionary experience of the alchemist as he works in his laboratory and “theorizes.”⁸



145. Laboratory and oratory.—Khunrath, *Amphitheatrum sapientiae* (1604)



146. Mercurius as “uniting symbol.”—Valentinus, “Duodecim claves.” in *Musaeum hermeticum* (1678)

The dragon in itself is a *monstrum*—a symbol combining the chthonic principle of the serpent and the aerial principle of the bird. It is, as Ruland says,⁹ a variant of Mercurius. But Mercurius is the divine winged Hermes (fig. 146) manifest in matter, the god of revelation, lord of thought and sovereign psychopomp. The liquid metal, *argentum vivum*—“living silver,” quicksilver—was the wonderful substance that

perfectly expressed the nature of the *σίμβωλον*: that which glistens and animates within. When the alchemist speaks of Mercurius, on the face of it he means quicksilver, but inwardly he means the world-creating spirit concealed or imprisoned in matter. The dragon is probably the oldest pictorial symbol in alchemy of which we have documentary evidence. It appears as the *ούρο βόρος*, the tail-eater, in the Codex Marcianus (fig. 147), which dates from the tenth or eleventh century,¹⁰ together with the legend: *νῆ τὸ πᾶν* (the One, the All).¹¹ Time and again the alchemists reiterate that the *opus* proceeds from the one and leads back to the one,¹² that it is a sort of circle like a dragon biting its own tail (cf. figs. 20, 44, 46, 47). For this reason the *opus* was often called *circularis* (circular) or else *rota* (the wheel) (fig. 80). Mercurius stands at the beginning and end of the work: he is the *prima materia*, the *caput corvi*, the *nigredo*; as dragon he devours himself and as dragon he dies, to rise again as the *lapis*. He is the play of colours in the *cauda pavonis* and the division into four elements. He is the hermaphrodite that was in the beginning, that splits into the classical brother-sister duality and is reunited in the *coniunctio*, to appear once again at the end in the radiant form of the *lumen novum*, the stone. He is metallic yet liquid, matter yet spirit, cold yet fiery,¹³ poison and yet healing draught—a symbol uniting all opposites (fig. 148).¹⁴



147. Uroboros.—Codex Marcianus (11th cent.)



148. Mercurius as caduceus, uniting the paired opposites.—“Figurarum Aegyptiorum secretarum” (MS., 18th cent.)

II. THE SPIRIT IN MATTER

[405] All these ideas were the common property of alchemy from earliest times. Zosimos, writing in the third century A.D., quotes one of the very oldest authorities on alchemy in his treatise “Concerning the Art and Its Interpretation,”¹⁵ namely Ostances,¹⁶ who belongs to the dawn of history and was known even to Pliny. His connection with Democritus, another of the earliest alchemical writers, probably dates from the first century B.C.¹⁷ This Ostances is reported to have said:

Go to the waters of the Nile and there you will find a stone that has a spirit [*πνεῦμα*]. Take this, divide it, thrust in your hand and draw out its heart: for its soul [*ψυχή*] is in its heart¹⁸ [fig. 149]. [An interpolator adds:] There, he says, you will find this stone that has a spirit, which refers to the expulsion of the quicksilver [*ἐξένδραργύρωσις*].¹⁹

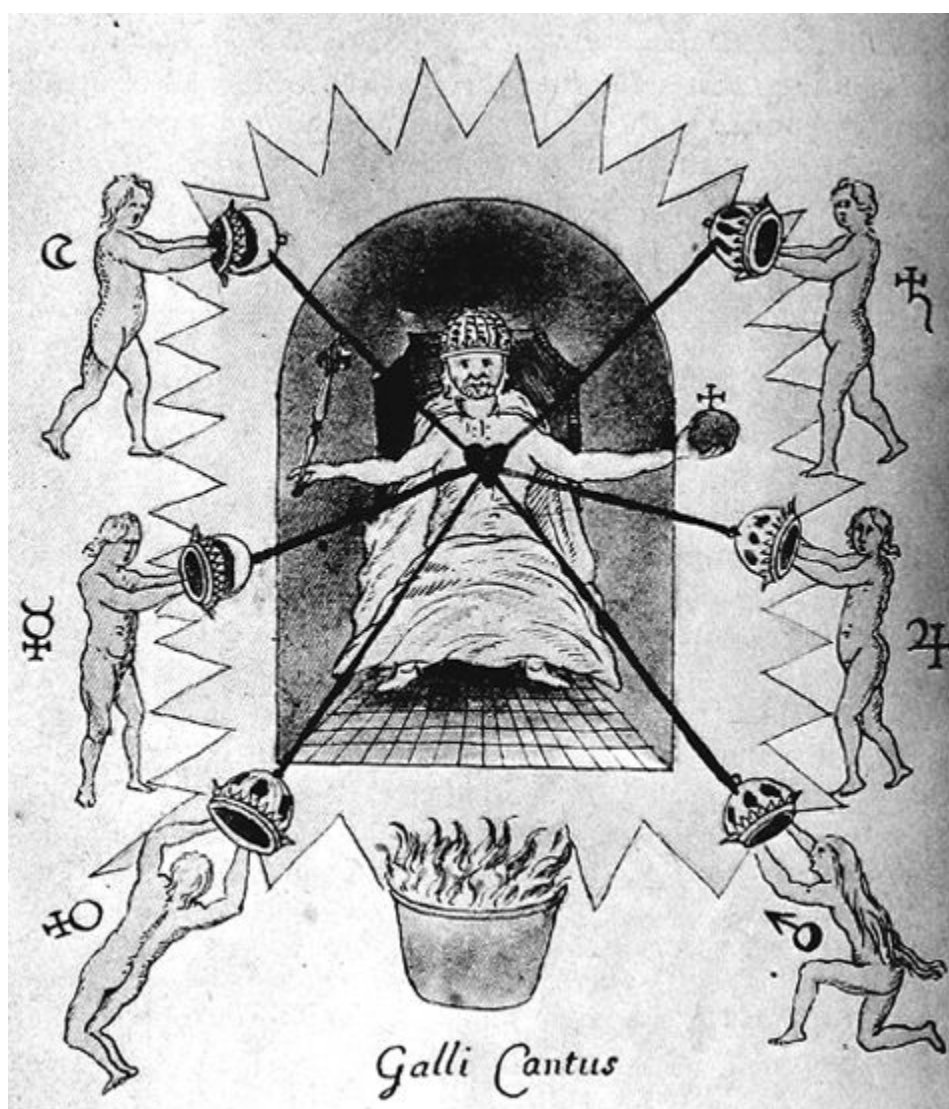

149. The sick king (*prima materia*), from whose heart the planet-children receive their crowns.—“La Sagesse des anciens” (MS., 18th cent.)

[406] Nietzsche’s metaphor in *Zarathustra*, “an image slumbers for me in the stone,” says much the same thing, but the other way round. In antiquity the material world was filled with the projection of a psychic secret, which from then on appeared as the secret of matter and remained so until the decay of alchemy in the eighteenth century. Nietzsche, with his ecstatic intuition, tried to wrest the secret of the superman from the stone in which it had long been slumbering. It was in the likeness of this slumbering image that he wished to create the superman, whom, in the language of antiquity, we may well call the divine man. But it is the other way about with the alchemists: they were looking for the marvellous stone that harboured a pneumatic essence in order to win from it the substance that penetrates all substances—since it is itself the stone-penetrating “spirit”—and transforms all base metals into noble ones by a process of coloration. This “spirit-substance” is like quicksilver, which lurks unseen in the ore and must first be expelled if it is to be recovered *in substantia*. The possessor of this penetrating Mercurius (fig. 150) can “project” it into other substances and transform them from the imperfect into the perfect state.²⁰ The imperfect state is like the sleeping state; substances lie in it like the “sleepers chained

in Hades” (fig. 151)²¹ and are awakened as from death to a new and more beautiful life by the divine tincture extracted from the inspired stone. It is quite clear that we have here a tendency not only to locate the mystery of psychic transformation in matter, but at the same time to use it as a *theoria* for effecting chemical changes.



150. The penetrating Mercurius.—“Speculum veritatis” (MS., 17th cent.)

[407] Just as Nietzsche made absolutely sure that nobody could mistake the superman for a sort of spiritual or moral ideal, so it is emphasized that the tincture or divine water is far from being merely curative and ennobling in its effects, but that it may also act as a deadly poison which penetrates other bodies as pervasively as the pneuma penetrates its stone.²²

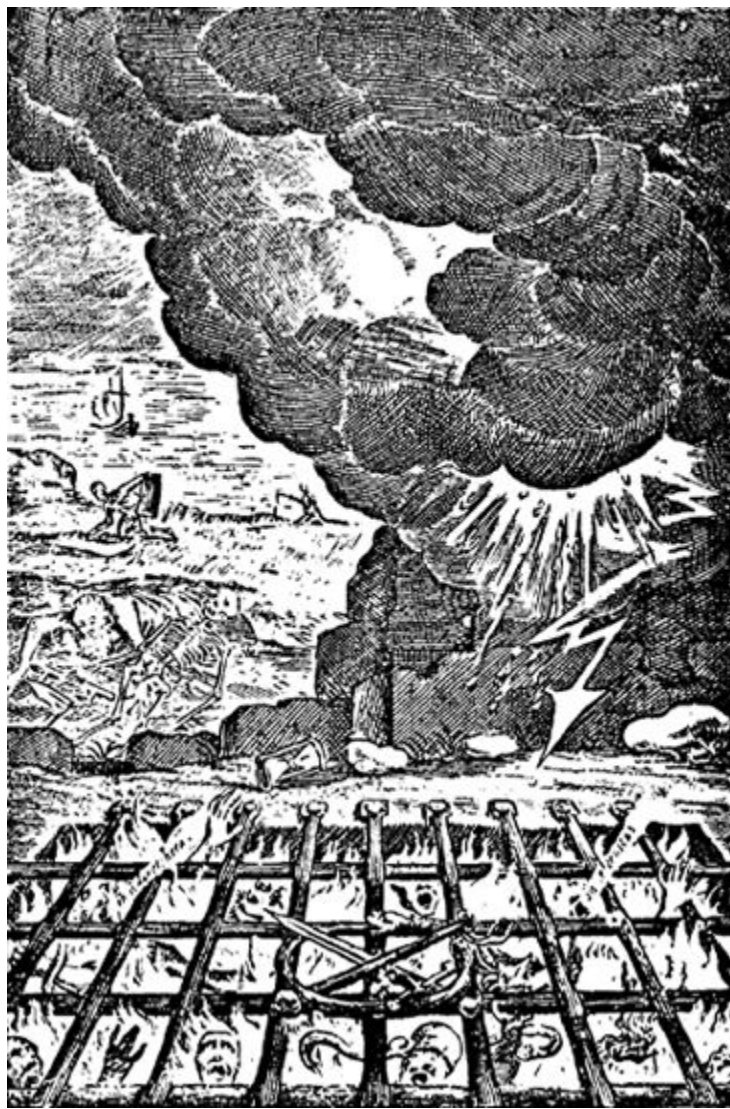

151. Prisoners in the underworld.—Izquierdo, *Praxis exercitiorum spiritualium* (1695)

[408] Zosimos was a Gnostic who was influenced by Hermes. In his missive to Theosebeia he recommends the “krater” as a vessel of transformation: she should, he says, hasten to the Poimandres in order to be baptized in the krater.²³

[409] This krater refers to the divine vessel of which Hermes tells Thoth in the treatise entitled *ὁ κρατήρ*.²⁴ After the creation of the world, God filled this vessel with nous (*νοῦς* = pneuma) and sent it down to earth as a kind of baptismal font. By so doing God gave man, who wished to free himself from his natural, imperfect, sleeping state of *ἄνοια* (or, as we should say, insufficient consciousness), an opportunity to dip himself in the nous and thus partake of the higher state of *ἔννοια*, i.e., enlightenment or higher consciousness (fig. 159). The nous is thus a kind of *βαφεῖον*, dyestuff or tincture, that ennobles base substances. Its function is the exact equivalent of the tincturing stone-extract, which is also a pneuma and, as Mercurius, possesses the Hermetic dual significance of redeeming psychopomp²⁵ and quicksilver (fig. 152).

[410] Clearly enough, then, Zosimos had a mystic or Gnostic philosophy of sorts whose basic ideas he projected into matter. When we speak of psychological projection we must, as I have already pointed out, always remember that it is an

unconscious process that works only so long as it stays unconscious. Since Zosimos, like all the other alchemists, is convinced not only that his philosophy can be applied to matter but that processes also take place in it which corroborate his philosophical assumptions, it follows that he must have experienced, in matter itself, at the very least an identity between the behaviour of matter and the events in his own psyche. But, as this identity is unconscious, Zosimos is no more able than the rest of them to make any pronouncement about it. For him it is simply there, and it not only serves as a bridge, it actually *is* the bridge that unites psychic and material events in one, so that “what is within is also without.” Nevertheless an unconscious event which eludes the conscious mind will portray itself somehow and somewhere, it may be in dreams, visions, or fantasies. The idea of the pneuma as the Son of God, who descends into matter²⁶ and then frees himself from it in order to bring healing and salvation to all souls, bears the traits of a projected unconscious content (fig. 153). Such a content is an autonomous complex divorced from consciousness, leading a life of its own in the psychic non-ego and instantly projecting itself whenever it is constellated in any way—that is, whenever attracted by something analogous to it in the outside world. The psychic autonomy of the pneuma²⁷ is attested by the Neopythagoreans: in their view the soul was swallowed by matter and only mind—nous—was left. But the nous is outside man: it is his daemon. One could hardly formulate its autonomy more aptly. Nous seems to be identical with the god Anthropos: he appears alongside the demiurge and is the adversary of the planetary spheres. He rends the circle of the spheres and leans down to earth and water (i.e., he is about to project himself into the elements). His shadow falls upon the earth, but his image is reflected in the water. This kindles the love of the elements, and he himself is so charmed with the reflected image of divine beauty that he would fain take up his abode within it. But scarcely has he set foot upon the earth when Physis locks him in a passionate embrace. From this embrace are born the seven first hermaphroditic beings.²⁸ The seven are an obvious allusion to the seven planets and hence to the metals (figs. 154, 155; cf. figs. 21, 79) which in the alchemical view spring from the hermaphrodite Mercurius.



152. Above, Saturn eating his children and being sprinkled with Mercurial water (*lac virginis, vinum ardens*). Below, the regeneration in the bath.—Thomas Aquinas (pseud.), “De alchimia” (M.S., 16th cent.)



153. The artist lifting the homunculus, the “son of the philosophers,” out of the Hermetic vessel.—Kelley, *Tractatus de Lapide philosophorum* (1676)



154, 155. The king with the six planets or metals; the renewed king (*filius philosophorum*) worshipped by the six planets.—Kelley, *Tractatus de Lapide philosophorum* (1676)

[411] In such visionary images as the Anthropos glimpsing his own reflection there is expressed the whole phenomenon of the unconscious projection of autonomous contents. These myth-pictures are like dreams, telling us that a projection has taken place and also what has been projected. This, as the contemporary evidence shows, was nous, the divine daemon, the god-man, pneuma, etc. In so far as the standpoint of analytical psychology is realistic, i.e., based on the assumption that the contents of the psyche are realities, all these figures stand for an unconscious component of the personality which might well be endowed with a higher form of consciousness transcending that of the ordinary human being. Experience shows that such figures always express superior insight or qualities that are not yet conscious; indeed, it is extremely doubtful whether they can be attributed to the ego at all in the proper sense of the word. This problem of attribution may appear a captious one to the layman, but in practical work it is of great importance. A wrong attribution may bring about dangerous inflations which seem unimportant to the layman only because he has no idea of the inward and outward disasters that may result.²⁹

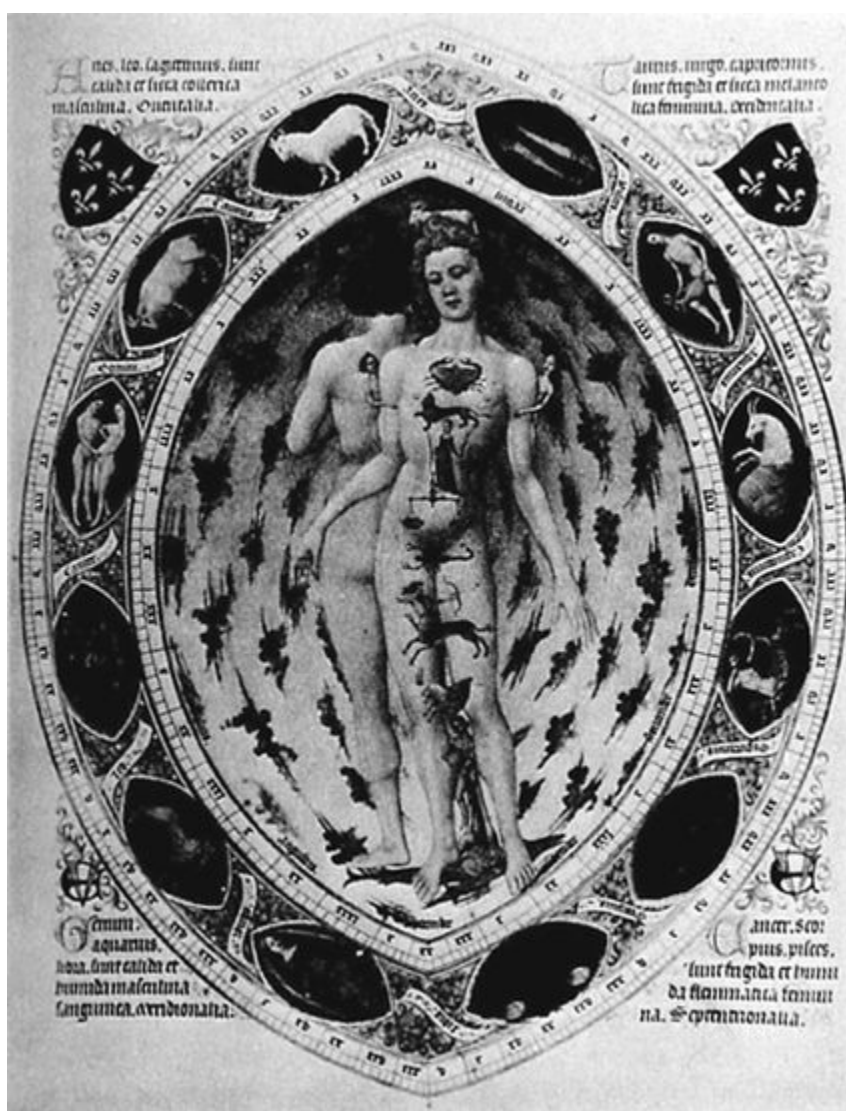

156. The Dyad (day and night): symbolical representation of the correspondence between zodiac and man.—“Très Riches Heures du duc de Berry” (MS., Chantilly, 15th cent.)

[412] As a matter of fact, we are dealing here with a content that up to the present has only very rarely been attributed to any human personality. The one great exception is Christ. As *νῑός τοῦ ἀνθρώπου* the Son of Man, and as *θεοῦ νῑός*, the Son of God, he embodies the God-man; and as an incarnation of the Logos by “pneumatic” impregnation, he is an avatar of the divine *νοῦς*.

[413] Thus the Christian projection acts upon the unknown in man, or upon the unknown man, who becomes the bearer of the “terrible and unheard-of secret.”³⁰ The pagan projection, on the other hand, goes beyond man and acts upon the unknown in the material world, the unknown substance which, like the chosen man, is somehow filled with God. And just as, in Christianity, the Godhead conceals itself in the man of low degree, so in the “philosophy” it hides in the uncomely stone. In the Christian projection the *descensus spiritus sancti* stops at the *living body* of the Chosen One, who is at once very man and very God, whereas in alchemy the descent goes right down into the darkness of inanimate matter whose nether regions, according to the Neopythagoreans, are ruled by evil.³¹ Evil and matter together form the Dyad, the

duality (fig. 156). This is feminine in nature, an *anima mundi*, the feminine Physis who longs for the embrace of the One, the Monad, the good and perfect.³² The Justinian Gnosis depicts her as Edem, virgin above, serpent below³³ (fig. 157). Vengefully she strives against the pneuma because, in the shape of the demiurge, the second form of God, he faithlessly abandoned her. She is “the divine soul imprisoned in the elements,” whom it is the task of alchemy to redeem.³⁴



157. *Anima Mercurii*.—“Figurarum Aegyptiorum secretarum” (MS., 18th cent.)

III. THE WORK OF REDEMPTION

[414] Now, all these myth-pictures represent a drama of the human psyche on the further side of consciousness, showing *man as both the one to be redeemed and the redeemer*. The first formulation is Christian, the second alchemical. In the first case man attributes the need of redemption to himself and leaves the work of redemption, the actual *ἔργον* or *opus*, to the autonomous divine figure; in the latter case man takes upon himself the duty of carrying out the redeeming *opus*, and attributes the state of suffering and consequent need of redemption to the *anima mundi* imprisoned in matter.³⁵

[415] In both cases redemption is a *work* (fig. 158). In Christianity it is the life and death of the God-man which, by a unique sacrifice, bring about the reconciliation of man, who craves redemption and is sunk in materiality, with God. The mystical effect of the God-man's self-sacrifice extends, broadly speaking, to all men, though it is efficacious only for those who submit through faith or are chosen by divine grace; but in the Pauline acceptance it acts as an apocatastasis and extends also to non-human creation in general, which, in its imperfect state, awaits redemption like the merely natural man. By a certain "synchronicity" of events, man, the bearer of a soul submerged in the world and the flesh, is potentially related to God at the moment when he, as Mary's Son, enters into her, the *virgo terrae* and representative of matter in its highest form; and, potentially at least, man is fully redeemed at the moment when the eternal Son of God returns again to the Father after undergoing the sacrificial death.

[416] The ideology of this *mysterium* is anticipated in the myths of Osiris, Orpheus, Dionysus, and Hercules, and in the conception of the Messiah among the Hebrew prophets.³⁶ These anticipations go back to the primitive hero myths where the conquest of death is already an important factor.³⁷ The projections upon Attis and Mithras, more or less contemporary with the Christian one, are also worth mentioning. The Christian projection differs from all these manifestations of the mystery of redemption and transformation by reason of the historical and personal figure of Jesus. The mythical event incarnates itself in him and so enters the realm of world history as a unique historical and mystical phenomenon.

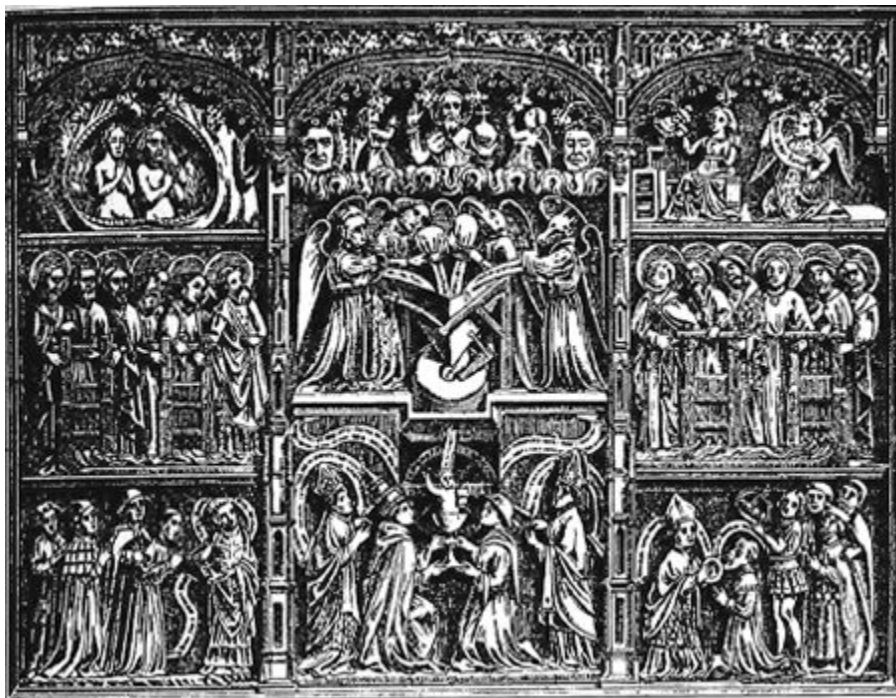

158. The "Mill of the Host." The Word, in the form of scrolls, is poured into a mill by the four evangelists, to reappear as the Infant Christ in the chalice. (Cf. John 1 : 14: "And the word was made flesh....")—High altar of church at Tribsees, Pomerania (15th cent.)

[417] In the figure of the divine hero, God himself wrestles with his own imperfect, suffering, living creation; he even takes its suffering condition upon himself and, by this sacrificial act, accomplishes the *opus magnum*, the ἄθλον of salvation and victory over death. As regards the actual performance of this entirely metaphysical work, man is powerless to do anything really decisive. He looks to his Redeemer, full of faith and confidence, and does what he can in the way of “imitation”; but this never reaches the point where man himself becomes the Redeemer—or at least his own redeemer. Yet a complete imitation and reestablishment of Christ in the believer would necessarily lead to such a conclusion. But this is out of the question. Were such an approximation to occur, then Christ would have re-established himself in the believer and replaced the latter’s personality. We should have to be satisfied with this statement were it not for the existence of the Church. The institution of the Church means nothing less than the everlasting continuation of the life of Christ and its sacrificial function. In the *officium divinum* or, in Benedictine parlance, the *opus divinum*, Christ’s sacrifice, the redeeming act, constantly repeats itself anew while still remaining the unique sacrifice that was accomplished, and is accomplished ever again, by Christ himself inside time and outside all time. This *opus supernaturale* is represented in the sacrifice of the Mass. In the ritual act the priest as it were shows forth the mystical event, but the real agent is Christ, who sacrifices himself everywhere always. Though his sacrificial death occurred in time it is an essentially timeless occurrence. In the Thomist view the Mass is not a real *immolatio* (sacrifice) of the body of Christ but a “re-presentation” of his sacrificial death.³⁸ Such an interpretation would be sufficient and consistent were it not for the transubstantiation of the offered substances, the bread and wine. This offering is meant as a *sacrificium*, literally a “making sacred.” The etymology of the German word for sacrifice, *Opfer*, is obscure, it being a moot point whether it comes from *offerre*, “to offer,” or from *operari*, “to effect, to be active.” In its ancient usage *operari Deo* meant to serve the god or to sacrifice to him. But if the *Opfer* is an *opus*, then it is far more than an *oblatio*, the offering of such a modest gift as bread and wine. It must be an effectual act, giving the ritual words spoken by the priest a causal significance. The words of the consecration (*qui pridie quam pateretur*, etc.) are therefore to be taken not merely as representative, but as the *causa efficiens* of the transubstantiation. That is why the Jesuit Lessius (d. 1623) called the words of the consecration the “sword” with which the sacrificial lamb is slaughtered.³⁹ The so-called theory of mactation (slaughtering) occupies an important place in the literature of the Mass, though it has not been generally accepted in its more objectionable outgrowths. Perhaps the clearest of all is the Greek ritual as described by the Archbishop Nikolaus Kabasilas of Thessalonika (d. circa 1363).⁴⁰ In the first (preparatory) part of the Mass the bread and wine are placed not on the main altar but on the *πρόθεσις*, a sort of sideboard. There the priest cuts a piece off the loaf and repeats the text, “He is led as a lamb to the slaughter.”

Then he lays it on the table and repeats, “The lamb of God is sacrificed.” The sign of the cross is then imprinted on the bread and a small lance stabbed into its side, to the text, “But one of the soldiers with a spear pierced his side and forthwith came there out blood and water.” At these words water and wine are mixed in the chalice. Then comes the *oblatio* in solemn procession, with the priest carrying the offering. (Here the *δῶρον*, the gift, represents the giver: Christ the sacrificant is also the sacrificed.) Thus the priest re-enacts the traditional event, and in so far as Christ, in the sacramental state, possesses a *vita corporea actualis*,⁴¹ an actual bodily life, one could say that a physical slaying⁴² (*mortificatio*) of his body has taken place. This happens as a result of the consecrating words spoken by the priest, and the destruction of the offering, the *oblatio occisi ad cultum Dei* (the offering up of the slain to the service of God), brings about the transubstantiation. The latter is a transmutation of the elements, which pass from a natural, soiled, imperfect material state into a subtle body. The bread, which must be wheaten, signifies the body, and the wine, representing blood, the soul. After the transubstantiation a piece of the host is mingled with the wine, thus producing the *coniunctio* of the soul with the body (fig. 159) and establishing the living body of Christ, namely the unity of the Church.

[418] St. Ambrose called the transformed bread *medicina*. It is the *φάρμακον ἀθανασίας*, the drug of immortality, which, in the act of communion, displays its characteristic effect in and on the believer—the effect of uniting the body with the soul. This takes the form of a healing of the soul and a *reformatio* of the body. The text of the Missal shows us how this is meant:

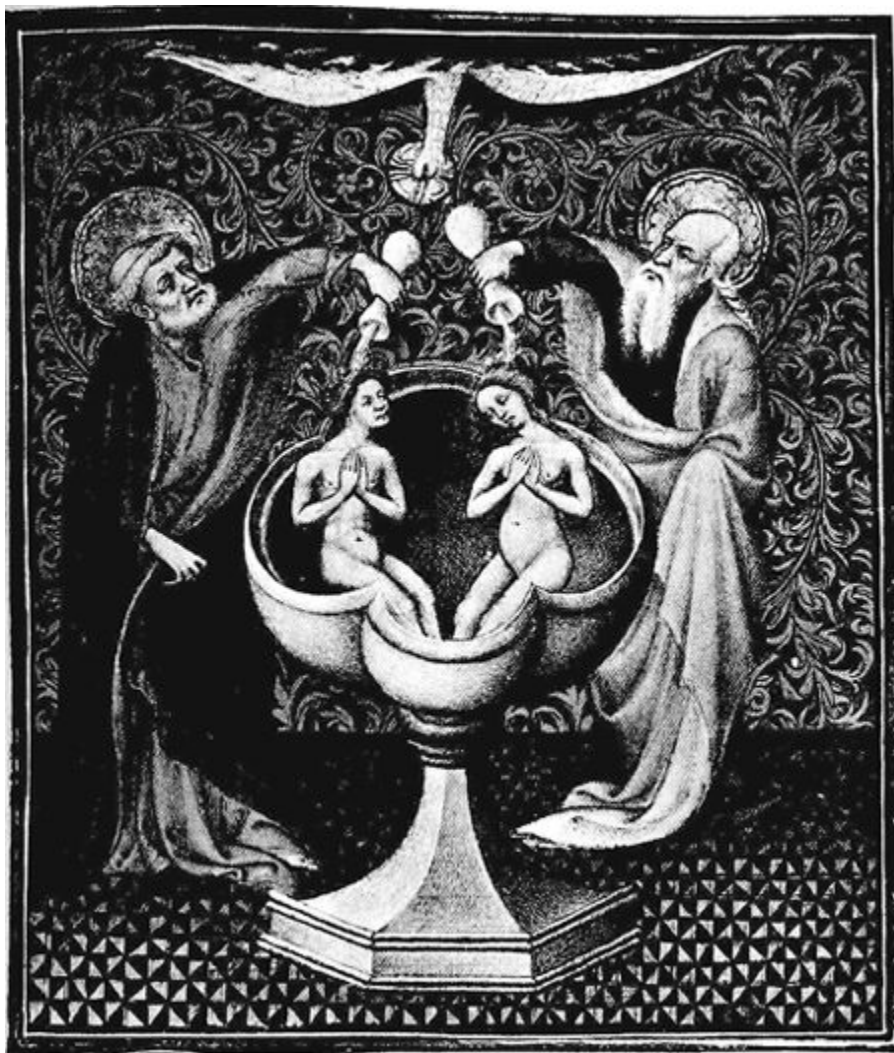

159. The *coniunctio* of soul and body: an ecclesiastical version of the alchemical marriage bath.—“Grandes heures du duc de Berry” (MS., 1413)

Da nobis per huius aquae et vini mysterium, eius divinitatis esse consortes, qui humanitatis nostrae fieri dignatus est particeps, Jesus Christus ... (Grant that through the mystery of this water and wine, we may have fellowship in the divine nature of Him who vouchsafed to become partaker of our humanity ...).

[419] Perhaps I may be allowed to introduce a personal remark here. It was a real revelation for me, as a Protestant, to read the words of the Offertory for the first time: “Deus, qui humanae substantiae dignitatem mirabiliter condidisti” (O God, who didst marvellously create the dignity of human nature) and “qui humanitatis nostrae fieri dignatus est particeps” (who vouchsafed to become partaker of our humanity). What respect for the dignity of human nature! *Deus et homo!* There is no sign of that unworthy sinful man whom Protestantism has so often slandered in the past and is only too ready to slander again. Moreover, there seems to be still something else hidden in this almost “transcendental” estimate of man. For if God “dignatus est” to become partaker of our human nature, then man may also deem himself worthy to become partaker of the divine nature. In a certain sense this is just what the priest does in the performance of the sacrificial mystery, when he offers himself as the

victim in place of Christ; and the congregation does likewise when it eats the consecrated body and thus shares in the substance of Deity.

[420] By pronouncing the consecrating words that bring about the transformation, the priest redeems the bread and wine from their elemental imperfection as created things. This idea is quite unchristian—it is alchemical. Whereas Catholicism emphasizes the effectual presence of Christ, alchemy is interested in the fate and manifest redemption of the substances, for in them the divine soul lies captive and awaits the redemption that is granted to it at the moment of release. The captive soul then appears in the form of the “Son of God.” For the alchemist, the one primarily in need of redemption is not man, but the deity who is lost and sleeping in matter. Only as a secondary consideration does he hope that some benefit may accrue to himself from the transformed substance as the panacea, the *medicina catholica*, just as it may to the imperfect bodies, the base or “sick” metals, etc. His attention is not directed to his own salvation through God’s grace, but to the liberation of God from the darkness of matter. By applying himself to this miraculous work he benefits from its salutary effect, but only incidentally. He may approach the work as one in need of salvation, but he knows that his salvation depends on the success of the work, on whether he can free the divine soul. To this end he needs meditation, fasting, and prayer; more, he needs the help of the Holy Ghost as his *πάρεδρος*.⁴³ Since it is not man but matter that must be redeemed, the spirit that manifests itself in the transformation is not the “Son of Man” but, as Khunrath very properly puts it,⁴⁴ the *filius macrocosmi*. Therefore, what comes out of the transformation is not Christ but an ineffable material being named the “stone,” which displays the most paradoxical qualities apart from possessing *corpus, anima, spiritus*, and supernatural powers (fig. 214). One might be tempted to explain the symbolism of alchemical transformation as a parody of the Mass were it not pagan in origin and much older than the latter.

[421] The substance that harbours the divine secret is everywhere, including the human body.⁴⁵ It can be had for the asking and can be found anywhere, even in the most loathsome filth⁴⁶ (fig. 256). In these circumstances the *opus* is no longer a ritualistic *officium*, but the same work of redemption which God himself accomplished upon mankind through the example of Christ, and which is now recognized by the philosopher who has received the *donum spiritus sancti*, the divine art, as his own individual *opus*. The alchemists emphasize this point: “He who works through the spirit of another and by a hired hand will behold results that are far from the truth; and conversely he who gives his services to another as assistant in the laboratory will never be admitted to the Queen’s mysteries.”⁴⁷ One might quote the words of Kabasilas: “As kings, when they bring a gift to God, bear it themselves and do not permit it to be borne by others.”

[422] Alchemists are, in fact, decided solitaries;⁴⁸ each has his say in his own way.⁴⁹ They rarely have pupils, and of direct tradition there seems to have been very little, nor is there much evidence of any secret societies or the like.⁵⁰ Each worked in the laboratory for himself and suffered from loneliness. On the other hand, quarrels were rare. Their writings are relatively free of polemic, and the way they quote each other shows a remarkable agreement on first principles, even if one cannot understand what they are really agreeing about.⁵¹ There is little of that disputatiousness and splitting of hairs that so often mar theology and philosophy. The reason for this is probably the fact that “true” alchemy was never a business or a career, but a genuine *opus* to be achieved by quiet, self-sacrificing work. One has the impression that each individual tried to express his own particular experiences, quoting the dicta of the masters only when they seemed to offer analogies.

[423] All, from the very earliest times, are agreed that their art is sacred and divine,⁵² and likewise that their work can be completed only with the help of God. This science of theirs is given only to the few, and none understands it unless God or a master has opened his understanding.⁵³ The knowledge acquired may not be passed on to others unless they are worthy of it.⁵⁴ Since all the essentials are expressed in metaphors they can be communicated only to the intelligent, who possess the gift of comprehension.⁵⁵ The foolish allow themselves to be infatuated by literal interpretations and recipes, and fall into error.⁵⁶ When reading the literature, one must not be content with just *one* book but must possess many books,⁵⁷ for “one book opens another.”⁵⁸ Moreover one must read carefully, paragraph by paragraph; then one will make discoveries.⁵⁹ The terminology is admitted to be quite unreliable.⁶⁰ Sometimes the nature of the coveted substance will be revealed in a dream.⁶¹ The *materia lapidis* may be found by divine inspiration.⁶² The practice of the art is a hard road⁶³ and the longest road.⁶⁴ The art has no enemies except the ignorant.⁶⁵

[424] It goes without saying that there are good and bad authors in alchemical literature as elsewhere. There are productions by charlatans, simpletons, and swindlers. Such inferior writings are easily recognized by their endless recipes, their careless and uneducated composition, their studied mystification, their excruciating dulness, and their shameless insistence on the making of gold. Good books can always be recognized by the industry, care, and visible mental struggles of the author.



160. Symbol of the art as union of water and fire.—Eleazar, *Uraltes chymisches Werk* (1760)



161. The *prima materia* as Saturn devouring his children.—*Mutus liber* (1702)

4. THE PRIMA MATERIA

I. SYNONYMS FOR THE MATERIA

[425] The basis of the *opus*, the *prima materia*, is one of the most famous secrets of alchemy. This is hardly surprising, since it represents the unknown substance that carries the projection of the autonomous psychic content. It was of course impossible to specify such a substance, because the projection emanates from the individual and is consequently different in each case. For this reason it is incorrect to maintain that the alchemists never said what the *prima materia* was; on the contrary, they gave all too many definitions and so were everlastingly contradicting themselves. For one alchemist the *prima materia* was quicksilver, for others it was ore, iron, gold, lead, salt, sulphur, vinegar, water, air, fire, earth, blood, water of life, *lapis*, poison, spirit, cloud, sky, dew, shadow, sea, mother, moon, dragon, Venus, chaos, microcosm (fig. 162). Ruland's *Lexicon* gives no less than fifty synonyms, and a great many more could be added.

[426] Besides these half chemical, half mythological definitions there are also some "philosophical" ones which have a deeper meaning. Thus in the treatise of Komarios¹ we find the definition "Hades." In Olympiodorus the black earth contains the "accursed of God" (θεοκατάρατος). The "Consilium coniugii" says that the father of gold and silver—i.e., their *prima materia*—is "the animal of earth and sea," or "man," or a "part of man," e.g., his hair, blood, etc. Dorn calls the *prima materia* "Adamica" and—basing himself on Paracelsus—*limbus microcosmicus*. The material of the stone is "no other than the fiery and perfect Mercurius" and the true hermaphroditic "Adam and Microcosm" (= man)² (see fig. 163). Hermes Trismegistus is said to have called the stone the "orphan." Since Dorn was a pupil of Paracelsus his views are probably connected with the Anthropos doctrine of his master. For this I must refer the reader to my essay "Paracelsus as a Spiritual Phenomenon." Further connections between man and the *prima materia* are mentioned in other authors, but I cannot quote them all here.



162. The unfettered opposites in chaos. “Chaos” is one of the names for the *prima materia*.

—Marolles, *Tableaux du temple des muses* (1655)

[427] The mercurial dragon of Greek alchemy, surnamed ἔν τὸ πᾶν gave rise to descriptions of the *prima materia* as *Unum*, *Unica Res*,³ and *Monad*⁴ and to the statement in the “*Liber Platonis quattorum*” that man is well qualified to complete the work because he possesses that which is *simple*, i.e., the soul.⁵ Mylius describes the *prima materia* as the *elementum primordiale*. It is the “pure subject and the unity of forms,” and in it any form whatsoever may be assumed (*in quo retinetur quaelibet forma cum possibilitate*).⁶

[428] In the second version of the *Turba*, Eximindus says:⁷

I make known to you, ye sons of the doctrine, that the beginning of all creatures is a certain primary everlasting and infinite nature which cooks and rules everything, and whose active and passive [aspects] are known and recognized only by those on whom the knowledge of the sacred art has been bestowed.

[429] In Sermo IX of the *Turba*⁸ “Eximendus” puts forward a theory of creation that corresponds to the Biblical one (creation through the “Word”) but stands in flagrant contradiction to the above, according to which the beginning is a *natura perpetua et*

infinita. In the *Rosarium* the *prima materia* is called *radix ipsius* (root of itself). Because it roots in itself it is autonomous and dependent on nothing.

II. THE INCREATUM

[430] Being a *radix ipsius*, the *prima materia* is a true *principium*, and from this it is but a step to the Paracelsan view that it is something *increatum*, uncreated. In his “*Philosophia ad Athenienses*,” Paracelsus says that this unique (*unica*) *materia* is a great secret having nothing in common with the elements. It fills the entire *regio aetherea*, and is the mother of the elements and of all created things (fig. 163). Nothing can express this mystery, nor has it been created (*nec etiam creatum fuit*). This uncreated mystery was prepared (*praeparatum*) by God in such a way that nothing will ever be like it in the future nor will it ever return to what it was.⁹ For it was so corrupted as to be beyond reparation (which presumably refers to the Fall). Dorn’s rendering gives the sense of the original text.¹⁰



163. Earth as *prima materia*, suckling the son of the philosophers.—Mylius, *Philosophia reformata* (1622)

[431] The autonomy and everlastingness of the *prima materia* in Paracelsus suggest a principle equal to the Deity, corresponding to a *dea mater*. Just how Paracelsus managed to reconcile such a view with his professions of Christianity is his own private concern; nor is it by any means an isolated instance. The interpretations contained in “*Aquarium sapientum*”¹¹—interesting on account of their truly preposterous character and hardly to be outdone even by *Aurora*—carry Paracelsan speculation still further, though without mentioning the author. The following texts, for example, are applied to the *prima materia*: “and his going forth is from the beginning, from the days of eternity” (Micah 5 : 2, D.V.), and “before Abraham was

made, I am” (John 8 : 58, D.V.). This is supposed to show that the stone is without beginning and has its *primum Ens* from all eternity, and that it too is without end and will exist in all eternity. To understand this properly, one must open wide the eyes of the soul and the spirit and observe and discern accurately by means of the inner light. God has lit this light in nature and in our hearts from the beginning.¹² And in the same way, continues the author, that the stone together with its material has a thousand names and is therefore called “miraculous,” all these names can in eminent degree be predicated of God,¹³ and the author thereupon proceeds to this application. A Christian can hardly believe his ears, but this conclusion only repeats what has already been said quite plainly in the “Liber Platonis quartorum”: “Res ex qua sunt res, est Deus invisibilis et immobilis”¹⁴ (That from which things arise is the invisible and immovable God). The first “res” is the subject matter of the divine art. It is true that very few of the philosophers pressed forward to this conclusion *expressis verbis*, but it is an aspect that makes their hints and veiled allusions decidedly more transparent. Moreover such a conclusion was inevitable psychologically, because the unconscious, being unknown, is bound to coincide with itself everywhere: lacking all recognizable qualities, no unconscious content can be distinguished from any other. This is not a logical sophistry but a very real phenomenon of great practical importance, for it affects the problems of identity and identification in social life, which are based on the collective (and indiscriminable) nature of unconscious contents. These, once they have taken possession of certain individuals, irresistibly draw them together by mutual attraction and knit them into smaller or larger groups which may easily swell into an avalanche.

[432] The above quotations clearly show that the alchemists came to project even the highest value—God—into matter. With the highest value thus safely embedded in matter, a starting-point was given for the development of genuine chemistry on the one hand and of the more recent philosophical materialism on the other, with all the psychological consequences that necessarily ensue when the picture of the world is shifted 180 degrees. However remote alchemy may seem to us today, we should not underestimate its cultural importance for the Middle Ages. Today is the child of the Middle Ages and it cannot disown its parents.

III. UBIQUITY AND PERFECTION

[433] The *prima materia* has the quality of ubiquity: it can be found always and everywhere, which is to say that projection can take place always and everywhere. The English alchemist Sir George Ripley (c. 1415–90) writes: “The philosophers tell the inquirer that birds and fishes bring us the *lapis*,¹⁵ every man has it, it is in every place, in you, in me, in everything, in time and space.”¹⁶ “It offers itself in lowly form [*vili figura*]. From it there springs our eternal water [*aqua permanens*].”¹⁷ According

to Ripley the *prima materia* is water; it is the material principle of all bodies,¹⁸ including mercury.¹⁹ It is the *hyle* which the divine act of creation brought forth from the chaos as a dark sphere²⁰ (*sphaericum opus*: cf. fig. 34).²¹ The chaos is a *massa confusa* that gives birth to the stone (figs. 125, 164). The hylical water contains a hidden elemental fire.²² In the treatise “De sulphure” hell-fire (*ignis gehennalis*) is attributed to the element earth as its inner opposite.²³ According to Hortulanus, the stone arises from a *massa confusa* containing in itself all the elements²⁴ (fig. 162). Just as the world came forth from a *chaos confusum*,²⁵ so does the stone.²⁶ The idea of the rotating aquasphere reminds us of the Neopythagoreans: in Archytas the world-soul is a circle or sphere;²⁷ in Philolaos it draws the world round with it in its rotation.²⁸ The original idea is to be found in Anaxagoras, where the nous gives rise to a whirlpool in chaos.²⁹ The cosmogony of Empedokles is also relevant: here the σφᾱῖρος (spherical being) springs from the union of dissimilars, owing to the influence of φιλία. The definition of this spherical being as εἰδαιμονέστατος Θεός, “the most serene God,” sheds a special light on the perfect, “round” nature of the lapis,³⁰ which arises from, and constitutes, the primal sphere; hence the *prima materia* is often called lapis (figs. 164, 165). The initial state is the hidden state, but by the art and the grace of God it can be transmuted into the second, manifest state. That is why the *prima materia* sometimes coincides with the idea of the initial stage of the process, the *nigredo*. It is then the black earth in which the gold or the lapis is sown like the grain of wheat (cf. fig. 48). It is the black, magically fecund earth that Adam took with him from Paradise, also called antimony and described as a “black blacker than black” (*nigrum nigrius nigro*).³¹



164. Mercurius, standing on the round chaos, holding the scales which signify the *pondus et mensura*. The *rotundum* is a prefiguration of the gold.—“Figurarum Aegyptiorum secretarum” (MS., 18th cent.)



165. “L’occasione”: Mercurius standing on the globe (the *rotundum*). The caduceus and horns of plenty nearby symbolize the richness of his gifts.—Cartari, *Le imagini de i dei* (1581)

IV. THE KING AND THE KING’S SON

[434] As the grain of fire lies concealed in the *hyle*, so the King’s Son lies in the dark depths of the sea as though dead, but yet lives and calls from the deep³² (fig. 166): “Whosoever will free me from the waters and lead me to dry land, him will I prosper with everlasting riches.”³³

[435] The connection with the *Rex marinus* of the “*Visio Arislei*”³⁴ is obvious. Arisleus³⁵ tells of his adventure with the *Rex marinus*, in whose kingdom nothing prospers and nothing is begotten. Moreover there are no philosophers there. Only like mates with like,³⁶ consequently there is no procreation. The King must seek the counsel of the philosophers and mate Thabritius with Beya,³⁷ his two children whom he has hatched in his brain³⁸ (fig. 167).



166. Background, the *Rex marinus* calling for help; foreground, his renewed form with the *rotundum* and the *columba spiritus sancti*.—Trismosin, “Splendor solis” (MS., 1582)

[436] When we are told that the King is *exanimis*, inanimate, or that his land is unfruitful, it is equivalent to saying that the hidden state is one of latency and potentiality. The darkness and depths of the sea symbolize the unconscious state of an invisible content that is projected. Inasmuch as such a content belongs to the total personality³⁹ and is only apparently severed from its context by projection, there is always an attraction between conscious mind and projected content. Generally it takes the form of a fascination. This, in the alchemical allegory, is expressed by the King’s cry for help from the depths of his unconscious, dissociated state. The conscious mind should respond to this call: one should *operari regi*, render service to the King, for this would be not only wisdom but salvation as well.⁴⁰ Yet this brings with it the necessity of a descent into the dark world of the unconscious, the ritual *κατάβασις εἰς ἄντρον*, the perilous adventure of the night sea journey (figs. 69, 170, 171), whose end and aim is the restoration of life, resurrection, and the triumph over death (figs. 172, 174, 177). Arisleus and his companions brave the quest, which ends in catastrophe, the death of Thabritius. His death is a punishment for the incestuous *coniunctio oppositorum* (figs. 223, 226). The brother-sister pair stands allegorically

for the whole conception of opposites. These have a wide range of variation: dry-moist, hot-cold, male-female, sun-moon, gold-silver, mercury-sulphur, round-square, water-fire, volatile-solid, physical-spiritual, and so on.⁴¹ The *regius filius* is a rejuvenated form of the Father-King. The youth is frequently shown with a sword and represents the spirit, while the father represents the body. In the *Rosarium* version of the “Visio” the death of the son is the result of his complete disappearance into the body of Beya during coitus. In another version he is eaten by his father (fig. 168), or the Sun is drowned in Mercurius or swallowed by the lion (fig. 169). Thabritius is the masculine, spiritual principle of light and Logos which, like the Gnostic Nous, sinks into the embrace of physical nature (Physis). Death therefore represents the completion of the spirit’s descent into matter. The alchemists depicted the sinful nature of this occurrence in various ways but, because they do not appear to have quite understood it, they rationalize or minimize the incest, in itself so repellent.⁴²

CONIVNCTIO SIVE *Coitus.*



**O Luna durch meyn umbgeben/vnd susse mynne/
Wirstu schön/ starck/vnd gewaltig als ich byn.
O Sol/ du bist vber alle liecht zu erkennen/
So bedarffstu doch mein als der han der hennen.**

167. Allegory of the psychic union of opposites. [Verses: “O Luna, folded by my embrace, / Be you as strong as I, as fair of face. / O Sol, brightest of all lights known to men, / And yet you need me, as the cock the hen.”]—*Rosarium philosophorum* (1550)



168. The king as *prima materia*, devouring his son.—Lambspringk, “Figurae et emblemata,” in *Musaeum hermeticum* (1678)



169. The “green lion” devouring the sun.—*Rosarium philosophorum* (1550)



170. The night sea journey. Joseph in the cistern, Christ in the sepulchre, Jonah swallowed by the whale.—*Biblia pauperum* (1471)

V. THE MYTH OF THE HERO

[437] Resulting as it did from the advice of the philosophers, the death of the King's Son is naturally a delicate and dangerous matter. By descending into the unconscious, the conscious mind puts itself in a perilous position, for it is apparently extinguishing itself. It is in the situation of the primitive hero who is devoured by the dragon. Since all this means a diminution or extinction of consciousness, an *abaissement du niveau mental* equivalent to that "peril of the soul" which is primitive man's greatest dread (i.e., the fear of ghosts⁴³), the deliberate and indeed wanton provocation of this state is a sacrilege or breach of taboo attended by the severest punishments. Accordingly the King imprisons Arisleus and his companions in a triple glass house together with the corpse of the King's Son. The heroes are held captive in the underworld at the bottom of the sea, where, exposed to every kind of terror, they languish for eighty days in an intense heat. At the request of Arisleus, Beya is imprisoned with them. (The *Rosarium* version of the "Visio" interprets the prison as Beya's womb.⁴⁴) Clearly, they have been overpowered by the unconscious and are helplessly abandoned, which means that they have volunteered to die in order to beget a new and fruitful life in that region of the psyche which has hitherto lain fallow in darkest unconsciousness, and under the shadow of death (fig. 171).



171. Hercules on the night sea journey in the vessel of the sun.—Base of an Attic vase (5th cent. B.C.)

[438] Although the possibility of life is hinted at by the brother-sister pair, these unconscious opposites must be activated by the intervention of the conscious mind, otherwise they will merely remain dormant. But this is a dangerous undertaking. We can understand the anxious plea in *Aurora consurgens*: “Horridas nostrae mentis purga tenebras, accende lumen sensibus!”⁴⁵ We can also understand why Michael Maier found few that were willing to plunge into the sea.⁴⁶ Arisleus is in danger of succumbing to the fate of Theseus and Peirithous, who descended into Hades and grew fast to the rocks of the underworld, which is to say that the conscious mind, advancing into the unknown regions of the psyche, is overpowered by the archaic forces of the unconscious: a repetition of the cosmic embrace of *Nous* and *Physis*. The purpose of the descent as universally exemplified in the myth of the hero is to show that only in the region of danger (watery abyss, cavern, forest, island, castle, etc.) can one find the “treasure hard to attain” (jewel, virgin, life-potion, victory over death) (fig. 172).

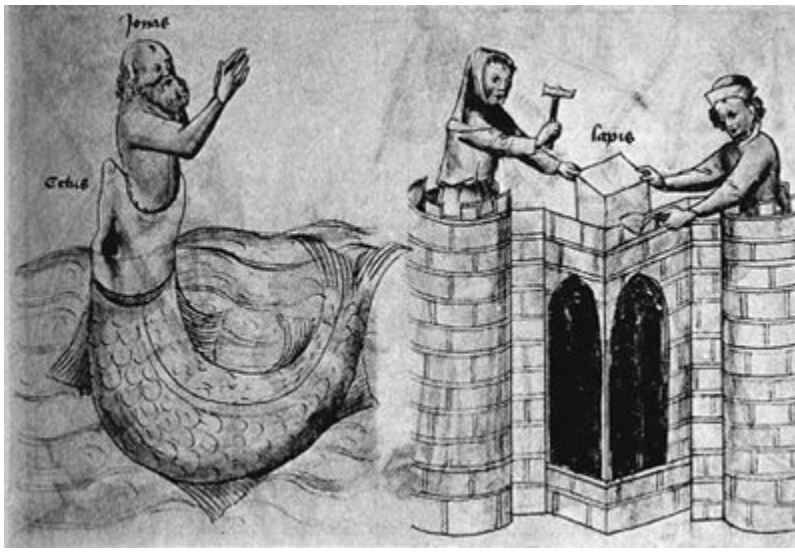

172. Jonah emerging from the belly of the whale. The goal of the night sea journey is equivalent to the *lapis angularis* or cornerstone.—“Speculum humanae salvationis” (Cod. Lat. 512, Paris, 15th cent.)



173. The slaying of the king (*mortificatio*).—Stolcius de Stolcenberg, *Viridarium chymicum* (1624)

[439] The dread and resistance which every natural human being experiences when it comes to delving too deeply into himself is, at bottom, the fear of the journey to Hades. If it were only resistance that he felt, it would not be so bad. In actual fact, however, the psychic substratum, that dark realm of the unknown,⁴⁷ exercises a fascinating attraction that threatens to become the more overpowering the further he penetrates into it.⁴⁸ The psychological danger that arises here is the disintegration of personality into its functional components, i.e., the separate functions of consciousness, the complexes, hereditary units, etc. Disintegration—which may be

functional or occasionally a real schizophrenia—is the fate which overtakes Gabricus (in the *Rosarium* version): he is dissolved into atoms in the body of Beya,⁴⁹ this being equivalent to a form of *mortificatio* (fig. 173).



174. Jonah in the whale.—Early Christian earthenware lamp



175. The wolf as *prima materia*, devouring the dead king. In the background, sublimation of the *prima materia* and rebirth of the king.—Maier, *Scrutinium chymicum* (1687)

[440] Here again we have a repetition of the *coniunctio* of Nous and Physis.⁵⁰ But the latter is a cosmogonic event, whereas this is a catastrophe brought about by the intervention of the philosophers. So long as consciousness refrains from acting, the opposites will remain dormant in the unconscious. Once they have been activated, the *regius filius*—spirit, Logos, Nous—is swallowed up by Physis; that is to say, the body and the psychic representatives of the organs gain mastery over the conscious

mind. In the hero myth⁵¹ this state is known as being swallowed up in the belly of the whale or dragon⁵² (fig. 174). The heat there is usually so intense that the hero loses his hair,⁵³ i.e., he is reborn bald as a babe (fig. 176). This heat is the *ignis gehennalis*, the hell into which Christ descended in order to conquer death as part of his *opus*.

[441] The philosopher makes the journey to hell as a “redeemer.” The “hidden fire” forms the inner antithesis to the cold wetness of the sea.⁵⁴ In the “Visio” this heat is undoubtedly the warmth of incubation,⁵⁵ equivalent to the self-incubating or “brooding” state of meditation. In Indian yoga we find the kindred idea of *tapas*, self-incubation.⁵⁶ The aim of *tapas* is the same as in the “Visio”: transformation and resurrection (cf. fig. 177).



176. Jonah in the belly of the whale.—Khludov Psalter (Byzantine, 9th cent.)



177. The Resurrection: Samson with the city gates of the Philistines, Christ rising from the grave, Jonah being spewed forth by the whale.—*Biblia pauperum* (1470)

VI. THE HIDDEN TREASURE

[442] The “treasure hard to attain,” whose presence was suspected in the dark *prima materia*, is symbolized by the alchemists in various ways. Christopher of Paris, for instance, says that the chaos (as *prima materia*) is the work of all-wise nature. Our understanding (*intellectus*), aided by the “celestial and glowing spirit,” must transform this natural work of art—chaos—into the celestial nature of the quintessence, and into the life-giving (*vegetabilis*) essence of heaven. The precious substance is potentially contained in this chaos as a *massa confusa* of all the elements rolled into one, and man must diligently apply his mind to it so that “our heaven” may come into reality (*ad actum*).⁵⁷

[443] Johannes Grasseus quotes the view that the *prima materia* is the lead (*plumbum*) of the philosophers, also called the “lead of the air”⁵⁸ (an allusion to the inner opposite). This lead contains the radiant white dove (fig. 178), called the “salt of the metals.” The dove is the “chaste, wise, and rich Queen of Sheba, veiled in white, who was willing to give herself to none but King Solomon.”⁵⁹

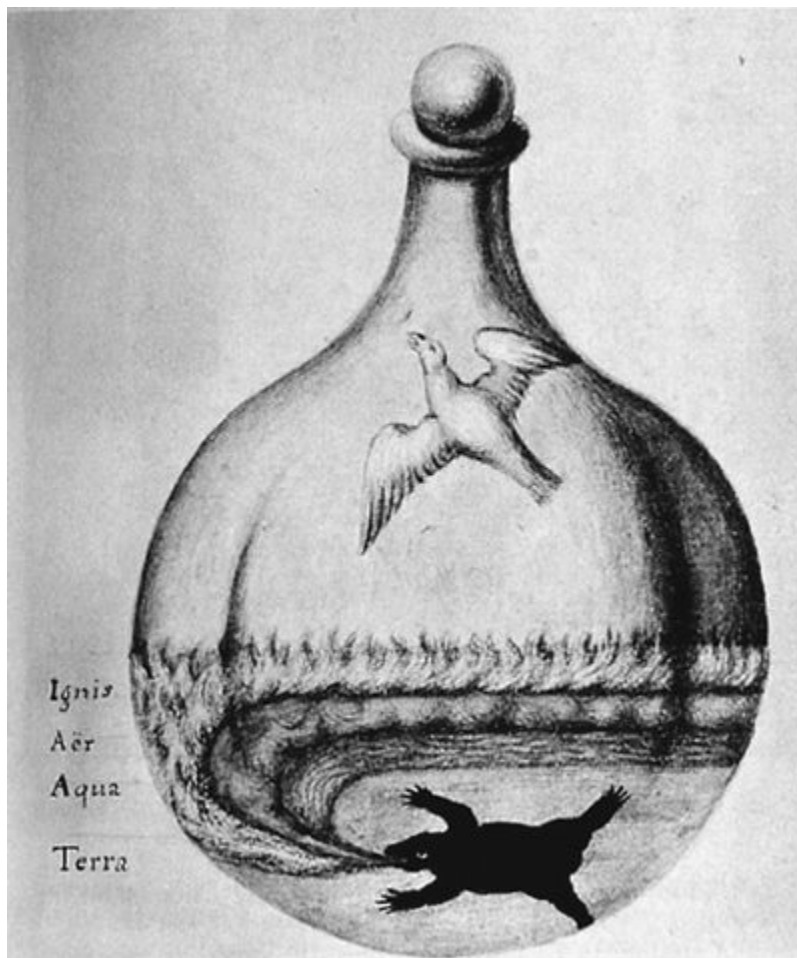

178. The dove (*avis Hermetis*) rising from the four elements as symbol of the spirit freed from the embrace of Physis.
—“De summa et universalis medicinae sapientiae veterum philosophorum” (M.S., 18th cent.)



179. The alchemical trinity: the king and his son with Hermes between them (Hermes = *Spiritus Mercurii*).—
Lamspringk, “Figurae et emblemata,” in *Musaeum hermeticum* (1678)

[444] According to Basilus Valentinus, the earth (as *prima materia*) is not a dead body, but is inhabited by a spirit that is its life and soul. All created things, minerals included, draw their strength from the earth-spirit. This spirit is life, it is nourished by the stars, and it gives nourishment to all the living things it shelters in its womb. Through the spirit received from on high, the earth hatches the minerals in her womb (cf. [fig. 163](#)) as the mother her unborn child. This invisible spirit is like the reflection in a mirror, intangible, yet it is at the same time the root of all the substances necessary to the alchemical process or arising therefrom (*radix nostrorum corporum*).⁶⁰



180. The Christian Trinity with the Holy Ghost as a winged man.—Engraving (15th cent.) by the Master of the Berlin Passion

[445] A similar idea is to be found in Michael Maier.⁶¹ The sun, by its many millions of revolutions, spins the gold into the earth. Little by little the sun has imprinted its image on the earth, and that image is the gold. The sun is the image of God, the heart⁶² is the sun's image in man, just as gold is the sun's image in the earth (also called *Deus terrenus*), and God is known in the gold. This golden image of God is the *anima aurea*, which, when breathed into common quicksilver, changes it into gold.

[446] Ripley is of the opinion that the fire must be extracted from the chaos and made visible.⁶³ This fire is the Holy Ghost, who unites father and son.⁶⁴ He is often represented as a winged old man,⁶⁵ i.e., Mercurius in the form of the god of revelation, who is identical with Hermes Trismegistus⁶⁶ and, together with the King and the King's Son, forms the alchemical trinity (figs. 179, 180). God wrought this fire in the bowels of the earth, just as he wrought the purging flames of hell, and in this fire⁶⁷ God himself glows with divine love.⁶⁸





182. Christ as the Saviour of souls.—Mural painting (12th cent.) church of the Braunweiler monastery, Rhineland

5. THE LAPIS-CHRIST PARALLEL

I. THE RENEWAL OF LIFE

[447] The examples given in the last chapter show that there is a spirit hidden in the *prima materia*, just as there was in the Nile stone of Ostanes. This spirit was eventually interpreted as the Holy Ghost in accordance with the ancient tradition of the Nous swallowed up by the darkness while in the embrace of Physis—with this difference, however, that it is not the supreme feminine principle, earth, who is the devourer, but Nous in the form of Mercurius or the tail-eating Uroboros (fig. 147). In other words, the devourer is a sort of material earth-spirit, an hermaphrodite possessing a masculine-spiritual and feminine-corporeal aspect (fig. 183; cf. figs. 54, 125). The original Gnostic myth has undergone a strange transformation: Nous and Physis are indistinguishably one in the *prima materia* and have become a *natura abscondita*.

[448] The psychological equivalent of this theme is the projection of a highly fascinating unconscious content which, like all such contents, exhibits a numinous —“divine” or “sacred”—quality. Alchemy set itself the task of acquiring this “treasure hard to attain” and of producing it in visible form, as the physical gold or the panacea or the transforming tincture—in so far as the art still busied itself in the laboratory. But since the practical, chemical work was never quite free from the unconscious contents of the operator which found expression in it, it was at the same time a psychic activity which can best be compared with what we call active imagination.¹ This method enables us to get a grasp of contents that also find expression in dream life. The process is in both cases an irrigation of the conscious mind by the unconscious, and it is related so closely to the world of alchemical ideas that we are probably justified in assuming that alchemy deals with the same, or very similar, processes as those involved in active imagination and in dreams, i.e., ultimately with the process of individuation.



[449] Earlier on, we left Arisleus and his companions, together with Beya and the dead Thabritius, in the triple glass house where they had been imprisoned by the *Rex marinus*. They suffer from the intense heat, like the three whom Nebuchadnezzar cast into the fiery furnace (fig. 184). King Nebuchadnezzar had a vision of a fourth, “like the Son of God,” as we are told in Daniel 3 : 25. This vision is not without bearing on alchemy, since there are numerous passages in the literature stating that the stone is *trinus et unus* (fig. 185; cf. fig. 1). It consists of the four elements, with fire representing the spirit concealed in matter. This is the fourth, absent and yet present, who always appears in the fiery agony of the furnace and symbolizes the divine presence—succour and the completion of the work. And, in their hour of need, Arisleus and his companions see their master Pythagoras in a dream and beg him for help. He sends them his disciple Harforetus, the “author of nourishment.”² So the work is completed and Thabritius comes to life again.³ We may suppose that Harforetus brought them the miraculous food, though this only becomes clear through a discovery of Ruska’s, who gave us access to the text of the Codex Berolinensis. There, in an introduction that is missing from the printed versions of the “Visio,”⁴ we read: “Pythagoras says, ‘Ye write and have written down for posterity how this most precious tree is planted, and how he that eats of its fruits shall hunger no more.’”⁵ Since the “Visio” was written for the express purpose of leaving an example of the alchemical process to posterity, it naturally deals with the planting of trees, and the end of the legend is designed to show the miraculous regenerating effects of the fruit. While Arisleus was in such dire straits, and Thabritius lay in the sleep of death, the tree⁶ was evidently growing and bearing fruit. The part played by Arisleus in the glass house is entirely passive. The decisive action comes from the master, who sends his messenger with the food of life.



184. The three youths in the fiery furnace.—Early Christian ornament on sarcophagus from Villa Carpegna, Rome



185. Below, the triad as unity; above, the quaternity standing on the binarius.—Valentinus, "Duodecim claves," in *Mus. herm.* (1678)

[450] We are told that a man can receive the secret knowledge only through divine inspiration or from the lips of a master, and also that no one can complete the work except with the help of God.⁷ In the "Visio" it is the legendary master, the divine Pythagoras,⁸ who takes the place of God⁹ and completes the work of regeneration (fig. 187). This divine intervention, as we may venture to call it, occurs in a dream, when Arisleus sees the master and implores his help. If the union of the opposites—mind and body—portrayed by Thabritius and Beya, the putting to death, and the cremation in the furnace are, according to one alchemist,¹⁰ the equivalent of the offertory in the Mass, we find an analogy to the petition for help in the *memento vivorum*—the intercession for the living—and in the commemoration of martyrs, both of which precede the transubstantiation in the *ordo missae*. The invocation is

made “pro redemptione animarum suarum, pro spe salutis et incolumnitatis suae” (for the redemption of their souls, for the hope of their health and welfare), and the saints are remembered in order that God, for the sake of their merits and prayers, may grant “that we be defended in all things with the help of Thy protection.” The petition ends with the *epiclesis*, which ushers in the transubstantiation: “ut nobis corpus et sanguis fiat” (that it may become for us the Body and the Blood), i.e., the miraculous food,¹¹ the *φάρμακον ζωῆς*. In the “Visio” it is the fruit of the immortal tree that brings salvation (figs. 188–90). But when the Church speaks of the “fructus sacrificii missae”—the fruits of the sacrifice of the Mass—it is not quite the same thing, since moral and other effects are meant, not the consecrated substances themselves which are likewise produced *ex opere operato* (“from the performed work”).

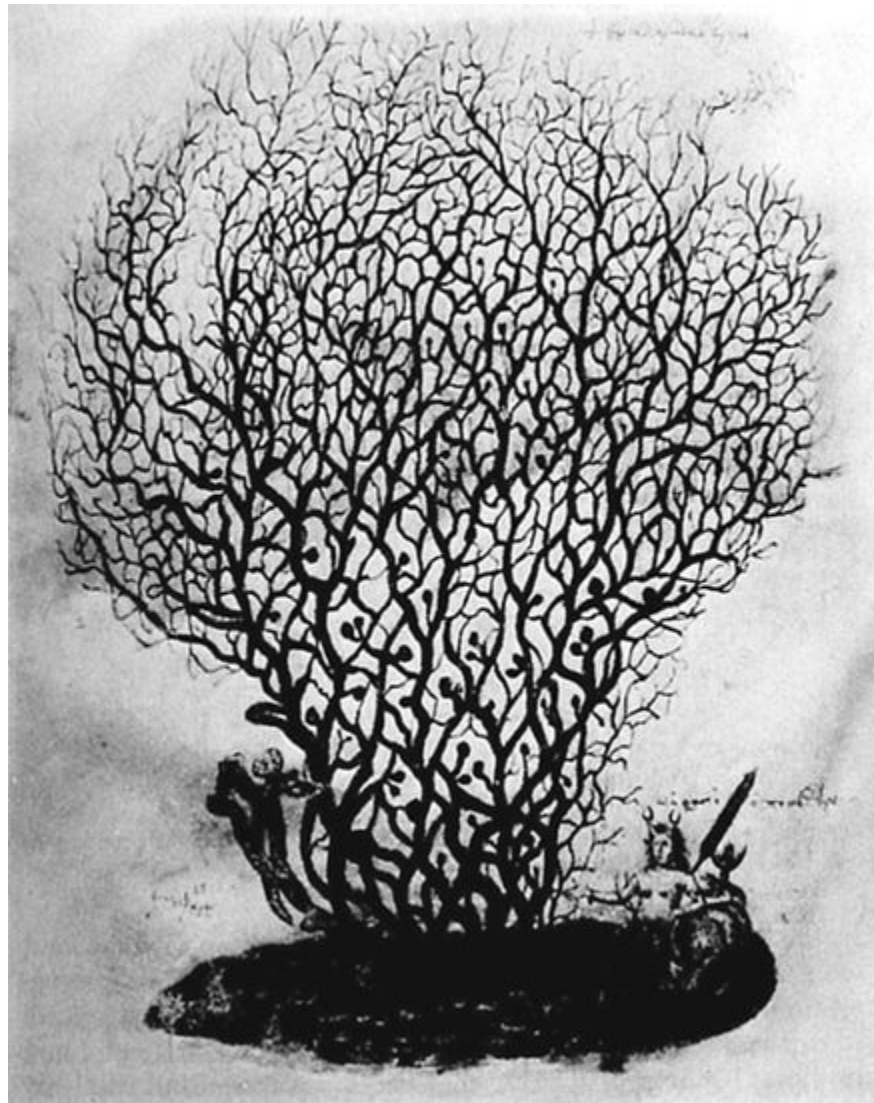

186. The tree of coral in the sea.—Dioscorides, “De materia medica” (MS., Vienna, 16th cent.)



187. The dragon spewing forth Jason, after drinking the potion prepared by Athene.—Attic vase (5th cent. B.C.)



188. The tree of the philosophers, surrounded by symbols of the *opus*.—Mylius, *Philosophia reformata* (1622)



189. Dragon with tree of the Hesperides.—Boschius, *Symbolographia* (1702)

[451] Here we come to a parting of the ways. The Christian receives the fruits of the Mass for himself personally and for the circumstances of his own life in the widest sense. The alchemist, on the other hand, receives the *fructus arboris immortalis* not merely for himself but first and foremost for the King or the King's Son, for the perfecting of the coveted substance. He may play a part in the *perfectio*, which brings him health, riches, illumination, and salvation; but since he is the redeemer of God and not the one to be redeemed, he is more concerned to perfect the substance than himself. Moral qualities he takes for granted and considers them only in so far as they help or hinder the *opus*. We could say that he lays the whole emphasis on the effect *ex opere operantis* ("of the work of the operator"), naturally to a much higher degree than the Church, since he takes the place of the Christ who sacrifices himself in the Mass. One should not for a moment suppose that he presumes to the role of redeemer from religious megalomania. He does so even less than the officiating priest who figuratively sacrifices Christ. The alchemist always stresses his humility and begins his treatises with invocations to God. He does not dream of identifying himself with Christ; on the contrary, it is the coveted substance, the *lapis*, that he likens to Christ. It is not really a question of identification at all, but of the hermeneutic *sicut*—"as" or "like"—which characterizes the analogy. For medieval man, however, analogy was not so much a logical figure as a secret identity, a remnant of primitive thinking which is still very much alive. An instructive example of this is the rite of hallowing the fire on the Saturday before Easter (fig. 191).¹² The fire is "like unto" Christ, an *imago Christi*. The stone from which the spark is struck is the "cornerstone"—another *imago*; and the spark that leaps from the stone is yet again an *imago Christi*. The analogy with the extraction of the pneuma from the stone in the saying of Ostanès forces itself upon us. We are already familiar with the idea of pneuma as fire, and with Christ as fire, and fire as the earth's inner counter-element; but the "firestone" from which the spark is struck is also analogous to the rocky sepulchre, or the stone before it. Here Christ lay as one asleep or in the fetters of death during the

three days of his descent into hell, when he went down to the *ignis gehennalis*, from which he rises again as the New Fire (fig. 234).



190. Mayan ritual tree with serpent.—Dresden Codex



191. Descent of the Holy Ghost in the form of cloven tongues.—Munich Lectionary or *Perikopenbuch* (12th cent.)

[452] Without knowing it, the alchemist carries the idea of the *imitatio* a stage further and reaches the conclusion we mentioned earlier, that complete assimilation to the Redeemer would enable him, the assimilated, to continue the work of redemption in the depths of his own psyche. This conclusion is unconscious, and consequently the alchemist never feels impelled to assume that Christ is doing the work in him. It is by virtue of the wisdom and art which he himself has acquired, or which God has bestowed upon him, that he can liberate the world-creating *Nous* or *Logos*, lost in the

world's materiality, for the benefit of mankind. The artifex himself bears no correspondence to Christ; rather he sees this correspondence to the Redeemer in his wonderful stone. From this point of view, alchemy seems like a continuation of Christian mysticism carried on in the subterranean darkness of the unconscious—indeed some mystics pressed the materialization of the Christ figure even to the appearance of the stigmata. But this unconscious continuation never reached the surface, where the conscious mind could have dealt with it. All that appeared in consciousness were the symbolic symptoms of the unconscious process. Had the alchemist succeeded in forming any concrete idea of his unconscious contents, he would have been obliged to recognize that he had taken the place of Christ—or, to be more exact, that he, regarded not as ego but as self,¹³ had taken over the work of redeeming not man but God. He would then have had to recognize not only himself as the equivalent of Christ, but Christ as a symbol of the self. This tremendous conclusion failed to dawn on the medieval mind. What seems like a monstrous presumption to the Christian European would have been self-evident to the spirit of the Upanishads. Modern man must therefore consider himself fortunate not to have come up against Eastern ideas until his own spiritual impoverishment was so far gone that he did not even notice what he was coming up against. He can now deal with the East on the quite inadequate and therefore innocuous level of the intellect, or else leave the whole matter to Sanskrit specialists.



192. The quaternity of the cross in the zodiac, surrounded by the six planets. Mercurius corresponds to the cross between sun and moon: a paraphrase of ♄.—Böhme, *Signatura rerum* (1682)

II. EVIDENCE FOR THE RELIGIOUS INTERPRETATION OF THE LAPIS

a. Raymond Lully

[453] It is not surprising that the *lapis*-Christ parallel came to the fore among the medieval Latin authors at a comparatively early date, since alchemical symbolism is steeped in ecclesiastical allegory. Although there is no doubt that the allegories of the Church Fathers enriched the language of alchemy, it remains in my opinion exceedingly doubtful just how far the *opus alchemicum*, in its various forms, can be regarded as a transmogrification of ecclesiastical rites (baptism, Mass) and dogmas (Christ's conception, birth, passion, death, and resurrection). Undeniably, borrowings were made over and over again from the Church, but when we come to the original basic ideas of alchemy we find elements that derive from pagan, and more particularly from Gnostic, sources. The roots of Gnosticism do not lie in Christianity at all—it is far truer to say that Christianity was assimilated through Gnosticism.¹⁴

Apart from this we have a Chinese text,¹⁵ dating from the middle of the second century, which displays fundamental similarities with Western alchemy. Whatever the connection between China and the West may have been, there is absolutely no doubt that parallel ideas exist outside the sphere of Christianity, in places where Christian influence is simply out of the question. A. E. Waite¹⁶ has expressed the opinion that the first author to identify the stone with Christ was the Paracelsist, Heinrich Khunrath (1560–1605), whose *Amphitheatrum* appeared in 1598. In the writings of the somewhat later Jakob Böhme, who frequently uses alchemical terms, the stone has already become a metaphor for Christ (fig. 192). Waite's assumption is undoubtedly erroneous, for we have much earlier testimonies to the connection between Christ and the *lapis*, the oldest that I have so far been able to discover being contained in the *Codicillus* (Ch. IX) of Raymond Lully (1235–1315). Even if many of the treatises ascribed to him were written by his Spanish and Provençal disciples, that does not alter the approximate date of his main works, to which the *Codicillus* belongs. At any rate I know of no authoritative opinion that puts this treatise later than the fourteenth century. There it is said:

And as Jesus Christ, of the house of David, took on human nature for the deliverance and redemption of mankind, who were in the bonds of sin on account of Adam's disobedience, so likewise in our art that which has been wrongfully defiled by one thing is absolved by its opposite; cleansed, and delivered from that stain.¹⁷

b. Tractatus aureus

[454] A still older source would assuredly be the "Tractatus aureus"—ascribed to Hermes and regarded as of Arabic origin even in the Middle Ages—were Christ mentioned directly by name. The reason why I nevertheless quote it is that it describes things which bear a remarkable resemblance to the mysterious happenings at Eastertide, and yet are clothed in quite another language. The passage runs as follows:

Our precious stone, that was cast upon the dung-heap, is altogether vile.... But when we marry the crowned king with the red daughter, she will conceive a son in the gentle fire, and shall nourish him through our fire.... Then is he transformed, and his tincture remains red as flesh. Our son of royal birth takes his tincture from the fire, and death, darkness, and the waters flee away. The dragon shuns the light of the sun, and our dead son shall live. The king shall come forth from the fire and rejoice in the marriage. The hidden things shall be disclosed, and the virgin's milk be whitened. The son is become a warrior fire and surpasses the tincture, for he himself is the treasure and himself is attired in the philosophic matter. Come hither, ye sons of

wisdom, and rejoice, for the dominion of death is over, and the son reigns; he wears the red garment [fig. 193],¹⁸ and the purple is put on.¹⁹

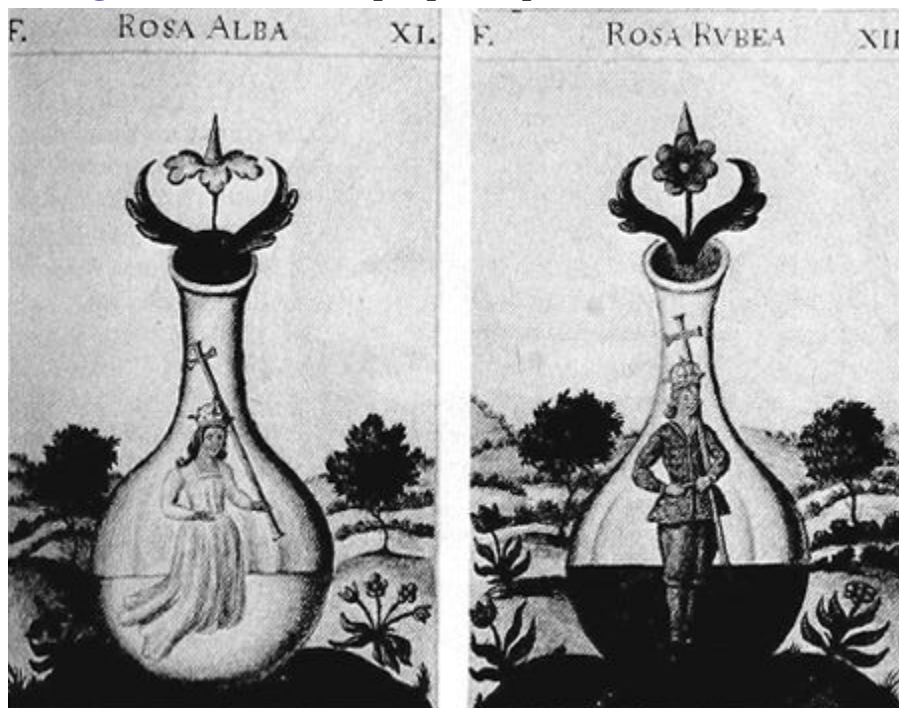

193. The white and the red rose as end-product of the transformation of king and queen.—“Trésor des trésors” (MS., 17th cent.)

[455] We can take this text as a variant of the mythical God-man and his triumph over death, and thus as an analogy of the Christian drama. Since the age and origin of this Hermetic text are still unknown, we cannot decide with any certainty whether Christian influence is at work here. Probably not. There is no reason to suspect Christian influence in the very early texts, such as that of Komarios.²⁰ (The Christian prefaces, etc., to these manuscripts are interpolations by Byzantine monastic copyists.) And yet it is just the Komarios text that has all the characteristics of a regeneration mystery, although here the resurrection of the dead is effected not by a redeemer but by the ὕδωρ θεῖον (the *aqua permanens* of the Latinists; cf. fig. 194), to which the Christian water symbolism (*aqua* = *spiritus veritatis*, baptism, and Eucharist) forms an unmistakable parallel.

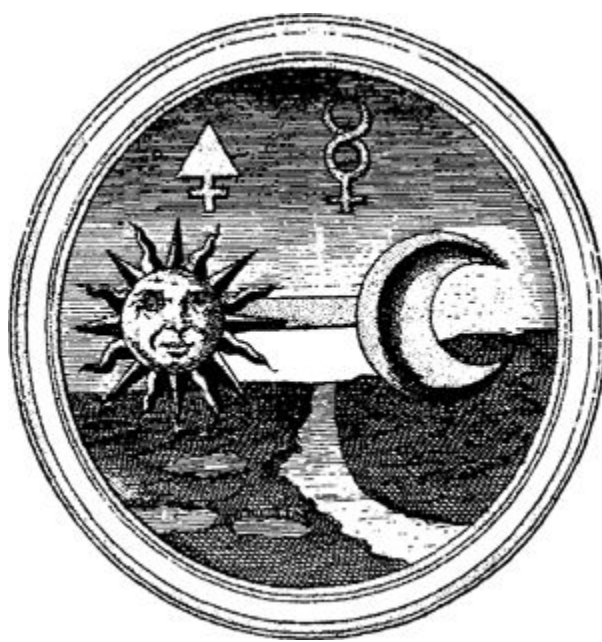

194. Sulphur as sun and Mercurius as moon bridging the river of “eternal water.”

— Barchusen, *Elementa chemiae* (1718)

c. Zosimos and the Doctrine of the Anthropos

[456] In the later texts, however, which are ascribed to Zosimos, we find the Son of God in unmistakable association with the priestly art (*ἱερατικῆ τέχνη*). I give the relevant passages in a literal translation:²¹

4: ... If you have meditated and have dwelt in human community, you will see that the Son of God has become all things for the sake of devout souls: in order to draw the soul forth from the dominion of Heimarmene²² into the [realm of the] incorporeal, behold how he has become all—God, angel, and man capable of suffering.²³ For having power in all, he can become all as he wills; and he obeys the Father inasmuch as he penetrates²⁴ all bodies and illuminates the mind of each soul,²⁵ spurring²⁶ it on to follow him up to the blessed region where it²⁷ was before the beginning of corporeal things,²⁸ yearning and led by him into the light.²⁹

5: And consider the tablet which Bitos³⁰ also wrote, and the thrice-great Plato³¹ and the infinitely great Hermes, saying that³² the first man is designated with the first hieratic word Thoyth,³³ who is the interpreter of all things that are and the giver of names to all corporeal things. The Chaldeans, Parthians, Medes, and Hebrews call him Adam, which is, being interpreted, virgin earth, blood-red [or bloody] earth, fiery³⁴ or carnal earth. This is to be found in the libraries of the Ptolemies. They put it³⁵ in every sanctuary, and especially in the Serapeum, at the time when Asenas³⁶ went to the High Priest of Jerusalem,³⁷ who sent Hermes, who translated the whole of the Hebrew into Greek and Egyptian.

6: So the first man is called by us Thoyth and by them Adam, which is a name in the language of the angels; but with reference to his body³⁸ they named him

symbolically after the four elements³⁹ of the whole heavenly sphere [fig. 195]. For his letter A stands for ascent [ἀνατολή: the East] or the air; D for descent [δύσις: the West] ...⁴⁰ because it [the earth] is heavy; A for arctic [ἄρκτος: the North]; and M for meridian [μεσημβρία: the South], the midmost of these bodies, the fire that burns in the midst of the fourth region.⁴¹ Thus the fleshly Adam according to his outward and visible form is called Thoyth, but the spiritual man in him has a proper name as well as the name by which he is called. His proper name as yet⁴² I know not: for Nikotheus alone knows this, and he is not to be found. But his common name is Man [φῶς], which is Light [φῶς]; wherefore it came that men are called φῶτας.

7: Now when the Man of Light⁴³ abode in Paradise, pervaded⁴⁴ by the breath of Heimarmene, they [the elements]⁴⁵ persuaded him, who was without evil and free from their activity, to put on the Adam that was with him,⁴⁶ namely the Adam wrought of the four elements of Heimarmene⁴⁷ [cf. figs. 82, 117]. And he in his innocence did not turn aside; but they boasted that he was their slave. [Wherefore] Hesiod⁴⁸ called the outer man the bond with which⁴⁹ Zeus bound Prometheus. But after this fetter Zeus sent him yet another: Pandora, whom the Hebrews call Eve. For, in the allegorical language, Prometheus and Epimetheus are but one man, namely soul and body. And sometimes he⁵⁰ bears the likeness of the soul, sometimes that of the spirit, and sometimes the likeness of the flesh [fig. 196], because of the disobedience of Epimetheus, who heeded not the counsel of Prometheus, his own mind.⁵¹ For our mind⁵² says: “The Son of God, having power in all things and becoming all things when⁵³ he wills, appears⁵⁴ as he wills to each. Jesus Christ made himself one with Adam and bore him up to that place where the Men of Light dwelt before.”⁵⁵



195. Creator, macrocosm, and microcosm in human form, the microcosm surrounded by the elements.—St. Hildegarde of Bingen, “Liber divinorum operum” (MS., 12th cent.)

8: But he appeared to the very feeble as a man capable of suffering and like one scourged. And after he had privily stolen away the Men of Light that were his own,⁵⁶ he made known that in truth he did not suffer, and that death was trampled down and cast out. And to this day and to the end of the world⁵⁷ he is present in many places,⁵⁸ both secretly and openly consorting with his own,⁵⁹ counselling them secretly, yea through their own minds,⁶⁰ to suffer confusion⁶¹ with the Adam who was with them, that he might be beaten away from them⁶² and slain, this blind chatterer who is envious of the spiritual Man of Light. [Thus] they kill their Adam.

9: And these things are so until the coming of the daemon Antimimos, the jealous one,⁶³ who seeks to lead them astray as before,⁶⁴ declaring that he is the Son of God, although he is formless in both body and soul. But they, having become wiser since the true Son of God has taken possession of them, deliver up to him their own Adam to be put to death, and bring their shining spirits safely back to the place where they were before the beginning of the world. Yet before Antimimos, the jealous one, does this,⁶⁵ he sends his forerunner from Persia, who circulates false fables and leads men astray through the power of Heimarmene. The letters of his name are nine, if you

keep the diphthong,⁶⁶ corresponding to Heimarmene. Later, at the end of about seven periods,⁶⁷ he will appear in his own⁶⁸ shape.

10: And only the Hebrews and the sacred books of Hermes [tell of] these things concerning the Man of Light and his guide the Son of God, and concerning the earthly Adam and his guide Antimimos, who blasphemously calls himself the Son of God to lead men astray. But the Greeks call the earthly Adam Epimetheus, who was counselled by his own mind, his brother, not to accept the gifts of Zeus. Yet, inasmuch as he erred and afterwards repented, seeking the abode of bliss, he⁶⁹ makes everything plain and fully advises them that have spiritual hearing. But those that have only bodily hearing are slaves of Heimarmene, for they neither understand nor admit anything else.

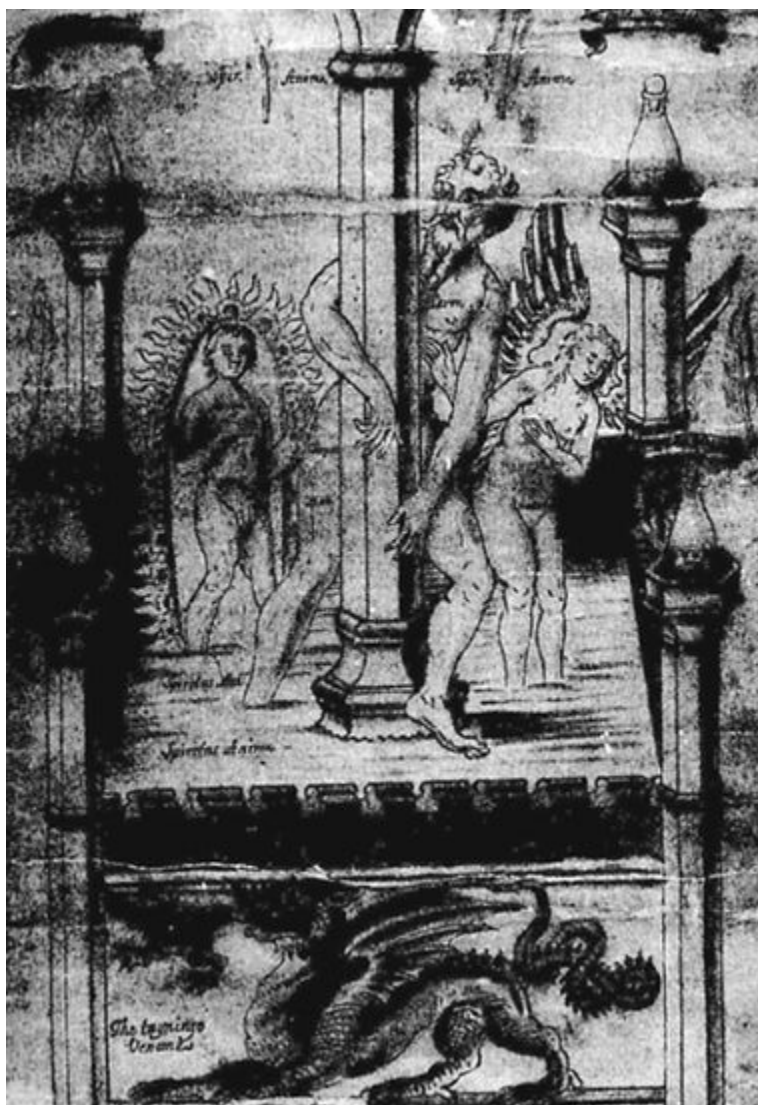

196. The three manifestations of the Anthropos during his transformation: body, soul, spirit. Below, dragon and toad as preliminary forms.—“Ripley Scrowle” (MS., 1588)

11: And all who meet with success in the matter of colourings at the propitious moment, consider nothing but the great book about furnaces, for they do not esteem the art; nor do they understand the poet when he says: “But the gods have not given to men equally.”⁷⁰ Neither do they observe and see the manner of men’s lives: how,

even in the same art, men may reach the goal in different ways and practise the same art in different ways, according to their different characters and the constellations of the stars in the exercise of the same art; how one worker is inactive,⁷¹ another alone,⁷² one blasphemously desiring too much, another too timid and therefore without progress—this is so in all the arts—and how those who practise the same art use different implements and procedures, having also different attitudes to the spiritual conception of it and its practical realization.

12: And this is more to be considered in the sacred art than in all the other arts....

[457] To all appearances, Zosimos' Son of God is a Gnostic Christ who has more affinity with the Iranian conception of Gayomart than with the Jesus of the Gospels. The author's connections with Christianity are by no means clear, since he undoubtedly belonged to the Hermetic Poimandres sect, as is evident from the passage about the Krater.⁷³ As in later Christian alchemy, the Son of God is a sort of paradigm of sublimation, i.e., of the freeing of the soul from the grip of Heimarmene. In both cases he is identical with Adam, who is a quaternity compounded of four different earths. He is the Anthropos, the first man, symbolized by the four elements, just like the *lapis* which has the same structure. He is also symbolized by the cross, whose ends correspond to the four cardinal points (fig. 197; cf. figs. 82, 192). This motif is often replaced by corresponding journeys, such as those of Osiris,⁷⁴ the labours of Herakles,⁷⁵ the travels of Enoch,⁷⁶ and the symbolic *peregrinatio* to the four quarters in Michael Maier⁷⁷ (1568–1622) (cf. fig. 97). Journeys are also related of Hermes Trismegistus,⁷⁸ and this may have inspired Maier's *peregrinatio*, although it is more probable that Maier imagined the *opus* as a wandering or odyssey, rather like the voyage of the Argonauts in quest of the *aureum vellus* (Golden Fleece), so beloved of the alchemists, a theme that figures in the title of more than one treatise. Alexander's campaign is mentioned in a treatise ascribed to Albertus Magnus, the journey ending in the discovery of Hermes' grave, where a stork is perched on the tree instead of a phoenix.⁷⁹



197. Christ in the midst of the four rivers of paradise, evangelists, Fathers of the Church, virtues, etc.—Peregrinus, “Speculum virginum” (MS., 13th cent.)



198. Anser or cygnus Hermelis.—Hermaphroditisches Sonn- und Mondskind (1752)

[458] Adam corresponds to Thoth (Θωϋς), the Egyptian Hermes (fig. 68). Adam’s inner, spiritual man is named φῶς (light). Nikotheos, who knows the Man of Light’s secret name, occurs twice in Zosimos as a mysterious personage,⁸⁰ and he is also mentioned in a Coptic Gnostic text as one who has beheld the Monogenes (*unigenitus*). Porphyry, in his life of Plotinus, speaks of him as the author of an

Apocalypse.⁸¹ The Manichees reckon him among the prophets, along with Shēm, Sēm, Enōš, and Enoch.⁸²

[459] Prometheus and Epimetheus represent the inner and outer man, like Christ and Adam. The ability to “become all,” attributed to the Son of God, is an attribute not only of the pneuma but of the alchemical Mercurius, whose boundless powers of transformation are praised⁸³ in accordance with the versatility of the astrological Mercury (fig. 24). He is the *materia lapidis*, the transforming substance par excellence, and is said to penetrate all bodies⁸⁴ like a poison⁸⁵ (fig. 150).

[460] Antimimos, the imitator and evil principle, appears as the antagonist of the Son of God: he too considers himself to be God’s son. Here the opposites inherent in the deity are clearly divided. We meet this daemon in many other places as the *ἀντίμιμον πνεῦμα*: he is the spirit of darkness in a man’s body, compelling his soul to fulfil all his sinful tendencies.⁸⁶ The alchemical parallel to this polarity is the double nature of Mercurius, which shows itself most clearly in the Uroboros, the dragon that devours, fertilizes, begets, slays, and brings itself to life again. Being hermaphroditic, it is compounded of opposites and is at the same time their uniting symbol (fig. 148): at once deadly poison, basilisk, scorpion, panacea, and saviour (fig. 199).



199. Hermaphrodite on the winged globe of chaos, with the seven planets and the dragon.

—Jamsthaler, *Vitorium spagyricum* (1625)

[461] Zosimos discloses practically the whole of the recondite and highly peculiar theology of alchemy, by drawing a parallel between the esoteric meaning of the *opus* and the Gnostic mystery of redemption. This is only one indication that the lapis-

Christ parallel of the scholastic alchemists had a pagan Gnostic precursor and was by no means a mere speculation of the Middle Ages.



200. Eagle and swan as symbols of the sublimated *spiritus*. In the foreground, Saturn.

—Mylius, *Philosophia reformatata* (1622)

d. Petrus Bonus

[462] The oldest source to treat specifically of the stone's connection with Christ would appear to be a text, *Pretiosa margarita novella*, written by Petrus Bonus of Ferrara between 1330 and 1339,⁸⁷ from which I give the following extract:⁸⁸

This art is partly natural and partly divine or supernatural. At the end of the sublimation [fig. 200] there germinates, through the mediation of the spirit, a shining white soul [*anima candida*] which flies up to heaven with the spirit [cf. fig. 134]. This is clearly and manifestly the stone. So far the procedure is indeed somewhat marvellous, yet still within the framework of nature. But as regards the fixation and permanence of the soul and spirit at the end of the sublimation, this takes place when the secret stone is added, which cannot be grasped by the senses, but only by the intellect, through inspiration or divine revelation, or through the teaching of an initiate. Alexander says that there are two categories: seeing through the eye and understanding through the heart.⁸⁹ This secret stone is a gift of God. There could be no alchemy without this stone. It is the heart and tincture of the gold, regarding which Hermes says: "It is needful that at the end of the world heaven and earth be united: which is the philosophic Word."⁹⁰ Pythagoras also said in the *Turba*: "God

concealed this from Apollo, so that the world should not be destroyed.” Thus alchemy stands above nature and is divine. The whole difficulty of the art lies in this stone. The intellect cannot comprehend it, so must believe it, like the divine miracles and the foundation of the Christian creed. Therefore God alone is the operator, while nature remains passive. It was through their knowledge of the art that the old philosophers knew of the coming of the end of the world and the resurrection of the dead. Then the soul will be united with its original body for ever and ever. The body will become wholly transfigured [*glorificatum*], incorruptible, and almost unbelievably subtilized,⁹¹ and it will penetrate all solids. Its nature will be as much spiritual as corporeal. When the stone decomposes to a powder like a man in his grave, God restores to it soul and spirit, and takes away all imperfection; then is that substance [*illa res*] strengthened and improved, as after the resurrection a man becomes stronger and younger than he was before. The old philosophers discerned the Last Judgment in this art, namely in the germination and birth of this stone, for in it the soul to be beatified [*beatificandae*] unites with its original body, to eternal glory. So also the ancients knew that a virgin must conceive and bring forth, for in their art the stone begets, conceives, and brings itself forth.⁹² Such a thing can happen only by the grace of God. Therefore Alphidius⁹³ says of the stone that its mother was a virgin and that its father had never known woman. They knew besides that God would become man on the Last Day of this art⁹⁴ [*in novissima die huius artis*], when the work is perfected; and that begetter and begotten, old man and boy, father and son, all become one. Now, since no creature except man can unite with God, on account of their dissimilarity, God must needs become one with man. And this came to pass in Christ Jesus and his virgin mother.⁹⁵ Therefore Balgus says in the *Turba*: “O what miracles of nature, that have changed the soul of the old man into a youthful body, and the father has become the son” [cf. [figs. 166, 167](#)]. In like manner Plato, writing of alchemical matters, wrote a gospel which was completed long after by John the Evangelist. Plato wrote the opening verses from “In the beginning was the Word” to “There was a man sent from God.”⁹⁶ God has shown the philosopher this wonderful example that he might perform supernatural works. Morienus says that God has entrusted this *magisterium* to his philosophers or prophets, for whose souls he has prepared a dwelling in his paradise.⁹⁷

[463] This text, which is at least a century older than Khunrath, shows beyond all doubt that the connection between the mystery of Christ and the mystery of the *lapis* was even then so obvious that the philosophical *opus* seemed like a parallel and imitation—perhaps even a continuation—of the divine work of redemption.

e. “Aurora consurgens” and the Doctrine of Sapientia

[464] The next source is *Aurora consurgens*,⁹⁸ of which a manuscript copy of the fifteenth century, the Codex Rhenoviensis, from the monastery at Rheinau, is to be found in Zurich. Unfortunately the manuscript is mutilated and begins only at the fourth parable. I was made aware of it through the fact that the printer of *Artis auriferae* (1593) published only [Part II](#) of *Aurora*. He prefixed to it a short notice to the reader in which he says that he has purposely omitted the entire treatise consisting of parables or allegories because the author, in the ancient manner of obscurantists (*antiquo more tenebrionum*), treated almost the whole Bible—particularly Proverbs, Psalms, but above all the Song of Songs—in such a way as to suggest that the Holy Scriptures had been written solely in honour of alchemy. The author, he says, has even profaned the most holy mystery of the incarnation and death of Christ by turning it into the mystery of the *lapis*—not, of course, with any evil intent, as he, the typographer Conrad Waldkirch, readily admits, but as was only to be expected in that benighted epoch (*seculum illud tenebrarum*). By this Waldkirch meant the pre-Reformation epoch, whose conception of man and the world, and experience of the divine presence in the mystery of matter, had entirely vanished from the purview of the Protestants of his own day.

[465] The treatise is preserved entire in the Codex Parisinus Latinus 14006. There is also a printing of it in the compilation edited by Johannes Rhenanus, *Harmoniae inperscrutabilis chymico-philosophicae Decades duae* (Frankfort, 1625).⁹⁹ The age of the text, which is attributed to St. Thomas Aquinas (d. 1274), may be gauged more or less from the fact that the most recent author quoted in it is Albertus Magnus (1193–1280). The other authors who are everywhere quoted in the fifteenth century—Arnold of Villanova (d. 1313) and Raymond Lully (d. 1315)—are not mentioned. Since Thomas was canonized in 1323 and was thus at the height of his fame, it was worth while ascribing texts to him from that time on. We shall probably not be far out if we put the date in the first half of the fourteenth century. The author is evidently a cleric who knows his Vulgate by heart. His whole idiom is steeped in Biblical quotation, just as his mind is full of alchemical philosophy. Alchemy is for him absolutely identical with the *Sapientia Dei*. He begins his treatise with words taken from the Wisdom of Solomon (7 : 11) and Proverbs (1 : 20–21):

Venerunt mihi omni bona pariter cum illa¹⁰⁰ sapientia austri, quae foris praedicat, in plateis dat vocem suam, in capite turbarum clamitat, in foribus portarum urbis profert verba sua dicens:¹⁰¹ Accedite ad me et illuminamini et operationes vestrae non confundentur;¹⁰² omnes qui concupiscitis me¹⁰³ divitiis meis adimplemini. Venite ergo filii, audite me, scientiam Dei docebo vos. Quis sapiens et intelligit hanc, quam Alphidius dicit homines et pueros in viis et plateis praeterire et cottidie a iumentis et pecoribus in sterquilinio conculcari....

(All good things come to me together with her,¹⁰⁰ that Wisdom of the south, who preacheth abroad, who uttereth her voice in the streets,¹⁰¹ crieth out at the head of the multitudes, and in the entrance of the gates of the city uttereth her words, saying: “Come ye to me and be enlightened, and your operations shall not be confounded;¹⁰² all ye that desire me shall be filled with my riches.¹⁰³ Come, children, hearken to me, I will teach you the science of God. Who is wise, and understandeth this, of which Alphidius saith, that men and children pass her by daily in the streets and public places, and she is trodden into the mire by beasts of burden and by cattle ...”)



201. Sapientia as mother of the wise.—Thomas Aquinas (pseud.), “De alchimia” (MS., 16th cent.)

[466] The *sapientia austri* is, in patristic usage,¹⁰⁴ the wisdom of the Holy Ghost. For our author Sapientia is the “regina Austri, quae ab oriente dicitur venisse, ut aurora consurgens”—Queen of the South,¹⁰⁵ who is said to have come from the east, like unto the morning rising¹⁰⁶ (fig. 201).

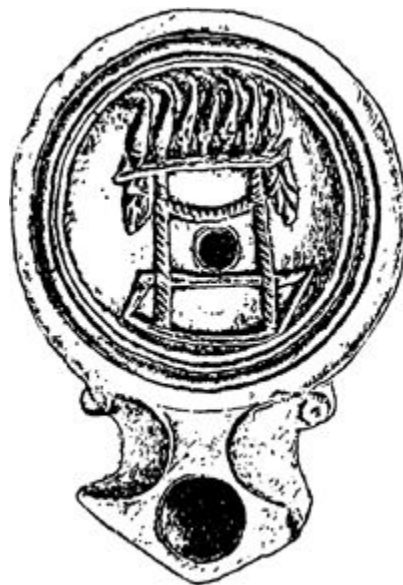

202. Communion table with seven fish.—Christian earthenware lamp, Carthage

[467] Without mentioning our text, the *Rosarium* quotes it as follows:¹⁰⁷

This [Sapientia] is my daughter, for whose sake men say that the Queen of the South came out of the east, like the rising dawn, in order to hear, understand, and behold the wisdom of Solomon; power, honour, strength, and dominion are given into her hand; she wears the royal crown of seven glittering stars, like a bride adorned for her husband, and on her robe is written in golden lettering, in Greek, Arabic, and Latin: I am the only daughter of the wise, utterly unknown to the foolish.

[468] This is without doubt a citation from *Aurora*. The original text has twelve instead of seven stars, the latter evidently referring to the seven stars in the hand of the apocalyptic “one like unto the Son of Man” (Rev. 1 : 13; 2 : 1). These represent the seven angels of the seven Churches and the seven spirits of God (fig. 202). The historical *sous-entendu* of the seven is the antique company of seven gods who later took up their abode in the seven metals of alchemy (figs. 21, 79, 154). They were deposed by science only during the last one hundred and fifty years. For Paracelsus the gods were still enthroned as archons in the *mysterium magnum* of the *prima materia*, “to their own undoing and ours.”¹⁰⁸

[469] The twelve stars of the original text refer to the twelve disciples and the twelve signs of the zodiac (figs. 92, 100). The Agathodaimon serpent on Gnostic gems also has seven or twelve rays about its head (figs 203–5). In Clement’s second homily it is observed that the number of apostles corresponds to the twelve months.¹⁰⁹ In the Manichean system the saviour constructs a cosmic wheel with twelve buckets—the zodiac—for the raising of souls.¹¹⁰ This wheel has a significant connection¹¹¹ with the *rota* or *opus circulatorium* of alchemy,¹¹² which serves the same purpose of sublimation. As Dorn says: “The wheel of creation takes its rise from the *prima materia*, whence it passes to the simple elements.”¹¹³ Enlarging on the idea of the *rota philosophica* (cf. figs. 80, 104), Ripley says that the wheel must be turned by the four seasons and the four quarters, thus connecting this symbol with the *peregrinatio* and the quaternity. The wheel turns into the wheel of the sun rolling round the heavens, and so becomes identical with the sun-god or -hero who submits to arduous labours and to the passion of self-cremation, like Herakles, or to captivity and dismemberment at the hands of the evil principle, like Osiris. A well-known parallel to the chariot of the sun is the fiery chariot in which Elijah ascended to heaven (figs. 206, 207).¹¹⁴ Accordingly Pseudo-Aristotle says:¹¹⁵ “Take the serpent, and place it on the chariot with four wheels, and let it be turned about on the earth until it is immersed in the depths of the sea, and nothing more is visible but the blackest dead sea.” The image used here is surely that of the sun sinking into the sea, save that the sun has been replaced by the mercurial serpent, i.e., the substance to be transformed. Michael Maier actually takes the *opus circulatorium* as an image of the sun’s course:

For while the hero, like a joyful giant,¹¹⁶ rises in the east and hastens to his sinking in the west, that he may forever return out of the east, he sets in motion these circulations, depositing in the shining substance of the quicksilver, as in a mirror, forms [wherein] by human diligence the gold may be sought, cleansed from impurities, tested by fire and water, and put to a use pleasing to God the Creator.¹¹⁷

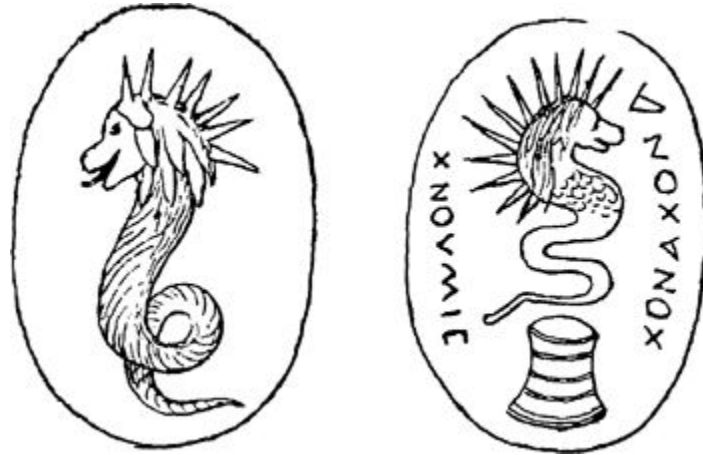

203, 204. The Chnuphis serpent with seven-rayed crown; the lion-headed, twelve-rayed XNOYMIC-serpent, over an altar-stone.—Gnostic gem and amulet



205. Goddess of fate as serpent with seven heads.—Seal of St. Servatius, from Maastricht Cathedral

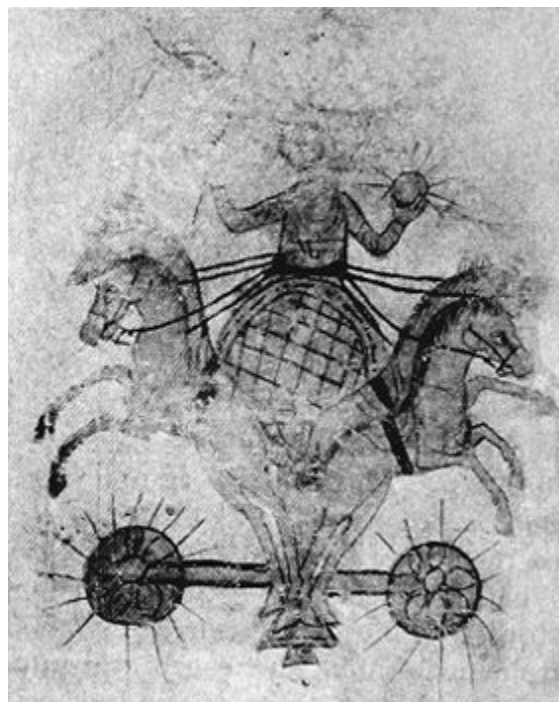

[470] The circle described by the sun is the “line that runs back on itself, like the snake that with its head bites its own tail, wherein God may be discerned.” Maier calls it the “shining clay moulded by the wheel [rota] and hand of the Most High and Almighty Potter” into that earthly substance wherein the sun’s rays are collected and caught. This substance is the gold.¹¹⁸ In “Introitus apertus,”¹¹⁹ Philalethes elaborates Maier’s views: there is in “our” mercury, he says, a fiery sulphur or sulphureous fire. This fire is the “spiritual seed” which our Virgin¹²⁰ has gathered in herself, because unspotted virginity can admit of “spiritual love,” according to the author of the Hermetic mystery and as experience itself shows. It is to be noted that this virgin, who being “unspotted” (*intemerata*) is obviously analogous to the Virgin Mary, is made pregnant by a seed deriving not from any Holy Ghost but from a “sulphureous fire,” i.e., an *ignis gehennalis*.¹²¹ The virgin is Mercurius¹²² (fig. 208). who, owing to the presence of sulphur, the active masculine principle, is hermaphroditic.¹²³ Sulphur is the *aurum volatile* (fig. 209), a “spiritual” gold, the *aurum non vulgi* of the *Rosarium* and at the same time the “*primum movens, quod rotam vertit axemque vertit in gyrum*” (prime mover that turns wheel and axle in a circle).



207. The ascension of Elijah.—Early Christian mural painting, crypt of Lucina, Rome



208. Mercurius as *anima mundi*.—"Turba philosophorum" (MS., Paris, 16th cent.)

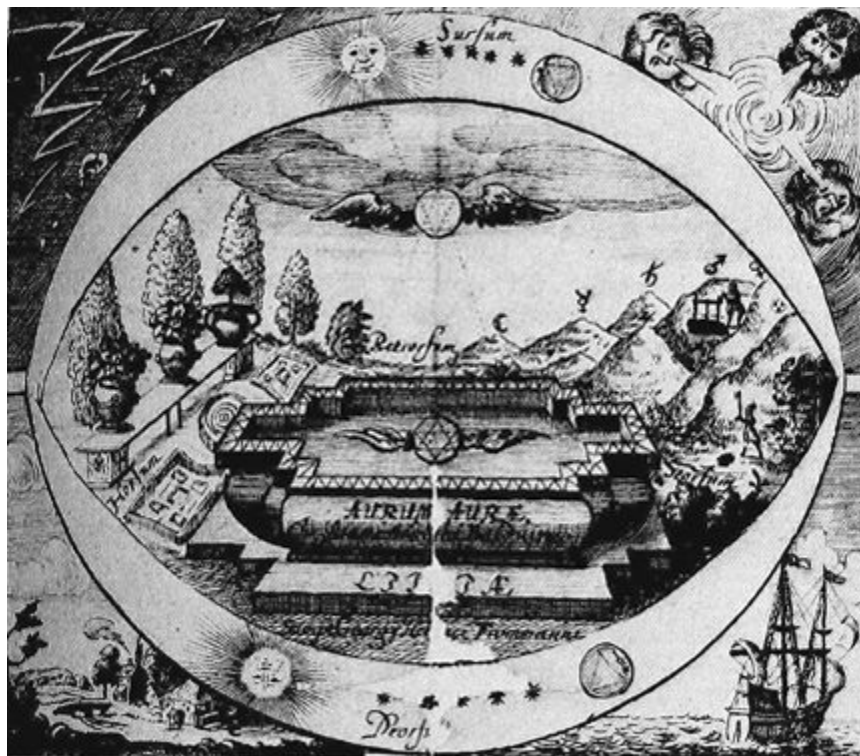

209. The winged sphere (*aurum aurae*) as the end-product of the *opus*, and its reflection in the fountain of life. Symbolic representation of the *opus* with attributes (trees, planetary mountains, etc.).—Balduinus, *Aurum*

- [471] Laurentius Ventura¹²⁴ cannot resist connecting the wheel with the vision of Ezekiel. Thus, speaking of the *lapis*, he says that Ezekiel saw “in its shape the wheel within the wheel and the spirit of the living creature that was in the midst of the wheels”¹²⁵ (figs. 109, 207). “Wherefore,” he says, “this *mysterium* has been called by some the *Deus terrestris*.”¹²⁶ It appears that this last thought is not a conceit of Ventura’s but, as he says, a quotation from “Lilium,” a source I have been unable to trace, though it must go back to the fourteenth century or even earlier.¹²⁷
- [472] The idea of the circulatory *opus*, or rotating arcane substance, finds expression as early as Komarios, who speaks of the “mystery of the whirlwind in the manner of a wheel” (μυστήριον τῆς λαίλαπος τροχοῦ δίκην).¹²⁸ Compare Zach. 9 : 14 (D.V.): “... and the Lord God will sound the trumpet and go in the whirlwind of the south.” The mystic logion of Zosimos probably has some bearing here:¹²⁹ “And what meaneth this: ‘the nature that conquers the natures,’ and ‘it is perfected and becometh like a whirl’?” [καί γίνεται ἰλιγγιῶσα]. The transforming substance is an analogy of the revolving universe, of the macrocosm, or a reflection of it imprinted in the heart of matter. Psychologically, it is a question of the revolving heavens being reflected in the unconscious, an *imago mundi* that was projected by the alchemist into his own *prima materia*. But such an interpretation is somewhat one-sided, since the idea of the arcane substance is itself an archetype, expressed most simply in the idea of the soul-spark (*scintilla*, *Spinther*) and the Monad.
- [473] The personification of Sapientia in the Wisdom of Solomon evidently caused the author of *Aurora* to identify her with the “Queen of the South.” In alchemy she always appears as *Sapientia Dei*, and in the writings of the Church Fathers the south wind is an allegory of the Holy Ghost, presumably because it is hot and dry. For the same reason the process of sublimation is known in Arabic alchemy as the “great south wind,” referring to the heating of the retort.¹³⁰ The Holy Ghost, too, is fiery and causes an exaltation. His equivalent, so to speak, is the hidden fire, the *spiritus igneus* dwelling in Mercurius, whose opposite poles are an *agens* (i.e., fire) and a *patiens* (i.e., quicksilver). When therefore Abu’l Qāsim speaks of the fire as the “great south wind,” he is in agreement with the ancient Greek view that Hermes was a wind-god¹³¹ (figs. 210, 211).



210. "The wind hath carried it in his belly" ("Tabula smaragdina"). The *foetus spagyricus* is the renewed Mercurius.
—Maier, *Scrutinium chymicum* (1687)

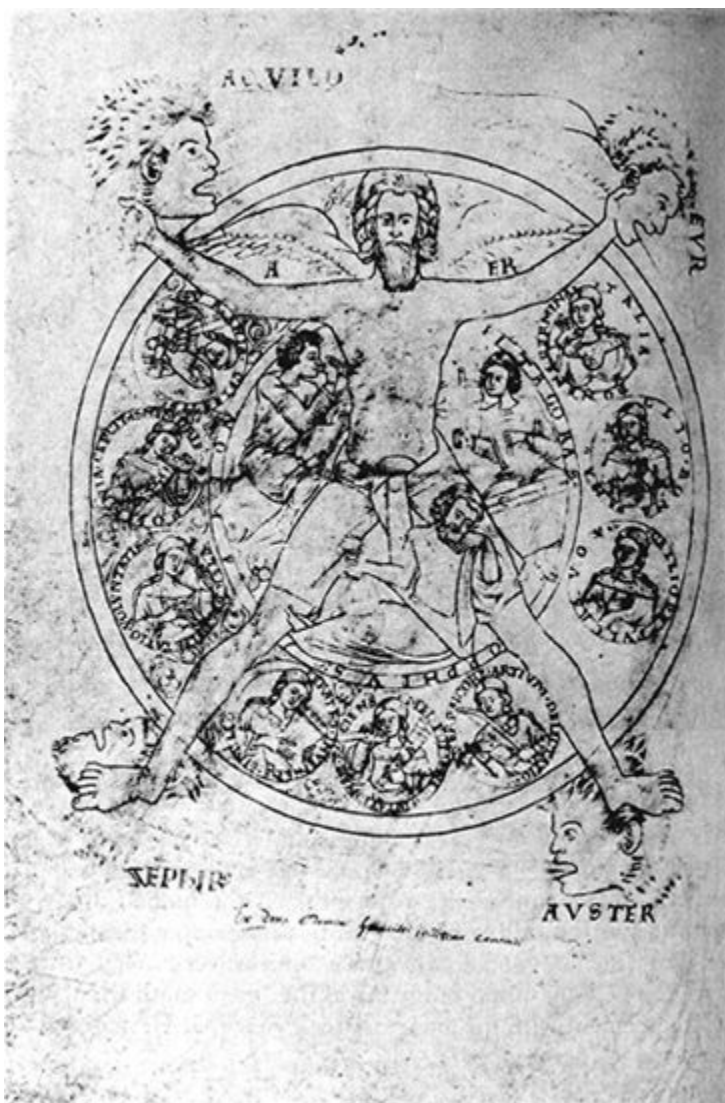

211. The god Aër as procreator of all harmony. In the inner circle, Arion, Pythagoras, Orpheus; in the outer, the nine muses; in the corners, the four winds.—“Recueil des fausses décrétales” (MS., 13th cent.)



212. The Trinity as *tricephalus*.—*Speculum humane salvationis* (Augsburg, 1480)

[474] I have dwelt at some length on the opening passages of *Aurora* because they are an excellent illustration of the composition as a whole as regards both language and subject matter. Here I will mention only a few of the *lapis*-Christ parallels. In ch. II the author calls “the science” (i.e., alchemy) a gift and a sacrament of God, a divine matter that the wise have veiled in images. From this it appears that the *opus alchemicum* is deemed the equal of the *opus divinum* or Mass.¹³² In ch. VI the stone is described in the words of the Song of Songs 5 : 16, “Such is my beloved,” and Ps. 44 : 3 (D.V.), “Behold ye him, beautiful above the sons of men, at whose beauty the sun and moon wonder.”¹³³ The *filius philosophorum* is here identified with the “bridegroom” who, as we know, is interpreted as Christ. In the second parable, “Of the Flood of Waters and of Death,” we read: “Then the fulness of the time shall come, when God shall send his son,¹³⁴ as he hath said, whom he hath appointed heir of all things, by whom also he made the world,¹³⁵ to whom he said of old time: “Thou art my Son, today have I begotten thee,¹³⁶ to whom the Wise Men from the East brought three precious gifts ...” Here again Christ is a parallel of the *lapis*. In the fourth parable, “Of the Philosophic Faith,” a parallel is drawn with the Holy Trinity (cf. figs. 179, 180): “... like as the Father is, so is the Son, and so also is the Holy Spirit, and these three are One: body, spirit, and soul; for all perfection consisteth in the number three, that is, in measure, number, and weight.”

[475] The sixth parable, “Of Heaven and Earth and the Arrangement of the Elements,” says:

In the *Turba philosophorum* it is written: The earth, since it is heavy, beareth all things,¹³⁷ for it is the foundation of the whole heaven, because it appeared dry¹³⁸ at the separation of the elements.¹³⁹ Therefore in the Red Sea there was a way without

hindrance, since this great and wide sea¹⁴⁰ smote the rock¹⁴¹ and the metallic waters¹⁴² flowed forth [fig. 213]. Then the rivers¹⁴³ disappeared in dry land, which make the city of God joyful;¹⁴⁴ when this mortal shall put on immortality, and the corruption of the living shall put on incorruption, then indeed shall that word come to pass which is written, Death is swallowed up in victory. O death, where is thy victory?¹⁴⁵ Where thy sin abounded, there now grace doth more abound. For as in Adam all die, so also in Christ all shall be made alive. For by a man indeed came death, and by himself the resurrection of the dead. For the first Adam and his sons took their beginning from the corruptible elements, and therefore it was needful that the composed should be corrupted, but the second Adam, who is called the philosophic man, from pure elements entered into eternity. Therefore what is composed of simple and pure essence, remaineth for ever.¹⁴⁶ As Senior saith: There is One thing, that never dieth,¹⁴⁷ for it continueth by perpetual increase, when the body shall be glorified in the final resurrection of the dead, wherefore the Creed beareth witness to the resurrection of the flesh and eternal life after death. Then saith the second Adam to the first and to his sons:¹⁴⁸ Come, ye blessed of my Father, possess you the eternal kingdom prepared for you from the beginning of the Work,¹⁴⁹ and eat my bread and drink the wine which I have mingled for you, for all things are made ready for you. He that hath ears to hear, let him hear what the spirit of the doctrine saith to the sons of the discipline concerning the earthly and the heavenly Adam, which the philosophers treat of in these words: When thou hast water from earth, air from water, fire from air, earth from fire,¹⁵⁰ then shalt thou fully and perfectly possess our art.



213. Moses striking water from the rock.—Bible Moralisee (MS., 13th cent.)

[476] What is particularly interesting in this passage is the parallel between the *lapis* or the *aqua sapientum* and the second Adam, which connects Christ—through the quotation in Senior (n. 147)—with the alchemical doctrine of the Anthropos: Christ is identified with the *homo philosophicus*, the Microcosm (fig. 214), the “One that dieth not, and bringeth alive anything dead.” The *homo philosophicus* appears to have two meanings: he is the “One,” i.e., the tincture or elixir of life, but he is also the everlasting inner man, identical or at least connected with the Anthropos (cf. figs. 117, 195). (This doctrine is elaborated by Paracelsus.¹⁵¹)

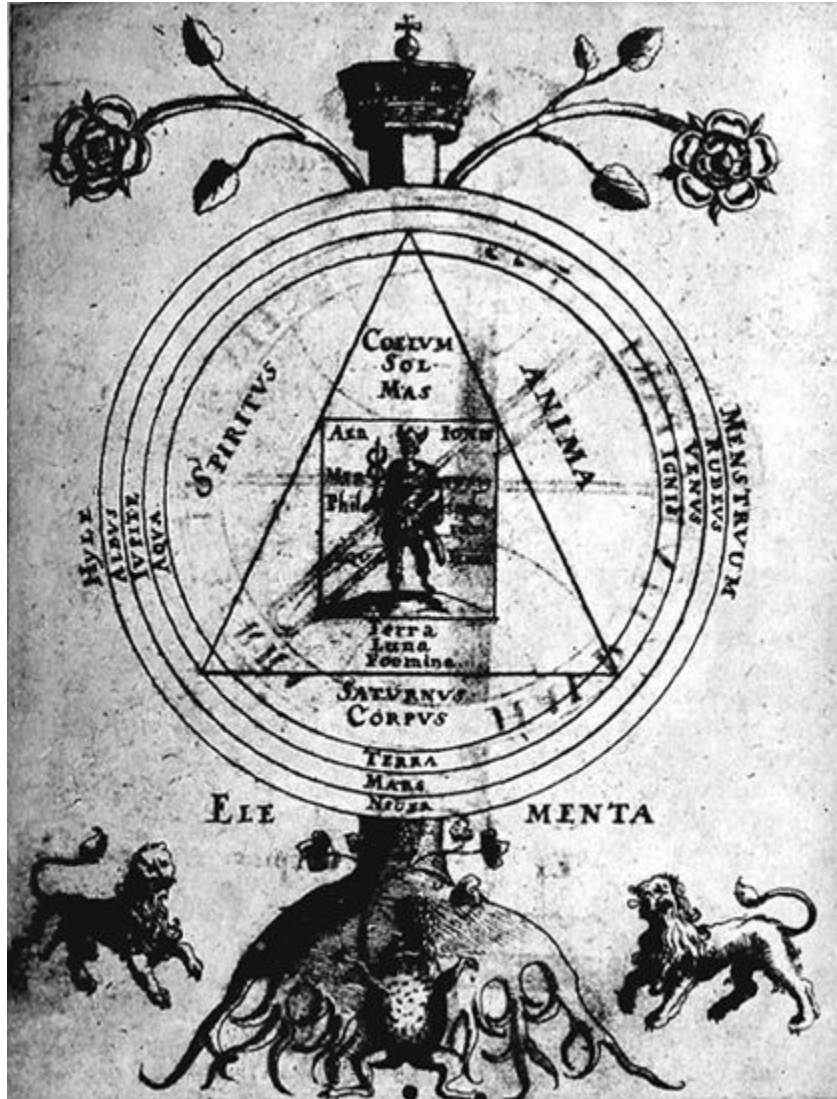

214. Symbol of Hermetic transformation: the *homo philosophicus* Mercurius.—Samuel Norton, *Mercurius redivivus* (1630)

[477] *Aurora* continues in the same vein and gives us in the seventh and last parable a “Confabulation of the Lover with the Beloved” (which Luther’s Bible interprets as “the mutual love of Christ and his Church”), closing with the words: “Behold, how good and pleasant it is for two to dwell together in unity. Let us make therefore three tabernacles, one for thee, a second for me, and a third for our sons, for a threefold cord is not easily broken.” These three tabernacles the author connects with the “Liber trium verborum” of Kalid.¹⁵² The Three Words “wherein is hidden all the

science” are to be “given to the pious, that is to the poor,¹⁵³ from the first man even unto the last.” The Three Words are: “For three months water preserveth the foetus in the womb; air nourisheth it for the second three; fire guardeth it for the third three.” “And this word,” adds Kalid, “and this teaching and the dark goal, stand open so that all may see the truth.”

[478] Although the three tabernacles, according to the preceding text, are intended for the *sponsus Christus* and, we may suppose, for *Sapientia* as the *sponsa*, yet in the end *Sapientia* herself speaks and offers two of the tabernacles to the adept and the philosophers, the sons of wisdom. The “threefold cord” (fig. 215) refers primarily to the bond between *Sapientia* and her adepts, but, as the reference to Kalid’s Three Words shows, it also means the threefold process which holds the body, soul, and spirit of the transforming substance together in imperishable union¹⁵⁴ (cf. figs. 185, 196). The chemical compound thus produced is the end-result of the *opus*, i.e., the *filius philosophorum* or *lapis* in a sense comparable with the “mystical body” of the Church (fig. 234): Christ the vine, the whole; the disciples the branches, the parts. One does indeed have the impression that the anonymous author of this treatise has hitched the Holy Scriptures to the triumphal car of alchemy, as was not unjustly alleged against him. It is astonishing to see how, with a perfectly clear conscience, he launches forth into the most hair-raising interpretations without the least awareness of what he is doing. As I have shown in “Paracelsus as a Spiritual Phenomenon,” we find a similar attitude in Paracelsus some two hundred years later, and also in the author of “*Aquarium sapientum*.” Our author betrays such a ready acquaintance with the Vulgate that we might suspect him of being in holy orders. Moreover we have the testimony of the humanist Patrizi that Hermetic philosophy was not felt to be in any way inimical to the Christianity of the Church. On the contrary, people regarded it as a mainstay of the Christian faith. For which reason Patrizi addressed a plea to Pope Gregory XIV requesting him to let Hermes take the place of Aristotle.¹⁵⁵



215. The completion of the process. Inscription: “*oculatus abis*” (provided with eyes, thou goest thy way). Hermes as Anthropos, united with the artifex and *soror* through the threefold cord. Below, Hercules, a favourite symbol because of his *opera*. Background, the ladder which is no longer needed.—*Mutus liber* (1702)

[479] The text of *Aurora* is of historical importance in that it must be more than two hundred years older than Khunrath (1598) and Böhme (1610). Curiously enough, Böhme’s first work bears the title “*Aurora, oder die Morgenröte im Aufgang*” (Aurora, or the Rising Dawn). Can it be that Böhme knew *Aurora consurgens*, at least by name?

f. Melchior Cibirensis and the Alchemical Paraphrase of the Mass

[480] The next source for the *lapis*-Christ identity is an interesting document from the beginning of the sixteenth century, addressed, as its title shows,¹⁵⁶ to Ladislaus, King of Hungary and Bohemia. The author’s name was Nicholas Melchior of Hermannstadt.¹⁵⁷ He expounded the alchemical process in the form of a Mass (fig. 216), which he arranged as follows:



216. The artifex as priest. Left, Earth suckling the Mercurius-child: “matrix eius terra est” (“Tabula smaragdina”).—
Melchior Cibinensis, *Symbolum*, from Maier, *Symbola aureae mensae* (1617)

INTROITUS MISSAE: Fundamentum vero artis est corporum solutio. (The basis of the Art is the dissolution of the bodies.)

KYRIE, FONIS BONITATIS, inspirator sacrae artis, a quo bona cuncta tuis fidelibus procedunt, Eleison. (Our Lord, fount of goodness, inspirer of the sacred art, from whom all good things come to your faithful, have mercy.)

CHRISTE, Hagie, lapis benedicte artis scientiae qui pro mundi salute inspirasti lumen scientiae, ad extirpandum Turcam, Eleison. (Christ, Holy one, blessed stone of the art of the science who for the salvation of the world hast inspired the light of the science, for the extirpation of the Turk, have mercy.)

KYRIE, IGNIS DIVINE, pectora nostra juva, ut pro tua laude pariter sacramenta artis expandere possimus, Eleison. (Our Lord, divine fire, help our hearts, that we may be able, to your praise, to expand the sacraments of the art, have mercy.)

GLORIA IN EXCELSIS [merely an invocation].

COLLECTA [Prayer before the epistle is read. The main idea is that “thy servant N.N.” may practise the “sacred art of alchemy” to the glory of God and the propagation of the Christian faith].

EPISTOLA [merely an invocation].

GRADUALE [usually a chorale consisting of verses from the Psalms; in the old days it was sung on the steps, *gradus*, of the ambo]: Surge aquilo et veni auster.¹⁵⁸ perfla hortum meum et fluant aromata illius. (Arise, O north wind, and come, O south wind; blow through my garden, and let the aromatical spices thereof flow).

VERSUS: Descendit sicut pluvia in vellus, et sicut stillicidia, stillantia super terram. Alleluja. O felix conditor terrae, nive albior, suavitate dulcior, f[r]agrans in fundo vasis instar balsami. O salutaris medicina hominum, quae curas ... omnem corporis languorem.... O fons sublimis ex quo vere scaturit vera aqua vitae, in praedium tuorum fidelium. (He descends like rain upon the fleece, and as showers falling gently upon the earth. Alleluja. O blest creator of the earth, whiter than snow, sweeter than sweetness, fragrant at the bottom of the vessel like balsam. O

salutary medicine for men, that curest every weakness of the body: O sublime fount whence gushes forth truly the true water of life into the garden of thy faithful.)

An Ave Praeclara follows the Gospel.

[481] Here I will stress only a few of the most important points. After the reading of Gospel and Creed, Melchior introduces an Ave—not an Ave Maria, but an “Ave Praeclara,”¹⁵⁹—of which he mentions only these two words, without the continuation. “Ave Praeclara” is the opening of a hymn to the Virgin Mary, which has been attributed to various authors, including Albertus Magnus, whose putative authorship must have been particularly interesting to an alchemist. Rémy de Gourmont, in his *Le Latin mystique*,¹⁶⁰ quotes the following legend taken from the so-called Osnabrück Register of Santa Maria: A virgin in royal raiment appeared to Albertus in a dream and reproached him for not having shown himself sufficiently grateful to the Virgin Mary for the blessing she had bestowed. It was on account of this dream that Albertus composed the Ave Praeclara. An alchemist would find it full of alluring allusions:

Ave praeclara maris stella, in lucem gentium Maria divinitus orta...

Virgo, decus mundi, regina coeli, praelecta ut sol, pulchra lunaris ut fulgor...

Fac fontem dulcem, quem in deserto petra demonstravit,

degustare cum sincera fide, renesque constringi lotos

in mari, anguem aeneum in cruce speculari [fig. 217].

Fac igni sancto patrisque verbo, quod, rubus ut

flamma, tu portasti, virgo mater facta, pecuali

pelle distinctos,¹⁶¹ pede, mundis labiis, cordeque propinquare.

Hail, clear-shining star of the sea, Mary, divinely born for the enlightenment of the nations...

Virgin, ornament of the world, queen of heaven, elect above all like the sun, lovely as the light of the moon...

Let us drink in steadfast faith of the sweet stream that flowed from the rock in the desert, and, girding our loins that the sea has bathed, gaze on the crucified brazen serpent [fig. 217].

O Virgin, who hast been made mother by the sacred fire and the Father’s word, which thou didst bear like the Burning Bush, let us, as cattle ringstraked, speckled and spotted,¹⁶¹ draw near with our feet, with pure lips and heart.

[482] While Melchior’s text leaves it an open question whether “praeclara” means the *aqua vitae*, he leaves us in no doubt that it refers not only to the Virgin but to a hymn in her praise, for he goes on to say: “The Ave Praeclara must be sung; it shall be called the ‘testament of the art,’ since the whole chemical art is figuratively concealed therein,¹⁶² and blessed is he that understands this sequence.”

[483] By “this sequence” he means a hymn to Mary, in all probability the one we have quoted above, as is clear from Melchior’s next words. In any case the Virgin is identified with the arcanum of the art, possibly on the authority—then at its height—of Raymond Lully.¹⁶³ We come across a similar idea in the treatise of Komarios: “Ostanes and his companions said to Cleopatra: ‘The whole awful and marvellous secret is hidden in thee.’”¹⁶⁴



217. The crucified *serpens mercurialis*, the brazen serpent of Moses.—Abraham le Juif, “Livre des figures hiéroglyphiques” (MS., 18th cent.)

[484] Melchior now gives his alchemical paraphrase of the hymn to Mary:

Hail beautiful lamp of heaven, shining light¹⁶⁵ of the world! Here art thou united with the moon, here is made the band of Mars¹⁶⁶ [*copula martialis*] and the conjunction of Mercury.¹⁶⁷ From these three is born through the magistry of the art, in the river bed, the strong giant¹⁶⁸ whom a thousand times a thousand seek, when these three shall have dissolved, not into rain water ... but into mercurial water, into this our blessed gum¹⁶⁹ which dissolves of itself and is named the Sperm of the Philosophers. Now he¹⁷⁰ makes haste to bind and betroth himself to the virgin bride, and to get her with child in the bath over a moderate fire [fig. 218]. But the virgin

will not become pregnant at once unless she be kissed in repeated embraces. Then she conceives in her body, and thus is begotten the child of good omen, in accordance with the order of nature. Then will appear in the bottom of the vessel the mighty Ethiopian, burned, calcined, discoloured, altogether dead and lifeless¹⁷¹ [fig. 219]. He asks to be buried, to be sprinkled with his own moisture and slowly calcined¹⁷² till he shall arise in glowing form from the fierce fire.... Behold a wondrous restoration and renewal of the Ethiopian! Because of the bath of rebirth he takes a new name, which the philosophers call the natural sulphur and their son, this being the stone of the philosophers. And behold it is *one* thing, *one* root, *one* essence with nothing extraneous added and from which much that was superfluous is taken away by the magistry of the art.... It is the treasure of treasures, the supreme philosophical potion, the divine secret of the ancients. Blessed is he that finds such a thing. One that has seen this thing writes and speaks openly, and I know that his testimony is true. Praise be to God for evermore!

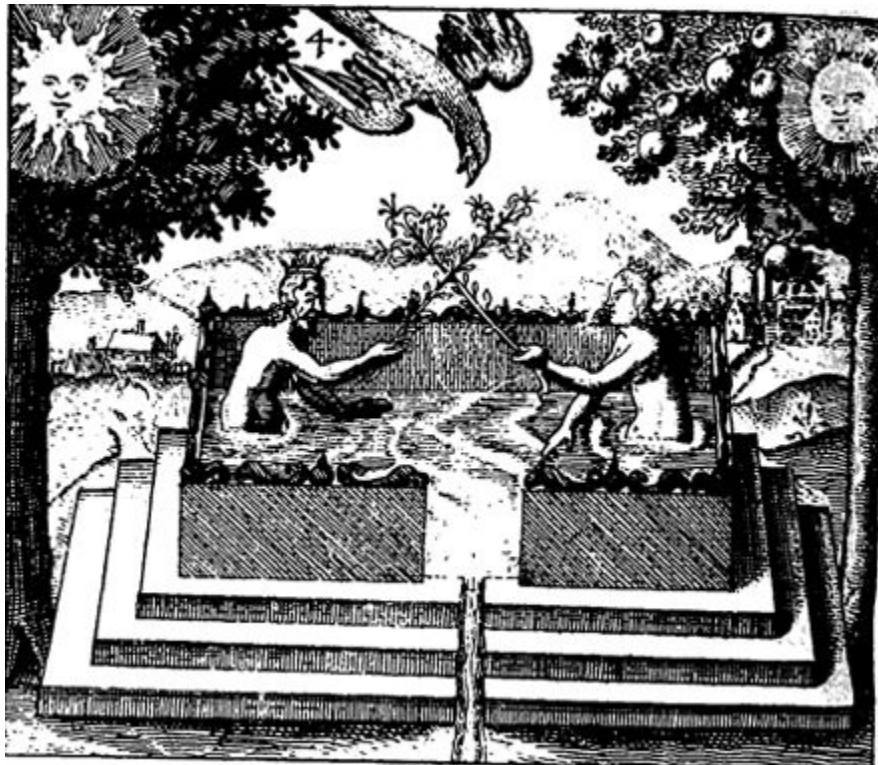

218. The “bath of the philosophers.”—Mylius, *Philosophia reformata* (1622)



219. The “Ethiopian” as the *nigredo*.—Trismosin, “Splendor solis” (MS., 1582)

[485] The liturgy proper ends here. What now follows is a sort of recapitulation of the main parts. Melchior associates the Offertory with the stone that the builders rejected and that became the head of the corner. “This is the Lord’s doing, and it is marvellous in our eyes.” Then comes the Secret, leading over to the alchemical oblation. The offering is the *opus*, i.e., “our work of the blessed art of alchemy,” which “shall ever be dedicated to the glorious name of God and to the saving reformation of the Church, through our Lord Jesus Christ, Amen.”

[486] The regeneration of the Ethiopian is actually the equivalent of the transubstantiation, but the Consecration is missing. Melchior takes the *Ave Praeclara* sequence to include the transubstantiation as a mystery *in gremio virginis*. This view is supported by tradition, as is shown by the following passage from Senior: “The full moon is the philosophical water and the root of the science, for she is the mistress of moisture, the perfect round stone and the sea, wherefore I know that the moon is the root of this hidden science.”¹⁷³

[487] Being the mistress of moisture, the moon, like Isis, is the *prima materia* in the form of water and thus the mother of the “Hydrolith,” the water-stone—another name

for the *lapis* and hence for Christ. Since the terms *scientia* and *prima materia* are often used as though they were identical, *scientia* or *sapientia* is here identical with the moon, the feminine principle (fig. 220); hence the Gnostic doctrine of Sophia as the mother or bride of Christ.

[488] Last of all comes the “Post-communion”: “Glory be to our King who comes out of the fire,¹⁷⁴ who is illumined and crowned with the diadem, for ever and ever, Amen.” In conclusion there is a form of compline for the strengthening of the Christian faith and the extermination of the Turk.

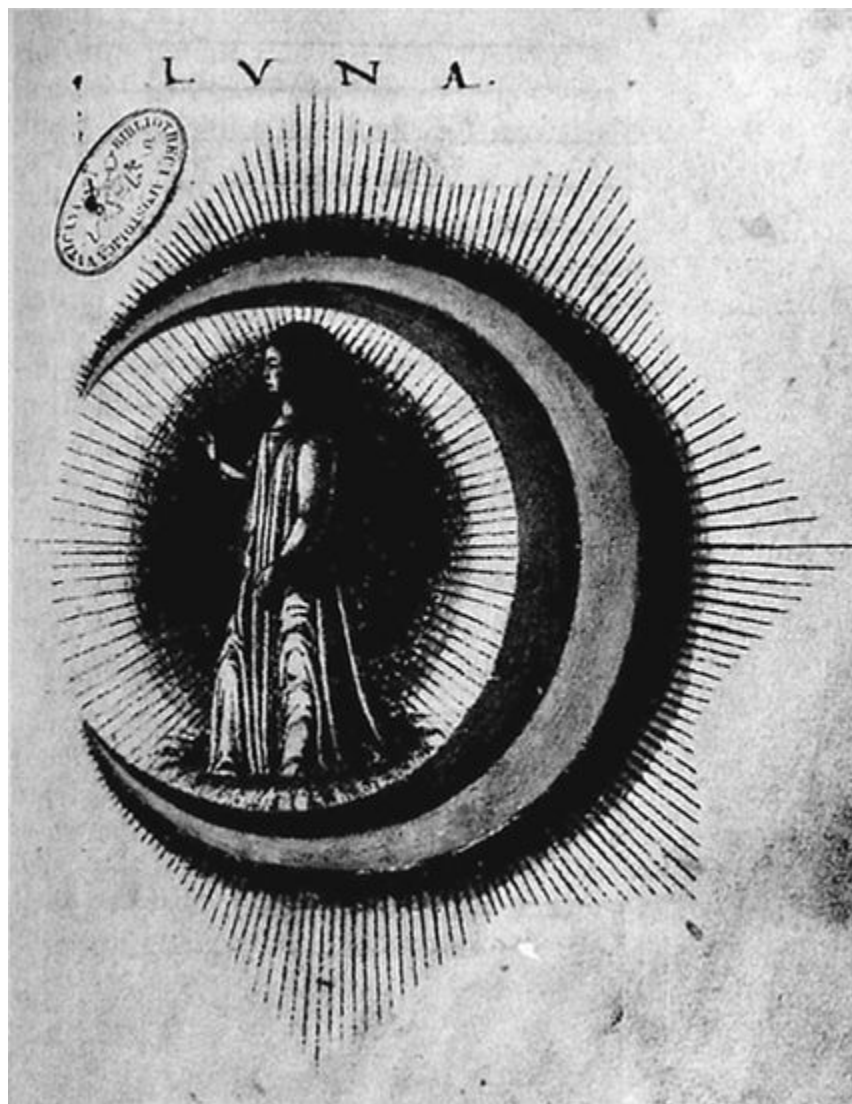

220. Figure of the moon.—Codex Urbanus Latinus 899 (15th cent.)

[489] Apart from its bad taste the text is highly illuminating for our theme. Melchior obviously recognized the analogy between the two *opera* and naïvely substituted the individual *opus*, in all its poverty, for the time-honoured words of the Mass. He lived at the time of the Reformation, and not so long afterwards the Mass was replaced, over a wide area of Europe, by the far from sacrosanct words of various preachers all declaring the word of God in their own way. Melchior was doing something of this kind. If we grant him the right to a subjective credo he becomes more acceptable. It is clear enough from the text that he felt the alchemical process to be the equivalent of

the transubstantiation in the Mass, and that he had the need to express his experience¹⁷⁵ in precisely that form. It is to be noted, however, that he puts the alchemical transmutation not in the place of the transubstantiation but somewhere in the vicinity of the Credo, so that the action breaks off before the Consecration. In the second version of the recapitulation the climax of the rite is again missing, and the sequence jumps straight from the Secret at the Offertory to the Post-communion. This peculiarity may be explained by the holy awe of the most solemn and moving part of the Mass, namely the Consecration. One could therefore take it as at least an indirect sign of a conflict of conscience—a conscience torn between the experience of a rite acting from without and an individual experience acting from within. Although Christ is nowhere mentioned as the *lapis* or *medicina*, their identity is overpoweringly evident from the whole drift of the text.

g. Sir George Ripley

[490] Additional evidence, which ought to have been known to Waite, is furnished (cf. [figs. 30, 92, 196, 228, 251, 257](#)) by his countryman Sir George Ripley (1415–90), canon of Bridlington, whose main work, “*Liber duodecim portarum*,”¹⁷⁶ is prefaced by a table of philosophical correspondences, compiled by B. à Portu, Aquitanus. The table sets forth the correspondences between the seven metals and chemical substances and what are called “types,” by which are meant the alchemical symbols, e.g., tinctures, the ages of man, signs of the zodiac, and so forth. These correspondences include seven mysteries, the *Mysterium Altaris* (i.e., the Mass) being attributed to gold, whereas the alchemical equivalent is the *transmutatio* ([fig. 221](#)). The kind of grain that belongs to this mystery is *triticum* (wheat). B. à Portu is probably to be identified with Bernhardus Georgius Penotus, the Paracelsist, who was born between 1520 and 1530 at Port-Ste-Marie in Guienne (part of the old Aquitaine) and who died in 1620 in the poorhouse at Yverdon (Vaud, Switzerland), hoary with age and disillusioned with the Paracelsan optimism that had fired his student days in Basel. He shared the inevitable fate of those who lacked sufficient humour to understand the testy old master and who found that the secret teaching about the *aurum non vulgi* remained all too secret. But his table shows that the analogy between the *opus* and the Mass was also valid in Paracelsist circles. Paracelsus was a contemporary of Melchior’s, but may well have reached similar conclusions independently, for such ideas were then in the air. Michael Maier was sufficiently impressed by Melchior’s analogy to use it as Symbol XI ([fig. 216](#)) in his *Symbola aureae mensae* (1617), with the motto: “*Lapis, ut infans, lacte nutriendus est virginali*” (The stone, like to an infant, is to be fed with virgin’s milk) [[cf. fig. 222](#)].

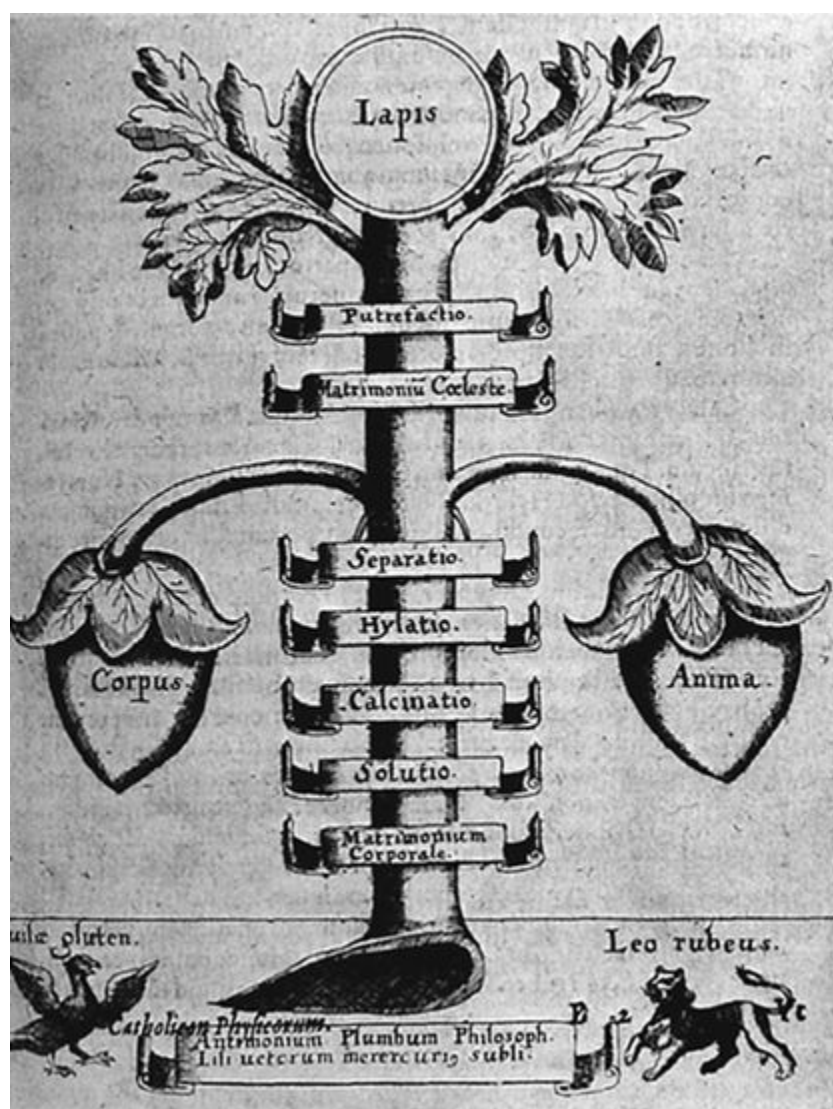

221. *Arbor philosophica*: the tree as symbol of the stages in the transformation process.

—Samuel Norton, *Catholicon physicorum* (1630)

[491] We find the following legend in the “*Cantilena Ripplaei*”:¹⁷⁷

There was once a noble king [the *caput corporum*] who had no descendants. He lamented his sterility and concluded that a *defectus originalis* must have arisen in him, although he was “nurtured under the wings of the sun” without any natural bodily defects. He says, in his own words: “Alas, I fear and know for a certainty that unless I can obtain the help of the species at once, I shall never beget a child. But I have heard with astonishment, by the mouth of Christ above, that I shall be born anew.” He then wished to return to his mother’s womb and to dissolve himself in the *prima materia*. His mother encouraged him in this venture, and forthwith concealed him under her robe, until she had incarnated him again in herself. She then became pregnant. During her pregnancy she ate peacock’s flesh and drank the blood of the green lion. At length she brought forth the child, who resembled the moon and then changed into the splendour of the sun. The son once more became king. The text says: “God gave thee the glorious, glittering armoury of the four elements, and the Crowned Maid [*Virgo redimita*] was in their midst.” A wonderful balsam flowed

from her [cf. [fig. 222](#)] and she shone with a radiant face, adorned with the precious stone. But in her lap lay the green lion,¹⁷⁸ with blood flowing from his side [cf. [fig. 242](#)]. She was crowned with a diadem and was set as a star in the highest heaven. The king became a supreme victor triumphant, a great healer of the sick and a redeemer [*reformer*] of all sins.



222. The sea of renewal arising from virgin's milk. Symbolic representation of the life.
—giving power of the unconscious (= whale).—Stolcius de Stolcenberg, *Viridarium chymicum* (1624)



223. *Mortificatio*, or *nigredo* and *putrefactio*: Sol and Luna overcome by death after the *coniunctio*.—Mylius, *Philosophia reformata* (1622)

Christ said: “I, if I be lifted up, will draw all men unto me.”¹⁸⁰ From that time forward, when both parts, having been crucified and exanimated, are betrothed to one another, man and wife shall be buried together [fig. 223] and afterward quickened again by the spirit of life. Then must they be raised to heaven, so that body and soul may be there transfigured and enthroned on the clouds; then they will draw all bodies to their own high estate [fig. 224].

[493] If we realize that the author was no layman but a learned canon, we can hardly suppose him to have been unaware of the parallels with certain fundamental ideas of Christian dogma. It is never said outright that the stone is Christ, but the sacred figures can easily be recognized in the guise of the King and the Virgin-Mother. Ripley must have made a deliberate choice of these parallels without being conscious of any blasphemy. The Basel typographer, Conrad Waldkirch, would have rained fire and brimstone on his head. Ripley belonged to an age when God and his mysteries still dwelt in nature, when the mystery of redemption was at work on every level of existence, because unconscious happenings still lived in untroubled, paradisaical participation with matter and could be experienced there.



[494] I came across a last outcropping of this medieval view of the world in my youth, in the form of the following tale. We had at that time a cook from the Swabian part of the Black Forest, on whom fell the duty of executing the victims from the poultry yard destined for the kitchen. We kept bantams, and bantam cocks are renowned for their singular quarrelsomeness and malice. One of these exceeded all others in savagery, and my mother commissioned the cook to dispatch the malefactor for the Sunday roast. I happened to come in just as she was bringing back the decapitated cock and saying to my mother: “He died like a Christian, although he was so wicked. He cried out, ‘Forgive me, forgive me!’ before I cut off his head, so now he’ll go to heaven.” My mother answered indignantly: “What nonsense! Only human beings go to heaven.” The cook retorted in astonishment: “But of course there’s a chicken heaven for chickens just as there’s a human heaven for humans.” “But only people have an immortal soul and a religion,” said my mother, equally astonished. “No, that’s not so,” replied the cook. “Animals have souls too, and they all have their special heaven, dogs, cats, and horses, because when the Saviour of men came down to earth, the chicken saviour also came to the chickens, and that’s why they must repent of their sins before they die if they want to go to heaven.”

[495] The theology of our cook is a remnant of that folklore mentality which saw the drama of redemption going on at all levels and could therefore discover it even in the mysterious and incomprehensible transformations of matter.

[496] As to the details of the “Cantilena,” the sick king who was nevertheless born perfect is the man who suffers from spiritual sterility. In the vision of Arisleus the land is unfruitful because only like mates with like, instead of the opposites being united. The philosophers advise the king to join his son and daughter together and make the land fruitful again by means of a brother-sister incest (fig. 225). With Ripley it is a mother-son incest. Both forms are familiar to alchemy and constitute the prototype of the royal marriage (fig. 32). This endogamous mating is simply a variant of the Uroboros, which, because it is by nature hermaphroditic, completes the circle in itself. The king in Arisleus remarks that he is king because he has a son and a daughter, while his subjects have none on account of their sterility. The “gestation in the brain”¹⁸¹ points to a psychic content, or more accurately to a psychic pair of opposites that can become creative of their own accord (fig. 226). But evidently the king has so far not allowed his children to propagate, by repressing or ignoring the manifestations of their vitality. It looks as though he had been unconscious of their existence and had only become aware of their significance on the advice of the philosophers. The blame for his sterility is to be sought in the projection of

unconscious contents, which can neither develop nor find “redemption” until they are integrated with consciousness. The brother-sister pair stands for the unconscious or for some essential content (fig. 227). A modern psychologist would therefore have advised the king to remember the existence of his unconscious and so put an end to his stagnation. As generally happens in such cases, an opposition, a painful conflict, thereupon comes to the surface, and it is easy to understand why the king preferred to remain unconscious of it. Since the conflict is never lacking in moral complications, it is, from this point of view, appropriately expressed in the morally obnoxious form of incest. In Ripley the mother-incest is disguised under the classical rite of adoption, but the mother becomes pregnant all the same. The vanishing of the king under his mother’s robes corresponds to the total dissolution of Gabricus in the body of Beya in the second version of the “Visio Arislei.”¹⁸² The king represents the domineering conscious mind which, in the course of coming to terms with the unconscious, is swallowed up by it. This brings about the *nigredo* (cf. figs. 34, 137, 219), a state of darkness that eventually leads to the renewal and rebirth of the king.



225. The love-potion being handed to the brother-sister pair.—Maier, *Scrutinium chymicum* (1687)



226. *Coniunctio* of opposites in the Hermetic vessel or in water (= unconscious).—“Trésor des trésors” (MS., 17th cent.)



227. *Coniunctio* as a fantastic monstrosity.—Brant, *Hexastichon* (1503)



228. The plumed king who plucks out his feathers for food.—“Ripley Scrowle” (MS., 1588)



229. Eagle as symbol of the spirit ascending from the *prima materia*.—*Hermaphroditisches Sonn- und Mondskind*
(1752)

[497] The strange idea of the king “nurtured under the wings of the sun” (fig. 228) may refer to the passage in Malachi (D.V., 4 : 2) which helped to put the early worship of Christ as Helios or Sol on a rational basis—a tendency that St. Augustine still had to combat: “But unto you that fear my name the Sun of justice shall arise, and health in his wings; and you shall go forth and shall leap like calves of the herd.” The passage has always been understood as a Messianic prophecy, and was obviously known to Ripley. The “wings of the sun”¹⁸³ is a very ancient image, and one which must have touched the Hebrew Malachi very closely: for it is the Egyptian sun-symbol. He who is nourished by this sun is the son of God, i.e., the king.¹⁸⁴

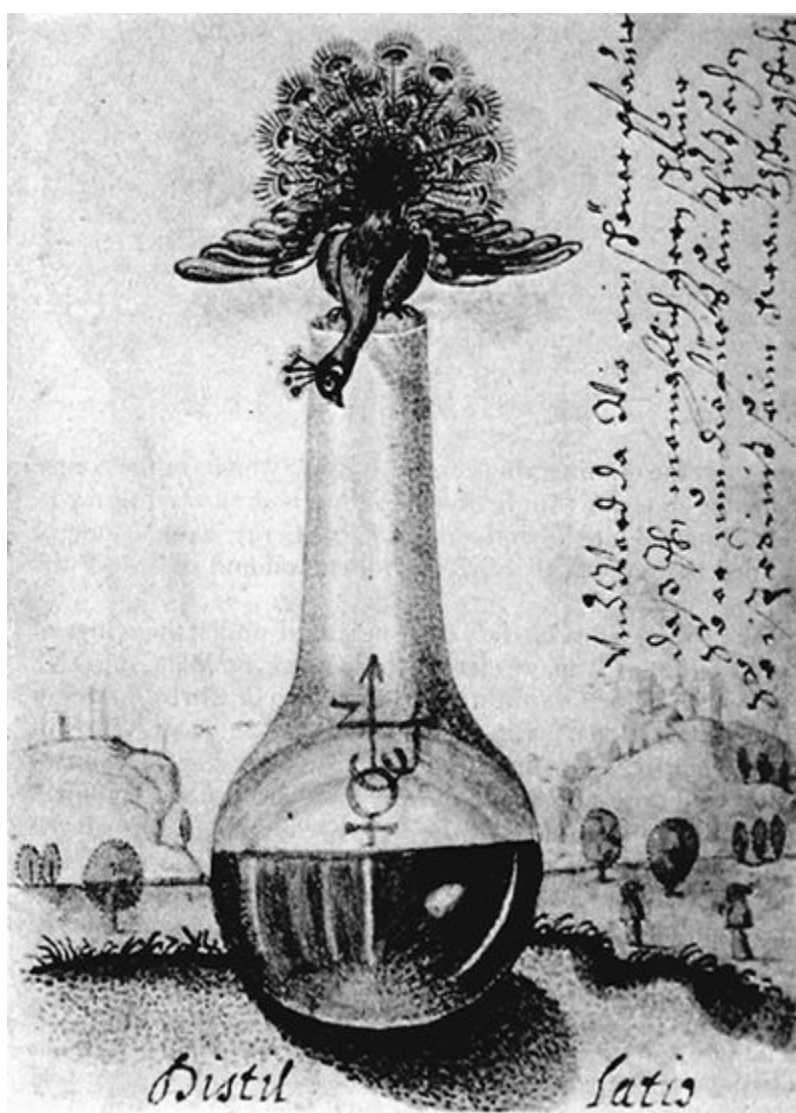

230. The peacock rising from the retort.—18th cent. MS.

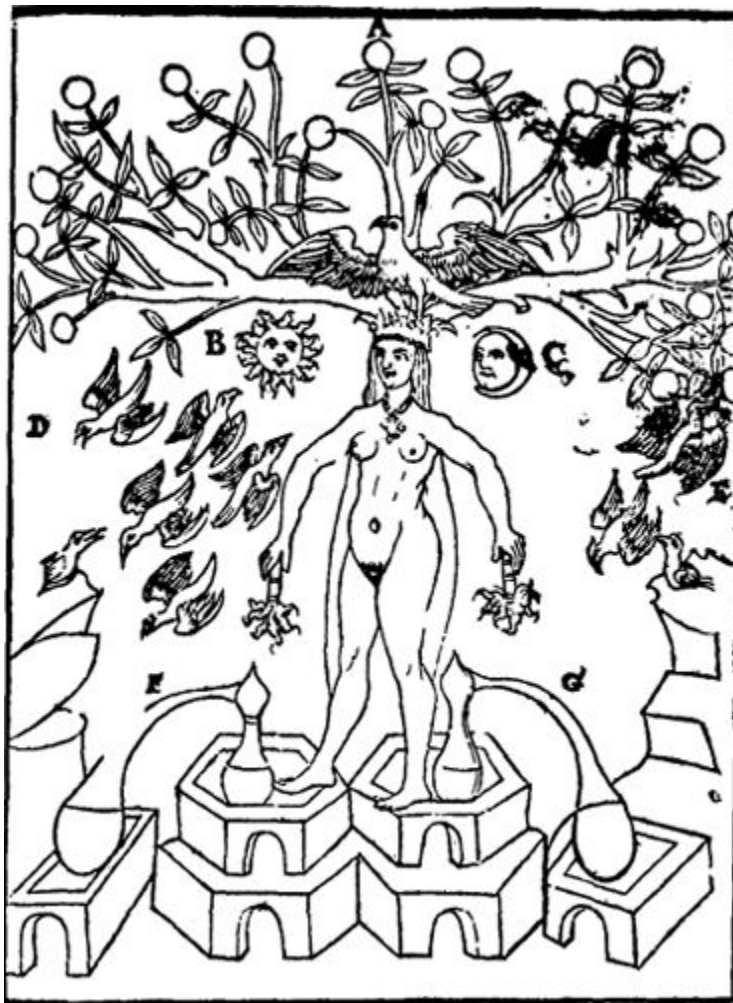

231. Mercurius as virgin (Pandora) and *arbor philosophica*.—Reusner, *Pandora* (1588)

[498] Just as in the vision of Arisleus the king's dead son is brought back to life by the fruit of the philosophical tree, so in Ripley the sick king is to be healed by the "species"—obviously a *φάρμακον ζωής* or *elixir vitae*. The mother's food during her pregnancy is blood and peacock's flesh. The peacock is an early Christian symbol for the Redeemer, though it is doubtful whether Ripley knew this. But the peacock (figs. 111, 230) is second cousin to the phoenix,¹⁸⁵ a Christ symbol he must surely have known (see the figures in the "Ripley Scrowle"). The blood comes from the green lion that lies in the lap of the virgin, bleeding from a wound in his side;¹⁸⁶ these are clearly communion and Pietà symbols. The green lion is also one of the forms of Mercurius.¹⁸⁷

[499] As the giver of new birth, the mother is identical with the tree. In the 1588 edition of *Pandora* the tree is shown as a naked virgin¹⁸⁸ wearing a crown (fig. 231). The *arbor philosophica* is a favourite symbol for the alchemical process, and when Ripley speaks of the "Crowned Maid" (*virgo redimita*) we at once recognize the *anima mundi*, the feminine half of Mercurius (fig. 208).

[500] The "Cantilena" ends with the apotheosis of the virgin-mother. This the above-mentioned *Pandora* depicts as a glorification of Mary, the *assumptio Beatae Mariae Virginis* (fig. 232). After her death, by a divine miracle her body was again united

with her soul and both together were taken up to heaven. This has long been the view of the Church, although it has only recently been promulgated as a dogma. In [fig. 232](#) she is marked with the words “terra” and “corpus Lyb” (body) and “die wonn der jung-frowenn wardt” (who became the joy of virgins); the dove descends upon her, and God the Father touches her with his right hand in benison. She is crowned. The figure of God holding the orb is inscribed “Anima Seel” and “Jesse pater, filius et mater.” “Mater” refers to the Queen of Heaven enthroned beside him, the King; for in her the earth substance, becoming transfigured in her resurrected body, is absorbed into the Godhead.¹⁸⁹ On the left is a bearded figure equal in rank to God the Father, inscribed “Sapientia Wyssheit.” In the shield below there is a picture of the rebis being freed from the *prima materia*. The whole has the form of a mandala, framed by the emblems of the evangelists. The inscription at the bottom of the picture reads: “Figura speculi Sanctae Trinitatis. Gstalt des Spiegels der Heiligen Dryheit” (Figure of the Mirror of the Holy Trinity).¹⁹⁰

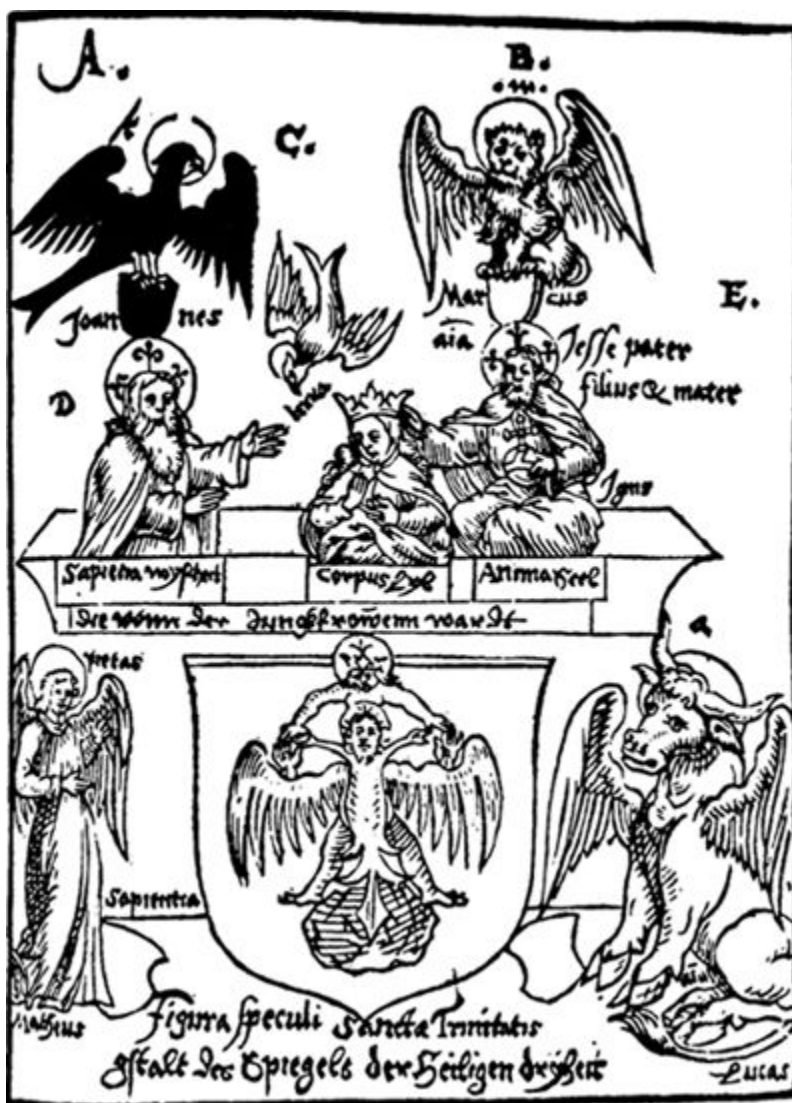

232. Glorification of the body portrayed as coronation of the Virgin Mary. Sapientia (*Hermes senex*) takes the place of the Son, and the Holy Ghost has a quite separate entity. Together they form a quaternity. Below, extraction of the spirit of Mercurius from the *prima materia*.

—*Speculum Trinitatis* from Reusner, *Pandora* (1588)



233. Christian quaternity: the Three and the One (Trinity and Mary).—French School (1457), detail

[501] Ripley portrays his king as victor, healer of the sick, and redeemer from sin. At the end of the *Rosarium* there is a picture of the Risen Christ with the inscription (fig. 234):

After my many sufferings and great martyrty
I rise again transfigured, of all blemish free.



234. The Risen Christ as symbol of the *filius philosophorum*.—*Rosarium philosophorum* (1550)

h. The Epigoni

[502] By “Epigoni” I mean the authors of the seventeenth century, an age which saw the full flowering of alchemy but which also inaugurated its downfall by separating the *mystica* more and more clearly from the *physica*. The mystical and philosophical trend became ever more pronounced, while on the other hand chemistry proper began to mark itself off more distinctly. The age of science and technology was dawning, and the introspective attitude of the Middle Ages was fast approaching its decline. Religious and metaphysical values became less and less able to give adequate expression to the psychic experiences brought to light by the *opus alchymicum*. Only after the lapse of several centuries did it fall to empirical psychology to throw new light on the obscure psychic content of Hermetic experiences.

[503] In the literature written at the close of the sixteenth and the beginning of the seventeenth centuries, mystical speculation, no doubt encouraged by humanism and the schism of the Church, began to emerge from behind the veil of the earlier esotericism, in so far as it was possible for the authors to express the inexpressible at all in words and images. But the pictorial symbolism they produced, much of it quite grotesque, not only made no contribution towards elucidating the arcanum but was

largely responsible for devaluing it in the eyes of the profane, thus accelerating the decay of Hermetic wisdom. How much was lost to the spiritual heritage of Europe in this way we, with our sharpened psychological understanding, are just beginning to realize, as we contemplate the unparalleled disorganization of our continent. Happily the loss is not irreparable: *natura tamen usque recurret*.

[504] In what follows I should like to mention a few more *lapis*-Christ parallels drawn from this literature.

[505] In the treatise entitled “Liber de arte chymica,”¹⁹¹ by an anonymous author,¹⁹² there is a Mercurius-*lapis* parallel which I cannot pass over without mention, since it is an *aequiparatio* of Mercurius with the Virgin Mary:

Give ear¹⁹³ to this profound parable: The ethereal heaven was closed to all men, so that they descended into hell and remained imprisoned there forever. But Christ Jesus unlocked the gate of the ethereal Olympus, and threw open the realm of Pluto, that the souls might be freed, when the Virgin Mary, with the cooperation of the Holy Ghost in an unutterable mystery and most profound sacrament, conceived in her virginal womb that which was most sublime in heaven and on earth, and finally bore for us the Saviour of the whole world, who by his overflowing goodness shall save all those who are lost in their sins, if only the sinner will often turn to him. But the Virgin remained incorrupt and inviolate; wherefore it is not without good reason that Mercurius is made equal [*non immerito ... aequiparatur*] to the most glorious and worshipful Virgin Mary. For Mercurius is virginal, because he has never increased any kind of metallic body in the bowels of the earth, and yet has generated the stone for us by means of the solution of “heaven”; that is to say, he opens the gold and leads out the soul, which you must understand as a divinity [*divinitatem*]; and for a little while he carries it in his belly and in his own time he changes it into a purified body, whence there shall come to us the boy [*puer*], the *lapis*, by whose blood the lower bodies are tintured [*tincta*], and taken back whole to the golden heaven.¹⁹⁴

[506] As the *anima mundi*, Mercurius can in fact be compared with the Gnostic *παρθένος τοῦ φωός* (virgin of light) and with the Christian Virgin Mary (figs. 8, 105, 107, 164, 165, 208)—or even, as the text asserts, made her “equal,” though note that I am only giving the opinion of our anonymous author. The “puer” would then be the *filius macrocosmi* (figs. 64, 192, 214, 234) and as such an analogy of Christ. The author too draws this conclusion, for he compares the corporeal nature of Christ with the effects of the stone:

In Christ’s body, because he committed no sin, and on account also of the miraculous union of the divine essence, there was such a great affinity [*affinitas*] of the elements and such an alliance thereof [*colligatio*] that he would never have died, had he not

sought death of his own free will, in order to redeem mankind for whose sake he was born.¹⁹⁵

[507] In the stone, as we know, the chaotic antagonism of the elements is replaced by the most intense mutual alliance, which is what makes the stone incorruptible, this being the reason why, in our author's opinion, it has the same effect as the blood of the Saviour: "sanitas atque vita diuturna in foelicitate, propter quam praecipue lapis noster est petendus" (health and long life in felicity, on account of which our stone is chiefly to be sought).¹⁹⁶

[508] To the doubtful authors also belongs the much-quoted Basilius Valentinus, a pseudonymous writer who is supposed to have lived at the beginning of the fifteenth century.¹⁹⁷ Johann Thölde (c. 1600), of Frankenhausen in Thuringia, is sometimes considered as the possible author of the so-called Valentinus texts, which began to appear in 1602. One of the earliest references to them is to be found in Michael Maier's *Symbola aureae mensae* (1617). Maier is exceedingly uncertain as to the authorship of these writings: "Obscurus omnibus manere quam innotescere maluit" (Rather than become notorious he preferred to remain unknown to everyone). Stylistically, the writings undoubtedly belong to the end of the sixteenth century at the earliest. The author is strongly influenced by Paracelsus and has taken over his idea of the Archaeus as well as his doctrines about astral and elemental spirits.¹⁹⁸ In the complete edition of 1700, now lying before me, there is an "Allegoria sanctissimae trinitatis et lapidis philosophici," from which I extract the following:

Therefore *Mercurius philosophorum* is to be considered a spiritual body, as the philosophers call him. From God the Father was born his own Son Jesus Christ, who is God and man, and is without sin, and who also had no need to die. But he died of his own free will, and rose again for the sake of his brothers and sisters, that they might live with him without sin for ever. So, too, is the gold without flaw, and is fixed, potent to withstand all examinations, and glorious; yet, for the sake of its imperfect and sick brothers and sisters, it dies and rises again, glorious and redeemed, and tinctures them to eternal life, making them perfect like to pure gold.

The third person of the Trinity is God the Holy Ghost, a comforter sent by our Lord Jesus Christ to his faithful Christians to strengthen and console them in the faith until eternal life. Therefor the *Spiritus Solis* is likewise *materialis* or *Mercurius corporis*. When they come together, he is called *Mercurius duplicatus*; that is, the two spirits, God the Father and God the Holy Ghost: but God the Son is the *homo glorificatus*, like our glorified and fixed gold, the *lapis philosophorum*; wherefore this *lapis* is also called *trinus*: namely *ex duabus aquis vel spiritibus, minerali & vegetabili*, and from the animal *sulphure Solis*.¹⁹⁹

[509] In the year 1619, there appeared an alchemical book of devotions entitled *Wasserstein der Weysen*. On page 67, the anonymous author says that he will now set forth how the rejected cornerstone (*lapis angularis* = Christ) “accords and is in exceeding subtle and artful agreement with the terrestrial and corporeal Philosophical Stone,” from which it will be seen “how that the terrestrial Philosophical Stone is a veritable Harmonia, Contrafactur, and Prototype of the true spiritual and heavenly Stone Jesu Christ.” The demonstration occupies close on fifty pages. The book made a great stir, and even Jakob Böhme is to be counted among its admirers. Kopp, who mentions the book,²⁰⁰ is scandalized by the blasphemous mixture of alchemical ideas—which make use of highly obnoxious symbols—and religion. We should not, however, judge medieval naïveté too severely, but must try to understand what such an unwieldy language was intended to convey.

[510] The *lapis*-Christ parallel plays an important role in Jakob Böhme (1575–1624), but I do not want to go into this here. A characteristic passage is to be found in *De signatura rerum*.²⁰¹

[511] It is clear enough from this material what the ultimate aim of alchemy really was: it was trying to produce a *corpus subtile*, a transfigured and resurrected body, i.e., a body that was at the same time spirit.²⁰² In this it finds common ground with Chinese alchemy, as we have learned from *The Secret of the Golden Flower*. There the main concern is the “diamond body,” in other words, the attainment of immortality through the transformation of the body. The diamond is an excellent symbol because it is hard, fiery, and translucent. Orthelius²⁰³ tells us that the philosophers have never found a better medicament than that which they called the noble and blessed stone of the philosophers, on account of its hardness, transparency, and rubeous hue.

[512] This same Orthelius also wrote at length on the “theology” of the *lapis*. Since he is later than Böhme I mention him here only because of his preoccupation with the spirit embedded in matter:

There are said to be two treasures: one is the written word and the other is the word become fact [*verbum factum*]. In the *verbum scriptum* Christ is still in swaddling clothes in his cradle [*in cunis suis involutus*]; but in the *verbum dictum et factum* the word is incarnate in God’s creatures, and there, in a manner of speaking, we may touch it with our hands. From them we must raise up our treasure, for the word is nothing other than the fire, the life, and the spirit which the Holy Trinity did scatter abroad from the beginning of creation, and which brooded [*incubavit*] on the face of the waters, and which was breathed into [*inspiratus*] all things by the word of God, and embodied in them, as it is written: “The spirit of God filled the whole world.” Some have expressed the opinion that this world spirit [*spiritus mundi*] was the third person of the Godhead; but they have not considered the word “Elohim,”

which, being plural, extends to *all* persons of the Trinity. They say this spirit proceeded from thence and was by it created, that it became corporeal, and is the chief constituent of the Saviour [*salvatoris*] or Philosophical Stone, and is the true medium whereby body and soul are held united during our life [fig. 235].



235. Alchemical quaternity: the Three and the One (body and female principle).—*Rosarium philosophorum* (1550)

The *spiritus mundi*, that lay upon the waters of old, impregnated them and hatched a seed within them, like a hen upon the egg. It is the virtue that dwells in the inward parts of the earth, and especially in the metals; and it is the task of the art to separate the *Archaeus*,²⁰⁴ the *spiritus mundi*, from matter, and to produce a quintessence whose action may be compared with that of Christ upon mankind.

[513] Once more the Gnostic vision of Nous entangled in the embrace of Physis flashes forth in the work of this latecomer to alchemy. But the philosopher who once descended like a Hercules into the darkness of Acheron to fulfil a divine *opus* has become a laboratory worker with a taste for speculation; having lost sight of the lofty goal of Hermetic mysticism, he now labours to discover a tonic potion that will “keep body and soul together,” as our grandfathers used to say of a good wine. This change of direction in alchemy was due to the all-powerful influence of Paracelsus, the father

of modern medicine. Ortelius is already tending towards natural science, leaving mystical experience to the Church.

[514] Paracelsus and Böhme between them split alchemy into natural science and Protestant mysticism. The stone returned to its former condition: *vilis vilissimus*, the vilest of the vile, *in via eiectus*, thrown out into the street, like Spitteler's jewel. Morienus²⁰⁵ could say again today: "Take that which is trodden underfoot in the dunghill, for if thou dost not, thou wilt fall on thine head when thou wouldst climb without steps"—meaning that if a man refuses to accept what he has spurned, it will recoil upon him the moment he wants to go higher.

[515] The *lapis*-Christ parallel recurs all through the last days of alchemy in the seventeenth century, but only in epigonic form. This was the age that saw the rise of the secret societies, above all the Rosicrucians—the best proof that the secret of alchemy had worn itself out. For the whole *raison d'être* of a secret society is to guard a secret that has lost its vitality and can only be kept alive as an outward form. Michael Maier allows us a glimpse into this tragedy: at the end of his chef-d'œuvre he confesses that in the course of his grand *peregrinatio* he found neither Mercurius nor the phoenix, but only a feather—his pen! This is a delicate hint at his realization that the great adventure had led to nothing beyond his copious literary achievements, whose merits would no doubt have gone unremembered had it depended solely on the spirit of the next three centuries. But, although the growing materialism of the age dismissed alchemy as a huge disappointment and an absurd aberration, there is yet "quaedam substantia in Mercurio quae nunquam moritur"—a fascination that never entirely disappeared, even when wrapped in the fool's garb of goldmaking.



236. Contents of the *vas Hermetis*.—Kelley, *Tractatus de Lapide philosophorum* (1676)



237. The artifex at work with his *soror mystica*.—*Mutus liber* (1702)

6. ALCHEMICAL SYMBOLISM IN THE HISTORY OF RELIGION

I. THE UNCONSCIOUS AS THE MATRIX OF SYMBOLS

[516] After chemistry in the real sense had broken away from the groping experiments and speculations of the royal art, only the symbolism was left as a sort of phantasmal mist, seemingly devoid of all substance. Yet it never lost a certain fascinating quality, and there was always somebody who felt its enchantment in greater or lesser degree. A symbolism as rich as that of alchemy invariably owes its existence to some adequate cause, never to mere whim or play of fancy. At the very least it is the expression of an essential part of the psyche. This psyche, however, was unknown, for it is rightly called the unconscious. Although there is, materialistically speaking, no *prima materia* at the root of everything that exists, yet nothing that exists could be discerned were there no discerning psyche. Only by virtue of psychic existence do we have any “being” at all. Consciousness grasps only a fraction of its own nature, because it is the product of a preconscious psychic life which made the development of consciousness possible in the first place. Consciousness always succumbs to the delusion that it developed out of itself, but scientific knowledge is well aware that all consciousness rests on unconscious premises, in other words on a sort of unknown *prima materia*; and of this the alchemists said everything that we could possibly say about the unconscious. For instance, the *prima materia* comes from the mountain in which there are no differences,¹ or as Abu’l Qāsim says, it is “derived from one thing, and not from separate things, nor from things distinguishing or distinguished.”² And in the *mysterium magnum* of Paracelsus, which is the same as the *prima materia*, “there is no kind of gender.”³ Or the *prima materia* is found in the mountain where, as Abu’l Qāsim also says, everything is upside down: “And the top of this rock is confused with its base, and its nearest part reaches to its farthest, and its head is in the place of its back, and vice versa.”⁴

[517] Such statements are intuitions about the paradoxical nature of the unconscious, and the only place where intuitions of this kind could be lodged was in the unknown aspect of things, be it of matter or of man. There was a feeling, often expressed in the literature, that the secret was to be found either in some strange creature or in man’s brain.⁵ The *prima materia* was thought of as an ever-changing substance, or else as the essence or soul of that substance. It was designated with the name “Mercurius,” and was conceived as a paradoxical double being called *monstrum*, *hermaphroditus*, or *rebis* (cf. [figs. 125, 199](#)). The lapis-Christ parallel establishes an analogy between the transforming substance and Christ ([fig. 192](#)), in the Middle Ages doubtless under

the influence of the doctrine of transubstantiation, though in earlier times the Gnostic tradition of older pagan ideas was the dominant factor. Mercurius is likened to the serpent hung on the cross (John 3 : 14) (figs. 217, 238), to mention only one of the numerous parallels.



238. The brazen serpent of Moses on the cross: *serpens mercurialis* (cf. fig. 217).—Eleazar, *Uraltes chymisches Werk* (1760)



239. Unicorn, the horn a narwhal horn.—Amman, *Ein new Thierbuch* (1569)^{5a}

II. THE PARADIGM OF THE UNICORN

a. The Unicorn in Alchemy

[518] I have chosen the example of the unicorn in order to show how the symbolism of Mercurius is intermingled with the traditions of pagan Gnosticism and of the Church. The unicorn is not a single, clearly defined entity but a fabulous being with a great many variations: there are, for instance, one-horned horses, asses, fish, dragons,

scarabs, etc. Therefore, strictly speaking, we are more concerned with the theme of the single horn (the alicorn). In the *Chymical Wedding* of Rosencreutz, a snow-white unicorn appears and makes his obeisance before the lion. Lion and unicorn are both symbols of Mercurius. A little further on in the book the unicorn gives place to a white dove,⁶ another symbol of Mercurius, who, in his volatile form of *spiritus*, is a parallel of the Holy Ghost. At least ten out of the fifteen figures in Lamspringk's symbols⁷ are representations of the dual nature of Mercurius. Figure III shows the unicorn facing a stag (fig. 240). The latter, as *cervus fugitivus*, is also a symbol of Mercurius.⁸ Mylius⁹ illustrates the *opus* by a series of seven symbols, of which the sixth is the unicorn couched under a tree, symbolizing the spirit of life that leads the way to resurrection (cf. fig. 188). Penotus¹⁰ gives a table of symbols where the unicorn, together with the lion, the eagle, and the dragon, is the co-ordinate of gold. The *aurum non vulgi*, like the lion,¹¹ eagle, and dragon,¹² is a synonym for Mercurius. The poem entitled "Von der Materi und Prattick des Steins"¹³ says:



240. Stag and unicorn, symbolizing soul and spirit.—Lamspringk, "Figurae et emblemata," in *Musaeum hermeticum* (1625 edn.)

I am the right true Unicorn.
 What man can cleave me hoof from horn
 And join my body up again
 So that it no more falls in twain?

[519] Here I must refer once again to Ripley, where we meet the “green lion lying in the queen’s lap with blood flowing from his side.” This image is an allusion on the one hand to the Pieta, on the other to the unicorn wounded by the hunter and caught in the lap of a virgin (figs. 241, 242), a frequent theme in medieval pictures. True, the green lion has replaced the unicorn here, but that did not present any difficulty to the alchemist since the lion is likewise a symbol of Mercurius. The virgin represents his passive, feminine aspect, while the unicorn or the lion illustrates the wild, rampant, masculine, penetrating force of the *spiritus mercurialis*. Since the symbol of the unicorn as an allegory of Christ and of the Holy Ghost was current all through the Middle Ages, the connection between them was certainly known to the alchemists, so that there can be no question that Ripley had in his mind, when he used this symbol, the affinity, indeed the identity, of Mercurius with Christ.



241. Virgin taming a unicorn.—Thomas Aquinas (pseud.), “De alchimia” (MS., 16th cent.)



242. Slaying the unicorn in the Virgin's lap. (Note the significance of the "wound in his side.")—Initial from MS. Harley 4751, London

b. The Unicorn in Ecclesiastical Allegory

[520] The language of the Church borrows its unicorn allegories from the Psalms, where the unicorn stands in the first place for the might of the Lord, as in Psalm 29 : 6: "He maketh them also to skip like a calf; Lebanon and Sirion like a young unicorn"¹⁴; and in the second place for the vitality of man (figs. 243, 244), as in Psalm 92 : 10: "But my horn shalt thou exalt like the horn of an unicorn. ..." ¹⁵ The power of evil is also compared to the strength of the unicorn, as in Psalm 22 : 21: "Save me from the lion's mouth: for thou hast heard me from the horns of the unicorns."¹⁶ On these metaphors is based Tertullian's allusion to Christ: "His glory is that of a bull, his horn is that of a unicorn."¹⁷ This refers to the blessing of Moses (Deut. 33 : 13, 14, 17):



243. Unicorn crest of the von Gachnang family (Thurgau, Switzerland).—From the Zurich Roll of Arms (1340)

... Blessed of the Lord be his land, for the precious things of heaven, for the dew, and for the deep that coucheth beneath,

And for the precious fruits brought forth by the sun, and for the precious things put forth by the moon, ...

His glory is like the firstling of his bullock, and his horns are like the horns of unicorns: with them he shall push the people together to the ends of the earth....

[521] From this it is clear that the horn of the unicorn signifies the health, strength, and happiness of the blessed. “Thus,” says Tertullian, “Christ was named the bull on account of two qualities: the one hard [*ferus*, ‘wild, untamed’] as a judge, the other gentle [*mansuetus*, ‘tame’] as a saviour. His horns are the ends of the cross. ...” Justin Martyr¹⁸ interprets the same passage in a similar way: “*Cornua unicornis cornu eius*. For no one can say or prove that the horns of the unicorn could be found in any other object or in any other shape than in that represented by the cross.” For the might of God is manifest in Christ. Accordingly Priscillian calls God one-horned: “One-horned is God, Christ a rock to us, Jesus a cornerstone, Christ the man of men.”¹⁹ Just as the unicorn symbolizes the uniqueness of the Unigenitus, so St. Nilus uses it to express the fearless independence of the καλόγηρος the monk: Μονόκερώς ἔστιν οὗτος, ζῶν αὐτόνομον (he is a unicorn, a creature on his own).²⁰



244. The glorification of Ariosto. (The horse's forelock is twisted into a stiff plait to make it look like the horn of the unicorn.)—Drawing by Giovanni Battista Benvenuti, called Ortolano (1488–?1525)



245. The Virgin Mary with the loving unicorn in the “enclosed garden.”—Swiss tapestry (1480)

[522] St. Basil takes the *filius unicornium* to be Christ. The origin of the unicorn is a mystery, says St. Ambrose, like Christ’s procreation. Nicolas Caussin, from whom I have culled these extracts, observes that the unicorn is a fitting symbol for the God of the Old Testament, because in his wrath he reduced the world to confusion like an angry rhinoceros (unicorn) until, made captive by love, he was soothed in the lap of a virgin.²¹ This ecclesiastical train of thought has its parallel in the alchemical taming of the lion and the dragon (fig. 246). Concerning the conversion of the Old Testament Jehovah into the God of Love in the New Testament, Picinelli says: “Of a truth God, terrible beyond measure, appeared before the world peaceful and wholly tamed after dwelling in the womb of the most blessed Virgin. St. Bonaventure said: Christ was tamed and pacified by the most kindly Mary, so that he should not punish the sinner with eternal death.”²²



246. Mandala with four ornamental medallions containing a stag, lion, griffin, and unicorn.

—Pavement from St. Urban’s Monastery, Lucerne



247. Virgin with unicorn.—Khludov Psalter (Byzantine, 9th cent.)

[523] In his *Speculum de mysteriis ecclesiae*, Honorius of Autun says:

The very fierce animal with only one horn is called unicorn. In order to catch it, a virgin is put in a field; the animal then comes to her and is caught, because it lies down in her lap. Christ is represented by this animal, and his insuperable strength²³ by its horn. He, who lay down in the womb of the Virgin, has been caught by the hunters; that is to say, he was found in human shape by those who loved him²⁴ [fig. 247].



[524] St. Rupert²⁵ compares Christ to the rhinoceros, and Bruno of Würzburg²⁶ simply calls him *cornu* (horn). Caussin writes that Albertus Magnus, in his “Hypotyposes,” mentions the Virgin in connection with the monoceros. Albertus was an expert on alchemy and drew his quotations from the Hermetic treatises. In the “Tabula smaragdina” there is a “son” of immense strength who comes down to earth and penetrates everything solid. It is not only in astrology that Virgo is an earth-sign: in Tertullian and Augustine the Virgin actually signifies earth (fig. 248). Isidore of Seville emphasizes the “perforating” effects of the unicorn.²⁷ In the “Tabula” the mother-son incest is very thinly disguised,²⁸ a fact of which the alchemist Albertus was possibly aware.



249. Wild unicorn.—From Bock, *Kräuterbuch* (1595)

[525] As I said before, the unicorn has more than one meaning. It can also mean evil. The *Physiologus Graecus*,²⁹ for instance, says of the unicorn that “it is a swift-running animal, having one horn, and evilly disposed towards man” (μνησίκακον δέ ὑπάρχει ἐν ἀνθρώποις). And St. Basil says: “And take heed unto thyself, O man, and

beware of the unicorn, who is the Demon [fig. 249]. For he plotteth evil against man, and he is cunning in evil-doing.”

[526] These examples should suffice to show how close is the connection between alchemical symbolism and the language of the Church. It is to be noted in the ecclesiastical quotations that the unicorn also contains the element of evil (fig. 250). Originally a monstrous and fabulous beast, it harbours in itself an inner contradiction, a *complexio oppositorum*, which makes it a singularly appropriate symbol for the *monstrum hermaphroditum* of alchemy.³⁰



250. Wild man riding the unicorn.—Engraving from the sequence of the *Grösseres Kartenspiel*, by the monogrammist E.S. (c. 1463)

c. The Unicorn in Gnosticism

[527] There is also a connection between the language of the Church and pagan Gnostic symbolism. Hippolytus, giving an account of the doctrine of the Naassenes, says that the serpent dwells in all things and creatures, and that all temples were named after her (ναούις ἀπὸ τοῦ νάα; a play on the words νάα; = serpent, ναός = temple). Every shrine, he says, every initiation (ηλετή), and every mystery is

dedicated to the serpent. This immediately recalls the passage in the “Tabula smaragdina”: “Pater omnis telesmi totius mundi est hic” (This is the father of the perfection of the whole world). Τέλος, τελετή, and τελεσμός all mean the same: perfection and maturation of the *corpora imperfecta*, and of the alchemist himself.³¹

These [Naassenes] say that the serpent is the moist element, as Thales of Miletus also said,³² and that nothing which exists, whether immortal or mortal, animate or inanimate, could exist without it.

[528] This definition of the serpent agrees with the alchemical Mercurius, who is likewise a kind of water: the “divine water” (ὕδωρ θεῖον), the wet, the *humidum radicale* (radical moisture), and the spirit of life, not only indwelling in all living things, but immanent in everything that exists, as the world-soul. Hippolytus continues:

They say, too, that all things are subject to her [the serpent], that she is good and has something of everything in herself as in the horn of the one-horned bull [ἐν κέρατι τάουρου μονοκέρωτος]. She imparts beauty and ripeness to all things....

[529] Like the alicorn, therefore, the serpent is an alexipharmic and the principle that brings all things to maturity and perfection. We are already familiar with the unicorn as a symbol of Mercurius, the transforming substance par excellence which also ripens and perfects unripe or imperfect bodies and is consequently acclaimed in alchemy as the *salvator* and *servator*. “The serpent,” says Hippolytus, “penetrates everything, as if coming forth from Edem and dividing herself into the four first principles.”³³ That everything proceeds from the One is a fundamental tenet of alchemy (fig. 251): “As all things proceed from the One ... so all things are born of this one thing,” says the “Tabula smaragdina”; and also that the One divides into the four elements (fig. 252) and then recombines into unity. The *prima materia* is called among other things the “paradisal earth” which Adam took with him on his expulsion from Paradise. *Mercurius philosophorum* consists of the four elements (cf. fig. 214). In one of the Mystery hymns quoted by Hippolytus, Osiris is named the “heavenly horn of the moon” (ἐπουράνιον μηνὸς κέρας), and the same primal being is also called Sophia and Adam.³⁴ These analogies we already know in their alchemical aspect. Another one mentioned by Hippolytus is the “many-formed Attis.” The changeability and multiformity of Mercurius is a key idea in alchemy. It is hardly necessary to enter into the ideas which this pagan system took over from Christianity; comparison with the Christian quotations should suffice.

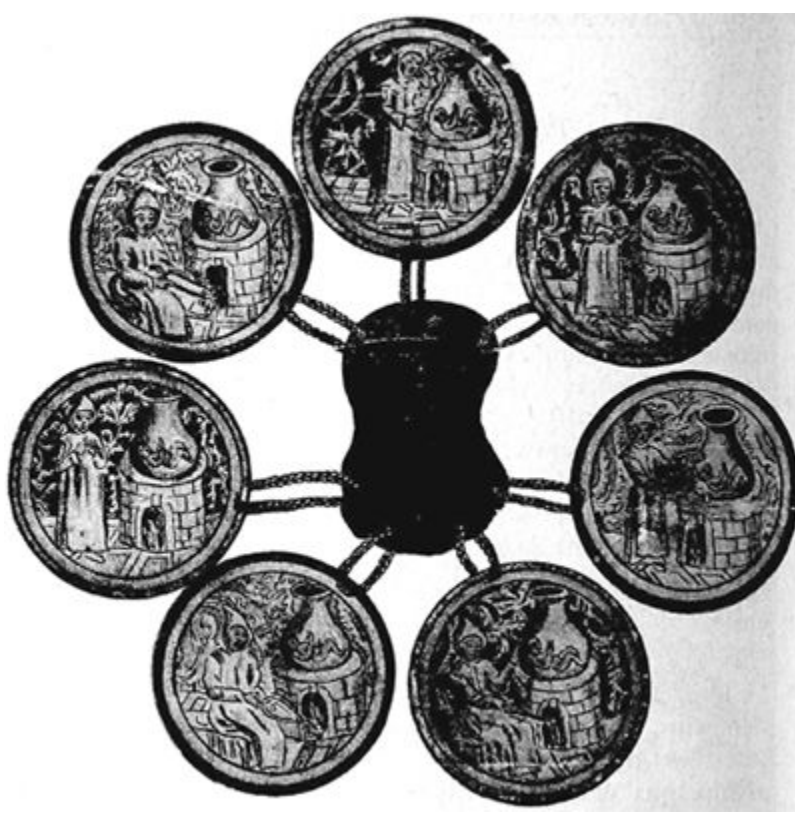

251. The seven stages of the alchemical process shown as a unity.—“Ripley Scrowle” (MS., 1588)



252. Chastity.—“Les Triomphes du Pétrarque” (MS., 16th cent.)



253. Harpokrates encircled by the Uroboros.—Gnostic gem

d. The One-Horned Scarabaeus

[530] An important source of information concerning the unicorn symbolism of Mercurius is the *Hieroglyphica* of Horapollo (ch. 10). This author says that the third genus of the scarab is unicornered (μονόκερως) and, on account of this peculiarity, sacred to Mercurius, like the ibis. Moreover the scarab is a μονογενής (only-begotten, *unigena*) in so far as it is an αὐτογενὲς ζῶον (a creature born of itself). In Paracelsus the *prima materia* is an *incretum*, and throughout alchemy, as Mercurius, *serpens*, or *draco*, it is bisexual, capable of self-fertilization and self-parturition (fig. 253). The *unicus filius* is the *filius philosophorum*, i.e., the stone. The scarab undergoes the same dismemberment as the dragon, the “separation of the elements,” in a papyrus text: “The sun-beetle, the winged ruler standing at heaven’s meridian, was beheaded and dismembered.”³⁵ I would also mention the “sixth parable” in “Splendor solis,”³⁶ where the *separatio* is portrayed as a dismembered corpse, accompanied by the text: “Rosinus³⁷ says that he would like to make plain a vision that he has seen of a man who was dead, whose body was yet all white like a salt, and whose limbs were divided, and his head was of fine gold but separated from the body. ...”³⁸ The golden head referred originally to the head of Osiris who is described in a Greek papyrus as “headless.”³⁹ The Greek alchemists styled themselves “Children of the Golden Head.”⁴⁰

[531] The scarab is seldom mentioned in alchemical literature, but among the old texts it can be found in the “Consilium coniugii”: “Nulla aqua fit quelles, nisi illa que fit de scarabaeis aquae nostrae”⁴¹ (No water will become the elixir save that which comes from the scarabs of our water). The *aqua nostra* is nothing other than the *aqua divina*, i.e., Mercurius.

e. The Unicorn in the Vedas

[532] The track of the unicorn in pre-Christian days leads us to the East.⁴² We meet it as early as the hymns of the Atharva-Veda (III, 7) in a “charm against *kshetriya*,

hereditary disease”:⁴³

1. Upon the head of the nimble antelope a remedy grows! He has driven the *kshetriya* in all directions by means of the horn.

2. The antelope has gone after thee with his four feet. O horn, loosen the *kshetriya* that is knitted into his heart!

3. (The horn) that glistens yonder like a roof with four wings (sides), with that do we drive out every *kshetriya* from thy limbs.

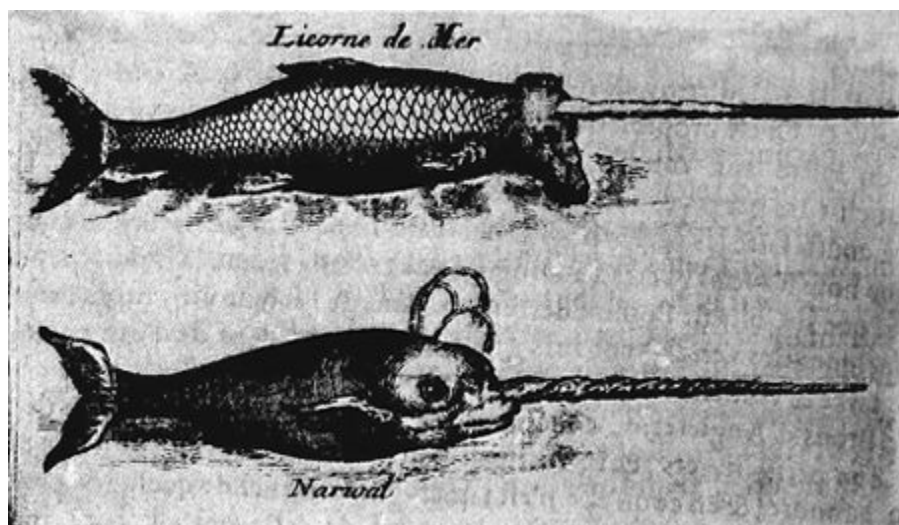

254. The so-called sea-unicorn (*monodon*, *monoceros*). Its tusk was used as a model in old pictures of the unicorn.—

Pommet, *Histoire gènèrale des drogues* (1694)

[533] The fish of Manu (cf. [fig. 254](#)) seems to have been unicornered, although this is not specifically stated: but always its horn is mentioned, never its horns. According to the legend recounted in the Shatapatha-Brahmana,⁴⁴ Manu hooked a fish which grew larger and larger and eventually towed him over the flood to dry land. Manu tied his ship to its horn.⁴⁵ The fish is an incarnation of Vishnu ([fig. 255](#)), and Manu means “man.”⁴⁶ In many respects he corresponds to the Greek Anthropos: he is the father of humanity and is descended direct from God, here called Svayambhu, the “Self-So,” i.e., Brahma. He is a God-man, identified with Prajapati, Lord of created things, and even with Brahman itself, the highest soul. In the Rig-Veda he is named Father Manu, and is said to have begotten mankind on his daughter. He is the founder of the social and moral order,⁴⁷ the first sacrificiant and priest.⁴⁸ He transmitted the Upanishadic doctrine to mankind.⁴⁹ It is of particular interest that he is also derived from the androgynous Viraj. The Shatapatha-Brahmana associates him with a bull who was entrusted with the task of annihilating the Asuras and Rakshas (demons hostile to the gods).⁵⁰ Lastly, Manu is the father of medicine,⁵¹ and, in Buddhist tradition, Lord of the Golden Age.⁵² The horn, then, is connected with a figure which, in both name and character, has close affinities with the Anthropos.

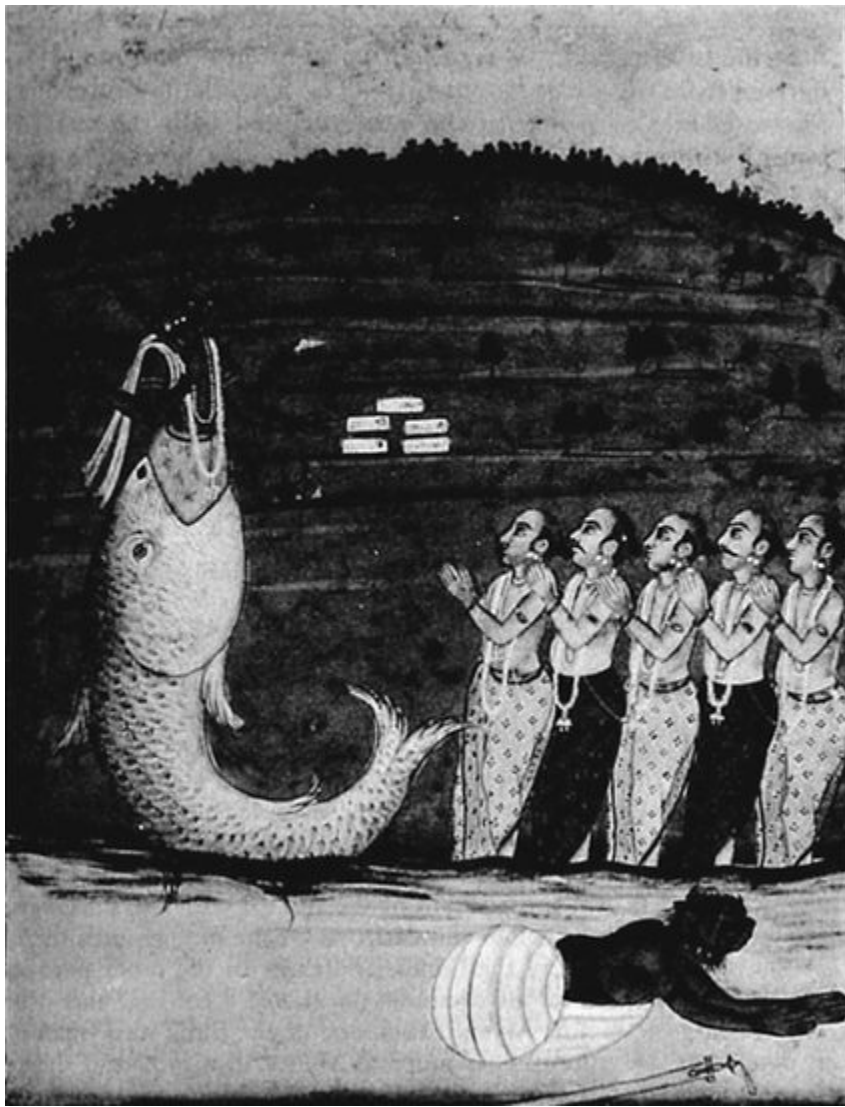

255. Vishnu in his fish incarnation.—18th-cent. Indian miniature

[534] The virgin and unicorn motif is to be found in the Ramayana and in the Mahabharata (III, 110–113). A hermit by name of Rishyashringa (gazelle's horn), son of Vibhandaka or Ekasringa (one-horn), is fetched out of his solitary retreat by the king's daughter Shanta, who marries him; or, in another version, he is seduced by a courtesan. Only by this means can the terrible drought that is scourging the land be broken.⁵³

f. The Unicorn in Persia

[535] There is an impressive account of the unicorn in the Bundahish (Ch. XIX):

Regarding the three-legged ass, they say that it stands amid the wide-formed ocean, and its feet are three, eyes six, mouths nine, ears two, and horn one, body white, food spiritual, and it is righteous. And two of its six eyes are in the position of eyes, two on the top of the head, and two in the position of the hump; with the sharpness of those six eyes it overcomes and destroys. Of the nine mouths three are in the head, three in the hump, and three in the inner part of the flanks; and each mouth is about the size of a cottage, and it is itself as large as Mount Alvand. Each

one of the three feet, when it is placed on the ground, is as much as a flock of a thousand sheep comes under when they repose together; and each pastern is so great in its circuit that a thousand men with a thousand horses may pass inside. As for the two ears, it is Mazendaran which they will encompass. The one horn is as it were of gold and hollow, and a thousand branch horns have grown upon it, some befitting a camel, some befitting a horse, some befitting an ox, some befitting an ass, both great and small. With that horn it will vanquish and dissipate all the vile corruption due to the efforts of noxious creatures.

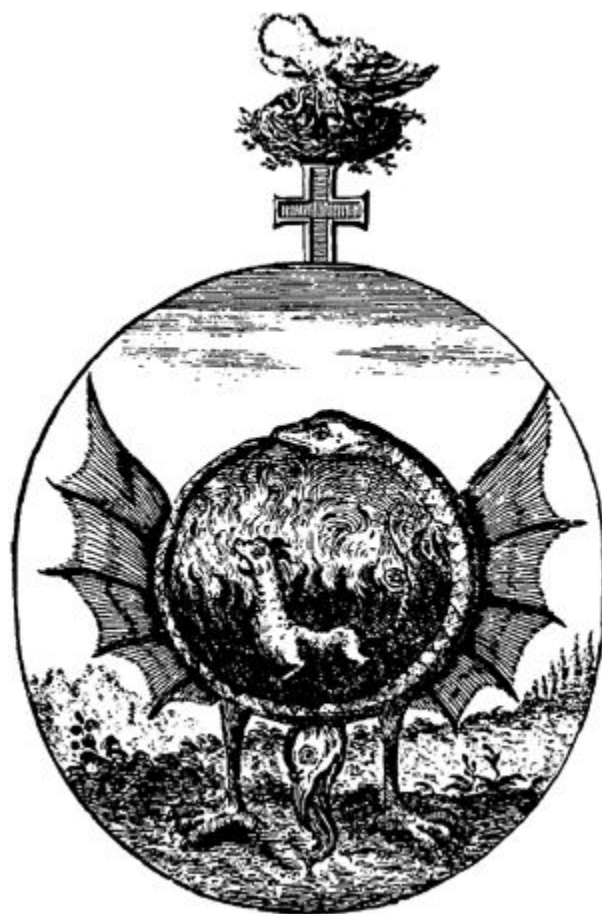

256. Fabulous monster containing the *massa confusa*, from which rises the pelican (symbol of Christ and the *lapis*).

—*Hermaphroditisches Sonn- und Mondskind* (1752)

When that ass shall hold its neck in the ocean its ears will terrify, and all the water of the wide-formed ocean will shake with agitation, and the side of Ganavad will tremble. When it utters a cry all the female water-creatures, of the creatures of Auharmazd, will become pregnant; and all pregnant noxious water-creatures, when they hear that cry, will cast their young. When it stales in the ocean all the sea-water will become purified, which is in the seven regions of the earth—it is even on that account when all asses which come into water stale in the water—as it says thus: “If, O three-legged ass! you were not created for the water, all the water in the sea would have perished from the contamination which the poison of the evil spirit has brought into its water, through the death of the creatures of Auharmazd.”

Tiîstar seizes the water more completely from the ocean with the assistance of the three-legged ass. Of ambergris also (ambar-ik) it is declared, that it is the dung of the three-legged ass; for if it has much spirit food, then also the moisture of the liquid nourishment goes through the veins pertaining to the body into the urine, and the dung is cast away.⁵⁴

[536] The monster is evidently based on the number three. Its ass aspect is reminiscent of the Indian wild onager in Ctesias, but, as a cosmological being, it recalls the monstrous personifications of the *prima materia* (fig. 256) in Arabic alchemy. In the “Book of Ostanès,” for instance, one such monster (with the wings of a vulture, the head of an elephant, and the tail of a dragon) gives the adept the key to the treasure-house.⁵⁵ The ass stands in the ocean, like the tree Gokard that grows from the deep mud of the sea.⁵⁶ The Bundahish says of this tree:

... it is necessary as a producer of the renovation of the universe, for they prepare its immortality therefrom.... Some say it is the proper-curing, some the energetic-curing, some the all-curing.⁵⁷

[537] The ass and the tree⁵⁸ are evidently related, because they both represent the power of life, procreation, and healing. This is a truly primitive equation: both are or have mana. The Arabic alchemists likewise obtain their *prima materia* from the tree in the western land. We read in the book of Abu’l Qāsim:⁵⁹



257. The transformations of Mercurius. The Melusina (Lilith) on the tree is Sapientia.—“Ripley Scrowle” (MS., 1588)

This prime matter which is proper for the form of the Elixir is taken from a single tree which grows in the lands of the West... And this tree grows on the surface of the ocean as plants grow on the surface of the earth. This is the tree of which whosoever eats, man and jinn obey him; it is also the tree of which Adam (peace be upon him!) was forbidden to eat, and when he ate thereof he was transformed from his angelic form to human form. And this tree may be changed into every animal shape.

[538] The monster and the tree both stand for the *φάρμακον ἀθανασίας*, the elixir, the alexipharmic, and the panacea. The tree’s peculiar power to change into any animal shape is also attributed to *Mercurius versipellis* (fig. 257).

[539] The ass is a *daemon triunus*, a chthonic trinity, which is portrayed in Latin alchemy as a three-headed monster and identified with Mercurius, salt, and sulphur.⁶⁰ The classical rumour about the worship of an ass in the Temple of Jerusalem, and the graffito on the Palatine showing a mock crucifixion,⁶¹ I will mention only in passing; likewise the saturnine aspect of Jehovah and Ialdabaoth as demiurges, which brings these figures into conjunction with the equally saturnine *prima materia*.

g. The Unicorn in Jewish Tradition

[540] The Talmud⁶² tells the story of how the unicorn (*re'em*) escaped the flood: it was tied to the outside of the ark because, owing to its gigantic size, it could not go inside. Og, the King of Bashan, survived the flood in the same way. The passage runs:

The preservation of the unicorn is easily explained by those who say that the flood did not descend on the Land of Israel; but how was it preserved in the opinion of those who say that the flood did descend? R. Jannai answered: They took young unicorns into the ark.—But Rabba b. Bar Hana reported that he had seen a young unicorn as large as Mount Tabor, which measures forty parasangs, and that the girth of its neck was three parasangs, and its head one and a half parasangs, and that the Jordan was choked with the dirt it voided.⁶³ R. Johanan answered: They took [only] its head into the ark.—But the master said that its head measured one and a half parasangs.—Peradventure they took the tip of its nose into the ark.— ... But when the ark rose on the water?—Reš Laqiš answered: They tied its horns to the ark.—But R. Hisda said that they had sinned with heat and were punished with hot water.⁶⁴—How was the ark preserved⁶⁵ in your opinion? And moreover where was Og, the King of Bashan?⁶⁶—Peradventure a miracle happened to them and [the water] remained cold at the sides of the ark.

[541] There is a corresponding version of this story in the midrash collection entitled *Pirkê R. Eliezer*, according to which Og “sat down on a piece of wood under the gutter of the ark.”⁶⁷

[542] The “Targum Pseudo-Jonathan,” commenting on Genesis 14 : 13, says that Og stayed on the roof of the ark.⁶⁸

[543] According to one Talmud legend,⁶⁹ Og was descended from one of the fallen angels mentioned in Genesis 6 who “came in unto” the daughters of men: “Take note, Sihon and Og were brothers, for the master said: ‘Sihon and Og were the sons of Ahijah the son of Samhazai.’”⁷⁰ The commentary of Rashi says that Sihon and Og were the sons of Ahijah “who was descended from Shemhazai and Azael, the two angels who came down to earth in the days of Enoch.”

[544] Og’s gigantic size is described in several passages of the Talmud—probably at its most gigantic in “Tractate Nidda”:⁷¹

Abba Saul, according to others R. Johanan, said: “I was a digger of graves. One day I was chasing a deer, and I found myself inside the thigh-bone of a dead man; I chased the deer for three parasangs, yet I did not catch up with him, nor had the thigh-bone come to an end. When I turned back they told me: ‘It belonged to Og, the King of Bashan.’”

[545] It is conceivable that there is an inner connection between Og and the unicorn: both escaped the flood by being somehow attached to the outside of the ark, and both are gigantic. Moreover we saw that the unicorn was compared to Mount Tabor, and Og also is connected with a mountain: he uprooted a mountain and hurled it on the camp of the Israelites.⁷² The parallel is carried still further in one midrash:⁷³ the unicorn is a mountain and is threatened by a lion, and, in the continuation of the story, Og is killed by Moses, “the servant of Jahweh,” who is so often compared to a lion in the Old Testament. The midrash runs:

R. Huna bar Idi said: At the time when David was still tending the sheep, he went and found the unicorn [*re'em*] asleep in the desert, and thinking it was a mountain he climbed to the top and pastured his flock there. Then the unicorn shook himself and stood up. And David rode on his back and reached up to heaven. And in that hour David spoke to God: If thou wilt take me down from this unicorn I will build thee a temple, one hundred cubits in size, like the horn of this unicorn.... What did the Holy One, blessed be He, do for him? He ordained that a lion should come, and when the unicorn saw the lion, he was afraid and crouched down before him, because the lion is his king, and David descended on to the earth. But when David saw the lion, he was afraid. Therefore it is said: “Save me from the lion’s mouth, for thou hast heard [freed] me from the horns of the unicorns.”

[546] Another midrash⁷⁴ shows the unicorn fighting with the lion. Here it is explicitly called the unicorn (*ha-unicorius*) and not *re'em*. The passage runs:



259. The ch'i-lin announcing the birth of Confucius. "Before K'ung-tse was born, a ch'i-lin came to the governor's house in Tsou and spat out a jade tablet, bearing the inscription: 'The son of the mountain crystal [lit. water-essence] will perpetuate the fallen kingdom of Chou and be a king without a crown.' His mother was astonished and tied an embroidered bow to the unicorn's horn. The beast stayed for two nights and then departed."—From a Chinese illustrated work (c. 18th cent.), *Shèng Chi-t'u*



260. The ch'i-lin announcing the death of Confucius. "In the 14th year of the reign of the Duke Ai [of Lu—481 B.C.] a ch'i-lin was caught on a winter hunt in the West. This gave K'ung-tse a severe shock and he stopped writing the *Ch'un-t's'in*. The *K'ung-t's'ung-tse* [collection of stories about Confucius] says: While the clan of Shu-sun [aristocratic family in Lu] were firing some undergrowth they caught a ch'i-lin. No one recognized it. They threw it away at Wu-fu crossroads. [The disciple] Jan-yu reported it and said: 'The body of a stag with a horn of flesh, is that not the heavenly monster of ill omen?' K'ung-tse went to look at it. He wept and said: 'It is a ch'i-lin! The ch'i-lin, benevolent beast, appears and dies. My Tao is exhausted.' "—From *Shèng Chi-t'u*

h. The Unicorn in China

[548] The unicorn also appears in China. According to the *Li Chi*, or *Book of Rites*, there are four beneficent or spiritual animals: the unicorn (*ch'i-lin*), the phoenix, the tortoise, and the dragon. The *ch'i-lin* is chief among four-footed beasts. "It resembles the stag, but is larger, with the tail of an ox and the hoofs of a horse: it has a single horn of flesh, there are five colours in the hair of its back, and the hair of its belly is yellow (or brown), it does not tread any living grass underfoot nor eat any living creature; it shows itself when perfect rulers [*chen-jen*] appear and the *Tao* of the king is accomplished." If it is wounded, this is an evil omen. Its first appearance was in the garden of the Yellow Emperor (2697 B.C.). Later two unicorns sojourned in P'ing-yang, Emperor Yao's capital. A unicorn appeared to the mother of Confucius when she was pregnant (fig. 259), and, as an omen before the death of the sage, it chanced that a charioteer wounded a unicorn (fig. 260).⁷⁵ It is worth noting that the male unicorn is called *ch'i* and the female *lin*, so that the generic term is formed by the

union of both characters (*ch'i-lin*).⁷⁶ The unicorn is thus endowed with an androgynous quality. Its connection with the phoenix and the dragon also occurs in alchemy, where the dragon stands for the lowest form of Mercurius and the phoenix for the highest.

[549] As mentioned before, the horn of the rhinoceros is an alexipharmic and for this reason is, even today, a favourite article of commerce between the African east coast and China, where it is made into poison-proof drinking cups. The *Physiologus Graecus* tells us that when a snake has poisoned their drinking water, the animals, noticing the poison, will wait for the unicorn to come down to the water; “for his horn is a symbol of the cross” (σταυρὸν ἐκτυπώσας τῷ κέρατι αὐτοῦ), and by drinking he dissipates the virulence of the poison.⁷⁷

i. The Unicorn Cup

[550] The healing cup is not unconnected with the “cup of salvation,” the Eucharistic Chalice, and with the vessel used in divination. Migne⁷⁸ says that Cardinal Torquemada always kept a unicorn cup at table: “La corne de licorne préserve des sortilèges” (fig. 261). Hippolytus, in his summing up of the teachings of the Naassenes, says that the Greeks called “Geryon of the threefold body” the “heavenly horn of the moon.” But Geryon was the “Jordan,”⁷⁹ the “masculo-feminine Man in all things, by whom all things were made.” In this connection Hippolytus mentions the cup of Joseph and Anacreon:



261. Pope with the unicorn as the symbol of the Holy Ghost.—From Scaliger, *Explanatio imaginum* (1570); antithesis to Paracelsus, *Auslegung der Figuren* (1569)

The words “without him was not any thing made”⁸⁰ refer to the world of forms, because this was created without his help through the third and fourth [members of

the quaternity]. For this is ... the cup from which the king, when he drinks, draws his omens.⁸¹ The Greeks likewise alluded to this secret in the Anacreontic verses:

My tankard tells me
Speaking in mute silence
What I must become.

This alone sufficed for it to be known among men, namely the cup of Anacreon which mutely declares the ineffable secret. For they say Anacreon's cup is dumb; yet Anacreon affirms that it tells him in mute language what he must become, that is, spiritual and not carnal, if he will hear the secret hidden in silence. And this secret is the water which Jesus, at that fair marriage, changed into wine. That was the great and true beginning of the miracles which Jesus wrought in Cana in Galilee, and thus he showed forth the kingdom of heaven. This [beginning] is the kingdom of heaven that lies within us as a treasure, like the "leaven hidden in three measures of meal."⁸²



262. The lunar unicorn.—Reverse of a medal (1447) by Antonio Pisano

[551] We have seen that the "heavenly horn of the moon" is closely connected with the unicorn. Here it means not only "Geryon of the threefold body"⁸³ and the Jordan, but the hermaphroditic Man as well, who is identical with the Johannine Logos. The "third and fourth" are water and earth; these two elements are thought of as forming the lower half of the world in the alchemical retort, and Hippolytus likens them to a cup (κόνδυ). This is the divining-vessel of Joseph and Anacreon: the water stands for the content and the earth for the container, i.e., the cup itself. The content is the water that Jesus changed into wine, and the water is also represented by the Jordan, which signifies the Logos, thus bringing out the analogy with the Chalice. Its content gives life and healing, like the cup in IV Ezra (14 : 39–40):



263. The Champion Pendant (front view), made from the horn of a narwhal set in enamelled gold. On the back, bits of the horn have been scraped off for medicinal purposes (16th cent.?)

Then I opened my mouth, and Io! there was reached unto me a full cup, which was full as it were with water, but the colour of it was like fire.⁸⁴

And I took it and drank; and when I had drunk,
My heart poured forth understanding,
wisdom grew in my breast,
and my spirit retained its memory.⁸⁵

[552] The secret of the cup is also the secret of the horn, which in its turn contains the essence of the unicorn as bestower of strength, health, and life (fig. 263). The alchemists attribute the same qualities to their stone, calling it the “carbuncle.”⁸⁶ According to legend, this stone may be found under the horn of the unicorn, as Wolfram von Eschenbach says:

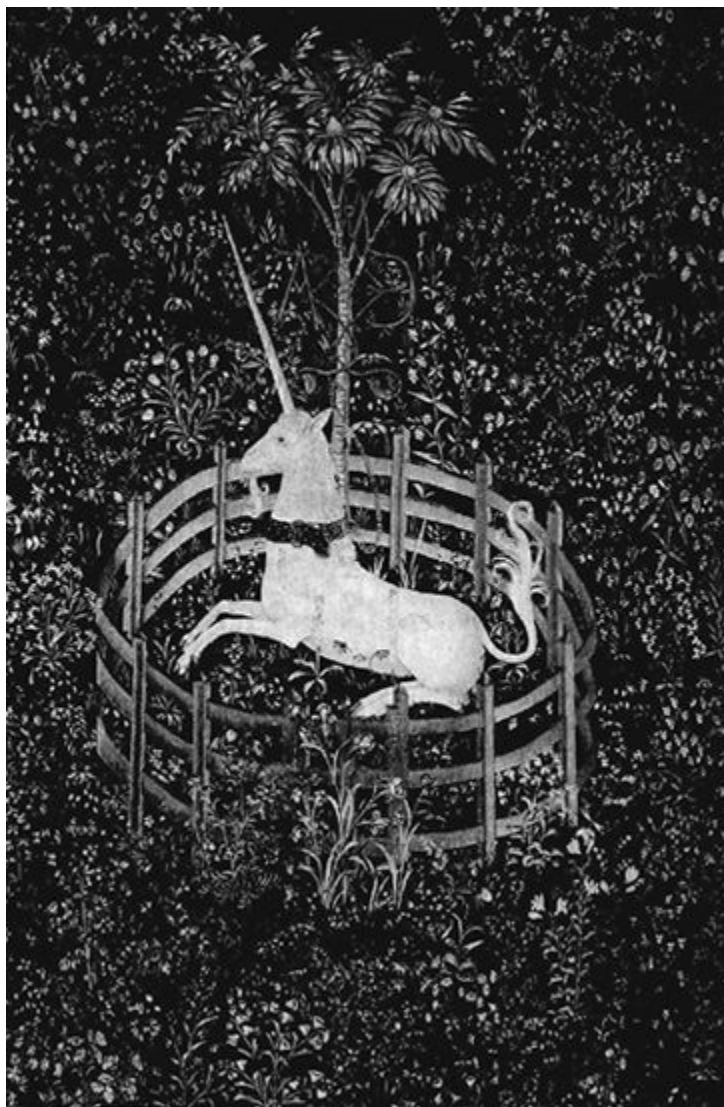

264. Mandala of the unicorn and the tree of life.—Verteuil tapestry (15th cent.), “The Hunt of the Unicorn”

We caught the beast called Unicorn
That knows and loves a maiden best
And falls asleep upon her breast;
We took from underneath his horn
The splendid male carbuncle stone
Sparkling against the white skull-bone.⁸⁷

[553] The horn as an emblem of vigour and strength has a masculine character, but at the same time it is a cup, which, as a receptacle, is feminine.⁸⁸ So we are dealing here with a “uniting symbol”⁸⁹ that expresses the bipolarity of the archetype (fig. 264).

[554] These assorted unicorn symbolisms aim at giving no more than a sample of the extremely intricate and tangled connections between pagan and natural philosophy, Gnosticism, alchemy, and ecclesiastical tradition, which, in its turn, had a deep and lasting influence on the world of medieval alchemy. I hope that these examples have made clear to the reader just how far alchemy was a religious-philosophical or

“mystical” movement. It may well have reached its peak in Goethe’s religious *Weltanschauung*, as this is presented to us in *Faust*.



265. The unicorn and his reflection, depicting the motto “De moy je m’èpouvante.”

—Boschius, *Symbolographia* (1702)



266. Double-headed eagle with crowns of Pope and Emperor, symbolizing the kingdoms of both worlds. The eagle is covered with eyes (enlightenment!).—Codex Palatinus Latinus 412 (15th cent.)

EPILOGUE



267. The *prima materia* as the dragon, being fertilized by the Holy Ghost (the *avis Hermetis*).—"Hermes Bird,"
Theatrum chemicum Britannicum (1652)

[555] What the old philosophers meant by the *lapis* has never become quite clear. This question can be answered satisfactorily only when we know exactly what the unconscious content was that they were projecting. The psychology of the unconscious alone is in a position to solve this riddle. It teaches us that so long as a content remains in the projected state it is inaccessible, which is the reason why the labours of those authors have revealed so little to us of the alchemical secret. But the yield in symbolic material is all the greater, and this material is closely related to the process of individuation.

[556] In dealing with alchemy we must always consider what an important part this philosophy played in the Middle Ages, what a vast literature it left behind, and what a far-reaching effect it had on the spiritual life of the time. How far the claims of alchemy itself went in this direction is best shown by the *lapis*-Christ parallel, a fact which may explain, or excuse, my excursions into fields that seem to have nothing to do with alchemy. For the moment we embark upon the psychology of alchemical thought we must take account of connections that seem, on the face of it, very remote from the historical material. But if we try to understand the phenomenon from inside, i.e., from the standpoint of the psyche, we can start from a central position where many lines converge, however far apart they may be in the external world. We are then confronted with the underlying human psyche which, unlike consciousness, hardly changes at all in the course of many centuries. Here, a truth that is two thousand years old is still the truth today—in other words, it is still alive and active. Here too we find those fundamental psychic facts that remain unchanged for thousands of years and will still be unchanged thousands of years hence. From this point of view, the recent past and the present seem like episodes in a drama that began in the grey mists of antiquity and continues through the centuries into a remote future. This drama is an "Aurora consurgens"—the dawning of consciousness in mankind.

[557] The alchemy of the classical epoch (from antiquity to about the middle of the seventeenth century) was, in essence, chemical research work into which there entered, by way of projection, an admixture of unconscious psychic material. For this reason the psychological conditions necessary for the work are frequently stressed in the texts. The contents under consideration were those that lent themselves to projection upon the unknown chemical substance. Owing to the impersonal, purely objective nature of matter, it was the impersonal, collective archetypes that were projected: first and foremost, as a parallel to the collective spiritual life of the times, the image of the spirit imprisoned in the darkness of the world. In other words, the state of relative unconsciousness in which man found himself, and which he felt to be painful and in need of redemption, was reflected in matter and accordingly dealt with in matter. Since the psychological condition of any unconscious content is one of potential reality, characterized by the polar opposites “being” and “not-being,” it follows that the union of opposites must play a decisive role in the alchemical process. The result is something in the nature of a “uniting symbol,” and this usually has a numinous character.¹ The projection of the redeemer-image, i.e., the correspondence between Christ and the *lapis*, is therefore almost a psychological necessity, as is the parallelism between the redeeming *opus* or *officium divinum* and the magistry—with the essential difference that the Christian *opus* is an *operari* in honour of God the Redeemer undertaken by man who stands in need of redemption, while the alchemical *opus* is the labour of Man the Redeemer in the cause of the divine world-soul slumbering and awaiting redemption in matter. The Christian earns the fruits of grace *ex opere operato*, but the alchemist creates for himself—*ex opere operantis* in the most literal sense—a “panacea of life” which he regards either as a substitute for the Church’s means of grace or as the complement and parallel of the divine work of redemption that is continued in man. The two opposed points of view meet in the ecclesiastical formula of the *opus operatum* and the *opus operantis*²—but in the last analysis they are irreconcilable. Fundamentally it is a question of polar opposites: the collective or the individual, society or personality. This is a modern problem in so far as it needed the hypertrophy of collective life and the herding together of incredible masses of people in our own day to make the individual aware that he was being suffocated in the toils of the organized mob. The collectivism of the medieval Church seldom or never exerted sufficient pressure on the individual to turn his relations with society into a general problem. So this question, too, remained on the level of projection, and it was reserved for our own day to tackle it with at least an embryonic degree of consciousness under the mask of neurotic individualism.

[558] Some time previous to this latest development, however, alchemy had reached its final summit, and with it the historical turning-point, in Goethe’s *Faust*, which is

steeped in alchemical forms of thought from beginning to end. The essential Faustian drama is expressed most graphically in the scene between Paris and Helen. To the medieval alchemist this episode would have represented the mysterious *coniunctio* of Sol and Luna in the retort (fig. 268); but modern man, disguised in the figure of Faust, recognizes the projection and, putting himself in the place of Paris or Sol, takes possession of Helen or Luna, his own inner, feminine counterpart. The objective process of the union thus becomes the subjective experience of the artifex: instead of watching the drama, he has become one of the actors. Faust's personal intervention has the disadvantage that the real goal of the entire process—the production of the incorruptible substance—is missed. Instead Euphorion, who is supposed to be the *filius philosophorum*, imperishable and “incombustible,” goes up in flames and disappears—a calamity for the alchemist and an occasion for the psychologist to criticize Faust, although the phenomenon is by no means uncommon. For every archetype, at its first appearance and so long as it remains unconscious, takes possession of the whole man and impels him to play a corresponding role. Consequently Faust cannot resist supplanting Paris in Helen's affections, and the other “births” and rejuvenations, such as the Boy Charioteer and the Homunculus, are destroyed by the same greed. This is probably the deeper reason why Faust's final rejuvenation takes place only in the post-mortal state, i.e., is projected into the future. Is it a mere coincidence that the perfected figure of Faust bears the name (which we have already met) of one of the most famous of the early alchemists: “Marianus” or, in its more usual spelling, Morienus?

PHILOSOPHORVM FERMENTATIO.



**Hye wird Sol aber verschlossen
Vnd mit Mercurio philosophorum vbergossen.**

268. *Fermentatio*, symbolic representation of the *coniunctio spirituum*. [Verses: “But here King Sol is tight shut in / And Mercurius philosophorum pours over him.”]—*Rosarium philosophorum* (1550)

[559] By identifying with Paris, Faust brings the *coniunctio* back from its projected state into the sphere of personal psychological experience and thus into consciousness. This crucial step means nothing less than the solution of the alchemical riddle, and at the same time the redemption of a previously unconscious part of the personality. But every increase in consciousness harbours the danger of inflation, as is shown very clearly in Faust’s superhuman powers. His death, although necessary in his day and generation, is hardly a satisfactory answer. The rebirth and transformation that follow the *coniunctio* take place in the hereafter, i.e., in the unconscious—which leaves the problem hanging in the air. We all know that Nietzsche took it up again in *Zarathustra*, as the transformation into the superman; but he brought the superman into dangerously close proximity with the man-in-the-street. By so doing he inevitably called up all the latter’s reserves of anti-Christian resentment, for his superman is the overweening pride, the hybris, of individual consciousness, which must necessarily collide with the collective power of Christianity and lead to the catastrophic destruction of the individual. We know just how, and in what an exceedingly characteristic form, this fate overtook Nietzsche,

tam ethice quam physice. And what kind of an answer did the next generation give to the individualism of Nietzsche's superman? It answered with a collectivism, a mass organization, a herding together of the mob, *tam ethice quam physice*, that made everything that went before look like a bad joke. Suffocation of the personality and an impotent Christianity that may well have received its death-wound—such is the unadorned balance sheet of our time.

[560] Faust's sin was that he identified with the thing to be transformed and that had been transformed. Nietzsche overreached himself by identifying his ego with the superman Zarathustra, the part of the personality that was struggling into consciousness. But can we speak of Zarathustra as a part of the personality? Was he not rather something superhuman—something which man is not, though he has his share in it? Is God really dead, because Nietzsche declared that he had not been heard of for a long time? May he not have come back in the guise of the superman?

[561] In his blind urge for superhuman power, Faust brought about the murder of Philemon and Baucis. Who are these two humble old people? When the world had become godless and no longer offered a hospitable retreat to the divine strangers Jupiter and Mercury, it was Philemon and Baucis who received the superhuman guests. And when Baucis was about to sacrifice her last goose for them, the metamorphosis came to pass: the gods made themselves known, the humble cottage was changed into a temple, and the old couple became immortal servitors at the shrine.

[562] In a sense, the old alchemists were nearer to the central truth of the psyche than Faust when they strove to deliver the fiery spirit from the chemical elements, and treated the mystery as though it lay in the dark and silent womb of nature. It was still outside them. The upward thrust of evolving consciousness was bound sooner or later to put an end to the projection, and to restore to the psyche that which had been psychic from the beginning. Yet, ever since the Age of Enlightenment and in the era of scientific rationalism, what indeed was the psyche? It had become synonymous with consciousness. The psyche was "what I know." There was no psyche outside the ego. Inevitably, then, the ego identified with the contents accruing from the withdrawal of projections. Gone were the days when the psyche was still for the most part "outside the body" and imagined "those greater things" which the body could not grasp. The contents that were formerly projected were now bound to appear as personal possessions, as chimerical phantasms of the ego-consciousness. The fire chilled to air, and the air became the great wind of Zarathustra and caused an inflation of consciousness which, it seems, can be damped down only by the most terrible catastrophe to civilization, another deluge let loose by the gods upon inhospitable humanity.

[563] An inflated consciousness is always egocentric and conscious of nothing but its own existence. It is incapable of learning from the past, incapable of understanding contemporary events, and incapable of drawing right conclusions about the future. It is hypnotized by itself and therefore cannot be argued with. It inevitably dooms itself to calamities that must strike it dead. Paradoxically enough, inflation is a regression of consciousness into unconsciousness. This always happens when consciousness takes too many unconscious contents upon itself and loses the faculty of discrimination, the *sine qua non* of all consciousness. When fate, for four whole years, played out a war of monumental frightfulness on the stage of Europe—a war that *nobody* wanted—nobody dreamed of asking exactly who or what had caused the war and its continuation. Nobody realized that European man was possessed by something that robbed him of all free will. And this state of unconscious possession will continue undeterred until we Europeans become scared of our “god-almightiness.” Such a change can begin only with individuals, for the masses are blind brutes, as we know to our cost. It seems to me of some importance, therefore, that a few individuals, or people individually, should begin to understand that there are contents which do not belong to the ego-personality, but must be ascribed to a psychic non-ego. This mental operation has to be undertaken if we want to avoid a threatening inflation. To help us, we have the useful and edifying models held up to us by poets and philosophers—models or *archetypi* that we may well call remedies for both men and the times. Of course, what we discover there is nothing that can be held up to the masses—only some hidden thing that we can hold up to ourselves in solitude and in silence. Very few people care to know anything about this; it is so much easier to preach the universal panacea to everybody else than to take it oneself, and, as we all know, things are never so bad when everybody is in the same boat. No doubts can exist in the herd; the bigger the crowd the better the truth—and the greater the catastrophe.

[564] What we may learn from the models of the past is above all this: that the psyche harbours contents, or is exposed to influences, the assimilation of which is attended by the greatest dangers. If the old alchemists ascribed their secret to matter, and if neither Faust nor Zarathustra is a very encouraging example of what happens when we embody this secret in ourselves, then the only course left to us is to repudiate the arrogant claim of the conscious mind to be the whole of the psyche, and to admit that the psyche is a reality which we cannot grasp with our present means of understanding. I do not call the man who admits his ignorance an obscurantist; I think it is much rather the man whose consciousness is not sufficiently developed for him to be aware of his ignorance. I hold the view that the alchemist’s hope of conjuring out of matter the philosophical gold, or the panacea, or the wonderful stone, was only in part an illusion, an effect of projection; for the rest it corresponded

to certain psychic facts that are of great importance in the psychology of the unconscious. As is shown by the texts and their symbolism, the alchemist projected what I have called the process of individuation into the phenomena of chemical change. A scientific term like “individuation” does not mean that we are dealing with something known and finally cleared up, on which there is no more to be said.³ It merely indicates an as yet very obscure field of research much in need of exploration: the centralizing processes in the unconscious that go to form the personality. We are dealing with life-processes which, on account of their numinous character, have from time immemorial provided the strongest incentive for the formation of symbols. These processes are steeped in mystery; they pose riddles with which the human mind will long wrestle for a solution, and perhaps in vain. For, in the last analysis, it is exceedingly doubtful whether human reason is a suitable instrument for this purpose. Not for nothing did alchemy style itself an “art,” feeling—and rightly so—that it was concerned with creative processes that can be truly grasped only by experience, though intellect may give them a name. The alchemists themselves warned us: “Rumpite libros, ne corda vestra rumpantur” (Rend the books, lest your hearts be rent asunder), and this despite their insistence on study. Experience, not books, is what leads to understanding (fig. 269).

[565] In the foregoing study of dream-symbols I have shown how such an experience looks in reality. From this we can see more or less what happens when an earnest inquiry is turned upon the unknown regions of the soul. The forms which the experience takes in each individual may be infinite in their variations, but, like the alchemical symbols, they are all variants of certain central types, and these occur universally. They are the primordial images, from which the religions each draw their absolute truth.



269. The artifex and his *soror mystica* making the gesture of the secret at the end of the work.—*Mutus liber* (1702)



270. The phoenix as symbol of resurrection.—Boschius, *Symbolographia* (1702)

BIBLIOGRAPHY

The items of the bibliography are arranged alphabetically under two headings: *A.* Ancient volumes containing collections of alchemical tracts by various authors; *B.* General bibliography, including cross-references to the material in *A.* Short titles of the ancient volumes are printed in capital letters.

BIBLIOGRAPHY

A. VOLUMES CONTAINING COLLECTIONS OF ALCHEMICAL WORKS BY VARIOUS AUTHORS

ARS CHEMICA, quod sit licita recte exercentibus, probationes doctissimorum iurisconsultorum ... Argentorati [Strasbourg], 1566. *Contents quoted in this volume:*

- i Septem tractatus seu capitula Hermetis Trismegisti aurei [pp. 7–31; usually referred to as “Tractatus aureus”]
- ii Tabula smaragdina [pp. 32–33]
- iii Studium Consilii coniugii de massa solis et lunae [pp. 48–263; usually referred to as “Consilium coniugii”]

ARTIS AURIFERAE quam chemiam vocant ... Basileae [Basel], [1593]. 2 vols.

Contents quoted in this volume:

VOLUME I

- i Turba philosophorum [two versions: pp. 1–64, 65–139]
- ii Allegoriae super librum Turbae [pp. 139–45]
- iii Aenigmata ex visione Arislei et allegoriis sapientum [pp. 146–54; usually referred to as “Visio Arislei”]
- iv In Turbam philosophorum exercitationes [pp. 154–82]
- v Aurora consurgens, quae dicitur Aurea hora [pp. 185–246; Part II only]
- vi Rosinus ad Sarratantam episcopum [pp. 277–319]
- vii Maria Prophetissa: Practica ... in artem alchemicam [pp. 319–24]
- viii Kalid: Liber trium verborum [pp. 352–61]
- ix Merlinus: Allegoria de arcano lapidis [pp. 392–96]
- x Liber de arte chimica [pp. 575–631]

VOLUME II

- xi Morienus Romanus: Sermo de transmutatione metallorum [pp. 7–54]
- xii Rosarium philosophorum [pp. 204–384; contains a second version of “Visio Arislei” at pp. 246ff.]

AUREUM VELLUS, oder Guldin Schatz und Kunstkammer ... von dem ... bewehrten Philosopho Salomone Trismosino, Rorschach, 1598.

Contents quoted in this volume:

- i [Trismosin:] Splendor solis [Tract. III, pp. 3–59]
- ii Melchior, Cardinal Bishop of Brixen: Von dem gelben und rotten Mann [Tract. III, pp. 177–91]

For translations of this volume, see: *La Toyson d'or, ou La Fleur des thresors ...*
Translated from German into French by L. I. Paris, 1612. / “The Golden Fleece, or The
Flower of Treasures.” Translated by William Backhouse, 1718. / In MS. Bodleian 7597,
Oxford.

MANGETUS, JOANNES JACOBUS (ed.). *BIBLIOTHECA CHEMICA CURIOSA, seu Rerum ad
alchemiam pertinentium thesaurus instructissimus ...* Geneva, 1702. 2 vols.

Contents quoted in this volume:

VOLUME I

- i Hoghelande: De alchemiae difficultatibus [pp. 336–68]
- ii Hermes Trismegistus: Tractatus aureus de lapidis physici secreto [pp. 400–445]
- iii Turba philosophorum [pp. 445–65; another version, pp. 480–94]
- iv Allegoriae sapientum supra librum Turbae philosophorum XXIX distinctiones [pp. 467–79]
- v Geber. Summa perfectionis magisterii [pp. 519–57]
- vi Lully: Compendium artis alchemiae et naturalis philosophiae secundum naturalem cursum [pp. 875–78]
- vii Lully: Codicillus, seu vade mecum aut Cantilena [pp. 880–911]
- vii-a Mutus liber, in quo tamen tota philosophia hermetica, figuris hieroglyphicis depingitur [unpaged; bound in Mellon Alchemical Library copy]

VOLUME II

- viii Bonus: Margarita pretiosa novella correctissima [pp. 1–80]
- ix Rosarium philosophorum [pp. 87–119]
- x Ficinus [Marsilio Ficino]: Liber de arte chimica [pp. 172–83]
- xi [Zadith] Senior: De chymia [pp. 198–235]
- xii Ripley: Liber duodecim portarum [pp. 275–85]
- xiii Sendivogius: Parabola, seu Aenigma philosophicum [pp. 474–75]
- xiv Orthelius: Epilogus et recapitulatio in Novum lumen Sendivogii [pp. 526–30]
- xv [Siebmacher:] Hydrolithus sophericus, seu Aquarium sapientum [pp. 537–58]
- xvi Grasseus: Lilium inter spinas [pp. 596–600]
- xvii [Espagnet:] Arcanum hermeticae philosophiae [pp. 649–61]

*In hoc volumine DE ALCHEMIA continentur haec. Gebri Arabis ... De investigatione
perfectionis metallorum ...* Norimbergae [Nuremberg], 1541.

Contents quoted in this volume:

- i Rosarius minor [pp. 309–37]
- ii Tabula smaragdina Hermetis Trismegisti [p. 363]

MUSAEUM HERMETICUM reformatum et amplification ... continens tractatus chemicos XXI praestantissimos ... Francofurti [Frankfort], 1678. (For translation, see (B) WAITE, ARTHUR EDWARD.) (Also an edn. of 1625. See [fig. 240.](#))

Contents quoted in this volume:

- i [Hermes Trismegistus:] Tractatus aureus de lapide philosophorum [pp. 1–52]
- ii Madathanus Aureum saeculum redivivum [pp. 53–72]
- iii [Siebmacher:] Hydrolithus sophericus, seu Aquarium sapientum [pp. 73–144]
- iv Mehung: Demonstratio naturae [pp. 145–71]
- v Flamel: Tractatus brevis sive Summarium philosophicum [pp. 172–79]
- vi [Barcius (F. von Sternberg):] Gloria mundi, alias Paradysi tabula [pp. 203–304]
- vii Lamspringk: De lapide philosophico figurae et emblemata [pp. 337–72]
- viii [Maier:] Tripus aureus, hoc est, Tres tractatus chymici selectissimi [pp. 373–544]
- ix Valentinus: Practica una cum duodecim clavibus [pp. 377–432; Duodecim claves, pp. 393–423]
- x Norton: Crede mihi, seu Ordinale [pp. 433–532]
- xi Cremer: Testamentum [pp. 533–44]
- xii Sendivogius: Novum lumen chemicum e naturae fonte et manuali experientia depromptum [pp. 545–600]
- xiii [Sendivogius:] Novi luminis chemici tractatus alter de sulphure [pp. 601–46]
- xiv Philalethes: Introitus apertus ... [pp. 647–700]
- xv Philalethes: Metallorum metamorphosis [pp. 714–74]
- xvi Philalethes: Fons chymicae veritatis [pp. 799–814]

THEATRUM CHEMICUM, praecipuos selectorum auctorum tractatus ... continens. Ursellis [Ursel], 1602. 3 vols. (Vol. IV, Argentorati [Strasbourg], 1613; Vol. V, 1622; Vol. VI, 1661.)

Contents quoted in this volume:

VOLUME I

- i Hoghelande: Liber de alchemiae difficultatibus [pp. 121–215]
- ii Dorn: Speculativae philosophiae, gradus septem vel decem continens [pp. 255–310]
- iii Dorn: Physica genesis [pp. 367–404]
- iv Dorn: Physica Trismegisti [pp. 405–37]
- v Dorn: De spagirico artificio Trithemii sententia [pp. 437–50]
- vi Dorn: Philosophia meditativa [pp. 450–72]
- vii Dorn: Philosophia chemica ad meditativam comparata [pp. 472–517]
- viii Dorn: Congeries Paracelsicae chemicae de transmutationibus metallorum [pp. 557–646]

- ix Bernard of Treviso: Liber de alchemia [pp. 773–803]
x Zacharius: Opusculum philosophiae naturalis metallorum [pp. 804–48]

VOLUME II

- xi Aegidius de Vadis: Dialogus inter naturam et filium philosophiae [pp. 95–123]
xii Penotus: Philosophi potius occultare artem conati sunt quam patefacere ... [p. 123; a table]
xiii Quercetanus: Ad Jacobi Auberti Vendonis de ortu et causis metallorum contra chemicos explicationem [pp. 202]
xiv Dee: Monas hieroglyphica [pp. 218–43]
xv Ventura: De ratione conficiendi lapidis [pp. 244–356]
xvi Richardus Anglicus: Correctorium alchymiae [pp. 442–66]
xvii Albertus Magnus: Super arborem Aristotelis [pp. 524–27]

VOLUME III

- xviii [Melchior:] Addam et processum sub forma missae [pp. 853–60]

VOLUME IV

- xix Von der Materi und Prattick des Steins [pp. 284–93]
xx Aphorismi Basiliani sive Canones Hermetici [pp. 368–71]
xxi Sendivogius: Dialogus Mercurii, alchymistae, et naturae [pp. 509–17]
xxii Arnaldus de Villanova: Carmen [pp. 614–15]
xxiii Guilhelmus Tecenensis: Liliium ... de spinis evulsum [pp. 1000–1027]

VOLUME V

- xxiv Turba philosophorum [pp. 1–57]
xxv Allegoriae sapientum ... supra librum Turbae [pp. 64–100]
xxvi Tractatus Micreris suo discipulo Mirnefindo [pp. 101–13]
xxvii Liber Platonis quartorum ... [pp. 114–208]
xxviii Tractatus Aristotelis alchymistae ad Alexandrum Magnum de lapide philosophico [pp. 880–92]
xxix Epistola ad ... Hermannum archiepiscopum Coloniensem de lapide philosophico [pp. 893–900]

VOLUME VI

- xxx Espagnet: Instructio ... de arbore solari [pp. 163–94]
xxxi Christopher of Paris: Elucidarius artis transmutatoriae metallorum [pp. 195–293]
xxxii Grasseus: Arca arcani ... [pp. 294–381]

THEATRUM CHEMICUM BRITANNICUM. Containing Severall Poeticall Pieces of Our Famous English Philosophers, Who Have Written the Hermetique Mysteries in Their Owne Ancient Language. Collected with annotations by Elias Ashmole. London, 1652.

Contents quoted in this volume:

- i Norton: The Ordinall of Alchimy [pp. 1–106]
- ii Liber patris sapientiae [pp. 195–212]
- iii [Lully:] Hermes Bird [pp. 213–26]
- iv Verses Belonging to an Emblematicall Scrowle: Supposed to Be Invented by Geo: Ripley [pp. 375–79]

B. GENERAL BIBLIOGRAPHY

ABRAHAM LE JUIF. “Livre des figures hiéroglyphiques.” See *Codices and MSS.*, xxxiv.

_____. See also ELEAZAR, ABRAHAM.

ABU’L QĀSIM. See HOLMYARD.

ADOLPHUS SENIOR. See SENIOR, ADOLPHIS.

AEGIDIUS DE VADIS. “Dialogus inter naturam. . . .” See (A) *Theatrum chemicum*, xi.

AELIAN (Claudius Aelianus). *De natura animalium libri XVII*. Edited by R. Hercher. Leipzig, 1864–66. 2 vols.

AGRIPPA VON NETTESHEYM, HEINRICH (HENRICIS) CORNELIUS. *De incertitudine et vanitate omnium scientiarum et artium*. The Hague, 1653. English translation: *The Vanity of Arts and Sciences*. London, 1676.

ALBERTUS MAGNUS. *Philosophia naturalis*. Basel, 1650.

_____. “Super arborem Aristotelis.” See (A) *Theatrum chemicum*, xvii.

“Allegoriae sapientum supra librum Turbae.” See (A) *Theatrum chemicum*, xxv, and *Artis auriferae*, ii.

ALLENDY, RENÉ FÉLIX. *Le Symbolisme des nombres*. Second edn., Paris, 1948.

AMMAN, JOST (illus.). *Ein new Thierbuch*. With verses by G. Schaller. Frankfort on the Main, 1569.

“Aphorismi Basiliani.” See (A) *Theatrum chemicum*, xx.

APULEIUS, LUCIUS. *The Golden Ass. Being the Metamorphoses of Lucius Apuleius*. With an English translation by W. Adlington (1566), revised by S. Gaselee. (Loeb Classical Library.) London and New York, 1915.

AQUINAS, THOMAS. See THOMAS.

“Arislei Visio.” See (A) *Artis auriferae*, iii and xii.

[ARISTEAS.] *The Letter of Aristeas*. [Edited by H. G. Meecham.] Manchester, 1935. For translation, see: *The Oldest Version of the Bible: “Aristeas” on Its Traditional Origin*.

- Edited by Henry George Meecham. London, 1932.
- ARISTOTLE. [*De coelo.*] ... *On the Heavens*. With an English translation by W. K. C. Guthrie. (Loeb Classical Library.) London and Cambridge, Mass., 1939.
- _____. *Meteorologica*. Edited by Immanuel Bekker. Berlin, 1829.
- ARISTOTLE, pseud. "Tractatus ... alchymistae ad Alexandrum Magnum. ..." See (A) *Theatrum chemicum*, xxviii.
- ARNALDUS DE VILLANOVA. "Carmen." See (A) *Theatrum chemicum*, xxii.
- ARNOBIUS. *Adversus gentes*. See MIGNE, *PL.*, vol. 5, cols. 713–1290.
- Atharva-Veda. See BLOOMFIELD.
- AUGUSTINE, SAINT. *Tractatus in Joannis Evangelium*. Tract. XXXIV. See MIGNE, *P.L.*, vol. 35, cols. 1652–57. For translation, see: HENRY BROWNE (trans.). [Saint Augustine's] *Homilies on the Gospel According to Saint John, and His First Epistle*. (Library of Fathers of the Holy Catholic Church.) Oxford, 1848.
- Aurea catena Homeri*. Frankfort and Leipzig, 1723.
- "Aurora consurgens." See (A) *Artis auriferae*, v; Codices and MSS., xxxi and xlix; FRANZ, M.-L. VON; RHENANUS, JOHANNES.
- AVALON, ARTHUR (pseud. of Sir John George Woodroffe) (ed. and trans.). *The Serpent Power (Shat-cakra-nirūpana and Pādukāpanchaka)*. (Tantrik Texts.) London, 1919.
- BACON, ROGER. *The Mirror of Alchimy ... with Certaine Other Worthie Treatises of the Like Argument*. London, 1597.
- BALDUINUS, CHRISTIANUS ADOLPHUS. *Aurum superius et inferius aurae superioris et inferioris hermeticum*. Frankfort and Leipzig, 1675.
- BARCHUSEN [BARKHAUSEN], JOHANN CONRAD. *Elementa chemiae*. Leiden, 1718.
- BARNAUD, NICOLAS. *Triga chemica de lapide philosophico tractatus tres*. Leiden, 1599.
- BATIFFOL, PIERRE. *Studia patristica*. Fasc. 1 and 2. Paris, 1889–90. ("Le Livre de la Prière d'Asenath," fasc. 1, pp. 1–37.)
- BAYNES, CHARLOTTE AUGUSTA. *A Coptic Gnostic Treatise Contained in the Codex Brucianus —Bruce MS. 96, Bodleian Library, Oxford*. Cambridge, 1933.
- BERNARD (OF CLAIRVAUX), SAINT. *Sermo IV de Ascensione Domini*. In: *Sermones de Tempore*. See MIGNE, *P.L.*, vol. 183, cols. 35–359.
- BERNARD OF TREVISO [Bernardus Trevisanus]. "Liber de alchemia." See (A) *Theatrum chemicum*, ix.
- BERNOULLI, RUDOLF. "Spiritual Development as Reflected in Alchemy and Related Disciplines," in *Spiritual Disciplines*. (Papers from the Eranos Yearbooks, 4.) New York (Bollingen Series 30) and London, 1960. (Orig. in *Eranos-Jahrbuch 1935*.)

- BÉROALDE DE VERVILLE, FRANCOIS (trans.). *Le Tableau des riches inventions couvertes du voile des feintes amoureuses, qui sont representees dans le Songe de Poliphile ...* Paris, 1600. Contains the “Recueil stéganographique.” For original, see COLONNA; for English paraphrase, see FIERZ-DAVID.
- BERTHELOT, MARCELLIN. *La Chimie au moyen âge.* (Histoire des sciences.) Paris, 1893. 3 vols.
- _____. *Collection des anciens alchimistes grecs.* Paris, 1887–88. 3 vols.
- _____. *Les Origines de l’alchimie.* Paris, 1885.
- Bible moralisée. See Codices and MSS., xx.
- Biblia pauperum.* (Gesellschaft der Bibliophilen.) Weimar, 1906. (After an edn. of 1471.)
- BISCHOFF, ERICH (ed. and trans.). *Die Elemente der Kabbalah.* Berlin, 1913. 2 vols.
- BLOOMFIELD, MAURICE (trans.). *Hymns of the Atharva-Veda.* (Sacred Books of the East, 42.) Oxford, 1897.
- BOCK, HIERONYMUS. *Kräuterbuch.* Strasbourg, 1595.
- BÖHME, JAKOB. *Des gottseligen, hocheleuchteten Jacob Böhmen Teutonici Philosophi alle Theosophische Schrifften.* Amsterdam, 1682. (A number of parts, separately paginated and variously bound up, the parts themselves being unnumbered. Referred to below as “Schrifften.”)
- _____. *The Works of Jacob Behmen,* [Trans. and ed. by G. Ward and T. Langcake.] London, 1764–81. 4 vols. Referred to below as “Works.”
- _____. *Aurora, oder Die Morgenröte in Aufgang.* See “Schrifften.” For translation, see “Works,” I (“Aurora”).
- _____. *De signatura rerum.* See “Schrifften”; for translation, see CLIFFORD BAX (ed.). *The Signature of All Things, with Other Writings by Jacob Boehme.* Translated by John Ellistone. (Everyman’s Library.) London and New York, 1912.
- _____. *Gespräch einer erleuchteten und unerleuchteten Seele.* See “Schrifften.” For translation, see BAX, as previous entry.
- _____. *Hohe und tiefe Gründe von dem dreyfachen Leben des Menschen.* See “Schrifften.” For translation, see “Works,” II (“A High and Deep Search concerning the Threefold Life of Man”).
- _____. *Vom irdischen und himmlischen Mysterium.* See “Schrifften.” For translation, see Six *Theosophic Points and Other Writings.* Translated by John Rolleston Earle. London, 1919. (“On the Earthly and Heavenly Mystery,” pp. 141–62.)
- BONUS, PETRUS. *Pretiosa margarita novella de thesauro ac pretiosissimo philosophorum lapide ...* Edited by Janus Lacinius. Venice, 1546. For translation see ARTHUR EDWARD WAITE (trans.). *The New Pearl of Great Price.* London, 1894. See also (A) *Bibliotheca chemica curiosa*, viii.

- BÖRNER, C. G. [firm of booksellers, Leipzig.] *Auctions-Katalog 184*. Leipzig, 1914.
(Catalogue of A. O. Meyer collection of drawings.)
- BOSCHIUS, JACOBUS. *Symbolographia, sive De arte symbolica sermones septem*. Augsburg, 1702.
- BOUSSET, WILHELM. *Hauptprobleme der Gnosis*. (Forschungen zur Religion und Literatur des Alten und Neuen Testaments, 10.) Göttingen, 1907.
- BRANT, SEBASTIAN. *Hexastichon ... in memorabiles evangelistarum figuras*. [No place of publication.] 1503.
- BRAUN, JOSEPH. *Liturgisches Handlexikon*. Regensburg, 1922.
- Brihadaranyaka Upanishad. See MAX MÜLLER.
- BRUCHMANN, CARL FRIEDRICH HEINRICH (ed.). *Epitheta Deorum quae apud poetas Graecos leguntur*. (Ausführliches Lexikon der griechischen und römischen Mythologie. Supplement.) Leipzig, 1893.
- BRUNO, SAINT, BISHOP of WÜRZBURG. *Expositio psalmorum*. See MIGNE, *P.L.*, vol. 142, cols. 49–568.
- BUBER, SALOMON (ed.). *Midrasch Tehillim*. The Buber text translated into German and edited by August Wünsche. Trier, 1892.
- BUDGE, SIR E. A. WALLIS (ed.). *The Book of the Dead. Facsimiles of the Papyri of Hunefer, Anhai, Kerasher ...* London, 1899.
- _____. *The Gods of the Egyptians*. London, 1904. 2 vols.
- _____. *Osiris and the Egyptian Resurrection*. London, 1911. 2 vols.
- BÜHLER, JOHANN GEORG (trans.). *The Laws of Mann*. (Sacred Books of the East, 25.) London, 1886.
- Bundahish. See WEST.
- CARTARI, VINCENZO. *Le imagini de i dei de gli antichi*. Lyons, 1581. For French translation, see: *Les Images des dieux des anciens*. [Translated and enlarged by Antoine du Verdier.] Lyons, 1581.
- CATELANUS, LAURENTIUS. *Ein schöner newer historischer Discurs, von der Natur, Tugenden, Eigenschafften, und Gebrauch dess Einhorns*. [Translated by Georgius Faber.] Frankfort on the Main, 1625.
- CAUSSIN, NICOLAS. *De symbolica Aegyptiorum sapientia. Polyhistor symbolicus, Electorum Symbolorum, et Parabolarum historicarum stromata*. Paris, [1618] and 1631.
- [CELLINI, BENVENUTO.] *The Life of Benvenuto Cellini*. Newly translated into English by John Addington Symonds. 4th edn., London, 1896.
- CHAMPOLLION, JEAN FRANÇOIS. *Panthéon égyptien*. Paris, 1823–35.
- CHARLES, ROBERT HENRY (ed.). *The Apocrypha and Pseudepigrapha of the Old Testament in English*. Oxford, 1913. 2 vols. Chhandogya Upanishad. See MAX MÜLLER.

CHRISTOPHER OF PARIS (Christophorus Parisiensis). “Elucidarius artis transmutatoriae.” See (A) *Theatrum chemicum*, xxxi.

CLEMEN, PAUL. *Die romanische Monumentalmalerei in den Rheinlanden*. (Gesellschaft für rheinische Geschichtskunde, 32.) Düsseldorf, 1916.

CLEMENT OF ALEXANDRIA. *Stromata*. See MIGNE, P.G., vol. 8, col. 685 vol. 9, col. 602. For translation, see WILLIAM WILSON (trans.). *The Writings of Clement of Alexandria*. (Ante-Nicene Christian Library, 4, 12.) Edinburgh, 1867, 1869. 2 vols.

CLEMENT OF ROME (Pope Clement I). *Homilia II*. See MIGNE, P.G., vol. 2, cols. 77–112. For translation, see THOMAS SMITH, PETER PETERSON, and JAMES DONALDSON (trans.). *The Clementine Homilies and the Apostolical Constitutions*. (Ante-Nicene Christian Library, 17.) Edinburgh, 1870. (Pp. 32–56.)

Codices and Manuscripts.

- i Codex of Akhmim. See DIETERICH, *Nehyia*.
- i-a Aschaffenburg. Bibliothek. Codex 13 (earlier 3.) 13th cent. Evangeliary.
- i-b Berlin. Codex Berolinensis. See RUSKA, *Turba*.
- i-c Bingen. Abbey of St. Hildegarde. “Scivias.” 12th cent.
- ii Chantilly. Musée Condé. Bibliothèque. MS. 1284. “Les Très Riches Heures du duc de Berry.” 15th cent.
- iii Dresden. Sächsische Landesbibliothek. An old Mexican MS. (Codex Dresdensis.)
- iv Florence. Biblioteca Medicea-Laurenziana. MS. (Ashburnham 1166) “Miscellanea d’alchimia.” 14th cent.
- v Leiden. Rijksuniversiteit Bibliotheek. Codex Vossianus 29. Thomas Aquinas, pseud. “De alchimia.” 16th cent.
- vi London. British Museum. MS. Additional 1316. Emblematical Figures in red chalk, of the process of the Philosophers’ Stone, with Latin interpretations. 17th cent.
- vii _____. _____. MS. Additional 5025. Four rolls drawn in Lübeck. 1588. (The “Ripley Scrowle.”)
- viii _____. _____. MS. Additional 5245. Cabala mineralis, Rabbi Simeon ben Cantara.
- ix _____. _____. MS. Additional 19352. Theodore Psalter, 1066. See also TIKKANEN.
- x _____. _____. MS. Harley 3469. Salomon Trismosin. “Splendor solis.” 1582.
- xi _____. _____. MS. Harley 4751. “Historia animalium cum picturis.”
- xii Lucca. Biblioteca governativa. Codex 1942. Saint Hildegarde of Bingen. “Liber divinatorum operum.” 12th cent.
- xiii Manuscripts in author’s possession. “La Sagesse des anciens.” 18th cent.
- xiv _____. “Figurarum Aegyptiorum secretarum ...” 18th cent. See also xxi, xxxiv.
- xv Milan. Biblioteca Ambrosiana. Codex I.
- xvi Modena. Biblioteca. Codex Estensis Latinus 209. “De Sphaera.” 15th cent.
- xvii Munich. Staatsbibliothek. Codex Germanicus 598. “Das Buch der heiligen Dreifaltigkeit und Beschreibung der Heimlichkeit von Veränderung der Metallen.” 1420.
- xviii _____. _____. Codex Latinus 15713. *Perikopenbuch* or Lectionary. 12th cent.
- xix Oxford. Bodleian Library. MS. Bruce 96 (Codex Brucianus). See also BAYNES.
- xx _____. _____. MS. 270b. Bible moralisée. 13th cent.
- xxi Paris. Bibliothèque de l’Arsenal. MS. 973. “Explication des figures hiéroglyphiques des Aegyptiens. ...” 1

- cent.
- xxii _____. _____. MS. 974. “De summa et universalis medicinae sapientiae veterum philosophorum.” 18th cent.
- xxiii _____. _____. MS. 975. “Trésor des trésors.” 17th cent.
- xxiv _____. _____. MS. 5061. Jean Thenaud. “Traité de la cabale.” 16th cent.
- xxv _____. _____. MS. 5076. “Trésor de sapience.” 15th cent.
- xxvi _____. _____. MS. 6577. “Traité d’alchimie.” 17th cent.
- xxvii _____. Bibliothèque nationale. Codex Latinus 511. “Speculum humanae salvationis.” 14th cent.
- xxviii _____. _____. Codex Latinus 512. “Speculum humanae salvationis.” 15th cent.
- xxix _____. _____. Codex Latinus 7171. “Turba philosophorum.” 16th cent.
- xxx _____. _____. MS. Latin 919. “Grandes heures du duc de Berry.” 1413.
- xxxi _____. _____. MS. Latin 14006. “Aurora consurgens.” 15th cent. See also “Aurora consurgens.”
- xxxii _____. _____. MS. Français 116. “Roman de Lancelot du Lac.” 15th cent.
- xxxiii _____. _____. MS. Français 594. Petrarch. “Les triomphes du poethe messire François Pétrarque.” 16th cent.
- xxxiv _____. _____. MS. Français 14765. Abraham le Juif. “Livre des figures hiéroglyphiques.” 18th cent. (Contains also “Alchimie de Flamel, ecrite en chiffres en 12 clefs ... par Denis Molinier,” or “Pratique,” pp. 20-21.)
- xxxv _____. _____. MS. Français 14770. “Recueil de figures astrologiques.” 18th cent.
- xxxvi Preobrazhensk, Russia. Monastery of St. Nicholas. Codex 129. Khludov Psalter. 9th cent. See also ТИХОНОВ.
- xxxvii Reims. Bibliothèque. “Recueil des fausses décrétales.” 13th cent.
- xxxviii Rome. Biblioteca Angelica. Codex 1474. Alcadini. “De balneis Puteolanis.” 14th cent.
- xxxix Tübingen. Universitätsbibliothek. MS. c. 1400.
- xl Vatican. Biblioteca Vaticana. Codex Palatinus Latinus 412. Wynandi de Stega. “Adamas colluctantium aquilarum.” 15th cent.
- xl-a _____. _____. Codex Palatinus Latinus 413. “Speculum humanae saluacionis.” 15th cent.
- xli _____. _____. Codex Palatinus Latinus 565. Peregrinus, “Speculum virginum seu Dialogus cum Theodo virgine.” 13th cent.
- xlii _____. _____. Codex Reginensis Latinus 1458. 17th cent.
- xliiii _____. _____. Codex Urbanus Latinus 365. Dante. “Inferno,” “Purgatorio,” “Paradiso.” 15th cent.
- xliv _____. _____. Codex Urbanus Latinus 899. 15th cent.
- xlv _____. _____. Codex Vaticanus Latinus 681. Peter Lombard. “De sacramentis.” 14th cent.
- xlvi _____. _____. Codex Vaticanus Latinus 7286. “Speculum veritatis.” 17th cent.
- xlvii Venice. Codex Marcianus. 11th cent. See also BERTHELOT, *Alchimistes grecs*, Introduction, p. 132.
- xlviii Vienna. Nationalbibliothek. Codex Medicus Graecus 1. Dioscorides. “De materia medica.” 16th cent.
- xlix Zurich. Zentralbibliothek. Codex Rhenoviensis 172. “Aurora consurgens.” 15th cent. See also xxxi.
- l Zwiefalten Abbey. Breviary no. 128. 12th cent. See also LÖFFLER.

COLONNA, FRANCESCO. *Hypnerotomachia Poliphili* ... Venice, 1499. For French translation, see BÉROALDE DE VERVILLE; for English paraphrase, see FIERZ-DAVID.

“Consilium coniugii.” See (A) *Ars chemica*, iii.

- CORNELL, JOHAN HENRIK. *The Iconography of the Nativity of Christ*. (Uppsala universitets årskrift 1924. Filosofi, språkvetenskap och historiska vetenskaper, 3.) Uppsala, 1924.
- COSMAS. *χριστιανικὴ τοπογραφία*. Cosmae Aegyptii monachi Christiana topographia.... (Bernard de Montfaucon, *Collectio nova patrum et scriptorum Graecorum*, 2.) Paris, 1706. For translation, see JOHN WATSON MCCRINDLE (trans.). *Κοσμά αἰγυπτοῦ μοναχοῦ χριστιανικὴ τοπογραφία*. *The Christian Topography of Cosmas, an Egyptian Monk*. London, 1897.
- CREMER, JOHN. “Testamentum.” See (A) *Musaeum hermeticum*, xi.
- CTESIAS (Ktesias). See MCCRINDLE.
- CUMONT, FRANZ. *Textes et monuments figurés relatifs aux mystères de Mithra*. Brussels, 1894–99. 2 vols.
- DARMSTAEDTER, ERNST. *Die Alchemie des Geber*. Berlin, 1922.
- “De arte chimica.” See (A) *Artis auriferae*, x.
- DEE, JOHN. “Monas hieroglyphica.” See (A) *Theatrum chemicum*, xiv.
- DELACOTTE, JOSEPH. *Guillaume de Digulleville ... Trois romans-oèmes du XIV^e siècle*. Paris, 1932.
- DELACROIX See GOETHE.
- “De summa et universalis medicinae sapientiae veterum philosophorum.” See *Codices and MSS.*, xxii.
- DEUSSEN, PAUL. *Allgemeine Geschichte der Philosophie* Leipzig, 1906. 2 vols.
- [DIDYMUS OF ALEXANDRIA.] *Physiologus Graecus*. See SBORDONE.
- DIELS, HERMANN. *Die Fragmente der Vorsokratiker*. Berlin, 1912. 2 vols.
- DIETERICH, ALBRECHT. *Nekyia: Beiträge zur Erklärung der neuentdeckten Petrusapokalypse*. Leipzig and Berlin, 1913.
- _____. (ed.). “Papyrus magica Musei Lugdunensis Batavi ...,” *Jahrbücher für classische Philologie* (Leipzig), Supplement, XVI (1888), 747–829.
- DIODORUS SICULUS. *Bibliotheca historica*. With an English translation by C. H. Oldfather. (Loeb Classical Library.) London and Cambridge, Mass., 1933–47. 10 vols.
- DIOGENES LAERTIUS. *Lives of Eminent Philosophers*. With an English translation by R. D. Hicks. (Loeb Classical Library.) London and New York, 1925. 2 vols.
- DIOSCORIDES “De materia medica.” See *Codices and MSS.*, xlvi.
- DORN, GERHARD. “Congeries Paracelsicae chemicae de transmutationibus metallorum.” See (A) *Theatrum chemicum*, viii.
- _____. “De spagirico artificio Trithemii sententia.” See (A) *Theatrum chemicum*, v.
- _____. “Philosophia chemica ad meditativam comparata.” See (A) *Theatrum chemicum*, vii.
- _____. “Philosophia meditativa.” See (A) *Theatrum chemicum*, vi.

- _____, "Physica genesis." See (A) *Theatrum chemicum*, iii.
- _____. "Physica Trismegisti." See (A) *Theatrum chemicum*, iv.
- _____. "Speculativae philosophiae, gradus septem vel decem continens." See (A) *Theatrum chemicum*, ii.
- DREYFUSS, J. *Adam und Eva nach der Auffassung des Midrasch*. Strasbourg, 1894.
- [ECKHART, MEISTER.] *Meister Eckhart*, by Franz Pfeiffer. Translated ... by C. de B. Evans. London, 1924. 2 vols.
- EGGELING, JULIUS. See *Shatapatha-Brahmana*.
- EHRENSTEIN, THEODOR (ed.). *Das Alte Testament im Bilde*. Vienna, 1923.
- EISENSTEIN, JUDAH DAVID (ed.). *Ozar Midrashim*. New York, 1915.
- EISLER, ROBERT. *Orpheus—the Fisher*. London, 1921.
- ELEAZAR, ABRAHAM (Abraham le Juif). *Uraltes chymisches Werk*, Leipzig, 1760.
- _____. See also Codices and MSS., xxxiv.
- [ELIEZER BEN HYRCANUS.] *Pirkê de Rabbi Eliezer*. Translated and edited by Gerald Friedlander. London and New York, 1916.
- EMERSON, RALPH WALDO. *Essays: First Series*. (Complete Works, Centenary Edition, 2.) Boston and New York, 1903. [Jung's copy.]
- Enoch, Book of. See CHARLES, *Apocrypha and Pseudepigrapha*, II, pp. 163ff. For Slavonic Book of Enoch, see *ibid.*, pp. 425ff.
- EPIPHANIUS. [*Panarium*.] *Contra octoginta haereses opus quod inscribitur Panarium sive Arcula*. See MIGNE, P.G., vol. 41, col. 173 to vol. 42, col. 832.
- "Epistola ad Hermannum." See (A) *Theatrum chemicum*, xxix.
- Esdras, Second Book of. Included in Holy Bible, Apocrypha. See also CHARLES, *Apocrypha*, II, pp. 542–624, where it is called IV Ezra.
- ESPAGNET, JEAN D'. "Arcanum hermeticae philosophiae." See (A) *Bibliotheca chemica*, xvii.
- _____. "Instructio ... de arbore Solari." See (A) *Theatrum chemicum*, xxx.
- EUCHERIUS OF LYONS. *Formularium spiritalis intelligentiae ad Uranium*, Lib. I. See MIGNE, P.L., vol. 50, cols. 727–772.
- EUSEBIUS OF ALEXANDRIA. "Constantini Oratio ad Sanctorum coetum." See MIGNE, P.G., vol. 20, cols. 1233–1316.
- EUSEBIUS OF CAESAREA. *Evangelica praeparatio*. See MIGNE, P.G., vol. 21, cols. 853–64. For translation, see: EDWIN HAMILTON GIFFORD (ed.). *Eusebii Pamphili Evangelicae praeparationis libri XV*. Oxford, 1903. 4 vols.
- EVOLA, J. *La tradizione ermetica*. Bari, 1931.
- "Exercitationes in Turbam." See (A) *Artis auriferae*, iv.

- FALKE, JAKOB VON. *Geschichte des deutschen Kunstgewerbes*. (Geschichte des deutschen Kunst, 5.) Berlin, 1888.
- FECHNER, GUSTAV THEODOR. *Elemente der Psychophysik*. 2nd edn., Leipzig, 1889. 2 vols.
- FERGUSON, JOHN. *Bibliotheca chemica*. Glasgow, 1906. 2 vols.
- FERGUSON, JOHN C, and ANESAKI, MASAHARU. *Chinese and Japanese [Mythology]*. (Mythology of All Races, ed. John Arnott McCulloch, 8.) Boston and London, 1928.
- FICINO, MARSILIO. *Auctores Platonici*. Venice, 1497.
- _____. “Liber de arte chimica.” See (A) *Bibliotheca chemica*, x.
- [FIERZ-DAVID, LINDA.] *The Dream of Poliphilo*. Related and interpreted by Linda Fierz-David. Translated by Mary Hottinger. (Bollingen Series 25.) New York, 1950.
- FIGULUS, BENEDICTUS. *Rosarium novum olympicum et benedictum*. Basel, 1608.
- “Figurarum Aegyptiorum secretarum.” See Codices and MSS., xiv, xxi, xxxiv.
- FIRMICUS MATERNUS, JULIUS. *De errore profanarum religionum*. (Corpus scriptorum ecclesiasticorum latinorum, 2.) Vienna, 1867. See also MIGNE, P.L., vol. 12, cols. 981–1050.
- FLAMEL, NICOLAS. “Alchimie de Flamel ...” See Codices and MSS., xxxiv.
- _____. “Tractatus brevis.” See (A) *Musaeum hermeticum*, v.
- FLAUBERT, GUSTAVE. *La Tentation de Saint Antoine*. Paris, 1874.
- FLEISCHER, HEINRICH LIEBERECHT (ed.). *Hermes Trismegistus an die menschliche Seele*. Text in Arabic and German. Leipzig, 1870.
- FLUDD, ROBERT.... *summum bonum....* Frankfort on the Main, 1629.
- _____. *Utriusque cosmi maioris scilicet et minoris metaphysica, physica atque technica historia*. Oppenheim, 1617.
- FÖRSTER, MAX. “Adams Erschaffung und Namengebung. Ein lateinisches Fragment des s.g. slawischen Henoch,” *Archiv für Religionswissenschaft* (Leipzig), XI (1908), 477–529.
- FOUCART, PAUL FRANÇOIS. *Les Mystères d’Eleusis*. Paris, 1914.
- FRANCK, ADOLPHE. *La Kabbale*. Paris, 1843. For German translation, see: *Die Kabbala ...* Translated by Ad. Gelinek. Leipzig, 1844.
- FRANZ, MARIE-LOUISE VON (ed.). *Aurora Consurgens: A Document Attributed to Thomas Aquinas on the Problem of Opposites in Alchemy*. Translated by R. F. C. Hull and A. S. B. Glover. New York (Bollingen Series) and London, 1966.
- FROBENIUS, LEO. *Das Zeitalter des Sonnengottes*. Berlin, 1904.
- GAUGLER, ERNST. “Das Spätjudentum.” In: *Mensch und Gottheit in den Religionen*. Bern, 1942. (Pp. 277–313.)
- GEBER (Jābir ibn Hayyān). *De alchimia libri tres*. Strasbourg, 1529.
- _____. “Livre de la miséricorde.” See BERTHELOT, *La Chimie au moyen âge*, III, pp. 163–90.

- _____. *Summa perfectionis de alchimia*. Strasbourg, 1529, 1531. See also (A) *Bibliotheca chemica*, v. For translation, see: WILLIAM SALMON. *Medicina practica; or, Practical Physick*. London, 1692.
- Geheime Figuren der Rosenkreuzer, aus dem 16ten und 17ten Jahrhundert*. Altona, 1785–88. 2 vols.
- GEISBERG, MAX (ed.). *Die Kupferstiche des Meisters E.S.* Berlin, 1924.
- GILLEN, OTTO. *Ikonographische Studien zum Hortus deliciarum der Herrad von Landsberg*. (Kunstwissenschaftliche Studien, 9.) Berlin, 1931.
- GLANVILLE, BARTHOLOMEW DE. *Le Propriétaire des choses*. [Translated from *Liber de proprietatibus rerum* by Jean Corbichon.] Lyons, 1482.
- “Gloria mundi.” See (A) *Musaeum hermeticum*, vi.
- GNOSIUS, DOMINICUS. See HERMES TRISMEGISTUS.
- GOETHE, JOHANN WOLFGANG VON. *Dichtung und Wahrheit*. See *Sämtliche Werke*, vols. 22–25. For translation, see: MINNA STEELE SMITH (trans.). *Poetry and Truth, from My Own Life*. London, 1908. 2 vols.
- _____. *Sämtliche Werke*. Jubilee edition, edited by Eduard von der Hellen. Stuttgart and Berlin, 1902–7. 40 vols.
- _____. *Faust; A Tragedy*. In a modern translation by Alice Raphael. With plates after the lithographs of Eugène Delacroix. New York, 1939.
- _____. *Faust, Part One*. Translated by Philip Wayne. (Penguin Classics.) Harmondsworth and Baltimore, 1949. 6th impression.
- _____. *Faust, Part Two*. Translated by Philip Wayne. (Penguin Classics.) Harmondsworth and Baltimore, 1959.
- GOLDSCHMIDT, LAZARUS (ed.). *Der babylonische Talmud*. Berlin, 1929–36. 12 vols. For English translation, see Talmud.
- GOURMONT, RENÉ DE. *Le Latin mystique*. Paris, 1913.
- “Grandes heures du duc de Berry.” See Codices and MSS., xxx.
- GRASSEUS, JOHANNES (Grashoff, Johann). “Lilium inter spinas.” See (A) *Bibliotheca chemica*, xvi.
- _____. “Arca arcani.” See (A) *Theatrum chemicum*, xxxii.
- GRENFELL, BERNARD PYNE; DREXEL, LUCY WHARTON; and HUNT, ARTHUR S. (eds.). *New Sayings of Jesus*. New York and London, 1904.
- GUILHELMUS TECENENSIS. “Lilium de spinis evulsum.” See (A) *Theatrum chemicum*, xxiii.
- GUILLAUME DE DIGULLEVILLE. See DELACOTTE.
- GYSIN, FRITZ. *Gotische Bildteppiche der Schweiz*. Basel, 1941.
- HALL, MANLY PALMER. *Codex Rosae Crucis*. Los Angeles, 1938.

- HALM, KARL FELIX VON (ed.). *Rhetores Latini minores*. Leipzig, 1863.
- HAMBRUCH, PAUL (ed.). *Südseemärchen....* Jena, 1916.
- HAMMER-PURGSTALL, JOSEPH. *Mémoire sur deux coffrets gnostiques du moyen dge*. Paris, 1835.
- HÄNDLER, OTTO. *Die Predigt*. Berlin, 1941.
- HARNACK, ADOLF VON. *History of Dogma*. Translated [by Neil Buchanan] from the 3rd German edition. London, 1894–99. 7 vols. (Paperback reissue, with same pagination, New York, 1961. 7 vols. in 4.)
- HARRISON, JANE ELLEN. *Themis: a Study of the Social Origins of Greek Religion*. Cambridge, 1912.
- HASTINGS, JAMES (ed.). *Encyclopaedia of Religion and Ethics*. Edinburgh and New York, 1908–27. 13 vols.
- HAUCK, ALBERT (ed.). *Realencyklopädie für protestantische Theologie und Kirche*. Leipzig, 1896–1913. 24 vols.
- HEGEMONIUS. *Acta Archelai*. Edited by Charles Henry Beeson. Leipzig, 1906.
- HENNINC, WALTER. “Ein manichäisches Henochbuch,” *Sitzungsberichte der preussischen Akademie der Wissenschaften* (Berlin), *Philosophisch-historische Klasse*, 1934, 27–35. *Hermaphroditisches Sonn- und Mondskind. Das ist: Des Sohns deren Philosophen natürlich-übernatürliche Gebährung, Zerstörung und Regenerierung*. Mainz, 1752.
- “Hermes Bird.” See (A) *Theatrum chemicum Britannicum*, iii.
- HERMES TRISMEGISTUS. *An die menschliche Seele*. See FLEISCHER.
- _____. *Tractatus vere aureus, de lapidis philosophici secreto ... cum scholiis Dominici Gnosii*. (“Tractatus aureus.”) Leipzig, 1610. See also (A) *Ars chemica*, i (this version gives the main points only); (A) *Musaeum hermeticum*, i; (A) *Bibliotheca chemica curiosa*, ii.
- _____. See also “Tabula smaragdina.”
- HERODOTUS. [*Histories*.] Translated by J. Enoch Powell. Oxford, 1949. 2 vols.
- HERRAD OF LANDSBERG. *Hortus deliciarum*. See KELLER and STRAUB.
- HERRLIBERGER, DAVID. *Heilige Ceremonien oder Religionsübungen der abgöttischen Völcker der Welt*. Zurich, 1748.
- HERRMANN, PAUL. *Nordische Mythologie in gemeinverständlicher Darstellung*. Leipzig, 1903.
- HESIOD. *Theogony*. In: *The Homeric Hymns and Homerica*. With translation by Hugh G. Evelyn-White. (Loeb Classical Library.) London and New York, 1915.
- HILDEGARDE OF BINGEN, SAINT. “Liber divinatorum operum.” See *Codices and MSS.*, xii.
- _____. “Scivias.” MS. (12th cent.), Abbey of St. Hildegarde, Bingen. In: M. BÖCKELER (ed.). *Wisse die Wege; Scivias*. Salzburg, 1954.

- HIPPOLYTUS. *Elenchos*. (*Hippolytus' Werke*. Edited by Paul Wendland. Vol. III.) Leipzig, 1916. For translation, see: FRANCIS LEGGE, (trans.). *Philosophumena; or, The Refutation of All Heresies*. London and New York, 1921. 2 vols.
- HOGHELANDE, THEOBALD DE. "Liber de alchemiae difficultatibus." See (A) *Theatrum chemicum*, i; (A) *Bibliotheca chemica curiosa*, i.
- HOLMYARD, ERIC JOHN (ed. and trans.). *Kitāb al-'ilm al-muktasab fi zinā'at adhdhahab* [Book of knowledge acquired concerning the cultivation of gold]. [By Abu'l Qāsim Muhammad ibn Ahmad al-'Irāqī.] Paris, 1923.
- HOLTZMANN, ADOLF. *Indische Sagen*. Edited by Moriz Winternitz. Jena, 1921.
- HOMER. *The Odyssey*. With an English translation by A. T. Murray. (Loeb Classical Library.) London and New York, 1919. 2 vols.
- HONORIUS OF AUTUN. *Speculum ecclesiae*. See MIGNE, *P.L.*, vol. 172, cols. 807–1108.
- [HORAPOLLO NILIACUS.] *Hori Apollinis Selecta hieroglyphica, sive Sacrae notae Aegyptiorum, et insculptae imagines*. Rome, 1597. For translation, see: GEORGE BOAS (trans. and ed.). *The Hieroglyphics of Horapollo*. (Bollingen Series 23.) New York, 1950.
- HORTULANUS, pseud. (Joannes de Garlandia). "Commentarius in Tabulam Smaragdinam Hermetis Trismegisti." See (A) *De alchemia*, iii. See also RUSKA, *Tabula smaragdina*, pp. 180ff. For translation, see: "A Briefe Commentarie upon the Smaragdine Table of Hermes of Alchemy," in BACON, *The Mirror of Alchimy*, q.v.
- IAMBlichUS. *De mysteriis Aegyptiorum, Chaldaeorum, Assyriorum*. ... Venice, 1491. For translation, see: THOMAS TAYLOR (trans.). *Iamblichus on the Mysteries of the Egyptians*. 2nd edn., London, 1895.
- IGNATIUS OF LOYOLA, SAINT. [*Exercitia spiritualia*.] *The Spiritual Exercises of St. Ignatius Loyola, with a Continuous Commentary*. 2nd edn. New York and London, 1923.
- INMAN, THOMAS. *Ancient Pagan and Modern Christian Symbolism Exposed and Explained*. New York, 1879.
- IRENAEUS, SAINT. *Contra [or Adversus] haereses libri quinque*. See MIGNE, *P.G.*, vol. 7, cols. 433–1224. For translation, see JOHN KEBLE (trans.). *Five Books of S. Irenaeus ... against Heresies*. Oxford, 1872.
- ISIDORE OF SEVILLE, SAINT. *Liber etymologiarum*. See MIGNE, *P.L.*, vol. 82, cols. 73–728.
- IZQUIERDO, SEBASTIAN. *Praxis exercitiorum spiritualium P.N.S. Ignatii*. Rome, 1695.
- JACOBI, JOLANDE. *The Psychology of C. G. Jung*. Translated by Ralph Manheim. 6th edn., New Haven and London, 1962.
- JAMES, MONTAGUE RHODES (ed. and trans.). *The Apocryphal New Testament*. Oxford, 1924.
- JAMES, WILLIAM. *Pragmatism: A New Name for Some Old Ways of Thinking*. London and Cambridge, Mass., 1907.

JAMSTHALER, HERBRANDT. *Viatorium spagyricum. Das ist: Ein gebenedeyter spagyrischer Wegweiser*. Frankfort on the Main, 1625.

[Jatakas.] *The Jataka; or, Stories of the Buddha's Former Births*. Edited and translated by Edward Byles Cowell. Cambridge, 1895–1913. 6 vols.

JOHANNES A MEHUNG (Jean de Meung). “Demonstratio naturae.” See (A) *Musaeum hermeticum*, iv.

JOSEPH BEN GORION (pseud. of Micha Jozef Berdyczewski). *Die Sagen der Juden*. Collected and revised by M. J. bin Gorion. The text translated into German by R. Ramberg-Berdyczewski. Edited by Rahel and Emanuel bin Gorion [i.e., R. and E. Berdyczewski]. Frankfort on the Main, 1913–27. 5 vols.

JOSEPHUS, FLAVIUS. *Antiquitates Judaicae*. In: *Josephus*. With an English translation by H. St J. Thackeray. (Loeb Classical Library.) London and New York, 1926–43. 7 vols.

JUNG, CARL GUSTAV. *Aion. Collected Works*,* Vol. 9, ii.

_____. “The Archetypes of the Collective Unconscious.” In: *Collected Works*,* Vol. 9, i.

_____. “Basic Postulates of Analytical Psychology.” In: *Collected Works*,* Vol. 8.

_____. “Concerning Mandala Symbolism.” In: *Collected Works*,* Vol. 9, i.

_____. “Concerning Rebirth.” In: *Collected Works*,* Vol. 9, i.

_____. *Memories, Dreams, Reflections*. Recorded and edited by Aniela Jaffé. Translated by Richard and Clara Winston. New York and London, 1963. (Edns. separately paginated.)

_____. *Mysterium Coniunctionis. Collected Works*,* Vol. 14.

_____. “Paracelsus as a Spiritual Phenomenon.” In: *Collected Works*,* Vol. 13.

_____. “Paracelsus the Physician.” In: *Collected Works*,* Vol. 15.

_____. *Psychological Types. Collected Works** Vol. 6. Alternative source: Translation by H. G. Baynes. New York and London, 1923.

_____. “The Psychology of the Child Archetype.” *Collected Works*,* Vol. 9, i.

_____. “Psychology and Religion.” In: *Collected Works*,* Vol. 11.

_____. “Psychology of the Transference.” In: *Collected Works*,* Vol. 16.

_____. “The Relations between the Ego and the Unconscious.” In: *Collected Works*,* Vol. 7.

_____. “The Spirit Mercurius.” In: *Collected Works*,* Vol. 13.

_____. *Symbols of Transformation. Collected Works** Vol. 5. (A translation of *Symbole der Wandlung*, Zurich, 1951. For the translation of the superseded version, *Wandlungen und Symbole der Libido*, see: *Psychology of the Unconscious*. Translated by Beatrice M. Hinkle. New York, 1916; London, 1917; new edn., 1921.)

_____. “The Transcendent Function.” In: *Collected Works*,* Vol. 8.

_____. “Transformation Symbolism in the Mass.” In: *Collected Works*,* Vol. 11.

_____. “The Visions of Zosimos.” In: *Collected Works*,* Vol. 13.

* For details of the *Collected Works of C. G. Jung*, see announcement at end of this volume.

_____. See also WILHELM.

JURAIN, ABTALA. *Hyle und Coahyl*. Translated from Ethiopian into Latin and from Latin into German by Johannes Elias Müller, Hamburg, 1732.

JUSTIN [MARTYR], SAINT. *Dialogus cum Tryphone Judaeo*. See MIGNE, P.G., vol. 6, cols. 471–800. For translation, see: MARCUS DODS, GEORGE REITH, and B. P. PRATTEN (trans.). *The Writings of Justin Martyr and Athenagoras*. (Ante-Nicene Christian Library, 2.) Edinburgh, 1867.

KALID (Khalid ibn Jazid ibn Muawiyah). “Liber trium verborum.” See (A) *Artis auriferae*, viii.

KELLER, G., and STRAUB, A. (trans.). *Herrad von Landsberg Hortus deliciarum*. Strasbourg, 1879–99 (1901).

KELLEY, EDWARD. *Tractatus duo egregii, de Lapide philosophorum*. Hamburg and Amsterdam, 1676.

KERÉNYI, KAROLY [or C.]. *Die griechisch-orientalische Romanliteratur in religionsgeschichtlicher Beleuchtung*. Tübingen, 1927.

Khludov Psalter. See Codices and MSS., xxxvi.

KHUNRATH, HEINRICH CONRAD. *Amphitheatrum sapientiae aeternae solius verae, Christiano-kabalisticum, divino-magicum ... Tertrium, Catholicon*. Hanau, 1609.

_____. *Von hylealischen, das ist, pri-materialischen catholischen, oder algemeinem natürlichen Chaos*. Magdeburg, 1597.

KING, CHARLES WILLIAM. *The Gnostics and their Remains, Ancient and Mediaeval*. London, 1864.

KNORR VON ROSENROTH, CHRISTIAN. *Kabbala denudata seu Doctrina Hebraeorum*. Sulzbach, 1677–84. 2 vols.

KNUCHEL, EDUARD FRITZ. *Die Umwandlung in Kult, Magie und Rechtsbrauch*. Basel, 1919.

KOEMSTEDT, R. *Vormittelalterliche Malerei*. Augsburg, 1929.

KOPP, HERMANN. *Die Alchemie in älterer und neuerer Zeit*. Heidelberg, 1886. 2 vols.

Koran, The. Translated from the Arabic by the Rev. J. M. Rodwell. (Everyman's Library, 380.) London and New York, 1909.

KOSMAS. See COSMAS.

KRAMP, JOSEPH. *Die Opferanschauungen der römischen Messliturgie*. Regensburg, 1924.

[KRATES.] “The Book of Krates.” See BERTHELOT, *La Chimie au moyen âge*, III, pp. 44–75.

LACTANTIUS, FIRMIANUS. *Opera omnia*. Edited by Samuel Brandt and Georg Laubmann. (Corpus scriptorum ecclesiasticorum latinorum.) Vienna, 1890–97. 3 vols. For translation, see: WILLIAM FLETCHER (trans.). *The Works of Lactantius*. (Ante-Nicene Christian Library, 21–22.) Edinburgh, 1871. 2 vols.

- LAIGNEL-LAVASTINE, MAXIME (ed.). *Histoire générale de la médecine*. Paris, 1936–49. 3 vols.
- LAJARD, JEAN BAPTISTE FÉLIX. “Mémoire sur une représentation figurée de la Vénus orientale androgyne,” *Nouvelles annales de l’Institut archéologique* (Paris), I (1836).
- LAMBSRINGK. “De lapide philosophico figurae et emblemata.” See (A) *Musaeum hermeticum*, vii.
- LANG, JOSEPH BERNHARD. *Hat ein Gott die Welt erschaffen?* Bern, 1942.
- La Légende latine de S. Brandaines...* Edited by Achille Jubinal. Paris, 1836.
- LEISEGANG, HANS. *Die Gnosis*. Leipzig, 1924.
- _____. *Der heilige Geist*. Leipzig, 1919.
- LENORMANT, CHARLES, and WITTE, JEAN JOSEPH ANTOINE MARIE, Baron de. *Élite des monuments céramographiques*. Paris, 1844–61. 8 vols.
- LIBAVIUS, ANDREAS. *Alchymia ... recognita, emendata, et aucta*. Frankfort on the Main, 1606.
- “Liber patris sapientiae.” See (A) *Theatrum chemicum Britannicum*, ii.
- [Li-Chi.] *The Li-Ki*. In: *The Texts of Confucianism*, Vol. III. Translated by James Legge. (Sacred Books of the East, 27.) Oxford, 1885.
- LIPPMANN, EDMUND O. VON. *Entstehung und Ausbreitung der Alchemie*. Berlin, 1919–54. 3 vols.
- LOFFLER, KARL. *Schwäbische Buchmalerei in romanischer Zeit*. Augsburg, 1928.
- LOMBARDUS, PETRUS. See PETRUS.
- LÜDERS, HORSTMANN. *Nachrichten von der königlichen Gesellschaft der Wissenschaften zu Göttingen. Geschäftliche Mittheilungen aus dem Jahre 1897*. Göttingen, 1897.
- LULLY, RAYMOND. “Codicillus.” See (A) *Bibliotheca chemica curiosa*, vii.
- _____. “Compendium artis alchemiae....” See (A) *Bibliotheca chemica curiosa*, vi.
- LYDUS, JOANNES. *De mensibus*. Edited by Richard Wünsch. Leipzig, 1898.
- MCCRINDLE, JOHN WATSON (trans.). *Ancient India, as Described by Ktesias ...* Being a translation of the abridgement of his “Indika” by Photios. Calcutta, 1882.
- _____. See also COSMAS.
- MACKENNA, STEPHEN (trans.). *Plotinus: The Enneads*. Second edn., revised by B. S. Page. London, 1956. (Porphyry’s *Life of Plotinus* is translated on pp. 1–20.)
- MADATHANUS, HENRICUS. “Aureum saeculum redivivum.” See (A) *Musaeum hermeticum*, ii.
- MAIER, MICHAEL. *De circulo physico quadrato*. Oppenheim, 1616.
- _____. *Secretioris naturae secretorum scrutinium chymicum*. Frankfort on the Main, 1687. (Usually called *Scrutinium chymicum*.)
- _____. *Symbola aureae mensae duodecim nationum*. Frankfort on the Main, 1617.

- _____. *Tripus aureus, hoc est, Tres tractatus chymici selectissimi*. Frankfort on the Main, 1618. See also (A) *Musaeum hermeticum*, viii.
- _____. *Viatorium, hoc est, De montibus planetarum septem seu metallorum*. Rouen, 1651.
- MAIURI, AMEDEO. *La villa dei misteri*. Rome, 1931. 2 vols.
- MANGET, JEAN JACQUES. See (A) *Bibliotheca chemica curiosa*.
- MARIA PROPHETISSA (Maria the Jewess). “Practica. ...” See (A) *Artis auriferae*, vii.
- MAROLLES, MICHEL DE. *Tableaux du temple des muses*. Paris, 1655.
- MASPERO, GASTON CAMILLE CHARLES. *Études de mythologie et d’archéologie égyptiennes*. Paris, 1893–1913. 7 vols.
- MAX MÜLLER, FRIEDRICH (trans.). *The Upanishads*. Parts I and II. (Sacred Books of the East, I and XV.) Oxford, 1879 and 1884.
- MEHUNG. See JOHANNES A MEHUNG.
- MELCHIOR, CARDINAL BISHOP OF BRIXEN. “Von dem gelben und rotten Mann.” See (A) *Aureum vellus*, ii.
- MELCHIOR, NICHOLAS, OF HERMANNSTADT (Cibinensis) (Nicolaus Melchior Szebeni). “Addam et processum ...” See (A) *Theatrum chemicum*, xviii.
- _____. *Symbolum*. In MAIER, *Symbola ...*, q.v. (pp. 507–52).
- MELITO OF SARDIS. *De baptismo*. See PITRA, *Analecta sacra*, II, pp. 3–5.
- MERLINUS. “Allegoria de arcano lapidis.” See (A) *Artis auriferae*, ix.
- MERZ, WALTHER (ed.). *Die Wappenrolle von Zürich*. Zurich, 1930.
- MEYRINK, GUSTAV. *Der Golem*. Leipzig, 1915. For translation, see: MADGE PEMBERTON (trans.). *The Golem*. London, 1928.
- _____. (ed.). *Thomas Aquinas: Abhandlung über den Stein der Weysen*. Munich, 1925.
- MICHELSPACHER, STEFFAN. *Cabala, speculum artis et naturae, in alchymia*. Augsburg, 1654.
- MICRERIS. “Tractatus Micreris.” See (A) *Theatrum chemicum*, xxvi.
- Midrash Tehillim. See BUBER.
- MIGNE, JACQUES PAUL. *Dictionnaire des sciences occultes*. Paris, 1846–48. 2 vols.
- _____. (ed.). *Patrologiae cursus completus*.
- [P.L.] Latin series. Paris, 1844–64. 221 vols.
- [P.G.] Greek series. Paris, 1857–66. 166 vols.
- (These works are referred to in the text as “Migne, P.L.” and “Migne, P.G.” respectively. References are to columns, not to pages.)
- MOLSDORF, WILHELM. *Christliche Symbolik der Mittelalterlichen Kunst*. Leipzig, 1926.
- MORIENUS ROMANUS. “Sermo de transmutatione metallorum.” See (A) *Artis auriferae*, xi.
- MUELLER, NIKOLAUS. *Glauben, Wissen und Kunst der alten Hindus....* Mainz, 1822.

- Munich Lectionary (*Perikopenbuch*). See Codices and MSS., xviii.
- Mutus liber in quo tamen tota philosophia hermetica, figuris hieroglyphicis depingitur*. La Rochelle, 1677. See also (A) *Bibliotheca chemica curiosa*, vii-a (for illustrations in present work).
- MYLIUS, JOHANN DANIEL. *Philosophia reformata*. Frankfort on the Main, 1622.
- NAZARI, GIOVANNI BATTISTA. *Della tramutatione metallica sogni tre*. Brescia, 1599.
- NIERENSTEIN, M., and CHAPMAN, P. F. "Enquiry into the Authorship of the *Ordinall of Alchimy*," *Isis* (Bruges), XVIII:53 (Oct. 1932), 290–321.
- NIETZSCHE, FRIEDRICH WILHELM. *Thus Spake Zarathustra*. Translated by Thomas Common. London, 1932.
- [NILUS, SAINT.] *Anonymi vita S. Nili*. In MIGNE, P.G., vol. 120, cols. 9–166.
- NORTON, SAMUEL. *Catholicon physicorum, seu Modus conficiendi tincturam physicam et alchymicam*. Frankfort on the Main, 1630.
- _____. *Mercurius redivivus, seu Modus conficiendi lapidem philosophicum tum album, quam rubeum e Mercurio*. Frankfort on the Main, 1630.
- NORTON, THOMAS. *The Ordinall of Alchimy*. A facsimile reproduction from the *Theatrum chemicum Britannicum*, with annotations by Elias Ashmole. Edited by Eric John Holmyard. London, 1928. See also (A) *Theatrum chemicum Britannicum*, i; (A) *Musaeum hermeticum*, x.
- OPPENHEIM, GUSTAV. *Tabula Fabula et Asenathae apocrypha...* Berlin, 1886.
- ORIGEN. *Homiliae in Jeremiam*. See MIGNE, P.G., vol. 13, cols. 255–544.
- ORTHELIUS. "Epilogus et recapitulatio." See (A) *Bibliotheca chemica curiosa*, xiv.
- PARACELSUS (Theophrastus Bombast of Hohenheim). See: JOHANN HUSER (ed.). *Aureoli Philippi Theophrasti Bombasts von Hohenheim Paracelsi ... Opera Bücher und Schrifften*. Strasbourg, 1589–91. 10 parts. Reprinted 1603, 1616. 2 vols. See also: KARL SUDHOFF and WILHELM MATTHIESSEN (ed.). *Theophrast von Hohenheim genannt Paracelsus Sämtliche Werke*. First section. *Medizinische Schriften*. Munich and Berlin, 1922–33, 14 vols.
- _____. *Auslegung der Figuren, so zu Nürenberg gefunden seind worden, gefürt in grunt der Magischen Weissagung, durch Doctorem Theophrastum von Hohenheim*. [Fastenmess,] 1569.
- _____. *Das Buch Azoth seu De ligno vitae*. See HUSER, Vol. 2, or SUDHOFF, Vol. 14, pp. 547ff.
- _____. *De vita longa*. See SUDHOFF, Vol. 3, pp. 247ff.
- _____. *Ein ander Erklärung der gantzen Astronomie*. See HUSER, Vol. 2, or SUDHOFF, Vol. 12, pp. 447ff.
- _____. *Philosophia ad Athenienses*. See SUDHOFF, Vol. 13, pp. 387ff.
- _____. *Theoretica schemata seu Typi*. See HUSER, Vol. 1, pp. 670–82.

- PATRIZI, FRANCESCO. *Nova de universis philosophia*. Venice, 1593.
- PENOTUS, BERNHARDUS GEORGIUS (Bernardus à Portu). “Philosophi potius ...” (a table). See (A) *Theatrum chemicum*, xii.
- PEREGRINUS. “Speculum virginum.” See Codices and MSS., xli.
- [PETRARCH.] “Les triomphes du poethe messire Franéoyoys PÉtrarche.” See Codices and MSS., xxxiii.
- PETRONIUS ARBITER. [Works.] With an English translation by Michael Heseltine. (Loeb Classical Library.) London and New York, 1913.
- PETRUS LOMBARDUS (Peter Lombard). “De sacramentis.” See Codices and MSS., xlv.
- PHILALETHES, EIRENAEUS, *Erklärung der Hermetisch poetischen Werke Herrn Georgii Riplaei*. Hamburg, 1741. (A translation of the following.)
- _____. *Ripley Reviv'd; or, An Exposition upon Sir George Ripley's Hermetico-Poetical Works*. London, 1678.
- _____. “Fons chymicae veritatis.” See (A) *Musaeum hermeticum*, xvi.
- _____. “Introitus apertus.” See (A) *Musaeum hermeticum*, xiv.
- _____. “Metallorum metamorphosis.” See (A) *Musaeum hermeticum*, xv.
- PHILO. [Works.] Translated by Francis Henry Colson and George Herbert Whitaker. (Loeb Classical Library.) London and Cambridge, Mass., 1929– . 10 vols. (in progress).
- PHILOSTRATUS. *The Life of Apollonius of Tyana...* Translated by Frederick Cornwallis Conybeare. (Loeb Classical Library.) London and New York, 1912. 2 vols.
- PHOTIUS. *Bibliotheca*. Edited by J. Bekker. Berlin, 1824–25. 2 vols. For French translation, see: *Bibliothèque*. Edited and translated by René Henry. Paris, 1959–62. 3 vols.
- Physiologus*. See SBORDONE.
- PICINELLI, PHILIPPUS. *Mundus symbolicus*. Cologne, 1680–81.
- PIGNATELLI, JACOBUS. *Consultationes canonicae*. Geneva, 1700. 11 vols.
- Pirkê de Rabbi Eliezer*. See ELIEZER BEN HYRCANUS.
- Pistis Sophia*. Translated (into German) by Carl Schmidt. Leipzig, 1925. English trans. by George William Horner. London, 1924.
- PITRA, JEAN BAPTISTE (ed.). *Analecta sacra ...* Paris, 1876–91. 8 vols. (II, pp. 3–5, contains Melito of Sardis, *De baptismo*.)
- _____. *Spicilegium solesmense*. Paris, 1852–58. 4 vols.
- PLATO. *The Collected Dialogues*. Edited by Edith Hamilton and Huntington Cairns. (Bollingen Series 71.) New York, 1961. (*Phaedrus*, pp. 475–525; *Philebus*, pp. 1086–1150; *Timaeus*, pp. 1151–1211.)
- PLATO, pseud. “Liber Platonis quattorum.” See (A) *Theatrum chemicum*, xxvii.

- PLINY. [*Historia naturalis.*] *Natural History*. With an English translation by H. Rackham. (Loeb Classical Library.) London, 1938–45. 11 vols.
- POMMET, P. *Histoire générale des drogues*. Paris, 1694.
- PORPHYRY. See MACKENNA.
- PORTA, GIAMBATTISTA DELLA. *De distillationibus libri IX*. Strasbourg, 1609.
- PREISENDANZ, KARL (ed.). *Papyri Graecae magicae*. Leipzig and Berlin, 1928–31. 2 vols.
- PRINZ, HUGO. *Altorientalische Symbolik*. Berlin, 1915.
- PRISCILLIAN. [*Opera*] *Priscilliani quae supersunt*. Edited by Georg Schepss. (Corpus scriptorum ecclesiasticorum latinorum, 18.) Vienna, 1889.
- PRZYWARA, ERICH. *Deus semper major*. Freiburg im Breisgau, 1938. 3 vols.
- PUËCH, HENRI CHARLES. “The Concept of Redemption in Manichaeism,” in *The Mystic Vision*. (Papers from the Eranos Yearbooks, 6.) New York (Bollingen Series 30) and London, 1968. (Orig. in *Eranos-Jahrbuch 1936*.)
- QUERCETANUS, JOSEPHUS. “Ad Jacobi Auberti Vendonis de ortu. ...” See (A) *Theatrum chemicum*, xiii.
- RABANUS MAURUS. *Allegoriae in universam sacram scripturam*. See MIGNE, *P.L.*, vol. 112, cols. 849–1088.
- “Recueil des fausses décrétales.” See *Codices and MSS.*, xxxvii.
- “Recueil de figures astrologiques.” See *Codices and MSS.*, xxxv.
- REITZENSTEIN, RICHARD. “Alchemistische Lehrschriften und Märchen bei den Arabern.” In: *Heliodori carmina quattuor*. (Religionsgeschichtliche Versuche und Vorarbeiten, XIX, 2.) Giessen, 1923. (Pp. 63–86.)
- _____. *Die hellenistischen Mysterienreligionen*. Leipzig, 1910.
- _____. *Poimandres: Studien zur griechisch-ägyptischen und frühchristlichen Literatur*. Leipzig, 1904.
- REUSNER, HIERONYMUS. *Pandora: Das ist, die edelst Gab Gottes, oder der Werde und heilsame Stein der Weysen*. Basel, 1588.
- REYMANN, LEONHARD. *Nativität-Kalender*. 1515. See STRAUSS.
- RHENANUS, JOHANNES. *Solis e puteo emergentis sive dissertationis chymotechnicae libri tres*. Frankfort on the Main, 1613.
- _____. (ed.). *Harmoniae inperscrutabilis chymico-philosophicae Decades duae*. Frankfort on the Main, 1625. (A text of “Aurora consurgens” is given in Decas II, pp. 175ff.)
- RICHARDUS ANGLICUS (Richard of Wendover). “Correctorium alchymiae.” See (A) *Theatrum chemicum*, xvi.
- RIPLEY, GEORGE. “Cantilena Riplaei.” See *Opera*, below. For translation, see: JUNG, *Mysterium Coniunctionis*, ch. IV, 4.

_____. *Opera omnia chemica*. Kassel, 1649.

_____. “Liber duodecim portarum.” See (A) *Bibliotheca chemica curiosa*, xii.

_____. “Verses Belonging to an Emblematicall Scrowle.” See (A) *Theatrum chemicum Britannicum*, iv; Codices and MSS., vii.

“Roman de Lancelot du Lac.” See Codices and MSS., xxxii.

Rosario dela gloriosa vergine Maria. Venice, 1524. See INMAN.

Rosarium philosophorum. Secunda pars alchimiae de lapide philosophico vero modo praeparando.... Cum figuris rei perfectionem ostendentibus. (Vol. 2 of *De alchimia*.) Frankfort on the Main, 1550. See also (A) *Artis auriferae*, xii; (A) *Bibliotheca chemica curiosa*, ix.

“Rosarius minor.” See (A) *De alchemia*, i.

ROSCHER, WILHELM HEINRICH (ed.). *Ausführliches Lexikon der griechischen und römischen Mythologie*. Leipzig, 1884–1937. 6 vols.

_____. *Hermes der Windgott*. Leipzig, 1878.

ROSENCREUTZ, CHRISTIAN. *Chymische Hochzeit*. Reprinted from a Strasbourg 1616 edition. Edited by F. Maack. Berlin, 1913. For translation, see: *The Hermetick Romance, or The Chymical Wedding*. Translated by E. Foxcroft. London, 1690.

RULAND, MARTIN. *Lexicon alchemiae, sive Dictionarium alchemisticum*. Frankfort on the Main, 1612. For translation, see: *A Lexicon of Alchemy*. London, 1892.

RUPERT, SAINT. *De trinitate et operibus ejus*. See MIGNE, *P.L.*, vol. 167, cols. 199–1828.

RUPESCISSA, JOANNES DE. *La Vertu et propriété de la quinte essence*. Lyons, 1581.

RUSKA, JULIUS FERDINAND. “Die Vision des Arisleus.” See SUDHOFF, *Historische Studien*.

_____. “Die siebzig Bücher des Gabir ibn Hajjan.” See the following, pp. 38–47.

_____ (ed.). *Studien zur Geschichte der Chemie*. Memorial volume to Edmund O. von Lippmann on his seventieth birthday. Berlin, 1927.

_____. *Tabula Smaragdina; ein Beitrag zur Geschichte der hermetischen Literatur*. Heidelberg, 1926.

_____. *Turba Philosophorum: ein Beitrag zur Geschichte der Alchemie*. (Quellen und Studien zur Geschichte der Naturwissenschaften und der Medizin, 1.) Berlin, 1931.

“Sagesse des anciens, La.” See Codices and MSS., xiii.

SALZER, ANSELM, *Die Sinnbilder und Beiworte Mariens in der deutschen Literatur und lateinischen Hymnen-Poesie des Mittelalters*. Linz, 1893.

SANCHEZ, THOMAS. *Opus morale in praecepta decalogi, sive Summa casuum conscientiae*. Paris, Antwerp, 1615–22. 2 vols.

SBORDONE, F. (ed.). *Physiologus*. Milan, Genoa, Rome, Naples, 1936.

SCALIGER, PAULUS. [*Explanatio imaginum*.] *P. Principis de la Scala primi tomi Miscellaneorum de rerum caussis....* Cologne, 1570.

- SCHEDEL, HARTMANN. *Das Buch der Chroniken*. Nuremberg, 1493.
- SCHEFTELOWITZ, ISINOR. "Das Hörnermotiv in den Religionen," *Archiv für Religionswissenschaft* (Leipzig), XV (1912), 451–87.
- SCHMIDT, CARL (ed. and trans.). "Gnostische Schriften in koptischer Sprache aus dem Codex Brucianus herausgegeben," *Texte und Untersuchungen der altchristlichen Literatur* (Leipzig), VIII (1892), 1–692.
- SCHMIEDER, KARL CHRISTOPH. *Geschichte der Alchemie*. Halle, 1832.
- SCHRADER, EBERHARD. "Die Vorstellung vom $\mu\omicron\nu\acute{o}\kappa\epsilon\pi\acute{\omega}\varsigma$ und ihr Ursprung," *Sitzungsberichte der königlichen preussischen Akademie der Wissenschaften* (Berlin), 1892, 573–81.
- SCHULTZ, WOLFGANG. *Dokumente der Gnosis*. Jena, 1910.
- SCOTT, WALTER (ed.). *Hermetica*. Oxford, 1924–36. 4 vols.
- SENDIVOGIUS, MICHAEL (Michal Sendiwoj). "Dialogus Mercurii ..." See (A) *Theatrum chemicum*, xxi.
- _____. "Novi luminis chemici tractatus alter de sulphure." See (A) *Musaeum hermeticum*, xiii.
- _____. "Novum lumen chemicum." See (A) *Musaeum hermeticum*, xii.
- _____. "Parabola. ..." See (A) *Bibliotheca chemica curiosa*, xiii.
- SENIOR (Zadith ben Hamuel). *De chemia Senioris antiquissimi philosophi libellus*. Strasbourg, 1566. See also (A) *Bibliotheca chemica curiosa*, xi.
- _____. *Tabula chymica*. In: *Philosophiae chymicae IV. vetustissima scripta*. Frankfurt on the Main, 1605.
- SENIOR, ADOLPHUS. *Azoth, sive Aureliae occultae philosophorum ...* Frankfurt on the Main, 1613.
- Shatapatha-Brahmana*. Part I, Books I and II. Edited and translated by Julius Eggeling. (Sacred Books of the East, 12.) Oxford, 1882.
- [Shêng Chi-t'u.] *The Life of Confucius, Reproduced from a Book entitled Shêng Chi-t'u, being Rubbings from the Stone "Tablets of the Holy Shrine."* Shanghai [1934?].
- SHEPARD, ODELL. *The Lore of the Unicorn*. London and Boston, 1930.
- Sibylline Oracles. See CHARLES, *Apocrypha*, Vol. II, pp. 368–406.
- SIEBMACHER, JOHANN AMBROSIUS. "Hydrolithus sophicus." See (A) *Bibliotheca chemica curiosa*, xv; *Musaeum hermeticum*, iii.
- SILBERER, HERBERT. *Problems of Mysticism and Its Symbolism*. Translated by Smith Ely Jelliffe. New York, 1917.
- Slavonic Book of Enoch. See CHARLES, *Apocrypha*.
- Speculum humanae salvationis*. (i) ... *cum Speculo S. Mariae Virginis*. Augsburg, 1480. (ii) Codices and MSS., xxvii; xxviii; xl-a.

“Speculum veritatis.” See Codices and MSS., xlvi.

SPITTELER, CARL. *Prometheus and Epimetheus*. Translated by James Fullarton Muirhead. London, 1931.

“Splendor solis.” See TRISMOSIN.

SPRINGER, ANTON HEINRICH. *Handbuch der Kunstgeschichte*. 7th edn., Leipzig, 1902–4. 4 vols.

STAPLETON, HENRY ERNEST and HUSAIN, M. HIDAYAT (eds.). *Three Arabic Treatises on Alchemy, by Muhammad ibn Umail*. (Asiatic Society of Bengal: Memoirs, XII, 1.) Calcutta, 1933.

STEEB, JOANNES CHRISTOPHORUS. *Coelum sephiroticum ...* Mainz, 1679.

STEINSCHNEIDER, MORITZ. *Die europäischen Übersetzungen aus dem arabischen bis Mitte des 17. Jahrhunderts*. (Sitzungsberichte der kaiserlichen Akademie der Wissenschaften in Wien, Philosophisch-historische Klasse, 149, 151.) Vienna, 1904–5. 2 parts.

STEVENSON, JAMES. “Ceremonial of Hasjelti Dailjis and Mythical Sand Painting of the Navajo Indians,” *Eighth Annual Report of the Bureau of Ethnology to the Secretary of the Smithsonian Institution 1886–87* (Washington, 1891), 229–85.

STOBAEUS, JOANNES. *Eclogarum physicarum et ethicarum libri duo*. Edited by T. Gainsford. Oxford, 1850. 2 vols.

STOLCIUS DE STOLCENBERG, DANIEL. *Viridarium chymicum figuris cupro incisus adornatum et poeticis picturis illustratum ...* Frankfort on the Main, 1624.

STRAUSS, HEINZ ARTUR. *Der astrologische Gedanke in der deutschen Vergangenheit*. Munich, 1926.

[SUDHOFF, KARL, ed.] *Historische Studien und Skizzen zur Naturund Heilwissenschaft*. Memorial volume presented to Georg Sticker upon his seventieth birthday. Berlin, 1930.

“Tabula smaragdina” (“The Emerald Table of Hermes Trismegistus”). See (i) RUSKA; (ii) (A) *Ars chemica*, ii; (iii) (A) *De Alchemia*, ii; (iv) for translation, BACON, *The Mirror of Alchemy*, q.v.

[Talmud.] *The Babylonian Talmud*. Translated into English under the editorship of I. Epstein. London, 1935–48. 34 vols. See also GOLDSCHMIDT.

TAYLOR, F. SHERWOOD. “A Survey of Greek Alchemy,” *Journal of Hellenic Studies* (London), L (1930), 109–39.

TECENENSIS. See GUILHELMUS TECENENSIS.

TERTULLIAN [Quintus Septimius Clemens Tertullianus]. *Apologeticus adversus Gentes pro Christianis*. See MIGNE, *P.L.*, vol. 1, cols. 257–536. For translation, see: SYDNEY THELWALL (trans.). *The Writings of ... Tertullianus*. (Ante-Nicene Christian Library, 11, 15, 18.) Edinburgh, 1869–70. 3 vols. Vol. I, pp. 53–140.

_____. *De came Christi*. See MIGNE, *P.L.*, vol. 2, cols. 751–92. For translation see: THELWALL (as above), Vol. II, pp. 163–214.

_____. *Liber adversus Judaeos*. See MIGNE, *P.L.*, vol. 2, cols. 595–642. For translation, see: THELWALL (as above), Vol. III, pp. 201–88.

THENAUD, JEAN. “Traité de la cabale.” See *Codices and MSS.*, xxiv.

THEODORE PSALTER. See *Codices and MSS.*, ix.

THOMAS AQUINAS, pseud. “De alchimia.” See *Codices and MSS.*, v.

_____. See also MEYRINK.

THURNEISSER ZUM THURN, LEONHART. *Quinta essentia, das ist die höchste Subtilitet, Krafft und Wirkung, beider der fürtrefflichen (und menschlichem Geschlecht den nutzlichsten) Künsten der Medicina, und Alchemia*. Leipzig, 1574.

TIKKANEN, JOHAN JAKOB. *Die Psalterillustration im Mittelalter*. (*Acta Societatis Scientiarum Fennicae*, XXXI, 5.) Helsingfors, 1903.

Toyson d’Or, La. See (A) *Aureum vellus*.

Tractatus aureus. See HERMES TRISMEGISTUS.

“Tractatus rhythmicus novus vom Stein der Weysen.” See FIGULUS (pp. 58–70).

“Très Riches Heures du duc de Berry.” See *Codices and MSS.*, ii.

“Trésor de sapience.” See *Codices and MSS.*, xxv.

“Trésor des trésors.” See *Codices and MSS.*, xxiii.

TRISMOSIN, SALOMON. “Splendor solis.” See *Codices and MSS.*, x. See also: *Splendor solis: Alchemical Treatises of Solomon Trismosin*. With explanatory notes by J. K. London, 1920.

_____. *La Toyson d’or*. See (A) *Aureum vellus*.

Turba philosophorum. See (A) *Theatrum chemicum*, xxiv; (A) *Artis auriferae*, i; (A) *Bibliotheca chemica curiosa*, iii; *Codices and MSS.*, xxix; RUSKA.

_____. *Auriferae artis ... sive Turba philosophorum*. Basel, 1572. 2 vols.

Tz’u-yuan [Chinese lexicon]. 26th edn., Shanghai, 1930.

Upanishads. Translated by F. Max Müller. (*Sacred Books of the East*, 1, 15.) Oxford, 1879 and 1884. 2 vols.

_____. See also *Brihadaranyaka Upanishad*; *Chhandogya Upanishad*.

VALENTINUS, BASILIUS. *Chymische Schriften*. Hamburg, 1700.

_____. “Practica una. ...” See (A) *Musaeum hermeticum*, ix.

VALLI, LUIGI. “Die Geheimsprache Dantes und der Fedeli d’Amore,” *Europäische Revue* (Berlin), VI Jahrgang: I Halbband (January–June, 1930), 92–112.

Vedic Hymns. Part I: Hymns to Maruts ... Part II: Hymns to Agni ... Translated by F. Max Müller and Hermann Oldenberg. (*Sacred Books of the East*, 32, 46.) Oxford, 1891 and 1897. 2 vols.

- VENTURA, LAURENTIUS. *De ratione conficiendi lapidis philosophici*. Basel, 1571. See also (A) *Theatrum chemicum*, xv.
- VIRGIL. [Works.] Translated by H. Rushton Fairclough. (Loeb Classical Library.) London and New York, 1929. 2 vols.
- Viridarium chymicum*. See STOLCIUS.
- VOLLERS, KARL. "Chidher," *Archiv für Religionswissenschaft* (Leipzig), XII (1909), 234–84. "Von der Materi und Prattick des Steins." See (A) *Theatrum chemicum*, xix.
- VREESWYCK, GOOSEN VAN. *De Groene Leeuw*. Amsterdam, 1672.
- WAITE, ARTHUR EDWARD. *The Hermetic Museum Restored and Enlarged*. London, 1893. 2 vols. Repr., 1953. A translation of (A) *Musaeum hermeticum*.
- _____. *The Secret Tradition in Alchemy. Its Development and Records*. London, 1926.
- _____. See also BONUS; *Musaeum hermeticum*.
- Wasserstein der Weysen, das ist, Ein chymisch Tractätlein*. Frankfort on the Main, 1619.
- [WEI PO-YANG.] "An Ancient Chinese Treatise on Alchemy Entitled Ts'an T'ung Ch'i, written by Wei Po-yang about 142 A.D. NOW translated ... by Lu-ch'iang Wu," *Isis* (Bruges), XVII:53 (Oct., 1932), 210–89.
- WESSELY, CARL. "Griechische Zauberpapyrus von Paris und London," *Denkschriften der kaiserlichen Akademie der Wissenschaften* (Vienna), *Philosophisch-historische Classe*, XXXVI (1888), 2, 27–208.
- WEST, EDWARD WILLIAM (trans.). *Pahlavi Texts*. (Sacred Books of the East, 5.) Oxford, 1880. (Contains the Bundahish.)
- WILHELM, RICHARD. *Kung-Tse, Leben und Werk*. (Frommanns Klassiker der Philosophie, 25.) Stuttgart, 1925.
- _____. *The Secret of the Golden Flower; a Chinese Book of Life*. Translated [into German] and explained ... with a foreword and commentary by C. G. Jung. Translated into English by Cary F. Baynes. New and revised edn. London and New York, 1962.
- WILKEN, ULRICH. *Urkunden der Ptolemäerzeit*. Berlin, 1927.
- WIRTH, ALBRECHT. *Aus orientalischen Chroniken*. Frankfort on the Main, 1894.
- WOLFF, TONI. "Einführung in die Grundlagen der komplexen Psychologie" In: *Studien zu C. G. Jungs Psychologie*. Zurich, 1959. (Pp. 15–230.)
- WOLFRAM VON ESCHENBACH. *Parsifal und Titirel*. Edited by Karl Bartsch. (Deutsche Classiker des Mittelalters, 9–11.) Leipzig, 1875–77. 3 vols.
- WOODROFFE, SIR JOHN GEORGE. *Shakti and Shakta*. Madras, 1920.
- _____. See also AVALON.
- ZACHARIUS, DIONYSIUS. "Opusculum philosophiae. ..." See (A) *Theatrum chemicum*, x.
- ZADITH SENIOR. See SENIOR.

ZELLER, EDUARD. *Die Philosophie der Griechen in ihrer geschichtlichen Entwicklung dargestellt*. Tübingen, 1856. 3 vols.

ZIMMER, HEINRICH. *Myths and Symbols in Indian Art and Civilization*. Edited by Joseph Campbell. (Bollingen Series 6.) New York, 1946.

ZÖCKLER, OTTO. "Probabilismus." See HAUCK, *Realencyklopädie*, XVI, pp. 66ff.

ZOSIMOS. "Rosinus ad Sarratantam episcopum." See (A) *Artis auriferae*, vi.

ZUNZ, LEOPOLD. *Die gottesdienstlichen Vorträge der Juden, historisch entwickelt*. Berlin, 1932. (First published 1832.)

Zwiefalten Abbey Breviary. See Codices and MSS., 1. See also LÖFFLER.

INDEX

The following subjects are indexed under collective entries: ANIMALS (including birds, insects, reptiles, etc., and fabulous beasts), BIBLE, CODICES & MSS., COLOURS (including alchemical terms), and NUMBERS. The references to illustrations, by “*fig.*,” indicate data included in the List of Illustrations (pp. xvff) as well as in the text captions. For references to “names of individual authors and treatises” in alchemical collections, see the Bibliography, part A (pp. 487ff), where these are listed. Italic type is used for all literary titles, whether MS. or printed, except in the case of papers under the entry for Jung, whose titles appear in quotation marks.

INDEX

A

- abaissement du niveau mental*, 89, 333
- ablutio*, 231; *see also* bath
- Abraham/Abram, 206, 322
- Abraham le Juif, *see* Eleazar
- absurd, the, 15
- Abu'l Qāsim, 387, 433, 460
- ace of clubs, 76, 169
- acetum fontis*, 74
- Acheron, 430
- Acta Archelai*, 365n, 380n, 383n
- active imagination, *see* imagination
- actor, 185
- Adam, 115, 15n, 246, 327, 358, 391, 450f, 460
- as Anthropos, 362ff, 368, 370, 392
 - creation of, 145, 221n, *fig.* 71
 - earthly/spiritual, 362ff, 370, 392
 - as *prima materia*, 319n, *fig.* 131
 - quaternity of, 363, 368
 - second, 392
- Addam et processum* (Melchior), 396n
- Adech, 115, 161n, 456n
- Ademarus, 171n
- Ad Jacobi Auberti Vendonis* (Quercetanus), 239n
- Adolphus Senior, 76n
- adoption, rite of, 415
- Aegidius de Vadis, 127n, 319n, 325n, 371n
- Aelian, 442n, 447n
- Aenesidemus, 299n

aenigma regis, 112, 186, *fig. 54*

Aenigmata ex Visione Arislei et allegoriis sapientum, see *Visio Arislei*

aeon, *fig. 7*

Aesculapius, 180, *fig. 77*

affects, 143, 190

Agathodaimon, 379

aggression, 89

Agrippa, Heinrich Cornelius, 206, 314*n*

Ahasuerus, 123

Ahijah, 461

Ahmed ibn-Tulun, mosque of, 118

air/aer, 126*n*, 178, 205, 229, 263*f*, 280*ff*, 285*f*, 363, 392, 394, *fig. 211*

 lead of the, 340

 as *prima materia*, 299*n*, 301*n*, 317

airplane, 113, 117

Alain of Lille, 398*n*

albedo, see COLOURS

Albertus Magnus, 370, 376, 386*n*, 398*f*, 401*n*, 445*f*, *fig. 117*

alchemist, 243*ff*, 258, 267, 278, 289, 291*f*, 352*ff*, 477*f*, 481*f*, *figs. 2, 124, 133, 137, 143, 144*

 and Church, 35, 353

 mystification by, 73, 243*f*, 289, 316

 psychology of, 251*f*

 as redeemer, see *opus alchymicum*, as work of redemption

 solitary life of, 35, 314; see also *artifex*

alchemy, aberration of, 279, 431

 allegorical aspect, 34

 Arabic, 266, 290, 387, 458*f*

 as “art,” 482

 black art, 67, 80

 and chemistry, 23, 34, 37, 227*f*, 239, 242*ff*, 245, 270, 288*f*, 423, 432

 Chinese, 76, 357, 428

 Christian, 26, 368

and Christianity, [23f](#), [33ff](#)
and Christian sacraments, [306ff](#), [350ff](#), [396ff](#), [424ff](#), [426f](#), [428f](#), [476f](#)
classical, [228](#), [476](#)
downfall of, [37](#), [227](#), [423](#)
goal of, [232ff](#), [260](#), [267](#), [272](#)
and heresy, [34](#), [74](#), [112](#)
and individuation, [3](#), [35](#), [346](#), [475](#)
and Manicheism, [380n](#)
obscurity of, [34](#), [35](#), [227](#), [244](#), [288f](#), [424](#)
pagan, [26](#)
as philosophy, [24](#), [131](#), [227](#), [290](#), [423](#), [471](#)
and projection, *q.v.*; psychological significance, [23](#), [228](#)
redemption in, *q.v.*; symbolism of, *q.v.*; task of, [306](#)
and transformation, *q.v.*; two parts of, [228](#), [242f](#), [270](#), [289ff](#), [423](#)
alcheringa, [131](#)
Alexander the Great, [370](#)
Alexander Polyhistor, [299n](#)
alexipharmic, [443n](#), [449](#), [460](#), [466](#)
alicorn, [436](#), [449](#); *see also* horn
Allegoria de arcano lapidis (Merlinus), [337n](#), [391n](#)
allegoriae Christi, [17](#)
Allegoriae sapientum, [76n](#), [120n](#), [162n](#)
Allegoriae super librum Turbae, [236n](#), [325n](#), [335n](#), [348n](#)
allegories: patristic, [17](#), [357](#)
 of sheep & shepherd, [58](#)
Allendy, René, [206](#)
Alphidius, [270](#), [352n](#), [375](#), [378](#)
alum, [401n](#)
ambergris, dung of ass, [458](#)
Ambrose, St., [310](#), [442](#)
America, [67](#), [141](#), [154](#)
Amitabha, [98](#)
Amman, Jost, *fig.* [239](#)

Ammon, King, [361n](#)

Ammon-Ra, [fig. 66](#)

amor perfectissimus, [274](#)

amplification, [28](#), [289](#)

Anacreon, [467](#)

analysis: end & goal of, [4](#)

method, [5f](#)

of objective psyche, [43f](#)

process, [4](#), [5](#)

prolonged, [5f](#)

termination, [4](#)

analyst, *see* doctor

analytical psychology, [3](#), [9n](#), [289](#), [302](#)

Anaxagoras, [301n](#), [325](#), [327n](#)

Anaximander, [320n](#)

Anaximenes, [301n](#), [320n](#)

ancestor(s), human and animal, [131](#)

symbolism, [134f](#)

ancestral: land, [131](#)

life, [134](#)

spirits, [131](#)

Ancient of Days, [206](#)

androgyny: of Anthropos, [161](#)

of Christ, [19](#), [22](#), [464](#)

of unicorn, [466](#); *see also* hermaphrodite

angel(s), [163n](#), [202](#), [208](#), [210f](#), [237n](#), [263n](#), [274](#), [282](#), [361](#)

fallen, [197](#), [461](#)

language of, [363](#)

seven, [379](#)

anima (archetype), [57](#), [74](#), [93](#), [104](#), [180](#), [214](#), [fig. 132](#)

archetype, [73n](#), [83](#), [150n](#)

Christianization of, [86](#)

contamination with shadow, [177n](#)

creative function, 177
ego and, 177n
as evil, 151
-image, 73&n
inferior (fourth) function, 112, 115, 150f, 155, 196
mediator between conscious/unconscious, 177n
non-ego nature of, 106
personification of unconscious, 54, 83, 104, 112, 150, 177n
psychopomp, 58, fig. 19
regression to antiquity, 86
as sister, 73
soul-image, 9n
splitting of, 88
sun-worshipper, 84, 87
wicked, 190; *see also* woman, unknown/veiled

anima (soul), 231
as *aqua permanens*, 234
exaltatio of, 262&n
fiery, 282
separatio of, 263n
smoke, 278n; *see also* soul

anima aurea, 344
anima candida, 374
anima corporalis, 280, 282
anima intellectualis, 87
Anima Mercurii, fig. 157
anima mundi, figs. 91, 208
as Anthropos, fig. 117
Mercurius, q.v.; psychopomp, fig. 8
redemption of, 202, 304f, 306, 477, *see also* redemption
round, 84n, 88, 325

anima rationalis, 263f, 267, 434n

animal(s): ancestors, 131
four beneficent, 465

instincts, 131, 148, 150

psyche, 81, 90

representing unconscious, 145

souls, 412

transformed into men, 143f

ANIMALS:

anser Hermetis, fig. 198

antelope, 453

ape, 129, 133f, 137, 142f, 150, 180

—man, 89, 91, fig. 35

Thoth as, 133f; see also baboon; gibbon

ass, 458

graffito of, 460

one-horned, 436, 447n, 456ff, 464

three-legged, 456ff

worship of, 460

avis Hermetis, 370n, figs. 178, 267

baboon, 133

Thoth as, 133, 137

basilisk, 134, 260, 372

bear, 89, 187f, fig. 90

bird(s), 164, 201, 212, 292, 323, 417n

black, 203

gold and silver, 287

symbol of thought, 201f

— of spiritualization, 66, fig. 22; see also specific birds

boar, 447n

bull/bullock, 143, 369n, 440, 456

and cow, 141f

one-horned, 449

camel, 457

cat, 412

cervus fugitivus, 66, 146, 437

ch'i-lin (Chinese unicorn), 465f, figs. 259, 260

cock, 96, 412

and hen, *fig. 167*

cockchafer, 128

cygnus Hermetis, *fig. 198*

cynocephalus, Thoth as, 137, *fig. 68*

deer, 462

dog, 143, 412

dove, white, 340, 420, 436, 437*n*, *figs. 134, 166, 178*

dragon, 23, 134, 235, 291*ff*, 358, 372, 464*f*, *figs. 46, 47, 73, 118, 187, 189, 196, 199*

four-headed, 285

and hero myth, 333*ff*

mercurial, 66, 161, 166, 319, 381, 437, 452, 466, *figs. 38, 54*

one-horned, 436

as *prima materia*, 23, 285, 317, 452, *fig. 267*

tail-eating, 286; *see also* serpent; uroboros

duckling, 63

eagle, 48*n*, 134, 169*n*, 201*ff*, 234, 285*f*, 437, *figs. 97, 200, 229*

double, *figs. 20, 98, 266*

Mercurius as, 66, 437

elephant, 89, 447*n*, 458

fish, 131, 141, 307*n*, 323

of Manu, 454

one-horned, 436, *fig. 254*

round, 325*n*

seven, *fig. 202*

of Vishnu, *fig. 255*

gazelle, horn of, 456

gibbon, 124, 129, 137, 142

goat, 81

goose, 370*n*, 480

griffin, *fig. 246*

hamsa (swan), 344*n*

hen, 63, 430

and cock, *fig. 167*

horse, 412, 447n, 457, 465, *figs.* 206, 244
 one-horned, 436
ibex, 143
ibis, 452
“kartazonon,” 447n
lamb, 108, 309, 310n, *fig.* 62
lion, 134, 252, 331, 436
 allegory of Christ, 463
 — of devil, 66, 190
 golden, 287
 green, 285, 409, 420, 437f, *fig.* 169
 Mercurius as, 66, 436ff, 463
 red, 285
 taming, 443
 and unicorn, 436, 437n, 462ff, *figs.* 246, 258
lizard, 292n, 458n
mares, man-eating, 369n
monkey, 180, *fig.* 67; *see also* ape
monoceros, *see* unicorn
onager, 458
ox(en), 369n, 457, 465
peacock, 212, *fig.* 230
 allegory of Christ, 419
 flesh, 409, 419
 tail (*cauda pavonis*), 188, 231, 286, 293, *fig.* 111
pelican, 370n
 allegory of Christ, *figs.* 89, 256
 philosophical vessel, 128n
phoenix, 202, 287, 369n, 370, 417n, 431, 465f, *figs.* 4, 93, 270
 allegory of Christ, 419
pig, 96
poodle, 69
ram, 58n
raven, 134, 202, 286, *fig.* 115

Mercurius as, 66
re'em, 460, 462*f*
rhinoceros, 442, 445
 horn of, 466
salamander, 276, 292*n*, 458*n*, *fig.* 138
scarab/scarabaeus, one-horned, 436, 452*f*
scorpion, 372
sea-unicorn (monodon), *fig.* 254
serpent, 54, 96, 134, 143, 148, 155, 157, 166, 217, 235, 252, 382, *figs.* 54, 70, 86,
 183, 190, 203-5
 Agathodaimon, 379
 Christ as, 144
 describing a circle, 54, 81, 103, 222
 four-horned, 230*n*
 green, 166
 healing, 144, 180, 449
 Kundalini, 180
 mercurial, 23, 26, 166, 252, 292, 381, 434, 449, 452, *fig.* 130
 —, crucified, 399, *figs.* 217, 238
 Naassene, 449
 as *spiritus mercurii*, 458*n*
 as transforming substance, 134; *see also* dragon; uroboros
sheep, 456, *fig.* 17
 Christian symbolism, 58*n*, 310*n*
 land of, 58
snake, *see* serpent
spider, 115, 217, *fig.* 108
stag, 437, 465, *figs.* 240, 246; *see also* *cervus fugitivus*
stork, 370
sun beetle, 452
swan, 286, 344*n*, *fig.* 200
toad, 437*n*, *fig.* 196
tortoise, 157, 465, *figs.* 75, 76
unicorn, 409*n*, 420*n*, 435*ff*, *figs.* 239, 250, 252
 in alchemy, 435*ff*

androgyny of, 466
and ark, 460ff
in China, 465f, *figs.* 259, 260
Christ as, 438ff&n, 444f, 463
as *complexio oppositorum*, 447
crest, *fig.* 243
and cross, 440f, 444n, 466
cup, 447n, 466ff
in ecclesiastical allegory, 439f
and Eve, *fig.* 248
in Gnosticism, 449f
as Holy Ghost, 438, *fig.* 261
horn, *q.v.*; in Jewish tradition, 460ff
and lion, 436, 437n, 462ff, *figs.* 246, 258
lunar, *fig.* 262
as *monstrum*, 447, 464
in Persia, 456ff
as power of evil, 439, 446f
and his reflection, *fig.* 265
sea-unicorn, *fig.* 254
and stag, 437, *fig.* 240
symbol of Mercurius, 435ff, 449, 452, 463f
and tree of life, 437, *fig.* 264
in Vedas, 453ff
and virgin, 420n, 438, 442ff&n, 456, *figs.* 241, 242, 245, 247
wild, *fig.* 249
uroboros, 126, 293, 345, 371, 413, *figs.* 7, 46, 47, 108, 147, 253
 as Mercury, *fig.* 20
 as *prima materia*, *fig.* 13; *see also* dragon; serpent
vulture, 169&n, 202, 458
whale, 338, *figs.* 170, 172, 174, 176, 177, 222
wolf, 338n, *fig.* 175
worm(s), 166, 260
animality, primordial, 25, 177

animation, of environment, 49
of psychic atmosphere, 49, 52f, 89
of unconscious, 155

animus, 9n, fig. 132

Anthony, St., of Egypt, 49

Anthropos, 185, 202, 302, 319, figs. 65, 196
Adam as, 362ff, 368, 370, 392
androgyny of, 161
as *anima mundi*, fig. 117
born of Autogenes, 109
Christ as, 304, 368, 392, fig. 64
doctrine, 360ff, 392
with four elements, 368, figs. 82, 117
as fourth, 161f
in Gnosticism, 107, 161, 232, 299
Hermes as, fig. 215
as *homo maximus*, 134
as *homo philosophicus*, 161, 392
lapis as, 133, 232
liberated soul as, 202
Manu as, 454, 456
Mercurius as, fig. 16
Nous as, 301f
original man, 133, 192, 232
quadripartite, 133
as sphere, 84n
vision of, in sea, 49n
as wholeness, 162

anticipation, 54, 103, 127, 169

ἀντίμιμον πνεῦμα, 13, 36, 371

Antimimos, 366, 371

antimony, 327

antinomy, 11n, 20f
of good and evil, 22

anxiety, 63; *see also* fear

apaches, gang of, 192

ape, of God, 142, 158, *fig.* 67

man, 89, 91

Aphorismi Basiliani, 161*n*

Apocalypse, *see* BIBLE *s.v.*

Revelation

of Enoch, 58*n*

apocatastasis, 306

Apocrypha, *see* BIBLE

Apollonius of Tyana, 234

apperception, 264

Apuleius, 55, 57

aqua divina, 35

Mercurius as, 453; *see also* below

aqua mercurialis, 161, 162*n*, 234, *fig.* 152

aqua nostra, 74, 120, 122, 171, 174, 192

as fire, 120, 232*n*, 234*n*

as Mercurius, 453

aqua permanens, 69, 76*n*, 232, 252, 360

as *argentum vivum*, 69

as fire, 232, 238*n*

as *lapis*, 122*n*, 234*f&n*, 324

as Mercurius, 69, 35, 238*&n*

as *prima materia*, *q.v.*; as *vas*, 238*&n*

aqua philosophica, 392*n*

aqua sapientum, 392

aqua vitae, 74, 399

Aquarium sapientum, 254*n*, 270*n*, 282*n*, 322, 396

aquasphere, 325

aquilo (north wind), 398*&n*

Aquinas, *see* Thomas

arbiter mundi, 8, 15

arbor immortalis, 352

arbor philosophica, 420, *figs.* 122, 131, 188, 221, 231

arbor sapientiae, 197

Arca arcani (Grasseus) 342n, 436n, 386n

arcanum, 399, 424; *see also* transforming substance

Arcanum hermeticae philosophiae, *see* Espagnet

Archaeus, 426, 430

Archelaos, 327n

Archelaus of Miletus, 301n

archetype(s), activated, 32, 36

anima, 73n, 83, 150n

transforming substance, 386

bipolarity of, 471

contents, in East and West, spontaneity of, 17

divine child, 166

equivalents of dogmas, 17

as “eternal presence,” 221

father, 123

God as, 14

of God-image, 11&n, 12f, 14

of healing serpent, 144

of hero, 14

identification with, 36f

indeterminate nature, 18

and intuition, 137

of mandala, 46, 221f

numinous, 36

possession by, 36, 478

production of, 16

projection of, 11, 34, 37, 476

of redeemer’s lowly origin, 28

religion-creating, 29

of self, 18f, 22, 25f

of son, 24

of unconscious, 17, 32, 36, 221
wise old man, 93, 123, 190, 250n

Archons, 197, 363n, 379

Archytas, 325

argentum vivum, 74, 235
Mercurius as, 69, 132, 292, 402n; see also quicksilver

Argonauts, 370

argosy, 159

Aries, *fig.* 17

Arion, *fig.* 211

Ariosto, *fig.* 244

Arisleus, 327, 329, 333f, 346ff, 412f, 419
see also *Visio Arislei*

Aristeas, letter of, 363n

Aristotle, 264n, 396

Aristotle (pseudo), 120n, 124n, 125, 128n, 251, 381, 392n
see also *Tractatus Aristotelis*

Arjuna, 118

Ark, unicorn and, 460ff

Arnaldus (Arnold of) de Villanova, 16n, 180n, 316n, 377, 386n

Arnobius, 144n

Aros, 161, 314n

Ars chemica, see names of individual treatises

arsenic of the philosophers, 286

artifex, 37, 202, 255&n, 273, 355, 477, *figs.* 17, 136, 140, 141, 216
qualities required of, 270ff, 278
and *soror mystica*, *figs.* 132, 140, 215, 237, 269

Artis auriferae, 376; see also names of individual authors and treatises

ascent, motif of, 55f, 155, 159, 363
and descent, 54, 62, 164f
and sublimation, 57

asceticism, 140f

Asenas/Asenath, 362&n

associations, to dreams, 44, 289

astrology, 34, 206, 245, 446

of Olympus, 162

astrum, 165f, 278, 372

Asuras, 456

Atharva-Veda, 453

Athene, *fig.* 187

Atlases, 285

Atman, 8, 14, 17, 162

as self, 107

Attis, 24, 307, 452

attitude, 182

conscious, 44, 74

infantile, 73

rationalistic, 50, 57, 59, 84

type, 196

Western/Eastern, 7f

attritio, 29

augmentatio, 239

Augustine, St., 46, 84, 417, 446

aurea apprehensio, 270

Aurea catena Homeri, 114n

Aureum saeculum redivivum (Madathanus), 254n

Aureum vellus, 396n, 452n

Aurora consurgens, 76n, 234n, 237n, 238n, 270, 271n, 273, 289n, 315n, 322, 327n, 334, 342n, 352n, 376ff, 402n, 428n, 436n, 437n

aurum, see gold

aurum aurea, *fig.* 209

Aurum hermeticum (Balduinus), *fig.* 209

aurum non vulgi, 34, 383, 408, 437

aurum nostrum, 34, 78, 159

aurum philosophicum, 78, 80, 124, 169, 171; see also gold, philosophical

aurum potabile, 232

aurum vitreum, 78
aurum volatile, 383
auster (south wind), 398&n; see also wind
Australian aborigines, 131
auto-eroticism, 5
Autogenes, see Monogenes
autonomy, of psyche, 50, 86, 146, 183f
 of unconscious, 46, 54, 89, 184, 333n
autosuggestion, and dreams, 218
auxiliary function, see function
Avalokiteshvara, 98
Avalon, Arthur, 96n, 144n, 180n, 280n, fig. 39
Avantius, Josephus, 252n
“Ave Praeclara,” 398f
avidya, 96
Azael, 461
Azoch/azoth, 159n, 286, 458n
Aztecs, 181

B

Bacchus, fluid of, 162n
Baccius, Andreas, 437n
Bach, Johann Sebastian, 140
bailiffs, four, 165
Balduinus, Christian A., fig. 209
Balgus, 375
Balinus, 234n
ball(s): red, 83, 84, 103
 yellow, 188
balsam, 409
baptism, 231, 257n, 357, 360
 of Christ, 443n
baptisma, 231

Barchusen (Barkhausen), Johann Conrad, [figs. 120, 127, 130, 136, 194](#)

Bardesanes, [330n](#)

Barnaud, Nicolas, [437n](#)

Bartholomaeus Anglicus, *see* Glanville

Basil, St., [442, 447](#)

basilisk, [134](#)

Basilius Valentinus, *see* Valentinus

basin, of fountain, [174](#)
 of sister, [69, 74, 83](#)

bath, [401f, figs. 27, 57, 118, 134, 152, 159, 218](#)

Batiffol, Pierre, [362n](#)

Baucis, [480](#)

Baynes, Charlotte A., [107n, 108n, 109n, 110n, 371n](#)

beard, man with, *see* Pointed Beard

bearings, at sea, taking, [104](#)

Bede, [443n](#)

Behemoth, [464](#)

“behind,” as region of unconscious, [48](#)

Belinus, [234n](#)

beloved, carrier of anima image, [73n](#)
 in Song of Songs, [389, 394](#)

Benvenuti, Giovanni Battista (Ortolano), [fig. 244](#)

Bernard, St., [165](#)

Bernard of Treviso, [258, 289](#)

Bernardus à Portu, [406](#); *see also* Penotus

Bernoulli, Jakob, [217](#)

Bernoulli, R., [228](#)

Béroalde de Verville, François, [53n, 86n, 239n, 250n, 269, 336n, 453n, figs. 4, 5, 33](#)

Berthelot, Marcellin, [55n, 62n, 76n, 120n, 159n, 160n, 234n, 236n, 237n, 250n, 252n, 276n, 293n, 295n, 297n, 304n, 306n, 315n, 319n, 339n, 359n, 360ffnn, 368n, 371n, 386n, 401n, 433n, 458n, fig. 147](#)

Beya, variant spellings, [329n](#); *see also* Thabritius

Bhagavad-Gita, [118](#)

Bhulia Busty, 96

BIBLE, 8, 12, 376, 442

Old Testament, 221*n*

Daniel, 346

Deuteronomy, 437*n*, 440

Ecclesiasticus, 377*n*

Exodus, 443*n*

Ezekiel (Ezechiel), 165, 385&*n*, *fig.* 109

Genesis, 23*n*, 263, 362*n*, 399*n*, 461&*n*, 467*n*

Habakkuk (Habacuc), 378*n*

Isaiah (Isaias), 2, 359*n*

Job, 206, 435*n*, 443*n*, *fig.* 239

Jonas (Jonah), 327*n*

Lamentations, 327*n*

Malachi(as), 417

Micah (Michias), 322

Proverbs, 377*f*

Psalms, 280*n*, 327*n*, 376, 377*n*, 382*n*, 389, 391*n*, 398, 437*n*, 439*f*, 443*n*, 462*n*

Song of Songs (Canticles), 71*n*, 327*n*, 378*n*, 389*f*

Wisdom of Solomon, 377, 386

Zacharias (Zechariah), 386

New Testament: I Corinthians, 391*n*

Ephesians, 271*n*, 307*n*

Galatians, 363*n*, 389*n*

Hebrews, 389*n*

John, 118, 254*n*, 322, 375, 410*n*, 419*n*, 434, 467*n*, *fig.* 158

Luke, 327*n*, 378*n*, 404*n*

Matthew, 378*n*, 392*n*

Philippians, 125*n*

Revelation (Apocalypse), 108, 327*n*, 379

Apocrypha: IV Ezra (II Esdras), 48*n*, 468

Peter, 53*n*

Pseudepigrapha, *see* Enoch

Biblia pauperum, *figs.* 170, 177

Bibliotheca chemica, see names of individual authors and treatises

Binah, 206

binarius, *fig.* 185

bird(s), see under ANIMALS

Bischoff, Erich, 206*n*

Bithus of Dyrhachium, 361*n*

biting motif, 143, 145, 189*f*, *fig.* 118

Bitos, 361

Bitys, 361*n*

“black art,” 67, 80

Blake, William, *figs.* 14, 19

blasphemy, 10*f*, 410, 427

Blemmides, Nikephorus, 339*n*

blood, 178, 260, 309, 343*n*

of green lion, 409, 420

as *prima materia*, 317, 319

of red lion, 285

soul dwells in, 279*f*, 343*n*

Bloomfield, Maurice, 453*n*

Bock, Hieronymus, *fig.* 249

bodhisattva, 129

body, acceptance of, 123

Christ’s, 308*ff*

diamond, 108*n*, 131, 428

divine secret in, 313

father as, 331

as fourth, 125

and mind, 269, 279*f*, 350

mystical, 394

psychic representatives of, 338

separation of spirit from, 124*f*, 263*n*, 269, 428*n*

body/soul, 220, 279*f*, 280*ff*, 371, 410, 429*f*, 480

—, *coniunctio*/union, 310*f*, 374*f*, 420, *fig.* 159

body/soul/spirit, 126n, 285, 390, 394, *fig.* 196
—, of Anthropos, 360ff
—, *lapis* as, 178, 313
—, Mercurius as, 319n
subtle, 277ff, 310, 429
transfiguration, 374f, 410, 392, 427
— of Virgin's, 420, *figs.* 224, 232

Böhme, Jakob (Jacob Behmen), 165–66, 227, *fig.* 192, 357, 396, 427, 428, 430

Bonellus, 234

Boniface, St., 353n

Bonus, Petrus, 162, 315n, 373ff, *fig.* 79

Book of the Dead, Egyptian, 133, 208n, *fig.* 102

Boschius, Jacobus, *figs.* 37, 84, 89, 94, 111, 181, 189, 265, 270

Bousset, Wilhelm, 360n, 371n

bowl, silver, 197

Boy Charioteer, 178, 478

boys, motif of, 153; *fig.* 95; see also *puer*

Brahma, 454, *fig.* 75
city of, 108

brain, 87, 206, 267, 433
gestation in, 329, 413
—stone, 433n
trust, 141

Brant, Sebastian, *fig.* 227

Braun, Joseph, 353n

bread and wine, eucharistic, 308ff, 392

Brendan, St., 309n

bridge, see rainbow bridge

Brihadaranyaka Upanishad, 161

bronze, leprous, 159

brooding, heat of, 339

brother/sister motif, 235, 295, *fig.* 118; see also incest

Bruchmann, C. F. H., 132n

Bruno of Würzburg, 445

Bry, J. T. de, *fig. 8*

Bubastis, 83

Buddha, 17ff, 98, 108n, 128f, 206

Buddhism, 19, 96, 202, 456

Budge, E. A. W., 65n, 133n, 208n, *fig. 102*

Bühler, Johann Georg, 454n

Bundahish, 456ff, 458n, 464

Buri, 330n

Burning Bush, 399

C

Cabala, 205, 319n

Cabiri, 156, 158f, 190, 199, 204, *fig. 77*

caduceus, 6, *figs. 23, 148, 165*

Cairo, 118

calcinatio/calcination, 231, 239, 402n

calendar, 206, 210f, *figs. 41, 44*

calx viva, 344n

cambar, 235

Campion Pendant, *fig. 263*

Cana, miracle of, 467

caput corvi, 293

caput mortuum, 401n

corporum, 408

carbon, 218

carbuncle, 469&n, 471

cardinal points, four, 191, 197, 368; *see also* quarters

Carmen (Villanova), 161n

carnival, 143

Cartari, Vincenzo, 132, *fig. 165*

castle, 126n, 335, *fig. 50*

Catelanus, Laurentius, 437n

cathedra, 248

cathedral, Basel, 217n

collapsed, 141

Catholicism, 20, 73, 312

cauda pavonis, 188, 231, 286, 293, *fig.* 111

Caussin, Nicolas, 419n, 442, 445

cave, 153, 186, 335

—, man, 89

Cellini, Benvenuto, 291n

centre, with circle, allegory of God, 106f

circumambulation of, *q.v.*, *see also* square

concentration on, 145f, 154, 163, 190

of consciousness, ego as, 41

dark, 186f

development of psychic, 28f

dissolution of, 178

deity in, 150, *fig.* 109, *see also* mandala, centre of

finding the, 104, 114, 164, 166, 175, 188

healing significance of, 29, 98

lapis as, 98, 118

life-creating, 178f

of mandala, *q.v.*; as mediator, 128n

objective, 104

of personality, 41, 99, 105

—, not identical with ego, 41, 99, 104, 105, 137

—, self as, 41, 106, 205, 220

place of creative change, 145

point of reflection, 171, 204

quaternity of, 205, 218, *fig.* 31

spiral movement round, 28, 217f

symbols of, 29, 41, 217ff

as *temenos*, animals in, 54, 124, 137, 142, 148, 150

timelessness of, 105

unknown, 218

as *vitrum*, 171; see also circle

cervus fugitivus, see ANIMALS

chain, Homeric, 114

chairs, four, 186

chahra system, 280

Chaldeans, 267n, 362

chalice, 466, 468, fig. 158

 Damascus, 141

Champollion, Jean Francois, fig. 66

chaos, 74, 144, 202, 230, 285, 301n, 325, figs. 4, 125, 164, 199

 as *prima materia*, 202, 230, 254, 262n, 317, 319n, 325n, 340, 344, fig. 162

 “strange son of,” 91; see also *massa confusa/informis*; Tiamat

Chapman, P. F., and M. Nierenstein, 291n

chariot, of sun, 381, fig. 206

charity, 271

Charles, R. H., 58n, 197n, 221n, 369n, 469n

Chastity, fig. 252

chemistry, 227, 323, 432

 and alchemy, *q.v.*; of matter, 34

chemist’s shop, 120

Chhandogya Upanishad, 456n

Ch’ien, 129, fig. 61

child, 60, 180n

 Christ, fig. 42

 divine, 166, fig. 87

 gods, fig. 96, see also Cabiri

 children, motif of, 189f, 199, 204

 “children’s land,” 58f

childhood, 184

 regression/return to, 60, 62, 115, 118, 189f

 state, 62, 172f, 189f

childishness, 59f, 150

ch’i-lin (Chinese unicorn), see ANIMALS

China, 22, 107, 129, 150, 330n, 357

unicorn in, 465f, figs. 259, 260

Chnuphis, 237n

serpent, fig. 203

Christ, 12, 17ff, 23, 84, 184f, 206f, 353f, 391, 394, 419, figs. 18, 101, 197

Adam as, 365

allegories of, 17

androgyny of, 19, 22, 464

as Anthropos, 304, 368, 392, fig. 64

archetype, 17, 19

as bridegroom, 389

as bull, 440

coniunctio on mountain, 160

descent to hell, 53n, 339, 354

dogmatic, 17f, 185

esoteric, 120

as *filius macrocosmi*, 425

as *filius philosophorum*, 389, fig. 234

as fire, 120, 196, 353f, fig. 58

gnostic, 368

historicity of, 35, 185

as *homo philosophicus*, 392

as horn, 445

identity with calendar, 206

imitation of, 7, 22, 32, 35, 308, 354

as *lapis, q.v.*; as living water, 390n

as Logos/Nous, 304

and Mass, 308ff

as Mercurius, 438

as microcosm, 392

Pantokrator, 133

as pelican, figs. 89, 256

as phoenix, 419

pre-Christian, 185

as Redeemer, 184, 306, 308f, 354f, 358, *fig.* 182
risen, 422, *figs.* 177, 234
in rose, 108n
sacrificial death, 306, 308f, 353
as second Adam, 392
in sepulchre, *fig.* 170
as serpent, 144
as sun, 84, 208, 417
symbol of self, 18f, 208, 355
symbol in mandala, 129, *fig.* 62
as transforming substance, 434
as unicorn, 438ff&n, 444f, 463
as vine, 394
yoke of, 21n, 22

Christianity, 7f, 11f, 15ff, 20ff, 33f, 143, 355
and alchemy, 23, 33f, 352f, 428ff, 476
good and evil in, 22
and modern mentality, 150
and paganism, 11
world religion, 19

Christianos, 159, 315n

Christopher of Paris, 340

χρυσάνθεμον, 76n

chthonic: bear, 187
= dark, 175f
femininity of unconscious, 23f
gods, 158, 329n
Mercurius, 65
prison, 190
serpent, 292
trinity, 460
underworld, 25

Ch'un-ts'iu, *fig.* 260

Church, 4, 17, 27f, 30ff, 73, 138ff, 210, 308ff

alchemist and, 35, 353
Fathers, 17f, 386, fig. 197
return to, 4, 33
seven churches, 379
schism of, 424
chymical wedding, 37, 232, 402n, 436, 463
cibatio, 239
Cibinensis, see Melchior
Cienfuegos, Alvarez, 309n
circle, 42n, 54, 81, 95f, 104, 118, 124f, 128&n, 174, 191f, 209f, 325, 382
 with centre, allegory of God, 106f
 divided into four, 106, 128n, 150, 164, 191, 197
 magic, 42n, 54, 95, 106, 118, 148, 167
 movement in a, 103f, 180, 188, 192
 —, opus as, 293, 381f, 386
 and *rotatio*, 165
 squared, 169
 squaring of, 96, 124, 127, 128n, 167, figs. 59, 60
circulatio/circulation, 164, 172, 186, 191, 192f, 197
circumambulatio/circumambulation, 28, 108n, 127, 128n, 145, 148, 174, 179n, 180,
 190, 206
cista, 157
citrinitas, see COLOURS
city, 107, 126n
 of Brahma, 108
 with four gates, 108f
 as *rotundum*, 127n
 as *temenos*, 107, fig. 31
civilization, Christian, hollowness of, 12
Clement, of Alexandria, 109n
 of Rome, 380
Cleopatra, 120n, 401
clock, cosmic, 105
 pendulum, 104ff, 112, 120, 181

- world, 203f
- cloud(s), 248, 250, 285f
- as *prima materia*, 317
- clover, 164, 169
- coagulatio/coagulation, 239, 285f
- coal, 218
- CODICES AND MSS. (*boldface numerals refer to Bibliography*)
- Akhmim, **i**, 53n
- Aschaffenburg: *Evangelary*, i-a, *fig.* 109
- Berlin: *Berolinensis*, i-b, 347n, 348
- Bingen: *Scivias* (Hildegard), i-c, *fig.* 126
- Chantilly: *Les Très Riches Heures*, **ii**, *fig.* 156
- Dresden, **iii**, *fig.* 190
- Florence: *Miscellanea d'alchimia*, **iv**, *figs.* 131, 135
- Leiden: Vossianus 29, *De Alchimia* (Thos. Aquinas, pseud.), **v**, *figs.* 9, 17, 20, 38, 90, 99, 129, 140, 152, 201, 241
- London: *Emblematical Figures in red chalk*, **vi**, *fig.* 15
- Ripley Scrowle, **vii**, 420, 458n, *figs.* 30, 92, 196, 228, 251, 257
- Cabala mineralis*, **viii**, *fig.* 121
- Theodore Psalter*, **ix**, *fig.* 206
- Splendor solis* (Trismosin), **x**, *figs.* 32, 95, 134, 166, 219
- Historia animalium cum picturis* (Harley 4751), **xi**, *fig.* 242
- Lucca: *Liber divinorum operum* (Hildegarde), **xii**, *fig.* 195
- Manuscripts in author's possession: *La Sagesse des anciens*, **xiii**, *fig.* 149
- Figurarum Aegyptiorum secretarum*, **xiv**, 232n, 276n, *figs.* 23, 148, 157, 164
- Milan: Bibl. Ambrosiana, *Codex I*, **xv**, *fig.* 27
- Modena: Est. Lat. 209, *De Sphaera*, **xvi**, *fig.* 56
- Munich: Staatsbibl., Germanicus 598, *Das Buch der hl. Dreifaltigkeit*, **xvii**, 422n, 424n, *fig.* 224
- , *Lectionary (Perikopenbuch)*, **xviii**, *fig.* 191
- Oxford: Bodleian, *Brucianus*, **xix**, 107f
- , *Bible moralisée*, **xx**, *fig.* 213
- Paris: Bibl. de l'Arsenal, *Explication des figures hiéroglyphiques*, **xxi**, 276n
- , *De summa medicinae sapientiae*, **xxii**, *fig.* 178

- , *Trésor des trésors*, [xxiii](#), [figs. 193, 226](#)
- , *Traité de la cabale* (Thenaud), [xxiv](#), [figs. 6, 74](#)
- , *Trésor de sapience*, [xxv](#), [fig. 248](#)
- , *Traité d'alchimie*, [xxvi](#), [fig. 116](#)
- Bibl. nationale, *Speculum humanae salvationis* (Lat. 511), [xxvii](#), [fig. 67](#)
- , (Lat. 512), [xxviii](#), [fig. 172](#)
- , *Turba philosophorum*, [xxix](#), [fig. 208](#)
- , *Grandes heures du duc de Berry*, [xxx](#), [fig. 159](#)
- , *Aurora consurgens*, [xxxi](#), [376](#)
- , *Roman de Lancelot du Lac*, [xxxii](#), [fig. 88](#)
- , *Les triomphes du poethe messire François Petrarche*, [xxxiii](#), [fig. 252](#)
- , *Livre des figures hiéroglyphiques* (Abraham le Juif), [xxxiv](#), [fig. 217](#)
- , —, *Alchimie de Flamel*, [276n](#)
- , *Recueil de figures astrologiques*, [xxxv](#), [fig. 85](#)

Preobrazhensk, Russia: *Khludov Psalter*, [xxxvi](#), [figs. 176, 247](#)

Reims: Bibl., *Recueil des fausses décrétales*, [xxxvii](#), [fig. 211](#)

Rome: Bibl. Angelica, *De balneis Puteolanis*, [xxxviii](#), [fig. 57](#)

Tübingen: MS., [xxxix](#), [fig. 24](#)

Vatican: Bibl. Vaticana, Pal. Lat. [412](#)

Adamas colluctancium aquilarum (Wynandi de Stega), [xl](#), [figs. 73, 98, 266](#)

—, Pal. Lat. [413](#), *Speculum humanae saluacionis*, [xl-a](#), [figs. 105, 107](#)

—, Pal. Lat. [565](#), *Speculum virginum* (Peregrinus), [xli](#), [fig. 197](#)

—, Reg. Lat. 1458, [xlii](#), [fig. 106](#)

—, Urb. Lat. [365](#), [xlili](#), [figs. 69, 83](#)

—, Urb. Lat. 899, [xliv](#), [figs. 35, 220](#)

—, Vat. Lat. 681, *De sacramentis* (Peter Lombard), [xlv](#), [fig. 104](#)

—, Vat. Lat. 7286, *Speculum veritatis*, [xlvi](#), [figs. 80, 150](#)

Venice: Marcianus, [xlvii](#), [293](#), [fig. 147](#)

Vienna: Nationalbibl., *Med. Graecus I* (Dioscorides), [xlviii](#), [fig. 186](#)

Zurich: Zentralbibl., Rhenoviensis [172](#), *Aurora consurgens*, [xlix](#), [376](#)

Zwiefalten Abbey: *Breviary No. 128, 1*, [fig. 62](#)

Codicillus (Lully), [295n](#), [358](#), [401n](#)

cogitatio, [267&n](#), [274](#), [295n](#)

cognition, [374](#)

coincidentia oppositorum, self as, 186; see also opposites

coins, golden, 80f, 103, 246n

coitus, 231, 331, 401n; see also *coniunctio*

collective consciousness, father as, 71

collective psyche, 57, 81; see also unconscious

collective unconscious, see unconscious

collectivism, 477, 479

Colonna, Francesco, 86; see also Béroalde de Verville

colour(s), in alchemy, 251, 368

four, 26, 164, 169, 187, 193, 197, 203, 213n, 229

three, 26, 126n, 169, 212f, 229f, 260

COLOURS:

albedo, 231f; see also *leukosis*; white

black/blackening, 126n, 169, 229f, 271, 390n

“black blacker than black,” 327

art, 67, 80

bird, 203

eagle, 201

earth, 319, 327

Mass, 150

ravens, 286

sea, 381

soul, 214

sun, 110, fig. 34

tail, 177n

water, 285

see also *melanosis*; *nigredo*

blue, 164, 187, 192f, 197, 212ff

disc, 203f, 212

flower, 76, 79f, 103, 164, 166, 169

sea/sky, 213

brown, crystal throne, 210, 214

citrinitas, 189, 229, 232; see also saffron; yellow, *xanthosis*

gold(en), child, 166

circle, 210, 213
colour of God the Father, 212
crowns, 210
fleece, 159, 370
flower, 76, 80, 107, 131, 182n, *figs.* 30, 133
glass, 232
head, 453
heaven, 210f, 425
lion, 287
mandala, 214
pill/seed, 182
ring, 204
snake, 144
tincture, 374, 425
and silver: birds, crowns, 287
fountains, *fig.* 38
sea, 285
green/greenness, 159, 164, 187, 192, 197, 212f, 214, 251, 370n
 colour of Holy Ghost, 212f
 land, 58
 lion, 285, 409, 420, 437f, *fig.* 169
 plant, 154
 snake, 166
 tree, 174
 womb, 154; see also *viriditas*
grey, 251
iosis, 229; see also red; *rubedo*
iridescent, 251
leukosis, 229; see also *albedo*; white
melanosis, 229; see also black; *nigredo*
nigredo, 36, 188, 229f, 251, 271, 273, 286, 293, 327, 401n, 417, *figs.* 34, 115, 137,
 219, 223; see also black; *melanosis*
purple, king, 287, 359; spirits, 210
red/reddening, 126n, 164, 169, 187f, 192, 197, 212, 229, 232, 251, 260
 ball, 83f, 103

colour of God the Son, 212

daughter, 358

earth, 362

garment, 359&n

gum, 161, 401n

haired man, 154f, 162, 260

sea, 390

slave, 153n

tincture, 232, 358

and white: double eagle, fig. 20

lily, 287

rose, figs. 13, 30, 193; see also *iosis*; *rubedo*

rubedo, 188f, 232; see also *iosis*; red

saffron, 260; see also *citrinitas*; *xanthosis*; yellow

sapphire, 210

silver, bowl, 197; eagle, 285, 287; rain, 286; stream, 285

tinctura: alba, 232; >*rubea*, 124

violet, darkness, 270

viriditas, 159, 229; see also green

white/whitening, 126n, 169, 229, 231f, 250n, 270, 271

dove, 340, 436, 437n, figs. 134, 166, 178

eagle, 287

elixir/fermentation, 286

gum, 401n

head, 206

sulphur, 390n

tincture, 232

unicorn, 436

water, 285; see also *albedo*; *leukosis*

xanthosis, 229; see also *citrinitas*; saffron; yellow

yellow/yellowing, 126n, 164, 169, 187, 188f, 192, 197, 229

balls/light, 188

emperor, 466; see also *citrinitas*; saffron; *xanthosis*

Commentarius (Hortulanus), 169n, 325n

Communion, 310f

“companion,” 117f

Compendium artis alchemiae (Lully), 250n

compensation, 23f, 27, 44, 46, 52, 54, 83, 118

downward, 174

completeness, and perfection, 159

complex, autonomous, 301, 337

complexio oppositorum, unicorn as, 447

confession/confessional, 4, 20f

conflict, 27, 31, 153, 174, 184, 186

Christian, of good and evil, 22

of conscience, 406

of father/mother world, 23f

self as, 21

Confucius, 466, *figs.* 259, 260

Congeries Paracelsicae chemicae (Dorn), 237n, 251, 267, 391n

coniunctio, 231, 239, 295, 458n, 479, *fig.* 227

brother/sister, *see* incest

heaven/earth, *fig.* 74

king/daughter, 358

king/queen, *fig.* 116

king/son, 162n

lapis/son, 110

mother/son, *see* incest

Nous/Physis, 302, 331, 335, 338

of opposites, 329, *figs.* 167, 226, *see also* union

Sol/Luna, *q.v.*; soul/body, 310, *fig.* 159

spirituum, *fig.* 268

two *Mercurii*, 40n

upper/lower, *fig.* 78

conscience, 8, 20n, 406

consciousness, autarky of, 137

childish, 59f, 62

collective, [71](#)

dawning of, [476](#)

differentiation of, [50](#), [60](#), [63](#)

as discrimination, [25](#), [481](#)

dissolution/extinction, [88f](#), [333f](#)

ego as centre of, [41](#)

heart as, [374n](#)

history of modern, [33f](#)

inflation of, 213, 479ff
as *intellectus*, 264
invasion by unconscious, 48n, 49, 59
light as, 186
masculine, 23f, 152
rational attitude, 50, 57, 59, 84
as psyche, 480
regression of, 11, 481
self evolving into, 81n
sub/super-, 137, 155, 280
subjective psyche, 43
and unconscious, 19, 23ff, 32, 34, 41, 43f, 106, 127, 137, 152, 182f, 329n, 333ff,
355, 374n, 432f
—, collaboration, 84, 329, 334, 338
—, compensatory relationship, 24, 44, 46
conflict, 50, 146, 148, 153, 415
dialectic, 4f, 29, 417
—, separation, 11, 58, 137
symmetry, 171, 193
union, 50, 57, 87, 137, 144, 221, 413; see also unconscious
Consecration, 309f, 404f
Consilium coniugii, 76n, 161, 234n, 237n, 315n, 319, 386n, 453
contamination, by unconscious, 26, 112, 152f, 158, 177n, 196
context, dream, 33, 44f, 289
contritio, 29
conversion, religious, 4f
coral, tree of, 348n, fig. 186
Cornell, Johan H., fig. 42
cornerstone (*lapis angularis*), 35, 81, 183, 353, 404, 427, 442, fig. 172
coronation, 47, 57, 110ff
of Virgin, figs. 224, 232
corpus: astrale, 162
subtile, 427, see also body, subtle
Corpus Hermeticum, 290; see also Scott

Correctorium Alchymiae (Richardus Anglicus), 258, 260n
correspondence(s), four series of, 262ff of metals and types, 408
 of soul and God, 1ff
lift-theory of, 245
 of zodiac and man, *fig.* 156
cosmic: aspect of dreams, 171f, 180f
 clock, 105, 205
 effluences, four, 129, *fig.* 61
 flower, 172
 self, 107
 wheel, 96, 380, *fig.* 40
cosmogony, Egyptian, 71n
cosmos, rationality of, 146
 vas as, 236
creation, 25, 246, 320, 325, *fig.* 126
Creator, *figs.* 1, 195
Crede mihi (Norton), 270n, 291n
creed, 4, 14f, 16, 374, 392
cremation, 350
Cremer, John, 291n
croquet ball, 113, 115
cross, 32, 35, 150, 193n, 309, 368, *figs.* 42, 62, 192
 ace of clubs as, 76, 169
 distorted, 164, 169
 Rosie, 76
 unicorn's horn as, 440f, 444n, 466
crown, 48, 107, 120n, 210, 286, 379, 420
Crowned Maid, 409, 420
crucifix(ion), 21, 141, *figs.* 28, 53
 mock, 460
crystal(s), 170f, 218, 285
 throne, 210, 214
Ctesias, 44n, 458

culture, psychological, 12
Cumont, F., 380n, 381n
cup, of Joseph and Anacreon, 467f
 poison-proof, 466
 unicorn, 466ff
Cybele, 24
cygnus Hermetis, see ANIMALS
cynocephalus, see ANIMALS
cypress, attribute of Virgin, fig. 26

D

dactyls, 157; see also Cabiri
daemon, intellect as, 69
 Nous as, 301
 triunus, ass as, 460
Dame à la Licorne, fig. 258
dance hall, 193
Dante Alighieri, 53n, 172, 209, figs. 19, 69, 83
dark/darkness(es), 150, 175, 177, 286f, 329, 335
 half of personality, 31
 —, of psyche, 29
 “horrible, of mind,” 36, 271, 273, 334
 son of, 36; see also COLOURS s.v. *nigredo*
Darmstaedter, Ernst, 271n
daughter, red, 358; see also mother
David, 358, 462, fig. 28
De Alchemia, see names of individual authors and treatises
De alchemiae difficultatibus (Hoghelande), 238n, 248n, 250n, 251n, 254n, 258n, 315n, 319n
dea mater, 322
death, 124, 231, 329, 331, 333, 390n
 ritual, 131, 306f, 308
 spiritual, 81, 83

victory over, 307f, 329, 335, 339, 358f, 391; see also *mortificatio*
death's head, 83
De chemia, see Senior (Zadith)
decoctio, 251
Dee, John, 319n
De flavo et rubeo viro (Melchior of Brixen), 396n
Degenhardus, 342n
deity: feminine element in, 152
 in centre, 97f, 108&n, 128f, 150, figs. 42, 62, 109
 as hermaphrodite, 302n, 330n, fig. 183
 in lotus, 108, 180n
Delacotte, Joseph, 209n
Delacroix, Eugène, fig. 36
De lapide philosophico figurae et emblemata (Lambspringk), 339n, 344n, 371n, 437,
 figs. 168, 179, 240
Delphinas, 332n
Demeter, 24
demiurge, 102, 302, 306, 460
Democritus, pseudo, 242, 295
demon: as monkey, fig. 67
 as unicorn, 447; see also daemon; devil
Demonstratio naturae (Mehung), 270n
depreciation, of soul. 8ff, 101
 of unconscious, 50
De ratione conficiendi lapidis (Ventura), 354n, 385n
descent, motif of, 141, 201, 363, see also ascent
 ad inferos, 36
 Christ's, into hell, see Christ; in hero myth, 333ff
 into unconscious, 329, 333; see also *nekyia*
De spagirico artificio (Dorn), 260, 320
destiny, 34
De sulphure (Sendivogius), 279&nf, 325, 340n
Deus terrestris/terrenus, 232, 343, 385

Deussen, Paul, [107n](#)

devaluation, [10n](#); *see also* “nothing but”

devil, [30n](#), [32](#), [163&n](#)

ape of *God/simia Dei*, [134](#), [142](#), [158](#), *fig. 67*

counterpart of Christ, [19](#)

fourth person in deity, [151](#)

haunting lonely places, [49](#)

as intellect, [69](#), [91](#), *fig. 36*

lion, [66](#), [160](#)

Mercurius, [66](#), [134](#)

north wind, [398n](#)

taking possession of souls, [11n](#); *see also* Mephistopheles; *ἀντίμιμον πνεῦμα*;

Antimimos

devouring, motif of, [190](#), [331](#), [338](#), [345](#), *figs. 130*, [168](#), [169](#), [175](#)

dew, as *prima materia*, [317](#)

diadem, [110](#), [290n](#), [469n](#)

dialectic, conscious/unconscious, [4f](#), [29](#); *see also* unconscious

Dialogus inter naturam et filii (Aegidius de Vadis), [127n](#);, [319n](#), [325n](#), [371n](#)

Dialogus Mercurii (Sendivogius), [66n](#)

diamond, [170f](#), [186f](#), [190](#), [218](#), [428](#)

body, [108n](#), [131](#), [428](#)

Didymus of Alexandria, [444n](#)

Diels, Hermann, [327n](#)

Dieterich, Albrecht, [53n](#), [361n](#)

differentiated function, *see* function

differentiation, of consciousness, [50](#), [60](#), [63](#)

Digulleville, Guillaume de, *see* Guillaume

Ding an sich, self as, [182](#)

Diodorus, [369n](#)

Diogenes Laertius, [264n](#)

Diomedes, [369n](#)

Dionysus(os)/Dionysian mystery, [89f](#), [131](#), [140ff](#), [150](#), [307](#)

Dioscorides, *fig. 186*

disc, blue, [203f](#), [212](#)
discrimination, [25](#), [263](#), [481](#)
disintegration, psychic, [62](#)
 of personality, [337](#)
dismemberment, motif of, [89](#), [307n](#), [381](#), [452](#)
disorientation, [59](#)
dissolution, alchemical, [285f](#)
 of centre, [178](#)
 of consciousness, [88f](#)
 Dionysus as, [90](#)
distillation, circular, [124](#), [128n](#)
Divina Coinmedia, [53n](#); see also Dante
divination, [466](#), [468](#)
divine child, [166](#)
divisio, [230](#), see also *separatio*
Djābir, see Geber
dmigs-pa, [96](#)
doctor, dream symbol, [106](#), [113](#)
 function in analysis, [6](#), [223](#)
 and patient's shadow, [30](#)
doer, and deed, [31](#)
dogma, [10](#), [13](#), [15](#), [34](#), [74](#)
 alchemy and, [290](#), [357](#)
 analogies to alchemical process, [35](#)
 efficacy of, [185](#)
 and paradox, [16](#)
 and practice, in religion, [22](#)
“doll woman,” [106](#)
dominants, collective, [35](#)
 Christian, [36](#)
 of conscious life, [36](#)
 of unconscious, [245](#), [276](#)
dorje(s), [98](#)

twelve, 108n
Dorn, Gerard, 148, 230n, 237n, 251, 254n, 255, 260, 267, 269, 319&n, 321, 381
doubt, precious gift, 8
dragon, *see* ANIMALS
dream(s), and autosuggestion, 218
 compensation by, 23, 44, 46, 54, 174
 context, 44ff
 and enantiodromia, 84
 interpretation, 44, 289
 isolated and serial, 44, 45f
 mandalas in, 27, 42, 48, 95, 103, 222n
 method of deciphering, 44ff
 parallel, 44
 and projection, 302
 psychology of, 177n
 revelation in, 252n, 315, 374
 sent by God, 10
 spirality of motifs, 28, 177, 179f, 217
 symbols of individuation, 41
 symbolism and alchemy, 33, 346
 theory of, 43
Dreyfuss, J., 145n
duality, 22f, 204f, 304, 330n
dunghill, 80, 358, 430
Duodecim claves (Valentinus), 338n, 342, *figs.* 146, 185
duration, eternal, 48
dwarf(s), 63, 153, 190
 gods, 157, 199; *see also* Cabiri
Dyad, 304, 330n, *fig.* 156

E

earth, 65, 84, 114, 126n, 205, 229, 262ff, 285f, 325, 342f, 390, 392, *fig.* 81
 Adam as, 362
 black, 319, 327

blood-red, 362
-bound, man as, 114
feminine, 23, 83, 150, 152n, 345, *fig.* 74
four earths, 368
as fourth, 26, 468
gods, 177n
mother, 214, *fig.* 216
paradisaal, 450
as *prima materia*, 317, 342, 450, *fig.* 163
spirit, 342, 345
square, 128, 150
and Virgin, 152, 306, 446
East and West, 205, 307n, 322, 369n
 contrasting attitudes, 7f
Easter, 353, 358
Eckhart, Meister, 10, 102n, 117n
eclipse, of sun, moon, 286
ecstasy, drunken, 140n, 143
Edem, 304, 450
education, psychological, 7
 Christian, 12
 Protestant, 20
egg, 201f, 217, 238, 339n, 430, *figs.* 22, 98
Eggeling, Julius, 454n, 456n
ego, 8, 30n, 81, 99, 104ff, 177n, 193, 304, 355, 480
 centre of consciousness, 41
 -consciousness, 177n, 193
 and non-ego, 106, 113, 117, 481
 -personality, 481
 —, negative, 177n, *see also* shadow
 and self, 41, 106, 117, 355&n
Egypt, burial ladder in, 57
Egyptians, 133, 137, 362n
Ehrenstein, Theodor, *figs.* 184, 207, 213

Eisenstein, Judah David, 462n

Eisler, Robert, 140n, *figs.* 174, 202

Ekasringa, 456

Eleazar, Abraham (le Juif), 34n, *figs.* 10, 11, 12, 46, 47, 160, 217, 238

elements, four, 26, 84, 124, 128, 133, 166, 169, 205, 229, 263ff, 325, 346, 363, 368, 381, 409, 450, *figs.* 46, 47, 64, 66, 93, 114, 117, 178

- Mercurius and, 450
- as *prima materia*, 317
- projection into, 299
- separation of the, 230, 262n, 263, 390, 452
- spheres of, 84

elementum primordiale, 320

Eleusis, mysteries of, 83

Elijah, 381, *fig.* 207

elixir/*elixir vitae*, 98, 171, 179n, 232, 392, 419, 453, 460

- white, 286

El-Khidr, 118, 120

Elohim, 429

Elucidarius artis transmutatoriae (Christopher of Paris), 340n

Emerson, Ralph Waldo, 343n

Emmaus, disciples and, 118

empathy, 20

Empedocles, 84n, 325, 330n

enantiodromia, 83f, 86

enclosed space, *see* square

end, and goal, in analysis, 4

energy, 192

- retention of, 49
- surplus, 89

enlightenment, 57, *fig.* 136

- age of, 16, 480

Enoch, 369, 371, 461

- Book of, 58n, 197, 369n

—, Slavonic, [221n](#)
Enōš, [371](#)
ens primum, [330n](#)
Ἐν τὸ πᾶν, [293](#), [319](#)
entelechy, Faust's, [163n](#)
 of self, [183](#)
epiclesis, [351](#)
Epigoni, [423ff](#)
Epilogus et recapitulatio in Novum lumen Sendivogii (Orthelius), [374n](#), [428n](#)
Epimetheus, [365f](#), [371](#)
Epiphanius, [160](#), [380n](#)
Epistola ad Hermannum, [80n](#), [236n](#)
Erinyes, [299n](#)
escapism, [5](#)
Escobar, [20nf](#)
Espagnet, Jean d', [255n](#), [338n](#), [390n](#)
eternity, [105](#), [210f](#)
ether, [264](#), [301n](#)
ethics, Christian, [12](#)
Ethiopian, [401ff](#), *fig.* [219](#)
 man and woman, [286](#)
 treatise, *see* Jurain
Etna, *fig.* [94](#)
Eucharist, [360](#)
Eucherius, [378n](#)
Euphorion, [178](#), [478](#)
Eurystheus, [307n](#)
Eusebius, of Alexandria, [84n](#)
Eusebius of Caesarea, [362n](#)
evangelists, four, [109](#), [129](#), [208](#), [420](#), *figs.* [62](#), [99](#), [101](#), [109](#), [158](#), [197](#)
Evans, C. de B., [102n](#), [112n](#)
Eve, [151n](#), [246](#), [319n](#), [365](#), *figs.* [135](#), [248](#)
evil, [23](#), [25](#), [30ff](#), [102](#), [304](#), [371](#), [381](#)

anima as, 151
doctor and, 31
reality of, 17, 21
and unicorn, 439, 446f; *see also* good/evil
Evola, J., 228, 242n
exaltio, 239, 262ff&n
exchange, theme of, 47, 71
excommunication, 73f, 128
Exercitationes in Turbam, *see In Turbam philosophorum exercitationes*
Eximindus/Eximenus, 320&n
experience: inner/religious, 9, 11, 12f, 14f, 35, 36, 167
of life, 50, 62, 481f
of opposites, 20
eyes, of mind/spirit/understanding, 250f, 255, 269f, 322
Ezekiel, wheels of, 165, 385&n, *fig.* 109

F

faeces, 260
fairies, 52
fairytales, 63
faith, 29, 35, 306, 308
justification by, 31
and — works, 31
Falke, Jakob von, *fig.* 158
Fall, the, 246, 321
familiaris, 66, 69, *fig.* 77
Holy Ghost as, 147
fantasies, 29, 32, 202, 277
fascination, by unconscious, 329, 336, 345
fate, 20, 30n, 361n
goddesses of, *figs.* 6, 205
father, 49f, 115, 120
archetypal, 123

embodiment of traditional spirit, 50, 63, 71, 123
as informing spirit, 123
and mother, guilt of, 115f
return to, 62
father-world/mother-world, 23ff, 73
Fathers of the Church, *see* Church
Faust, 36f, 53n, 67, 155, 156n, 158, 162, 471, 477f
 Faust, 67, 69, 83, 91, 163, 178, 214, 477ff, *fig.* 55
fear, 177, 192, 336
 of ghosts, 333&n
 of God, 271
 of going mad, 32
 of psychology, 17
 of unconscious, 52, 217
Fechner, G. T., 264n
feeling, function of, 115, 158
felix culpa, 30
female forms, throng/plurality of, 49f, 52f, 54, 88, 118, *fig.* 33
feminine: earth, *q.v.*; even numbers, 22f
 four as, 26
 unconscious, 23f, 52, 112, 150, 214
 masculine/feminine, *q.v.*
Ferdinand I, Emperor, 396n
Ferguson, John, 258n, 373n, 424n
Ferguson, John C., 466n
Feritis, 234n
fermentatio/fermentation, 239, 262n, 319n, *fig.* 268
 white, 286
fertility, earth's, 83
fertilization, of dragon by Holy Ghost, *fig.* 267
 of earth by heaven, *fig.* 74
Ficino, Marsilio, 177n, 290, 424n
field, Monad as, 107

fifteen steps of light and darkness, 62

Figulus, Benedictus, 278n, 315n, 316n

Figurae (Lambspringk), see *De lapide philosophico figurae et emblemata*

figures, non-Christian, 18

sacred, 9, 11, 13, 18ff

filius Dei, see Son of God

filius hermaphroditus, fig. 23

filius macrocosmi, 24, 313

Christ as, 425

lapis as, 232, 425

as redeemer, 24

filius philosophorum, 25, 166, 237, 394, 452, 458n, 478, figs. 30, 153, 155

Christ as, 389, fig. 234

end-result of opus, 394

as hermaphrodite, 25, fig. 23

Mercurius as, fig. 22

filius regius, see *regius filius*

filth, as alchemical substance, 260, 313; see also dunghill

finger, fourth, 186

fire, 270, 280, 282, 327, 363, 394

and air/earth/water, 205, 229, 263f, 317, 392

as *aqua nostra/permanens*, 120, 232n, 234n

Christ as, 120, 196, 353f, fig. 58

everlasting, 126n, 196

four grades of, 285

as fourth, 26, 126n, 196, 346, 363

hallowing of, 353

of hell, 325, 344, see also *ignis gehennalis*

holy, 194

of Holy Ghost, 344, 387, fig. 191

lapis as, 120n

Mercurius, 188, 238, 295&n, 387, fig. 130

mountain, 197, fig. 94

music, 194, 196

new, 353n, 354
pneuma, 264, 353f
prima materia, 232, 317
and soul, 264n
south wind, 387
spirit, 346
temple, 15
vas as, 238&n, 239n
warrior, 358
and water, 205, 232, 236, 239n, 269, 330, 382, 469, *fig. 1*
—, union of, *figs. 72, 160*
firestone, 354
Firmicus Maternus, Julius, 57
fish, *see* ANIMALS
Flamel, Nicolas, 276n, 371n
Flaubert, Gustave, 49
fleece, golden, 159, 370
Fleischer, H. L., 84n
flood, 460ff
flos, 76n
 sapientum, *fig. 13*
flower, 118, 175
 blue, 76, 79f, 103, 164, 166, 169
 dream motif, 28
 eightfold, 166, 172, 175, *fig. 85*
 golden, 76&n, 80, 107, 131, 182n, *figs. 30, 133*
 as mandala, 107, 175
 Mary as Flower of the Sea, 180n
 seven-petalled, *fig. 37*; *see also* Jung and Wilhelm; lily; lotus; rose
Fludd, Robert, *figs. 8, 29, 50*
foetus spagyricus, *fig. 210*
folklore, 33, 412
Fons chymicae veritatis (Philalethes), 238n

fons mercurialis, 252, *fig. 25*

signatus, 71; *see also* fountain

food, miraculous, 347f, 352

forest, primeval, 89, 180, 335

form/forma, 260&n, 320

“severe,” 156f; *see also* image

Förster, Max, 221n

Foucart, Paul Francois, 83n

fountain, 71n, 117f, 174f, *fig. 84*

attribute of Virgin, 71, *fig. 26*

mercurial, 252, *fig. 25*

of Sol/Luna, *fig. 38*

of youth/life, *figs. 56, 209*

Fracastoro, Girolamo, 426n

Franck, Adolphe, 206

Franz, Marie-Louise von, 360n, 376n

Freemasons, 90

French sickness, 426n

Freud, Sigmund/Freudian, 62, 131

Frictes, 234n

friend, dreamer’s, 123, 184

Frobenius, Leo, 307n, 339n

fugitive slave, *see servus fugitivus*

fulness of life, 16, 194, 196

functions, four, 69, 106, 151ff, 193, *fig. 49*

auxiliary, 106, 152f, 196

differentiated/masculine, 106, 113, 152ff

inferior/fourth/undifferentiated, 26, 106, 112, 115, 151ff, 155, 158, 168, 175, 196

—, and anima, *q.v.*; intellectual, 127

polarity of, 197, 199; *see also* feeling; thinking

furnace, 238n, 291, 346f, *figs. 2, 113, 119*

great book of, 368

three youths in, *fig. 184*

furrow, 54

G

Gabricus, variant spellings, 329n; *see also* Thabritius

Galatea, 178

Galla Placidia, *fig.* 18

garden, 117, 186, *figs.* 84, 245

attribute of Virgin, *fig.* 26

philosophical, 118, 174, 238n

gate(s), attribute of Virgin, *fig.* 26

of city, four, 108, 109&n

—, twelve, 107

“Gathering, House of the,” 194, 196, *fig.* 93

Gaugler, Ernst, 306n

Gayomart, 368

Geber, 255n, 271, 288f, 314nf, 371n, *fig.* 119

Gebrina Sphinx, 289

Geheime Figuren der Rosenkreuzer, 69n, 227n

Geisberg, Max, *fig.* 250

Gellone, 208n

genii, 202

Geryon, oxen of, 369

of threefold body, 466, 468

Gessner, Conrad, 373n

getting stuck: of soul, 10

universalism and, 30

ghosts, fear of, 333&n

giant(s), 285, 382, 401, 461n

gibbon, 124, 129, 137, 142

girls, wanton, 336n; *see also* female forms

glaciers, 180

Glanville, Bartholomew de, *fig.* 64

glass, filled with gelatinous mass, 177f; *see also* *vitrum*

globe, 84, 87, 103, *figs.* 64, 165, 199

Gloria mundi, 254*n*, 344*n*, 371*n*, 417*n*

glue, 178

“of the world,” 161

Gnosis/gnosticism, 25, 33, 35, 107, 160*f*, 299, 314*n*, 372, 404, 430, 434, 435, 449, 471

cabalistic, 306*n*

and Christ/Christianity, 208, 357

Justinian, 304

original man in, 133, 232

goal: images of, 221

of man, wholeness as, 6, 30, 162, 221

of psychic process, 4*ff*

symbols of, 29, 232*ff*

of therapeutic process, 27

god(s), 34*n*, 180, 245

archaic, 12

Babylonian, 65, 197

chthonic, 158, 329*n*

degradation of ancient, 65

Mercury and, 65

nine/ten, 65

seven, 65, 197, 379; *see also* dwarf-gods; planets

God, 10*f*, 13*ff*, 107, 165*f*, 254, 361

and alchemical art, 271*f*, 280*ff*, 374*f*, 396*ff*

ape of, *q.v.*; archetype, 14

circle with centre, 106*f*

divers forms of, 15

divine hero, 308

and evil, 30

fear of, 271

gold, the colour of, 212

—, earthly image of, 343*f*

and hell fire, 344

hermaphrodite, 302*n*, 330*nf*

imagination of, 280, 282
incarnation, *q.v.*; jealous, 314*n*
kingdom of, 8
in lap of Virgin, 442*n*
and *lapis*, 322, 374, 429
liberation from matter, 312
love for, 21*n*
man in likeness of, 10*n*
mother of, 22
and nature, 464
in Old and New Testaments, 442*f*
one-horned, 442
“outside,” 9, 11
partaker of human nature, 312
polarity of, 465
projected into matter, 323
proof of, 14
as *prima materia*, 322*f*
quaternity of, *figs.* 233, 235
redemption of, in alchemy, 312, 352, 355
res as, 264, 323
science of, 377, 389
Son of, *q.v.*; soul and, 10*ff*, 17, 166
soul as vice-regent of, 279*f*
spirit of, 205, 428
Summum bonum, 464
sun as image of, 343, *fig.* 181
threefold nature of, 74, *see also* Trinity
and unicorn, 440, 442
unity of, 25
wrath of, 166; *see also Deus terrestris/terrenus*

God-almightiness, 481; *see also* inflation

God-image, archetype of, 11&*n*, 12*f*, 14

God-man, Christ as, 304, 306, 359

Manu, 454

Goethe, J. W. von, 67, 158f, 162, 471, 477ff; see also *Faust*

Gokard, tree, 458

gold, 66, 78f, 189, 327, 344, 408, 427, 437

coins, 80f, 103, 246n

colour of God, 212

as *Deus terrenus*, 343

image of sun in earth, 343, 382f

and Mercury, 65f

philosophical, 35, 159, 232, 482

—, *lapis as*, 243

prima materia, 317

quaternity of, 169

rotundum/sphere, 84n, 88, fig. 164

and silver, 262n, 285f, 319, 330

solar, 79

spiritual, 383

tincture of, *lapis as*, 374, 425

viscous, 161; see also *aurum*; COLOURS

Golden Ass (Apuleius), 57n

golden fleece, see fleece

Golden Flower, Secret of the (Wilhelm/Jung), 42, 98, 428

goldmaking, 34, 78, 122, 239, 243, 316, 339n, 431

Goldschmidt, Lazarus, 460n, 461n, 462n

good/evil, 17, 19, 21f, 31, 152, 166, 186

capabilities of soul, 10

relativism of, 22

union of, in self, 21

Gourmont, Rémy de, 398

grace, 7, 13n, 27, 30, 306, 312, 327, 375, 391, 477

grail, 179nf, 188, fig. 88

grain of wheat, 80, 255, 327, 408

graphite, 218

Grasseus, Johannes, [340](#), [342n](#), [386n](#), [436n](#)

gravity, spirit of, [62](#)

Gregory XII, Pope, [258n](#)

XIV, [396](#)

Grenfell, B. P., et al., [323n](#)

griffin, [fig. 246](#)

Ground, the, [8](#)

Guilhelmus Tecenensis, [386n](#)

Guillaume de Digulleville, [209ff](#), [420n](#)

guilt, [30](#), [115f](#)

Güldeneyn Tractat vom philosophischen Stein, [69](#)

gum (arabic), [161](#), [178](#), [235](#), [401&n](#)

Gysin, Fritz, [fig. 245](#)

H

Hades, [53n](#), [143](#), [297](#), [299n](#), [319](#), [335f](#), [369n](#), [figs. 21, 151](#); see also *nekyia*; night sea journey

Hagia Sophia, [138](#), [142](#)

hair, loss of, [339](#)

Hall, Manly Palmer, [227n](#)

hallucinations, [49f](#), [251](#)

Halm, Karl F., [370n](#)

Hambruch, Paul, [307n](#)

Hamlet, [83](#)

Hammer-Purgstall, Joseph, [144n](#), [fig. 70](#)

hamsa, see ANIMALS

Handler, Otto, [6n](#)

“hanging on” to analysis, [5f](#), [28](#)

haoma, [458n](#)

happiness, [148](#)

Harforetus, [347&n](#)

Harmoniae inperscrutabilis (Rhenanus), [376](#)

harmony, sublime, [204](#); see also [fig. 211](#)

Harnack, Adolf von, [21n](#)
Harpokrates, [347n](#), [figs. 52](#), [253](#)
Harrison, Jane, [fig. 139](#)
Hastings, James, [330n](#)
hat, as mandala, [47f](#), [107](#), [185](#), [222](#)
hate, [32](#)
Hauck, Albert, [308nf](#)
head(s), [47f](#), [84n](#), [87](#), [143](#)
 golden, [453](#)
 three in one, [206](#), [fig. 212](#)
 transfigured, [143f](#), [180](#)
 white, [206](#); *see also* skull
hearing, spiritual/bodily, [368](#)
heart, [343](#), [374&n](#), [fig. 149](#)
heat, of underworld, [333](#), [338](#), [346](#)
heathenism, [12](#)
heaven, [246f](#)
 of animals, [412](#)
 golden, [210f](#), [425](#)
 as masculine, [152n](#)
 threefold, [266](#)
Hebrews, [362](#), [365f](#)
Hegemonius, *see Acta Archelai*
Heimarmene, [34](#), [361ff](#), [368](#)
Helen, [477f](#)
Helios, [57](#), [76](#), [417](#); *see also* sun
hell, descent to, [53n](#), [335f](#), [339](#), [354](#), [369n](#); *see also* Hades
hellfire, [325](#), [344](#); *see also* ignis *gehennalis*
Henning, Walter, [37n](#)
Hera, [330n](#)
Heraclitus, [120](#), [143](#), [196](#), [229](#), [327n](#)
Heraclius, Emperor, [293n](#), [347n](#)
Herakles/Hercules, [91](#), [307](#), [369](#), [381](#), [430](#), [figs. 171](#), [215](#)

heredity, 114

heresy, 73, 112

alchemy as, 34

hermaphrodite, 80, 205, 232, 319, 345, 383, 434, 467, *figs.* 54, 123, 125, 199

Adam as, 151*n*

Anthropos as, 161

crowned, 112, *fig.* 116

crucified, 330*n*

deity as, 302*n*, 330*nf*, *fig.* 183

double eagle as, *fig.* 20

filius as, 25, *fig.* 23

lapis as, 112, 202, 232

Mercurius as, 65, 161, 235, 293, 302, 372, 383; 434, *fig.* 125

Nous as, 330*n*, 345

prima materia as, 319*n*, 434

rebis as, 202, *fig.* 199

unicorn as, 447

uroboros as, 413; *see also* androgyny

Hermaphroditisches Sonn- und Mondskind, *figs.* 3, 123, 198, 229, 256

Hermes, *fig.* 139

four-headed, 132

god of revelation, 65, 132, 292, 344

ithyphallic, 132, *fig.* 63

Kyllenios, 468*n*

psychopomp, 67, 292, 299, *figs.* 9, 23, 45

round and square, 132

senex, *fig.* 232

as *Spiritus Mercurii*, *fig.* 179

as Thoth, *q.v.*; as wind-god, 299*n*, 387; *see also* Mercurius

Hermes Bird (Lully), *fig.* 267

Hermes Trismegistus, 114*n*, 133, 178, 236*n*, 250*n*, 255*n*, 299, 319, 330*n*, 344, 358*f*,
361*ff*, 370, 374, 390*n*, 396, *fig.* 128

An die menschliche Seele, 177*n*

as Anthropos, *fig.* 215

grave of, 370
quotations from, in *Rosarium*, 79, 109f, 110n, 112, 118, 168n, 169, 271n, 433n; see also *Tabula smaragdina*; *Tractatus aureus*

Hermetic: philosophy, 29, 171, 227f, 290, 396, 424
vessel, 180n, 236n, 250, 276, *figs.* 23, 120, 121, 153, 226, 230, 236; see also *vas Hermetica*, see *Corpus Hermeticum*; Scott

hero, divine, 308
archetype, 14
myth of, 307, 333ff, 338
sun-, 381f

Herodotus, 83

Herrad of Landsberg, *figs.* 28, 53

Herrliberger, David, *fig.* 44

Herrmann, Paul, 330n

Hesiod, 365

Hesperides, Garden of the, 369n

Hesychius, 362n,
hierosgamos, 37, 329n

Hildegarde of Bingen, *figs.* 126, 195

Hinayana (Buddhism), 202

Hippolytus, 208, 304n, 449ff, 466ff

Hiranyagarbha, 17

hobgoblins, 199

Hoghelande, Theobald de, 238n, 248f, 251, 254, 258, 315n, 319n

Hokhmah, 206

Holmyard, E. J., 387n, 433f, 460n

Holtzmann, Adolf, 456n

Holy Ghost, 24, 147, 246, 345, 378, 383, 425, 427, *figs.* 180, 191
as familiar, 147
as fire, 344, 387
green colour of, 212
as mediator, 152
as Mercurius, 437

as *paredros*, 313
as Sophia, 152
as south wind, 386
as unicorn, 438, *fig.* 261
as winged old man, 344

Homer, see *Odyssey*

Homeric chain, 114&n

homilectics, 6n

homo maximus, 134

homo philosophicus, 161, 392
as Mercurius, *fig.* 214

homo totus, 6

Homoforus, 380n

homunculus, 162, 178, 199, 478, *figs.* 22, 121, 153

Honorius of Autun, 444

Horapollo, 452, *fig.* 7

Horfoltus, 347n

horizon, quartering of, 106

horizontal/vertical, 193f, 213
circle/disc, 203f, 210, 213f

horn, of moon, 450, 466, 468
of narwhal, *figs.* 239, 263
of plenty, *fig.* 165
of unicorn/unicorned animals, 436, 439ff&n, 477n, 449, 453n, 466ff
of unicorn, as alexipharmic, 443n, 447n, 449, 466
—, as symbol of cross, 440f, 444n, 466
—, as uniting symbol, 471

Horos, 161n

horoscope, 206, *fig.* 100

Hortulanus, 169n, 325

hortus conclusus, 186; see also garden

Hortus deliciarum (Herrad of Landsberg), *figs.* 28, 53

Horus, four sons of, 208, *fig.* 102

hostility, 25
hotel, 154
house, astrological, 206, 246
“House of the Gathering,” 194, 196, *fig. 93*
humidum radicale, 449
Huser, John, 162*n*
hybrids, 330*n*
hybris, of consciousness, 479
hydrolith, 404
hyle, 234, 324, 327; *see also* matter
Hypnerotomachia Poliphili (Colonna), *see* Béroalde de Verville

I

“I” and “You,” 5
Ialdabaoth, 460
Iamblichus, 361*n*
idea(s), 245, 262*n*

- eternal, 131, 263*n*
- externalized, 11
- Platonic, 263
- simple/primordial, 264, 269

ideal, search for the, 7

- Christ as, 8

ideation, 193*n*
identification, 131, 323, 353, 479

- with archetypes, 36*f*

identity, and identification, 323

- of psyche and matter, 267, 269, 299*f*
- secret, 353

Ignatius, *see* Loyola
ignis, *see* fire
ignis gehennalis, 325, 339, 354, 383
ignis noster, 232, 234*n*

illuminatio/illumination, 10, 57, 63, 91, 148, 254, 299, 352, 361; *see also* revelation

illusion, 49, 251*f*

image(s): archetypal, 27

divine/sacred, 12, 16

dogmatic, 27

fantastic, 33

of goal, 221

God-image, *q.v.*; inner, 15, 96, 167

mental, 96

outward, 14

primordial, 25, 483, *see also* archetypes

“severe,” 158, 163, 204

in stone, 296

of woman, 194*f*; *see also* anima

imagination, 167, 250, 252, 274, 279, 282

active, 96, 250*f*, 255, 257, 346

as condition of opus, 255, 278, 282

of fire, 280

of God, 282

meditation and, 274*ff*

power of, 196, 278

soul and, 279*f*

as star in man, 277

true, 250, 252, 257, 276

imago: Christi, 353

mundi, 386

imitatio Christi, *see* Christ, imitation of

immolatio, 308&*n*

immortality, 10, 180*f*, 184, 307*n*, 362, 428, 458

imprint(er), 14, 17

Incarnation, 10*n*, 24, 185, 376

incest: brother/sister, 110*n*, 153*n*, 329*ff*, 334, 337, 412*ff*, 415, *fig.* 118, 225

king/daughter, 358

mother/son, 131, 329*n*, 332*n*, 333*n*, 412*ff*, 415

regression to, 131

incorporation motif, 338n; *see also* devouring; swallowing

incorruptible substance, 37, 478

in creatum, 320f&n, 452

incubation, sleep of, 131

 warmth of, 339

India, 8, 150, 161; *see also* *Upanishads*; yoga

individualism, neurotic, 477

individuation, 124, 194, 215, 222, 482

 process, 89, 115, 185

 —, and alchemy, 3, 35, 346, 475

 —, dream symbols of, 41

 —, unconscious, 35

ineptia mysterii, 20

infantilism, 59, 62, 73, 115, 131, 134, 199

inferior function, *see* function

inflation, 213, 304, 479ff

informatio, 165, 262n

initiation, 54, 63, 131, 140n, 449

Inman, Thomas, *fig.* 87

insanity, fear of, 32, 52

inspiration, divine, 252n, 254&n, 315, 348, 374

instinct, 73

 animal, 131, 148, 150

 loss of 59, 137

 world of, 120, 123, 157

Instructio de arbore solari, 255n

integration, 148

 of self, 196

 of unconscious, 131, 413

intellect, 52, 62f, 67f, 86, 91, 93, 106, 114f, 128f, 141, 148, 250, 260, 267, 315n, 340, 374

 deposition of, 69, 73

devilish aspect of, 69, 91, *fig. 36*
differentiation of, 86
as employee, 67, 106
helpful, 129
= spirit, 141
symbolized by Mercurius, 69
— by mirror, 115
intelligence, 264*f*
 needed for opus, 260, 263*n*, 315
intoxication, 131, 143
Introitus apertus (Philalethes), 188*n*, 234*n*, 248*n*, 274*n*, 289*n*, 383
intuition, 114*f*, 117, 137, 202, 296, 433
In Turbam philosophorum exercitationes, 234, 235*n*, 237*n*
iosis, *see* COLOURS
Irenaeus, 109*n*
iron, 317
irrationality, of dogma, 16
Ishvara, 154
Isidore of Seville, 443*n*, 446
Isis, 57, 161*n*, 329*n*, 404
 festivities of, 83
Islam, 19, 118
island, 48, 335
isolation, 137
 by a secret, 49, 52, 54, 89
Izquierdo, Sebastian, *fig. 151*

J

Jabir ibn-Hayyan, *see* Gcber
Jacob: dream of, *fig. 14*: his ladder, 57*n*
Jahweh, 462; *see also* Jehovah
James, M. R., 196*n*
James, William, 10*n*

Jamsthalcr, Herbrandt, *figs.* 59, 115, 137, 199

Janet, Pierre, 89

Jason, *fig.* 187

Jalaka, 456n

Jehovah, 197, 205, 443, 460, 464

Jerusalem, heavenly, 108

 High Priest of, 362n, 363

 temple of, 460

Jesuits, 20n, 30

Jesus/Lord, 21, 36, 120, 138, 196, 308, 323n, 467f; *see also* Christ

jeux de pauine, 143

jewel, *see* stone

Jews, 90, 206

jinn, 460

Jonah and whale, *figs.* 170, 172, 174, 171, 177

Jordan, 461, 467f

Joseph, 362n, *fig.* 170

 cup of, 467

Joseph bin Gorion, 461n

Josephus, 362n

journey, to East, 187

 to four quarters, 307n, 368f, *see also peregrinatio*

 to Hades, 53n, 335f, 339, 354, 369n, *fig.* 69; *see also* night sea journey

Julian the Apostate, 76

Jung, C. G., works: *Aion*, 160n

 “Archetypes of the Collective Unconscious,” 177n

 “Basic Postulates of Analytical Psychology,” 43n

 “Concerning Mandala Symbolism,” 29n, *fig.* 43

 “Concerning Rebirth,” 118

Mysterium Coniunctionis, 147n, 346n, 408n

Paracelsica, 322n

 “Paracelsus as a Spiritual Phenomenon.” 53n, 89n, 115n, 124n, 133n, 161n, 192n, 232n, 304n, 314n, 319, 322n, 392n, 396, 449n, 456n, 460n

“Paracelsus the Physician,” 290n

Psychological Types, 9n, 73n, 83n, 106n, 151n, 193n, 196n, 295n, 471n, 476n, 482n

“Psychology and Religion,” 9, 29, 140n, 197n, 203n, 230n

“Psychology of the Child Archetype.” 166n

“Psychology of the Transference,” 390n

Psychology of the Unconscious, 215

“Relations between the Ego and the Unconscious,” 41, 54n, 73n, 93n, 213n, 274n

“The Spirit Mercurius,” 132n

Symbols of Transformation, 215n, 338n, 460n

“The Transcendent Function,” 346n

“Transformation Symbolism in the Mass,” 84n

“The Visions of Zosimos,” 62n, 252n

and Wilhelm, *Secret of the Golden Flower*, 42, 96n, 98f, 131n, 172n, 215n, 428

Jupiter, 480

Jurain, Abtala, 246n

justification by faith/works, 31

Justin Martyr, 390n, 440

K

ka, 57

Kabasilas, Nikolaus, 309, 313

Kalid, 272&n, 313n, 394

Kant, I., 182

κατάβάσις ἐῖς ἄντρον, 329

Keller, G., *figs.* 28, 53

Kelley, Edward, *figs.* 16, 86, 141, 153, 154, 155, 236

Kerasher, Papyrus of, 208n

Kerenyi, Karl [C.], 362n

kernel, 193

Kether, 206

khilkor, 96

Khunrath, Heinrich Conrad, 124f, 161, 252n, 254, 257, 275, 290n, 313, 314n, 319, 357, 375, 396, 469n, *fig.* 145

King. Charles William, *figs.* 45, 52, 203, 204, 205, 253

king, 110*f*

aenigma regis, 112, 186, *fig.* 54

awakening of, *fig.* 9

caput mortuum, 408

/daughter incest, 358

death of, 337*n*, *figs.* 173, 175

—, by drinking water, 391*n*

filius philosophorum, *fig.* 155

God's son, 417

hermaphrodite, 112

lapis, 112, 469*n*

with planets, *figs.* 79, 149, 154, 155

plumed, *fig.* 228

prima materia, 409, *figs.* 149, 168

and queen, 210, 214, 232, 287, 420, *fig.* 183

— as hermaphrodite, *fig.* 116

rebirth of, 162*n*, 408*ff*, 417, *fig.* 175

redeemer, 409, 422

as *Rex marinus*, 153*n*, 327, 346, *fig.* 166

—, brain children of, 329, 413, *see also* Thabritius

in Ripley's *Cantilena*, 408*ff*

sick, 412, 419, *fig.* 149

Sol, 162, *fig.* 79

sterile, 327, 408, 412*f*

in *Visio Arislei*, 327*f*, 333, 412*ff*

king's son, 162&*n*, 327*f*, 337*n*, 338*n*, 344, 352, 358, 412*f*, *fig.* 179

death of, 329, 331, 333, 346, 348

devoured by king, *fig.* 168

rebirth of, 330*f*, 347, 419; *see also regius filius*; Thabritius

Kingdom, of God, 8

of Heaven, 20, 140, 467

Klettenberg, Fräulein von, 67

Knorr von Rosenroth, Christian, 206

Knuchel, Eduard Fritz, [54n](#)
Koemstedt, Rudolf, [fig. 186](#)
Komarios, [120n](#), [299n](#), [319](#), [359](#), [386](#), [401](#)
Kopp, Hermann, [376n](#), [424n](#), [426n](#), [427](#)
Koran, [118](#), [120](#), [138](#)
Kosmas, [447n](#)
Kramp, Joseph, [309n](#)
krater, [299](#), [368](#)
Krates, Book of, [250n](#), [252](#), [276n](#)
Krishna, [118](#)
kshetriya, [453](#)
Kundalini: yoga, [144](#), [154](#)
 serpent, [180](#)
K'ung-ts'ung-tse, [fig. 260](#)
kybric/kibrit, [329n](#), [401n](#), [402n](#), [458n](#)

L

laboratory and oratory, [fig. 145](#)
Lacinius, Janus, *see* Bonus, Petrus
Lactantius, [144n](#), [264n](#)
lac virginis, [fig. 152](#); *see also* virgin's milk
ladder, [57](#), [62](#), [figs. 15](#), [215](#)
 Jacob's, [57n](#)
Ladislaus II, King of Hungary, [396](#)
Laignel-Lavastine, Maxime, [fig. 61](#)
Lajard, Jean Baptiste Felix, [fig. 183](#)
Lamaism, [95f](#); *see also* mandala, Lamaic
Lamb, the, [108](#), [fig. 62](#)
Lambspringk, [339n](#), [344n](#), [371n](#), [437](#), [figs. 168](#), [179](#), [240](#)
lamias, [52](#)
land, ancestral, [131](#)
 children's, [58ff](#)
 of sheep, [58](#)

Lang, Joseph Bernhard, 23n

lapis (philosophorum), 74, 79, 124, 181, 289, 482

Adam, 319n

aethereus, 243

albus, 232

angularis, 35, 427, *fig. 172*, see also *cornerstone*

Anthropos, 132, 232

aqua permanens, 122n, 234f&n, 324

arising from chaos, 325

aurum non vulgi, 243

beginning and goal of opus, 178, 232, 320n, 322

birth of, 354, 375

body/soul/spirit, 178, 313

brought by birds and fish, 323

carbuncle, 469&n

centre, 98, 118

—Christ parallel, 33, 133, 353f, 357, 372, 374, 389ff, 396ff, 424ff, 434, 475f, *fig. 99*

coniunctio with son/brother, 110&n

consists of four elements, 161, 169&n, 346, 368

crystal, 170

Deus terrestris, 232, 385

diamond, 170, 187

divinus, 120

elixir vitae, 179n

exilis, 80, 180n

filius macrocosmi, 232
fire, 120n
flos, 76n
found in dunghill/filth, 80f, 313, 358, 430
as God, 322
golden tincture, 374, 425
grows from flesh and blood, 178
helper, 118
hermaphrodite, 112, 202, 232
internalis, 120
invisibilitatis, 178, 182, 243
king, 112, 469n
light and darkness, 79, 109
living, 118, 178, 319n
— philosophical, man as, 148, 269
master, 112
medicament, 428
Mercurius, 66f, 285, 293, 319, 424f
Monad, 320n
orphan, 319
paradoxical, 313
pelican, *fig.* 256
philosophical gold, 243
prima materia, 232, 285, 317, 325
production of, 74, 112, 120, 128, 167, 168n, 169, 254
puer, 425
redeemer, 374f
revealed by God, 252n, 254, 315, 374
roundness of, 128, 169, 325, 404
salvator, 232, 429
sanctuary, *fig.* 51
self, 118, 182, 202
simplicity of, 169, 319n
son, *fig.* 13

spirit in, 275, 295, 345, 429
theology of, 428f
has thousand names, 322
three colours of, 169n
time symbol of, fig. 99
treasure hard to attain, 170
trinus, 427f
— *et unus*, 346
ubiquity of, 81, 324
vas, 179n, 236
vilis, 123, 324, 358, 430
vitrum, 171&n
volatility of, 275
water of, 161
white sulphur, 390n; see also *filius philosophorum*; stone

Last Judgment, 329n, 374

lato, 286

lead, 317, 338n, 437n
of the air, 340

left, the, 163, 168, 171f, 174, 186
hand, 186
— path, 131
movement to, 124, 127, 142f, 166, 171, 188, 190, 192f, 197, 206
“throttling of,” 154, 163, 168, 171
is the unconscious, 127, 163, 171, 186; see also right

Légende latine de S. Brandaines, 309n

Leisegang, Hans, 160n, 301n

LeNormant, Charles, fig. 63

leprosy, 255n
of metals, 159

Lessius, 309

leukosis, see COLOURS

Leviathan, 464, fig. 28

Libavius, A., 285, fig. 142

Liber de alchemia (Bernard of Treviso), 258
Liber de arte chymica, 375n, 424
Liber de perfecti magisterii (Geber), 271
Liber duodecim portarum (Ripley), 406
Liber patris sapientiae, fig. 1
Liber Platonis quartorum, 88n, 237n, 262, 264, 266n, 267n, 319, 322, 434n
Liber trium verborum Kallid, 394&n
libido, 192, 340n
Li Chi, 465
life, 73, 81, 178, 196, 343, 347
 fulness of, 16, 194, 196
 life force, 120, 161
 renewal of, 345ff
life-mass, shapeless/gelatinous, 143ff, 177ff
lift, 154f
light, 186f, 188f, 331
 circulation of, 172, 186
 dark, 110
 and darkness, 19, 62, 109
 “everything must be ruled by,” 89, 91, 143, 180
 inner, 270, 322, 370
 kept from those behind, 48
 Man/men of, 363ff, 370
 spark of, 107, 109
 Virgin of, 425
 yellow, 188
like with like, union of, 327, 412
Lilith, fig. 257
Lilium de spinis evulsum (Guilhelmus Tecenensis), 386&n
Lilium inter spinas (Grasseus), 386&n
Lilius, 386n, 469n
Lilliputians, 189
lily, red and white, 287

limbus microcosmicus, 319

lime, 344n

of eagle, 285

lingam, 180

Lingdam Gomchen, 96

Lippmann, E. O. von, 76n, 272n, 295n, 394n, 402n

Litany of Loreto, 180n, 186

Löffter, Karl, *fig.* 62

Logos, 254n, 304, 331, 338, 355, 468, *fig.* 104

Loki motif, 196

Lombard, Peter, *see* Peter Lombard

loneliness, of alchemist, 35, 314

lop-sidedness, 172ff, 190

lotus: deity in/on, 108n, 180n, *figs.* 52, 102

femininity of, 107, 150, 180n

as self, *fig.* 75

Louis II, 396n

love: and hate, 32

see also amor perfectissimus; charity

Loyola, Ignatius, 127, 274n

Lüders, Horstmann, 456n

ludus puerorum, 199, *fig.* 95

Lully, Raymond, 250, 258, 295n, 357f, 373n, 377, 386n, 401

lumen naturae, 254, 270, 322

Luna, *see* moon; Sol and Luna

lunatics, 49

Luther, Martin, 394

Lydus, Johannes, 362n

M

McCrinkle, John Watson, 447n

macrocosm, 386, *fig.* 195

see also filius macrocosmi

mactation, 309

Madathanus, 254n

magisterium/magistry, 120, 128n, 159, 276, 293n, 375, 401f, 437n, 476

magnesia, 125&n

Mahabharata, 456

Mahayana (Buddhism), 96ff, 202

Maier, Michael, 84n, 125n, 243n, 273, 288, 289n, 295n, 313n, 327n, 329n, 332n; 335, 343, 352, 369n, 382f, 398, 408, 426, 430n, 431, *fig.* 31, 60, 78, 81, 97, 138, 144, 175, 210, 216, 225

Maiuri, Amedeo, 140n

male/female, *see* masculine

man, archaic, 131

blindfolded, *figs.* 16, 93

and Christ(ianity), 7f

dual nature of, 114

fragmentary, 7f

future, 6

guilt of, 115f

inner, 7f, 12, 370

—, as Anthropos, 392

— and outer, 7f, 371

of light, 363ff

likeness of God, 10n

masculo-feminine, 467

as microcosm, 24, 319, *fig.* 195

natural, 81

opus and his transformation, 262ff

original, 84n, 133, 161f, 232, *see also* Anthropos

philosophical, 161, 192

physical, five as, 193n

as *prima materia*, 319

primitive, *q. v.*; as redeemer, *see opus alchymicum*, as work of redemption

redemption of, 24, 306ff, 358

red-haired, 154f, 162, 260

self-integration of, 81, *see also* individuation
taking place of intellect, 63
unknown, 93, 304
Western, 9, 27
—, and Eastern, differences, 7f
wholeness of, 6, 18, 27, 30, 84, 162, 221

mana, 458
 personality, 93

mandala, as archetype, 46, 221f
 as atomic nucleus, 183
 as building, 126
 centre of, 42n, 175, 183
 —, deity in, 97f, 108&n, 128f, 180n, *figs.* 42, 62
 as non-ego centre of personality, 99, 105
 coronation of Virgin as, 420, *fig.* 232
 disturbed, 193&n, 213
 ecclesiastical, 206
 expresses attitude, 182
 four-dimensional, 205
 five-rayed, 218
 golden, 214
 hat as, 47f, 107, 185, 222
 horoscope as, 206, *fig.* 100
 Lamaic, 96, 107, 126, 181
 medieval, 129
 “metaphysical” nature of, 98, 105
 model of space-time, 205
 as *perpetuum mobile*, 104f, 181, 222
 as philosophical garden, 174, *figs.* 26, 84
 quaternity of, 155
 ring as, 199, 201
 as rose, 174f
 as self, 181
 square, 42n, 96, 126, 128, *fig.* 62

symbolism, 19, 41f, 95ff, 166, 182, 206, 222
symbol of unity, 27
three-dimensional, 204f, 213
unused, 186
uroboros as, 126
as wholeness, 166, 175, 199
as world clock, 203ff; *see also* Vajramandala
mandorla, Christ in, *fig.* 101
Manget, J. J.: *Bibliotheca chemica curiosa*, 424n, *fig.* 128; *see also* names of individual authors and treatises
Manichaeus, 366n
Manichees/Manicheism, 371, 375n, 380&n, 383n
Manu, 454f
Marcion, 102, 331n
Maria Prophetissa/the Jewess, 236, 314n, 401n, 402n, *fig.* 78
 axiom of, 23, 26, 160
Mariamne, 160n
Marianus, 272n, 479
Marius Victorinus, 370n
Marolles, Michel de, *fig.* 162
marriage, royal, 413; *see also* chymical wedding; *coniunctio*; *hierosgamos*
Mars, 338n, 401
Maruts, 456n
Mary, Virgin, 24, 108n, 214, *figs.* 26, 105, 107, 233
 and Albertus Magnus, 398f
 as arcanum, 399
 assumption of, 420
 coronation of, *figs.* 224, 232
 as earth, 152, 306, 446
 as flower of the sea, 180
 as *fons signatus*, 71
 God of Old Testament and, 442f
 as *hortus conclusus*, 186
 hymns to, 186, 398f

Mercurius as, 383, 424f, *fig.* 38
as *rosa mystica*, 186
and unicorn, 420ff, 438, 442ff&n, *figs.* 241, 242, 245, 247
as *vas*, 180n, *fig.* 87; see also mother, of God
masculine/feminine: deity, 152, 330n
man, 467
numbers, 22f, 26
opposites, 37, 152&n, 330
pneuma, 331n
principles, 23ff; see also hermaphrodite
Masculus, 337n
Maspero, Sir Gaston, 65
Mass, 308ff
alchemical paraphrase of, 396ff
Black, 150
opus and, 312f, 350ff, 357, 389, 408
massa: confusa, 144, 230, 264, 319n, 325, 340, *fig.* 256
—, as *prima materia*, 178, 325
informis, 144, 178, 262f
materia: confusa, 325n
globosa, 88
hypostatica, 252
materia prima, see *prima materia*
materialism, philosophical, 323
matrimonium, 231
alchymicum, 161; see also *coniunctio*; *hierosgamos*
matrix, *vas* as, 237n
matter, chemistry of, 34
descent of spirit (Nous/pneuma) into, 301, 304, 331, 335, 338, 345, 430
and evil, 304
formed by illusion, 252
God projected into, 323
intermediate realm between mind and, 278f, 283
and mind, 228, 260, 269, 301

projection into, *q.v.*; and psyche, 228, 279, 301
—, identity of, 267, 269, 299*f*
redemption of divine soul/spirit from, 306, 312, 355, 477, 480, *fig.* 178
secret in, *q.v.*; spirit in, *q.v.*; the unknown in, 304, 433

Maui, 307*n*

Maximilian, Emperor (1515), 426*n*

Max Müller, F., 162*n*

Maya, *fig.* 108

Mayan ritual tree, *fig.* 190

Mazzuchelli, G. M., 373*n*

measure, right, 32

Medes, 362

mediator, centre as, 128*n*
 divine, 7, 29
 Holy Ghost as, 152

medicament, incorrupt, 269
 lapis as, 428

medicina, 406
 catholica, 312
 transformed bread as, 310

meditatio/meditation, 146, 255, 273*f*, 274*ff*, 312, 339, *fig.* 137

Mehung, Jean de, 270*n*

Meier, C. A., *fig.* 112

melancholia, 36

melanosis, *see* COLOURS

Melchior, Cardinal Bishop of Brixen, 396*n*

Melchior Cibirensis, 350*n*, 396*ff*&*n*, 408, *fig.* 216

Melito of Sardis, 208*n*

Melusina, 53, 304*n*, 458*n*, *figs.* 10-12, 132, 257

mens, 257, 263, 269*f*; *see also* mind

Mephistopheles, 67, 91, 106, 163
 as *familiaris*, 69

Merculinus, 337*n*

Mercurius, *figs.* 24, 80, 127, 164, 165, 192, 257
anima mundi, 132*f*, 188, 420, 425, 449, *figs.* 91, 208
anima Mercurii, *fig.* 157
Anthropos, *fig.* 16
aqua divina, 449, 453
— *nostra*, 453
— *permanens/water*, 69, 235, 238&n, 285*f*, 401
astrological, 69, 371
body/soul/spirit, 319*n*
caput corvi, 293
cauda pavonis, 293
cervus (servus) fugitivus, 66, 146, 437
child, *fig.* 216
Christ, 438
chthonic, 65
coniunctio of, 401*n*
cross between sun and moon, *fig.* 192
devil, 66, 134
dove, 436*f*, *fig.* 134
dragon, *q.v.* under ANIMALS;
dual nature, 65*ff*, 285, 299, 371, 437, 464, *figs.* 22, 86
duplicatus, 427
eagle, 66, 437
earth spirit, 345
familiaris, 66
feminine, 383*n*, 438
fiery sulphur in, 383
filius, *fig.* 22
fire, 188, 238, 295&n, 387
foetus spagyricus, *fig.* 210
fountain of, 252, *fig.* 25
goblin, 66
god of revelation, *see* Hermes; helpful spirit, 66
hermaphrodite, *q.v.*; Holy Ghost, 437

homo philosophicus, [fig. 214](#)
intellect, [69](#)
lapis, [66f](#), [285](#), [293](#), [319](#), [424f](#)
lion, [66](#), [436f](#), [463](#)
—, green, [285](#), [420](#), [fig. 160](#)
master-workman, [166](#)
matter and spirit, [295](#)
monster, [460](#)
moon, [383n](#), [fig. 194](#)
multiformity of, [352](#)
nigredo, [293](#)
Nous, [345](#)
oil, [371n](#)
paredros, [66](#)
penetrating, [297](#), [371&n](#), [438](#), [fig. 150](#)
in philosopher's egg, [fig. 22](#)
philosophorum, [426](#), [450](#), [fig. 268](#)
phoenix, [466](#)
pneuma, [299](#)
poison, [371](#)
powers of transformation, [371](#)
prima materia, [66](#), [285](#), [293](#), [434](#), [452](#)
psychopomp, [67](#), [292](#), [299](#)
quadratus, [26](#)
quadripartite, [133](#)
quicksilver, [65f](#), [69](#), [74](#), [132](#), [292f](#)
raven, [66](#)
redeemer, [372](#), [449](#)
salamander, [fig. 138](#)
and scarab, [452](#)
senex, [115](#), [fig. 134](#)
serpent, *q.v.* under ANIMALS
spirit, [69](#), [293](#), [297](#), [345](#), [437](#), [458n](#), [figs. 134](#), [179](#)
sun drowned in, [252](#), [331](#)

tension of opposites in, 464
three-headed/*tricepsialis*, 26, 460, *fig. 16*
transforming substance, 26, 131ff, 146, 371, 434, 449
triunity, 26
and unicorn, 435ff, 449, 452, 463f
uniting symbol, 295, *figs. 146, 148*
uroboros, 293, 345, *fig. 147*
use of term in alchemy, 26n
versipellis, 460
as vessel, 238&n
in vessel, *figs. 120, 121*
as Virgin, 383, 424f, 438, *figs. 38, 231*
virgin of light, 425
virgin-serpent, 304n, *figs. 157, 257*
vivus, 74
wheel, 166
winged, 202, 292; see also *aqua/spiritus mercurialis*
mercury (element), 26n, 65, 235, 246, 324, 330; see also quicksilver
Mercury (planet), 26n, 65, 371
 conjunction of, 401
 as double-headed eagle and uroboros, *fig. 20*
Merlinus, 337n, 391n
mermaids, 156, *fig. 12*; see also Melusina
Meru, world mountain, 108
Merz, Walther, *fig. 243*
Messiah, 307
Metallorum metamorphosis (Philalethes), 238n, 239n, 371n
metal(s), molten, 251
 seven, 65, 246, 302, 379, 408
 sick, 312
 unripe, of philosophers, 285
metaphysical: assertions, 14, 29
 definition of, 98n, 105
metropolis, 107

Meung, *see* Mehung
Meyrink, Gustav, 48, 80, 241n
Michael (archangel), 362n
Michelspacher, Steffan, *fig.* 93
microcosm, Christ as, 392
 man as, 24, 319, *fig.* 195
 prima materia, 317, 319&n
Middle Ages, 86, 323
Midrash Tehillim, 462n
Migne, Jacques-Paul, 15n, 84n, 144n, 152n, 165n, 390n, 398n, 440n, 442n, 444n, 445n, 446n, 466&n
Milky Way, 180
Mill of the Host, *fig.* 158
mind, 257f, 260, 263, 269f, 361, 365f
 and body, 269, 279f, 350
 eyes of, 251, 255, 270
 medieval, 150
 and salt, 257; *see also matter*
miraculous food, 347, 352
mirror, instrument of navigation, 113ff, 117
 magic, *fig.* 55
mirror-image, 172, 174
Missal, 311
 Beuron edition of, 309n
Mithras/Mithraism, 142, 307, 340n
Mohammed, 275n
Mohammed ibn Umail, 392n; *see also* Senior (Zadith)
Molsdorf, Wilhelm, *fig.* 180
 μῶλυ, 76n
Monad, 107ff&n, 110, 124, 304, 319&n, 330n, 386
 as field and city, 107
 twelve, 107, 109n
Monas hieroglyphica (Dee), 319n

monoceros, *see* ANIMALS

Monogenes/*μονογενής*, 107*f*, 110, 118, 371, 452

monogrammist E.S., *fig.* 250

monster/*monstrum*, 292, 434, 447, 458*f*, *figs.* 227, 256

soul as, 166

moon, 141, 383*ff*, 401*ff*, 404, 446, *figs.* 106, 220

condition in opus, 232

eclipse, 286

“heavenly horn of the,” 450, 466*ff*

as *prima materia*, 317, 404; *see also* sun and moon

moral code, 30

Morienus Romanus, 272*f*, 293*n*, 313*ff*, 314*n*, 375&*n*, 430, 479

Morpheus, 202

mortificatio, 231, 309, 337, 420*n*, *figs.* 135, 173, 223; *see also* death

Moses, 118, 120, 246, 248, 401*n*, 440, 462, *fig.* 213

serpent of, *figs.* 217, 238

sister of, 160

mosque, 118, 138, 142

mother, 15, 69, 73&*n*, 110, 115, 141, 420, *fig.* 6

city, 107, 110

and daughter, 24

of elements, *in creatum* as, 321

of God, 22, *see also* Mary, Virgin

nature, 165*f*

as *prima materia*, 317

primordial, 24

and son, 24, *see also* incest

as unconscious, 71, 74

world, 23*f*

motion, perpetual, 104*f*, 181

mountain(s), 160, 285*f*, 433, 462

of adepts, *fig.* 93

burning, 194, 197, *fig.* 94

coniunctio on, 160
four, 166
and unicorn, 461n
world, 108
Muller, Nikolaus, *figs.* 72, 75
Musaeum hermeticum, see names of individual authors and treatises
muses, nine, *fig.* 211
Mutus liber, *figs.* 2, 22, 113, 124, 132, 133, 143, 161, 215, 237, 269
Mylius, J. D., 76n, 110n, 225, 239n, 320, 381n, 437, *figs.* 21, 34, 114, 125, 163, 188, 200, 218, 223
mysteries, Dionysian, 89f, 131, 140ff, 150, 307
 of Eleusis, 83
 of Isis, 57
 of Sabazius, 144
 of Samothrace, 468n
 transformation, 81, *fig.* 70
mysterium, 306
 altaris, 408
 incretum, 322n
 iniquitatis, 166, 383n
 magnum, 12, 34n, 321n, 379, 433
mysticism, Christian, 355
 Hermetic, 430
 Protestant, 430
mystification, by alchemists, 73, 243f, 289, 316
 and real mystery, 244
myth(ology), 25, 33; see also hero

N

Naassenes, 208, 449, 466, 468ff
Nature, 266, 464
 classical feeling for, 34
 composite/discriminated, 262ff
 conquers nature, 386

Eternal/Mother, 165
natura abscondita, 345
principle of, 110, 124n; see also *lumen naturae*

Navajo Indians, sand-painting of, *fig.* 110

Nazareth, 101

Nazari, Giovanni Battista, 252&n

Nebuchadnezzar, 346

nekyia, 53&n, 120, 141; see also Hades; night sea journey

Neoplatonism, 83, 86

Neopythagoreanism, 83, 299n, 301, 302n, 304, 325, 330n, 350n

Neptune, 156, *fig.* 132

neurosis, 33, 215
treatment of, 5

New Testament, see BIBLE

Nicomachus, 302n, 330n

Nierenstein, M., & Chapman, P. F., 291n

Nietzsche, F. W., 81, 89, 143, 144, 155, 183, 296f, 479

night club, 172

nightmares, 32, 192

night sea journey, 329, *figs.* 170, 171, 172
see also *nekyia*

nigredo, see COLOURS

Nikotheus, 361n, 363, 370

Nile, 295, 345

Nilus, St., 442

non-ego, 62, 128, 301
nature of anima, 106
as self, 117; see also ego

Norton, Samuel, *figs.* 122, 214, 221

Norton, Thomas, 270n, 291n

Nostoc, 178

“nothing but,” 10&n, 91, 123, 220

Notker Balbulus, 335n

Nous/*voŪς*, 325, 361*n*, 365*n*, 366*n*

as Anthropos, 301*f*

Christ as, 304

as daemon, 301

descent into Physis, 301, 304, 331, 335, 338, 345; 430

as hermaphrodite, 330*n*, 345

in krater, 299

liberation of, 355

as Mercurius, 345

as tincture, 299

as uroboros, 345; *see also* pneuma

Novum lumen chemicum (Sendivogius), 250&*n*, 254*n*

NUMBERS:

one, 124, 255, 274, 293&*n*, 304, 319, 320*n*, 392, 402, 450

and two, 22, 23, 26, 160, 162*n*

and three, 15, 22, 151, 162, 206, 212, *figs.* 16, 185, 212, *see also* Trinity

and four, 22, 124, 162

as fourth (axiom of Maria), 23, 26, 160; *see also* Monad; unity; *Unum*

two, and one, 22, 23, 26, 160, 162*n*

and three, 23, 26, 160, 162&*n*; *see also* binarius; duality; Dyad

three, 76, 125, 157, 163, 193*n*, 204*ff*, 210, 212, 266, 285, 390, 394, 456, 458

and one, *q.v.*; and two, *q.v.*; and four, dilemma of, 26*f*, 96, 154*f*, 159*f*, 196, 208, 213, 218, *fig.* 59

colours, *q.v.*; as masculine, 26

the third, 23, 26, 160, 467*f*; *see also* ternarius; triad; Trinity

four, 106, 108*f*, 115, 123, 124*f*, 128*n*, 129, 132, 143, 148*n*, 155, 159*f*, 163, 165*f*, 169, 186, 193&*n*, 197, 199, 203*f*, 205*ff*, 218, 229, 346, 363, 368*f*, 381, 409, 450, *figs.* 82, 93, 117, 206, 211

and one, 22, 124, 162

in one, 35

and three, dilemma of, *see* three; and five, 218

alchemical stages, 229, *fig.* 114

colours, *q.v.*; elements, *q.v.*; evangelists, *q.v.*; as feminine, 26

and Hermes, 132

rivers of paradise, *figs.* 62, 109, 197

sons of Horus, 208, *fig.* 102

the fourth, 23, 26, 125, 126n, 151, 157f, 160ff, 186, 213, 346, 467f; *see also*
quartering; quaternity; *tetraktys*

five, 162n, 193n

and four, 218

six, 162, 193n, 456

planets, *q.v.*; and seven, *figs.* 20, 126; *see also senarius*

seven, 63ff, 67, 76, 158, 163, 197, 209, 246f, 302, 366, 379, 408, 457, *figs.* 5, 28,
29, 202, 203, 205

and six, *figs.* 20, 126

and eight, dilemma of, 67, 154f, 158f, 162, *fig.* 85

alchemical stages, 76, *figs.* 29, 93, 221, 251

planets, *q.v.*; the seventh, 63, 67, 197

eight, 67, 154, 158, 162f, 175, 188, 205, *fig.* 80

and seven, dilemma of, *see* seven

the eighth, 158, 162

nine, 65, 84, 366, 456, *fig.* 211

ten, 65, 205, *fig.* 117

twelve, 107, 108n, 193n, 212, 379ff

alchemical stages, 239, *fig.* 122

fifteen, steps of light and darkness, 62

sixteen, 205

twenty-two, 205

thirty-two, 203f, 205f

even and odd, 22f, 330n

numina, 183

numinous, 182, 196, 345, 476, 482

archetypes, 36

nuts: four cracked, 197, 199

hard, 193

nymphs, 86, 88, 89, 221, *fig.* 33

O

objective psyche, 43, 46, 215, 218, 221f

objectivity, of psyche, 28

of psychology, [15](#), [18](#)
oblatio, [309f](#), [404](#)
oblong(s), [192ff](#), [213](#)
obscene stories, [83](#)
“*obscurum per obscurius*,” [35](#), [227](#), [244](#)
occiput, [267](#), [434n](#); *see also* skull
Odyssey, [53n](#), [368n](#)
Oedipus, [289](#)
Offertory, [312](#), [350](#), [404f](#)
Og, king of Bashan, [460ff](#)
ogre, [63](#), [65](#)
oil, [232n](#), [234](#)
 from hearts of statues, [295n](#)
 Mercurius as, [371n](#)
Old Testament, *see* BIBLE
Olympiodorus, [236n](#), [315n](#), [319](#), [362n](#)
Olympus, [67](#), [158](#), [162](#), [425](#)
Omar, mosque of, [275n](#)
Omphale, [307n](#)
On (Heliopolis), [362n](#)
Only-Begotten, [35](#); *see also* Monogenes
Ophites, [144](#), [331n](#)
Oppenheim, Gustav, [362n](#)
opposites, Christian tension of, [23](#)
 coniunctio of, *q.v.*; in deity, [330n](#), [371](#)
 as enantiodromia, [83f](#), [86](#)
 experience of, [20ff](#)
 identity of, [282](#)
 irreconcilable, [152](#)
 non-union of, [412](#)
 pairs of, [152](#), [232](#), [33f&n](#), [413](#), [476](#)
 —, projection, [282](#)
 polar, [476f](#)

in *prima materia*, 329n, fig. 162
problem of, 19ff, 37, 280
separation of, 25
synthesis of, 153&n
unconscious, 334, 338
union of, 6, 22, 37, 205, 231, 295, 330n, 350, 476, figs. 113, 167, see also
 coniunctio
—, self as, 19, 25, 186
warring, 186
opus alchymicum, 124, 146, 167, 171, 199, 228f, 239, 242ff, 266, 288ff, 352, 394, 424,
 482, figs. 4, 75, 132, 209, 215
 aims of, 33
 as *arbor philosophica*, 420, figs. 188, 221
 and Christianity, 33
 in *Faust*, 36, 37
 and imagination, 167, 274ff, 282f
 and Mass, 312f, 352f, 357, 389, 396ff, 408
 mental prerequisites for, 255ff, 269ff
 as odyssey, 370, fig. 97
 and projection, q.v.; psychic transformation process, 62, 144f, 148, 262ff, 289, 297,
 383n
 secret of, q.v.; stages, q.v.; symbols of, figs. 4, 122, 188
 as uroboros, 293
 as wheel, 293, 380f, 385f, fig. 80
 as work of redemption, 304f, 306ff, 312f, 329n, 339, 352ff, 372, 375, 412f, 477
opus circulatorium/circularare, 293, 381f, 386
opus divinum, 308, 313, 329n, 389, 430, 476
opus supernaturale, 308
Opusculum philosophiae naturalis (Zacharius), 260&n
Ordinale (Norton), 270n
Ordinall of Alchimy (Norton), 291n
ore, 317
organs, psychic representatives of, 338
orgy/orgies, Dionysian, 131, 143

Origen, 196n

original man, *see* man; Anthropos

original sin, 20, 30, 358

Orpheus, 307, *fig.* 211

Orthelii Epilogus, 374n, 428

Orthelius, 428, 430

Ortolano, *see* Benvenuti

Osiris, 208, 307, 362n, 369, 381, 401n, 450, 453, *fig.* 102

Osnabruck Register of Santa Maria, 398

Ostancs, 252, 295, 345, 353, 401, 458

P

padma, *see* lotus

paganism, 11f, 143

in alchemy, 464

Palingenius, Marcellus, 243n

palm, attribute of Virgin Mary, *fig.* 26

panacea, 232, 312, 346, 372, 460, 477, 481, 482

Pandora, 365, *figs.* 13, 231

panic, 129

Papyri Graecae Magicae, 132

Papyrus of Hunefer Kerasher, 208n

Parabola (Sendivogius), 252n, 315n

Paracelsus, 34n, 35, 53, 67, 115, 161n, 162, 178, 239, 277n, 290n, 304n, 314n, 319, 320ff, 348n, 379, 392, 408, 426, 430, 433, 452, 456n, *fig.* 261

paradise, 209, 221n, 246, 327, 363, 375, 450

four rivers of, *figs.* 62, 109, 197

honeycomb of, 362n

tree of, in sea, 348n

paradox(es), 148, 150

in religion, 11n, 15f; *see also* antinomy

πάρεδρος, 66, 313

parents, return to, 62

Paris, judgment of, [fig. 9](#)
and Helen, [477f](#)
Parmenides, [258](#)
Parthians, [362](#)
Patrizi, Francesco, [396](#)
Paul, St., [124](#), [138](#)
paut neteru, [65](#)
pearl, [270](#), [fig. 61](#)
Peirithous, [335](#)
pelican, philosophical, vessel, [128](#); *see also* ANIMALS
pendulums, [203f](#); *see also* clock
penetration, point of, [188f](#)
Penotus, Bernhardus Georgius, [408](#), [437](#)
perception, sense, [146](#), [263f](#), [269](#), [374n](#)
subliminal, [137](#)
peregrinatio, [369ff](#), [381](#), [431](#), [fig. 97](#)
Peregrinus, [fig. 197](#)
Pernath, Athanasius, [48](#)
perpetuum mobile, [105](#), [181](#), [222](#)
persecution mania, [49](#)
Persephone, [24](#)
Persepolis, [453n](#)
personality, alteration of, [49](#)
centre of, *q.v.*; dark half of, [31](#)
disintegration of, [337](#)
evolution of, [35](#)
flattening of, [194](#)
partial, [9n](#), [81](#)
renewal of, [74](#), [144](#), [148](#)
split, [115](#), [118](#)
total, [106](#), [329](#)
unified, [81](#)
personification, [54](#), [69](#), [115](#), [150](#)

meaning of, 169

Peter Lombard, *fig.* 104

Petrarch, *fig.* 252

Petronius, 167n

Phaedrus, 361n

phallus, tree as, *fig.* 131

phantasia, 167

φάρμακον ἄθανασίας, 98, 310, 460

phenomenology, religious, 33

 of self, 19

Philalethes, Eirenaeus, 146, 188n, 234n, 238n, 239n, 248n, 274, 289n, 371n, 383

Philebus, 361n

Philemon, 480

Philo, 362n

Philolaos, 325

philosophers' stone, see *lapis*

Philosophia chemica (Dorn), 260&n, 381n

Philosophia meditativa (Dorn), 255&n, 260n

Philosophi potius occultare (Penotus), 408, 437&n

philosophy, Gnostic, 35, 299, see also Gnosis

 Hermetic, q.v.; mystical, 228

 natural, 34, 66

Philostratus, 447n

φῶς ὡς, 363&n

Photius, 365n

φνσικά/μυστικά, 228, 242, 423

Physica genesis (Dorn), 260n, 32n

Physica Trismegisti (Dorn), 237n, 254n, 260n

Physiologus Graecus, 443n, 446, 466

Physis, 202, 304, *fig.* 178; see also Nous

Picinelli, Philippus, 165n, 443

Pico della Mirandola, Gianfrancesco, 424n

Pictor, Albertus, *fig.* 42

Pignatelli, Jacobus, [34n](#)
pill, golden, [182](#)
pilot, [113](#), [117](#)
Pirke Rabbi Eliezer, [461](#)
Pisano, Antonio, *fig.* [262](#)
Pisces, [212](#)
pissing manikin, *fig.* [121](#)
Pistis Sophia, [160n](#), [371n](#)
Pitra, J. B., [208n](#), [444n](#)
Pityis, [361n](#)
planets, [137](#), [170](#), *fig.* [100](#)
 gods of, [34](#), [65](#), *figs.* [21](#), [23](#)
 and metals, [65](#), [246](#), [302](#), [379](#), [408](#)
 seven, [55f](#), [165](#), [246f](#), [302](#), *figs.* [20](#), [29](#), [199](#)
 — spheres of, [57](#), [302](#), *fig.* [51](#)
 —. stairway of, [55](#)
 six, [162](#), *figs.* [154](#), [155](#), [192](#)
 —, sons of King Sol, *fig.* [79](#)
plant motif, in dreams, [28](#), [154](#)
Plato, [84n](#), [361](#), [362n](#), [375](#)
Platonis liber Quartorum, see *Liber Platonis quartorum*
play of goats, [81](#)
pleroma, [107f](#)
Pliny, [295](#), [361n](#), [447n](#)
Plotinus, [371](#)
Pluto, [425](#)
 daughter of, [161n](#)
pneuma, *fig.* [134](#)
 autonomy of, [301](#)
 descent into matter, *q.v.*; fire, [264](#), [353f](#)
 male-female, [331n](#)
 as Mercurius, [299](#)
 of Nile stone, [295](#)

penetrating, 299&n
powers of transformation, 371
Son of God, 301
as wind, 301n; see also Nous
Poimandres, 299, 350n, 365n
sect, 314n, 368
Poimen, 185
“Pointed Beard”, 67f, 89, 91, 106, 163
poison, etymology of *iosis*, 229n
Mercurius as, 295
as *prima materia*, 235, 317
and unicorn, 443n, 447n, 449, 466
Pole, the, 188
Polia, Lady, 86
Poliphilo, 53, 86, 120, 252, 336n, fig. 33; see also Béroalde de Verville
Pommet, P., fig. 254
Pompeii, Villa dei Misteri, 140n
Porphyry, 237n, 371
Porta, Giambattista della, fig. 76
Portu, Bernardus à, see Penotus
possession, 143, 481
by archetypes, 36, 478
Potipherah, 362n
Potter, Most High and Almighty, 382
potter’s wheel, see wheel
Practica Mariae, 160n, 239n, 314n, 402n
Prajapati, 454
prefiguration, doctrine of, 185
Preisendanz, Karl, 132n, 452n, 453n
Pretiosa margarita novella (Bonus), 162, 315n, 373ff, fig. 79
prima materia, 23, 65, 124, 159, 178, 188, 202, 289, 293, 317ff, 379, 420, 432f
as Adam, 319, fig. 131
air, 317

aqua permanens/water, 232, 234f, 263, 317, 324, 404
bisexuality of, 452
blood, 317, 319
body and spirit, 319n
changeability of, 433f
chaos, *q.v.*; cloud, 317
dea mater, 322
dew, 317
dragon, 23, 285, 317, 319, 452, *fig.* 267
earth, 317, 342, 450, *fig.* 163
eternity of, 322
Eve, *fig.* 135
fire, 232, 317
God as, 322f
gold, 317
green lion, 285
gum, 235
Hades, 319
heaven and earth, 319n
hermaphrodite, 319n, 434
increatum, 320ff, 352
Isis, 404
king, 409, *figs.* 149, 168
known to God only, 254
lapis, 232, 285, 317, 325
lead, 340
man, 319
massa confusa, 178, 319n, 325
Mercurius, *q.v.*; microcosm, 317, 319&n
Monad, 319, 386
monster, 319n, 434, 458
moon, 317, 404
mother, 317
nigredo, 188, 230, 327

opposites in, 329n, *fig.* 162
ore/iron, 317
poison, 235, 317
radix ipsius, 320
rebis, 434
res, 319, 322f
salt, 317
Saturn, *fig.* 161
sea, 235, 317
self-begetting, 319n
shadow, 317
sky, 317
spirit, 317
— in, 342, 345, *figs.* 129, 229, 232
sublimation of, *fig.* 175
sulphur, 317
has thousand names, 124, 234, 322
ubiquity of, 313, 323ff
= unconscious, 433
unknown substance, 317
Unum, 319
urine, 235
uroboros, *fig.* 13
vas, 236
Venus, 317
vinegar, 235, 317
water of life, 317
wolf, *fig.* 178
Prime Cause, 14
primitive man, 115, 333
 psychology of, 33, 278
prince, in dream, 186
 of this world, 465
Prinz, Hugo, *fig.* 26

Priscillian, 442

probabilism, 20ff&n, 30

projection, 146, 239, 279

into anima, 83

of Anthropos, 302

of archetypes, 11, 34, 37, 476

Christian, 304, 307

definition of, 245

and *Faust* drama, 477ff

of God-image, 11

imagination and, 250, 279, 282f

into man, 304

into mandala, 183

into matter, 34, 37, 228, 244, 267, 270, 277, 296, 299f, 304, 386, 476

—. of God, 323

of opposites, 282

into opus, 245ff, 250, 274, 282f, 317

pagan, 304, 307

of redeemer image, 476

religious, 10f

of shadow, 29

significance of alchemical term, 297n

of unconscious contents, 329, 345, 374n, 413, 475ff

of wholeness on family, 115

withdrawal of, 479

Prometheus, 365, 366n, 371

prophets, 36

Hebrew, 307

Protestantism, 8, 312

Proteus, 289

Przywara, Erich, 27n

psyche, animal, 81, 90

archaic, 11

autonomy of, 46, 50, 54, 146, 183f

childhood, 4
and Christ ideal, 7
coalesces with body, 220
collective, 57, 81
as consciousness, 480f
creative capacity of, 184
definition of, 8n
goal-seeking, 5, 221
God-image in, 14
historical, 58, 67
knowledge of, 5, 9, 14
layers of, 33, 137
and matter, *q.v.*; mystery of, 3f
objective, 43, 46, 215, 218, 221f
and opus, 242ff, 255, 257, 258, 270
—, as transformation process, 62, 144f, 148, 262ff, 289, 297, 383n
personal, 217f
and projection, *q.v.*; and psychologism, 8f, 13
reality of, 8, 91, 302, 481
subjective, 43
total, 69
totality of, as self, *q.v.*; as the unconscious, 432
unknown, 182, 323, 432
as water, 74; *see also* soul
psychologism, 9, 13
psychology: “compartment”, 6
empirical, 14, 17, 277
fear of, 17
objectivity of, 15, 18
personalistic, 33
primitive, 33, 278
and religion, 9, 13f, 15, 17, 29
and theology, 18
transcendental, 242ff

of the unconscious, [16f](#), [26](#), [37](#), [276](#), [475](#), [482](#); *see also* analytical psychology
psychopomp, [58](#), [67](#), [292](#), [299](#), [figs. 8](#), [9](#), [19](#), [23](#)
psychosis, [148](#), [217](#), [333n](#); *see also* schizophrenia
psychotherapy/psychotherapist, [4ff](#), [27](#), [30](#), [32](#), [33](#), [36](#); *see also* doctor
Ptolemies, libraries of, [362](#)
Pueblo Indians, [131](#), [182](#)
Puëch, Henri Charles, [371n](#)
puer, [425](#)
pulses, thirty-two, [204f](#)
Purusha, [14](#), [17](#), [161](#)
putrefactio/putrefaction, [231f](#), [239](#), [286](#), [figs. 48](#), [221](#), [223](#)
putting together, motif of, [177n](#)
pygmies, [fig. 96](#); *see also* Cabiri; dwarf
Pyramid inscriptions, [65](#)
pyrites, [76n](#)
Pythagoras, [87n](#), [336n](#), [347ff](#), [374](#), [fig. 211](#)

Q

quadrangle, Lamaic, [128](#); *see also* square
quadrangular garden, attribute of Virgin Mary, [fig. 26](#)
quadratura circuli, [96](#), [128n](#), [figs. 59](#), [60](#); *see also* circle, squaring of
qualities, four, [229](#)
quartering/tetrameria, [106](#), [124](#), [133](#), [149](#), [162n](#), [191](#), [229](#)
quarters, four, [106](#), [132](#), [205f](#), [363](#), [381](#); *see also* journey; *peregrinatio*
quaternity, [26](#), [115](#), [193](#), [229f](#), [381](#), [467](#), [figs. 185](#), [192](#), [232](#)
 of Adam, [363](#), [368](#)
 alchemical, [169](#), [fig. 235](#)
 of centre, [205](#), [218](#), [fig. 31](#)
 Christian, [fig. 233](#)
 as feminine, [205](#)
 and trinity, [169](#), [205f](#), [230](#); *see also* NUMBERS S.V. four
queen, of heaven, [420](#)
 and king, *q.v.*; of Sheba, [340](#), [437n](#)

of the South, 378f, 386
Quercetanus, Josephus, 239
quicklime, 344n
quicksilver, 26n, 65f, 69, 79, 132, 235, 260, 288, 292f, 297, 299, 317, 344, 382, 387,
402n
expulsion of, 295; see also *argentum vivum*; mercury
quintessence, 124, 205, 264, 278, 340, 430

R

Rabanus Maurus, 378n
radix ipsius, 320
railway journey, 48
rain, silver, 286
rainbow, 113, 187, 193, 214, 286
rainbow bridge, 57, 60, 114, 202
Rakshas, 456
Ramayana, 456
Rashi, commentary of, 461
rationalism/rationalist, 7, 32, 50, 480
attitude, *q.v.*
rationality, of cosmos, 146
rationalizations, pseudo-scientific, 9
Raymundus, 169
reality, 114, 191f, 214
potential, 282, 476
psychic, 73
subtle, 283
realization, 175, 190, 197, 204, 214, 222, 283
rebirth, see regeneration; renewal
rebis, 202, 243, 420, 434, *fig.* 125
rectangle, see square
Recueil stéganographique, see Béroalde de Verville
redeemer, 35, 129, 306, 308

Christ as, *q v.*; king as, 409, 422
lapis as, 374*f*, see also *salvator*
lowly origin of, 28
man as, see redemption, in alchemy
Mercurius as, 372, 449; see also saviour
redemption, in alchemy, 24, 306*ff*, 312*f*, 329*n*, 339, 352*ff*, 372, 375, 412, 413, 476*ff*
—, of divine soul/spirit in matter, 202, 306, 312, 355, 477, 480, *fig.* 178
—, of God, 312, 352, 355
in Christianity, 30, 306*ff*, 351, 358
red-haired man, 154*f*, 162
blood of, 260
Red Sea, 390
re'em, see ANIMALS
reflection, 115, 183, 302, 386
left and right reversed by, 171*f*
Reformation, 8, 406
regeneration, 74, 350, 359, 404, *fig.* 152; see also renewal
regimina, four, 26
three, 205
regio; aetherea, 321
nymphididica, 89
regius filius, 330*f*, 338; see also king; king's son
regression, 175*f*, 180
to childhood, 59*f*, 62, 115, 118
to Helios, 76
historical, 88
to incest, 131
to paganism, 11, 86, 141
to unconsciousness, 481
Reitzenstein, Richard, 55*n*, 98*n*, 145*n*, 228, 237*n*, 272*n*, 293*n*, 302*n*, 361*ff&nn*, 370*n*
rejection, motif of, 71, 74, 80*ff*, 86, 123, 155, 185
rejuvenation, Faust's, 478*f*
relativity, of time and space, in unconscious, 138, 182

religion(s), 194, 196

archetypal forms in, 33

certainty in, 16

classical, 35

history of, 33

logical contradictions in, 15

outward form of, 11*f*

paradoxes and, 15*f*

pre-Christian, 24

psychological education and, 7

psychology and, 9, 13*f*, 15, 17, 29

truth of each, 483; *see also* experience

Rembrandt, *fig.* 55

Renaissance, 86

renewal, of Ethiopian, 402

of king, 162*n*, 408*ff*, 417, *fig.* 175

of life, [345f](#)
of personality, [74](#), [144](#), [148](#)
rites of, [131](#), [134](#), [137](#), [144](#)
sea of, [fig. 222](#)
repentance, [30](#)
repression, [59](#)
res (simplex), [263n](#), [264](#), [319](#), [320n](#), [322](#)
resin of the wise, [161](#)
resistance, [50](#), [197](#)
resurrection, [231](#), [307n](#), [329](#), [339](#), [357](#), [359](#), [374](#), [392](#), [437](#), [figs. 177](#), [270](#)
Reusner, Hieronymus, [420&n](#), [figs. 13](#), [231](#), [232](#)
revelation, divine/in dreams, [10](#), [252&n](#), [315](#), [374](#)
 god of, *see* Hermes
revolution in Switzerland, dream of, [154](#)
Rex marinus, *see* king
Reymann, Leonhard, [fig. 100](#)
Rhasis, [315n](#)
Rhenanus, Johannes, [157n](#), [376](#)
rhythms, three, [204f](#), [212](#)
Richardus Anglicus, [258](#), [260](#)
rift, in Christian order, [22](#), [27](#)
right/right side, and left, [171f](#), [174](#), [192f](#)
 movement to, [127](#), [192f](#); *see also* left
Rig-Veda, [454](#)
rimpoche, [96](#)
ring, [186f](#), [199f](#), [204](#)
Ripley, Sir George, [232n](#), [237n](#), [238n](#), [283n](#), [323ff](#), [324](#), [344](#), [371n](#), [381](#), [406ff](#), [437f](#), [464](#)
Ripley Scrowle, [325n](#), [417n](#), [420](#), [458n](#), [figs. 30](#), [92](#), [196](#), [228](#), [251](#), [257](#)
Rishyashringa, [456](#)
rites of initiation, [54](#)
 of renewal, [131](#), [134](#), [137](#), [144](#)
 of transformation, [fig. 70](#)
river(s), [123](#)

four, 128n
—, of paradise, *figs.* 62, 109, 197
rock-paintings. Rhodesian, 97
rope ladders, 193
rosa msstica, 186
Rosario de la gloriosa vergine Maria, *fig.* 87
Rosarius philosophorum, 78f&nf, 109, 110n, 112, 118, 120n, 124n, 128, 148, 159, 167nf, 169, 178n, 180n, 232n, 243n, 257f, 271, 272n, 276, 290n, 293n, 295n, 315n, 316n, 320, 331, 333, 335n, 337, 371n, 379, 383, 386n, 390n, 422, 433n, 469n, *figs.* 25, 54, 167, 169, 234, 235, 268
Rosarium minor, 174n
Roscher, W. H., 387n, *fig.* 77
rose(s), 76, 107, 172, 174f, *figs.* 13, 29, 30, 83, 193
 Christ in, 108n
 garden of philosophers, 118, 174, 238n
 noble, 246
Rosenreutz, Christian, 402n, 436; *see also* chymical wedding
Rosicrucians, 76, 314n, 431
“Rosie Crosse,” 76
Rosinus, 452
Rosinus ad Sarratantam, 371ff, 452
rota, *see* wheel
rotation/*rotatio*, 104, 124, 164f, 188, 191f, 194, 210, 325
 see also *circulatio*; circumambulation
rotundum, 88, *figs.* 34, 165, 166
 city as, 127n
 head/skull as, 84n
 prefiguration of gold, *fig.* 164
 production of, 88; *see also* “round” motif
“round” motif, examples of: *anima mundi*, 84n, 88, 325
 circle, 128
 croquet ball, 115
 fish in the sea, 325n
 gold, 84n, 88, *fig.* 209

hat, 48

head, 87

Hermes, 132

lapis, 128, 169, 325, 404

original man, 84n

potter's wheel, 191

simple body, 169

soul, 83f

table, 175, 177&n, 186

temple, *fig. 26*

vas, 87, 128n, 236f&n

wholeness/self symbolized by, 115, 117n, 191; see also *rotundum*; sphere

royal marriage, 413; see also chymical wedding

rubedo, see COLOURS

Rubicon, 120, 123f

Rudra, 456n

Ruellc, Charles, 360nff, 356nf

Ruland, Martin, 239, 274, 276f, 278n, 292, 317, 402n, 420n, 430n

running away, motif of, 5, 49, 54, 114, 143, 145ff, 154, 174, 189, 192

Rupert, St., 445

Rupescissa, Johannes de, 394n

Rusch, C., *fig. 230*

Ruska, J. F., 57n, 76n, 86, 153n, 234n, 254n, 255n, 257n, 271n, 276n, 315n, 320n, 327n, 347n, 348, 360ff&nn, 390n, 392n, 401nf; see also *Turba*

rust, 159

S

Sabazius, 144

Sachse Codex, 227n

sacrifice: to the dead, 53n

Christ's, in Mass, 306f, 308ff, 312, 352f

etymology of, 309; see also *oblatio*; Offertory

sacrificium intellectus, 50

sal, *see* salt

sal sapientiae, 257

salt, 257, 288, 453, 460

of metals, 340, 437n

prima materia, 317

salvation, 29, 36, 74, 79, 127, 154, 301, 308, 312, 329, 352; *see also* redemption

salvator, lapis as, 232, 429

macrocosmi, 24

Salzer, Anselm, 108n, 447n

Samhazai/Shemhazai, 461

Samothrace, mysteries of, 468n

Samson, *fig.* 177

Sanchez, Thomas, 34n

sand-painting, *fig.* 110

Sapientia (Dei), 342n, 377ff, 386, 394, 404, 420, *figs.* 201, 232, 257

austri, 378

Saturn, 338n, *figs.* 134, 152, 200

prima materia, *fig.* 161

satyr play, 81, 89, 131

savages, battle between, 174, 184

saviour, 185, 196n, 246, 425, 429, *figs.* 107, 182

chicken, 412

in Manicheism, 380; *see also* redeemer

Sbordone, F., 446n, 466n

Scaiolae, 115, 314n

scala lapidis, *fig.* 15

Scaliger, Paulus, *fig.* 261

scarab/scarabaeus, 436, 452f

Schedel, Hartmann, *fig.* 71

Scheftelowitz, Isidor, 471n

Schiller, J. C. F. von, 155

schizophrenia, 89, 337

Schmidt, Carl, 160n, 371n

Schmieder, Karl C., 424n, 426n

Schoen, Erhard, fig. 100

Schopenhauer, A., 115

Schrader, Eberhard, 453n

Schultz, Wolfgang, 302n, 330n

science, and astrology, 386

and consciousness, 34

and faith, 14

of God, 377, 389

scientia, 404

scintillae, 301n, 386

Scites, 234&n

Scott, Walter, 299n, 344n, 350n, 360ffnn

Scoyaris, 314n

sea, 48, 117, 188, 285ff, 317, 327, 339, 390&n, fig. 186

as *prima materia*, 235, 317

of renewal, fig. 222

symbol of (collective) unconscious, 48, 118, 156, 188, 202, 329, fig. 222

seasons, 132, 191, 206, 381

secrecy, of alchemists, 243; *see also* mystification

secret, divine, 313, 404

of goldmaking, 243

of healing cup, 467, 469

isolation by a, 49, 52, 54, 89

in matter, 244, 267, 296, 313, 321, 433, 481

of opus, 78, 257f, 279, 283&n, 288, 290n, 317, 431, figs. 132, 269

personal, 52, 244

societies, 314&n, 430f

“terrible/marvellous,” 304, 401

seed, of unity, 25

golden, 182

seeing, art of, 13

Seele, translation of, 8n

self: allegory of Christ, 19
antinomial character of, 21
archetype of, 18f, 22, 25f
— unity, 25
Atman as, 8, 107
attitude to, 182
borderline concept, 182, 355n
centre of personality, 41, 106, 205, 220
— collective unconscious, 188
as conflict, 21, 186
— and unity, 21
cosmic, 107
devaluation of, 8
Ding an sich, 182
and ego, 41, 106, 117, 355&n
entelechy of, 183
indefiniteness of, 18, 19
individuality/uniqueness of, 19
and integration, 81, 196
as *lapis invisibilitatis*, 182
latent, 81n
as lotus, *fig. 75*
mandala as, 181
as non-ego, 117
as objectivity of psyche, 28
origin in instinct, 120
paradoxical, 19, 21
phenomenology of, 19
as Pole, 188
quaternity of, 218ff
realization of, 190, 222
roundness of, 115, 191
Son of Man anticipation of, 208
as spirit, 220

as stranger's hat, 185
symbolized by Christ, 18f, 208, 355
— garden with fountain, 118
— El-Khidr, 118
— sun, 83
symbols of, 18, 93, 188, 215ff
as totality of religious figures, 18
— of psyche, 41, 106, 182, 205
transcends consciousness, 182, 202
treasure hard to attain, 117f, 163
union of good and evil, 21f
— of opposites, 19, 186
as wholeness, 18, 115, 222, 329n
self-cremation, 307n, 381
self-fertilization, 161, 452
self-incubation, 339
self-realization, 194
self-redemption, 184
self-sacrifice, 306
semel credidisse, 12
senarius, 162n
Sendivogius, Michael, 66n, 250n, 252n, 254n, 279nf, 315n, 340n, 428n
Senior, Adolphus, *see* Adolphus Senior
Senior (Zadith), 159n, 234n, 248n, 250, 252, 271, 392, 404, 428n, *fig.* 128
sense perception, *see* perception
separatio/separation, 452
— of elements, 230, 239, 262n, 263, 390
— of spirit and body, 124, 263n
Sepher Yetsirah, 205
Sephiroth, 205
Septem tractatus seu capitula Hermetis Trismegisti aurei, 255n
Serapeum, 362
Sermo de transmutatione metallorum (Morienus Romanus), 272n, 293n, 313nf, 430n

serpens mercurii/mercurialis, see ANIMALS s.v. serpent

Servatius, St., [fig. 206](#)

servus fugitivus, [66](#), [146](#), [437](#)

Setheus, [107f](#)

“seventh, the,” [63](#), [67](#)

 mountain, [197](#)

shadow, [29ff](#), [32](#), [36f](#), [93](#), [151n](#), [168n](#), [196](#)

 and anima, [177&n](#)

 encounter with, [31](#), [36](#)

 as *prima materia*, [317](#)

Shakti, [97](#)

Shatapatha-Brahmana, [454](#), [456](#)

Shaw, Bernard, [138](#), [194](#)

Sheba, Queen of, [340](#)

sheep, land of, [58](#)

Shem, [371](#)

Shêng Chi T’u, [figs. 259](#), [260](#)

Shepard, Odell, [471n](#)

shepherd/Poimen, [58](#), [185](#), [307n](#)

 of Aries and Taurus, [fig. 17](#)

 Christ as, [fig. 18](#)

ship, [104](#), [107](#), [201f](#), [fig. 97](#)

Shiva, [97](#), [108n](#), [129](#), [154](#), [fig. 75](#)

bindu, [180](#)

Shri-Chakra-Sambhara Tantra, [96](#)

Shri-Yantra, [fig. 39](#)

Sibylline Oracles, [363n](#)

sidpe-korlo, [96](#), [fig. 40](#)

Siebmacher, see *Aquarium sapientum*

Sihon, [461](#)

Silberer, Herbert, [69](#), [228](#)

silver, [197](#), [262n](#), [285ff](#), [319](#), [fig. 38](#)

 condition in opus, [232](#)

simia Dei, 134; see also ape, of God

Simon Magus, 357n

simple/simplicity, 124, 169, 264

soul, 264, 267, 320, 434n; see also *res*

sin(s), 21, 31f, 117, 152, 391

original, 20, 358

“outside,” 8

and repentance, 30

Sinai, Mount, 197

“sinister” side, as unconscious, 127, 163; see also left

sirens, 52

sister, 69, 73&n, 83, 115

as anima, 73; see also incest

skull, 83

as *vas*, 87, 267, 434n, *figs.* 75, 135

sky, as *prima materia*, 317

slave, red, 153n

Slavonic Book of Enoch, 221n, 363n

smoke, 278n, 282, 285

Socrates, 234n

Sol, 76, 162; 234, 417, *figs.* 79, 133, 268

et eius umbra, 168n, *fig.* 81

niger, 110, *fig.* 34; see also Helios; sun

Sol and Luna, 202, *fig.* 38

coniunctio, 390n, 401n, 477, *figs.* 13, 23, 27, 32, 113, 141, 161, 223; see also sun
and moon

soldiers, 155, 163, 190

solificatio, 57f, 63, 76, 80, 84

Solomon, King, 342, 378n, 379

solstice, 133, 199

olutio, 230, 239, 262n

“*somnia a Deo missa*,” 10

son, of chaos, 91

of darkness, 36
and father differentiation, 24
of Great World, 275
of Tiamat, 25
upper and lower, 24; see also *filius*

Son of God, and Antimimos, 366, 371
“becoming all,” 360f, 365, 371
Christian belief in, 15, 36
and classical myth, 307n
in flower, 107f
as the fourth, 346
as God-man, 304, 306
as Gnostic Christ, 368
as liberated divine soul, 312
Monogenes as, 107
one with Adam, 365, 368
pneuma as, 301
and priestly art, 360
produced by alchemist, 112
red colour of, 212
in Zosimos, 360ff

Son of Man, 208, 304, 313, 379

Songe de Poliphile, 53n, 239n, 250n, 336n, 453n, *figs.* 4, 5, 33; see also Béroalde de Verville

Sophe, Book of, 306n

Sophia, 152, 404, 450

sorceress, 190

soror mystica, and artifex, *figs.* 132, 140, 215, 237, 269

soul, 124, 178, 194, 196
abode of evil, 17, 101f
aerial, 232n
affliction of, 272f
and body, *q.v.*; of Christian, 11f
Christianization of, 12

definitions of, [8n](#)
deification of, [13](#)
devaluation of, [8ff](#), [11](#), [101](#)
dwells in blood, [279f](#), [343n](#)
fiery nature of, [264n](#)
freed from Heimarmene, [361f](#), [368](#)
and God, *q.v.*; as guide, [fig. 19](#)
-image, [9n](#)
and imagination, [279f](#), [282](#)
immortality of, [10](#)
loss of, [59](#), [115](#)
as monster, [166](#)
and nature, [263f](#)
by nature Christian, [12n](#), [21](#)
perils of, [54](#), [333](#)
psychology and, [9](#), [13f](#)
redemption of divine, [202](#), [306](#), [312](#), [355](#), [477](#), [480](#), [fig. 178](#)
religious function of, [12f](#)
respect for, [102](#)
simplicity of, [264](#), [267](#), [320](#), [434n](#)
-sparks, [301n](#), [386](#)
a sphere, [83f](#)
a square, [336n](#)
transcendental energy, [9n](#)
as the unconscious, [280](#)
wheel for raising, [380&n](#)
winged, [fig. 139](#)
a worm, [166](#); see also *anima*; psyche
source of life, [73](#), [83](#), [84](#), [120](#), [123](#), [131](#), [137](#)
south, the, queen of, [378f](#)
wind of, [386f](#), [398](#)
wisdom of, [377](#)
space and time, [105](#), [205](#), [214](#), [220](#)
relativity of, in unconscious, [138](#), [182](#)

spark, of light, 107, 109, 251

soul-, 301n, 386

struck from firestone, 353f, 390n

species, the, 408, 419

Speculativae philosophiae (Dorn), 251n, 260n

sperm of philosophers, 401

sphaericum opus, 325

sphere(s), 154, 285ff

anima mundi, 84n, 88, 325

Empedoclean, 84n, 325

original man, 84n

seven, 209

— planetary, 57, 302, fig. 51

soul, 83f

vas, 87, 128n, 236f&n

winged, fig. 209

of water, 325n; see also globe

rotundum; “round” motif

spinther, 107, 109, 301n, 386

spiral, of inner development in dreams, 28, 177, 179f, 217

spirit, and body, *q.v.*; breath of, 285, fig. 115

creative, 282

devil as aerial, fig. 36

earth-, 342, 345

eyes of spirit/mind, 250, 251, 255, 270, 322

filius regius, 330f, 338

of God, 205, 428

of gravity, 62

hermaphrodite, 345

as intellect, 141

in *lapis*/Nile stone, 275, 295, 345, 429

in matter/*prima materia*, 267, 278, 293, 295ff, 342, 345, 428, 476, 480, figs. 129, 229, 232

as Mercurius, *q.v.*; and nature, 464

as *prima materia*, 317
as quintessence, 124
redemption of divine, 306, 312, 355, 477, 480, *fig.* 178
self as, 220
traditional, 73
—, father as, 50, 63, 71, 123
transforming substance, 26*n*
uroboros, 345
water from, 205
world-, 429

spirits, ancestral, 131
 astral, 426
 eternal, 165
 fugitive, 250
 in *prima materia*, *figs.* 129, 229, 232
 seven, of God, 379
 shining, 366

spiritus; creator, 282
 igneus, 387
 mercurialis/mercurii, 67, 325*n*, 438, 458*n*, *fig.* 179
 metallorum, 34
 mundi, 429*f*
 vitae, 132, 437, *fig.* 109

Spitteler, Carl, 81, 123, 430

Splendor solis, 452

split personality, *see* personality

sponsus/sponsa, 14, 394, *fig.* 103

square, animals transformed in, 143*ff*
 Chinese earth-, 128, 150
 —, as *yoni*, 150
 circumambulation of, 108*n*, 124, 127, 143*ff*, 172, 189, 193
 city, *fig.* 31
 dance hall, 193
 garden, *figs.* 26, 84

“House of the Gathering,” 194f, *fig.* 93
imprisonment in, 189, 190
mandala, 42n, 96, 126, 128, *fig.* 62
oblongs and, 192f, 213
rotating, 194
rotundum and, 127n
round and, Hermes as, 132
soul as, 336n
as *temenos*, 131
—, feminine nature of, 186
as temple, 126
triangle and, 125, 126n, 128, 169
with unknown woman, 164
squaring the circle, *see* circle
stages of alchemical transformation, 228ff, *figs.* 15, 133, 142
 four, 229, *fig.* 114
 seven, 76, *figs.* 29, 93, 221, 251
 twelve, 239, *fig.* 122
stair(s), 54, 62, 174
 stairway of seven planets, 55
Stapleton, H. E., 392n
star(s), eight-rayed, 190, 192
 North, 188
 rotating, 104
 seven, 197
 seven/twelve, 379
 shooting, 172
Steeb, Joannes Christophorus, 433n
steed of the Church, *fig.* 53
Stefano da Sant’Agnese, *fig.* 103
Steinschneider, Moritz, 88n, 234n
Stephanos of Alexandria, 159n
steps, *see* stair(s)
sterility, king’s, 327, 408, 412f

Stevenson, James, *fig.* 110

stigmata, 7, 355, *fig.* 58

Stobaeus, John, 327*n*

Stoic(s), 299*n*

 doctrine, 264*n*

Stolcius de Stolcenberg, Daniel, *figs.* 48, 173, 222

stone(s), living philosophical, 148, 269

 precious, 186, 192, 210, 270, 335, 358, 409

 —, as rejected jewel in Spitteler, 81, 123, 430

 spirit in, 295*f*, 345

 uncomely, 80, 180*n*, 304; *see also* cornerstone; *lapis*

Straub, A., *figs.* 28, 53

Strauss, Heinz Arthur, *fig.* 100

stupa, 126*ff*

subconscious/superconscious, 137, 155, 280

subject, transcendental, 8

subjective psyche, 43

subjectivism, 15

sublimatio/sublimation, 57, 124, 239, 275, 307*n*, 368, 374, 381, 386, 428*n*, *figs.* 175, 200

substance(s), consecrated, 308*f*, 352

 incorruptible, 37, 478

 metaphysical, 269

 noble, 273

 one, 234; *see also* arcanum; transforming/arcane substance

subtle body, 277*ff*, 310, 427

succubi, 49

succus lunariae, 74

Sudhoff, Karl, 162*n*, 321*n*, 379*n*, 433*n*

suffering, moral, 21*f*

suggestion, 27, 44

sulcus primigenius, 54

sulphur, 166, 288, 329*n*, 330, 383, 402&*n*, 460, *fig.* 194

philosophorum, 234, 428n

prima materia, 317

white, as *lapis*, 390n

Summa perfectionis (Geber), 255n, 271n, 314n

Summarium philosophorum (Flamel), see *Tractatus brevis*

Summum bonum, God as, 464

sun, 48, 57&n, 66, 76f, 83f, 131f, 170, 176, 188, 330f, 381f, 401n

black, see *Sol* s.v. *niger*; chariot, *fig.* 206

Christ as, 84, 208, 417

condition in opus, 232

devoured by lion, 252, *fig.* 169

eclipse of, 286

-god, 57, 381

gold the image of, in earth, 343, 382f

image of God, 343, 382, *fig.* 181

of justice, 417

and *opus circulatorium*, 382

source of life, 84

symbol of divinity of self, 83

-vessel, *fig.* 171

wings of, 408, 417

worship, 84f&n, 88; see also *Helios*; *Sol*

sun and moon, 247, 276, 330, 389, 409, 440, *figs.* 57, 183, 194

coniunctio, see *Sol* and *Luna*

eclipse of, 286

furnaces, *fig.* 113

hermaphrodite, *Mercurius* as, *fig.* 125

Mercurius, standing on, *fig.* 22

—, as cross between, *fig.* 192

trees, *fig.* 116

Super arborem Aristotelis (Albertus Magnus), 370n, 401n

Super Tabulam smaragdinam Commentarius (Hortulanus), 169n, 325&n

superman, 296f, 479f

superstition, 32, 63, 153

Svayambhu, 454

swallowing, motif of, 190, 331, 338, 345, 417; *see also* devouring; incorporation

sweat-bath, 339n

sword, 117n, 309, 331

symbol(s), alchemical, *figs.* 3, 4, 112, *see also* symbolism

of centre, 29, 41, 217ff

Christ, 19

Christian, 25, 76

cosmogonic, 25

formation, 482

of the goal, 232ff

of Mercurius, *q.v.*; nature of, 283

of *prima materia*, *q.v.*; religious, 127

of self, *q.v.*; *typos as*, 17

unconscious as matrix of, 432ff

of unity, mandala as, 27

uniting, 295, 372, 471, 476, *figs.* 146, 148

of uroboros, 293

of *vas*, 238

symbolism, alchemical, 33f, 424, 432f, 483

—, in relation to Christian and Gnostic, 33, 435, 471

—, — Church, 447

—, — dream symbolism, 33, 346

—, — individuation process, 35, 475

—, — psychology of unconscious, 37

animal and ancestor, 134f

Christian, 22, 25

Gnostic, 449

fish, 141, 307n

mandala, *q.v.*; serpent, 144

unicorn, 452, 471

water, 74, 360

symbolon, 185

symmetry, 171f, 174, 193, 197

lack of, 218
symptoms, removal of, 4f
symbolic, 355
synchronicity, 306
syncretism, Greco-Roman, 55, 86, 301n
Taoist, 98
Synesius, 315n
Szebeni, Nicholas Melchior, *see* Melchior Cibinensis

T

tabernacles, three, 394
table, round, 175, 177&n, 186
Tableau des riches inventions, *see* *Songe de Poliphile*
taboo area, 54, 81, 196; *see also* *temenos*
Tabor, Mount, 461f
Tabula chymica (Senior), 390n
Tabula smaragdina, 164n, 178, 255n, 271n, 360n, 371n, 401n, 444ff, 445, 449f, *figs.* 210, 216
tail-eater, 293, 382, *figs.* 13, 46, 47; *see also* ANIMALS s.v. uroboros
Talmud, 460ff, 462n
Tantra/Tantric, 180f, 280; *see also* yoga
Tao, 14, 466
Taoism, 98, 182
Taos, 131
tapas, 339
target, 104, *fig.* 48
Targum Pseudo-Jonathan, 461, 462n
Taurus, *fig.* 17
Taylor, F. Sherwood, 293n
taxi, 172, 186
Tecenensis, *see* *Guilhelmus Tecenensis*
Tehom, 23
Telesphorus, *fig.* 77

telum passionis, [figs. 80, 131](#)

temenos, [54, 81, 106f, 168](#)

city as, [fig. 31](#)

compensatory significance, [83](#)

feminine nature, [186](#)

garden as, [118](#)

as prison, [190](#)

sacred building, [140](#)

square as, [131](#)

womb as, [131](#)

temple, [96, 126, figs. 26, 93](#)

tension, and circular movement, [104, 145, 148, 190, 192](#)

ternarius, [125](#)

ternary and quaternary systems, [96](#)

terra alba foliata, [232](#)

terror, motif of, [89](#)

Tertullian, [12n, 15f, 20, 152, 440, 446](#)

Testamentum (Cremer), [291n](#)

testudo, [157n, fig. 76](#)

tetraktys, [150, 169](#)

tetrameria, *see* quartering

tetramorph, [109n, figs. 53, 65](#)

tetrapeza, [109](#)

Thabritius, death of, [329, 331, 333, 346, 348](#)

rebirth, [330f, 347, 419](#)

and Beya, gestation in brain, [329, 413](#)

incest, [153n, 252, 331, 337&n, 350, 412, 415](#)

in triple glass house, [333, 346](#)

variant spellings, [329n](#)

Thales, [159, 449](#)

Theatrum chemicum, *see names of individual authors and treatises*

Theatrum chemicum Britannicum, [458n, figs. 1, 118, 267](#); *see also Ordinall of Alchimy*

Thenaud, Jean, [figs. 6, 74](#)

Theodoret, 383n
theologian(s), 6n, 12f, 17, 28, 183
theology, and psychology, 18
 of *lapis*, 428f
theoria, 289, 290n
Theosebeia, 299
theosophy, 101
therapist, *see* doctor
Theseus, 335
thinking, function of, 158
Thölde, Johann, 426
Thomas (Aquinas), pseudo, 271, 376
Toth, 133f, 137, 299, 361n, 370, *fig.* 68
thought, symbolized by birds, 201f
Thoyth(os), 362&n
threefold and fourfold universe, *fig.* 1
 threefold cord, 394, *fig.* 215
throne, crystal, 210, 214
Thurneisser zum Thurn, *fig.* 91
Tiamat, 23, 25
Tikkanen, Johann Jakob, *figs.* 176, 247
Timaeus, 84n, 362n
time, and eternity, 212
 and place, 191f
 -symbol of *lapis*, *fig.* 99; *see also* space and time
timelessness of centre, 105
tinctura: alba, 232
 rubea, 124
tincture, 239, 286, 297, 299, 346, 392, 428n
 golden, 374, 425
 red, 232, 358
 white, 232
Tom Thumb, 63

Torquemada, Cardinal, 466

torture, 335n

totality, as ego plus non-ego, 106

of personality, 106, 329

“psyche” as, 9n

self as, of psyche, 41, 106, 182, 207

—, of religious figures, 18

of transforming substance, 133; *see also* wholeness

tower, 107

attribute of Virgin Mary, *fig.* 26

Toyson d’or, La (Trismosin), *fig.* 112; *see also Aureum vellus*

Tractatus Aristotelis, 128n, 251, 381n

Tractatus aureus, 109n, 110, 118n, 124n, 148n, 150n, 152n, 168n, 169, 236n, 254n, 272n, 319n, 358f, 404n

... *cum Scholiis Gnosii*, 128n, 236n

Tractatus brevis (Flamel), 371n

Tractatus Micreris, 386n

tram-car, 115f

transcendental, clock, 105

energy, soul as, 9n

prejudice, 18

psychology, 242n

self as, 182, 205

subject, 8

unconscious, 137

transference, unresolved, 5

transformation, alchemical, 79, 132f, 228, 313, 428, 479, *figs.* 121, 214

animals into men, 143ff, 177

in Mass, *see* transubstantiation; mysteries, *q.v.*; place of, 145, 196

psychic, 62, 144f, 148, 289, 297, 383n

psychic/alchemical parallel, 262ff

stages, *q.v.*; vessel of, 267, 299, *see also vas*

yogic, 339

transforming/arcane substance, archetype of, 386

body/soul/spirit of, 394
Christ as, 434
consists of four elements, 133
devilish/divine, 134
flos, 76n
gum arabic, 161
identity of psyche and, 267
macrocosm, 386
magnesia, 125n
Mercurius, 26n, 131ff, 146, 371, 434, 449
movements of, 164n
Nostoc, 178
rotating, 386
round and square, 133
veritas, 269; *see also* arcanum
transmutation, alchemical, 228, 406, 408
 in Mass, 310, *see also* transubstantiation
transubstantiation, 308ff, 351, 404, 406, 434
treasure, 84, 123, 358
 “hard to attain,” 117, 158, 170, 335, 340ff, 346
 self as, 117f, 163
treatment, analytical, 4f, 29, 31
tree, 28, 166, 174
 of Adam, 460, *fig.* 131
 and ass, 458
 of coral in sea, 348n, *fig.* 186
 of Eve, *fig.* 135
 Gokard, 458
 of Hermetic philosophy, 29
 of Hesperides, *fig.* 189
 immortal, 348n, 352
 of life, *figs.* 26, 264
 with life-giving fruit, 197, 348
 Mayan, *fig.* 190

and Melusina, 458n, *fig.* 257
as mother/virgin, 420, *fig.* 231
philosophical, 255, 276, 419, *fig.* 188, see also *arbor philosophica*
in Western land, 460

triad, *fig.* 185

triangle/quadrangle, 125, 126n, 128, 169, *fig.* 75

Triga chemica (Barnaud), 437n

Trimurti picture, *fig.* 75

Trinity/trinity, 151, 169, 193n, 212, 214, 390, 437ff
alchemical, 344, *fig.* 179
cabalistic, 206
chthonic, 460
Cross and, 76
masculine, 22, 205
and quaternity, 169, 205f, 230
and seed of unity, 25
as *tricephalus*, *fig.* 212; see also NUMBERS s.v. three

triple glass house, 333, 346, 348

Tripus aureus (Maier), 290, *fig.* 144

Trismegistus, see Hermes Trismegistus

Trismosin, Salomon, *figs.* 32, 95, 112, 134, 166, 219

triunity, Mercurius as, 26

trust in God, 31

truth, alchemical, 258, 260
of contradictions, 15, 20
and faith, 29
paradoxical, 16, 150

Tscharner, E. H. von, 466n

Turba philosophorum, 57n, 76n, 86, 122n, 153n, 234n, 254n, 257n, 258, 314n, 320, 327n, 329n, 339n, 347n, 348n, 374, 375f, 386n, 390, 392n, 402n

Turfan Fragment, 371n

typos/type, 14, 17f, 221; see also archetype

Tz'u-yuan, 465n

U

ὕδωρ θείον, 122n, 297, 360, 449

as poison, 299

“ugliest man,” 155

Ulmannus, 424n

Umail (Hamuel) Muhammad bin, 376n; *see also* Senior (Zadith)

unconscious, activation/animation of, 49, 52f, 89, 155

anima, personification of, 54, 84, 103f, 112, 150, 177n

animal impulses of, 145, 157, 190

approach of, 48, 50ff

archetypes of, 17, 32, 36, 221

autonomy of, 46, 54, 89, 184, 333n

“behind” as, 48

centralizing processes in, 217ff, 482

chthonic, 24

collective, 26, 32f, 36, 48, 57n, 62f, 188, 221

—, mother as, 71, 74

—, and personal, 62f

compensation by, 24f, 44, 46, 54

and consciousness, *q.v.*; contamination by, 26, 112, 152f, 158, 177n, 196

cosmic aspect, 171

depotentialization of, 123

depreciation of, 50

descent into, 329, 333

dialectic/coming to terms with, 4f, 29, 93, 153, 274, 417

dominants of, 245, 276

and eternity, 105

experience of, 50, 52, 103, 245

fascination by, 218, 329, 336, 345

fear of, 52, 217

feminine, 23f, 52, 112, 150, 214

guidance by, 60

as the “hereafter,” 479

illimitable, 182

images in, 13
integration of, 131, 413
intuitions from, 117, 137, 433
invasion by, 48n, 49
left/sinister, 127, 163, 171, 186
mask of, 25
matrix of symbols, 432ff
necessary evil, 183
numinous, 182, 345
as objective psyche, 43f, 46, 215
order in, 148
outside nature, 283
over-powering by, 333n, 334f
paradoxical, 433
personal, 32, 62f, 177n
as *prima materia*, 433
projection of, *q.v.*; psyche as, 432
psychology of, 16f, 26, 37, 276, 475, 482
sea as (collective), 48, 117f, 156, 188, 329, *fig.* 222
secret of opus in, 258
self latent in, 81n
skeleton in cupboard, 159
space-time relativity of, 138, 182
spiral/circular movement of, 28, 103, 217
and sub/superconscious, 137, 155, 280
synthetic work of, 215
transcendental, 137
underestimation of, 194
as unknown psyche, 182, 323, 432
as whale, *fig.* 222
unconsciousness, 6, 26, 96, 150, 186, 334, 476, 481
“under,” motif of, 58, 113
understanding, 50, 250, 260, 264, 271, 340, 483
golden, 270

underworld, 25, 333, 335, *figs.* 69, 151

unicorn, *see* ANIMALS

Unigenitus, 371, 442; *see also* Monogenes

union, of dissimilars, 325

of irreconcilables, 146, *fig.* 72

king/son, 162*n*, 344

like/like, 327, 412

of opposites, *q.v.*; of sexes, *fig.* 60

soul/body, 311, 374*f*, 420

water/fire, *figs.* 72, 160

unity: archetype of, self as, 25

divine, 25

seed of, 25

of seven alchemical stages, *fig.* 251

symbolized by circle, 124

— mandala, 27

as synthesis of four, 124, 161*n*, *see also* Maria, axiom of

universe, opus a model of, 164

threefold and fourfold, *fig.* 1

unknown/veiled woman, *see* woman

Unum, 319

Upanishads, 107, 355, 454; *see also* *Brihadaranyaka*; *Chhandogya*

upper and lower, 22, 24, 123, 128*n*, *fig.* 78

urina puerorum, *fig.* 121

urine, as *aqua permanens*, *fig.* 121

as *prima materia*, 235

uroboros, *see* ANIMALS

uterus, 179*f**n*

vas as, 237; *see also* womb

V

Vajramandala, 108*n*, *fig.* 43

valencies, four, 218

Valentinus, Basilus, 291n, 338n, 342, 426, *figs.* 146, 185

Valentinus the Gnostic, 330n

Valli, Luigi, 174n

variety performance, 80f, 89, 103

vas, as *aqua permanens*, 238&n

bene clausum/well sealed, 146, 167, 246

cave, 186

cerebri, 434n

cosmos, 236

egg, 202, 238, *fig.* 22

fire, 238&n, 239n

furnace, 236, 346, *figs.* 2, 113, 119

garden, 238n

grail, 180n

Hermetic, 236, *figs.* 120, 121, 153, 226n

krater, 299

lapis, 179n, 236

Mercurius, 238&n

mirabile, 236, 237n

mystic, *fig.* 23

pelican, 128n

prima materia, 236

as retort, *fig.* 230

round, 87, 128n, 236&n

skull, 87, 267, 434n, *fig.* 75

unum, 178, 236, 293n, *fig.* 86

Virgin, 180n, *fig.* 87

Vedas, 453; see also *Atharva-Veda*; *Rig-Veda*

Vedic Hymns, 454n

Ventura, Laurentius, 254, 385f

Venus, 86, 110n, 317, 401n

verdigris, 159

veritas, 269

Verteuil tapestry, *fig.* 264

vertical/horizontal, *see* horizontal

vessel, *see* *vas*

Vibhandaka, 456

Villa dei Misteri, Pompeii, 140n

Vindemia Hermetis, 199

vinegar, 273

 celestial, 235

prima materia, 317

vinum ardens, 74, 239n, *fig.* 152

Viraj, 456

Virgil, 39, 251, *fig.* 69

virgin(s), 335, 383, 398, 401, 409, 456

 of light, 425

 male, 383n

 -mother, 375, 420

 -serpent, 304&n, *figs.* 157, 257

 seven, *fig.* 5

Virgin, *see* Mary, Virgin

virgin's milk, 358, 408, *fig.* 222

Virgo, 446

virgo redimita, 409, 420

virgo terrae, 306

viriditas, *see* COLOURS

Vishnu, 454, *figs.* 75, 255

Visio Arislei, 153n, 252, 276, 327, 329n, 331, 333, 339, 347n, 348ff, 413n, 415

vision(s), 250, 252, 291&n, 346

 sea as birthplace of, 48n

 symbolized by dragon, 291

vitrification, 402n

vitrum (vitreum), 78, 171, 232

vitrum aureum/malleabile, 232

voice, in dreams, 49, 60, 86f, 89, 91, 143, 172, 194f

volatility, 275, 428n

Vollers, Karl, [118n](#)

Von der Maleri und Prattick des Steins, [437](#)

von Gachnang family crest, [fig. 243](#)

Vreecswyck, Goosen van, [fig. 51](#)

Vulcan, [166](#), [401n](#)

W

Wagner, Richard, [194](#)

Waite, Arthur Edward, [314n](#), [357](#), [406](#)

Waldkirch, Conrad, [376](#), [410](#)

walk, motif of, [62](#), [79](#)

Walpurgisnacht, [53n](#), [91](#)

war, [153](#), [190](#), [481](#)

Wasserstein der Weysen, [427](#)

water, and air/earth/fire, [205](#), [229](#), [263f](#), [317](#), [392](#)

Christian symbolism, [360](#)

composite, [234f](#)

descent to, [193](#)

divina/aqua, [35](#), [122n](#), [297](#), [449](#), [453](#)

drinking, [141n](#)

and fire, *q.v.*; as fire, [120](#), [232n](#), [234n](#)

and foetus, [394](#)

healing, [297f](#), [390n](#)

king dissolving in, [391n](#)

as *lapis*, [122n](#), [234f&n](#), [324](#)

of *lapis*, [161](#)

of life, [71ff](#), [123](#), [192](#), [317](#), [398n](#)

living, [118](#), [390n](#)

Mercurius, *q.v.*, see also *aqua mercuriails*; metallic, [391](#)

moon, [404](#)

mythical, [160](#)

philosophical, [234f](#), [404](#)

prima materia, *q.v.*; “special,” [102](#), [122](#)

from spirit, [205](#)

spirit of God on, 280, 428
-stone, 404
symbol of psyche, 74
as third, 468
vas, 238&n
into wine, 467f; see also *aqua*
Wei Po-yang, 357n
well, attribute of Virgin, *fig. 26*
Wessely, Carl, 361n
West, Edward William, 458n
West, and East, 7f, 205, 307n, 369n, 382
Western, land, 197, 369n, 460
man, 9, 27
—, and Eastern, 7f
wheel, 169, 293, 380ff, 386, *fig. 65*
in Böhme, 165f
cosmic/world, 96, 380, *fig. 40*
eight-spoked, 154, 163f, *fig. 80*
in Ezekiel, 165, 385, *fig. 109*
Mercurius, 166
potter's, 190f, 382
for raising souls, 380&n
self, 191
wholeness, 166
wholeness, 117, 123, 155, 214
as Anthropos, 162
as charisma/fate, 30&n
as completeness, 159
as conscious/unconscious man, 18
demands of, 175
ethical, 6n;
experience of, 20
goal of man, 6, 162, 221
— of psychotherapy, 27

indescribable, 18
of man, 30, 84
and number three, 26
projection of, 115
religion as, 196
self as, 18, 115, 222, 329n
symbolized by: *cauda pavonis*, *fig. 111*
croquet ball, 115
four elements, *fig. 93*
mandala, 166, 175, 199
ring, 199
rose, 175
round table, 177n
sun, 84
wheel, 166; *see also* totality
whore, menstruum of, 290n
wild man, *figs. 35, 250*
Wilhelm, Richard, 466n; *see also* Jung
Wilken, Ulrich, 362n
will of God, 30n
wind(s), 178, 285, 301n, *fig. 210*
 four, *fig. 211*
 north, 398&n
 south, 386f, 398
window, blocked, 48
wine, 140, 307n, 467f
 eucharistic, 308ff
Wirth, Albrecht, 71n
Wisdom, 205f
 of Holy Ghost, 378
 of Solomon, 378n, 379, *see also* BIBLE
 sons of, 358, 394
 of the South, 377; *see also* Sapientia
wise old man, 93, 123, 190, 250n

Wise Men from the East, 389
witch, 199
Witte, Jean Joseph Antoine Marie, Baron de, *fig. 63*
Wolff, Toni, 43n
Wolfram von Eschenbach, 180n, 469, 471n
woman, unknown/veiled, 54, 57f, 83f, 93, 103f, 106, 113, 115, 123, 154, 164, 168, 175, 179, 188, 192, 199; *see also* anima
womb, 131, 151
 of Beya, 334, 337n
 green, 154
 of Mary, 108n; *see also* uterus
Woodroffe, Sir John, 144n
Word, the, 320, 374, 375, *fig. 158*
world: clock, *q.v.*; mountain, 108
 principles, three, 96
 soul, *see anima mundi*; wheel, 96, 385, *fig. 40*
Wynandi de Stega, *figs. 73, 98, 266*

X

xanthosis, *see* COLOURS

Y

yang/yin, 37, 152, 330n
yantra, 95
year, as symbol, 164, 191f
Yellow Emperor, 466
Ymir, 330n
yoga, 101, 127, 166, 339
 Kundalini, 144, 154
 Tantric, 95
yoni, 150

Z

Zacharius, Dionysius, 260

Zacharias, Pope, [353n](#)
Zadith, *see* Senior
Zagreus, [90](#)
Zaibar, [402n](#)
Zarathustra (Nietzsche), [81](#), [144](#), [155](#), [296](#), [479ff](#)
Zeller, Eduard, [299nf](#), [304n](#), [325n](#), [330n](#), [336n](#), [350n](#)
Zeno, [264n](#)
Zeus, [330n](#), [365f](#)
Zimmer, Heinrich, [96n](#)
Zöckler, Otto, [24](#), [20nf](#)
zodiac, [133](#), [165](#), [193n](#), [206](#), [210](#), [212](#), [245](#), [379f](#), [408](#), *figs.* [92](#), [93](#), [100](#), [104](#), [156](#), [192](#)
Zosimos, [55](#), [62](#), [234n](#), [252](#), [276n](#), [295](#), [299f](#), [314n](#), [360ff](#), [386](#), [433n](#), [452n](#)
Zunz, Leopold, [461n](#)
Zurich, Peterhofstatt, [106](#)
Zurich Roll of Arms, *fig.* [243](#)

THE COLLECTED WORKS OF *C. G. JUNG*

THE PUBLICATION of the first complete edition, in English, of the works of C. G. Jung was undertaken by Routledge and Kegan Paul, Ltd., in England and by Bollingen Foundation in the United States. The American edition is number XX in Bollingen Series, which since 1967 has been published by Princeton University Press. The edition contains revised versions of works previously published, such as *Psychology of the Unconscious*, which is now entitled *Symbols of Transformation*; works originally written in English, such as *Psychology and Religion*; works not previously translated, such as *Aion*; and, in general, new translations of virtually all of Professor Jung's writings. Prior to his death, in 1961, the author supervised the textual revision, which in some cases is extensive. Sir Herbert Read (d. 1968), Dr. Michael Fordham, and Dr. Gerhard Adler compose the Editorial Committee; the translator is R. F. C. Hull (except for Volume 2) and William McGuire is executive editor.

The price of the volumes varies according to size; they are sold separately, and may also be obtained on standing order. Several of the volumes are extensively illustrated. Each volume contains an index and in most a bibliography; the final volumes will contain a complete bibliography of Professor Jung's writings and a general index to the entire edition.

In the following list, dates of original publication are given in parentheses (of original composition, in brackets). Multiple dates indicate revisions.

• 1. PSYCHIATRIC STUDIES

On the Psychology and Pathology of So-Called Occult Phenomena (1902)

On Hysterical Misreading (1904)

Cryptomnesia (1905)

On Manic Mood Disorder (1903)

A Case of Hysterical Stupor in a Prisoner in Detention (1902)

On Simulated Insanity (1903)

A Medical Opinion on a Case of Simulated Insanity (1904)

A Third and Final Opinion on Two Contradictory Psychiatric Diagnoses (1906)

On the Psychological Diagnosis of Facts (1905)

†2. EXPERIMENTAL RESEARCHES

Translated by Leopold Stein in collaboration with Diana Riviere

STUDIES IN WORD ASSOCIATION (1904–7, 1910)

The Associations of Normal Subjects (by Jung and F. Riklin)

An Analysis of the Associations of an Epileptic

The Reaction-Time Ratio in the Association Experiment

Experimental Observations on the Faculty of Memory

Psychoanalysis and Association Experiments

The Psychological Diagnosis of Evidence

Association, Dream, and Hysterical Symptom

The Psychopathological Significance of the Association Experiment

Disturbances in Reproduction in the Association Experiment

The Association Method

The Family Constellation

PSYCHOPHYSICAL RESEARCHES (1907–8)

On the Psychophysical Relations of the Association Experiment

Psychophysical Investigations with the Galvanometer and Pneumograph in Normal and Insane Individuals (by F. Peterson and Jung)

Further Investigations on the Galvanic Phenomenon and Respiration in Normal and Insane Individuals (by C. Ricksher and Jung)

Appendix: Statistical Details of Enlistment (1906); New Aspects of Criminal Psychology (1908); The Psychological Methods of Investigation Used in the Psychiatric Clinic of the University of Zurich (1910); On the Doctrine of Complexes ([1911] 1913); On the Psychological Diagnosis of Evidence (1937)

•3. THE PSYCHOGENESIS OF MENTAL DISEASE

The Psychology of Dementia Praecox (1907)

The Content of the Psychoses (1908/1914)

On Psychological Understanding (1914)

A Criticism of Bleuler's Theory of Schizophrenic Negativism (1911)

On the Importance of the Unconscious in Psychopathology (1914)

On the Problem of Psychogenesis in Mental Disease (1919)

Mental Disease and the Psyche (1928)

On the Psychogenesis of Schizophrenia (1939)

Recent Thoughts on Schizophrenia (1957)

Schizophrenia (1958)

†4. FREUD AND PSYCHOANALYSIS

Freud's Theory of Hysteria: A Reply to Aschaffenburg (1906)

The Freudian Theory of Hysteria (1908)

The Analysis of Dreams (1909)

A Contribution to the Psychology of Rumour (1910–11)

On the Significance of Number Dreams (1910–11)

Morton Prince, "The Mechanism and Interpretation of Dreams": A Critical Review (1911)

On the Criticism of Psychoanalysis (1910)

Concerning Psychoanalysis (1912)

The Theory of Psychoanalysis (1913)

General Aspects of Psychoanalysis (1913)

Psychoanalysis and Neurosis (1916)

Some Crucial Points in Psychoanalysis: A Correspondence between Dr. Jung and Dr. Loÿ (1914)

Prefaces to "Collected Papers on Analytical Psychology" (1916, 1917)

The Significance of the Father in the Destiny of the Individual (1909/1949)

Introduction to Kranefeldt's "Secret Ways of the Mind" (1930)

Freud and Jung: Contrasts (1929)

‡ 5. SYMBOLS OF TRANSFORMATION (1911–12/1952)

PART I

Introduction

Two Kinds of Thinking

The Miller Fantasies: Anamnesis

The Hymn of Creation

The Song of the Moth

PART II

Introduction

The Concept of Libido

The Transformation of Libido

The Origin of the Hero

Symbols of the Mother and of Rebirth

The Battle for Deliverance from the Mother

The Dual Mother

The Sacrifice

Epilogue

Appendix: The Miller Fantasies

•6. PSYCHOLOGICAL TYPES (1921)

Introduction

The Problem of Types in the History of Classical and Medieval Thought

Schiller's Ideas on the Type Problem

The Apollinian and the Dionysian

The Type Problem in Human Character

The Type Problem in Poetry

The Type Problem in Psychopathology

The Type Problem in Aesthetics

The Type Problem in Modern Philosophy

The Type Problem in Biography

General Description of the Types

Definitions

Epilogue

Four Papers on Psychological Typology (1913, 1925, 1931, 1936)

†7. TWO ESSAYS ON ANALYTICAL PSYCHOLOGY

On the Psychology of the Unconscious (1917/1926/1943)

The Relations between the Ego and the Unconscious (1928)

Appendix: New Paths in Psychology (1912); The Structure of the Unconscious (1916) (new versions, with variants, 1966)

‡8. THE STRUCTURE AND DYNAMICS OF THE PSYCHE

On Psychic Energy (1928)

The Transcendent Function ([1916]/1957)

A Review of the Complex Theory (1934)

The Significance of Constitution and Heredity in Psychology (1929)

Psychological Factors Determining Human Behavior (1937)

Instinct and the Unconscious (1919)

The Structure of the Psyche (1927/1931)

On the Nature of the Psyche (1947/1954)

General Aspects of Dream Psychology (1916/1948)

On the Nature of Dreams (1945/1948)

The Psychological Foundations of Belief in Spirits (1920/1948)

Spirit and Life (1926)

Basic Postulates of Analytical Psychology (1931)

Analytical Psychology and *Weltanschauung* (1928/1931)

The Real and the Surreal (1933)

The Stages of Life (1930–1931)

The Soul and Death (1934)

Synchronicity: An Acausal Connecting Principle (1952)

Appendix: On Synchronicity (1951)

•9. PART 1. THE ARCHETYPES AND THE COLLECTIVE UNCONSCIOUS

Archetypes of the Collective Unconscious (1934/1954)

The Concept of the Collective Unconscious (1936)

Concerning the Archetypes, with Special Reference to the Anima Concept
(1936/1954)

Psychological Aspects of the Mother Archetype (1938/1954)

Concerning Rebirth (1940/1950)

The Psychology of the Child Archetype (1940)

The Psychological Aspects of the Kore (1941)

The Phenomenology of the Spirit in Fairytales (1945/1948)

On the Psychology of the Trickster-Figure (1954)

Conscious, Unconscious, and Individuation (1939)

A Study in the Process of Individuation (1934/1950)

Concerning Mandala Symbolism (1950)

Appendix: Mandalas (1955)

•9. PART II. AION (1951)

RESEARCHES INTO THE PHENOMENOLOGY OF THE SELF

The Ego

The Shadow

The Syzygy: Anima and Animus

The Self

Christ, a Symbol of the Self

The Sign of the Fishes

The Prophecies of Nostradamus

The Historical Significance of the Fish

The Ambivalence of the Fish Symbol

The Fish in Alchemy

The Alchemical Interpretation of the Fish

Background to the Psychology of Christian Alchemical Symbolism

Gnostic Symbols of the Self

The Structure and Dynamics of the Self

Conclusion

• 10. CIVILIZATION IN TRANSITION

The Role of the Unconscious (1918)

Mind and Earth (1927/1931)

Archaic Man (1931)

The Spiritual Problem of Modern Man (1928/1931)

The Love Problem of a Student (1928)

Woman in Europe (1927)

The Meaning of Psychology for Modern Man (1933/1934)

The State of Psychotherapy Today (1934)

Preface and Epilogue to “Essays on Contemporary Events” (1946)

Wotan (1936)

After the Catastrophe (1945)

The Fight with the Shadow (1946)

The Undiscovered Self (Present and Future) (1957)

Flying Saucers: A Modern Myth (1958)

A Psychological View of Conscience (1958)

Good and Evil in Analytical Psychology (1959)

Introduction to Wolff’s “Studies in Jungian Psychology” (1959)

The Swiss Line in the European Spectrum (1928)

Reviews of Keyserling’s “America Set Free” (1930) and “La Révolution Mondiale” (1934)

The Complications of American Psychology (1930)

The Dreamlike World of India (1939)

What India Can Teach Us (1939)

Appendix: Documents (1933–1938)

†11. PSYCHOLOGY AND RELIGION: WEST AND EAST

WESTERN RELIGION

Psychology and Religion (The Terry Lectures) (1938/1940)

A Psychological Approach to the Dogma of the Trinity (1942/1948)

Transformation Symbolism in the Mass (1942/1954)

Forewords to White's "God and the Unconscious" and Werblowsky's "Lucifer and Prometheus" (1952)

Brother Klaus (1933)

Psychotherapists or the Clergy (1932)

Psychoanalysis and the Cure of Souls (1928)

Answer to Job (1952)

EASTERN RELIGION

Psychological Commentaries on "The Tibetan Book of the Great Liberation" (1939/1954) and "The Tibetan Book of the Dead" (1935/1953)

Yoga and the West (1936)

Foreword to Suzuki's "Introduction to Zen Buddhism" (1939)

The Psychology of Eastern Meditation (1943)

The Holy Men of India: Introduction to Zimmer's "Der Weg zum Selbst" (1944)

Foreword to the "I Ching" (1950)

•12. PSYCHOLOGY AND ALCHEMY (1944)

Prefatory note to the English Edition ([1951?] added 1967)

Introduction to the Religious and Psychological Problems of Alchemy

Individual Dream Symbolism in Relation to Alchemy (1936)

Religious Ideas in Alchemy (1937)

Epilogue

†13. ALCHEMICAL STUDIES

Commentary on "The Secret of the Golden Flower" (1929)

The Visions of Zosimos (1938/1954)

Paracelsus as a Spiritual Phenomenon (1942)

The Spirit Mercurius (1943/1948)

The Philosophical Tree (1945/1954)

‡14. MYSTERIUM CONIUNCTIONIS (1955–56)

AN INQUIRY INTO THE SEPARATION AND
SYNTHESIS OF PSYCHIC OPPOSITES IN ALCHEMY

The Components of the Coniunctio

The Paradoxa

The Personification of the Opposites

Rex and Regina

Adam and Eve

The Conjunction

•15. THE SPIRIT IN MAN, ART, AND LITERATURE

Paracelsus (1929)

Paracelsus the Physician (1941)

Sigmund Freud in His Historical Setting (1932)

In Memory of Sigmund Freud (1939)

Richard Wilhelm: In Memoriam (1930)

On the Relation of Analytical Psychology to Poetry (1922)

Psychology and Literature (1930/1950)

“Ulysses”: A Monologue (1932)

Picasso (1932)

†16. THE PRACTICE OF PSYCHOTHERAPY

GENERAL PROBLEMS OF PSYCHOTHERAPY

Principles of Practical Psychotherapy (1935)

What Is Psychotherapy? (1935)

Some Aspects of Modern Psychotherapy (1930)

The Aims of Psychotherapy (1931)

Problems of Modern Psychotherapy (1929)

Psychotherapy and a Philosophy of Life (1943)

Medicine and Psychotherapy (1945)

Psychotherapy Today (1945)

Fundamental Questions of Psychotherapy (1951)

SPECIFIC PROBLEMS OF PSYCHOTHERAPY

The Therapeutic Value of Abreaction (1921/1928)

The Practical Use of Dream-Analysis (1934)

The Psychology of the Transference (1946)

Appendix: The Realities of Practical Psychotherapy ([1937] added, 1966)

‡17. THE DEVELOPMENT OF PERSONALITY

Psychic Conflicts in a Child (1910/1946)

Introduction to Wickes's "Analyses der Kinderseele" (1927/1931)

Child Development and Education (1928)

Analytical Psychology and Education: Three Lectures (1926/1946)

The Gifted Child (1943)

The Significance of the Unconscious in Individual Education (1928)

The Development of Personality (1934)

Marriage as a Psychological Relationship (1925)

•18. THE SYMBOLIC LIFE

Miscellaneous Writings

†19. GENERAL BIBLIOGRAPHY OF C. G. JUNG'S WRITINGS

†20. GENERAL INDEX TO THE COLLECTED WORKS

See also:

C. G. JUNG: LETTERS

Selected and edited by Gerhard Adler, in collaboration with Aniela Jaffé. Translations from the German by R.F.C. Hull.

VOL. 1: 1906–1950

VOL. 2: 1951–1961

THE FREUD/JUNG LETTERS

Edited by William McGuire, translated by
Ralph Manheim and R.F.C. Hull

C. G. JUNG SPEAKING: Interviews and Encounters

Edited by William McGuire and R.F.C. Hull

C. G. JUNG: Word and Image

Edited by Aniela Jaffé

¹ It is worth noting that a Protestant theologian, writing on homiletics, had the courage to demand wholeness of the preacher from the ethical point of view. He substantiates his argument by referring to my psychology. See Händler, *Die Predigt*.

²[The translation of the German word *Seele* presents almost insuperable difficulties on account of the lack of a single English equivalent and because it combines the two words “psyche” and “soul” in a way not altogether familiar to the English reader. For this reason some comment by the Editors will not be out of place.

[In previous translations, and in this one as well, “psyche”—for which Jung in the German original uses either *Psyche* or *Seele*—has been used with reference to the totality of *all* psychic processes (cf. Jung, *Psychological Types*, Def. 48); i.e., it is a comprehensive term. “Soul,” on the other hand, as used in the technical terminology of analytical psychology, is more restricted in meaning and refers to a “function complex” or partial personality and never to the whole psyche. It is often applied specifically to “anima” and “animus”; e.g., in this connection it is used in the composite word “soul-image” (*Seelenbild*). This conception of the soul is more primitive than the Christian one with which the reader is likely to be more familiar. In its Christian context it refers to “the transcendental energy in man” and “the spiritual part of man considered in its moral aspect or in relation to God.” (Cf. definition in *The Shorter Oxford English Dictionary*.)

[In the above passage in the text (and in similar passages), “soul” is used in a non-technical sense (i.e., it does not refer to “animus” or “anima”), nor does it refer to the transcendental conception, but to a psychic (phenomenological) fact of a highly numinous character. This usage is adhered to except when the context shows clearly that the term is used in the Christian or Neoplatonic sense.—EDITORS.]

³ [The term “nothing but” (*nichts als*), which occurs frequently in Jung to denote the habit of explaining something unknown by reducing it to something apparently known and thereby devaluing it, is borrowed from William James, *Pragmatism*, p. 16: “What is higher is explained by what is lower and treated for ever as a case of ‘nothing but’—nothing but something else of a quite inferior sort.”]

⁴ The dogma that man is formed in the likeness of God weighs heavily in the scales in any assessment of man—not to mention the Incarnation.

⁵ The fact that the devil too can take possession of the soul does not diminish its significance in the least.

⁶ It is therefore psychologically quite unthinkable for God to be simply the “wholly other,” for a “wholly other” could never be one of the soul’s deepest and closest intimacies—which is precisely what God is. The only statements that have psychological validity concerning the God-image are either paradoxes or antinomies.

⁷ Tertullian, *Apologeticus*, xvii: “Anima naturaliter christiana.”

⁸ Since it is a question here of human effort, I leave aside acts of grace which are beyond man’s control.

⁹ Tertullian, *De carne Christi*, 5 (Migne, *P.L.*, vol. 2, col. 751).

¹⁰ Zöckler (“Probabilismus,” p. 67) defines it as follows: “Probabilism is the name generally given to that way of thinking which is content to answer scientific questions with a greater or lesser degree of probability. The moral probabilism with which alone we are concerned here consists in the principle that acts of ethical self-determination are to be guided not by conscience but according to what is probably right, i.e., according to whatever has been recommended by any representative or doctrinal authority.” The Jesuit probabilist Escobar (d. 1669) was, for instance, of the opinion that if the penitent should plead a probable opinion as the motive of his action, the father-

confessor would be obliged to absolve him even if he were not of the same opinion. Escobar quotes a number of Jesuit authorities on the question of how often one is bound to love God in a lifetime. According to one opinion, loving God once shortly before death is sufficient; another says once a year or once every three or four years. He himself comes to the conclusion that it is sufficient to love God once at the first awakening of reason, then once every five years, and finally once in the hour of death. In his opinion the large number of different moral doctrines forms one of the main proofs of God's kindly providence, "because they make the yoke of Christ so light" (Zöckler, p. 68). Cf. also Harnack, *History of Dogma*, VII, pp. 101ff.

¹¹ Cf. Genesis 1 : 2.

¹² The reader will find a collection of these myth motifs in Lang, *Hat ein Gott die Welt erschaffen?* Unfortunately philological criticism will have much to take exception to in this book, interesting though it is for its Gnostic trend.

¹³ In alchemical writings the word "Mercurius" is used with a very wide range of meaning, to denote not only the chemical element mercury or quicksilver, Mercury (Hermes) the god, and Mercury the planet, but also—and primarily—the secret "transforming substance" which is at the same time the "spirit" indwelling in all living creatures. These different connotations will become apparent in the course of the book. It would be misleading to use the English "Mercury" and "mercury," because there are innumerable passages where neither word does justice to the wealth of implications. It has therefore been decided to retain the Latin "Mercurius" as in the German text, and to use the personal pronoun (since "Mercurius" is personified), the word "quicksilver" being employed only where the chemical element (Hg) is plainly meant. [*Author's note for the English edn.*]

¹⁴ Przywara, *Deus semper maior*, I, pp. 71ff.

¹⁵ See the illustrations in Jung, "Concerning Mandala Symbolism."

¹⁶ *Contritio* is "perfect" repentance; *attritio* "imperfect" repentance (*contritio imperfecta*, to which category *contritio naturalis* belongs). The former regards sin as the opposite of the highest good; the latter reprehends it not only on account of its wicked and hideous nature but also from fear of punishment.

¹⁷ A religious terminology comes naturally, as the only adequate one in the circumstances, when we are faced with the tragic fate that is the unavoidable concomitant of wholeness. "My fate" means a daemonic will to precisely that fate—a will not necessarily coincident with my own (the ego will). When it is opposed to the ego, it is difficult not to feel a certain "power" in it, whether divine or infernal. The man who submits to his fate calls it the will of God; the man who puts up a hopeless and exhausting fight is more apt to see the devil in it. In either event this terminology is not only universally understood but meaningful as well.

¹⁸ Paracelsus still speaks of the "gods" enthroned in the *mysterium magnum* (*Philosophia ad Athenienses*, p. 403), and so does the 18th-cent. treatise of Abraham Eleazar, *Uraltes chymisches Werk*, which was influenced by Paracelsus.

¹⁹ Cf. Sanchez, *Opus morale*, Decalog. 2, 49n., 51; and Pignatelli, *Consultationes canonicae*, canon ix.

¹ I must emphasize that this education was not historical, philological, archaeological, or ethnological. Any references to material derived from these fields came unconsciously to the dreamer.

² “Mandala” (Sanskrit) means “circle,” also “magic circle.” Its symbolism includes—to mention only the most important forms—all concentrically arranged figures, round or square patterns with a centre, and radial or spherical arrangements.

³ For this concept see Jung, “Basic Postulates of Analytical Psychology,” and Wolff, “Einführung in die Grundlagen der komplexen Psychologie,” pp. 34ff.

⁴ I intentionally omit an analysis of the words “complementary” and “compensatory,” as it would lead us too far afield.

¹ The sea is a favourite place for the birth of visions (i.e., invasions by unconscious contents). Thus the great vision of the eagle in II Esdras 11 : 1 rises out of the sea, and the vision of “Man”—*ἄνθρωπος*—in 13: 3, 25, and 51 comes up “from the midst of the sea.” Cf. also 13 : 52: “Like as thou canst neither seek out nor know the things that are in the deep of the sea: even so can no man upon earth see my Son. ...”

² *Νεκρία* from *νέκρς* (corpse), the title of the eleventh book of the *Odyssey*, is the sacrifice to the dead for conjuring up the departed from Hades. *Nekyia* is therefore an apt designation for the “journey to Hades,” the descent into the land of the dead, and was used by Dieterich in this sense in his commentary on the Codex of Akhmim, which contains an apocalyptic fragment from the Gospel of Peter (*Nekyia: Beiträge zur Erklärung der neuentdeckten Petrusapokalypse*). Typical examples are the *Divine Comedy*, the classical *Walpurgisnacht* in *Faust*, the apocryphal accounts of Christ’s descent into hell, etc.

³ Cf. the French edition of *Hypnerotomachia*, called *Le Tableau des riches inventions* or *Songe de Poliphile* (1600), trans. Bérolalde de Verville. (See fig. 4.) [The original Italian edn. appeared in 1499.]

⁴ For details see Jung, “Paracelsus as a Spiritual Phenomenon,” pars. 179f., 214ff.

⁵ Knuchel, *Die Umwandlung in Kult, Magie und Rechtsbrauch*.

⁶ A piece of land, often a grove, set apart and dedicated to a god.

⁷ For the concept of the “anima,” see Jung, “The Relations between the Ego and the Unconscious,” pars. 296ff.

⁸ Zosimos lived c. A.D. 300. Cf. Reitzenstein, *Poimandres*, pp. 9ff.; Berthelot, *Collection des anciens alchimistes grecs*, III, i, 2.

⁹ The ladder motif is confirmed in dreams 12 and 13 (pars. 78 and 82). Cf. also Jacob’s ladder (fig. 14).

¹⁰ *De errore profanarum religionum*: “Animo descensus per orbem solis tribuitur” (It is said [by the pagans] that the soul descends through the circle of the sun).

¹¹ *The Golden Ass*.

¹² Cf. Ruska, *Turba*.

¹³ Cf. “collective unconscious” in Jung, *Psychological Types*, Def. 56.

¹⁴ The direct source of the Christian sheep symbolism is to be found in the visions of the Book of Enoch 89 : 10ff. (Charles, *Apocrypha and Pseudepigrapha*, II, p. 252). The Apocalypse of Enoch was written about the beginning of the 1st cent. B.C.

¹⁵ In the vision of Enoch, the leader and prince appears first as a sheep or ram: Book of Enoch 89 : 48 (Charles, II, p. 254).

¹⁶ Berthelot, *Collection des anciens alchimistes grecs*, III, i, 2. Cf. also Jung, “The Visions of Zosimos.”

¹⁷ Budge, in *Gods of the Egyptians*, I, p. 87, uses this expression.

¹⁸ *Études de mythologie*, II, p. 245.

¹⁹ Cf. the entertaining dialogue between the alchemist and Mercurius in Sendivogius, “Dialogus,” *Theatr. chem.*, IV.

²⁰ Goethe, *Dichtung und Wahrheit*.

²¹ Printed in *Geheime Figuren der Rosenkreuzer*.

²² *Problems of Mysticism and Its Symbolism*.

²³ For water as origin, cf. Egyptian cosmogony, among others.

²⁴ Wirth, *Aus orientalischen Chroniken*, p. 199.

²⁵ “A fountain sealed”: Song of Songs 4 : 12.

²⁶ This is really a normal life-process, but it usually takes place quite unconsciously. The anima is an archetype that is always present. (Cf. Jung, *Psychological Types*, Defs. 48, 49, and “The Relations between the Ego and the Unconscious,” pars. 296ff.) The mother is the first carrier of the anima-image, which gives her a fascinating quality in the eyes of the son. It is then transferred, via the sister and similar figures, to the beloved.

²⁷ Cf. dream 23 of second series (par. 212, also par. 220).

²⁸ Concerning the “golden flower” of medieval alchemy (cf. fig. 30), see Adolphus Senior, *Azoth*. The golden flower comes from the Greek χρυσάνθιον (Berthelot, *Alch. grecs*, III, xlix. 19) and χρυσάνθεμον = ‘golden flower’, a magical plant like the Homeric μῶλυ, which is often mentioned by the alchemists. The golden flower is the noblest and purest essence of gold. The same name is sometimes given to pyrites. (Cf. Lippmann, *Entstehung und Ausbreitung der Alchemie*, I, p. 70.) The strength of the *aqua permanens* is also called *flos*, ‘flower’ (*Turba*, ed. Ruska, p. 214, 20). *Flos* is used by later alchemists to express the mystical transforming substance. (Cf. “flos citrinus” in *Aurora consurgens*; “flos aeris aureus” in “Consil. coniug., *Ars chemica*,” p. 167; “flos est aqua nummosa [Mercurius]” in “Allegoriae sapientum,” p. 81; “flos operis est lapis” in Mylius, *Philosophia reformata*, p. 30.)

²⁹ Reprinted in *Artis auriferae*, II, pp. 204ff. (1593) and *Bibliotheca chemica curiosa*, II, pp. 87ff. (1702). My quotations are usually taken from the 1593 version.

³⁰ As the *Rosarium* says: “Aurum nostrum non est aurum vulgi” (Our gold is not the common gold). *Art. aurif.*, II, p. 220.

³¹ “Quia lapis noster scilicet argentum vivum occidentale, quod praetulit se auro et vicit illud, est illud quod occidit et vivere facit.”—*Ibid.*, p. 223.

³² “Intelligite, filii sapientum, quod hic lapis preciosissimus clamat, ... et lumen meum omne lumen superat ac mea bona omnibus bonis sunt sublimiora.... Ego gigno lumen, tenebrae autem naturae meae sunt. ...” *Ibid.*, p. 239. Concerning the Hermes quotations in *Rosarium*, see *infra*, par. 140, n. 17.

³³ “Epistola ad Hermannum,” *Theatr. chem.*, V, p. 899.

³⁴ This does not mean that the self is created, so to speak, only during the course of life; it is rather a question of its becoming conscious. The self exists from the very beginning, but is latent, that is, unconscious. Cf. my later explanations.

³⁵ Foucart, *Les Mystères d’Eleusis*.

³⁶ [*Histories*, II, 58; trans. Powell, I, p. 137.]

³⁷ See *Psychological Types*, Def. 18.

³⁸ Cf. Fleischer, *Hermes Trismegistus*, p. 6; also the spherical form of Plato’s Original Man and the σφαῖρος of Empedocles. As in the *Timaeus*, the alchemical *anima mundi*, like the “soul of the substances,” is spherical, and so is the gold (cf. fig. 209). (See Maier, *De circulo physico*, pp. 11f.) For the connection between the *rotundum* and the skull or head, see Jung, “Transformation Symbolism in the Mass,” pp. 239ff.

³⁹ Cf. St. Augustine’s argument that God is not this sun but he who made the sun (*In Joannis Evang. Tract.*, XXXIV, 2) and the evidence of Eusebius, who actually witnessed “Christian” sun-worship (*Constantini Oratio ad Sanctorum*

Coelum, VI; Migne, *P.G.*, vol. 20, cols. 1245–50).

⁴⁰ Béroalde de Verville, in his introduction [“Recueil stéganographique”] to the French translation (1600) of *Hypnerotomachia*, plainly adopts this view.

⁴¹ “He said [it] himself.” The phrase originally alluded to the authority of Pythagoras.

⁴² Cf. “Liber Platonis quattorum,” *Theatr. chem.*, V, pp. 149ff., 174. This treatise is a Harranite text of great importance for the history of alchemy. It exists in Arabic and Latin, but the latter version is unfortunately very corrupt. The original was probably written in the 10th cent. Cf. Steinschneider, *Die europäischen Übersetzungen aus dem Arabischen*.

⁴³ Cf. “Paracelsus as a Spiritual Phenomenon,” par. 214.

⁴⁴ I wrote this passage in spring, 1935.

⁴⁵ For these concepts see Jung, “The Relations between the Ego and the Unconscious.”

¹ Cf. Wilhelm and Jung, *Secret of the Golden Flower*, and Zimmer, *Myths and Symbols in Indian Art and Civilization*.

² Avalon, *The Serpent Power*, VII.

³ Cf. Reitzenstein, *Die hellenistischen Mysterienreligionen*.

⁴ The quotation marks indicate that I am not positing anything by the term “metaphysical”: I am only using it figuratively, in the psychological sense, to characterize the peculiar statements made by dreams.

⁵ As Meister Eckhart says, “It is not outside, it is inside: wholly within.”—Trans. Evans, p. 8.

⁶ [Inasmuch as the five mandala dreams and visions listed in par. 127 necessarily figure in this new series (though actually part of the first dream-series), the author initiated the number sequence of the new—i.e., the mandala—series with them.—EDITORS.]

⁷ As the dream at most alludes to me and does not name me, the unconscious evidently has no intention of emphasizing my personal role.

⁸ Cf. Jung, *Psychological Types*, ch. X.

⁹ Deussen, *Allgemeine Geschichte der Philosophie*, I.

¹⁰ Baynes, *A Coptic Gnostic Treatise*, p. 89.

¹¹ The Buddha, Shiva, etc., in the lotus (fig. 52); Christ in the rose, in the womb of Mary (ample material on this theme in Salzer, *Die Sinnbilder und Beiworte Mariens*); the seeding-place of the diamond body in the golden flower. Cf. the circumambulation of the square in dream 16, par. 164.

¹² Baynes, *A Coptic Gnostic Treatise*, p. 58. Cf. the Vajramandala (fig. 43), where the great *dorje* is found in the centre surrounded by the twelve smaller *dorjes*, like the one Monad with the “twelve Monads as a crown upon its head.” Moreover there is a *dorje* in each of the four gates.

¹³ Baynes. p. 94.

¹⁴ *Ibid.*, p. 70. Similar to the tetramorph, the steed of the Church (fig. 53).

¹⁵ Cf. Irenaeus, *Adversus haereses*, III, xi, and Clement of Alexandria, *Stromata*, V, vi.

¹⁶ *Art. aurif.*, II, pp. 239f. The Hermes quotations come from the fourth chapter of “Tractatus aureus” (*Ars chemica*, pp. 23f., or *Bibl. chem.*, I, pp. 427f).

¹⁷ “Ego gigno lumen, tenebrae autem naturae meae sunt ... me igitur et filio meo conjuncto, nihil melius ac venerabilius in mundo fieri potest.” The Hermes sayings as quoted by the anonymous author of the *Rosarium* contain deliberate alterations that have far more significance than mere faulty readings. They are authentic recastings, to which he lends higher authority by attributing them to Hermes. I have compared the three printed editions of the “Tractatus aureus,” 1566, 1610, and 1702, and found that they all agree. The *Rosarium* quotation runs as follows in the “Tractatus aureus”: “Iam Venus ait: Ego genero lumen, nec tenebrae meae naturae sunt ... me igitur et fratri meo iunctis nihil melius ac venerabilius” (Venus says: I beget the light, and the darkness is not of my nature ... therefore nothing is better or more worthy of veneration than the conjunction of myself and my brother).

¹⁸ Baynes, p. 87.

¹⁹ Cf. Mylius, *Philosophia reformata*, p. 19.

²⁰ *Art. aurif.*, II, p. 356.

²¹ Ibid., p. 359.

²² Ibid.

²³ Cf. Jung, “The Relations between the Ego and the Unconscious,” pars. 296ff.

²⁴ The Homeric chain in alchemy is the series of great wise men, beginning with Hermes Trismegistus, which links earth with heaven. At the same time it is the chain of substances and different chemical states that appear in the course of the alchemical process. Cf. *Aurea catena Homeri*.

²⁵ Jung, “Paracelsus as a Spiritual Phenomenon,” pars. 209ff.

²⁶ Meister Eckhart says: “‘I came not upon earth to bring peace but a sword; to cut away all things, to part thee from brother, child, mother and friend, which are really thy foes.’ For verily thy comforts are thy foes. Doth thine eye see all things and thine ear hear all things and thy heart remember them all, then in these things thy soul is destroyed.”—Trans. Evans, I, pp. 12–13.

²⁷ Cf. Jung, “Concerning Rebirth,” pp. 135ff.

²⁸ Vollers, “Chidher,” p. 235.

²⁹ *Art. aurif.*, II, p. 239. This is a Hermes quotation from the “Tractatus aureus,” but in the edition of 1566 (*Ars chemica*) it runs: “Largiri vis mihi meum ut adiuvem te” (You want to give me freely what is mine, that I may help you).

³⁰ A quotation from Aristotle in the *Rosarium*, *Art. aurif.*, II, p. 317, says: “Elige tibi pro lapide, per quem reges venerantur in Diadematibus suis ... quia ille est propinquus igni” (Choose for your stone that through which kings are venerated in their crowns ... because that [stone] is near to the fire).

³¹ Cf. the treatise of Komarios, in which Cleopatra explains the meaning of the water (Berthelot, *Collection des anciens alchimistes grecs*, IV, xx).

³² *Rosarium*, *Art. aurif.*, II, p. 378: “Lapis noster hic est ignis ex igne creatus et in ignem vertitur, et anima eius in igne moratur” (This our stone is fire, created of fire, and turns into fire; its soul dwells in fire). This may have been based on the following: “Item lapis noster, hoc est ignis ampulla, ex igne creatus est, et in eum vertitur” (Likewise this our stone, i.e., the flask of fire, is created out of fire and turns back into it).—“Allegoriae sapientum,” *Bibl. chem. curiosa*, I, p. 468a.

³³ *Aqua nostra* is also called *aqua permanens*, corresponding to the ὕδωρ θεῖον of the Greeks: “aqua permanens, ex qua quidem aqua lapis noster pretiosissimus generatur,” we read in the “Turba philosophorum,” *Art. aurif.*, I, p. 14. “Lapis enim est haec ipsa permanens aqua et dum aqua est, lapis non est” (For the stone is this selfsame permanent water; and while it is water it is not the stone).—Ibid., p. 16. The commonness of the “water” is very often emphasized, as for instance in *ibid.*, p. 30. “Quod quaerimus publice minimo pretio venditur, et si nosceretur, ne tantillum venderent mercatores” (What we are seeking is sold publicly for a very small price, and if it were recognized, the merchants would not sell it for so little).

³⁴ The alchemists give only obscure hints on this subject, e.g., the quotation from Aristotle in *Rosarium* (*Art. aurif.*, II, p. 318): “Fili, accipere debes de pinguiori carne” (Son, you must take of the fatter flesh). And in the “Tractatus aureus,” ch. IV, we read: “Homo a principio naturae generatur, cuius viscera carnea sunt” (Man is generated from the principle of Nature whose inward parts are fleshy).

³⁵ Cf. “Paracelsus as a Spiritual Phenomenon,” pars. 185ff.

³⁶ *Von hylealischen Chaos*, p. 204.

³⁷ "... having a desire to be dissolved and to be with Christ" (Phil. (D.V.) 1 : 23).

³⁸ The "magnesia" of the alchemists has nothing to do with magnesia (MgO). In Khunrath (ibid., p. 161) it is the "materia coelestis et divina," i.e., the "materia lapidis Philosophorum," the arcane or transforming substance.

³⁹ Ibid., p. 203.

⁴⁰ Ibid., p. 207.

⁴¹ There is a figurative representation of this idea in Maier, *Scrutinium chymicum*: Emblema XXI. But Maier interprets the *ternarius* differently (cf. fig. 60). He says (p. 63): "Similiter volunt Philosophi quadrangulum in triangulum ducendum esse, hoc est, in corpus, spiritum et animam, quae tria in trinis coloribus ante rubedinem praevisis apparent, utpote corpus seu terra in Saturni nigredine, spiritus in lunari albedine, tanquam aqua, anima sive aer in solari citrinitate. Tum triangulus perfectus erit, sed hic vicissim in circulum mutari debet, hoc est in rubedinem invariabilem." (Similarly the philosophers maintain that the quadrangle is to be reduced to a triangle, that is, to body, spirit, and soul. These three appear in three colours which precede the redness: the body, or earth, in Saturnine blackness; the spirit in lunar whiteness, like water; and the soul, or air, in solar yellow. Then the triangle will be perfect, but in its turn it must change into a circle, that is into unchangeable redness.) Here the fourth is fire, and an *everlasting* fire.

⁴² Cf. "city" and "castle" in commentary to dream 10, pars. 137ff. (See figs. 31, 50, 51.) The alchemists similarly understand the *rotundum* arising out of the square as the *oppidum* (city). See Aegidius de Vadis, "Dialogus inter naturam et filium Philosophiae," *Theatr. chem.*, II, p. 115.

⁴³ A quotation attributed to Pseudo-Aristotle ("Tractatus Aristotelis," *Theatr. chem.*, V, pp. 880ff.), but not traceable.

⁴⁴ In the *Tractatus aureus ... cum Scholiis Dominici Gnosii* (1610), p. 43, there is a drawing of the "secret square of the sages." In the centre of the square is a circle surrounded by rays of light. The scholium gives the following explanation: "Divide lapidem tuum in quatuor elementa ... et coniunge in unum et totum habebis magisterium" (Reduce your stone to the four elements ... and unite them into one and you will have the whole magistry)—a quotation from Pseudo-Aristotle. The circle in the centre is called "mediator, pacem faciens inter inimicos sive elementa imo hic solus efficit quadraturam circuli" (the mediator, making peace between enemies, or [the four] elements; nay rather he alone effects the squaring of the circle).—Ibid., p. 44. The circumambulation has its parallel in the "circulatio spirituum sive distillatio circularis, hoc est exterius intro, interius foras: item inferius et superius, simul in uno circulo convenient, neque amplius cognoscas. quid vel exterius, vel interius, inferius vel superius fuerit: sed omnia sint unum in uno circulo sive vase. Hoc enim vas est Pelecanus verus Philosophicus, nec alius est in toto mundo quaerendus." (... circulation of spirits or circular distillation, that is, the outside to the inside, the inside to the outside, likewise the lower and the upper; and when they meet together in one circle, you could no longer recognize what was outside or inside, or lower or upper; but all would be one thing in one circle or vessel. For this vessel is the true philosophical Pelican, and there is no other to be sought for in all the world.) This process is elucidated by the accompanying drawing. The little circle is the "inside," and the circle divided into four is the "outside": four rivers flowing in and out of the inner "ocean."—Ibid., pp. 262f.

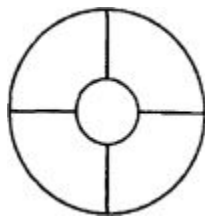

⁴⁵ Wilhelm and Jung, *Secret of the Golden Flower* (1962 edn.), p. 22.

⁴⁶ Cf. Jung, “The Spirit Mercurius.”

⁴⁷ Ed. Preisendanz, *Papyri Graecae Magicae*, I, p. 195.

⁴⁸ Cf. Bruchmann, *Epitheta deorum*, s.v.

⁴⁹ *Les Images des dieux*, p. 403.

⁵⁰ “Paracelsus as a Spiritual Phenomenon,” pars. 168, 206ff.

⁵¹ Budge, *The Gods of the Egyptians*, I, pp. 21 and 404.

⁵² It was considered at length in my “Psychology and Religion.” pp. 24ff.

⁵³ Orphic mosaic from Tramithia (Eisler, *Orpheus—the Fisher*, pp. 271f.). We can take this inscription as a joke without offending against the spirit of the ancient mysteries. (Cf. the frescoes in the Villa dei Misteri in Pompeii—Maiuri, *La Villa dei Misteri*—where drunkenness and ecstasy are not only closely related but actually one and the same thing.) But, since initiations have been connected with healing since their earliest days, the advice may possibly be a warning against water drinking, for it is well known that the drinking water in southern regions is the mother of dysentery and typhoid fever.

⁵⁴ Eisler, *Orpheus—the Fisher*.

⁵⁵ This is roughly the opinion of the dreamer.

⁵⁶ Cf. figs. 170, 171, 172, 174, 176, 177.

⁵⁷ Arnobius, *Adversus gentes*, V, 21 (Migne. *P.L.*, vol. 5, col. 1125). For similar practices during the Middle Ages, cf. Hammer-Purgstall, *Mémoire sur deux coffrets gnostiques du moyen age*. See fig. 70.

⁵⁸ Avalon, *The Serpent Power*; Woodroffe, *Shakti and Shakta*.

⁵⁹ The alchemists refer to Lactantius, *Opera*, I, p. 14, 20: “a chaos, quod est rudis inordinataeque materiae confusa congeries” (from the chaos, which is a confused assortment of crude disordered matter).

⁶⁰ Dreyfuss, *Adam und Eva*, quoted by Reitzenstein, *Poimandres*, p. 258.

⁶¹ Pseudonymous author (“peaceable lover of truth”) who lived in England at the beginning of the 17th century.

⁶² Philalethes, *Ripley Reviv’d*, p. 100.

⁶³ [Cf. *Mysterium Coniunctionis*, p. 288, n. 116.—EDITORS.]

⁶⁴ Cf. the commentary to dream 10, second series, par. 141: “And, being chained to the arms and breast of my mother, and to her substance, I cause my substance to hold together and rest.” (“Tractatus aureus,” ch. IV.)

⁶⁵ The idea of the anima as I define it is by no means a novelty but an archetype which we meet in the most diverse places. It was also known in alchemy, as the following scholium proves (“Tractatus aureus,” in *Bibl. chem. curiosa*, I, p. 417): “Quemadmodum in sole ambulantis corpus continuo sequitur umbra ... sic hermaphroditus noster Adamicus, quamvis in forma masculi appareat semper tamen in corpore occultatam Evam sive foeminam suam secum circumfert” (As the shadow continually follows the body of one who walks in the sun, so our hermaphroditic Adam,

though he appears in the form of a male, nevertheless always carries about with him Eve, or his wife, hidden in his body).

⁶⁶ Cf. Jung, *Psychological Types*, Def. 30.

⁶⁷ “Tractatus aureus,” *Ars chemica*, p. 12: “Verum masculus est coelum foeminae et foemina terra masculi” (The male is the heaven of the female, and the female is the earth of the male).

⁶⁸ *Adversus Judaeos*, 13 (Migne, *P.L.*, vol. 2, col. 655).

⁶⁹ Alchemy regarded this synthesis as one of its chief tasks. The *Turba philosophorum* (ed. Ruska, p. 26) says: “Coniungite ergo masculinum servi rubei filium suae odoriferae uxori et iuncti artem gignunt” (Join therefore the male son of the red slave to his sweet-scented wife, and joined together they will generate the Art). This synthesis of opposites was often represented as a brother-and-sister incest, which version undoubtedly goes back to the “Visio Arislei,” *Art. aurif.*, I (see fig. 167), where the cohabitation of Thabritius and Beya, the children of the *Rex marinus*, is described (see *infra*, pars. 434ff.).

⁷⁰ [Based on the translation by Philip Wayne (*Faust, Part Two*, pp. 145f.). Slight modifications have been necessary to accommodate his version to Jung’s commentary.—TRANS.]

⁷¹ The *testudo* (tortoise) is an alchemical instrument, a shallow bowl with which the cooking-vessel was covered on the fire. See Rhenanus, *Solis e puteo emergentis*, p. 40.

⁷² Jung, *Symbols of Transformation*, index, s.v.

⁷³ *Art. aurif.*, II, p. 220: a quotation from Senior. *Viriditas* is occasionally called *azoth*, which is one of the numerous synonyms for the stone.

⁷⁴ According to Berthelot (*Origines de l’alchimie*, p. 100), the anonymous author called Christianos was a contemporary of Stephanos of Alexandria, and must therefore have lived about the beginning of the 7th century.

⁷⁵ Berthelot, *Alchimistes grecs*, VI, v, 6. The almost bestial *κραυγάζειν* (shriek) points to an ecstatic condition.

⁷⁶ A treatise (of Arabic origin?) is ascribed to her under the title “Practica Mariae Prophetissae in artem alchemicam,” *Art. aurif.*, I, pp. 319ff.

⁷⁷ *Panarium*, XXVI. Concerning further possible connections with Mariamne and with the Mary Magdalene of the *Pistis Sophia*, cf. Leisegang, *Die Gnosis*, pp. 113f., and Schmidt, “Gnostische Schriften,” pp. 596ff. [On *Panarium*, cf. *Aion*, pars. 314ff.]

⁷⁸ Aros = Horos. *Ἰσις προφήτις τῷ νιῷ αὐτῆς* (Berthelot, *Alchimistes grecs*, I, xiii) may be an earlier version of the Maria dialogue. Isis and Maria were easy to confuse.

⁷⁹ “Matrimonifica gummi cum gummi vero matrimonio.”—*Art. aurif.*, I, p. 320.

⁸⁰ *Von hylealischen Chaos*, pp. 239f.

⁸¹ “Aphorismi Basiliani,” *Theatr. chem.*, IV, p. 368.

⁸² *Ars chemica*, pp. 247, 255.

⁸³ Arnaldus de Villanova (“Carmen,” *Theatr. chem.*, IV, p. 614) has summed up the quintessence of Maria’s treatise very aptly in the following verses:

“Maria mira sonat breviter, quod talia tonat.

Gummis cum binis fugitivum figit in imis....

Filia Plutonis consortia iungit amoris,
Gaudet in assata sata per tria sociata.”

(Maria utters brief wonders because such are the things that she thunders. She fixes what runs to the bottom with double-strong gums.... This daughter of Pluto unites love’s affinities, Delighting in everything sown, roasted, assembled by threes.)

⁸⁴ Cf. my remarks on Paracelsus’ “Adech” in “Paracelsus as a Spiritual Phenomenon,” pars. 168, 203ff.

⁸⁵ 1. 4. 3. (Cf. Max Müller, *The Upanishads*, II, pp. 85–86.)

⁸⁶ There is a rather different formulation in Distinction XIV of the “Allegoriae sapientum” (*Theatr. chem.*, V, p. 86): “Unum et est duo, et duo et sunt tria, et tria et sunt quatuor, et quatuor et sunt tria, et tria et sunt duo, et duo et sunt unum” (One, and it is two; and two, and it is three; and three, and it is four; and four, and it is three; and three, and it is two; and two, and it is one). This evidently represents the quartering (tetrameria) of the one and the synthesis of the four in one.

⁸⁷ In Sudhoff/Matthiessen, XII.

⁸⁸ Folio VIII^v. The *aqua mercurialis* is characterized here as the “bright and clear fluid of Bacchus.” The king and the son are united in the operation, so that at the end only the renewed king and his five servants are left. The *senarius* (sixth) plays a modest role only in later alchemy.

⁸⁹ Paracelsus, *Opera*, ed. Huser, I, p. 503.

⁹⁰ The angels bear Faust’s “immortal part” to heaven, after cheating the devil of it. This, in the original version, is “Faust’s entelechy.”

⁹¹ Cf. the movements of the transforming substance in the “Tabula smaragdina” (*De alchemia*, p. 363).

⁹² “Suo nobis descensu suavem ac salubrem dedicavit ascensum.” *Sermo IV de Ascensione Domini* (Migne, *P.L.*, vol. 183, col. 312).

⁹³ Picinelli, *Mundus symbolicus*, s.v. “rota.”

⁹⁴ “Vom irdischen und himmlischen Mysterium,” ch. V, 1f.

⁹⁵ *Von dem dreyfachen Leben*, ch. IX, 58f.

⁹⁶ *De signatura rerum*, ch. XIV, 15 (trans. Bax, p. 179).

⁹⁷ *Ibid.*, 16 (p 179).

⁹⁸ *Ibid.*

⁹⁹ *Ibid.*, IV, 28 (Bax, p. 37).

¹⁰⁰ Cf. Jung, “The Psychology of the Child Archetype.”

¹⁰¹ Böhme, *De signatura rerum*, ch. IV, 27 (Bax, p. 37).

¹⁰² Böhme, *Gespräch einer erleuchteten und unerleuchteten Seele*, 11–24.

¹⁰³ *Rosarium, Art. aurif.*, II, p. 214.

¹⁰⁴ *Ibid.*, p. 213: “Nec intrat in eum [lapidem], quod non sit ortum ex eo, quoniam si aliquid extranei sibi apponatur, statim corrumpitur” (Nothing enters into it [the stone] that did not come from it; since, if anything extraneous were to be added to it, it would at once be spoiled).

¹⁰⁵ Petronius, *Satyricon*, par. 38: “Phantasia non homo” (He’s a fantasy, not a man).

¹⁰⁶ Prescription for preparation of the *lapis* (Hermes quotation in *Rosarium, Art. aurif.*, II, p. 317): “Fili, extrahe a radio suam umbram: accipe ergo quartam partem sui, hoc est, unam partem de fermento et tres partes de corpore imperfecto,” etc. (Son, extract from the ray its shadow: then take a fourth part of it, i.e., one part of the ferment and three parts of the imperfect body, etc.). For *umbra*, see *ibid.*, p. 233: “Fundamentum artis est sol et eius umbra” (The basis of the art is the sun and its shadow) (fig. 81). The above quotation gives only the sense of the “Tractatus aureus” and is not literal.

¹⁰⁷ Cf. dream 58, par. 304. The alchemical vulture, eagle, and crow are all essentially synonymous.

¹⁰⁸ This quotation from Hermes is likewise an arbitrary reading. The passage runs literally: “Ego sum albus nigri et rubeus albi et citrinus rubei et certe veridicus sum” (I am the white of the black, and the red of the white, and the yellow of the red, and I speak very truth). In this way three meanings are expressed by four colours, in contrast to the formula of Hortulanus which attributes four natures and three colours to the *lapis*.—*De alchemia*, p. 372.

¹⁰⁹ *Art. aurif.*, II, p. 207: “Lapis noster est ex quatuor elementis.”

¹¹⁰ *Ibid.*, p. 208: “In auro sunt quatuor elementa in aequali proportione aptata.”

¹¹¹ *Ibid.*, p. 317: “Recipe de simplicissimo et de rotundo corpore, et noli recipere de triangulo vel quadrangulo sed de rotundo: quia rotundum est propinquius simplicitati quam triangulus. Notandum est ergo, quod corpus simplex nullum habens angulum, quia ipsum est primum et posterius in planetis, sicut Sol in stellis.”

¹¹² A quotation from Ademar (ibid., p. 353): “[Lapis] nihilominus non funditur, nec ingreditur, nec permiscetur, sed vitrificatur” (But [the stone] can neither be melted nor penetrated nor mixed but is made as hard as glass).

¹¹³ There are very interesting parapsychological parallels to this, but I cannot enter upon them here.

¹¹⁴ See pars. 245f., 258f.; and my commentary on *The Secret of the Golden Flower*, ch. I, sec. 2.

¹¹⁵ Valli, “Die Geheimsprache Dantes.”

¹¹⁶ Cf. “Rosarius minor,” *De alchemia*, p. 309.

¹¹⁷ “Symbola Pythagore phylosophi” in Ficino, *Auctores platonici*, Fol. X, III, says: “Ab eo, quod nigram caudam habet abstinere, terrestrium enim deorum est” (Keep your hands from that which has a black tail, for it belongs to the gods of the earth).

¹¹⁸ Although the theme of this study does not permit a full discussion of the psychology of dreams, I must make a few explanatory remarks at this point. Sitting together at one table means relationship, being connected or “put together.” The round table indicates that the figures have been brought together for the purpose of wholeness. If the anima figure (the personified unconscious) is separated from ego-consciousness and therefore unconscious, it means that there is an isolating layer of personal unconscious embedded between the ego and the anima. The existence of a personal unconscious proves that contents of a personal nature which could really be made conscious are being kept unconscious for no good reason. There is thus an inadequate or even non-existent consciousness of the shadow. The shadow corresponds to a negative ego-personality and includes all those qualities we find painful or regrettable. Shadow and anima, being unconscious, are then contaminated with each other, a state that is represented in dreams by “marriage” or the like. But if the existence of the anima (or the shadow) is accepted and understood, a separation of these figures ensues, as has happened in the case of our dreamer. The shadow is thus recognized as belonging, and the anima as not belonging, to the ego.

¹¹⁹ Cf. what I have said about the anima in “The Archetypes of the Collective Unconscious.” pars. 53ff. In Hermes’ treatise, *An die menschliche Seele*, she is called “the highest interpreter and nearest custodian (of the eternal),” which aptly characterizes her function as mediator between conscious and unconscious.

¹²⁰ *Rosarium, Art. aurif.*, II, p. 237.

¹²¹ *Ibid.*, p. 238.

¹²² p. 236.

¹²³ p. 231.

¹²⁴ The uterus is the centre, the life-giving vessel (fig. 87). The stone, like the grail, is itself the creative vessel, the *elixir vitae*. It is surrounded by the spiral, the symbol of indirect approach by means of the *circumambulatio*.

¹²⁵ The centre of the mandala corresponds to the calyx of the Indian lotus, seat and birthplace of the gods. This is called the *padma*, and has a feminine significance. In alchemy the *vas* is often understood as the uterus where the “child” is gestated. In the Litany of Loreto, Mary is spoken of three times as the “*vas*” (“*vas spirituale*,” “*honorabile*,” and “*insigne devotionis*”) and in medieval poetry she is called the “flower of the sea” which shelters the Christ (cf. dream 36). The grail (fig. 88) is closely related to the Hermetic vessel: Wolfram von Eschenbach calls the stone of the grail “*lapsit exillis*.” Arnold of Villanova (d. ?1312) calls the *lapis* “*lapis exilis*,” the uncomely stone (*Rosarium, Art. aurif.*, II, p. 210), which may be of importance for the interpretation of Wolfram’s term.

¹²⁶ See Avalon, *The Serpent Power*.

¹²⁷ Synonymous with the “golden flower.”

¹²⁸ Projection is considered here a spontaneous phenomenon, and not the deliberate extrapolation of anything. It is not a phenomenon of the will.

¹²⁹ “In polo est cor Mercurii, qui verus est ignis, in quo requies est Domini sui, navigans per mare hoc magnum ... cursum dirigit per aspectum astri septentrionalis”—Philalethes, “Introitus apertus,” *Musaeum hermeticum*, p. 655.

¹³⁰ See “Paracelsus as a Spiritual Phenomenon,” pars. 229, 237.

¹³¹ “Disturbed” mandalas occur from time to time. They consist of all forms that deviate from the circle, square, or regular cross, and also of those based not on the number four but on three or five. The numbers six and twelve are something of an exception. Twelve can be based on either four or three. The twelve months and the twelve signs of the zodiac are definite symbolic circles in daily use. And six is likewise a well-known symbol for the circle. Three suggests the predominance of ideation and will (trinity), and five that of the physical man (materialism).

¹³² Cf. the psychological functions in *Psychological Types*, ch. X.

¹³³ *Psychological Types*, pars. 556ff.

¹³⁴ “Ait autem ipse salvator: Qui iuxta me est, iuxta ignem est, qui longe est a me, longe est a regno” (The Saviour himself says: He that is near me is near the fire. He that is far from me is far from the kingdom).—Origen, *Homiliae in Jeremiam*, XX, 3; cited in James, *Apocryphal New Testament*, p. 35.

¹³⁵ Book of Enoch 18 13 and ch. 21 (Charles, *Apocrypha and Pseudepigrapha*, II, pp. 200, 201).

¹³⁶ A more detailed commentary on this dream is to be found in Jung, “Psychology and Religion,” pars. 59ff.

¹³⁷ This vision is treated in greater detail in Jung, “Psychology and Religion,” pars. 112ff.

¹³⁸ Bischoff, *Die Elemente der Kabbalah*, I, pp. 63ff. Further associations with “32” on pp. 175ff.

- ¹³⁹ Agrippa, *De incertitudine*, II, ch. XV.
- ¹⁴⁰ Franck, *Die Kabbala*, p. 137.
- ¹⁴¹ Knorr von Rosenroth, *Kabbala denudata*, I, p. 602.
- ¹⁴² Allendy, *Le Symbolisme des nombres*, p. 378.
- ¹⁴³ Bas-relief at Philae (Budge, *Osiris and the Egyptian Resurrection*, I, p. 3); and *The Book of the Dead* (1899), Papyrus of Hunefer, pl. 5. Sometimes there are three with animal heads and one with a human head, as in the Papyrus of Kerasher (*ibid.*). In a 7th-century manuscript (Gellone) the evangelists actually wear their animal heads, as in several other Romanesque monuments.
- ¹⁴⁴ So called by Melito of Sardis, *De baptismo*, in Pitra, *Analecta sacra*, II, p. 5.
- ¹⁴⁵ Delacotte, *Guillaume de Digulleville*.
- ¹⁴⁶ An idea which corresponds to dream 21 (par. 198), of the large sphere containing many little spheres.
- ¹⁴⁷ Cf. my remarks on “inflation” in “The Relations between the Ego and the Unconscious,” pars. 227ff.
- ¹⁴⁸ Cf. my commentary on *The Secret of the Golden Flower*, pars. 31ff. Cf. also “Concerning Mandala Symbolism.”
- ¹⁴⁹ Revised edition: *Symbols of Transformation*.
- ¹⁵⁰ In the cloisters of Basel Cathedral.
- ¹⁵¹ This was observed chiefly in men, but whether it was mere chance I am unable to say.
- ¹⁵² Observed mainly in women. But it occurs so rarely that it is impossible to draw any further conclusions.
- ¹⁵³ I have mentioned only a few of these parallels here.
- ¹⁵⁴ The image that presents itself in this material as a goal may also serve as the origin when viewed from the historical standpoint. By way of example I would cite the conception of paradise in the Old Testament, and especially the creation of Adam in the Slavonic Book of Enoch. Charles, *Apocrypha and Pseudepigrapha*, II, 425ff.; Förster, “Adams Erschaffung und Namengebung.”
- ¹⁵⁵ If we divide the four hundred dreams into eight groups of fifty each, we come to the following results:

I	6	mandalas
II	4	”
III	2	”
IV	9	”
V	11	”
VI	11	”
VII	11	”
VIII	17	”

So a considerable increase in the occurrence of the mandala motif takes place in the course of the whole series.

- ¹⁵⁶ “The most natural and perfect work is to generate its like.”

¹ An alarming example of this kind of “alchemy” is to be found in the illustrated work *Geheime Figuren der Rosenkreuzer*, belonging to the 16th and 17th centuries. The so-called Sachse Codex, belonging to the first half of the 18th century, also gives an excellent idea of this amazing literature. (Cf. Hall, *Codex Rosae Crucis*.)

² “Spiritual Development as Reflected in Alchemy and Related Disciplines.”

³ *La tradizione ermetica*.

⁴ This word comes from *íos* (poison). But since it has about the same meaning as the red tincture of later alchemy I have translated *iosis* as “reddening.”

⁵ This is particularly evident in the writings of Dorn, who violently attacked the quaternity from the trinitarian standpoint, calling it the “quadricornutus serpens” (four-horned serpent). See Jung, “Psychology and Religion,” pars. 103f.

⁶ Cf. Jung, “Paracelsus as a Spiritual Phenomenon,” pars. 165ff., 203ff.

⁷ *Rosarium, Art. aurif.*, II, p. 264: the *aqua permanens* is the “fiery form of the true water.” Ripley, *Opera omnia chemica*, p. 62: “Anima aerea est secretus ignis nostrae philosophiae, oleum nostrum, nostra aqua mystice” (The aerial soul is the secret fire of our philosophy, our oil, our mystic water). “Figurarum Aegyptiorum secretarum” (MS. in author’s coll.), p. 6: “The water of the philosophers is fire.” Philalethes, “Introitus apertus,” *Mus. herm.*, p. 653: “Est nempe in Aqua nostra requisitus ... Ignis” etc. (For in our water fire ... is sought). *Aurora* I, ch. XI, parab. VI: Senior saith: “And when they desire to extract this divine water, which is fire, they warm it with their fire, which is water, which they have measured unto the end and have hidden on account of the unwisdom of fools.” *Aurora* II, *Art. aurif.*, I, p. 212 (quotation from Senior): “Ignis noster est aqua.” *Ibid.*, p. 227: “Philosophus autem per aquam, vulgus vero per ignem” (The philosopher through water, ordinary people through fire).

⁸ Zosimos, in Berthelot, *Alch. grecs*, III, lii, 2.

⁹ “Turba philosophorum,” *Art. aurif.*, I, p. 14: “... aqua permanens, ex qua quidem aqua lapis noster preciosissimus generatur” (... the permanent water, out of which water our most precious stone is generated). “Con., coniug.” *Ars chem.*, p. 128: “Lapidem esse aquam fontis vivi” (That stone is water of a living fountain).

¹⁰ *Ibid.*, p. 66: “Vita uniuscuiusque rei ... est vivum quod non moritur, quamdiu mundus est, quia est caput mundi” etc. ([Water is] the life of everything; it is alive because it does not die as long as the world exists, for it is the head [i.e., principle] of the world).

¹¹ Scites, Frictes, Feritis = Socrates (*Turba* [ed. Ruska], p. 25).

¹² Bonellus, Balinus, Belinus = Apollonius of Tyana (Steinschneider and Berthelot, cited in Ruska, *ibid.*, p. 26).

¹³ “In Turbam philosophorum exercitationes,” *Art. aurif.*, I, p. 167.

¹⁴ For instance, “Unum in uno circulo sive vase” (One in one circle or vessel).—Scholia to the Hermetic “Tractatus aureus,” *Bibl. chem. curiosa*, I, p. 442.

¹⁵ Therefore it is called “domus vitrea sphaeratis sive circularis” (the spherical or circular house of glass).—“Epistola ad Hermannum,” *Theatr. chem.*, V, p. 896. The *vas* is a “sphaera, quam cribrum vocamus” (sphere, which we call a sieve).—“Allegoriae super librum Turbae,” *Art. aurif.*, I, p. 144. This idea appears as early as Greek alchemy, for instance in Olympiodorus (Berthelot, *Alch. grecs*, II, iv, 44, 11. 17–18). The *vas* is an *ὄργανον κυκλικόν, ἀφιάλη σφαιροειδής* (a circular instrument, a phial of spherical shape).

¹⁶ “Vas spagyricum ad similitudinem vasis naturalis construendum. Videmus enim totum caelum et elementa similitudinem habere sphaerici corporis, in cuius centro viget ignis calor inferioris ... necessarium igitur fuit nostrum ignem poni extra nostrum vas, et sub eius rotundi fundi centro, instar solis naturalis.” (The spagyric vessel is to be constructed after the model of the natural vessel. For we see that the whole sky and the elements resemble a spherical body, in the centre of which lives the heat of the lower fire.... It was therefore necessary to put our fire outside our vessel, beneath the centre of its rounded base, like the natural sun.)—Dorn, “Physica Trismegisti,” *Theatr. chem.*, I, p. 430. “Vas est sicut opus Dei in vase germinis divi” (The vessel is like the work of God in the vessel of divine germination). “Vas autem factum est rotundum ad imitationem superi[oris] et inferi[oris]” (The vessel is made round, in imitation of the upper and the lower).—“Liber Platonis quattorum,” *Theatr. chem.*, V, pp. 148, 152. Reitzenstein (*Poimandres*, p. 141) is therefore justified in comparing the *vas mirabile* on the head of the angel (in the treatise “Isis to Horus” in Berthelot, *Alch. grecs*, I, xiii, 1) to the *κύκλος δισκοειδής* on the head of Chnuphis in Porphyry. (Cf. fig. 203.)

¹⁷ Dorn, “Congeries,” *Theatr. chem.*, I, p. 574: “Vas nostrum ad hunc modum esse debet, ut in eo materia regi valeat a caelestibus corporibus. Influentiae namque caelestes invisibiles et astrorum impressiones apprime necessariae sunt ad opus.” (Our vessel must be such that in it matter can be influenced by the heavenly bodies. For the invisible celestial influences and the impressions of the stars are necessary to the work.)

¹⁸ *Vas as matrix*: Ripley, *Opera omnia*, p. 23; “In Turbam philosophorum exercitationes,” *Art. aurif.*, I, p. 159; *Aurora II*, *Art. aurif.*, I, p. 203; “Consil. coniug.,” *Ars chem.*, p. 204.

¹⁹ Ripley, *Opera omnia*, p. 30: “In uno vitro debent omnia fieri, quod sit forma ovi” (Everything must be done in one glass, which must be egg-shaped).

²⁰ Philalethes, “Fons chymicae veritatis,” *Mus. herm.*, p. 803: “Quum igitur de vase nostro loquimur, intellige aquam nostram, quum de igne, itidem aquam intellige, et quum de furno disputamus, nihil ab aqua diversum aut divisum volumus” (When, therefore, we speak of “our vessel,” understand “our water”; when we speak of fire, again understand water; and when we discuss the furnace, we mean nothing that is different or distinct from water). Mercurius, i.e., the *aqua permanens*, is “vas nostrum verum occultum, hortus item Philosophicus, in quo Sol noster orietur et surgit” (our true hidden vessel, and also the Philosophical Garden in which our sun rises and ascends). (Philalethes, “Metallorum metamorphosis,” *Mus. herm.*, p. 770.) Other names are *mater*, *ovum*, *furnus secretus*, etc. (Ibid., p. 770; also *Aurora II*, *Art. aurif.*, I, p. 203). “The vessel of the Philosophers is their water” (Hermes quotation in Hoghelande, “De alchimiae difficultatibus,” *Theatr. chem.*, I, p. 199).

²¹ *Vas = ignis verus* (Philalethes, “Metallorum metamorphosis,” *Mus. herm.*, p. 770) and *vinum ardens, ignis* (Mylius, *Philosophia reformata*, p. 245). “[Vas Hermetis] est mensura ignis tui” (The vessel of Hermes is the measure of your fire). “Practica Mariae,” *Art. aurif.*, I, p. 323. In the alchemical commentary (“Recueil stéganographique”) to Bérolalde de Verville’s *Songe de Poliphile*, fire and water are interpreted morally as “flames and tears.”

²² Quercetanus, “De ortu et causis metallorum,” *Theatr. chem.*, II, pp. 198ff.

²³ Even Meyrink (in the 20th century) still believed in the possibility of the alchemical procedure. We find a remarkable report of his own experiments in his introduction to *Aquinas: Abhandlung über den Stein*, pp. xxixff.

¹ Evola (*La tradizione ermetica*, pp. 28f.) says: “The spiritual constitution of man in the premodern cycles of culture was such that each physical perception had simultaneously a psychic component which ‘animated’ it, adding a ‘significance’ to the bare image, and at the same time a special and potent emotional tone. Thus ancient physics was both a theology and a transcendental psychology, by reason of the illuminating flashes from metaphysical essences which penetrated through the matter of the bodily senses. Natural science was at once a spiritual science, and the many meanings of the symbols united the various aspects of a single knowledge.”

² *Rosarium, Art. aurif.*, II, p. 231: “Et ille dicitur lapis invisibilitatis, lapis sanctus, res benedicta” (And it is called the stone of invisibility, the sacred stone, the blessed thing).

³ Maier, *Symbola aureae mensae*, p. 386: “... non parvis sumptibus illam invenere artem,/Qua non ars dignior ulla est,/Tingendi lapidem Aetherium ...” (... not with small expense did they find that art, than which there is no more worthy art; the art of tincturing the ethereal stone). This is a reference to Marcellus Palingenius, “poeta et sacerdos,” and his group.

⁴ “Omnes receptae spernendae sunt in arte” (*Rosarium, Art. aurif.*, II, p. 223).

⁵ Jurain, *Hyle und Coahyl; aus dem Aethiopischen ins Lateinische, und aus dem Lateinischen in das Teutsche translätiret und übergesezt durch D. Johann Elias Müller* (Hamburg, 1732). The text is by no means old, and bears all the traits of the decadent period (18th century). I am indebted to Prof. Th. Reichstein (Basel) for introducing me to this little book.

⁶ Rose noble = English gold coin of the 15th and 16th centuries.

⁷ “De alchimiae difficultatibus,” *Theatr. chem.*, I, p. 164. Likewise Philalethes, “Introitus apertus,” *Mus. herm.*, p. 687: “Terra enim germinandi avida aliquid semper fabricat, interdum aves aut bestias reptiliaque in vitro conspiciere imaginabere ...” (The earth, being eager to germinate, always produces something; sometimes you will imagine that you see birds or beasts or reptiles in the glass). The man on the cathedra undoubtedly refers to a vision of Hermes such as can be found in the old treatise *Senioris Zadith filii Hamuelis Tabula chymica*, pp. 1ff. (see fig. 128). Senior was an Arabic author of the 10th century. The figure as depicted in the treatise, of a wise old man holding the book of secrets on his knees, was taken over in the frontispiece of Bérolalde de Verville, *Le Songe de Poliphile* (see fig. 4). The oldest vision extant of this kind is perhaps that of Krates. The “Book of Krates” was handed down in Arabic and—in its present form—would appear to belong to the 9th century, but the greater part of it is of Greek origin and therefore considerably older. Berthelot gives the following passage: “Then I saw an old man, the handsomest of men, sitting in a chair. He was dressed in white, and was holding in his hand a board from the chair, on which rested a book.... When I asked who this old man was, I was told: He is Hermes Trismegistus, and the book he has in front of him is one of those which contain the explanation of the secret things he has hidden from men.” (*La Chimie au moyen âge*, III, pp. 46ff.)

⁸ “De alch. diff.,” *Theatr. chem.*, I, p. 199. It is not clear whether by “scripture” he means the traditional description of the vessel in the treatises of the masters, or the Holy Scripture.

⁹ Sendivogius, “Novum lumen,” *Mus. herm.*, p. 574.

¹⁰ “Compendium,” *Bibl. chem. curiosa*, I, p. 875.

¹¹ “Speculativa philosophia,” *Theatr. chem.*, I, p. 275.

¹² Hoghelande, “De alch. diff.,” *Theatr. chem.*, I, p. 150.

¹³ Text of the operative passage: "... quasi Materia Hypostatica fingit se in aquam demersum per illusionem. ..." The illusion could refer to *demergere* or to *fingere*. Since the former makes no sense I have chosen the latter possibility.

¹⁴ *Theatr. chem.*, V, p. 884.

¹⁵ *Della tramutatione metallica*. A song by Josephus Avantius about Nazari runs: "Somnia credentur vix; non tamen omnia falsa, / Quae tali fuerint praemeditata viro" (The dreams will hardly be believed; they are not, however, all false that were meditated by such a man).

¹⁶ *Art. aurif.*, I, pp. 146ff.

¹⁷ Berthelot, *Chimie au moyen âge*, III, p. 119.

¹⁸ Cf. Jung, "The Visions of Zosimos."

¹⁹ Sendivogius, "Parabola," *Bibl. chem.*, II, p. 475. Khunrath (*Von hylealischen Chaos*, p. 42) says; "[The] Cabalistic *habitaculum Materiae Lapidis* was originally made known from on high through Divine Inspiration and special Revelation, both with and without instrumental help, 'awake as well as asleep or in dreams.'"

²⁰ "De ratione conficiendi lapidis," *Theatr. chem.*, II, p. 256.

²¹ *Von hylealischen Chaos*, p. 185.

²² Similar views in Hoghelande, "De alch. diff.," *Theatr. chem.*, I, p. 154; *Turba*, ed. Ruska, p. 155, 8; and Dorn, "Physica Trismegisti," *Theatr. chem.*, I, p. 413; and these tracts in *Musaeum hermeticum*: "Tractatus aureus," p. 8; Madathanus, "Aureum saeculum," p. 55; "Aquarium sapientum," p. 75; "Gloria mundi," p. 212.

²³ "De alch. diff.," *Theatr. chem.*, I, p. 194. He refers there to *Turba XXXIX* (ed. Ruska, p. 147, 2): "Maius est, quam quod ratione percipiatur [nisi] divina inspiratione" (It is too great to be conceived by reason without divine inspiration).

²⁴ "De alch. diff.," p. 205.

²⁵ Sendivogius, "Novum lumen," *Mus. herm.*, p. 577: "Materia prima, quam solus Deus scit."

²⁶ Khunrath, *Von hyleal. Chaos*, pp. 71f. Note the implied reference to the Logos (John 1 : 9–11).

²⁷ "Instructio de arbore," *Theatr. chem.*, VI, p. 168. [Though Espagnet is held on good authority to be the author of this work and it is listed under his name in the bibliography for purposes of reference, his authorship is controversial. —EDITORS.]

²⁸ "Quaeso, oculis mentis hanc grani tritici arbusculam secundum omnes suas circumstantias aspice, ut arborem Philosophorum plantare ... queas."

²⁹ *Theatr. chem.*, I, p. 472: "Ex aliis nunquam unum facies quod quaeris, nisi prius ex te ipso fiat unum."

³⁰ Probably a reference to the "Tabula smaragdina" (ed. Ruska, p. 2): "Et sicut omnes res fuerunt ab uno, meditatione unius: sic omnes res natae," etc. (And as all things proceed from the One, through the meditation of the One, so all things are born ... etc.). Hence the rule that the alchemist must not have any serious physical defects, mutilated limbs, etc. See Geber, *Summa perfectionis*, Lib. I: "Si vero fuerit artificis corpus debile et aegrotum, sicut febrientium, vel leprosum corpora, quibus membra cadunt, et in extremis vitae laborantium, et iam aetatis decrepitae senum ad artis complementum non perveniet. His igitur naturalibus corporis impotentiis impeditur artifex in intentione sua." (But if the body of the artifex is weak and sick, like bodies of people with fever or leprosy, whose limbs fall off, or like the bodies of people labouring at the end of their life, or of old men of decrepit age, he will not achieve the completion of the Art. By these natural disabilities of the body the artifex is hindered in his intention.)

Another old text, the “Septem tractatus seu capitula Hermetis Trismegisti aurei,” *Ars chemica*, ch. I, gives similar advice: “Ecce vobis exposui, quod celatum fuerat, quoniam opus vobiscum, et apud vos est, quod intus arripiens et permanens in terra vel in mari habere potes” (I have expounded to you what had been hidden; the work is with you and among you, and grasping it steadfastly you can have it on land or sea).

³¹ *Art. aurif.*, II, p. 244. Ruska (*Turba*, p. 342) dates the *Rosarium* to the middle of the 15th century.

³² “Pone ergo mentem tuam super salem, nec cogites de aliis. Nam in *ipsa sola* occultatur scientia et arcanum praecipuum, et secretissimum omnium antiquorum Philosophorum.” The *Bibliotheca chemica* version, p. 95, has “*ipsa sola*”; likewise the *Rosarium philosophorum* of 1550. Unfortunately I have no access to the manuscripts.

³³ Cf. the *sal sapientiae* which, according to the ancient rite of baptism, was and still is given to the baptized.

³⁴ Khunrath, *Von hyleal. Chaos*, pp. 257, 260, 262.

³⁵ *Ibid.*, p. 258.

³⁶ *Art. aurif.*, II, p. 214: “Et vide secundum naturam, de qua regenerantur corpora in visceribus terrae. Et hoc imaginare per veram imaginationem et non phantasticam.” (And look according to nature, by which the bodies are regenerated in the bowels of the earth. And imagine this with the true and not with the fantastic imagination.)

³⁷ *Ibid.*, p. 243: “Et invenitur in omni loco et in quolibet tempore et apud omnem rem, cum inquisitio aggravat inquirentem” (And it is found in every place and at any time and in every circumstance, when the search lies heavy on the searcher).

³⁸ Canon of St. Paul’s, London, physician in chief to Pope Gregory XII, died c. 1252 (Ferguson, *Bibliotheca chemica*, II, p. 271).

³⁹ *Theatr. chem.*, II, p. 444.

⁴⁰ “Liber de alchemia,” *Theatr. chem.*, I, p. 793: “Parmenides ... qui me primum retraxit ab erroribus, et in rectam viam direxit” (Parmenides ... who first pulled me back from errors, and directed me into the straight path).

⁴¹ “De alch. diff.,” *Theatr. chem.*, I, pp. 213f.

⁴² *Ibid.*, p. 206.

⁴³ Zacharius, “Opusculum,” *Theatr. chem.*, I, pp. 813, 815f.

⁴⁴ Richardus, “Correctorium alchymiae,” *Theatr. chem.*, II, p. 451.

⁴⁵ *Ibid.*, p. 459.

⁴⁶ In *Theatr. chem.*, I.

⁴⁷ “Philosophia chemica,” *Theatr. chem.*, I, p. 485: “Verum forma quae hominis est intellectus, initium est, medium, et finis in praeparationibus: et ista denotatur a croceo colore, quo quidem indicatur hominem esse maiorem formam et principalem in opere spagirico.” The *forma* works through *informatio* (also described as *fermentatio*). *Forma* is identical with *idea*. Gold, silver, and so on are forms of matter, therefore one can make gold if one succeeds in impressing the form of gold (*impressio formae*) on the *informis massa* or chaos, i.e., the *prima materia*.

⁴⁸ *Theatr. chem.*, V.

⁴⁹ *Ibid.*, p. 137.

⁵⁰ This “book” explains “quid separetur et praeparetur.” The *separatio* or *solutio* refers to the decomposition of the original matter into elements.

⁵¹ The text says: "... liber in exaltatione animae, cum sit separatio naturae, et ingenium in conversione sua a materia sua" (... the book [treating of] the exaltation of the soul, its separation from nature, its intrinsic spirituality and its conversion from its own materiality). The *anima* is separated from its body (*separatio*). As an *ingenium*, it is the body's essential quality or "soul," whose material nature has to be transformed into something higher.

⁵² "Est sicut praeparatio totius, et conversio naturae ad simplex ... et necesse est in eo elevari ab animalitate, plus quam natura, ut assimuletur praeparation[e] ipsis intelligentiis, altissimis, veris" (It is like the preparation of the whole, and the conversion of nature to the simple ... and it is necessary to rise above animality more than does nature, in order to be assimilated by means of this preparation to the highest, truest intelligences). So the chief work falls to the intellect, namely sublimation up to the highest stage, where nature is transformed into the *res simplex*, which, in accordance with its own nature, is akin to the spirits, angels, and eternal ideas. In the second column this highest stage is fire, "qui est super omnia elementa, et agit in eis"; in the third column it is the ethereal (highest) form of transformed nature, and in the fourth it is the goal of the whole process.

⁵³ There is an introductory remark to this series: "Vel si vis potes illas [*scil.* exaltationes] comparare elementis" (If you wish you can compare those [exaltations] to the elements).

⁵⁴ "... rationis vere dirigentis ad veritatem" (... [of] reason that truly leads to truth).

⁵⁵ The *effectus* refer to the preceding stages in the process of transformation.

⁵⁶ 'Ανωτάτω μὲν οὖν εἶναι τό πῦρ (Fire has the uppermost place).—Diogenes Laertius, *Lives of Eminent Philosophers*, VII, i (on Zeno), 137.

⁵⁷ Stoic doctrine

⁵⁸ The soul still has a luminous or fiery nature in Lactantius.

⁵⁹ Aristotle, *De Coelo* (trans. Guthrie, I, p. 3), and *Meteorologica* (ed. Bekker), I, p. 3.

⁶⁰ *Ibid.*, XII, p. 7: God is οὐσία τις αἰδιος καί ἀκίνητος (an eternal and immovable being).

⁶¹ Fechner (*Elemente der Psychophysik*, II, p. 526) thinks in the same way: "That which is psychically homogeneous and simple is associated with physical multiplicity, whereas physical multiplicity contracts psychically into the homogeneous, the simple, and yet simpler."

⁶² *Theatr. chem.*, V, p. 145.

⁶³ Instead of "intelligentiae."

⁶⁴ Instead of "intelligentia."

⁶⁵ Instead of "et quid."

⁶⁶ "Et dixit philosophus in libro Dialogorum: Circuivi tres coelos, scilicet coelum naturae compositae, coelum naturae discretae et coelum animae. Cum autem volui circumire coelum intelligentiae, dixit mihi anima, non habes illuc iter, et attraxit me natura et attractus sum. Hoc autem dictum principale, non posuit philosophus ad significandam hanc scientiam, sed quia voluit ut sermones sui non vacarent manifestatione, virtutis liberantis creaturam, et voluit per eos in hac specie operis, ut cognoscatur praeparatio deterior, per praeparationem superiorem."—"Liber Platonis Quartorum," *Theatr. chem.*, V, p. 145.

⁶⁷ *Ibid.*, p. 144: "Sedentes super flumina Eufrates sunt Caldaeii ... priores, qui adinvenerunt extrahere cogitationem" (The Chaldaeans dwelling on the river Euphrates were ... the first to find out how to extract the cogitation).

⁶⁸ *Ibid.*, p. 137.

⁶⁹ Ibid., p. 124: “Si utaris opere exteriori, non utaris nisi occipitio capitis et invenies” (If you use an exterior operation you should use only the occiput and then you will find [the goal]). The conjecture “goal” is subject to the reservation that I have not yet been able to obtain the Arabic text.

⁷⁰ Ibid., p. 124: “Os capitis est mundum et est ... minus os, quod sit in [h]omine [text: nomine], et vas mansionis cogitationis et intellectus ...” (The skull is pure and ... moreover it is a comparatively small bone in [man], and it is the vessel of cogitation and intellect ...).

⁷¹ “Res convertuntur per tempus ad intellectum per certitudinem, quantum partes assimilantur in compositione et in forma. Cerebrum vero propter vicinitatem cum anima rationali [the “et” here should be deleted] permixtioni oportuit assimilari, et anima rationalis est simplex sicut diximus.”

⁷² “Speculativa philosophia,” *Theatr. chem.*, I. p. 265.

⁷³ Ibid., p. 298.

⁷⁴ Ibid., p. 264.

⁷⁵ Ibid., p. 266.

⁷⁶ Ibid., p. 267: “Transmutemini de lapidibus mortuis in vivos lapides philosophicos.”

⁷⁷ To *Le Tableau des riches inventions*.

⁷⁸ Mehung, “Demonstratio naturae,” *Mus. herm.*, p. 157: “liberi et vacui anima.” (Jean de Meung, born between 1250 and 1280.)

⁷⁹ Norton, “Ordinale,” *Mus. herm.*, p. 519: “nam mens eius cum opere consentiat. ...”

⁸⁰ “Aquarium sapientum,” *Mus. herm.*, p. 107.

⁸¹ *Aurora consurgens* I, ch. X, parab. V: “Alfidius: Scito quod hanc scientiam habere non poteris, quousque mentem tuam deo purifices, hoc est in corde omnem corruptionem deleas.”

⁸² The text has “... virtus, de qua dicitur: virtus ornat animam. Et Hermes: et recipit virtutem superiorum et inferiorum planetarum et sua virtute penetrat omnem rem solidam.” (... virtue of which it is said: virtue adorneth the soul. And Hermes: and it receiveth the virtue of the upper and lower planets and by its virtue penetrateth every solid thing.) Cf. “Tabula smaragdina,” ed. Ruska, p. 2: “et recipit vim superiorum et inferiorum.”

⁸³ The text explains by quoting the Vulgate, Eph. 4 : 23, 24: “Renovamini [autem] spiritu mentis vestrae, et induite novum hominem ...” (D.V.: “And be renewed in the spirit of your mind: and put on the new man ...”) and adds: “hoc est intellectum subtilem.”

⁸⁴ *Aurora* I, ch. IV, parab. IV: “... horridas nostrae mentis purga tenebras.”

⁸⁵ Ibid.: “Senior: et facit omne nigrum album ...”

⁸⁶ *Art. aurif.*, II, p. 228. The text in Geber’s *Summa perfectionis* is much more detailed. It occupies the whole of ch. V of Lib. I, under the title “De impedimentis ex parte animae artificis.” See Darmstaedter, *Die Alchemie des Geber*, pp. 20ff.

⁸⁷ *Art. aurif.*, II, p. 227: “Deum timere, in quo dispositionis tuae visus est, et adjuvatio cujuslibet sequestrati.” This quotation derives from the “Tractatus aureus” in what was probably the first edition (*Ars chemica*). But there the passage (which comes at the beginning of ch. II) runs: “Fili mi, ante omnia moneo te Deum timere, in quo est nisus tuae dispositionis et adunatio cuiuslibet sequestrati” (My son, above all I admonish thee to fear God in whom is the

strength of thy disposition, and companionship for the solitary, whosoever he may be). Concerning the alteration of the Hermes quotations in *Rosarium*, see par. 140, n. 17.

⁸⁸ Cf. Reitzenstein. “Alchemistische Lehrschriften.” Morienus (Morieneus or Marianus) is said to have been the teacher of the Omayyad prince, Kalid or Khalid ibn-Jazid ibn-Muawiyah (635–704). Cf. Lippmann, *Entstehung und Ausbreitung der Alchemie*, I, p. 357. The passage is to be found in Morienus, “De transmutatione metallorum,” *Art. aurif.*, II, pp. 22f.

⁸⁹ “Quibus eam a primaeva rerum natura conferre disposuit” (ibid., p. 22).

⁹⁰ “Animos suos etiam ipsi regere non possunt diutius, nisi usque ad terminum,” etc. (ibid., p. 23).

⁹¹ “... nisi per animae afflictionem” (ibid., pp. 17f.).

⁹² Maier, *Symbola aureae mensae*, p. 568.

⁹³ Ibid., p. 144.

⁹⁴ Ibid., p. 143.

⁹⁵ P. 327: “Meditatio (s.v.) dicitur, quoties cum aliquo alio colloquium habetur internum, qui tamen non videtur. Ut cum Deo ipsum invocando, vel cum se ipso, vel proprio angelo bono.” This description is very similar to the *colloquium* in the *Exercitia spiritualia* of Ignatius of Loyola. All the authors are unanimous in emphasizing the importance of meditation. Examples are unnecessary.

⁹⁶ Cf. Jung. “The Relations between the Ego and the Unconscious,” pars. 341ff.

⁹⁷ “Introitus apertus,” *Mus. herm.*, p. 693.

⁹⁸ “... novam volatilitatem citra ullam manuum impositionem meditabitur.”

⁹⁹ Cf. the Mohammedan legend of the rock in the mosque of Omar, at Jerusalem, which wanted to fly up with Mohammed when he ascended to heaven.

¹⁰⁰ *Von hyleal, Chaos*, pp. 274f.

¹⁰¹ I take this text from a manuscript in my possession entitled “Figurarum Aegyptiorum secretarum ...” *Incipit*: “Ab omni aevo aegyptiorum sacerdotes.” Colophon: “laus jesu in saecula.” (Fol. 47, parchment, 18th cent.) The pictures in this manuscript are identical with those in MS. No. 973 (18th cent.), Bibliothèque de l’Arsenal, Paris. They come from the “Pratique” of Nicolas Flamel (1330–1418). The origin of the Latin text in my manuscript is at present unknown. (See figs. 23, 148, 157, 164.) [See also *Mysterium Coniunctionis*, par. 720.]

¹⁰² *Art. aurif.*, I. Cf. Ruska’s version in *Historische Studien und Skizzen* (ed. Sudhoff), pp. 22ff. A still older series of visions is that of Zosimos in [Ἐπι ἀπερτῆς (Berthelot, *Alch. grecs*, III) and also of Krates (Berthelot, *Chimie au moyen âge*, III).

¹⁰³ “Astrum in homine, coeleste sive supracoeleste corpus.” Since Ruland joins forces with Paracelsus here, I refer the reader to my “Paracelsus as a Spiritual Phenomenon” [especially par. 173].

¹⁰⁴ Ruland, *Lexicon*, s.v. “astrum”: “virtus et potentia rerum, ex praeparationibus acquisita” (the virtue and power of things, that is acquired through the preparations). Hence also extract or Quinta Essentia.

¹⁰⁵ Figulus (*Rosarium novum olympicum*, p. 109) says: “[Anima] is a subtle imperceptible smoke.”

¹⁰⁶ Sendivogius, in *Mus. herm.*, pp. 601ff.

¹⁰⁷ Ibid., p. 618.

¹⁰⁸ Avalon, *The Serpent Power*.

¹⁰⁹ “Et ... volavit super pennas ventorum.”—Vulgate, Ps. 17: 11 (A.V., Ps. 18 : 10).

¹¹⁰ Sendivogius, “De sulphure,” *Mus. herm.*, p. 612.

¹¹¹ *Ibid.*, p. 615. Christ is similarly “imagined” in us—“Aquarium sapientum,” *Mus. herm.*, p. 113: “Deus, antequam Christus filius eius in nobis formatus imaginatusque fuit, nobis potius terribilis Deus” (Before Christ his son was formed and imagined in us, God was more terrible to us).

¹¹² All “our secrets” are formed from an “image” (*imago*), says Ripley (*Opera omnia chemica*, p. 9).

¹ Maier, *Symbola aureae mensae*, p. 202: “Sunt enim plerique libri adeo obscure scripti, ut a solis auctoribus suis percipiantur” (For many of the books are written so obscurely that they are understood only by their authors). Cf. also Maier, *Scrutinium chymicum*, p. 33.

² For instance, the second part of the *Aurora*, in *Art. aurif.*, I.

³ Philalethes (“Introitus apertus,” *Mus. herm.*, p. 660): “Sunt enim in principiis nostris multae heterogenae superfluitates, quae in puritatem nunquam reduci possunt, ea propter penitus expurgare illas expedit, quod factu impossibile erit absque arcanorum nostrorum theoria, qua medium docemus, quo cum ex meretricis menstruo excernatur Diadema Regale” (For there are in our initial material many superfluities of various kinds which can never be reduced to purity. Therefore it is advantageous to wash them all out thoroughly, but this cannot be done without the *theoria* of our secrets, in which we give instructions for extracting the Royal Diadem from the menstruum of a whore). The *Rosarium philosophorum*, subtitled *secunda pars alchemiae*, is such a *theoria* in the true sense of a *visio* (spectacle, watching scenes in a theatre, etc.). Cf. the *theorica* of Paracelsus, in Jung, “Paracelsus the Physician,” par. 41.

⁴ There is a similar illustration in Khunrath’s *Amphitheatrum* (cf. fig. 145).

⁵ John Cremer, Abbot of Westminster, who lived at the beginning of the 14th century. His “Testamentum” is printed in the *Musaeum Hermeticum*.

⁶ Basilus Valentinus, a legendary or fictitious personality.

⁷ Thomas Norton, putative author of the famous “Ordinall of Alchimy.” On the question of his personality, cf. Nierenstein and Chapman, “Enquiry into the Authorship of the *Ordinall of Alchimy*.”

⁸ The vision of the father of Benvenuto Cellini—described in Cellini’s autobiography, I, iv, p. 6—gives us a good idea of such visions: “When I was about five years old my father happened to be in a basement chamber of our house, where they had been washing, and where a good fire of oak logs was still burning; he had a viol in his hand, and was playing and singing alone beside the fire. The weather was very cold. Happening to look into the fire, he spied in the middle of those most burning flames a little creature like a lizard, which was sporting in the core of the intensest coals. Becoming instantly aware of what the thing was, he had my sister and me called, and pointing it out to us children, gave me a great box on the ears, which caused me to howl and weep with all my might. Then he pacified me good-humouredly, and spoke as follows: ‘My dear little boy, I am not striking you for any wrong that you have done, but only to make you remember that that lizard which you see in the fire is a salamander, a creature which has never been seen before by anyone of whom we have credible information.’ So saying, he kissed me and gave me some pieces of money.”

⁹ *Lexicon alchemiae*, s.v. “draco.”

¹⁰ Cf. Taylor, “A Survey of Greek Alchemy.”

¹¹ Reproduced in Berthelot, *Alch. grecs*. Introduction, p. 132.

¹² *Rosarium*, *Art. aurif.*, II, p. 206: “Unius ergo esto voluntatis in opere naturae, nec modo hoc, modo illud attentare praesumas quia in rerum multitudine ars nostra non perficitur. Quantumcunque enim diversificentur eius nomina, tamen semper una sola res est, et de eadem re. ...” (Therefore you must be single-minded in the work of nature, and you must not try now this, now that, because our art is not perfected in a multiplicity of things. For however much its names may differ, yet it is ever one thing alone, and from the *same* thing. ...) “Unus est lapis, una medicina, unum

vas, unum regimen, unaque dispositio” (One is the stone, one the medicine, one the vessel, one the method, and one the disposition). Cf. Reitzenstein, “Alchemistische Lehrschriften,” p. 71. Morienus (“De transmutatione metall.,” *Art. aurif.*, II, pp. 25f.) quotes the Emperor Heraclius (610–41): “Hercules dixit: Hoc autem magisterium ex una primum radice procedit quae postmodum in plures res expanditur et iterum ad unam revertitur. ...” (Hercules [Heraclius] said: This magistry proceeds first from one root, which afterwards expands into several things, and returns again to the one.)

¹³ *Rosarium*, *Art. aurif.*, II, p. 210: “Scitote ergo, quod argentum vivum est ignis, corpora comburens magis quam ignis” (Know therefore that the quicksilver is a fire which burns bodies more than fire [itself]).

¹⁴ Cf. the meaning of the uniting symbol in Jung, *Psychological Types*, pars. 318ff.

¹⁵ Berthelot, *Alch. grecs*, III, vi, 5.

¹⁶ A text ascribed to Ostanes, and transmitted in Arabic, is to be found in Berthelot, *Chimie au moyen âge*, III, pp. 116ff.; also a Greek text in Berthelot, *Alch. grecs*, IV, ii.

¹⁷ Lippmann, *Entstehung und Ausbreitung der Alchemie*, I, p. 334.

¹⁸ Cf. Maier, *Symbola aureae mensae*, p. 19: “[ol]eum extrahere a cordibus statuarum” (extract the oil from the hearts of statues), referring to Raymond Lully. “Codicillus” (*Bibl. chem. curiosa*, I, p. 894). Cf. also the “extraction of the cogitation” mentioned above (par. 375, n. 67).

¹⁹ Berthelot, *Alch. grecs*, III, vi, 5.

²⁰ It is indeed remarkable that the alchemists should have picked on the term *proiectio* in order to express the application of the philosophical Mercurius to base metals.

²¹ Berthelot, *Alch. grecs*, IV, xx, 8.

²² *Ibid.*, III, vi, 8.

²³ *Ibid.*, III, li, 8.

²⁴ Scott, *Hermetica*, I, pp. 149ff.

²⁵ Here we probably enter the realm of Neopythagorean ideas. The penetrating quality of the soul-pneuma is mentioned in Aenesidemus (Zeller, *Die Philosophie der Griechen*, III, p. 26). He also speaks of aer as the original substance, corresponding to the pneuma of the Stoics (p. 23). Hermes, whose pneumatic (wind-) quality (see figs. 210, 211) is indicated by his wings, leads the souls to the Highest, according to Alexander Polyhistor (p. 75), but the impure souls are fettered in the underworld by the Erinyes with unbreakable bonds, like the imperfect ones who in the treatise of Komarios are “chained in Hades” (see fig. 151).

²⁶ The cabalistic idea of God pervading the world in the form of soul-sparks (*scintillae*) and the Gnostic idea of the Spinther (spark) are similar.

²⁷ The concepts of nous and pneuma are used promiscuously in syncretism. The older meaning of pneuma is wind, which is an aerial phenomenon: hence the equivalence of aer and pneuma (Zeller, *Die Philosophie der Griechen*, III, p. 23). Whereas in Anaximenes the original substance is aer (*ibid.*, I, pp. 713ff.), in Archelaus of Miletus, the pupil of Anaxagoras, God is aer and nous. In Anaxagoras the world-creator is Nous, who produces a whirlpool in chaos and thus brings about the separation of ether and air (*ibid.*, I, pp. 687ff.). Concerning the idea of pneuma in syncretism, cf. Leisegang, *Der heilige Geist*, pp. 26ff.

²⁸ Schultz, *Dokumente der Gnosis*, p. 64; Reitzenstein, *Poimandres*, p. 50. In the Neopythagorean view, hermaphroditism is also an attribute of the deity. Cf. Nicomachus, in Zeller, *Philosophie der Griechen*, III, p. 107.

²⁹ The effect of inflation is that one is not only “puffed up” but too “high up.” This may lead to attacks of giddiness, or to a tendency to fall downstairs, to twist one’s ankle, to stumble over steps and chairs, and so on.

³⁰ Berthelot, *Alch. grecs*, IV, xx, 8: τὸ μυστήριον τὸ φρικτὸν καὶ παράδοξον.

³¹ Zeller, *Philosophie der Griechen*, II, p. 152.

³² *Ibid.*, III, pp. 99, 151.

³³ Hippolytus, *Elenchos*, V, 26, 1.—Alchemy transferred the Edem-motif to Mercurius, who was likewise represented as virgin above, serpent below. This is the origin of the Melusina in Paracelsus (see “Paracelsus as a Spiritual Phenomenon,” pars. 179f.).

³⁴ Cf. the salvation and purification of the ἔν τοῖς στοιχείοις συνδεθῆσα θεία ψυχή in the Book of Sophe (Berthelot, *Alch. grecs*, III, xlii, 1).

³⁵ Late Jewish (cabalistic) Gnosis developed a very similar attitude to that of alchemy. Cf. the excellent description by Gaugler, “Das Spätjudentum,” pp. 279ff.

³⁶ The main points of resemblance are: in Osiris, his God-man nature, which guarantees human immortality, his corn characteristics, his dismemberment and resurrection; in Orpheus, the taming of the passions, the fisherman, the good shepherd, the teacher of wisdom, the dismemberment; in Dionysus, his wine characteristics, the ecstatic revelations, the fish symbolism, the dismemberment and resurrection; in Hercules, his subjection to Eurystheus and Omphale, his labours (mainly to redeem suffering humanity from various evils), the cross formed by his journeys (labours 7–10 lead South-North-East-West, while labours 11–12 lead upwards; cf. St. Paul: Eph. 3 : 18), his self-cremation and *sublimatio* culminating in divinity.

³⁷ Cf. for instance, the Polynesian myth of Maui (Hambruch, *Südseemärchen*, p. 289). Further material in Frobenius, *Das Zeitalter des Sonnengottes*.

³⁸ Hauck, *Realencyklopädie*, XII, p. 689, 35: “Celebratio huius sacramenti est imago quaedam repraesentativa passionis Christi, quae est vera eius immolatio” (The celebration of this sacrament is a kind of image that represents Christ’s passion, which is his true immolation).

³⁹ This point of view finds acceptance in the Beuron edition of the Missal (p. x).

⁴⁰ Kramp, *Die Opferanschauungen der römischen Messliturgie*, p. 114.

⁴¹ “Vita corporea actualis sensitiva aut a sensibus pendens” (A real bodily life, apprehended by the senses or dependent on the senses).—Cardinal Álvarez Cienfuegos, S.J. (d. 1739), in Hauck, *Realencyklopädie*, XII, p. 693, 59.

⁴² Cf. sacrifice of the lamb in the “Vita S. Brendani,” from *La Légende latine de S. Brandaines* (based on 11th–13th century MSS.), p. 12: “Dixitque sanctus Brendanus fratribus: ‘Faciamus hic *opus divinum*, et sacrificemus Deo agnum immaculatum, quia hodie cena Domini est.’ Et ibi manserunt usque in Sabbatum sanctum Pasche. Invenerunt eciam ibi multos greges ovium unius coloris, id est albi, ita ut non possent terram videre pre multitudine ovium. Convocatis autem fratribus, vir sanctus dixit eis: ‘Accipite que sunt necessaria ad diem festum de grege.’ Illi autem acceperunt unam ovem et cum illam ligassent per cornua, sequebatur quasi domestica, sequens illorum vestigia. At ille: ‘Accipite, inquit, unum agnum immaculatum.’ Qui cum viri Dei mandata complerent, paraverunt omnia ad

opus diei crastine. ...” (And St. Brendan said to the brothers: “Let us perform here the divine work and sacrifice to God an immaculate lamb, for today is the supper of the Lord.” And they remained there until Holy Saturday. They also found there many flocks of sheep of one colour, i.e., white, so that they could not see the ground because of the great number of sheep. The holy man called the brothers together and said to them: “Take from the flock what you need for the feast day.” And they took one sheep, and when they had bound it by the horns, it followed as if it were a domestic animal, following in their footsteps. And he said: “Take an immaculate lamb.” And when they had done the bidding of the man of God, they prepared everything for the work of the following day.)

Ibid., p. 34: “Confestim tunc cantaverunt tres psalmos: ‘Miserere mei, Deus, et Domine refugium, et Deus, deus meus.’ Ad terciam vero alios tres: ‘Omnes gentes, Deus in nomine, Dilexi quoniam,’ cum alleluya. Deinde immolaverunt agnum immaculatum, et omnes venerunt ad communionem dicentes: ‘Hoc sacrum corpus Domini, et Salvatoris nostri, sanguinem sumite vobis in vitam aeternam.’” (At once they sang three psalms: “Have mercy on me, O God,” and “Lord, thou hast been our refuge,” and “O God, my God”; and at terce three others: “O clap your hands, all ye nations,” “Save me, O God, by thy name,” and “I have loved, because,” with alleluia. Then they sacrificed an immaculate lamb, and they all came to communion, saying: “This is the sacred body of the Lord our Saviour, take the blood unto you for life eternal.”)

⁴³ Ἰϊάρεδρος = ministering spirit. So Khunrath and others.

⁴⁴ Von hyleal. *Chaos*, p. 59 et passim. The much earlier Morienus (“De transmutatione metall.,” *Art. aurif.*, II. p. 37) says: “In hoc enim lapide quattuor continentur elementa, assimilaturque Mundo et Mundi composition!” (For in this stone the four elements are contained, and it is made similar to the World and the composition of the World).

⁴⁵ Morienus says to King Kalid (ibid., p. 37): “Haec enim res a te extrahitur: cuius etiam minera tu existis, apud te namque illam inveniunt, et ut verius confitear, a te accipiunt: quod cum probaveris, amor eius et dilectio in te augebitur. Et scias hoc verum et indubitabile permanere.” (For this thing is extracted from thee, and thou art its ore [raw material]; in thee they find it, and that I may speak more plainly, from thee they take it; and when thou hast experienced this, the love and desire for it will be increased in thee. And know that this remains true and indubitable.)

⁴⁶ “In stercore invenitur.”

⁴⁷ Maier, *Symbola aureae mensae*, p. 336.

⁴⁸ Khunrath (*Von hyleal, Chaos*, p. 410), for instance, says: “So work even in the laboratory by thyself alone, without collaborators or assistants, in order that God, the Jealous, may not withdraw the art from thee, on account of thy assistants to whom He may not wish to impart it.”

⁴⁹ Geber, “Summa perfectionis,” *Bibl. chem.*, I, p. 557b: “Quia nobis solis artem per nos solos investigatam tradimus et non aliis ...” (Because we hand down the art which we alone have investigated, to ourselves alone and to no one else ...).

⁵⁰ I am setting aside the later Rosicrucians and the early “Poimandres” community, of which Zosimos speaks [infra, par. 456]. Between these two widely separated epochs I have found only one questionable passage, in the “Practica Mariae Prophetissae” (*Art. aurif.*, I, p. 323) (see fig. 78), where the “interlocutor” Aros (Horus) asks Maria: “O domina, obedisti in societate Scoyari: O prophetissa, an invenisti in secretis Philosophorum ...” (O lady, did you obey in the society of Scoyarus: O Prophetess, did you find the secrets of the philosophers ...?). The name *Scoyaris* or *Scoyarus* recalls the mysterious *Scayolus* in the writings of Paracelsus (*De vita longa*), where it means the adept.

(*Scayolae* are the higher spiritual forces or principles. See “Paracelsus as a Spiritual Phenomenon,” pars. 206ff.) Is there perhaps a connection here? At any rate there seems to be an allusion to a *societas*. The treatise of Maria may go back to very early times and thus to the Gnostic societies. Agrippa (*De incertitudine scientiarum*, ch. XC) mentions an alchemical initiation vow which may possibly refer to the existence of secret societies. Waite (*The Secret Tradition in Alchemy*) comes to a negative conclusion in this respect.

⁵¹ The *Turba philosophorum* is an instructive example in this respect.

⁵² Morienus, “De transmut. metall.,” *Art. aurif.*, II, p. 37: “Magisterium est arcanum Dei gloriosi.” “Consil. coniug.,” *Ars chemica*, p. 56: “Donum et secretorum secretum Dei.” *Rosarium*, *Art. aurif.*, II, p. 280; “Divinum mysterium a Deo datum et in mundo non est res sublimior post animam rationalem” (The divine mystery was given by God and there is in the world no thing more sublime except the rational soul).

⁵³ *Ibid.*, pp. 212, 228.

⁵⁴ *Ibid.*, pp. 219, 269.

⁵⁵ *Ibid.*, p. 230. Alchemy is superior to all other sciences in the opinion of Djabir or Geber (8th cent.): “Indeed, any man who is learned in any science whatever, who has not given part of his time to the study of one of the principles of the Work, in theory or in practice, his intellectual culture is utterly insufficient” (Berthelot, *Chimie au moyen âge*, III, p. 214). Djabir is said to have been a Christian or Sabaeen. (See also Ruska, “Die siebzig Bücher des Gabir ibn Hajjan,” p. 38.) Synesius also appeals to the intelligence (Berthelot, *Alch. grecs*, II, iii, 16). Olympiodorus even compares the art to the divine intelligence (*ibid.*, II, iv, 45) and appeals to the intelligence of his public (*ibid.*, II, iv, 55). Christianos too lays stress on intelligence (*ibid.*, VI, i, 4, and iii, 2). Likewise *Aurora* II, in *Art. aurif.*, I, “Prologus”: “oportet intellectum valde subtiliter et ingeniose acuere” (one must sharpen the intellect very subtly and ingeniously).

⁵⁶ *Rosarium*, *Art. aurif.*, II, p. 210.

⁵⁷ Hoghelande, “De alchem. difficultatibus,” *Bibl. chem. curiosa*, I, p. 342: “Librorum magnam habeat copiam.”

⁵⁸ “Rhasis dixit: liber enim librum aperit.” (Quoted by Bonus, “Pret. marg. nov.,” *Bibl. chem.*, II, ch. VIII.)

⁵⁹ *Rosarium*, *Art. aurif.*, II, p. 230.

⁶⁰ *Ibid.*, pp. 211, 243, 269.

⁶¹ Sendivogius, “Parabola,” *Bibl. chem. curiosa*, II, p. 475: “Aqua Philosophica tibi in somno aliquoties manifestata” (The philosophic water that was shown to you a number of times in a dream).

⁶² Figulus, *Rosarium novum olympicum*, ch. XI.

⁶³ Figulus, “Tractatulus rhythmicus,” in *ibid.*, part I, p. 58.

⁶⁴ *Rosarium*, *Art. aurif.*, II, p. 230.

⁶⁵ Arnold of Villanova, in *ibid.*, p. 210.

¹ Berthelot, *Alch. grecs*, IV, xx, 8.

² Dorn, “Congeries Paracelsicae chemicae,” *Theatr. chem.*, I, p. 578. In the same place Dorn explains: “Mercurium istum componi corpore, spiritu et anima, eumque naturam elementorum omnium et proprietatem assumpsisse. Quapropter ingenio et intellectu validissimis adseverarunt suum lapidem esse animale, quem etiam vocaverunt suum Adamum, qui suam invisibilem Evam occultam in suo corpore gestaret. ...” (This Mercurius is composed of body, spirit, and soul, and has assumed the nature and quality of all the elements. Wherefore they affirmed with most powerful genius and understanding that their stone was a living thing, which they also called their Adam, who bore his invisible Eve hidden in his body. ...) Hoghelande (“De alch. diff.,” *Theatr. chem.*, I, pp. 178f.) says: “They have compared the *prima materia* to everything, to male and female, to the hermaphroditic monster, to heaven and earth, to body and spirit, chaos, microcosm, and the confused mass [*massa confusa*]; it contains in itself all colours and potentially all metals; there is nothing more wonderful in the world, for it begets itself, conceives itself and gives birth to itself.”

³ “Tractatus aureus,” *Mus. herm.*, p. 10, and many other passages.

⁴ Dee, “Monas hieroglyphica,” *Theatr. chem.*, II, p. 218. In Aegidius de Vadis (“Dialogus,” *Theatr. chem.*, II, p. 110) the monad is the effective *forma* in matter. Khunrath (*Amphitheatrum*, p. 203) writes: “In Cabala est hominis ad monadis simplicitatem reducti, cum Deo, Unio: id in Physico-Chemia ad Lapidis nostri ... cum Macrocosmo Fermentatio.” (In the Cabala it is the Union of man, reduced to the simplicity of the monad, with God; in Physico-Chemistry it is the Fermentation [of] man reduced to [the simplicity of] our stone, with the Macrocosm.) There is a similar passage in his *Von hyleal. Chaos* (pp. 33, 204), where the monad is more a symbol of the perfected *lapis*. Dorn (“De spagirico artificio Trithemii sententia,” *Theatr. chem.*, I, p. 441) says: “In uno est enim unum et non est unum, est simplex et in quaternario componitur” (For in the One there is and there is not the One; it is simple and it is composed in the quaternity). In his doctrine of the *res simplex* Dorn is very much influenced by the “Liber Platonis quartorum.” (On one occasion he even mentions magic.) In the same passage he also uses the term *monad* for the goal: “A ternario et quaternario fit ad monadem progressus” (The progression is from the ternary and the quaternary to the Monad). The term *lapis* is used all through the literature for the beginning and the goal.

⁵ *Theatr. chem.*, V, p. 130.

⁶ Mylius, *Philosophia reformata*, p. 174.

⁷ *Art. aurif.*, I, p. 66. Eximindus (Eximidius or Eximenus in the first version) is a corruption of Anaximenes or Anaximander.

⁸ *Turba* (ed. Ruska), p. 116.

⁹ Sudhoff/Matthiessen edn., XIII, p. 390: “Thus the supreme artist has prepared a great uncreated mystery and no mystery will ever be the same nor will it ever return, for, just as cheese will never again become milk, so generation will never return to its first state.” Dorn (“Physica genesis,” *Theatr. chem.*, I, p. 380) translates: “Increatum igitur mysterium hoc fuit ab altissimo opifice Deo praeparatum, ut ei simile nunquam futurum sit, nec ipsum unquam rediturum, ut fuit.”

¹⁰ Paracelsus continues (XIII, pp. 390f.): “This *mysterium magnum* was a mother to all the elements, and in them likewise a grandmother to all stars, trees, and creatures of the flesh; for all sentient and insentient creatures, and all others of a like form, are born from the *mysterium magnum*, just as children are born from a mother. And it is a

mysterium magnum, one unique mother of all mortal things, and they have all originated in her” and so on. “Now, whereas all other mortal beings grew out of and originated in the *mysterium increatum*, it is to be understood that no creature was created earlier, later, or in particular, but all were created together. For the highest arcanum and great treasure of the creator has fashioned all things in the *increatedum*, not in form, not in essence, not in quality, but they were in the *increatedum*, as an image is in the wood, although this same is not to be seen until the other wood is cut away: thus is the image recognized. Nor is the *mysterium increatum* to be understood in any other manner, save that through its separation the corporeal and the insentient severally took on the form and shape that are their own.”

¹¹ *Mus. herm.*, pp. 73ff. Here I must correct a mistake which crept into my *Paracelsica*. Not only the author referred to there (pp. 173f.) but the “Aquarium” as well is concerned with heresies, and in an equally negative way. [See “Paracelsus as a Spiritual Phenomenon,” par. 231.—EDITORS.]

¹² *Ibid.*, pp. 106f.

¹³ *Ibid.*, p. 111.

¹⁴ *Theatr. chem.*, V, p. 145.

¹⁵ Cf. Grenfell et al., *New Sayings of Jesus*, pp. 15f.: “Jesus saith, (Ye ask? who are those) that draw us (to the kingdom, if) the kingdom is in Heaven? ... the fowls of the air, and all beasts that are under the earth or upon the earth, and the fishes of the sea. ...”

¹⁶ Ripley, *Opera omnia chemica*, p. 10.

¹⁷ *Ibid.*, p. 130.

¹⁸ *Ibid.*, p. 369.

¹⁹ *Ibid.*, p. 427.

²⁰ *Ibid.*, p. 9.

²¹ In the “Ripley Scrowle” (British Museum, MS. Add. 5025), the sphere of water is represented with dragon’s wings (cf. fig. 228). In the “Verses belonging to an emblematicall scrowle” (*Theatr. chem. Brit.*, p. 376) the “spiritus Mercurii” says:

“Of my blood and water I wis,
Plenty in all the world there is.
It runneth in every place;

Who it findeth he hath grace:
In the world it runneth over all,
And goeth round as a ball.”

²² Ripley, *Opera omnia chemica*, p. 197.

²³ *Mus. herm.*, p. 606.

²⁴ “Hortulani commentarius” in *De alchemia*, p. 366.

²⁵ Cf. Aegidius de Vadis (“Dialogus,” *Theatr. chem.*, II, p. 101): “The chaos is the *materia confusa*. This *materia prima* is necessary to the art. Four elements are mixed in a state of disorder in the *materia prima*, because earth and water, which are heavier than the other elements, reached the sphere of the moon, while fire and air, which are lighter than the others, descended as far as the centre of the earth; for which reason such a *materia* is rightly called disordered. Only a part of this disordered material remained in the world, and this is known to everyone and is sold publicly.”

²⁶ Hortulanus, “Commentarius,” *De alchemia*, p. 371.

²⁷ Zeller, *Die Philosophie der Griechen*, III, p. 120.

²⁸ Ibid., p. 102; also p. 154.

²⁹ Ibid., p. 687.

³⁰ Also defined as “the round fish in the sea” (“Allegoriae super librum Turbae,” *Art. aurif.*, I, p. 141).

³¹ Maier, *Symbola aureae mensae*, pp. 379f.

³² Ibid., p. 380.

³³ Cf. the beginning of Parable VII in *Aurora* I, ch. XII: “Be turned to me with all your heart and do not cast me aside because I am black and swarthy, because the sun hath changed my colour [Cant. 1 : 5f.] and the waters have covered my face [Jonas 2 : 6] and the earth hath been polluted and defiled [Psalm 105 : 38] in my works, for there was darkness over it [Luc. 23 : 44] because I stick fast in the mire of the deep [Psalm 68 : 3] and my substance is not disclosed. Wherefore out of the depths have I cried [Psalm 129 : 1] and from the abyss of the earth with my voice to all you that pass by the way. Attend and see me, if any shall find one like unto me [Lam. 1 : 12], I will give into his hand the morning star [Apoc. 2 : 28].”

³⁴ *Art. aurif.*, I, pp. 146ff.

³⁵ Cf. Ruska, *Turba*, p. 23. Arisleus is a corruption of Archelaos, owing to Arabic transcription. This Archelaos may be a Byzantine alchemist of the 8th or 9th century. He has left us a poem on the sacred art. But since the *Turba*, which is ascribed to Arisleus, goes back to Arabic tradition—as Ruska points out—we must assume that Archelaos lived much earlier. Ruska, therefore, identifies him with the pupil of Anaxagoras (ibid., p. 23). The alchemists would have been particularly interested in his idea that the *νοῦς* is mixed with air: *ἀέρα καὶ νοῦν τὸν θεόν* (Stobaeus, *Eclogarum*, I, p. 56).

³⁶ The pairing of like with like is to be found as early as Heraclitus (Diels, *Fragmente der Vorsokratiker*, I, p. 79¹⁰).

³⁷ Also Gabricus, Cabricus, Cabritis, Kybric: Arabic *kibrit* = sulphur. Beja, Beya, Beua: Arabic *al-baida* = the white one. (Ruska, *Turba*, p. 324.)

³⁸ “Ego tamen filium et filiam meo in cerebro gestavi” (“Visio Arislei,” *Art. aurif.*, I, p. 147). In Maier, *Symbola aureae mensae*, pp. 343f. (see n. 42 infra), it is a question of mother-incest, for there Gabritius is married to his mother Isis because they were the only pair of this kind. Evidently a chthonic pair of gods (symbolizing the opposites latent in the *prima materia*) is celebrating the *hierosgamos*.

³⁹ The “whole” or “self” comprises both conscious and unconscious contents.

⁴⁰ There is ample evidence in the literature to show that *divitiae* and *salus* are spiritual *bona futura*, and refer as much to the salvation of the soul as to the well-being of the body. We must not forget that the alchemist is not in the least concerned to torment himself with moral scruples, on the assumption that man is a sinful nonentity who complies with God’s work of redemption by his irreproachable ethical behaviour. The alchemist finds himself in the role of a “redeemer” whose *opus divinum* is more a continuation of the divine work of redemption than a precautionary measure calculated to guard against possible damnation at the Last Judgment.

⁴¹ The antithetical nature of the *ens primum* is an almost universal idea. In China the opposites are *yang* and *yin*, odd and even numbers, heaven and earth, etc.; there is also a union of them in the hermaphrodite. (Cf. Hastings, *Encyclopaedia*, IV, p. 140.) Empedokles: *νεῖκος* and *φιλία* of the elements (Zeus-fire, Hera-air). The second period of creation saw the birth of hybrids, similar to the northern Ymir and Buri (Herrmann, *Nordische Mythologie*, p. 574). Neopythagoreans: Monad = masculine, Dyad = feminine (Zeller, *Die Philosophie der Griechen*, III, p. 98). In

Nicomachus, the Deity is the odd and even number, therefore male-female (ibid., p. 107). Hermes Trismegistus: The Nous is hermaphroditic. Bardesanes (A.D. 154–223?): Crucified hermaphrodite (Schultz, *Dokumente der Gnosis*, p. lv). Valentinus: The creator of the world is the mother-father, and in Marcion the Gnostic, the Primordial Father is hermaphroditic. Among the Ophites, the Pneuma is male-female (ibid., p. 171).

⁴² Maier, *Symbola aureae mensae*, p. 344: “Delphinus, anonymus philosophus in Secreti Maximi tractatu De Matre cum filio ex necessitate naturae conjungenda clarissime loquitur: si enim unus sit masculus et una foemina, eius mater, in mundo, annon hi duo conjungendi sint, ut genus humanum inde multiplicetur? ... eodem modo cum saltem in arte Chymica sint duo subjecta, quorum unus alterius mater est. haec copulanda. ...” (Delphinus, an anonymous philosopher in the treatise “The Greatest Secret,” speaks very clearly about the Mother who must by natural necessity be united with the son. For, if there were in the world only one male and only one female, and she his mother, would they not have to be united, in order that mankind might be multiplied? In the same way, at any rate in the Chemical Art, since there are two subjects of which one is the mother of the other, they must be united. ...)

On p. 515 of the same book there is an “Epithalamium honori nuptiarum Matris Beiae et filii Gabrici,” which begins as follows:

“Ipsa maritali dum nato foedere mater
Jungitur, incestum ne videatur opus.
Sic etenim Natura iubet, sic alma requirit
Lex Fati, nec ea est res male grata Deo.”

(When the mother is joined with the son in the covenant of marriage, count it not as incest. For so doth nature ordain, so doth the holy law of fate require, and the thing is not displeasing to God.)

⁴³ The fear of ghosts means, psychologically speaking, the overpowering of consciousness by the autonomous contents of the unconscious. This is equivalent to mental derangement.

⁴⁴ *Art. aurif.*, II, pp. 246ff.

⁴⁵ I, ch. IX, par. IV. [Originally from a sequence of Notker Balbulus (c. 840–912).—EDITORS.] The passage is apparently derived from the first *oratio* of the third Sunday in Advent: “et mentis nostrae tenebras gratia tuae visitationis illustra.”

⁴⁶ “Nonnulli perierunt in opere nostro” (Not a few have perished in our work), the *Rosarium* says. The element of torture is also emphasized in “Allegoriae super librum Turbae,” *Art. aurif.*, I, pp. 139ff.: “Accipe hominem, tonde eum, et trahe super lapidem ... donec corpus eius moriatur ...” (Take a man, shave him, and drag him over a stone ... until his body dies ...).

⁴⁷ For the quadratic enclosure as the domain of the psyche, cf. the motif of the square in Part II, supra. According to Pythagoras the soul is a square (Zeller, *Die Philosophie der Griechen*, III, p. 120).

⁴⁸ Symbolized by a sorceress or by wanton girls, as in *Poliphilo*. Cf. fig. 33, and Béroalde de Verville, *Le Songe de Poliphile*. Similar themes in Part II of this volume.

⁴⁹ *Art. aurif.*, II, p. 246: “Nam Beya ascendit super Gabricum, et includit eum in suo utero. quod nil penitus videri potest de eo. Tantoque amore amplexata est Gabricum, quod ipsum totum in sui naturam concepit, et in partes indivisibiles divisit. Unde Mercurinus ait: ...

“Per se solvuntur, per se quoque conficiuntur,

Ut duo qui fuerant, unum quasi corpore fiant.”

(Then Beya mounted upon Gabricus and enclosed him in her womb, so that nothing at all could be seen of him any more. And she embraced Gabricus with so much love that she absorbed him completely into her own nature, and divided him into indivisible parts. Wherefore Mercurinus says: Through themselves they are dissolved, through themselves they are put together, so that they who were two are made one, as though of one body.) (NOTE: “Mercurinus” is a correction of the text’s “Masculus.”) The King, like the King’s Son, is killed in a variety of ways. He may be struck down, or else he drinks so much water that he sickens and dissolves in it (Merlinus, “Allegoria de arcano lapidis,” *Art. aurif.*, I, pp. 392ff.).

⁵⁰ Valentinus, “Practica,” *Mus. herm.*, p. 394. In another version of the incorporation motif, Mars feeds the body of the King to the famished wolf (*fame acerrima occupatus*), the son of Saturn (lead). The wolf symbolizes the *prima materia*’s appetite for the King, who often takes the place of the Son (fig. 175; cf. also figs. 166, 168, 169).

⁵¹ Cf. *Symbols of Transformation*, passim.

⁵² Espagnet, “Arcanum hermeticae philosophiae,” *Bibl. chem. curiosa*, II, p. 655, §LXVII: “This first digestion takes place as if in a belly.”

⁵³ Frobenius, *Das Zeitalter des Sonnengottes*.

⁵⁴ *Turba philosophorum* (Sermo LXVIII): “Our work ... results from a generation in the sea.”

⁵⁵ Cf. the king’s sweat-bath, fig. XIV of the Lambspringk “Figurae,” *Mus. herm.*, p. 369, among others. We find exactly the same idea in the hatching of the egg in goldmaking, as described by Nikephorus Blemmides: *περὶ τῆς ψοχρυσοποιίας* (Berthelot, *Alch. grecs*, VI, xx).

⁵⁶ Cf. Jung, *Symbols of Transformation*, p. 380.

⁵⁷ Christopher, “Elucidarius,” *Theatr. chem.*, VI, p. 228. Cf. Mithras’ birth from a stone “solo aestu libidinis” (through the sole heat of libido).

⁵⁸ Cf. Sendivogius, “De sulphure,” *Mus. herm.*, p. 612: “extra leve et invisible, intus vero grave, visibile et fixum” (outside it [the element air] is light and invisible, but inside heavy, visible, and solid).

⁵⁹ Grasseus, “Area arcani,” *Theatr. chem.*, VI, p. 314. He mentions the Augustinian monk Degenhardus as the author of this image, which, as in *Aurora* (ch. V), is an obvious allusion to Sapientia.

⁶⁰ “Practica,” *Mus. herm.*, pp. 403f.

⁶¹ *De circulo physico quadrato*. There is a parallel idea in Emerson, *Essays*, I, pp. 301ff. [In Jung’s copy, “Circles”; but cf. also “Intellect.”—EDITORS.]

⁶² Heart and blood as seat of the soul.

⁶³ *Opera omnia*, p. 146.

⁶⁴ For instance, in Lambspringk’s “Figurae et emblemata,” *Mus. herm.*, p. 371. See fig. 179.

⁶⁵ A similar idea is to be found in the Indian *hamsa* (swan).

⁶⁶ Scott, *Hermetica*, I and II.

⁶⁷ Also defined as *calx viva* (quicklime).

⁶⁸ “Gloria mundi,” *Mus. herm.*, pp. 246f.

¹ For a discussion of this method see Jung, “The Transcendent Function,” and *Mysterium Coniunctionis*, pp. 494ff., 528ff.—EDITORS.]

² Harforetus = Horfoltus of the Codex Berolinensis (Ruska, *Turba*, p. 324). In Ruska’s opinion, he is identical with the Emperor Heraclius (610–641), but the mystical role he plays in the “Visio” points rather to some connection with Harpocrates.

³ The “Visio Arislei” (*Art. aurif.*, I, p. 149) has: “ad Regem dicentes: quod filius tuus vivit, qui morti fuerat deputatus” (they said to the king: your son is alive, who was accounted dead). The Codex Berolinensis (in Ruska, *Turba*) has: “et misimus ad regem, quod filius tuus commotus est” (and we sent [word] to the king: Your son has been moved). (NOTE: “Commotus” is evidently intended to mean that he “moves” again or is “quick,” alive.)

⁴ I use the edition of 1593 in *Artis auriferae*, I, pp. 146ff.

⁵ Ruska, *Turba*, p. 324. In the *Art. aurif.*, I, this passage is changed to “how to gather the fruits of that immortal tree.”

⁶ The tree is often a *coralium* or *coralius*, coral, therefore, a “sea-tree” (fig. 186) (“the living coral growing in the sea”—“Allegoriae super librum Turbae,” *Art. aurif.*, I, p. 141). Cf. the tree of paradise in the sea in Paracelsus, *Das Buch Azoth*, p. 529.

⁷ Hence the recurrent formulae, “Deo adiuvante,” “Deo concedente,” etc.

⁸ The Neopythagoreans regarded Pythagoras as God incarnate. Cf. Zeller, *Die Philosophie der Griechen*, III, p. 130.

⁹ As Hermes takes the place of Poimandres. Cf. Scott, *Hermetica*, I and II.

¹⁰ Melchior Cibinensis. (See pars. 480ff.)

¹¹ Cf. the quotation from Alphidius in Maier, *Symbola aureae mensae*, p. 65, and also in *Aurora consurgens* I, ch. I: “Qui hanc scientiam invenerit, cibus eius legitimus erit et sempiternus” (He who hath found this science, it shall be his rightful food for ever). Parable VII of *Aurora* says: “Ex his enim grani huius fructibus cibus vitae conficitur, qui de coelo descendit. Si quis ex eo manducaverit, vivet sine fame. De illo namque pane edent pauperes et saturabuntur et laudabunt Dominum, qui requirunt eum, et vivent corda eorum in saeculum.” (For from the fruits of this grain is made the food of life which cometh down from heaven. If any man shall eat of it, he shall live without hunger. For of that bread the poor shall eat and shall be filled, and they shall praise the Lord that seek him, and their hearts shall live for ever.)

¹² The rite of blessing the New Fire seems to have originated in France; at any rate it was already known there in the 8th century, although it was not yet practised in Rome, as is proved by a letter from Pope Zacharias to St. Boniface. It appears to have reached Rome only in the 9th century. (See “Feuerweihe” in Braun, *Liturgisches Handlexikon*.)

¹³ Although I take every available opportunity to point out that the concept of the self, as I have defined it, is not identical with the conscious, empirical personality, I am always meeting with the misunderstanding which equates the self with the ego. Owing to the fundamentally indefinable nature of human personality, the self must remain a borderline concept, expressing a reality to which no limits can be set.

¹⁴ Cf. for example Simon Magus, who belonged to the apostolic era and already possessed a richly developed system.

¹⁵ Wei Po-yang, “An Ancient Chinese Treatise on Alchemy.”

¹⁶ *The Secret Tradition in Alchemy*.

¹⁷ “Et ut Jesus Christus de stirpe Davidica pro liberatione et dissolutione generis humani, peccato captivati, ex transgressione Adae, naturam assumpsit humanam, sic etiam in arte nostra quod per unum nequiter maculatur, per aliud suum contrarium a turpitudine illa absolvitur, lavatur et resolvitur.”—*Bibl. chem.*, I, p. 884, 2.

¹⁸ Cf. the *lectio* for Wednesday in Holy Week (Isa. 62 : 11; 63 : 1–7). “Wherefore art thou red in thine apparel, and thy garments like him that treadeth in the wine-fat?” and ... “their blood shall be sprinkled upon my garments ...” (A.V., Isa. 63 : 2, 3). Cf. the *pallium sanguineum* of other authors.

¹⁹ *Ars chemica* (1566), pp. 21f.

²⁰ Berthelot, *Alch. grecs*, IV, xx. The text probably belongs to the 1st century.

²¹ From the Greek text in Berthelot. *Alch. grecs*, III, xlix, 4–12, translated there into French by Ruelle. Ruska (“*Tabula smaragdina*,” pp. 24–31) also gives a translation of pars. 2–19. Scott (*Hermetica*, IV, pp. 104ff.) gives this part of the text in Greek with a commentary. Cf. further Bousset, *Hauptprobleme der Gnosis*, pp. 190ff. The translation given here [i.e., the German version—TRANS.] was made by myself with the help of Dr. Marie-Louise von Franz and differs in several points from the Ruelle and Ruska versions.

²² Heimarmene = fate, natural necessity.

²³ The passage beginning with “behold” is omitted by Reitzenstein as a Christian interpolation. Cf. Reitzenstein, *Poimandres*, p. 103; also Ruska, “*Tab. smarag.*,” p. 25.

²⁴ *Ibid.*, p. 25: “dwelling in every body.” *διήκειν* has more the meaning of “penetrate.” Cf. Bousset, *Hauptprobleme der Gnosis*, p. 191.

²⁵ *ἑκάστης* Codd. The conjecture *ἑκάστου* is superfluous.

²⁶ *ἀνορμάω* can only be meant transitively. Ruelle and Ruska translate: “So he (i.e., the son of God) has ascended. ...” But this interpretation takes all sense from the following accusatives which refer to the object *νοῦν*

²⁷ The *νοῦς*. Cf. Reitzenstein, *Poimandres*, p. 103, note 11.

²⁸ Ruska: “before it put on the flesh.” But *τὸ σωματικὸν* as predicate to *γενέσθαι* could not have an article. The sense is rather “before the creation.” Cf. par. 9, where the men of light rescue their spiritual part by taking it *ἔπου καὶ πρὸ τοῦ κόσμου ἦσαν*.

²⁹ *ἀκολουθοῦντα*, *ὀρεγόμενον* and *ὀδηγούμενον* refer to *νοῦν* which is also the object of *ἀνώρμησεν*. Scott (*Hermetica*, IV, p. 119) transfers this whole paragraph to the end of par. 8, because, in his opinion, it is not suitable to a Hermetic doctrine. But it constitutes the proof of the preceding idea that man should not struggle outwardly against his destiny, but should only strive inwardly for self-knowledge, the outward submission of the Son of God to suffering being an example of this.

³⁰ Cf. Reitzenstein, *Poimandres*, pp. 107–8. Iamblichus (*De mysteriis Aegyptiorum*, VIII, 4) mentions a prophet Bitys as an interpreter of Hermes at the court of King Ammon. He is said to have found the writings of Hermes at Saïs. Cf. *ibid.*, X, 7: *αὐτὸ δὲ τὸ ἀγαθὸν τὸ μὲν θεῖον ἡγοῦνται τὸν πρὸς αὐτὸν ἔνωσιν. ὅπερ Βίτυς ἐκ τῶν πρὸς αὐτὸν ἔνωσιν. ὅπερ Βίτυς ἐκ τῶν Ἑρμαϊκῶν βιβλίων μεθηρμήνευσεν*. According to Dieterich (“*Papyrus magica musei Lugdunensis Batavi*,” p. 753) he is identical with the Thessalonian Pity of the Magic Papyrus (Wessely, “*Griechische Zauberpapyrus*,” pp. 95, 92, 98: Πίτυος ἀγωγή—βασιλεῖ Ὀσάνη Πίτυς χαίρειν—ἀγωγή Πίτυος βασιλέως—Πίτυος θεσσαλοῦ). He may also be identical, again, according to Dieterich, with Bithus of

Dyrrhachium mentioned by Pliny (Book XXVIII). Scott (*Hermetica*, IV, pp. 129–30) suggests inserting “Nikotheos” or “which I wrote,” and has a drawing in mind.

³¹ Cf. *Philebus* (18b), *Phaedrus* (274c).

³² Scott’s splitting up of this sentence is inadmissible. In *Philebus* (18), Thoth is not represented as the “first man” but actually as the “divine man” and the giver of names to all things.

³³ Ruska: “what Thoythos interprets is in the holy language.” But Thoythos must be gen. explicat. to *φωνή*. for in other places the nominative is “Thoyth.” Cf. Bousset, *Hauptprobleme der Gnosis*, p. 191.

³⁴ *πνρά* Codd.: probably *πνρρά* = “fire-coloured.” Cf. Scott, *Hermetica*, IV, p. 121: “The interpretation of Adam as *γῆ παρθένος* is clearly a combination of the derivation from the Hebrew ‘adamah’ = *γῆ* (Philo, i. 62) and from the Greek *ἀδμής* = *παρθένος*. Hesychius gives *ἀδάμα παρθενική γῆ*. The sense is doubtless Josephus, *Ant.*, I, i. 2: *σημαίνει δὲ τοῦτο (Ἰ Αδάμος) πνρρὸς ἐπειδήπερ ἀπὸ γῆς πνρρᾶς γῆς ἐγεγόνει, τοιαύτη γὰρ ἔστιν ἡ παρθένος γῆ*. Compare Olympiodorus (Berthelot, p. 89 [*Alch. grecs*, II, iv, 32]): *οὔτος (Ἰ Αδάμ) γὰρ πάντων ἀνθρώπων πρῶτος ἐγένετο ἐκ τῶν τεσσάρων στοιχείων, καλεῖται δὲ καὶ παρθένος γῆ, καὶ πνρ[ρ]ά γῆ, καὶ σαρκίνη γῆ, καὶ γῆ αἰματώδης*. Cf. Eusebius, *Evangelica praeeparatio*, 11, 6, 10, sq. ...”

³⁵ *δν* Codd.; Reitzenstein and Ruska: *ῶν*. It is also possible that *δν* refers to the first man: namely that they exhibited him as Osiris in every sanctuary. We find evidence for this in Lydus, *De mensibus*, IV, 53: “For there are many conflicting opinions among the theologians regarding the God who is worshipped by the Hebrews. For the Egyptians, and above all Hermes, maintain that he is Osiris, the one who exists, of whom Plato in the *Timaeus* says: ‘which is the being that has no origin.’” Cf. Reitzenstein, *Poimandres*, p. 185, concerning the alleged transmission of the Jewish ideas to Egypt.

³⁶ *παρεκάλεσεν*: ‘A ... Codd.; Reitzenstein and Ruska: *παρεκάλεσαν Ἀσενᾶν* “When they [the Ptolemies] sent for Asenas” (masc. or fem.). Ruelle, on the other hand, takes Asenas as subject of *παρεκάλεσεν*. Nothing is known concerning a high priest named Asenas. It is very probable—as Scott (*Hermetica*, IV, p. 122) remarks—that Asenath, the beautiful daughter of the Egyptian priest Potipherah of On (Heliopolis), is meant. She bore Joseph two sons during his Egyptian imprisonment, according to Gen. 41 : 50. In a midrash which has undergone a Christian revision, we find a legend of this Asenath falling in love with Joseph when he appeared as Pharaoh’s steward; he rejected her, however, on account of her being an unbeliever. She then became a convert and did penance, whereupon a male messenger from heaven (in the recension: Michael)—whom she received as a *δαίμων πάρεδρος*, *spiritus familiaris*, in truly pagan fashion—gave her a honeycomb of paradise to eat and thus endowed her with immortality. He announces that Joseph will come to court her, and that from now on she will be called the “place of refuge.”—Cf. also Batiffol, “Le Livre de la Prière d’Asenath,” and Reitzenstein. *Die hellenistischen Mysterienreligionen*, pp. 248f.; further, Oppenheim, *Fabula Josephi et Asenathae*; Wilken, *Urkunden der Ptolemäerzeit*; and Kerényi, *Die griechisch-orientalische Romanliteratur in religionsgeschichtlicher Beleuchtung*, pp. 104f. It is possible that the messenger from heaven was originally Hermes. Hence our text might read as follows: “At the time when Asenath went to the High Priest of Jerusalem for help, who sent Hermes, who translated. ...” W. Scott suggests replacing Asenath by “Eleazar,” who, according to the Aristeas Letter, put the translation of the LXX (Septuagint) in hand; in this case one would also have to change the messenger Hermes into *έρμηνέα*, “interpreter.” But it is more likely that we are dealing with an altogether different legend.

³⁷ *τῶν ἀρχιεροσολύμων* Codd. Conjecture *τὸν ἀρχιερέα Ἰεροσολύμων*. Cf. Reitzenstein, Ruska, and Scott.

³⁸ Κατά τὸ σῶμα might also be understood as “in the corporeal language” in contrast to the “angel language” mentioned before. Elsewhere Zosimos contrasts the spiritual language with an ἔνσωμος φρῖσις.

³⁹ Also letters (στοιχεῖα)

⁴⁰ Here we can probably assume a lacuna containing the element earth, or possibly the elements earth and water. Anyhow the text is corrupt here. Ruska suggests putting τὸ δεύτερον α τὸν ἀέρα instead of τὸν ἀέρα, to indicate the North. Scott is probably right to leave τὸν ἀέρα (the air), for the object was to combine the points of the compass with the elements; Scott therefore adds γῆ (earth) after the word δύσις (descent). As justification for inserting ἄρκτος Scott quotes the Sibylline Oracles, III, 24: αὐτὸς δὴ θεός, ἔσθ' ὁ πλάσας τετραγράμματον Ἀδάμ τὸν πρῶτον πλασθέντα καὶ οὖνομα πληρώσαντα ἀνατολίην **τε δύσιν τε μεσημβρίην τε τε καὶ ἄρκτον**, and the Slavonic Book of Enoch, ch. 30.

⁴¹ Ruska: “The midmost of these bodies is the ripening fire which points to the midst of the fourth region.” Reitzenstein omits all this part.

⁴² ἀγνοῶν Codd.; Reitzenstein conjectures ἀγνοῶ. διὰ τὸ τέως Codd., literally “with regard to the foregoing.”

⁴³ This is a pun on τὸ φῶς (light) and the Homeric ὁ φῶς (man). See Ruska.

⁴⁴ Reitzenstein: διαπνεομένῳ, referring to Paradise: “in Paradise where blew the breath of Fate.”

⁴⁵ Reitzenstein adds “the archons” in explanation. But it is more likely to be the elements (στοιχεῖα) mentioned above. Cf. Gal. 4 : 9, for instance.

⁴⁶ παρ' αὐτοῦ Codd.; Reitzenstein, Scott, and Ruska παρ' αὐτῶν “the Adam that was with them.”

⁴⁷ Cf. in particular Bousset, *Hauptprobleme*, p. 193.

⁴⁸ *Theogony*, 614.

⁴⁹ δν Codd. Reitzenstein conjectures ῶ.

⁵⁰ “Prometheus” Codd. is omitted by Reitzenstein, because it probably refers to the whole man.

⁵¹ Reitzenstein conj.: νοῦ.

⁵² Personified in Reitzenstein: Nous (as Poimandres).

⁵³ ὅτε Codd.; Reitzenstein has ὅτι (whatever he wills).

⁵⁴ Φαίνει Codd.; Ruska and Scott have Φαίνεται (appears). Possibly the next sentence sets forth the essential meaning of the Son of Man?

⁵⁵ Reitzenstein deletes this whole sentence as a Christian interpolation. According to Photius (*Bibliotheca*, 170: ed. Bekker. I, p. 11) Zosimos was later interpreted in a Christian sense. Scott deletes the words “Jesus Christ” and simply takes “the Son of God” as the subject.

⁵⁶ στήσας Codd.; Reitzenstein and Scott have στήσας. Ruska translates: “laying aside his own humanity.” Concerning the stealing, cf. Hegemonius, *Acta Archelai*, XII, where it is said of God: “Hac de causa ... furatur eis [the “principes”] animam suam” (For this reason ... he steals from them [i.e., the princes] their soul [or “his soul”]).

⁵⁷ Reitzenstein, too, relates this to what follows.

⁵⁸ τόποισι Codd.; Reitzenstein has ἔπεισι (“he goes to ...”).

⁵⁹ Conj.: συνῶν; Reitzenstein, Bousset, and Scott have συλῶν Codd.; συλλαῶν: “he converses” (Ruelle).

- ⁶⁰ Ruelle: “He counselled his own to exchange secretly their spirit with that of Adam which they had within them. ...” But this makes *διά* superfluous. Cf. also the passage *Φησὶ γὰρ ὁ νοῦς ἡμῶν ...* and the beginning of our text, where the Redeemer leads the soul back by enlightening the Nous of each soul.
- ⁶¹ *ἔχειν* can mean “to have to suffer.” The adversaries evidently mean to injure the Men of Light.
- ⁶² Reitzenstein eliminates the second *παρ’ αὐτῶν*. But *παρά* can also mean “away from someone’s side.”
- ⁶³ *δι’ οὗ ζηλούμενος* Codd.; Reitzenstein has *διαζηλούμενος*.
- ⁶⁴ Omitted by Reitzenstein. But the meaning is “before the coming of the Redeemer.”
- ⁶⁵ *πρὶν ἧ* can be construed with accusative and infinitive, and then Antimimos is subject of *τολμῆσαι* and not object of *ἀποστέλλει*. Ruska inserts *υἱὸς Θεοῦ* as subject of *τολμῆσαι*. But he has not been spoken of for a long time, because he has already appeared. It is more likely that Antimimos himself has a forerunner.
- ⁶⁶ Reitzenstein and Scott suggest *Μανιχαῖος* (Manichaeus).
- ⁶⁷ *περίοδον* Codd.; Reitzenstein has *περιόδους*.
- ⁶⁸ *ἐαντῷ* Codd.; Reitzenstein has *ἐαντοῦ*.
- ⁶⁹ Reitzenstein and Ruska conjecture a lacuna after “seeking the abode of bliss,” and connect “he” with Prometheus. This is unnecessary, since Epimetheus through his own fate “interprets”—*ἐρμηνεύει*—to those of spiritual understanding what is to be done.
- ⁷⁰ As Scott remarks, this is probably an inexact quotation of the *Odyssey*, VIII, 167—*οὕτως οὐ πάντεσσι θεοὶ χαριέντα δίδουσι ἄνδρασιν*” from a context showing how different individuals are differently gifted by the gods. Zosimos goes on to explain how in all arts men have an individual method of working.
- ⁷¹ *ἄγων* Codd.; Ruska conjectures *ἀργὸν*, Scott *ἄκρον*.
- ⁷² Ruska has *Φιλόπνοος* instead of *μόνος*, but it is drawbacks that are enumerated here.
- ⁷³ Berthelot, *Alch. grecs*, III, li, 8.
- ⁷⁴ Diodorus, *Bibliotheca*, I, p. 27.
- ⁷⁵ The Cretan bull led him to the south; the man-eating mares of Diomedes to the north (Thrace); Hippolytus to the east (Scythia); and the oxen of Geryon to the west (Spain). The Garden of the Hesperides (the western land of the dead) leads on to the twelfth labour, the journey to Hades (Cerberus).
- ⁷⁶ Book of Enoch 17–36 (Charles, *Apocrypha and Pseudepigrapha*, II, pp. 199ff.). The journeys lead to the four quarters of the earth. In the west he finds a fourfold underworld of which three parts are dark and one is light.
- ⁷⁷ The journey begins in Europe and leads to America, to Asia, and finally to Africa in search of Mercurius and the phoenix (*Symbola aureae mensae*, pp. 572ff.).
- ⁷⁸ In Marius Victorinus (Halm, *Rhetores Latini minores*, p. 223; quoted by Reitzenstein, *Poimandres*, p. 2653).
- ⁷⁹ “Super arborem Aristotelis,” *Theatr. chem.*, II, p. 527: “Alexander invenit sepulcrum Hermetis et quandam arborem sitam ab extra intus tenentem viriditatem gloriosam: super eam ciconia ibi sedebat, quasi se appellans circulum Lunarem: et ibi ipse aedificavit sedes aureas et posuit terminum itineribus suis idoneum.” (Alexander found the tomb of Hermes and outside it a certain tree with a glorious greenness inside. And on it there sat a stork, as it were calling itself the circle of the Moon. And there he built golden seats and put a fitting end to his travels.) The stork is an *avis Hermetis*, like the goose (fig. 198) and pelican.

- ⁸⁰ In the same treatise: Berthelot, *Alch. grecs*, III, xlix, 1.
- ⁸¹ Baynes, *A Coptic Gnostic Treatise*, pp. 84ff. Cf. also Bousset, *Hauptprobleme der Gnosis*, p. 189; Schmidt, “Gnostische Schriften,” pp. 135ff.; also Turfan Frag., sig. M 299a, in Henning, “Ein Manichäisches Henochbuch,” pp. 27f.
- ⁸² Puëch, “The Concept of Redemption in Manichaeism,” p. 257.
- ⁸³ Philalethes, “Metallorum metamorphosis,” p. 771: “Se pro libitu suo transformat, ut varias larvas induat” (He transforms himself as he pleases, assuming various shapes [masks]). Aegidius de Vadis, “Dialogus,” *Theatr. chem.*, II, p. 118: “Dicitur enim Mercurius propter suam mirabilem convertibilitatis adhaerentiam” (For he is called Mercurius because of his wonderful ability to transform himself).
- ⁸⁴ “Tab. smarag.”: “Omnem rem solidam penetrabit” (He will penetrate every solid thing). *Rosarium, Art. aurif.*, II, p. 259: “Est oleum mundissimum penetrativum in corporibus” (He is a most pure oil penetrating the bodies). “Rosinus ad Sarratantam,” *Art. aurif.*, I, p. 302: “... spiritus vivus, et in mundo talis non est, qualis ipse est: et ipse penetrat omne corpus ...” (A living spirit such as there is none other in the world, as he is; and he penetrates all bodies).
- ⁸⁵ Geber, “Livre de la misericorde,” in Berthelot, *Chimie au moyen âge*, p. 181. “Then he spreads his poison” (Lambspringk, “Figurae,” *Mus. herm.*, p. 352); “Venenosus vapor” (Flamel, “Summarium philosophicum,” *Mus. herm.*, p. 173); “Spiritus venenum” (Ripley, *Opera omnia*, p. 24); “Mercurius lethalis est” (“Gloria mundi,” *Mus. herm.*, p. 250).
- ⁸⁶ *Pistis Sophia*: trans. Schmidt, pp. 46, 207.
- ⁸⁷ Printed in *Bibliotheca chemica curiosa*, II. Gessner mentions Bonus as a contemporary of Raymond Lully (1235–1315), but Mazzuchelli (1762) maintains that Pietro Antonio Boni lived about 1494. Ferguson (*Bibliotheca chemica*, I, p. 115) leaves the question undecided. Hence the above dates are given with reserve. The first edition of the *Pret. marg. nov.* is that of Lacinius (1546). fol. i ff.: “Quia consuevit non solum. ...” The introduction in *Bibliotheca chemica curiosa* is missing here. All the authors quoted in the text lived before the 14th century. Nor does the material supply any reasons for dating the text later than the first half of the 14th century.
- ⁸⁸ *Bibl. chem.*, II, ch. VI, pp. 29ff.
- ⁸⁹ The psychological equivalents of these two categories are conscious cognition based on sense-perception, and the projection of unconscious contents. For these latter *cor* is an apt designation, since the heart region (fig. 149) represents a more primitive localization of consciousness, and, even at a higher level, still harbours emotive thoughts, i.e., contents that are very much under the influence of the unconscious.
- ⁹⁰ “Quod verbum est philosophicum.” I feel impelled to translate this phrase as above, because of the later alchemical distinction between Christ as the “verbum scriptum” and the *lapis* as “verbum dictum et factum” (“Orthelii Epilogus,” *Bibl. chem.*, II, p. 526).
- ⁹¹ “subtilitatem fere incredibilem.”
- ⁹² As an analogy of God.
- ⁹³ Reputed to be an Arab philosopher of the 12th century.
- ⁹⁴ Presumably in the alchemical work, whose procedure resembles the creation and end of the world.
- ⁹⁵ Cf. the detailed later account in “Liber de arte chimica,” *Art. aurif.*, I, pp. 581, 613.

⁹⁶ Bonus is referring to an older Pseudo-Platonic text which I have not yet been able to trace. Evidently it contained a *lapis-Christ* parallel. Possibly—as in the case of the “Tractatus aureus”—the original source was Arabic (Sabaeen?).

⁹⁷ These are the *electi*. Manichean influences are not inconceivable in Morienus.

⁹⁸ Part I of the text has been translated and edited, with a commentary, by Marie-Louise von Franz. [Published in English under the title *Aurora Consurgens: A Document Attributed to Thomas Aquinas on the Problem of Opposites in Alchemy*.] *Aurora consurgens* is an extremely characteristic example of the mystical side of alchemy, affording deep insight into this extraordinary state of mind, which is sufficient justification for a separate publication of the whole of Part I.

⁹⁹ Decas II, pp. 175ff. Cf. Kopp, *Die Alchemie*, II, p. 343.

¹⁰⁰ Vulgate, Sap. 7 : 11: “Venerunt autem mihi omnia bona pariter cum illa [sapientia], et innumerabilis honestas per manus illius” (D.V.: “Now all good things came to me together with her, and innumerable riches through her hands”).

¹⁰¹ Vulgate, Prov. 1 : 20–21 verbatim (D.V.: “Wisdom preacheth abroad: she uttereth her voice in the streets, at the head of the multitudes she crieth out, in the entrance of the gates of the city she uttereth her words, saying ...”).

¹⁰² Vulgate, Ps. 33: 6: “Accedite ad eum [Dominum], et illuminamini: et facies vestrae non confundentur” (D.V.: “Come ye to him and be enlightened: and your faces shall not be confounded”). Also Vulgate, Ecclus. 24 : 30: “Qui audit me non confundetur, et qui operantur in me non peccabunt” (D.V.: “He that hearkeneth to me shall not be confounded: and they that work by me shall not sin”).

¹⁰³ Vulgate, Ecclus. 24 : 26: “Transite ad me, omnes qui concupiscitis me, et a generationibus meis implemini” (D.V.: “Come over to me, all ye that desire me: and be filled with my fruits”).

¹⁰⁴ Eucherius, *Formularium spiritualis intelligentiae*, and Rabanus, *Allegoriae*, among others. Cf. Vulgate, Hab. 3 : 3: “Deus ab austro veniet, et Sanctus de monte Pharan” (D.V.: “God will come from the south: and the holy one from Mount Pharan”).

¹⁰⁵ Vulgate, Matt. 12 : 42 (Luke 11 : 31 is almost identical): “Regina austri surget in iudicio cum generatione ista, et condemnabit eam: quia venit a finibus terrae audire sapientiam Salomonis, et ecce plus quam Salomon hic” (D.V.: “The queen of the south shall rise in judgment with this generation and shall condemn it: because she came from the ends of the earth to hear the wisdom of Solomon. And behold a greater than Solomon here”).

¹⁰⁶ Ch. V. Cf. Vulgate, Cant. 6 : 9: “Quae est ista quae progreditur quasi aurora consurgens, pulchra ut luna, electa ut sol ...” (D.V.: “Who is she that cometh forth as the morning rising, fair as the moon, bright as the sun ...”).

¹⁰⁷ *Art. aurif.*, II, p. 294.

¹⁰⁸ Sudhoff, XIII, p. 403.

¹⁰⁹ Cumont, *Textes et monuments*, I. p. 356.

¹¹⁰ Hegemonius, *Acta Archelai*, pp. 12f.: “Cum autem vidisset pater vivens adfligi animam in corpore, quia est miserator et misericors, misit filium suum dilectum ad salutem animae; haec enim causa et propter Homoforum misit eum. Et veniens filius transformavit se in speciem hominis; et adparebat quidem hominibus ut homo, cum non esset homo, et homines putabant eum natum esse. Cum ergo venisset, machinam quandam concinnatam ad salutem animarum, id est rotam, statuit, habentem duodecim urceos; quae per hanc spheram vertitur, hauriens animas morientium quasque luminare maius, id est sol, radiis suis adimens purgat et lunae tradit, et ita adimpletur lunae discus, qui a nobis ita appellatur.”

(But when the living father saw that the soul was tormented in the body, he sent—because he is charitable and compassionate—his beloved son for the salvation of the soul. For this cause he sent him, and on account of Homoforus. And the son came and changed into human form, and showed himself to men as a man, although he was no man, and the people thought that he had been born. And when he came he made a device for the redemption of souls, and set up a wheel with twelve buckets, which is turned by the rotation of the sphere and raises the souls of the dying; these are caught by the rays of the greater light, which is the sun, and purified and passed on to the moon, and thus is the disc of the moon filled, as we say.) The same passage is to be found in the *Panarium* of Epiphanius, Haer. LXVI.

¹¹¹ There are secret connections, or at least striking parallels, between alchemy and Manicheism which still need investigating.

¹¹² Ripley (d. 1490) describing the transformation of earth into water, water into air, and air into fire, says (*Opera omnia*, p. 23): “sic rotam elementorum circumrotasti” (Thus did you revolve the wheel of the elements).

¹¹³ “Philosophia chemica,” *Theatr. chem.*, I, p. 492: “A materia prima generationis rota sumit exordium, ad elementa simplicia transiens.” Cf. also Mylius. *Phil. ref.*, p. 104: “Toties ergo reiterandum est coelum super terram, donee terra fiat coelestis et spiritualis, et coelum fiat terrestre, et iungetur cum terra, tunc completum est opus” (So many times must the heaven above the earth be reproduced, until the earth becomes heavenly and spiritual, and heaven becomes earthly, and is joined to the earth: then the work will be finished).

¹¹⁴ Cumont, *Textes et monuments*, I, p. 178.

¹¹⁵ “Tractatus Aristotelis,” *Theatr. chem.*, V, p. 885.

¹¹⁶ Reference to the Vulgate. Ps. 18 : 6–7 (D.V.): “He hath set his tabernacle in the sun: and he, as a bridegroom coming out of his bride chamber, hath rejoiced as a giant to run the way. His going out is from the end of heaven.”

¹¹⁷ “Dum Heroes ille, tanquam gigas exultans, ab ortu exurgit, et in occasum properans demergitur, ut iterum ab ortu redeat continue, has circulationes causatur, inque materia splendida argenti vivi, velut in speculo, ideas relinquit, ut humana industria aurum inquiratur, ab adhaerentibus segregetur, igne, aqua examinetur, et in usum Deo Creatori placentem transferatur.” (*De circulo quadrato*, p. 15.)

¹¹⁸ Maier, *ibid.*, pp. 15f.

¹¹⁹ *Mus. herm.*, p. 661.

¹²⁰ “Nihilominus intemerata remanens” (nevertheless remaining undefiled). Cf. “mater amata, intemerata” (beloved mother, undefiled) of Latin hymnology; also the “virgo pulchra, ornata, ad persuadendum valde apta” (virgin beautiful, adorned, well suited for persuading), who appears sometimes as male and sometimes as female in the Manichean *Acta Archelai*.

¹²¹ Such parallels show, in spite of all assurances to the contrary, how much the alchemical work is a *mysterium iniquitatis* from the Christian point of view. On an objective view, however, it is simply a chthonic mystery which, as Part II of this volume shows, has its roots in the transformative processes of the unconscious.

¹²² The feminine nature of Mercurius is connected with the moon.

¹²³ The “male virgin” is also a Manichean idea in the writings of Theodoret.

¹²⁴ His work *De ratione conficiendi lapidis philosophici* was printed at Basel in 1571.

¹²⁵ Ezech. 1 : 15 (D.V.): “Now as I beheld the living creatures, there appeared upon the earth by the living creatures one wheel with four faces. And the appearance of the wheels and the work of them was like the appearance of the sea: and the four had all one likeness. And their appearance and their work was as it were a wheel in the midst of a wheel ... for the spirit of life was in the wheels.”

¹²⁶ *Theatr. chem.*, II, p. 259.

¹²⁷ As a matter of fact, there are two treatises known to me that are entitled “Lilium”: the “Lilium inter spinas” of Grasseus (*Bibl. chem.*, II), which belongs to the 17th century, and the “Lilium de spinis evulsum” of Guilhelmus Tecenensis (*Theatr. chem.*, IV), who lived at the end of the 16th and beginning of the 17th century. The date puts the former “Lilium” out of court; but the latter might be considered because it is highly probable that the treatise is wrongly ascribed to Guilhelmus. To judge by its contents and the authors quoted (there are numerous quotations from the *Turba*, “Tractatus Micreris” [*Theatr. chem.*, V], Geber, and so on, but Albertus, Lully, and Arnaldus are missing), it appears to be an old text which might perhaps belong to the time of the “Cons, coniug.” But the above passage is not to be found. “Lilium” or “Lilius” is also quoted in the *Rosarium*.

¹²⁸ Berthelot, *Alch. grecs*, IV, xx, 17.

¹²⁹ *Ibid.*, III, i.

¹³⁰ Holmyard, *Kitāb al-'ilm al-muktasab*, p. 43: “... but what of the speech of *Hermes* in which he says: ‘The great South wind when it acts makes the clouds to rise and raises the cloud of the sea’? He said, If the powdering is not successful the compound will not ascend into the top of the retort, and even if it does ascend it will not pour into the receiver. It is necessary to mix with it the first and second waters before it will ascend to the top of the retort. ‘That,’ he said, ‘is the Great South Wind?’ He said: ‘Yea, O King’” etc.

¹³¹ Roscher, *Hermes der Windgott*.

¹³² See next section.

¹³³ Psalm 44 (in A.V., Psalm 45) is defined as an *Epithalamium Christianum*—a Christian bridal song.

¹³⁴ Gal. (D.V.) 4 : 4.

¹³⁵ Heb. (D.V.) 1 : 2.

¹³⁶ Heb. (D.V.) 1 : 5; 5 : 5.

¹³⁷ Ruska, *Turba*, p. 178.

¹³⁸ Espagnet, “Arcanum,” *Bibl. chem.*, II, p. 656, §LXXIII: “Lapidis generatio fit ad exemplum generationis mundi, suum enim chaos et materiam suam primam habeat necesse est, in qua confusa fluctuant elementa donec spiritu igneo separantur.... Congregantur aquae in unum, et apparet Arida.” (The generation of the stone takes place on the model of the creation of the world. For it is necessary that it have its own chaos and its own prima materia, in which the elements are to float about in confusion until they are separated by the fiery spirit. The waters are gathered into one [place] and the dry land [Arida] appears.)

¹³⁹ *Ibid.*: “[in nigredine] denique separatur lapis in quatuor elementa confusa, quod contingit per retrogradationem luminarium” (Lastly [in the blackness] the stone is separated into the four elements mingled together, which is brought about by the retrograde movement of the stars). This refers to the *coniunctio* of Sol and Luna, who *post coitum* are overcome by death (see fig. 223). Cf. the illustrations in the *Rosarium*, reproduced in my “Psychology of

the Transference.” Espagnet (*Bibl. chem.*, II, p. 655, §LXIVf.): “Nigro colori succedit albus” (on the black follows the white). This white sulphur is the *lapis*.

¹⁴⁰ The “Sea” of the philosophers. “Mare sapientiae” was one of the titles of Hermes (Senior, *Tabula chymica*, p. 31)—evidently an allusion to Moses.

¹⁴¹ The healing water also flows from the stone whence the pneumatic spark is struck. In later alchemical literature this stone is often likened to Christ (as also in Church hermeneutics), from whom the miraculous water flows. Thus Justin Martyr says (“Dialogus cum Tryphone Judaeo,” Migne, *P.G.*, vol. 6, col. 639): “As a spring of living water from God, in the land of the heathen barren of all knowledge of God, has this Christ gushed forth [see fig. 213], who appeared also to your people, and healed them that from their birth and in the flesh were blind, dumb, and lame.... Also he awoke the dead.... This he did in order to convince those who are ready to believe in him that, even if a man be afflicted with any bodily infirmity and yet keeps the commandments given by Christ, he shall be awakened at the second coming with an uncrippled body, after Christ has made him immortal and incorruptible and without sorrow.”

¹⁴² A frequent image: Mercurial water (*rivuli aurei*), etc.

¹⁴³ Like the “pluviae et imbres” that drench and fertilize the thirsty earth. The king in alchemy is thirsty and drinks water until he dissolves. Cf. Merlinus, “Allegoria,” *Art. aurif.*, I, p. 392.

¹⁴⁴ Ps. 45 : 5 (D.V.): “The stream of the river maketh the city of God joyful.”

¹⁴⁵ I Cor. (D.V.) 15 : 53f.: “For this corruptible must put on incorruption: and this mortal must put on immortality. And when this mortal hath put on immortality, then shall come to pass the saying that is written: *Death is swallowed up in victory. O death, where is thy victory? O death, where is thy sting?*”

¹⁴⁶ Cf. Ruska, *Turba*, pp. 182f., 115f.

¹⁴⁷ A Hermes quotation in Senior. *De chemia*, p. 71 (see also *Bibl. chem.*, II, p. 227a): “Est mundus minor. Item est unum quod non moritur, quamdiu fuerit mundus, et vivificat quodlibet mortuum” etc. (It is the smaller world [i.e., the Microcosm = Man]. One thing there is that dieth not, so long as the world shall endure, and it bringeth alive anything dead.) The passage refers to the *aqua philosophica*. Senior is the Latin name for Mohammed ibn Umail (10th cent.), whose work was published by Stapleton in *Three Arabic Treatises on Alchemy*.

¹⁴⁸ The philosophers.

¹⁴⁹ Matt. 25 : 34, with “beginning of the Work” substituted for “foundation of the world.”

¹⁵⁰ A quotation from Pseudo-Aristotle; cf. *Rosarium*, *Art. aurif.*, II, p. 286.

¹⁵¹ Jung, “Paracelsus as a Spiritual Phenomenon,” pars. 165ff., 203ff.

¹⁵² *Art. aurif.*, I, pp. 352ff. Kalid refers to the Omayyad prince Khalid ibn-Yazid (end of the 7th century), though there is good reason for believing that this treatise was not written by him at all. (Cf. Lippmann, *Entstehung und Ausbreitung der Alchemie*, II, p. 122, for the literature on this question.)

¹⁵³ Another name for the alchemists. Cf. “Les pures hommes évangélisants” in Rupescissa, *La Vertu et la propriété de la quinte essence*, p. 31.

¹⁵⁴ Here the process has three parts, in contrast to the four parts in Greek alchemy. But this may be due only to the analogy with the nine months of pregnancy. Cf. Kalid, *Art. aurif.*, I, pp. 358ff.

¹⁵⁵ Patrizi, *Nova de universis philosophia*.

¹⁵⁶ “Addam et processum sub forma missae, a Nicolao Cibinensi, Transilvano, ad Ladislaum Ungariae et Bohemiae regem olim missum,” *Theatr. chem.*, III, pp. 853ff.

¹⁵⁷ Not identical with Melchior, Cardinal Bishop of Brixen, to whom the treatise “Von dem gelben und rotten Mann,” in *Aureum vellus*, is attributed. Our author was the chaplain Nicolaus Melchior Szebeni, at the king’s court as astrologer from 1490. He remained there after the death of Ladislaus II in 1516, under Louis II (1506–26). Following the defeat of Mohács (1526) and the death of Louis II, Melchior fled to the court of Ferdinand I in Vienna. He was executed by the latter in 1531. Our document must therefore have been written before 1516. Ladislaus II became King of Bohemia in 1471 and of Hungary in 1490. We find the remark “ad extirpandum Turcam” in the text. It is true that Buda was conquered by the Turks only in 1541, but the land had long suffered from Turkish invasions. [Hermannstadt is the German name of the Romanian (formerly Hungarian) city of Sibiu or Cibiú (whence “Cibinensis”).—EDITORS.]

¹⁵⁸ *Aquilo* (north wind) is an allegory of the devil, *auster* an allegory of the Holy Ghost. Cf. Migne, *P.L.*, vol. 219: “Index de allegoriis.” Among the authorities quoted we meet Alain of Lille (Alanus de Insulis), who was well known to the alchemists (Maier, *Symbola aureae mensae*, p. 259).

¹⁵⁹ Perhaps he is enlarging on the “water of life” that has just been mentioned, or more probably the “salutary medicine” a little earlier, which is really the main theme.

¹⁶⁰ Pp. 129f.

¹⁶¹ See Gen. 30 : 32ff.

¹⁶² “Sequentia sancti evangelii, sub tono, Ave praeclara, cantetur; quam testamentum artis volo nuncupari, quoniam tota ars chemica, tropicis in ea verbis occultatur, et beatus,” etc.

¹⁶³ Cf. his “Codicillus,” *Bibl. chem.*, I, pp. 880ff.

¹⁶⁴ “Ἐλ σοι κέκρυπται ὄλον τὸ μυστήριον τὸ Φρικτὸ καὶ παράδοξον (Berthelot, *Alch. grecs*, IV, xx, 8).

¹⁶⁵ Sun.

¹⁶⁶ Reference to Venus and Mars, caught in the net of Vulcan.

¹⁶⁷ *Coniunctio* of Mercurius, but with whom? Or it is a *coniunctio* of two Mercurii, one male and one female? It seems to be a union of Sol with Luna, Mars, and Mercury.

¹⁶⁸ Ruska, “Tab. smarag.,” p. 2: “Hic est totius fortitudinis fortitudo fortis” (He is the strong strength of all strength).

¹⁶⁹ This is the substance which was the special concern of Maria, the “Prophetissa” and “sister of Moses.” *Art. aurif.*, I, p. 320: “Recipe alumen de Hispania, gummi album et gummi rubeum, quod est kibric Philosophorum ... et matrimonifica gummi cum gummi vero matrimonio” (Take alum from Spain, white gum and red gum, which is the kibric of the philosophers ... and join in true marriage gum with gum).

¹⁷⁰ Presumably Sol, perhaps in the form of “gum.” The coitus of Sol and Luna in the bath is a central mythologem in alchemy, and is celebrated in numerous illustrations (cf. figs. 159, 167, 218).

¹⁷¹ Namely the *caput mortuum*, the head of Osiris in the *nigredo* state. The Ethiopian comes from a treatise attributed to Albertus: “Super arborem Aristotelis,” *Theatr. chem.*, II. The passage runs (p. 526): “...quousque caput nigrum aethiopis portans similitudinem, fuerit bene lavatum et inceperit albescere. ...” (... until the black head bearing the resemblance of the Ethiopian is well washed and begins to turn white. ...). In Rosencreutz’s *Chymical Wedding* the presumptive queen of the drama is the temporary concubine of a Moor. Cf. also *Aurora consurgens*, ch. VI, parable 1.

¹⁷² The calcination probably corresponds to incineration, while the incandescent ash tends towards vitrification. This operation may likewise come from Maria Prophetissa: “Vitrifica super illud Kibrich et Zuboch [alias Zibeic] et ipsa sunt duo fumi complectentes duo lumina” (Vitrify over it Kibrich and Zuboch [alias Zibeic] and they are two vapours enveloping two lights). “Practica,” *Art. aurif.*, I, p. 321. “Zaibac, Zeida, Zaibar, Zibatam ... id est argentum vivum.” Zaibar = Mercurius. Ruland’s *Lexicon: zibag* (Arabic) = quicksilver. Lippmann, *Entstehung*, p. 409. *Kibric* = *kibrit* (Arabic) = sulphur. Cf. also Ruska, *Turba*, p. 348: “Arabisches Register.”

¹⁷³ *De chemia*, pp. 35f.

¹⁷⁴ Quotation from the “Tractatus aureus,” *Ars chemica*, p. 22. It should be mentioned that Melchior recommends reading the 10th chapter of Luke before the Creed. This chapter would appear to have no connection with his theme except for the fact that it ends with the significant words: “But *one thing* is necessary. *Mary* hath chosen the best part, which shall not be taken away from her” (D.V.).

¹⁷⁵ The subjective character of the experience comes out in the incidental remark of the author: “et scio quod verum est testimonium eius” (and I *know* that his testimony is true).

¹⁷⁶ *Bibl. chem. curiosa*, II, pp. 275ff., and *Theatr. chem.*, II, pp. 123ff.

¹⁷⁷ Ripley, *Opera omnia chemica*, pp. 421ff. [Professor Jung gives the “Cantilena” in prose paraphrase. For a complete translation in verse form, with commentary, see Jung, *Mysterium Coniunctionis*, pars. 370ff. In lines 7–8 of the paraphrase, the present reading replaces a reference to the “tree of Christ,” as the consequence of an emendation authorized by Professor Jung; cf. *ibid.*, par. 380, n. 88. Accordingly, a representation of “Christ on the tree of life” in fig. 222 has been replaced by another subject.—EDITORS.]

¹⁷⁸ The green lion is also a synonym for the unicorn. See fig. 242.

¹⁷⁹ *Opera omnia*, p. 81.

¹⁸⁰ John 12 : 32.

¹⁸¹ “Meo in cerebro gestavi”: “Visio Arislei,” *Art. aurif.*, I, p. 147.

¹⁸² *Art. aurif.*, II, p. 246: “Et includit eum in suo utero, quod nil penitus videri potest de eo. Tantoque amore amplexata est Gabricum, quod ipsum totum in sui naturam concepit et in partes indivisibiles divisit.” (And she enclosed him in her womb so that nothing at all could be seen of him any more. And she embraced Gabricus with so much love that she absorbed him completely in her own nature, and divided him into indivisible parts.)

¹⁸³ The feathers of the phoenix, and of other birds, play a great role in alchemy, particularly in the writings of Ripley. Cf. “Scrowle,” *Theatr. chem. Brit.* (See also figs. 229, 266, 270.)

¹⁸⁴ “Gloria mundi,” *Mus. herm.*, p. 221: “Lapis ... per Solem et Lunam generatus ... primum ... suum partum in terra accepit et tamen frangitur, destruitur, et mortificatur ... per vaporem generatur, et denuo nascitur, cum vento in mare venit ... atque cum vento ex mari in terram venit ... et cito iterum evanescit... Et quamvis cottidie denuo nascatur, nihilominus tamen ab initio mundi ille fuit. ...” (The stone ... begotten by the sun and the moon ... was first born ... on the earth, and yet it is broken, destroyed and mortified.... It is generated through vapour, and is born anew, with the wind it comes to the sea ... and with the wind it comes from the sea to the earth, ... and quickly evaporates again.... And though it is daily born anew, yet nevertheless it existed from the beginning of the world. ...) (Cf. John 1 : 1 and 14.)

¹⁸⁵ Cf. Caussin, *De symbolica Aegyptiorum sapientia*, p. 71: s.v. “phoenix.”

¹⁸⁶ The wounding of the lion refers to his sacrifice and mortification during the process. He is sometimes shown maimed, with his paws cut off. Cf. for instance Reusner, *Pandora*, p. 227. Note the wounded unicorn lying in the lap of the virgin. (Cf. fig. 242.)

¹⁸⁷ Ruland, *Lexicon*: “Leo viridis, quorundam opinione aurum” (The green lion; according to some people’s opinion, gold).

¹⁸⁸ p. 225.

¹⁸⁹ Cf. the vision of Guillaume de Digulleville (pars. 315ff.).

¹⁹⁰ This picture goes back to the Codex Germanicus (see fig. 224; cf. also figs. 233, 235).

¹⁹¹ In *Art. aurif.*, I, pp. 575ff.

¹⁹² The author is supposed to be no less a person than Marsilio Ficino (1433–99). Manget (*Bibl. chem. curiosa*, II, p. 172) is of this opinion. The treatise is said (Schmieder, *Geschichte der Alchemie*, p. 235) to be contained in the collected edition (Basel, 1561 and 1576) of Ficino’s works. (See also Ferguson, *Bibliotheca chemica*, I, p. 268, and Kopp, *Die Alchemie*, I, p. 212.) But it happens that the treatise (*Art. aurif.*, I, p. 596) mentions the murder of Pico della Mirandola—“Quis non intempestivam Pici Mirandulani necem lachrymis non madefaceret?” (Who would not shed tears over the untimely killing of Pico della Mirandola?)—which can only refer to the nephew of the great Pico, Gianfrancesco Pico della Mirandola, who was murdered in 1533. This *terminus a quo* occurred 34 years after the death of Ficino. The reference (*Art. aurif.*, I, p. 625) to the Minorite Father, Ulmannus, and his illustrated treatise makes it more probable that the author was a German writing in the middle of the 16th century. It is possible that the treatise of Ulmannus is connected with the *Dreifaltigkeitsbuch*. Schmieder’s statement is anyway incorrect, for I have ascertained that the treatise is *not* contained in the Basel edition.

¹⁹³ The text has a misprint: “auri” instead of “audi.” Cf. *Art. aurif.*, I, p. 608: “audi similitudinem arduam.”

¹⁹⁴ *Ibid.*, p. 582.

¹⁹⁵ *Ibid.*, p. 686.

¹⁹⁶ *Ibid.*, p. 627.

¹⁹⁷ According to Schmieder (*Geschichte der Alchemie*), the Emperor Maximilian ordered a search of the Benedictine monasteries in 1515 to find out whether a monk of this name was mentioned in their registers, but no such name was found. There does not seem to be any truth in this report. Nor do there seem to be any manuscripts that could be dated before the 17th century. (See Kopp, *Die Alchemie*, I, p. 31.)

¹⁹⁸ He also mentions the *lues Gallica*, which it appears was first described as the *morbis Gallicus* (French sickness) by the Italian physician, Fracastoro, in a didactic poem published in 1530.

¹⁹⁹ Valentinus, *Chymische Schriften*, p. 364.

²⁰⁰ *Die Alchemie*, I, p. 254.

²⁰¹ X, 76f., and XII, 10 (Bax, pp. 126f., 154).

²⁰² *Aurora consurgens* II, *Art. aurif.*, I, pp. 228f.: “... Et notandum quod duplex est sublimatio: una corporalis, alia spiritualis: corporalis quantum ad terreatem, spiritualis quantum ad igneatem.... Facite corpus spirituale et fixum volatile.... Senior dicit: Egrediatur spiritus a corpore qui est ignis.... Unde dicitur, quod tinctura fit a natura volantium: Et illud quod firmat et fixat ipsum spiritum, est fixum et perpetuum et incremabile et nominatur sulphur Philosophorum.” (... And it is to be noted that the sublimation is twofold: one corporeal, the other spiritual; corporeal

as regards earthliness, spiritual as regards fieriness.... Make the body spiritual, and the fixed volatile.... Senior says: Let the spirit which is fire go out of the body.... Whence it is said that the tincture arises from the nature of flying things. And that which makes the spirit itself firm and fixed, is fixed and eternal and cannot be burned and is called the sulphur of the Philosophers.)

²⁰³ “Epilogus et recapitulatio Orthelii,” *Bibl. chem. curiosa*, II, p. 527. We know of Orthelius only as a commentator on Michael Sendivogius, who lived in the second half of the 16th century.

²⁰⁴ “Archaeus est summus, exaltatus et invisibilis spiritus, qui separatur a corporibus, occulta naturae virtus” (The Archaeus is the highest exalted and invisible spirit, which is separated from the bodies, the hidden virtue [or quality] of nature). Cf. Ruland’s *Lexicon alchemiae*, which is strongly influenced by Paracelsus.

²⁰⁵ Cf. Maier, *Symbola aureae mensae*, p. 141. The words quoted do not come in this form from Morienus himself, but Maier uses them as a characteristic motto for Morienus in that section of his book dealing with this author. The original passage is to be found in Morienus, “De transmut. metall.,” *Art. aurif.*, II, pp. 35f.

¹ Abu'l Qāsim, in Holmyard, *Kitāb al-'ilm*, p. 24: “And this prime matter is found in a mountain containing an immense collection of created things. In this mountain is every sort of knowledge that is found in the world. There does not exist knowledge or understanding or dream or thought or sagacity or opinion or deliberation or wisdom or philosophy or geometry or government or power or courage or excellence or contentment or patience or discipline or beauty or ingenuity or journeying or orthodoxy or guidance or precision or growth or command or dominion or kingdom or vizierate or rule of a councillor or commerce that is not present there. And there does not exist hatred or malevolence or fraud or villainy or deceit or tyranny or oppression or perverseness or ignorance or stupidity or baseness or violence or cheerfulness or song or sport or flute or lyre or marriage or jesting or weapons or wars or blood or killing that is not present there.”

² Ibid., p. 22.

³ Sudhoff, XIII, p. 402.

⁴ *Kitāb al-'ilm*, p. 23.

⁵ “Cum igitur spiritus ille aquarum supracoelestium in cerebro sedem et locum acquisierit,” etc. (When therefore that spirit of the supra-celestial waters has taken up his abode and sea: in the brain ... etc.) (Steeb, *Coelum sephiroticum*, p. 117). The “stone that is no stone” is the λίθος ἔγκέφαλος, ‘brain-stone’ (Berthelot, *Alch. grecs*, I, iii, 1) and the ἀλαβάστρινος ἔγκέφαλος, ‘alabaster brain’ (ibid., I, iv, 1); Zosimos defines the despised, and at the same time precious, material as ἀδώρητον καὶ θεοδώρητον: “not given and given by God” (ibid., III, ii, 1). “Accipe cerebrum eius”: Hermes in the *Rosarium*, *Art. aurif.*, II, p. 264. The “os occiput” is used in the work because “cerebrum est mansio partis divinae” (the brain is the seat of the divine part) (“Liber Platonis quartorum,” *Theatr. chem.*, V, p. 124). The “occiput” is the “vas cerebri” (ibid., p. 148) (cf. figs. 75, 135). The brain is “... sedes animae rationalis. Nam est triangulus compositione et est propinquius omnibus membris corporis ad similitudinem simplicis ...” (... the seat of the rational soul. For it is triangular in composition [shape] and is nearer to simplicity than all other parts of the body ...) (ibid., p. 127). It is the organ which is nearest to the simplicity of the soul, and is therefore the bridge to spiritual transformation (ibid., p. 187).

^{5a} [The following translation, in verse 2, line 8, cites Job 39 : 9, where the passage actually is. The German versifier may have had in mind the references in Chapter 37 to the devastating power of God, signified allegorically by the unicorn.—EDITORS.

This is the Unicorn you see/
He is not found in our country.
Arlunnus says these animals
Lust greatly after pretty girls.
This way to catch him is the best/
A youth in women's clothes is dressed
And then with mincing steps he flaunts
About the Unicorn's bright haunts.
For when this creature spies a maid
Straight in her lap he lays his head.
The huntsman/ doffing his disguise/

Here is another Unicorn/
Churning the ground up with his horn.
No one can tame this animal/
He is so fierce/ so full of guile.
You have just heard how he is caught
Through his desire with maids to sport.
Even the patient Job observes/
In Chapter Thirty-Nine/ ninth verse:
That man hath never yet been born
Who'll bind and break the Unicorn/
Or fix the harness to his rib/

Saws off the horn and wins the prize.

And make him bide beside the crib.]

⁶ Rosencreutz, *Chymical Wedding*, p. 73. Concerning the dove, cf. *Aurora* I, Ch. VI: “Nive dealbabuntur in Selmon, et pennae columbae deargenteatae et posteriora dorsi eius in pallore auri: talis erit mihi filius dilectus. ...” (They shall be whited with snow in Selmon, and shall be as the wings of a dove covered with silver, and the hinder parts of her back with the paleness of gold. Such shall be to me a beloved son.) Grasseus, “Area arcani,” *Theatr. chem.*, VI, p. 314: “Plumbum philosophorum ... in quo splendida columba alba inest, quae sal metallorum vocatur, in quo magisterium operis consistit. Haec est casta sapiens et dives illa regina ex Saba velo albo induta. ...” (The lead of the philosophers in which is the shining white dove, which is called the salt of metals, in which consists the magistry of the work. This is that chaste, wise, and rich queen of Sheba clothed in a white veil.) *Aurora* I, Ch. XII: “Et dabit mihi pennas sicut columbae [Vulg., Ps. 54 : 7] et volabo cum ea in coelo et dicam tunc: Vivo ego in aeternum [Deut. 32 : 40]. ...” ([And she will] give me wings like a dove, and I will fly with her to heaven, and then say: I live for ever.)

⁷ *Mus. herm.*, pp. 338ff.; originally in Barnaud, *Triga chemica*.

⁸ The fourth illustration in *Musaeum Hermeticum*, placed before the first treatise.

⁹ *Philosophia reformata*, p. 316.

¹⁰ *Theatr. chem.*, II, p. 123.

¹¹ Medieval tradition associates the unicorn with the lion “because this animal is as strong, wild, and cruel as the lions.” “This,” says Andreas Baccius, “is the reason why they called this animal *lycornu* in France and Italy.” Here *lycornu* is evidently derived from “lion.” Cf. Catelanus, *Ein schöner neuer historischer Discurs, von der Natur, Tugenden, Eigenschafften, und Gebrauch dess Einhorns*, p. 22.

¹² Much the same is said of the unicorn as of the dragon, which as a denizen of the underworld lives in gorges and caverns. Thus unicorns “hide themselves and dwell in barren places on the high mountains, in the deepest, darkest, and most out-of-the-way caves and dens of wild beasts, amid toads and other noxious, loathly reptiles.” *Ibid.*, p. 23.

¹³ *Theatr. chem.*, IV, p. 286.

¹⁴ Vulgate: “... et comminuet eas tamquam vitulum Libani: et dilectus quemadmodum filius unicornium.” (D.V., Ps. 28 : 6: “And [he] shall reduce them to pieces; as a calf of Libanus, and as the beloved son of unicorns.”)

¹⁵ Vulgate: “Et exaltabitur sicut unicornis cornu meum. ...” (D.V., Ps. 91 : 11: “But my horn shall be exalted like that of the unicorn. ...”)

¹⁶ Vulgate: “Salva me ex ore leonis, et a cornibus unicornium humilitatem meam.” (D.V., Ps. 21 : 22: “Save me from the lion’s mouth; and my lowness from the horns of the unicorns.”)

¹⁷ “Tauri decor eius, cornua unicornis, cornua eius.” (Tertullian, *Adversus Judaeos*, Ch. X; Migne, *P.L.*, vol. 2, col. 626.)

¹⁸ “Dialogus cum Tryphone Judaeo,” ch. 91 (Migne, *P.G.*, vol. 6, col. 691).

¹⁹ “Unicornis est Deus, nobis petra Christus, nobis lapis angularis Jesus, nobis hominum homo Christus.” Priscillian, *Opera*, p. 24.

²⁰ *Vita*, Migne, *P.G.*, vol. 120, col. 69, ch. XCI. The hermit-nature of the unicorn is mentioned in Aelian, *De natura animalium*, xvi, 20.

²¹ *De symbolica Aegyptiorum sapientia*, p. 401. Cf. also p. 348: “[Dei] fortitudo similis est Rhinoceroti, Exod. 15. Unicornis non admittit in antro cohabitorem: filius Dei aedificavit in saecula, hoc est in utero B[eatae] V[irginis].”

(The strength of God is similar to [that of] the Rhinoceros, Exod. 15. The Unicorn does not admit of a fellow-dweller in his cave. The son of God has built for the centuries, i.e., in the womb of the Blessed Virgin.) Cf. Ps. 77 : 69: “Et aedificavit sicut unicornium sanctificium suum, in terra quam fundavit in saecula” (D.V.: “And he built his sanctuary as of unicorns, in the land which he founded for ever”; A.V., Ps. 78: 69: “And he built his sanctuary like high palaces, like the earth which he hath established for ever”). Pp. 348f.: “The horn of the unicorn acts as an alexipharmic, because it expels the poison from the water, and this refers allegorically to the baptism of Christ [i.e., the consecration of the baptismal water]: rightly is it applied to Christ baptized, who, like the chosen son of unicorns, sanctified the streams of water to wash away the filth of all our sins, as Bede says.” The wildness of the unicorn is emphasized in Job (A.V.) 39 : 9–10: “Will the unicorn be willing to serve thee, or abide by thy crib? Canst thou bind the unicorn with his band in the furrow? or will he harrow the valleys after thee?”

²² *Mundus symbolicus*, I, 419, b: “S. Bonaventura: Christus, inquit, per mansuetissimam Mariam mansuescit et placatur, ne se de peccatore per mortem aeternam ulciscatur.” The myth of the virgin and the unicorn is handed down by Isidore of Seville (*Etymologiarum*, xii, 62). The source book is the *Physiologus Graecus*: Πῶς δὲ ἀγρεύεται; παρθένον ἔμπροσθεν αὐτοῦ. Καὶ ἄλλεται εἰς τὸν κόλπον τῆς παρθένου καὶ ἡ παρθένον θάλπει τὸ ζῶον καὶ αἶρει εἰς τὸ παλάτιον τῶν βασιλέων. (How is it hunted? They cast a sacred virgin before it. And it leaps into the lap of the virgin, and the virgin warms the animal with love and bears it to the palace of the kings.)—Pitra, *Spicilegium solesmense*, III, p. 355 (“Veterum Gnosticorum in Physiologum allegoricae interpretationes”). The *Physiologus* may go back to Didymus of Alexandria, a Christian hermeneutic of the 4th cent.

²³ “Insuperabilis fortitudo,” cf. “Tab. smarag.,” “Totius fortitudinis fortitudo fortis” (Strong strength of all strength). Honorius, *Speculum*, Migne, *P.L.*, vol. 172, col. 847: “[Christus] ... cuius virtus ut unicornis fuit, quia omnia obstantia cornu supprimit, quia Christus principatus et potestates mundi cornibus crucis perdomuit” ([Christ] ... whose strength [virtue] was like that of the unicorn, because he crushed all that was in his way with his horn, for Christ subjugated the principalities and powers of the world with the horns of the cross).

²⁴ “Qui in uterum Virginis se reclinans captus est a venatoribus id est in humana forma inventus est a suis amatoribus.”

²⁵ *De Trinitate* (Migne, *P.L.*, vol. 167, col. 1739).

²⁶ *Expositio psalmorum* (Migne, *P.L.*, vol. 142, col. 182): “In te inimicos nostros ventilabimus cornu. Et in nomine tuo spernemus insurgentes in nobis ... cornu vero nostrum Christus est, idem et nomen Patris in quo adversarii nostri vel ventilantur vel spernuntur.” (In thee we shall crush our enemies with the horn. In thy name we shall scorn those that rise up against us ... but our horn is Christ, and also the name of the Father through whom our adversaries are crushed or scorned.)

²⁷ *Etymologiarum* (Migne, *P.L.*, vol. 82), xii, 62: “... aut ventilet aut perforet.”

²⁸ It is true that the son’s mother is the moon, but “nutrix eius terra est” (the earth is his nurse) (cf. fig. 163). “Ascendit a terra in coelum”: therefore he is of earthly origin, ascends to heaven and returns again to permeate the earth.

²⁹ Sbordone, *Physiologus*, p. 263, 1–8.

³⁰ The monstrous nature of the unicorn is described by Pliny (*Hist. nat.*, Lib. VIII, ch. 21): A horse’s body, an elephant’s feet, and the tail of a wild boar. There is a fantastic description, which might have been especially

interesting to alchemists, in the Ἰνδικὰ of Ctesias (c. 400 B.C.): “From what I hear, the wild ass in India is not much smaller than the horse. The head is of a purplish hue but the rest of the body is white, and the colour of the eyes is dark blue. There is a horn on the forehead, nearly one and a half cubits in length; the lower part of the horn is white, the upper part purple, but the middle is pitch black. I hear that the Indians drink out of these brightly coloured horns, but only the most aristocratic Indians. Moreover the horns are bound at intervals with gold rings for this purpose, as the beautiful arm of a statue is decorated with bracelets. They say that anyone who drinks from this horn is immune to incurable diseases, for he is not seized by spasms or killed by poisons and, if he has drunk anything harmful, he vomits and is cured.” (*Ancient India*, trans. McCrindle, p. 363.) Also Aelian, *De natura animalium*, IV, 52, III, 41, and XVI, 20. In the last passage, Aelian says that in India the animal is called the “Kartazonon”: “The strength of its horn is invincible. It is fond of lonely pastures and wanders about alone.... It seeks solitude.” Philostratus, in his *Vita Apollonii* (Book III, ch. 2), relates that when anyone drinks from a cup made of a unicorn’s horn, he is immune throughout the day to illness and pain, he can also walk through fire, and the strongest poison does him no harm. In the Χριστιανικὴ Τοπογραφία of Kosmas (beginning of the 6th century), it is related that the unicorn, in order to escape from its hunters, will plunge into an abyss and land on its horn, which is so strong that it breaks the fall (trans. McCrindle, p. 361). The complete patristic literature is to be found in Salzer, *Die Sinnbilder*, pp. 44ff.

³¹ See Jung, “Paracelsus the Physician,” pars. 27f., and “Paracelsus as a Spiritual Phenomenon,” par. 158.

³² Thales taught that water was the first principle.

³³ The passages quoted above are to be found in Hippolytus, *Elenchos*, V, 9, 12 to 15.

³⁴ *Ibid.*, V, 9, 8.

³⁵ From a Greek magic papyrus in Preisendanz, *Papyri Graecae Magicae*, II, p. 60, lines 44f.

³⁶ *Aureum vellus*.

³⁷ “Rosinus” is a corruption of Zosimos.

³⁸ This recalls the mysterious saying “Aufer caput, corpus ne tangito” (Carry away the head, but don’t touch the body).—Béroalde de Verville, *Le Songe de Poliphile*, Folio c, III.

³⁹ From a Greek magic papyrus in Preisendanz, *Papyri Graecae Magicae*, I, p. 185, line 99.

⁴⁰ *Χρυσέας κεφαλῆς παῖδες* (Berthelot, III, x, 1).

⁴¹ *Ars chem.*, p. 119.

⁴² I had better not enter into the question of whether the unicorn existed in Assyrian and Babylonian culture. Schrader (“Die Vorstellung vom Μονόκερωσ,” pp. 573ff.) tries to derive the whole idea of the unicorn from the representations of what appear to be one-horned animals, such as those of Persepolis, thus, in my opinion, falsely interpreting these monuments. He does not, however, take the Indian sources into account.

⁴³ Bloomfield, *Hymns of the Atharva-Veda*, p. 15.

⁴⁴ Eggeling, *Shatapatha-Brahmana*, pp. 216ff.

⁴⁵ “The fish then swam up to him, and to its horn he tied the rope of the ship and by that means he passed swiftly up to yonder northern mountain [Himalaya]” (*ibid.*, p. 217, 5).

⁴⁶ Bühler, *Laws of Manu*, Introduction, p. xiv. Manu “is the *heros eponymos* of the human race, and by his nature belongs both to gods and to men” (*ibid.*, p. lvii).

⁴⁷ *Ibid.*, pp. lvii f.

- ⁴⁸ *Vedic Hymns*, Part II, p. 96: “As thou didst perform sacrifice to the gods with the sacrificial food of the wise Manu, a sage together with sages, thus, O highly truthful Hotri,” etc.
- ⁴⁹ Chhandogya Upanishad, Part I, p. 44, 4.
- ⁵⁰ Eggeling, *Shatapatha-Brahmana*, p. 29, 14.
- ⁵¹ *Vedic Hymns*, Part I, p. 427, 13: “O Maruts, those pure medicines of yours, the most beneficent and delightful, O heroes, those which Manu, our father, chose, those I crave from Rudra, as health and wealth.”
- ⁵² Cf. my remarks on the Adech of Paracelsus (“Paracelsus as a Spiritual Phenomenon,” pars. 168, 203ff.).
- ⁵³ Holtzmann, *Indische Sagen*, pp. 131ff.; and Lüders, *Nachrichten*. The story is also to be found in the Buddhist Jataka 526 (trans. Cowell, V, pp. 100–106).
- ⁵⁴ West, *Pahlavi Texts*, pp. 67ff.
- ⁵⁵ Berthelot, *Chimie au moyen âge*, III, p. 120.
- ⁵⁶ West, *Pahlavi Texts*, p. 65 (XVIII, 1).
- ⁵⁷ *Ibid.*, pp. 65–66 (XVIII, 1, 9).
- ⁵⁸ In this connection we may note the curious fact that a lizard is concealed in the tree: “The evil spirit has formed therein, among those which enter as opponents, a lizard as an opponent in that deep water, so that it may injure the Hôm” (Bundahish, XVIII, 2 in West, *Pahlavi Texts*, p. 65). Hôm = Haoma, the plant of immortality. In alchemy, the *spiritus mercurii* that lives in the tree is represented as serpent, salamander, or Melusina. We find the last-mentioned in the “Ripley Scrowle,” where the lizard is half a woman and is celebrating the *coniunctio* (marriage) with the *filius philosophorum* (see fig. 257). The “Verses belonging to an Emblematicall Scrowle” (*Theatr. chem. Brit.*, p. 375) run as follows:

“And Azot is truly my Sister,
And Kibrick forsooth is my Brother:
The Serpent of Arabia is my name,
The which is leader of all this game.”

- ⁵⁹ Holmyard, *Kitāb al-’ilm*, p. 23.
- ⁶⁰ Cf. fig. 54 and “Paracelsus as a Spiritual Phenomenon,” frontispiece.
- ⁶¹ [Reproduced in *Symbols of Transformation*, Pl. XLIII.]
- ⁶² Goldschmidt, *Der babylonische Talmud*, X, p. 359 (“Tractate Zebahim,” Fol. 113b). Cf. the *Talmud*, ed. Epstein, “Tract. Zebahim,” pp. 559f.
- ⁶³ Cf. the parallel passage in Goldschmidt, *Der babylonische Talmud*, VIII, p. 203 (“Tractate Baba Bathra,” Fol. 73b; *Talmud*, ed. Epstein, pp. 290f.).
- ⁶⁴ The water was hot, so that even if the unicorn had been able to breathe, it would still have been scalded to death. (See Goldschmidt’s comments.)
- ⁶⁵ This refers to Gen. 6 : 14, where the ark was smeared with pitch within and without. The pitch would have been melted by the hot water. (See Goldschmidt’s comments.)

- ⁶⁶ The Talmud saga according to which Og survived the flood is to be found in *Der babylonische Talmud*, XII, p. 552 (“Tractate Nidda,” Fol. 61a; *Talmud*, ed. Epstein, p. 433): “For it is said [Gen. 14 : 13]: ‘and there came one that had escaped, and told Abram the Hebrew,’ and R. Johanan said: ‘That was Og who escaped the flood.’”
- ⁶⁷ Trans. Friedlander, p. 167. Zunz (*Die gottesdienstlichen Vorträge*, p. 277) dates this collection to the 8th cent. at earliest.
- ⁶⁸ Retold in Joseph bin Gorion, *Sagen der Juden*, I, p. 208.
- ⁶⁹ *Der babylonische Talmud*, XII, p. 552 (“Tractate Nidda,” Fol. 61a; *Talmud*, ed. Epstein, p. 433).
- ⁷⁰ The most important of the giants mentioned in Gen. 6 : 4. (See Goldschmidt’s comments.)
- ⁷¹ Fol. 24b (*Talmud*, ed. Epstein, p. 168).
- ⁷² Goldschmidt, *Der babylonische Talmud*, I, p. 237 (“Tractate Berachoth,” Fol. 54b; *Talmud*, ed. Epstein, p. 330), and “Targum Pseudo-Jonathan” on Num. 21 : 35.
- ⁷³ Midrash Tehillim (ed. Buber), on Ps. 22 : 21: “Save me from the lion’s mouth: for thou hast heard me from the horns of the unicorns.”
- ⁷⁴ “The Ten Tribes” in Eisenstein, *Ozar Midrashim*, p. 468b.
- ⁷⁵ From the *Tz’u-yuan*, s.v. “Ch’i-lin.” The text of the captions for figs. 259 and 260 was specially translated from the Chinese for the Swiss edn. of the present volume by Dr. E. H. von Tschärner. For further reference to this Confucius legend, cf. Wilhelm, *Kung-Tse, Leben und Werk*, pp. 189 and 60.
- ⁷⁶ Ferguson, *Chinese [Mythology]*, p. 98.
- ⁷⁷ Sbordone, *Physiologus*, p. 321, 10–17.
- ⁷⁸ Migne, *Dictionnaire des sciences occultes*, s.v. “Licorne.”
- ⁷⁹ Analogy to Γῆ-ῥύων.
- ⁸⁰ John 1 : 3f.
- ⁸¹ Allusion to the cup of Joseph in Gen. 44 : 4–5: “... Wherefore have ye rewarded evil for good? Is not this it in which my lord drinketh, and whereby indeed he divineth?” (A.V.)
- ⁸² Hippolytus, *Elenchos*, V, 8, 4–7. It should be pointed out that, immediately after the symbols mentioned above, the *Elenchos* goes on to the ithyphallic figures of the Samothracian Mysteries and to Hermes Kyllenios, as further analogies of the arcanum of the Naassenes.
- ⁸³ Hippolytus states that the three parts of Geryon are rational, psychic, and earthly.
- ⁸⁴ Cf. the alchemical equivalence of water and fire.
- ⁸⁵ Charles, *Apocrypha and Pseudepigrapha*, II, p. 623.
- ⁸⁶ Cf. a quotation from Lilius in *Rosarium, Art. aurif.*, II, p. 329: “In fine exhibit tibi Rex suo diademate coronatus, fulgens ut Sol, clarus ut carbunculus ... perseverans in igne” (At the end the King will come forth to you crowned with his diadem, resplendent as the Sun, lambent as the carbuncle ... abiding in the fire). The *lapis* is “shimmering carbuncle light” or “the carbuncle stone shining in the firelight” (Khunrath, *Von hyleal. Chaos*, pp. 227, 242; also *Amphitheatrum*, p. 202).
- ⁸⁷ *Parzival*, Book IX, lines 1494–1501 (in Wolfram von Eschenbach, *Parzival und Titurel*, II; translation from Shepard, *The Lore of the Unicorn*, p. 82).

⁸⁸ Scheftelowitz, “Das Hörnermotiv in den Religionen.”

⁸⁹ Cf. *Psychological Types*, pars. 318ff. and Def. 51.

¹ Cf. Jung, *Psychological Types*, pars. 318ff.

² [These Latin phrases may be translated: *ex opere operato*, ‘by the performed work’; *ex opere operantis*, ‘by the work of the operator’; *opus operatum*, ‘the performed work’; *opus operantis*, ‘the work of the operator.’—EDITORS.]

³ Cf. Jung, *Psychological Types*, Def. 29.

- Published 1957; 2nd edn., 1970.
- † Published 1973.
- Published 1960.
- † Published 1961.
- ‡ Published 1956; 2nd edn., 1967. (65 plates, 43 text figures.)
- Published 1971.
- † Published 1953; 2nd edn., 1966.
- ‡ Published 1960; 2nd edn., 1969.
- Published 1959; 2nd edn., 1968. (Part I: 79 plates, with 29 in colour.)
- Published 1964; 2nd edn., 1970. (8 plates.)
- † Published 1958; 2nd edn., 1969.
- Published 1953; 2nd edn., completely revised, 1968. (270 illustrations.)
- † Published 1968. (50 plates, 4 text figures.)
- ‡ Published 1963; 2nd edn., 1970. (10 plates.)
- Published 1966.
- † Published 1954; 2nd edn., revised and augmented, 1966. (13 illustrations.)
- ‡ Published 1954.
- Published 1976.
- † Published 1979.

BOLLINGEN SERIES XX

THE COLLECTED WORKS

OF

C. G. JUNG

VOLUME 13

EDITORS

SIR HERBERT READ

MICHAEL FORDHAM, M.D., M.R.C.P.

GERHARD ADLER, PH.D.

WILLIAM MCGUIRE, *executive editor*



The *spiritus mercurialis* and his transformations represented as a monstrous dragon. It is a quaternity, in which the fourth is at the same time the unity of the three, the unity being symbolized by the mystagogue Hermes. The three (above) are (left to right): Luna, Sol. and coniunctio Solis et Lunae in Taurus, the House of Venus. Together they form ☿ = Mercurius. Illuminated drawing in a German alchemical ms., c. 1600

ALCHEMICAL STUDIES

C. G. JUNG

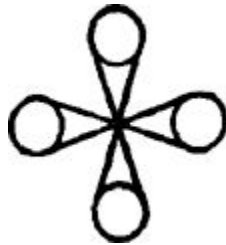

TRANSLATED BY R. F. C. HULL

54 ILLUSTRATIONS

BOLLINGEN SERIES XX

PRINCETON UNIVERSITY PRESS

COPYRIGHT © 1967 BY BOLLINGEN FOUNDATION, NEW YORK, N.Y.
PUBLISHED BY PRINCETON UNIVERSITY PRESS, PRINCETON, N.J.
ALL RIGHTS RESERVED

Second printing, 1970

THIS EDITION IS BEING PUBLISHED IN THE UNITED STATES OF AMERICA BY PRINCETON UNIVERSITY PRESS AND IN ENGLAND BY ROUTLEDGE & KEGAN PAUL, LTD. IN THE AMERICAN EDITION, ALL THE VOLUMES COMPRISING THE COLLECTED WORKS CONSTITUTE NUMBER XX IN BOLLINGEN SERIES. THE PRESENT VOLUME IS NUMBER 13 OF THE COLLECTED WORKS AND WAS THE FIFTEENTH TO APPEAR.

LIBRARY OF CONGRESS CATALOGUE CARD NUMBER: 75-156

ISBN 0-691-09760-7

MANUFACTURED IN THE U.S.A.

EDITORIAL NOTE

When we compare the essays in the present volume with Jung's monumental *Mysterium Coniunctionis*, with *Psychology and Alchemy* and to a lesser extent *Aion*, we realize their special value as an introduction to his researches into alchemy. The three longer works, published earlier in this edition, have an impact which to the uninitiated is well-nigh overwhelming. After them these shorter and more manageable works will be turned to, if not for relaxation—their erudition forbids that—at least with a feeling of lively interest, as preliminary studies for the weightier volumes which they now appear to summarize. Much of the symbolic matter has been referred to in other earlier publications: the visions of Zosimos in “Transformation Symbolism in the Mass,” and Mercurius in all the above-mentioned works but more especially in “The Psychology of the Transference,” while “The Philosophical Tree” develops the theme of the tree symbol discussed sporadically in *Symbols of Transformation*. The “Commentary on *The Secret of the Golden Flower*” is of considerable historical interest. Jung says in *Memories, Dreams, Reflections* (ch. 7): “Light on the nature of alchemy began to come to me only after I had read the text of the *Golden Flower*, that specimen of Chinese alchemy which Richard Wilhelm sent me in 1928. I was stirred by the desire to become more closely acquainted with the alchemical texts.” “Paracelsus as a Spiritual Phenomenon” stands out as a separate study with a powerful appeal, perhaps because Jung could identify himself rather closely and sympathetically with that dynamic and explosive personage, his own countryman. Because of its emphasis on alchemical sources, it is included in the present volume rather than in Volume 15 with two shorter essays on Paracelsus as a personality and physician.

*

The Editors and the translator are greatly indebted to the late Mr. A. S. B. Glover for the translation of the Latin, Greek, and French passages in the text, as well as for his tireless work in checking the references and bibliographical data, which continued until shortly before his death in January 1966.

For assistance in explicating Noël Pierre's poem, grateful acknowledgment is made to Comte Pierre Crapon de Caprona (Noël Pierre), to Miss Paula Deitz, and to Mr. Jackson Mathews.

For help and co-operation in obtaining the photographs for the plates in this volume the Editors are much indebted to the late Mrs. Marianne Niehus-Jung, who made

materials available from Professor Jung's collection; to Dr. Jolande Jacobi and Dr. Rudolf Michel, in charge of the picture collection at the C. G. Jung Institute, Zurich; and to Mr. Hellmut Wieser, of Rascher Verlag, Zurich. The frontispiece, an almost exact coloured replica of a woodcut published by the author in *Paracelsica*, was discovered fortuitously in a manuscript in the Mellon Collection of the Alchemical and Occult. It is reproduced by courtesy of Mr. Paul Mellon and the Yale University Library. The Editors are indebted also to Mr. Laurence Witten for his advice and assistance in regard to it.

VOLUME 13 ALCHEMICAL STUDIES

TABLE OF CONTENTS

EDITORIAL NOTE

LIST OF ILLUSTRATIONS

I

Commentary on “The Secret of the Golden Flower”

Translated from the “Europäischer Kommentar” to *Das Geheimnis der goldenen Blüte: Ein chinesisches Lebensbuch*, 5th edn. (Zurich: Rascher, 1957).

Foreword to the Second German Edition

1. Difficulties Encountered by a European in Trying to Understand the East
2. Modern Psychology Offers a Possibility of Understanding
3. The Fundamental Concepts
 - A. TAO
 - B. THE CIRCULAR MOVEMENT AND THE CENTRE
4. Phenomena of the Way
 - A. THE DISINTEGRATION OF CONSCIOUSNESS
 - B. ANIMUS AND ANIMA
5. The Detachment of Consciousness from the Object
6. The Fulfilment
7. Conclusion

Examples of European Mandalas

II

The Visions of Zosimos

Translated from “Die Visionen des Zosimos,” *Von den Wurzeln des Bewusstseins* (Zurich: Rascher, 1954).

I. The Texts

II. Commentary

1. GENERAL REMARKS ON THE INTERPRETATION
2. THE SACRIFICIAL ACT
3. THE PERSONIFICATIONS
4. THE STONE SYMBOLISM
5. THE WATER SYMBOLISM
6. THE ORIGIN OF THE VISION

III

Paracelsus as a Spiritual Phenomenon

Translated from “Paracelsus als geistige Erscheinung,” *Paracelsica: Zwei Vorlesungen über den Arzt und Philosophen Theophrastus* (Zurich: Rascher, 1942).

Foreword to *Paracelsica*

1. The Two Sources of Knowledge: The Light of Nature and the Light of Revelation

- A. MAGIC
- B. ALCHEMY
- C. THE ARCANES TEACHING
- D. THE PRIMORDIAL MAN

2. “De vita longa”: An Exposition of the Secret Doctrine

- A. THE ILIASTER
- B. THE AQUASTER
- C. ARES
- D. MELUSINA
- E. THE FILIUS REGIUS AS THE ARCANES SUBSTANCE (MICHAEL MAIER)
- F. THE PRODUCTION OF THE ONE, OR CENTRE, BY DISTILLATION

3. The Natural Transformation Mystery

- A. THE LIGHT OF THE DARKNESS
- B. THE UNION OF MAN'S TWO NATURES
- C. THE QUATERNITY OF THE HOMO MAXIMUS
- D. THE RAPPROCHEMENT WITH THE UNCONSCIOUS

4. The Commentary of Gerard Dorn

- A. MELUSINA AND THE PROCESS OF INDIVIDUATION
- B. THE HIEROSGAMOS OF THE EVERLASTING MAN
- C. SPIRIT AND NATURE
- D. THE ECCLESIASTICAL SACRAMENT AND THE OPUS ALCHYMICUM

5. Epilogue

IV

The Spirit Mercurius

Translated from "Der Geist Mercurius," *Symbolik des Geistes* (Zurich: Rascher, 1948).

Part I

- 1. The Spirit in the Bottle
- 2. The Connection between Spirit and Tree
- 3. The Problem of Freeing Mercurius

Part II

- 1. Introductory
- 2. Mercurius as Quicksilver and/or Water
- 3. Mercurius as Fire
- 4. Mercurius as Spirit and Soul
 - A. MERCURIUS AS AN AERIAL SPIRIT
 - B. MERCURIUS AS SOUL

5. The Dual Nature of Mercurius
6. The Unity and Trinity of Mercurius
7. The Relation of Mercurius to Astrology and the Doctrine of the Archons
8. Mercurius and Hermes
9. Mercurius as the Arcane Substance
10. Summary

V

The Philosophical Tree

Translated from “Der philosophische Baum,” *Von den Wurzeln des Bewusstseins* (Zurich: Rascher, 1954).

I. Individual Representations of the Tree Symbol

II. On the History and Interpretation of the Tree Symbol

1. THE TREE AS AN ARCHETYPAL IMAGE
2. THE TREE IN THE TREATISE OF JODOCUS GREVERUS
3. THE TETRASOMIA
4. THE IMAGE OF WHOLENESS
5. THE NATURE AND ORIGIN OF THE PHILOSOPHICAL TREE
6. DORN'S INTERPRETATION OF THE TREE
7. THE ROSE-COLOURED BLOOD AND THE ROSE
8. THE ALCHEMICAL MIND
9. VARIOUS ASPECTS OF THE TREE
10. THE HABITAT OF THE TREE
11. THE INVERTED TREE
12. BIRD AND SNAKE
13. THE FEMININE TREE-NUMEN
14. THE TREE AS THE LAPIS
15. THE DANGERS OF THE ART
16. UNDERSTANDING AS A MEANS OF DEFENCE
17. THE MOTIF OF TORTURE

18. THE RELATION OF SUFFERING TO THE CONIUNCTIO

19. THE TREE AS MAN

20. THE INTERPRETATION AND INTEGRATION OF THE UNCONSCIOUS

BIBLIOGRAPHY

INDEX

LIST OF ILLUSTRATIONS

For “Commentary on *The Secret of the Golden Flower*”

Four stages of meditation

Drawings from the *Hui Ming Ching*, as reproduced in the original Swiss edition of *Das Geheimnis der goldenen Blüte* (1929).

A1–A10. Examples of European mandalas

Drawings or paintings by patients in analysis. Author’s collection, except A4: C. G. Jung Institute.

For “Paracelsus as a Spiritual Phenomenon”

The *spiritus mercurialis* represented as a monstrous dragon

Illuminated drawing from a German alchemical ms., c. 1600, in the collection of Paul Mellon (now in the Yale University Library). It replaces an almost identical woodcut from Nazari, *Della tramutazione metallica sogni tre* (Brescia, 1599), reproduced in *Paracelsica*. P: Yale Univ. Library.

B1. A fish meal, with statue of the hermaphrodite

Miniature from “Le livre des ansienes estoires,” in British Museum MS. Add. 15268 (13th cent.), fol. 242^v. P: British Museum.

B2. The *filius* or *rex* in the form of a hermaphrodite

Woodcut from *Rosarium philosophorum* (second part of *De alchimia*, 1550), fol. X, iii^v (copy in author’s collection).

B3. The Rebis

Painting from “Das Buch der hl. Dreifaltigkeit . . . und Beschreibung der Heimlichkeit von Veränderung der Metallen” (1420), in the Codex Germanicus 598, Staatsbibliothek, Munich. P: Staatsbibliothek.

B4. Melusina as the *aqua permanens*

Woodcut in Reusner, *Pandora* (1588), p. 249 (copy in author’s collection).

B5. The anima as Melusina

Drawing from a variant of the Ripley *Scrowle* (1588), British Museum MS. Sloane 5025. P: British Museum.

B6. The King's Son and Hermes on a mountain

Engraving from Lambspringk, "De lapide philosophico," fig. XII, in *Musaeum hermeticum* (1678), p. 365. P: C. G. Jung Institute.

B7. The Pelican, in which the distillation takes place

Page from Rhenanus, *Solis e puteo* (1613), as reproduced in *Paracelsica*.

For "The Philosophical Tree"

Figs. 1–32. Drawings, paintings, etc., by patients in analysis

Author's collection, except Fig. 9: from Gerhard Adler, *Studies in Analytical Psychology*, pl. 12, reproduced by courtesy of Dr. Adler; Figs. 22, 25, 27, 30, and 31 (a design in embroidery): C. G. Jung Institute.

COMMENTARY ON “THE SECRET OF THE GOLDEN FLOWER”

[In late 1929, in Munich, Jung and the sinologist Richard Wilhelm published *Das Geheimnis der goldenen Blüte: Ein chinesisches Lebensbuch*, consisting of Wilhelm’s translation of an ancient Chinese text, *T’ai I Chin Hua Tsung Chih* (Secret of the Golden Flower), with his notes and discussion of the text, and a “European commentary” by Jung. Earlier the same year, the two authors had published in the *Europäische Revue* (Berlin), V: 2/8 (Nov.), 530-42, a much abbreviated version entitled “Tschang Scheng Schu; Die Kunst das menschliche Leben zu verlängern” (i.e., “Ch’ang Sheng Shu; The Art of Prolonging Life”), an alternative title of the “Golden Flower.”

[In 1931, Jung’s and Wilhelm’s joint work appeared in English as *The Secret of the Golden Flower: A Chinese Book of Life*, translated by Cary F. Baynes (London and New York), containing as an appendix Jung’s memorial address for Wilhelm, who had died in 1930. (For “In Memory of Richard Wilhelm,” see Vol. 15 of the *Collected Works*.)

[A second, revised edition of the German original was published in 1938 (Zurich), with a special foreword by Jung and his Wilhelm memorial address. Two more (essentially unaltered) editions followed, and in 1957 appeared a fifth, entirely reset edition (Zurich), which added a related text, the *Hui Ming Ching*, and a new foreword by Salome Wilhelm, the translator’s widow.

[Mrs. Baynes prepared a revision of her translation, and this appeared in 1962 (New York and London), including Jung’s foreword and the additional Wilhelm material. (Her revised translation of Jung’s commentary alone had appeared in an anthology, *Psyche and Symbol*, edited by Violet S. de Laszlo, Anchor Books, New York, 1958.)

[The following translation of Jung’s commentary and his foreword is based closely on Mrs. Baynes’ version, from which some of the editorial notes have also been taken over. Four pictures of the stages of meditation, from the *Hui Ming Ching*, which accompanied the “Golden Flower” text, have been reproduced because of their pertinence to Jung’s commentary; and the examples of European mandalas have been retained, though most of them were published, in a different context, in “Concerning

Mandala Symbolism,” Vol. 9, part i, of the *Collected Works*. The chapters have been given numbers.

—EDITORS.]

FOREWORD TO THE SECOND GERMAN EDITION

My deceased friend, Richard Wilhelm, co-author of this book, sent me the text of *The Secret of the Golden Flower* at a time that was crucial for my own work. This was in 1928. I had been investigating the processes of the collective unconscious since the year 1913, and had obtained results that seemed to me questionable in more than one respect. They not only lay far beyond everything known to “academic” psychology, but they also overstepped the bounds of any medical, purely personal, psychology. They confronted me with an extensive phenomenology to which hitherto known categories and methods could no longer be applied. My results, based on fifteen years of effort, seemed inconclusive, because no possibility of comparison offered itself. I knew of no realm of human experience with which I might have backed up my findings with some degree of assurance. The only analogies—and these, I must say, were far removed in time—I found scattered among the reports of the heresiologists. This connection did not in any way ease my task; on the contrary, it made it more difficult, because the Gnostic systems consist only in small part of immediate psychic experiences, the greater part being speculative and systematizing recensions. Since we possess only very few complete texts, and since most of what is known comes from the reports of Christian opponents, we have, to say the least, an inadequate knowledge of the history as well as the content of this strange and confused literature, which is so difficult to evaluate. Moreover, considering the fact that a period of not less than seventeen to eighteen hundred years separates us from that age, support from that quarter seemed to me extraordinarily risky. Again, the connections were for the most part of a subsidiary nature and left gaps at just the most important points, so that I found it impossible to make use of the Gnostic material.

The text that Wilhelm sent me helped me out of this difficulty. It contained exactly those items I had long sought for in vain among the Gnostics. Thus the text afforded me a welcome opportunity to publish, at least in provisional form, some of the essential results of my investigations.

At that time it seemed to me a matter of no importance that *The Secret of the Golden Flower* is not only a Taoist text concerned with Chinese yoga, but is also an alchemical treatise. A deeper study of the Latin treatises has taught me better and has shown me that the alchemical character of the text is of prime significance, though I shall not go into this point more closely here. I would only like to emphasize that it was the text of the *Golden Flower* that first put me on the right track. For in medieval alchemy we have

the long-sought connecting link between Gnosis and the processes of the collective unconscious that can be observed in modern man.¹

I would like to take this opportunity to draw attention to certain misunderstandings to which even well-informed readers of this book have succumbed. Not infrequently people thought that my purpose in publishing it was to put into the hands of the public a recipe for achieving happiness. In total misapprehension of all that I say in my commentary, these readers tried to imitate the “method” described in the Chinese text. Let us hope these representatives of spiritual profundity were few in number!

Another misunderstanding gave rise to the opinion that, in my commentary, I was to some extent describing my own therapeutic method, which, it was said, consisted in my instilling Eastern ideas into my patients for therapeutic purposes. I do not believe there is anything in my commentary that lends itself to that sort of superstition. In any case such an opinion is altogether erroneous, and is based on the widespread view that psychology was invented for a specific purpose and is not an empirical science. To this category belongs the superficial as well as unintelligent opinion that the idea of the collective unconscious is “metaphysical.” On the contrary, it is an *empirical* concept to be put alongside the concept of instinct, as is obvious to anyone who will read with some attention.

C. G. J.

Küsnacht / Zurich, 1938

1. DIFFICULTIES ENCOUNTERED BY A EUROPEAN IN TRYING TO UNDERSTAND THE EAST

[1] A thorough Westerner in feeling, I cannot but be profoundly impressed by the strangeness of this Chinese text. It is true that some knowledge of Eastern religions and philosophies helps my intellect and my intuition to understand these things up to a point, just as I can understand the paradoxes of primitive beliefs in terms of “ethnology” or “comparative religion.” This is of course the Western way of hiding one’s heart under the cloak of so-called scientific understanding. We do it partly because the *misérable vanité des savants* fears and rejects with horror any sign of living sympathy, and partly because sympathetic understanding might transform contact with an alien spirit into an experience that has to be taken seriously. Our so-called scientific objectivity would have reserved this text for the philological acumen of sinologists, and would have guarded it jealously from any other interpretation. But Richard Wilhelm penetrated too deeply into the secret and mysterious vitality of Chinese wisdom to allow such a pearl of intuitive insight to disappear into the pigeon-holes of specialists. I am greatly honoured that his choice of a psychological commentator has fallen upon me.

[2] This, however, involves the risk that this precious example of more-than-specialist insight will be swallowed by still another specialism. Nevertheless, anyone who belittles the merits of Western science is undermining the foundations of the Western mind. Science is not indeed a perfect instrument, but it is a superb and invaluable tool that works harm only when it is taken as an end in itself. Science must serve; it errs when it usurps the throne. It must be ready to serve all its branches, for each, because of its insufficiency, has need of support from the others. Science is the tool of the Western mind, and with it one can open more doors than with bare hands. It is part and parcel of our understanding, and it obscures our insight only when it claims that the understanding it conveys is the only kind there is. The East teaches us another, broader, more profound, and higher understanding—understanding through life. We know this only by hearsay, as a shadowy sentiment expressing a vague religiosity, and we are fond of putting “Oriental wisdom” in quotation marks and banishing it to the dim region of faith and superstition. But that is wholly to misunderstand the realism of the East. Texts of this kind do not consist of the sentimental, overwrought mystical intuitions of pathological cranks and

recluses, but are based on the practical insights of highly evolved Chinese minds, which we have not the slightest justification for undervaluing.

[3] This assertion may seem bold, perhaps, and is likely to cause a good deal of head-shaking. Nor is that surprising, considering how little people know about the material. Its strangeness is indeed so arresting that our puzzlement as to how and where the Chinese world of thought might be joined to ours is quite understandable. The usual mistake of Western man when faced with this problem of grasping the ideas of the East is like that of the student in *Faust*. Misled by the devil, he contemptuously turns his back on science and, carried away by Eastern occultism, takes over yoga practices word for word and becomes a pitiable imitator. (Theosophy is our best example of this.) Thus he abandons the one sure foundation of the Western mind and loses himself in a mist of words and ideas that could never have originated in European brains and can never be profitably grafted upon them.

[4] An ancient adept has said: "If the wrong man uses the right means, the right means work in the wrong way."¹ This Chinese saying, unfortunately only too true, stands in sharp contrast to our belief in the "right" method irrespective of the man who applies it. In reality, everything depends on the man and little or nothing on the method. The method is merely the path, the direction taken by a man; the way he acts is the true expression of his nature. If it ceases to be this, the method is nothing more than an affectation, something artificially pieced on, rootless and sapless, serving only the illegitimate goal of self-deception. It becomes a means of fooling oneself and of evading what may perhaps be the implacable law of one's being. This is far removed from the earthiness and self-reliance of Chinese thought. It is a denial of one's own nature, a self-betrayal to strange and unclean gods, a cowardly trick for the purpose of feigning mental superiority, everything in fact that is profoundly contrary to the spirit of the Chinese "method." For these insights spring from a way of life that is complete, genuine, and true to itself; from that ancient, cultural life of China which grew logically and organically from the deepest instincts, and which, for us, is forever inaccessible and impossible to imitate.

[5] Western imitation is a tragic misunderstanding of the psychology of the East, every bit as sterile as the modern escapades to New Mexico, the blissful South Sea islands, and central Africa, where "the primitive life" is played at in deadly earnest while Western man secretly evades his menacing duties, his *Hic Rhodus hic salta*. It is not for us to imitate what is foreign to our organism or to play the missionary; our task is to build up our Western civilization, which sickens with a thousand ills. This has to be done on the spot, and by the European just as he is, with all his Western ordinariness, his marriage problems, his neuroses, his social and political delusions, and his whole philosophical disorientation.

[6] We should do well to confess at once that, fundamentally, we do not understand the utter unworldliness of a text like this—that actually we do not want to understand it. Have we, perhaps, a dim suspicion that a mental attitude which can direct the glance inward to that extent is detached from the world only because these people have so completely fulfilled the instinctive demands of their natures that there is nothing to prevent them from glimpsing the invisible essence of things? Can it be that the precondition for such a vision is liberation from the ambitions and passions that bind us to the visible world, and does not this liberation come from the sensible fulfilment of instinctive demands rather than from the premature and fear-ridden repression of them? Are our eyes opened to the spirit only when the laws of the earth are obeyed? Anyone who knows the history of Chinese culture and has carefully studied the *I Ching*, that book of wisdom which for thousands of years has permeated all Chinese thought, will not lightly wave these doubts aside. He will be aware that the views set forth in our text are nothing extraordinary to the Chinese, but are actually inescapable psychological conclusions.

[7] For a long time the spirit, and the sufferings of the spirit, were positive values and the things most worth striving for in our peculiar Christian culture. Only in the course of the nineteenth century, when spirit began to degenerate into intellect, did a reaction set in against the unbearable dominance of intellectualism, and this led to the unpardonable mistake of confusing intellect with spirit and blaming the latter for the misdeeds of the former. The intellect does indeed do harm to the soul when it dares to possess itself of the heritage of the spirit. It is in no way fitted to do this, for spirit is something higher than intellect since it embraces the latter and includes the feelings as well. It is a guiding principle of life that strives towards superhuman, shining heights. Opposed to this *yang* principle is the dark, feminine, earthbound *yin*, whose emotionality and instinctuality reach back into the depths of time and down into the labyrinth of the physiological continuum. No doubt these are purely intuitive ideas, but one can hardly dispense with them if one is trying to understand the nature of the human psyche. The Chinese could not do without them because, as the history of Chinese philosophy shows, they never strayed so far from the central psychic facts as to lose themselves in a one-sided over-development and over-valuation of a single psychic function. They never failed to acknowledge the paradoxicality and polarity of all life. The opposites always balanced one another—a sign of high culture. One-sidedness, though it lends momentum, is a mark of barbarism. The reaction that is now beginning in the West against the intellect in favour of feeling, or in favour of intuition, seems to me a sign of cultural advance, a widening of consciousness beyond the narrow confines of a tyrannical intellect.

[8] I have no wish to depreciate the tremendous differentiation of the Western intellect; compared with it the Eastern intellect must be described as childish.

(Naturally this has nothing to do with intelligence.) If we should succeed in elevating another, and possibly even a third psychic function to the dignified position accorded to the intellect, then the West might expect to surpass the East by a very great margin. Therefore it is sad indeed when the European departs from his own nature and imitates the East or “affects” it in any way. The possibilities open to him would be so much greater if he would remain true to himself and evolve out of his own nature all that the East has brought forth in the course of the millennia.

[9] In general, and looked at from the incurably externalistic standpoint of the intellect, it would seem as if the things the East values so highly were not worth striving for. Certainly the intellect alone cannot comprehend the practical importance Eastern ideas might have for us, and that is why it can classify them as philosophical and ethnological curiosities and nothing more. The lack of comprehension goes so far that even learned sinologists have not understood the practical use of the *I Ching*, and consider the book to be no more than a collection of abstruse magic spells.

2. MODERN PSYCHOLOGY OFFERS A POSSIBILITY OF UNDERSTANDING

[10] Observations made in my practical work have opened out to me a quite new and unexpected approach to Eastern wisdom. In saying this I should like to emphasize that I did not have any knowledge, however inadequate, of Chinese philosophy as a starting point. On the contrary, when I began my career as a psychiatrist and psychotherapist, I was completely ignorant of Chinese philosophy, and only later did my professional experience show me that in my technique I had been unconsciously following that secret way which for centuries had been the preoccupation of the best minds of the East. This could be taken for a subjective fancy—which was one reason for my previous reluctance to publish anything on the subject—but Richard Wilhelm, that great interpreter of the soul of China, enthusiastically confirmed the parallel and thus gave me the courage to write about a Chinese text that belongs entirely to the mysterious shadow-land of the Eastern mind. At the same time—and this is the extraordinary thing—its content forms a living parallel to what takes place in the psychic development of my patients, none of whom is Chinese.

[11] In order to make this strange fact more intelligible to the reader, it must be pointed out that just as the human body shows a common anatomy over and above all racial differences, so, too, the human psyche possesses a common substratum transcending all differences in culture and consciousness. I have called this substratum the collective unconscious. This unconscious psyche, common to all mankind, does not consist merely of contents capable of becoming conscious, but of latent predispositions towards identical reactions. The collective unconscious is simply the psychic expression of the identity of brain structure irrespective of all racial differences. This explains the analogy, sometimes even identity, between the various myth motifs and symbols, and the possibility of human communication in general. The various lines of psychic development start from one common stock whose roots reach back into the most distant past. This also accounts for the psychological parallelisms with animals.

[12] In purely psychological terms this means that mankind has common instincts of ideation and action. All conscious ideation and action have developed on the basis of these unconscious archetypal patterns and always remain dependent on them. This is especially the case when consciousness has not attained any high degree of clarity,

when in all its functions it is more dependent on the instincts than on the conscious will, more governed by affect than by rational judgment. This ensures a primitive state of psychic health, but it immediately becomes lack of adaptation when circumstances arise that call for a higher moral effort. Instincts suffice only for a nature that remains more or less constant. An individual who is guided more by the unconscious than by conscious choice therefore tends towards marked psychic conservatism. This is the reason why the primitive does not change in the course of thousands of years, and also why he fears anything strange and unusual. It might easily lead to maladaptation, and thus to the greatest psychic dangers—to a kind of neurosis, in fact. A higher and wider consciousness resulting from the assimilation of the unfamiliar tends, on the other hand, towards autonomy, and rebels against the old gods who are nothing other than those mighty, primordial images that hitherto have held our consciousness in thrall.

[13] The stronger and more independent our consciousness becomes, and with it the conscious will, the more the unconscious is thrust into the background, and the easier it is for the evolving consciousness to emancipate itself from the unconscious, archetypal pattern. Gaining in freedom, it bursts the bonds of mere instinctuality and finally reaches a condition of instinctual atrophy. This uprooted consciousness can no longer appeal to the authority of the primordial images; it has Promethean freedom, but it also suffers from godless hybris. It soars above the earth and above mankind, but the danger of its sudden collapse is there, not of course in the case of every individual, but for the weaker members of the community, who then, again like Prometheus, are chained to the Caucasus of the unconscious. The wise Chinese would say in the words of the *I Ching*: When *yang* has reached its greatest strength, the dark power of *yin* is born within its depths, for night begins at midday when *yang* breaks up and begins to change into *yin*.

[14] The doctor is in a position to see this cycle of changes translated literally into life. He sees, for instance, a successful businessman attaining all his desires regardless of death and the devil, and then, having retired at the height of his success, speedily falling into a neurosis, which turns him into a querulous old woman, fastens him to his bed, and finally destroys him. The picture is complete even to the change from masculine to feminine. An exact parallel to this is the story of Nebuchadnezzar in the Book of Daniel, and Caesarean madness in general. Similar cases of one-sided exaggeration of the conscious standpoint, and the resultant yin-reaction from the unconscious, form no small part of the psychiatrist's clientele in our time, which so overvalues the conscious will as to believe that "where there's a will there's a way." Not that I wish to detract in the least from the high moral value of the will. Consciousness and the will may well continue to be considered the highest cultural achievements of humanity. But of what use is a morality that destroys the man? To

bring the will and the capacity to achieve it into harmony seems to me to require more than morality. Morality *à tout prix* can be a sign of barbarism—more often wisdom is better. But perhaps I look at this with the eyes of a physician who has to mend the ills following in the wake of one-sided cultural achievements.

[15] Be that as it may, the fact remains that a consciousness heightened by an inevitable one-sidedness gets so far out of touch with the primordial images that a breakdown ensues. Long before the actual catastrophe, the signs of error announce themselves in atrophy of instinct, nervousness, disorientation, entanglement in impossible situations and problems. Medical investigation then discovers an unconscious that is in full revolt against the conscious values, and that therefore cannot possibly be assimilated to consciousness, while the reverse is altogether out of the question. We are confronted with an apparently irreconcilable conflict before which human reason stands helpless, with nothing to offer except sham solutions or dubious compromises. If these evasions are rejected, we are faced with the question as to what has become of the much needed unity of the personality, and with the necessity of seeking it. At this point begins the path travelled by the East since the beginning of things. Quite obviously, the Chinese were able to follow this path because they never succeeded in forcing the opposites in man's nature so far apart that all conscious connection between them was lost. The Chinese owe this all-inclusive consciousness to the fact that, as in the case of the primitive mentality, the yea and the nay have remained in their original proximity. Nonetheless, it was impossible not to feel the clash of opposites, so they sought a way of life in which they would be what the Indians call *nirvandva*, free of opposites.

[16] Our text is concerned with this way, and the same problem comes up with my patients also. There could be no greater mistake than for a Westerner to take up the direct practice of Chinese yoga, for that would merely strengthen his will and consciousness against the unconscious and bring about the very effect to be avoided. The neurosis would then simply be intensified. It cannot be emphasized enough that we are not Orientals, and that we have an entirely different point of departure in these matters. It would also be a great mistake to suppose that this is the path every neurotic must travel, or that it is the solution at every stage of the neurotic problem. It is appropriate only in those cases where consciousness has reached an abnormal degree of development and has diverged too far from the unconscious. This is the *sine qua non* of the process. Nothing would be more wrong than to open this way to neurotics who are ill on account of an excessive predominance of the unconscious. For the same reason, this way of development has scarcely any meaning before the middle of life (normally between the ages of thirty-five and forty), and if entered upon too soon can be decidedly injurious.

[17] As I have said, the essential reason which prompted me to look for a new way was the fact that the fundamental problem of the patient seemed to me insoluble unless violence was done to one or the other side of his nature. I had always worked with the temperamental conviction that at bottom there are no insoluble problems, and experience justified me in so far as I have often seen patients simply outgrow a problem that had destroyed others. This “outgrowing,” as I formerly called it, proved on further investigation to be a new level of consciousness. Some higher or wider interest appeared on the patient’s horizon, and through this broadening of his outlook the insoluble problem lost its urgency. It was not solved logically in its own terms, but faded out when confronted with a new and stronger life urge. It was not repressed and made unconscious, but merely appeared in a different light, and so really did become different. What, on a lower level, had led to the wildest conflicts and to panicky outbursts of emotion, from the higher level of personality now looked like a storm in the valley seen from the mountain top. This does not mean that the storm is robbed of its reality, but instead of being in it one is above it. But since, in a psychic sense, we are both valley and mountain, it might seem a vain illusion to deem oneself beyond what is human. One certainly does feel the affect and is shaken and tormented by it, yet at the same time one is aware of a higher consciousness looking on which prevents one from becoming identical with the affect, a consciousness which regards the affect as an object, and can say, “I *know* that I suffer.” What our text says of indolence, “Indolence of which a man is conscious, and indolence of which he is unconscious, are a thousand miles apart,”¹ holds true in the highest degree of affect.

[18] Now and then it happened in my practice that a patient grew beyond himself because of unknown potentialities, and this became an experience of prime importance to me. In the meantime, I had learned that all the greatest and most important problems of life are fundamentally insoluble. They must be so, for they express the necessary polarity inherent in every self-regulating system. They can never be solved, but only outgrown. I therefore asked myself whether this outgrowing, this possibility of further psychic development, was not the normal thing, and whether getting stuck in a conflict was pathological. Everyone must possess that higher level, at least in embryonic form, and must under favourable circumstances be able to develop this potentiality. When I examined the course of development in patients who quietly, and as if unconsciously, outgrew themselves, I saw that their fates had something in common. The new thing came to them from obscure possibilities either outside or inside themselves; they accepted it and grew with its help. It seemed to me typical that some took the new thing from outside themselves, others from inside; or rather, that it grew into some persons from without, and into others from within. But the new thing never came exclusively either

from within or from without. If it came from outside, it became a profound inner experience; if it came from inside, it became an outer happening. In no case was it conjured into existence intentionally or by conscious willing, but rather seemed to be borne along on the stream of time.

[19] We are so greatly tempted to turn everything into a purpose and a method that I deliberately express myself in very abstract terms in order to avoid prejudicing the reader in one way or the other. The new thing must not be pigeon-holed under any heading, for then it becomes a recipe to be used mechanically, and it would again be a case of the “right means in the hands of the wrong man.” I have been deeply impressed by the fact that the new thing prepared by fate seldom or never comes up to conscious expectations. And still more remarkable, though the new thing goes against deeply rooted instincts as we have known them, it is a strangely appropriate expression of the total personality, an expression which one could not imagine in a more complete form.

[20] What did these people do in order to bring about the development that set them free? As far as I could see they did nothing (*wu wei*²) but let things happen. As Master Lü-tsu teaches in our text, the light circulates according to its own law if one does not give up one’s ordinary occupation. The art of letting things happen, action through non-action, letting go of oneself as taught by Meister Eckhart, became for me the key that opens the door to the way. We must be able to let things happen in the psyche. For us, this is an art of which most people know nothing. Consciousness is forever interfering, helping, correcting, and negating, never leaving the psychic processes to grow in peace. It would be simple enough, if only simplicity were not the most difficult of all things. To begin with, the task consists solely in observing objectively how a fragment of fantasy develops. Nothing could be simpler, and yet right here the difficulties begin. Apparently one has no fantasy fragments—or yes, there’s one, but it is too stupid! Dozens of good reasons are brought against it. One cannot concentrate on it—it is too boring—what would come of it anyway—it is “nothing but” this or that, and so on. The conscious mind raises innumerable objections, in fact it often seems bent on blotting out the spontaneous fantasy activity in spite of real insight and in spite of the firm determination to allow the psychic process to go forward without interference. Occasionally there is a veritable cramp of consciousness.

[21] If one is successful in overcoming the initial difficulties, criticism is still likely to start in afterwards in the attempt to interpret the fantasy, to classify it, to aestheticize it, or to devalue it. The temptation to do this is almost irresistible. After it has been faithfully observed, free rein can be given to the impatience of the conscious mind; in fact it must be given, or obstructive resistances will develop. But each time the

fantasy material is to be produced, the activity of consciousness must be switched off again.

[22] In most cases the results of these efforts are not very encouraging at first. Usually they consist of tenuous webs of fantasy that give no clear indication of their origin or their goal. Also, the way of getting at the fantasies varies with individuals. For many people, it is easiest to write them down: others visualize them, and others again draw or paint them with or without visualization. If there is a high degree of conscious cramp, often only the hands are capable of fantasy; they model or draw figures that are sometimes quite foreign to the conscious mind.

[23] These exercises must be continued until the cramp in the conscious mind is relaxed, in other words, until one can let things happen, which is the next goal of the exercise. In this way a new attitude is created, an attitude that accepts the irrational and the incomprehensible simply because it is happening. This attitude would be poison for a person who is already overwhelmed by the things that happen to him, but it is of the greatest value for one who selects, from among the things that happen, only those that are acceptable to his conscious judgment, and is gradually drawn out of the stream of life into a stagnant backwater.

[24] At this point, the way travelled by the two types mentioned earlier seems to divide. Both have learned to accept what comes to them. (As Master Lü-tsu teaches: “When occupations come to us, we must accept them; when things come to us, we must understand them from the ground up.”³) One man will now take chiefly what comes to him from outside, and the other what comes from inside. Moreover, the law of life demands that what they take from outside and inside will be the very things that were always excluded before. This reversal of one’s nature brings an enlargement, a heightening and enrichment of the personality, if the previous values are retained alongside the change—provided that these values are not mere illusions. If they are not held fast, the individual will swing too far to the other side, slipping from fitness into unfitness, from adaptedness into unadaptedness, and even from rationality into insanity. The way is not without danger. Everything good is costly, and the development of personality is one of the most costly of all things. It is a matter of saying yea to oneself, of taking oneself as the most serious of tasks, of being conscious of everything one does, and keeping it constantly before one’s eyes in all its dubious aspects—truly a task that taxes us to the utmost.

[25] A Chinese can always fall back on the authority of his whole civilization. If he starts on the long way, he is doing what is recognized as being the best thing he could possibly do. But the Westerner who wishes to set out on this way, if he is really serious about it, has all authority against him—intellectual, moral, and religious. That is why it is infinitely easier for him to imitate the Chinese way and leave the

troublesome European behind him, or else to seek the way back to the medievalism of the Christian Church and barricade himself behind the wall separating true Christians from the poor heathen and other ethnographic curiosities encamped outside. Aesthetic or intellectual flirtations with life and fate come to an abrupt halt here: the step to higher consciousness leaves us without a rearguard and without shelter. The individual must devote himself to the way with all his energy, for it is only by means of his integrity that he can go further, and his integrity alone can guarantee that his way will not turn out to be an absurd misadventure.

[26] Whether his fate comes to him from without or from within, the experiences and happenings on the way remain the same. Therefore I need say nothing about the manifold outer and inner events, the endless variety of which I could never exhaust in any case. Nor would this be relevant to the text under discussion. On the other hand, there is much to be said about the psychic states that accompany the process of development. These states are expressed symbolically in our text, and in the very same symbols that for many years have been familiar to me from my practice.

3. THE FUNDAMENTAL CONCEPTS

A. TAO

[27] The great difficulty in interpreting this and similar texts¹ for the European is that the author always starts from the central point, from the point we would call the goal, the highest and ultimate insight he has attained. Thus our Chinese author begins with ideas that demand such a comprehensive understanding that a person of discriminating mind has the feeling he would be guilty of ridiculous pretension, or even of talking utter nonsense, if he should embark on an intellectual discourse on the subtle psychic experiences of the greatest minds of the East. Our text, for example, begins: “That which exists through itself is called the Way.” The *Hui Ming Ching* begins with the words: “The subtlest secret of the Tao is human nature and life.”

[28] It is characteristic of the Western mind that it has no word for Tao. The Chinese character is made up of the sign for “head” and the sign for “going.” Wilhelm translates Tao by *Sinn* (Meaning). Others translate it as “way,” “providence,” or even as “God,” as the Jesuits do. This illustrates our difficulty. “Head” can be taken as consciousness,² and “going” as travelling a way, and the idea would then be: to go consciously, or the conscious way. This is borne out by the fact that the “light of heaven” which “dwells between the eyes” as the “heart of heaven” is used synonymously with Tao. Human nature and life are contained in the “light of heaven” and, according to the *Hui Ming Ching*, are the most important secrets of the Tao. “Light” is the symbolical equivalent of consciousness, and the nature of consciousness is expressed by analogies with light. The *Hui Ming Ching* is introduced with the verses:

If thou wouldst complete the diamond body with no outflowing,
Diligently heat the roots of consciousness³ and life.
Kindle light in the blessed country ever close at hand,
And there hidden, let thy true self always dwell.

[29] These verses contain a sort of alchemical instruction as to the method or way of producing the “diamond body,” which is also mentioned in our text. “Heating” is necessary; that is, there must be an intensification of consciousness in order that light may be kindled in the dwelling place of the true self. Not only consciousness, but life

itself must be intensified: the union of these two produces conscious life. According to the *Hui Ming Ching*, the ancient sages knew how to bridge the gap between consciousness and life because they cultivated both. In this way the *sheli*, the immortal body, is “melted out” and the “great Tao is completed.”⁴

[30] If we take the Tao to be the method or conscious way by which to unite what is separated, we have probably come close to the psychological meaning of the concept. At all events, the separation of consciousness and life cannot very well be understood as anything else than what I described earlier as an aberration or uprooting of consciousness. There can be no doubt, either, that the realization of the opposite hidden in the unconscious—the process of “reversal”—signifies reunion with the unconscious laws of our being, and the purpose of this reunion is the attainment of conscious life or, expressed in Chinese terms, the realization of the Tao.

B. THE CIRCULAR MOVEMENT AND THE CENTRE

[31] As I have pointed out, the union of opposites⁵ on a higher level of consciousness is not a rational thing, nor is it a matter of will; it is a process of psychic development that expresses itself in symbols. Historically, this process has always been represented in symbols, and today the development of personality is still depicted in symbolic form. I discovered this fact in the following way. The spontaneous fantasy products I discussed earlier become more profound and gradually concentrate into abstract structures that apparently represent “principles” in the sense of Gnostic *archai*. When the fantasies take the form chiefly of thoughts, intuitive formulations of dimly felt laws or principles emerge, which at first tend to be dramatized or personified. (We shall come back to these again later.) If the fantasies are drawn, symbols appear that are chiefly of the *mandala*⁶ type. *Mandala* means “circle,” more especially a magic circle. Mandalas are found not only throughout the East but also among us. The early Middle Ages are especially rich in Christian mandalas; most of them show Christ in the centre, with the four evangelists, or their symbols, at the cardinal points. This conception must be a very ancient one, because Horus and his four sons were represented in the same way by the Egyptians.⁷ It is known that Horus with his four sons has close connections with Christ and the four evangelists. An unmistakable and very interesting mandala can be found in Jakob Böhme’s book *XL Questions concerning the Soule*.⁸ It is clear that this mandala represents a psychocosmic system strongly coloured by Christian ideas. Böhme calls it the “Philosophical Eye”⁹ or the “Mirror of Wisdom,” by which is obviously meant a *summa* of secret knowledge. Most mandalas take the form of a flower, cross, or wheel, and show a distinct tendency towards a quaternary structure reminiscent of the Pythagorean *tetraktys*, the basic number. Mandalas of this sort also occur as sand paintings in the religious ceremonies of the Pueblo and Navaho Indians.¹⁰ But the

most beautiful mandalas are, of course, those of the East, especially the ones found in Tibetan Buddhism, which also contain the symbols mentioned in our text. Mandala drawings are often produced by the mentally ill, among them persons who certainly did not have the least idea of any of the connections we have discussed.¹¹

[32] Among my patients I have come across cases of women who did not draw mandalas but danced them instead. In India there is a special name for this: *mandala nrithya*, the mandala dance. The dance figures express the same meanings as the drawings. My patients can say very little about the meaning of the symbols but are fascinated by them and find that they somehow express and have an effect on their subjective psychic state.

[33] Our text promises to “reveal the secret of the Golden Flower of the great *One*.” The golden flower is the light, and the light of heaven is the Tao. The golden flower is a mandala symbol I have often met with in the material brought me by my patients. It is drawn either seen from above as a regular geometric pattern, or in profile as a blossom growing from a plant. The plant is frequently a structure in brilliant fiery colours growing out of a bed of darkness, and carrying the blossom of light at the top, a symbol recalling the Christmas tree. Such drawings also suggest the origin of the golden flower, for according to the *Hui Ming Ching* the “germinal vesicle” is the “dragon castle at the bottom of the sea.”¹² Other synonyms are the “yellow castle,” the “heavenly heart,” the “terrace of living,” the “square inch field of the square foot house,” the “purple hall of the city of jade,” the “dark pass,” the “space of former heaven.”¹³ It is also called the “boundary region of the snow mountains,” the “primordial pass,” the “kingdom of greatest joy,” the “boundless country,” the “altar upon which consciousness and life are made.” “If a dying man does not know this germinal vesicle,” says the *Hui Ming Ching*, “he will not find the unity of consciousness and life in a thousand births, nor in ten thousand aeons.”¹⁴

[34] The beginning, where everything is still one, and which therefore appears as the highest goal, lies at the bottom of the sea, in the darkness of the unconscious. In the germinal vesicle, consciousness and life (or human nature and life, *hsing-ming*) are still a “unity, inseparably mixed like the sparks in the refining furnace.” “Within the germinal vesicle is the fire of the ruler.” “All the sages began their work at the germinal vesicle.”¹⁵ Note the fire analogies. I know a series of European mandala drawings in which something like a plant seed surrounded by membranes is shown floating in the water. Then, from the depths below, fire penetrates the seed and makes it grow, causing a great golden flower to unfold from the germinal vesicle.

[35] This symbolism refers to a quasi-alchemical process of refining and ennobling. Darkness gives birth to light; out of the “lead of the water region” grows the noble gold; what is unconscious becomes conscious in the form of a living process of

growth. (Indian Kundalini yoga offers a perfect analogy.¹⁶) In this way the union of consciousness and life takes place.

[36] When my patients produce these mandala pictures, it is naturally not the result of suggestion; similar pictures were being made long before I knew their meaning or their connection with the practices of the East, which, at that time, were wholly unknown to me. The pictures arise quite spontaneously, and from two sources. One source is the unconscious, which spontaneously produces fantasies of this kind; the other is life, which, if lived with utter devotion, brings an intuition of the self, of one's own individual being. When the self finds expression in such drawings, the unconscious reacts by enforcing an attitude of devotion to life. For in complete agreement with the Eastern view, the mandala is not only a means of expression but also produces an effect. It reacts upon its maker. Age-old magical effects lie hidden in this symbol, for it is derived from the "protective circle" or "charmed circle," whose magic has been preserved in countless folk customs.¹⁷ It has the obvious purpose of drawing a *sulcus primigenius*, a magical furrow around the centre, the temple or *temenos* (sacred precinct), of the innermost personality, in order to prevent an "outflowing" or to guard by apotropaic means against distracting influences from outside. Magical practices are nothing but projections of psychic events, which then exert a counter-influence on the psyche and put a kind of spell upon the personality. Through the ritual action, attention and interest are led back to the inner, sacred precinct, which is the source and goal of the psyche and contains the unity of life and consciousness. The unity once possessed has been lost, and must now be found again.

[37] The unity of the two, life and consciousness, is the Tao, whose symbol would be the central white light, also mentioned in the *Bardo Thödol*.¹⁸ This light dwells in the "square inch" or in the "face," that is, between the eyes. It is a visualization of the "creative point," of that which has intensity without extension, in conjunction with the "field of the square inch," the symbol for that which has extension. The two together make the Tao. Human nature (*hsing*) and consciousness (*hui*) are expressed in light symbolism, and therefore have the quality of intensity, while life (*ming*) would coincide with extensity. The one is *yang*-like, the other *yin*-like. The aforementioned mandala of a somnambulist girl, aged fifteen and a half, whom I had under observation some thirty years ago, shows in its centre a spring of "Primary Force," or life energy without extension, whose emanations clash with a contrary spatial principle—in complete analogy with the basic idea of our Chinese text.

[38] The "enclosure," or *circumambulatio*, is expressed in our text by the idea of "circulation." The circulation is not merely movement in a circle, but means, on the one hand, the marking off of the sacred precinct and, on the other, fixation and concentration. The sun-wheel begins to turn; the sun is activated and begins its

course—in other words, the Tao begins to work and takes the lead. Action is reversed into non-action; everything peripheral is subordinated to the command of the centre. Therefore it is said: “Movement is only another name for mastery.” Psychologically, this circulation would be the “movement in a circle around oneself,” so that all sides of the personality become involved. “The poles of light and darkness are made to rotate,” that is, there is an alternation of day and night.

[39] The circular movement thus has the moral significance of activating the light and dark forces of human nature, and together with them all psychological opposites of whatever kind they may be. It is nothing less than self-knowledge by means of self-brooding (Sanskrit *tapas*). A similar archetypal concept of a perfect being is that of the Platonic man, round on all sides and uniting within himself the two sexes.

[40] One of the best modern parallels is the description which Edward Maitland, the biographer of Anna Kingsford,¹⁹ gave of his central experience. He had discovered that when reflecting on an idea, related ideas became visible, so to speak, in a long series apparently reaching back to their source, which to him was the divine spirit. By concentrating on this series, he tried to penetrate to their origin. He writes:

I was absolutely without knowledge or expectation when I yielded to the impulse to make the attempt. I simply experimented on a faculty . . . being seated at my writing-table the while in order to record the results as they came, and resolved to retain my hold on my outer and circumferential consciousness, no matter how far towards my inner and central consciousness I might go. For I knew not whether I should be able to regain the former if I once quitted my hold of it, or to recollect the facts of the experience. At length I achieved my object, though only by a strong effort, the tension occasioned by the endeavour to keep both extremes of the consciousness in view at once being very great.

Once well started on my quest, I found myself traversing a succession of spheres or belts . . . the impression produced being that of mounting a vast ladder stretching from the circumference towards the centre of a system, which was at once my own system, the solar system, the universal system, the three systems being at once diverse and identical. . . . Presently, by a supreme, and what I felt must be a final effort . . . I succeeded in polarizing the whole of the convergent rays of my consciousness into the desired focus. And at the same instant, as if through the sudden ignition of the rays thus fused into a unity, I found myself confronted with a glory of unspeakable whiteness and brightness, and of a lustre so intense as well-nigh to beat me back. . . . But though feeling that I had to explore further, I resolved to make assurance doubly sure by piercing if I could the almost blinding lustre, and seeing what it enshrined. With a great effort I succeeded, and the glance revealed to me that which I had felt must be there. . . . It was the dual form of the Son . . . the

unmanifest made manifest, the unformulate formulate, the unindividuate individuate, God as the Lord, proving through His duality that God is Substance as well as Force, Love as well as Will, Feminine as well as Masculine, Mother as well as Father.

[41] He found that God is two in one, like man. Besides this he noticed something that our text also emphasizes, namely “suspension of breathing.” He says ordinary breathing stopped and was replaced by an internal respiration, “as if by breathing of a distinct personality within and other than the physical organism.” He took this being to be the “entelechy” of Aristotle and the “inner Christ” of the apostle Paul, the “spiritual and substantial individuality engendered within the physical and phenomenal personality, and representing, therefore, the rebirth of man on a plane transcending the material.”

[42] This genuine²⁰ experience contains all the essential symbols of our text. The phenomenon itself, the vision of light, is an experience common to many mystics, and one that is undoubtedly of the greatest significance, because at all times and places it proves to be something unconditioned and absolute, a combination of supreme power and profound meaning. Hildegard of Bingen, an outstanding personality quite apart from her mysticism, writes in much the same way about her central vision:

Since my childhood I have always seen a light in my soul, but not with the outer eyes, nor through the thoughts of my heart; neither do the five outer senses take part in this vision. . . . The light I perceive is not of a local kind, but is much brighter than the cloud which supports the sun. I cannot distinguish height, breadth, or length in it. . . . What I see or learn in such a vision stays long in my memory. I see, hear, and know in the same moment. . . . I cannot recognize any sort of form in this light, although I sometimes see in it another light that is known to me as the living light. . . . While I am enjoying the spectacle of this light, all sadness and sorrow vanish from my memory.²¹

[43] I myself know a few individuals who have had personal experience of this phenomenon. So far as I have been able to understand it, it seems to have to do with an acute state of consciousness, as intense as it is abstract, a “detached” consciousness (see *infra*, pars. 64ff.), which, as Hildegard implies, brings into awareness areas of psychic happenings ordinarily covered in darkness. The fact that the general bodily sensations disappear during the experience suggests that their specific energy has been withdrawn and has apparently gone towards heightening the clarity of consciousness. As a rule, the phenomenon is spontaneous, coming and going on its own initiative. Its effect is astonishing in that it almost always brings about a solution of psychic complications and frees the inner personality from

emotional and intellectual entanglements, thus creating a unity of being which is universally felt as “liberation.”

[44] Such a symbolic unity cannot be attained by the conscious will because consciousness is always partisan. Its opponent is the collective unconscious, which does not understand the language of the conscious mind. Therefore it is necessary to have the magic of the symbol which contains those primitive analogies that speak to the unconscious. The unconscious can be reached and expressed only by symbols, and for this reason the process of individuation can never do without the symbol. The symbol is the primitive exponent of the unconscious, but at the same time an idea that corresponds to the highest intuitions of the conscious mind.

[45] The oldest mandala drawing known to me is a palaeolithic “sun-wheel,” recently discovered in Rhodesia. It, too, is based on the quaternary principle. Things reaching so far back into human history naturally touch upon the deepest layers of the unconscious, and can have a powerful effect on it even when our conscious language proves itself to be quite impotent. Such things cannot be thought up but must grow again from the forgotten depths if they are to express the supreme insights of consciousness and the loftiest intuitions of the spirit, and in this way fuse the uniqueness of present-day consciousness with the age-old past of life.

4. PHENOMENA OF THE WAY

A. THE DISINTEGRATION OF CONSCIOUSNESS

[46] The meeting between the narrowly delimited, but intensely clear, individual consciousness and the vast expanse of the collective unconscious is dangerous, because the unconscious has a decidedly disintegrating effect on consciousness. According to the *Hui Ming Ching*, this effect belongs to the peculiar phenomena of Chinese yoga. It says: “Every separate thought takes shape and becomes visible in colour and form. The total spiritual power unfolds its traces. . . .”¹ The relevant illustration in the text [stage 4] shows a sage sunk in contemplation, his head surrounded by tongues of fire, out of which five human figures emerge; these five again split up into twenty-five smaller figures.² This would be a schizophrenic process if it were to become a permanent state. Therefore the *Hui Ming Ching*, as though warning the adept, continues: “The shapes formed by the spirit-fire are only empty colours and forms. The light of human nature (*hsing*) shines back on the primordial, the true.”

[47] So we can understand why the figure of the protecting circle was seized upon. It is intended to prevent the “outflowing” and to protect the unity of consciousness from being burst asunder by the unconscious. The text seeks to mitigate the disintegrating effect of the unconscious by describing the thought-figures as “empty colours and forms,” thus depotentiating them as much as possible. This idea runs through the whole of Buddhism (especially the Mahayana form) and, in the instructions to the dead in *The Tibetan Book of the Dead*, it is even pushed to the point of explaining the favourable as well as the unfavourable gods as illusions still to be overcome. It is certainly not within the competence of the psychologist to establish the metaphysical truth or untruth of this idea; he must be content to determine so far as possible its psychic effect. He need not bother himself whether the shape in question is a transcendental illusion or not, since faith, not science, has to decide this point. In any case we are moving on ground that for a long time has seemed to be outside the domain of science and was looked upon as wholly illusory. But there is no scientific justification for such an assumption; the substantiality of these things is not a scientific problem since it lies beyond the range of human perception and judgment and thus beyond any possibility of proof. The psychologist is concerned not with the substantiality of these complexes but with psychic

experience. Without a doubt they are psychic contents that can be experienced, and their autonomy is equally indubitable. They are fragmentary psychic systems that either appear spontaneously in ecstatic states and evoke powerful impressions and effects, or else, in mental disturbances, become fixed in the form of delusions and hallucinations and consequently destroy the unity of the personality.



Stage 1: Gathering the light

Pages 30–33:

Four stages of meditation, with inspirational texts, from the *Hui Ming Ching*

嬰兒現形圖

此時丹熟更須慈母惜嬰兒

氣穴法名無蓋藏
 歲包於寂寂包空
 我阿空中誰氏子
 龜云是你主人翁

衍江坐卧
 抱璞守雌
 轉轉若存
 念氣在茲

夫媾媾之真
 孕媾媾之子
 傳其精交其
 神以其氣何
 其神隨如大
 小無行其真

滯龍今已化飛龍
 變現神通不可窮
 一朝跳出珠光外
 一身直到紫微宮

神水沆液
 脫離根株
 內外無塵
 長養聖胎



他日雲飛方見真人朝上帝

Stage 2: Origin of a new being in the place of power

圖 心 真 拱 端



Stage 3: Separation of the spirit-body for independent existence



Stage 4: The centre in the midst of conditions

[48] Psychiatrists are always ready to believe in toxins and the like, and even to explain schizophrenia in these terms, putting next to no emphasis on the psychic contents as such. On the other hand, in psychogenic disturbances (hysteria, obsessional neurosis, etc.), where toxic effects and cell degeneration are out of the question, split-off complexes are to be found similar to those occurring in somnambulistic states. Freud would like to explain these spontaneous split-offs as due to unconscious repression of sexuality, but this explanation is by no means valid in all cases, because contents that the conscious mind cannot assimilate can emerge just as spontaneously out of the unconscious, and in these cases the repression theory is inadequate. Moreover, their autonomy can be observed in daily life, in affects that obstinately obtrude themselves against our will and, in spite of the most strenuous efforts to repress them, overwhelm the ego and force it under their control. No wonder the primitive sees in these moods a state of possession or sets them down to a loss of soul. Our colloquial speech reflects the same thing when we say: "I don't know what has got into him today," "he is possessed of the devil," "he is beside himself," etc. Even legal practice recognizes a degree of diminished responsibility in a state of affect. Autonomous psychic contents are thus quite common experiences for us. Such contents have a disintegrating effect upon consciousness.

[49] But besides the ordinary, familiar affects there are subtler, more complex emotional states that can no longer be described as affects pure and simple but are fragmentary psychic systems. The more complicated they are, the more they have the character of personalities. As constituents of the psychic personality, they necessarily have the character of “persons.” Such fragmentary systems are to be found especially in mental diseases, in cases of psychogenic splitting of the personality (double personality), and of course in mediumistic phenomena. They are also encountered in the phenomenology of religion. Many of the earlier gods developed from “persons” into personified ideas, and finally into abstract ideas. Activated unconscious contents always appear at first as projections upon the outside world, but in the course of mental development they are gradually assimilated by consciousness and reshaped into conscious ideas that then forfeit their originally autonomous and personal character. As we know, some of the old gods have become, via astrology, nothing more than descriptive attributes (martial, jovial, saturnine, erotic, logical, lunatic, and so on).

[50] The instructions of *The Tibetan Book of the Dead* in particular help us to see how great is the danger that consciousness will be disintegrated by these figures. Again and again the dead are instructed not to take these shapes for truth, not to confuse their murky appearance with the pure white light of *Dharmakaya* (the divine body of truth). That is to say, they are not to project the *one* light of highest consciousness into concretized figures and dissolve it into a plurality of autonomous fragmentary systems. If there were no danger of this, and if these systems did not represent menacingly autonomous and disintegrative tendencies, such urgent instructions would not be necessary. Allowing for the simpler, polytheistic attitude of the Eastern mind, these instructions would be almost the equivalent of warning a Christian not to let himself be blinded by the illusion of a personal God, let alone by the Trinity and the host of angels and saints.

[51] If tendencies towards dissociation were not inherent in the human psyche, fragmentary psychic systems would never have been split off; in other words, neither spirits nor gods would ever have come into existence. That is also the reason why our time has become so utterly godless and profane: we lack all knowledge of the unconscious psyche and pursue the cult of consciousness to the exclusion of all else. Our true religion is a monotheism of consciousness, a possession by it, coupled with a fanatical denial of the existence of fragmentary autonomous systems. But we differ from the Buddhist yoga doctrines in that we even deny that these systems are experienceable. This entails a great psychic danger, because the autonomous systems then behave like any other repressed contents: they necessarily induce wrong attitudes since the repressed material reappears in consciousness in a spurious form. This is strikingly evident in every case of neurosis and also holds true for the

collective psychic phenomena. Our time has committed a fatal error; we believe we can criticize the facts of religion intellectually. Like Laplace, we think God is a hypothesis that can be subjected to intellectual treatment, to be affirmed or denied. We completely forget that the reason mankind believes in the “daemon” has nothing whatever to do with external factors, but is simply due to a naïve awareness of the tremendous inner effect of autonomous fragmentary systems. This effect is not abolished by criticizing it—or rather, the name we have given it—or by describing the name as false. The effect is collectively present all the time; the autonomous systems are always at work, for the fundamental structure of the unconscious is not affected by the deviations of our ephemeral consciousness.

[52] If we deny the existence of the autonomous systems, imagining that we have got rid of them by a mere critique of the name, then the effect which they still continue to exert can no longer be understood, nor can they be assimilated to consciousness. They become an inexplicable source of disturbance which we finally assume must exist somewhere outside ourselves. The resultant projection creates a dangerous situation in that the disturbing effects are now attributed to a wicked will outside ourselves, which is naturally not to be found anywhere but with our neighbour *de l'autre côté de la rivière*. This leads to collective delusions, “incidents,” revolutions, war—in a word, to destructive mass psychoses.

[53] Insanity is possession by an unconscious content that, as such, is not assimilated to consciousness, nor can it be assimilated since the very existence of such contents is denied. This attitude is equivalent to saying: “We no longer have any fear of God and believe that everything is to be judged by human standards.” This hybris or narrowness of consciousness is always the shortest way to the insane asylum. I recommend the excellent account of this problem in H. G. Wells’s novel *Christina Alberta’s Father*, and Schreber’s *Memoirs of My Nervous Illness*.

[54] It must stir a sympathetic chord in the enlightened European when it is said in the *Hui Ming Ching* that the “shapes formed by the spirit-fire are only empty colours and forms.” That sounds thoroughly European and seems to suit our reason to a T. We think we can congratulate ourselves on having already reached such a pinnacle of clarity, imagining that we have left all these phantasmal gods far behind. But what we have left behind are only verbal spectres, not the psychic facts that were responsible for the birth of the gods. We are still as much possessed by autonomous psychic contents as if they were Olympians. Today they are called phobias, obsessions, and so forth; in a word, neurotic symptoms. The gods have become diseases; Zeus no longer rules Olympus but rather the solar plexus, and produces curious specimens for the doctor’s consulting room, or disorders the brains of politicians and journalists who unwittingly let loose psychic epidemics on the world.

[55] So it is better for Western man if he does not know too much about the secret insights of the Oriental sages to begin with, for, as I have said, it would be a case of the “right means in the hands of the wrong man.” Instead of allowing himself to be convinced once more that the daemon is an illusion, he ought to experience once more the reality of this illusion. He should learn to acknowledge these psychic forces anew, and not wait until his moods, nervous states, and delusions make it clear in the most painful way that he is not the only master in his house. His dissociative tendencies are actual psychic personalities possessing a differential reality. They are “real” when they are not recognized as real and consequently projected; they are relatively real when they are brought into relationship with consciousness (in religious terms, when a cult exists); but they are unreal to the extent that consciousness detaches itself from its contents. This last stage, however, is reached only when life has been lived so exhaustively and with such devotion that no obligations remain unfulfilled, when no desires that cannot safely be sacrificed stand in the way of inner detachment from the world. It is futile to lie to ourselves about this. Wherever we are still attached, we are still possessed; and when we are possessed, there is one stronger than us who possesses us. (“Verily I say unto thee, thou shalt by no means come out thence, until thou hast paid the uttermost farthing.”) It is not a matter of indifference whether one calls something a “mania” or a “god.” To serve a mania is detestable and undignified, but to serve a god is full of meaning and promise because it is an act of submission to a higher, invisible, and spiritual being. The personification enables us to see the relative reality of the autonomous system, and not only makes its assimilation possible but also depotentiates the daemonic forces of life. When the god is not acknowledged, egomania develops, and out of this mania comes sickness.

[56] Yoga takes acknowledgment of the gods as something self-evident. Its secret instruction is intended only for those whose consciousness is struggling to disentangle itself from the daemonic forces of life in order to enter into the ultimate undivided unity, the “centre of emptiness,” where “dwells the god of utmost emptiness and life,” as our text says.³ “To hear such a teaching is difficult to attain in thousands of aeons.” Evidently the veil of Maya cannot be lifted by a merely rational resolve; it requires a most thorough going and persevering preparation consisting in the full payment of all debts to life. For as long as unconditional attachment through *cupiditas* exists, the veil is not lifted and the heights of a consciousness free of contents and free of illusion are not attained; nor can any trick nor any deceit bring this about. It is an ideal that can ultimately be realized only in death. Until then there are the real and relatively real figures of the unconscious.

B. ANIMUS AND ANIMA

[57] According to our text, among the figures of the unconscious there are not only the gods but also the animus and anima. The word *hun* is translated by Wilhelm as animus. And indeed, the term “animus” seems appropriate for *hun*, the character for which is made up of the sign for “clouds” and that for “demon.” Thus *hun* means “cloud-demon,” a higher breath-soul belonging to the *yang* principle and therefore masculine. After death, *hun* rises upward and becomes *shen*, the “expanding and self-revealing” spirit or god. “Anima,” called *p’o*, and written with the characters for “white” and “demon,” that is, “white ghost,” belongs to the lower, earthbound, bodily soul, the *yin* principle, and is therefore feminine. After death, it sinks downward and becomes *kuei* (demon), often explained as “the one who returns” (i.e., to earth), a revenant, a ghost. The fact that the animus and anima part after death and go their ways independently shows that, for the Chinese consciousness, they are distinguishable psychic factors; originally they were united in “the one effective, true human nature,” but in the “house of the Creative” they are two. “The animus is in the heavenly heart.” “By day it lives in the eyes [i.e., in consciousness]; at night it houses in the liver.” It is “that which we have received from the great emptiness, that which is identical in form with the primal beginning.” The anima, on the other hand, is the “energy of the heavy and the turbid”; it clings to the bodily, fleshly heart. Its effects are “sensuous desires and impulses to anger.” “Whoever is sombre and moody on waking . . . is fettered to the anima.”⁴

[58] Many years ago, before Wilhelm acquainted me with this text, I used the term “anima”⁵ in a way quite analogous to the Chinese definition of *p’o*, and of course entirely apart from any metaphysical premise. To the psychologist, the anima is not a transcendental being but something quite within the range of experience, as the Chinese definition makes clear: affective states are immediate experiences. Why, then, speak of the anima and not simply of moods? The reason is that affects have an autonomous character, and therefore most people are under their power. But affects are delimitable contents of consciousness, parts of the personality. As such, they partake of its character and can easily be personified—a process that still continues today, as I have shown. The personification is not an idle invention, since a person roused by affect does not show a neutral character but a quite distinct one, entirely different from his ordinary character. Careful investigation has shown that the affective character of a man has feminine traits. From this psychological fact derives the Chinese doctrine of the *p’o* soul as well as my own concept of the anima. Deeper introspection or ecstatic experience reveals the existence of a feminine figure in the unconscious, hence the feminine name: anima, psyche, *Seele*. The anima can be defined as the image or archetype or deposit of all the experiences of man with woman. As we know, the poets have often sung the anima’s praises.⁶ The connection

of anima with ghost in the Chinese concept is of interest to parapsychologists inasmuch as mediumistic “controls” are very often of the opposite sex.

[59] Although Wilhelm’s translation of *hun* as “animus” seems justified to me, nonetheless I had important reasons for choosing the term “Logos” for a man’s “spirit,” for his clarity of consciousness and his rationality, rather than the otherwise appropriate expression “animus.” Chinese philosophers are spared certain difficulties that aggravate the task of the Western psychologist. Like all mental and spiritual activity in ancient times, Chinese philosophy was exclusively a component of the masculine world. Its concepts were never understood psychologically, and therefore were never examined as to how far they also apply to the feminine psyche. But the psychologist cannot possibly ignore the existence of woman and her special psychology. For these reasons I would prefer to translate *hun* as it appears in man by “Logos.” Wilhelm in his translation uses Logos for *hsing*, which can also be translated as “essence of human nature” or “creative consciousness.” After death, *hun* becomes *shen*, “spirit,” which is very close, in the philosophical sense, to *hsing*. Since the Chinese concepts are not logical in our sense of the word, but are intuitive ideas, their meanings can only be elicited from the ways in which they are used and from the constitution of the written characters, or from such relationships as obtain between *hun* and *shen*. *Hun*, then, would be the light of consciousness and reason in man, originally coming from the *logos spermatikos* of *hsing*, and returning after death through *shen* to the Tao. Used in this sense the expression “Logos” would be especially appropriate, since it includes the idea of a universal being, and thus covers the fact that man’s clarity of consciousness and rationality are something universal rather than individually unique. The Logos principle is nothing personal, but is in the deepest sense impersonal, and thus in sharp contrast to the anima, which is a personal demon expressing itself in thoroughly personal moods (“animosity”!).

[60] In view of these psychological facts, I have reserved the term “animus” strictly for women, because, to answer a famous question, *mulier non habet animam, sed animum*. Feminine psychology exhibits an element that is the counterpart of a man’s anima. Primarily, it is not of an affective nature but is a quasi-intellectual factor best described by the word “prejudice.” The conscious side of woman corresponds to the emotional side of man, not to his “mind.” Mind makes up the “soul,” or better, the “animus” of woman, and just as the anima of a man consists of inferior relatedness, full of affect, so the animus of woman consists of inferior judgments, or better, opinions. As it is made up of a plurality of preconceived opinions, the animus is far less susceptible of personification by a single figure, but appears more often as a group or crowd. (A good example of this from parapsychology is the “Imperator” group in the case of Mrs. Piper.⁷) On a low level the animus is an inferior Logos, a caricature of the differentiated masculine mind, just as on a low level the anima is a

caricature of the feminine Eros. To pursue the parallel further, we could say that just as *hun* corresponds to *hsing*, translated by Wilhelm as Logos, so the Eros of woman corresponds to *ming*, “fate” or “destiny,” interpreted by Wilhelm as Eros. Eros is an interweaving; Logos is differentiating knowledge, clarifying light. Eros is relatedness, Logos is discrimination and detachment. Hence the inferior Logos of woman’s animus appears as something quite unrelated, as an inaccessible prejudice, or as an opinion which, irritatingly enough, has nothing to do with the essential nature of the object.

[61] I have often been accused of personifying the anima and animus as mythology does, but this accusation would be justified only if it could be proved that I concretize these concepts in a mythological manner for psychological use. I must declare once and for all that the personification is not an invention of mine, but is inherent in the nature of the phenomena. It would be unscientific to overlook the fact that the anima is a psychic, and therefore a personal, autonomous system. None of the people who make the charge against me would hesitate for a second to say, “I dreamed of Mr. X,” whereas, strictly speaking, he dreamed only of a representation of Mr. X. The anima is nothing but a representation of the personal nature of the autonomous system in question. What the nature of this system is in a transcendental sense, that is, beyond the bounds of experience, we cannot know.

[62] I have defined the anima as a personification of the unconscious in general, and have taken it as a bridge to the unconscious, in other words, as a function of relationship to the unconscious. There is an interesting point in our text in this connection. The text says that consciousness (that is, the personal consciousness) comes from the anima. Since the Western mind is based wholly on the standpoint of consciousness, it must define the anima in the way I have done. But the East, based as it is on the standpoint of the unconscious, sees consciousness as an effect of the anima. And there can be no doubt that consciousness does originate in the unconscious. This is something we are apt to forget, and therefore we are always attempting to identify the psyche with consciousness, or at least to represent the unconscious as a derivative or an effect of consciousness (as in the Freudian repression theory). But, for the reasons given above, it is essential that we do not detract from the reality of the unconscious, and that the figures of the unconscious be understood as real and effective factors. The person who has understood what is meant by psychic reality need have no fear that he has fallen back into primitive demonology. If the unconscious figures are not acknowledged as spontaneous agents, we become victims of a one-sided belief in the power of consciousness, leading finally to acute tension. A catastrophe is then bound to happen because, for all our consciousness, the dark powers of the psyche have been overlooked. It is not we who personify them; they have a personal nature from the very beginning. Only when this

is thoroughly recognized can we think of depersonalizing them, of “subjugating the anima,” as our text expresses it.

[63] Here again we find an enormous difference between Buddhism and the Western attitude of mind, and again there is a dangerous semblance of agreement. Yoga teaching rejects all fantasy products and we do the same, but the East does so for entirely different reasons. In the East there is an abundance of conceptions and teachings that give full expression to the creative fantasy; in fact, protection is needed against an excess of it. We, on the other hand, regard fantasy as worthless subjective day-dreaming. Naturally the figures of the unconscious do not appear in the form of abstractions stripped of all imaginative trappings; on the contrary, they are embedded in a web of fantasies of extraordinary variety and bewildering profusion. The East can reject these fantasies because it has long since extracted their essence and condensed it in profound teachings. But we have never even experienced these fantasies, much less extracted their quintessence. We still have a large stretch of experience to catch up with, and only when we have found the sense in apparent nonsense can we separate the valuable from the worthless. We can be sure that the essence we extract from our experience will be quite different from what the East offers us today. The East came to its knowledge of inner things in childlike ignorance of the external world. We, on the other hand, shall explore the psyche and its depths supported by an immense knowledge of history and science. At present our knowledge of the external world is the greatest obstacle to introspection, but the psychological need will overcome all obstructions. We are already building up a psychology, a science that gives us the key to the very things that the East discovered—and discovered only through abnormal psychic states.

5. THE DETACHMENT OF CONSCIOUSNESS FROM THE OBJECT

[64] By understanding the unconscious we free ourselves from its domination. That is really also the purpose of the instructions in our text. The pupil is taught to concentrate on the light of the innermost region and, at the same time, to free himself from all outer and inner entanglements. His vital impulses are guided towards a consciousness void of content, which nevertheless permits all contents to exist. The *Hui Ming Ching*¹ says of this detachment:

A halo of light surrounds the world of the law.

We forget one another, quiet and pure, all-powerful and empty.

The emptiness is irradiated by the light of the heart of heaven.

The water of the sea is smooth and mirrors the moon in its surface.

The clouds disappear in blue space; the mountains shine clear.

Consciousness reverts to contemplation; the moon-disk rests alone.

[65] This description of fulfilment depicts a psychic state that can best be characterized as a detachment of consciousness from the world and a withdrawal to a point outside it, so to speak. Thus consciousness is at the same time empty and not empty. It is no longer preoccupied with the images of things but merely contains them. The fullness of the world which hitherto pressed upon it has lost none of its richness and beauty, but it no longer dominates. The magical claim of things has ceased because the interweaving of consciousness with world has come to an end. The unconscious is not projected any more, and so the primordial *participation mystique* with things is abolished. Consciousness is no longer preoccupied with compulsive plans but dissolves in contemplative vision.

[66] How did this effect come about? (We assume, of course, that the Chinese author was first of all not a liar; secondly, that he was of sound mind; and thirdly, that he was an unusually intelligent man.) To understand and explain this detachment, we must proceed by a roundabout way. It is an effect that cannot be simulated; nothing would be more childish than to make such a psychic state an object of aesthetic experiment. I know this effect very well from my practice; it is the therapeutic effect *par excellence*, for which I labour with my students and patients, and it consists in the dissolution of *participation mystique*. By a stroke of genius, Lévy-Bruhl singled out what he called *participation mystique* as being the hallmark of the primitive

mentality.² What he meant by it is simply the indefinitely large remnant of non-differentiation between subject and object, which is still so great among primitives that it cannot fail to strike our European consciousness very forcibly. When there is no consciousness of the difference between subject and object, an unconscious identity prevails. The unconscious is then projected into the object, and the object is introjected into the subject, becoming part of his psychology. Then plants and animals behave like human beings, human beings are at the same time animals, and everything is alive with ghosts and gods. Civilized man naturally thinks he is miles above these things. Instead of that, he is often identified with his parents throughout his life, or with his affects and prejudices, and shamelessly accuses others of the things he will not see in himself. He too has a remnant of primitive unconsciousness, of non-differentiation between subject and object. Because of this, he is magically affected by all manner of people, things, and circumstances, he is beset by disturbing influences nearly as much as the primitive and therefore needs just as many apotropaic charms. He no longer works magic with medicine bags, amulets, and animal sacrifices, but with tranquillizers, neuroses, rationalism, cult of the will, etc.

[67] But if the unconscious can be recognized as a co-determining factor along with consciousness, and if we can live in such a way that conscious and unconscious demands are taken into account as far as possible, then the centre of gravity of the total personality shifts its position. It is then no longer in the ego, which is merely the centre of consciousness, but in the hypothetical point between conscious and unconscious. This new centre might be called the self. If the transposition is successful, it does away with the *participation mystique* and results in a personality that suffers only in the lower storeys, as it were, but in its upper storeys is singularly detached from painful as well as from joyful happenings.

[68] The production and birth of this superior personality is what is meant when our text speaks of the “holy fruit,” the “diamond body,” or any other kind of incorruptible body. Psychologically, these expressions symbolize an attitude that is beyond the reach of emotional entanglements and violent shocks—a consciousness detached from the world. I have reasons for believing that this attitude sets in after middle life and is a natural preparation for death. Death is psychologically as important as birth and, like it, is an integral part of life. What happens to the detached consciousness in the end is a question the psychologist cannot be expected to answer. Whatever his theoretical position he would hopelessly overstep the bounds of his scientific competence. He can only point out that the views of our text in regard to the timelessness of the detached consciousness are in harmony with the religious thought of all ages and with that of the overwhelming majority of mankind. Anyone who thought differently would be standing outside the human order and would, therefore, be suffering from a disturbed psychic equilibrium. As a doctor, I make every effort to

strengthen the belief in immortality, especially with older patients when such questions come threateningly close. For, seen in correct psychological perspective, death is not an end but a goal, and life's inclination towards death begins as soon as the meridian is passed.

[69] Chinese yoga philosophy is based upon this instinctive preparation for death as a goal. In analogy with the goal of the first half of life—procreation and reproduction, the means of perpetuating one's physical existence—it takes as the goal of spiritual existence the symbolic begetting and birth of a "spirit-body," or "breath-body," which ensures the continuity of detached consciousness. It is the birth of the pneumatic man, known to the European from antiquity, but which he seeks to produce by quite other symbols and magical practices, by faith and a Christian way of life. Here again we stand on a foundation quite different from that of the East. Again the text sounds as though it were not so very far from Christian ascetic morality, but nothing could be more mistaken than to assume that it actually means the same thing. Behind our text is a civilization thousands of years old, one which is built up organically on primitive instincts and knows nothing of that brutal morality so suited to us as recently civilized Teutonic barbarians. For this reason the Chinese are without the impulse towards violent repression of the instincts that poisons our spirituality and makes it hysterically exaggerated. The man who lives with his instincts can also detach from them, and in just as natural a way as he lived with them. Any idea of heroic self-conquest would be entirely foreign to the spirit of our text, but that is what it would infallibly amount to if we followed the instructions literally.

[70] We must never forget our historical antecedents. Only a little more than a thousand years ago we stumbled out of the crudest beginnings of polytheism into a highly developed Oriental religion which lifted the imaginative minds of half-savages to a height that in no way corresponded to their spiritual development. In order to keep to this height in some fashion or other, it was inevitable that the instinctual sphere should be largely repressed. Thus religious practice and morality took on a decidedly brutal, almost malignant, character. The repressed elements naturally did not develop, but went on vegetating in the unconscious, in their original barbarism. We would like to scale the heights of a philosophical religion, but in fact are incapable of it. To grow up to it is the most we can hope for. The Amfortas wound and the Faustian split in the Germanic man are still not healed; his unconscious is still loaded with contents that must first be made conscious before he can be free of them. Recently I received a letter from a former patient which describes the necessary transformation in simple but trenchant words. She writes:

Out of evil, much good has come to me. By keeping quiet, repressing nothing, remaining attentive, and by accepting reality—taking things as they are, and not as I

wanted them to be—by doing all this, unusual knowledge has come to me, and unusual powers as well, such as I could never have imagined before. I always thought that when we accepted things they overpowered us in some way or other. This turns out not to be true at all, and it is only by accepting them that one can assume an attitude towards them.³ So now I intend to play the game of life, being receptive to whatever comes to me, good and bad, sun and shadow forever alternating, and, in this way, also accepting my own nature with its positive and negative sides. Thus everything becomes more alive to me. What a fool I was! How I tried to force everything to go according to the way I thought it ought to!

[71] Only on the basis of such an attitude, which renounces none of the Christian values won in the course of Christian development, but which, on the contrary, tries with Christian charity and forbearance to accept even the humblest things in one's own nature, will a higher level of consciousness and culture become possible. This attitude is religious in the truest sense, and therefore therapeutic, for all religions are therapies for the sorrows and disorders of the soul. The development of the Western intellect and will has given us an almost fiendish capacity for aping such an attitude, with apparent success, despite the protests of the unconscious. But it is only a matter of time before the counterposition asserts itself all the more harshly. Aping an attitude always produces an unstable situation that can be overthrown by the unconscious at any time. A safe foundation is found only when the instinctive premises of the unconscious win the same respect as the views of the conscious mind. No one should blind himself to the fact that this necessity of giving due consideration to the unconscious runs violently counter to our Western, and in particular the Protestant, cult of consciousness. Yet, though the new always seems to be the enemy of the old, anyone with a more than superficial desire to understand cannot fail to discover that without the most serious application of the Christian values we have acquired, the new integration can never take place.

6. THE FULFILMENT

[72] A growing familiarity with the spirit of the East should be taken merely as a sign that we are beginning to relate to the alien elements within ourselves. Denial of our historical foundations would be sheer folly and would be the best way to bring about another uprooting of consciousness. Only by standing firmly on our own soil can we assimilate the spirit of the East.

[73] Speaking of those who do not know where the true springs of secret power lie, an ancient adept says, "Worldly people lose their roots and cling to the treetops." The spirit of the East has grown out of the yellow earth, and our spirit can, and should, grow only out of our own earth. That is why I approach these problems in a way that has often been charged with "psychologism." If "psychology" were meant, I should indeed be flattered, for my aim as a psychologist is to dismiss without mercy the metaphysical claims of all esoteric teachings. The unavowed purpose of gaining power through words, inherent in all secret doctrines, ill accords with our profound ignorance, which we should have the modesty to admit. I quite deliberately bring everything that purports to be metaphysical into the daylight of psychological understanding, and do my best to prevent people from believing in nebulous power-words. Let the convinced Christian believe, by all means, for that is the duty he has taken upon himself; but whoever is not a Christian has forfeited the charisma of faith. (Perhaps he was cursed from birth with not being able to believe, but merely to know.) Therefore, he has no right to put his faith elsewhere. One cannot grasp anything metaphysically, one only can do so psychologically. Therefore I strip things of their metaphysical wrappings in order to make them objects of psychology. In that way I can at least extract something understandable from them and avail myself of it, and I also discover psychological facts and processes that before were veiled in symbols and beyond my comprehension. In doing so I may perhaps be following in the footsteps of the faithful, and may possibly have similar experiences; and if in the end there should be something ineffably metaphysical behind it all, it would then have the best opportunity of showing itself.

[74] My admiration for the great philosophers of the East is as genuine as my attitude towards their metaphysics is irreverent.¹ I suspect them of being symbolical psychologists, to whom no greater wrong could be done than to take them literally. If it were really metaphysics that they mean, it would be useless to try to understand

them. But if it is psychology, we can not only understand them but can profit greatly by them, for then the so-called “metaphysical” comes within the range of experience. If I assume that God is absolute and beyond all human experience, he leaves me cold. I do not affect him, nor does he affect me. But if I know that he is a powerful impulse of my soul, at once I must concern myself with him, for then he can become important, even unpleasantly so, and can affect me in practical ways—which sounds horribly banal, like everything else that is real.

[75] The epithet “psychologism” applies only to a fool who thinks he has his soul in his pocket. There are certainly more than enough such fools, for although we know how to talk big about the “soul,” the depreciation of everything psychic is a typically Western prejudice. If I make use of the concept “autonomous psychic complex,” my reader immediately comes up with the ready-made prejudice that it is “nothing but a psychic complex.” How can we be so sure that the soul is “nothing but”? It is as if we did not know, or else continually forgot, that everything of which we are conscious is an image, and that image *is* psyche. The same people who think that God is depreciated if he is understood as something moved in the psyche, as well as the moving force of the psyche—i.e., as an autonomous complex—can be so plagued by uncontrollable affects and neurotic states that their wills and their whole philosophy of life fail them miserably. Is that a proof of the impotence of the psyche? Should Meister Eckhart be accused of “psychologism” when he says, “God must be born in the soul again and again”? I think the accusation of “psychologism” can be levelled only at an intellect that denies the genuine nature of the autonomous complex and seeks to explain it rationalistically as the consequence of known causes, i.e., as something secondary and unreal. This is just as arrogant as the metaphysical assertion that seeks to make a God outside the range of our experience responsible for our psychic states. Psychologism is simply the counterpart of this metaphysical presumption, and is just as childish. Therefore it seems to me far more reasonable to accord the psyche the same validity as the empirical world, and to admit that the former has just as much “reality” as the latter. As I see it, the psyche is a world in which the ego is contained. Maybe there are fishes who believe that they contain the sea. We must rid ourselves of this habitual illusion of ours if we wish to consider metaphysical assertions from the standpoint of psychology.

[76] A metaphysical assertion of this kind is the idea of the “diamond body,” the incorruptible breath-body which grows in the golden flower or in the “field of the square inch.”² This body is a symbol for a remarkable psychological fact which, precisely because it is objective, first appears in forms dictated by the experience of biological life—that is, as fruit, embryo, child, living body, and so on. This fact could be best expressed by the words “It is not I who live, it lives me.” The illusion of the supremacy of consciousness makes us say, “I live.” Once this illusion is shattered by

a recognition of the unconscious, the unconscious will appear as something objective in which the ego is included. The attitude towards the unconscious is then analogous to the feeling of the primitive to whom the existence of a son guarantees continuation of life—a feeling that can assume grotesque forms, as when the old Negro, angered at his son's disobedience, cried out, "There he stands with my body, but does not even obey me!"

[77] It is, in fact, a change of feeling similar to that experienced by a father to whom a son has been born, a change known to us from the testimony of St. Paul: "Yet not I, but Christ liveth in me." The symbol "Christ" as "son of man" is an analogous psychic experience of a higher spiritual being who is invisibly born in the individual, a pneumatic body which is to serve us as a future dwelling, a body which, as Paul says, is put on like a garment ("For as many of you as have been baptized into Christ have put on Christ"). It is always a difficult thing to express, in intellectual terms, subtle feelings that are nevertheless infinitely important for the individual's life and well-being. It is, in a sense, the feeling that we have been "replaced." but without the connotation of having been "deposed." It is as if the guidance of life had passed over to an invisible centre. Nietzsche's metaphor, "in most loving bondage, free," would be appropriate here. Religious language is full of imagery depicting this feeling of free dependence, of calm acceptance.

[78] This remarkable experience seems to me a consequence of the detachment of consciousness, thanks to which the subjective "I live" becomes the objective "It lives me." This state is felt to be higher than the previous one; it is really like a sort of release from the compulsion and impossible responsibility that are the inevitable results of *participation mystique*. This feeling of liberation fills Paul completely; the consciousness of being a child of God delivers one from the bondage of the blood. It is also a feeling of reconciliation with all that happens, for which reason, according to the *Hui Ming Ching*, the gaze of one who has attained fulfilment turns back to the beauty of nature.

[79] In the Pauline Christ symbol the supreme religious experiences of West and East confront one another: Christ the sorrow-laden hero, and the Golden Flower that blooms in the purple hall of the city of jade. What a contrast, what an unfathomable difference, what an abyss of history! A problem fit for the crowning work of a future psychologist!

[80] Among the great religious problems of the present is one which has received scant attention, but which is in fact the main problem of our day: the evolution of the religious spirit. If we are to discuss it, we must emphasize the difference between East and West in their treatment of the "jewel," the central symbol. The West lays stress on the human incarnation, and even on the personality and historicity of Christ,

whereas the East says: “Without beginning, without end, without past, without future.”³ The Christian subordinates himself to the superior divine person in expectation of his grace; but the Oriental knows that redemption depends on the work he does on himself. The Tao grows out of the individual. The *imitatio Christi* has this disadvantage: in the long run we worship as a divine example a man who embodied the deepest meaning of life, and then, out of sheer imitation, we forget to make real our own deepest meaning—self-realization. As a matter of fact, it is not altogether inconvenient to renounce one’s own meaning. Had Jesus done so, he would probably have become a respectable carpenter and not a religious rebel to whom the same thing would naturally happen today as happened then.

[81] The imitation of Christ might well be understood in a deeper sense. It could be taken as the duty to realize one’s deepest conviction with the same courage and the same self-sacrifice shown by Jesus. Happily not everyone has the task of being a leader of humanity, or a great rebel; and so, after all, it might be possible for each to realize himself in his own way. This honesty might even become an ideal. Since great innovations always begin in the most unlikely places, the fact that people today are not nearly as ashamed of their nakedness as they used to be might be the beginning of a recognition of themselves as they really are. Hard upon this will follow an increasing recognition of many things that formerly were strictly taboo, for the reality of the earth will not forever remain veiled like the *virgines velandae* of Tertullian. Moral unmasking is but a step further in the same direction, and behold, there stands man as he is, and admits to himself that he is as he is. If he does this in a meaningless way he is just a muddled fool; but if he knows the significance of what he is doing he could belong to a higher order of man who makes real the Christ symbol, regardless of the suffering involved. It has often been observed that purely concrete taboos or magical rites in an early stage of a religion become in the next stage something psychic, or even purely spiritual symbols. An outward law becomes in the course of time an inward conviction. Thus it might easily happen to contemporary man, especially Protestants, that the person Jesus, now existing outside in the realm of history, might become the higher man within himself. Then we would have attained, in a European way, the psychological state corresponding to Eastern enlightenment.

[82] All this is a step in the evolution of a higher consciousness on its way to unknown goals, and is not metaphysics as ordinarily understood. To that extent it is only “psychology,” but to that extent, too, it is experienceable, understandable and—thank God—real, a reality we can do something with, a living reality full of possibilities. The fact that I am content with what can be experienced psychically, and reject the metaphysical, does not amount, as any intelligent person can see, to a gesture of scepticism or agnosticism aimed at faith and trust in higher powers, but means approximately the same as what Kant meant when he called the thing-in-itself a

“merely negative borderline concept.” Every statement about the transcendental is to be avoided because it is only a laughable presumption on the part of a human mind unconscious of its limitations. Therefore, when God or the Tao is named an impulse of the soul, or a psychic state, something has been said about the knowable only, but nothing about the unknowable, about which nothing can be determined.

7. CONCLUSION

[83] The purpose of my commentary is to attempt to build a bridge of psychological understanding between East and West. The basis of every real understanding is man, and therefore I had to speak of human beings. This must be my excuse for having dealt only with general aspects, and for not having entered into technical details. Technical directions are valuable for those who know, for example, what a camera is, or a combustion engine, but they are useless for anyone who has no idea of such apparatus. Western man for whom I write is in an analogous position. Therefore it seemed to me important above all to emphasize the agreement between the psychic states and symbolisms of East and West. These analogies open a way to the inner chambers of the Eastern mind, a way that does not require the sacrifice of our own nature and does not confront us with the threat of being torn from our roots. Nor is it an intellectual telescope or microscope offering a view of no fundamental concern to us because it does not touch us. It is the way of suffering, seeking, and striving common to all civilized peoples; it is the tremendous experiment of becoming conscious, which nature has laid upon mankind, and which unites the most diverse cultures in a common task.

[84] Western consciousness is by no means the only kind of consciousness there is; it is historically conditioned and geographically limited, and representative of only one part of mankind. The widening of our consciousness ought not to proceed at the expense of other kinds of consciousness; it should come about through the development of those elements of our psyche which are analogous to those of the alien psyche, just as the East cannot do without our technology, science, and industry. The European invasion of the East was an act of violence on a grand scale, and it has left us with the duty—*noblesse oblige*—of understanding the mind of the East. This is perhaps more necessary than we realize at present.

EXAMPLES OF EUROPEAN MANDALAS

The pictures that now follow were produced in the way described in the text, by patients during the course of treatment.¹ The earliest picture dates from 1916. All the pictures were done independently of any Eastern influence. The *I Ching* hexagrams in picture No. 4 come from Legge's translation in the Sacred Books of the East series, but they were put into the picture only because their content seemed, to the university-trained patient, especially meaningful for her life. No European mandalas known to me (I have a fairly large collection) achieve the conventionally and traditionally established harmony and perfection of the Eastern mandala. I have made a choice of ten pictures from among an infinite variety of European mandalas, and they ought, as a whole, to illustrate clearly the parallelism between Eastern philosophy and the unconscious mental processes in the West.

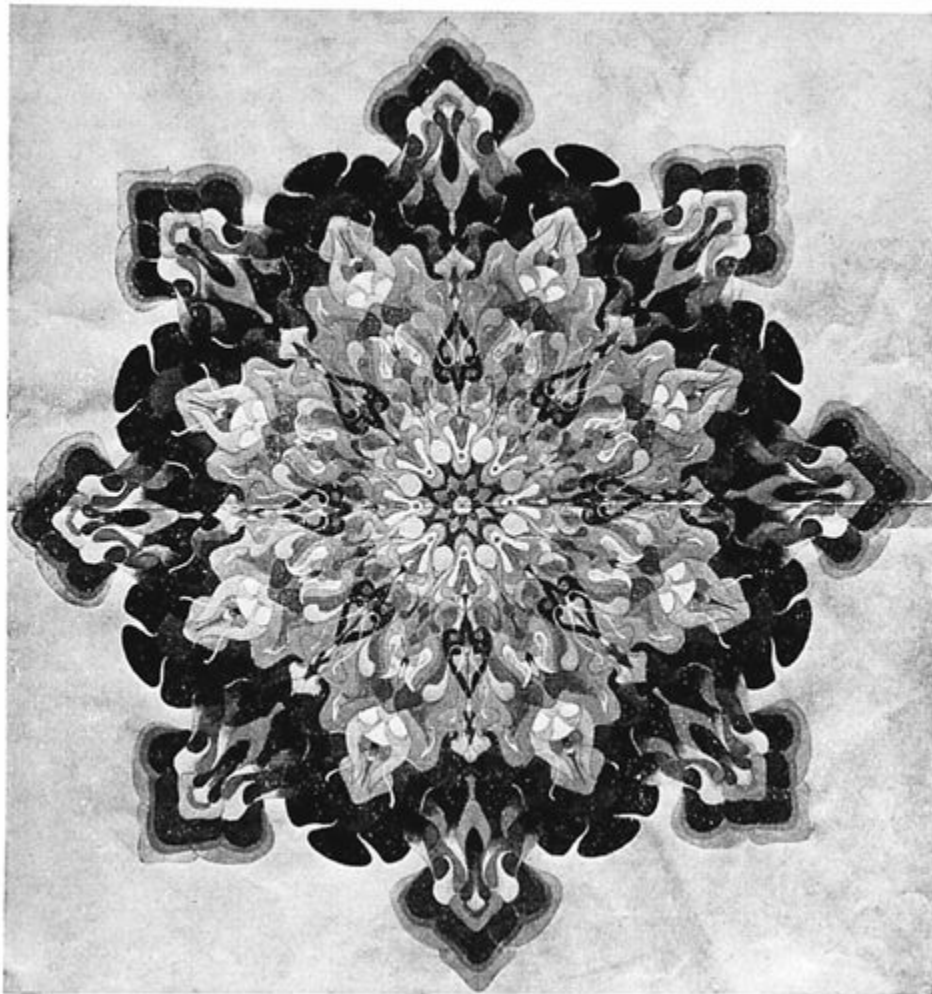

♀ The Golden Flower represented as the most splendid of all flowers

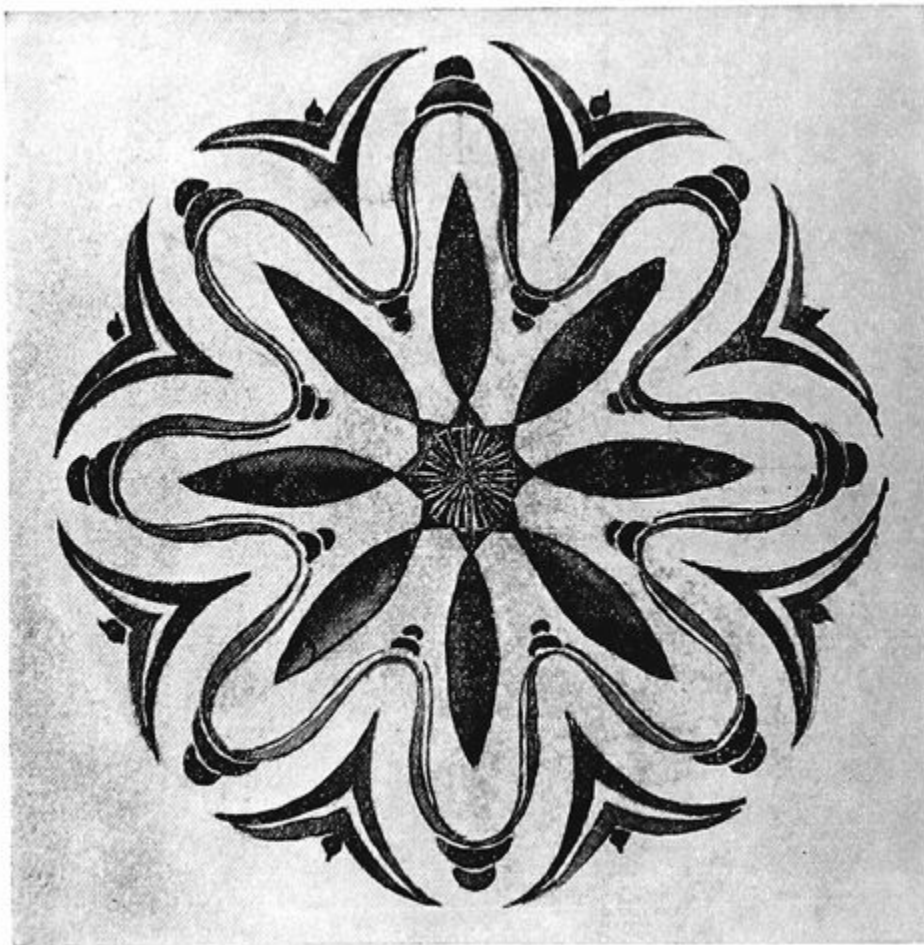

♀ In the centre, the Golden Flower; radiating out from it, fishes as fertility symbols (corresponding to the thunderbolts of Lamaic mandalas)

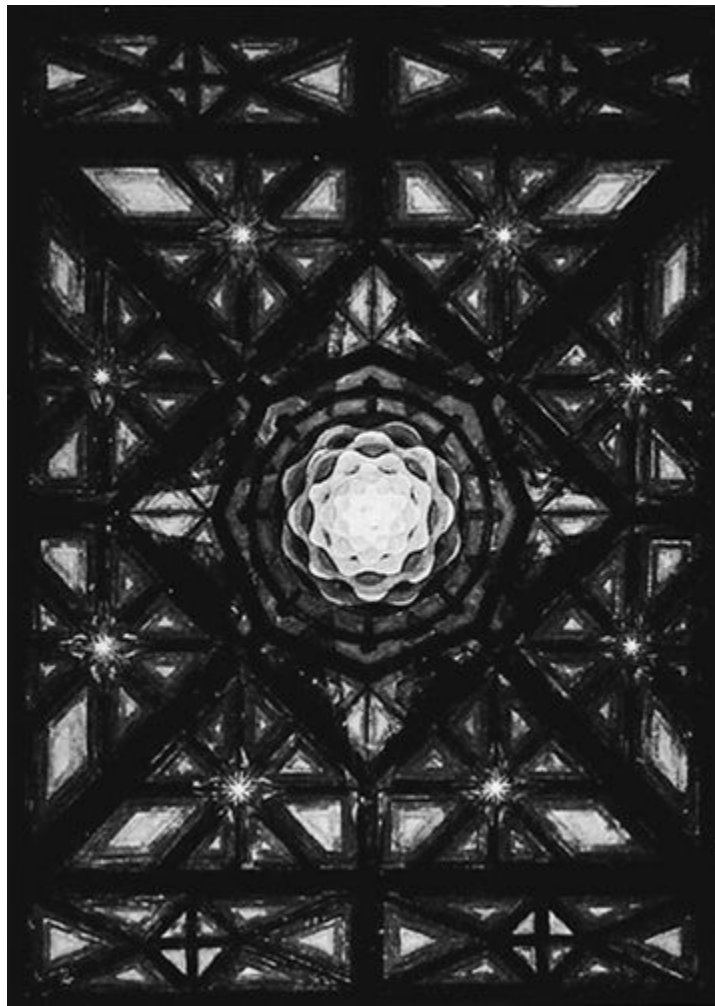

♂ A luminous flower in the centre, with stars rotating about it. Around the flower, walls with eight gates. The whole conceived as a transparent window

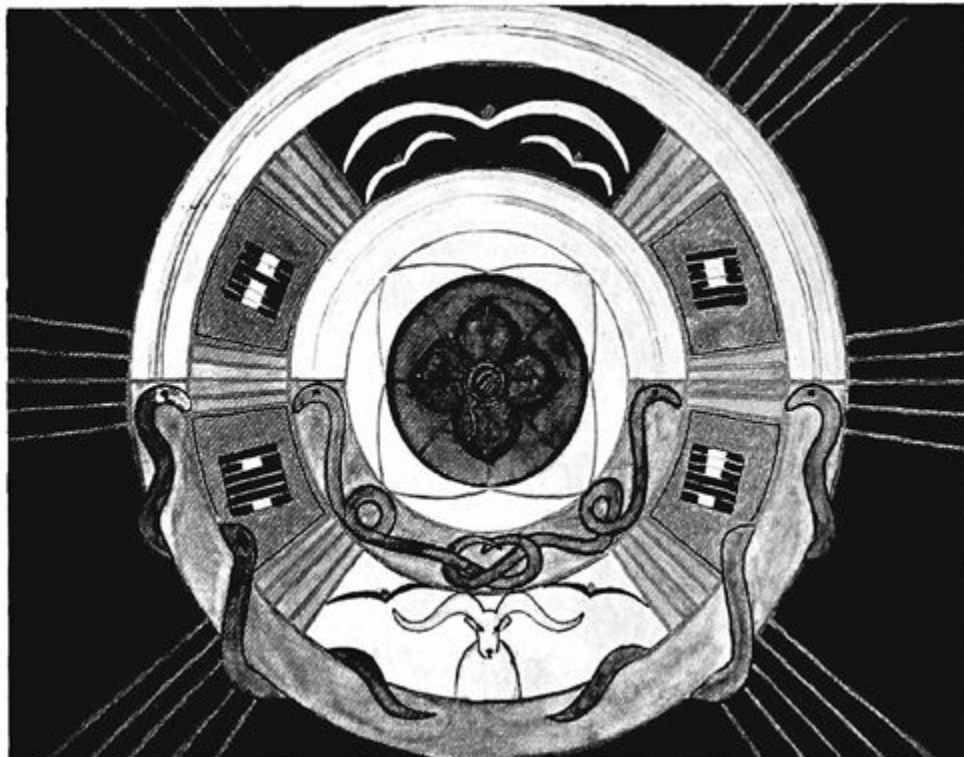

♀ Separation of the air-world and the earth-world. (Birds and serpents.) In the centre, a flower with a golden star



♀ Separation of the light from the dark world; the heavenly from the earthly soul. In the centre, a representation of contemplation

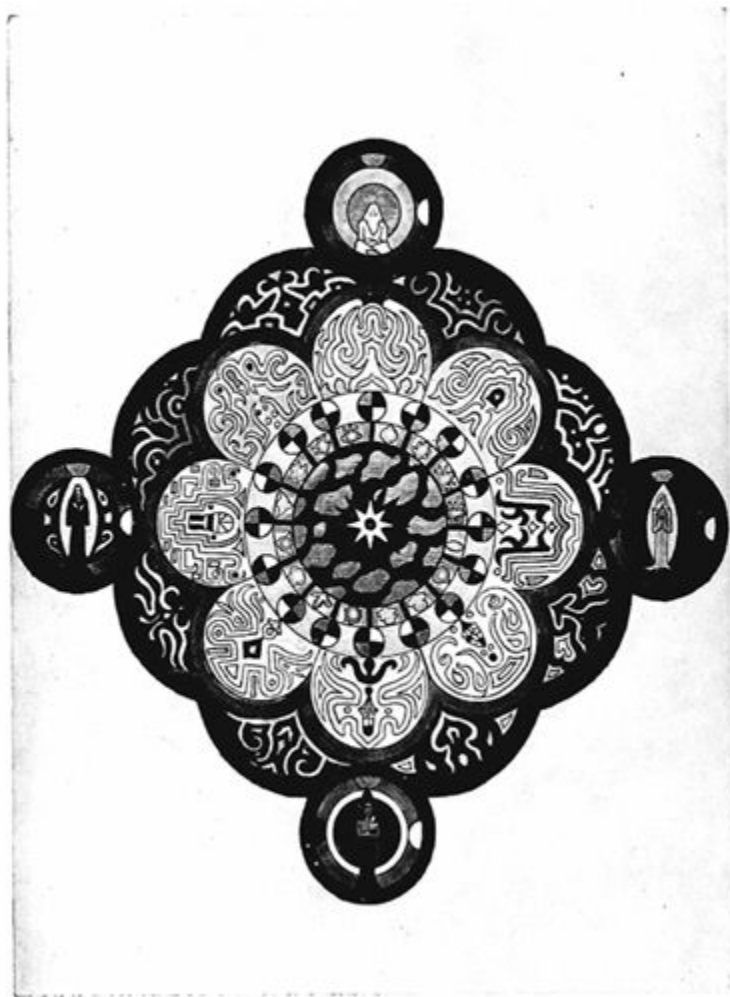

♂ In the centre, the white light, shining in the firmament; in the first circle, protoplasmic life-seeds; in the second, rotating cosmic principles which contain the four primary colours; in the third and fourth, creative forces working inward and outward. At the cardinal points, the masculine and feminine souls, both again divided into light and dark

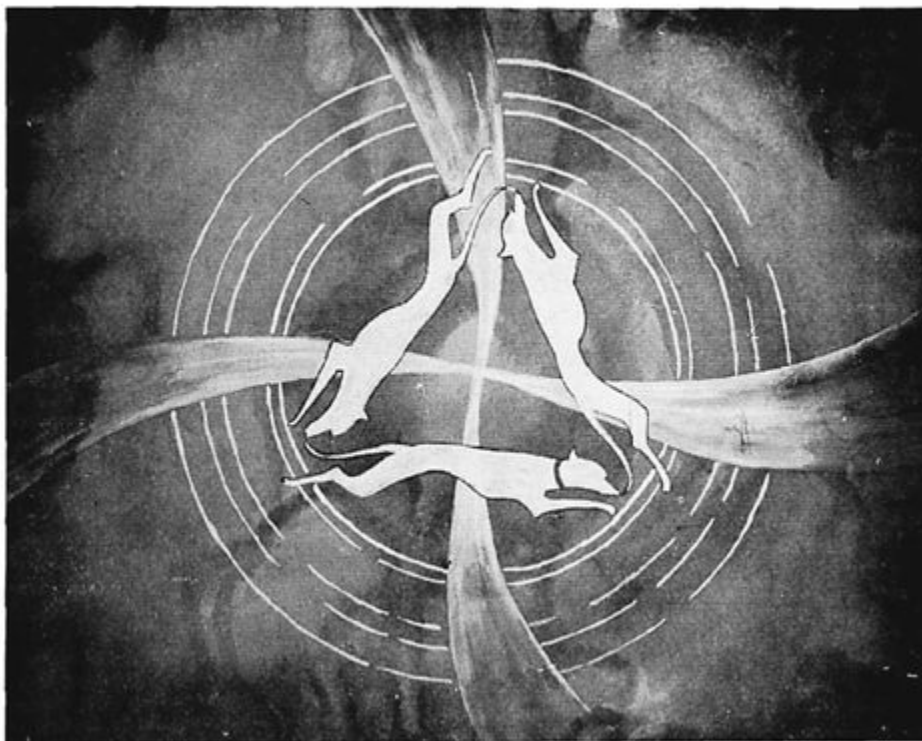

♀ Representation of the *tetraktys* in circular movement



♀ A child in the germinal vesicle with the form primary colours included in the circular movement

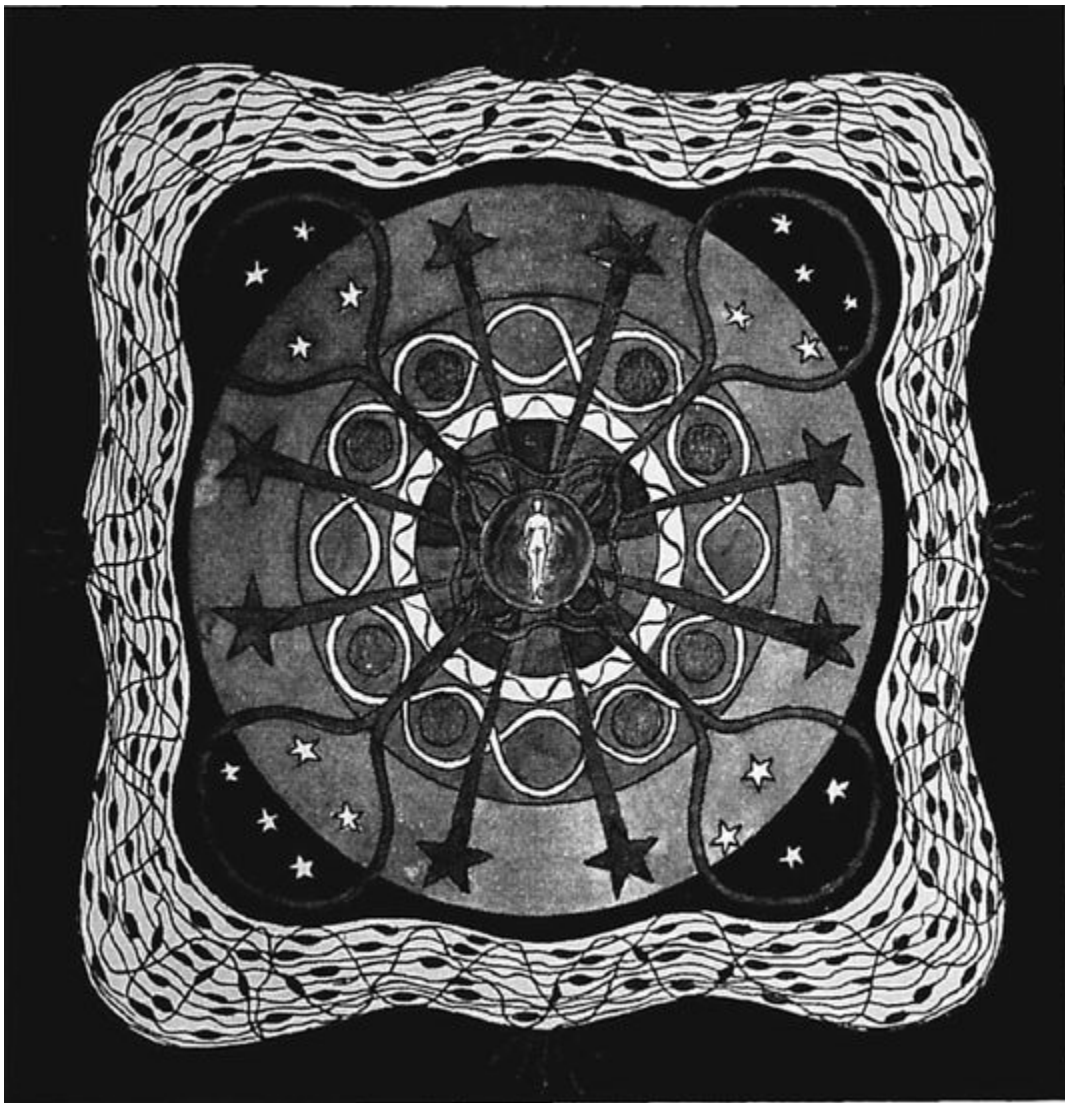

♀ In the centre, the germinal vesicle with a human figure nourished by blood vessels which have their origin in the cosmos. The cosmos rotates around the centre, which attracts its emanations. Around the outside is spread nerve tissue indicating that the process takes place in the solar plexus



♂ A mandala as a fortified city with wall and moat. Within, a broad moat surrounding a wall fortified with sixteen towers and with another inner moat. This moat encloses a central castle with golden roofs whose centre is a golden temple



THE VISIONS OF ZOSIMOS

[Originally given as a lecture to the Eranos Conference at Ascona, Switzerland, in August 1937, and published under the title “Einige Bemerkungen zu den Visionen des Zosimos,” *Eranos-Jahrbuch* 1937 (Zurich, 1938). Revised and considerably expanded, as “Die Visionen des Zosimos,” in *Von den Wurzeln des Bewusstseins: Studien über den Archetypus* (Psychologische Abhandlungen, Vol. IX; Zurich, 1954), which version is translated here.—EDITORS.]

THE TEXTS

[85] I must make clear at once that the following observations on the visions of Zosimos of Panopolis, an important alchemist and Gnostic of the third century A.D., are not intended as a final explanation of this extraordinarily difficult material. My psychological contribution is no more than an attempt to shed a little light on it and to answer some of the questions raised by the visions.

[86] The first vision occurs at the beginning of “The Treatise of Zosimos the Divine concerning the Art.”¹ Zosimos introduces the treatise with some general remarks on the processes of nature and, in particular, on the “composition of the waters” (θέσις ὑδάτων) and various other operations, and closes with the words: “... and upon this simple system of many colours is based the manifold and infinitely varied investigation of all things.” Thereupon the text begins:²

(III, i, 2.) And as I spoke thus I fell asleep, and I saw a sacrificer³ standing before me, high up on an altar, which was in the shape of a bowl. There were fifteen steps leading up to the altar. And the priest stood there, and I heard a voice from above saying to me: “I have performed the act of descending the fifteen steps into the darkness, and of ascending the steps into the light. And he who renews me is the sacrificer, by casting away the grossness of the body; and by compelling necessity I am sanctified as a priest and now stand in perfection as a spirit.” And on hearing the voice of him who stood upon the altar, I inquired of him who he was. And he answered me in a fine voice, saying: “I am Ion,⁴ the priest of the inner sanctuaries, and I submit myself to an unendurable torment.⁵ For there came one in haste at early morning, who overpowered me, and pierced me through with the sword, and dismembered me in accordance with the rule of harmony.⁶ And he drew off the skin of my head with the sword, which he wielded with strength, and mingled the bones with the pieces of flesh, and caused them to be burned upon the fire of the art, till I perceived by the transformation of the body that I had become spirit. And that is my unendurable torment.” And even as he spoke thus, and I held him by force to converse with me, his eyes became as blood. And he spewed forth all his own flesh. And I saw how he changed into the opposite of himself, into a mutilated anthroparion,⁷ and he tore his flesh with his own teeth, and sank into himself.

(III, i, 3.) Full of fear I awoke from sleep, and I thought to myself: “Is not this the composition of the waters?” And I was assured that I had well understood, and again I fell asleep. I saw the same bowl-shaped altar and, on the upper part, boiling water, and a numberless multitude of people in it. And there was no one near the altar whom I could question. Then I went up to the altar to see this sight. And I perceived an anthroparion, a barber⁸ grown grey with age, who said to me: “What are you looking at?” I replied that I was astonished to see the seething of the water, and the men burning and yet alive. He answered me thus: “The sight that you see is the entrance, and the exit, and the transformation.” I asked him: “What transformation?” and he answered: “This is the place of the operation called embalming. Those who seek to obtain the art⁹ enter here, and become spirits by escaping from the body.” Then I said to him: “And you, are you a spirit?” And he answered: “Yes, a spirit and a guardian of spirits.” As we spoke, while the boiling continued and the people uttered distressful cries, I saw a brazen man holding a leaden tablet in his hand. And he spoke with a loud voice, looking upon the tablet: “I command all those who are undergoing the punishment to be calm, to take each of them a leaden tablet, to write with their own hand, and to keep their eyes upraised in the air and their mouths open, until their uvula swell.”¹⁰ The deed followed the word, and the master of the house said to me: “You have beheld, you have stretched your neck upward and have seen what is done.” I replied that I had seen, and he continued: “This brazen man whom you see is the priest who sacrifices and is sacrificed, and spews forth his own flesh. Power is given him over this water and over the people who are punished.”¹¹

(III, v, 1.) At last I was overcome with the desire to mount the seven steps and to see the seven punishments, and, as was suitable, in a single day; so I went back in order to complete the ascent. Passing it several times, I at length came upon the path. But as I was about to ascend, I lost my way again; greatly discouraged, and not seeing in which direction I should go, I fell asleep. And while I was sleeping, I saw an anthroparion, a barber clad in a robe of royal purple, who stood outside the place of punishments. He said to me: “Man, what are you doing?” and I replied: “I have stopped here because, having turned aside from the road, I have lost my way.” And he said: “Follow me.” And I turned and followed him. When we came near to the place of punishments, I saw my guide, this little barber, enter that place, and his whole body was consumed by the fire.

(III, v, 2.) On seeing this, I stepped aside, trembling with fear; then I awoke, and said within myself: “What means this vision?” And again I clarified my understanding, and knew that this barber was the brazen man, clad in a purple garment. And I said to myself: “I have well understood, this is the brazen man. It is needful that first he must enter the place of punishments.”

(III, v, 3.) Again my soul desired to mount the third step also. And again I followed the road alone, and when I was near the place of punishments, I again went astray, not knowing my way, and I stopped in despair. And again, as it seemed, I saw an old man whitened by years, who had become wholly white, with a blinding whiteness. His name was Agathodaimon. Turning himself about, the old man with white hair gazed upon me for a full hour. And I urged him: "Show me the right way." He did not come towards me, but hastened on his way. But I, running hither and thither, at length came to the altar. And when I stood at the top of the altar, I saw the white-haired old man enter the place of punishments. O ye demiurges of celestial nature! Immediately he was transformed by the flame into a pillar of fire. What a terrible story, my brethren! For, on account of the violence of the punishment, his eyes filled with blood. I spoke to him, and asked: "Why are you stretched out there?" But he could barely open his mouth, and groaned: "I am the leaden man, and I submit myself to an unendurable torment." Thereupon, seized with great fear, I awoke and sought within myself the reason for what I had seen. And again I considered and said to myself: "I have well understood, for it means that the lead is to be rejected, and in truth the vision refers to the composition of the liquids."

(III, v^{bis}.) Again I beheld the divine and holy bowl-shaped altar, and I saw a priest clothed in a white robe reaching to his feet, who was celebrating these terrible mysteries, and I said: "Who is this?" And the answer came: "This is the priest of the inner sanctuaries. It is he who changes the bodies into blood, makes the eyes clairvoyant, and raises the dead." Then, falling again to earth, I again fell asleep. And as I was ascending the fourth step, I saw, to the east, one approaching, holding a sword in his hand. And another [came] behind him, bringing one adorned round about with signs, clad in white and comely to see, who was named the Meridian of the Sun.¹² And as they drew near to the place of punishments, he who held the sword in his hand [said]: "Cut off his head, immolate his body, and cut his flesh into pieces, that it may first be boiled according to the method,¹³ and then delivered to the place of punishments." Thereupon I awoke and said: "I have well understood, this concerns the liquids in the art of the metals." And he who bore the sword in his hand said again: "You have completed the descent of the seven steps." And the other answered, as he caused the waters to gush forth from all the moist places: "The procedure is completed."

(III, vi, 1.) And I saw an altar which was in the shape of a bowl, and a fiery spirit stood upon the altar, and tended the fire for the seething and the boiling and the burning of the men who rose up from it. And I inquired about the people who stood there, and I said: "I see with astonishment the seething and the boiling of the water, and the men burning and yet alive!" And he answered me, saying: "This boiling that you see is the place of the operation called embalming. Those who seek to obtain the

art enter here, and they cast their bodies from them and become spirits. The practice [of the art] is explained by this procedure; for whatever casts off the grossness of the body becomes spirit.”

[87] The Zosimos texts are in a disordered state. At III, i, 5 there is a misplaced but obviously authentic résumé or amplification of the visions, and at III, i, 4 a philosophical interpretation of them. Zosimos calls this whole passage an “introduction to the discourse that is to follow” (III, i, 6).

(III, i, 5.) In short, my friend, build a temple from a single stone, like to white lead, to alabaster, to Proconnesian marble,¹⁴ with neither end nor beginning in its construction.¹⁵ Let it have within it a spring of the purest water, sparkling like the sun. Note carefully on what side is the entrance to the temple, and take a sword in your hand; then seek the entrance, for narrow is the place where the opening is. A dragon lies at the entrance, guarding the temple. Lay hold upon him; immolate him first; strip him of his skin, and taking his flesh with the bones, separate the limbs; then, laying [the flesh of] the limbs¹⁶ together with the bones at the entrance of the temple, make a step of them, mount thereon, and enter, and you will find what you seek.¹⁷ The priest, that brazen man, whom you see seated in the spring and composing the substance, [look on] him not as the brazen man, for he has changed the colour of his nature and has become the silver man; and if you will, you will soon have him [as] the golden man.

(III, i, 4.) And after I had seen this apparition, I awoke, and I said to myself: “What is the cause of this vision? Is not that boiling white and yellow water the divine water?” And I found that I had well understood. And I said: “Beautiful it is to speak and beautiful to hear, beautiful to give and beautiful to receive, beautiful to be poor and beautiful to be rich. How does nature teach giving and receiving? The brazen man gives and the hydrolith receives; the metal gives and the plant receives; the stars give and the flowers receive; the heavens give and the earth receives; the thunderclaps give forth darting fire. And all things are woven together and all things are undone again; all things are mingled together and all things combine; and all things unite and all things separate; all things are moistened and all things are dried; and all things flourish and all things fade in the bowl of the altar. For each thing comes to pass with method and in fixed measure and by exact¹⁸ weighing of the four elements. The weaving together of all things and the undoing of all things and the whole fabric of things cannot come to pass without method. The method is a natural one, preserving due order in its inhaling and its exhaling; it brings increase and it brings decrease. And to sum up: through the harmonies of separating and combining, and if nothing of the method be neglected, all things bring forth nature. For nature

applied to nature transforms nature. Such is the order of natural law throughout the whole cosmos, and thus all things hang together.”

(III, i, 6.) This introduction is the key which shall open to you the flowers of the discourse that is to follow, namely, the investigation of the arts, of wisdom, of reason and understanding, the efficacious methods and revelations which throw light upon the secret words.

II

COMMENTARY

1. GENERAL REMARKS ON THE INTERPRETATION

[88] Although it looks as if this were a series of visions following one after the other, the frequent repetitions and striking similarities suggest rather that it was essentially a single vision which is presented as a set of variations on the themes it contains. Psychologically at least, there is no ground for supposing that it is an allegorical invention. Its salient features seem to indicate that for Zosimos it was a highly significant experience which he wished to communicate to others. Although alchemical literature contains a number of allegories which without doubt are merely didactic fables and are not based on direct experience,¹ the vision of Zosimos may well have been an actual happening. This seems to be borne out by the manner in which Zosimos himself interprets it as a confirmation of his own preoccupation: “Is not this the composition of the waters?” Such an interpretation seems—to us at any rate—to leave out of account the most impressive images in the vision, and to reduce a far more significant complex of facts to an all too simple common denominator. If the vision were an allegory, the most conspicuous images would also be the ones that have the greatest significance. But it is characteristic of any subjective dream interpretation that it is satisfied with pointing out superficial relationships which take no account of the essentials. Another thing to be considered is that the alchemists themselves testify to the occurrence of dreams and visions during the opus.² I am inclined to think that the vision or visions of Zosimos were experiences of this kind, which took place during the work and revealed the nature of the psychic processes in the background.³ In these visions all those contents emerge which the alchemists unconsciously projected into the chemical process and which were then perceived there, as though they were qualities of matter. The extent to which this projection was fostered by the conscious attitude is shown by the somewhat overhasty interpretation given by Zosimos himself.

[89] Even though his interpretation strikes us at first as somewhat forced, indeed as far-fetched and arbitrary, we should nevertheless not forget that while the conception of the “waters” is a strange one to us, for Zosimos and for the alchemists in general it had a significance we would never suspect. It is also possible that the mention of the

“water” opened out perspectives in which the ideas of dismemberment, killing, torture, and transformation all had their place. For, beginning with the treatises of Democritus and Komarios, which are assigned to the first century A.D., alchemy, until well into the eighteenth century, was very largely concerned with the miraculous water, the *aqua divina* or *permanens*, which was extracted from the lapis, or prima materia, through the torment of the fire. The water was the *humidum radicale* (radical moisture), which stood for the *anima media natura* or *anima mundi* imprisoned in matter,⁴ the soul of the stone or metal, also called the *anima aquina*. This anima was set free not only by means of the “cooking,” but also by the sword dividing the “egg,” or by the *separatio*, or by dissolution into the four “roots” or elements.⁵ The *separatio* was often represented as the dismemberment of a human body.⁶ Of the *aqua permanens* it was said that it dissolved the bodies into the four elements. Altogether, the divine water possessed the power of transformation. It transformed the *nigredo* into the *albedo* through the miraculous “washing” (*ablutio*); it animated inert matter, made the dead to rise again,⁷ and therefore possessed the virtue of the baptismal water in the ecclesiastical rite.⁸ Just as, in the *benedictio fontis*, the priest makes the sign of the cross over the water and so divides it into four parts,⁹ so the mercurial serpent, symbolizing the *aqua permanens*, undergoes dismemberment, another parallel to the division of the body.¹⁰

[90] I shall not elaborate any further this web of interconnected meanings in which alchemy is so rich. What I have said may suffice to show that the idea of the “water” and the operations connected with it could easily open out to the alchemist a vista in which practically all the themes of the vision fall into place. From the standpoint of Zosimos’ conscious psychology, therefore, his interpretation seems rather less forced and arbitrary. A Latin proverb says: *canis panem somniat, piscator pisces* (the dog dreams of bread, the fisherman of fish). The alchemist, too, dreams in his own specific language. This enjoins upon us the greatest circumspection, all the more so as that language is exceedingly obscure. In order to understand it, we have to learn the psychological secrets of alchemy. It is probably true what the old Masters said, that only he who knows the secret of the stone understands their words.¹¹ It has long been asserted that this secret is sheer nonsense, and not worth the trouble of investigating seriously. But this frivolous attitude ill befits the psychologist, for any “nonsense” that fascinated men’s minds for close on two thousand years—among them some of the greatest, e.g., Newton and Goethe¹²—must have something about it which it would be useful for the psychologist to know. Moreover, the symbolism of alchemy has a great deal to do with the structure of the unconscious, as I have shown in my book *Psychology and Alchemy*. These things are not just rare curiosities, and anyone who wishes to understand the symbolism of dreams cannot close his eyes to the fact that the dreams of modern men and women often contain the very images

and metaphors that we find in the medieval treatises.¹³ And since an understanding of the biological compensation produced by dreams is of importance in the treatment of neurosis as well as in the development of consciousness, a knowledge of these facts has also a practical value which should not be underestimated.

2. THE SACRIFICIAL ACT

[91] The central image in our dream-vision shows us a kind of sacrificial act undertaken for the purpose of alchemical transformation. It is characteristic of this rite that the priest is at once the sacrificer and the sacrificed. This important idea reached Zosimos in the form of the teachings of the “Hebrews” (i.e., Christians).¹ Christ was a god who sacrificed himself. An essential part of the sacrificial act is dismemberment. Zosimos must have been familiar with this motif from the Dionysian mystery-tradition. There, too, the god is the victim, who was torn to pieces by the Titans and thrown into a cooking pot,² but whose heart was saved at the last moment by Hera. Our text shows that the bowl-shaped altar was a cooking vessel in which a multitude of people were boiled and burned. As we know from the legend and from a fragment of Euripides,³ an outburst of bestial greed and the tearing of living animals with the teeth were part of the Dionysian orgy.⁴ Dionysius was actually called *ὁ ἀμέριστος καὶ μεμεριομένος νοῦς* (the undivided and divided spirit).⁵

[92] Zosimos must also have been familiar with the flaying motif. A well-known parallel of the dying and resurgent god Attis⁶ is the flayed and hanged Marsyas. Also, legend attributes death by flaying to the religious teacher Mani, who was a near-contemporary of Zosimos.⁷ The subsequent stuffing of the skin with straw is a reminder of the Attic fertility and rebirth ceremonies. Every year in Athens an ox was slaughtered and skinned, and its pelt stuffed with straw. The stuffed dummy was then fastened to a plough, obviously for the purpose of restoring the fertility of the land.⁸ Similar flaying ceremonies are reported of the Aztecs, Scythians, Chinese, and Patagonians.⁹

[93] In the vision, the skinning is confined to the head. It is a scalping as distinct from the total *ἀποδερμάτωσις* (skinning) described in III, i, 5. It is one of the actions which distinguish the original vision from the description of the process given in this résumé. Just as cutting out and eating the heart or brain of an enemy is supposed to endow one with his vital powers or virtues, so scalping is a *pars pro toto* incorporation of the life principle or soul.¹⁰ Flaying is a transformation symbol which I have discussed at greater length in my essay “Transformation Symbolism in the Mass.” Here I need only mention the special motif of torture or punishment (*κόλασις*), which is particularly evident in the description of the dismemberment and

scalping. For this there is a remarkable parallel in the Akhmim manuscript of the Apocalypse of Elijah, published by Georg Steindorff.¹¹ In the vision it is said of the leaden homunculus that “his eyes filled with blood” as a result of the torture. The Apocalypse of Elijah says of those who are cast “into eternal punishment”: “their eyes are mixed with blood”;¹² and of the saints who were persecuted by the Anti-Messiah: “he will draw off their skins from their heads.”¹³

[94] These parallels suggest that the *κόλασις* is not just a punishment but the torment of hell. Although *κόλασις* would have to be translated as *poena*, this word nowhere occurs in the Vulgate, for in all the places where the torments of hell are mentioned the word used is *cruciare* or *cruciatu*s, as in Revelation 14 : 10, “tormented with fire and brimstone,” or Revelation 9 : 5, “the torment of a scorpion.” The corresponding Greek word is *βασανίζειν* or *βασανισμ*, ‘torture’. For the alchemists it had a double meaning: *βασανίζειν* also meant ‘testing on the touchstone’ (*βάσσωσ*) The *lapis Lydius* (touchstone) was used as a synonym for the *lapis philosophorum*. The genuineness or incorruptibility of the stone is proved by the torment of fire and cannot be attained without it. This *leitmotiv* runs all through alchemy.

[95] In our text the skinning refers especially to the head, as though signifying an extraction of the soul (if the primitive equation *skin* = *soul* is still valid here). The head plays a considerable role in alchemy, and has done so since ancient times. Thus Zosimos names his philosophers the “sons of the Golden Head.” I have dealt with this theme elsewhere,¹⁴ and need not go into it again now. For Zosimos and the later alchemists the head had the meaning of the “omega element” or “round element” (*στοιχεῖον στρογγύλον*), a synonym for the arcane or transformative substance.¹⁵ The decapitation in section III, v^{bis} therefore signifies the obtaining of the arcane substance. According to the text, the figure following behind the sacrificer is named the “Meridian of the Sun,” and his head is to be cut off. This striking off of the golden head is also found in the manuscript of *Splendor solis* as well as in the Rorschach printing of 1598. The sacrifice in the vision is of an initiate who has undergone the experience of the *solificatio*. In alchemy; sun is synonymous with gold. Gold, as Michael Maier says, is the “circulatory work of the sun,” “shining clay moulded into the most beauteous substance, wherein the solar rays are gathered together and shine forth.”¹⁶ Mylius says that the “water comes from the rays of the sun and moon.”¹⁷ According to the “Aurelia occulta,” the sun’s rays are gathered together in the quicksilver.¹⁸ Dorn derives all metals from the “invisible rays” of heaven,¹⁹ whose spherical shape is a prototype of the Hermetic vessel. In view of all this, we shall hardly go wrong in supposing that the initiate named the “Meridian of the Sun” himself represents the arcane substance. We shall come back to this idea later.

[96] Let us turn now to other details of the vision. The most striking feature is the “bowl-shaped altar.” It is unquestionably related to the *krater* of Poimandres. This was the vessel which the demiurge sent down to earth filled with Nous, so that those who were striving for higher consciousness could baptize themselves in it. It is mentioned in that important passage where Zosimos tells his friend and *soror mystica*, Theosebeia: “Hasten down to the shepherd and bathe yourself in the *krater*, and hasten up to your own kind (γένοϋς).”²⁰ She had to go down to the place of death and rebirth, and then up to her “own kind,” i.e., the twice-born, or, in the language of the gospels, the kingdom of heaven.

[97] The *krater* is obviously a wonder-working vessel, a font or piscina, in which the immersion takes place and transformation into a spiritual being is effected. It is the *vas Hermetis* of later alchemy. I do not think there can be any doubt that the *krater* of Zosimos is closely related to the vessel of Poimandres in the *Corpus Hermeticum*.²¹ The Hermetic vessel, too, is a uterus of spiritual renewal or rebirth. This idea corresponds exactly to the text of the *benedictio fontis*, which I quoted earlier in a footnote.²² In “Isis to Horus,”²³ the angel brings Isis a small vessel filled with translucent or “shining” water. Considering the alchemical nature of the treatise, we could take this water as the divine water of the art,²⁴ since after the prima materia this is the real arcanum. The water, or water of the Nile, had a special significance in ancient Egypt: it was Osiris, the dismembered god *par excellence*.²⁵ A text from Edfu says: “I bring you the vessels with the god’s limbs [i.e., the Nile] that you may drink of them; I refresh your heart that you may be satisfied.”²⁶ The god’s limbs were the fourteen parts into which Osiris was divided. There are numerous references to the hidden, divine nature of the arcane substance in the alchemical texts.²⁷ According to this ancient tradition, the water possessed the power of resuscitation; for it was Osiris, who rose from the dead. In the “Dictionary of Goldmaking,”²⁸ Osiris is the name for lead and sulphur, both of which are synonyms for the arcane substance. Thus lead, which was the principal name for the arcane substance for a long time, is called “the sealed tomb of Osiris, containing all the limbs of the god.”²⁹ According to legend, Set (Typhon) covered the coffin of Osiris with lead. Petasios tells us that the “sphere of the fire is restrained and enclosed by lead.” Olympiodorus, who quotes this saying, remarks that Petasios added by way of explanation: “The lead is the water which issues from the masculine element.”³⁰ But the masculine element, he said, is the “sphere of fire.”

[98] This train of thought indicates that the spirit which is a water, or the water which is a spirit, is essentially a paradox, a pair of opposites like water and fire. In the *aqua nostra* of the alchemists, the concepts of water, fire, and spirit coalesce as they do in religious usage.³¹

[99] Besides the motif of water, the story that forms the setting of the Isis treatise also contains the motif of violation. The text says:³²

Isis the Prophetess to her son Horus: My child, you should go forth to battle against the faithless Typhon for the sake of your father's kingdom, while I retire to Hormanuthi, Egypt's [city] of the sacred art, where I sojourned for a while. According to the circumstances of the time and the necessary consequences of the movement of the spheres,³³ it came to pass that a certain one among the angels, dwelling in the first firmament, watched me from above and wished to have intercourse with me. Quickly he determined to bring this about. I did not yield, as I wished to inquire into the preparation of the gold and silver. But when I demanded it of him, he told me he was not permitted to speak of it, on account of the supreme importance of the mysteries; but on the following day an angel, Amnael, greater than he, would come, and he could give me the solution of the problem. He also spoke of the sign of this angel—he bore it on his head and would show me a small, unpitched vessel filled with a translucent water. He would tell me the truth. On the following day, as the sun was crossing the midpoint of its course, Amnael appeared, who was greater than the first angel, and, seized with the same desire, he did not hesitate, but hastened to where I was. But I was no less determined to inquire into the matter.³⁴

[100] She did not yield to him, and the angel revealed the secret, which she might pass only to her son Horus. Then follow a number of recipes which are of no interest here.

[101] The angel, as a winged or spiritual being, represents, like Mercurius, the volatile substance, the pneuma, the *ἀσώματον* (disembodied). Spirit in alchemy almost invariably has a relation to water or to the radical moisture, a fact that may be explained simply by the empirical nature of the oldest form of “chemistry,” namely the art of cooking. The steam arising from boiling water conveys the first vivid impression of “metasomatosi,” the transformation of the corporeal into the incorporeal, into spirit or pneuma. The relation of spirit to water resides in the fact that the spirit is hidden in the water, like a fish. In the “*Allegoriae super librum Turbae*”³⁵ this fish is described as “round” and endowed with “a wonder-working virtue.” As is evident from the text,³⁶ it represents the arcane substance. From the alchemical transformation, the text says, is produced a collyrium (eyewash) which will enable the philosopher to see the secrets better.³⁷ The “round fish” seems to be a relative of the “round white stone” mentioned in the *Turba*.³⁸ Of this it is said: “It has within itself the three colours and the four natures and is born of a living thing.” The “round” thing or element is a well-known concept in alchemy. In the *Turba* we encounter the *rotundum*: “For the sake of posterity I call attention to the *rotundum*, which changes the metal into four.”³⁹ As is clear from the context, the *rotundum* is identical with the *aqua permanens*. We meet the same train of thought in Zosimos. He says of the round or omega element: “It consists of two parts. It belongs to the

seventh zone, that of Kronos,⁴⁰ in the language of the corporeal (*κατὰ τὴν ἔνσωμον*); but in the language of the incorporeal it is something different, that may not be revealed. Only Nikotheos knows it, and he is not to be found.⁴¹ In the language of the corporeal it is named Okeanos, the origin and seed, so they say, of all the gods.”⁴² Hence the *rotundum* is outwardly water, but inwardly the arcanum. For the Peratics, Kronos was a “power having the colour of water,”⁴³ “for the water, they say, is destruction.”

[102] Water and spirit are often identical. Thus Hermolaus Barbarus⁴⁴ says: “There is also a heavenly or divine water of the alchemists, which was known both to Democritus and to Hermes Trismegistus. Sometimes they call it the divine water, and sometimes the Scythian juice, sometimes pneuma, that is spirit, of the nature of aether, and the quintessence of things.”⁴⁵ Ruland calls the water the “spiritual power, a spirit of heavenly nature.”⁴⁶ Christopher Steeb gives an interesting explanation of the origin of this idea: “The brooding of the Holy Spirit upon the waters above the firmament brought forth a power which permeates all things in the most subtle way, warms them, and, in conjunction with the light, generates in the mineral kingdom of the lower world the mercurial serpent, in the plant kingdom the blessed greenness, and in the animal kingdom the formative power; so that the supracelestial spirit of the waters, united with the light, may fitly be called the soul of the world.”⁴⁷ Steeb goes on to say that when the celestial waters were animated by the spirit, they immediately fell into a circular motion, from which arose the perfect spherical form of the *anima mundi*. The *rotundum* is therefore a bit of the world soul, and this may well have been the secret that was guarded by Zosimos. All these ideas refer expressly to Plato’s *Timaeus*. In the *Turba*, Parmenides praises the water as follows: “O ye celestial natures, who at a sign from God multiply the natures of the truth! O mighty nature, who conquers the natures and causes the natures to rejoice and be glad!⁴⁸ For she it is in particular, whom God has endowed with a power which the fire does not possess. . . . She is herself the truth, all ye seekers of wisdom, for, liquefied with her substances, she brings about the highest of works.”⁴⁹

[103] Socrates in the *Turba* says much the same: “O how this nature changes body into spirit! . . . She is the sharpest vinegar, which causes gold to become pure spirit.”⁵⁰ “Vinegar” is synonymous with “water,” as the text shows, and also with the “red spirit.”⁵¹ The *Turba* says of the latter: “From the compound that is transformed into red spirit arises the principle of the world,” which again means the world soul⁵² *Aurora consurgens* says: “Send forth thy Spirit, that is water . . . and thou wilt renew the face of the earth.” And again: “The rain of the Holy Spirit melteth. He shall send out his word . . . his wind shall blow and the waters shall run.”⁵³ Arnaldus de Villanova (1235–1313) says in his “Flos Florum”: “They have called water spirit, and it is in truth spirit.”⁵⁴ The *Rosarium philosophorum* says categorically: “Water is

spirit.”⁵⁵ In the treatise of Komarios (1st cent, A.D.), the water is described as an elixir of life which wakens the dead sleeping in Hades to a new springtime.⁵⁶ Apollonius says in the *Turba*:⁵⁷ “But then, ye sons of the doctrine, that thing needs the fire, until the spirit of that body is transformed and left to stand through the nights, and turns to dust like a man in his grave. After this has happened, God will give it back its soul and its spirit, and, the infirmity being removed, that thing will be stronger and better after its destruction, even as a man becomes stronger and younger after the resurrection than he was in the world.” The water acts upon the substances as God acts upon the body. It is coequal with God and is itself of divine nature.

[104] As we have seen, the spiritual nature of the water comes from the “brooding” of the Holy Spirit upon the chaos (Genesis 1 : 3). There is a similar view in the *Corpus Hermeticum*: “There was darkness in the deep and water without form; and there was a subtle breath, intelligent, which permeated the things in Chaos with divine power.”⁵⁸ This view is supported in the first place by the New Testament motif of baptism by “water and spirit,” and in the second place by the rite of the *benedictio fontis*, which is performed on Easter Eve.⁵⁹ But the idea of the wonder-working water derived originally from Hellenistic nature philosophy, probably with an admixture of Egyptian influences, and not from Christian or biblical sources. Because of its mystical power, the water animates and fertilizes but also kills.

[105] In the divine water, whose dyophysite nature (τὸ στοιχεῖον τὸ διμερές)⁶⁰ is constantly emphasized, two principles balance one another, active and passive, masculine and feminine, which constitute the essence of creative power in the eternal cycle of birth and death.⁶¹ This cycle was represented in ancient alchemy by the symbol of the uroboros, the dragon that bites its own tail.⁶² Self-devouring is the same as self-destruction,⁶³ but the union of the dragon’s tail and mouth was also thought of as self-fertilization. Hence the texts say: “The dragon slays itself, weds itself, impregnates itself.”⁶⁴

[106] This ancient alchemical idea reappears dramatically in the vision of Zosimos, much as it might in a real dream. In III, i, 2 the priest Ion submits himself to an “unendurable torment.” The “sacrificer” performs the act of sacrifice by piercing Ion through with a sword. Ion thus foreshadows that dazzling white-clad figure named the “Meridian of the Sun” (III, v^{bis}), who is decapitated, and whom we have connected with the *solificatio* of the initiate in the Isis mysteries. This figure corresponds to the kingly mystagogue or psychopomp who appears in a vision reported in a late medieval alchemical text, the “Declaratio et Explicatio Adolphi,” which forms part of the “Aurelia occulta.”⁶⁵ So far as one can judge, the vision has no connection whatever with the Zosimos text, and I also doubt very much whether one should attribute to it the character of a mere parable. It contains certain features that are not traditional but are entirely original, and for this reason it seems likely that it

was a genuine dream-experience. At all events, I know from my professional experience that similar dream-visions occur today among people who have no knowledge of alchemical symbolism. The vision is concerned with a shining male figure wearing a crown of stars. His robe is of white linen, dotted with many-coloured flowers, those of green predominating. He assuages the anxious doubts of the adept, saying: "Adolphus, follow me. I shall show thee what is prepared for thee, so that thou canst pass out of the darkness into the light." This figure, therefore, is a true Hermes Psychopompos and initiator, who directs the spiritual *transitus* of the adept. This is confirmed in the course of the latter's adventures, when he receives a book showing a "parabolic figure" of the Old Adam. We may take this as indicating that the psychopomp is the second Adam, a parallel figure to Christ. There is no talk of sacrifice, but, if our conjecture is right, this thought would be warranted by the appearance of the second Adam. Generally speaking, the figure of the king is associated with the motif of the *mortificatio*.

[107] Thus in our text the personification of the sun or gold is to be sacrificed,⁶⁶ and his head, which was crowned with the aureole of the sun, struck off, for this contains, or is, the arcanum.⁶⁷ Here we have an indication of the psychic nature of the arcanum, for the head of a man signifies above all the seat of consciousness.⁶⁸ Again, in the vision of Isis, the angel who bears the secret is connected with the meridian of the sun, for the text says that he appeared as "the sun was crossing the midpoint of its course." The angel bears the mysterious elixir on his head and, by his relationship to the meridian, makes it clear that he is a kind of solar genius or messenger of the sun who brings "illumination," that is, an enhancement and expansion of consciousness. His indecorous behaviour may be explained by the fact that angels have always enjoyed a dubious reputation as far as their morals are concerned. It is still the rule for women to cover their hair in church. Until well into the nineteenth century, especially in Protestant regions, they had to wear a special hood⁶⁹ when they went to church on Sundays. This was not because of the men in the congregation, but because of the possible presence of angels, who might be thrown into raptures at the sight of a feminine coiffure. Their susceptibility in these matters goes back to Genesis 6 : 2, where the "sons of God" displayed a particular penchant for the "daughters of men," and bridled their enthusiasm as little as did the two angels in the Isis treatise. This treatise is assigned to the first century A.D. Its views reflect the Judaeo-Hellenistic angelology⁷⁰ of Egypt, and it might easily have been known to Zosimos the Egyptian.

[108] Such opinions about angels fit in admirably with masculine as well as with feminine psychology. If angels are anything at all, they are personified transmitters of unconscious contents that are seeking expression. But if the conscious mind is not ready to assimilate these contents, their energy flows off into the affective and instinctual sphere. This produces outbursts of affect, irritation, bad moods, and sexual

excitement, as a result of which consciousness gets thoroughly disoriented. If this condition becomes chronic, a dissociation develops, described by Freud as repression, with all its well-known consequences. It is, therefore, of the greatest therapeutic importance to acquaint oneself with the contents that underlie the dissociation.

[109] Just as the angel Annael brings the arcane substance with him, so the “Meridian of the Sun” is himself a representation of it. In alchemical literature, the procedure of transfixing or cutting up with the sword takes the special form of dividing the philosophical egg. It, too, is divided with the sword, i.e., broken down into the four natures or elements. As an arcanum, the egg is a synonym for the water.⁷¹ It is also a synonym for the dragon (mercurial serpent)⁷² and hence for the water in the special sense of the microcosm or monad. Since water and egg are synonymous, the division of the egg with the sword is also applied to the water. “Take the vessel, cut it through with the sword, take its soul . . . thus is this water of ours our vessel.”⁷³ The vessel likewise is a synonym for the egg, hence the recipe: “Pour into a round glass vessel, shaped like a phial or egg.”⁷⁴ The egg is a copy of the World-Egg, the egg-white corresponding to the “waters above the firmament,” the “shining liquor,” and the yolk to the physical world.⁷⁵ The egg contains the four elements.⁷⁶

[110] The dividing sword seems to have a special significance in addition to those we have noted. The “Consilium coniugii” says that the marriage pair, sun and moon, “must both be slain by their own sword, imbibing immortal souls until the most hidden interior [i.e., the previous] soul is extinguished.”⁷⁷ In a poem of 1620, Mercurius complains that he is “sore tormented with a fiery sword.”⁷⁸ According to the alchemists, Mercurius is the old serpent who already in paradise possessed “knowledge,” since he was closely related to the devil. It is the fiery sword brandished by the angel at the gates of paradise that torments him,⁷⁹ and yet he himself is this sword. There is a picture in the “Speculum veritatis”⁸⁰ of Mercurius killing the king and the snake with the sword—“gladio proprio se ipsum interficiens.” Saturn, too, is shown pierced by a sword.⁸¹ The sword is well suited to Mercurius as a variant of the *telum passionis*, Cupid’s arrow.⁸² Dorn, in his “Speculativa philosophia,”⁸³ gives a long and interesting interpretation of the sword: it is the “sword of God’s wrath,” which, in the form of Christ the Logos, was hung upon the tree of life. Thus the wrath of God was changed to love, and “the water of Grace now bathes the whole world.” Here again, as in Zosimos, the water is connected with the sacrificial act. Since the Logos, the Word of God, is “sharper than any two-edged sword” (Hebrews 4 : 12), the words of the Consecration in the Mass were interpreted as the sacrificial knife with which the offering is slain.⁸⁴ One finds in Christian symbolism the same “circular” Gnostic thinking as in alchemy. In both the sacrificer is the sacrificed, and the sword that kills is the same as that which is killed.

[111] In Zosimos this circular thinking appears in the sacrificial priest's identity with his victim and in the remarkable idea that the homunculus into whom Ion is changed devours himself.⁸⁵ He spews forth his own flesh and rends himself with his own teeth. The homunculus therefore stands for the uroboros, which devours itself and gives birth to itself (as though spewing itself forth). Since the homunculus represents the transformation of Ion, it follows that Ion, the uroboros, and the sacrificer are essentially the same. They are three different aspects of the same principle. This equation is confirmed by the symbolism of that part of the text which I have called the "résumé" and have placed at the end of the visions. The sacrificed is indeed the uroboros serpent, whose circular form is suggested by the shape of the temple, which has "neither beginning nor end in its construction." Dismembering the victim corresponds to the idea of dividing the chaos into four elements or the baptismal water into four parts. The purpose of the operation is to create the beginnings of order in the *massa confusa*, as is suggested in III, i, 2: "in accordance with the rule of harmony." The psychological parallel to this is the reduction to order, through reflection, of apparently chaotic fragments of the unconscious which have broken through into consciousness. Without knowing anything of alchemy or its operations, I worked out many years ago a psychological typology based on the four functions of consciousness as the ordering principles of psychic processes in general. Unconsciously, I was making use of the same archetype which had led Schopenhauer to give his "principle of sufficient reason" a fourfold root.⁸⁶

[112] The temple built of a "single stone" is an obvious paraphrase of the lapis. The "spring of purest water" in the temple is a fountain of life, and this is a hint that the production of the round wholeness, the stone, is a guarantee of vitality. Similarly, the light that shines within it can be understood as the illumination which wholeness brings.⁸⁷ Enlightenment is an increase of consciousness. The temple of Zosimos appears in later alchemy as the *domus thesaurorum* or *gazophylacium* (treasure-house).⁸⁸

[113] Although the shining white "monolith" undoubtedly stands for the stone, it clearly signifies at the same time the Hermetic vessel. The *Rosarium* says: "One is the stone, one the medicine, one the vessel, one the procedure, and one the disposition."⁸⁹ The scholia to the "Tractatus aureus Hermetis" put it even more plainly: "Let all be one in one circle or vessel."⁹⁰ Michael Maier ascribes to Maria the Jewess ("sister of Moses") the view that the whole secret of the art lay in knowledge of the Hermetic vessel. It was divine, and had been hidden from man by the wisdom of the Lord.⁹¹ *Aurora consurgens* II⁹² says that the natural vessel is the *aqua permanens* and the "vinegar of the philosophers," which obviously means that it is the arcane substance itself. We should understand the "Practica Mariae"⁹³ in this sense when it says that the Hermetic vessel is "the measure of your fire" and that it

had been “hidden by the Stoics”;⁹⁴ it is the “toxic body” which transforms Mercurius and is therefore the water of the philosophers.⁹⁵ As the arcane substance the vessel is not only water but also fire, as the “*Allegoriae sapientum*” makes clear: “Thus our stone, that is the flask of fire, is created from fire.”⁹⁶ We can therefore understand why Mylius⁹⁷ calls the vessel the “root and principle of our art.” Laurentius Ventura⁹⁸ calls it “Luna,” the *foemina alba* and mother of the stone. The vessel that is “not dissolved by water and not melted by fire” is, according to the “*Liber quartorum*,”⁹⁹ “like the work of God in the vessel of the divine seed (*germinis divi*), for it has received the clay, moulded it, and mixed it with water and fire.” This is an allusion to the creation of man, but on the other hand it seems to refer to the creation of souls, since immediately afterwards the text speaks of the production of souls from the “seeds of heaven.” In order to catch the soul God created the *vas cerebri*, the cranium. Here the symbolism of the vessel coincides with that of the head, which I have discussed in my “Transformation Symbolism in the Mass.”¹⁰⁰

[114] The *prima materia*, as the radical moisture, has to do with the soul because the latter is also moist by nature¹⁰¹ and is sometimes symbolized by dew.¹⁰² In this way the symbol of the vessel gets transferred to the soul. There is an excellent example of this in Caesarius of Heisterbach:¹⁰³ the soul is a spiritual substance of spherical nature, like the globe of the moon, or like a glass vessel that is “furnished before and behind with eyes” and “sees the whole universe.” This recalls the many-eyed dragon of alchemy and the snake vision of Ignatius Loyola.¹⁰⁴ In this connection the remark of Mylius¹⁰⁵ that the vessel causes “the whole firmament to rotate in its course” is of special interest because, as I have shown, the symbolism of the starry heaven coincides with the motif of polyophtalmia.¹⁰⁶

[115] After all this we should be able to understand Dorn’s view that the vessel must be made “by a kind of squaring of the circle.”¹⁰⁷ It is essentially a psychic operation, the creation of an inner readiness to accept the archetype of the self in whatever subjective form it appears. Dorn calls the vessel the *vas pellicanicum*, and says that with its help the *quinta essentia* can be extracted from the *prima materia*.¹⁰⁸ The anonymous author of the scholia to the “*Tractatus aureus Hermetis*” says: “This vessel is the true philosophical Pelican, and there is none other to be sought for in all the world.”¹⁰⁹ It is the lapis itself and at the same time contains it; that is to say, the self is its own container. This formulation is borne out by the frequent comparison of the lapis to the egg or to the dragon which devours itself and gives birth to itself.

[116] The thought and language of alchemy lean heavily on mysticism: in the Epistle of Barnabas¹¹⁰ Christ’s body is called the “vessel of the spirit.” Christ himself is the pelican who plucks out his breast feathers for his young.¹¹¹ According to the teachings of Herakleon, the dying man should address the demiurgic powers thus: “I am a vessel more precious than the feminine being who made you. Whereas your

mother knew not her own roots, I know of myself, and I know whence I have come, and I call upon the imperishable wisdom which is in the Father¹¹² and is the Mother of your mother, which has no mother, but also has no male companion.”¹¹³

[117] In the abstruse symbolism of alchemy we hear a distant echo of this kind of thinking, which, without hope of further development, was doomed to destruction under the censorship of the Church. But we also find in it a groping towards the future, a premonition of the time when the projection would be taken back into man, from whom it had arisen in the first place. It is interesting to see the strangely clumsy ways in which this tendency seeks to express itself in the phantasmagoria of alchemical symbolism. The following instructions are given in Johannes de Rupescissa: “Cause a vessel to be made in the fashion of a Cherub, which is the face of God, and let it have six wings, like to six arms folding back upon themselves; and above, a round head. . . .”¹¹⁴ From this it appears that although the ideal distilling vessel should resemble some monstrous kind of deity, it nevertheless had an approximately human shape. Rupescissa calls the quintessence the “ciel humain” and says it is “comme le ciel et les étoiles.” The Book of El-Habib¹¹⁵ says: “Man’s head likewise resembles a condensing apparatus.” Speaking of the four keys for unlocking the treasure-house, the “Consilium coniugii”¹¹⁶ explains that one of them is “the ascent of the water through the neck to the head of the vessel, that is like a living man.” There is a similar idea in the “Liber quattorum”: “The vessel . . . must be round in shape, that the artifex may be the transformer of the firmament and the brain-pan, just as the thing which we need is a simple thing.”¹¹⁷ These ideas go back to the head symbolism in Zosimos, but at the same time they are an intimation that the transformation takes place in the head and is a psychic process. This realization was not something that was clumsily disguised afterwards; the laborious way in which it was formulated proves how obstinately it was projected into matter. Psychological knowledge through withdrawal of projections seems to have been an extremely difficult affair from the very beginning.

[118] The dragon, or serpent, represents the initial state of unconsciousness, for this animal loves, as the alchemists say, to dwell “in caverns and dark places.” Unconsciousness has to be sacrificed; only then can one find the entrance into the head, and the way to conscious knowledge and understanding. Once again the universal struggle of the hero with the dragon is enacted, and each time at its victorious conclusion the sun rises: consciousness dawns, and it is perceived that the transformation process is taking place inside the temple, that is, in the head. It is in truth the inner man, presented here as a homunculus, who passes through the stages that transform the copper into silver and the silver into gold, and who thus undergoes a gradual enhancement of value.

[119] It sounds very strange to modern ears that the inner man and his spiritual growth should be symbolized by metals. But the historical facts cannot be doubted, nor is the idea peculiar to alchemy. It is said, for instance, that after Zarathustra had received the drink of omniscience from Ahuramazda, he beheld in a dream a tree with four branches of gold, silver, steel, and mixed iron.¹¹⁸ This tree corresponds to the metallic tree of alchemy, the *arbor philosophica*, which, if it has any meaning at all, symbolizes spiritual growth and the highest illumination. Cold, inert metal certainly seems to be the direct opposite of spirit—but what if the spirit is as dead and as heavy as lead? A dream might then easily tell us to look for it in lead or quicksilver! It seems that nature is out to prod man's consciousness towards greater expansion and greater clarity, and for this reason continually exploits his greed for metals, especially the precious ones, and makes him seek them out and investigate their properties. While so engaged it may perhaps dawn on him that not only veins of ore are to be found in the mines, but also kobolds and little metal men, and that there may be hidden in lead either a deadly demon or the dove of the Holy Ghost.¹¹⁹

[120] It is evident that some alchemists passed through this process of realization to the point where only a thin wall separated them from psychological self-awareness. Christian Rosencreutz is still this side of the dividing line, but with *Faust* Goethe came out on the other side and was able to describe the psychological problem which arises when the inner man, or greater personality that before had lain hidden in the homunculus, emerges into the light of consciousness and confronts the erstwhile ego, the animal man. More than once Faust had inklings of the metallic coldness of Mephistopheles, who had first circled round him in the shape of a dog (uroboros motif). Faust used him as a familiar spirit and finally got rid of him by means of the motif of the cheated devil; but all the same he claimed the credit for the fame Mephistopheles brought him as well as for the power to work magic. Goethe's solution of the problem was still medieval, but it nevertheless reflected a psychic attitude that could get on without the protection of the Church. That was not the case with Rosencreutz: he was wise enough to stay outside the magic circle, living as he did within the confines of tradition. Goethe was more modern and therefore more incautious. He never really understood how dreadful was the Walpurgisnacht of the mind against which Christian dogma offered protection, even though his own masterpiece spread out this underworld before his eyes in two versions. But then, an extraordinary number of things can happen to a poet without having serious consequences. These appeared with a vengeance only a hundred years later. The psychology of the unconscious has to reckon with long periods of time like this, for it is concerned less with the ephemeral personality than with age-old processes, compared with which the individual is no more than the passing blossom and fruit of the rhizome underground.

3. THE PERSONIFICATIONS

[121] What I have taken as a résumé, namely the piece we have been discussing, Zosimos calls a *προοίμιον*, an introduction.¹ It is therefore not a dream-vision; Zosimos is speaking here in the conscious language of his art, and expresses himself in terms that are obviously familiar to his reader. The dragon, its sacrifice and dismemberment, the temple built of a single stone, the miracle of goldmaking, the transmutation of the anthroparia, are all current conceptions in the alchemy of his day. That is why this piece seems to us a conscious allegory, contrasting with the authentic visions, which treat the theme of transmutation in an unorthodox and original way, just as a dream might do. The abstract spirits of the metals are pictured here as suffering human beings; the whole process becomes like a mystic initiation and has been very considerably psychologized. But Zosimos' consciousness is still so much under the spell of the projection that he can see in the vision nothing more than the "composition of the waters." One sees how in those days consciousness turned away from the mystic process and fastened its attention upon the material one, and how the projection drew the mind towards the physical. For the physical world had not yet been discovered. Had Zosimos recognized the projection, he would have fallen back into the fog of mystic speculation, and the development of the scientific spirit would have been delayed for an even longer time. For us, matters are different. It is just the mystic content of his visions that is of special importance for us, because we are familiar enough with the chemical processes which Zosimos was out to investigate. We are therefore in a position to separate them from the projection and to recognize the psychic element they contain. The résumé also offers us a standard of comparison which enables us to discern the difference between its style of exposition and that of the visions. This difference supports our assumption that the visions are more like a dream than an allegory, though there is little possibility of our reconstructing the dream from the defective text that has come down to us.

[122] The representation of the "alchemystical" process by persons needs a little explanation. The personification of lifeless things is a remnant of primitive and archaic psychology. It is caused by unconscious identity,² or what Lévy-Bruhl called *participation mystique*. The unconscious identity, in turn, is caused by the projection of unconscious contents into an object, so that these contents then become accessible to consciousness as qualities apparently belonging to the object. Any object that is at all interesting provokes a considerable number of projections. The difference between primitive and modern psychology in this respect is in the first place qualitative, and in the second place one of degree. Consciousness develops in civilized man by the acquisition of knowledge and by the withdrawal of projections. These are recognized as psychic contents and are reintegrated with the psyche. The alchemists concretized or personified practically all their most important ideas—the

four elements, the vessel, the stone, the prima materia, the tincture, etc. The idea of man as a microcosm, representing in all his parts the earth or the universe,³ is a remnant of an original psychic identity which reflected a twilight state of consciousness. An alchemical text⁴ expresses this as follows:

Man is to be esteemed a little world, and in all respects he is to be compared to a world. The bones under his skin are likened to mountains, for by them is the body strengthened, even as the earth is by rocks, and the flesh is taken for earth, and the great blood vessels for great rivers, and the little ones for small streams that pour into the great rivers. The bladder is the sea, wherein the great as well as the small streams congregate. The hair is compared to sprouting herbs, the nails on the hands and feet, and whatever else may be discovered inside and outside a man, all according to its kind is compared to the world.

[123] Alchemical projections are only a special instance of the mode of thinking typified by the idea of the microcosm. Here is another example of personification:⁵

Now mark further Best Beloved / how you should do / you should go to the house / there you will find two doors / that are shut / you should stand a while before them / until one comes / and opens the door / and goes out to you / that will be a Yellow Man / and is not pretty to look upon / but you should not fear him / because he is unshapely / but he is sweet of word / and will ask you / my dear what seekest thou here / when truly I have long seen no man / so near this house / then you should answer him / I have come here and seek the Lapidem Philosophorum / the same Yellow Man will answer you and speak thus / my dear friend since you now have come so far / I will show you further / you should go into the house / until you come to a running fountain / and then go on a little while / and there will come to you a Red Man / he is Fiery Red and has Red eyes / you should not fear him on account of his ugliness / for he is gentle of word / and he also will ask you / my dear friend / what is your desire here / when to me you are a strange guest / and you should answer him / I seek the Lapidem Philosophorum. . . .

[124] Personifications of metals are especially common in the folktales of imps and goblins, who were often seen in the mines.⁶ We meet the metal men several times in Zosimos,⁷ also a brazen eagle.⁸ The “white man” appears in Latin alchemy: “Accipe illum album hominem de vase.” He is the product of the conjunction of the bridegroom and bride,⁹ and belongs to the same context of thought as the oft-cited “white woman” and “red slave,” who are synonymous with Beya and Gabricus in the “Visio Arislei.” These two figures seem to have been taken over by Chaucer:¹⁰

The statue of Mars upon a carte stood,
Armed, and looked grym as he were wood;

And over his heed ther shynen two figures

Of sterres, that been cleped in scriptures,

That oon Puella, that oother Rubeus.

[125] Nothing would have been easier than to equate the love story of Mars and Venus with that of Gabricus and Beya (who were also personified as dog and bitch), and it is likely that astrological influences also played a part. Thanks to his unconscious identity with it, man and cosmos interact. The following passage, of the utmost importance for the psychology of alchemy, should be understood in this sense: “And as man is composed of the four elements, so also is the stone, and so it is [dug] out of man, and you are its ore, namely by working; and from you it is extracted, namely by division; and in you it remains inseparably, namely through the science.”¹¹ Not only do things appear personified as human beings, but the macrocosm personifies itself as a man too. “The whole of nature converges in man as in a centre, and one participates in the other, and man has not unjustly concluded that the material of the philosophical stone may be found everywhere.”¹² The “Consilium coniugii”¹³ says: “Four are the natures which compose the philosophical man.” “The elements of the stone are four, which, when well proportioned to one another, constitute the philosophical man, that is, the perfect human elixir.” “They say that the stone is a man, because one cannot attain to it¹⁴ save by reason and human knowledge.” The above statement “you are its ore” has a parallel in the treatise of Komarios:¹⁵ “In thee [Cleopatra] is hidden the whole terrible and marvellous secret.” The same is said of the “bodies” (σώματα, i.e., ‘substances’): “In them the whole secret is concealed.”¹⁶

4. THE STONE SYMBOLISM

[126] Zosimos contrasts the body (σάρξ in the sense of ‘flesh’) with the spiritual man (πνευματικός).¹ The distinguishing mark of the spiritual man is that he seeks self-knowledge and knowledge of God.² The earthly, fleshly man is called Thoth or Adam. He bears within him the spiritual man, whose name is light (φῶς). This first man, Thoth-Adam, is symbolized by the four elements. The spiritual and the fleshly man are also named Prometheus and Epimetheus. But “in allegorical language” they “are but one man, namely soul and body.” The spiritual man was seduced into putting on the body, and was bound to it by “Pandora, whom the Hebrews call Eve.”³ She played the part, therefore, of the anima, who functions as the link between body and spirit, just as Shakti or Maya entangles man’s consciousness with the world. In the “Book of Krates” the spiritual man says: “Are you capable of knowing your soul completely? If you knew it as you should, and if you knew what could make it better, you would be capable of knowing that the names which the philosophers gave it of old are not its true names.”⁴ This last sentence is a standing phrase which is applied

to the names of the lapis. The lapis signifies the inner man, the ἄνθρωπος πνευματικός, the *natura abscondita* which the alchemists sought to set free. In this sense the *Aurora consurgens* says that through baptism by fire “man, who before was dead, is made a living soul.”⁵

[127] The attributes of the stone—incorruptibility, permanence, divinity, triunity, etc.—are so insistently emphasized that one cannot help taking it as the *deus absconditus* in matter. This is probably the basis of the lapis-Christ parallel, which occurs as early as Zosimos⁶ (unless the passage in question is a later interpolation). Inasmuch as Christ put on a “human body capable of suffering” and clothed himself in matter, he forms a parallel to the lapis, the corporeality of which is constantly stressed. Its ubiquity corresponds to the omnipresence of Christ. Its “cheapness,” however, goes against the doctrinal view. The divinity of Christ has nothing to do with man, but the healing stone is “extracted” from man, and every man is its potential carrier and creator. It is not difficult to see what kind of conscious situation the lapis philosophy compensates: far from *signifying* Christ, the lapis *complements* the common conception of the Christ figure at that time.⁷ What unconscious nature was ultimately aiming at when she produced the image of the lapis can be seen most clearly in the notion that it originated in matter and in man, that it was to be found everywhere, and that its fabrication lay at least potentially within man’s reach. These qualities all reveal what were felt to be the defects in the Christ image at that time: an air too rarefied for human needs, too great a remoteness, a place left vacant in the human heart. Men felt the absence of the “inner” Christ who belonged to every man. Christ’s spirituality was too high and man’s naturalness was too low. In the image of Mercurius and the lapis the “flesh” glorified itself in its own way; it would not transform itself into spirit but, on the contrary, “fixed” the spirit in stone, and endowed the stone with all the attributes of the three Persons. The lapis may therefore be understood as a symbol of the inner Christ, of God in man. I use the expression “symbol” on purpose, for though the lapis is a parallel of Christ, it is not meant to replace him. On the contrary, in the course of the centuries the alchemists tended more and more to regard the lapis as the culmination of Christ’s work of redemption. This was an attempt to assimilate the Christ figure into the philosophy of the “science of God.” In the sixteenth century Khunrath formulated for the first time the “theological” position of the lapis: it was the *filius macrocosmi* as opposed to the “son of man,” who was the *filius microcosmi*. This image of the “Son of the Great World” tells us from what source it was derived: it came not from the conscious mind of the individual man, but from those border regions of the psyche that open out into the mystery of cosmic matter. Correctly recognizing the spiritual one-sidedness of the Christ image, theological speculation had begun very early to concern itself with Christ’s body, that is, with his materiality, and had temporarily solved the problem

with the hypothesis of the resurrected body. But because this was only a provisional and therefore not an entirely satisfactory answer, the problem logically presented itself again in the Assumption of the Blessed Virgin, leading first to the dogma of the Immaculate Conception and finally to that of the Assumption. Though this only postpones the real answer, the way to it is nevertheless prepared. The assumption and coronation of Mary, as depicted in the medieval illustrations, add a fourth, feminine principle to the masculine Trinity. The result is a quaternity, which forms a real and not merely postulated symbol of totality. The totality of the Trinity is a mere postulate, for outside it stands the autonomous and eternal adversary with his choirs of fallen angels and the denizens of hell. Natural symbols of totality such as occur in our dreams and visions, and in the East take the form of mandalas, are quaternities or multiples of four, or else squared circles.

[128] The accentuation of matter is above all evident in the choice of the *stone* as a God-image. We meet this symbol in the very earliest Greek alchemy, but there are good reasons for thinking that the stone symbol is very much older than its alchemical usage. The stone as the birthplace of the gods (e.g., the birth of Mithras from a stone) is attested by primitive legends of stone-births which go back to ideas that are even more ancient—for instance, the view of the Australian aborigines that children’s souls live in a special stone called the “child-stone.” They can be made to migrate into a uterus by rubbing the “child-stone” with a *churinga*. *Churingas* may be boulders, or oblong stones artificially shaped and decorated, or oblong, flattened pieces of wood ornamented in the same way. They are used as cult instruments. The Australians and the Melanesians maintain that *churingas* come from the totem ancestor, that they are relics of his body or of his activity, and are full of *arunquiltha* or mana. They are united with the ancestor’s soul and with the spirits of all those who afterwards possess them. They are taboo, are buried in caches or hidden in clefts in the rocks. In order to “charge” them, they are buried among the graves so that they can soak up the mana of the dead. They promote the growth of field-produce, increase the fertility of men and animals, heal wounds, and cure sicknesses of the body and the soul. Thus, when a man’s vitals are all knotted up with emotion, the Australian aborigines give him a blow in the abdomen with a stone *churinga*.⁸ The *churingas* used for ceremonial purposes are daubed with red ochre, anointed with fat, bedded or wrapped in leaves, and copiously spat on (spittle = mana).⁹

[129] These ideas of magic stones are found not only in Australia and Melanesia but also in India and Burma, and in Europe itself. For example, the madness of Orestes was cured by a stone in Laconia.¹⁰ Zeus found respite from the sorrows of love by sitting on a stone in Leukadia. In India, a young man will tread upon a stone in order to obtain firmness of character, and a bride will do the same to ensure her own faithfulness. According to Saxo Grammaticus, the electors of the king stood on

stones in order to give their vote permanence.¹¹ The green stone of Arran was used both for healing and for taking oaths on.¹² A cache of “soul stones,” similar to *churingas*, was found in a cave on the river Birs near Basel, and during recent excavations of the pole-dwellings on the little lake at Burgaeschi, in Canton Solothurn, a group of boulders was discovered wrapped in the bark of birch trees. This very ancient conception of the magical power of stones led on a higher level of culture to the similar importance attached to gems, to which all kinds of magical and medicinal properties were attributed. The gems that are the most famous in history are even supposed to have been responsible for the tragedies that befell their owners.

[130] A myth of the Navaho Indians of Arizona gives a particularly graphic account of the primitive fantasies that cluster round the stone.¹³ In the days of the great darkness,¹⁴ the ancestors of the hero saw the Sky Father descending and the Earth Mother rising up to meet him. They united, and on the top of the mountain where the union took place the ancestors found a little figure made of turquoise.¹⁵ This turned into (or in another version gave birth to) Estsánatlehi, “the woman who rejuvenates or transforms herself.” She was the mother of the twin gods who slew the primordial monsters, and was called the mother or grandmother of the gods (*yéi*). Estsánatlehi is the most important figure in the matriarchal pantheon of the Navaho. Not only is she the “woman who transforms herself,” but she also has two shapes, for her twin sister, Yolkaíestsan, is endowed with similar powers. Estsánatlehi is immortal, for though she grows into a withered old woman she rises up again as a young girl—a true *Dea Natura*. From different parts of her body four daughters were born to her, and a fifth from her spirit. The sun came from the turquoise beads hidden in her right breast, and from white shell beads in her left breast the moon. She issues reborn by rolling a piece of skin from under her left breast. She lives in the west, on an island in the sea. Her lover is the wild and cruel Sun Bearer, who has another wife; but he has to stay at home with her only when it rains. The turquoise goddess is so sacred that no image may be made of her, and even the gods may not look on her face. When her twin sons asked her who their father was, she gave them a wrong answer, evidently to protect them from the dangerous fate of the hero.

[131] This matriarchal goddess is obviously an anima figure who at the same time symbolizes the self. Hence her stone-nature, her immortality, her four daughters born from the body, plus one from the spirit, her duality as sun and moon, her role as paramour, and her ability to change her shape.¹⁶ The self of a man living in a matriarchal society is still immersed in his unconscious femininity, as can be observed even today in all cases of masculine mother-complexes. But the turquoise goddess also exemplifies the psychology of the matriarchal woman, who, as an anima figure, attracts the mother-complexes of all the men in her vicinity and robs them of their independence, just as Omphale held Herakles in thrall, or Circe reduced her

captives to a state of bestial unconsciousness—not to mention Benoît's Atlantida, who made a collection of her mummified lovers. All this happens because the anima contains the secret of the precious stone, for, as Nietzsche says, "all joy wants eternity." Thus the legendary Ostanes, speaking of the secret of the "philosophy," says to his pupil Cleopatra: "In you is hidden the whole terrible and marvellous secret. . . . Make known to us how the highest descends to the lowest, and how the lowest ascends to the highest, and how the midmost draws near to the highest, and is made one with it."¹⁷ This "midmost" is the stone, the mediator which unites the opposites. Such sayings have no meaning unless they are understood in a profoundly psychological sense.

[132] Widespread as is the motif of the stone-birth (cf. the creation myth of Deucalion and Pyrrha), the American cycle of legends seems to lay special emphasis on the motif of the stone-body, or animated stone.¹⁸ We meet this motif in the Iroquois tale of the twin brothers. Begotten in a miraculous manner in the body of a virgin, a pair of twins were born, one of whom came forth in the normal way, while the other sought an abnormal exit and emerged from the armpit, thereby killing his mother. This twin had a body made of flint. He was wicked and cruel, unlike his normally born brother.¹⁹ In the Sioux version the mother was a tortoise. Among the Wichita, the saviour was the great star in the south, and he performed his work of salvation on earth as the "flint man." His son was called the "young flint." After completing their work, both of them went back into the sky.²⁰ In this myth, just as in medieval alchemy, the saviour coincides with the stone, the star, the "son," who is "super omnia lumina." The culture hero of the Natchez Indians came down to earth from the sun, and shone with unendurable brightness. His glance was death-dealing. In order to mitigate this, and to prevent his body from corrupting in the earth, he changed himself into a stone statue, from which the priestly chieftains of the Natchez were descended.²¹ Among the Taos Pueblos, a virgin was made pregnant by beautiful stones and bore a hero son,²² who, owing to Spanish influence, assumed the aspect of the Christ child.²³ The stone plays a similar role in the Aztec cycle of legends. For instance, the mother of Quetzalcoatl was made pregnant by a precious green stone.²⁴ He himself had the cognomen "priest of the precious stone" and wore a mask made of turquoise.²⁵ The precious green stone was an animating principle and was placed in the mouth of the dead.²⁶ Man's original home was the "bowl of precious stone."²⁷ The motif of transformation into stone, or petrification, is common in the Peruvian and Colombian legends and is probably connected with a megalithic stone-cult,²⁸ and perhaps also with the palaeolithic cult of *churinga*-like soul-stones. The parallels here would be the menhirs of megalithic culture, which reached as far as the Pacific archipelago. The civilization of the Nile valley, which originated in megalithic times, turned its divine kings into stone statues for the express purpose of making the king's

ka everlasting. In shamanism, much importance is attached to crystals, which play the part of ministering spirits.²⁹ They come from the crystal throne of the supreme being or from the vault of the sky. They show what is going on in the world and what is happening to the souls of the sick, and they also give man the power to fly.³⁰

[133] The connection of the lapis with immortality is attested from very early times. Ostanos (possibly 4th cent. B.C.) speaks of “the Nile stone that has a spirit.”³¹ The lapis is the panacea, the universal medicine, the alexipharmic, the tincture that transmutes base metals into gold and gravel into precious stones. It brings riches, power, and health; it cures melancholy and, as the *vivus lapis philosophicus*, is a symbol of the saviour, the Anthropos, and immortality. Its incorruptibility is also shown in the ancient idea that the body of a saint becomes stone. Thus the Apocalypse of Elijah says of those who escape persecution by the Anti-Messiah:³² “The Lord shall take unto him their spirit and their souls, their flesh shall be made stone, no wild beast shall devour them till the last day of the great judgment.” In a Basuto legend reported by Frobenius,³³ the hero is left stranded by his pursuers on the bank of a river. He changes himself into a stone, and his pursuers throw him across to the other side. This is the motif of the *transitus*: the “other side” is the same as eternity.

5. THE WATER SYMBOLISM

[134] Psychological research has shown that the historical or ethnological symbols are identical with those spontaneously produced by the unconscious, and that the lapis represents the idea of a transcendent totality which coincides with what analytical psychology calls the self. From this point of view we can understand without difficulty the apparently absurd statement of the alchemists that the lapis consists of body, soul, and spirit, is a living being, a homunculus or “homo.” It symbolizes man, or rather, the inner man, and the paradoxical statements about it are really descriptions and definitions of this inner man. Upon this connotation of the lapis is based its parallelism with Christ. Behind the countless ecclesiastical and alchemical metaphors may be found the language of Hellenistic syncretism, which was originally common to both. Passages like the following one from Priscillian, a Gnostic-Manichaean heretic of the fourth century, must have been extremely suggestive for the alchemists: “One-horned is God, Christ a rock to us, Jesus a cornerstone, Christ the man of men”¹—unless the matter was the other way round, and metaphors taken from natural philosophy found their way into the language of the Church via the Gospel of St. John.

[135] The principle that is personified in the visions of Zosimos is the wonder-working water, which is both water and spirit, and kills and vivifies. If Zosimos, waking from his dream, immediately thinks of the “composition of the waters,” this is the obvious

conclusion from the alchemical point of view. Since the long-sought water, as we have shown,² represents a cycle of birth and death, every process that consists of death and rebirth is naturally a symbol of the divine water.

[136] It is conceivable that we have in Zosimos a parallel with the Nicodemus dialogue in John 3. At the time when John's gospel was written, the idea of the divine water was familiar to every alchemist. When Jesus said: "Except a man be born of water and of the spirit . . .," an alchemist of that time would at once have understood what he meant. Jesus marvelled at the ignorance of Nicodemus and asked him: "Art thou a master in Israel, and knowest not these things?" He obviously took it for granted that a teacher (*διδάσκαλος*) would know the secret of water and spirit, that is, of death and rebirth. Whereupon he went on to utter a saying which is echoed many times in the alchemical treatises: "We speak that we do know, and testify that we have seen." Not that the alchemists actually cited this passage, but they thought in a similar way. They talk as if they had touched the arcanum or gift of the Holy Spirit with their own hands, and seen the workings of the divine water with their own eyes.³ Even though these statements come from a later period, the spirit of alchemy remained more or less the same from the earliest times to the late Middle Ages.

[137] The concluding words of the Nicodemus dialogue, concerning "earthly and heavenly things," had likewise been the common property of alchemy ever since Democritus had written of the "physika and mystika," also called "somata and asomata," "corporalia and spiritualia."⁴ These words of Jesus are immediately followed by the motif of the ascent to heaven and descent to earth.⁵ In alchemy this would be the ascent of the soul from the mortified body and its descent in the form of reanimating dew.⁶ And when, in the next verse, Jesus speaks of the serpent lifted up in the wilderness and equates it with his own self-sacrifice, a "Master" would be bound to think of the uroboros, which slays itself and brings itself to life again. This is followed by the motif of "everlasting life" and the panacea (belief in Christ). Indeed, the whole purpose of the opus was to produce the incorruptible body, "the thing that dieth not," the invisible, spiritual stone, or *lapis aethereus*. In the verse, "For God so loved the world that he gave his only begotten Son . . .," Jesus identifies himself with the healing snake of Moses; for the Monogenes is synonymous with the Nous, and this with the serpent-saviour or Agathodaimon. The serpent is also a synonym for the divine water. The dialogue may be compared with Jesus' words to the woman of Samaria in John 4 : 14: "... a well of water springing up into everlasting life."⁷ Significantly enough, the conversation by the well forms the context for the teaching that "God is Spirit" (John 4 : 24).⁸

[138] In spite of the not always unintentional obscurity of alchemical language, it is not difficult to see that the divine water or its symbol, the uroboros, means nothing other than the *deus absconditus*, the god hidden in matter, the divine Nous that came down

to Physis and was lost in her embrace.⁹ This mystery of the “god become physical” underlies not only classical alchemy but also many other spiritual manifestations of Hellenistic syncretism.¹⁰

6. THE ORIGIN OF THE VISION

[139] Since alchemy is concerned with a mystery both physical and spiritual, it need come as no surprise that the “composition of the waters” was revealed to Zosimos in a dream. His sleep was the sleep of incubation, his dream “a dream sent by God.” The divine water was the alpha and omega of the process, desperately sought for by the alchemists as the goal of their desire. The dream therefore came as a dramatic explanation of the nature of this water. The dramatization sets forth in powerful imagery the violent and agonizing process of transformation which is itself both the producer and the product of the water, and indeed constitutes its very essence. The drama shows how the divine process of change manifests itself to our human understanding and how man experiences it—as punishment, torment,¹ death, and transfiguration. The dreamer describes how a man would act and what he would have to suffer if he were drawn into the cycle of the death and rebirth of the gods, and what effect the *deus absconditus* would have if a mortal man should succeed by his “art” in setting free the “guardian of spirits” from his dark dwelling. There are indications in the literature that this is not without its dangers.²

[140] The mystical side of alchemy, as distinct from its historical aspect, is essentially a psychological problem. To all appearances, it is a concretization, in projected and symbolic form, of the process of individuation. Even today this process produces symbols that have the closest connections with alchemy. On this point I must refer the reader to my earlier works, where I have discussed the question from a psychological angle and illustrated it with practical examples.

[141] The causes that set such a process in motion may be certain pathological states (for the most part schizophrenic) which produce very similar symbols. But the best and clearest material comes from persons of sound mind who, driven by some kind of spiritual distress, or for religious, philosophical, or psychological reasons, devote particular attention to their unconscious. In the period extending from the Middle Ages back to Roman times, a natural emphasis was laid on the inner man, and since psychological criticism became possible only with the rise of science, the inner factors were able to reach consciousness in the form of projections much more easily than they can today. The following text³ may serve to illustrate the medieval point of view:

For as Christ says in Luke 11: The light of the body is the eye, but if your eye is evil or becomes so, then your body is full of darkness and the light within you becomes

darkness. Moreover, in the seventeenth chapter he says also: Behold, the kingdom of God is within you—from which it is clearly seen that knowledge of the light in man must emerge in the first place from within and cannot be placed there from without, and many passages in the Bible bear witness to this, namely, that the external object (as it is usually called), or the sign written to help us in our weakness, is in Matthew 24 merely a testimony of the inner light of grace planted in and imparted to us by God. So, too, the spoken word is to be heeded and considered only as an indication, an aid and a guide to this. To take an example: a white and a black board are placed in front of you and you are asked which is black and which is white. If the knowledge of the two different colours were not previously within you, you would never be able to answer from these mere mute objects or boards the question put to you, since this knowledge does not come from the boards themselves (for they are mute and inanimate), but originates in and flows forth from your innate faculties which you exercise daily. The objects (as stated earlier) indeed stimulate the senses and cause them to apprehend, but in no way do they give knowledge. This must come from within, from the apprehender, and the knowledge of such colours must emerge in an act of apprehension. Similarly, when someone asks you for a material and external fire or light from a flint (in which the fire or light is hidden) you cannot put this hidden and secret light into the stone, but rather you must arouse, awaken, and draw forth the hidden fire from the stone and reveal it by means of the requisite steel striker which must be necessarily at hand. And this fire must be caught and vigorously fanned up in good tinder well prepared for this purpose, if it is not to be extinguished and disappear again. Then, afterwards, you will obtain a truly radiant light, shining like fire, and as long as it is tended and preserved, you will be able to create, work, and do with it as you please. And, likewise hidden in man, there exists such a heavenly and divine light which, as previously stated, cannot be placed in man from without, but must emerge from within.

For not in vain and without reason has God bestowed on and given to man in the highest part of his body two eyes and ears in order to indicate that man has to learn and heed within himself a twofold seeing and hearing, an inward and an outward, so that he may judge spiritual things with the inward part and allot spiritual things to the spiritual (I Corinthians 2), but also give to the outward its portion.

[142] For Zosimos and those of like mind the divine water was a *corpus mysticum*.⁴ A personalistic psychology will naturally ask: how did Zosimos come to be looking for a *corpus mysticum*? The answer would point to the historical conditions: it was a problem of the times. But in so far as the *corpus mysticum* was conceived by the alchemists to be a gift of the Holy Spirit, it can be understood in a quite general sense as a visible gift of grace conferring redemption. Man's longing for redemption is universal and can therefore have an ulterior, personalistic motive only in exceptional

cases, when it is not a genuine phenomenon but an abnormal misuse of it. Hysterical self-deceivers, and ordinary ones too, have at all times understood the art of misusing everything so as to avoid the demands and duties of life, and above all to shirk the duty of confronting themselves. They pretend to be seekers after God in order not to have to face the truth that they are ordinary egoists. In such cases it is well worth asking: Why are you seeking the divine water?

[143] We have no reason to suppose that all the alchemists were self-deceivers of this sort. The deeper we penetrate into the obscurities of their thinking, the more we must admit their right to style themselves “philosophers.” Throughout the ages, alchemy was one of the great human quests for the unattainable. So, at least, we would describe it if we gave rein to our rationalistic prejudices. But the religious experience of grace is an irrational phenomenon, and cannot be discussed any more than can the “beautiful” or the “good.” Since that is so, no serious quest is without hope. It is something instinctive, that cannot be reduced to a personal aetiology any more than can intelligence or musicality or any other in born propensity. I am therefore of the opinion that our analysis and interpretation have done justice to the vision of Zosimos if we have succeeded in understanding its essential components in the light of how men thought then, and in elucidating the meaning and purpose of its *mise en scène*. When Kékulé had his dream of the dancing pairs and deduced from it the structure of the benzol ring, he accomplished something that Zosimos strove for in vain. His “composition of the waters” did not fall into as neat a pattern as did the carbon and hydrogen atoms of the benzol ring. Alchemy projected an inner, psychic experience into chemical substances that seemed to hold out mysterious possibilities but nevertheless proved refractory to the intentions of the alchemist.

[144] Although chemistry has nothing to learn from the vision of Zosimos, it is a mine of discovery for modern psychology, which would come to a sorry pass if it could not turn to these testimonies of psychic experience from ancient times. Its statements would then be without support, like novelties that cannot be compared with anything, and whose value it is almost impossible to assess. But such documents give the investigator an Archimedean point outside his own narrow field of work, and therewith an invaluable opportunity to find his bearings in the seeming chaos of individual events.



PARACELSUS AS A SPIRITUAL PHENOMENON

[Originally a lecture, “Paracelsus als geistige Erscheinung,” which, revised and expanded, was published in *Paracelsica: Zwei Vorlesungen über den Arzt und Philosophen Theophrastus* (Zurich, 1942).

[In the present translation, chapter and section headings have been added to elucidate the structure of the monograph. Two brief statements found among Jung’s posthumous papers have, because of their relevance to the subject-matter, been added as footnotes on pp. 136 and 144.—EDITORS.]

FOREWORD TO "PARACELSICA"

This little book comprises two lectures delivered this year on the occasion of the four-hundredth anniversary of the death of Paracelsus.¹ The first, "Paracelsus the Physician,"² was delivered to the Swiss Society for the History of Medicine and the Natural Sciences at the annual meeting of the Society for Nature Research, Basel, September 7, 1941; the second, "Paracelsus as a Spiritual Phenomenon," was given at the Paracelsus celebrations in Einsiedeln, October 5, 1941. The first lecture goes into print unaltered except for a few minor changes. But the special nature of the theme has obliged me to take the second lecture out of its original framework and to expand it into a proper treatise. The stylistic form and scope of a lecture are not suited to portray the unknown and enigmatic Paracelsus who stands beside or behind the figure we meet in his prolific medical, scientific, and theological writings. Only when they are taken together do they give a picture of this contradictory and yet so significant personality.

I am aware that the title of this lecture is somewhat presumptuous. The reader should take it simply as a contribution to our knowledge of the arcane philosophy of Paracelsus. I do not claim to have said anything final or conclusive on this difficult subject, and am only too painfully aware of gaps and inadequacies. My purpose was confined to providing clues that might point the way to the roots and psychic background of his philosophy, if such it can be called. Besides all the other things he was, Paracelsus was, perhaps most deeply of all, an alchemical "philosopher" whose religious views involved him in an unconscious conflict with the Christian beliefs of his age in a way that seems to us inextricably confused. Nevertheless, in this confusion are to be found the beginnings of philosophical, psychological, and religious problems which are taking clearer shape in our own epoch. Because of this, I have felt it almost an historical duty to contribute what I may in appreciation of prescient ideas which he left behind for us in his treatise *De vita longa*.

C. G. J.

October 1941

1. THE TWO SOURCES OF KNOWLEDGE: THE LIGHT OF NATURE AND THE LIGHT OF REVELATION

[145] The man whose death four hundred years ago we commemorate today exerted a powerful influence on all subsequent generations, as much by sheer force of his personality as by his prodigious literary activity. His influence made itself felt chiefly in the field of medicine and natural science. In philosophy, not only was mystical speculation stimulated in a fruitful way, but philosophical alchemy, then on the point of extinction, received a new lease of life and enjoyed a renaissance. It is no secret that Goethe, as is evident from the second part of *Faust*, still felt the impact of the powerful spirit of Paracelsus.

[146] It is not easy to see this spiritual phenomenon in the round and to give a really comprehensive account of it. Paracelsus was too contradictory or too chaotically many-sided, for all his obvious one-sidedness in other ways. First and foremost, he was a physician with all the strength of his spirit and soul, and his foundation was a firm religious belief. Thus he says in his *Paragranum*:¹ “You must be of an honest, sincere, strong, true faith in God, with all your soul, heart, mind, and thought, in all love and trust. On the foundation of such faith and love, God will not withdraw his truth from you, and will make his works manifest to you, believable, visible, and comforting. But if, not having such faith, you are against God, then you will go astray in your work and will have failures, and in consequence people will have no faith in you.” The art of healing and its demands were the supreme criterion for Paracelsus. Everything in his life was devoted to this goal of helping and healing. Around this cardinal principle were grouped all his experiences, all his knowledge, all his efforts. This happens only when a man is actuated by some powerful emotional driving force, by a great passion which, undeterred by reflection and criticism, overshadows his whole life. The driving force behind Paracelsus was his compassion. “Compassion,” he exclaims, “is the physician’s schoolmaster.”² It must be inborn in him. Compassion, which has driven many another great man and inspired his work, was also the supreme arbiter of Paracelsus’s fate.

[147] The instrument which he put at the service of his great compassion was his science and his art, which he took over from his father. But the dynamism at the back of his work, the compassion itself, must have come to him from the prime source of everything emotional, that is, from his mother, of whom he never spoke. She died young, and she probably left behind a great deal of unsatisfied longing in her son—so

much that, so far as we know, no other woman was able to compete with that far-distant mother-imago, which for that reason was all the more formidable. The more remote and unreal the personal mother is, the more deeply will the son's yearning for her clutch at his soul, awakening that primordial and eternal image of the mother for whose sake everything that embraces, protects, nourishes, and helps assumes maternal form, from the Alma Mater of the university to the personification of cities, countries, sciences, and ideals. When Paracelsus says that the mother of the child is the planet and star, this is in the highest degree true of himself. To the mother in her highest form, Mater Ecclesia, he remained faithful all his life, despite the very free criticism he levelled at the ills of Christendom in that epoch. Nor did he succumb to the great temptation of that age, the Protestant schism, though he may well have had it in him to go over to the other camp. Conflict was deeply rooted in Paracelsus's nature; indeed, it had to be so, for without a tension of opposites there is no energy, and whenever a volcano, such as he was, erupts, we shall not go wrong in supposing that water and fire have clashed together.

[148] But although the Church remained a mother for Paracelsus all his life, he nevertheless had two mothers: the other was Mater Natura. And if the former was an absolute authority, so too was the latter. Even though he endeavoured to conceal the conflict between the two maternal spheres of influence, he was honest enough to admit its existence; indeed, he seems to have had a very good idea of what such a dilemma meant. Thus he says: "I also confess that I write like a pagan and yet am a Christian."³ Accordingly he named the first five sections of his *Paramirum de quinque entibus morborum* "Pagoya." "Pagoyum" is one of his favourite neologisms, compounded of "paganum" and the Hebrew word "goyim." He held that knowledge of the nature of diseases was pagan, since this knowledge came from the "light of nature" and not from revelation.⁴ "Magic," he says, is "the preceptor and teacher of the physician,"⁵ who derives his knowledge from the *lumen naturae*. There can be no doubt the "light of nature" was a second, independent source of knowledge for Paracelsus. His closest pupil, Adam von Bodenstein, puts it like this: "The Spagyric has the things of nature not by authority, but by his own experience."⁶ The concept of the *lumen naturae* may derive from the *Occulta philosophia* of Agrippa von Nettesheim (1533), who speaks of a *luminositas sensus naturae* that extends even to the four-footed beasts and enables them to foretell the future.⁷ Paracelsus says accordingly:

It is, therefore, also to be known that the auguries of the birds are caused by these innate spirits, as when cocks foretell future weather and peacocks the death of their master and other such things with their crowing. All this comes from the innate spirit and is the Light of Nature. Just as it is present in animals and is natural, so also it dwells within man and he brought it into the world with himself. He who is chaste is

a good prophet, natural as the birds, and the prophecies of birds are not contrary to nature but are of nature. Each, then, according to his own state. These things which the birds announce can also be foretold in sleep, for it is the astral spirit which is the invisible body of nature.⁸ And it should be known that when a man prophesies, he does not speak from the Devil, not from Satan, and not from the Holy Spirit, but he speaks from the innate spirit of the invisible body which teaches *Magiam* and in which the *Magus* has his origin.⁹

The light of nature comes from the *Astrum*: “Nothing can be in man unless it has been given to him by the Light of Nature, and what is in the Light of Nature has been brought by the stars.”¹⁰ The pagans still possessed the light of nature, “for to act in the Light of Nature and to rejoice in it is divine despite being mortal.” Before Christ came into the world, the world was still endowed with the light of nature, but in comparison with Christ this was a “lesser light.” “Therefore we should know that we have to interpret nature according to the spirit of nature, the Word of God according to the spirit of God, and the Devil according to his spirit also.” “He who knows nothing of these things is a gorged pig and will not leave room for instruction and experience.” The light of nature is the *quinta essentia*, extracted by God himself from the four elements, and dwelling “in our hearts.”¹¹ It is enkindled by the Holy Spirit.¹² The light of nature is an intuitive apprehension of the facts, a kind of illumination.¹³ It has two sources: a mortal and an immortal, which Paracelsus calls “angels.”¹⁴ “Man,” he says, “is also an angel and has all the latter’s qualities.” He has a natural light, but also a light outside the light of nature by which he can search out supernatural things.¹⁵ The relationship of this supernatural light to the light of revelation remains, however, obscure. Paracelsus seems to have held a peculiar trichotomous view in this respect.

[149] The authenticity of one’s own experience of nature against the authority of tradition is a basic theme of Paracelsan thinking. On this principle he based his attack on the medical schools, and his pupils¹⁶ carried the revolution even further by attacking Aristotelian philosophy. It was an attitude that opened the way for the scientific investigation of nature and helped to emancipate natural science from the authority of tradition. Though this liberating act had the most fruitful consequences, it also led to that conflict between knowledge and faith which poisoned the spiritual atmosphere of the nineteenth century in particular. Paracelsus naturally had no inkling of the possibility of these late repercussions. As a medieval Christian, he still lived in a unitary world and did not feel the two sources of knowledge, the divine and the natural, as the conflict it later turned out to be. As he says in his “*Philosophia sagax*”: “There are, therefore, two kinds of knowledge in this world: an eternal and a temporal. The eternal springs directly from the light of the Holy Spirit, but the other directly from the Light of Nature.” In his view the latter kind is ambivalent: both

good and bad. This knowledge, he says, “is not from flesh and blood, but from the stars in the flesh and blood. That is the treasure, the natural *Summum Bonum*.” Man is twofold, “one part temporal, the other part eternal, and each part takes its light from God, both the temporal and the eternal, and there is nothing that does not have its origin in God. Why, then, should the Father’s light be considered pagan, and I be recognized and condemned as a pagan?” God the Father created man “from below upwards,” but God the Son “from above downwards.” Therefore Paracelsus asks: “If Father and Son are one, how then can I honour two lights? I would be condemned as an idolater: but the number one preserves me. And if I love two and accord to each its light, as God has ordained for everyone, how then can I be a pagan?”

[150] It is clear enough from this what his attitude was to the problem of the two sources of knowledge: both lights derive from the unity of God. And yet—why did he give the name “Pagoyum” to what he wrote in the light of nature? Was he playing with words, or was it an involuntary avowal, a dim presentiment of a duality in the world and the soul? Was Paracelsus really unaffected by the schismatic spirit of the age, and was his attack on authority really confined only to Galen, Avicenna, Rhazes, and Arnaldus de Villanova?

A. MAGIC

[151] Paracelsus’s scepticism and rebelliousness stop short at the Church, but he also reined them in before alchemy, astrology, and magic, which he believed in as fervently as he did in divine revelation, since in his view they proceeded from the authority of the *lumen naturae*. And when he speaks of the divine office of the physician, he exclaims: “I under the Lord, the Lord under me, I under him outside my office, and he under me outside his office.”¹⁷ What kind of spirit addresses us in these words? Do they not recall those of the later Angelus Silesius?

I am as great as God,
And he is small like me;
He cannot be above,
Nor I below him be.

[152] There is no denying that the human ego’s affinity with God here raises a distinct claim to be heard and also to be recognized as such. That is the spirit of the Renaissance—to give man in his mightiness, intellectual power, and beauty a visible place beside God. *Deus et Homo* in a new and unprecedented sense! Agrippa von Nettesheim, Paracelsus’s older contemporary and an authority on the Cabala, declares in his sceptical and contumacious book *De incertitudine et vanitate scientiarum*:¹⁸

Agrippa spares no man.

He contemns, knows, knows not, weeps, laughs, waxes wroth,
reviles, carps at all things;
being himself philosopher, demon, hero, God,
and all things.

Paracelsus to be sure did not rise to such unfortunate heights of modernity. He felt at one with God and with himself. Wholly and unremittingly engaged in the practical art of healing, his busy mind wasted no time on abstract problems, and his irrational, intuitive nature never pursued logical reflections so far that they resulted in destructive insights.

[153] Paracelsus had one father, whom he held in love and respect, but, as we have said, like every true hero he had two mothers, a heavenly one and an earthly one—Mother Church and Mother Nature. Can one serve two mothers? And even if, like Paracelsus, one feels oneself a physician created by God, is there not something suspicious about pressing God into one's service inside the physician's office, so to speak? One can easily object that Paracelsus said this, like so much else, only in passing and that it is not to be taken all that seriously. He himself would probably have been astonished and indignant if he had been taken at his word. The words that flowed into his pen came less from deep reflection than from the spirit of the age in which he lived. No one can claim to be immune to the spirit of his own epoch or to possess anything like a complete knowledge of it. Regardless of our conscious convictions, we are all without exception, in so far as we are particles in the mass, gnawed at and undermined by the spirit that runs through the masses. Our freedom extends only as far as our consciousness reaches. Beyond that, we succumb to the unconscious influences of our environment. Though we may not be clear in a logical sense about the deepest meanings of our words and actions, these meanings nevertheless exist and they have a psychological effect. Whether we know it or not, there remains in each of us the tremendous tension between the man who *serves* God and the man who *commands* God to do his bidding.

[154] But the greater the tension, the greater the potential. Great energy springs from a correspondingly great tension of opposites. It was to the constellation of the most powerful opposites within him that Paracelsus owed his almost daemonic energy, which was not an unalloyed gift of God but went hand in hand with his impetuous and quarrelsome temperament, his hastiness, impatience, discontentedness, and his arrogance. Not for nothing was Paracelsus the prototype of Faust, whom Jacob Burckhardt once called "a great primordial image" in the soul of every German. From Faust the line leads direct to Nietzsche, who was a Faustian man if ever there was one. What still maintained the balance in the case of Paracelsus and Angelus Silesius—"I under God and God under me"—was lost in the twentieth century, and

the scale sinks lower and lower under the weight of an ego that fancies itself more and more godlike. Paracelsus shared with Angelus Silesius his inner piety and the touching but dangerous simplicity of his relationship to God. But alongside this spirituality a countervailing chthonic spirit made itself felt to an almost frightening degree: there was no form of manticism and magic that Paracelsus did not practise himself or recommend to others. Dabbling in these arts—no matter how enlightened one thinks one is—is not without its psychological dangers. Magic always was and still is a source of fascination. At the time of Paracelsus, certainly, the world teemed with marvels: everyone was conscious of the immediate presence of the dark forces of nature. Astronomy and astrology were not yet separated. Kepler still cast horoscopes. Instead of chemistry there was only alchemy. Amulets, talismans, spells for healing wounds and diseases were taken as a matter of course. A man so avid for knowledge as Paracelsus could not avoid a thorough investigation of all these things, only to discover that strange and remarkable effects resulted from their use. But so far as I know he never uttered a clear warning about the psychic dangers of magic for the adept.¹⁹ He even scoffed at the doctors because they understood nothing of magic. But he does not mention that they kept away from it out of a quite justifiable fear. And yet we know from the testimony of Conrad Gessner, of Zurich, that the very doctors whom Paracelsus attacked shunned magic on religious grounds and accused him and his pupils of sorcery. Writing to Crato von Crafftheim²⁰ about Paracelsus's pupil Adam von Bodenstein, Gessner says: "I know that most people of this kind are Arians and deny the divinity of Christ . . . Oporin in Basel, once a pupil of Theophrastus and his private assistant [*familiaris*], reported strange tales concerning the latter's intercourse with demons. They are given to senseless astrology, geomancy, necromancy, and other forbidden arts. I myself suspect that they are the last of the Druids, those of the ancient Celts who were instructed for several years in underground places by demons. It is also certain that such things are done to this very day at Salamanca in Spain. From this school also arose the wandering scholars, as they are commonly called. The most famous of these was Faust, who died not so long ago." Elsewhere in the same letter Gessner writes: "Theophrastus has assuredly been an impious man and a sorcerer [*magus*], and has had intercourse with demons."²¹

[155] Although this judgment is based in part on the unreliable testimony of Oporin and is essentially unfair or actually false, it nevertheless shows how unseemly, in the opinion of contemporary doctors of repute, was Paracelsus's preoccupation with magic. He himself, as we have said, had no such scruples. He drew magic, like everything else worth knowing, into his orbit and tried to exploit it medically for the benefit of the sick, unperturbed by what it might do to him personally or what the implications might be from the religious point of view. For him magic and the wisdom of nature had their place within the divinely ordained order as a *mysterium et*

magnale Dei, and so it was not difficult for him to bridge the gulf into which half the world had plunged.²² Instead of experiencing any conflict in himself, he found his arch-enemy outside in the great medical authorities of the past, as well as in the host of academic physicians against whom he let fly like the proper Swiss mercenary he was. He was infuriated beyond measure by the resistance of his opponents and he made enemies everywhere. His writings are as turbulent as his life and his wanderings. His style is violently rhetorical. He always seems to be speaking importunately into someone's ear—someone who listens unwillingly, or against whose thick skin even the best arguments rebound. His exposition of a subject is seldom systematic or even coherent; it is constantly interrupted by admonitions, addressed in a subtle or coarse vein to an invisible auditor afflicted with moral deafness. Paracelsus was a little too sure that he had his enemy in front of him, and did not notice that it was lodged in his own bosom. He consisted of two persons who never really confronted one another. He nowhere betrays the least suspicion that he might not be at one with himself. He felt himself to be undividedly one, and all the things that constantly thwarted him had of course to be his external enemies. He had to conquer them and prove to them that he was the “Monarcha,” the sovereign ruler, which secretly and unknown to himself was the very thing he was not. He was so unconscious of the conflict within him that he never noticed there was a second ruler in his own house who worked against him and opposed everything he wanted. But every unconscious conflict works out like that: one obstructs and undermines oneself. Paracelsus did not see that the truth of the Church and the Christian standpoint could never get along with the thought implicit in all alchemy, “God under me.” And when one unconsciously works against oneself, the result is impatience, irritability, and an impotent longing to get one's opponent down whatever the means. Generally certain symptoms appear, among them a peculiar use of language: one wants to speak forcefully in order to impress one's opponent, so one employs a special, “bombastic” style full of neologisms which might be described as “power-words.”²³ This symptom is observable not only in the psychiatric clinic but also among certain modern philosophers, and, above all, whenever anything unworthy of belief has to be insisted on in the teeth of inner resistance: the language swells up, overreaches itself, sprouts grotesque words distinguished only by their needless complexity. The word is charged with the task of achieving what cannot be done by honest means. It is the old word magic, and sometimes it can degenerate into a regular disease. Paracelsus was afflicted with this malady to such a degree that even his closest pupils were obliged to compile “onomastica” (word-lists) and to publish commentaries. The unwary reader continually stumbles over these neologisms and is completely baffled at first, for Paracelsus never bothered to give any explanations even when, as often happens, the word was a *hapax legomenon* (one that occurs only once). Often it is only by comparing a number of passages that one can approximately make out the sense.

There are, however, mitigating circumstances: doctors have always loved using magically incomprehensible jargon for even the most ordinary things. It is part of the medical persona. But it is odd indeed that Paracelsus, who prided himself on teaching and writing in German, should have been the very one to concoct the most intricate neologisms out of Latin, Greek, Italian, Hebrew, and possibly even Arabic.

[156] Magic is insidious, and therein lies its danger. At one point, where Paracelsus is discussing witchcraft, he actually falls into using a magical witch-language without giving the least explanation. For instance, instead of “Zwirnfaden” (twine) he says “Swindafnerz,” instead of “Nadel” (needle) “Dallen,” instead of “Leiche” (corpse) “Chely,” instead of “Faden” (thread) “Daphne,” and so on.²⁴ In magical rites the inversion of letters serves the diabolical purpose of turning the divine order into an infernal disorder. It is remarkable how casually and unthinkingly Paracelsus takes over these magically distorted words and simply leaves the reader to make what he can of them. This shows that Paracelsus must have been thoroughly steeped in the lowest folk beliefs and popular superstitions, and one looks in vain for any trace of disgust at such squalid things, though in his case its absence was certainly not due to lack of feeling but rather to a kind of natural innocence and naïveté. Thus he himself recommends the magical use of wax manikins in cases of sickness,²⁵ and seems to have designed and used amulets and seals.²⁸ He was convinced that physicians should have an understanding of the magic arts and should not eschew sorcery if this might help their patients. But this kind of folk magic is not Christian, it is demonstrably pagan—in a word, a “Pagoyum.”

B. ALCHEMY

[157] Besides his manifold contacts with folk superstition there was another, more respectable source of “pagan” lore that had a great influence on Paracelsus. This was his knowledge of and intense preoccupation with alchemy, which he used not only in his pharmacology and pharmaceuticals but also for “philosophical” purposes. Since earliest times alchemy contained, or actually was, a secret doctrine. With the triumph of Christianity under Constantine the old pagan ideas did not vanish but lived on in the strange arcane terminology of philosophical alchemy. Its chief figure was Hermes or Mercurius, in his dual significance as quicksilver and the world soul, with his companion figures Sol (= gold) and Luna (= silver). The alchemical operation consisted essentially in separating the prima materia, the so-called chaos, into the active principle, the soul, and the passive principle, the body, which were then reunited in personified form in the *coniunctio* or “chymical marriage.” In other words, the *coniunctio* was allegorized as the hierosgamos, the ritual cohabitation of Sol and Luna. From this union sprang the *filius sapientiae* or *filius philosophorum*,

the transformed Mercurius, who was thought of as hermaphroditic in token of his rounded perfection. [Cf. [fig. B2.](#)]

[158] The *opus alchymicum*, in spite of its chemical aspects, was always understood as a kind of rite after the manner of an *opus divinum*. For this reason Melchior Cibirensis, at the beginning of the sixteenth century, could still represent it in the form of a Mass,²⁷ since long before this the *filius* or *lapis philosophorum* had been regarded as an allegory of Christ.²⁸ Many things in Paracelsus that would otherwise remain incomprehensible must be understood in terms of this tradition. In it are to be found the origins of practically the whole of his philosophy in so far as it is not Cabalistic. It is evident from his writings that he had a considerable knowledge of Hermetic literature.²⁹ Like all medieval alchemists he seems not to have been aware of the true nature of alchemy, although the refusal of the Basel printer Conrad Waldkirch, at the end of the sixteenth century, to print the first part of *Aurora consurgens* (a treatise falsely ascribed to St. Thomas Aquinas) on account of its “blasphemous character”³⁰ shows that the dubious nature of alchemy was apparent even to a layman. To me it seems certain that Paracelsus was completely naïve in these matters and, intent only on the welfare of the sick, used alchemy primarily for its practical value regardless of its murky background. Consciously, alchemy for him meant a knowledge of the *materia medica* and a chemical procedure for preparing medicaments, above all the well-loved arcana, the secret remedies. He also believed that one could make gold and engender homunculi.³¹ This aspect of it was so predominant that one is inclined to forget that alchemy meant very much more to him than that. We know this from a brief remark in the *Paragranum*, where he says that the physician himself is “ripened” by the art.³² This sounds as though the alchemical maturation should go hand in hand with the maturation of the physician. If we are not mistaken in this assumption, we must further conclude that Paracelsus not only was acquainted with the arcane teachings of alchemy but was convinced of their rightness. It is of course impossible to prove this without detailed investigation, for the esteem which he expressed for alchemy throughout his writings might in the end refer only to its chemical aspect. This special predilection of his made him a forerunner and inaugurator of modern chemical medicine. Even his belief in the transmutation of metals and in the *lapis philosophorum*, which he shared with many others, is no evidence of a deeper affinity with the mystic background of the *ars aurifera*. And yet such an affinity is very probable since his closest followers were found among the alchemical physicians.³³

C. THE ARCANES TEACHING

[159] In the course of our inquiry we shall have to scrutinize more closely the arcane teaching of alchemy, which is so important for an understanding of the spiritual side

of Paracelsus. I must ask the reader to forgive me in advance for putting his attention and patience to such a severe test. The subject is abstruse and wrapped in obscurity, but it constitutes an essential part of the Paracelsan spirit and exerted a profound influence on Goethe, so much so that the impressions he gained in his Leipzig days continued to engross him even in old age: indeed, they formed the matrix for *Faust*.

[160] When one reads Paracelsus, it is chiefly the technical neologisms that seem to give out mysterious hints. But when one tries to establish their etymology and their meaning, as often as not one ends up in a blind alley. For instance, one can guess that “Iliaster” or “Yliastrum” is composed etymologically of ὕλη (matter) and ἄστρον (star), and that it means about the same as the *spiritus vitae* of classical alchemy, or that “Cagastrium” is connected with κακὸς (bad) and ἄστήρ, or that “Anthos” and “Anthera” are embellishments of the alchemical *flores*. Even his philosophical concepts, such as the doctrine of the *astrum*, only lead us back to the known alchemical and astrological tradition, from which we can see that his doctrine of the *corpus astrale* was not a new discovery. We find this idea already in an old classic, the “Tractatus Aristotelis,” where it is said that the “planets in man” have a more powerful influence than the heavenly bodies,³⁴ and when Paracelsus says that the medicine is found in the *astrum*, we read in the same treatise that “in man, who is made in the image of God, can be found the cause and the medicine.”

[161] But that other pivot of Paracelsus’s teaching, his belief in the light of nature, allows us to surmise connections which illuminate the obscurities of his *religio medica*. The light hidden in nature and particularly in human nature likewise belongs to the stock of ancient alchemical ideas. Thus the “Tractatus Aristotelis” says: “See therefore that the light which is in thee be not darkness.” The light of nature is indeed of great importance in alchemy. Just as, according to Paracelsus, it enlightens man as to the workings of nature and gives him an understanding of natural things “by cagastic magic” (*per magiam cagasticam*),³⁵ so it is the aim of alchemy to beget this light in the shape of the *filius philosophorum*. An equally ancient treatise of Arabic provenance attributed to Hermes,³⁶ the “Tractatus aureus,” says (Mercurius is speaking): “My light excels all other lights, and my goods are higher than all other goods. I beget the light, but the darkness too is of my nature. Nothing better or more worthy of veneration can come to pass in the world than the union of myself with my son.”³⁷ In the “Dicta Belini” (Belinus is a pseudo-Apollonius of Tyana) Mercurius says: “I enlighten all that is mine, and I make the light manifest on the journey from my father Saturn.”³⁸ “I make the days of the world eternal, and I illumine all lights with my light.”³⁹ Another author says of the “chymical marriage” from which arises the *filius philosophorum*: “They embrace and the new light is begotten of them, which is like no other light in the whole world.”⁴⁰

[162] This idea of the light, with Paracelsus as with other alchemists, coincides with the concept of Sapiientia and Scientia. We can safely call the light the central mystery of philosophical alchemy. Almost always it is personified as the *filius*, or is at least mentioned as one of his outstanding attributes. It is a δαιμόνιον pure and simple. Often the texts refer to the need for a familiar spirit who should help the adept at his work. The Magic Papyri do not hesitate to enlist the services even of the major gods.⁴¹ The *filius* remains in the adept's power. Thus the treatise of Haly, king of Arabia, says: "And that son . . . shall serve thee in thy house in this world and in the next."⁴² Long before Paracelsus, as I have said, this *filius* was equated with Christ. The parallel comes out very clearly in the sixteenth-century German alchemists who were influenced by Paracelsus. For instance, Heinrich Khunrath says: "This [the *filius philosophorum*], the Son of the Macrocosm, is God and creature . . . that [Christ], is the son of God, the θεάνθρωπος, that is, God and man; the one conceived in the womb of the Macrocosm, the other in the womb of the Microcosm, and both of a virginal womb. . . . Without blasphemy I say: In the Book or Mirror of Nature, the Stone of the Philosophers, the Preserver of the Macrocosm, is the symbol of Christ Jesus Crucified, Saviour of the whole race of men, that is, of the Microcosm. From the stone you shall know in natural wise Christ, and from Christ the stone."⁴³

[163] To me it seems certain that Paracelsus was just as unconscious of the full implications of these teachings as Khunrath was, who also believed he was speaking "without blasphemy." But in spite of this unconsciousness they were of the essence of philosophical alchemy,⁴⁴ and anyone who practised it thought, lived, and acted in the atmosphere of these teachings, which perhaps had an all the more insidious effect the more naïvely and uncritically one succumbed to them. The "natural light of man" or the "star in man" sounds harmless enough, so that none of the authors had any notion of the possibilities of conflict that lurked within it. And yet that light or *filius philosophorum* was openly named the greatest and most victorious of all lights, and set alongside Christ as the Saviour and Preserver of the world! Whereas in Christ God himself became man, the *filius philosophorum* was extracted from matter by human art and, by means of the opus, made into a new light-bringer. In the former case the miracle of man's salvation is accomplished by God; in the latter, the salvation or transfiguration of the universe is brought about by the mind of man—"Deo concedente," as the authors never fail to add. In the one case man confesses "I under God," in the other he asserts "God under me." Man takes the place of the Creator. Medieval alchemy prepared the way for the greatest intervention in the divine world order that man has ever attempted: alchemy was the dawn of the scientific age, when the daemon of the scientific spirit compelled the forces of nature to serve man to an extent that had never been known before. It was from the spirit of alchemy that Goethe wrought the figure of the "superman" Faust, and this superman

led Nietzsche's Zarathustra to declare that God was dead and to proclaim the will to give birth to the superman, to "create a god for yourself out of your seven devils."⁴⁵ Here we find the true roots, the preparatory processes deep in the psyche, which unleashed the forces at work in the world today. Science and technology have indeed conquered the world, but whether the psyche has gained anything is another matter.

[164] Paracelsus's preoccupation with alchemy exposed him to an influence that left its mark on his spiritual development. The inner driving-force behind the aspirations of alchemy was a presumption whose daemonic grandeur on the one hand and psychic danger⁴⁶ on the other should not be underestimated. Much of the overbearing pride and arrogant self-esteem, which contrasts so strangely with the truly Christian humility of Paracelsus, comes from this source. What erupted like a volcano in Agrippa von Nettesheim's "himself demon, hero, God" remained, with Paracelsus, hidden under the threshold of a Christian consciousness and expressed itself only indirectly in exaggerated claims and in his irritable self-assertiveness, which made him enemies wherever he went. We know from experience that such a symptom is due to unadmitted feelings of inferiority, i.e., to a real failing of which one is usually unconscious. In each of us there is a pitiless judge who makes us feel guilty even if we are not conscious of having done anything wrong. Although we do not know what it is, it is as though it were known somewhere. Paracelsus's desire to help the sick at all costs was doubtless quite pure and genuine. But the magical means he used, and in particular the secret content of alchemy, were diametrically opposed to the spirit of Christianity. And that remained so whether Paracelsus was aware of it or not. Subjectively, he was without blame; but that pitiless judge condemned him to feelings of inferiority that clouded his life.

D. THE PRIMORDIAL MAN

[165] This crucial point, namely the arcane doctrine of the marvellous son of the philosophers, is the subject of unfriendly but perspicacious criticism by Conrad Gessner. Apropos the works of a pupil of Paracelsus, Alexander à Suchten,⁴⁷ he writes to Crato: "But look who it is whom he reveals to us as the son of God, namely none other than the spirit of the world and of nature, and the same who dwells in our bodies (it is a wonder that he does not add the spirit of the ox and the ass!). This spirit can be separated from matter or from the body of the elements by the technical procedures of the Theophrastus school. If anyone were to take him at his word, he would say that he had merely voiced a principle of the philosophers, but not his own opinion. He repeats it, however, in order to express his agreement. And I know that other Theophrastians besmirch such things with their writings, from which it is easy to conclude that they deny the divinity of Christ. I myself am entirely convinced that

Theophrastus has been an Arian. They endeavour to persuade us that Christ was a quite ordinary man, and that in him was no other spirit than in us.”⁴⁸

[166] Gessner’s charge against the Theophrastus school and against the Master himself applies to alchemy in general. The extraction of the world soul from matter was not a peculiarity of Paracelsan alchemy. But the charge of Arianism is unjustified. It was obviously prompted by the well-known parallel between the *filius philosophorum* and Christ, though so far as I know this nowhere occurs in Paracelsus’s own writings. On the other hand, in a treatise called “Apokalypsis Hermetis,” ascribed by Huser to Paracelsus, there is a complete alchemical confession of faith which lends Gessner’s charge a certain weight. There Paracelsus says of the “spirit of the fifth essence”: “This is the spirit of truth, whom the world cannot comprehend without the inspiration of the Holy Ghost, or without the instruction of those who know him.”⁴⁹ “He is the soul of the world,” moving all and preserving all. In his initial earthly form (that is, in his original Saturnine darkness) he is unclean, but he purifies himself progressively during the ascent through his watery, aerial, and fiery forms. Finally, in the fifth essence, he appears as the “clarified body.”⁵⁰ “This spirit is the secret that has been hidden since the beginning of things.”

[167] Paracelsus is speaking here as a true alchemist. Like his pupils, he draws the Cabala, which had been made accessible to the world at large through Pico della Mirandola and Agrippa, into the scope of his alchemical speculations. “All you who are led by your religion to prophesy future events and to interpret the past and the present to people, you who see abroad and read hidden letters and sealed books, who seek in the earth and in walls for what is buried, you who learn great wisdom and art—bear in mind if you wish to apply all these things, that you take to yourselves the religion of the Gabal and walk in its light, for the Gabal is well-founded. Ask and it will be granted to you, knock, you will be heard and it will be opened unto you. From this granting and opening there will flow what you desire: you will see into the lowest depths of the earth, into the depths of hell, into the third heaven. You will gain more wisdom than Solomon, you will have greater communion with God than Moses and Aaron.”⁵¹

[168] Just as the wisdom of the Cabala coincided with the Sapientia of alchemy, so the figure of Adam Kadmon was identified with the *filius philosophorum*. Originally this figure may have been the ἄνθρωπος φωτεινός, the “man of light” who was imprisoned in Adam, and whom we encounter in Zosimos of Panopolis (third century).⁶² But the man of light is an echo of the pre-Christian doctrine of the Primordial Man. Under the influence of Marsilio Ficino and Pico della Mirandola, these and other Neoplatonic ideas had already become popularized in the fifteenth century and were known to nearly every educated person. In alchemy they fell in with the remnants of classical tradition. Besides this there were the views of the

Cabala, which had been philosophically assessed by Pico.⁵³ He and Agrippa⁵⁴ were probably the sources for Paracelsus's somewhat scanty knowledge of the Cabala. For Paracelsus the Primordial Man was identical with the "astral" man: "The true man is the star in us."⁵⁵ "The star desires to drive man towards great wisdom."⁵⁶ In his *Paragranum* he says: "For heaven is man and man is heaven, and all men are one heaven, and heaven is only one man."⁵⁷ Man stands in the relationship of a son to the inner heaven,⁵⁸ which is the Father, whom Paracelsus calls the *homo maximus*⁵⁹ or Adech,⁶⁰ an arcane name derived from Adam. Elsewhere he is called Archeus: "He is therefore similar to man and consists of the four elements and is an Archeus and is composed of four parts; say then, he is the great Cosmos."⁶¹ Undoubtedly this is the Primordial Man, for Paracelsus says: "In the whole Ides there is but One Man, the same is extracted by the Iliastrum⁶² and is the Protoplast." Ides or Ideus is "the gate through which all created things have proceeded," the "globule or materia" from which man was created.⁶³ Other secret names for the Primordial Man are Idechtrum⁶⁴ and Protothoma.⁶³ The number of names alone shows how preoccupied Paracelsus was with this idea. The ancient teachings about the Anthropos or Primordial Man assert that God, or the world-creating principle, was made manifest in the form of a "first-created" (*protoplastus*) man, usually of cosmic size. In India he is Prajāpati or Purusha, who is also "the size of a thumb" and dwells in the heart of every man, like the Iliaster of Paracelsus. In Persia he is Gayomart (*gayō-maretan*, 'mortal life'), a youth of dazzling whiteness, as is also said of the alchemical Mercurius. In the *Zohar* he is Metatron, who was created together with light. He is the celestial man whom we meet in the visions of Daniel, Ezra, Enoch, and also in Philo Judaeus. He is one of the principal figures in Gnosticism, where, as always, he is connected with the question of creation and redemption.⁶⁶ This is the case with Paracelsus.

2. "DE VITA LONGA": AN EXPOSITION OF THE SECRET DOCTRINE

[169] The treatise *De vita longa*,¹ difficult as it is to understand in parts, gives us some information on this point, though we have to extricate it with an effort from the arcane terminology in which it is embedded. The treatise is one of the few that were written in Latin; the style is exceedingly strange, but all the same it contains so many significant hints that it is worth investigating more closely. Adam von Bodenstein, who edited it, says in a dedicatory letter² to Ludwig Wolfgang von Hapsberg, governor of Badenweiler, that it was "taken down from the mouth of Paracelsus and carefully revised." The obvious inference is that the treatise is based on notes of Paracelsus's lectures and is not an original text. As Bodenstein himself wrote fluent and easily understandable Latin, quite unlike that of the treatise, one must assume that he did not devote any particular attention to it and made no effort to put it into more intelligible form, otherwise much more of his own style would have crept in. Probably he left the lectures more or less in their original state, as is particularly apparent towards the end. It is also likely that he had no very clear understanding of what they were about, any more than had the supposed translator Oporin. This is not surprising, as the Master himself all too often lacks the necessary clarity when discussing these complicated matters. Under these circumstances it is difficult to say how much should be put down to incomprehension and how much to undisciplined thinking. Nor is the possibility of actual errors in transcription excluded.³ In our interpretation, therefore, we are on uncertain ground from the start, and much must remain conjecture. But as Paracelsus, for all his originality, was strongly influenced by alchemical thinking, a knowledge of the earlier and contemporary alchemical treatises, and of the writings of his pupils and followers, is of considerable help in interpreting some of the concepts and in filling out certain gaps. An attempt to comment on and to interpret the treatise, therefore, is not entirely hopeless, despite the admitted difficulties.

A. THE ILIASTER

[170] The treatise is mainly concerned with the conditions under which longevity, which in Paracelsus's opinion extends up to a thousand years or more, can be attained. In what follows I shall give chiefly the passages that relate to the secret doctrine and are of help in explaining it.⁴ Paracelsus starts by giving a definition of life, as follows: "Life, by Hercules, is nothing other than a certain embalmed Mumia, which preserves the mortal body from the mortal worms and from corruption⁵ by means of a mixed saline solution." Mumia was well known in the Middle Ages as a medicament, and it consisted of the pulverized parts of real Egyptian mummies, in which there was a flourishing trade. Paracelsus attributes incorruptibility to a special virtue or agent named "balsam." This was something like a natural elixir, by means of which the body was kept alive or, if dead, incorruptible.⁶ By the same logic, a scorpion or venomous snake necessarily had in it an alexipharmic, i.e., an antidote, otherwise it would die of its own poison.

[171] Paracelsus goes on to discuss a great many arcane remedies, since diseases shorten life and have above all to be cured. The chief among these remedies are gold and pearls, which latter can be transformed into the *quinta essentia*. A peculiar potency is attributed to *Cheyri*,⁷ which fortifies the microcosmic body so much that it "must necessarily continue in its conservation through the universal anatomy of the four elements."⁸ Therefore the physician should see to it that the "anatomy" (= structure) of the four elements "be contracted into the one anatomy of the microcosm, not out of the corporeal, but out of that which preserves the corporeal." This is the balsam, which stands even higher than the *quinta essentia*, the thing that ordinarily holds the four elements together. It "excels even nature herself" because it is produced by a "bodily operation."⁹ The idea that the art can make something higher than nature is typically alchemical. The balsam is the life principle, the *spiritus mercurii*, and it more or less coincides with the Paracelsan concept of the Iliaster. The latter is higher than the four elements and determines the length of life. It is therefore roughly the same as the balsam, or one could say that the balsam is the pharmacological or chemical aspect of the Iliaster.¹⁰ The Iliaster has three forms: *Iliaster sanctitus*,¹¹ *paratetus*,¹² and *magnus*. They are subordinate to man ("microcosmo subditi") and can be brought "into one gamonymus." Since Paracelsus attributes a special "vis ac potestas coniunctionis" to the Iliaster, this enigmatic "gamonymus" (γάμος = marriage, ὄνομα = name) must be interpreted as a kind of chymical wedding, in other words as an indissoluble, hermaphroditic union.¹³ There are as many Iliastri as there are men; that is to say in every man there is an Iliaster that holds together each individual's peculiar combination of qualities.¹⁴ It therefore seems to be a kind of universal formative principle and principle of individuation.

[172] The Iliaster forms the starting point for the arcane preparation of longevity. “We will explain what is most needful in this process regarding the Iliaster. In the first place, the impure animate body must be purified through the separation of the elements, which is done by your meditating upon it; this consists in the confirmation of your mind beyond all bodily and mechanic work.”¹⁵ In this way a “new form is impressed” on the impure body.

[173] I have translated *imaginatio* here by “meditating.” In the Paracelsist tradition *imaginatio* is the active power of the *astrum* (star) or *corpus coeleste sive supracoeleste* (Ruland), that is, of the higher man within. Here we encounter the psychic factor in alchemy: the artifex accompanies his chemical work with a simultaneous mental operation which is performed by means of the imagination. Its purpose is to cleanse away the impure admixture and at the same time to bring about the “confirmation” of the mind. The Paracelsan neologism *confirmamentum* is probably not without reference to the “firmament.” During this work man is “raised up in his mind, so that he is made equal to the Enochdiani” (those who enjoy an unusually long life, like Enoch).¹⁶ Hence his “interior anatomy” must be heated to the highest degree.¹⁷ In this way the impurities are consumed and only the solid is left, “without rust.” While the artifex heats the chemical substance in the furnace he himself is morally undergoing the same fiery torment and purification.¹⁸ By projecting himself into the substance he has become unconsciously identical with it and suffers the same process. Paracelsus does not fail to point out to his reader that this fire is not the same as the fire in the furnace. This fire, he says, contains nothing more of the “Salamandrine Essence or Melusinian Ares,” but is rather a “*retorta distillatio* from the midst of the centre, beyond all coal fire.” Since Melusina is a watery creature, the “Melusinian Ares”¹⁹ refers to the so-called “Aquaaster,”²⁰ which stands for the watery aspect of the Iliaster, i.e., the Iliaster which animates and preserves the liquids in the body. The Iliaster is without doubt a spiritual, invisible principle although it is also something like the *prima materia*, which, however, in alchemical usage by no means corresponds to what we understand by matter. For the alchemists the *prima materia* was the *humidum radicale* (radical moisture),²¹ the water,²² the *spiritus aquae*,²³ and *vapor terrae*;²⁴ it was also called the “soul” of the substances,²⁵ the *sperma mundi*,²⁶ Adam’s tree of paradise with its many flowers, which grows on the sea,²⁷ the round body from the centre,²⁸ Adam and the accursed man,²⁹ the hermaphroditic monster,³⁰ the One and the root of itself,³¹ the All,³² and so on. The symbolical names of the *prima materia* all point to the *anima mundi*, Plato’s Primordial Man, the Anthropos and mystic Adam, who is described as a sphere (= wholeness), consisting of four parts (uniting different aspects in itself),

hermaphroditic (beyond division by sex), and damp (i.e., psychic). This paints a picture of the self, the indescribable totality of man.

[174] The Aquaster, too, is a spiritual principle; for instance, it shows the adept the “way by which he can search out divine magic.” The adept himself is an “aquastric magician.” The “scayolic³³ Aquaster” shows him the “great cause” with the help of the *Trarames* (ghostly spirits). Christ took his body from the celestial Aquaster, and the body of Mary was “necrocomic”³⁴ and “aquastric.” Mary “came from the iliastic Aquaster.” There, Paracelsus emphasizes, she stood on the moon (the moon is always related to water). Christ was born in the celestial Aquaster. In the human skull there is an “aquastric fissure,” in men on the forehead, in women at the back of the head. Through this fissure women are liable to be invaded in their “cagastric” Aquaster by a crowd of diabolical spirits; but men, through their fissure, give birth, “not cagastrically but necrocomically, to the necrocomic *Animam vel spiritum vitae microcosmi*, the iliastic spirit of life in the heart.” In the “centre of the heart dwells the true soul, the breath of God.”³⁵

[175] From these quotations it is easy to see what the Aquaster means. Whereas the Iliaster seems to be a dynamic spiritual principle, capable of both good and evil, the Aquaster, because of its watery nature, is more a “psychic” principle with quasimaterial attributes (since the bodies of Christ and Mary partook of it). But it functions psychically as a “necrocomic” (i.e., telepathic) agent related to the spiritual world, and as the birthplace of the *spiritus vitae*. Of all the Paracelsan concepts, therefore, the Aquaster comes closest to the modern concept of the unconscious. So we can see why Paracelsus personifies it as the homunculus and describes the soul as the celestial Aquaster. Like a true alchemist, he thought of the Aquaster and Iliaster as extending both upwards and downwards: they assume a spiritual or heavenly form as well as a quasi-material or earthly one. This is in keeping with the axiom from “*Tabula smaragdina*”: “What is below is like what is above, that the miracle of the one thing may be accomplished.” This one thing is the lapis or *filius philosophorum*.³⁶ As the definitions and names of the prima materia make abundantly plain, matter in alchemy is material and spiritual, and spirit spiritual and material. Only, in the first case matter is *cruda, confusa, grossa, crassa, densa*, and in the second it is *subtilis*. Such, too, is the opinion of Paracelsus.

C. ARES

[176] Rather superficially, Adam von Bodenstein conceives “Ares” to be the “prime nature of things, determining their form and species.”³⁷ Ruland lumps it together with the Iliaster and Archeus. But whereas the Iliaster is the hypostasis of being in general (“*generis generalissimi substantia*”), Archeus is given the role of a “dispenser of nature” (*naturae dispensator*) and “initiator.” Ares, however, is the “assigner, who

extends the peculiar nature to each species, and gives individual form.”³⁸ It can therefore be taken as the principle of individuation in the strict sense. It proceeds from the supracelestial bodies, for “such is the property and nature of supracelestial bodies that they straightway produce out of nothing a corporeal imagination [*imaginationem corporalem*], so as to be thought a solid body. Of this kind is Ares, so that when one thinks of a wolf, a wolf appears.”³⁹ This world is like the creatures composed of the four elements. From the elements arise things which are in no way like their origins, but nonetheless Ares bears them all in himself.”⁴⁰

[177] Ares, accordingly, is an intuitive concept for a preconscious, creative, and formative principle which is capable of giving life to individual creatures. It is thus a more specific principle of individuation than the Iliaster, and as such it plays an important role in the purification of the natural man by fire and his transformation into an “Enochdianus.” The fire he is heated with is, as we have seen, no ordinary fire, since it does not contain either the “Melusinian Ares” or the “Salamandrine Essence.” The salamander symbolizes the fire of the alchemists. It is itself of the nature of fire, a fiery essence. According to Paracelsus, Salamandrini and Saldini are men or spirits of fire, fiery beings. It is an old tradition that, because they have proved their incorruptibility in the fire, such creatures enjoy a particularly long life. The salamander is also the “incombustible sulphur”—another name for the arcane substance from which the lapis or *filius* is produced. The fire for heating the artifex contains nothing more of the nature of the salamander, which is an immature, transitional form of the *filius*, that incorruptible being whose symbols indicate the self.

[178] Paracelsus endows Ares with the attribute “Melusinian.” Since Melusina undoubtedly belongs to the watery realm, the realm of the nymphs, this attribute imports a watery character into the concept of Ares, which in itself is spiritual. Ares is thus brought into relationship with the lower, denser region and is intimately connected with the body. As a result, Ares becomes so like the Aquaster that it is scarcely possible to distinguish them conceptually. It is characteristic of Paracelsan thinking, and of alchemy in general, that there are no clear-cut concepts, so that one concept can take the place of another *ad infinitum*. At the same time every concept behaves hypostatically, as though it were a substance that could not at the same time be another substance. This typical primitive phenomenon is found also in Indian philosophy, which swarms with hypostases. Examples of this are the myths of the gods, which, as in Greek and Egyptian mythology, make utterly contradictory statements about the same god. Despite their contradictions, however, the myths continue to exist side by side without disturbing one another.

D. MELUSINA

[179] As we shall meet with Melusina several times more in the course of our interpretation, we must examine more closely the nature of this fabulous creature, and in particular the role she plays in Paracelsus. As we know, she belongs to the realm of the Aquaster, and is a water-nymph with the tail of a fish or snake. In the original old French legend she appears as “mère Lusine,” the ancestress of the counts of Lusignan. When her husband once surprised her in her fish-tail, which she had to wear only on Saturdays, her secret was out and she was forced to disappear again into the watery realm. She reappeared only from time to time, as a presage of disaster.

[180] Melusina comes into the same category as the nymphs and sirens who dwell in the “Nymphidida,” the watery realm.⁴¹ In the treatise “De sanguine,”⁴² the nymph is specified as a *Schröttli*, ‘nightmare.’ Melusines, on the other hand, dwell in the blood.⁴³ Paracelsus tells us in “De pygmaeis”⁴⁴ that Melusina was originally a nymph who was seduced by Beelzebub into practising witchcraft. She was descended from the whale in whose belly the prophet Jonah beheld great mysteries. This derivation is very important: the birthplace of Melusina is the womb of the mysteries, obviously what we today would call the unconscious. Melusines have no genitals,⁴⁵ a fact that characterizes them as paradisaic beings, since Adam and Eve in paradise had no genitals either.⁴⁶ Moreover paradise was then beneath the water “and still is.”⁴⁷ When the devil glided into the tree of paradise the tree was “saddened,” and Eve was seduced by the “infernal basilisk.”⁴⁸ Adam and Eve “fell for” the serpent and became “monstrous,” that is, as a result of their slip-up with the snake they acquired genitals.⁴⁹ But the Melusines remained in the paradisaic state as water creatures and went on living in the human blood. Since blood is a primitive symbol for the soul,⁵⁰ Melusina can be interpreted as a spirit, or at any rate as some kind of psychic phenomenon. Gerard Dorn confirms this in his commentary on *De vita longa*, where he says that Melusina is a “vision appearing in the mind.”⁵¹ For anyone familiar with the subliminal processes of psychic transformation, Melusina is clearly an anima figure. She appears as a variant of the mercurial serpent, which was sometimes represented in the form of a snake-woman⁵² by way of expressing the monstrous, double nature of Mercurius. The redemption of this monstrosity was depicted as the assumption and coronation of the Virgin Mary.⁵³

E. THE FILIUS REGIUS AS THE ARCANUM SUBSTANCE (MICHAEL MAIER)

[181] It is not my intention to enter more closely into the relations between the Paracelsan Melusines and the mercurial serpent. I only wish to point out the alchemical prototypes that may have had an influence on Paracelsus, and to suggest that the longing of Melusina for a soul and for redemption has a parallel in that kingly substance which is hidden in the sea and cries out for deliverance. Of this *filius regius* Michael Maier says:⁵⁴ “He lives and calls from the depths:⁵⁵ Who shall

deliver me from the waters and lead me to dry land? Even though this cry be heard of many, yet none takes it upon himself, moved by pity, to seek the king. For who, they say, will plunge into the waters? Who will imperil his life by taking away the peril of another? Only a few believe his lament, and think rather that they hear the crashing and roaring of Scylla and Charybdis. Therefore they remain sitting indolently at home, and give no thought to the kingly treasure, nor to their own salvation.”

[182] We know that Maier can have had no access to the *Philosophumena* of Hippolytus, long believed lost, and yet it might well have served him as a model for the king’s lament. Treating of the mysteries of the Naassenes, Hippolytus says: “But what that form is which comes down from above, from the Uncharacterized [*ἀχαρακτηρίστου*], no man knows. It is found in earthly clay, and yet none recognize it. But that is the god who dwells in the great flood.⁵⁸ In the Psalter he calls and cries out from many waters.⁵⁷ The many waters, they say, are the multitude of mortal men, whence he calls and cries aloud to the uncharacterized Man:⁵⁸ Save mine Only-Begotten⁵⁹ from the lions.”⁶⁰ And he receives the reply [Isaiah 43 : 1ff.]: “And now thus saith the Lord that created thee, O Jacob, and formed thee, O Israel: Fear not, for I have redeemed thee, and called thee by thy name. Thou art mine. When thou shalt pass through the waters, I will be with thee, and the rivers shall not cover thee. When thou shalt walk through the fire, thou shalt not be burnt, and the flames shall not burn in thee.” Hippolytus goes on to quote Psalm 23 : 7ff., (DV), referring it to the ascent (*ἀνοδος*) or regeneration (*ἀναγέννησις*) of Adam: “Lift up your gates, O ye princes, and be ye lifted up, O eternal gates, and the King of Glory shall enter in. Who is this King of Glory? The Lord who is strong and mighty, the Lord mighty in battle. . . . But who, say the Naassenes, is this King of Glory? A worm and no man, the reproach of men and the outcast of the people.”⁶¹

[183] It is not difficult to see what Michael Maier means. For him the *filius regius* or *Rex marinus*, as is evident from a passage in the text not quoted here, means antimony,⁶² though in his usage it has only the name in common with the chemical element. In reality it is the secret transformative substance, which fell from the highest place into the darkest depths of matter where it awaits deliverance. But no one will plunge into these depths in order, by his own transformation in the darkness and by the torment of fire, to rescue his king. They cannot hear the voice of the king and think it is the chaotic roar of destruction. The sea (*mare nostrum*) of the alchemists is their own darkness, the unconscious. In his way, Epiphanius⁶³ correctly interpreted the “mire of the deep” (*limus profundi*) as “matter born of the mind, smutty reflections and muddy thoughts of sin.” Therefore David in his affliction had said (Psalm 68 : 3, DV): “I stick fast in the mire of the deep.” For the Church Father these dark depths could only be evil itself, and if a king got stuck in them it was on account of his own sinfulness. The alchemists took a more optimistic view: the dark

background of the soul contains not only evil but a king in need of, and capable of, redemption, of whom the *Rosarium* says: “At the end of the work the king will go forth for thee, crowned with his diadem, radiant as the sun, shining like the carbuncle . . . constant in the fire.”⁶⁴ And of the worthless prima materia they say: “Despise not the ash, for it is the diadem of thy heart, and the ash of things that endure.”⁶⁵

[184] These quotations give one an idea of the mystic aura that surrounded the figure of the *filius regius*, and I do not think it superfluous to have drawn attention to that distant period when the central ideas of philosophical alchemy were being freely discussed by the Gnostics. Hippolytus gives us perhaps the most complete insight into their analogical thinking, which is akin to that of the alchemists. Anyone who came into contact with alchemy during the first half of the sixteenth century could not fail to feel the fascination of these Gnostic ideas. Although Maier lived and wrote more than seventy years after Paracelsus, and we have no reason to suppose that Paracelsus was acquainted with the heresiologists, his knowledge of the alchemical treatises, and particularly of Hermes [Fig. B6] which he so often quotes, would have sufficed to impress upon him the figure of the *filius regius* and also that of the much lauded Mater Natura—a figure not entirely in accord with the views of Christianity. Thus the “Tractatus aureus Hermetis” says: “O mightiest nature of the natures, who containest and separatest the midmost of the natures, who comest with the light and art born with the light, who hast given birth to the misty darkness, who art the mother of all beings!”⁶⁶ This invocation echoes the classical feeling for nature, and its style is reminiscent of the oldest alchemical treatises, such as those of pseudo-Democritus, and of the Greek Magic Papyri. In this same treatise we encounter the *Rex coronatus* and *filius noster rex genitus*, of whom it is said: “For the son is a blessing and possesses wisdom. Come hither, ye sons of the wise, and let us be glad and rejoice, for death is overcome, and the son reigns; he is clothed with the red garment, and the purple [*chermes*] is put on.” He lives from “our fire,” and nature “nourishes him who shall endure for ever” with a “small fire.” When the son is brought to life by the opus, he becomes a “warrior fire” or a “fighter of fire.”⁶⁷

F. THE PRODUCTION OF THE ONE, OR CENTRE, BY DISTILLATION

[185] After this discussion of some of the basic concepts of alchemy, let us come back to the Paracelsan process of transforming the Iliaster. Paracelsus calls this process a *retorta distillatio*. The purpose of distillation in alchemy was to extract the volatile substance, or spirit, from the impure body. This process was a psychic as well as a physical experience. The *retorta distillatio* is not a known technical term, but presumably it meant a distillation that was in some way turned back upon itself. It might have taken place in the vessel called the Pelican [Fig. B7], where the distillate runs back into the belly of the retort. This was the “circulatory distillation,” much

favoured by the alchemists. By means of the “thousandfold distillation” they hoped to achieve a particularly “refined” result.⁶⁸ It is not unlikely that Paracelsus had something like this in mind, for his aim was to purify the human body to such a degree that it would finally unite with the *maior homo*, the inner spiritual man, and partake of his longevity. As we have remarked, this was not an ordinary chemical operation, it was essentially a psychological procedure. The fire to be used was a symbolical fire, and the distillation had to start “from the midst of the centre” (*ex medio centri*).

[186] The accentuation of the centre is again a fundamental idea in alchemy. According to Michael Maier, the centre contains the “indivisible point,” which is simple, indestructible, and eternal. Its physical counterpart is gold, which is therefore a symbol of eternity.⁶⁹ In Christianos the centre is compared to paradise and its four rivers. These symbolize the philosophical fluids (*ὕγρα*), which are emanations from the centre.⁷⁰ “In the centre of the earth the seven planets took root, and left their virtues there, wherefore in the earth is a germinating water,” says *Aurora consurgens*.⁷¹ Benedictus Figulus⁷² writes:

Visit the centre of the earth,
There you will find the global fire.
Rectify it of all dirt,
Drive it out with love and ire. . . .

He calls this centre the “house of fire” or “Enoch,” obviously borrowing the latter term from Paracelsus. Dorn says that nothing is more like God than the centre, for it occupies no space, and cannot be grasped, seen, or measured. Such, too, is the nature of God and the spirits. Therefore the centre is “an infinite abyss of mysteries.”⁷³ The fire that originates in the centre carries everything upward, but when it cools everything falls back again to the centre. “The physiochemists call this movement circular, and they imitate it in their operations.” At the moment of culmination, just before the descent, the elements “conceive the male seeds of the stars,” which enter into the elemental matrices (i.e., the non-sublimated elements) during the descent. Thus all created things have four fathers and four mothers. The conception of the seeds results from the “influxum et impressionem” of Sol and Luna, who thus function as nature gods, though Dorn does not say this quite as clearly.⁷⁴

[187] The creation of the elements and their ascent to heaven through the force of the fire serve as a model for the spagyric process. The lower waters, cleansed of their darkness, must be separated from the celestial waters by a carefully regulated fire. “In the end it will come to pass that this earthly, spagyric foetus clothes itself with heavenly nature by its ascent, and then by its descent visibly puts on the nature of the centre of the earth, but nonetheless the nature of the heavenly centre which it

acquired by the ascent is secretly preserved.”⁷⁵ The spagyric birth (*spagirica foetura*) is nothing other than the *filius philosophorum*, the inner, eternal man in the shell of the outer, mortal man. The *filius* is not only a panacea for all bodily defects, it also conquers the “subtle and spiritual sickness in the human mind.” “For in the One,” says Dorn,⁷⁶ “is the One and yet not the One; it is simple and consists of the number four. When this is purified by the fire in the sun,⁷⁷ the pure water⁷⁸ comes forth, and, having returned to simplicity,⁷⁹ it [the quaternity as unity] will show the adept the fulfilment of the mysteries. This is the centre of the natural wisdom, whose circumference, closed in itself, forms a circle: an immeasurable order reaching to infinity.” “Here is the number four, within whose bounds the number three, together with the number two combined into One, fulfils all things, which it does in miraculous wise.” In these relations between four, three, two, and one is found, says Dorn, the “culmination of all knowledge and of the mystic art, and the infallible midpoint of the centre (*infallibile medii centrum*).”⁸⁰ The One is the midpoint of the circle, the centre of the triad, and it is also the “novenary foetus” (*foetus novenarius*), i.e., it is as the number nine to the ogdoad, or as the quintessence to the quaternity.³¹

[188] The midpoint of the centre is fire. On it is modelled the simplest and most perfect form, which is the circle. The point is most akin to the nature of light,⁸² and light is a *simulacrum Dei*.⁸³ Just as the firmament was created in the midst of the waters above and below the heavens, so in man there is a shining body, the radical moisture, which comes from the sphere of the heavenly waters.⁸⁴ This body is the “sidereal balsam,” which maintains the animal heat. The spirit of the supracelestial waters has its seat in the brain, where it controls the sense organs. In the microcosm the balsam dwells in the heart,⁸⁵ like the sun in the macrocosm. The shining body is the *corpus astrale*, the “firmament” or “star” in man. Like the sun in the heavens, the balsam in the heart is a fiery, radiant centre. We meet this solar point in the *Turba*,⁸⁶ where it signifies the “germ of the egg, which is in the yolk, and that germ is set in motion by the hen’s warmth.” The “*Consilium coniugii*” says that in the egg are the four elements and the “red sun-point in the centre, and this is the young chick.”⁸⁷ Mylius interprets this chick as the bird of Hermes,⁸⁸ which is another synonym for the mercurial serpent.

[189] From this context we can see that the *retorta distillatio ex medio centri* results in the activation and development of a psychic centre, a concept that coincides psychologically with that of the self.

G. THE CONIUNCTIO IN THE SPRING

[190] At the end of the process, says Paracelsus, a “physical lightning” will appear, the “lightning of Saturn” will separate from the lightning of Sol, and what appears in this lightning pertains “to longevity, to that undoubtedly great Iliaster.”⁸⁹ This process does not take anything away from the body’s weight but only from its “turbulence,”

and that “by virtue of the translucent colours.”⁸⁰ “Tranquillity of mind”⁹¹ as a goal of the opus is stressed also by other alchemists. Paracelsus has nothing good to say about the body. It is “bad and putrid.” When it is alive, it lives only from the “Mumia.” Its “continual endeavour” is to rot and turn back into filth. By means of the Mumia the “peregrinus microcosmus” (wandering microcosm) controls the physical body, and for this the arcana are needed.⁹² Here Paracelsus lays particular stress on Thereniabin⁹³ and Nostoch⁹⁴ (as before on Cheyri) and on the “tremendous powers” of Melissa. Melissa is singled out for special honour because in ancient medicine it was considered to be a means of inducing happiness, and was used as a remedy for melancholia and for purging the body of “black, burnt-out blood.”⁹⁵ It unites in itself the powers of the “supracelestial coniunctio,” and that is “Iloch, which comes from the true Aniadus.” As Paracelsus had spoken just before of Nostoch, the Iliaster has changed under his eyes into Iloch. The Aniadus that now makes its appearance constitutes the essence of Iloch, i.e., of the coniunctio. But to what does the coniunctio refer? Before this Paracelsus had been speaking of a separation of Saturn and Sol. Saturn is the cold, dark, heavy, impure element, Sol is the opposite. When this separation is completed and the body has been purified by Melissa and freed from Saturnine melancholy, then the coniunctio can take place with the long-living inner, or astral, man,⁹⁶ and from this conjunction arises the “Enochdianus.” Iloch or Aniadus appears to be something like the virtue or power of the everlasting man. This “Magnale” comes about by the “exaltation of both worlds,” and “in the true May, when the exaltations of Aniada begin, these should be gathered.” Here again Paracelsus outdoes himself in obscurity, but this much at least is evident, that Aniadus denotes a springtime condition, the “efficacy of things,” as Dorn defines it.



A fish meal, with accompanying statue of the hermaphrodite. Though the picture is undoubtedly secular, it contains echoes of early Christian motifs. The significance of the hermaphrodite in this context is unknown to me. British Museum. MS. Add. 15268 (13th cent.)



The *filius* or *rex* in the form of a hermaphrodite. The axiom of Maria is represented by 1 + 3 snakes: the *filius*, as mediator, unites the one with the three. Characteristically, he has bat's wings. To the right is the Pelican, symbol of the *distillatio circulatoria*; to the left, the *arbor philosophica* with golden flowers; underneath, the chthonic triad as a three-headed serpent. From *Rosarium philosophorum* (1550), fol. X, iiiv



The Rebis: from “Book of the Holy Trinity and Description of the Secret of the Transmutation of Metals” (1420), in the Codex Germanicus 598 (Staatsbibliothek, Munich), fol. 105v. The illustration may have served as a model for the hermaphrodite in the *Rosarium* (pl. B2)



Melusina as the (*aqua permanens*, opening the side of the *filius* (an allegory of Christ) with the lance of Longinus. The figure in the middle is Eve (earth), who is reunited with Adam (Christ) in the coniunctio. From their union is born the hermaphrodite, the incarnate Primordial Man. To the right is the athanor (furnace) with the vessel in the

centre, from which the lapis (hermaphrodite) will arise. The vessels on either side contain Sol and Luna. Woodcut from Reusner's *Pandora: Das ist, die edelst Gab Gottes, oder der werde und heilsame Stein der Weysen* (Basel, 1588), p. 249



The anima as Melusina, embracing a man rising out of the sea (= unconscious): a *coniunctio animae cum corpore*. The gnomes are the planetary spirits in the form of *paredroi* (familiaris). British Museum. MS. Sloane 5025, a variant of the Ripley *Scrowle* (1588)



The King's Son (*filius regis*) and the mystagogue Hermes on a mountain, an obvious allusion to the Temptation (Luke, ch. 4). The accompanying text says: "Another mountain of India lies in the vessel, which the Spirit and Soul, as son and guide, have together ascended." The two are called spirit and soul because they represent volatile substances which rise up during the heating of the prima materia. From Lamspringk, "De lapide philosophico," fig.

XII. in *Musaeum hermeticum* (Frankfurt a. M., 1678), p. 365

P R I M V S.

Sed si simplicium partes spirituosæ essentia crassamentis, & terrenis fæcibus immeris, ut tenuiores, & puriores evadant, & crassis illis, & impuris exonerentur, & in fæcibus relinquunt, velut medicis usibus inepta, oportet multiplicatis viribus, in se ipsas resolvantur, & reducantur, ut assiduo motu circumgyrata nobiliorem vim, & magis egregiam sortiantur. Vas excogitatum est, quod Pelicanū vocant, quod ad avis Pelicani figuram adumbratum est, in quo simplicium partes magis tenues per collum ductæ, & per rostrum in apertū pectus infixum quasi in ventum super fæces regerantur, iterumque per collum sublata indefatigabili motu aquositate, crassitiam recipientem paulatim exhauriant, & simplicia assidua rotatione non solum depurentur: sed etiam altius virtutes exaltentur. Vas, E, litera insignitur.

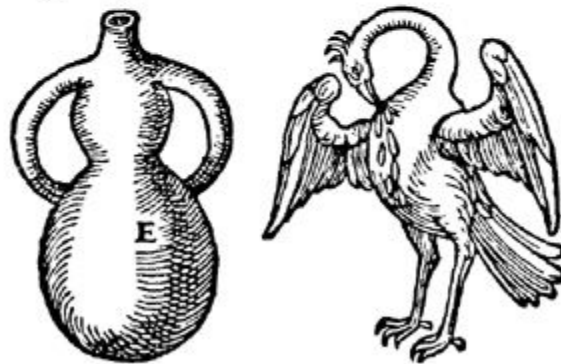

Alii verò alio modo effingunt. Duo vasa capiunt, quod alteri alter innectatur & quod unum recipit alteri reddit, utrumque alterius altero alvo rostro infixitur, H

Picture of the Pelican. the vessel in which the circulatory distillation takes place. Page from Rhenanus, *Solis e puteo emergentis sive dissertationis chymotechnicae libri tres* (Frankfurt a. M., 1613)

[191] We meet this motif in one of the earliest Greek texts, entitled the “Instruction of Cleopatra by the Archpriest Komarios,”⁹⁷ where Ostanēs⁹⁸ and his companions say to Cleopatra:

Make known to us how the highest descends to the lowest, and the lowest ascends to the highest, and the midmost draws near to the lowest and the highest, so that they are made one with it;⁹⁹ how the blessed waters come down from above to awaken the dead, who lie round about in the midst of Hades, chained in the darkness; how the elixir of life comes to them and awakens them, rousing them out of their sleep. . . .

[192] Cleopatra answers:

When the waters come in, they awaken the bodies and the spirits, which are imprisoned and powerless. . . . Gradually they bestir themselves, rise up, and clothe themselves in bright colours,¹⁰⁰ glorious as the flowers in spring. The spring is glad and rejoices in the blossoming ripeness they have put on.

[193] Ruland defines Aniada¹⁰¹ as “fruits and powers of paradise and heaven; they are also the Christian Sacraments . . . those things which by thought, judgment, and imagination promote longevity in us.”¹⁰² They seem therefore to be powers that confer everlasting life, an even more potent *φάρμακον ἀθανασίας* than Cheyri, Thereniabin, Nostoch, and Melissa. They correspond to the blessed waters of Komarios and also, apparently, to the Communion substances. In the spring all the forces of life are in a state of festive exaltation, and the *opus alchymicum* should also begin in the spring¹⁰³ (already in the month of Aries, whose ruler is Mars). At that time the Aniada should be “gathered,” as though they were healing herbs. There is an ambiguity here: it could also mean the gathering together of all the psychic powers for the great transformation. The hierosgamos of Poliphilo likewise takes place in the month of May,¹⁰⁴ that is, the union with the soul, the latter embodying the world of the gods. At this marriage the human and the divine are made one; it is an “exaltation of both worlds,” as Paracelsus says. He adds significantly: “And the exaltations of the nettles burn too, and the colour of the little flame¹⁰⁵ sparkles and shines.” Nettles were used for medicinal purposes (the preparation of nettle water), and were collected in May because they sting most strongly when they are young. The nettle was therefore a symbol of youth, which is “most prone to the flames of lust.”¹⁰⁶ The allusion to the stinging nettle and the *flammula* is a discreet reminder that not only Mary but Venus, too, reigns in May. In the next sentence Paracelsus remarks that this power can be “changed into something else.” There are exaltations, he says, far more powerful than the nettle, namely the Aniada, and these are found not in the matrices, that is, in the physical elements, but in the heavenly ones. The Ideus would be nothing if it had not brought forth greater things. For it had made another May, when heavenly flowers bloomed. At this time Anachmus¹⁰⁷ must be extracted and preserved, even as “musk rests in the pomander¹⁰⁸ and the virtue of gold in laudanum.”¹⁰⁹ One can enjoy longevity only when one has gathered the powers of Anachmus. To my knowledge, there is no way of distinguishing Anachmus from Aniadus.

3. THE NATURAL TRANSFORMATION MYSTERY

[194] Aniadus (or Aniadam), interpreted by Bodenstein and Dorn as the “efficacy of things,” is defined by Ruland as “the regenerated spiritual man in us, the heavenly body implanted in us Christians by the Holy Ghost through the most Holy Sacraments.” This interpretation does full justice to the role which Aniadus plays in the writings of Paracelsus. Though it is clearly related to the sacraments and to the Communion in particular, it is equally clear that there was no question of arousing or implanting the inner man in the Christian sense, but of a “scientific” union of the natural with the spiritual man with the aid of arcane techniques of a medical nature. Paracelsus carefully avoids the ecclesiastical terminology and uses instead an esoteric language which is extremely difficult to decipher, for the obvious purpose of segregating the “natural” transformation mystery from the religious one and effectively concealing it from prying eyes. Otherwise the welter of esoteric terms in this treatise would have no explanation. Nor can one escape the impression that this mystery was in some sense opposed to the religious mystery: as the “nettle” and the *flammula* show, the ambiguities of Eros were also included in it.¹ It had far more to do with pagan antiquity, as is evidenced by the *Hypnerotomachia Poliphili*, than with the Christian mystery. Nor is there any reason to suppose that Paracelsus was sniffing out nasty secrets; a more cogent motive was his experience as a physician who had to deal with man as he is and not as he should be and biologically speaking never can be. Many questions are put to a doctor which he cannot honestly answer with “should” but only from his knowledge and experience of nature. In these fragments of a nature mystery there is nothing to suggest a misplaced curiosity or perverse interest on Paracelsus’s part; they bear witness rather to the strenuous efforts of a physician to find satisfactory answers to psychological questions which the ecclesiastical casuist is inclined to twist in his own favour.

[195] This nature mystery was indeed so much at odds with the Church—despite the superficial analogies—that the Hungarian alchemist Nicolaus Melchior Szebeny,² court astrologer to Ladislaus II (1471–1516), made the bold attempt to present the *opus alchymicum* in the form of a Mass.³ It is difficult to prove whether and to what extent the alchemists were aware that they were in conflict with the Church. Mostly they showed no insight into what they were *doing*. This is true also of Paracelsus—except for a few hints about the “Pagoyum.” It is the more understandable that no real self-criticism could come about, since they genuinely believed that they were

performing a work well-pleasing to God on the principle “quod natura relinquit imperfectum, ars perficit” (what nature left imperfect, the art perfects). Paracelsus himself was wholly filled with the godliness of his profession as a doctor, and nothing disquieted or disturbed his Christian faith. He took it for granted that his work supplemented the hand of God and that he was the faithful steward of the talent that had been entrusted to him. And as a matter of fact he was right, for the human soul is not something cut off from nature. It is a natural phenomenon like any other, and its problems are just as important as the questions and riddles which are presented by the diseases of the body. Moreover there is scarcely a disease of the body in which psychic factors do not play a part, just as physical ones have to be considered in many psychogenic disturbances. Paracelsus was fully alive to this. In his own peculiar way he took the psychic phenomena into account as perhaps none of the great physicians ever did before or after him. Although his homunculi, *Trarames*, *Durdales*, nymphs, Melusines, etc., are the grossest superstitions for us so-called moderns, for a man of Paracelsus’s time they were nothing of the sort. In those days these figures were living and effective forces. They were projections, of course; but of that, too, Paracelsus seems to have had an inkling, since it is clear from numerous passages in his writings that he was aware that homunculi and suchlike beings were creatures of the imagination. His more primitive cast of mind attributed a reality to these projections, and this reality did far greater justice to their psychological effect than does our rationalistic assumption of the absolute unreality of projected contents. Whatever their reality may be, functionally at all events they behave just like realities. We should not let ourselves be so blinded by the modern rationalistic fear of superstition that we lose sight completely of those little-known psychic phenomena which surpass our present scientific understanding. Although Paracelsus had no notion of psychology, he nevertheless affords—precisely because of his “benighted superstition”—deep insights into psychic events which the most up-to-date psychology is only now struggling to investigate again. Even though mythology may not be “true” in the sense that a mathematical law or a physical experiment is true, it is still a serious subject for research and contains quite as many truths as a natural science; only, they lie on a different plane. One can be perfectly scientific about mythology, for it is just as good a natural product as plants, animals or chemical elements.

[196] Even if the psyche were a product of the will, it would still not be outside nature. No doubt it would have been a greater achievement if Paracelsus had developed his natural philosophy in an age when the psyche had been discredited as an object of scientific study. As it was, he merely included in the scope of his investigations something that was already present, without being obliged to prove its existence anew. Even so his achievement is sufficiently great, despite the fact that we moderns

still find it difficult to estimate correctly the full psychological implications of his views. For what, in the end, do we know about the causes and motives that prompted man, for more than a thousand years, to believe in that “absurdity” the transmutation of metals and the simultaneous psychic transformation of the artifex? We have never seriously considered the fact that for the medieval investigator the redemption of the world by God’s son and the transubstantiation of the Eucharistic elements were not the last word, or rather, not the last answer to the manifold enigmas of man and his soul. If the *opus alchymicum* claimed equality with the *opus divinum* of the Mass, the reason for this was not grotesque presumption but the fact that a vast, unknown Nature, disregarded by the eternal verities of the Church, was imperiously demanding recognition and acceptance. Paracelsus knew, in advance of modern times, that this Nature was not only chemical and physical but also psychic. Even though his Trames and whatnot cannot be demonstrated in a test tube, they nevertheless had their place in his world. And even if, like all the rest of them, he never produced any gold, he was yet on the track of a process of psychic transformation that is incomparably more important for the happiness of the individual than the possession of the red tincture.

A. THE LIGHT OF THE DARKNESS

[197] So when we try to elucidate the riddles of the *Vita longa* we are following the traces of a psychological process that is the vital secret of all seekers after truth. Not all are vouchsafed the grace of a faith that anticipates all solutions, nor is it given to all to rest content with the sun of revealed truth. The light that is lighted in the heart by the grace of the Holy Spirit, that same light of nature, however feeble it may be, is more important to them than the great light which shines in the darkness and which the darkness comprehended not. They discover that in the very darkness of nature a light is hidden, a little spark without which the darkness would not be darkness.⁴ Paracelsus was one of these. He was a well-intentioned, humble Christian. His ethics and his professed faith were Christian, but his most secret, deepest passion, his whole creative yearning, belonged to the *lumen naturae*, the divine spark buried in the darkness, whose sleep of death could not be vanquished even by the revelation of God's son. The light from above made the darkness still darker; but the *lumen naturae* is the light of the darkness itself, which illuminates its own darkness, and this light the darkness comprehends. Therefore it turns blackness into brightness, burns away "all superfluities," and leaves behind nothing but "faecem et scoriam et terram damnatam" (dross and scoriae and the rejected earth).

[198] Paracelsus, like all the philosophical alchemists, was seeking for something that would give him a hold on the dark, body-bound nature of man, on the soul which, intangibly interwoven with the world and with matter, appeared before itself in the terrifying form of strange, demoniacal figures and seemed to be the secret source of life-shortening diseases. The Church might exorcise demons and banish them, but that only alienated man from his own nature, which, unconscious of itself, had clothed itself in these spectral forms. Not separation of the natures but union of the natures was the goal of alchemy. From the time of Democritus its *leitmotiv* had been: "Nature rejoices in nature, nature conquers nature, nature rules over nature."⁵ This principle is pagan in feeling and an expression of nature worship. Nature not only contains a process of transformation—it is itself transformation. It strives not for isolation but for union, for the wedding feast followed by death and rebirth. Paracelsus's "exaltation in May" is this marriage, the "gamonymus" or hierosgamos of light and darkness in the shape of Sol and Luna. Here the opposites unite what the light from above had sternly divided. This is not so much a reversion to antiquity as a continuation of that religious feeling for nature, so alien to Christianity, which is expressed most beautifully in the "Secret Inscription" in the Great Magic Papyrus of Paris:⁶

Greetings, entire edifice of the Spirit of the air, greetings, Spirit that penetratest from heaven to earth, and from earth, which abideth in the midst of the universe, to the

uttermost bounds of the abyss, greetings, Spirit that penetratest into me, and shakest me, and departest from me in goodness according to God's will; greetings, beginning and end of irremovable Nature, greetings, thou who revolvest the elements which untiringly render service, greetings, brightly shining sun, whose radiance ministereth to the world, greetings, moon shining by night with disc of fickle brilliance, greetings, all ye spirits of the demons of the air, greetings, ye for whom the greeting is offered in praise, brothers and sisters, devout men and women! O great, greatest, incomprehensible fabric of the world, formed in a circle! Heavenly One, dwelling in the heavens, aetherial spirit, dwelling in the aether, having the form of water, of earth, of fire, of wind, of light, of darkness, star-glittering, damp-fiery-cold Spirit! I praise thee, God of gods, who hast fashioned the world, who hast established the depths upon the invisible support of their firm foundation, who hast separated heaven and earth, and hast encompassed the heavens with golden, eternal wings, and founded the earth upon eternal bases, who hast hung the aether high above the earth, who hast scattered the air with the self-moving wind, who hast laid the waters round about, who callest forth the tempests, the thunder, the lightning, the rain: Destroyer, Begetter of living things, God of the Aeons, great art thou, Lord, God, Ruler of All!

[199] Just as this prayer has come down to us embedded in a mass of magical recipes, so does the *lumen naturae* rise up from a world of kobolds and other creatures of darkness, veiled in magical spells and almost extinguished in a morass of mystification. Nature is certainly equivocal, and one can blame neither Paracelsus nor the alchemists if, anxiously aware of their responsibilities, they cautiously expressed themselves in parables. This procedure is indeed the more appropriate one in the circumstances. What takes place between light and darkness, what unites the opposites, has a share in both sides and can be judged just as well from the left as from the right, without our becoming any the wiser: indeed, we can only open up the opposition again. Here only the symbol helps, for, in accordance with its paradoxical nature, it represents the "tertium" that in logic does not exist, but which in reality is the living truth. So we should not begrudge Paracelsus and the alchemists their secret language: deeper insight into the problems of psychic development soon teaches us how much better it is to reserve judgment instead of prematurely announcing to all and sundry what's what. Of course we all have an understandable desire for crystal clarity, but we are apt to forget that in psychic matters we are dealing with processes of experience, that is, with transformations which should never be given hard and fast names if their living movement is not to petrify into something static. The protean mythologem and the shimmering symbol express the processes of the psyche far more trenchantly and, in the end, far more clearly than the clearest concept; for the symbol not only conveys a visualization of the process but—and this is perhaps just as important—it also brings a re-experiencing of it, of that twilight which we can

learn to understand only through inoffensive empathy, but which too much clarity only dispels. Thus the symbolic hints of marriage and exaltation in the “true May,” when the heavenly flowers bloom and the secret of the inner man is made manifest, by the very choice and sound of the words convey a vision and experience of a climax whose significance could be amplified only by the finest flights of the poets. But the clear and unambiguous concept would find not the smallest place where it would fit. And yet something deeply significant has been said, for as Paracelsus rightly remarks: “When the heavenly marriage is accomplished, who will deny its superexcellent virtue?”

B. THE UNION OF MAN'S TWO NATURES

[200] Paracelsus is concerned here with something of great importance, and in recognition of this I have put in an apologia for the symbol, which unites what is divided. But he too felt the need of some explanation. Thus he says in the second chapter of Book V that man has two life forces: one of them natural, the other “aerial, wherein is nothing of the body.” (We would say that life has a physiological and a psychic aspect.) He therefore ends *De vita longa* with a discussion of incorporeal things. “Miserable in this respect are mortals to whom Nature has denied her first and best treasure, which the monarchy of Nature contains, namely, the *lumen naturae!*”⁷ he exclaims, leaving us in no doubt what the *lumen naturae* meant to him. He says that he will now go beyond Nature and consider Aniadus. Let no one take exception to what he will now set forth concerning the power of the Guarini, Saldini, Salamandrini, and Melusina. If any should be astonished at his words, he should not let that detain him, but should rather read to the end, when he will understand all.

[201] Those live longest, says Paracelsus, who have lived “the aerial life” (*vitam aeream*). Their life lasts anything from six hundred to a thousand or eleven hundred years, and this is because they have lived in accordance with the “rule of the Magnalia, which are easily understood.” One should therefore imitate Aniadus, “and that by means of the air alone”—that is, by psychic means—“whose power is so great that the end of life has nothing in common with it. Further, if the said air be wanting, that which lies hidden in the capsule will burst forth.” By the “capsule” Paracelsus probably means the heart. The soul or *anima iliastri* dwells in the fire of the heart. It is *impassibilis* (non-sentient, incapable of suffering), whereas the cagastric soul, which is *passibilis*, “floats” on the water of the capsule.⁸ The heart is also the seat of the imagination, and is the “sun in the Microcosm.”⁹ Hence the *anima iliastri* can burst forth from the heart when it lacks “air”; that is to say, if psychic remedies are not applied, death occurs prematurely.¹⁰ Paracelsus continues: “But if this [i.e., the *anima iliastri*] should be wholly filled with that [air] which renews itself again, and is then moved into the centre, that is, outside that under which it lay

hidden before and still lies hid [i.e., in the heart capsule], then as a tranquil thing it is not heard at all by anything corporeal, and resounds only as Aniadus, Adech, and Edochinum. Whence comes the birth of that great Aquaster, which is born beyond Nature” (i.e., supernaturally).¹¹

[202] The meaning of this laborious explanation seems to be that by psychic means the soul is not only prevented from escaping but is also brought back into the centre, the heart region. But this time it is not enclosed in the *capsula cordis*, where it lay hidden and as it were imprisoned till then; it is now outside its previous habitation. This indicates a certain degree of freedom from bondage to the body, hence the “tranquillity” of the soul, which, when it dwelt inside the heart, was too much exposed to the power of imagination, to Ares and the formative principle. The heart, for all its virtues, is a restless and emotional thing, all too easily swayed by the turbulence of the body. In it dwells that lower, earthbound, “cagastric” soul which has to be separated from the higher, more spiritual Iliaster. In this liberated and more tranquil sphere the soul, unheard by the body, can re-echo those higher entities, Aniadus, Adech, and Edochinum, who form the upper triad.

[203] We have seen already that Adech stands for the inner *homo maximus*. He is the astral man, the manifestation of the macrocosm in the microcosm. Since he is named along with Aniadus and Edochinum, they are probably parallel designations. Aniadus certainly has this meaning, as mentioned earlier. Edochinum seems to be a variant of Enochdianus: Enoch belonged to the race of protoplasts related to the Original Man, who “tasted not death,” or at any rate lived for several hundred years. The three different names are probably only amplifications of the same conception—that of the deathless Original Man, to whom the mortal man can be approximated by means of the alchemical opus. As a result of this approximation the powers and attributes of the *homo maximus* flow like a helpful and healing stream into the earthly nature of the microcosmic mortal man. Paracelsus’s conception of the *homo maximus* does much to elucidate the psychological motives of the alchemical opus in general, since it shows how the main product of the work, the *aurum non vulgi* or *lapis philosophorum*, came to have such a variety of names and definitions: elixir, panacea, tincture, quintessence, light, east, morning, Aries, living fount, fruit-tree, animal, Adam, man, *homo altus*, form of man, brother, son, father, *pater mirabilis*, king, hermaphrodite, *deus terrenus*, *salvator*, *servator*, *filius macrocosmi*, and so on.¹² In comparison with the “mille nomina” of the alchemists, Paracelsus used only about ten names for this entity, which exercised the speculative fantasy of the alchemists for more than sixteen hundred years.

[204] Dorn’s commentary lays particular emphasis on the significance of this passage. According to him, these three—Aniadus, Adech, and Edochinum—form the one “pure and well-tempered element” (*elementum purum temperatum*) as contrasted

with the four, impure, gross, and worldly elements, which are far removed from longevity. From these three comes the “mental vision” of that great Aquaster, which is born supernaturally. That is to say, from the Aniadic mother, with the aid of Adech and through the power of the imagination, comes the great vision, which impregnates the supernatural matrix so that it gives birth to the invisible foetus of longevity, that is created or begotten by the invisible or extrinsic Iliaster. Dorn’s insistence on three as opposed to four is based on his polemical attitude to the axiom of Maria and to the relation of the quaternity to the Trinity, which I have discussed elsewhere.¹³ Characteristically, Dorn overlooks the fact that the fourth is in this case the microcosmic mortal man, who complements the upper triad.¹⁴

[205] Union with the *homo maximus* produces a new life, which Paracelsus calls “vita cosmographica.” In this life “time appears as well as the body Jesahach” (*cum locus tum corpus Jesahach*).¹⁵ *Locus* can mean “time” as well as “space,” and since, as we shall see, Paracelsus is here concerned with a sort of Golden Age, I have translated it as “time.” The *corpus Jesahach* may thus be the *corpus glorificationis*, the resurrected body of the alchemists, and would coincide with the *corpus astrale*.

C. THE QUATERNITY OF THE HOMO MAXIMUS

[206] In this last chapter Paracelsus makes almost untranslatable allusions to the four Scaiolae, and it is not at all clear what could be meant. Ruland, who had a wide knowledge of the contemporary Paracelsist literature, defines them as “spiritual powers of the mind” (*spirituales mentis vires*), qualities and faculties which are fourfold, to correspond with the four elements. They are the four wheels of the fiery chariot that swept Elijah up to heaven. The Scaiolae, he says, originate in the mind of man, “from whom they depart and to whom they are turned back” (*a quo recedunt, et ad quem reflectuntur*).

[207] Like the four seasons and the four quarters of heaven, the four elements are a quaternary system of orientation which always expresses a totality. In this case it is obviously the totality of the mind (*animus*), which here would be better translated as “consciousness” (including its contents). The orienting system of consciousness has four aspects, which correspond to four empirical functions: thinking, feeling, sensation (sense-perception), intuition. This quaternity is an archetypal arrangement.¹⁶ As an archetype, it can be interpreted in any number of ways, as Ruland shows: he interprets the four first of all psychologically, as *phantasia*¹⁷ *imaginatio*,¹⁸ *speculatio*,¹⁹ and *agnata fides* (inborn faith). This interpretation is of value only so far as it alludes unmistakably to certain psychic functions. Since every archetype is psychologically a *fascinosum*, i.e., exerts an influence that excites and grips the imagination, it is liable to clothe itself in religious ideas (which are themselves of an archetypal nature). Accordingly Ruland says that the four Scaiolae

also stand for the four main articles²⁰ of the Christian faith: baptism, belief in Jesus Christ, the sacrament of the Last Supper, and love of one's neighbour.²¹ In Paracelsus, Scaiola are lovers of wisdom. He says: "Ye pious filii Scaiolae et Anachmi."²² The Anachmus (= Aniadus) is therefore closely connected with the four Scaiolae. So it would not be overbold to conclude that the four Scaiolae correspond to the traditional quadripartite man and express his all-encompassing wholeness. The quadripartite nature of the *homo maximus* is the basis and cause of all division into four: four elements, seasons, directions, etc.²³ In this last chapter, says Paracelsus, the Scaiolae caused him the greatest difficulties,²⁴ "for in them is nothing of mortality." But, he assures us, whoever lives "by reason of the Scaiolae" is immortal, and he proves this by the example of the Enochdiani and their descendants. Dorn explains the difficulty of the Scaiolae by saying that the mind must exercise itself with extraordinary labours (*mentem exercere miris laboribus*), and, as there is in the Scaiolae nothing of mortality, this work exceeds our mortal endeavours.²⁵

[208] Although Dorn, like Ruland, emphasizes the psychic nature of the Scaiolae ("mental powers and virtues, properties of the arts of the mind"), so that actually they are attributes of the natural man and must therefore be mortal, and although Paracelsus himself says in other writings that even the *lumen naturae* is mortal, it is nevertheless asserted here that the natural powers of the mind are immortal and belong to the *Archa*—the principle that existed before the world. We hear nothing more about the "mortality" of the *lumen naturae*, but rather of eternal principles, of the *invisibilis homo maximus* (Dorn) and his four Scaiolae, which appear to be interpreted as mental powers and psychological functions. This contradiction is resolved when we bear in mind that these concepts of Paracelsus were the result not of rational reflection but of intuitive introspection, which was able to grasp the quaternary structure of consciousness and its archetypal nature. The one is mortal, the other immortal.

[209] Dorn's explanation as to why the Scaiolae are "difficult" might also be extended to Adech (= Adam, Anthropos),²⁶ who is the ruler of the Scaiolae and/or their quintessence. Paracelsus actually calls him "that difficult Adech." Also, it is "that great Adech" who hinders our intentions.²⁷ The difficulties of the art play no small role in alchemy. Generally they are explained as technical difficulties, but often enough, in the Greek texts as well as in the later Latin ones, there are remarks about the psychic nature of the dangers and obstacles that complicate the work. Partly they are demonic influences, partly psychic disturbances such as melancholia. These difficulties find expression also in the names and definitions of the *prima materia*, which, as the raw material of the opus, provides ample occasion for wearisome trials of patience. The *prima materia* is, as one can so aptly say in English, "tantalizing": it is cheap as dirt and can be had everywhere, only nobody knows it; it is as vague and

evasive as the lapis that is to be produced from it; it has a “thousand names.” And the worst thing is that without it the work cannot even be begun. The task of the alchemist is obviously like shooting an arrow through a thread hung up in a cloud, as Spitteler says. The prima materia is “saturnine,” and the malefic Saturn is the abode of the devil, or again it is the most despised and rejected thing, “thrown out into the street,” “cast on the dunghill,” “found in filth.” These epithets reflect not only the perplexity of the investigator but also his psychic background, which animates the darkness lying before him, so that he discovers in the projection the qualities of the unconscious. This easily demonstrable fact helps to elucidate the darkness that shrouds his spiritual endeavours and the *labor Sophiae*: it is a process of coming to terms with the unconscious, which always sets in when a man is confronted with its darkness. This confrontation forced itself on the alchemist as soon as he made a serious effort to find the prima materia.

D. THE RAPPROCHEMENT WITH THE UNCONSCIOUS

[210] I do not know how many or how few people today can imagine what “coming to terms with the unconscious” means. I fear they are only too few. But perhaps it will be conceded that the second part of Goethe’s *Faust* presents only incidentally and in doubtful degree an aesthetic problem, but primarily and in far greater degree a human one. It was a preoccupation that accompanied the poet right into old age, an alchemical encounter with the unconscious, comparable to the *labor Sophiae* of Paracelsus. It is on the one hand an endeavour to understand the archetypal world of the psyche, on the other hand a struggle against the sanity-threatening danger of fascination by the measureless heights and depths and paradoxes of psychic truth. The denser, concretistic, daytime mind here reaches its limits; for the “Cedurini” (Paracelsus), the “men of crasser temperament” (Dorn), there is no way into “the untrodden, the untreadable regions”—“and in this place,” says Paracelsus, “the Aquaster does not break in” (the damp soul that is akin to matter). Here the human mind is confronted with its origins, the archetypes; the finite consciousness with its archaic foundations; the mortal ego with the immortal self, Anthropos, purusha, atman, or whatever else be the names that human speculation has given to that collective preconscious state from which the individual ego arose. Kinsman and stranger at once, it recognizes and yet does not recognize that unknown brother who steps towards it, intangible yet real. The more it is bound by time and space, the more it will feel the other as “that difficult Adech” who crosses its purpose at every misguided step, who gives fate an unexpected twist, and sets it as a task the very thing it feared. Here we must feel our way with Paracelsus into a question that was never openly asked before in our culture, and was never clearly put, partly from sheer unconsciousness, partly from holy dread. Moreover, the secret doctrine of the

Anthropos was dangerous because it had nothing to do with the teachings of the Church, since from that point of view Christ was a reflection—and only a reflection—of the inner Anthropos. Hence there were a hundred good reasons for disguising this figure in indecipherable secret names.

[211] That being so, we may perhaps be able to understand another dark passage from the concluding chapter, which runs: “If, therefore, I should count myself among the Scaiolae [or: Scaioli, ‘lovers of wisdom’] in the manner of the Necrolii [= adepts], that would be something which in my view should be undertaken, but it is hindered by that great Adech, who deflects our purpose but not the procedure. I leave this to you theoreticians to discuss.”²⁸

[212] One gets the impression that Adech is almost hostile to the adept, or at least intent on frustrating him in some way. From our above reflections, which are based on practical experience, we have seen how problematical is the relation of the ego to the self. We have only to make the further assumption that this is what Paracelsus meant. And this does indeed seem to be the case: he “counts himself” among the Scaioli, the philosophers, or “implants himself” in the Scaiolae, the quaternity of the Original Man—which seems to me a quite possible conception since another synonym for the quaternity is Paradise with its four rivers, or the eternal city, the Metropolis, with its four gates²⁹ (the alchemical equivalent is the *domus sapientiae* and the squared circle). He would thus find himself in the immediate vicinity of Adech and would be a citizen of the eternal city—another echo of Christian ideas. The fact that Adech does not deflect the work (*modus* here presumably means method, procedure, as contrasted with *propositum*, purpose, intention) is understandable since Paracelsus is no doubt speaking of the alchemical opus, which always remains the same as a general procedure though its goal may vary: sometimes it is the production of gold (*chrysopoea*), sometimes the elixir, sometimes the *aurum potabile* or, finally, the mysterious *filius unicus*. Also, the artifex can have a selfish or an idealistic attitude towards the work.

4. THE COMMENTARY OF GERARD DORN

[213] We now come to the end of the treatise *De vita longa*. Paracelsus here sums up the whole operation in an extremely condensed way which makes interpretation even more hazardous than usual. As with so many other passages in the *Vita longa*, we must ask ourselves: Is the author being intentionally obscure, or can't he help it? Or should we ascribe the confusion to his editor, Adam von Bodenstein? The obscurities of this last chapter have no parallel in all Paracelsus's writings. One would be inclined to let the whole treatise go hang did it not contain things which seem to belong to the most modern psychological insights.

[214] I now give the original text of Paracelsus together with Dorn's commentary for the benefit of readers who wish to form their own judgment:

Paracelsus: *De vita longa* (1562), Lib. V, cap. V, pp. 94f.

Atque ad hunc modum abiit e
nymphididica natura
intervenientibus Scaiolis in aliam
transmutationem permansura
Melosyne, si difficilis ille Adech
annuisset, qui utrunque existit, cum
mors tum vita Scaiolarum. Annuit
praeterea prima tempora, sed ad
finem seipsum immutat. Ex quibus
colligo supermonica¹ figmenta in
cyphantis aperire fenestram. Sed ut
ea figantur, recusant gesta
Melosynes, quae cuiusmodi sunt,
missa facimus. Sed ad naturam
nymphididicam. Ea ut in animis
nostris concipiatur, atque ita ad
annum aniadin² immortales
perveniamus arripimus characteres
Veneris, quos et si vos una cum aliis
cognoscitis, minime tamen
usurpatis. Idipsum autem
absolvimus eo quod in prioribus
capitibus indicavimus, ut hanc vitam

And in this manner, through the
intervention of the Scaiolae, Melusina
departs from her nymphididic nature, to
remain in another transmutation if that
difficult Adech permit, who rules over
both the death and life of the Scaiolae.
Moreover, he permits the first times, but
at the end he changes himself. From
which I conclude that the supermonic¹
figments in the Cyphanta open a window.
But in order to become fixed, they have to
oppose the acts of Melusina, which, of
whatever kind they may be, we dismiss to
the nymphididic realm. But in order that
[she] may be conceived in our minds, and
we arrive immortal at the year Aniadin,²
we take the characters of Venus, which,
even if you know yourselves one with
others, you have nevertheless put to little
use. With this we conclude what we
treated of in the earlier chapters, that we
may safely attain that life over which
Aniadinus dominates and reigns, and which

secure tandem adsequamur, in qua aniadus dominatur ac regnat, et cum eo, cui sine fine assistimus, permanet. Haec atque alia arcana, nulla re prorsus indigent.³ Et in hunc modum vitam longam conclusam relinquimus.

endures for ever with him, in whom we are present without end. This and other mysteries are in need of nothing whatever.³ And herewith we end our discourse on longevity.

Dorn: *De vita longa* (1583), p. 178

[Paracelsus] ait Melosinam, i.e. apparentem in mente visionem . . . e nymphididica natura, in aliam transmutationem abire, in qua permansura[m] esse, si modo difficilis ille Adech, interior homo vdl. annuerit, hoc est, faveret: qui quidem utrunque efficit, videlicet mortem, et vitam Scaiolearum, i.e. mentalium operationum. Harum tempora prima, i.e. initia annuit, i.e. admittit, sed ad finem seipsum immutat, intellige propter intervenientes ac impediens distractiones, quo minus consequantur effectum inchoatae, scl. operationes. Ex quibus [Paracelsus] colligit supermonica¹ figmenta, hoc est, speculationes aenigmaticas, in cyphantis [vas stillatorium], i.e. separationum vel praeparationum operationibus, aperire fenestram, hoc est, intellectum, sed ut figantur, i.e. ad finem perducantur, recusant gesta Melosines, hoc est, visionum varietates, et observationes, quae cuius modi sunt (ait) missa facimus.

[Paracelsus] says that Melusina, i.e., the vision appearing in the mind, departs from her nymphididic nature into another transmutation, in which she will remain if only that difficult Adech, that is, the inner man, permit, that is, approve: who brings about both, that is, death and life, of the Scaiolae, that is, the mental operations. The first times, that is, the beginnings, of these he permits, that is, favours; but at the end he changes himself, namely because of the distractions that intervene and impede, so that the things begun, that is, the operations, do not obtain their effect.

Ad naturam nymphididicam rediens, ut in animis nostris concipiatur, inquit atque hac via ad annum aniadin² perveniamus, hoc est, ad vitam longam per imaginationem, arripimus characteres Veneris, i.e. amoris scutum et lorica ad viriliter adversis resistendum obstaculis: amor enim

From which [Paracelsus] concludes that the supermonic¹ figments, that is, enigmatical speculations, in the Cyphanta [distilling vessel], open a window, that is, the understanding, by means of the operations of separation or preparation; but in order to become fixed, that is, brought to an end, they

omnem difficultatem superat: quos et si vos una cum aliis cognoscitis, putato characteres, minime tamen usurpatis. Absolvit itaque iam Paracelsus ea, quae prioribus capitibus indicavit in vitam hanc secure consequendam, in qua dominatur et regnat aniadus, i.e. rerum efficia et cum ea is, cui sine fine assistimus, permanet, aniadus nempe coelestis: Haec atque alia arcana nulla re prorsus indigent.³

have to oppose the acts of Melusina, that is, divers visions and observations, which of whatever kind they may be, he says, we dismiss. Returning to the nymphididic realm, in order that [she] may be conceived in our minds, and that in this way we may attain to the year Aniadin,² that is, to a long life by imagination, we take the characters, of Venus, that is, the shield and buckler of love, to resist manfully the obstacles that confront us, for love overcomes all difficulties; which characters, even if you know yourselves one with others, you have nevertheless put to little use. And thus Paracelsus brings to an end those things which he treated of in the earlier chapters, that we may safely obtain that life over which Aniadus, that is, the efficacy of things, dominates and reigns, and which endures for ever with him, namely the heavenly Aniadus, in whom we are present without end: this and other mysteries are in need of nothing whatever.³

A. MELUSINA AND THE PROCESS OF INDIVIDUATION

[215] The text certainly needs a commentary! The Scaiolae, as the four parts, limbs, or emanations of the Anthropos,⁴ are the organs with which he actively intervenes in the world of appearances or by which he is connected with it, just as the invisible *quinta essentia*, or aether, appears in this world as the four elements or, conversely, is composed out of them. Since the Scaiolae, as we have seen, are also psychic functions, these must be understood as manifestations or effluences of the One, the invisible Anthropos. As functions of consciousness, and particularly as *imaginatio*, *speculatio*, *phantasia*, and *fides*, they “intervene” and stimulate Melusina, the water-nixie, to change herself into human form. Dorn thinks of this as a “vision appearing in the mind” and not as a projection on a real woman. So far as our biographical knowledge extends, this latter possibility does not seem to have occurred to Paracelsus either. In Colonna’s *Hypnerotomachia Poliphili* the Lady Polia attains a high degree of reality (far more so than Dante’s ethereal Beatrice but still not as much

as Helen in *Faust II*), yet even she dissolves into a lovely dream as the sun rises on the first day of May:

... tears shone in her eyes like clear crystals, like round pearls, like the dew which Aurora strews on the clouds of dawn. Sighing like a heavenly image, like incense of musk and amber rising to give delight to the spirits of heaven, she dissolved into thin air, leaving nought behind her but a breath of heavenly fragrance. So, with my happy dream, she vanished from my sight, saying as she went: Poliphilo, most dear beloved, farewell!⁵

[216] Polia dissolves just before the long-desired union with her lover. Helen, on the other hand, vanishes only with the dissolution of her son Euphorion. Though Paracelsus gives clear indications of the nuptial mood with his “exaltation” in May and his allusion to the stinging nettle and the little flame, he disregards entirely the projection on a real person or a concretely visualized, personified image, but chooses instead the legendary figure of Melusina. Now this figure is certainly not an allegorical chimera or a mere metaphor: she has her particular psychic reality in the sense that she is a glamorous apparition who, by her very nature, is on one side a psychic vision but also, on account of the psyche’s capacity for imaginative realization (which Paracelsus calls Ares), is a distinct objective entity, like a dream which temporarily becomes reality. The figure of Melusina is eminently suited to this purpose. The anima belongs to those borderline phenomena which chiefly occur in special psychic situations. They are characterized by the more or less sudden collapse of a form or style of life which till then seemed the indispensable foundation of the individual’s whole career. When such a catastrophe occurs, not only are all bridges back into the past broken, but there seems to be no way forward into the future. One is confronted with a hopeless and impenetrable darkness, an abysmal void that is now suddenly filled with an alluring vision, the palpably real presence of a strange yet helpful being, in the same way that, when one lives for a long time in great solitude, the silence or the darkness becomes visibly, audibly, and tangibly alive, and the unknown in oneself steps up in an unknown guise.

[217] This peculiarity of the anima is found also in the Melusina legend: Emmerich, Count of Poitiers, had adopted Raymond, the son of a poor kinsman. The relation between adoptive father and son was harmonious. But once, on the hunt, when pursuing a wild boar, they got separated from the rest and went astray in the forest. Night fell and they lit a fire to warm themselves. Suddenly the Count was attacked by the boar, and Raymond struck at it with his sword. But by an unlucky accident the blade rebounded and dealt the Count a mortal blow. Raymond was inconsolable, and in despair mounted his horse to flee he knew not where. After a time he came to a meadow with a bubbling spring. There he found three beautiful women. One of them

was Melusina, who by her clever counsel saved him from dishonour and a homeless fate.

[218] According to the legend, Raymond found himself in the catastrophic situation we have described, when his whole way of life had collapsed and he faced ruin. That is the moment when the harbinger of fate, the anima, an archetype of the collective unconscious, appears. In the legend Melusina sometimes has the tail of a fish and sometimes that of a snake; she is half human, half animal. Occasionally she appears only in snake form. The legend apparently has Celtic roots,⁶ but the motif is found practically everywhere. It was not only extraordinarily popular in Europe during the Middle Ages, but occurs also in India, in the legend of Urvashi and Pururavas, which is mentioned in the Shatapatha-Brāhmaṇa.⁷ It also occurs among the North American Indians.⁸ The motif of half-man, half-fish is universally disseminated. Special mention should be made of Conrad Vecerius,⁹ according to whom Melusina, or Melyssina, comes from an island in the sea where nine sirens dwell, who can change into any shape they want. This is of particular interest as Paracelsus mentions Melusina along with “Syrena.”¹⁰ The tradition probably goes back to Pomponius Mela,¹¹ who calls the island “Sena” and the beings who dwell there “Senae.” They cause storms, can change their shape, cure incurable diseases, and know the future.¹² Since the mercurial serpent of the alchemists is not infrequently called *virgo* and, even before Paracelsus, was represented in the form of a Melusina, the latter’s capacity to change her shape and to cure diseases is of importance in that these peculiarities were also predicated of Mercurius, and with special emphasis. On the other hand, Mercurius was also depicted as the grey-bearded Mercurius *senex* or Hermes Trismegistus, from which it is evident that two empirically very common archetypes, namely the anima and the Wise Old Man,¹³ flow together in the symbolic phenomenology of Mercurius. Both are daemons of revelation and, in the form of Mercurius, represent the panacea. Again and again Mercurius is called *versatilis*, *versipellis*, *mutabilis*, *servus* or *cervus fugitivus*, Proteus, etc.

[219] The alchemists, and Paracelsus too, were no doubt confronted often enough with the dark abyss of not-knowing, and, unable to go forward, were on their own admission dependent on revelation or illumination or a helpful dream. For this reason they needed a “ministering spirit,” a familiar or *πάρεδρος*, to whose invocation the Greek Magic Papyri bear witness. The snake form of the god of revelation, and of spirits in general, is a universal type.

[220] Paracelsus seems to have known nothing of any psychological premises. He attributes the appearance and transformation of Melusina to the effect of the “intervening” Scaiolae, the driving spiritual forces emanating from the *homo maximus*. The opus was subordinated to them, for its aim was to raise man to the sphere of the Anthropos. There is no doubt that the goal of the philosophical

alchemist was higher self-development, or the production of what Paracelsus calls the *homo maior*, or what I would call individuation. This goal confronts the alchemist at the start with the loneliness which all of them feared, when one has “only” oneself for company. The alchemist, on principle, worked alone. He formed no school. This rigorous solitude, together with his preoccupation with the endless obscurities of the work, was sufficient to activate the unconscious and, through the power of imagination, to bring into being things that apparently were not there before. Under these circumstances “enigmatical speculations” arise in which the unconscious is visually experienced as a “vision appearing in the mind.” Melusina emerges from the watery realm and assumes human form—sometimes quite concretely, as in *Faust I*, where Faust’s hopelessness leads him straight into the arms of Gretchen, in which form Melusina would doubtless remain were it not for the catastrophe which drives Faust still deeper into magic: Melusina changes into Helen. But she does not remain even there, for all attempts at concretization are shattered like the retort of the homunculus against the throne of Galatea. Another power takes over, “that difficult Adech,” who “at the end changes himself.” The greater man “hinders our purpose,” for Faust has to change himself at death into a boy, the *puer aeternus*, to whom the true world will be shown only after all desirousness has fallen away from him. “Miserable mortals, to whom Nature has denied her first and best treasure, the *lumen naturae!*”

[221] It is Adech, the inner man, who with his Scaiolae guides the purpose of the adept and causes him to behold fantasy images from which he will draw false conclusions, devising out of them situations of whose provisional and fragile nature he is unaware. Nor is he aware that by knocking on the door of the unknown he is obeying the law of the inner, future man, and that he is disobedient to this law whenever he seeks to secure a permanent advantage or possession from his work. Not his ego, that fragment of a personality, is meant; it is rather that a wholeness, of which he is a part, wants to be transformed from a latent state of unconsciousness into an approximate consciousness of itself.

[222] The “acts of Melusina” are deceptive phantasms compounded of supreme sense and the most pernicious nonsense, a veritable veil of Maya which lures and leads every mortal astray. From these phantasms the wise man will extract the “supermonic” elements, that is, the higher inspirations; he extracts everything meaningful and valuable as in a process of distillation,¹⁴ and catches the precious drops of the *liquor Sophiae* in the ready beaker of his soul, where they “open a window” for his understanding. Paracelsus is here alluding to a discriminative process of critical judgment which separates the chaff from the wheat—an indispensable part of any rapprochement with the unconscious. It requires no art to become stupid; the whole art lies in extracting wisdom from stupidity. Stupidity is the

mother of the wise, but cleverness never. The “fixation” refers alchemically to the lapis but psychologically to the consolidation of feeling. The distillate must be fixed and held fast, must become a firm conviction and a permanent content.

B. THE HIEROSGAMOS OF THE EVERLASTING MAN

[223] Melusina, the deceptive Shakti, must return to the watery realm if the work is to reach its goal. She should no longer dance before the adept with alluring gestures, but must become what she was from the beginning: a part of his wholeness.¹⁵ As such she must be “conceived in the mind.” This leads to a union of conscious and unconscious that was always present unconsciously but was always denied by the one-sidedness of the conscious attitude. From this union arises that wholeness which the introspective philosophy of all times and climes has characterized with an inexhaustible variety of symbols, names, and concepts. The “mille nomina” disguise the fact that this coniunctio is not concerned with anything tangible or discursively apprehensible; it is an experience that simply cannot be reproduced in words, but whose very nature carries with it an unassailable feeling of eternity or timelessness.

[224] I will not repeat here what I have said elsewhere on this subject. It makes no difference anyway what one says about it. Paracelsus does, however, give one more hint which I cannot pass over in silence: this concerns the “characters of Venus.”¹⁶

[225] Melusina, being a water-nixie, is closely connected with Morgana, the “sea-born,” whose classical counterpart is Aphrodite, the “foam-born.” Union with the feminine personification of the unconscious is, as we have seen, a well-nigh eschatological experience, a reflection of which is to be found in the Apocalyptic Marriage of the Lamb, the Christian form of the hierosgamos. The passage runs (Revelation 19 : 6–10):

And I heard as it were the voice of a great multitude, and as the voice of many waters, and as the voice of mighty thunderings, saying, Alleluia; for the Lord God omnipotent reigneth.

Let us be glad and rejoice, and give honour to him: for the marriage of the Lamb is come, and his wife hath made herself ready.

And to her was granted that she should be arrayed in fine linen, clean and white: for the fine linen is the righteousness of saints.

And he saith unto me: Write, Blessed are they which are called unto the marriage supper of the Lamb. And he saith unto me, These are the true sayings of God.

And I fell at his feet to worship him. And he said unto me, See thou do it not: I am thy fellowservant, and of thy brethren . . .

[226] The “he” of the text is the angel that speaks to John; in the language of Paracelsus, he is the *homo maior*, Adech. I need hardly point out that Venus is closely related to the love-goddess Astarte, whose sacred marriage-festivals were known to everyone. The experience of union underlying these festivals is, psychologically, the embrace and coming together again of two souls in the exaltation of spring, in the “true May”; it is the successful reuniting of an apparently hopelessly divided duality in the wholeness of a single being. This unity embraces the multiplicity of all beings. Hence Paracelsus says: “If you know yourselves one with others.” Adech is not *my* self, he is also that of my brothers: “I am thy fellowservant, and of thy brethren.” That is the specific definition of this experience of the coniunctio: the self which includes me includes many others also, for the unconscious that is “conceived in our mind” does not belong to me and is not peculiar to me, but is everywhere. It is the quintessence of the individual and at the same time the collective.

[227] The participants in the marriage of the Lamb enter into eternal blessedness; they are “virgins, which were not defiled with women” and are “redeemed from among men” (Rev. 14 : 4). In Paracelsus the goal of redemption is “the year Aniadin,” or time of perfection, when the One Man reigns for ever.

C. SPIRIT AND NATURE

[228] Why did Paracelsus not avail himself of the Christian imagery, when it expresses the same thought so very clearly? Why does Venus appear in the place of Melusina, and why is it not the marriage of the Lamb, but a hierosgamos of Venus and Mars, as the text itself hints? The reason is probably the same as that which compelled Francesco Colonna to make Poliphilo seek his beloved Polia not with the Mother of God but with Venus. For the same reason the boy in Christian Rosencreutz's *Chymical Wedding*¹⁷ led the hero down to an underground chamber, on the door of which was a secret inscription graven in copper characters. Copper (*cuprum*) is correlated with the Cyprian (Aphrodite, Venus). In the chamber they found a three-cornered tomb containing a copper cauldron, and in it was an angel holding a tree that dripped continually into the cauldron. The tomb was supported by three animals: an eagle, an ox, and a lion.¹⁸ The boy explained that in this tomb Venus lay buried, who had destroyed many an upright man. Continuing their descent, they came to the bedchamber of Venus and found the goddess asleep on a couch. Indiscreetly, the boy twitched the coverlet away and revealed her in all her naked beauty.¹⁹

[229] The ancient world contained a large slice of nature and a number of questionable things which Christianity was bound to overlook if the security of a spiritual standpoint was not to be hopelessly compromised. No penal code and no moral code, not even the sublimest casuistry, will ever be able to codify and pronounce just judgment upon the confusions, the conflicts of duty, and the invisible tragedies of the natural man in collision with the exigencies of culture. "Spirit" is one aspect, "Nature" another. "You may pitch Nature out with a fork, yet she'll always come back again," says the poet.²⁰ Nature *must not* win the game, but she *cannot* lose. And whenever the conscious mind clings to hard and fast concepts and gets caught in its own rules and regulations—as is unavoidable and of the essence of civilized consciousness—nature pops up with her inescapable demands. Nature is not matter only, she is also spirit. Were that not so, the only source of spirit would be human reason. It is the great achievement of Paracelsus to have elevated the "light of nature" to a principle and to have emphasized it in a far more fundamental way than his predecessor Agrippa. The *lumen naturae* is the natural spirit, whose strange and significant workings we can observe in the manifestations of the unconscious now that psychological research has come to realize that the unconscious is not just a "subconscious" appendage or the dustbin of consciousness, but is a largely autonomous psychic system for compensating the biases and aberrations of the conscious attitude, for the most part functionally, though it sometimes corrects them by force. Consciousness can, as we know, be led astray by naturalness as easily as by spirituality, this being the logical consequence of its freedom of choice. The

unconscious is not limited only to the instinctual and reflex processes of the cortical centres; it also extends beyond consciousness and, with its symbols, anticipates future conscious processes. It is therefore quite as much a “supra-consciousness.”

[230] Convictions and moral values would have no meaning if they were not believed and did not possess exclusive validity. And yet they are man-made and time-conditioned assertions or explanations which we know very well are capable of all sorts of modifications, as has happened in the past and will happen again in the future. All that has happened during the last two thousand years shows that they are reliable signposts for certain stretches of the way, then comes a painful upheaval, which is felt as subversive and immoral, until a new conviction takes root. So far as the essential traits of human nature remain the same, certain moral values enjoy permanent validity. The most meticulous observance of the Ten Commandments, however, is no obstacle to the more refined forms of turpitude, and the far loftier principle of Christian love of one’s neighbour can lead to such tangled conflicts of duty that sometimes the Gordian knot can only be cut with a very unchristian sword.

D. THE ECCLESIASTICAL SACRAMENT AND THE OPUS ALCHYMICUM

[231] Paracelsus, like many others, was unable to make use of the Christian symbolism because the Christian formula inevitably suggested the Christian solution and would thus have conduced to the very thing that had to be avoided. It was nature and her particular “light” that had to be acknowledged and lived with in the face of an attitude that assiduously overlooked them. This could only be done under the protective aegis of the arcanum. But one should not imagine Paracelsus or any other alchemist settling down to invent an arcane terminology that would make the new doctrine a kind of private code. Such an undertaking would presuppose the existence of definite views and clearly defined concepts. But there is no question of that: none of the alchemists ever had any clear idea of what his philosophy was really about. The best proof of this is the fact that everyone with any originality at all coined his own terminology, with the result that no one fully understood anybody else. For one alchemist, Lully was an obscurantist and a charlatan and Geber the great authority; while for another, Geber was a Sphinx and Lully the source of all enlightenment. So with Paracelsus: we have no reason to suppose that behind his neologisms there was a clear, consciously disguised concept. It is on the contrary probable that he was trying to grasp the ungraspable with his countless esotericisms, and snatched at any symbolic hint that the unconscious offered. The new world of scientific knowledge was still in a nascent dream-state, a mist heavy with the future, in which shadowy figures groped about for the right words. Paracelsus was not reaching back into the past; rather, for lack of anything suitable in the present, he was using the old remnants to give new form to a renewed archetypal experience. Had the alchemists

felt any serious need to revive the past, their erudition would have enabled them to draw on the inexhaustible storehouse of the heresiologists. But except for the “*Aquarium sapientum*,”²¹ which likewise treats of heresies, I have found only one alchemist (of the sixteenth century) who shudderingly admits to having read the *Panarium* of Epiphanius. Nor are any secret traces of Gnostic usages to be found, despite the fact that the texts swarm with unconscious parallels.

[232] To return to our text: it is clear that it describes a procedure for attaining nothing less than immortality (“that we may arrive immortal at the year Aniadin”). There is, however, only one way to this goal, and that is through the sacraments of the Church. These are here replaced by the “sacrament” of the *opus alchymicum*, less by word than by deed, and without the least sign of any conflict with the orthodox Christian standpoint.

[233] Which way did Paracelsus hold to be the true one? Or were both of them true for him? Presumably the latter, and the rest he “leaves to the theoreticians to discuss.”

[234] What is meant by the “characters of Venus” remains obscure. The “sapphire”²² which Paracelsus prized so much, the *cheyri*, *ladanum*, *muscus*, and *ambra* belong, according to Agrippa,²³ to Venus. The goddess undoubtedly appears in our text on a higher level, in keeping with her classical cognomens: *docta*, *sublimis*, *magistra rerum humanarum divinarumque*, etc.²⁴ One of her characters is certainly love in the widest sense, so Dorn is not wrong when he interprets them as the “shield and buckler of love.” Shield and buckler are martial attributes, but there is also a *Venus armata*.²⁵ Mythologically, the personified Amor is a son of Venus and Mars, whose cohabitation in alchemy is a typical coniunctio.²⁶ Dorn, despite being a Paracelsist, had a decidedly polemical attitude towards certain fundamental tenets of alchemy,²⁷ so that a Christian love of one’s neighbour, well armed against evil, suited him very well. But so far as Paracelsus is concerned this interpretation is doubtful. The word Venus points in quite another direction, and since the Christian gifts of grace were included in his Catholic faith he had in any case no need of a christianized Amor. On the contrary, a Venus Magistra or Aphrodite Urania, or even a Sophia, would have seemed to him more appropriate to the mystery of the *lumen naturae*. The words “*minime tamen usurpatis*” might also be a hint at discretion.²⁸ Hence the Venus episode in the *Chymical Wedding* may have more bearing on the interpretation of this cryptic passage than Dorn’s well-meant circumlocution.

[235] The concluding reference to a “life without end” under the dominion of Aniadius is very reminiscent of Rev. 20 : 4: “... and they lived and reigned with Christ a thousand years.” The year Aniadin would thus correspond to the thousand-year reign in the Apocalypse.

[236] In conclusion I would remark that the survey of the secret doctrine which I have attempted to sketch here makes it seem likely that besides the physician and Christian

in Paracelsus there was also an alchemical philosopher at work who, pushing every analogy to the very limit, strove to penetrate the divine mysteries. The parallel with the mysteries of the Christian faith, which we can only feel as a most dangerous conflict, was no Gnostic heresy for him, despite the most disconcerting resemblances; for him as for every other alchemist, man had been entrusted with the task of bringing to perfection the divine will implanted in nature, and this was a truly sacramental work. To the question “Are you, as it would seem, an Hermetic?” he could have replied with Lazarello: “I am a Christian, O King, and it is no disgrace to be that and an Hermetic at the same time.”²⁹

5. EPILOGUE

[237] I had long been aware that alchemy is not only the mother of chemistry, but is also the forerunner of our modern psychology of the unconscious. Thus Paracelsus appears as a pioneer not only of chemical medicine but of empirical psychology and psychotherapy.

[238] It may seem that I have said too little about Paracelsus the self-sacrificing physician and Christian, and too much about his dark shadow, that other Paracelsus, whose soul was intermingled with a strange spiritual current which, issuing from immemorial sources, flowed beyond him into a distant future. But—*ex tenebris lux*—it was precisely because he was so fascinated by magic that he was able to open the door to the realities of nature for the benefit of succeeding centuries. The Christian and the primitive pagan lived together in him in a strange and marvellous way to form a conflicting whole, as in other great Renaissance figures. Although he had to endure the conflict, he was spared that agonizing split between knowledge and faith that has riven the later epochs. As a man he had one father, but as a spirit he had two mothers. His spirit was heroic, because creative, and as such was doomed to Promethean guilt. The secular conflict that broke out at the turn of the sixteenth century, and whose living image stands before our eyes in the figure of Paracelsus, is a prerequisite for higher consciousness; for analysis is always followed by synthesis, and what was divided on a lower level will reappear, united, on a higher one.

IV

THE SPIRIT MERCURIUS

[Given as two lectures at the Eranos Conference, Ascona, Switzerland, in 1942, the theme of which was “The Hermetic Principle in Mythology, Gnosis, and Alchemy.” Published as “Der Geist Mercurius,” *Eranos-Jahrbuch 1042* (Zurich, 1943); revised and expanded in *Symbolik des Geistes: Studien über psychische Phänomenologie . . .* (Psychologische Abhandlungen, VI; Zurich, 1948). An English translation by Gladys Phelan and Hildegard Nagel, titled *The Spirit Mercury*, was published as a book by the Analytical Psychology Club of New York, Inc., in 1953, and forms the basis of the present translation. Some brief chapters have been combined.—EDITORS.]

Ἑρμῆ κοσμοκράτωρ, ἐγκάρδιε, κύκλε σελήνης,
στρογγύλε καὶ τετράγωνε, λόγων ἀρχηγέτα γλώσσης,
πειθοδικαιόσυνε, χλαμυδηφόρε, πτηνοπέδιλε,
παμφώνου γλώσσης μεδέων, θνητοῖσι προφῆτα . . .

(Hermes, ruler of the world, dweller in the heart, circle of the moon, Round and square, inventor of the words of the tongue, Obedient to justice, wearer of the chlamys, shod in winged sandals, Guardian of the many-sounding tongue, prophet to mortals.)

—A Magic Papyrus (Preisendanz, II, p. 139)

Part I

1. THE SPIRIT IN THE BOTTLE

[239] In my contribution¹ to the symposium on Hermes I will try to show that this many-hued and wily god did not by any means die with the decline of the classical era, but on the contrary has gone on living in strange guises through the centuries, even into recent times, and has kept the mind of man busy with his deceptive arts and healing gifts. Children are still told Grimm's fairytale of "The Spirit in the Bottle," which is ever-living like all fairytales, and moreover contains the quintessence and deepest meaning of the Hermetic mystery as it has come down to us today:

Once upon a time there was a poor woodcutter. He had an only son, whom he wished to send to a high school. However, since he could give him only a little money to take with him, it was used up long before the time for the examinations. So the son went home and helped his father with the work in the forest. Once, during the midday rest, he roamed the woods and came to an immense old oak. There he heard a voice calling from the ground, "Let me out, let me out!" He dug down among the roots of the tree and found a well-sealed glass bottle from which, clearly, the voice had come. He opened it and instantly a spirit rushed out and soon became half as high as the tree. The spirit cried in an awful voice: "I have had my punishment and I will be revenged! I am the great and mighty spirit Mercurius, and now you shall have your reward. Who so releases me, him I must strangle." This made the boy uneasy and, quickly thinking up a trick, he said, "First, I must be sure that you are the same spirit that was shut up in that little bottle." To prove this, the spirit crept back into the bottle. Then the boy made haste to seal it and the spirit was caught again. But now the spirit promised to reward him richly if the boy would let him out. So he let him out and received as a reward a small piece of rag. Quoth the spirit: "If you spread one end of this over a wound it will heal, and if you rub steel or iron with the other end it will turn into silver." Thereupon the boy rubbed his damaged axe with the rag, and the axe turned to silver and he was able to sell it for four hundred thaler. Thus father and son were freed from all worries. The young man could return to his studies, and later, thanks to his rag, he became a famous doctor.²

[240] Now, what insight can we gain from this fairytale? As you know, we can treat fairytales as fantasy products, like dreams, conceiving them to be spontaneous statements of the unconscious about itself.

[241] As at the beginning of many dreams something is said about the scene of the dream action, so the fairytale mentions the forest as the place of the magic happening. The forest, dark and impenetrable to the eye, like deep water and the sea, is the container of the unknown and the mysterious. It is an appropriate synonym for the unconscious. Among the many trees—the living elements that make up the forest—one tree is especially conspicuous for its great size. Trees, like fishes in the water, represent the living contents of the unconscious. Among these contents one of special significance is characterized as an “oak.” Trees have individuality. A tree, therefore, is often a symbol of personality.³ Ludwig II of Bavaria is said to have honoured certain particularly impressive trees in his park by having them saluted. The mighty old oak is proverbially the king of the forest. Hence it represents a central figure among the contents of the unconscious, possessing personality in the most marked degree. It is the prototype of the *self*, a symbol of the source and goal of the individuation process. The oak stands for the still unconscious core of the personality, the plant symbolism indicating a state of deep unconsciousness. From this it may be concluded that the hero of the fairytale is profoundly unconscious of himself. He is one of the “sleepers,” the “blind” or “blindfolded,” whom we encounter in the illustrations of certain alchemical treatises.⁴ They are the unawakened who are still unconscious of themselves, who have not yet integrated their future, more extensive personality, their “wholeness,” or, in the language of the mystics, the ones who are not yet “enlightened.” For our hero, therefore, the tree conceals a great secret.⁵

[242] The secret is hidden not in the top but in the roots of the tree;⁶ and since it is, or has, a personality it also possesses the most striking marks of personality—voice, speech, and conscious purpose, and it demands to be set free by the hero. It is caught and imprisoned against its will, down there in the earth among the roots of the tree. The roots extend into the inorganic realm, into the mineral kingdom. In psychological terms, this would mean that the self has its roots in the body, indeed in the body’s chemical elements. Whatever this remarkable statement of the fairytale may mean in itself, it is in no way stranger than the miracle of the living plant rooted in the inanimate earth. The alchemists described their four elements as *radices*, corresponding to the Empedoclean *rhizomata*, and in them they saw the constituents of the most significant and central symbol of alchemy, the *lapis philosophorum*, which represents the goal of the individuation process.

[243] The secret hidden in the roots is a spirit sealed inside a bottle. Naturally it was not hidden away among the roots to start with, but was first confined in a bottle, which was then hidden. Presumably a magician, that is, an alchemist, caught and imprisoned it. As we shall see later, this spirit is something like the numen of the tree, its *spiritus vegetativus*, which is one definition of Mercurius. As the life principle of the tree, it is a sort of spiritual quintessence abstracted from it, and could also be

described as the *principium individuationis*. The tree would then be the outward and visible sign of the realization of the self. The alchemists appear to have held a similar view. Thus the “Aurelia occulta” says: “The philosophers have sought most eagerly for the centre of the tree which stands in the midst of the earthly paradise.”⁷ According to the same source, Christ himself is this tree.⁸ The tree comparison occurs as early as Eulogius of Alexandria (c. A.D. 600), who says: “Behold in the Father the root, in the Son the branch, and in the Spirit the fruit: for the substance [*οὐσία*] in the three is one.”⁹ Mercurius, too, is *trinus et unus*.

[244] So if we translate it into psychological language, the fairytale tells us that the mercurial essence, the *principium individuationis*, would have developed freely under natural conditions, but was robbed of its freedom by deliberate intervention from outside, and was artfully confined and banished like an evil spirit. (Only evil spirits have to be confined, and the wickedness of this spirit was shown by its murderous intent.) Supposing the fairytale is right and the spirit was really as wicked as it relates, we would have to conclude that the Master who imprisoned the *principium individuationis* had a good end in view. But who is this well-intentioned Master who has the power to banish the principle of man’s individuation? Such power is given only to a ruler of souls in the spiritual realm. The idea that the principle of individuation is the source of all evil is found in Schopenhauer and still more in Buddhism. In Christianity, too, human nature is tainted with original sin and is redeemed from this stain by Christ’s self-sacrifice. Man in his “natural” condition is neither good nor pure, and if he should develop in the natural way the result would be a product not essentially different from an animal. Sheer instinctuality and naïve unconsciousness untroubled by a sense of guilt would prevail if the Master had not interrupted the free development of the natural being by introducing a distinction between good and evil and outlawing the evil. Since without guilt there is no moral consciousness and without awareness of differences no consciousness at all, we must concede that the strange intervention of the master of souls was absolutely necessary for the development of any kind of consciousness and in this sense was for the good. According to our religious beliefs, God himself is this Master—and the alchemist, in his small way, competes with the Creator in so far as he strives to do work analogous to the work of creation, and therefore he likens his microcosmic opus to the work of the world creator.¹⁰

[245] In our fairytale the natural evil is banished to the “roots,” that is, to the earth, in other words the body. This statement agrees with the historical fact that Christian thought in general has held the body in contempt, without bothering much about the finer doctrinal distinctions.¹¹ For, according to doctrine, neither the body nor nature in general is evil *per se*: as the work of God, or as the actual form in which he manifests himself, nature cannot be identical with evil. Correspondingly, the evil spirit in the

fairytale is not simply banished to the earth and allowed to roam about at will, but is only hidden there in a safe and special container, so that he cannot call attention to himself anywhere except right under the oak. The bottle is an artificial human product and thus signifies the intellectual purposefulness and artificiality of the procedure, whose obvious aim is to isolate the spirit from the surrounding medium. As the *vas Hermeticum* of alchemy, it was “hermetically” sealed (i.e., sealed with the sign of Hermes);¹² it had to be made of glass, and had also to be as round as possible, since it was meant to represent the cosmos in which the earth was created.¹³ Transparent glass is something like solidified water or air, both of which are synonyms for spirit. The alchemical retort is therefore equivalent to the *anima mundi*, which according to an old alchemical conception surrounds the cosmos. Caesarius of Heisterbach (thirteenth century) mentions a vision in which the soul appeared as a spherical glass vessel.¹⁴ Likewise the “spiritual” or “ethereal” (*aethereus*) philosophers’ stone is a precious *vitrum* (sometimes described as *malleabile*) which was often equated with the gold glass (*aurum vitreum*) of the heavenly Jerusalem (Rev. 21 : 21).

[246] It is worth noting that the German fairytale calls the spirit confined in the bottle by the name of the pagan god, Mercurius, who was considered identical with the German national god, Wotan. The mention of Mercurius stamps the fairytale as an alchemical folk legend, closely related on the one hand to the allegorical tales used in teaching alchemy, and on the other to the well-known group of folktales that cluster round the motif of the “spellbound spirit.” Our fairytale thus interprets the evil spirit as a pagan god, forced under the influence of Christianity to descend into the dark underworld and be morally disqualified. Hermes becomes the demon of the mysteries celebrated by all *tenebriones* (obscurantists), and Wotan the demon of forest and storm; Mercurius becomes the soul of the metals, the metallic man (*homunculus*), the dragon (*serpens mercurialis*), the roaring fiery lion, the night raven (*nycticorax*), and the black eagle—the last four being synonyms for the devil. In fact the spirit in the bottle behaves just as the devil does in many other fairytales: he bestows wealth by changing base metal into gold; and like the devil, he also gets tricked.

2. THE CONNECTION BETWEEN SPIRIT AND TREE

[247] Before continuing our discussion of the spirit Mercurius, I should like to point out a not unimportant fact. The place where he lies confined is not just any place but a very essential one—namely, under the oak, the king of the forest. In psychological terms, this means that the evil spirit is imprisoned in the roots of the self, as the secret hidden in the principle of individuation. He is not identical with the tree, nor with its roots, but has been put there by artificial means. The fairytale gives us no reason to think that the oak, which represents the self, has grown out of the spirit in the bottle; we may rather conjecture that the oak presented a suitable place for concealing a secret. A treasure, for instance, is preferably buried near some kind of landmark, or else such a mark is put up afterwards. The tree of paradise serves as a prototype for this and similar tales: it, too, is not identical with the voice of the serpent which issued from it.¹ However, it must not be forgotten that these mythical motifs have a significant connection with certain psychological phenomena observed among primitive peoples. In all such cases there is a notable analogy with primitive animism: certain trees are animated by souls—have the character of personality, we would say—and possess a voice that gives commands to human beings. Amaury Talbot² reports one such case from Nigeria, where a native soldier heard an *oji* tree calling to him, and tried desperately to break out of the barracks and hasten to the tree. Under cross-examination he alleged that all those who bore the name of the tree now and then heard its voice. Here the voice is undoubtedly identical with the tree. These psychic phenomena suggest that originally the tree and the daemon were one and the same, and that their separation is a secondary phenomenon corresponding to a higher level of culture and consciousness. The original phenomenon was nothing less than a nature deity, a *tremendum* pure and simple, which is morally neutral. But the secondary phenomenon implies an act of discrimination which splits man off from nature and thus testifies to the existence of a more highly differentiated consciousness. To this is added, as a tertiary phenomenon testifying to a still higher level, the moral qualification which declares the voice to be an evil spirit under a ban. It goes without saying that this third level is marked by a belief in a “higher” and “good” God who, though he has not finally disposed of his adversary, has nevertheless rendered him harmless for some time to come by imprisonment (Rev. 20: 1–3).

[248] Since at the present level of consciousness we cannot suppose that tree daemons exist, we are forced to assert that the primitive suffers from hallucinations, that he hears his own unconscious which has projected itself into the tree. If this theory is correct—and I do not know how we could formulate it otherwise today—then the second level of consciousness has effected a differentiation between the object “tree” and the unconscious content projected into it, thereby achieving an act of enlightenment. The third level rises still higher and attributes “evil” to the psychic content which has been separated from the object. Finally a fourth level, the level reached by our consciousness today, carries the enlightenment a stage further by denying the objective existence of the “spirit” and declaring that the primitive has heard nothing at all, but merely had an auditory hallucination. Consequently the whole phenomenon vanishes into thin air—with the great advantage that the evil spirit becomes obviously non-existent and sinks into ridiculous insignificance. A fifth level, however, which is bound to take a quintessential view of the matter, wonders about this conjuring trick that turns what began as a miracle into a senseless self-deception—only to come full circle. Like the boy who told his father a made-up story about sixty stags in the forest, it asks: “But what, then, was all the rustling in the woods?” The fifth level is of the opinion that something did happen after all: even though the psychic content was not the tree, nor a spirit in the tree, nor indeed any spirit at all, it was nevertheless a phenomenon thrusting up from the unconscious, the existence of which cannot be denied if one is minded to grant the psyche any kind of reality. If one did not do that, one would have to extend God’s *creatio ex nihilo*—which seems so obnoxious to the modern intellect—very much further to include steam engines, automobiles, radios, and every library on earth, all of which would presumably have arisen from unimaginably fortuitous conglomerations of atoms. The only thing that would have happened is that the Creator would have been renamed Conglomeratio.

[249] The fifth level assumes that the unconscious exists and has a reality just like any other existent. However odious it may be, this means that the “spirit” is also a reality, and the “evil” spirit at that. What is even worse, the distinction between “good” and “evil” is suddenly no longer obsolete, but highly topical and necessary. The crucial point is that so long as the evil spirit cannot be proved to be a subjective psychic experience, then even trees and other suitable objects would have, once again, to be seriously considered as its lodging places.

3. THE PROBLEM OF FREEING MERCURIUS

[250] We will not pursue the paradoxical reality of the unconscious any further now, but will return to the fairytale of the spirit in the bottle. As we have seen, the spirit Mercurius bears some resemblance to the “cheated devil.” The analogy, however, is only a superficial one, since, unlike the gifts of the devil, the gold of Mercurius does not turn to horse droppings but remains good metal, and the magic rag does not turn to ashes by morning but retains its healing power. Nor is Mercurius tricked out of a soul that he wanted to steal. He is only tricked into his own better nature, one might say, in that the boy succeeds in bottling him up again in order to cure his bad mood and make him tractable. Mercurius becomes polite, gives the young fellow a useful ransom and is accordingly set free. We now hear about the student’s good fortune and how he became a wonder-working doctor, but—strangely enough—nothing about the doings of the liberated spirit, though these might be of some interest in view of the web of meanings in which Mercurius, with his many-sided associations, entangles us. What happens when this pagan god, Hermes-Mercurius-Wotan, is let loose again? Being a god of magicians, a *spiritus vegetativus*, and a storm daemon, he will hardly have returned to captivity, and the fairytale gives us no reason to suppose that the episode of imprisonment has finally changed his nature to the pink of perfection. The bird of Hermes has escaped from the glass cage, and in consequence something has happened which the experienced alchemist wished at all costs to avoid. That is why he always sealed the stopper of his bottle with magic signs and set it for a very long time over the lowest fire, so that “he who is within may not fly out.” For if he escapes, the whole laborious opus comes to nothing and has to be started all over again. Our lad was a Sunday’s child and possibly one of the poor in spirit, on whom was bestowed a bit of the Kingdom of Heaven in the shape of the self-renewing tincture, with reference to which it was said that the opus needed to be performed only once.¹ But if he had lost the magic rag he would certainly never have been able to produce it a second time, by himself. It looks as though some Master had succeeded in capturing the mercurial spirit and then hid him in a safe place, like a treasure—perhaps putting him aside for some future use. He may even have planned to tame the wild Mercurius to serve him as a willing “familiar,” like Mephisto—such trains of thought are not strange to alchemy. Perhaps he was disagreeably surprised when he returned to the oak tree and found that his bird had flown. At any rate, it might have been better not to have left the fate of the bottle to chance.

[251] Be that as it may, the behaviour of the boy—successfully as it worked out for him—must be described as alchemically incorrect. Apart from the fact that he may have infringed upon the legitimate claims of an unknown Master by setting Mercurius free, he was also totally unconscious of what might follow if this turbulent spirit were let loose upon the world. The golden age of alchemy was the sixteenth and the first half of the seventeenth century. At that time a storm bird did indeed escape from a spiritual vessel which the daemons must have felt was a prison. As I have said, the alchemists were all for not letting Mercurius escape. They wanted to keep him in the bottle in order to transform him: for they believed, like Petasios, that lead (another arcane substance) was “so bedevilled and shameless that all who wish to investigate it fall into madness through ignorance.”² The same was said of the elusive Mercurius who evades every grasp—a real trickster who drove the alchemists to despair.³

Part II

1. INTRODUCTORY

[252] The interested reader will want, as I do, to find out more about this spirit—especially what our forefathers believed and said about him. I will therefore try with the aid of text citations to draw a picture of this versatile and shimmering god as he appeared to the masters of the royal art. For this purpose we must consult the abstruse literature of alchemy, which has not yet been properly understood. Naturally, in later times, the history of alchemy was mainly of interest to the chemist. The fact that it recorded the discovery of many chemical substances and drugs could not, however, reconcile him to the pitiful meagreness, so it seemed to him, of its scientific content. He was not in the position of the older authors, such as Schmieder, who could look on the possibility of goldmaking with hopeful esteem and sympathy; instead he was irritated by the futility of the recipes and the fraudulence of alchemical speculation in general. To him alchemy was bound to seem a gigantic aberration that lasted for more than two thousand years. Had he only asked himself whether the chemistry of alchemy was authentic or not, that is, whether the alchemists were really chemists or merely spoke a chemical jargon, then the texts themselves would have suggested a line of observation other than the purely chemical. The scientific equipment of the chemist does not, however, fit him to pursue this other line, since it leads straight into the history of religion. Thus it was a philologist, Reitzenstein, whom we have to thank for preliminary researches of the greatest value in this field. It was he who recognized the mythological and Gnostic ideas embedded in alchemy, thereby opening up the whole subject from an angle which promises to be most fruitful. For alchemy, as the earliest Greek and Chinese texts show, originally formed part of Gnostic philosophical speculations which also included a detailed knowledge of the techniques of the goldsmith and ironsmith, the faker of precious stones, the druggist and apothecary. In East and West alike, alchemy contains as its core the Gnostic doctrine of the Anthropos and by its very nature has the character of a peculiar doctrine of redemption. This fact necessarily escaped the chemist, although it is expressed clearly enough in the Greek and Latin texts as well as in the Chinese of about the same period.

[253] To begin with, of course, it is almost impossible for our scientifically trained minds to feel their way back into that primitive state of *participation mystique* in

which subject and object are identical. Here the findings of modern psychology stood me in very good stead. Practical experience shows us again and again that any prolonged preoccupation with an unknown object acts as an almost irresistible bait for the unconscious to project itself into the unknown nature of the object and to accept the resultant perception, and the interpretation deduced from it, as objective. This phenomenon, a daily occurrence in practical psychology and more especially in psychotherapy, is without doubt a vestige of primitivity. On the primitive level, the whole of life is governed by animistic assumptions, that is, by projections of subjective contents into objective situations. For example, Karl von den Steinen says that the Bororos think of themselves as red cockatoos, although they readily admit that they have no feathers.¹ On this level, the alchemists' assumption that a certain substance possesses secret powers, or that there is a *prima materia* somewhere which works miracles, is self-evident. This is, however, not a fact that can be understood or even thought of in chemical terms, it is a psychological phenomenon. Psychology, therefore, can make an important contribution towards elucidating the alchemists' mentality. What to the chemist seem to be the absurd fantasies of alchemy can be recognized by the psychologist without too much difficulty as psychic material contaminated with chemical substances. This material stems from the collective unconscious and is therefore identical with fantasy products that can still be found today among both sick and healthy people who have never heard of alchemy. On account of the primitive character of its projections, alchemy, so barren a field for the chemist, is for the psychologist a veritable gold-mine of materials which throw an exceedingly valuable light on the structure of the unconscious.

[254] Since in what follows I shall often refer to the original texts, it might be as well to say a few words about this literature, some of which is not easily accessible. I shall leave out of account the few Chinese texts that have been translated, and shall only mention that *The Secret of the Golden Flower*, published by Richard Wilhelm and myself, is representative of its class. Nor can I consider the Indian "Quicksilver System."² The Western literature I have used falls into four groups:

1. *Texts by ancient authors.* This group comprises mainly Greek texts, which have been edited by Berthelot, and those transmitted by the Arabs, likewise edited by him. They date from the period between the first and eighth centuries.

2. *Texts by the early Latinists.* The most important of these are translations from the Arabic (or Hebrew?). Recent research shows that most of these texts derive from the Harranite school, which flourished until about 1050, and was also, probably, the source of the *Corpus Hermeticum*. To this group belong certain texts whose Arabic origin is doubtful but which at least show Arabic influence—for instance, the "Summa perfectionis" of Geber and the Aristotle and Avicenna treatises. This period extends from the ninth to the thirteenth century.

3. *Texts by the later Latinists.* These comprise the principal group and range from the fourteenth to the seventeenth century.

4. *Texts in modern European languages.* Sixteenth to seventeenth century. After that, alchemy fell into decline, which is why I have only occasionally used eighteenth-century texts.

2. MERCURIUS AS QUICKSILVER AND/OR WATER

[255] Mercurius was first understood pretty well everywhere as *hydrargyrum*¹ (Hg), quicksilver or *argentum vivum* (Fr. *vifargent* or *argent vive*). As such, it was called *vulgaris* (common) and *crudus*. As a rule, *mercurius philosophicus* was specifically distinguished from this, as an avowedly arcane substance that was sometimes conceived to be present in *mercurius crudus*, and then, again, to differ from it completely. It was the true object of the alchemical procedure. Quicksilver, because of its fluidity and volatility, was also defined as water. A popular saying is: “Aqua manus non madefaciens” (the water that does not make the hands wet).² Other designations are *aqua vitae*,³ *aqua alba*,⁴ *aqua sicca*.⁵ The last designation, dry water, is paradoxical, for which reason I should like to call special attention to it as characterizing the nature of the object described. *Aqua septies distillata* (seven times distilled water) and *aqueum subtile*⁶ point to the sublimated (“spiritual”) nature of the philosophic Mercurius. Many treatises simply speak of Mercurius as water.⁷ The doctrine of the *humidum radicale* (root-moisture or radical moisture) underlies such designations as *humidum album*,⁸ *humiditas maxime permanens incombustibilis et unctuosa*,⁹ and *humiditas radicalis*.¹⁰ Mercurius is also said to arise from the moisture like a vapour¹¹ (which again points to his spiritual nature), or to rule the water.¹² The “divine water” (ὕδωρ θεῖον) so often mentioned in the Greek texts is quicksilver.¹³ Mercurius as the arcane substance and golden tincture is indicated by the designation *aqua aurea*¹⁴ and by the description of the water as *Mercurii caduceus*.¹⁵

3. MERCURIUS AS FIRE

[256] Many treatises define Mercurius simply as fire.¹ He is *ignis elementaris*² *noster naturalis ignis certissimus*,³ which again indicates his “philosophic” nature. The *aqua mercurialis* is even a divine fire.⁴ This fire is “highly vaporous” (*vaporosus*).⁵ Indeed, Mercurius is really the only fire in the whole procedure.⁶ He is an “invisible fire, working in secret.”⁷ One text says that the “heart” of Mercurius is at the North Pole and that he is like a fire (northern lights).⁸ He is, in fact, as another text says, “the universal and scintillating fire of the light of nature, which carries the heavenly spirit within it.”⁹ This passage is particularly important as it relates Mercurius to the *lumen naturae*, the source of mystical knowledge second only to the holy revelation of the Scriptures. Once more we catch a glimpse of the ancient role of Hermes as the god of revelation. Although the *lumen naturae*, as originally bestowed by God upon his creatures, is not by nature ungodly, its essence was nevertheless felt to be abysmal, since the *ignis mercurialis* was also connected with the fires of hell. It seems, however, that the alchemists did not understand hell, or its fire, as absolutely outside of God or opposed to him, but rather as an internal component of the deity, which must indeed be so if God is held to be a *coincidentia oppositorum*. The concept of an all-encompassing God must necessarily include his opposite. The *coincidentia*, of course, must not be too radical or too extreme, otherwise God would cancel himself out.¹⁰ The principle of the coincidence of opposites must therefore be completed by that of absolute opposition in order to attain full paradoxicality and hence psychological validity.

[257] The mercurial fire is found in the “centre of the earth,” or dragon’s belly, in fluid form. Benedictus Figulus writes: “Visit the centre of the earth, there you will find the global fire.”¹¹ Another treatise says that this fire is the “secret, infernal fire, the wonder of the world, the system of the higher powers in the lower.”¹² Mercurius, the revelatory light of nature, is also hell-fire, which in some miraculous way is none other than a rearrangement of the heavenly, spiritual powers in the lower, chthonic world of matter, thought already in St. Paul’s time to be ruled by the devil. Hell-fire, the true energetic principle of evil, appears here as the manifest counterpart of the spiritual and the good, and as essentially identical with it in substance. After that, it can surely cause no offence when another treatise says that the mercurial fire is the “fire in which God himself burns in divine love.”¹³ We are not deceiving ourselves if we feel in scattered remarks of this kind the breath of true mysticism.

[258] Since Mercurius is himself of fiery nature, fire does not harm him: he remains unchanged within it, rejoicing like the salamander.¹⁴ It is unnecessary to point out that quicksilver does not behave like this but vaporizes under heat, as the alchemists themselves knew from very early times.

4. MERCURIUS AS SPIRIT AND SOUL

[259] If Mercurius had been understood simply as quicksilver, there would obviously have been no need for any of the appellations I have listed. The fact that this need arose points to the conclusion that one simple and unmistakable term in no way sufficed to designate what the alchemists had in mind when they spoke of Mercurius. It was certainly quicksilver, but a very special quicksilver, “our” Mercurius, the essence, moisture, or principle behind or within the quicksilver—that indefinable, fascinating, irritating, and elusive thing which attracts an unconscious projection. The “philosophic” Mercurius, this *servus fugitivus* or *cervus fugitivus* (fugitive slave or stag), is a highly important unconscious content which, as may be gathered from the few hints we have given, threatens to ramify into a set of far-reaching psychological problems. The concept swells dangerously and we begin to perceive that the end is nowhere in sight. Therefore we would rather not tie this concept prematurely to any special meaning, but shall content ourselves with stating that the philosophic Mercurius, so dear to the alchemist as the transformative substance, is obviously a projection of the unconscious, such as always takes place when the inquiring mind lacks the necessary self-criticism in investigating an unknown quantity.

[260] As has already been indicated, the psychic nature of the arcane substance did not escape the alchemists; indeed, they actually defined it as “spirit” and “soul.” But since these concepts—especially in earlier times—were always ambiguous, we must approach them with caution if we want to gain a moderately clear idea of what the terms *spiritus* and *anima* meant in alchemical usage.

A. MERCURIUS AS AN AERIAL SPIRIT

[261] Hermes, originally a wind god, and his counterpart the Egyptian Thoth, who “makes the souls to breathe,”¹ are the forerunners of the alchemical Mercurius in his aerial aspect. The texts often use the terms *pneuma* and *spiritus* in the original concrete sense of “air in motion.” So when Mercurius is described in the *Rosarium philosophorum* (fifteenth century) as *aereus* and *volans*² (winged), and in Hoghelande (sixteenth century) as *totus aereus et spiritualis*,³ what is meant is nothing more than a gaseous state of aggregation. Something similar is meant by the poetic expression *serenitas aerea* in the Ripley *Scrowle*,⁴ and by the same author’s statement that Mercurius is changed into wind.⁵ He is the *lapis elevatus cum vento* (the stone uplifted by the wind).⁶ The expressions *spirituale corpus*⁷ and *spiritus visibilis, tamen*

*impalpabilis*⁸ (visible yet impalpable spirit) might also mean little more than “air” if one recalls the aforementioned vapour-like nature of Mercurius, and the same is probably true even of the *spiritus prae cunctis valde purus*⁹ (pre-eminently pure spirit). The designation *incombustibilis*¹⁰ is more doubtful, since this was often synonymous with *incompactibilis* and then meant “eternal,” as we shall see later. Penotus (sixteenth century), a pupil of Paracelsus, stresses the corporeal aspect when he says that Mercurius is “nothing other than the spirit of the world become body within the earth.”¹¹ This expression shows better than anything else the contamination—inconceivable to the modern mind—of two separate realms, spirit and matter; for to people in the Middle Ages the *spiritus mundi* was also the spirit which rules nature, and not just a pervasive gas. We find ourselves in the same dilemma when another author, Mylius, in his *Philosophia reformata*,¹² describes Mercurius as an “intermediate substance” (*media substantia*), which is evidently synonymous with his concept of the *anima media natura*¹³ (soul as intermediate nature), for to him Mercurius was the “spirit and soul of the bodies.”¹⁴

B. MERCURIUS AS SOUL

[262] “Soul” represents a higher concept than “spirit” in the sense of air or gas. As the “subtle body” or “breath-soul” it means something non-material and finer than mere air. Its essential characteristic is to animate and be animated; it therefore represents the life principle. Mercurius is often designated as *anima* (hence, as a feminine being, he is also called *foemina* or *virgo*), or as *nostra anima*.¹⁵ The *nostra* here does not mean “our own” soul but, as in *aqua nostra*, *Mercurius noster*, *corpus nostrum*, refers to the arcane substance.

[263] However, *anima* often appears to be connected with *spiritus*, or is equated with it.¹⁶ For the spirit shares the living quality of the soul, and for this reason Mercurius is often called the *spiritus vegetativus*¹⁷ (spirit of life) or *spiritus seminalis*.¹⁸ A peculiar appellation is found in that seventeenth-century forgery which purports to be the secret book of Abraham le Juif, mentioned by Nicolas Flamel (fourteenth century). The epithet is *spiritus Pythonis* (from *φύω*, ‘to procreate,’ *φυτόν*, ‘creature,’ *φύτωρ*, ‘procreator,’ and *Python*, the Delphic serpent), and is accompanied by the serpent sign: Ω,¹⁹ Very much more material is the definition of Mercurius as a “life-giving power like a glue, holding the world together and standing in the middle between body and spirit.”²⁰ This concept corresponds to Mylius’ definition of Mercurius as the *anima media natura*. From here it is but a step to the identification of Mercurius with the *anima mundi*,²¹ which is how Avicenna had defined him very much earlier (twelfth to thirteenth century). “He is the spirit of the Lord which fills the whole world and in the beginning swam upon the waters. They call him also the spirit of Truth, which is hidden from the world.”²² Another text says that Mercurius is the

“supracelestial spirit which is conjoined with the light, and rightly could be called the *anima mundi*.”²³ It is clear from a number of texts that the alchemists related their concept of the *anima mundi* on the one hand to the world soul in Plato’s *Timaeus* and on the other to the Holy Spirit, who was present at the Creation and played the role of procreator (*φύτωρ*), impregnating the waters with the seed of life just as, later, he played a similar role in the *obumbratio* (overshadowing) of Mary.²⁴ Elsewhere we read that a “life-force dwells in *Mercurius non vulgaris*, who flies like solid white snow. This is a spirit of the macrocosmic as of the microcosmic world, upon whom, after the *anima rationalis*, the motion and fluidity of human nature itself depends.”²⁵ The snow represents the purified Mercurius in the state of *albedo* (= spirituality); here again matter and spirit are identical. Worth noting is the duality of soul caused by the presence of Mercurius: on the one hand the immortal *anima rationalis* given by God to man, which distinguishes him from animals; on the other hand the mercurial life-soul, which to all appearances is connected with the *inflatio* or *inspiratio* of the Holy Spirit. This fundamental duality forms the psychological basis of the two sources of illumination.

C. MERCURIUS AS SPIRIT IN THE INCORPOREAL, METAPHYSICAL SENSE

[264] In many of the passages it remains doubtful whether *spiritus* means spirit in an abstract sense.²⁰ It is moderately certain that this is so in Dorn, for he says that “Mercurius possesses the quality of an incorruptible spirit, which is like the soul, and because of its incorruptibility is called intellectual”²⁷—i.e., pertaining to the *mundus intelligibilis*. One text expressly calls him “spiritual and hyperphysical,”²⁸ and another says that the spirit of Mercurius comes from heaven.²⁹ Laurentius Ventura (sixteenth century) may well have been associating himself with the “Platonis liber quartorum” and hence with the neo-Platonist ideas of the Harranite school when he defined the spirit of Mercurius as “completely and entirely like itself” (*sibi omnino similis*) and *simplex*,³⁰ for this Harranite text defines the arcane substance as the *res simplex* and equates it with God.³¹

[265] The oldest reference to the mercurial *pneuma* occurs in an Ostanes quotation of considerable antiquity (possibly pre-Christian), which says: “Go to the streamings of the Nile, and there you will find a stone that has a spirit.”³² In Zosimos Mercurius is characterized as incorporeal (*ἀσώματον*),³³ and by another author as ethereal (*αἰθερῶδες πνεῦμα*) and as having become rational or wise (*σώφρων γενομένη*).³⁴ In the very old treatise “Isis to Horus” (first century) the divine water is brought by an angel and is clearly of celestial or possibly daemonic origin, since according to the text the angel Annael who brings it is not a morally irreproachable figure.³⁵ For the alchemists, as we know not only from the ancient but also from the later writers, Mercurius as the arcane substance had a more or less secret connection with the

goddess of love. In the “Book of Krates,” which was transmitted by the Arabs and is possibly of Alexandrian origin, Aphrodite appears with a vessel from the mouth of which pours a ceaseless stream of quicksilver,³⁶ and in the *Chymical Wedding* of Christian Rosencreutz the central mystery is his visit to the secret chamber of the sleeping Venus.

[266] The fact that Mercurius is interpreted as spirit and soul, in spite of the spirit-body dilemma which this involves, indicates that the alchemists themselves conceived of their arcane substance as something that we today would call a psychic phenomenon. Indeed, whatever else spirit and soul may be, from the phenomenological point of view they are psychic structures. The alchemists never tired of drawing attention to the psychic nature of Mercurius. So far we have concerned ourselves with, statistically, the commonest synonyms such as water and fire, spirit and soul, and it is now possible for us to conclude that these exemplify a psychological state of affairs best characterized by (or, indeed, actually demanding) an antinomian nomenclature. Water and fire are classic opposites and can be valid definitions of one and the same thing only if this thing unites in itself the contrary qualities of water and fire. The psychologem “Mercurius” must therefore possess an essentially antinomian dual nature.

5. THE DUAL NATURE OF MERCURIUS

[267] Mercurius, following the tradition of Hermes, is many-sided, changeable, and deceitful. Dorn speaks of “that inconstant Mercurius,”¹ and another calls him *versipellis* (changing his skin, shifty).² He is *duplex*³ and his main characteristic is duplicity. It is said of him that he “runs round the earth and enjoys equally the company of the good and the wicked.”⁴ He is “two dragons,”⁵ the “twin,”⁶ made of “two natures”⁷ or “two substances.”⁸ He is the “giant of twofold substance,” in explanation of which the text⁹ cites the twenty-sixth chapter of Matthew, where the sacrament of the Last Supper is instituted. The Christ analogy is thus made plain. The two substances of Mercurius are thought of as dissimilar, sometimes opposed; as the dragon he is “winged and wingless.”¹⁰ A parable says: “On this mountain lies an ever-waking dragon, who is called Pantophthalmos, for he is covered with eyes on both sides of his body, before and behind, and he sleeps with some open and some closed.”¹¹ There is the “common and the philosophic” Mercurius;¹² he consists of “the dry and earthy, the moist and viscous.”¹³ Two of his elements are passive, earth and water, and two active, air and fire.¹⁴ He is both good and evil.¹⁵ The “Aurelia occulta” gives a graphic description of him:¹⁶

I am the poison-dripping dragon, who is everywhere and can be cheaply had. That upon which I rest, and that which rests upon me, will be found within me by those who pursue their investigations in accordance with the rules of the Art. My water and fire destroy and put together; from my body you may extract the green lion and the red. But if you do not have exact knowledge of me, you will destroy your five senses with my fire. From my snout there comes a spreading poison that has brought death to many. Therefore you should skilfully separate the coarse from the fine, if you do not wish to suffer utter poverty. I bestow on you the powers of the male and the female, and also those of heaven and of earth. The mysteries of my art must be handled with courage and greatness of mind if you would conquer me by the power¹⁷ of fire, for already very many have come to grief, their riches and labour lost. I am the egg of nature, known only to the wise, who in piety and modesty bring forth from me the microcosm, which was prepared for mankind by Almighty God, but given only to the few, while the many long for it in vain, that they may do good to the poor with my treasure and not fasten their souls to the perishable gold. By the philosophers I am named Mercurius; my spouse is the [philosophic] gold; I am the old dragon, found everywhere on the globe of the earth, father and mother, young and

old, very strong and very weak, death and resurrection, visible and invisible, hard and soft; I descend into the earth and ascend to the heavens, I am the highest and the lowest, the lightest and the heaviest; often the order of nature is reversed in me, as regards colour, number, weight, and measure; I contain the light of nature; I am dark and light; I come forth from heaven and earth; I am known and yet do not exist at all,¹⁸ by virtue of the sun's rays all colours shine in me, and all metals. I am the carbuncle of the sun, the most noble purified earth, through which you may change copper, iron, tin, and lead into gold.

[268] Because of his united double nature Mercurius is described as hermaphroditic. Sometimes his body is said to be masculine and his soul feminine, sometimes the reverse. The *Rosarium philosophorum*, for example, has both versions.¹⁹ As *vulgaris* he is the dead masculine body, but as “our” Mercurius he is feminine, spiritual, alive and life-giving.²⁰ He is also called husband and wife,²¹ bridegroom and bride, or lover and beloved.²² His contrary natures are often called *Mercurius sensu strictiori* and sulphur, the former being feminine, earth, and Eve, and the latter masculine, water, and Adam.²³ In Dorn he is the “true hermaphroditic Adam,”²⁴ and in Khunrath he is “begotten of the hermaphroditic seed of the Macrocosm” as “an immaculate birth from the hermaphroditic matter” (i.e., the *prima materia*).²⁵ Mylius calls him the “hermaphroditic monster.”²⁶ As Adam he is also the microcosm, or even “the heart of the microcosm,”²⁷ or he has the microcosm “in himself, where are also the four elements and the *quinta essentia* which they call Heaven.”²⁸ The term *coelum* for Mercurius does not, as one might think, derive from the *firmamentum* of Paracelsus, but occurs earlier in Johannes de Rupescissa (fourteenth century).²⁹ The term *homo* is used as a synonym for “microcosm,” as when Mercurius is named the “Philosophic ambisexual Man.”³⁰ In the very old “Dicta Belini” (Belinus or Balinus is a corruption of Apollonius of Tyana), he is the “man rising from the river,”³¹ probably a reference to the vision of Ezra.³² In Trismosin's *Splendor solis* (sixteenth century) there is an illustration of this.³³ The idea itself may go back to the Babylonian teacher of wisdom, Oannes. The designation of Mercurius as the “high man”³⁴ does not fit in badly with such a pedigree. The terms Adam and microcosm occur frequently in the texts,³⁵ but the Abraham le Juif forgery unblushingly calls Mercurius Adam Kadmon.³⁶ As I have discussed this unmistakable continuation of the Gnostic doctrine of the Anthropos elsewhere,³⁷ there is no need for me to go more closely now into this aspect of Mercurius.³⁸ Nevertheless, I would like to emphasize once again that the Anthropos idea coincides with the psychological concept of the self. The atman and purusha doctrine as well as alchemy give clear proofs of this.

[269] Another aspect of the dual nature of Mercurius is his characterization as *senex*³⁹ and *puer*.⁴⁰ The figure of Hermes as an old man, attested by archaeology, brings him into direct relation with Saturn—a relationship which plays a considerable role in

alchemy (see *infra*, pars. 274ff.). Mercurius truly consists of the most extreme opposites; on the one hand he is undoubtedly akin to the godhead, on the other he is found in sewers. Rosinus (Zosimos) even calls him the *terminus ani*.⁴¹ In the Bundahish,⁴² the anus of Garotman is “like hell on earth.”

6. THE UNITY AND TRINITY OF MERCURIUS

[270] In spite of his obvious duality the unity of Mercurius is also emphasized, especially in his form as the lapis. “In all the world he is One.”¹ The unity of Mercurius is at the same time a trinity, with clear reference to the Holy Trinity, although his triadic nature does not derive from Christian dogma but is of earlier date. Triads occur as early as the treatise of Zosimos, *περὶ ἀρετῆς* (Concerning the Art).² Martial calls Hermes *omnia solus el ter unus* (All and Thrice One).³ In Monakris (Arcadia), a three-headed Hermes was worshipped, and in Gaul there was a three-headed Mercurius.⁴ This Gallic god was also a psychopomp. The triadic character is an attribute of the gods of the underworld, as for instance the three-bodied Typhon, three-bodied and three-faced Hecate,⁵ and the “ancestors” (*τριτοπάτορες*) with their serpent bodies. According to Cicero,⁶ these latter are the three sons of Zeus the King, the *rex antiquissimus*.⁷ They are called the “forefathers” and are wind-gods;⁸ obviously by the same logic the Hopi Indians believe that snakes are at the same time flashes of lightning auguring rain. Khunrath calls Mercurius *triunus*⁹ and *ternarius*.¹⁰ Mylius represents him as a three-headed snake.¹¹ The “Aquarium sapientum” says that he is a “triune, universal essence which is named Jehova.¹² He is divine and at the same time human.”¹³

[271] From all this one must conclude that Mercurius corresponds not only to Christ, but to the triune divinity in general. The “Aurelia occulta” calls him “Azoth,” and explains the term as follows: “For he is the A and O that is everywhere present. The philosophers have adorned [him] with the name Azoth, which is compounded of the A and Z of the Latins, the alpha and omega of the Greeks, and the aleph and tau of the Hebrews:

$$A \left\{ \begin{array}{c} Z \\ \omega \\ \aleph \end{array} \right\} \text{Azoth.}''^{14}$$

The parallel with the Trinity could not be more clearly indicated. The anonymous commentator of the “Tractatus aureus” puts the parallel with Christ as Logos just as unmistakably. All things proceed from the “philosophic heaven adorned with an infinite multitude of stars,”¹⁵ from the creative Word incarnate, the Johannine Logos, without which “was not any thing made that was made.” The commentator says: “Thus the Word of renewal is invisibly inherent in all things, but it is not evident in elementary solid bodies unless they have been brought back to the fifth, or heavenly

and astral essence. Hence this Word of renewal is the seed of promise, or the philosophic heaven refulgent with the infinite lights of the stars.”¹⁶ Mercurius is the Logos become world. The description given here may point to his basic identity with the collective unconscious, for as I tried to show in my essay “On the Nature of the Psyche,”¹⁷ the image of the starry heaven seems to be a visualization of the peculiar nature of the unconscious. Since Mercurius is often called *filius*, his sonship is beyond question.¹⁸ He is therefore like a brother to Christ and a second son of God, though in point of time he must be accounted the elder and the first-born. This idea goes back to the conceptions of the Euchites reported in Michael Psellus,¹⁹ who believed that God’s first son was Satanaël²⁰ and that Christ was the second.²¹ However, Mercurius is not only the counterpart of Christ in so far as he is the “son”; he is also the counterpart of the Trinity as a whole in so far as he is conceived to be a chthonic triad. According to this view he would be equal to one half of the Christian Godhead. He is indeed the dark chthonic half, but he is not simply evil as such, for he is called “good *and* evil,” or a “system of the higher powers in the lower.” He calls to mind that double figure which seems to stand behind both Christ and the devil—that enigmatic Lucifer whose attributes are shared by both. In Rev. 22 : 16 Christ says of himself: “I am the root and the offspring of David, the bright and the morning star.”

[272] One peculiarity of Mercurius which undoubtedly relates him to the Godhead and to the primitive creator god is his ability to beget himself. In the “*Allegoriae super librum Turbae*” he says: “The mother bore me and is herself begotten of me.”²² As the uroboros dragon, he impregnates, begets, bears, devours, and slays himself, and “himself lifts himself on high,” as the *Rosarium* says,²³ so paraphrasing the mystery of God’s sacrificial death. Here, as in many similar instances, it would be rash to assume that the alchemists were as conscious of their reasoning processes as perhaps we are. But man, and through him the unconscious, expresses a great deal that is not necessarily conscious in all its implications. Nevertheless I should like to avoid giving the impression that the alchemists were absolutely unconscious of their thought-processes. How little this was so is proved by the above quotations. But although Mercurius, in many texts, is stated to be *trinus et unus*, this does not prevent him from sharing very strongly the *quaternity* of the lapis, with which he is essentially identical. He thus exemplifies that strange dilemma which is posed by the problem of three and four—the well-known axiom of Maria Prophetissa. There is a classical *Hermes tetracephalus* as well as the *Hermes tricephalus*.²⁴ The ground-plan of the Sabaeen temple of Mercurius was a triangle inside a square.²⁵ In the scholia to the “*Tractatus aureus*” the sign for Mercurius is a square inside a triangle surrounded by a circle (symbol of totality).²⁶

7. THE RELATION OF MERCURIUS TO ASTROLOGY AND THE DOCTRINE OF THE ARCHONS

[273] One of the roots of the peculiar philosophy relating to Mercurius lies in ancient astrology and in the Gnostic doctrine of the archons and aeons, which is derived from it. Between Mercurius and the planet there is a relation of mystical identity due either to contamination or to an actual spiritual identity. In the first case quicksilver is simply the planet Mercury as it appears in the earth (just as gold is simply the sun in the earth);¹ in the second, the “spirit” of quicksilver is identical with the planetary spirit. Both spirits individually, or the two as one spirit, were personified and called upon for aid or magically conjured into service as a *paredros* or “familiar.” Within the alchemical tradition we find directions for such procedures in the Harranite treatise “*Clavis maioris sapientiae*” of Artefius,² which agree with descriptions of the invocations mentioned by Dozy and de Goeje.³ There are also references to procedures of this kind in the “*Liber Platonis quatorum*.”⁴ Parallel with this is the account according to which Democritus received the secret of the hieroglyphs from the genius of the planet Mercury.⁵ The spirit Mercurius appears here in the role of a mystagogue, as in the *Corpus Hermeticum* or the visions of Zosimos. He plays the same role in the remarkable dream-vision recorded in “*Aurelia occulta*,” where he appears as the Anthropos with a crown of stars.⁶ As the little star near the sun, he is the child of sun and moon.⁷ But contrariwise he is also the begetter of his parents;⁸ or, as the treatise of Wei Po-yang (c. A.D. 142) remarks, the gold (sun) gets its qualities from Mercurius.⁹ (Owing to the contamination, the astrological myth is always thought of in chemical terms as well.) Because of his half-feminine nature, Mercurius is often identified with the moon¹⁰ and Venus.¹¹ As his own divine consort he easily turns into the goddess of love, just as in his role of Hermes he is ithyphallic. But he is also called the “most chaste virgin.”¹² The relation of quicksilver to the moon (silver) is obvious enough. Mercurius as the shining and shimmering planet, appearing like Venus close to the sun in the morning or evening sky, is like her a Lucifer, a light-bringer (*φωσφόροζ*). He heralds, as the morning star does, only much more directly, the coming of the light.

[274] But the most important of all for an interpretation of Mercurius is his relation to Saturn. Mercurius *senex* is identical with Saturn, and to the earlier alchemists especially, it is not quicksilver, but the lead associated with Saturn, which usually represents the prima materia. In the Arabic text of the *Turba*¹³ quicksilver is identical

with the “water of the moon and of Saturn.” In the “Dicta Belini” Saturn says: “My spirit is the water that loosens the rigid limbs of my brothers.”¹⁴ This refers to the “eternal water” which is just what Mercurius is. Raymund Lully remarks that “a certain oil of a golden colour is extracted from the philosophic lead.”¹⁵ In Khunrath Mercurius is the “salt of Saturn,”¹⁶ or Saturn is simply Mercurius. Saturn “draws the eternal water.”¹⁷ Like Mercurius, Saturn is hermaphroditic.¹⁸ Saturn is “an old man on a mountain, and in him the natures are bound with their complement [i.e., the four elements], and all this is in Saturn.”¹⁹ The same is said of Mercurius. Saturn is the father and origin of Mercurius, therefore the latter is called “Saturn’s child.”²⁰ Quicksilver comes “from the heart of Saturn or is Saturn,”²¹ and a “bright water” is extracted from the plant Saturnia, “the most perfect water and flower in the world.”²² This statement of Sir George Ripley, Canon of Bridlington, is a most remarkable parallel to the Gnostic teaching that Kronos (Saturn) is a “power of the colour of water” (ὕδατόχρους) which destroys everything, since “water is destruction.”²³

[275] Like the planetary spirit of Mercurius, the spirit of Saturn is “very suited to this work.”²⁴ One of the manifestations of Mercurius in the alchemical process of transformation is the lion, now green and now red. Khunrath calls this transformation “luring the lion out of Saturn’s mountain cave.” From ancient times the lion was associated with Saturn.²⁵ Khunrath calls him “the lion of the Catholic tribe,”²⁶ paraphrasing the “lion of the tribe of Judah”—an allegory of Christ.²⁷ He calls Saturn “the lion green and red.”²⁸ In Gnosticism Saturn is the highest archon, the lion-headed Ialdabaoth,²⁹ meaning “child of chaos.” But in alchemy the child of chaos is Mercurius.³⁰

[276] The relation to and identity with Saturn is important because Saturn is not only a *maleficus* but actually the dwelling-place of the devil himself. Even as the highest archon and demiurge his Gnostic reputation was not the best. According to one Cabalistic source, Beelzebub was associated with him.³¹ Mylius says that if Mercurius were to be purified, then Lucifer would fall from heaven.³² A contemporary marginal note in a seventeenth-century treatise in my possession explains the term sulphur, the masculine principle of Mercurius,³³ as *diabolus*. If Mercurius is not exactly the Evil One himself, he at least contains him—that is, he is morally neutral, good and evil, or as Khunrath says: “Good with the good, evil with the evil.”³⁴ His nature is more exactly defined, however, if one conceives him as a *process* that begins with evil and ends with good. A rather deplorable but picturesque poem in *Verus Hermes* (1620) summarizes the process as follows:

A weakling babe, a greybeard old,
Surnamed the Dragon: me they hold
In darkest dungeon languishing

That I may be reborn a king.

A fiery sword makes me to smart,
Death gnaws my flesh and bones apart.
My soul and spirit fast are sinking,
And leave a poison, black and stinking.

To a black crow am I akin,
Such be the wages of all sin.
In deepest dust I lie alone,
O that the Three would make the One!

O soul, O spirit with me stay,
That I may greet the light of day.
Hero of peace, come forth from me,
Whom the whole world would like to see!

[277] In this poem Mercurius is describing his own transformation, which at the same time signifies the mystic transformation of the artifex; for not only Mercurius but also what happens to him is a projection of the collective unconscious. This, as can easily be seen from what has gone before, is the projection of the individuation process, which, being a natural psychic occurrence, goes on even without the participation of consciousness. But if consciousness participates with some measure of understanding, then the process is accompanied by all the emotions of a religious experience or revelation. As a result of this, Mercurius was identified with Sapiaientia and the Holy Ghost. It is therefore very probable that those heresies which began with the Euchites, Paulicians, Bogomils, and Cathars, and which developed the concept of the Paraclete very much in the spirit of the founder of Christianity, were continued in alchemy, partly unconsciously and partly under a deliberate disguise.³⁵

8. MERCURIUS AND HERMES

[278] We have already met with a number of alchemical statements which show plainly that the character of the classical Hermes was faithfully reproduced later in the figure of Mercurius. This is in part an unconscious repetition, in part a spontaneous re-experience, and finally also a conscious reference to the pagan god. There can be no doubt that Michael Maier was consciously alluding to Hermes as pointer of the way (*ὁδηγός*) when he said that he found on his mystic peregrination a statue of Mercurius pointing the way to paradise,¹ and that he was referring to Hermes the mystagogue when he made the Erythraean Sibyl say of Mercurius: “He will make you a witness of the mysteries of God and the secrets of nature.”² Again, as the *divinus ternarius*, Mercurius is the revealer of divine secrets,³ or in the form of gold is conceived to be the soul of the arcane substance (magnesia),⁴ or the fructifier of the philosophical tree.⁵ In the “Epigramma Mercurio philosophico dicatum”⁶ he is called the messenger of the gods, the hermeneut (interpreter), and the Egyptian “Theutius” (Thoth). Maier even goes so far as to relate him to Hermes Kyllenios when he calls him “this faithless and all too elusive Arcadian youth,”⁷ for in Arcadia was the sanctuary of Kyllenios, the ithyphallic Hermes. In the scholia to the “Tractatus aureus” Mercurius is named outright the “Kyllenian hero.”⁸ Maier’s words might also be a reference to Eros. And in fact, in Rosencreutz’s *Chymical Wedding*, Mercurius does appear in the form of Cupid,⁹ and punishes the adept for his curiosity in visiting the Lady Venus by wounding him in the hand with an arrow. The arrow is the “dart of passion” (*telum passionis*), which is also an attribute of Mercurius.¹⁰ He is an “archer,” and indeed one who “shoots without a bowstring” and is “nowhere to be found on earth,”¹¹ so is obviously a daemon. In the Table of Symbols in Penotus¹² he is associated with nymphs, which reminds one of the pastoral god, Pan. His lasciviousness is borne out by an illustration in the *Tripus chemicus* of Sendivogius,¹³ where he appears on a triumphal chariot drawn by a cock and a hen, and behind him is a naked pair of embracing lovers. In this connection may also be mentioned the numerous somewhat obscene pictures of the coniunctio in old prints, often preserved merely as pornographica. Pictures in old manuscripts of excretory acts, including vomiting, likewise belong to this sphere of the “underworldly Hermes.”¹⁴ Again, Mercurius represents the “continuous cohabitation”¹⁵ which is found in unalloyed form in the Tantric Shiva-Shakti concept. Connections between Greek and Arabic alchemy and India are not unlikely. Reitzenstein¹⁶ reports the story of Padmanaba

from a Turkish book of folklore¹⁷ about the forty viziers, which may date back to the time of the Moguls. Already in the first centuries of our era, Indian religious influences were at work in southern Mesopotamia, and in the second century B.C. there were Buddhist monasteries in Persia. In the royal temple of Padmanabhapura in Travancore (c. fifteenth century) I found two reliefs representing an entirely non-Indian *senex ithyphallicus* with wings. In one of them he stands up to his waist in the bowl of the moon. One is reminded of the winged ithyphallic old man who pursues the “blue” or “doglike”¹⁸ woman in Hippolytus. Kyllenios does in fact appear in Hippolytus¹⁹ as identical on the one hand with the Logos and on the other with the wicked Korybas, the phallus, and the demiurgic principle in general.²⁰ Another aspect of this dark Mercurius is the mother-son incest, which may be traceable to Mandaean influences: there Nabu (Mercurius) and Istar (Astarte) form a syzygy. Astarte is the mother and love goddess throughout the whole Near East, where she is also tainted with the incest motif. Nabu is the “Messiah of the Lie,” who because of his malice is punished and kept in prison by the sun.²¹ The texts remind us again and again that Mercurius is “found in the dung-heaps,” but they add ironically that “many have grubbed in the dung-heaps, but extracted nothing thereby.”²²

[279] This dark Mercurius must once again be understood as representing the initial *nigredo* state, the lowest being a symbol of the highest and vice versa:

Anfang und Ende

Reichen sich die Hände.²³

He is the uroboros, the One and All, the union of opposites accomplished during the alchemical process, of which Penotus says:²⁴

Mercurius is begotten by nature as the son of nature and the fruit of the liquid element. But even as the Son of Man is begotten by the philosopher and created as the fruit of the Virgin, so must he [Mercurius] be raised from the earth and cleansed of all earthiness, then he ascends entire into the air, and is changed into spirit. Thus is fulfilled the word of the philosopher: He ascends from earth to heaven and receives the power of Above and Below, and puts off his earthy and impure nature and clothes himself in the heavenly nature.

[280] Since Penotus is here referring to the “Tabula smaragdina,” it must be emphasized that he departs from the spirit of the “Tabula” in one essential point. In the version of Penotus, the ascent of Mercurius is in entire accord with the Christian transformation of the hylic into the pneumatic man. The “Tabula,” on the other hand, says: “He ascends from earth to heaven and descends again to earth, and receives the power of Above and Below. His power is complete when he has returned to earth.” So it is not a question of a one-way ascent to heaven, but, in contrast to the route followed by the Christian Redeemer, who comes from above to below and from there

returns to the above, the *filius macrocosmi* starts from below, ascends on high, and, with the powers of Above and Below united in himself, returns to earth again. He carries out the reverse movement and thereby manifests a nature contrary to that of Christ and the Gnostic Redeemers, while on the other hand he displays a certain affinity with the Basilidian concept of the third sonship. Mercurius has the circular nature of the uroboros, hence he is symbolized by the *circulus simplex* of which he is at the same time the centre.²⁵ He can therefore say of himself: “I am One and at the same time Many in myself.”²⁶ This same treatise says that the centre of the circle in man is the earth, and calls it the “salt” to which Christ referred when he said: “Ye are the salt of the earth.”²⁷

[281] Hermes is a god of thieves and cheats, but also a god of revelation who gave his name to a whole philosophy. Seen in historical retrospect, it was a moment of the utmost significance when the humanist Patrizi proposed to Pope Gregory XIV that Hermetic philosophy should take the place of Aristotle in ecclesiastical doctrine. At that moment two worlds came into contact, which—after heaven knows what happenings!—must yet be united in the future. At that time it was obviously impossible. A psychological differentiation of religious as well as scientific views is still needed before a union can begin to be brought about.²⁸

9. MERCURIUS AS THE ARCANE SUBSTANCE

[282] Mercurius, it is generally affirmed, is the arcanum,¹ the prima materia,² the “father of all metals,”³ the primeval chaos, the earth of paradise, the “material upon which nature worked a little, but nevertheless left imperfect.”⁴ He is also the ultima materia, the goal of his own transformation, the stone,⁵ the tincture, the philosophic gold, the carbuncle, the philosophic man, the second Adam, the analogue of Christ, the king, the light of lights, the *deus terrestris*, indeed the divinity itself or its perfect counterpart. Since I have already discussed the synonyms and meanings of the stone elsewhere there is no need for me to go into further details now.

[283] Besides being the prima materia of the lowly beginning as well as the lapis as the highest goal, Mercurius is also the process which lies between, and the means by which it is effected. He is the “beginning, middle, and end of the work.”⁶ Therefore he is called the Mediator,⁷ Servator, and Salvator. He is a mediator like Hermes. As the *medicina catholica* and *alexipharmakon* he is the “preserver [*servator*] of the world.” He is the “healer [*salvator*] of all imperfect bodies”⁸ and the “image of Christ’s incarnation,”⁹ the *unigenitus* “consubstantial with the parental hermaphrodite.”¹⁰ Altogether, in the macrocosm of nature he occupies the position which Christ holds in the *mundus rationalis* of divine revelation. But as the saying “My light surpasses all other lights”¹¹ shows, the claim of Mercurius goes even further, which is why the alchemists endowed him with the attributes of the Trinity¹² in order to make clear his complete correspondence to God. In Dante, Satan is three-headed and therefore three-in-one. He is the counterpart of God in the sense that he is God’s antithesis. The alchemists did not hold this view of Mercurius; on the contrary, they saw him as a divine emanation harmonious with God’s own being. The stress they laid on his capacity for self-generation, self-transformation, self-reproduction, and self-destruction contradicts the idea that he is a created being. It is therefore only logical when Paracelsus and Dorn state that the prima materia is an “increatedum” and a principle coeternal with God. This denial of *creatio ex nihilo* is supported by the fact that in the beginning God found the Tehom already in existence, that same maternal world of Tiamat whose son we encounter in Mercurius.¹³

10. SUMMARY

[284] The multiple aspects of Mercurius may be summarized as follows:

(1) Mercurius consists of all conceivable opposites. He is thus quite obviously a duality, but is named a unity in spite of the fact that his innumerable inner contradictions can dramatically fly apart into an equal number of disparate and apparently independent figures.

(2) He is both material and spiritual.

(3) He is the process by which the lower and material is transformed into the higher and spiritual, and vice versa.

(4) He is the devil, a redeeming psychopomp, an evasive trickster, and God's reflection in physical nature.

(5) He is also the reflection of a mystical experience of the artifex that coincides with the *opus alchymicum*.

(6) As such, he represents on the one hand the self and on the other the individuation process and, because of the limitless number of his names, also the collective unconscious.¹

* * *

[285] Certainly goldmaking, as also chemical research in general, was of great concern to alchemy. But a still greater, more impassioned concern appears to have been—one cannot very well say the “investigation”—but rather the *experience* of the unconscious. That this side of alchemy—the *μυστικά*—was for so long misunderstood is due solely to the fact that nothing was known of psychology, let alone of the supra-personal, collective unconscious. So long as one knows nothing of psychic actuality, it will be projected, if it appears at all. Thus the first knowledge of psychic law and order was found in the stars, and was later extended by projections into unknown matter. These two realms of experience branched off into sciences: astrology became astronomy, and alchemy chemistry. On the other hand, the peculiar connection between character and the astronomical determination of time has only very recently begun to turn into something approaching an empirical science. The really important psychic facts can neither be measured, weighed, nor seen in a test tube or under a microscope. They are therefore supposedly indeterminable, in other words they must be left to people who have an inner sense for them, just as colours must be shown to the seeing and not to the blind.

[286] The store of projections found in alchemy is, if possible, even less known, and there is a further drawback which makes closer investigation extremely difficult. For, unlike the astrological constituents of character which, if negative, are at most unpleasant for the individual, though amusing to his neighbour, the alchemical projections represent collective contents that stand in painful contrast—or rather, in compensatory relation—to our highest rational convictions and values. They give the strange answers of the natural psyche to the ultimate questions which reason has left untouched. Contrary to all progress and belief in a future that will deliver us from the sorrowful present, they point back to something primeval, to the apparently hopelessly static, eternal sway of matter that makes our fondly believed-in world look like a phantasmagoria of shifting scenes. They show us, as the redemptive goal of our active, desirous life, a symbol of the inorganic—the stone—something that does not live but merely exists or “becomes,” the passive subject of a limitless and unfathomable play of opposites. “Soul,” that bodiless abstraction of the rational intellect, and “spirit,” that two-dimensional metaphor of dry-as-dust philosophical dialectic, appear in alchemical projection in almost physical, plastic form, like tangible breath-bodies, and refuse to function as component parts of our rational consciousness. The hope for a psychology without the soul is brought to nothing, and the illusion that the unconscious has only just been discovered vanishes: in a somewhat peculiar form, admittedly, it has been known for close on two thousand years. Let us, however, not delude ourselves: no more than we can separate the constituents of character from the astronomical determinants of time are we able to separate that unruly and evasive Mercurius from the autonomy of matter. Something of the projection-carrier always clings to the projection, and even if we succeed to some degree in integrating into our consciousness the part we recognize as psychic, we shall integrate along with it something of the cosmos and its materiality; or rather, since the cosmos is infinitely greater than we are, we shall have been assimilated by the inorganic. “Transform yourselves into living philosophical stones!” cries an alchemist, but he did not know how infinitely slowly the stone “becomes.” Anyone who gives serious thought to the “natural light” that emanates from the projections of alchemy will certainly agree with the Master who spoke of the “wearisomeness of the interminable meditation” demanded by the work. In these projections we encounter the phenomenology of an “objective” spirit, a true matrix of psychic experience, the most appropriate symbol for which is matter. Nowhere and never has man controlled matter without closely observing its behaviour and paying heed to its laws, and only to the extent that he did so could he control it. The same is true of that objective spirit which today we call the unconscious: it is refractory like matter, mysterious and elusive, and obeys laws which are so non-human or suprahuman that they seem to us like a *crimen laesae majestatis humanae*. If a man puts his hand to the opus, he

repeats, as the alchemists say, God's work of creation. The struggle with the unformed, with the chaos of Tiamat, is in truth a primordial experience.

[287] Since the psyche, when directly experienced, confronts us in the "living" substance it has animated and appears to be one with it, Mercurius is called *argentum vivum*. Conscious discrimination, or consciousness itself, effects that world-shattering intervention which separates body from soul and divides the spirit Mercurius from the *hydrargyrum*, as if drawing off the spirit into the bottle, to speak in terms of our fairytale. But since body and soul, in spite of the artificial separation, are united in the mystery of life, the mercurial spirit, though imprisoned in the bottle, is yet found in the roots of the tree, as its quintessence and living numen. In the language of the Upanishads, he is the personal atman of the tree. Isolated in the bottle, he corresponds to the ego and the principle of individuation, which in the Indian view leads to the illusion of individual existence. Freed from his prison, Mercurius assumes the character of the supra-personal atman. He becomes the *one* animating principle of all created things, the *hiranyagarbha* (golden germ),² the supra-personal self, represented by the *filius macrocosmi*, the *one* stone of the wise. "Rosinus ad Sarratantam" cites a saying of "Malus Philosophus"³ which attempts to formulate the psychological relation of the lapis to consciousness: "This stone is below thee, as to obedience; above thee, as to dominion; therefore from thee, as to knowledge; about thee, as to equals."⁴ Applied to the self, this would mean: "The self is subordinate to you, yet on the other hand rules you. It is dependent on your own efforts and your knowledge, but transcends you and embraces all those who are of like mind." This refers to the collective nature of the self, since the self epitomizes the wholeness of the personality. By definition, wholeness includes the collective unconscious, which as experience seems to show is everywhere identical.

[288] The encounter of the poor student with the spirit in the bottle portrays the spiritual adventure of a blind and unawakened human being. The same motif underlies the tale of the swineherd who climbed the world-tree,⁵ and also forms the *leitmotiv* of alchemy. For what it signifies is the individuation process as it prepares itself in the unconscious and gradually enters consciousness. The commonest alchemical symbol for this is the tree, the *arbor philosophica*, which derives from the paradisaical tree of knowledge. Here, as in our fairytale, a demonic serpent, an evil spirit, prods and persuades to knowledge. In view of the Biblical precedent, it is not surprising that the spirit Mercurius has, to say the least, a great many connections with the dark side. One of his aspects is the female serpent-daemon, Lilith or Melusina, who lives in the philosophical tree. At the same time, he not only partakes of the Holy Spirit but, according to alchemy, is actually identical with it. We have no choice but to accept this shocking paradox after all we have learnt about the ambivalence of the spirit archetype. Our ambiguous Mercurius simply confirms the

rule. In any case, the paradox is no worse than the Creator's whimsical notion of enlivening his peaceful, innocent paradise with the presence of an obviously rather dangerous tree-snake, "accidentally" located on the very same tree as the forbidden apples.

[289] It must be admitted that the fairytale and alchemy both show Mercurius in a predominantly unfavourable light, which is all the more striking because his positive aspect relates him not only to the Holy Spirit, but, in the form of the lapis, also to Christ and, as a triad, even to the Trinity. It looks as if it were precisely these relationships which led the alchemists to put particular stress on the dark and dubious quality of Mercurius, and this militates strongly against the assumption that by their lapis they really meant Christ. If this had been their meaning, why should they have renamed Christ the *lapis philosophorum*? The lapis is at most a counterpart or analogy of Christ in the physical world. Its symbolism, like that of Mercurius who constitutes its substance, points, psychologically speaking, to the self, as also does the symbolic figure of Christ.⁶ In comparison with the purity and unity of the Christ symbol, Mercurius-lapis is ambiguous, dark, paradoxical, and thoroughly pagan. It therefore represents a part of the psyche which was certainly not moulded by Christianity and can on no account be expressed by the symbol "Christ." On the contrary, as we have seen, in many ways it points to the devil, who is known at times to disguise himself as an angel of light. The lapis formulates an aspect of the self which stands apart, bound to nature and at odds with the Christian spirit. It represents all those things which have been eliminated from the Christian model. But since they possess living reality, they cannot express themselves otherwise than in dark Hermetic symbols. The paradoxical nature of Mercurius reflects an important aspect of the self—the fact, namely, that it is essentially a *complexio oppositorum*, and indeed can be nothing else if it is to represent any kind of totality. Mercurius as *deus terrestris* has something of that *deus absconditus* (hidden god) which is an essential element of the psychological self, and the self cannot be distinguished from a God-image (except by incontestable and unprovable faith). Although I have stressed that the lapis is a symbol embracing the opposites, it should not be thought of as a—so to speak—more complete symbol of the self. That would be decidedly incorrect, for actually it is an image whose form and content are largely determined by the unconscious. For this reason it is never found in the texts in finished and well-defined form; we have to combine all the scattered references to the various arcane substances, to Mercurius, to the transformation process and the end product. Although the lapis in one aspect or another is almost always the subject discussed, there is no real consensus of opinion in regard to its actual form. Almost every author has his own special allegories, synonyms, and metaphors. This makes it clear that the stone, though indeed an object of general experiment, was to an even greater extent

an outcropping of the unconscious, which only sporadically crossed the borderline of subjectivity and gave rise to the vague general concept of the *lapis philosophorum*.

[290] Opposed to this figure veiled in the twilight of more or less secret doctrines there stands, sharply outlined by dogma, the Son of Man and Salvator Mundi, Christ the Sol Novus, before whom the lesser stars pale. He is the affirmation of the daylight of consciousness in trinitarian form. So clear and definite is the Christ figure that whatever differs from him must appear not only inferior but perverse and vile. This is not the result of Christ's own teaching, but rather of what is taught about him, and especially of the crystal purity which dogma has bestowed upon his figure. As a result, a tension of opposites such as had never occurred before in the whole history of Christianity beginning with the Creation arose between Christ and the Antichrist, as Satan or the fallen angel. At the time of Job, Satan is still found among the sons of God. "Now there was a day," it says in Job 1 : 6, "when the sons of God came to present themselves before the Lord, and Satan came also among them." This picture of a celestial family reunion gives no hint of the New Testament "Get thee hence, Satan" (Matthew 4 : 10), nor yet of the dragon chained in the underworld for a thousand years (Rev. 20 : 2). It looks as if the superabundance of light on one side had produced an all the blacker darkness on the other. One can also see that the uncommonly great diffusion of black substance makes a sinless being almost impossible. A loving belief in such a being naturally involves cleansing one's own house of black filth. But the filth must be dumped somewhere, and no matter where the dump lies it will plague even the best of all possible worlds with a bad smell.

[291] The balance of the primordial world is upset. What I have said is not intended as a criticism, for I am deeply convinced not only of the relentless logic but of the expediency of this development. The emphatic differentiation of opposites is synonymous with sharper discrimination, and that is the *sine qua non* for any broadening or heightening of consciousness. The progressive differentiation of consciousness is the most important task of human biology and accordingly meets with the highest rewards—vastly increased chances of survival and the development of power technology. From the phylogenetic point of view, the effects of consciousness are as far-reaching as those of lung-breathing and warm-bloodedness. But clarification of consciousness necessarily entails an obscuration of those dimmer elements of the psyche which are less capable of becoming conscious, so that sooner or later a split occurs in the psychic system. Since it is not recognized as such it is projected, and appears in the form of a metaphysical split between the powers of light and the powers of darkness. The possibility of this projection is guaranteed by the presence of numerous archaic vestiges of the original daemons of light and darkness in any age. It seems likely, therefore, that the tension of opposites in Christianity is

derived to a still unclarified degree from the dualism of ancient Persia, though the two are not identical.

[292] There can be no doubt that the moral consequences of the Christian development represent a very considerable advance compared with the ancient Israelite religion of law. The Christianity of the synoptic gospels signifies little more than a coming to terms with issues inside Judaism, which may fairly be compared with the much earlier Buddhist reformation inside Hindu polytheism. Psychologically, both reformations resulted in a tremendous strengthening of consciousness. This is particularly evident in the maieutic method employed by Shakyamuni. But the sayings of Jesus manifest the same tendency, even if we discard as apocryphal the clearest formulation of this kind, the logion in Codex Bezae to Luke 6 : 4: "Man, if thou knowest what thou doest, thou art blessed. If thou knowest it not, thou art accursed and a transgressor of the law." At all events, the parable of the unjust steward (Luke 16) has not found its way into the Apocrypha, where it would have fitted so well.

[293] The rift in the metaphysical world has slowly risen into consciousness as a split in the human psyche, and the struggle between light and darkness moves to the battleground within. This shift of scene is not entirely self-evident, for which reason St. Ignatius Loyola considered it necessary to open our eyes to the conflict and impress it on our feelings by means of the most drastic spiritual exercises.⁷ These efforts, for obvious reasons, had only a very limited range of application. And so, strangely enough, it was the medical men who, at the turn of the nineteenth century, were forced to intervene and get the obstructed process of conscious realization going again. Approaching the problem from a scientific angle, and innocent of any religious aim, Freud uncovered the abysmal darkness of human nature which a would-be enlightened optimism had striven to conceal. Since then psychotherapy, in one form or another, has persistently explored the extensive area of darkness which I have called the shadow. This attempt of modern science opened the eyes of only a few. However, the historic events of our time have painted a picture of man's psychic reality in indelible colours of blood and fire, and given him an object lesson which he will never be able to forget if—and this is the great question—he has today acquired enough consciousness to keep up with the furious pace of the devil within him. The only other hope is that he may learn to curb a creativity which is wasting itself in the exploitation of material power. Unfortunately, all attempts in that direction look like bloodless Utopias.

[294] The figure of Christ the Logos has raised the *anima rationalis* in man to a level of importance which remains unobjectionable so long as it knows itself to be below and subject to the *κύριος*, the Lord of Spirits. Reason, however, has set itself free and proclaimed itself the ruler. It has sat enthroned in Notre Dame as *Déesse Raison* and

heralded events that were to come. Our consciousness is no longer confined within a sacred temenos of otherworldly, eschatological images. It was helped to break free by a force that did not stream down from above—like the *lumen de lumine*—but came up with tremendous pressure from below and increased in strength as consciousness detached itself from the darkness and climbed into the light. In accordance with the principle of compensation which runs through the whole of nature, every psychic development, whether individual or collective, possesses an optimum which, when exceeded, produces an enantiodynamia, that is, turns into its opposite. Compensatory tendencies emanating from the unconscious may be noted even during the approach to the critical turning-point, though if consciousness persists in its course they are completely repressed. The stirrings in the darkness necessarily seem like a devilish betrayal of the ideal of spiritual development. Reason cannot help condemning as unreasonable everything that contradicts it or deviates from its laws, in spite of all evidence to the contrary. Morality can permit itself no capacity for change, for whatever it does not agree with is inevitably immoral and has therefore to be repressed. It is not difficult to imagine the multitude of energies which must flow off into the unconscious under such conscious domination.

[295] Hesitantly, as in a dream, the introspective brooding of the centuries gradually put together the figure of Mercurius and created a symbol which, according to all the psychological rules, stands in a compensatory relation to Christ. It is not meant to take his place, nor is it identical with him, for then indeed it could replace him. It owes its existence to the law of compensation, and its object is to throw a bridge across the abyss separating the two psychological worlds by presenting a subtle compensatory counterpoint to the Christ image. The fact that in *Faust* the compensatory figure is not, as one might almost have expected from the author's classical predilections, the wily messenger of the gods, but, as the name "Mephistopheles"⁸ shows, a *familiaris* risen from the cesspits of medieval magic, proves, if anything, the ingrained Christian character of Goethe's consciousness. To the Christian mentality, the dark antagonist is always the devil. As I have shown, Mercurius escapes this prejudice by only a hair's breadth. But he escapes it, thanks to the fact that he scorns to carry on opposition at all costs. The magic of his name enables him, in spite of his ambiguity and duplicity, to keep outside the split, for as an ancient pagan god he possesses a natural undividedness which is impervious to logical and moral contradictions. This gives him invulnerability and incorruptibility, the very qualities we so urgently need to heal the split in ourselves.

[296] If one makes a synopsis of all the descriptions and alchemical pictures of Mercurius, they form a striking parallel to the symbols of the self derived from other sources. One can hardly escape the conclusion that Mercurius as the lapis is a symbolic expression for the psychological complex which I have defined as the self.

Similarly, the Christ figure must be viewed as a self symbol, and for the same reasons. But this leads to an apparently insoluble contradiction, for it is not at first clear how the unconscious can shape two such different images from one and the same content, which moreover possesses the character of totality. Certainly the centuries have done their spiritual work upon these two figures, and one is inclined to assume that both have been in large measure anthropomorphized during the process of assimilation. For those who hold that both figures are inventions of the intellect, the contradiction is quickly resolved. It then merely reflects the subjective psychic situation: the two figures would stand for man and his shadow.

[297] This very simple and obvious solution is, unfortunately, founded on premises that do not stand up to criticism. The figures of Christ and the devil are both based on archetypal patterns, and were never invented but rather *experienced*. Their existence preceded all cognition of them,⁹ and the intellect had no hand in the matter, except to assimilate them and if possible give them a place in its philosophy. Only the most superficial intellectualism can overlook this fundamental fact. We are actually confronted with two different images of the self, which in all likelihood presented a duality even in their original form. This duality was not invented, but is an autonomous phenomenon.

[298] Since we naturally think from the standpoint of consciousness, we inevitably come to the conclusion that the split between consciousness and the unconscious is the sole cause of this duality. But experience has demonstrated the existence of a preconscious psychic functioning and of corresponding autonomous factors, the archetypes. Once we can accept the fact that the voices and delusions of the insane and the phobias and obsessions of the neurotic are beyond rational control, and that the ego cannot voluntarily fabricate dreams but simply dreams what it has to, then we can also understand that the gods came first and theology later. Indeed, we must go a step further and assume that in the beginning there were two figures, one bright and one shadowy, and only afterwards did the light of consciousness detach itself from the night and the uncertain shimmer of its stars.

[299] So if Christ and the dark nature-deity are autonomous images that can be directly experienced, we are obliged to reverse our rationalistic causal sequence, and instead of deriving these figures from our psychic conditions, must derive our psychic conditions from these figures. This is expecting a good deal of the modern intellect but does not alter the logic of our hypothesis. From this standpoint Christ appears as the archetype of consciousness and Mercurius as the archetype of the unconscious. As Cupid and Kyllenios, he tempts us out into the world of sense; he is the *benedicta viriditas* and the *multi flores* of early spring, a god of illusion and delusion of whom it is rightly said: "Invenitur in vena / Sanguine plena" (He is found in the vein swollen with blood). He is at the same time a Hermes Chthonios and an Eros, yet it is

from him that there issues the “light surpassing all lights,” the *lux moderna*, for the lapis is none other than the figure of light veiled in matter.¹⁰ It is in this sense that St. Augustine quotes I Thessalonians 5 : 5, “Ye are all the children of light, and the children of the day: we are not of the night, nor of darkness,” and distinguishes two forms of knowledge, a *cognitio vespertina* and a *cognitio matutina*, the first corresponding to the *scientia creaturae* and the second to the *scientia Creatoris*.¹¹ If we equate *cognitio* with consciousness, then Augustine’s thought would suggest that the merely human and natural consciousness gradually darkens, as at nightfall. But just as evening gives birth to morning, so from the darkness arises a new light, the *stella matutina*, which is at once the evening and the morning star—Lucifer, the light-bringer.

[300] Mercurius is by no means the Christian devil—the latter could rather be said to be a “diabolization” of Lucifer or of Mercurius. Mercurius is an adumbration of the primordial light-bringer, who is never himself the light, but a *φωσφόρος* who brings the light of nature, the light of the moon and the stars which fades before the new morning light. Of this light St. Augustine says that it will never turn to darkness unless the Creator is abandoned by the love of his creatures. But this, too, belongs to the rhythm of day and night. As Hölderlin says in “Patmos”;

and shamefully

A power wrests away the heart from us;

For the Heavenly each demand sacrifice,

But if it should be withheld,

Never has that led to good.

[301] When all visible lights are extinguished one finds, according to the words of the wise Yajñavalkya, the light of the self. “What then is the light of man? Self is his light. It is by the light of the self that a man rests, goes forth, does his work and returns.”¹² Thus, with Augustine, the first day of creation begins with self-knowledge, *cognitio sui ipsius*,¹³ by which is meant a knowledge not of the ego but of the self, that objective phenomenon of which the ego is the subject.¹⁴ Then, following the order of the days of creation in Genesis, comes knowledge of the firmament, of the earth, the sea, the plants, the stars, the animals of the water and air, and finally, on the sixth day, knowledge of the land animals and of *ipsius hominis*, of man himself. The *cognitio matutina* is self-knowledge, but the *cognitio vespertina* is knowledge of man.¹⁵ As Augustine describes it, the *cognitio matutina* gradually grows old as it loses itself in the “ten thousand things” and finally comes to man, although one would expect this to have happened already with the onset of self-knowledge. But if this were true, Augustine’s parable would have lost its meaning by contradicting itself. Such an obvious lapse cannot be ascribed to so gifted a man. His real meaning

is that self-knowledge is the *scientia Creatoris*,¹⁶ a morning light revealed after a night during which consciousness slumbered, wrapped in the darkness of the unconscious. But the knowledge arising with this first light finally and inevitably becomes the *scientia hominis*, the knowledge of man, who asks himself: "Who is it that knows and understands everything? Why, it is myself." That marks the coming of darkness,¹⁷ out of which arises the seventh day, the day of rest: "But the rest of God signifies the rest of those who rest in God."¹⁸ The Sabbath is therefore the day on which man returns to God and receives anew the light of the *cognitio matutina*. And this day has no evening.¹⁹ From the symbological standpoint it may not be without significance that Augustine had in mind the pagan names of the days of the week. The growing darkness reaches its greatest intensity on the day of Venus (Friday), and changes into Lucifer on Saturn's day. Saturday heralds the light which appears in full strength on Sun-day. As I have shown, Mercurius is closely related not only to Venus but more especially to Saturn. As Mercurius he is *juvenis*, as Saturn *senex*.

[302] It seems to me that Augustine apprehended a great truth, namely that every spiritual truth gradually turns into something material, becoming no more than a tool in the hand of man. In consequence, man can hardly avoid seeing himself as a knower, yes, even as a creator, with boundless possibilities at his command. The alchemist was basically this sort of person, but much less so than modern man. An alchemist could still pray: "Purge the horrible darkneses of our mind," but modern man is already so darkened that nothing beyond the light of his own intellect illuminates his world. "Occasus Christi, passio Christi."²⁰ That surely is why such strange things are happening to our much lauded civilization, more like a *Götterdämmerung* than any normal twilight.

[303] Mercurius, that two-faced god, comes as the *lumen naturae*, the Servator and Salvator, only to those whose reason strives towards the highest light ever received by man, and who do not trust exclusively to the *cognitio vespertina*. For those who are unmindful of this light, the *lumen naturae* turns into a perilous *ignis fatuus*, and the psychopomp into a diabolical seducer. Lucifer, who could have brought light, becomes the father of lies whose voice in our time, supported by press and radio, revels in orgies of propoganda and leads untold millions to ruin.

V

THE PHILOSOPHICAL TREE

[Originally written for a Festschrift planned to mark the 70th birthday of Gustav Senn, professor of botany at the University of Basel. Owing to the untimely death of Professor Senn, the Festschrift did not appear, and Jung's essay, entitled "Der philosophische Baum," was published in the *Verhandlungen der Naturforschenden Gesellschaft Basel*, LVI (1945): 2, 411-23. A revised and expanded version appeared in *Von den Wurzeln des Bewusstseins: Studien über den Archetypus* (Psychologische Abhandlungen, Vol. IX; Zurich, 1954), from which the present translation is made.—EDITORS.]

All theory, my friend, is grey,
But green life's golden tree.

Faust I

INDIVIDUAL REPRESENTATIONS OF THE TREE SYMBOL

[304] An image which frequently appears among the archetypal configurations of the unconscious is that of the tree or the wonder-working plant. When these fantasy products are drawn or painted, they very often fall into symmetrical patterns that take the form of a mandala. If a mandala may be described as a symbol of the self seen in cross section, then the tree would represent a profile view of it: the self depicted as a process of growth. I shall not discuss here the conditions under which these pictures are produced, for I have already said all that is necessary in my essays “A Study in the Process of Individuation” and “Concerning Mandala Symbolism.” The examples I now propose to give all come from a series of pictures in which my patients tried to express their inner experiences.

[305] In spite of the diversity of the tree symbol, a number of basic features may be established. In the first part of my essay I shall comment on the pictures that have been reproduced and then, in the second part, give an account of the philosophical tree in alchemy and its historical background. My case material has not been influenced in any way, for none of the patients had any previous knowledge of alchemy or of shamanism. The pictures were spontaneous products of creative fantasy, and their only conscious purpose was to express what happens when unconscious contents are taken over into consciousness in such a way that it is not overwhelmed by them and the unconscious not subjected to any distortion. Most of the pictures were done by patients who were under treatment, but some by persons who were not, or were no longer, under any therapeutic influence. I must emphasize that I carefully avoided saying anything in advance that might have had a suggestive effect. Nineteen of the thirty-two pictures were done at a time when I myself knew nothing of alchemy, and the rest before my book *Psychology and Alchemy* was published.

Figure 1

[306] The tree stands by itself on an island in the sea. Its great size is indicated by the fact that the upper part of it is cut off by the edge of the picture. The buds and the little white flowers suggest the coming of spring, when the great tree, whose age far

exceeds the span of human existence, will awaken to new life. The solitariness of the tree and its axial position in the centre of the picture bring to mind the world-tree and the world-axis—attributes with which the tree symbol is almost universally endowed. These traits give expression to the inner process at work in the painter, and show that it has nothing to do with his personal psychology. Here the tree represents a symbol that is universal and alien to the personal consciousness. It is possible, however, that the painter was making conscious use of the Christmas tree in order to illustrate his inner state.

Figure 2

[307] The abstract stylization and the position of the tree on the globe of the earth illustrate the feeling of spiritual isolation. To make up for this, the perfect symmetry of the crown points to a union of opposites. This is the motivating force and the goal of the individuation process. If the painter of such a picture neither identifies with the tree nor is assimilated by it,¹ he will not succumb to the danger of an auto-erotic isolation, but will only be intensely aware that his ego personality is confronted with a symbolical process he must come to terms with because it is just as real and undeniable as his ego. One can deny and nullify this process in all sorts of ways, but in doing so all the values represented by the symbol are lost. A naïvely curious mind will naturally cast round for a rational explanation, and if it does not find one at once it either makes do with a facile and completely inadequate hypothesis or else turns away in disappointment. It seems to be very hard for people to live with riddles or to let them live, although one would think that life is so full of riddles as it is that a few more things we cannot answer would make no difference. But perhaps it is just this that is so unendurable, that there are irrational things in our own psyche which upset the conscious mind in its illusory certainties by confronting it with the riddle of its existence.

Figure 3

[308] The picture shows a tree of light that is at the same time a candelabrum. The abstract form of the tree points to its spiritual nature. The ends of the branches are lighted candles illuminating the darkness of an enclosed space, perhaps a cave or vault. The secret and hidden nature of the process is thus emphasized and its function made clear: the illumination of consciousness.

Figure 4

[309] Although cut out of gold-foil, the tree is realistic. It is still in the wintry, leafless state of sleep. It rises up against a cosmic background and bears in its branches a

large golden ball, probably the sun. The gold indicates that though the painter does not yet have a living, conscious relation to this content, she nevertheless has an emotional intuition of its great value.

Figure 5

[310] The tree is leafless but bears little red flowers, harbingers of spring. The branches are tipped with flames, and fire leaps up from the water out of which the tree is growing. So the tree is also something like the jet of a fountain. The symbol of the fountain, the *fontina*, is known in alchemy; in the alchemical pictures it is often shown as a medieval town fountain,² and the upright part in the middle would correspond to the tree. The union of fire and water expresses the union of opposites. The picture bears out the alchemical saying: “Our water is fire.”

Figure 6

[311] The tree is red and looks like a branch of coral. It is not reflected in the water, but grows simultaneously downwards and upwards. The four mountains in the lower half of the picture are not reflections either, for their opposites are five mountains. This suggests that the lower world is not a mere reflection of the upper world, but that each is a world in itself. The tree stands in the middle between two walls of rock, representing the opposites. The four mountains also appear in [Figure 24](#).

Figure 7

[312] The tree has broken with irresistible force through the earth’s crust, heaving up mountainous boulders on either side. The painter is expressing an analogous process in himself, which runs its course of necessity and cannot be checked by any amount of resistance. Since the boulders are snow-capped mountains, the tree has the cosmic character of the world-tree.

Figure 8

[313] The tree is leafless, but its branches end in little flames like a Christmas tree. Instead of growing from the earth or water, it grows out of the body of a woman. The painter was a Protestant and was not familiar with the medieval symbolism of Mary as earth and *stella maris*.

Figure 9

[314] The tree is old and huge and stands on a tangle of roots which is strongly emphasized. Two dragons are approaching from left and right. In the tree there is a

boy who has climbed up to watch the dragons. We are reminded of the dragons that guard the tree of the Hesperides, and of the snakes that guard the hoard. The conscious side of the boy is in a rather precarious situation because the modicum of security it has just acquired is liable to be devoured again by the unconscious. The turmoil of the unconscious is indicated by the tangled roots as well as by the evidently enormous dragons and the tininess of the child. The tree itself is not threatened inasmuch as its growth is independent of human consciousness. It is a natural process, and it is even dangerous to risk disturbing it since it is guarded by dragons. But because this is a natural and ever-present process it can give man protection provided that he summons up courage enough to climb into the tree despite its guardians.

Figure 10

[315] Once again we meet the two dragons, but in the form of crocodiles. The tree is abstract and doubled, and is loaded with fruit. For all its duality it gives the impression of being a single tree. This, besides the ring that unites the two trees, points to the union of opposites which are also represented by the two crocodiles. In alchemy, Mercurius is symbolized by the tree as well as by the dragon. He is notoriously “duplex,” is both masculine and feminine, and is made one in the hierogamos of the chymical wedding. The synthesis of Mercurius forms an important part of the alchemical procedure.

Figure 11

[316] Although tree and snake are both symbols of Mercurius, they stand for two different aspects on account of the latter’s dual nature. The tree corresponds to the passive, vegetative principle, the snake to the active, animal principle. The tree symbolizes earthbound corporeality, the snake emotionality and the possession of a soul. Without the soul the body is dead, and without the body the soul is unreal. The union of the two, which is plainly imminent in this picture, would mean the animation of the body and the materialization of the soul. Similarly, the tree of paradise is an earnest of the real life which awaits the first parents when they emerge from their initial childlike (i.e., pleromatic) state.

Figure 12

[317] Tree and snake are united. The tree bears leaves, and the sun rises in its midst. The roots are snakelike.

Figure 13

[318] The stylized tree has in its trunk a locked door leading to a hidden recess. The middle branch is decidedly snakelike and bears a luminous body like a sun. The simple-minded bird, representing the painter, weeps because it has forgotten the key to the door. It obviously suspects that there is something valuable inside the tree.

Figure 14

[319] The same painter did a number of variations on the treasure motif. Here and in the next picture it takes the form of a hero myth: the hero discovers a sealed coffer in a hidden vault, with a wonderful tree growing out of it. The little green dragon that follows the hero like a dog corresponds to the familiar spirit of the alchemists, the mercurial serpent or *draco viridis*. Mythlike fantasies of this kind are not infrequent, and are more or less the equivalent of alchemical parables or didactic tales.

Figure 15

[320] The tree does not want to yield up the treasure and clasps the coffer all the tighter. When the hero touches the tree, a flame springs out at him. It is a fire-tree, like that of the alchemists, and like the world-tree of Simon Magus.

Figure 16

[321] Many birds are sitting on the leafless tree, a motif found also in alchemy. The tree of wisdom (Sapientia) is surrounded by numerous birds, as in Reusner's *Pandora* (1588), or else the birds fly round the figure of Hermes Trismegistus, as in *Dechemia* (1566).³ The tree is shown guarding a treasure. The precious stone hidden in its roots recalls Grimm's fairytale of the bottle hidden in the roots of the oak tree, which contained the spirit Mercurius. The stone is a dark blue sapphire, but its connection with the sapphire stone in Ezekiel, which played a great role in ecclesiastical allegory, was not known to the painter. The special virtue of the sapphire is that it endows its wearer with chastity, piety, and constancy. It was used as a medicament for "comforting the heart."⁴ The lapis was called the "sapphirine flower."⁵ Birds, as winged beings, have always symbolized spirit or thoughts. So the many birds in our picture mean that the thoughts of the painter are circling round the secret of the tree, the treasure hidden in its roots. This symbolism underlies the parables of the treasure in the field, the pearl of great price, and the grain of mustard seed. Only, the alchemists were not referring to the Kingdom of Heaven, but to the "admirandum Mundi Maioris Mysterium" (the wondrous mystery of the macrocosm), and it looks as though the sapphire in the picture has a similar meaning.

Figure 17

[322] This was done by the same painter, but at a much later stage, when the same idea reappeared in differentiated form. Her technical ability has also improved. The birds have been replaced by heart-shaped blossoms, for the tree has now come alive. Its four branches correspond to the square-cut sapphire, whose “constancy” is emphasized by the little uroboros encircling it. In Horapollo the uroboros is the hieroglyph of eternity.^{5a} For the alchemists the self-devouring dragon was hermaphroditic because it begot and gave birth to itself. They therefore called the sapphirine flower (i.e., the lapis) “Hermaphroditum flos saphyricus.” Constancy and permanence are expressed not only in the age of the tree but also in its fruit, the lapis. Like a fruit, the lapis is at the same time a seed, and although the alchemists constantly stressed that the “seed of corn” dies in the earth, the lapis despite its seedlike nature is incorruptible. It represents, just as man does, a being that is forever dying yet eternal.

Figure 18

[323] The picture shows an initial state in which the tree is unable to raise itself from the earth in spite of its cosmic nature. It is a case of regressive development, probably due to the fact that while the tree has a natural tendency to grow away from the earth into a cosmic space filled with strange astronomical and meteorological phenomena, this would mean reaching up into an eerie unearthly world and making contact with otherworldly things which are terrifying to the earthbound rationality of the natural man. The upward growth of the tree would not only endanger the supposed security of his earthly existence but would be a threat to his moral and spiritual inertia, because it would carry him into a new time and a new dimension where he could not get along without making considerable efforts at readaptation. The patient in these cases is held back not by mere cowardice, but by a largely justifiable fear that warns him of the exacting demands of the future, without his being aware of what these demands are or knowing the dangers of not fulfilling them. His anxious resistance and aversion seem quite groundless, and it is only too easy for him to rationalize them away and, with a little assistance, brush them aside like a troublesome insect. The result is just the psychic situation shown by our picture: an inturned growth which throws the supposedly solid earth into increasing turmoil. Secondary fantasies then arise which, according to the patient’s disposition, revolve round sexuality or the power drive or both. This leads sooner or later to the formation of neurotic symptoms and to the almost unavoidable temptation for both patient and analyst to take these fantasies seriously as causative factors and thus to overlook the real task.

Figure 19

[324] This picture, done by a different patient, shows that [Figure 18](#) is not unique. It is, however, no longer a case of unconscious regression, but of one that is becoming conscious, which is why the tree has a human head. We cannot tell from the picture whether the witchlike tree nymph is clutching at the earth or rising unwillingly from it. This is in complete accord with the divided state of the patient's consciousness. But the upright trees standing around show that within or outside herself she has perceived living examples of the way trees ought to grow. She has interpreted the tree as a witch and the regressive growth as the cause of magical effects of a sinister nature.

Figure 20

[325] The tree stands in isolation dominating the top of a mountain. It is thick with leaves and has in its trunk a doll swathed in multicoloured wrappings. The painter was reminded of the harlequin motif. The fool's motley shows that she felt she was dealing with something crazy and irrational. She was conscious of having thought of Picasso, whose style was apparently suggested by the harlequin's dress. The association probably has a deeper meaning and is not just a superficial combination of ideas. It was this same impression of irrationality that led to the regressive development in the two previous pictures. All three cases are concerned with a process which the modern mind finds extremely disturbing, and not a few of my patients have openly confessed their fear of any such autonomous development of their psychic contents. In these cases it is of the greatest therapeutic value if one can demonstrate to them the historicity of their apparently unique and unassimilable experiences. When a patient begins to feel the inescapable nature of his inner development, he may easily be overcome by a panic fear that he is slipping helplessly into some kind of madness he can no longer understand. More than once I have had to reach for a book on my shelves, bring down an old alchemist, and show my patient his terrifying fantasy in the form in which it appeared four hundred years ago. This has a calming effect, because the patient then sees that he is not alone in a strange world which nobody understands, but is part of the great stream of human history, which has experienced countless times the very things that he regards as a pathological proof of his craziness.

Figure 21

[326] The doll in the previous picture contained a sleeping human figure undergoing metamorphosis like the larva of an insect. Here as well the tree acts as a mother to the human figure hidden in its trunk. This accords with the traditional maternal significance of the tree.

Figure 22

[327] The development has gone a stage further. The sleeping figure awakes, half emerges from the tree and makes contact with the animal world. The “tree-born” is thus characterized not only as a child of nature but as an autochthonous primordial being growing treelike out of the earth. The tree nymph is an Eve who, instead of being taken from Adam’s side, has come into existence independently. This symbol is evidently intended to compensate not merely the one-sidedness and unnaturalness of the ultra-civilized man but also, and in particular, the biblical myth of the secondary creation of Eve.

Figure 23

[328] The tree nymph carries the sun and is a figure composed of light. The wavy band in the background is red, and consists of living blood that flows round the grove of transformation. This indicates that the transformation is not just an airy fantasy, but is a process that reaches down into the somatic sphere or even arises from it.

Figure 24

[329] This drawing combines various motifs from the preceding pictures but lays particular stress on the light- or sun-symbol, which is represented as a quaternity. It is watered by four rivers each done in a different colour. They flow down from what the patient called four heavenly or “metaphysical” mountains. We met the four mountains earlier in [Figure 6](#). They also appear in the drawing of a male patient which I mentioned in *Psychology and Alchemy*,⁶ where the four rivers are reproduced in Figs. 62 and 109. In all these cases I am as little responsible for the number four as I am for all the other alchemical, Gnostic, and mythological quaternities. My critics seem to have the funny idea that I have a special liking for the number four and therefore find it everywhere. Just for once, they should look into an alchemical treatise—but that is evidently too much of an effort. Since “scientific” criticism is ninety per cent prejudice, it invariably takes a very long time for the facts to be recognized.

[330] The number four, like the squaring of the circle, is not accidental, which is why—to take an example known even to my critics—there are not three or, for that matter, five directions, but precisely four. I will only mention in passing that, besides this, the number four possesses special mathematical properties. The quaternary elements in our picture, as well as accentuating the light-symbol, amplify it in such a way that it is not difficult to see what is meant: an acceptance of wholeness by the little female figure, an intuitive apprehension of the self.

Figure 25

[331] A still later stage is shown here. The female figure is no longer just the recipient or bearer of the light-symbol but has been drawn into it. The personality is more powerfully affected than in the previous picture. This increases the danger of identification with the self—a danger not to be taken lightly. Anyone who has passed through such a development will feel tempted to see the goal of his experiences and efforts in union with the self. Indeed, there are suggestive precedents for this, and in the present case it is altogether possible. But there are certain factors in the picture which enable the painter to distinguish her ego from the self. She was an American woman who was influenced by the mythology of the Pueblo Indians: the corn-cobs characterize the female figure as a goddess. She is fastened to the tree by a snake, and thus forms an analogy to the crucified Christ, who, as the self, was sacrificed for earthly humanity, just as Prometheus was chained to the rock. Man’s efforts to achieve wholeness correspond, as the divine myth shows, to a voluntary sacrifice of

the self to the bondage of earthly existence. Here I will only point out this correspondence without going into it further.

[332] In this picture, then, there are so many elements of the divine myth that unless the patient's consciousness were utterly blinded (and there are no signs of this) she could easily discriminate between ego and self. At this stage it is important not to succumb to an inflation, such as would inevitably supervene with all its very unpleasant consequences if, at the moment when the self became recognizable, she identified with it and thus blinded herself to the insight she had attained. If the natural impulse to identify with the self is recognized, one then has a good chance of freeing oneself from a state of unconsciousness. But if this opportunity is overlooked or not used, the situation does not remain the same as before but gives rise to a repression coupled with dissociation of the personality. The development of consciousness which the realization of the self might have led to turns into a regression. I must emphasize that this realization is not just an intellectual act but is primarily a moral one, in comparison with which intellectual understanding is of secondary importance. For this reason, the symptoms I have described can also be observed in patients who, from inferior motives which they will not admit, refuse a task that has been laid upon them by fate.

[333] I would like to draw attention to a further peculiarity: the tree has no leaves, and its branches could just as well be roots. All its vitality is concentrated in the centre, in the human figure that represents its flower and fruit. A person whose roots are above as well as below is thus like a tree growing simultaneously downwards and upwards. The goal is neither height nor depth, but the centre.

Figure 26

[334] The idea developed in the previous picture reappears here in slightly variant form. This idea may truly be said to be in the process of delineating itself, for the conscious mind of the patient follows only a vague feeling which gradually takes shape in the act of drawing. She would have been quite unable to formulate beforehand, in a clear concept, what she wanted to express. The structure of the picture is a mandala divided into four, with the midpoint displaced downwards, beneath the feet of the figure. The figure stands in the upper section and thus belongs to the realm of light. This mandala is an inversion of the traditional Christian cross, whose long upright is below the cross-beam. We must conclude from the picture that the self was realized first of all as an ideal figure of light which nonetheless takes the form of an inverted Christian cross. Whereas the latter's point of intersection is near the top, so that the goal of unconscious striving towards the centre is displaced upwards, the downward glance of the figure shows that her goal should lie below. The short upright beam of the cross of light rests on the black earth, and the figure

holds in her left hand a black fish drawn from the dark sphere. The *mudrā*-like,⁷ hesitant gesture of the right hand, directed towards the fish coming from the left (i.e., from the unconscious), is characteristic of the patient, who had studied theosophy and was therefore under Indian influence. The fish has a soteriological significance whether conceived in Christian or in Indian terms (as the fish of Manu and as an avatar of Vishnu). There is reason to conjecture (see [Figure 29](#)) that the patient was acquainted with the Bhagavadgītā, which says (X, 31): “Among fishes I am Makara.” Makara is a dolphin or a species of Leviathan, and is one of the symbols of the *svādhīsthāna-chakra* in Tantric yoga. This centre is localized in the bladder and is characterized as the water region by the fish and moon symbols. As the *chakras* are presumably equivalent to earlier localizations of consciousness (the *anāhata-chakra*, for instance, corresponding to the *φρῆνες* of the Greeks),⁸ *svādhīsthāna* is probably the earliest localization of all. From this region comes the fish symbol with its age-old numen. We are reminded of the “days of Creation,” of the time when consciousness arose, when the primordial unity of being was barely disturbed by the twilight of reflection,⁹ and man swam like a fish in the ocean of the unconscious. In this sense the fish signifies a restoration of the pleromatic paradisaic state or, in the language of Tibetan Tantrism, of the Bardo.¹⁰

[335] The plants at the foot of the figure are really rooted in the air. Tree, tree nymph, and plants are all lifted up from the earth or, more probably, are on the point of coming down to it. This is also suggested by the fish as emissary of the deep. The situation is in my experience an unusual one and may be due to theosophical influences. Filling the conscious mind with ideal conceptions is a characteristic feature of Western theosophy, but not the confrontation with the shadow and the world of darkness. One does not become enlightened by imagining figures of light, but by making the darkness conscious. The latter procedure, however, is disagreeable and therefore not popular.

Figure 27

[336] Unlike the previous picture, this one is thoroughly Western, although it comes into the archetypal category of the god’s birth from the tree or lotus blossom. The archaic plant world of the carboniferous era illustrates the mood the painter was in when she intuitively apprehended the birth of the self. The human figure growing out of the archaic plant represents the union and quintessence of the four heads at its base, in agreement with the alchemical view that the lapis is composed of four elements. Awareness of the archetype imbues the experience with a primeval character. The division of the plant into six segments, like so much else in the realm of fantasy, may be purely accidental. Nevertheless, it should not be forgotten that the

number six (the *senarius*) was considered in ancient times “aptissimus generationi” (most fit for generation).¹¹

Figure 28

[337] Drawn by the same patient as [Figure 26](#). The female figure wearing a tree-crown is in a sitting position—again a displacement downwards. The black earth that was previously far below her feet is now in her body as a black ball, in the region of the *manipūra-chakra*, which coincides with the solar plexus. (The alchemical parallel to this is the “black sun.”)¹² This means that the dark principle, or shadow, has been integrated and is now felt as a kind of centre in the body. Possibly this integration is connected with the eucharistic significance of the fish: eating the fish brings about a *participation mystique* with God.¹³

[338] Numerous birds are flying round the tree. As birds represent winged thoughts, we must conclude that the female figure progressively detached itself from the world of thought as the centre was displaced downwards, and that the thoughts have consequently returned to their natural element. She and her thoughts were identical before, with the result that she was raised above the earth as though she were an aerial being, while her thoughts lost their freedom of flight, since they had to support the whole weight of a human being in the air.

Figure 29

[339] The process of separation from the world of thought continues. A masculine daemon,¹⁴ who has obviously woken up all of a sudden, reveals himself with an air of triumph: he is the animus, the personification of masculine thinking in a woman (and of her masculine side in general). The patient’s previous state of suspension turns out to have been an animus possession, which is now sloughed off. Differentiation between her feminine consciousness and her animus means liberation for both. The sentence “I am the Game of the gambler” probably refers to Bhagavadgītā X, 36: “I am the game of dice.”¹⁰ Krishna says this of himself. The section in which it occurs begins with the words (X, 20-21): “I am the self, O Gudākesha! seated in the hearts of all beings. I am the beginning and the middle and the end also of all beings. I am Vishnu among the Adityas;¹⁶ the beaming sun among the shining bodies.”

[340] Like Krishna, Agni is the game of dice in the Shatapatha-Brāhmaṇa of the Yajur-Veda: “He (the Adhvaryu)¹⁷ throws down the dice, with ‘Hallowed by Svāhā,¹⁸ strive ye with Surya’s¹⁰ rays for the middlemost place among brethren!’ For that gaming ground is the same as ‘ample Agni,’ and those dice are his coals, thus it is him (Agni) he thereby pleases.”²⁰

[341] Both texts relate light, sun, and fire, as well as the god, to the game of dice. Similarly the Atharva-Veda speaks of the “brilliance that is in the chariot, in the dice, in the strength of the bull, in the wind, Parjanya,²¹ and in the fire of Varuna.”²² The “brilliance” corresponds to what is known in primitive psychology as “mana,” and in the psychology of the unconscious as “libido investment” or “emotional value” or “feeling tone.” In point of emotional intensity, which is a factor of decisive importance for the primitive consciousness, the most heterogeneous things—rain, storm, fire, the strength of the bull, and the passionate game of dice—can be identical. In emotional intensity, game and gambler coincide.

[342] This train of thought may help to explain the mood of the picture, which expresses liberation and relief. The patient evidently felt this moment as a breath of the divine numen. As the Bhagavadgītā text makes clear, Krishna is the self, with which the patient’s animus identifies. This identification is a regular occurrence when the shadow, the dark side, has not been sufficiently realized. Like every archetype, the animus has a Janus face, and besides this the limitation of being a merely masculine principle. He is therefore quite unfitted to represent totality, whether of God or the self. He must be content with an intermediate position. The generalizations characteristic of Indian theosophy, however, induced the patient, by a kind of psychological short-circuit, to identify the animus at least provisionally with wholeness, and to put him in the place of the self.

Figure 30

[343] The same motif as in [Figure 29](#) is shown here in differentiated form by the painter of [Figure 2](#). The stylization of the leafless tree is highly abstract, and so is the gnomelike figure in a monkish robe. The outstretched arms express balance and the cross motif. The ambiguity of the figure is emphasized on the one hand by the bird coming down from above,²³ painted like a fantastic flower, and on the other by the obviously phallic arrow rising up from the roots below. The daemon thus represents an equilibrium of left and right as well as a union of intellect and sexuality, just as the alchemical Mercurius duplex, in the form of the lapis, is a quaternity composed of the four elements. The striped band running down the globe recalls the mercurial band which I discussed in “A Study in the Process of Individuation.”²⁴ There the patient herself took it to be quicksilver.

[344] The concept of the alchemical Mercurius derives exclusively from masculine psychology and symbolizes the typical opposition in a man between *Nous* and sex, owing to the absence of the feminine Eros which would unite them. The animus figure in the picture is a piece of purely masculine psychology that has crystallized out of a woman’s psyche during the process of individuation.

Figure 31

[345] Embroidery by the same patient as before. The tree has turned into a blossoming lotus plant, with the gnomelike figure sitting in the flower, reminding us that the lotus is the birthplace of the gods. Eastern influences are evident in these two figures, but of a different kind from those we met in [Figures 28](#) and [29](#). It is not a matter of Indian theosophy learnt and imitated in the West, for the present patient was born in the East without, however, consciously absorbing its theosophy. But inwardly she was permeated by it so thoroughly that it had a very disturbing effect on her psychic balance.

[346] In this figure the daemon has visibly taken a back place, but the crown of the tree has undergone a rich development: leaves and blossoms appear, forming a wreath, a corona, round a flowerlike centre. The alchemists used the term *corona* or *diadema cordis tui* (diadem of thy heart), meaning by it a symbol of perfection. The crown appears in the figure as the crowning point or culmination of the developmental process symbolized by the tree. It has taken the form of a mandala, the “golden flower” of Chinese and the “sapphirine flower” of Western alchemy. The animus no longer usurps the place of the self, but has been transcended by it.

Figure 32

[347] I reproduce this picture with some hesitation because, unlike the others, its material is not “pure” in the sense of being uninfluenced by what the patient read or picked up by hearsay. It is nevertheless “authentic” in so far as it was produced spontaneously and expresses an inner experience in the same way as all the others, only much more clearly and graphically because the patient was able to avail herself of ideas that fitted her theme better. Consequently, it combines a great deal of material which I do not want to comment on here, as its essential components have already been discussed or will be found in the relevant literature. The actual composition of the tree is at any rate original. I reproduce the picture only to show what kind of influence a knowledge of the symbolism can have on such configurations.

[348] I will bring my picture series to a close with a literary example of spontaneous tree symbolism. In his poem “Soleil Noir” (1952), Noël Pierre, a modern French poet who is personally unknown to me, has described an authentic experience of the unconscious:

J’arrivais de la sorte sur une crape

D’où baïllait un aven embué.

Une foule compacte s'y pressait
Des quatre directions. Je m'y mêlais.
Je remarquais que nous roulions en spirale,
Un tourbillon dans l'entonnoir nous aspirait.
Dans l'axe, un catalpa gigantesque
Où pendaient les cœurs des morts,
A chaque fourche avait élu résidence
Un petit sage qui m'observait en clignotant.
... ..
Jusqu'au fond, où s'étalent les lagunes.
Quelle quiétude, au Nœud des Choses!
Sous l'Arbre de ma Vie, le Dernier Fleuve
Entoure une Ile où s'érige
Dans les brumes un cube de roche grise,
Une Forteresse, la Capitale des Mondes.²⁵

[349] The main characteristics of this description are: (1) Universal midpoint of mankind. (2) Spiral rotation.²⁶ (3) Tree of life and death. (4) The heart as the centre of man's vitality in conjunction with the tree.²⁷ (5) Natural wisdom in the form of a dwarf. (6) The island as seat of the tree of life. (7) Cube = philosophers' stone = treasure guarded by the tree.

II

ON THE HISTORY AND INTERPRETATION OF THE TREE SYMBOL

1. THE TREE AS AN ARCHETYPAL IMAGE

[350] After having given some examples of spontaneously produced, modern tree symbols in the first part of this essay, I should like, in the second part, to say something about the historical background of the tree symbol in order to justify my title “The Philosophical Tree.” Although it will be obvious to anyone acquainted with the material that my examples are nothing more than special instances of a widely disseminated tree symbolism, it is nevertheless of importance, in interpreting the individual symbols, to know something about their historical antecedents. Like all archetypal symbols, the symbol of the tree has undergone a development of meaning in the course of the centuries. It is far removed from the original meaning of the shamanistic tree, even though certain basic features prove to be unalterable. The psychoid form underlying any archetypal image retains its character at all stages of development, though empirically it is capable of endless variations. The outward form of the tree may change in the course of time, but the richness and vitality of a symbol are expressed more in its change of meaning. The aspect of meaning is therefore essential to the phenomenology of the tree symbol. Taken on average, the commonest associations to its meaning are growth, life, unfolding of form in a physical and spiritual sense, development, growth from below upwards and from above downwards, the maternal aspect (protection, shade, shelter, nourishing fruits, source of life, solidity, permanence, firm-rootedness, but also being “rooted to the spot”), old age, personality,¹ and finally death and rebirth.



The tree bears buds and white blossoms. It stands on an island. In the background is the sea



The tree stands on the globe, and reminded the painter of the baobab whose roots burst the planetoid on which St. Exupéry's *Little Prince* dwelt. It also recalls the world-tree of Pherekydes, the shamanic tree, and the world-axis



Abstract tree represented as seven-branched candelabrum or Christmas tree. The lights symbolize the illumination and expansion of consciousness



Montage in gold-foil, analogous to the alchemical *arbor aurea* and cosmic tree. The golden globes are heavenly bodies



The tree grows in water. It bears red flowers, but it consists also of fire licking up from the water, and the branches are tipped with flame



The tree is painted bright red, and grows in the water simultaneously upwards and downwards

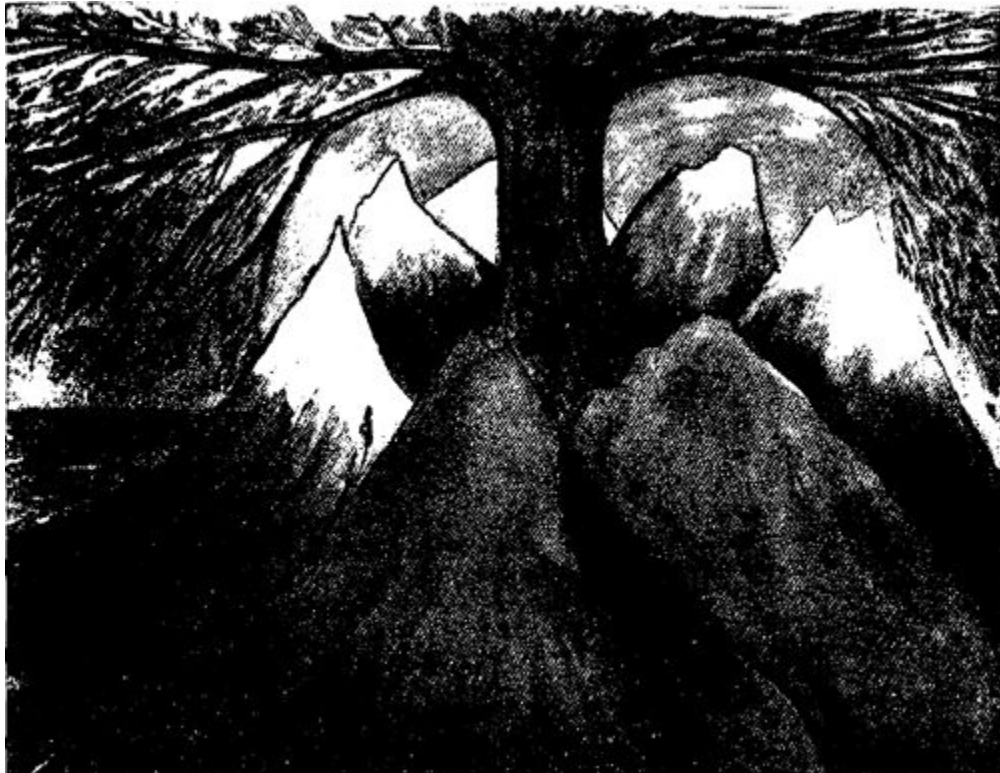

The tree thrusts up from below and breaks through the earth's surface



Its branches tipped with flame, the tree grows out of the body of a woman. She is synonymous with earth and water, an embodiment of the idea that the tree is a process originating in the unconscious. Cf. the Mexican world-tree which grows in the belly of the earth goddess (Lewis Spence. *The Gods of Mexico*, p. 58)



Drawing by an eleven-year-old boy

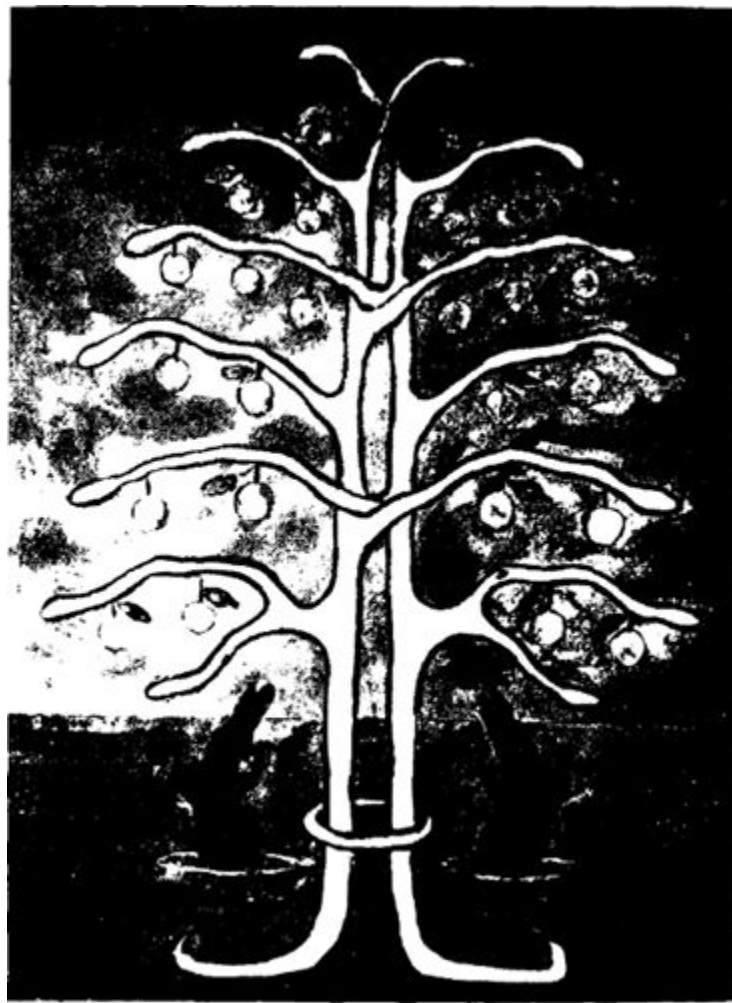

Union of opposites represented by two trees growing into one another and joined by a ring. The crocodiles in the water are the separated opposites, which are therefore dangerous

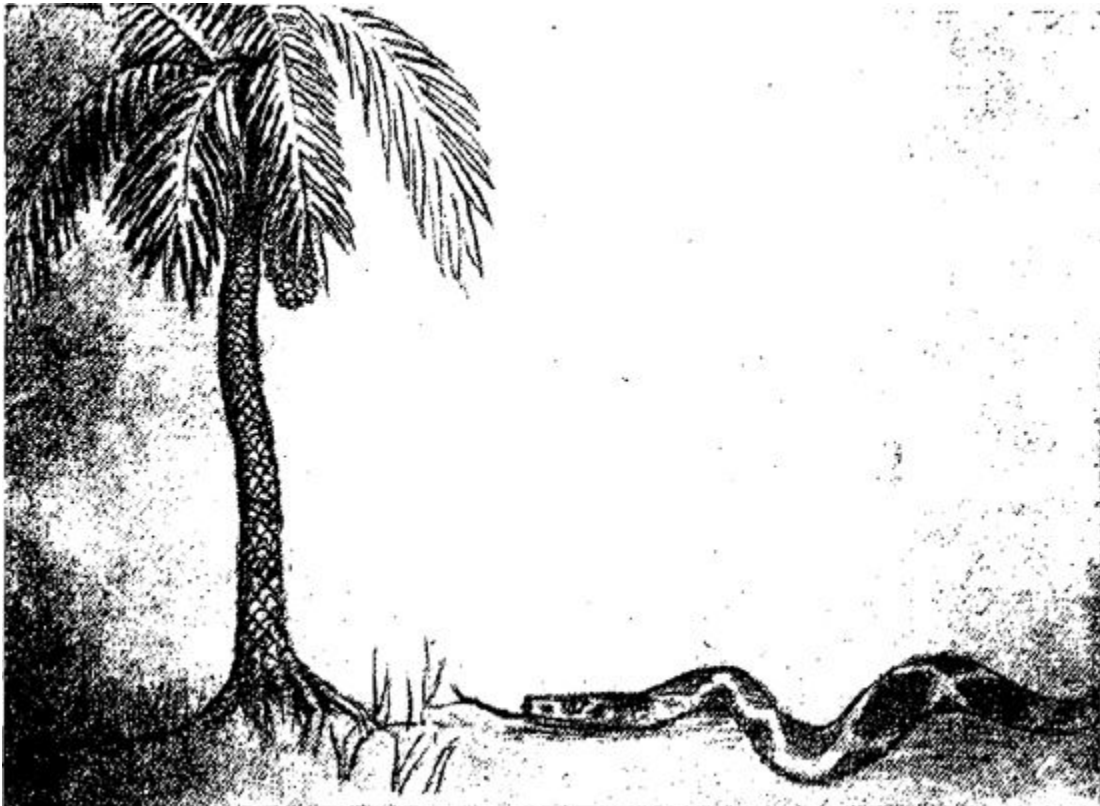

The vertical growth of the tree contrasts with the horizontal movement of the snake. The snake is about to take up its abode in the tree of knowledge



Corresponding to the sun in the branches, the snake in the roots of the tree wears a halo, an indication of the successful union of tree and snake



The tree has 4 + 1 branches. The central branch bears the sun, the other four bear stars. The tree is hollow inside and is shut by a door. The bird weeps “because it has forgotten the key”



This and the following picture come from a series depicting the hero myth. The hero is accompanied by a familiar in the form of a small, green, crowned dragon. The tree grows out of a coffer containing the secret treasure



The tree clasps the coffer in its roots, and a flame springs out of a leaf as the hero touches it



Done by the same patient at an earlier stage. In the roots of the tree a sapphire lies hidden

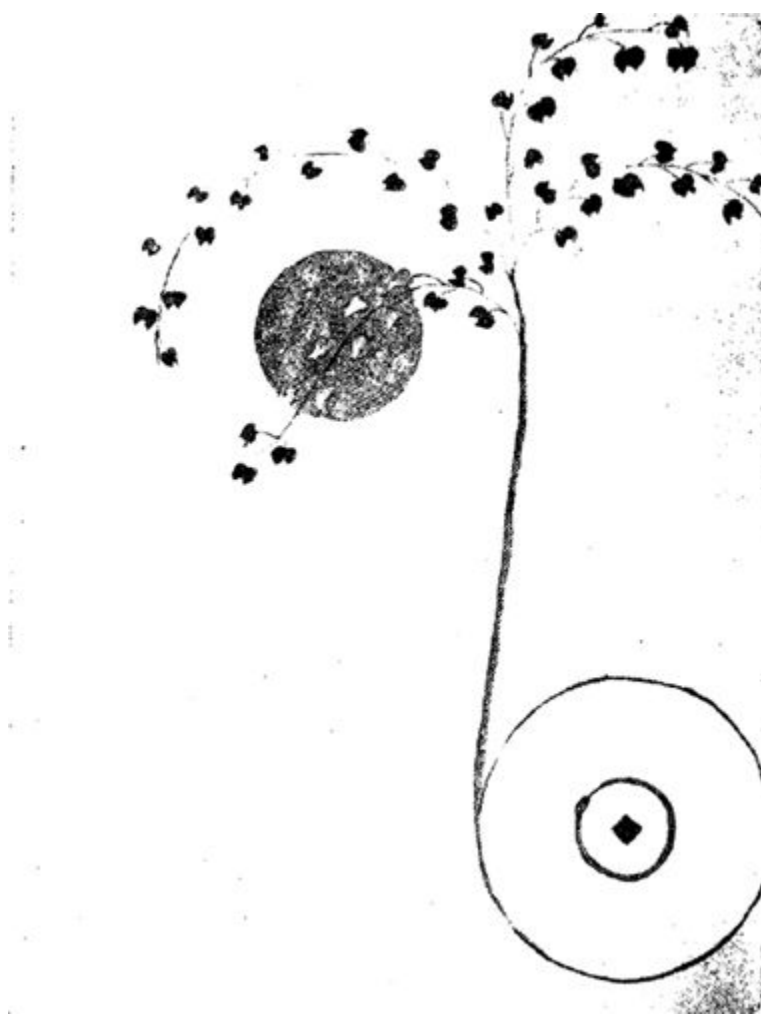

Done later by the same patient. A blossoming tree with sun disk grows out of a magic circle enclosing the uroboros with the sapphire at the centre



The cosmic tree is caught by the earth and cannot grow upwards



The same regressive state (depicted by a different painter), but coupled with greater consciousness

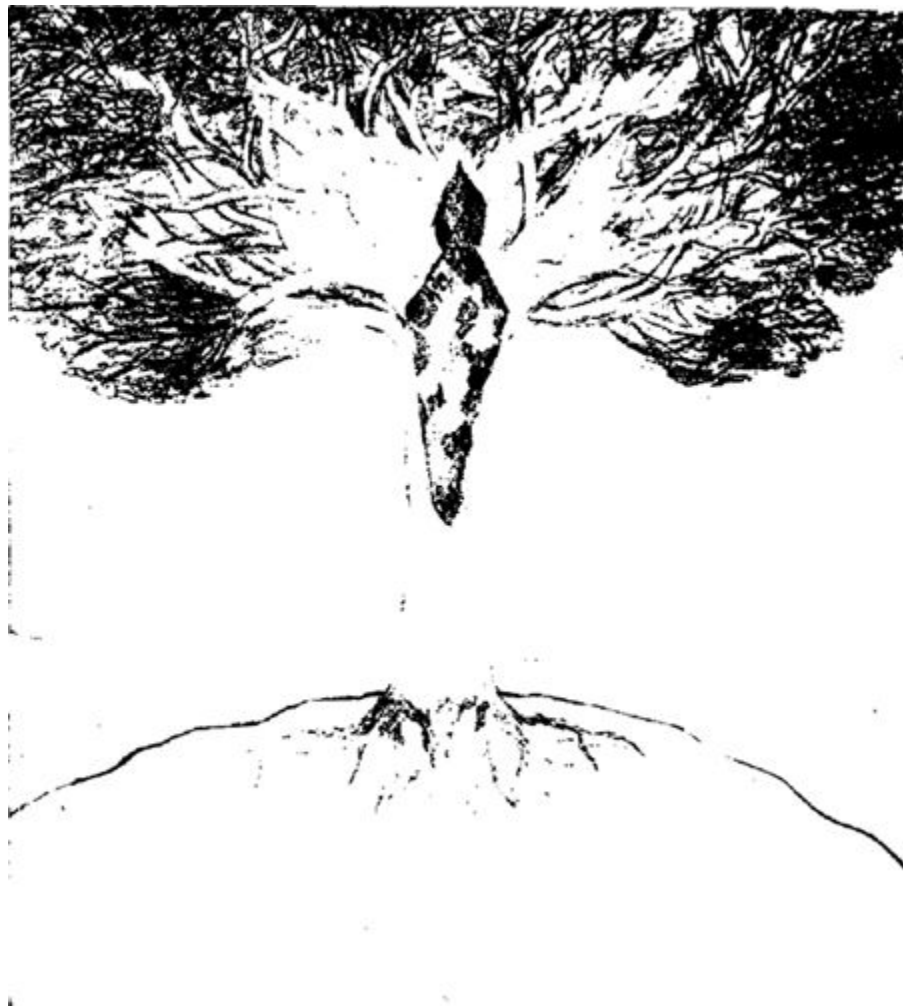

The tree has a cosmic character, with a multicoloured doll hidden in its trunk



The same motif done by a different patient. The sleeping figure is now visible



The hidden figure awakens and half emerges from the tree. The snake whispers in her ear: bird, lion, lamb, and pig complete the paradisaical scene



The tree itself assumes human form and carries the sun. In the background is a wavy band of blood, surging rhythmically round the island

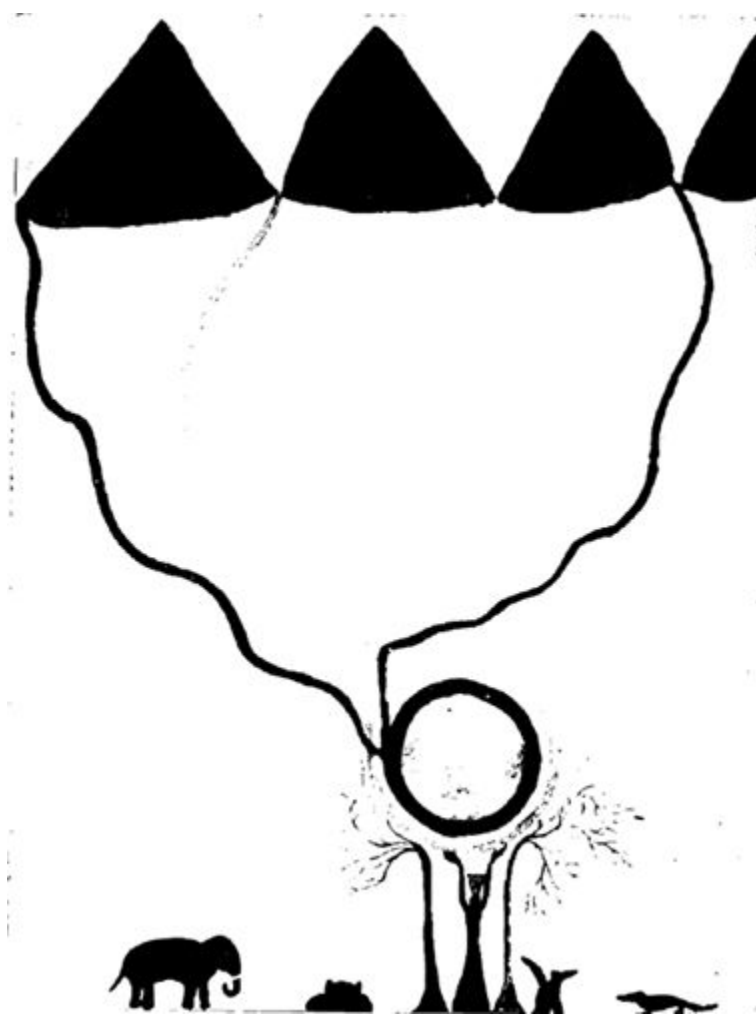

Done by the same painter as [Figures 13-17](#). A female figure has taken the place of the tree. The sun disk is now a symbol of individuation, and is characterized as such by the quaternity fed by four different-coloured rivers flowing down from four mountains, and flanked by four animals. The scene is paradisaical



The tree is a female figure encircled by a snake and holding two globes of light. The cardinal points are marked by corn-cobs and four animals: bird, tortoise, lion, and grasshopper



Most of the tree has been replaced by a female figure, the lower part taking the form of a cross. Below is the earth, in the sky a rainbow



The tree stands in a forest of prehistoric mare's-tails. It grows like the pistil of a flower (in six stages) from a calyx bearing four human heads. A woman's head rises out of the petals



Drawn by the same patient as [Figure 26](#). The foliage growing out of the woman's head is surrounded by flying birds



Awake my Soul
stretch every nerve.

"I am the Game of the gambler."

Drawn by the same patient, but here the tree grows out of a man's head rising above the rainbow



Painted by the same patient as [Figure 2](#). A stylized world-tree surmounting a globe with a multicoloured band running down it. The trunk is a daemonic masculine figure with a bird coming down from above and a phallic symbol rising up from below



Made by the same patient. The tree has turned into a lotus with a gnomelike figure inside. His head is encircled by a mandala with a flowerlike centre, surrounded by a wreath or corona



Here again the tree is painted like a flower, and symbolizes the union of a number of opposites. Below, a swan and a catlike creature; then Adam and Eve, hiding their faces in shame; then a kingfisher with fish and a three-headed snake; in the centre, the four cherubim of Ezekiel, flanked by sun and moon; then the flower of light with a crowned boy inside; at the top, a bird with a shining egg and a crowned serpent, and two hands pouring water out of a jug

[351] This characterization is the deposit of many years of research into the statements of individual patients. Even the layman reading this essay will be struck by the amount of material from fairytale, myth, and poetry that appears in the illustrations. In this connection it is astonishing how relatively seldom the persons I interrogated were conscious of sources of this kind. The main reasons for this are: (1) In general, people think little, if at all, about the origins of dream images, and still less about myth motifs. (2) The sources have been forgotten. (3) The sources were never in any sense conscious; that is to say, the images are new, archetypal creations.

[352] The third possibility is much less rare than one might suppose. On the contrary, it occurs so frequently that comparative research into symbols becomes unavoidable in elucidating the spontaneous products of the unconscious. The widely held view that mythologems or myth motifs² are always connected with a tradition proves untenable, since they may reappear anywhere, at any time, and in any individual regardless of tradition. An image can be considered archetypal when it can be shown to exist in the records of human history, in identical form and with the same meaning. Two extremes must be distinguished here: (1) The image is clearly defined and is

consciously connected with a tradition. (2) The image is without doubt autochthonous, there being no possibility let alone probability of a tradition.³ Every degree of mutual contamination may be found between these two extremes.

[353] In consequence of the collective nature of the image it is often impossible to establish its full range of meaning from the associative material of a single individual. But since it is of importance to do this for practical therapeutic purposes, the necessity of comparative research into symbols for medical psychology becomes evident on these grounds also.⁴ For this purpose the investigator must turn back to those periods in human history when symbol formation still went on unimpeded, that is, when there was still no epistemological criticism of the formation of images, and when, in consequence, facts that in themselves were unknown could be expressed in definite visual form. The period of this kind closest to us is that of medieval natural philosophy, which reached its zenith in the seventeenth century, and in the eighteenth century gradually left the field to science. It attained its most significant development in alchemy and Hermetic philosophy. Here, as in a reservoir, were collected the most enduring and the most important mythologems of the ancient world. It is significant that Hermetic philosophy was, in the main, practised by physicians.⁵

2. THE TREE IN THE TREATISE OF JODOCUS GREVERUS

[354] I would now like to show how the phenomenology of the tree is reflected in the medium of the epoch immediately preceding the one just mentioned. Holmberg,¹ who wrote a comprehensive study of the tree of life, says that it is “mankind’s most magnificent legend,” thus confirming that the tree occupies a central position in mythology and is so widespread that its ramifications are to be found everywhere. The tree appears frequently in the medieval alchemical texts and in general represents the growth of the arcane substance and its transformation into the philosophical gold (or whatever the name of the goal may be). We read in the treatise of Pelagios that Zosimos had said the transformation process was like “a well-tended tree, a watered plant, which, beginning to ferment because of the plentiful water, and sprouting in the humidity and warmth of the air, puts forth blossoms and fruits by virtue of the great sweetness and special quality (*ποιότητι*) of nature.”²

[355] A typical example of this process is to be found in the treatise of Jodocus Greverus, which was first printed in Leiden, 1588.³ The whole opus is depicted as the sowing and nurturing of the tree in a well-tended garden, into which nothing extraneous might enter. The soil consists of purified Mercurius; Saturn, Jupiter, Mars, and Venus form the trunk (or trunks)⁴ of the tree, and the sun and moon supply their seeds. These planetary names refer partly to the corresponding metals, but we can see what they meant from the author’s qualifying remark: “For there enters into this work not the common gold, nor the common Mercurius, nor the common silver, nor

anything else that is common, but [the metals] of the Philosophers.”⁵ The ingredients of the work might therefore be anything. At any rate they are imaginary ones, even though they were expressed outwardly by chemical substances. The planetary names refer ultimately not only to metals but, as every alchemist knew, to the (astrological) temperaments, that is, to psychic factors. These consist of instinctive dispositions which give rise to specific fantasies and desires and so reveal their character. Avarice as one of the original motives of the royal art is still apparent in the term *aurum non vulgi*, though it is just here that we discern the change of motivation and the displacement of the goal to another plane. In the parable that comes at the end of the treatise the wise old man says to the adept: “Son, lay aside the snares of worldly appetites.”⁶ Even when, as is often undoubtedly the case, the procedure given by an author has no other aim than the production of the common gold, the psychic meaning of the opus nevertheless comes through in the symbolic nomenclature he employs in spite of his conscious attitude. In the treatise of Greverus this stage has been overcome and it is openly admitted that the goal of the opus is “not of this world.” Accordingly, at the conclusion of his treatise on the “universal process of our work,”⁷ the author avows that it is a “gift of God, containing the secret of the undivided oneness of the Holy Trinity. O most excellent science, theatre of all nature and its anatomy, earthly astrology,⁸ proof of God’s omnipotence, testimony to the resurrection of the dead, example of the remission of sins, infallible proof of the judgment to come and mirror of eternal blessedness.”⁹

[356] A modern reader of this hymnlike paean of praise cannot help feeling that it is exaggerated and out of key, for one cannot imagine how the science of alchemy could, for instance, contain the Holy Trinity. Such enthusiastic comparisons with the mysteries of religion had already caused offence in the Middle Ages.¹⁰ Far from being rarities, they even became a *leitmotiv* of certain treatises in the seventeenth century, which however had their precursors in the thirteenth and fourteenth centuries. In my view they should not always be taken as spurious mystification, for the authors had something definite in mind. They obviously saw a parallel between the alchemical process and religious ideas—a parallel which is certainly not immediately perceptible to us. A bridge between two such very different realms of thought can be constructed only when we take into account the factor common to both: the *tertium comparationis* is the psychological element. Naturally an alchemist would have defended himself just as indignantly against the charge that his ideas about chemical substances were fantasies as would a metaphysician today, who still thinks that his statements amount to more than anthropomorphisms. Just as the alchemist was unable to distinguish between things as they are and the notions he had about them, so the modern metaphysician still believes that his views give valid expression to their metaphysical object. It obviously never occurred to either of them

that a great diversity of views concerning their respective objects has been held since earliest times. But unlike metaphysicians, and unlike theologians in particular, the alchemists displayed no polemical tendencies; at most they lamented the obscurity of the authors whom they could not understand.

[357] It is clear to every reasonable person that in both cases we are concerned primarily with ideas born of fantasy—which is not to say that their unknown object does not exist. No matter what the ideas refer to, they are always organized by the same psychic laws, that is, by the archetypes. In their way the alchemists realized this when they insisted on the parallelism between their ideas and religious ones, as when Greverus compares his synthetic process with the Trinity. The common archetype in this case is the number three. As a Paracelsist, he must have been acquainted with the Paracelsan triad of sulphur, salt, and Mercurius. Sulphur belongs to the sun or represents it, and salt stands in the same relation to the moon. However, he says nothing about a synthesis of this kind.¹¹ Sun and moon supply the seeds that are planted in the earth (= Mercurius), and presumably the four other planets form the trunk of the tree. The four that are to be united into one refer to the tetrasomia of Greek alchemy, where, corresponding to the planets, they stand for lead, tin, iron, and copper.¹² Hence in his process of *henosis* (unification or synthesis), as Michael Maier correctly understood it,¹³ what Greverus had in mind was not the three basic Paracelsan substances but the ancient tetrasomia, which at the end of his treatise he compares with the “union of persons in the Holy Trinity.” For him the triad of sun, moon, and Mercurius was the starting point, the initial material as it were, in so far as it signified the seed of the tree and the earth in which it was sown. This is the so-called *coniunctio triptativa*. But here he is concerned with the *coniunctio tetraptiva*,¹⁴ whereby the four are joined in the “union of persons.” This is a characteristic example of the dilemma of three and four, which plays a great role in alchemy as the well-known axiom of Maria Prophetissa.¹⁵

3. THE TETRASOMIA

[358] The aim of the tetrasomia is the reduction (or synthesis) of a quaternio of opposites to unity. The names of the planets themselves indicate two dyads, one benevolent (Jupiter and Venus), the other malefic (Saturn and Mars), and such dyads often constitute an alchemical quaternity.¹ Zosimos gives the following description of the transformation process that is needed for the preparation of the tincture:

You have need of an earth formed from two bodies and a water formed from two natures to water it. When the water has been mingled with the earth . . . the sun must act on this clay and transform it into stone. This stone must be burnt, and that burning will bring out the secret of this matter, that is to say its spirit, which is the tincture² sought by the philosophers.³

As the text shows, the synthesis depends on the unification of a double dyad. This is expressed particularly clearly in another archetypal form of the same idea: in the structure of the royal marriage, which follows that of the cross-cousin marriage.⁴

[359] As a rule, the lapis is synthesized from the quaternity of the elements or from the ogdoad of elements plus qualities (cold/warm, moist/dry). Similarly Mercurius, known from ancient times as *quadratus*, is the arcane substance through whose transformation the lapis, or goal of the opus, is produced. Thus in the love-magic of Astrampsychos the invocation to Hermes says:

Your names . . . are in the four corners of the heavens. I know also your forms, which are: in the East you have the form of an ibis, in the West you have the form of a dog-headed baboon, in the North you have the form of a serpent, but in the South you have the form of a wolf. Your plant is the grape,⁵ which in that place is the olive.⁶ I know also your wood: it is ebony, etc.⁷

[360] The fourfold Mercurius is also the tree or its *spiritus vegetativus*. The Hellenistic Hermes is on the one hand an all-encompassing deity, as the above attributes show, but on the other hand, as Hermes Trismegistus, he is the arch-authority of the alchemists. The four forms of Hermes in Egyptian Hellenism are clearly derived from the four sons of Horus. A god with four faces is mentioned as early as the Pyramid Texts of the fourth and fifth dynasties.⁸ The faces obviously refer to the four quarters of heaven—that is, the god is all-seeing. Budge points out that in chapter CXII of the Egyptian Book of the Dead the same god appears as the ram of Mendes with four heads.⁹ The original Horus, who represented the face of heaven, had long hair hanging down over his face, and these strands of hair were associated with the four pillars of Shu, the air god, which supported the four-cornered plate of the sky. Later the four pillars became associated with the four sons of Horus, who replaced the old gods of the four quarters of heaven. Hapi corresponded to the North, Tuamutef to the East, Amset to the South, and Qebhsennuf to the West. They played a large role in the cult of the dead, watching over the life of the dead man in the underworld. His two arms corresponded to Hapi and Tuamutef, his legs to Amset and Qebhsennuf. The Egyptian quaternity consisted of two dyads, as is evident from the text of the Book of the Dead: “Then said Horus to Re, Give me two divine brethren in the city of Pe and two divine brethren in the city of Nekhen, who [have sprung] from my body.”¹⁰ The quaternity is in fact a *leitmotiv* in the ritual for the dead: four men carry the coffin with the four Canopic jars, there are four sacrificial animals, all instruments and vessels are fourfold. Formulas and prayers are repeated four times, etc.¹¹ It is evident from this that the quaternity was of special importance for the dead man: the four sons of Horus had to see to it that the four parts (i.e., the wholeness) of the body were preserved. Horus begot his sons with his mother Isis. The incest motif,

which was continued in Christian tradition and extended into late medieval alchemy, thus begins far back in Egyptian antiquity. The four sons of Horus are often shown standing on a lotus before their grandfather Osiris, Mestha¹² having a human head, Hapi the head of an ape, Tuamutef the head of a jackal, and Qebhsennuf the head of a hawk.

[361] The analogy with the vision of Ezekiel (chapters 1 and 10) is at once apparent. There the four cherubim had “the likeness of a man.” Each of them had four faces, a man’s, a lion’s, an ox’s, and an eagle’s, so that, as with the four sons of Horus, one quarter was human and three quarters animal. In the love-magic of Astrampsychos, on the other hand, all four forms are animal, probably because of the magic purport of the incantation.¹³

[362] In keeping with the Egyptian predilection for multiples of four, there are 4×4 faces in the vision of Ezekiel.¹⁴ Moreover each of the cherubim has a wheel. In later commentaries the four wheels were interpreted as Merkabah, the chariot.¹⁵ Corresponding to the four pillars of Shu and the four sons of Horus as gods of the four quarters, who bear up the floor of the sky, there was “a firmament as the colour of terrible crystal, stretched forth over the heads” of the cherubim. On it stood the throne of him who had “the appearance of a man,” the counterpart of Osiris, who with the help of the older Horus and of Set had climbed up to heaven.

[363] The four wings of the cherubim recall the winged female genies who protect the coffin of Pharaoh. Each of the Horus sons had a female counterpart who fulfilled this same tutelary function. The cherubim, too, were protective genies, as is apparent from Ezekiel 28 : 14 and 16.¹⁶ The apotropaic significance of the quaternity is borne out by Ezekiel 9 : 4, where the prophet, at the behest of the Lord, sets a cross¹⁷ on the foreheads of the righteous to protect them from punishment. It is evidently the sign of God, who himself has the attribute of quaternity. The cross is the mark of his protégés. As attributes of God and also symbols in their own right, the quaternity and the cross signify wholeness. Thus Paulinus of Nola says:

Extended on the four arms of the wood of the cross, he reached out to the four quarters of the world, that he might draw together unto life the peoples from every shore; and because Christ our God by the death of the cross shows himself all things to all men, that life may come into being and evil be destroyed, A and Ω stand beside the cross, each letter by its three strokes displaying a different figure in threefold wise, a single meaning perfected in triple form.¹⁸

[364] In the spontaneous symbolism of the unconscious the cross as quaternity refers to the self, to man’s wholeness.¹⁹ The sign of the cross is thus an indication of the healing effect of wholeness, or of becoming whole.

[365] Four animals also appear in the vision of Daniel. The first was like a lion and was “made stand upon the feet as a man, and a man’s heart was given to it.” The second was like a bear, the third like a leopard, and the fourth was a beast “dreadful and terrible,” with “great iron teeth” and “ten horns.”²⁰ Only the special treatment of the lion in any way recalls the human quarter of the tetramorph. All four of them are beasts of prey or, in psychological terms, functions that have succumbed to desire, lost their angelic character, and become daemonic in the worst sense. They represent the negative and destructive aspect of the four angels of God who, as the Book of Enoch shows, form his inner court. This regression has nothing to do with magic (see n. 13) but rather expresses the daemonization of man, or of certain powerful individuals. Accordingly Daniel interprets the four beasts as four kings which shall arise out of the earth (7 : 17, A.V.). The interpretation continues (7 : 18): “But the saints of the most High shall take the kingdom, and possess the kingdom for ever, even for ever and ever.” Like the lion with the human heart, this surprising interpretation is based on the positive aspect of the quaternity and refers to a blessed, protected state of things when four guardian angels reign in heaven and four just kings on earth, and the saints possess the kingdom. But this happy state is about to disappear, for the fourth beast in the quaternity has assumed monstrous form, has ten horns and represents “the fourth kingdom upon earth, which shall be diverse from all kingdoms, and shall devour the whole earth” (7 : 23). In other words, a monstrous lust for power will make the human quarter unconscious again. This is a psychological process which can be observed only too often both individually and collectively. It has recurred countless times in the history of mankind.

[366] Via Daniel and Enoch, the quaternity of God’s sons penetrated very early into Christian ideology. There are the three synoptic gospels and the one gospel of St. John, to which were assigned as emblems the symbols of the cherubim. The four gospels are as it were the pillars of Christ’s throne, and in the Middle Ages the tetramorph became the riding animal of the Church. But it was Gnostic speculation in particular that appropriated the quaternity. This theme is so far-reaching that it cannot be dealt with more closely here. I would only draw attention to the synonymy of Christ, Logos, and Hermes,²¹ and the derivation of Jesus from the so-called “second tetrad”²² among the Valentinians. “Thus our Lord in his fourfoldness preserves the form of the tetraktys and is composed of (1) the spiritual, which comes from Achamoth, (2) the psychic, which comes from the world-creator, (3) the body prepared with ineffable art, and (4) the divine, the saviour.”²³

[367] The alchemical tetrasomia and its reduction to unity therefore have a long prehistory which reaches back far beyond the Pythagorean tetraktys into Egyptian antiquity. From all this we can see without difficulty that we are confronted with the archetype of a *totality image divided into four*. The resultant conceptions are always

of a central nature, characterize divine figures, and carry over those qualities to the arcane substances of alchemy.

[368] It is not the task of empirical psychology to speculate about the possible metaphysical significance of this archetype. We can only point out that in spontaneous psychic products such as dreams and fantasies the same archetype is at work and in principle produces over and over again the same figures, meanings, and values *autochthonously*. Anyone who studies impartially the above series of dream pictures will be able to convince himself of the validity of my conclusions.

4. THE IMAGE OF WHOLENESS

[369] After this excursus into the history of the Hermetic quaternity, let us turn back to the image of wholeness in alchemy.

[370] One of the commonest and most important of the arcana is the *aqua permanens*, the ὕδωρ θεῖον of the Greeks. This, according to the unanimous testimony of both the ancient and the later alchemists, is an aspect of Mercurius, and of this divine water Zosimos says in his fragment περὶ τοῦ θείου ὕδατος:

This is the great and divine mystery which is sought, for it is the whole [τοῦτο γὰρ ἔστι τὸ πᾶν]. And from it is the whole and through the same is the whole. Two natures, one substance [οὐσία]. But the one [substance] attracts the one, and the one rules the one. This is the silver water, male and female, which forever flees. . . . For it is not to be ruled. It is the whole in all things. And it has life and spirit and is destructive [ἀναιρετικόν].¹

[371] With regard to the central significance of the *aqua permanens* I must refer the reader to my earlier writings.² The “water” is just as much the arcanum of alchemy as are Mercurius, the lapis, the *filius philosophorum*, etc. Like them it is a totality image, and as the above Zosimos quotation shows, this was so even in the Greek alchemy of the third century A.D. The text leaves no doubt in this respect: the water is wholeness. It is the “silver water” (= *hydrargyrum*), but not the ὕδωρ ἀεικίνητον, ‘ever-moving water,’ i.e., ordinary quicksilver which in Latin alchemy was called *Mercurius crudus* as distinct from *Mercurius nonvulgi*. In Zosimos the quicksilver is a πνεῦμα (spirit).³

[372] Zosimos’s “whole” is a microcosm, a reflection of the universe in the smallest particle of matter, and is therefore found in everything organic and inorganic. Because the microcosm is identical with the macrocosm, it attracts the latter and thus brings about a kind of apocatastasis, a restoration of all individua to the original wholeness. Thus “every grain becomes wheat, and all metal gold,” as Meister Eckhart says; and the little, single individual becomes the “great man,” the *homo*

maximus or *Anthropos*, i.e., the self. The moral equivalent of the physical transmutation into gold is *self-knowledge*, which is a re-remembering of the *homo totus*.⁴ Olympiodorus, citing Zosimos's exhortation to Theosebeia, says:

If thou wilt calmly humble thyself in relation to thy body, thou wilt calm thyself also in relation to the passions, and by acting thus, thou wilt summon the divine to thyself, and in truth the divine, which is everywhere⁵ will come to thee. But when thou knowest thyself, thou knowest also the God who is truly one.⁶

Hippolytus bears this out in his account of the Christian doctrine:

But thou shalt speak with God and be joint heir with Christ. . . . For thou wilt have become God [*γέγονας γὰρ θεός*]. For whatever sufferings thou didst undergo as a man, thou hast shown that thou art a man; but whatever is appurtenant to a God, that God has promised to bestow, because thou hast been made divine [*θεοποιηθῆς*], since thou hast been begotten immortal [*γεννηθείς*]. That is the "Know thyself," the knowing of the God who made thee. For to him who knoweth himself it is given to be known of Him by whom he is called.⁷

[373] The foregoing account of the associative background of the tree, prompted by the treatise of Jodocus Greverus, seemed to me a necessary prelude to a discussion of the significance of the tree in alchemy. A general survey of this kind may help the reader not to lose sight of the whole amid the unavoidable confusion of alchemical opinions and fantasies. Unfortunately my exposition will not be rendered any easier by my having to give numerous parallels from other fields of study. These, however, cannot be dispensed with, because the views of the alchemists were derived to a large extent from unconscious archetypal assumptions which also underlie other domains of human thought.

5. THE NATURE AND ORIGIN OF THE PHILOSOPHICAL TREE

[374] In my book *Psychology and Alchemy* I devoted a special chapter¹ to the projection of psychic contents (hallucinations, visions, etc.) and therefore need not dwell here on the spontaneous production of the tree symbol among the alchemists. Suffice to say that the adept saw branches and twigs² in the retort, where his tree grew and blossomed.³ He was advised to contemplate its growth, that is, to reinforce it with active imagination. The vision was the thing to be sought (*res quaerenda*).⁴ The tree was "prepared" in the same way as salt.⁵ And just as the tree grew in the water, so also it was putrefied in it, "burnt" or "cooled" with the water.⁶ It was called oak,⁷ vine,⁸ myrtle.⁹ Djēbir ibn Hayyēn says of the myrtle: "Know that the myrtle is the leaf and the twig; it is a root yet no root. It is both a root and a branch. As a root, it is unquestionably a root if it be set over against the leaves and the fruits. It is

separate from the trunk and forms part of the deep roots.” The myrtle, he says, is “what Maria¹⁰ calls the golden rungs, what Democritus calls the green bird. . . . It has been so called because of its green colour and because it is like the myrtle, in that it keeps its green colour for a long time despite the alternations of heat and cold.”¹¹ It has seven branches.¹²

[375] Gerard Dorn says of the tree:

After nature has planted the root of the metallic tree in the midst of her womb, viz., the stone which shall bring forth the metals, the gem, the salt, the alum, the vitriol, the salty spring, sweet, cold, or warm, the tree of coral or the Marcasita,¹³ and has set its trunk in the earth, this trunk is divided into different branches, whose substance is a liquid, not after the manner of water, nor of oil, nor of clay,¹⁴ nor of slime, but is not to be thought of otherwise than as the wood born of the earth, which is not earth although growing from it. The branches spread in such a way that the one is separated from the other by a space of two or three climates and as many regions: from Germany even as far as Hungary and beyond. In this way the branches of different trees spread through the whole globe of the earth, as in the human body the veins spread through the different limbs, which are separated from one another.

The fruits of this tree drop off, and the tree itself dies and vanishes in the earth. “Afterwards, in accordance with natural conditions, another new [tree] is there.”¹⁵

[376] In this text Dorn draws an impressive picture of the growth, expansion, death, and rebirth of the philosophical tree. Its branches are veins running through the earth, and although they spread to the most distant points of the earth’s surface they all belong to the same immense tree, which apparently renews itself. The tree is obviously thought of as a system of blood vessels. It consists of a liquid like blood, and when this comes out it coagulates into the fruit of the tree.¹⁶ Strangely enough, in ancient Persian tradition the metals are connected with the blood of Gayomart: his blood, soaking into the earth, turned into the seven metals.

[377] Dorn appends to his description of the tree a brief observation which I would not like to withhold from the reader since it affords an important insight into what is in its way the classic mode of alchemical thinking. He says:

This and suchlike things proceed from the true physics and from the springs of the true philosophy, from which, by meditative contemplation of the wondrous works of God, the true knowledge of the supreme author and of his powers dawns upon the spiritual eyes of the philosophers, even as to the fleshly eyes the light is made visible. To those eyes the hidden is revealed. But that Greek Satan has implanted in the philosophic field of the true wisdom the tares¹⁷ and their false seeds, namely Aristotle, Albertus, Avicenna,¹⁸ Rasis,¹⁹ and men of that kidney, who are inimical to

the light of God and the light of nature, and have perverted the whole physical truth from the time when they turned the name Sophia into Philosophia.²⁰

[378] Dorn was a Platonist and a fanatical opponent of Aristotle and, quite obviously, of the scientific empiricists as well. His attitude was essentially the same as that of Robert Fludd in respect of John Kepler.²¹ Basically, it was the old controversy about universals, the opposition between realism and nominalism, which in our scientific age has been decided in favour of a nominalistic tendency. Whereas the scientific attitude seeks, on the basis of careful empiricism, to explain nature in her own terms, Hermetic philosophy had for its goal an explanation that included the psyche in a total description of nature. The empiricist tries, more or less successfully, to forget his archetypal explanatory principles, that is, the psychic premises that are a *sine qua non* of the cognitive process, or to repress them in the interests of “scientific objectivity.” The Hermetic philosopher regarded these psychic premises, the archetypes, as inalienable components of the empirical world-picture. He was not yet so dominated by the object that he could ignore the palpable presence of psychic premises in the form of eternal ideas which he felt to be real. The empirical nominalist, on the other hand, already had the modern attitude towards the psyche, namely, that it had to be eliminated as something “subjective,” and that its contents were nothing but ideas formulated *a posteriori*, mere *flatus vocis*. His hope was to be able to produce a picture of the world that was entirely independent of the observer. This hope has been fulfilled only in part, as the findings of modern physics show: the observer cannot be finally eliminated, which means that the psychic premises remain operative.

[379] In the case of Dorn we can see how the archetypal tree, which consisted of the ramifications of the bronchi, blood vessels, and veins of ore, was projected upon the empirical world and gave rise to a totalistic view which embraced the whole of organic and inorganic nature and the “spiritual” world as well. The fanatical defence of his standpoint shows that Dorn was gnawed by inner doubt and was fighting a lost battle. Neither he nor Fludd could hold up the march of events, and today we see how the spokesmen of so-called objectivity are defending themselves with similar outbursts of affect against a psychology that demonstrates the necessity of psychic premises.

6. DORN'S INTERPRETATION OF THE TREE

[380] In his treatise “Congeries Paracelsicae chemicae de transmutatione metallorum” Dorn writes:¹

On account of likeness alone, and not substance, the Philosophers compare their material to a golden tree with seven branches, thinking that it encloses in its seed the

seven metals, and that these are hidden in it, for which reason they call it a living thing. Again, even as natural trees bring forth divers blossoms in their season, so the material of the stone causes the most beautiful colours to appear² when it puts forth its blossoms.³ Likewise they have said that the fruit of their tree strives up to heaven, because out of the philosophic earth there arises a certain substance, like to the branches of a loathsome sponge.⁴ Whence they have put forward the opinion that the point about which the whole art turns lies in the living things of nature [*in vegetabilibus naturae*] and not in the living things of matter; and also because their stone contains within it soul, body, and spirit, as do living things. From a likeness not altogether remote they have called this material virgin's milk and blessed rose-coloured blood, although that belongs only to the prophets and sons of God. For this reason the Sophists have supposed that the philosophic matter consists of animal or human blood.

[381] Dorn then enumerates the substances with which "frivolous triflers" operate, such as urine, milk, eggs, hair, and various kinds of salts and metals. These "Sophists" take the symbolical names concretely and attempt to make the magistry out of the most unsuitable ingredients. They were obviously the chemists of those days, who, as a result of their concretistic misunderstanding, worked with common materials, whereas the philosophers called their stone animate because, at the final operations, by virtue of the power of this most noble fiery mystery, a dark red liquid, like blood, sweats out drop by drop from their material and their vessel. And for this reason they have prophesied that in the last days a most pure⁵ man, through whom the world will be freed, will come to earth and will sweat bloody drops of a rosy or red hue, whereby the world will be redeemed from its Fall. In like manner, too, the blood of their stone will free the leprous metals⁶ and also men from their diseases.⁷ Wherefore they have said, not without good reason, that their stone is animate [*animalem*]. Concerning this, Mercurius speaks as follows to King Calid, "To know this mystery is permitted only to the prophets of God,"⁸ and that is the reason why the stone is called animate. For in the blood of this stone is hidden its soul. It is also composed of body, spirit, and soul. For a like reason they have called it their microcosm, because it contains the similitude of all things of this world, and therefore again they say that it is animate, as Plato calls the macrocosm animate. But now the ignorant have come, who believe that the stone is threefold and is hidden in threefold kind [*genere*], namely vegetable, animal, and mineral, whence it has come to pass that they themselves have sought for it in minerals.⁹ But this teaching is far removed from the opinion of the Philosophers, who maintain that their stone is vegetable, animal, and mineral in one and the same form.

[382] This remarkable text explains the tree as a metaphorical form of the arcane substance, a living thing that comes into existence according to its own laws, and

grows, blossoms, and bears fruit like a plant. This plant is likened to the sponge, which grows in the depths of the sea and seems to have an affinity with the mandrake (n. 4). Dorn then makes a distinction between the “living things of nature” and those of matter. By the last-named are obviously meant concrete, material organisms. But it is not so clear what the former are meant to be. A sponge that bleeds and a mandrake that shrieks when pulled up are neither “vegetabilia materiae” nor are they found in nature, at least not in nature as we know it, though they may occur in that more comprehensive, Platonic nature as Dorn understood it, that is, in a nature that includes psychic “animalia,” i.e., mythologems and archetypes. Such are the mandrake and similar organisms. How concretely Dorn visualized them is a moot point. At any rate the “stone that is no stone, nor of the nature of stone” (n. 9) comes into this category.

7. THE ROSE-COLOURED BLOOD AND THE ROSE

[383] The mysterious rose-coloured blood occurs in several other authors. In Khunrath, for instance, the “lion lured forth from the Saturnine mountain” had rose-coloured blood.¹ This lion, signifying “all and conquering all,” corresponds to the $\pi\tilde{\alpha}\nu$ or $\pi\acute{\alpha}\nu\tau\alpha$ of Zosimos, i.e., totality. Khunrath further mentions (p. 276) the costly Catholick Rosy-Coloured Blood and Aetheric Water that flows forth Azothically² from the side of the innate Son of the Great World when opened by the power of the Art. Through the same alone, and by no other means, are Vegetable, Animal, and Mineral things, by the ablution of their impurities, raised to the highest Natural perfection, in accordance with Nature and by the Art.

[384] In the “Aquarium sapientum” the “son of the great world” (*filius macrocosmi*, the lapis) is correlated with Christ,³ who is the *filius microcosmi*, and his blood is the quintessence, the red tincture. This is the true and authentic duplex Mercurius or Giant⁴ of twofold substance....⁵ God by nature, man, hero, etc., who hath the celestial Spirit in him, which quickeneth all things . . . he is the sole and perfect Healer of all imperfect bodies and men, the true and heavenly physician of the soul . . . the triune universal essence,⁶ which is called Jehovah.⁷

[385] These panegyrics of the alchemists have often been regretted as examples of bad taste or ridiculed as exuberant fantasies—most unfairly, it seems to me. They were serious people, the alchemists, and they can be understood only when taken seriously, however hard this may hit our own prejudices. It was never their intention to exalt their stone into a world saviour, nor did they purposely smuggle into it a whole lot of known and unknown mythology any more than we do in our dreams. They simply found these qualities in their idea of a body composed of the four elements and capable of uniting all opposites, and were just as amazed at this discovery as anyone would be who had a singularly impressive dream and then came across an unknown

myth which fitted it exactly. No wonder, therefore, that they endowed the stone or the red tincture, which they really believed could be produced, with all the qualities they had discovered in their idea of such an object. This makes it easier for us to understand a statement that is entirely characteristic of the alchemical way of thinking. It occurs on the same page as the above quotation from “*Aquarium sapientum*” and runs:

Even as, I say, this earthly and philosophic stone, together with its material, has many different names, indeed it is said almost a thousand, for which reason it is also called wonderful, even so can these and other afore-mentioned names and titles be applied much more properly, and indeed in the highest degree, to Almighty God and the Supreme Good.

It obviously never occurred to the author, as we with our prejudiced view are quick to assume, that he had simply transferred God’s attributes to the stone.

[386] It is evident from this that the stone for the alchemists was nothing less than a primordial religious experience which, as good Christians, they had to reconcile with their beliefs. This accounts for that ambiguous identity or parallelism between Christ as the *filius microcosmi* and the *lapis philosophorum* as the *filius macrocosmi*, or even the substitution of the one for the other.

[387] The lapis-Christ parallel was presumably the bridge by which the mystique of the Rose entered into alchemy. This is evident first of all from the use of “Rosarium” or “Rosarius” (rose-gardener) as a book title. The first *Rosarium* (there are several), first printed in 1550, is for the greater part ascribed to Arnaldus de Villanova. It is a compilation whose historical components have not yet been sorted out. Arnaldus lived in the second half of the thirteenth century. He is also credited with the *Rosarium cum figuris*, where the rose is the symbol of relationship between king and queen. The reader will find a detailed account of this in my “Psychology of the Transference,” which reproduces the *Rosarium* illustrations.

[388] The rose has the same meaning in Mechthild of Magdeburg. The Lord spoke to her, saying: “Look at my heart, and see!” A most beautiful rose with five petals covered his whole breast, and the Lord said: “Praise me in my five senses, which are indicated by this rose.” As is explained later, the five senses are the vehicles of Christ’s love for man (e.g., “through the sense of smell he has always a certain loving affection directed towards man”).⁸

[389] In the spiritual sense the rose, like the *hortus aromatum* (garden of spices),⁹ *hortus conclusus*,¹⁰ and *rosa mystica*,¹¹ is an allegory of Mary, but in the worldly sense it is the beloved, the rose of the poets, the “fedeli d’amore” of that time. And just as Mary is allegorized in St. Bernard¹² as the *medium terrae* (centre of the earth), in Rabanus Maurus¹³ as the “city,” in Godfrey, Abbot of Admont, as the “fortress”¹⁴

and the “house of divine wisdom,”¹⁵ and in Alan of Lille as the *acies castrorum* (army with banners),¹⁶ so the rose has the significance of a mandala, as is clear from the heavenly rose in Dante’s *Paradiso*. Like its equivalent, the Indian lotus, the rose is decidedly feminine. In Mechthild of Magdeburg it must be understood as a projection of her own feminine Eros upon Christ.¹⁷

[390] It seems as though the rose-coloured blood of the alchemical redeemer¹⁸ was derived from a rose mysticism that penetrated into alchemy, and that, in the form of the red tincture, it expressed the healing or whole-making effect of a certain kind of Eros. The strange concretism of this symbol is explained by the total absence of psychological concepts. Dorn was therefore bound to understand the rose-coloured blood as a “*vegetabile naturae*,” in contrast to ordinary blood, which was a “*vegetabile materiae*.” As he says, the soul of the stone is in its blood. Since the stone represents the *homo totus*,¹⁹ it is only logical for Dorn to speak of the “*putissimus homo*” when discussing the arcane substance and its bloody sweat, for that is what it is all about. *He* is the arcanum, and the stone and its parallel or prefiguration is Christ in the garden of Gethsemane.²⁰ This “most pure” or “most true” man must be no other than what he is, just as “*argentum putum*” is unalloyed silver; he must be entirely man, a man who knows and possesses everything human and is not adulterated by any influence or admixture from without. This man will appear on earth only “in the last days.” He cannot be Christ, for Christ by his blood has already redeemed the world from the consequences of the Fall.²¹ Christ may be the “*purissimus homo*,” but he is not “*putissimus*.” Though he is man, he is also God, not pure silver but gold as *well*, and therefore not “*putus*.” On no account is it a question here of a future Christ and *salvator microcosmi*, but rather of the alchemical *servator cosmi* (preserver of the cosmos), representing the still unconscious idea of the whole and complete man, who shall bring about what the sacrificial death of Christ has obviously left unfinished, namely the deliverance of the world from evil. Like Christ he will sweat a redeeming blood, but, as a “*vegetabile naturae*,” it is “rose-coloured”; not natural or ordinary blood, but symbolic blood, a psychic substance, the manifestation of a certain kind of Eros which unifies the individual as well as the multitude in the sign of the rose and makes them whole, and is therefore a panacea and an alexipharmic.

[391] The second half of the sixteenth century saw the beginning of the Rosicrucian movement, whose motto—*per crucem ad rosam*—was anticipated by the alchemists. Goethe caught the mood of this Eros very well in his poem “*Die Geheimnisse*.” Such movements, as also the emergence of the idea of Christian charity with its emotional overtones,²² are always indicative of a corresponding social defect which they serve to compensate. In the perspective of history, we can see clearly enough what this defect was in the ancient world; and in the Middle Ages as well, with its cruel and

unreliable laws and feudal conditions, human rights and human dignity were in a sorry plight. One would think that in these circumstances Christian love would be very much to the point. But what if it is blind and without insight? Solicitude for the spiritual welfare of the erring sheep can explain even a Torquemada. Love alone is useless if it does not also have understanding. And for the proper use of understanding a wider consciousness is needed, and a higher standpoint to enlarge one's horizon. That is why Christianity as a historical force has not rested content with admonishing man to love his neighbour, but has also performed a higher cultural task which it is impossible to overestimate. It has educated man to a higher consciousness and responsibility. Certainly love is needed for that, but a love combined with insight and understanding. Their function is to illuminate regions that are still dark and to add them to consciousness—regions in the outside world as well as those within, in the interior world of the psyche. The blinder love is, the more it is instinctual, and the more it is attended by destructive consequences, for it is a dynamism that needs form and direction. Therefore a compensatory Logos has been joined to it as a light that shines in the darkness. A man who is unconscious of himself acts in a blind, instinctive way and is in addition fooled by all the illusions that arise when he sees everything that he is not conscious of in himself coming to meet him from outside as projections upon his neighbour.

8. THE ALCHEMICAL MIND

[392] The alchemists seem to have had an inkling of this state of mind; at any rate it got mixed up with their opus. Already in the fourteenth century they had discovered that what they were searching for reminded them not only of all manner of mysterious substances, remedies, and poisons, but of various living things, plants and animals, and, finally, of some strange mythological figure, a dwarf, earth-spirit or metal-spirit, or even of something like a God-man. Thus in the first half of the fourteenth century, Petrus Bonus of Ferrara wrote that in a certain letter Rhazes had said:

With this red stone the philosophers exalted themselves above all others and foretold the future. They prophesied not only in general but also in particular. Thus they knew that the day of judgment and the end of the world must come, and the resurrection of the dead, when each soul will be united with its former body and will no more be separated from it for ever. Then each glorified body will be changed, possess incorruptibility and brightness, and an almost unbelievable subtlety, and it will penetrate all solids,¹ because its nature will then be of the nature of spirit as well as body. . . . It is a nature which, when it is moistened and left for many nights in that condition, is like a dead man, and then that thing needs the fire, until the spirit of that body is extracted and left to stand through the nights, and falls to dust like a man in his grave. And when all this has happened, God will give it back its soul and its body,

and take away its imperfection; then will that thing be strengthened and improved, as after the resurrection a man becomes stronger and younger than he was in this world. . . . Thus the philosophers have beheld the Last Judgment in this art, namely the germination and birth of this stone, which is miraculous rather than rational; for on that day the soul to be beatified unites with its former body through the mediation of the spirit, to eternal glory. . . . So also the old philosophers of this art knew and maintained that a virgin must conceive and bring forth, because in their art the stone conceives of itself, becomes pregnant, and brings itself forth. . . . And because they beheld the miraculous conception, pregnancy, birth, and nourishment of this stone, they concluded that a woman who is a virgin will conceive without a man, become pregnant and give birth in miraculous wise, and remain a virgin as before. . . . As Alphidius says, this stone is cast out into the streets, is lifted up into the clouds, dwells in the air, feeds in the streams and rests on the tops of the mountains. Its mother is a virgin, its father knows not woman. . . . The philosophers also knew that God must become man on the last day of this art, whereon is the fulfilment of the work; begetter and begotten become altogether one; old man and boy, father and son, become altogether one; thus all old things are made new.² God himself has entrusted this magistry to his philosophers and prophets, for whose souls he has prepared a dwelling place in his paradise.³

[393] As this text makes very plain, Petrus Bonus discovered that the alchemical opus anticipated, feature for feature, the sacred myth of the generation, birth, and resurrection of the Redeemer, for he was quite convinced that the ancient authorities of the art, Hermes Trismegistus, Moses, Plato, and others knew the whole process long ago and consequently had prophetically anticipated the coming salvation in Christ. He was not in any way conscious that the situation might be the reverse and that the alchemists were drawing on ecclesiastical tradition and subsequently approximated their operations to the sacred legend. The degree of his unconsciousness is more than merely astonishing: it is instructive. This extraordinary blindness shows us that there must have been an equally powerful motive behind it. Bonus was not the only one to make this declaration, though he was the first; in the next three hundred years it became increasingly widespread and caused offence. Bonus was an erudite scholastic and, quite apart from his religious beliefs, was intellectually well in a position to recognize his error. But what impelled him to this view was the fact that he was indeed drawing on a source more ancient than ecclesiastical tradition: when contemplating the chemical changes that took place during the opus, his mind became suffused with archetypal, mythological parallels and interpretations, just as had happened to the old pagan alchemists, and as still happens today when the imagination is given free play in the observation and investigation of the products of the unconscious. Under these conditions forms of

thought emerge in which one can afterwards discover parallels with mythological motifs, including Christian ones; parallels and similarities which perhaps one would never have suspected at first sight. So it was with the old adepts who, not knowing anything about the nature of chemical substances, reeled from one perplexity to the next: willy-nilly they had to submit to the overwhelming power of the numinous ideas that crowded into the empty darkness of their minds. From these depths a light gradually dawned upon them as to the nature of the process and its goal. Because they were ignorant of the laws of matter, its behaviour did not do anything to contradict their archetypal conception of it. Occasionally they made chemical discoveries in passing, as was only to be expected; but what they really discovered, and what was an endless source of fascination to them, was the symbolism of the individuation process.

[394] Petrus Bonus could not but recognize that the alchemical symbols which had been discovered in an entirely different way agreed in a remarkable manner with those of the Christian story of salvation. In their efforts to fathom the secrets of matter the alchemists had unexpectedly blundered into the unconscious, and thus, without at first being aware of it, they became the discoverers of a process which underlies Christian symbolism among others. It did not take more than a couple of centuries for the more reflective among them to realize what the quest for the stone was actually about. Hesitantly at first, hint by hint, and then with unmistakable clarity, the stone revealed to them its identity with man himself, with a supraordinate factor that could actually be found within him, with Dorn's "quid," which today can be identified without difficulty with the self, as I have shown elsewhere.⁴

[395] In their various ways, the alchemists struggled to come to terms with the lapis-Christ parallel. They did not find a solution, nor was this possible so long as their conceptual language was not freed from projection into matter and did not become psychological. Only in the following centuries, with the growth of natural science, was the projection withdrawn from matter and entirely abolished together with the psyche. This development of consciousness has still not reached its end. Nobody, it is true, any longer endows matter with mythological properties. This form of projection has become obsolete. Projection is now confined to personal and social relationships, to political Utopias and suchlike. Nature has nothing more to fear in the shape of mythological interpretations, but the realm of the spirit certainly has, more particularly that realm which commonly goes by the name of "metaphysics." There mythologems claiming to utter the absolute truth still tumble over one another, and anyone who dresses up his mythologem in solemn enough words believes that he has made a valid statement, and even makes a virtue of not possessing the modesty becoming to our limited human intelligence, which knows that it does not know. Such people even think that God himself is menaced whenever anyone dares to

interpret their archetypal projections for what they are, namely, human statements, which no reasonable person supposes signify nothing, seeing that even the most preposterous statements of the alchemists have their meaning, though not the one which they themselves, with but few exceptions, sought to give their symbols, but one which only the future could formulate. Whenever we have to do with mythologems it is advisable to assume that they mean more than what they appear to say. Just as dreams do not conceal something already known, or express it under a disguise, but try rather to formulate an as yet unconscious fact as clearly as possible, so myths and alchemical symbols are not euhemeristic allegories that hide artificial secrets. On the contrary, they seek to translate natural secrets into the language of consciousness and to declare the truth that is the common property of mankind. By becoming conscious, the individual is threatened more and more with isolation, which is nevertheless the *sine qua non* of conscious differentiation. The greater this threat, the more it is compensated by the production of collective and archetypal symbols which are common to all men.

[396] This fact is expressed in a general way by the religions, where the relation of the individual to God or the gods ensures that the vital link with the regulating images and instinctual powers of the unconscious is not broken. Naturally this is true only so long as the religious ideas have not lost their numinosity, i.e., their thrilling power. Once this loss has occurred, it can never be replaced by anything rational. Compensating primordial images then appear in the form of mythological ideas such as alchemy produced in abundance and as may also be found in our own dreams. In both cases, consciousness reacts to these revelations in the same characteristic way: the alchemist reduced his symbols to the chemical substances he worked with, while the modern man reduces them to personal experiences, as Freud also does in his interpretation of dreams. Both of them act as though they knew to what known quantities the meaning of their symbols could be reduced. And both, in a sense, are right: for just as the alchemist was caught in his own alchemical dream language, so modern man, caught in the toils of egohood, uses his personal psychological problems as a *façon de parler*. In both cases the representational material is derived from already existing conscious contents. The result of this reduction, however, is not very satisfactory—so little, in fact, that Freud saw himself obliged to go back as far as possible into the past. In so doing he finally hit upon an uncommonly numinous idea, the archetype of incest. He thus found something that to some extent expressed the real meaning and purpose of symbol production, which is to bring about an awareness of those primordial images that belong to all men and can therefore lead the individual out of his isolation. Freud's dogmatic rigidity is explained by the fact that he succumbed to the numinous effect of the primordial image he had discovered. If we assume with him that the incest motif is the source of all modern man's

psychological problems as well as of alchemical symbolism, this gets us nowhere as regards the *meaning* of the symbols. On the contrary, we have landed ourselves in a blind alley, for we shall only be able to say that all symbolism, present and future, derives from the primal incest. That is what Freud actually thought, for he once said to me: “I only wonder what neurotics will do in the future when it is generally known what their symbols mean.”

[397] Luckily for us, symbols mean very much more than can be known at first glance. Their meaning resides in the fact that they compensate an unadapted attitude of consciousness, an attitude that does not fulfil its purpose, and that they would enable it to do this if they were understood.⁵ But it becomes impossible to interpret their meaning if they are reduced to something else. That is why some of the later alchemists, particularly in the sixteenth century, abhorred all vulgar substances and replaced them by “symbolic” ones which allowed the nature of the archetype to glimmer through. This does not mean that the adept ceased to work in the laboratory, only that he kept an eye on the symbolic aspect of his transmutations. This corresponds exactly to the situation in the modern psychology of the unconscious: while personal problems are not overlooked (the patient himself takes very good care of that!), the analyst keeps an eye on their symbolic aspects, for healing comes only from what leads the patient beyond himself and beyond his entanglement in the ego.

9. VARIOUS ASPECTS OF THE TREE

[398] What the tree meant to the alchemists cannot be ascertained either from a single interpretation or from a single text. In order to discover this, a great many sources must be compared. We shall therefore turn to further statements about the tree. Pictures of the tree are often given in the medieval texts. Some of them are reproduced in *Psychology and Alchemy*. Sometimes the prototype is the tree of paradise, hung not with apples but with sun-and-moon fruit, like the trees in the treatise of Michael Maier in the *Musaeum hermeticum*,¹ or else it is a sort of Christmas tree, adorned with the seven planets and surrounded by allegories of the seven phases of the alchemical process. Standing beneath the tree are not Adam and Eve but Hermes Trismegistus as an old man and the adept as a youth. Behind Hermes Trismegistus is King Sol sitting on a lion accompanied by a fire-spitting dragon, and behind the adept is the moon goddess Diana sitting on a whale accompanied by an eagle.² The tree is generally in leaf and living, but sometimes it is quite abstract and expressly stands for the phases of the process.³

[399] In the Ripley *Scrowle*⁴ the serpent of paradise dwells in the top of the tree in the shape of Melusina—“desinit in [anguem] mulier formosa superne.”⁵ This is combined with a motif that is not in the least Biblical but is primitive and shamanistic: a man, presumably the adept, is halfway up the tree and meets Melusina,

or Lilith, coming down from above. The climbing of the magical tree is the heavenly journey of the shaman, during which he encounters his heavenly spouse. In medieval Christianity the shamanistic anima was transformed into Lilith,⁶ who according to tradition was the serpent of paradise and Adam's first wife, with whom he begot a horde of demons. In this picture primitive traditions cross with Judaeo-Christian ones. I have never come across the climbing of the tree in the pictures done by my patients, and have met it only as a dream motif. The motif of ascent and descent occurs in modern dreams chiefly in connection with a mountain or a building, or sometimes a machine (lift, aeroplane, etc.).

[400] The motif of the leafless or dead tree is not common in alchemy, but is found in Judaeo-Christian tradition as the tree of paradise that died after the Fall. An old English legend⁷ reports what Seth saw in the Garden of Eden. In the midst of paradise there rose a shining fountain, from which four streams flowed, watering the whole world. Over the fountain stood a great tree with many branches and twigs, but it looked like an old tree, for it had no bark and no leaves. Seth knew that this was the tree of whose fruit his parents had eaten, for which reason it now stood bare. Looking more closely, Seth saw that a naked snake without a skin⁸ had coiled itself round the tree. It was the serpent by whom Eve had been persuaded to eat of the forbidden fruit. When Seth took a second look at paradise he saw that the tree had undergone a great change. It was now covered with bark and leaves, and in its crown lay a little newborn babe wrapped in swaddling clothes, that wailed because of Adam's sin. This was Christ, the second Adam. He is found in the top of the tree that grows out of Adam's body in representations of Christ's genealogy.

[401] Another alchemical motif is the truncated tree. In the frontispiece to the French edition (1600) of Francesco Colonna's *Hypnerotomachia Poliphili* (Venice, 1499), it forms the counterpart to the lion with cut-off paws,⁹ which appears as an alchemical motif in Reusner's *Pandora* (1588). Blaise de Vigenère (1523–?1569), who was influenced by the Cabala, speaks of the "caudex arboris mortis" (trunk of the tree of death) that sent out a red death-ray.¹⁰ "Tree of death" is synonymous with "coffin." The strange recipe, "Take the tree and place in it a man of great age,"¹¹ should probably be understood in this sense. This motif is a very ancient one, and occurs in the ancient Egyptian tale of Bata, preserved in a papyrus of the nineteenth dynasty. There the hero placed his soul on the topmost blossom of an acacia-tree. When the tree was cut down with treacherous intent, his soul was found again in the form of a seed. With this the dead Bata was restored to life. When he was killed a second time in the form of a bull, two persea trees grew out of the blood. But when these were cut down, a chip of the wood fertilized the queen, who bore a son: he was the reborn Bata, who then became Pharaoh, a divine being. It is evident that the tree here is an instrument of transformation.¹² Vigenère's "caudex" is similar to the truncated tree in

Poliphilo. This image probably goes back to Cassiodorus, who allegorizes Christ as a “tree cut down in his passion.”¹³

[402] More frequently the tree appears bearing flowers and fruit. The Arabian alchemist Abu'l Qēsīm (13th cent.) describes its four kinds of blossoms as red, midway between white and black, black, and midway between white and yellow.¹⁴ The four colours refer to the four elements that are combined in the opus. The quaternity as a symbol of wholeness means that the goal of the opus is the production of an all-embracing unity. The motif of the double quaternity, the ogdoad, is associated in shamanism with the world-tree: the cosmic tree with eight branches was planted simultaneously with the creation of the first shaman. The eight branches correspond to the eight great gods.¹⁵

[403] The *Turba* has much to say about the fruit-bearing tree.¹⁶ Its fruits are of a special kind. The “Visio Arislei” speaks of “this most precious tree, of whose fruit he who eats shall never hunger.”¹⁷ The parallel to this in the *Turba* runs: “I say that that old man does not cease to eat of the fruits of that tree . . . until that old man becomes a youth.”¹⁸ These fruits are here equated with the bread of life in John 6 : 35, but they go back beyond that to the Ethiopic Book of Enoch (second century B.C.), where it is said that the fruits of the tree in the Western Land will be the food of the elect.¹⁹ This is a clear hint of death and renewal. It is not always the fruit of the tree, but of the *granum frumenti*, the grain of wheat, from which the food of immortality is prepared, as in *Aurora consurgens* I: “For from the fruits of this grain is made the food of life, which cometh down from heaven.”²⁰ Manna, Host, and panacea form here an unfathomable mixture. The same idea of a miraculous spiritual food is mentioned in the Arisleus vision. There it is said that Harforetus (Harpokrates), a “disciple of Pythagoras” and the “author of nourishment,” came to the help of Arisleus and his companions, evidently with the fruits of the tree that are mentioned in Ruska’s edition of Berlin Codex Q. 584.²¹ In the Book of Enoch the fruits of the tree of wisdom are likened to grapes, and this is of interest inasmuch as in the Middle Ages the philosophical tree was sometimes called a vine,²² with reference to John 15 : 1, “I am the true vine.” The fruits and seeds of the tree were also called sun and moon,²³ to which the two trees of paradise corresponded.²⁴ The sun-and-moon fruits presumably go back to Deuteronomy 33 : 13f. (DV): “[Blessed] of the Lord be his land . . . [for] the fruits brought forth by the sun and by the moon . . .²⁵ and [for] the fruits of the everlasting hills.” Laurentius Ventura²⁶ says: “Sweet of smell is this apple, rich in colour this little apple,” and pseudo-Aristotle says in his “Tractatus ad Alexandrum Magnum”:²⁷ “Gather the fruits, for the fruit of this tree has led us into the darkness and through the darkness.” This ambiguous advice evidently alludes to a knowledge which was not on the best of terms with the prevailing world-view.

[404] Benedictus Figulus calls the fruit “the golden apple of the Hesperides, to be pluck’t from the blest philosophic tree,”²⁸ the tree representing the opus and the fruit its results, i.e., the gold of which it is said: “Our gold is not the common gold.”²⁹ A special light is thrown on the meaning of the fruit by a saying in “Gloria mundi”: “Take the fire, or quicklime, of which the philosophers speak, which grows on trees, for in that [fire] God himself burns with divine love.”³⁰ God himself dwells in the fiery glow of the sun and appears as the fruit of the philosophical tree and thus as the product of the opus, whose course is symbolized by the growth of the tree. This remarkable saying loses its strangeness if we remember that the goal of the opus was to deliver the *anima mundi*, the world-creating spirit of God, from the chains of Physis. Here this idea has activated the archetype of the tree-birth, which is known to us chiefly from the Egyptian and Mithraic spheres of culture. A conception prevalent in shamanism is that the ruler of the world lives in the top of the world-tree,³¹ and the Christian representation of the Redeemer at the top of his genealogical tree might be taken as a parallel. In [Figure 27](#), the woman’s head rising “like the pistil of a flower” might be compared with the Mithras relief from Osterburken (Germany).³²

[405] Sometimes the tree is small and young, something like the “grani tritici arbuscula” (little trees of wheat grains),³³ sometimes large and old, taking the form of an oak³⁴ or the world-tree, in so far as it bears the sun and moon as its fruits.

10. THE HABITAT OF THE TREE

[406] The philosophical tree usually grows alone and, according to Abu’l Qēsim, “on the sea” in the Western Land, which presumably means on an island. The secret moon-plant of the adepts is “like a tree planted in the sea.”¹ In a parable in Mylius² the sun-and-moon tree stands on an island in the sea and grows out of the wonderful water that is extracted by the power of the magnet from the rays of the sun and moon. Khunrath says: “From this little salty fountain grows also the tree of the sun and moon, the red and white coral tree of our sea.”³ Salt and sea-water signify in Khunrath among other things the maternal Sophia from whose breasts the *filii Sapientiae*, the philosophers, drink. Abu’l Qēsim might well have been acquainted with Persian traditions (his surname al-Iraqi also brings him geographically nearer to Persia), and more particularly with the legend of the tree in the Bundahish that grows in the sea named Vourukasha, or of the tree of life that grows in the fountain of Ardvī Sūra Anēhita.⁴

[407] The tree (or wonderful plant) also has its habitat on the mountains. Since the imagery of the Book of Enoch was often taken as a model, it should be mentioned that there the tree in the Western Land stood on a mountain.⁵ In the “Practica Mariae Prophetissae”⁶ the wonderful plant is described as “growing on hills.” The Arabic treatise of Ostanēs in the “Kitâb el Foçul”⁷ says: “It is a tree that grows on the tops of

mountains.” The relation of tree to mountain is not accidental, but is due to the original and widespread identity between them: both are used by the shaman for the purpose of his heavenly journey.⁸ Mountain and tree are symbols of the personality and of the self, as I have shown elsewhere; Christ, for instance, is symbolized by the mountain⁹ as well as by the tree.¹⁰ Often the tree stands in a garden, as an obvious reminder of Genesis. Thus the trees of the seven planets grow in the “private garden” of the blessed isles.¹¹ In Nicolas Flamel (1330?–?1418) the “most highly praised tree” grows in the garden of the philosophers.¹²

[408] As we have seen, the tree has a special connection with water, salt, and seawater, and thus with the *aqua permanens*, the true arcanum of the adepts. This as we know is Mercurius, who is not to be confused with Hg, the *mercurius crudus sive vulgaris*.¹³ Mercurius is the tree of the metals.¹⁴ He is the prima materia,¹⁵ or else its source.¹⁶ The god Hermes (= Mercurius) “watered his tree with that water, and with his glass made the flowers grow high.”¹⁷ I cite this passage because it expresses the subtle alchemical idea that the artifex and the arcanum are one and the same. The water that makes the tree grow but also consumes it¹⁸ is Mercurius, who is called “duplex” because he unites the opposites in himself, being both a metal and a liquid. Hence he is called both water and fire. As the sap of the tree he is therefore also fiery (cf. Fig. 15), that is to say the tree is of a watery and a fiery nature. In Gnosticism we encounter the “great tree” of Simon Magus, which consists of “supracelestial fire.” “From it all flesh is fed.”¹⁹ It is a tree like the one that appeared to Nebuchadnezzar in a dream. Its branches and leaves are consumed, but “the fruit, when it is ready formed and has received its shape, is brought into a barn and not cast into the fire.”²⁰ This image of the “supracelestial fire” accords on the one hand with the much earlier “ever-living fire” of Heraclitus, and on the other with the much later interpretation of Mercurius as fire and as the *spiritus vegetativus* that pervades the whole of nature, both animating and destructive. The fruit that is “not cast into the fire” is naturally the man who has stood the test, the “pneumatic” man of the Gnostics. One of the synonyms for the lapis, which likewise signifies the inner, integrated man, is “frumentum nostrum” (our grain).²¹

[409] The tree is often represented as metallic,²² usually golden.²³ Its connection with the seven metals implies a connection with the seven planets, so that the tree becomes the world-tree, whose shining fruits are the stars. Michael Maier attributes the woody parts to Mercurius, the (fourfold) flowers to Saturn, Jupiter, Venus, and Mars, and the fruits to Sol and Luna.²⁴ The tree with seven branches (= seven planets) is mentioned in *Aurora consurgens* II²⁵ and identified with the Lunatica or Berissa,²⁶ “whose root is the metallic earth, its trunk red tinged with a certain blackness; its leaves are like the leaves of Marjoram, and are thirty in number according to the age of the moon in its waxing and waning; its flower is yellow.” It is clear from this

description that the tree symbolizes the whole opus. Accordingly Dorn says:²⁷ “Let therefore the tree [of the planets or metals] be planted and its root be ascribed to Saturn, and let that inconstant Mercurius and Venus, arising in the trunk and branches, offer to Mars²⁸ the leaves and fruit-bearing flowers.” The relation to the world-tree is also apparent when Dorn says that “nature has planted the root of the [metallic] tree in the midst of her womb.”²⁹

11. THE INVERTED TREE

[410] The tree is frequently called the “inverted tree” (*arbor inversa*).¹ Laurentius Ventura (16th cent.) says: “The roots of its ores are in the air and the summits in the earth. And when they are torn from their places, a terrible sound is heard and there follows a great fear.”² Ventura is obviously thinking of the mandrake, which, when tied to the tail of a black dog, shrieks when it is torn out of the earth. The “Gloria mundi” likewise mentions that the philosophers had said that “the root of its minerals is in the air and its head in the earth.”³ Sir George Ripley says that the tree has its roots in the air and, elsewhere, that it is rooted in the “glorified earth,” in the earth of paradise or in the future world.

[411] Similarly, Vigenère states that a “Rabbi, the son of Josephus Carnitolus,” had said: “The foundation of every lower structure is affixed above and its summit is here below, like an inverted tree.”⁴ Vigenère had some knowledge of the Cabala and is here comparing the philosophical tree with the tree of the Sefiroth, which is actually a mystical world-tree. But for him this tree also signifies man. He substantiates the singular idea that man is implanted in paradise by the roots of his hair with a reference to Song of Songs 7 : 5 (DV): “Thy head is like Carmel, and the hairs of thy head as the purple of the king bound in the channels” (... *comae capitis tui sicut purpura Regis vincta*⁵ *canalibus*). The “canales” are little tubes, perhaps some kind of head ornament.⁶ Knorr von Rosenroth is of the opinion that the “great tree” refers to Tifereth, the bridegroom of Malchuth.⁷ The upper Sefira Binah is named the “root of the tree,”⁸ and in Binah is rooted the tree of life. Because this stood in the middle of the garden, it was called the *linea media* (middle line). Through this middle line, which was as it were the trunk of the Sefiroth system, it brought life down to earth from Binah.⁹

[412] The idea that man is an inverted tree seems to have been current in the Middle Ages. The humanist Andrea Alciati (d. 1550) says in his *Emblemata cum commentariis*: “It pleased the Physicists to see man as a tree standing upside down, for what in the one is the root, trunk, and leaves, in the other is the head and the rest of the body with the arms and feet.”¹⁰ The link with Indian conceptions is provided by Plato.¹¹ Krishna says in the Bhagavadgītē (ch. 15): “I am the Himalaya among

mountains and the *ashvattha* among trees.” The *ashvattha* (*Ficus religiosa*) pours down from above the drink of immortality, soma.¹² The Bhagavadgītē continues:

There is a fig tree
In ancient story,
The giant Ashvattha,
The everlasting,
Rooted in heaven,
Its branches earthward;
Each of its leaves
Is a song of the Vedas,
And he who knows it
Knows all the Vedas.

Downward and upward
Its branches bending
Are fed by the gunas,
The buds it puts forth
Are the things of the senses,
Roots it has also
Reaching downward
Into this world,
The roots of man’s action.¹³

[413] The alchemical illustrations showing the opus as a tree and its phases as the leaves¹⁴ are very reminiscent of the Indian conception of deliverance through the Veda, i.e., through knowledge. In Hindu literature the tree grows from above downwards, whereas in alchemy (at least according to the pictures) it grows from below upwards. In the illustrations to the *Pretiosa margarita novella* of 1546,¹⁵ it looks very like an asparagus plant. [Figure 27](#) in my picture series contains the same motif, and indeed the upthrusting stalks of asparagus are a graphic representation of the way previously unconscious contents push into consciousness. In East and West alike, the tree symbolizes a living process as well as a process of enlightenment, which, though it may be grasped by the intellect, should not be confused with it.

[414] The tree as guardian of the treasure appears in the alchemical fairytale of “The Spirit in the Bottle.” As it contains the treasure which appears in its fruit, the tree is a symbol of the *chrysopoea* (goldmaking) or *ars aurifera* in general, in accordance

with the principle laid down by “Hercules”:¹⁶ “This magistry arises in the beginning from one root, which afterwards expands into several substances and then returns to the one.”¹⁷ Ripley likens the artifex to Noah cultivating the vine,¹⁸ in Djēbir the tree is the “mystic myrtle,”¹⁹ and in Hermes the “vine of the wise.”²⁰ Hoghelande says: “But the fruits go forth from the most perfect tree in early spring and flower at the beginning of the end.”²¹ It is clear from this that the life of the tree represents the opus, which as we know coincides with the seasons.²² The fact that the fruits appear in the spring and the flowers in the autumn may be connected with the motif of reversal (*arbor inversa!*) and the *opus contra naturam*. The “Allegoriae sapientum supra librum Turbae” give the following recipe: “Again, plant this tree on the stone, that it fear not the buffetings of the winds; that the birds of heaven may come and multiply on its branches, for thence cometh wisdom.”²³ Here too the tree is the true foundation and arcanum of the opus. This arcanum is the much-praised *thesaurus thesaurorum*. Just as the tree of the metals has seven branches, so also has the tree of contemplation, as a treatise entitled “De arbore contemplationis” shows.²⁴ There the tree is a palm with seven branches and on each branch sits a bird: “pavo, [illegible word], cignus, [h]arpia, filomena, hyrundo, fenix,” and on each a flower: “viola, gladiola, lilium, rosa, crocus, solsequium, flos [... ?],” all of which have a moral significance. These ideas are very much like those of the alchemists. They contemplated their tree in the retort, where, according to the *Chymical Wedding*, it was held in the hand of an angel.²⁵

12. BIRD AND SNAKE

[415] Birds, as I have said, have a special relation to the tree. The “Scriptum Alberti” says that Alexander, on his great journey, found a tree which had its “glorious greenness” (*viriditas gloriosa*) within. On this tree sat a stork, and there Alexander built a golden palace to “set a fitting end to his travels.”¹ The tree with the bird stands for the opus and its consummation. The motif also appears in picture form.² The fact that the leaves of the tree (the *viriditas gloriosa*) grew inwards is another instance of the *opus contra naturam* and at the same time a concrete expression of introversion in the contemplative state.

[416] The snake, too, with obvious reference to the Bible story, is connected with the tree, first of all in a general way since it is properly speaking the mercurial serpent which, as the chthonic *spiritus vegetativus*, rises from the roots into the branches, and then more specifically because it represents the tree-numen and appears as Melusina.³ The mercurial serpent is the arcane substance that transforms itself inside the tree and thus constitutes its life. This is substantiated by the “Scriptum Alberti.” The text is probably a commentary on a picture which unfortunately is not given in the edition of 1602. It begins with the statement: “This is a picture of heaven, which is named the

heavenly sphere, and contains eight most noble figures, viz., the first figure, which is named the first circle and is the circle of the Deity,” etc.⁴ It is clear from this that it was a picture of concentric circles. The first, outermost, circle contains the “*verba divinitatis*,” the divine world order; the second the seven planets; the third the “corruptible” and “creative” elements (*generabilia*); the fourth a raging dragon issuing from the seven planets; the fifth “the head and the death” of the dragon. The head of the dragon “lives in eternity,” is named the “*vita gloriosa*,” and “the angels serve it.” The *caput draconis* is here obviously identified with Christ, for the words “the angels serve it” refer to Matthew 4 : 11, where Christ has just repudiated Satan. But if the dragon’s head is identified with Christ, then the dragon’s tail must be identical with Antichrist or the devil. According to our text the whole of the dragon’s body is absorbed by the head, so that the devil is integrated with Christ. For the dragon fought against the *imago Dei*, but by the power of God it was implanted in the dragon and formed its head: “The whole body obeys the head, and the head hates the body, and slays it beginning from the tail, gnawing it with its teeth, until the whole body enters into the head and remains there for ever.”⁵ The sixth circle contains six figures and two birds, namely storks. The figures are presumably human, for the text says one of them looked like an Ethiopian.⁶ It appears that the stork is a *vas circulatorium* (a vessel for circular distillation), like the Pelican.⁷ Each of the six figures represents three phases of transformation and together with the two birds they form an ogdoad as a symbol of the transformation process. The seventh circle, says the text, shows the relation of the “*verba divinitatis*” and the seven planets to the eighth circle, which contains the golden tree. The author states he would rather keep quiet about the content of the seventh circle, because this is where the great secret begins, which can be revealed only by God himself. Here is found the stone which the king wears in his crown. “Wise women hide it, foolish virgins show it in public, because they wish to be plundered.” “Popes, certain priests, and monks revile it, because it was so commanded of them by God’s law.”

[417] The golden tree in the eighth circle shines “like lightning.” Lightning in alchemy, as in Jakob Böhme, signifies sudden rapture and illumination.⁸ On the tree sits a stork. Whereas the two storks in the sixth circle represent the distilling apparatus for two transformations of three phases each, the stork sitting on the golden tree has a far wider significance. Since ancient times it was held to be the “*pia avis*” (devout bird), and appears as such in Haggadic tradition,⁹ despite being listed among the unclean beasts in Leviticus 11 : 19. Its piety may go back to Jeremiah 8 : 7: “Yea, the stork in the heaven knoweth her appointed times . . . but my people know not the judgment of the Lord.” In imperial Rome the stork was an allegory of piety, and in Christian tradition it is an allegory of Christ the judge, because it destroys snakes. Just as the snake or dragon is the chthonic numen of the tree, so the stork is its spiritual principle

and thus a symbol of the Anthropos.¹⁰ Among the forerunners of the alchemical stork must be counted the stork Adebar in Teutonic mythology, which brings back to earth the souls of the dead that were renewed in the fountain of Hulda.¹¹ The attribution of the “Scriptum” to Albertus Magnus is highly questionable. To judge by its style, its discussion of the philosophical tree can hardly be dated earlier than the sixteenth century.

13. THE FEMININE TREE-NUMEN

[418] As the seat of transformation and renewal, the tree has a feminine and maternal significance. We have seen from Ripley’s *Scrowle* that the tree-numen is Melusina. In *Pandora* the trunk of the tree is a crowned, naked woman holding a torch in each hand, with an eagle sitting in the branches on her head,¹ On Hellenistic monuments Isis has the form of Melusina and one of her attributes is the torch. Other attributes are the vine and the palm. Leto and Mary² both gave birth under a palm, and Maya at the birth of the Buddha was shaded by the holy tree. Adam, “so the Hebrews say,” was created out of the “earth of the tree of life,” the “red Damascene earth.”³ According to this legend, Adam stood in the same relation to the tree of life as Buddha to the Bodhi tree.

[419] The feminine-maternal nature of the tree appears also in its relation to Sapientia. The tree of knowledge in Genesis is in the Book of Enoch the tree of wisdom, whose fruit resembles the grape.⁴ In the teachings of the Barbeliots, reports Irenaeus,⁵ the Autogenes finally created “the man perfect and true, whom they also called Adamas.” With him was created perfect knowledge: “From [the perfect] man and gnosis is born the tree, which they also call gnosis.”⁶ Here we find the same connection of man with the tree as in the case of Adam and the Buddha. A similar connection is found in the *Acta Archelai*: “But that tree which is in paradise, whereby the good is known, is Jesus and the knowledge of him which is in the world.”⁷ “For thence [i.e., from the tree] cometh wisdom,” says the “*Allegoriae sapientum*.”⁸

[420] Similar ideas of the tree are found in alchemy. We have already met the conception of man as an inverted tree, a view found also in the Cabala. The *Pirke de Rabbi Eliezer*⁹ says: “R. Zehira said, ‘Of the fruit of the tree’—here ‘tree’ only means man, who is compared to the tree, as it is said, ‘For man is the tree of the field’ (Deuteronomy 20 : 19).” In the gnosis of Justin the trees in the Garden of Eden are angels, while the tree of knowledge of good and evil is the third of the motherly angels, the Naas.¹⁰ This division of the tree-soul into a masculine and a feminine figure corresponds to the alchemical Mercurius as the life principle of the tree, for as an hermaphrodite he is duplex.¹¹ The picture in *Pandora*, where the tree trunk is a woman’s body, refers to Mercurius in his feminine role of wisdom, who in his

masculine aspect is symbolized by the figure of Mercurius Senex or Hermes Trismegistus.

14. THE TREE AS THE LAPIS

[421] Just as the tree and man are central symbols in alchemy, so also is the lapis in its double significance as the prima and ultima materia. The above-mentioned quotation from the “Allegoriae sapientum”—“Plant this tree on the stone, that it fear not the buffetings of the winds”—seems to be an allusion to the parable of the house that was built on sand and fell when the floods came and the winds blew (Matthew 7 : 26-27). The stone might therefore mean simply the sure foundation afforded by the right prima materia. But the context points to the symbolic significance of the stone, as the preceding sentence makes clear: “Take wisdom with all thy power, for from it thou shalt drink eternal life, until thy [stone] is congealed and thy sluggishness depart, for thence cometh life.”¹

[422] “The prima materia is an oily water and is the philosophic stone, from which branches multiply into infinity,” says Mylius.² Here the stone is itself the tree and is understood as the “fiery substance” (the *ὕγρὰ οὐσία* of the Gnostics) or as the “oily water.” As water and oil do not mix, this represents the double or contrary nature of Mercurius.

[423] Similarly the “Consilium coniugii,” commenting on Senior, says: “Thus the stone is perfected of and in itself. For it is the tree whose branches, leaves, flowers, and fruits come from it and through it and for it, and it is itself whole or the whole [*tota vel totum*] and nothing else.”³ Hence the tree is identical with the stone and, like it, a symbol of wholeness. Khunrath says:

Of itself, from, in, and through itself is made and perfected the stone of the wise. For it is one thing only: like a tree (says Senior), whose roots, stem, branches, twigs, leaves, flowers, and fruit are of it and through it and from it and on it, and all come from one seed. It is itself everything, and nothing else makes it.⁴

[424] In the Arabic “Book of Ostanès” there is a description of the arcane substance, or the water, in its various forms, first white, then black, then red, and finally a combustible liquid or a fire which is struck from certain stones in Persia. The text continues:

It is a tree that grows on the tops of the mountains, a young man born in Egypt, a prince from Andalusia, who desires the torment of the seekers. He has slain their leaders. . . . The sages are powerless to oppose him. I can see no weapon against him save resignation, no charger but knowledge, no buckler but understanding. If the seeker finds himself before him with these three weapons, and slays him, he [the

prince] will come to life again after his death, will lose all power against him, and will give the seeker the highest power, so that he will arrive at his desired goal.⁵

[425] The chapter in which this passage occurs begins with the words: “The sage has said, what the student needs first of all is to know the stone, the object of the aspirations of the ancients.” The water, the tree, the young Egyptian, and the Andalusian prince all refer to the stone. Water, tree, and man appear here as its synonyms. The prince is an important symbol that needs a little elucidation, for it seems to echo an archetypal motif that is found in the Gilgamesh epic. There Enkidu, the chthonic man and shadow of Gilgamesh, is created by the gods at the behest of the insulted Ishtar, so that he may kill the hero. In the same way the prince “desires the torment of the seekers.” He is their enemy and “has slain their leaders,” that is, the masters and authorities of the art.

[426] This motif of the hostile stone is formulated in the “*Allegoriae sapientum*” as follows: “Unless thy stone shall be an enemy, thou wilt not attain to thy desire.”⁶ This enemy appears in alchemy in the guise of the poisonous or fire-spitting dragon and also as the lion. The lion’s paws must be cut off,⁷ and the dragon must be killed, or else it kills or devours itself on the principle of Democritus: “Nature rejoices in nature, nature rules over nature, and nature conquers nature.”⁸

[427] The slaying of the alchemical authorities cannot fail to remind us of the intriguing picture in *Pandora* of Melusina stabbing Christ’s side with a lance.⁹ Melusina corresponds to the Edem of the Gnostics and represents the feminine aspect of Mercurius, i.e., the female Nous (Naas of the Naassenes), which in the form of the serpent seduced our first parents. A parallel to this would be the aforementioned quotation from the “*Tractatus ad Alexandrum Magnum*”: “Gather the fruits, for the fruit of the tree has led us into the darkness and through the darkness.”¹⁰ As this admonition clearly contradicts the authority of the Bible and the Church, one can only suppose that it was uttered by someone who was consciously opposed to the ecclesiastical tradition.

[428] The connection with the Gilgamesh epic is of interest because Ostanés was thought to be a Persian and a contemporary of Alexander the Great. As a further parallel to the initial hostility of Enkidu and the Andalusian prince and of the stone in general we might cite the Khidr legend.¹¹ Khidr, the messenger of Allah, at first frightens Moses by his misdeeds. Considered as a visionary experience or as a didactic tale, the legend sets forth the relation of Moses on the one hand to his shadow, his servant Joshua ben Nun, and on the other hand to the self, Khidr.¹² The lapis and its synonyms are likewise symbols of the self. Psychologically, this means that at the first meeting with the self all those negative qualities can appear which almost invariably characterize an unexpected encounter with the unconscious.¹³ The danger is that of an inundation by the unconscious, which in a bad case may take the

form of a psychosis if the conscious mind is unable to assimilate, either intellectually or morally, the invasion of unconscious contents.

15. THE DANGERS OF THE ART

[429] *Aurora consurgens* I says in regard to the dangers which threaten the artifex: “O how many understand not the sayings of the wise; these have perished because of their foolishness, for they lacked spiritual understanding.”¹ Hoghelande is of the opinion that “the whole art is rightly to be held both difficult and dangerous, and anyone who is not improvident will eschew it as most pernicious.”² Aegidius de Vadis feels the same when he says: “I shall keep silent about this science, which has led most of those who work in it into confusion, because there are few indeed who find what they seek, but an infinite number who have plunged to their ruin.”³ Hoghelande, citing Haly, says: “Our stone is life to him who knows it and *how* it is made, and he who knows not and has not made it and to whom no assurance⁴ is given when it will be born, or who thinks it another stone, has already prepared himself for death.”⁵ Hoghelande makes it clear that it is not just the danger of poisoning⁶ or of possible explosions but of mental aberrations: “Let him take care to recognize and guard against the deceptions of the devil, who often insinuates himself into the chemical operations, that he may hold up the laborants with vain and useless things to the neglect of the works of nature.”⁷ He authenticates this danger by a quotation from Alphidius: “This stone proceeds from a sublime and most glorious place of great terror, which has given over many sages to death.”⁸ He also cites Moyses: “This work comes about as suddenly as the clouds come from heaven,” adding a quotation from Micreris: “If you should suddenly see this transformation, wonder, fear, and trembling will befall you; therefore work with caution.”⁹

[430] The danger of daemonic agencies is likewise mentioned in the “Liber Platonis quartorum”: “At a certain hour during the preparation certain kinds of spirits will oppose the work, and at another time this opposition will not be present.”¹⁰ The clearest of all is Olympiodorus (sixth century): “And all the while the demon Ophiuchos instils negligence, impeding our intentions; everywhere he creeps about, within and without, causing oversights, fear, and unpreparedness, and at other times he seeks by harassments and injuries to make us abandon the work.”¹¹ He also mentions that lead is possessed of a demon which drives men mad.¹²

[431] The miracle of the stone which the alchemist expected or experienced must have been intensely numinous, and this would explain his holy dread of profaning the mystery. “No one can disclose the name of the stone without damning his soul, for he cannot justify himself before God,” says Hoghelande.¹³ This conviction should be taken seriously. His treatise is the work of an honest and reasonable man, and differs very much to its advantage from the pretentious obscurantism of other treatises,

particularly those of Lully. Since the stone had “a thousand names,” one only wonders which of them it was that Hoghelande did not wish to disclose. The stone was indeed a great embarrassment to the alchemists, for since it had never been made no one could say what it really was. The most probable hypothesis, it seems to me, is that it was a psychic experience, which would account for the repeatedly expressed fear of mental disturbance.

[432] Wei Po-yang, the oldest Chinese alchemist known to us (2nd cent, A.D.), gives an instructive account of the dangerous consequences of making mistakes during the opus. After a brief résumé of the latter he describes the *chên-yên*, the true or complete man, who is the beginning and end of the work: “He is and he is not. He resembles a vast pool of water, suddenly sinking and suddenly floating.” He appears as a material substance, like Dorn’s *Veritas*,¹⁴ and in it are “mixed the squareness, the roundness, the diameter, and the dimensions, which restrain one another, having been in existence before the beginning of the heavens and the earth: lordly, lordly, high and revered.”¹⁵ This again conveys that impression of extreme numinosity which we found in Western alchemy.

[433] The author goes on to speak of a region “closed on all sides, its interior made up of intercommunicating labyrinths. The protection is so complete as to turn back all that is devilish and undesirable. . . . Cessation of thought is desirable and worries are preposterous. The divine *ch’i* (air, spirit, ethereal essence) fills the quarters and it cannot be held back. Whoever retains it will prosper and he who loses it, will perish.” For the latter will employ the “false method”: he will direct himself in all things by the course of the sun and the stars, in other words will lead a rationally ordered life in accordance with the rules of Chinese conduct. But this is not pleasing to the *tao* of the feminine principle (*yin*), or, as we should say, the ordering principles of consciousness are not in harmony with the unconscious (which in a man has a feminine character). If the adept at this point orders his life according to rules traditionally regarded as rational he brings himself into danger. “Disaster will come to the black mass.” The black mass is the *massa confusa*, the chaos or *nigredo* of Western alchemy, the prima materia, which is black outside and white inside, like lead. It is the *chên-yên* hidden in the darkness, the whole man, who is threatened by the rational and correct conduct of life, so that individuation is hindered or deflected into the wrong path. The *ch’i*, the quintessence (the rose-coloured blood of Western alchemy) cannot be “held back”: the self struggles to make itself manifest and threatens to overpower consciousness.¹⁶ This danger was particularly great for the Western alchemist, because the ideal of the *imitatio Christi* led him to regard the sweating out of the soul-substance in the form of the rose-coloured blood as a task that had actually been enjoined upon him. He felt morally obliged to realize the demands of the self regardless of whether these demands taxed him too highly. It

seemed to him that God and his highest moral principles required this self-sacrifice. It is indeed a self-sacrifice, a true *θυσία* of the self, when a man gives way to the urgency of these demands and perishes, for then the self has lost the game as well, having destroyed the human being who should have been its vessel. This danger, as the Chinese Master rightly observes, occurs when the traditional, moral, and rational principles of conduct are put into force at a moment when something other than social life is in question, namely, the integration of the unconscious and the process of individuation.

[434] Wei Po-yang gives a graphic description of the physiological and psychic consequences of error: “Gases from food consumed will make noises inside the intestines and stomach. The right essence (*ch’i*) will be exhaled and the evil one inhaled. Days and nights will be passed without sleep, moon after moon. The body will then be tired out, giving rise to an appearance of insanity. The hundred pulses will stir and boil so violently as to drive away peace of mind and body.” Nor will it be of any avail (following conscious morality) to build a temple, to watch diligently and bring gifts to the altar morning and night. “Ghostly things will make their appearance, at which he will marvel even in his sleep. He is then led to rejoice, thinking that he is assured of longevity.¹⁷ But all of a sudden he is seized by an untimely death.” The author adds the moral: “A slight error has thus led to a grave disaster.” The insights of Western alchemy did not penetrate to these depths. Nevertheless, the alchemists were aware of the subtle dangers of the work, and they knew that high demands were made not only on the intelligence of the adept but also on his moral qualities. Thus the invitation to the royal marriage in Christian Rosencreutz¹⁸ runs:

Keep watch, and ward,
Thyself regard;
Unless with diligence thou bathe,
The Wedding can’t thee harmless save;
He’ll damage have that here delays;
Let him beware, too light that weighs.

[435] It is clear from what happens in the *Chymical Wedding* that it was not concerned solely with the transformation and union of the royal pair, but also with the individuation of the adept. The union with the shadow and the anima is a difficulty not to be taken lightly. The problem of opposites that then makes its appearance and the unanswerable questions that this entails lead to the constellation of compensating archetypal contents in the form of numinous experiences. What complex psychology discovered only late was known long ago to the alchemists—*symbolice*—despite their limited intellectual equipment. Laurentius Ventura expresses this insight in a few succinct words: “The perfection of the work does not lie in the power of the

artifex, but God the most merciful himself bestows it upon whom he will. And in this point lies all the danger.”¹⁹ We might add that the words “the most merciful” should probably be taken as an apotropaic euphemism.

16. UNDERSTANDING AS A MEANS OF DEFENCE

[436] After this discussion of the dangers that threaten the adept, let us turn back to the Ostances quotation in section 14. The adepts knew that they could offer no resistance to the lapis in the form of the Andalusian prince. It seemed to be stronger than they, and the text says that they had only three weapons—“resignation,” the charger of “knowledge,” and the buckler of “understanding.” It is evident from this that on the one hand they thought themselves well advised to adopt a policy of nonresistance, while on the other they sought refuge in intelligence and understanding. The superior power of the lapis is attested by the saying: “The philosopher is not the master of the stone, but rather its minister.”¹ Obviously they had to submit to its power, but with a reserve of understanding which would finally enable them to slay the prince. We shall probably not go wrong if we assume that the adepts tried as best they could to understand that apparently invincible thing and thereby break its power. It is not only a well-known fairytale motif (Rumpelstiltskin!) but also a very ancient primitive belief that he who can guess the secret name has power over its possessor. In psychotherapy it is a well-known fact that neurotic symptoms which seem impossible to attack can often be rendered harmless by conscious understanding and experience of the contents underlying them. This is obvious enough, because the energy which maintained the symptom is then put at the disposal of consciousness, causing an increase of vitality on the one hand and a reduction of useless inhibitions and suchlike disturbances on the other.

[437] In order to understand the Ostances text, one must bear such experiences in mind. They occur whenever previously unconscious, numinous contents emerge into consciousness either spontaneously or through the application of a method. As in all magic texts, it is supposed that the power of the conquered daemon will pass into the adept. Our modern consciousness can hardly resist the temptation to think in the same way. We readily assume that psychic contents can be completely disposed of by insight. This is true only of contents that do not mean very much anyway. Numinous complexes of ideas may be induced to change their form, but since their content can take any number of forms it does not vanish in the sense of being rendered wholly ineffective. It possesses a certain autonomy, and when it is repressed or systematically ignored it reappears in another place in a negative and destructive guise. The devil whom the magician fancies he has bound to his service fetches him in the end. It is a waste of effort to try to use the daemon as a familiar for one’s own purposes; on the contrary, the autonomy of this ambivalent figure should be

religiously borne in mind, for it is the source of that fearful power which drives us towards individuation. Consequently the alchemists did not hesitate to endow their stone with positively divine attributes and to put it, as a microcosm and a man, on a par with Christ—“and in this point lies all the danger.” We neither can nor should try to force this numinous being, at the risk of our own psychic destruction, into our narrow human mould, for it is greater than man’s consciousness and greater than his will.

[438] Just as the alchemists occasionally betrayed a tendency to use the symbols produced by the unconscious as spellbinding names, so does modern man make analogous use of intellectual concepts for the opposite purpose of denying the unconscious, as though with reason and intellect its autonomy could be conjured out of existence. Curiously enough, I have critics who think that I of all people want to replace the living psyche by intellectual concepts. I do not understand how they have managed to overlook the fact that my concepts are based on empirical findings and are nothing but names for certain areas of experience. Such a misunderstanding would be comprehensible if I had omitted to present the facts on which I base my statements. My critics assiduously overlook the obvious truth that I speak of the facts of the living psyche and have no use for philosophical acrobatics.

17. THE MOTIF OF TORTURE

[439] The Ostanes text gives us valuable insight into the phenomenology of the individuation process as the alchemists experienced it. The reference to the “torment” which the prince desires for the artifex is particularly interesting. This motif appears in the Western texts but in inverse form, the tormented one being not the artifex but Mercurius, or the lapis or tree. The reversal of roles shows that the artifex imagines he is the tormentor whereas in fact he is the tormented. This becomes clear to him only later, when he discovers the dangers of the work to his own cost. A typical example of the projected torture is the vision of Zosimos.¹ The *Turba* says: “Take the old black spirit and destroy and torture² with it the bodies, until they are changed.”³ Elsewhere a philosopher tells the assembled sages: “The tortured thing, when it is immersed in the body, changes it into an unalterable and indestructible nature.”⁴ Mundus in Sermo XVIII says: “How many there be who search out these applications⁵ and [even] find some, but yet cannot endure the torments.”⁶

[440] These quotations show that the concept of torture is an ambiguous one. In the first case it is the bodies, the raw materials of the work, that are tormented; in the second case the tormented thing is without doubt the arcane substance, which is often called *res*; and in the third case it is the investigators themselves who cannot endure the torments. This ambiguity is no accident and has its deeper reasons.

[441] In the old texts that are contemporaneous with the Latin translation of the *Turba* there are gruesome recipes in the manner of the Magic Papyri, as for instance the disembowelling⁷ or plucking of a live cock,⁸ the drying of a man over a heated stone,⁹ the cutting off of hands and feet,¹⁰ etc. Here the torture is applied to the body. But we find another version in the equally old “Tractatus Micreris.”¹¹ There it is said that just as the Creator separates souls from bodies and judges and rewards them, “so we also must use flattery [*adulatio uti*]¹² on these souls and condemn them to the heaviest punishments [*poenis*, with marginal note: *laboribus*].” At this point an interlocutor raises the doubt as to whether the soul can be treated in this way, since it is “tenuous” and no longer inhabits the body. The Master replies: “It must be tormented with the most subtle spiritual thing, namely with the fiery nature which is akin to it. For if its body were tormented, the soul would not be tormented, and the torment would not reach it; for it is of spiritual nature, to be touched only by something spiritual.”¹³

[442] Here it is not the raw material that is tortured but the soul which has been extracted from it and must now suffer a spiritual martyrdom. The “soul” corresponds as a rule to the arcane substance, either the *prima materia* or the means by which it is transformed. Petrus Bonus, who, as we have seen, was one of the first medieval alchemists to wonder about the scope of his art, says that just as Geber met with difficulties “we also were plunged into stupor [*in stuporem adducti*] for a long time and were hidden under the cloak of despair. But when we came back to ourselves and tormented our thoughts with the torment of unlimited reflection, we beheld the substances.” He then cites Avicenna, who had said that it was necessary for us “to discover this operation [the *solutio*] through ourselves [*per nos ipsos*].” “These things were known to us before the experiment, as a consequence of long, intense, and scrupulous meditation.”¹⁴

[443] Petrus Bonus puts the suffering back into the investigator by stressing his mental torments. In this he is right, because the most important discoveries of the alchemists sprang from their meditations on their own psychic processes, which, projected in archetypal form into the chemical substances, dazzled their minds with unlimited possibilities. The same prior knowledge of the results is generally admitted, as when Dorn says: “It is not possible for any mortal to understand this art unless he is previously enlightened by the divine light.”¹⁵

[444] The tormenting of the substances also occurs in Sir George Ripley: “The unnatural fire must torment the bodies, for it is the dragon violently burning, like the fire of hell.”¹⁶ With Ripley the projection of the torments of hell is explicit and complete, as with so many others. Only with the authors of the sixteenth and seventeenth centuries does the insight of Petrus Bonus break through again. Dorn’s view is emphatic: “Wherefore the Sophists . . . have persecuted this Mercurius with various torments, some with sublimations, coagulations, precipitations, mercurial

aquae fortes, etc., all of which are mistaken courses to be avoided.”¹⁷ Among the Sophists he reckons also Geber and Albertus, “surnamed the Great,” as he mockingly adds. In his “*Physica Trismegisti*” he even declares that the time-honoured blackness (*melanosis, nigredo*) is a projection: “For Hermes saith, ‘From thee shall all obscurity flee away,’¹⁸ he saith not ‘from the metals.’ By obscurity naught else is to be understood save the darkness of disease, and sickness of body and mind.”¹⁹

[445] Many passages in *Aurora consurgens* I are significant in this respect. In the “Book of Ostanès” the philosophers shed tears over the stone, which is enclosed in another stone, so that, bedewed by their tears, it loses its blackness and becomes white as a pearl.²⁰ A Gratianus quotation in the *Rosarium* says: “In alchemy there is a certain noble substance . . . in the beginning whereof is wretchedness with vinegar, but in the end joy with gladness.”²¹ The “*Consilium coniugii*” equates the *nigredo* with melancholia.²² Vigenère says of the Saturnine lead: “Lead signifies the vexations and aggravations with which God afflicts us and troubles our senses.”²³ This adept was aware that lead, which had always been considered an arcane substance, was identical with the subjective state of depression. Similarly, the personified *prima materia* in the “*Aurelia occulta*” says of her brother Saturn that his spirit was “overcome by the passion of melancholy.”²⁴

[446] In this context of thought, where suffering and sadness play so great a role, it is not surprising that the tree was brought into connection with the cross of Christ. This analogy was supported by the old legend that the wood of the cross came from the tree of paradise.²⁵ Another thing that contributed to it was the quaternity, whose symbol is the cross;²⁶ for the tree possesses a quaternary quality by reason of the fact that it represents the process by which the four elements are united. The quaternity of the tree goes back beyond the Christian era. It is found in Zarathustra’s vision of the tree with four branches made of gold, silver, steel, and “mixed iron.”²⁷ This image reappears later in the alchemical tree of the metals, which was then compared with the cross of Christ. In Ripley the royal pair, the supreme opposites, are crucified for the purpose of union and rebirth.²⁸ “If I be lifted up, [as Christ says,] then I will draw all men unto me. . . . From that time forward, when both parts, having been crucified and exanimated, are espoused, man and woman shall be buried together and are afterward quickened again by the spirit of life.”²⁹

[447] The tree also appears as a symbol of transformation in a passage in Dorn’s “*Speculativa philosophia*,” which is very interesting from the point of view of the psychology of religion: “[God] hath determined to snatch the sword of his wrath from the hands of the angel, substituting in place thereof a three-pronged hook of gold, hanging the sword on a tree: and so God’s wrath is turned into love.”³⁰ Christ as Logos is the two-edged sword, which symbolizes God’s wrath, as in Revelation 1 : 16.

[448] The³¹ somewhat unusual allegory of Christ as the sword hanging on a tree is almost certainly an analogy of the serpent hanging on the cross. In St. Ambrose³² the “serpent hung on the wood” is a “*typus Christi*,” as is the “brazen serpent on the cross” in Albertus Magnus.³³ Christ as Logos is synonymous with the Naas, the serpent of the Nous among the Ophites. The Agathodaimon (good spirit) had the form of a snake, and in Philo the snake was considered the “most spiritual” animal. On the other hand, its cold blood and inferior brain-organization do not suggest any noticeable degree of conscious development, while its unrelatedness to man makes it an alien creature that arouses his fear and yet fascinates him. Hence it is an excellent symbol for the two aspects of the unconscious: its cold and ruthless instinctuality, and its Sophia quality or natural wisdom, which is embodied in the archetypes. The Logos-nature of Christ represented by the chthonic serpent is the maternal wisdom of the divine mother, which is prefigured by Sapiientia in the Old Testament. The snake-symbol thus characterizes Christ as a personification of the unconscious in all its aspects, and as such he is hung on the tree in sacrifice (“wounded by the spear” like Odin).

[449] Psychologically, this snake sacrifice must be understood as an overcoming of unconsciousness and, at the same time, of the attitude of the son who unconsciously hangs on his mother. The alchemists used the same symbol to represent the transformation of Mercurius,³⁴ who is quite definitely a personification of the unconscious, as I have shown.³⁵ I have come across this motif several times in dreams, once as a crucified snake (with conscious reference to John 3 : 14), then as a black spider hung on a pole which changed into a cross, and finally as the crucified body of a naked woman.

18. THE RELATION OF SUFFERING TO THE CONIUNCTIO

[450] In the above quotation from Dorn, the three-pronged hook of gold refers to Christ, for in medieval allegory the hook with which God the Father catches the Leviathan is the crucifix. The golden trident is, of course, an allusion to the Trinity, and the fact that it is “golden” is an alchemical *sous-entendu*, just as the idea of God’s transformation in this strange allegory of Dorn’s is intimately bound up with the alchemical *mysterium*. The notion of God throwing out a hook is of Manichaeic origin: he used the Primordial Man as a bait for catching the powers of darkness. The Primordial Man was named “Psyche,” and in Titus of Bostra he is the world soul (*ψυχῆ ἀπάντων*).¹ This psyche corresponds to the collective unconscious, which, itself of unitary nature, is represented by the unitary Primordial Man.

[451] These ideas are closely related to the Gnostic conception of Sophia-Achamoth in Irenaeus. He reports that

the *Ἐνθύμησις* [reflection] of the Sophia who dwells above, compelled by necessity, departed with suffering from the Pleroma into the darkness and empty spaces of the void. Separated from the light of the Pleroma, she was without form or figure, like an untimely birth, because she comprehended nothing [i.e., became unconscious]. But the Christ dwelling on high, outstretched upon the cross, took pity on her, and by his power gave her a form, but only in respect of substance, and not so as to convey intelligence [i.e., consciousness]. Having done this, he withdrew his power, and returned [to the Pleroma], leaving Achamoth to herself, in order that she, becoming sensible of the suffering caused by separation from the Pleroma, might be influenced by the desire for better things, while possessing in the meantime a kind of odour of immortality left in her by Christ and the Holy Spirit.²

[452] According to these Gnostics, it was not the Primordial Man who was cast out as a bait into the darkness, but the feminine figure of Wisdom, Sophia-Achamoth. In this way the masculine element escaped the danger of being swallowed by the dark powers and remained safe in the pneumatic realm of light, while Sophia, partly by an act of reflection and partly driven by necessity, entered into relation with the outer darkness. The sufferings that befell her took the form of various emotions—sadness, fear, bewilderment, confusion, longing; now she laughed and now she wept. From these affects (*διαθέσεις*) arose the entire created world.

[453] This strange creation myth is obviously “psychological”: it describes, in the form of a cosmic projection, the separation of the feminine anima from a masculine and spiritually oriented consciousness that strives for the final and absolute victory of the spirit over the world of the senses, as was the case in the pagan philosophies of that epoch no less than in Gnosticism. This development and differentiation of consciousness left a literary deposit in the *Metamorphoses* of Apuleius, and more particularly in his tale of *Amor and Psyche*, as Erich Neumann has shown in his study of that work.

[454] The emotional state of Sophia sunk in unconsciousness (*αγνοία*), her formlessness, and the possibility of her getting lost in the darkness characterize very clearly the anima of a man who identifies himself absolutely with his reason and his spirituality. He is in danger of becoming dissociated from his anima and thus losing touch altogether with the compensating powers of the unconscious. In a case like this the unconscious usually responds with violent emotions, irritability, lack of control, arrogance, feelings of inferiority, moods, depressions, outbursts of rage, etc., coupled with lack of self-criticism and the misjudgments, mistakes, and delusions which this entails.

[455] In such a state a man soon loses touch with reality. His spirituality becomes ruthless, arrogant, and tyrannical. The more unadapted his ideology is, the more it demands recognition and is determined to gain it if necessary by force. This state is a

definite *πάθος*, a suffering of the soul, though at first it is not perceived as such because of lack of introspection, and only gradually comes to consciousness as a vague malaise. Eventually this feeling forces the mind to recognize that something is wrong, that one is indeed suffering. This is the moment when physical or psychological symptoms appear which can no longer be banished from consciousness. Expressed in the language of myth, Christ (the principle of masculine spirituality) perceives the sufferings of Sophia (i.e., the psyche) and thereby gives her form and existence. But he leaves her to herself so that she should feel the full force of her sufferings. What this means psychologically is that the masculine mind is content merely to perceive psychic suffering, but does not make itself conscious of the reasons behind it, and simply leaves the anima in a state of *agnoia*. This process is typical and can be observed today not only in all masculine neuroses but among so-called normal people who have come into conflict with the unconscious thanks to their one-sidedness (usually intellectual) and psychological blindness.

[456] Although, in this psychologem, the Primordial Man (Christ) is still the means for conquering the darkness, he nevertheless shares his role with a feminine being, Sophia, who coexisted with him in the Pleroma. Moreover, the Crucified no longer appears as the bait on God's fishing rod; instead, he "takes pity" on the formless feminine half, revealing himself to her outstretched upon the cross. The Greek text uses here a strong expression: *ἔπεκταθέντα*, which lays particular emphasis on stretching and extension. This image of torment is held before her so that she may recognize his sufferings, and he hers. But before this recognition can take place, Christ's masculine spirituality withdraws into the world of light. This *dénouement* is typical: as soon as the light catches a glimpse of the darkness and there is a possibility of uniting with it, the power drive that is inherent in the light as well as in the darkness asserts itself and will not budge from its position. The one will not darken its radiance, and the other will not give up its gratifying emotions. Neither of them notices that their suffering is one and the same and is due to the process of becoming conscious, whereby an original unity is split into two irreconcilable halves. There can be no consciousness without this act of discrimination, nor can the resultant duality be reunified without the extinction of consciousness. But the original wholeness remains a desideratum (*ὄρεχθῆ τῶν διαφερόνων*) for which Sophia longs more than does the Gnostic Christ. It is still the case today that discrimination and differentiation mean more to the rationalistic intellect than wholeness through the union of opposites. That is why it is the unconscious which produces the symbols of wholeness.³

[457] These symbols are usually quaternary and consist of two pairs of opposites crossing one another (e.g., left/right, above). The four points demarcate a circle, which, apart from the point itself, is the simplest symbol of wholeness and therefore

the simplest God-image.⁴ This reflection has some bearing on the emphasis laid on the cross in our text, since the cross as well as the tree is the medium of conjunction. Hence St. Augustine likened the cross to a bridal bed, and in the fairytale the hero finds his bride in the top of a great tree,⁵ where also the shaman finds his heavenly spouse, as does the alchemist. The coniunctio is a culminating point of life and at the same time a death, for which reason our text mentions the “fragrance of immortality.” On the one hand the anima is the connecting link with the world beyond and the eternal images, while on the other hand her emotionality involves man in the chthonic world and its transitoriness.

19. THE TREE AS MAN

[458] Like the vision of Zarathustra, the dream of Nebuchadnezzar, and the report of Bardesanes (A.D. 154–222) on the god of the Indians,¹ the old Rabbinic idea that the tree of paradise was a man² exemplifies man’s relationship to the philosophical tree. According to ancient tradition men came from trees or plants.³ The tree is as it were an intermediate form of man, since on the one hand it springs from the Primordial Man and on the other hand it grows into a man.⁴ Naturally the patristic conception of Christ as a tree or vine⁵ exerted a very great influence. In *Pandora*, as we have said, the tree is represented in the form of a woman, in agreement with the pictures reproduced in the first part of this essay, which, unlike the alchemical pictures, were done mostly by women. This raises the question of how the feminine tree-numen should be interpreted. The results of our investigation of the historical material have shown that the tree can be interpreted as the Anthropos or self. This interpretation is particularly obvious in the symbolism of the “Scriptum Alberti”⁶ and is confirmed by the fantasy material expressed in our pictures. The interpretation of the feminine tree-numen as the self therefore holds good for women, but for the alchemists and humanists the feminine representation of the tree is an obvious projection of the anima figure.⁷ The anima personifies the femininity of a man but not the self. Correspondingly, the patients who drew [Figures 29](#) and [30](#) depict the tree-numen as the animus. In all these cases the contrasexual symbol has covered up the self. This is what regularly happens when the man’s femininity, the anima, or the woman’s masculinity, the animus, is not differentiated enough to be integrated with consciousness, so that the self is only potentially present as an intuition but is not yet actualized.

[459] In so far as the tree symbolizes the opus and the transformation process “tam ethice quam physice” (both morally and physically), it also signifies the life process in general. Its identity with Mercurius, the *spiritus vegetativus*, confirms this view. Since the opus is a life, death, and rebirth mystery, the tree as well acquires this significance and in addition the quality of wisdom, as we have seen from the view of

the Barbeliots reported in Irenaeus: "From man [= Anthropos] and gnosis is born the tree, which they also call gnosis."⁸ In the Gnosis of Justin, the angel Baruch, named the "wood of life,"⁹ is the angel of revelation, just as the sun-and-moon tree in the Romance of Alexander foretells the future.¹⁰ However, the cosmic associations of the tree as world-tree and world-axis take second place among the alchemists as well as in modern fantasies, because both are more concerned with the individuation process, which is no longer projected into the cosmos. An exception to this rule may be found in the rare case, reported by Nelken,¹¹ of a schizophrenic patient in whose cosmic system the Father-God had a tree of life growing out of his breast. It bore red and white fruits, or spheres, which were worlds. Red and white are alchemical colours, red signifying the sun and white the moon. On the top of the tree sat a dove and an eagle, recalling the stork on the sun-and-moon tree in the "Scriptum Alberti." Any knowledge of the alchemical parallels was quite out of the question in this case.

[460] On the evidence of the material we have collected, we can see that the spontaneous products of the unconscious in modern man depict the archetype of the tree in a way that brings out quite plainly the historical parallels. So far as I can judge, the only historical models of which my patients might have made conscious use are the Biblical tree of paradise and one or two fairytales. But I cannot recall a single case in which it was spontaneously admitted that the patient was consciously thinking of the Bible story. In every case the image of the tree presented itself spontaneously, and whenever a feminine being attached itself to the tree, none of the patients associated it with the snake on the tree of knowledge. The pictures show more of an affinity with the ancient idea of the tree nymph than with the Biblical prototype. In Jewish tradition the snake is also interpreted as Lilith. There is a strong prejudice in favour of the assumption that certain forms of expression exist only because a pattern for them may be found in the respective sphere of culture. If that were so in the present instance, all expressions of this type would have to be modelled on the tree of paradise. But that, as we have seen, is not the case: the long obsolete concept of the tree nymph predominates over the tree of paradise or Christmas tree; in fact there are even allusions to the equally obsolete cosmic tree and even to the *arbor inversa*, which, although it found its way into alchemy via the Cabala, nowhere plays a role in our culture. Our material is, however, fully in accord with the widespread, primitive shamanistic conceptions of the tree and the heavenly bride,¹² who is a typical anima projection. She is the *ayami* (familiar, protective spirit) of the shaman ancestors. Her face is half black, half red. Sometimes she appears in the form of a winged tiger.¹³ Spitteler also likens the "Lady Soul" to a tiger.¹⁴ The tree represents the life of the shaman's heavenly bride,¹⁵ and has a maternal significance.¹⁶ Among the Yakuts a tree with eight branches is the birthplace

of the first man. He is suckled by a woman the top part of whose body grows out of the trunk.¹⁷ This motif is also found among my examples (Figure 22).

[461] As well as with a feminine being, the tree is also connected with the snake, the dragon, and other animals, as in the case of Yggdrasil,¹⁸ the Persian tree Gaokerena in the lake of Vourukasha, or the tree of the Hesperides, not to mention the holy trees of India, in whose shadow may often be seen dozens of *naga* (= snake) stones.¹⁹

[462] The inverted tree plays a great role among the East Siberian shamans. Kagarow has published a photograph of one such tree, named Nakassä, from a specimen in the Leningrad Museum. The roots signify hairs, and on the trunk, near the roots, a face has been carved, showing that the tree represents a man.²⁰ Presumably this is the shaman himself, or his greater personality. The shaman climbs the magic tree in order to find his true self in the upper world. Eliade says in his excellent study of shamanism: “The Eskimo shaman feels the need for these ecstatic journeys because it is above all during trance that he becomes truly himself: the mystical experience is necessary to him as a constituent of his true personality.”²¹ The ecstasy is often accompanied by a state in which the shaman is “possessed” by his familiars or guardian spirits. By means of this possession he acquires his “‘mystical organs,’ which in some sort constitute his true and complete spiritual personality.”²² This confirms the psychological inference that may be drawn from shamanistic symbolism, namely that it is a projection of the individuation process. This inference, as we have seen, is true also of alchemy, and in modern fantasies of the tree it is evident that the authors of such pictures were trying to portray an inner process of development independent of their consciousness and will. The process usually consists in the union of two pairs of opposites, a lower (water, blackness, animal, snake, etc.) with an upper (bird, light, head, etc.), and a left (feminine) with a right (masculine). The union of opposites, which plays such a great and indeed decisive role in alchemy, is of equal significance in the psychic process initiated by the confrontation with the unconscious, so the occurrence of similar or even identical symbols is not surprising.

20. THE INTERPRETATION AND INTEGRATION OF THE UNCONSCIOUS

[463] It has not yet been understood in many quarters—nor, I am sorry to say, by my medical colleagues—how a series of fantasies such as I have described comes into existence in the first place, and secondly why I concern myself so much with comparative research into a symbolism that is unknown to them. I am afraid that all sorts of uncorrected prejudices still impede understanding, above all the arbitrary assumption that neuroses as well as dreams consist of nothing but repressed infantile memories and wishes, and that psychic contents are either purely personal or, if impersonal, are derived from the collective consciousness.

[464] Psychic disturbances, like somatic disturbances, are highly complex phenomena which cannot be explained by a purely aetiological theory. Besides the cause and the unknown X of the individual's disposition, we must also take into account the teleological aspect of fitness in biology, which in the psychic realm would have to be formulated as *meaning*. In psychic disturbances it is by no means sufficient in all cases merely to bring the supposed or real causes to consciousness. The treatment involves the integration of contents that have become dissociated from consciousness—not always as a result of repression, which very often is only a secondary phenomenon. Indeed, it is usually the case that, in the course of development following puberty, consciousness is confronted with affective tendencies, impulses, and fantasies which for a variety of reasons it is not willing or not able to assimilate. It then reacts with repression in various forms, in the effort to get rid of the troublesome intruders. The general rule is that the more negative the conscious attitude is, and the more it resists, devalues, and is afraid, the more repulsive, aggressive, and frightening is the face which the dissociated content assumes.

[465] Every form of communication with the split-off part of the psyche is therapeutically effective. This effect is also brought about by the real or merely supposed discovery of the causes. Even when the discovery is no more than an assumption or a fantasy, it has a healing effect at least by suggestion if the analyst himself believes in it and makes a serious attempt to understand. If on the other hand he doubts his aetiological theory, his chances of success sink at once, and he then feels compelled to look at least for real causes which would be convincing to an intelligent patient as well as to himself. If he is inclined to be critical, this task may become a heavy burden, and often he will not succeed in overcoming his doubts. The success of the treatment is then in jeopardy. This dilemma explains the fanatical doctrinairism of Freudian orthodoxy.

[466] I will illustrate the problem by means of an example which I came across recently. A certain Mr. X, who was unknown to me, wrote that he had read my book *Answer to Job*, which had interested him very much and put him in a great commotion. He had given it to his friend Y to read, and Y had thereupon had the following dream: *He was back in the concentration camp and saw a mighty eagle circling above it, looking for prey. The situation became dangerous and frightening, and Y wondered how he was to protect himself. He thought he might be able to fly up in a rocket-propelled aircraft and shoot down the eagle.* X described Y as a rationalistic intellectual who had spent a long time in a concentration camp. X and Y both referred the dream to the affects that had been released by the reading of my book on the previous day. Y went to X for advice about the dream. X was of the opinion that the eagle spying on Y referred to himself, whereupon Y rejoined that he didn't believe it, but thought the eagle referred to me, the author of the book.

[467] X now wanted to hear my opinion. It is in general a tricky business to try to interpret the dreams of people one does not know personally, and in the absence of amplificatory material. We must therefore content ourselves with asking a few questions which are suggested by what material there is. Why, for instance, should X think he knew that the eagle referred to himself? From what I could gather from the letter, it appeared that X had imparted a certain amount of psychological knowledge to his friend and therefore felt himself in the role of a mentor who could, as it were, see through his friend's game from above. At any rate he was toying with the idea that it was disagreeable for Y to be spied upon by him, the psychologist. X was thus in the position of a psychotherapist who by means of the sexual theory knows in advance what is lurking behind neuroses and dreams, and who, from the lofty watchtower of superior insight, gives the patient the feeling that he is being seen through. In the dreams of his patient he always expects himself to appear in whatever disguise may be invented by the mystic "censor." In this way X readily came to conjecture that he was the eagle.

[468] Y was of a different opinion. He seems not to have been conscious of being invigilated or seen through by X, but, reasonably enough, went back to the obvious source of his dream, namely my book, which had evidently made an impression on him. For this reason he named me the eagle. We can conclude from this that he felt he was being somehow meddled with, as though someone had found him out, or had put his finger on a sore spot in a way that wasn't entirely to his liking. There was no need for him to be conscious of this feeling, for otherwise it would hardly have been represented in a dream.

[469] Here interpretation clashes against interpretation, and the one is as arbitrary as the other. The dream itself does not give the least indication in either direction. One might perhaps hazard the view that Y was rather afraid of the superior insight of his friend and therefore disguised him under the façade of the eagle so as not to recognize him. But did Y himself make his dream? Freud supposes the existence of a censor who is responsible for these transmogrifications. As against this I take the view, reinforced by experience, that a dream is quite capable, if it wants to, of naming the most painful and disagreeable things without the least regard for the feelings of the dreamer. If the dream does not in fact do so, there is no sufficient reason for supposing that it means something other than what it says. I therefore maintain that when our dream says "eagle" it means an eagle. Thus I insist on the very aspect of dreams which makes them appear so nonsensical to our reason. It would be so much simpler and more reasonable if the eagle meant Mr. X.

[470] In my view, then, the task of the interpretation is to find out what the eagle, aside from our personal fantasies, might mean. I would therefore advise the dreamer to start investigating what the eagle is *qua* eagle, and what general meanings may be

attributed to it. The solution of this task leads straight into the history of symbols, and here we find the concrete reason why I concern myself with researches which are apparently so remote from the doctor's consulting room.

[471] Once the dreamer has established the general meanings of the eagle which are new and unknown to him (for he will have been familiar with many of them from literature and common speech), he must investigate in what relationship the experience of the previous day, namely the reading of my book, stands to the symbol of the eagle. The question is: what was it that affected him so much that it gave rise to the fairytale motif of a great eagle capable of injuring or making off with a grown man? The image of an obviously gigantic (i.e., mythical) bird, circling high in the sky and surveying the earth with all-seeing eye, is indeed suggestive in view of the content of my book, which is concerned with the fate of man's idea of God.

[472] In the dream Y is back in the concentration camp, which is supervised by an "eagle eye." This points clearly enough to a situation which is feared by the dreamer and which makes his energetic defence measures seem plausible. In order to shoot down the mythical bird, he wants to employ the most advanced technological invention—a rocket-propelled aircraft. This is one of the greatest triumphs of the rationalistic intellect and is diametrically opposed to the mythical bird, whose menacing presence is to be averted with its help. But what kind of danger lurks in my book for such a personality? The answer to this is not difficult when one knows that Y is a Jew. At all events a door is opened to problems that lead into regions that have nothing to do with personal resentments. It is rather a question of those principles, dominants, or ruling ideas which regulate our attitude to life and the world, of convictions and beliefs which, as experience shows, are indispensable psychic phenomena. Indeed they are so indispensable that when the old systems of thought collapse new ones instantly take their place.

[473] Neuroses, like all illnesses, are symptoms of maladjustment. Because of some obstacle—a constitutional weakness or defect, wrong education, bad experiences, an unsuitable attitude, etc.—one shrinks from the difficulties which life brings and thus finds oneself back in the world of the infant. The unconscious compensates this regression by producing symbols which, when understood objectively, that is, by means of comparative research, reactivate general ideas that underlie all such natural systems of thought. In this way a change of attitude is brought about which bridges the dissociation between man as he is and man as he ought to be.

[474] Something of the sort is taking place in our dream: Y may well be suffering from a dissociation between a highly rationalistic, intellectualized consciousness and an equally irrational background which is anxiously repressed. The anxiety appears in the dream and should be acknowledged as a real fact belonging to the personality, for it is nonsense to assert that one has no anxiety only because one is incapable of

discovering the reason for it. Yet that is what one generally does. If the anxiety could be accepted, there would also be a chance of discovering and understanding the reason. This reason is vividly portrayed by the eagle in the dream.

[475] Assuming that the eagle is an archaic God-image whose power a person cannot escape, then it makes very little difference in practice whether he believes in God or not. The fact that his psyche is so constituted as to produce such phenomena should be enough for him, for he can no more get rid of his psyche than he can get rid of his body, neither of which can be exchanged for another. He is a prisoner of his own psychophysical constitution, and must reckon with this fact whether he will or no. One can of course live in defiance of the demands of the body and ruin its health, and the same can be done in regard to the psyche. Anyone who wants to live will refrain from these tricks and will at all times carefully inquire into the body's and the psyche's needs. Once a certain level of consciousness and intelligence has been reached, it is no longer possible to live one-sidedly, and the whole of the psychosomatic instincts, which still function in a natural way among primitives, must consciously be taken into account.

[476] In the same way that the body needs food, and not just any kind of food but only that which suits it, the psyche needs to know the meaning of its existence—not just any meaning, but the meaning of those images and ideas which reflect its nature and which originate in the unconscious. The unconscious supplies as it were the archetypal form, which in itself is empty and irrepresentable. Consciousness immediately fills it with related or similar representational material so that it can be perceived. For this reason archetypal ideas are locally, temporally, and individually conditioned.

[477] The integration of the unconscious takes place spontaneously only in rare cases. As a rule special efforts are needed in order to understand the contents spontaneously produced by the unconscious. Where certain general ideas, which are regarded as valid or are still efficacious, already exist, they act as a guide to understanding, and the newly acquired experience is articulated with or subordinated to the existing system of thought. A good example of this is afforded by the life of the patron saint of Switzerland, Niklaus von der Flüe, who, by dint of long meditation and with the help of a little book written by a German mystic, gradually turned his terrifying vision of God into an image of the Trinity. Or again, the traditional system may be understood in a new way as a result of the new experiences.

[478] It goes without saying that all personal affects and resentments participate in the making of a dream and can therefore be read from its imagery. The analyst, especially at the beginning of a treatment, will have to be satisfied with this, since it seems reasonable to the patient that his dreams come from his personal psyche. He would be completely bewildered if the collective aspect of his dreams were pointed

out to him. Freud himself, as we know, tried to reduce myth motifs to personal psychology, in defiance of his own insight that dreams contain archaic residues. These are not personal acquisitions, but vestiges of an earlier collective psyche. There are, however, not a few patients who, as if to prove the reversibility of psychological rules, not only understand the universal significance of their dream symbols but also find it therapeutically effective. The great psychic systems of healing, the religions, likewise consist of universal myth motifs whose origin and content are collective and not personal; hence Lévy-Bruhl rightly called such motifs *représentations collectives*. The conscious psyche is certainly of a personal nature, but it is by no means the whole of the psyche. The foundation of consciousness, the psyche *per se*, is unconscious, and its structure, like that of the body, is common to all, its individual features being only insignificant variants. For the same reason it is difficult or almost impossible for the inexperienced eye to recognize individual faces in a crowd of coloured people.

[479] When, as in the dream of the eagle, symbols appear which have nothing about them that would point to a particular person, there is no ground for assuming that such a person is being disguised. On the contrary, it is much more probable that the dream means just what it says. So when a dream apparently disguises something and a particular person therefore seems indicated, there is an obvious tendency at work not to allow this person to appear, because, in the sense of the dream, he represents a mistaken way of acting or thinking. When, for instance, as not infrequently happens in women's dreams, the analyst is represented as a hairdresser (because he "fixes" the head), the analyst is being not so much disguised as devalued. The patient, in her conscious life, is only too ready to acknowledge any kind of authority because she cannot or will not use her own head. The analyst (says the dream) should have no more significance than the hairdresser who puts her head right so that she can then use it herself.

[480] If, therefore, instead of reducing the dream symbols to circumstances, things, or persons which the analyst presumes to know in advance, we regard them as real symbols pointing to something unknown, then the whole character of analytical therapy is altered. The unconscious is then no longer reduced to known, conscious factors (this procedure, incidentally, does *not* abolish the dissociation between conscious and unconscious) but is recognized as in fact unconscious, and the symbol is not reduced either but is amplified by means of the context which the dreamer supplies and by comparison with similar mythologems so that we can see what the unconscious intends it to mean. In this way the unconscious can be integrated and the dissociation overcome. The reductive procedure, on the other hand, leads away from the unconscious and merely reinforces the one-sidedness of the conscious mind. The more rigorous of Freud's pupils have failed to follow up the Master's lead with a

deeper exploration of the unconscious and have remained satisfied with reductive analysis.

[481] As I have said, the confrontation with the unconscious usually begins in the realm of the personal unconscious, that is, of personally acquired contents which constitute the shadow, and from there leads to archetypal symbols which represent the collective unconscious. The aim of the confrontation is to abolish the dissociation. In order to reach this goal, either nature herself or medical intervention precipitates the conflict of opposites without which no union is possible. This means not only bringing the conflict to consciousness; it also involves an experience of a special kind, namely, the recognition of an alien “other” in oneself, or the objective presence of another will. The alchemists, with astonishing accuracy, called this barely understandable thing Mercurius, in which concept they included all the statements which mythology and natural philosophy had ever made about him: he is God, daemon, person, thing, and the innermost secret in man; psychic as well as somatic. He is himself the source of all opposites, since he is duplex and *utriusque capax* (“capable of both”). This elusive entity symbolizes the unconscious in every particular, and a correct assessment of symbols leads to direct confrontation with it.

[482] As well as being an irrational experience, this confrontation is a process of realization. Accordingly the alchemical opus consisted of two parts: the work in the laboratory, with all its emotional and daemonic hazards, and the *scientia* or *theoria*, the guiding principle of the opus by which its results were interpreted and given their proper place. The whole process, which today we understand as psychological development, was designated the “philosophical tree,” a “poetic” comparison that draws an apt analogy between the natural growth of the psyche and that of a plant. For this reason it seemed to me desirable to discuss in some detail the processes which underlie both alchemy and the modern psychology of the unconscious. I am aware, and hope I have also made it clear to the reader, that merely intellectual understanding is not sufficient. It supplies us only with verbal concepts, but it does not give us their true content, which is to be found in the living experience of the process as applied to ourselves. We would do well to harbour no illusions in this respect: no understanding by means of words and no imitation can replace actual experience. Alchemy lost its vital substance when some of the alchemists abandoned the laboratorum for the oratorium, there to befuddle themselves with an ever more nebulous mysticism, while others converted the oratorium into a laboratorum and discovered chemistry. We feel sorry for the former and admire the latter, but no one asks about the fate of the psyche, which thereafter vanished from sight for several hundred years.

BIBLIOGRAPHY

BIBLIOGRAPHY

The items of the bibliography are arranged alphabetically under two headings: *A.* Ancient volumes containing collections of alchemical tracts by various authors; *B.* General bibliography, including cross-references to the material in section *A.* Short titles of the ancient volumes are printed in capital letters.

A. COLLECTIONS OF ALCHEMICAL TRACTS BY VARIOUS AUTHORS

ARS CHEMICA, quod sit licita recte exercentibus, probationes doctissimorum iurisconsultorum. ... Argentorati [Strasbourg], 1566.

Contents quoted in this volume:

- i Septem tractatus seu capitula Hermetis Trismegisti aurei [pp. 7–31; usually referred to as “Tractatus aureus”]
- ii Hortulanus: Commentariolum in Tabulam Smaragdinam [pp. 33–47]
- iii Studium Consilii coniugii de massa solis et lunae [pp. 48–263; usually referred to as “Consilium coniugii”]

ARTIS AURIFERAE quam chemiam vocant. ... Basileae [Basel], [1593]. 2 vols.

Contents quoted in this volume:

VOLUME I

- i Allegoriae super librum Turbae [pp. 139–45]
- ii Aenigmata ex visione Arislei philosophi et allegoriis sapientum [pp. 146–54; usually referred to as “Visio Arislei”]
- iii In Turbam philosophorum exercitationes [pp. 154–82]
- iv Aurora consurgens, quae dicitur Aurea hora [pp. 185–246]
- v [Zosimos:] Rosinus ad Sarratantam episcopum [pp. 277–319]
- vi Maria Prophetissa: Practica . . . in artem alchemicam [pp. 319–24]
- vii Calid: Liber secretorum alchemiae [pp. 325–51]
- viii Opusculum authoris ignoti [pp. 389–92]
- ix Tractatulus Avicennae [pp. 405–37]
- x Liber de arte chymica [pp. 575–632]

VOLUME II

- x*i* Morienus Romanus: Sermo de transmutatione metallorum [pp. 7–54]
- x*ii* Scala philosophorum [pp. 107–70]
- x*iii* Rosarium philosophorum [pp. 204–384]
- x*iv* Arnold of Villanova: Flos florum [pp. 470–88]

AUREUM VELLUS, oder Guldin Schatz und Kunstkammer . . . von dem . . . bewehrten Philosopho Salomone Trismosino. Rorschach, 1598.

Contents quoted in this volume:

- i* Trismosin: Splendor solis [Tract. III, pp. 3–59]
- ii* Melchior, Cardinal Bishop of Brixen; Vom dem Gelben und Roten Mann [Tract. III, pp. 177–91]

DE ALCHEMIA. Nuremberg, 1541.

Contents quoted in this volume:

- i* Geber: Summae perfectionis metallorum sive perfecti magisterii libri duo [pp. 20–205]
- ii* Tabula smaragdina [p. 363]
- iii* Hortulanus: Super Tabulam Smaragdinam Commentarius [pp. 364–73]

DE ALCHIMIA opuscula complura. Frankfurt a. M., 1550. 2 vols. *Contents quoted in this volume:*

VOLUME II

Rosarium philosophorum [whole volume]

MANGETUS, JOHANNES JACOBUS (ed.). *BIBLIOTHECA CHEMICA CURIOSA, seu Rerum ad alchemiam pertinentium thesaurus instructissimus.* . . . Geneva, 1702. 2 vols.

Contents quoted in this volume:

VOLUME I

- i* Hermes Trismegistus: Tractatus aureus [pp. 400–45]
- ii* Dicta Belini [pp. 478–79]
- iii* Lully: Codicillus seu vade mecum aut Cantilena [pp. 880–911]
- iv* Braceschus: Lignum vitae [pp. 911–38]
- v* [Altus:] Mutus liber [pp. 938–53]

VOLUME II

- vi* Bonus: Margarita pretiosa novella correctissima [pp. 1–80]
- vii* Rosarium philosophorum [pp. 87–119; a second version, pp. 119–33]
- viii* Sendivogius: Parabola, seu Aenigma philosophicum [pp. 474–75]

MUSAEUM HERMETICUM reformatum et amplificatum . . . continens tractatus chimicos XXI praestantissimos . . .

Francofurti [Frankfurt a. M.], 1678. For translation, see ARTHUR EDWARD WAITE (ed. and trans.). *The Hermetic Museum restored and enlarged*. London, 1893. 2 vols.

Contents quoted in this volume:

(The entries in parentheses show the title and pagination of the treatises in the Waite translation)

- i [Hermes Trismegistus:] Tractatus aureus de lapide philosophorum [pp. 1–52] (“The Golden Tract,” I, 7–56)
- ii [Siebmacher:] Hydrolithus sophicus, seu Aquarium sapientum [pp. 73–144] (“The Sophie Hydrolith,” I, 7–120)
- iii Flamel: Tractatus brevis seu Summarium philosophicum [pp. 172–79] (“A Short Tract, or Philosophical Summary,” I, 141–47)
- iv Via veritatis unicae [pp. 181–202] (“The Only True Way,” I, 151–64)
- v [Barcius (F. von Sternberg):] Gloria mundi [pp. 203–304] (“The Glory of the World,” I, 167–243)
- vi Lambspringk: De lapide philosophico figurae et emblemata [pp. 337–72] (“The Book of Lambspring,” I, 273–306)
- vii Basilius Valentinus: Practica [pp. 377–432] (“Practica,” I, 312–57)
- viii Norton: Crede mihi, seu Ordinale [pp. 433–532] (“Believe-Me, or The Ordinal of Alchemy,” II, 2–67)
- ix Sendivogius: Novum lumen chemicum [pp. 545–600] (“The New Chemical Light,” II, 81–158)
- x Philalethes: Introitus apertus [pp. 647–700] (“An Open Entrance to the Closed Palace of the King,” II, 163–98)
- xi Maier: Subtilis allegoria super secreta chymiae [pp. 701–40] (“A Subtle Allegory Concerning the Secrets of Alchemy,” II, 201–23)
- xii Philalethes: Metallorum metamorphosis [pp. 741–74] (“The Metamorphosis of Metals,” II, 225–45)
- xiii Philalethes: Brevis manuductio. ad rubinum caelestem [pp. 775–98] (“A Brief Guide to the Celestial Ruby,” II, 246–60)
- xiv Philalethes: Fons chymicae veritatis [pp. 799–814] (“The Fount of Chemical Truth,” II 261–69)

THEATRUM CHEMICUM, praecipuos selectorum auctorum tractatus . . . continens. Argentorati [Strasbourg], Vols. I–IV, 1659; Vol. V, 1660; Vol. VI, 1661.

Contents quoted in this volume:

VOLUME I

- i Hoghelande: De alchemiae difficultatibus [pp. 109–91]
- ii Dorn: Speculativa philosophia [pp. 228–76]
- iii Dorn: Physica genesis [pp. 326–61]
- iv Dorn: Physica Trismegisti [pp. 362–87]
- v Dorn: Physica Trithemii [pp. 388–99]
- vi Dorn: Philosophia chemica [pp. 418–57]

- vii Dorn: De tenebris contra naturam et vita brevi [pp. 457–72]
- viii Dorn: Duellum animi cum corpore [pp. 472–85]
- ix Dorn: Congeries Paracelsicae chemicae [pp. 491–568]
- x Dorn: De genealogia mineralium [pp. 568–91]
- xi Penotus: De medicamentis chemicis [pp. 592–682]
- xii Bernardus Trevisanus: De chemico miraculo (De alchimia) [pp. 683–709]

VOLUME II

- xiii Aegidius de Vadis: Dialogus inter naturam et filium philosophiae [pp. 85–109]
- xiv Penotus: Table of Symbols [facing p. 109]
- xv Ripley: Duodecim portarum axiomata philosophica [pp. 109–23]
- xvi Dee: Monas hieroglyphica [pp. 192–215]
- xvii Ventura: De ratione conficiendi lapidis (De lapide philosophico) [pp. 215–312]
- xviii Albertus Magnus: De alchimia [pp. 423–58]
- xix Albertus Magnus: Scriptum super arborem Aristotelis [in *ibid.*]

VOLUME III

- xx Jodocus Greverus: Secretum nobillissimum et verissimum [pp. 699–722]
- xxi Melchior Cibinensis: Addam et processum sub forma missae [pp. 758–61]

VOLUME IV

- xxii Artefius: Clavis maioris sapientiae [pp. 198–213]
- xxiii Happelius: Aphorismi Basiliani [pp. 327–30]
- xxiv Sendivogius: Dialogus Mercurii alchymistae et naturae [pp. 449–56]
- xxv Aenigma philosophorum sive symbolum Saturni [pp. 457–61]
- xxvi [Beatus:] Aurelia occulta [pp. 462–512]
- xxvii Hermes Trismegistus: Tractatus aureus cum scholiis [pp. 592–705]

VOLUME V

- xxviii Allegoriae sapientum supra librum Turbae [pp. 57–89]
- xxix Tractatus Micreris [pp. 90–101]
- xxx Platonis liber quartorum [pp. 101–85]
- xxxix Tractatus Aristotelis alchymistae ad Alexandrum magnum [pp. 787–98]
- xxxii Epistola ad Hermannum [pp. 799–805]

- xxxiii Vigenerus: De igne et sale [pp. 1–139]
 xxxiv Anonymi Galli Instructio de arbore solari [pp. 166–94]
 xxxv Orthelius: Epilogus et recapitulatio in Novum lumen chymicum Sendivogii [pp. 430–58]

THEATRUM CHEMICUM BRITANNICUM. Containing Severall Poeticall Pieces of Our Famous English Philosophers, Who Have Written the Hermetique Mysteries in Their Owne Ancient Language. Collected with annotations by Elias Ashmole. London, 1652.

Contents quoted in this volume:

- i Norton: The Ordinall of Alchemy [pp. 1–106]
 ii Ripley: Verses belonging to an Emblematicall Scrowle [pp. 375–79]
 iii Ripley: Preface to “Medulla” [pp. 389–92]

B. GENERAL BIBLIOGRAPHY

ABU’L QASIM MUHAMMAD IBN AHMAD AL-‘IRĀQĪ. *Kitāb al-‘ilm al-muktasab* (Book of knowledge acquired concerning the cultivation of gold). Edited and translated by E. J. Holmyard. Paris, 1923.

Acta S. Hildegardis. In MIGNE, *P.L.*, Vol. 197, cols. 9–90.

ADLER, GERHARD. *Studies in Analytical Psychology.* London and New York, 1948.

AEGIDIUS DE VADIS. “Dialogus inter naturam et filium philosophiae.” See (A) *Theatrum chemicum*, xiii.

“Aenigma philosophicum.” See (A) MANGETUS, *Bibliotheca chemica curiosa*, viii.

“Aenigma philosophorum sive symbolum Saturni.” See (A) *Theatrum chemicum*, xxv.

“Aenigmata ex visione Arislei et allegoriis sapientum.” See (A) *Artis auriferae*, ii.

AGRICOLA, GEORG(IUS). *De animantibus subterraneis.* Basel, 1549.

AGRIPPA VON NETTESHEIM, HEINRICH CORNELIUS. *De incertitudine et vanitate scientiarum.* Cologne, 1584. For translation, see: *The Vanity of Arts and Sciences.* London, 1684.

_____. *De occulta philosophia libri tres.* Cologne, 1533.

ALAN OF LILLE (Alanus de Insulis). *Elucidatio in Cantica Cantorum.* In MIGNE, *P.L.*, vol. 210, cols. 51–110.

ALBERTUS MAGNUS. “De alchemia.” See (A) *Theatrum chemicum*, xviii.

_____. “De mineralibus et rebus metallicis” (“Mineralium libri quinque”). In: AUGUSTE AND EMIL BORGNET (eds.). *Beati Alberti Magni Opera omnia.* Paris, 1890–99. 38 vols. (Vol. 5, pp. 1–103.)

_____. “Scriptum super arborem Aristotelis.” See (A) *Theatrum chemicum*, xix.

ALCIATI, ANDREA. *Emblemata cum commentariis.* Padua, 1621.

ALDROVANDUS, ULYSSES. *Dendrologiae libri duo.* Bologna, [1667]. 2 vols.

AL-‘IRĀQĪ. See ABU’L QASIM.

“Allegoriae sapientum supra librum Turbae XXIX distinctiones.” See (A) *Theatrum chemicum*, xxviii.

- “Allegoriae super librum Turbae.” See (A) *Artis auriferae*, i.
- [ALTUS.] *Mutus liber*. La Rochelle, 1677. See also (A) MANGETUS, *Bibliotheca chemica curiosa*, v.
- AMBROSE, SAINT. *De interpellatione Job et David*. In MIGNE, *P.L.*, vol. 14, cols. 798–850.
- _____. *De XLII mansionibus filiorum Israel*. In MIGNE, *P.L.*, vol. 17, cols. 9–40.
- APASTAMBA. In: *Sacred Laws of the Āryas*. Translated by G. Bühler Part I: Apastamba and Gautama. (Sacred Books of the East, 2.) Oxford, 1879.
- Apocalypse of Elias. See STEINDORFF, GEORG.
- APULEIUS, LUCIUS. *The Golden Ass*. Translated (1566) by William Adlington and revised by Stephen Gaselee. London and New York (Loeb Classical Library) 1915. Another version: Translated by Robert Graves. (Penguin Classics.) Harmondsworth, 1954.
- “Aquarium sapientum.” See (A) *Musaeum hermeticum*, ii.
- [ARISLEUS.] “Aenigmata ex visione Arislei et allegoriis sapientum.” See (A) *Artis auriferae*, ii.
- [ARISTOTLE, PSEUDO-] “Tractatus Aristotelis alchymistae ad Alexandrum magnum de lapide philosophico.” See (A) *Theatrum chemicum*, xxxi.
- ARNOLD OF VILLANOVA (Arnaldus). “Flos florum Arnaldi.” See (A) *Artis auriferae*, xiv.
- ARTEFIUS. “Clavis maioris sapientiae.” See (A) *Theatrum chemicum*, xxii.
- ASHVAGHOSHA. “Buddha-carita.” Translated by E. B. Cowell. In: *Buddhist Mahayana Texts*. (Sacred Books of the East, 49.) Oxford, 1894.
- Atharva-Veda. See *Hymns of the Atharva-Veda*.
- AUGUSTINE, SAINT. *The Confessions*. Translated by Francis Joseph Sheed. London and New York, 1943.
- _____. *De civitate Dei*. In MIGNE, *P.L.*, vol. 41. For translation, see: *The City of God*. Translated by Marcus Dods et al. (The Works of Aurelius Augustine, 2.) Edinburgh, 1872.
- _____. *Liber de Spiritu et Anima*. In MIGNE, *P.L.*, vol. 40, cols. 779–832.
- _____. *De vera religione*. In MIGNE, *P.L.*, vol. 34, cols. 121–72. For translation, see: “Of True Religion,” in J. H. S. BURLEIGH (ed. and trans.). *Augustine: Earlier Writings*. (Library of Christian Classics, 6.) London and Philadelphia, 1953.
- _____. *Dialogus Quaestionum LXV*. In MIGNE, *P.L.*, vol. 40, cols. 733–52.
- _____. *Enarrationes in Psalmos*. In MIGNE, *P.L.*, vols. 36, 37. For translation, see: S. HOBGIN and F. CORRIGAN (trans.). *St. Augustine on the Psalms*. Westminster (Md.) and London, 1960–. 2 vols. published.
- “Aurea hora.” See “Aurora consurgens.”
- “Aurelia occulta.” See (A) *Theatrum chemicum*, xxvi.
- “Aurora consurgens.” See (A) *Artis auriferae*, iv; Codices and MSS., xvii; FRANZ, M.-L. VON.
- AVALON, ARTHUR, pseud. (Sir John Woodroffe) (ed. and trans.). *The Serpent Power* (Shat-cakra-nirūpana and Pādukāpañchaka). (Tantrik Texts.) London, 1919.
- AVICENNA. See “Tractatulus Avicennae,” in (A) *Artis auriferae*, ix.
- BARING-GOULD, SABINE. *Curious Myths of the Middle Ages*. London, 1869.

- Barnabas, Epistle of. See LAKE, KIRSOPP.
- BAYNES, CHARLOTTE AUGUSTA. *A Coptic Gnostic Treatise contained in the Codex Brucianus—Bruce MS. 96, Bodleian Library, Oxford*. Cambridge, 1933.
- BELLETÊTE, _____ (trans.). *Contes turcs en langue turque, extraits du roman intitulé “Les Quarante Vizirs.”* [By Shaikh-zadah or Şeyhzada.] Paris, 1812.
- BENOIT, PIERRE. *Atlantida*. Translated by M. C. Tongue and Mary Ross. New York, 1920.
- BERNARD, SAINT. *Sermones de tempore*. In MIGNE, P.L., vol. 183, cols. 35–359.
- BERNARDUS TREVISANUS. “De chemico miraculo (De alchimia).” See (A) *Theatrum chemicum*, xii.
- BÉROALDE DE VERVILLE, FRANÇOIS (trans.). *Le Tableau des riches inventions couvertes du voile des feintes amoureuses, qui sont représentées dans le Songe de Poliphile*. . . Paris, 1600.
- BERTHELOT, MARCELLIN. *La Chimie au moyen âge*. (Histoire des sciences.) Paris, 1893. 3 vols.
 _____. *Collection des anciens alchimistes grecs*. Paris, 1887–88. 3 vols.
 _____. *Les Origines de l’alchimie*. Paris, 1885.
- BEZOLD, CARL (ed. and trans.). *Mě’arrath Gazzē. Die Schatzhöhle*. Leipzig, 1883–88. 2 parts.
- [Bhagavadgītā.] *The Bhagavadgītā, with the Sanatsugātiya and the Anugītā*. Translated by Kashinath Trimbak Telang. (Sacred Books of the East, 8.) Oxford, 1882. Another version: SWAMI PRABHAVANANDA and CHRISTOPHER ISHERWOOD (trans.). *The Song of God*. London, 1947. (Also, with differing pagination, Hollywood, 1944.)
- BODENSTEIN, ADAM VON. *Onomasticon*. See: *Dictionarium Theophrasti Paracelsi . . . a Gerardo Dorneo collectum*. Frankfurt a. M., 1583.
- [BÖHME, [JAKOB.] *XL Questions concerning the Soule*. Propounded by Dr. Balthasar Walter. And answered, by Jacob Behmen. [Translated by John Sparrow.] London, 1665.
- BONUS, PETRUS. *Pretiosa margarita novella de thesauro ac pretiosissimo philosophorum lapide*. . . . Edited by Janus Lacinius. Venice, 1546. For translation, see: A. E. WAITE. *The New Pearl of Great Price*. London, 1894. See also (A) MANCETUS, *Bibliotheca chemica curiosa*, vi.
- BOUSSET, WILHELM. *Hauptprobleme der Gnosis*. (Forschungen der Religion und Literatur des Alten und Neuen Testaments, 10.) Göttingen, 1907.
- BRACESCHUS, JOHANNES. “Lignum vitae.” See (A) MANGETUS, *Bibliotheca chemica curiosa*, iv.
- “Brevis manuductio.” See (A) *Musaeum hermeticum*, xiii.
- Brihadāranyaka Upanishad. See HUME.
- BUDGE, ERNEST ARTHUR WALLIS. *Amulets and Superstitions*. London, 1930.
 _____. (ed. and trans.). *The Book of the Dead*. An English translation of the Theban Recension. (Books on Egypt and Chaldaea, 6, 7, 8.) 2nd edn., London, 1909. 3 vols.
 _____. *The Gods of the Egyptians*. London, 1904. 2 vols.
- Bundahish. In: E. W. WEST (trans.). *Pahlavi Texts*, vol. I (Sacred Books of the East, 5.) Oxford, 1880–97.
- CAESARIUS OF HEISTERBACH. *Dialogus miraculorum*. Edited by Joseph Strange. Cologne, 1851. For translation, see: H. VON E. SCOTT and C.C.S. BLAND (trans.). *Dialogue on Miracles*. London, 1929.

CALID. "Liber secretorum." See (A) *Artis auriferae*, vii.

"Canticum de creatione." see HORSTMANN.

CARTER, JAMES BENEDICT. *Epitheta Deorum quae apud Poetas Latinas leguntur. (Ausführliches Lexikon der griechischen und römischen Mythologie, ed. W. H. Roscher, Supplement.)* Leipzig, 1902.

CASSIODORUS, MARCUS AURELIUS. *Historia Tripartita*. In MIGNE, P.L., vol. 70, cols. 879–1214.

CHARLES, ROBERT HENRY (ed.). *The Apocrypha and Pseudepigrapha of the Old Testament in English*. Oxford, 1913. 2 vols.

CHAUCER, GEOFFREY. *The Complete Works*. Edited by F. N. Robinson. (Student's Cambridge Edition.) Boston, 1933.

Chhândogya Upanishad. In: *The Upanishads*. Translated by F. Max Müller. (Sacred Books of the East, 1, 15.) Oxford, 1900. 2 vols. (Vol. 1, 1–144.)

CHRÉTIEN DE TROYES. See HILKA.

CHRISTENSEN, ARTHUR (EMANUEL). *Les Types du premier homme et du premier roi dans l'histoire légendaire des Iraniens*. (Archives d'études orientales, 14.) Stockholm, 1917, 1934. 2 parts.

CHWOLSOHN, DANIEL (Khwol'son, Daniil Avraamovich). *Die Ssabier und der Ssabismus*. St. Petersburg, 1856. 2 vols.

CIBINENSIS (SZE BENY), NICHOLAS MELCHIOR. "Addam et processum sub forma missae." See (A) *Theatrum chemicum*, xxi.

CICERO, MARCUS TULLIUS. *De natura deorum*. In: *M. Tullii Ciceronis Scripta quae manserunt omnia*, ed. C. F. W. Müller, Part IV, vol. 2. Leipzig, 1878. (pp. 1–142.)

Codices and Manuscripts.

- i Basel. University Library. AX. 128b. Contains "De arbore contemplationis."
- ii _____. _____. "Alchymistisches MS."
- iii Berlin. Codex Berolinensis Latinus 532.
- iv _____. Codex Berolinensis Latinus Q. 584.
- v Leiden. University Library. Codex Vossianus Chemicus 520 (29). 16th cent.
- vi London. British Museum. MS. Additional 10302. 16th cent.
- vii _____. _____. MS. Sloane 5025. 1588. "Four Rolls Drawn in Lübeck" (The Ripley Scrowle).
- viii _____. _____. MS. Additional 15268. 13th cent. "Le Livre des Ansienes Estoires."
- ix Munich. Staatsbibliothek. Codex Germanicus 598. 1420. "Das Buch der heiligen Dreifaltigkeit und Beschreibung der Heimlichkeit von Veränderung der Metallen."
- ix-a New Haven. Yale University Library. German alchemical ms. (Mellon Coll.). c. 1600.
- x Paris. Bibliothèque nationale. MS. gr. 2250.
- xi _____. _____. MS. gr. 2252.
- xii _____. _____. MS. gr. 2419.
- xiii _____. Bibliothèque Ste. Geneviève. MS. 2263–64. "Lapidis philosophorum nomina."

- xiv St. Gall. Codex N. Vadiensis 390. 15th cent. Contains the “Turba philosophorum.”
- xv _____. Codex Germanicus Alchemicus Vadiensis. 16th cent.
- xvi Vatican. Codex Vaticanus Latinus 7286. 17th cent.
- xvii Zurich. Zentralbibliothek. Codex Rhenoviensis 172. 15th cent. “Aurora consurgens.”
- COLONNA, FRANCESCO. *Hypnerotomachia Poliphili* . . . Venice, 1499. For French translation, see BÉROALDE DE VERVILLE; for English paraphrase, see FIERZ-DAVID.
- “Consilium coniugii.” See (A) *Ars chemica*, iii.
- COOMARASWAMY, ANANDA K. “The Inverted Tree,” *Quarterly Journal of the Mythic Society* (Bangalore), XXIX (1938–39), 111–49.
- Corpus Hermeticum. See SCOTT, *Hermética*.
- CRAWLEY, ALFRED ERNEST. *The Idea of the Soul*. London, 1909.
- CUMONT, FRANZ. *Testes et monuments figurés relatifs aux mystères de Mithra*. Brussels, 1894–99. 2 vols.
- “De arte chymica.” See (A) *Artis auriferae*, x.
- De chemia*. See ZADITH SENIOR.
- “Declaratio et explicatio Adolphi.” See “Aurelia occulta.”
- DEE, JOHN. “Monas hieroglyphica.” See (A) *Theatrum chemicum*, xvi.
- DEURSEN, ARIE VAN. *Der Heilbringer*. (Dissertation.) Groningen, 1931
- DEUSSEN, PAUL. *Allgemeine Geschichte der Philosophie*. Leipzig, 1894–1917. 2 vols. in 6 parts.
- “Dicta Belini.” See “Allegoriae sapientum.” See also (A) MANGETUS, *Bibliotheca chemica curiosa*, ii.
- DIETERICH, ALBRECHT. *Eine Mithrasliturgie*. Leipzig, 1903.
- [DIOSCORIDES.] *Petri Andreae Matthioli Medici Senensis Commentarū in libros sex Pedacii Dioscoridis Anazarbei de medica materia*. Venice, 1554.
- DJĀBIR IBN HAYYĀN. “Le Livre du Mercure oriental. . . .” In BERTHELOT, *Moyen âge*, vol. 3, pp. 214f.
- DORN, GERARD. “Congeries Paracelsicae chemicae.” See (A) *Theatrum chemicum*, ix.
- _____. “De tenebris contra naturam et vita brevi.” See (A) *Theatrum chemicum*, vii.
- _____. “Duellum animi cum corpore.” See (A) *Theatrum chemicum*, viii.
- _____. “De genealogia mineralium.” See (A) *Theatrum chemicum*, x.
- _____. “Philosophia chemica.” See (A) *Theatrum chemicum*, vi.
- _____. “Physica genesis.” See (A) *Theatrum chemicum*, iii.
- _____. “Physica Trismegisti.” See (A) *Theatrum chemicum*, iv.
- _____. “Physica Trithemii.” See (A) *Theatrum chemicum*, v.
- _____. “Speculativa philosophia.” See (A) *Theatrum chemicum*, ii.
- _____. See also PARACELUS, *De vita longa*.
- DOZY, REINHART, and DE GOEJE, M. J. “Nouveaux documents pour l’étude de la religion des Harraniens.” *Actes du sixième congrès international des Orientalistes, 1883*. London, 1885.

- DU CANCE, CHARLES DU FRESNE. *Glossarium ad scriptores mediae et infimae Latinitatis*. 1733–36. 6 vols. New edn., Graz, 1954. 10 vols. in 5.
- EISLER, ROBERT. *Weltenmantel und Himmelszelt*. Munich, 1910. 2 vols.
- ELEAZAR, ABRAHAM. *Uraltes chymisches Werck*. Leipzig, 1760. (Part II has separate pagination.)
- El-Habib, Book of. See BERTHELOT, *Chimie au moyen âge*, III.
- ELIADE, MIRCEA. *Shamanism: Archaic Techniques of Ecstasy*. Translated from the French by Willard R. Trask. New York (Bollingen Series) and London 1964.
- [ELIEZER BEN HYRCANUS.] *Pirkê de Rabbi Eliezer*. Translated and edited by Gerald Friedlander. London and New York, 1916.
- Elijah, Apocalypse of. See Apocalypse of Elias.
- Enoch, Book of. See CHARLES, *Apocrypha and Pseudepigrapha*.
- EPIPHANIUS. *Ancoratus und Panarium*. Edited by Karl Holl. (Griechische Christliche Schriftsteller.) Leipzig, 1915–33. 3 vols. (*Ancoratus*, vol. I, pp. 1–149; *Panarium*, vol. I, p. 169 through vol. III).
- “Epistola ad Hermannum.” See (A) *Theatrum chemicum*, xxxii.
- EUCHERIUS, BISHOP OF LYONS. *Liber formularum spiritalis intelligentiae*. In MIGNE, P.G., vol. 50, cols. 727–72.
- EURIPIDES. “The Cretans” (fragment). In DIETERICH, q.v.
- EUTHYMIOS ZIGABENOS. *Panoplia dogmatica*. In MIGNE, P.G., vol. 130, cols. 129ff.
- EUTYCHIUS, PATRIARCH OF ALEXANDRIA. *Annales*. In MIGNE, P.G., vol. III, cols. 907–1156.
- EVANS-WENTZ, W. Y. (ed.). *The Tibetan Book of the Dead*. With a Psychological Commentary by C. G. Jung. 3rd edn., London and New York, 1957.
- “Exercitationes in Turbam.” See (A) *Artis auriferae*, iii.
- Ezra, Fourth Book of. See CHARLES, *Apocrypha and Pseudepigrapha*.
- FERGUSON, JOHN. *Bibliotheca chemica*. Glasgow, 1906. 2 vols.
- FERGUSON, JAMES. *Tree and Serpent Worship*. London, 1868.
- FIGINO, MARSILIO. *De vita libri tres*. Basel, 1549.
- FIERZ-DAVID, LINDA. *The Dream of Poliphilo*. Translated by Mary Hottinger. New York (Bollingen Series) and London, 1950.
- FIGULUS, BENEDICTUS. *Paradisus aureolus hermeticus*. . . . Frankfurt a. M., 1608.
- _____. *Rosarium novum olympicum et benedictum*. Basel, 1608.
- FIRMICUS MATERNUS, JULIUS. *Liber de errore profanarum religionum*. See: *M. Minucii Felicis Octavii et Julii Firmici Materni Liber de errore profanarum religionum*. Ed. Karl Halm. (Corpus scriptorum ecclesiasticorum latinorum, 2.) Vienna, 1867.
- FLAMEL, NICOLAS. “Summarium philosophicum.” See (A) *Musaeum hermeticum*, iii.
- “Fons chymicae veritatis.” See (A) *Musaeum hermeticum*, xiv.
- FRANZ, MARIE-LOUISE VON (ed.). *Aurora Consurgens: A Document Attributed to Thomas Aquinas on the Problem of Opposites in Alchemy*. Translated by R. F. C. Hull and A. S. B. Glover. New York (Bollingen Series) and London,

1966.

- _____. "Die Passio Perpetuae." In: C. G. JUNG. *Aion*. (Psychologische Abhandlungen, 8.) Zurich, 1951.
- FRAZER, JAMES G. *The Golden Bough*. London, 1911–15. 12 vols. (Part I: *The Magic Art*, vols. 1 and 2. Part IV: *Adonis, Attis, Osiris*, vols. 5, 6.)
- _____. *Totemism and Exogamy*. London, 1910. 4 vols.
- FROBENIUS, LEO. *Das Zeitalter des Sonnengottes*. Vol. I (no more published). Berlin, 1904.
- GALEN, CLAUDIUS. *De simplicium medicamentorum facultatibus libri XI*. Lyons, 1561.
- GAUDENTIUS, SAINT. *Sermo XIX*. In MIGNE, *P.L.*, vol. 20, cols. 981–93.
- GEBER. *Summae perfectionis*. See (A) *De alchemia* (1541), i.
- [GESSNER, CONRAD.] *Epistolarum medicinalium Conradi Gesneri, philosophi et medici . . . Libri III*. Tiguri [Zurich], 1577.
- "Gloria mundi." See (A) *Musaeum hermeticum*, v.
- GODFREY (GODEFRIDUS), ABBOT OF ADMONT. *Homilia III in Dominica I Adventus*. In MIGNE, *P.L.*, vol. 174, cols. 32–36.
- _____. *Homilia LXIII in Vigiliam Assumptionis*. In MIGNE, *P.L.*, vol. 174, cols. 957–59.
- GOETHE, JOHANN WOLFGANG VON. *Faust*. An abridged version. Translated by Louis MacNeice. London, 1951.
- _____. *Faust: Part Two*. Translated by Philip Wayne. Harmondsworth, 1959.
- GOURMONT, RÉMY DE. *Le Latin mystique*. 4th edn., Paris, 1930.
- GRAY, RONALD D. *Goethe the Alchemist*. Cambridge, 1952.
- GREGORY THE GREAT, SAINT. *Moralia in Job*. In MIGNE, *P.L.*, vol. 75, col. 509–vol. 76, col. 782.
- _____. *In septem Psalmos penitentiales expositio*. In MIGNE, *P.L.*, vol. 79, cols. 549–658.
- _____. *Super Cántica Cantorum expositio*. In MIGNE, *P.L.*, vol. 79, cols. 471–548.
- GREVERUS, JODOCUS. "Secretum." See (A) *Theatrum chemicum*, xx.
- GRIMM, JACOB. *Teutonic Mythology*. Translated by James Steven Stallybrass. London, 1880–88. 4 vols.
- [GRIMM, JACOB AND WILHELM.] *Grimm's Fairy Tales*. Translated by Margaret Hunt and revised by James Stern. New York, 1944.
- GRÜNBAUM, MAX. *Jüdisch-deutsche Chrestomathie*. Leipzig, 1882.
- HAGGARD, HENRY RIDER. *She*. London, 1887.
- HAPPELIUS, NICOLAUS NIGER. "Aphorismi Basiliani." See (A) *Theatrum chemicum*, xxiii.
- HASTINGS, JAMES (ed.). *Encyclopaedia of Religion and Ethics*. Edinburgh and New York, 1908–27. 13 vols.
- HEGEMONIUS. *Acta Archelai*. Edited by Charles Henry Beeson. (Griechische Christliche Schriftsteller.) Leipzig, 1906.
- HERMES TRISMEGISTUS. "Tabula smaragdina." See (A) *De alchemia* (1541), ii.
- _____. "Tractatus aureus." See (A) *Ars chemica*, i; MANGETUS, *Bibliotheca chemica curiosa*, i; *Musaeum hermeticum*, i; *Theatrum chemicum*, xxvii.
- HERMOLAUS BARBARUS. *Corollarium in Dioscoridem*. See MAIER, *Symbola aureae mensae*.
- HILDEGARD OF BINGEN. *Acta*. In MIGNE, *P.L.*, vol. 197, col. 18.

- HILKA, ALFONS. *Der altfranzösische Prosa-Alexander-Roman nach der Berliner Bildhandschrift*. Halle, 1920.
- _____ (ed.). *Der Percevalroman (Li Contes del Graal)*. Von Christian von Troyes. (Christian von Troyes, Sämtliche erhaltene Werke, ed. Wendelin Foerster, 5.) Halle, 1932.
- HIPPOLYTUS. *Elenchos*. See: *Hippolytus' Werke*. Vol. III. Edited by Paul Wendland. (Griechische Christliche Schriftsteller.) Leipzig, 1916. For translation, see: *Philosophumena, or, The Refutation of All Heresies*. Translated by Francis Legge. (Translations of Christian Literature.) London and New York, 1921. 2 vols.
- HOGHELANDE, THEOBALD DE. "De alchemiae difficultatibus." See (A) *Theatrum chemicum*, i.
- HOLMBERG, UNO. *Der Baum des Lebens*. In: *Annales Academiae Scientiarum Fennicae*, Series B, vol. 16. Helsinki, 1922–23.
- HOLMYARD, ERIC JOHN. See ABU'L QĀSIM.
- HONORIUS OF AUTUN. *Speculum de mysteriis ecclesiae*. In MIGNE, P.L., vol. 172, cols. 807–1108.
- HORACE. *Epistola* I.
- [HORAPOLLO NILIACUS.] *The Hieroglyphics of Horapollo*. Translated by George Boas. New York (Bollingen Series), 1950.
- HORSTMANN, CARL. *Sammlung altenglischer Legenden*. Heilbronn, 1878–81. 2 vols. ("Canticum de creatione," vol. I, pp. 124–38.)
- HORTULANUS. "Commentarius" or "Commentariolum." See (A) *Ars chemica*, ii; *De alchemia* (1541), iii.
- HUME, ROBERT ERNEST (trans.). *The Thirteen Principal Upanishads*. 1921.
- Hymns of the Atharva-Veda*. Translated by M. Bloomfield. (Sacred Books of the East, 42.) Oxford, 1897.
- HYSLOP, JAMES H. *Science and a Future Life*. Boston, 1905.
- I Ching, or Book of Changes*. The Richard Wilhelm [German] translation rendered into English by Cary F. Baynes. New York (Bollingen Series), 1950; London, 1951. 2 vols.; 3rd edn. in 1 vol., 1967.
- [_____.] *The Yi King*. Translated by James Legge. (Sacred Books of the East, 16.) 2nd edn., Oxford, 1899.
- [IGNATIUS LOYOLA, SAINT.] *The Spiritual Exercises of St. Ignatius Loyola*. Edited and translated by Joseph Rickaby, S.J. 2nd edn., London, 1923.
- "Instructio de arbore solari." See (A) *Theatrum chemicum*, xxxiv.
- "Introitus apertus." See (A) *Musaeum hermeticum*, x.
- IRENÆUS. *Adversus [or Contra] haereses libri quinque*. In MIGNE, P.G., vol. 7, cols. 433–1224. For translation, see: *The Writings of Irenaeus*. Translated by Alexander Roberts and W. H. Rambaut. (Ante-Nicene Christian Library, 5, 9.) Edinburgh, 1868–69. 2 vols.
- "Isis to Horus." See SCOTT, *Hermetica*.
- JACOBSOHN, HELMUTH. *Die dogmatische Stellung des Königs in der Theologie der alten Aegypter*. (Aegyptologische Forschungen, herausgegeben von Alexander Scharff, 8.) Gluckstadt, Hamburg, and New York, 1939.
- JAFFÉ, ANIELA. "Bilder und Symbole aus E. T. A. Hoffmanns Märchen 'Der Goldne Topf.'" In: C. G. Jung. *Gestaltungen des Unbewussten*. (Psychologische Abhandlungen, 8.) Zurich, 1950.
- JUNG, CARL GUSTAV. *Aion: Researches into the Phenomenology of the Self. Collected Works*,* vol. 9, part ii.
- _____. "Answer to Job." In: *Collected Works*, vol. 11.

- _____. "The Archetypes of the Collective Unconscious." In: *Collected Works*, vol. 9, part i.
- _____. "Concerning Mandala Symbolism." In: *Collected Works*, vol. 9, part i.
- _____. "Concerning Rebirth." In: *Collected Works*, vol. 9, part i.
- _____. *Memories, Dreams, Reflections*. Recorded by Aniela Jaffé. Translated by Richard and Clara Winston. New York and London, 1963.
- _____. *Mysterium Coniunctionis*. *Collected Works*, vol. 14.
- _____. "On the Nature of the Psyche." In: *Collected Works*, vol. 8.
- _____. "Paracelsus the Physician." In: *Collected Works*, vol. 15.
- _____. "The Phenomenology of the Spirit in Fairytales." In: *Collected Works*, vol. 9, part i.
- _____. *Psychiatric Studies*. *Collected Works*, vol. 1.
- _____. "A Psychological Approach to the Dogma of the Trinity." In: *Collected Works*, vol. 11.
- _____. *Psychological Types*. *Collected Works*, vol. 6. Alternative source: Translation by H. G. Baynes. New York and London, 1923.
- _____. *Psychology and Alchemy*. *Collected Works*, vol. 12.
- _____. "The Psychology of Dementia Praecox." In: *Collected Works*, vol. 3.
- _____. "Psychology and Religion." In: *Collected Works*, vol. 11.
- _____. *Psychology and Religion: West and East*. *Collected Works*, vol. 11.
- _____. "The Psychology of the Transference." In: *Collected Works*, vol. 16.
- _____. "Richard Wilhelm: In Memoriam." In: *Collected Works*, vol. 15.
- _____. *The Spirit in Man, Art, and Literature*. *Collected Works*, vol. 15.
- _____. "A Study in the Process of Individuation." In: *Collected Works*, vol. 9, part i.
- _____. *Symbols of Transformation*. *Collected Works*, vol. 5.
- _____. "Transformation Symbolism in the Mass." In: *Collected Works*, vol. 11.
- _____. *Two Essays on Analytical Psychology*. *Collected Works*, vol. 7.
- _____. See also PAULI; WILHELM.
- KAGAROW, EUGEN. "Der umgekehrte Schamanerbaum," *Archiv für Religionswissenschaft* (Leipzig and Berlin), XXVII (1929), 183–85.
- KERN, OTTO (ed.). *Orphicorum fragmenta*. Berlin, 1922.
- KHUNRATH, HENRICUS (HEINRICH). *Amphitheatrum sapientiae aeternae*. Hanau, 1609.
- _____. *Von hylealischen Chaos*. Magdeburg, 1597.
- KIRCHER, ATHANASIVS. *Mundus subterraneus*. Amsterdam, 1678. 2 vols.
- KNORR VON ROSENROTH, CHRISTIAN. *Kabbala Denudata*. Sulzbach and Frankfurt a. M., 1677–84. 2 vols.
- KNUCHEL, EDUARD FRITZ. *Die Umwandlung in Kult, Magie und Rechtsbrauch*. (Schriften der Schweizerischen Gesellschaft für Volkskunde, 15.) Basel, 1919.
- KOMARIOS. See BERTHELOT, *Collection des anciens alchimistes grecs*, Treatise IV.
- KOPP, HERMANN. *Die Alchemie in älterer und neuerer Zeit*. Heidelberg, 1886. 2 vols.

- Koran. Translated by N. J. Dawood. Harmondsworth, 1956.
- Krates, Book of. See BERTHELOT, *La Chimie au moyen âge*, vol. III.
- KRICKEBERG, W. (ed. and trans.). *Indianermärchen aus Nordamerika*. (Die Märchen der Weltliteratur.) Jena, 1924.
- _____. *Märchen der Azteken, Inka, Maya und Muiska*. (Die Märchen der Weltliteratur.) Jena, 1928.
- KRUEGER, GUSTAV. *Das Dogma von der Dreieinigkeit und Gottmenschheit in seiner geschichtlichen Entwicklung dargestellt*. (Lebens-fragen; Schriften und Reden, edited by Heinrich Weinel.) Tübingen, 1905.
- LACINIUS. See BONUS.
- LAKE, KIRSOPP (ed. and trans.). *The Apostolic Fathers*. (Loeb Classical Library.) London and New York, 1914. 2 vols.
- ("Epistle of Barnabas," I, 340–409.)
- "Lambspringk, The Book of." See (A) *Musaeum hermeticum*, vi.
- LASZLO, VIOLET S. DE (ed.). *Psyche and Symbol: A Selection from the Writings of C. G. Jung*. Garden City, N.Y., 1958.
- [LAZARELLO, LUDOVICUS.] *Contenta in hoc volumine: Pimander Mercurü Trismegisti . . . Asclepius ejusdem Mercurii . . . item Crater Hermetis a Lazarelo Septempedano*. (No date or place.) (Folios 32–42^r.)
- LÉVY-BRUHL, LUCIEN. *Primitive Mentality*. Translated by Lilian A. Clare. London and New York, 1923.
- "Lignum vitae." See BRACESCHUS.
- LIPPMANN, EDMUND O. VON. *Entstehung und Ausbreitung der Alchemie*. Berlin, 1919–54. 3 vols.
- LULLY, RAYMOND. "Codicillus." See (A) Mangetus, *Bibliotheca chemica curiosa*, iii.
- MAIER, MICHAEL. *De circulo physico quadrato*. Oppenheim, 1616.
- _____. *Secretioris naturae secretorum scrutinium chymicum*. Frankfurt a. M., 1687.
- _____. "Subtilis allegoria super secreta chymiae." See (A) *Musaeum hermeticum*, xi.
- _____. *Symbola aureae mensae duodecim nationum*. Frankfurt a. M., 1617.
- MAITLAND, EDWARD. *Anna Kingsford: Her Life, Letters, Diary, and Work*. London, 1896. 2 vols.
- Maitrayana-Brāhmana Upanishad. In: *The Upanishads*. Translated by F. Max Müller. (Sacred Books of the East, 1, 15.) Oxford, 1900. 2 vols. (Vol. 2, pp. 287–346.)
- MARIA PROPHETISSA. "Practica." See (A) *Artis auriferae*, vi.
- MARSILIO FICINO. *De vita libri tres*. Basel, 1549.
- MARTIAL (Marcus Valerius Martialis). *Epigrammata*. Edited by Walter Gebert. Leipzig, 1896.
- MATTHEWS, WASHINGTON. "The Mountain Chant: A Navajo Ceremony." *Fifth Annual Report of the Bureau of Ethnology, 1883–84*. Washington, 1887. (Pp. 385–467.)
- MEAD, G. R. S. *The Doctrine of the Subtle Body in Western Tradition*. London, 1919.
- MECHTHILD OF MAGDEBURG. *Liber gratiae spiritualis*. Venice, 1578.
- MELCHIOR OF BRIXEN. "Vom dem Gelben und Rotten Mann." See (A) *Aureum vellus*, ii.
- MELCHIOR CIBINENSIS (SZEKENYI), NICHOLAS. "Addam et processum sub forma missae. See (A) *Theatrum chemicum*,
xxi.
- MICHELSPACHER, STEFFAN. *Cabala, speculum artis et naturae, in alchymia*. Augsburg, 1654. (German version: *Cabala, Spiegel der Kunst und Natur: in Alchymia*. Augsburg, 161, 1616.)

MIGNE, JACQUES PAUL (ed.). *Patrologiae cursus completus*.

[P.L.] Latin series. Paris, 1844–64. 221 vols.

[P.G.] Greek series. Paris, 1857–66. 166 vols.

(These works are referred to as “Migne, P.L.” and “Migne, P.G.” respectively.)

[Missal.] *The Missal in Latin and English*. Edited by J. O’Connell and H.P.R. Finberg. London, 1949.

MORIENUS ROMANUS. “De transmutatione metallorum.” See (A) *Artis auriferae*, xi.

MÜLLER, MARTIN. . . . *Paracelsus Sämtliche Werke: Erste Abteilung. Registerband*. (Nova Acta Paracelsica, Supplementum.) Einsiedeln, 1960.

“Mutus liber.” See ALTUS.

MYLIUS, JOHANN DANIEL. *Philosophia reformata*. Frankfurt a. M., 1622.

NAZARI, GIOVANNI BATTISTA, *Della tramutatione metallica sogni tre*. Brescia, 1599.

NEALE, J. M. *Collected Hymns, Sequences and Carols*. London, 1914.

NELKEN, JAN. “Analytische Beobachtungen über Phantasien eines Schizophrenen,” *Jahrbuch für psychoanalytische und psychopathologische Forschungen* (Vienna and Leipzig), IV (1912), 504–62.

NEUMANN, ERICH. *Amor and Psyche: The Psychic Development of the Feminine*. A Commentary on the tale by Apuleius. Translated by Ralph Manheim. New York (Bollingen Series) and London, 1956.

NIETZSCHE, FRIEDRICH WILHELM. *Thus Spake Zarathustra*. See: *The Portable Nietzsche*. Selected and translated by Walter Kaufmann. New York, 1954.

NINCK, MARTIN. *Götter und Jenseitsglauben der Germanen*. Jena [1937].

NORTON, THOMAS. “The Ordinal of Alchemy.” See (A) *Musaeum hermeticum*, viii; (A) *Theatrum chemicum britannicum*, i.

“Novum lumen chemicum.” See (A) *Musaeum hermeticum*, ix.

OLYMPIODORUS. See BERTHELOT, *Collection des anciens alchimistes grecs*, Treatise II.

ONIANS, RICHARD BROXTON. *The Origins of European Thought*. 2nd edn., Cambridge, 1954.

“Opusculum authoris ignoti.” See (A) *Artis auriferae*, viii.

ORTHELIUS. “Epilogus.” See (A) *Theatrum chemicum*, xxxv.

OSTANES. See BERTHELOT, *La Chimie au moyen âge*, vol. III; *Collection des anciens alchimistes grecs*, Treatises III, IV.

PANTHEUS. *Ars transmutationis metallicae*. Venice, 1519.

PARACELSUS (Theophrastus Bombast of Hohenheim). *Theophrast von Hohenheim genannt Paracelsus Sämtliche Werke*. First section: *Medizinische, naturwissenschaftliche und philosophische Schriften*. Edited by Karl Sudhoff and Wilhelm Matthiessen. Munich and Berlin, 1922–33. 14 vols. Second section: *Theologische und religionsphilosophische Schriften*. Edited by Karl Sudhoff, Wilhelm Matthiessen, and K. Goldammer. Munich and Wiesbaden, 1923–. 5 vols. published. (In the references below, this edn. is cited as “Sudhoff”; all vols. are in the first section except “De religione perpetua.”)

_____. *Aureoli Philippi Theophrasti Bombasts von Hohenheim Paracelsi . . . Philosophi et Medici Opera Bücher und Schriften*. Strasbourg, 1603–16. 2 vols. (In the references below, this edn. is cited as “Huser.”)

_____. “Archidoxis magicae.” In: Huser, II, 544–73.

- _____. *Astronomia magna*. In: Sudhoff, XII, 1–444.
- _____. “Das Buch Meteorum.” In: Huser, II, 69–96.
- _____. “Caput de morbis somnii.” In: Sudhoff, IX, 359–62.
- _____. “De caducis.” In: Sudhoff, VIII, 263–308; Huser, I, 589–607.
- _____. “De morbis amentium.” In: Huser, I, 486–506.
- _____. “De natura rerum.” In: Sudhoff, XI, 309–403.
- _____. “De nymphis.” In: Sudhoff, XIV, 115–51; see also “De pygmaeis,” below.
- _____. “De pestilitate.” In: Huser, I, 326–56.
- _____. “De podagricis.” In: Huser, I, 563–77.
- _____. “De pygmaeis.” See “Liber de nymphis, sylphis, pygmaeis, et salamandris, et de caeteris spiritibus,” in Huser, II, 180–92.
- _____. “De religione perpetua.” In: Sudhoff, Part 2, I, 89–107.
- _____. “De sanguine ultra mortem.” In: Huser, II, 267–71.
- _____. “De tartaro: Fragmenta anatomiae.” In: Sudhoff, III, 461–76.
- _____. *De vita longa*. In: Sudhoff, III, 249–92. Other editions: (1) Edited by Adam von Bodenstein. Basel, 1562. (2) *Theophrasti Paracelsi Libri V de Vita Longa*. Edited by Gerard Dorn. Frankfurt a. M., 1583.
- _____. “Fragmenta.” In: Sudhoff, III, 292–308.
- _____. “Fragmenta medica.” In: Huser, I, 131–69.
- _____. “Labyrinthus medicorum errantium.” In: Sudhoff, XI, 161–221.
- _____. “Liber Azoth.” In: Huser, II, 519–43.
- _____. *Das Buch Paragranum*. Edited by Franz Strunz. Leipzig, 1903.
- _____. *Paramirum primum*. In: Sudhoff, I, 163–239.
- _____. “Philosophia ad Athenienses.” In: Huser, II, 1–19.
- _____. “Von der Astronomiey.” In: Huser, I, 212–18.
- _____. “Von den dreyen ersten essentiis.” In: Huser, I, 323–26.
- _____. “Von Erkantnus des Gestirns.” In: Sudhoff, XII, 495–98.
- _____. *The Hermetical and Alchemical Writings of Aureolus Philippus Theophrastus Bombast of Hohenheim, called Paracelsus the Great*. Translated by A. E. Waite. London, 1894. 2 vols.
- PAULI, W. “The Influence of Archetypal Ideas on the Scientific Theories of Kepler.” Translated by Priscilla Silz. In: C. G. JUNG and W. PAULI, *The Interpretation of Nature and the Psyche*. New York (Bollingen Series) and London, 1955.
- PAULINUS OF NOLA. *Poemata*. In MIGNE, *P.L.*, vol. 61, cols. 437–710.
- PAUSANIAS. *Descriptio Graeciae*. Edited by Friedrich Spiro. Leipzig, 1903. 3 vols.
- PENOTUS. “De medicamentis chemicis.” See (A) *Theatrum chemicum*, xi.
- _____. Table of Symbols. See (A) *Theatrum chemicum*, xiv.
- PERNETY, A. J. *Dictionnaire mytho-hermétique*. Paris, 1787.
- _____. *Les Fables égyptiennes et grecques*. Paris, 1758. 2 vols.

- PETRIE, WILLIAM FLINDERS. *Egyptian Tales, translated from the Papyri*. London, 1895. 2 series.
- PHILALETHES, EIRENAEUS. "Brevis manuductio ad rubinum caelestem." See (A) *Musaeum hermeticum*, xiii.
- _____. "Fons chymicae veritatis." See (A) *Musaeum hermeticum*, xiv.
- _____. "Introitus apertus." See (A) *Musaeum hermeticum*, x.
- _____. "Metallorum metamorphosis." See (A) *Musaeum hermeticum*, xii.
- PHILO. "De opificio mundi" ("On the Account of the World's Creation given by Moses"). In: *Works*, translated by T. H. Colson and G. H. Whitaker. (Loeb Classical Library.) New York and London, 1929-. 10 vols. (I, 6-137.)
- PICINELLUS, PHILIPPUS. *Mundus symbolicus*. Cologne, 1687. 2 vols.
- PICO DELLA MIRANDOLA, JOANNES. "De arte cabalistica." In *Opera omnia*, I.
- _____. *Heptaplus*. In *Opera omnia*, I.
- _____. *Opera omnia*. Basel, 1572-73. 2 vols.
- PIERRE, NOËL. *Soleil noir*. Paris, 1952.
- Pirkê de Rabbi Eliezer*. See ELIEZER BEN HYRCANUS.
- PITRA, JEAN-BAPTISTE (ed.). *Analecta sacra Spicilegio Solesmensi praeparata*. Paris, 1876-91. 8 vols.
- "Platonis liber quattorum." See (A) *Theatrum chemicum*, xxx.
- POMPONIUS MELA. *Chronographia*. Edited by Carl Frick. Leipzig, 1880.
- PORDAGE, JOHN. *Ein gründlich philosophisch Sendschreiben von rechten und wahren Stein der Weisheit*. In FRIEDRICH ROTH-SCHOLTZ (ed.). *Deutsche Theatrum Chemicum*. Nürnberg, 1728-32. 3 vols. (I, 557-96.)
- _____. *Sophia*. Amsterdam, 1699. (In German: translated from English MS.)
- "Practica Mariae." See (A) *Artis auriferae*, vi.
- PREISENDANZ, KARL. *Papyri Graecae Magicae: Die griechischen Zauberpapyrien*. Berlin, 1928-31. 2 vols.
- PRELLER, LUDWIG. *Griechische Mythologie*. Leipzig, 1854. 2 vols.
- PREUSCHEN, ERWIN. *Antilegomena*. Giessen, 1901.
- [PRISCILLIAN.] *Priscilliani quae supersunt*. Edited by Georg Schepss. (Corpus Scriptorum Ecclesiasticorum Latinorum, 18.) Vienna, Prague, Leipzig, 1889.
- PRITCHARD, JAMES B. (ed.). *Ancient Near Eastern Texts relating to the Old Testament*. 2nd edn., Princeton, 1955.
- Prodromus Rhodostauroticus, Parergi philosophici*. . . . n.d., 1620. (Contains *Verus Hermes*.)
- PSELLUS, MICHAEL. *De daemonibus*. Translated by Marsilio Ficino. 1497.
- RABANUS MAURUS. *Allegoriae in Sacram Scripturam*. In MIGNE, P.L., vol. 112, cols. 850-1088.
- RAHNER, HUGO. "Die seelenheilende Blume." In *Eranos-Jahrbuch XII*, Festgabe für C. G. Jung, Zurich, 1945. (Pp. 117-239.)
- REINACH, SALOMON. *Cultes, mythes, et religions*. Paris, 1905-23. 5 vols.
- REITZENSTEIN, RICHARD. *Alchemistische Lehrschriften und Märchen bei den Arabern*. (Religionsgeschichtliche Versuche und Vorarbeiten, 19, part 3.) Giessen, 1923.
- _____. *Poimandres: Studien zur griechisch-ägyptischen und frühchristlichen Literatur*. Leipzig, 1904.

- _____ and SCHAEDEER, H. *Studien zum antiken Synkretismus aus Iran und Griechenland*. (Studien der Bibliothek Warburg, 7.) Berlin, 1926.
- REUSNER, HIERONYMUS. *Pandora: Das ist, die edelst Gab Gottes, oder der Werde und heilsame Stein der Weysen*. Basel, 1588.
- RHENANUS, JOANNES (ed.). *Solis e puteo emergentis sive dissertationis chymotechnicae libri tres*. Frankfurt a. M., 1613.
- RIPLEY, GEORGE. *Opera omnia chemica*. Cassel, 1649.
- _____. *Chymische Schrifften*. Erfurt, 1624.
- _____. “Duodecim portarum axiomata philosophica.” See (A) *Theatrum chemicum*, xv.
- _____. Preface to “Medulla.” See (A) *Theatrum chemicum britannicum*, iii.
- _____. “Verses belonging to an Emblematicall Scrowle.” See (A) *Theatrum chemicum britannicum*, ii.
- “Rosarium philosophorum.” See (A) *Artis auriferae*, xiii; (A) *De alchimia* (1550); (A) MANGETUS, *Bibliotheca chemica curiosa*, vii.
- ROSCHER, W. H. (ed.). *Ausführliches Lexikon der griechischen und römischen Mythologie*. Leipzig, 1884–1937. 6 vols.
- ROSENCREUTZ, CHRISTIAN (pseud. of Johann Valentin Andreae). *Chymische Hochzeit*. Strasbourg, 1616. For translation, see: *The Hermetick Romance, or The Chymical Wedding*. Translated by E. Foxcroft. London, 1690.
- “Rosinus ad Sarratantam Episcopum.” See (A) *Artis auriferae*, v.
- RULAND, MARTIN. *Lexicon alchemiae sive Dictionarium alchemisticum*. Frankfurt a. M., 1612. For translation, see: *A Lexicon of Alchemy*. London, 1892.
- RUPESCISSA, JOHANNES DE (JEAN DE ROCHETAILLADE OR ROQUETAILLADE). *La Vertu et propriété de la quinte essence de toutes choses*. Lyons, 1581.
- RUSKA, JULIUS (ed.). *Turba Philosophorum*. (Quellen und Studien zur Geschichte der Naturwissenschaften und der Medizin, 1.) Berlin, 1931.
- “Scala philosophorum.” See (A) *Artis auriferae*, xii.
- SCALIGER, JOSEPH JUSTUS. *Animadversiones in Chronologia Eusebii*. In his: *Thesaurus temporum, Eusebii . . . chronicorum canonum . . . libri duo*. 1606.
- SCHEVILL, MARGARET E. *Beautiful on the Earth*. Santa Fe (New Mexico), 1945.
- SCHOPENHAUER, ARTHUR. “On the Fourfold Root of the Principle of Sufficient Reason.” In: *Two Essays by Arthur Schopenhauer*. Translated anonymously. (Bohn’s Philosophical Library.) London, 1889. (Pp. 1–189.)
- SCHREBER, DANIEL PAUL. *Memoirs of My Nervous Illness*. Translated by Ida Macalpine and Richard A. Hunter. (Psychiatric Monograph Series, 1.) London, 1955.
- SCHWEITZER, BERNHARD. *Herakles*. Tübingen, 1922.
- SCOTT, WALTER (ed.). *Hermetica*. Oxford, 1924–36. 4 vols.
- SENDIVOGIUS, MICHAEL (Michal Sendiwoj). “Dialogus Mercurii alchymistae et naturae.” See (A) *Theatrum chemicum*, xxiv.
- _____. “Novum lumen chemicum.” See (A) *Musaeum hermeticum*, ix.
- _____. “Parabola, seu Aenigma philosophicum.” See (A) MANGETUS, *Bibliotheca chemica curiosa*, viii.
- _____. *Tripus chemicus*. Strasbourg, 1628.

- SENIOR. See ZADITH.
- ŞEYHZADE. See BELLETÊTE.
- Shatapatha-Brâhmana*. Translated by Julius Eggeling. (Sacred Books of the East, 12, 26, 41, 43, 44.) Oxford, 1882–1900. 5 vols.
- SPENCE, LEWIS. *The Gods of Mexico*. London, 1923.
- SPENCER, SIR WALTER R., and GILLEN, FRANCIS JAMES. *The Northern Tribes of Central Australia*. London, 1904.
- SPIELREIN, SABINA. “Über den psychologischen Inhalt eines Falls von Schizophrenie.” *Jahrbuch für psychoanalytische und psychopathologische Forschung* (Leipzig and Vienna), III (1912), 329–400.
- SPITTELER, CARL. *Prometheus and Epimetheus*. Translated by James Fullarton Muirhead. London, 1931.
- STEEB, JOHANN CHRISTOPH. *Coelum Sefhiroticum Hebraeorum*. Mainz, 1679.
- STEINDORFF, GEORG (ed.). *Die Apokalypse des Elias*. (Texte und Untersuchungen, N. S., 2, part 3a.) Leipzig, 1899.
- STEINEN, KARL VON DEN. *Unter den Naturvölkern Zentral-Brasiliens*. Berlin, 1894.
- STEVENSON, JAMES. “Ceremonial of Hasjelti Dailjis and Mythical Sand Painting of the Navajo Indians.” *Eighth Annual Report of the Bureau of Ethnology, 1886–87*. Washington, 1891. (Pp. 235–85.)
- STOBAEUS, JOHN. *Anthologium*. Edited by Kurt Wachsmuth and Otto Hense. Berlin, 1884–1912. 5 vols.
- SZEBENY. See CIBINENSIS.
- TABERNAEMONTANUS, JACOBUS THEODORUS. *Kräuterbuch*. [Herbal.] Basel, 1731. 2 vols.
- “Tabula smaragdina.” See HERMES TRISMEGISTUS.
- TALBOT, AMAURY. *In the Shadow of the Bush*. London, 1912.
- TODD, RUTHVEN. “Coleridge and Paracelsus, Honeydew and LSD,” *London Magazine*, March 1967.
- “Tractatulus Avicennae.” See (A) *Artis auriferae*, ix.
- “Tractatus Aristotelis.” See (A) *Theatrum chemicum*, xxxi.
- “Tractatus aureus.” See (A) *Ars chemica*, i; (A) MANGETUS, *Bibliotheca chemica curiosa*, i; *Musaeum hermeticum*, i.
- “Tractatus Micreris.” See (A) *Theatrum chemicum*, xxix.
- TRISMOSIN, SALOMON. “Splendor solis.” See (A) *Aureum vellus*, i. For translation, see: *Splendor solis: Alchemical Treatises of Salomon Trismosin*. With explanatory notes by J. K. London, 1920.
- “Turba philosophorum.” See RUSKA.
- USENER, HERMANN. *Das Weihnachtsfest*. 2nd edn., Bonn, 1911.
- VALENTINUS, BASILIUS. “Practica.” See (A) *Musaeum hermeticum*, vii.
- VECERIUS, CONRADUS. “De rebus gestis Imperatoris Henrici VII.” In: *Germaniae Historicorum ...* Edited by Christianus Urstisius (Wurstisen) of Basel. Frankfurt a. M., 1585. 2 vols. (Vol. II, pp. 63–64.)
- Vedanta-Sutras*. Translated by G. Thibaut. (Sacred Books of the East, 34, 38, 48.) Oxford, 1890–1904. 3 vols.
- VENTURA, LAURENTIUS. “De ratione conficiendi lapidis.” See (A) *Theatrum chemicum*, xvii.
- Verus Hermes*. See *Prodromus Rhodostauroticus*.
- VETTIUS, VALENS. *Anthologiarum libri*. Edited by Wilhelm Kroll. Berlin, 1908.
- “Via veritatis unicae.” See (A) *Musaeum hermeticum*, iv.

VIGENERUS, BLASIUS. “De igne et sale.” See (A) *Theatrum chemicum*, xxxiii.

“Visio Arislei.” See ARISLEUS.

WALDE, ALOIS. *Lateinisches Etymologisches Wörterbuch*. Edited by J. B. Hofmann. 3rd edn., Heidelberg, 1938–54. 2 vols.

Wasserstein der Weysen, Der. Frankfurt a. M., 1619.

[WEI PO-YANG.] “An Ancient Chinese Treatise on Alchemy entitled Ts’an T’ung Ch’i, written by Wei Po-yang about 142 A.D.” (translated by Lu-ch’iang Wu and Tenney L. Davis), *Isis* (Bruges), XVIII (1932), 210–89.

WELLS, HERBERT GEORGE. *Christina Alberta’s Father*. London, 1925.

WILHELM, RICHARD, and JUNG, C. G. *The Secret of the Golden Flower: A Chinese Book of Life*. Translated by Cary F. Baynes. London and New York, 1931; new edn., 1962.

WINDISCHMANN, FR. *Zoroastrische Studien*. Berlin, 1863.

WÜNSCHE, AUGUST. “Die Sagen von Lebensbaum und Lebenswasser,” *Ex Oriente Lux* (Leipzig), I (1905), parts 2, 3.

ZADITH SENIOR (Zadith ben Hamuel). *De chemia Senioris antiquissimi philosophi libellus*. Strasbourg, 1566.

ZÖCKLER, OTTO. *The Cross of Christ*. Translated by Maurice J. Evans. London, 1877.

INDEX

INDEX

Under alchemical collections, when cross reference is made to “individual treatises in Bibl. A,” see above pp. 353ff, where names of these and their authors are listed.

A

Aaron, 130

aberrations, mental, 323

ablutio, 68

ablution, 292

abortifacient, 135n

above and below, 104n, 140, 233, 264, 336

 growth from, 272

Abraham le Juif, 213, 220; *see also* Eleazar

Abu'l Qāsim al-'Irāqī, 139n, 226n, 305, 308, 309n, 310n

acacia tree, 305

Achamoth, 283, 334

action and non-action, 16n, 25

Adam, 81n, 94, 113n, 131&n, 137n, 139, 143, 146, fig. B4, 166, 169, 219, 220, 318

 earthly, 169n

 and Eve, fig. 32, 303

 first wife of, 303

 genitals of, 143

 heavenly, 169n

 man of light imprisoned in, 130

 mystic, 139

 Old, 80

 parable, 83n

 second, 80

 —, Christ as, 304

—, Mercurius as, 235
sin of, 304
tree of paradise of, 138
true hermaphroditic, 219
with Venus in bath, 226n
Adam Kadmon, 130, 220, 220n
Adamas, 283n, 318
Adam von Bodenstein, *see* Bodenstein
adaptation, lack of, 12
adaptedness, 18
Adebar (stork), 317
Adech, 131&n, 164, 165&n, 166, 169, 172
 difficult, 170, 171, 173, 174, 179
 great, 170, 171
 homo maior, 182
adept(s), 126, 139, 151, 171f, 172n, 179f, 231, 275, 299, 302f, 309, 327, 331
 individuation of, 326
 moon-plant of, 308
Adhvaryu, 267
Adityas, 267
Adler, Gerhard, xiv
Admont, Godfrey Abbot of, *see* Godfrey
adulatio, 329n
Aegidius de Vadis, 217n, 322
“Aenigma VI,” 68n, 93n, 105n; *see also* “Visio Arislei”
“Aenigma Bononiense,” 199n
“Aenigma philosophorum,” 227n
Aeons, 162
aer elementalis, 136n
aerial life, 163
aesthetic experiment, 45
aestphara, 134n
aether, 76, 162, 176
 soul rooted in, 312n

aetiology, 108, 342

affect(s), 12, 15, 34, 35, 41, 45, 82, 334, 343

- autonomous character of, 39
- outbursts of, 289
- personal, 346
- uncontrollable, 50

affective: nature of man, Mars characterizes, 141n

- states, 39

Agathodaimon (good spirit), 62, 67n, 74n, 104, 333

age, old, 272

aggregation, gaseous, 212

agnata fides, 167

Agni, 267

agnoia, 336

agnosticism, 54

Agricola, Georg, 93n

Agrippa von Nettesheim, 114&n, 115n, 117, 128, 130f, 131n, 155n, 156n, 181n, 184, 187

Ahuramazda, 89

air, 164, 165n, 213 217, 226n, 232, 236n, 265, 311n, 324

- demons spirits of, 161
- god, 279
- in motion, 212
- synonym for spirit, 197
- world, fig. A4

aircraft, rocket-propelled, 343, 345

Akhmim manuscript, 71

Al-Irāqī, *see* Abu'l Qāsim

alabaster, 64

Alan of Lille, 294n, 295

albedo, 68, 214; *see also* spirituality

Albertus Magnus, 123n, 138n, 288, 331, 333

- “Scriptum,” 310n, 315, 317, 338, 339

alchemical: and astrological tradition, 125

- authorities, slaying of, 321

confession of faith, 129
dream language, 301
fantasies, 285
and Freudian reduction of symbols, 301
language, 104
literature, 60*n*, 66, 82, 105*n*
maturation, 124
Mercurius, 269
metaphors, 102
opus, 166, 172
philosophy, 206*n*
physician, 124
process, 303
projections, 92, 238
quaternity, 278
redeemer, 295
retort, 197
speculation, fraudulence of, 204
stork, 317
symbols, 299, 301
thinking, 288, 293
transformation, 70, 75, 227
tree, 285

alchemist(s), 59, 66-69, 71, 74, 83, 92, 96, 102, 107, 178
Arabic, 150*n*
Chinese, 126*n*
fantasies of, 285, 293
German, 126
goal of, 161
Latin, 150*n*, 154*n*
pagan, 299
philosophical, 124*n*, 161
water of, 76

alchemy, 67*f*, 72*f*, 78*n*, 84, 89, 91, 116, 119, 121*f*

absurd fantasies of, 205
aim of, 125
ancient, 79
arcane teaching of, 124
chemistry of, 204
Chinese, 1ff
—, golden flower of, 269
classical, 104, 125
connections between Greek/Arabic and India, 231
doctrine of redemption in, 205
gigantic aberration, 204
goal of, 161
golden age of, 203
Greek, 97, 284
—, tetrasomia of, 277
Latin, 64n, 93, 287n
literature of, 204
matter in, 140
medieval, 4, 100, 127, 280
metallic tree of, 89
mystical side of, 105
mythological and gnostic ideas in, 204
Paracelsan, 129
philosophical, 111, 122, 126f, 147
philosophical aim of, 135n
projections of, 239
psychic danger of, 128
psychic factor in, 137
psychological secrets of, 69
psychology of, 93
secret content of, 129
a secret doctrine, 122
spirit of, 103, 128
spiritual trends of, 144n

symbolism of, 69, 80, 88
thought and language of, 87
true nature of, 123
Western, 324f
—, sapphirine flower of, 269
“alchemystical” process, 91
alcheringa time, 98n
“Alchymistisches MS,” *see* Codices and Manuscripts
Alciati, Andrea, 273n, 312
Aldrovandus, Ulysses, 338n
aleph and tau, 222
Alexander, Romance of, 306n, 339
Alexander à Suchten, 129
Alexander the Great, 315, 321
alexipharmakon, *see* Mercurius
alexipharmic, 101, 135, 274n, 296
alga, gelatinous, 153n
“Allegoriae sapientum supra librum Turbae” (*Theatr. chem.*), 85, 314, 318-21, 329n; *see also* “Dicta Belini”
“Allegoriae super librum Turbae” (*Art. aurif.*), 75, 85n, 105n, 223, 226n, 304n, 308n
allegory(-ies), 66
 of Christ, stork as, 317
 conscious, 91
 ecclesiastical, 259
 euhemeristic, 301
 of Mary, the rose is, 294
 of piety, stork as, 317
Alma Mater, 112
almond-tree, 87n
alpha and omega, 222, 281
Alphidius, 298&n, 323
altar, 62, 325
 bowl-shaped, 59, 60, 63, 65, 70, 73
alternation of day and night, 25
alum, 287

amber, 176
ambergris, 155n
ambiguity, of Mercurius, 245
ambivalence, of spirit archetype, 240
ambra, 155n, 187
Ambrose, Saint, 292n, 296n, 309n, 333
ambrosia, fount of, 308n
American (Indian) legends, 99
Amfortas wound, 47
Annael, 75, 82, 215
Amor, 187
amputation, 304n 329
Amset, 280
amulets, 45, 119, 122
Amygdalos (almond-tree), 87n
Anachmus(-i), 155&n, 156, 168
analogy(-ies), 55
 primitive, 28
analysis, 189
 reductive, 348; *see also* psychotherapy
analyst as hairdresser, 347
anatomy, 11, 135
 comparative, 273n
 interior, 137, 138n
ancestor(s): shaman, 340
 soul of, 97
 world of, 98n
Ancient of Days, 281n
 Andalusian prince, lapis as, 320, 321, 327
angel(s): 35, 73, 75, 81&n, 83&n, 115, 130n, 169n, 182f, 183n, 195n, 215, 315n, 316, 318, 332
 Baruch, 339
 definition of, 82
 dubious morality of, 81
 fallen, 96

—, wives of, [143n](#)
four, of God, [282](#)
—, guardian, [282](#)
motherly, [318](#)
of revelation, [339](#)

angelic qualities of man, [130n](#)
angelology, Judaeo-Hellenistic, [81](#)
Angelus Silesius, [117f](#)
anhāta-chakra, [265](#)
Aniada/Aniadus, [131n](#), [153-56](#), [163-66](#), [168&n](#), [174](#), [175](#), [188](#)
Aniadin, year, [174](#), [175](#), [183](#), [186](#), [188](#)
anima, [38](#), [41](#), [95](#), [177f](#), [211](#), [335f](#), [338](#)
 assimilation of, [180n](#)
 caricature of feminine Eros, [41](#)
 as Chinese *p'o* soul, [39](#)
 connection with ghost, [40](#)
 consciousness as effect of, [42](#)
 contains secret of precious stone, [99](#)
 definition of, [40](#)
 emotionality of, [337](#)
 figure, [99](#)
 —, tree a projection of, [338](#)
 function of, [180n](#)
 inferior Eros of, [41](#)
 as link with eternal images, [337](#)
 — with world beyond, [337](#)
 Melusina as, [fig. B5](#), [144](#)
 personification of unconscious, [42](#)
 possession, [180n](#)
 projection, [340](#)
 psychic, personal autonomous system, [42](#)
 shamanistic, [303](#)
 as soul, [132n](#)
 subjugating, [42](#)

union with, 326

anima: aquina, 68

iliastri, 164

media natura, 67, 213f, 266n

mundi, 67, 77, 128n, 129, 139, 197, 214, 307

rationalis, 214, 244

animal(s), 12, 45, 114, 159, 166, 196, 248, 297, 341

body, 103n

fertility of, 97

four, 282, fig. 24, fig. 25

—, sacrificial, 280

heat, 151

helpful, 195n

or human blood, 290

kingdom, 77

principle, 257

riding, of the Church, 283

sacred, 63n

sacrifices, 45

snake, most spiritual, 333

tearing of living, 70

three, 183

triad of, 141n; *see also* ape; baboon; bat; bear; birds; bitch; bull; cat; chick; cock; cockatoo; crocodile; crow; dog; dolphin; dove; dragon; eagle; fish; fox; grasshopper; hawk; hen; horse; ibis; jackal; kingfisher; leopard; lion; ox; peacock; phoenix; pig; puppy; ram; raven; salamander; scorpion; serpent; snake; spider; squirrel; stag; stork; swan; tiger; tortoise; whale; wolf

animate stone, 291

animation of body, 257

animism, primitive, 199

animosity, 41

animus, 38, 268f

as Chinese *hun* soul, 38

figure, 269

inferior Logos, 41

opinions, 41
possession, 267

Anthera, 125

Anthos, 125, 135n

anthroparion / anthroparia, 60&n, 62
transmutation of, 91

anthropomorphism(s), 276

Anthropos, 101, 132, 139, 169, 171, 179, 225, 284, 338
Gnostic doctrine of, 205, 220
invisible, 176
secret doctrine of, 171
or self, tree as, 338
stork a symbol of the, 317

Antichrist, 242
dragon's tail identical with, 316
as fallen angel, 242
as Satan, 242

antidote, 135

Anti-Messiah, 71, 101

Antimimos, 105n

antimony, as transformative substance, 146

antiquity, 46, 161
pagan, 157

anus, 220

anxiety, in dream, 345

Anyadei, 154n; *see also* spring, eternal; Paradise

Apastamba, 267n

ape, 280

Aphrodite, 182f, 216
day of, 226n
Urania, 187

Apocalypse, 188
of Elijah, 71, 101

Apocalyptic Marriage of Lamb, 182

apocatastasis, 284

Apocrypha, 244

Apollonius, 78

Apollonius of Tyana (pseudo-), 126, 219; *see also* “Dicta Belini”

apostle, 113n

apothecary, 205

apotropaic, 24

 charms, 45

 euphemism, 326

 significance of quaternity, 281

apparatus, distilling, 88, 317; *see also* Pelican

apple(s), 302, 306f

 forbidden, 241

 of the Hesperides, 307

 of the Holy Spirit, 309n

Apuleius, Lucius, 63n, 183n, 335

aqua(e): alba, 207

aurea, 208

divina/permanens, 67f, 76, 78n, 85, 132n, 150n, fig. B4, 284, 329n

 —, connection of tree with, 309

fortes, 331

mercurialis, 141n, 209

nostra, 74, 77n, 213

pura, 150n

septies distillata, 207

sicca, 207

vitae, 207

 —, *perennis*, 79n

“Aquarium sapientum,” 186, 207n, 209n, 214n, 217n, 222, 235n, 292f, 293n

Aquaster, 137-140, 142f, 171

 close to concept of the unconscious, 140

 great, 164

 —, vision of, 166

aqueum subtile, 207

Arab(s), 206

Arabic alchemy, 231

arbor: aurea, 310n, fig. 4

inversa, 340

philosophica, 89, 131, 240; see also tree(s)

Arcadia, 230; see also Monakris

arcane: doctrine, 129

name, 131

philosophy of Paracelsus, 110: remedy (-ies), 135, 156n

substance(s), 72, 74f, 82, 83n, 85, 142, 145, 203, 207f, 211, 213, 216, 226n, 230, 242, 274, 278, 283, 291, 315, 320, 329f

—, bloody sweat of, 290, 295

—, lead as, 331

—, Mercurius as, 216, 235ff

—, as *res simplex* and God, 215

teachings of alchemy, 124

terminology, 122, 133, 186

arcanum(-a), 73, 76, 81f, 102, 104n, 123, 135n, 153n, 185, 187n, 309

identical with artifex, 309

Mercurius as, 235

Archa, 169

archai, Gnostic, 22

archaic: God-image, 345

residues in dreams, 347

Archelaus, 123n

archetypal: and collective symbols, 301 (see also symbols);

concept of perfect being, 26

configurations of the unconscious, 253

dreams, 69n

explanatory principles, 288f

ideas, 346

image, 272

patterns, unconscious, 12

projections, 300

symbols, 272, 302, 348

tree, 272, 289

archetype(s), 84, 139n, 171, 177, 178, 246, 266, 277, 283, 289, 292, 302, 333

- anima as, 40
- of consciousness, Christ as, 247
- a *fascinosum*, 168
- of incest, 301
- of self, 87
- of tree, 339
- of tree-birth, 307
- of unconscious, Mercurius as, 247

Archeus, 131, 140

- dispenser of nature, 140

Archimedean point, 108

archon(s): and aeons, Gnostic doctrine of, 225

- in Athens, 98n
- Saturn, the highest, 228

Ardvī Sūra Anāhita, fountain of, 308

Ares, 138n, 140-42, 165, 177

- a formative principle, 141
- as Mars, 141n
- Melusinian, 138, 142
- as principle of individuation, 140

argent vive/argentum vivum, 207, 239

argentum putum (unalloyed silver), 290n, 295

Arianism, 119, 129

Aries, 141n, 166, 311n

- month of, 154

Arisleus, 306; see also “Visio Arislei”

Aristotelian philosophy, 115

Aristotle, 27, 206, 288

Aristotle, pseudo-, 125, 146n, 220n, 307, 321

army with banners (*acies castrorum*), 295

Arnaldus de Villanova, 78, 116, 123n, 294

arrow, 231

phallic, 263

ars aurifera, 124, 314

Ars chemica, 82n, 83n, 85n, 88n, 94n, 103n, 128n, 138n, 147n, 152n, 217n, 236n, 310n, 320n, 331n; *see also individual treatises in Bibl. A*

Art, the, 61, 64, 124, 135, 292, 300

- dangers of, 322ff
- and *deus absconditus*, 105
- rules of, 218
- secret(s) of, 75n, 85

art(s): forbidden, 119

- of healing, 111, 117
- kabbalistic, 113n
- magic, 122
- of metals, 63
- royal, 204, 275
- sacred, 74

Artefius, 225

artifex, 67n, 88, 137f, 142, 314, 322, 326, 328f

- attitude towards the work, 172
- identical with arcanum, 309
- Mercurius, reflection of mystical experience of, 237
- mystic transformation of, 229

Artis auriferae, 60n, 66n, 68nf, 73n, 75n, 78nf, 85n, 93nf, 103n, 105n, 123n, 126n, 139n, 147n, 207n, 209n, 212n, 215n, 217n, 223n, 226nf, 232n, 235nf, 240n 276n, 278n, 286nf, 290n, 291n, 304n, 308n, 310n, 314n, 327n, 329n, 331n; *see also individual treatises in Bibl. A*

arunquiltha, 97

asat (non-existing), 218n

ascent, 62, 130, 146, 154

- and descent, 104n, 218
- , motif of, 59, 103&n, 304
- of Mercurius, 233

ash, 147

Ashvaghosha, 338n

ashvattha (*Ficus religiosa*), 312f, 313n

Ask, 337n
asparagus plant, 313
ass, 129, 183n
assimilation, 38
 of anima, 180n
 of unfamiliar, 12
Assumption of Blessed Virgin, 96
Astarte, *see* Ishtar
Astrampsychos, 279f
astrology, 35, 116, 118f, 225, 237
 earthly, 276
 relation of Mercurius to, 225
astronomy, 113n, 118, 237
astrum (star), 114, 130n, 137
 doctrine/theory, 114n, 125; *see also* star
athanor, *fig.* B4
Atharva-Veda, 268
 Hymns of the, 313n
Athens, 70
 archons in, 98n
Atlantida, *see* Benoit
atman, 171, 220
 personal, of tree, 239
 supra-personal, 239
atom(s), 108, 201
atrophy, instinctual, 12f
Attic fertility and rebirth ceremonies, 70
Attis, 70
 pine tree of, 305n
attitude, change of, 345
auguries, 114
Augustine, St., 247-50, 337
“Aurelia occulta,” 72, 80, 83n, 196, 217n, 218, 222, 225, 226n, 233n, 331
aureole of sun, 80f

Aureum vellus, 68n, 92n, 219n; see also individual treatises in *Bibl. A*

Aurora, 176

Aurora consurgens, 77, 85, 95, 123, 149, 208n, 209n, 212n, 219n, 220n, 276n, 279n, 310, 322, 331

ed von Franz, 69n, 78n, 123n, 306&n, 322n

aurum: non vulgi, 166, 275

philosophicum seu potabile, 274n

potabile, 172

vitreum, 198

Australians (aborigines), 97, 98n

“*Authoris ignoti opusculum*,” 94n

authority(-ies), 18, 112, 116

alchemical, slaying of, 321

of *lumen naturae*, 116

of tradition, 115

autochthonous image, 273

auto-erotic isolation, 254

Autogenes, the, 318

autonomous: character of effects, 39

images, 247

psychic, complex, 50

—, contents, 35, 37

autonomy, 12, 328

of complexes, 34

of matter, 238

of unconscious, 328

Avalon, Arthur (Sir John Woodroffe), 24n, 265n

avarice, 275

Avicenna, 116, 206, 214, 288, 330; see also “*Tractatulus Avicennae*”

axiom of Maria, 151n, fig. B2, 166, 224, 278; see also Maria Prophetissa

ayami (familiar, protective spirit), 340

Azoth, 222, 292n

Aztec(s), 71, 100

baboon, dog-headed, [279](#)
Badenweiler, [133](#)
Baldzamen, [135n](#)
Balgus, [314n](#)
Balinus, *see* Belinus
ball, black, [266](#)
balsam, [134f](#), [135n](#)
 in the heart, [152](#)
 sidereal, [151](#)
baobab, [fig. 2](#)
baptism, [68n](#), [168](#)
 by fire, [95](#)
 by water and spirit, [78](#)
barbarism, [9](#), [13](#)
Barbeliots, [318](#), [338](#)
Barbelo = “God is four,” [131n](#)
barber, [60&n](#), [62](#)
Bardesanes, [337](#)
Bardo, the, [265](#)
Bardo Thödol, *see* *Tibetan Book of the Dead*
Baring-Gould, Sabine, [178n](#)
Barnabas, Epistle of, [87](#)
Baruch, angel, [339](#)
Basel, [98](#)
basilisk, infernal, [143](#)
Basilius Valentinus, [212n](#)
Basuto legend, [101](#)
bat, wings of, [fig. B2](#)
Bata, Egyptian tale of, [305](#), [337n](#)
Baynes, Cary F., [1](#)
Baynes, Charlotte Augusta, [172n](#)
Baynes, H. G., [340n](#)
bear, [282](#)
Bear, Great, [141n](#)

Beatrice, 176; *see also* Dante

Beelzebub, 143

Saturn as, 228

Beeson, Charles Henry, 318n

beginning, 23

of work, Mercurius as, 235

being, unity of, 28

unfathomable, 210n

universal, 40

belief in Jesus Christ, 168

Belinus/Balinus, 126, 219; *see also* “Dicta Belini”

Bellator ignis, 148n

Belletête, 231n

beloved, lover and, 219

below, *see* above and below

benedicta viriditas, 247

benedictio fontis 68&n, 73

rite of, 78

Benoit, Pierre, 99

benzol ring, 108

Berissa, 310

Bernard, Saint, 294n

Bernardus Trevisanus, 217n, 228n, 235n, 308n, 332n

Berthelot, Marcellin, 59n, 60n, 63n, 206

La Chimie au moyen âge, 60n, 66n, 68n, 79n, 82nf, 88n, 95n, 215nf, 226n, 286n, 309n, 314n, 320n, 331n

Collection des anciens alchimistes grecs, 59nf, 68n, 73nf, 76n, 78n, 82n, 93n 95n 98nf, 101n, 105n, 128n, 131n, 138n, 139n 149n 151n 154n 161n 203n, 208n, 215n 221n, 226n, 274n 279n 284nf, 290n, 314n, 321n, 323n

Les Origines de l'alchimie, 277n

Bethlehem, 70n

Beya, and Gabricus, 93

bezoar, 155n

Bezold, Carl, 332n

Bhagavadgītā, 265, 267n, 268, 312f

Bible, [315](#), [321](#); see also Apocrypha; New Testament; Old Testament; *Sainte Bible*
Bibliotheca chemica curiosa (ed. Manget), [67n](#), [85n](#), [126n](#), [141n](#), [219n](#), [224n](#), [236n](#),
[298n](#); see also individual treatises in *Bibl. A*

Binah, [312](#)

biology, human, [243](#)

bird(s), [fig. A4](#), [114](#), [258f](#), [268](#), [341](#), [figs. 3](#), [22](#), [25](#), [26](#), [30](#), [32](#)

green, [286](#)

of heaven, [314](#)

of Hermes, [152](#), [202](#)

mythical, [344f](#)

relation to the tree, [315](#)

representing winged thoughts, [266](#); see also *List under animals*

Birs (river), [98](#)

birth, [46](#)

of Buddha, [318](#)

and death, cycle of, [79](#), [102](#)

germination and, of stone, [298](#)

of Redeemer, [298](#)

stone-, [97](#), [99](#)

tree-, [266](#), [307](#); see also rebirth; twice-born

birthplace of gods: lotus as, [269](#)

stone as, [97](#)

bitch, [93](#)

black: ball, [266](#)

crow, [229](#)

dog, [311](#)

earth, [265f](#)

fish, [265](#)

raven, [92n](#)

spider, [333](#)

spirit, old, [329](#)

substances, [242](#)

Sun, [266](#)

blackness, see *melanosis/nigredo*

Bland, C. C. S., and Scott, H. von E., [86n](#), [198n](#)

blasphemy, 127
blessedness, eternal, 182
blindness, psychological, 336
blood, 84n, 116, 143, 244, 262, 279n, 287f, 290, 292, 295n, 305, fig. 23
 animal or human, 290
 black, burnt out, 153
 bodies into, 63
 bondage of, 52
 eyes, became as, 60
 —, filled with, 62, 71
 fire-coloured, 77n
 of Gāyōmart, 288
 of lion, 295n
 magic, 83n
 redeeming, 296
 rose-coloured, 290, 292, 295, 325
 spiritual, 77n
 of stone, 20f, 295
 symbol of soul, 143
 symbolic, 296
 vein, swollen with, 247
 vessels, fig. A9, 289
 —, tree as system of, 287
bloody sweat, of arcane substance, 290, 295
blossom(s), 269, 290
 heart-shaped, 259
 lotus, 266
 white, fig. 1; see also flower(s)
blue woman, 232
Bodenstein, Adam von, 113, 115n, 119, 133&n, 140, 153n, 157, 173, 187n
 (ed.) *De vita longa*, 113n, 141n, 156n, 163n
Bodhi tree, 318
body(-ies), 63, 77f, 92, 94, 97, 99, 107, 122, 138, 141n, 142, 153, 163, 165, 195, 197,
 236n, 257, 278&n, 285, 329, 346
 Adam's, 131n

animal, [103n](#)
animation of, [257](#)
breath-, *see* breath
calcined, [165n](#)
centre in the, [266](#)
chemical elements of, [195](#)
of Christ, [87](#), [96](#), [140](#)
clarified, [130](#)
consumed by fire, [62](#)
dense, [160n](#)
diamond, [21](#), [46](#), [51](#)
division into four, [60n](#), [68](#)
escape from, [61](#)
of flint, [100](#)
glorified, [297](#)
heavenly, [125](#), [157](#), [fig. 4](#)
human, [11](#)
imperfect, [293](#)
impure, [137](#), [148](#)
incorruptible, [46](#), [104](#)
invisible, [114n](#)
—, of nature, [114](#)
Jesahach, [167](#)
light of, [106](#)
living, [52](#)
of Mary, [139f](#)
microcosmic, [135](#)
mortal, [134](#)
mortified, [103](#)
mystic, [107n](#)
physical, [51n](#)
pneumatic, [52](#)
resurrected, [96](#), [167](#)
round, [139](#)

sensations of, 28
shining, 151f, 157
soul and spirit contained in stone, 290f
and soul, separation of, 239
spirit-, figs. 32, 46
—, dilemma of, 216
spirit of, 103n
and spirit, 214
—, link between, 95
stone-, motif of, 99
or substance, 132n
subtle, 104n, 213
transformation of, 60
turbulence of, 152, 165
visible and natural, 114n
wholeness of, 280; see also *corpus*

Böhme, Jakob, 22, 317

Bogomils, 223n, 229

bones, 60

Bonus, Petrus, 297f, 298n, 299, 330f; see also Lacinius

Book of the Dead, 280; see also *Tibetan Book of the Dead*

Book of El-Habib, 68n, 82n, 88

“Book of the Holy Trinity . . .,” see Codices and Manuscripts, “Das Buch der heiligen Dreifaltigkeit . . .”

Book of Krates, see Krates

Book of Ostanes, see Ostanes

Borgnet. A. and E., 138n

Bororos, 205

Bostra, Titus of, 334

bottle, spirit in (tale), 193, 194n, 195, 197, 199, 202, 239f 258

Bousset, Wilhelm, 132n, 228n, 232n, 334n

boy, 183, 256
crowned, fig. 32

Braceschus, Johannes, 141n

brain: cutting out and eating, 71

identity of structure, 11
-pan, 88
structure of, 152
branches: four, 332
seven, 315
brass: eagle, 93
man, 61*f*, 64
serpent, 333
bread of life, 306
breath: -bodies, 46, 238
—, as carrier of life, 51*n*
—, incorruptible, 51
control, 27, 51*n*
of God, 139
-soul, 213
—, higher, 39
subtle, 78
“Brevis manuctio,” 217*n*, 228*n*
bridal bed, cross as, 337
bride, 226*n*, 337
bridegroom and, 93, 219
tree and the heavenly, 340
bridegroom, 292*n*
and bride, 93, 219
Brihadāranyaka Upanishad, 248*n*
bronchi, 289
brooding of Holy Spirit, 78
brothers, motif of two hostile, 246*n*
“Buch der heiligen Dreifaltigkeit . . .,” *see* Codices and Manuscripts
“Buch des Weisen Magus,” 240*n*
Buddha (Shakyamuni): birth of, 318
maieutic method of, 243
named tree of paradise, 338*n*
Buddhism, 29, 42, 196, 243

in Persia, 231
Tibetan, 22, 29
yoga in, 36
Budge, E. A. Wallis, 22n, 73n, 79n, 155n, 279n
(tr.) *The Book of the Dead*, 280
bull, 155n, 305
strength of, 268
Bundahish, 220, 308, 337n
Burckhardt, Jacob, 118
Burgaeschi, Lake, 98
Burma, 97
businessman, neurosis of, 13
Bythos, 87n

C

Cabala, 117, 130f, 137n, 304, 311, 318, 340
Cabalistic: interpretation of Adam, 169n
Paracelsan philosophy not, 123
Caesarius of Heisterbach, 86, 197, 198n
cagastic: Aquaster, 139
magic, 125&n
soul, 164f
“Cagastrium,” 125&n
Calid, 77n, 290n, 291n
calx, 138n
candelabrum, 255
Canopic jars, four, 280
capsule, of heart, 164
capulsa cordis, 165
caput corvi, 266n
caput draconis, 316; see also dragon
carboniferous era, 266
carbuncle, 147
Mercurius as, 235

Carmel, [312](#)
Carnitolus, Josephus, [311](#)
Carter, J. B., [187n](#)
Cassiodorus, Marcus Aurelius, [305](#)
castle: dragon, [23](#)
 yellow, [23](#)
castration complex, [304n](#)
casuistry, [184](#)
cat, [fig. 32](#)
cataract, of Nile, [279n](#)
Cathars, [229&n](#); *see also* Bogomils
Catholic: Monad, [151n](#)
 tribe, lion of, [228](#)
cauda pavonis (peacock's tail), [152n](#), [154n](#), [290n](#)
cedar tree, [337n](#)
Cedurini, [171](#)
celestial: Aquaster, [139](#)
 —, soul as, [140](#)
 family reunion, [242](#)
 spirit, [292f](#)
cell degeneration, [34](#)
Celts, [119](#)
censor, [343](#)
centre, [21](#), [24f](#), [fig. 33](#), [138f](#), [139n](#), [148f](#), [149n](#), [164f](#), [233](#), [264f](#), [271n](#), [337n](#)
 in the body, [266](#)
 command of, [25](#)
 of earth, [149](#), [210](#)
 of emptiness, [38](#)
 fiery, [152](#)
 fire in, [149](#), [151](#)
 flowerlike, [269](#), [fig. 31](#)
 of heart, [139](#)
 heart as, [271](#)
 heavenly, [150](#)

“an infinite abyss of mysteries,” 149
midpoint of, 151
of natural wisdom, 151
psychic, 152
of tree, 196
of universal system, 26
ceremonies, religious, 22
cervus fugitivus, see *servus fugitivus*
cesspits, of medieval magic, 245
chakras, 265&n
“Ch’ang Sheng Shu; The Art of Prolonging Life,” 1
change(s): of attitude, 345
 cycle of, 13
chaos, 78, 84, 122, 136n, 141n, 325
 Mercurius, child of, 228
 —, as primeval, 235
 son of, 136n
 of Tiamat, 239
character, 39
 affective, of man, 40
 astrological constituents of, 238
chariot(s), 268, 281
 fiery, 167
 stone, 281n
charity, Christian, 296
Charles, R. H., 149n, 219n, 306n, 308n, 318n; see also Enoch, Book of
charm (s), apotropaic, 45
chastity, 259
Chaucer, Geoffrey, 93
Cheiri Paracelsicum, 135n; see also *Cheyri*
chemical: elements, 159
 —, of body, 195
 medicine, 124
 processes, 67

substances, *see* substances

chemist, [204f](#)

chemistry, [108](#), [119](#), [189](#), [238](#), [274n](#), [349](#)

of alchemy, [204](#)

chên-yên, [324f](#)

chermes, [148&n](#)

Cherub, [88](#), [281n](#)

cherubim, [281](#)

four, of Ezekiel, [fig. 32](#)

Cheyri, [135&n](#), [153f](#), [187&n](#); *see also* *Cheiri*

Chhândogya Upanishad, [218n](#), [313n](#)

ch'i, [324f](#)

chick, [152](#)

child, 52

Christ, 100

of God, 52

Mercurius as, *see* Mercurius

-stone, 97

Sunday's, 202

children of light, 247

chimaera, 141*n*

China, 340*n*

cultural life of, 8

soul of, 11

Chinese, 14, 18, 47, 71

alchemists, 126*n*

alchemy, v

—, golden flower of, 1, 269

conduct, 324

consciousness, 39

culture, 8

doctrine of *p'o* soul, 40

philosophy, 9, 11, 40, 50*n*

thought, 8

wisdom, 6

yoga, 4, 14, 29

chlamys, 192

Chrétien de Troyes, 223*n*

Christ, 22, 52, 70, 80, 84*n*, 103*n*, 104*n*, 106, 113*n*, 115, 126, 131*n* 139*n* 188, 196&*n*,
223, 233, 236, 241, 246*f*, 281, 283, 285, 295, 298, 328, 334

allegory of, 123, fig. B4

as archetype of consciousness, 247

body of, 87, 96, 140

child, 100

compared with earthly stone, 292*n*

crucified, 263

defects in image of, 95

divinity of, 95, 119, 129
dragon's head identified with, 316
Enoch prefiguration of, 137n
figure, 246
as *filius microcosmi*, 294
future, 296
genealogical tree of, 307
genealogy of, 304
Gnostic, 336
humanity of, 104n
image, 245
—, one-sidedness of, 96
incarnation of, 292n
—, Mercurius as image of, 235
inner, 27, 96
Jesus, Saviour of Microcosm, 127
-lapis parallel, 95f
and *lapis philosophorum*, identity of, 294
as lion, 228n
the Logos, 83, 222, 244, 332, 333
masculine spirituality of, 335f
Mercurius as, 222, 235
— as brother to, 222
— in compensatory relation to, 245
named tree of paradise, 338n
omnipresence of, 95
as ordinary man, 129
passion of, 105n
the Pelican, 87
personality and historicity of, 53
as personification of the unconscious, 333
Primordial Man, 336
purissimus homo, 295f
reflection of inner Anthropos, 171

rock, 102
second Adam, 304
Sol Novus, 242
as “son of man,” 52
sorrow-laden hero, 53
spirituality of, 96
stork as allegory of, 317
as sword, 333
symbol, 54, 241
— of inner, 96
—, Pauline, 53
symbolized by mountain tree, 309
throne of, 283
tree, 196
— or vine, 338
work of redemption, 96; *see also* Jesus

Christendom, ills of, 112

Christensen, Arthur, 220*n*, 337*n*

Christian(s), 35, 53, 70

ascetic morality, 46

character of Goethe’s consciousness, 245

charity, 296

— and forbearance, 48

church, medievalism of, 18 (*see also* Church)

consciousness, 128

convinced, 49

cross, inverted, 264

culture, 9

development, 48

devil, 247*n*

—, a diabolization of Lucifer, 247*f*

dogma, 90, 221

faith, four main articles of, 168

—, mysteries of, 188

ideas, 22, 172
ideology, 283
imagery, 183
knowledge, 113n
love of one's neighbour, 185, 187
mandalas, 22
mentality, 245
motifs, early, fig. B1
mystery, 103n
Paracelsus as, 160
Redeemer, 233
Sacraments, 154
story of salvation, 299
symbolism, 84, 185, 300
tradition, 280, 317
values, 48

Christianity, 122, 161, 184, 196, 198, 241, 296
early, 51n
founder of, 229
history of, 242
medieval, 303
spirit of, 129
tension of opposites in, 243

Christianos, 149

Christmas tree, 23, 254f

chrysopoea (gold-making), 172
tree symbol of, 314

chthonic: half of godhead, Mercurius as, 222
numen of tree as snake, dragon, 317
serpent, 333
triad, fig. B2, 223

Church, 116, 120, 158, 161, 171, 321
censorship of, 88
eternal verities of, 160

Fathers, [292n](#)
language of, [102](#)
Mother, [112](#), [117](#)
protection of, [90](#)
riding animal of, [283](#)
sacraments of, [186](#)
churinga(s), [97f](#), [100](#)
Chwolsohn, Daniel, [60n](#), [224n](#), [312n](#)
chymical marriage / wedding, [123](#), [126](#), [136](#), [257](#)
Chymical Wedding, see Rosencreutz
Cibinensis, see Szebeny
Cicero, Marcus Tullius, [221](#)
ciconia vel storca, [316n](#)
cinnabar, meridian of, [63n](#)
Circe, [99](#)
circle, [151](#), [161](#), [224](#), [233](#), [336](#), [337n](#)
 charmed, [24](#)
 magic, [22](#), [24](#), [90](#), [fig. 17](#)
 of moon, [192](#), [226n](#)
 movement in, [25](#)
 —, around oneself, [25](#)
 One midpoint of, [151](#)
 protective, [24](#), [29](#)
 simplest and most perfect form, [151](#)
 squaring of, [86&n](#), [96](#), [172](#)
 symbol of wholeness, [337](#)
circular: movement, [21](#), [25](#), [149f](#)
 temple, [84](#)
 thinking, [84](#)
 uroboros, [233](#)
circulus simplex, [233](#)
circumambulatio, [25](#)
circumrotation, [151n](#)
city, [295](#)

eternal, [172](#)
fortified, [fig. A10](#)
of jade, [23](#), [53](#)
of Nekhen, [280](#)
of Pe, [280](#)

civilization: Chinese, [18](#)
 Western, [8](#)

civilized: consciousness, [184](#)
 peoples, [55](#)

clay, [278](#), [287](#)

Cleopatra, [94](#), [99](#), [154](#)

cloud-demon, [39](#)

coagulation(s), [287n](#), [331](#)

cock(s), [105n](#), [114](#), [231](#), [329](#)

cockatoo, red, [205](#)

code: moral, [184](#)
 penal, [184](#)

Codices and Manuscripts:

 Basel: “Alchymistisches MS.”: [144n](#)
 “De arbore contemplationis,” AX. 128b: [315n](#)
 Berlin: Cod. Berol. Lat. 532: [152n](#)
 Cod. Berol. Lat. Q.584: [67n](#), [305n](#), [306](#)
 Leiden: Cod. Voss. Chem. 520 (29): [83n](#), [231n](#)
 London: “Le Livre des Ansienes Estoires”: BM MS. Add. 15268: [fig. B1](#)
 Ripley Scrowle, BM MS. Sloane 5025: [fig. B5](#), [199n](#), [212](#), [286n](#), [303](#), [306n](#), [317](#)
 Munich: Cod. Germ. 598 (“Buch der hlg. Dreifaltigkeit”): [144n](#), [fig. B3](#)
 New Haven: German alch. ms. (Mellon Coll.): *frontisp.*
 Paris: BN MS. gr. 2250: [154n](#)
 BN MS. gr. 2252: [64n](#)
 BN MS. gr. 2419: [228n](#)
 Ste. Gen. MS. 2263-64: [166n](#)
 St. Gall: Cod. Germ. Alch. Vad.: [144n](#)
 Cod. Vad. 390: [76n](#)
 Vatican: Cod. Vat. Lat. 7286: [83n](#)

Zurich: Cod. Rhenov. 172: [144n](#), [220n](#), [231n](#)
Other: MS Akhmim: [71](#)
Cod. Bezae: [243](#)
coelum (heaven), [136n](#)
as Mercurius, [219](#)
as *quinta essentia*, [219](#)
coffer, [figs. 14-15](#), [258](#)
coffin, as tree of death, [304](#)
cognitio: matutina, [247-49](#)
 sui ipsius, [248](#)
 vespertina, [247f](#), [250](#)
cognitive process, [289](#)
cohabitation of Sol and Luna, [123](#)
coincidentia oppositorum, God as, [209f](#)
cold/warm, [278](#)
Coleridge, S. T., [153n](#)
collective: and archetypal symbols, [301](#)
 consciousness, [341](#)
 delusions, [36](#)
 nature of self, [240](#)
 psyche, [347](#)
 psychic phenomena, [36](#)
 soul, [240n](#)
 unconscious, *see* unconscious
collyrium, [75](#)
Colonna, Francesco: *Hypnerotomachia Poliphili*, [141n](#), [157](#), [176](#), [183](#), [304](#)
colour(s), [23](#), [59](#), [106](#), [152&n](#), [154](#), [218](#), [238](#), [290](#), [339](#)
 empty, and forms, [29](#), [37](#)
 four, [305](#)
 four primary, [figs. A6](#), [A8](#)
 three, [76](#); *see also* black; blue; green; purple; red; white; yellow
Colson, T. H., and G. H. Whitaker, [266n](#)
combustible liquid, [320](#)
Communion, [157](#)

substances, 154

comparative: anatomy, 273n

 research into symbols/symbolism, 273, 341

compassion, 112

compensation: biological, by dreams, 69

 law/principle of, 245

compensatory: Logos, 297

 powers of the unconscious, 335

 primordial images, 301

 relation to Christ symbolized by Mercurius, 245

 tendencies from unconscious, 245

complex(es): autonomous, 50f (see also systems)

 autonomy of, 34

 castration, 304n

 numinous, 328

 psychology, 326

 split-off, 34

complexio oppositorum, 241

composition: of the liquids, 62

 of the waters, 59f, 66, 91, 102, 105, 108

concentration, 25

concentration camp, 342f

concretization, 105, 179

condensing apparatus, 88

conduct: Chinese, 324

 principles of, 325

configurations, archetypal, of the unconscious, 253

confirmamentum, 137

conflict(s), 13, 15, 116, 120, 127, 189, 244

 between knowledge and faith, 115

 of duty, 184f

 in Paracelsus, 112

 of opposites, 348

 with the unconscious, 336

coniunctio, [123](#), [135n](#), [152f](#), [153n](#), [fig. B4](#), [181f](#), [187&n](#), [337](#)

animae cum corpore, [fig. B5](#)

fourfold, [278n](#)

noblest, [278n](#)

obscene pictures of, [231](#)

relation of suffering to the, [334](#)

supracelestial, [153](#)

tetraptiva, [277](#), [278n](#)

threefold, [278n](#)

triptativa, [277](#)

conjunction, [137](#)

cross as medium of, [337](#)

of sun and moon, [79n](#)

tree as medium of, [337](#)

conscious: attitude, aberrations of, [185](#)

—, one-sidedness of, [181](#)

differentiation, [301](#)

discrimination, [239](#)

expectations, [16](#)

judgment, [17](#)

mind, *see* mind

morality, [325](#)

psyche, [347](#)

realization, [244](#)

and unconscious, dissociation between, [34](#)

union with unconscious, [180](#)

way, [20](#)

will, [12f](#), [28](#)

willing, [16](#)

consciousness, [11-14](#), [16](#), [20](#), [37](#), [42](#), [89](#), [94](#), [150](#), [197](#), [260](#), [301](#)

acute state of, [27](#)

broadening or heightening of, [243](#)

Chinese, [39](#)

Christ as archetype of, [247](#)

Christian, 128
— character of Goethe's, 245
circumferential, 26
civilized, 184
clarification of, 243
clarity of, 28, 40
collective, 341
cramp of, 17
creative, 40
cult of, 36
daylight of, 242
detachment of, 27, 44f, 46, 52
development of, 69
differentiation of, 200, 243, 335
disintegration of, 29
divided, 260
as effect of anima, 42
evolution of higher, 54
extinction of, 336
finite, 171
fire as, 151n
four functions of, 84
free of contents, 38
functions of, 176
head is seat of, 81
higher, 15, 18, 48, 73, 189, 200, 297
as *hui*, 21n, 25
illumination of, 255
— and expansion of, fig. 3
illusion of supremacy of, 52
individual, 29
inner and central, 26
intensification of, 21
language of, *see* language

and life, [21](#), [23](#)
—, union of, [21](#)–[25](#);
light of, [90](#), [247](#)
—, and reason, [40](#)
localizations of, [265](#)
masculine, [335](#)
modern, [327](#)
monotheism of, [36](#)
moral, [196](#)
narrowness of, [37](#)
natural, [247](#)
ordering principles of, [325](#)
orienting system of, [167](#)
is partisan, [28](#)
possession by, [36](#)
present level of, [28](#), [200](#)
primitive, [268](#)
Protestant cult of, [48](#)
quaternary structure of, [169](#)
rational, [238](#), [345](#)
relation of lapis to, [240](#)
separation of, and life, [21](#)
strengthening of, [243](#)
supra-, [184](#)
symbols compensate unadapted attitude of, [302](#)
twilight state of, [92](#)
unconscious not derivative of, [42](#)
and unconscious, split between, [246](#)
unity of, [29](#)
uprooted, [12](#), [21](#), [49](#)
Western, [55](#)
widening of, [9](#), [55](#), [296](#)

Consecration in Mass, [84](#)
conservatism, psychic, [12](#)

consideratio, 165n

“Consilium coniugii,” 82n, 83, 88, 94, 103n, 107n, 128n, 152&n, 217n 310n 319, 331

constancy, 259

Constantine, Emperor, 122

contemplatio, 165n

contemplation, 29n, 44, fig. A5

of life of Jesus, 165n

sage in, 29

tree of, 315

content(s): repressed, 36

unconscious, *see* unconscious

contradictions, logical and moral, 245

conviction, inward, 54

cooking, 68, 75

Coomaraswamy, A. K., 310n, 313n, 337n

copper, 89, 183, 218, 277

coral, tree of, 308&n

cor altum, 249n

corn: seed of, 259

cobs, 263, fig. 25

corners, four, of the heavens, 279

corona, 269, fig. 31

corporalia and spiritualia, 103

corporeal/incorporeal, 75

language of, 76

corporeality, 257

corpus: astrale, 125, 152, 167, 168n

coeleste sive supracoeleste, 137

glorificationis, 130n, 167

Jesahach, 167

mysticum, 104n, 107

nostrum, 213

Corpus Hermeticum, 73, 78, 206, 225

corruption, 134&n

cortical centres, 185
cosmic principles, fig. A6
 projection, 335
 tree, *see* tree
cosmos, materiality of, 239
Crato von Crafftheim, 119
Crawley, Alfred Ernest, 143n
creatio ex nihilo, 201
 denial of, 236
creation, 132
 days of, 248, 265
 of man, 86
 myth, 99
 of souls, 86
Creator: knowledge of the, 247n
 love and praise of the, 247n
 renamed Conglomeratio, 201
crocodile(s), 79n, 257, fig. 10
cross, 22, 281n, 332, fig. 26
 as bridal bed, 337
 connection of tree with, 332
 of light, 265
 medium of conjunction, 337
 motifs, 268
 as quaternity, 282, 332
 serpent on the, 333
 sign of, 68, 282
cross-cousin marriage, 278
crow, black, 229
crowd, 41
crowfoot, 155n
crown, 269, 317
 King's, 80n
 mural, 303n

of stars, 80
crowned: boy, [fig. 32](#)
dragon, [fig. 14](#)
serpent, [fig. 32](#)
crucifix, [334](#); *see also* cross
crystal(s), [101](#)
terrible, [281](#)
cube, [271](#)&*n*
cult, [37](#)
of consciousness, [36](#)
of the dead, [280](#)
instrument, churinga as, [97](#)
stone-, [100](#)
culture, [11](#)
Chinese, [8](#)
Christian, [9](#)
hero, [100](#)
megalithic, [100](#)
Cumont, Franz, [307](#)*n*
Cupid, [247](#)
arrow of, [83](#)
Mercurius as, [231](#)
cupiditas, [38](#)
cutting off of hands and feet, [329](#)
cycle: birth and death, [79](#), [102](#)
death and rebirth, [105](#)
Cyphanta, [175](#)
Cyprian, the, [183](#)

D

Daemogorgon, Mars called, [141](#)*n*
daemon(s), [36](#), [203](#), [231](#), [268](#)*f*, [285](#)*n*
conquered, [327](#)
as a familiar, [328](#)

is an illusion, 37
masculine, 267
Mercurius as storm, 202
of revelation, 178
of scientific spirit, 128
serpent-, female, 240
tree, 200

daemonic: agencies, 323
forces of life, 38

daemonization of man, 282

Daimorgon, 141*n*

Damascene earth, 318

dance: mandala, 23
round, of stars, 226*n*

danger(s): of the Art, 322, 327, 329
psychic nature of, 170

Daniel: Book of, 13, 132, 281*n*, 282*n*, 283
vision of, 282

Dante Alighieri, 141*n*, 176, 236, 295, 311*n*

dark: abyss of not-knowing, 178
background of soul, 147
Mercurius, *see* Mercurius
powers of psyche, 42

darkness(es), 24, 162, 170, 177, 242, 245, 247, 249, 325, 335*f*
creatures of, 162
horrible, of our mind, 250
of human nature, 244
light of, 160*ff*
of nature, 160
of night, 236*n*
poles of light and, 25
of Saturn, 126*n*, 130, 152*n*
world of, 265

daughters: of men, 81

four, 98f

David, 146, 223

Davis, T. L., and Lu-ch'iang Wu, 126n, 226n, 324n

day(s): of judgment, 297

- and night, rhythm of, 248
- a single, 62, 79n

of week, pagan names of, 249

day-dreaming, subjective, 43

dead, 29, 35, 68

- awakened, 290n
- cult of the, 280
- God, 128
- hearts/souls of, 271n, 317
- resurrection of, 297
- tree, *see* tree; *see also* death; Egyptian Book of the Dead; *Tibetan Book of the Dead*

De alchemia, 126n, 140n, 147n, 210n, 297n; *see also* individual treatises in *Bibl. A*

Dea Natura, 98

“De arbore contemplationis,” *see* Codices and Manuscripts

“De arte chymica,” *see* “Liber de arte chymica”

death, 38ff 46, 105, 164&n, 166, 218, 228, 322, 326

- cycle of birth and, 79, 102
- dealing poison, 323
- of dragon, 316
- not end but goal, 46
- figurative, 63n
- and life, 51n
- ray, red, 304
- and rebirth, 73, 102, 105
- , of philosophical tree, 287
- survival after, 51n
- tree of, 304
- , life and, 271

decapitation, 72

De chemia, *see* Zadith Senior

“Declarado et Explicatio Adolphi,” 80

decomposition, 134n

Dee, John, 155n, 220n, 322n, 332n

deep heart (*cor altum*), 249n

Déesse Raison, 244

defecation, 220n

de Goeje, M. J., *see* Dozy

deity, nature, 200, 247

delusion(s), 34, 37, 105n 335

 collective, 36

 of insane, 246

 Mercurius a god of, 247

 social and political, 8

demiurge, 73, 221n, 222n, 228

 powers of, 87

 principle of, 232

Democritus, 67, 76, 103, 161, 225, 286, 321

 pseudo-, 77n, 147

demon(s), 39, 89, 117, 119, 128, 161

 of air, 161

 of forest, 198

 lead possessed of a, 323

 personal, 41

demonology, primitive, 42

“Demorgon,” 141n

dependence, free, 52

depersonalizing of unconscious figures, 42

depression(s), 331, 335

descent, 59, 63, 150, 154

 ascent and, 59, 103n, 104n, 218, 304

 of Mercurius, 233

detachment, 41

 of consciousness, 44f, 52

 inner, 38

Deucalion, 99

Deursen, Arie van, 100n

deus: absconditus, 95, 104f, 241

terrenus, 166

terrestris, Mercurius as, 235, 241; *see also* god(s)

Deussen, Paul, 206n

Deuteronomy, 306, 318

development: Christian, 48

of meaning, 272

of personality, 18, 21

psychic, 11f, 15, 21, 162, 245

regressive, 260f

spiritual, 47, 245

devil(s), 7, 83, 90, 105n, 113n, 114f, 128n, 143, 170, 183n, 223, 241, 245f, 328

deceptions of the, 323

dragon's tail identical with, 316

Mercurius as, 237

Saturn dwelling place of, 228

seven, 128&n

tricked, 198

within, 244

dew, 86, 176, 305n

reanimating, 103

Dharmakaya, 35

diabolization, of Lucifer and Mercurius, 248

diabolus, sulphur as, 228

diadem, 147, 269

diadema cordis tui, 269

dialectic, philosophical, 238

“Dialogus Mercurii, Alchymistae et Naturae.” *see* Sendivogius

diamond body, 21, 46, 51

Diana (goddess), 303

dice, game of, 267f

“Dicta Belini”: (1) *Distinctio XXVIII*, in *Theatr. chem.* V, 197n

(2) *Theatr. chem.* I, 227
(3) *Bibl. chem. curiosa*, 219, 236n
(4) *Rosarium*, in *Art. aurif.*, 126, 227
“Dictionary of Goldmaking,” 74
Dieterich, Albrecht, 70n
difference(s), racial, 11
 differentiation, 336
 conscious, 301
 of consciousness, *see* consciousness
 of Western intellect, 9; *see also* non-differentiation
Dionysius, 70
Dioscorides, 155n, 156
Dioskoros, 138n
discrimination, 41, 200, 243, 336
 conscious, 239
disease(s): “ens spirituale” of, 113n
 gods have become, 37
 obscurity as darkness of, 331
disembowelling, 329
dismemberment/dismembering, 60, 67f, 70&n, 71, 73, 84, 87n, 91, 304n
disorder, infernal, 122
disorientation, 13
 philosophical, 8
displacement: downwards, 266f
 upwards, 265
dispositions: individual, 342
 instinctive, 275
dissociation, 35, 37, 82, 342, 345
 between conscious and unconscious, 34
 of personality, 264
distillation, 148, 180
 circulatory, 148
 thousandfold, 148
 vessel of, *fig. B7*, 88, 317; *see also* Pelican; *retorta distillatio*

distilling apparatus, 317

disturbance(s), mental/psychic, 34, 324, 342; *see also* aberration; disease

divided: consciousness, 260

 into four, totality image, 283

divine: attributes of stone, 328

 dynamism of self, 285

 fire, 209

 light, 107, 330

 love, 210, 307

 magic, 139

 mother, 333

 mysteries, 188

 myth, 263

 numen, 268

 office of physician, 116

 revelation, 116, 236

 secrets, Mercurius as revealer of, 230

 spark, 160

 spirit, 26

 water, *see* water; will, *see* will

Divine Comedy, *see* Dante

divinity/Divinity, 149

 of Christ, 95, 119, 129

 itself, Mercurius as, 235

 triune, Mercurius as, 222

divinus ternarius, Mercurius as, 230

division, 93

 into four, 68*n*, 82*n*, 83*n*, 168

 by sex, 139

Djābir ibn Hayyān, 215*n*, 286, 314

doctor(s), 13, 119, 121

doctrinairism, Freudian, 342

doctrine(s): arcane, 129

 Buddhist yoga, 36

Gnostic, of Anthropos, 171, 205, 220
of redemption, in alchemy, 205
secret, 49, 133ff, 188, 242

dog, 69, 73n, 90, 93, 258
black, 311
-like woman, 232
as logos, 232n
as psychopomp, 232n

dogma, 242, 293n
Christian, 90, 221

doll, 261, fig. 20

dolphin, 265

domus: ignis, 210n
sapientiae, 172
domus thesaurorum or *gazophylacium* (treasure-house), 85

Dorn, Gerard, 86f, 115n, 124n, 134n, 149ff, 154, 157, 165n, 166n 169, 171, 176, 187, 215, 217, 236, 287ff, 291&n, 292, 295, 330f, 334
“quid” of, 300
veritas of, 324
WORKS: “Congeries Paracelsicae,” 86n, 209n, 227n, 230n, 235n, 289, 310n, 331n
“De tenebris contra naturam et vita brevi,” 217n, 311n
“Duellum animi cum corpore,” 151n
“De genealogia mineralium,” 287n, 311n
“Philosophia chemica,” 86f, 235n
“Physica genesis.” 139n, 149n, 150
“Physica Trismegisti,” 150n, 330f
“Physica Trithemii,” 150n, 151n
“Speculativa philosophia,” 72, 83, 332
ed., *De vita longa* (Paracelsus), 131n, 144, 164n, 168n, 172n, 173ff, 187n

double: contrary nature of Mercurius, 319
dyads, unification of, 278

dove, 339
of Holy Ghost, 89, 92n

downwards, displacement, *see* displacement

Dozy, R., and M. J. de Goeje, 225&n

draco viridis, 258; *see also* serpent, dragon

dragon(s), 64, 79n, 87, 89f, 132n, 198, 228, 257, 330, 340

belly of, 210

chained in the underworld, 242

chthonic numen of tree, 317

divine water, 82n

egg synonym for, 82

ever-waking, 217

fire-spitting, 303, 321

green, crowned, fig. 14

head of, 291n, 316

—, and tail of, 79n

killing of, 83n

little green, 258

many-eyed, 86

old, 218

poison-dripping, 218

poisonous, 321

self-devouring, 259

tail-eater, 79, 132n

tail, identified with Antichrist/devil, 316

two, 217, 256f

uroboros, 223

winged and wingless, 217; *see also* serpent, mercurial

dream(s), 66, 89, 91, 96, 114n, 176f, 194, 246, 283, 293, 300f, 341, 343

alchemical language of, 301

anxiety in, 345

apparent disguise in, 347

archaic residues in, 347

archetypal, 69n

-experience(s), 67n, 80

Freud's interpretation of, 301

helpful, 179

images, 273
interpretation, subjective, 66
language, 69
means what it says, 347
of Nebuchadnezzar, 272n, 337
of Poliphilo, *see* Poliphilo
sent by God, 105
symbolism of, 69, 347
-vision, 80
women's, 347
world of, 98n
of Zarathustra, 89
of Zosimos, 102; *see also* day-dreaming
EXAMPLE: An eagle circles over Y's concentration camp; he thinks of shooting it
from a rocket-propelled aircraft, 342-47
Dreifaltigkeitsbuch, *see* Codices and Manuscripts: Munich
drink, of immortality, 313
drive, power, 260
drug(s), 153n, 204
Druids, 119
dualism: of ancient Persia, 243; *see also* Cathars
duality, 182, 214, 237, 246, 257, 336
of God, 26
of Mercurius, *see* Mercurius; of sonship, 223n
of soul, 214
in world and soul, 116
Du Cange, C. du F., 148n, 322n
dungheaps, 146n, 170, 232
duplex, Mercurius, 309, 319
Durdales, 158
dwarf, 271, 297
dyad(s), 278, 280
dynamism, divine, of self, 285n

eagle, 183, 280, 303, 317, 339, 343ff, 347

black, 198

brazen, 93

“eye,” 344

earth(s), 39, 49, 92, 217, 219, 233, 236n, 248, 256, 278, fig. 8

black, 265n

centre of, 149, 210

glorified, 311

goddess, fig. 8

Mary as, 256

Mercurius, of paradise, 235

metallic. 310

philosophic, 290

purified. 218

reality of, 54

red Damascene, 318

salt of, 233

-spirit, 297

two, 278n

-world, fig. A4

Earth: Mother, 98

Spirit, 79n

earthly: Adam, 169n

astrology, 276

firmament of Paracelsus, 276n

paradise, 196

stone, Christ compared with, 292n

East/east, 14, 22, 42f, 166

European invasion of, 55

mind of, 56

philosophers of, 50

practices of, 24

psychology of, 8

religious experiences of, 53

spirit of, [49](#)
and West, [55](#)
—, difference between, [53](#)

Easter Eve, [78](#)

Eastern: enlightenment, [54](#)
ideas, [7](#), [10](#)
intellect, [9](#), [55f](#)
mandalas, [56](#)
occultism, [7](#)
philosophers, [6](#), [56](#)
realism, [7](#), [288](#)
religions, [6](#)
wisdom, [11](#)

Ebionites, [223n](#)

ecclesiastical: allegory, [259](#)
Sacrament, [185ff](#)
terminology, [157](#)
tradition, [299](#), [321](#)

Echidna: symbol of Mercurius, [144n](#)

Eckhart, Meister, [16](#), [50](#), [114n](#), [284](#)

eclipse, [79n](#)

ecstatic: experience, [40](#)
states, [34](#)
journey, [341](#)

Edda, [337n](#)

Edem, [321](#)

Eden, river of, [319n](#)

Edfu, [73](#)

Edochinum, [131](#), [164ff](#)

effect: numinous, of archetypal symbols, [302](#)
therapeutic, of detachment, [45](#)

efficacy, of things, [154](#), [157](#), [175](#)

efflorescence, of metallic salts, [146n](#)

egg(s), [63](#), [83](#), [87](#), [290](#)

division of, 82
germ of, 152&n
identity of, with uroboros, 82n
of nature, 218
nomenclature of, 82n
Olympiodorus on, 82n
philosophical, 82
shining, fig. 32
synonym, for dragon, 82
—, for vessel, 82
—, for water, 82
-white, 82

ego, 34, 45, 51f, 90, 180&n, 239, 246, 248, 254, 263, 285n
affinity with God, 117
centre of consciousness, 45
-centricity, 285n
entanglement in the, 302
godlike, 118
-mania, 38
mortal, 171
personality, 254
relation of to self, 172

Egypt, 81
ancient, 73

Egyptian(s): Book of the Dead, 279
Hellenism, 279
mummies, 134
mythology, 142
quaternity, 280
tale of Bata, 305, 337n
young, 320

Eisler, Robert, 307n

Eleazar, Abraham, 213n, 220n, 333n

element(s), 150

ascent of, 150

body's chemical, 195

chemical, 159

creation of, 150

Eucharistic, 159

four, 65, 68, 82, 92ff, 115, 129, 131, 135&n, 141, 152, 166ff, 168n, 176, 195, 219, 227, 266, 269, 278n, 293, 305, 332

head-, 291n

heavenly, 155

masculine, 74

of Mercurius, 217

ogdoad of, 278

omega, *see* omega

physical, 155

quaternity of, 278

round, 72, 76

of the stone, 314n

“supermonic,” 180

Eliade, Mircea, 70n, 101n, 305n, 307n, 309n, 340n, 341n

Elias, *see* Elijah

Eliezer ben Hyrcanus, Rabbi, 318, 337n

Elijah/Elias, 136n, 167

Apocalypse of, 71, 101

elixir, 166, 172

human, 94

of life, 51n, 78&n, 81, 154

natural, 134

embalming, 61, 64

Embla, 337n

embryo, 52

Emmerich, Count of Poitiers, 177

emotion, 15

emotional: intensity, 268

value, 268

emotionality, 9, 257

empathy, 163

Empedoclean *rhizomata*, 195

empirical nominalist, 289

emptiness: centre of, 38

 great, 39

enantiodromia, 245

enclosure, 25

end of work, Mercurius as, 235

energy: life, 25

 of bodily sensations, 28

English “rescue circles,” 51n

“Enigma of Bologna,” 338n

Enkidu, 321

 shadow of Gilgamesh, 320

enlightenment, 85, 186, 200, 280n

 Eastern, 54

 tree symbolizes, 313f

Enoch, 132, 136n, 137&n, 149, 166, 176n, 210n, 283

 Book of, 143n, 149n, 282, 306, 308, 318

 Ethiopic Book of, 306

 prefiguration of Christ, 137n

 “son of man,” 149n

Enochdianus(-um, -i), 137, 142, 153, 165n, 166, 168

Enos, 138n

ens spirituale, of diseases, 113n

entanglement(s): in the ego, 302

 emotional and intellectual, 28

entelechy, of Aristotle, 27

epidemic(s), psychic, 37

“Epigramma Mercurio philosophico dicatum,” 230

Epimetheus, 94

Epimetheus, Franciscus, 144n; *see also* Reusner

Epiphanius, [88n](#), [146&n](#), [186](#), [223n](#), [228n](#), [309n](#)

Epistle of Barnabas, [87](#)

“Epistola ad Hermannum,” [226n](#), [259n](#)

equilibrium, psychic, [46](#)

left/right, [269](#)

Eranos Jahrbuch: (1936, 1937), [4n](#)

(1937), [58](#)

(1942), [191](#)

(1945), [310n](#)

Eros, [157](#), [230](#), [247](#), [295f](#)

anima as caricature of feminine, [41](#)

feminine, [295](#)

Erythraean Sibyl, [230](#)

Esdras, [147n](#)

essence/Essence: ethereal, [324](#)

fifth, [130](#)

mercurial, [196](#)

Salamandrine, [138](#), [142](#)

triune, [293](#)

Estsánatlehi, [98](#)

eternal: blessedness, [182](#)

ideas, [289](#)

man, [306n](#)

principle(s), [169](#)

water, [227](#)

eternity, [141n](#)

feeling of, [181](#)

hieroglyph of, uroboros as, [259](#)

“Ethiopian,” The, [60n](#), [316](#)

Ethiopic Book of Enoch, *see* Enoch

ethnology, [6](#), [51n](#)

Eucharistic: elements, [159](#)

significance of fish, [266](#)

Eucherius. Bishop of Lyons, [104n](#)

Euchites, 223, 229
euhemeristic allegories, 301
Eulogius of Alexandria, 196
euphemism, apotropaic, 326
Euphorion, 176
Euripides, 70
Europäische Revue, 1
Europe, 97
European: consciousness, 45
 enlightened, 37
 invasion of the East, 55
 mandalas, 2, 22n, 24, 56; *see also* Western
Euthymios Zigabenos, 223n
Euty chius, Patriarch of Alexandria, 60n
evangelists: four, 22
 three, 183n
Evans-Wentz, W. Y., 25n, 265n
Eve, 83n, 95, 143, fig. B4, 219, 262, 304
 Adam and, 303
 Adamic Mercurius in, 235n
 genitals of, 143
evening knowledge, 248n; *see also cognitio*
everlasting hills, 306
evil, 47, 165n, 183n, 187, 197, 200, 223
 counterpart of good, 210
 good and, *see* good and evil
 hell-fire, substance of good and, 210
 individuation, source of all, 196
 spirit, 196-201, 240
exaltation, 153ff
 in May, 161, 163, 176, 182
 of spring, 182
excoction, 152n
excretory acts, 231

exercises, spiritual, 244

“Exercitationes in Turbam philosophorum,” 60n, 68n, 83n, 217n, 235n, 236n

expansion, of consciousness, fig. 3; *see also* consciousness

experience(s): inner, 16

 psychic, 27n, 52

extensity, 25

eye(s), 25, 39

 “eagle,” 344

 fleshly, 288

 philosophical, 22

 spiritual, 288

eyewash, 75

Ezekiel: Book of, 136n, 258, 281

 four cherubim of, fig. 32

 vision of, 280

Ezra, 132, 219n

 Fourth Book of, 219n

 vision of, 132, 219

F

fables, didactic, 66

face(s), 25; four, *see* four

faith, 7, 34, 46, 54, 187, 241

 alchemical confession of, 129

 charisma of, 49

 in God, 111

 grace of, 160

 inborn, 167f

 and knowledge, conflict between, 115

 —, split between, 189

 mysteries of Christian, 188

Fall, 290, 295, 304

familiar(s), fig. B5, 179, 203, 225, 341

 daemon as, 328

familiaris, 245

family reunion, celestial, 242

fantasy(-ies), 16, 22, 24, 43, 276, 283, 285, 339, 342

activity, spontaneous, 17

of alchemists, 205, 293

creative, 43, 253

ideas born of, 277

images, 179

modern, of tree, 341

mythlike, 258

personal, 344

primitive, 98

products, 21, 194, 205, 253

secondary, 260

fascination, 171

fate(s), 15*f*, 41, 171, 184*n*, 264

aesthetic flirtations with, 18

of psyche, 349

father(s)/Father, 52, 112, 166

Church, 292*n*

four, 150

-God, 339

God is Mother and, 27

of lies, Lucifer as, 250

of all metals, 235

-mother, 220*n*

and Son, 116

Faust, 47, 118, 119

for the drama, see Goethe

“fedeli d’amore,” 294

feeling(s), 9, 167

consolidation of, 180

of eternity, 181

tone, 268

feet, cutting off of, [329](#)
female: genies, winged, [281](#)
 male and, powers of, [218](#)
 serpent-daemon, [240](#)
feminine, [13](#)
 anima is, [39](#)
 aspect of Mercurius, *see* Mercurius
 character of unconscious, [325](#)
 Eros, [295](#)
 figure in unconscious, [40](#)
 nature of tree, *see* tree
 principle, fourth, [96](#)
 psyche/soul, [40](#), [fig. A6](#)
 psychology, [41](#), [82](#)
 significance of Yggdrasil, [340](#); *see also* masculine
femininity: of man, [338](#)
 unconscious, [99](#)
Ferdinand I, [119n](#), [158n](#)
Ferguson, John, [141n](#), [229n](#)
Fergusson, James, [340n](#)
fertility: ceremonies, Attic, [70](#)
 of land, [71](#)
 of men and animals, [97](#)
 significance of churingas, [100n](#)
 symbol, fish as, [fig. A2](#)
Ficino, Marsilio, [131](#), [134n](#), [223n](#)
Ficus religiosa, *see* *ashvattha*
fides, [176](#)
field: of square inch, [25](#), [51](#)
 treasure in the, [259](#)
fiery: and gaseous poison, [278n](#)
 pillar, [310n](#)
Fierz-David, Linda, [176n](#)
fifth essence, [130](#)

spirit of, 130
fig tree, 313
figments, “supermonic,” 173f
Figulus, Benedictus, 149, 210, 307
Fihrist, 240n
fili Sapiientiae, 308
filius, 142, 150&n, 168n, figs. B2, B4
 canis coelici coloris, 232n, and see puppy
 ignis, 127n
 macrocosmi, 96, 166, 233, 240, 292, 293n
 —, lapis philosophorum as, 294
 Mercurius as, 222
 microcosmi, 96, 292
 —, Christ as, 294
 noster rex genitus, 148
 philosophorum, 123, 125ff, 129, 130, 140, 150, 284
 —, son of macrocosm, 126
 regis, fig. B6
 regius, 145ff
 sapientiae, 123
 unicus, 172
 unigenitus, 172n
 “unius diei,” lapis as, 248n; see also son(s)
filth, 146n, 153, 170, 242f
fire, 24, 63f, 74, 77n, 78, 79n, 85f, 107, 113n 138n 141n, 142, 146f, 150, 153n 162, 216, 218, 244, 268, 279n, 298, 307, 309n, fig. 5
 of the art, 60
 baptism by, 95
 in centre, 149
 coal, 138
 as consciousness, 151n
 divine, 209
 of divine love, 210, 307
 ever-living, 310
 fighter of, 148

global, 149, 210
of heart, 164
of hell, *see* hell
house of, 149
invisible, 209
mercurial, 210
Mercurius as, 209ff, 310
midpoint of centre, 151
our, 148
pillar of, 62
secret, infernal, 210
sphere of, 74
spirits of, 142
spiritual, 150n
-spitting dragon, 303, 321
struck from stones in Persia, 320
in sun, 150
supracelestial, 310
symbolical, 148
system of higher and lower powers, 210
tongues of, 29
torment of, 67, 72, 146
-tree, 258, 339n
unnatural, 330
warrior, 148
and water, *see* water,
—, union of, 255
firmament, *fig. A6*, 137, 248, 281
 earthly, of Paracelsus, 276n
 in man, 152
firmamentum, 219
Firmicus Maternus, Julius, 70n
firm-rootedness, 272
First Cause, 232n

first parents, 257
First Thomas, 132n
fish(es), 51, 69, 75, 76n, 143, 177, 194, fig. 32
 black, 265
 as fertility symbols, fig. A2
 half-man, half-, motif of, 178
 meal, fig. B1
 pot-, 155n
 round, 75f
 symbol, 265
fishing rod, God's, 336
fitness, in biology, 342
five mountains, 256
fixation, 25, 180
flame(s), 155
Flamel, Nicolas, 213, 217n, 306n, 309&n, 333n
flammula, 155n, 157
flattery, 329
flatus vocis, 289
flaying, 70, 71, 87n
flesh, 60f, 63f, 84, 92, 94, 96, 101, 103n, 104n, 114n, 116, 228, 310
fleshly eyes, 288
flint, 107, 113n
 body, 100
 man, 100
flores, alchemical, 125
Flos cheiri, 135n
flower(s), 22, fig. A4, 154, 253, 255, 268, 271n, 290n, 314, 320
 discoloured, 286n
 golden/Golden, 23f, 51, 53, figs. A1, A2, B2
 —, of Chinese alchemy, 269
 —, origin of, 23
 heavenly, 155, 163
 of light, fig. 32

luminous, [fig. A3](#)
red, [fig. 5](#)
flowerlike centre, [269](#), [fig. 31](#)
Fludd, Robert, [288f](#)
foam-born, [182](#)
foemina alba, [182](#)
foetus: of longevity, [166](#)
 novenary, [151](#)
 spagyric, [150&n](#)
folk: beliefs, [122](#)
 customs, [24](#)
 magic, [122](#)
“Fons chymicae veritatis,” [209n](#)
font, [73](#), [78n](#)
fontina, [255](#)
food of immortality, [306](#)
force(s): life-, [214](#)
 —, daemonic, [38](#)
 of nature, [128](#)
forest, [193f](#), [200](#)
 demon of, [198](#)
 king of, [194](#), [199](#)
 of mares’-tails, [fig. 27](#)
forethought, [221n](#)
form, psychoid, [272](#)
fortress, [294](#)
fount(ain), [255](#)
 of ambrosia, [308n](#)
 of Ardvī Sūra Anāhita, [308](#)
 of gold and silver, [103n](#)
 of Hulda, [317](#)
 of life, [84](#), [103n](#)
 of living water, [104n](#)
 of renewal, [332n](#)

salty, 308

four, 166, 275*n*, 277

- angels, 176*n*, 282
- animals, 282, figs. 24, 25
- arms, 281
- branches, 332
- Canopic jars, 280
- cherubim, 280
 - of Ezekiel, fig. 32
- colours, 305, figs. A6, A8
- corners of the heavens, 279
- daughters, 98*f*
- directions, 168
- division into, *see* division; elements, *see* elements
- evangelists, 22
- faces, 279*n*, 280
 - of God/god, 176*n*, 279
- fathers and mothers, 150
- functions, 167
- gates, 172
- gospels, 283
- guardian angels, 282
- heads, 266, fig. 27
- kings, 282
- main articles of Christian faith, 168
- mountains, 256, 262, fig. 24
- multiples of, 96, 280
- number, 150*f*, 262*f*
- pillars of Shu, 279, 281
- quarters, 271*n*, 281
 - of heaven, 167
 - of the world, 281
- quaternions, 280*n*
- rivers, 262, fig. 24

— of paradise, 149, 172
roots, 68
sacrificial animals, 280
Scaiolae, 167
seasons, 167f
sons of Horus, 22, 279ff
streams, 304, 319n
three and, dilemma, 224
totality image, divided into, 283
wheels, 167, 281
wings of the cherubim, 281; *see also* quaternity

fourfold: coniunctio, 278n
 Mercurius, 279

fourth, the, 167

fox, 195n

Foxcroft, T., *see* Rosencreutz

Franz. Marie-Louise von, 63n, 99n
 (ed.) *Aurora consurgens*, 69n, 78n, 95n, 123n, 149n, 306n, 322n, 323n
 “Die Passio Perpetuae,” 316n

Frazer, James G., 70n, 71n, 97n, 98n, 194n

freedom, Promethean, 12

Freud, Sigmund, 34, 82, 244, 302, 347
 interpretation of dreams, 301

Freudian: and alchemical reduction of symbols, 301
 orthodoxy, doctrinairism of, 342
 repression theory, 42

Friday, day of Venus, 249

Friedlander, Gerald, 318&n, 337n

Frobenius, Leo, 101

fruit(s), 52
 -bearing tree, 166, 305
 forbidden, 304
 and herbs of paradise, 306n
 holy, 46

nourishing, 272
sun-and-moon, 303, 306, 308f
frumentum nostrum, 310
fulfilment, 44, 49, 53
fulmination, metallic, 152n
function(s): of anima, 180n
 of consciousness, *see* consciousness
 four, 167 (*see also* under *individual functions*);
 higher mental, 139n
 of persona, 180n
 psychic, 9, 169, 176
furnace, fig. B4
future Christ, 296

G

Gabal, the, 130
Gabricus and Beya, 93
Galatea, 179
Galen, Claudius, 116, 135n, 287n
game of dice, 267f
gamonymus, 136, 161; *see also* hierosgamos
Gaokerena, Persian tree, 340
Garden/garden: ascetic, 309n
 of Eden, 304, 318
 of Gethsemane, 295
 of philosophers, 309
 of spices, *see hortus aromatum*
garment, purple, 62
Garotman, anus of, 220
gas(es), 213, 325
 fiery poison of, 278n
gates, four, 172
Gaudentius, Saint, 104n
Gaul, 221

Gayomart/*gayō-maretan* 132, 220n, 337n

blood of, 288

Geber, 186, 206, 210n, 330f

Geley, Gustave, 51n

gem(s), 98, 287

Genesis, 78, 81, 137n, 248, 309, 318

genies: protective, 281

winged female, 281

genitals of Adam and Eve, 143

Gentiles, gods of, 141n

geomancy, 119

geometric pattern, 23

Germanic man. Faustian split in, 47

germinal vesicle, 23f, figs. A8, A9

germination and birth of stone, 298

Gessner, Conrad, 119, 129

Gethsemane, garden of, 295

ghost, 45

connection with anima, 40

white, 39

giant of twofold substance, 217, 292f&n

Gilbert Islands, 337n

Gilgamesh: epic, 320f

glass, 197

gold, 198

“Gloria mundi,” 92n, 207n, 210n, 219n, 226n, 286n, 307, 310n, 311

glorified: body, 297

“earth,” 311

Glory, King of, 146

Glover, A. S. B., vi, 59n, 293n, 296n

gnome(s), fig. B5

Gnosis, 4, 318, 338f

Gnostic(ism), 4, 59, 131n, 132, 195n, 228, 310, 319, 321, 334f

analogical thinking of, 147

archai, 22
Christ, 336
doctrine of, Anthropos, 205, 220
—, archons and aeons, 225
heresy, 102, 188
ideas, 147
and mythological ideas in alchemy, 204
pneumatic man of, 310
Redeemers, 233
speculation, 283
systems, 3
thinking, circular, 84
goal, 17, 20, 264f, 274
of alchemist, 179:
of alchemy, 161
of first half of life, 46
highest, 23
of individuation process, 195
Mercurius is, of his own transformation, 235
of opus, 152, 180, 275f, 279, 299, 305, 307
of psyche, 25
of spiritual existence, 46
goblins, 93
God, 20, 26, 37, 50f, 54, 77f, 81n, 86, 88n, 102, 106f, 116f, 126, 128, 132, 164n, 169n,
182, 197, 209, 236, 268, 284, 292, 300, 317, 324f
affinity of ego with, 117
arcane substance as *res simplex* and, 215
attribute of quaternity of, 281
attributes of, 82n
— transferred to the stone, 294
breath of, 139
child of, 52
as *coincidentia oppositorum*, 209
dead, 128
dream sent by, 105

duality of, [26](#)
face of, [88](#)
faith in, [111](#)
Father-, [339](#)
is Feminine and Masculine, [27](#)
first son of, [223](#)
fish-eating brings participation with, [266](#)
fishing rod of, [336](#)
“is four,” [131n](#)
four angels of, [282](#)
— faces of, [176n](#)
“higher and good,” [200](#)
is hypothesis, [36](#)
illusion of personal, [35](#)
-image, stone as, [97](#)
image of, [125](#)
of Jews, [222](#)
kingdom of, [106](#)
knowledge of, [94](#)
light of, [288](#)
is Love, and Will, [26](#)
-man, [297](#)
in man, [96](#)
man’s idea of, [344](#)
Mercurius, second son of, [222](#)
Mother of, [183](#)
is — and Father, [27](#)
as product of the opus, [307](#)
Satan is counterpart of, [236](#)
science of, [96](#)
second son of, [223](#)
sign of, [281](#)
Son of, [103n](#), [159f](#)
sons of, [81](#), [283](#)

spirit of, 136n
is Spirit, 104
is Substance and Force, 26
terrifying vision of, 346
transformation of, 334
is two in one, 27
Word of, 83, 87n, 115, 195n
wrath of, 83
“under me,” 121, 127
union with, 249n
unity of, 116
god(s), 36, 38f, 45, 70, 98, 267n, 268
acknowledgment of, 38
air, 279
birth of, 37
have become diseases, 37
dismembered, 73
earlier, 35
-eating (teoqualo), 81n
favourable and unfavourable, 29
with four faces, 279
of Gentiles, 141n
Hermes, of revelation, 209, 233
—, of thieves and cheats, 233
hidden, 241 (see also *deus absconditus*)
of illusion and delusion, Mercurius as, 247
of Indians, 337
lotus as birthplace of, 269
of magicians, Mercurius as, 202
masters of, 50n
nature, 150
origin and seed of, 76
phantasmal, 37
become physical, 104

rain-, 268n
of revelation, 179
sacrifice of, 80n
sky-, 268n
solar, 267n
stone as birthplace of, 97
sun-, 8n
two-faced, 250
of the underworld, triadic character of, 221
“of utmost emptiness and life,” 38
wind-, 221
world of, 155; *see also* deity; *deus*

goddess: earth, fig. 8
of love, *see* love
matriarchal, 99
moon, Diana, 303
mother, 183n
turquoise, 99; *see also* Dea Natura; Déesse Raison

Godfrey, Abbot of Admont, 295n

god-image, 241, 337
archaic, 345
self as indistinguishable from, 241

Goethe, J. W. von, 69, 136n, 296
consciousness of, has Christian character, 245
Faust, 7, 90, 111, 124, 128, 170, 179, 245
(trans. L. MacNeice), 79n
Faust II (trans. P. Wayne), 120n, 176, 183n
“Die Geheimnisse,” 296

gold, 24, 72, 75, 77, 89, 101, 122f, 135, 155, 160, 172, 255, 277n, 284, 296, 307, 332
branch of tree, 89
common, 275
essence of, 135n
glass, 198
making of, 51n, 91, 204, 237, 314

of Mercurius, 202
perishable, 218
personification of, 314
philosophic(al), 218, 274
—, Mercurius is, 207, 211
potable, 135*n*
and silver, fountain of, 103*n*
sun, 226
—, in the earth, 225
symbol of eternity, 149

golden: Age, 167
apple of the Hesperides, 307
flower, *see* flower
germ, 240
man, 64
oil, 227
star, *fig.* A4
temple, *fig.* A10
tincture, 208
tree, *see* tree
trident, 334

goldsmith, 204

good, 47, 183*n*, 184*n*
evil as counterpart of, 210

good and evil, 196, 201, 228
Mercurius as, 218

Gordian knot, 185

Gospel(s), 68*n*
four, 283
language of, 73
John, 87*n*, 102, 103*n*, 104, 182, 283, 306, 333, 338*n*
Luke, 106, 136*n*, *fig.* B6, 295*n*
Matthew, 106, 217, 242, 292*n*, 316, 319
synoptic, 243, 283

Götterdämmerung, 250
Gourmont, Rémy de, 333n
goyim, 113
grace, 53, 108, 187
grain: of mustard seed, 259
 sowing of, 73n
 of wheat, 306
 as *granum frumenti*, 306
grape(s), 279n, 306, 318
grasshopper, fig. 25
Gratianus, 331
graves, 97
Graves, Robert, 63n
Gray, Ronald D., 69n
Great Magic Papyrus of Paris, 161; *see also* Preisendanz
Greek: alchemy, 97, 284
 —, and Arabic, connections between, and India, 231
 —, tetrasomia of, 277
 Magic Papyri, 126, 148, 179, 192, 226n, 329
 mythology, 142
 Satan, 288
green: bird, 286
 crowned dragon, fig. 14
 and red lion, *see* lion
greenness: blessed, 77
 glorious greenness (*viriditas gloriosa*), 315
Gregory XIV, Pope, 233
Gregory the Great, Saint, 228n, 309n, 338n
Gretchen, 179; *see also* Faust
Greverus, Jodocus, 274f, 275n, 277, 285, 306n, 310n
greybeard, 228
griffins, Hyperborean, 63n
Grimm, Jacob and Wilhelm, 178n, 194n
 fairy tale of spirit in bottle, 193, 194n, 258; *see also* bottle, spirit in

group, Emperor, 41
grove of transformation, 262
growth, 24
 from above/below, 272
 inturned, 260
 process of self depicted as, 253
 regressive, 261
Grünbaum, Max, 317n
guardian: angels, four, 282
 spirit, 71n, 341
 of spirits, 61, 105
Guarini, 163
Gudākesha, 267
guilt, 196
 Promethean, 189
gumma (= *aqua permanens*), 329n; see also *aqua divina*
 gunas, 313
gypsum, 287n

H

Hades, 78&n, 154, 290n
Haggadic tradition, 317
Haggard, Henry Rider, 99n
hair, 92, 279, 287n, 290, 312, 340
 women's, 81
hallucination(s), 34, 200, 286
Halm, Karl, 70n
halo, fig. 12
Haly, King of Arabia, 126, 223n, 322
hand(s), 17
 and feet, cutting off of, 329
hapax legomenon, 121
Hapi, 279
Happeliuss, Nicolaus Niger, 214n, 219n

happening, outer, 16
happiness, 153, 160
hare, 195n
Harforetus (Harpokrates), 306
harlequin motif, 261
harmony(-ies), 65
 rule of, 60, 84
Harpokrates, *see* Harforetus
Harran, priests of, 81n
Harranite school, 81n, 147n, 206, 215
Hastings, James, 97n
hawk, 280
head(s), 29, 72, 80, 86, 88, 280, 312, 341, 347, figs. 27-29
 of dragon, *see* dragon
 -element, 291n
 entrance into, 89
 four heads, 266, fig. 27
 mystery, Harranite, 81n
 skinning of, 71f
 of snake, 291n
 sons of the Golden, 72
 symbolism, 88
 temple in, 89
healing: art of, 111, 117
 psychic systems of, 347
 snake of Moses, 104
heart(s), 70, 73, 139, 152, 160, 164, 192, 248, 259, 267, 294
 bodily, fleshly, 39
 capsule, 164,
 centre of, 139
 as centre, 271
 cutting out and eating, 71
 of the dead, 271n
 deep, 249n

diadem of, 147, 269
fire of, 164
heavenly, 23, 39, 44
high, 249n
of Mercurius, at North Pole, 209n
of the microcosm, 219
region, 165
-shaped, 271n
—, blossoms, 259; see also *cor altum*

heathen, 18

heating, 21

heaven(s), 219n

ascent to, one way, 233
birds of, 314
four corners of, 279
heart of, 44
invisible rays of, 72
kingdom of, 73, 87n, 202, 259
light of, see light
philosophic, 222
“space of former,” 23
spirits of, 176
starry, Mercurius as, 222
waters above and below, 151; see also *coelum*

heavenly: Adam, 169n

bodies, 125
elements, 155
flowers, 155, 163
heart, 23
image, 176
Jerusalem, 198
journey of the shaman, 303, 309
marriage, 163
physician of soul, 293

rose, 295
spirit, 209
spouse, 337
waters, 151
Hebrews, 95
Hebrews, Epistle to the, 83
Hecate, triple, 221
Hegemonius, 318*n*
Helen, in *Faust*, 176, 179
Helia Artista, 123*n*
hell, 96, 165*n*
 fire(s) of, 209, 210, 330
Hellenistic: Hermes, 279
 nature philosophy, 79
 syncretism, 102, 104
hen, 231
henosis, 277
Hera, 70
Heraclitus, 310
Heraclius, 314*n*
Herakleon, 87&*n*
Herakles, 99
heresiologists, 3, 147, 186
heresy(-ies), 186, 229
 Gnostic, 188
hermaphrodite, 123, 136*n*, figs. B1-4, 166
 Mercurius as, 319
 — parental, 236
hermaphroditic: monster, 139, 219
 true, Adam, 219
 union, 136
 Venus, 187*n*
hermeneut, 230
Hermes, 60*n*, 122, 123*n*, 125*n*, 126*n*, 147, fig. B6, 192*f*, 193*n*, 197*f*, 217, 220, 226*n*,
230, 283, 309, 331

All and Thrice One, 221
bird of, 152, 202
Chthonios, 247
god of revelation, 209, 233
— thieves and cheats, 233
Hellenistic, 279
ithyphallic, 230
Kyllenios, 230
-Mercurius-Wotan, 202
Psychopompos, 80
three-headed, 221, 224
tetracephalus, 224
tree of, 309n
underworldly, 231
vine of the wise, 314
wind god, 212

Hermes Trismegistus, 76, 103n, 178, 258, 279, 291n, 298, 303
Mercurius symbolized by, 319; *see also* “Tractatus aureus”

Hermetic: literature, 123
philosopher, 289
philosophy, 233, 274, 288
quaternity, 283
symbols, 241
vessel, *see vas Hermetis*

Hermolaus Barbarus, 76n

hero, 98, 101, 117, 128, 183n, 194, 258, 292, 305, 320, 337, fig. 15
culture, 100
dangerous fate of, 99
Kyllenian, 230
myth, 258, fig. 14
of peace, 229
struggle of, with dragon, 89

Hesperides: golden apple of, 307

tree of, 256, 308n, 340

hexagrams, 56

hieroglyph of eternity, uroboros as, 259

hierogamos, 123, 155, 180ff, 183, 257

 of light and darkness, 161

high heart (*cor altum*), 249n

Hildegard of Bingen, 27f

Hilka, Alfons, 223n, 306n

hills, everlasting, 306

Himalayas, 312

Hindu polytheism, 243

Hinkle, Beatrice, 26n

Hippolytus, 76n, 87n, 146f, 195n, 227n, 232, 283n, 285, 310n, 319n, 339n

hiranyagarbha (golden germ), 240

history, 43

 of religion, 204

 of symbols, 344

Hobgin, S., and Corrigan, F., 249n

Hölderlin, Friedrich, 248

Hoghelande, Theobald de, 85n, 105n, 138n, 139n, 207n, 212, 215n, 314, 322, 323n, 324

Holl, Karl, 146n

Holmberg, Uno, 274, 291n

Holmyard, Eric John, 139n, 226n, 305n, 309n, 310n

holy: dread, 171

 sacraments, 157

 Scripture, 286n

 trees of India, 340

Holy Ghost, 78n, 157

 dove of, 89

 inspiration of, 130

 Sapientia and, Mercurius identified with, 229

Holy Spirit, *see* Spirit, Holy

Holy Trinity, *see* Trinity

Homeric *μῶλυ*, 310n

homo: altus, 166
 maior, 179, 182
 maximus, 13&n, 166, 168, 179, 284, 291n
 —, inner, 165
 —, quaternity of, 167
 —, union with, 167
 purissimus, Christ the, 295f
 putissimus, 295
 synonym for microcosm, 219
 totus, 284, 295
homunculus(-i), 60n, 84, 89, 90, 102, 123, 140, 158f, 179, 198
 leaden, 71
honeydew, 153n
Honorius of Autun, 87n
hook, three-pronged, 332, 334
Horace, 184n
Horapollo, 259
Horfoltus, 67n
Hormanuthi, 74
horoscopes, 118
horoscopum, 130n
horse, Odin's, 340n
Horstmann, Carl, 304n
Hortulanus, 69n, 103n, 140n
hortus aromatum/conclusus, 294
Horus, 74f, 280
 and four sons, 22
 older, 281
 as rising sun, 280n
Host, 306
house: “of the Creative,” 39
 of fire, 149
hsing (human nature), 21n, 25, 29, 40f
 -*ming* (human nature and life), 23

hui (consciousness), 21n, 25

Hui Ming Ching (Book of Consciousness and Life), 1, 2, 20f, 21n, 23, 29, 30, 37, 44, 53

Hulda, fountain of, 317

human: anatomy, 273n, 274n

or animal blood, stone consists of, 290

biology, 243

incarnation, 53

mind, 54

nature, *see* nature

humanists, 338

humanity, cultural achievements of, 13

leader of, 53

Hume, Robert Ernest, 248n

humiditas, 207

humidum, 138, 207

hun soul, 41

as animus, 38, 40

as “cloud-demon,” 39

as Logos, 40

hundred pulses, 325

Hunt, Margaret, 194n

husband and wife, Mercurius as, 219

Huser, Johann, 112n, 114n, 115n, 117, 122n, 125n, 129, 130n, 131n, 139n, 143, 164n, 172n

hybris, 12, 37

hydrargyrum, 239, 284

Mercurius as, 207

hydrolith, 64

hylic into pneumatic man, Christian transformation of, 233

Hymns of the Atharva-veda, 313n

Hypnerotomachia Poliphili, *see* Colonna; Poliphilo

hypostases, 142

hypothesis of God, 36

Hyslop, James H., 41n

hysteria, 34

hysterical self-deceivers, 107

I

laldabaoth, 222n

lion-headed, 228

ibis, 279

Ibn Sina, 288n; *see also* Avicenna

I Ching, 8, 10, 13, 56, fig. A4

idea(s), 26

abstract, 35

archetypal, 346

born of fantasy, 277

Eastern, 10

eternal, 289

Gnostic, 147

intuitive, 9, 40

man's, of God, 344

—, in alchemy, 204

numinous, 299, 301

personified, 35

religious, 301

world of, 132n

ideation, conscious, and action, 12

Idechtrum, 132

identification of psyche with consciousness, 42

with self, 263

identity, of Christ and *lapis*, 294

mystical, 225

psychic, 92

stone's with man, 300

unconscious, 45, 91, 93

of uroboros and egg, 82n

ideology, Christian, 283

Ides/Ideus, 131f, 154

Ignatius Loyola, Saint, [86](#), [165n](#), [217n](#), [244&n](#)

ignis: coelestis, [77n](#)

elementaris, [209](#)

fatuus, [250](#)

mercurialis, [209](#)

ignition, [138n](#)

Iliaster/Iliastrum/Iliadus/Iliastes/Yliastrun/Yliedes/Yliedus, [125&n](#), [131&n](#), [132&n](#),
[134f](#), [136n](#), [140](#), [142](#)

extrinsic, [166](#)

great, [152](#)

hypostasis of being, [140](#)

as principle of individuation, [137](#)

sanctitus, [136](#)

spiritual, [165](#)

— principle, [140](#)

transformation of, [148](#)

watery aspect of, [138](#)

iliastric: Aquaster, [139](#)

spirit, [139](#)

illumination, [81](#), [85](#), [89](#), [115](#), [317](#)

of consciousness, *see* consciousness

revelation or, [179](#)

two sources of, [214](#)

illusion(s), [18](#), [29](#), [38](#), [297](#)

daemon is, [37](#)

Mercurius a god of, [247](#)

of personal God, [35](#)

transcendental, [34](#)

Iloch, [153](#)

image(s), [66](#), [274](#)

archetypal, [272](#)

—, tree as, [272](#)

autochthonous, [273](#)

autonomous, [247](#)

Christ, *see* Christ

compensating, primordial, 301
dream, 273
eschatological, 244
eternal, 337
fantasy, 179
God-, 97
of God, 125
heavenly, 176
primordial, 12f, 118, 301f
—, of the mother, 112
is psyche, 50
regulating, and unconscious, 301
totality, 284
—, divided into four, 283
two different, of self, *see* self
of wholeness, 283
imagery, 52
 Christian, 183
imaginatio, 137, 167, 176
 per sensus, 165n
imagination, 154, 159, 164ff, 168, 175, 179, 299
 active, 61n, 165n, 286
 corporeal, 140
imago: Dei, 249n, 316
 mother-, 112
imitatio Christi, 53, 325
imitation, 181n
 Western, 8
Immaculate Conception, 96
immortality, 46, 51n, 136n, 186
 connection of lapis with, 101
 drink of, 313
 food of, 306: fragrance of, 337
 odour of, 334

Imperator group, 41
imps, 93
impulses, vital, 44
impure metals, 290n
incarnation(s), 29n
 of Christ, *see* Christ
incest, 280
 archetype, 301
 mother-son, 232
 primal, 302
incineratio, 128n
incorporeal, *see* corporeal/incorporeal
incorruptibility, 134, 136n, 142
 of Mercurius, 245f
in creatum, 236
India(n), 14, 23, 24, 97, 132, 142, 178, 281n
 connections between Greek/Arabic alchemy and, 231
 god of the, 337
 holy trees of, 340
 “Quicksilver System,” 206
 theosophy, 268, 269
Indians, American, 99f, 178
 Aztec, 100
 Hopi, 221
 Iroquois, 99
 Natchez, 100
 Navaho, 22
 Peruvian, 100
 Pueblo, 22, 100, 263
 Sioux, 100
 Thompson and Shuswap, 71n
 Wichita, 100
individuality, spiritual, 27
individuation, 28, 105, 179, 325, 327

of the adept, 326
principle of, 137, 142, 199, 239
—, Ares as, 140
process, 176, 194, 240, 254, 269, 325, 328, 339, 341
—, goal of, 195
—, Mercurius represents, 237
—, projection of, 229
—, symbolism of, 299
source of all evil, 196
symbol of, fig. 24

indolence, 15

infantile memories/wishes, repressed, 341

inferior Logos, animus as, 41

inferiority, feelings of, 128f, 335

inflation, 263, 326n

initiate, 63n, 72, 80

initiation, 91

inner: experience, 16
homo maximus, 165
light, 106
man, 87n, 89f, 106, 157, 179, 249n
—, or astral, 131, 165, 168n
—, imaginary, 165n
—, law of future, 180
—, secret of, 163
—, spiritual, 148
things, 43
world, 180n

innovations, 53

inorganic, 239
realm, 195
stone, symbol of the, 238

insane, delusions of the, 246

insanity, 18, 36, 325

inside, 15f, 18

insight(s), 17, 28

- destructive, 117
- secret, 37
- superior, 343f

instinct(s), 8, 12

- atrophy of, 12f
- concept of, 5
- deeply rooted, 16
- of ideation and action, 12
- psychosomatic, 346
- repression of, 47

instinctive: demands, 8

- dispositions, 275

instinctuality, 9, 12, 196, 333

“Instructio de arbore solari,” 308n

“Instruction of Cleopatra by the Archpriest Komarios,” 154

integration: new, 48

- of unconscious, 325, 346

intellect, 6, 9, 50, 201, 238, 246f, 269, 314, 328

- Eastern, 9
- externalistic, 10
- rationalist(ic), 336,
- Western, 48

intellectualism, 9, 246

intensity, 25

- emotional, 268

interpretation, 67

- of dreams, 66, 347
- of unconscious, 341

“Introitus apertus,” *see* Philalethes

introspection, 40

- intuitive, 169
- lack of, 335

introversion, 315
intuition(s), 6, 9, 167
 mystical, 7
 of the self, 24
 of the spirit, 28
intuitive: ideas, 9, 40
 introspection, 169
invisibilis homo maximus, 169
invulnerability of Mercurius, 245
Ion, 60, 80, 84
Ionians, 60n
Iranian tradition, 337n
Irenaeus, 318, 334&n, 338, 339n
iron, 14n, 194, 218, 277, 332
 mixed, branch of tree, 89
ironsmith, 204
Iroquois, 99
irrationality, 17, 261
irritation, 82
Isaiah, 146
Isherwood, Christopher, see Prabhavananda
Ishtar/Istar/Astarte, 182, 232, 320
 Semitic, 308n
Isis, 73, 183n, 303n
 attributes of, 318
 has form of Melusina, 318
 mysteries, 80, 183n
 treatise, 74, 81
 vision of, 81
“Isis to Horus,” 73, 215
island, 253, 271, 308, figs. 1, 23
isles, blessed, 309
isolation, 301
 auto-erotic, 254

Israel, [146](#)
Istar, *see* Ishtar
Istria, [298n](#)
ithyphallic old man, winged, [232](#)

J

jackal, [280](#)
Jacob, [146](#)
Jacobi, Jolande, [vi](#)
Jacobsohn, Helmuth, [73n](#), [337n](#)
Jaffé, Aniela, [315n](#)
James, William, [41n](#)
jars, four Canopic, [280](#)
Jehova, Mercurius as, [222](#)
Jeremiah, [317](#)
Jerusalem, heavenly, [198](#)
Jesuits, [20](#)
Jesus, [53f](#), [102ff](#), [283](#)
 belief in, [168](#)
 contemplation of the life of, [165n](#)
 a cornerstone, [102](#)
 sayings of, [243](#)
 tree is, [318](#); *see also* Christ
jewel, [53](#)
Jewish tradition, [339](#); *see also* Israel; Hebrews; Judaism
Jews, God of, [222](#)
Job, [242](#)
Johannes de Rupescissa, [88](#), [219&n](#)
John, Gospel of St., *see* Gospel(s)
Jonah, [143](#)
Jordan, [74n](#)
Joshua ben Nun, Moses' relation to, [321](#)
journalists, [37](#)
journey: ecstatic, [341](#)

heavenly, of the shaman, 303, 309

Judah, lion of the tribe of, 228, 295n

Judaism, 243; *see also* Israel; Hebrews; Jewish tradition

judgment/Judgment: conscious, 17

 day of, 297

 Last, 298

 rational, 12

Jûnân ben Merqûlius, son of Mercury, 60n

Jung, Carl Gustav:

 CASES IN SUMMARY (*in order of presentation, numbered for reference*):

 [1] Woman patient wrote him letter. —47f

 [2] Somnambulist girl, aged 15½, drew mandala (not illus. here).— 23n, 25

 [3] University-trained woman, drew mandala, fig. A4.—56

 [4] Patient, drew figs. 2, 30, 31.—254f, 268f, 338

 [5] Patient, drew figs. 26, 28, 29.—264-68, 338

 WORKS: *Aion*, 75n, 76n, 94n, 241n, 254n, 266n, 280n, 283n, 284n, 295n, 300n
 322n, 324n, 325n

Answer to Job, 342

 “The Archetypes of the Collective Unconscious,” 22n, 178n

 “Concerning the Archetypes, with special reference to the Anima Concept,” 178n

 “Concerning Mandala Symbolism,” 2, 22n, 56n, 253, 282n

 “Concerning Rebirth,” 321n,

Memories, Dreams, Reflections, v

Mysterium Coniunctionis, v, 83n, 199n, 220n, 226n, 230n, 232n, 248n, 290n, 310n,
 332n, 337n, 338n

 “On the Nature of the Psyche,” 86n, 217n, 222

 “Paracelsus the Physician,” 119n, 178n

 “Phenomenology of the Spirit in Fairytales, The,” 240n, 337n

Psychiatric Studies, 23n

 “A Psychological Approach to the Dogma of the Trinity,” 84n, 151n, 167n

Psychological Types, 21n, 40n, 91n, 340n

Psychology and Alchemy, v, 4n, 60n, 66n, 68n, 69n, 76n, 80n, 83n, 89n, 95n, 104n,
 123n, 131n, 144n 151n, 153n, 158n, 168n, 172n, 186n, 195n, 220n, 236n, 241n,
 253, 258n, 262n 276n, 278n, 284n, 286n, 295n, 302n 303n, 304n, 306n, 308n,
 313n, 314n, 315n, 316n, 317n, 321n, 333n, 336n, ’

“The Psychology of Dementia Praecox,” 121n

“Psychology and Religion,” 92n, 151n, 166n, 187n

“The Psychology of the Transference,” v, 86n, 157n, 195n, 225n, 278n, 294

“Richard Wilhelm: In Memoriam,” 1

“A Study in the Process of Individuation,” 22n, 56n, 253, 269, 317n, 336n

Symbols of Transformation, 231n, 340n

“Transformation Symbolism in the Mass,” v, 61n, 70n, 71, 72n, 81n, 83n, 86, 226n

Two Essays on Analytical Psychology, 39n

(with W. Pauli) *The Interpretation of Nature and the Psyche*, 228n

Jupiter, 275, 278, 310

brightness of, 152n

justice, light of, 249n

Justin Martyr, 104n

Gnosis of, 318, 339

K

ka of king, 101

Kabbalist, Satan is, 114n

kabbalistic arts, 113n

Kagarow, Eugen, 340

Kalid, *see* Calid

Kalighat (Calcutta), 97n

Kant, Immanuel, 54

Kaufmann, Walter, 128n

Kékulé von Stradnitz, F. A., 108

Kenset, 279n

Kepler, John, 118, 288

kermes, 148n

Kern, Otto, 312n

Khidr, 321

Khunrath, Heinrich, 96, 126f, 219, 221, 227f, 292, 308, 320n

Amphitheatrum, 127n

Von hylealischen Chaos, 151n, 207n, 218n, 219n, 221n, 223n, 226n, 227n, 228n, 230n, 236n, 292n, 308n, 320n

killing, 67, 321

of dragon, 83n

king(s), 83, 146f, 166, 228, 272n, 312n, 317

crown of, 80n

divine, 101

of forest, 194, 199

four, 282

of Glory, 146

ka, 101

Mercurius, 235

purple of, 312

Sol, 303

son, fig. B6; see also *filius*

king and queen, 294

kingfisher, fig. 32

Kingsford, Anna, 26

Kircher, Athanasius, 93n

kiss of the Lord, 295n

“Kitâb el Foçul,” 309

knife, sacrificial, 84

Knorr von Rosenroth, Christian, 312&n.

knowledge, 83, 320, 327

acquisition of, 92

Christian, 113n

of Creator, 247n

of creature, 247n, 248n

deliverance through, 313

differentiating, 41

and faith, conflict between, 115

—, split between, 189

of God, 94

of man, 248f

natural, 113n

paradise tree of, see tree

tree of, 318, 339, fig. 11
two forms of, 247
—sources of, 111, 116
true, 288
Knuchel, E. F., 24n
kobold(s), 89, 162
Komarios, 67, 94, 98n, 154
Kopp, Hermann, 298n
Koran, 318n, 321n
Korybas, 232
krater, 73
“Krates, Book of,” 66n, 83n, 99, 216, 226n, 278n
Krickeberg, W., 100n
Krishna, 267f, 312
Kronos, 76, 227
Krueger, C., 196n
kuai (demon), 39
Kyllenios, 232, 247
sanctuary of, 230

L

laboratorium, 349
labor Sophiae, 170f
labyrinths, 324
Lacinius, Janus, 68n, 288n, 298n, 313, 330n,” *see also* Bonus
Laconia, 97
lac virginis, 207n
ladanum, 156n, 187
ladder, 26
Ladislav II, 158
“Lady Soul,” 340
Lake, Kirsopp, 87n
lake of Vourukasha, 308, 340
lamb/Lamb, fig. 22

Apocalyptic Marriage of, 182f
Lambspringk, fig. B6, 83n
language: alchemical, 104
—, dream, 301
allegorical, 94
of conscious mind/consciousness, 28, 301
dream, 69
esoteric, 157
secret, 162
“Lapidis philosophorum nomina,” see Codices and Manuscripts
lapis, 67, 84, 87, 92f, 96, 101f, 140, 142, fig. B4, 168n, 170, 174n, 180, 224, 241f, 247, 259, 269, 278n, 279, 284, 310, 329
aethereus, 104
as Andalusian prince, 320, 327
—Christ parallel, 95f, 102, 294, 300
connection with immortality, 101
consists of body, soul and spirit, 102
elevatus cum vento, 212
as “filius unius diei,” 248n
Lydius, 72
Mercurius as, see Mercurius; names of, 95
philosophorum, 72, 123f, 166, 195, 241f
—and Christ, identity of, 294
—as *filius macrocosmi*, 294
as prima materia, 319
as quintessence of elements, 168n
relation to consciousness, 240
as self, 101
signifies inner man, 95
as *spiritus humidus et aereus*, 104n
as symbol of God in man, 96
tree as, 319
Laplace, Pierre Simon, Marquis de, 36
Last Supper, 168, 217, 292n
Latinists, 206

laudanum, [155](#), [156n](#)

law(s), [22](#), [44](#)

of compensation, [245](#)

of the earth, [8](#)

of inner, future man, [180](#)

of life, [18](#)

mathematical, [159](#)

of matter, [239](#)

outward, [54](#)

psychic, [237](#), [277](#)

of reason, [245](#)

transgression of, [243](#)

unconscious, of our being, [8](#), [21](#)

of unconscious, [239](#)

Lazarello, Ludovicus, [188](#)

lead, [60n](#), [74&n](#), [89](#), [105n](#), [128n](#), [203](#), [218](#), [226](#), [277](#), [325](#)

as arcane substance, [331](#)

philosophic, [227](#)

possessed of a demon, [323](#)

as prima materia, [305n](#)

Saturnine, [331](#)

is water, [74](#)

of the water region, [24](#)

white, [64](#)

leaden: homunculus, [71](#)

man, [62](#)

leafless tree, *see* tree

left/right, [265](#), [336](#)

equilibrium of, [269](#)

or masculine/feminine, [341](#)

legal practice, [34](#)

legend(s): American, [99](#)

Aztec, [100](#)

Basuto, [101](#)

Khidr, [321](#)
Peruvian and Colombian, [100](#)
sacred, [299](#)
Legge, Francis, [76n](#), [87n](#), [145](#), [285n](#), [310n](#)
Legge, James, [56](#)
leopard, [282](#)
leprous metals, [290&n](#)
Leto, [318](#)
letting things happen, [16f](#)
Leukadia, [97](#)
Leviathan, [265](#), [334](#)
Leviticus, [317](#)
Lévy-Bruhl, Lucien, [45](#), [91](#), [347](#)
liberation, [52](#)
“Liber de arte chymica,” [103n](#), [220n](#)
Liber mutus, see *Altus*
“Liber Platonis quattorum,” [85n](#), [86](#), [88](#), [139n](#), [215](#), [225](#), [227n](#), [323](#)
life, [24](#), [284](#)
 aerial, [163](#)
 aesthetic flirtations with, [18](#)
 biological, [52](#)
 bread of, [306](#)
 consciousness and, see *consciousness*; continuation of, [51n](#), [52](#)
 and death, [51n](#)
 —, tree of, [271](#)
 devotion, [24](#)
 elixir of, see *elixir*
 energy, [25](#)
 everlasting, [154](#)
 -force, [214](#)
 fountain of, [84](#), [103n](#)
 human nature and, see *nature*
 law of, [18](#)
 length of, [135](#)

middle, 46
middle of, 14
as *ming*, 25
mystery of, 239
Paracelsus'
definition of, 134
principle, 135, 213
— of tree, 196
problems of, 15
-soul, mercurial, 214
source of, 272
stream of, 17
tree of, *see* tree
urge, 15
wood of, 339

light, 20*f*, 24, 59, 77, 85, 94, 107, 125*ff*, 147, 162, 166, 236, 236*n*, 242, 245, 262, 268, 299, 341
from above, 160*f*
of the body, 106
-bringer, 127, 226
—, Lucifer the, 247
—, primordial, 248
central mystery of philosophical alchemy, 126
central white, 25
children of, 247
circulation of, 16
clarifying, 41
coming of, 226
of consciousness, 90, 247
— and reason, 40
cross of, 265
of darkness, 160*ff*
divine, 107, 330
figure(s) of, 264*f*
flower of, *fig.* 32

gathering the, 30
globes of, fig. 25
of God, 288
of heaven, 20
— is Tao, 23
heavenly, between the eyes, 22n
of Holy Spirit, 116
of human nature, 29
inaccessible, 74n
inner, 106
of innermost region, 44
of man's own intellect, 250
of justice, 249n
of lights, Mercurius as, 235
man of, 104n, 130f, 131n
in man, 106
Mercurius, of nature, 209f
of moon and stars, 248
natural, 239
—, of man, 127
nature of, 151
of nature, 111, 113-16, 160, 184f, 209, 218, 248, 288
new, 126
— morning, 248
pneumatic realm of, 334
poles of, and darkness, 25
pure white, 35
rays of, 63n
realm of, 264
of revelation, 111, 115
seat of heavenly, 20n
of self, 248
that shines in darkness, 297
simulacrum Dei, 151

supernatural, 115
surpassing all lights, 247
-symbol(s), 150n, 262f
symbolism, 25
tree of, 255
vision of, 27
white, fig. A6
world of, 336
yellow, 126n

light and darkness: daemons of, 243
 struggle between, 244

lightning, 152&n, 162, 221, 317
 physical, 152

Lilith, 199n, 240, 303, 339

Lilius, 147n

Lille, Alan of, *see* Alan

limus profundi, 146

linea media (middle line), 312

lion(s), 73n, 145n, 183, 280, 282, 292, 303, figs. 22, 25
 allegory of Christ, 228
 associated with Saturn, 227
 blood of, 295n
 of Catholic tribe, 228
 cut-off paws of, 304, 321
 fiery, 198
 green and red, 218, 226n, 227f
 -headed Ialdabaoth, 228
 Mercurius as green and red, 227
 of tribe of Judah, 228, 295n

Lippmann, Edmund O. von, 146n, 287n

liquid, combustible, 320

liquor Sophiae, 180

Litigius, 141n

liver, 39

“Livre des ansienes estoires,” *see* Codices and Manuscripts

Livre d’Heures du Duc de Berry, 308n

Llewellyn, R. T., 106, 111n, 130n

loathsome sponge, 290

lūcustae, 287n

logical contradictions, 245

logos, 40, 83, 232, 283

animus as inferior, 41

Christ as, *see* Christ; compensatory, 297

dog as, 232n

Johan-nine, 222

Mercurius, become world, 222

principle, 41

spermatikos, 40

Lolium temulentum, 288n

longevity, 134, 137, 148, 152, 153n, 154, 156, 166, 174, 326

Longinus, *fig. B4*

Lord: kiss of the, 295n

of Spirits, 244

of trees, 337n

Loreto, Litany of, 294n

loss of soul, 34

lotus, 280, 295, *fig. 31*

as birthplace of the gods, 269

blossom, 266

love, 83, 187, 296f

Christian, of one’s neighbour, 168, 185

divine, 210, 307

—, fire of, 210, 307

goddess of, 216, 232

-magic, 280

-play of royal marriage, 329n

and praise of Creator, 247n

shield and buckler of, 175, 187

lover(s): and beloved, 219
of wisdom, 168, 171; see also *Scaïoli*

lower, 341
world, 256

Lu-ch'iang Wu, and T. L. Davis, 126n, 226n, 324n

Lucifer, 223, 226, 228, 249
father of lies, 250
light-bringer, 247, 250

lūcusta, 287n

Ludwig II of Bavaria, 194

Ludwig Wolfgang von Hapsberg, 133

Luke, Gospel of St., see Gospel(s)

Lully, Raymond, 123n, 141n, 186, 227, 235n, 298n, 324

lumen de lumine, 244

lumen naturae, 113n, 114n, 160, 162f, 169, 179, 184, 187, 209, 250
authority of, 116
Mercurius as, 209f; see also light s.v. of nature

luminositas sensus naturae, 114

Luna, 86, 136n, 150, fig. B4, 310
cohabitation with Sol, 123
as silver, 122; see also moon

Lunatica, 310

lung-breathing, 243

Lusignan, counts of, 143

lust, flames of, 155

Lü-tsu, Master, 16f

lutum, 287n

lux moderna, 247

M

MacNeice, Louis, see Goethe

macrocosm, 94, 127, 152, 165, 236, 259, 284, 291
hermaphroditic seed of, 219
Preserver of, 127

son of, 126
madness, 203, 261
 Caesarean, 13
Magi, 113n
Magia, 114
magic(al), 45, 90, 113, 116, 118, 120f, 179, 189, 282
 arts, 122
 blood, 83n
 cagastric, 125&n
 circle, 22, 24, 90
 divine, 139
 folk, 122
 furrow, 24
 love-, 280
 medieval cesspits of, 245: practices, 24, 46
 psychic dangers of, for adept, 119
 rag, 203
 rites, 54, 122
 spells, 10
 of symbol, 28
 texts, 327
 tree, 303, 341
 word, 121
Magic Papyrus(-i), 126, 148, 179, 192, 226n, 329
magician(s), 195, 328
 aquastric, 139
Mercurius, god of, 202
magistry, 69n, 290, 291n, 298, 314
Magnalia, 163
magnesia, 207n, 216n, 230
magnet, 308
magus, 114, 119, 240n
Magus, Simon, 258, 310, 339n
Mahayana Buddhism, 29

Maheshvarapurana, 206n

Mahrya, 337n

Maier, Michael, 69n, 72, 76n, 79n, 82n, 85, 145-48, 160n, 227n, 230, 275n 277, 303, 306n, 310

maior homo, 148

Maitland, Edward, 26

Maitrayana-Brahmana Upanishad, 240n

Makara, 265

maladaptation, 12

Malchuth, 312

male and female, powers of, 218

“Malus Philosophus,” 240

man (men)/Man, 40

accursed, 139

angelic qualities of, 130n

animal, go; astral, 131, 165, 168n

basis of real understanding, 55

begetting of, 73n

brazen, 61f, 64

celestial, 132

civilized, 45

contemporary, 54

creation of, 86

daemonization of, 282

earthly, fleshly, 94

eternal, 306n

everlasting, 180ff

Faustian spirit in, 47

femininity of, 338

fertility of, 97

firmament in, 152

flint, 100

form of, 166

God-, 297

God in, 96

golden, 64
half-/half-fish, motif of, 178
high, Mercurius as, 235
higher, 54
himself, knowledge of, 248
idea of God, 344
incarnate, Primordial, fig. B4
inner *see* inner
— or astral, 153
—, eternal, 150
interior, 131*n*
as inverted tree, 312
knowledge of, 249
lapis signifies inner, 95, 102
leadен, 62
light in/of, 106, 127
of light, 104*n*, 130*f*, 131*n*
Mars characterizes affective nature of, 141*n*
metal, 89, 93
metallic, 198
as microcosm, 92, 166*f*
most pure, 290
natural, 169, 184, 260
—, purification of, 142
One, 131, 183
Original, 166
outer, mortal, 150
philosophic, Mercurius as, 235
— ambisexual, Mercurius as, 219
philosophical, 94
planets in, 125&*n*
pneumatic, 46, 310
Primordial, 87*n*, 129, 131&*n*, 132, 139, 165*n*, 220*n*, 334, 337&*n*
—, (Christ), 336

—, unitary, [334](#)

—, is world soul, [334](#)

quadripartite, [168](#)

quaternity of Original, [172](#)

rebirth of, [27](#)

Red, [92n](#), [93](#)
regenerated spiritual, [157](#)
rooted in paradise by hair, [312](#)
and his shadow, [246](#)
silver, [64](#)
son of, [96](#), [232](#)
—, historical personality of, [165n](#)
and his soul, [160](#)
spiritual, [94f](#), [131n](#)
star in, [127](#), [152](#)
stone's identity with, [300](#)
totality of, [139](#)
tree as, [337](#)
— of paradise as, [337](#)
true or complete, [324](#)
true spirit in, [136n](#)
true, is star, [131](#)
uncharacterized, [145](#)
Western, [55](#)
white, [93](#)
whole, [325](#)
— and complete, [296](#)
Wise Old, [178](#)
Yellow, [92](#); see also *homo*

mana, [97](#), [268](#)
of dead, [97](#)

Mandaean influences, [232](#)

mandala(s), [22f](#), [28](#), [96](#), [249n](#), [253](#), [269](#), [fig. 31](#)
Christian, [22](#)
divided into four, [264](#)
Eastern, [56](#)
European, [2](#), [22n](#), [24](#), [56](#)
Lamaic, [fig. A2](#)
nrithya, dance, [23](#)

rose as, 295
of somnambulist (Jung's case), 23n, 25
symbol, 23

mandrake, 290n, 291f, 311

Manget/Mangetus, Johannes Jacobus, see *Bibliotheca chemica*

Mani, 70

mania, 38

manifest, occultation of the, 151n

manikins, wax, 122, 122n

manipūra-chakra, 266

manna, 306
fat or oil of, 153n

manticism, 118

Manu, 265

manuscripts, see Codices and Manuscripts

marble, Proconnesian, 64

Marcasita, 287&n

mare nostrum, 146, 237

mares, -tails, forest of, fig. 27

Maria (the Jewess) Prophetissa, 85, 286n, 308
axiom of, 151n, fig. B2, 166, 224, 278

Marjoram, 311

Marmara, 64n

marriage: Apocalyptic, of Lamb, 182f
chymical, see chymical marriage cross-cousin, 278
heavenly, 163
pair, 83
problems, 8
royal, 278, 326
—, love-play of the, 329n
see also *hierosgamos*

Mars, 93, 135n, 141n, 154, 187, 275, 278, 310
characterizes affective nature of man, 14n
and Venus, 93, 183

Marsyas, 70

Martial, 221&n

martyrdom, spiritual, 330

Mary, 155, 294, 318

allegories of, 294

body of, 139, 140

coronation of, 144

as earth, 256

Immaculate Conception, 96

obumbratio of, 214

masculine, 13, 39

aspect of Mercurius, 319

consciousness, 334

daemon, 267

differentiated mind, 41

-feminine, 341

— division of tree-soul, 319

mind, 336

neuroses, 336

principle, 268

psychology, 81f, 269

soul, fig. A6

sulphur, principle of Mercurius, 228

thinking, 267

Trinity, 96

masculinity, woman's, 338

mass psychoses, 36

Mass, 123, 160

opus alchymicum in form of, 158

massa confusa, 84, 325

Mater: ecclesia, 112

Gloriosa, 183n

Natura, 112, 147

materia: medica, 123

torturing of, [105n](#); *see also* *prima materia*

materiality of cosmos, [239](#)

materialization of soul, [257](#)

maternal: feminine, nature of tree, [317f](#)
 significance of tree, [261](#)

matriarchal society, [99](#)

matter, [67](#), [89](#), [95](#), [97](#), [104](#), [125](#), [127](#), [129](#), [138](#), [146](#), [161](#), [171](#), [184](#), [238f](#), [284](#), [300](#)
 in alchemy, [140](#)
 autonomy of, [238](#)
 hermaphroditic, [219](#)
 inert, [68](#)
 laws of, [239](#)
 mystery of cosmic, [96](#)
 philosophic, [290](#)
 projection into, [300](#)
 secrets of, [299](#)
 and spirit, contamination of, [212](#)
 —, identical, [214](#)
 unknown, [237](#)

Matthew, Gospel of St., *see* *Gospel(s)*

Matthews, Washington, [22n](#)

maturation: alchemical, [124](#)
 of physician, [124](#)

May, [176](#)
 exaltation in, [161](#)
 —, true, [163](#)
 month of, [155](#)
 the true, [153](#)

Maya, [95](#), [318](#)
 veil of, [38](#), [180](#)

maydew, [153n](#)

Mayryana, [337n](#)

Mead, G. R. S., [104n](#)

meaning, [20](#), [342](#)

development of, 272
one's own, 53
of psyche's existence, 346
Mechthild of Magdeburg, 294f
media substantia, 213
mediator, 99, fig. B2, 235n
 Mercurius as, 235
medical: psychology, 273
 schools, 115
medicina catholica, 274n
 Mercurius as, 235
medicine, 111
 bags, 45
 chemical, 124
 fiery, 78n
 Germanization of, 144n
medieval: Christianity, 18, 303
 magic, cesspits of, 245
meditatio, 165n
meditation, 30, 137, 330, 346
 interminable, 239
mediumistic: "controls," 40
 phenomena, 35
megalithic: culture, 100f
Meister Eckhart, *see* Eckhart melancholia, 153, 170, 331
melancholy, 101
 Saturnine, 153
Melanesians, 97
melanosis (blackness), 331, 341
Melchior of Brixen, 92n
Melchior Cibinensis, *see* Szebeny
Melchisedek, 137n
Melissa, 153&n, 154
Mellon, Paul, Alchemical Collection, vi

melothesia, 92n

Melusina, 138, 142ff, 145, fig. B5, 163, 173-80, 182, 183, 199, 240, 303, 315, 317, 321

as *anima*, fig. B5, 144

Isis has form of, 318

psychic reality of, 176

transformation of, 179

as tree-numen, 315

vision appearing in mind, 144, 174

Melusines, 158

Melusinian Ares, 138, 142

Melyssina, *see* Melusina

membranes, in mandalas, 24

memories, repressed infantile, 341

Mendes, ram of, 279

menhirs, 100

mental: aberrations, 323

diseases, 35

disturbances, 34, 324

processes, 56

Mephistopheles, 136n, 203, 245

coldness of, 90; *see also* Goethe, *Faust*

mercurial: essence, 196

fire, 210

life-soul, 214

pneuma, 215

poisoning, 323

serpent, *see* serpent; spirit, *see* spirit

Mercurius, 67n, 75, 78n, 79n, 83, 85, 96, 122f, 125f, 132n, 136n, 178, 187n, 193n, 196f, 202f, 207ff, 275, 277, 284, 291, 309ff, 329

Adamic, in Eve, 235n

aerial, 212

is akin to godhead, 220

alchemical, 269

as *alexipharmakon*, 235

ambiguity of, 249

as *anima*, 213
as analogue of Christ, 235
antinomian nature of, 216
as arcane substance/arcanum, 216, 235ff
as archetype of unconscious, 247
ascent of, 233
has attributes of Venus, 226n
is begetter of his parents, 226
as beginning, middle and end of work, 235
as carbuncle, 235
changed into wind, 212
as child of chaos, 228
— of Saturn, 76n, 227
— of sun and moon, 76n, 225
and Christ, as brothers, 222
—, in compensatory relationship, 245
as Christ, 222, 235
as chthonic half of Godhead, 222
coelum as, 219
common, 275
—, and philosophic, 217
consists of opposites, 220, 237
continuous cohabitation of, 231
contrary nature of, 319
corporeal aspect of, 212
as Cupid, 231
dark, 232
— and dubious quality of, 241
descent of, 233
as *deus terrestris*, 235, 241
is devil, 237
diabolization of, 248
is divinity itself, 235
as *divinus ternarius*, 230

duality of, 144, 217ff, 221, 232n, 237, 319
duplex, 79n, 269, 292, 309, 319
duplicity of, 217, 245
as earth of paradise, 235
Echidna symbol of, 144n
elements of, 217
endowed with attributes of Trinity, 236
evasive, 195n
as father of all metals, 235
as Father-Mother, 220n
feminine aspect of, 321
—, role of wisdom, 319
as fiery and perfect, 235n
as *filius*, 222
as fire, 209ff, 310
as *foemina*, 213
found in dung-heaps, sewers, 220, 232
fourfold, 279
or Giant, 292
as glue, 213f
as goal of his own transformation, 235
God, of illusion and delusion, 247
—, of magicians, 202
gold of, 202
as good and evil, 218
as green and red lion, 227
heart of, at North Pole, 209&n
is hell-fire, 210
as hermaphrodite, 319
Hermes-Wotan, 202
as “high man,” 219
as husband and wife, 219
as *hydrargyrum*, 207
identified with *anima mundi*, 214

— collective unconscious, 222, 237
— Moon and Venus, 226
— Sapientia and Holy Ghost, 229
— tree, 338
is *ignis elementaris*, 209
as image of Christ's incarnation, 235
incorruptibility of, 245f
invulnerability of, 245
as Jehova, 222
juvenis, 250
as king, 235
as Kyllenian hero, 230
as lapis, 221, 235, 241, 246
lasciviousness, 231
as life principle of tree, 319
as light of lights, 235
— of nature, 209f
as Logos become world, 222
has many-sided associations, 202
masculine aspect of, 319
as Mediator, 235
as *medicina catholica*, 235
is most chaste virgin, 226
multiple aspects of, 237
as mystagogue, 225
noster, 213
—, *naturalis ignis certissimus*, 209
non vulgaris/vulgi, 214, 284
nostra anima, 213
“our,” 211, 219
Paracelsan, 136n
paradoxical nature of, 241
as parental hermaphrodite, 236
persecuted with torments, 331

as personification of unconscious, 333
philosophicus/philosophorum, 136n, 207, 211
— ambisexual Man, 219
— gold, 235
— man, 235
positive aspect of, 241
as prima materia, 239, 309
as primeval chaos, 235
psychic nature of, 216
psychologem of, 216
as *puer*, 220
— *leprosus*, 226n
quadratus, 278
as quicksilver, 207ff
as redeeming psychopomp, 237
as reflection of mystical experience of artifex, 237
relation to astrology, 225
— to Saturn, 226, 250
— to Venus, 250
represents individuation process, 237
— the self, 237
as revealer of divine secrets, 230
as salt of Saturn, 227
as Salvator, 235
as second Adam, 235
— son of God, 222
self-destruction/transformation of, 236
as *senex*, 178, 220, 226, 250
as Servator, 235
as son of Tiamat, 236
as soul of metals, 198
as source of all opposites, 348
as spirit, *see* spirit
as spirit and soul of the bodies, 213

as *spiritus vegetativas*, 202, 310
as starry heaven, 222
as stone, 235
as storm daemon, 202
sulphur, is fire hidden in, 228n
—, is masculine principle of, 228
as supracelestial spirit, 214
symbols of, 257
symbolized by Hermes Trismegistus, 319
synthesis of, 257
as system of higher and lower powers, 222
as *terminus ani*, 220
three-headed, 221
— snake, 222
as tincture, 235
transformation of, 333
as tree of metals, 309
as tree-numen, 239
triad of sulphur, salt and, 277
— of sun, moon and, 277
triadic nature of, 221
as trickster, 203, 237
as trinity and quaternity, 222
trinity and unity of, 221ff
as *trinus et unus*, 196
as triune divinity, 222
as *triunus* and *ternarius*, 221
turns into goddess of love, 226
two substances of, 217
as *ultima materia*, 235
undividedness of, 245
as *unigenitus*, 235
unites opposites, 309f
as unity, 237

utriusque capax, 348
vapour-like nature of, 212
and Venus, 226n
as *virgo*, 213
as water, 207ff, 309
mercury, 277n; *see also* quicksilver
Mercury: external, 135n
 planet, 225
 son of, 60n
mère Lusine, 143
meridian, 46
 of the Sun, 63, 72, 80ff; *see also* life, middle
Merkabah, 281
Mesopotamia, 231
“Messiah of the Lie,” 232
Mestha, 280
metal(s), 72, 89, 218, 227n, 287, 290, 331
 base, 101
 impure, 290n
 leprosit of, 291n
 leprous, 290
 men, 89, 93
 Mercurius, father of all, 235
 of philosophers, 219n, 275
 seven, 288f, 337
 —, connection of tree with, 310
 -spirit, 297
 spirits of, 91
 transmutation of, 124
 tree of, 315, 332; *see also* antimony; brass; copper; gold; iron; lead; mercury;
 quicksilver; silver; steel; tin
metallic: earth, 310
 men, 89, 93, 198
 tree, *see* tree
metamorphosis, 261

metaphysical: assertions, 51
 mountains, 262
 presumption, 51
 split, 243
 world, 244

metaphysicians(s), 276f

metaphysics, 50, 54, 300

metasomatosiis, 75

Metatron, 132

method, 7, 16, 21, 63, 65, 327
“false,” 324

Metropolis, 172

Mexico, ancient, 81n
 world-tree, fig. 8

Michelspacher, Steffan, 195n

Micreris, 323

microcosm, 82, 127, 135, 137n, 138n, 152, 165, 218f 220, 284, 285n, 291
 heart of, 164
 homo as synonym for, 219
 man as, 92
 Saviour of, 127
 stone as, 328
 wandering, 153

Middle Ages, 22, 106
 Late, 103

midpoint, universal, 271

Migne, Jacques Paul (ed. *P.G.* and *P.L.*), 60n, 248n, 249n, 281n, 294n, 295n, 333n

milk, virgin’s, 290

mind, 41, 104n
 conscious, 17, 184, 255
 —, impatience of, 17
 —, language of, 28
 —, one-sidedness of, 348
 differentiated masculine, 41

Eastern, 55f,
—, polytheistic attitude of, 35
—, shadowland of, 11
horrible darkness of, 250
human, 54
masculine, 336
Melusina, vision appearing in, 144, 174
primitive, 51n
tranquillity of, 152
Walpurgisnacht of, 90
Western, 6, 7, 20, 42
mine(s), 89, 93
mineral(s), see metal
mineral kingdom, 77, 195
ming (life), 25, 41
mire of the deep, 146f
mirror of Wisdom, 22
Missal, 68n, 78n
Mithras, 97
 relief from Osterburken, 307
Moguls, 231
moist/dry, 278
moisture, 86n
monad, 82
 Catholic, 151n
Monakris (Arcadia), 221
Monogenes, 104, 172n
monolith, 85
monotheism of consciousness, 36
monster(s): hermaphroditic, 139, 219
 primordial, 98
 with vulture's wings, 79n
moods, 34, 37, 39, 335
 bad, 82

personal, 41
moon, 44, 72, 76n, 86, 98f, 161, 226&n, 265, 275&n, 277, 308, 311, 339, fig. 32
bowl of, 231
circle of, 192, 226n
goddess Diana, 303
horns of, 155n
mother and wife of sun, 150n
-plant, of the adepts, 308
related to water, 139
sickle, 155n
and stars, light of, 248
and sun, 79n
—, Mercurius, child of, 76n, 225
— and Mercurius, triad of, 277
—, tree, 306n, 308, 339
tree of, 303n
and Venus, Mercurius identified with, 226
water of, and of Saturn, 227; *see also* Luna
moral: code, 184
consciousness, 196
contradictions, 245
qualities, 326
unmasking, 54
values, 185
morality, 13, 245
brutal, 47
Christian ascetic, 46
conscious, 325
Morgana, 182
Morienus Romanus, 123n, 314n
morning, knowledge, 249; *see also* *cognitio*
mortality, 133n, 168f
mortificatio, 60n, 68n, 80, 83n, 87n
Moses, 113n, 130, 291n, 298, 321

healing snake of, 104
relation of, to self/shadow, 321

Mother/mother(s), 87f, 100, 184n

- Aniadic, 166
- Church a, 117
- complexes, masculine, 99
- divine, 333
- four, 150
- Father, Mercurius as, 220n
- God is, and Father, 27
- of God, 183, 333n
- goddess, 183n
- image of, 112
- imago, 112
- Nature, 117
- of Quetzalcoatl, 100
- son, incest, 232
- of twin gods, 98
- two, 112, 117, 189; *see also* Mater; matriarchal society; mère Lusine

Motherhood, Queen of, 184n

motherly angels, 318

motif(s): of ascent/descent, *see* ascent

- cross, 268
- dismemberment, 304n
- double quaternity, 305
- early Christian, fig. B1
- harlequin, 261
- incest, 232, 280, 302
- mutilation, 304n
- myth, 11, 273
- mythological, 69n, 299
- spellbound spirit, 198
- torture, 328
- treasure, 258

two hostile brothers, 246n

motion, circular, 77

mountain(s), 15, fig. B6, 195n, 227, 256, 261, 291n, 298, 312

- boundary region of snow, 23
- five, 256
- four, 256, 262, fig. 24
- metaphysical, 262
- relation of tree to, 309
- Saturnine, 292
- symbol of personality/self, 309
- tree's habitation, 308
- world, 291n

movement, circular, 21, 25

Moyses, 323

mudrā, 265

Müller, Martin, 168n

Muirhead, James Fullerton, 340n

multi flores, 247

Mumia, 134, 152

mummy(-ies), Egyptian, 134

Mundus/mundus, 329

- intelligibilis*, 215
- rationalis*, 236

mural crown, 303n

Musa, 291n

Musaeum hermeticum, 82n, 83n, 92n, 105n, fig. B6, 186n, 207n, 208n, 209n, 212n, 214n, 215n, 217n, 219n, 220n, 222n, 226n, 228n, 230n, 231n, 235n, 286n, 292n, 303, 306n, 307n, 309n, 310n, 311n; *see also names of individual treatises in Bibl. A*

Musaios, 291n

muscus, 156n, 187

musicality, 108

musk, 155, 176

mustard seed, 259

mutilation, motif of, 304n; *see also* dismemberment

Mutus liber, 195n

Mylius, Johann Daniel, [72](#), [85f](#), [126n](#), [127n](#), [138n](#), [152&n](#), [207n](#), [209n](#), [213](#), [214](#), [217n](#),
[219&n](#), [221](#), [222n](#), [226n](#), [227n](#), [228&n](#), [235n](#), [266n](#), [303n](#), [306n](#), [308&n](#), [309n](#),
[319&n](#)

myrtle, [286](#)

 mystic, [314](#)

mystagogue, [80](#)

 Mercurius as, [225](#)

mysterium: alchemical, [334](#)

et magnale Dei, [120](#)

mystery(-ies), [63](#)

 Christian, [103n](#), [188](#)

 divine, [188](#)

 of Harranite head, [81n](#)

 Isis, [80](#), [183n](#)

 of life, [239](#)

 of Naassenes, [145](#)

 natural transformation, [157](#)

 nature, [158](#)

 rebirth —, opus a, [338](#)

 of religion, [276](#)

 -tradition, Dionysian, [70](#)

mystic(s), [27](#), [195](#)

 Adam, [139](#)

 body, [107n](#)

 Mercurius a reflection of, experience of artifex, [237](#)

 peregrination, [230](#)

 speculation, [91](#), [111](#)

 transformation, [136n](#)

mysticism, [87](#)

 nebulous, [349](#)

 rose, [295](#)

 true, [210](#)

mystification, [162](#)

 spurious, [276](#)

mystique of the Rose, [294](#)

myth(s), [98](#), [301](#)
 creation, [99](#)
 divine, [263](#)
 hero, [258](#), [fig. 14](#)
 motifs, [11](#), [69n](#), [273](#), [299](#)
 motifs, universal, [347](#)
 sacred, [298](#)
mythical bird, [344f](#)
mythlike fantasies, [258](#)
mythologem(s), [162](#), [273f](#), [292](#), [300](#), [348](#)
mythology, [41](#), [69n](#), [159](#), [274](#), [293](#), [348](#)
 Greek and Egyptian, [142](#)
 Teutonic, [317](#)

N

Naas, [319&n](#), [321](#), [333](#)
Naassenes, [146](#), [232n](#), [319n](#)
 mysteries of, [145](#); *see also* Naas
 Nabu, [232](#)
al-Nadim, Ibn, [240n](#)
naga stones, [340](#)
Nagel, Hildegard, [191](#)
Nakassä, [340](#)
naked(ness), [53](#)
 snake, [304](#)
name(s): pagan, of days of week, [249](#)
 secret, [327](#)
 spellbinding, [328](#)
Natchez Indians, [100](#)
natura abscondita, [95](#)
natural: consciousness, [247](#)
 elixir, [134](#)
 light, [239](#)
 man, purification of, [142](#)

philosophy, [102](#), [159](#), [274](#), [348](#)
psyche, [238](#)
science, *see* science
secrets, [301](#)
spirit, [184](#)
transformation mystery, [157](#)
wisdom, [271](#), [333](#)
—, centre of, [151](#)
naturalness, [185](#)
nature(s), [197](#)
 collective, of self, [240](#)
 contrary, of Mercurius, [319](#)
 double/dual/triodic, of Mercurius, *see* Mercurius
 feminine-maternal of tree. [317f](#)
 four, [76](#), [94](#) (*see also* elements, four)
 human, darkness of, [244](#)
 —, essence of, [40](#)
 —, as *hsing*, [21n](#), [25](#)
 —, and life, [20](#), [23](#)
 —, light of, [29](#)
 —, light and dark forces of, [25](#)
 —, true, [39](#)
 of light, [151](#)
 of man, *see* man
 nymphididic, [173f](#)
 one's own, [48](#)
 Platonic, [292](#)
 reversal of one's, [18](#)
 separation of, [161](#)
 true, of alchemy, [123](#)
 two, [284](#)
 union of, [161](#)
Nature/nature, [65](#), [160](#), [184](#)
 converges in man, [94](#)

darkness of, [160](#)
deity, [200](#)
—, dark, [247](#)
egg of, [218](#)
forces of, [128](#)
gods, [150](#)
invisible body of, [114](#)
monarchy of, [163](#)
Mother, [117](#)
mystery, [158](#)
philosophy, Hellenistic, [79](#)
wisdom of, [120](#)
worship, [161](#)

Navaho Indians, [22](#), [98](#)

Nazari, G. Battista, [67n](#)

Neale, J. M., *Collected Hymns, Sequences and Carols*, [293n](#), [296n](#)

Nebuchadnezzar, [13](#), [310](#)
dream of, [272n](#), [337](#)

necrocomica, [139n](#)

necrolica, [172n](#)

Necrolii, [171](#), [172n](#)

necromancy, [119](#)

Negro, [52](#)

Nekhen, city of, [280](#)

Nelken, Jan, [339&n](#)

neologism(s), [113](#), [121&n](#), [124](#), [137](#), [186](#)

Neoplatonic(-ist): ideas, [131](#), [215](#)
Ides, [132n](#)

Neptune, [303n](#)

nervousness, [13](#), [37](#)

nettle(s), [155](#), [176](#)

Neumann, Erich, [335](#)

neurosis(-es), [8](#), [12ff](#), [36](#), [45](#), [341](#), [343](#), [345](#)
masculine, [336](#)

treatment of, 69

neurotic(s), 302

- states, 50
- symptoms, 37

new: enemy of the old, 48

- thing, 15*f*

New Testament, 78, 242

- Corinthians I, 107, 296*n*
- Hebrews, 83
- Thessalonians, 247; *see also* Gospels; Revelation

Newton, Sir Isaac, 69

Nicodemus, 102*f*

Nietzsche, F. W., 52, 99, 118, 128&*n*, 332; *see also* Zarathustra

nightmare, 143

nigredo, 68, 79*n*, 165*n*, 232, 266, 325, 331, 341

Niklaus von der Flüe, 346

Nikotheos, 76

Nile, 215

- stone, 101
- valley, civilization of, 101
- water of, 73

Ninck, Martin, 340*n*

nine: number, 157

- sirens, 178

nirdvandva, 14

nivis, 207*n*

Noah, 314

nome, 279*n*

nomenclature: antinomian, 216

- of egg, 82*n*
- symbolic, 275

nominalism, 288*f*

non-action, 16, 25

non-differentiation, 45

non-existing (*asat*), 218n
northern lights, 209
Norton, Thomas, 197n, 203n
Nostoc(s)/Nostoch, 153n, 154
not-knowing, dark abyss of, 178
Notre Dame, as *Déesse Raison*, 244
nourishing fruits, 272
Nous, 73, 104, 269
 female, 321
 opposition with sex, 269
 serpent of, 333
number: basic, 22
 one, two, three, four, 151
 symbolism, 151n; *see also* one; two; three; four; five; six; seven; nine; hundred; ten thousand
numen: chthonic, of tree, dragon/snake as, 317
 divine, 268
 tree-, 195, 315, 317
 —, as animus, 338
 —, feminine, 338
 —, Mercurius as, 239
 vegetation, 220n
numinosity, 301, 324
numinous: complexes, 328
 effect, 302
 ideas, 299, 301
Nyagrodha, 313n
nycticorax, 198
nymph(s), 142f, 158, 231
 tree-, witchlike, 260
 water-, 143
Nymphidida, 143
nymphididic realm, 173f

oak, [193f](#), [197](#), [199](#), [203](#), [286](#), [308](#), [332n](#)

Oannes, [219](#)

object, [15](#)

and subject, [45](#)

objectivity, scientific, [6](#), [289](#)

obscurantist(s), [198](#)

obscurity as the darkness of disease, [331](#)

obsession(s), [37](#), [246](#)

obsessional neurosis, [34](#)

obumbratio of Mary, [214](#)

occult, manifestation of, [151n](#)

occultism, Eastern, [7](#)

Odin, [333](#)

horse of, [340n](#)

odour of immortality, [334](#)

ogdoad, [151](#), [305](#)

of elements, [278](#)

as symbol of the transformation process, [316](#)

oil, [287](#)

golden, [227](#)

Okeanos, [76](#)

old: age, [272](#)

Old Testament, [333](#); *see also* Apocrypha; Daniel; Deuteronomy; Ezekiel; Ezra; Genesis; Jeremiah; Job; Psalms

older Horus, [281](#)

olive, [279&n](#)

Olympian(s), [37](#)

Olympiodorus, [74](#), [82n](#), [105n](#), [128n](#), [139n](#), [203n](#), [284f](#), [323](#)

Olympus, [37](#)

omega: alpha and, [222](#), [281](#)

element, [72](#), [76](#)

omniscience, drink of, [89](#)

Omphale, [99](#)

One, [148](#), [150](#), [151](#), [176](#)

and All, [232](#)

Father and Son are, [116](#)
and Many, [233](#)
and the root of itself, [139](#)
impure/pure, [151n](#)
midpoint of circle, [151](#)
substance, [284](#)

one-sidedness, [9](#), [13](#), [262](#), [336](#)
of conscious mind, [348](#)

Onians, R. B., [265n](#)

Onkelos, [169n](#)

Only-Begotten, [145](#)

onomastica, [121](#)

Ophites, [333](#)

Ophiuchos demon, [323](#)

opinion(s), animus, [41](#)

opium, [156n](#)

Oporin, [119](#), [133](#)

opposite(s), [9](#), [14](#), [51n](#), [99](#), [216](#), [237](#), [242](#), [245](#), [256](#), [293](#), [332](#)
clash of, [14](#), [348](#)
differentiation of, [243](#)
free of (*nirvandva*), [14](#)
Mercurius consists of, [220](#), [237](#)
— source of, [318](#)
— unites, [309f](#)
pairs of, [336](#)
play of, [238](#)
problem of, [326](#)
psychological, [25](#)
quaternio of, [278](#)
reduction/synthesis of, [278](#)
tension of, [112](#), [118](#), [242](#)
—, in Christianity, [243](#)
union of, [21](#), [151n](#), [162](#), [210](#), [232](#), [254](#), [255](#), [257](#), [336](#), [341](#)

EXAMPLES: action/non-action, [16n](#)

active/passive, 79
corporeal/incorporeal, 75
life/death, 51n
masculine/feminine, 79
Nous/sex, 269
physical/spiritual, 51n
Sol/Luna, 161
water/fire, 74, 216
water/spirit, 74
yang/yin, 9
yea/nay, 14

opposition: absolute, 210
 between Nous and sex, 269

opus, 66, 67n, 88n, 104, 127, 141n, 148, 170, 179, 202f, 239, 275, 297ff 322n
 alchemical, *alchymicum*, 123, 154, 160, 185ff, 186, 237; 166, 172
 —, two parts of, 348
 completion of, 152n
 contra naturam, 314f
 divinum, 123, 160
 in form of a Mass, 158
 goal of, see goal
 God as product of, 307
 microcosmic, 197
 mistakes during, 324
 a rebirth mystery, 338
 relation to zodiac, 314n
 as tree, 313
 —, symbolizes whole, 311

oratorium, 349
order, divine, 122
Orestes, madness of, 97
orgy, Dionysian, 70
Oriental, 53
 religion, 47

Sages, 37
wisdom, 7; *see also* Eastern
orientation, quaternary systems of, 167
Original: Man, 166
sin, 196
wholeness, 284, 336
Orpheus, 291*n*
Orthelius, 94*n*
orthodoxy, Freudian, 342
Osiris, 73*f*, 280*f*
principle of all moisture, 74*n*
sealed tomb of, 74
Ostanes, 79*n*, 99, 101, 154, 215, 247*n*, 279*n*, 309, 314*n*, 320, 321, 327*f*, 331
Osterburken, 307
other: shore, 206*n*
side, 101
ourselves, split in, 246
outer happening, 16
outflowing, 24, 29
outgrowing of problem, 14*f*
outside, 15*f*, 18
ox, 70, 129, 183, 280
oxides, 104*n*, 290*n*

P

Pacific culture, 101
Gilbert Islands, 337*n*
Padmanaba, 231
Padmanabhapura, temple of, 231
pagan(s), 113*f*, 116, 122, 189
alchemists, 299
antiquity, 157
lore, 122
paganum, 113

pagodas, [281n](#)
Pagoyum, [113n](#), [116](#), [122n](#)
painting(s), sand, [22](#)
pair, royal, [332](#)
 transformation and unity of, [326](#)
palaeolithic: cult of soul-stones, [100](#)
 sun-wheel, [28](#)
palm, [318](#)
 tree, [315](#)
Pan, [231](#)
panacea, [104](#), [150](#), [166](#), [178](#), [274n](#), [296](#), [306](#)
Pandora, [94](#)
Pandora, see Reusner
pansy, mountain, [135n](#)
Pantheus, *Ars transmutationis metallica*, [227n](#)
Pantophthalmos, [217](#)
papyri: magic, see Magic Papyri; Greek Magic, see Greek s.v.
parable: of house built on sand, [319](#)
 of the unjust steward, [243f](#)
parabolic figure, [80](#)
Paracelsus, [212](#), [219](#), [236](#)
 alchemy, [129](#)
 arcane philosophy, [110](#)
 Christian, [160](#)
 definition of life, [134](#)
 earthly firmament, [276n](#)
Pagoyum(a), [113](#), [122](#), [158](#)
 substances, [277](#)
 thinking, [115](#), [142](#)
 triad, [277](#)
WORKS: “Apokalypsis Hermetis,” [129](#)
 “Archidoxis magicae,” [122n](#)
 Astronomia magna, [114n](#), [115n](#), [131n](#)
 “Das Buch Meteorum,” [143n](#)

“Caput de morbis somnii,” 113n, 114n

“De caducis,” 112n, 117n

“De morbis amentium,” 122n

“De natura rerum,” 123n

“De nymphis,” 115n

“De pestilente,” 114n, 122n, 164n

De philosophia occulta, 181n

“De podagricis,” 114n, 115n, 130n

“De pygmaeis,” 143

“De religione perpetua,” 130n

“De sanguine ultra mortem,” 143

“De tartaro: fragmenta anatomiae,” 132n

De vita longa, 113n, 124n, 131n, 133ff, 135n, 136n, 144, 160, 172n 173ff, 187n

“Fragmenta,” 164n, 180n

“Fragmenta medica,” 114n, 135n, 153n

“Labyrinthus medicorum errantium,” 113n, 114n, 115n

“Liber Azoth,” 125n, 139n, 143n, 164n, 172n

Das Buch Paragranum, 111, 124, 131n, 178n, 187n

Paramirum de quinque entibus morborum, 113, 115n, 122n

Paramirum primum, 113n

“Philosophia ad Athenienses,” 143n

“Philosophia sagax,” 116

“Von der Astronomie,” 131n

“Von den dreyen ersten essentiis,” 131n

“Von Erkantnus des Gestirns,” 113n

Paraclete, 229

Pāra-da, 206n

paradise, 83, 131n, 143, 154n, 230, 241, 298, 308n, 311n

Adam’s tree of, 138

earthly, 196

four rivers of, 149, 172, fig. 24

fruits and herbs of, 306n

Mercurius, earth of, 235

serpent of, 303

tree in, 318
tree of, *see* tree
paradoxicality of life, 9
parallelism(s), psychological, 12
paraphysiological theory, Geley's, 51n
parapsychology, 40f
paredros, 126n, fig. 5, 179, 225
parent(s): first, 257, 321
 identification with, 45
Paris MS., *see* Codices and Manuscripts
Parjanya, 268
Parmenides, 77
participation mystique, 52, 91, 205, 266
 dissolution of, 45, 47n
 primordial, 44
Patagonians, 71
pater mirabilis, 166
Patrizzi, Francesco, 233
pattern, geometric, 23
Paul, St., 52
 inner Christ of, 27
Paul, of Constantinople, 309n
Pauli, W., 288n
Paulicians, 229
Paulinus of Nola, 281&n
Pausanias, 97n
paws, cut-off, lion with, 304, 321
Pe, city of, 280
peace, hero of, 229
peacock(s), 114
 tail, 290n
pearl(s), 135, 176
 of great price, 259
Pelagios, 274

Pelican, 148, figs. B2, B7, 316
 philosophical, 87
penal code, 184
Penotus, 212&n, 223n, 231, 232&n, 233
Peratics, 76
peregrinus microcosmus, 153
perfection, symbol of, 269
permanence, 259, 272
Pernety, A. J., 141n, 166n, 187n
persea trees, 305, 337n
Persia(n), 132
 ancient, dualism of, 243
 Buddhist monasteries in, 231
 fire struck from stones in, 320
 tradition, 288, 308
 tree, 340
persona, 180n, medical, 121
personal: affects, 346
 fantasies, 344
 problems, 301f,
 psyche/psychology, 347
 resentments, 345f
 unconscious, 348
personality, 25, 35, 39, 194, 272, 341
 all sides of, 25
 development of, 18, 21
 dissociation of, 264
 double, 35
 ego, 254
 enlargement of, 18
 ephemeral/greater, 90
 higher level of, 15
 inner(most), 24, 28
 marks of, 195

phenomenal, 27
psychic, 35, 37
psychogenic splitting of, 35
superior, 46
symbol of, 194
symbolized by mountain and tree, 309
total, 16, 45
trees animated by souls, have, 199
unity of, 14, 34
wholeness of, 240

personification, 38f, 41, 92, 112
 anima as, of unconscious, 42
 of lifeless things, 91
 of metals, 93
 of sun or gold, 80
 of trees, 194n

Petasios, 74, 105n, 203

Petri, Henric, 144n

Petrie, W. F., 305n

petrification, 100

phallic: arrow, 263
 symbol, fig. 30

phallus, 232

phantasia, 167n, 176

Pharaoh, 305

pharmaceutics, 122

pharmacology, 122
φάρμακον ἀθανασίας, 154

phases, seven, of the alchemical process, 303

Phelan, Gladys, 191

phenomena: collective psychic, 36
 telepathic, 139n

Pherekydes, fig. 2

phial, spherical, 82n

Philaletha/Philalethes, Eirenaeus, [208n](#), [209n](#), [210n](#), [212n](#), [217n](#), [219n](#), [220n](#), [228n](#),
[231n](#), [286n](#)

Philo Judaeus, [132](#), [266n](#), [333](#)

philosophers, [70](#), [95](#)

Chinese, [40](#), [50n](#)

Eastern, [50](#)

Hermetic, [289](#)

garden of, [309](#)

metal of, [219n](#)

modern, [121](#)

secrets of, [76n](#)

son of, [129](#)

stone of, [198](#), [271](#)

vinegar/water of, [85](#)

philosophic(al): alchemists, [124n](#), [161](#)

alchemy, aim of, [135n](#)

“common and, Mercurius,” [217](#)

dialectic, [238](#)

earth, [290](#)

Eye, [22](#)

gold, [218](#), [274](#)

heaven, [222](#)

lead, [227](#)

man, [94](#), [235](#)

matter, [290](#)

speculation, [124n](#)

stone, [94](#), [293](#) tree, *see* tree

waters, [279n](#)

philosophic ambisexual man, Mercurius as, [219](#)

philosophy(-ies), [111](#)

alchemical, [206n](#)

Aristotelian, [116](#)

Chinese, [9](#), [11](#), [40](#)

—, yoga, [4](#), [14](#), [29](#)

Eastern, [6](#), [56](#)

Hellenistic nature, 79
Hermetic, 233, 274, 288
Indian, 142
of life, 50
natural, 102, 159, 348
—, medieval, 274
Paracelsan, not Cabalistic, 123
true, 288
phobia(s), 37, 246
phoenix, 128*n*, 226*n*
Phrygian(s), 87*n*
physical: elements, 155
 lightning, 152
 and spiritual, 51*n*
 symptoms, 335
physician(s): academic, 120
 alchemical, 124
 divine office of, 116
 heavenly, of the soul, 293
 maturation of, 124
physics: modern, 289
 true, 288
physika and mystika, 103
physiochemists, 149
physiological continuum, 9
Physis, 104, 307
Picasso, Pablo, 261
Picinellus, Philippus, 155*n*, 317*n*
Pico della Mirandola, Joannes, 130, 131, 137*n* 169*n*
Pierre, Noël, 270*f*
piety, stork as allegory of, 317
pig, fig. 22
pillar(s): fiery/pneumatic/solar, 310*n*
 of Shu, four, 279, 281

pine tree of Attis, 305n
pinguedo mannae, 153n; *see also* manna
Piper, Leonora, 41&n
Pirkê de Rabbi Eliezer, *see* Eliezer
piscina, 73
Pitra, Jean-Baptiste, 74n, 309n
plague balls, 155n
planetary spirits, fig. B5, 225, 227
planets, 141n, 181n, 277, 316
 in man, 125n
 seven, 303, 310
 —, trees of, 309
plant(s), 23, 45, 248, 297
 asparagus, 313
 kingdom, 77
 moon-, of the adepts, 308
 reivas, 337n
 seed, 24
 symbolism, 194
 wonder-working, 253
Plato, 77, 139, 214, 298, 312&n
Platonic: man, 26
 nature, 292
“Platonis liber quartorum,” *see* “Liber Platonis quartorum”
Pleroma, 87n, 334, 336
Plutarch, 74n
pneuma, 75f, 87n, 212, 284
 mercurial, 215
pneumatic: body, 52
 man, 46, 233
 pillar, 310n
p’o soul, 39, 40
Poimandres, 73
point(s), 151, 337

cardinal, [fig. 25](#)
creative, visualization of, [25](#)
indivisible, [148](#)
sun-, [152&n](#)
poison(s), [135](#), [229](#), [297](#)
 death-dealing, [323](#)
 -dripping dragon, [218](#)
 fiery and gaseous, [278n](#)
poisoning, [322](#)
 mercurial, [323](#)
poisonous: dragon, [218](#), [321](#)
 tincture, [284n](#)
Pola (Istria), [298n](#)
polarity, [26](#)
 of life, [9](#)
 in self-regulating systems, [15](#)
pole(s): of light and darkness, [25](#)
 star, [141n](#)
pole-dwellings, [98](#)
Polia, [176](#), [183](#)
Poliphilo, [176](#), [183](#), [305](#)
 hierosgamos of, [155](#); *see also* Francesco Colonna
political Utopias, [300](#)
politician(s), [37](#)
polyophthalmia, [86](#), [217n](#)
polytheism, [47](#)
 Hindu, [243](#)
pomander, [155&n](#)
Pomponius Mela, [178&n](#)
ponderatio, [165n](#)
Pordage, John, [157n](#), [306n](#)
pornographica, [231](#)
possession: of animus, [267](#)
 by consciousness, [36](#)

state of, 34

“poures hommes evangelisans,” 229n

power(s): compensating, of the unconscious, 335

- of darkness, 243, 334
- drive, 260
- to fly, 101
- of light, 243
- material, 244
- through words, 49
- trust in higher, 54
- words, 121

Prabhavananda, Swami, and Isherwood, C., 313n

“Practica Mariae Prophetissae,” see Maria Prophetissa

praise of the Creator, 247n

Prajāpati, 132

precinct, sacred (*temenos*), 24f, 244

precipitations, 331

Preisendanz, Karl, 126n, 148, 161n, 179, 192, 226n, 279n, 329n

prejudice(s), 41, 45

Preller, Ludwig, 70n, 227n

premises, psychic, 289

“Pretiosa margarita novella correctissima” see Bonus; Lacinius

Preuschen, Erwin, 104n

priest, 59, 60f, 64, 68, 70

- sacrificial, 59n, 84
- in white robe, 63

prima compositio, 136n

prima materia, 60n, 67, 73, 77n, 86f, 92, 105n, 122, 136n, 138f, 140, 147, fig. B6, 170, 205, 219, 227, 236, 319&n, 325, 330f

- lapis as, 319
- lead as, 305n
- Mercurius as, 235, 309

primal incest, 302

Primary Force, 25

primeval time, 98n

primitive(s), [12](#), [34](#), [52](#), [346](#)

analogies, [28](#)

animism, [199](#)

beliefs/paradoxes of, [6](#)

consciousness, [268](#)

demonology, [42](#)

instincts, [47](#)

life, [8](#)

mentality, [14](#), [45](#), [51n](#)

psychology, [268](#)

primordial/Primordial: image, *see* image

light-bringer, [248](#)

Man, *see* man

monsters, [98](#)

participation mystique, [44](#)

pass, [23](#)

tree, [337n](#)

unity, [265](#)

world, [243](#)

prince, Andalusian, [320f](#), [328](#)

principium individuationis, [196](#)

principle(s), [22](#)

animal, [257](#)

animating, [239](#)

archetypal explanatory, [288f](#)

of compensation, [245](#)

of conduct, [325](#)

cosmic, [fig. A6](#)

demiurgic, [232](#)

eternal, [169](#)

feminine, *tao* of the, [324](#)

formative, [137](#), [165](#)

fourth, feminine, [96](#)

of individuation, *see* individuation

life, [135](#), [213](#)

—, of tree, Mercurius as, [319](#)

masculine, [268](#)

ordering, of consciousness, [325](#)

psychic, [140](#)

spiritual, [138ff](#)

—, of stork, tree as, [317](#)

of sufficient reason, [84](#)

vegetative, [257](#)

Priscillian, [102&n](#)

Pritchard, J. B., [338n](#)

problem(s): insoluble, of life, [15](#)

of opposites, [326](#)

outgrowing of, [14](#)

personal, [301f](#)

procedure, reductive, [348](#)

process(es): alchemical, seven phases of, [303](#)

chemical, [67](#)

cognitive, [289](#)

of growth, self depicted as, [253](#)

of individuation, *see* individuation

psychic, [16f](#), [67](#), [88](#)

of realization, [348](#)

spagyric, [150](#)

of transformation, *see* transformation; unconscious mental, [56](#)

procreation, [46](#), [213f](#)

Prodromus Rhodostauroticus, [312n](#); *see also* *Verus Hermes*

products: spontaneous, of unconscious, [273](#), [299](#), [339](#), [346](#)

projection, [36](#), [67](#), [88](#), [91](#), [106](#), [138](#), [159](#), [170](#), [176](#), [211](#), [238](#), [286](#), [297](#), [330f](#)

alchemical, [92](#), [238](#)

of alchemy, [239](#)

anima, [340](#)

of — figure, tree a, [338](#)

archetypal, [300](#)

-carrier, 238
of collective unconscious, 229
cosmic, 335
of dissociated tendencies, 37
of individuation process, 229
into matter, 300
on outside world, 35
of psychic actuality, 237
— events, 24
into tree, 200
of unconscious, 205, 211
— contents into an object, 91
of torture, 329
withdrawal of, 89

Prokonnesos, 64*n*

Prometheus, 12, 94, 263
guilt, 189

προόμιον, 90

propaganda, 250

prophet, 59*n*, 113*n*, 114

protective genies, 281

Protestant(s), 54, 81
cult of consciousness, 48
schism, 112

Proteus, 178

protoplast(s), 132, 166

Protothoma, 132

Psalm(s), 145&n, 146, 292*n*

Psellus, Michael, 223&*n*

psyche/Psyche, 9, 11, 16, 24, 35, 40, 42*f*, 51, 55, 92, 128, 159, 162, 239, 235, 288*f*, 346
abolishment of, 300
archetypal world of, 171
border regions of, 96
collective/conscious, 347

conscious image is, 50
dark powers of, 42
dimmer elements of, 243
existence/meaning of, 346
fate of, 349
feminine, 40
goal of, *see* goal
interior world of, 297
living, 328
natural, 238
personal, 347
Primordial Man named, 334
reality of, 201
unconscious, 11, 36
woman's, split in, 269

psychiatrists, 34

psychic: actuality, projection of, 237
autonomous system, *see* system
centre, 152
collective, phenomena, 36
complex, autonomous, 50
complications, solution of, 28
contents, 34, 92
—, autonomous, 35, 37
controls, 41*n*
danger of alchemy, 128
development, *see* development
definition of, 51*n*
disturbances, 342
epidemics, 37
equilibrium, 46
events, projection of, 24
experience(s), 27*n*, 52
factor in alchemy, 137

facts, 37
happenings, 28
identity, 92
laws, 237, 277
nature of Mercurius, 216
— Scaiolae, 169
operation, 86
personality(-ies), 35, 37
premises, 289
principle, 140
processes, *see* processes
reality, *see* reality
—, of man, 244
state(s), 19, 23, 44, 54f
—, abnormal, 43
suffering, 336
systems, of healing, 347
—, split in the, 243
transformation, 144, 155, 160
truth, 171
vision, 177

psychogenic disturbances, 34, 157
psychoid form, 272
psychologem, 336
 Mercurius, 216
psychological: blindness, 336
 rules, reversibility of, 347
 symptoms, 335
psychologism, 49, 50f
psychologist(s), 34, 39, 46, 69
 symbolical, 50
 Western, 40
psychology, 4, 43, 50f, 51n, 159
 academic, 3

of alchemy, 93
complex, 326
of the East, 8
feminine, 41, 82
masculine, 81*f*, 269
medical, 3, 273
and metaphysics, 49, 54
modern, 91
personal, 347
personalistic, 107
primitive, 268
— and archaic, 91
of religion, 332
shamanistic, 70*n*
of the unconscious, 90, 189, 268
without soul, 238; *see also* typology, psychological
psychopomp, 80, 136*n*, 221, 250
 dog as, 232*n*
 Mercurius as redeeming, 237
psychosis(-es), 322
 mass, 36
psychosomatic instincts, 346
psychotherapy, 189, 205, 244, 327; *see also* analysis
Pueblo Indians, 22, 100
 mythology of, 263
puer aeternus, 179
puer leprosus, Mercurius as, 226*n*
puff-ball(s), 290
pulses, hundred, 325
punishment(s), 60*n*, 61, 71, 105, 281, 330
 place of, 62*f*
puppy of celestial hue, 232*n*
pure man, 290
purification, 138

of natural man, 142
purple, 148, 312&n
Pururavas, 178
Purusha, 132, 171, 220
putrefaction, 83n, 134n
Pyramid Text(s), 279&n
pyrites, 287n
Pyrrha, 99
Pythagoras, 306
 tetraktys of, 22
Python, 213

Q

Qebhsennuf, 280
quadratus, Mercurius as, 278
quality(-ies): moral, 326
 of wisdom, 338
quarter(s), four, 271n, 281
Quaternarius, 151n
quaternary: principle, 28
 structure, 22, 169
 symbols, 336
 system, 167
quaternio(s): four, 280n
 of opposites, 278
quaternity(-ies), 151, 166f, 262, 269, 282, 305, fig. 24
 alchemical, 278
 apotropaic significance of, 281
 cross as, 282
 double motif of, 305
 Egyptian, 280
 of the elements, 278
 God's attribute of, 281
 of God's sons, 283

Hermetic, 283
of Original Man, 172
symbolized by cross/tree, 332
as unity, 151
Queen of Motherhood, 184n
quest for the stone, 300
Quetzalcoatl, mother of, 100
quicklime, 307
quicksilver, 72, 77n, 79n, 89, 107n, 122, 131n, 135n, 141n, 206n, 207f, 210f, 216, 225ff, 269, 284
 fixation of, 73n
 spirit of, 225
 system, Indian, 206
 as water, 207; *see also* mercury
“quid,” of Dorn, 300
quinta essentia, 87, 115, 135, 176, 219
 as *coelum*, 219
quintessence, 76, 88, 135n, 151, 166, 168n, 169, 196, 239, 265, 292, 325
 of individual and collective, 182

R

Rabanus, Maurus, 295&n
Rabbi, son of Josephus Carnitolus, 311
Rabbi Eliezer, *see* Eliezer
racial differences, 11
radical moisture, 67, 75, 77n, 86, 138, 151
radices, 195
Rahner, Hugo, 310n
rain, 221, 268
 -god, 268n
rainbow, *figs.* 26, 29
ram, of Mendes, 279
ranunculus, 155n
Rasis, *see* Rhazes

rationalism(-ality), [18](#), [40](#), [45](#)
 of consciousness, [345](#)
 of intellect, [336](#), [345](#)
raven, [92n](#), [198](#)
ray(s): death-, red, [304](#)
 of Surya, [267](#)
Raymond (in Melusina legend), [177](#)
Raziel, [137n](#)
Re, [280](#)
realism, Eastern, [7](#), [288](#)
reality, [51](#)
 differential, [37](#)
 of earth, [54](#)
 living, [54](#)
 of psyche, [201](#)
 psychic, [42](#)
 —, concept of, [51n](#)
 —, of man, [244](#)
 —, of Melusina, [176](#)
 relative, [38](#)
 of unconscious, [42](#), [201](#)
 —, paradoxical, [202](#)
realization, [90](#)
 conscious, [244](#)
 imaginative, [177](#)
 of the opposite, [21](#)
 process of, [348](#)
 of the self, [264](#)
 of Tao, [21](#)
realm: of light, [264](#)
 of spirit, [300](#)
reason, [13](#), [184](#), [238](#), [244](#), [250](#), [328](#), [335](#), [344](#)
 laws of, [245](#)
rebirth, [332](#)

ceremonies, 70
and death, 73, 102
—, cycle of, 105
—, of philosophical tree, 287
of man, 27, 68n
mystery, opus a, 338
—, tree a, 338
spiritual, 73; *see also* twice-born

Rebis, fig. B3

red/Red, 339
cockatoo(s), 205
Damascene earth, 318
flowers, fig. 5
and green lion, *see* lion
Man, 92n, 93
slave, 93
stone, 297
tincture, *see* tincture

redeemer(s), 307
alchemical, 295
Christian, 233
generation, birth and resurrection of, 298
Gnostic, 233
origin of, lowliness of, 146n

redemption, 53, 132, 145, 147, 159, 183n
alchemical, doctrine of, 205
by blood, 299
Christ's work of, 96
goal of, 183
man's longing for, 107

reduction: of opposites to unity, 278
of symbols, alchemical/Freudian, 301

refining, 24

reflection, 334

rational, 169
torment of unlimited, 330
twilight of, 265
regeneration, 184n
regression, 264, 282, 345
 unconscious, 260
Reinach, Salomon, 221n
Reitzenstein, Richard, 73n, 188n, 204, 228n, 231&n
 and H. Schaeder, 89n, 220n, 332n
reivas plant, 337n
relatedness, 41
 inferior, 41
relationship, function of, 42
religio medica, 129
religion(s), 54
 comparative, 6
 Eastern, 6
 facts of, 36
 history of, 204
 mysteries of, 276
 Oriental, 47
 phenomenology of, 35
 philosophical, 47
 as psychic systems of healing, 347
 psychology of, 332; *see also* Christianity; Protestant
religious: ceremonies, 22
 experiences of West and East, 53
 ideas, 301
 language, 52
 practice, 47
 problems of the present, 53
 segregation of — from natural transformation mystery, 157
 spirit, evolution of, 53
 therapies for disorders of soul, 48

thought, 46
remedy(-ies), arcane, 135, 156n
remission of sins, 276
Renaissance, 189
 spirit of, 117
renewal: fount of, 332n
 spiritual, 73
 and transformation, tree as seat of, 317
 word of, 222
repercussion, alchemical, 138n
représentations collectives, 347
repression, 8, 82, 264, 342
 of contents, 36
 Freudian, theory, 42
 of infantile memories and wishes, 341
 theory, 34
 unconscious, of sexuality, 34
 violent, of instincts, 47
reproduction, goal of first half of life, 46
res, 329
 quaerenda, 286
 simplex, 88n, 215
“rescue circles,” English, 51n
research: comparative, 345
 —, into symbolism, 273, 341
resentments, personal, 345f
resignation, 320, 327
resistance(s), 17, 260
 inner, 121
 non-, 327
respiration, internal, 27
responsibility, 297
 diminished, 34
resurrection, 218, 276, 298

of the dead, 297
resuscitation, water has power of, 74
retort, 148, 316n
 alchemical, 197
 tree in the, 315
retorta distillatio, 138, 148, 152
reunion with unconscious laws, 21
Reusner, Hieronymus, 144n, fig. B4, 258, 304, 317, 319, 321&n, 338
revelation, 113, 209, 229
 angel of, 339
 daemons of, 178
 divine, 116, 236
 god of, 179
 light of, 111, 115
Revelation, Book of, 71, 182, 187, 197n, 200, 223, 242, 332
revenant, 39
reverberatio, 165n
reverberation, alchemical, 138n
reverberatorium, 138n
reversal: motif of, 314
 of one's nature, 18
 process of, 21
revolution(s), 36
rex: fig. B2
 antiquissimus, 221
 coronatus, 148
 marinus, 146
Rhazes/Rasis, 116, 141n, 288&n, 297
Rhenanus, Joannes, fig. B7, 316n
rhizomata, 195
rhizome, 90
Rhodesia, 28
Rickaby, Joseph, 165n, 244n
riddles, 255

rift in metaphysical world, 244

Rimas, 240n; *see also* Zosimos

Ripley, George, 212n, 227, 230, 231n, 235n, 286n, 309n, 311, 314&n, 330, 332&n
“Axiomata philosophica,” 215n, 309n, 330n
“Cantilena,” 83n
“Verses belonging to an Emblematicall Scrowle,” fig. B5, 212, 286n, 303, 306n, 317
tree in, 199n

rite(s): of *benedictio fontis*, 78
ecclesiastical, 68
magical, 54, 122
pre-Christian, 68n

ritual action, 25

river(s): of Eden, 319n
four, 262, fig. 24
—, of paradise, 149, 172

rocket-propelled aircraft, 343, 345

Romanus, St., 74n

Rome, imperial, 317

root(s), 87n, 195ff, 239, 257ff, 264, 268, 275n, 286, 311n, 313, 315, 320, 340, figs. 12, 15
of All, 195n
four, 68
One and, of itself, 139, 151
secret in, of tree, 195
of self, 199

Roquetaillade, Jean de, 229n; *see also* Rupescissa

rosa mystica, 294
“Rosarium philosophorum,” 68n, 69n, 73n, 77n, 78, 79n, 85, 103n, 126n, 139n, 144n, 147&n, 153n, figs. B2, B3, 207n, 212&n, 215n, 219&n, 220n, 221n, 222n 223, 226n, 232n, 235n, 336n, 294, 331, 327n
“Rosarius” (rose-gardener), 294

Roscher, W. H.: *Lexicon*, 141n, 221n

rose(s), 294
flowers of Venus, 183n

heavenly, 295
as mandala, 295
mysticism, 295
mystique of the, 294
sign of the, 296
rose-coloured blood, *see* blood
Rosencreutz, Christian, *go*, 183, 187, 216, 330, 315, 326
Rosicrucian movement, 296
Rosinus, 220, 240*n*; *see also* Zosimos
“Rosinus ad Sarratantam,” 94*n*, 226*n*, 240, 322*n*
rotation, spiral, 271
Roth-Scholtz, Friedrich, 157*n*
rotundum, 76
round: body, 139
 element, 72, 76
royal: art, 204, 275
 marriage, 278, 326
Ruelle, C. E., 59*n*
Ruland, Martin, 137, 138*n*, 140, 154, 157, 167*f*, 168*n*, 169, 219*n*, 220*n*
 Lexicon alchemiae, 76*n*, 78*n*, 134*n*, 135*n*, 136*n*, 139*n*, 140*n*, 144*n*, 152*n*, 153*n*,
 154*n*, 259*n*, 279*n*, 287*n*
Rumpelstiltskin, 327
Rupescissa, Johannes de, 123*n*, 138*n*, 148*n*, 229*n*
Ruska, Julius, ed.: *Turba philosophorum*, 67*n*, 76&*n*, 77&*n*, 78*n*, 82*n*, 105*n*, 138*n*,
 152&*n*, 227, 240*n*, 305&*n*, 306*n*, 314*n*, 322*n*, 329&*n*
rust, 138, 141*n*

S

Sabaeon(s), 60*n*
Sabbath, 249
sacraments: Christian, 154
 of the Church, 186
 ecclesiastical, 185*ff*
 Holy, 157

sacred: legend, [299](#)

myth, [298](#)

precinct, [24f](#)

Sacred Books of the East, [56](#), [218n](#), [240n](#), [267n](#), [178n](#)

sacrifice(s), [72](#)

animal(s), 45, 280
of god, 80n
snake, 333; *see also* knife, sacrificial

sacrificer, 80
is sacrificed, 84

sage(s): ancient, 21
in contemplation, 29, 30-33
oriental, 37

saint(s), 35, 71, 182, 282
body of, becomes stone, 101

Sainte Bible traduit . . . sous la direction de l'École Biblique de Jérusalem, 281n

St. Exupéry, Antoine de, *fig. 2*

St. Vitus's Dance, 122n

Salamanca, 119

salamander, 142, 210

Salamandrine Essence, 138, 142

Salamandrini, 142, 163

Saldini, 142, 163

salt(s), 136n, 277, 286&n, 287, 290&n, 308
connection of tree with, 309
earthly, 141n, 233
efflorescence of metallic, 146n
interior, 135n

salty: fountain, 308
spring, 287

salvation, 184n, 298
Christian story of, 299, man's, 127
of universe, 127

salvator/Salvator, 166, 250
Mercurius as, 235
microcosmi, 296
Mundi, 242

Samaria, woman of, 104

sand paintings, 22

Sapientia, [126](#), [130](#), [258](#), [333](#)

and Holy Ghost, Mercurius identified with, [229](#)

tree's relation to, [318](#)

sapphire, [187&n](#), [258f](#), [figs. 16, 17](#)

stone, [258](#)

sapphirine: flower, [187n](#), [269](#)

material, [187n](#), [259](#)

Satan, [81n](#), [114](#), [316](#)

Antichrist as, [242](#)

counterpart of God, [236](#)

Greek, [288](#)

a Kabbalist, [114n](#)

three-headed, [141n](#), [236](#)

Satanaël, [223](#)

Saturday, *see* days of the week

Saturn, [67n](#), [76n](#), [83](#), [126](#), [128n](#), [141n](#), [170](#), [220](#), [226ff](#), [278](#), [305n](#), [310f](#), [331](#)

as Beelzebub, [228](#)

child of, [76n](#), [227](#)

darkness of, [126n](#), [152n](#)

day of, [228n](#), [249n](#)

highest archon, [228](#)

lightning of, [152](#)

lion associated with, [227](#)

Mercurius, relation to, [226](#), [250](#)

and Sol, separation of, [153](#)

spirit of, [227](#)

“Saturn's Chyld,” [227n](#)

Saturnia, plant, [227](#)

Saturnine: darkness, [130](#)

form, [128n](#)

lead, [331](#)

melancholy, [153](#)

mountain, [292](#)

saviour, [100](#)

serpent-, 104
symbol of, 101; *see also* Salvator

Saxo Grammaticus, 98

Scaiolae, 133n, 139n, 155n, 168&n, 171-174, 176, 179
four, 167
psychic nature of, 169

Scaioli, 168&n, 172

“Scala philosophorum,” 278n

Scaliger, J. J., 137n

scalping, 71

scayolic, Aquaster, 139

Scayolus, 168n

Schaeder, H., *see* Reitzenstein

Schevill, Margaret E., 98n

schizophrenia, 34, 70n
process of, 29
states of, 106

Schmieder, K. C., 204

Schopenhauer, Arthur, 84, 167n, 196

Schreber, D. P., 37

Schröttli, 143

Schweitzer, Bernard, 221n, 224n

science, 6, 7, 34, 43, 55, 106, 128, 244
of God, 96
natural, 111, 115, 159, 300
Western, 6

scientia/Scientia, 126
creaturae, 247
Creatoris, 247, 249
hominis, 249

scorpion, 71, 79n, 134

Scott, H. von E., *see* Bland, C. C. S.

Scott, Walter, 73n, 78n; *see also* *Corpus Hermeticum*

“Scriptum Alberti,” *see* Albertus Magnus

Scripture(s), [209](#), [286n](#); *see also* New and Old Testament

Scylla and Charybdis, [145](#)

Scythian(s), [71](#)

juice, [76](#)

sea, [44](#), [51](#), [92](#), [139](#), [146](#), [fig. B5](#), [178](#), [194](#), [209n](#), [248](#), [253](#), [291](#), [fig. 1](#)

-born, [182](#)

bottom of, [23](#)

depths of, [87n](#)

kingly substance, hidden in, [145](#)

tree planted in the, [308](#)

water, [308](#)

—, connection of tree with, [309](#)

seat of heavenly light, [20n](#)

second: Adam, Christ the, [304](#)

tetrad, [283](#)

secret(s), [199](#)

artificial, [301](#)

content of alchemy, [129](#)

doctrines, *see* doctrines

—, of Anthropos, [171](#)

infernal fire, [210](#)

of inner man, [163](#)

language, [162](#)

of matter, [299](#)

Mercurius, revealer of divine, [230](#)

name, [327](#)

natural, [301](#)

of philosophers, [76n](#)

power, [49](#)

in roots of tree, [195](#)

stone, [291](#)

treasure, [fig. 14](#)

seducer, diabolical, [250](#)

seed(s): of corn, [259](#)

divine, 86
of gods, 76
Seele, 40
Sefiroth, 312
self, 45, 99, 101, 139, 142, 152, 182, 194f, 220, 240f, 249, 263, 267ff, 282, 284, 300, 325, 338
 Anthropos or, tree as, 338
 archetype of, 87
 birth of, 266
 centre of total personality, 45
 collective nature of, 240
 deus absconditus as element of, 24
 divine dynamism of, 285n
 identification with, 263
 immortal, 171
 indistinguishable from God-image, 241
 light of the, 248
 Mercurius represents, 237
 Moses' relation to, 321
 as process of growth, 253
 realization of the, 264
 roots of, 199
 sacrifice of, 263
 supra-personal, 240
 symbolized by mountain/tree, 309
 symbol(ism) of, 241, 246, 253, 280n
 tree, visible sign of realization of, 196
 union with, 263
self-awareness, psychological, 90
self-brooding, 26
self-conquest, heroic, 47
self-deception, 7, 200
self-destruction/devouring, 79
 dragon, 259
 of Mercurius, 236

self-development, 179
self-fertilization, 79
self-generation / reproduction / transformation of Mercurius, 236
self-knowledge, 25, 94&n, 248f, 249n, 284
self-realization, 53
self-regulating systems, 15
self-sacrifice, 325
Sena/Senae, 178
senarius, 266
Sendivogius, Michael, 67n, 203n, 207n, 231
senex: draco, 220n
 ithyphallicus, 231
 Mercurius as, 220, 250
Senior, Zadith, *see* Zadith
Senn, Gustav, 251
sensation(s), 167
 bodily, 28
sense: organs, 152
 -perception, 167
separatio, 68
separation: of body and soul, 239
 from world of thought, 267
“Septem tractatus hermetis,” *see* “Tractatus aureus”
serenitas aerea, 212
Seringapatam, 340n
serpens mercurialis, 198; *see also* serpent, mercurial
serpent(s), fig. A4, 79n, 89, 103, 141n, 143, 146n, 199, 279, 304, 319n, 321
 brazen, 333
 chthonic, 333
 on the cross, 333
 crowned, fig. 32
 -daemon, female/daemonic, 240
 Delphic, 213
 Indian, 63n

mercurial, 68, 77, 82, 144f, 152, 258, 315 (*see also* dragon)
of the Nous, 333
old, 83
of paradise, 303
-saviour, 104
three-headed, fig. B2; *see also* snake

servator, 166
 cosmi, 296
 Mercurius as, 235, 250

servus (cervus) fugitivus, 178, 211

Set (Typhon), 74, 281

Seth, 137n, 304

seven: branches, 315
 devils, 128&n
 -fold star, 225
 metals, 288f, 337
 planets, 303, 310
 trees of, 309

sex(uality), 260, 269
 division by, 139
 excitement of, 82
 opposition with Nous, 269
 theory of, 343
 unconscious repression of, 34

shadow, 47, 244, 265f, 268, 348
 of Gilgamesh, 320
 man and his, 246
 union with, 326

Shakti, 95, 180

Shakyamuni, *see* Buddha

shaman, 70n, 337, 341
 East Siberian, 340
 heavenly journey of the, 303, 309
 true personality of, 341

shamanism, [101](#), [253](#), [305](#), [341](#)

shaman(ist)ic

anima, [303](#)

psychology, primitive, [70n](#)

symbolism, [341](#)

tree, [fig. 2](#), [272](#)

shape(s), [37](#)

Shatapatha Brāhmana, [178](#), [267](#), [313n](#)

Sheed, F. J., [249n](#)

sheli, [21](#)

shen (spirit), [39](#), [40](#)

shining bodies, [151f](#), [157](#)

Shiva, [206n](#)

-Shakti, [231](#)

Shu, four pillars of, [279](#), [281](#)

Siberian shamans, [340](#)

Sidgwick, Mrs. Henry, [41n](#)

sign: of God, [281](#)

of the rose, [296](#)

signa Thau, [281n](#)

silver, [75](#), [89](#), [122](#), [194](#), [226](#), [277n](#), [296](#), [332](#)

branch of tree, [89](#)

common, [275](#)

gold and, fountain of, [103n](#)

man, [64](#)

unalloyed, [290n](#), [295](#)

waters, [284](#)

white elixir of, [135n](#)

Simon (Magus), [137n](#)

simplicity, [16](#), [151&n](#)

sin(s): Adam's, [304](#)

original, [196](#)

remission of, [276](#)

wages of all, [229](#)

Sinn, 20

sinology(-ists), 6, 10

Sioux, 100

sirens, 143n

nine, 178

six (number), 266

skin, 64, 92

of head, 60

stuffing of, 70

skinning, 71f

sky-god, 268n

Sky Father, 98

slave, fugitive, 211

slaying, of alchemical authorities, 321; *see also* killing

sleep, 114&n; of incubation, 105

snake(s), 83, 134, fig. B2, 177; 221; 256f, 263, 271n, 314, 340f, figs. 11, 12

as chthonic numen of tree, 317

connected with tree, 315

crucified, 333

head of, 291n

healing of Moses, 104

as most spiritual animal, 333

naked, 304

as symbol of unconscious, 333

three-headed, fig. 32

—, Mercurius as, 222

tree-, 241

tree and, union of, fig. 12

as tree-numen, 315

vision, 86

—, of Ignatius Loyola, 217n

-woman, 144; *see also* serpent

snow, 214

society, matriarchal, 99

Socrates, 77

Sol, 136n, 150, fig. B4, 303, 310

cohabitation with Luna, 123

as gold, 122

lightning of, 152

Novus, Christ the, 242

and Saturn, separation of, 153; *see also* sun

solar: gods, 267n

pillar, 310n

plexus, 37, fig. A9, 266

point, 152

solidity, 272

solificatio, 72, 80

Solomon, 130

Solothurn (canton), 98

solutio, 330

solution, saline, 134

soma, 313

somata and asomata, 103

somatic: disturbances, 342

sphere, 262

somnambulist, 23n, 25

somnambulistic states, 34

son(s), 116

existence of, 52

of the Golden Head, 72

King's, fig. B6

mother-, incest, 232

only begotten, 169n

of philosophers, 129

-ship, duality of, 223n; *see also filius*

Son, 26

Father and, 116

of God, *see* God

—, first and second, 223
of Macrocosm, 126
of Man, 96, 232
Song of God, 313n; see also *Bhagavadgītā*
Song of Songs, 312
Sophia, 187, 308, 334, 336
-Achamoth, 334
perverted into *Philosophia*, 288
sufferings of, 335
Sophists, 290, 331
sorcerer (Magus), 119
sorcery, 119, 122
soror mystica, 73
soul(s), 9, 41, 50, 51n, 71, 78, 83, 88n, 94f, 97, 122, 141n, 145n, 161, 164f, 180, 211, 213, 216, 236n, 238, 257, 278n, 330
of ancestor, 97
animation of, 257
ascent of, 103
body and, see body and soul
body and spirit contained in stone, 290f
breath-, 213
cagastic, 164f
as celestial Aquaster, 140
children's, 97
collective, 240n
creation of, 86
damp, 171
dark background of, 147
darkness of, 79n
of the dead, 317
descent of, 86n
duality of, 214
— in world and, 116
earth-bound bodily, 39
extraction of, 72, 329n, 330

heavenly, and earthly, [fig. A6](#)
—, physician of the, [293](#)
Iliastic, [136n](#)
impulse of, [54](#)
as intermediate nature, [213](#)
“Lady Soul,” [340](#)
loss of, [34](#)
masculine and feminine, [fig. A6](#)
master of, [197](#)
mercurial life-, [214](#)
Mercurius, of metals, [198](#)
moist, [77n](#)
“nothing but,” [50](#)
psychology without, [238](#)
Primordial Man as world-, [334](#)
reasoning, [249n](#)
rooted in the aether, [312n](#)
ruler of, [196](#)
of the sick, [101](#)
simple, [88n](#)
skin is, [72](#)
as spherical glass vessel, [197](#)
spirit and, *see* spirit
of stone, [68](#)
stones, [98](#)
-substance, [325](#)
of the substance(s), [138](#), [150n](#)
suffering of the, [335](#)
tranquillity of, [165](#)
tree-, [319](#)
trees animated by, have personality, [199](#)
true, [139](#)
union with, [155](#)
world, [77](#), [122](#), [129](#), [214](#)

of world, 77, 130; see also *anima mundi*
source of life, 272
spagirica foetura, 150
spagyric/Spagyric, 113, 135n, 150&n, 180n
spark, divine, 160
spatial principle, 25
specialism, 6
spectres, verbal, 37
speculatio, 167, 176
speculation(s): alchemical, fraudulence of, 204
 enigmatical, 175, 179
 Gnostic, 283
 mystic(al), 91, 111
 philosophical, 124n
 theological, 96
“Speculum veritatis,” 83
speech, colloquial, 34
spell(s), 119, 162
 magic, 10
spellbinding names, 328
Spence, Lewis, 81n, fig. 8
Spencer, W. R., and F. J. Gillen, 97n
sperma mundi, 138
sphere(s), 26
 movement of, 74f
 somatic, 262
spider, black, 333
Spielrein, Sabina, 70n
spiral rotation, 271&n
spirit(s), 8, 36, 51n, 60f, 64, 75, 77f, 89, 96-99, 102, 113n, 140, 141n, 148, 149n, 154, 161f, 165n, 180n, 181n, 184, 193, 196, 211, 213, 216, 236n, 238, 259, 278&n, 284, 323f
 in abstract sense, 215
 aerial, 212
 aetherial, 162

of the age/epoch, 116ff
of the air, 161
in/of alchemy, 75, 103, 104n, 128
archetype, ambivalence of, 240
astral, 114
and body, *see* body
in bottle, *see* bottle
celestial, 292f
of Christianity, 129
chthonic, 118
daemon of the scientific, 128
diabolical, 139
of discretion, 228n
divine, 26
earth-, 297
Earth, 79n
of the East, 49
evil, 196-201, 240
evolution of religious, 53
expanding and self-revealing, 39
familiar, 90, 126, 258, 340
fiery, 63
of the fifth essence, 130
-fire, 29, 37
of fire, 142
ghostly, 139
God is, 104
of God, 136n
guardian, 71n, 341
of heaven, 176
heavenly, 209
iliastric, 139
innate, 114&n, 141n
intuitions of, 28

kabbalistic, [114n](#)
of life, [213](#)
link between body and, [95](#)
Lord of, [244](#)
man's, [40](#)
and matter, contamination of, [212](#)
matter and, identical, [214](#)
Mercurial, [136n](#), [203](#), [239](#)
Mercurius, [258](#)
metal-, [297](#)
ministering, [101](#), [179](#)
natural, [184](#)
objective, [239](#)
— existence of, [200](#)
old black, [329](#)
planetary, [fig. B5](#), [225](#), [227](#)
poor in, [202](#)
of quicksilver, [225](#)
reality, [201](#)
realm of, [300](#)
red, [77](#)
of Renaissance, [117](#)
of Saturn, [227](#)
scientific, [91](#)
soul, body and, contained in stone, [290f](#)
and Soul, [fig. B6](#), [229](#)
spellbound, motif of the, [198](#)
of stars, [181n](#)
of stone, [247n](#)
sufferings of, [9](#)
supracelestial, Mercurius as, [214](#)
—, of the waters, [77](#)
in tree, [200](#)
true, in man, [136n](#)

of truth, [130](#), [214](#)

undivided and divided, [70](#)

victory of the, [335](#)

a volatile body, [51n](#)

as water, [74](#), [76](#), [78](#)

of the world, [212](#), see also *anima mundi*

Spirit, Holy, [78](#), [214](#), [240f](#), [334](#)

apples of, [309n](#)

gift of, [102](#), [107](#), [114f](#)

grace of, [160](#)

inflatio or *inspiratio* of, [214](#)

light of, [116](#)

“Spirit in the Bottle, The,” see *bottle* s.v.; *Grimm* s.v.

spiritual: being, [52](#)

blood, [77n](#)

development, [47](#), [245](#)

exercises, [244](#)

eyes, [288](#)

Iliaster, [140](#), [165](#)

man, [94f](#), [131n](#)

—, inner, [148](#)

—, growth of, [89](#)

martyrdom, [330](#)

and physical, [51n](#)

power, [29](#)

principle, [138ff](#)

symbols, [54](#)

trends of alchemy, [144n](#)

truth, turning into something material, [250](#)

understanding, [322](#)

Spiritual Exercises, see *Ignatius Loyola*

spirituality, [47](#), [118](#), [185](#), [214](#), [335](#)

of Christ, [96](#)

masculine, Christ’s, [335f](#)

spiritus, 211f

aquae, 138

humidus et aereus, lapis as, 104n

mercurialis, 79n, 131n, 150n

mercurii, 128n, 135

mundi, 213

Phytonis, 213

prae cunctis valde purus, 212

seminalis, 213

vegetativus, 195, 213, 240n, 338

—, chthonic, 315

—, Mercurius, 202, 310

visibilis, tamen impalpabilis, 212

vitae, 125, 131n, 136n, 140

Spitteler, Carl, 170, 340&n

spittle, 97

Splendor solis, 68n, 72, 219&n

split: between consciousness and the unconscious, 246

between knowledge and faith, 189

in human psyche, 244

metaphysical, 243

sponge, 290n; 291

loathsome, 290

spouse, heavenly, 337

spring, 154, 247, 253, 255, 290n, 314

eternal, 154n; 156n

exaltation of, 182

salty, 287

zodion, 311n

square, 224

inch, 25

squaring of circle, *see* circle

squirrel, 340n

stag(s), 200

fugitive, 211
star(s), [fig. A3](#), [114](#), [125](#), [137](#), [141n](#), [184n](#), [222](#), [237](#), [247f](#), [fig. 13](#)
 crown of, [80](#), [225](#)
 evening, [247](#)
 in flesh and blood, [116](#), golden, [fig. A4](#)
 jelly, [153n](#)
 male seeds of, [150](#)
 in man, [127](#), [152](#)
 moon and, light of, [248](#)
 morning, [223](#), [226](#), [247](#)
 Pole, [141n](#)
 round dance of, [226n](#)
 sevenfold, [225](#)
 in south, [100](#)
 spirits of, [181n](#)
 true man is, [131](#)
 water, [138n](#) see also *stella*
state: paradisaal, [265](#)
 of suspension, [267](#)
status iustitiae originalis/naturae integrae, [197n](#)
Steeb, Johann Christoph, [77&n](#), [82n](#), [151n](#), [214n](#), [215n](#), [318n](#)
steel, [194](#), [332](#)
 branch of tree, [89](#)
Steindorff, Georg, [71n](#), [101n](#)
Steinen, Karl von den, [205&n](#)
stella: maris. [256](#)
 matutina, [247](#)
Stern, James, [194n](#)
Stevenson, James, [22n](#)
Stobaeus, John, [337n](#)
stoics, [85n](#)
stone(s), [85](#), [92f](#), [100](#), [103n](#), [107](#), [119n](#), [141n](#), [146n](#), [236n](#), [240](#), [278](#), [293](#), [314](#), [317](#), [322](#),
[331](#)
 Adamic, [235n](#)
 is animate, [99](#), [291](#)

of Arran, green, 98
attributes of, 95
blood of, 290f, 295
-birth(s), 97, 99
as birthplace of gods, 97
-body, motif of, 99
chariots, 281n
child-, 97
consists of animal or human blood, 290
contains body, soul, spirit, 290f
-cult, megalithic, 100
divine attributes of, 328
earthly, Christ compared with, 292n
element of the, 314n
an enemy, 321
germination and birth of, 298
God's attributes transferred to, 294
as God-image, 97
green, 100
healing, 95
heated, 329
hostile, 320
identity with man, 300
incorruptibility of, 72
magic(al), 97, 98
Mercurius as, 235
as a microcosm, 328
mother of, 86
naga, 340
Nile, 101
ochrepainted, 97n
as outcropping of the unconscious, 242
in Persia, fire struck from, 320
of philosophers, 127, 198

philosophic, [94](#), [293](#)
precious, [258](#)
—, faker of, [204](#)
preserver of macrocosm, [127](#)
quest for the, [300](#)
red, [297](#)
round white, [76](#)
sapphire, [258](#)
secret, [291](#)
— of, [69](#), [99](#)
soul, [98](#), [100](#)
that has a spirit, [247n](#)
statues, [101](#)
that is no stone, [291n](#), [292](#)
symbol, [97](#)
— of the inorganic, [238](#)
symbolism, [94](#)
of the wise, [320](#); *see also* lapis
stork, [315f](#), [339](#)
Adebar, [317](#)
an allegory of Christ, [317](#)
storm, [15](#), [268](#)
demon of, [198](#)
stream(s): four, [304](#), [319n](#)
of life, [17](#)
of time, [16](#)
strength of bull, [268](#)
structure: quaternary, [22](#)
of unconscious, [36](#)
Strunz, Franz, [111n](#), [124n](#), [131n](#)
stupidity, mother of the wise, [180](#)
subconscious, [185](#)
subject and object, [45](#)
sublimation(s), [104n](#), [153n](#), [165n](#), [331](#)

substance(s): arcane, *see* arcane

antimony, transformative, 146

black, 242

chemical, 204f, 275f, 299, 301, 310

Communion, 154

intermediate, 213

kingly, hidden in sea, 145

living, 239

moist, 319n

noble, 331

one, 284

Paracelsan, 277

soul-, 325

symbolic, 302

tormenting of the, 330

transformative, 211

two of Mercurius, 217

—fold, 292

volatile, 148, fig. B6

vulgar, 302

succus lunariae, 226n

Sudhoff, Karl (ed. of Paracelsus): 113n, 114n, 117n, 123n, 130, 131n, 132n, 133n, 153n, 180n

suffering (s), 330, 332 334

psychic, 336

relation of to the coniunctio, 334

of Sophia, 335

of the soul, 335

suggestion, 24

sulcus primigenius, 24

sulphur, 74, 136n, 141n, 187n, 219, 277

diabolus, 228

fire hidden in Mercurius, 228n

incombustible, 142

masculine principle of Mercurius, 228

summa of secret knowledge, 22

Summum Bonum, natural, 116

sun/Sun, 25, 27, 47, 63n, 64, 72, 80n, 98ff, 141n, 147, 152, 161, 176, 225, 226n, 232, 249n, 255, 257f, 262, 268, 275&n, 277f, 307f, 324, 339, figs. 12, 13, 23, 32

aureole of, 80f

Bearer, 99

birthplace of spiritual fire, 150n

black, 266

called after God, 150n

carbuncle of, 218

child of, 76n

circulatory work of, 72

dark counter-, 76n (*see also* Saturn)

-day, 250

disk, 155n, figs. 17, 24

-god, 81n, 267&n

gold, 225, 226

heart as, in Microcosm, 164

Mercurius, child of moon and, 76n, 225

—, and moon, triad of, 277

Meridian of, 63, 72, 80ff

and moon, 79n, 83

—, -fruit, 303, 306, 309

—, tree, 306n, 308, 309

personification of, 80

-point, 152&n

rays of, 218

rises, 89

rising, Horus as, 280n

-symbol, 262

synonymous with gold, 72

tree of, 303n

wheel, 25

—, paleolithic, 28; *see also* Sol; solar

Sunday's child, 202

superiority, mental, 8
superman, 128
supermonic: elements, 180
 figments, 173f
superstition(s), 7, 122, 158
 folk, 122
 rationalistic fear of, 159
supracelestial fire, 310
survival after death, 51n; *see also* immortality
Surya, 267&n
suspension, state of, 267
svādhsthāna-chakra, 265
Svāhā, 267
swan, fig. 32
sweat, bloody, of arcane substance, 290, 295
swine-herd, 240
Switzerland, patron saint of, 346
sword, 60, 63f, 68, 80, 82&n, 83f, 177, 185
 Christ as, 333
 fiery, 83n, 228
 of God's wrath, 83, 332
 hanging on a tree, 333
 two-edged, 83, 332
Sylvester II, Pope, 81n
symbol(s), 12, 19, 21f, 27, 46-49, 162f
 alchemical, 299, 301
 — and Freudian reduction of, 301
 of the Anthropos, stork a, 317
 archetypal, 272, 302, 348
 Christ, 54
 — as “son of man,” 52
 of chrysopoea, tree as, 314
 collective and archetypal, 301
 compensate unadapted attitude of conscious, 302

contrasexual, 338
cross as, of quaternity, 332
dream, reductive interpretation of, 347
ethnological, 101
fish, 265, fig. A2
formation, 274
Hermetic, 241
history of, 344
of individuation, fig. 24
“jewel” the central, 53
light, *see* light
magic of, 28
mandala, 23
meaning of, 302
of Mercurius, *see* Mercurius
of perfection, 269
of personality, 194
phallic, fig. 30
is primitive exponent of unconscious, 28
production, 301
quaternary, 336
research into, 273
of saviour, 101
snake-, 333
of soul, 143
spiritual, 54
stone, *see* stone
sun, 262
theriomorphic, 183*n*
of totality, 96
transformation, 71
process of —, ogdoad as, 316
tree, *see* tree
of the unconscious, snake as, 333

of wholeness, 320, 337

symbolic: blood, 296

 nomenclature, 275

 substances, 302

symbolism, 24, 55

 of alchemy, 69, 80, 88

 Christian, 84, 185, 300

 comparative research into, 341

 of dreams, 69

 head, 88

 of individuation process, 299

 light, 25

 number, 151*n*

 plant, 194

 of self, 280*n*

 shamanistic, 341

 spontaneous tree symbolism, 270

 — of the unconscious, 282

 of starry heaven, 86

 stone, 94

 water, 101

“Symbolum Saturni,” 303*n*, 309*n*

symptom(s): neurotic, 37, 260, 327

 physical or psychological, 335

syncretism, Hellenistic, 102, 104

Synesios, 138*n*

synthesis, 189, 277

 of Mercurius, 257

 of opposites to unity, 278; see also *henosis*

Syrena, 178

Syriktes, 87*n*

syzygy, 232

Szebeny, Nicholas Melchior (Cibinensis), 123&*n*, 158&*n*

Tabernaemontanus, Jacobus Theodorus, [135n](#), [153n](#), [156n](#)

taboo, [54](#), [97](#)

“Tabula smaragdina,” [103n](#), [104n](#), [140](#), [226n](#), [233](#), [297n](#), [331n](#)

T'ai I Chin Hua Tsung Chih, [1](#)

Talbot, Amaury, [199n](#)

talismans, [119](#)

Tantrism, [231](#), [265](#)

tao/Tao (Way), [20f](#), [25](#), [40](#), [54](#)

of feminine principle, [324](#)

grows out of the individual, [53](#)

is light of heaven, [23](#)

realization of, [21](#)

Taoism, [4](#), [16](#)

Taos Pueblos, [100](#)

tapas, [26](#)

tares, [288](#)

tau, aleph and, [222](#)

Taurus, [155n](#)

Tav, [281n](#)

technology, [55](#), [128](#)

Tehom, [236](#)

teleological aspect of fitness, [342](#)

telepathic phenomena, [139n](#)

telum passionis (cupid's arrow), [83](#), [231](#)

temenos (sacred precinct), [24](#), [244](#)

temperaments, astrological, [275](#)

temple, [24](#), [64](#), [89](#), [195n](#), [325](#)

built of a single stone, [91](#)

circular, [84](#)

golden, fig. A10

of Zosimos, 85
Temptation, the, [fig. B6](#)
Ten Commandments, 185
“ten thousand things,” 249
tenebriones, 198
teoqualo (god-eating), 81n
terminology: arcane, 122, 133, 186
 ecclesiastical, 157
terminus ani, Mercurius as, 220
ternarius, 15n
 Mercurius, 221
terra alba foliata, 207n
tertium, 162
Tertullian, 54
tetrad, second, 283
tetraktys, [fig. A7](#), 283
 Pythagorean, 22
tetramorph, 282f
tetrasomia, 82n, 275n, 277, 283
 of Greek alchemy, 277
Teutonic: barbarians, 47
 mythology, 317
texts, magic, 327
Tezcatlipoca, 81n
Thales, 319n
θεάνθρωπος, 127
Theatrum chemicum, 72n, 80n, 83n, 85n, 88n, 94n, 105n, 123n, 125n, 138n, 139n, 146n, 149n, 150n, 151n, 155n, 158n, 196n, 197n, 203n, 209n, 212n, 214n, 215n, 217n, 218n, 219n, 222n, 223n, 226n, 227n, 228n, 229n, 230n, 231n, 232n, 235n, 259n, 275n, 279n, 286n, 287n, 288n, 289n, 305n, 306n, 307n, 309n, 310n, 311n, 312n, 314n, 315n, 319n, 321n, 322n, 323n, 324n, 326n, 330n, 332n; see also names of individual treatises in *Bibl. A*
Theatrum chemicum Britannicum. 197n, 203n, 227n; see also names of individual treatises in *Bibl. A*
Theodore the Studite, 309n

Theologia, 113n
theologian(s), 277
theology, 113n, 247
theophany, 74n
Theophrastus, 119
 school, 129
theory: aetiological, 342
 sexual, 343
Theosebeia, 73, 284
theosophy, 7
 Indian, 268f
 Western, 265
therapeutic: effect, 45
 method, Jung's, 4
Thereniabin, 153n, 154
thesaurus thesaurum, 315
Thessalonians I, Epistle to, 247
Theutius (Thoth), 230; *see also* Thoth
thing(s): -in-itself, 54
 inner, 43
 magical claim of, 44
 new, 15f
 simple, 88
thinking, 167
 alchemical, 288
 alchemical way of, 293
 analogical, of Gnostics, 147
 Gnostic, circular, 84
 masculine, 267
 Paracelsan, 115, 142
 philosophical, 168n
third sonship, Basilidian concept of, 233
thistle, 155n
Thomas Aquinas, 123

Thompson and Shuswap Indians, [71n](#)

Toth, [94](#), [212](#), [230](#)

thought(s), [29](#), [259](#), [267](#)

cessation of, [324](#)

Chinese, [8](#)

-figures, [29](#)

religious, [46](#)

winged, birds representing, [266](#)

world of, [266](#)

—, separation from, [267](#)

three, [166](#), [277](#)

-bodied Hecate, [221](#)

— Typhon, [221](#)

-fold coniunctio, [278n](#)

and four dilemma, [224](#), [278](#)

-headed, Mercurius, *see* Mercurius

—, Satan, [236](#)

—, snake, *see* snake

number, [151](#)

-in-one, Satan as, [236](#)

Persons, [96](#)

-pronged hook, [332](#), [334](#); *see also* triads; Trinity

throne, Christ's, [283](#)

thunderbolts, [fig. A2](#)

thunderstorms, [267n](#)

Tiamat: chaos of, [239](#)

maternal world of, [236](#)

Tibetan: Buddhism, [22](#)

Tantrism, [265](#)

Tibetan Book of the Dead (Bardo Thödol), [25](#), [29](#), [35](#), [265](#)

Tifereth, [312](#)

tiger, [340&n](#)

time: astronomical determination of, [238](#)

our, [36](#)

of perfection, 174n, 183
primeval *alcheringa*, 98n
stream of, 16
timelessness, 181
tin, 218, 277
tincture, 92, 101, 166, 278n
 golden, 208
 poisonous, 284n
 Mercurius as, 235
 red, 160, 292f, 295
 self-renewing, 203
Titans, 70
Todd, Ruthven, 153n
torch, 318
torment(s), 105, 328f, 336
 fiery, 138
 of fire, 67, 72, 146
 of hell, 71, 331
 Mercurius persecuted with, 331
 unendurable, 60, 62, 80
 of unlimited reflection, 330
tormenting of substances, 330
Torquemada, 296
tortoise, 100, fig. 25
torture(-ing), 67, 71, 105n, 329
 of materia, 105n
 motif of, 328
 projected, 329
totality, 167, 224, 241, 246, 268
 image, *see* image
 of man, 139
 symbol of, 96
 transcendent, 101; *see also* wholeness
totem ancestor, 97

touchstone, 72

Toxcatl, festival of, 81n

toxins, 34

“Tractatulus Avicennae,” 79n

“Tractatus Aristotelis,” see Aristotle, pseudo-

“Tractatus aureus,” 144n

in *Bibl. chem.*, I, 85, 224

in *De alchimia* and *Bibl. chem.*, II, 125f

in *Ars chem.*, 138n, 147n, 236n

in *Theatr. chem.*, IV, 87, 222, 230, 233n, 235n

in *Mus. herm.*, 207n, 209n, 212n, 215n, 217n, 235n

“Tractatus Micreris,” 219n, 329

tradition(s), 273

alchemical and astrological, 125

authority of, 115

Christian, 280, 317

ecclesiastical, 299, 321

Haggadic, 317

Iranian, 337n, Jewish, 339

Persian, 288, 308

Sabaeen, 60n

trance, 341

tranquillizer(s), 45

transcendental statements, 54

transfiguration, 105

transformation, 61, 67, 70n, 88, 146, 162, 323

alchemical, 70, 75, 227

Christian, of hylic into pneumatic man, 233

God’s, 334

grove of, 262

of Iliaster, 148

of Melusina, 179

of Mercurius, 333

Mercurius, goal of his own, 235

mystic, [136n](#)
—, of artifex, [229](#)
natural, mystery, [157](#)
power of, [68](#)
process of, [67n](#), [89](#), [105](#), [242](#), [274](#), [278](#)
—, ogdoad as symbol of, [316](#)
psychic, [144](#), [155](#), [160](#)
into spiritual being, [73](#)
into stone, [100](#)
symbol, [71](#)
tree, as seat of, [317](#)
— symbol of, [332](#)
and unity of royal pair, [326](#)
transformative: or arcane substance, [72](#), [74](#), [211](#)
 antimony as, [146](#)
transitus, [101](#)
 of adept, [80](#)
transmutation, [91](#)
 of metals, [124](#), [159](#)
transubstantiation, [159](#)
Trarames, [139](#), [158](#), [160](#)
Travancore, [231](#)
treasure, [163](#), [179](#), [199](#), [203](#), [218](#), [258](#), [259](#), [271](#)
 in field, [259](#)
 kingly, [145](#)
 motif, [258](#)
 secret, [fig. 14](#)
 tree as guardian of, [314](#)
treasure-house, [85](#), [88](#)
tree(s), [183](#), [193ff](#), [201](#), [308](#), [320](#), [329](#)
 Adam's, *see* Adam
 animated by souls, [199](#)
 as Anthropos, or self, [338](#)
 archetypal, [289](#)

as archetypal image, 272
archetype of, 339
birds' relation to, 315
-birth, 266
—, archetype of, 307
-born, 262
in Bundahish, 308
centre, 196
Christ the, 196, 338
Christ's genealogical, 307
Christmas, 23, 253, 256, 303, 340, fig. 2
of contemplation, 315
of coral, 287, 308&n
cosmic, 305, 340, figs. 4, 18, 20
—, associations of, 339
and cross, 332
daemon, 200
of death, 304
dragon is chthonic numen of, 317
feminine-maternal nature of, 261, 317f
as fiery pillar, fig. 313, 310n
fire-, 258, 339n
with four metallic/branches, 89, 332
fruit-, 166, 305
as gnosis, 318
golden, 289, 310, 316f
as guardian of treasure, 314
and heavenly bride, 340
of Hermes, 309n
of Hesperides, 256
holy, of India, 340
identity of, with Mercurius, 338
immortal, 67n
individuality of, 194

inverted (*arbor inversa*), 311, 314, 318, 340
—, man as, 312n
as Jesus, 318
of knowledge, 318, 339, fig. 11
as lapis, 319
leafless or dead, 256, 264, 268, 304
of life, 83, 196n, 274, 308, 312, 318, 339
— and death, 271
—, rooted in Binah, 312
life principle of, 196
of light, 255
Lord of, 337n
magic(al), 303, 341
as man, 337
maternal significance of, 261
medium of conjunction, 337
Mercurius and, *see* Mercurius
metallic, 286, 310, 311, 315, 332
—, of alchemy, 89
modern fantasies of, 341
of moon, 303n
on mountaintop, 308, 320
-numen, 195, 315, 317, 318
nymph, 262, 265, 339
—, witchlike, 260
oji, 199
opus as, 313, 338
of paradise/paradisal, 143, 199, 257, 302, 304, 318, 332, 339f
—, Buddha/Christ named, 338n
—, of knowledge, 240
—, as man, 337
—, two, 306
personal atman of, 239
personification of, 194n

philosophical, [230](#), [240](#), [253](#), [287](#)
planted in sea, [308](#)
as pneumatic pillar, [310n](#)
primordial, [337n](#)
projection into, [200](#)
—, of anima figure, [338](#)
quaternity of, [332](#)
rebirth mystery, [338](#)
relation of, to mountain, [309](#)
—, to Sapienta, [318](#)
in the retort, [315](#)
in Ripley *Scrowle*, [199n](#)
rooted in air, [311](#)
as seat of transformation and renewal, [317](#)
secret in roots of, [195](#)
of Sefiroth, [312](#)
and seven metals, [310](#)
of seven planets, [309](#)
shaman(ist)ic, [fig. 2](#), [272](#)
snake, [241](#), [315](#)
—, chthonic numen of, [317](#)
and —, union of, [fig. 12](#)
as solar pillar, [310n](#)
-soul, division of into masculine/feminine, [319](#)
spirit in, *see* spirit
is spiritual principle of stork, [317](#)
of sun, [303n](#)
— and moon, [306n](#), [308](#), [339](#)
sword hanging on the, [333](#)
symbol(s), [195n](#), [253](#), [270](#), [272](#)
—, of *chrysopoea* (gold-making), [314](#)
—, of enlightenment, [313f](#)
—, of personality and self, [309](#)
—, of transformation, [332](#)

—, of whole opus, 311
as system of blood vessels, 287
truncated, 304f
or vine, Christ as, 338
visible sign of realization of self, 196
-voice, 199
and water, 309
in Western Land, 306
white, 305n
of wisdom, 258, 306, 318
as woman, 338
world-, *see* world
Zarathustra's vision of, 332; *see also* acacia; almond; ash; *ashvattha*; baobab;
Bodhi; cedar; fig; forest; Gaokerena; myrtle; nettle; oak; olive; palm; perseae;
pine; plants

tremendum, 200

Trevisanus, Bernardus, *see* Bernardus

triad(s), 151, 221, 241

of animals, 141n

chthonic, fig. B2, 223

indivisible, 221n

lower, 141n, 183n

Paracelsan, 277

sun/moon/Mercurius, 277

upper, 165, 167

triadic: character of gods of underworld, 221

nature of Mercurius, 221

triangle, 224

trident, golden, 334

Trinity, 35, 103n, 151n, 166, 222, 241, 277, 334, 336

Holy, 221, 276

—, union of persons in, 277

masculine, 96

Mercurius as, *see* Mercurius

totality of, 96

union of, 278n

upper, 141n, 183n

Trismegistos, 221n; *see also* Hermes Trismegistus

Trismosin, Salomon, 68n, 219; *see also* *Splendor solis*

triune essence, 293

triunus, Mercurius, *see* Mercurius

truth, 77, 249n, 301

absolute, 300

divine body of, 35

living, 162

psychic, 171

revealed, 160

seekers after, 160

spirit of, 130, 214

spiritual, turning into something material, 250

Tuamutef, 280

Turba philosophorum, *see* Ruska

turquoise, 98, 100

twice-born, 73; *see also* rebirth

twilight, 163, 247n, 250

of reflection, 265

twins, 100

two: dragons, 217, 256f

dyads, 280

earths, 278n

-faced god, 250

fold substance, giant of, *see* giant

mothers, 112, 117, 189

natures, 284

number, 151

parts of alchemical opus, 348

sources of knowledge, 116

substances of Mercurius, 217

trees of paradise, 306

waters, [278n](#); *see also* duality
twofold substance, [217](#), [292f&n](#)
Typhon, three-bodied, [221](#); *see also* Set
typology, psychological, [84](#)
ὑδωρ θεῶν, [150n](#), [208](#), [284](#); *see also* water

U

Uitzilopochtli, [81n](#)
ultima materia: lapis as, [319](#)
 Mercurius as, [235](#)
unadaptedness, [18](#)
unconscious, [12ff](#), [24](#), [47f](#), [52](#), [101](#), [106](#), [143](#), [146](#), [fig. B5](#), [170](#), [179](#), [184](#), [201](#), [224](#), [242](#),
[256](#), [265](#), [299](#)
 anima personification of, [42](#)
 Aquastra close to concept of, [140](#)
 archetypal configurations of, [253](#)
 autonomy of, [328](#)
 Caucasus of, [12](#)
 chaotic fragments of, [84](#)
 Christ as personification of, [333](#)
 compensating powers of, [335](#)
 compensatory tendencies from, [245](#)
 conflict with, [336](#)
 confrontation/encounter with, [322](#), [341](#), [348](#)
 and conscious, dissociation/split between, [34](#), [246](#)
 contents of, [36](#), [82](#), [91](#)
 darkness of, [23](#)
 not derivative of consciousness, [42](#)
 disintegrating effect of, [29](#)
 feminine character of, [325](#)
 figures of, [38](#), [42f](#)
 instinctuality of nature's wisdom of, [333](#)
 integration of, [325](#), [346](#)
 interpretation of, [341](#)

inundation by, 322
laws of, 21, 239
Mercurius as archetype of, 247
— personification of, 333
paradoxical reality of, 202
personal, 348
predominance of, 14
projection of, 205, 211
psychology of, 90, 189, 268, 302, 348
rapprochement with, 170, 180
reality of, 42, 201
regression, 260
regulating images and, 301
snake as symbol of, 333
spontaneous products of, 273, 299, 339, 346
— statements of, 194
— symbolism of, 282
stone as outcropping of, 242
structure of, 36, 69, 205
union with conscious, 180
— feminine personification of, 182
water as, 151*n*

unconscious, collective, 3, 28*f*, 177, 205, 240, 266*n*, 334, 348
definition of, 11
Mercurius identified with, 222, 237
processes of, in modern man, 4
projection of, 229

unconsciousness, 89, 127, 171, 180, 194, 196, 264, 280*n*, 299
bestial, 99
overcoming of, 333
primitive, 45
Sophia sunk in, 335

understanding, 89, 229, 296*f*, 320, 327, 346
bridge of psychological, 55

Eastern, 7
intellectual, 264, 349
psychological, 49
scientific, 6, 159
spiritual, 322
underworld, dragons chained in, 242
unification, 277
 of double dyads, 278; see also *henosis*
unigenitus, Mercurius as, 235
union, 332, 348
 with anima, 326
 conscious/unconscious, 180
 consciousness/life, 21, 24
 with feminine personification of unconscious, 182
 fire/water, 255
 with God, 249n
 hermaphroditic, 136
 natural/spiritual man, 157
 of opposites, see opposite(s)
 of persons, 278
 —, in Holy Trinity, 277
 with self, 263
 with shadow, 326
 with soul, 159
 tree/snake, fig. 12
 of Trinity, 278n
unity, 26, 38, 169n, 182, 237, 305
 of being, 28
 consciousness/life, 23, 25
 original, 336
 primordial, 265
 quaternity as, 151
 transformation and, of royal pair, 326
 and trinity of Mercurius, 221ff

universal(s): being, 40
 controversy about, 288
 midpoint, 271
 mythmotifs, 11, 273
 significance of dream symbols, 347
unjust steward, parable of, 243f
Upanishad(s), 239
 Chhāndogya, 313n
 Maitrayana-Brahmana, 240n
Upa-Puranas, 206n
upper world, 256, 341
upwards displacement, 265
uræus, 303n
urine, 290
uroboros, fig. 17, 79, 82n, 84, 103f, 132n, 232
 circular nature of, 233
 dragon, 223
 as hieroglyph of eternity, 259
 motif, 90
urtica, 155n
Urvashi, 178
Usener, Hermann, 283n
uterus, 73, 97
Utopia(s): bloodless, 244
 political, 300
utriusque capax, Mercurius as, 348
uvæ Hermetis, 279n
uvula, 61

V

Valentinians, 283
Valentinus, Basilius, 208n, 215n, 217n, 220n, 226n
valley, 15
value(s), 18

conscious, 13
emotional, 268
moral, 185
— reversal of, 183n
vapor terrae, 138
vapour, 207
Varuna, 268&n
vas: cerebri (cranium), 86
 circulatorium (vessel of circular distillation), 316 (*see also* distillation; Pelican)
Hermeticum, 197
 Hermetis, 72f, 85
 pellicanicum, 87
Vecerius, Conrad, 78&n
Veda(s), 267n, 313
Vedanta-Sutras, 240n
vegetative principle, 257
veil of Maya, 38, 180
vein swollen with blood, 247
venom, 79n
Ventura, Laurentius, 85f, 215, 226n, 235n 307n 311&n 323n
Venus, 135n, 155, 156n, 181ff, 231, 275, 278, 310f
 with Adam in bath, 226n
 characters of, 174f, 187
 day of (Friday), 249
 hermaphroditic, 187ff
 house of, 155
 Magistra, 187
 and Mars, 93
 Mercurius has attributes of, 226&n
 ship of, 155n
 sleeping, 216
 Venus armata, 187
Verus Hermes, 83n, 214n, 220n, 228; *see also* *Prodromus Rhodostauroticus*
vesicant, 155n

vesicle, germinal, *see* germinal

Vespers, 296n

vessel(s), 73, 82, 87f, 92, figs. B4, B6, 290

of circular distillation, 316

distilling, 88, 175 (*see also* Pelican)

as fire, 85

as *foemina alba*, 86

glass, 105n

with god's limbs, 73

hermetic, 72f, 85

as Luna, 86

“root and principle of our art,” 85

synonym for egg, 82

wonder-working, 73

Vettius Valens, 312n

“Via veritatis unicae,” 209n

victory of the spirit, 335

vif-argent, 207

de Vigenère, Blaise (Vigenerus, Blasius), 304&n, 305, 311, 312&n, 331

vindemia, 279n

Hermetis, 314n

vine, 286, 306, 314, 318

tree or, Christ as, 338

true, 279n, 306

of the wise, Hermes, 314

vinegar, 77, 331

of philosophers, 85

quicksilver as, 77n

Viola petraea lutea (mountain pansy), 135n

violation, motif of, 74

virgin(s), 100, 182, 298

foolish, 317

Mercurius, most chaste, 226

milk, 290

Virgin, the, [103n](#), [184n](#), [232](#)

virgines velandae, [54](#)

virgo, [178](#)

viriditas, benedicta, [287n](#)

gloriosa, [315](#)

Vishnu, [265](#), [267](#)

“Visio Arislei,” [60n](#), [66n](#), [67n](#), [93](#), [305](#), [329n](#)

“Aenigma VI,” [68n](#), [93n](#), [105n](#); *see also* Arisleus

vision(s), [62](#), [64](#), [66](#), [68](#), [96](#), [176](#), [179](#), [197](#), [286](#)

of Aquaster, [166](#)

of Arisleus, [306](#)

contemplative, [44](#)

of Daniel, Ezra, Enoch, [132](#)

of Ezekiel, [280](#)

of Hildegard of Bingen, [27](#)

of Isis, [81](#)

of Krates, [83](#)

of light, [27](#)

Melusina, appearing in mind, [144](#), [174](#)

psychic, [177](#)

snake, [86](#), [217n](#)

terrifying, of God, [346](#)

of Zarathustra, [332](#), [337](#)

of Zosimos, [225](#)

vis Mercurii, [136n](#)

visualization, [17](#)

of creative point, [25](#)

“*vita cosmographica*,” [167](#)

vitam aeream, [163](#)

vitis, [279n](#)

arborea, [286n](#)

sapientum, [286n](#)

vitriol, [287](#)

vitrum, [198](#)

viziers, forty, 231
volatile substances, 148, fig. B6
vomiting, 231
Vouroukasha, 308
 lake of, 340
Vulgate, 71, 103n, 281n, 306n

W

Wachsmuth, K., and O. Hense, 337n
Walde, Alois, 288n
Waldkirch, Conrad, 123, 276n
wallflower, yellow, 135n
Walpurgisnacht of mind, 90
wandering scholars, 119
war, 36
warmbloodedness, 243
washing, miraculous, 68
Wasserstein der Weysen, Der, 104n, 105n, 106
water(s), 24, 44, 63, 67, 68n, 72, 74ff, 78, 82n, 88, 138, 145f, 162, 163n, 182, 194, 214, 216-19, 256, 278, 286f, 309n, 320, 324, 341, figs. 5, 8, 10, 32
 above and below heavens, 151
 baptismal, 68, 84
 blessed, 78n, 154
 boiling, 60
 bright, 227
 celestial, 77, 150
 composition of, *see* composition
 is destruction, 76, 227
 divine, 64, 68, 102-105, 107, 208, 215, 284, 322n
 —, of alchemists, 76
 —, of the art, 73
 —, dyophysite nature of, 79
 dragon as divine, 82n
 egg synonym for, 82

eternal, 227
ever-moving, 284
and fire, 74, 112, 208n
—, the union of, 255
above the firmament, 77, 82
fount of living, 104n
germinating, 149
of Grace, 83
heavenly, 151
lower, 150
as *Mercurii caduceus*, 208
Mercurius as, 207ff, 309
miraculous, 67
moon related to, 139
of moon and Saturn, 227
nettle, 155
of Nile, 73
-nixie, 176, 182
-nymph, 143
oily, 319
of philosophers, 85
philosophic(al), 67n, 279n
power of resuscitation, 74
pure, 150
quicksilver as, 207
region, 265
sea, 308
seething of, 61
shining, 73
silver, 284
as spirit, 74, 76, 78
spring of purest, 64, 84
star, 138n
symbolism, 101ff

symbols of divine, [73n](#)
synonym for spirit, [197](#)
translucent, [75](#)
tree and, [309](#)
two, [278n](#)
as unconscious, [151n](#)
as wholeness, [284](#)
wonderful, [308](#)
wonderworking, [79](#), [102](#); *see also* aqua

watery: aspect of Iliaster, [138](#)
realm, [142f](#), [179f](#)

Way (Tao), [20](#)
conscious, [20](#)

Wayne. Philip, [120n](#), [183n](#)

wedding, chymical, [136](#), [257](#); *see also* Rosencreutz

Wei Po-yang, [126n](#), [226&n](#), [324n](#), [325](#)

Wells, H.G., [37](#)

Wendland, Paul, [232n](#)

West: difference between East and, [53](#)
dogmatists of, [50n](#)
and East, [55](#)
reaction against intellect in, [9](#)
religious experiences of, [53](#)

Western: alchemy, sapphire flower of, [269](#)
attitude of mind, [42](#)
civilization, [8](#)
cult of consciousness, [48](#)
imitation, [8](#)
intellect, differentiation of, [9](#)
— and will, [48](#)
Land, [308](#)
—, tree in the, [306](#)
man, [8](#), [14](#), [18](#), [37](#), [51n](#), [55](#)
mind, [6](#), [42](#)

prejudice, 50
psychology, 40
science, 6
theosophy, 265; *see also* European

whale, 143, 303
sperm-, 155n

wheat, grain of, 306

wheel(s), 22, 281
four, 167, 281
sun, 25

white, 339
blossom, fig. 1
dove, 92n
elixir of silver, 135n
ghost, 39
man, 93
tree, 305n
woman, 93

whole: and complete man, 296
conflicting, 189
man, 325

wholeness, 139, 168, 180, 182, 195, 263, 268, 281f, 305
of body, 280
image of, 283
original, 284, 336
of personality, 240
round, 85
of self, 263
symbol of, 320, 337
water is, 284

Wichita, 100

Wilhelm, Richard, 1, 3, 4, 6, 11, 20, 38-41, 50n, 206

Wilhelm, Salome, 1

will(s), 14, 21, 34, 50, 159

conscious, [12f](#), [16](#), [28](#)
cult of, [45](#)
divine, [188](#)
moral value of, [13](#)
wind(s), [162](#), [268](#)
 buffetings of the, [314](#), [319](#)
 -gods, [221](#)
 Mercurius changed into, [212](#)
 as pneuma, [87n](#)
Windischmann, F., [308n](#)
window, transparent, [fig. A3](#)
winged: female genies, [281](#)
 tiger, [340](#)
wings, four, of the cherubim, [281](#)
wisdom, [13](#), [77](#), [180](#), [314](#), [319](#), [334](#)
 of Cabala, [130](#)
 Chinese, [6](#)
 Eastern, [11](#)
 Mirror of, [22](#)
 natural, [271](#), [333](#)
 —, centre of, [151](#)
 Oriental, [7](#)
 quality of, [338](#)
 tree of, [196](#)
wise, stone of the, [320](#); *see also* lapis
witch, [261](#)
 -butter, [153n](#)
 -craft, [121](#), [143](#)
 -language, [121](#)
wolf, [141&n](#), [279](#)
woman(-en), [23](#), [40f](#)
 blue, doglike, [232](#)
 dreams of, [347](#)
 masculinity of, [338](#)

psyche of, 269
psychology of matriarchal, 40, 99
of Samaria, 104
snake-, 144
tree in form of, 338
white, 93
wonder-working plant, 253
wood of life, 339
woodcutter, 193
word/Word: creative, 222
 of God, *see* God
 magic, 121
 of renewal, 222
work, dangers of the, 329; *see also* Art
world: air, *fig.* A4
 of ancestors, 98*n*
 -axis, 253, 291*n*, *fig.* 2
 —, tree as, 339
 beyond, 337
 chthonic, 337
 -creating principle, 132
 of darkness, 265
 of dreams, 98*n*
 duality in, and soul, 116
 earth-, *fig.* A4
 -egg, 82
 empirical, 51
 external, 43
 four quarters of, 281
 fullness of, 44
 of gods, 155
 of ideas, 132*n*
 inner, 180*n*
 interior, of the psyche, 297

intermediate, [51n](#)
of light, [336](#)
— and dark, [fig. A5](#)
lower, [256](#)
macrocosmic, [214](#)
Mercurius as Logos become, [222](#)
metaphysical, rift in the, [244](#)
microcosmic, [214](#)
-mountain, [291n](#)
order, divine, [127](#)
physical, [91](#)
primordial, [243](#)
principle of, [77](#)
Son of the Great, [96](#), [292](#)
soul of, *see* soul, *anima mundi*;
spirit of, [212](#)
of thought, [266f](#)
-tree, [240](#), [253](#), [256](#), [258](#), [291n](#), [305](#), [307f](#), [310f](#), [figs. 2](#), [30](#)
—, Mexican, [fig. 8](#)
—, mystical, [312](#)
tree as, [339](#)
unitary, [116](#)
upper, [256](#), [341](#)
worm, [146](#)
 intestinal, [146n](#)
Wotan, [198](#)
 Hermes-Mercurius-, [202](#)
wrath of God, [83](#)
Wünsche, August, [317n](#)
wu wei, [16](#)

Y

Yajñavakya, [248](#)
Yajur-Veda, [267](#)

Yakuts, [340](#)

yang, [9](#), [13](#), [25](#)

principle, [39](#)

Yellow: Man, [92](#)

wallflower, [135n](#)

Yggdrasil, [340&n](#)

yin, [9](#), [13](#), [25](#), [324](#)

principle, [39](#)

-reaction, [13](#)

tiger a symbol of, [340n](#)

Yliastrum, *see* Iliaster

yoga, [38](#), [165n](#)

Buddhist doctrines, [36](#)

Chinese, [4](#), [14](#), [29](#), [46](#)

exercises, [51n](#)

Indian Kundalini, [24](#)

practices, [7](#)

Tantric, [265](#)

teaching, [43](#)

Yolkaiestsan, [98](#)

youth, nettle a symbol of, [155](#)

Z

Zadith Senior, [82n](#), [138n](#), [258n](#), [286n](#), [307n](#), [319f](#)

Zarathustra, [128](#), [332](#)

dream of, [89](#)

vision of, [337](#)

—, the tree, [332](#)

Zeus, [37](#), [97](#)

the king, [221](#)

triops, [221n](#)

zodiac, [155n](#)

relation of opus to, [314n](#)

zodion, spring, [311n](#)

Zöckler, Otto, [332n](#)

Zohar, [132](#)

zone, seventh, [76](#)

Zosimos of Panopolis (Rimas/Rosinus), [59](#), [66](#), [90](#), [130](#), [131n](#), [215](#), [220](#), [221](#), [240n](#),
[274](#), [279n](#), [284](#), [292](#), [314n](#), [329n](#)

conscious psychology of, [68](#)

dream of, [102](#)

temple of, [85](#)

visions of, [59](#), [215n](#), [225](#), [329](#)

THE COLLECTED WORKS OF

C. G. JUNG

THE PUBLICATION of the first complete edition, in English, of the works of C. G. Jung was undertaken by Routledge and Kegan Paul, Ltd., in England and by Bollingen Foundation in the United States. The American edition is number XX in Bollingen Series, which since 1967 has been published by Princeton University Press. The edition contains revised versions of works previously published, such as *Psychology of the Unconscious*, which is now entitled *Symbols of Transformation*; works originally written in English, such as *Psychology and Religion*; works not previously translated, such as *Aion*; and, in general, new translations of virtually all of Professor Jung's writings. Prior to his death, in 1961, the author supervised the textual revision, which in some cases is extensive. Sir Herbert Read (d. 1968), Dr. Michael Fordham, and Dr. Gerhard Adler compose the Editorial Committee; the translator is R. F. C. Hull (except for Volume 2) and William McGuire is executive editor.

The price of the volumes varies according to size; they are sold separately, and may also be obtained on standing order. Several of the volumes are extensively illustrated. Each volume contains an index and, in most cases, a bibliography; the final volume will contain a complete bibliography of Professor Jung's writings and a general index to the entire edition.

In the following list, dates of original publication are given in parentheses (of original composition, in brackets). Multiple dates indicate revisions.

*1. PSYCHIATRIC STUDIES

On the Psychology and Pathology of So-Called Occult Phenomena (1902)

On Hysterical Misreading (1904)

Cryptomnesia (1905)

On Manic Mood Disorder (1903)

A Case of Hysterical Stupor in a Prisoner in Detention (1902)

On Simulated Insanity (1903)

A Medical Opinion on a Case of Simulated Insanity (1904)

A Third and Final Opinion on Two Contradictory Psychiatric Diagnoses (1906)

On the Psychological Diagnosis of Facts (1905)

2. EXPERIMENTAL RESEARCHES

Translated by Leopold Stein in collaboration with Diana Riviere

STUDIES IN WORD ASSOCIATION (1904–7)

The Associations of Normal Subjects (by Jung and F. Riklin)

Experimental Observations on Memory

The Psychological Diagnosis of Evidence

An Analysis of the Associations of an Epileptic

The Association Method (1910)

The Family Constellation (1910)

Reaction-Time in the Association Experiment

Disturbances in Reproduction in the Association Experiment

The Psychopathological Significance of the Association Experiment

Psychoanalysis and Association Experiments

Association, Dream, and Hysterical Symptom

PSYCHOPHYSICAL RESEARCHES (1907–8)

On Psychophysical Relations of the Association Experiment

Psychophysical Investigations with the Galvanometer and Pneumograph in Normal and Insane Individuals (by F. Peterson and Jung)

Further Investigations on the Galvanic Phenomenon and Respiration in Normal and Insane Individuals (by C. Ricksher and Jung)

†3. THE PSYCHOGENESIS OF MENTAL DISEASE

The Psychology of Dementia Praecox (1907)

The Content of the Psychoses (1908/1914)

On Psychological Understanding (1914)

A Criticism of Bleuler's Theory of Schizophrenic Negativism (1911)

On the Importance of the Unconscious in Psychopathology (1914)

On the Problem of Psychogenesis in Mental Disease (1919)

Mental Disease and the Psyche (1928)

On the Psychogenesis of Schizophrenia (1939)

Recent Thoughts on Schizophrenia (1957)

Schizophrenia (1958)

*4. FREUD AND PSYCHOANALYSIS

Freud's Theory of Hysteria: A Reply to Aschaffenburg (1906)

The Freudian Theory of Hysteria (1908)

The Analysis of Dreams (1909)

A Contribution to the Psychology of Rumour (1910–11)

On the Significance of Number Dreams (1910–11)

Morton Prince, "The Mechanism and Interpretation of Dreams": A Critical Review (1911)

On the Criticism of Psychoanalysis (1910)

Concerning Psychoanalysis (1912)

The Theory of Psychoanalysis (1913)

General Aspects of Psychoanalysis (1913)

Psychoanalysis and Neurosis (1916)

Some Crucial Points in Psychoanalysis: A Correspondence between Dr. Jung and Dr. Loÿ (1914)

Prefaces to "Collected Papers on Analytical Psychology" (1916, 1917)

The Significance of the Father in the Destiny of the Individual (1909/1949)

Introduction to Kranefeldt's "Secret Ways of the Mind" (1930)

Freud and Jung: Contrasts (1929)

†5. SYMBOLS OF TRANSFORMATION (1911–12/1952)

PART I

Introduction

Two Kinds of Thinking

The Miller Fantasies: Anamnesis

The Hymn of Creation

The Song of the Moth

PART II

Introduction

The Concept of Libido

The Transformation of Libido

The Origin of the Hero

Symbols of the Mother and of Rebirth

The Battle for Deliverance from the Mother

The Dual Mother

The Sacrifice

Epilogue

Appendix: The Miller Fantasies

6. PSYCHOLOGICAL TYPES (1921)

Introduction

The Problem of Types in the History of Classical and Medieval Thought

Schiller's Ideas on the Type Problem

The Apollinian and the Dionysian

The Type Problem in Human Character

The Type Problem in Poetry

The Type Problem in Psychopathology

The Type Problem in Aesthetics

The Type Problem in Modern Philosophy

The Type Problem in Biography

General Description of the Types

Definitions

Epilogue

Four Papers on Psychological Typology (1913, 1925, 1931, 1936)

***7. TWO ESSAYS ON ANALYTICAL PSYCHOLOGY**

On the Psychology of the Unconscious (1917/1926/1943)

The Relations between the Ego and the Unconscious (1928)

Appendices: New Paths in Psychology (1912): The Structure of the Unconscious (1916) (new versions, with variants, 1966)

†8. THE STRUCTURE AND DYNAMICS OF THE PSYCHE

On Psychic Energy (1928)

The Transcendent Function ([1916]/1957)

A Review of the Complex Theory (1934)

The Significance of Constitution and Heredity in Psychology (1929)

Psychological Factors Determining Human Behavior (1937)

Instinct and the Unconscious (1919)

The Structure of the Psyche (1927/1931)
On the Nature of the Psyche (1947/1954)
General Aspects of Dream Psychology (1916/1948)
On the Nature of Dreams (1945/1948)
The Psychological Foundations of Belief in Spirits (1920/1948)
Spirit and Life (1926)
Basic Postulates of Analytical Psychology (1931)
Analytical Psychology and *Weltanschauung* (1928/1931)
The Real and the Surreal (1933)
The Stages of Life (1930—1931)
The Soul and Death (1934)
Synchronicity: An Acausal Connecting Principle (1952)
Appendix: On Synchronicity (1951)

***9. PART I. THE ARCHETYPES AND THE COLLECTIVE UNCONSCIOUS**

Archetypes of the Collective Unconscious (1934/1954)
The Concept of the Collective Unconscious (1936)
Concerning the Archetypes, with Special Reference to the Anima Concept
(1936/1954)
Psychological Aspects of the Mother Archetype (1938/1954)
Concerning Rebirth (1940/1950)
The Psychology of the Child Archetype (1940)
The Psychological Aspects of the Kore (1941)
The Phenomenology of the Spirit in Fairytales (1945/1948)
On the Psychology of the Trickster-Figure (1954)
Conscious, Unconscious, and Individuation (1939)
A Study in the Process of Individuation (1934/1950)
Concerning Mandala Symbolism (1950)
Appendix: Mandalas (1955)

***9. PART II. AION (1951)**

RESEARCHES INTO THE PHENOMENOLOGY OF THE SELF

The Ego

The Shadow

The Syzygy: Anima and Animus

The Self

Christ, a Symbol of the Self

The Sign of the Fishes

The Prophecies of Nostradamus

The Historical Significance of the Fish

The Ambivalence of the Fish Symbol

The Fish in Alchemy

The Alchemical Interpretation of the Fish

Background to the Psychology of Christian Alchemical Symbolism

Gnostic Symbols of the Self

The Structure and Dynamics of the Self

Conclusion

*10. CIVILIZATION IN TRANSITION

The Role of the Unconscious (1918)

Mind and Earth (1927/1931)

Archaic Man (1931)

The Spiritual Problem of Modern Man (1928/1931)

The Love Problem of a Student (1928)

Woman in Europe (1927)

The Meaning of Psychology for Modern Man (1933/1934)

The State of Psychotherapy Today (1934)

Preface and Epilogue to “Essays on Contemporary Events” (1946)

Wotan (1936)

After the Catastrophe (1945)

The Fight with the Shadow (1946)

The Undiscovered Self (Present and Future) (1957)

Flying Saucers: A Modern Myth (1958)

A Psychological View of Conscience (1958)

Good and Evil in Analytical Psychology (1959)

Introduction to Wolff’s “Studies in Jungian Psychology” (1959)

The Swiss Line in the European Spectrum (1928)

Reviews of Keyserling's "America Set Free" (1930) and "La Révolution Mondiale" (1934)

The Complications of American Psychology (1930)

The Dreamlike World of India (1939)

What India Can Teach Us (1939)

Appendix: Documents (1933–1938)

†11. PSYCHOLOGY AND RELIGION: WEST AND EAST

WESTERN RELIGION

Psychology and Religion (The Terry Lectures) (1938/1940)

A Psychological Approach to the Dogma of the Trinity (1942/1948)

Transformation Symbolism in the Mass (1942/1954)

Forewords to White's "God and the Unconscious" and Werblowsky's "Lucifer and Prometheus" (1952)

Brother Klaus (1933)

Psychotherapists or the Clergy (1932)

Psychoanalysis and the Cure of Souls (1928)

Answer to Job (1952)

EASTERN RELIGION

Psychological Commentaries on "The Tibetan Book of the Great Liberation" (1939/1954) and "The Tibetan Book of the Dead" (1935/1953)

Yoga and the West (1936)

Foreword to Suzuki's "Introduction to Zen Buddhism" (1939)

The Psychology of Eastern Meditation (1943)

The Holy Men of India: Introduction to Zimmer's "Der Weg zum Selbst" (1944)

Foreword to the "I Ching" (1950)

*12. PSYCHOLOGY AND ALCHEMY (1944)

Prefatory Note to the English Edition ([1951?] added 1967)

Introduction to the Religious and Psychological Problems of Alchemy

Individual Dream Symbolism in Relation to Alchemy (1936)

Religious Ideas in Alchemy (1937)

Epilogue

†13. ALCHEMICAL STUDIES

Commentary on “The Secret of the Golden Flower” (1929)

The Visions of Zosimos (1938/1954)

Paracelsus as a Spiritual Phenomenon (1942)

The Spirit Mercurius (1943/1948)

The Philosophical Tree (1945/1954)

‡14. MYSTERIUM CONIUNCTIONIS (1955–56)

AN INQUIRY INTO THE SEPARATION AND

SYNTHESIS OF PSYCHIC OPPOSITES IN ALCHEMY

The Components of the Coniunctio

The Paradoxa

The Personification of the Opposites

Rex and Regina

Adam and Eve

The Conjunction

*15. THE SPIRIT IN MAN, ART, AND LITERATURE

Paracelsus (1929)

Paracelsus the Physician (1941)

Sigmund Freud in His Historical Setting (1932)

In Memory of Sigmund Freud (1939)

Richard Wilhelm: In Memoriam (1930)

On the Relation of Analytical Psychology to Poetry (1922)

Psychology and Literature (1930/1950)

“Ulysses”: A Monologue (1932)

Picasso (1932)

†16. THE PRACTICE OF PSYCHOTHERAPY

GENERAL PROBLEMS OF PSYCHOTHERAPY

Principles of Practical Psychotherapy (1935)

What Is Psychotherapy? (1935)

Some Aspects of Modern Psychotherapy (1930)

The Aims of Psychotherapy (1931)

Problems of Modern Psychotherapy (1929)

Psychotherapy and a Philosophy of Life (1943)

Medicine and Psychotherapy (1945)

Psychotherapy Today (1945)

Fundamental Questions of Psychotherapy (1951)

SPECIFIC PROBLEMS OF PSYCHOTHERAPY

The Therapeutic Value of Abreaction (1921/1928)

The Practical Use of Dream-Analysis (1934)

The Psychology of the Transference (1946)

Appendix: The Realities of Practical Psychotherapy ([1937] added, 1966)

‡17. THE DEVELOPMENT OF PERSONALITY

Psychic Conflicts in a Child (1910/1946)

Introduction to Wickes's "Analyse der Kinderseele" (1927/1931)

Child Development and Education (1928)

Analytical Psychology and Education: Three Lectures (1926/1946)

The Gifted Child (1943)

The Significance of the Unconscious in Individual Education (1928)

The Development of Personality (1934)

Marriage as a Psychological Relationship (1925)

18. MISCELLANY

Posthumous and Other Miscellaneous Works

19. BIBLIOGRAPHY AND INDEX

Complete Bibliography of C. G. Jung's Writings

General Index to the Collected Works

¹ The reader will find more about this in two essays published by me in the *Eranos Jahrbuch* 1936 and 1937. [This material is now contained in *Psychology and Alchemy*, Parts II and III.—EDITORS.]

¹ [*The Secret of the Golden Flower* (1962 edn.), p. 63.]

¹ [*The Golden Flower* (1962 edn.), p. 42.]

² [The Taoist idea of action through non-action.—C.F.B.]

³ [*The Golden Flower* (1962 edn.), p. 51.]

- ¹ Cf. the *Hui Ming Ching* (Book of Consciousness and Life) in *The Secret of the Golden Flower* (1962 edn.), pp. 69ff.
- ² The head is also the “seat of heavenly light.”
- ³ In the *Hui Ming Ching*, “human nature” (*hsing*) and “consciousness” (*hui*) are used interchangeably.
- ⁴ *The Golden Flower* (1962 edn.), p. 70.
- ⁵ Cf. *Psychological Types*, ch. V.
- ⁶ [For a fuller discussion of the *mandala*, see “A Study in the Process of Individuation” and “Concerning Mandala Symbolism” in *The Archetypes and the Collective Unconscious*. For examples of European mandalas, see below, after p. 56.—EDITORS.]
- ⁷ Cf. Wallis Budge, *The Gods of the Egyptians*.
- ⁸ [The mandala is reproduced in “A Study in the Process of Individuation,” p. 297.]
- ⁹ Cf. the Chinese concept of the heavenly light between the eyes.
- ¹⁰ Matthews, “The Mountain Chant: A Navajo Ceremony” (1887), and Stevenson, “Ceremonial of Hasjelti Dailjis” (1891).
- ¹¹ The mandala of a somnambulist is reproduced in *Psychiatric Studies*, p. 40.
- ¹² *The Golden Flower* (1962 edn.), p. 70.
- ¹³ [Ibid., p. 22.]
- ¹⁴ [Ibid., p. 70.]
- ¹⁵ [Ibid., p. 71.]
- ¹⁶ Cf. Avalon, *The Serpent Power*.
- ¹⁷ Cf. the excellent collection in Knuchel, *Die Umwandlung in Kult, Magie und Rechtsbrauch*.
- ¹⁸ Evans-Wentz, *The Tibetan Book of the Dead*.
- ¹⁹ Anna Kingsford, *Her Life, Letters, Diary, and Work*, pp. 129f. I am indebted for this reference to my colleague, Dr. Beatrice Hinkle, New York.
- ²⁰ Such experiences are genuine, but their genuineness does not prove that all the conclusions or convictions forming their content are necessarily sound. Even in cases of lunacy one comes across perfectly valid psychic experiences. [Author’s note added in the first (1931) English edition.]
- ²¹ [Acta S. Hildegardis, in Migne, *P.L.*, vol. 197, col. 18.]

¹ *The Golden Flower* (1962 edn.), pp. 76f. [For elucidation of the four pictures from the *Hui Ming Ching* reproduced here, see *ibid.*, pp. 75–77.—EDITORS.]

² These are recollections of earlier incarnations that arise during contemplation.

³ [*The Golden Flower*, p. 22.]

⁴ [*The Golden Flower*, pp. 26 and 28.]

⁵ Cf. *Two Essays on Analytical Psychology*, pars. 296ff.

⁶ Cf. *Psychological Types*, ch. V.

⁷ Cf. Hyslop, *Science and a Future Life*, pp. 113ff. [Mrs. Leonora Piper, an American psychic medium active about 1890–1910 in the U.S. and England, was studied by William James, Mrs. Henry Sidgwick, Hyslop, and others. A group of five of her psychic controls had the collective name “Imperator.”—EDITORS.]

¹ [*The Golden Flower* (1962 edn.), pp. 77f.]

² Lévy-Bruhl, *Primitive Mentality*.

³ Dissolution of *participation mystique*.

¹ The Chinese philosophers—in contrast to the dogmatists of the West—are only grateful for such an attitude, because they also are masters of their gods. [Note by Richard Wilhelm in original edn.]

² Our text is somewhat unclear as to whether by “continuation of life” a survival after death or a prolongation of physical existence is meant. Expressions such as “elixir of life” and the like are exceedingly ambiguous. In the later additions to the text it is evident that the yoga instructions were also understood in a purely physical sense. To a primitive mind, there is nothing disturbing in this odd mixture of the physical and the spiritual, because life and death are by no means the complete opposites they are for us. (Particularly interesting in this connection, apart from the ethnological material, are the communications of the English “rescue circles” with their thoroughly archaic ideas.) The same ambiguity with regard to survival after death is found in early Christianity, where immortality depends on very similar assumptions, i.e., on the idea of a breath-body as the carrier of life. (Geley’s parapsychological theory would be the latest incarnation of this ancient idea.) But since in our text there are warnings about the superstitious use of it—warnings, for example, against the making of gold—we can safely insist on the spiritual purport of the instructions without contradicting their meaning. In the states which the instructions seek to induce the physical body plays an increasingly unimportant part anyway, since it is replaced by the breath-body (hence the importance of breath control in all yoga exercises). The breath-body is not something “spiritual” in our sense of the word. It is characteristic of Western man that he has split apart the physical and the spiritual for epistemological purposes. But these opposites exist together in the psyche and psychology must recognize this fact. “Psychic” means physical *and* spiritual. The ideas in our text all deal with this “intermediate” world which seems unclear and confused because the concept of psychic reality is not yet current among us, although it expresses life as it actually is. Without soul, spirit is as dead as matter, because both are artificial abstractions; whereas man originally regarded spirit as a volatile body, and matter as not lacking in soul.

³ *The Golden Flower* (1962 edn.), p. 77.

¹ [The following mandalas are also published, with more detailed comments, in “Concerning Mandala Symbolism”: A1 (fig. 9), A3 (fig. 6), A5 (fig. 25). A6 (fig. 28), A7 (fig. 38), A8 (fig. 37), A9 (fig. 26), A10 (fig. 36); in “A Study of the Process of Individuation”: A4 (Picture 9). A2 is not republished. In *Memories, Dreams, Reflections*, Jung tells of painting the pictures reproduced in A3 and A10 (see the N.Y. edn., p. 197 and Pl. XI; London edn., pp. 188f. and facing p. 241). Cross reference in “Concerning Mandala Symbolism” indicates that he also painted the picture in A6. —EDITORS.]

¹ “Ζωσίρον τοῦ θείου περί ἀρετῆς.” ‘Αρετή here should not be translated as “virtue” or “power” (“vertu” in Berthelot) but as “the Art,” corresponding to the Latin *ars nostra*. The treatise has nothing whatever to do with virtue.

² Berthelot, *Collection des anciens alchimistes grecs*, with translations into French by C. E. Ruelle. [The present translation is by A. S. B. Glover from the Greek text in Berthelot, with reference also to Ruelle’s French and Jung’s German. The section numeration is Berthelot’s.—EDITORS.]

³ The *ἱερονργός* is the sacrificial priest who performs the ceremonies. The *ἱερεύς* is rather the *ἱεροφάντης* the prophet and revealer of the mysteries. No difference is made between them in the text.

⁴ Ion occurs in the Sabaeen tradition as Jûnân ben Merqûlius (son of Mercury), the ancestor of the Ionians (el-Jûnâniûn). [Cf. Eutychius, *Annales*, in Migne, *P.G.*, vol. 111, col. 922.] The Sabaeans consider him the founder of their religion. Cf. Chwolsohn, *Die Ssabier und der Ssabismus*, I, pp. 205, 796, and II, p. 509. Hermes, too, was considered a founder (I, p. 521).

⁵ Κόλασις, literally ‘punishment.’ Here it means the torment which the prima materia has to undergo in order to be transformed. This procedure is called *mortificatio*. [For an example, see the *mortificatio* of the “Ethiopian” in *Psychology and Alchemy*, par. 484. Also infra, “The Philosophical Tree,” ch. 17.—EDITORS.]

⁶ Διασπάσας κατὰ ἀύστασιν ἀρρονίας. Berthelot has “démembrant, suivant les règles de la combinaison.” It refers to the division into four bodies, natures, or elements. Cf. Berthelot, *Alch. grecs*, II, iii, 11 and *Chimie au moyen âge*, III, p. 92. Also “Visio Arislei,” *Artis auriferae*, I, p. 151, and “Exercitationes in Turbam IX,” *ibid.*, p. 170.

⁷ εἶδον αὐτόν ὡς τούναντίον ἀνθρωπάριον κολοβόν. If I am not mistaken, the concept of the *homunculus* appears here for the first time in alchemical literature.

⁸ I read ξνρουργός instead of the meaningless ξηρουργός in the text. Cf. III, v, 1, where the barber does in fact appear as an anthroparion. (Or should it be taken adjectivally: ξνρουργὸν ἀνθρωπάριον?) The anthroparion is grey because, as we shall see, he represents the lead.

⁹ Or “moral perfection.”

¹⁰ Evidently a particularly convulsive opening of the mouth is meant, coupled with a violent contraction of the pharynx. This contraction was a kind of retching movement for bringing up the inner contents. These had to be written down on the tablets. They were inspirations coming from above that were caught, as it were, by the upraised eyes. The procedure might be compared with the technique of active imagination.

¹¹ [In the Swiss edition (*Von den Wurzeln des Bewusstseins*, pp. 141–45) this section, though numbered III, i, 3 only, continues into III, i, 4, 5, and 6 without a break, the whole being run together as a single section. III, i, 5, then reappears at the end of the sequence of visions (par. 87), but in variant form, as a “résumé,” and the reasons for its placement there are explained in the commentary (pars. 93, 111, 121). As no explanation is given for its duplication under III, i, 3, and the variations are in the main merely stylistic, we have omitted it at this point and reconstituted III, i, 4–6 at the end of the sequence. The wording of Jung’s interpolation at par. 87 has been altered to account for this change. The sections are presented in the order III, i, 5, III, i, 4, III, i, 6 on the assumption that III, i, 4 is not meant to form a part of the “résumé” proper, but, as stated in the Eranos version of “Transformation Symbolism in the Mass,” is rather “Zosimos” own commentary on his visions” and “a general philosophical conclusion” (*The Mysteries*, pp. 311f.).—EDITORS.]

¹² Καὶ ἄλλος ὀπζσω αὐτοῦ φέρων περιηκονισμένον τινά λευκοφόρον καὶ ὠραῖον τήν ὄψιν, οὐ τὸ ὄνομα ἔκαλεῖο μεσουράννισμα ἡλίου. Berthelot: “Un autre, derrière lui, portait un objet circulaire, d’une blancheur éclatante, et très beau à voir appelé Méridien du Cinnabre.” It is not clear why μεσουράννισμα ἡλίου is translated as “meridian of the cinnabar,” thus making it a chemical analogy, περιηκονισμένον τινά must refer to a person and not to a thing. Dr. M.-L. von Franz has drawn my attention to the following parallels in Apuleius. He calls the *stola olympiaca* with which the initiate was clad a “precious scarf with sacred animals worked in colour on every part of it; for instance, Indian serpents and Hyperborean griffins.” “I . . . wore a white palm-tree chaplet with its leaves sticking out all round like rays of light.” The initiate was shown to the people “as when a statue is unveiled, dressed like the sun.” The sun, which he now was, he had seen the previous night, after his figurative death. “At midnight I saw the sun shining as if it were noon.” (*The Golden Ass*, trans. Graves, p. 286.)

¹³ Literally, δργανικῶς.

¹⁴ The island of Prokonnesos was the site of the famous Greek marble quarry, now called Marmara (Turkey).

¹⁵ That is, circular.

¹⁶ The Greek has only μέλος. I follow the reading of codex Gr. 2252 (Paris).

¹⁷ The *res quaesita* or *quaerenda* is a standing expression in Latin alchemy.

¹⁸ Οὐγγιασμῶ.

¹ For example, the “Visio Arislei” (*Art. aurif.*, I, pp. 146ff.) and the visions in the “Book of Krates” (Berthelot, *Chimie au moyen âge*, III, pp. 44–75).

² Cf. *Psychology and Alchemy*, pars. 347ff.

³ The opus extended over a period with no fixed limits. During this time the artifex had to devote himself “religiously” to the process of transformation. Since the process was subjective as well as objective, it is not surprising that it included dream-experiences. G. Battista Nazari (*Della tramutatione metallica sogni tre*, 1599) actually represented the opus in the form of (allegorical) dreams. “The philosophic water is sometimes manifested to thee in sleep,” says the “Parabola” of Sendivogius (*Bibliotheca chemica*, II, p. 475). We cannot suppose that the author had any knowledge of the visions of Zosimos; the reference is probably to the “Visio Arislei,” as suggested by the following (p. 475 b): “Solum fructum arboris Solaris vidi in somniis Saturnum Mercurio nostro imponere” (I saw in dreams the sole fruit of the tree of the sun impose Saturn on our Mercurius). Cf. the end of the “Visio Arislei”: “Vidimus te magistrum in somniis. Petiimus ut nobis subsidium Horfolto discipulo tuo offeras, qui nutrimenti auctor est” (We saw thee, the master, in dreams. We besought that thou wouldst offer us for our help thy disciple Horfoltus, who is the author of nourishment).—Codex Q. 584 (Berlin), fol 21^v. Ruska, ed., *Turba Philosophorum*, pp. 327f. The beginning of the “Visio” shows how the fruit of “that immortal tree” may be gathered.

⁴ In our text (III, v. 3) it is the Agathodaimon itself that suffers transformation.

⁵ Division into four elements after the *mortificatio* occurs in “Exercitationes in Turbam IC” (*Art. aurif.*, I, p. 170), also in “Aenigma” VI (*ibid.*, p. 151). For division of the egg into four, see the Book of El-Habib (Berthelot, *Moyen âge*, III, p. 92). The division into four was known as *τετραμερὲς τῆν φιλοσοφίαν* (Berthelot, *Alch. grecs*, III, xlv, 5).

⁶ For example, in Trismosin, *Splendor solis (Aureum vellus*, p. 27). The same in *Splendor Solis* (London, 1920, repr.), Pl. X, and Lacinius, *Pretiosa margarita novella* (Venice, 1546), fol. *** xii.

⁷ “It is the water that kills and vivifies” (*Rosarium philosophorum*, in *Art. aurif.*, II, p. 214).

⁸ Just as baptism is a pre-Christian rite, according to the testimony of the gospels, so, too, the divine water is of pagan and pre-Christian origin. The Praefatio of the *Benedictio Fontis* on Easter Eve says: “May this water, prepared for the rebirth of men, be rendered fruitful by the secret inpouring of his divine power; may a heavenly offering, conceived in holiness and reborn into a new creation, come forth from the stainless womb of this divine font; and may all, however distinguished by age in time or sex in body, be brought forth into one infancy by the motherhood of grace” (*The Missal in Latin and English*, p. 429).

⁹ “The priest divides the water crosswise with his hand” (*ibid.*).

¹⁰ Cf. *Psychology and Alchemy*, pars. 334, 530.

¹¹ Cf. “Hortulanus super Epistolam Hermetis” in *Rosarium*, *Art. aurif.*, II, p. 270. *Aurora Consurgens* (ed. von Franz), pp. 39–41: “For she [this science] is clear to them that have understanding . . . she seemeth easy to them that have knowledge of her.” Maier, *Symbola aureae mensae*, p. 146: “. . . that they should not understand his words, save those who are judged worthy of this very great magistry.”

¹² Cf. Gray, *Goethe the Alchemist*.

¹³ It has often been objected that symbols of this sort do not occur in dreams at all. Naturally they do not occur in all dreams or in just any dreams, but only in special ones. The differences between dreams are as great as those between individuals. A particular constellation of the unconscious is needed to produce such dreams, i.e., archetypal dreams

containing mythological motifs. (Examples in *Psychology and Alchemy*, Part II.) But they cannot be recognized without a knowledge of mythology, which not all psychologists possess.

- ¹ Provided, of course, that the passages in question are not interpolations by copyists, who were mostly monks.
- ² Preller, *Griechische Mythologie*, I, p. 437.
- ³ Fragment 472 N2, “The Cretans.” Cited in Dieterich, *Mithrasliturgie*, p. 105.
- ⁴ Cf. “Transformation Symbolism in the Mass,” pp. 231f. For dismemberment, transformation, and recomposition in a case of schizophrenia, see Spielrein, “Ueber den psychologischen Inhalt eines Falles von Schizophrenie,” pp. 358ff. Dismemberment is a practically universal motif of primitive shamanistic psychology. It forms the main experience in the initiation of a shaman. Cf. Eliade, *Shamanism*, pp. 53ff.
- ⁵ Firmicus Maternus, *Liber de errore profanarum religionum* (ed. Halm), ch. 7, p. 89.
- ⁶ Attis has close affinities with Christ. According to tradition, the birthplace at Bethlehem was once an Attis sanctuary. This tradition has been confirmed by recent excavations.
- ⁷ Frazer, *The Golden Bough*, Part IV: *Adonis, Attis, Osiris*, pp. 242ff.
- ⁸ *Ibid.*, p. 249.
- ⁹ *Ibid.*, p. 246.
- ¹⁰ Among the Thompson and Shuswap Indians in British Columbia the scalp signifies a helpful guardian spirit. Frazer, *Totemism and Exogamy*, III, pp. 417, 427.
- ¹¹ *Die Apokalypse des Elias*.
- ¹² *Ibid.*, p. 43, 5, line 1.
- ¹³ P. 95, 36, line 8.
- ¹⁴ “Transformation Symbolism in the Mass,” pp. 240ff.
- ¹⁵ *Ibid.*
- ¹⁶ *De circulo physico quadrato*, pp. 15f.
- ¹⁷ *Philosophia reformata*, p. 313.
- ¹⁸ *Theatrum chemicum*, IV (1659), p. 496.
- ¹⁹ “Speculativa philosophia,” *ibid.*, I (1659), p. 247.
- ²⁰ Berthelot, *Alch. grecs*, III, li, 8.
- ²¹ Scott, *Hermetica*, I, Book IV, and Reitzenstein, *Poimandres*, pp. 8ff.
- ²² See *supra*, par. 89, n. 8.
- ²³ Berthelot, *Alch. grecs*, I, xiii, 1f.
- ²⁴ The arcanum is here symbolized by the sowing of the grain and the begetting of man, lion, and dog. In chemical usage it refers to the fixation of quicksilver (*ibid.*, I, xiii, 6–9). Quicksilver was one of the older symbols for the divine water on account of its silvery-white sheen. In *Rosarium* it is called “aqua clarissima” (*Art. aurif.*, II, p. 213).
- ²⁵ Budge, *The Gods of the Egyptians*, II, pp. 122ff.
- ²⁶ Jacobsohn, *Die dogmatische Stellung des Königs in der Theologie der alten Aegypter*, p. 50.
- ²⁷ Cf. the identification of the Agathodaimon with the transformative substance, *supra*, III, v, 3.
- ²⁸ Berthelot, *Alch. grecs*, I, ii.

²⁹ Ὀσιρίς ἔστιν ἡ ταφή ἐσφιγμένη, κρύπτουσα πάντα πάντα τὰ Ὀσίριδος μέλη: Treatise of Olympiodorus of Alexandria (ibid., II, iv, 42). Here Osiris is the “principle of all moisture” in agreement with Plutarch. This refers to the relatively low melting point of lead.

³⁰ Ibid., II, iv, 43.

³¹ Cf. the hymn of St. Romanus on the theophany: “... him who was seen of old in the midst of three children as dew in the fire, now a fire flickering and shining in the Jordan, himself the light inaccessible” (Pitra, *Analecta sacra*, I, 21).

³² Berthelot, *Alch. grecs*, I, xiii, 1–4.

³³ Instead of φενρικῆς in the text.

³⁴ The secrets of the art.

³⁵ *Art. aurif.*, I, pp. 141f.

³⁶ “There is in the sea a round fish, lacking bones and scales [?], and it has in itself a fatness, a wonder-working virtue, which if it be cooked on a slow fire until its fatness and moisture have wholly disappeared, and then be thoroughly cleansed, is steeped in sea water until it begins to shine. . . .” This is a description of the transformation process. [Cf. *Aion*, pars. 195ff.]

³⁷ “... whose anointed eyes could easily look upon the secrets of the philosophers.”

³⁸ Codex Vadiensis 390 (St. Gall), 15th cent. (mentioned by Ruska, *Turba*, p. 93). Concerning the fish, see *Aion*, ch. X.

³⁹ Sermo XLI.

⁴⁰ That is, Saturn, who was regarded as the dark “counter-sun.” Mercurius is the child of Saturn, and also of the sun and moon.

⁴¹ Cf. *Psychology and Alchemy*, par. 456, §6.

⁴² Berthelot, *Alch. grecs*, III, xix, 1.

⁴³ Δύναρις γάρ φησὶν ὑδατόχρους, ἦντινα δύναμιν, φησί, τοντέστι τόν κρόνον. Hippolytus, *Elenchos*, V, 16, 2 (trans. Legge, *Philosophumena*, I, p. 154).

⁴⁴ 1454–1493. Cardinal archbishop of Aquileia, and a great humanist.

⁴⁵ *Corollarium in Dioscoridem*. Cited in Maier, *Symb. aur. mens.*, p. 174.

⁴⁶ *Lexicon alchemiae*, pp. 46f.

⁴⁷ *Coelum Sephiroticum*, p. 33.

⁴⁸ An allusion to the axiom of pseudo-Democritus.

⁴⁹ Ruska, p. 190.

⁵⁰ P. 197.

⁵¹ Pp. 200f. *Aqua nostra* is “fire, because it burns all things and reduces them to powder; quicksilver is vinegar” (Quotation from Calid in *Rosarium*, p. 218). “Our water is mightier than fire. . . . And fire in respect thereto is like water in respect to common fire. Therefore the philosophers say: Burn our metal in the mightiest fire” (ibid., p. 250). Hence the “water” is a kind of superfire, an *ignis coelestis*.

⁵² Contrary to Ruska (*Turba*, p. 201, n. 3), I adhere to the reading in the MSS. because it is simply a synonym for the moist soul of the prima materia, the radical moisture. Another synonym for the water is “spiritual blood” (ibid., p. 129), which Ruska rightly collates with *πυρρόν αἷμα* (fire-coloured blood) in the Greek sources. The equation fire = spirit is common in alchemy. Thus, as Ruska himself remarks (p. 271), Mercurius (a frequent synonym for the *aqua permanens*, cf. Ruland’s *Lexicon*) is called *φάρμακον πύρινον* (fiery medicine).

⁵³ Cf. *Aurora Consurgens* (ed. von Franz), pp. 85, 91.

⁵⁴ *Art. aurif.*, II, p. 482.

⁵⁵ Ibid., II, p. 239.

⁵⁶ Berthelot, *Alch. grecs*, IV, xx, 8: “Make known to us how the blessed waters come down from above to awaken the dead, who lie round about in the midst of Hades, chained in the darkness; how the elixir of life comes to them and awakens them, rousing them out of their sleep. . . .”

⁵⁷ P. 139.

⁵⁸ Scott, *Hermetica*, I, p. 147.

⁵⁹ Praefatio: “May the power of the Holy Ghost descend into this brimming font, and may it make the whole substance of the water fruitful in regenerative power” (*Missal*, p. 431).

⁶⁰ It shares this quality with Mercurius duplex.

⁶¹ “In the floods of life, in the storm of work,
In ebb and flow,
In warp and weft,
Cradle and grave,
An eternal sea,
A changing patchwork,
A glowing life,
At the whirring loom of Time I weave
The living clothes of the Deity.”

Thus the Earth Spirit, the *spiritus mercurialis*, to Faust. (Trans. by MacNeice, p. 23.)

⁶² In Egypt the darkness of the soul was represented as a crocodile (Budge, *The Gods of the Egyptians*, I, p. 286).

⁶³ In the Book of Ostanès (Berthelot, *Chimie au moyen âge*, III, p. 120) there is a description of a monster with wings of a vulture, an elephant’s head, and a dragon’s tail. These parts mutually devour one another.

⁶⁴ Of the quicksilver (*aqua vitae, perennis*) it is said: “This is the serpent which rejoices in itself, impregnates itself, and brings itself forth in a single day; it slays all things with its venom, and will become fire from the fire (*et ab igne ignis fuerit*).” (“Tractatulus Avicennae,” *Art. aurif.*, I, p. 406.) “The dragon is born in the *nigredo* and feeds upon its Mercurius and slays itself” (*Rosarium*, ibid., II, p. 230). “The living Mercurius is called the scorpion, that is, venom; for it slays itself and brings itself back to life” (ibid., pp. 271f.). The oft-cited saying, “The dragon dieth not save with its brother and sister,” is explained by Maier (*Symb. aur. mens.*, p. 466) as follows: “For whenever the heavenly sun and moon meet in conjunction, this must take place in the head and tail of the dragon; in this comes about the conjunction and uniting of sun and moon, when an eclipse takes place.”

⁶⁵ *Theatr. chem.*, IV (1659), pp. 509ff.

⁶⁶ The killing (*mortificatio*) of the king occurs in later alchemy (cf. *Psychology and Alchemy*, Fig. 173). The king's crown makes him a kind of sun. The motif belongs to the wider context of the sacrifice of the god, which developed not only in the West but also in the East, and particularly in ancient Mexico. There the personifier of Tezcatlipoca ("fiery mirror") was sacrificed at the festival of Toxcatl (Spence, *The Gods of Mexico*, pp. 97ff.). The same thing happened in the cult of Uitzilopochtli, the sun-god (*ibid.*, p. 73), who also figured in the eucharistic rite of the *teoqualo*, "god-eating" (cf. "Transformation Symbolism in the Mass," pp. 223f.).

⁶⁷ The solar nature of the victim is confirmed by the tradition that the man destined to be beheaded by the priests of Harran had to have fair hair and blue eyes (*ibid.*, p. 240).

⁶⁸ Cf. my remarks on the Harranite head mystery and the legendary head oracle of Pope Sylvester II (*ibid.*, pp. 240f.).

⁶⁹ Its form can still be seen in the deacon's hood.

⁷⁰ According to Rabbinic tradition the angels (including Satan) were created on the second day of Creation (the day of the moon). They were immediately divided on the question of creating man. Therefore God created Adam in secret, to avoid incurring the displeasure of the angels.

⁷¹ "They compared the water to an egg, because it surrounds everything that is within it, and has in itself all that is necessary" ("Consilium coniugii," *Ars chemica*, p. 140). "Having all that is necessary" is one of the attributes of God.

⁷² Maier, *Symb. aur. mens.*, p. 466. Cf. Senior, *De chemia*, p. 108: "The dragon is the divine water."

⁷³ *Mus. herm.*, p. 785.

⁷⁴ *Ibid.*, p. 90.

⁷⁵ Steeb, *Coelum Sephiroticum*, p. 33.

⁷⁶ *Turba*, Sermo IV, p. 112. Cf. also the "nomenclature of the egg" in Berthelot, *Alch. grecs*, I, iv, and Olympiodorus on the egg, the tetrasomia, and the spherical phial (II, iv, 44). Concerning the identity of uroboros and egg, and the division into four, see the Book of El-Habib (Berthelot, *Moyen âge*, III, pp. 92, 104). There is a picture of the egg being divided with the sword in Emblem VIII of Maier's *Scrutinium chymicum* (p. 22), with the inscription: "Take the egg and pierce it with a fiery sword." Emblem XXV shows the killing of the dragon. Killing with the sword is also shown in Lambspringk's Symbol II (*Musaeum hermeticum*, p. 345), titled "Putrefactio." Killing and division into four go together. "Mortificatio (scl. Lapidis) separatio elementorum" ("Exercit. in Turb. IX"). Cf. the dramatic fights with the dragon in the visions of Krates (Berthelot, *Moyen âge*, III, pp. 73ff.).

⁷⁷ *Ars chemica*, p. 259.

⁷⁸ *Verus Hermes*, p. 16. [Cf. *infra*, par. 276.]

⁷⁹ This motif also occurs in the Adam parable in "Aurelia occulta" (*Theatr. chem.*, IV, 1659, pp. 511f.), which describes how the angel had to deal Adam several bloody wounds with his sword because he refused to move out of Paradise. Adam is the arcane substance, whose "extraction from the garden" of Eve is finally accomplished by means of blood magic.

⁸⁰ Codex Vat. Lat. 7286 (17th cent.). Fig. 150 in *Psychology and Alchemy*.

⁸¹ Codex Vossianus 29 (Leiden), fol. 73.

⁸² Ripley's "Cantilena," verse 17. [Cf. *Mysterium Coniunctionis*, p. 285.—EDITORS.]

- ⁸³ *Theatr. chem.*, I (1659), p. 254. Cf. “Transformation Symbolism in the Mass,” pp. 234f. [Also cf. *infra*, pars. 447f.]
- ⁸⁴ *Ibid.*, p. 215.
- ⁸⁵ The parallel to this is the old view that Christ drank his own blood (*ibid.*, p. 211).
- ⁸⁶ Cf. my “A Psychological Approach to the Dogma of the Trinity,” p. 167.
- ⁸⁷ The shining of the vessel is often mentioned, as in “*Allegoriae super librum Turbae*” (*Art. aurif.*, I, p. 143): “... until you see the vessel gleam and shine like a jacinth.”
- ⁸⁸ *Ars chemica*, p. 9.
- ⁸⁹ 1550 edn., fol. A III.
- ⁹⁰ *Bibl. chem.*, I, p. 442.
- ⁹¹ *Symb. aur. mens.*, p. 63.
- ⁹² *Art. aurif.*, I, p. 203.
- ⁹³ *Ibid.*, p. 323.
- ⁹⁴ The “Stoics” are also mentioned in “*Liber quartorum*,” *Theatr. chem.*, V (1660), p. 128.
- ⁹⁵ Hoghelande, “*De difficult. alch.*,” *Theatr. chem.*, I (1659), p. 177.
- ⁹⁶ *Theatr. chem.*, V (1660), p. 60.
- ⁹⁷ *Phil. ref.*, p. 32.
- ⁹⁸ *Theatr. chem.*, II (1659), p. 246.
- ⁹⁹ *Ibid.*, V (1660), p. 132.
- ¹⁰⁰ Pp. 239ff.
- ¹⁰¹ The moisture is “retentive of souls” (“*Lib. quart.*,” *Theatr. chem.*, V, 1660, p. 132).
- ¹⁰² Cf. the descent of the soul in my “*Psychology of the Transference*,” pars. 483 and 497.
- ¹⁰³ *Dialogus miraculorum*, Dist. IV, ch. xxxix (Eng. edn., p. 42).
- ¹⁰⁴ Cf. my “*On the Nature of the Psyche*,” p. 198.
- ¹⁰⁵ *Phil. ref.*, p. 33.
- ¹⁰⁶ “*On the Nature of the Psyche*,” pp. 198f.
- ¹⁰⁷ *Theatr. chem.*, I (1659), pp. 506f.: “Our vessel . . . should be made according to true geometrical proportion and measure, and by a kind of squaring of the circle.”
- ¹⁰⁸ *Ibid.*, p. 442.
- ¹⁰⁹ *Ibid.*, IV (1659), p. 698. [Cf. *infra*, Fig. B7.]
- ¹¹⁰ Lake, *Apostolic Fathers*, I, p. 383.
- ¹¹¹ Honorius of Autun, *Speculum de myst. eccl.* (Migne, *P.L.*, vol. 172, col. 936). Christ’s tearing of the breast, the wound in his side, and his martyr’s death are parallels of the alchemical *mortificatio*, dismemberment, flaying, etc., and pertain like these to the birth and revelation of the inner man. Cf. the report in Hippolytus (*Elenchos*, V, 9, 1–6) of the Phrygian system. The Phrygians taught that the Father of all things was called Amygdalos (almond-tree), was pre-existent, and bore in himself the “perfect fruit pulsating and stirring in the depths.” He “tore his breast and gave birth to his invisible, nameless and unnameable child.” That was the “Invisible One, through whom all things were

made, and without whom nothing was made” (an allusion to John 1 : 3). He was “Syriktes, the piper.” i.e., the wind (pneuma). He was “thousand-eyed, not to be comprehended,” the Word (ῥῆμα) of God, the Word of annunciation and great power.” He was “hidden in the dwelling where the roots of all things are established.” He was the “Kingdom of Heaven, the grain of mustard-seed, the indivisible point . . . which none know save the spiritual alone.” (Cf. Legge trans., *Philosophumena*, I, pp. 140f.)

¹¹² Herakleon taught that the Ground of the world was a Primordial Man named Bythos (depths of the sea), who was neither male nor female. From this being was produced the inner man, his counterpart, who “came down from the Pleroma on high.”

¹¹³ Epiphanius, *Panarium* (ed. Holl), II, pp. 46f.

¹¹⁴ *La Vertu et propriété de la quinte essence*, p. 26.

¹¹⁵ Berthelot, *Moyen âge*, III, p. 80.

¹¹⁶ *Ars chemica*, p. 110.

¹¹⁷ *Theatr. chem.*, V (1660), p. 134. The *res simplex* refers, ultimately, to God. It is “insensible.” The soul is simple, and the “opus is not perfected unless the matter is turned into the simple” (p. 116). “The understanding is the simple soul,” and “knows also what is higher than it, and the One God surrounds it, whose nature it cannot comprehend” (p. 129). “That from which things have their being is the invisible and immoveable God, by whose will the understanding is created” (p. 129).

¹¹⁸ Reitzenstein and Schaeder, *Studien zum antiken Synkretismus aus Iran und Griechenland*, p. 45.

¹¹⁹ [Cf. *Psychology and Alchemy*, par. 443.]

- ¹ [Supra, par. 87 (III, i, 6).]
- ² Cf. *Psychological Types*, Def. 25.
- ³ Cf. the medieval *melothesia*. [For a definition, see “Psychology and Religion,” p. 67, n. 5.—EDITORS.]
- ⁴ “Gloria mundi,” *Mus. herm.*, p. 270.
- ⁵ “Ein Philosophisches Werck und Gespräch, von dem Gelben und Rotten Mann Reverendissimi Domini Melchioris Cardinalis et Episcopi Brixiensis,” reprinted in *Aureum vellus*, pp. 177f. After the Red Man he finds the Black Raven, and from this comes the White Dove.
- ⁶ Cf. the interesting examples in Agricola, *De animantibus subterraneis*, and Kircher, *Mundus subterraneus*, lib. VIII, cap. IV.
- ⁷ *Alch. grecs*, III, xxxv.
- ⁸ *Ibid.*, III, xxix, 18f.
- ⁹ “Aenigma” VI, in *Art. aurif.*, I, p. 151.
- ¹⁰ *The Canterbury Tales* (ed. Robinson), p. 43 (The Knight’s Tale, 2041–45).
- ¹¹ “Rosinus ad Sarrat.,” *Art. aurif.*, I, p. 311.
- ¹² “Orthelii epilogus,” *Theatr. chem.*, VI (1661), p. 438.
- ¹³ *Ars chemica*, pp. 247, 253, 254.
- ¹⁴ The text has “ad Deum” (instead of “ad eum”), which is meaningless. Statements like “our body is our Stone” (“Authoris ignoti opusculum,” *Art. aurif.*, I, p. 392) are doubtful, because “corpus nostrum” can just as well mean the arcane substance.
- ¹⁵ *Alch. grecs*, IV, xx, 8.
- ¹⁶ IV, xx, 16.
- ¹ III, xlix, 4.
- ² The importance of self-knowledge is stressed in the alchemical texts. Cf. *Aion*, pp. 162ff.
- ³ For a translation of the entire text, see *Psychology and Alchemy*, par. 456.
- ⁴ Berthelot, *Moyen âge*, III, p. 50.
- ⁵ Cf. *Aurora Consurgens* (ed. M.-L. von Franz), p. 87.
- ⁶ *Alch. grecs*, III, xlix, 4.
- ⁷ Cf. infra, “The Spirit Mercurius,” pars. 289ff.
- ⁸ Spencer and Gillen, *The Northern Tribes of Central Australia*, pp. 257ff.
- ⁹ Hastings, *Encyclopaedia of Religion and Ethics*, XI, p. 874b, and Frazer, *Magic Art*, I, pp. 160ff. Similar ochre-painted stones can still be seen in India today, for instance in the Kalighat at Calcutta.
- ¹⁰ Pausanias, *Descriptio Graeciae* (ed. Spiro), I, p. 300.
- ¹¹ So did the archons in Athens when taking their oath.
- ¹² Frazer, *Magic Art*, I, p. 161.
- ¹³ Schevill, *Beautiful on the Earth*, pp. 24ff. and 38ff.

- ¹⁴ For the Australian aborigines, this would be the primeval *alcheringa* time, which means both the world of the ancestors and the world of dreams.
- ¹⁵ Cf. the treatise of Komarios (Berthelot, *Alch. grecs*, IV, xx, 2): “Go up into the highest cave on the thick-wooded mountain, and behold there a stone on the mountain top. And take from the stone the male. . . .”
- ¹⁶ Cf. Rider Haggard’s *She*.
- ¹⁷ *Alch. grecs*, IV, xx, 8.
- ¹⁸ I am indebted to Dr. M.-L. von Franz for this material.
- ¹⁹ Krickeberg, *Indianermärchen aus Nordamerika*, pp. 92ff.
- ²⁰ Van Deursen, *Der Heilbringer*, p. 227.
- ²¹ *Ibid.*, p. 238.
- ²² Cf. the fertility significance of the *churingas*.
- ²³ Van Deursen, p. 286.
- ²⁴ Krickeberg. *Märchen der Azteken, Inka, Maya und Muiska*, p. 36.
- ²⁵ *Ibid.*, p. 65.
- ²⁶ P. 330.
- ²⁷ P. 317.
- ²⁸ P. 382.
- ²⁹ Eliade, *Shamanism*, p. 52.
- ³⁰ *Ibid.*, pp. 363f.
- ³¹ *Alch. grecs*, III, vi, 5, 12ff.
- ³² Steindorff, *Apokalypse des Elias*, 36, 17–37, 1, p. 97.
- ³³ *Das Zeitalter des Sonnengottes*, p. 106.

¹ Tractatus I, *Corp. Script. Eccl. Lat.*, XVIII, p. 24.

² See supra, par. 105.

³ "... which I have seen with my own eyes and touched with my hands" (*Rosarium*, in *Art. aurif.*, II, p. 205).

⁴ It must be remembered, however, that John uses other terms than those found in the alchemy of the time: *τᾶ ἑπίγεια* and *τᾶ ἑπιουράνια* (*terrena* and *coelestia* in the Vulgate).

⁵ The source for this is Hermes Trismegistus in the "Tabula smaragdina": "It ascends from earth to heaven and descends again to earth. . . . The wind hath borne it in his belly." This text was always interpreted as referring to the stone (cf. Hortulanus, "Commentariolum," *Ars chemica*). But the stone comes from the "water." A perfect alchemical parallel to the Christian mystery is the following passage from the "Consilium coniug." (ibid., p. 128): "And if I ascend naked into heaven, then will I come clothed to earth and perfect all minerals. And if we are baptized in the fountain of gold and silver, and the spirit of our body ascends to heaven with the father and the son, and descends again, our souls will revive, and my animal body will remain white." The anonymous author of "Liber de arte chymica" (*Art. aurif.*, I, pp. 612f.) speaks in the same way: "It is certain that the earth cannot ascend, except first the heaven descend, for the earth is said to be raised up to heaven, when, dissolved in its own spirit, it is at last united therewith. I will satisfy thee with this parable: The Son of God descending into the Virgin, and there clothed with flesh, is born as man, who having shown us the way of truth for our salvation, suffered and died for us, and after his resurrection returned into heaven, where the earth, that is mankind, is exalted above all the circles of the world, and is placed in the intellectual heaven of the most holy Trinity. In like manner, when I die, my soul, helped by the grace and the merits of Christ, will return to the fount of life whence it descended. The body returns to earth, and at the last judgment of the world the soul, descending from heaven, will carry it with her, purified, to glory."

⁶ The motif of ascent and descent is based partly on the motion of water as a natural phenomenon (clouds, rain, etc.).

⁷ Justin Martyr says: "As a fount of living water from God . . . this Christ gushed forth" (cited in Preuschen, *Antilegomena*, p. 129). Gaudentius (Sermo XIX) compares Christ's humanity to water (Migne, *P.L.*, vol. 20, col. 983). Eucherius of Lyons (*Liber formularum spiritalis intelligentiae*) says that Christ "carried up to heaven the flesh he assumed for us" (ibid., vol. 50, col. 734). This idea coincides with the saying in the "Tab. smarag." that the arcanum "ascends from earth to heaven, and descends again to earth, and receives the power of Above and Below."

⁸ "Spirit" in alchemy means anything volatile, all evaporable substances, oxides, etc., but also, as a projected psychic content, a *corpus mysticum* in the sense of a "subtle body." (Cf. Mead, *The Doctrine of the Subtle Body in Western Tradition*.) It is in this sense that the definition of the lapis as a *spiritus humidus et aereus* should be understood. There are also indications that spirit was understood as "mind," which could be refined by "sublimation."

⁹ Cf. the fate of the "man of light" in Zosimos (*Psychology and Alchemy*, par. 456).

¹⁰ In the oldest sources this mystery is expressed in symbolical terms. But from the 13th cent. on there are more and more texts which reveal the mystical side of the arcanum. One of the best examples is the German treatise *Der Wasserstein der Weysen*, "A Chymical Tract, wherein the Way is Shown, the Materia Named, and the Process Described."

¹ The element of torture, so conspicuous in Zosimos, is not uncommon in alchemical literature. “Slay the mother, cutting off her hands and feet” (“Aenigma” VI, *Art. aurif.*, I, p. 151). Cf. *Turba*, Sermones XVIII, XLVII, LXIX. “Take a man, shave him, and drag him over a stone . . . until his body dies.” “Take a cock, pluck it alive, then put its head in a glass vessel” (“Alleg. sup. lib. Turb.,” *Art. aurif.*, I, pp. 139ff.). In medieval alchemy the torturing of the materia was an allegory of Christ’s passion (cf. *Der Wasserstein der Weysen*, p. 97).

² “The foundation of this art, for whose sake many have perished” (*Turba*, Sermo XV). Zosimos mentions Antimimos, the demon of error (*Alch. grecs*, III, xlix, 9). Olympiodorus quotes the saying of Petasios that lead (prima materia) was so “shameless and bedevilled” that it drove the adepts mad (ibid., II, iv, 43). The devil caused impatience, doubt, and despair during the work (*Mus. herm.*, p. 461). Hoghelande describes how the devil deceived him and his friend with delusions (“De difficult. alchem.,” *Theatr. chem.*, I, 1659, pp. 152ff.). The dangers that threatened the alchemists were obviously psychic. Cf. *infra*, pars. 429ff.

³ *Der wasserstein der Weysen*, pp. 73ff. [For this translation I am indebted to Dr. R. T. Llewellyn.—TRANSLATOR.]

⁴ This term occurs in alchemy, e.g.: “Congeal [the quicksilver] with its mystic body” (“Consilium coniug.,” *Theatr. chem.*, I, 1659, p. 137).

¹ [Philippus Aureolus Theophrastus Bombastus von Hohenheim, known as Paracelsus, born 1493, in Einsiedeln, died Sept. 21, 1541, in Salzburg.—EDITORS.]

² [In *Coll. Works*, Vol. 15.—EDITORS.]

¹ Ed. Strunz, p. 97. [For the translation of the direct quotations from Paracelsus in the text and footnotes of this section I am indebted to Dr. R. T. Llewellyn.—TRANSLATOR.]

² “De caducis,” ed. Huser, I, p. 589.

³ “Therefore Christian knowledge is better than natural knowledge, and a prophet or an apostle better than an astronomer or a physician . . . but I am compelled to add that the sick need a physician not apostles, just as prognostications require an astronomer not a prophet” (“Von Erkantnus des Gestirns,” ed. Sudhoff, XII, pp. 496f.).

⁴ He says in the fourth treatise of *Paramirum primum* (ed. Sudhoff, I, p. 215), speaking of the “ens spirituale” of diseases: “If we are to talk of the *Ens Spirituale*, we admonish you to put aside the style which you call theological. For not everything which is called *Theologia* is holy and also not everything it treats of is holy. And, moreover, not everything is true which the uncomprehending deal with in theology. Now although it is true that theology describes this *Ens* most powerfully, it does not do so under the name and text of our fourth *Pagoyum*. And, in addition, they deny what we are proving. But there is one thing which you must understand from us. namely, that the ability to recognize this *Ens* does not come from Christian belief, for it is a *Pagoyum* to us. It is, however, not contrary to the belief in which we shall depart from this life. Accordingly, you must recognize that in no way are you to understand an *Ens* as being of the spirits, by saying they are all devils, for then you are talking nonsensically and foolishly like the Devil.”

⁵ Cf. “Labyrinthus medicorum,” ed. Sudhoff, XI, pp. 207f.: “And as the Magi from the East found Christ in the star by means of this sign, so is fire found in the flint. Thus are the arts found in nature, and it is easier to see the latter than it was to look for Christ.”

⁶ *De vita longa* (1562), p. 56. In “Caput de morbis somnii” (ed. Sudhoff, IX, p. 360), Paracelsus says of the *lumen naturae*: “Look at Adam and Moses and others. They sought in themselves what was in man and have revealed it and all kabbalistic arts and they knew nothing alien to man neither from the Devil nor from the spirits, but derived their knowledge from the Light of Nature. This they nurtured in themselves . . . it comes from nature which contains its manner of activity within itself. It is active during sleep and hence things must be used when dormant and not awake—sleep is waking for such arts—for things have a spirit which is active for them in sleep. Now it is true that Satan in his wisdom is a Kabbalist and a powerful one. So, too, are these innate spirits in man . . . for it is the Light of Nature which is at work during sleep and is the invisible body and was nevertheless born like the visible and natural body. But there is more to be known than the mere flesh, for from this very innate spirit comes that which is visible . . . the Light of Nature which is man’s mentor dwells in this innate spirit.” Paracelsus also says that though men die, the mentor goes on teaching (*Astronomia magna*, ed. Sudhoff, XII, p. 23; “De podagricis,” ed. Huser, I, p. 566).

⁷ *Occulta philosophia*, p. lxxviii. The *lumen naturae* also plays a considerable role in Meister Eckhart.

⁸ Cf. the fine saying in “Fragmenta medica” (ed. Huser, I, p. 141): “Great is he whose dreams are right, that is, who lives and moves harmoniously in this kabbalistic, innate spirit.”

⁹ “Caput de morbis somnii,” ed. Sudhoff, IX, p. 361.

¹⁰ *Astronomia magna*, ed. Sudhoff, XII, p. 23; also “Lab. med.,” ed. Sudhoff, ch. II. and “De pestilitate,” Tract. I (ed. Huser, I, p. 327). The *astrum* theory had been foreshadowed in the *Occulta philosophia* of Agrippa, to whom Paracelsus was much indebted.

¹¹ *Astronomia magna*, ed. Sudhoff, XII, pp. 36 and 304.

¹² *Paramirum*, pp. 35f.

¹³ “Lab. med.,” ed. Sudhoff, ch. VIII.

¹⁴ “De podagricis,” ed. Huser, I, p. 566.

¹⁵ “De nymphis,” prologue (ed. Sudhoff, XIV, p. 115).

¹⁶ Adam von Bodenstein and Gerard Dorn, for instance.

¹⁷ “De caducis,” ed. Sudhoff, VIII, p. 267.

¹⁸ I used the edition of 1584, “as finally revised by the author.”

¹⁹ He did, however, once remark that he had found the stone which others sought “to their own hurt.” But many other alchemists say the same.

²⁰ [Personal physician to Ferdinand I. Cf. Jung, “Paracelsus the Physician,” pars. 21f.—EDITORS.]

²¹ *Epistolarum medicinalium Conradi Gessneri*, fol. IV.

²²

“I’m left to struggle still towards the light:
Could I but break the spell, all magic spurning,
And clear my path, all sorceries unlearning,
Free then, in Nature’s sight, from evil ban,
I’d know at last the worth of being man.”

(*Faust: Part Two*, trans. Wayne, pp. 263f.) Faust’s belated insight never dawned on Paracelsus.

²³ This expression was in fact used by an insane patient to describe her own neologisms. [See “The Psychology of Dementia Praecox,” pars. 155, 208—EDITORS]

²⁴ He calls this procedure likewise a “pagoyum.” “De pestilitate,” Tract. IV, ch. II (ed. Huser, I, p. 353).

²⁵ For instance, the violent form of St. Vitus’s Dance is cured by “a wax manikin into which oaths are stuck.” “De morbis amentium,” Tract. II, ch. III (ed. Huser, I, p. 501); also *Paramirum*, ch. V.

²⁶ “Archidoxis magicae,” ed. Huser, II, p. 546.

²⁷ *Theatrum chemicum*, III (1659), pp. 758ff. Cf. *Psychology and Alchemy*, pars. 480ff.; *Aurora Consurgens* (ed. von Franz), p. 43: “For [the science] is a gift and sacrament of God and a divine matter.”

²⁸ Cf. *Psychology and Alchemy*, Part III, ch. 5: “The Lapis-Christ Parallel.”

²⁹ He mentions Hermes, Archelaus, Morienus, Lully, Arnaldus, Albertus Magnus, Helia Artista, Rupescissa, and others.

³⁰ *Artis auriferae* (1593), I, p. 185.

³¹ “De natura rerum,” ed. Sudhoff, XI, p. 313.

³² *Das Buch Paragranum*, ed. Strunz, p. 13.

³³ His influence showed itself not so much in any essential modification of alchemical methods as in deepened philosophical speculation. The most important of these philosophical alchemists was the physician Gerard Dorn, of Frankfurt am Main. He wrote a detailed commentary on one of Paracelsus’s rare Latin treatises, *De vita longa*. See *infra*, pars. 213ff.

³⁴ “Nam Planetae Sphaerae et elementa in homine per revolutionem sui Zodiaci verius et virtuosius operantur, quam aliena corpora seu signa superiora corporalia” (For the planets, spheres, and elements in man work more truly and powerfully through the revolution of their zodiac than foreign bodies or the higher bodily signs). *Theatr. chem.*, V (1660), p. 790.

³⁵ “Liber Azoth,” ed. Huser, II, p. 522. The *Cagastrium* is an inferior or “bad” form of the *Yliastrum*. That it is this “cagastic” magic which opens the understanding is worth noting.

³⁶ Hermes is an authority often cited by Paracelsus.

³⁷ Quoted from the version in *Rosarium philosophorum*, vol. II of *De alchimia* (1550), p. 133. Reprinted in *Bibliotheca chemica curiosa*, II, pp. 87ff.

³⁸ The light arises from the darkness of Saturn.

³⁹ Quoted from the version of *Rosarium* in *Art. aurif.*, II, pp. 379 and 381. The original (1550) edition of the *Rosarium* is based on a text that dates back to about the middle of the 15th cent.

⁴⁰ Mylius. *Philosophia reformata*, p. 244. (Mylius was the greatest of the alchemical compilers and gave extracts from numerous ancient texts, mostly without naming the sources.) Significantly, the oldest of the Chinese alchemists, Wei-Po-yang, who lived about A.D. 140, was familiar with this idea. He says: “He who properly cultivates his innate nature will see the yellow light shine forth as it should.” (Lu-ch’iang Wu and T. L. Davis, “An Ancient Chinese Treatise on Alchemy,” p. 262.)

⁴¹ Preisendanz, *Papyri Graecae Magicae*, I, p. 137, Pap. IV, line 2081, concerning the acquisition of a *paredros*.

⁴² Quoted in *Rosarium* (*Art. aurif.*, II, p. 248). Cf. Preisendanz, II, pp. 45-46. line 48: “I know thee, Hermes, and thou knowest me. I am thou and thou art I, and thou shouldst serve me in all things.”

⁴³ *Amphitheatrum sapientiae aeternae*, p. 197: “Hie, filius mundi maioris, Deus et creatura . . . ille (scl. Christus) filius Dei θεάνθρωπος, h. e. Deus et homo: Unus in utero mundi maioris; alter in utero mundi minoris, uterque Virgineo, conceptus. . . . Absque blasphemia dico: Christi crucifixi, salvatoris totius generis humani, i.e., mundi minoris, in Naturae libro, et ceu Speculo, typus est Lapis Philosophorum servator mundi maioris. Ex lapide Christum naturaliter cognoscito et ex Christo lapidem.”

⁴⁴ Mylius (*Phil. ref.*, p. 97) says of the *filius ignis*: “Here lies all our philosophy.”

⁴⁵ *Thus Spake Zarathustra* (trans. Kaufmann), p. 176: “Lonely one, you are going the way to yourself. And your way leads past yourself and your seven devils. . . . You must consume yourself in your own flame; how could you wish to become new unless you had first become ashes! Lonely one, you are going the way of the creator: you would create a god for yourself out of your seven devils.” Cf. “Consilium coniugii,” *Ars chemica*, p. 237: “Our stone slays itself with its own dart”; and the role of the *incineratio* and the phoenix among the alchemists. The devil is the Saturnine form of the *anima mundi*.

⁴⁶ These were known to the alchemists since earliest times. Olympiodorus, for instance, says that in lead (Saturn) there is a shameless demon (the *spiritus mercurii*) who drives men mad. (Berthelot, *Alchimistes grecs*, II, iv, 43.)

⁴⁷ Born in Danzig at the beginning of the 16th cent., studied in Basel.

⁴⁸ *Epistolarum medicinalium Conradi Gessneri*, Lib. I, fol. 2^r.

⁴⁹ This is a recurrent formula in alchemical treatises.

⁵⁰ The *corpus glorificationis* of other authors.

⁵¹ “De religione perpetua,” ed. Sudhoff, Part 2, I, pp. 100f. An equally presumptuous view is expressed in “De podagricis” (ed. Huser, I, p. 565): “Thus man acquires his angelic qualities from heaven and is heavenly. He who knows the angels knows the *astra*, he who knows the *astra* and the *horoscopum* knows the whole world, and knows how to bring together man and the angels.” [This and the above passage in the text are translated by Dr. R. T. Llewellyn.—TRANSLATOR.]

⁵² In Zosimos the “man of light” ($\phi\acute{\omega}\varsigma$ = man, $\phi\tilde{\omega}\varsigma$ = light) is simply called $\phi\tilde{\omega}\varsigma$. He is the spiritual man who has clothed himself in Adam’s body. Christ let Adam approach ($\pi\rho\omicron\sigma\eta\tilde{\nu}$) and accepted him into paradise (Berthelot, *Alch. grecs*, III, xlix, 5-10). Cf. *Psychology and Alchemy*, par. 456.

⁵³ “De arte cabalistica,” *Opera omnia*, I.

⁵⁴ *Occulta philosophia*.

⁵⁵ *Astronomia magna*, ed. Sudhoff, XII, p. 55.

⁵⁶ *Ibid.*, p. 62.

⁵⁷ Ed. Strunz, p. 56; also “Von der Astronomie,” ed. Huser, I, p. 215.

⁵⁸ Strunz, p. 55.

⁵⁹ Pico della Mirandola also uses this term in *Heptaplus*, I, ch. VII (*Opera omnia*, I, p. 59).

⁶⁰ *De vita longa* (ed. Dorn), pp. 169ff. Adech is the “interior man,” presumably identical with Aniadus and Edochinum (see *infra*). Concerning the *homo maximus* see *Paragranum*, pp. 45, 59. Dorn calls Adech the “invisibilem hominem maximum.”

⁶¹ “Von den dreyen ersten essentiis.” ch. IX, ed. Huser, I, p. 325. The idea that the Primordial Man consists of four parts is found also in Gnosticism (Barbelo = “God is four”).

⁶² The Iliastrum (or Iliaster) is something like the *spiritus vitae* or *spiritus mercurialis* of the alchemists. This is the occult agent in quicksilver, which, extracted in the form of the *aqua permanens*, serves, in highly paradoxical fashion, to separate the occult agent, the anima (soul), from the body (or substance). The contradiction is due to the fact that Mercurius is a self-transforming being, represented as a dragon that devours itself from the tail (uroboros = tail-eater), or else as two dragons eating each other. The function of the Iliaster is just as paradoxical: it is itself a created thing, but it brings all creatures out of a potential state of existence in the world of ideas (which is probably the meaning of Paracelsus’s Neoplatonic “Ides”) into actual existence. [See also *infra*, pars. 170ff.]

⁶³ “De tartaro: Fragmenta anatomiae,” ed. Sudhoff. III. p. 462.

⁶⁴ *Ibid.*, p. 465: “He is the first man and the first tree and the first created of everything whatsoever.”

⁶⁵ = “First Thomas,” i.e., the first unbeliever and doubter.

⁶⁶ Bousset, *Hauptprobleme der Gnosis*, pp. 16ff.

¹ Ed. Sudhoff, III.

² Fol. d2^r of the 1st edn. (1562).

³ To give but one example: one passage says that “there is nothing of mortality in the Scaiolae,” while another speaks of the “death and life of the Scaiolae” (infra, pars. 207, 214). Not much reliance should therefore be placed on Bodenstein’s “revision.” As against my view that the *Vita longa* consists of lecture notes, one must consider the fact that there are original fragments written in German (ed. Sudhoff, III, pp. 295ff.). These may be Paracelsus’s drafts for a German version. The date of composition of the *Vita longa* is perhaps 1526. No original MSS. of Paracelsus have been preserved (ibid., pp. xxxiiff.).

⁴ The following discussion makes no attempt to evaluate the treatise as a whole, for which reason I have not considered the *De vita libri tres* of Marsilio Ficino an important contribution in this respect.

⁵ The word *aestphara* in the Latin may be of Arabic origin. Dorn translates it as *corruptio*. Another possible derivation is $\phi\acute{\alpha}\rho\omega$, ‘to render invisible,’ ‘to kill,’ and $\alpha\lambda\sigma\acute{\tau}\acute{o}\omega$, ‘to cleave,’ ‘to dismember.’ Corruption or putrefaction involves decomposition and hence the disappearance of the previous form. “Nihil mehercle vita est aliud, nisi Mummia quaedam Balsamita, conservans mortale corpus a mortalibus vermibus et aestphara, cum impressa liquoris sallium commistura.”

⁶ Ruland, *A Lexicon of Alchemy*, p. 69 (s.v. *Balsamum s. Balsamus*): “It is the liquor of an interior salt most carefully and naturally preserving its body from corruption. . . . In German the term [is] Baldzamen [‘soon together’], i.e., quickly joined [*celeriter coniunctum*: hence a means of promoting the coniunctio, see infra]. External Balsam of the Elements is liquor of external Mercury . . . the firmamental essence of existences, the Quintessence.” Hence *B. internus* is a *liquor Mercurii interni*.

⁷ *Cheyri* is the yellow wallflower [*Cheiranthus cheiri*, incorrectly given as] *Viola petraea lutea* [mountain pansy] in the *Herbal* of Tabernaemontanus; it is abortifacient and restorative. The plant bears four-petalled yellow blossoms. Galen (*De simplicium medicamentorum facultatibus*, Lib. VII) says it has a carminative and warming effect. In Ruland (*Lexicon*, p. 98), *Cheyri Paracelsicum*, as applied to minerals, is quicksilver; *Flos cheiri* is the white elixir of silver, also the essence of gold. “Others say it is potable gold,” hence it is an arcanum subserving the philosophical aim of alchemy. Paracelsus himself alludes to its fourfold nature: “. . . and the Spagyric makes a temperate being out of the four [elements], as the flower Cheiri shows.” “Fragmenta medica,” ed. Sudhoff, III, p. 301.

⁸ “Quod per universam quatuor elementorum anatomiam perdurare in sua conservatione debet” (Lib. IV, ch. I). In the German fragments to the *Vita longa* Paracelsus says: “For Cheiri is more than Venus, Anthos more than Mars.”

⁹ Probably by a process of extraction.

¹⁰ [The following passage is a slight condensation of a note entitled “The Concept of Mercurius in Hermetic Philosophy,” dated Einsiedeln, Oct. 11, 1942, discovered among Jung’s posthumous papers:

“This concept—if one can call it such—not only has a wealth of meanings but appears in variant form as Iliastrum, Iliastes, Iliadus, Yleides, Yleidus, etc. Such an intensification of Paracelsus’s etymological proclivities indicates that a special importance attaches to an idea so variously named. Sometimes the Iliaster is the *principium*, the *prima materia*, the *chaos*, the *prima compositio*, consisting of the three basic substances, Mercurius, sulphur, and salt; sometimes it is the *aer elementalis* or *coelum*, ‘the true spirit in man, which pervades all his limbs’; sometimes the ‘occult virtue of nature, by which all thing[s] increase, are nourished, multiply, and quicken,’ as Ruland, a pupil

of Paracelsus, defines it (*Lexicon*, p. 181); sometimes the *spiritus vitae*, which is none other than *vis Mercurii*. It is thus identical with the Mercurial spirit, which was the central concept of alchemy from the oldest times to its heyday in the seventeenth century. Like the *Mercurius philosophorum*, the Paracelsan Mercurius is a child of Sol and Luna, born with the help of sulphur and salt, the ‘strange son of chaos,’ as Goethe calls Mephistopheles. Paracelsus names it ‘omne fumosum et humidum in quovis corpore,’ the moist, breathlike or vaporous soul dwelling in all bodies. In its highest form the Iliaster signifies the passage of the mind or soul into another world, as took place with Enoch, Elias, and others. (Ruland, *Lexicon*, p. 181. Cf. Ezek. 1 : 13 and Luke 10 : 18.) Not only is it the life-giver, it is the psychopomp in the mystic transformation, leading the way to incorruptibility or immortality. The ‘seed of the Iliastic soul’ is the spirit of God himself, and on it is imprinted ‘God’s likeness.’”—EDITORS.]

¹¹ *Sanctitus* from *sancire*, ‘to make unalterable or inviolable’; *sanctitus* = *affirmatus*, ‘made firm.’ Ruland (*Lexicon*, p. 181): “The first, or implanted [Iliaster] is the span of life.”

¹² Probably derived from *παραιτέομαι*, ‘to obtain by prayer,’ ‘to entreat.’ Ruland: “The second Iliaster, prepared Iliaster.”

¹³ The product of Sol and Luna was represented as a hermaphrodite.

¹⁴ *De vita longa*, Lib. IV, cap. IV: “Eius ultra mille sunt species . . . potius iuxta hoc, ut quilibet microcosmus peculiarem suam, atque adeo perfectam coniunctionem habeat, quilibet, inquam, utrinque perfectam suam ac propriam virtutem” (There are more than a thousand species thereof . . . so that each microcosm may have its own special and even perfect conjunction, each, I say, its own perfect and peculiar virtue).

¹⁵ Lib. IV, cap. VI: “Quod maxime necessarium est in hoc processu erga iliastrium, describamus: Principio ut impurum animatum depuretur citra separationem elementorum, quod fit per tuam ipsius imaginationem, cum ea in animi tui confirmamento consistit, praeter omnem corporalem ac mechanicum laborem.”

¹⁶ Cf. Gen. 5: 23-24: “And all the days of Enoch were three hundred sixty and five years. And Enoch walked with God: and he was not; for God took him.” According to the chronologist Scaliger (*Animadversiones in chronologia Eusebii*) Enoch was responsible for the division of the year. Enoch was also considered a prefiguration of Christ, like Melchisedek. Cf. Pico della Mirandola (“De arte cabalistica,” *Opera omnia*, I, p. 3020): “Denuo Simon ait, pater noster Adam, rursus ex Seth nepotem suscepit, memor eius Cabalae, quam sibi Raziel tradiderat, quod ex sua propagatione nasceretur homo futurus salvator. Quare vocatus est Enos, id est, homo.” (Again Simon says that our father Adam received another grandchild from Seth, having in mind that Cabala which Raziel had handed down to him, that of his seed should be born a man who would be a saviour. Wherefore he was called Enos, that is, Man.)

¹⁷ Lib. IV, ch. VI: “Quare microcosmum in sua interiore anatomia reverberari oportet in supremam usque reverberationem” (Wherefore the microcosm in its interior anatomy must be reverberated up to the highest reverberation). This takes place in the *reverberatorium*, a calcining furnace. “Reverberation is ignition, reducing substances under the influence of a potent fire, and by means of reverberation and repercussion, into a fine calx” (Ruland, p. 276).

¹⁸ The “Tractatus aureus” says (ch. IV): “Burn up the body of the air with very much fire, and it will imbue you with the grace you seek” (*Ars chemica*, p. 24).

¹⁹ Arcs is sometimes masculine, too.

²⁰ From *aqua* and *astrum* = ‘water star.’

- ²¹ Albertus Magnus, “De mineralibus et rebus metallicis” (Borgnet, vol. V, Tract. I, ch. 2).
- ²² Rupescissa in Hoghelande, “De alchemiae difficultatibus,” *Theatr. chem.*, I (1659), p. 172.
- ²³ Mylius. *Phil. ref.*, p. 16.
- ²⁴ *Ibid.*
- ²⁵ Dialogue between Synesios and Dioskoros in Berthelot, *Alch. grecs*, II, iii.
- ²⁶ *Turba Philosophorum* (ed. Ruska), Sermo XIII, p. 122; Hoghelande, in *Theatr. chem.*, I (1659), p. 150. A quotation from Senior.
- ²⁷ Abu’l Qāsim, *Kitāb al-’ilm al-muktasab*, ed. Holmyard, p. 23.
- ²⁸ Dorn, “Physica genesis,” *Theatr. chem.*, I (1659), p. 349. Dorn says further: “Of the centre there is no end, and no pen can rightly describe its power and the infinite abyss of its mysteries.”
- ²⁹ Olympiodorus in Berthelot, *Alch. grecs*, II, iv, 32. The myth of the θεοκατάρακτος is to be found *ibid.*, 52.
- ³⁰ Hoghelande, “De alch. diff.,” p. 159.
- ³¹ *Rosarium philosophorum*, in *Art. aurif.*, II, p. 369.
- ³² “Liber Platonis quartorum,” *Theatr. chem.*, V (1660), p. 118.
- ³³ Scaiolae are something like higher mental functions, comparable psychologically to the archetypes. See *infra*, pars. 206ff.
- ³⁴ “Necrocomic” relating to the sphere of the *necrocomica*, i.e., telepathic phenomena or events indicative of the future. Ruland (*Lexicon*, p. 238) describes them as “signs falling from heaven upon earth.”
- ³⁵ “Liber Azoth,” pp. 521ff.
- ³⁶ Hortulanus, “Commentarius,” *De alchemia*, pp. 363ff.
- ³⁷ *Onomasticon*, pp. 18f.
- ³⁸ Ruland, *Lexicon*, p. 38.
- ³⁹ Arcs = Mars. The reference to the wolf supports this interpretation, for the wolf is the animal of Mars. Johannes Braceschus of Brixen, a contemporary of Paracelsus, states in his “Lignum vitae” (*Bibl. chem.*, I, pp. 911ff.) that the principle of the life-prolonging medicine is Mars, to which he refers the saying of Rhazes: “Accipe petram post ingressum Solis in arietem” (Take the stone after the sun’s entry into Aries). Braceschus continues: “This thing [Mars] is a man whose complexion is choleric. . . . This hot and bilious man is iron . . . it is called a man because it has soul, body, and spirit. . . . That metal, although it is begotten by the virtue of all the stars and planets, is nevertheless especially begotten in the earth by virtue of the most high and mighty Pole Star called the Great Bear.” Mars is also called the Daemogorgon, “ancestor of all the gods of the Gentiles.” “Surrounded on all sides by thick clouds and darkness, he walks in the midmost bowels of the earth, and is there hidden . . . not begotten of any, but eternal and the father of all things.” He is a “shapeless chimaera.” Daemogorgon is explained as the “god of the earth, or a terrible god, and iron.” (For Paracelsus, as we saw, the body purified by the fire was associated with iron, in so far as the residue was “without rust.”) “The ancients attributed to him eternity and chaos for companions: eternity and the prepared quicksilver, which is . . . the eternal liquor.” He is the serpent, the *aqua mercurialis*. “The first son of Daemogorgon was Litigius, that is, the sulphur which is called Mars.” “Chaos is that earthly salt called Saturn; for it is matter and in it everything is without form.” All living and dead things are contained in it, or proceed from it. Daemogorgon, or Mars, thus corresponds to the Ares of Paracelsus. Pernety (*Dictionnaire mytho-hermétique*) defines

“Daimorgon” as the “genius of the earth,” “the fire which quickens nature, and in particular that innate and life-giving spirit of the earth of the sages, which acts throughout the whole course of the operations of the great work.” Pernety also mentions “Demorgon” and a treatise of the same name by Raymund Lully. This treatise is not mentioned in Ferguson’s *Bibliotheca chemica* (1906), but it might be a reference to the “Lignum vitae” of Braceschus, which is a dialogue between Lully and a pupil. Roscher (*Lexicon*, I, col. 987) defines Demogorgon as “an enigmatic god. Might be derived from δημιουργός.” Astrologically. Mars characterizes the instinctual and affective nature of man. The subjugation and transformation of this nature seems to be the theme of the alchemical opus. It is worth noting that Colonna’s *Hypnerotomachia* begins with the wolf as the initiating animal; he also has this significance in Canto I of Dante’s *Inferno*, where he appears in a triad of animals. This lower triad corresponds to the upper Trinity; therefore we meet it again as the tricephalous Satan in Canto XXXIV.

⁴⁰ Bodenstein, *De vita longa*, Lib. I, ch. VII, p. 21.

⁴¹ “Das Buch Meteorum” (ed. Huser), p. 79. In the Book of Enoch 19: 2 the wives of the fallen angels changed into sirens.

⁴² P. 271.

⁴³ Ibid., p. 4; “Philosophia ad Athenienses,” Lib. I, ch. XIII.

⁴⁴ Ed. Huser, II, p. 189.

⁴⁵ “Liber Azoth,” p. 534.

⁴⁶ Ibid., pp. 523, 537.

⁴⁷ P. 542.

⁴⁸ P. 539.

⁴⁹ Pp. 539, 541.

⁵⁰ Crawley, *The Idea of the Soul*, pp. 19 and 237.

⁵¹ P. 178. See *infra*, par. 214.

⁵² As in Reusner’s *Pandora* (1588), Codex Germanicus Alchemicus Vadiensis (St. Gall, 16th cent.), and Codex Rhenoviensis (Zurich, 15th cent). [Cf. Figs. B 3-5.]

[The following (undated) note on *Pandora* was found among Jung’s posthumous papers:

“*Pandora* is one of the earliest synoptic accounts of alchemy, and it may be the first that was written in German. It was first published by Henric Petri in Basel, 1588. It is apparent from the foreword that the author was the physician Hieronymus Reusner, who, however, hides under the pseudonym Franciscus Epimetheus, by whom the book was allegedly ‘made.’ Reusner dedicates it to Dr. Ruland, the well-known compiler of the *Lexicon alchemiae sive Dictionarium alchemisticum* (Frankfurt a. M., 1612). The text of *Pandora* is a compilation in the manner of the *Rosarium philosophorum* (1550), which is copiously cited. But other sources are used besides this, for instance the ‘Tractatus aureus Hermetis.’ Reusner was a pupil of Paracelsus. His book, being written in German, is a contribution to the Germanization of medicine that was started by Paracelsus, and, as the foreword shows, to Paracelsus’s revival of the spiritual trends of alchemy. The actual text remains uninfluenced by these innovations and runs along the traditional lines. It contains nothing that is not found in the earlier authors, though the long list of synonyms at the end deserves special mention. This contains a number of Arabic and quasi-Arabic terms which, it appears, multiplied greatly during the 16th century. But the chief value of *Pandora* lies in the series of eighteen symbolical pictures at

the end of the volume. As usual, they do not explain the text, or only very indirectly, but they are of considerable interest as regards the secret content of alchemy. Some of the pictures date from the 15th century and are taken from the *Dreifaltigkeitsbuch* (Codex Germanicus 598, 1420, Staatsbibliothek, Munich), but most are from the 16th century. The chief source is probably the ‘Alchymistisches Manuscript’ in the Universitätsbibliothek, Basel. One of the pictures (the Echidna symbol of Mercurius) may come from a 16th-century MS. in St. Gall.”—EDITORS.]

⁵³ See *Psychology and Alchemy*, Figs. 224 and 232.

⁵⁴ *Symbola aureae mensae*, p. 380.

⁵⁵ Psalm 129 : 1 (DV): “Out of the depth I have cried to thee, O Lord.”

⁵⁶ Psalm 29: 10 (AV): “The Lord sitteth upon the flood: yea, the Lord sitteth King for ever.”

⁵⁷ Psalm 28 : 3 (DV): “The voice of the Lord is upon the waters; the God of majesty hath thundered; the Lord is upon many waters.”

⁵⁸ *In the sense of θεός ἄνθρωπος.*

⁵⁹ τῆν μονογενῆ μου. This feminine “only-begotten” seems to refer to a daughter, or to the soul, as Psalm 34: 17 (DV) affirms: “Rescue thou my soul from their malice: my only one from the lions.”

⁶⁰ Psalm 21 : 22 (DV): “Save me from the lion’s mouth. . . .”

⁶¹ Hippolytus, *Elenchos*, V, 8. The extreme lowliness of the redeemer’s origin is expressed even more strongly in alchemy: the stone is “cast on the dunghill,” “found in filth,” etc. The “Tractatus Aristotelis” says (*Theatr. chem.*, V, 1660, p. 787): “Lapidem animale esse, qui tanquam serpens ex corruptione perfectissimae naturae humanae de industria inter duos montes emissus gignitur, scinditur et prolabitur, et in fossa cavernae clauditur” (The living stone which is industriously brought forth as a serpent between the two mountains from the corruption of the most perfect human nature, is torn away and slips forth, and is shut up in a hollow cave). σκώληξ in conjunction with ἔξουδένημα, ‘outcast.’ might therefore be interpreted as an intestinal worm.

⁶² From ἀνθεμόνιον, the efflorescence of metallic salts. Cf. Lippmann, *Entstehung und Ausbreitung der Alchemie*, II, p. 40.

⁶³ *Panarium* (ed. Holl), Haer. 36, cap. 4 (II, pp. 47ff).

⁶⁴ *Art. aurif.*, II, p. 329, quotation from Lilius. Cf. The vision of the “man coming up from the midst of the sea” (II Esdras 13 : 25 and 51).

⁶⁵ *Rosarium philosophorum (De alchimia, 1550)*, fol. L3^v.

⁶⁶ *Ars chemica*, p. 21. The “Tractatus aureus” is of Arabic origin, but its content dates back to much older sources. It may have been transmitted by the Harranite school.

⁶⁷ *Bellator ignis* is ambiguous. *Chermes* = arab. *kermes* = ‘purple,’ L. *carmesinus* = Ital. *chermisi*, whence F. *cramoisi*, E. carmine, crimson. Cf. Du Cange, *Glossarium*, s.v. “carmesinus.”

⁶⁸ Rupescissa, *La Vertu et propriété de la quinte essence de toutes choses*, p. 26.

⁶⁹ *De circulo physico quadrato*, pp. 27ff.

⁷⁰ Berthelot, *Alch. grecs*, VI, i, 2.

⁷¹ Ed. von Franz, p. 125.

⁷² *Rosarium novum olympicum*, Pars. I, p. 71. Enoch is the “son of man” (Book of Enoch, in Charles, *Apocrypha and Pseudepigrapha*, II, p. 237).

⁷³ “Nam ut ipsa [Divinitas] incomprehensibilis, invisibilis, non mensurabilis, infinita, indeterminata, et siquid ultra dici potest, omnia similiter in centro quadrare convenireque certum est. Hoc enim quia locum nullum occupat ob quantitatis carentiam, comprehendi non potest, videri nec mensurari. Tum etiam cum ea de causa infinitum sit, et absque terminis, locum non occupat, nec depingi potest, vel imitatione fingi, Nihilominus omnia quae locum etiam non implent ob carentiam corpulentiae, ut sunt spiritus omnes, centro comprehendi possunt, quod utraque sint incomprehensibilia.” (For it is certain that it [the Divinity] is incomprehensible, invisible, immeasurable, infinite, indeterminable, and if aught more may be said, that it squares and brings all things together in a centre. For this, because it occupies no space, since it lacks quantity, cannot be comprehended, seen, or measured. Also because for that reason it is infinite and has no bounds, it occupies no space, nor can it be depicted, nor can any likeness of it be made. Nevertheless all things which likewise fill no place because they lack body, as is the case with all spirits, can be comprehended in the centre, for both are incomprehensible. As therefore there is no end of the centre, no pen can rightly describe its power and the infinite abyss of its mysteries.) (“Physica genesis,” *Theatr. chem.*, I, 1659, pp. 339f.)

⁷⁴ *Ibid.*, p. 349. In “Physica Trismegisti” (*ibid.*, p. 375) Dorn says: “[Sol] primus post Deum pater ac parens omnium vocatus est, cum in eo quorumvis seminaria virtus atque formalis delitescit.” (The Sun is called after God the father and parent of all things, since in him lies hidden the seminal and formal virtue of everything whatever.) P. 376: “Lunam esse matrem et uxorem solis, quae foetum spagiricum a sole conceptum in sua matrice uteroque, vento gestat in aere.” (The moon is the mother and wife of the sun, who bears in her aerial womb the spagyric foetus conceived from the sun.) From this it is evident that the *filius* is begotten of nature gods in a very unchristian manner.

⁷⁵ *Ibid.*, p. 363.

⁷⁶ “Physica Trithemii,” *Theatr. chem.*, I (1659), p. 391

⁷⁷ The sun is the birthplace of the “spiritual fire,” mentioned above. Light-symbols always refer psychologically to consciousness or to a content that is becoming conscious.

⁷⁸ The *aqua pura* is the *aqua permanens* of the Latin and Arabic alchemists and the ὕδωρ θεῖον of the Greeks. It is the *spiritus mercurialis* in water form, which in turn serves to extract the “soul” of the substance. The *spiritus mercurialis* corresponds to the spiritual fire, hence *aqua* = *ignis*. Although these terms are used indiscriminately, they are not the same, since fire is active, spiritual, emotional, close to consciousness, whereas water is passive, material, cool, and of the nature of the unconscious. Both are necessary to the alchemical process since this is concerned with the union of opposites. Cf. *Psychology and Alchemy*, Fig. 4.

⁷⁹ Khunrath (*Von hylealischen Chaos*, p. 203) says that the *ternarius*, purified “by the Circumrotation or Circular Philosophical revolving of the Quaternarius . . . is brought back to the highest and most pure Simplicity . . . of the plusquamperfect Catholic Monad. . . . The impure, crude One becomes an exceeding pure and subtle One, through the manifestation of the occult and the occultation of the manifest.”

⁸⁰ “Physica Trithemii,” p. 391.

⁸¹ Dorn, “Duellum animi cum corpore,” *Theatr. chem.*, I (1659), p. 482. This number symbolism refers to the axiom of Maria: “One becomes Two, Two becomes Three, and out of the Third comes One as the Fourth” (Berthelot, *Alch. greccs*, VI, v, 6). This axiom runs through the whole of alchemy, and is not unconnected with Christian speculations

regarding the Trinity. Cf. my “Psychology and Religion,” p. 60, and “A Psychological Approach to the Dogma of the Trinity,” pp. 164ff.

⁸² Steeb, *Coelum Sephiroticum*, p. 19.

⁸³ *Ibid.*, p. 38.

⁸⁴ p. 42.

⁸⁵ p. 117.

⁸⁶ Ed. Ruska, p. 94. Cf. Codex Berolinensis 532, fol. 154^v: “... the sun-point, that is the germ of the egg, which is in the yolk.”

⁸⁷ *Ars chemica*. The “Consilium coniugii” may date from the 13th cent.

⁸⁸ *Phil. ref.*, p. 131.

⁸⁹ There is only *one* flash of lightning, which changes the darkness of Saturn into the brightness of Jupiter. Ruland (*Lexicon*, p. 153) states: “Metallic fulmination is, with the higher metals, a process of purging. . . . Fulmination is a metallic gradation, with excoction, educing the pure part, the perfection thereof being indicated by an irradiating splendour.”

⁹⁰ The colours refer to the *cauda pavonis*, which appears just before the completion of the opus.

⁹¹ Cf. *infra*, pars. 201f.

⁹² “For from mortal man can nothing be called forth which produces longevity, for longevity is outside the body.” “Fragmenta medica,” ed. Sudhoff, III, p. 291.

⁹³ *Theraniabin* is a favourite arcanum of Paracelsus. It is *pinguedo mannae* (the fat or oil of manna), popularly known as honeydew—a sticky, resinous coating on leaves, with a sweetish taste. This honey, Paracelsus says, falls from the air. Being a heavenly food, it assists sublimation. He also calls it “maydew.” [For a possible connection between ergot-based honeydew and Coleridge’s image in “Kubla Khan,” see Todd, “Coleridge and Paracelsus, Honeydew and LSD.”—EDITORS.]

⁹⁴ *Nostoch* is not, as Bodenstein supposes, a species of fire, but a gelatinous alga that appears after continuous rain. These algae are still known as Nostocs in modern botany. It was earlier supposed that Nostocs fell from the air, or from the stars. (They are also called star jelly and witches’-butter.) Ruland (*Lexicon*, p. 240) defines it as “a ray or radiation of a certain star, or its offscouring, superfluity, etc. cast on earth.” Hence, like *theraniabin*, it is a sublimating arcanum, because it comes from heaven.

⁹⁵ Tabernaemontanus. *Herbal*, s.v. “Melissa.”

⁹⁶ For this reason the coniunctio is depicted as the embrace of two winged beings, as in the *Rosarium*. Cf. *Psychology and Alchemy*, Fig. 268.

⁹⁷ The text is assigned to the 1st cent. A.D. Berthelot, *Alch. grecs*, IV, xx, 8.

⁹⁸ An already legendary (Persian) alchemist of perhaps the 4th cent. B.C.

⁹⁹ I insert in Berthelot’s text the reading of MS. Paris 2250 (καὶ κατώτατον ὥστε), which makes better sense.

¹⁰⁰ The *cauda pavonis* of the Latin alchemists.

¹⁰¹ The nominative plural corresponding to *aniadorum* is presumably *aniada* rather than *aniadi*.

¹⁰² *Lexicon*, p. 30.

¹⁰³ A derivation that would come closest in meaning to the term *Aniadus* would be from ἄνύειν, “to perfect, complete.” The form *Anyadei*, defined by Ruland (*Lexicon*, p. 32) as “eternal spring, the new world, the Paradise to come,” argues in favour of this.

¹⁰⁴ Taurus, the zodiacal sign of May, is the House of Venus. In the Greek-Egyptian zodiac the bull carries the sun-disk, which rests in the sickle moon (the ship of Venus), an image of the coniunctio. (Cf. Budge, *Amulets and Superstitions*, p. 410.) The Taurus sign is composed of the sun-disk with the moon’s horns: ☉. Cf. the alchemical parallel in Dee, “Monas hieroglyphica,” *Theatr. chem.*, II (1659), pp. 200ff.

¹⁰⁵ I have given a literal translation of “nitetque ac splendet flammulae color.” But since Paracelsus was familiar with Agrippa’s *De occulta philosophia*, he may have been referring to, or quoting, a passage from this work. In Book I, ch. XXVII, we read of trees and plants that “are armed with sharp thorns, or burn, prick, or cut the skin by their contact, such as the thistle, nettle, and little flame (*flammula*).” Here *flammula* is the name for various kinds of crowfoot (*ranunculus*), which was used as a corrosive and vesicant and is mentioned as such in Dioscorides (*Medica materia*, p. 295).

¹⁰⁶ Picinellus, *Mundus symbolicus*, s.v. “urtica.”

¹⁰⁷ Anachmus is mentioned along with the Scaiolae; see *infra*, par. 207.

¹⁰⁸ Pomander = *pomambra* = *pomum ambrae*. *Ambra* is a bezoar of the pot-fish or sperm-whale, prized on account of its perfume (ambergris). These and other aromatics were used as “plague balls” to drive away the fetid vapours of sick rooms. *Muscus* is mentioned as an aromatic in Dioscorides (*Medica materia*, p. 42). In Agrippa (*Occult. phil.*, I, p. xxxiv) the aromatics subordinated to Venus include “ladanum, ambra muscus.” In our text “muscus in pomambra” is immediately followed by “laudanum.” According to Dioscorides (*Med. mat.*, p. 106), *ladanum* is the juice of an exotic plant whose leaves “acquire in the spring a certain fattiness . . . out of which is made what is called ladanum.” Tabernaemontanus says this juice is aromatic.

¹⁰⁹ *Laudanum* is the arcane remedy of Paracelsus. It has nothing to do with opium, though it may be derived from the above-mentioned *ladanum*. Adam von Bodenstein (*De vita longa*, p. 98) mentions two *laudanum* recipes of Paracelsus.

- ¹ Confirmation of this may be found in the work of the alchemist and mystic John Pordage (1607–1681), “Ein Philosophisches Send-Schreiben vom Stein der Weissheit,” printed in Roth-Scholtz, *Deutsches Theatrum chemicum*, I, pp. 557-596. For text, see my “Psychology of the Transference,” pars. 507ff.
- ² Condemned to death under Ferdinand I, and executed in Prague, May 2, 1531. See *Psychology and Alchemy*, par. 480 and n.
- ³ “Addam et processum sub forma missae, a Nicolao Cibirnsi, Transilvano, ad Ladislaum Ungariae et Bohemiae regem olim missum,” *Theatr. chem.*, III (1659), pp. 758ff.
- ⁴ “Pharmaco ignito spolianda densi est corporis umbra” (The drug being ignited, the shadow of the dense body is to be stripped away). Maier, *Symbola aureae mensae*, p. 91.
- ⁵ ‘Η φύσις τῆ φύσις τέρπεται, καὶ ἡ φύσις τὴν φύσιν νικᾷ, καὶ ἡ φύσις τὴν φύσιν κρατεῖ Berthelot, *Alch, grecs*, II, i, 3,
- ⁶ Preisendanz, *Papyri Graecae Magicae*, I. p. III.
- ⁷ “Miseros hoc loco mortales, quibus primum ac optimum thesaurum (quam naturae monarchia in se claudit) natura recusavit, puta, naturae lumen,” *De vita longa*, ed. Bodenstein, p. 88.
- ⁸ “Liber Azoth,” p. 534.
- ⁹ “De pestilitate,” Tract. I, ed. Huser, I, p. 334.
- ¹⁰ “Nihil enim aliud mors est, nisi dissolutio quaedam, quae ubi accidit, tum demum moritur corpus. . . . Huic corpori Deus adiunxit aliud quoddam, puta coeleste, id quod in corpore vitae existit. Hoc opus, hic labor est, ne in dissolutionem, quae mortalium est et huic soli adiuncta, erumpat.” (For death is nothing but a kind of dissolution which takes place when the body dies. . . . To this body God has added a certain other thing of a heavenly nature, that of the life which exists in the body. This is the task, this the toil: that it burst not forth at the dissolution which is the lot of mortals, but is joined to this [body] alone.) “Fragmenta,” ed. Sudhoff, III, p. 292.
- ¹¹ “Sequuntur ergo qui vitam aeream vixerunt, quorum alii a 600 annis ad 1000 et 1 too annum pervenerunt, id quod iuxta praescriptum magnalium quae facile deprehenduntur, ad hunc modum accipe: Compara aniadum, idque per solum aera, cuius vis tanta est, ut nihil cum illo commune habeat terminus vitae. Porro si abest iam dictus aer, erumpit extrinsecus id, quod in capsula delitescit. Jam si idem ab illo, quod denuo renovatur fuerit refertum, ac denuo in medium perlatum, scilicet extra id sub quo prius delitescibat, imo adhuc delitescit, iam ut res tranquilla prorsus non audiat a re corporali, et ut solum aniadum adech, denique et edochinum resonet.” Lib. V, cap. III.

Dorn (*De vita longa*, p. 167) comments on this passage as follows:

a) The *imitation of Aniadus* is effected under the influence of “imaginationis, aestimationis vel phantasiae,” which is equivalent to “air” = spirit. By this is obviously meant the kind of active imagination that takes place in yoga or in the spiritual exercises of Ignatius Loyola, who employs the terms *consideratio*, *contemplatio*, *meditatio*, *ponderatio*, and *imaginatio per sensus* for the “realization” of the imagined content. (Cf. *The Spiritual Exercises of St. Ignatius Loyola*, trans. Rickaby, in particular pp. 40ff., the meditation on Hell.) The realization of Aniadus has about the same purpose as the contemplation of the life of Jesus in these exercises, with the difference that in the former case it is the unknown Primordial Man who is assimilated through individual experience, whereas in the later it is the known, historical personality of the Son of Man.

b) The *lack of air* is explained by Dorn as due to the fact that it was “exhausted” by the efforts required for the realization.

c) That which *bursts forth from the heart* is evil, which dwells in the heart. Dorn continues: “Indeed it is constrained under the vehicle under which it still lies hid.” His conjecture of evil and constraint is not supported by the text. On the contrary, Dorn overlooks the preceding *depuratio* as a result of which the operation takes place in an already purified (“calcined”) body. The *reverberatio* and the subsequent subliming processes have already removed the denser elements, including the *nigredo* and evil.

d) As a result of his conjecture Dorn is obliged to read “intranquilla” for “tranquilla.”

e) Dorn here defines Adech as the “imaginary inner man” and Edochinum as Enochdianum.

¹² “Lapidis philosophorum nomina,” MS. 2263-64, Ste. Geneviève, Paris, vol. II, fol. 129, and Pernety, *Fables égyptiennes et grecques*, I, pp. 136ff.

¹³ “Psychology and Religion,” p. 60.

¹⁴ Cf. “A Psychological Approach to the Dogma of the Trinity,” pp. 164ff.

¹⁵ Lib. V, cap. V. Jesahach is not a known Hebrew word.

¹⁶ Concerning the logical aspect of this arrangement see Schopenhauer, “On the Fourfold Root of the Principle of Sufficient Reason.”

¹⁷ Even at that time *phantasia* meant a subjective figment of the mind without objective validity.

^{18, 19} See p. 168.

¹⁸ An image-making, form-giving, creative activity of the mind. For Paracelsus it was the *corpus astrale*, or the creative power of the astral man.

¹⁹ By this is meant “philosophical” thinking.

²⁰ Ruland was a Protestant.

²¹ “Whereby we attain not merely prolonged but eternal life,” adds Ruland. Dorn (*De vita longa*, pp. 176f.) agrees with Ruland’s psychological interpretation.

²² [Sudhoff, XIV, p. 644. This could be translated either as “Ye pious sons, Scaiolae and Anachmi” (nom. pl.) or as “Ye pious sons of Scaiola (gen. fem. sing.) and Anachmus” (gen. masc. sing.). Scaiolae must be fem. and therefore can hardly be in apposition to “filii.” The quotation has been located and checked, and begins: “Now mark well in this my philosophy: I have written a special treatise on the nymphis, pygmaeis, silvestribus, gnomis for the love and delectation of the true Scaiolis (*den waren Scaiolis zuliebe und gefallen*). Therefore, ye pious filii Scaiolae et Anachmi . . .” This may be Jung’s source for the statement that the “Scaioli are lovers of wisdom.” (If Scaiolis is taken as masc. in this context, the nom. sing. would be Scaiolus and the nom. pl. Scaioli.) Cf. *Psychology and Alchemy*, par. 422, n. 50: “Scayolus . . . means the adept.” Neither Scaiolus nor Scaioli can be traced from the *Registerband* to the Sudhoff edn., compiled by Martin Müller (Einsiedeln, 1960).—TRANSLATOR.]

²³ For this reason it is said that the lapis or *filius* contains the four elements or is their quintessence, which can be extracted from them, like Aniadus.

²⁴ “In quo me plurimum offendunt Scaiolae” (Dorn, p. 174).

²⁵ *Ibid.*, p. 177.

²⁶ The following passages from Pico della Mirandola (*Opera omnia*, I, p. 3018), on the Cabalistic interpretation of Adam, may have been known to Paracelsus: “Dixit namque Deus: Ecce Adam sicut unus ex nobis, non ex vobis inquit, sed unus ex nobis. Nam in vobis angelis, numerus est et alteritas. In nobis, id est, Deo, unitas infinita, aeterna, simplicissima et absolutissima. . . . Hinc sane coniiicimus alterum quendam esse Adam coelestem, angelis in coelo demonstratum, unum ex Deo, quem verbo fecerat, et alterum esse Adam terrenum. . . . Iste, unus est cum Deo, hic non modo alter est, verumetiam alius et aliud a Deo. . . . Quod Onkelus . . . sic interpretatur. . . . Ecce Adam fuit unigenitus meus.” (And God said, Lo, Adam is as one of us—he said not “of you,” but “of us.” For in you angels there is number and difference; but in us, that is, in God, there is unity, infinite, eternal, simple, and absolute. . . . Hence we clearly conjecture that there is a certain other heavenly Adam, shown to the angels in heaven, the one from God, whom he made by his word, and the other, earthly Adam. . . . The former is one with God, the latter not only second, but other and separate from God. . . . Which Onkelos thus interprets: Lo, Adam was my only begotten son.)

²⁷ See next note and par. 214.

²⁸ “Porro si pro ratione Necroliorum Scaiolis insereret, esset quod excipiendum ducerem, id quod maximus ille Adech antevertit et propositum nostrum, at non modum deducit: Quod vobis Theoricis discutiendum relinquo” (*De vita longa*, ed. Dorn, pp. 174f). *Necrolii* are the adepts (“Liber Azoth,” p. 524). *Necrolia* or *necrolica* means “medicine conserving life” (*De vita longa*, p. 173).

²⁹ The Monogenes (*filius unigenitus*) is identical with the city, and his limbs with its gates. Cf. Baynes, *A Coptic Gnostic Treatise*, pp. 58 and 89; also *Psychology and Alchemy*, pars. 138f.

¹ From *super* = ‘above,’ and *monere* = ‘inspire,’ hence ‘inspired from above.’

² Not found anywhere else. May be interpreted as the “time of perfection.”

³ A favourite saying of the alchemists, applied to the lapis.

¹ See above.

^{2, 3} See above.

⁴ For a parallel, cf. Enoch 40 : 2, where God has four faces and is surrounded by the four angels of the Face.

⁵ *The Dream of Poliphilo* (ed. Fierz-David), p. 210.

⁶ Grimm, *Teutonic Mythology*, I, p. 434.

⁷ Sacred Books of the East, XXVI, p. 91.

⁸ Baring-Gould, *Curious Myths of the Middle Ages*, pp. 502ff.

⁹ “De rebus gestis Imperatoris Henrici VII,” *Germaniae Historiarum* (ed. Urstisius), II, pp. 63f.

¹⁰ *Paragranum*, p. 105. [Cf. “Paracelsus the Physician,” par. 24.]

¹¹ Fl. 1st cent. A.D.

¹² *Chronographia*, ed. Frick, p. 67.

¹³ Cf. my “Archetypes of the Collective Unconscious” and “Concerning the Archetypes, with Special Reference to the Anima Concept.”

¹⁴ “And so this spirit is extracted and separated from the other spirit, and then the Spagyric has the wine of health.” (“Fragmenta,” ed. Sudhoff, III, p. 305.)

¹⁵ The apparent contradiction between the rejection of the *gesta Melosines* and the assimilation of the anima is due to the fact that the *gesta* occur in a state of anima possession, for which reason they must be prevented. The anima is thereby forced into the inner world, where she functions as the medium between the ego and the unconscious, as does the persona between the ego and the environment.

¹⁶ This recalls the “signs and characters of the planets” in Agrippa, which are imprinted on man at birth as on everything else. But man has, conversely, the faculty of re-approximating himself to the stars: “Potest enim animus noster per imaginationem vel rationem quandam imitatione, ita alicui stellae conformari, ut subito cuiusdam stellae muneribus impleatur. . . . Debemus igitur in quovis opere et rerum applicatione vehementer affectare, imaginari, sperare firmissimeque credere, id enim plurimum erit adiumento . . . animum humanum quando per suas passiones et effectus ad opus aliquod attentissimus fuerit, coniungi ipsum cum stellarum animis, etiam cum intelligentiis: et ita quoque coniunctum causam esse ut mirabilis quaedam virtus operibus ac rebus nostris infundatur, cum quia est in eo rerum omnium apprehensio et potestas, tum quia omnes res habent naturalem obedientiam ad ipsum, et de necessitate efficaciam et movent ad id quod desiderat nimis forti desiderio. Et secundum hoc verificatur artificium characterum, imaginum, incantationum et sermonum, etc. . . . Animus enim noster quando fertur in aliquem magnum excessum alicuius passionis vel virtutis, arripit saepissime ex se ipso horam vel opportunitatem fortiorem, etc. . . . hie est modus per quem invenitur efficacia [operationum].” (For through a certain mental faculty our spirit can thus by imitation be made like to some star, so that it is suddenly filled with the functions of a star. . . . We ought therefore in every work and application of things eagerly to aspire, imagine, hope, and most firmly believe, for that will be a very great help. . . . [*De occult, phil.*, Lib. I, cap. 66.] The human spirit, when through its passions and operations it is highly intent upon any work, should join itself with the spirits of the stars, yea, with their intelligences; and when thus conjoined, be the cause that a certain wonderful virtue is infused into our works and affairs, both because there is in it a grasping of and power over all things, and because all things have a natural and necessarily efficacious obedience to it, and move towards what it desires with an extremely strong desire. And according to this is verified the work of the characters, images, incantations, and words, etc. . . . For when our spirit is moved to any great excess of any passion or virtue, it very often snatches for itself a more effective hour or opportunity, etc. . . . This is the way by which the efficacy [of the operations] is found.) (Lib. I, cap. 67.)

¹⁷ Trans. Foxcroft, pp. 126ff.

¹⁸ The lower triad, corresponding to the upper Trinity, and consisting of the theriomorphic symbols of the three evangelists. The angel as the fourth symbol occupies a special position, which in the Trinity is assigned to the devil. Reversal of moral values: what is evil above is good below, and vice versa.

¹⁹ In the *Golden Ass* of Apuleius the process of redemption begins at the moment when the hero, who has been changed into an ass because of his dissolute life, succeeds in snatching a bunch of roses from the hand of the priest of Isis, and eating them. Roses are the flowers of Venus. The hero is then initiated into the mysteries of Isis, who, as a mother goddess, corresponds to the Mater Gloriosa in *Faust II*. It is of interest to note the analogies between the prayer to the Mater Gloriosa at the end of *Faust* and the prayer to Isis at the end of the *Golden Ass*:

(*Faust II*, trans. Wayne, p. 288)

O contrite hearts, seek with your eyes
The visage of salvation;

Blissful in that gaze, arise
Through glad regeneration.

Now may every pulse of good
Seek to serve before thy face;

Virgin, Queen of Motherhood,
Keep us, Goddess, in thy grace.

(*Golden Ass*)

You are indeed the holy preserver of humankind,
Offering amid the evil chances of the unfortunate the kindly
protection of a mother,
And no smallest moment that passes is devoid of your favours,
But both by land and by sea you care for men, driving off life's
storms and stretching out to them your saving hand; wherewith
you unravel the most tangled webs of fate, and calm the temp
of fortune, and control the varied wanderings of the stars.

Wherefore, poor though I am, I will do what I may as a devotee.

To keep ever hidden in my heart the vision of your divine face at
most holy godhead.

²⁰ Horace, *Epist.* I. x. 24.

²¹ *Musaeum hermeticum*, pp. 73ff. [This sentence has been altered in accordance with the correction given in *Psychology and Alchemy*, 2nd edn., par. 431, n. 11.—TRANSLATOR.]

²² “For before the sapphire existed, there was no arcanum” (*Paragranum*, p. 77). *De vita longa*, ed. Dorn, p. 72: “They are to be referred to the cheyri and the sapphirine flower, i.e., to those two precious stones of the philosophers.” Bodenstein (*Onomasticon*, p. 64): “The sapphirine material: that liquid in which there is no harmful matter.”

²³ *Occult. phil.*, I, cap. 28, p. xxxiv.

²⁴ Carter, *Epitheta Deorum*, s.v. “Venus.”

²⁵ *Ibid.*

²⁶ The hermaphroditic Venus was regarded as typifying the coniunctio of Sulphur and Mercurius. Cf. Pernety, *Fables égyptiennes et grecques*, II, p. 119.

²⁷ Cf. “Psychology and Religion,” p. 60.

²⁸ It could be translated as “you have mentioned not at all.”

²⁹ Lazarello, *Crater Hermetis* (1505), fol. 32^{r-v}. (As in Reitzenstein, *Poimandres*, p. 320.)

¹ I give only a general survey of the Mercurius concept in alchemy and by no means an exhaustive exposition of it. The illustrative material cited should therefore be taken only as examples and makes no claim to completeness. [For the “symposium on Hermes” see the editorial note on p. 191.—EDITORS.]

² [Author’s paraphrase. Cf. “The Spirit in the Bottle,” *Grimm’s Fairy Tales* (trans. Hunt, rev. Stern), pp. 458-62.—EDITORS.]

³ Concerning personification of trees, see Frazer, *The Magic Art*, II, ch. 9. Trees are also the dwelling places of spirits of the dead or are identical with the life of the newborn child (ibid., I, p. 184).

⁴ Cf. the title-page of *Mutus liber*, showing an angel waking the sleeper with a trumpet (“The Psychology of the Transference,” Fig. 11). Also the illustration in Michelspacher’s *Cabala, speculum artis et naturae (Psychology and Alchemy*, Fig. 93). In the foreground, before a mountain upon which is a temple of the initiates, stands a blindfolded man, while further back another man runs after a fox which is disappearing into a hole in the mountain. The “helpful animal” shows the way to the temple. The fox or hare is itself the “evasive” Mercurius as guide (ὁδηγός).

⁵ For additional material on the tree symbol, see infra, “The Philosophical Tree,” Part II.

⁶ This motif was used in the same sense by the Gnostics. Cf. Hippolytus, *Elenchos*, V, 9, 15, where the many-named and thousand-eyed “Word of God” is “hidden in the root of All.”

⁷ *Theatrum chemicum*, IV (1659), p. 500.

⁸ Ibid., p. 478: “(Christ), who is the tree of life both spiritual and bodily.”

⁹ Krueger, *Das Dogma von der Dreieinigheit und Gottmenschheit*, p. 207.

¹⁰ In the “Dicta Belini” Mercurius even says: “Out of me is made the bread from which comes the whole world, and the world is formed from my mercy, and it fails not, because it is the gift of God” (Distinctio XXVIII, in *Theatr. chem.*, V, 1660, p. 87).

¹¹ Cf. the doctrine of the *status iustitiae originalis* and *status naturae integrae*.

¹² Cf. Rev. 20 : 3: “and set a seal upon him.”

¹³ “The Fift is of Concord and of Love, / Betweene your Warkes and the Spheare above.”—Norton’s “Ordinall of Alchimy,” *Theatrum chemicum Britannicum*, ch. 6, p. 92.

¹⁴ *Dialogus miraculorum*, trans. by Scott and Bland, I, pp. 42, 236.

¹ Mercurius, in the form of Lilith or Melusina, appears in the tree in the Ripley Scrowle. To this context belongs also the hamadryad as an interpretation of the so-called “Aenigma Bononiense.” Cf. *Mysterium Coniunctionis*, pp. 68f.

² *In the Shadow of the Bush*, pp. 31f.

¹ “For he that shall end it once for certeyne, / Shall never have neede to begin againe.”—Norton’s “Ordinall of Alchimy,” *Theatr. chem. Brit.*, ch. 4, p. 48.

² Olympiodorus in Berthelot, *Alchimistes grecs*, II, iv, 43.

³ Cf. the entertaining “Dialogus Mercurii alchymistae et naturae,” in *Theatr. chem.*, IV (1659), pp. 449ff.

¹ Von den Steinen, *Unter den Naturvölkern Zentral-Brasiliens*, pp. 352f., 512.

² Cf. Deussen, *Allgemeine Geschichte der Philosophie*, I, Part 3, pp. 336ff. This undoubtedly alchemical philosophy belongs to the fairly late (medieval) *Upa-Puranas*, more particularly to the *Maheshvarapurana*, hence to a doctrine principally concerned with Shiva. “Pāra-da” (bestowing the Other Shore) signifies quicksilver.

- ¹ From ὕδωρ, ‘water,’ and ἄργυρος, ‘silver.’
- ² E.g., Hoghelande, “De alchemiae difficultatibus,” *Theatr. chem.*, I (1659), p. 161.
- ³ “Aquarium sapientum,” *Musaeum hermeticum*, pp. 84, 93.
- ⁴ *Ibid.*, p. 84. Hence also *lac virginis*, *nivis*, *terra alba foliata*, *magnesia*, etc.
- ⁵ Hoghelande, p. 161.
- ⁶ Mylius, *Philosophia reformata*, p. 176.
- ⁷ “Novum lumen,” *Mus. herm.*, p. 581; “Tractatus aureus,” *ibid.*, p. 34; “Gloria mundi,” *ibid.*, p. 250; Khunrath, *Von hylealischen Chaos*, p. 214.
- ⁸ *Rosarium philosophorum*, in *Artis auriferae*, II, p. 376.
- ⁹ “Tractatus aureus,” *Mus. herm.*, p. 39.
- ¹⁰ Mylius, *Phil. ref.*, p. 31.
- ¹¹ “Gloria mundi,” p. 244.
- ¹² *Aurora consurgens* II, in *Art. aurif.*, I, p. 189. This text remarks that the water is fire (p. 212).
- ¹³ Berthelot, *Alch. grecs*, IV, vii, 2.
- ¹⁴ Basilus Valentinus, “Practica,” *Mus. herm.*, p. 404.
- ¹⁵ Philaletha, “Metallorum metamorphosis,” *ibid.*, p. 771, and “Introitus apertus,” *ibid.*, p. 654.

- ¹ *Aurora consurgens* II, in *Art. aurif.*, I, p. 212; Dorn, “Congeries Paracelsicae,” *Theatr. chem.*, I (1659), p. 502; Mylius, *Phil. ref.*, p. 245.
- ² “Via veritatis,” *Mus. herm.*, p. 200.
- ³ “Tractatus aureus,” *ibid.*, p. 39.
- ⁴ “Aquarium sapientum,” *ibid.*, p. 91.
- ⁵ *Ibid.*, p. 90.
- ⁶ “There is no fire in all the work save Mercurius” (“Fons chymicae veritatis,” *ibid.*, p. 803).
- ⁷ “Metall. metamorph.,” *ibid.*, p. 766.
- ⁸ “At the Pole is the heart of Mercurius, which is the true fire, in which is the resting place of his Lord, sailing through this great sea” (“Introit. apert.,” *Mus. herm.*, p. 655). A somewhat obscure symbolism!
- ⁹ “Aquarium sap.,” *ibid.*, p. 84.
- ¹⁰ This is a purely psychological explanation having to do with human conceptions and statements and not with the unfathomable Being.
- ¹¹ Figulus, *Rosarium novum olympicum*, Pars I, p. 71. This is the “domus ignis idem Enoch.” Cf. “Paracelsus as a Spiritual Phenomenon,” *supra*, par. 186.
- ¹² “Ignis infernalis secretus . . . mundi miraculum, virtutum superiorum in inferioribus systema” (“Introit. apert.,” p. 654).
- ¹³ “Ignis in quo Deus ipse ardet amore divino” (“Gloria mundi,” p. 246).
- ¹⁴ “For it is he who overcomes the fire, and is himself not overcome by the fire, but rests in it as a friend, rejoicing in it” (Geber, “Summa perfectionis,” *De alchemia*, cap. LXIII, p. 139).

- ¹ This characteristic of Mercurius is stressed in *Aurora consurgens* II, in *Art. aurif.*, I, pp. 146 and 190: “He makes the nostrils [of the foetus] in the fifth month.”
- ² *Rosarium*, pp. 252, 271.
- ³ *Theatrum chemicum*, I (1659), p. 169.
- ⁴ 16th cent. British Museum, MS. Add. 10302.
- ⁵ Ripley, *Opera*, p. 35.
- ⁶ “Tractatus aureus,” *Mus. herm.*, p. 39.
- ⁷ *Rosarium*, p. 282.
- ⁸ Basilius Valentinus, “Practica,” *Mus. herm.*, p. 404.
- ⁹ “Introit. apert.,” *ibid.*, p. 654.
- ¹⁰ *Rosarium*, p. 252.
- ¹¹ *Theatr. chem.*, I (1659), p. 600.
- ¹² P. 183.
- ¹³ P. 19.
- ¹⁴ P. 308.
- ¹⁵ “Tractatus aureus,” *Mus. herm.*, p. 39.
- ¹⁶ Mylius, *Phil. ref.*, p. 308: “(Mercurius est) spiritus et anima corporis.” The same in Ventura, *Theatr. chem.*, II (1659), p. 282, and in “Tractatus Micreris,” *ibid.*, V (1660), p. 92.
- ¹⁷ Aegidius de Vadis, *ibid.*, II (1659), p. 106.
- ¹⁸ Philaletha, “Metall. metamorph.,” *Mus. herm.*, p. 766.
- ¹⁹ Abraham Eleazar, *Uraltes Chymisches Werck*, pp. 29ff. “Phyton is the life of all things,” p. 34.
- ²⁰ Happelius, “Aphorismi Basiliani,” *Theatr. chem.*, IV (1659), p. 327.
- ²¹ *Verus Hermes* (1620).
- ²² “Aquarium sap.,” *Mus. herm.*, p. 85.
- ²³ Steeb, *Coelum Sephiroticum*, p. 33.
- ²⁴ *Ibid.*, p. 39.
- ²⁵ Happelius, *loc. cit.*
- ²⁶ For instance, Djābir in Berthelot, *Chimie au moyen âge*, III, p. 169; *Rosarium*, in *Art. aurif.*, II, p. 339; Hoghelande, *Theatr. chem.*, I (1602), pp. 153, 183.
- ²⁷ *Theatr. chem.*, I (1659), p. 419. The same in Ripley, “Axiomata,” *ibid.*, II (1659), p. 123.
- ²⁸ “Tractatus aureus,” *Mus. herm.*, p. 11. Here cited from Valentinus.
- ²⁹ Steeb, *Coelum Sephiroticum*, p. 137.
- ³⁰ *Theatr. chem.*, II (1659), p. 231.
- ³¹ *Ibid.*, V (1660), p. 129.
- ³² Berthelot, *Alch. grecs*, III, vi, 5.
- ³³ *Ibid.*, III, xxviii, 5.

³⁴ Ibid., IV, vii, 2.

³⁵ Ibid., I, xiii, 3. [Cf. supra, “The Visions of Zosimos,” pars. 97ff.]

³⁶ Berthelot, *Moyen âge*, III, p 63.

- ¹ *Theatr. chem.*, I (1659), p. 470.
- ² Aegidius de Vadis, *ibid.*, II (1659), p. 105.
- ³ “Aquarium sap.,” *Mus. herm.*, p. 84; Trevisanus, in *Theatr. chem.*, I (1659), p. 695; Mylius, *Phil. ref.*, p. 176.
- ⁴ “Aurelia occulta,” *Theatr. chem.*, IV (1659), p. 506.
- ⁵ “Brevis manuctio,” *Mus. herm.*, p. 788.
- ⁶ Valentinus, “Practica,” *ibid.*, p. 425.
- ⁷ Mylius, *Phil. ref.*, p. 18; “Exercitationes in Turbam,” *Art. aurif.*, I, pp. 159, 161.
- ⁸ Dorn, in *Theatr. chem.*, I (1659), p. 420.
- ⁹ “Aquarium sap.,” *Mus. herm.*, p. 111. [Cf. *infra*, par. 384. n. 5.]
- ¹⁰ “Summariium philosophicum,” *ibid.*, pp. 172f.
- ¹¹ Cf. the snake vision of Ignatius Loyola and the polyophtalmia motif discussed in “On the Nature of the Psyche,” pp. 198f.
- ¹² “Tractatus aureus,” *Mus. herm.*, p. 25.
- ¹³ “Consilium coniugii,” *Ars chemica* (1566), p. 59.
- ¹⁴ *Rosarium*, in *Art. aurif.*, II, p. 208.
- ¹⁵ Khunrath, *Hyl. Chaos*, p. 218.
- ¹⁶ *Theatr. chem.*, IV (1659), pp. 501ff.
- ¹⁷ I read *vi* instead of *vim*.
- ¹⁸ This paradox recalls the Indian *asat* (non-existing). Cf. Chhāndogya Upanishad, VI, ii, 1 (Sacred Books of the East, II, p. 93).
- ¹⁹ *Art. aurif.*, II, pp. 239, 249.
- ²⁰ “Introit. apert.,” *Mus. herm.*, p. 653.
- ²¹ “Gloria mundi,” *ibid.*, p. 250.
- ²² *Aurora consurgens* I, Parable VII.
- ²³ Ruland, *Lexicon alchemiae*, p. 47.
- ²⁴ *Theatr. chem.*, I (1659), p. 510.
- ²⁵ *Hyl. Chaos*, p. 62.
- ²⁶ *Phil. ref.*, p. 19.
- ²⁷ Happelius in *Theatr. chem.*, IV (1659), p. 327.
- ²⁸ *Phil. ref.*, p. 5.
- ²⁹ *La Vertu et propriété de la quinte essence*, p. 15. The “metal of the philosophers” will become like “heaven,” says the “Tractatus Micreris,” *Theatr. chem.*, V (1660), p. 100.
- ³⁰ Khunrath, *Hyl. Chaos*, p. 195.
- ³¹ Manget, *Bibliotheca chemica*, I, p. 478b.
- ³² IV Ezra 13 : 25-53. Cf. Charles, *Apocrypha and Pseudepigrapha*, II, pp. 618f.
- ³³ In *Aureum vellus* (1598), Tract 3: *Splendor Solis* (1920 facsimile), p. 23, PI. VIII.

- ³⁴ Ruland, *Lexicon alchemiae*, p. 47.
- ³⁵ John Dee in *Theatr. chem.*, II (1659), p. 195; *Rosarium*, in *Art. aurif.*, II, p. 309.
- ³⁶ Eleazar, *Uraltes Chymisches Werck*, p. 51. Adam Kadmon is the Primordial Man; cf. *Mysterium Coniunctionis*, ch. V.
- ³⁷ “Paracelsus as a Spiritual Phenomenon,” supra, pars. 165ff., and *Psychology and Alchemy*, index, s.v.
- ³⁸ Gayomart also is a kind of vegetation numen like Mercurius, and like him fertilizes his mother, the earth. At the place where his life came to an end the earth turned to gold, and where his limbs disintegrated various metals appeared. Cf. Christensen, *Les Types du premier homme et du premier roi dans l’histoire légendaire des Iraniens*, pp. 26, 29.
- ³⁹ *Senex draco* in Valentinus, “Practica,” *Mus. herm.*, p. 425. In *Verus Hermes* (1620), pp. 15, 16, Mercurius is also designated with the Gnostic name “Father-Mother.”
- ⁴⁰ “De arte chimica,” *Art. aurif.*, I, p. 581. *Regius puellus* in “Introit. apert.,” *Mus. herm.*, pp. 678, 655.
- ⁴¹ *Art. aurif.*, I, p. 310. Here it is the stone identical with Mercurius that is so called. The context disallows the reading “anni.” The passage which follows soon after, “nascitur in duobus montibus,” refers to the “Tractatus Aristotelis” (*Theatr. chem.*, V, 1660, pp. 787ff.), where the act of defecation is described. (Cf. supra, “Paracelsus as a Spiritual Phenomenon,” par. 182, n. 61.) Corresponding illustrations for *Aurora consurgens* may be found in the Codex Rhenoviensis.
- ⁴² Ch. XXVIII. Cf. Reitzenstein and Schaeder, *Studien zum antiken Synkretismus aus Iran und Griechenland*, p. 119.

- ¹ *Rosarium*, in *Art. aurif.*, II, p. 253.
- ² Berthelot, *Alch. grecs*, III, vi, 18: “The unity of the composition [produces] the indivisible triad, and thus an undivided triad composed of separate elements creates the cosmos, through the forethought [*προνοία*] of the First Author, the cause and demiurge of creation; wherefore he is called Trismegistos, having beheld triadically that which is created and that which creates.”
- ³ *Epigrammata*, V, 24.
- ⁴ Reinach, *Cultes, mythes et religions*, III, pp. 160f.
- ⁵ Schweitzer, *Herakles*, pp. 84ff.
- ⁶ *De natura deorum*, 3, 21, 53.
- ⁷ There is also a *Zeus triops*.
- ⁸ Roscher, *Lexicon*, V, col. 1208.
- ⁹ *Hyl. Chaos*, pp. 6 and 199.
- ¹⁰ *Ibid.*, p. 203.
- ¹¹ *Phil. ref.*, p. 96.
- ¹² This peculiar designation refers to the demiurge, the saturnine Ialdabaoth, who was connected with the “God of the Jews.”
- ¹³ *Mus. herm.*, p. 112.
- ¹⁴ *Theatr. chem.*, IV (1659), p. 507.
- ¹⁵ *Ibid.*, p. 614.
- ¹⁶ *Ibid.*, p. 615.
- ¹⁷ Pp. 198f.
- ¹⁸ Cf. *Rosarium*, in *Art. aurif.*, II, p. 248: “filius . . . coloris coelici” (cited from Haly’s “Secretum”); Khunrath, *Hyl. Chaos*, passim: “filius macrocosmi,” p. 59: “unigenitus”; Penotus in *Theatr. chem.*, I (1659), p. 601: “filius hominis, fructus virginis.”
- ¹⁹ *De daemonibus* (trans. Marsilio Ficino), fol. N. Vv.
- ²⁰ Cf. the report on the Bogomils in Euthymios Zigabenos, “Panoplia dogmatica” (Migne, *P.G.*, vol. 130, cols. 129ff.).
- ²¹ The duality of the sonship appears to date back to the Ebionites in Epiphanius: “Two, they assert, were raised up by God, the one (is) Christ, the other the devil” (*Panarium*, XXX, 16, 2).
- ²² *Art. aurif.*, I, p. 151. *The same is said of God in the Contes del Graal of Chrétien de Troyes:*

“Ce doint icil glorieus pere

Qui de sa fille fist sa mere.”

(Hilka; *Der Percevalroman*, p. 372.)

²³ *Art. aurif.*, II, p. 339.

²⁴ Schweitzer, *Herakles*, p. 84.

²⁵ Chwolsohn, *Die Ssabier und der Ssabismus*, II, p. 367.

- ¹ Maier, *Circulus physicus quadratus*, pp. 15ff.
- ² *Theatr. chem.*, IV (1659), pp. 198ff.
- ³ “Nouveaux documents pour l’étude de la religion des Harraniens,” p. 341.
- ⁴ *Theatr. chem.*, V (1660), pp. 101ff.
- ⁵ Berthelot, *Alch. grecs*, Introduction, p. 236.
- ⁶ *Theatr. chem.*, IV (1659), p. 510. [Supra, par. 106.] He corresponds to the *stella semptemplex* which appears at the end of the work. “... cook, until the sevenfold star appears, running about through the sphere” (ibid., p. 508). Cf. the early Christian idea of Christ as the leader of the “round dance” of the stars. (“Transformation Symbolism in the Mass,” pp. 273ff.)
- ⁷ “Tabula smaragdina,” *Rosarium*, in *Art. aurif.*, II, p. 253, and Mylius. *Phil. ref.*, p. 101.
- ⁸ “Allegoriae super librum Turbae,” *Art. aurif.*, I, p. 155: “origo Solis”; Ventura, *Theatr. chem.*, II (1659), p. 296: “The sun rises together with the moon in the belly of Mercurius.”
- ⁹ Wei Po-yang, “An Ancient Chinese Treatise,” p. 241.
- ¹⁰ “Epistola ad Hermannum,” *Theatr. chem.*, V (1660), p. 800; “Gloria mundi,” *Mus. herm.*, pp. 224, 244. As the arcane substance magnesia he is called the “full moon” (*Rosarium*, in *Art. aurif.*, II, p. 231) and *succus lunariae* (p. 211). He has fallen down from the moon (Berthelot, *Alch. grecs*, III, vi, 9). The sign for Mercurius is ☿ in the “Book of Krates” (Berthelot, *Moyen âge*, III, p. 48). In the Greek Magic Papyri, Hermes is invoked as “circle of the moon” (Preisendanz, *Papyri Graecae Magicae*, I, p. 195).
- ¹¹ Vision of Krates in Berthelot, *Moyen âge*, III, p. 63. As Adam with Venus in the bath, Valentinus, “Practica,” *Mus. herm.*, p. 425 (cf. *Mysterium Coniunctionis*, pp. 303, 383). As *Sal Veneris*, green and red lion (= Venus), Khunrath, *Hyl. Chaos*, pp. 91, 104. The substance of Mercurius consists of Venus (Mylius, *Phil. ref.*, p. 17). Since his mother Venus is the *matrix corrupta*, Mercurius as her son is the *puer leprosus* (“Rosinus ad Sarratantam,” *Art. aurif.*, I, p. 318). In the Magic Papyri. the day of Aphrodite is associated with Hermes (Preisendanz, *Pap. Graec. Mag.*, II, p. 120). In Al-’Irāqī the attributes of Venus are identical with those of Mercurius: sister, bride, air, green, green lion, phoenix (Holmyard, p. 420).
- ¹² “Aurelia occulta,” *Theatr. chem.*, IV (1659), p. 480.
- ¹³ Ed. Ruska, p. 204.
- ¹⁴ *Art. aurif.*, II, p. 379. The same in Dorn, *Theatr. chem.*, I (1659), pp. 560f.
- ¹⁵ Cited in Mylius, *Phil. ref.*, p. 302.
- ¹⁶ *Hyl. Chaos*, p. 197.
- ¹⁷ “Aenigma philosophorum,” *Theatr. chem.*, IV (1659), pp. 458ff.
- ¹⁸ *Hyl. Chaos*, p. 195.
- ¹⁹ “Rhasis Epist.” in Maier, *Symb. aur. mens.*, p. 211. Like Saturn, Mercurius combines all metals in himself (ibid., p. 531).
- ²⁰ Mylius, *Phil. ref.*, p. 305. “Saturn’s Chyld” in Ripley’s “Medulla” (*Theatr. chem. Brit.*, p. 391).
- ²¹ Pantheus, *Ars transmut. metall.*, fol. 9f.
- ²² Ripley, *Opera*, p. 317.

- ²³ Hippolytus, *Elenchos*, V, 16, 2.
- ²⁴ “Liber Platonis quartorum,” *Theatr. chem.*, V (1660), pp. 127, 136.
- ²⁵ Preller, *Griechische Mythologie*, I, p. 43.
- ²⁶ *Hyl. Chaos*, p. 93.
- ²⁷ Cf. Christ as lion in the *Ancoratus* of Epiphanius and as lion cub in St. Gregory, *In Septem Psalm. Penit.*, Ps. 5 : 10 (Migne. *P.L.*, vol. 79, col. 609).
- ²⁸ *Hyl. Chaos*, p. 195.
- ²⁹ Bousset, *Hauptprobleme der Gnosis*, pp. 10, 321, 352.
- ³⁰ For Saturn’s day as the last day of creation, see *infra*, par. 301.
- ³¹ Codex Parisiensis 2419, fol. 277^r. Cited in Reitzenstein, *Poimandres*, p. 75.
- ³² *Phil. ref.*, p. 18.
- ³³ Sulphur is the “fire hidden in Mercurius” (Trevisanus in *Theatr. chem.*, I, 1659, p. 700). He is identical with Mercurius: “Sulphur is mercurial and Mercurius is sulphureal” (“Brevis manuductio,” *Mus. herm.*, p. 788).
- ³⁴ *Hyl. Chaos*, p. 186. Therefore, he says, we should pray to God for the spirit of discretion, that it may teach us the distinction between good and evil.
- ³⁵ It is conceivable that the curious name for the alchemists in Rupescissa’s *La Vertu et propriété de la quinte essence*, “les pources hommes evangelisans,” goes back to the Cathar *perfecti* and *pauperes Christi*. Rupescissa (Jean de Roque-taillade) lived about the middle of the 14th cent. He was a critic of the Church and the clergy (Ferguson, *Bibliotheca chemica*, II, p. 305). The Cathar trials lasted into the middle of the 14th cent.

- ¹ *Symb. aur. mens.*, p. 592. [Cf. *Mysterium Coniunctionis*, pars. 276ff.]
- ² *Ibid.*, p. 600.
- ³ Dorn, in *Theatr. chem.*, I (1659), p. 547.
- ⁴ Khunrath, *Hyl. Chaos*, p. 233.
- ⁵ Ripley, in *Theatr. chem.*, II (1659), p. 113.
- ⁶ *Mus. herm.*, p. 738.
- ⁷ *Symb. aur. mens.*, p. 386.
- ⁸ *Theatr. chem.*, IV (1659), p. 673.
- ⁹ Also in the form of the boy showing the way and the “age-old son of the mother.”
- ¹⁰ Ripley, *Opera*, pp. 421ff.
- ¹¹ “Introit. apert.,” *Mus. herm.*, p. 653.
- ¹² *Theatr. chem.*, II (1659), facing p. 109.
- ¹³ P. 67.
- ¹⁴ E.g., Codex Rhenoviensis, Zurich, and Codex Vossianus, Leyden.
- ¹⁵ For this motif see *Symbols of Transformation*, pp. 209f.
- ¹⁶ *Alchemische Lehrschriften und Märchen bei den Arabern*, pp. 77f.
- ¹⁷ Belletête, trans., *Contes tures*.
- ¹⁸ *κνανοειδῆ* or *κνανοειδῆ*. Hippolytus, *Elenchos*, V, 20, 6 and 7 (ed. Wendland) has the latter reading. The alchemical equivalents of this strange mythologem support both possibilities: Dog as Logos, psychopomp, and *filiius canis coelici coloris* (puppy of celestial hue), all referring to Mercurius. [Cf. *Mysterium Coniunctionis*, pars. 174ff.]
- ¹⁹ *Elenchos*, V, 7, 29.
- ²⁰ The duality of the Mercurius concept has a parallel in the syncretist views of the Naassenes, who sought to grasp and express the psychological experience of the paradoxical First Cause. But I must be content with this hint.
- ²¹ Bousset, *Hauptprobleme der Gnosis*, pp. 43, 55, 142.
- ²² *Rosarium*, in *Art. aurif.*, II, p. 243.
- ²³ “Beginnings and ends/Touch hands.”
- ²⁴ *Theatr. chem.*, I (1659), p. 601.
- ²⁵ “Tractatus aureus cum scholiis,” *ibid.*, IV, p. 608.
- ²⁶ “Aurelia occulta,” *ibid.*, p. 507.
- ²⁷ *Ibid.*, p. 489.
- ²⁸ [This paragraph originally ended the monograph.—EDITORS.]

- ¹ “Tract. aur. cum scholiis,” *Theatr. chem.*, IV (1659), p. 608.
- ² Mylius, *Phil. ref.*, p. 179; “Tract. aureus,” *Mus. herm.*, p. 25; Trevisanus in *Theatr. chem.*, I (1659), p. 695.
- ³ “Exercit. in Turb.,” *Art. aurif.*, I, p. 154.
- ⁴ *Rosarium*, *ibid.*, II, p. 231.
- ⁵ Ventura, in *Theatr. chem.*, II (1659), p. 232: “lapis benedictus”; Dorn, in *Theatr. chem.*, I (1659), p. 510: “fiery and perfect Mercurius”; p. 520: “The Adamic stone is made out of the Adamic Mercurius in the woman Eve”; Lully, *Codicillus*, pp. 880f.: “The good that is sought is our stone and Mercurius.”
- ⁶ “Tract. aur. cum scholiis,” *Theatr. chem.*, IV (1659), p. 608.
- ⁷ “Exercit. in Turb.,” *Art. aurif.*, I, p. 170; Ripley, *Chymische Schrifften*, p. 31; “Tract. aur. cum scholiis,” p. 610: “A mediator making peace between enemies.”
- ⁸ “Aquarium sap.,” *Mus. herm.*, p. 111.
- ⁹ *Ibid.*, p. 118.
- ¹⁰ Khunrath, *Hyl. Chaos*, p. 59.
- ¹¹ “Septem Tract. hermet.,” *Ars chemica*, p. 22. *Rosarium*, p. 381: “I illumine the air with my light and warm the earth with my heat, I bring forth and nourish the things of nature, plants and stones, and with my power I take away the darkness of night, and cause day to endure in the world, and I lighten all lights with my light, even those in which there is no splendour nor greatness. For all these arc of my work, when I put upon me my garments; and those who seek me, let them make peace between me and my bride.” This is cited from the “Dicta Belini” (printed in Manget’s *Bibl. chem.*, I, p. 478). There are variations in the text. I have quoted the passage in full because of its psychological interest.
- ¹² “For in the Stone arc body, soul, and spirit, and yet it is one stone” (“Exercit. in Turb.,” *Art. aurif.*, I, p. 170).
- ¹³ Cf. *Psychology and Alchemy*, par. 26.

¹ Hence the designation of Mercurius as *mare nostrum*.

² Cf. Maitrayana-Brāhmana Upanishad, V, 8 (Sacred Books of the East, vol. 15, p. 311). He occurs as the *spiritus vegetativus* and collective soul in the Vedānta-Sūtras (ibid., vol. 34, p. 173, and vol. 48, p. 578).

³ The treatise of Rosinus (Zosimos) is probably of Arabic origin. “Malus” might be a corruption of “Magus.” The *Fihrist* of Ibn al-Nadīm (A.D. 987) lists, along with writings of Rimas (Zosimos), two works by Magus one of which is entitled “The Book of the Wise Magus (?) on the Art” (Ruska, *Turba*, p. 272).

⁴ *Art. aurif.*, I, p. 310.

⁵ Cf. “The Phenomenology of the Spirit in Fairytales,” pp. 231ff.

⁶ [Cf. *Psychology and Alchemy*, ch. 5, “The Lapis-Christ Parallel,” and *Aion*, ch. 5, “Christ, a Symbol of the Self.”—EDITORS.]

⁷ *The Spiritual Exercises* (trans. Rickaby), pp. 75ff.

⁸ [From *L. mephitis*, a noxious exhalation from the earth.—TRANSLATOR.]

⁹ Evidence for this is the widespread motif of the two hostile brothers.

¹⁰ Cf. the saying of Ostanēs concerning the stone that has a spirit.

¹¹ “For the knowledge of the creature, in comparison with the knowledge of the Creator, is but a twilight; and so it dawns and breaks into morning when the creature is drawn to the love and praise of the Creator. Nor is it ever darkened, save when the Creator is abandoned by the love of the creature.”—*The City of God*, XI, vii.

¹² Brihadāranyaka Upanishad, IV, 3, 6 (cf. Hume, *The Thirteen Principal Upanishads*, p. 133).

¹³ “And when it [the creature’s knowledge] comes to the knowledge of itself, that is one day” (Et hoc cum facit in cognitione sui ipsius, dies unus est).—*The City of God*, XI, vii. This may be the source for the strange designation of the lapis as “filius unius diei.” [Cf. *Mysterium Coniunctionis*, pp. 335, 504.]

¹⁴ “Since no knowledge is better than that by which man knows himself, let us examine our thoughts, words, and deeds. For what does it avail us if we are to investigate carefully and understand rightly the nature of all things, yet do not understand ourselves?”—*Liber de Spiritu et Anima*, LI (Migne, *P.L.*, vol. 40, cols. 816-17). This book is a very much later treatise falsely attributed to Augustine.

¹⁵ “Wherefore the knowledge of the creature, which is in itself evening knowledge, was in God morning knowledge; for the creature is more plainly seen in God than it is seen in itself.”—*Dialogus Quaestionum LXV*, Quaest. XXVI (Migne, *P.L.*, vol. 40, col. 741).

¹⁶ The *Liber de Spiritu et Anima* attributes very great importance to self-knowledge, as being an essential condition for union with God. “There are some who seek God through outward things, forsaking that which is in them, and in them is God. Let us therefore return to ourselves, that we may ascend to ourselves. . . . At first we ascend to ourselves from these outward and inferior things. Secondly, we ascend to the high heart. . . . In the third ascent we ascend to God” (chs. LI–LII; Migne, *P.L.*, vol. 40, col. 817). The “high heart” (*cor altum*; also “deep heart”) is the mandala divided into four, the *imago Dei*, or self. The *Liber de Spiritu et Anima* is in the mainstream of Augustinian tradition. Augustine himself says (*De vera religione LXXII*, Migne, *P.L.*, vol. 34, col. 154): “Go not outside, return into yourself; truth dwells in the inner man. And if you find that you are by nature changeable, transcend yourself. But remember that when you transcend yourself, you must transcend yourself as a reasoning soul.”

¹⁷ “Evening descends when the sun sets. Now the sun has set for man, that is to say, that light of justice which is the presence of God.”—*Enarrationes in Ps. XXIX*, II, 16 (trans. Hobgin and Corrigan, I, p. 308). These words refer to Ps. 30 : 5 (A.V.): “Weeping may tarry for the night but joy cometh in the morning.”

¹⁸ *The City of God*, XI, viii. Cf. also *Dialog. Quaest. LXV*, Quaest. XXVI,

¹⁹ *Confessions* (trans. Sheed), p. 289.

²⁰ *Enarrationes in Ps. CIII*, Sermo III, 21 (Migue, *P.L.*, vol. 37, col. 1374).

- ¹ Cf. *Aion*, pp. 24ff.
- ² [Cf. “The Psychology of the Transference,” Fig. 1.]
- ³ [Cf. *Psychology and Alchemy*, Figs. 231 (the *Pandora* picture) and 128 (the *Hermes* picture). *De chemia* is the work by Zadith Senior.—EDITORS.]
- ⁴ Ruland, *A Lexicon of Alchemy*, p. 286.
- ⁵ “Epistola ad Hermannum,” *Theatrum chemicum*, V (1660), p. 804.
- ^{5a} [But cf. *The Hieroglyphics of Horapollo*, tr. Boas, p. 57.]
- ⁶ Par. 217.
- ⁷ *Mudrā* (Skt.) is a ritual or magical gesture.
- ⁸ For the *chakra* theory see Avalon, *The Serpent Power*, and concerning *φρένες* see Onians, *The Origins of European Thought*, pp. 14ff.
- ⁹ [Cf. supra, par. 301.]
- ¹⁰ Cf. Evans-Wentz, *The Tibetan Book of the Dead*, pp. 101ff.
- ¹¹ Philo, “De opificio mundi” [see Colson/Whitaker trans., I, p. 13].
- ¹² Synonymous with the *caput corvi* and *nigredo*. Cf. Mylius, *Philosophia reformata*, p. 19, who says that in the *nigredo* the *anima media natura* holds sway. This is roughly the equivalent of what I call the collective unconscious.
- ¹³ Cf. *Aion*, pp. 113ff.
- ¹⁴ By which I mean the Greek *δαίμων* and not the Christian devil.
- ¹⁵ Sacred Books of the East, VIII, p. 91. Unfortunately I was unable to ask the patient about the source of this saying, but I know she was acquainted with the *Bhagavadgītā*.
- ¹⁶ Solar gods.
- ¹⁷ The priest who recites the prayers of the *Yajur-Veda*.
- ¹⁸ *Suāhā* is one of the holy syllables. It is uttered at the recitation of the *Veda* during thunderstorms (*Apastamba*, in *SBE*, II, p. 45) and at sacrifices to the gods (*ibid.*, p. 48).
- ¹⁹ *Surya* = sun.
- ²⁰ *SBE*, XLI, p. 112.
- ²¹ Rain-god.
- ²² *SBE*, XLII, p. 116. [*Varuna* = sky-god.]
- ²³ Cf. the stork on the tree, *infra*, pars. 415ff.
- ²⁴ P. 292, Picture 3.
- ²⁵ [From verses XXVI-XXVII; with kind permission of Editions Pierre Seghers.

“And then I came upon an outcropping of rock
From which yawned a mist-covered pit.
A dense crowd was hastening thither
From the four quarters. I mingled among them.
I noticed that we were turning in a spiral.

A vortex in the funnel sucked us in.
In the centre, a colossal catalpa
On which hung the hearts of the dead.
At each fork had chosen to settle
A little sage who winked as he saw me.

... ..

At the very bottom, where the lagoons spread out,
What quietness, at the hub of things!
Beneath the tree of my life, the last river
Surrounds an island where there rises
In the mists a cube of grey rock,
A Fortress, the Capital of the Worlds.”]

²⁶ Often represented by a snake.

²⁷ Cf. the heart-shaped leaves and flowers in Figs. 14, 15, 17.

¹ In the dream of Nebuchadnezzar the king himself is a tree. There is a very ancient, indeed primitive idea that the tree actually represents the life of a man; for instance, a tree is planted at the birth of a child, and its and the child's fates are identical. "Therefore the tree is the image and mirror of our condition" (Alciati, *Emblemata cum commentariis*, p. 888b).

² Including figures of speech.

³ It is not always easy to prove this, because the tradition is often unconscious yet is recalled cryptomnesically.

⁴ The relation is similar to that between comparative anatomy and human anatomy. with the difference that in psychology the comparative findings have a practical as well as a theoretical importance.

⁵ We can say this not only because very many well-known alchemists were physicians, but also because chemistry in those days was essentially a pharmacopeia. The object of the quest was not merely the *aurum philosophicum seu potabile*, but the *medicina catholica*, the panacea and alexipharmic.

¹ Holmberg, *Der Baum des Lebens*, p. 9.

² Berthelot, *Collection des anciens alchimistes grecs*, IV, i, 12.

³ “Secretum nobilissimum et verissimum Venerabilis Viri Domini Iodoci Greveri Presbyteri,” as reprinted in *Theatrum chemicum*, III (1659), pp. 699-722.

⁴ The text has: “Saturnus, Jupiter, etc. sunt trunci,” which might mean that there are several trunks, or that the trunk consists of the four. Evidently Michael Maier, who cites Greverus (*Symbola aureae mensae*, p. 269), was not clear about this either, for he ascribes to Greverus the view that Mercurius is the root, Saturn, Jupiter, Mars, and Venus are the trunk and branches, sun and moon the leaves and flowers of the tree. In my opinion he correctly understands the four as the classical tetrasomia (see *infra*).

⁵ “Secretum,” p. 700.

⁶ p. 720.

⁷ p. 721.

⁸ “Anatomia” and “astrologia terrestris” are specifically Paracelsan concepts. Accordingly the *terminus a quo* for the treatise is the second half of the 16th cent. “Astrologia terrestris” might also be translated as the “earthly firmament” of Paracelsus.

⁹ ... argumentum omnipotentiae Dei, testimonium resurrectionis mortuorum, exemplum remissionis peccatorum, infallibile futuri iudicii experimentum et speculum aeternae beatitudinis.” “Secretum,” p. 721.

¹⁰ Cf. the refusal of the Basel printer, Conrad Waldkirch, to include *Aurora consurgens* I in *Artis auriferae*. See *Psychology and Alchemy*, par. 464.

¹¹ He does mention, however, gold, silver, and mercury as initial ingredients which have to be prepared and purified first, so that “common substances” (*vulgaria*) may become “physical ones” (*physica*) (p. 702). Here “physical” means *non vulgi*, i.e., symbolic.

¹² Berthelot, *Les Origines de l'alchimie*, p. 59.

¹³ *Supra*, par. 355. 11. 4.

¹⁴ “Triptativa coniunctio: id est, Trinitatis unio fit ex corpore, spiritu et anima. . . . Sic ista Trinitas in essentia est unitas: quia coaeternae simul sunt et coaequales. Tetraptiva coniunctio dicitur principiorum correctio.” (The threefold coniunctio: that is, the union of the Trinity is composed of body, spirit, and soul. . . . Thus the Trinity is in its essence a unity for they are coeternal and coequal. The fourfold coniunctio is called the correction of the principles.)—“Scala philosophorum,” *Art. aurif.*, II, p. 138. The *coniunctio tetraptiva* is called the “noblest coniunctio” because it produces the lapis by uniting the four elements.

¹⁵ *Psychology and Alchemy*, pars. 26, 209.

- ¹ “And in our opus there are two earths and two waters.”—“Scala phil.,” *Art. aurif.*, II, p. 137.
- ² According to the “Book of Krates,” the tincture is a “fiery and gaseous poison.”—Berthelot, *La Chimie au moyen âge*, III, p. 67.
- ³ *Ibid.*, p. 82.
- ⁴ Cf. “The Psychology of the Transference,” ch. 2.
- ⁵ *Vitis* was the name given to the philosophical tree in late antiquity, and the opus was called the “vintage” (*vindemia*). An Ostanos quotation in Zosimos (Berthelot, *Alch. grecs*, III, vi, 5) says: “Press the grape.” Cf. Hoghelande in *Theatr. chem.*, I (1659), p. 180: “Man’s blood and the red juice of the grape is our fire.” *Uvae Hermetis* = “philosophical water” (Ruland, *Lexicon*, p. 325). Concerning the “true vine” see the interpretation in *Aurora consurgens* II (*Art. aurif.*, I, p. 186). *Vinum* is a frequent synonym for the *aqua permanens*. Cf. “Hermes the vintager” in Berthelot, *Alch. grecs*, VI, v. 3.
- ⁶ The olive is the equivalent of the grape inasmuch as both are pressed and yield a precious juice.
- ⁷ Preisendanz, *Papyri Graecae Magicae*. II, pp. 45f.
- ⁸ Pyramid Text of Pepi I: “Homage to thee, O thou who hast four faces which rest and look in turn upon what is in Kenset. . . .” (Budge, *The Gods of the Egyptians*, I, p. 85). Kensest was the first nome (district) of ancient Egypt, the region of the first cataract (*ibid.*, II, p. 42).
- ⁹ *Ibid.*, I, p. 496. For illustration, see *ibid.*, II, p. 311.
- ¹⁰ *Ibid.*, I, p. 497; cf. p. 210.
- ¹¹ I, p. 491.
- ¹² A later form of Amset.
- ¹³ The one human head would indicate consciousness of an aspect or function of the individual psyche. Horus as the rising sun is the enlightener, just as the vision of Ezekiel signifies enlightenment. On the other hand magic, if it is to be effective, always presupposes unconsciousness. This would explain the absence of the human face.
- ¹⁴ Cf. the symbolism of the self, whose totality is characterized by four quaternions: *Aion*, pp. 242ff.
- ¹⁵ The old pagodas in India are actually stone chariots on which the gods are enthroned. In Daniel 7 : 9, the Ancient of Days sits on a throne.
- ¹⁶ “A cherub stretched out and protecting,” “covering cherub.”
- ¹⁷ [“Mark” in DV, AV, RSV, and Hebrew Bible. Vulgate: “signa Than.” Cf. *La Sainte Bible, traduit en français sous la direction de l’Ecole Biblique de Jérusalem* (Paris, 1956), where the word is translated as “croix,” with a note: “literally Tav, as Vulgate translates. This letter had, in the ancient alphabet, exactly the shape of a cross.”—TRANSLATOR.]
- ¹⁸ *Carmina*, XIX, verse 640 (Migne, *P.L.*, vol. 61, cols. 546f.):

“Qui cruce dispensa per quattuor extima ligni
 Quattuor attingit dimensum partibus orbem
 Ut trahat ad vitam populos ex omnibus oris
 Et quia morte crucis cunctis deus omnia Christus
 Extat in exortum vitae finemque malorum,

Alpha crucem circumstat et Ω , tribus utraque virgis

Littera diversam trina ratione figuram

Perficiens, quia perfectum est mens una, triplex vis.”

¹⁹ Cf. “Concerning Mandala Symbolism.”

²⁰ Daniel 7 : 4ff.

²¹ [And Adamas: cf. *Aion*, pp. 208f.—EDITORS.] Hippolytus, *Elenchos*, V, 7, 29ff.

²² *Elenchos*, VI, 51, 1.

²³ Usener, *Das Weihnachtsfest*, p. 149.

¹ Berthelot, *Alch. grecs*, III, ix. Cf. the poisonous tincture, supra, par. 358, n. 2.

² *Psychology and Alchemy*, pars. 336f.

³ Berthelot, *Alch. grecs*, III, vi, 5. Cf. supra, “The Spirit Mercurius,” pars. 264f.

⁴ Cf. *Aion*, pp. 162ff.

⁵ The immediately preceding passage remarks that God “is everywhere” and “not in the smallest place, like the daemon” (οὐκ ἐν τόπῳ ἐλαχίστῳ ὡς τὸ δαιμόνιον). Thus one of God’s attributes is infinity, whereas the distinguishing mark of the daemon is limitation in space, Man as microcosm would then be included in the concept of the daemonic, and psychologically this would mean that the ego, separated and split off from God, is likely to become daemonic as soon as it accentuates its independence of God by its egocentricity. The divine dynamism of the self, which is identical with the dynamism of the cosmos, is then placed at the service of the ego, and the latter is daemonized. This would account for the magically effective personality of those historical figures whom Burckhardt called the “great despoilers.” *Exempla sunt odiosa*.

⁶ Berthelot, *Alch. grecs*, II, iv, 26.

⁷ *Elenchos*, X, 34, 4 (cf. Legge, *Philosophumena*, II, p. 178).

¹ Pars. 342ff.

² “When the body is dissolved, there will sometimes appear two branches, sometimes three, sometimes more. . . .” (*Theatr. chem.*, I, 1659, pp. 147f.).

³ “... that it may grow within the glass like a tree,” “it made it grow upward in its glass with discoloured flowers” (Ripley, *Opera*, p. 86). “The philosophical tree flourished with its branches” (“Introitus apertus,” *Musaeum hermeticum*, p. 694).

⁴ “Senior, the author of *Lilium*, says that the sight of it [the vessel] is more to be desired than the scripture” (Hoghelande, *Theatr. chem.*, I, 1659, p. 177). Cf. also *Psychology and Alchemy*, par. 360.

⁵ “The salt and the tree can be made in any moist and convenient place” (“Gloria mundi,” *Mus. herm.*, p. 216).

⁶ Ripley, *Opera*, pp. 39, 46; cf. “Tractatus aureus de lapide,” *Mus. herm.*, p. 39.

⁷ Ripley. *Opera*, p. 46.

⁸ *Vitis arborea* in Ripley’s *Scrowle* (British Museum, MS. Sloane 5025). “Do you not know that all holy Scripture is written in parables? For Christ the Son of God followed this method, and said, I am the true vine.” (*Aurora consurgens* II, *Art. aurif.*, I, p. 186.) *Vitis sapientum* (ibid., p. 193, and “Hermetis Trismegisti Tractatus aureus,” *Theatr. chem.*, IV, 1659, p. 613).

⁹ Djābir ibn Hayyān, “Le Livre du Mercure oriental, occidental, et du feu de la pierre,” in Berthelot, *Moyen âge*, III, pp. 214f.

¹⁰ Maria Prophetissa.

¹¹ Referring to the *viriditas benedicta* of Latin alchemy, here an allusion to the incorruptibility of the fruit of the tree.

¹² “Galen speaks of the Philosophical tree, which has seven branches” (*Art. aurif.*, I, p. 222).

¹³ “Marcasita = an imperfect metallic substance” (Ruland, *Lexicon*, p. 217). In chemistry, a collective name for various pyrites (Lippmann, *Entstehung und Ausbreitung der Alchemie*, indices).

¹⁴ *Lutum* is gypsum or clay; mixed with hair, it was used for sealing the lids of vessels (Lippmann, I, p. 663).

¹⁵ “De genealogia mineralium,” *Theatr. chem.*, I (1659), p. 574.

¹⁶ “Their [the fruits’] coagulation takes place instantaneously.” The fruits are “sent forth at the extremities of the *locustae*.” *Locustae* are the tips of the branches (Ruland, p. 209: “tops or young shoots of trees”). The form *lūcusta* in MS. seems to derive from *lucus*, ‘grove’ (Walde, *Lateinisches Etymologisches Wörterbuch*, I, p. 818).

¹⁷ In text, *Lolium temulentum* L.

¹⁸ Ibn Sina (980-1037), a physician and opponent of alchemy.

¹⁹ abu-Bakr Muhammad ibn-Zakāriya’ al-Rāzi (d. 925), also named Rasis or Rhazes, physician and alchemist. Known in the West by his “Excerpta ex libro luminis luminum” in Lacinius, *Pretiosa margarita novella*, pp. 167ff.

²⁰ *Theatr. chem.*, I (1659), p. 574.

²¹ Pauli, “The Influence of Archetypal Ideas on the Scientific Theories of Kepler,” in Jung and Pauli, *Interpretation of Nature and the Psyche*.

¹ *Theatr. chem.*, I (1659), pp. 513ff.

² An allusion to the many colours of the *cauda pavonis* (peacock's tail), whose appearance heralds the attainment of the goal.

³ Cf. the awakened dead in Hades, who grow like the flowers in spring. Berthelot, *Alch. grecs*, IV, xx, 9.

⁴ The terrestrial equivalent of the sponge was said to be the puff-ball. Sponges could hear and were sentient. When torn up, they exuded a juice like blood. Cf. the mandrake, which shrieks when it is torn up. "When they are torn from their places, it is heard and there will be a great noise." (Calid, "Liber secretorum," *Art. aurif.*, I, p. 343.) For the sponge, see *Mysterium Coniunctionis*. p. 134 and n. 205.

⁵ *Putus* can also mean 'genuine' or 'unadulterated.' *Argentum putum* is unalloyed silver. *Putus* instead of *purus* is significant, see next section.

⁶ Impure metals, oxides, and salts.

⁷ Human diseases are the equivalent of the *leprositae* of the metals. The text has *liberabat*, but the sense requires *liberabit*, as the prophecy is not yet fulfilled.

⁸ The quotation is not literal. Calid ("Liber secretorum," *Art. aurif.*, I, p. 325) says: "You must know, brother, that this magistry of ours concerning the secret stone, and our honoured office, is a great secret of God, which he has hidden from his people, and has willed to reveal to none save those who have faithfully deserved well as sons and have known his *goodness* and greatness." Dorn interprets the speaker, perhaps rightly, as Hermes (Trismegistus), who later on in the text speaks of "my own disciple, Musa." Moses, who was counted as an alchemist, was identified with Musaios, the teacher of Orpheus.

⁹ Here too Dorn may be referring to Calid, who says (*ibid.*, p. 342): "Take this stone that is no stone nor of the nature of stone. Moreover, it is a stone whose substance is generated on the top of the mountains [*in capite montium*], and the philosopher chose to say 'mountains' instead of 'living things' [*animalia*]." (The text is corrupt.) The stone is found in the head of a snake or a dragon, or is the "head-element" itself, as in Zosimos. World-mountain, world-axis, world-tree, and *homo maximus* are synonymous. Cf. Holmberg, *Der Baum des Lebens*, pp. 20, 21, 25.

- ¹ Von hylealischen Chaos, p. 93; cf. also p. 197.
- ² For Azoth, see “The Spirit Mercurius,” supra, par. 271.
- ³ *Mus. herm.*, p. 118: “Christ is compared and united with the earthly stone . . . it is an outstanding type and lifelike image of the incarnation of Christ.”
- ⁴ Psalm 18: 6: “he, as a bridegroom coming out of his bride chamber, hath rejoiced as a giant to run the way” was referred by the Church Fathers to Christ.
- ⁵ The text refers here to Matth. 26, obviously meaning verses 26ff., the institution of the Last Supper. [The phrase “giant of twofold substance” (*geminae gigas substantiae*) seems to have been first used by St. Ambrose, in line 19 of his Christmas hymn beginning “Intende qui regis Israel.” The relevant stanza is translated by J. M. Neale, *Collected Hymns, Sequences and Carols*, p. 104: “Proceeding from His chamber free,/ The royal hall of chastity,/Giant of twofold substance, straight/His destined way He runs elate.”—A.S.B.G.]
- ⁶ The anonymous author of “Aquarium sapientum” was not altogether clear about the triune essence, for he says it is “of one, a divine essence, then of two, of God and man, that is, of three persons, of four, namely of three persons and one divine essence, as also of five, of three persons and two essences, namely one divine and one human” (p. 112). The *filius macrocosmi* seems to have loosened up the dogma quite considerably.
- ⁷ “Aquarium sapientum,” pp. 111f.
- ⁸ *Liber gratiae spiritualis* (Venice, 1578), pp. 107f.
- ⁹ Alan of Lille, *Elucidatio in Cant. Cant.* 6 (Migne, *P.L.*, vol. 210, col. 95).
- ¹⁰ *Ibid.*, col. 82.
- ¹¹ Litany of Loreto.
- ¹² *Sermo II in Fesio Pentecostes* (Migne, *P.L.*, vol. 183, col. 327).
- ¹³ *Allegoriae in Sacram Scripturam* (Migne, *P.L.*, vol. 112, col. 897).
- ¹⁴ *Homilia III in Dominicam I Adventus* (Migne, *P.L.*, vol. 174, col. 32).
- ¹⁵ *Homilia LXIII in Vigiliam Assumptionis* (*ibid.*, col. 957).
- ¹⁶ *Elucidatio* (Migne, *P.L.*, vol. 210, col. 94).
- ¹⁷ Cf. the chapter on the kiss of the Lord, where there is a similar projection (*Liber gratiae*, p. 90).
- ¹⁸ The blood, that is, of the lion, which is equated with the lion of the tribe of Judah (= Christ).
- ¹⁹ Cf. *Psychology and Alchemy*, “The Lapis-Christ Parallel,” and *Aion*, ch. 5.
- ²⁰ Luke 22 : 44: “... and his sweat was as it were great drops of blood falling down to the ground.”
- ²¹ [The text continues: “and one has never heard that his blood was rose-coloured.” There is, however, an interesting reference to “cruore ejus roseo gustando vivimus Deo” (by tasting his rosy blood we live to God) in a very well-known hymn, beginning “Ad coenam agni providi,” formerly attributed to St. Ambrose, but though now denied him, known to date back to the 6th or early 7th century. For centuries past it has been the liturgical hymn sung at Vespers in the Easter season in the Roman church. Cf. Neale, *Collected Hymns*, p. 194. —A.S.B.G.]
- ²² Cf. I Cor. 13 : 4ff.

¹ Allusion to “Tabula smaragdina”: “This is the strong strength of all strength, for it will overcome every subtle thing, and penetrate every solid thing” (*De alchemia*, p. 363).

² Of *Alphidius* nothing is known. He is an oft-cited author, who may have lived in the 12th–13th cents. (Cf. Kopp, *Die Alchemie*, II, pp. 339. 363).

³ “Pret. marg. nov.,” *Bibliotheca chemica*, II, p. 30. Alleged date of composition is 1330. Janus Lacinius, who first printed the treatise in 1546, says (fol. 701) that Bonus “was living in the city of Pola in Istria about the year 1338,” and (fol. 46^v) that he was a contemporary (*coaetaneus*) of Raymund Lully (1235–1315).

⁴ *Aion*, pp. 164f.

⁵ As archetypal symbols are numinous, they have an effect even though they cannot be grasped intellectually.

¹ P. 702. Cf. “Symbolum Saturni,” in Mylius, *Phil. ref.*, p. 313: “Not far from there I was conducted to a meadow, in which was planted a remarkable garden with various kinds of trees, most excellent to behold. And among these trees he showed me seven that were distinguished by name; among these I perceived two outstanding ones, higher than the others, of which one bore a fruit like to the brightest and most refulgent sun, and its leaves were like gold. But the other brought forth the whitest fruits, more brightly shining than lilies, and its leaves were like quicksilver. They were named by Neptune the tree of the sun and the tree of the moon.”

² *Psychology and Alchemy*, Fig. 188.

³ *Ibid.*, Figs. 122, 221.

⁴ *Ibid.*, Fig. 257. [Cf. also *supra*, Fig. B5.]

⁵ “A beautiful woman in her upper part, she passes into a [snake].” (“Anguis” is my adaptation for “piscis.”) A late Hellenistic statue of Isis shows her as a beautiful goddess wearing the mural crown and carrying a torch, but whose lower half changes into a *uraeus*.

⁶ The classic representation is to be found in the *Scrowle* of Sir George Ripley, Canon of Bridlington, probably the most important English alchemist (1415–90).

⁷ Horstmann, *Sammlung altenglischer Legenden*, I, pp. 124ff.

⁸ The tree’s lack of bark and the snake’s lack of skin indicate the identity between them.

⁹ *Psychology and Alchemy*, Fig. 4. The motif of mutilation occurs in “Allegoriae super librum Turbae,” *Art. aurif.*, I, pp. 140, 151. These amputations have nothing to do with a so-called castration complex, but refer to the motif of dismemberment.

¹⁰ “De igne et sale,” *Theatr. chem.*, VI (1661), p. 119.

¹¹ Hoghelande (*Theatr. chem.*, I, 1659, p. 145), referring to *Turba*, Sermo LVIII (ed. Ruska, p. 161): “Take that white tree and build around it a round dark house covered with dew, and place in it a man of great age, a hundred years old,” etc. The old man is Saturn = lead as prima materia.

¹² Flinders Petrie, *Egyptian Tales*, 2nd series, XVIIIth to XIXth dynasty, pp. 36ff.

¹³ A parallel to the pine tree of Attis.

¹⁴ *Kitāb al-’ilm al-muktasab*, ed. Holmyard, p. 23.

¹⁵ Eliade, *Shamanism*, pp. 70-187.

¹⁶ Pp. 127, 147, 162.

¹⁷ Codex Q. 584 (Berlin), fol. 21^V (Ruska, *Turba*, p. 324).

¹⁸ Sermo. LVIII, Ruska, p. 161.

¹⁹ Charles, *Apocrypha and Pseudepigrapha*, II, pp. 204f. From the fruits of the sun-and-moon tree is prepared “the immortal fruit, which has life and blood.” “The blood causes all unfruitful trees to bear fruit of the same nature as the apple” (Mylius, *Phil. ref.*, p. 314).

²⁰ *Aurora Consurgens* (ed. von Franz), p. 143.

²¹ *Turba* p. 324. Cf. *Psychology and Alchemy*, par. 449 and n. 2.

²² As in Ripley’s *Scrowle*: “vitis arborea.”

- ²³ Maier, *Symb. aur. mens.*, p. 269, also the “Secretum” of Greverus (*Theatr. chem.*, III, 1659, p. 700) and the “Summarium philosophicum” of Flamel (*Mus. herm.*, p. 175). Cf. Pordage, *Sophia*, p. 10: “Here I saw the fruits and herbs of paradise, whereof my eternal man should thenceforward eat, and live.”
- ²⁴ These trees also occur in the Romance of Alexander as the “most holy trees of the sun and moon, which will declare the future to you” (Hilka, *Der altfranzösische Prosa-Alexander-Roman*, p. 204).
- ²⁵ Vulgate: “de pomis fructuum solis ac lunae.” The alchemists naturally took this version as authoritative. The original text has, as in AV: “... The precious fruits brought forth by the sun, and the precious things put forth by the moon.”
- ²⁶ *Theatr. chem.*, II (1659), p. 241. (“Dulce pomum est odorum, floridus hie pomulus.”)
- ²⁷ *Ibid.*, V (1660), p. 790. (“Collige fructus quia fructus arboris seduxit nos in et per obscurum.”)
- ²⁸ The title of this book runs in part: *Paradisus aureolus hermeticus ... in cuius . . . offertur instructio, quomodo aureola Hesperidum poma, ab arbore benedicta philosophica sint decerpenda, etc.*
- ²⁹ Senior, *De chemia*, p. 92.
- ³⁰ *Mus. herm.*, p. 246.
- ³¹ Eliade, *Shamanism*, pp. 70f.
- ³² Cumont, *Textes et Monuments figurés relatifs aux mystères de Mithra*, II, p. 350, and Eisler, *Weltenmantel und Himmelszelt*, II, p. 519.
- ³³ “Instructio de arbore solari,” *Theatr. chem.*, VI (1661), p. 168.
- ³⁴ Bernardus Trevisanus, *Theatr. chem.*, I (1659), p. 706.

- ¹ “Allegoriae super librum Turbae,” *Art. aurif.*, I, p. 141. Evidently a reference to the tree of the Hesperides on an island, where also the fount of ambrosia and the dragon are found. Cf. the coral tree (*ibid.*, p. 143) and *Psychology and Alchemy*, par. 449, n. 6. In the *Livre d’Heures du Duc de Berry*, Paradise is shown as a round island in the sea.
- ² *Phil. ref.*, p. 313.
- ³ *Hyl. Chaos*, p. 270.
- ⁴ Windischmann, *Zoroastrische Studien*, pp. 90, 171.
- ⁵ Perhaps in remembrance of the shrines of the Semitic Astarte on mountains. Cf. Charles, *Apocrypha and Pseudepigrapha*, II, pp. 204f.
- ⁶ *Art. aurif.*, I, p. 321.
- ⁷ Berthelot, *Moyen âge*, III, p. 117.
- ⁸ Eliade, *Shamanism*, pp. 266f.
- ⁹ Epiphanius, *Ancoratus*, 40; St. Ambrose, *De interpellatione Job et David*, I, iv, 17 (Migne, *P.L.*, vol. 14, col. 818): “A mountain small and great.”
- ¹⁰ St. Gregory the Great, *Moralia in Job*, XIX, 1 (Migne, *P.L.*, vol. 76, col. 97): “A fruitful tree to be cultivated in our hearts.”
- ¹¹ “Symposium Saturni,” in Mylius, *Phil. ref.*, p. 313. Cf. the hymn for St. Paul of Constantinople in Theodore the Studite: “O most blessed one, from the cradle thou didst flourish like a comely plant in the ascetic garden; thou gavest forth a pleasant odour, bowed down with the finest apples of the Holy Spirit” (Pitra, *Analecta sacra*, I, p. 337).
- ¹² *Mus. herm.*, p. 177.
- ¹³ Cf. “The Spirit Mercurius,” *supra*, par. 255.
- ¹⁴ Flamel, *Mus. herm.*, p. 177, also p. 175.
- ¹⁵ “The Spirit Mercurius,” *supra*, pars. 282ff.
- ¹⁶ Abu’l Qāsim, *Kitāb al-’ilm al-muktasab*, ed. Holmyard, p. 23.
- ¹⁷ Ripley, “Duodecim portarum,” *Theatr. chem.*, II (1659), p. 113, and *Opera omnia*, p. 86.
- ¹⁸ The tree of Hermes is burnt to ashes with the “humiditas maxime permanens,” as Ripley says (*ibid.*, p. 39). Cf. p. 46: “That water has fire within it.”
- ¹⁹ Hippolytus, *Elenchos*, VI, 9, 8ff. (Legge, II, p. 5).
- ²⁰ *Ibid.* Cf. the Indian parallel in Coomaraswamy, “The Inverted Tree,” p. 126: “The tree is a fiery pillar as seen from below, a solar pillar as seen from above, and a pneumatic pillar throughout; it is a tree of light.” The reference to the motif of the pillar is significant.
- ²¹ “Gloria mundi,” *Mus. herm.*, p. 240.
- ²² Mercurius is named “arbor metallorum.” For an interpretation of this symbol see Dorn, “Congeries Paracelsicae,” *Theatr. chem.*, I (1659), p. 508.
- ²³ *Arbor aurea* in “Scriptum Alberti,” *ibid.*, II (1659), p. 456; also Abu’l Qāsim, ed. Holmyard, p. 54, and “Consilium coniugii,” *Ars chemica*, p. 211.
- ²⁴ *Symb. aur. mens.*, p. 269, with reference to Greverus.
- ²⁵ *Art. aurif.*, I, p. 222.

²⁶ This plant derives ultimately from the Homeric $\mu\tilde{\omega}\lambda\nu$ (see *Mysterium Coniunctionis*, p. 133 and n. 200). Cf. Rahner, “Die seelenheilende Blume,” *Eranos-Jahrbuch* XII (1945), 117ff.

²⁷ “De tenebris contra naturam,” *Theatr. chem.*, I (1659), p. 470. (“Plantetur itaque arbor ex eis [planetis s. metallis], cuius radix adscribatur Saturno, per quam varius ille Mercurius ac Venus truncum et ramos ascendentes, folia floresque fructum ferentes Marti praebent.”)

²⁸ That is, to Aries, whose ruler is Mars; hence to the first spring zodiac.

²⁹ “De genealogia mineralium,” *Theatr. chem.*, I (1659), p. 574.

- ¹ Presumably Dante means this in *Purgatorio*, XXII, 131ff.
- ² “Radices suarum mincrarum sunt in aere et summitates in terra. Et quando evelluntur a suis locis, auditur sonus terribilis et sequitur timor magnus.” (“De ratione conficiendi lapidis,” *Theatr. chem.*, II, 1659, p. 226.)
- ³ *Mus. herm.*, pp. 240, 270
- ⁴ “Rabbi Josephi Carnitoli filius . . . inquit: fundamentum omnis structurae inferioris supra est affixum et eius culmen hic infra est sicut arbor inversa.” (“De igne et sale,” *Theatr. chem.*, VI, 1661, p. 39.) It is also said in the *Prodromas Rhodostauroticus* (fol. Vv) that the ancients called man an inverted tree.
- ⁵ The text has, erroneously, “iuncta” for “vincta.”
- ⁶ More accurate translation, as in RSV: “your flowing locks are like purple; a king is held captive in the tresses.”
- ⁷ *Cabbala denudata*, I, p. 166.
- ⁸ *Ibid.*, p. 77.
- ⁹ *Ibid.*, p. 629.
- ¹⁰ P. 888: “Inversam arborem stantem videri hominem placet Physicis, quod enim radix ibi, truncus et frondes, hic caput est et corpus reliquum cum brachiis et pedibus.”
- ¹¹ Cf. Chwolsohn, *Die Ssabier und der Ssabismus*, II, p. 373. *Timaeus* 90A: “... seeing that we are not an earthly but a heavenly plant.” Vettius Valens, *Anthologiarum* IX, p. 330, 23. Orphic fragment. Kern, No. 228a: “But the soul in man is rooted in the aether.”
- ¹² Chhāndogya Upanishad, VIII, 5, 3 (SBE, I, p. 131). Shatapatha-Brāhmana (SBE, XLIV, p. 317): “The Nyagrodha with cups—for when the gods were performing sacrifice, they tilted over those Soma cups, and turned downwards they took root, whence the Nyagrodhas, when turned downwards (*nyak*) take root (*roha*).” The *ashvattha* is the seat of the gods (*Hymns of the Atharva-Veda*, V, 4; SBE, XLII, p. 4). Cf. Coomaraswamy, “The Inverted Tree,” pp. 122f.
- ¹³ *The Song of God* (trans. Prabhavananda and Isherwood), pp. 146f.
- ¹⁴ *Psychology and Alchemy*, Figs. 122 and 221.
- ¹⁵ Fol. **vff.
- ¹⁶ The Byzantine emperor Heraclius (610–641).
- ¹⁷ Morienus, “De transmutatione metallorum,” *Art. aurif.*, II, pp. 25f. “Hoc autem magisterium ex una primum radice procedit, quae postmodum in plures res expenditur et iterum ad unam revertitur.”
- ¹⁸ *Opera omnia*, p. 46.
- ¹⁹ Berthelot, *Moyen âge*, III, pp. 214f.
- ²⁰ Cited in Hoghelande, *Theatr. chem.*, I (1659), p. 147. The “vintage of Hermes” (*vindemia Hermetis*) goes back to an Ostanos quotation in Zosimos (Berthelot, *Alch. grecs*, III, vi, 5).
- ²¹ Loc. cit. “Quidem fructus exeunt a perfectissima arbore primo vere et in exitus initio florent,” Hoghelande is referring to the *Turba*, Sermo LVIII, where Balgus is asked: “Why have you ceased to speak of the tree, of which he who eats its fruit shall never hunger?”
- ²² The opus begins in the spring, when the conditions are most favourable (cf. “Paracelsus as a Spiritual Phenomenon,” supra, pars. 190ff.) and the “element of the stone is most abundant” (Ventura, *Theatr. chem.*, II, 1659, p. 253). The relation of the opus to the zodiac is shown in *Psychology and Alchemy*, Fig. 92.

²³ *Theatr. chem.*, V (1660), p. 61. “Item planta hanc arborem super lapidem, ne ventorum cursus timeat, ut volatilia coeli veniant et supra ramos eius gignant, inde enim sapientia surgit.”

²⁴ MS. in Basel University Library, AX. 128b.

²⁵ Cf. supra, “Paracelsus as a Spiritual Phenomenon,” par. 228.

¹ *Theatr. chem.*, 11 (1659), p. 458.

² *Psychology and Alchemy*, Fig. 231, and *Mus. herm.*, p. 201.

³ *Psychology and Alchemy*, par. 537, n. 58, and Figs. 10-12, 157, 257. Cf. also Jaffé, "Bilder und Symbole aus E. T. A. Hoffmanns Märchen 'Der Goldene Topf,'" p. 300ff.

⁴ *Theatr. chem.*, II (1659), p. 456.

⁵ *Ibid.*, p. 457.

⁶ Cf. von Franz, "Passio Perpetuae," pp. 463ff.

⁷ For the importance of the vessel in alchemy see *Psychology and Alchemy*, index, s.v. vas/vessel. The *ciconia vel storca* was a kind of retort (Rhenanus, *Solis e puteo emergentis*, Lib. I, 22). [Cf. supra, Fig. B7.]

⁸ Cf. "A Study in the Process of Individuation," pp. 295ff.

⁹ Grünbaum, *Jüdisch-deutsche Chrestomathie*, p. 174.

¹⁰ Picinellus, *Mundus symbolicus*, I, p. 281.

¹¹ Wünsche, "Die Sagen vom Lebensbaum und Lebenswasser," pp. 85f.

¹ *Psychology and Alchemy*, Fig. 231.

² Cf. Koran. Sura XIX.

³ Steeb, *Coelum Sephiroticum*, p. 49.

⁴ Charles, *Apocrypha and Pseudepigrapha*, II, p. 207.

⁵ *Adversus haereses*, Lib. I, 29, 3.

⁶ “Ex Anthrope autem et Gnosin natum lignum, quod et ipsum Gnosin vocant.”

⁷ “Illa autem arbor quae est in paradiso, ex qua agnoscitur bonum, ipse est Jesus et scientia eius quae est in mundo.” Hegemonius, *Acta Archelai* (ed. Beeson), p. 18, lines 15ff.

⁸ *Theatr. chem.*, V (1660), p. 61.

⁹ Trans. and ed. Friedlander, p. 150. The *Pirke* dates from 7th–8th cents. Eliezer (ben Hyrcanus) lived in the 2nd cent.

¹⁰ Hippolytus, *Elenchos*, V, 26, 6. Naas, the serpent, is the prima materia of the Naassenes, a “moist substance” like Thales’ water. It is substantial to all things and contains all things. It is like the river of Eden, which divides into four streams (V, 9, 13ff.).

¹¹ Cf. “The Spirit Mercurius,” supra, pars. 268f.

¹ “Item accipe sapientiam vi intensissima[m] et ex ea vitam hauries aeternam, donec tuus [lapis] congeletur ac tua pigredo exeat, tunc inde vita fit” (*Theatr. chem.*, V, 1660, p. 61).

² *Phil. ref.*, p. 260. For “rami infiniti multiplicantur” I read “infinite.”

³ *Ars chemica*, p. 160.

⁴ *Hyl. Chaos*, pp. 20f.

⁵ Berthelot, *Moyen âge*, III, p. 117.

⁶ “Nisi lapis tuus fuerit inimicus, ad opratum non pervenies” (*Theatr. chem.*, V, 1660, p. 9).

⁷ See illustration in Reusner’s *Pandora*, p. 227. Also *Psychology and Alchemy*, Fig. 4.

⁸ Ἡ γὰρ φύσις τὴν φύσιν τέρπει, καὶ ἡ φύσις τὴν φύσιν κρατεῖ καὶ ἡ φύσις τὴν φύσιν νικᾷ (Berthelot, *Alch. grecs.*, I, iii, 12).

⁹ See supra, Fig. B4.

¹⁰ *Theatr. chem.*, V (1660), p. 790.

¹¹ Koran, Sura XVIII.

¹² Cf. “Concerning Rebirth,” pp. 135ff.

¹³ *Aion*, pp. 8ff.

¹ *Aurora Consurgens* (ed. von Franz), p. 117. “This is therefore a great sign, in the investigation of which some have perished” (*Art. aurif.*, II, p. 264). “Know ye, who seek after wisdom, that the foundation of this art, on account of which many have perished, is a thing stronger and more sublime than all other things” (“Turba,” in *Art. aurif.*, I, p. 83).

² “De alchimiae difficultatibus,” *Theatr. chem.*, I (1659), p. 131.

³ “Dialogus inter naturam et filium philosophorum,” *ibid.*, II (1659), p. 104.

⁴ Cf. Du Cange, *Glossarium*, II, p. 275, “certificatio.”

⁵ “Lapis noster est vita ei qui ipsum scit et eius factum et qui nesciverit et non fecit et non certificabitur quando nascetur aut putabit alium lapidem, iam paravit se morti” (Hoghelande, *Theatr. chem.*, I, 1659, p. 182).

⁶ This danger was well known. “Because of the fires and sulphurous exhalations it brings with it, the opus is highly dangerous” (Dee, “Monas hieroglyphica,” *Theatr. chem.*, II, 1659, p. 196). “I [the divine water] give them a blow in the face, that is a wound, which makes them toothless, and brings about many infirmities through the smoke” (“Rosinus ad Sarratantam,” *Art. aurif.*, I, p. 293). “From the beginning the opus is like a death-dealing poison” (Ventura, “De ratione conficiendi lapidis,” *Theatr. chem.*, II, 1659, p. 258). The alchemists seem to have known about mercurial poisoning.

⁷ “Cautus sit in diaboli illusionibus dignoscendis et praecavendis, qui se chemicis operationibus saepius immiscet, ut operantes circa vana et inutilia detineat praetermissis naturae operibus” (Hoghelande, p. 126). *Aurora Consurgens* (ed. von Franz, p. 51) speaks of the “evil odours and vapours that infect the mind of the laborant.”

⁸ Hoghelande, p. 160. “Hie lapis a loco gloriosissimo sublimi maximi Terroris procedit, qui multos sapientes neci dedit.”

⁹ *Ibid.*, p. 181.

¹⁰ *Theatr. chem.*, V (1660), p. 126.

¹¹ Berthelot, *Alch. grecs*, II, iv, 28.

¹² *Ibid.*, II, iv, 43 and 46.

¹³ *Theatr. chem.*, I (1659), p. 160. “Nomen lapidis patefacere nemo potest sub animae suae condemnatione, quia coram Deo rationem reddere non posset.”

¹⁴ *Aion*, pp. 161ff.

¹⁵ Wei Po-yang, “An Ancient Chinese Treatise on Alchemy,” pp. 237ff.

¹⁶ *Aion*, pp. 23ff.

¹⁷ This is a typical symptom of inflation. A person with a famous name once assured me he would live a very long time; he needed at least 150 years. A year later he was dead. In this case the inflation was obvious even to a layman.

¹⁸ *The Chymical Wedding* (trans. Foxcroft), p. 6.

¹⁹ “(Operis perfectio) non est enim in potestate artificis, sed cui vult ipse Deus clementissimus largitur. Et in hoc puncto totum est periculum.” *Theatr. chem.* II (1659), p. 296.

¹ “Philosophus non est magister lapidis, sed potius eius minister.” *Ros. phil.* in *Art. aurif.*, II, pp. 356f.

¹ Cf. supra, pars. 86-87.

² “Diruite et cruciate.”

³ Ed. Ruska, p. 152.

⁴ Ibid., p. 168.

⁵ By “appliciones” are meant the arcane substances, such as the “gumma” (= *aqua permanens*) mentioned in the text.

⁶ *Poenas*, corresponding to the *κολάσεις* in Zosimos; supra, par. 86 (III, i, 2).

⁷ Preisendanz, *Pap, Graec. Mag.*, I, p. 79.

⁸ “Allegoriae sapientum,” Art. *aurif.*, I, p. 140.

⁹ Ibid., p. 139.

¹⁰ “Visio Arislei,” *ibid.*, p. 151.

¹¹ “Micreris” is a corruption of “Mercurius” due to Arabic transliteration.

¹² *Adulatio* usually refers to the love-play of the royal marriage. Here it serves to extract the souls.

¹³ *Theatr. chem.*, V (1660), p. 93.

¹⁴ Lacinius, *Pret. marg. nov.*, fol. 45^v.

¹⁵ “Physica Trismegisti,” *Theatr. chem.*, I (1659), p. 366.

¹⁶ “Ignis contra naturam debet excruciare corpora, ipse est draco violenter comburens, ut ignis inferni” (“Duodecim portarum,” *Theatr. chem.*, II, 1659, p. 113).

¹⁷ “Congeries Paracelsicae,” *ibid.*, I (1659), p. 516.

¹⁸ Quotation from “Tab. smarag.”

¹⁹ “(Hermes) dicit enim ‘a te fugiet omnis obscuritas,’ non dicit ‘a metallis.’ Per obscuritatem nihil aliud intelligitur quam tenebrae morborum et aegritudinem corporis atque mentis.” (*Theatr. chem.*, I, 1659, p. 384.)

²⁰ Berthelot, *Moyen âge*, III, p. 118.

²¹ “In Alchimia est quoddam corpus nobile, ... in cuius principio erit miseria cum aceto, sed in fine gaudium cum laetitia” (Art. *aurif.*, II, p. 278).

²² *Ars chemica*, pp. 125f.

²³ *Theatr. chem.*, VI (1661), p. 76.

²⁴ Ibid., IV (1660), p. 505.

²⁵ Zöckler, *The Cross of Christ*, and Bezold, *Die Schatzhöhle*, pp. 5, 35.

²⁶ Dee, *Theatr. chem.*, II (1659), p. 202.

²⁷ Reitzenstein and Schaefer, *Studien zum antiken Synkretismus aus Iran und Griechenland*, p. 45.

²⁸ Cf. the oak in the fount of renewal in Trevisanus, “De chemico miraculo,” *Theatr. chem.*, I (1659), pp. 683ff. [*Mysterium Coniunctionis*, pp. 70f.]

²⁹ Ripley, *Opera omnia*, p. 81. “Si exaltatus fuero, tunc omnes ad me traham. Ab eo tempore, quo partes sunt desponsatae, quae sunt crucifixae et exanimatae contumulantur simul mas et foemina et postea revivificantur spiritu vitae.”

³⁰ *Theatr. chem.*, I (1659), p. 254. “(Deus) conclusit angelo gladium irae suae de manibus eripere, cuius loco tridentem hamum substituit aureum, gladio ad arborcm suspenso: et sic mutata est ira Dei in amorem.”

³¹ [In the Swiss edn., this and the following par. were given at the end of sec. 18.—EDITORS.]

³² *De XLII Mansionibus Filiorum Israel*, XXXV (Migne, *P.L.*, vol. 17, col. 34).

³³ In his hymn to the Mother of God: “Ave praeclara maris Stella.” Cf. Gourmont, *Le Latin mystique*, p. 150. [Also *Psychology and Alchemy*, par. 481 and Fig. 217.]

³⁴ Sec illustration in Eleazar, *Uraltes chymisches Werch*, facing p. 26. The book is a forgery of Flamel’s “Rindenbuch.” [Cf. *Mysterium Coniunctionis*, p. 410.]

³⁵ “The Spirit Mercurius,” pars. 284ff.

¹ Bousset, *Hauptprobleme der Gnosis*, p. 178.

² *Adversus haereses*, I, 4.

³ *Psychology and Alchemy*, pars. 122ff., and “A Study in the Process of Individuation.”

⁴ “God is a circle whose centre is everywhere and the circumference nowhere.” [Cf. *Mysterium Coniunctionis*, p. 47.]

⁵ [Cf. “The Phenomenology of the Spirit in Fairytales,” pp. 231ff.]

- ¹ Stobaeus, I, 3 (ed. Wachsmuth, I, pp. 67f.), referring to a wooden statue in a cave, with outstretched arms (like one crucified), the right side male, the left side female. It could sweat and bleed.
- ² “‘Of the fruit of the tree’—here tree only means man, who is compared to a tree” (*Pirke de Rabbi Eliezer*, trans. Friedlander, p. 150). “As is a tree, just such as is the Lord of Trees, so indeed is man” (Coomaraswamy, “The Inverted Tree,” p. 138).
- ³ In Iranian tradition the seven metals flowed into the earth from the body of Gayomart, the Primordial Man. Out of them grew the *reivas* plant, from which the first men, Mahrya and Mayryana, sprang. (Cf. Ask and Embla, the first men in the Edda.) Christensen, *Les Types du premier homme et du premier roi dans l’histoire légendaire des Iraniens*, p. 35. In the Gilbert Islands, men and gods come from the primordial tree.
- ⁴ *Ibid.*, p. 18, and the Bundahish, 15, 1. The cedar and perseia tree play the same role in the ancient Egyptian tale of Bata. Cf. Jacobsohn, *Die dogmatische Stellung des Königs in der Theologie der alten Aegypter*, p. 13. It is to be regretted that these transformation processes, which are of great interest as regards the psychology of religion, are omitted in Pritchard’s recension of the Bata fairytale in his *Ancient Near Eastern Texts*.
- ⁵ “Fruitful tree” in St. Gregory the Great, *Super Cant. Cant.*, II, 4 (Migne, *P.L.*, vol. 79, col. 495). Cf. also supra, par. 407, n. 10. As vine in John 15 : 1. The Buddha, like Christ (supra, par. 419), was named the tree of paradise (*Buddha-Carita* of Ashvaghosha: SBE, XLIX, p. 157).
- ⁶ Supra, section 12.
- ⁷ Cf. Aldrovandus (1522–1605) and his interpretation of the “Enigma of Bologna” (*Dendrologia*, I, p. 211), in *Mysterium Coniunctionis*, pp. 68ff.
- ⁸ *Adversus haereses*, I, 29, 3. The fire-tree of Simon Magus is a similar conception (Hippolytus, *Elenchos*, VI, 9, 8).
- ⁹ *Ibid.*, V, 26, 6.
- ¹⁰ See supra, par. 403, n. 24.
- ¹¹ “Analytische Beobachtungen über Phantasien eines Schizophrenen,” p. 541.
- ¹² Eliade, *Shamanism*, pp. 73f., 142, 344, 346.
- ¹³ *Ibid.*, p. 72.
- ¹⁴ *Prometheus and Epimetheus* (trans. Muirhead), p. 38. (Cf. *Psychological Types*, trans. Baynes, p. 212.) In China, the tiger is a symbol of *yin*.
- ¹⁵ Eliade, p. 75.
- ¹⁶ Pp. 117–18.
- ¹⁷ P. 272.
- ¹⁸ Squirrel, stag. Yggdrasil means “Odin’s horse.” (Ninck, *Götter und Jenseitsglauben der Germanen*, p. 191.) For the feminine significance of Yggdrasil see *Symbols of Transformation*, p. 296.
- ¹⁹ For instance, before the gate of the fort at Seringapatam. Cf. Fergusson, *Tree and Serpent Worship*.
- ²⁰ Kagarow, “Der umgekehrte Schamanenbaum,” p. 183.
- ²¹ *Shamanism*, p. 293.
- ²² *Ibid.*, p. 328.

* For details of the *Collected Works of C. G. Jung*, see announcement at the end of this volume.

- * Published 1957; 2nd edn., 1970.
- † Published 1960.
- * Published 1961.
- † Published 1956; 2nd edn., 1967. (65 plates, 43 text figures.)
- * Published 1953; 2nd edn., 1966.
- † Published 1960; 2nd edn., 1969.
- * Published 1959; 2nd edn., 1968. (Part I: 79 plates, with 29 in colour.)
- * Published 1964; 2nd edn., 1970. (8 plates.)
- † Published 1958; 2nd edn., 1969.
- * Published 1953; 2nd edn., completely revised, 1968. (270 illustrations.)
- † Published 1968. (50 plates, 4 text figures.)
- ‡ Published 1963; 2nd edn., 1970. (10 plates.)
- * Published 1966.
- † Published 1954; 2nd edn., revised and augmented, 1966. (13 illustrations.)
- ‡ Published 1954.

B O L L I N G E N S E R I E S X X

THE COLLECTED WORKS

OF

C. G. JUNG

VOLUME 14

EDITORS

SIR HERBERT READ

MICHAEL FORDHAM, M.D., M.R.C.P.

GERHARD ADLER, PH.D.

WILLIAM MCGUIRE, *executive editor*

MYSTERIUM CONIUNCTIONIS

AN INQUIRY INTO THE SEPARATION AND SYNTHESIS OF PSYCHIC
OPPOSITES IN ALCHEMY

C. G. JUNG

SECOND EDITION

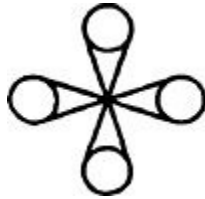

TRANSLATED BY R. F. C. HULL

BOLLINGEN SERIES XX

PRINCETON UNIVERSITY PRESS

COPYRIGHT © 1963 BY BOLLINGEN FOUNDATION, NEW YORK, N. Y. SECOND EDITION COPYRIGHT
© 1970 BY PRINCETON UNIVERSITY PRESS PUBLISHED BY PRINCETON UNIVERSITY PRESS,
PRINCETON, N. J.

ALL RIGHTS RESERVED

Second printing, 1974

Third printing, 1976

First Princeton/Bollingen Paperback printing, 1977

THE HARDCOVER EDITION IS PUBLISHED IN THE UNITED STATES OF AMERICA BY PRINCETON UNIVERSITY PRESS AND IN ENGLAND BY ROUTLEDGE AND KEGAN PAUL, LTD. IN THE AMERICAN EDITION ALL THE VOLUMES COMPRISING THE COLLECTED WORKS CONSTITUTE NUMBER XX IN BOLLINGEN SERIES, SPONSORED BY BOLLINGEN FOUNDATION. THE PRESENT VOLUME IS NUMBER 14 OF THE COLLECTED WORKS AND WAS THE TWELFTH TO APPEAR.

Translated from *Mysterium Coniunctionis: Untersuchung über die Trennung und Zusammensetzung der seelischen Gegensätze in der Alchemie*, Parts I and II, published by Rascher Verlag, Zurich, 1955 and 1956 (Vols. X and XI of *Psychologische Abhandlungen*, edited by C. G. Jung)

ISBN 0-691-01816-2 (paperback edn.)

ISBN 0-691-09766-6 (hardcover edn.)

LIBRARY OF CONGRESS CATALOGUE CARD NUMBER: 75-156

PRINTED IN THE UNITED STATES OF AMERICA

EDITORIAL NOTE*

Volume 14 of the Collected Works presents Jung's last great work, on which he was engaged for more than a decade, from 1941 to 1954. He finished it in his eightieth year. As is to be expected from its culminating position in his writings and from its subject matter, the book gives a final account of his lengthy researches into alchemy.

Jung's interest in the symbolical significance of alchemy for modern depth psychology first found expression, in 1929, in his commentary to *The Secret of the Golden Flower*. The theme was taken up again in his Eranos lectures of 1935 and 1936, which formed the basis of *Psychology and Alchemy*, originally published in 1944. Further researches led to the publication of essays now included in *Alchemical Studies*, Volume 13 of the Collected Works. A preliminary study of the special symbolism of the *coniunctio* in relation to psychotherapeutic problems appeared in *The Psychology of the Transference* (1946), while the connection between philosophical alchemy and Christianity was elaborated in *Aion* (1951). All these themes are brought together in *Mysterium Coniunctionis*, where Jung continues his work of interpretation by examining in detail a number of texts taken from the alchemical classics. The scope of the book is indicated in its subtitle: "An Inquiry into the Separation and Synthesis of Psychic Opposites in Alchemy." This process, summed up in the trenchant formula *solve et coagula*—"dissolve and coagulate"—underlies the *opus alchymicum* and may be symbolically understood as the process of psychic integration.

The focus of the book is on the symbolism of the *coniunctio* and the preceding stages of dissociation. These are known in alchemy as the *chaos* or *prima materia*, and they lead via the intermediate stages to a resolution of the conflict of opposites in the production of the *lapis philosophorum*. Fresh evidence is brought to bear upon Jung's thesis that the *lapis* is not only a parallel of the Christ figure, but a symbolical prefiguration of psychic totality, or the self.

Jung's inquiry is of a highly advanced character and necessitates a wide knowledge of the concepts of analytical psychology in general and Jung's previous publications on alchemy in particular. The reader who follows Jung in his search for a deeper understanding of the *opus alchymicum* will not only discover in this book new and fascinating aspects of the history of the European mind but will also be rewarded by fresh insights into such basic psychological problems as the structure of the self and the ego and their relation to one another, the nature of transference and countertransference, and the process of active imagination. In many ways this book is the summing up of all Jung's later work.

The English edition differs from the Swiss in the following particulars. It comprises Volumes I and II of that version. Volume III is an edition and study by Marie-Louise von Franz of *Aurora Consurgens*, a thirteenth-century treatise traditionally attributed to Thomas Aquinas and rediscovered by Jung, which has been issued in English as a companion volume to *Mysterium Coniunctionis*, but outside the Collected Works. The paragraph numbers of the present work do not correspond to those in the two Swiss volumes, which run in separate sequence. Further, many of the longer paragraphs have been broken up, and in certain instances the material has been rearranged within the chapters to facilitate the exposition. The most important of these changes were made with the author's consent.

In order not to overload the footnotes, the Latin and Greek passages have been put into an appendix. An asterisk in a footnote indicates that the quotation translated there or in the main text will be found in the appendix under the corresponding footnote number of the chapter in question.

Two sections of this work were previously published: [Chapter II, section 3](#), appeared as “Das Rätsel von Bologna” in *Beitrag zur Festschrift Albert Oeri* (Basel, 1945), pp. 265–79 (translated as “The Bologna Enigma,” *Ambix*, London, II, 1946, 182–91); [Chapter III, section 3](#), appeared as “De Sulphure” in *Nova Acta Paracelsica* (Einsiedeln), V (1948), 27–40.

For the second edition, numerous corrections and revisions have been made in cross-references to other volumes of the Collected Works now available, and likewise in the Bibliography.

The *Gesammelte Werke* edition of the present work appeared in 1968 as, in effect, a reprint of the 1955/1956 Swiss edition, retaining its textual arrangement and paragraph numbering. In order to facilitate cross-reference between the English and German text, a table has been added to this edition, correlating the paragraph numbers: see below, pp. 697ff.

One paragraph (183 in Vol. II, p. 124 of the *Gesammelte Werke* edition) was inadvertently omitted in the first edition of the present volume. It should follow paragraph 518 on page 368 and is translated here as paragraph 518a.

[518a] The reader must pardon my use of metaphors that are linguistically analogous to dogmatic expressions. If you have conceptions of things you can have no conceptions of, then the conception and the thing appear to coincide. Nor can two different things you know nothing of be kept apart. I must therefore expressly emphasize that I do not go in for either metaphysics or theology, but am concerned with psychological facts on the borderline of the knowable. So if I make use of certain expressions that are

reminiscent of the language of theology, this is due solely to the poverty of language, and not because I am of the opinion that the subject-matter of theology is the same as that of psychology. Psychology is very definitely not a theology; it is a natural science that seeks to describe experienceable psychic phenomena. In doing so it takes account of the way in which theology conceives and names them, because this hangs together with the phenomenology of the contents under discussion. But as empirical science it has neither the capacity nor the competence to decide on questions of truth and value, this being the prerogative of theology.

TRANSLATOR'S NOTE

Standard translations of Latin and Greek texts have been used where they conformed more or less to the author's own versions, and they are referred to in the footnotes. Where such translations were unsuitable or nonexistent, as is particularly the case with the texts in the appendix, an English version has been supplied by Mr. A. S. B. Glover. To him I would like to express my deepest thanks for his tireless help in preparing this book. My thanks are also due to Miss Barbara Hannah and Dr. Marie-Louise von Franz, for reading through the typescript and making many valuable suggestions.

VOLUME 14 MYSTERIUM CONIUNCTIONIS

TABLE OF CONTENTS

EDITORIAL NOTE

TRANSLATOR'S NOTE

LIST OF PLATES

FOREWORD

I. The Components of the Coniunctio

1. THE OPPOSITES
2. THE QUATERNIO AND THE MEDIATING ROLE OF MERCURIUS
3. THE ORPHAN, THE WIDOW, AND THE MOON
4. ALCHEMY AND MANICHAEISM

II. The Paradoxa

1. THE ARCANESUBSTANCE AND THE POINT
2. THE SCINTILLA
3. THE ENIGMA OF BOLOGNA

III. The Personification of the Opposites

1. INTRODUCTION
2. SOL
3. SULPHUR
4. LUNA
 - a. *The Significance of the Moon*
 - b. *The Dog*
 - c. *An Alchemical Allegory*

d. *The Moon-Nature*

5. SAL

a. *Salt as the Arcane Substance*

b. *The Bitterness*

c. *The Red Sea*

d. *The Fourth of the Three*

e. *Ascent and Descent*

f. *The Journey through the Planetary Houses*

g. *The Regeneration in Sea-water*

h. *The Interpretation and Meaning of Salt*

IV. Rex and Regina

1. INTRODUCTION

2. GOLD AND SPIRIT

3. THE TRANSFORMATION OF THE KING

4. THE REGENERATION OF THE KING (*Ripley's "Cantilena"*)

5. THE DARK SIDE OF THE KING

6. THE KING AS ANTHROPOS

7. THE RELATION OF THE KING-SYMBOL TO CONSCIOUSNESS

8. THE RELIGIOUS PROBLEM OF THE KING'S RENEWAL

9. REGINA

V. Adam and Eve

1. ADAM AS THE ARCANESUBSTANCE

2. THE STATUE

3. ADAM AS THE FIRST ADEPT

4. THE POLARITY OF ADAM

5. THE "OLD ADAM"

6. THE TRANSFORMATION

7. ROTUNDUM, HEAD, AND BRAIN

8. ADAM AS TOTALITY

VI. The Conjunction

1. THE ALCHEMICAL VIEW OF THE UNION OF OPPOSITES
2. STAGES OF THE CONJUNCTION
3. THE PRODUCTION OF THE QUINTESSENCE
4. THE MEANING OF THE ALCHEMICAL PROCEDURE
5. THE PSYCHOLOGICAL INTERPRETATION OF THE PROCEDURE
6. SELF-KNOWLEDGE
7. THE MONOCOLUS
8. THE CONTENT AND MEANING OF THE FIRST TWO STAGES
9. THE THIRD STAGE: THE UNUS MUNDUS
10. THE SELF AND THE BOUNDS OF KNOWLEDGE

Epilogue

APPENDIX: LATIN AND GREEK TEXTS

BIBLIOGRAPHY

INDEX

TABLE OF PARAGRAPH CORRELATIONS

LIST OF PLATES

The plates follow [page 330](#)

1. “Third Picture of John”
From the *Hexastichon* of Sebastian Brant (1502), fol. a.v^r
2. “Second Picture of Luke”
From the *Hexastichon* of Sebastian Brant (1502), fol. c.iii^r
3. “Jezoth Le Juste”
From an 18th cent. ms., “Abraham le Juif,” Bibliothèque Nationale, Fr. 14765. PI. 8
4. The Two Unipeds
From a Latin ms., “Figurarum aegyptiorum secretarum” (author’s collection). p. 20
5. The “Revelation of the Hidden”
From the author’s “Figurarum aegyptiorum secretarum,”. p. 27
6. The Worldly and the Spiritual Power
From the author’s “Figurarum aegyptiorum secretarum,”. p. 31
7. The Royal Pair
From the author’s “Figurarum aegyptiorum secretarum,”. p. 33
8. The Eye-Motif in a Modern Painting
Author’s collection
9. The Eye-Motif in a Modern Painting
Author’s collection
10. The Nigredo
From the *Theatrum chemicum*, Vol. IV (1613). p. 570

FOREWORD

This book—my last—was begun more than ten years ago. I first got the idea of writing it from C. Kerényi's essay on the Aegean Festival in Goethe's *Faust*.¹ The literary prototype of this festival is *The Chymical Wedding* of Christian Rosencreutz, itself a product of the traditional hierogamos symbolism of alchemy. I felt tempted, at the time, to comment on Kerényi's essay from the standpoint of alchemy and psychology, but soon discovered that the theme was far too extensive to be dealt with in a couple of pages. Although the work was soon under way, more than ten years were to pass before I was able to collect and arrange all the material relevant to this central problem.

As may be known, I showed in my book *Psychology and Alchemy*, first published in 1944,² how certain archetypal motifs that are common in alchemy appear in the dreams of modern individuals who have no knowledge of alchemical literature. In that book the wealth of ideas and symbols that lie hidden in the neglected treatises of this much misunderstood "art" was hinted at rather than described in the detail it deserved; for my primary aim was to demonstrate that the world of alchemical symbols definitely does not belong to the rubbish heap of the past, but stands in a very real and living relationship to our most recent discoveries concerning the psychology of the unconscious. Not only does this modern psychological discipline give us the key to the secrets of alchemy, but, conversely, alchemy provides the psychology of the unconscious with a meaningful historical basis. This was hardly a popular subject, and for that reason it remained largely misunderstood. Not only was alchemy almost entirely unknown as a branch of natural philosophy and as a religious movement, but most people were unfamiliar with the modern discovery of the archetypes, or had at least misunderstood them. Indeed, there were not a few who regarded them as sheer fantasy, although the well-known example of whole numbers, which also were discovered and not invented, might have taught them better, not to mention the "patterns of behaviour" in biology. Just as numbers and instinctual forms do exist, so there are many other natural configurations or types which are exemplified by Lévy-Bruhl's *représentations collectives*. They are not "metaphysical" speculations but, as we would expect, symptoms of the uniformity of *Homo sapiens*.

Today there is such a large and varied literature describing psychotherapeutic experiences and the psychology of the unconscious that everyone has had an opportunity to familiarize himself with the empirical findings and the prevailing theories about them. This is not true of alchemy, most accounts of which are vitiated by the erroneous assumption that it was merely the precursor of chemistry. Herbert

Silberer³ was the first to try to penetrate its much more important psychological aspect so far as his somewhat limited equipment allowed him to do so. Owing to the paucity of modern expositions and the comparative inaccessibility of the sources, it is difficult to form an adequate conception of the problems of philosophical alchemy. It is the aim of the present work to fill this gap.

As is indicated by the very name which he chose for it—the “spagyric”⁴ art—or by the oft-repeated saying “solve et coagula” (dissolve and coagulate), the alchemist saw the essence of his art in separation and analysis on the one hand and synthesis and consolidation on the other. For him there was first of all an initial state in which opposite tendencies or forces were in conflict; secondly there was the great question of a procedure which would be capable of bringing the hostile elements and qualities, once they were separated, back to unity again. The initial state, named the *chaos*, was not given from the start but had to be sought for as the *prima materia*. And just as the beginning of the work was not self-evident, so to an even greater degree was its end. There are countless speculations on the nature of the end-state, all of them reflected in its designations. The commonest are the ideas of its permanence (prolongation of life, immortality, incorruptibility), its androgyny, its spirituality and corporeality, its human qualities and resemblance to man (*homunculus*), and its divinity.

The obvious analogy, in the psychic sphere, to this problem of opposites is the dissociation of the personality brought about by the conflict of incompatible tendencies, resulting as a rule from an inharmonious disposition. The repression of one of the opposites leads only to a prolongation and extension of the conflict, in other words, to a neurosis. The therapist therefore confronts the opposites with one another and aims at uniting them permanently. The images of the goal which then appear in dreams often run parallel with the corresponding alchemical symbols. An instance of this is familiar to every analyst: the phenomenon of the transference, which corresponds to the motif of the “chymical wedding.” To avoid overloading this book, I devoted a special study to the psychology of the transference,⁵ using the alchemical parallels as a guiding thread. Similarly, the hints or representations of wholeness, or the self, which appear in the dreams also occur in alchemy as the numerous synonyms for the *lapis Philosophorum*, which the alchemists equated with Christ. Because of its great importance, this last relationship gave rise to a special study, *Aion*. Further offshoots from the theme of this book are my treatises “The Philosophical Tree,” “Synchronicity: An Acausal Connecting Principle,” and “Answer to Job.”

The first and second parts of this work⁶ are devoted to the theme of the opposites and their union. The third part is an account of, and commentary on, an alchemical text, which, evidently written by a cleric, probably dates from the thirteenth century and discloses a highly peculiar state of mind in which Christianity and alchemy interpenetrate. The author tries, with the help of the mysticism of the Song of Songs, to

fuse apparently heterogeneous ideas, partly Christian and partly derived from natural philosophy, in the form of a hymnlike incantation. This text is called *Aurora consurgens* (also *Aurea hora*), and traditionally it is ascribed to St. Thomas Aquinas. It is hardly necessary to remark that Thomist historians have always reckoned it, or wanted to reckon it, among the spurious and false writings, no doubt because of the traditional depreciation of alchemy. This negative evaluation of alchemy was due, in the main, to ignorance. People did not know what it meant to its adepts because it was commonly regarded as mere gold-making. I hope I have shown in my book *Psychology and Alchemy* that, properly understood, it was nothing of the sort. Alchemy meant a very great deal to people like Albertus Magnus and Roger Bacon, and also to St. Thomas Aquinas. We have not only the early testimony of Zosimos of Panopolis from the third century, but that of Petrus Bonus of Ferrara from the beginning of the fourteenth century, which both point to the parallelism of the alchemical arcanum and the God-man. *Aurora consurgens* tries to amalgamate the Christian and alchemical view, and I have therefore chosen it as an example of how the spirit of medieval Christianity came to terms with alchemical philosophy, and as an illustration of the present account of the alchemical problem of opposites.⁷

Today, once again, we hear tendentious voices still contesting the hypothesis of the unconscious, declaring that it is nothing more than the personal prejudice of those who make use of this hypothesis. Remarkably enough, no consideration is given to the proofs that have been put forward; they are dismissed on the ground that all psychology is nothing more than a preconceived subjective opinion. It must be admitted that probably in no other field of work is there so great a danger of the investigator's falling a victim to his own subjective assumptions. He of all people must remain more than ever conscious of his "personal equation." But, young as the psychology of unconscious processes may be, it has nevertheless succeeded in establishing certain facts which are gradually gaining general acceptance. One of these is the polaristic structure of the psyche, which it shares with all natural processes. Natural processes are phenomena of energy, constantly arising out of a "less probable state" of polar tension. This formula is of special significance for psychology, because the conscious mind is usually reluctant to see or admit the polarity of its own background, although it is precisely from there that it gets its energy.

The psychologist has only just begun to feel his way into this structure, and it now appears that the "alchemystical" philosophers made the opposites and their union one of the chief objects of their work. In their writings, certainly, they employed a symbolical terminology that frequently reminds us of the language of dreams, concerned as these often are with the problem of opposites. Since conscious thinking strives for clarity and demands unequivocal decisions, it has constantly to free itself from counterarguments and contrary tendencies, with the result that especially incompatible contents either

remain totally unconscious or are habitually and assiduously overlooked. The more this is so, the more the unconscious will build up its counterposition. As the alchemists, with but few exceptions, did not know that they were bringing psychic structures to light but thought that they were explaining the transformations of matter, there were no psychological considerations to prevent them, for reasons of sensitiveness, from laying bare the background of the psyche, which a more conscious person would be nervous of doing. It is because of this that alchemy is of such absorbing interest to the psychologist. For this reason, too, it seemed necessary to my co-worker and myself to subject the alchemical conception of opposites, and their union or reconciliation, to a thoroughgoing investigation. However abstruse and strange the language and imagery of the alchemists may seem to the uninitiated, they become vivid and alive as soon as comparative research reveals the relationship of the symbols to processes in the unconscious. These may be the material of dreams, spontaneous fantasies, and delusional ideas on the one hand, and on the other hand they can be observed in works of creative imagination and in the figurative language of religion. The heterogeneous material adduced for comparison may seem in the highest degree baffling to the academically educated reader who has met these items only in an impersonal context—historical, ethnic, or geographical—but who does not know their psychological affinities with analogous formations, themselves derived from the most varied sources. He will naturally be taken aback, at first, if certain symbols in ancient Egyptian texts are brought into intimate relationship with modern findings concerning the popular religion of India and at the same time with the dreams of an unsuspecting European. But what is difficult for the historian and philologist to swallow is no obstacle for the physician. His biological training has left him with far too strong an impression of the comparability of all human activities for him to make any particular to-do about the similarity, indeed the fundamental sameness, of human beings and their psychic manifestations. If he is a psychiatrist, he will not be astonished at the essential similarity of psychotic contents, whether they come from the Middle Ages or from the present, from Europe or from Australia, from India or from the Americas. The processes underlying them are instinctive, therefore universal and uncommonly conservative. The weaver-bird builds his nest in his own peculiar fashion no matter where he may be, and just as we have no grounds for assuming that he built his nest differently three thousand years ago, so it is very improbable that he will alter his style in the next three thousand. Although contemporary man believes that he can change himself without limit, or be changed through external influences, the astounding, or rather the terrifying, fact remains that despite civilization and Christian education, he is still, morally, as much in bondage to his instincts as an animal, and can therefore fall victim at any moment to the beast within. This is a more universal truth than ever before, guaranteed independent of education, culture, language, tradition, race, and locality.

Investigation of alchemical symbolism, like a preoccupation with mythology, does not lead one away from life any more than a study of comparative anatomy leads away from the anatomy of the living man. On the contrary, alchemy affords us a veritable treasure-house of symbols, knowledge of which is extremely helpful for an understanding of neurotic and psychotic processes. This, in turn, enables us to apply the psychology of the unconscious to those regions in the history of the human mind which are concerned with symbolism. It is just here that questions arise whose urgency and vital intensity are even greater than the question of therapeutic application. Here there are many prejudices that still have to be overcome. Just as it is thought, for instance, that Mexican myths cannot possibly have anything to do with similar ideas found in Europe, so it is held to be a fantastic assumption that an uneducated modern man should dream of classical myth-motifs which are known only to a specialist. People still think that relationships like this are far-fetched and therefore improbable. But they forget that the structure and function of the bodily organs are everywhere more or less the same, including those of the brain. And as the psyche is to a large extent dependent on this organ, presumably it will—at least in principle—everywhere produce the same forms. In order to see this, however, one has to abandon the widespread prejudice that the psyche is identical with consciousness.

C. G. JUNG

October 1954

MYSTERIUM CONIUNCTIONIS

AN INQUIRY

INTO THE SEPARATION AND SYNTHESIS

OF PSYCHIC OPPOSITES IN ALCHEMY

THE COMPONENTS OF THE CONIUNCTIO

1. THE OPPOSITES

[1] The factors which come together in the coniunctio are conceived as opposites, either confronting one another in enmity or attracting one another in love.¹ To begin with they form a dualism; for instance the opposites are *humidum* (moist) / *siccum* (dry), *frigidum* (cold) / *calidum* (warm), *superiora* (upper, higher) / *inferiora* (lower), *spiritus-anima* (spirit-soul) / *corpus* (body), *coelum* (heaven) / *terra* (earth), *ignis* (fire) / *aqua* (water), bright / dark, *agens* (active) / *patiens* (passive), *volatile* (volatile, gaseous) / *fixum* (solid), *pretiosum* (precious, costly; also *carum*, dear) / *vile* (cheap, common), *bonum* (good) / *malum* (evil), *manifestum* (open) / *occultum* (occult; also *celatum*, hidden), *oriens* (East) / *occidens* (West), *vivum* (living) / *mortuum* (dead, inert), *masculus* (masculine) / *foemina* (feminine), Sol / Luna. Often the polarity is arranged as a quaternio (quaternity), with the two opposites crossing one another, as for instance the four elements or the four qualities (moist, dry, cold, warm), or the four directions and seasons,² thus producing the cross as an emblem of the four elements and symbol of the sublunary physical world.³ This fourfold Physis, the cross, also appears in the signs for earth ♁, Venus ♀, Mercury ☿, Saturn ♄, and Jupiter ♃.⁴

[2] The opposites and their symbols are so common in the texts that it is superfluous to cite evidence from the sources. On the other hand, in view of the ambiguity of the alchemists' language, which is "tam ethice quam physice" (as much ethical as physical), it is worth while to go rather more closely into the manner in which the texts treat of the opposites. Very often the masculine-feminine opposition is personified as King and Queen (in the *Rosarium philosophorum* also as Emperor and Empress), or as *servus* (slave) or *vir rubeus* (red man) and *mulier candida* (white woman);⁵ in the "Visio Arislei" they appear as Gabricus (or Thabritius) and Beya, the King's son and daughter.⁶ Theriomorphic symbols are equally common and are often found in the illustrations.⁷ I would mention the eagle and toad ("the eagle flying through the air and the toad crawling on the ground"), which are the "emblem" of Avicenna in Michael Maier,⁸ the eagle representing Luna "or Juno, Venus, Beya, who is fugitive and winged like the eagle, which flies up to the clouds and receives the rays of the sun in his eyes." The toad "is the opposite of air, it is a contrary element, namely earth, whereon alone it moves by slow steps, and does not trust itself to

another element. Its head is very heavy and gazes at the earth. For this reason it denotes the philosophic earth, which cannot fly [i.e., cannot be sublimated], as it is firm and solid. Upon it as a foundation the golden house⁹ is to be built. Were it not for the earth in our work the air would fly away, neither would the fire have its nourishment, nor the water its vessel.”¹⁰

[3] Another favourite theriomorphic image is that of the two birds or two dragons, one of them winged, the other wingless. This allegory comes from an ancient text, *De Chemia Senioris antiquissimi philosophi libellus*.¹¹ The wingless bird or dragon prevents the other from flying. They stand for Sol and Luna, brother and sister, who are united by means of the art.¹² In Lamspringk's "Symbols"¹³ they appear as the astrological Fishes which, swimming in opposite directions, symbolize the spirit / soul polarity. The water they swim in is *mare nostrum* (our sea) and is interpreted as the body.¹⁴ The fishes are "without bones and cortex."¹⁵ From them is produced a *mare immensum*, which is the *aqua permanens* (permanent water). Another symbol is the stag and unicorn meeting in the "forest."¹⁶ The stag signifies the soul, the unicorn spirit, and the forest the body. The next two pictures in Lamspringk's "Symbols" show the lion and lioness,¹⁷ or the wolf and dog, the latter two fighting; they too symbolize soul and spirit. In Figure VII the opposites are symbolized by two birds in a wood, one fledged, the other unfledged. Whereas in the earlier pictures the conflict seems to be between spirit and soul, the two birds signify the conflict between spirit and body, and in Figure VIII the two birds fighting do in fact represent that conflict, as the caption shows. The opposition between spirit and soul is due to the latter having a very fine substance. It is more akin to the "hylical" body and is *densior et crassior* (denser and grosser) than the spirit.

[4] The elevation of the human figure to a king or a divinity, and on the other hand its representation in subhuman, theriomorphic form, are indications of the *transconscious character* of the pairs of opposites. They do not belong to the ego-personality but are supraordinate to it. The ego-personality occupies an intermediate position, like the "anima inter bona et mala sita" (soul placed between good and evil). The pairs of opposites constitute the phenomenology of the paradoxical *self*, man's totality. That is why their symbolism makes use of cosmic expressions like *coelum / terra*.¹⁸ The intensity of the conflict is expressed in symbols like fire and water,¹⁹ height and depth,²⁰ life and death.²¹

2. THE QUATERNIO AND THE MEDIATING ROLE OF MERCURIUS

[5] The arrangement of the opposites in a quaternity is shown in an interesting illustration in Stolcenberg's *Viridarium chymicum* (Fig. XLII), which can also be

found in the *Philosophia reformata* of Mylius (1622, p. 117). The goddesses represent the four seasons of the sun in the circle of the Zodiac (Aries, Cancer, Libra, Capricorn) and at the same time the four degrees of heating,²² as well as the four elements “combined” around the circular table.²³ The synthesis of the elements is effected by means of the circular movement in time (*circulatio, rota*) of the sun through the houses of the Zodiac. As I have shown elsewhere,²⁴ the aim of the *circulatio* is the production (or rather, reproduction) of the Original Man, who was a sphere. Perhaps I may mention in this connection a remarkable quotation from Ostanes in Abu’l-Qasim, describing the intermediate position between two pairs of opposites constituting a quaternio:

Ostanes said, Save me, O my God, for I stand between two exalted brilliancies known for their wickedness, and between two dim lights; each of them has reached me and I know not how to save myself from them. And it was said to me, Go up to Agathodaimon the Great and ask aid of him, and know that there is in thee somewhat of his nature, which will never be corrupted. . . . And when I ascended into the air he said to me, Take the child of the bird which is mixed with redness and spread for the gold its bed which comes forth from the glass, and place it in its vessel whence it has no power to come out except when thou desirest, and leave it until its moistness has departed.²⁵

[6] The quaternio in this case evidently consists of the two *malefici*, Mars and Saturn (Mars is the ruler of Aries, Saturn of Capricorn); the two “dim lights” would then be feminine ones, the moon (ruler of Cancer) and Venus (ruler of Libra). The opposites between which Ostanes stands are thus masculine / feminine on the one hand and good / evil on the other. The way he speaks of the four luminaries—he does not know how to save himself from them—suggests that he is subject to Heimarmene, the compulsion of the stars; that is, to a transconscious factor beyond the reach of the human will. Apart from this compulsion, the injurious effect of the four planets is due to the fact that each of them exerts its specific influence on man and makes him a diversity of persons, whereas he should be *one*.²⁶ It is presumably Hermes who points out to Ostanes that something incorruptible is in his nature which he shares with the Agathodaimon,²⁷ something divine, obviously the germ of unity. This germ is the gold, the *aurum philosophorum*,²⁸ the bird of Hermes or the son of the bird, who is the same as the *filius philosophorum*.²⁹ He must be enclosed in the *vas Hermeticum* and heated until the “moistness” that still clings to him has departed, i.e., the *humidum radicale* (radical moisture), the prima materia, which is the original chaos and the sea (the unconscious). Some kind of coming to consciousness seems indicated. We know that the synthesis of the four was one of the main preoccupations of alchemy, as was, though to a lesser degree, the synthesis of the seven (metals, for instance). Thus in the same text Hermes says to the Sun:

. . . I cause to come out to thee the spirits of thy brethren [the planets], O Sun, and I make them for thee a crown the like of which was never seen; and I cause thee and them to be within me, and I will make thy kingdom vigorous.³⁰

This refers to the synthesis of the planets or metals with the sun, to form a crown which will be “within” Hermes. The crown signifies the kingly totality; it stands for unity and is not subject to Heimarmene. This reminds us of the seven- or twelve-rayed crown of light which the Agathodaimon serpent wears on Gnostic gems,³¹ and also of the crown of Wisdom in the *Aurora Consurgens*.³²

[7] In the “Consilium coniugii” there is a similar quaternio with the four qualities arranged as “combinations of two contraries, cold and moist, which are not friendly to heat and dryness.”³³ Other quaternions are: “The stone is first an old man, in the end a youth, because the *albedo* comes at the beginning and the *rubedo* at the end.”³⁴ Similarly the elements are arranged as two “manifesta” (water and earth), and two “occulta” (air and fire).³⁵ A further quaternio is suggested by the saying of Bernardus Trevisanus: “The upper has the nature of the lower, and the ascending has the nature of the descending.”³⁶ The following combination is from the “Tractatus Micreris”: “In it [the Indian Ocean]³⁷ are images of heaven and earth, of summer, autumn, winter, and spring, male and female. If thou callest this spiritual, what thou doest is probable; if corporeal, thou sayest the truth; if heavenly, thou liest not; if earthly, thou hast well spoken.”³⁸ Here we are dealing with a double quaternio having the structure shown in the diagram on page 10.

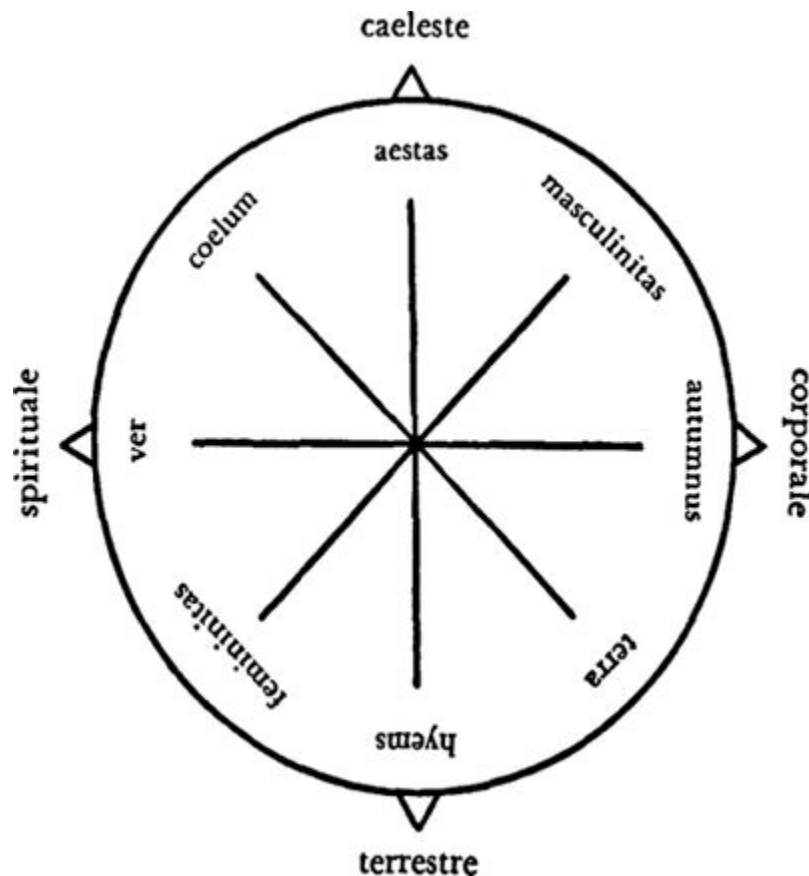

[8] The double quaternio or ogdoad stands for a totality, for something that is at once heavenly and earthly, spiritual or corporeal, and is found in the “Indian Ocean,” that is to say in the unconscious. It is without doubt the Microcosm, the mystical Adam and bisexual Original Man in his prenatal state, as it were, when he is identical with the unconscious. Hence in Gnosticism the “Father of All” is described not only as masculine and feminine (or neither), but as Bythos, the abyss. In the scholia to the “Tractatus aureus Hermetis”³⁹ there is a quaternio consisting of *superius / inferius*, *exterius / interius*. They are united into one thing by means of the circular distillation, named the Pelican:⁴⁰ “Let all be one in one circle or vessel.” “For this vessel is the true philosophical Pelican, nor is any other to be sought after in all the world.” The text gives the following diagram:

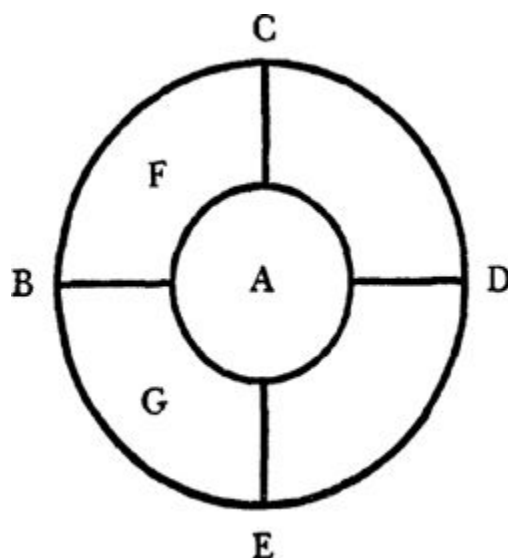

[9] B C D E represent the outside, A is the inside, “as it were the origin and source from which the other letters flow, and likewise the final goal to which they flow back,”⁴¹ F G stands for Above and Below. “Together the letters A B C D E F G clearly signify the hidden magical Septenary.” The central point A, the origin and goal, the “Ocean or great sea,” is also called a *circulus exiguus*, very small circle, and a “mediator making peace between the enemies or elements, that they may love one another in a meet embrace.”⁴² This little inner circle corresponds to the Mercurial Fountain in the *Rosarium*, which I have described in my “Psychology of the Transference.” The text calls it “the more spiritual, perfect, and nobler Mercurius,”⁴³ the true arcane substance, a “spirit,” and goes on:

For the spirit alone penetrates all things, even the most solid bodies.⁴⁴ Thus the catholicity of religion, or of the true Church, consists not in a visible and bodily gathering together of men, but in the invisible, spiritual concord and harmony of those who believe devoutly and truly in the one Jesus Christ. Whoever attaches himself to a particular church outside this King of Kings, who alone is the shepherd of the true spiritual church, is a sectarian, a schismatic, and a heretic. For the

Kingdom of God cometh not with observation, but is within us, as our Saviour himself says in the seventeenth chapter of St. Luke.⁴⁵

That the Ecclesia spiritualis is meant is clear from the text: “But you will ask, where then are those true Christians, who are free from all sectarian contagion?” They are “neither in Samaria, nor in Jerusalem, nor in Rome, nor in Geneva, nor in Leipzig,” but are scattered everywhere through the world, “in Turkey, in Persia, Italy, Gaul, Germany, Poland, Bohemia, Moravia, England, America, and even in farthest India.” The author continues: “God is Spirit,⁴⁶ and those who worship him must worship him in the spirit and in truth. After these examinations and avowals I leave it to each man to judge who is of the true Church, and who not.”⁴⁷

[10] From this remarkable excursus we learn, first of all, that the “centre” unites the four and the seven into one.⁴⁸ The unifying agent is the spirit Mercurius, and this singular spirit then causes the author to confess himself a member of the Ecclesia spiritualis, for the spirit is God. This religious background is already apparent in the choice of the term “Pelican” for the circular process, since this bird is a well-known allegory of Christ.⁴⁹ The idea of Mercurius as a peacemaker, the mediator between the warring elements and producer of unity, probably goes back to Ephesians 2 : 13ff.:

But now in Christ Jesus you who once were far off have been brought near in the blood of Christ. For he is our peace, who has made both one, and has broken down the dividing wall of hostility, by abolishing in his flesh the law of commandments and ordinances, that he might create in himself one new man in place of two, so making peace, and might reconcile both to God in one body through the cross, thereby bringing the hostility to an end. And he came and preached peace to you who were far off and peace to those who were near; for through him we both have access in one Spirit to the Father. So then you are no longer strangers and sojourners, but you are fellow citizens with the saints and members of the household of God, built upon the foundation of the apostles and prophets, Christ himself being the chief cornerstone, in whom the whole structure is joined together and grows into a holy temple in the Lord; in whom you are also built into it for a dwelling place of God in the Spirit. [RSV]⁵⁰

[11] In elucidating the alchemical parallel we should note that the author of the scholia to the “Tractatus aureus Hermetis” prefaces his account of the union of opposites with the following remark:

Finally, there will appear in the work that ardently desired blue or cerulean colour, which does not darken or dull the eyes of the beholder by the healing power of its brilliance, as when we see the splendour of the outward sun. Rather does it sharpen

and strengthen them, nor does he [Mercurius] slay a man with his glance like the basilisk, but by the shedding of his own blood he calls back those who are near to death, and restores to them unimpaired their former life, like the pelican.⁵¹

Mercurius is conceived as “spiritual blood,”⁵² on the analogy of the blood of Christ. In Ephesians those who are separated “are brought near in the blood of Christ.” He makes the two one and has broken down the dividing wall “in his flesh.” *Caro* (flesh)⁵³ is a synonym for the prima materia and hence for Mercurius. The “one” is a “new man.” He reconciles the two “in one body,”⁵⁴ an idea which is figuratively represented in alchemy as the two-headed hermaphrodite. The two have one spirit, in alchemy they have one soul. Further, the lapis is frequently compared to Christ as the *lapis angularis* (cornerstone).⁵⁵ As we know, the temple built upon the foundation of the saints inspired in the *Shepherd of Hermas* a vision of the great building into which human beings, streaming from the four quarters, inserted themselves as living stones, melting into it “without seam.”⁵⁶ The Church is built upon the rock that gave Peter his name (Matthew 16 : 18).

[12] In addition, we learn from the scholia that the circle and the Hermetic vessel are one and the same, with the result that the mandala, which we find so often in the drawings of our patients, corresponds to the vessel of transformation. Consequently, the usual quaternary structure of the mandala⁵⁷ would coincide with the alchemists’ quaternio of opposites. Lastly, there is the interesting statement that an *Ecclesia spiritualis* above all creeds and owing allegiance solely to Christ, the Anthropos, is the real aim of the alchemists’ endeavours. Whereas the treatise of Hermes is, comparatively speaking, very old, and in place of the Christian Anthropos mystery⁵⁸ contains a peculiar paraphrase of it, or rather, its antique parallel,⁵⁹ the scholia cannot be dated earlier than the beginning of the seventeenth century.⁶⁰ The author seems to have been a Paracelsist physician. Mercurius corresponds to the Holy Ghost as well as to the Anthropos; he is, as Gerhard Dorn says, “the true hermaphroditic Adam and Microcosm”:

Our Mercurius is therefore that same [Microcosm], who contains within him the perfections, virtues, and powers of Sol [in the dual sense of sun and gold], and who goes through the streets [*vicos*] and houses of all the planets, and in his regeneration has obtained the power of Above and Below, wherefore he is to be likened to their marriage, as is evident from the white and the red that are conjoined in him. The sages have affirmed in their wisdom that all creatures are to be brought to one united substance.⁶¹

Accordingly Mercurius, in the crude form of the prima materia, is in very truth the Original Man disseminated through the physical world, and in his sublimated form he is that reconstituted totality.⁶² Altogether, he is very like the redeemer of the

Basilidians, who mounts upward through the planetary spheres, conquering them or robbing them of their power. The remark that he contains the powers of Sol reminds us of the above-mentioned passage in Abu'l-Qasim, where Hermes says that he unites the sun and the planets and causes them to be within him as a crown. This may be the origin of the designation of the lapis as the “crown of victory.”⁶³ The “power of Above and Below” refers to that ancient authority the “Tabula smaragdina,” which is of Alexandrian origin.⁶⁴ Besides this, our text contains allusions to the Song of Songs: “through the streets and houses of the planets” recalls Song of Songs 3 : 2: “I will . . . go about the city in the streets, and in the broad ways I will seek him whom my soul loveth.”⁶⁵ The “white and red” of Mercurius refers to 5 : 10: “My beloved is white and ruddy.” He is likened to the “matrimonium” or coniunctio; that is to say he is this marriage on account of his androgynous form.

3. THE ORPHAN, THE WIDOW, AND THE MOON

[13] In the text cited at the end of the last section Dorn continues: “Hermes Trismegistus called the stone ‘orphan’.”⁶⁶ “Orphan” as the name of a precious stone is found in Albertus Magnus. The stone was called “orphan” because of its uniqueness—“it was never seen elsewhere”—and it was said to be in the Emperor’s crown. It was “wine-coloured” and sometimes shone in the night, “but nowadays it does not shine [any more] in the darkness.”⁶⁷ As Albertus Magnus was an authority on alchemy, he may have been the direct source both for Dorn and for Petrus Bonus (see n. 66). “Orphan” as the name of a gem may therefore mean something like the modern “solitaire”—a very apt name for the unique lapis Philosophorum. Apart from Dorn and Petrus Bonus, it seems that this name is found only in the *Carmina Heliodori*.⁶⁸ There it refers to the ὀρφανὸς ἑξέοικος (homeless orphan) who is slain at the beginning of the work for purposes of transformation.

[14] The terms “son of the widow” and “children of the widow” appear to be of Manichaean origin. The Manichaeans themselves were called “children of the widow.”⁶⁹ The “orphan” referred to by Hermes must therefore have for his counterpart a *vidua* (widow) as the prima materia. For this there are synonyms such as *mater*, *matrix*, *Venus*, *regina*, *femina*, *virgo*, *puella praegnans*, “virgin in the centre of the earth,”⁷⁰ *Luna*,⁷¹ *meretrix* (whore), *vetula* (old woman), more specifically *vetula extenuata* (enfeebled, exhausted),⁷² *Mater Alchimia*, “who is dropsical in the lower limbs and paralysed from the knees down,”⁷³ and finally *virago*. All these synonyms allude to the virginal or maternal quality of the prima materia, which exists without a man⁷⁴ and yet is the “matter of all things.”⁷⁵ Above all, the prima materia is the mother of the lapis, the *filius philosophorum*. Michael Maier⁷⁶ mentions the treatise of an anonymous author Delphinus, which he dates to some time before

1447.⁷⁷ He stresses that this author insisted particularly on the mother-son incest. Maier even constructs a genealogical tree showing the origin of the seven metals. At the top of the tree is the lapis. Its father is “Gabritius,” who in turn was born of Isis and Osiris. After the death of Osiris Isis married their son Gabritius;⁷⁸ she is identified with Beya—“the widow marries her son.” The widow appears here as the classical figure of the mourning Isis. To this event Maier devotes a special “Epithalamium in Honour of the Nuptials of the Mother Beya and Her Son Gabritius.”⁷⁹ “But this marriage, which was begun with the expression of great joyfulness, ended in the bitterness of mourning,” says Maier, adding the verses:

Within the flower itself there grows the gnawing canker:

Where honey is, there gall, where swelling breast, the chancre.⁸⁰

For, “when the son sleeps with the mother, she kills him with the stroke of a viper” (*viperino conatu*). This viciousness recalls the murderous role of Isis,⁸¹ who laid the “noble worm” in the path of the heavenly Father, Ra.⁸² Isis, however, is also the healer, for she not only cured Ra of the poisoning but put together the dismembered Osiris. As such she personifies that arcane substance, be it dew⁸³ or the *aqua permanens*⁸⁴ which unites the hostile elements into one. This synthesis is described in the myth of Isis, “who collected the scattered limbs of his body and bathed them with her tears and laid them in a secret grave beneath the bank of the Nile.”⁸⁵ The cognomen of Isis was *χημεία*, the Black One.⁸⁶ Apuleius stresses the blackness of her robe (*palla nigerrima*, ‘robe of deepest black’),⁸⁷ and since ancient times she was reputed to possess the elixir of life⁸⁸ as well as being adept in sundry magical arts.⁸⁹ She was also called the Old One,⁹⁰ and she was rated a pupil of Hermes,⁹¹ or even his daughter.⁹² She appears as a teacher of alchemy in the treatise “Isis the Prophetess to her Son Horus.”⁹³ She is mentioned in the role of a whore in Epiphanius, where she is said to have prostituted herself in Tyre.⁹⁴ She signifies earth, according to Firmicus Maternus,⁹⁵ and was equated with Sophia.⁹⁶ She is *μυριώνυμος*, ‘thousand-named’, the vessel and the matter (*χώρα καὶ ἕλη*) of good and evil.⁹⁷ She is the moon.⁹⁸ An inscription invokes her as “the One, who art All.”⁹⁹ She is named *σώτεια*, the redemptrix.¹⁰⁰ In Athenagoras she is “the nature of the Aeon, whence all things grew and by which all things are.”¹⁰¹

[15] All these statements apply just as well to the prima materia in its feminine aspect: it is the moon, the mother of all things, the vessel, it consists of opposites, has a thousand names, is an old woman and a whore, as Mater Alchimia it is wisdom and teaches wisdom, it contains the elixir of life in potentia and is the mother of the Saviour and of the *filius Macrocosmi*, it is the earth and the serpent hidden in the earth, the blackness and the dew and the miraculous water which brings together all that is divided. The water is therefore called “mother,” “my mother who is my

enemy,” but who also “gathers together all my divided and scattered limbs.”¹⁰² The *Turba* says (Sermo LIX):

Nevertheless the Philosophers have put to death the woman who slays her husbands, for the body of that woman is full of weapons and poison. Let a grave be dug for that dragon, and let that woman be buried with him, he being chained fast to that woman; and the more he winds and coils himself about her, the more will he be cut to pieces by the female weapons which are fashioned in the body of the woman. And when he sees that he is mingled with the limbs of the woman, he will be certain of death, and will be changed wholly into blood. But when the Philosophers see him changed into blood, they leave him a few days in the sun, until his softness is consumed, and the blood dries, and they find that poison. What then appears, is the hidden wind.¹⁰³

The coniunctio can therefore take more gruesome forms than the relatively harmless one depicted in the *Rosarium*.¹⁰⁴

- [16] It is clear from these parallels that Maier was fully justified in giving the name Isis to the prima materia or feminine transformative substance.¹⁰⁵ As Kerényi has brilliantly shown, using the example of Medea,¹⁰⁶ there is in that myth a typical combination of various motifs: love, trickery, cruelty, motherliness, murder of relatives and children, magic, rejuvenation, and—gold.¹⁰⁷ This same combination appears in Isis and in the prima materia and forms the core of the drama instigated by the mother-world, without which no union seems possible.
- [17] In Christian tradition the widow signifies the Church; in St. Gregory¹⁰⁸ the analogy is the story of the widow’s cruse of oil (II Kings 4). St. Augustine says: “The whole Church is one widow, desolate in this world.”¹⁰⁹ She “lacketh a husband, lacketh a man,” for her bridegroom has not yet come. So too the soul is “destitute in the world.” “But,” Augustine continues, “thou art not an orphan, thou art not reckoned as a widow . . . Thou hast a friend . . . Thou art God’s orphan, God’s widow.”¹¹⁰
- [18] Another tradition to be considered in regard to the widow is the Cabala. There the abandoned Malchuth is the widow, as Knorr von Rosenroth says: “[Almanah] Widow. This is Malchuth, when Tifereth is not with her.”¹¹¹ Tifereth¹¹² is the son¹¹³ and is interpreted by Reuchlin as the Microcosm. Malchuth¹¹⁴ is Domina, the Mistress.¹¹⁵ She is also called Shekinah,¹¹⁶ the “indwelling” (of God), and virago.¹¹⁷ The Sefira Tifereth is the King, and in the usual arrangement of the Sefiroth he occupies the second place:

Kether

Tifereth

Yesod
Malchuth.

Kether, the Crown, corresponds to the upward-growing root of the Tree of the Sefiroth.¹¹⁸ Yesod¹¹⁹ signifies the genital region of the Original Man, whose head is Kether. Malchuth, conforming to the archetypal pattern, is the underlying feminine principle.¹²⁰ In this wicked world ruled by evil Tifereth is *not* united with Malchuth.¹²¹ But the coming Messiah will reunite the King with the Queen, and this mating will restore to God his original unity.¹²² The Cabala develops an elaborate hierosgamos fantasy which expatiates on the union of the soul with the Sefiroth of the worlds of light and darkness, “for the desire of the upper world for the God-fearing man is as the loving desire of a man for his wife, when he woos her.”¹²³ Conversely, the Shekinah is present in the sexual act:

The *absconditus sponsus* enters into the body of the woman and is joined with the *abscondita sponsa*. This is true also on the reverse side of the process, so that two spirits are melted together and are interchanged constantly between body and body. . . . In the indistinguishable state which arises it may be said almost that the male is with the female, neither male nor female,¹²⁴ at least they are both or either. So is man affirmed to be composed of the world above, which is male, and of the female world below. The same is true of woman.¹²⁵

[19] The Cabala also speaks of the *thalamus* (bride chamber) or nuptial canopy beneath which sponsus and sponsa are consecrated, Yesod acting as *paranympus* (best man).¹²⁶ Directly or indirectly the Cabala was assimilated into alchemy. Relationships must have existed between them at a very early date, though it is difficult to trace them in the sources. Late in the sixteenth century we come upon direct quotations from the *Zohar*, for instance in the treatise “De igne et sale” by Blasius Vigenerus.¹²⁷ One passage in this treatise is of especial interest to us as it concerns the mythologem of the coniunctio:

[The Sefiroth] end in Malchuth or the moon, who is the last to descend and the first to ascend from the elemental world. For the moon is the way to heaven, so much so that the Pythagoreans named her the heavenly earth and the earthly heaven or star,¹²⁸ because in the elemental world all inferior nature in respect to the heavenly, and the heavenly in respect to the intelligible world, is, as the *Zohar* says, feminine and passive, and is as the moon to the sun. In the same measure as [the moon] withdraws from the sun, until she is in opposition to him, so does her light increase in relation to us in this lower world, but diminishes on the side that looks upwards. Contrariwise, in her conjunction, when she is totally darkened for us, she is fully illuminated on that side which faces the sun. This should teach us that the more our intellect

descends to the things of sense, the more it is turned away from intelligible things, and the reverse likewise.¹²⁹

The identification of Malchuth with Luna forms a link with alchemy, and is another example of the process by which the patristic symbolism of sponsus and sponsa had been assimilated much earlier. At the same time, it is a repetition of the way the originally pagan hierosgamos was absorbed into the figurative language of the Church Fathers. But Vigenerus adds something that seems to be lacking in patristic allegory, namely the darkening of the other half of the moon during her opposition. When the moon turns upon us her fullest radiance, her other side is in complete darkness. This strict application of the Sol-Luna allegory might have been an embarrassment to the Church, although the idea of the “dying” Church does take account, to a certain extent, of the transience of all created things.¹³⁰ I do not mention this fact in order to criticize the significance of the ecclesiastical Sol-Luna allegory. On the contrary I want to emphasize it, because the moon, standing on the borders of the sublunary world ruled by evil, has a share not only in the world of light but also in the daemonic world of darkness, as our author clearly hints. That is why her changefulness is so significant symbolically: she is duplex and mutable like Mercurius, and is like him a mediator; hence their identification in alchemy.¹³¹ Though Mercurius has a bright side concerning whose spirituality alchemy leaves us in no doubt, he also has a dark side, and its roots go deep.

[20] The quotation from Vigenerus bears no little resemblance to a long passage on the phases of the moon in Augustine.¹³² Speaking of the unfavourable aspect of the moon, which is her changeability, he paraphrases Ecclesiasticus 27 : 12 with the words: “The wise man remaineth stable as the sun, but a fool is changed as the moon,”¹³³ and poses the question: “Who then is that fool who changeth as the moon, but Adam, in whom all have sinned?”¹³⁴ For Augustine, therefore, the moon is manifestly an ally of corruptible creatures, reflecting their folly and inconstancy. Since, for the men of antiquity and the Middle Ages, comparison with the stars or planets tacitly presupposes astrological causality, the sun causes constancy and wisdom, while the moon is the cause of change and folly (including lunacy).¹³⁵ Augustine attaches to his remarks about the moon a moral observation concerning the relationship of man to the spiritual sun,¹³⁶ just as Vigenerus did, who was obviously acquainted with Augustine’s epistles. He also mentions (Epistola LV, 10) the Church as Luna, and he connects the moon with the wounding by an arrow: “Whence it is said: They have made ready their arrows in the quiver, to shoot in the *darkness of the moon* at the upright of heart.”¹³⁷ It is clear that Augustine did not understand the wounding as the activity of the new moon herself but, in accordance with the principle “omne malum ab homine,” as the result of man’s wickedness. All the same, the addition “in obscura luna,” for which there is no warrant in the original text,

shows how much the new moon is involved. This hint of the admitted dangerousness of the moon is confirmed when Augustine, a few sentences later on, cites Psalm 71 : 7: “In his days justice shall flourish, and abundance of peace, until the moon shall be destroyed.”¹³⁸ Instead of the strong “interficiatur” the Vulgate has the milder “auferatur”—shall be taken away or fail.¹³⁹ The violent way in which the moon is removed is explained by the interpretation that immediately follows: “That is, the abundance of peace shall grow until it consumes all changefulness of mortality.” From this it is evident that the moon’s nature expressly partakes of the “changefulness of mortality,” which is equivalent to death, and therefore the text continues: “For then the last enemy, death, shall be destroyed, and whatever resists us on account of the weakness of the flesh shall be utterly consumed.” Here the destruction of the moon is manifestly equivalent to the destruction of death.¹⁴⁰ The moon and death significantly reveal their affinity. Death came into the world through original sin and the seductiveness of woman (= moon), and mutability led to corruptibility.¹⁴¹ To eliminate the moon from Creation is therefore as desirable as the elimination of death. This negative assessment of the moon takes full account of her dark side. The “dying” of the Church is also connected with the mystery of the moon’s darkness.¹⁴² Augustine’s cautious and perhaps not altogether unconscious disguising of the sinister aspect of the moon would be sufficiently explained by his respect for the Ecclesia-Luna equation.

[21] All the more ruthlessly, therefore, does alchemy insist on the dangerousness of the new moon. Luna is on the one hand the brilliant whiteness of the full moon, on the other hand she is the blackness of the new moon, and especially the blackness of the eclipse, when the sun is darkened. Indeed, what she does to the sun comes from her own dark nature. The “Consilium coniugii”¹⁴³ tells us very clearly what the alchemists thought about Luna:

The lion, the lower sun,¹⁴⁴ grows corrupt through the flesh. [His flesh is weak because he suffers from “quartan fever.”¹⁴⁵] Thus is the lion¹⁴⁶ corrupted in his nature through his flesh, which follows the times of the moon,¹⁴⁷ and is eclipsed. For the moon is the *shadow of the sun*, and with corruptible bodies she is consumed, and through her corruption is the lion eclipsed with the help of the moisture of Mercurius,¹⁴⁸ yet his eclipse is changed to usefulness and to a better nature, and one more perfect than the first.

The changefulness of the moon and her ability to grow dark are interpreted as her corruptibility, and this negative quality can even darken the sun. The text continues:

During the increase, that is during the fullness of the blackness of the lead, which is our ore, my light¹⁴⁹ is absent, and my splendour is put out.

Then comes a passage which may have inspired the picture of the death of the royal pair in the *Rosarium*, but which is also significant as regards the dark side of the conjunction of Sol and Luna:¹⁵⁰

After this¹⁵¹ is completed, you will know that you have the substance which penetrates all substances, and the nature which contains nature, and the nature which rejoices in nature.¹⁵² It is named the Tyriac¹⁵³ of the Philosophers, and it is also called the poisonous serpent, because, like this, it bites off the head of the male in the lustful heat of conception, and giving birth it dies and is divided through the midst. So also the moisture of the moon,¹⁵⁴ when she receives his light, slays the sun, and at the birth of the child of the Philosophers she dies likewise, and at death the two parents yield up their souls to the son, and die and pass away. *And the parents are the food of the son . . .*

[22] In this psychologem all the implications of the Sol-Luna allegory are carried to their logical conclusion. The daemonic quality which is connected with the dark side of the moon, or with her position midway between heaven and the sublunary world,¹⁵⁵ displays its full effect. Sun and moon reveal their antithetical nature, which in the Christian Sol-Luna relationship is so obscured as to be unrecognizable, and the two opposites cancel each other out, their impact resulting—in accordance with the laws of energetics—in the birth of a third and new thing, a son who resolves the antagonisms of the parents and is himself a “united double nature.” The unknown author of the “Consilium”¹⁵⁶ was not conscious of the close connection of his psychologem with the process of transubstantiation, although the last sentence of the text contains clearly enough the motif of *teoqualo*, the “god-eating” of the Aztecs.¹⁵⁷ This motif is also found in ancient Egypt. The Pyramid text of Unas (Vth dynasty) says: “Unas rising as a soul, like a god who liveth upon his fathers and feedeth upon his mothers.”¹⁵⁸ It should be noted how alchemy put in the place of the Christian sponsus and sponsa an image of totality that on the one hand was material, and on the other was spiritual and corresponded to the Paraclete. In addition, there was a certain trend in the direction of an *Ecclesia spiritualis*. The alchemical equivalent of the God-Man and the Son of God was Mercurius, who as an hermaphrodite contained in himself both the feminine element, Sapiencia and matter, and the masculine, the Holy Ghost and the devil. There are relations in alchemy with the Holy Ghost Movement which flourished in the thirteenth and fourteenth centuries and was chiefly connected with the name of Joachim of Flora (1145–1202), who expected the imminent coming of the “third kingdom,” namely that of the Holy Ghost.¹⁵⁹

[23] The alchemists also represented the “eclipse” as the descent of the sun into the (feminine) Mercurial Fountain,¹⁶⁰ or as the disappearance of Gabricus in the body of Beya. Again, the sun in the embrace of the new moon is treacherously slain by the

snake-bite (*conatu viperino*) of the mother-beloved, or pierced by the *telum passionis*, Cupid's arrow.¹⁶¹ These ideas explain the strange picture in Reusner's *Pandora*,¹⁶² showing Christ being pierced with a lance by a crowned virgin whose body ends in a serpent's tail.¹⁶³ The oldest reference to the mermaid in alchemy is a quotation from Hermes in Olympiodorus: "The virginal earth is found in the tail of the virgin."¹⁶⁴ On the analogy of the wounded Christ, Adam is shown in the Codex Ashburnham pierced in the side by an arrow.¹⁶⁵

[24] This motif of wounding is taken up by Honorius of Autun in his commentary on the Song of Songs.¹⁶⁶ "Thou hast wounded my heart, my sister, my spouse; thou hast wounded my heart with one of thy eyes, and with one hair of thy neck" (DV).¹⁶⁷ The sponsa says (1 : 4): "I am black, but comely," and (1 : 5) "Look not upon me because I am black, because the sun hath scorched me." This allusion to the *nigredo* was not missed by the alchemists.¹⁶⁸ But there is another and more dangerous reference to the bride in 6 : 4f.: "Thou art beautiful, O my love, as Tirzah, comely as Jerusalem, terrible as an army with banners. Turn away thine eyes from me, for they have overcome me . . . 10: Who is this that looketh forth as the rising dawn [*quasi aurora consurgens*],¹⁶⁹ fair as the moon, bright as the sun, terrible as an army with banners?"¹⁷⁰ The bride is not only lovely and innocent, but witch-like and terrible, like the side of Selene that is related to Hecate. Like her, Luna is "all-seeing," an "all-knowing" eye.¹⁷¹ Like Hecate she sends madness, epilepsy, and other sicknesses. Her special field is love magic, and magic in general, in which the new moon, the full moon, and the moon's darkness play a great part. The animals assigned to her—stag, lion, and cock¹⁷²—are also symbols of her male partner in alchemy. As the chthonic Persephone her animals, according to Pythagoras, are dogs,¹⁷³ i.e., the planets. In alchemy Luna herself appears as the "Armenian bitch."¹⁷⁴ The sinister side of the moon plays a considerable role in classical tradition.

[25] The sponsa is the dark new moon—in Christian interpretation the Church in the nuptial embrace¹⁷⁵—and this union is at the same time a wounding of the sponsus, Sol or Christ. Honorius comments on "Thou hast wounded my heart" as follows:

By heart is signified love, which is said to be in the heart, and the container is put in the place of the contained; and this metaphor is taken from the lover who loves his beloved exceeding much, so that his heart is wounded with love. So was Christ upon the cross wounded for love of his Church.¹⁷⁶ "Thou didst first wound my heart when I was scourged for thy love, that I might make thee my sister. . . . Again thou didst wound my heart with one of thine eyes¹⁷⁷ when, hanging upon the cross, I was wounded for love of thee, that I might make thee my bride to share my glory."¹⁷⁸

[26] The moment of the eclipse and mystic marriage is death on the cross. In the Middle Ages the cross was therefore logically understood as the mother. Thus in the

Middle English “Dispute between Mary and the Cross,” the cross is a “false tree” that destroyed Mary’s fruit with a deadly drink. She laments: “My sonys stepmodir I thee calle.” Sancta Crux replies:

Lady, to thee I owe honour . . .

Thi fruyt me florysschith in blood colour.¹⁷⁹

[27] The motif of wounding in alchemy goes back to Zosimos (3rd cent.) and his visions of a sacrificial drama.¹⁸⁰ The motif does not occur in such complete form again. One next meets it in the *Turba*: “The dew is joined to him who is wounded and given over to death.”¹⁸¹ The dew comes from the moon, and he who is wounded is the sun.¹⁸² In the treatise of Philaletha, “Introitus apertus ad occlusum Regis palatium,”¹⁸³ the wounding is caused by the bite of the rabid “Corascene” dog,¹⁸⁴ in consequence of which the hermaphrodite child suffered from hydrophobia.¹⁸⁵ Dorn, in his “De tenebris contra naturam,” associates the motif of wounding and the poisonous snake-bite with Genesis 3: “For the sickness introduced into nature by the serpent, and the deadly wound she inflicted, a remedy is to be sought.”¹⁸⁶ Accordingly it is the task of alchemy to root out the original sin, and this is accomplished with the aid of the *balsamum vitae* (balsam of life), which is “a true mixture of the natural heat with its radical moisture.” “The life of the world is the light of nature and the celestial sulphur,¹⁸⁷ whose substance is the aetheric moisture and heat of the firmament, like to the sun and moon.”¹⁸⁸ The conjunction of the moist (= moon) and the hot (= sun) thus produces the balsam, which is the “original and incorrupt” life of the world. Genesis 3 : 15, “he shall bruise your head, and you shall bruise his heel” (RSV), was generally taken as a prefiguration of the Redeemer. But since Christ was free from the stain of sin the wiles of the serpent could not touch him, though of course mankind was poisoned. Whereas the Christian belief is that man is freed from sin by the redemptory act of Christ, the alchemist was evidently of the opinion that the “restitution to the likeness of original and incorrupt nature” had still to be accomplished by the art, and this can only mean that Christ’s work of redemption was regarded as incomplete. In view of the wickednesses which the “Prince of this world,”¹⁸⁹ undeterred, goes on perpetrating as liberally as before, one cannot withhold all sympathy from such an opinion. For an alchemist who professed allegiance to the *Ecclesia spiritualis* it was naturally of supreme importance to make himself an “unspotted vessel” of the Paraclete and thus to realize the idea “Christ” on a plane far transcending a mere imitation of him. It is tragic to see how this tremendous thought got bogged down again and again in the welter of human folly. A shattering example of this is afforded not only by the history of the Church, but above all by alchemy itself, which richly merited its own condemnation—in ironical fulfilment of the dictum “In sterquiliniis invenitur” (it is found in cesspools). Agrippa von Nettesheim

was not far wrong when he opined that “Chymists are of all men the most perverse.”¹⁹⁰

- [28] In his “Mysterium Lunae,” an extremely valuable study for the history of alchemical symbolism, Rahner¹⁹¹ mentions that the “waxing and waning” of the bride (Luna, Ecclesia) is based on the *kenosis*¹⁹² of the bridegroom, in accordance with the words of St. Ambrose:¹⁹³

Luna is diminished that she may fill the elements. Therefore is this a great mystery. To her it was given by him who confers grace upon all things. He emptied her that he might fill her, as he also emptied himself that he might fill all things. He emptied himself that he might come down to us. He came down to us that he might rise again for all. . . . Thus has Luna proclaimed the mystery of Christ.¹⁹⁴

- [29] Thus the changefulness of the moon is paralleled by the transformation of the pre-existent Christ from a divine into a human figure through the “emptying,” that passage in Philippians (2 : 6) which has aroused so much comment: “. . . who, though he was in the form of God, did not count equality with God a thing to be clung to, but emptied himself, taking the form of a servant, being born in the likeness of men” (RSV / DV).¹⁹⁵ Even the most tortuous explanations of theology have never improved on the lapidary paradox of St. Hilary: “Deus homo, immortalis mortuus, aeternus sepultus” (God-man, immortal-dead, eternal-buried).¹⁹⁶ According to Ephraem Syrus, the *kenosis* had the reverse effect of unburdening Creation: “Because the creatures were weary of bearing the prefigurations of his glory, he disburdened them of those prefigurations, even as he had disburdened the womb that bore him.”¹⁹⁷

- [30] St. Ambrose’s reference to the *kenosis* makes the changing of the moon causally dependent on the transformation of the bridegroom. The darkening of Luna then depends on the sponsus, Sol, and here the alchemists could refer to the darkening of the beloved’s countenance in Song of Songs 1 : 4–5. The sun, too, is equipped with darts and arrows. Indeed, the secret poisoning that otherwise emanates from the coldness and moisture of the moon is occasionally attributed to the “cold dragon,” who contains a “volatile fiery spirit” and “spits flames.” Thus in Emblem L of the *Scrutinium*¹⁹⁸ he is given a masculine role: he wraps the woman in the grave in a deadly embrace. The same thought occurs again in Emblem V, where a toad is laid on the breast of the woman so that she, suckling it, may die as it grows.¹⁹⁹ The toad is a cold and damp animal like the dragon. It “empties” the woman as though the moon were pouring herself into the sun.²⁰⁰

4. ALCHEMY AND MANICHAISM

[31] At the beginning of the last section I mentioned the term “orphan” for the lapis. Here the motif of the unknown or absent father seems to be of special importance. Mani is the best-known example of the “son of the widow.” His original name was said to be *Κούβρικος* (Cubricus); later he changed it to Manes, a Babylonian word meaning “vessel.”²⁰¹ As a four-year-old boy he was sold as a slave to a rich widow. She came to love him, and later adopted him and made him her heir. Together with her wealth he inherited the “serpent’s poison” of his doctrine—the four books of Scythianos, the original master of his adoptive father Terebinthos, named “Budda.”²⁰² Of this Scythianos there is a legendary biography which equates him with Simon Magus;²⁰³ like him, he is said to have come to Jerusalem at the time of the apostles. He propounded a dualistic doctrine which, according to Epiphanius,²⁰⁴ was concerned with pairs of opposites: “white and black, yellow and green, moist and dry, heaven and earth, night and day, soul and body, good and evil, right and wrong.” From these books Mani concocted his pernicious heresy which poisoned the nations. “Cubricus” is very like the alchemical Kybrius,²⁰⁵ Gabricus,²⁰⁶ Kibrich,²⁰⁷ Kybrich, Kibric,²⁰⁸ Kybrig, Kebrick,²⁰⁹ Alkibric,²¹⁰ Kibrit,²¹¹ Kibrith,²¹² Gabricius, Gabrius,²¹³ Thabritius, Thabritis,²¹⁴ and so on.²¹⁵ The Arabic word *kibrit* means sulphur.

[32] In the *Aurora consurgens* “sulphur nigrum” stands side by side with “vetula,” the first being a synonym for spirit and the second for soul. Together they form a pair roughly comparable to the devil and his grandmother. This relationship also occurs in Rosencreutz’s *Chymical Wedding*,²¹⁶ where a black king sits beside a veiled old woman. The “black sulphur” is a pejorative name for the active, masculine substance of Mercurius and points to its dark, saturnine nature, which is evil.²¹⁷ This is the wicked Moorish king of the *Chymical Wedding*, who makes the king’s daughter his concubine (*meretrix*), the “Ethiopian” of other treatises,²¹⁸ analogous to the “Egyptian” in the “Passio Perpetuae,”²¹⁹ who from the Christian point of view is the devil. He is the activated darkness of matter, the *umbra Solis* (shadow of the sun), which represents the virginal-maternal prima materia. When the doctrine of the “Increatum”²²⁰ began to play a role in alchemy during the sixteenth century, it gave rise to a dualism which might be compared with the Manichaeon teaching.²²¹

[33] In the Manichaeon system matter (*hyle*) is personified by the dark, fluid, human body of the evil principle. As St. Augustine says, the substance of evil “had its own hideous and formless bulk, either gross which they called earth, or thin and tenuous like the air; for they imagine it to be some malignant mind creeping over the earth.”²²² The Manichaeon doctrine of the Anthropos shares the dual form of its Christ figure with alchemy, in so far as the latter also has a dualistic redeemer: Christ as saviour of man (Microcosm), and the lapis Philosophorum as saviour of the Macrocosm. The doctrine presupposes on the one hand a Christ incapable of suffering (*impatibilis*), who takes care of souls, and on the other hand a Christ

capable of suffering (*patibilis*),²²³ whose role is something like that of a *spiritus vegetativus*, or of Mercurius.²²⁴ This spirit is imprisoned in the body of the princes of darkness and is freed as follows by angelic beings who dwell in the sun and moon: assuming alternately male and female form they excite the desires of the wicked and cause them to break out in a sweat of fear, which falls upon the earth and fertilizes the vegetation.²²⁵ In this manner the heavenly light-material is freed from the dark bodies and passes into plant form.²²⁶

[34] The inflammation by desire has its analogy in the alchemist's gradual warming of the substances that contain the arcanum. Here the symbol of the sweat-bath plays an important role, as the illustrations show.²²⁷ Just as for the Manichaeans the sweat of the archons signified rain,²²⁸ so for the alchemists sweat meant dew.²²⁹ In this connection we should also mention the strange legend reported in the *Acta Archelai*, concerning the apparatus which the "son of the living Father" invented to save human souls. He constructed a great wheel with twelve buckets which, as they revolved, scooped up the souls from the deep and deposited them on the moon-ship.²³⁰ In alchemy the *rota* is the symbol of the *opus circulatorium*. Like the alchemists, the Manichaeans had a "virago," the male virgin Joel,²³¹ who gave Eve a certain amount of the light-substance.²³² The role she plays in regard to the princes of darkness corresponds to that of Mercurius duplex, who like her sets free the secret hidden in matter, the "light above all lights," the *filius philosophorum*. I would not venture to decide how much in these parallels is to be ascribed directly to Manichaean tradition, how much to indirect influence, and how much to spontaneous revival.

[35] Our starting-point for these remarks was the designation of the lapis as "orphan," which Dorn mentions apparently out of the blue when discussing the union of opposites. The material we have adduced shows what an archetypal drama of death and rebirth lies hidden in the coniunctio, and what immemorial human emotions clash together in this problem. It is the moral task of alchemy to bring the feminine, maternal background of the masculine psyche, seething with passions, into harmony with the principle of the spirit—truly a labour of Hercules! In Dorn's words:

Learn therefore, O Mind, to practise sympathetic love in regard to thine own body, by restraining its vain appetites, that it may be apt with thee in all things. To this end I shall labour, that it may drink with thee from the fountain of strength,²³³ and, when the two are made one, that ye find peace *in* their union. Draw nigh, O Body, to this fountain, that with thy Mind thou mayest drink to satiety and hereafter thirst no more after vanities. O wondrous efficacy of this fount, which maketh one of two, and peace between enemies! The fount of love can make *mind* out of spirit and soul, but this maketh *one man* of mind and body.²³⁴

THE PARADOXA

1. THE ARCANE SUBSTANCE AND THE POINT

[36] The tremendous role which the opposites and their union play in alchemy helps us to understand why the alchemists were so fond of paradoxes. In order to attain this union, they tried not only to visualize the opposites together but to express them in the same breath.¹ Characteristically, the paradoxes cluster most thickly round the arcane substance, which was believed to contain the opposites in uncombined form as the prima materia, and to amalgamate them as the lapis Philosophorum. Thus the lapis² is called on the one hand base, cheap, immature, volatile, and on the other hand precious, perfect, and solid; or the prima materia is base and noble,³ or precious and *parvi momenti* (of little moment). The materia is visible to all eyes, the whole world sees it, touches it, loves it, and yet no one knows it.⁴ “This stone therefore is no stone,”⁵ says the *Turba*, “that thing is cheap and costly, dark, hidden, and known to everyone, having one name and many names.”⁶ The stone is “thousand-named” like the gods of the mystery religions, the arcane substance is “One and All” (ἐν τὸ πᾶν). In the treatise of Komarios, where “the philosopher Komarios teaches the Philosophy to Cleopatra,” it is said: “He showed with his hand the unity of the whole.”⁷ Pelagios asks: “Why speak ye of the manifold matter? The substance of natural things is one, and of one nature that which conquers all.”⁸

[37] Further paradoxes: “I am the black of the white and the red of the white and the yellow of the red”;⁹ or “The principle of the art is the raven, who flies without wings in the blackness of night and in the brightness of day.”¹⁰ The stone is “cold and moist in its manifest part, and in its hidden part is hot and dry.”¹¹ “In lead is the dead life,”¹² or “Burn in water and wash in fire.”¹³ The “*Allegoriae sapientum*” speak of two figures, one of which is “white and lacking a shadow, the other red and lacking the redness.”¹⁴ A quotation from “Socrates” runs: “Seek the coldness of the moon and ye shall find the heat of the sun.”¹⁵ The opus is said to be “a running without running, moving without motion.”¹⁶ “Make mercury with mercury.”¹⁷ The philosophical tree has its roots in the air¹⁸ (this is probably a reference to the tree of the Sefiroth). That paradox and ambivalence are the keynotes of the whole work is shown by *The Chymical Wedding*: over the main portal of the castle two words are written: “Congratulor, Condoleo.”¹⁹

[38] The paradoxical qualities of Mercurius have already been discussed in a separate study.²⁰ As Mercurius is the principal name for the arcane substance, he deserves mention here as the paradox *par excellence*. What is said of him is obviously true of the lapis, which is merely another synonym for the “thousand-named” arcane substance. As the “Tractatus aureus de Lapide” says: “Our matter has as many names as there are things in the world.”²¹ The arcane substance is also synonymous with the Monad and the Son of Man mentioned in Hippolytus:

Monoïmos . . . thinks that there is some such Man of whom the poet speaks as Oceanus, when he says: Oceanus, origin of gods and origin of men.²² Putting this into other words, he says that the Man is all, the source of the universe, unbegotten, incorruptible, everlasting; and that there is a Son of the aforesaid Man, who is begotten and capable of suffering, and whose birth is outside time, neither willed nor predetermined. . . .²³ This Man is a single Monad, uncompounded and indivisible, yet compounded and divisible; loving and at peace with all things yet warring with all things and at war with itself in all things; unlike and like itself, as it were a musical harmony containing all things; . . . showing forth all things and giving birth to all things. It is its own mother, its own father, the two immortal names. The emblem of the whole man (τελείου ἀνθρώπου), says Monoïmos, is the jot or tittle.²⁴ This one tittle is the uncompounded, simple, unmixed Monad, having its composition from nothing whatsoever, yet composed of many forms, of many parts. That single, undivided jot is the many-faced, thousand-eyed, and thousand-named jot of the iota. This is the emblem of that perfect and invisible Man. . . . The Son of the Man is the one iota, the one jot flowing from on high, full and filling all things, containing in himself everything that is in the Man, the Father of the Son of the Man.²⁵

[39] The alchemists seem to have visualized their lapis or prima materia in a similar manner. At any rate they were able to cap the paradoxes of Monoïmos. Thus they said of Mercurius: “This spirit is generated from the substances of the sea²⁶ and calls himself moist, dry, and fiery,”²⁷ in close agreement with the invocation to Hermes in the magic papyrus entitled “The Secret Inscription,” where Hermes is addressed as a “damp-fiery-cold spirit” (ὕγροπυρινοψυχρὸν πνεῦμα).²⁸

[40] The mystery of the smallest written sign, the point, is also known to alchemy. The point is the symbol of a mysterious creative centre in nature. The author of the “Novum lumen”²⁹ admonishes his reader:

But you, dear reader, you will have above all to consider the point in nature . . . and you need nothing else, but take care lest you seek that point in the vulgar metals, where it is not. For these metals, the common gold more especially, are dead. But our metals are alive, they have a spirit, and they are the ones you must take. For know that fire is the life of the metals.

The point is identical with the *prima materia* of the metals, which is a “fatty water” (*aqua pinguis*), the latter being a product of the moist and the hot.

[41] John Dee (1527–1607) speculates as follows: “It is not unreasonable to suppose, that by the four straight lines which run in opposite directions from a single, individual point, the mystery of the four elements is indicated.” According to him, the quaternity consists of four straight lines meeting in a right angle. “Things and beings have their first origin in the point and the monad.”³⁰ The centre of nature is “the point originated by God,”³¹ the “sun-point” in the egg.³² This, a commentary on the *Turba* says, is the “germ of the egg in the yolk.”³³ Out of this little point, says Dorn in his “*Physica Genesis*,” the wisdom of God made with the creative Word the “huge machine” of the world.³⁴ The “*Consilium coniugii*” remarks that the point is the chick (*pullus*).³⁵ Mylius adds that this is the bird of Hermes,³⁶ or the spirit Mercurius. The same author places the soul in the “midpoint of the heart” together with the spirit, which he compares with the angel who was “infused with the soul at this point” (i.e., in the womb).³⁷ Paracelsus says that the “*anima iliastris*” dwells in the fire in the heart. It is “incapable of suffering,” whereas the “*anima cagastis*” is capable of suffering and is located in the water of the pericardium.³⁸ Just as earth corresponds to the triangle and water to the line, so fire corresponds to the point.³⁹ Democritus stresses that fire consists of “fiery globules.”⁴⁰ Light, too, has this round form, hence the designation “sun-point.” This point is on the one hand the world’s centre, “the salt-point in the midst of the great fabric of the whole world,” as Khunrath calls it (salt = *Sapientia*). Yet it is “not only the bond but also the destroyer of all destructible things.” Hence this “world-egg is the ancient Saturn, the . . . most secret lead of the sages,” and the “ambisexual Philosophic Man of the Philosophers, the Catholick Androgyne of the Sophists,” the *Rebis*, etc.⁴¹ The most perfect form is round, because it is modelled on the point. The sun is round and so is fire, since it is composed of the “fiery globules” of Democritus. God fashioned the sphere of light round himself. “God is an intelligible sphere whose centre is everywhere and whose circumference is nowhere.”⁴² The point symbolizes light and fire, also the Godhead in so far as light is an “image of God” or an “exemplar of the Deity.” This spherical light modelled on the point is also the “shining or illuminating body” that dwells in the heart of man. The light of nature is the “radical moisture” (*humidum radicale*) which, as “balsam,” works from the heart, like the sun in the macrocosm and, we must conclude, like God in the “supracelestial world.” Thus does Steeb describe the *δεύτερος θεός*, the “second God” in man.⁴³ The same author derives the gold from the dew or supracelestial balsam sinking into the earth. Here he is probably referring to the older formulations of Maier,⁴⁴ where the sun generates the gold in the earth. Hence the gold, as Maier says, obtains a “simplicity” approaching that of the circle (symbol of eternity) and the indivisible point. The gold has a “circular form.”⁴⁵ “This is the

line which runs back upon itself, like the snake that with its head bites its own tail, wherein that supreme and eternal painter and potter, God, may rightly be discerned.”⁴⁶ The gold is a “twice-bisected circle,” i.e., one divided into four quadrants and therefore a quaternity, a division made by nature “that contraries may be bound together by contraries.”⁴⁷ It can therefore, he says, be compared to the “sacred city,” Jerusalem⁴⁸ (cf. Revelation 21 : 10ff.). It is “a golden castle engirt with a triple wall,”⁴⁹ “a visible image of eternity.”⁵⁰ “Though gold be mute so far as sound or voice is concerned, yet by virtue of its essence it proclaims and everywhere bears witness to God.” And just as God is “one in essence,” so the gold is “one homogeneous substance.”⁵¹ For Dorn the unity of God,⁵² the “unarius,” is the “centre of the ternarius,” the latter corresponding to the circle drawn round the centre.⁵³ The point as the centre of the quaternio of the elements is the place where Mercurius “digests and perfects.”⁵⁴

2. THE SCINTILLA

[42] The point is identical with the *σπινθήρ*,⁵⁵ scintilla, the “little soul-spark” of Meister Eckhart.⁵⁶ We find it already in the teachings of Saturninus.⁵⁷ Similarly Heraclitus, “the physicist,” is said to have conceived the soul as a “spark of stellar essence.”⁵⁸ Hippolytus says that in the doctrine of the Sethians the darkness “held the brightness and the spark of light in thrall,”⁵⁹ and that this “smallest of sparks” was finely mingled in the dark waters⁶⁰ below.⁶¹ Simon Magus⁶² likewise teaches that in semen and milk there is a very small spark which “increases and becomes a power⁶³ boundless and immutable.”⁶⁴

[43] Alchemy, too, has its doctrine of the scintilla. In the first place it is the fiery centre of the earth, where the four elements “project their seed in ceaseless movement.” “For all things have their origin in this source, and nothing in the whole world is born save from this source.” In the centre dwells the Archaeus, “the servant of nature,” whom Paracelsus also calls Vulcan, identifying him with the Adech, the “great man.”⁶⁵ The Archaeus, the creative centre of the earth, is hermaphroditic like the Protanthropos, as is clear from the epilogue to the “Novum lumen” of Sendivogius: “When a man is illuminated by the light of nature, the mist vanishes from his eyes, and without difficulty he may behold the point of our magnet, which corresponds to both centres of the rays, that is, those of the sun and the earth.” This cryptic sentence is elucidated by the following example: When you place a twelve-year-old boy side by side with a girl of the same age, and dressed the same, you cannot distinguish between them. But take their clothes off⁶⁶ and the difference will become apparent.⁶⁷ According to this, the centre consists in a conjunction of male and

female. This is confirmed in a text by Abraham Eleazar,⁶⁸ where the arcane substance laments being in the state of *nigredo*:

Through Cham,⁶⁹ the Egyptian, I must pass. . . . Noah must wash me . . . in the deepest sea, that my blackness may depart. . . . I must be fixed to this black cross, and must be cleansed therefrom with wretchedness and vinegar, and made white, that . . . my heart may shine like a carbuncle, and the old Adam come forth from me again. O! Adam Kadmon, how beautiful art thou! . . . Like Kedar I am black henceforth, ah! how long! O come, my Mesech,⁷⁰ and disrobe me, that mine inner beauty may be revealed. . . . O Shulamite, afflicted within and without, the watchmen of the great city will find thee and wound thee, and rob thee of thy garments . . . and take away thy veil. Who then will lead me out from Edom, from thy stout wall? . . . Yet shall I be blissful again when I am delivered from the poison wherewith I am accursed, and my inmost seed and first birth comes forth. . . . For its father is the sun, and its mother the moon.⁷¹

[44] It is clear from this text that the “hidden” thing, the invisible centre, is Adam Kadmon, the Original Man of Jewish gnosis. It is he who laments in the “prisons” of the darkness,⁷² and who is personified by the black Shulamite of the Song of Songs. He is the product of the conjunction of sun and moon.

[45] The scintillae often appear as “golden and silver,” and are found in multiple form in the earth.⁷³ They are then called “oculi piscium” (fishes’ eyes).⁷⁴ The fishes’ eyes are frequently mentioned by the authors, probably first by Morienus Romanus⁷⁵ and in the “Tractatus Aristotelis,”⁷⁶ and then by many later ones.⁷⁷ In Manget there is a symbol, ascribed to the “philosopher Malus,”⁷⁸ which shows eyes in the stars, in the clouds, in the water and in the earth. The caption says: “This stone is under you, and near you, and above you, and around you.”⁷⁹ The eyes indicate that the lapis is in the process of evolution and grows from these ubiquitous eyes.⁸⁰ Ripley remarks that at the “desiccation of the sea” a substance is left over that “shines like a fish’s eye.”⁸¹ According to Dorn, this shining eye is the sun,⁸² which plunges the “centre of its eye” into the heart of man, “as if it were the secret of warmth and illumination.” The fish’s eye is always open, like the eye of God.⁸³ Something of the sort must have been in the mind of the alchemists, as is evidenced by the fact that Eirenaeus Orandus⁸⁴ used as a motto for his edition of Nicolas Flamel⁸⁵ the words of Zechariah 4 : 10: “And they shall rejoice and see the plummet [*lapidem stanneum*] in the hand of Zorobabel. These are the seven eyes of the Lord that run to and fro through the whole earth.” 3 : 9 is also relevant: “Upon one stone there are seven eyes” (DV). Firmicus Maternus may be referring to the latter passage when he says:⁸⁶ “The sign of one profane sacrament is *θεὸς ἐκ πέτρας* . . . [god from the rock].⁸⁷ The other is the stone which God promised to send to strengthen the foundations of the promised Jerusalem.⁸⁸ Christ is

signified to us by the venerable stone.”⁸⁹ Just as the “one stone” meant, for the alchemists, the lapis,⁹⁰ so the fishes’ eyes meant the seven eyes or the one eye of God, which is the sun.

[46] The Egyptians held that the eye is the seat of the soul; for example, Osiris is hidden in the eye of Horus.⁹¹ In alchemy the eye is the *coelum* (heaven): “It is like an eye and a seeing of the soul, whereby the state of the soul and her intentions are oftentimes made known to us, and through the rays and the glance [of heaven] all things take form.”⁹² In Steeb’s view, which agrees with that of Marsilius Ficinus,⁹³ the “coelum” is a “virtus,” indeed a “certain perfect, living being.”⁹⁴ Hence the alchemists called their *quinta essentia* “coelum.” The idea of a *virtus* is borne out by the description of the Holy Ghost as an eye,⁹⁵ a parallel to the invocation to Hermes: “Hermes . . . the eye of heaven.”⁹⁶ The eye of God emits power and light,⁹⁷ likewise the fishes’ eyes are tiny soul-sparks from which the shining figure of the filius is put together. They correspond to the particles of light imprisoned in the dark Physis, whose reconstitution was one of the chief aims of Gnosticism and Manichaeism. There is a similar nexus of ideas in the *siddhaśila* of Jainism: “The *loka* [world] is held in the middle of the *aloka* [void], in the form of the trunk of a man, with *siddhaśila* at the top, the place where the head should be. This *siddhaśila* is the abode of the omniscient souls, and may be called the spiritual eye of the universe.”⁹⁸

[47] The eye, like the sun, is a symbol as well as an allegory of consciousness.⁹⁹ In alchemy the *scintillulae* are put together to form the gold (Sol), in the Gnostic systems the atoms of light are reintegrated. Psychologically, this doctrine testifies to the personality- or ego-character of psychic complexes: just as the distinguishing mark of the ego-complex is consciousness, so it is possible that other, “unconscious” complexes may possess, as splinter psyches, a certain luminosity of their own.¹⁰⁰ From these atoms is produced the Monad (and the lapis in its various significations), in agreement with the teachings of Epicurus, who held that the concourse of atoms even produced God.¹⁰¹

[48] In his chapter on knowledge,¹⁰² Dorn uses the concept of the scintillae in moral form: “Let every man consider diligently in his heart what has been said above, and thus little by little he will come to see with his mental eyes a number of sparks shining day by day and more and more and growing into such a great light that thereafter all things needful to him will be made known.” This light is the “light of nature.” As Dorn says in his “Philosophia meditativa”:

What madness deludes you? For in you, and not proceeding from you, he wills all this to be found, which you seek outside you and not within yourselves. Such is the vice of the common man, to despise everything his own, and always to lust after the strange. . . . The life, the light of men, shineth in us, albeit dimly, and as though in

darkness.¹⁰³ It is not to be sought as proceeding from us, though it is in us and not of us,¹⁰⁴ but of Him to Whom it belongeth, Who hath deigned to make us his dwelling place. . . . He hath implanted that light in us that we may see in its light the light of Him who dwelleth in light inaccessible, and that we may excel his other creatures. In this especially we are made like unto Him, that He hath given us a spark of His light. Thus the truth is to be sought not in ourselves, but in the image of God¹⁰⁵ which is within us.¹⁰⁶

[49] In Dorn's view there is in man an "invisible sun," which he identifies with the Archeus.¹⁰⁷ This sun is identical with the "sun in the earth" (in agreement with the passage from "Novum lumen," supra, par. 43). The invisible sun enkindles an elemental fire which consumes man's substance¹⁰⁸ and reduces his body to the prima materia. It is also compared with "salt" or "natural balsam," "which has in itself corruption and protection against corruption." This paradoxical aspect is borne out by a curious saying: "Man is the bait, wherein the sparks struck by the flint, i.e., Mercurius, and by the steel,¹⁰⁹ i.e., heaven, seize upon the tinder and show their power."¹¹⁰ Mercurius as the "flint" is evidently thought of here in his feminine, chthonic form, and "heaven" stands for his masculine, spiritual quintessence. From the (nuptial) impact between the two the spark is struck, the Archeus, which is a "corrupter of the body," just as the "chemist" is a "corrupter of metals." This negative aspect of the scintilla is remarkable, but it agrees very well with the alchemists' less optimistic, medico-scientific view of the world.¹¹¹ For them the dark side of the world and of life had not been conquered, and this was the task they set themselves in their work. In their eyes the fire-point, the divine centre in man, was something dangerous, a powerful poison which required very careful handling if it was to be changed into the panacea. The process of individuation, likewise, has its own specific dangers. Dorn expresses the standpoint of the alchemists in his fine saying: "There is nothing in nature that does not contain as much evil as good."¹¹²

[50] In Khunrath¹¹³ the scintilla is the same as the elixir: "Now the elixir is well and truly called a shining splendour, or perfect scintilla of him who alone is the Mighty and Strong. . . . It is the true Aqua Permanens, eternally living."¹¹⁴ The "radical moisture" is "animated . . . by a fiery spark of the World-Soul, for the spirit of the Lord filleth the whole world."¹¹⁵ He also speaks of a plurality of sparks: "There are . . . fiery sparks of the World-Soul, that is of the light of nature, dispersed or scattered at God's command in and through the fabric of the great world into all fruits of the elements everywhere."¹¹⁶ The scintilla is associated with the doctrine of the Anthropos: "The Son of the Great World . . . is filled, animated and impregnated . . . with a fiery spark of Ruach Elohim, the spirit, breath, wind or blowing of the triune God, from . . . the Body, Spirit, and Soul of the World, or . . . Sulphur and Salt, Mercury and the universal fiery spark of the light of nature."¹¹⁷ The "fiery sparks of

the World-Soul” were already in the chaos, the prima materia, at the beginning of the world.¹¹⁸ Khunrath rises to Gnostic heights when he exclaims: “And our Catholick Mercury, by virtue of his universal fiery spark of the light of nature, is beyond doubt Proteus, the sea god of the ancient pagan sages, who hath the key to the sea and . . . power over all things: son of Oceanos and Tethys.”¹¹⁹ Many centuries lie between Monoïmos and Khunrath. The teachings of Monoïmos were completely unknown in the Middle Ages,¹²⁰ and yet Khunrath hit upon very similar thoughts which can hardly be ascribed to tradition.

3. THE ENIGMA OF BOLOGNA¹²¹

[51] These paradoxes culminate in an allegedly ancient “monument,” an epitaph said to have been found in Bologna, known as the Aelia-Laelia-Crispis Inscription. It was appropriated by the alchemists, who claimed, in the words of Michael Maier, that “it was set up by an artificer of old to the honour of God and in praise of the chymic art.”¹²² I will first give the text of this highly remarkable inscription:

D. M.

Aelia Laelia Crispis, nec mulier, nec androgyna, nec puella, nec iuvenis, nec anus, nec casta, nec meretrix, nec pudica, sed omnia.

Sublata neque fame, nec ferro, nec veneno, sed omnibus.—Nec coelo, nec aquis, nec terris, sed ubique iacet.

Lucius Agatho Priscius, nec maritus, nec amator, nec necessarius, neque moerens, neque gaudens, neque flens, hanc neque molem, nec pyramidem, nec sepulchrum, sed omnia.

Scit et nescit, (quid) cui posuerit.

(Hoc est sepulchrum, intus cadaver non habens.

Hoc est cadaver, sepulchrum extra non habens.

Sed cadaver idem est et sepulchrum

D. M.

Aelia Laelia Crispis, neither man nor woman, nor mongrel, nor maid, nor boy, nor crone, nor chaste, nor whore, nor virtuous, but all.

Carried away neither by hunger, nor by sword, nor by poison, but by all.—Neither in heaven, nor in earth, nor in water, but everywhere is her resting place.

Lucius Agatho Priscius, neither husband, nor lover, nor kinsman, neither mourning, nor rejoicing, nor weeping, (raised up) neither mound, nor pyramid, nor tomb, but all.

He knows and knows not (what)¹²³ he raised up to whom.

(This is a tomb that has no body in it.

This is a body that has no tomb round it.

But body and tomb are the same.)

sibi.)

[52] Let it be said at once: this epitaph is sheer nonsense, a joke,¹²⁴ but one that for centuries brilliantly fulfilled its function as a flypaper for every conceivable projection that buzzed in the human mind. It gave rise to a “cause célèbre,” a regular psychological “affair” that lasted for the greater part of two centuries and produced a spate of commentaries, finally coming to an inglorious end as one of the spurious texts of the *Corpus Inscriptionum Latinarum*, and thereafter passing into oblivion. The reason why I am digging up this curiosity again in the twentieth century is that it serves as a paradigm for that peculiar attitude of mind which made it possible for the men of the Middle Ages to write hundreds of treatises about something that did not exist and was therefore completely unknowable. The interesting thing is not this futile stalking-horse but the projections it aroused. There is revealed in them an extraordinary propensity to come out with the wildest fantasies and speculations—a psychic condition which is met with today, in a correspondingly erudite milieu, only as an isolated pathological phenomenon. In such cases one always finds that the unconscious is under some kind of pressure and is charged with highly affective contents. Sometimes a differential diagnosis as between tomfoolery and creativity is difficult to make, and it happens again and again that the two are confused.

[53] Such phenomena, whether historical or individual, cannot be explained by causality alone, but must also be considered from the point of view of what happened afterwards. Everything psychic is pregnant with the future. The sixteenth and seventeenth centuries were a time of transition from a world founded on metaphysics to an era of immanentist explanatory principles, the motto no longer being “omne animal a Deo” but “omne vivum ex ovo.” What was then brewing in the unconscious came to fruition in the tremendous development of the natural sciences, whose youngest sister is empirical psychology. Everything that was naively presumed to be a knowledge of transcendental and divine things, which human beings can never know with certainty, and everything that seemed to be irretrievably lost with the decline of the Middle Ages, rose up again with the discovery of the psyche. This premonition of future discoveries in the psychic sphere expressed itself in the phantasmagoric speculations of philosophers who, until then, had appeared to be the arch-pedlars of sterile verbiage.

[54] However nonsensical and insipid the Aelia-Laelia epitaph may look, it becomes significant when we regard it as a question which no less than two centuries have asked themselves: What is it that you do not understand and can only be expressed in unfathomable paradoxes?

[55] Naturally I do not lay this question at the door of that unknown humorist who perpetrated this “practical joke.” It existed long before him in alchemy. Nor would he

ever have dreamt that his joke would become a *cause célèbre*, or that it would lead his contemporaries and successors to question the nature of the psychic background—a question which, in the distant future, was to replace the certainties of revealed truth. He was only a *causa instrumentalis*, and his victims, as naïve and innocent as himself, made their first, involuntary steps as psychologists.

[56] It seems that the first report of the Aelia-Laelia inscription appeared in the treatise of a certain Marius L. Michael Angelus, of Venice, in the year 1548, and as early as 1683¹²⁵ Caesar Malvasius¹²⁶ had collected no less than forty-five¹²⁷ attempts at interpretation. In alchemical literature, the treatise of the physician Nicholas Barnaud, of Crest (Dauphiné), who lived in the second half of the sixteenth century, has been preserved. He gave an alchemical interpretation of the inscription in, it appears, 1597.¹²⁸ To begin with, I shall keep to his interpretation and that of the learned Michael Maier.

[57] Maier maintains that Aelia and Laelia represent two persons who are united in a single subject, named Crispis. Barnaud calls Aelia “solar,” presumably a derivation from *ἄελιος*, ‘sun.’ Laelia he interprets as “lunar.” Crispis (curly-haired), thinks Maier, comes from the curly hairs which are converted into a “very fine powder.”¹²⁹ Maier obviously has in mind the tincture, the arcane substance. Barnaud on the other hand says that “our materia” is “obvoluta, intricata,” therefore curly. These two persons, says Maier, *are* neither man nor woman, but they once *were*; similarly, the subject *was* in the beginning an hermaphrodite but no longer *is* so, because though the arcane substance is composed of sponsus and sponsa, and is thus as it were bisexual, as a third thing it is new and unique. Neither is the subject a maid or virgin, because she would be “intact.” In the opus, however, the virgin is called a mother although she has remained a virgin. Nor is the subject a boy, because the consummation of the coniunctio contradicts this, nor a crone,¹³⁰ because it still retains its full strength, nor a whore,¹³¹ because it has nothing to do with money, nor is it virtuous, because the virgin has cohabited with a man. The subject, he says, is a man and a woman, because they have completed the conjugal act, and an hermaphrodite because two bodies are united in one. It is a girl because it is not yet old, and a youth because it is in full possession of its powers. It is an old woman because it outlasts all time (i.e., is incorruptible). It is a whore because Beya¹³² prostituted herself to Gabritius before marriage. It is virtuous because the subsequent marriage gave absolution.¹³³

[58] “But all” is the real explanation of the enigma: all these designations refer to qualities of the *one thing*, and these were thought of as existing, but they are not entities in themselves. The same is true of the “Carried away” passage. The substance (uroboros) devours itself and thus suffers no hunger; it does not die by the sword but “slays itself with its own dart,” like the scorpion, which is another synonym for the

arcane substance.¹³⁴ It is not killed by poison because, as Barnaud says, it is a “good poison,” a panacea with which it brings itself to life again.¹³⁵ At the same time it is killed by all three: by hunger for itself, by the sword of Mercurius,¹³⁶ and by its own poison as snake or scorpion. “By all” again points to the arcane substance, as Barnaud says: “This is everything, it has within itself everything needful for its completion, everything can be predicated of it, and it of everything.”¹³⁷ “For the One is the whole, as the greatest Chymist saith: because [of the One] everything is, and if the whole had not the whole [in itself], the whole would not be.”¹³⁸

[59] That the arcanum is neither in heaven, nor on earth, nor in water is explained by Maier as a reference to the lapis, which “is found everywhere.” It is found in all the elements and not only in one of them. Here Barnaud is rather more subtle, for he equates heaven with the soul, earth with the body, and water with the spirit,¹³⁹ and thus arrives at the idea of the wholeness of a living organism. “Our material,” he says, “is simultaneously in heaven, on earth, and in the water, as if wholly in the whole and wholly in each part; so that those parts, though otherwise divisible, can no longer be separated from one another after they are made one: the whole Law and Prophets of alchemy seem to depend upon this.”¹⁴⁰

[60] Barnaud explains the name of him who raised the tomb, Lucius Agatho Priscius, as follows: Lucius is “lucid,” “endowed with the most lucid intellect”,¹⁴¹ Agatho is “good-natured” (Gk. *ἀγαθός*, ‘good’), “upright”; Priscius is “priscus” (pristine), “senior” (of ancient time), “reckoned among those upright Philosophers of old.” Maier maintains that these names “signified the chief requisite necessary for the fulfilment of the art.”

[61] “Neither husband nor lover” etc. means that Aelia Laelia drew him to herself “as the magnet the iron” and changed him into her “nebulous and black nature.” In the coniunctio he became her husband, and was “necessary”¹⁴² to the work. But Maier does not tell us to what extent he was *not* the husband etc. Barnaud says: “These are the chief causes, namely marriage, love, and consanguinity, which move a man to raise a column to the dead in the temple of memory, and none of these can here be considered.” Lucius had another purpose in mind: he wished the art, “which teaches everything, which is of all things the most precious and is concealed under this enigma, to appear upon the scene,” so that the investigators might “apply themselves to the art and true science, which surpasses all else in worth.” True, he makes an exception of “that holiest investigation [*agnitionem*] of God and Christ, whereon our salvation depends,”¹⁴³ a proviso we often meet in the texts.

[62] Maier ignores the negative in “neither mourning” etc. just as he did in “neither husband.” “In truth,” he says, “all this can as well be said positively of Lucius and not negatively.” On the other hand Barnaud remarks that it draws a picture of an

“intrepid philosopher, smooth and rounded.”¹⁴⁴ “Neither mound” etc. is again explained positively by Maier: Aelia is herself the mound, which endures as something firm and immovable. This is a reference to the incorruptibility which the opus sought to achieve. He says the pyramid signifies a “flame to eternal remembrance,” and this was Aelia herself. She was buried because Lucius “did everything he had to do in her name.” He takes her place, as it were, just as the *filius philosophorum* takes the place of the maternal *prima materia*, which till then had been the only effective arcane substance. Barnaud declares that though Lucius is a building, it does not fulfil its purpose (since it is a symbol). “But all” he refers to the “*Tabula smaragdina*,” because the epitaph as a whole points to the “*medicina summa et catholica*.”

[63] By “He knows and knows not” Maier thinks that Lucius knew it at first but no longer knew it afterwards, because he himself was ungratefully forgotten. It is not clear to me what this is intended to mean. Barnaud takes the monument as an allegory of the lapis, of which Lucius knew. He explains the “quid” as “quantum,” for Lucius probably did not know how much the stone weighed. Neither, of course, did he know for what future discoverer he had made the inscription. Barnaud’s explanation of “quid” is decidedly feeble. It would be more to the point to remember that the lapis is a fabulous entity of cosmic dimensions which surpasses human understanding. Consideration for the prestige of the alchemist may have prevented him from indulging this suggestive thought, for as an alchemist he could not very well admit that the artifex himself did not know what he was producing with his art. Had he been a modern psychologist he might have realized, with a little effort, that man’s totality, the self, is by definition¹⁴⁵ beyond the bounds of knowledge.

[64] With “This is a tomb” etc. we reach the first *positive* statement (barring the names) of the inscription. Maier’s opinion is that this has nothing to do with the tomb, which was no tomb, but that Aelia herself is meant. “For she herself is the container, converting into herself the contained; and thus she is a tomb or receptacle that has no body or content in it, as was said of Lot’s wife, who was her own tomb without a body, and a body without a tomb.”¹⁴⁶ He is evidently alluding to the second version of the “Arisleus Vision,” which says: “With so much love did Beya embrace Gabricus that she absorbed him wholly into her own nature and dissolved him into indivisible particles.”¹⁴⁷ Ripley says that at the death of the king all his limbs were torn into “atoms.”¹⁴⁸ This is the motif of dismemberment which is well known in alchemy.¹⁴⁹ The atoms are or become “white sparks” shining in the *terra foetida*.¹⁵⁰ They are also called the “fishes’ eyes.”¹⁵¹

[65] The explanation of Aelia herself as the “tomb” would naturally appeal to an alchemist, as this motif plays a considerable role in the literature. He called his vessel

a “tomb,”¹⁵² or, as in the *Rosarium*, a “red tumulus of rock.” The *Turba* says that a tomb must be dug for the dragon and the woman.¹⁵³ Interment is identical with the *nigredo*.¹⁵⁴ A Greek treatise describes the alchemical process as the “eight graves.”¹⁵⁵ Alexander found the “tomb of Hermes” when he discovered the secret of the art.¹⁵⁶ The “king” is buried in Saturn,¹⁵⁷ an analogy of the buried Osiris.¹⁵⁸ “While the *nigredo* of the burial endures, the woman rules,”¹⁵⁹ referring to the eclipse of the sun or the conjunction with the new moon.

[66] Thus, concludes Maier, tomb and body are the same. Barnaud says:

Bury, they say, each thing in the grave of the other. For when Sulphur, Sal and Aqua, or Sol, Luna and Mercurius, are in our material, they must be extracted, conjoined, buried and mortified, and turned into ashes. Thus it comes to pass that the nest of the birds becomes their grave, and conversely, the birds absorb the nest and unite themselves firmly with it. This comes to pass, I say, that soul, spirit and body, man and woman, active and passive, in one and the same subject, when placed in the vessel, heated with their own fire and sustained by the outward magistry of the art, may in due time escape [to freedom].¹⁶⁰

In these words the whole secret of the union of opposites is revealed, the *summa medicina*, which heals not only the body but the spirit. The word “escape” presupposes a state of imprisonment which is brought to an end by the union of opposites. The Hindus described this as *nirdvandva*, “free from the opposites,” a conception that, in this form at least, is alien to the Christian West because it relativizes the opposites and is intended to mitigate, or even heal, the irreconcilable conflict in the militant Christian attitude.¹⁶¹

[67] The interpretation here given of this enigmatic inscription should be taken for what it is: a testament to the alchemical way of thinking, which in this instance reveals more about itself than the epitaph would seem to warrant. But here we must tread carefully, for a good many other explanations are possible and have, in fact, been given.¹⁶² Above all, we have to consider the genuineness of the monument and its origin. None of the three authors so far mentioned actually saw the inscription. At the time of Malvasius, in 1683, there were apparently only two original transcripts of it, one in Bologna, the other in Milan. The one in Bologna ends with the words “cui posuerit.” The other, in Milan, adds “Hoc est sepulcrum” etc., and also a “quid” to the “Scit et nescit” of the Bologna version. Further, at the head of the Milan version there is an unelucidated “A.M.P.P.D.” in place of the “D.M.” (Diis Manibus) at the head of the other. Malvasius states that the monument was destroyed,¹⁶³ but he cites eyewitnesses who claimed to have seen the inscription and copied it, in particular Joannes Turrius of Bruges, who in January 1567 wrote a letter to Richardus Vitus (Richard White of Basingstoke) saying that he had “read the epitaph with his own

eyes” in the villa of Marcus Antonius de la Volta, “at the first milestone outside the Porta Mascharella,” Bologna. It was, as the eyewitness and commentator Joannes Casparius Gevartius reports, let into the wall joining the villa to the church. A few of the chiselled letters were “worn with time and corroded by a kind of rust,” which, he says, testified to its antiquity.¹⁶⁴ Malvasius endeavoured to prove its genuineness with the help of numerous other Roman epitaphs,¹⁶⁵ and advanced the following theory:

The inscription speaks of a daughter who is to be born to Laelius and who is destined for Agatho as a bride; but she is neither daughter nor bride, because, though conceived, she is not born, and not born, because she miscarried. Therefore Agatho, long chosen as the husband, disappointed in such great hope and betrayed by fate, rightly mocks himself, or pretends to mock himself, with this enigmatic inscription.¹⁶⁶

[68] Malvasius goes out of his way to be fair to the author of the epitaph. He calls Agatho “very skilled in this science and that”;¹⁶⁷ indeed he compares him, as being a “pre-eminent worshipper of the exceedingly auspicious number Three,”¹⁶⁸ to Hermes Trismegistus, and calls him “Thrice-Greatest,” an allusion to the concluding sentence of the “Tabula smaragdina.”¹⁶⁹ He does this because the inscription is divided into three parts,¹⁷⁰ to which he devotes a long dissertation. Here he gets into difficulties with the four elements and the four qualities, and, like all the alchemists, flounders about in his attempts to interpret the axiom of Maria.¹⁷¹ His idea of a miscarriage likewise comes within the sphere of alchemy (not to mention Gnosticism),¹⁷² for we read in the “Tractatus Aristotelis”:¹⁷³ “This serpent is impetuous, seeking the issue [death] before birth, wishing to lose the foetus and desiring a miscarriage.”¹⁷⁴ This refers, of course, to the Mercurial serpent or prima materia, which, the treatise maintains,¹⁷⁵ strives to pass quickly through the transformation process and to force the light-seeds of the *anima mundi* hidden within it into flower.

[69] Of the numerous interpretations made by the commentators I would like to mention one which seems to me worth rescuing from oblivion. This is the view expressed by the two friends of Malvasius (see n. 127), namely that Lucius Agatho was a real person, but that Aelia was a “fictitious woman,” or perhaps an “evil genius” in female form or an “ungodly spirit,” who in the opinion of one of them “flies about in the air,” and according to the other dwells in the earth and was “enclosed and affixed in a Junonian oak”; a “sylvan sprite, nymph, or hamadryad” who, when the oak was cut down and burnt, was obliged to seek another dwelling-place and so was found, “as if dead, in this sarcophagus.” Thus it was that she was “praised, described, and commemorated by the loved and loving Agatho.”¹⁷⁶

[70] According to this interpretation, Aelia is Agatho’s anima, projected into a “Junonian oak.” The oak is the tree of Jupiter, but it is also sacred to Juno.¹⁷⁷ In a metaphorical sense, as the feminine carrier of the anima projection, it is Jupiter’s

spouse and Agatho's beloved. Mythologically, nymphs, dryads, etc. are nature- and tree-numina, but psychologically they are anima projections,¹⁷⁸ so far as masculine statements are concerned.

[71] This interpretation can be found in the *Dendrologia* of one of the above-mentioned friends, Ulysses Aldrovandus:

I maintain that Aelia Laelia Crispis was one of the Hamadryads . . . who was tied to an oak in the neighbourhood of the city of Bologna, or shut up inside it. She appeared to him both in the tenderest and in the harshest form, and while for some two thousand years she had made a show of inconstant looks like a Proteus, she bedevilled the love of Lucius Agatho Priscius, then a citizen of Bologna, with anxious cares and sorrows, which assuredly were conjured up from chaos, or from what Plato calls Agathonian confusion.¹⁷⁹

One can hardly imagine a better description of the feminine archetype that typifies a man's unconscious than the figure of this "most hazardous beloved" (*incertissima amasia*), who pursues him like a teasing sprite amid the stillness of the "groves and springs." It is clear from the text of the inscription that it gives no ground for interpreting Aelia as a wood nymph. Aldrovandus tells us, however, that the Porta Mascharella in Bologna, near which the inscription was alleged to have been found, was called "Junonia" in Roman times, from which he concludes that Juno was obviously the spiritus loci. In support of his hypothesis that Aelia was a dryad, the learned humanist cites a Roman epitaph that was found in this region:

CLODIA PLAVTILLA
SIBI ET
QVERCONIO AGATHONI
MARITO OPTIMO

This epitaph does in fact occur in the *Corpus Inscriptionum Latinarum*,¹⁸⁰ but there the operative words are:

Q. VERCONIO AGATHONI

So Quintus Verconius must suffer his name to be changed to Querconius to suit the author.

[72] Aldrovandus explains the puzzling "hoc est sepulcrum" by saying that the oak supplied the necessary building material for the tomb! In substantiation of this he adds that there was in that locality a village with the name of "Casaralta,"¹⁸¹ which he analyses into *casa* (house), *ara* (altar), *alta* (high).

[73] As a further contribution he quotes an Italian poem about a great oak, "representing," he says, "the world of the elements, planted as it were in a heavenly

garden, where Sun and Moon are spread out like two flowers.”¹⁸² This allusion to the world-oak of Pherecydes leads us straight to the sun-and-moon tree of alchemy, to the red and white lily,¹⁸³ the red slave and the white woman (or white dove),¹⁸⁴ and the four-hued blossoms of the Tree in the Western Land.¹⁸⁵ Reusner’s *Pandora* portrays the tree as a torch-bearing woman, its top sprouting out of her crowned head.¹⁸⁶ Here the tree is personified by its feminine numen.

[74] Aldrovandus’s interpretation is essentially alchemical, as we can see from the treatise of Bernardus Trevisanus (Count of the March and Trevis, 1406–90).¹⁸⁷ He tells the parable¹⁸⁸ of an adept who finds a clear spring set about with the finest stone and “secured to the trunk of an oak-tree,” the whole surrounded by a wall. This is the King’s bath in which he seeks renewal. An old man, Hermes the mystagogue, explains how the King had this bath built: he placed in it an old oak, “cloven in the midst.”¹⁸⁹ The fountain was surrounded by a thick wall, and “first it was enclosed in hard, bright stone, then in a hollow oak.”¹⁹⁰

[75] The point of the parable, evidently, is to bring the oak into connection with the bath. Usually this is the nuptial bath of the royal pair. But here the Queen is missing, for it is only the King who is renewed. This unusual version¹⁹¹ of the motif suggest that the oak, as the feminine numen, has taken the place of the Queen. If this assumption is correct, it is particularly significant that the oak is first said to be “cloven” and later to be “hollow.” Now it seems to be the upright trunk or “stock” of the fountain,¹⁹² now a living tree casting a shadow, now the trough of the fountain. This ambiguity refers to the different aspects of the tree: as the “stock,” the oak is the source of the fountain, so to speak; as the trough it is the vessel, and as the protecting tree it is the mother.¹⁹³ From ancient times the tree was man’s birthplace;¹⁹⁴ it is therefore a source of life. The alchemists called both the vessel and the bath the “womb.”¹⁹⁵ The cloven or hollow trunk bears out this interpretation.¹⁹⁶ The King’s bath is itself a matrix, the tree serving as an attribute of the latter. Often, as in the Ripley Scrowle,¹⁹⁷ the tree stands in the nuptial bath, either as a pillar or directly as a tree in whose branches the numen appears in the shape of a mermaid (= anima) with a snake’s tail.¹⁹⁸ The analogy with the Tree of Knowledge is obvious.¹⁹⁹ The Dodonian oak was the abode of an oracle, the anima here playing the role of prophetess.²⁰⁰ The snake-like Mercurius appears as a tree numen in Grimm’s fairytale of “The Spirit in the Bottle.”²⁰¹

[76] The tree has a remarkable relation to the old man in the *Turba*:

Take that white tree and build around it a round dark house covered with dew, and place in it²⁰² a man of great age, a hundred years old, and close the house upon them and make it fast, so that no wind or dust can get in. Then leave them for one hundred and eighty days in their house. I say that that old man ceases not to eat of the fruits of

that tree until the completion of that number [180], and that old man becomes a youth. O what wondrous natures, which have changed the soul of that old man into a youthful body, and the father is become the son.²⁰³

[77] In this context we may perhaps cite a rather obscure text from Senior:²⁰⁴

Likewise Marchos²⁰⁵ said, It is time for this child to be born, and he related the following parable: We shall build him a house, which is called the grave of Sihoka. He [or Mariyah]²⁰⁶ said, There is an earth²⁰⁷ near us, which is called 'tormos,'²⁰⁸ where there are serpents [or witches]²⁰⁹ that eat the darkness²¹⁰ out of the burning stones, and on these stones they drink the blood of black goats.²¹¹ While they remain in the darkness, they conceive in the baths²¹² and give birth²¹³ in the air, and they stride on the sea,²¹⁴ and they inhabit vaults and sepulchres, and the serpent fights with the male, and the male continues forty nights in the grave, and forty nights in the little house.²¹⁵

[78] The Latin translation "serpent" for "witch" is connected with the widespread primitive idea that the spirits of the dead are snakes. This fits in with the offering of goat's blood, since the sacrifice of black animals to the chthonic numina was quite customary. In the Arabic text the "witches" refer to the female demons of the desert, the jinn. The grave-haunting numen is likewise a widespread idea that has lingered on into Christian legend. I have even met it in the dream of a twenty-two-year-old theological student, and I give this dream again so that those of my readers who are familiar with the language of dreams will be able to see the full scope of the problem we are discussing.²¹⁶

[79] *The dreamer was standing in the presence of a handsome old man dressed entirely in black. He knew it was the white magician. This personage had just addressed him at considerable length, but the dreamer could no longer remember what it was about. He recalled only the closing words: "And for this we need the help of the black magician." At that moment the door opened and in came another old man exactly like the first, except that he was dressed in white. He said to the white magician, "I need your advice," but threw a sidelong, questioning glance at the dreamer, whereupon the white magician answered: "You can speak freely, he is an innocent." The white-clad black magician then related his story. He had come from a distant land where something extraordinary had happened. The country was ruled by an old king who felt his death near and had therefore sought out a worthy tomb for himself. There were in that land a great number of tombs from ancient times, and the king had chosen the finest for himself. According to legend, it was the tomb of a virgin who had died long ago. The king caused it to be opened, in order to get it ready for use. But when the bones were exposed to the light of day they suddenly took on life and changed into a black horse, which galloped away into the desert. The*

black magician had heard this story and immediately set forth in pursuit of the horse. After a journey of many days through the desert he reached the grasslands on the other side. There he met the horse grazing, and there also he came upon the find on account of which he now needed the advice of the white magician. For he had found the lost keys of paradise, and he did not know what to do with them. Here the dream ended.

[80] The tomb was obviously haunted by the spirit of the virgin, who played the part of the king's anima. Like the nymph in Malvasius, she was forced to leave her old dwelling-place. Her chthonic and sombre nature is shown by her transformation into a black horse, a kind of demon of the desert. We have here the widespread conception of the anima as horsewoman and nightmare, a real "ungodly spirit," and at the same time the well-known fairytale motif of the aging king whose vitality is at an end. As a *sous-entendu* a magical, life-renewing marriage with the nymph seems to be planned (somewhat in the manner of the immortal Merlin's marriage with his fairy), for in paradise, the garden of love with the apple-tree, all opposites are united. As Isaiah says:

He will make her wilderness like Eden, and her desert like the garden of the Lord [51 : 3].

There the wolf shall dwell with the lamb, and the leopard shall lie down with the kid; and the calf and the young lion and the fatling together; and a little child shall lead them. And the cow and the bear shall feed; their young ones shall lie down together; and the lion shall eat straw like the ox. And the suckling child shall play on the hole of the asp, and the weaned child shall put his hand on the cockatrice's den [11 : 6f.].

There white and black come together in kingly marriage, "as a bridegroom decketh himself with ornaments, and as a bride adorneth herself with her jewels" (61 : 10). The two antithetical magicians are obviously making ready the work of union, and what this must mean for a young theologian can be conceived only as that colossal problem whose solution was considered by the more speculative alchemists to be their chief task. Therefore the Senior text continues:

He [the male] will be roused,²¹⁷ like the white doves,²¹⁸ and his step shall rejoice, and he shall cast his seed upon the marble²¹⁹ into the image [or spirit that dwells in the marble], and the ravens will come flying, and will fall upon it and gather it up. Then they will fly to the tops of the mountains, whither none can climb, and they will become white,²²⁰ and multiply. . . . Likewise no man hath known this, unless he himself hath conceived it in his head.

[81] This text describes the resurrection after death, and if we are not deceived, it takes the form of a coniunctio, a coming together of the white (dove) and the black (raven), the latter being the spirit that dwells in the tombstone (see n. 219). Since, as often happens, theriomorphic symbols (snakes and doves) are used for the male and female elements, this points to the union of unconscious factors.²²¹ The ravens that gather up the seed (or the product of the union?) and then fly with it to the tops of the mountains²²² represent the helpful spirits or familiars who complete the work when the skill of the artifex has failed him. They are not, as in *Faust*, beautiful angels but dark messengers of heaven, who at this point themselves become white.²²³ Even in *Faust* the angels are not entirely innocent of the arts of seduction,²²⁴ and the angels' inability to sin is, as we know, to be taken so relatively that women have to keep their heads covered in church on account of the moral frailty of these winged messengers, which has more than once proved disastrous in ancient times (e.g., Genesis 6 : 2).

[82] Similar motifs occur in modern dreams, and can be found in persons who have never been remotely concerned with alchemy. For instance, a patient had the following dream: "*A large pile of wood was burning at the foot of a high wall of rock; the flames shot up with clouds of smoke. It was a lonely and romantic spot. High in the air, a flock of great black birds circled round the fire. From time to time one of the birds plunged straight into the blaze and was joyfully burnt to death, turning white in the process.*"²²⁵ As the dreamer himself remarked, the dream had a numinous quality, and this is quite understandable in view of its meaning: it repeats the miracle of the phoenix, of transformation and rebirth (the transformation of the *nigredo* into the *albedo*, of unconsciousness into "illumination") as described in the verses from the *Rosarium philosophorum*:

Two eagles fly up with feathers aflame,
Naked they fall to earth again.
Yet in full feather they rise up soon . . .²²⁶

[83] After this digression on transformation and resurrection, let us turn back to the motif of the oak-tree, whose discussion was started by the commentators on the Enigma.

[84] We come across the oak in yet another alchemical treatise, the "Introitus apertus" of Philaletha.²²⁷ There he says: "Learn, then, who are the companions of Cadmus; who is the serpent that devoured them; and what the hollow oak to which Cadmus spitted the serpent."

[85] In order to clarify this passage, I must go back to the myth of Cadmus, a kinsman of the Pelasgian Hermes Ithyphallikos.²²⁸ The hero set out to find his lost sister Europa, whom Zeus had carried away with him after turning himself into a bull.

Cadmus, however, received the divine command to give up the search, and instead to follow a cow, with moon markings on both her sides, until she lay down, and there to found the city of Thebes. At the same time he was promised Harmonia, the *daughter* of Ares and Aphrodite as a wife. When the cow had lain down, he wanted to sacrifice her, and he sent his companions to fetch water. They found it in a grove sacred to Ares, which was guarded by a dragon, the *son* of Ares. The dragon killed most of the companions, and Cadmus, enraged, slew it and sowed the dragon's teeth.

Immediately armed men sprang up, who fell to fighting among themselves until only five remained. Cadmus was then given Harmonia to wife. The spitting of the snake (dragon) to the oak seems to be an addition of Philaetha's. It represents the banishment of the dangerous daemon into the oak,²²⁹ a point made not only by the commentary on the Aelia inscription in Malvasius but by the fairytale of "The Spirit in the Bottle."

[86] The psychological meaning of the myth is clear: Cadmus has lost his sister-anima because she has flown with the supreme deity into the realm of the suprahuman and the subhuman, the unconscious. At the divine command he is not to regress to the incest situation, and for this reason he is promised a wife. His sister-anima, acting as a psychopomp in the shape of a cow (to correspond with the bull of Zeus), leads him to his destiny as a dragon-slayer, for the transition from the brother-sister relationship to an exogamous one is not so simple. But when he succeeds in this, he wins "Harmonia," who is the *dragon's sister*. The dragon is obviously "disharmony," as the armed men sprung from its teeth prove. These kill one another off as though exemplifying the maxim of Pseudo-Democritus, "nature subdues nature," which is nothing less than the *uroboros* conceptually formulated. Cadmus holds fast to Harmonia while the opposites in projected form slaughter one another. This image is a representation of the way in which a split-off conflict behaves: it is its own battleground. By and large this is also true of yang and yin in classical Chinese philosophy. Hand in hand with this self-contained conflict there goes an unconsciousness of the moral problem of opposites. Only with Christianity did the "metaphysical" opposites begin to percolate into man's consciousness, and then in the form of an almost dualistic opposition that reached its zenith in Manichaeism. This heresy forced the Church to take an important step: the formulation of the doctrine of the *privatio boni*, by means of which she established the identity of "good" and "being." Evil as a *μη ὄν* (something that does not exist) was laid at man's door—*omne bonum a Deo, omne malum ab homine*.²³⁰ This idea together with that of original sin formed the foundation of a moral consciousness which was a novel development in human history: one half of the polarity, till then essentially metaphysical, was reduced to a psychic factor, which meant that the devil had lost the game if he could not pick on some moral weakness in man. Good, however, remained a metaphysical substance

that originated with God and not with man. Original sin had corrupted a creature originally good. As interpreted by dogma, therefore, good is still wholly projected but evil only partly so, since the passions of men are its main source. Alchemical speculation continued this process of integrating metaphysical projections in so far as it began to dawn on the adept that both opposites were of a psychic nature. They expressed themselves first of all in the duplicity of Mercurius, which, however, was cancelled out in the unity of the stone. The lapis was—*Deo concedente*—made by the adept and was recognized as an equivalent of the *homo totus*. This development was extremely important, because it was an attempt to integrate opposites that were previously projected.

[87] Cadmus is interpreted alchemically as Mercurius in his masculine form (Sol). He seeks his feminine counterpart, the quicksilver, which is his sister (Luna), but she meets him in the shape of the Mercurial serpent, which he must first kill because it contains the furious conflict of warring elements (the chaos). From this arises the harmony of the elements, and the coniunctio can now take place. The spoils of the struggle, in this case the dragon's skin, are, according to ancient custom, offered to the hollow oak, the mother, who is the representative of the sacred grove and the fount. In other words, it is offered up to the unconscious as the source of life, which produces harmony out of disharmony.²³¹ Out of the hostility of the elements there arises the bond of friendship between them, sealed in the stone, and this bond guarantees the indissolubility and incorruptibility of the lapis. This piece of alchemical logic is borne out by the fact that, according to the myth, Cadmus and Harmonia *turned to stone* (evidently because of an *embarras de richesse*: perfect harmony is a dead end). In another version, they turn into *snakes*, “and even into a basilisk,” Dom Pernety²³² remarks, “for the end-product of the work, incorporated with its like, acquires the power ascribed to the basilisk, so the philosophers say.” For this fanciful author Harmonia is naturally the prima materia, and the marriage of Cadmus,²³³ which took place with all the gods assisting, is the coniunctio of Sol and Luna, followed by the production of the tincture or lapis. Pernety's interpretation of Harmonia would be correct only if she were still allied with the dragon. But since she lost the reptile, she had logically to change herself and her husband into snakes.

[88] Thus Malvasius, as well as the more interesting of the commentators, remain within the magic circle of alchemical mythologems. This is not surprising, since Hermetic philosophy, in the form it then took, was the only intellectual instrument that could help fill the dark gaps in the continuity of understanding. The Enigma of Bologna and its commentaries are, in fact, a perfect paradigm of the method of alchemy in general. It had exactly the same effect as the unintelligibility of chemical processes: the philosopher stared at the paradoxes of the Aelia inscription, just as he stared at the retort, until the archetypal structures of the collective unconscious began

to illuminate the darkness.²³⁴ And, unless we are completely deluded, the inscription itself seems to be a fantasy sprung from that same paradoxical *massa confusa* of the collective unconscious. The contradictoriness of the unconscious is resolved by the archetype of the nuptial coniunctio, by which the chaos becomes ordered. Any attempt to determine the nature of the unconscious state runs up against the same difficulties as atomic physics: the very act of observation alters the object observed. Consequently, there is at present no way of objectively determining the real nature of the unconscious.

[89] If we are not, as Malvasius was, convinced of the antiquity of the Aelia inscription, we must look round in the medieval literature for possible sources or at least analogies. Here the motif of the triple prediction, or triple cause, of death might put us on the right trail.²³⁵ This motif occurs in the “Vita Merlini” in the old French romance *Merlin*, as well as in its later imitations in the Spanish and English literature of the fifteenth century. But the most important item, it seems to me, is the so-called “Epigram of the Hermaphrodite,” attributed to Mathieu de Vendôme (ca. 1150):

When my pregnant mother bore me in her womb,
they said she asked the gods what she would bear.
A boy, said Phoebus, a girl, said Mars, neither, said Juno.
And when I was born, I was a hermaphrodite.
Asked how I was to meet my end, the goddess replied: By arms;
Mars: On the cross; Phoebus: By water. All were right.
A tree overshadowed the waters, I climbed it;
the sword I had with me slipped, and I with it.
My foot caught in the branches, my head hung down in the stream;
And I—male, female, and neither—suffered by water, weapon, and cross.²³⁶

[90] Another parallel, but dating from late antiquity, is mentioned by Maier. It is one of the “Platonic Riddles” and runs: “A man that was not a man, seeing yet not seeing, in a tree that was not a tree, smote but did not smite with a stone that was not a stone a bird that was not a bird, sitting yet not sitting.”²³⁷ The solution is: A one-eyed eunuch grazed with a pumice-stone a bat hanging from a bush.²³⁸ This joke was, of course, too obvious to lend itself to alchemical evaluation. Similarly, the Epigram of the Hermaphrodite was not, so far as I know, taken up by the alchemists, though it might have been a more suitable subject for exegesis. This kind of jest probably underlies the Aelia inscription. The seriousness with which the alchemists took it, however, is justified not only because there is something serious in every joke, but because paradox is the natural medium for expressing transconscious facts. Hindu philosophy, which likewise struggled to formulate transcendental concepts, often comes very near to the paradoxes so beloved of the alchemists, as the following

example shows: “I am not a man, neither am I a god, a goblin, a Brahmin, a warrior, a merchant, a shudra, nor disciple of a Brahmin, nor householder, nor hermit of the forest, nor yet mendicant pilgrim: Awakener to Myself is my name.”²³⁹

[91] Another source that needs seriously considering is mentioned by Richard White of Basingstoke.²⁴⁰ He maintains that Aelia Laelia is “Niobe transformed,” and he supports this interpretation by referring to an epigram attributed to Agathias Scholasticus, a Byzantine historian:²⁴¹

This tomb has no body in it.

This body has no tomb round it.

But it is itself body and tomb.²⁴²

White, convinced that the monument was genuine, thinks that Agathias wrote his epigram in imitation of it, whereas in fact the epigram must be its predecessor or at least have derived from the same source on which the unknown author of the Aelia inscription drew.

[92] Niobe seems to have an anima-character for Richard White, for, continuing his interpretation, he takes Aelia (or Haelia, as he calls her) to be the soul, saying with Virgil: “Fiery is her strength, and heavenly her origin. From this Haelia takes her name.”²⁴³ She was called Laelia, he says, on account of Luna, who exerts a hidden influence on the souls of men. The human soul is “androgynous,” “because a girl has a masculine and a man a feminine soul.”²⁴⁴ To this remarkable psychological insight he adds another: the soul is also called an “old woman,” because the spirit of young people is weak. This aptly expresses the psychological fact that, in people with an all too youthful attitude of consciousness, the anima is often represented in dreams as an old woman.

[93] It is clear that Richard White points even more plainly to the anima in the psychological sense than Aldrovandus. But whereas the latter stressed her mythological aspect, White stresses her philosophical aspect. In his letter of February 1567 to Johannes Turrius, he writes that the soul is an idea “of such great power that she creates the forms and things themselves,” also “she has within herself the ‘selfness’ of all mankind.”²⁴⁵ She transcends all individual differences. “Thus, if the soul would know herself, she must contemplate herself, and gaze into that place where the power of the soul, Wisdom, dwells.”²⁴⁶ This is just what happened to the interpreters of the Bolognese inscription: in the darkness of the enigma, the psyche gazed at herself and perceived the wisdom immanent in her structure—the wisdom that is her strength. And, he adds, “man is nothing other than his soul.”²⁴⁷ It should be noted that he describes this soul quite differently from the way it would be described by a biological or personalistic psychology today: it is devoid of all individual

differences, it contains the “selfness of all mankind,” it even creates the objective world by the power of its wisdom. This description is far better suited, one would think, to the *anima mundi* than to the *anima vagula* of the personal man, unless he means that enigmatic background of everything psychic, the collective unconscious. White comes to the conclusion that the inscription means nothing less than the soul, the form imprinted on and bound to matter.²⁴⁸ This, again, is what happened to the interpreters: they formulated the baffling inscription in accordance with the imprint set upon it by the psyche.

[94] White’s interpretation is not only original but profoundly psychological. His deserts are certainly not diminished by his having, so it would seem, arrived at his deeper view only after he received Turrius’s letter of January 1567. Turrius was of the opinion that “Aelia and Laelia” stood for “form and matter.” He interprets “neither in heaven, nor on earth, nor in water” as follows: “Since the *prima materia* is *nothing*, but is conceived solely by the imagination, it cannot be contained in any of these places.”²⁴⁹ It is not an object of the senses, but is “conceived solely by the intellect,” therefore we cannot know how this material is constituted. It is evident that Turrius’s interpretation likewise describes the projection of the psyche and its contents, with the result that his secondary explanations are a *petitio principii*.

[95] As is clear from the title of his book, *Allegoria peripatetica de generatione, amicitia, et privatione in Aristotelicum Aenigma Elia Lelia Crispis*,²⁵⁰ Fortunius Licetus reads the whole philosophy of Aristotle into the monument. He mentions the report that it was “sculptured in stone, formerly set in a high position on the walls of St. Peter’s,” but he does not say that he saw it with his own eyes, for in his day it was no longer in existence, if ever it existed at all. He thinks the inscription contains the summation of a serious philosophical theory about the origin of mundane things, a theory that was “scientifico-moralis” or “ethico-physica.” “It is the author’s intention to combine in a way to be marvelled at the attributes of generation, friendship, and privation.”²⁵¹ That is why, he says, the monument is a true treasure-house.

[96] After reviewing a number of earlier authors who had devoted themselves to the same theme, Licetus mentions the work of Joannes Casparius Gevartius,²⁵² who propounded the theory that the inscription described the nature of Love. This author cites the comic poet Alexis in Athenaeus:

I think that the painters, or, to put it more concisely, all who make images of this god, are unacquainted with Eros. For he is neither female nor male; again, neither god nor man, neither stupid nor yet wise, but rather composed of elements from everywhere, and bearing many qualities under a single form. For his audacity is that of a man, his timidity a woman’s; his folly argues madness, his reasoning good sense; his

impetuosity is that of an animal, his persistence that of adamant, his love of honour that of a god.²⁵³

[97] Unfortunately I was unable to get hold of the original treatise of Gevartius. But there is a later author, Caietanus Felix Veranius, who takes up the Eros theory apparently as his own discovery in his book, *Pantheon argenteae Elocutionis*.²⁵⁴ He mentions a number of earlier commentators, amongst whom Gevartius is conspicuously absent. As Gevartius is named in the earlier lists, it is scarcely likely that Veranius was unacquainted with him. The suspicion of plagiarism is almost unescapable. Veranius defends his thesis with a good deal of skill, though considering the undeniable paradoxicality of Eros the task he sets himself is not too difficult. I will mention only one of his arguments, concerning the end of the inscription. “The inscription ends,” he says, “with ‘scit et nescit quid cui posuerit,’ because though the author of this enigmatic inscription knows that he has dedicated it to Love, he does not know what Love really is, since it is expressed by so many contradictions and riddles. Therefore he knows and does not know know to whom he dedicated it.”

[98] I mention the interpretation of Veranius mainly because it is the forerunner of a theory which was very popular at the end of the nineteenth and the beginning of the twentieth century, namely Freud’s sexual theory of the unconscious. Veranius even goes so far as to conjecture that Aelia Laelia had a special talent for eroticism (therein anticipating Aldrovandus). He says: “Laelia was a whore; Crispis comes from ‘curly-haired,’ because curly-haired people are frailer than others and more prone to the allurements of Love.” Here he quotes Martial: “Who’s that curly-headed fellow who’s always running round with your wife, Marianus? Who *is* that curly-headed fellow?”²⁵⁵

[99] Now it is, as a matter of fact, true that apart from the personal striving for power, or *superbia*, love, in the sense of *concupiscentia*, is the dynamism that most infallibly brings the unconscious to light. And if our author was of the type whose besetting sin is concupiscence, he would never dream that there is any other power in heaven or earth that could be the source of his conflicts and confusions. Accordingly, he will cling to his prejudice as if it were a universal theory, and the more wrong he is the more fanatically he will be convinced of its truth. But what can love mean to a man with a hunger for power! That is why we always find two main causes of psychic catastrophes: on the one hand a disappointment in love and on the other hand a thwarting of the striving for power.

[100] The last interpretation I shall mention is one of the most recent. It dates from 1727, and though its argument is the stupidest its content is the most significant. How it can be both is explained by the fact that the discovery of significance is not always coupled with intelligence. The spirit bloweth where it listeth. . . . Despite the

inadequacy of his equipment, the author, C. Schwartz,²⁵⁶ managed to get hold of a brilliant idea whose import, however, entirely escaped him. His view was that Lucius Agatho Priscius meant his monument to be understood as the *Church*. Schwartz therefore regards the inscription as being not of classical but of Christian origin, and in this, as compared with the others, he is undoubtedly right. His arguments, however, are threadbare—to take but one example, he tries to twist “D.M.” into “Deo Magno.” Although his interpretation is not in the least convincing, it nevertheless remains a significant fact that the symbol of the Church in part expresses and in part substitutes for all the secrets of the soul which the humanistic philosophers projected into the Aelia inscription. In order not to repeat myself, I must refer the reader to what I said about the protective function of the Church in “Psychology and Religion.”²⁵⁷

[101] The interpretive projections we have been examining are, with the exception of the last, identical with the psychic contents that dropped out of their dogmatic framework at the time of the Renaissance and the Great Schism, and since then have continued in a state of secularization where they were at the mercy of the “immanentist” principle of explanation, that is, a naturalistic and personalistic interpretation. The discovery of the collective unconscious did something to alter this situation, for, within the limits of psychic experience, the collective unconscious takes the place of the Platonic realm of eternal ideas. Instead of these models giving form to created things, the collective unconscious, through its archetypes, provides the *a priori* condition for the assignment of meaning.

[102] In conclusion, I would like to mention one more document that seems relevant to our context, and that is the anecdote about Meister Eckhart’s “daughter”:

A daughter came to the Dominican convent asking for Meister Eckhart. The porter said, Who shall I tell him? She answered, I do not know. Why do you not know? he inquired. Because, she said, I am neither virgin nor spouse, nor man nor wife nor widow nor lady nor lord nor wench nor thrall. The porter went off to Meister Eckhart. Do come out, he said, to the strangest wight that ever I heard, and let me come too and put your head out and say, Who is asking for me? He did so. She said to him what she had said to the porter. Quoth he, My child, thou hast a shrewd and ready tongue, I prithee now thy meaning? An I were a virgin, she replied, I were in my first innocence; spouse, I were bearing the eternal word within my soul unceasingly; were I a man I should grapple with my faults; wife, should be faithful to my husband. Were I a widow I should be ever yearning for my one and only love; as lady I should render fearful homage; as wench I should be living in meek servitude to God and to all creatures; and as thrall I should be working hard, doing my best tamely to serve my master. Of all these things I am no single one, and am the one thing and the other

running thither. The Master went away and told his pupils, I have been listening to the most perfect person I ween I ever met.²⁵⁸

[103] This story is more than two hundred years older than the earliest reference to the Aelia inscription, and therefore, if there is any literary influence at all, it could at most be derived from Mathieu de Vendôme, which seems to me just as unlikely as that Meister Eckhart's vision of the "naked boy" was derived from the classical *puer aeternus*. In both cases we are confronted with a significant archetype, in the first that of the divine maiden (anima), in the second that of the divine child (the self).²⁵⁹ As we know, these primordial images can rise up anywhere at any time quite spontaneously, without the least evidence of any external tradition. This story could just as well have been a visionary rumour as a fantasy of Meister Eckhart or of one of his pupils. It is, however, rather too peculiar to have been a real happening. But occasionally reality is quite as archetypal as human fantasy, and sometimes the soul seems to "imagine things outside the body,"²⁶⁰ where they fall to playing, as they do in our dreams.

III

THE PERSONIFICATION OF THE OPPOSITES

1. INTRODUCTION

[104] The alchemist's endeavours to unite the opposites culminate in the "chymical marriage," the supreme act of union in which the work reaches its consummation. After the hostility of the four elements has been overcome, there still remains the last and most formidable opposition, which the alchemist expressed very aptly as the relationship between male and female. We are inclined to think of this primarily as the power of love, of passion, which drives the two opposite poles together, forgetting that such a vehement attraction is needed only when an equally strong resistance keeps them apart. Although enmity was put only between the serpent and the woman (Genesis 3 : 15), this curse nevertheless fell upon the relationship of the sexes in general. Eve was told: "Thy desire shall be to thy husband, and he shall rule over thee." And Adam was told: "Cursed is the ground for thy sake . . . because thou hast hearkened unto the voice of thy wife" (3 : 16f.). Primal guilt lies between them, an *interrupted state of enmity*, and this appears unreasonable only to our rational mind but not to our psychic nature. Our reason is often influenced far too much by purely physical considerations, so that the union of the sexes seems to it the only sensible thing and the urge for union the most sensible instinct of all. But if we conceive of nature in the higher sense as the totality of all phenomena, then the physical is only one of her aspects, the other is pneumatic or spiritual. The first has always been regarded as feminine, the second as masculine. The goal of the one is union, the goal of the other is discrimination. Because it overvalues the physical, our contemporary reason lacks spiritual orientation, that is, *pneuma*. The alchemists seem to have had an inkling of this, for how otherwise could they have come upon that strange myth of the country of the King of the Sea, where only like pairs with like and the land is unfruitful?¹ It was obviously a realm of innocent friendship, a kind of paradise or golden age, to which the "Philosophers," the representatives of the physical, felt obliged to put an end with their good advice. But what happened was not by any means a natural union of the sexes; on the contrary it was a "royal" incest, a sinful deed that immediately led to imprisonment and death and only afterwards restored the fertility of the country. As a parable the myth is certainly ambiguous; like alchemy in general, it can be understood spiritually as well as physically, "tam moralis quam chymica."² The physical goal of alchemy was gold, the *panacea*, the

elixir of life; the spiritual one was the rebirth of the (spiritual) light from the darkness of Physis: healing self-knowledge and the deliverance of the pneumatic body from the corruption of the flesh.

[105] A subtle feature of the “*Visio Arislei*” is that the very one who is meditating a pairing of the sexes is king of the land of innocence. Thus the *rex marinus* says: “Truly I have a son and a daughter, and therefore I am king over my subjects, because they possess nothing of these things. Yet I have borne a son and a daughter in my brain.”³ Hence the king is a potential traitor to the paradisaic state of innocence because he can generate “in his head,” and he is king precisely because he is capable of this sin against the previous state of innocence. Since he can be different from them he is *more* than any of his subjects and therefore rightly their king, although, from the physical standpoint, he is counted a bad ruler.⁴

[106] Here again we see the contrast between alchemy and the prevailing Christian ideal of attempting to restore the original state of innocence by monasticism and, later, by the celibacy of the priesthood. The conflict between worldliness and spirituality, latent in the love-myth of Mother and Son, was elevated by Christianity to the mystic marriage of sponsus (Christ) and sponsa (Church), whereas the alchemists transposed it to the physical plane as the coniunctio of Sol and Luna. The Christian solution of the conflict is purely pneumatic, the physical relations of the sexes being turned into an allegory or—quite illegitimately—into a sin that perpetuates and even intensifies the original one in the Garden. Alchemy, on the other hand, exalted the most heinous transgression of the law, namely incest, into a symbol of the union of opposites, hoping in this way to bring back the golden age. For both trends the solution lay in extrapolating the union of sexes into another medium: the one projected it into the spirit, the other into matter. But neither of them located the problem in the place where it arose—the soul of man.

[107] No doubt it would be tempting to assume that it was more convenient to shift such a supremely difficult question on to another plane and then represent it as having been solved. But this explanation is too facile, and is psychologically false because it supposes that the problem was asked consciously, found to be painful, and consequently moved on to another plane. This stratagem accords with our modern way of thinking but not with the spirit of the past, and there are no historical proofs of any such neurotic operation. Rather does all the evidence suggest that the problem has always seemed to lie outside the psyche as known to us. Incest was the hierogamos of the gods, the mystic prerogative of kings, a priestly rite, etc. In all these cases we are dealing with an archetype of the collective unconscious which, as consciousness increased, exerted an ever greater influence on conscious life. It certainly seems today as if the ecclesiastical allegories of the bridegroom and bride,

not to mention the now completely obsolete alchemical coniunctio, had become so faded that one meets with incest only in criminology and the psychopathology of sex. Freud's discovery of the Oedipus complex, a special instance of the incest problem in general, and its universal incidence have, however, reactivated this ancient problem, though mostly only for doctors interested in psychology. Even though laymen know very little about certain medical anomalies or have a wrong idea of them, this does not alter the facts any more than does the layman's ignorance of the actual percentage of cases of tuberculosis or psychosis.

[108] Today the medical man knows that the incest problem is practically universal and that it immediately comes to the surface when the customary illusions are cleared away from the foreground. But mostly he knows only its pathological side and leaves it steeped in the odium of its name, without learning the lesson of history that the painful secret of the consulting-room is merely the embryonic form of a perennial problem which, in the suprapersonal sphere of ecclesiastical allegory and in the early phases of natural science, created a symbolism of the utmost importance. Generally he sees only the "materia vilis et in via eiecta" from the pathological side and has no idea of its spiritual implications. If he saw this, he could also perceive how the spirit that has disappeared returns in each of us in unseemly, indeed reprehensible guise, and in certain predisposed cases causes endless confusion and destruction in great things as in small. The psychopathological problem of incest is the aberrant, natural form of the union of opposites, a union which has either never been made conscious at all as a psychic task or, if it was conscious, has once more disappeared from view.

[109] The persons who enact the drama of this problem are man and woman, in alchemy King and Queen, Sol and Luna. In what follows I shall give an account of the way in which alchemy describes the symbolic protagonists of the supreme opposition.

2. SOL

[110] In alchemy, the sun signifies first of all gold, whose sign it shares. But just as the "philosophical" gold is not the "common" gold,⁵ so the sun is neither just the metallic gold⁶ nor the heavenly orb.⁷ Sometimes the sun is an active substance hidden in the gold and is extracted as the *tinctura rubea* (red tincture). Sometimes, as the heavenly body, it is the possessor of magically effective and transformative rays. As gold and a heavenly body⁸ it contains an active sulphur of a red colour, hot and dry.⁹ Because of this red sulphur the alchemical sun, like the corresponding gold, is red.¹⁰ As every alchemist knew, gold owes its red colour to the admixture of Cu (copper), which he interpreted as Kypris (the Cyprian, Venus), mentioned in Greek alchemy as the

transformative substance.¹¹ Redness, heat, and dryness are the classical qualities of the Egyptian Set (Gk. Typhon), the evil principle which, like the alchemical sulphur, is closely connected with the devil. And just as Typhon has his kingdom in the forbidden sea, so the sun, as *sol centralis*, has its sea, its “crude perceptible water,” and as *sol coelestis* its “subtle imperceptible water.” This sea water (*aqua pontica*) is extracted from sun and moon. Unlike the Typhonian sea, the life-giving power of this water is praised, though this does not mean that it is invariably good.¹² It is the equivalent of the two-faced Mercurius, whose poisonous nature is often mentioned. The Typhonian aspect of the active sun-substance, of the red sulphur, of the water “that does not make the hands wet,”¹³ and of the “sea water” should not be left out of account. The author of the “*Novum lumen chemicum*” cannot suppress a reference to the latter’s paradoxical nature: “Do not be disturbed because you sometimes find contradictions in my treatises, after the custom of the philosophers; these are necessary, if you understand that no rose is found without thorns.”¹⁴

[111] The active sun-substance also has favourable effects. As the so-called “balsam” it drips from the sun and produces lemons, oranges, wine, and, in the mineral kingdom, gold.¹⁵ In man the balsam forms the “radical moisture, from the sphere of the supracelestial waters”; it is the “shining” or “lucent body” which “from man’s birth enkindles the inner warmth, and from which come all the motions of the will and the principle of all appetition.” It is a “vital spirit,” and it has “its seat in the brain and its governance in the heart.”¹⁶

[112] In the “*Liber Platonis Quartorum*,” a Sabaeen treatise, the *spiritus animalis* or solar sulphur is still a *πνεῦμα παρέδρον*, a ministering spirit or familiar who can be conjured up by magical invocations to help with the work.¹⁷

[113] From what has been said about the active sun-substance it should be clear that Sol in alchemy is much less a definite chemical substance than a “virtus,” a mysterious power¹⁸ believed to have a generative¹⁹ and transformative effect. Just as the physical sun lightens and warms the universe, so, in the human body, there is in the heart a sunlike arcanum from which life and warmth stream forth.²⁰ “Therefore Sol,” says Dorn, “is rightly named the first after God, and the father and begetter of all,²¹ because in him the seminal and formal virtue of all things whatsoever lies hid.”²² This power is called “sulphur.”²³ It is a hot, daemonic principle of life, having the closest affinities with the sun in the earth, the “central fire” or “*ignis gehennalis*” (fire of hell). Hence there is also a *Sol niger*, a black sun, which coincides with the *nigredo* and *putrefactio*, the state of death.²⁴ Like Mercurius, Sol in alchemy is ambivalent.

[114] The miraculous power of the sun, says Dorn, is due to the fact that “all the simple elements are contained in it, as they are in heaven and in the other heavenly bodies.”

“We say that the sun is a single element,” he continues, tacitly identifying it with the quintessence. This view is explained by a remarkable passage from the “*Consilium coniugii*”: “The Philosophers maintained that the father of the gold and silver is the animating principle [*animal*] of earth and water, or man or part of a man, such as hair, blood, menstruum, etc.”²⁵ The idea at the back of this is that primitive conception of a universal power of growth, healing, magic, and prestige,²⁶ which is to be found as much in the sun as in men and plants, so that not only the sun but man too, and especially the enlightened man, the adept, can generate the gold by virtue of this universal power. It was clear to Dorn (and to other alchemists as well) that the gold was not made by the usual chemical procedures,²⁷ for which reason he called gold-making (*chrysopoeia*) a “miracle.” The miracle was performed by a *natura abscondita* (hidden nature), a metaphysical entity “perceived not with the outward eyes, but solely by the mind.”²⁸ It was “infused from heaven,²⁹ provided that the adept had approached as closely as possible to things divine and at the same time had extracted from the substances the subtlest powers “fit for the miraculous act.” “There is in the human body a certain aethereal substance, which preserves its other elemental parts and causes them to continue,”³⁰ he says. This substance or virtue is hindered in its operations by the “corruption of the body”; but “the Philosophers, through a kind of divine inspiration, knew that this virtue and heavenly vigour can be freed from its fetters, not by its contrary . . . but by its like.”³¹ Dorn calls it “*veritas*.” “It is the supreme power, an unconquerable fortress, which hath but very few friends, and is besieged by innumerable enemies.” It is “defended by the immaculate Lamb,” and signifies the heavenly Jerusalem in the inner man. “In this fortress is the true and indubitable treasure, which is not eaten into by moths, nor dug out by thieves, but remaineth for ever, and is taken hence after death.”³²

[115] For Dorn, then, the spark of divine fire implanted in man becomes what Goethe in his original version of *Faust* called Faust’s “entelechy,” which was carried away by the angels. This supreme treasure “the animal man understandeth not. . . . We are made like stones, having eyes and seeing not.”³³

[116] After all this, we can say that the alchemical Sol, as a “certain luminosity” (*quaedam luminositas*), is in many respects equal to the *lumen naturae*. This was the real source of illumination in alchemy, and from alchemy Paracelsus borrowed this same source in order to illuminate the art of medicine. Thus the concept of Sol has not a little to do with the growth of modern consciousness, which in the last two centuries has relied more and more on the observation and experience of natural objects. Sol therefore seems to denote an important psychological fact. Consequently, it is well worth while delineating its peculiarities in greater detail on the basis of the very extensive literature.

[117] Generally Sol is regarded as the masculine and active half of Mercurius, a supraordinate concept whose psychology I have discussed in a separate study.³⁴ Since, in his alchemical form, Mercurius does not exist in reality, he must be an unconscious projection, and because he is an absolutely fundamental concept in alchemy he must signify the unconscious itself. He is by his very nature the unconscious, where nothing can be differentiated; but, as a *spiritus vegetativus* (living spirit), he is an active principle and so must always appear in reality in differentiated form. He is therefore fittingly called “duplex,” both active and passive. The “ascending,” active part of him is called Sol, and it is only through this that the passive part can be perceived. The passive part therefore bears the name of Luna, because she borrows her light from the sun.³⁵ Mercurius demonstrably corresponds to the cosmic Nous of the classical philosophers. The human mind is a derivative of this and so, likewise, is the diurnal life of the psyche, which we call consciousness.³⁶ Consciousness requires as its necessary counterpart a dark, latent, non-manifest side, the unconscious, whose presence can be known only by the light of consciousness.³⁷ Just as the day-star rises out of the nocturnal sea, so, ontogenetically and phylogenetically, consciousness is born of unconsciousness and sinks back every night to this primal condition. This duality of our psychic life is the prototype and archetype of the Sol-Luna symbolism. So much did the alchemist sense the duality of his unconscious assumptions that, in the face of all astronomical evidence, he equipped the sun with a shadow: “The sun and its shadow bring the work to perfection.”³⁸ Michael Maier, from whom this saying is taken, avoids the onus of explanation by substituting the shadow of the earth for the shadow of the sun in the forty-fifth discourse of his *Scrutinium*. Evidently he could not wholly shut his eyes to astronomical reality. But then he cites the classical saying of Hermes: “Son, extract from the ray its shadow,”³⁹ thus giving us clearly to understand that the shadow is contained in the sun’s rays and hence could be extracted from them (whatever that might mean). Closely related to this saying is the alchemical idea of a black sun, often mentioned in the literature.⁴⁰ This notion is supported by the self-evident fact that without light there is no shadow, so that, in a sense, the shadow too is emitted by the sun. For this physics requires a dark object interposed between the sun and the observer, a condition that does not apply to the alchemical Sol, since occasionally it appears as black itself. It contains both light and darkness. “For what, in the end,” asks Maier, “is this sun without a shadow? The same as a bell without a clapper.” While Sol is the most precious thing, its shadow is *res vilissima* or *quid vilius alga* (more worthless than seaweed). The antinomian thinking of alchemy counters every position with a negation and vice versa. “Outwardly they are bodily things, but inwardly they are spiritual,” says Senior.⁴¹ This view is true of all alchemical qualities, and each thing bears in itself its opposite.⁴²

[118] To the alchemical way of thinking the shadow is no mere *privatio lucis*; just as the bell and its clapper are of a tangible substantiality, so too are light and shadow. Only thus can the saying of Hermes be understood. In its entirety it runs: “Son, extract from the ray its shadow, and the corruption that arises from the mists which gather about it, befoul it and veil its light; for it is consumed by necessity and by its redness.”⁴³ Here the shadow is thought of quite concretely; it is a mist that is capable not only of obscuring the sun but of befouling it (“coinquinare”—a strong expression). The redness (*rubedo*) of the sun’s light is a reference to the red sulphur in it, the active burning principle, destructive in its effects. In man the “natural sulphur,” Dorn says, is identical with an “elemental fire” which is the “cause of corruption,” and this fire is “enkindled by an invisible sun unknown to many, that is, the sun of the Philosophers.” The natural sulphur tends to revert to its first nature, so that the body becomes “sulphurous” and fitted to receive the fire that “corrupts man back to his first essence.”⁴⁴ The sun is evidently an instrument in the physiological and psychological drama of return to the *prima materia*, the death that must be undergone if man is to get back to the original condition of the simple elements and attain the incorrupt nature of the pre-worldly paradise. For Dorn this process was spiritual and moral as well as physical.

[119] Sol appears here in a dubious, indeed a “sulphurous” light: it corrupts, obviously because of the sulphur it contains.⁴⁵

[120] Accordingly, Sol is the transformative substance, the *prima materia* as well as the gold tincture. The anonymous treatise “*De arte chymica*” distinguishes two parts or stages of the lapis. The first part is called the *sol terrenus* (earthly sun). “Without the earthly sun, the work is not perfected.”⁴⁶ In the second part of the work Sol is joined with Mercurius.

On earth these stones are dead, and they do nothing unless the activity of man is applied to them. [Consider]⁴⁷ the profound analogy of the gold: the aethereal heaven was locked to all men, so that all men had to descend into the underworld, where they were imprisoned for ever. But Christ Jesus unlocked the gate of the heavenly Olympus and threw open the realm of Pluto, that the souls might be freed, when the Virgin Mary, with the cooperation of the Holy Ghost in an unutterable mystery and deepest sacrament, conceived in her virgin womb that which was most excellent in heaven and upon earth, and finally bore for us the Redeemer of the whole world, who by his overflowing goodness shall save all who are given up to sin, if only the sinner shall turn to him. But the Virgin remained incorrupt and inviolate: therefore not without good reason is Mercurius made equal [*aequiparatur*] to the most glorious and worshipful Virgin Mary.⁴⁸

It is evident from this that the coniunctio of Sol and Mercurius is a hierosgamos, with Mercurius playing the role of bride. If one does not find this analogy too offensive, one may ask oneself with equanimity whether the arcanum of the opus alchymicum, as understood by the old masters, may not indeed be considered an equivalent of the dogmatic mystery. For the psychologist the decisive thing here is the subjective attitude of the alchemist. As I have shown in *Psychology and Alchemy*, such a profession of faith is by no means unique.⁴⁹

[121] The metaphorical designation of Christ as Sol⁵⁰ in the language of the Church Fathers was taken quite literally by the alchemists and applied to their *sol terrenus*. When we remember that the alchemical Sol corresponds psychologically to consciousness, the diurnal side of the psyche, we must add the Christ analogy to this symbolism. Christ appears essentially as the *son*—the son of his mother-bride. The role of the son does in fact devolve upon ego-consciousness since it is the offspring of the maternal unconscious. Now according to the arch authority, the “*Tabula smaragdina*,” Sol is the father of Mercurius, who in the above quotation appears as feminine and as the mother-bride. In that capacity Mercurius is identical with Luna, and—via the Luna-Mary-Ecclesia symbolism—is equated with the Virgin. Thus the treatise “*Exercitationes in Turbam*” says: “As blood is the origin of flesh, so is Mercurius the origin of Sol . . . and thus Mercurius is Sol and Sol is Mercurius.”⁵¹ Sol is therefore father and son at once, and his feminine counterpart is mother and daughter in one person; furthermore, Sol and Luna are merely aspects of the same substance that is simultaneously the cause and the product of both, namely Mercurius duplex, of whom the philosophers say that he contains everything that is sought by the wise. This train of thought is based on a quaternity:

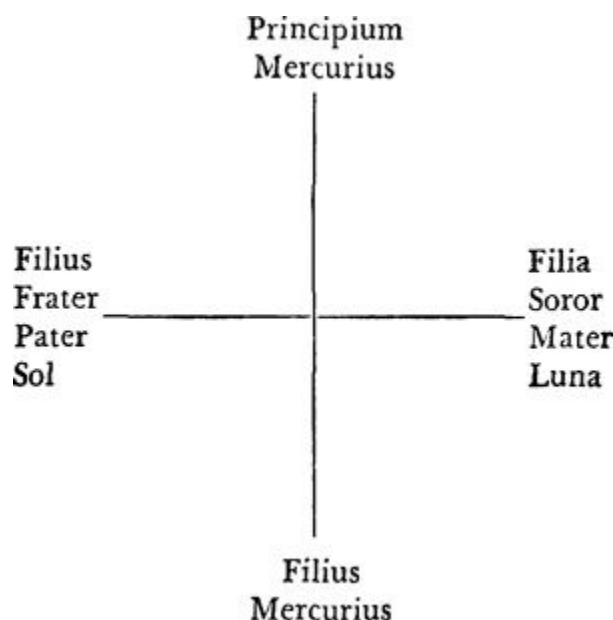

[122] Although the Sol symbolism is reminiscent of the dogmatic models, its basic schema is very different; for the dogmatic schema is a Trinity embracing only the Deity but not the universe.⁵² The alchemical schema appears to embrace only the

material world, yet, on account of its quaternary character, it comes near to being a representation of totality as exemplified in the symbol of the cross erected between heaven and earth. The cross is by implication the Christian totality symbol: as an instrument of torture it expresses the sufferings on earth of the incarnate God, and as a quaternity it expresses the universe, which also includes the material world. If we now add to this cruciform schema the four protagonists of the divine world-drama—the Father as *auctor rerum*, the Son, his counterpart the Devil (to fight whom he became man), and the Holy Ghost, we get the following quaternity:

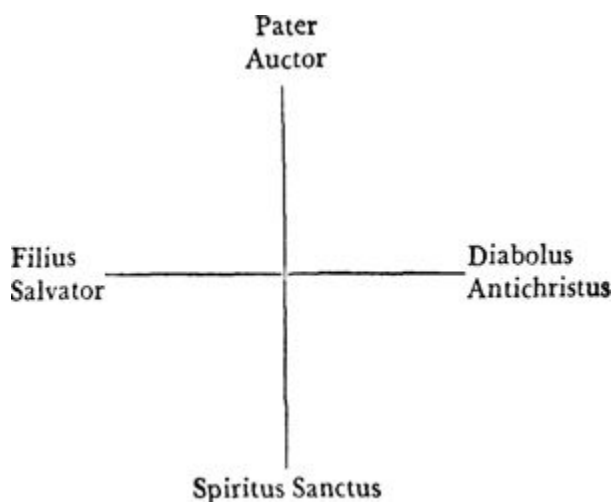

[123] I will not discuss the various aspects of this quaternity more closely here, as I have already done so in a separate study.⁵³ I mention it only for comparison with the alchemical one. Quaternities such as these are logical characteristics of Gnostic thinking, which Koepgen has aptly called “circular.”⁵⁴ We have already met similar figures in our account of the opposites, which were often arranged in quaternities. The rhythm of both schemas is divided into three steps:



[124] The alchemical drama leads from below upwards, from the darkness of the earth to the winged, spiritual *filius macrocosmi* and to the *lux moderna*; the Christian drama, on the other hand, represents the descent of the Kingdom of Heaven to earth. One has the impression of a mirror-world, as if the God-man coming down from above—as in the Gnostic legend—were reflected in the dark waters of Physis. The relation of the unconscious to the conscious mind is to a certain extent complementary, as elementary psychogenic symptoms and dreams caused by simple somatic stimuli prove.⁵⁵ (Hence the strange idea, taught for instance by Rudolf Steiner, that the Hereafter possesses qualities complementary to those of this world.) Careful observation and analysis show, however, that not all dreams can be regarded

mechanically as mere complementary devices but must be interpreted rather as attempts at *compensation*, though this does not prevent very many dreams from having, on a superficial view, a distinct complementary character. Similarly, we could regard the alchemical movement as a reflection of the Christian one.⁵⁶ Koepgen makes a significant distinction between two aspects of Christ: the descending, incarnate God, and the ascending, Gnostic Christ who returns to the Father. We cannot regard the latter as the same as the alchemical *filius regius*, although Koepgen's schema offers an exact parallel to the alchemical situation.⁵⁷ The redeemer figure of alchemy is not commensurable with Christ. Whereas Christ is God and is begotten by the Father, the *filius regius* is the soul of nature, born of the world-creating Logos, of the Sapiaientia Dei sunk in matter. The *filius regius* is also a son of God, though of more distant descent and not begotten in the womb of the Virgin Mary but in the womb of Mother Nature: he is a "third sonship" in the Basilidian sense.⁵⁸ No traditional influences should be invoked in considering the conceptual structure of this filius; he is more an autochthonous product deriving from an unconscious, logical development of trends which had already reached the field of consciousness in the early Christian era, impelled by the same unconscious necessity as produced the later development of ideas. For, as our modern experience has shown, the collective unconscious is a living process that follows its own inner laws and gushes up like a spring at the appointed time. That it did so in alchemy in such an obscure and complicated way was due essentially to the great psychological difficulties of antinomian thinking, which continually came up against the demand for the logical consistency of the metaphysical figures, and for their emotional absoluteness. The "bonum superexcedens" of God allows no integration of evil. Although Nicholas Cusanus ventured the bold thought of the *coincidentia oppositorum*, its logical consequence—the relativity of the God-concept—proved disastrous for Angelus Silesius, and only the withered laurels of the poet lie on his grave. He had drunk with Jacob Boehme at the fount of Mater Alchimia. The alchemists, too, became choked in their own confusions.

[125] Once again, therefore, it is the medical investigators of nature who, equipped with new means of knowledge, have rescued these tangled problems from projection by making them the proper subject of psychology. This could never have happened before, for the simple reason that there was no psychology of the unconscious. But the medical investigator, thanks to his knowledge of archetypal processes, is in the fortunate position of being able to recognize in the abstruse and grotesque-looking symbolisms of alchemy the nearest relatives of those serial fantasies which underlie the delusions of paranoid schizophrenia as well as the healing processes at work in the psychogenic neuroses. The overweening contempt which other departments of science have for the apparently negligible psychic processes of "pathological

individuals” should not deter the doctor in his task of helping and healing the sick. But he can help the sick psyche only when he meets it as the unique psyche of that particular individual, and when he knows its earthly and unearthly darknesses. He should also consider it just as important a task to defend the standpoint of consciousness, clarity, “reason,” and an acknowledged and proven good against the raging torrent that flows for all eternity in the darkness of the psyche—a πάντα ῥεῖ that leaves nothing unaltered and ceaselessly creates a past that can never be retrieved. He knows that there is nothing purely good in the realm of human experience, but also that for many people it is better to be convinced of an absolute good and to listen to the voice of those who espouse the superiority of consciousness and unambiguous thinking. He may solace himself with the thought that one who can join the shadow to the light is the possessor of the greater riches. But he will not fall into the temptation of playing the law-giver, nor will he pretend to be a prophet of the truth: for he knows that the sick, suffering, or helpless patient standing before him is not the public but is Mr or Mrs X, and that the doctor has to put something tangible and helpful on the table or he is no doctor. His duty is always to the individual, and he is persuaded that nothing has happened if this individual has not been helped. He is answerable to the individual in the first place and to society only in the second. If he therefore prefers individual treatment to collective ameliorations, this accords with the experience that social and collective influences usually produce only a mass intoxication, and that only man’s action upon man can bring about a real transformation.⁵⁹

[126] It cannot have escaped the alchemists that their Sol had something to do with man. Thus Dorn says: “From the beginning man was sulphur.” Sulphur is a destructive fire “enkindled by the invisible sun,” and this sun is the Sol Philosophorum,⁶⁰ which is the much sought-after and highly praised philosophic gold, indeed the goal of the whole work.⁶¹ In spite of the fact that Dorn regards the sun and its sulphur as a kind of physiological component of the human body, it is clear that we are dealing with a piece of physiological mythology, i.e., a projection.

[127] In the course of our inquiry we have often seen that, despite the complete absence of any psychology, the alchemical projections sketch a picture of certain fundamental psychological facts and, as it were, reflect them in matter. One of these fundamental facts is the primary pair of opposites, consciousness and unconsciousness, whose symbols are Sol and Luna.

[128] We know well enough that the unconscious appears personified: mostly it is the anima⁶² who in singular or plural form represents the collective unconscious. The personal unconscious is personified by the shadow.⁶³ More rarely, the collective unconscious is personified as a Wise Old Man.⁶⁴ (I am speaking here only of

masculine psychology, which alone can be compared with that of the alchemists.) It is still rarer for Luna to represent the nocturnal side of the psyche in dreams. But in the products of active imagination the symbol of the moon appears much more often, as also does the sun, which represents the luminous realm of the psyche and our diurnal consciousness. The modern unconscious has little use for sun and moon as dream-symbols.⁶⁵ Illumination (“a light dawns,” “it is becoming clear,” etc.) can be expressed just as well or even better in modern dreams by switching on the electric light.

[129] It is therefore not surprising if the unconscious appears in projected and symbolized form, as there is no other way by which it might be perceived. But this is apparently not the case with consciousness. Consciousness, as the essence of all conscious contents, seems to lack the basic requirements for a projection. Properly understood, projection is not a voluntary happening; it is something that approaches the conscious mind from “outside,” a kind of sheen on the object, while all the time the subject remains unaware that he himself is the source of light which causes the cat’s eye of the projection to shine. Luna is therefore conceivable as a projection; but Sol as a projection, since it symbolizes consciousness, seems at first glance a contradiction in terms, yet Sol is no less a projection than Luna. For just as we perceive nothing of the real sun but light and heat and, apart from that, can know its physical constitution only by inference, so our consciousness issues from a dark body, the ego, which is the indispensable condition for all consciousness, the latter being nothing but the association of an object or a content with the ego. The ego, ostensibly the thing we know most about, is in fact a highly complex affair full of unfathomable obscurities. Indeed, one could even define it as a *relatively constant personification of the unconscious itself*, or as the Schopenhauerian mirror in which the unconscious becomes aware of its own face.⁶⁶ All the worlds that have ever existed before man were physically *there*. But they were a nameless happening, not a definite actuality, for there did not yet exist that minimal concentration of the psychic factor, which was also present, to speak the word that outweighed the whole of Creation: That is the world, and this is I! That was the first morning of the world, the first sunrise after the primal darkness, when that inchoately conscious complex, the ego, the son of the darkness, knowingly sundered subject and object, and thus precipitated the world and itself into definite existence,⁶⁷ giving it and itself a voice and a name. The refulgent body of the sun is the ego and its field of consciousness—*Sol et eius umbra*: light without and darkness within. In the source of light there is darkness enough for any amount of projections, for the ego grows out of the darkness of the psyche.

[130] In view of the supreme importance of the ego in bringing reality to light, we can understand why this infinitesimal speck in the universe was personified as the sun,

with all the attributes that this image implies. As the medieval mind was incomparably more alive than ours to the divine quality of the sun, we may assume that the totality character of the sun-image was implicit in all its allegorical or symbolic applications. Among the significations of the sun as totality the most important was its frequent use as a God-image, not only in pagan times but in the sphere of Christianity as well.

[131] Although the alchemists came very close to realizing that the ego was the mysteriously elusive arcane substance and the longed-for lapis, they were not aware that with their sun symbol they were establishing an intimate connection between God and the ego. As already remarked, projection is not a voluntary act; it is a natural phenomenon beyond the interference of the conscious mind and peculiar to the nature of the human psyche. If, therefore, it is this nature that produces the sun symbol, nature herself is expressing an identity of God and ego. In that case only unconscious nature can be accused of blasphemy, but not the man who is its victim. It is the rooted conviction of the West that God and the ego are worlds apart. In India, on the other hand, their identity was taken as self-evident. It was the nature of the Indian mind to become aware of the world-creating significance of the consciousness⁶⁸ manifested in man.⁶⁹ The West, on the contrary, has always emphasized the littleness, weakness, and sinfulness of the ego, despite the fact that it elevated one man to the status of divinity. The alchemists at least suspected man's hidden godlikeness, and the intuition of Angelus Silesius finally expressed it without disguise.

[132] The East resolves these confusing and contradictory aspects by merging the ego, the personal atman, with the universal atman and thus explaining the ego as the veil of Maya. The Western alchemist was not consciously aware of these problems. But when his unspoken assumptions and his symbols reached the plane of conscious gnosis, as was the case with Angelus Silesius, it was precisely the littleness and lowliness of the ego⁷⁰ that impelled him to recognize its identity with its extreme opposite.⁷¹ It was not the arbitrary opinions of deranged minds that gave rise to such insights, but rather the nature of the psyche itself, which, in East and West alike, expresses these truths either directly or clothed in transparent metaphors. This is understandable when we realize that a world-creating quality attaches to human consciousness as such. In saying this we violate no religious convictions, for the religious believer is at liberty to regard man's consciousness (through which, as it were, a second world-creation was enacted) as a divine instrument.

[133] I must point out to the reader that these remarks on the significance of the ego might easily prompt him to charge me with grossly contradicting myself. He will perhaps remember that he has come across a very similar argument in my other writings. Only there it was not a question of ego but of the *self*, or rather, of the

personal atman in contradistinction and in relation to the suprapersonal atman. I have defined the self as the totality of the conscious and the unconscious psyche, and the ego as the central reference-point of consciousness. It is an essential part of the self, and can be used *pars pro toto* when the significance of consciousness is borne in mind. But when we want to lay emphasis on the psychic totality it is better to use the term “self.” There is no question of a contradictory definition, but merely of a difference of standpoint.

3. SULPHUR⁷²

[134] Because of the singular role it plays in alchemy, sulphur deserves to be examined rather more closely. The first point of interest, which we have already touched on, is its relation to Sol: it was called the prima materia of Sol, Sol being naturally understood as the gold. As a matter of fact, sulphur was sometimes identified with gold.⁷³ Sol therefore derives from sulphur. The close connection between them explains the view that sulphur was the “companion of Luna.”⁷⁴ When the gold (Sol) and his bride (Luna) are united, “the coagulating sulphur, which in the corporal gold was turned outwards [*extroversion*], is turned inwards” (i.e., introverted).⁷⁵ This remark indicates the psychic double nature of sulphur (*sulphur duplex*); there is a red and a white sulphur, the white being the active substance of the moon, the red that of the sun.⁷⁶ The specific “virtue” of sulphur is said to be greater in the red variety.⁷⁷ But its duplicity also has another meaning: on the one hand it is the prima materia, and in this form it is burning and corrosive (*adurens*), and “hostile” to the matter of the stone; on the other hand, when “cleansed of all impurities, it is the matter of our stone.”⁷⁸ Altogether, sulphur is one of the innumerable synonyms for the prima materia⁷⁹ in its dual aspect, i.e., as both the initial material and the end-product. At the beginning it is “crude” or “common” sulphur, at the end it is a sublimation product of the process.⁸⁰ Its fiery nature is unanimously stressed,⁸¹ though this fieriness does not consist merely in its combustibility but in its occult fiery nature. As always, an allusion to occult qualities means that the material in question was the focus of projections which lent it a numinous significance.

[135] In keeping with its dual nature sulphur is on the one hand corporal and earthly,⁸² and on the other an occult, spiritual principle. As an earthly substance it comes from the “fatness of the earth,”⁸³ by which was meant the radical moisture as prima materia. Occasionally it is called “cinis extractus a cinere” (ash extracted from ash).⁸⁴ “Ash” is an inclusive term for the scoriae left over from burning, the substance that “remains below”—a strong reminder of the chthonic nature of sulphur. The red variety is thought of as masculine,⁸⁵ and under this aspect it represents the gold or Sol.⁸⁶ As a chthonic being it has close affinities with the dragon, which is called “our

secret sulphur.”⁸⁷ In that form it is also the *aqua divina*, symbolized by the uroboros.⁸⁸ These analogies often make it difficult to distinguish between sulphur and Mercurius, since the same thing is said of both. “This is our natural, most sure fire, our Mercurius, our sulphur,” says the “Tractatus aureus de lapide.”⁸⁹ In the *Turba* quicksilver is a fiery body that behaves in exactly the same way as sulphur.⁹⁰ For Paracelsus sulphur, together with Sal (salt), is the begetter of Mercurius, who is born of the sun and moon.⁹¹ Or it is found “in the depths of the nature of Mercurius,”⁹² or it is “of the nature of Mercurius,”⁹³ or sulphur and Mercurius are “brother and sister.”⁹⁴ Sulphur is credited with Mercurius’ “power to dissolve, kill, and bring metals to life.”⁹⁵

[136] This intimate connection with Mercurius makes it evident that sulphur is a spiritual or psychic substance of universal import, of which nearly everything may be said that is said of Mercurius. Thus sulphur is the soul not only of metals but of all living things; in the “Tractatus aureus” it is equated with “nostra anima” (our soul).⁹⁶ The *Turba* says: “The sulphurs are souls that were hidden in the four bodies.”⁹⁷ Paracelsus likewise calls sulphur the soul.⁹⁸ In Mylius sulphur produces the “ferment” or “soul which gives life to the imperfect body.”⁹⁹ The “Tractatus Micreris” says: “. . . until the green son appears, who is its¹⁰⁰ soul, which the Philosophers have called the green bird and bronze and sulphur.”¹⁰¹ The soul is also described as the “hidden part [*occultum*] of the sulphur.”¹⁰²

[137] In the sphere of Christian psychology, green has a spermatic, procreative quality, and for this reason it is the colour attributed to the Holy Ghost as the creative principle.¹⁰³ Accordingly Dorn says: “The male and universal seed, the first and most potent, is the solar sulphur, the first part and most potent cause of all generation.”¹⁰⁴ It is the life-spirit itself. In his “De tenebris contra naturam” Dorn says: “We have said before that the life of the world is the light of nature and the celestial sulphur, whose substrate [*subiectum*] is the aetheric moisture and the heat of the firmament, namely Sol and Luna.”¹⁰⁵ Sulphur has here attained cosmic significance and is equated with the light of nature, the supreme source of knowledge for the natural philosophers. But this light does not shine unhindered, says Dorn. It is obscured by the darkness of the elements in the human body. For him, therefore, sulphur is a shining, heavenly being. Though this sulphur is a “son who comes from imperfect bodies,” he is “ready to put on the white and purple garments.”¹⁰⁶ In Ripley he is a “spirit of generative power, who works in the moisture.”¹⁰⁷ In the treatise “De sulphure” he is the “virtue of all things” and the source of illumination and of all knowledge.¹⁰⁸ He knows, in fact, everything.¹⁰⁹

[138] In view of the significance of sulphur it is worth our while to take a look at its effects as described by the alchemists. Above all, it burns and consumes: “The little

power of this sulphur is sufficient to consume a strong body.”¹¹⁰ The “strong body” is the sun, as is clear from the saying: “Sulphur blackens the sun and consumes it.” Then, it causes or signifies the putrefactio, “which in our day was never seen,” says the *Rosarium*.¹¹¹ A third capacity is that of coagulating,¹¹² and a fourth and fifth those of tincturing (*tingere, colorare*) and maturing (*maturare*).¹¹³ Its “putrefying” effect is also understood as its ability to “corrupt.” Sulphur is the “cause of imperfection in all metals,” the “corrupter of perfection,” “causing the blackness in every operation”; “too much sulphurousness is the cause of corruption,” it is “bad and not well mixed,” of an “evil, stinking odour and of feeble strength.” Its substance is dense and tough, and its corruptive action is due on the one hand to its combustibility and on the other to its “earthy feculence.” “It hinders perfection in all its works.”¹¹⁴

[139] These unfavourable accounts evidently impressed one of the adepts so much that, in a marginal note, he added “diabolus” to the *causae corruptionis*.¹¹⁵ This remark is illuminating: it forms the counterpoint to the luminous role of sulphur, for sulphur is a “Lucifer” or “Phosphorus” (light-bringer), from the most beautiful star in the chymic firmament down to the *candelulae*, “little bits of sulphurous tow such as old women sell for lighting fires.”¹¹⁶ In addition to so many other qualities, sulphur shares this extreme paradox with Mercurius, besides having like him a connection with Venus, though here the allusion is veiled and more discreet: “Our Venus is not the common sulphur, which burns and is consumed with the combustion of the fire and of the corruption; but the whiteness of the Venus of the Sages is consumed with the combustion of the white and the red [*albedinis et rubedinis*], and this combustion is the entire whitening [*dealbatio*] of the whole work. Therefore two sulphurs are mentioned and two quicksilvers,¹¹⁷ and these the Philosophers have named one and one,¹¹⁸ and they rejoice in one another,¹¹⁹ and the one contains the other.”¹²⁰

[140] Another allusion to Venus occurs in one of the parables in “De sulphure,”¹²¹ about an alchemist who is seeking the sulphur. His quest leads him to the grove of Venus, and there he learns through a voice, which later turns out to be Saturn’s, that Sulphur is held a prisoner at the command of his own mother. He is praised as the “artificer of a thousand things,” as the heart of all things, as that which endows living things with understanding, as the begetter of every flower and blossom on herb and tree, and finally as the “painter of all colours.”¹²² This might well be a description of Eros. In addition we learn that he was imprisoned because in the view of the alchemists he had shown himself too obliging towards his mother. Although we are not told who his mother was, we may conjecture that it was Venus herself who shut up her naughty Cupid.¹²³ This interpretation is corroborated by the fact, firstly, that Sulphur, unknown to the alchemist, was in the grove of Venus¹²⁴ (woods, like trees, have a maternal significance); secondly, that Saturn introduced himself as the “governor of the prison,” and all alchemists with knowledge of astrology would have been familiar

with the secret nature of Saturn;¹²⁵ thirdly, that after the disappearance of the voice the alchemist, falling asleep, saw in the same grove a fountain and near it the personified Sulphur; and, finally, that the vision ends with the chymical “embrace in the bath.” Here Venus is undoubtedly the *amor sapientiae* who puts a check on Sulphur’s roving charms. The latter may well derive from the fact that his seat in the Uroboros is in the tail of the dragon.¹²⁶ Sulphur is the masculine element par excellence, the “sperma homogeneum”;¹²⁷ and since the dragon is said to “impregnate himself,” his tail is the masculine and his mouth the feminine organ. Like Beya,¹²⁸ who engulfed her brother in her own body and dissolved him into atoms, the dragon devours himself from the tail upwards until his whole body has been swallowed into his head.¹²⁹ Being the inner fire of Mercurius,¹³⁰ Sulphur obviously partakes of his most dangerous and most evil nature, his violence being personified in the dragon and the lion, and his concupiscence in Hermes Kyllenios.¹³¹ The dragon whose nature sulphur shares is often spoken of as the “dragon of Babel” or, more accurately, the “dragon’s head” (*caput draconis*), which is a “most pernicious poison,” a poisonous vapour breathed out by the flying dragon. The dragon’s head “comes with great swiftness from Babylon.” However, the “winged dragon” that stands for quicksilver becomes a poison-breathing monster only after its union with the “wingless dragon,” which corresponds to sulphur.¹³² Sulphur here plays an evil role that accords well with the sinful “Babel.” Furthermore, this dragon is equated with the human-headed serpent of paradise, which had the “*imago et similitudo Dei*” in its head, this being the deeper reason why the dragon devours its hated body. “His head lives in eternity, and therefore it is called glorious life, and the angels serve him.”¹³³ This is a reference to Matthew 4: 11: “Then the devil leaveth him, and behold, angels came and ministered unto him.”

[141] Hence we get the parallel of the dragon’s head with Christ, corresponding to the Gnostic view that the son of the highest divinity took on the form of the serpent in paradise in order to teach our first parents the faculty of discrimination, so that they should see that the work of the demiurge was imperfect. As the son of the seven planets the dragon is clearly the *filius macrocosmi* and, as such, a parallel figure to Christ and at the same time his rival.¹³⁴ The dragon’s head contains the precious stone, which means that consciousness contains the symbolic image of the self, and just as the lapis unites the opposites so the self assimilates contents of consciousness and the unconscious. This interpretation fully accords with the traditional significance of the dragon’s head as a favourable omen.

[142] From what has been said it should be evident that sulphur is the essence of an active substance. It is the “spirit of the metals,”¹³⁵ forming with quicksilver, the other “spirit of nature,” the two principles and the matter of the metals, since these two principles are themselves metals *in potentia*.¹³⁶ Together with Mercurius it also forms

the lapis.¹³⁷ In fact, it is the “heart of all things”¹³⁸ and the “virtue of all things.”¹³⁹ Enumerating, along with water and moisture, the synonyms for the lapis as the “whole secret and life of all things whatsoever,” the “*Consilium coniugii*” says: “The oil that takes up the colour, that is, the radiance of the sun, is itself sulphur.”¹⁴⁰ Mylius compares it to the rainbow: “The sulphur shines like the rainbow above the waters . . . the bow of Isis stands half on the pure, liquid, and flowing water and half on the earth . . . hence the whole property of sulphur and its natural likeness are expressed by the rainbow.” Thus sulphur, so far as it is symbolized by the rainbow, is a “divine and wonderful experience.” A few lines further on, after mentioning sulphur as one of the components of the water, Mylius writes that Mercurius (i.e., the water) must be cleansed by distillation “from all foulness of the earth, and then Lucifer, the impurity and the accursed earth, will fall from the golden heaven.”¹⁴¹ Lucifer, the most beautiful of the angels, becomes the devil, and sulphur is “of the earth’s foulness.” Here, as in the case of the dragon’s head, the highest and the lowest are close together. Although a personification of evil, sulphur shines above earth and water with the splendour of the rainbow, a “natural vessel”¹⁴² of divine transformation.

[143] From all this it is apparent that for the alchemists sulphur was one of the many synonyms for the mysterious transformative substance.¹⁴³ This is expressed most plainly in the *Turba*:¹⁴⁴ “Therefore roast it for seven days, until it becomes shining like marble, because, when it does, it is a very great secret [*arcanum*], since sulphur has been mixed with sulphur; and thereby is the greatest work accomplished, by mutual affinity, because natures meeting their nature mutually rejoice.”¹⁴⁵ It is a characteristic of the arcane substance to have “everything it needs”; it is a fully autonomous being, like the dragon that begets, reproduces, slays, and devours itself. It is questionable whether the alchemists, who were anything but consistent thinkers, ever became fully conscious of what they were saying when they used such images. If we take their words literally, they would refer to an “*Increatum*,” a being without beginning or end, and in need of “no second.” Such a thing can by definition only be God himself, but a God, we must add, seen in the mirror of physical nature and distorted past recognition. The “One” for which the alchemists strove corresponds to the *res simplex*, which the “*Liber quartorum*” defines as God.¹⁴⁶ This reference, however, is unique, and in view of the corrupt state of the text I would not like to labour its significance, although Dorn’s speculations about the “One” and the “unarius” are closely analogous. The *Turba* continues: “And yet they are not different natures, nor several, but a single one, which unites their powers in itself, through which it prevails over the other things. See you not that the Master has begun with the One and ended with the One? For he has named those unities the water of the sulphur, which conquers the whole of nature.”¹⁴⁷ The peculiarity of sulphur is also expressed in the paradox that it is “*incredibile*” (incombustible), “ash extracted from

ash.”¹⁴⁸ Its effects as *aqua sulfurea* are infinite.¹⁴⁹ The “Consilium coniugii” says: “Our sulphur is not the common sulphur,”¹⁵⁰ which is usually said of the philosophical gold. Paracelsus, in his “Liber Azoth,” describes sulphur as “lignum” (wood), the “linea vitae” (line of life), and “fourfold” (to correspond with the four elements); the spirit of life is renewed from it.¹⁵¹ Of the philosophical sulphur Mylius says that such a thing is not to be found on earth except in Sol and Luna, and it is known to no man unless revealed to him by God.¹⁵² Dorn calls it the “son begotten of the imperfect bodies,” who, when sublimated, changes into the “highly esteemed salt of four colours.” In the “Tractatus Micreris” it is even called the “treasure of God.”¹⁵³

[144] These references to sulphur as the arcane and transformative substance must suffice. I would only like to stress Paracelsus’ remark about its fourfold nature, and that of his pupil Dorn about the four colours as symbols of totality. The psychic factor which appears in projection in all similarly characterized arcane substances is the unconscious self. It is on this account that the well-known Christ-lapis¹⁵⁴ parallel reappears again and again, as for instance in the above-mentioned parable of the adept’s adventure in the grove of Venus. As we saw, he fell asleep after having a long and instructive conversation with the voice of Saturn. In his dream he beholds the figures of two men by the fountain in the grove, one of them Sulphur, the other Sal. A quarrel arises, and Sal gives Sulphur an “incurable wound.” Blood pours from it in the form of “whitest milk.” As the adept sinks deeper into sleep, it changes into a river. Diana emerges from the grove and bathes in the miraculous water. A prince (Sol), passing by, espies her, they are inflamed for love of one another, and she falls down in a swoon and sinks beneath the surface. The prince’s retinue refuse to rescue her for fear of the perilous water,¹⁵⁵ whereupon the prince plunges in and is dragged down by her to the depths. Immediately their souls appear above the water and explain to the adept that they will not go back into “bodies so polluted,” and are glad to be quit of them. They would remain afloat until the “fogs and clouds” have disappeared. At this point the adept returns to his former dream, and with many other alchemists he finds the corpse of Sulphur by the fountain. Each of them takes a piece and operates with it, but without success.¹⁵⁶ We learn, further, that Sulphur is not only the “medicina” but also the “medicus”—the wounded physician.¹⁵⁷ Sulphur suffers the same fate as the body that is pierced by the lance of Mercurius. In Reusner’s *Pandora*¹⁵⁸ the body is symbolized as Christ, the second Adam, pierced by the lance of a mermaid, or a Lilith or Edem.¹⁵⁹

[145] This analogy shows that sulphur as the arcane substance was set on a par with Christ, so that for the alchemists it must have meant something very similar. We would turn away in disgust from such an absurdity were it not obvious that this analogy, sometimes in clear and sometimes in veiled form, was thrust upon them by the unconscious. Certainly there could be no greater disparity than that between the

holiest conception known to man's consciousness and sulphur with its evil-smelling compounds. The analogy therefore is in no sense evidential but can only have arisen through intense and passionate preoccupation with the chemical substance, which gradually formed a *tertium comparationis* in the alchemist's mind and forced it upon him with the utmost insistence. The common denominator of these two utterly incommensurable conceptions is the self, the image of the whole man, which reached its finest and most significant development in the "Ecce Homo," and on the other hand appears as the meanest, most contemptible, and most insignificant thing, and manifests itself to consciousness precisely in that guise. As it is a concept of human totality, the self is by definition greater than the ego-conscious personality, embracing besides this the personal shadow and the collective unconscious. Conversely, the entire phenomenon of the unconscious appears so unimportant to ego-consciousness that we would rather explain it as a *privatio lucis*¹⁶⁰ than allow it an autonomous existence. In addition, the conscious mind is critical and mistrustful of everything hailing from the unconscious, convinced that it is suspect and somehow dirty. Hence the psychic phenomenology of the self is as full of paradoxes as the Hindu conception of the atman, which on the one hand embraces the universe and on the other dwells "no bigger than a thumb" in the heart. The Eastern idea of atman-purusha corresponds psychologically to the Western figure of Christ, who is the second Person of the Trinity and God himself, but, so far as his human existence is concerned, conforms exactly to the suffering servant of God in Isaiah¹⁶¹—from his birth in a stable among the animals to his shameful death on the cross between two thieves.

[146] The contrast is even sharper in the Naassene picture of the Redeemer, as reported by Hippolytus:¹⁶² "Lift up your heads, O ye gates, and be ye lift up, ye everlasting doors, and the King of glory shall come in."¹⁶³ This is the wonder of wonders. 'For who,' saith he [the Naassene], 'is this King of glory? A worm and no man, a reproach of men, and despised of the people;¹⁶⁴ this same is the King, and mighty in battle.'" But the battle, say the Naassenes, refers to the warring elements in the body. This association of the passage from the Psalms with the idea of conflict is no accident, for psychological experience shows that the symbols of the self appear in dreams and in active imagination at moments of violent collision between two opposite points of view, as compensatory attempts to mitigate the conflict and "make enemies friends." Therefore the lapis, which is born of the dragon, is extolled as a saviour and mediator since it represents the equivalent of a redeemer sprung from the unconscious. The Christ-lapis parallel vacillates between mere analogy and far-reaching identity, but in general it is not thought out to its logical conclusion, so that the dual focus remains. This is not surprising since even today most of us have not got round to understanding Christ as the psychic reality of an archetype, regardless of his

historicity. I do not doubt the historical reality of Jesus of Nazareth, but the figure of the Son of Man and of Christ the Redeemer has archetypal antecedents. It is these that form the basis of the alchemical analogies.

[147] As investigators of nature the alchemists showed their Christian attitude by their “pistis” in the object of their science, and it was not their fault if in many cases the psyche proved stronger than the chemical substance and its well-guarded secrets by distorting the results. It was only the acuter powers of observation in modern man which showed that weighing and measuring provided the key to the locked doors of chemical combination, after the intuition of the alchemists had stressed for centuries the importance of “measure, number, and weight.”¹⁶⁵ The prime and most immediate experience of matter was that it is animated, which for medieval man was self-evident; indeed every Mass, every rite of the Church, and the miraculous effect of relics all demonstrated for him this natural and obvious fact. The French Enlightenment and the shattering of the metaphysical view of the world were needed before a scientist like Lavoisier had the courage finally to reach out for the scales. To begin with, however, the alchemists were fascinated by the soul of matter, which, unknown to them, it had received from the human psyche by way of projection. For all their intensive preoccupation with matter as a concrete fact they followed this psychic trail, which was to lead them into a region that, to our way of thinking, had not the remotest connection with chemistry. Their mental labours consisted in a predominantly intuitive apprehension of psychic facts, the intellect playing only the modest role of a famulus. The results of this curious method of research proved, however, to be beyond the grasp of any psychology for several centuries. If one does not understand a person, one tends to regard him as a fool. The misfortune of the alchemists was that they themselves did not know what they were talking about. Nevertheless, we possess witnesses enough to the high esteem in which they held their science and to the wonderment which the mystery of matter instilled into them. For they discovered—to keep to sulphur as our example—in this substance, which was one of the customary attributes of hell and the devil, as well as in the poisonous, crafty, and treacherous Mercurius, an analogy with the most sacrosanct figure of their religion. They therefore imbued this arcanum with symbols intended to characterize its malicious, dangerous, and uncanny nature, choosing precisely those which in the positive sense were used for Christ in the patristic literature. These were the snake, the lion, the eagle, fire, cloud, shadow, fish, stone, the unicorn and the rhinoceros, the dragon, the night-raven, the man encompassed by a woman, the hen, water, and many others. This strange usage is explained by the fact that the majority of the patristic allegories have in addition to their positive meaning a negative one. Thus in St. Eucherius¹⁶⁶ the rapacious wolf “in its good part” signifies the apostle Paul, but “in its bad part” the devil.

[148] From this we would have to conclude that the alchemists had discovered the psychological existence of a shadow which opposes and compensates the conscious, positive figure. For them the shadow was in no sense a *privatio lucis*; it was so real that they even thought they could discern its material density, and this concretism led them to attribute to it the dignity of being the matrix of an incorruptible and eternal substance. In the religious sphere this psychological discovery is reflected in the historical fact that only with the rise of Christianity did the devil, the “eternal counterpart of Christ,” assume his true form, and that the figure of Antichrist appears on the scene already in the New Testament. It would have been natural for the alchemists to suppose that they had lured the devil out of the darkness of matter. There were indeed indications of this, as we have seen, but they are exceptions. Far more prevalent and truly characteristic of alchemy was the optimistic notion that this creature of darkness was destined to be the *medicina*, as is proved by the use of the term “*medicina et medicus*” for the untrustworthy sulphur. The very same appellation appears as an allegory of Christ in St. Ambrose.¹⁶⁷ The Greek word *φάρμακον* (poison and antidote) is indicative of this ambivalence. In our parable of the sulphur the river of “most dangerous” water, which caused so many deaths, is analogous to the water from the side of Christ and the streams that flowed from his belly. What in one place is a river of grace is a deadly poison in another—harbouring within it, however, the potentialities of healing.

[149] This is not mere euphemism or propitiatory optimism, but rather an intuitive perception of the compensating effect of the counter-position in the unconscious, which should not be understood dualistically as an absolute opposite but as a helpful though nonetheless dangerous complement to the conscious position. Medical experience shows that the unconscious is indeed actuated by a compensatory tendency, at any rate in normal individuals. In the domain of pathology I believe I have observed cases where the tendency of the unconscious would have to be regarded, by all human standards, as essentially destructive. But it may not be out of place to reflect that the self-destruction of what is hopelessly inefficient or evil can be understood in a higher sense as another attempt at compensation. There are murderers who feel that their execution is condign punishment, and suicides who go to their death in triumph.

[150] So, although the alchemists failed to discover the hidden structure of matter, they did discover that of the psyche, even if they were scarcely conscious of what this discovery meant. Their naive Christ-lapis parallel is at once a symbolization of the chemical arcanum and of the figure of Christ. The identification or paralleling of Christ with a chemical factor, which was in essence a pure projection from the unconscious, has a reactive effect on the interpretation of the Redeemer. For if A (Christ) = B (lapis), and B = C (an unconscious content), then A = C. Such

conclusions need not be drawn consciously in order to be made effective. Given the initial impulse, as provided for instance by the Christ-lapis parallel, the conclusion will draw itself even though it does not reach consciousness, and it will remain the unspoken, spiritual property of the school of thought that first hit upon the equation. Not only that, it will be handed down to the heirs of that school as an integral part of their mental equipment, in this case the natural scientists. The equation had the effect of channelling the religious numen into physical nature and ultimately into matter itself, which in its turn had the chance to become a self-subsistent “metaphysical” principle. In following up their basic thoughts the alchemists, as I have shown in *Psychology and Alchemy*, logically opposed to the son of the spirit a son of the earth and of the stars (or metals), and to the Son of Man or *filius microcosmi* a *filius macrocosmi*, thus unwittingly revealing that in alchemy there was an autonomous principle which, while it did not replace the spirit, nevertheless existed in its own right. Although the alchemists were more or less aware that their insights and truths were of divine origin, they knew they were not sacred revelations but were vouchsafed by individual inspiration or by the *lumen naturae*, the *sapientia Dei* hidden in nature. The autonomy of their insights showed itself in the emancipation of science from the domination of faith. Human intolerance and shortsightedness are to blame for the open conflict that ultimately broke out between faith and knowledge. Conflict or comparison between incommensurables is impossible. The only possible attitude is one of mutual toleration, for neither can deprive the other of its validity. Existing religious beliefs have, besides their supernatural foundation, a basis in psychological facts whose existence is as valid as those of the empirical sciences. If this is not understood on one side or the other it makes no difference to the facts, for these exist whether man understands them or not, and whoever does not have the facts on his side will sooner or later have to pay the price.

[151] With this I would like to conclude my remarks on sulphur. This arcane substance has provided occasion for some general reflections, which are not altogether fortuitous in that sulphur represents the active substance of the sun or, in psychological language, the *motive factor in consciousness*: on the one hand the will, which can best be regarded as a dynamism subordinated to consciousness, and on the other hand compulsion, an involuntary motivation or impulse ranging from mere interest to possession proper. The unconscious dynamism would correspond to sulphur, for compulsion is the great mystery of human life. It is the thwarting of our conscious will and of our reason by an inflammable element within us, appearing now as a consuming fire and now as life-giving warmth.

[152] The *causa efficiens et finalis* of this lack of freedom lies in the unconscious and forms that part of the personality which still has to be added to the conscious man in order to make him whole. At first sight it is but an insignificant fragment—a *lapis*

exilis, in via eiectus, and often inconvenient and repellent because it stands for something that demonstrates quite plainly our secret inferiority. This aspect is responsible for our resistance to psychology in general and to the unconscious in particular. But together with this fragment, which could round out our consciousness into a whole, there is in the unconscious an already existing wholeness, the “homo totus” of the Western and the *Chên-yên* (true man) of Chinese alchemy, the round primordial being who represents the greater man within, the Anthropos, who is akin to God. This inner man is of necessity partly unconscious, because consciousness is only part of a man and cannot comprehend the whole. But the whole man is always present, for the fragmentation of the phenomenon “Man” is nothing but an effect of consciousness, which consists only of supraliminal ideas. No psychic content can become conscious unless it possesses a certain energy-charge. If this falls, the content sinks below the threshold and becomes unconscious. The possible contents of consciousness are then sorted out, as the energy-charge separates those capable of becoming conscious from those that are not. This separation gives rise on the one hand to consciousness, whose symbol is the sun, and on the other hand to the shadow, corresponding to the *umbra solis*.

[153] Compulsion, therefore, has two sources: the shadow and the Anthropos. This is sufficient to explain the paradoxical nature of sulphur: as the “corrupter” it has affinities with the devil, while on the other hand it appears as a parallel of Christ.

4. LUNA

a. The Significance of the Moon

[154] Luna, as we have seen, is the counterpart of Sol, cold,¹⁶⁸ moist, feebly shining or dark, feminine, corporeal, passive. Accordingly her most significant role is that of a partner in the coniunctio. As a feminine deity her radiance is mild; she is the lover. Pliny calls her a “womanly and gentle star.” She is the sister and bride, mother and spouse of the sun.¹⁶⁹ To illustrate the sun-moon relationship the alchemists often made use of the Song of Songs (Canticles),¹⁷⁰ as in the “confabulation of the lover with the beloved” in *Aurora Consurgens*.¹⁷¹ In Athens the day of the new moon was considered favourable for celebrating marriages, and it still is an Arabian custom to marry on this day; sun and moon are marriage partners who embrace on the twenty-eighth day of the month.¹⁷² According to these ancient ideas the moon is a vessel of the sun: she is a universal receptacle, of the sun in particular¹⁷³; and she was called “infundibulum terrae” (the funnel of the earth), because she “receives and pours out”¹⁷⁴ the powers of heaven. Again, it is said that the “moisture of the moon” (*lunaris humor*) takes up the sunlight,¹⁷⁵ or that Luna draws near to the sun in order to

“extract from him, as from a fountain, universal form and natural life”;¹⁷⁶ she also brings about the conception of the “universal seed of the sun” in the quintessence, in the “belly and womb of nature.”¹⁷⁷ In this respect there is a certain analogy between the moon and the earth, as stated in Plutarch and Macrobius.¹⁷⁸ *Aurora Consurgens* says that “the earth made the moon,”^{178a} and here we should remember that Luna also signifies silver. But the statements of the alchemists about Luna are so complex that one could just as well say that silver is yet another synonym or symbol for the arcanum “Luna.” Even so, a remark like the one just quoted may have been a reference to the way in which ore was supposed to have been formed in the earth: the earth “receives” the powers of the stars, and in it the sun generates the gold, etc. The *Aurora consurgens* therefore equates the earth with the bride: “I am that land of the holy promise,”¹⁷⁹ or at any rate it is in the earth that the hierosgamos takes place.¹⁸⁰ Earth and moon coincide in the *albedo*, for on the one hand the sublimated or calcined earth appears as *terra alba foliata*, the “sought-for good, like whitest snow,”¹⁸¹ and on the other hand Luna, as mistress of the *albedo*,¹⁸² is the *femina alba* of the coniunctio¹⁸³ and the “mediatrix of the whitening.”¹⁸⁴ The lunar sulphur is white, as already mentioned. The *plenilunium* (full moon) appears to be especially important: When the moon shines in her fulness the “rabid dog”, the danger that threatens the divine child,¹⁸⁵ is chased away. In Senior the full moon is the arcane substance.

[155] In ancient tradition Luna is the giver of moisture and ruler of the water-sign Cancer (♋). Maier says that the *umbra solis* cannot be destroyed unless the sun enters the sign of Cancer, but that Cancer is the “house of Luna, and Luna is the ruler of the moistures”¹⁸⁶ (juice, sap, etc.). According to *Aurora consurgens* II, she is herself the water,¹⁸⁷ the “bountiful nurse of the dew.”¹⁸⁸ Rahner, in his “Mysterium Lunae,” shows the extensive use which the Church Fathers made of the allegory of the moon-dew in explaining the effects of grace in the ecclesiastical sacraments. Here again the patristic symbolism exerted a very strong influence on the alchemical allegories. Luna secretes the dew or sap of life. “This Luna is the sap of the water of life, which is hidden in Mercurius.”¹⁸⁹ Even the Greek alchemists supposed there was a principle in the moon (τὴν τῆς σελήνης οὐσίαν), which Christianos¹⁹⁰ calls the “ichor of the philosopher” (τά ἕγρὰ τοῦ φιλοσόφου).¹⁹¹ The relation of the moon to the soul, much stressed in antiquity,¹⁹² also occurs in alchemy though with a different nuance. Usually it is said that from the moon comes the dew, but the moon is also the *aqua mirifica*¹⁹³ that extracts the souls from the bodies or gives the bodies life and soul. Together with Mercurius, Luna sprinkles the dismembered dragon with her moisture and brings him to life again, “makes him live, walk, and run about, and change his colour to the nature of blood.”¹⁹⁴ As the water of ablution, the dew falls from heaven, purifies the body, and makes it ready to receive the soul;¹⁹⁵ in other words, it brings

about the *albedo*, the white state of innocence, which like the moon and a bride awaits the bridegroom.

[156] As the alchemists were often physicians, Galen's views must surely have influenced their ideas about the moon and its effects. Galen calls Luna the "princeps" who "rightly governs this earthly realm, surpassing the other planets not in potency, but in proximity." He also makes the moon responsible for all physical changes in sickness and health, and regards its aspects as decisive for prognosis.

[157] The age-old belief that the moon promotes the growth of plants led in alchemy not only to similar statements but also to the curious idea that the moon is itself a plant. Thus the *Rosarium* says that Sol is called a "great animal" whereas Luna is a "plant."¹⁹⁶ In the alchemical pictures there are numerous sun-and-moon trees.¹⁹⁷ In the "Super arborem Aristotelis," the "circle of the moon" perches in the form of a stork on a wonderworking tree by the grave of Hermes.¹⁹⁸ Galen¹⁹⁹ explains the *arbor philosophica* as follows: "There is a certain herb or plant, named Lunatica or Berissa,²⁰⁰ whose roots are metallic earth, whose stem is red, veined with black, and whose flowers are like those of the marjoram; there are thirty of them, corresponding to the age of the moon in its waxing and waning. Their colour is yellow."²⁰¹ Another name for Lunatica is Lunaria, whose flowers Dorn mentions, attributing to them miraculous powers.²⁰² Khunrath says: "From this little salty fountain grows also the tree of the sun and moon, the red and white coral-tree of our sea," which is that same Lunaria and whose "salt" is called "Luna Philosophorum et dulcedo sapientum" (sweetness of the sages).²⁰³ The "Allegoriae super librum Turbae" describe the moon-plant thus: "In the lunar sea²⁰⁴ there is a sponge planted, having blood and sentience [*sensum*],²⁰⁵ in the manner of a tree that is rooted in the sea and moveth not from its place. If thou wouldst handle the plant, take a sickle to cut it with, but have good care that the blood floweth not out, for it is the poison of the Philosophers."²⁰⁶

[158] From all this it would seem that the moon-plant is a kind of mandrake and has nothing to do with the botanical Lunaria (honesty). In the herbal of Tabernaemontanus, in which all the magico-medicinal properties of plants are carefully listed, there is no mention of the alchemical Lunatica or Lunaria. On the other hand it is evident that the Lunatica is closely connected with the "tree of the sea" in Arabian alchemy²⁰⁷ and hence with the *arbor philosophica*,²⁰⁸ which in turn has parallels with the Cabalistic tree of the Sefiroth²⁰⁹ and with the tree of Christian mysticism²¹⁰ and Hindu philosophy.²¹¹

[159] Ruland's remark that the sponge "has understanding" (see n. 205) and Khunrath's that the essence of the Lunaria is the "sweetness of the sages" point to the general idea that the moon has some secret connection with the human mind.²¹² The alchemists have a great deal to say about this, and this is the more interesting as we

know that the moon is a favourite symbol for certain aspects of the unconscious—though only, of course, in a man. In a woman the moon corresponds to consciousness and the sun to the unconscious. This is due to the contrasexual archetype in the unconscious: anima in a man, animus in a woman.

[160] In the gnosis of Simon Magus, Helen (Selene) is *πρώτη ἔννοια*,²¹³ *sapientia*,²¹⁴ and *ἐπίνοια*.²¹⁵ The last designation also occurs in Hippolytus: “For Epinoia herself dwelt in Helen at that time.”²¹⁶ In his ‘*Απόφασις μεγάλη* (“Great Explanation”), Simon says:

There are two offshoots from all the Aeons, having neither beginning nor end, from one root, and this root is a certain Power [*δύναμις*], an invisible and incomprehensible Silence [*σιγή*]. One of them appears on high and is a great power, the mind of the whole [*νοῦς τῶν ὅλων*], who rules all things and is a male; the other below is a great Thought [*ἐπίνοια μεγάλη*], a female giving birth to all things. Standing opposite one another, they pair together and cause to arise in the space between them an incomprehensible Air, without beginning or end; but in it is a Father who upholds all things and nourishes that which has beginning and end. This is he who stood, stands, and shall stand, a masculo-feminine Power after the likeness of the pre-existing boundless Power which has neither beginning nor end, abiding in solitude [*μονότητι*].²¹⁷

[161] This passage is remarkable for several reasons. It describes a *coniunctio Solis et Lunae* which Simon, it seems, concretized in his own life with Helen, the harlot of Tyre, in her role as Ishtar. As a result of the pairing with the *soror* or *filia mystica*, there was begotten a masculo-feminine pneuma, curiously designated “Air.” Since pneuma, like spirit, originally meant air in motion, this designation sounds archaic or else deliberately physcistic. It is evident, however, that air is used here in the spiritual sense of pneuma since its progenitors bear names—*νοῦς*, *ἔννοια*, *ἐπίνοια*—which have a noetic character and thus pertain to the spiritual sphere. Of these three names Nous is the most general concept, and in Simon’s day it was used indiscriminately with pneuma. Ennoia and Epinoia mean nothing that could not be rendered just as well by Nous; they differ from the latter only in their special character, emphasizing the more specific contents of the inclusive term Nous. Further, they are both of the feminine gender required in this context, whereas Nous is masculine. All three indicate the essential similarity of the components of the syzygy and their “spiritual” nature.

[162] Anyone familiar with alchemy will be struck by the resemblance between Simon’s views and the passage in the “*Tabula smaragdina*”:

And as all things proceed from the One, through the meditation of the One, so all things proceed from this one thing, by adaptation.²¹⁸

Its father is the Sun, its mother the Moon; the wind hath carried it in his belly.²¹⁹

[163] Since “all things” proceed from the meditation of the One, this is true also of Sol and Luna, who are thus endowed with an originally pneumatic character. They stand for the primordial images of the spirit, and their mating produces the *filius macrocosmi*. Sol and Luna in later alchemy are undoubtedly arcane substances and volatilia, i.e., spirits.²²⁰

[164] We will now see what the texts have to say about Luna’s noetic aspect. The yield is astonishingly small; nevertheless there is the following passage in the *Rosarium*:

Unless ye slay me, your understanding will not be perfect, and in my sister the moon the degree of your wisdom increases, and not with another of my servants, even if ye know my secret.²²¹

Mylius copies out this sentence uncritically in his *Philosophia reformata*.²²² Both he and the *Rosarium* give the source as the “Metaphora Belini de sole.”²²³ The “Dicta Belini” are included in the “Allegoriae sapientum,” but there the passage runs:

I announce therefore to all you sages, that unless ye slay me, ye cannot be called sages. But if ye slay me, your understanding will be perfect, and it increases in my sister the moon according to the degree of our wisdom, and not with another of my servants, even if ye know my secret.²²⁴

Belinus, as Ruska is probably right in conjecturing, is the same as Apollonius of Tyana,²²⁵ to whom some of the sermons in the *Turba* are attributed. In Sermo 32, “Bonellus” discusses the problem of death and transformation, likewise touched on in our text. The other sermons of Bonellus have nothing to do with our text, however, nor does the motif of resurrection, on account of its ubiquity, signify much, so that the “Dicta” in all probability have no connection with the *Turba*. A more likely source for the “Dicta” would be the (Harranite?) treatise of Artefius, “Clavis maioris sapientiae”:²²⁶ “Our master, the philosopher Belenius, said, Set your light in a vessel of clear glass, and observe that all the wisdom of this world revolves round the following three . . .”²²⁷ And again: “But one day my master, the philosopher Bolemus, called me and said, Eh! my son, I hope that thou art a man of spiritual understanding and canst attain to the highest degree of wisdom.”²²⁸ Then follows an explanation about how two contrary natures, active and passive, arose from the first simple substance. In the beginning God said “without uttering a word,” “Let there be such a creature,” and thereupon the simple (*simplex*) was there. Then God created nature or the prima materia, “the first passive or receptive [principle], in which everything was present in principle and in potency.” In order to end this state of suspension God created the “*causa agens*, like to the circle of heaven, which he resolved to call Light. But this Light received a certain sphere, the first creature, within its

hollowness.” The properties of this sphere were heat and motion. It was evidently the sun, whereas the cold and passive principle would correspond to the moon.²²⁹

[165] It seems to me not unlikely that the “Dicta Belini” are connected with this passage from Artefius rather than with the *Turba*, since they have nothing to do with the sermons of Apollonius. They may therefore represent a tradition independent of the *Turba*, and this is the more likely since Artefius seems to have been a very ancient author of Arabic provenance.²³⁰ He shares the doctrine of the “simplex” with the “Liber quatorum,”²³¹ which too is probably of Harranite origin. I mention his theory of the creation here despite the fact that it has no parallels in the “Dicta.” It seemed to me worth noting because of its inner connection with the “Apophysis megale” of Simon Magus. The “Dicta” are not concerned with the original separation of the natures but rather with the synthesis which bears much the same relation to the sublimation of the human mind (*exaltatio intellectus*) as the procedures of the “Liber quatorum.”²³²

[166] Besides the connection between Luna and intellect we must also consider their relation to Mercurius, for in astrology and mythology Mercurius is the divine factor that has most to do with Epinoia. The connections between them in alchemy have classical antecedents. Leaving aside the relation of Hermes to the Nous, I will only mention that in Plutarch Hermes sits in the moon and goes round with it (just as Heracles does in the sun).²³³ In the magic papyri, Hermes is invoked as follows: “O Hermes, ruler of the world, thou who dwellest in the heart, circle of the moon, round and square.”²³⁴

[167] In alchemy Mercurius is the rotundum *par excellence*. Luna is formed of his cold and moist nature, and Sol of the hot and dry;²³⁵ alternatively she is called “the proper substance of Mercurius.”²³⁶ From Luna comes the *aqua Mercurialis* or *aqua permanens*;²³⁷ with her moisture, like Mercurius, she brings the slain dragon to life.²³⁸ As we have seen, the circle of the moon is mentioned in the “Super arborem Aristotelis,” where “a stork, as it were calling itself the circle of the moon,” sits on a tree that is green within instead of without.²³⁹ Here it is worth pointing out that the soul, whose connection with the moon has already been discussed, was also believed to be round. Thus Caesarius of Heisterbach says that the soul has a “spherical nature,” “after the likeness of the globe of the moon.”²⁴⁰

[168] Let us now turn back to the question raised by the quotation in the *Rosarium* from the “Dicta Belini.” It is one of those approximate quotations which are typical of the *Rosarium*.²⁴¹ In considering the quotation as a whole it should be noted that it is not clear who the speaker is. The *Rosarium* supposes that it is Sol. But it can easily be shown from the context of the “Dicta” that the speaker could just as well be the filius Philosophorum, since the woman is sometimes called “soror,” sometimes

“mater,” and sometimes “uxor.” This strange relationship is explained by the primitive fact that the son stands for the reborn father, a motif familiar to us from the Christian tradition. The speaker is therefore the father-son, whose mother is the son’s sister-wife. “According to the degree of our wisdom” is contrasted with “your understanding;” it therefore refers to the wisdom of the *Sol redivivus*, and presumably also to his sister the moon, hence “our” and not “my” wisdom. “The degree” is not only plausible but is a concept peculiar to the opus, since Sol passes through various stages of transformation from the dragon, lion, and eagle²⁴² to the hermaphrodite. Each of these stages stands for a new degree of insight, wisdom, and initiation, just as the Mithraic eagles, lions, and sun-messengers signify grades of initiation. “Unless ye slay me” usually refers to the slaying of the dragon, the *mortificatio* of the first, dangerous, poisonous stage of the anima (= Mercurius), freed from her imprisonment in the prima materia.²⁴³ This anima is also identified with Sol.²⁴⁴ Sol is frequently called Rex, and there is a picture showing him being killed by ten men.²⁴⁵ He thus suffers the same *mortificatio* as the dragon, with the difference that it is never a suicide. For Sol, in so far as the dragon is a preliminary form of the *filius Solis*, is in a sense the father of the dragon, although the latter is expressly said to beget itself and is thus an increatum.²⁴⁶ At the same time Sol, being his own son, is also the dragon. Accordingly there is a *coniugium* of the dragon and the woman, who can only be Luna or the lunar (feminine) half of Mercurius.²⁴⁷ As much as Sol, therefore, Luna (as the mother) must be contained in the dragon. To my knowledge there is never any question of her *mortificatio* in the sense of a slaying. Nevertheless she is included with Sol in the death of the dragon, as the *Rosarium* hints: “The dragon dieth not, except with his brother and his sister.”²⁴⁸

[169] The idea that the dragon or Sol must die is an essential part of the mystery of transformation. The *mortificatio*, this time only in the form of a mutilation, is also performed on the lion, whose paws are cut off,²⁴⁹ and on the bird, whose wings are clipped.²⁵⁰ It signifies the overcoming of the old and obsolete as well as of the dangerous preliminary stages which are characterized by animal-symbols.

[170] In interpreting the words “your understanding increases in my sister,” etc., it is well to remember that a philosophical interpretation of myths had already grown up among the Stoics, which today we should not hesitate to describe as psychological. This work of interpretation was not interrupted by the development of Christianity but continued to be assiduously practised in a rather different form, namely in the hermeneutics of the Church Fathers, which was to have a decided influence on alchemical symbolism. The Johannine interpretation of Christ as the pre-worldly Logos is an early attempt of this kind to put into other words the “meaning” of Christ’s essence. The later medievalists, and in particular the natural philosophers, made the Sapientia Dei the nucleus of their interpretation of nature and thus created a

new nature-myth. In this they were very much influenced by the writings of the Arabs and of the Harranites, the last exponents of Greek philosophy and gnosis, whose chief representative was Tabit ibn Qurra in the tenth century. One of these writings, the “Liber Platonis quartorum,” is a dialogue in which Thebed (Tabit) speaks in person. In this treatise the intellect as a tool of natural philosophy plays a role that we do not meet again until the sixteenth century, in Gerhard Dorn. Pico della Mirandola appeals to the psychological interpretation of the ancients and mentions that the “Greek Platonists” described Sol as *διάνοια*²⁵¹ and Luna as *δόξα*,²⁵² terms that are reminiscent of Simon’s Nous and Epinoia.²⁵³ Pico himself defines the difference as that between “scientia” and “opinio.”²⁵⁴ He thinks that the mind (*animus*), turning towards the spirit (*spiritus*) of God, shines and is therefore called Sol. The spirit of God corresponds to the *aquae superiores*, the “waters above the firmament” (Gen. 1 : 7). But in so far as the human mind turns towards the “waters under the firmament” (*aquae inferiores*), it concerns itself with the “sensuales potentiae,” “whence it contracts the stain of infection” and is called Luna.²⁵⁵ In both cases it is clearly the human spirit or psyche, both of which have, however, a double aspect, one facing upwards to the light, the other downwards to the darkness ruled by the moon (“The sun to rule the day, the moon also to govern the night”). “And while,” says Pico, “we wander far from our fatherland and abide in this night and darkness of our present life, we make most use of that which turns us aside to the senses, for which reason we think many things rather than know them,”²⁵⁶—a pessimistic but no doubt accurate view that fully accords with the spiritual benightedness and sinful darkness of this sublunary world, which is so black that the moon herself is tarnished by it.

[171] The moon appears to be in a disadvantageous position compared with the sun. The sun is a concentrated luminary: “The day is lit by a single sun.” The moon, on the other hand—“as if less powerful”—needs the help of the stars when it comes to the task of “composition and separation, rational reflection, definition,” etc.²⁵⁷ The appetites, as “potentiae sensuales,” pertain to the sphere of the moon; they are anger (*ira*) and desire (*libido*) or, in a word, *concupiscentia*. The passions are designated by animals because we have these things in common with them, and, “what is more unfortunate, they often drive us into leading a bestial life.”²⁵⁸ According to Pico, Luna “has an affinity with Venus, as is particularly to be seen from the fact that she is sublimated in Taurus, the House of Venus, so much that she nowhere else appears more auspicious and more beneficent.”²⁵⁹ Taurus is the house of the hierogamy of Sol and Luna.²⁶⁰ Indeed, Pico declares that the moon is “the lowest earth and the most ignoble of all the stars,”²⁶¹ an opinion which recalls Aristotle’s comparison of the moon with the earth. The moon, says Pico, is inferior to all the other planets.²⁶² The novilunium is especially unfavourable, as it robs growing bodies of their nourishment and in this way injures them.²⁶³

[172] Psychologically, this means that the union of consciousness (Sol) with its feminine counterpart the unconscious (Luna) has undesirable results to begin with: it produces poisonous animals such as the dragon, serpent, scorpion, basilisk, and toad;²⁶⁴ then the lion, bear, wolf, dog,²⁶⁵ and finally the eagle²⁶⁶ and the raven. The first to appear are the cold-blooded animals, then warm-blooded predators, and lastly birds of prey or ill-omened scavengers. The first progeny of the *matrimonium luminarium* are all, therefore, rather unpleasant. But that is only because there is an evil darkness in both parents which comes to light in the children, as indeed often happens in real life. I remember, for instance, the case of a twenty-year-old bank clerk who embezzled several hundred francs. His old father, the chief cashier at the same bank, was much pitied, because for forty years he had discharged his highly responsible duties with exemplary loyalty. Two days after the arrest of his son he decamped to South America with a million. So there must have been “something in the family.” We have seen in the case of Sol that he either possesses a shadow or is even a *Sol niger*. As to the position of Luna, we have already been told what this is when we discussed the new moon. In the “Epistola Solis ad Lunam crescentem”²⁶⁷ Sol cautiously says: “If you do me no hurt, O moon.”²⁶⁸ Luna has promised him complete dissolution while she herself “coagulates,” i.e., becomes firm, and is clothed with his blackness (*induta fuero nigredine tua*).²⁶⁹ She assumes in the friendliest manner that her blackness comes from *him*. The matrimonial wrangle has already begun. Luna is the “shadow of the sun, and with corruptible bodies she is consumed, and through her corruption . . . is the Lion eclipsed.”²⁷⁰

[173] According to the ancient view, the moon stands on the border-line between the eternal, aethereal things and the ephemeral phenomena of the earthly, sublunar realm.²⁷¹ Macrobius says: “The realm of the perishable begins with the moon and goes downwards. Souls coming into this region begin to be subject to the numbering of days and to time. . . . There is no doubt that the moon is the author and contriver of mortal bodies.”²⁷² Because of her moist nature, the moon is also the cause of decay.²⁷³ The loveliness of the new moon, hymned by the poets and Church Fathers, veils her dark side, which however could not remain hidden from the fact-finding eye of the empiricist.²⁷⁴ The moon, as the star nearest to the earth, partakes of the earth and its sufferings, and her analogy with the Church and the Virgin Mary as mediators has the same meaning.²⁷⁵ She partakes not only of the earth’s sufferings but of its daemonic darkness as well.²⁷⁶

b. The Dog

[174] This dark side of the moon is hinted at in the ancient invocation to Selene as the “dog” or “bitch” (*κυών*), in the Magic Papyri.²⁷⁷ There it is also said that in the second hour Helios appears as a dog.²⁷⁸ This statement is of interest in so far as the

“symbolizatio”²⁷⁹ by the dog²⁸⁰ entered Western alchemy through Kalid’s “Liber secretorum,” originally, perhaps, an Arabic treatise. All similar passages that I could find go back, directly or indirectly, to Kalid.²⁸¹ The original passage runs:

Hermes²⁸² said, My son, take a Corascene dog and an Armenian bitch, join them together, and they will beget a dog of celestial hue, and if ever he is thirsty, give him sea water to drink: for he will guard your friend, and he will guard you from your enemy, and he will help you wherever you may be, always being with you, in this world and in the next. And by dog and bitch, Hermes meant things which preserve bodies from burning and from the heat of the fire.²⁸³

Some of the quotations are taken from the original text, others from the variant in the *Rosarium*, which runs:

Hali, philosopher and king of Arabia, says in his Secret: Take a Coetanean²⁸⁴ dog and an Armenian bitch, join them together, and they two will beget for you a puppy [*filius canis*] of celestial hue: and that puppy will guard you in your house from the beginning, in this world and in the next.²⁸⁵

As explanatory parallels, the *Rosarium* mentions the union of the white and red, and cites Senior: “The red slave has wedded the white woman.” It is clear that the mating must refer to the royal marriage of Sol and Luna.

[175] The theriomorphic form of Sol as a lion and dog and of Luna as a bitch shows that there is an aspect of both luminaries which justifies the need for a “symbolizatio” in animal form. That is to say the two luminaries are, in a sense, animals or appetites, although, as we have seen, the “*potentiae sensuales*” are ascribed only to Luna. There is, however, also a *Sol niger*, who, significantly enough, is contrasted with the daytime sun and clearly distinguished from it. This advantage is not shared by Luna, because she is obviously sometimes bright and sometimes dark. Psychologically, this means that consciousness by its very nature distinguishes itself from its shadow, whereas the unconscious is not only contaminated with its own negative side but is burdened with the shadow cast off by the conscious mind. Although the solar animals, the lion and the eagle, are nobler than the bitch, they are nevertheless animals and beasts of prey at that, which means that even our sun-like consciousness has its dangerous animals. Or, if Sol is the spirit and Luna the body, the spirit too may be corrupted by pride or concupiscence, a fact which we are inclined to overlook in our one-sided admiration of the “spirit.”

[176] Kalid’s “son of the dog” is the same as the much extolled “son of the philosophers.” The ambiguity of this figure is thus stressed: it is at once bright as day and dark as night, a perfect *coincidentia oppositorum* expressing the divine nature of the self. This thought, which seems an impossible one for our Christian feelings, is

nevertheless so logical and so irresistible that, by however strange and devious a route, it forced its way into alchemy. And because it is a natural truth it is not at all surprising that it became articulate very much earlier. We are told in the *Elenchos* of Hippolytus that, according to Aratus,

Cynosura²⁸⁶ is the [little] Bear, the Second Creation, the small, narrow way,²⁸⁷ and not the great Bear [ἡ ἑλίκη]. For it leads not backward, but guides those who follow it forward to the straight way, being the tail of the Dog. *For the Logos is a dog* [κύων γὰρ ὁ λόγος] who guards and protects the sheep against the wiles of the wolves, and chases the wild beasts from Creation and slays them, and begets all things. For Cyon [κύων], they say, means the Begetter.²⁸⁸

Aratus associates the Dog with the growth of plants, and continues:

But with the rising of the Dog-star, the living are distinguished by the Dog from the dead, for in truth everything withers that has not taken root. *This Dog, they say, being a certain divine Logos*, has been established judge of the quick and the dead, and as the Dog is seen to be the star of the plants, so is the Logos, they say, in respect of the heavenly plants, which are men. For this reason the Second Creation Cynosura stands in heaven as an image of the rational creature [λογικῆς κτίσεως]. But between the two Creations stretches the Dragon, hindering anything of the Great Creation from entering the lesser, and watching over everything that exists [τὰ καθεστηκότα] in the Great Creation, like the Kneeler,²⁸⁹ observing how and in what manner each thing exists [καθέστηκε] in the Lesser Creation.

[177] Kalid's *filius canis*²⁹⁰ is “of celestial hue,” an indication of its heavenly origin from the great luminaries. The blue colour or likeness to a dog²⁹¹ is also attributed to the woman who in Hippolytus is described as *περεηφικόλα*,²⁹² and who is pursued by a grey-haired, winged, ithyphallic old man (*πρεσβύτης*). He is named *φάος ρύντης*, Flowing Light, and she is *ἡ φικόλα*, “which means Dark Water” (*τὸ σκοτεινὸν ὕδωρ*).²⁹³ Behind these figures may be discerned a *coniunctio Solis et Lunae*, both the sun and the new moon appearing in their unfavourable aspect. Here too there arises between them the “harmony” of an intermediary spirit (*πνεῦματος*), roughly corresponding to the position of the *filius philosophorum*.^{293a} Kalid's *filius* plays the role of a guiding spirit or familiar whose invocation by magic is so typical of the Harranite texts. A parallel to the dog-spirit is the poodle in *Faust*, out of whom Mephistopheles emerges as the familiar of Faust the alchemist.

[178] In this connection I would like to mention the incest dream of a woman patient: *Two dogs were copulating. The male went head first into the female and disappeared in her belly.*²⁹⁴ Theriomorphic symbolism is always an indication of a psychic process occurring on an animal level, i.e., in the instinctual sphere. The dream depicts a

reversed birth as the goal of a sexual act. This archetypal situation underlies the incest motif in general and was present in modern man long before any consciousness of it. The archetype of incest is also at the back of the primitive notion that the father is reborn in the son, and of the heirosgamos of mother and son in its pagan and Christian form;²⁹⁵ it signifies the highest and the lowest, the brightest and the darkest, the best and the most detestable. It represents the pattern of renewal and rebirth, the endless creation and disappearance of symbolic figures.

[179] The motif of the dog is a necessary counterbalance to the excessively praised “light-nature” of the stone. Apart from the saying of Kalid there is still another aspect of the dog, of which, however, we find only sporadic hints in the literature. One such passage occurs in the “De ratione conficiendi lapidis philosophici” of Laurentius Ventura:²⁹⁶

Therefore pull down the house, destroy the walls, extract therefrom the purest juice²⁹⁷ with the blood, and cook that thou mayest eat. Wherefore Arnaldus saith in the Book of Secrets:²⁹⁸ Purify the stone, grind the door to powder, tear the bitch to pieces, choose the tender flesh, and thou wilt have the best thing. In the one thing are hidden all parts, in it all metals shine. Of these [parts], two are the artificers, two the vessels, two the times, two the fruits, two the ends, and one the salvation.²⁹⁹

[180] This text abounds in obscurities. In the preceding section Ventura discusses the unity of the lapis and the medicina, mentioning the axioms “Introduce nothing alien” and “Nothing from outside”³⁰⁰ with quotations from Geber, the *Turba*, and the “Thesaurus thesaurorum” of Arnaldus.³⁰¹ Then he turns to the “superfluities to be removed.”³⁰² The lapis, he says, is “by nature most pure.” It is therefore sufficiently purified when it is “led out of its proper house and enclosed in an alien house.” The text continues:

In the proper house the flying bird is begotten, and in the alien house³⁰³ the tincturing stone. The two flying birds³⁰⁴ hop on to the tables and heads of the kings,³⁰⁵ because both, the feathered bird and the plucked,³⁰⁶ have given [us] this visible art³⁰⁷ and cannot relinquish the society of men.³⁰⁸ The father³⁰⁹ of [the art] urges the indolent to work, its mother³¹⁰ nourishes the sons who are exhausted by their labours, and quickens and adorns their weary limbs.

Then follows the passage “Therefore pull down the house,” etc. If the reader has perused the foregoing passage with the footnotes he will see that these instructions are the typical alchemical procedure for extracting the spirit or soul, and thus for bringing unconscious contents to consciousness. During the *solutio*, *separatio*, and *extractio* the *succus lunariae* (juice of the moon-plant), blood, or *aqua permanens* is either applied or extracted. This “liquid” comes from the unconscious but is not

always an authentic content of it; often it is more an effect of the unconscious on the conscious mind. The psychiatrist knows it as the indirect effect of constellated unconscious contents which attracts or diverts attention to the unconscious and causes it to be assimilated. This process can be observed not only in the gradual formation of hypochondriac obsessions, phobias, and delusions, but also in dreams, fantasies, and creative activities when an unconscious content enforces the application of attention. This is the *succus vitae*,³¹¹ the blood, the vital participation which the patient unconsciously forces on the analyst too, and without which no real therapeutic effect can be achieved. The attention given to the unconscious has the effect of incubation, a brooding³¹² over the slow fire needed in the initial stages of the work;³¹³ hence the frequent use of the terms *decoctio*, *digestio*, *putrefactio*, *solutio*. It is really as if attention warmed the unconscious and activated it, thereby breaking down the barriers that separate it from consciousness.

[181] In order to set free the contents hidden in the “house”³¹⁴ of the unconscious (*anima in compedibus!*) the “matrix” must be opened. This matrix is the “canicula,” the moon-bitch, who carries in her belly that part of the personality which is felt to be essential, just as Beya did Gabricus. She is the vessel which must be broken asunder in order to extract the precious content, the “tender flesh,”³¹⁵ for this is the “one thing” on which the whole work turns. In this one thing all parts of the work are contained.³¹⁶ Of these parts two are the artificers, who in the symbolical realm are Sol and Luna, in the human the adept and his *soror mystica*,³¹⁷ and in the psychological realm the masculine consciousness and the feminine unconscious (*anima*). The two vessels are again Sol and Luna,³¹⁸ the two times are probably the two main divisions of the work, the *opus ad album et ad rubeum*.³¹⁹ The former is the *opus Lunae*, the latter the *opus Solis*.³²⁰ Psychologically they correspond to the constellation of unconscious contents in the first part of the analytical process and to the integration of these contents in actual life. The two fruits³²¹ are the fruit of the sun-and-moon tree,³²² gold and silver, or the reborn and sublimated Sol and Luna. The psychological parallel is the transformation of both the unconscious and the conscious, a fact known to everyone who methodically “has it out” with his unconscious. The two ends or goals are these transformations. But the salvation is one, just as the thing is one: it is the same thing at the beginning as at the end, it was always there and yet it appears only at the end. This thing is the self, the indescribable totality, which though it is inconceivable and “irrepresentable” is none the less necessary as an intuitive concept. Empirically we can establish no more than that the ego is surrounded on all sides by an unconscious factor. Proof of this is afforded by the association experiment, which gives a graphic demonstration of the frequent failure of the ego and its will. The psyche is an equation that cannot be “solved” without the factor of the unconscious;

it is a totality which includes both the empirical ego and its transconscious foundation.

[182] There is still another function of the dog in alchemy which has to be considered. In the “Introitus apertus” of Philaletha we find the following passage:

This Chamaeleon is the infant hermaphrodite, who is infected from his very cradle by the bite of the rabid Corascene dog, whereby he is maddened and rages with perpetual hydrophobia; nay, though of all natural things water is the closest to him, yet he is terrified of it and flees from it. O fate! Yet in the grove of Diana there is a pair of doves, which assuage his raving madness. Then will the impatient, swarthy, rabid dog, that he may suffer no return of his hydrophobia and perish drowned in the waters, come to the surface half suffocated; but do thou chase him off with pails of water and blows, and keep him at a distance, and the darkness will disappear. When the moon is at the full, give him wings and he will fly away as an eagle, leaving Diana’s birds dead behind him.³²³

[183] Here the connection with the moon tells us that the dark, dangerous, rabid dog changes into an eagle at the time of the plenilunium. His darkness disappears and he becomes a solar animal. We may therefore assume that his sickness was at its worst at the novilunium. It is clear that this refers to a psychic disturbance³²⁴ which at one stage also infected the “infant hermaphrodite.” Probably that too occurred at the novilunium,³²⁵ i.e., the stage of *nigredo*. Just how the mad dog with its terror of water got into the water at all is not clear, unless perhaps it was in the *aquae inferiores* from the beginning. The text is preceded by the remark: “Whence will come the Chamaeleon or our Chaos, in which all secrets are hid in their potential state.” The chaos as prima materia is identical with the “waters” of the beginning. According to Olympiodorus lead (also the prima materia) contains a demon that drives the adept mad.³²⁶ Curiously enough, Wei Po-yang, a Chinese alchemist of the second century, compares lead to a madman clothed in rags.³²⁷ Elsewhere Olympiodorus speaks of the “one cursed by God” who dwells in the “black earth.” This is the mole, which, as Olympiodorus relates from a Hermetic book, had once been a man who divulged the mysteries of the sun and was therefore cursed by God and made blind. He “knew the shape of the sun, as it was.”³²⁸

[184] It is not difficult to discern in these allusions the dangers, real or imaginary, which are connected with the unconscious. In this respect the unconscious has a bad reputation, not so much because it is dangerous in itself as because there are cases of latent psychosis which need only a slight stimulus to break out in all their catastrophic manifestations. An anamnesis or the touching of a complex may be sufficient for this. But the unconscious is also feared by those whose conscious attitude is at odds with their true nature. Naturally their dreams will then assume an

unpleasant and threatening form, for if nature is violated she takes her revenge. In itself the unconscious is neutral, and its normal function is to compensate the conscious position. In it the opposites slumber side by side; they are wrenched apart only by the activity of the conscious mind, and the more one-sided and cramped the conscious standpoint is, the more painful or dangerous will be the unconscious reaction. There is no danger from this sphere if conscious life has a solid foundation. But if consciousness is cramped and obstinately one-sided, and there is also a weakness of judgment, then the approach or invasion of the unconscious can cause confusion and panic or a dangerous inflation, for one of the most obvious dangers is that of identifying with the figures in the unconscious. For anyone with an unstable disposition this may amount to a psychosis.

[185] The raving madness of the infected “infant” is assuaged (we should really say “with caresses,” for that is the meaning of “mulcere”) by the doves of Diana. These doves form a pair—a love pair, for doves are the birds of Astarte.³²⁹ In alchemy they represent, like all winged creatures, spirits or souls, or, in technical terms, the *aqua*, the extracted transformative substance.³³⁰ The appearance of a pair of doves points to the imminent marriage of the *filius regius* and to the dissolution of the opposites as a result of the union. The *filius* is merely infected by the evil, but the evil itself, the mad dog, is sublimated and changed into an eagle at the plenilunium. In the treatise of Abraham Eleazar, the lapis in its dark, feminine form appears instead of the dog and is compared to the Shulamite in the Song of Songs. The lapis says: “But I must be like a dove.”³³¹

[186] There is another passage in the “Introitus apertus” which is relevant in this context:

If thou knowest how to moisten this dry earth with its own water, thou wilt loosen the pores of the earth, and this thief from outside will be cast out with the workers of wickedness, and the water, by an admixture of the true Sulphur, will be cleansed from the leprous filth and from the superfluous dropsical fluid, and thou wilt have in thy power the fount of the Knight of Treviso, whose waters are rightfully dedicated to the maiden Diana. Worthless is this thief, armed with the malignity of arsenic, from whom the winged youth fleeth, shuddering. And though the central water is his bride, yet dare he not display his most ardent love towards her, because of the snares of the thief, whose machinations are in truth unavoidable. Here may Diana be propitious to thee, who knoweth how to tame wild beasts, and whose twin doves will temper the malignity of the air with their wings, so that the youth easily entereth in through the pores, and instantly shaketh the foundations of the earth,³³² and raises up a dark cloud. But thou wilt lead the waters up even to the brightness of the moon, and the

darkness that was upon the face of the deep shall be scattered by the spirit moving over the waters. Thus by God's command shall the Light appear.³³³

[187] It is evident that this passage is a variation on the theme of the preceding text. Instead of the infant hermaphrodite we have the winged youth, whose bride is the fountain of Diana (Luna as a nymph). The parallel to the mad dog is the thief or ne'er-do-well who is armed with the "malignity of arsenic." His malignity is assuaged by the wings of the doves, just as the dog's rabies was. The youth's wings are a token of his aerial nature; he is a pneuma that penetrates through the pores of the earth and activates it—which means nothing less than the connubium of the living spirit with the "dry, virgin earth," or of the wind with the waters dedicated to the maiden Diana. The winged youth is described as the "spirit moving over the waters," and this may be a reference not only to Genesis but to the angel that troubled the pool of Bethesda.³³⁴ His enemy, the thief who lies in wait for him, is, we are told earlier, the "outward burning vaporous sulphur," in other words *sulphur vulgi*, who is armed with the evil spirit, the devil, or is held captive by him in hell,³³⁵ and is thus the equivalent of the dog choked in the water. That the dog and the thief are identical is clear from the remark that Diana knows how to tame wild beasts. The two doves do in fact turn out to be the pair of lovers who appear in the love-story of Diana and the shepherd Endymion. This legend originally referred to Selene.

[188] The appearance of Diana necessarily brings with it her hunting animal the dog, who represents her dark side. Her darkness shows itself in the fact that she is also a goddess of destruction and death, whose arrows never miss. She changed the hunter Actaeon, when he secretly watched her bathing, into a stag, and his own hounds, not recognizing him, thereupon tore him to pieces. This myth may have given rise first to the designation of the lapis as the *cervus fugitivus* (fugitive stag),³³⁶ and then to the rabid dog, who is none other than the vindictive and treacherous aspect of Diana as the new moon. The parable we discussed in the chapter on sulphur likewise contains the motif of the "surprise in the bath." But there it is Helios himself who spies her, and the relationship is a brother-sister incest that ends with their both being drowned. This catastrophe is inherent in the incest, for through incest the royal pair is produced after animals have been killed or have killed one another.³³⁷ The animals (dragon, lion, snake, etc.) stand for evil passions that finally take the form of incest. They are destroyed by their own ravenous nature, just as are Sol and Luna, whose supreme desire culminates apparently in incest. But since "all that passes is but a parable," incest, as we have said before, is nothing but a preliminary form of the unio oppositorum.³³⁸ Out of chaos, darkness, and wickedness there rises up a new light once death has atoned for the "unavoidable machinations" of the Evil One.

c. An Alchemical Allegory

[189] The newcomer to the psychology of the unconscious will probably find the two texts about the mad dog and the thief very weird and abstruse. Actually they are no more so than the dreams which are the daily fare of the psychotherapist; and, like dreams, they can be translated into rational speech. In order to interpret dreams we need some knowledge of the dreamer's personal situation, and to understand alchemical parables we must know something about the symbolic assumptions of the alchemists. We amplify dreams by the personal history of the patient, and the parables by the statements found in the text. Armed with this knowledge, it is not too difficult in either case to discern a meaning that seems sufficient for our needs. An interpretation can hardly ever be convincingly proved. Generally it shows itself to be correct only when it has proved its value as a heuristic hypothesis. I would therefore like to take the second of Philaletha's texts, which is rather clearer than the first, and try to interpret it as if it were a dream.

Tu si aridam hanc Terram, aqua sui If thou knowest how to moisten this dry
generis rigare sciveris, poros Terrae earth with its own water, thou wilt
laxabis, loosen the pores of the earth,

[190] If you will contemplate your lack of fantasy, of inspiration and inner aliveness, which you feel as sheer stagnation and a barren wilderness, and impregnate it with the interest born of alarm at your inner death, then something can take shape in you, for your inner emptiness conceals just as great a fulness if only you will allow it to penetrate into you. If you prove receptive to this "call of the wild," the longing for fulfilment will quicken the sterile wilderness of your soul as rain quickens the dry earth. (Thus the Soul to the Laborant, staring glumly at his stove and scratching himself behind the ear because he has no more ideas.)

et externus hic fur cum Operatoribus and this thief from outside will be cast
nequitiae foras projicietur, out with the workers of wickedness,

[191] You are so sterile because, without your knowledge, something like an evil spirit has stopped up the source of your fantasy, the fountain of your soul. The enemy is your own crude sulphur, which burns you with the hellish fire of desirousness, or *concupiscentia*. You would like to make gold because "poverty is the greatest plague, wealth the highest good."³³⁹ You wish to have results that flatter your pride, you expect something useful, but there can be no question of that as you have realized with a shock. Because of this you no longer even *want* to be fruitful, as it would only be for God's sake but unfortunately not for your own.

purgabitur aqua per additamentum and the water, by an admixture of the
Sulphuris veri a sorde leprosa, et ab true Sulphur, will be cleansed from the
humore hydropico superfluo leprous filth and from the superfluous
dropsical fluid,

[192] Therefore away with your crude and vulgar desirousness, which childishly and shortsightedly sees only goals within its own narrow horizon. Admittedly sulphur is a vital spirit, a “Yetser Ha-ra,”³⁴⁰ an evil spirit of passion, though like this an active element; useful as it is at times, it is an obstacle between you and your goal. The water of your interest is not pure, it is poisoned by the leprosy of desirousness which is the common ill. You too are infected with this collective sickness. Therefore bethink you for once, “extrahe cogitationem,” and consider: What is behind all this desirousness? A thirsting for the eternal, which as you see can never be satisfied with the best because it is “Hades” in whose honour the desirous “go mad and rave.”³⁴¹ The more you cling to that which all the world desires, the more you are Everyman, who has not yet discovered himself and stumbles through the world like a blind man leading the blind with somnambulistic certainty into the ditch. Everyman is always a multitude. Cleanse your interest of that collective sulphur which clings to all like a leprosy. For desire only burns in order to burn itself out, and in and from this fire arises the true living spirit which generates life according to its own laws, and is not blinded by the shortsightedness of our intentions or the crude presumption of our superstitious belief in the will. Goethe says . . .

That livingness I praise

Which longs for flaming death.³⁴²

This means burning in your own fire and not being like a comet or a flashing beacon, showing others the right way but not knowing it yourself. The unconscious demands your interest for its own sake and wants to be accepted for what it is. Once the existence of this opposite is accepted, the ego can and should come to terms with its demands. Unless the content given you by the unconscious is acknowledged, its compensatory effect is not only nullified³⁴³ but actually changes into its opposite, as it then tries to realize itself literally and concretely.

habebisque in posse Comitum a Trevis and thou wilt have in thy power the
Fontinam, cujus Aquae sunt proprie Fount of the Knight of Treviso, whose
Dianae Virgini dicatae. waters are rightfully dedicated to the
maiden Diana.

[193] The fountain of Bernardus Trevisanus is the bath of renewal that was mentioned earlier. The ever-flowing fountain expresses a continual flow of interest toward the unconscious, a kind of constant attention or “religio,” which might also be called devotion. The crossing of unconscious contents into consciousness is thus made considerably easier, and this is bound to benefit the psychic balance in the long run. Diana as the numen and nymph of this spring is an excellent formulation of the figure we know as the anima. If attention is directed to the unconscious, the unconscious will yield up its contents, and these in turn will fructify the conscious like a fountain

of living water. For consciousness is just as arid as the unconscious if the two halves of our psychic life are separated.

Hic fur est nequam arsenicali malignitate Worthless is this thief, armed with the
armatus, quem juvenis alatus horret et malignity of arsenic, from whom the
fugit. winged youth fleeth, shuddering.

[194] It is evidently a difficult thing, this “cleansing from leprous filth”; indeed, d’Espagnet calls it a labour of Hercules. That is why the text turns back to the “thief” at this point. The thief, as we saw, personifies a kind of self-robbery. He is not easily shaken off, as it comes from a habit of thinking supported by tradition and milieu alike: anything that cannot be exploited in some way is uninteresting—hence the devaluation of the psyche. A further reason is the habitual depreciation of everything one cannot touch with the hands or does not understand. In this respect our conventional system of education—necessary as it was—is not entirely free from the blame of having helped to give the empirical psyche a bad name. In recent times this traditional error has been made even worse by an allegedly biological point of view which sees man as being no further advanced than a herd-animal and fails to understand any of his motivations outside the categories of hunger, power, and sex. We think in terms of thousands and millions of units, and then naturally there are no questions more important than whom the herd belongs to, where it pastures, whether enough calves are born and sufficient quantities of milk and meat are produced. In the face of huge numbers every thought of individuality pales, for statistics obliterate everything unique. Contemplating such overwhelming might and misery the individual is embarrassed to exist at all. Yet the real carrier of life is the individual. He alone feels happiness, he alone has virtue and responsibility and any ethics whatever. The masses and the state have nothing of the kind. Only man as an individual human being lives; the state is just a system, a mere machine for sorting and tabulating the masses. Anyone, therefore, who thinks in terms of men minus the individual, in huge numbers, atomizes himself and becomes a thief and a robber to himself. He is infected with the leprosy of collective thinking and has become an inmate of that insalubrious stud-farm called the totalitarian State. Our time contains and produces more than enough of that “crude sulphur” which with “arsenical malignity” prevents man from discovering his true self.

[195] I was tempted to translate *arsenicalis* as ‘poisonous’. But this translation would be too modern. Not everything that the alchemists called “arsenic” was really the chemical element As. “Arsenic” originally meant ‘masculine, manly, strong’ (ἀρσην) and was essentially an arcanum, as Ruland’s *Lexicon* shows. There arsenic is defined as an “hermaphrodite, the means whereby Sulphur and Mercury are united. It has communion with both natures and is therefore called Sun and Moon.”³⁴⁴ Or arsenic is

“Luna, our Venus, Sulphur’s companion” and the “soul.” Here arsenic is no longer the masculine aspect of the arcane substance but is hermaphroditic and even feminine. This brings it dangerously close to the moon and the crude sulphur, so that arsenic loses its solar affinity. As “Sulphur’s companion” it is poisonous and corrosive. Because the arcane substance always points to the principal unconscious content, its peculiar nature shows in what relation that content stands to consciousness. If the conscious mind has accepted it, it has a positive form, if not, a negative one. If on the other hand the arcane substance is split into two figures, this means that the content has been partly accepted and partly rejected; it is seen under two different, incompatible aspects and is therefore taken to be two different things.

[196] This is what has happened in our text: the thief is contrasted with the winged youth, who represents the other aspect, or personifies the “true sulphur,” the spirit of inner truth which measures man not by his relation to the mass but by his relation to the mystery of the psyche. This winged youth (the spiritual Mercurius) is obviously aware of his own weakness and flees “shuddering” from the crude sulphur. The standpoint of the inner man is the more threatened the more overpowering that of the outer man is. Sometimes only his invisibility saves him. He is so small that no one would miss him if he were not the *sine qua non* of inner peace and happiness.³⁴⁵ In the last resort it is neither the “eighty-million-strong nation” nor the State that feels peace and happiness, but the individual. Nobody can ever get round the simple computation that a million noughts in a row do not add up to 1, just as the loudest talk can never abolish the simple psychological fact that the larger the mass the more nugatory is the individual.

[197] The shy and delicate youth stands for everything that is winged in the psyche or that would like to sprout wings. But it dies from the poison of organizational thinking and mass statistics; the individual succumbs to the madness that sooner or later overtakes every mass—the death-instinct of the lemmings. In the political sphere the name for this is war.

Et licet Aqua centralis sit hujus Sponsa, And though the central Water is his
tamen Amorem suum erga illam bride, yet dare he not display his most
ardentissimum non audet exerere, ob ardent love towards her, because of the
latronis insidias, cujus technae sunt vere snares of the thief, whose machinations
inevitabiles. are in truth unavoidable.

[198] The goal of the winged youth is a higher one than the fulfilment of collective ideals, which are all nothing but makeshifts and conditions for bare existence. Since this is the absolute foundation, nobody will deny their importance, but collective ideals are not by a long way the breath of life which a man needs in order to live. If his soul does not live nothing can save him from stultification. His life is the soil in

which his soul can and must develop. He has only the mystery of his living soul to set against the overwhelming might and brutality of collective convictions.

[199] It is the age-old drama of opposites, no matter what they are called, which is fought out in every human life. In our text it is obviously the struggle between the good and the evil spirit, expressed in alchemical language just as today we express it in conflicting ideologies. The text comes close to the mystical language of the Baroque—the language of Jacob Boehme (1575–1624), Abraham of Franckenberg (1593–1652), and Angelus Silesius (1624–1677).

[200] We learn that the winged youth is espoused to the “central Water.” This is the fountain of the soul or the fount of wisdom,³⁴⁶ from which the inner life wells up. The nymph of the spring is in the last analysis Luna, the mother-beloved, from which it follows that the winged youth is Sol, the *filius solis, lapis, aurum philosophicum, lumen luminum, medicina catholica, una salus*, etc. He is the best, the highest, the most precious *in potentia*. But he will become real only if he can unite with Luna, the “mother of mortal bodies.” If not, he is threatened with the fate of the puer aeternus in *Faust*, who goes up in smoke three times.³⁴⁷ The adept must therefore always take care to keep the Hermetic vessel well sealed, in order to prevent what is in it from flying away. The content becomes “fixed” through the mystery of the coniunctio, in which the extreme opposites unite, night is wedded with day, and “the two shall be one, and the outside as the inside, and the male with the female neither male nor female.”³⁴⁸ This apocryphal saying of Jesus from the beginning of the second century is indeed a paradigm for the alchemical union of opposites. Obviously this problem is an eschatological one, but, aside from the somewhat tortuous language of the times, it cannot be called abstruse since it has universal validity, from the *tao* of Lao-tzu to the *coincidentia oppositorum* of Cusanus. The same idea penetrated into Christianity in the form of the apocalyptic marriage of the Lamb (Rev. 22 : 9ff.), and we seldom find a high point of religious feeling where this eternal image of the royal marriage does not appear.

[201] I can do no more than demonstrate the existence of this image and its phenomenology. What the union of opposites really “means” transcends human imagination. Therefore the worldly-wise can dismiss such a “fantasy” without further ado, for it is perfectly clear: *tertium non datur*. But that doesn’t help us much, for we are dealing with an eternal image, an archetype, from which man can turn away his mind for a time but never permanently.³⁴⁹ Whenever this image is obscured his life loses its proper meaning and consequently its balance. So long as he knows that he is the carrier of life and that it is therefore important for him to live, then the mystery of his soul lives also—no matter whether he is conscious of it or not. But if he no longer sees the meaning of his life in its fulfilment, and no longer believes in man’s eternal

right to this fulfilment, then he has betrayed and lost his soul, substituting for it a madness which leads to destruction, as our time demonstrates all too clearly.

[202] The “machinations of the thief,” our text says, are “unavoidable.” They are an integral part of the fateful drama of opposites, just as the shadow belongs to the light. Reason, however, cannot turn this into a convenient recipe, for inevitability does not diminish the guilt of what is evil any more than the merit of what is good. Minus remains minus, and guilt, as ever, has to be avenged. “Evil follows after wrong,” says the Capuchin friar in Wallenstein’s camp—a banal truth that is too readily forgotten, and because of this the winged youth cannot lead his bride home as quickly as he would wish. Evil cannot be eradicated once and for all; it is an inevitable component of life and is not to be had without paying for it. The thief whom the police do not catch has, nonetheless, robbed himself, and the murderer is his own executioner.

[203] The thief in our text is armed with all evil, but in reality it is merely the ego with its shadow where the abysmal depths of human nature begin to appear. Increasing psychological insight hinders the projection of the shadow, and this gain in knowledge logically leads to the problem of the union of opposites. One realizes, first of all, that one cannot project one’s shadow on to others, and next that there is no advantage in insisting on their guilt, as it is so much more important to know and possess one’s own, because it is part of one’s own self and a necessary factor without which nothing in this sublunary world can be realized. Though it is not said that Luna personifies the dark side, there is as we have seen something very suspicious about the new moon. Nevertheless the winged youth loves his moon-bride and hence the darkness to which she belongs, for the opposites not only flee one another but also attract one another. We all know that evil, especially if it is not scrutinized too closely, can be very attractive, and most of all when it appears in idealistic garb. Ostensibly it is the wicked thief that hinders the youth in his love for the chaste Diana, but in reality the evil is already lurking in the ideal youth and in the darkness of the new moon, and his chief fear is that he might discover himself in the role of the common sulphur. This role is so shocking that the noble-minded youth cannot see himself in it and puts the blame on the wiles of the enemy. It is as if he dared not know himself because he is not adult enough to accept the fact that one must be thankful if one comes across an apple without a worm in it and a plate of soup without a hair.

Esto hic tibi Diana propitia, quae feras Here may Diana be propitious to thee,
domare novit, who knoweth how to tame wild beasts,

[204] The darkness which is opposed to the light is the unbridled instinctuality of nature that asserts itself despite all consciousness. Anyone who seeks to unite the opposites certainly needs Diana to be propitious to him, for she is being considered

as a bride and it has yet to be seen what she has to present in the way of wild animals. Possibly the thief will appear quite insignificant by comparison.

cujus binae columbae pennis suis aeris and whose twin doves will temper the malignitatem temperabunt, malignity of the air with their wings,

[205] The tender pair of doves is an obviously harmless aspect of the same instinctuality, though in itself the theriomorphic symbol would be capable of an “interpretation from above downwards.” Nonetheless, it should not be interpreted in this sense because the aspect of untamed animality and evil is represented in the previous quotation by the mad dog and in this one by the thief. In contrast to this, the doves are emblems of innocence and of marital love as well as of the Holy Ghost and Sapientia, of Christ and his Virgin Mother.³⁵⁰ From this context we can see what the dove is intended to represent: it is the exact counterpart to the malignity of the thief. Together they represent the attack, first from one side and then from the other, of a dualistic being on the more restricted consciousness of man. The purpose or result of this assault is the widening of consciousness, which has always, it seems, followed the pattern laid down in Genesis 3 : 4f.: “Ye shall not surely die, for God doth know that in the day ye eat thereof, then your eyes shall be opened, and ye shall be as gods, knowing good and evil.”

[206] It is obviously a moment of supreme possibilities both for good and for evil. Usually, however, it is first one and then the other: the good man succumbs to evil, the sinner is converted to good, and that, to an uncritical eye, is the end of the matter. But those endowed with a finer moral sense or deeper insight cannot deny that this seeming one-after-another is in reality a happening of events side-by-side, and perhaps no one has realized this more clearly than St. Paul, who knew that he bore a thorn in the flesh and that the messenger of Satan smote him in the face lest he be “exalted above measure.”³⁵¹ The one-after-another is a bearable prelude to the deeper knowledge of the side-by-side, for this is an incomparably more difficult problem. Again, the view that good and evil are spiritual forces outside us, and that man is caught in the conflict between them, is more bearable by far than the insight that the opposites are the ineradicable and indispensable preconditions of all psychic life, so much so that life itself is guilt. Even a life dedicated to God is still lived by an ego, which speaks of an ego and asserts an ego in God’s despite, which does not instantly merge itself with God but reserves for itself a freedom and a will which it sets up outside God and against him. How *can* it do this against the overwhelming might of God? Only through self-assertion, which is as sure of its free will as Lucifer. All distinction from God is separation, estrangement, a falling away. The Fall was inevitable even in paradise. Therefore Christ is “without the stain of sin,” because he stands for the whole of the Godhead and is not distinct from it by reason of his

manhood.³⁵² Man, however, is branded by the stain of separation from God. This state of things would be insupportable if there were nothing to set against evil but the law and the Decalogue, as in pre-Christian Judaism—until the reformer and rabbi Jesus tried to introduce the more advanced and psychologically more correct view that not fidelity to the law but love and kindness are the antithesis of evil. The wings of the dove temper the malignity of the air, the wickedness of the aerial spirit (“the prince of the power of the air”—Ephesians 2 : 2), and they alone have this effect.

quod per poros facile ingreditur so that the youth easily entereth in
adolescens, concutit statim (terrae through the pores, and instantly shaketh
sedes), nubemque tetricam suscitatur. the foundations of the earth,³⁵³ and
raiseth up a dark cloud.

[207] Once the malignity is tempered, sinfulness and its evil consequences are mitigated too, and that which has wings can embrace the earth. For now we come to the consummation of the hierosgamos, the “earthing” of the spirit and the spiritualizing of the earth, the union of opposites and reconciliation of the divided (Ephesians 2 : 14),³⁵⁴ in a word the longed-for act of redemption whereby the sinfulness of existence, the original dissociation, will be annulled in God. The earthquake is on the one hand an allusion to Christ’s descent into hell and his resurrection, and on the other hand a shaking of the humdrum earthly existence of man, into whose life and soul meaning has at last penetrated, and by which he is at once threatened and uplifted.

[208] This is always an intuitive experience that is felt as a concrete reality. It is the prefiguration and anticipation of a future condition, a glimmering of an unspoken, half-conscious union of ego and non-ego. Rightly called a *unio mystica*, it is the fundamental experience of all religions that have any life in them and have not yet degenerated into confessionalism; that have safeguarded the mystery of which the others know only the rites it produced—empty bags from which the gold has long since vanished.

[209] The earthquake sends up a dark cloud: consciousness, because of the revolution of its former standpoint, is shrouded in darkness, just as the earth was at Christ’s death, which was followed by a resurrection. This image tells us that the widening of consciousness is at first upheaval and darkness, then a broadening out of man to the whole man. This “Man,” being indescribable, is an intuitive or “mystical” experience, and the name “Anthropos” is therefore very apt because it demonstrates the continuity of this idea over the millennia.

tu undas superinduces ad Lunae usque But thou wilt lead the waters up even to
candorem, the brightness of the moon,

[210] As we have seen, water here has the meaning of “fructifying interest,” and its leading upwards means that it now turns towards the plenilunium, the gracious and serene complement of the sinister new moon and its perils.

atque ita Tenebrae, quae supra abyssi and the darkness that was upon the face
faciem erant, per spiritum se in aquis of the deep shall be scattered by the
moventem discutientur. Sic jubente Deo spirit moving over the waters. Thus by
Lux apparebit. God’s command shall the Light appear.

[211] The eye that hitherto saw only the darkness and danger of evil turns towards the circle of the moon, where the ethereal realm of the immortals begins, and the gloomy deep can be left to its own devices, for the spirit now moves it from within, convulses and transforms it. When consciousness draws near to the unconscious not only does *it* receive a devastating shock but something of its light penetrates into the darkness of the unconscious. The result is that the unconscious is no longer so remote and strange and terrifying, and this paves the way for an eventual union. Naturally the “illumination” of the unconscious does not mean that from now on the unconscious is less unconscious. Far from it. What happens is that its contents cross over into consciousness more easily than before. The “light” that shines at the end is the *lux moderna* of the alchemists, the new widening of consciousness, a further step in the realization of the Anthropos, and every one of these steps signifies a rebirth of the deity.

[212] Herewith we end our contemplation of the text. The question now arises: Did the alchemists really have such thoughts and conceal them in their ornate metaphors? In other words, did Philaletha, the pseudonymous author of our text, have anything like the thoughts and ideas which I have put forward by way of interpretation? I regard this as out of the question, and yet I believe that these authors invariably said the best, most apposite, and clearest thing they could about the matter in hand. For our taste and our intellectual requirements this performance is, however, so unsatisfactory that we ourselves feel compelled to make a renewed attempt to say the same thing in still clearer words. It seems obvious to us that what we think about it was never thought by the alchemists, for if it had been it would doubtless have come out long ago. The “philosophers” took the greatest pains to unearth and reveal the secret of the stone, accusing the ancients of having written too copiously and too obscurely. If they, on their own admission, wrote “typice, symbolice, metaphoricæ,” this was the best they could do, and it is thanks to their labours that we are today in a position to say anything at all about the secrets of alchemy.

[213] All understanding that is not directly of a mathematical nature (which, incidentally, understands nothing but merely formulates) is conditioned by its time. Fundamental to alchemy is a true and genuine mystery which since the seventeenth

century has been understood unequivocally as psychic. Nor can we moderns conceive it to be anything except a psychic product whose meaning may be elicited by the methods and empirical experience of our twentieth century medical psychology. But I do not imagine for a moment that the psychological interpretation of a mystery must necessarily be the last word. If it is a mystery it must have still other aspects. Certainly I believe that psychology can unravel the secrets of alchemy, but it will not lay bare the secret of these secrets. We may therefore expect that at some time in the future our attempt at explanation will be felt to be just as “metaphorical and symbolical” as we have found the alchemical one to be, and that the mystery of the stone, or of the self, will then develop an aspect which, though still unconscious to us today, is nevertheless foreshadowed in our formulations, though in so veiled a form that the investigator of the future will ask himself, just as we do, whether we knew what we meant.

d. *The Moon-Nature*

[214] We have treated at some length of the sinister and dangerous aspect of the new moon. In this phase the climax of the moon’s waning, which in folklore is not always considered auspicious, is reached. The new moon is dangerous at childbirth and weddings. If a father dies at the waning moon, this brings the children bad luck. One also has to bow to the sickle moon or it will bring bad luck. Even the light of the moon is dangerous as it causes the moon-sickness, which comes from the “moon-wolf.” The marriage bed, pregnant women, and small children should be protected from the moonlight. Whoever sews by moonlight sews the winding-sheet, and so on.³⁵⁵

[215] The passage on the moon in Paracelsus’ “De pestilitate” (III, 95) catches very aptly the atmosphere which hangs round the pale moonlight:

Now mark this: Wherever there is a disheartened and timid man in whom imagination has created the great fear and impressed it on him, the moon in heaven aided by her stars is the *corpus* to bring this about. When such a disheartened timid man looks at the moon under the full sway of his imagination, he looks into the *speculum venenosum magnum naturae* [great poisonous mirror of nature], and the sidereal spirit and *magnes hominis* [magnet of man] will thus be poisoned by the stars and the moon. But we shall expound this more clearly to you as follows. Through his imagination the timid man has made his eyes basilisk-like, and he infects the mirror, the moon, and the stars, through himself at the start, and later on so that the moon is infected by the imagining man; this will happen soon and easily, by dint of the magnetic power which the sidereal body and spirit exerts upon the celestial bodies [viz.] the moon and the stars in great Nature [viz., the Macrocosm]. Thus man in turn will be poisoned by this mirror of the moon and the stars which he has looked at; and

this because (for, as you can see, it happens quite naturally) a pregnant woman at the time of menstruation similarly stains and damages the mirror by looking into it. For at such a time she is poisonous and has basilisk's eyes *ex causa menstrui et venenosi sanguinis* [because of the menstrual and poisonous blood] which lies hidden in her body and nowhere more strongly than in her eyes. For there the sidereal spirit of the stained body lies open and naked to the sidereal magnet. *Quia ex menstruo et venenoso sanguine mulieris causatur et nascitur basiliscus, ita luna in coelo est oculus basilisci coeli* [Because as the basilisk is caused and born from the menstrual and poisonous blood of a woman, thus the moon in the sky is the eye of the basilisk of heaven]. And as the mirror is defiled by the woman, thus conversely the eyes, the sidereal spirit, and the body of man are being defiled by the moon, for the reason that at such time the eyes of the timid imagining man are weak and dull, and the sidereal spirit and body draw poison out of the mirror of the moon into which you have looked. But not so that only one human being has the power thus to poison the moon with his sight, no; hence I say that, mostly, menstruating women do poison the moon and the stars much more readily and also more intensely than any man, easily so. Because as you see that they poison and stain the mirror made of metallic material—and what is even more, the glass mirror—much more and sooner they defile the moon and the stars at such a time. And even if at such time the moon only shines on water and the woman looks at the water, the moon will be poisoned, and by still many more means, but it would not do to reveal all this clearly. And such poisoning of the moon happens for this reason: it is the naked eye of the spirit and of the sidereal body and it often grows new and young as you can see. Just as a young child who looks into a mirror which was looked at by a menstruating woman will become long-sighted and cross-eyed and his eyes will be poisoned, stained, and ruined, as the mirror was stained by the menstruating woman; and so also the moon, and also the human being, is poisoned. And as the moon, when it grows new and young, is of a poisonous kind, this you shall notice in two ways, namely in the element of water and also in wood, loam, etc.: as this, when it is gathered at the wrong time will not burn well, but be worm-eaten, poisonous, bad, and putrid, so is also the moon, and that is why it can be poisoned so easily by merely looking at it and the moon with its light is the *humidum ignis* [moisture of fire], of a cold nature, for which reason it is capable of receiving the poison easily.³⁵⁶

[216] In the Table of Correspondences in Penotus³⁵⁷ the following are said to pertain to the moon: the snake, the tiger, the Manes, the Lemurs, and the *dei infernales*. These correlations show clearly how Penotus was struck by the underworld nature of the moon.³⁵⁸ His “heretical” empiricism led him beyond the patristic allegories to a recognition of the moon's dark side, an aspect no longer suited to serve as an allegory of the beautiful bride of Christ. And just as the bitch was forgotten in the lunar

allegory of the Church, so too our masculine judgment is apt to forget it when dealing with an over-valued woman. We should not deceive ourselves about the sinister “tail” of the undoubtedly desirable “head”: the baying of Hecate is always there, whether it sound from near or from far. This is true of everything feminine and not least of a man’s anima. The mythology of the moon is an object lesson in female psychology.³⁵⁹

[217] The moon with her antithetical nature is, in a sense, a prototype of individuation, a prefiguration of the self: she is the “mother and spouse of the sun, who carries in the wind and the air the spagyric embryo conceived by the sun in her womb and belly.”³⁶⁰ This image corresponds to the psychologem of the pregnant anima, whose child is the self, or is marked by the attributes of the hero. Just as the anima represents and personifies the collective unconscious, so Luna represents the six planets or spirits of the metals. Dorn says:

From Saturn, Mercury, Jupiter, Mars and Venus nothing and no other metal can arise except Luna [i.e., silver]. . . . For Luna consists of the six spiritual metals and their powers, of which each has two. . . . From the planet Mercury, from Aquarius and Gemini, or from Aquarius and Pisces, Luna has her liquidity [*liquatio*] and her white brightness . . ., from Jupiter, Sagittarius, and Taurus her white colour and her great stability in the fire . . ., from Mars, Cancer, and Aries her hardness and fine resonance . . ., from Venus, Gemini, and Libra her degree of solidity [*coagulationis*] and malleability . . ., from Sol, Leo, and Virgo her true purity and great endurance against the strength of the fire . . ., from Saturn, Virgo, and Scorpio, or from Capricorn, her homogeneous body, her pure cleanness [*puram munditiem*], and steadfastness against the force of the fire.³⁶¹

[218] Luna is thus the sum and essence of the metals’ natures, which are all taken up in her shimmering whiteness. She is multi-natured, whereas Sol has an exceptional nature as the “seventh from the six spiritual metals.” He is “in himself nothing other than pure fire.”³⁶² This role of Luna devolves upon the anima, as she personifies the plurality of archetypes, and also upon the Church and the Blessed Virgin, who, both of lunar nature, gather the many under their protection and plead for them before the *Sol iustitiae*. Luna is the “universal receptacle of all things,” the “first gateway of heaven,”³⁶³ and William Mennens³⁶⁴ says that she gathers the powers of all the stars in herself as in a womb, so as then to bestow them on sublunary creatures.³⁶⁵ This quality seems to explain her alleged effect in the *opus ad Lunam*, when she gives the tincture the character and powers of all the stars. The “Fragment from the Persian Philosophers” says: “With this tincture all the dead are revived, so that they live for ever, and this tincture is the first-created ferment,³⁶⁶ namely that ‘to the moon,’³⁶⁷ and it is the light of all lights and the flower and fruit of all lights,³⁶⁸ which lighteth all things.”³⁶⁹

[219] This almost hymn-like paean to the *materia lapidis* or the tincture refers in the first instance to Luna, for it is during her work of whitening that the illumination takes place. She is the “mother in this art.” In her water “Sol is hidden like a fire”³⁷⁰—a parallel to the conception of Selene as the *μήτηρ τοῦ κόσμου* in Plutarch. On the first day of the month of Phamenoth, Osiris enters into Selene, and this is evidently equivalent to the synodos in the spring. “Thus they make the power of Osiris to be fixed in the moon.”³⁷¹ Selene, Plutarch says, is male-female and is impregnated by Helios. I mention these statements because they show that the moon has a double light, outside a feminine one but inside a masculine one which is hidden in it as a fire. Luna is really the mother of the sun, which means, psychologically, that the unconscious is pregnant with consciousness and gives birth to it. It is the night, which is older than the day:

Part of the darkness which gave birth to light,
That proud light which is struggling to usurp
The ancient rank and realm of Mother Night.³⁷²

[220] From the darkness of the unconscious comes the light of illumination, the *albedo*. The opposites are contained in it *in potentia*, hence the hermaphroditism of the unconscious, its capacity for spontaneous and autochthonous reproduction. This idea is reflected in the “Father-Mother” of the Gnostics,³⁷³ as well as in the naïve vision of Brother Klaus³⁷⁴ and the modern vision of Maitland.³⁷⁵ the biographer of Anna Kingsford.

[221] Finally, I would like to say a few words about the psychology of the moon, which is none too simple. The alchemical texts were written exclusively by men, and their statements about the moon are therefore the product of masculine psychology. Nevertheless women did play a role in alchemy, as I have mentioned before, and this makes it possible that the “symbolization” will show occasional traces of their influence. Generally the proximity as well as the absence of women has a specifically constellating effect on the unconscious of a man. When a woman is absent or unattainable the unconscious produces in him a certain femininity which expresses itself in a variety of ways and gives rise to numerous conflicts. The more one-sided his conscious, masculine, spiritual attitude the more inferior, banal, vulgar, and biological will be the compensating femininity of the unconscious. He will, perhaps, not be conscious at all of its dark manifestations, because they have been so overlaid with saccharine sentimentality that he not only believes the humbug himself but enjoys putting it over on other people. An avowedly biological or coarse-minded attitude to women produces an excessively lofty valuation of femininity in the unconscious, where it is pleased to take the form of Sophia or of the Virgin. Frequently, however, it gets distorted by everything that misogyny can possibly

devise to protect the masculine consciousness from the influence of women, so that the man succumbs instead to unpredictable moods and insensate resentments.

[222] Statements by men on the subject of female psychology suffer principally from the fact that the projection of unconscious femininity is always strongest where critical judgment is most needed, that is, where a man is involved emotionally. In the metaphorical descriptions of the alchemists, Luna is primarily a reflection of a man's unconscious femininity, but she is also the principle of the feminine psyche, in the sense that Sol is the principle of a man's. This is particularly obvious in the astrological interpretation of sun and moon, not to mention the age-old assumptions of mythology. Alchemy is inconceivable without the influence of her elder sister astrology, and the statements of these three disciplines must be taken into account in any psychological evaluation of the luminaries. If, then, Luna characterizes the feminine psyche and Sol the masculine, consciousness would be an exclusively masculine affair, which is obviously not the case since woman possesses consciousness too. But as we have previously identified Sol with consciousness and Luna with the unconscious, we would now be driven to the conclusion that a woman cannot possess a consciousness.

[223] The error in our formulation lies in the fact, firstly, that we equated the moon with the unconscious as such, whereas the equation is true chiefly of the unconscious of a man; and secondly, that we overlooked the fact that the moon is not only dark but is also a giver of light and can therefore represent consciousness. This is indeed so in the case of woman: her consciousness has a lunar rather than a solar character. Its light is the "mild" light of the moon, which merges things together rather than separates them. It does not show up objects in all their pitiless discreteness and separateness, like the harsh, glaring light of day, but blends in a deceptive shimmer the near and the far, magically transforming little things into big things, high into low, softening all colour into a bluish haze, and blending the nocturnal landscape into an unsuspected unity.

[224] For purely psychological reasons I have, in other of my writings, tried to equate the masculine consciousness with the concept of Logos and the feminine with that of Eros. By Logos I meant discrimination, judgment, insight, and by Eros I meant the capacity to relate. I regarded both concepts as intuitive ideas which cannot be defined accurately or exhaustively. From the scientific point of view this is regrettable, but from a practical one it has its value, since the two concepts mark out a field of experience which it is equally difficult to define.

[225] As we can hardly ever make a psychological proposition without immediately having to reverse it, instances to the contrary leap to the eye at once: men who care nothing for discrimination, judgment, and insight, and women who display an almost

excessively masculine proficiency in this respect. I would like to describe such cases as the regular exceptions. They demonstrate, to my mind, the common occurrence of a psychically predominant contrasexuality. Wherever this exists we find a forcible intrusion of the unconscious, a corresponding exclusion of the consciousness specific to either sex, predominance of the shadow and of contrasexuality, and to a certain extent even the presence of symptoms of possession (such as compulsions, phobias, obsessions, automatisms, exaggerated affects, etc.). This inversion of roles is probably the chief psychological source for the alchemical concept of the hermaphrodite. In a man it is the lunar anima, in a woman the solar animus, that influences consciousness in the highest degree. Even if a man is often unaware of his own anima-possession, he has, understandably enough, all the more vivid an impression of the animus-possession of his wife, and vice versa.

[226] Logos and Eros are intellectually formulated intuitive equivalents of the archetypal images of Sol and Luna. In my view the two luminaries are so descriptive and so superlatively graphic in their implications that I would prefer them to the more pedestrian terms Logos and Eros, although the latter do pin down certain psychological peculiarities more aptly than the rather indefinite “Sol and Luna.” The use of these images requires at any rate an alert and lively fantasy, and this is not an attribute of those who are inclined by temperament to purely intellectual concepts. These offer us something finished and complete, whereas an archetypal image has nothing but its naked fullness, which seems inapprehensible by the intellect. Concepts are coined and negotiable values; images are life.

[227] If our formula regarding the lunar nature of feminine consciousness is correct—and in view of the *consensus omnium* in this matter it is difficult to see how it should not be—we must conclude that this consciousness is of a darker, more nocturnal quality, and because of its lower luminosity can easily overlook differences which to a man’s consciousness are self-evident stumbling-blocks. It needs a very moon-like consciousness indeed to hold a large family together regardless of all the differences, and to talk and act in such a way that the harmonious relation of the parts to the whole is not only not disturbed but is actually enhanced. And where the ditch is too deep, a ray of moonlight smoothes it over. A classic example of this is the conciliatory proposal of St. Catherine of Alexandria in Anatole France’s *Penguin Island*. The heavenly council had come to a deadlock over the question of baptism, since although the penguins were animals they had been baptized by St. Maël. Therefore she says: “That is why, Lord, I entreat you to give old Maël’s penguins a human head and breast so that they can praise you worthily. And grant them also an immortal soul—but only a little one!”³⁷⁶

[228] This “lunatic” logic can drive the rational mind to the white heat of frenzy. Fortunately it operates mostly in the dark or cloaks itself in the shimmer of innocence. The moon-nature is its own best camouflage, as at once becomes apparent when a woman’s unconscious masculinity breaks through into her consciousness and thrusts her Eros aside. Then it is all up with her charm and the mitigating half-darkness; she takes a stand on some point or other and captiously defends it, although each barbed remark tears her own flesh, and with brutal short-sightedness she jeopardizes everything that is the dearest goal of womanhood. And then, for unfathomable reasons—or perhaps simply because it is time—the picture changes completely: the new moon has once more been vanquished.

[229] The Sol who personifies the feminine unconscious is not the sun of the day but corresponds rather to the *Sol niger*. It is not the real *Sol niger* of masculine psychology, the alter ego, the Brother Medardus of E. T. A. Hoffmann’s story “The Devil’s Elixir,” or the crass identity of opposites which we meet with in Jekyll and Hyde. The unconscious Sol of woman may be dark, but it is not “coal black” (*ἀνθρακώδης*), as was said of the moon; it is more like a chronic eclipse of the sun, which in any case is seldom total. Normally a woman’s consciousness emits as much darkness as light, so that, if her consciousness cannot be entirely light, her unconscious cannot be entirely dark either. At any rate, when the lunar phases are repressed on account of too powerful solar influences, her consciousness takes on an overbright solar character, while on the other hand her unconscious becomes darker and darker—*nigrum nigrius nigro*—and both are unendurable for both in the long run.

[230] Her *Sol niger* is as void of light and charm as the gentling moonlight is all heavenly peace and magic. It protests too much that it is a light, because it is no light, and a great truth, because it invariably misses the mark, and a high authority, which nevertheless is always wrong, or is only as right as the blind tom-cat who tried to catch imaginary bats in broad daylight, but one day caught a real one by mistake and thereafter became completely unteachable. I do not want to be unfair, but that is what the feminine Sol is like when it obtrudes too much. (And it has to obtrude a bit if the man is to understand it!)

[231] As a man normally gets to know his anima only in projected form, so too a woman in the case of her dark sun. When her Eros is functioning properly her sun will not be too dark, and the carrier of the projection may even produce some useful compensation. But if things are not right with her Eros (in which case she is being unfaithful to Love itself), the darkness of her sun will transfer itself to a man who is anima-possessed and who dispenses inferior spirit, which as we know is as intoxicating as the strongest alcohol.

[232] The dark sun of feminine psychology is connected with the father-*imago*, since the father is the first carrier of the *animus-image*. He endows this virtual image with substance and form, for on account of his *Logos* he is the source of “spirit” for the daughter. Unfortunately this source is often sullied just where we would expect clean water. For the spirit that benefits a woman is not mere intellect, it is far more: it is an attitude, the spirit by which a man lives.³⁷⁷ Even a so-called “ideal” spirit is not always the best if it does not understand how to deal adequately with nature, that is, with the animal man. This really would be ideal. Hence every father is given the opportunity to corrupt, in one way or another, his daughter’s nature, and the educator, husband, or psychiatrist then has to face the music. For “what has been spoiled by the father”³⁷⁸ can only be made good by a father, just as “what has been spoiled by the mother” can only be repaired by a mother. The disastrous repetition of the family pattern could be described as the psychological original sin, or as the curse of the *Atrides* running through the generations. But in judging these things one should not be too certain either of good or of evil. The two are about equally balanced. It should, however, have begun to dawn on our cultural optimists that the forces of good are not sufficient to produce either a rational world-order or the faultless ethical behaviour of the individual, whereas the forces of evil are so strong that they imperil any order at all and can imprison the individual in a devilish system that commits the most fearful crimes, so that even if he is ethical-minded he must finally forget his moral responsibility in order to go on living. The “malignity” of collective man has shown itself in more terrifying form today than ever before in history, and it is by this objective standard that the greater and the lesser sins should be measured. We need more casuistic subtlety, because it is no longer a question of extirpating evil but of the difficult art of putting a lesser evil in place of a greater one. The time for the “sweeping statements” so dear to the evangelizing moralist, which lighten his task in the most agreeable way, is long past. Nor can the conflict be escaped by a denial of moral values. The very idea of this is foreign to our instincts and contrary to nature. Every human group that is not actually sitting in prison will follow its accustomed paths according to the measure of its freedom. Whatever the intellectual definition and evaluation of good and evil may be, the conflict between them can never be eradicated, for no one can ever forget it. Even the Christian who feels himself delivered from evil will, when the first rapture is over, remember the thorn in the flesh, which even St. Paul could not pluck out.

[233] These hints may suffice to make clear what kind of spirit it is that the daughter needs. They are the truths which speak to the soul, which are not too loud and do not insist too much, but reach the individual in stillness—the individual who constitutes the meaning of the world. It is this knowledge that the daughter needs, in order to pass it on to her son.

5. SAL

a. Salt as the Arcane Substance

[234] In this section I shall discuss not only salt but a number of symbolisms that are closely connected with it, such as the “bitterness” of the sea, sea-water and its baptismal quality, which in turn relates it to the “Red Sea.” I have included the latter in the scope of my observations but not the symbol of the sea as such. Since Luna symbolizes the unconscious, Sal, as one of its attributes, is a special instance of the lunar symbolism. This explains the length of the present entire chapter: extensive digressions are necessary in order to do justice to the various aspects of the unconscious that are expressed by salt, and at the same time to explain their psychological meaning.

[235] Owing to the theory of “correspondentia,” regarded as axiomatic in the Middle Ages, the principles of each of the four worlds—the intelligible or divine, the heavenly, the earthly, and the infernal³⁷⁹—corresponded to each other. Usually, however, there was a division into three worlds to correspond with the Trinity: heaven, earth, hell.³⁸⁰ Triads were also known in alchemy. From the time of Paracelsus the most important triad was Sulphur-Mercurius-Sal, which was held to correspond with the Trinity. Georg von Welling, the plagiarist of Johann Rudolf Glauber, still thought in 1735 that his triad of fire, sun, and salt³⁸¹ was “in its root entirely one thing.”³⁸² The use of the Trinity formula in alchemy is so common that further documentation is unnecessary. A subtle feature of the Sulphur-Mercurius-Sal formula is that the central figure, Mercurius, is by nature androgynous and thus partakes both of the masculine red sulphur and of the lunar salt.³⁸³ His equivalent in the celestial realm is the planetary pair Sol and Luna, and in the “intelligible” realm Christ in his mystical androgyny, the “man encompassed by the woman,”³⁸⁴ i.e., sponsus and sponsa (Ecclesia). Like the Trinity, the alchemical “triunity” is a quaternity in disguise owing to the duplicity of the central figure: Mercurius is not only split into a masculine and a feminine half, but is the poisonous dragon and at the same time the heavenly lapis. This makes it clear that the dragon is analogous to the devil and the lapis to Christ, in accordance with the ecclesiastical view of the devil as an autonomous counterpart of Christ. Furthermore, not only the dragon but the negative aspect of sulphur, namely *sulphur comburens*, is identical with the devil, as Glauber says: “Verily, sulphur is the true black devil of hell, who can be conquered by no element save by salt alone.”³⁸⁵ Salt by contrast is a “light” substance, similar to the lapis, as we shall see.

[236] From all this we get the following schema:

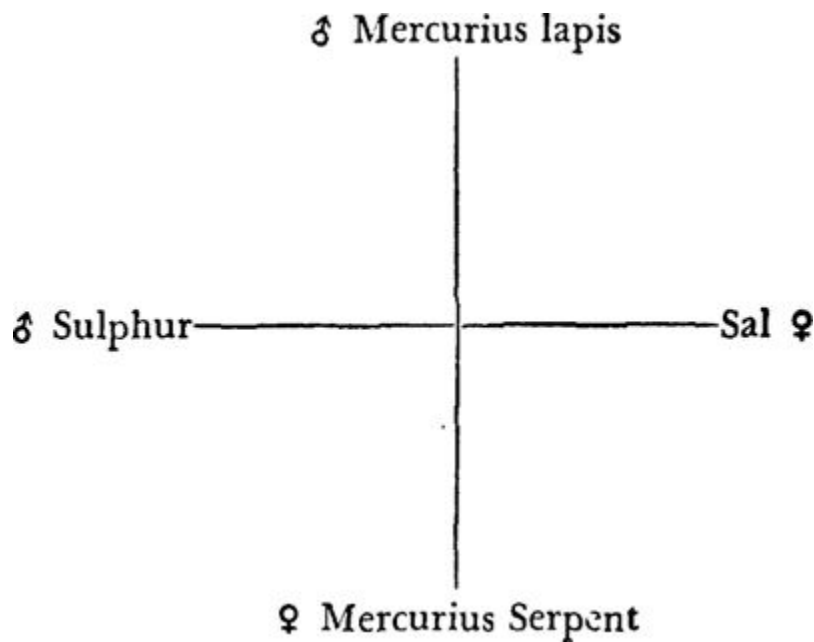

[237] Here we have another of those well-known quaternities of opposites which are usually masked as a triad, just as the Christian Trinity is able to maintain itself as such only by eliminating the fourth protagonist of the divine drama. If he were included there would be, not a Trinity, but a Christian Quaternity. For a long time there had been a psychological need for this, as is evident from the medieval pictures of the Assumption and Coronation of the Virgin; it was also responsible for elevating her to the position of mediatrix, corresponding to Christ's position as the mediator, with the difference that Mary only transmits grace but does not generate it. The recent promulgation of the dogma of the Assumption emphasizes the taking up not only of the soul but of the body of Mary into the Trinity, thus making a dogmatic reality of those medieval representations of the quaternity which are constructed on the following pattern:

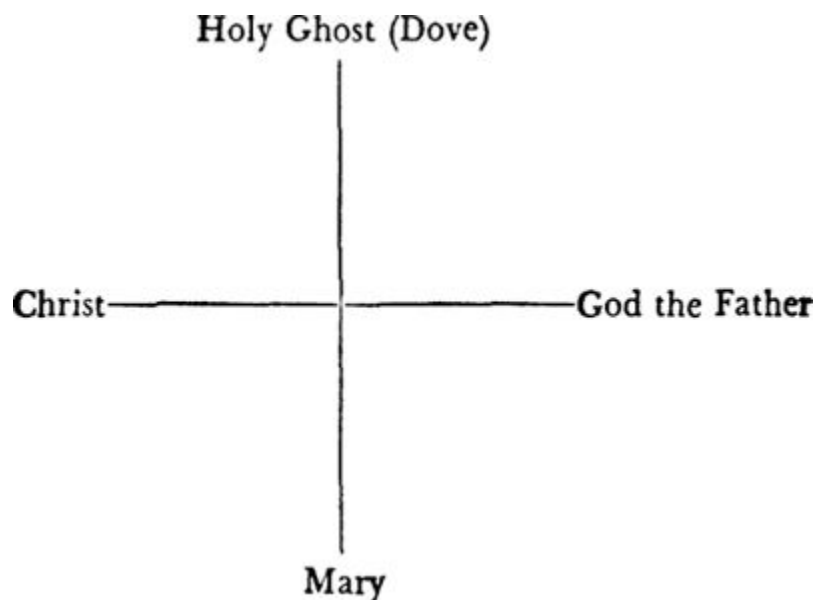

Only in 1950, after the teaching authority in the Church had long deferred it, and almost a century after the declaration of the dogma of the Immaculate Conception, did the Pope, moved by a growing wave of popular petitions,³⁸⁶ feel compelled to

declare the Assumption as a revealed truth. All the evidence shows that the dogmatization was motivated chiefly by the religious need of the Catholic masses. Behind this stands the archetypal numen of feminine deity,³⁸⁷ who, at the Council of Ephesus in 431, imperiously announced her claim to the title of “Theotokos” (God-bearer), as distinct from that of a mere “Anthropotokos” (man-bearer) accorded to her by the Nestorian rationalists.

[238] The taking up of the body had long been emphasized as an historical and material event, and the alchemists could therefore make use of the representations of the Assumption in describing the glorification of matter in the opus. The illustration of this process in Reusner’s *Pandora*³⁸⁸ shows, underneath the coronation scene, a kind of shield between the emblems of Matthew and Luke, on which is depicted the extraction of Mercurius from the prima materia. The extracted spirit appears in monstrous form: the head is surrounded by a halo, and reminds us of the traditional head of Christ, but the arms are snakes and the lower half of the body resembles a stylized fish’s tail.³⁸⁹ This is without doubt the *anima mundi* who has been freed from the shackles of matter, the *filius macrocosmi* or Mercurius-Anthropos, who, because of his double nature, is not only spiritual and physical but unites in himself the morally highest and lowest.³⁹⁰ The illustration in *Pandora* points to the great secret which the alchemists dimly felt was implicit in the Assumption. The proverbial darkness of sublunary matter has always been associated with the “prince of this world,” the devil. He is the metaphysical figure who is excluded from the Trinity but who, as the counterpart of Christ, is the *sine qua non* of the drama of redemption.³⁹¹ His equivalent in alchemy is the dark side of Mercurius duplex and, as we saw, the active sulphur. He also conceals himself in the poisonous dragon, the preliminary, chthonic form of the *lapis aethereus*. To the natural philosophers of the Middle Ages, and to Dorn in particular, it was perfectly clear that the triad must be complemented by a fourth, as the lapis had always been regarded as a quaternity of elements. It did not disturb them that this would necessarily involve the evil spirit. On the contrary, the dismemberment and self-devouring of the dragon probably seemed to them a commendable operation. Dorn, however, saw in the quaternity the absolute opposite of the Trinity, namely the female principle, which seemed to him “of the devil,” for which reason he called the devil the “four-horned serpent.” This insight must have given him a glimpse into the core of the problem.³⁹² In his refutation he identified woman with the devil because of the number two, which is characteristic of both. The devil, he thought, was the binarius itself, since it was created on the second day of Creation, on Monday, the day of the moon, on which God failed to express his pleasure, this being the day of “doubt” and separation.³⁹³ Dorn puts into words what is merely hinted at in the *Pandora* illustration.

[239] If we compare this train of thought with the Christian quaternity which the new dogma has virtually produced (but has not defined as such), it will immediately be apparent that we have here an “upper” quaternio which is supraordinate to man’s wholeness and is psychologically comparable to the Moses quaternio of the Gnostics.³⁹⁴ Man and the dark abyss of the world, the *deus absconditus*, have not yet been taken up into it. Alchemy, however, is the herald of a still-unconscious drive for maximal integration which seems to be reserved for a distant future, even though it originated with Origen’s doubt concerning the ultimate fate of the devil.³⁹⁵

[240] In philosophical alchemy, salt is a cosmic principle. According to its position in the quaternity, it is correlated with the feminine, lunar side and with the upper, light half. It is therefore not surprising that Sal is one of the many designations for the arcane substance. This connotation seems to have developed in the early Middle Ages under Arabic influence. The oldest traces of it can be found in the *Turba*, where salt-water and sea-water are synonyms for the *aqua permanens*,³⁹⁶ and in Senior, who says that Mercurius is made from salt.³⁹⁷ His treatise is one of the earliest authorities in Latin alchemy. Here “Sal Alkali” also plays the role of the arcane substance, and Senior mentions that the *dealbatio* was called “salsatura” (marination).³⁹⁸ In the almost equally old “Allegoriae sapientum” the lapis is described as “salsus” (salty).³⁹⁹ Arnaldus de Villanova (1235?—1313) says: “Whoever possesses the salt that can be melted, and the oil that cannot be burned, may praise God.”⁴⁰⁰ It is clear from this that salt is an arcane substance. The *Rosarium*, which leans very heavily on the old Latin sources, remarks that the “whole secret lies in the prepared common salt,”⁴⁰¹ and that the “root of the art is the soap of the sages” (*sapo sapientum*), which is the “mineral” of all salts and is called the “bitter salt” (*sal amarum*).⁴⁰² Whoever knows the salt knows the secret of the old sages.⁴⁰³ “Salts and alums are the helpers of the stone.”⁴⁰⁴ Isaac Hollandus calls salt the medium between the *terra sulphurea* and the water. “God poured a certain salt into them in order to unite them, and the sages named this salt the salt of the wise.”⁴⁰⁵

[241] Among later writers, salt is even more clearly the arcane substance. For Mylius it is synonymous with the tincture;⁴⁰⁶ it is the earth-dragon who eats his own tail, and the “ash,” the “diadem of thy heart.”⁴⁰⁷ The “salt of the metals” is the lapis.⁴⁰⁸ Basilus Valentinus speaks of a “sal spirituale.”⁴⁰⁹ It is the seat of the virtue which makes the “art” possible,⁴¹⁰ the “most noble treasury,”⁴¹¹ the “good and noble salt,” which “though it has not the form of salt from the beginning, is nevertheless called salt”; it “becomes impure and pure of itself, it dissolves and coagulates itself, or, as the sages say, locks and unlocks itself”;⁴¹² it is the “quintessence, above all things and in all creatures.”⁴¹³ “The whole magistry lies in the salt and its solution.”⁴¹⁴ The “permanent radical moisture” consists of salt.⁴¹⁵ It is synonymous with the “incombustible oil,”⁴¹⁶ and is altogether a mystery to be concealed.⁴¹⁷

[242] As the arcane substance, it is identified with various synonyms for the latter. Above all it is an “ens centrale.” For Khunrath salt is the “physical centre of the earth.”⁴¹⁸ For Vigenerus it is a component of “that virginal and pure earth which is contained in the centre of all composite elementals, or in the depths of the same.”⁴¹⁹ Glauber calls salt the “concentrated centre of the elements.”⁴²⁰

[243] Although the arcane substance is usually identified with Mercurius, the relation of salt to Mercurius is seldom mentioned. Senior, as we noted, says that “by divers operations” Mercurius is made from salt,⁴²¹ and Khunrath identifies Mercurius with common salt.⁴²² The rarity of the identification strikes us just because the “salt of the wise” really implies its relation to Mercurius. I can explain this only on the supposition that salt did not acquire its significance until later times and then at once appeared as an independent figure in the Sulphur-Mercurius-Sal triad.

[244] Salt also has an obvious relation to the earth, not to the earth as such, but to “our earth,” by which is naturally meant the arcane substance.⁴²³ This is evident from the aforementioned identification of salt with the earth-dragon. The full text of Mylius runs:

What remains below in the retort is our salt, that is, our earth, and it is of a black colour, a dragon that eats his own tail. For the dragon is the matter that remains behind after the distillation of water from it, and this water is called the dragon’s tail, and the dragon is its blackness, and the dragon is saturated with his water and coagulated, and so he eats his tail.⁴²⁴

The rarely mentioned relation of salt to the *nigredo*⁴²⁵ is worth noting here, for because of its proverbial whiteness salt is constantly associated with the *albedo*. On the other hand we would expect the close connection between salt and water, which is in fact already implicit in the sea-water. The *aqua pontica* plays an important role as a synonym for the *aqua permanens*, as also does “mare” (sea). That salt, as well as Luna, is an essential component of this is clear from Vigenerus: “There is nothing wherein the moisture lasts longer, or is wetter, than salt, of which the sea for the most part consists. Neither is there anything wherein the moon displays her motion more clearly than the sea, as can be seen . . . from its ebb and flow.” Salt, he says, has an “inexterminable humidity,” and “that is the reason why the sea cannot be dried up.”⁴²⁶ Khunrath identifies the *femina alba* or *candida* with the “crystalline salt,” and this with the white water.⁴²⁷ “Our water” cannot be made without salt,⁴²⁸ and without salt the opus will not succeed.⁴²⁹ According to Rupescissa (ca. 1350), salt is “water, which the dryness of the fire has coagulated.”⁴³⁰

b. The Bitterness

[245] Inseparable from salt and sea is the quality of *amaritudo*, ‘bitterness’. The etymology of Isidore of Seville was accepted all through the Middle Ages: “Mare ab amaro.”⁴³¹ Among the alchemists the bitterness became a kind of technical term. Thus, in the treatise “Rosinus ad Euthicium,”⁴³² there is the following dialogue between Zosimos and Theosebeia: “This is the stone that hath in it glory and colour. And she: Whence cometh its colour? He replied: From its exceeding strong bitterness. And she: Whence cometh its bitterness and intensity? He answered: From the impurity of its metal.” The treatise “Rosinus ad Sarratantam episcopum”⁴³³ says: “Take the stone that is black, white, red, and yellow, and is a wonderful bird that flies without wings in the blackness of the night and the brightness of the day: in the bitterness that is in its throat the colouring will be found.” “Each thing in its first matter is corrupt and bitter,” says Ripley. “The bitterness is a tincturing poison.”⁴³⁴ And Mylius: “Our stone is endowed with the strongest spirit, bitter and brazen (*aeneus*)”;⁴³⁵ and the *Rosarium* mentions that salt is bitter because it comes from the “mineral of the sea.”⁴³⁶ The “Liber Alze”⁴³⁷ says: “O nature of this wondrous thing, which transforms the body into spirit! . . . When it is found alone it conquers all things, and is an excellent, harsh, and bitter acid, which transmutes gold into pure spirit.”⁴³⁸

[246] These quotations clearly allude to the sharp taste of salt and sea-water. The reason why the taste is described as bitter and not simply as salt may lie first of all in the inexactness of the language, since *amarus* also means ‘sharp’, ‘biting’, ‘harsh’, and is used metaphorically for acrimonious speech or a wounding joke. Besides this, the language of the Vulgate had an important influence as it was one of the main sources for medieval Latin. The moral use which the Vulgate consistently makes of *amarus* and *amaritudo* gives them, in alchemy as well, a nuance that cannot be passed over. This comes out clearly in Ripley’s remark that “each thing in its first matter is corrupt and bitter.” The juxtaposition of these two attributes indicates the inner connection between them: corruption and bitterness are on the same footing, they denote the state of imperfect bodies, the initial state of the *prima materia*. Among the best known synonyms for the latter are the “chaos” and the “sea,” in the classical, mythological sense denoting the beginning of the world, the sea in particular being conceived as the *παμμήτηρ*, ‘matrix of all creatures’.⁴³⁹ The *prima materia* is often called *aqua pontica*. The salt that “comes from the mineral of the sea” is by its very nature bitter, but the bitterness is due also to the impurity of the imperfect body. This apparent contradiction is explained by the report of Plutarch that the Egyptians regarded the sea as something impure and untrustworthy (*μηδὲ σύμφυλον αὐτῆς*), and as the domain of Typhon (Set); they called salt the “spume of Typhon.”⁴⁴⁰ In his *Philosophia reformata*, Mylius mentions “sea-spume” together with the “purged or purified” sea, rock-salt, the bird, and Luna as equivalent

synonyms for the *lapis occultus*.⁴⁴¹ Here the impurity of the sea is indirectly indicated by the epithets “purged” or “purified.” The sea-spume is on a par with the salt and—of particular interest—with the bird, naturally the bird of Hermes, and this throws a sudden light on the above passage from Rosinus, about the bird with bitterness in its throat. The bird is a parallel of salt because salt is a spirit,⁴⁴² a volatile substance, which the alchemists were wont to conceive as a bird.

[247] As the expulsion of the spirit was effected by various kinds of burning (*combustio, adustio, calcinatio, assatio, sublimatio, incineratio*, etc.), it was natural to call the end-product “ash”—again in a double sense as *scoria, faex*, etc., and as the spirit or bird of Hermes. Thus the *Rosarium* says: “Sublime with fire, until the spirit which thou wilt find in it [the substance] goeth forth from it, and it is named the bird or the ash of Hermes. Therefore saith Morienus: Despise not the ashes, for they are the diadem of thy heart, and the ash of things that endure.”⁴⁴³ In other words, the ash is the spirit that dwells in the glorified body.

[248] This bird or spirit is associated with various colours. At first the bird is black, then it grows white feathers, which finally become coloured.⁴⁴⁴ The Chinese cousin of the *avis Hermetis*, the “scarlet bird,” moults in a similar way.⁴⁴⁵ We are told in the treatise of Wei Po-yang: “The fluttering Chu-niao flies the five colours.”⁴⁴⁶ They are arranged as follows:

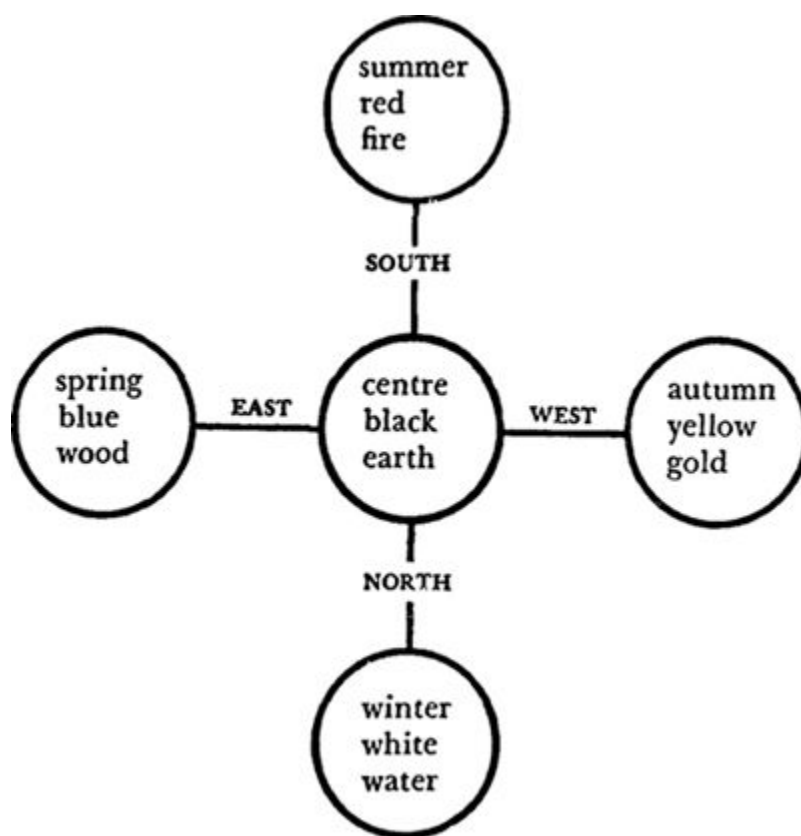

[249] Earth occupies the central position as the fifth element, though it is not the quintessence and goal of the work but rather its basis, corresponding to terra as the arcane substance in Western alchemy.⁴⁴⁷

[250] As regards the origin and meaning of the *avis Hermetis*, I would like to mention the report of Aelian that the ibis is “dear to Hermes, the father of words, since in its form it resembles the nature of the Logos; for its blackness and swift flight could be compared to the silent and introverted [ἐνδον ἐπιστρεφόμενῳ] Logos, but its whiteness to the Logos already uttered and heard, which is the servant and messenger of the inner word.”⁴⁴⁸

[251] It is not easy for a modern mind to conceive salt, a cold-damp, lunar-terrestrial substance, as a bird and a spirit. Spirit, as the Chinese conceive it, is yang, the fiery and dry element, and this accords with the views of Heraclitus as well as with the Christian concept of the Holy Ghost as tongues of fire. Luna, we have seen, is unquestionably connected with *mens*, *manas*, mind, etc. But these connections are of a somewhat ambiguous nature. Although the earth can boast of an earth-spirit and other daemons, they are after all “spirits” and not “spirit.” The “cold” side of nature is not lacking in spirit, but it is a spirit of a special kind, which Christianity regarded as demonic and which therefore found no acclaim except in the realm of the magical arts and sciences. This spirit is the snake-like *Nous* or *Agathodaimon*, which in Hellenistic syncretism merges together with *Hermes*. Christian allegory and iconography also took possession of it on the basis of John 3 : 14: “And as Moses lifted up the serpent in the wilderness, even so must the Son of man be lifted up.” The mercurial serpent or “spirit *Mercurius*” is the personification and living continuation of the spirit who, in the prayer entitled the “Secret Inscription” in the Great Magic Papyrus of Paris, is invoked as follows:

Greetings, entire edifice of the Spirit of the air, greetings, Spirit that penetratest from heaven to earth, and from earth, which abideth in the midst of the universe, to the uttermost bounds of the abyss, greetings, Spirit that penetratest into me, and shakest me. . . . Greetings, beginning and end of irremovable Nature, greetings, thou who revolvest the elements that untiringly render service, greetings, brightly shining sun, whose radiance ministereth to the world, greetings, moon shining by night with disc of fickle brilliance, greetings, all ye spirits of the demons of the air. . . . O great, greatest, incomprehensible fabric of the world, formed in a circle! . . . dwelling in the aether, having the form of water, of earth, of fire, of wind, of light, of darkness, star-glittering, damp-fiery-cold Spirit! [ὕγροπυρινοψυχρὸν πνεῦμα].⁴⁴⁹

[252] Here is a magnificent description of a spirit that is apparently the exact opposite of the Christian *pneuma*. This antique spirit is also the spirit of alchemy, which today we can interpret as the unconscious projected into heavenly space and external objects. Although declared to be the devil by the early Christians, it should not be identified outright with evil; it merely has the uncomfortable quality of being beyond good and evil, and it gives this perilous quality to anyone who identifies with it, as

we can see from the eloquent case of Nietzsche and the psychic epidemic that came after him. This spirit that is “beyond good and evil” is not the same as being “six thousand feet above good and evil,” but rather the same distance below it, or better, before it. It is the spirit of the chaotic waters of the beginning, before the second day of Creation, before the separation of the opposites and hence before the advent of consciousness. That is why it leads those whom it overcomes neither upwards nor beyond, but back into chaos. This spirit corresponds to that part of the psyche which has not been assimilated to consciousness and whose transformation and integration are the outcome of a long and wearisome opus. The artifex was, in his way, conscious enough of the dangers of the work, and for this reason his operations consisted largely of precautions whose equivalents are the rites of the Church.

[253] The alchemists understood the return to chaos as an essential part of the opus. It was the stage of the *nigredo* and *mortificatio*, which was then followed by the “purgatorial fire” and the *albedo*. The spirit of chaos is indispensable to the work, and it cannot be distinguished from the “gift of the Holy Ghost” any more than the Satan of the Old Testament can be distinguished from Yahweh. The unconscious is both good and evil and yet neither, the matrix of all potentialities.

[254] After these remarks—which seemed to me necessary—on the “salt-spirit,” as Khunrath calls it, let us turn back to the *amaritudo*. As the bitter salt comes from the impure sea, it is understandable that the “Gloria mundi” should call it “mostly black and evil-smelling in the beginning.”⁴⁵⁰ The blackness and bad smell, described by the alchemists as the “stench of the graves,” pertain to the underworld and to the sphere of moral darkness. This impure quality is common also to the *corruptio*, which, as we saw, Ripley equates with bitterness. Vigenerus describes salt as “corruptible,” in the sense that the body is subject to corruption and decay and does not have the fiery and incorruptible nature of the spirit.⁴⁵¹

[255] The moral use of qualities that were originally physical is clearly dependent, particularly in the case of a cleric like Ripley, on ecclesiastical language. About this I can be brief, as I can rely on Rahner’s valuable “Antenna Crucis II: Das Meer der Welt.” Here Rahner brings together all the patristic allegories that are needed to understand the alchemical symbolism. The patristic use of “mare” is defined by St. Augustine: “Mare saeculum est” (the sea is the world).⁴⁵² It is the “essence of the world, as the element . . . subject to the devil.” St. Hilary says: “By the depths of the sea is meant the seat of hell.”⁴⁵³ The sea is the “gloomy abyss,” the remains of the original pit,⁴⁵⁴ and hence of the chaos that covered the earth. For St. Augustine this abyss is the realm of power allotted to the devil and demons after their fall.⁴⁵⁵ It is on the one hand a “deep that cannot be reached or comprehended”⁴⁵⁶ and on the other the “depths of sin.”⁴⁵⁷ For Gregory the Great the sea is the “depths of eternal death.”⁴⁵⁸

Since ancient times it was the “abode of water-demons.”⁴⁵⁹ There dwells Leviathan (Job 3 : 8),⁴⁶⁰ who in the language of the Fathers signifies the devil. Rahner documents the patristic equations: *diabolus* = *draco* = Leviathan = *cetus magnus* = *aspis* (adder, asp) = *draco*.⁴⁶¹ St. Jerome says: “The devil surrounds the seas and the ocean on all sides.”⁴⁶² The bitterness of salt-water is relevant in this connection, as it is one of the peculiarities of hell and damnation which must be fully tasted by the meditant in Loyola’s *Exercises*. Point 4 of Exercise V says he must, in imagination, “taste with the taste bitter things, as tears, sadness, and the worm of conscience.”⁴⁶³ This is expressed even more colourfully in the Spiritual Exercises of the Jesuit Sebastian Izquierdo (1686): “Fourthly, the taste will be tormented with a rabid hunger and thirst, with no hope of alleviation; and its food will be bitter wormwood, and its drink water of gall.”⁴⁶⁴

c. The Red Sea

[256] It might almost be one of the alchemical paradoxes that the Red Sea, in contrast to the significance ordinarily attached to “mare,” is a term for the healing and transforming baptismal water,⁴⁶⁵ and is thus an equivalent of the alchemical *aqua pontica*. St. Augustine says, “The Red Sea signifies baptism”;⁴⁶⁶ and, according to Honorius of Autun, “the Red Sea is the baptism reddened by the blood of Christ, in which our enemies, namely our sins, are drowned.”⁴⁶⁷

[257] We must also mention the Peratic interpretation of the Red Sea. The Red Sea drowned the Egyptians, but the Egyptians were all “non-knowers” (οἱ ἀγνοοῦντες). The exodus from Egypt signifies the exodus from the body, which is Egypt in miniature, being the incarnation of sinfulness, and the crossing (περᾶσαι)⁴⁶⁸ of the Red Sea is the crossing of the water of corruption, which is Kronos. The other side of the Red Sea is the other side of Creation. The arrival in the desert is a “genesis outside of generation” (ἐξω γενέσεως γενέσθαι). There the “gods of destruction” and the “god of salvation” are all together.⁴⁶⁹ The Red Sea is a water of death for those that are “unconscious,” but for those that are “conscious” it is a baptismal water of rebirth and transcendence.⁴⁷⁰ By “unconscious” are meant those who have no gnosis, i.e., are not enlightened as to the nature and destiny of man in the cosmos. In modern language it would be those who have no knowledge of the contents of the personal and collective unconscious. The personal unconscious is the shadow and the inferior function,⁴⁷¹ in Gnostic terms the sinfulness and impurity that must be washed away by baptism. The collective unconscious expresses itself in the mythological teachings, characteristic of most mystery religions, which reveal the secret knowledge concerning the origin of all things and the way to salvation. “Unconscious” people who attempt to cross the sea without being purified and without the guidance of enlightenment are drowned; they get stuck in the

unconscious and suffer a spiritual death in so far as they cannot get beyond their one-sidedness. To do this they would have to be more conscious of what is unconscious to them and their age, above all of the inner opposite, namely those contents to which the prevailing views are in any way opposed. This continual process of getting to know the counterposition in the unconscious I have called the “transcendent function,”⁴⁷² because the confrontation of conscious (rational) data with those that are unconscious (irrational) necessarily results in a modification of standpoint. But an alteration is possible only if the existence of the “other” is admitted, at least to the point of taking conscious cognizance of it. A Christian of today, for instance, no longer ought to cling obstinately to a one-sided credo, but should face the fact that Christianity has been in a state of schism for four hundred years, with the result that every single Christian has a split in his psyche. Naturally this lesion cannot be treated or healed if everyone insists on his own standpoint. Behind those barriers he can rejoice in his absolute and consistent convictions and deem himself above the conflict, but outside them he keeps the conflict alive by his intransigence and continues to deplore the pig-headedness and stiff-neckedness of everybody else. It seems as if Christianity had been from the outset the religion of chronic squabblers, and even now it does everything in its power never to let the squabbles rest. Remarkably enough, it never stops preaching the gospel of neighbourly love.

[258] We should get along a lot better if we realized that the majority views of “others” are condoned by a minority in ourselves. Armed with this psychological insight, which today no longer has the character of revelation since common sense can grasp it, we could set out on the road to the union of the opposites and would then, as in the Peratic doctrine, come to the place where the “gods of destruction and the god of salvation are together.” By this is obviously meant the destructive and constructive powers of the unconscious. This *coincidentia oppositorum* forms a parallel to the Messianic state of fulfilment described in Isaiah 11 : 6ff. and 35 : 5ff., though with one important difference: the place of “genesis outside of generation”—presumably an *opus contra naturam*— is clearly not paradise but ἡ ἔρημος the desert and the wilderness. Everyone who becomes conscious of even a fraction of his unconscious gets outside his own time and social stratum into a kind of solitude, as our text remarks. But only there is it possible to meet the “god of salvation.” Light is manifest in the darkness, and out of danger the rescue comes. In his sermon on Luke 19: 12 Meister Eckhart says: “And who can be nobler than the man who is born half of the highest and best the world has to offer, and half of the innermost ground of God’s nature and God’s loneliness? Therefore the Lord speaks in the prophet Hosea: I will lead the noble souls into the wilderness, and speak into their hearts. One with the One, One from the One, and in the One itself the One, eternally!”⁴⁷³

[259] I have gone into this Hippolytus text at some length because the Red Sea was of special significance to the alchemists. Sermo LXII of the *Turba* mentions the “Tyrian dye, which is extracted from our most pure Red Sea.” It is the parallel of the *tinctura philosophorum*, which is described as black and is extracted “from the sea.”⁴⁷⁴ The old treatise “Rosinus ad Euthiciam” says: “And know that our Red Sea is more tincturing than all seas, and that the poison,⁴⁷⁵ when it is cooked and becomes foul and discoloured, penetrates all bodies.”⁴⁷⁶ The tincture is the “dip” and the baptismal water of the alchemists, here asserted to come from the Red Sea. This idea is understandable in view of the patristic and Gnostic interpretation of the Red Sea as the blood of Christ in which we are baptized; hence the paralleling of the tincture, salt, and *aqua pontica* with blood.⁴⁷⁷

[260] The Red Sea appears in a very peculiar manner in the “Tractatus Aristotelis ad Alexandrum Magnum,” where a recipe says:

Take the serpent, and place it in the chariot with four wheels, and let it be turned about on the earth until it is immersed in the depths of the sea, and nothing more is visible but the blackest dead sea. And there let the chariot with the wheels remain, until so many fumes rise up from the serpent that the whole surface [*planities*] becomes dry, and by desiccation sandy and black. All that is the earth which is no earth, but a stone lacking all weight. . . . [And when the fumes are precipitated in the form of rain,] you should bring the chariot from the water to dry land, and then you have placed the four wheels upon the chariot, and will obtain the result if you will advance further to the Red Sea, running without running, moving without motion [*currens sine cursu, movens sine motu*].⁴⁷⁸

[261] This curious text requires a little elucidation. The serpent is the *prima materia*, the *Serpens Hermetis*, “which he [Hermes] sent to King Antiochus, that he might do battle with thee [Alexander] and thine army.”⁴⁷⁹ The serpent is placed “in the chariot of its vessel and is led hither and thither by the fourfold rotation of the natures, but it should be securely enclosed.” The wheels are the “wheels of the elements.” The vessel or vehicle is the “spherical tomb” of the serpent.⁴⁸⁰ The fourfold rotation of the natures corresponds to the ancient tetrameria of the opus (its division into four parts), i.e., transformation through the four elements, from earth to fire. This symbolism describes in abbreviated form the essentials of the opus: the serpent of Hermes or the *Agathodaimon*, the *Nous* that animates the cold part of nature—that is, the unconscious—is enclosed in the spherical vessel of diaphanous glass which, on the alchemical view, represents the world and the soul.⁴⁸¹ The psychologist would see it rather as the psychic reflection of the world, namely, *consciousness* of the world and the psyche.⁴⁸² The transformation corresponds to the psychic process of assimilation and integration by means of the transcendent function.⁴⁸³ This function unites the

pairs of opposites, which, as alchemy shows, are arranged in a quaternio when they represent a totality. The totality appears in quaternary form only when it is not just an unconscious fact but a conscious and differentiated totality; for instance, when the horizon is thought of not simply as a circle that can be divided into any number of parts but as consisting of four clearly defined points. Accordingly, one's given personality could be represented by a continuous circle, whereas the conscious personality would be a circle divided up in a definite way, and this generally turns out to be a quaternity. The quaternity of basic functions of consciousness meets this requirement. It is therefore only to be expected that the chariot should have four wheels,⁴⁸⁴ to correspond with the four elements or natures. The chariot as a spherical vessel and as consciousness rests on the four elements or basic functions,⁴⁸⁵ just as the floating island where Apollo was born, Delos, rested on the four supports which Poseidon made for it. The wheels, naturally, are on the outside of the chariot and are its motor organs, just as the functions of consciousness facilitate the relation of the psyche to its environment. It must, however, be stressed that what we today call the schema of functions is archetypally prefigured by one of the oldest patterns of order known to man, namely the quaternity, which always represents a consciously reflected and differentiated totality. Quite apart from its almost universal incidence it also appears spontaneously in dreams as an expression of the total personality. The "chariot of Aristotle" can be understood in this sense as a symbol of the self.

[262] The recipe goes on to say that this symbolic vehicle should be immersed in the sea of the unconscious for the purpose of heating and incubation,⁴⁸⁶ corresponding to the state of *tapas*,⁴⁸⁷ incubation by means of "self-heating." By this is obviously meant a state of introversion in which the unconscious content is brooded over and digested. During this operation all relations with the outside world are broken off; the feelers of perception and intuition, discrimination and valuation are withdrawn. The four wheels are "placed upon the chariot": outside everything is quiet and still, but deep inside the psyche the wheels go on turning, performing those cyclic evolutions which bring the mandala of the total personality,⁴⁸⁸ the ground-plan of the self, closer to consciousness. But so long as consciousness has not completed the process of integration it is covered by the "blackest dead sea," darkened by unconsciousness and oppressed by heat, as was the hero in the belly of the whale during the night sea journey.⁴⁸⁹ Through the incubation the snake-like content is vapourized, literally "sublimated," which amounts to saying that it is recognized and made an object of conscious discrimination.

[263] The "evaporatio" is followed by the "desiccation of the surface," which then appears "sandy and black." Here the imagery changes: the allusion to the subsiding flood means psychologically that the black blanket of unconsciousness hiding the nascent symbol is drawn away. "Arena" (sand) is defined as the "pure substance of

the stone,”⁴⁹⁰ and accordingly the text describes the regenerated earth as a “stone lacking all weight.” The text does not explain just why it is weightless, but it is evident that nothing material, which alone has weight, is left over, and all that remains is the psychic content of the projection.

[264] The opus is far from having come to an end at this point, for the *nigredo* (*terra nigra*) still prevails and the substance of the stone is still black. It is therefore necessary for the “fumes” (*evaporationes*) to precipitate and wash off the blackness, “whence the whole earth becomes white.” The rain now falls so copiously that the earth is almost turned into a sea. Hence the direction that the chariot should be brought to dry land. This is clearly another allusion to Noah’s Ark and the flood.⁴⁹¹ With the coming of the flood the previous state of chaos would be restored, and the result of the opus would again be swamped by unconsciousness. This motif recurs in the form of the dragon that pursued Leto and the woman crowned with stars (Rev. 12 : 1f.).

[265] If the chariot reaches dry land, this obviously means that the content has become visible and remains conscious, “and then,” says the text, “you have placed the wheels upon the chariot.”⁴⁹² The four natures or elements are gathered together and are contained in the spherical vessel, i.e., the four aspects or functions are integrated with consciousness, so that the state of totality has almost been attained. Had it really been attained the opus would be consummated at this point, but the “result” (*effectus*) is obtained only by advancing further. The “result” therefore means something more than integration of the four natures. If we take the loading of the chariot as the conscious realization of the four functions, this does in fact denote only the possibility of remaining conscious of the whole previous material, that is, of the principal aspects of the psyche. The question then arises as to how all these divergent factors, previously kept apart by apparently insuperable incompatibilities, will behave, and what the ego is going to do about it.

[266] The singular image of the Nous-serpent enthroned on a chariot reminds us of the chariot-driving, snake-shaped gods of southern India, for instance on the immense black temple at Puri, which is itself a chariot of stone. I certainly don’t want to suggest that there is any direct Indian influence in our text, for there is another model closer to hand, and that is Ezekiel’s vision of the four creatures, with the faces respectively of a man, a lion, an ox, and an eagle. These four figures are associated with four wheels, “their construction being as it were a wheel within a wheel. When they went, they went in any of their four directions without turning as they went.”⁴⁹³ Together they formed the moving throne of a figure having “the appearance of a man.” In the Cabala this chariot (Merkabah) plays an important role as the vehicle on which the believers mount up to God and the human soul unites with the world-soul.

[267] An interpretation of the four wheels as the *quadriga* and vehicle of divinity is found in a window medallion by Suger, the twelfth-century maker of stained glass for the Abbey of Saint-Denis.⁴⁹⁴ The chariot which is depicted bears the inscription “QUADRIGE AMINADAB,” referring to the Song of Songs 6: 11 (DV): “My soul troubled me for the chariots of Aminadab.”⁴⁹⁵ God the Father stands on a four-wheeled chariot holding the crucifix before him. In the corners of the medallion are the four emblems of the evangelists, the Christian continuation of Ezekiel’s winged creatures. The four gospels form, as it were, a quaternary podium on which the Redeemer stands.

[268] Still another source might be Honorius of Autun. In his commentary on Song of Songs 6 : 11, he says that his “animalis vita” was troubled because the chariot signified the four evangelists. It was this chariot that the apostles and their followers had driven through the world. For Christ had said in the gospels: “Except ye repent, ye shall all likewise perish” (Luke 13: 3). And it was to him, Honorius, that the words were addressed: “Return, return, O Shulamite” (Song of Songs 6 : 13).⁴⁹⁶

[269] Psychologically the vision of Ezekiel is a symbol of the self consisting of four individual creatures and wheels, i.e., of different functions. Three of the faces are theriomorphic and only one anthropomorphic, which presumably means that only one function has reached the human level, whereas the others are still in an unconscious or animal state. The problem of three and four (trinity and quaternity) plays a great role in alchemy as the “axiom of Maria”⁴⁹⁷ and, like the vision of Ezekiel, is concerned with the God-image. The symbols of the self are as a rule symbols of totality, but this is only occasionally true of God-images. In the former the circle and the quaternity predominate, in the latter the circle and the trinity—and this, moreover, only in the case of abstract representations, which are not the only ones to occur.

[270] These hints may throw a little light on the strange idea of the serpent-chariot. It is a symbol of the arcane substance and the quintessence, of the aether that contains all four elements, and at the same time a God-image or, to be more accurate, an image of the *anima mundi*. This is indicated by the Mercurial serpent, which in its turn was interpreted by the alchemists as the “spirit of life that was in the wheels” (DV).⁴⁹⁸ We should also mention that according to Ezekiel 1 : 18 the inter-revolving wheels “were full of eyes round about.” The old illustrators therefore produced something like an astrolabe in their attempts to depict the vision. The notion of wheels is naturally connected with movement in all directions, for the “eyes of the Lord run to and fro through the whole earth” (Zech. 4 : 10). It is said of the horses, too, that they “walk to and fro through the earth” (Zech. 6 : 7). Eyes are round and in common speech are likened to “cart-wheels.” They also seem to be a typical symbol for what I have called the “multiple luminosities of the unconscious.” By this I mean the seeming

possibility that complexes possess a kind of consciousness, a luminosity of their own, which, I conjecture, expresses itself in the symbol of the soul-spark, multiple eyes (*polyophtalmia*), and the starry heaven.⁴⁹⁹

[271] By reason of its “solar” nature the eye is a symbol of consciousness, and accordingly multiple eyes would indicate a multiplicity of conscious centres which are co-ordinated into a unity like the many-faceted eye of an insect. As Ezekiel’s vision can be interpreted psychologically as a symbol of the self, we may also mention in this connection the Hindu definition of the self—here *hiranyagarbha*—as the “collective aggregate of all individual souls.”⁵⁰⁰

[272] Ezekiel’s vision is of psychological importance because the quaternity embodied in it is the vehicle or throne of him who had the “appearance of a man.” Together with the “spirit of life” in the wheels it represents the empirical self, the totality of the four functions. These four are only partly conscious. The auxiliary functions are partly, and the “inferior” or subliminal function is wholly, autonomous; they cannot be put to conscious use and they reach consciousness only indirectly as a *fait accompli*, through their sometimes disturbing effects. Their specific energy adds itself to the normal energy of the unconscious and thereby gives it an impulse that enables it to irrupt spontaneously into consciousness. As we know, these invasions can be observed systematically in the association experiment.⁵⁰¹

[273] The quaternity of the self appears in Ezekiel’s vision as the true psychological foundation of the God-concept. God uses it as his vehicle. It is possible for the psychologist to verify the structure of this foundation, but beyond that the theologian has the last word. In order to clear up any misunderstandings, especially from the theological side, I would like to emphasize yet again that it is not the business of science to draw conclusions which go beyond the bounds of our empirical knowledge. I do not feel the slightest need to put the self in place of God, as short-sighted critics have often accused me of doing. If Indian philosophers equate the atman with the concept of God and many Westerners copy them, this is simply their subjective opinion and not science. A *consensus generalis* on this point would in itself be yet another fact which, for the empirical psychologist, is as well worth considering as the remarkable view of many theologians that religious statements have nothing to do with the psyche. Similarly, it is characteristic of the mystical philosophy of the alchemists that the Mercurial serpent is enthroned on the chariot. He is a living spirit who uses as his chariot the body that consists of the four elements. In this sense the chariot is the symbol of earthly life. A Georgian fairytale closes with the verses:

I have dragged a cart up the mountain,

It has become like a mountain.

[274] As I have said, the process of transformation does not come to an end with the production of the quaternity symbol. The continuation of the opus leads to the dangerous crossing of the Red Sea, signifying death and rebirth. It is very remarkable that our author, by his paradox “running without running, moving without motion,” introduces a coincidence of opposites just at this point, and that the Hippolytus text speaks, equally paradoxically, of the “gods of destruction and the god of salvation” being together. The quaternity, as we have seen, is a quaternio of opposites, a synthesis of the four originally divergent functions. Their synthesis is here achieved in an image, but in psychic reality becoming conscious of the whole psyche⁵⁰³ faces us with a highly problematical situation. We can indicate its scope in a single question: What am I to do with the unconscious?

[275] For this, unfortunately, there are no recipes or general rules. I have tried to present the main outlines of what the psychotherapist can observe of this wearisome and all too familiar process in my study “The Relations between the Ego and the Unconscious.” For the layman these experiences are a *terra incognita* which is not made any more accessible by broad generalizations. Even the imagination of the alchemists, otherwise so fertile, fails us completely here. Only a thorough investigation of the texts could shed a little light on this question. The same task challenges our endeavours in the field of psychotherapy. Here too are thousands of images, symbols, dreams, fantasies, and visions that still await comparative research. The only thing that can be said with some certainty at present is that there is a gradual process of approximation whereby the two positions, the conscious and the unconscious, are both modified. Differences in individual cases, however, are just as great as they were among the alchemists.

d. The Fourth of the Three

[276] In the course of his mystic peregrination⁵⁰⁴ Maier reached the Red (“Erythraean”) Sea, and in the following way: he journeyed to the four directions, to the north (Europe), to the west (America), to the east (Asia).⁵⁰⁵ Leaving Asia and turning south to Africa, he found a statue of Mercury, made of silver, and with a golden head. The statue pointed to Paradise, which he espied far off. Now because of its four rivers, and because it was the abode of the originally androgynous Primordial Man (Adam), the Garden of Eden was a favourite mandala in Christian iconography, and is therefore a symbol of totality and—from the psychological point of view—of the self. If we take the four directions and the four elements (see note 505) as a symbolical equivalent of the four basic functions of consciousness, we can say that

Maier had become conscious of three of them by the time he reached Asia. This brings him to the fourth and last, the “inferior” function, which is the darkest and the most unconscious of all. “Africa” is not a bad image for this. But just as Maier was about to direct his steps thither, he had a vision of paradise as the primordial image of wholeness, which showed him that the goal of his journey lay in the attainment of this wholeness. By the time he reached Africa, he says, the sun was in its house, Leo, and the moon was in Cancer, “the moon having Cancer for the roof of its house”. The proximity of the two houses indicates a *coniunctio Solis et Lunae*, the union of supreme opposites, and this is the crowning of the opus and the goal of the peregrination. He adds: “And this gave me great hope of the best augury.”

[277] The fourth function has its seat in the unconscious. In mythology the unconscious is portrayed as a great animal, for instance Leviathan, or as a whale, wolf, or dragon. We know from the myth of the sun-hero that it is so hot in the belly of the whale that his hair falls out.⁵⁰⁶ Arisleus and his companions likewise suffer from the great heat of their prison under the sea.⁵⁰⁷ The alchemists were fond of comparing their fire to the “fire of hell” or the flames of purgatory. Maier gives a description of Africa which is very like a description of hell: “uncultivated, torrid, parched,⁵⁰⁸ sterile and empty.”⁵⁰⁹ He says there are so few springs that animals of the most varied species assemble at the drinking-places and mingle with one another, “whence new births and animals of a novel appearance are born,” which explained the saying “Always something new out of Africa.” Pans dwelt there, and satyrs, dog-headed baboons, and half-men, “besides innumerable species of wild animals.” According to certain modern views, this could hardly be bettered as a description of the unconscious. Maier further reports that in the region of the Red Sea an animal is found with the name of “Ortus” (rising, origin). It had a red head with streaks of gold reaching to its neck, black eyes, a white face, white forepaws, and black hindpaws. He derived the idea of this animal from the remark of Avicenna: “That thing whose head is red, its eyes black and its feet white, is the magistry.”⁵¹⁰ He was convinced that the legend of this creature referred to the phoenix, which was likewise found in that region. While he was making inquiries about the phoenix he “heard a rumour” that not far off a prophetess, known as the Erythraean Sibyl, dwelt in a cave. This was the sibyl who was alleged to have foretold the coming of Christ. Maier is probably referring here not to the eighth book of the Sibylline Oracles, verse 217, at which point thirty-four verses begin with the following letters: IHΣΟΥΣ ΧΡΕΙΣΤΟΣ ΘΕΟΥ ΥΙΟΣ ΣΩΤΗΡ ΣΤΑΥΡΟΣ,⁵¹¹ but to the report of St. Augustine in *Decivitate dei*,⁵¹² which was well known in the Middle Ages. He also cites the passage about the sibyl in the *Constantini Oratio* of Eusebius and emphasizes that the sibylline prophecy referred to the “coming of Christ in the flesh.”^{512a}

[278] We have seen earlier that the “Erythraean Sea” is a mysterious place, but here we meet with some noteworthy details. To begin with, our author reaches this sea just when he has completed the journey through the three continents and is about to enter the critical fourth region. We know from the Axiom of Maria and from *Faust* the crucial importance of that seemingly innocent question at the beginning of the *Timaeus*:

SOCRATES: One, two, three—but where, my dear Timaeus, is the fourth of those guests of yesterday who were to entertain me today?

TIMAEUS: He suddenly felt unwell, Socrates; he would not have failed to join our company if he could have helped it.⁵¹³

[279] The transition from three to four is a problem⁵¹⁴ on which the ambiguous formulation of Maria does not shed very much light.⁵¹⁵ We come across the dilemma of three and four in any number of guises, and in Maier’s *Symbola aureae mensae* as well the step from three to four proves to be an important development presaged by the vision of paradise. The region of the Red Sea is proverbially hot, and Maier reached it at the end of July, “in the intense heat of summer.” He was, in fact, “getting hot,” uncommonly hot, as hot as hell, for he was approaching that region of the psyche which was not unjustly said to be inhabited by “Pans, Satyrs, dog-headed baboons, and half-men.” It is not difficult to see that this region is the animal soul in man. For just as a man has a body which is no different in principle from that of an animal, so also his psychology has a whole series of lower storeys in which the spectres from humanity’s past epochs still dwell, then the animal souls from the age of Pithecanthropus and the hominids, then the “psyche” of the cold-blooded saurians, and, deepest down of all, the transcendental mystery and paradox of the sympathetic and parasymphathetic psychoid processes.

[280] So it is not surprising that our world-voyager felt that he had landed in the hottest place—he was in Arabia Felix—in the sweltering heat of summer! He was painfully aware that he was risking his skin: “It’s your concern when your neighbour’s wall is on fire.”⁵¹⁶ He was the banquet-giver and the guest, the eater and the eaten in one person.

[281] “The innumerable species of animals” begin to show up already by the Red Sea, headed by the fabulous four-footed “Ortus,” which combines in itself the four alchemical colours, black, white, red, and yellow⁵¹⁷ (the gold streaks on head and neck). Maier does not hesitate to identify the Ortus with the phoenix, the other legendary inhabitant of Arabia Felix,⁵¹⁸ less perhaps on account of its appearance than on account of its name; for the phoenix, too, after consuming itself in the land of Egypt, each time rose renewed, like the reborn sun in Heliopolis.

[282] The Ortus is the alchemical “animal” which represents the living quaternity in its first synthesis. In order to become the ever-living bird of the spirit it needs the transforming fire, which is found in “Africa,” that is, in the encounter with and investigation of the fourth function and the animal soul represented by the Ortus. By interpreting it as the phoenix, Maier gave it a far-reaching change of meaning, as we shall see. For besides his animal soul he also discovered in its vicinity a kind of feminine soul, a virgin, to whom he at first appeared like an importunate guest.⁵¹⁹ This was the sibyl who foretold the coming of Christ. Thus, by the Red Sea, he met the animal soul in the form of a monstrous quaternity, symbolizing, so to speak, the prima materia of the self and, as the phoenix, rebirth. The mystery alluded to here is not only the encounter with the animal soul but, at the same time and in the same place, the meeting with the anima, a feminine psychopomp who showed him the way to Mercurius and also how to find the phoenix.⁵²⁰

[283] It is worth noting that the animal is the symbolic carrier of the self. This hint in Maier is borne out by modern individuals who have no notion of alchemy.⁵²¹ It expresses the fact that the structure of wholeness was always present but was buried in profound unconsciousness, where it can always be found again if one is willing to risk one’s skin to attain the greatest possible range of consciousness through the greatest possible self-knowledge—a “harsh and bitter drink” usually reserved for hell. The throne of God seems to be no unworthy reward for such trials. For self-knowledge—in the total meaning of the word—is not a one-sided intellectual pastime but a journey through the four continents, where one is exposed to all the dangers of land, sea, air, and fire. Any total act of recognition worthy of the name embraces the four—or 360!—aspects of existence. Nothing may be “disregarded.” When Ignatius Loyola recommended “imagination through the five senses”⁵²² to the meditant, and told him to imitate Christ “by use of his senses,”⁵²³ what he had in mind was the fullest possible “realization” of the object of contemplation. Quite apart from the moral or other effects of this kind of meditation, its chief effect is the training of consciousness, of the capacity for concentration, and of attention and clarity of thought. The corresponding forms of Yoga have similar effects. But in contrast to these traditional modes of realization, where the meditant projects himself into some prescribed form, the self-knowledge alluded to by Maier is a projection into the empirical self as it actually is. It is not the “self” we like to imagine ourselves to be after carefully removing all the blemishes, but the empirical ego just as it is, with everything that it does and everything that happens to it. Everybody would like to be quit of this odious adjunct, which is precisely why in the East the ego is explained as illusion and why in the West it is offered up in sacrifice to the Christ figure.

[284] By contrast, the aim of the mystical peregrination is to understand all parts of the world, to achieve the greatest possible extension of consciousness, as though its

guiding principle were the Carpocratic⁵²⁴ idea that one is delivered from no sin which one has not committed. Not a turning away from its empirical “so-ness,” but the fullest possible experience of the ego as reflected in the “ten thousand things”—that is the goal of the peregrination.⁵²⁵ This follows logically from the psychological recognition that God cannot be experienced at all unless this futile and ridiculous ego offers a modest vessel in which to catch the effluence of the Most High and name it with his name. The significance of the vas-symbol in alchemy shows how concerned the artifex was to have the right vessel for the right content: “One is the lapis, one the medicament, one the vessel, one the procedure, and one the disposition.” The *aqua nostra*, the transformative substance, is even its own vessel.⁵²⁶ From this it is but a step to the paradoxical statement of Angelus Silesius:

God is my centre when I close him in,
And my circumference when I melt in him.⁵²⁷

[285] Maier’s Erythraean quadruped, the Ortus, corresponds to the four-wheeled chariot of Pseudo-Aristotle. The tetramorph, too, is a product of early medieval iconography,⁵²⁸ combining the four winged creatures of Ezekiel’s vision into a four-footed monster. The interpretation of the Ortus as the phoenix connects it with Christ, whose coming was prophesied by the Sibyl; for the phoenix is a well-known allegory of the resurrection of Christ and of the dead in general.⁵²⁹ It is the symbol of transformation *par excellence*. In view of this well-known interpretation of the phoenix and of the Erythraean oracle, it is amazing that any author at the beginning of the seventeenth century should dare to ask the sibyl, not to show him the way to Christ, but to tell him where he could find Mercurius! This passage offers another striking proof of the parallelism between Mercurius and Christ. Nor does the phoenix appear here as a Christ allegory but as the bearer and birthplace of the universal medicine, the “remedy against wrath and pain.” As the sibyl once foretold the coming of the Lord, so now she is to point the way to Mercurius. Christ is the Anthropos, the Primordial Man; Mercurius has the same meaning, and the Primordial Man stands for the round, original wholeness, long ago made captive by the powers of this world. In Christ’s case the victory and liberation of the Primordial Man were said to be complete, so that the labours of the alchemists would seem to be superfluous. We can only assume that the alchemists were of a different opinion, and that they sought their remedy against wrath and pain in order to complete what they considered to be Christ’s unfinished work of redemption.

[286] It is characteristic of Maier’s views that the idea of most importance is not Mercurius, who elsewhere appears strongly personified, but a substance brought by the phoenix, the bird of the spirit. It is this inorganic substance, and not a living being, which is used as a symbol of wholeness, or as a means towards wholeness, a

desideratum apparently not fulfilled by the Christ-symbol.⁵³⁰ Involuntarily one asks oneself whether the intense personalization of the divine figures, as is customary in Christianity and quite particularly in Protestantism,⁵³¹ is not in the end compensated, and to some extent mitigated, by a more objective point of view emanating from the unconscious.

e. Ascent and Descent

[287] In his quest for wholeness so far, Michael Maier, besides crossing three continents and travelling in three directions, has discovered a statue of Mercurius pointing the way to paradise; he has glimpsed paradise from afar, he has found the animal soul and the sibylline anima, who now counsels him to journey to the seven mouths of the Nile (Ostia Nili), in order to seek for Mercurius. The continuation of his pilgrimage recalls the flight of the phoenix from Arabia, where it lives, to Egypt, where it dies and arises anew. We may therefore expect that something similar will befall the author. We are not told anything of his crossing of the Red Sea and of his recapitulation, in the reverse direction, of the miraculous wanderings of the children of Israel. We do, however, soon learn that something like a rebirth mystery is to take place, because Maier compares the seven mouths of the Nile to the seven planets. He first reaches the Canopic Gate, the western mouth of the delta, where he finds Saturn domiciled. Of the remaining planets we can recognize only Mars with certainty, as the description of the cities where the others dwell is not very clear. Amid innumerable hazards he traverses the seven regions without meeting Mercurius. He does not find him even in his own city. Finally he has to turn back and retrace his steps until he reaches the Canopic Gate, where this time he finds Mercurius. Although he learns from him all sorts of secrets, he fails to find the phoenix. Later, he will return again in order to discover the panacea. In his “Epigramma ad Phoenicem” he begs the wonderful bird to give the wise man its feathers,⁵³² and in his epigram to the “Medicina Phoeniciae” he rates it above “riches and gold, and he who does not think so is not a man but a beast.”⁵³³

[288] The experience of the fourth quarter, the region of fire (i.e., the inferior function), is described by Maier as an ascent and descent through the seven planetary spheres. Even if the peregrination up to this point was not an allegory of the opus alchymicum, from now on it certainly is. The opus is a “transitus,” a *πέρασις* in the Gnostic sense, a “transcension” and transformation whose subject and object is the elusive Mercurius. I will not discuss the nature of the transitus here in any great detail, as this would be the proper concern of an account of the opus itself. One aspect of the transitus, however, is the ascent and descent through the planetary spheres, and to this we must devote a few words. As the “Tabula smaragdina” shows, the purpose of the ascent and descent is to unite the powers of Above and Below. A

feature worthy of special notice is that in the opus there is an ascent followed by a descent, whereas the probable Gnostic-Christian prototype depicts first the descent and then the ascent. There are numerous evidences of this in the literature and I do not need to cite them here. I will quote only the words of one of the great Greek Fathers, St. Basil, who says in his explanation of Psalm 17 : 10⁵³⁴ (“And he bowed the heavens and came down, and a black cloud was under his feet”): “David says here: God came down from heaven to help me and to chastise his enemies. But he clearly prophesies the incarnation [ἐνανθρωπήσας] of Christ when he says: He bowed the heavens and came down. For he did not break through the heavens and did not make the mystery manifest, but came down to earth secretly, like rain upon the fleece,⁵³⁵ because the incarnation was secret and unknown, and his coming into the world-order [ἐν τῇ οἰκονομίᾳ] was hidden.”⁵³⁶ Commenting on the next verse (“And he was borne upon the cherubim, and he flew”), Basil says: “For in ascending he rose above the Cherubim, whom David named also the wings of the wind, on account of their winged and stormy nature. By the wings of the wind is also meant the cloud which took him up.”⁵³⁷ Irenaeus sums up the mystery in the lapidary saying: “For it is He who descended and ascended for the salvation of men.”⁵³⁸

[289] In contrast to this, in alchemy the ascent comes first and then the descent. I would mention the ascent and descent of the soul in the *Rosarium* illustrations⁵³⁹ and above all the exordium in the “Tabula smaragdina,” whose authority held sway throughout the Middle Ages:

IV. Its father is the sun, its mother the moon; the wind hath carried it in his belly; its nurse is the earth.

VI. Its power is complete when it is turned towards the earth.

VIII. It ascendeth from the earth to heaven, and descendeth again to the earth, and receiveth the power of the higher and lower things. So wilt thou have the glory of the whole world.⁵⁴⁰

[290] These articles (whose subject is sometimes masculine and sometimes neuter) describe the “sun-moon child” who is laid in the cradle of the four elements, attains full power through them and the earth, rises to heaven and receives the power of the upper world, and then returns to earth, accomplishing, it seems, a triumph of wholeness (“gloria totius mundi”). The words “So wilt thou have” are evidently addressed to the Philosopher, for he is the artifex of the *filius philosophorum*. If he succeeds in transforming the arcane substance he will simultaneously accomplish his own wholeness, which will manifest itself as the glory of the whole world.

[291] There can be no doubt that the arcane substance, whether in neuter or personified form, rises from the earth, unites the opposites, and then returns to earth, thereby achieving its own transformation into the elixir. “He riseth up and goeth down in the

tree of the sun,” till he becomes the elixir, says the “Consilium coniugii.”⁵⁴¹ The text continues:

Someone hath said,⁵⁴² And when I rise naked to heaven, then shall I come clothed upon the earth, and shall perfect all minerals.⁵⁴³ And if we are baptized in the fountain of gold and silver, and the spirit of our body [i.e., the arcane substance] ascends into heaven with the father and the son, and descends again, then shall our souls revive, and my animal body will remain white, that is, [the body] of the moon.⁵⁴⁴

[292] Here the union of opposites consists in an ascent to heaven and a descent to earth in the bath of the tincture. The earthly effect is first a perfection of minerals, then a resuscitation of souls and a transfiguration of the animal body, which before was dark. A parallel passage in the “Consilium” runs:

His soul rises up from it⁵⁴⁵ and is exalted to the heavens, that is, to the spirit, and becomes the rising sun (that is, red), in the waxing moon, and of solar nature.⁵⁴⁶ And then the lantern with two lights,⁵⁴⁷ which is the water of life, will return to its origin, that is, to earth. And it becomes of low estate, is humbled and decays, and is joined to its beloved,⁵⁴⁸ the terrestrial sulphur.⁵⁴⁹

[293] This text describes the ascent of the soul of the arcane substance, the incombustible sulphur. The soul as Luna attains its plenilunium, its sunlike brilliance, then wanes into the novilunium and sinks down into the embrace of the terrestrial sulphur, which here signifies death and corruption. We are reminded of the gruesome conjunction at the new moon in Maier’s *Scrutinium chymicum*, where the woman and the dragon embrace in the grave.⁵⁵⁰ The description Dorn gives in his “Physica Trismegisti” is also to the point: “In the end it will come to pass that this earthly, spagyric birth clothes itself with heavenly nature by its ascent, and then by its descent visibly puts on the nature of the centre of the earth, but nonetheless the nature of the heavenly centre which it acquired by the ascent is secretly preserved.”⁵⁵¹ This “birth” (*foetura*) conquers the “subtile and spiritual sickness in the human mind and also all bodily defects, within as well as without.” The medicament is produced “in the same way as the world was created.” Elsewhere Dorn remarks that the “foetus spagyricus” is forced by the fire to rise up to heaven (*caelum*), by which he means from the bottom of the vessel to the top, and from there it descends again after attaining the necessary degree of ripeness, and returns to earth: “This spirit becomes corporeal again, after having become spirit from a body.”⁵⁵²

[294] As if in contradiction to the “Tabula smaragdina,” whose authority he follows here, Dorn writes in his “Philosophia speculativa”: “No one ascends into the heaven which ye seek, unless he who descends from the heaven which ye do not seek, enlighten him.”⁵⁵³ Dorn was perhaps the first alchemist to find certain statements of his “art” problematical,⁵⁵⁴ and it was for this reason that he provided his *foetus*

spagyricus, who behaves in an all too Basilidian manner, with a Christian alibi. At the same time he was conscious that the artifex was indissolubly one with the opus.⁵⁵⁵ His speculations are not to be taken lightly as they are occasionally of the greatest psychological interest, e.g.: “The descent to the four and the ascent to the monad are simultaneous.”⁵⁵⁶ The “four” are the four elements and the monad is the original unity which reappears in the “denarius” (the number 10), the goal of the opus; it is the unity of the personality projected into the unity of the stone. The descent is analytic, a separation into the four components of wholeness; the ascent synthetic, a putting together of the denarius. This speculation accords with the psychological fact that the confrontation of conscious and unconscious produces a dissolution of the personality and at the same time regroups it into a whole. This can be seen very clearly in moments of psychic crisis, for it is just in these moments that the symbol of unity, for instance the mandala, occurs in a dream. “Where danger is, there / Arises salvation also,” says Hölderlin.

[295] While the older authors keep strictly to the “Tabula smaragdina,”⁵⁵⁷ the more modern ones, under the leadership of Dorn, tend to present the process the other way round. For instance, Mylius says that the earth cannot ascend unless heaven comes down first. And even then the earth can be sublimated to heaven only if it is “dissolved in its own spirit⁵⁵⁸ and becomes one substance therewith.”⁵⁵⁹ The Paracelsist Penotus is even more emphatic. Speaking of Mercurius, he says:

As to how the son of man [*filius hominis*] is generated by the philosopher and the fruit of the virgin is produced, it is necessary that he be exalted from the earth and cleansed of all earthliness; then he rises as a whole into the air and is changed into spirit. Thus the word of the philosopher is fulfilled: He ascends from earth to heaven and puts on the power of Above and Below, and lays aside his earthly and uncleanly nature.”⁵⁶⁰

This complete identification of the lapis with the “son of man” must obviously end with its ascension. But that contradicts the original and widespread conception of the lapis as the tincture or medicine, which has meaning and value only if it applies itself to the base substances of the lower world. The upper world is in need of no medicine, since it is incorruptible anyway. A redeemer who proceeds from matter and returns to matter gradually became unthinkable. Those who identified the lapis absolutely with Christ stopped working in the laboratory, and those who preferred laboratory work slowly gave up their mystic language.

[296] Ascent and descent, above and below, up and down, represent an emotional realization of opposites, and this realization gradually leads, or should lead, to their equilibrium. This motif occurs very frequently in dreams, in the form of going up- and downhill, climbing stairs, going up or down in a lift, balloon, aeroplane, etc.⁵⁶¹ It

corresponds to the struggle between the winged and the wingless dragon, i.e., the uroboros. Dorn describes it also as the “circular distillation”⁵⁶² and as the “spagyric vessel” which has to be constructed after the likeness of the natural vessel, i.e., in the form of a sphere. As Dorn interprets it, this vacillating between the opposites and being tossed back and forth means being contained *in* the opposites. They become a vessel in which what was previously now one thing and now another floats vibrating, so that the painful suspension between opposites gradually changes into the bilateral activity of the point in the centre.⁵⁶³ This is the “liberation from opposites,” the *nirvandva* of Hindu philosophy, though it is not really a philosophical but rather a psychological development. The “Aurelia occulta” puts this thought in the words of the dragon: “Many from one and one from many, issue of a famous line, I rise from the lowest to the highest. The nethermost power of the whole earth is united with the highest. I therefore am the One and the Many within me.”⁵⁶⁴ In these words the dragon makes it clear that he is the chthonic forerunner of the self.

f. The Journey through the Planetary Houses

[297] Returning now to Michael Maier’s journey to the seven mouths of the Nile, which signify the seven planets, we bring to this theme a deepened understanding of what the alchemists meant by ascent and descent. It was the freeing of the soul from the shackles of darkness, or unconsciousness; its ascent to heaven, the widening of consciousness; and finally its return to earth, to hard reality, in the form of the tincture or healing drink, endowed with the powers of the Above. What this means psychologically could be seen very clearly from the *Hypnerotomachia*⁵⁶⁵ were its meaning not overlaid by a mass of ornate detail. It should therefore be pointed out that the whole first part of the book is a description of the dreamer’s ascent to a world of gods and heroes, of his initiation into a Venus mystery, followed by the illumination and semi-apotheosis of Poliphilo and his Polia. In the second, smaller part this leads to disenchantment and the cooling off of the lovers, culminating in the knowledge that it was all only a dream. It is a descent to earth, to the reality of daily life, and it is not altogether clear whether the hero managed to “preserve in secret the nature of the heavenly centre which he acquired by the ascent.”⁵⁶⁶ One rather doubts it. Nevertheless, his exciting adventure has left us a psychological document which is a perfect example of the course and the symbolism of the individuation process. The spirit, if not the language, of alchemy breathes through it and sheds light even on the darkest enigmas and riddles of the Masters.⁵⁶⁷

[298] Maier’s journey through the planetary houses begins with Saturn, who is the coldest, heaviest, and most distant of the planets, the maleficus and abode of evil, the mysterious and sinister Senex (Old Man), and from there he ascends to the region of the sun, to look for the Boy Mercurius, the longed-for and long-sought goal of the

adept. It is an ascent ever nearer to the sun, from darkness and cold to light and warmth, from old age to youth, from death to rebirth. But he has to go back along the way he came, for Mercurius is not to be found in the region of the sun but at the point from which he originally started. This sounds very psychological, and in fact life never goes forward except at the place where it has come to a standstill.⁵⁶⁸ The sought-for Mercurius is the *spiritus vegetativus*, a living spirit, whose nature it is to run through all the houses of the planets, i.e., the entire Zodiac. We could just as well say through the entire horoscope, or, since the horoscope is the chronometric equivalent of individual character, through all the characterological components of the personality. Individual character is, on the old view, the curse or blessing which the gods bestowed on the child at its birth in the form of favourable or unfavourable astrological aspects. The horoscope is like the “chirographum,” the “handwriting of the ordinances against us . . . which Christ blotted out; and he took it out of the way, nailing it to his cross. And after having disarmed the principalities and powers he made a show of them openly, and triumphed over them.”⁵⁶⁹

[299] This very ancient idea of what we might call an inborn bill of debt to fate is the Western version of a prenatal karma. It is the archons, the seven rulers of the planets, who imprint its fate upon the soul. Thus Priscillian (d. c. 385) says that the soul, on its descent to birth, passes through “certain circles” where it is made captive by evil powers, “and in accordance with the will of the victorious prince is forced into divers bodies, and his handwriting inscribed upon it.”⁵⁷⁰ Presumably this means that the soul is imprinted with the influences of the various planetary spheres. The descent of the soul through the planetary houses corresponds to its passage through the gates of the planets as described by Origen: the first gate is of lead and is correlated with Saturn,⁵⁷¹ from which it is clear that Maier is following an old tradition.⁵⁷² His peregrinatio chymica repeats the old “heavenly journey of the soul,” an idea which seems to have been developed more particularly in Persia.

[300] I shall not go more closely here into the transitus through the planetary houses;⁵⁷³ it is sufficient to know that Michael Maier, like Mercurius, passes through them on his mystic journey.⁵⁷⁴ This journey is reminiscent of the voyage of the hero, one motif of which becomes evident in the archetypal meeting at the critical place (the “ford”) with the Ortus, its head showing the four colours. There are other motifs too. Where there is a monster a beautiful maiden is not far away, for they have, as we know, a secret understanding so that the one is seldom found without the other. The sibyl, the guide of souls, shows the hero the way to Mercurius, who in this case is Hermes Trismegistus, the supreme mystagogue.

[301] In the *Shepherd of Hermas* it is related that the hero, while travelling along the Via Campana, met a monster resembling a dragon of the sea (κῆτος):

And the beast had on its head four colours, black, then the colour of flame and blood, then golden, then white. After I had passed the beast by and had gone about thirty feet further, lo! a maiden met me, ‘adorned as if coming forth from the bridal chamber,’ all in white and with white sandals, veiled to the forehead, and a turban for a head-dress, but her hair was white.⁵⁷⁵

[302] The similarity between the two stories is so complete that one is tempted to assume that Maier had read the *Shepherd of Hermas*. This is not very likely. Though he had a good education in the humanities I can see in his writings no evidence that he was familiar with the patristic literature, and in his references to the writings of Albertus and Thomas Aquinas⁵⁷⁶ he might easily have let slip a remark of this kind. But one finds nothing, and it does not seem very probable, either, that Maier had direct knowledge of the New Testament Apocrypha.

[303] Hermas interprets the maiden as the Church, and Maier, fifteen hundred years later, as the Erythraean Sibyl, which only goes to show once more that the newer is the older. The “supreme mistress” led Hermas to the kingdom of the triune God, but Maier she leads to Hermes Trismegistus and Trisomatos, the triadic Mercurius, who would reveal to him the secret of the phoenix’s resurrection.⁵⁷⁷ He can find Mercurius only through the rite of the ascent and descent, the “circular distillation,” beginning with the black lead, with the darkness, coldness, and malignity of the malefic Saturn; then ascending through the other planets to the fiery Sol, where the gold is heated in the hottest fire and cleansed of all impurities; and finally returning to Saturn, where this time he meets Mercurius and receives some useful teachings from him. Saturn has here changed from a star of ill omen into a “domus barbae” (House of the Beard), where the “wisest of all,” Thrice-Greatest Hermes, imparts wisdom.⁵⁷⁸ Hermas too begins with the blackness; his mistress gives him the following explanation:

The black is this world in which you are living; the colour of fire and blood means that this world must be destroyed in blood and fire. The golden part is you, who have fled from this world, for even as gold is tried in the fire and becomes valuable, so also you who live among them are tried. . . . The white part is the world to come, in which the elect of God shall dwell; for those who have been chosen by God for eternal life will be without spot and pure.⁵⁷⁹

[304] In alchemy the fire purifies, but it also melts the opposites into a unity. He who ascends unites the powers of Above and Below and shows his full power when he returns again to earth.⁵⁸⁰ By this is to be understood the production on the one hand of the panacea or *Medicina Catholica*, and on the other, of a living being with a human form, the *filius philosophorum*, who is often depicted as a youth or hermaphrodite or child. He is a parallel of the Gnostic Anthropos, but he also appears as an Anthroparion, a kind of goblin, a familiar who stands by the adept in his work and

helps the physician to heal.⁵⁸¹ This being ascends and descends and unites Below with Above, gaining a new power which carries its effect over into everyday life. His mistress gives Hermas this advice: “Therefore do not cease to speak to the ears of the saints”⁵⁸²—in other words, work among your fellow men by spreading the news of the Risen.

[305] Just as Maier on his return met Mercurius, so Hermas in his next vision met the Poimen, the shepherd, “a white fleece round his shoulders, a knapsack on his back, and a staff in his hand.” Hermas recognized that “it was he to whom I was handed over,”⁵⁸³ namely the shepherd of the lamb, which was himself. In iconography the good shepherd has the closest connections with Hermes Kriophoros (the lamb-bearer); thus even in antiquity these two saviour figures coalesced. Whereas Hermas is “handed over” to his shepherd, Hermes hands over his art and wisdom to his pupil Maier and thus equips him to do something himself and to work with the aid of the magic caduceus. This, for a physician who was an alchemist, took the place of the staff of Asklepios, which had only one snake. The sacred snake of the Asklepieion signified: The god heals; but the caduceus, or Mercurius in the form of the coniunctio in the retort, means: In the hands of the physician lie the magic remedies granted by God.⁵⁸⁴

[306] The numerous analogies between two texts so far apart in time enable us to take a psychological view of the transformations they describe. The sequence of colours coincides by and large with the sequence of the planets. Grey and black correspond to Saturn⁵⁸⁵ and the evil world; they symbolize the beginning in darkness, in the melancholy, fear, wickedness, and wretchedness of ordinary human life. It is Maier from whom the saying comes about the “noble substance which moves from lord to lord, in the beginning whereof is wretchedness with vinegar.”⁵⁸⁶ By “lord” he means the archon and ruler of the planetary house. He adds: “And so it will fare with me.” The darkness and blackness can be interpreted psychologically as man’s confusion and lostness; that state which nowadays results in an anamnesis, a thorough examination of all those contents which are the cause of the problematical situation, or at any rate its expression. This examination, as we know, includes the irrational contents that originate in the unconscious and express themselves in fantasies and dreams. The analysis and interpretation of dreams confront the conscious standpoint with the statements of the unconscious, thus widening its narrow horizon. This loosening up of cramped and rigid attitudes corresponds to the solution and separation of the elements by the *aqua permanens*, which was already present in the “body” and is lured out by the art. The water is a soul or spirit, that is, a psychic “substance,” which now in its turn is applied to the initial material. This corresponds to using the dream’s meaning to clarify existing problems. “Solutio” is defined in this sense by Dorn.⁵⁸⁷

[307] The situation is now gradually illuminated as is a dark night by the rising moon. The illumination comes to a certain extent from the unconscious, since it is mainly dreams that put us on the track of enlightenment. This dawning light corresponds to the *albedo*, the moonlight which in the opinion of some alchemists heralds the rising sun. The growing redness (*rubedo*) which now follows denotes an increase of warmth and light coming from the sun, consciousness. This corresponds to the increasing participation of consciousness, which now begins to react emotionally to the contents produced by the unconscious. At first the process of integration is a “fiery” conflict, but gradually it leads over to the “melting” or synthesis of the opposites. The alchemists termed this the *rubedo*, in which the marriage of the red man and the white woman, Sol and Luna, is consummated. Although the opposites flee from one another they nevertheless strive for balance, since a state of conflict is too inimical to life to be endured indefinitely. They do this by wearing each other out: the one eats the other, like the two dragons or the other ravenous beasts of alchemical symbolism.

[308] Astrologically, as we have said, this process corresponds to an ascent through the planets from the dark, cold, distant Saturn to the sun. To the alchemists the connection between individual temperament and the positions of the planets was self-evident, for these elementary astrological considerations were the common property of any educated person in the Middle Ages as well as in antiquity. The ascent through the planetary spheres therefore meant something like a shedding of the characterological qualities indicated by the horoscope, a retrogressive liberation from the character imprinted by the archons. The conscious or unconscious model for such an ascent was the Gnostic redeemer, who either deceives the archons by guile or breaks their power by force. A similar motif is the release from the “bill of debt to fate.” The men of late antiquity in particular felt their psychic situation to be fatally dependent on the compulsion of the stars, *Heimarmene*, a feeling which may be compared with that inspired by the modern theory of heredity, or rather by the pessimistic use of it. A similar demoralization sets in in many neuroses when the patient takes the psychic factors producing the symptoms as though they were unalterable facts which it is useless to resist. The journey through the planetary houses, like the crossing of the great halls in the Egyptian underworld, therefore signifies the overcoming of a psychic obstacle, or of an autonomous complex, suitably represented by a planetary god or demon. Anyone who has passed through all the spheres is free from compulsion; he has won the crown of victory and become like a god.

[309] In our psychological language today we express ourselves more modestly: the journey through the planetary houses boils down to becoming conscious of the good and the bad qualities in our character, and the apotheosis means no more than

maximum consciousness, which amounts to maximal freedom of the will. This goal cannot be better represented than by the alchemical symbol of the *μεσουράνισμα ἡλίου* (position of the sun at noon) in Zosimos.⁵⁸⁸ But at the zenith the descent begins. The mystic traveller goes back to the Nile mouth from which he started. He repeats, as it were, the descent of the soul which had led in the first place to the imprinting of the “chirographum.” He retraces his steps through the planetary houses until he comes back to the dark Saturn. This means that the soul, which was imprinted with a horoscopic character at the time of its descent into birth, conscious now of its godlikeness, beards the archons in their lairs and carries the light undisguised down into the darkness of the world.

[310] Here again psychology makes no special claims. What before was a burden unwillingly borne and blamed upon the entire family, is seen by the greatest possible insight (which can be very modest!) to be no more than the possession of one’s own personality, and one realizes—as though this were not self-evident!—that one cannot live from anything except what one is.

[311] On returning to the house of Saturn our pilgrim finds the long-sought Mercurius.⁵⁸⁹ Maier passes remarkably quickly over this highly significant encounter and mentions merely their “numerous conversations” without, however, disclosing their content. This is the more surprising in that Mercurius either personifies the great teacher or else has the character of the arcane substance, both of which would be a fruitful source for further revelations. For Mercurius is the light-bringing Nous, who knows the secret of transformation and of immortality.

[312] Let us assume that Maier’s sudden silence is no mere accident but was intentional or even a necessity. This assumption is not entirely without justification since Maier was one of the founders of the international Rosicrucian Society,⁵⁹⁰ and would therefore have no doubt been in a position to expatiate at length upon the Hermetic arcana. What we know of the so-called Rosicrucian secrets does nothing to explain why they were hushed up. This, incidentally, is true of most “mysteries” of this kind. It is very significant that the “mysteries” of the early Church turned soon enough into “sacraments.” The word “mystery” became a misnomer, since everything lay open in the rite. Andreas Rosencreutz used as a motto for his *Chymical Wedding*: “Mysteries profaned and made public fade and lose their grace. Therefore, cast not pearls before swine, nor spread roses for the ass.” This attitude might have been a motive for silence. People had so often got to know of things that were kept secret in the mysteries under the most fearsome oaths and had wondered why on earth they should ever have been the object of secrecy. Self-importance or the prestige of the priesthood or of the initiates seemed the obvious deduction. And there can be no doubt that the mysteries often were abused in this way. But the real reason was the

imperative need to participate in *a* or perhaps *the* secret without which life loses its supreme meaning. The secret is not really worth keeping, but the fact that it is still obstinately kept reveals an equally persistent psychic motive for keeping secrets, and that is the real secret, the real mystery. It is indeed remarkable and “mysterious” that this gesture of keeping something secret should be made at all. Why does man need to keep a secret, and for what purpose does he invent an artificial one which he even decks out as an ineffably holy rite? The thing hidden is always more or less irrelevant, for in itself it is no more than an image or sign pointing to a content that cannot be defined more closely. This content is certainly not a matter for indifference since it indicates the living presence of a numinous archetype. The essential thing is the hiding, an expressive gesture which symbolizes something unconscious and “not to be named” lying behind it; something, therefore, that is either not yet conscious or cannot or will not become conscious. It points, in a word, to the presence of an unconscious content, which exacts from consciousness a tribute of constant regard and attention. With the application of interest the continual perception and assimilation of the effects of the “secret” become possible. This is beneficial to the conduct of life, because the contents of the unconscious can then exert their compensatory effect and, if taken note of and recognized, bring about a balance that promotes health. On a primitive level, therefore, the chief effect of the mysteries is to promote health, growth, and fertility. If there were nothing good in the rite it would presumably never have come into existence or would long since have perished. The tremendous psychic effect of the Eleusinian mysteries, for instance, is beyond question. Psychotherapeutic experience has made the meaning of secrets once more a topical question, not only from the religious or philosophical point of view but also in respect of the demands of conscience with which individuation confronts a man.

[313] Maier’s silence is eloquent, as we soon find when we try to see the psychological equivalent of the descent and of the discovery of Mercurius. The maximal degree of consciousness confronts the ego with its shadow, and individual psychic life with a collective psyche. These psychological terms sound light enough but they weigh heavy, for they denote an almost unendurable conflict, a psychic strait whose terrors only he knows who has passed through it. What one then discovers about oneself and about man and the world is of such a nature that one would rather not speak of it; and besides, it is so difficult to put into words that one’s courage fails at the bare attempt. So it need not be at all a frivolous evasion if Maier merely hints at his conversations with Mercurius. In the encounter with life and the world there are experiences that are capable of moving us to long and thorough reflection, from which, in time, insights and convictions grow up—a process depicted by the alchemists as the philosophical tree. The unfolding of these experiences is regulated, as it were, by two archetypes: the anima, who expresses *life*, and the “Wise Old Man,” who personifies

meaning.⁵⁹¹ Our author was led in the first place by the anima-sibyl to undertake the journey through the planetary houses as the precondition of all that was to follow. It is therefore only logical that, towards the end of the descent, he should meet Thrice-Greatest Hermes, the fount of all wisdom. This aptly describes the character of that spirit or thinking which you do not, like an intellectual operation, perform yourself, as the “little god of this world,” but which happens to you as though it came from another, and greater, perhaps the great spirit of the world, not inappositely named Trismegistus. The long reflection, the “immensa meditatio” of the alchemists is defined as an “internal colloquy with another, who is invisible.”⁵⁹²

[314] Possibly Maier would have revealed to us something more if Mercurius had not been in such a hurry to take upon himself “the role of arbiter between the owl and the birds who were fighting it.”⁵⁹³ This is an allusion to a work of Maier’s entitled *Jocus severus* (Frankfurt a. M., 1617), where he defends the wisdom of alchemy against its detractors, a theme that also plays an important part in his *Symbola aureae mensae* in the form of argument and counterargument. One is therefore justified in assuming that Maier got into increasing conflict with himself and his environment the more he buried himself in the secret speculations of Hermetic philosophy. Indeed nothing else could have been expected, for the world of Hermetic images gravitates round the unconscious, and the unconscious compensation is always aimed at the conscious positions which are the most strongly defended because they are the most questionable, though its apparently hostile aspect merely reflects the surly face which the ego turns towards it. In reality the unconscious compensation is not intended as a hostile act but as a necessary and helpful attempt to restore the balance. For Maier it meant an inner and outer conflict which was not abolished, but only embittered, by the firmness of his convictions. For every one-sided conviction is accompanied by the voice of doubt, and certainties that are mere beliefs turn into uncertainties which may correspond better with the truth. The truth of the “sic et non” (yes and no), almost, but not quite, recognized by Abelard, is a difficult thing for the intellect to bear; so it is no wonder that Maier got stuck in the conflict and had to postpone his discovery of the phoenix until doomsday. Fortunately he was honest enough not to assert that he had ever made the lapis or the philosophical gold, and for this reason he never spread a veil of deception over his work. Thanks to his scrupulousness his late successors are at least able to guess how far he had progressed in the art, and where his labours came to a standstill. He never succeeded, as we can now see, in reaching the point where conflict and argument become logically superfluous, where “yes and no” are two aspects of the same thing. “Thou wilt never make the One which thou seekest,” says the master, “except first there be made one thing of thyself.”⁵⁹⁴

[315] After these long digressions on the interrelated symbols that branch out from the sea and its various aspects, we will resume our discussion of salt and salt-water.

[316] The *aqua pontica* (or *aqua permanens*) behaves very much like the baptismal water of the Church. Its chief function is ablution, the cleansing of the sinner, and in alchemy this is the “lato,” the impure body;⁵⁹⁵ hence the oft-repeated saying attributed to Elbo Interfecto: ⁵⁹⁶ “Whiten the lato⁵⁹⁷ and rend the books, lest your hearts be rent asunder.”⁵⁹⁸ In the *Rosarium* the ablution⁵⁹⁹ of the lato occurs in variant form: it is cleansed not by water but by “Azoth and fire,”⁶⁰⁰ that is, by a kind of baptism in fire, which is often used as a synonym for water.⁶⁰¹ The equivalent of this in the Catholic rite is the plunging of a burning candle into the font, in accordance with Matthew 3 : 11: “He shall baptize you with the Holy Ghost, and with fire.”⁶⁰² The alchemists did not hesitate to call the transformative process a “baptism.” Thus the “Consilium coniugii” says: “And if we are baptized in the fountain of gold and silver, and the spirit of our body ascends into heaven with the father and the son, and descends again, then our souls shall revive and my animal body will remain white, that is, [the body] of the moon.”⁶⁰³ The subject of this sentence is Sol and Luna. The *Aurora consurgens* I distinguishes three kinds of baptism, “in water, in blood, and in fire,”⁶⁰⁴ the Christian ideas being here transferred directly to the chemical procedure. The same is true of the idea that baptism is a submersion in death, following Colossians 2 : 12: “(Ye are) buried with him in baptism, wherein also ye are risen with him.” In his Table of Symbols, Penotus⁶⁰⁵ correlates the “moon, the spirits and ghosts of the dead [*Manes et Lemures*], and gods of the underworld” with the “mystery of baptism,” and the corresponding stage in the opus is the *solutio*, which signifies the total dissolution of the imperfect body in the *aqua divina*, its submersion, mortification,⁶⁰⁶ and burial. The putrefaction takes place in the grave, and the foul smell that accompanies it is the stench of the graves.⁶⁰⁷ The motif of imprisonment in the underworld is found in Greek alchemy, in the treatise of Komarios: “Lock them [the substances] in Hades.”⁶⁰⁸ The rebirth from the floods (*κλύδωνες*) of Hades and from the grave recurs in Cyril of Jerusalem: “That saving flood is both your sepulchre and your mother,”⁶⁰⁹ and in St. Augustine: “The water leads him down, as if dying, into the grave; the Holy Spirit brings him up, as if rising again, into heaven.”⁶¹⁰

[317] The treatise of Ostanus⁶¹¹ says that when preparing the *ὑδωρ θεϊον*, the vessel with the ingredients should be immersed in sea-water, and then the divine water will be perfected. It is, so to speak, gestated in the womb of the sea-water. The text says: “This [divine] water makes the dead living and the living dead, it lights the darkness and darkens the light, concentrates [*δράσεται*] the sea-water and quenches fire.” As this miraculous water occurs even in the oldest texts, it must be of pagan rather than of Christian origin. The oldest Chinese treatise known to us (A.D. 142) likewise

contains this idea of the divine water: it is the “flowing pearl” (quicksilver), and the divine *ch’i*, meaning ‘air, spirit, ethereal essence’. The various essences are likened to “spring showers in abundance,”⁶¹² and this recalls the “blessed water” in the treatise of Komarios, which brings the spring.⁶¹³ The age-old use of water at sacrifices and the great role it played in Egypt, where Western alchemy originated, may well have foreshadowed the water symbolism of later times. Folk ideas and superstitions such as we find in the Magic Papyri may have made their contribution, too; the following words might just as well have been taken from an alchemical treatise: “I am the plant named Baïs, I am a spout of blood . . . , the outgrowth of the abyss.⁶¹⁴ . . . I am the sacred bird Phoenix.⁶¹⁵ . . . I am Helios. . . . I am Aphrodite. . . . I am Kronos, who has showed forth the light. . . . I am Osiris, named water, I am Isis, named dew, I am Esenephys, named spring.”⁶¹⁶ The personified ὕδωρ θεῖον might well have spoken like that.

[318] The effect of Christian baptism is the washing away of sin and the acceptance of the neophyte into the Church as the earthly kingdom of Christ, sanctification and rebirth through grace, and the bestowal of an “indelible character” on the baptized. The effect of the *aqua permanens* is equally miraculous. The “Gloria mundi” says: “The mystery of every thing is life, which is water; for water dissolves the body into spirit and summons a spirit from the dead.”⁶¹⁷ Dissolution into spirit, the body’s volatilization or sublimation, corresponds chemically to evaporation, or any rate to the expulsion of evaporable ingredients like quicksilver, sulphur, etc. Psychologically it corresponds to the conscious realization and integration of an unconscious content. Unconscious contents lurk somewhere in the body like so many demons of sickness, impossible to get hold of, especially when they give rise to physical symptoms the organic causes of which cannot be demonstrated. The “spirit” summoned from the dead is usually the spirit Mercurius, who, as the *anima mundi*, is inherent in all things in a latent state. It is clear from the passage immediately following that it is salt of which it is said: “And that is the thing which we seek: all our secrets are contained in it.” Salt, however, “takes its origin from Mercurius,” so salt is a synonym for the arcane substance. It also plays an important part in the Roman rite: after being blessed it is added to the consecrated water, and in the ceremony of baptism a few grains of the consecrated salt are placed in the neophyte’s mouth with the words: “Receive the salt of wisdom: may it be a propitiation for thee unto eternal life.”

[319] As the alchemists strove to produce an incorruptible “glorified body,” they would, if they were successful, attain that state in the *albedo*, where the body became spotless and no longer subject to decay. The white substance of the ash⁶¹⁸ was therefore described as the “diadem of the heart,” and its synonym, the white foliated earth (*terra alba foliata*), as the “crown of victory.”⁶¹⁹ The ash is identical with the “pure water” which is “cleansed from the darkness of the soul, and of the black

matter, for the wickedness (*malitia*) of base earthiness has been separated from it.”⁶²⁰ This “*terrestreitas mala*” is the “*terra damnata*” (accursed earth) mentioned by other authors; it is what Goethe calls the “trace of earth painful to bear,” the moral turpitude that cannot be washed off. In Senior the ash is synonymous with *vitrum* (glass), which, on account of its incorruptibility and transparency, seemed to resemble the glorified body. Glass in its turn was associated with salt, for salt was praised as “that virgin and pure earth,” and the “finest crystalline glass” is composed mainly of *sal Sodae* (soda salts), with sand added as a binding agent. Thus the raw material of glass-making (technically known as the “batch”) is “formed from two incorruptible substances.”⁶²¹ Furthermore, glass is made in the fire, the “pure” element. In the sharp or burning taste of salt the alchemists detected the fire dwelling within it, whose preservative property it in fact shares. Alexander of Macedon is cited as saying: “Know that the salt is fire and dryness.”⁶²² Or, “the salts are of fiery nature.”⁶²³ Salt has an affinity with sulphur, whose nature is essentially fiery.⁶²⁴ Glauber maintains that “fire and salt are in their essential nature one thing” and are therefore “held in high esteem by all sensible Christians, but the ignorant know no more of these things than a cow, a pig, or a brute, which live without understanding.” He also says the “Abyssinians” baptized with water and fire. Without fire and salt the heathen would not have been able to offer sacrifice, and the evangelist Mark had said that “every one shall be salted with fire, and every sacrifice shall be salted with salt.”⁶²⁵

h. The Interpretation and Meaning of Salt

[320] Salt as much as ash is a synonym for the *albedo* (or *dealbatio*), and is identical with “the white stone, the white sun, the full moon, the fruitful white earth, cleansed and calcined.”⁶²⁶ The connecting link between ash and salt is potash, and the burning and corrosive property of lye (caustic solution) is well known.⁶²⁷ Senior mentions that the *dealbatio* was known as “*salsatura*” (marination).⁶²⁸

[321] Some light is thrown on the numerous overlapping significations of salt, and the obscurity begins to clear up, when we are informed, further, that one of its principal meanings is *soul*. As the white substance it is the “white woman,” and the “salt of our magnesia”⁶²⁹ is a “spark of the *anima mundi*.”⁶³⁰ For Glauber the salt is feminine and corresponds to Eve.⁶³¹ The “*Gloria mundi*” says: “The salt of the earth is the soul.”⁶³² This pregnant sentence contains within it the whole ambiguity of alchemy. On the one hand the soul is the “*aqua permanens*, which dissolves and coagulates,” the arcane substance which is at once the transformer and the transformed, the nature which conquers nature. On the other hand it is the human soul imprisoned in the body as the *anima mundi* is in matter, and this soul undergoes the same transformations by death and purification, and finally by glorification, as the lapis. It is the tincture

which “coagulates” all substances, indeed it even “fixes” (*figit*) itself; it comes “from the centre of the earth and is the destroyed earth, nor is there anything on the earth like to the tincture.”⁶³³ The soul is therefore not an earthly but a transcendental thing, regardless of the fact that the alchemists expected it to appear in a retort. This contradiction presented no difficulties to the medieval mind. There was a good reason for this: the philosophers were so fascinated by their own psychisms that, in their naïveté, they faithfully reproduced the inner psychic situation externally. Although the unconscious, personified by the *anima*, is in itself transcendental, it can appear in the sphere of consciousness, that is, in this world, in the form of an “influence” on conscious processes.

[322] Just as the world-soul pervades all things, so does salt. It is ubiquitous and thus fulfils the main requirement of an arcane substance, that it can be found everywhere. No doubt the reader will be as conscious as I am of how uncommonly difficult it is to give an account of salt and its ubiquitous connections. It represents the feminine principle of Eros, which brings everything into relationship, in an almost perfect way. In this respect it is surpassed only by Mercurius, and the notion that salt comes from Mercurius is therefore quite understandable. For salt, as the soul or spark of the *anima mundi*, is in very truth the daughter of the *spiritus vegetativus* of creation. Salt is far more indefinite and more universal than sulphur, whose essence is fairly well defined by its fiery nature.

[323] The relationship of salt to the *anima mundi*, which as we know is personified by the Primordial Man or Anthropos, brings us to the analogy with Christ. Glauber himself makes the equation $\text{Sal: Sol} = \text{A} : \Omega$,⁶³⁴ so that salt becomes an analogue of God. According to Glauber, the sign for salt \ominus was originally \oplus ,⁶³⁵ a double totality symbol; the circle representing non-differentiated wholeness, and the square discriminated wholeness.⁶³⁶ As a matter of fact there is another sign for salt, ♁ in contradistinction to ♀ Venus, who certainly has less to do with understanding and wisdom than has salt. Salt, says Glauber, was the “first fiat” at the creation.⁶³⁷ Christ is the salt of wisdom which is given at baptism.⁶³⁸ These ideas are elaborated by Georg von Welling: Christ is the salt, the fiat is the Word that is begotten from eternity for our preservation. Christ is the “sweet, fixed salt of silent, gentle eternity.” The body, when salted by Christ, becomes tinctured and therefore incorruptible.⁶³⁹

[324] The Christ parallel runs through the late alchemical speculations that set in after Boehme, and it was made possible by the *sal: sapientia* equation. Already in antiquity salt denoted wit, good sense, good taste, etc., as well as spirit. Cicero, for instance, remarks: “In wit [*sale*] and humour Caesar . . . surpassed them all.”⁶⁴⁰ But it was the Vulgate that had the most decisive influence on the formation of alchemical concepts. In the Old Testament, even the “salt of the covenant”⁶⁴¹ has a moral

meaning. In the New Testament, the famous words “Ye are the salt of the earth” (Matthew 5 : 13) show that the disciples were regarded as personifications of higher insight and divine wisdom, just as, in their role of ἀπόστολοι (proclaimers of the message), they functioned as “angels” (ἄγγελοι, ‘messengers’), so that God’s kingdom on earth might approximate as closely as possible to the structure of the heavenly hierarchy. The other well-known passage is at Mark 9 : 50, ending with the words: “Have salt in yourselves, and have peace one with another.” The earliest reference to salt in the New Testament (Colossians 4 : 6) likewise has a classical flavour: “Let your speech be alway with grace, and seasoned with salt, that ye may know how ye ought to answer every man.”

[325] Here salt undoubtedly means insight, understanding, wisdom. In both Matthew and Mark the salt is liable to lose its savour. Evidently this salt must keep its tang, just as the wise virgins kept their lamps trimmed. For this purpose a flexibility of mind is needed, and the last thing to guarantee this is rigid insistence on the necessity of faith. Everyone will admit that it is the task of the Church to safeguard her store of wisdom, the *aqua doctrinae*, in its original purity, and yet, in response to the changing spirit of the times, she must go on altering it and differentiating it just as the Fathers did. For the cultured Greco-Roman world early Christianity was among other things a message in philosophical disguise, as we can see quite plainly from Hippolytus. It was a competing philosophical doctrine that reached a certain peak of perfection in St. Thomas. Until well into the sixteenth century the degree of philosophical truth of Christian doctrine corresponded to that of scientific truth today.

[326] The physicians and natural philosophers of the Middle Ages nevertheless found themselves faced with problems for which the Church had no answer. Confronted with sickness and death, the physicians did not hesitate to seek counsel with the Arabs and so resuscitate that bit of the ancient world which the Church thought she had exterminated for ever, namely the Mandaean and Sabaeen remnants of Hellenistic syncretism. From them they derived a *sal sapientiae* that seemed so unlike the doctrine of the Church that before long a process of mutual assimilation arose which put forth some very remarkable blossoms. The ecclesiastical allegories kept, so far as I can judge, to the classical usage of Sal. Only St. Hilary (d. 367) seems to have gone rather more deeply into the nature of salt when he remarks that “salt contains in itself the element of water and fire, and by this is one out of two.”⁶⁴² Picinellus observes: “Two elements which stir up an implacable enmity between themselves are found in wondrous alliance in salt. For salt is wholly fire and wholly water.”⁶⁴³ For the rest he advises a sparing use of salt: “Let the word be sprinkled with salt, not deluged with it,”⁶⁴⁴ and another, earlier allegorist, the Jesuit Nicholas Caussin,⁶⁴⁵ does not mention salt at all.

[327] This is not altogether surprising, for how do wisdom and revelation square with one another? As certain books of the Old Testament canon show, there is, besides the wisdom of God which expresses itself in revelation, a human wisdom which cannot be had unless one works for it. Mark 9 : 50 therefore exhorts us to make sure that we always have enough salt in us, and he is certainly not referring to divine revelation, for this is something no man can produce on his own resources. But at least he can cultivate and increase his own human wisdom. That Mark should offer this warning, and that Paul should express himself in a very similar way, is in accord with the traditional Judeo-Hellenism of the Jewish communities at that time. An authoritarian Church, however, leaves very little room for the salt of human wisdom. Hence it is not surprising that the *sal sapientiae* plays an incomparably greater role outside the Church. Irenaeus, reporting the views of the Gnostics, says: “The spiritual, they say, [is] sent forth to this end, that, being united here below with the psychic, it may take form, and be instructed simultaneously by intercourse with it. And this they declare to be the salt and the light of the world.”⁶⁴⁶ The union of the spiritual, masculine principle with the feminine, psychic principle is far from being just a fantasy of the Gnostics: it has found an echo in the Assumption of the Virgin, in the union of Tifereth and Malchuth, and in Goethe’s “the Eternal Feminine leads us upward and on.” Hippolytus mentions this same view as that of the Sethians. He says:

But when this wave is raised from the water by the wind and made pregnant in its nature, and has received within itself the reproductive power of the feminine, it retains the light scattered from on high together with the fragrance of the spirit [*πνεύματος*],⁶⁴⁷ and that is Nous given shape in various forms. This [light] is a perfect God, who is brought down from the unbegotten light on high and from the spirit into man’s nature as into a temple, by the power of nature and the movement of the wind. It is engendered from the water and commingled and mixed with the bodies as if it were the salt of all created things, and a light of the darkness struggling to be freed from the bodies, and not able to find a way out. For some very small spark of the light is mingled with the fragrance from above. . . . [Here follows a corrupt and controversial passage which I pass over.] . . . Therefore every thought and care of the light from above is how and in what way the Nous may be delivered from the death of the sinful and dark body, from the father below [*τοῦ κάτωθεν*],⁶⁴⁸ who is the wind which raised up the waves in tumult and terror, and begot Nous his own perfect son, who is yet not his own son in substance. For he was a ray of light from on high, from that perfect light overpowered in the dark and terrible, bitter polluted water, and a shining spirit carried away over the water ...⁶⁴⁹

[328] This strangely beautiful passage contains pretty well everything that the alchemists endeavoured to say about salt: it is the spirit, the turning of the body into light (*albedo*), the spark of the *anima mundi*, imprisoned in the dark depths of the sea

and begotten there by the light from above and the “reproductive power of the feminine.” It should be noted that the alchemists could have known nothing of Hippolytus, as his *Philosophumena*, long believed lost, was rediscovered only in the middle of the nineteenth century in a monastery on Mount Athos. Anyone familiar with the spirit of alchemy and the views of the Gnostics in Hippolytus will be struck again and again by their inner affinity.

[329] The clue to this passage from the *Elenchos*, and to other similar ones, is to be found in the phenomenology of the self.⁶⁵⁰ Salt is not a very common dream-symbol, but it does appear in the cubic form of a crystal,⁶⁵¹ which in many patients’ drawings represents the centre and hence the self; similarly, the quaternary structure of most mandalas reminds one of the sign for salt  mentioned earlier. Just as the numerous synonyms and attributes of the lapis stress now one and now another of its aspects, so do the symbols of the self. Apart from its preservative quality salt has mainly the metaphorical meaning of sapientia. With regard to this aspect the “Tractatus aureus” states: “It is said in the mystic language of our sages, He who works without salt will never raise dead bodies. . . . He who works without salt draws a bow without a string. For you must know that these sayings refer to a very different kind of salt from the common mineral. . . . Sometimes they call the medicine itself ‘Salt.’”⁶⁵² These words are ambiguous: here salt means “wit” as well as wisdom. As to the importance of salt in the opus, Johannes Grasseus says of the arcane substance: “And this is the Lead of the Philosophers, which they also call the lead of the air. In it is found the shining white dove, named the salt of the metals, wherein is the whole magistry of the work. This [dove] is the pure, chaste, wise, and rich Queen of Sheba.”⁶⁵³ Here salt, arcane substance (the paradoxical “lead of the air”), the white dove (*spiritus sapientiae*), wisdom, and femininity appear in one figure. The saying from the “Gloria mundi” is quite clear: “No man can understand this Art who does not know the salt and its preparation.”⁶⁵⁴ For the “Aquarium sapientum” the *sal sapientiae* comes from the *aqua benedicta* or *aqua pontica*, which, itself an extract, is named “heart, soul, and spirit.” At first the *aqua* is contained in the prima materia and is “of a blood-red colour; but after its preparation it becomes of a bright, clear, transparent white, and is called by the sages the Salt of Wisdom.”⁶⁵⁵ Khunrath boldly summarizes these statements about the salt when he says: “Our water cannot be made without the salt of wisdom, for it is the salt of wisdom itself, say the philosophers; a fire, and a salt fire, the true Living Universal Menstruum.” “Without salt the work has no success.”⁶⁵⁶ Elsewhere he remarks: “Not without good reason has salt been adorned by the wise with the name of Wisdom.” Salt is the lapis, a “mystery to be hidden.”⁶⁵⁷ Vigenerus says that the Redeemer chose his disciples “that they might be the salt of men and proclaim to them the pure and incorruptible doctrine of the gospel.” He reports the “Cabalists” as saying that the “computatio”⁶⁵⁸ of the Hebrew word for salt

(*melach*) gives the number 78. This number could be divided by any divisor and still give a word that referred to the divine Name. We will not pursue the inferences he draws from this but will only note that for all those reasons salt was used “for the service of God in all offerings and sacrifices.”⁶⁵⁹ Glauber calls Christ the *sal sapientiae* and says that his favourite disciple John was “salted with the salt of wisdom.”⁶⁶⁰

[330] Apart from its lunar wetness and its terrestrial nature, the most outstanding properties of salt are bitterness and wisdom. As in the double quaternio of the elements and qualities, earth and water have coldness in common, so bitterness and wisdom would form a pair of opposites with a third thing between. (See diagram on facing page.) The factor common to both, however incommensurable the two ideas may seem, is, psychologically, the function of *feeling*. Tears, sorrow, and disappointment are bitter, but wisdom is the comforter in all psychic suffering. Indeed, bitterness and wisdom form a pair of alternatives: where there is bitterness wisdom is lacking, and where wisdom is there can be no bitterness. Salt, as the carrier of this fateful alternative, is co-ordinated with the nature of woman. The masculine, solar nature in the right half of the quaternio knows neither coldness, nor a shadow, nor heaviness, melancholy, etc., because, so long as all goes well, it identifies as closely as possible with consciousness, and that as a rule is the idea which one has of oneself. In this idea the shadow is usually missing: first because nobody likes to admit to any inferiority, and second because logic forbids something white to be called black. A good man has good qualities, and only the bad man has bad qualities. For reasons of prestige we pass over the shadow in complete silence. A famous example of masculine prejudice is Nietzsche’s Superman, who scorns compassion and fights against the “Ugliest Man”—the ordinary man that everyone is. The shadow must not be seen, it must be denied, repressed, or twisted into something quite extraordinary. The sun is always shining and everything smiles back. There is no room for any prestige-diminishing weakness, so the *sol niger* is never seen. Only in solitary hours is its presence feared.

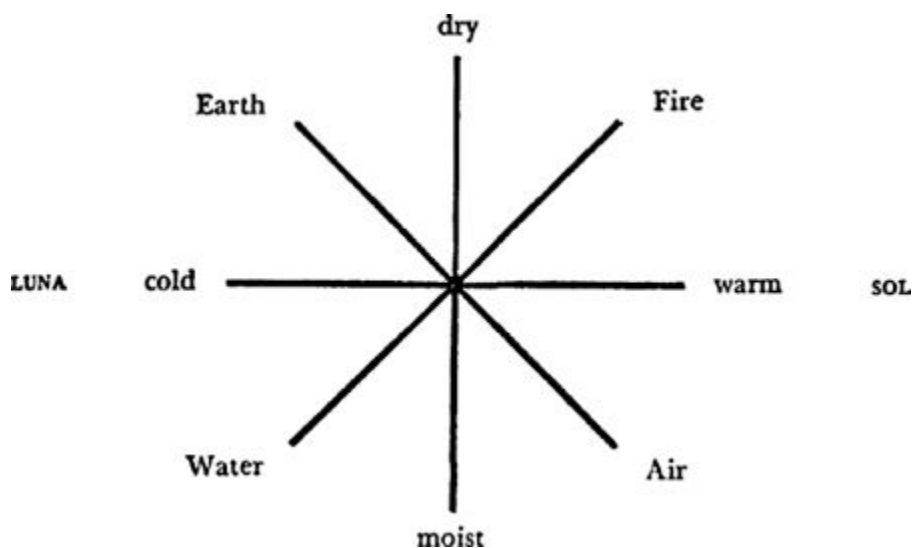

[331] Things are different with Luna: every month she is darkened and extinguished; she cannot hide this from anybody, not even from herself. She knows that this same Luna is now bright and now dark—but who has ever heard of a dark sun? We call this quality of Luna “woman’s closeness to nature,” and the fiery brilliance and hot air that plays round the surface of things we like to call “the masculine mind.”

[332] Despite all attempts at denial and obfuscation there is an unconscious factor, a black sun, which is responsible for the surprisingly common phenomenon of masculine split-mindedness, when the right hand mustn’t know what the left is doing. This split in the masculine psyche and the regular darkening of the moon in woman together explain the remarkable fact that the woman is accused of all the darkness in a man, while he himself basks in the thought that he is a veritable fount of vitality and illumination for all the females in his environment. Actually, he would be better advised to shroud the brilliance of his mind in the profoundest doubt. It is not difficult for this type of mind (which besides other things is a great trickster like Mercurius) to admit a host of sins in the most convincing way, and even to combine it with a spurious feeling of ethical superiority without in the least approximating to a genuine insight. This can never be achieved without the participation of feeling; but the intellect admits feeling only when it is convenient. The novilunium of woman is a source of countless disappointments for man which easily turn to bitterness, though they could equally well be a source of wisdom if they were understood. Naturally this is possible only if he is prepared to acknowledge his black sun, that is, his shadow.

[333] Confirmation of our interpretation of salt as Eros (i.e., as a feeling relationship) is found in the fact that the bitterness is the origin of the *colours* (par. 245). We have only to look at the drawings and paintings of patients who supplement their analysis by active imagination to see that colours are feeling-values. Mostly, to begin with, only a pencil or pen is used to make rapid sketches of dreams, sudden ideas, and fantasies. But from a certain moment on the patients begin to make use of colour, and this is generally the moment when merely intellectual interest gives way to emotional participation. Occasionally the same phenomenon can be observed in dreams, which at such moments are dreamt in colour, or a particularly vivid colour is insisted upon.

[334] Disappointment, always a shock to the feelings, is not only the mother of bitterness but the strongest incentive to a differentiation of feeling. The failure of a pet plan, the disappointing behaviour of someone one loves, can supply the impulse either for a more or less brutal outburst of affect or for a modification and adjustment of feeling, and hence for its higher development. This culminates in wisdom if feeling is supplemented by reflection and rational insight. Wisdom is never violent: where wisdom reigns there is no conflict between thinking and feeling.

[335] This interpretation of salt and its qualities prompts us to ask, as in all cases where alchemical statements are involved, whether the alchemists themselves had such thoughts. We know from the literature that they were thoroughly aware of the moral meaning of the *amaritudo*, and by *sapientia* they did not mean anything essentially different from what we understand by this word. But how the wisdom comes from the bitterness, and how the bitterness can be the source of the colours, on these points they leave us in the dark. Nor have we any reason to believe that these connections were so self-evident to them that they regarded any explanation as superfluous. If that were so, someone would have been sure to blurt it out. It is much more probable that they simply said these things without any conscious act of cognition. Moreover, the sum of all these statements is seldom or never found consistently formulated in any one author; rather one author mentions one thing and another another, and it is only by viewing them all together, as we have tried to do here, that we get the whole picture.⁶⁶¹ The alchemists themselves suggest this method, and I must admit that it was their advice which first put me on the track of a psychological interpretation. The *Rosarium* says one should “read from page to page,” and other sayings are “He should possess many books” and “One book opens another.” Yet the complete lack, until the nineteenth century, of any psychological viewpoint (which even today meets with the grossest misunderstandings) makes it very unlikely that anything resembling a psychological interpretation penetrated into the consciousness of the alchemists. Their moral concepts moved entirely on the plane of synonym and analogy, in a word, of “correspondence.” Most of their statements spring not from a conscious but from an unconscious act of thinking, as do dreams, sudden ideas, and fantasies, where again we only find out the meaning afterwards by careful comparison and analysis.

[336] But the greatest of all riddles, of course, is the ever-recurring question of what the alchemists really meant by their substances. What, for instance, is the meaning of a “sal spirituale”? The only possible answer seems to be this: chemical matter was so completely unknown to them that it instantly became a carrier for projections. Its darkness was so loaded with unconscious contents that a state of *participation mystique*,⁶⁶² or unconscious identity, arose between them and the chemical substance, which caused this substance to behave, at any rate in part, like an unconscious content. Of this relationship the alchemists had a dim presentiment—enough, anyway, to enable them to make statements which can only be understood as psychological.

[337] Khunrath says: “And the Light was made Salt, a body of salt, the salt of wisdom.”⁶⁶³ The same author remarks that the “point in the midst of the salt” corresponds to the “Tartarus of the greater world,” which is hell.⁶⁶⁴ This coincides with the conception of the fire hidden in the salt. Salt must have the paradoxical

double nature of the arcane substance. Thus the “Gloria mundi” says that “in the salt are two salts,” namely sulphur and the “radical moisture,” the two most potent opposites imaginable, for which reason it was also called the Rebis.⁶⁶⁵ Vigenerus asserts that salt consists of two substances, since all salts partake of sulphur and quicksilver.⁶⁶⁶ These correspond to Khunrath’s “king and queen,” the two “waters, red and white.”⁶⁶⁷ During the work the salt “assumes the appearance of blood.”⁶⁶⁸ “It is certain,” says Dorn, “that a salt, the natural balsam of the body, is begotten from human blood. It has within it both corruption and preservation against corruption, for in the natural order there is nothing that does not contain as much evil as good.”⁶⁶⁹ Dorn was a physician, and his remark is characteristic of the empirical standpoint of the alchemists.

[338] The dark nature of salt accounts for its “blackness and foetid smell.”⁶⁷⁰ At the dissolution of living bodies it is the “last residue of corruption,” but it is the “prime agent in generation.”⁶⁷¹ Mylius expressly identifies salt with the uroboros-dragon.⁶⁷² We have already mentioned its identification with the sea of Typhon; hence one could easily identify it with the sea-monster Leviathan.⁶⁷³ At all events there is an amusing relationship between salt and the Leviathan in Abraham Eleazar, who says with reference to Job 40 : 15:⁶⁷⁴ “For Behemoth is a wild ox, whom the Most High has salted up with Leviathan and preserved for the world to come,”⁶⁷⁵ evidently as food for the inhabitants of paradise,⁶⁷⁶ or whatever the ‘world to come’ may mean.

[339] Another direful aspect of salt is its relation to the malefic Saturn, as is implied by Grasseus in that passage about the white dove and the philosophical lead. Speaking of the identity of sea and salt, Vigenerus points out that the Pythagoreans called the sea the “tear of Kronos,” because of its “bitter saltness.”⁶⁷⁷ On account of its relation to Typhon salt is also endowed with a murderous quality,⁶⁷⁸ as we saw in the chapter on Sulphur, where Sal inflicts on Sulphur an “incurable wound.” This offers a curious parallel to Kundry’s wounding of Amfortas in *Parsifal*. In the parable of Sulphur Sal plays the sinister new-moon role of Luna.

[340] As a natural product, salt “contains as much evil as good.” As the sea it is the *παμμήτηρ*, ‘mother of all things’; as the tear of Kronos it is bitterness and sadness; as the “sea-spume” it is the scum of Typhon, and as the “clear water” it is Sapiencia herself.

[341] The “Gloria mundi” says that the aqua permanens is a “very limpid water, so bitter as to be quite undrinkable.”⁶⁷⁹ In a hymn-like invocation the text continues: “O water of bitter taste, that preservest the elements! O nature of propinquity, that dissolvest nature! O best of natures, which overcomest nature herself! . . . Thou art crowned with light and art born . . . and the quintessence ariseth from thee.”⁶⁸⁰ This water is like none on earth, with the exception of that “fount in Judaea” which is

named the “Fount of the Saviour or of Blessedness.” “With great efforts and by the grace of God the philosophers found that noble spring.” But the spring is in a place so secret that only a few know of its “gushing,” and they know not the way to Judaea where it might be found. Therefore the philosopher⁶⁸¹ cries out: “O water of harsh and bitter taste! For it is hard and difficult for any man to find that spring.”⁶⁸² This is an obvious allusion to the arcane nature and moral significance of the water, and it is also evident that it is not the water of grace or the water of the doctrine but that it springs from the *lumen naturae*. Otherwise the author would not have emphasized that Judaea was in a “secret place,” for if the Church’s teachings were meant no one would need to find them in a secret place, since they are accessible to everyone. Also, it would be quite incomprehensible why the philosopher should exclaim: “O water, held worthless by all! By reason of its worthlessness and tortuousness⁶⁸³ no one can attain perfection in the art, or perceive its mighty virtue; for all four elements are, as it were, contained in it.” There can be no doubt that this is the *aqua permanens* or *aqua pontica*, the primal water which contains the four elements.

[342] The psychological equivalent of the chaotic water of the beginning⁶⁸⁴ is the unconscious, which the old writers could grasp only in projected form, just as today most people cannot see the beam in their own eye but are all too well aware of the mote in their brother’s. Political propaganda exploits this primitivity and conquers the naive with their own defect. The only defence against this overwhelming danger is recognition of the shadow. The sight of its darkness is itself an illumination, a widening of consciousness through integration of the hitherto unconscious components of the personality. Freud’s efforts to bring the shadow to consciousness are the logical and salutary answer to the almost universal unconsciousness and projection-proneness of the general public. It is as though Freud, with sure instinct, had sought to avert the danger of nation-wide psychic epidemics that threatened Europe. What he did not see was that the confrontation with the shadow is not just a harmless affair that can be settled by “reason.” The shadow is the primitive who is still alive and active in civilized man, and our civilized reason means nothing to him. He needs to be ruled by a higher authority, such as is found in the great religions. Even when Reason triumphed at the beginning of the French Revolution it was quickly turned into a goddess and enthroned in Notre-Dame.

[343] The shadow exerts a dangerous fascination which can be countered only by another *fascinosum*. It cannot be got at by reason, even in the most rational person, but only by illumination, of a degree and kind that are equal to the darkness but are the exact opposite of “enlightenment.” For what we call “rational” is everything that seems “fitting” to the man in the street, and the question then arises whether this “fitness” may not in the end prove to be “irrational” in the bad sense of the word. Sometimes, even with the best intentions this dilemma cannot be solved. This is the

moment when the primitive trusts himself to a higher authority and to a decision beyond his comprehension. The civilized man in his closed-in environment functions in a fitting and appropriate manner, that is, rationally. But if, because of some apparently insoluble dilemma, he gets outside the confines of civilization, he becomes a primitive again; then he has irrational ideas and acts on hunches; then he no longer thinks but “it” thinks in him; then he needs “magical” practices in order to gain a feeling of security; then the latent autonomy of the unconscious becomes active and begins to manifest itself as it has always done in the past.

[344] The good tidings announced by alchemy are that, as once a fountain sprang up in Judaea, so now there is a secret Judaea the way to which is not easily found, and a hidden spring whose waters seem so worthless⁶⁸⁵ and so bitter that they are deemed of no use at all. We know from numerous hints⁶⁸⁶ that man’s inner life is the “secret place” where the *aqua solvens et coagulans*, the *medicina catholica* or panacea, the spark of the light of nature,⁶⁸⁷ are to be found. Our text shows us how much the alchemists put their art on the level of divine revelation and regarded it as at least an essential complement to the work of redemption. True, only a few of them were the elect who formed the golden chain linking earth to heaven, but still they were the fathers of natural science today. They were the unwitting instigators of the schism between faith and knowledge, and it was they who made the world conscious that the revelation was neither complete nor final. “Since these things are so,” says an ecclesiastic of the seventeenth century, “it will suffice, after the light of faith, for human ingenuity to recognize, as it were, the refracted rays of the Divine majesty in the world and in created things.”⁶⁸⁸ The “refracted rays” correspond to the “certain luminosity” which the alchemists said was inherent in the natural world.

[345] Revelation conveys general truths which often do not illuminate the individual’s actual situation in the slightest, nor was it traditional revelation that gave us the microscope and the machine. And since human life is not enacted exclusively, or even to a noticeable degree, on the plane of the higher verities, the source of knowledge unlocked by the old alchemists and physicians has done humanity a great and welcome service—so great that for many people the light of revelation has been extinguished altogether. Within the confines of civilization man’s wilful rationality apparently suffices. Outside of this shines, or should shine, the light of faith. But where the darkness comprehendeth it not (this being the prerogative of darkness!) those labouring in the darkness must try to accomplish an opus that will cause the “fishes’ eyes” to shine in the depths of the sea, or to catch the “refracted rays of the divine majesty” even though this produces a light which the darkness, as usual, does not comprehend. But when there is a light in the darkness which comprehends the darkness, darkness no longer prevails. The longing of the darkness for light is fulfilled only when the light can no longer be rationally explained by the darkness.

For the darkness has its own peculiar intellect and its own logic, which should be taken very seriously. Only the “light which the darkness comprehendeth not” can illuminate the darkness. Everything that the darkness thinks, grasps, and comprehends by itself is dark; therefore it is illuminated only by what, to it, is unexpected, unwanted, and incomprehensible. The psychotherapeutic method of active imagination offers excellent examples of this; sometimes a numinous dream or some external event will have the same effect.

[346] Alchemy announced a source of knowledge, parallel if not equivalent to revelation, which yields a “bitter” water by no means acceptable to our human judgment. It is harsh and bitter or like vinegar,⁶⁸⁹ for it is a bitter thing to accept the darkness and blackness of the *umbra solis* and to pass through this valley of the shadow. It is bitter indeed to discover behind one’s lofty ideals narrow, fanatical convictions, all the more cherished for that, and behind one’s heroic pretensions nothing but crude egotism, infantile greed, and complacency. This painful corrective is an unavoidable stage in every psychotherapeutic process. As the alchemists said, it begins with the *nigredo*, or generates it as the indispensable prerequisite for synthesis, for unless the opposites are constellated and brought to consciousness they can never be united. Freud halted the process at the reduction to the inferior half of the personality and tended to overlook the daemonic dangerousness of the dark side, which by no means consists only of relatively harmless infantilisms. Man is neither so reasonable nor so good that he can cope *eo ipso* with evil. The darkness can quite well engulf him, especially when he finds himself with those of like mind. Mass-mindedness increases unconsciousness and then the evil swells like an avalanche, as contemporary events have shown. Even so, society can also work for good; it is even necessary because of the moral weakness of most human beings, who, to maintain themselves at all, must have some external good to cling on to. The great religions are psychotherapeutic systems that give a foothold to all those who cannot stand by themselves, and they are in the overwhelming majority.

[347] In spite of their undoubtedly “heretical methods” the alchemists showed by their positive attitude to the Church that they were cleverer than certain modern apostles of enlightenment. Also—very much in contrast to the rationalistic tendencies of today—they displayed, despite its “tortuousness,” a remarkable understanding of the imagery upon which the Christian cosmos is built. This world of images, in its historical form, is irretrievably lost to modern man; its loss has spiritually impoverished the masses and compelled them to find pitiful substitutes, as poisonous as they are worthless. No one can be held responsible for this development. It is due rather to the restless tempo of spiritual growth and change, whose motive forces go far beyond the horizon of the individual. He can only hope to keep pace with it and try to understand it so far that he is not blindly swallowed up by it. For that is the alarming thing about mass

movements, even if they are good, that they demand and must demand blind faith. The Church can never explain the truth of her images because she acknowledges no point of view but her own. She moves solely within the framework of her images, and her arguments must always beg the question. The flock of harmless sheep was ever the symbolic prototype of the credulous crowd, though the Church is quick to recognize the wolves in sheep's clothing who lead the faith of the multitude astray in order to destroy them. The tragedy is that the blind trust which leads to perdition is practised just as much inside the Church and is praised as the highest virtue. Yet our Lord says: "Be ye therefore wise as serpents,"⁶⁹⁰ and the Bible itself stresses the cleverness and cunning of the serpent. But where are these necessary if not altogether praiseworthy qualities developed and given their due? The serpent has become a by-word for everything morally abhorrent, and yet anyone who is not as smart as a snake is liable to land himself in trouble through blind faith.

[348] The alchemists knew about the snake and the "cold" half of nature,⁶⁹¹ and they said enough to make it clear to their successors that they endeavoured by their art to lead that serpentine Nous of the darkness, the *serpens mercurialis*, through the stages of transformation to the goal of perfection (*telesmus*).⁶⁹² The more or less symbolical or projected integration of the unconscious that went hand in hand with this evidently had so many favourable effects that the alchemists felt encouraged to express a tempered optimism.

IV

REX AND REGINA

1. INTRODUCTION

[349] We have already met the royal pair, and particularly the figure of the King, several times in the course of our inquiry, not to mention the material which was presented under this head in *Psychology and Alchemy*. Conforming to the prototype of Christ the King in the Christian world of ideas, the King plays a central role in alchemy and cannot, therefore, be dismissed as a mere metaphor. In the "Psychology of the Transference" I have discussed the deeper reasons for a more comprehensive treatment of this symbol. Because the king in general represents a superior personality exalted above the ordinary, he has become the carrier of a myth, that is to say, of the statements of the collective unconscious. The outward paraphernalia of kingship show this very clearly. The crown symbolizes his relation to the sun, sending forth its rays; his bejewelled mantle is the starry firmament; the orb is a replica of the world; the lofty throne exalts him above the crowd; the address "Majesty" approximates him to the gods. The further we go back in history the more evident does the king's divinity become. The divine right of kings survived until quite recent times, and the Roman Emperors even usurped the title of a god and demanded a personal cult. In the Near East the whole essence of kingship was based far more on theological than on political assumptions. There the psyche of the whole nation was the true and ultimate basis of kingship: it was self-evident that the king was the magical source of welfare and prosperity for the entire organic community of man, animal, and plant; from him flowed the life and prosperity of his subjects, the increase of the herds, and the fertility of the land. This signification of kingship was not invented *a posteriori*; it is a psychic *a priori* which reaches far back into prehistory and comes very close to being a natural revelation of the psychic structure. The fact that we explain this phenomenon on rational grounds of expediency means something only for us; it means nothing for primitive psychology, which to a far higher degree than our objectively oriented views is based on purely psychic and unconscious assumptions.

[350] The theology of kingship best known to us, and probably the most richly developed, is that of ancient Egypt, and it is these conceptions which, handed down by the Greeks, have permeated the spiritual history of the West. Pharaoh was an incarnation of God¹ and a son of God.² In him dwelt the divine life-force and

procreative power, the *ka*: God reproduced himself in a human mother of God and was born from her as a God-man.³ As such he guaranteed the growth and prosperity of the land and the people,⁴ also taking it upon himself to be killed when his time was fulfilled, that is to say when his procreative power was exhausted.⁵

[351] Father and son were consubstantial,⁶ and after his death Pharaoh became the father-god again,⁷ because his *ka* was consubstantial with the father.⁸ The *ka* consisted, as it were, of Pharaoh's ancestral souls, fourteen of which were regularly worshipped by him,⁹ corresponding to the fourteen *kas* of the creator-god.¹⁰ Just as Pharaoh corresponded on the human plane to the divine son, so his *ka* corresponded to the divine Procreator, the *ka-mutef*,¹¹ the "bull of his mother," and his mother corresponded to the mother of the gods (e.g., Isis).

[352] This gives rise to a peculiar double trinity, consisting on the one hand of a divine series, father-god, divine son, the *ka-mutef*, and on the other hand a human series, father-god, human divine son (Pharaoh), and Pharaoh's *ka*. In the first series the father changes into the son and the son into the father through the procreative power of the *ka-mutef*. All three figures are consubstantial. The second, divine-human series, which is likewise bound into a unity by consubstantiality, represents the manifestation of God in the earthly sphere.¹² The divine mother is not included in either triunity; she stands outside it, a figure now wholly divine, now wholly human. We should mention in this connection a late Egyptian trinity amulet discussed by Spiegelberg: Horus and Hathor sit facing one another, and between them and over them hovers a winged serpent. The three deities all hold the *ankh* (symbol of life). The inscription says: "Baït is one, Hathor one, Akori one, one is their power. Greetings, Father of the World, greetings, three-formed God."¹³ Baït is Horus. The amulet, which is three-cornered, may date from the first or second century A.D. Spiegelberg writes: "For my feeling this epigram, despite its Greek form, breathes an Egyptian spirit of Hellenistic nature and contains nothing Christian. But it is born of a spirit that made its contribution to the development of the dogma of the Trinity in Christianity."¹⁴ The illustrations of the coniunctio in the *Rosarium*, showing King, Queen, and the dove of the Holy Ghost, correspond to the figures on the amulet exactly.¹⁵

2. GOLD AND SPIRIT

[353] The striking analogy between certain alchemical ideas and Christian dogma is not accidental but in accordance with tradition. A good part of the symbolism of the king derives from this source. Just as Christian dogma derives in part from Egypto-Hellenistic folklore, as well as from the Judaeo-Hellenistic philosophy of writers like

Philo, so, too, does alchemy. Its origin is certainly not purely Christian, but is largely pagan or Gnostic. Its oldest treatises come from that sphere, among them the treatise of Komarios (1st cent.?) and the writings of Pseudo-Democritus (1st to 2nd cent.) and Zosimos (3rd cent.). The title of one of the latter's treatises is "The True Book of Sophe¹⁶ the Egyptian and Divine Lord of the Hebrews, [and] of the Powers of Sabaoth."¹⁷ Berthelot thinks that Zosimos really was the author, and this is quite possible. The treatise speaks of a knowledge or wisdom that comes from the Aeons:

Ungoverned (*ἀβασιλευτος*) and autonomous is its origin; it is non-material (*αἴλος*) and it seeks none of the material and wholly corruptible¹⁸ bodies. For it acts without being acted upon (*ἀπαθῶς*) But, on their asking for a gift, the symbol of the chymic art comes forth from creation for those who rescue and purify the divine soul chained in the elements, that is, the divine Pneuma mingled with the flesh. For as the sun is the blossom of fire, and the heavenly sun is the right eye of the world, so also the copper, when purification makes it to blossom, is an earthly sun, a king upon earth, like the sun in heaven.¹⁹

[354] It is clear from this and from the text that follows that the "symbol of the chymic art" (*τὸ συμβολὸν τῆς χημείας*), the king, is none other than gold, the king of metals.²⁰ But it is equally clear that the gold comes into being only through the liberation of the divine soul or pneuma from the chains of the "flesh." No doubt it would have suited our rational expectations better if the text had said not "flesh" but "ore" or "earth." Although the elements are mentioned as the prison of the divine psyche, the whole of nature is meant, *Physis* in general; not just ore and earth but water, air, and fire, and besides these the "flesh," an expression that already in the third century meant the "world" in a moral sense as opposed to the spirit, and not simply the human body. Consequently, there can be no doubt that the *chrysopoeia* (gold-making) was thought of as a psychic operation running parallel to the physical process and, as it were, independent of it. The moral and spiritual transformation was not only independent of the physical procedure but actually seemed to be its *causa efficiens*. This explains the high-flown language, which would be somewhat out of place in a merely chemical recipe. The psyche previously imprisoned in the elements and the divine spirit hidden in the flesh overcome their physical imperfection and clothe themselves in the noblest of all bodies, the royal gold. Thus the "philosophic" gold is an embodiment of psyche and pneuma, both of which signify "life-spirit." It is in fact an "aurum non vulgi," a living gold, so to speak, which corresponds in every respect to the lapis. It, too, is a living being with a body, soul, and spirit, and it is easily personified as a divine being or a superior person like a king, who in olden times was considered to be God incarnate.²¹ In this connection Zosimos availed himself of a primordial image in the form of the divine Anthropos, who at that time had attained a crucial significance in philosophy and religion, not only in Christianity but also in

Mithraism. The Bible as well as the Mithraic monuments and the Gnostic writings bear witness to this. Zosimos has, moreover, left us a long testimony on this theme.²² The thoughts of this writer, directly or indirectly, were of decisive importance for the whole philosophical and Gnostic trend of alchemy in the centuries that followed. As I have dealt with this subject in considerable detail in *Psychology and Alchemy* I need not go into it here. I mention it only because the above passage from Zosimos is, to my knowledge, the earliest reference to the king in alchemy. As an Egyptian, Zosimos would have been familiar with the mystique of kingship, which at that time was enjoying a new efflorescence under the Caesars, and so it was easy for him to carry over the identity of the divine pneuma with the king into alchemical practice, itself both physical and pneumatic, after the older writings of Pseudo-Democritus had paved the way with their views on *Θεία φύσις* (divine nature).²³

[355] The definition of the king as pneuma carried considerably more weight than his interpretation as gold. Ruland's *Lexicon* defines Rex as follows: "Rex—King, Soul, Spiritual Water which gives Moisture to the Female and is restored to the Fountain whence it was derived. The Spirit is Water."²⁴ Here Rex is still the divine soul, the moist Osiris,²⁵ a life-giving, fertilizing pneuma and not primarily the physical gold. The mystique of the king comes out even more clearly in Khunrath: "When at last," he says, "the ash-colour, the whitening, and the yellowing are over, you will see the Philosophical Stone, our King and Lord of Lords, come forth from the couch and throne of his glassy sepulchre²⁶ onto the stage of this world, in his glorified body, regenerated and more than perfect, shining like a carbuncle, and crying out, Behold, I make all things new."²⁷ In his story of how the lapis is made, Khunrath describes the mystic birth of the king. Ruach Elohim (the spirit of God) penetrated to the lowest parts and to the centre (*meditullium*) of the virginal *massa confusa*, and scattered the sparks and rays of his fruitfulness. "Thus the form impressed itself [*forma informavit*], and the purest soul quickened and impregnated the tohu-bohu, which was without form and void." This was a "mysterium typicum" (a "symbolical" mystery), the procreation of the "Preserver and Saviour of the Macrocosm and the Microcosm. The Word is become flesh . . . and God has revealed himself in the flesh, the spirit of God has appeared in the body. This, the son of the Macrocosm . . . that, the son of God, the God-man . . . the one in the womb of the Macrocosm, the other in the womb of the Microcosm," and both times the womb was virginal. "In the Book or Mirror of Nature, the Stone of the Wise, the Preserver of the Macrocosm, is the symbol of Christ Jesus Crucified, Saviour of the whole race of men, that is, of the Microcosm."²⁸ The "son of the Macrocosm" begotten by the divine pneuma (the Egyptian *ka-mutef*) is "of like kind and consubstantial with the Begetter." His soul is a spark of the world-soul. "Our stone is three and one, which is to say triune, namely earthly, heavenly, and divine." This reminds us of the Egyptian sequence: Pharaoh,

ka, God. The triune stone consists of “three different and distinct substances: Sal-Mercurius-Sulphur.”²⁹

3. THE TRANSFORMATION OF THE KING

[356] As the Egyptian mystique of kingship shows, the king, like every archetype, is not just a static image; he signifies a dynamic process whereby the human carrier of the mystery is included in the mysterious drama of God’s incarnation. This happened at the birth of Pharaoh, at his coronation,³⁰ at the Heb-Sed festival, during his reign, and at his death. The texts and illustrations of the “birth-chamber” in the temple depict the divine procreation and birth of Pharaoh in the form of the mystic marriage of the Queen Mother and the Father-God. The Heb-Sed festival served to associate his *ka* with the cultivation of the soil and, presumeably, to preserve or strengthen his powers.³¹ The identity of his *ha* with the Father-God was finally confirmed at his death and sealed for all time. The transformation of the king from an imperfect state into a perfect, whole, and incorruptible essence is portrayed in a similar manner in alchemy. It describes either his procreation and birth, in the form of a hierosgamos, or else his imperfect initial state and his subsequent rebirth in perfect form. In what follows I shall give a few examples of this transformation.

[357] Among the older medieval treatises there is the so-called “Allegoria Merlini.”³² So far as the name Merlinus is concerned, I must leave it an open question whether it refers to the magician Merlin³³ or is a corruption of Mercurinus.³⁴ The allegory tells us of a certain king who made ready for battle. As he was about to mount his horse he wished for a drink of water. A servant asked him what water he would like, and the king answered: “I demand the water which is closest to my heart, and which likes me above all things.” When the servant brought it the king drank so much that “all his limbs Avere filled and all his veins inflated, and he himself became discoloured.” His soldiers urged him to mount his horse, but he said he could not: “I am heavy and my head hurts me, and it seems to me as though all my limbs were falling apart.” He demanded to be placed in a heated chamber where he could sweat the water out. But when, after a while, they opened the chamber he lay there as if dead. They summoned the Egyptian and the Alexandrian physicians, who at once accused one another of incompetence. Finally the Alexandrian physicians gave way to the Egyptian physicians, who tore the king into little pieces, ground them to powder, mixed them with their “moistening” medicines, and put the king back in his heated chamber as before. After some time they fetched him out again half-dead. When those present saw this, they broke out into lamentation, crying: “Alas, the king is dead.” The physicians said soothingly that he was only sleeping. They then washed him with sweet water until the juice of the medicines departed from him, and mixed

him with new substances. Then they put him back in the chamber as before. When they took him out this time he was really dead. But the physicians said: “We have killed him that he may become better and stronger in this world after his resurrection on the day of judgment.” The king’s relatives, however, considered them mountebanks, took their medicines away from them, and drove them out of the kingdom. They now wanted to bury the corpse, but the Alexandrian physicians, who had heard of these happenings, counselled them against it and said they would revive the king. Though the relatives were very mistrustful they let them have a try. The Alexandrian physicians took the body, ground it to powder a second time, washed it well until nothing of the previous medicines remained, and dried it. Then they took one part of sal ammoniac and two parts of Alexandrian nitre, mixed them with the pulverized corpse, made it into a paste with a little linseed oil, and placed it in a crucible-shaped chamber with holes bored in the bottom; beneath it they placed a clean crucible and let the corpse stand so for an hour. Then they heaped fire upon it and melted it, so that the liquid ran into the vessel below. Whereupon the king rose up from death and cried in a loud voice: “Where are my enemies? I shall kill them all if they do not submit to me!” All the kings and princes of other countries honoured and feared him. “And when they wished to see something of his wonders, they put an ounce of well-purified mercury in a crucible, and scattered over it as much as a millet-seed of finger-nails or hair or of their blood, blew up a light charcoal fire, let the mercury cool down with these, and found the stone, as I do know.”

[358] This parable contains the primitive motif of the murder or sacrifice of the king for the purpose of renewing his kingly power and increasing the fertility of the land. Originally it took the form of killing the old and impotent king. In this tale the king was afflicted with a “dropsy” both real and metaphorical: he suffered from a general plethora and a total oedema because he drank too much of the special “water.” One would be inclined to think that the “water closest to his heart which liked him above all things” was *eau de vie* and that he suffered from cirrhosis of the liver, were it not that the extraction of the moist psyche from the elements was a preoccupation of alchemy long before the distillation of alcohol.³⁵ The idea was to extract the *pneuma* or psyche or “virtue” from matter (e.g., from gold) in the form of a volatile or liquid substance, and thereby to mortify the “body.” This *aqua permanens*³⁶ was then used to revive or reanimate the “dead” body and, paradoxically, to extract the soul again.³⁷ The old body had to die; it was either sacrificed or simply killed, just as the old king had either to die or to offer sacrifice to the gods (much as Pharaoh offered libations to his own statue). Something of this kind was celebrated at the Sed festival. Moret thinks the Sed ceremony was a kind of humanized regicide.³⁸

[359] Water has always played a role at sacrifices as the “animating” principle. A text from Edfu says: “I bring thee the vessels with the limbs of the gods [i.e., the Nile],

that thou mayest drink of them; I refresh my heart that thou mayest rejoice.” The water of the Nile was the real “consolamentum” of Egypt. In the Egyptian fairytale, Anubis found that the heart of his dead brother Bata, which Bata had placed on a cedar-flower, had turned into a cedar-cone. He put it in a vessel of cold water, and the heart soaked it up and Bata began to live again.³⁹ Here the water is life-giving. But of the *aqua permanens* it was said: “It kills and vivifies.”

[360] The king has numerous connections with water. In the parable of Sulphur cited earlier, the king drowns in it with Diana.⁴⁰ The hierosgamos was often celebrated in water. The motif of drowning also takes the form of an inward drowning, namely dropsy. Mater Alchimia is dropsical in the lower limbs.⁴¹ Or the king is dropsical and conceals himself in the “belly of the horse” in order to sweat out the water.⁴² The water appears also as a bath, as in the “Dicta Alani,” where the “old man” sits in the bath.⁴³ Here I would recall the king’s bath in Bernardus Trevisanus, which I have discussed earlier.⁴⁴ Water is used for baptism, immersion, and cleansing. The cleansing of Naaman (II Kings 5 : 10ff.) is often cited as an allegory of this.⁴⁵

[361] In our parable the wonderful water already has that decomposing and dissolving property which anticipates the king’s dismemberment.⁴⁶ The dissolution of the initial material plays a great role in alchemy as an integral part of the process. Here I will mention only the unique interpretation of the *solutio* given by Dorn. In his “Speculativa philosophia” he discusses the seven stages of the work. The first stage begins with the “study of the philosophers,” which is the way to the investigation of truth.

But the truth is that from which nothing can be missing, to which nothing can be added, nay more, to which nothing can be opposed. . . . The truth therefore is a great strength and an impregnable fortress . . . , an unconquerable pledge to them that possess it. In this citadel is contained the true and undoubted stone and treasure of the philosophers, which is not eaten into by moths, nor dug out by thieves, but remaineth for ever when all things else are dissolved, and is appointed for the ruin of many, but for the salvation of others. This is a thing most worthless to the vulgar, spurned above all things and hated exceedingly, yet it is not hateful but lovable, and to philosophers precious above gems.⁴⁷

[362] In his “Recapitulation of the First Stage” Dorn says:

It is the study of the Chemists to liberate that unsensual truth⁴⁸ from its fetters in things of sense, for through it the heavenly powers are pursued with subtle understanding. . . .⁴⁹ Knowledge is the sure and undoubted resolution [*resolutio*] by experiment of all opinions concerning the truth. . . . Experiment is manifest demonstration of the truth, and resolution the putting away of doubt. We cannot be resolved of any doubt save by experiment, and there is no better way to make it than

on ourselves. Let us therefore verify what we have said above concerning the truth, beginning with ourselves. We have said above that piety consists in knowledge of ourselves,⁵⁰ and hence it is that we make philosophical knowledge begin from this also. But no man can know himself unless he know *what* and not *who* he is,⁵¹ on whom he depends and whose he is (for by the law of truth no one belongs to himself), and to what end he was made. With this knowledge piety begins, which is concerned with two things, namely, with the Creator and the creature that is made like unto him. For it is impossible for the creature to know himself of himself, unless he first know his Creator. . . .⁵² No one can better know the Creator, than the workman is known by his work.⁵³

[363] Later Dorn says:

The chemical putrefaction is compared to the study of the philosophers, because as the philosophers are disposed to knowledge by study, so natural things are disposed by putrefaction to solution [*ad solutionem*]. To this is compared philosophical knowledge, for as by solution bodies are dissolved [*solvuntur*], so by knowledge are the doubts of the philosophers resolved [*resolvuntur*].⁵⁴

He says in his “*Physica Trithemii*”:

The first step in the ascent to higher things is the study of faith, for by this is the heart of man disposed to solution in water [*ad solutionem in aquam*].⁵⁵

Finally, in his “*Philosophia chemica*,” Dorn asserts:

Dissolution is knowledge, or the spagyric⁵⁶ union of the male with the female, the latter receiving from him all that ought to be received. This is the beginning of the special generation whereby the effect of our spagyric marriage is sensually apprehended, namely, the union of the twofold seed to form the embryo.⁵⁷

[364] It is evident from these statements that Dorn understood the alchemical *solutio* primarily as a spiritual and moral phenomenon and only secondarily as a physical one. The first part of the work is a psychic “solution” of doubts and conflicts, achieved by self-knowledge, and this is not possible without knowledge of God. The spiritual and moral *solutio* is conceived as a “spagyric marriage,” an inner, psychic union which by analogy and magic correspondence unites the hostile elements into *one* stone. By inquiring into the “quid,” and by spiritual understanding, the selfish hardness of the heart—caused by original sin—is dissolved: the heart turns to water. The ascent to the higher stages can then begin. Egocentricity is a necessary attribute of consciousness and is also its specific sin.⁵⁸ But consciousness is confronted by the objective fact of the unconscious, often enough an avenging deluge. Water in all its forms—sea, lake, river, spring—is one of the commonest typifications of the unconscious, as is also the lunar femininity that is closely associated with water. The dissolution of the heart in water would therefore correspond to the union of the male

with the female, and this in turn to the union of conscious and unconscious, which is precisely the meaning of the “spagyric marriage.”⁵⁹ Similarly, the citadel or fortress is a feminine symbol, containing within it the treasure of the “truth,” also personified as Wisdom.⁶⁰ This wisdom corresponds to salt, which is co-ordinated with the moon. The spagyric union produces an embryo whose equivalents are the homunculus and the lapis. The lapis, of course, is a symbol of the self.⁶¹

[365] If after this glimpse into the psychology of the *solutio* we turn back to the “Allegoria Merlini,” several things will become clear: the king personifies a hypertrophy of the ego which calls for compensation. He is about to commit an act of violence—a sure sign of his morally defective state. His thirst is due to his boundless concupiscence and egotism. But when he drinks he is overwhelmed by the water, i.e., by the unconscious, and medical help becomes necessary. The two groups of doctors further assist his dissolution by dismemberment and pulverization.⁶² The original of this may be the dismemberment of Osiris and Dionysus.⁶³ The king is subjected to various forms of dissolution: dismemberment, trituration, dissolution in water.⁶⁴ His transfer to the heated chamber is the prototype of the “laconicum” (sweat-bath) of the king, often shown in later illustrations; it is a therapeutic method which we meet again in the American Indian “sweat-lodge.” The chamber also signifies the grave. The difference between the Egyptian and the Alexandrian physicians seems to be that the former moistened the corpse but the latter dried it (or embalmed or pickled it). The technical error of the Egyptians, therefore, was that they did not separate the conscious from the unconscious sufficiently, whereas the Alexandrians avoided this mistake.⁶⁵ At any rate they succeeded in reviving the king and evidently brought about his rejuvenation.

[366] If we examine this medical controversy from the standpoint of alchemical hermeneutics many of the allusions can be understood in a deeper sense. For instance the Alexandrians, though making just as thorough use of the Typhonian technique of dismemberment, avoided the (Typhonian) sea-water and dried the pulverized corpse, using instead the other constituent of the *aqua pontica*, namely salt in the form of *sal ammoniac* (mineral salt or rock-salt, also called *sal de Arabia*) and *sal nitri* (saltpetre).⁶⁶ Primarily the preservative quality of both salts is meant, but secondarily, in the mind of the adepts, “marination” meant the “in-forming” penetration of *sapientia* (Dorn’s “veritas”) into the ignoble mass, whereby the corruptible form was changed into an incorruptible and immutable one.

[367] Certainly there is little trace of this in our somewhat crude parable. Also, the transformation of the king seems to betoken only the primitive renewal of his life-force, for the king’s first remark after his resuscitation shows that his bellicosity is undiminished. In the later texts, however, the end-product is never just a

strengthening, rejuvenation or renewal of the initial state but a transformation into a higher nature. So we are probably not wrong in attributing a fairly considerable age to this parable. One ground for this assumption is the conflict between the Alexandrian and Egyptian physicians, which may hark back to pre-Islamic times when the old-fashioned, magical remedies of the Egyptians still led to skirmishes with the progressive, more scientific medicine of the Greeks. Evidence for this is the “technical” blunder of the Egyptian method—contamination of conscious and unconscious—which the more highly differentiated consciousness of the Greeks was able to avoid.

4. THE REGENERATION OF THE KING (Ripley's "Cantilena")

[368] It should not be overlooked that no reason was given why the king was in need of renewal. On a primitive level the need for renewal was self-evident, since the magic power of the king decreased with age. This is not so in later parables, where the original imperfection of the king itself becomes a problem.

[369] Thus the author of the following parable, Sir George Ripley (1415–90), Canon of Bridlington, was already revolving in his mind the problem of the “sick king.” I must leave to one side the question of how far this idea was influenced by the Grail Legend. It is conceivable that Ripley, as an Englishman, would have been acquainted with this tradition. Apart from the rather doubtful evidence of the “lapis exillis” (“lapsit exiliis” in Wolfram von Eschenbach), I have not been able to find any more likely traces of the Grail cycle in alchemical symbolism, unless one thinks of the mystic vessel of transformation, the *tertium comparationis* for which would be the chalice in the Mass.

The first five verses of the *Cantilena*⁶⁷ are as follows:

Behold! And in this *Cantilena* see

The hidden Secrets of Philosophy:

What Joy arises from the Merry Veines

Of Minds elated by such dulcid Straines!

Through Roman Countreys as I once did passe,

Where Mercuries Nuptiall celebrated was,

And feeding Stoutly (on the Bride-Groomes score)

I learn'd these Novelties unknown before.

There was a certaine Barren King by birth,

Composèd of the Purest, Noblest Earth,
By nature Sanguine and Devoute, yet hee
Sadly bewailèd his Authoritie.

Wherefore am I a King, and Head of all
Those Men and Things that be Corporeall?
I have no Issue, yet I'le not deny
'Tis Mee both Heaven and Earth are Rulèd by.

Yet there is either a Cause Naturall
Or some Defect in the Originall,
Though I was borne without Corruption
And nourished 'neath the Pinions of the Sunne.⁶⁸

[371] The cleric's language betrays him: "original defect" is a paraphrase of "original sin," and the "pinions of the sun" are the "wings of the sun of justice" (Malachi 4 : 2: "The sun of justice shall arise with healing in his wings"). Possibly there is a connection here between the *Cantilena* and the remark of Senior that the male without wings is under the winged female.⁶⁹ The *Cantilena* condenses the winged female on the one hand with the winged sun-disk of Malachi and on the other with the idea of the nourishing mother—a kind of dreamlike contamination.

[372] *Verses 6 and 7*

Each Vegetative which from the Earth proceeds
Arises up with its own proper Seeds;
And Animalls, at Seasons, speciously
Abound with Fruit and strangly Multiply.

Alas, my Nature is Restricted so
No Tincture from my Body yet can flow.
It therefore is Infoecund: neither can
It ought availe, in Generating Man.⁷⁰

Here again the ecclesiastical language is noticeable: the tincture is identical with the *aqua permanens*, the wonderful water of transformation which corresponds to the Church's "water of grace." The water that should flow from the body may be analogous to the "rivers from the belly of Christ," an idea that plays a great role not only in ecclesiastical metaphor but also in alchemy.⁷¹ With regard to the ecclesiastical language I would call attention to Hugo Rahner's most instructive essay, "Flumina de ventre Christi." Origen speaks of "the river our saviour" (*salvator noster fluvius*).⁷² The analogy of the pierced Redeemer with the rock from which Moses struck water

was used in alchemy to denote the extraction of the *aqua permanens* or of the soul from the lapis; or again, the king was pierced by Mercurius.⁷³ For Origen water meant the “water of doctrine” and the “fount of science.” It was also a “fountain of water springing up in the believer.” St. Ambrose speaks of the “fountains of wisdom and knowledge.”⁷⁴ According to him paradise, with its fourfold river of the Logos, is the ground of the soul;⁷⁵ he also calls this river the innermost soul, since it is the “principle,” the *κοιλία* (*venter*), and the *νοῦς*.⁷⁶ These few examples from the many collected by Rahner may suffice to put the significance of the *aqua permanens*, the arcane substance par excellence, in the right perspective. For the alchemists it was wisdom and knowledge, truth and spirit, and its source was in the inner man, though its symbol was common water or sea-water. What they evidently had in mind was a ubiquitous and all-pervading essence, an *anima mundi* and the “greatest treasure,” the innermost and most secret numinosum of man. There is probably no more suitable psychological concept for this than the collective unconscious, whose nucleus and ordering “principle” is the self (the “monad” of the alchemists and Gnostics).

[373]

Verses 8 and 9

My Bodies Masse is of a Lasting-Stuffe,
 Exceeding delicate, yet hard enough;
 And when the Fire Assays to try my Sprite,
 I am not found to Weigh a Graine too light.

My Mother in a Sphaere gave birth to mee,
 That I might contemplate Rotunditie;
 And be more Pure of kind than other things,
 By Right of Dignity the Peer of Kings.⁷⁷

The “house of the sphere” is the *vas rotundum*, whose roundness represents the cosmos and, at the same time, the world-soul, which in Plato surrounds the physical universe from outside. The secret content of the Hermetic vessel is the original chaos from which the world was created. As the *filius Macrocosmi* and the first man the king is destined for “rotundity,” i.e., wholeness, but is prevented from achieving it by his original defect.

[374]

Verse 10

Yet to my Griefe I know, unlesse I feed
 On the Specifics I so sorely need
 I cannot Generate: to my Amaze
 The End draws near for me, Ancient of Daies.⁷⁸

This verse confirms the decrepit condition of the king, who apart from his original defect, or because of it, is also suffering from senile debility. It was a bold stroke for a canon to identify the king with the “Ancient of Days” from Daniel 7 : 9: “I beheld till the thrones were cast down, and the Ancient of Days did sit, whose garments were white as snow, and the hair of his head like pure wool: his throne was like the fiery flame, and his wheels as burning fire.” There can be no doubt that Ripley the alchemist was here speculating over the head of Ripley the cleric to hit upon an idea that in the Middle Ages must have seemed like blasphemy: the identification of the transformative substance with God. To our way of thinking this kind of allegory or symbolization is the height of absurdity and unintelligibility. It was even hard for the Middle Ages to swallow.⁷⁹ But where it met with acceptance, as in philosophical alchemy, it does much to explain the hymnlike or at any rate highly emotional language of some of the treatises. We have here, in fact, a new religious declaration: God is not only in the unspotted body of Christ and continually present in the consecrated Host but—and this is the novel and significant thing—he is also hidden in the “cheap,” “despised,” common-or-garden substance, even in the “uncleanness of this world, in filth.”⁸⁰ He is to be found only through the art, indeed he is its true object and is capable of progressive transformation—“Deo adjuvante.” This strange theologem did not, of course, mean that for the alchemists God was nothing but a substance that could be obtained by chemical transformation—far from it. Such an aberration was reserved rather for those moderns who put matter or energy in the place of God. The alchemists, so far as they were still pagans, had a more mystical conception of God dating from late antiquity, which, as in the case of Zosimos, could be described as Gnostic; or if they were Christians, their Christianity had a noticeable admixture of heathenish magical ideas about demons and divine powers and an *anima mundi* inherent or imprisoned in physical nature. The *anima mundi* was conceived as that part of God which formed the quintessence and real substance of Physis, and which was to God—to use an apt expression of Isidore⁸¹—as the “accrescent soul” (προσφύνης ψυχή, ‘grown-on’) was to the divine soul of man. This accrescent soul was a second soul that grew through the mineral, vegetable, and animal kingdoms up to man, pervading the whole of nature, and to it the natural forms were attached like appendages (προσαρτήματα). This strange idea of Isidore’s is so much in keeping with the phenomenology of the collective unconscious that one is justified in calling it a projection of this empirically demonstrable fact in the form of a metaphysical hypostasis.

[375] It will not have escaped the reader how primitive the idea of God’s ageing and need of renewal is. It does in fact derive from ancient Egypt, though one is at a loss to imagine from what sources, other than the Bible, a Canon of Bridlington in the fifteenth century could have borrowed such a theology. His writings at any rate allow

no conjectures in this respect. There is something of a clue, however, in the alchemical tradition itself, in the idea of a corrupt arcane substance whose corruption is due to original sin. A similar idea appears in the Grail tradition of the sick king, which has close connections with the transformation mystery of the Mass. The king is the forbear of Parsifal, whom one could describe as a redeemer figure, just as in alchemy the old king has a redeemer son or becomes a redeemer himself (the lapis is the same at the beginning and at the end). Further, we must consider certain medieval speculations concerning God's need of improvement and the transformation of the wrathful God of the Old Testament into the God of Love in the New: for, like the unicorn, he was softened by love in the lap of a virgin. Ideas of this kind are found as early as Bonaventure, the Franciscan saint, who died in 1274.⁸² We should also remember that, in the figurative language of the Church, God the Father was represented as an old man and his birth as a rejuvenation in the Son. In a hymn to the Church as an analogy of the Mother of God Paulinus of Nola says:

Sister and wife at once; for without the use of the body

Mentally she unites, for the Spouse is God, not a man.

Out of this mother is born the Ancient as well as the infant ...⁸³

[376] Although the candidate for baptism ("reborn into a new infancy") is meant here, the point of the analogy is that God the Father, a bearded old man, is worshipped *in* God the Son as a newborn child.

[377] The contrast between *senex* and *puer* touches at more than one point on the archetype of God's renewal in Egyptian theology, especially when the underlying homoousia comes out as clearly as in the verses of Ephraem Syrus: "The Ancient of Days, in his sublimity, dwelt as a babe in the womb."⁸⁴ "Thy Babe, O Virgin, is an old man; he is the Ancient of Days and precedes all time."⁸⁵

[378] Nowhere in this material, however, do we find the very specific motif of God's senescence, and the source Ripley could have used remains obscure. Even so, there is always the possibility of an autochthonous revival of the mythologem from the collective unconscious. Nelken has published a case of this kind. His patient was a primary-school teacher who suffered from paranoia. He developed a theory about a Father-God with immense procreative powers. Originally he had 550 *membra virilia*, but in the course of time they were reduced to three. He also possessed two scrota with three testicles each. His colossal sperm production weakened him in the end, and finally he shrank to a five-ton lump and was found chained up in a ravine. This psychologem contains the motif of ageing and loss of procreative power. The patient was the rejuvenated Father-God or his avatar.⁸⁶ The embellishment of the archetypal theme is in this case completely original, so that we can safely take it as an autochthonous product.

[379] In Ripley's case there is the more immediate possibility that he modified for his own purpose the conception of the Ancient of Days and his youthful son the Logos, who in the visions of Valentinus the Gnostic and of Meister Eckhart was a small boy. These concepts are closely related to those of Dionysus, youngest of the gods, and of the Horus-child, Harpocrates, Aion, etc. All naturally imply the renewal of the ageing god. The step from the world of Christian ideas back into paganism is not a long one,⁸⁷ and the naturalistic conclusion that the father dwindles when the son appears, or that he is rejuvenated in the son, is implicit in all these age-old conceptions, whose effect is all the stronger the more they are consciously denied. Such a combination of ideas is almost to be expected in a cleric like Ripley, even though, like all alchemists, he may not have been conscious of their full import.

[380] *Verses 11–12*

Utterly perish'd is the Flower of Youth,
Through all my Veines there courses naught but Death.
Marvelling I heard Christ's voice,⁸⁸ that from above
I'le be Reborne, I know not by what Love.

Else I God's Kingdom cannot enter in:
And therefore, that I may be Borne agen,
I'le Humbled be into my Mother's Breast,
Dissolve to my First Matter, and there rest.⁸⁹

[381] In order to enter into God's Kingdom the king must transform himself into the *prima materia* in the body of his mother, and return to the dark initial state which the alchemists called the "chaos." In this *massa confusa* the elements are in conflict and repel one another; all connections are dissolved. Dissolution is the prerequisite for redemption. The celebrant of the mysteries had to suffer a figurative death in order to attain transformation. Thus, in the Arisleus vision, Gabricus is dissolved into atoms in the body of his sister-wife. We have seen from the analogy with the Ancient of Days what the alchemist's goal was: both artifex and substance were to attain a perfect state, comparable to the Kingdom of God. I will not discuss, for the moment, the justification for this seemingly presumptuous comparison, but would remind the reader that in the opinion of the alchemists themselves the transformation was a miracle that could take place only with God's help.

[382] *Verse 13*

Hereto the Mother Animates the King,
Hasts his Conception, and does forthwith bring
Him closely hidden underneath her Traine,

Till, from herself, she'd made him Flesh againe.⁹⁰

[383] Here the “chymical wedding” takes the form of the ancient rite of adoption, when the child to be adopted was hidden under the skirts of the adoptive mother and then drawn forth again.⁹¹

In this way Ripley circumvented the scandal of the customary incest.

[384] The adoption was represented in ancient times either by a figurative act of birth or by the suckling of the adoptive child. In this manner Heracles was “adopted” by Hera. In a hymn to Nebo⁹² the god says to Asurbanipal:

Small wert thou, Asurbanipal, when I left thee with the divine Queen of Nineveh,
Feeble wert thou, Asurbanipal, when thou didst sit in the lap of the divine Queen of Nineveh,
Of the four udders that were placed in thy mouth thou didst suck from two,
And in two thou didst bury thy face ...⁹³

[385] Concealment under the skirt is a widely disseminated rite, and until quite recently was still practised by the Bosnian Turks. The motif of the “tutelary Madonna” in a mantle has a similar meaning, namely, the adoption of the believer.

[386] Ripley's adoption scene may derive from the “lion-hunt” of Marchos,⁹⁴ where mention is made of a fire which “comes out over the coals, even as the pious mother steps over the body of her son.” And again: “He likened the subtlety of the fire's heat to the stepping of the pious mother over the body of her son.”⁹⁵ These sentences form part of a dialogue between King Marchos and his mother. In contrast to the *Cantilena*, however, it is not the king who is to be transformed but the lion (see pars. 409f.).

[387] *Verses 14–17*

'Twas wonderfull to see with what a Grace
This Naturall Union made at one Imbrace
Did looke; and by a Bond both Sexes knitt,
Like to a Hille and Aire surrounding it.

The Mother unto her Chast Chamber⁹⁶ goes,
Where in a Bed of Honour she bestowes
Her weary'd selfe, 'twixt Sheets as white as Snow
And there makes Signes of her approaching Woe.

Ranke Poison issuing from the Dying Man
Made her pure Orient face look foule and wan:
Hence she commands all Strangers to be gone,

Seals upp her Chamber doore, and lyes Alone.

Meanwhile she of the Peacocks Flesh did Eate

And Dranke the Greene-Lyons Blood with that fine Meate,

Which Mercurie, bearing the Dart of Passion,

Brought in a Golden Cupp of Babilon.⁹⁷

[388] The pregnancy diet described here is the equivalent of the “cibatio,” the “feeding” of the transformative substance. The underlying idea is that the material to be transformed had to be impregnated and saturated, either by imbibing the tincture, the *aqua propria* (its “own water,” the soul), or by eating its “feathers” or “wings” (volatile spirit), or its own tail (uroboros), or the fruit of the philosophical tree. Here it is “peacock’s flesh.” The peacock is an allusion to the *cauda pavonis* (peacock’s tail). Immediately before the *albedo* or *rubedo*⁹⁸ “all colours” appear, as if the peacock were spreading his shimmering fan. The basis for this phenomenon may be the iridescent skin that often forms on the surface of molten metal (e.g., lead).⁹⁹ The “omnes colores” are frequently mentioned in the texts as indicating something like totality. They all unite in the *albedo*, which for many alchemists was the climax of the work. The first part was completed when the various components separated out from the chaos of the *massa confusa* were brought back to unity in the *albedo* and “all become one.” Morally this means that the original state of psychic disunity, the inner chaos of conflicting part-souls which Origen likens to herds of animals,¹⁰⁰ becomes the “vir unus,” the unified man. Eating the peacock’s flesh is therefore equivalent to integrating the many colours (or, psychologically, the contradictory feeling-values) into a single colour, white. Norton’s “Ordinall of Alchimy” says:

For everie Colour whiche maie be thought,

Shall heere appeare before that White be wrought.¹⁰¹

[389] The lapis contains or produces all colours.¹⁰² Hoghelande says that the “Hermaphroditic monster” contains all colours.¹⁰³ Poetic comparisons are also used, such as Iris, the rainbow,¹⁰⁴ or the iris of the eye.¹⁰⁵ The eye and its colours are mentioned by Hippolytus. He calls attention to the Naassene analogy between the four rivers of paradise and the senses. The river Pison, which waters Havilah, the land of gold, corresponds to the eye: “This, they say, is the eye, which by its bearing and its colours bears witness to what is said.”¹⁰⁶ Abu’l-Qasim speaks of the tree with multicoloured blossoms.¹⁰⁷ Mylius says: “Our stone is the star-strewn Sol, from whom every colour proceeds by transformation, as flowers come forth in the spring.”¹⁰⁸ The “Tractatus Aris-totelis” gives a more elaborate description: “Everything that is contained beneath the circle of the moon . . . is made into one at the quadrangular ending,¹⁰⁹ as if it were a meadow decked with colours and sweet-smelling flowers of divers kinds, which were conceived in the earth by the dew of heaven.”¹¹⁰

[390] The stages of the work are marked by seven colours which are associated with the planets.¹¹¹ This accounts for the relation of the colours to astrology, and also to psychology, since the planets correspond to individual character components. The *Aurora Consurgens* relates the colours to the soul.¹¹² Lagneus associates the four principal colours with the four temperaments.¹¹³ The psychological significance of the colours comes out quite clearly in Dorn: “Truly the form which is the intellect of man is the beginning, middle, and end of the preparations, and this form is indicated by the yellow colour, which shows that man is the greater and principal form in the spagyric work, and one mightier than heaven.”¹¹⁴ Since the gold colour signifies intellect, the principal “informer” (formative agent) in the alchemical process, we may assume that the other three colours also denote psychological functions, just as the seven colours denote the seven astrological components of character. Consequently the synthesis of the four or seven colours would mean nothing less than the integration of the personality, the union of the four basic functions, which are customarily represented by the colour quaternio blue-red-yellow-green.¹¹⁵

[391] The *cauda pavonis* was a favourite theme for artistic representation in the old prints and manuscripts. It was not the tail alone that was depicted, but the whole bird. Since the peacock stands for “all colours” (i.e., the integration of all qualities), an illustration in Khunrath’s *Amphitheatrum sapientiae* logically shows it standing on the two heads of the Rebis, whose unity it obviously represents. The inscription calls it the “bird of Hermes” and the “blessed greenness,” both of which symbolize the Holy Ghost or the Ruach Elohim, which plays a great role in Khunrath.¹¹⁶ The *cauda pavonis* is also called the “soul of the world, nature, the quintessence, which causes all things to bring forth.”¹¹⁷ Here the peacock occupies the highest place as a symbol of the Holy Ghost, in whom the male-female polarity of the hermaphrodite and the Rebis is integrated.

[392] Elsewhere Khunrath says that at the hour of conjunction the blackness and the raven’s head and all the colours in the world will appear, “even Iris, the messenger of God, and the peacock’s tail.” He adds: “Mark the secrets of the rainbow in the Old and New Testament.”¹¹⁸ This is a reference to the sign of God’s covenant with Noah after the flood (Gen. 10 : 12f.) and to the “one in the midst of the four and twenty elders,” who “was to look upon like a jasper and a sardine-stone, and there was a rainbow round about the throne, in sight like unto an emerald” (Rev. 4 : 3f.),¹¹⁹ and to the vision of the angel with a rainbow on his head (Rev. 10 : 1).¹²⁰ Iris as the “messenger of God” is of special importance for an understanding of the opus, since the integration of all colours points, as it were, to a coming of God, or even to his presence.

[393] The colour green, stressed by Khunrath, is associated with Venus. The “Introitus apertus” says: “But in the gentle heat the mixture will liquefy and begin to swell up, and at God’s command will be endowed with spirit, which will soar upward carrying the stone with it, and will produce new colours, first of all the green of Venus, which will endure for a long time.”¹²¹ Towards the end of this procedure, which was known as the regimen of Venus, the colour changes into a livid purple, whereupon the philosophical tree will blossom. Then follows the regimen of Mars, “which displays the ephemeral colours of the rainbow and the peacock at their most glorious.” In “these days” the “hyacinthine colour”¹²² appears, i.e., blue.

[394] The livid purple that appears towards the end of the regimen of Venus has something deathly about it. This is in accord with the ecclesiastical view of purple, which expresses the “mystery of the Lord’s passion.”¹²³ Hence the regimen of Venus leads by implication to passion and death, a point I would emphasize in view of the reference to the “dart of passion” in the *Cantilena*. A passage from the “*Aquarium sapientum*” shows that colours are a means of expressing moral qualities and situations: “While the digestion¹²⁴ and coction of the dead spiritual body goes forward in man, there may be seen, as in the earthly opus, many variegated colours and signs, i.e., all manner of sufferings, afflictions, and tribulations, the chiefest of which . . . are the ceaseless assaults of the world, the flesh, and the devil.”¹²⁵

[395] These statements concerning the regimen of Venus are confirmed in Penotus’s Table of Symbols, where the peacock is correlated with the “mysterium coniugii” and with Venus, as is also the green lizard. Green is the colour of the Holy Ghost, of life, procreation and resurrection. I mention this because Penotus correlates the *coniugium* with the “*dii mortui*” (dead gods), presumably because they need resurrecting. The peacock is an ancient Christian symbol of resurrection, like the phoenix. According to a late alchemical text,¹²⁶ the bronze tablets in the labyrinth at Meroë showed Osiris, after his regeneration by Isis, mounting a chariot drawn by peacocks, in which he drives along triumphing in his resurrection, like the sun.

[396] In Dorn the “dead spiritual body” is the “bird without wings.” It “changes into the raven’s head and finally into the peacock’s tail, after which it attains to the whitest plumage of the swan and, last of all, to the highest redness, the sign of its fiery nature.”¹²⁷ This plainly alludes to the phoenix, which, like the peacock, plays a considerable role in alchemy as a symbol of renewal and resurrection,¹²⁸ and more especially as a synonym for the lapis.

[397] The *cauda pavonis* announces the end of the work, just as Iris, its synonym, is the messenger of God. The exquisite display of colours in the peacock’s fan heralds the imminent synthesis of all qualities and elements, which are united in the “rotundity” of the philosophical stone. For seventeen hundred years, as I have shown in

Psychology and Alchemy, the lapis was brought into more or less clear connection with the ancient idea of the Anthropos. In later centuries this relationship extended to Christ, who from time immemorial was this same Anthropos or Son of Man, appearing in the gospel of St. John as the cosmogonic Logos that existed before the world was: "In the beginning was the Word, and the Word was with God, and the Word was God . . . All things were made by him, and without him was not any thing made that was made." According to the teachings of the Basilidians, the "God who is not" cast down a certain seed which, like a grain of mustard-seed, contained the whole plant, or, "like a peacock's egg, had in itself a varied multitude of colours."¹²⁹ In this seed was a "threefold sonship, consubstantial with the God who is not." In alchemy, the end of the work announced by the *cauda pavonis* was the birth of the *filius regius*. The display of colours in the Basilidian doctrine therefore occurred at the right place. Again one must ask: tradition—or spontaneous generation?

[398] The peacock is an attribute of Juno, and one of the cognomens of Iris is Junonia. Just as the Queen Mother or the mother of the gods grants renewal, so the peacock annually renews his plumage, and therefore has a relation to all the changes in nature. De Gubernatis says:

The serene and starry sky and the shining sun are peacocks. The deep-blue firmament shining with a thousand brilliant eyes, and the sun rich with the colours of the rainbow, present the appearance of a peacock in all the splendour of its eye-bespangled feathers. When the sky or the thousand-rayed sun (*sahasrânśu*) is hidden by clouds, or veiled by autumnal mists, it again resembles the peacock, which, in the dark part of the year, like a great number of vividly coloured birds, sheds its beautiful plumage, and becomes drab and unadorned; the crow which had put on the peacock's feathers then caws with the other crows in funereal concert. In winter the peacock-crow has nothing left to it except its shrill disagreeable cry, which is not dissimilar to that of the crow. It is commonly said of the peacock that it has an angel's feathers, a devil's voice, and a thief's walk.¹³⁰

This would explain Dorn's connecting the peacock with the raven's head (*caput corvi*).

[399] Certain subsidiary meanings of the peacock in medieval literature are worth mentioning. Picinellus says that the peacock, contrasted with the sun, signifies the "righteous man, who, although adorned with the colours of a thousand virtues, yet has a share in the greater glory of the divine presence"; it also signifies the man who, "spotted by repeated sins, rises again to integrity of spirit." The peacock expresses the "inner beauty and perfection of the soul."¹³¹ Merula mentions that the peacock will empty and destroy a vessel containing poison,¹³² yet another peculiarity which may account for the peacock's position in alchemy, since it brings about and betokens

the transformation of the poisonous dragon into the healing medicine. Merula also asserts that the peahen does not introduce her young to their father until they are fully grown, from which Picinellus drew an analogy with the Blessed Virgin, who likewise presents her charges to God only in the perfect state. Here again the motif of renewal through the mother is struck.¹³³

[400] If, therefore, the Queen Mother eats peacock flesh during her pregnancy, she is assimilating an aspect of herself, namely, her capacity to grant rebirth, whose emblem the peacock is. According to Augustine, peacock flesh has the peculiarity of not turning rotten.¹³⁴ It is, as the alchemists would say, a “cibus immortalis,” like the fruits of the philosophical tree with which Arisleus and his companions were fed in the house of rebirth at the bottom of the sea. Peacock flesh was just the right food for the mother in her attempt to rejuvenate the old king and to give him immortality.

[401] While peacock flesh¹³⁵ was the queen’s diet, her drink was the blood of the green lion. Blood¹³⁶ is one of the best-known synonyms for the *aqua permanens*, and its use in alchemy is often based on the blood symbolism and allegories of the Church.¹³⁷ In the *Cantilena* the *imbibitio* (saturation)¹³⁸ of the “dead”¹³⁹ arcane substance is performed not on the king, as in the “Allegoria Merlini,” but on the queen. The displacement and overlapping of images are as great in alchemy as in mythology and folklore. As these archetypal images are produced directly by the unconscious, it is not surprising that they exhibit its contamination of content¹⁴⁰ to a very high degree. This is what makes it so difficult for us to understand alchemy. Here the dominant factor is not logic but the play of archetypal motifs, and although this is “illogical” in the formal sense, it nevertheless obeys natural laws which we are far from having explained. In this respect the Chinese are much in advance of us, as a thorough study of the *I Ching* will show. Called by short-sighted Westerners a “collection of ancient magic spells,” an opinion echoed by the modernized Chinese themselves, the *I Ching* is a formidable psychological system that endeavours to organize the play of archetypes, the “wondrous operations of nature,” into a certain pattern, so that a “reading” becomes possible. It was ever a sign of stupidity to depreciate something one does not understand.

[402] Displacement and overlapping of images would be quite impossible if there did not exist between them an essential similarity of substance, a homoousia. Father, mother, and son are of the same substance, and what is said of one is largely true of the other. This accounts for the variants of incest—between mother and son, brother and sister, father and daughter, etc. The uroboros is one even though in the twilight of the unconscious its head and tail appear as separate figures and are regarded as such. The alchemists, however, were sufficiently aware of the homoousia of their basic substances not only to call the two protagonists of the coniunctio drama the *one*

Mercurius, but to assert that the prima materia and the vessel were identical. Just as the *aqua permanens*, the moist soul-substance, comes from the body it is intended to dissolve, so the mother who dissolves her son in herself is none other than the feminine aspect of the father-son. This view current among the alchemists cannot be based on anything except the essential similarity of the substances, which were not chemical but psychic; and, as such, appurtenances not of consciousness, where they would be differentiated concepts, but of the unconscious, in whose increasing obscurity they merge together in larger and larger contaminations.

[403] If, then, we are told that the queen drank blood, this image corresponds in every respect to the king drinking water,¹⁴¹ to the king's bath in the trough of the oak, to the king drowning in the sea, to the act of baptism, to the passage through the Red Sea, and to the suckling of the child by the mother of the gods. The water and the containing vessel always signify the mother, the feminine principle best characterized by *yin*, just as in Chinese alchemy the king is characterized by *yang*.¹⁴²

[404] In alchemy the lion, the "royal" beast, is a synonym for Mercurius,¹⁴³ or, to be more accurate, for a stage in his transformation. He is the warm-blooded form of the devouring, predatory monster who first appears as the dragon. Usually the lion-form succeeds the dragon's death and eventual dismemberment. This in turn is followed by the eagle. The transformations described in Rosencreutz's *Chymical Wedding* give one a good idea of the transformations and symbols of Mercurius. Like him, the lion appears in dual form as lion and lioness,¹⁴⁴ or he is said to be Mercurius duplex.¹⁴⁵ The two lions are sometimes identified with the red and white sulphur.¹⁴⁶ The illustrations show a furious battle between the wingless lion (red sulphur) and the winged lioness (white sulphur). The two lions are prefigurations of the royal pair, hence they wear crowns. Evidently at this stage there is still a good deal of bickering between them, and this is precisely what the fiery lion is intended to express—the passionate emotionality that precedes the recognition of unconscious contents.¹⁴⁷ The quarrelling couple also represent the uroboros.¹⁴⁸ The lion thus signifies the arcane substance, described as *terra*,¹⁴⁹ the body or unclean body.¹⁵⁰ Further synonyms are the "desert place,"¹⁵¹ "poison, because it [this earth] is deadly," "tree, because it bears fruit," or "hidden matter [hyle], because it is the foundation of all nature and the substance [*subiectum*] of all elements."¹⁵² In apparent contradiction to this Maier cites from Ripley's "Tractatus duodecim portarum" the remark that the green lion is a "means of conjoining the tinctures between sun and moon."¹⁵³ It is, however, psychologically correct to say that emotion unites as much as it divides. Basilius Valentinus takes the lion as the arcane substance, calling it the trinity composed of Mercurius, Sal, and Sulphur, and the equivalent of draco, aquila, rex, spiritus, and corpus.¹⁵⁴ The "Gloria Mundi" calls the green lion the mineral stone that "consumes a

great quantity of its own spirit,”¹⁵⁵ meaning self-impregnation by one’s own soul (imbibitio, cibatio, nutritio, penetratio, etc.).¹⁵⁶

[405] Besides the green lion there was also, in the later Middle Ages, a red lion.¹⁵⁷ Both were Mercurius.¹⁵⁸ The fact that Artefius mentions a magic use of the lion (and of the snake) throws considerable light on our symbol: he is “good” for battle,¹⁵⁹ and here we may recall the fighting lions and the fact that the king in the “Allegoria Merlini” began drinking the water just when he was venturing forth to war. We shall probably not be wrong if we assume that the “king of beasts,” known even in Hellenistic times as a transformation stage of Helios,¹⁶⁰ represents the old king, the *Antiquus dierum* of the *Cantilena*, at a certain stage of renewal, and that perhaps in this way he acquired the singular title of “*Leo antiquus*.”¹⁶¹ At the same time he represents the king in his theriomorphic form, that is, as he appears in his unconscious state. The animal form emphasizes that the king is overpowered or overlaid by his animal side and consequently expresses himself only in animal reactions, which are nothing but emotions. Emotionality in the sense of uncontrollable affects is essentially bestial, for which reason people in this state can be approached only with the circumspection proper to the jungle,¹⁶² or else with the methods of the animal-trainer.

[406] According to the statements of the alchemists the king changes into his animal attribute, that is to say he returns to his animal nature, the psychic source of renewal. Wieland made use of this psychologem in his fairytale “*Der Stein der Weisen*,”¹⁶³ in which the dissipated King Mark is changed into an ass, though of course the conscious model for this was the transformation of Lucius into a golden ass in Apuleius.¹⁶⁴

[407] Hoghelande ranks the lion with the dog.¹⁶⁵ The lion has indeed something of the nature of the rabid dog we met with earlier, and this brings him into proximity with sulphur, the fiery dynamism of Sol. In the same way the lion is the “potency” of King Sol.¹⁶⁶

[408] The aggressive strength of the lion has, like sulphur, an evil aspect. In Honorius of Autun the lion is an allegory of Antichrist and the devil,¹⁶⁷ in accordance with I Peter 5 : 8: “... your adversary the devil, as a roaring lion, walketh about, seeking whom he may devour.” But in so far as the lion and lioness are forerunners of the (incestuous) *coniunctio*, they come into the category of those theriomorphic pairs who spend their time fighting and copulating, e.g., cock and hen, the two serpents of the caduceus, the two dragons, etc. The lion has among other things an unmistakable erotic aspect. Thus the “*Introitus apertus*” says: “Learn what the doves of Diana are,¹⁶⁸ who conquer the lion with caresses; the green lion, I say, who in truth is the Babylonish dragon, who kills all with his venom. Learn, lastly, what the caduceus of Mercury is, wherewith he works miracles, and what are those nymphs whom he

holds enchanted, if thou wouldst fulfil thy wish” (i.e., the completion of the work).¹⁶⁹ The reference to the “Babylonish” dragon is not altogether accidental, since in ecclesiastical language “Babylon” is thoroughly ambiguous.¹⁷⁰ Nicholas Flamel likewise alludes to Babylon when he says that the stink and poisonous breath of burning mercury are nothing other than the “dragon’s head which goes forth with great haste from Babylon, which is surrounded by two or three milestones.”¹⁷¹

[409] In the “lion hunt” of Marchos¹⁷² the lion, as we have seen, takes the place of the king. Marchos prepares a trap and the lion, attracted by the sweet smell of a stone that is obviously an eye-charm,¹⁷³ falls into it and is swallowed by the magic stone. “And this stone, which the lion loves, is a woman.”¹⁷⁴ The trap was covered by a “glass roof,” and the interior, called by Senior the “*cucurbita*,” is here called the “*thalamus*” (bridal chamber). The lion therefore falls like a bridegroom into the bridal chamber, where the magic stone that is “good for the eyes” and is a woman, lies on a bed of coals. This stone swallows (*transglutit*) the lion “so that nothing more of him was to be seen.” This is a parallel of the Arisleus vision, where Beya causes Gabricus to disappear into her body.

[410] In the “lion hunt” the incest, though veiled, is clear enough. The love-affair is projected on the lion, the animal nature or “accrescent soul” of the king; in other words it is enacted in his unconscious or in a dream. Because of his ambiguous character the lion is well suited to take over the role of this indecorous lover. As the king is represented by his animal and his mother by the magic stone, the royal incest can take place as though it were happening somewhere “outside,” in quite another sphere than the personal world of the king and his mother. Indeed the marriage not only seems to be “unnatural” but is actually intended to be so. The tabooed incest is imposed as a task and, as the wealth of allegories shows, it is always in some symbolical form and never concrete. One has the impression that this “sacral” act, of whose incestuous nature the alchemists were by no means unconscious, was not so much banished by them into the *cucurbita* or glass-house but was taking place in it all the time. Whoever wished to commit this act in its true sense would therefore have to get outside himself as if into an external glasshouse, a round *cucurbita* which represented the microcosmic space of the psyche. A little reason would teach us that we do not need to get “outside ourselves” but merely a little deeper *into* ourselves to experience the reality of incest and much else besides, since in each of us slumbers the “beastlike” primitive who may be roused by the doves of Diana (n. 168). This would account for the widespread suspicion that nothing good can come out of the psyche. Undoubtedly the hierogamos of the substances is a projection of unconscious contents. These contents, it is usually concluded, therefore belong to the psyche and, like the psyche itself, are “inside” man, Q.E.D. As against this the fact remains that only a very few people are or ever were conscious of having any

incestuous fantasies worth mentioning. If such fantasies are present at all they are *not yet* conscious, like the collective unconscious in general. An analysis of dreams and other products of the unconscious is needed to make these fantasies visible. To that end considerable resistances have to be overcome, as though one were entering a strange territory, a region of the psyche to which one feels no longer related, let alone identical with it; and whoever has strayed into that territory, either out of negligence or by mistake, feels outside himself and a stranger in his own house. I think one should take cognizance of these facts and not attribute to our personal psyche everything that appears as a psychic content. After all, we would not do this with a bird that happened to fly through our field of vision. It may well be a prejudice to restrict the psyche to being “inside the body.” In so far as the psyche has a non-spatial aspect, there may be a psychic “outside-the-body,” a region so utterly different from “my” psychic space that one has to get outside oneself or make use of some auxiliary technique in order to get there. If this view is at all correct, the alchemical consummation of the royal marriage in the *cucurbita* could be understood as a synthetic process in the psyche “outside” the ego.¹⁷⁵

[411] As I have said, the fact that one can get into this territory somehow or other does not mean that it belongs to me personally. The ego is Here and Now, but the “outside-of-the-ego” is an alien There, both earlier and later, before and after.¹⁷⁶ So it is not surprising that the primitive mind senses the psyche outside the ego as an alien country, inhabited by the spirits of the dead. On a rather higher level it takes on the character of a shadowy semi-reality, and on the level of the ancient cultures the shadows of that land beyond have turned into ideas. In Gnostic-Christian circles these were developed into a dogmatic, hierarchically arranged cosmogonic and chiliastic system which appears to us moderns as an involuntary, symbolic statement of the psyche concerning the structure of the psychic non-ego.¹⁷⁷

[412] This region, if still seen as a spectral “land beyond,” appears to be a whole world in itself, a macrocosm. If, on the other hand, it is felt as “psychic” and “inside,” it seems like a microcosm of the smallest proportions, on a par with the race of dwarfs in the casket, described in Goethe’s poem “The New Melusine,” or like the interior of the *cucurbita* in which the alchemists beheld the creation of the world, the marriage of the royal pair, and the homunculus.¹⁷⁸ Just as in alchemical philosophy the Anthroparion or homunculus corresponds, as the lapis, to the Anthropos, so the chymical weddings have their dogmatic parallels in the marriage of the Lamb, the union of sponsus and sponsa, and the hierosgamos of the mother of the gods and the son.

[413] This apparent digression from our theme seemed to me necessary in order to give the reader some insight into the intricate and delicate nature of the lion-symbol,

whose further implications we must now proceed to discuss.

[414] The blood of the green lion drunk by the queen is handed to her in a “golden cup of Babylon.” This refers to the “great whore” in Rev. 17 : 1ff., “that sitteth upon many waters, with whom the kings of the earth have committed fornication, and the inhabitants of the earth have been made drunk with the wine of her fornication . . . having a golden cup in her hand full of abominations and filthiness of her fornication . . .”

[415] The whore (*meretrix*) is a well-known figure in alchemy. She characterizes the arcane substance in its initial, “chaotic,” maternal state. The “Introitus apertus” says that the chaos is like a mother of the metals. It is also called “our Luna” before the royal diadem is extracted from the “menstruum of our whore,”¹⁷⁹ i.e., before the king is reborn from the moon-mother. The “Tractatus aureus de lapide” says of the arcane substance: “That noble whore Venus¹⁸⁰ is clothed and enveloped in abounding colour.” This colour “has a reddish appearance.”¹⁸¹ The nobility of this Venus derives from the fact that she is also the queen, the “chaste bride” of the king.¹⁸² In his “Practica de lapide” Basilus Valentinus says: “This tincture is the rose¹⁸³ of our Masters, of Tyrian hue, called also the red blood of the dragon, described by many, and the purple cloak¹⁸⁴ . . . with which the queen is covered.”¹⁸⁵ A variant says: “That precious substance is the Venus of the ancients, the hermaphrodite, who has two sexes.”¹⁸⁶ Maier writes: “In our chemistry there is Venus and Cupid. For Psyche is the female, Cupid the male, who is held to be the dragon.”¹⁸⁷ The “opus ad rubeum” (reddening) takes place in the second house of Venus (Libra).¹⁸⁸ Accordingly the *Turba* remarks that Venus “precedes the sun.”¹⁸⁹ Flamel takes Venus as an important component of the arcane substance; in an apostrophe to the Magnesia he says: “Thou bearest within thee the many-formed image of Venus, the cupbearer and fire-spitting servant,”¹⁹⁰ the latter referring to the sulphurous aspect of Mercurius. Mercurius also plays the role of cup-bearer in the *Cantilena*. In Flamel the lapis is born of the conjunction of “Venus pugnax” (fighting Venus)¹⁹¹ and Mercurius—evidently a reference to the quarrelling that precedes their union (cf. the fighting lions). In Valentinus’s poem on the *prima materia lapidis* Venus is identified with the fountain, the mother and bride of the king, in which her “fixed” father is drowned:

A stone there is, and yet no stone,
In it doth Nature work alone.
From it there welleth forth a fount
In which her Sire, the Fixed, is drown’d:
His body and life absorbed therein
Until the soul’s restored agen.¹⁹²

[416] In other texts Venus represents the queen at the wedding, as in the “Introitus apertus”: “See to it that you prepare the couch of Venus carefully, then lay her on the marriage bed,” etc.¹⁹³ In general, Venus appears as the feminine aspect of the king, or as we should say, his anima. Thus Valentinus says of Adam and Venus in the bath:

So saith the Wise Man: Nought they be
Except the Double Mercurie!

The King in the bath and the *connubium* with Venus¹⁹⁴ or with the mother are the same thing: the “man encompassed by the woman.” Sometimes he and sometimes she is hermaphroditic,¹⁹⁵ because at bottom they are nothing other than Mercurius duplex. Venus or the whore corresponds to the erotic aspect of the lion, who in turn is an attribute of the king. As in the Apocalypse the seven-headed dragon is the riding-animal of the Great Whore, so in Valentinus the lion is the mount of Mercurius duplex (portrayed in his feminine aspect).¹⁹⁶ Khunrath equates Venus with the green lion.¹⁹⁷ Since Sulphur is to Sol as Leo is to Rex, we can see why Khunrath regards Venus as the *anima vegetativa* of sulphur.¹⁹⁸ The most subtle substance must, when mixed with Sol, be preserved in a bottle whose stopper is marked with the sign of the cross,¹⁹⁹ just as an evil spirit is banished by a crucifix.²⁰⁰ The relation of the stone to Venus occurs as early as the Greek texts, which speak of the “Cytherean stone” and the “pearl of Cythera.”²⁰¹ In the Arabic “Book of Krates”²⁰² Venus is endowed with tincturing power; she is therefore called “scribe.” Since she holds the vessel from which quicksilver continually flows, the word “écrivain” very probably refers to Thoth-Mercurius. In the vision of Krates Venus appears surrounded by a number of Indians who shoot arrows at him. This image occurs again in Senior’s vision of Hermes Trismegistus, at whom nine eagles shot their arrows. Mercurius is the archer who, chemically, dissolves the gold, and, morally, pierces the soul with the dart of passion. As Kyllenios he is identical with Cupid, who likewise shoots arrows in Rosencreutz’s *Chymical Wedding*.²⁰³

[417] The corrupt nature of Venus is stressed in “Rosinus ad Sarratantam”:

And mark that Nature in the beginning of her origin intends to make the Sun or the Moon, but cannot, because of Venus, [who is] a corrupt [and] mixed quicksilver, or because of the foetid earth. Wherefore, as a child in its mother’s womb accidentally contracts a weakness and a corruption by reason of the place, although the sperm was clean, [and] the child is nevertheless leprous and unclean because of the corrupt womb, so it is with all imperfect metals, which are corrupted by Venus and the foetid earth.²⁰⁴

[418] Lastly, I would mention the king’s daughter in the play in the *Chymical Wedding*, who was chosen as the bride but because of her coquetry was made captive by the

King of the Moors. She agrees to be his concubine, and thus proves herself a regular *meretrix*. Rosencreutz's visit to the sleeping Venus shows that this two-faced goddess is somehow secretly connected with the opus.²⁰⁵

[419] Evidently on account of its close connection with Venus the green lion has, surprisingly enough, rose-coloured blood, as mentioned by Dorn²⁰⁶ and by his contemporary, Khunrath.²⁰⁷ The latter ascribes rose-coloured blood to the *filius macrocosmi* as well.²⁰⁸ This peculiarity of the green lion's blood establishes its connection not only with the filius, a well-known Christ parallel, but above all with the rose, whose symbolism produced not only the popular title "Rosarium" (rose-garden) but also the "Rosen-creuz" (Rosie Cross). The white and the red rose²⁰⁹ are synonyms for the *albedo*²¹⁰ and *rubedo*. The tincture is "of a rosy colour" and corresponds to the blood of Christ, who is "compared and united" with the stone.²¹¹ He is the "heavenly foundation-stone and corner-stone."²¹² The rose-garden is a "garden enclosed" and, like the rose, a soubriquet of Mary, the parallel of the "locked" prima materia.²¹³

[420] The relation of the love-goddess to red dates back to ancient times.²¹⁴ Scarlet²¹⁵ is the colour of the Great Whore of Babylon and her beast. Red is the colour of sin.²¹⁶ The rose is also an attribute of Dionysus. Red and rose-red are the colour of blood, a synonym for the *aqua permanens* and the soul, which are extracted from the prima materia and bring "dead" bodies to life.²¹⁷ The prima materia is called "meretrix" and is equated with "Great Babylon," just as are the dragon and the lion with the dragon of "Babel." The stone, the *filius regius*, is the son of this whore. In ecclesiastical tradition the son of the whore is Antichrist, begotten by the devil, as we read in the "Elucidarium" of Honorius of Autun.²¹⁸

[421] Certain of the ecclesiastical symbols prove to be acutely dualistic, and this is also true of the rose. Above all it is an allegory of Mary and of various virtues. Its perfume is the odour of sanctity, as in the case of St. Elizabeth and St. Teresa. At the same time it symbolizes human beauty (*venustas*), indeed the lust of the world (*voluptas mundi*).²¹⁹

[422] Like the rose, the figure of the mother-beloved shines in all the hues of heavenly and earthly love. She is the chaste bride and whore who symbolizes the prima materia, which "nature left imperfected." It is clear from the material we have cited that this refers to the anima. She is that piece of chaos which is everywhere and yet hidden, she is that vessel of contradictions and many colours—a totality in the form of a *massa confusa*, yet a substance endowed with every quality in which the splendour of the hidden deity can be revealed.

[423] The food of the Queen Mother—peacock's flesh and lion's blood—consists of the goddess's own attributes, that is to say she eats and drinks herself. The

“Consilium coniugii” formulates this as follows: “And so at length it sinks down into one content through saturation with the one ferment, water, for water is the ferment of water.”²²⁰ It is always the same idea, which is best expressed by the uroboros. Unexpectedly but not surprisingly we come across a similar formulation in ecclesiastical literature, in the remark of St. John Chrysostom that Christ was the first to eat his own flesh and drink his own blood (at the institution of the Last Supper).²²¹ Tertullian says: “In the same way the Lord applied to himself two Greek letters, the first and the last, as figures of the beginning and end which are united in himself. For just as Alpha continues on until it reaches Omega, and Omega completes the cycle back again to Alpha, so he meant to show that in him is found the course of all things from the beginning to the end and from the end back to the beginning, so that every divine dispensation should end in him through whom it began.”²²² This thought corresponds exactly to what the alchemists sought to express by the uroboros, the *ὄφις τὸ πᾶν*. The uroboros is a very ancient pagan symbol, and we have no reason to suppose that the idea of a self-generating and self-devouring being was borrowed from Christianity, e.g., from Tertullian, although the analogy with Christ, who as the one God begets himself and voluntarily offers himself for sacrifice, and then in the rite of the Eucharist, through the words of the consecration, performs his own immolation, is very striking. The concept of the uroboros must be much older, and may ultimately go back to ancient Egyptian theology, to the doctrine of the homoousia of the Father-God with the divine son, Pharaoh.

[424] In the *Cantilena*, the mythologem of the uroboros is unexpectedly, and most unusually, translated into feminine form: it is not the father and son who merge into one another, but the mother who merges with her own substance, “eating her own tail” or “impregnating herself,” as the king in the “Allegoria Merlini” drank his “own” water.²²³ The queen is in a condition of psychic pregnancy: the anima has become activated and sends her contents into consciousness. These correspond to the peacock’s flesh and the lion’s blood. If the products of the anima (dreams, fantasies, visions, symptoms, chance ideas, etc.) are assimilated, digested, and integrated, this has a beneficial effect on the growth and development (“nourishment”) of the psyche. At the same time the *cibatio* and *imbibitio* of the anima-mother indicate the integration and completion of the entire personality. The anima becomes creative when the old king renews himself in her. Psychologically the king stands first of all for Sol, whom we have interpreted as consciousness. But over and above that he represents a dominant of consciousness, such as a generally accepted principle or a collective conviction or a traditional view. These systems and ruling ideas “age” and thereby forcibly bring about a “metamorphosis of the gods” as described in Spitteler’s *Olympian Spring*. It seldom occurs as a definite collective phenomenon. Mostly it is a change in the individual which may, under certain conditions, affect

society “when the time is fulfilled.” In the individual it only means that the ruling idea is in need of renewal and alteration if it is to deal adequately with the changed outer or inner conditions.

[425] The fact that the king played a large role in medieval alchemy for several hundred years proves that, from about the thirteenth century onwards, the traces of the king’s renewal surviving from Egyptian and Hellenistic times began to gain in importance because they had acquired a new meaning. For as the West started to investigate nature, till then completely unknown, the doctrine of the *lumen naturae* began to germinate too. Ecclesiastical doctrine and scholastic philosophy had both proved incapable of shedding any light on the nature of the physical world. The conjecture thereupon arose that just as the mind revealed its nature in the light of divine revelation, so nature herself must possess a “certain luminosity” which could become a source of enlightenment. It is therefore understandable that for those individuals whose particular interest lay in the investigation of natural things the dogmatic view of the world should lose its force as the *lumen naturae* gained in attraction, even though the dogma itself was not directly doubted. The more serious alchemists, if we are to believe their statements, were religious people who had no thought of criticizing revealed truth. There is in the literature of alchemy, so far as I can judge, no attack on dogma. The only thing of this kind is a depreciation of the Aristotelian philosophy sponsored by the Church in favour of Hermetic Neoplatonism.²²⁴ Not only were the old Masters not critical of ecclesiastical doctrine, they were, on the contrary, convinced that their discoveries, real or imaginary, would enrich the doctrine of the correspondence of heavenly and earthly things, since they endeavoured to prove that the “mystery of faith” was reflected in the world of nature.²²⁵ They could not guess that their passion for investigating nature would detract as much as it did from revealed truth, and that their scientific interests could be aroused only as the fascination of dogma began to pall. And so, as in dreams, there grew up in their unconscious the compensating image of the king’s renewal.

[426] These considerations make it the more comprehensible that it was a cleric who wrote the *Cantilena*. It is indeed something of a descent to the underworld when he makes Mercurius, “bearing the dart of passion,” the emblem of Cupid,²²⁶ hand the queen the blood-potion in a “golden cup of Babylon.” This, as we have seen, is the golden cup “full of the abomination and filthiness of fornication,” and it is quite obvious that she is being ruthlessly regaled with her own psychic substances. These are animal substances she has to integrate, the “accrescent soul”-peacock and lion with their positive and negative qualities; and the draught is given to her in the cup of fornication, which emphasizes still more the erotic nature of the lion, his lust and greed. Such an integration amounts to a widening of consciousness through profound insight.

[427] But why should such an unpalatable diet be prescribed for the queen? Obviously because the old king lacked something, on which account he grew senile: the dark, chthonic aspect of nature. And not only this but the sense that all creation was in the image of God, the antique feeling for nature, which in the Middle Ages was considered a false track and an aberration. Dark and unfathomable as the earth is, its theriomorphic symbols do not have only a reductive meaning, but one that is prospective and spiritual. They are paradoxical, pointing upwards and downwards at the same time. If contents like these are integrated in the queen, it means that her consciousness is widened in both directions. This diet will naturally benefit the regeneration of the king by supplying what was lacking before. Contrary to appearances, this is not *only* the darkness of the animal sphere, but rather a spiritual nature or a natural spirit which even has its analogies with the mystery of faith, as the alchemists were never tired of emphasizing.

[428] During her pregnancy, therefore, the queen undergoes something akin to a psychotherapeutic treatment, whereby her consciousness is enriched by a knowledge of the collective unconscious and, we may assume, by her inner participation in the conflict between her spiritual and chthonic nature. Often the law governing the progressive widening of consciousness makes the evaluation of the heights and depths into a moral task transcending the limits of convention. Failure to know what one is doing acts like guilt and must be paid for as dearly. The conflict may even turn out to be an advantage since, without it, there could be no reconciliation and no birth of a supraordinate third thing. The king could then be neither renewed nor reborn. The conflict is manifested in the long sickness of the queen.

[429]

Verse 18

Thus great with Child, nine months she languishèd
And Bath'd her with the Teares which she had shed
For his sweete sake, who from her should be Pluckt
Full-gorg'd with Milke which now the Greene-Lyon suckt.²²⁷

The uroboric relationship between queen and lion is quite evident here: she drinks his blood while he sucks her milk. This singular notion is explained by what we would consider an offensive identification of the queen with the mother of God, who, personifying humanity, takes God into her lap and suckles him at her breast. The lion, as an allegory of Christ, returns the gift by giving humanity his blood. This interpretation is confirmed in the later verses. Angelus Silesius makes use of a similar image in his epigram on the “humanized” God:

God drank the Virgin's milk, left us his wine;

[430]

Verse 19

Her Skin in divers Colours did appeare,
Now Black, then Greene, anon 'twas Red and Cleare.
Oft-times she would sit upright in her Bed,
And then again repose her Troubled Head.²²⁹

This display of colours is an indication of the queen's Venus and peacock nature (*cauda pavonis*). Psychologically it means that during the assimilation of the unconscious the personality passes through many transformations, which show it in different lights and are followed by ever-changing moods. These changes presage the coming birth.

[431]

Verse 20

Thrice Fifty Nights she lay in grievous Plight,
As many Daies in Mourning sate upright.
The King Revivèd was in Thirty more,
His Birth was Fragrant as the Prim-Rose Flower.²³⁰

[432] There are, in alchemy, two main kinds of smell, the "stench of graves" and the perfume of flowers, the latter being a symbol of resurgent life. In ecclesiastical allegory and in the lives of the saints a sweet smell is one of the manifestations of the Holy Ghost, as also in Gnosticism. In alchemy the Holy Ghost and Sapiientia are more or less identical; hence the smell of flowers attests that the rebirth of the king is a gift of the Holy Ghost or of Sapiientia, thanks to whom the regeneration process could take place.

[433]

Verses 21–24

Her Wombe which well proportion'd was at first
Is now Enlarg'd a Thousand fold at least,
That it bear Witnessse to his Genesis:
The End by Fires the best Approved is.

Her Chamber without Corners smoothly stands,
With Walls erected like her outstretched hands;
Or else the Fruit of her ripe Womb should spoil,
And a sicke Son reward her labouring Toil.

A burning Stove was plac'd beneath her Bed,

And on the same another Flourished:
Trimm'd up with Art, and very Temperate,
Lest her fine Limbes should freeze for lack of Heate.

Her Chamber doore was Lock'd and Bolted fast,
Admitting none to Vex her, first or last;
The Furnace-mouth was likewise Fasten'd so
That thence no Vaporous Matter forth could go.²³¹

This is the image of the homunculus in the Hermetic vessel!

[434]

Verse 25

And when the Child's Limbs there had putrefy'd,
The Foulness of the Flesh was laid aside,
Making her²³² fair as Luna, when anon
She coils towards²³³ the Splendour of the Sun.²³⁴

This is an attempt to describe the transformation in the sealed chamber. It is not clear whether the mother has already given birth to the child, and whether “there” (*ibi*) refers to the chamber or to the gravid uterus. The latter seems to me more probable in view of the next verse. Altogether verse 25 is obscure and clumsy in the extreme. The only thing to emerge with any clarity is the death and decomposition of the foetus in the uterus or in the chamber, and then the sudden appearance of Luna in the place of the mother after the “foulness of the flesh” had fallen away. Anyhow there is a tangle of thoughts here such as is frequently found in the texts. We must suppose that the poet meant something sensible with his apparent jumble of words, and that only his limited capacity for poetic expression prevented him from making himself intelligible. He was in fact trying to express a very difficult thought, namely the nature of the critical transformation. Chemically speaking, the “mother” overflowing with milk and tears is the solution, the “mother liquid” or matrix. She is the “water” in which the old king, as in the Arisleus vision, is dissolved into atoms. Here he is described as a *foetus in utero*. The dissolution signifies his death, and the uterus or *cucurbita* becomes his grave, that is, he disappears in the solution. At this moment something in the nature of a miracle occurs: the material solution loses its earthy heaviness, and solvent and solute together pass into a higher state immediately following the *cauda pavonis*, namely the *albedo*. This denotes the first stage of completion and is identified with Luna. Luna in herself is spirit, and she at once joins her husband Sol, thus initiating the second and usually final stage, the *rubedo*. With that the work is completed, and the lapis, a living being endowed with soul and spirit and an incorruptible body, has taken shape.

[435] We know that what hovered before the mind of the alchemist during this transformation was the almost daily miracle of transubstantiation at the Mass. This would very definitely have been the case with Canon Ripley. We have already seen from a number of examples how much religious conceptions were mixed up with his alchemical interests. The queen in the *Cantilena* is neither a wife nor mother in the first place but a “tutelary madonna” who adopts the king as her son—an indication that she stands in the same relationship to the king as Mater Ecclesia to the believer. He dies and is buried as if in the Church or in consecrated ground, where he awaits resurrection in a glorified body.

[436] The elevation of the “matrix,” the chemical solution, from the state of materiality to Luna is the classic allegory of the Church, as Ripley doubtless knew. The goddess who suddenly intervenes in the opus is depicted in the *Mutus liber*, where she appears equally suddenly during the procedure, as a naked female figure crowned with the sign of the moon and bearing a child in her arms. The miracle is there described as an intervention of the gods,²³⁵ who, like god-parents, take the place of the earthly parents and arrange for the spiritual procreation of the *foetus spagyricus*. It is inevitable that Luna should stand for the Virgin and/or the Church in the *Cantilena* because the *senex-puer* is described by Ripley himself as the “Ancient of Days.” Since the mother at this moment has brought about the histolysis of the old king, so that only a single homogeneous solution remains, we must assume that Luna, appearing in the place of the mother, has become identical with the solution and now carries the king in her body as her adopted son. This gives the king immortality in a divine and incorruptible body. In the *Mutus liber* there then follows an adoption by Sol and after that a *coniunctio Solis et Lunae*, and the adoptive child, now consubstantial with Sol and Luna, is included in the ceremony.

[437] Something of this sort seems to occur in the *Cantilena*: Luna and her adoptive son are at first identical in one and the Same solution. When Luna takes over this condition she is presumably in her novilunium and hastens to her union with Sol. The new moon is associated with uncanniness and snakiness, as we saw earlier.²³⁶ I therefore interpret “spirificans in splendorem Solis” as “winding like a snake into the radiance of the sun.” Woman is morally suspect in alchemy and seems closely akin to the serpent of paradise, and for this and other reasons Canon Ripley might easily think of the new moon’s approach to the sun as a “spiram facere.”²³⁷ It should not be forgotten that a learned alchemist of the fifteenth century would have a knowledge of symbols at least as great as our own in the present exposition (if you discount the psychology), and in some cases perhaps greater. (There are still numerous unpublished MSS. in existence to which I have had no access.)

Her time being come, the Child Conceiv'd before
Issues re-borne out of her Wombe once more;
And thereupon resumes a Kingly State,
Possessing fully Heaven's Propitious Fate.

The Mother's Bed which erstwhile was a Square
Is shortly after made Orbicular;
And everywhere the Cover, likewise Round
With Luna's Lustre brightly did abound.²³⁸

[439] The second strophe confirms that the entire solution has changed into Luna, and not only is *it* transformed, but the vessel containing the matrix. The “bed,” which before was a square, now becomes round like the full moon. The “cooperculum” (cover) points more to a vessel than a bed, and this cover shines like the moon. As the cover is obviously the top part of the vessel it indicates the place where the moon rises, that is, where the content of the vessel is sublimated. The squaring of the circle, a favourite synonym for the magistry, has been accomplished. Anything angular is imperfect and has to be superseded by the perfect, here represented by the circle.²³⁹ The mother is both content (mother liquid) and container, the two being often identified; for instance, the vessel is equated with the *aqua permanens*.²⁴⁰ The production of the round and perfect means that the son issuing from the mother has attained perfection, i.e., the king has attained eternal youth and his body has become incorruptible. As the square represents the quaternio of mutually hostile elements, the circle indicates their reduction to unity. The One born of the Four is the Quinta Essentia. I need not go into the psychology of this process here as I have done so already in *Psychology and Alchemy*.

[440] *Verse 28*

Thus from a Square, the Bed a Globe is made,
And Purest Whiteness from the Blackest Shade;
While from the Bed the Ruddy Son doth spring
To grasp the Joyful Sceptre of a King.²⁴¹

[441] Vessel and content and the mother herself, who contains the father, have become the son, who has risen up from “blackest shade” to the pure whiteness of Luna and attained his redness (*rubedo*) through the *solificatio*. In him all opposites are fused together.

[442] *Verse 29*

Hence God unlock'd the Gates of Paradise,
Rais'd him like Luna to th'Imperiall Place,

Sublim'd him to the Heavens, and that being done,
Crown'd him in Glory, aequall with the Sun.²⁴²

[443] Here Ripley describes the renewal of the king and the birth of the son as the manifestation of a new redeemer—which sounds very queer indeed in the mouth of a medieval ecclesiastic. The sublimation of Luna (“uti Luna”) to the “imperial place” is an unmistakable paraphrase on the one hand of the Assumption of the Virgin and on the other of the marriage of the bride, the Church. The unlocking of paradise means nothing less than the advent of God’s Kingdom on earth. The attributes of sun and moon make the *filius regius* into the rearsen Primordial Man, who is the cosmos. It would be wrong to minimize the importance of this jubilee or to declare it is nonsense. One cannot dismiss all the alchemists as insane. It seems to me more advisable to examine the motives that led a cleric, of all people, to postulate a divine revelation outside his credo. If the lapis were nothing but gold the alchemists would have been wealthy folk; if it were the panacea they would have had a remedy for all sickness; if it were the elixir they could have lived a thousand years or more. But all this would not oblige them to make religious statements about it. If nevertheless it is praised as the second coming of the Messiah one must assume that the alchemists really did mean something of the kind. Although they regarded the art as a charisma, a gift of the Holy Ghost or of the *Sapientia Dei*,²⁴³ it was still man’s work, and, even though a divine miracle was the decisive factor, the mysterious filius was still concocted artificially in a retort.

[444] In the face of all this one is driven to the conjecture that medieval alchemy, which evolved out of the Arabic tradition sometime in the thirteenth century, and whose most eloquent witness is the *Aurora consurgens*, was in the last resort a continuation of the doctrine of the Holy Ghost, which never came to very much in the Church.²⁴⁴ The Paraclete descends upon the single individual, who is thereby drawn into the Trinitarian process.²⁴⁵ And if the spirit of procreation and life indwells in man, then God can be born in him—a thought that has not perished since the time of Meister Eckhart.²⁴⁶ The verses of Angelus Silesius are in this respect quite unequivocal:

If by God’s Holy Ghost thou art beguiled,
There will be born in thee the Eternal Child.

If it’s like Mary, virginal and pure,
Then God will impregnate your soul for sure.

God make me pregnant, and his Spirit shadow me,
That God may rise up in my soul and shatter me.

What good does Gabriel’s ‘Ave, Mary’ do

[445] Here Angelus expresses as a religious and psychological experience what the alchemists experienced in and through matter, and what Ripley is describing in his tortuous allegory. The nature of this experience is sufficient to explain the rapt language of certain verses in the *Cantilena*. He was speaking of something greater than the effects of grace in the sacraments: God himself, through the Holy Ghost, enters the work of man, in the form of inspiration as well as by direct intervention in the miraculous transformation. In view of the fact that such a miracle never did occur in the retort, despite repeated assertions that someone had actually succeeded in making gold, and that neither a panacea nor an elixir has demonstrably prolonged a human life beyond its due, and that no homunculus has ever flown out of the furnace—in view of this totally negative result we must ask on what the enthusiasm and infatuation of the adepts could possibly have been based.

[446] In order to answer this difficult question one must bear in mind that the alchemists, guided by their keenness for research, were in fact on a hopeful path since the fruit that alchemy bore after centuries of endeavour was chemistry and its staggering discoveries. The emotional dynamism of alchemy is largely explained by a premonition of these then-unheard-of possibilities. However barren of useful or even enlightening results its labours were, these efforts, notwithstanding their chronic failure, seem to have had a psychic effect of a positive nature, something akin to satisfaction or even a perceptible increase in wisdom. Otherwise it would be impossible to explain why the alchemists did not turn away in disgust from their almost invariably futile projects. Not that such disillusionments never came to them; indeed the futility of alchemy brought it into increasing disrepute. There remain, nevertheless, a number of witnesses who make it quite clear that their hopeless fumbling, inept as it was from the chemical standpoint, presents a very different appearance when seen from a psychological angle. As I have shown in *Psychology and Alchemy*, there occurred during the chemical procedure psychic projections which brought unconscious contents to light, often in the form of vivid visions. The medical psychologist knows today that such projections may be of the greatest therapeutic value. It was not for nothing that the old Masters identified their *nigredo* with melancholia and extolled the opus as the sovereign remedy for all “afflictions of the soul”; for they had discovered, as was only to be expected, that though their purses shrank their soul gained in stature—provided of course that they survived certain by no means inconsiderable psychic dangers. The projections of the alchemists were nothing other than unconscious contents appearing in matter, the same contents that modern psychotherapy makes conscious by the method of active imagination before they unconsciously change into projections. Making them conscious and giving form to what is unformed has a specific effect in cases where

the conscious attitude offers an overcrowded unconscious no possible means of expressing itself. In these circumstances the unconscious has, as it were, no alternative but to generate projections and neurotic symptoms. The conscious milieu of the Middle Ages provided no adequate outlet for these things. The immense world of natural science lay folded in the bud, as also did that questing religious spirit which we meet in many of the alchemical treatises and which, we may well conjecture, was closely akin to the empiricism of scientific research.

[447] Perhaps the most eloquent witness to this spirit was Meister Eckhart, with his idea of the birth of the son in human individuals and the resultant affiliation of man to God.²⁴⁸ Part of this spirit was realized in Protestantism, another part was intuited by the mystics who succeeded Boehme, in particular by Angelus Silesius, who quite literally “perished in the work.” He advanced even beyond Protestantism to an attitude of mind that would have needed the support of Indian or Chinese philosophy and would therefore not have been possible until the end of the nineteenth century at the earliest. In his own age Angelus could only wither away unrecognized, and this was the tragedy that befell him. A third part took shape in the empirical sciences that developed independently of all authority, and a fourth appropriated to itself the religious philosophies of the East and transplanted them with varying degrees of skill and taste in the West.

[448] No thinking person will wish to claim that the present state of affairs represents a durable end-state. On the contrary, everyone is convinced that the tempo of change and transition has speeded up immeasurably. Everything has become fragmented and dissolved, and it is impossible to see how a “higher” synthesis could take place in any of the spiritual organizations that still survive without their having to be modified to an almost intolerable degree. One of the greatest obstacles to such a synthesis is sectarianism, which is always right and displays no tolerance, picking and fomenting quarrels for the holiest of reasons in order to set itself up in the place of religion and brand anyone who thinks differently as a lost sheep, if nothing worse. But have any human beings the right to totalitarian claims? This claim, certainly, is so morally dangerous that we would do better to leave its fulfilment to Almighty God rather than presume to be little gods ourselves at the expense of our fellow-men.

[449] *Verse 30*

Four Elements, Brave Armes, and Polish'd well
God gave him, in the midst whereof did dwell
The Crownèd Maid, ordainèd for to be
In the Fifth Circle of the Myserie.²⁴⁹

[450] To the regenerated king, now endowed with the qualities of the cosmic Anthropos, God gives the four elements as the weapons with which he shall conquer the world. It is a figure that reminds us of the Manichaeon “First Man,” who, armed with the five elements, came down to fight against the darkness.²⁵⁰ The elements are evidently conceived as circles, for the Quinta Essentia, the “Maid,” appears in the fifth. The circular representation of the elements was well known in medieval alchemy.²⁵¹ The Maid is “crowned” (*redimita*), and in her we recognize the crowned Virgin, the Queen of Heaven, who recalls the old pictures of the *anima media natura*

or *anima mundi*. She is the divine life indwelling in the world, or the pneuma that moved over the waters, implanted its seed in them, and so was held captive in the body of Creation. The *anima mundi* is the feminine half of Mercurius.²⁵²

[451] In the *Cantilena* the Maid is the rejuvenated Queen Mother who now appears as the bride. Her redemption is achieved through the long sufferings of the mother, i.e., through the pains of the opus, which are compared to the Passion.²⁵³

[452] The establishment of the Maid in the fifth circle is an indication that the quintessence, portraying the disharmonious elements as a unity, is equivalent to aether, the finest and most subtle substance. She therefore participates in the world of the spirit and at the same time represents the material, sublunary world. Her position corresponds on the one hand to that of Luna and on the other to that of the Blessed Virgin.

[453]

Verses 31–35

With all delicious Unguent flowèd she
When Purg'd from Bloody Menstruosity:
On every side her Count'nance Brightly shone,
She being Adorn'd with every Precious Stone.

A Lyon Greene did in her Lapp reside
(The which an Eagle²⁵⁴ fed), and from his side
The Blood gush'd out: The Virgin drunck it upp,
While Mercuries Hand did th'Office of a Cupp.

The wondrous Milk she hasten'd from her Breast,
Bestow'd it frankly on the Hungry Beast,
And with a Sponge his Furry Face she dry'd
Which her own Milk had often Madefy'd.

Upon her Head a Diadem she did weare,
With fiery Feet sh'Advanced into the Aire;
And glittering Bravelly in her Golden Robes
She took her Place amidst the Starry Globes.

The Dark Clouds being Dispers'd, so sate she there,
And woven to a Network in her Haire
Were Planets, Times, and Signes, the while the King
With his Glad Eyes was her Beleagering.²⁵⁵

[454] Here the apotheosis of the Queen is described in a way that instantly reminds us of its prototype, the coronation of the Virgin Mary. The picture is complicated by the images of the Pietà on the one hand and the mother, giving the child her breast, on the other. As is normally the case only in dreams, several images of the Mother of God have contaminated one another, as have also the allegories of Christ as child and lion, the latter representing the body of the Crucified with the blood flowing from his side. As in dreams, the symbolism with its grotesque condensations and overlappings of contradictory contents shows no regard for our aesthetic and religious feelings; it is as though trinkets made of different metals were being melted in a crucible and their contours flowed into one another. The images have lost their pristine force, their clarity and meaning. In dreams it often happens—to our horror—that our most cherished convictions and values are subjected to just this iconoclastic mutilation. It also happens in the psychoses, when the patients sometimes come out with the most appalling blasphemies and hideous distortions of religious ideas. We find the same thing in “belles” lettres—I need only mention Joyce’s *Ulysses*, a book which E. R. Curtius has not unjustly described as a work of Antichrist.²⁵⁶ But such products spring more from the spirit of the age than from the perverse inventive gifts of the author. In our time we must expect “prophets” like James Joyce. A similar spirit prevailed at the time of the Renaissance, one of its most striking manifestations being the *Hexastichon* of Sebastian Brant.²⁵⁷ The illustrations in this little book are freakish beyond belief. The main figure in each is an evangelical symbol, for instance the eagle of St. John, and round it and on it are allegories and emblems of the principal events, miracles, parables, etc., in the gospel in question. These creations may be compared with the fantasies of George Ripley, for neither author had any inkling of the dubious nature of what he was doing. Yet in spite of their dreamlike quality these products seem to have been constructed with deliberate intent. Brant even numbered the main components of his pictures according to the chapters of the Gospel, and again in Ripley’s paraphrase of the sacred legend each item can easily be enucleated from its context. Brant thought of his pictures as mnemotechnical exercises that would help the reader to recall the contents of the gospels, whereas in fact their diabolical freakishness stamps itself on the mind far more than the recollection, say, that John 2 coincides with the marriage at Cana. The image of the Virgin with the wounded lion in her lap has the same kind of unholy fascination, precisely because it deviates so strangely from the official image to which we are accustomed.

[455] I have compared the tendency to fantastic distortion to a melting down of images, but this gives the impression that it is an essentially destructive process. In reality—and this is especially so in alchemy—it is a process of assimilation between revealed truth and knowledge of nature. I will not attempt to investigate what the unconscious motives were that animated Sebastian Brant, and I need say nothing more about

James Joyce here, as I have discussed this question in my essay “Ulysses: A Monologue.” These melting processes all express a relativization of the dominants of consciousness prevailing in a given age. For those who identify with the dominants or are absolutely dependent on them the melting process appears as a hostile, destructive attack which should be resisted with all one’s powers. Others, for whom the dominants no longer mean what they purport to be, see the melting as a longed-for regeneration and enrichment of a system of ideas that has lost its vitality and freshness and is already obsolete. The melting process is therefore either something very bad or something highly desirable, according to the standpoint of the observer.²⁵⁸

[456] In the latter category we must distinguish two kinds of alchemists: those who believed that the revealed truth represented by the Church could derive nothing but gain if it were combined with a knowledge of the God in nature; and those for whom the projection of the Christian mystery of faith into the physical world invested nature with a mystical significance, whose mysterious light outshone the splendid incomprehensibilities of Church ceremonial. The first group hoped for a rebirth of dogma, the second for a new incarnation of it and its transformation into a natural revelation.

[457] I lay particular stress on the phenomena of assimilation in alchemy because they are, in a sense, a prelude to the modern approximation between empirical psychology and Christian dogma—an approximation which Nietzsche clearly foresaw. Psychology, as a science, observes religious ideas from the standpoint of their psychic phenomenology without intruding on their theological content. It puts the dogmatic images into the category of psychic contents, because this constitutes its field of research. It is compelled to do so by the nature of the psyche itself; it does not, like alchemy, try to explain psychic processes in theological terms, but rather to illuminate the darkness of religious images by relating them to similar images in the psyche. The result is a kind of amalgamation of ideas of—so it would seem—the most varied provenience, and this sometimes leads to parallels and comparisons which to an uncritical mind unacquainted with the epistemological method may seem like a devaluation or a false interpretation. If this were to be construed as an objection to psychology one could easily say the same thing about the hermeneutics of the Church Fathers, which are often very risky indeed, or about the dubious nature of textual criticism. The psychologist has to investigate religious symbols because his empirical material, of which the theologian usually knows nothing, compels him to do so. Presumably no one would wish to hand over the chemistry of albuminous bodies to some other department of science on the ground that they are organic and that the investigation of life is a matter for the biologist. A rapprochement between empirical science and religious experience would in my opinion be fruitful for both. Harm can result only if one side or the other remains unconscious of the limitations

of its claim to validity. Alchemy, certainly, cannot be defended against the charge of unconsciousness. It is and remains a puzzle whether Ripley ever reflected on his theological enormities and what he thought about them. From a scientific point of view, his mentality resembles that of a dream-state.

[458] The coronation of the Virgin and the heavenly marriage bring us to the final strophes of the *Cantilena*.

[459] *Verses 36–3*

Thus He of all Triumphant Kings is Chiefe,
Of Bodies sicke the only Grand Reliefe:
Such a Reformist of Defects, that hee
Is worshipp'd both by King and Commonalty.

To Princes, Priests he yields an Ornament,
The Sicke and Needy Sort he doth content:
What man is there this Potion will not bless,
As banishes all thought of Neediness?²⁵⁹

[460] This is the apotheosis of the *filius regius*, as we find it in numerous treatises. Thus the “Tractatus aureus”²⁶⁰ says: “The king comes forth from the fire and rejoices in the marriage. The son is become a warrior of the fire and surpasses the tinctures, for he himself is the treasure and himself is attired in the philosophic matter. Come hither, ye sons of wisdom, let us be glad and rejoice, for the dominion of death is over, and the son reigns; he is clothed with the red garment, and the purple is put on.” The reborn king is the “wonder of the world,” “an exceeding pure spirit”;²⁶¹ he is, the “Aquarium sapientum” assures us, “the most elect, the most subtile, the purest, and noblest of all the heavenly spirits, to whom all the Test yield obedience as to their King, who bestows on men all health and prosperity, heals all sickness, gives to the God-fearing temporal honour and long life, but to the wicked who abused him, eternal punishment. . . . In sum, they have designated him the chief of all things under heaven, and the marvellous end and epilogue of all philosophic works. Hence some devout philosophers of old have affirmed that he was divinely revealed to Adam, the first man, and thereafter was awaited with peculiar longing by all the holy Patriarchs.”²⁶² “The Almighty,” remarks the “Introitus,” “has made him known by a most notable sign, whose birth²⁶³ is declared throughout the East on the horizon of his hemisphere. The wise Magi saw it at the beginning of the era, and were astonished, and straightway they knew that the most serene King was born in the world. Do you, when you see his star, follow it to the cradle, and there you shall behold the fair infant. Cast aside your defilements, honour the royal child, open your treasure, offer a

gift of gold; and after death he will give you flesh and blood, the supreme Medicine in the three monarchies of the earth.”²⁶⁴ The clothing of the elixir with the “kingly garment” is also found in the *Turba*.²⁶⁵ The “Consilium coniugii” describes the king as “descending from heaven.”²⁶⁶ Mylius says of King Sol that “Phoebus with shining hair of gold sits in the midst, like a king and emperor of the world, grasping the sceptre and the helm.” In him are “all the powers of heaven.”²⁶⁷ In another place he cites the following quotation: “And at last the king will go forth crowned with his diadem, radiant as the sun, bright as the carbuncle.”²⁶⁸ Khunrath speaks of the “wondrous natural triune Son of the Great World,” whom the sages name “their Son and crowned King, artificially hatched from the egg of the world.”²⁶⁹ Elsewhere he says of the *filius Mundi Maioris*:

The Son of the great World [Macrocosm] who is Theocosmos, i.e., a divine power and world (but whom even today, unfortunately, many who teach nature in a pagan spirit and many builders of medical science reject in the high university schools), is the exemplar of the stone which is Theanthropos, i.e., God and man (whom, as Scripture tells us, the builders of the Church have also rejected); and from the same, in and from the Great World Book of Nature, [there issues] a continuous and everlasting doctrine for the wise and their children: indeed, it is a splendid living likeness of our Saviour Jesus Christ, in and from the Great World which by nature is very similar to him (as to miraculous conception, birth, inexpressible powers, virtues, and effects); so God our Lord, besides his Son’s Biblical histories, has also created a specific image and natural representation for us in the Book of Nature.²⁷⁰

[461] These few examples, together with those already quoted in *Psychology and Alchemy*, may give the reader some idea of the way in which the alchemists conceived the triumphant king.

[462]

Verse 38

Wherefore, O God, graunt us a Peece of This,²⁷¹
That through the Encrease²⁷² of its own Species
The Art may be Renew’d, and Mortal Men
Enjoy for aye its Thrice-Sweet Fruits. AMEN.²⁷³

[463] Here ends the *Cantilena*, one of the most perfect parables of the renewal of the king. It does not, of course, compare with the much more elaborate development of the myth in Christian Rosencreutz. (His *Chymical Wedding* is so rich in content that I could touch on it only lightly here.) The latter part of *Faust II* likewise contains the same motif of the transformation of the old man into a boy, together with all the necessary indicia of the heavenly marriage. This theme, too, as in alchemy, runs through the whole of *Faust* and repeats itself on three different levels (Gretchen,

Helen, Queen of Heaven), just as the king's renewal takes a form that was destined to fail three times before Faust's death (the Boy Charioteer, the Homunculus, and Euphorion).

5. THE DARK SIDE OF THE KING

[464] Besides the *Cantilena*, there are various other descriptions²⁷⁴ of the king's renewal, enriched with numerous details, which I will not discuss here so as not to overburden this chapter. The material we have adduced may suffice to illustrate the essential features of the transformation process. Nevertheless, the myth of the king's renewal has so many ramifications that our exposition so far does not cover the entire range of the symbol. In this section, therefore, I shall try to shed a little more light on the critical phase of the *nigredo*, the phase of decay and death.



“Third Picture of John”

From the *Hexastichon* of Sebastian Brant (1502), fol. a.v^r



c ij

“Second Picture of Luke”

From the *Hexastichon* of Sebastian Brant (1502), fol. c.iii^r



“Jezoth le Juste”

From an 18th cent ms., “Abraham le Juif.” Bibliotheque Nationale, Fr. 14765, Pl. 8



The Two Unipeds

From a Latin ins., "Figurarum aegyptiorum secretarum" (author's collection), p. 20



The "Revelation of the Hidden"

From the author's "Figuraruan aegyptiorum secretarum," p. 27



The Worldly and the Spiritual Power
From the author's "Figurarum aegyptiorum secretarum," p. 31



The Royal Pair

From the author's "Figurarum aegyptiorum secretarum," p. 33



The Eye-Motif in a Modern Painting



The Eye-Motif in a Modern Painting
Author's collection



The Nigredo
From the Theatrum chemicum, Vol. IV (1613), p. 570

[465] The king's decline, as we saw, was due to imperfection or sickness. In the *Cantilena* his sickness was sterility. The figure of the sterile king may perhaps come from the "Arisleus Vision,"²⁷⁵ where the King of the Sea rules over an unfruitful country, although he himself is not sterile. Usually the king is connected in some way with the world of darkness. Thus, in the "Introitus," he is at first the "secret, infernal fire,"²⁷⁶ but as the reborn *puellus regius* (kingly boy) he is an allegory of Christ. In Michael Maier the king is dead and yet imprisoned alive in the depths of the sea, whence he calls for help.²⁷⁷ The following story of the king is from Trismosin's *Splendor solis*:

The old Philosophers declared they saw a Fog rise, and pass over the whole face of the earth, they also saw the impetuosity of the Sea, and the streams over the face of the earth, and how these same became foul and stinking in the darkness. They further saw the king of the Earth sink, and heard him cry out with eager voice,²⁷⁸ "Whoever saves me shall live and reign with me for ever in my brightness on my royal throne," and Night enveloped all things. The day after, they saw over the King an apparent Morning Star, and the light of Day clear up the darkness, and bright Sunlight pierce through the clouds, with manifold coloured rays of brilliant brightness, and a sweet perfume from the earth, and the Sun shining clear. Herewith was completed the Time when the King of the Earth was released and renewed, well apparelled, and quite handsome, surprising with his beauty the Sun and Moon. He was crowned with three costly crowns, the one of Iron, the other of Silver, and the third of pure Gold. They saw in his right hand a Sceptre with Seven Stars, all of which gave a golden Splendour [etc., etc.].²⁷⁹

[466] The seven stars are a reference to Rev. 1 : 16: "And he had in his right hand seven stars." He who held them was "like unto the Son of man," in agreement with the *puellus regius* in the "Introitus." The king sinking in the sea is the arcane substance, which Maier calls the "antimony of the philosophers."²⁸⁰ The arcane substance corresponds to the Christian dominant, which was originally alive and present in consciousness but then sank into the unconscious and must now be restored in renewed form. Antimony is associated with blackness: antimony trisulphide is a widely used Oriental hair-dye (*kohl*). On the other hand antimony pentasulphide, "gold-sulphur" (*Sulphur auratum antimonii*) is orange-red.

[467] The sunken king of alchemy went on living as the "metal king," the "regulus" of metallurgy. This is the name for the lumps of metal formed beneath the slag in melting and reducing ores. The term *Sulphur auratum antimonii*, like gold-sulphur, indicates the strong predominance of sulphur in combination with antimony. Sulphur, as we have seen, is the active substance of Sol and is foul-smelling: sulphur dioxide and sulphuretted hydrogen give one a good idea of the stink of hell. Sulphur is an

attribute of Sol as Leo is of Rex. Leo, too, is ambiguous: on the one hand he is an allegory of the devil and on the other is connected with Venus. The antimony compounds known to the alchemists (Sb_2S_5 , Sb_2S_3) therefore contained a substance which clearly exemplified the nature of Rex and Leo, hence they spoke of the “triumph of antimony.”²⁸¹

[468] As I have shown in *Psychology and Alchemy*,²⁸² the sunken king forms a parallel to Parable VII of *Aurora Consurgens*:^{282a} Be turned to me with all your heart and do not cast me aside because I am black and swarthy, because the sun hath changed my colour and the waters have covered my face and the land hath been polluted and defiled in my works; for there was darkness over it, because I stick fast in the mire of the deep and my substance is not disclosed. Wherefore out of the depths have I cried, and from the abyss of the earth with my voice to all you that pass by the way. Attend and see me, if any shall find one like unto me, I will give into his hand the morning star.

[469] The “mire of the deep” refers to Psalm 68 : 3 (Vulgate) : “Infixus sum in limo profundi et non est substantia” (AV 69 : 2: “I sink in deep mire, where there is no standing”). David’s words are interpreted by Epiphanius²⁸³ as follows: there is a material which consists of “miry reflections” and “muddy thoughts of sin.” But of Psalm 130 : 1: “Out of the depths have I cried to thee, O Lord,” he gives the following interpretation: “After the saints are so graced that the Holy Ghost dwells within them, he gives them, after having made his habitation in the saints, the gift to look into the deep things of God, that they may praise him from the depths, as also David declares: ‘Out of the depths,’ he says, ‘have I cried to thee, O Lord.’”²⁸⁴

[470] These contradictory interpretations of the “depths” (*profunda*) come much closer together in alchemy, often so close that they seem to be nothing more than two different aspects of the same thing. It is natural that in alchemy the depths should mean now one and now the other, to the despair of all lovers of consistency. But the eternal images are far from consistent in meaning. It is characteristic of the alchemists that they never lost sight of this polarity, thereby compensating the world of dogma, which, in order to avoid ambiguity, emphasizes the one pole to the exclusion of the other. The tendency to separate the opposites as much as possible and to strive for singleness of meaning is absolutely necessary for clarity of consciousness, since discrimination is of its essence. But when the separation is carried so far that the complementary opposite is lost sight of, and the blackness of the whiteness, the evil of the good, the depth of the heights, and so on, is no longer seen, the result is one-sidedness, which is then compensated from the unconscious without our help. The counterbalancing is even done against our will, which in consequence must become more and more fanatical until it brings about a

catastrophic enantiodromia. Wisdom never forgets that all things have two sides, and it would also know how to avoid such calamities if ever it had any power. But power is never found in the seat of wisdom; it is always the focus of mass interests and is therefore inevitably associated with the illimitable folly of the mass man.

[471] With increasing one-sidedness the power of the king decays, for originally it had consisted just in his ability to unite the polarity of all existence in a symbol. The more distinctly an idea emerges and the more consciousness gains in clarity, the more monarchic becomes its content, to which everything contradictory has to submit. This extreme state has to be reached, despite the fact that the climax always presages the end. Man's own nature, the unconscious, immediately tries to compensate, and this is distasteful to the extreme state, which always considers itself ideal and is moreover in a position to prove its excellence with the most cogent arguments. We cannot but admit that it is ideal, but for all that it is imperfect because it expresses only one half of life. Life wants not only the clear but also the muddy, not only the bright but also the dark; it wants all days to be followed by nights, and wisdom herself to celebrate her carnival, of which indeed there are not a few traces in alchemy. For these reasons, too, the king constantly needs the renewal that begins with a descent into his own darkness, an immersion in his own depths, and with a reminder that he is related by blood to his adversary.

[472] According to the *Ancoratus* of Epiphanius, the phoenix emerges from his ashes first in the form of a worm:

When the bird is dead, indeed utterly consumed, and the flames are extinguished, there are left only the crude remnants of the flesh. From this there comes forth in one day an unseemly worm, which puts on wings and becomes as new; but on the third day it matures, and after growing to full stature with the aid of the medicines found in that place, it shows itself, and hastens upward once more to its own country, and there rests.²⁸⁵

So, too, the king rises from his "infernal fire" as a crowned dragon.²⁸⁶ He is the Mercurial serpent, which is especially connected with evil-smelling places ("it is found on the dunghills").²⁸⁷ The fact that the passage in the *Ancoratus* stresses the "one day" may perhaps throw some light on the apparently unique reference in Khunrath's *Amphitheatrum* to the "filius unius (SVI) diei"²⁸⁸ as a designation for the "Hermaphrodite of nature," i.e., the arcane substance. He is there synonymous with "Saturn,"²⁸⁹ the ambisexual Philosophic Man of the philosophers, the lead of the sages, the Philosophic World-Egg . . . the greatest wonder of the world, the Lion, green and red . . . A lily among thorns."²⁹⁰

[473] As we have seen, the *filius regius* is identical with Mercurius and at this particular stage also with the Mercurial serpent. This stage is indicated in Khunrath

by Saturn, the dark, cold *maleficus*; by the world-egg, obviously signifying the initial state, and finally by the green and red lion, representing the animal soul of the king. All this is expressed by the dragon or serpent as the *summa summarum*. The dragon as the lowest and most inchoate form of the king is, we are constantly told, at first a deadly poison but later the alexipharmic itself.

[474] In the myth of the phoenix as reported by Pliny we again meet the worm: "... from its bones and marrow is born first a sort of maggot, and this grows into a chicken."²⁹¹ This version is repeated in Clement of Rome,²⁹² Artemidorus,²⁹³ Cyril of Jerusalem,²⁹⁴ St. Ambrose,²⁹⁵ and Cardan.²⁹⁶ In order to understand the phoenix myth it is important to know that in Christian hermeneutics the phoenix is made an allegory of Christ, which amounts to a reinterpretation of the myth.²⁹⁷ The self-burning of the phoenix corresponds to Christ's self-sacrifice, the ashes to his buried body, and the miraculous renewal to his resurrection.²⁹⁸ According to Horapollo (4th cent.), whose views were taken over by later writers,²⁹⁹ the phoenix signifies the soul and its journey to the land of rebirth.³⁰⁰ It stands for the "long-lasting restitution of things" (*ἀποκατάστασιν πολυχρόνιον*); indeed, it is renewal itself.³⁰¹ The idea of apocatastasis or restitution (Acts 3 : 21) and re-establishment in Christ (Ephesians 1 : 10, DV)³⁰² may well have helped the assimilation of the phoenix allegory, quite apart from the main motif of renewal.

[475] Khunrath's insertion of the word "SVI," in capital letters, after "unius" plainly indicates that he was referring to something divine. This can only be some analogy of God or Christ. Nowhere else in the alchemical texts is this "one" day mentioned, except for an occasional remark that by the special grace of God the opus could be completed in one day. Khunrath's "SVI" seems to refer rather to God, in the sense that the *filius regius* is born on "His" day, the day that belongs to God or is chosen by him. Since the phoenix is mainly an allegory of resurrection, this one day of birth and renewal must be one of the three days of Christ's burial and descent into hell. But there is nothing about this one day in Christian dogma, unless Khunrath, who had a speculative mind, was anticipating the arguments of certain Protestant dogmaticians who, following Luke 23 : 43,³⁰³ propounded the theory that after his death Christ did not immediately descend into hell (as in Catholic dogma), but remained in paradise until Easter morning. And just as there was an earthquake at the moment when Christ's soul separated from his body in death, so there was another earthquake on Easter morning (Matthew 28 : 2). During this earthquake Christ's soul was reunited with his body,³⁰⁴ and only then did he descend into hell to "preach to the spirits in prison" (I Peter 3 : 19). Meanwhile the angel at the tomb appeared in his place and spoke to the women. The descent into hell is supposed to be limited to this short space of time.³⁰⁵

[476] On this view the “one day” would be Easter Day. In alchemy the uniting of the soul with the body is the miracle of the coniunctio, by which the lapis becomes a living body. The phoenix signifies precisely this moment.³⁰⁶ The alchemical transformation was often compared to the rising of the sun. But apart from the fact that there is not the slightest ground for supposing that such speculations ever entered Khunrath’s head, the Easter morning hypothesis does not seem very satisfactory. The special element of the *worm* is missing, which Epiphanius stresses in connection with the one day. It seems as though this element should not be overlooked in explaining the *filius unius diei*. The one day probably refers to Genesis 1:5: “And there was evening and there was morning, one day” (RSV).³⁰⁷ This was after the separation of light from darkness (or the creation of light), and here it should be remembered that darkness precedes the light and is its mother.³⁰⁸ The son of this one day is the Light, the Logos (John 1:5), who is the Johannine Christ.³⁰⁹ So interpreted, the son of one day immediately becomes related to the “Hermaphrodite of nature,”³¹⁰ the Philosophic Man, and to Saturn, the tempter and oppressor,³¹¹ who, as Ialdabaoth and the highest archon, is correlated with the lion. All these figures are synonyms for Mercurius.

[477] There is a didactic poem, *Sopra la composizione della pietra dei Philosophic* by Fra Marcantonio Crasselame, which was published in a work significantly entitled *La Lumière sortant par soi-mesme des Ténèbres*.³¹² As the title shows, this is not the light that was created by the Logos, but a spontaneous, self-begotten light. The poem begins with the creation of the world and declares that the Word created chaos:

At the Omnipotent’s first word, shadowy Chaos, formless mass, came from the void.

But who knows how all things were made? Only the “sons of the Art”:

O emulous Sons of Divine Hermes, to whom the paternal Art makes Nature visible without any veil, you, you alone, know how the eternal Hand fashioned earth and Heaven out of shapeless Chaos. Your own great Work clearly shows you that God made Everything in the same manner as the Physical Elixir is produced.

[478] The *opus alchymicum* recapitulates the secret of creation which began with the incubation of the waters. Mercurius, a living and universal spirit, descends into the earth and mingles with the impure sulphurs, thus becoming fixed:

If I be clearly understood, your unknown Mercury is nothing other than a living innate universal Spirit which, ever agitated in aerial vapour, descends from the Sun to fill the empty Centre of the Earth; whence it later issues forth from the impure Sulphurs and, from volatile, becomes fixed and, having taken form, imparts its form to the radical moisture.

[479] But through his descent Mercurius is made captive and can be freed only by the art:

But where is this golden Mercury, this radical moisture, which, dissolved in sulphur and salt, becomes the animated seed of the metals? Ah, he is incarcerated and held so fast that even Nature cannot release him from the harsh prison, unless the Master Art open the way.

[480] It is a spirit of light that descends from the sun,³¹³ a living spirit that lives in all creatures as the spirit of wisdom,³¹⁴ and teaches man the art whereby the “soul enchained in the elements” may be freed. From Mercurius comes the illumination of the adept, and it is through his work that Mercurius is freed from his chains. This Mercurius duplex, who ascends and descends, is the uroboros, by definition an “increatum.”³¹⁵ It is the snake that begets itself from itself.³¹⁶ Although the poem takes Mercurius chiefly as a spirit of light, the uroboros is a *Ἑρμῆς καταχθόνιος* (subterranean Hermes). Mercurius is a compound of opposites, and the alchemists were primarily concerned with his dark side, the serpent.

[481] It is an age-old mythological idea that the hero, when the light of life is extinguished, goes on living as a snake and is worshipped as a snake.³¹⁷ Another widespread primitive idea is the snake-form of the spirits of the dead. This may well have given rise to the worm version of the phoenix myth.

[482] In Amente, the Egyptian underworld, dwells the great seven-headed snake,³¹⁸ and in the Christian underworld is the most celebrated snake of all, the devil, “that old serpent.”³¹⁹ Actually it is a pair of brothers that inhabit hell, namely death and the devil, the devil being characterized by the snake and death by worms. In old German the concepts of worm, snake, and dragon coalesce, as they do in Latin (*vermis*, *serpens*, *draco*). The underworld signifies hell³²⁰ and the grave.³²¹ The worm or serpent is all-devouring death. The dragon-slayer is therefore always a conqueror of death. In Germanic mythology, too, hell is associated with worms. The *Edda* says:

A hall did I see
Far from the sun,
On the shore of death,
The door to the north.
Dripping poison
Drops from the roof;
The chamber walls
Are bodies of worms.³²²

Hell in Old English is called the “worm’s hall” (*wyrmsele*) and in Middle High German it is the “worm-garden.”³²³

[483] Like the heroes and spirits of the dead, the gods too (particularly the earth-gods), are associated with the snake, as are Hermes and Asklepios.³²⁴ Indeed, the Greek god of healing, on being hatched from the egg, seems to have taken the form of a snake.³²⁵ An inscription on the temple of Hathor at Denderah reads:³²⁶

The sun, who has existed from the beginning, rises up like a falcon out of the midst of his lotus-bud. When the doors of his petals open in sapphire-coloured splendour, he has sundered the night from the day. Thou risest up like the sacred snake as a living spirit, creating the beginnings and shining in thy glorious form in the barge of the sunrise. The divine Lord whose image dwells in secret in the temple at Denderah is made the creator of the world by his work. Coming as one, he multiplies himself a millionfold when the light goes forth from him in the form of a child.³²⁷

The comparison of the god to a snake reminds us of his chthonic form in the underworld, just as the rejuvenated phoenix (falcon) first takes the form of a worm.³²⁸ As Christianity borrowed a good deal from the Egyptian religion it is not surprising that the allegory of the snake found its way into the world of Christian ideas (John 3 : 14) and was readily seized on by the alchemists.³²⁹ The dragon is an allegory of Christ as well as of the Antichrist.³³⁰ A remarkable parallel occurs in the anonymous treatise, “De promissionibus” (5th cent.).³³¹ It concerns a version of the legend of St. Sylvester, according to which this saint imprisoned a dragon in the Tarpeian Rock and so rendered him harmless. The other version of this story is related by a “certain monk” who discovered that the alleged dragon, to whom offerings of virgins were made, was nothing but a mechanical device. St. Sylvester locked the dragon up with a chain, as in Rev. 20 : 1; but in the parallel story the artificial dragon “brandished a sword in its mouth,” like the Son of Man in Rev. 1 : 16.³³²

6. THE KING AS ANTHROPOS

[484] I have drawn attention earlier³³³ to the passage in Hippolytus where the Gnostic interpretation of Psalm 24 : 7–10 is discussed. The rhetorical question of the psalm, “Who is this king of glory?” is answered in Hippolytus thus: “A worm and no man, the reproach of men and the outcast of the people.”³³⁴ He is the king of glory, mighty in battle.” This passage, says Hippolytus, refers to Adam and his “ascension and rebirth, that he may be born spiritual, not fleshly.”³³⁵ The worm therefore signifies the second Adam, Christ. Epiphanius also mentions the worm as an allegory of Christ,³³⁶ though without substantiating it further.

[485] This train of thought is consciously or unconsciously continued in alchemy. The “Aquarium sapientum” says:³³⁷

And firstly it is here to be noted, that the Sages have called this decomposed product, on account of its blackness (Cant. 1), the raven's head. In the same way Christ (Isa. 53) had no form nor comeliness, was the vilest of all men, full of griefs and sicknesses, and so despised that men even hid their faces from him, and he was esteemed as nothing. Yea, in the 22nd Psalm [Vulgate] he complains of this, that he is a worm and no man, the laughing-stock and contempt of the people; indeed, it is not unfitly compared with Christ when the putrefied body of the Sun lies dead, inactive, like ashes, in the bottom of the phial, until, as a result of greater heat, its soul by degrees and little by little descends to it again, and once more infuses, moistens, and saturates the decaying and all but dead body, and preserves it from total destruction. So also did it happen to Christ himself, when at the Mount of Olives, and on the cross, he was roasted³³⁸ by the fire of the divine wrath³³⁹ (Matt. 26, 27), and complained that he was utterly deserted by his heavenly Father, yet none the less was always (as is wont to happen also to an earthly body through assiduous care and nourishing) comforted and strengthened (Matt. 4, Luke 22) and, so to speak, imbued, nourished, and supported with divine nectar; yea, when at last, in his most sacred passion, and at the hour of death, his strength and his very spirit were completely withdrawn from him, and he went down to the lowest and deepest parts below the earth (Acts 1, Eph. 1, I Peter 3), yet even there he was preserved, refreshed, and by the power of the eternal Godhead raised up again, quickened, and glorified (Rom. 14), when finally his spirit, with its body dead in the sepulchre, obtained a perfect and indissoluble union, through his most joyful resurrection and victorious ascension into heaven, as Lord and Christ (Matt. 28) and was exalted (Mark 16) to the right hand of his Father; with whom through the power and virtue of the Holy Spirit as true God and man he reigns and rules over all things in equal power and glory (Ps. 8), and by his most powerful word preserveth and upholdeth all things (Hebr. 1) and maketh all things one (Acts 17). And this wondrous Union and divine Exaltation angels and men, in heaven and on earth and under the earth (Philipp. 2, 1 Peter 1) can scarce comprehend, far less meditate upon, without fear and terror; and his virtue, power, and roseate Tincture³⁴⁰ is able even now to change, and tint, and yet more, perfectly to cure and heal us sinful men in body and soul: of which things we shall have more to say below . . . Thus, then, we have briefly and simply considered the unique heavenly foundation and corner-stone Jesus Christ, that is to say, *how he is compared and united with the earthly philosophical stone of the Sages, whose material and preparation, as we have heard, is an outstanding type and lifelike image of the incarnation of Christ.*

[486] The various fatalities which the old king has to suffer—immersion in the bath or in the sea, dissolution and decomposition, extinction of his light in the darkness, incineration in the fire, and renewal out of the chaos—are derived by the alchemists

from the dissolution of the “matter” in acids, from the roasting of ores, the expulsion of sulphur or mercury, the reduction of metallic oxides, and so forth, as if these chemical procedures yielded a picture which, with a little straining of the imagination, could be compared with Christ’s sufferings and his final triumph. The fact that they projected the Passion as an unconscious premise into the chemical transformations was not at all clear to the alchemists.³⁴¹ Naturally, under these circumstances, they were able to prove with complete success that their alleged observations coincided with the Passion. Only, it was not a question of their making observations on matter, but of introspection. Since, however, genuine projections are never voluntarily made but always appear as preconscious factors, there must have been something in the unconscious of the alchemists which lent itself to projection (i.e., had a tendency to become conscious because of its energy charge), and on the other hand found in the alchemical operations a “hook” that attracted it, so that it could express itself in some way. Projection is always an indirect process of becoming conscious—indirect because of the check exercised by the conscious mind, by the pressure of traditional or conventional ideas which take the place of real experience and prevent it from happening. One feels that one possesses a valid truth concerning the unknown, and this makes any real knowledge of it impossible. The unconscious factor must necessarily have been something that was incompatible with the conscious attitude. What it was in reality we learn from the statements of the alchemists: a myth that had much in common not only with many mythologems of pagan origin but above all with Christian dogma. If it were identical with the dogma and appeared in projection it would show that the alchemists had a thoroughly anti-Christian attitude (which was not the case). Lacking such an attitude a projection of this kind would be psychologically impossible. But if the unconscious complex represented a figure that deviated from the dogma in certain essential features, then its projection becomes possible, for it would then be in opposition to the dogma approved by consciousness and would have arisen by way of compensation.

[487] In this and my other writings I have constantly stressed the peculiar nature of the alchemists’ statements and need not recapitulate what I have said. I should only like to point out that the central idea of the *filius philosophorum* is based on a conception of the Anthropos in which the “Man” or the “Son of Man” does not coincide with the Christian, historical redeemer figure. The alchemical Anthropos comes closer to the Basilidian conception of him as reported by Hippolytus: “For he [the Redeemer] . . . is in their view the inner spiritual man in the psychic . . . which is the Sonship that left the soul here not to die but to remain according to its nature, just as the first Sonship left behind on high the Holy Ghost, who is conterminous with him, in the appropriate place, clothing himself in his own soul.”³⁴²

[488] The inner spiritual man bears a resemblance to Christ—that is the unconscious premise for the statements about the *filius regius*.³⁴³ This idea contradicts the dogmatic view and therefore has every reason to be repressed and projected. At the same time it is the logical consequence of a spiritual situation in which the historical figure had long since disappeared from consciousness, while his spiritual presence was stressed all the more strongly in the form of the inner Christ or God who is born in the soul of man. The outward fact of the dogmatic Christ was answered from within by that inner primordial image which had produced a Purusha or a Gayomart long before the Christian era and made the assimilation of the Christian revelation possible. The ultimate fate of every dogma is that it gradually becomes soulless. Life wants to create new forms, and therefore, when a dogma loses its vitality, it must perforce activate the archetype that has always helped man to express the mystery of the soul. Note that I do not go so far as to say that the archetype actually *produces* the divine figure. If the psychologist were to assert that, he would have to possess a sure knowledge of the motives that underlie all historical development and be in a position to demonstrate this knowledge. But there is no question of that. I maintain only that the psychic archetype makes it possible for the divine figure to take form and become accessible to understanding. But the supremely important motive power which is needed for this, and which sets the archetypal possibilities in motion at a given historical moment, cannot be explained in terms of the archetype itself. Only experience can establish which archetype has become operative, but one can never predict that it *must* enter into manifestation. Who, for instance, could logically have foretold that the Jewish prophet Jesus would give the decisive answer to the spiritual situation in the age of Hellenistic syncretism, or that the slumbering image of the Anthropos would waken to world dominion?

[489] The limitations of human knowledge which leave so many incomprehensible and wonderful things unexplained do not, however, exempt us from the task of trying to understand the revelations of the spirit that are embodied in dogma, otherwise there is a danger that the treasures of supreme knowledge which lie hidden in it will evaporate into nothing and become a bloodless phantom, an easy prey for all shallow rationalists. It would be a great step forward, in my opinion, if at least it were recognized how far the truth of dogma is rooted in the human psyche, which is not the work of human hands.

[490] The inner spiritual man of the Gnostics is the Anthropos, the man created in the image of the Nous, the ἀληθινὸς ἄνθρωπος (true man).³⁴⁴ He corresponds to the *chên-yên* (true man) of Chinese alchemy. The *chên-yên* is the product of the opus. On the one hand he is the adept who is transformed by the work,³⁴⁵ on the other he is the homunculus or filius of Western alchemy, who also derives from the true man.³⁴⁶ The treatise of Wei Po-yang says:

The ear, the eye, and the mouth constitute the three precious things. They should be closed, to stop communication. The True Man living in a deep abyss, floats about the centre of the round vessel . . . The mind is relegated to the realm of Nonexistence so as to acquire an enduring state of thoughtlessness. When the mind is integral, it will not go astray. In its sleep, it will be in God's embrace, but during its waking hours it is anxious about the continuation or termination of its existence.³⁴⁷

This true man is Dorn's "vir unus" and at the same time the lapis Philosophorum.³⁴⁸

[491] The "true man" expresses the Anthropos in the individual human being. Compared with the revelation of the Son of Man in Christ this seems like a retrograde step, for the historical uniqueness of the Incarnation was *the* great advance which gathered the scattered sheep about one shepherd. The "Man" in the individual would mean, it is feared, a scattering of the flock. This would indeed be a retrograde step, but it cannot be blamed on the "true man"; its cause is rather all those bad human qualities which have always threatened and hindered the work of civilization. (Often, indeed, the sheep and the shepherd are just about equally inept.) The "true man" has nothing to do with this. Above all he will destroy no valuable cultural form since he himself is the highest form of culture. Neither in the East nor in the West does he play the game of shepherd and sheep, because he has enough to do to be a shepherd to himself.

[492] If the adept experiences his own self, the "true man," in his work, then, as the passage from the "Aquarium sapientum" shows, he encounters the analogy of the true man—Christ—in new and direct form, and he recognizes in the transformation in which he himself is involved a similarity to the Passion. It is not an "imitation of Christ" but its exact opposite: an assimilation of the Christ-image to his own self, which is the "true man."³⁴⁹ It is no longer an effort, an intentional straining after imitation, but rather an involuntary experience of the reality represented by the sacred legend. This reality comes upon him in his work, just as the stigmata come to the saints without being consciously sought. They appear spontaneously. The Passion *happens to* the adept, not in its classic form—otherwise he would be consciously performing spiritual exercises—but in the form expressed by the alchemical myth. It is the arcane substance that suffers those physical and moral tortures; it is the king who dies or is killed, is dead and buried and on the third day rises again. And it is not the adept who suffers all this, rather *it* suffers in him, *it* is tortured, *it* passes through death and rises again. All this happens not to the alchemist himself but to the "true man," who he feels is near him and in him and at the same time in the retort. The passion that vibrates in our text and in the *Aurora* is genuine, but would be totally incomprehensible if the lapis were nothing but a chemical substance. Nor does it originate in contemplation of Christ's Passion; it is the real experience of a man who has got involved in the compensatory contents of the unconscious by investigating

the unknown, seriously and to the point of self-sacrifice. He could not but see the likeness of his projected contents to the dogmatic images, and he might have been tempted to assume that his ideas were nothing else than the familiar religious conceptions, which he was using in order to explain the chemical procedure. But the texts show clearly that, on the contrary, a real experience of the opus had an increasing tendency to assimilate the dogma or to amplify itself with it. That is why the text says that Christ was “compared and united” with the stone. The alchemical Anthropos showed itself to be independent of any dogma.³⁵⁰

[493] The alchemist experienced the Anthropos in a form that was imbued with new vitality, freshness and immediacy, and this is reflected in the enthusiastic tone of the texts. It is therefore understandable that every single detail of the primordial drama would be realized in quite a new sense. The *nigredo* not only brought decay, suffering, death, and the torments of hell visibly before the eyes of the alchemist, it also cast the shadow of its melancholy over his own solitary soul.³⁵¹ In the blackness of a despair which was not his own, and of which he was merely the witness, he experienced how *it* turned into the worm and the poisonous dragon.³⁵² From inner necessity the dragon destroyed itself (*natura naturam vincit*) and changed into the lion,³⁵³ and the adept, drawn involuntarily into the drama, then felt the need to cut off its paws³⁵⁴ (unless there were two lions who devoured one another). The dragon ate its own wings as the eagle did its feathers.³⁵⁵ These grotesque images reflect the conflict of opposites into which the researcher’s curiosity had led him. His work began with a *katabasis*, a journey to the underworld as Dante also experienced it,³⁵⁶ with the difference that the adept’s soul was not only impressed by it but radically altered. *Faust I* is an example of this: the transformation of an earnest scholar, through his pact with the devil, into a worldly cavalier and crooked careerist. In the case of the fanciful Christian Rosencreutz the descent to Venus led only to his being slightly wounded in the hand by Cupid’s arrow. The texts, however, hint at more serious dangers. Olympiodorus says:³⁵⁷ “Without great pains this work is not perfected; there will be struggles, violence, and war. And all the while the demon Ophiuchos³⁵⁸ instils negligence (*ὀλιγωρίαν*), impeding our intentions; everywhere he creeps about, both within and without, causing oversights, anxiety, and unexpected accidents, or else keeping us from the work by harassments (*λύπαις*) and injuries.” The philosopher Petasios (Petesis), quoted by Olympiodorus, expresses himself even more strongly: “So bedevilled (*δαιμονοπληξίας*) and shameless (*ἀναιδείας*) is the lead³⁵⁹ that all who wish to investigate it fall into madness through ignorance.” That this is not just empty talk is shown by other texts, which often emphasize how much the psyche of the laborant was involved in the work. Thus Dorn, commenting on the quotation from Hermes, “All obscurity shall yield before thee,” says:

For he saith, All obscurity shall yield before thee; he saith not, before the metals. By obscurity is to be understood naught else but the darkness of diseases and sickness of body and mind . . . The author's intention is, in sum, to teach them that are adepts in spagyric medicine how with a very small dose, such as is suggested by a grain of mustard seed,³⁶⁰ however it be taken, to cure all diseases indifferently, by reason of the simplicity of union³⁶¹ effective in the medicine, so that no variety of the multitude of maladies may resist it. But manifold as are the obscurities of the weaknesses of the mind, as insanity [*vesania*], mania, frenzy [*furia*], stupidity [*stoliditas*], and others like, by which the spirit [*animus*] is darkened and impaired, yet by this single spagyric medicine they are perfectly cured. And it not only restores health to the spirit [*animo*], but also sharpens the ingenuity and mind of men, that all things may be miraculously easy³⁶² for them in understanding [*intellectu*] and perception [*perceptu*], and nothing be hid from them which is in the upper or lower world.³⁶³

The sentence from the “Tabula smaragdina,” “He will conquer every subtle thing,” Dorn interprets as follows: the subtle thing is Mercurius, or the “spiritual obscurities that occupy the mind”; in other words it is spirit. Hence the darkness is a demon that possesses the spirit (as in Olympiodorus) and can be cast out by the work (“it expels every subtle thing”).³⁶⁴ Sickness is an imprinting of evil (*impressio mali*) and is healed through the “repression of evil by the action of the true and universal centre upon the body.” This centre is the unarius or the One, in which the unitary man (*unicus homo*) is rooted. If, therefore, he is to recover from his bodily and spiritual sicknesses, “let him study to know and to understand exactly the centre, and apply himself wholly thereto, and the centre will be freed from all imperfections and diseases,³⁶⁵ that it may be restored to its state of original monarchy.”³⁶⁶

[494] These passages from Dorn refer less to the dangers of the work than to the healing through the outcome of the work. But the means of healing come from Mercurius, that spirit³⁶⁷ of whom the philosophers said: “Take the old black spirit, and destroy therewith the bodies until they are changed.”^{367a} The destruction of the bodies is depicted as a battle, as in Sermo 42 of the *Turba*: “Excite war between the copper and the quicksilver, since they strive to perish and first become corrupt.” “Excite the battle between them and destroy the body of the copper, till it becomes powder.”³⁶⁸ This battle is the *separatio*, *divisio*, *putrefactio*, *mortificatio*, and *solntio*, which all represent the original chaotic state of conflict between the four hostile elements. Dorn describes this vicious, warlike quaternity allegorically as the four-horned serpent, which the devil, after his fall from heaven, sought to “infix” in the mind of man.³⁶⁹ Dorn puts the motif of war on a moral plane³⁷⁰ and thereby approximates it to the modern concept of psychic dissociation, which, as we know, lies at the root of the psychogenic psychoses and neuroses. In the “furnace of the cross” and in the fire, says the “Aquarium sapientum,” “man, like the earthly gold,

attains to the true black Raven's Head; that is, he is utterly disfigured and is held in derision by the world,³⁷¹ and this not only for forty days and nights, or years,³⁷² but often for the whole duration of his life; so much so that he experiences more heartache in his life than comfort and joy, and more sadness than pleasure . . . Through this spiritual death his soul is entirely freed."³⁷³ Evidently the *nigredo* brought about a deformation and a psychic suffering which the author compared to the plight of the unfortunate Job. Job's unmerited misfortune, visited on him by God, is the suffering of God's servant and a prefiguration of Christ's Passion. One can see from this how the figure of the Son of Man gradually lodged itself in the ordinary man who had taken the "work" upon his own shoulders.

[495] In the second century of our era Wei Po-yang, quite uninfluenced by Western alchemy and unhampered by the preconceptions of our Christian psychology, gave a drastic account of the sufferings caused by a technical blunder during the opus:

Disaster will come to the black mass: gases from food consumed will make noises inside the intestines and stomach. The right essence will be exhaled and the evil one inhaled. Days and nights will be passed without sleep, moon after moon. The body will then be tired out, giving rise to an appearance of insanity. The hundred pulses will stir and boil so violently as to drive away peace of mind and body . . . Ghostly things will make their appearance, at which he will marvel even in his sleep. He is then led to rejoice, thinking that he is assured of longevity. But all of a sudden he is seized by an untimely death.³⁷⁴

So we can understand why Khunrath writes:

But chiefly pray to God . . . for the good gift of discretion, the good spirit of discriminating good from evil, who may lead thee into true knowledge and understanding of the Light of Nature, into her Great Book. So wilt thou extricate thyself from the labyrinth of very very many deceitful Papers, and even books of Parchment, and arrive right well at the ground of truth.³⁷⁵

[496] The depressions of the adept are also described in the "Tractatus aureus":

My son, this is the hidden stone of many colours, which is born in one colour; know this and conceal it. By this, the Almighty favouring, the greatest diseases are escaped, and every sorrow,³⁷⁶ distress, evil, and hurtful thing is made to depart. It leads from darkness to light, from this desert wilderness to a secure habitation, and from poverty and straits into freedom.³⁷⁷

[497] These testimonies suffice to show that the adept was not only included in his work but also knew it.

7. THE RELATION OF THE KING-SYMBOL TO CONSCIOUSNESS

[498] The apotheosis of the king, the renewed rising of the sun, means, on our hypothesis, that a new dominant of consciousness has been produced and that the psychic potential is reversed. Consciousness is no longer under the dominion of the unconscious, in which state the dominant is hidden in the darkness, but has now glimpsed and recognized a supreme goal. The apotheosis of the king depicts this change, and the resultant feeling of renewal is expressed nowhere more plainly than in some of our loveliest chorals. Ripley's *Cantilena* includes mother Luna, the maternal aspect of night, in this transfiguration, which reminds us of the apotheosis at the end of *Faust II*. It is as though the moon had risen in the night with as much splendour as the sun. And just as the Queen "flows with all delicious unguent" so, in the Acts of Thomas,³⁷⁸ a sweet smell pours from the heavenly goddess. She is not only the mother but the "Kore, daughter of the light." She is the Gnostic Sophia,³⁷⁹ who corresponds to the alchemical mother. If our interpretation of King Sol is correct,³⁸⁰ then the apotheosis must also have made mother Luna visible, that is to say made the unconscious conscious. What at first sight seems a contradiction in terms resolves itself, on closer examination, as the coming into consciousness of an essential content of the unconscious. It is primarily the feminine element in man, the anima,³⁸¹ that becomes visible; secondly the moonlight, which enables us to see in the dark, and represents an illumination of the unconscious, or its permeability to light; and thirdly, the moon stands for the rotundum, about which I have written in *Psychology and Alchemy*.³⁸² In the sublunary world her roundness (*plenilunium, circulus lunaris*)³⁸³ corresponds, as the mirror-image of the sun, to the Anthropos, the psychological self, or psychic totality.

[499] The moon is the connecting-link between the concept of the Virgin Mother and that of the child, who is round, whole, and perfect. The new birth from the moon can therefore be expressed as much by the Christian's joy at Eastertide as by the mystic dawn, the *aurora consurgens*; for the risen king is the "soul, which is infused into the dead stone."³⁸⁴ The idea of roundness is also found in the crown, symbol of kingship. "Corona regis" is cited as synonymous with ashes, body, sea, salt, mother and Blessed Virgin,³⁸⁵ and is thus identified with the feminine element.

[500] This peculiar relationship between rotundity and the mother is explained by the fact that the mother, the unconscious, is the place where the symbol of wholeness appears. The fact that the rotundum is, as it were, contained in the anima and is prefigured by her lends her that extraordinary fascination which characterizes the "Eternal Feminine" in the good as well as the bad sense. At a certain level, therefore, woman appears as the true carrier of the longed-for wholeness and redemption.

[501] The starting-point of our explanation is that the king is essentially synonymous with the sun and that the sun represents the daylight of the psyche, consciousness,

which as the faithful companion of the sun's journey rises daily from the ocean of sleep and dream, and sinks into it again at evening. Just as in the round-dance of the planets, and in the star-strewn spaces of the sky, the sun journeys along as a solitary figure, like any other one of the planetary archons, so consciousness, which refers everything to its own ego as the centre of the universe, is only one among the archetypes of the unconscious, comparable to the King Helios of post-classical syncretism, whom we meet in Julian the Apostate, for instance. This is what the complex of consciousness would look like if it could be viewed from one of the other planets, as we view the sun from the earth. The subjective ego-personality, i.e., consciousness and its contents, is indeed seen in its various aspects by an unconscious observer, or rather by an observer placed in the "outer space" of the unconscious. That this is so is proved by dreams, in which the conscious personality, the ego of the dreamer, is seen from a standpoint that is "toto coelo" different from that of the conscious mind. Such a phenomenon could not occur at all unless there were in the unconscious other standpoints opposing or competing with ego-consciousness. These relationships are aptly expressed by the planet simile. The king represents ego-consciousness, the subject of all subjects, as an object. His fate in mythology portrays the rising and setting of this most glorious and most divine of all the phenomena of creation, without which the world would not exist as an object. For everything that is only is because it is directly or indirectly known, and moreover this "known-ness" is sometimes represented in a way which the subject himself does not know, just as if he were being observed from another planet, now with benevolent and now with sardonic gaze.

[502] This far from simple situation derives partly from the fact that the ego has the paradoxical quality of being both the subject and the object of its own knowledge, and partly from the fact that the psyche is not a unity but a "constellation" consisting of other luminaries besides the sun. The ego-complex is not the only complex in the psyche.³⁸⁶ The possibility that unconscious complexes possess a certain luminosity, a kind of consciousness, cannot be dismissed out of hand, for they can easily give rise to something in the nature of secondary personalities, as psychopathological experience shows. But if this is possible, then an observation of the ego-complex from another standpoint somewhere in the same psyche is equally possible. As I have said, the critical portrayal of the ego-complex in dreams and in abnormal psychic states seems to be due to this.

[503] The conscious mind often knows little or nothing about its own transformation, and does not want to know anything. The more autocratic it is and the more convinced of the eternal validity of its truths, the more it identifies with them. Thus the kingship of Sol, which is a natural phenomenon, passes to the human king who personifies the prevailing dominant idea and must therefore share its fate. In the

phenomenal world the Heraclitan law of everlasting change, *πάντα ῥεῖ*, prevails; and it seems that all the true things must change and that only that which changes remains true.

[504] Pitilessly it is seen from another planet that the king is growing old, even before he sees it himself: ruling ideas, the “dominants,” change, and the change, undetected by consciousness, is mirrored only in dreams. King Sol, as the archetype of consciousness, voyages through the world of the unconscious, one of its multitudinous figures which may one day be capable of consciousness too. These lesser lights are, on the old view, identical with the planetary correspondences in the psyche which were postulated by astrology. When, therefore, an alchemist conjured up the spirit of Saturn as his familiar, this was an attempt to bring to consciousness a standpoint outside the ego, involving a relativization of the ego and its contents. The intervention of the planetary spirit was besought as an aid. When the king grows old and needs renewing, a kind of planetary bath is instituted—a bath into which all the planets pour their “influences.”³⁸⁷ This expresses the idea that the dominant, grown feeble with age, needs the support and influence of those subsidiary lights to fortify and renew it. It is, as it were, dissolved in the substance of the other planetary archetypes and then put together again. Through this process of melting and recasting there is formed a new amalgam of a more comprehensive nature, which has taken into itself the influences of the other planets or metals.³⁸⁸

[505] In this alchemical picture we can easily recognize the projection of the transformation process: the aging of a psychic dominant is apparent from the fact that it expresses the psychic totality in ever-diminishing degree. One can also say that the psyche no longer feels wholly contained in the dominant, whereupon the dominant loses its fascination and no longer grips the psyche so completely as before. On the other hand its content and meaning are no longer properly understood, or what is understood fails to touch the heart. A “sentiment d’incomplétude” of this kind produces a compensatory reaction which attracts other regions of the psyche and their contents, so as to fill up the gap. As a rule this is an unconscious process that always sets in when the attitude and orientation of the conscious mind have proved inadequate. I stress this point because the conscious mind is a bad judge of its own situation and often persists in the illusion that its attitude is just the right one and is only prevented from working because of some external annoyance. If the dreams were observed it would soon become clear why the conscious assumptions have become unworkable. And if, finally, neurotic symptoms appear, then the attitude of consciousness, its ruling idea, is contradicted, and in the unconscious there is a stirring up of those archetypes that were the most suppressed by the conscious attitude. The therapist then has no other course than to confront the ego with its adversary and thus initiate the melting and recasting process. The confrontation is

expressed, in the alchemical myth of the king, as the collision of the masculine, spiritual father-world ruled over by King Sol with the feminine, chthonic mother-world symbolized by the *aqua permanens* or by the chaos.

[506] The illegitimate aspect of this relationship appears as incest, veiled, in the *Cantilena*, by adoption—which nevertheless results in the pregnancy of the mother. As I have explained elsewhere, incest expresses the union of elements that are akin or of the same nature; that is to say the adversary of Sol is his own feminine chthonic aspect which he has forgotten. Sol's reflected light is the feminine Luna, who dissolves the king in her moistness. It is as though Sol had to descend into the watery deep of the sublunary world in order to unite the "powers of Above and Below" (as in Faust's journey to the Mothers). The unworkable conscious dominant disappears in menacing fashion among the contents rising up from the unconscious, thus bringing about a darkening of the light. The warring elements of primeval chaos are unleashed, as though they had never been subjugated. The battle is fought out between the dominant and the contents of the unconscious so violently that reason would like to clamp down on unreason. But these attempts fail, and go on failing until the ego acknowledges its impotence and lets the furious battle of psychic powers go its own way. If the ego does not interfere with its irritating rationality, the opposites, just *because* they are in conflict, will gradually draw together, and what looked like death and destruction will settle down into a latent state of concord, suitably expressed by the symbol of pregnancy.³⁸⁹ In consequence the king, the previous dominant of consciousness, is transformed into a real and workable whole, whereas before he had only pretended to wholeness.

[507] The *Cantilena* shows us what that dominant was which is subjected to transformation not only in Ripley but in many other alchemists: it was the Christian view of the world in the Middle Ages. This problem is of such dimensions that one cannot expect a medieval man to have been even remotely conscious of it. It was bound to work itself out in projection, unconsciously. For this reason, too, it can hardly be grasped even today—which is why the psychological interpretation of the One, the *filius regius*, meets with the greatest difficulties. From the hymnlike manner in which the alchemists praised their "son" it is quite evident that they meant by this symbol either Christ himself or something that corresponded to him. Naturally they were not concerned with the historical personality of Jesus, which at that time was completely covered up by the dogmatic figure of the second Person of the Trinity. The latter symbol had slowly crystallized out in the course of the centuries, though it was clearly prefigured in the Logos of St. John. Nor was the conception of God as *senex* and *puer* peculiar to the alchemists, for many clerics who were not alchemists took it as a transformation of the wrathful and vindictive Yahweh of the Old Testament into the God of Love of the New. Thus the archetype of the king's renewal

manifested itself not only among the “philosophers” but also in ecclesiastical circles.³⁹⁰

[508] There can be a psychological explanation of the *filius regius* only when this image has sloughed off its projected form and become a purely psychic experience. The Christ-lapis parallel shows clearly enough that the *filius regius* was more a psychic event than a physical one, since as a physical event it can demonstrably never occur and as a religious experience it is beyond question. There are many passages in the texts that can be interpreted—strange as this may sound—as an experience of Christ in matter. Others, again, lay so much emphasis on the lapis that one cannot but see in it a renewal and completion of the dogmatic image. An unequivocal substitution of the *filius regius* for Christ does not, to my knowledge, occur in the literature, for which reason one must call alchemy Christian even though heretical. The Christ-lapis remains an ambiguous figure.

[509] This is of considerable importance as regards a psychological interpretation of the *filius regius*. In any such view the place of matter, with its magical fascination, is taken by the unconscious, which was projected into it. For our modern consciousness the dogmatic image of Christ changed, under the influence of evangelical Protestantism, into the personal Jesus, who in liberal rationalism, which abhorred all “mysticism,” gradually faded into a mere ethical prototype. The disappearance of the feminine element, namely the cult of the Mother of God, in Protestantism was all that was needed for the spirituality of the dogmatic image to detach itself from the earthly man and gradually sink into the unconscious. When such great and significant images fall into oblivion they do not disappear from the human sphere, nor do they lose their psychic power. Anyone in the Middle Ages who was familiar with the mysticism of alchemy remained in contact with the living dogma, even if he was a Protestant. This is probably the reason why alchemy reached its heyday at the end of the sixteenth and in the seventeenth century: for the Protestant it was the only way of still being Catholic. In the opus alchymicum he still had a completely valid transformation rite and a concrete mystery. But alchemy did not flourish only in Protestant countries; in Catholic France it was still widely practised during the eighteenth century, as numerous manuscripts and published works testify, such as those of Dom Pernety (1716–1800?), Lenglet du Fresnoy (1674–1752?), and the great compilation of Manget, published 1702. This is not surprising, as in France at that time the modern anti-Christian “schism” was brewing which was to culminate in the Revolution—that relatively harmless prelude to the horrors of today. The decline of alchemy during the Enlightenment meant for many Europeans a descent of all dogmatic images—which till then had been directly present in the ostensible secrets of chemical matter—to the underworld.

[510] Just as the decay of the conscious dominant is followed by an irruption of chaos in the individual,³⁹¹ so also in the case of the masses (Peasant Wars, Anabaptists, French Revolution, etc.), and the furious conflict of elements in the individual psyche is reflected in the unleashing of primeval blood-thirstiness and lust for murder on a collective scale. This is the sickness so vividly described in the *Cantilena*. The loss of the eternal images is in truth no light matter for the man of discernment. But since there are infinitely many more men of no discernment, nobody, apparently, notices that the truth expressed by the dogma has vanished in a cloud of fog, and nobody seems to miss anything. The discerning person knows and feels that his psyche is disquieted by the loss of something that was the life-blood of his ancestors. The undiscerning *ἀνοοι* miss nothing, and only discover afterwards in the papers (much too late) the alarming symptoms that have now become “real” in the outside world because they were not perceived before inside, in oneself, just as the presence of the eternal images was not noticed. If they had been, a threnody for the lost god would have arisen, as once before in antiquity at the death of Great Pan.³⁹² Instead, all well-meaning people assure us that one has only to believe he is still there—which merely adds stupidity to unconsciousness. Once the symptoms are really outside in some form of sociopolitical insanity, it is impossible to convince anybody that the conflict is in the psyche of every individual, since he is now quite sure where his enemy is. Then, the conflict which remains an intrapsychic phenomenon in the mind of the discerning person, takes place on the plane of projection in the form of political tension and murderous violence. To produce such consequences the individual must have been thoroughly indoctrinated with the insignificance and worthlessness of his psyche and of psychology in general. One must preach at him from all the pulpits of authority that salvation always comes from outside and that the meaning of his existence lies in the “community.” He can then be led docilely to the place where of his own natural accord he would rather go anyway: to the land of childhood, where one makes claims exclusively on others, and where, if wrong is done, it is always somebody else who has done it. When he no longer knows by what his soul is sustained, the potential of the unconscious is increased and takes the lead. Desirousness overpowers him, and illusory goals set up in the place of the eternal images excite his greed. The beast of prey seizes hold of him and soon makes him forget that he is a human being. His animal affects hamper any reflection that might stand in the way of his infantile wish-fulfillments, filling him instead with a feeling of a new-won right to existence and intoxicating him with the lust for booty and blood.

[511] Only the living presence of the eternal images can lend the human psyche a dignity which makes it morally possible for a man to stand by his own soul, and be convinced that it is worth his while to persevere with it. Only then will he realize that the conflict is *in him*, that the discord and tribulation are his riches, which should not

be squandered by attacking others; and that, if fate should exact a debt from him in the form of guilt, it is a debt to himself. Then he will recognize the worth of his psyche, for nobody can owe a debt to a mere nothing. But when he loses his own values he becomes a hungry robber, the wolf, lion, and other ravening beasts which for the alchemists symbolized the appetites that break loose when the black waters of chaos—i.e., the unconsciousness of projection—have swallowed up the king.³⁹³

[512] It is a subtle feature of the *Cantilena* that the pregnancy cravings of the mother are stilled with peacock's flesh and lion's blood, i.e., with her own flesh and blood.³⁹⁴ If the projected conflict is to be healed, it must return into the psyche of the individual, where it had its unconscious beginnings. He must celebrate a Last Supper with himself, and eat his own flesh and drink his own blood; which means that he must recognize and accept the other in himself. But if he persists in his one-sidedness, the two lions will tear each other to pieces. Is this perhaps the meaning of Christ's teaching, that each must bear his own cross? For if you have to endure yourself, how will you be able to rend others also?

[513] Such reflections are justified by the alchemical symbolism, as one can easily see if one examines the so-called allegories a little more closely and does not dismiss them at the start as worthless rubbish. The miraculous feeding with one's own substance—so strangely reflecting its prototype, Christ—means nothing less than the integration of those parts of the personality which are still outside ego-consciousness. Lion and peacock, emblems of concupiscence and pride, signify the overweening pretensions of the human shadow, which we so gladly project on our fellow man in order to visit our own sins upon him with apparent justification. In the age-old image of the uroboros lies the thought of devouring oneself and turning oneself into a circulatory process, for it was clear to the more astute alchemists that the prima materia of the art was man himself.³⁹⁵ The uroboros is a dramatic symbol for the integration and assimilation of the opposite, i.e., of the shadow. This "feed-back" process is at the same time a symbol of immortality, since it is said of the uroboros that he slays himself and brings himself to life, fertilizes himself and gives birth to himself. He symbolizes the One, who proceeds from the clash of opposites, and he therefore constitutes the secret of the prima materia which, as a projection, unquestionably stems from man's unconscious. Accordingly, there must be some psychic datum in it which gives rise to such assertions, and these assertions must somehow characterize that datum even if they are not to be taken literally. What the ultimate reason is for these assertions or manifestations must remain a mystery, but a mystery whose inner kinship with the mystery of faith was sensed by the adepts, so that for them the two were identical.

8. THE RELIGIOUS PROBLEM OF THE KING'S RENEWAL

[514] Medical psychology has recognized today that it is a therapeutic necessity, indeed, the first requisite of any thorough psychological method, for consciousness to confront its shadow.³⁹⁶ In the end this must lead to some kind of union, even though the union consists at first in an open conflict, and often remains so for a long time. It is a struggle that cannot be abolished by rational means.³⁹⁷ When it is wilfully repressed it continues in the unconscious and merely expresses itself indirectly and all the more dangerously, so no advantage is gained. The struggle goes on until the opponents run out of breath. What the outcome will be can never be seen in advance. The only certain thing is that both parties will be changed; but what the product of the union will be it is impossible to imagine. The empirical material shows that it usually takes the form of a subjective experience which, according to the unanimous testimony of history, is always of a religious order. If, therefore, the conflict is consciously endured and the analyst follows its course without prejudice, he will unfailingly observe compensations from the unconscious which aim at producing a unity. He will come across numerous symbols similar to those found in alchemy—often, indeed, the very same. He will also discover that not a few of these spontaneous formations have a numinous quality in harmony with the mysticism of the historical testimonies. It may happen, besides, that a patient, who till then had shut his eyes to religious questions, will develop an unexpected interest in these matters. He may, for instance, find himself getting converted from modern paganism to Christianity or from one creed to another, or even getting involved in fundamental theological questions which are incomprehensible to a layman. It is unnecessary for me to point out here that not every analysis leads to a conscious realization of the conflict, just as not every surgical operation is as drastic as a resection of the stomach. There is a minor surgery, too, and in the same way there is a minor psychotherapy whose operations are harmless and require no such elucidation as I am concerned with here. The patients I have in mind are a small minority with certain spiritual demands to be satisfied, and only these patients undergo a development which presents the doctor with the kind of problem we are about to discuss.

[515] Experience shows that the union of antagonistic elements is an irrational occurrence which can fairly be described as “mystical,” provided that one means by this an occurrence that cannot be reduced to anything else or regarded as in some way unauthentic. The decisive criterion here is not rationalistic opinions or regard for accepted theories, but simply and solely the value for the patient of the solution he has found and experienced. In this respect the doctor, whose primary concern is the preservation of life, is in an advantageous position, since he is by training an empiricist and has always had to employ medicines whose healing power he knew

even though he did not understand how it worked. Equally, he finds all too often that the scientifically explained and attested healing power of his medicines does not work in practice.

[516] If, now, the alchemists meant by their old king that he was God himself, this also applies to his son. They themselves must have shrunk from thinking out the logical consequences of their symbolism, otherwise they would have had to assert that God grows old and must be renewed through the art. Such a thought would have been possible at most in the Alexandrian epoch, when gods sprang up like mushrooms. But for medieval man it was barely conceivable.³⁹⁸ He was far more likely to consider that the art would change something in himself, for which reason he regarded its product as a kind of *φάρμακον*. Had he had any idea of “psychology,” he would almost certainly have called his healing medicament “psychic” and would have regarded the king’s renewal as a transformation of the conscious dominant—which naturally has nothing to do with a magical intervention in the sphere of the gods.

[517] Man’s ideas and definitions of God have followed one another kaleidoscopically in the course of the millennia, and the evangelist Mark would have been very much astonished if he could have taken a look at Harnack’s *History of Dogma*. And yet it is not a matter of indifference which definitions of his conscious dominant man considers to be binding, or what sort of views he happens to have in this regard. For on this depends whether consciousness will be king or not. If the unconscious rules to the exclusion of all else, everything is liable to end in destruction, as the present state of things gives us reason to fear. If the dominant is too weak, life is wasted in fruitless conflict because Sol and Luna will not unite. But if the son is the dominant, then Sol is his right eye and Luna his left. The dominant must contain them both, the standpoint of ego-consciousness and the standpoint of the archetypes in the unconscious. The binding force that inevitably attaches to a dominant should not mean a prison for one and a *carte-blanche* for the other, but duty and justice for both.

[518] What the nature is of that unity which in some incomprehensible way embraces the antagonistic elements eludes our human judgment, for the simple reason that nobody can say what a being is like that unites the full range of consciousness with that of the unconscious. Man knows no more than his consciousness, and he knows himself only so far as this extends. Beyond that lies an unconscious sphere with no assignable limits, and it too belongs to the phenomenon Man. We might therefore say that perhaps the One is like a man, that is, determined and determinable and yet undetermined and indeterminable. Always one ends up with paradoxes when knowledge reaches its limits. The ego knows it is part of this being, but only a part. The symbolic phenomenology of the unconscious makes it clear that although consciousness is accorded the status of spiritual kingship with all its attendant

dangers, we cannot say what kind of king it will be. This depends on two factors: on the decision of the ego and the assent of the unconscious. Any dominant that does not have the approval of the one or the other proves to be unstable in the long run. We know how often in the course of history consciousness has subjected its highest and most central ideas to drastic revision and correction, but we know little or nothing about the archetypal processes of change which, we may suppose, have taken place in the unconscious over the millennia, even though such speculations have no firm foundation. Nevertheless the possibility remains that the unconscious may reveal itself in an unexpected way at any time.*

[519] The alchemical figure of the king has provoked this long discussion because it contains the whole of the hero myth including the king's—and God's—renewal, and on the other hand because, as we conjecture, it symbolizes the dominant that rules consciousness. "King Sol" is not a pleonasm; it denotes a consciousness which is not only conscious as such but is conscious in a quite special way. It is controlled and directed by a dominant that, in the last resort, is the arbiter of values. The sun is the common light of nature, but the king, the dominant, introduces the human element and brings man nearer to the sun, or the sun nearer to man.³⁹⁹

[520] Consciousness is renewed through its descent into the unconscious, whereby the two are joined. The renewed consciousness does not *contain* the unconscious but forms with it a totality symbolized by the son. But since father and son are of one being, and in alchemical language King Sol, representing the renewed consciousness, *is* the son, consciousness would be absolutely identical with the King as dominant. For the alchemists this difficulty did not exist, because the King was projected into a postulated substance and hence behaved merely as an object to the consciousness of the artifex. But if the projection is withdrawn by psychological criticism, we encounter the aforesaid difficulty that the renewed consciousness apparently coincides with the renewed king, or son. I have discussed the psychological aspect of this problem in the second of the *Two Essays on Analytical Psychology*, in the chapter on the "mana personality." The difficulty cannot be resolved by purely logical argument but only by careful observation and analysis of the psychic state itself. Rather than launch out into a detailed discussion of case-histories I would prefer to recall the well-known words of Paul, "I live, yet not I, but Christ liveth in me" (Gal. 2 : 20), which aptly describe the peculiar nature of this state. From this we can see that that other, earlier state, when the king aged and disappeared, is marked by a consciousness in which a critical ego knowingly took the place of the sick king, looking back to an earlier "mythical" time when this ego still felt absolutely dependent on a higher and mightier non-ego. The subsequent disappearance of the feeling of dependence and the simultaneous strengthening of criticism are felt as progress, enlightenment, liberation, indeed as redemption, although a one-sided and

limited being has usurped the throne of a king. A personal ego seizes the reins of power to its own destruction; for mere egohood, despite possessing an *anima rationalis*, is not even sufficient for the guidance of personal life, let alone for the guidance of men. For this purpose it always needs a “mythical” dominant, yet such a thing cannot simply be invented and then believed in. Contemplating our own times we must say that though the need for an effective dominant was realized to a large extent, what was offered was nothing more than an arbitrary invention of the moment. The fact that it was also believed in goes to prove the gullibility and cluelessness of the public and at the same time the profoundly felt need for a spiritual authority transcending egohood. An authority of this kind is never the product of rational reflection or an invention of the moment, which always remains caught in the narrow circle of ego-bound consciousness; it springs from traditions whose roots go far deeper both historically and psychologically. Thus a real and essentially religious renewal can be based, for us, only on Christianity. The extremely radical reformation of Hinduism by the Buddha assimilated the traditional spirituality of India in its entirety and did not thrust a rootless novelty upon the world. It neither denied nor ignored the Hindu pantheon swarming with millions of gods, but boldly introduced Man, who before that had not been represented at all. Nor did Christ, regarded simply as a Jewish reformer, destroy the law, but made it, rather, into a matter of conviction. He likewise, as the regenerator of his age, set against the Greco-Roman pantheon and the speculations of the philosophers the figure of Man, not intending it as a contradiction but as the fulfilment of a mythologem that existed long before him—the conception of the Anthropos with its complex Egyptian, Persian, and Hellenistic background.

[521] Any renewal not deeply rooted in the best spiritual tradition is ephemeral; but the dominant that grows from historical roots act like a living being within the ego-bound man. He does not possess it, it possesses him; therefore the alchemists said that the artifex is not the master but rather the minister of the stone—clearly showing that the stone is indeed a king towards whom the artifex behaves as a subject.

[522] Although the renewed king corresponds to a renewed consciousness, this consciousness is as different from its former state as the *filius regius* differs from the enfeebled old king. Just as the old king must forgo his power and make way for the little up start ego, so the ego, when the renewed king returns, must step into the background. It still remains the *sine qua non* of consciousness,⁴⁰⁰ but it no longer imagines that it can settle everything and do everything by the force of its will. It no longer asserts that where there’s a will there’s a way. When lucky ideas come to it, it does not take the credit for them, but begins to realize how dangerously close it had been to an inflation. The scope of its willing and doing becomes commensurate with reality again after an Ash Wednesday has descended upon its pre-sumptuousness.⁴⁰¹

[523] We can compare the logical sequence of psychological changes with the alchemical symbolism as follows:

Ego-bound state with feeble dominant	Sick king, enfeebled by age, about to die
Ascent of the unconscious and/or descent of the ego into the unconscious	Disappearance of the king in his mother's body, or his dissolution in water
Conflict and synthesis of conscious and unconscious	Pregnancy, sick-bed, symptoms, display of colours
Formation of a new dominant; circular symbols (e.g., mandala) of the self	King's son, hermaphrodite, rotundum ⁴⁰²

[524] Though the comparison holds good on average, the symbolism of the *Cantilena* differs from the above schema in that the apotheosis of the *filius regius* takes place simultaneously with that of Queen Luna, thus paralleling the marriage in the Apocalypse. The Christian prototype gained the upper hand in Ripley, whereas usually the coniunctio precedes the production of the lapis and the latter is understood as the child of Sol and Luna. To that extent the lapis exactly corresponds to the psychological idea of the self, the product of conscious and unconscious. In Christian symbolism, on the other hand, there is a marriage of the Lamb (the Apocalyptic Christ) with the bride (Luna-Ecclesia). Because the lapis is itself androgynous, a synthesis of male and female, there is no need for another coniunctio. The symbolical androgyny of Christ does not, curiously enough, eliminate the marriage of the Lamb—the two things exist side by side.

[525] We have here a discrepancy between the alchemical and psychological symbolism and the Christian. It is indeed difficult to imagine what kind of coniunctio beyond the union of conscious (male) and unconscious (female) in the regenerated dominant could be meant, unless we assume, with the dogmatic tradition, that the regenerated dominant also brings the *corpus mysticum* of mankind (Ecclesia as Luna) into glorious reality. Among the alchemists, who were mostly solitaries by choice, the motif of the Apocalyptic marriage, characterized as the marriage of the Lamb (Rev. 19 : 7ff.), is missing, the accent here lying on the sacrificial appellation "lamb." According to the oldest and most primitive tradition the king, despite his dignity and power, was a victim offered up for the prosperity of his country and his people, and in his godlike form he was even eaten. As we know, this archetype underwent an extremely complicated development in Christianity. From the standpoint of Christian symbolism the alchemists' conception of the goal lacked, firstly, the motif of the heavenly marriage and, secondly, the almost more important motif of sacrifice and the totem meal. (The mourned gods of Asia Minor—Tammuz, Adonis, etc.—were, in all probability, originally sacrifices for the fruitfulness of the year.) The lapis was

decidedly an ideal for hermits, a goal for isolated individuals. Besides that, it was a food (*cibus immortalis*), could be multiplied indefinitely, was a living being with body, soul, and spirit, an androgyne with incorruptible body, etc. Though likened to King Sol and even named such, it was not a sponsus, not a victim, and belonged to no community; it was like the “treasure hid in a field, the which when a man hath found, he hideth” (Matt. 13 : 44), or like “one pearl of great price,” for which a man “went and sold all that he had, and bought it” (Matt. 13 : 46). It was the well-guarded, precious secret of the individual.⁴⁰³ And though the old Masters emphasized that they would not hide their secret “jealously”⁴⁰⁴ and would reveal it to all seekers, it was perfectly clear that the stone remained the preoccupation of the individual.

[526] In this connection it should not be forgotten that in antiquity certain influences, evidently deriving from the Gnostic doctrine of the hermaphroditic Primordial Man,⁴⁰⁵ penetrated into Christianity and there gave rise to the view that Adam had been created an androgyne.⁴⁰⁶ And since Adam was the prototype of Christ, and Eve, sprung from his side, that of the Church, it is understandable that a picture of Christ should develop showing distinctly feminine features.⁴⁰⁷ In religious art the Christ-image has retained this character to the present day.⁴⁰⁸ Its veiled androgyny reflects the hermaphroditism of the lapis, which in this respect has more affinity with the views of the Gnostics.

[527] In recent times the theme of androgyny has been subjected to quite special treatment in a book by a Catholic writer which merits our attention. This is *Die Gnosis des Christentums*, by Georg Koepgen, an important work that appeared in 1939 with the episcopal imprimatur in Salzburg, and since then has been placed on the Index. Of the Apollinian-Dionysian conflict in antiquity, Koepgen says it found its solution in Christianity because “in the person of Jesus the male is united with the female.” “Only in him do we find this juxtaposition of male and female in unbroken unity.” “If men and women can come together as equals in Christian worship, this has more than an accidental significance: it is the fulfilment of the androgyny that was made manifest in Christ” (p. 316). The change of sex in the believer is suggested in Rev. 14 : 4: “These are they that were not defiled with women; for they are virgins.” Koepgen says of this passage: “Here the new androgynous form of existence becomes visible. Christianity is neither male nor female, it is male-female in the sense that the male paired with the female in Jesus’s soul. In Jesus the tension and polaristic strife of sex are resolved in an androgynous unity. And the Church, as his heir, has taken this over from him: she too is androgynous.” As regards her constitution the Church is “hierarchically masculine, yet her soul is thoroughly feminine.” “The virgin priest . . . fulfils in his soul the androgynous unity of male and female; he renders visible again the psychic dimension which Christ showed us for the first time when he revealed the ‘manly virginity’ of his soul.”⁴⁰⁹

[528] For Koepgen, therefore, not only Christ is androgynous but the Church as well, a remarkable conclusion the logic of which one cannot deny. The consequence of this is a special emphasis on bisexuality and then on the peculiar identity of the Church with Christ, which is based also on the doctrine of the *corpus mysticum*. This certainly forestalls the marriage of the Lamb at the end of time, for the androgyne “has everything it needs”⁴¹⁰ and is already a *complexio oppositorum*. Who is not reminded here of the fragment from the Gospel according to the Egyptians cited by Clement of Alexandria: “When ye have trampled on the garment of shame, and when the two become one and the male with the female is neither male nor female.”⁴¹¹

[529] Koepgen introduces his book with a dedication and a motto. The first is: “Renatis praedestinatione” (To those who are reborn out of predestination), and the second is from John 14 : 12: “He that believeth on me, the works that I do he shall do also, and greater works than these shall he do.” The dedication echoes the motif of election, which the author shares with the alchemists. For Morienus had said of alchemy:

God vouchsafes this divine and pure science to his faithful and his servants, that is, to those on whom nature made it proper to confer it from the beginning of things. For this thing can be naught else but the gift of God most high, who commits and shows it as he will, and to whom he will of his faithful servants. For the Lord selects of his servants those whom he wills and chooses, to seek after this divine science which is concealed from man, and having sought it to keep it with them.⁴¹²

Dorn says much the same: “For it sometimes comes about, after many years, many labours, much study . . . that some are chosen, when much knocking,⁴¹³ many prayers, and diligent enquiry have gone before.”⁴¹⁴

[530] The quotation from John is taken from the fourteenth chapter, where Christ teaches that whoever sees him sees the Father. He is in the Father and the Father is in him. The disciples are in him and he in them, moreover they will be sent the Holy Ghost as Paraclete and will do works that are greater than his own. This fourteenth chapter broaches a question that was to have great repercussions for the future: the problem of the Holy Ghost who will remain when Christ has gone, and who intensifies the interpenetration of the divine and the human to such a degree that we can properly speak of a “Christification” of the disciples. Among the Christian mystics this identity was carried again and again to the point of stigmatization. Only the mystics bring creativity into religion. That is probably why they can feel the presence and the workings of the Holy Ghost, and why they are nearer to the experience of brotherhood in Christ.

[531] Koepgen thinks along the same lines, as his dedication and motto show. It is easy to see what happens when the logical conclusion is drawn from the fourteenth chapter of John: the *opus Christi* is transferred to the individual. He then becomes the

bearer of the mystery, and this development was unconsciously prefigured and anticipated in alchemy, which showed clear signs of becoming a religion of the Holy Ghost and of the Sapientia Dei. Koepgen's standpoint is that of creative mysticism, which has always been critical of the Church. Though this is not obviously so in Koepgen, his attitude betrays itself indirectly in the living content of his book, which consistently presses for a deepening and broadening of the dogmatic ideas. Because he remained fully conscious of his conclusions, he does not stray so very far outside the Church, whereas the alchemists, because of their unconsciousness and naive lack of reflection, and unhampered by intellectual responsibility, went very much further in their symbolism. But the point of departure for both is the procreative, revelatory working of the Holy Ghost, who is a "wind that bloweth where it listeth," and who advances beyond his own workings to "greater works than these." The creative mystic was ever a cross for the Church, but it is to him that we owe what is best in humanity.⁴¹⁵

9. REGINA

[532] We have met the figure of the Queen so often in the course of our exposition that we need say only a few words about her here. We have seen that as Luna she is the archetypal companion of Sol. Together they form the classic alchemical syzygy, signifying on the one hand gold and silver, or something of the kind,⁴¹⁶ and on the other the heavenly pair described in *Aurora Consurgens*:

Therefore I will rise and go into the city, seeking in the streets and the broad ways a chaste virgin to espouse, comely in face, more comely in body, most comely in her garments, that she may roll back the stone from the door of my sepulchre and give me wings like a dove, and I will fly with her into heaven and then say: I live for ever, and will rest in her, for the Queen stood on my right hand in gilded clothing, surrounded with variety. . . . O Queen of the heights, arise, make haste, my love, my spouse, speak, beloved, to thy lover, who and of what kind and how great thou art. . . . My beloved, who is ruddy, hath spoken to me, he hath sought and besought: I am the flower of the field and the lily of the valleys, I am the mother of fair love and of fear and of knowledge and of holy hope. As the fruitful vine I have brought forth a pleasant odour, and my flowers are the fruit and honour and riches. I am the bed of my beloved, . . . wounding his heart with one of my eyes and with one hair of my neck. I am the sweet smell of ointments giving an odour above all aromatical spices, and like unto cinnamon and balsam and chosen myrrh.⁴¹⁷

[533] The prototype of this spiritual *Minne* is the relationship of King Solomon to the Queen of Sheba. Johannes Grasseus says of the white dove that is hidden in the lead:

“This is the chaste, wise, and rich Queen of Sheba, veiled in white, who was willing to give herself to none but King Solomon. No human heart can sufficiently investigate all this.”⁴¹⁸ Penotus says:

You have the virgin earth, give her a husband who is fitting for her! She is the Queen of Sheba, hence there is need of a king crowned with a diadem—where shall we find him? We see how the heavenly sun gives of his splendour to all other bodies, and the earthly or mineral sun will do likewise, when he is set in his own heaven, which is named the “Queen of Sheba,” who came from the ends of the earth to behold the glory of Solomon. So, too, our Mercury has left his own lands and clothed himself with the fairest garment of white, and has given himself to Solomon, and not to any other who is a stranger [*extraneo*] and impure.⁴¹⁹

[534] Here Mercurius in feminine form is the queen, and she is the “heaven” wherein the sun shines. She is thus thought of as a medium surrounding the sun—“a man encompassed by a woman,” as was said of Christ⁴²⁰—or as Shiva in the embrace of Shakti. This medium has the nature of Mercurius, that paradoxical being, whose one definable meaning is the unconscious.⁴²¹ The queen appears in the texts as the maternal vessel of Sol and as the aureole of the king, i.e., as a crown.⁴²² In the “Tractatus aureus de Lapide”⁴²³ the queen, at her apotheosis,⁴²⁴ holds a discourse in which she says:

After death is life restored to me. To me, poor as I am, were entrusted the treasures of the wise and mighty. Therefore I, too, can make the poor rich, give grace to the humble, and restore health to the sick. But I am not yet equal to my most beloved brother, the mighty king, who has yet to be raised from the dead. But when he comes, he will verily show that my words are the truth.

[535] In this “soror et sponsa” we can easily discern the analogy with the Church, which, as the *corpus mysticum*, is the vessel for the *anima Christi*. This vessel is called by Penotus the “Queen of Sheba,” referring to the passage in Matthew 12 :42 (also Luke 11 : 31): “For she [the queen of the south] came from the uttermost parts of the earth to hear the wisdom of Solomon.” In this connection I would like to mention a passage in the “Speculum de Mysteriis” of Honorius of Autun, which likewise refers to the “queen of the south.” He says:⁴²⁵

John abandoned his bride and, himself a virgin, followed the son of a virgin. And because for love of her he despised the bond of the flesh, Christ loved him before all the disciples. For while the Queen of the South gave her body and her blood to the disciples, John lay in the bosom of Jesus and drank from that fount of wisdom; which secret of the Word he afterward committed to the world; the Word, namely, which is hidden in the Father, because in the bosom of Jesus are hidden all the treasures of wisdom and knowledge.⁴²⁶

[536] In the passage from the “Tractatus aureus” it is the Queen of the South who is entrusted with the treasures of the wise and mighty, and in Honorius she gives her body and blood to the disciples. In both cases she seems to be identified with Jesus. We can see from this how close was the thought of Christ’s androgyny, and how very much the queen and the king are one, in the sense that body and soul or spirit and soul are one.⁴²⁷ As a matter of fact the queen corresponds to the soul (anima) and the king to spirit, the dominant of consciousness.⁴²⁸ In view of this interpretation of the queen we can understand why the secret of the work was sometimes called the “Reginae Mysteria.”⁴²⁹

[537] The close connection between king and queen is due to the fact that occasionally they both suffer the same fate: she is dissolved with him in the bath (in another version she is the bath itself). Thus Eleazar says of the king’s bath: “For in this fiery sea the king cannot endure; it robs the old Albaon⁴³⁰ of all his strength and consumes his body and turns it to blood-red blood. Nor is the queen freed; she must perish in this fiery bath.”⁴³¹

[538] Further, it is not surprising that king and queen form as it were a unity, since they are in effect its forerunners. The situation becomes worthy of note only because of the interpretation we have given it: that in the mythologem the king, as the dominant of consciousness, is almost identical with the archetypal figure that personifies the unconscious, namely the anima. The two figures are in some respects diametrically opposed to one another, as are conscious and unconscious; but, just as male and female are united in the human organism, so the psychic material remains the same whether in the conscious or in the unconscious state. Only, sometimes it is associated with the ego, sometimes not.

[539] The anima in her negative aspect—that is, when she remains unconscious and hidden—exerts a possessive influence on the subject. The chief symptoms of this possession are blind moods and compulsive entanglements on one side, and on the other cold, unrelated absorption in principles and abstract ideas. The negative aspect of the anima indicates therefore a special form of psychological maladjustment. This is either compensated from the conscious side or else it compensates a consciousness already marked by a contrary (and equally incorrect) attitude. For the negative aspect of the conscious dominant is far from being a “God-given” idea; it is the most egoistic intention of all, which seeks to play an important role and, by wearing some kind of mask, to appear as something favourable (identification with the persona!). The anima corresponding to this attitude is an intriguer who continually aids and abets the ego in its role, while digging in the background the very pits into which the infatuated ego is destined to fall.

[540] But a conscious attitude that renounces its ego-bound intentions—not in imagination only, but in truth—and submits to the suprapersonal decrees of fate, can claim to be serving a king. This more exalted attitude raises the status of the anima from that of a temptress to a psychopomp.⁴³² The transformation of the kingly substance from a lion into a king has its counterpart in the transformation of the feminine element from a serpent into a queen. The coronation, apotheosis, and marriage signalize the equal status of conscious and unconscious that becomes possible at the highest level—a *coincidentia oppositorum* with redeeming effects.

[541] It would certainly be desirable if a psychological explanation and clarification could be given of what seems to be indicated by the mythologem of the marriage. But the psychologist does not feel responsible for the existence of what cannot be known; as the handmaid of truth he must be satisfied with establishing the existence of these phenomena, mysterious as they are. The union of conscious and unconscious symbolized by the royal marriage is a mythological idea which on a higher level assumes the character of a psychological concept. I must expressly emphasize that the psychological concept is definitely not derived from the mythologem, but solely from practical investigation of both the historical and the case material. What this empirical material looks like has been shown in the dream-series given in *Psychology and Alchemy*. It serves as a paradigm in place of hundreds of examples, and it may therefore be regarded as more than an individual curiosity.

[542] The psychological union of opposites is an intuitive idea which covers the phenomenology of this process. It is not an “explanatory” hypothesis for something that, by definition, transcends our powers of conception. For, when we say that conscious and unconscious unite, we are saying in effect that this process is inconceivable. The unconscious is unconscious and therefore can neither be grasped nor conceived. The union of opposites is a transconscious process and, in principle, not amenable to scientific explanation. The marriage must remain the “mystery of the queen,” the secret of the art, of which the *Rosarium* reports King Solomon as saying:

This is my daughter, for whose sake men say that the Queen of the South came out of the east, like the rising dawn, in order to hear, understand, and behold the wisdom of Solomon. Power, honour, strength, and dominion are given into her hand; she wears the royal crown of seven glittering stars, like a bride adorned for her husband, and on her robe is written in golden lettering, in Greek, Arabic, and Latin: “I am the only daughter of the wise, utterly unknown to the foolish.”⁴³³

[543] The Queen of Sheba, Wisdom, the royal art, and the “daughter of the philosophers” are all so interfused that the underlying psychologem clearly emerges: the art is queen of the alchemist’s heart, she is at once his mother, his daughter, and

his beloved, and in his art and its allegories the drama of his own soul, his individuation process, is played out.

V

ADAM AND EVE

1. ADAM AS THE ARCANE SUBSTANCE

[544] Like the King and Queen, our first parents are among those figures through whom the alchemists expressed the symbolism of opposites. Adam is mentioned far more frequently than Eve, and for this reason we shall have to concern ourselves first and principally with him. He will give us plenty to get on with, as he figures in a great variety of significations which enter the world of alchemical ideas from the most heterogeneous sources.

[545] Ruland defines Adam as a synonym for the *aqua permanens*, in contradistinction to Eve, who signifies earth. Water is the prime arcane substance, and is therefore the agent of transformation as well as the substance to be transformed. As “water” is synonymous with Mercurius, we can understand the remark of John Dee that “that other Mercurius” who appears in the course of the work is the “Mercurius of the Philosophers, that most renowned Microcosm and Adam.”¹ Adam is mentioned as the arcane substance in Rosinus. His correlates are lead and “Azoch,”² both, like Adam,³ of hermaphroditic nature. Similarly, Dorn says that the lapis was called “Adam, who bore his invisible Eve hidden in his body.”⁴ This archaic idea occasionally turns up in the products of the insane today.⁵ The dual nature of Adam is suggested in the “Gloria mundi”: “When Almighty God had created Adam and set him in paradise, he showed him two things in the future, saying, ‘Behold, Adam, here are two things: one fixed and constant, the other fugitive.’”⁶

[546] As the transformative substance, therefore, Adam is also the king⁷ who is renewed in the bath. Basilus Valentinus says in his poem: “Adam sat in the bath which the old Dragon had prepared, and in which Venus found her companion.”⁸

[547] It was a bold stroke, even for a Baroque imagination, to bring together Adam and Venus. In the poem Venus is the “fountain that flows from the stone and submerges her father, absorbing his body and life into herself.” She is thus a parallel figure to Beya, who dissolved Gabricus into atoms in her body. In the same section in which Ruland mentions Adam as a synonym for water he states that he was also called the “tall man.”⁹ Ruland was a Paracelsist, so this expression may well coincide with the “great man” of Paracelsus, the Adech,¹⁰ whom Ruland defines as “our inner and invisible man.”¹¹

[548] Accordingly the arcane substance would appear to be the “inner” man or Primordial Man, known as Adam Kadmon in the Cabala. In the poem of Valentinus, this inner man is swamped by the goddess of love—an unmistakable psychologem for a definite and typical psychic state, which is also symbolized very aptly by the Gnostic love-affair between Nous and Physis. In both cases the “higher spiritual man” is the more comprehensive, supra-ordinate totality which we know as the self. The bath, submersion, baptism, and drowning are synonymous, and all are alchemical symbols for the unconscious state of the self, its embodiments, as it were—or, more precisely, for the unconscious process by which the self is “reborn” and enters into a state in which it can be experienced. This state is then described as the “*filius regius*.” The “old dragon” who prepared the bath, a primeval creature dwelling in the caverns of the earth, is, psychologically, a personification of the instinctual psyche, generally symbolized by reptiles. It is as though the alchemists were trying to express the fact that the unconscious itself initiates the process of renewal.

[549] Adam’s bath is also mentioned in a Latin manuscript in my possession, where an unspecified being or creature addresses Adam thus: “Hear, Adam, I will speak with you. You must go with me into the bath; you know in what manner we are influenced the one by the other, and how you must pass through me. Thus I step up to you with my sharpened arrows, aiming them at your heart ...”¹²

[550] Here again Adam is the transformative substance, the “old Adam” who is to renew himself. The arrows recall the *telum passionis* of Mercurius and the shafts of Luna, which the alchemists, via the mysticism of Hugh of St. Victor¹³ and others, referred to that well-known passage in the Song of Songs: “Thou hast wounded my heart,” as we have seen earlier.¹⁴ The speaker in the manuscript must be feminine, as immediately before there is a reference to the cohabitation of man and woman.

[551] Both texts point to a hierosgamos which presupposes a kind of consanguineous relationship between *sponsus* and *sponsa*. The relationship between Adam and Eve is as close as it is difficult to define. According to an old tradition Adam was androgynous before the creation of Eve.¹⁵ Eve therefore was more himself than if she had been his sister. Adam’s highly unbiblical marriage is emphasized as a hierosgamos by the fact that God himself was present at the ceremony as best man (*paranympus*).¹⁶ Traces of cabalistic tradition are frequently noticeable in the alchemical treatises from the sixteenth century on. Both our texts are fairly late and so fall well within this tradition.

[552] We must now turn to the question of why it was that Adam should have been selected as a symbol for the prima materia or transformative substance. This was probably due, in the first place, to the fact that he was made out of clay, the “ubiquitous” *materia vilis* that was axiomatically regarded as the prima materia and

for that very reason was so tantalizingly difficult to find, although it was “before all eyes.” It was a piece of the original chaos, of the *massa confusa*, not yet differentiated but capable of differentiation; something, therefore, like shapeless, embryonic tissue. Everything could be made out of it.¹⁷ For us the essential feature of the prima materia is that it was defined as the “massa confusa” and “chaos,” referring to the original state of hostility between the elements, the disorder which the artifex gradually reduced to order by his operations. Corresponding to the four elements there were four stages of the process (*tetrameria*), marked by four colours, by means of which the originally chaotic arcane substance finally attained to unity, to the “One,” the lapis, which at the same time was an homunculus.¹⁸ In this way the Philosopher repeated God’s work of creation described in Genesis 1. No wonder, therefore, that he called his prima materia “Adam” and asserted that it, like him, consisted or was made out of the four elements. “For out of the four elements were created our Father Adam and his children,” says the *Turba*.¹⁹ And Gabir ibn Hayyan (Jabir)²⁰ says in his “Book of Balances”:

The Pentateuch says, regarding the creation of the first being, that his body was composed of four things, which thereafter were transmitted by heredity: the warm, the cold, the moist, and the dry. He was in fact composed of earth and water, a body and a soul. Dryness came to him from the earth, moisture from the water, heat from the spirit, and cold from the soul.²¹

The later literature often mentions Adam as a *compositio elementorum*.²² Because he was composed out of the four cosmic principles he was called the Microcosm.²³ The “Tractatus Micreris” says:²⁴

Even so is man called the lesser world [*mundus minor*], because in him is the figure of the heavens, of the earth, of the sun and moon, a visible figure upon earth and [at the same time] invisible, wherefore he is named the lesser world. Therefore the old Philosophers said of him, When the water fell upon the earth, Adam was created, who is the lesser world.²⁵

Similar views of Adam are found elsewhere; thus the *Pirke de Rabbi Eliezer* says that God collected the dust from which Adam was made from the four corners of the earth.²⁶ Rabbi Meir (2nd cent.) states that Adam was made from dust from all over the world. In Mohammedan tradition Tabari, Masudi, and others say that when the earth refused to provide the material for Adam’s creation the angel of death came along with three kinds of earth: black, white, and red.²⁷ The Syrian “Book of the Cave of Treasures” relates:

And they saw God take a grain of dust from the whole earth, and a drop of water from the whole sea, and a breath of wind from the upper air, and a little warmth from the nature of fire. And the angels saw how these four weak elements, the dry, the

moist, the cold, and the warm, were laid in the hollow of his hand. And then God made Adam.²⁸

The poet Jalal-ud-din Rumi says that the earth from which Adam was made had seven colours.²⁹ A collection of English riddles from the fifteenth century asks the following questions concerning Adam's creation:

Questions bitwene the Maister of Oxinford and his scoler: Whereof was Adam made? Of VIII thingis: the first of earthe, the second of fire, the IIIrd of wynde, the IIIIth of clowdys, the Vth of aire where thorough he speketh and thinketh, the VIth of dewe whereby hi sweteth, the VIIth of flowres wherof Adam hath his ien, the VIIIth is salte wherof Adam hath salt teres.³⁰

[553] This material clearly shows the tetradic and ogdoadic nature of Adam, and there is also that characteristic uncertainty as to three and seven: four elements, four colours, four qualities, four humours,³¹ and three and seven colours.³²

[554] Dorn calls the ternarius (the number three) "peculiar to Adam" (*Adamo proprius*). And because the ternarius was the "offspring of the unarius" (the number one), the devil, whose nature is binary, could do nothing against him, but had to make his attack upon Eve,³³ "who was divided from her husband as a natural binarius from the unity of his ternarius."³⁴ Vigenerus, commenting on I Cor. 15 : 47,³⁵ writes:

For the elements are circular [in their arrangement], as Hermes makes clear, each being surrounded by two others with which it agrees in one of those qualities peculiar to itself, as [for instance] earth is between fire and water, partaking in the dryness of fire and the coldness of water. . . .³⁶ Man, therefore, who is an image of the great world, and is called the microcosm or little world (as the little world, made after the similitude of its archetype, and compounded of the four elements, is called the great man), has also his heaven and his earth. For the soul and the understanding are his heaven; his body and senses his earth. Therefore, to know the heaven and earth of man, is the same as to have a full and complete knowledge of the whole world and of the things of nature.³⁷

[555] The circular arrangement of the elements in the world and in man is symbolized by the mandala and its quaternary structure. Adam would then be a quaternarius, as he was composed of red, black, white, and green dust from the four corners of the earth, and his stature reached from one end of the world to the other.³⁸ According to one Targum, God took the dust not only from the four quarters but also from the sacred spot, the "centre of the world."³⁹ The four quarters reappear in the (Greek) letters of Adam's name: *anatole* (sunrise, East), *dysis* (sunset, West), *arktos* (Great Bear, North), *mesembria* (noon, South).⁴⁰ The "Book of the Cave of Treasures" states that Adam stood on the spot where the cross was later erected, and that this spot was the centre of the earth. Adam, too, was buried at the centre of the earth—on

Golgotha. He died on a Friday, at the same hour as the Redeemer.⁴¹ Eve bore two pairs of twins—Cain and Lebhûdhâ, Abel and Kelîmath—who later married each other (marriage quaternio). Adam's grave is the "cave of treasures." All his descendants must pay their respects to his body and "not depart from it." When the Flood was approaching, Noah took Adam's body with him into the ark. The ark flew over the flood on the wings of the wind from east to west and from north to south, thus describing a cross upon the waters.

[556] At the midpoint where Adam was buried, the "four corners come together; for when God created the earth his power ran along in front of it, and the earth ran after his power from four sides like winds and gentle breezes, and there his power stopped and came to rest. And there will be accomplished the redemption for Adam and all his children." Over the grave where the cross would stand there grew a tree, and there too was the altar of Melchizedek. When Shem laid the body on the ground,

the four sides moved away from one another, the earth opened in the form of a cross, and Shem and Melchizedek laid the body inside. And as soon as they had done this, the four sides moved together again and covered the body of our Father Adam, and the doors of the earth were closed. And the same spot was named the Place of the Skull, because the head of all men was laid there, and Golgotha, because it was round . . . and Gabbatha, because all the nations were gathered in it.⁴²

"There the power of God will appear, for the four corners of the world have there become one," say the Ethiopic *Clementines*.⁴³ God said to Adam: "I shall make thee God, but not now; only after the passing of a great number of years."⁴⁴ The apocryphal "Life of Adam and Eve" says that the east and north of paradise were given to Adam, but the west and south to Eve.⁴⁵ The *Pirke de Rabbi Eliezer* relates that Adam was buried in the double cave Machpelah, and that Eve, Abraham and Sara, Isaac and Rebecca, Jacob and Leah were buried there too. "Therefore the cave was named Kiriath Arba', the City of Four, because four husbands and wives were buried there."⁴⁶

[557] I do not want to pile up proofs of Adam's quaternary nature, but only to give it due emphasis. Psychologically the four are the four orienting functions of consciousness, two of them perceptive (irrational), and two discriminative (rational). We could say that all mythological figures who are marked by a quaternity have ultimately to do with the structure of consciousness. We can therefore understand why Isaac Luria attributed every psychic quality to Adam: he is the psyche *par excellence*.⁴⁷

[558] The material I have presented is so suggestive that no detailed commentary is needed. Adam stands not only for the psyche but for its totality; he is a symbol of the self, and hence a visualization of the "irrepresentable" Godhead. Even if all the texts

here cited were not available to the alchemists, a knowledge of the Zosimos treatises or of certain Cabalistic traditions would have been sufficient to make quite clear to them what was meant when the arcane substance was called Adam. I need hardly point out how important these historical statements are from the psychological point of view: they give us valuable indications of the way in which the corresponding dream-symbols should be evaluated. We do not devalue statements that originally were intended to be metaphysical when we demonstrate their psychic nature; on the contrary, we confirm their factual character. But, by treating them as psychic phenomena, we remove them from the inaccessible realm of metaphysics, about which nothing verifiable can be said, and this disposes of the impossible question as to whether they are “true” or not. We take our stand simply and solely on the facts, recognizing that the archetypal structure of the unconscious will produce, over and over again and irrespective of tradition, those figures which reappear in the history of all epochs and all peoples, and will endow them with the same significance and numinosity that have been theirs from the beginning.

2. THE STATUE

[559] An old tradition says that Adam was created “a lifeless statue.” It is worthy of remark that the statue plays a mysterious role in ancient alchemy. One of the earliest Greek treatises, the Book of Komarios,⁴⁸ says:

After the body had been hidden in the darkness, [the spirit] found it full of light. And the soul united with the body, since the body had become divine through its relation to the soul, and it dwelt in the soul. For the body clothed itself in the light of divinity, and the darkness departed from it, and all were united in love, body, soul, and spirit, and all became one; in this the mystery is hidden. But the mystery was fulfilled in their coming together, and the house was sealed, and the statue [*ἀνδρίας*] was erected, filled with light and divinity.⁴⁹

Here the statue evidently denotes the end-product of the process, the lapis Philosophorum or its equivalent.

[560] The statue has a somewhat different significance in the treatise of Senior,⁵⁰ who speaks of the “water that is extracted from the hearts of statues.” Senior is identical with the Arabian alchemist Ibn ‘Umail al-Tamimi. He is reported to have opened tombs and sarcophagi in Egypt and to have removed the mummies.⁵¹ Mummies were supposed to possess medicinal virtues, and for this reason bits of corpses had long been mentioned in European pharmacy under the name of “mumia.”⁵² It is possible that “mumia” was also used for alchemical purposes. It is mentioned in Khunrath as synonymous with the prima materia.⁵³ In Paracelsus, who may have been Khunrath’s

source for this, “Mumia balsamita” has something to do with the elixir, and is even called the physical life-principle itself.⁵⁴ Senior’s statues may well have been Egyptian sarcophagi, which as we know were portrait-statues. In the same treatise there is a description of a statue (of Hermes Trismegistus) in an underground chapel. Senior says: “I shall now make known to you what that wise man who made the statue has hidden in that house; in it he has described that whole science, as it were, in the figure, and taught his wisdom in the stone, and revealed it to the discerning.” Michael Maier comments: “That is the statue from whose heart the water is extracted.” He also mentions that a stone statue which pronounced oracles was dedicated to Hermes in Achaia Pharis.

[561] In Raymond Lully (Ramon Llull) there is an “oil that is extracted from the heart of statues,” and moreover “by the washing of water and the drying of fire.”⁵⁵ This is an extremely paradoxical operation in which the oil evidently serves as a mediating and uniting agent.

[562] There is an allusion to the statues in Thomas Norton’s “Ordinall of Alkimy”:

But holy *Alkimy* of right is to be loved,
Which treateth of a precious Medicine,
Such as trewly maketh *Gold* and *Silver* fine:
Whereof example for Testimonie
Is in a Citty of *Catilyony*.
Which *Raymund Lully*, *Knight*, men [do] suppose,
Made in seaven Images the trewth to disclose;
Three were good *Silver*, in shape like Ladies bright,
Everie each of Foure were *Gold* and like a Knight:
In borders of their Clothing Letters did appeare,
Signifying in Sentence as it sheweth here.⁵⁶

[563] The “seven” refer to the gods of the planets, or the seven metals.⁵⁷ The correlation of the “three” (Venus, moon, earth) with silver (Luna) and of the “four” with gold (Sol) is remarkable in that three is usually considered a masculine and four a feminine number.⁵⁸ As Lully was undoubtedly acquainted with Senior this legend seems like a concretization of Senior’s saying.⁵⁹

[564] The idea of a precious substance hidden in the “statue” is an old tradition and is particularly true of the statues of Hermes or Mercurius. Pseudo-Dionysius⁶⁰ says that the pagans made statues (*ἀνδριάντας*) of Mercurius and hid in them a simulacrum of the god. In this way they worshipped not the unseemly herm but the image hidden inside.⁶¹ Plato is referring to these statues when he makes Alcibiades say that Socrates “bears a strong resemblance to those figures of Silenus in statuaries’ shops,

represented holding pipes or flutes; they are hollow inside, and when they are taken apart you see that they contain little figures [αγάλματα] of gods.”⁶²

[565] It must have appealed very much to the imagination of the alchemists that there were statues of Mercurius with the real god hidden inside. Mercurius was their favourite name for that being who changed himself, during the work, from the prima materia into the perfected lapis Philosophorum. The figure of Adam readily lent itself as a biblical synonym for the alchemical Mercurius, first because he too was androgynous, and second because of his dual aspect as the first and second Adam. The second Adam is Christ, whose mystical androgyny is established in ecclesiastical tradition.⁶³ I shall come back to this aspect of Adam later.

[566] According to the tradition of the Mandaeans, Adam was created by the seven in the form of a “lifeless bodily statue” which could not stand erect. This characteristic expression “bodily statue” frequently recurs in their literature and recalls the Chaldaean myth handed down by the Naassenes, that man’s body was created by the demons and was called a statue (ἀνδριάς).⁶⁴ Ptahil, the world-creator, tried to “throw the soul into the statue,” but Manda d’Hayye, the redeemer, “took the soul in his arms” and completed the work without Ptahil.⁶⁵ In this connection we may note that there is a description of the statue of Adam in Cabalistic literature.⁶⁶

[567] As Adam has always been associated with the idea of the second Adam in the minds of Christian writers,⁶⁷ it is readily understandable that this idea should reappear among the alchemists. Thus Mylius says:

There now remains the second part of the philosophical practice, by far the more difficult, by much the more sublime. In this we read that all the sinews of talent, all the mental efforts of many philosophers have wearied themselves. For it is more difficult to make a man live again, than to slay him. Here is God’s work besought: for it is a great mystery to create souls, and to mould the lifeless body into a living statue.⁶⁸

This living statue refers to the end-result of the work; and the work, as we have seen, was on the one hand a repetition of the creation of the world, and on the other a process of redemption, for which reason the lapis was paraphrased as the risen Christ. The texts sometimes strike a chiliastic note with their references to a golden age when men will live forever without poverty and sickness.⁶⁹ Now it is remarkable that the statue is mentioned in connection with the eschatological ideas of the Manichaeans as reported by Hegemonius: the world will be consumed with fire and the souls of sinners chained for all eternity, and “then shall these things be, when the statue shall come.”⁷⁰ I would not venture to say whether the Manichaeans influenced the alchemists or not, but it is worth noting that in both cases the statue is connected

with the end-state. The tradition reported by Hegemonius has been confirmed by the recently discovered original work of Mani, the *Kephalaia*.⁷¹ This says:

At that time [the Father of Greatness] made the messenger and Jesus the radiant and the Virgin of Light and the Pillar of Glory and the gods. . . .⁷² The fourth time, when they shall weep, is the time when the statue [*ἀνδριάς*] shall raise itself on the last day. . . .⁷³ At that same hour, when the last statue shall rise, they shall weep. . . .⁷⁴ The first rock is the pillar [*στῦλος*] of glory, the perfect man, who has been summoned by the glorious messenger. . . . He bore the whole world and became the first of all bearers. . . .⁷⁵ The intellectual element [*νοερόν*] [gathered itself] into the pillar of glory, and the pillar of glory into the first man. . . .⁷⁶ The garments, which are named the Great Garments, are the five intellectual elements, which have [made perfect] the body of the pillar of glory, the perfect man.⁷⁷

It is clear from these extracts that the statue or pillar is either the perfect Primordial Man (*τέλειος ἄνθρωπος*) or at least his body, both at the beginning of creation and at the end of time.

[568] The statue has yet another meaning in alchemy which is worth mentioning. In his treatise “De Igne et Sale” Vigenerus calls the sun the “eye and heart of the sensible world and the image of the invisible God,” adding that St. Dionysius called it the “clear and manifest statue of God.”⁷⁸ This statement probably refers to Dionysius’s *De divinis nominibus* (ch. IV): “The sun is the visible image of divine goodness.”⁷⁹ Vigenerus translated *εἰκών* not by “imago” but by “statua,” which does not agree with the Latin text of the collected edition brought out by Marsilio Ficino in 1502–3, to which he may have had access. It is not easy to see why he rendered *εἰκών* by “statua,” unless perhaps he wished to avoid repeating the word “imago” from the end of the preceding sentence. But it may also be that the word “cor” recalled to his mind Senior’s phrase “from the hearts of statues,” as might easily happen with so learned an alchemist. There is, however, another source to be considered: it is evident from this same treatise that Vigenerus was acquainted with the *Zohar*. There the Haye Sarah on Genesis 28:22 says that Malchuth is called the “statue” when she is united with Tifereth.⁸⁰ Genesis 28 : 22 runs: “And this stone, which I have set for a pillar, shall be God’s house.”⁸¹ The stone is evidently a reminder that here the upper (Tifereth) has united with the lower (Malchuth): Tifereth the son⁸² has come together with the “Matrona”⁸³ in the hierosgamos. If our conjecture is correct, the statue could therefore be the Cabalistic equivalent of the lapis Philosophorum, which is likewise a union of male and female. In the same section of Vigenerus’s treatise the sun does in fact appear as the bridegroom.⁸⁴ As Augustine is quoted a few lines later, it is possible that Vigenerus was thinking of that passage where Augustine says:

Like a bridegroom Christ went forth from his chamber, he went out with a presage of his nuptials into the field of the world. He ran like a giant exulting on his way, and

came to the marriage bed of the cross, and there, in mounting it, he consummated his marriage. And when he perceived the sighs of the creature, by a loving exchange he gave himself up to the torment in place of his bride. He yielded up also the carbuncle, as the jewel of his blood, and he joined the woman to himself for ever. “I have espoused you to one husband,” says the apostle, “that I may present you as a chaste virgin to Christ” [2 Cor. 11 : 2].⁸⁵

[569] Since Adam signifies not only the beginning of the work, the *prima materia*, but also the end, the *lapis*, and the *lapis* is the product of the royal marriage, it is possible that Vigenerus’s “*statua Dei*,” replacing the more usual “*imago Dei*,” has some connection with the Cabalistic interpretation of the stone of Bethel, which in turn marked the union of Tifereth and Malchuth. The statue stands for the inert materiality of Adam, who still needs an animating soul; it is thus a symbol for one of the main preoccupations of alchemy.

3. ADAM AS THE FIRST ADEPT

[570] Not always in alchemy is Adam created out of the four elements. The “*Introitus apertus*,” for instance, says that the soul of the gold is united with Mercurius in lead, “that they may bring forth Adam and his wife Eve.”⁸⁶ Here Adam and Eve take the place of King and Queen. But in general Adam, being composed of the four elements, either *is* the *prima materia* and the arcane substance itself,⁸⁷ or he brought it with him from paradise, at the beginning of the world, as the first adept. Maier mentions that Adam brought antimony (then regarded as an arcane substance)⁸⁸ from paradise.⁸⁹ The long line of “Philosophers” begins with him. The “*Aquarium sapientum*” asserts that the secret of the stone was revealed to Adam from above and was subsequently “sought after with singular longing by all the Holy Patriarchs.”⁹⁰ The “*Gloria mundi*” says: “The Lord endowed Adam with great wisdom, and such marvellous insight that he immediately, without the help of any teacher—simply by virtue of his original righteousness—had a perfect knowledge of the seven liberal arts, and of all animals, plants, stones, metals, and minerals. Nay, what is more, he had a perfect understanding of the Holy Trinity, and of the coming of Christ in the flesh.”⁹¹ This curious opinion is traditional and comes mainly from Rabbinic sources.⁹² Aquinas, too, thought that Adam, because of his perfection, must have had a knowledge of all natural things.⁹³ In Arabian tradition Shîth (Seth) learnt medicine from him.⁹⁴ Adam also built the Ka’ba, for which purpose the angel Gabriel gave him the ground-plan and a precious stone. Later the stone turned black because of the sins of men.⁹⁵

[571] The Jewish sources are even more explicit. Adam understood all the arts,⁹⁶ he invented writing, and from the angels he learnt husbandry and all the professions including the art of the smith.⁹⁷ A treatise from the eleventh century lists thirty kinds of fruit which he brought with him from paradise.⁹⁸ Maimonides states that Adam wrote a book on trees and plants.⁹⁹ Rabbi Eliezer credits Adam with the invention of the leap-year.¹⁰⁰ According to him, the tables on which God later inscribed the law came from Adam.¹⁰¹ From Eliezer, probably, derives the statement of Bernardus Trevisanus that Hermes Trismegistus found seven stone tables in the vale of Hebron, left over from antediluvian times. On them was a description of the seven liberal arts. Adam had put these tables there after his expulsion from paradise.¹⁰² According to Dorn, Adam was the first “practitioner and inventor of the arts.” He had a knowledge of all things “before and after the Fall,” and he also prophesied the renewal and chastening of the world by the flood.¹⁰³ His descendants set up two stone tables on which they recorded all the “natural arts” in hieroglyphic script. Noah found one of these tables at the foot of Mount Ararat, bearing a record of astronomy.¹⁰⁴

[572] This legend probably goes back to Jewish tradition, to stories like the one mentioned in the *Zohar*:

When Adam was in paradise, God sent the holy angel Raziel,¹⁰⁵ the keeper of the higher secrets, to him with a book, in which the higher holy wisdom was set forth. In this book two and seventy kinds of wisdom were described in six hundred and seventy sections. By means of this book there were given to him fifteen hundred keys to wisdom, which were known to none of the higher holy men, and all remained secret until this book came to Adam. . . . Henceforth he kept this book hid and secret, daily using this treasure of the Lord, which discovered to him the higher secrets of which even the foremost angels knew nothing, until he was driven out of paradise. But when he sinned and transgressed the command of the Lord, this book fled from him. . . . He bequeathed it to his son Seth. And from Seth it came to Enoch, and from him . . . to Abraham.¹⁰⁶

[573] In the *Clementine Homilies* (2nd cent.) Adam is the first of a series of eight incarnations of the “true prophet.” The last is Jesus.¹⁰⁷ This idea of a pre-existent seer may spring from Jewish or Judaeo-Christian tradition, but in China it is vividly realized in the figure of P’an Ku.¹⁰⁸ He is represented as a dwarf clad in a bear-skin or in leaves; on his head he has two horns.¹⁰⁹ He proceeded from *yang* and *yin*, fashioned the chaos, and created heaven and earth. He was helped by four symbolic animals—the unicorn, the phoenix, the tortoise, and the dragon.¹¹⁰ He is also represented with the sun in one hand and the moon in the other. In another version he has a dragon’s head and a snake’s body. He changed himself into the earth with all its creatures and thus proved to be a real *homo maximus* and Anthropos. P’an Ku is of

Taoist origin and nothing seems to be known of him before the fourth century A.D.¹¹¹ He reincarnated himself in Yüan-shih T'ien-tsun, the First Cause and the highest in heaven.¹¹² As the fount of truth he announces the secret teaching, which promises immortality, to every new age. After completing the work of creation he gave up his bodily form and found himself aimlessly floating in empty space. He therefore desired rebirth in visible form. At length he found a holy virgin, forty years old, who lived alone on a mountain, where she nourished herself on air and clouds. She was hermaphroditic, the embodiment of both *yang* and *yin*. Every day she collected the quintessence of sun and moon. P'an Ku was attracted by her virgin purity, and once, when she breathed in, he entered into her in the form of a ray of light, so that she became pregnant. The pregnancy lasted for twelve years, and the birth took place from the spinal column. From then on she was called T'ai-yüan Sheng-mu, "the Holy Mother of the First Cause."¹¹³ The relatively late date of the legend leaves the possibility of Christian influence open. All the same, its analogy with Christian and Persian ideas does not prove its dependence on these sources.

[574] The series of eight incarnations of the "true prophet" is distinguished by the special position of the eighth, namely Christ. The eighth prophet is not merely the last in the series; he corresponds to the first and is at the same time the fulfilment of the seven, and signifies the entry into a new order. I have shown in *Psychology and Alchemy* (pars. 200ff.), with the help of a modern dream, that whereas the seven form an uninterrupted series, the step to the eighth involves hesitation or uncertainty and is a repetition of the same phenomenon that occurs with three and four (the Axiom of Maria). It is very remarkable that we meet it again in the Taoist series of "eight immortals" (*hsien-yên*): the seven are great sages or saints who dwell in heaven or on the earth, but the eighth is a *girl* who sweeps up the fallen flowers at the southern gate of heaven.¹¹⁴ The parallel to this is Grimm's tale of the seven ravens: there the seven brothers have one sister.¹¹⁵ One is reminded in this connection of Sophia, of whom Irenaeus says: "This mother they also call the Ogdoad, Sophia, Terra, Jerusalem, Holy Spirit, and, with a masculine reference, Lord."¹¹⁶ She is "below and outside the Pleroma." The same thought occurs in connection with the seven planets in Celsus's description of the "diagram of the Ophites," attacked by Origen.¹¹⁷ This diagram is what I would call a mandala—an ordering pattern or pattern of order which is either consciously devised or appears spontaneously as a product of unconscious processes.¹¹⁸ The description Origen gives of the diagram is unfortunately not particularly clear, but at least we can make out that it consisted of ten circles, presumably concentric, since he speaks of a circumference and a centre.¹¹⁹ The outermost circle was labelled "Leviathan" and the innermost "Behemoth," the two apparently coinciding, for "Leviathan" was the name for the centre as well as the

circumference.¹²⁰ At the same time, “the impious diagram said that the Leviathan . . . is the soul that has permeated the universe.”¹²¹

[575] Origen had got hold of a diagram like the one used by Celsus and discovered in it the names of the seven angels Celsus alludes to. The prince of these angels was called the “accursed God,” and they themselves were called sometimes gods of light and sometimes “archons.” The “accursed God” refers to the Judaeo-Christian world-creator, as Origen duly notes. Yahweh appears here obviously as the prince and father of the seven archons.¹²² The first of them had a “lion’s form” and was named Michael; the second was a bull and was named Suriel, the bull-formed; the third, Raphael, had the form of a snake; the fourth, named Gabriel, the form of an eagle; the fifth, Thauthabaoth, the form of a bear; the sixth, Erataoth, the form of a dog; and the seventh had the form of an ass and was called Onoël or Taphabaoth or Tharthataoth.¹²³

[576] It is to be presumed that these names were distributed among the eight inner circles. The seven archons correspond to the seven planets and represent so many spheres with doors which the celebrant has to pass through on his ascent. Here, says Origen, is the origin of the Ogdoad, which, clearly, must consist of the seven and their father Yahweh. At this point Origen mentions, as the “first and seventh,” Ialdabaoth, of whom we have not heard before. This supreme archon, as we know from other sources too, is lion-headed or lion-like.¹²⁴ He would therefore correspond to Michael in the Ophitic diagram, the first in the list of archons. “Ialdabaoth” means “child of chaos”; thus he is the first-born of a new order that supersedes the original state of chaos. As the first son, he is the last of the series,¹²⁵ a feature he shares with Adam and also with Leviathan, who, as we have seen, is both circumference and centre. These analogies suggest that the diagram showed a series of concentric circles.¹²⁶ The old world-picture, with the earth as the centre of the universe, consisted of various “heavens”—spherical layers or spheres—arranged concentrically round the centre and named after the planets. The outermost planetary sphere or archon was Saturn. Outside this would be the sphere of the fixed stars (corresponding to Leviathan as the tenth circle in the diagram), unless we postulated some place for the demiurge or for the father or mother of the archons. It is evident from the text that an Ogdoad is meant,¹²⁷ as in the system of Ptolemy reported by Irenaeus.¹²⁸ There the eighth sphere was called Achamoth (Sophia, Sapientia),¹²⁹ and was of feminine nature, just as in Damascius the hebdomad was attributed to Kronos and the ogdoad to Rhea.¹³⁰ In our text the virgin Prunicus is connected with the mandala of seven circles:¹³¹ “They have further added on top of one another sayings of the prophets, circles included in circles . . . and a power flowing from a certain Prunicus, a virgin, a living soul.”¹³²

[577] The “circles included in circles” point decisively to a concentric arrangement, as we find it, significantly enough, in Herodotus’s description¹³³ of the seven circular walls of Ecbatana.¹³⁴ The ramparts of these walls were all painted in different colours; of the two innermost and highest walls one was silvered and the other gilded. The walls obviously represented the concentric circles of the planets, each characterized by a special colour.

[578] In the introduction to his diagram Celsus reports on the idea, found among the Persians and in the Mithraic mysteries, of a stairway with seven doors and an eighth door at the top. The first door was Saturn and was correlated with lead, and so on. The seventh door was gold and signified the sun. The colours are also mentioned.¹³⁵ The stairway represents the “passage of the soul” (*animae transitus*). The eighth door corresponds to the sphere of the fixed stars.

[579] The archetype of the seven appears again in the division of the week and the naming of its days, and in the musical octave, where the last note is always the beginning of a new cycle. This may be a cogent reason why the eighth is feminine: it is the *mother* of a new series. In Clement’s line of prophets the eighth is Christ. As the first and second Adam he rounds off the series of seven, just as, according to Gregory the Great, he, “coming in the flesh, joined the Pleiades, for he had within himself, at once and for ever, the works of the sevenfold Holy Spirit.”¹³⁶ These references should suffice to show the special nature of the eighth and its tendency to be feminine in Christian gnosis.

[580] Adam’s dual nature reappears in Christ: he is male-female. Boehme expresses this by saying that Christ was a “virgin in mind.”¹³⁷ She is “an image of the holy number Three,”¹³⁸ “eternally uncreated and ungenerated.”¹³⁹ Where the “Word” is, there is the virgin, for the “Word” is in her.¹⁴⁰ She is the “woman’s seed,”¹⁴¹ which shall bruise the head of the serpent (Gen. 3 : 15).¹⁴² He who shall tread on its head is Christ, who thus appears identical with the seed of the woman or with the virgin. In Boehme the virgin has the character of an anima, for “she is given to be a companion to thee in thy soul,”¹⁴³ and at the same time, as divine power and wisdom, she is in heaven and in paradise.¹⁴⁴ God took her to him to be his “spouse.”¹⁴⁵ She expresses all the profundity and infinity of the Godhead,¹⁴⁶ thus corresponding to the Indian Shakti.¹⁴⁷ The androgynous unity of Shiva and Shakti is depicted in Tantric iconography as permanent cohabitation.¹⁴⁸

[581] Boehme’s ideas had a strong influence on Franz von Baader, who asserted that God gave Adam a helpmeet (*adjutor*) through whom Adam “was to have brought forth without an external woman,” as Mary did without a man. But Adam “fell for”¹⁴⁹ the bestial act of copulation and was in danger of himself sinking to the level of a beast. God, recognizing this possibility, thereupon created Eve as a “salutary counter-

institution [*rettende Gegenanstalt*], to prevent an otherwise unavoidable and deeper descent of man . . . into animal nature.”¹⁵⁰ When Adam threatened to sink into it nevertheless, his divine androgyny departed from him, but was preserved in Eve as the “woman’s seed,” with the help of which man would free himself from the “seed of the serpent.” For “he who was born in the Virgin Mary is the same who had to depart from Adam on account of his fall.”¹⁵¹

[582] The presence of a divine pair or androgyne in the human soul is touched upon by Origen: “They say that as the sun and moon stand as the two great lights in the firmament of heaven, so in us Christ and the Church.”¹⁵² And thus, too, Adam and Eve are in each of us, as Gregory the Great says; Adam standing for the spirit, Eve for the flesh.¹⁵³

[583] Origen, like Clement of Rome, credits Adam with the gift of prophecy, “for he prophesied a great mystery in Christ and the Church, saying, ‘Therefore shall a man leave his father and mother, and shall cleave unto his wife, and they shall be one flesh.’”¹⁵⁴ (Gen. 2 : 24; cf. Matt. 19 : 5 and Mark 10 : 7.)

[584] I shall end this account of the excellent equipment of the first man with an Arabian legend, which is not without a deeper meaning. When Adam left Paradise, God sent the angel Gabriel to him with an offer of three gifts of which he should choose one: modesty, intelligence, and religion. Without hesitation Adam chose intelligence. Thereupon Gabriel commanded modesty and religion to return at once to heaven. But they refused, invoking God’s own command never to part from intelligence, wherever it might be found. For the Prophet had said: “Never submit to one who has no trace of intelligence.”¹⁵⁵

4. THE POLARITY OF ADAM

[585] There has always existed a widely felt need to think of the first man as having a “light” nature; hence the frequent comparison with the sun. The alchemists did not insist on this aspect, so I need say only a few words about it here. Usually, however, in the non-chemical literature Adam is a “light” figure whose splendour even outshines that of the sun. He lost his radiance owing to the Fall.¹⁵⁶ Here we have a hint of his dual nature: on the one hand shining and perfect, on the other dark and earthy. Haggadic interpretation derives his name from *adamah*, earth.¹⁵⁷

[586] His dual nature is confirmed by Origen: one Adam was made out of earth, the other “after the image and likeness of God. He is our inner man, invisible, incorporeal, unspotted, and immortal.”¹⁵⁸ Similar views are expressed by Philo.¹⁵⁹ It is worth noting that in Colossians 1:15 Christ is this “image of the invisible God, the firstborn of every creature.”

[587] Adam’s dual nature is reflected in his hermaphroditism. Thus Dorn says that the “fiery and perfect Mercurius” is the “true hermaphroditic Adam.”¹⁶⁰ This idea occurs among the Naassenes. “These men,” says Hippolytus, “worship as the beginning of all things, according to their own statement, a Man and a Son of Man. But this Man is masculo-feminine [*ἀρσενόθηλυς*] and is called by them Adamas; and hymns to him are many and various.” He quotes as an example: “From thee the father, through thee the mother, the two immortal names, parents of the Aeons, O citizen of heaven, O Man of the Great Name!”¹⁶¹ Adam is masculo-feminine also in Jewish tradition. In *Midrash Rabbah* VIII, 1¹⁶² he is an androgyne, or a man and woman grown into one body with two faces. God sawed the body in two and made each half a back.¹⁶³ Through his androgyny Adam has affinities with Plato’s sphere-shaped Original Being as well as with the Persian Gayomart. This idea has left a few traces in alchemy. For instance, Glauber attributes the sign of the circle to Adam and the square to Eve.¹⁶⁴ The circle is usually the sign for gold and sun. It is found in the latter sense in the “Book of the Cave of Treasures”: “Then God made Adam. . . . And when the angels saw his glorious appearance, they were moved by the beauty of the sight; for they saw the form of his countenance, while it was enkindled, in shining splendour like to the ball of the sun, and the light of his eyes like to the sun, and the form of his body like to the light of a crystal.”¹⁶⁵ An Arabic Hermes-text on the creation of Adam relates that, when the virgin (Eve) came to power, the angel Harus (Horus) arose from the unanimous will of the planets. This Harus took sixty spirits from the planets, eighty-three from the zodiac, ninety from the highest heaven, one hundred and twenty-seven from the earth, three hundred and sixty spirits in all,

mixed them together and created out of them Adamanus, the first man, “after the form of the highest heaven.”¹⁶⁶ The number 360 and the “form of heaven” both indicate his circular shape.

[588] Aside, however, from his androgyny there is a fundamental polarity in Adam which is based on the contradiction between his physical and spiritual nature. This was felt very early, and is expressed in the view of Rabbi Jeremiah ben Eleazar that Adam must have had two faces, in accordance with his interpretation of Psalm 139 : 5: “Thou hast beset me behind and before”,¹⁶⁷ and in the Islamic view that Adam’s soul was created thousands of years before his body and then refused to enter the figure made of clay, so that God had to put it in by force.¹⁶⁸

[589] According to a Rabbinic view Adam even had a tail.¹⁶⁹ His condition at first was altogether most inauspicious. As he lay, still inanimate, on the ground, he was of a greenish hue, with thousands of impure spirits fluttering round who all wanted to get into him. But God shooed them away till only one remained, Lilith, the “mistress of spirits,” who succeeded in so attaching herself to Adam’s body that she became pregnant by him. Only when Eve appeared did she fly away again.¹⁷⁰ The daemonic Lilith seems to be a certain aspect of Adam, for the legend says that she was created with him from the same earth.¹⁷¹ It throws a bad light on Adam’s nature when we are told that countless demons and spooks arose from his nocturnal emissions (*ex nocturno seminis fluxu*). This happened during the one hundred and thirty years which he had to spend apart from Eve, banished from the heavenly court “under the anathema of excommunication.”¹⁷² In Gnosticism the original man Adamas, who is nothing but a paraphrase of Adam,¹⁷³ was equated with the ithyphallic Hermes and with Korybas, the pederastic seducer of Dionysus,¹⁷⁴ as well as with the ithyphallic Cabiri.¹⁷⁵ In the *Pistis Sophia* we meet a Sabaoth Adamas, the ruler (*τύραννος*) of the Aeons, who fights against the light of Pistis Sophia¹⁷⁶ and is thus wholly on the side of evil. According to the teachings of the Bogomils, Adam was created by Satanaël, God’s first son and the fallen angel, out of mud. But Satanael was unable to bring him to life, so God did it for him.¹⁷⁷ Adam’s inner connection with Satan is likewise suggested in Rabbinic tradition, where Adam will one day sit on Satan’s throne.¹⁷⁸

[590] As the first man, Adam is the *homo maximus*, the Anthropos, from whom the macrocosm arose, or who is the macrocosm. He is not only the prima materia but a universal soul which is also the soul of all men.¹⁷⁹ According to the Mandaeans he is the “mystery of the worlds.”¹⁸⁰ The conception of the Anthropos first penetrated into alchemy through Zosimos, for whom Adam was a dual figure—the fleshly man and the “man of light.”¹⁸¹ I have discussed the significance of the Anthropos idea at such length in *Psychology and Alchemy* that no further documentation is needed here. I

shall therefore confine myself to material that is of historical interest in following the thought-processes of the alchemists.

[591] Already in Zosimos¹⁸² three sources can be distinguished: Jewish, Christian, and pagan. In later alchemy the pagan-syncretistic element naturally fades into the background to leave room for the predominance of the Christian element. In the sixteenth century, the Jewish element becomes noticeable again, under the influence of the Cabala, which had been made accessible to a wider public by Johann Reuchlin¹⁸³ and Pico della Mirandola.¹⁸⁴ Somewhat later the humanists then made their contribution from the Hebrew and Aramaic sources, and especially from the *Zohar*. In the eighteenth century an allegedly Jewish treatise appeared, Abraham Eleazar's *Uraltes Chymisches Werck*,¹⁸⁵ making copious use of Hebraic terminology and claiming to be the mysterious "Rindenbuch" of Abraham the Jew, which, it was said, had revealed the art of gold-making to Nicholas Flamel (1330–1417).¹⁸⁶ In this treatise there is the following passage:

For Noah must wash me in the deepest sea, with pain and toil, that my blackness may depart; I must lie here in the deserts among many serpents, and there is none to pity me; I must be fixed to this black cross, and must be cleansed therefrom with wretchedness and vinegar¹⁸⁷ and made white, that the inwards of my head may be like the sun or Marez,¹⁸⁸ and my heart may shine like a carbuncle, and the old Adam come forth again from me. O! Adam Kadmon, how beautiful art thou! And adorned with the rikmah¹⁸⁹ of the King of the World! Like Kedar¹⁹⁰ I am black henceforth; ah! how long! O come, my Mesech,¹⁹¹ and disrobe me, that mine inner beauty may be revealed. . . . O that the serpent roused up Eve! To which I must testify with my black colour that clings to me, and that is become mine by the curse of this persuasion, and therefore am I unworthy of all my brothers. O Sulamith afflicted within and without, the watchmen of the great city will find thee and wound thee, strip thee of thy garments and smite thee, and take away thy veil. . . . Yet shall I be blest again when I am delivered from the poison brought upon me by the curse, and mine inmost seed and first birth comes forth. For its father is the sun, and its mother the moon. Yea, I know else of no other bridegroom who should love me, because I am so black. Ah! do thou tear down the heavens and melt my mountains! For thou didst crumble the mighty kingdoms of Canaan like dust, and crush them with the brazen serpent of Joshua and offer them up to Algir Δ [fire], that she who is encompassed by many mountains may be freed.¹⁹²

[592] It is evident that the speaker is the feminine personification of the prima materia in the *nigredo* state. Psychologically this dark figure is the unconscious anima. In this condition she corresponds to the *nefesh* of the Cabalists.¹⁹³ She is "desire"; for as Knorr von Rosenroth trenchantly remarks: "The mother is nothing but the inclination

of the father for the lower.”^{193a} The blackness comes from Eve’s sin. Sulamith (the Shulamite)¹⁹⁴ and Eve (Hawa, earth) are contaminated into a single figure, who contains in herself the first Adam, like the mother her child, and at the same time awaits the second Adam, i.e., Adam before the Fall, the perfect Original Man, as her lover and bridegroom. She hopes to be freed by him from her blackness. Here again we encounter the mysticism of the Song of Songs as in the *Aurora consurgens* I. Jewish gnosis (Cabala) combines with Christian mysticism: sponsus and sponsa are called on the one hand Tifereth and Malchuth and on the other Christ and the Church.¹⁹⁵ The mysticism of the Song of Songs¹⁹⁶ appeared in Jewish-Gnostic circles during the third and fourth centuries, as is proved by the fragments of a treatise called *Shiur Koma* (“The Measure of the Body”). It concerns a “mysticism only superficially Judaicized by references to the description of the Beloved in the Song of Songs.”¹⁹⁷ The figure of Tifereth belongs to the Sefiroth system, which is conceived to be a tree. Tifereth occupies the middle position. Adam Kadmon is either the whole tree or is thought of as the mediator between the supreme authority, En Soph, and the Sefiroth.¹⁹⁸ The black Shulamite in our text corresponds to Malchuth as a widow, who awaits union with Tifereth and hence the restoration of the original wholeness. Accordingly, Adam Kadmon here takes the place of Tifereth. He is mentioned in Philo and in the midrashic tradition. From the latter source comes the distinction between the heavenly and earthly Adam in I Cor. 15 : 47: “The first man was of the earth, earthy; the second man is from heaven, heavenly” (DV), and verse 45: “The first man, Adam, became a living soul; the last Adam became a life-giving spirit” (DV). Thus the original hylicpsychic man is contrasted with the later pneumatic man.

[593] The *Tractatus de Revolutionibus Animarum*, of Knorr von Rosenroth, [Part I](#), ch. 1, § 10, contains a passage which is of importance for the psychological interpretation of Adam:

Ezekiel 34 : 31 says, “Ye are Adam.”¹⁹⁹ This means, you are rightly called by the name of Adam. The meaning is: If the text were to be understood literally, it could rightly be objected that all the peoples of the world or the Gentiles are men after the same manner as the Israelites, that is, of upright stature. Wherefore it would have to be said: Ye are men. But in truth (the meaning is this: out of your souls was composed the microcosm of Adam). . . .²⁰⁰ § 11. Ye are Adam. (He says, as it were, that all the souls of the Israelites were in truth nothing but the first-created Adam.) And you were his sparks and his limbs.²⁰¹

Here Adam appears on the one hand as the body of the people of Israel²⁰² and on the other as its “general soul.” This conception can be taken as a projection of the interior Adam: the *homo maximus* appears as a totality, as the “self” of the people. As the inner man, however, he is the totality of the individual, the synthesis of all parts of the psyche, and therefore of the conscious and the unconscious. § 20 says: “And

therefore our masters have said: The son of David shall not come until all the souls that were in the body (of the first-created) have fully gone out.”²⁰³ The “going out” of the souls from the Primordial Man can be understood as the projection of a psychic integration process: the saving wholeness of the inner man—i.e., the “Messiah”—cannot come about until all parts of the psyche have been made conscious. This may be sufficient to explain why it takes so long for the second Adam to appear.

[594] The same treatise says: “From En Soph, from the most general One, was produced the universe, which is Adam Kadmon, who is One and Many, and of whom and in whom are all things.” “The differences of genera are denoted by concentric circles” which proceed from him or are contained in him. He is thus something like a schema of the psychic structure, in which the “specific differences [those characterizing species] are denoted by a straight line”²⁰⁴ (i.e., in a concentric system, by the radius). “Thus in Adam Kadmon are represented all the orders of things, both genera and species and individuals.”²⁰⁵

[595] Among the pagan sources we must distinguish an Egyptian one, concerned with the very ancient tradition of the God-man Osiris and the theology of kingship; a Persian one, derived from Gayomart; and an Indian one, derived from Purusha.²⁰⁶ The Christian source for alchemical ideas is the aforementioned Pauline doctrine of the first and second Adam.

5. THE “OLD ADAM”

[596] After these preliminary remarks we can turn back to Eleazar’s text, beginning with the significant passage in the middle where Adam appears. The reader is immediately struck by the expression “the old Adam,” who is evidently equated with Adam Kadmon. Rather than “the old” Adam we would expect “the second” or “the original” Adam, chiefly because “the old Adam” means above all the old, sinful, unredeemed man, in accordance with Romans 6 : 6: “Knowing this, that our old man is crucified with him, that the body of sin might be destroyed, that henceforth we should not serve sin.” That this passage must have been at the back of the author’s mind is shown by the sentence: “I must be fixed to this black cross, and must be cleansed therefrom with wretchedness and vinegar.”

[597] The author purports to be a Jew, but was clumsy enough not only to perpetrate anachronisms but to reveal his own unquestionably Christian psychology. He had a good knowledge of the Bible and was familiar with “Biblical” language. The language of his book is the stylistically and grammatically fluid German of the eighteenth century. He has a liking for edifying rhetoric (could he have been a theologian?) One thing is clear, at any rate, and that is that the expression “the old

Adam” on the lips of such a person can have only one meaning, namely, the “old man” whom we are to put off (Eph. 4 : 22) in accordance with the command in Colossians 3 : 9: “Put off the old man with his deeds.” These passages must have been known to the author, and he could easily have avoided the resultant contradiction or ambiguity by putting, instead of “old,” “original,” or something of that kind.

[598] I must beg the reader’s indulgence for apparently splitting hairs and harping somewhat pedantically on this little defect in the style of a none too careful author. But it is more than a question of a mere slip of the pen: a text that is riddled with ambiguities, that sets up the most unexpected relationships (Adam and the Shulamite!) and blends together the most heterogeneous situations, has unquestionable affinities with the structure of a dream and consequently necessitates a careful examination of its figures. A cliché like “the old Adam,” which can have no other meaning, does not occur in a dream-text without a very good reason, even though the author might have excused it as a mere “slip.” Even if—as seems to be the case here—he understood the “old” Adam as the “Ur-” or “original” Adam, he was compelled by some obscure intention to pick on “the old Adam,” which in this context is thoroughly ambiguous. Had it occurred in a real dream it would be a technical blunder for the interpreter to overlook this ostensible slip. As we know, these *quid pro quos* invariably happen at the critical places, where two contrary tendencies cross.

[599] Our suspicions have been aroused, and in what follows we shall pursue them on the assumption that “the old Adam” is not a mere accident but is one of those irritating ambiguities of which there is no lack in the alchemical texts. They are irritating because seldom if ever can it be ascertained with any certainty whether they arose from a conscious intention to deceive or from an unconscious conflict.

[600] The “old” Adam, evidently, can “come forth again” from the Shulamite, the black mother, only because he had once got into her in some way. But that can only have been the old, sinful Adam, for the blackness of the Shulamite is an expression for sin, the original sin, as the text shows. Behind this idea lies the archetype of the Anthropos who had fallen under the power of Physis, but it seems doubtful whether our author had any conscious knowledge of this myth. Had he really been familiar with Cabalistic thought he would have known that Adam Kadmon, the spiritual First Man, was an “Idea” in the Platonic sense, which could never be confused with the sinful man. By his equation “old Adam” = Adam Kadmon the author has contaminated two opposites. The interpretation of this passage must therefore be: from the black Shulamite comes forth the antithesis “old Adam”: Adam Kadmon. Her obvious connection with the earth as the mother of all living things makes it

clear that her son was the sinful Adam, but not Adam Kadmon, who, as we have seen, is an emanation of En Soph. Nevertheless, by contaminating the two, the text makes both of them issue from the Shulamite. The “old” Adam and the Primordial Man appear to be identical, and the author could excuse himself by saying that by “old” he meant the first or original Adam—a point which it is not easy to deny.

[601] As high as the Primordial Man stands on the one side, so low on the other is the sinful, empirical man. The phenomenon of contamination, which we meet so frequently in the psychology of dreams and of primitives, is no mere accident but is based on a common denominator; at some point the opposites prove to be identical, and this implies the possibility of their contamination. One of the commonest instances of this is the identity of the god and his animal attribute. Such paradoxes derive from the non-human quality of the god’s and the animal’s psychology. The divine psyche is as far above the human as the animal psyche reaches down into subhuman depths.

[602] The “old Adam” corresponds to the primitive man, the “shadow” of our present-day consciousness, and the primitive man has his roots in the animal man (the “tailed” Adam),²⁰⁷ who has long since vanished from our consciousness. Even the primitive man has become a stranger to us, so that we have to rediscover his psychology. It was therefore something of a surprise when analytical psychology discovered in the products of the unconscious of modern man so much archaic material, and not only that but the sinister darkness of the animal world of instinct. Though “instincts” or “drives” can be formulated in physiological and biological terms they cannot be pinned down in that way, for they are also psychic entities which manifest themselves in a world of fantasy peculiarly their own. They are not just physiological or consistently biological phenomena, but are at the same time, even in their content, meaningful fantasy structures with a symbolic character. An instinct does not apprehend its object blindly and at random, but brings to it a certain psychic “viewpoint” or interpretation; for every instinct is linked *a priori* with a corresponding image of the situation, as can be proved indirectly in cases of the symbiosis of plant and animal. In man we have direct insight into that remarkable world of “magical” ideas which cluster round the instincts and not only express their form and mode of manifestation but “trigger them off.”²⁰⁸ The world of instinct, simple as it seems to the rationalist, reveals itself on the primitive level as a complicated interplay of physiological facts, taboos, rites, class-systems, and tribal lore, which impose a restrictive form on the instinct from the beginning, preconsciously, and make it serve a higher purpose. Under natural conditions a spiritual limitation is set upon the unlimited drive of the instinct to fulfil itself, which differentiates it and makes it available for different applications. Rites on a primitive level are uninterpreted gestures; on a higher level they become mythologized.

[603] The primary connection between image and instinct explains the interdependence of instinct and religion in the most general sense. These two spheres are in mutually compensatory relationship, and by “instinct” we must understand not merely “Eros” but everything that goes by the name of “instinct.”²⁰⁹ “Religion” on the primitive level means the psychic regulatory system that is coordinated with the dynamism of instinct. On a higher level this primary interdependence is sometimes lost, and then religion can easily become an antidote to instinct, whereupon the originally compensatory relationship degenerates into conflict, religion petrifies into formalism, and instinct is vitiated. A split of this kind is not due to a mere accident, nor is it a meaningless catastrophe. It lies rather in the nature of the evolutionary process itself, in the increasing extension and differentiation of consciousness. For just as there is no energy without the tension of opposites, so there can be no consciousness without the perception of differences. But any stronger emphasis of differences leads to polarity and finally to a conflict which maintains the necessary tension of opposites. This tension is needed on the one hand for increased energy production and on the other for the further differentiation of differences, both of which are indispensable requisites for the development of consciousness. But although this conflict is unquestionably useful it also has very evident disadvantages, which sometimes prove injurious. Then a counter-movement sets in, in the attempt to reconcile the conflicting parties. As this process has repeated itself countless times in the course of the many thousand years of conscious development, corresponding customs and rites have grown up for the purpose of bringing the opposites together. These reconciling procedures are rites performed by man, but their content is an act of help or reconciliation emanating from the divine sphere, whether in the present or in the past. Generally the rites are linked up with the original state of man and with events that took place in the age of the heroes or ancestors. This is as a rule a defective state, or a situation of distress, which is helped by divine intervention, and the intervention is repeated in the rite. To take a simple example: When the rice will not grow, a member of the rice-totem clan builds himself a hut in the rice-field and tells the rice how it originally grew from the rice-ancestor. The rice then remembers its origin and starts growing again. The ritual anamnesis of the ancestor has the same effect as his intervention.

[604] The prime situation of distress consists either in a withdrawal of the favourable gods and the emergence of harmful ones, or in the alienation of the gods by man’s negligence, folly, or sacrilege, or else (as in the Taoist view) in the separation²¹⁰ of heaven and earth for unfathomable reasons, so that they can now come together again only if the wise man re-establishes Tao in himself by ritual meditation. In this way he brings his own heaven and earth into harmony.²¹¹

[605] Just as the rice spoils in the defective state, so too man degenerates, whether from the malignity of the gods or from his own stupidity or sin, and comes into conflict with his original nature. He forgets his origination from the human ancestor, and a ritual anamnesis is therefore required. Thus the archetype of Man, the Anthropos, is constellated and forms the essential core of the great religions. In the idea of the *homo maximus* the Above and Below of creation are reunited.

6. THE TRANSFORMATION

[606] The appearance of Adam Kadmon has characteristic consequences for the Shulamite: it brings about a *solificatio*, an illumination of the “inwards of the head.” This is a veiled but, for the psychology of alchemy, typical allusion to the “transfiguration” (*glorificatio*) of the adept or of his inner man. For Adam is “interior homo noster,” the Primordial Man in us.

[607] Seen in the light of the above remarks, Eleazar’s text assumes a by no means uninteresting aspect and, since its train of thought is characteristic of the basic ideas of alchemy, a meaning with many facets. It depicts a situation of distress corresponding to the alchemical *nigredo*: the blackness of guilt has covered the bridal earth as with black paint. The Shulamite comes into the same category as those black goddesses (Isis, Artemis, Parvati, Mary) whose names mean “earth.” Eve, like Adam, ate of the tree of knowledge and thereby broke into the realm of divine privileges—“ye shall be as gods, knowing good and evil.” In other words she inadvertently discovered the possibility of *moral* consciousness, which until then had been outside man’s range. As a result, a polarity was torn open with momentous consequences. There was a sundering of earth from heaven, the original paradise was shut down, the glory of the First Man was extinguished, Malchuth became a widow, the fiery *yang* went back aloft, and the damp *yin* enveloped humanity with darkness, degenerated through ever-increasing wantonness, and finally swelled into the black waters of the Deluge, which threatened to drown every living thing but on the other hand could be understood more hopefully as an ablution of the blackness. Noah, too, appears in a different light: he is no longer seen as someone running away from the catastrophe but as Lord of the Waters, the minister of the ablution. This operation does not seem to be enough, however, for the Shulamite promptly gets herself into the opposite kind of pickle—into the dry desert, where, like the children of Israel, she is menaced by evil in the form of poisonous serpents.²¹² This is an allusion to the tribulations of the Exodus, which in a sense was a repetition of the expulsion from paradise, since bidding farewell to the fleshpots of Egypt was quite as painful a prospect as the stony ground from which our first parents had to wrest a living in the sweat of their brows. But even with this last extremity the goal is not reached, for the Shulamite has still to be fixed to a black cross. The idea of the cross points beyond the simple antithesis to a double antithesis, i.e., to a quaternio. To the mind of the alchemist this meant primarily the intercrossing elements:

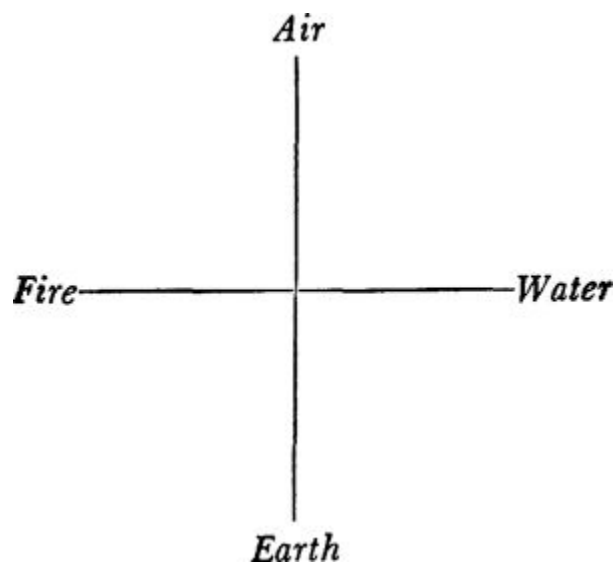

or the four qualities:

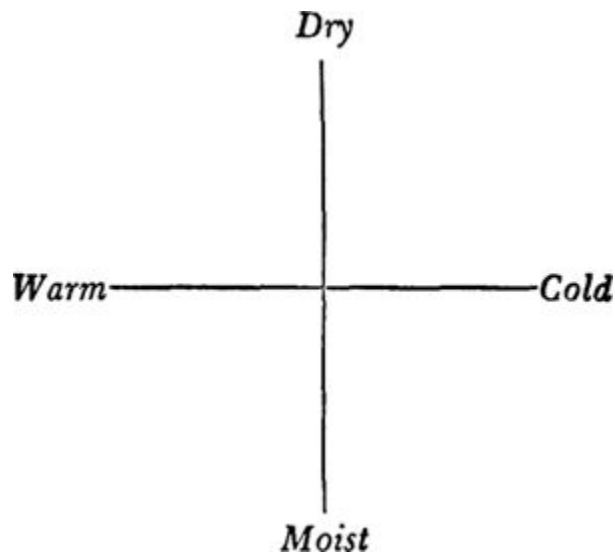

We know that this fastening to a cross denotes a painful state of suspension, or a tearing asunder in the four directions.²¹³ The alchemists therefore set themselves the task of reconciling the warring elements and reducing them to unity. In our text this state is abolished when the distressing blackness is washed off with “wretchedness and vinegar.” This is an obvious allusion to the “hyssop and gall” which Christ was given to drink. In the oft-quoted text of Maier, “wretchedness and vinegar” stand for the melancholia of the *nigredo*, as contrasted with the “joy and gladness” of the redeemed state. The washing with wretchedness and vinegar finally brings about the whitening as well as a *solificatio* of the “inwards of the head,” presumably the brain or even the soul. We can only interpret this as meaning that the Shulamite experienced a transformation similar to Parvati’s, who, saddened by her blackness, was given a golden skin by the gods. Here we must emphasize that it is the lapis or hermaphrodite which, as the god who is quartered or torn asunder or crucified on the Four, represents and suffers the discord of the elements, and at the same time brings about the union of the Four and besides that is identical with the product of the union. The alchemists could not help identifying their Primordial Man with Christ, for whom our author substitutes Adam Kadmon.

[608] Since sun and gold are equivalent concepts in alchemy, the *solificatio* means that the “inwards of the head”—whatever we are to understand by that—are transformed into light, or “Marez,” the precious white earth. The Shulamite’s heart, too, will shine “like a carbuncle.” From the time of the Middle Ages the carbuncle was regarded as a synonym for the lapis.²¹⁴ Here the allegory is transparent: as the head is illuminated, so the heart burns in love.

[609] The difference between Parvati and the Shulamite is, therefore, that whereas Parvati is transformed outwardly the Shulamite is transformed inwardly. Outwardly she remains as black as ever. Unlike the Shulamite of the Song of Songs, whose skin is “swarthy,” our Shulamite declares that her blackness “clings” to her as if painted on, and that one has only to disrobe her to bring her “inner beauty” to light. By the sin of Eve she is plunged, as it were, in ink, in the “tincture,” and blackened, just as in Islamic legend the precious stone that Allah gave Adam was blackened by his sin. If the poison of the curse is taken from her—which will obviously happen when the Beloved appears—then her “innermost seed,” her “first birth,” will come forth. According to the text this birth can refer only to the appearance of Adam Kadmon. He is the only one who loves her despite her blackness. But this blackness seems to be rather more than a veneer, for it will not come off; it is merely compensated by her inner illumination and by the beauty of the bridegroom. As the Shulamite symbolizes the earth in which Adam lay buried, she also has the significance of a maternal progenitrix. In this capacity the black Isis put together again the limbs of her dismembered brother-spouse, Osiris. Thus Adam Kadmon appears here in the classic form of the son-lover, who, in the hierosgamos of sun and moon, reproduces himself in the mother-beloved. Consequently the Shulamite takes over the ancient role of the hierodule of Ishtar. She is the sacred harlot (*meretrix*), which is one of the names the alchemist gave his arcane substance.

[610] The Shulamite’s reversion to type is not a stroke of genius on the part of our author, but merely the traditional alchemical view that “our infant,” the son of the Philosophers, is the child of sun and moon. But in so far as he represents the hermaphroditic Primordial Man himself, the son is at the same time the father of his parents. Alchemy was so saturated with the idea of the mother-son incest that it automatically reduced the Shulamite of the Song of Songs to her historical prototype.²¹⁵

[611] We have paid due attention to the recalcitrant nature of the Shulamite’s blackness. Now it is significant that the “old Adam” is mentioned at the very moment when the perfect, prelapsarian Adam, the shining Primordial Man, is obviously meant. Just as the black Shulamite misses the final apotheosis, the total *albedo*, so we lack the necessary confirmation that the first Adam is changed into the second, who at the

same time is the father of the first. We cannot suppress the suspicion that, just as the blackness will not disappear, so the old Adam will not finally change. This may be the deeper reason why the expression “the old Adam” did not worry the author but, on the contrary, seemed just right. It is, unfortunately, far truer to say that a change for the better does *not* bring a total conversion of darkness into light and of evil into good, but, at most, is a compromise in which the better slightly exceeds the worse. The complication introduced by the “old” Adam, therefore, does not seem to be merely fortuitous, since it forms a factor in an archetypal quaternio composed as follows:

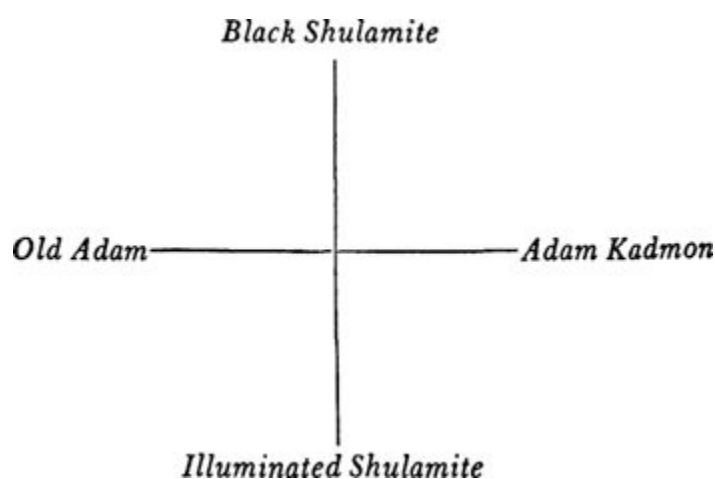

OR

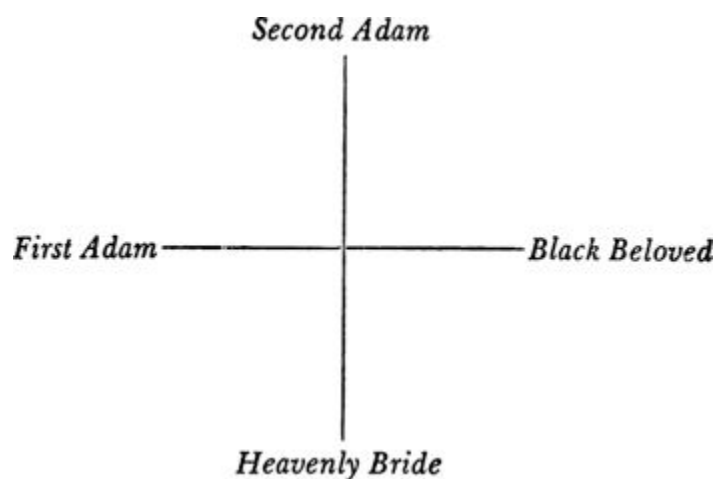

[612] This structure corresponds to the marriage quaternio discussed in the “Psychology of the Transference,”²¹⁶ which is based on certain psychic facts and has the following structure:

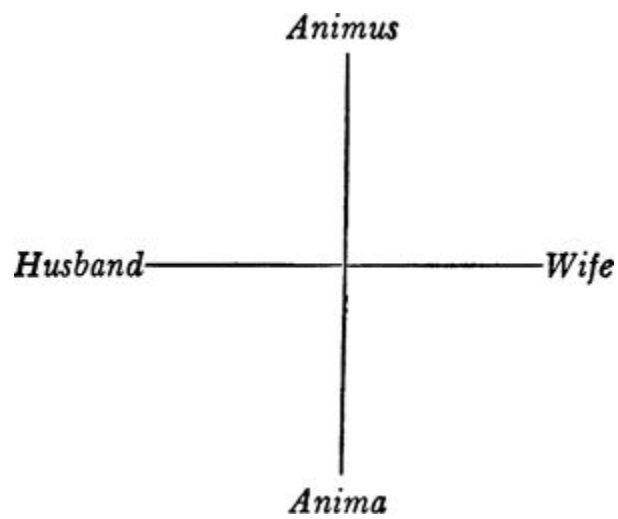

OR

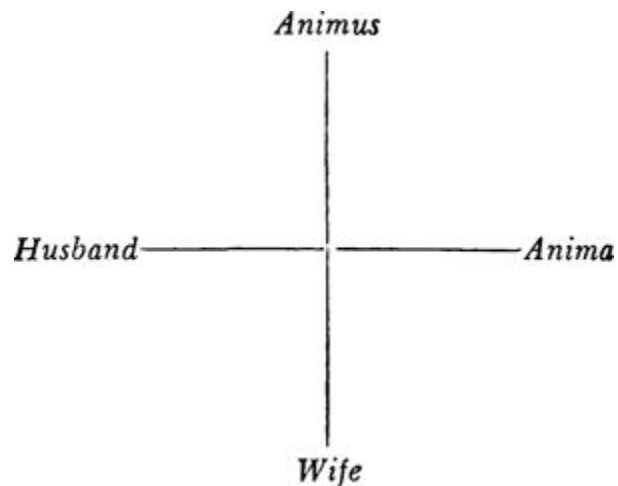

[613] Although this quaternio plays a considerable role in alchemy, it is not a product of alchemical speculation but an archetype which can be traced back to the primitive marriage-class system (four-kin system). As a quaternity it represents a whole judgment and formulates the psychic structure of man's totality. This expresses on the one hand the structure of the individual, i.e., a male or female ego in conjunction with the contrasexual unconscious, and on the other hand the ego's relation to the other sex, without which the psychological individual remains incomplete. (By this I mean primarily a *psychic* relationship.) But in this schema the idea of *transformation*, so characteristic of alchemy, is missing. As a scientific discipline, empirical psychology is not in a position to establish whether the conscious ego ranks "higher" or "lower" than the anima, which, like the ego, has a positive and a negative aspect. Science does not make value-judgments, and though psychology has a concept of "value" it is nothing but a concept of "intensity": one complex of ideas has a higher value when its power of assimilation proves stronger than that of another.²¹⁷ The alchemical idea of transformation is rooted in a spiritual concept of value which takes the "transformed" as being *more* valuable, better, higher, more spiritual, etc., and the empirical psychologist has nothing to set against this. But since evaluating and estimating are functions of feeling and nevertheless do play a role in psychology,

value must somehow be taken into account. This happens when an assertion or value-judgment is accepted as an intrinsic part of the description of an object.

[614] The moral as well as the energetic value of the conscious and the unconscious personality is subject to the greatest individual variations. Generally the conscious side predominates, though it suffers from numerous limitations. The schema of the psychological structure, if it is to be compared with the alchemical schema, must therefore be modified by the addition of the idea of transformation. This operation is conceivable in principle, as the process of making the anima and animus conscious does in fact bring about a transformation of personality. Hence it is the psychotherapist who is principally concerned with this problem. The foremost of his therapeutic principles is that conscious realization is an important agent for transforming the personality. The favourable aspect of any such transformation is evaluated as “improvement”—primarily on the basis of the patient’s own statements. The improvement refers in the first place to his psychic health, but there can also be a moral improvement. These statements become increasingly difficult or impossible to verify when the evaluation imperceptibly encroaches upon territory hedged about with philosophical or theoretical prejudices. The whole question of “improvement” is so delicate that it is far easier to settle it by arbitrary decision than by careful deliberation and comparison, which are an affront to all those “terrible simplifiers” who habitually cultivate this particular garden.

[615] Although the fact of transformation and improvement cannot be doubted, it is nevertheless very difficult to find a suitable term for it which is not open to misunderstanding and can be fitted into our schema. Medieval man, like our own simplifiers, was naive enough always to know what was “better.” We are not so sure, and besides this we feel to some extent answerable to those who hold a different opinion. We cannot cherish the joyful belief that everybody else is in the wrong. For this reason we shall probably have to give up the idea of expressing in the terminology of our schema the kind of transformation which is bound up with conscious realization and the wholeness (individuation) it brings in its train.

[616] For a naive-minded person the imperfect, corrupt old Adam is simply contrasted with the perfect “Primordial Man,” and the dark Eve with an illuminated and altogether nobler being. The modern viewpoint is much more realistic, as it withdraws the archetypal schema, which referred originally to a mythological situation, back from projection, and peoples the stage not with mythical lay-figures but with real human beings and their psyches. The man, or the masculine ego-consciousness, is then contrasted with an animus, the masculine figure in a woman’s unconscious, who compels her either to overvalue him or to protest against him. The corresponding figure that contrasts with the woman and her feminine ego-

consciousness is the anima, the source of all the illusions, over- and under-valuations of which a man makes himself guilty in regard to a woman. There is nothing to indicate in this schema that the man is better than the animus or vice versa, or that the anima is a “higher” being than the woman. Nor does it indicate in which direction the line of development is moving. Only one thing is clear, that when, as a result of a long, technical and moral procedure the patient obtains a knowledge of this structure, based on experience, and accepts the responsibility entailed by this knowledge, there follows an integration or *completeness* of the individual, who in this way approaches *wholeness* but not *perfection*, which is the ideal of certain world philosophies. In the Middle Ages “philosophy” prevailed over fact to such an extent that the base metal lead was credited with the power to turn into gold under certain conditions, and the dark, “psychic” man with the capacity to turn himself into the higher “pneumatic” man. But just as lead, which theoretically could become gold, never did so in practice, so the sober-minded man of our own day looks round in vain for the possibility of final perfection. Therefore, on an objective view of the facts, which alone is worthy of the name of science, he sees himself obliged to lower his pretensions a little, and instead of striving after the ideal of perfection to content himself with the more accessible goal of approximate completeness. The progress thereby made possible does not lead to an exalted state of spiritualization, but rather to a wise self-limitation and modesty, thus balancing the disadvantages of the lesser good with the advantage of the lesser evil.

[617] What prevents us from setting up a psychological schema fully corresponding to the alchemical one is ultimately, therefore, the difference between the old and the modern view of the world, between medieval romanticism and scientific objectivity.

[618] The more critical view which I have outlined here on the objective basis of scientific psychology is, however, implied in the alchemical schema. For even as the old Adam comes forth again and is present in the schema just as much as Adam Kadmon, so the blackness does not depart from the Shulamite, an indication that the transformation process is not complete but is still going on. That being so, the old Adam is not yet put off and the Shulamite has not yet become white.

[619] In the Cabalistic view Adam Kadmon is not merely the universal soul or, psychologically, the “self,” but is himself the process of transformation, its division into three or four parts (trimeria or tetrameria). The alchemical formula for this is the Axiom of Maria: “One becomes two, two becomes three, and out of the Third comes the One as the Fourth.”²¹⁸ The treatise of Rabbi Abraham Cohen Irija (Hacohen Herrera) says: “Adam Kadmon proceeded from the Simple and the One, and to that extent he is Unity; but he also descended and fell into his own nature, and to that extent he is Two. And again he will return to the One, which he has in him, and to the

Highest; and to that extent he is Three and Four.”²¹⁹ This speculation refers to the “essential Name,” the Tetragrammaton, which is the four letters of God’s name, “three different, and the fourth a repetition of the second.”²²⁰ In the Hebrew word YHVH (written without vowels), *he* is feminine and is assigned as a wife to *yod*²²¹ and to *vau*. As a result *yod*²²² and *vau*²²³ are masculine, and the feminine *he*, though doubled, is identical and therefore a single unit. To that extent the essential Name is a triad. But since *he* is doubled, the Name is also a tetrad or quaternity²²⁴—a perplexity which coincides most strangely with the Axiom of Maria. On the other hand the Tetragrammaton consists of a double marriage and thus agrees in an equally remarkable manner with our Adam diagrams. The doubling of the feminine *he* is archetypal,²²⁵ since the marriage quaternio presupposes both the difference and the identity of the feminine figures. This is true also of the two masculine figures, as we have seen, though here their difference usually predominates—not surprisingly, as these things are mostly products of the masculine imagination. Consequently the masculine figure coincides with man’s consciousness, where differences are practically absolute. Though the feminine figure is doubled it is so little differentiated that it appears identical. This double yet identical figure corresponds exactly to the anima, who, owing to her usually “unconscious” state, bears all the marks of non-differentiation.

[620] If we apply these considerations to the alchemical schema, we shall be able to modify it in a way that was not possible with the psychological one. We thus arrive at a formula which reduces both to the same denominator:

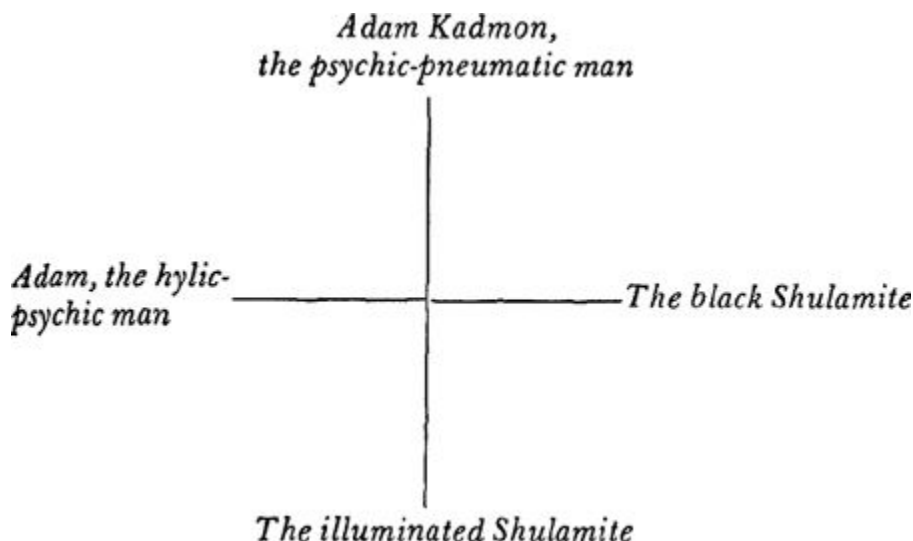

[621] The critical point, namely the fact that the transformation is not complete, comes out in the text itself; the desired perfection is relegated to the future, “that she who is encompassed by many mountains shall be freed.” For this a divine miracle is needed, the crushing and burning of Canaan, the tearing down of heaven, and the melting of mountains. One can see from these tours de force the magnitude of the difficulties that have to be overcome before perfection is reached.

[622] The reference to the mountains which encompass the Shulamite has a strange parallel in Parvati, whose name means “mountain dweller” and who was deemed the daughter of Himavat (Himalaya).²²⁶ Grieving over her blackness, for which her husband Shiva reproached her, she left him and withdrew to the solitude of the forest. And in her loneliness and seclusion the Shulamite exclaims:

What shall I say? I am alone among the hidden; nevertheless I rejoice in my heart, because I can live privily, and refresh myself in myself. But under my blackness I have hidden the fairest green.²²⁷

[623] The state of imperfect transformation, merely hoped for and waited for, does not seem to be one of torment only, but of positive, if hidden, happiness. It is the state of someone who, in his wanderings among the mazes of his psychic transformation, comes upon a secret happiness which reconciles him to his apparent loneliness. In communing with himself he finds not deadly boredom and melancholy but an inner partner; more than that, a relationship that seems like the happiness of a secret love, or like a hidden springtime, when the green seed²²⁸ sprouts from the barren earth, holding out the promise of future harvests. It is the alchemical *benedicta viriditas*, the blessed greenness, signifying on the one hand the “leprosy of the metals” (verdigris), but on the other the secret immanence of the divine spirit of life in all things. “O blessed greenness, which generatest all things!” cries the author of the *Rosarium*.²²⁹ “Did not the spirit of the Lord,” writes Mylius, “which is a fiery love, give to the waters when it was borne over them a certain fiery vigour, since nothing can be generated without heat? God breathed into created things . . . a certain germination or greenness, by which all things should multiply . . . They called all things green, for to be green means to grow . . . Therefore this virtue of generation and the preservation of things might be called the Soul of the World.”²³⁰

[624] Green signifies hope and the future, and herein lies the reason for the Shulamite’s hidden joy, which otherwise would be difficult to justify. But in alchemy green also means perfection. Thus Arnaldus de Villanova says: “Therefore Aristotle says in his book, Our gold, not the common gold, because the green which is in this substance signifies its total perfection, since by our magistry that green is quickly turned into truest gold.”²³¹ Hence the Shulamite continues:

But I must be like a dove with wings, and I shall come and be free at vespertime, when the waters of impurity are abated, with a green olive leaf; then is my head of the fairest Asophol,²³² and my hair curly-gleaming as the ☽. And Job says (27 : 5),²³³ that out of my ☿²³⁴ shall come forth blood. For it is all as △,²³⁵ shining red Adamah,²³⁶ mingled with a glowing △. Though I am poisonous, black, and hateful without, yet when I am cleansed I shall be the food of heroes; as out of the lion which Samson slew there afterward came forth honey. Therefore says Job 28 : 7: *Semitam non*

*cognovit ille avis, neque aspicit earn oculus vulturis.*²³⁷ For this stone belongeth only to the proven and elect of God.²³⁸

[625] It is the hope of the dark Shulamite that one day, at “vespertime,” probably in the evening of life, she will become like Noah’s dove, which, with the olive leaf in its beak, announced the end of the flood and appeared as the sign of God’s reconciliation with the children of men.²³⁹ The Song of Songs (2 : 14) says: “O my dove, that art in the clefts of the rock, in the secret places of the stairs, let me see thy countenance, let me hear thy voice . . .” In our text her head will be of gold, like the sun, and her hair like the moon. She thus declares herself to be a conjunction of the sun and moon. Indeed, a golden head and “bushy” hair are attributes of the Beloved.²⁴⁰ She is, in fact, mingled with the Beloved, from which it is evident that the perfect state melts *sponsus* and *sponsa* into *one* figure, the sun-and-moon child.²⁴¹ The black Shulamite, well matched by her “bushy locks, black as a raven,” becomes the moon, which in this way acquires its “curly-gleaming” hair.²⁴²

7. ROTUNDUM, HEAD, AND BRAIN

[626] Although the above passage from the Song of Songs is chiefly responsible for the “golden head,” it should be emphasized that this motif also occurs in alchemy without direct reference to the Song of Songs. “His head was of fine gold,” says the “Splendor solis” of the dismembered man whose body was “white like salt.”²⁴³ In Greek alchemy the adepts were called “children of the golden head.”²⁴⁴ The “simple” (i.e., arcane) substance was called the “Golden Head, after the god-sent Daniel, God’s mouthpiece.”²⁴⁵ According to legend, Pope Sylvester II (d. 1003), famed as the transmitter of Arabian science, possessed a golden head that imparted oracles.²⁴⁶ This legend may perhaps date back to the Harranite ceremony of the oracular head.²⁴⁷ The head has also the subsidiary meaning of the *corpus rotundum*, signifying the arcane substance.²⁴⁸ This is particularly relevant to our text, as the “inwards” of the head turned to gold and/or white earth. The latter is the *terra alba foliata* (foliated white earth), which in this case would be the brain. This conjecture is corroborated by the fact that the “inwards of the head” is, as it were, a literal translation of *ἐγκέφαλος μυελός* (marrow in the head). Besides this the brain is a synonym for the arcane substance, as is clear from a Hermes quotation in the *Rosarium*: “Take his brain, powder it with very strong vinegar . . . until it turns dark.”²⁴⁹ The brain was of interest to the alchemists because it was the seat of the “spirit of the supracelestial waters,”²⁵⁰ the waters that are above the firmament (Genesis 1 : 7). In the “Visio Arislei” the brain of the King of the Sea is the birthplace of the brother-sister pair.²⁵¹ The “Liber quartorum” calls the brain the “abode of the divine part.”²⁵² For the brain has a “proximity to the rational soul,” which in turn possesses “simplicitas,” a feature it

shares with God.²⁵³ Because the brain seemed secretly to participate in the alchemical process,²⁵⁴ Wei Po-yang states that “when the brain is properly tended for the required length of time, one will certainly attain the miracle.”²⁵⁵ References to the brain are also found in Greek alchemy, an especially large role being played by the *λίθος ἐγκέφαλος* (brain-stone), which was equated with the *λίθος οὐ λίθος* (stone that is no stone).²⁵⁶ The latter is one of the terms Zosimos uses for the brain; he also calls it “not given and given by God,” and the “Mithraic secret.”²⁵⁷ The treatise on the “Stone of Philosophy” says that “alabaster is whitest brain stone.”²⁵⁸ In the Table of Symbols in Penotus the brain is correlated with the *moon*, the mystery of baptism, and the “infernal gods.”²⁵⁹ The new moon signifies the *albedo* and the white stone;²⁶⁰ baptism has its parallel in the children of the King of the Sea, who were imprisoned in the glass-house at the bottom of the sea and transformed;²⁶¹ the infernal gods can be correlated with the brain as the seat of consciousness and intelligence, for consciousness leads an “ungodly” existence, having fallen away from the divine totality.²⁶²

[627] Zosimos is the connecting link between alchemy and Gnosticism, where we find similar ideas. There the brain (or cerebellum) “is in shape like the head of a dragon.”²⁶³ The wicked Korybas, having affinities on the one hand with Adam and on the other with the Kyllenic Hermes,²⁶⁴ comes “from the head on high and from the uncharacterized brain,”²⁶⁵ and penetrates all things; “we know not how and in what fashion he comes.” Here Hippolytus paraphrases John 5 : 37: “We have heard his voice, but we have not seen his shape,” an allusion to a partially unconscious factor. To emphasize this aspect, Hippolytus goes on to say that Korybas dwells in the “image of clay” (*ἐν τῷ πλάσματι τῷ χοϊκῷ*), i.e., in man.²⁶⁶ “This,” he continues, “is the God who dwells in the flood, of whom the Psalter says that he calls aloud and cries out from many waters.”²⁶⁷ We can take this as the longing of the unconscious for consciousness. When one considers that this passage dates from an age (*ca.* 2nd cent.) that had not the remotest conception of psychology in the modern sense, one must admit that Hippolytus, with the scanty means at his disposal, has managed to give a fairly decent account of the psychological facts. The Adam of whom the Naassenes speak is a “rock.”

This, they say, is Adamas, the chief corner-stone [*λίθος ὁ ἀκρογωνιαίος*], who has become the head [*κεφαλήν*] of the corner. For in the head is the characterized [*χαρακτηριστικόν*] brain, the substance from which the whole family is named [*χαρακτηρίζεται*], the “Adam whom I place in the foundations of Zion.”²⁶⁸ Allegorically, they mean the image [*πλάσμα*] of Man. But he who is so placed is Adam [the inner man, the foundation of Zion] . . . who has fallen from Adam the archman [*ἀρχανθρώπου*] on high.²⁶⁹

[628] These extracts are sufficient to show how original are the bases of alchemical ideas. If no continuity of tradition can be proven, we would be forced to assume that the same ideas can arise spontaneously, again and again, from an archetypal foundation.

8. ADAM AS TOTALITY

[629] Now that we have seen the significance of the brain and the moon-earth as the arcane substance, we can take up our commentary on Eleazar's text.

[630] An alchemical recipe says: "Sow the gold in foliated white earth."²⁷⁰ Thus the gold (sun) and the white earth, or moon²⁷¹ are united. In Christianity, as in alchemy, earth and moon are closely related, conjoined by the figure of the divine mother. The sun-moon conjunction takes place in the head, an indication of the psychic nature of this event.²⁷² As I said, the concept of the "psychic," as we understand it today, did not exist in the Middle Ages, and even the educated modern man finds it difficult to understand what is meant by "reality of the psyche." So it is not surprising that it was incomparably more difficult for medieval man to imagine something between "esse in re" and "esse in intellectu solo."²⁷³ The way out lay in "metaphysics."²⁷⁴ The alchemist was therefore compelled to formulate his quasichemical facts metaphysically too.²⁷⁵ Thus the white earth corresponds to the earth that signified "mankind, is exalted above all the circles of the World, and placed in the intellectual heaven of the most holy Trinity."²⁷⁶ (Where, we may add, it is obviously added to the Trinity as the "Fourth," thereby making it a totality.)²⁷⁷ This cheerful piece of heterodoxy remained unconscious and its consequences never appeared on the surface.

[631] The conclusion which Eleazar draws requires elucidation. It is in itself remarkable that he should paraphrase, in connection with the perfect state, i.e., the *coniunctio Solis et Lunae*, just that passage in Job (supra, par. 624) and say: "Out of my earth shall come forth blood." This is feasible only if the *coniunctio* symbolizes the production of the hermaphroditic second Adam, namely Christ and the *corpus mysticum* of the Church. In the ecclesiastical rite the equivalent of the *coniunctio* is the mixing of substances, or the Communion in both kinds. The passage from Job must therefore be interpreted as though Christ were speaking: "From my earth, my body, will come forth blood." In the Greek Orthodox rite the loaf of bread stands for Christ's body. The priest pierces it with a small silver lance, to represent by analogy the wound in his side from which blood and grace flow, and perhaps also the slaying of the victim (*mactatio Christi*).

[632] The alchemical earth, as we saw, is the arcane substance, here equated with the body of Christ and with *adamah*, the red earth of paradise. From *adamah* is traditionally derived the name Adam, so that here again the paradisaical earth is connected with the corpus mysticum. (This specifically Christian idea comports ill with the alleged Jewish authorship.) Nevertheless, it is strange that, as Eleazar says, this earth is “mingled with fire.” This recalls the alchemical idea of the “*ignis gehennalis*,” the “central fire”²⁷⁸ by whose warmth all nature germinates and grows, because in it dwells the Mercurial serpent, the salamander whom the fire does not consume, and the dragon that feeds on the fire.²⁷⁹ Though this fire is a portion of the fire of God’s spirit (Boehme’s “divine wrath-fire”), it is also Lucifer, the most beautiful of God’s angels, who after his fall became the fire of hell itself. Eleazar says: “This-old Father-Begetter²⁸⁰ will one day be drawn from the primordial Chaos,²⁸¹ and he is the fire-spewing dragon.” The dragon floating in the air is the universal “Phyton,²⁸² the beginning of all things.”²⁸³

[633] Another source for the fire mingled with earth might be the image of the Son of Man in Revelation 1 : 14f.:

His head and his hairs were white like wool, as white as snow, and his eyes were as a flame of fire, and his feet like unto fine brass,²⁸⁴ as if they burned in a furnace, and his voice as the sound of many waters. And he had in his right hand seven stars, and out of his mouth went a sharp two-edged sword, and his countenance was as the sun shineth in his strength.

Here again the head is compared to the sun, combined with the whiteness of the full moon. But the feet stand in the fire and glow like molten metal. We find the lower fire in Job 28 : 5: “*Terra igne subversa est*” (DV: “the earth hath been overturned with fire”). But “out of it cometh bread”—an image of the union of supreme opposites! In the Apocalyptic image we would hardly recognize the Son of Man, who is the true incarnation of God’s love. But actually this image comes nearer to the paradoxes of the alchemists than does the Christ of the gospels, whose inner polarity was reduced to vanishing-point after the “Get thee behind me, Satan” incident. In the Apocalypse it becomes visible again, and even more so in the symbolism of alchemy.²⁸⁵

[634] Our conjecture that Eleazar had in mind the Apocalyptic figure of the Son of Man is confirmed to the extent that there is an illustration of the “*fils de l’homme* ☿” (= Mercurius) in a French manuscript (18th cent.),²⁸⁶ bearing the name “Jezoth le Juste,” who is assigned the significant number 4×4 in the form of sixteen points (Pl. 3).²⁸⁷ This refers to the four cherubim in the vision of Ezekiel, each of which had four faces (Ezek. 1: 10, 10: 14). In unorthodox fashion he is dressed like a woman, as is often the case with the hermaphroditic Mercurius in alchemical illustrations of the seventeenth and eighteenth centuries. Models for this figure are the visions of St.

John the Divine (Rev. 1 and 4) and of Daniel (7 : 9ff.). “Jezoth” (= Yesod) is the ninth and middle Sefira in the lowest triad of the Cabalistic tree, and was interpreted as the creative and procreative power in the universe. Alchemically he corresponds to the *spiritus vegetativus*, Mercurius.²⁸⁸ Just as Mercurius has a phallic aspect in alchemy, being related to Hermes Kyllenios,²⁸⁹ so in the *Zohar* has Yesod; indeed the “Zaddik” or “Just One,” as Yesod is also called, is the organ of generation.²⁹⁰ He is the “spout of the waters” (*effusorium aquarum*),²⁹¹ or the “tube” (*fistula*) and “waterpipe” (*canalis*),²⁹² and the “spring of bubbling water” (*scaturigo*).²⁹³ Such comparisons mislead the modern mind into one-sided interpretations, for instance that Yesod is simply the penis, or, conversely, that the obviously sexual language has no basis in real sexuality. But in mysticism one must remember that no “symbolic” object has only one meaning; it is always several things at once. Sexuality does not exclude spirituality nor spirituality sexuality, for in God all opposites are abolished. One has only to think of the *unio mystica* of Simeon ben Yochai in *Zohar* III, which Scholem (see n. 290) barely mentions.

[635] Yesod has many meanings, which in the manuscript are related to Mercurius. In alchemy Mercurius is the “ligament” of the soul, uniting spirit and body. His dual nature enables him to play the role of mediator; he is bodily and spiritual and is himself the union of these two principles. Correspondingly, in Yesod is accomplished the mystery of the “unitio”²⁹⁴ of the upper, Tifereth, and the lower, Malchuth. He is also called the “covenant of peace.”²⁹⁵ Similar designations are “bread,” “chief of the Faces”²⁹⁶ (i.e., of the upper and lower), the “apex” which touches earth and heaven,²⁹⁷ “propinquus” (the Near One), since he is nearer to the Glory (Shekinah), i.e., Malchuth, than to Tifereth,²⁹⁸ and the “Strong One of Israel.”²⁹⁹ Yesod unites the emanation of the right, masculine side (Nezach, life-force) with the left, feminine side (Hod, beauty).³⁰⁰ He is called “firm, reliable, constant”³⁰¹ because he leads the emanation of Tifereth down into Malchuth.³⁰²

[636] Mercurius is often symbolized as a tree, and Yesod as *frutex* (tree-trunk) and *virgultum* (thicket).³⁰³ Mercurius is the *spiritus vegetativus*, spirit of life and growth, and Yesod is described as “vivus,” living,³⁰⁴ or “living for aeons.”³⁰⁵ Just as Mercurius is the prima materia and the basis of the whole process, so Yesod means “foundation.”³⁰⁶ “In natural things Yesod contains in himself quicksilver, for this is the basis of the whole art of transmutation”;³⁰⁷ not, of course, ordinary quicksilver, but “that which not without mystery is called a star.” From this star flow “the waters of the good God El, or quicksilver. . . . This quicksilver . . . is called the Spherical Water,” or “the water of baptism.”³⁰⁸

This water is called the daughter of Matred, that is . . . of a man who labours unweariedly at making gold. For this water flows not out of the earth, nor is it dug

out of mines, but is brought forth and perfected with great labour and much diligence. His wife is called the Water of gold, or such kind of water as gives rise to gold. And if this workman is espoused with her, he will engender a daughter, who will be the Water of the king's bath.³⁰⁹

On the basis of isopsephic³¹⁰ speculation the water of gold was identified with Yesod. The tablet with sixteen signs for gold or sun ☉ at the feet of the *filis de l'homme* seems to point to this (Pl. 3). The *Kabbala denudata* reproduces a "Kamea"³¹¹ containing not 2×8 but $8 \times 8 = 64$ numbers,³¹² "which represent the sum of the name of the golden water."³¹³

[637] As the prima materia is also called lead and Saturn, we should mention that the Sabbath is co-ordinated with Yesod, as is the letter Teth,³¹⁴ which stands under the influence of Shabtai (Saturn). In the same way that Mercurius, as a volatile substance, is named the bird, goose, chick of Hermes, swan, eagle, vulture, and phoenix, Yesod (as well as Tifereth) is called "pullus avis"³¹⁵ also "penna, ala" (feather, wing).³¹⁶ Feathers and wings play a role in alchemy too: the eagle that devours its own feathers or wings,³¹⁷ and the feathers of the phoenix in Michael Maier.³¹⁸ The idea of the bird eating its own feathers is a variant of the uroboros, which in turn is connected with Leviathan. Leviathan and the "great dragon" are names for both Yesod and Tifereth.³¹⁹

[638] Yesod is as a part to the whole, and the whole is Tifereth, who is named the sun.³²⁰ The feet of the Apocalyptic Son of Man, glowing as if in the fire, may have a connection with Malchuth, since the feet are the organ that touches the earth. The earth, Malchuth, is Yesod's "footstool."³²¹ Malchuth is also the "furnace", "the place destined for the cooking and decoction of the influence sent down to her by her husband for the nourishment of the hosts."³²²

[639] After this digression, let us turn back once more to Eleazar's text. The golden head with the silver moon-hair and the body made of red earth mingled with fire are the "inside" of a black, poisonous, ugly figure, which is how the Shulamite now appears. Obviously these negative qualities are to be understood in a moral sense, although chemically they signify the black lead of the initial state. But "inside" is the second Adam, a mystic Christ, as is made clear by the allegory of the lion which Samson slew, and which then became the habitation of a swarm of honey-bees: "Out of the eater came forth meat, and out of the strong came forth sweetness."³²³ These words were interpreted as referring to the *corpus Christi*, the Host,³²⁴ which Eleazar calls the "food of heroes." This strange expression and the still stranger conception of the "Christ" present in the Host are an allusion to the alchemical secret. That is why the author can say with Job 28 : 7 that the way is unknown, "neither hath the eye of

the vulture beheld it.” It is shrouded in mystery, for “the stone belongeth only to the proven and elect of God.”

[640] The lapis also figures in the Cabala: “Sometimes Adonai, the name of the last Sefira, and Malchuth herself, the Kingdom, are so called; for the latter is the foundation of the whole fabric of the world.”³²⁵ The stone is, indeed, of supreme importance, because it fulfils the function of Adam Kadmon as the “capital-stone, from which all the upper and lower hosts in the work of creation are brought into being.”³²⁶ It is called the “sapphirestone, because it takes on divers colours from the highest powers, and works in created things now in one wise, now in the contrary, administering at times good, at others evil, now life, now death, now sickness, now healing, now poverty, now riches.”³²⁷ The stone appears here as the power of fate; indeed, as the reference to Deuteronomy 32 : 39 shows, it is God himself.³²⁸ Knorr von Rosenroth was himself an alchemist, and his words here are written with deliberate intent.³²⁹ He emphasizes that the stone is the one “which the builders rejected and is become the head of the corner.”³³⁰ It occupies a middle position in the Sefiroth system since it unites in itself the powers of the upper world and distributes them to the lower.³³¹ According to its position, therefore, it would correspond to Tifereth.³³²

[641] I have found no evidence in the alchemical literature that the sapphire was an arcanum before the time of Paracelsus. It seems as though this author introduced it into alchemy from the Cabala as a synonym for the arcane substance:

For the virtue which lies in the sapphire is given from heaven by way of solution, coagulation, and fixation. Now, since heaven is created so as to work through these three things until it has achieved this [viz., the production of the sapphire and its virtues], so must the breaking up of the sapphire correspond to the same three procedures. This breaking up is such that the bodies vanish, and the arcanum remains. For before the sapphire existed, there was no arcanum. But subsequently, just as life was given to man, the arcanum was given to this material by heaven.³³³

We can recognize here relationships with Cabalistic ideas. Paracelsus’s pupil, Adam von Bodenstein, says in his *Onomasticon*: “The sapphire material: that liquid in which there is no harmful matter.”³³⁴ Dorn³³⁵ relates the “sapphirine flower” to the “Arcanum Cheyri” of Paracelsus.³³⁶ The “Epistola ad Hermannum” cites a certain G. Ph. Rodochaeus de Geleinen Husio:³³⁷ “Then arises the sapphirine flower of the hermaphrodite, the wondrous mystery of the Macrocosm, of which one part, if it be poured into a thousand parts of the melted Ophirizum, converts it all into its own nature.”³³⁸ This passage is influenced by Paracelsus.

[642] The Lapis Sapphirus or Sapphirinus is derived from Ezekiel 1 : 22 and 26, where the firmament above the “living creature” was like a “terrible crystal” and a

“sapphire stone” (also 10 : 1), and from Exodus 24 : 10: “And they saw the God of Israel: and under his feet as it were a work of sapphire stone, and as the heaven, when clear” (DV). In alchemy “our gold” is “crystalline”;³³⁹ the treasure of the Philosophers is “a certain glassy heaven, like crystal, and ductile like gold”;³⁴⁰ the tincture of gold is “transparent as crystal, fragile as glass.”³⁴¹ The “Book of the Cave of Treasures” says that Adam’s body “shone like the light of a crystal.”³⁴² The crystal, “which appears equally pure within and without,” refers in ecclesiastical language to the “unimpaired purity” of the Virgin.³⁴³ The throne in Ezekiel’s vision, says Gregory the Great, is rightly likened to the sapphire, “for this stone has the colour of air.”³⁴⁴ He compares Christ to the crystal in a way that served as a model for the language and ideas of the alchemists.³⁴⁵

[643] The combination of water and crystal is found also in the Cabalistic “Sifra de Zeniutha.” § 178 of Luria’s commentary says: “The second form is called crystalline dew, and this is formed of the Severity of the Kingdom³⁴⁶ of the first Adam, which entered into the Wisdom of Macroprosopus:³⁴⁷ hence in the crystal there appears a distinct red colour. And this [form] is the Wisdom whereof they said, that Judgments are rooted in it.”³⁴⁸ Although alchemy was undoubtedly influenced by such comparisons, the stone cannot be traced back to Christ, despite all the analogies.³⁴⁹ It was the mystical property of alchemy, this “stone that is no stone,” or the “stone that hath a spirit” and is found in the “streamings of the Nile.”³⁵⁰ It is a symbol that cannot be explained away as yet another supererogatory attempt to obscure the Christian mystery. On the contrary, it appears as a new and singular product which in early times gradually crystallized out through the assimilation of Christian ideas into Gnostic material; later, clear attempts were made in turn to assimilate the alchemical ideas to the Christian, though, as Eleazar’s text shows, there was an unbridgeable difference between them. The reason for this is that the symbol of the stone, despite the analogy with Christ, contains an element that cannot be reconciled with the purely spiritual assumptions of Christianity. The very concept of the “stone” indicates the peculiar nature of this symbol. “Stone” is the essence of everything solid and earthly. It represents feminine *matter*, and this concept intrudes into the sphere of “spirit” and its symbolism. The Church’s hermeneutic allegories of the cornerstone and the “stone cut out of a mountain without hands,”³⁵¹ which were interpreted as Christ, were not the source of the lapis symbol, but were used by the alchemists in order to justify it, for the *λίθος οὐ λίθος* was not of Christian origin. The stone was more than an “incarnation” of God, it was a concretization, a “materialization” that reached down into the darkness of the inorganic realm or even arose from it, from that part of the Deity which put itself in opposition to the Creator because, as the Basilidians say, it remained latent in the *panspermia* (universal seed-bed) as the formative principle of crystals, metals, and living organisms. The inorganic realm included regions, like

that of hell-fire, which were the dominion of the devil. The three-headed Mercurial serpent was, indeed, a triunity in matter³⁵²—the “lower triad”³⁵³—complementing the divine Trinity.

[644] We may therefore suppose that in alchemy an attempt was made at a symbolical *integration of evil* by localizing the divine drama of redemption in man himself. This process appears now as an extension of redemption beyond man to matter, now as an ascent of the *ἀντίμιμον πνεῦμα*, ‘spirit of imitation,’ or Lucifer, and as a reconciliation of this with the spirit descending from above, both the Above and Below undergoing a process of mutual transformation. It seems to me that Eleazar’s text conveys some idea of this, as the transformation of the black Shulamite takes place in three stages, which were mentioned by Dionysius the Areopagite as characterizing the mystical ascent: *emundatio καθαρισμός*, ‘purification’), *illuminatio (φωτισμός)*, *perfectio (τελεσμός)*.³⁵⁴ Dionysius refers the purification to Psalm 51 : 7 (AV): “Wash me, and I shall be whiter than snow”; and the illumination to Psalm 13 : 3 (AV): “Lighten mine eyes.” (The two heavenly luminaries, sun and moon, correspond on the old view to the two eyes.) The perfection he refers to Matthew 5 : 48: “Be ye therefore perfect, even as your Father which is in heaven is perfect.” Here we have one aspect of the approximation to divinity; the other aspect is exemplified by the image of the Apocalyptic Son of Man, described earlier.

[645] The transformation of the Shulamite as described in the text can thus be conceived as the preliminary stage of an individuation process, rising unexpectedly out of the unconscious in symbolical form, and comparable to a dream that seeks to outline this process and for that purpose makes use now of religious and now of “scientific” images. So regarded and looked at from a psychological angle, the following facts emerge.

[646] The *nigredo* corresponds to the darkness of the unconscious, which contains in the first place the inferior personality, the shadow. This changes into the feminine figure that stands immediately behind it, as it were, and controls it: the anima, whose typical representative the Shulamite is. “I am black, but comely”—not “hateful,” as Eleazar would have us believe, after having reconsidered the matter. For since nature was deformed by the sin of Adam, her blackness must in his view be regarded as ugliness, as the blackness of sin, as the Saturnine initial state, heavy and black as lead. But the Shulamite, the priestess of Ishtar, signifies earth, nature, fertility, everything that flourishes under the damp light of the moon, and also the natural life-urge. The anima is indeed the archetype of life itself, which is beyond all meaning and all moral categories. What at first struck us as incomprehensible, namely that the old Adam should come forth from her again, thus reversing the sequence of Creation, can now be understood, for if anyone knows how to live the natural life it is the old

Adam. Here he is not so much the old Adam as an Adam reborn from a daughter of Eve, an Adam restored to his pristine naturalness. The fact that she gives rebirth to Adam and that a black Shulamite produces the original man in his savage, unredeemed state rules out the suspicion that the “old” Adam is a slip of the pen or a misprint. There is a method in it, which allows us to guess what it was that induced the author to adopt a Jewish pseudonym. For the Jew was the handiest example, living under everyone’s eyes, of a non-Christian, and therefore a vessel for all those things a Christian could not or did not like to remember. So it was really very natural to put those dark, half-conscious thoughts which began with the Movement of the Free Spirit, the late Christian religion of the Holy Ghost, and which formed the life-blood of the Renaissance, into the mouth of an allegedly Jewish author. Just as the era of the Old Testament prophets began with Hosea, who was commanded by God to marry another Shulamite, so the *cours d’amour* of René d’Anjou, the minnesingers and saints with their passionate love of God, were contemporaneous with the Brethren of the Free Spirit. Eleazar’s text is nothing but a late echo of these centuries-old events which changed the face of Christianity. But in any such echo there is also a premonition of future developments: in the very same century the author of *Faust*, that momentous opus, was born.

[647] The Shulamite remains unchanged, as did the old Adam. And yet Adam Kadmon is born, a non-Christian second Adam, just at the moment when the transformation is expected. This extraordinary contradiction seems insoluble at first sight. But it becomes understandable when we consider that the illumination or *solificatio* of the Shulamite is not the first transformation but the second, and takes place within. The subject of transformation is not the empirical man, however much he may identify with the “old Adam,” but Adam the Primordial Man, the archetype within us. The black Shulamite herself represents the first transformation: it is the coming to consciousness of the black anima, the Primordial Man’s feminine aspect. The second, or *solificatio*, is the conscious differentiation of the masculine aspect—a far more difficult task. Every man feels identical with this, though in reality he is not. There is too much blackness in the archetype for him to put it all down to his own account, and so many good and positive things that he cannot resist the temptation to identify with them. It is therefore much easier to see the blackness in projected form: “The woman whom thou gavest to be with me, she gave me of the tree, and I did eat” holds true even of the most enlightened psychology. But the masculine aspect is as unfathomable as the feminine aspect. It would certainly not be fitting for the empirical man, no matter how swollen his ego-feelings, to appropriate the whole range of Adam’s heights and depths. Human being though he is, he has no cause to attribute to himself all the nobility and beauty a man can attain to, just as he would assuredly refuse to accept the guilt for the abjectness and baseness that make man

lower than an animal—unless, of course, he were driven by insanity to act out the role of the archetype.

[648] But although, when the masculine aspect of the Primordial Man “comes forth again,” it is the old Adam, who is black like the Shulamite, it is nevertheless the second Adam, i.e., the still older Adam before the Fall, Adam Kadmon. The ambiguity of this passage is too perfect for the author, who proves himself elsewhere to be a not particularly skilful forger, to have been conscious of it. The coming to consciousness of Adam Kadmon would indeed be a great illumination, for it would be a realization of the inner man or Anthropos, an archetypal totality transcending the sexes. In so far as this Man is divine, we could speak of a theophany. The Shulamite’s hope of becoming a “white dove” points to a future, perfect state. The white dove is a hint that the Shulamite will become Sophia,³⁵⁵ the Holy Ghost, while Adam Kadmon is an obvious parallel of Christ.

[649] If the alchemical process of thought corresponded only to the three stages of purification, illumination, perfection, it would be difficult to see the justification for paraphrasing the analogous Christian ideas, which are so patently betrayed, for instance, in the fixing to the “black cross.” But the need for a symbolism other than the Christian one is evident from the fact that the transformation process does not culminate in the second Adam and the white dove but in the lapis, which, with God’s help, is made by the empirical man. It is a half physical, half metaphysical product, a psychological symbol expressing something created by man and yet supra-ordinate to him. This paradox can only be something like the symbol of the *self*, which likewise can be brought forth, i.e., made conscious, by human effort but is at the same time by definition a pre-existent totality that includes the conscious and the unconscious.

[650] This is a thought that goes beyond the Christian world of ideas and involves a mystery consummated in and through man. It is as though the drama of Christ’s life were, from now on, located in man as its living carrier. As a result of this shift, the events formulated in dogma are brought within range of psychological experience and become recognizable in the process of individuation.

[651] It is naturally not the task of an empirical science to evaluate such spiritual developments from the standpoint of transcendental truth. It must content itself with establishing the existence of these processes and comparing them with parallel observations in modern man. It also has the right to attempt to map out the logical structure of such psychologems. The fact that it must push forward into regions where belief and doubt argue the question of truth does not prove that it has any intention of intervening or presuming to decide what the truth is. Its “truth” consists solely in establishing the facts and in explaining them without prejudice within the framework of empirical psychology. Under no circumstances is it entitled to say

whether the facts are valid or not, or to try to ascertain their moral or religious value. I must emphasize this so emphatically because my method is constantly suspected of being theology or metaphysics in disguise. The difficulty for my critics seems to be that they are unable to accept the concept of psychic reality. A psychic process is something that really exists, and a psychic content is as real as a plant or an animal. In spite of the fact that the duckbilled platypus, for example, cannot be logically derived from the general premises of zoology, it nevertheless indubitably exists, improbable as this may appear to prejudiced minds. It is not a fantasy and not just somebody's opinion but an immovable fact. It is perfectly true that one can play metaphysics with psychic facts, and particularly with ideas that have always been counted as metaphysical. But the ideas themselves are not metaphysical; they are empirically verifiable phenomena that are the proper subject of the scientific method.

[652] With the statements of the Cabala, which as we have seen found their way into alchemy, our interpretation of Adam attains a scope and a depth that can hardly be surpassed. This interpretation includes Eve as the feminine principle itself. She appears chiefly as the "lower," as Malchuth (kingdom), Shekinah (the Indwelling of God), or as Atarah (Crown), the equivalent below of Kether, the upper crown. She is also present in the "hermaphroditic" Sefiroth system, the right half of which is masculine and the left half feminine. Hence Adam Kadmon, as a personification of the whole "inverted tree," is androgynous, but the system itself is a highly differentiated coniunctio symbol, and, as such, divided into three parts (three columns of three Sefiroth each). According to Hippolytus, the Naassenes divided the hermaphroditic Adam into three parts, just as they did Geryon.³⁵⁶ Geryon was triple-bodied³⁵⁷ and the possessor of the splendid cattle on the island of Erythia. Heracles slew him with an arrow, on which occasion Hera was wounded in the breast. On the same journey Heracles had threatened to shoot the sun because his rays were too hot. So the slaying of Geryon was the last in a series of three sacrileges.

For they say of this Geryon [continues Hippolytus] that one part is spiritual, one psychic, and one earthly; and they hold that the knowledge of him is the beginning of the capacity to know God, for they say: "The beginning of wholeness is the knowledge of man, but the knowledge of God is perfect wholeness." All this, they say, the spiritual, the psychic, and the earthly, set itself in motion and came down together into one man, Jesus who was born of Mary; and there spoke through it [the spiritual, the psychic, and the earthly] these three men [i.e., the triple-bodied Geryon], each from his own substance to his own. For of all things there are three kinds, the angelic, the psychic, and the earthly; and three Churches, angelic, psychic, and earthly; and their names are the Chosen, the Called, and the Captive.³⁵⁸

[653] This conception bears a striking resemblance to the Sefiroth system.³⁵⁹ In particular, Geryon corresponds to the cosmogonic Adam Kadmon. He is the “masculo-feminine Man in all things, [whom] the Greeks call the heavenly horn of the moon.³⁶⁰ For they say all things were made by him, and without him was not any thing made.³⁶¹ That which was made in him is Life. This, they say, is Life—the unutterable generation [*γενεά*] of perfect men, which to earlier generations was unknown.”³⁶²

VI

THE CONJUNCTION

1. THE ALCHEMICAL VIEW OF THE UNION OF OPPOSITES

[654] Herbert Silberer rightly called the coniunctio the “central idea” of the alchemical procedure.¹ This author correctly recognized that alchemy was, in the main, symbolical, whereas the historian of alchemy, Eduard von Lippmann, a chemist, did not mention the term “coniunctio” even in his index.² Anyone who has but a slight acquaintance with the literature knows that the adepts were ultimately concerned with a union of the substances—by whatever names these may have been called. By means of this union they hoped to attain the goal of the work: the production of the gold or a symbolical equivalent of it. Although the coniunctio is unquestionably the primordial image of what we today would call chemical combination, it is hardly possible to prove beyond a doubt that the adept thought as concretely as the modern chemist. Even when he spoke of a union of the “natures,” or of an “amalgam” of iron and copper, or of a compound of sulphur and mercury, he meant it at the same time as a symbol: iron was Mars and copper was Venus, and their fusion was at the same time a love-affair. The union of the “natures” which “embrace one another” was not physical and concrete, for they were “celestial natures” which multiplied “by the command of God.”³ When “red lead” was roasted with gold it produced a “spirit,” that is, the compound became “spiritual,”⁴ and from the “red spirit” proceeded the “principle of the world.”⁵ The combination of sulphur and mercury was followed by the “bath” and “death.”⁶ By the combination of copper and the *aqua permanens*, which was usually quicksilver, we think only of an amalgam. But for the alchemists it meant a secret, “philosophical” sea, since for them the *aqua permanens* was primarily a symbol or a philosophical postulate which they hoped to discover—or believed they had discovered—in the various “fluids.” The substances they sought to combine in reality always had—on account of their unknown nature—a numinous quality which tended towards phantasmal personification. They were substances which, like living organisms, “fertilized one another and thereby produced the living being [ζῶον] sought by the Philosophers.”⁷ The substances seemed to them hermaphroditic, and the conjunction they strove for was a philosophical operation, namely the union of form and matter.⁸ This inherent duality explains the duplications that so often occur, e.g., two sulphurs, two quicksivers,⁹ *Venus alba et rubea*,¹⁰ *aurum nostrum* and *aurum vulgi*.

[655] It is therefore not surprising that the adepts, as we have seen in the previous chapters, piled up vast numbers of synonyms to express the mysterious nature of the substances—an occupation which, though it must seem utterly futile to the chemist, affords the psychologist a welcome explanation concerning the nature of the projected contents. Like all numinous contents, they have a tendency to self-amplification, that is to say they form the nuclei for an aggregation of synonyms. These synonyms represent the elements to be united as a pair of opposites;¹¹ for instance as man and woman, god and goddess, son and mother,¹² red and white,¹³ active and passive, body and spirit,¹⁴ and so on. The opposites are usually derived from the quaternio of elements,¹⁵ as we can see very clearly from the anonymous treatise “De sulphure,” which says:

Thus the fire began to work upon the air and brought forth Sulphur. Then the air began to work upon the water and brought forth Mercurius. The water began to work upon the earth and brought forth Salt. But the earth, having nothing to work upon, brought forth nothing, so the product remained within it. Therefore only three principles were produced, and the earth became the nurse and matrix of the others.

From these three principles were produced male and female, the male obviously from Sulphur and Mercurius, and the female from Mercurius and Salt.¹⁶ Together they bring forth the “incorruptible One,” the *quinta essentia*, “and thus quadrangle will answer to quadrangle.¹⁷”

[656] The synthesis of the incorruptible One or quintessence follows the Axiom of Maria, the earth representing the “fourth.” The separation of the hostile elements corresponds to the initial state of chaos and darkness. From the successive unions arise an active principle (sulphur) and a passive (salt), as well as a mediating, ambivalent principle, Mercurius. This classical alchemical trinity then produces the relationship of male to female as the supreme and essential opposition. Fire comes at the beginning and is acted on by nothing, and earth at the end acts on nothing. Between fire and earth there is no interaction; hence the four elements do not constitute a circle, i.e., a totality. This is produced only by the synthesis of male and female. Thus the square at the beginning corresponds to the quaternio of elements united in the *quinta essentia* at the end—“quadrangle will answer to quadrangle.”

[657] The alchemical description of the beginning corresponds psychologically to a primitive consciousness which is constantly liable to break up into individual affective processes—to fall apart, as it were, in four directions. As the four elements represent the whole physical world, their falling apart means dissolution into the constituents of the world, that is, into a purely inorganic and hence unconscious state. Conversely, the combination of the elements and the final synthesis of male and female is an achievement of the art and a product of conscious endeavour. The result

of the synthesis was consequently conceived by the adept as self-knowledge,¹⁸ which, like the knowledge of God, is needed for the preparation of the Philosophers' Stone.¹⁹ Piety is needed for the work, and this is nothing but knowledge of oneself.²⁰ This thought occurs not only in late alchemy but also in Greek tradition, as in the Alexandrian treatise of Krates (transmitted by the Arabs), where it is said that a perfect knowledge of the soul enables the adept to understand the many different names which the Philosophers have given to the arcane substance.²¹ The "Liber quartorum" emphasizes that there must be self-observation in the work as well as of events in due time.²² It is evident from this that the chemical process of the coniunctio was at the same time a psychic synthesis. Sometimes it seems as if self-knowledge brought about the union, sometimes as if the chemical process were the efficient cause. The latter alternative is decidedly the more frequent: the coniunctio takes place in the retort²³ or, more indefinitely, in the "natural vessel" or matrix.²⁴ The vessel is also called the grave, and the union a "shared death."²⁵ This state is named the "eclipse of the sun."²⁶

[658] The coniunctio does not always take the form of a direct union, since it needs—or occurs in—a medium: "Only through a medium can the transition take place,"²⁷ and, "Mercurius is the medium of conjunction."²⁸ Mercurius is the soul (anima), which is the "mediator between body and spirit."²⁹ The same is true of the synonyms for Mercurius, the green lion³⁰ and the *aqua permanens* or spiritual water,³¹ which are likewise media of conjunction. The "Consilium coniugii" mentions as a connective agent the sweet smell or "smoky vapour,"³² recalling Basilides' idea of the sweet smell of the Holy Ghost.³³ Obviously this refers to the "spiritual" nature of Mercurius, just as the spiritual water, also called *aqua aëris* (aerial water or air-water), is a life principle and the "marriage maker" between man and woman.³⁴ A common synonym for the water is the "sea," as the place where the chymical marriage is celebrated. The "Tractatus Micreris" mentions as further synonyms the "Nile of Egypt," the "Sea of the Indians," and the "Meridian Sea." The "marvels" of this sea are that it mitigates and unites the opposites.³⁵ An essential feature of the royal marriage is therefore the sea-journey, as described by Christian Rosencreutz.³⁶ This alchemical motif was taken up by Goethe in *Faust II*, where it underlies the meaning of the Aegean Festival. The archetypal content of this festival has been elaborated by Kerényi in a brilliant amplificatory interpretation. The bands of nereids on Roman sarcophagi reveal the "epithalamic and the sepulchral element," for "basic to the antique mysteries . . . is the identity of marriage and death on the one hand, and of birth and the eternal resurgence of life from death on the other."³⁷

[659] Mercurius, however, is not just the medium of conjunction but also that which is to be united, since he is the essence or "seminal matter" of both man and woman. *Mercurius masculinus* and *Mercurius foemineus* are united in and through *Mercurius*

menstrualis, which is the “aqua.”³⁸ Dorn gives the “philosophical” explanation of this in his “Physica Trismegisti”: In the beginning God created *one* world (*unus mundus*).³⁹ This he divided into two—heaven and earth. “Beneath this spiritual and corporeal binarius lieth hid a third thing, which is the bond of holy matrimony. This same is the medium enduring until now in all things, partaking of both their extremes, without which it cannot be at all, nor they without this medium be what they are, one thing out of three.”⁴⁰ The division into two was necessary in order to bring the “one” world out of the state of potentiality into reality. Reality consists of a multiplicity of things. But one is not a number; the first number is two, and with it multiplicity and reality begin.

[660] It is apparent from this explanation that the desperately evasive and universal Mercurius—that Proteus twinkling in a myriad shapes and colours—is none other than the “*unus mundus*,” the original, non-differentiated unity of the world or of Being; the *ἀγνοσία* of the Gnostics, the primordial unconsciousness.⁴¹ The Mercurius of the alchemists is a personification and concretization of what we today would call the collective unconscious. While the concept of the *unus mundus* is a metaphysical speculation, the unconscious can be indirectly experienced via its manifestations. Though in itself an hypothesis, it has at least as great a probability as the hypothesis of the atom. It is clear from the empirical material at our disposal today that the contents of the unconscious, unlike conscious contents, are mutually contaminated to such a degree that they cannot be distinguished from one another and can therefore easily take one another’s place, as can be seen most clearly in dreams. The indistinguishableness of its contents gives one the impression that everything is connected with everything else and therefore, despite their multifarious modes of manifestation, that they are at bottom a unity. The only comparatively clear contents consist of motifs or types round which the individual associations congregate. As the history of the human mind shows, these archetypes are of great stability and so distinct that they allow themselves to be personified and named, even though their boundaries are blurred or cut across those of other archetypes, so that certain of their qualities can be interchanged. In particular, mandala symbolism shows a marked tendency to concentrate all the archetypes on a common centre, comparable to the relationship of all conscious contents to the ego. The analogy is so striking that a layman unfamiliar with this symbolism is easily misled into thinking that the mandala is an artificial product of the conscious mind. Naturally mandalas can be imitated, but this does not prove that all mandalas are imitations. They are produced spontaneously, without external influence, even by children and adults who have never come into contact with any such ideas.⁴² One might perhaps regard the mandala as a reflection of the egocentric nature of consciousness, though this view would be justified only if it could be proved that the unconscious is a secondary phenomenon.

But the unconscious is undoubtedly older and more original than consciousness, and for this reason one could just as well call the egocentrism of consciousness a reflection or imitation of the “self”-centrism of the unconscious.

[661] The mandala symbolizes, by its central point, the ultimate unity of all archetypes as well as of the multiplicity of the phenomenal world, and is therefore the empirical equivalent of the metaphysical concept of a *unus mundus*. The alchemical equivalent is the lapis and its synonyms, in particular the Microcosm.⁴³

[662] Dorn’s explanation is illuminating in that it affords us a deep insight into the alchemical *mysterium coniunctionis*. If this is nothing less than a restoration of the original state of the cosmos and the divine unconsciousness of the world, we can understand the extraordinary fascination emanating from this mystery. It is the Western equivalent of the fundamental principle of classical Chinese philosophy, namely the union of *yang* and *yin* in *tao*, and at the same time a premonition of that “tertium quid” which, on the basis of psychological experience on the one hand and of Rhine’s experiments on the other, I have called “synchronicity.”⁴⁴ If mandala symbolism is the psychological equivalent of the *unus mundus*, then synchronicity is its para-psychological equivalent. Though synchronistic phenomena occur in time and space they manifest a remarkable independence of both these indispensable determinants of physical existence and hence do not conform to the law of causality. The causalism that underlies our scientific view of the world breaks everything down into individual processes which it punctiliously tries to isolate from all other parallel processes. This tendency is absolutely necessary if we are to gain reliable knowledge of the world, but philosophically it has the disadvantage of breaking up, or obscuring, the universal interrelationship of events so that a recognition of the greater relationship, i.e., of the unity of the world, becomes more and more difficult. Everything that happens, however, happens in the same “one world” and is a part of it. For this reason events must possess an *a priori* aspect of unity, though it is difficult to establish this by the statistical method. So far as we can see at present, Rhine seems to have successfully demonstrated this unity by his extrasensory-perception experiments (ESP).⁴⁵ Independence of time and space brings about a concurrence or meaningful coincidence of events not causally connected with one another—phenomena which till now were summed under the purely descriptive concepts of telepathy, clairvoyance, and precognition. These concepts naturally have no explanatory value as each of them represents an X which cannot be distinguished from the X of the other. The characteristic feature of all these phenomena, including Rhine’s psychokinetic effect and other synchronistic occurrences, is *meaningful coincidence*, and as such I have defined the synchronistic principle. This principle suggests that there is an inter-connection or unity of causally unrelated events, and

thus postulates a unitary aspect of being which can very well be described as the *unus mundus*.

[663] Mercurius usually stands for the arcane substance, whose synonyms are the panacea and the “spagyric medicine.” Dorn identifies the latter with the “balsam”⁴⁶ of Paracelsus, which is a close analogy of the *μύρον* of the Basilidians. In the *De vita longa* of Paracelsus, balsam as an *elixir vitae* is associated with the term “gamonymus,” which might be rendered “having the name of matrimony.”⁴⁷ Dorn thinks that the balsam, which “stands higher than nature,” is to be found in the human body and is a kind of aetheric substance.⁴⁸ He says it is the best medicament not only for the body but also for the mind (*mens*). Though it is a corporeal substance, as a combination of the spirit and soul of the spagyric medicine it is essentially spiritual.⁴⁹

We conclude that meditative philosophy consists in the overcoming of the body by mental union [*unio mentalis*]. This first union does not as yet make the wise man, but only the mental disciple of wisdom. The second union of the mind with the body shows forth the wise man, hoping for and expecting that blessed third union with the first unity [i.e., the *unus mundus*, the latent unity of the world]. May Almighty God grant that all men be made such, and may He be one in All.⁵⁰

* * *

[664] It is significant for the whole of alchemy that in Dorn’s view a mental union was not the culminating point but merely the first stage of the procedure. The second stage is reached when the mental union, that is, the unity of spirit and soul, is conjoined with the body. But a consummation of the *mysterium coniunctionis* can be expected only when the unity of spirit, soul, and body is made one with the original *unus mundus*. This third stage of the *coniunctio* was depicted⁵¹ after the manner of an Assumption and Coronation of Mary, in which the Mother of God represents the body. The Assumption is really a wedding feast, the Christian version of the hierosgamos, whose originally incestuous nature played a great role in alchemy. The traditional incest always indicated that the supreme union of opposites expressed a combination of things which are related but of unlike nature.⁵² This may begin with a purely intra-psychic *unio mentalis* of intellect or reason with Eros, representing feeling. Such an interior operation means a great deal, since it brings a considerable increase of self-knowledge as well as of personal maturity, but its reality is merely potential and is validated only by a union with the physical world of the body. The alchemists therefore pictured the *unio mentalis* as Father and Son and their union as the dove (the “spiration” common to both), but the world of the body they represented by the feminine or passive principle, namely Mary. Thus, for more than a thousand years, they prepared the ground for the dogma of the Assumption. It is true that the far-reaching implications of a marriage of the fatherly spiritual principle with

the principle of matter, or maternal corporeality, are not to be seen from the dogma at first glance. Nevertheless, it does bridge over a gulf that seems unfathomable: the apparently irremediable separation of spirit from nature and the body. Alchemy throws a bright light on the background of the dogma, for the new article of faith expresses in symbolical form exactly what the adepts recognized as being the secret of their coniunctio. The correspondence is indeed so great that the old Masters could legitimately have declared that the new dogma has written the Hermetic secret in the skies. As against this it will be said that the alchemists smuggled the mystic or theological marriage into their obscure procedures. This is contradicted by the fact that the alchymical marriage is not only older than the corresponding formulation in the liturgy and of the Church Fathers but is based on classical and pre-Christian tradition.⁵³ The alchemical tradition cannot be brought into relationship with the Apocalyptic marriage of the Lamb. The highly differentiated symbolism of the latter (lamb and city) is itself an offshoot of the archetypal hierosgamos, just as this is the source for the alchemical idea of the coniunctio.

[665] The adepts strove to realize their speculative ideas in the form of a chemical substance which they thought was endowed with all kinds of magical powers. This is the literal meaning of their uniting the *unio mentalis* with the body. For us it is certainly not easy to include moral and philosophical reflections in this amalgamation, as the alchemists obviously did. For one thing we know too much about the real nature of chemical combination, and for another we have a much too abstract conception of the mind to be able to understand how a “truth” can be hidden in matter or what an effective “balsam” must be like. Owing to medieval ignorance both of chemistry and of psychology, and the lack of any epistemological criticism, the two concepts could easily mix, so that things that for us have no recognizable connection with one another could enter into mutual relationship.

[666] The dogma of the Assumption and the alchemical *mysterium coniunctionis* express the same fundamental thought even though in very different symbolism. Just as the Church insists on the literal taking up of the physical body into heaven, so the alchemists believed in the possibility, or even in the actual existence, of their stone or of the philosophical gold. In both cases belief was a substitute for the missing empirical reality. Even though alchemy was essentially more materialistic in its procedures than the dogma, both of them remain at the second, anticipatory stage of the coniunctio, the union of the *unio mentalis* with the body. Even Dorn did not venture to assert that he or any other adept had perfected the third stage in his lifetime. Naturally there were as many swindlers and dupes as ever who claimed to possess the lapis or golden tincture, or to be able to make it. But the more honest alchemists readily admitted that they had not yet plumbed the final secret.

[667] One should not be put off by the physical impossibilities of dogma or of the coniunctio, for they are symbols in regard to which the allurements of rationalism are entirely out of place and miss the mark. If symbols mean anything at all, they are tendencies which pursue a definite but not yet recognizable goal and consequently can express themselves only in analogies. In this uncertain situation one must be content to leave things as they are, and give up trying to know anything beyond the symbol. In the case of dogma such a renunciation is reinforced by the fear of possibly violating the sanctity of a religious idea, and in the case of alchemy it was until very recently considered not worth while to rack one's brains over medieval absurdities. Today, armed with psychological understanding, we are in a position to penetrate into the meaning of even the most abstruse alchemical symbols, and there is no justifiable reason why we should not apply the same method to dogma. Nobody, after all, can deny that it consists of ideas which are born of man's imagining and thinking. The question of how far this thinking may be inspired by the Holy Ghost is not affected at all, let alone decided, by psychological investigation, nor is the possibility of a metaphysical background denied. Psychology cannot advance any argument either for or against the objective validity of any metaphysical view. I have repeated this statement in various places in order to give the lie to the obstinate and grotesque notion that a psychological explanation must necessarily be either psychologism or its opposite, namely a metaphysical assertion. The psychic is a phenomenal world in itself, which can be reduced neither to the brain nor to metaphysics.

[668] I have just said that symbols are tendencies whose goal is as yet unknown.⁵⁴ We may assume that the same fundamental rules obtain in the history of the human mind as in the psychology of the individual. In psychotherapy it often happens that, long before they reach consciousness, certain unconscious tendencies betray their presence by symbols, occurring mostly in dreams but also in waking fantasies and symbolic actions. Often we have the impression that the unconscious is trying to enter consciousness by means of all sorts of allusions and analogies, or that it is making more or less playful attempts to attract attention to itself. One can observe these phenomena very easily in a dream-series. The series I discussed in *Psychology and Alchemy* offers a good example.⁵⁵ Ideas develop from seeds, and we do not know what ideas will develop from what seeds in the course of history. The Assumption of the Virgin, for instance, is vouched for neither in Scripture nor in the tradition of the first five centuries of the Christian Church. For a long time it was officially denied even, but, with the connivance of the whole medieval and modern Church, it gradually developed as a "pious opinion" and gained so much power and influence that it finally succeeded in thrusting aside the necessity for scriptural proof and for a tradition going back to primitive times, and in attaining definition in spite of the fact that the content of the dogma is not even definable.⁵⁶ The papal declaration made a

reality of what had long been condoned. This irrevocable step beyond the confines of historical Christianity is the strongest proof of the autonomy of archetypal images.

2. STAGES OF THE CONJUNCTION

[669] The coniunctio affords another example of the gradual development of an idea in the course of the millennia. Its history flows in two main streams which are largely independent of one another: theology and alchemy. While alchemy has, except for a few traces, been extinct for some two hundred years, theology has put forth a new blossom in the dogma of the Assumption, from which it is evident that the stream of development has by no means come to a standstill. But the differentiation of the two streams has not yet passed beyond the framework of the archetypal hierosgamos, for the coniunctio is still represented as a union of mother and son or of a brother-sister pair. Already in the sixteenth century, however, Gerard Dorn had recognized the psychological aspect of the chymical marriage and clearly understood it as what we today would call the individuation process. This is a step beyond the bounds which were set to the coniunctio, both in ecclesiastical doctrine and in alchemy, by its archetypal symbolism. It seems to me that Dorn's view represents a logical understanding of it in two respects: first because the discrepancy between the chemical operation and the psychic events associated with it could not remain permanently hidden from an attentive and critical observer, and secondly because the marriage symbolism obviously never quite satisfied the alchemical thinkers themselves, since they constantly felt obliged to make use of other "uniting symbols," besides the numerous variants of the hierosgamos, to express the all but incomprehensible nature of the mystery. Thus the coniunctio is represented by the dragon embracing the woman in the grave,⁵⁷ or by two animals fighting,⁵⁸ or by the king dissolving in water,⁵⁹ and so on. Similarly, in Chinese philosophy the meaning of *yang* is far from exhausted with its masculine connotation. It also means dry, bright, and the south side of the mountain, just as the feminine *yin* means damp, dark, and the north side of the mountain.

[670] Although the esoteric symbolism of the coniunctio occupies a prominent position, it does not cover all aspects of the mysterium. In addition we have to consider the symbolism of death and the grave, and the motif of conflict. Obviously, very different if not contradictory symbolisms were needed to give an adequate description of the paradoxical nature of the conjunction. In such a situation one can conclude with certainty that none of the symbols employed suffices to express the whole. One therefore feels compelled to seek a formula in which the various aspects can be brought together without contradiction. Dorn attempted to do this with the means that were then at his disposal. He could do so the more easily as the current idea of

correspondentia came to his aid. For a man of those times there was no intellectual difficulty in postulating a “truth” which was the same in God, in man, and in matter. With the help of this idea he could see at once that the reconciliation of hostile elements and the union of alchemical opposites formed a “correspondence” to the *unio mentalis* which took place simultaneously in the mind of man, and not only in man but in God (“that He may be one in All”). Dorn correctly recognized that the entity in which the union took place is the psychological authority which I have called the self. The *unio mentalis*, the interior oneness which today we call individuation, he conceived as a psychic equilibration of opposites “in the overcoming of the body,” a state of equanimity transcending the body’s affectivity and instinctuality.⁶⁰ The spirit (*animus*), which is to unite with the soul, he called a “spiracle [*spiraculum*] of eternal life,” a sort of “window into eternity” (Leibniz), whereas the soul is an organ of the spirit and the body an instrument of the soul. The soul stands between good and evil and has the “option” of both. It animates the body by a “natural union,” just as, by a “supernatural union,” it is endowed with life by the spirit.⁶¹

[671] But, in order to bring about their subsequent reunion, the mind (*mens*) must be separated from the body—which is equivalent to “voluntary death”⁶²—for only separated things can unite. By this separation (*distractio*) Dorn obviously meant a discrimination and dissolution of the “composite,” the composite state being one in which the affectivity of the body has a disturbing-influence on the rationality of the mind. The aim of this separation was to free the mind from the influence of the “bodily appetites and the heart’s affections,” and to establish a spiritual position which is supraordinate to the turbulent sphere of the body. This leads at first to a dissociation of the personality and a violation of the merely natural man.

[672] This preliminary step, in itself a clear blend of Stoic philosophy and Christian psychology, is indispensable for the differentiation of consciousness.⁶³ Modern psychotherapy makes use of the same procedure when it objectifies the affects and instincts and confronts consciousness with them. But the separation of the spiritual and the vital spheres, and the subordination of the latter to the rational standpoint, is not satisfactory inasmuch as reason alone cannot do complete or even adequate justice to the irrational facts of the unconscious. In the long run it does not pay to cripple life by insisting on the primacy of the spirit, for which reason the pious man cannot prevent himself from sinning again and again and the rationalist must constantly trip up over his own irrationalities. Only the man who hides the other side in artificial unconsciousness can escape this intolerable conflict. Accordingly, the chronic duel between body and spirit seems a better though by no means ideal solution. The advantage, however, is that both sides remain conscious. Anything conscious can be corrected, but anything that slips away into the unconscious is

beyond the reach of correction and, its rank growth undisturbed, is subject to increasing degeneration. Happily, nature sees to it that the unconscious contents will irrupt into consciousness sooner or later and create the necessary confusion. A permanent and uncomplicated state of spiritualization is therefore such a rarity that its possessors are canonized by the Church.

[673] Since the soul animates the body, just as the soul is animated by the spirit, she tends to favour the body and everything bodily, sensuous, and emotional. She lies caught in “the chains” of Physis, and she desires “beyond physical necessity.” She must be called back by the “counsel of the spirit” from her lostness in matter and the world. This is a relief to the body too, for it not only enjoys the advantage of being animated by the soul but suffers under the disadvantage of having to serve as the instrument of the soul’s appetites and desires. Her wish-fantasies impel it to deeds to which it would not rouse itself without this incentive, for the inertia of matter is inborn in it and probably forms its only interest except for the satisfaction of physiological instincts. Hence the separation means withdrawing the soul and her projections from the bodily sphere and from all environmental conditions relating to the body. In modern terms it would be a turning away from sensuous reality, a withdrawal of the fantasy-projections that give “the ten thousand things” their attractive and deceptive glamour. In other words, it means introversion, introspection, meditation, and the careful investigation of desires and their motives. Since, as Dorn says, the soul “stands between good and evil,” the disciple will have every opportunity to discover the dark side of his personality, his inferior wishes and motives, childish fantasies and resentments, etc.; in short, all those traits he habitually hides from himself. He will be confronted with his shadow, but more rarely with the good qualities, of which he is accustomed to make a show anyway. He will learn to know his soul, that is, his anima and Shakti who conjures up a delusory world for him. He attains this knowledge, Dorn supposes, with the help of the spirit, by which are meant all the higher mental faculties such as reason, insight, and moral discrimination. But, in so far as the spirit is also a “window into eternity” and, as the *anima rationalis* immortal, it conveys to the soul a certain “divine influx” and the knowledge of higher things, wherein consists precisely its supposed animation of the soul. This higher world has an impersonal character and consists on the one hand of all those traditional, intellectual, and moral values which educate and cultivate the individual, and, on the other, of the products of the unconscious, which present themselves to consciousness as archetypal ideas. Usually the former predominate. But when, weakened by age or by criticism, they lose their power of conviction, the archetypal ideas rush in to fill the gap. Freud, correctly recognizing this situation, called the traditional values the “super-ego,” but the archetypal ideas remained unknown to him, as the belief in reason and the positivism of the nineteenth century

never relaxed their hold. A materialistic view of the world ill accords with the reality and autonomy of the psyche.

[674] The arcanum of alchemy is one of these archetypal ideas that fills a gap in the Christian view of the world, namely, the un-bridged gulf between the opposites, in particular between good and evil. Only logic knows a *tertium non datur*; nature consists entirely of such “thirds,” since she is represented by effects which resolve an opposition—just as a waterfall mediates between “above” and “below.” The alchemists sought for that effect which would heal not only the disharmonies of the physical world but the inner psychic conflict as well, the “affliction of the soul”; and they called this effect the lapis Philosophorum. In order to obtain it, they had to loosen the age-old attachment of the soul to the body and thus make conscious the conflict between the purely natural and the spiritual man. In so doing they rediscovered the old truth that every operation of this kind is a figurative death⁶⁴—which explains the violent aversion everybody feels when he has to see through his projections and recognize the nature of his anima. It requires indeed an unusual degree of self-abnegation to question the fictitious picture of one’s own personality. This, nevertheless, is the requirement of any psychotherapy that goes at all deep, and one realizes how oversimplified its procedures are only when the analyst has to try out his own medicine on himself. One can, as experience has often shown, relieve oneself of the difficult act of self-knowledge by shutting out the moral criterion with so-called scientific objectivity or unvarnished cynicism. But this simply means buying a certain amount of insight at the cost of artificially repressing an ethical value. The result of this deception is that the insight is robbed of its efficacy, since the moral reaction is missing. Thus the foundations for a neurotic dissociation are laid, and this in no way corresponds to the psychotherapist’s intention. The goal of the procedure is the *unio mentalis*, the attainment of full knowledge of the heights and depths of one’s own character.

[675] If the demand for self-knowledge is willed by fate and is refused, this negative attitude may end in real death. The demand would not have come to this person had he still been able to strike out on some promising by-path. But he is caught in a blind alley from which only self-knowledge can extricate him. If he refuses this then no other way is open to him. Usually he is not conscious of his situation, either, and the more unconscious he is the more he is at the mercy of unforeseen dangers: he cannot get out of the way of a car quickly enough, in climbing a mountain he misses his foothold somewhere, out skiing he thinks he can just negotiate a tricky slope, and in an illness he suddenly loses the courage to live. The unconscious has a thousand ways of snuffing out a meaningless existence with surprising swiftness. The connection of the *unio mentalis* with the death-motif is therefore obvious, even when death consists only in the cessation of spiritual progress.

[676] The alchemists rightly regarded “mental union in the overcoming of the body” as only the first stage of conjunction or individuation, in the same way that Khunrath understood Christ as the “Saviour of the Microcosm” but not of the Macrocosm, whose saviour was the lapis.⁶⁵ In general, the alchemists strove for a *total* union of opposites in symbolic form, and this they regarded as the indispensable condition for the healing of all ills. Hence they sought to find ways and means to produce that substance in which all opposites were united. It had to be material as well as spiritual, living as well as inert, masculine as well as feminine, old as well as young, and—presumably—morally neutral. It had to be created by man, and at the same time, since it was an “increatum,” by God himself, the *Deus terrestris*.

[677] The second step on the way to the production of this substance was the reunion of the spirit with the body. For this procedure there were many symbols. One of the most important was the chymical marriage, which took place in the retort. The older alchemists were still so unconscious of the psychological implications of the opus that they understood their own symbols as mere allegories or—semiotically—as secret names for chemical combinations, thus stripping mythology, of which they made such copious use, of its true meaning and using only its terminology. Later this was to change, and already in the fourteenth century it began to dawn on them that the lapis was more than a chemical compound. This realization expressed itself mainly in the Christ-parallel.⁶⁶ Dorn was probably the first to recognize the psychological implications for what they were, so far as this was intellectually possible for a man of that age. Proof of this is his demand that the pupil must have a good physical and, more particularly, a good moral constitution.⁶⁷ A religious attitude was essential.⁶⁸ For in the individual was hidden that “substance of celestial nature known to very few,” the “incorrupt medicament” which “can be freed from its fetters, not by its contrary but by its like.” The “spagyric medicine” whereby it is freed must be “conformable to this substance.” The medicine “prepares” the body so that the separation can be undertaken. For, when the body is “prepared,” it can be separated more easily from “the other parts.”

[678] Like all alchemists, Dorn naturally did not reveal what the spagyric medicine was. One can only suppose that it was thought of as physical, more or less. At the same time he says that a certain asceticism is desirable, and this may be a reference to the moral nature of the mysterious panacea. At any rate he hastens to add that the “assiduous reader” will thenceforth advance from the meditative philosophy to the spagyric and thence to the true and perfect wisdom. It sounds as if the assiduous reader had been engaged at the outset in reading and meditating, and as if the medicine and the preparation of the body consisted precisely in that.⁶⁹ Just as for Paracelsus the right “theoria” was part of the panacea, so for the alchemists was the symbol, which expresses the unconscious projections. Indeed, it is these that make

the substance magically effective, and for this reason they cannot be separated from the alchemical procedure whose integral components they are.

[679] The second stage of conjunction, the re-uniting of the *unio mentalis* with the body, is particularly important, as only from here can the complete conjunction be attained—union with the *unus mundus*. The reuniting of the spiritual position with the body obviously means that the insights gained should be made real. An insight might just as well remain in abeyance if it is simply not used. The second stage of conjunction therefore consists in making a reality of the man who has acquired some knowledge of his paradoxical wholeness.

[680] The great difficulty here, however, is that no one knows how the paradoxical wholeness of man can ever be realized. That is the crux of individuation, though it becomes a problem only when the loophole of “scientific” or other kinds of cynicism is not used. Because the realization of the wholeness that has been made conscious is an apparently insoluble task and faces the psychologist with questions which he can answer only with hesitation and uncertainty, it is of the greatest interest to see how the more unencumbered symbolical thinking of a medieval “philosopher” tackled this problem. The texts that have come down to us do not encourage the supposition that Dorn was conscious of the full range of his undertaking. Although in general he had a clear grasp of the role the adept played in the alchemical process, the problem did not present itself to him in all its acuteness, because only a part of it was enacted in the moral and psychological sphere, while for the rest it was hypostatized in the form of certain magical properties of the living body, or as a magical substance hidden within it. This projection spread over the problem a kind of mist which obscured its sharp edges. The alchemists still believed that metaphysical assertions could be proved (even today we have still not entirely freed ourselves from this somewhat childish assumption), and they could therefore entrench themselves behind seemingly secure positions in the Beyond, which they were confident would not be shaken by any doubts. In this way they were able to procure for themselves considerable alleviations. One has only to think what it means if in the misery and incertitude of a moral or philosophical dilemma one has a *quinta essentia*, a lapis or a panacea so to say in one’s pocket! We can understand this *deus ex machina* the more easily when we remember with what passion people today believe that psychological complications can be made magically to disappear by means of hormones, narcotics, insulin shocks, and convulsion therapy. The alchemists were as little able to perceive the symbolical nature of their ideas of the arcanum as we to recognize that the belief in hormones and shocks is a symbol. We would indignantly dismiss such an interpretation as a nonsensical suggestion.

3. THE PRODUCTION OF THE QUINTESSENCE

[681] Much of Dorn's argument moves in the sphere of symbols and soars on winged feet into the clouds. But that does not prevent his symbols from having a more mundane meaning which appears more or less accessible to our psychology. Thus, he knew that even the wise man could not reconcile the opposites unless "a certain heavenly substance hidden in the human body" came to his help, namely the "balsam," the quintessence, the "philosophic wine,"⁷⁰ a "virtue and heavenly vigour"⁷¹—in short, the "truth."⁷² This truth was the panacea. It is only indirectly hidden in the body, since in reality it consists in the *imago Dei* imprinted in man. This *imago* is the true quintessence and the "virtue" of the philosophic wine. The latter is therefore an apt synonym, because wine in the form of a liquid represents the body, but as alcohol it represents spirit, which would seem to correspond with the "heavenly virtue." This, although divided up among individuals, is universal; it is *one*, and when "freed from its fetters in the things of sense" it returns to its original state of unity. "This is one of the secrets of nature, whereby the spagyrics have attained to higher things."⁷³ The "wine" can be prepared from grain⁷⁴ and from all other seeds.⁷⁵ The extracted essence is reduced to its "greatest simplicity" by "assiduous rotary movements,"⁷⁶ whereby the pure is separated from the impure:

Then you will see the pureness floating to the top, transparent, shining, and of the colour of purest air. . . .⁷⁷ You will see the heretofore spagyric [i.e., secret] heaven, which you can bedeck with the lower stars, as the upper heaven is bedecked with the upper stars. . . .⁷⁸ Will now the unbelievers, who have imitated the Physicists, marvel that we handle in our hands the heaven and the stars? . . . For us, therefore, the lower stars are all individuals produced by nature in this lower world by their conjunction with heaven, like [the conjunction] of the higher with the lower elements.⁷⁹ Now I hear the voice of many raging against us, and crying out, Avaunt! let those men be destroyed who say that heaven can conjoin itself to earth . . .

[682] The caelum therefore is a heavenly substance and a universal form, containing in itself all forms, distinct from one another, but proceeding from one single universal form. Wherefore, he who knows how individuals can be led on to the most general genus by the spagyric art, and how the special virtues, one or more, can be impressed upon this genus, will easily find the universal medicine. . . . For since there is one single and most general beginning of all corruptions, and one universal fount of regenerating, restoring, and life-giving virtues, who, save a man bereft of his senses, will call such a medicine in doubt?⁸⁰

[683] Through the alchemical treatment of the "grana" (or grape-pips),

our Mercurius is concocted by the highest sublimation [*exaltatione*]. The mixture of the new heaven, of honey,⁸¹ Chelidonia,⁸² rosemary flowers,⁸³ Mercurialis,⁸⁴ of the red lily⁸⁵ and human blood,⁸⁶ with the heaven of the red or white wine or of Tartarus, can be undertaken. . . .⁸⁷ One can also make another mixture, namely that of heaven and the philosophical key,⁸⁸ by the artifice of generation.

[684] Here even Dorn remarks that the reader will hold his breath, adding:

It is true that these things are scarcely to be understood [*vix intelligibilia*] unless one has full knowledge of the terms used in the art, and these we consider we have defined in the second stage, treating of meditative knowledge. Meditative knowledge is thus the sure and undoubted resolution by expert certitude, of all manner of opinions concerning the truth. But opinion is an anticipation [*praesumptio*] of the truth, fixed in the mind and doubtful. Experiment, on the other hand, is manifest demonstration of the truth, and resolution the putting away of doubt. We cannot be resolved of any doubt save by experiment, and there is no better way to make it than on ourselves. . . . We have said earlier that piety consists in knowledge of ourselves, and hence we begin to explain meditative knowledge from this also. But no man can truly know himself unless first he see and know by zealous meditation . . . *what* rather than *who* he is, on whom he depends, and whose he is, and to what end he was made and created, and by whom and through whom.

[685] God made man to partake of his glory and created him in his image. “Even as we were created of the basest and most worthless clay, despised of all, so and no otherwise, by reason of the prime matter whereof we consist, are we more prone to everything vile than to him who out of vile matter created us of old to be most precious creatures, adorned with glory and honour little less than the angels.” From the basest matter God created gold and precious stones. Therefore, knowing our nature and our origin, we should abstain from pride, for God looks not upon the person but upon poverty and humility and hates pride. Only he who made the water and the wine can change the one into the other, and so also the earth into a living soul, and he endued it with his image and likeness for the certainty of our salvation. Nevertheless we became rebels through the sin of Adam, but God was reconciled with us. “Who will be so stony [*lapideus*], when he shall revolve in his mind the mystery of the divine goodness, as not to be reconciled with his enemy, however great the injury he received from him?” He who knows God will know his brother also. This is the foundation of the true philosophy. And he who observes all this in himself and frees his mind from all worldly cares and distractions,⁸⁹ “little by little and from day to day will perceive with his mental eyes and with the greatest joy some sparks of divine illumination.” The soul, moved by this, will unite with the body:

At length the body is compelled to resign itself to, and obey, the union of the two that are united [soul and spirit].⁹⁰ That is the wondrous transformation of the Philosophers, of body into spirit, and of the latter into body, of which there has been left to us by the sages the saying, Make the fixed volatile and the volatile fixed,⁹¹ and in this you have our Magistry. Understand this after the following manner: Make the unyielding body tractable, so that by the excellence of the spirit coming together with the soul it becomes a most stable body ready to endure all trials. For gold is tried in the fire. . . . Draw near, ye who seek the treasures in such diverse ways, know the rejected stone which is made the head of the corner. . . . In vain do they labour, all searchers after the hidden secrets of nature, when, looking for another way of ingress, they seek to reveal the virtues of earthly things through earthly things. Learn not heaven therefore through the earth, but learn the virtues of one by those of the other. Seek the incorruptible medicine which not only transmutes bodies from corruption to their true disposition [*temperamentum*], but preserves those so disposed [*temperata*] for any length of time. Such medicine you can find nowhere but in heaven. For heaven, by virtue of invisible rays coming together from all sides in the centre of the earth, penetrates, generates, and nourishes all elements, and all things that arise from the elements. This child of the two parents, of the elements and heaven, has in itself such a nature that the potentiality and actuality [*potentia et actu*] of both parents can be found in it. What will remain there till today [i.e., in the centre of the earth], save the stone in the spagyric generation?⁹² Learn from within thyself to know all that is in heaven and on earth, and especially that all was created for thy sake. Knowest thou not that heaven and the elements were formerly one, and were separated from one another by divine artifice, that they might bring forth thee and all things? If thou knowest this, the rest cannot escape thee. Therefore in all generation a separation of this kind is necessary. . . . Thou wilt never make from others the One which thou seekest, except first there be made one thing of thyself ...⁹³

4. THE MEANING OF THE ALCHEMICAL PROCEDURE

[686] Thus Dorn describes the secret of the second stage of conjunction. To the modern mind such contrivances of thought will seem like nebulous products of a dreaming fancy. So, in a sense, they are, and for this reason they lend themselves to decipherment by the method of complex psychology. In his attempt to make the obviously confused situation clearer, Dorn involved himself in a discussion of the ways and means for producing the quintessence, which was evidently needed for uniting the *unio mentalis* with the body. One naturally asks oneself how this alchemical procedure enters into it at all. The *unio mentalis* is so patently a spiritual and moral attitude that one cannot doubt its psychological nature. To our way of

thinking, this immediately sets up a dividing wall between the psychic and the chemical process. For us the two things are incommensurable, but they were not so for the medieval mind. It knew nothing of the nature of chemical substances and their combination. It saw only enigmatic substances which, united with one another, inexplicably brought forth equally mysterious new substances. In this profound darkness the alchemist's fantasy had free play and could playfully combine the most inconceivable things. It could act without restraint and, in so doing, portray itself without being aware of what was happening.

[687] The free-ranging psyche of the adept used chemical substances and processes as a painter uses colours to shape out the images of his fancy. If Dorn, in order to describe the union of the *unio mentalis* with the body, reaches out for his chemical substances and implements, this only means that he was illustrating his fantasies by chemical procedures. For this purpose he chose the most suitable substances, just as the painter chooses the right colours. Honey, for instance, had to go into the mixture because of its purifying quality. As a Paracelsist, Dorn knew from the writings of the Master what high praises he had heaped upon it, calling it the "sweetness of the earths," the "resin of the earth" which permeates all growing things, the "Indian spirit" which is turned by the "influence of summer" into a "corporeal spirit."⁹⁴ Thereby the mixture acquired the property not only of eliminating impurities but of changing spirit into body, and in view of the proposed conjunction of the spirit and the body this seemed a particularly promising sign. To be sure, the "sweetness of the earths" was not without its dangers, for as we have seen (n. 81) the honey could change into a deadly poison. According to Paracelsus it contains "Tartarum," which as its name implies has to do with Hades. Further, Tartarum is a "calcined Saturn" and consequently has affinities with this malefic planet. For another ingredient Dorn takes Chelidonia (*Chelidonium maius*, celandine), which cures eye diseases and is particularly good for night-blindness, and even heals the spiritual "benightedness" (affliction of the soul, melancholy-madness) so much feared by the adepts. It protects against "thunderstorms," i.e., outbursts of affect. It is a precious ingredient, because its yellow flowers symbolize the philosophical gold, the highest treasure. What is more important here, it draws the humidity, the "soul,"⁹⁵ out of Mercurius. It therefore assists the "spiritualization" of the body and makes visible the essence of Mercurius, the supreme chthonic spirit. But Mercurius is also the devil.⁹⁶ Perhaps that is why the section in which Lagneus defines the nature of Mercurius is entitled "Dominus vobiscum."⁹⁷

[688] In addition, the plant Mercurialis (dog's mercury) is indicated. Like the Homeric magic herb Moly, it was found by Hermes himself and must therefore have magical effects. It is particularly favourable to the coniunctio because it occurs in male and female form and thus can determine the sex of a child about to be conceived.

Mercurius himself was said to be generated from an extract of it—that spirit which acts as a mediator (because he is *utriusque capax*, “capable of either”) and saviour of the Macrocosm, and is therefore best able to unite the above with the below. In his ithyphallic form as Hermes Kyllenios, he contributes the attractive power of sexuality, which plays a great role in the coniunctio symbolism.⁹⁸ Like honey, he is dangerous because of his possibly poisonous effect, for which reason it naturally seemed advisable to our author to add rosemary to the mixture as an alexipharmic (antidote) and a synonym for Mercurius (*aqua permanens*), perhaps on the principle that “like cures like.” Dorn could hardly resist the temptation to exploit the alchemical allusion to “ros marinus,” sea-dew. In agreement with ecclesiastical symbolism there was in alchemy, too, a “dew of grace,” the *aqua vitae*, the perpetual, permanent, and two-meaninged ἵδωρ θεῖον, divine water or sulphur water. The water was also called *aqua pontica* (sea-water) or simply “sea.” This was the great sea over which the alchemist sailed in his mystic peregrination, guided by the “heart” of Mercurius in the heavenly North Pole, to which nature herself points with the magnetic compass.⁹⁹ It was also the bath of regeneration, the spring rain which brings forth the vegetation, and the “aqua doctrinae.”

[689] Another alexipharmic is the lily. But it is much more than that: its juice is “mercurial” and even “incombustible,” a sure sign of its incorruptible and “eternal” nature. This is confirmed by the fact that the lily was conceived to be Mercurius and the quintessence itself—the noblest thing that human meditation can reach (see n. 85). The red lily stands for the male and the white for the female in the coniunctio, the divine pair that unite in the hierosgamos. The lily is therefore a true “gamonymus” in the Paracelsan sense.

[690] Finally, the mixture must not lack the thing that really keeps body and soul together: human blood, which was regarded as the seat of the soul.¹⁰⁰ It was a synonym for the red tincture, a preliminary stage of the lapis; moreover, it was an old-established magic charm, a “ligament” for binding the soul either to God or the devil, and hence a powerful medicine for uniting the *unio mentalis* with the body. The admixture of human blood seems to me unusual if one assumes that the recipe was meant literally. We move here on uncertain ground. Although the vegetable ingredients are obviously indicated because of their symbolic value, we still do not know exactly how far the symbolism had a magical quality. If it had, then the recipe must be taken literally. In the case of blood, increased doubts arise because either it was simply a synonym for the *aqua permanens* and could then be practically any liquid, or else real blood was meant, and then we must ask where this blood came from. Could it have been the adept’s? This problem seems to me not entirely irrelevant, since Dorn, in his “Philosophia meditativa,” was greatly influenced, as we shall see, by the Sabaeen “Liber quartorum,” which he obviously knew although he

did not mention it. The Sabaeans were reputed to have sacrificed human victims for magical purposes,¹⁰¹ and even today human blood is used for signing pacts with the devil. It is also not so long since tramps were made drunk and quickly immured on a building site in order to make the foundations safe. A magical recipe of the sixteenth century, therefore, might easily have used human blood as a *pars pro toto*.

[691] This whole mixture was then joined “with the heaven of the red or white wine or of Tartarus.” The *caelum*, as we have seen, was the product of the alchemical procedure, which in this case consisted in first distilling the “philosophic wine.” Thereby the soul and spirit were separated from the body and repeatedly sublimated until they were free from all “phlegm,” i.e., from all liquid that contained no more “spirit.”¹⁰² The residue, called the *corpus* (body), was reduced to ashes in the “most vehement fire” and, hot water being added, was changed into a *lixivium asperrimum*, “very sharp lye,” which was then carefully poured off the ashes by tilting the vessel. The residue was treated in the same way again, until in the end no “asperitas” remained in the ashes. The lye was filtered and then evaporated in a glass vessel. What was left over was *tartarum nostrum* (“our winestone,” *calculus vini*), the natural “salt of all things.” This salt “can be dissolved into tartaric water, in a damp and cool place on a slab of marble.”¹⁰³ The tartaric water was the quintessence of the philosophic and even of ordinary wine, and was then subjected to the above-mentioned rotation. As in a centrifuge, the pure was separated from the impure, and a liquid “of the colour of the air” floated to the top. This was the *caelum*.

[692] I have detailed this process in order to give the reader a direct impression of the alchemical procedure. One can hardly suppose that all this is mere poppycock, for Dorn was a man who obviously took things seriously. So far as one can judge he meant what he said, and he himself worked in the laboratory. Of course we do not know what success he had chemically, but we are sufficiently informed about the results of his meditative exertions.

[693] The *caelum*, for Dorn, was the celestial substance hidden in man, the secret “truth,” the “sum of virtue,” the “treasure which is not eaten into by moths nor dug out by thieves.” In the world’s eyes it is the cheapest thing, but “to the wise more worthy of love than precious stones and gold, a good that passeth not away, and is taken hence after death.”¹⁰⁴ The reader will gather from this that the adept was describing nothing less than the kingdom of heaven on earth. I think that Dorn was not exaggerating, but that he wanted to communicate to his public something very important to him. He believed in the necessity of the alchemical operation as well as in its success; he was convinced that the quintessence was needed for the “preparation” of the body,¹⁰⁵ and that the body was so much improved by this “universal medicine” that the *coniunctio* with spirit and soul could be consummated.

If the production of the *caelum* from wine is a hair-raising chemical fantasy, our understanding ceases altogether when the adept mixes this heaven with his “gamonymous” and other magical herbs. But if the one consists mainly of fantasies so does the other. This makes it interesting. Fantasies always mean something when they are spontaneous. The question then arises: what is the psychological meaning of the procedure?

5. THE PSYCHOLOGICAL INTERPRETATION OF THE PROCEDURE

[694] The answer to this question concerns us very closely, because here we come upon something that is of particular interest to modern psychology: the adept produces a system of fantasies that has a special meaning for him. Although he keeps within the general framework of alchemical ideas, he does not repeat a prescribed pattern, but, following his own fancy, devises an individual series of ideas and corresponding actions which it is evident have a symbolic character. He starts with the production of the medicine that will unite the *unio mentalis*, his spiritual position, with the body. The ambiguity already begins here: is the “corpus” his human body or the chemical substance? Apparently it is, to start off with, his living body, which as everyone knows has different desires from the spirit. But hardly has the chemical process got under way than the “body” is what remains behind in the retort from the distillation of the wine, and this “phlegm” is then treated like the subtle body of the soul in the purgatorial fire. Like it, the residue from the wine must pass through many subliming fires until it is so purified that the “air-coloured” quintessence can be extracted from it.

[695] This singular identity, simply postulated and never taken as a problem, is an example of that “participation mystique” which Lévy-Bruhl very rightly stressed as being characteristic of the primitive mentality.¹⁰⁶ The same is true of the unquestionably psychic *unio mentalis*, which is at the same time a substance-like “truth” hidden in the body, which in turn coincides with the quintessence sublimed from the “phlegm.” It never occurred to the mind of the alchemists to cast any doubt whatsoever on this intellectual monstrosity. We naturally think that such a thing could happen only in the “dark” Middle Ages. As against this I must emphasize that we too have not quite got out of the woods in this respect, for a philosopher once assured me in all seriousness that “thought could not err,” and a very famous professor, whose assertions I had ventured to criticize, came out with the magisterial dictum: “It must be right because I have thought it.”

[696] All projections are unconscious identifications with the object. Every projection is simply there as an uncriticized datum of experience, and is recognized for what it is only very much later, if ever. Everything that we today would call “mind” and “insight” was, in earlier centuries, projected into things, and even today individual idiosyncrasies are presupposed by many people to be generally valid. The original, half-animal state of unconsciousness was known to the adept as the *nigredo*, the chaos, the *massa confusa*, an inextricable interweaving of the soul with the body, which together formed a dark unity (the *unio naturalis*). From this enchainment he

had to free the soul by means of the *separatio*, and establish a spiritual-psychic counter-position—conscious and rational insight—which would prove immune to the influences of the body. But such insight, as we have seen, is possible only if the delusory projections that veil the reality of things can be withdrawn. The unconscious identity with the object then ceases and the soul is “freed from its fetters in the things of sense.” The psychologist is well acquainted with this process, for a very important part of his psychotherapeutic work consists in making conscious and dissolving the projections that falsify the patient’s view of the world and impede his self-knowledge. He does this in order to bring anomalous psychic states of an affective nature, i.e., neurotic symptoms, under the control of consciousness. The declared aim of the treatment is to set up a rational, spiritual-psychic position over against the turbulence of the emotions.

[697] Projections can be withdrawn only when they come within the possible scope of consciousness. Outside that, nothing can be corrected. Thus, in spite of all his efforts, Dorn was unable to recognize the—for us—blatant projection of psychic contents into chemical substances and thereby dissolve it. Evidently his understanding in this respect still moved within the confines of the contemporary consciousness, even though in other respects it plumbed to greater depths than did the collective consciousness of that age. Thus it is that the psychic sphere representing the body miraculously appeared to the adept to be identical with chemical preparation in the retort. Hence he could believe that any changes he effected in the latter would happen to the former as well. Significantly enough, one seldom hears of the panacea or lapis being applied to the human body. As a rule the carrying out of the chemical procedure seemed sufficient in itself. At any rate it was for Dorn, and that is why his chemical *caelum* coincided with the heavenly substance in the body, the “truth.” For him this was not a duality but an identity; for us they are incommensurables that cannot be reconciled because, owing to our knowledge of chemical processes, we are able to distinguish them from psychic ones. In other words, our consciousness enables us to withdraw this projection.

[698] The list of ingredients to be mixed with the *caelum* gives us a glimpse into the nature of the psychic contents that were projected. In the honey, the “sweetness of the earths,”¹⁰⁷ we can easily recognize the balsam of life that permeates all living, budding, and growing things. It expresses, psychologically, the joy of life and the life urge which overcome and eliminate everything dark and inhibiting. Where spring-like joy and expectation reign, spirit can embrace nature and nature spirit. The Chelidonia, a synonym for the philosophical gold, corresponds to Paracelsus’s magic herb Cheyri (*Cheiranthus cheiri*). Like this, it has four-petalled yellow flowers. Cheyri, too, was related to the gold, since it was called “aurum potabile.” It therefore comes into the category of the Paracelsan “Aniada,” “perfectors from below

upward”—magical plants which are collected in the spring and grant long life.¹⁰⁸ Dorn himself, in his “Congeries Paracelsicae chemicae de transmutatione metallorum,” commented on Paracelsus’s *De vita longa*, where this information can be found. Celandine was one of the most popular curative and magical herbs in the Middle Ages, chiefly on account of its yellow, milky juice—a remedy for non-lactation. It was also called “enchanter’s nightshade.”¹⁰⁹ Like the Cheyri, it owes its singular significance to the quaternity of its gold-coloured flowers, as Paracelsus points out.¹¹⁰ The analogy with gold always signifies an accentuation of value: the addition of Chelidonia projects the highest value, which is identical with the quaternity of the self, into the mixture. If it “draws out the soul of Mercurius,” this means psychologically that the image of the self (the golden quaternity) draws a quintessence out of the chthonic spirit.

[699] I must agree with Dorn, and no doubt with the reader too, that this statement is “vix intelligibilis.” I can explain this only as a result of the extraordinary intellectual difficulties we get into when we have to wrestle seriously with a mind that could make no proper distinction between psyche and matter. The underlying idea here is that of Mercurius, a dual being who was as much spiritual as material. In my special study of that subject I have pointed out that outwardly Mercurius corresponds to quicksilver but inwardly he is a “deus terrenus” and an *anima mundi*— in other words, that part of God which, when he “imagined” the world, was as it were left behind in his Creation¹¹¹ or, like the Sophia of the Gnostics, got lost in Physis. Mercurius has the character which Dorn ascribes to the soul. He is “good with the good, evil with the evil,” and thus occupies a middle position morally. Just as the soul inclines to earthly bodies, so Mercurius frequently appears as the spirit in matter, in chthonic or even *καταχθόνιος* (underworldly) form, as in our text. He is then the (non-human) spirit who holds the soul captive in Physis, for which reason it must be liberated from him.

[700] In a psychological sense Mercurius represents the unconscious, for this is to all appearances that “spirit” which comes closest to organic matter and has all the paradoxical qualities attributed to Mercurius. In the unconscious are hidden those “sparks of light” (*scintillae*), the archetypes, from which a higher meaning can be “extracted.”¹¹² The “magnet” that attracts the hidden thing is the self, or in this case the “theoria” or the symbol representing it, which the adept uses as an instrument.¹¹³ The *extractio* is depicted figuratively in an illustration in Reusner’s *Pandora*: a crowned figure, with a halo, raising a winged, fish-tailed, snake-armed creature (the spirit), likewise crowned with a halo, out of a lump of earth.¹¹⁴ This monster represents the *spiritus mercurialis*, the soul of the world or of matter freed from its fetters; the *filius macrocosmi*, the child of sun and moon born in the earth, the hermaphroditic homunculus, etc. Basically all these synonyms describe the inner man

as a parallel or complement of Christ. The reader who seeks further information on this figure should refer to *Psychology and Alchemy*¹¹⁵ and *Aion*.¹¹⁶

[701] Let us now turn to another ingredient of the mixture, namely the “rosemary flowers” (*flores rosis marini*). In the old pharmacopeia, rosemary (*Rosmarinus officinalis*) was regarded as an antitoxin, presumably on symbolic grounds which may be connected with its curious name. *Ros marinus* (sea-dew) was for the alchemist a welcome analogy for the *aqua permanens*, which in its turn was Mercurius.¹¹⁷ But what lends rosemary its special significance is its sweet smell and taste. The “sweet odour” of the Holy Ghost occurs not only in Gnosticism but also in ecclesiastical language,¹¹⁸ and of course in alchemy—though here there are more frequent references to the characteristic stench of the underworld, the *odor sepulchrorum*. Rosemary was often used in marriage customs and as a love philtre, and therefore had—for the alchemist—a binding power, which was of course particularly favourable for the purpose of conjunction.¹¹⁹ Thus the Holy Ghost is the “spiration” binding Father and Son, just as, in alchemy, he occasionally appears as the “ligament” of body and soul. These different aspects of rosemary signify so many qualities which are imparted to the mixture.

[702] Mercurialis is a magic herb too, but unlike rosemary it is connected not with love but with sexuality, and is another “binding” power which, as we have mentioned, can even determine the sex of the child. The red lily, as the quintessence of sulphur (n. 85), represents the male partner in the alchemical marriage, the *servus rubeus* who unites with the *foemina candida*. With this figure the adept mixed himself into the potion, so to speak, and, to make the bond inviolable, he added human blood as a further ingredient. Being a “special juice” with which pacts with the devil are signed, it would magically consolidate the bond of marriage.

[703] This peculiar mixture was then to be united with the “heaven of the red or white wine or of Tartarus.” The *caelum* or blue tincture, as we have seen, was concocted from the “phlegm” of the wine or sublimated from the “wine-stone.” Just as the phlegm is the residue, in the bottom of the vessel, of the evaporated wine, so Tartarus, the underworld and realm of the dead, is the sediment or precipitate of a once living world. In Khunrath, *Sal tartari mundi maioris* is identical with *sal Saturni* and *sal Veneris*.¹²⁰ It contains—or is—the “scintilla Animae Mundi.”¹²¹ Tartar is the *sal sapientiae*.¹²² *Sal saturni* refers to Kronos enchained in Tartarus. Plutarch identifies Typhon with Tartarus.¹²³ This is in agreement with the malefic nature of Saturn. *Sal tartari* therefore has a sinister, underworldly nuance reminiscent of death and hell. Saturn (lead) is one of the best known synonyms for the prima materia, and hence is the matrix of the filius Philosophorum. This is the sought-for celestial substance, the *caelum*, etc.

[704] What are we to think of this most peculiar philtre? Did Dorn really mean that these magic herbs should be mixed together and that the air-coloured quintessence should be distilled from the “Tartarus,” or was he using these secret names and procedures to express a moral meaning? My conjecture is that he meant both, for it is clear that the alchemists did in fact operate with such substances and thought-processes, just as, in particular, the Paracelsist physicians used these remedies and reflections in their practical work. But if the adept really concocted such potions in his retort, he must surely have chosen his ingredients on account of their magical significance. He worked, accordingly, with *ideas*, with psychic processes and states, but referred to them under the name of the corresponding substances. With the honey the pleasure of the senses and the joy of life went into the mixture, as well as the secret fear of the “poison,” the deadly danger of worldly entanglements. With the Chelidonia the highest meaning and value, the self as the total personality, the healing and “whole-making” medicine which is recognized even by modern psychotherapy, was combined with spiritual and conjugal love, symbolized by rosemary; and, lest the lower, chthonic element be lacking, Mercurialis added sexuality, together with the red slave moved by passion,¹²⁴ symbolized by the red lily, and the addition of blood threw in the whole soul. All this was united with the azure quintessence, the *anima mundi* extracted from inert matter, or the God-image imprinted on the world—a mandala produced by rotation;¹²⁵ that is to say the whole of the conscious man is surrendered to the self, to the new centre of personality which replaces the former ego. Just as, for the mystic, Christ takes over the leadership of consciousness and puts an end to a merely ego-bound existence, so the *filius macrocosmi*, the son of the great luminaries and of the dark womb of the earth, enters the realm of the psyche and seizes the human personality, not only in the shining heights of consciousness but in the dark depths which have not yet comprehended the light that appeared in Christ. The alchemist was well aware of the great shadow which Christianity obviously had not assimilated, and he therefore felt impelled to create a saviour from the womb of the earth as an analogy and complement of God’s son who came down from above.

[705] The production of the *caelum* is a symbolic rite performed in the laboratory. Its purpose was to create, in the form of a substance, that “truth,” the celestial balsam or life principle, which is identical with the God-image. Psychologically, it was a representation of the individuation process by means of chemical substances and procedures, or what we today call active imagination. This is a method which is used spontaneously by nature herself or can be taught to the patient by the analyst. As a rule it occurs when the analysis has constellated the opposites so powerfully that a union or synthesis of the personality becomes an imperative necessity. Such a situation is bound to arise when the analysis of the psychic contents, of the patient’s

attitude and particularly of his dreams, has brought the compensatory or complementary images from the unconscious so insistently before his mind that the conflict between the conscious and the unconscious personality becomes open and critical. When this confrontation is confined to partial aspects of the unconscious the conflict is limited and the solution simple: the patient, with insight and some resignation or a feeling of resentment, places himself on the side of reason and convention. Though the unconscious motifs are repressed again, as before, the unconscious is satisfied to a certain extent, because the patient must now make a conscious effort to live according to its principles and, in addition, is constantly reminded of the existence of the repressed by annoying resentments. But if his recognition of the shadow is as complete as he can make it, then conflict and disorientation ensue, an equally strong Yes and No which he can no longer keep apart by a rational decision. He cannot transform his clinical neurosis into the less conspicuous neurosis of cynicism; in other words, he can no longer hide the conflict behind a mask. It requires a real solution and necessitates a third thing in which the opposites can unite. Here the logic of the intellect usually fails, for in a logical antithesis there is no third. The “solvent” can only be of an irrational nature. In nature the resolution of opposites is always an energetic process: she acts *symbolically* in the truest sense of the word,¹²⁶ doing something that expresses both sides, just as a waterfall visibly mediates between above and below. The waterfall itself is then the incommensurable third. In an open and unresolved conflict dreams and fantasies occur which, like the waterfall, illustrate the tension and nature of the opposites, and thus prepare the synthesis.

[706] This process can, as I have said, take place spontaneously or be artificially induced. In the latter case you choose a dream, or some other fantasy-image, and concentrate on it by simply catching hold of it and looking at it. You can also use a bad mood as a starting-point, and then try to find out what sort of fantasy-image it will produce, or what image expresses this mood. You then fix this image in the mind by concentrating your attention. Usually it will alter, as the mere fact of contemplating it animates it. The alterations must be carefully noted down all the time, for they reflect the psychic processes in the unconscious background, which appear in the form of images consisting of conscious memory material. In this way conscious and unconscious are united, just as a waterfall connects above and below. A chain of fantasy ideas develops and gradually takes on a dramatic character: the passive process becomes an action. At first it consists of projected figures, and these images are observed like scenes in the theatre. In other words, you dream with open eyes. As a rule there is a marked tendency simply to enjoy this interior entertainment and to leave it at that. Then, of course, there is no real progress but only endless variations on the same theme, which is not the point of the exercise at all. What is

enacted on the stage still remains a background process; it does not move the observer in any way, and the less it moves him the smaller will be the cathartic effect of this private theatre. The piece that is being played does not want merely to be watched impartially, it wants to compel his participation. If the observer understands that his own drama is being performed on this inner stage, he cannot remain indifferent to the plot and its dénouement. He will notice, as the actors appear one by one and the plot thickens, that they all have some purposeful relationship to his conscious situation, that he is being addressed by the unconscious, and that *it* causes these fantasy-images to appear before him. He therefore feels compelled, or is encouraged by his analyst, to take part in the play and, instead of just sitting in a theatre, really have it out with his alter ego. For nothing in us ever remains quite uncontradicted, and consciousness can take up no position which will not call up, somewhere in the dark corners of the psyche, a negation or a compensatory effect, approval or resentment. This process of coming to terms with the Other in us is well worth while, because in this way we get to know aspects of our nature which we would not allow anybody else to show us and which we ourselves would never have admitted.¹²⁷ It is very important to fix this whole procedure in writing at the time of its occurrence, for you then have ocular evidence that will effectively counteract the ever-ready tendency to self-deception. A running commentary is absolutely necessary in dealing with the shadow, because otherwise its actuality cannot be fixed. Only in this painful way is it possible to gain a positive insight into the complex nature of one's own personality.

6. SELF-KNOWLEDGE

[707] Expressed in the language of Hermetic philosophy, the ego-personality's coming to terms with its own background, the shadow, corresponds to the union of spirit and soul in the *unio mentalis*, which is the first stage of the coniunctio. What I call coming to terms with the unconscious the alchemists called "meditation." Ruland says of this: "Meditation: The name of an Internal Talk of one person with another who is invisible, as in the invocation of the Deity, or communion with one's self, or with one's good angel."¹²⁸ This somewhat optimistic definition must immediately be qualified by a reference to the adept's relations with his *spiritus familiaris*, who we can only hope was a good one. In this respect Mercurius is a rather unreliable companion, as the testimony of the alchemists agrees. In order to understand the second stage, the union of the *unio mentalis* with the body, psychologically, we must bear in mind what the psychic state resulting from a fairly complete recognition of the shadow looks like. The shadow, as we know, usually presents a fundamental contrast to the conscious personality. This contrast is the prerequisite for the

difference of potential from which psychic energy arises. Without it, the necessary tension would be lacking. Where considerable psychic energy is at work, we must expect a corresponding tension and inner opposition. The opposites are necessarily of a characterological nature: the existence of a positive virtue implies victory over its opposite, the corresponding vice. Without its counterpart virtue would be pale, ineffective, and unreal. The extreme opposition of the shadow to consciousness is mitigated by complementary and compensatory processes in the unconscious. Their impact on consciousness finally produces the uniting symbols.

[708] Confrontation with the shadow produces at first a dead balance, a standstill that hampers moral decisions and makes convictions ineffective or even impossible. Everything becomes doubtful, which is why the alchemists called this stage *nigredo*, *tenebrositas*, chaos, melancholia. It is right that the magnum opus should begin at this point, for it is indeed a well-nigh unanswerable question how one is to confront reality in this torn and divided state. Here I must remind the reader who is acquainted neither with alchemy nor with the psychology of the unconscious that nowadays one very seldom gets into such a situation. Nobody now has any sympathy with the perplexities of an investigator who busies himself with magical substances, and there are relatively few people who have experienced the effects of an analysis of the unconscious on themselves, and almost nobody hits on the idea of using the objective hints given by dreams as a theme for meditation. If the ancient art of meditation is practised at all today, it is practised only in religious or philosophical circles, where a theme is subjectively chosen by the meditant or prescribed by an instructor, as in the Ignatian *Exercitia* or in certain theosophical exercises that developed under Indian influence. These methods are of value only for increasing concentration and consolidating consciousness, but have no significance as regards effecting a synthesis of the personality. On the contrary, their purpose is to shield consciousness from the unconscious and to suppress it. They are therefore of therapeutic value only in cases where the conscious is liable to be overwhelmed by the unconscious and there is the danger of a psychotic interval.

[709] In general, meditation and contemplation have a bad reputation in the West. They are regarded as a particularly reprehensible form of idleness or as pathological narcissism. No one has time for self-knowledge or believes that it could serve any sensible purpose. Also, one knows in advance that it is not worth the trouble to know oneself, for any fool can know what he is. We believe exclusively in doing and do not ask about the doer, who is judged only by achievements that have collective value. The general public seems to have taken cognizance of the existence of the unconscious psyche more than the so-called experts, but still nobody has drawn any conclusions from the fact that Western man confronts himself as a stranger and that self-knowledge is one of the most difficult and exacting of the arts.

[710] When meditation is concerned with the objective products of the unconscious that reach consciousness spontaneously, it unites the conscious with contents that proceed not from a conscious causal chain but from an essentially unconscious process. We cannot know what the unconscious psyche is, otherwise it would be conscious. We can only conjecture its existence, though there are good enough grounds for this. Part of the unconscious contents is projected, but the projection as such is not recognized. Meditation or critical introspection and objective investigation of the object are needed in order to establish the existence of projections. If the individual is to take stock of himself it is essential that his projections should be recognized, because they falsify the nature of the object and besides this contain items which belong to his own personality and should be integrated with it. This is one of the most important phases in the wearisome process of self-knowledge. And since projections involve one in an inadmissible way in externalities, Dorn rightly recommends an almost ascetic attitude to the world, so that the soul may be freed from its involvement in the world of the body. Here only the “spirit” can help it, that is, the drive for knowledge of the self, on a plane beyond all the illusion and bemusement caused by projection.

[711] The *unio mentalis*, then, in psychological as well as in alchemical language, means knowledge of oneself. In contradistinction to the modern prejudice that self-knowledge is nothing but a knowledge of the ego, the alchemists regarded the self as a substance incommensurable with the ego, hidden in the body, and identical with the image of God.¹²⁹ This view fully accords with the Indian idea of *purusha-atman*.¹³⁰ The psychic preparation of the magisterium as described by Dorn is therefore an attempt, uninfluenced by the East, to bring about a union of opposites in accordance with the great Eastern philosophies, and to establish for this purpose a principle freed from the opposites and similar to the *atman* or *tao*. Dorn called this the *substantia coelestis*, which today we would describe as a transcendental principle. This “unum” is *nirvandva* (free from the opposites), like the *atman* (self).

[712] Dorn did not invent this idea but merely gave clearer expression to what had long been secret knowledge in alchemy. Thus we read in the “Liber octo capitulorum de lapide philosophorum” of Albertus Magnus,¹³¹ with reference to quicksilver (*Mercurius non vulgi*, the philosophical mercury):

Quicksilver is cold and moist, and God created all minerals with it, and it itself is aerial, and volatile in the fire. But since it withstands the fire for some time, it will do great and wonderful works, and it alone is a living spirit, and in all the world there is nothing like it that can do such things as it can . . . It is the perennial water, the water of life, the virgin’s milk, the fount, the alumen,¹³² and [whoever] drinks of it shall not perish. When it is alive it does certain works, and when it is dead it does other and

the greatest works. It is the serpent that rejoices in itself, impregnates itself, and gives birth in a single day, and slays all metals with its venom. It flees from the fire, but the sages by their art have caused it to withstand the fire, by nourishing it with its own earth until it endured the fire, and then it performs works and transmutations. As it is transmuted, so it transmutes. . . . It is found in all minerals and has a “symbolum”¹³³ with them all. But it arises midway between the earthly and the watery, or midway between [*mediocriter*]¹³⁴ a subtle living oil and a very subtle spirit. From the watery part of the earth it has its weight and motion from above downwards, its brightness, fluidity, and silver hue. . . . But quicksilver is clearly seen to have a gross substance, like the Monocalus,¹³⁵ which excels even gold in the heaviness of its immense weight.¹³⁶ When it is in its nature¹³⁷ it is of the strongest composition [*fortissimae compositionis*]¹³⁸ and of uniform nature, since it is not divided [or: is indivisible]. It can in no way be separated into parts, because it either escapes from the fire with its whole substance or endures with it in the fire. For this reason the cause of perfection is necessarily seen in it.

[713] Since Mercurius is the soul of the gold and of the silver, the conjunction of these two must be accomplished:

Our final secret consists in this, that one obtains the medicine which flows, before Mercurius evaporates. . . . There is no worthier or purer substance than the sun and its shadow the moon, without which no tincturing quicksilver can be produced. . . . He who understands, therefore, how to unite this with the sun or moon will obtain the arcanum, which is named the sulphur of the art.

[714] Mercurius is the prima materia. This must be dissolved at the beginning of the work, and the dissolved bodies then transformed into “spirits.” The transformation is effected by putrefaction, which is synonymous with the *nigredo*, the grave, and death. The spirits are joined together as *sponsus* and *sponsa*.

Our stone is of watery nature, because it is cold and moist. For such a disposition of the body is considered obvious or manifest. But breadth is the middle [*media*] disposition whereby depth is attained. This is the medium between depth and breadth, as between two extremes or opposites, and the passage from one opposite to the other or from one extreme to the other is impossible save by a medium disposition. [This is possible] because the stone is by nature cold and moist.

Mercurius is not only the lapis as *prima* materia but the lapis as *ultima* materia, the goal of the opus. Hence Albertus cites Geber: “One is the stone, one the medicine, and therein lies the whole magistry.”

[715] In these words Albertus Magnus, more than three hundred years earlier than Dorn, describes the celestial substance, the balsam of life, and the hidden truth. His description has roots that go still further back into Greek alchemy, but I cannot

discuss this here. His account is sufficient for our purpose: it describes a transcendental substance characterized, as is only to be expected, by a large number of antinomies. Unequivocal statements can be made only in regard to immanent objects; transcendental ones can be expressed only by paradox. Thus, they are and they are not (that is to say, not to be found in our experience). Even the physicist is compelled by experience to make antinomian statements when he wants to give a concrete description of transcendental facts, such as the nature of light or of the smallest particles of matter, which he represents both as corpuscles and as waves. In the same way, the quicksilver is a material substance and at the same time a living spirit whose nature can be expressed by all manner of symbolic synonyms—though only, it is true, when it is made fire-resistant by artificial means. The quicksilver is a substance and yet not a substance, since, as a natural element, it does not resist fire and can do this only through the secret of art, thereby turning into a magical substance so wonderful that there is no prospect of our ever coming across it in reality. This clearly means that quicksilver is the symbol for a transcendental idea which is alleged to become manifest in it when the art has made it capable of resisting fire. It is also assumed that this occult quality is at least potentially present in Mercurius, since he is the prima materia of all metals and is found in all minerals. He is not only the initial material of the process but also its end-product, the lapis Philosophorum. Thus he is at the outset a significant exception among the metals and chemical elements. He is the primordial matter from which God created all material things. The change which the artifex proposes to induce in it consists, among other things, in giving it “immense weight” and indivisible wholeness. This strange statement assumes another aspect when we compare it with the modern view that matter consists of extraordinarily, indeed “immensely” heavy elementary corpuscles which in a certain sense are of “uniform nature” and apparently indivisible. They are the bricks nature builds with and they therefore contain everything that nature contains, so that each of them represents the whole of the universe. From this point of view it almost seems as if Albertus Magnus had anticipated one of the greatest physical discoveries of our time. This, of course, would be to recognize only the physical truth of his intuition, but not the symbolic implications which were bound up with it in the medieval mind.

[716] If we have hazarded a parallel between Albertus’s views and the discontinuity of protons and energy quanta, we are obliged to attempt another parallel in regard to the symbolical statements. These, as we have seen from Dorn (*supra*, sec. 3), refer to the psychological aspect of Mercurius. In order to avoid needless repetition, I must here refer the reader to my earlier investigations of Mercurius and the symbols of the self in alchemy. Anyone who knows the extraordinary importance of the concept of psychic wholeness in the practical as well as theoretical psychology of the

unconscious will not be surprised to learn that Hermetic philosophy gave this idea, in the form of the lapis Philosophorum, pre-eminence over all other concepts and symbols. Dorn in particular made this abundantly and unequivocally clear, in which respect he has the authority of the oldest sources. It is not true that alchemy devised such an interpretation of the arcanum only at the end of the sixteenth century; on the contrary, the idea of the self affords the clue to the central symbols of the art in all centuries, in Europe, the Near East, and in China. Here again I must refer the reader to my previous works.¹³⁹ Unfortunately it is not possible to exhaust the wealth of alchemical ideas in a single volume.

[717] By introducing the modern concept of the self we can explain the paradoxes of Albertus without too much difficulty. Mercurius is matter and spirit; the self, as its symbolism proves, embraces the bodily sphere as well as the psychic. This fact is expressed particularly clearly in mandalas.¹⁴⁰ Mercurius is also the “water,” which, as the text emphasizes, occupies a middle position between the volatile (air, fire) and the solid (earth), since it occurs in both liquid and gaseous form, and also as a solid in the form of ice. Mercurius shares his “*aquaeositas*” with water, since on the one hand he is a metal and amalgamates himself in solid form with other metals, and on the other hand is liquid and evaporable. The deeper reason why he is so frequently compared with water is that he unites in himself all those numinous qualities which water possesses. Thus, as the central arcanum, the ἰδωρ θεῖον or *aqua permanens* dominated alchemy from those remote times when it was still the holy and blessed water of the Nile until well into the eighteenth century. In the course of time, mainly under Gnostic-Hermetic influence, it took on the significance of the *Nous*, with which the divine *krater* was filled so that those mortals who wished to attain consciousness could renew themselves in this baptismal bath; later it signified the *aqua doctrinae* and a wonder-working magical water. Its very ancient identification with *hydrargyrum*, quicksilver, drew the whole Hermes Trismegistus tradition into the immemorally numinous sphere of the water’s significance. This could happen all the more easily since its maternal aspect as the matrix and “nurse of all things” makes it an unsurpassable analogy of the unconscious. In this way the idea of the “water” could gradually develop into the tremendous paradox of Mercurius, who, as the “age-old son of the mother,” is the Hermetic spirit, and, as a chemical substance, a magically prepared quicksilver.

[718] The “serpent rejoicing in itself” (*luxurians in se ipso*) is the Democritean physis (*natura*) “which embraces itself”¹⁴¹ and is symbolized by the uroboros of Greek alchemy, a well-known emblem of Mercurius. It is the symbol of the union of opposites *par excellence* and an alchemical version of the proverb: *les extrêmes se touchent*. The uroboros symbolizes the goal of the process but not the beginning, the *massa confusa* or chaos, for this is characterized not by the union of the elements but

by their conflict. The expression “giving birth in a single day” (*in uno die parturiens*) likewise refers to Mercurius, since he (in the form of the lapis) was named the “son of one day.”¹⁴² This name refers to the creation of light in Genesis 1 : 5: “And there was evening and morning, one day.” As the “son of one day,” therefore, Mercurius is light. Hence he is praised as the *lux moderna* and a light above all lights.¹⁴³ He is thus Sunday’s child (born on the day of the sun), just as the planet Mercury is the nearest to the sun and was accounted its child. St. Bonaventure (1221–74) also speaks of the one day in his *Itinerarium*, where he discusses the three stages of illumination (*triplex illustratio*). The first stage consists in giving up the bodily and the temporal in order to attain the “first principle,” which is spiritual and eternal and “above us”:

We must enter into our mind [*mentem*], which is the eternal spiritual image of God within us, and this is to enter into the truth of the Lord; we must pass beyond ourselves to the eternal and preeminently spiritual, and to that which is above us . . . this is the threefold illumination of the one day.¹⁴⁴

The “one day” is the day on which light appeared over the darkness. I cite this passage not only for that reason but as a parallel to the three stages of conjunction in Dorn, which obviously originated in the exercises for spiritual contemplation in the early Middle Ages. The parallel is clearly discernible: first the turning away from the world of sense, then the turning towards the inner world of the mind and the hidden celestial substance, the image and truth of God, and finally the contemplation of the transcendental *unus mundus*, the potential world outside time, of which we shall have more to say below. But first we examine more closely Albertus’s statements on the nature of the quicksilver.

[719] The middle position ascribed to Mercurius provokes Albertus to a remarkable reflection: it seems to him that the concept of breadth (*latitudo*) expresses the “middle disposition” whereby depth can be attained. This disposition is the “medium between depth and breadth” (*media est inter profunditatem et latitudinem*), as between two extremes or opposites (*contraria*). The idea at the back of his mind is obviously that of a cross, for height is the complement of depth.¹⁴⁵ This would indicate the quaternity, a symbol of Mercurius quadratus, who, in the form of the lapis, consists of the four elements.¹⁴⁶ He thus forms the mid-point of the cosmic quaternity and represents the quinta essentia, the oneness and essence of the physical world, i.e., the anima mundi. As I have shown elsewhere, this symbol corresponds to the modern representations of the self.

7. THE MONOCOLUS

[720] Evidently in order to emphasize the unity of Mercurius, Albertus makes use of the expression “monocolus” (as is probably the right reading), or “uniped.” It seems to me that this must be an alchemical ἀπαξ λεγόμενον,¹⁴⁷ for I have found it nowhere else in the literature. The alchemist’s use of a rare or strange word generally served to emphasize the extraordinary nature of the object expressed by it. (As we know, with this trick one can also make banalities appear unusual.) Even though the word “monocolus” appears to be unique, the image is not, for the uniped occurs in several illustrated alchemical manuscripts, for instance in the aforementioned Paris codex (Fr. 14765) entitled “Abraham le Juif.”¹⁴⁸ As the title shows, this presumably purported to be, or was intended to replace, the zealously sought “Rindenbuch” of the same author, of which Nicholas Flamel gives an account in his autobiography and whose loss the alchemists so deeply deplored. Though this mythical work was never found, it was reinvented in Germany;¹⁴⁹ but this forgery has nothing to do with our manuscript. On page 324 of the manuscript we find the first in a series of pictures of unipeds (cf. Pl. 4). On the left there is a crowned man in a yellow robe, and on the right a priest in a white robe with a mitre. Each of them has only one foot. The inscription under the picture begins with the sign for Mercurius (☿) and runs: “There they make but one.” This refers to the preceding text, “For there is but one single thing, one medicine, and in it all our magistry consists; there are but two coadjutors who are made perfect here.”¹⁵⁰ The subject is obviously Mercurius duplex. In my chapter on Sulphur I have pointed out that it, especially in its red form, is identical with gold, the latter being generally regarded as “rex.” The red sceptre of the king might be an allusion to this. There is, as I have shown, a red and a white sulphur, so it too is duplex and identical with Mercurius. Red sulphur stands for the masculine, active principle of the sun, the white for that of the moon. As sulphur is generally masculine by nature and forms the counterpart of the feminine salt, the two figures probably signify the spirits of the arcane substance, which is often called rex, as in Bernardus Trevisanus.

[721] This curious separation or union of the figures occurs several times in the manuscript. In the next picture (Pl. 5), on page 331, the king on the left has a blue robe and a black foot, and the one on the right a black robe and a blue foot. Both the sceptres are red. The inscription runs: “Thus is it done, that what was hid may be revealed.”¹⁵¹ This refers, as the preceding text makes clear, to the *nigredo* which is about to ensue. The *nigredo* signifies the *mortificatio*, *putrefactio*, *solutio*, *separatio*, *divisio*, etc., a state of dissolution and decomposition that precedes the synthesis. This picture is followed by one showing the two figures separated, each with two feet. The figure on the left wears the spiritual crown and the one on the right the temporal, corresponding to the occult-spiritual and earthly-corporeal nature of sulphur. The figure on the left wears a robe whose right half is blue and the left black, the one on

the right the reverse. They thus complement one another. The text explains: “The colours of the 9th year and ½ this month of January 1772 are represented by these two figures. Likewise by the mortification of our natural ☿ and of the dead water reduced to another form.” The inscription under the picture runs: “A very long time, and by putrefaction, calcination, incineration, fixation, and coagulation the materials become solid, but this comes to pass naturally after a very long time.”

[722] This probably refers to the completion of the *nigredo* after a period of pregnancy, i.e., to the complete separation of Mercurius or the two sulphurs, or of their bodily and spiritual natures, corresponding to Dorn’s extraction of the soul from the body and the production of the *unio mentalis*. According to the picture, the one figure, as regards its colours, is the mirror-image of the other. This indicates a relationship of complementarity between *physis* and spirit, so that the one reflects the other.¹⁵² That, too, is probably the meaning of the “manifestation of the hidden”: through the *unio mentalis* that which is hidden in *physis* by projection is made conscious. In the *nigredo*, the “dark night of the soul,” the psychic contents free themselves from their attachment to the body, and the nature and meaning of this connection are recognized.

[723] In the next picture (p. 335) the two figures are united again (Pl. 6). Their colours and other attributes are the same. Each figure has only one blue foot. The inscription runs: “Wherefore saith the Philosopher: He obtaineth the Art who can manifest that which is hidden, and conceal that which is manifest.” And underneath: “Hic artem digne est consecutus” (Here is the art worthily followed, or: This man worthily followed the art), and: “The blue colour after the yellow which will lead to the complete blackness or putrefaction after a very long time.”

[724] On page 337 the (spiritual) king from the previous picture is joined to a similarly crowned queen (Pl. 7). He wears a black upper garment and a blue under garment. His crown has a black rim, but the mitre-like part is gold, as in the previous picture. He has one blue foot tipped with black, as if he had dipped it in black paint. The green-clad queen has her hand in his left sleeve, presumably indicating that she takes the place of the left—worldly or bodily—half of the king and appears as his “better half,” so to speak. Her feet are black. The text runs: “There comes about an inconstant fixation, then after a little the soft hardens. The watery becomes earthy and dry; thus a change of nature is made from one to the other; and a single colour in the form of a black Raven, and the ♁ [sulphur] of the male ☿ and of the female, have become of the same nature.” The inscription says: “Take therefore in God’s almighty name this black earth, reduce it very subtly and it will become like the head of a Raven.” As if explaining the *caput corvi* the text remarks that the “Silène endormy” is bound by the shepherds with garlands of flowers in all colours of the rainbow and,

after quaffing his wine, says: “I laugh at my bond. So say the philosophers that when the blackness appears one must rejoice.”¹⁵³ The text adds that Troy was reduced to ashes after ten years of siege.

[725] This picture represents the union of the monocolus with the earth (the body). As the sulphur of the male Mercurius he is a very active power,¹⁵⁴ for he is the red sulphur of the gold or the active principle of the sun. The king in the saffron-yellow robe was originally gold and the sun but has now become totally black—the *sol ni’ger*—and even his blue robe, signifying heaven, is covered with a black one.¹⁵⁵ Only the top of his crown displays the solar gold. Dame Earth wears the same crown (only it is all gold) and thus reveals that her nature is equivalent to his: both are sulphur. One could call the sulphur of the king the “spirit,” which, hiding its light in the darkness, unites with the queen.

[726] This earth is of a watery nature, corresponding to Genesis 1 : 2 and 6: “And the earth was without form, and void. . . . And the Spirit of God moved upon the face of the waters. . . . And God said, Let there be a firmament in the midst of the waters . . .” In this way heaven can embrace the sea instead of the earth. We may recall the myth of Isis and Osiris: Isis copulated with the spirit of the dead Osiris, and from this union sprang the god of the mysteries, Harpocrates. Osiris plays a certain role in the ancient alchemical texts: the brother/sister or mother/son pair are sometimes called Isis and Osiris.¹⁵⁶ In Olympiodorus¹⁵⁷ Osiris is lead, as arcane substance, and the principle of moisture;¹⁵⁸ in Firmicus Maternus he is the life-principle.¹⁵⁹ The alchemical interpretation of him as Mercurius has its parallel in the Naassene comparison of Osiris to Hermes.¹⁶⁰ Like the latter, he was represented ithyphallically, and this is significant in regard to the monocolus.¹⁶¹ He is the dying and resurgent God-man and hence a parallel to Christ. He is of a blackish colour (*μελάγχρους*)¹⁶² and was therefore called Aithiops,¹⁶³ in Christian usage the devil,¹⁶⁴ and in alchemical language the *prima materia*.¹⁶⁵ This antithesis is characteristic of Mercurius duplex. Wine as the blood of Osiris occurs in the ancient magical texts.¹⁶⁶ In the Egyptian texts Osiris had a sun-and-moon nature, and was therefore hermaphroditic like Mercurius.¹⁶⁷

[727] *Corvus* (crow or raven) or *caput corvi* (raven’s head) is the traditional name for the *nigredo* (*nox*, melancholia, etc.). It can also, as *pars pro toto*, mean a “capital” thing or “principle,” as for instance the *caput mortuum*, which originally meant the head of the black Osiris,¹⁶⁸ but later *Mercurius philosophorum*, who, like him, undergoes death and resurrection and transformation into an incorruptible state. Thus the anonymous author of the “*Novum lumen chemicum*” exclaims: “O our heaven! O our water and our Mercurius! O dead head or dregs of our sea! . . . And these are the epithets of the bird of Hermes,¹⁶⁹ which never rests.”¹⁷⁰ This bird of Hermes is the

raven, of which it is said: “And know that the head of the art is the raven, who flies without wings in the blackness of the night and the brightness of the day.”¹⁷¹ He is a restless, unsleeping spirit, “our aerial and volatile stone,” a being of contradictory nature.¹⁷² He is the “heaven” and at the same time the “scum of the sea.” Since he is also called “water,” one thinks of rain-water, which comes from the sea and falls from heaven. As a matter of fact the idea of clouds, rain, and dew is often found in the texts and is extremely ancient.¹⁷³ A papyrus text says: “I am the mother of the gods, named heaven; I am Osiris, named water; I am Isis, named dew; . . . I am Eidolos, likened to the true spirits.” Thus speaks a magician who wishes to conjure up his familiar: he himself is a spirit and thus akin to the bird of the night. In Christian tradition the raven is an allegory of the devil.¹⁷⁴

[728] Here we encounter the primitive archetypal form of spirit, which, as I have shown,¹⁷⁵ is ambivalent. This ambivalence or antagonism also appears in the ancient Egyptian pair of brothers, Osiris and Set, and in the Ebionite opposition of Christ and Satan. The night raven (*nycticorax*) is an allegory of Christ.¹⁷⁶

[729] Nowadays the *caput mortuum*, or colcothar, denotes “the brownish-red peroxide of iron which remains in the retort after the distillation of sulphuric acid from iron sulphate,”¹⁷⁷ whereas the *caput Osiridis* was black and was therefore called *caput corvi*. The “Aquarium sapientum” compares it with Christ, whose “visage was so marred more than any man” (Isaiah 52 : 14).¹⁷⁸ The blackening usually took forty days, corresponding to the forty days between Easter and Ascension, or Christ’s forty days’ fast in the wilderness, or the forty-year wanderings of the Jews in the desert.¹⁷⁹ In the heat of the *nigredo* the “*anima media natura* holds dominion.” The old philosophers called this blackness the Raven’s Head or black sun.¹⁸⁰ The *anima media natura* corresponds to the Platonic world-soul and the Wisdom of the Old Testament.¹⁸¹ In this state the sun is surrounded by the *anima media natura* and is therefore black. It is a state of incubation or pregnancy. Great importance was attached to the blackness as the starting point of the work.¹⁸² Generally it was called the “Raven.”¹⁸³ In our context the interpretation of the *nigredo* as *terra* (earth)¹⁸⁴ is significant. Like the *anima media natura* or Wisdom, earth is in principle feminine. It is the earth which, in Genesis, appeared out of the waters,¹⁸⁵ but it is also the “*terra damnata*.”¹⁸⁶

[730] The *caput mortuum* or *caput corvi* is the head of the black Osiris or Ethiopian, and also of the “Moor” in the *Chymical Wedding*.¹⁸⁷ The head was boiled in a pot and the broth poured into a golden ball. This gives us the connection with the “golden head” of the Greek alchemy, discussed earlier. The Moor in the *Chymical Wedding* is probably identical with the black executioner mentioned there, who decapitates the royal personages. In the end his own head is struck off.¹⁸⁸ In the further course of

events a black bird is beheaded.¹⁸⁹ Beheading is significant symbolically as the separation of the “understanding” from the “great suffering and grief” which nature inflicts on the soul. It is an emancipation of the “cogitatio” which is situated in the head, a freeing of the soul from the “trammels of nature.”¹⁹⁰ Its purpose is to bring about, as in Dorn, a *unio mentalis* “in the overcoming of the body.”

[731] The Moor or Ethiopian is the black, sinful man, whom St. Hilary (d. 367) compared to the raven. (“The raven made in the form of the sinner.”¹⁹¹) In the *Chymical Wedding* there is a black king, and in Schema XXIV Mylius represents the relation of king and queen under the symbol of two ravens fighting.¹⁹² Just as the raven symbolizes man’s black soul, so the *caput corvi* represents the head or skull (*testa capitis*), which in Sabaeen alchemy served as the vessel of transformation.¹⁹³ The Sabaeans were suspected of magical practices that presupposed the killing of a man. The “brain-pan or head of the element Man” therefore has a somewhat sinister aspect: they needed a human skull because it contained the brain and this was the seat of the understanding. “And the understanding exists in that organ, because it rules the soul and assists her liberation.”¹⁹⁴ “The corpus rotundum built the skull about itself as a stronghold, girt itself with this armour, and opened windows in it,” i.e., the five senses. But the corpus rotundum, “the living being, the form of forms and the genus of genera, is man.”¹⁹⁵ The “rotundum”¹⁹⁶ obviously refers not to the empirical but to the “round” or whole man, the *τέλειος ἄνθρωπος*. “Afterwards he drew the soul to the higher world, that he might give her freedom. The higher world has always an effect in man, which consists in the perfect inspiration of man at his death; nor shall he fail to reach the firmament, until that which proceeded from the higher world returns to its place.”¹⁹⁷ The higher world is the “world of worlds,” obviously the *mundus potentialis* of Dorn, who was inspired by this text as his use of the ideas of the stronghold (*castrum sapientiae*)¹⁹⁸ and of the “window” (*spiraculum vitae aeternae*) shows.

[732] The round vessel or stronghold is the skull. “The divine organ,” says the “Liber quartorum,” “is the head, for it is the abode of the divine part, namely the soul.” That is why the philosopher must “surround this organ with greater care than other organs.” Because of its roundness, “it attracts the firmament and is by it attracted; and it is attracted in similar manner by the attracter, until the attraction reaches its end in the understanding. Man is worthier than the beasts and closer to the simple, and this on account of his understanding.” The simple (*simplex* or *res simplex*) is the One,¹⁹⁹ the *natura caelestis* of Dorn, the round and perfect, the firmament or heaven in man.²⁰⁰ “Plato is of the opinion that the man whose righteousness is the greatest attains to the bountiful [*largam*] upper substance when he is assimilated by his work to the highest place.”²⁰¹ This shows us how the production of the *caelum* attracts the starry firmament and the influences (or spirits) of the planets into the Microcosm, just

as by the same operation man is likened to the “upper substance,” the *anima mundi* or *res simplex* or the “One.”

[733] In the *nigredo* the brain turns black. Thus a Hermes recipe cited in the *Rosarium* says: “Take the brain . . . grind it up with very strong vinegar, or with boys’ urine,²⁰² until it turns black.”²⁰³ The darkening or benightedness is at the same time a psychic state which, as we have seen, was called melancholia. In the “Aurelia occulta” there is a passage where the transformative substance in the *nigredo* state says of itself (cf. Pl. 10):

I am an infirm and weak old man, surnamed the dragon; therefore am I shut up in a cave, that I may be ransomed by the kingly crown. . . . A fiery sword inflicts great torments upon me; death makes weak my flesh and bones. . . . My soul and my spirit depart; a terrible poison, I am likened to the black raven, for that is the wages of sin; in dust and earth I lie, that out of Three may come One. O soul and spirit, leave me not, that I may see again the light of day, and the hero of peace whom the whole world shall behold may arise from me.²⁰⁴

* * *

[734] What our Abraham le Juif text says about the royal persons sounds like a mythologem: the sun, the king of the blue sky, descends to earth and it becomes night; he then unites with his wife, the earth or sea. The primordial image of Uranos and Gaia may well be the background of this picture. Similarly, in connection with the raven²⁰⁵ as the name for this situation, we must consider the creative night mentioned in an Orphic hymn, which calls it a bird with black wings that was fertilized by the wind (*pneuma*). The product of this union was the silver egg, which in the Orphic view contained heaven above and earth below, and was therefore a cosmos in itself, i.e., the Microcosm. In alchemy it is the philosophical egg. The French alchemists of the eighteenth century were familiar with the king, the hot, red sulphur of the gold, and called it Osiris; the moist (*aquosum*) they called Isis. Osiris was “the fire hidden in nature, the igneous principle . . . which animates all things”;²⁰⁶ Isis was “the passive and material principle of all things.” The dismemberment of Osiris corresponded to the *solutio*, *putretractio*, etc. Of this Dom Pernety,²⁰⁷ the source for these statements, says: “The solution of the body is the coagulation of the spirit.” The blackness pertains to Isis. (Apuleius says she was clad in a “shining robe of the deepest black.”) If heaven or the sun incline to her they are covered in her blackness.

[735] The relation of alchemical fantasies to the primordial images of Greek mythology is too well known for me to document it. The cosmogonic brother-sister incest,²⁰⁸ like the Creation itself, had been from ancient times the prototype of the alchemists’ great work. Yet we seek the Graeco-Roman tradition in vain for traces of the wonder-

working monocolus. We find him, perhaps, in Vedic mythology, and in a form that is highly significant for our context, namely, as an attribute of the sun-god Rohita²⁰⁹ (red sun), who was called the “one-footed goat”²¹⁰ (*agá ékapada*). In Hymn XIII, i of the *Atharva-veda* he is praised together with his wife Rohini. Of her it says: “Rise up, O steed, that art within the waters,” and “The steed that is within the waters is risen up.”²¹¹ The hymn begins with this invocation to Rohini, who is thereby united with Rohita after he has climbed to his highest place in heaven. The parallel with our French text is so striking that one would have to infer its literary dependence if there were any way of proving that the author was acquainted with the *Atharva-veda*. This proof is next to impossible, as Indian literature was not known in the West at all until the turn of the eighteenth century, and then only in the form of the *Oupnek’hat* of Anquetil du Perron,²¹² a collection of Upanishads in Persian which he translated into Latin.²¹³ The *Atharva-veda* was translated only in the second half of the nineteenth century.²¹⁴ If we wish to explain the parallel at all we have to infer an archetypal connection.

[736] From all this it appears that our picture represents the union of the spirit with material reality. It is not the common gold that enters into combination but the spirit of the gold, only the right half of the king, so to speak. The queen is a sulphur, like him an extract or spirit of earth or water, and therefore a chthonic spirit. The “male” spirit corresponds to Dorn’s *substantia coelestis*, that is, to knowledge of the inner light—the self or imago Dei which is here united with its chthonic counterpart, the feminine spirit of the unconscious. Empirically this is personified in the psychological anima figure, who is not to be confused with the “anima” of our mediaeval philosophers, which was merely a philosophical *anima vegetativa*, the “ligament” of body and spirit. It is, rather, the alchemical queen who corresponds to the psychological anima.²¹⁵ Accordingly, the coniunctio appears here as the union of a consciousness (spirit), differentiated by self-knowledge, with a spirit abstracted from previously unconscious contents. One could also regard the latter as a quintessence of fantasy-images that enter consciousness either spontaneously or through active imagination and, in their totality, represent a moral or intellectual viewpoint contrasting with, or compensating, that of consciousness. To begin with, however, these images are anything but “moral” or “intellectual”; they are more or less concrete visualizations that first have to be interpreted. The alchemist used them more as technical terms for expressing the mysterious properties which he attributed to his chemical substances. The psychologist, on the contrary, regards them not as allegories but as genuine symbols pointing to psychic contents that are not known but are merely suspected in the background, to the impulses and “idées forces” of the unconscious. He starts from the fact that connections which are not based on sense-experience derive from fantasy creations which in turn have psychic causes. These

causes cannot be perceived directly but are discovered only by deduction. In this work the psychologist has the support of modern fantasy material. It is produced in abundance in psychoses, dreams, and in active imagination during treatment, and it makes accurate investigation possible because the author of the fantasies can always be questioned. In this way the psychic causes can be established. The images often show such a striking resemblance to mythological motifs that one cannot help regarding the causes of the individual fantasies as identical with those that determined the collective and mythological images. In other words, there is no ground for the assumption that human beings in other epochs produced fantasies for quite different reasons, or that their fantasy images sprang from quite different *idées forces*, from ours. It can be ascertained with reasonable certainty from the literary records of the past that at least the universal human facts were felt and thought about in very much the same way at all times. Were this not so, all intelligent historiography and all understanding of historical texts would be impossible. Naturally there are differences, which make caution necessary in all cases, but these differences are mostly on the surface only and lose their significance the more deeply one penetrates into the meaning of the fundamental motifs.

[737] Thus, the language of the alchemists is at first sight very different from our psychological terminology and way of thinking. But if we treat their symbols in the same way as we treat modern fantasies, they yield a meaning such as we have already deduced from the problematical modern material. The obvious objection that the meaning conveyed by the modern fantasy-material has been uncritically transferred to the historical material, which the alchemists interpreted quite differently, is disproved by the fact that even in the Middle Ages confessed alchemists interpreted their symbols in a moral and philosophical sense. Their “philosophy” was, indeed, nothing but projected psychology. For as we have said, their ignorance of the real nature of chemical matter favoured the tendency to projection. Never do human beings speculate more, or have more opinions, than about things which they do not understand.

8. THE CONTENT AND MEANING OF THE FIRST TWO STAGES

[738] I would like to impress on the reader that the following discussion, far from being a digression, is needed in order to bring a little clarity into what seems a very confused situation. This situation arose because, for the purpose of amplification, we commented on three symbolic texts ranging over a period of more than five hundred years, namely those of Albertus Magnus, Gerard Dorn, and an anonymous author of the eighteenth century. These three authors were concerned, each in his own way, with the central events and figures of the magistry. One could, of course, adduce yet

other descriptions of the mysterious process of conjunction, but that would only make the confusion worse. For the purpose of disentangling the fine-spun web of alchemical fantasy these three texts are sufficient.

[739] If Dorn, then, speaks of freeing the soul from the fetters of the body, he is expressing in rather different language what Albertus Magnus describes as the preparation or transformation of the quicksilver, or what our unknown author depicts as the splitting of the king in the yellow robe. The arcane substance is meant in all three cases. Hence we immediately find ourselves in darkness, in the *nigredo*, for the *arcanum*, the mystery, is dark. If, following Dorn's illuminating hints, we interpret the freeing of the soul from the fetters of the body as a withdrawal of the naive projections by which we have moulded both the reality around us and the image of our own character, we arrive on the one hand at a *cognitio sui ipsius*, self-knowledge, but on the other hand at a realistic and more or less non-illusory view of the outside world. This stripping off of the veils of illusion is felt as distressing and even painful. In practical treatment this phase demands much patience and tact, for the unmasking of reality is as a rule not only difficult but very often dangerous. The illusions would not be so common if they did not serve some purpose and occasionally cover up a painful spot with a wholesome darkness which one hopes will never be illuminated. Self-knowledge is not an isolated process; it is possible only if the reality of the world around us is recognized at the same time. Nobody can know himself and differentiate himself from his neighbour if he has a distorted picture of him, just as no one can understand his neighbour if he had no relationship to himself. The one conditions the other and the two processes go hand in hand.

[740] I cannot describe the process of self-knowledge here in all its details. But if the reader wishes to form some idea of it, I would draw his attention to the wide variety of infantile assumptions and attachments which play a great role not only in psychopathology but in so-called normal life, and which cause endless complications in every sphere of human existence. Freud's lasting achievement in this field suffers only from the defect that, from the insights gained, a theory was prematurely abstracted which was then used as a criterion of self-knowledge: projections were recognized and corrected only so far as they were assumed to correspond to known infantile fantasies. That there are many other kinds of illusion is mentioned hardly at all in the literature, and for just that reason. As we have seen from Dorn, there are very many important things which are posited as self-evident and which do not exist, such as the alchemist's assumption that certain substances have magical qualities which in fact are projections of fantasy. The progressive correction of these brings us, however, to a frontier which at first cannot be crossed. As a rule it is set up by the spirit of the age with its specific conception of truth, and by the state of scientific knowledge prevailing at the time.

[741] Self-knowledge is an adventure that carries us unexpectedly far and deep. Even a moderately comprehensive knowledge of the shadow can cause a good deal of confusion and mental darkness, since it gives rise to personality problems which one had never remotely imagined before. For this reason alone we can into its former bondage and everything would have been as before. The volatile essence so carefully shut up and preserved in the Hermetic vessel of the *unio mentalis* could not be left to itself for a moment, because this elusive Mercurius would then escape and return to its former nature, as, according to the testimony of the alchemists, not infrequently happened. The direct and natural way would have been to give the soul its head, since we are told that it always inclines to the body. Being more attached to this than to the spirit, it would separate itself from the latter and slip back into its former unconsciousness without taking with it anything of the light of the spirit into the darkness of the body. For this reason the reunion with the body was something of a problem. Psychologically, it would mean that the insight gained by the withdrawal of projections could not stand the clash with reality and, consequently, that its truth could not be realized in fact, at least not to the desired degree or in the desired way. You can, as you know, forcibly apply the ideals you regard as right with an effort of will, and can do so for a certain length of time and up to a certain point, that is, until signs of fatigue appear and the original enthusiasm wanes. Then free will becomes a cramp of the will, and the life that has been suppressed forces its way into the open through all the cracks. That, unfortunately, is the lot of all merely rational resolutions.

[742] Since earliest times, therefore, men have had recourse in such situations to artificial aids, ritual actions such as dances, sacrifices, identification with ancestral spirits, etc., in the obvious attempt to conjure up or reawaken those deeper layers of the psyche which the light of reason and the power of the will can never reach, and to bring them back to memory. For this purpose they used mythological or archetypal ideas which expressed the unconscious. So it has remained to the present time, when the day of the believer begins and ends with prayer, that is, with a *rite d'entrée et de sortie*. This exercise fulfils its purpose pretty well. If it did not, it would long since have fallen into disuse. If ever it lost its efficacy to any great extent, it was always in individuals or social groups for whom the archetypal ideas have become ineffective. Though such ideas or “représentations collectives” are always true in so far as they express the unconscious archetype, their verbal and pictorial form is greatly influenced by the spirit of the age. If this changes, whether by contact with understand why the alchemists called their *nigredo* melancholia, “a black blacker than black,” night, an affliction of the soul, confusion, etc., or, more pointedly, the “black raven.” For us the raven seems only a funny allegory, but for the medieval adept it was, as we have said, a well-known allegory of the devil.²¹⁶ Correctly assessing the psychic danger in which he stood, it was therefore of the utmost

importance for him to have a favourable familiar as a helper in his work, and at the same time to devote himself diligently to the spiritual exercise of prayer; all this in order to meet effectively the consequences of the collision between his consciousness and the darkness of the shadow. Even for modern psychology the confrontation with the shadow is not a harmless affair, and for this reason it is often circumvented with cunning and caution. Rather than face one's own darkness, one contents oneself with the illusion of one's civic rectitude. Certainly most of the alchemists handled their *nigredo* in the retort without knowing what it was they were dealing with. But it is equally certain that adepts like Morienus, Dorn, Michael Maier, and others knew in their way what they were doing. It was this knowledge, and not their greed for gold, that kept them labouring at the apparently hopeless opus, for which they sacrificed their money, their goods, and their life.

[743] Their "spirit" was their own belief in the light—a spirit which drew the soul to itself from its imprisonment in the body; but the soul brought with it the darkness of the chthonic spirit, the unconscious. The separation was so important because the dark deeds of the soul had to be checked. The *unio mentalis* signified, therefore, an extension of consciousness and the governance of the soul's motions by the spirit of truth. But since the soul made the body to live and was the principle of all realization, the philosophers could not but see that after the separation the body and its world were dead.²¹⁷ They therefore called this state the grave, corruption, mortification, and so on, and the problem then arose of reanimation, that is, of reuniting the soul with the "inanimate" body. Had they brought about this reanimation in a direct way, the soul would simply have snapped back a foreign and possibly more advanced civilization, or through an expansion of consciousness brought about by new discoveries and new knowledge, then the rite loses its meaning and degenerates into mere superstition. Examples of this on a grand scale are the extinction of the ancient Egyptian civilization and the dying out of the gods of Greece and Rome. A similar phenomenon can be observed in China today.

[744] The demand that arises under such conditions is for a new interpretation, in accord with the spirit of the age, of the archetypes that compensate the altered situation of consciousness. Christianity, for instance, was a new and more suitable formulation of the archetypal myth, which in its turn gave the rite its vitality. The archetype is a living idea that constantly produces new interpretations through which that idea unfolds. This was correctly recognized by Cardinal Newman in regard to Christianity.²¹⁸ Christian doctrine is a new interpretation and development of its earlier stages, as we can see very clearly from the ancient tradition of the God-man. This tradition is continued in the unfolding of ecclesiastical dogma, and it is naturally not only the archetypes mentioned in the canonical writings of the New Testament that develop, but also their near relatives, of which we previously knew only the

pagan forerunners. An example of this is the newest dogma concerning the Virgin; it refers unquestionably to the mother goddess who was constantly associated with the young dying son. She is not even purely pagan, since she was very distinctly prefigured in the Sophia of the Old Testament. For this reason the definition of the new dogma does not really go beyond the *depositum fidei*, for the mother goddess is naturally implied in the archetype of the divine son and accordingly underwent a consistent development in the course of the centuries.²¹⁹ The *depositum fidei* corresponds in empirical reality to the treasure-house of the archetypes, the “gazophylacium” of the alchemists, and the collective unconscious of modern psychology.

[745] The objection raised by theologians that the final state of the dogma in any such development would be necessarily more complete or perfect than in the apostolic era is untenable. Obviously the later interpretation and formulation of the archetype will be much more differentiated than in the beginning. A glance at the history of dogma is sufficient to confirm this. One has only to think of the Trinity, for which there is no direct evidence in the canonical writings. But it does not follow from this that the primitive Christians had a less complete knowledge of the fundamental truths. Such an assumption borders on pernicious intellectualism, for what counts in religious experience is not how explicitly an archetype can be formulated but how much I am gripped by it. The least important thing is what I think about it.²²⁰

[746] The “living idea” is always perfect and always numinous. Human formulation adds nothing and takes away nothing, for the archetype is autonomous and the only question is whether a man is gripped by it or not. If he can formulate it more or less, then he can more easily integrate it with consciousness, talk about it more reasonably and explain its meaning a bit more rationally. But he does not possess it more or in a more perfect way than the man who cannot formulate his “possession.” Intellectual formulation becomes important only when the memory of the original experience threatens to disappear, or when its irrationality seems inapprehensible by consciousness. It is an auxiliary only, not an essential.

[747] Christianity, to return to our previous argument, was “a *unio mentalis* in the overcoming of the body.” In just this respect the rite fulfilled its purpose, so far as that is possible for fallible human beings. Ancient man’s sensuous delight in the body and in nature did not disappear in the process, but found free play in the long list of sins which has never at any time diminished in scope. His knowledge of nature, however, presents a special problem. Ever since antiquity it had flourished only in secret and among the few, but it handed down certain basic conceptions through the centuries and, in the later Middle Ages, fertilized man’s reawakened interest in natural bodies. Had the alchemists not had at least a secret premonition that their

Christian *unio mentalis* had not yet realized the union with the world of the body, their almost mystical thirst for knowledge would scarcely be explicable, let alone the symbolism, rivalling that of Christianity, which began to develop already at the end of the thirteenth century. The Christ-lapis parallel shows more clearly than anything else that the world of natural bodies laid claim to equality and hence to realization in the second stage of the coniunctio.

[748] This raised the question of the way in which the coniunctio could be effected. Dorn answered this by proposing, instead of an overcoming of the body, the typical alchemical process of the *separatio, solutio, incineratio, sublimatio*, etc. of the red or white wine, the purpose of this procedure being to produce a physical equivalent of the *substantia coelestis*, recognized by the spirit as the truth and as the image of God innate in man. Whatever names the alchemists gave to the mysterious substance they sought to produce, it was always a celestial substance, i.e., something transcendental, which, in contrast to the perishability of all known matter, was incorruptible, inert as a metal or a stone, and yet alive, like an organic being, and at the same time a universal medicament. Such a “body” was quite obviously not to be met with in experience. The tenacity with which the adepts pursued this goal for at least seventeen hundred years can be explained only by the numinosity of this idea. And we do indeed find, even in the ancient alchemy of Zosimos, clear indications of the archetype of the Anthropos,²²¹ as I have shown in *Psychology and Alchemy*; an image that pervades the whole of alchemy down to the figure of the homunculus in *Faust*. The idea of the Anthropos springs from the notion of an original state of universal animation, for which reason the old Masters interpreted their Mercurius as the *anima mundi*; and just as the original animation could be found in all matter, so too could the *anima mundi*. It was imprinted on all bodies as their *raison d'être*, as an image of the demiurge who incarnated in his own creation and got caught in it. Nothing was easier than to identify this *anima mundi* with the Biblical *imago Dei*, which represented the truth revealed to the spirit. For the early thinkers the soul was by no means a merely intellectual concept; it was visualized sensuously as a breath-body or a volatile but physical substance which, it was readily supposed, could be chemically extracted and “fixed” by means of a suitable procedure. This intention was served by the preparation of the *phlegma vini*. As I pointed out earlier, this was not the spirit and water of the wine but its solid residue, the chthonic and corporeal part which would not ordinarily be regarded as the essential and valuable thing about the wine.

[749] What the alchemist sought, then, to help him out of his dilemma was a chemical operation which we today would describe as a symbol. The procedure he followed was obviously an allegory of his postulated *substantia coelestis* and its chemical equivalent. To that extent the operation was not symbolical for him but purposive and rational. For us, who know that no amount of incineration, sublimation, and

centrifuging of the vinous residue can ever produce an “air-coloured” quintessence, the entire procedure is fantastic if taken literally. We can hardly suppose that Dorn, either, meant a real wine but, after the manner of the alchemists, *vinum ardens*, *acetum*, *spiritualis sanguis*, etc., in other words *Mercurius non vulgi*, who embodied the *anima mundi*. Just as the air encompasses the earth, so in the old view the soul is wrapped round the world. As I have shown, we can most easily equate the concept of Mercurius with that of the unconscious. If we add this term to the recipe, it would run: Take the unconscious in one of its handiest forms, say a spontaneous fantasy, a dream, an irrational mood, an affect, or something of the kind, and operate with it. Give it your special attention, concentrate on it, and observe its alterations objectively. Spare no effort to devote yourself to this task, follow the subsequent transformations of the spontaneous fantasy attentively and carefully. Above all, don’t let anything from outside, that does not belong, get into it, for the fantasy-image has “everything it needs.”²²² In this way one is certain of not interfering by conscious caprice and of giving the unconscious a free hand. In short, the alchemical operation seems to us the equivalent of the psychological process of active imagination.

[750] Ordinarily, the only thing people know about psychotherapy is that it consists in a certain technique which the analyst applies to his patient. Specialists know how far they can get with it. One can use it to cure the neuroses, and even the milder psychoses, so that nothing more remains of the illness except the general human problem of how much of yourself you want to forget, how much psychic discomfort you have to take on your shoulders, how much you may forbid or allow yourself, how much or how little you may expect of others, how far you should give up the meaning of your life or what sort of meaning you should give it. The analyst has a right to shut his door when a neurosis no longer produces any clinical symptoms and has debouched into the sphere of general human problems. The less he knows about these the greater his chances are of coming across comparatively reasonable patients who can be weaned from the transference that regularly sets in. But if the patient has even the remotest suspicion that the analyst thinks rather more about these problems than he says, then he will not give up the transference all that quickly but will cling to it in defiance of all reason—which is not so unreasonable after all, indeed quite understandable. Even adult persons often have no idea how to cope with the problem of living, and on top of that are so unconscious in this regard that they succumb in the most uncritical way to the slightest possibility of finding some kind of answer or certainty. Were this not so, the numerous sects and -isms would long since have died out. But, thanks to unconscious, infantile attachments, boundless uncertainty and lack of self-reliance, they all flourish like weeds.

[751] The analyst who is himself struggling for all those things which he seeks to inculcate into his patients will not get round the problem of the transference so easily.

The more he knows how difficult it is for him to solve the problems of his own life, the less he can overlook the fear and uncertainty or the frivolity and dangerously uncritical attitude of his patients. Even Freud regarded the transference as a neurosis at second hand and treated it as such. He could not simply shut the door, but honestly tried to analyze the transference away. This is not so simple as it sounds when technically formulated. Practice often turns out to be rather different from theory. You want, of course, to put a whole man on his feet and not just a part of him. You soon discover that there is nothing for him to stand on and nothing for him to hold on to. Return to the parents has become impossible, so he hangs on to the analyst. He can go neither backwards nor forwards, for he sees nothing before him that could give him a hold. All so-called reasonable possibilities have been tried out and have proved useless. Not a few patients then remember the faith in which they were brought up, and some find their way back to it, but not all. They know, perhaps, what their faith ought to mean to them, but they have found to their cost how little can be achieved with will and good intentions if the unconscious does not lend a hand. In order to secure its co-operation the religions have long turned to myths for help, or rather, the myths always flung out bridges between the helpless consciousness and the effective *idées forces* of the unconscious. But you cannot, artificially and with an effort of will, believe the statements of myth if you have not previously been gripped by them. If you are honest, you will doubt the truth of the myth because our present-day consciousness has no means of understanding it. Historical and scientific criteria do not lend themselves to a recognition of mythological truth; it can be grasped only by the intuitions of faith or by psychology, and in the latter case although there may be insight it remains ineffective unless it is backed by experience.

[752] Thus the modern man cannot even bring about the *unio mentalis* which would enable him to accomplish the second degree of conjunction. The analyst's guidance in helping him to understand the statements of his unconscious in dreams, etc. may provide the necessary insight, but when it comes to the question of real experience the analyst can no longer help him: he himself must put his hand to the work. He is then in the position of an alchemist's apprentice who is inducted into the teachings by the Master and learns all the tricks of the laboratory. But sometime he must set about the opus himself, for, as the alchemists emphasize, nobody else can do it for him. Like this apprentice, the modern man begins with an unseemly prima materia which presents itself in unexpected form—a contemptible fantasy which, like the stone that the builders rejected, is "flung into the street" and is so "cheap" that people do not even look at it. He will observe it from day to day and note its alterations until his eyes are opened or, as the alchemists say, until the fish's eyes, or the sparks, shine in the dark solution. For the eyes of the fish are always open and therefore must always

see, which is why the alchemists used them as a symbol of perpetual attention. (Pis. 8 and 9.)

[753] The light that gradually dawns on him consists in his understanding that his fantasy is a real psychic process which is happening to him personally. Although, to a certain extent, he looks on from outside, impartially, he is also an acting and suffering figure in the drama of the psyche. This recognition is absolutely necessary and marks an important advance. So long as he simply looks at the pictures he is like the foolish Parsifal, who forgot to ask the vital question because he was not aware of his own participation in the action. Then, if the flow of images ceases, next to nothing has happened even though the process is repeated a thousand times. But if you recognize your own involvement you yourself must enter into the process with your personal reactions, just as if you were one of the fantasy figures, or rather, as if the drama being enacted before your eyes were real. It is a psychic fact that this fantasy is happening, and it is as real as you—as a psychic entity—are real. If this crucial operation is not carried out, all the changes are left to the flow of images, and you yourself remain unchanged. As Dorn says, you will never make the One unless you become one yourself. It is, however, possible that if you have a dramatic fantasy you will enter the interior world of images as a *fictitious personality* and thereby prevent any real participation; it may even endanger consciousness because you then become the victim of your own fantasy and succumb to the powers of the unconscious, whose dangers the analyst knows all too well. But if you place yourself in the drama as you really are, not only does it gain in actuality but you also create, by your criticism of the fantasy, an effective counterbalance to its tendency to get out of hand. For what is now happening is the decisive rapprochement with the unconscious. This is where insight, the *unio mentalis*, begins to become real. What you are now creating is the beginning of individuation, whose immediate goal is the experience and production of the symbol of totality.

[754] It not infrequently happens that the patient simply continues to observe his images without considering what they mean to him. He can and he should understand their meaning, but this is of practical value only so long as he is not sufficiently convinced that the unconscious can give him valuable insights. But once he has recognized this fact, he should also know that he then has in his hands an opportunity to win, by his knowledge, independence of the analyst. This conclusion is one which he does not like to draw, with the result that he frequently stops short at the mere observation of his images. The analyst, if he has not tried out the procedure on himself, cannot help him over this stile—assuming, of course, that there are compelling reasons why the procedure should be continued. In these cases there is no medical or ethical imperative but only a command of fate, which is why patients who by no means lack the necessary acumen often come to a standstill at this point. As

this experience is not uncommon I can only conclude that the transition from a merely perceptive, i.e., *aesthetic*, attitude to one of *judgment* is far from easy. Indeed, modern psychotherapy has just reached this point and is beginning to recognize the usefulness of perceiving and giving shape to the images, whether by pencil and brush or by modelling. A musical configuration might also be possible provided that it were really composed and written down. Though I have never met a case of this kind, Bach's *Art of Fugue* would seem to offer an example, just as the representation of the archetypes is a basic feature of Wagner's music. (These phenomena, however, arise less from personal necessity than from the unconscious compensations produced by the *Zeitgeist*, though I cannot discuss this here.)

[755] The step beyond a merely aesthetic attitude may be unfamiliar to most of my readers. I myself have said little about it and have contented myself with hints.²²³ It is not a matter that can be taken lightly. I tried it out on myself and others thirty years ago and must admit that although it is feasible and leads to satisfactory results it is also very difficult. It can be recommended without misgiving if a patient has reached the stage of knowledge described above. If he finds the task too difficult he will usually fail right at the beginning and never get through the dangerous impasse. The danger inherent in analysis is that, in a psychopathically disposed patient, it will unleash a psychosis. This very unpleasant possibility generally presents itself at the beginning of the treatment, when, for instance, dream-analysis has activated the unconscious. But if it has got so far that the patient can do active imagination and shape out his fantasies, and there are no suspicious incidents, then there is as a rule no longer any serious danger. One naturally asks oneself what fear—if fear it is—prevents him from taking the next step, the transition to an attitude of judgment. (The judgment of course should be morally and intellectually binding.) There are sufficient reasons for fear and uncertainty because voluntary participation in the fantasy is alarming to a naive mind and amounts to an anticipated psychosis.

[756] Naturally there is an enormous difference between an anticipated psychosis and a real one, but the difference is not always clearly perceived and this gives rise to uncertainty or even a fit of panic. Unlike a real psychosis, which comes on you and inundates you with uncontrollable fantasies irrupting from the unconscious, the judging attitude implies a voluntary involvement in those fantasy-processes which compensate the individual and—in particular—the collective situation of consciousness. The avowed purpose of this involvement is to integrate the statements of the unconscious, to assimilate their compensatory content, and thereby produce a whole meaning which alone makes life worth living and, for not a few people, possible at all. The reason why the involvement looks very like a psychosis is that the patient is integrating the same fantasy-material to which the insane person falls victim because he cannot integrate it but is swallowed up by it. In myths the hero is

the one who conquers the dragon, not the one who is devoured by it. And yet both have to deal with the same dragon. Also, he is no hero who never met the dragon, or who, if he once saw it, declared afterwards that he saw nothing. Equally, only one who has risked the fight with the dragon and is not overcome by it wins the hoard, the “treasure hard to attain.” He alone has a genuine claim to self-confidence, for he has faced the dark ground of his self and thereby has gained himself. This experience gives him faith and trust, the *pistis* in the ability of the self to sustain him, for everything that menaced him from inside he has made his own. He has acquired the right to believe that he will be able to overcome all future threats by the same means. He has arrived at an inner certainty which makes him capable of self-reliance, and attained what the alchemists called the *unio mentalis*.

[757] As a rule this state is represented pictorially by a mandala. Often such drawings contain clear allusions to the sky and the stars and therefore refer to something like the “inner” heaven, the “firmament” or “Olympus” of Paracelsus, the Microcosm. This, too, is that circular product, the *caelum*,²²⁴ which Dorn wanted to produce by “assiduous rotary movements.” Because it is not very likely that he ever manufactured this quintessence as a chemical body, and he himself nowhere asserts that he did, one must ask whether he really meant this chemical operation or rather, perhaps, the *opus alchymicum* in general, that is, the transmutation of Mercurius duplex under the synonym of the red and white wine,²²⁵ thus alluding at the same time to the *opus ad rubeum et ad album*. This seems to me more probable. At any rate some kind of laboratory work was meant. In this way Dorn “shaped out” his intuition of a mysterious centre preexistent in man, which at the same time represented a cosmos, i.e., a totality, while he himself remained conscious that he was portraying the *self* in matter. He completed the image of wholeness by the admixture of honey, magic herbs, and human blood, or their meaningful equivalents, just as a modern man does when he associates numerous symbolic attributes with his drawing of a mandala. Also, following the old Sabaeen and Alexandrian models, Dorn drew the “influence” of the planets (*stellae inferiores*)—or Tartarus and the mythological aspect of the underworld—into his quintessence, just as the patient does today.²²⁶

[758] In this wise Dorn solved the problem of realizing the *unio mentalis*, of effecting its union with the body, thereby completing the second stage of the *coniunctio*. We would say that with this production of a physical equivalent the idea of the self had taken shape. But the alchemist associated his work with something more potent and more original than our pale abstraction. He felt it as a magically effective action which, like the substance itself, imparted magical qualities. The projection of magical qualities indicates the existence of corresponding effects on consciousness, that is to say the adept felt a numinous effect emanating from the lapis, or whatever he called the arcane substance. We, with our rationalistic minds, would scarcely attribute any

such thing to the pictures which the modern man makes of his intuitive vision of unconscious contents. But it depends on whether we are dealing with the conscious or with the unconscious. The unconscious does in fact seem to be influenced by these images. One comes to this conclusion when one examines more closely the psychic reactions of the patients to their own drawings: they do have in the end a quietening influence and create something like an inner foundation. While the adept had always looked for the effects of his stone outside, for instance as the panacea or golden tincture or life-prolonging elixir, and only during the sixteenth century pointed with unmistakable clarity to an inner effect, psychological experience emphasizes above all the subjective reaction to the formation of images, and—with a free and open mind—still reserves judgment in regard to possible objective effects.²²⁷

9. THE THIRD STAGE: THE UNUS MUNDUS

[759] The production of the lapis was the goal of alchemy in general. Dorn was a significant exception, because for him this denoted only the completion of the second stage of conjunction. In this he agrees with psychological experience. For us the representation of the idea of the self in actual and visible form is a mere *rite d'entrée*, as it were a propaedeutic action and mere anticipation of its realization. The existence of a sense of inner security by no means proves that the product will be stable enough to withstand the disturbing or hostile influences of the environment. The adept had to experience again and again how unfavourable circumstances or a technical blunder or—as it seemed to him—some devilish accident hindered the completion of his work, so that he was forced to start all over again from the very beginning. Anyone who submits his sense of inner security to analogous psychic tests will have similar experiences. More than once everything he has built will fall to pieces under the impact of reality, and he must not let this discourage him from examining, again and again, where it is that his attitude is still defective, and what are the blind spots in his psychic field of vision. Just as a lapis Philosophorum, with its miraculous powers, was never produced, so psychic wholeness will never be attained empirically, as consciousness is too narrow and too one-sided to comprehend the full inventory of the psyche. Always we shall have to begin again from the beginning. From ancient times the adept knew that he was concerned with the “res simplex,” and the modern man too will find by experience that the work does not prosper without the greatest simplicity. But simple things are always the most difficult.

[760] The One and Simple is what Dorn called the *unus mundus*, This “one world” was the *res simplex*.²²⁸ For him the third and highest degree of conjunction was the union of the whole man with the *unus mundus*. By this he meant, as we have seen, the potential world of the first day of creation, when nothing was yet “in actu,” i.e.,

divided into two and many, but was still one.²²⁹ The creation of unity by a magical procedure meant the possibility of effecting a union with the world—not with the world of multiplicity as we see it but with a potential world, the eternal Ground of all empirical being, just as the self is the ground and origin of the individual personality past, present, and future. On the basis of a self known by meditation and produced by alchemical means, Dorn “hoped and expected” to be united with the *unus mundus*.

[761] This potential world is the “mundus archetypus” of the Schoolmen. I conjecture that the immediate model for Dorn’s idea is to be found in Philo Judaeus, who, in his treatise *De mundi opificio*²³⁰ says that the Creator made in the intelligible world an incorporeal heaven, an invisible earth, and the idea of the air and the void. Last of all he created man, a “little heaven” that “bears in itself the reflections of many natures similar to the stars.” Here Philo points clearly to the idea of the Microcosm and hence to the unity of the psychic man with the cosmos. According to Philo, the relation of the Creator to the *mundus intelligibilis* is the “imago” or “archetypus” of the relation of the mind to the body. Whether Dorn also knew Plotinus is questionable. In his fourth Ennead (9, iff.) Plotinus discusses the problem of whether all individuals are merely one soul, and he believes he has good grounds for affirming this question. I mention Plotinus because he is an earlier witness to the idea of the *unus mundus*. The “unity of the soul” rests empirically on the basic psychic structure common to all souls, which, though not visible and tangible like the anatomical structure, is just as evident as it.

[762] The thought Dorn expresses by the third degree of conjunction is universal: it is the relation or identity of the personal with the suprapersonal atman, and of the individual tao with the universal tao. To the Westerner this view appears not at all realistic and all too mystic; above all he cannot see why a self should become a reality when it enters into relationship with the world of the first day of creation. He has no knowledge of any world other than the empirical one. Strictly speaking, his puzzlement does not begin here; it began already with the production of the *caelum*, the inner unity. Such thoughts are unpopular and distressingly nebulous. He does not know where they belong or on what they could be based. They might be true or again they might not—in short, his experience stops here and with it as a rule his understanding, and, unfortunately, only too often his willingness to learn more. I would therefore counsel the critical reader to put aside his prejudices and for once try to experience on himself the effects of the process I have described, or else to suspend judgment and admit that he understands nothing. For thirty years I have studied these psychic processes under all possible conditions and have assured myself that the alchemists as well as the great philosophies of the East are referring to just such experiences, and that it is chiefly our ignorance of the psyche if these experiences appear “mystic.”

[763] We should at all events be able to understand that the visualization of the self is a “window” into eternity, which gave the medieval man, like the Oriental, an opportunity to escape from the stifling grip of a one-sided view of the world or to hold out against it. Though the goal of the *opus alchymicum* was indubitably the production of the lapis or *caelum*, there can be no doubt about its tendency to spiritualize the “body.” This is expressed by the symbol of the “air-coloured” liquid that floats to the surface. It represents nothing less than a *corpus glorificationis*, the resurrected body whose relation to eternity is self-evident.

[764] Now just as it seems self-evident to the naive-minded person that an apple falls from the tree to the earth, but absurd to say that the earth rises up to meet the apple, so he can believe without difficulty that the mind is able to spiritualize the body without being affected by its inertia and grossness. But all effects are mutual, and nothing changes anything else without itself being changed. Although the alchemist thought he knew better than anyone else that, at the Creation, at least a little bit of the divinity, the *anima mundi*, entered into material things and was caught there, he nevertheless believed in the possibility of a one-sided spiritualization, without considering that the precondition for this is a materialization of the spirit in the form of the blue quintessence. In reality his labours elevated the body into proximity with the spirit while at the same time drawing the spirit down into matter. By sublimating matter he concretized spirit.

[765] This self-evident truth was still strange to medieval man and it has been only partially digested even by the man of today. But if a union is to take place between opposites like spirit and matter, conscious and unconscious, bright and dark, and so on, it will happen in a third thing, which represents not a compromise but something new, just as for the alchemists the cosmic strife of the elements was composed by the *λίθος οὐ λίθος* (stone that is no stone), by a transcendental entity that could be described only in paradoxes.²³¹ Dorn’s *caelum*, which corresponded to the stone, was on the one hand a liquid that could be poured out of a bottle and on the other the Microcosm itself. For the psychologist it is the self—man as he is, and the indescribable and super-empirical totality of that same man. This totality is a mere postulate, but a necessary one, because no one can assert that he has complete knowledge of man as he is. Not only in the psychic man is there something unknown, but also in the physical. We should be able to include this unknown quantity in a total picture of man, but we cannot. Man himself is partly empirical, partly transcendental; he too is a *λίθος οὐ λίθος*. Also, we do not know whether what we on the empirical plane regard as physical may not, in the Unknown beyond our experience, be identical with what on this side of the border we distinguish from the physical as psychic. Though we know from experience that psychic processes are related to material ones, we are not in a position to say in what this relationship consists or how

it is possible at all. Precisely because the psychic and the physical are mutually dependent it has often been conjectured that they may be identical somewhere beyond our present experience, though this certainly does not justify the arbitrary hypothesis of either materialism or spiritualism.

[766] With this conjecture of the identity of the psychic and the physical we approach the alchemical view of the *unus mundus*, the potential world of the first day of creation, when there was as yet “no second.” Before the time of Paracelsus the alchemists believed in *creatio ex nihilo*. For them, therefore, God himself was the principle of matter. But Paracelsus and his school assumed that matter was an “increated,” and hence coexistent and coeternal with God. Whether they considered this view monistic or dualistic I am unable to discover. The only certain thing is that for all the alchemists matter had a divine aspect, whether on the ground that God was imprisoned in it in the form of the *anima mundi* or *anima media natura*, or that matter represented God’s “reality.” In no case was matter de-deified, and certainly not the potential matter of the first day of creation. It seems that only the Paracelsists were influenced by the dualistic words of Genesis.²³²

[767] If Dorn, then, saw the consummation of the *mysterium coniunctionis* in the union of the alchemically produced *caelum* with the *unus mundus*, he expressly meant not a fusion of the individual with his environment, or even his adaptation to it, but a *unio mystica* with the potential world. Such a view indeed seems to us “mystical,” if we misuse this word in its pejorative modern sense. It is not, however, a question of thoughtlessly used words but of a view which can be translated from medieval language into modern concepts. Undoubtedly the idea of the *unus mundus* is founded on the assumption that the multiplicity of the empirical world rests on an underlying unity, and that not two or more fundamentally different worlds exist side by side or are mingled with one another. Rather, everything divided and different belongs to one and the same world, which is not the world of sense but a postulate whose probability is vouched for by the fact that until now no one has been able to discover a world in which the known laws of nature are invalid. That even the psychic world, which is so extraordinarily different from the physical world, does not have its roots outside the one cosmos is evident from the undeniable fact that causal connections exist between the psyche and the body which point to their underlying unitary nature.

[768] All that *is* is not encompassed by our knowledge, so that we are not in a position to make any statements about its total nature. Microphysics is feeling its way into the unknown side of matter, just as complex psychology is pushing forward into the unknown side of the psyche. Both lines of investigation have yielded findings which can be conceived only by means of antinomies, and both have developed concepts which display remarkable analogies. If this trend should become more pronounced in

the future, the hypothesis of the unity of their subject-matters would gain in probability. Of course there is little or no hope that the unitary Being can ever be conceived, since our powers of thought and language permit only of antinomian statements. But this much we do know beyond all doubt, that empirical reality has a transcendental background—a fact which, as Sir James Jeans has shown, can be expressed by Plato's parable of the cave. The common background of microphysics and depth-psychology is as much physical as psychic and therefore neither, but rather a third thing, a neutral nature which can at most be grasped in hints since in essence it is transcendental.

[769] The background of our empirical world thus appears to be in fact a *unus mundus*. This is at least a probable hypothesis which satisfies the fundamental tenet of scientific theory: "Explanatory principles are not to be multiplied beyond the necessary." The transcendental psychophysical background corresponds to a "potential world" in so far as all those conditions which determine the form of empirical phenomena are inherent in it. This obviously holds good as much for physics as for psychology, or, to be more precise, for macrophysics as much as for the psychology of consciousness.

[770] So if Dorn sees the third and highest degree of conjunction in a union or relationship of the adept, who has produced the *caelum*, with the *unus mundus*, this would consist, psychologically, in a synthesis of the conscious with the unconscious. The result of this conjunction or equation is theoretically inconceivable, since a known quantity is combined with an unknown one; but in practice as many far-reaching changes of consciousness result from it as atomic physics has produced in classical physics. The nature of the changes which Dorn expects from the third stage of the coniunctio can be established only indirectly from the symbolism used by the adepts. What he called *caelum* is, as we have seen, a symbolic prefiguration of the self. We can conclude from this that the desired realization of the whole man was conceived as a healing of organic and psychic ills, since the *caelum* was described as a universal medicine (the panacea, alexipharmic, *medicina catholica*, etc.). It was regarded also as the balsam and elixir of life, as a life-prolonging, strengthening, and rejuvenating magical potion. It was a "living stone," a λίθος ἐμψυχος (*baetylus*), a "stone that hath a spirit,"²³³ and the "living stone" mentioned in the New Testament,²³⁴ which in the *Shepherd of Hermas* is the living man who adds himself as a brick to the tower of the Church. Above all, its incorruptibility is stressed: it lasts a long time, or for all eternity; though alive, it is unmoved; it radiates magic power and transforms the perishable into the imperishable and the impure into the pure; it multiplies itself indefinitely; it is simple and therefore universal, the union of all opposites; it is the parallel of Christ and is called the Saviour of the Macrocosm. But the *caelum* also signifies man's likeness to God (*imago Dei*), the *anima mundi* in matter, and the truth

itself. It “has a thousand names.” It is also the Microcosm, the whole man (τέλειος ἄνθρωπος), *chên-yên*, a homunculus and a hermaphrodite. These designations and significations are but a small selection from the plethora of names mentioned in the literature.

[771] Not unnaturally, we are at a loss to see how a psychic experience of this kind—for such it evidently was—can be formulated as a rational concept. Undoubtedly it was meant as the essence of perfection and universality, and, as such, it characterized an experience of similar proportions. We could compare this only with the ineffable mystery of the *unio mystica*, or *tao*, or the content of *samadhi*, or the experience of *satori* in Zen, which would bring us to the realm of the ineffable and of extreme subjectivity where all the criteria of reason fail. Remarkably enough this experience is an empirical one in so far as there are unanimous testimonies from the East and West alike, both from the present and from the distant past, which confirm its unsurpassable subjective significance. Our knowledge of physical nature gives us no *point d'appui* that would enable us to put the experience on any generally valid basis. It is and remains a secret of the world of psychic experience and can be understood only as a numinous event, whose actuality, nevertheless, cannot be doubted any more than the fact that light of a certain wave-length is perceived as “red”—a fact which remains incomprehensible only to a man suffering from red-green blindness.

[772] What, then, do the statements of the alchemists concerning their arcanum mean, looked at psychologically? In order to answer this question we must remember the working hypothesis we have used for the interpretation of dreams: the images in dreams and spontaneous fantasies are symbols, that is, the best possible formulation for still unknown or unconscious facts, which generally compensate the content of consciousness or the conscious attitude. If we apply this basic rule to the alchemical arcanum, we come to the conclusion that its most conspicuous quality, namely, *its unity and uniqueness*—one is the stone, one the medicine, one the vessel, one the procedure, and one the disposition²³⁵—presupposes a *dissociated consciousness*. For no one who is one himself needs oneness as a medicine—nor, we might add, does anyone who is unconscious of his dissociation, for a *conscious* situation of distress is needed in order to activate the archetype of unity. From this we may conclude that the more philosophically minded alchemists were people who did not feel satisfied with the then prevailing view of the world, that is, with the Christian faith, although they were convinced of its truth. In this latter respect we find in the classical Latin and Greek literature of alchemy no evidences to the contrary, but rather, so far as Christian treatises are concerned, abundant testimony to the firmness of their Christian convictions. Since Christianity is expressly a system of “salvation,” founded moreover on God’s “plan of redemption,” and God is unity *par excellence*, one must ask oneself why the alchemists still felt a disunity in themselves, or not at

one with themselves, when their faith, so it would appear, gave them every opportunity for unity and unison. (This question has lost nothing of its topicality today, on the contrary!) The question answers itself when we examine more closely the other attributes that are predicated of the arcanum.

[773] The next quality, therefore, which we have to consider is its *physical* nature. Although the alchemists attached the greatest importance to this, and the “stone” was the whole *raison d’être* of their art, yet it cannot be regarded as merely physical since it is stressed that the stone was alive and possessed a soul and spirit, or even that it was a man or some creature like a man. And although it was also said of God that the world is his physical manifestation, this pantheistic view was rejected by the Church, for “God is Spirit” and the very reverse of matter. In that case the Christian standpoint would correspond to the “*unio mentalis* in the overcoming of the body.” So far as the alchemist professed the Christian faith, he knew that according to his own lights he was still at the second stage of conjunction, and that the Christian “truth” was not yet “realized.” The soul was drawn up by the spirit to the lofty regions of abstraction; but the body was de-souled, and since it also had claims to live the unsatisfactoriness of the situation could not remain hidden from him. He was unable to feel himself a whole, and whatever the spiritualization of his existence may have meant to him he could not get beyond the Here and Now of his bodily life in the physical world. The spirit precluded his orientation to physis and vice versa. Despite all assurances to the contrary Christ is not a unifying factor but a dividing “sword” which sunders the spiritual man from the physical. The alchemists, who, unlike certain moderns, were clever enough to see the necessity and fitness of a further development of consciousness, held fast to their Christian convictions and did not slip back to a more unconscious level. They could not and would not deny the truth of Christianity, and for this reason it would be wrong to accuse them of heresy. On the contrary, they wanted to “realize” the unity foreshadowed in the idea of God by struggling to unite the *unio mentalis* with the body.

[774] The mainspring of this endeavour was the conviction that this world was in a morbid condition and that everything was corrupted by original sin. They saw that the soul could be redeemed only if it was freed by the spirit from its natural attachment to the body, though this neither altered nor in any way improved the status of physical life. The Microcosm, i.e., the inner man, was capable of redemption but not the corrupt body. This insight was reason enough for a dissociation of consciousness into a spiritual and a physical personality. They could all declare with St. Paul: “O wretched man that I am, who shall deliver me from the body of this death?”²³⁶ They therefore strove to find the medicine that would heal all the sufferings of the body and the disunion of the soul, the *φάρμακον ἀθανασίας* which frees the body of its corruptibility, and the elixir vitae which grants the long life of

the Biblical aforesaid, or even immortality. Since most of them were physicians, they had plenty of opportunities to form an overwhelming impression of the transitoriness of human existence, and to develop that kind of impatience which refuses to wait till Kingdom come for more endurable conditions better in accord with the message of salvation. It is precisely the claims of the physical man and the unendurability of his dissociation that are expressed in this gnawing discontent. The alchemists, consequently, saw themselves faced with the extremely difficult task of uniting the wayward physical man with his spiritual truth. As they were neither unbelievers nor heretics, they could not and would not alter this truth in order to make it more favourably disposed to the body. Besides, the body was in the wrong anyway since it had succumbed to original sin by its moral weakness. It was therefore the body with its darkness that had to be "prepared." This, as we have seen, was done by extracting a quintessence which was the physical equivalent of heaven, of the potential world, and on that account was named "caelum." It was the very essence of the body, an incorruptible and therefore pure and eternal substance, a *corpus glorificatum*, capable and worthy of being united with the *unio mentalis*. What was left over from the body was a "terra damnata," a dross that had to be abandoned to its fate. The quintessence, the *caelum*, on the other hand, corresponded to the pure, incorrupt, original stuff of the world, God's adequate and perfectly obedient instrument, whose production, therefore, permitted the alchemist to "hope and expect" the conjunction with the *unus mundus*.

[775] This solution was a compromise to the disadvantage of physis, but it was nevertheless a noteworthy attempt to bridge the dissociation between spirit and matter. It was not a solution of principle, for the very reason that the procedure did not take place in the real object at all but was a fruitless projection, since the *caelum* could never be fabricated in reality. It was a hope that was extinguished with alchemy and then, it seems, was struck off the agenda for ever. But the dissociation remained, and, in quite the contrary sense, brought about a far better knowledge of nature and a sounder medicine, while on the other hand it deposed the spirit in a manner that would paralyse Dorn with horror could he see it today. The elixir vitae of modern science has already increased the expectation of life very considerably and hopes for still better results in the future. The *unio mentalis*, on the other hand, has become a pale phantom, and the *veritas Christiana* feels itself on the defensive. As for a truth that is hidden in the human body, there is no longer any talk of that. History has remorselessly made good what the alchemical compromise left unfinished: the physical man has been unexpectedly thrust into the foreground and has conquered nature in an undreamt-of way. At the same time he has become conscious of his *empirical* psyche, which has loosened itself from the embrace of the spirit and begun to take on so concrete a form that its individual features are now the object of clinical

observation. It has long ceased to be a life-principle or some kind of philosophical abstraction; on the contrary, it is suspected of being a mere epiphenomenon of the chemistry of the brain. Nor does the spirit any longer give it life; rather is it conjectured that the spirit owes its existence to psychic activity. Today psychology can call itself a science, and this is a big concession on the part of the spirit. What demands psychology will make on the other natural sciences, and on physics in particular, only the future can tell.

10. THE SELF AND THE BOUNDS OF KNOWLEDGE

[776] As I have repeatedly pointed out, the alchemist's statements about the lapis, considered psychologically, describe the archetype of the self. Its phenomenology is exemplified in mandala symbolism, which portrays the self as a concentric structure, often in the form of a squaring of the circle. Co-ordinated with this are all kinds of secondary symbols, most of them expressing the nature of the opposites to be united. The structure is invariably felt as the representation of a central state or of a centre of personality essentially different from the ego. It is of numinous nature, as is clearly indicated by the mandalas themselves and by the symbols used (sun, star, light, fire, flower, precious stone, etc.). All degrees of emotional evaluation are found, from abstract, colourless, indifferent drawings of circles to an extremely intense experience of illumination. These aspects all appear in alchemy, the only difference being that there they are projected into matter, whereas here they are understood as symbols. The arcanum chymicum has therefore changed into a psychic event without having lost any of its original numinosity.

[777] If we now recall to what a degree the soul has humanized and realized itself, we can judge how very much it today expresses the body also, with which it is coexistent. Here is a coniunctio of the second degree, such as the alchemists at most dreamed of but could not realize. Thus far the transformation into the psychological is a notable advance, *but only if the centre experienced proves to be a spiritus rector of daily life*. Obviously, it was clear even to the alchemists that one could have a lapis in one's pocket without ever making gold with it, or the *aurum potabile* in a bottle without ever having tasted that bittersweet drink—hypothetically speaking, of course, for they never succumbed to the temptation to use their stone in reality because they never succeeded in making one. The psychological significance of this misfortune should not be overestimated, however. It takes second place in comparison with the fascination which emanated from the sensed and intuited archetype of wholeness. In this respect alchemy fared no worse than Christianity, which in its turn was not fatally disturbed by the continuing non-appearance of the Lord at the Second Coming. The intense emotion that is always associated with the vitality an archetypal

idea conveys—even though only a minimum of rational understanding may be present—a premonitory experience of wholeness to which a subsequently differentiated understanding can add nothing essential, at least as regards the totality of the experience. A better developed understanding can, however, constantly renew the vitality of the original experience. In view of the inexhaustibility of the archetype the rational understanding derived from it means relatively little, and it would be an unjustifiable overestimation of reason to assume that, as a result of understanding, the illumination in the final state is a higher one than in the initial state of numinous experience. The same objection, as we have seen, was made to Cardinal Newman's view concerning the development of dogma, but it was overlooked that rational understanding or intellectual formulation adds nothing to the experience of wholeness, and at best only facilitates its repetition. The experience itself is the important thing, not its intellectual representation or clarification, which proves meaningful and helpful only when the road to original experience is blocked. The differentiation of dogma not only expresses its vitality but is needed in order to preserve its vitality. Similarly, the archetype at the basis of alchemy needs interpreting if we are to form any conception of its vitality and numinosity and thereby preserve it at least for our science. The alchemist likewise interpreted his experience as best he could, though without ever understanding it to the degree that psychological explanation makes possible today. But his inadequate understanding did not detract from the totality of his archetypal experience any more than our wider and more differentiated understanding adds anything to it.

[778] With the advance towards the psychological a great change sets in, for self-knowledge has certain ethical consequences which are not just impassively recognized but demand to be carried out in practice. This depends of course on one's moral endowment, on which as we know one should not place too much reliance. The self, in its efforts at self-realization, reaches out beyond the ego-personality on all sides; because of its all-encompassing nature it is brighter and darker than the ego, and accordingly confronts it with problems which it would like to avoid. Either one's moral courage fails, or one's insight, or both, until in the end fate decides. The ego never lacks moral and rational counterarguments, which one cannot and should not set aside so long as it is possible to hold on to them. For you only feel yourself on the right road when the conflicts of duty seem to have resolved themselves, and you have become the victim of a decision made over your head or in defiance of the heart. From this we can see the numinous power of the self, which can hardly be experienced in any other way. For this reason *the experience of the self is always a defeat for the ego*. The extraordinary difficulty in this experience is that the self can be distinguished only conceptually from what has always been referred to as "God," but not practically. Both concepts apparently rest on an identical numinous factor

which is a condition of reality. The ego enters into the picture only so far as it can offer resistance, defend itself, and in the event of defeat still affirm its existence. The prototype of this situation is Job's encounter with Yahweh. This hint is intended only to give some indication of the nature of the problems involved. From this general statement one should not draw the overhasty conclusion that in every case there is a hybris of ego-consciousness which fully deserves to be overpowered by the unconscious. That is not so at all, because it very often happens that ego-consciousness and the ego's sense of responsibility are too weak and need, if anything, strengthening. But these are questions of practical psychotherapy, and I mention them here only because I have been accused of underestimating the importance of the ego and giving undue prominence to the unconscious. This strange insinuation emanates from a theological quarter. Obviously my critic has failed to realize that the mystical experiences of the saints are no different from other effects of the unconscious.

[779] In contrast to the ideal of alchemy, which consisted in the production of a mysterious substance, a man, an *anima mundi* or a *deus terrenus* who was expected to be a saviour from all human ills, the psychological interpretation (foreshadowed by the alchemists) points to the concept of human wholeness. This concept has primarily a therapeutic significance in that it attempts to portray the psychic state which results from bridging over a dissociation between conscious and unconscious. The alchemical compensation corresponds to the integration of the unconscious with consciousness, whereby both are altered. Above all, consciousness experiences a widening of its horizon. This certainly brings about a considerable improvement of the whole psychic situation, since the disturbance of consciousness by the counteraction of the unconscious is eliminated. But, because all good things must be paid for dearly, the previously unconscious conflict is brought to the surface instead and imposes on consciousness a heavy responsibility, as *it* is now expected to solve the conflict. But it seems as badly equipped and prepared for this as was the consciousness of the medieval alchemist. Like him, the modern man needs a special method for investigating and giving shape to the unconscious contents in order to get consciousness out of its fix. As I have shown elsewhere, an experience of the self may be expected as a result of these psychotherapeutic endeavours, and quite often these experiences are numinous. It is not worth the effort to try to describe their totality character. Anyone who has experienced anything of the sort will know what I mean, and anyone who has not had the experience will not be satisfied by any amount of descriptions. Moreover there are countless descriptions of it in world literature. But I know of no case in which the bare description conveyed the experience.

[780] It is not in the least astonishing that numinous experiences should occur in the course of psychological treatment and that they may even be expected with some regularity, for they also occur very frequently in exceptional psychic states that are not treated and may even cause them. They do not belong exclusively to the domain of psychopathology but can be observed in normal people as well. Naturally, modern ignorance of and prejudice against intimate psychic experiences dismiss them as psychic anomalies and put them in psychiatric pigeon-holes without making the least attempt to understand them. But that neither gets rid of the fact of their occurrence nor explains it.

[781] Nor is it astonishing that in every attempt to gain an adequate understanding of the numinous experience use must be made of certain parallel religious or metaphysical ideas which have not only been associated with it from ancient times but are constantly used to formulate and elucidate it. The consequence, however, is that any attempt at scientific explanation gets into the grotesque situation of being accused in its turn of offering a metaphysical explanation. It is true that this objection will be raised only by one who imagines himself to be in possession of metaphysical truths, and assumes that they posit or give valid expression to metaphysical facts corresponding to them. It seems to me at least highly improbable that when a man says "God" there must in consequence exist a God such as he imagines, or that he necessarily speaks of a real being. At any rate he can never prove that there is something to correspond with his statement on the metaphysical side, just as it can never be proved to him that he is wrong. Thus it is at best a question of *non liquet*, and it seems to me advisable under these circumstances and in view of the limitations of human knowledge to assume from the start that our metaphysical concepts are simply anthropomorphic images and opinions which express transcendental facts either not at all or only in a very hypothetical manner. Indeed we know already from the physical world around us that in itself it does not necessarily agree in the least with the world as we perceive it. The physical world and the perceptual world are two very different things. Knowing this we have no encouragement whatever to think that our metaphysical picture of the world corresponds to the transcendental reality. Moreover, the statements made about the latter are so boundlessly varied that with the best of intentions we cannot know who is right. The denominational religions recognized this long ago and in consequence each of them claims that it is the only true one and, on top of this, that it is not merely a human truth but the truth directly inspired and revealed by God. Every theologian speaks simply of "God," by which he intends it to be understood that his "god" is *the* God. But one speaks of the paradoxical God of the Old Testament, another of the incarnate God of Love, a third of the God who has a heavenly bride, and so on, and each criticizes the other but never himself.

[782] Nothing provides a better demonstration of the extreme uncertainty of metaphysical assertions than their diversity. But it would be completely wrong to assume that they are altogether worthless. For in the end it has to be explained why such assertions are made at all. There must be some reason for this. Somehow men feel impelled to make transcendental statements. Why this should be so is a matter for dispute. We only know that in genuine cases it is not a question of arbitrary inventions but of involuntary numinous experiences which happen to a man and provide the basis for religious assertions and convictions. Therefore, at the source of the great confessional religions as well as of many smaller mystical movements we find individual historical personalities whose lives were distinguished by numinous experiences. Numerous investigations of such experiences have convinced me that previously unconscious contents then break through into consciousness and overwhelm it in the same way as do the invasions of the unconscious in pathological cases accessible to psychiatric observation. Even Jesus, according to Mark 3 : 21,²³⁷ appeared to his followers in that light. The significant difference, however, between merely pathological cases and “inspired” personalities is that sooner or later the latter find an extensive following and can therefore transmit their effect down the centuries. The fact that the long-lasting effect exerted by the founders of the great religions is due quite as much to their overwhelming spiritual personality, their exemplary life, and their ethical self-commitment does not affect the present discussion. Personality is only one root of success, and there were and always will be genuine religious personalities to whom success is denied. One has only to think of Meister Eckhart. But, if they do meet with success, this only proves that the “truth” they utter hits on a consensus of opinion, that they are talking of something that is “in the air” and is “spoken from the heart” for their followers too. This, as we know to our cost, applies to good and evil alike, to the true as well as the untrue.

[783] The wise man who is not heeded is counted a fool, and the fool who proclaims the general folly first and loudest passes for a prophet and Führer, and sometimes it is luckily the other way round as well, or else mankind would long since have perished of stupidity.

[784] The insane person, whose distinguishing mark is his mental sterility, expresses no “truth” not only because he is not a personality but because he meets with no consensus of opinion. But anyone who does, has to that extent expressed the “truth.” In metaphysical matters what is “authoritative” is “true,” hence metaphysical assertions are invariably bound up with an unusually strong claim to recognition and authority, because authority is for them the only possible proof of their truth, and by this proof they stand or fall. All metaphysical claims in this respect inevitably beg the question, as is obvious to any reasonable person in the case of the proofs of God.

[785] The claim to authority is naturally not in itself sufficient to establish a metaphysical truth. Its authority must also be backed by the equally vehement need of the multitude. As this need always arises from a condition of distress, any attempt at explanation will have to examine the psychic situation of those who allow themselves to be convinced by a metaphysical assertion. It will then turn out that the statements of the inspired personality have made conscious just those images and ideas which compensate the general psychic distress. These images and ideas were not thought up or invented by the inspired personality but “happened” to him as experiences, and he became, as it were, their willing or unwilling victim. A will transcending his consciousness seized hold of him, which he was quite unable to resist. Naturally enough he feels this overwhelming power as “divine.” I have nothing against this word, but with the best will in the world I cannot see that it proves the existence of a transcendent God. Suppose a benevolent Deity did in fact inspire a salutary truth, what about all those cases where a half-truth or unholy nonsense was inspired and accepted by an eager following? Here the devil would be a better bet or—on the principle “*omne malum ab homine*”—man himself. This metaphysical either-or explanation is rather difficult to apply in practice because most inspirations fall between the two extremes, being neither wholly true nor wholly false. In theory, therefore, they owe their existence to the co-operation of a good and a bad power. We would also have to suppose a common plan of work aiming at an only tolerably good goal, so to speak, or make the assumption that one power bungles the handiwork of the other or—a third possibility—that man is capable of thwarting God’s intention to inspire a perfect truth (the inspiration of a half-truth is naturally out of the question) with an almost daemonic energy. What, in any of these cases, would have happened to God’s omnipotence?

[786] It therefore seems to me, on the most conservative estimate, to be wiser not to drag the supreme metaphysical factor into our calculations, at all events not at once, but, more modestly, to make an unknown psychic or perhaps psychoid²³⁸ factor in the human realm responsible for inspirations and suchlike happenings. This would make better allowance not only for the abysmal mixture of truth and error in the great majority of inspirations but also for the numerous contradictions in Holy Writ. The psychoid aura that surrounds consciousness furnishes us with better and less controversial possibilities of explanation and moreover can be investigated empirically. It presents a world of relatively autonomous “images,” including the manifold God-images, which whenever they appear are called “God” by naïve people and, because of their numinosity (the equivalent of autonomy!), are taken to be such. The various religious denominations support this traditional viewpoint, and their respective theologians believe themselves, inspired by God’s word, to be in a position to make valid statements about him. Such statements always claim to be final and

indisputable. The slightest deviation from the dominant assumption provokes an unbridgeable schism. One cannot and may not think about an object held to be indisputable. One can only assert it, and for this reason there can be no reconciliation between the divergent assertions. Thus Christianity, the religion of brotherly love, offers the lamentable spectacle of one great and many small schisms, each faction helplessly caught in the toils of its own unique rightness.

[787] We believe that we can make assertions about God, define him, form an opinion about him, differentiate him as the only true one amongst other gods. The realization might by this time be dawning that when we talk of God or gods we are speaking of debatable images from the psychoid realm. The existence of a transcendental reality is indeed evident in itself, but it is uncommonly difficult for our consciousness to construct intellectual models which would give a graphic description of the reality we have perceived. Our hypotheses are uncertain and groping, and nothing offers us the assurance that they may ultimately prove correct. That the world inside and outside ourselves rests on a transcendental background is as certain as our own existence, but it is equally certain that the direct perception of the archetypal world inside us is just as doubtfully correct as that of the physical world outside us. If we are convinced that we know the ultimate truth concerning metaphysical things, this means nothing more than that archetypal images have taken possession of our powers of thought and feeling, so that these lose their quality as functions at our disposal. The loss shows itself in the fact that the object of perception then becomes absolute and indisputable and surrounds itself with such an emotional taboo that anyone who presumes to reflect on it is automatically branded a heretic and blasphemer. In all other matters everyone would think it reasonable to submit to objective criticism the subjective image he has devised for himself of some object. But in the face of possession or violent emotion reason is abrogated; the numinous archetype proves on occasion to be the stronger because it can appeal to a vital necessity. This is regularly the case when it compensates a situation of distress which no amount of reasoning can abolish. We know that an archetype can break with shattering force into an individual human life and into the life of a nation. It is therefore not surprising that it is called "God." But as men do not always find themselves in immediate situations of distress, or do not always feel them to be such, there are also calmer moments in which reflection is possible. If one then examines a state of possession or an emotional seizure without prejudice, one will have to admit that the possession in itself yields nothing that would clearly and reliably characterize the nature of the "possessing" factor, although it is an essential part of the phenomenon that the "possessed" always feels compelled to make definite assertions. Truth and error lie so close together and often look so confusingly alike that nobody in his right senses could afford *not* to doubt the things that happen to him in the possessed state. I John 4 : 1 admonishes us:

“Beloved, believe not every spirit, but try the spirits whether they are of God; because many false prophets are gone out into the world.” This warning was uttered at a time when there was plenty of opportunity to observe exceptional psychic states. Although, as then, we think we possess sure criteria of distinction, the rightness of this conviction must nevertheless be called in question, for no human judgment can claim to be infallible.

[788] in view of this extremely uncertain situation it seems to me very much more cautious and reasonable to take cognizance of the fact that there is not only a psychic but also a psychoid unconscious, before presuming to pronounce metaphysical judgments which are incommensurable with human reason. There is no need to fear that the inner experience will thereby be deprived of its reality and vitality. No experience is prevented from happening by a somewhat more cautious and modest attitude—on the contrary.

[789] That a psychological approach to these matters draws man more into the centre of the picture as the measure of all things cannot be denied. But this gives him a significance which is not without justification. The two great world-religions, Buddhism and Christianity, have, each in its own way, accorded man a central place, and Christianity has stressed this tendency still further by the dogma that God became very man. No psychology in the world could vie with the dignity that God himself has accorded to him.

EPILOGUE

[790] Alchemy, with its wealth of symbols, gives us an insight into an endeavour of the human mind which could be compared with a religious rite, an *opus divinum*. The difference between them is that the alchemical opus was not a collective activity rigorously defined as to its form and content, but rather, despite the similarity of their fundamental principles, an individual undertaking on which the adept staked his whole soul for the transcendental purpose of producing a *unity*. It was a work of reconciliation between apparently incompatible opposites, which, characteristically, were understood not merely as the natural hostility of the physical elements but at the same time as a moral conflict. Since the object of this endeavour was seen outside as well as inside, as both physical and psychic, the work extended as it were through the whole of nature, and its goal consisted in a symbol which had an empirical and at the same time a transcendental aspect.

[791] Just as alchemy, tapping its way in the dark, groped through the endless mazes of its theoretical assumptions and practical experiments over a course of many centuries, so the psychology of the unconscious that began with C. G. Carus took up the trail that had been lost by the alchemists. This happened, remarkably enough, at a moment in history when the aspirations of the alchemists had found their highest poetic expression in Goethe's *Faust*. At the time Carus wrote, he certainly could not have guessed that he was building the philosophical bridge to an empirical psychology of the future, which would take quite literally the old alchemical dictum: *in stercore invenitur*—"it is found in filth." Not, this time, in the cheap, unseemly substance, which, rejected by all, could be picked up anywhere in the street, but rather in the distressing darkness of the human psyche, which meanwhile had become accessible to clinical observation. There alone could be found all those contradictions, those grotesque phantasms and scurrilous symbols which had fascinated the mind of the alchemists and confused them as much as illuminated them. And the same problem presented itself to the psychologist that had kept the alchemists in suspense for seventeen hundred years: What was he to do with these antagonistic forces? Could he throw them out and get rid of them? Or had he to admit their existence, and is it our task to bring them into harmony and, out of the multitude of contradictions, produce a unity, which naturally will not come of itself, though it may—*Deo concedente*—with human effort?

[792] Herbert Silberer has the merit of being the first to discover the secret threads that lead from alchemy to the psychology of the unconscious. The state of psychological knowledge at that time was still too primitive and still too much wrapped up in

personalistic assumptions for the whole problem of alchemy to be understood psychologically. The conventional devaluation of alchemy on the one hand and of the psyche on the other had first to be cleared away. Today we can see how effectively alchemy prepared the ground for the psychology of the unconscious, firstly by leaving behind, in its treasury of symbols, illustrative material of the utmost value for modern interpretations in this field, and secondly by indicating symbolical procedures for synthesis which we can rediscover in the dreams of our patients. We can see today that the entire alchemical procedure for uniting the opposites, which I have described in the foregoing, could just as well represent the individuation process of a single individual, though with the not unimportant difference that no single individual ever attains to the richness and scope of the alchemical symbolism. This has the advantage of having been built up through the centuries, whereas the individual in his short life has at his disposal only a limited amount of experience and limited powers of portrayal. It is therefore a difficult and thankless task to try to describe the nature of the individuation process from case-material. Since one aspect tends to predominate in one case and another in another, and one case begins earlier and another later, and the psychic conditions vary without limit, only one or the other version or phase of the process can be demonstrated in any given instance. No case in my experience is comprehensive enough to show all the aspects in such detail that it could be regarded as paradigmatic. Anyone who attempted to describe the individuation process with the help of case-material would have to remain content with a mosaic of bits and pieces without beginning or end, and if he wanted to be understood he would have to count on a reader whose experience in the same field was equal to his own. Alchemy, therefore, has performed for me the great and invaluable service of providing material in which my experience could find sufficient room, and has thereby made it possible for me to describe the individuation process at least in its essential aspects.

APPENDIX

LATIN AND GREEK TEXTS

The asterisks (*) in the footnotes refer to the following passages quoted by the author in Latin or Greek. In general, only translations are given in the body of the book. The entries below carry the pertinent footnote numbers.

I. THE COMPONENTS OF THE CONIUNCTIO

3. In hoc lapide sunt quatuor elementa et assimilatur mundo et mundi compositioni. / Natura, inquam, dum circumgyravit aureum circulum, in ipso motu qualitates quatuor in eo aequavit, hoc est, homogeneam illam simplicitatem in sese redeuntem quadravit, sive in quadrangulum duxit aequilaterum, hac ratione, ut contraria a contrariis et hostes ab hostibus aeternis quasi vinculis colligentur, et invicem teneantur. / In circulo sunt elementa coniuncta vera amicitia.
8. aquila volans per aerem et bufo gradiens per terram.
12. Desponsavi ego duo luminaria in actu, et facta est illa quasi aqua in actu habens duo lumina.
18. Hermes: Necesse est ut in fine mundi coelum et terra coniungantur, quod verbum est philosophicum.
20. Sic absconditur altitudo et manifestatur profunditas.
21. de mortuo facit vivum.
23. . . . consurgit aequalitas . . . ex quatuor repugnantibus, in natura communicantibus.
/ καὶ Ὀρφεὺς οἶδε μὲν καὶ τὸν τοῦ
Διονύσου χαρατῆρα, πολλοὺς δὲ καὶ ἄλλους ἰδρύει περὶ τὴν ἡλιαχὴν τράπεζαν.
26. *Erat vir unus.* Nos, qui adhuc peccatores sumus, non possumus istum titulum laudis acquirere, quia unus quisque nostrum non est ‘unus’, sed multi. . . . Vides, quomodo ille qui putatur ‘unus’ esse, non est ‘unus’, sed tot in eo personae videntur esse, quot mores, quia et secundum scripturas ‘insipiens sicut luna mutatur’. / Ubi peccata sunt, ibi est multitudo . . . ubi autem virtus, ibi singularitas, ibi unio. / Intellige te habere intra te ipsum greges boum. . . . Intellige habere te et greges ovium et greges caprarum. . . . Intellige esse intra te etiam aves coeli. Nec mireris quod haec intra te esse dicimus; intellige te et alium mundum esse in parvo et esse intra te solem, esse lunam, esse etiam stellas. . . . Videas habere te

omnia, quae mundus habet. / Quatuor in caelo planetis imperfectioribus, quatuor in corpore nostro correspondere volunt elementa, ut Saturno, Mercurio, Veneri, et Marti, terra, aqua, aer, et ignis, ex quibus conflatum est, et infirmum propter partium imperfectionem. Plantetur itaque arbor ex eis, cuius radix adscribitur Saturno . . .

33. combinationes duarum contrarietatum, frigidum et humidum, quae . . . non sunt amicabilia caliditati et siccitati.
34. Puerulus tuus senex est, o virgo, ipse est Antiquus dierum et omnia praecessit tempora.
40. Dum enim rostrum applicat pectori, totum collum cum rostro flectitur in circularem formam. . . . Sanguis effluens e pectore mortuis pullis reddit vitam.
41. Tanquam principium et fons, a quo . . . defluunt; et simul etiam finis ultimus.
44. Omnem rem solidam penetrabit.
48. Talis est amor philosophicus, inter inanimatorum partes, et inimicitia, *qualis in partibus hominis*. Verum in illis, non magis quam in his, unio vera fieri non potest, corruptione dictarum partium non ablata prius ante coniunctionem: qua propter pacem inter inimicos est quod facias, ut amici conveniant in unum. In omnibus corporibus imperfectis, et ab ultimata sua perfectione deficientibus, sunt amicitia et inimicitia simul innatae; haec si tollatur hominis ingenio vel industria, necesse est alteram ad perfectionem suam ultimatam redire per artem, quam in hominis unione declaravimus.
49. Fertur etiam quod pellicanus in tantum pullos suos diligit, ut eos unguibus interimat. Tertia vero die prae dolore se ipsum lacerat, et sanguis de latere eius super pullos distillans eos a morte excitat. Pellicanus significat Dominum qui sic dilexit mundum ut pro eo daret Filium suum unigenitum, quem tertia die victorem mortis excitavit et super omne nomen exaltavit.
52. cuius vis est spiritualis sanguis id est tinctura. . . . Nam corpus incorporat spiritum per sanguinis tincturam; quia omne quod habet Spiritum, habet et sanguinem. / Sensibilis autem et vitalis (spiritus) sanguis est essentia; dicit enim alibi, omni spiritui carnis sanguis est.
53. Fili, accipere debes de pinguiori carne. / crescit ex carne et sanguine. / Ovum in carne capere. / Elige carnem teneram et habebis rem optimam. / An forte carnibus ad vesperam . . . ille significatur, qui traditus est propter delicta nostra.
54. Et tunc accipe vitrum cum sponso et sponsa, et proiice eos in fornacem, et fac assare per tres dies, et tunc erunt duo in carne una.

55. Quemadmodum Christus. . . . Lapis angularis ab aedificatoribus reiectus in sacra scriptura vocatur; ita quoque Lapidi Sophorum idem accidit ...
64. Recipit vim superiorum et inferiorum. Sic habebis gloriam totius mundi.
66. Mercurius Trismegistus . . . lapidem vocavit orphanum. / Hic lapis Orphanus proprio nomine caret.
78. *Ποίησον τὸ δεῖνα πρᾶγμα ἐμοὶ τῷ τῆς χήρας ὀρφανῷ κατατετιμημένης.*
- 79.
- Ipsa maritali dum nato foedere mater
Jungitur, incestum ne videatur opus.
Sic etenim natura iubet, sic alma requirit
Lex fati, nec ea est res male grata Deo.
83. *Ἐγὼ εἰμι Ἴσις ἡ καλουμένη δρόσος.*
95. *Ἴσιδος σῶμα γῆν.*
109. Omnis Ecclesia una vidua est, deserta in hoc saeculo.
111. (Almana) Vidua. Est Malchuth, quando Tiphereth non est cum ipsa.
116. Luna, terra, sponsa, matrona, regina coeli, piscina, mare, puteus, arbor scientiae boni et mali, cerva amorum (ita vocatur Malchuth potissimum ob mysterium novilunii), venter.
120. . . . quod Malchuth vocetur hortus irriguus Jesch. 58, 11 quando Jesod in Ipsa est, eamque adimplet, atque irrigat aquis supernis. / cum Malchuth influxum accipit a 50 portis per Jesod, tunc vocatur sponsa.
136. Anima quippe humana recedens a sole iustitiae, ab illa scl. interna contemplatione incommutabilis veritatis, omnes vires suas in terrena convertit et eo magis magisque obscuratur in interioribus ac superioribus suis; sed cum redire coeperit ad illam incommutabilem sapientiam, quanto magis ei propinquat affectu pietatis, tanto magis exterior homo corrumpitur, sed interior renovatur de die in diem omnisque lux illa ingenii, quae ad inferiora vergebat, ad superiora convertitur et a terrenis quodam modo aufertur, ut magis magisque huic saeculo moriatur et vita eius abscondatur cum Christo in Deo.
145. die enim quarto in quartum, quartanam naturaliter patitur.
150. Hoc itaque completo scias quod habes corpus corpora perforans et naturam naturam continentem et naturam natura laetantem, quod profecto tyriaca philosophorum vocatur et dicitur vipera, quia sicut vipera, concipiendo prae libidinis ardore, caput secat masculi et pariendo moritur et per medium secatur. Sic lunaris humor, concipiens lucem Solarem sibi convenientem, Solem necat et

- pariendo progeniem Philosophorum, ipsa similiter moritur et uterque parens moriendo animas filio tradunt et moriuntur et pereunt. Et parentes sunt cibus filii.
151. . . . incineretur corpus residuum, quod vocatur terra, a qua est extracta tinctura per aquam . . . Deinde capiti suo iunge et caudae.
152. ἡ φύσις τῇ φύσει τέρπεται, καὶ ἡ φύσις τὴν φύσιν νικᾷ, καὶ ἡ φύσις τὴν φύσιν κρατεῖ.
153. Sic tyrium nostrum (colorem) in unoquoque regiminis gradu sui coloris nomine nuncupamus. / Hoc est sulphur rubeum, luminosum in tenebris: et est hyacinthus rubeus, et toxicum igneum, et interficiens, et Leo victor, et malefactor, et ensis scindens, et Tyriaca sanans omnem infirmitatem.
161. Qui me Miserculam i.e. me habentem materiam Mercurialem et Lunarem . . . ac dilectum meum i.e. pinguedinem solarem mecum i.e. (c)um humiditate Lunari vinculaverit i.e. in unum corpus coniunxerit, *Sagitta Ex Pharetra nostra*.
164. Παρθένος ἡ γῆ εὐρίσκεται ἐν τῇ σὺρῃ τῆς παρθένου.
170. Pulchra es amica mea, suavis et decora sicut Jerusalem: *Terribilis ut castrorum acies ordinata*. 4: *Averte oculos tuos a me quia ipsi me avolare fecerunt . . .* 9: *Quae est ista, quae progreditur quasi aurora consurgens pulchra ut luna, electa ut sol, terribilis ut castrorum acies ordinata?*
176. Procedit Christus quasi sponsus de thalamo suo, praesagio nuptiarum exiit ad campum saeculi . . . pervenit usque ad crucis torum et ibi firmavit ascendendo coniugium; ubi eum sentiret anhelantem in suspiriis creaturam, commercio pietatis se pro coniuge dedit ad poenam . . . et copulavit sibi perpetuo iure matronam.
178. Per cor amor intelligitur, qui in corde esse dicitur, et continens pro contento ponitur, et est similitudo, ab illo qui nimirum aliquam amat, et eius cor amore vulneratur. Ita *Christus amore Ecclesiae vulneratus est in cruce*. Prius vulnerasti cor meum, quando causa amoris tui flagellatus sum, ut te facerem mihi sororem . . . iterum vulnerasti cor meum, quando amore tui in cruce pendens vulneratus sum, ut te sponsam mihi facerem gloriae participem, et hoc in uno oculorum tuorum.
181. . . . illo vulnerato, neci dato ros iungitur.
185. Hic est infans Hermaphroditus, qui a primis suis incunabulis per Canem Corascenum rabidum morsu infectus est, unde perpetua hydrophobia stultescit insanitque. / vilescit per ca[r]nem infirmatus Leo.
186. Naturae siquidem per serpentem introducto morbo, lethali que inflicto vulnere quaerendum est remedium.
188. Mundi vitam enim . . . esse naturae lucem atque caeleste sulphur, cuius subiectum est firmamentalis humor aethereus et calor, ut sol et luna.
190. Alcumistas omnium hominum esse perversissimos.

Minuitur Luna, ut elementa repleat.

Hoc est vere grande mysterium.

Donavit hoc ei qui omnibus donavit gratiam.

Exinanivit earn, ut repleat,

Qui etiam se exinanivit, ut omnes repleret.

Exinanivit enim se ut descenderet nobis,

Descendit nobis, ut ascenderet omnibus ...

Ergo annuntiavit Luna mysterium Christi.

196. Ut cum Deus homo, cum immortalis mortuus, cum aeternus sepultus est, non sit intelligentiae ratio, sed potestatis exceptio; ita rursus e contrario non sensus, sed virtutis modus sit, ut Deus ex homine, ut immortalis ex mortuo, ut aeternus sit ex sepulto.
197. Quia lassae erant creaturae ferendo figuras maiestatis eius, eas suis figuris exoneravit sicut exoneravit ventrem qui eum gestavit.
218. . . . umbra mortis, quoniam tempestas dimersit me; tunc coram me procident Aethiopes et inimici mei terram meam lingent / . . . at qui de dracone comedit non alius est, quam spiritualis Aethiops per draconis laqueos mutatus et ipse in serpentem.
221. *Τὸν θεὸν ἐξ ὕλης συγχρόνου καὶ ἀγενήτου πάντα πεποιηκέναι.*
227. Lapis . . . incipit propter angustiam carceris sudare.
228. Hic princeps sudat ex tribulatione sua cuius sudor pluviae sunt. / In postremis suis operationibus . . . liquor obscuras ac rubens instar sanguinis, ex sua materia suoque vase guttatim exudat; inde praesagium protulerunt, postremis temporibus hominem purissimum in terras venturum, per quem liberatio mundi fieret, hunc ipsum guttas rosei rubeive coloris et sanguineas emissurum, quo mundus a labe redimeretur.
229. Et Marcus dicit, concipiunt in balneis, significat calorem lentum et humidum balneorum, in quibus sudat lapis in principio dissolutionis suae. / Tunc accipitur corpus perfectissimum, et ponitur ad ignem Philosophorum; tunc . . . illud corpus humectatur, et emittit sudorem quendam sanguineum post putrefactionem et mortificationem, Rorem dico Coelicum, qui quidem Ros dicitur Mercurius Philosophorum sive Aqua permanens.
232. Quae cum adparuerit, maribus femina decora adparet, feminis vero adolescentem speciosum et concupiscibilem demonstrat.

II. THE PARADOXA

1. Antiquissimi philosophorum viderunt hunc lapidem in ortu et sublimatione sua . . . omnibus rebus mundi tam realibus quam intellectualibus . . . posse in

similitudinibus convenire. Unde quaecumque dici et tractari possunt de virtutibus et vitiis, de coelo et omnibus tam corporeis quam incorporeis, de mundi creatione . . . et de Elementis omnibus . . . et de corruptibilibus et incorruptibilibus et visibilibus et invisibilibus et de spiritu et anima et corpore . . . et de vita et morte, et bono et malo, de veritate et falsitate, de unitate et multitudine, de paupertate et divitiis, de volante et non volante, de bello et pace, de victore et victo et labore et requie, de somno et vigilia, de conceptione et partu, de puero et sene, de masculo et foemina, de forti et debili, de albis et rubeis et quibuslibet coloratis, de inferno et abyssis et eorum tenebris, ac etiam ignibus sulphureis, et de paradiso et eius celsitudine, et claritate ac etiam pulchritudine et gloria eius inaestimabili. Et breviter de iis, quae sunt et de iis quae non sunt et de iis quae loqui licet et quae loqui non licet possunt omnia dici de hoc lapide venerando.

6. (illa res) vilis et pretiosa, obscura celata et a quolibet nota, unius nominis et multorum nominum.

8. *Τὶ ὑμῖν καὶ τῇ πολλῇ ὕλῃ ἐνὸς ὄντος τοῦ φυσικοῦ καὶ μιᾶς φύσεως νικώσης τὸ πᾶν:*

16. Currens sine cursu, movens sine motu.

17. Fac Mercurium per Mercurium.

21. Tot haec nostra materia habet nomina, quod res sunt in mundo.

24. *εὐκοπώτερον δέ ἐστιν τὸν οὐρανὸν καὶ τὴν γῆν παρελθεῖν ἢ τοῦ νόμου μίαν κεραίαν πεσεῖν.*

27. Iste enim spiritus generatur ex rebus ponticis et ipse vocat ipsum humidum siccum igneum.

30. Puncti proinde, monadisque ratione, res et esse coeperunt primo.

33. Punctum solis id est germen ovi quod est in vitello, quod germen movetur calore gallinae.

34. O admiranda sapientia, quae ex punctulo vix intelligibili, quicquid unquam ingentis machinae huius, vastae ponderosaeque molis a creatione factum est, solo verbo potuit excitare.

37. Ego ducam te ad aeternam mortem, ad inferos et ad domum tenebrosam. Cui anima: Anime mi spiritus. Quare ad eum sinum non reducis, a quo me adulando exceperis? credebam te mihi deuinctum necessitudine. Ego quidem sum amica tua, ducamque te ad aeternam gloriam. / Sed miser ego abire cogor, cum te super omnes lapides preciosos constituero beatamque fecero. Quare te obsecro, cum ad regni solium deveneris, mei aliquando memor existes. / Quod si is spiritus apud animam et corpus manserit, perpetua ibidem esse corruptio.

42. Deus est figura intellectualis, cuius centrum est ubique, circumferentia vero nusquam.
49. triplici muro Castrum aureum circumdatum.
50. aeternitatis imago visibilis.
51. unus in essentia / una substantia homogenea.
59. *Ἵνα ἔχη τὸν σπινθῆρα δουλεύοντα.*
60. Rex natans in mari, clamans alta voce: Qui me eripiet, ingens praemium habebit. / . . . quis est homo qui vivit sciens et intelligens eruens animam meam de manu inferi?
72. Fuit quidam homo, qui nihil quidquam profuit nec detineri potuit: omnes enim carceres confregit, imo et poenas omnes parvi fecit, interea quidam simplex vel humilis et sincerus repertus est vir, qui hujus naturam bene noverat, et consilium tale dederat, ut is omnibus vestibus exutus denudetur. / Vestes abiectae illius ad pedes illius iacebant erantque nimis rancidae, foetidae, venenosae etc. atque tandem hunc in modum loqui incipiebat: ‘Stolam meam exui, quomodo eandem iterum induam?’
76. Quousque terra luceat veluti oculi piscium.
77. Grana instar piscium oculorum. / In principio . . . quasi grana rubea et in coagulatione velut oculi piscium. / Quando veluti oculi piscium in eo elucescunt.
79. Hic lapis est subtus te, supra te, et ergo a te, et circa te.
80. Cuius pulli rostro eruunt matri oculos.
86. Alterius profani sacramenti signum est *θεὸς ἐκ πέτρας* . . . alius est lapis, quem deus in confirmandis fundamentis promissae Hierusalem missurum se esse promisit: Christus nobis venerandi lapidis significatione monstratur.
91. *Ἐπι τὴν Αἴγυπτον ἐν ταῖς μάλιστα μελάγγειον οὖσαν ὥσπερ τὸ μέλαν τοῦ ὀφθαλμοῦ χημίαν καλοῦσιν καὶ καρδίᾳ παρεικάζουσιν.*
92. Est quasi oculus quidam visusque animae, quo saepe affectus animae nobis et consilium indicatur, cuius radiis et intuitu omnia coalescunt.
97. *Ἄοσιριν πολυόφθαλμον . . . πανταχῆ γὰρ ἐπιβάλλοντα τὰς ἀκτῖνας ὥσπερ ὀφθαλμοῖς πολλοῖς κτλ.*
101. *Ἐκ δὲ τῶν ἀτόμων συνελθουσῶν γενέσθαι καὶ τὸν θεὸν καὶ τὰ στοιχεῖα καὶ τὰ ἐν αὐτοῖς πάντα καὶ Ζῶα καὶ ἄλλα κτλ.*
104. Si homo res in maiori mundo transmutare novit . . . quanto magis id in microcosmo, hoc est, in se ipso noverit, quod extra se potest, modo cognoscat

hominis in homine thesaurum existere maximum et non extra ipsum.

107. Chemicam artem naturaliter exercet Archeus in homine.
108. Quia homo est in corruptione generatus, odio prosequitur eum sua propria substantia.
109. Armoniac sal id est stella. / Ista est optima, quae extrahitur vi chalybis nostri qui invenitur in ventre Arietis . . . ante debitam coctionem est summum venenum.
110. Homo quidam est esca, in qua[m] per cotem scl. Mercurium, et chalybem (scl.) Caelum, ignis huiusmodi scintillae excussae, fomentum accipiunt, viresque suas exserunt.
112. Nam in rerum natura nihil est, quod non in se mali tantum quantum boni contineat.
133. Matrimonium enim quasi pallium hoc quicquid est vitii, tegit et abscondit.
134. Scorpio i.e. venenum. Quia mortificat seipsum et seipsum vivificat. /
Εὐοί, δίκερως δίμορφε! deus iste vester non biformis est, sed multiformis . . . ipse est basiliscus et scorpio . . . ipse malitiosus anguis . . . ipse tortuosus draco, qui hamo ducitur . . . iste deus vester Lernaevi anguis crinibus adornatur.
135. . . . *ἀνάστηθι ἐκ τοῦ τάφου . . . καὶ τὸ φάρμακον τῆς ζωῆς εἰσῆλθεν πρὸς σέ . . .* / Spiritus tingens et aqua metallina perfundens se in corpus ipsum vivificando.
137. Hanc Omnia esse, Omnia in se habere, quibus indiget ad sui perfectionem, Omnia de ipsa praedicari posse et ipsam vicissim de omnibus.
138. Unum enim est totum, ut ait maximus Chimes, ob quod
Χύμης δὲ καλῶς ἀπεφῆνατο· Ἐν γὰρ τὸ πᾶν καὶ δι' αὐτοῦ τὸ πᾶν sunt omnia, et si totum non haberet totum nihil totum esset. /
γέγονεν. ἐν τὸ πᾶν. καὶ εἰ μὴ πᾶν ἔχοι τὸ πᾶν οὐ γέγονε τὸ πᾶν.
140. materiam nostram simul esse in caelo, terris et aquis, tanquam totam, in toto, et totam in qualibet parte: adeo ut partes illae, alioquin separabiles, nusquam ab invicem separari possint, postquam unum facta sunt: hinc tota Lex et Prophetia chemica pendere videtur.
144. Quisnam igitur liber? Sapiens, sibi qui imperiosus, quem neque pauperies neque mors neque vincula terrent, respondere cupidinibus, contemnere honores fortis, et in se ipso totus teres atque rotundus.
146. Nam ipsa est continens contentum in se convertens, atque sic est sepulchrum seu continens, non habens in se cadaver seu contentum, veluti Lothi coniunx ipsa sibi sepulchrum fuisse dicitur absque cadavere et cadaver absque sepulchro.
148. crassities aëris et omnia membra in atomos divellantur. /
ποτὲ δὲ νέκυν ἢ θεὸν ἢ τὸν ἄκαρπον / Et sicut sol a principio occultatur in lunam, ita in fine occultatus extrahitur a luna.
150. Nam et eius (corporis mortui) odor est malus, et odori sepulchrorum assimilatur.

151. Purus laton tandiu decoquitur, donec veluti oculi piscium elucescat.
152. Posito hoc Uno in suo sepulcro sphaerico. / (Vas) dicitur etiam sepulcrum.
157. Tumulus ergo in quo Rex noster sepelitur Saturnus . . . dicitur.
158. In adytis habent idolum Osiridis sepultum.
159. Hinc dicit Avicenna: Quamdiu apparuerit nigredo, dominatur obscura foemina, et ipsa est prior vis nostri lapidis.
162. Extat epitaphium antiquum Bononiae quod multorum fatigavit ingenia . . . Sunt qui hoc aenigma interpretentur animum hominis, alii nubium aquam, alii Nioben in Saxum mutatam, alii alia.
166. (Epitaphium) loquitur nempe . . . de filia Laelio nascitura, eademque sponsa Agathonis designata, sed non filia, sed non sponsa, quia concepta, non edita; quia non orta, sed aborta; qua propter tali ac tanta spe frustratus Agatho, jam pridem delectus in coniugem, et a sorte elusus, hac Aenigmatica Inscriptione iure merito sic et ipse lusit, vel ludentis speciem praebuit.
169. Itaque vocatus sum Hermes Trismegistus, habens tres partes philosophiae totius mundi.
170. Numero Deus impari gaudet.
174. Hic serpens est calidus, quaerens exitum ante ortum, perdere volens foetum, cupiens abortum.
175. Naturae subtilitas . . . causam dedit augmentationis et vitae, et se in naturas perfectissimas reduxit. / Hic Serpens . . . tanquam Bufo nigerrimus tumescit et . . . petit a sua tristitia liberari.
179. Dico Aeliam Laeliam Crispem ex Hamadryadibus unam fuisse . . . i.e. Quercui in Suburbano agro Bononiensi applicitam, seu inclusam, quae mollissima simul et asperrima apparens jam a bis mille forsitan annis inconstantissimos Protei in morem tenens vultus Lucii Agathonis Prisci civis tunc Bononiensis Amores ex Chao certe, i.e. confusione Agathonia . . . elicitos anxiiis curis et sollicitudinibus implevit.
182. Tertium tandem aenigma erit de Quercu, mundum elementarem repraesentantem in caelesti quodammodo viridario plantata, ubi Sol et Luna duo veluti flores circumferuntur.
189. Induxit quercum veterem fissam per medium, (qui) tuetur a solis radiis, umbram faciens.
190. Primo duro lapide et claro clauditur, tum demum cava quercu.
193. *Τὸ σωτήριον ἐκείνο ὕδωρ, καὶ τάφος ὑμῖν ἐγένετο καὶ μήτηρ.*
195. Per matricem, intendit fundum cucurbitae. / Vas spagiricum ad similitudinem vasis naturalis esse construendum.

196. Locus generationis, licet sit artificialis, tamen imitatur naturalem, quia est *concavus, conclusus*.
198. Quod enim est matrix embrioni, hoc est aqua fideli. In aqua enim fingitur et formatur. Primum dicebatur: Producant aquae reptile animae viventis. Ex quo autem Jordanis fluente ingressus est Dominus non amplius reptilia animarum viventium, sed animas rationales Spiritum Sanctum ferentes aqua producit.
199. Arbores quae in ipso (paradiso) sunt, concupiscentiae sunt et ceterae seductiones corrumpentes cogitationes hominum. Illa autem arbor quae est in paradiso, ex qua agnoscitur bonum, ipse est Jesus et scientia eius quae est in mundo; quam qui acceperit, discernit bonum a malo.
204. Item dixit Marchos et est tempus in isto genito quod nascitur de quo facit talem similitudinem. Tunc aedificabimus sibi talem domum, quae dicitur monumentum Sihoka. Dixit, terra est apud nos quae dicitur tormos, in qua sunt reptilia comedentes opaca ex lapidibus adurentibus, et bibunt super eis sanguinem hircorum nigrorum, manentes in umbra, concipiunt in balneis, et (pariunt) in aëre et gradiuntur supra mare et manent in monumentis et etiam manent in sepulchris, et pugnat reptile contra masculum suum, et in sepulchro manet masculus eius 40 noctibus ...
215. Christus in deserto quadraginta diebus totidemque noctibus ieiunavit, quemadmodum etiam per quadraginta menses in terra concionatus est, et miracula edidit, per quadraginta horas in sepulcro iacuit: quadraginta dies, inter resurrectionem a mortuis et ascensionem suam ad coelos, cum discipulis conversatus vivum esse ipsis repraesentavit.
219. Marmor coruscans est elixir ad album. / Et proiicient semen super marmore simulachrorum et in aqua sibi simili deifica, et venient corvi volantes, et cadunt super illud simulacrum. Intendit nigredinem . . . per corvos. / Maximum quidem mysterium est creare animas, atque corpus inanime in statuum viventem confingere. / Tunc autem haec fiet, cum statua venerit. / Semper extrahis oleum (= anima) a corde statuarum: quia anima est ignis in similitudine, et ignis occultatus. / Calefacimus eius aquam extractam a cordibus statuarum ex lapidibus. / Animas venerari in lapidibus: est enim mansio eorum in ipsis.
236. Cum mea me mater gravida gestaret in alvo,
Quid pareret fertur consuluisse deos.
Phoebus ait: Puer est; Mars: Femina; Juno: Neutrum.
Jam qui sum natus Hermaphroditus eram.
Quaerenti letum dea sic ait: Occidet armis;
Mars: Cruce; Phoebus: Aqua. Sors rata quaeque fuit.
Arbor obumbrat aquas; conscendo, labitur ensis

Quem tuleram casu, labor et ipse super;

Pes haesit ramis, caput incidit amne, tulique

—Vir, mulier, neutrum—flumina, tela, crucem.

237. Vir non vir, videns non videns, in arbore non in arbore, sedentem non sedentem, volucrem non volucrem, percussit non percussit, lapide non lapide.

ὅτι βάλοι ξύλω τε καὶ οὐ ξύλω καθημένην ὄρνιθα καὶ οὐκ ὄρνιθα ἀνὴρ τε

238. *κ' οὐκ ἀνὴρ λίθω τε καὶ οὐ λίθω * τούτων γάρ ἐστι τὸ μὲν νάρθηξ, τὸ δὲ νυκτηρίς, τὸ δὲ εὐνοῦχος, τὸ δὲ κίσηρις.*

242. Ὁ τύμβος οὗτος ἔνδον οὐκ ἔχει νεκρὸν [Οἱ νέκυν],

ὁ νεκρὸς οὗτος ἐκτὸς οὐκ ἔχει τάφον

ἀλλ' αὐτὸς αὐτοῦ νεκρὸς ἐστὶ καὶ τάφος.

243. Igneus est illi vigor et coelestis origo, a qua nunc hic Haelia nominatur.

245. Habet in se . . . totius Humanitatis quasi dicerem *αὐτότητα*.

246. Sic si seipsam volet anima cognoscere, in animam debet intueri, inque eum praecipue locum, in quo inest virtus animae, sapientia.

247. Nihil aliud esse hominem quam animam ipsius.

248. Animamque ut ideam hoc Epitaphio notari.

249. Prima materia cum nihil sit, sed imaginatione sola comprehendatur, nullo istorum locorum contineri potest.

251. Scopum Autoris esse mirifice complecti Generationis, Amicitiae ac Privationis attributa.

255.

Crispulus ille, quis est, uxori semper adhaeret?

Qui Mariane tuae? Crispulus iste quis est?

260. (Anima) quae extra corpus multa profundissima imaginatur et hisce assimilatur Deo.

III. THE PERSONIFICATION OF THE OPPOSITES

4. Domine, quamvis rex sis, male tamen imperas et regis.

5. Aurum nostrum non est aurum vulgi.

6. Aurum et argentum in metallina sua forma lapidis nostri materiam non esse.

7. Substantia aequalis, permanens, fixa, longitudine aeternitatis. / Est enim Sol radix incorruptibilis. / Immo non est aliud fundamentum artis quam sol et eius umbra.

9. Scias igitur quod ignis sulphur est, id est Sol.

10. Sol noster est rubeus et ardens. / Sol nihil aliud est, quam sulphur et argentum vivum.

15. (Tractans de quadam virtute invisibili) vocat eam balsamum, omnem corporis naturam excèdentem, qui duo corpora coniunctione conservat, et coeleste corpus una cum quatuor elementis sustentat.
18. Fatuum esset cum plurimis credere, solem esse duntaxat ignem caelestem.
20. Ut fons vitae corporis humani, centrum est cordis eius, vel id potius quod in eo delitescit arcanum, in quo viget calor naturalis.
21. Ἡλῖος ὁ πάντα ποιῶν.
22. quorumvis seminaria virtus atque formalis delitescit. / Punctum solis i. e. germen ovi, quod est in vitello.
23. Masculinum et universale semen primum et potissimum est eius naturae sulphur, generationum prima pars omnium, ac potissima causa. Proinde a Paracelso prolatum est, sol et homo per hominem, generant hominem.
24. Terra fecit Lunam . . . deinde ortus est sol . . . post tenebras quas posuisti ante ortum solis in ipsa.
27. Et hoc modo Alchemia est supra naturam et est divina. Et in hoc lapide est tota difficultas istius artis, neque potest assignari sufficiens ratio naturalis, quare hoc ita esse possit. Et sic cum intellectus non possit hoc comprehendere, nec satisfacere sibi, sed oportet ipsum credere, sicut in miraculosis rebus divinis, ita ut fundamentum fidei Christianae, quod supra naturam existit, a non credentibus primo existimetur verum omnino, quoniam finis eius miraculose et supra naturam completur. Ideo tunc solus Deus est operator, quiescente natura artifice.
29. Cum non suffecissem mirari de tanta rei virtute sibi coelitus indita et infusa.
30. Porro in humano corpore latet quaedam substantia caelestis naturae paucissimis nota, quae nullo penitus indiget medicamento, sed ipsamet est sibi medicamentum incorruptum.
33. Non intelligit animalis homo . . . facti sumus sicut lapides oculos habentes et non videntes.
37. Cum Solem . . . Plato visibilem filium Dei appellet, cur non intelligamus nos imaginem esse invisibilis filii. Qui si lux vera est illuminans omnem *mentem* expressissimum habet simulachrum hunc Solem, qui est lux imaginaria illuminans omne corpus.
38. Qui autem sapientum venenum sole et eius umbra tinxit, ad maximum pervenit arcanum. / In umbra solis est calor Lunae.
39. Fili, extrahe a radio umbram suam.

40. terra auri suo proprio spiritu solvitur. / . . . obscuratus est Sol in ortu suo. Et haec denigratio est operis initium, putrefactionis indicium, certumque commixtionis principium.
41. In manifesto sunt corporalia et in occulto spiritualia.
42. Sicut sol a principio occultatur in Lunam, ita in fine occultatus extrahitur a Luna.
45. quae ex radiis Solis vel Lunae vi magnetis extracta est.
46. Sine sole terreno opus Philosophicum non perficitur.
50. Sicut enim sol sub nube, sic sol iustitiae latuit sub humana carne.
81. Sulphur est omne id quod incenditur, nequicquam concipit flammam nisi ratione sulphuris. / Sulphur enim aliud nihil est quam purus ignis occultus in mercurio. / simplex ignis vivus, alia corpora mortua vivificans.
97. Sulfura sunt animae, quae in quatuor fuerant occultae corporibus.
101. quousque natus viridis tibi appareat, qui eius est anima, quam viridem avem et aes et sulphur philosophi nuncupaverunt.
104. Pater et semen virile. / Substantia sulphuris quasi semen paternum, activum et formativum.
108. Sed quod maius est, in Regno eius est speculum in quo totus Mundus videtur. Quicumque in hoc speculum inspicit, partes sapientiae totius Mundi in illo videre et addiscere potest, atque ita sapientissimus in hisce Tribus Regnis evadet.
109. Domine, scitne etiam Sulphur aliquid in metallis? Vox: Dixi tibi, quod omnia scit et in metallis multo melius quam alibi. / est cor omnium rerum.
116. candelulae, quas vetulae ad accendendum ignem vulgo vendunt. / elychnia ex sulphure, quo subducuntur fila aut ligna.
130. In Sulphure Philosophorum totum hoc arcanum latet, quod etiam in penetralibus Mercurii continetur.
133. Caput eius vivit in aeternum et ideo caput denominatur vita gloriosa, et angeli serviunt ei.
140. Animans autem vis, tanquam mundi glutinum, inter spiritum atque corpus medium est, atque utriusque vinculum, in Sulphure nimirum rubentis atque transparentis olei cuiusdam, veluti Sol in Majore Mundo, et cor Microcosmi.
141. ab omni feculentia terrestri, et cadit Lucifer: hoc est, immunditia et terra maledicta e coelo aureo.
143. pinguedo in cavernis terrae.
146. Res ex qua sunt res est Deus invisibilis et immobilis, cuius voluntate intelligentia condita est, et voluntate et intelligentia est anima simplex, per animam sunt naturae

discretæ, ex quibus generatæ sunt compositæ.

149. Non habet in actu suo finem, quia tingit in infinitum.

170. Idque Philosophi diversimodo indigitarunt, atque Sponso et Sponsæ (quemadmodum etiam Salomon in Cantico Canticorum suo ait) compararunt.

177. Verum Luna, cum infimus sit planetarum, ut matrix concipere fertur virtutes astrorum omnium, rebusque inferioribus deinceps impartiri . . . Luna universas siderum vires . . . gignendis rebus cunctis et potissimum earum seminibus infert inseritque. / . . . etiam in interraneis eiusdem (scl. terræ) visceribus lapidum, metallorum, imo animantium species excitando condendoque.

180. Iste vult concumbere cum matre sua in medio terræ. / Et coelum corporum incorruptibilium et inalterabilium sedes et vas est Luna, quæ humiditati præsidet, aquam et terram repræsentat.

181. Cum autem videris terram sicut nivem albissimam . . . est cinis a cinere et terra extractus, sublimatus, honoratus . . . est quaesitum bonum, terra alba foliata.

182. Primum enim opus ad Album in Domo Lunæ.

188. Sed nescio quæ proprietas . . . et quædam natura inest lumini, quod de ea defluit, quæ humectet corpora et velut occulto rore madefaciat.

191. *πηγή αέναος τοῦ παραδείσου.* / mortalium corporum autor et conditrix / *φυσικὸν* autem, id est crescendi natura, de lunari ad nos globositate perveniunt.

192. *τὴν δε ψυχὴν ἢ σελήνη . . . παρέσχεν εἰς τὴν γένεσιν.*

197. Forsitan vultis videre sacratissimas arbores Solis et Lunæ, quæ annuntient vobis futura.

204. In maris Luna est spongia plantata.

205. Illud vero quod est vapor, vel in eis partibus subtilitas non retinetur nisi a corpore duro . . . et quandoque est lapis qui circumdat substantias velut spongia. / Sol et Luna cum prima aqua calcinantur philosophice, ut corpora aperiantur, et fiant spongiosa et subtilia, ut aqua secunda melius possit ingredi. / Pars superior est anima, quæ totum lapidem vivificat et reviviscere facit. / Zoophyton, neque animal, neque frutex, sed tertiam habet quandam naturam.

208. quod radices suarum minerarum sunt in aëre, et summitates in terra. Et quando evelluntur a suis locis, auditur sonus terribilis, et sequitur timor magnus. Quare vade cito, quia cito evanescunt.

219. Et sicut omnes res fuerunt ab uno, meditatione unius: sic omnes res natae fuerunt ab hac una re, adaptatione. / Pater eius est Sol, mater eius Luna; portavit illud ventus in ventre suo. / Aër mediator inter ignem (= Sol) et aquam (= Luna) per calorem et humiditatem suam. / Aër est vita uniuscuiusque rei. / Natus sapientiæ in aëre nascitur.

220. . . spiritus et anima quando decocti fuerint, in iteratione destillationis, et tunc permiscentur permixtione universali, et unus retinebit alterum et fient unum. Unum in subtilitate et spiritualitate ...
227. Dixit magister noster Belenius Philosophus, ponas lumen tuum in vase vitreo claro et nota quod omnis sapientia mundi huius circa ista tria versatur.
228. Una vero die vocavit me magister meus Bolemus Philosophus et dixit mihi: eja fili, spero te esse hominem *spiritualis intellectus*, et quod poteris pertingere ad gradum supremum sapientiae.
234. Ἑρμῆ κοσμοκράτωρ, ἐγκάρδιε, κύκλε σελήνης, στρογγύλε καὶ τετράγωνε.
239. Ciconia serpentes devorat, carnes eius contra omnia venena valent.
243. Natus est draco in nigredine, et . . . interficit seipsum.
244. Mundi animam praecipue in Sole collocamus.
248. Draco non moritur nisi cum fratre suo et sorore sua.
253. intellectum qui actu est, Lunam eum, qui est potentia.
258. Hinc illud Chaldaeorum: Vas tuum inhabitant bestiae terrae, et apud Platonem in republica discimus habere nos domi diversa genera brutorum.
260. Et lunari certe semicirculo (☾) ad solare (☉) complementum perducto: Factum est vespere et mane dies unus. Sit ergo primus, quo lux est facta Philosophorum.
261. Lunam terram statuimus infimam ignobilissimamque omnium siderum, uti est terra omnium elementorum opacitate, itidem substantiae et maculis illi persimilem.
262. Lunam quidem scimus omnibus inferiorem.
270. Luna enim est umbra Solis, et cum corporibus corruptibilibus consumitur et per ipsius corruptionem . . . Leo eclipsatur.
271. Et sicut aetheris et aëris: ita divinorum et caducorum luna confinium est.
272. A luna deorsum natura incipit caducorum, ab hac animae sub numerum dierum cadere et sub tempus incipiunt. . . . Nec dubium est, quin ipsa sit mortalium corporum et autor et conditrix.
274. Secunda empirica (metodica) i.e. experientissima inventa est ab Esculapio.
276. . . . quod fieri dicunt, cum Lunae lumen incipit crescere, usque ad quintam decimam Lunam, et rursus ad tricesimam minui, et redire ad cornua, donec nihil penitus lucis in ea appareat. Secundum hanc opinionem Luna in allegoria . . . significat ecclesiam, quod ex parte quidem spirituali lucet ecclesia, ex parte autem carnali obscura est.
280. mitis electis, terribilis reprobis, pastor verus. / vel qui alii hujus gregis canes vocantur, nisi doctores sancti?
283. [Hermes] dixit: Fili, accipe canem masculum Corascenen et caniculam Armeniae, et iunge in simul, et parient canem coloris coeli, et imbibe ipsum una siti ex aqua

maris: quia ipse custodiet tuum amicum et custodiet te ab inimico tuo et adiuvabit te ubicunque sis, semper tecum existendo in hoc mundo et in alio. Et voluit dicere Hermes, pro cane et canicula, res quae conservant corpora a combustione ignis et eius caliditate.

285. Hali, Philosophus et Rex Arabiae in suo Secreto dicit: Accipe canem coëtaneum, et catulam Armeniae, iunge simul, et hi duo parient tibi filium canem, coloris coelici: et iste filius servabit te in domo tua ab initio in hoc Mundo et in alio.
299. Rumpe ergo domum, frange parietes, purissimum inde extrahe succum cum sanguine; coque ut edere possis. Unde dicit Arnaldus in libro Secretorum: Purga lapidem: tere portam: frange *caniculam*: elige carnem teneram, et habebis rem optimam. In una ergo re omnia membra latent, omnia metalla lucent. Horum duo sunt artifices, duo vasa, duo tempora, duo fructus, duo fines, una salus.
305. Utraque avis volans ad regum mensas et capita salit. / Et venient corvi volantes et cadunt supra illud.
306. Recipe Gallum, crista rubea coronatum et vivum plumis priva.
311. Aquae . . . , quae *Canis Balsami* dicitur, sive lac virginis, aut argentum vivum nostrum, seu anima, aut ventus aut cauda draconis.
315. . . . recipit ille globus carnem, id est coagulationem, et sanguinem, id est tincturam. / Ex his possunt philosophicae transmutationes intelligi: nonne scimus et panis et vini puriorem substantiam in carnem et sanguinem transmutari / Iam suam carnem sanguineam et rubeam tradit omnibus manducandam. / habere scientiam corporis, grossi, turbidi, carnei, quod est pondus naturarum, et pervenit ad animam simplicem.
316. Est enim lapis unus, una medicina, cui nil extranei additur, nec diminuitur, nisi quod superflua removentur. / Unus est lapis, una medicina, unum vas, unum regimen, unaque dispositio.
319. Primum enim opus ad Album in domo Lunae, secundum in secunda Mercurii domo terminari debet. Primum autem opus ad rubeum in secundo Veneris domicilio; postremum vero in altero regali Jovis solio desinet, a quo Rex noster potentissimus coronam pretiosissimis Rubinis contextam suscipiet. / Albus (lapis) in occasu Solis incipit apparere super facies aquarum, abscondens se usque ad mediam noctem et postea vergit in profundum. Rubeus vero ex opposito operatur, quia incipit ascendere super aquas in ortu Solis usque ad meridiem et postea descendit in profundum.
320. Et opus secundum est albificatio et rubificatio, et sapientes haec duo opera in unum contraxerunt. Nam quando loquuntur de uno, loquuntur etiam et de alio, unde diversificantur legentibus eorum scripta.

321. Cur arborem dimisisti narrare, cuius fructum qui comedit, non esuriet unquam? / Dico quod ille senex de fructibus illius arboris comedere non cessat ad numeri perfectionem, quousque senex ille iuvenis fiat. . . . Pater filius factus est.
322. Tibimet, Dei vates, in visione visus es tanquam vitis ampla, universum orbem implens divinis verbis, quasi fructibus. / An ignoratis quod tota divina pagina parabolice procedit? Nam Christus . . . modum servavit eundem et dixit: Ego sum vitis vera.
324. Spagyri . . . ex ipsa Luna oleum eliciunt . . . adversus morbum caducum, omnesque cerebri affectus.
326. *Μανίας περιπίπτουσιν ἄλλ' οὐ νοῖ.*
329. In philosophica Mercurii sublimatione sive praeparatione prima Hercules labor operanti incumbit . . . limen enim a cornutis belluis custoditur . . . earum ferocitatem sola Dianae insignia et Veneris columbae mulcebunt, si te fata vocant.
335. Claves habet ad carceres infernales, ubi sulphur ligatum iacet.
337. *Ψυχὴ . . . ἔλαφον (ἐλάφου Miller) μορφὴν περικειμένη κοπιᾷ θανάτῳ μελέτημα (θανάτου μελέτησι Diels) κρατουμένη.*
350. Columba fuit Dominus Jesus . . . dicens Pax Vobis . . . En Columba, en oliva virens in ore. / Unde Propheta exclamat: Quis dabit mihi pennas [sic] ut columbae, videlicet cogitationes contemplationesque immaculatas ac simplices.
358. Ego sum illuminans omnia mea et facio lunam apparere patenter de interiore de patri meo Saturno et etiam de matre dominante, quae mihi inimicatur.
360. matrem et uxorem solis, quae foetum spagiricum a sole conceptum in sua matrice uteroque vento gestat in aëre.
369. . . . cum hac tinctura vivificantur omnes mortui, ut semper vivant, et hoc est fermentum primum elementatum, et est ad Lunam, et hoc est lumen omnium luminum, et est flos et fructus omnium luminum, quod illuminat omnia.
370. Primum namque aqua destillata pro Luna aestumatur: Sol enim, tamquam ignis, in ea occultatus est.
379. Quartus est Infemalis intelligibili oppositus, ardoris et incendii absque ullo lumine.
383. Sal autem reperitur in nobili quodam Sale et in rebus omnibus; quo circa veteres Philosophi illud vulgarem Lunam appellarunt.
384. (Deum habere) circa se ipsum amorem. Quem alii spiritum intellectualem asseruere et igneum, non habentem formam, sed transformantem se in quaecumque voluerit, et coequantem se universis. . . . Unde rite per quandam similitudinem animae naturae Deum aut Dei virtutem, quae omnes res sustinet, Animam mediam naturam, aut animam Mundi appellamus.

397. Primo fit cinis, postea sal, et de illo sale per diversas operationes Mercurius Philosophorum.
404. Qui non gustaverit saporem salium, nunquam veniet ad optatum fermentum fermenti.
410. Alexander Magnus, Macedoniae Rex, ad nos, in Philosophia sua ita ait: Benedictus Deus in coelo siet, qui artem hanc in Sale creavit.
425. (In initio) Sal est nigrum ferme ac foetidum.
- 441.
- Est lapis occultus, et in imo fonte sepultus,
Vilis et eiectus, fimo vel stercore tectus ...
Et lapis hic avis, et non lapis, aut avis hic est ...
... nunc spuma maris vel acetum,
....
Nunc quoque gemma salis, Almisadir sal generalis
....
Nunc mare purgatum cum sulphure purificatum ...
445. . . . cuius collum aureus fulgor, reliquum corpus purpureus color in pennis cinxit.
451. Ad hoc, scl. (corpus) spirituale, ignis, ad illud vero scl. corruptibile Sal refertur.
453. Profundum maris sedem intelligamus inferni.
462. Diabolus maria undique circumdat et undique pontum.
463. (imaginationis) res amaras ut lachrymas, tristitiam et vermem conscientiae.
464. Gustus torquebitur perpetua fame sitique rabiosa, in quarum levamen dabitur miseris Damnatis pro cybo absynthium, pro potu autem aqua fellis.
466. Mare Rubrum significat Baptismum.
467. Mare rubrum est baptismus sanguine Christi rubicundus, in quo hostes scl. peccata, merguntur.
479. Melius est gaudere in opere, quam laetari in divitiis sive virtuoso labore.
509. Ibi Oryx in summo aestu sitibunda lachrymis quasi effusis et gemitibus iteratis ardorem solis detestari traditur.
510. Res, cuius caput est rubeum, oculi nigri et pedes albi, est magisterium.
516. Tum tua res agitur, paries cum proximus ardet.
518. Fenix arabie avis dicta quod colorem fenicium habeat et quod sit in toto orbe singularis et unica.
519. Quem tu hic quaeris, inquit, peregrine? Ad virginem non licitum est viro appropinquare.

529. Doceat nos haec avis vel exemplo sui resurrectionem credere. / Cur igitur Judaei iniqui, Domini nostri Jesu Christi triduanam resurrectionem non crediderunt, cum avis trium dierum spatio seipsam suscitaret?
532. Sapiens, pennas cui dabis, oro, tuas.
533. Divitiae cedant et opes, huic cedat et aurum, cui mens non eadem, non homo, sed pecus est.
540. Pater ejus est Sol, mater ejus Luna; portavit illud ventus in ventre suo; nutrix ejus terra est.
Vis ejus integra est, si versa fuerit in terram.
Ascendit a terra in coelum, iterumque descendit in terram et recipit vim superiorum et inferiorum. Sic habebis gloriam totius mundi.
550. Draco mulierem et haec illum interimit, simulque sanguine perfunduntur.
552. Aenigmate hoc olim involutum est a Philosophis: fac fixum, inquiunt, volatile, et rursus volatile fixum, et totum habebis magisterium.
553. Nemo enim ascendit in caelum, quod quaeritis, nisi qui de caelo (quod non quaeritis) descendit, illuminet eum.
555. Disce ex te ipso, quicquid est et in caelo et in terra, cognoscere, ut sapiens fias in omnibus. Ignoras caelum et elementa prius unum fuisse, divino quoque ab invicem artificio separata, ut et te et omnia generare possent? Si hoc nosti, reliquum et te fugere non potest, aut ingenio cares omni. Rursus in omni generatione, separatio talis est necessaria, qualem de te supra dixi fiendam, antequam ad verae philosophiae studia velum applices. Ex aliis nunquam unum facies quod quaeris, nisi prius ex te ipso fiat unum.
556. Simul descensus in quatuor et ascensus ad monadem. / Decoquendus igitur, assandus, et fundendus: ascendit atque descendit, quae quidem operationes omnes unica sunt igne solo facta (operatio).
557. Lapis noster transit in terram, terra in aquam, aqua in aerem, aer in ignem, ibi est status, sed descendetur e converso.
559. Hac similitudine tibi satisfaciam: Filius Dei delapsus in virginem ibique caro figuratus homo nascitur, qui cum nobis propter nostram salutem veritatis viam demonstrasset, pro nobis passus et mortuus, post resurrectionem in coelos remeant. Ubi terra, hoc est humanitas, exaltata est, super omnes circulos mundi, et in coelo intellectuali sanctissimae Trinitatis est collocata.
570. Dehinc (animam) descendentem per quosdam circulos a principatibus malignis capi et secundum voluntatem victoris principis in corpora diversa contrudi eisque adscribi chirographum.

578. Itaque vocatus sum Hermes Trismegistus, habens tres partes Philosophiae totius mundi.
580. Vis eius integra est, . . . si versa fuerit in terram.
584. Nam serpentes ideo introrsum spectantia capita habent ut significant inter se legatos colloqui et convenire debere . . . Unde enim . . . legati pacis caduceatores dicuntur . . . Quibus caduceis duo mala adduntur unum Solis aliud Lunae . . . Mercurius haec tam fera animalia concordat, nos quoque concordare debere certum est. / Alii Mercurium quasi medicurrium a latinis dictum volunt, quod inter coelum et inferos semper incurrat . . . Caduceus illi adeo adsignatur, quod fide media hostes in amicitiam conducit. / Perfacile is discordes animos in concordiam trahet, duosque angues, hoc est odia mutua, doctrinae suae virgâ in unum obligabit.
585. Primo regnat Saturnus in nigredine.
587. Ut per solutionem corpora solvuntur, ita per cognitionem resolvuntur philosophorum dubia.
595. Laton autem est immundum corpus.
597. Laton est ex Sole et Luna compositum corpus imperfectum citrinum; quod cum dealbaveris et . . . ad pristinam citrinitatem perduxeris, habes iterum Latonem . . ., tunc intrasti ostium, et habes artis principium.
600. Azoth et ignis latonem abluunt, et nigredinem ab eo auferunt.
601. Ignis et aqua latonem abluunt et eius nigredinem abstergunt.
602. *θεωρῶν ἐν μέσῳ τῶν ρείθρων τόν ποτε
παίδων τριῶν μέσον θανέντα δρόσον ἐν
πυρὶ νῦν πῦρ ἐν τῷ Ἰορδάνῃ λάμπρον κτλ.*
603. Et si in fonte auri et argenti *baptisati* fuerimus et spiritus corporis nostri cum patre et filio in coelum ascenderit, et descenderit, animae nostrae reviviscent, et corpus meum animale candidum permanebit, scl. Lunae.
604. Quando autem baptizat tunc infundit animam.
608. *Ἐν γὰρ τῷ Ἄδῃ κατάκλεισον αὐτά / ἐν τῷ Ἄδῃ κλείσατε αὐτά /
πιτρώσκουσιν αὐτὴν κλύδωνες . . . ἐν τῷ Ἄδει καὶ ἐν τῷ τάφῳ ἐν ᾧ
κατάκεινται. Ὄταν δὲ ἀνεωχθῇ ἡ τάφος, ἀναβήσονται αὐτὰ ἐξ Ἄδου ὡς
οἷα βρέφος ἐκ γαστροῦ.*
609. *Τὸ σωτήριον ἐκείνο ὕδωρ καὶ τάφος ὑμῖν ἐγένετο καὶ μήτηρ.*
610. Aqua velut morientem deducit in tumulum: spiritus sanctus velut resurgentem perducit ad caelum.
615. *ἀετὸς χαλκοῦς κατερχόμενος ἐν πηγῇ καθαρᾷ καὶ λουόμενος καθ' ἡμέραν
ἐντεῦθεν ἀνανεούμενος.
ἐγὼ φυτὸν ὄνομα βαίτις, ἐγὼ ἀπόρροια αἵματος . . . ὃ ἐκπεφυκὼς ἐκ τοῦ
Βυθοῦ . . ., ἐγὼ εἶμι τὸ ἱερὸν ὄρνεον Φοῖνιξ . . ., ἐγὼ εἶμι ὁ Ἥλιος*
616. *. . . ἐγὼ εἶμι Ἀφροδείτη . . . ἐγὼ εἶμι Κρόνος, ὃ δεδειχὼς φῶς . . .
ἐγὼ εἶμι Ὅσιρις ὃ καλούμενος ὕδωρ, ἐγὼ εἶμι Ἴσις ἢ καλουμένη δρόσος,
ἐγὼ εἶμι Ἡσενεφυς ἢ καλουμένη ἔαρ.*

619. Terra alba foliata est corona victoriae, quae est cinis extractus a cinere, et corpus eorum secundum.
626. lapis albus, sol albus, Luna plena, terra alba fructuosa, mundificata et calcinata.
633. *σώματα ὄντα πνεύματα γίνονται, ἵνα ἐν τῇ κατάβαφῇ τοῦ πνεύματος βάψει.*
640. Sale et facetiis Caesar . . . vicit omnes.
642. Sal est in se uno continens aquae et ignis elementum; et hoc ex duobus est unum.
661. *Τοσαύτη κλείς λόγου τῆς ἐγκυκλίου τέχνης ἢ σύνοψις.* / Quanto magis libros legebam, tanto magis mihi illuminabatur.
680. O aquam in acerba specie, quae tu elementa conservas! o naturam vicinitatis, quae tu naturam solvis! o naturam optumam, quae tu naturam ipsam superas! . . cum lumine coronata et nata es . . . et quinta essentia ex te orta est.
682. O aquam in amara acerbaque specie! Durum enim difficileque cui vis, ut fontem illum inveniat.
688. Quae cum ita sint, satis erit humano ingenio post lucem fidei, Divinae maiestatis veluti refractos radios in mundo, et rebus creatis agnoscere.
689. Esse in Chemia nobile aliquod corpus . . . in cuius initio sit miseria cum aceto, in fine vero gaudium cum laetitia, ita et mihi eventurum praesupposui, ut primo multa aspera, amara, tristia, taediosa gustarem, perferrem et experirer, tandem omnia laetiora et facilia visurus essem.
691. *ὁ καθολικὸς ὄφεις, φησὶν, οὗτός ἐστι ὁ σοφὸς τῆς Εὐας λόγος.*
692. Pater omnis telesmi est hic.

IV. REX AND REGINA

5. . . . occidit Osirim artuatimque laceravit et per omnes Nili fluminis ripas miseri corporis palpitantia membra proiecit. / Nam Liberum ad Solem volunt referre commenta Graecorum etc. . . . qui vidit puerum solem? quis fefellit? quis occidit? quis laceravit? quis divisit? quis membris ejus epulatus est? . . . sed et errorem istum physica rursum volunt ratione protegere: indivisam mentem et divisam, id est *τόν ἀμέριστον καὶ τόν μεμερισμένον νοῦν*, hac se putant posse ratione venerari.
13. *Εἰς Βαίτ, εἰς Ἀθώρ μία τῶν βία, εἰς δὲ Ἀκῶρι, χαῖρε πάτερ κόσμου, χαῖρε τρίμορφε θεός.*
17. *Βίβλος ἀληθῆς Σοφε Αἰγυπτίου καὶ θείου Ἑβραίων κυρίου τῶν δυναμέων Σαβαωθ.*
- 21.

Hostes meos omnes superavi et vici,
 Venenosumque draconem pedibus meis subegi,
 Sum Rex eximius et dives in terris

.....

Hinc mihi Hermes nomen *sylvarum domini* tribuit.

25. Inquiunt quidam, venerare humiditates, reges namque sunt magnanimi iniuriam non patientes, parce ergo eis et eorum capta benevolentiam, et suis oculis tibi dabunt, ut quodvis ab eis habebis.
27. Denique . . . videbis Lapidem Philosophicum Regem nostrum et Dominum Dominantium, prodire ex sepulchri vitrei sui thalamo ac throno in scenam mundanam hanc . . . clamantem: Ecce, Renovabo omnia.
28. Ihsuh Christi crucifixi, Salvatoris totius generis humani, id est Mundi minoris, in Naturae libro, et ceu Speculo, typus est, Lapis Philosophorum, Servator Mundi maioris.
37. Et scito quod aqua est quae occultum extrahit.
41. Cave ab hydropisi et diluvio Noe.
42. Equorum venter secretum est maximum: in hoc se abscondit noster hydropicus, ut sanitatem recuperet et ab omni aqua ad solem se exoneret.
43. Ita senex in balneo sedet, quem in vase optime sigillato et clauso contine, quoad Mercurius visibilis invisibilis fiat et occultetur.
45. Et ad Naaman dictum est: Vade et lavare septies in Jordano et mundaberis. Nam ipse est unum baptisma in absolutionem peccatorum.
46. O benedicta aquina forma pontica, quae elementa dissolvit.
50. . . . igitur homo, caelum, et terra unum sunt, etiam aer et aqua. Si homo res in maiori mundo transmutare novit . . . quanto magis id in microcosmo, hoc est in se ipso noverit, quod extra se potest, modo cognoscat hominis in homine thesaurum existere maximum, et non extra ipsum.
53. Nemo creatorem poterit melius cognoscere quam ex opere noscitur artifex.
69. Masculus autem est, qui sine alis existit sub foemina, foemina vero habet alas. Propterea dixerunt: Proiicite foeminam super masculum et ascendet masculus super foeminam.
73. Haec petra nisi fuerit percussa aquas non dabit.
74. Sonora vox, suavis et grata philosophantium auribus. O fons divitiarum inexhaustibilis veritatem et iustitiam sitientibus! O desolatorum imperfectioni solatium! Quid ultra quaeritis mortales anxii? cur infinitis animos vestros curis exagitatis miseri? quae vestra vos excaecat dementia quaeso? cum in vobis, non ex vobis sit omne quod extra vos, non apud vos quaeritis.

75. Paradisum ipsum non terrenum videri posse, non in solo aliquo, sed in nostro principali, quod animatur et vivificatur animae virtutibus, et infusione spiritus Dei.
84. Antiquus dierum cum sua celsitate habitavit, ut infans, in utero.
85. Puerulus tuus senex est, o virgo, ipse est Antiquus dierum et omnia praecessit tempora.
95. assimilavit subtilitatem caloris ignis, gressui piaie matris super ventrem filii sui.
102. Illa res . . . passim apparere colores facit. / hic est igitur lapis, quem omnibus nuncupavimus nominibus, qui opus recipit et bibit, et ex quo omnis color apparet. / Omnes Mundi colores manifestabuntur.
104. Dum autem Quinta Essentia in terra est, id in multiplicibus coloribus contrarii splendoris Solis cognoscis, quemadmodum cernis in Iride dum Sol per pluviam splendet.
105. *Τὴν κόρην τοῦ ὀφθαλμοῦ παραφέρει καὶ τὴν ἴριν τὴν οὐρανίαν.*
112. Qui animam meam levaverit, eius colores videbit.
116. Oro ex toto corde Misericordiam tuam, ut mittas mihi de caelis sanctis tuis Ruach Hhochmah-El, Spiritum Sapientiae tuae, qui mihi familiaris semper adsistat, me dextre regat, sapienter moneat, doceat; mecum sit, Oret, Laboret; mihi det bene velle, nosse, esse et posse in Physicis, Physicomedicis.
122. Hic sigillata mater in infantis sui ventre surgit et depuratur, ut ob tantam . . . puritatem putredo hinc exulet . . . Jam scias Virginem nostram terram ultimam subire cultivationem, ut in ea fructus Solis seminetur ac maturetur . . .
125. Quae tamen omnia bonum praenunciant indicium: quod videlicet tam bene vexatus homo tandem aliquando beatum exoptatumque exitum consecuturus siet: quemadmodum et ipsa SS. scriptura testis est, in qua (2 Tim. 3, Act. 4) legitur, quod videlicet omneis, qui beate in Christo Jesu vivere velint, persecutionem pati cogantur, quodque nos, per multas tribulationes et angustias, regnum coelorum ingredi necessum habeamus.
128. Foenix dicitur rubeus, et est Christus, de quo dicitur: Quis est iste, qui venit de Edom tinctis vestibibus de Bosra. / Quare ergo rubrum est indumentum tuum et vestimenta tua sicut calcantium in torculari? / Edom quod dicitur rufus, est Esau appellatus, propter rufum pulmentum quo a fratre suo Jacob est cibatus. / Tertia die avis reparatur, quia Christus tertia die suscitatur a Patre.
129. *Ἦ ὡς ὤν ταοῦ ἔχον ἐν ἑαυτῷ τὴν τῶν χρωμάτων ποικίλην πληθύν.*
131. Et certe solitudo, unicum conservandi spiritualis animi remedium amplissimam internae felicitatis occasionem praebet.
134. Si autem mortuus fuerit pavo, non marcescit eius caro nec foetidum dat odorem, sed manet tamquam condita aromatibus.

136. Hermes Princeps.—Post tot illata generi humano damna, Dei consilio: Artis que adminiculo, medicina salubris factus heic fluo.—Bibat ex me qui potest; lavet qui vult; turbet qui audet; bibite fratres et vivite.
138. totum elixir albedinis et rubedinis, et est aqua permanens, et aqua vitae et mortis, et lac virginis, herba ablutionis—et est fons animalis: de quo qui bibit, non moritur, et est susceptivum coloris et medicina eorum, et faciens acquirere colores, et est illud quod mortificat, siccatur et humectat, calefacit et infrigidat et facit contraria. / Et ipse est Draco, qui maritat se ipsum et impraegnat seipsum et parit in die suo, et interficit ex veneno suo omnia animalia. / Accede Corpus ad fontem hunc, ut cum tua Mente bibas ad satietatem et in posterum non sitias amplius vanitates. O admiranda fontis efficacia, quae de duobus unum, et pacem inter inimicos facit! Potest amoris fons de spiritu et anima mentem facere, sed hic de mente et corpore *virum unum* efficit. Gratias agimus tibi Pater, quod filios tuos inexhausti virtutum fontis tui participes facere dignatus sis. Amen.
148. Alii appellaverunt hanc terram Leonem viridem fortem in praelio; Alii draconem devorantem, congelantem vel mortificantem caudam suam.
150. Sed nullum corpus immundum ingreditur, excepto uno, quod vulgariter vocatur a philosophis Leo viridis.
151. quia depopulata (terra) est a suis spiritibus.
155. Qui sui ipsius spiritus tam multa devorat.
156. In Leone nostro viridi vera materia . . . et vocatur Adrop, Azoth, aut Duenech viride.
173. . . . lapidem, quem qui cognoscit, ponit illum super oculos suos.
178. Dixit enim ei mater sua: O Marchos, oportet ne hunc ignem esse leviolem calore febris? Dixit ei Marchos, o mater, fiat in statu febris. Revertor et accendo illum ignem.
189. Venus autem, cum sit orientalis, Solem praecedit.
193. Igneque debito videbis Emblema Operis magni, nempe nigrum, caudam pavonis, album, citrinum, rubeumque.
204. Et nota quod natura in principio suae originis intendit facere Solem vel Lunam, sed non potest propter Venerem, corruptum argentum vivum, commistum, vel propter terram foetidam, quare sicut puer in ventre matris suae ex corruptione matricis contrahit infirmitatem et corruptionem causa loci per accidens, quamvis sperma fuerit mundum, tamen puer sit leprosus et immundus causa matricis corruptae, et sic est de omnibus metallis imperfectis, quae corrumpuntur ex Venere, et terra foetida.
205. Leonem tuum in oriente quaeras, et aquilam ad meridiem in assumptum hoc opus nostrum . . . tuum iter ad meridiem dirigas oportet; sic in Cypro votum

consequeris, de quo latius minime loquendum.

210. Completur rosa alba tempore aestivali in Oriente.

213. . . . quomodo hortus aperiendus, et rosae nobiles in agro suo conspiciendae sient.

218. Antichristus in magna Babylonia de meretrice generis Dan nascetur. In matris utero diabolo replebitur et in Corozaim a maleficis nutrietur.

219.

Ut rosa per medias effloret roscida spinas,
sic Veneris nunquam gaudia felle carent.

220. Et ita tandem, in unum contentum corruat imbibendo cum uno fermento, id est aqua una, quia aqua est fermentum aquae.

221. *Πρῶτος αὐτὸς τοῦτο ἐποίησεν ἐνάγων αὐτοὺς ἀταράχως εἰς τὴν κοινωνίαν τῶν μυστηρίων· Διὰ τοῦτο τὸ ἑαυτοῦ αἷμα αὐτὸς ἔπιεν.*

222. Sic et duas Graeciae litteras, summam et ultimam, sibi induit Dominus, initii et finis concurrentium in se figuras uti quemadmodum A ad Ω usque volvitur (Apoc. I, 8) et rursus Ω ad A replicatur, ita ostenderent in se esse et initii decursum ad finem et finis recursum ad initium, ut omnis dispositio in eum desinens per quem coepta est.

224. Quicumque Chemicam artem addiscere vult, philosophiam, non Aristotelicam, sed eam quae veritatem docet, addiscat . . . nam eius doctrina tota consistit in amphibologia, quae mendaciorum optimum est pallium. Cum ipse Platonem, et reliquos reprehendisset, quaerendae famae gratia, nullum potuit commodius instrumentum reperisse, quam idem, quo in reprehendendo fuerat usus, amphibologico sermone scilicet, scripta sua contra sinistram oppugnantem, dextro subterfugio salvans, et e contra; quod Sophismatis genus in omnibus eius scriptis videre licet.

250. Quod cum cognovisset bonus pater tenebras ad terram suam supervenisse, produxit ex se virtutem, quae dicitur mater vitae, qua circumdedit primum hominem, quae sunt quinque elementa, id est ventus, lux, aqua, ignis et materia, quibus indutus, tamquam ad adparatum belli, descendit deorsum pugnare adversum tenebras.

263. Deinde fermentum tangit cum corpore imperfecto praeparato, ut dictum est, quousque fiant unum corpore, specie et aspectu et tunc dicitur Ortus; quia tunc natus est lapis noster, qui vocatus est rex a Philosophis, ut in Turba dicitur: Honorate regem nostrum ab igne venientem, diademate coronatum.

264. . . . quare signo ilium notabili notavit Omnipotens, cuius nativitas per Orientem in Horizonte Hemisphaerii sui philosophicum annunciat. Viderunt Sapientes in Evo Magi et obstupuerunt statimque agnoverunt Regem serenissimum in mundo natum. Tu, cum eius Astra conspexeris, sequere ad usque cunabula, ibi videbis infantem pulcrum, sordes semovendo, regium puellum honora, gazam aperi, auri donum

offeras, sic tandem post mortem tibi carnem sanguinemque dabit, summam in tribus Terrae Monarchiis medicinam.

265. Et videatis iksir vestitum regni vestimento.
266. Lapis Philosophorum est rex de coelo descendens, cuius montes sunt argentei rivuli aurei et terra lapides et gemmae pretiosae.
268. Quod infunditur anima corpori, et nascitur Rex coronatus. / Ego coronor, et diademate ornor, et regiis vestibus induor: quia corporibus laetitiam ingredi facio. / Cinerem ne vilipendas, quia Deus reddet ei liquefactionem et tunc ultimo Rex diademate rubeo divino nutu coronatur. Oportet te ergo hoc magisterium tentare.
272. Proiice ergo supra quodvis corpus, et ex eo tantum quantum vis, quoniam in duplo multiplicabitur Tinctura eius. Et si una pars sui primo convertit cum suis corporibus centum partes; secundo convertit mille. Tertio decem millia, quarto centum millia; quinto mille millia in solificum et lunificum verum.
277. Et quamvis exanimis ipse philosophicorum Rex videatur, tamen vivit et ex profundo clamat: Qui me liberabit ex aquis et in siccum reducet, hunc ego divitiis beabo perpetuus. Hic clamor etsi audiatur a multis, nulli tamen eius commiseratione ducti, quaerere regem subeunt. Quis enim, inquit, se demerget in aequor? Quis suo praesentaneo periculo alterius periculum levabit? Pauci sunt eius lamentationi creduli et putant vocem auditam esse Scillae et Charybdis resonos fragores et boatus. Hinc ociosi sedent domi nec regiam gazam, ut nec salutem curant.
280. Verum philosophorum antimonium in mari profundo, ut regius ille filius demersum delitescit.
289. Plumbum vexationes et molestias significat, per quas Deus nos visitat et ad resipiscentiam reducit. Quemadmodum enim plumbum omnes metallorum imperfectiones comburit et exterminat, unde Boethus Arabs illud aquam sulphuris vocat, ita quoque tribulatio in haec vita multas maculas, quas contraximus, a nobis abstergit: unde S. Ambrosius illam clavem coeli appellat.
291. Ex ossibus deinde et medullis eius nasci primo ceu vermiculum, inde fieri pullum.
301. Hic enim dum nascitur, rerum vicissitudo fit et innovatio.
306. Phoenix avis pavone pulchrior est; pavo enim aureas argenteasque habet alas; Phoenix vero hyacinthinas et smaragdinas, preciosorumque lapidum coloribus distinctas; coronam habet in capite.
316. Ascendit per se, nigrescit, descendit et albescit, crescit et decrescit . . . nascitur, moritur, resurgit, postea in aeternum vivit.
319. Eptacephalus draco, princeps tenebrarum, traxit de coelo cauda sua partem stellarum et nebula peccatorum eas obtexit, atque mortis tenebris obduxit.

335. *σκόληξ καὶ οὐκ ἄνθρωπος, ὄνειδος ἀνθρώπου καὶ ἐξουθένημα λαοῦ* αὐτός ἐστιν ὁ βασιλεὺς τῆς δόξης, ὁ ἐν πολέμῳ δυνατός.*
351. Nam requiei aditus nimis est coarctatus, neque ad illam quisquam potest ingredi, nisi per animae afflictionem.
352. Esse in Chemia nobile aliquod corpus, quod de domino ad dominum movetur.
361. quod vocat Plato intelligibile non sensibile. / Simplex est pars inopinabilis / est unius essentiae / Opus non perficitur nisi vertatur in simplex. / Conversio elementorum ad simplex. / Homo est dignior animalium et propinquior simplici et hoc propter intelligentiam.
362. Eiusque (veritatis) talem esse virtutem compererunt, ut miracula fecerit.
366. . . . ad amussim studeat centrum cognoscere ac scire, eoque se totum conferat, et centrum liberabitur ab omnibus imperfectionibus et morbis, ut ad prioris monarchiae statum restituatur.
- 367a. Accipite spiritum nigrum veterem, et eo corpora diruite et cruciate, quousque alterantur.
368. Irritate bellum inter aes et argentum vivum, quoniam peritum tendunt et corrumpuntur prius. / Inter ea pugnam irritate aerisque corpus diruite, donee pulvis fiat.
369. Diabolum ista in caelum erexisse decidens ac deiectus ab eo, nec non illa postmodum in mentem humanam infigere conatum fuisse, videlicet ambitionem, brutalitatem, calumniam, et divortium.
370. Homo a Deo in fornacem tribulationis collocatur et ad instar compositi Hermetici tamdiu omnis generis angustiiis, diversimodisque calamitatibus et anxietatibus premitur, donec veteri Adamo et carni (Ephes. 4) siet mortuus et tamquam vere novus homo . . . iterum resurgat.
373. Per spiritualem istam suam mortem, anima sua omnino eximitur.
380. Postremum vero (opus) in altero regali Jovis solio desinet, a quo Rex noster potentissimus coronam pretiosissimis Rubinis contextam suscipiet, “sic in se sua per vestigia volvitur annus.”
383. Ciconia ibi sedebat, quasi se appellans circulum lunarem.
384. Rex ortus est, id est anima . . . lapidi mortuo infusa est.
395. Haec enim res a te extrahitur; cuius etiam minera tu existis; apud te namque illam inveniunt, et, ut verius confitear, a te accipiunt; quod cum probaveris, amor eius et dilectio in te augebitur. Et scias hoc verum et indubitabile permanere.
411. *ὅταν τὸ τῆς αἰσχύνης ἔνδυμα πατήσητε, καὶ ὅταν γένηται τὰ δύο ἐν καὶ τὸ ἄρρεν μετὰ τῆς θηλείας οὔτε ἄρρεν οὔτε θῆλυ.*
412. Confert enim Deus hanc divinam et puram scientiam suis fidelibus et servis illis scilicet quibus eam a primaeva rerum natura conferre disposuit . . . Nam haec res

nihil nisi donum Dei altissimi (esse) potest; qui prout vult, et etiam cui vult, ex suis servis et fidelibus illud committit, et monstrat . . . Prae ponit enim Dominus ex suis servis quos vult et eligit, ut hanc scientiam divinam homini celatam quaerant, et quaesitam secum retineant.

413. Dicit enim primus spagirorum Dux: Pulsate et aperietur vobis.
414. Nam evenire quandoque solet, ut post multos annos, labores et studia . . . nonnulli sint electi, multis pulsationibus, orationibus et investigatione sedula praemissis.
416. Sic etiam Iapidis compositum Rex et Regina dicuntur . . . Sic vir et mulier dicuntur Masculus et femina propter copulam videlicet et actionem et passionem. Rosinus: Artis auri arcanum et mare et femina consistit.
420. Quem divus Plato in ignea substantia habitare posuit: intelligens videlicet inenarrabilem Dei in seipso splendorem et circa seipsum amorem.
429. Qui per alienum ingenium et manum mercenariam operatur, aliena a veritate opera videbit. Et vice versa, qui alteri servilem praestat operam, uti servus in arte, nunquam ad Reginae mysteria admittetur.

V. ADAM AND EVE

1. Iste est Philosophorum Mercurius, ille celeberrimus Microcosmus et Adam.
3. Accipe Adam et quod assimilatur Adam, nominasti hic Adam et tacuisti nomen foeminae seu Evae, et non nominans eam, quia scis quod homines qui sunt tui similes in mundo, sciunt quod illud, quod tibi assimilatur, est Eva.
4. Qua propter ingenio et intellectu validissimis adseverarunt suum lapidem esse animale, quem etiam vocaverunt suum Adamum, qui suam invisibilem Evam occultam in suo corpore gestaret ab eo momento, quo virtute summi conditoris omnium unita sunt. Ea de causa merito dici potest, Mercurium philosophorum nihil aliud esse, quam compositum eorum abstrusissimum Mercurium et non vulgarem illum . . . est in Mercurio quicquid quaerunt sapientes . . . lapidis philosophorum materia, nihil aliud est, quam . . . verus hermaphroditus Adam atque microcosmus. / Natura in primis requirit ab artifice, ut philosophicus Adam in Mercurialem substantiam adducatur. / . . . compositio huius sacratissimi Iapidis Adamici, fit ex sapientum Adamico Mercurio.
6. Ecce Adam heic duo sunt, fixatum et constans unum, fugax alterum.
7. Et Adamus erat Dominus, Rex et Imperator.
- 8.

Adam in balneo residebat,

In quo Venus sui similem reperiebat,

Quod praeparaverat senex Draco.

18. Secundus Adam qui dicitur homo philosophicus.
19. Ex quatuor autem elementis pater noster Adam et filii eius . . . creati sunt.
26. (Deus) incepit autem colligere pulverem primi hominis e quatuor terrae angulis, videlicet rubrum, nigrum, album et viridem. Ruber pulvis factus est sanguis, niger fuit pro visceribus, albus pro ossibus et nervis, viridis factus est corpus.
33. Scivit enim per ternarium Adami non patere potuisse aditum unario protegente ternarium, binarium igitur Evae tentavit ingredi.
34. . . . item non ignoravit Evam a viro suo divisam tanquam naturalem binarium ab unario sui ternarii.
36. Nam Elementa circularia sunt, ut Hermes sentit, quodlibet a duobus aliis circumdatur, cum quibus convenit in una qualitatibus ipsorum sibi appropriata, uti est terra inter ignem et aquam, participans de igne in siccitate, et de aqua in frigiditate. Et sic de caeteris.
37. Homo igitur, qui magni mundi est imago, et hinc microcosmus seu parvus mundus vocatus (sicut mundus ad archetypi sui similitudinem factus, et ex quatuor elementis compositus, magnus homo appellatur) etiam suum coelum et terram habet. Nam anima et intellectus sunt ejus coelum; corpus vero et sensualitas ejus terra. Adeo ut coelum et terram hominis cognoscere, idem sit quod plenam et integram totius mundi et rerum naturalium cognitionem habere.
47. In Adamo ergo protoplaste . . . continebantur omnes illae notiones sive Species supradictae a Psyche factiva usque ad singularitatem emanativam.
50. Deinde caput, manus et pedes (leonis) colligo, et calefacio eis aquam extractam a cordibus statuarum ex lapidibus albis et citrinis, quae cadit de coelo tempore pluviae.
52. Laudanum autem barbae eius, i.e. mumia vel ysopos aut sudor.
53. Universae creaturae fundamenta . . . contineantur in . . . Radicali humido, Mundi semine, Mumia, Materia prima.
55. Et ideo per ablutionem aquae et desiccationem ignis semper extrahis oleum a corde statuarum. / Hoc oleum est tinctura, aurum et anima, ac philosophorum unguentum. / Illud oleum seu aqua divina . . . et vocatur *Mediator*.
61. Faciebant autem in iis (statuis) cum ostia, tum concavitates, quibus deorum quos colebant, simulacra imponebant. Apparebant itaque viles eiuscemodi statuae Mercuriales, sed intra se deorum ornamenta (καλλωπισμούς) continebant.
65. proiiciet semen suum supra marmorem in simulachrum.

67. Duo Adam efficiuntur: unus, pater noster, in mortem, quia mortalis factus est, peccans: secundus, pater noster, in resurrectionem, quoniam immortalis cum esset, per mortem devicit mortem atque peccatum. Primus Adam, hic, pater: posterior illic, etiam primi Adam est pater.
68. Restat nunc pars altera philosophicae praxeos, longe quidem difficilior, longe sublimior. In quo omnes ingenii neruos, omnia denique mentis curricula multorum philosophorum elanguisse legimus. Difficilius et enim hominem faceres reviviscere, quam mortem oppetere. Hic Dei petitur opus: Maximum quidem mysterium est creare animas, atque corpus inanime in statuam viventem confingere.
70. . . . et ita dimittitur magnus ille ignis qui mundum consumat universum; deinde iterum demittunt animam, quae obicitur inter medium novi saeculi, ut omnes animae peccatorum vinciantur in aeternum. Tunc autem haec fient, cum statua venerit.
78. Nunc de igne terreno ad coelestem ut ascendamus, qui est sol, mundi sensibilis oculus et cor, et Dei invisibilis imago. S. Dionysius manifestam et claram Dei statuam illum vocat.
79. *(ἡλιος) ἡ τῆς θείας ἀγαθότητος ἐμφανῆς εἰκὼν. / "Ἡλιος ἐν τύπῳ θεοῦ ἐστὶν ἡ δὲ σελήνη ἀνθρώπου.*
82. (filius) Clarissimum est, quod ad Tiphereth pertineat.
83. Matris quoque nomine appellatur Malchuth, quia mater est omnium sub ipsa existentium usque ad finem totius Abyssis.
84. Pulchritudo eius (solis) cum sponso ex camera sua nuptiali prodeunte comparata. Et ipse tanquam sponsus procedens de thalamo suo.
85. Procedit Christus quasi sponsus de thalamo suo; praesagio nuptiarum exiit ad campum saeculi; cucurrit sicut gigas exsultando per viam: pervenit usque ad crucis thorum, et ibi firmavit ascendendo conjugium; ubi cum sentiret anhelantem in suspiriis creaturam, commercio pietatis se pro conjugio dedit ad poenam. Tradidit quoque carbunculum, tanquam sui sanguinis gemmam, et copulavit sibi perpetuo jure matronam. 'Aptavi vos,' inquit Apostolus, 'uni viro virginem castam exhibere Christo.'
88. Latere in antimonio plus virtutis medicinalis quam in ullo alio simplici ideoque etiam plus virtutis tingentis seu tincturae.
89. Et ideo dicitur quod lapis in quolibet homine. Et Adam portavit secum de paradiso, ex qua materia in quolibet homine lapis noster vel Elixir eliciatur.

100. Adam tradidit Enocho, qui introductus in mysterium embolysmi intercalavit annum.
101. Dixit Adam: hae sunt tabulae, quibus inscripturus est Sanctus benedictus digito suo.
103. Mundum per aquam esse renovandum vel potius castigandum, pauloque minus quam delendum.
119. Decem circulos a se invicem disiunctos complectebatur alter circulus, qui huius universitatis anima esse ferebatur, et cuius nomen erat Leviathan.
120. In eodem (diagrammate) reperi eum, qui vocatur Beemoth sub infimo circulo collocatum. Leviathanis nomen ab impii diagrammatis auctore bis erat scriptum, in superficie scl. et in centro circuli.
121. Animam tamen omnia permeantem impium hoc diagramma esse ponit.
124. Nunc autem angelum leoni similem aiunt habere cum astro Saturni necessitudinem.
125. Tibi, prime et septime . . . opus filio et patri perfectum.
130. *Τῷ μὲν Κρόνῳ προσήκει ἡ ἑβδομάς μάλιστα καὶ πρῶτως . . . τῇ δὲ 'Ρέα ἡ ὀγδοάς.*
131. Isti autem aliis alia addunt, Prophetarum dicta, circulos circulis inclusos . . . virtutum ex quadam Prunico virgine manantem, viventem animam.
135. Quia Solis et Lunae colores haec duo metalla referunt.
136. Redemptor autem noster in carne veniens, pleiades iunxit, quia operationes septiformis spiritus simul in se et cunctas et manentes habuit.
153. Habet in se unusquisque Adam et Evam. Sicut enim in illa prima hominis transgressione suggestit serpens, delectata est Eva, consensit Adam: sic et quotidie fieri videmus, dum suggerit diabolus, delectatur caro, consentit spiritus.
158. 'Plasmavit Deus hominem', id est finxit de terrae limo. Is autem qui ad imaginem Dei factus est et ad similitudinem, interior homo noster est, invisibilis et incorporalis et incorruptus atque immortalis.
159. *'Ο δὲ κατὰ τὴν εἰκόνα ἰδέα τις ἢ γένος, ἢ σφραγίς, νοητός, ἀσώματος οὔτε ἄρρεν οὔτε θῆλυ, ἀφθαρτος φύσει.*
187. Esse in Chemia nobile aliquod corpus, quod de domino ad dominum movetur, in cuius initio sit miseria cum aceto, in fine vero gaudium cum laetitia.
193. Psyche, quae ipsis nephesch dicitur, sit spiritus vitalis, non quatenus plane corporeus sed insitus ille atque primitivus et seminalis, quem recentiores *Archeum* vocant, cum quo correspondet Philosophorum anima vegetativa seu plastica, et Platonicorum τὸ ἐπιθυμητικὸν seu concupiscibile.
- 193a. Mater enim nil est nisi propensio Patris ad inferiora.

195. (Adam) a Cabbalistic Adam Kadmon dicitur, ad differentiam Adami Protoplastae . . . eo quod inter omnia a Deo emanata primum occupet locum, prout protoplastes in specie hominum: ita ut per illum nihil commodius intelligi queat, quam anima Messiae, quem et Paulus ad I Corinth. 15, vers. 45–49 indigitat.
201. . . . inquit Ezechiel 34, v. 31: Vos Adam estis. Id est, vos merito vocamini Adami nomine. Sensus enim est: si literaliter textus intelligendus esset, obiectio merito fieret, omnes etiam populos mundi sive gentiles eodem modo esse homines, quo Israelitae; statura nempe erecta. Ubi porro quoque dicendum fuisset, vos homines estis. Verum enim vero (sensus hic est, ex animabus vestris consistebat microcosmus Adami) . . . § 11: Vos estis Adam. (Quasi diceret omnes Israelitarum animas nihil aliud fuisse quam Adamum nimirum protoplasten:) Et vos scintillae illius atque membra ejus extitistis.
203. Hinc quoque dixerunt Magistri nostri: Non veniet filius David, donec plene exiverint omnes animae, quae fuerunt in corpore (nimirum protoplastae).
204. Differentias autem numericas referri ad dispositionem bilanciformem ubi facies faciei obvertitur, et duo vel plura ejusdem perfectionis, et speciei, tantum distinguuntur, ut mas et foemina. Quae differentiae numericae etiam denotantur per id, quod dicitur antea, et posterius.
218. *Τὸ ἐν γίνεται δύο, καὶ τὰ δύο γ', καὶ τοῦ γ' τοῦ τὸ ἐν τέταρτον.*
219. Jam Adam Kadmon emanavit ab uno simplici, adeoque est unitas: sed et descendit, et delapsus est in ipsam naturam suam, adeoque est duo. Iterumque reducitur ad unum, quod in se habet, et ad summum; adeoque est tria et quatuor.
220. Et haec est causa, quod nomen essenziale habeat quatuor literas, tres diversas, et unam bis sumptam: quoniam *He* primum est uxor *τοῦ Jod*; et alterum, uxor *τοῦ Vav*. Primum emanavit a *Jod*, via directa, et alterum a *Vav*, via conversa et reflexa.
222. *Jod*, quia simplex, est unum et primum quid, et simile uni, quod numeris; et puncto, quod corporibus omnibus prius est. Punctum autem, secundum longitudinem motum producit lineam, nempe *Vav*. / Litera *Jod* quae punctum ipsum, facta est principium, medium et finis; imo ipsa etiam principium Decadum et finis unitatum atque ideo redit in unum. / Quoniam Sapia Benedicti videbat, quod etiam in splendore hoc non possent manifestari mundi, cum Lux ibi adhuc nimis magna esset atque tenuis; hinc iterum innuit literae huic *Jod*, ut denuo descenderet et perrumperet sphaeram splendoris atque emitteret lucem suam, quae paulo crassior erat. / Lucem atque Influentiam insignem vibrabat in illam Sapientiam.
223. *Vav* denotat vitam, quae est emanatio et motus essentiae, quae in se ipsa manifestatur: estque medium uniendi, et connexionis, inter essentiam et intellectum.

225. *He* designat ens, quod est compositum ex essentia et existentia. / *He* ultimum est imago et similitudo intellectus vel mentis.
228. Viriditate enim videtur praefigurari virginitas.
229. O benedicta viriditas, quae cunctas res generas!
230. Nonne spiritus Domini, qui est amor igneus, quum ferebatur super aquas, edidit eisdem igneum quendam vigorem, cum nihil sine calore generari possit? Inspiravit Deus rebus creatis . . . quandam germinationem, hoc est viriditatem, qua sese cunctae res multiplicarent . . . Omnes res dicebant esse virides, cum esse viride crescere dicatur . . . Hanc ergo generandi virtutem rerumque conservationem Animam Mundi vocare libuit.
231. Unde Aristoteles ait in libro suo: Aurum nostrum, non aurum vulgi: quia illa viriditas, quae est in eo corpore, est tota perfectio eius. Quia illa viriditas, per nostrum magisterium cito vertitur in aurum verissimum.
- 238.
- Lapis candens fit ex tribus;
Nulli datur nisi quibus
Dei fit spiramine.
248. Vas . . . oportet esse rotundae figurae: Ut sit artifex huius mutator firmamenti et testae capitis. / Caput eius vivit in aeternum et ideo caput denominatur vita gloriosa et angeli serviunt ei. Et hanc imaginem posuit Deus in paradiso deliciarum, et in ea posuit suam imaginem et similitudinem. / . . . quousque caput nigrum aethiopis portans similitudinem fuerit bene lavatum.
249. Accipe cerebrum eius, aceto acerrimo terite . . . quousque obscuretur.
250. Cum igitur spiritus ille aquarum supracoelestium in cerebro sedem et locum acquisierit.
253. . . . oportet nos vertere membrum (scl. cerebri s. cordis) in principio operis, in id ex quo generatum est, et tunc convertimus ipsum per spiritum in id quod volumus. / . . . nam est triangulus compositione et est propinquius omnibus membris corporis ad similitudinem simplicis.
254. Maxima virtus mineralis est in quolibet homine, et maxime in capite inter dentes, ut suo tempore inventum est aurum in granis minutis et oblongis . . . propter hoc dicitur quod lapis est in quolibet homine.
263. τὸ σχῆμα τῆς παρεγκεφαλίδος εἰκὸς κεφαλῆ δράκοντος.
270. Similiter nominant hanc aquam Nubem vivificantem, mundum inferiorem et per haec omnia intelligunt Aquam foliatam, quae est aurum Philosophorum, quod vocavit dominus Hermes Ovum, habens multa nomina. Mundus inferior est corpus et cinis combustus, ad quem reducunt Animam honoratam. Et cinis combustus, et

anima, sunt aurum sapientum, quod seminant in terra sua alba, et terra margaritarum stellata, foliata, benedicta, sitiente, quam nominavit terram foliorum, et terram argenti, et terram auri. / In quo dixit Hermes: Seminate aurum in terram albam foliatam. Terra alba foliata est Corona victoriae, qua est cinis extractus a cinere ...

271. Ergo Luna mater et ager in quo solare seminarique debet semen . . . / (ait sol) Ego enim sum sicut semen seminatum in terram bonam . . . / Jam scias Virginem nostram terram, ultimam subire cultivationem, ut in ea fructus Solis seminetur ac maturetur. / Recipiam a te animam adulando. / Aqua supra terram incidente, creatus est Adam, qui et mundus est minor. / Terra dicitur mater elementorum, quia portat filium in ventre suo. / Quamvis in primo suo partu per Solem et Lunam generatus, et de terra in accretione sua postulatus siet. / Pater suscipit filium, hoc est, terra retinet spiritum. / Quia totius mundi ima pars terra est, aetheris autem ima pars luna est: Lunam quoque terram, sed aetheream, vocaverunt.
275. Accipe itaque tu, charissime, verborum meorum legitimum sensum, et intellige, quia philosophi similes sunt hortulanis et agricolis, qui primum quidem semina deligunt, et delecta non in vulgarem terram, sed in excultos agros, aut hortorum iugera seminant . . . / Habito autem Sole et Luna philosophorum tanquam semine bono, terra ipsa ab omnibus suis immunditiis et herbis inutilibus expurganda est et diligenti cultura elaboranda, in eamque sic elaboratam Solis et Lunae praedicta semina mittenda sunt ...
276. Ubi terra, hoc est humanitas, exaltata est super omnes circulos Mundi, et in caelo intellectuali sanctissimae Trinitatis est collocata. / Donum namque Dei est, habens mysterium individuae unionis sanctae Trinitatis. O scientiam praeclarissimam, quae est theatrum universae naturae, eiusque anatomia, astrologia terrestris, argumentum omnipotentiae Dei, testimonium resurrectionis mortuorum, exemplum remissionis peccatorum, infallibile futuri iudicii experimentum et speculum aeternae beatitudinis!
278. Quamobrem in centro terrae ignis est copiosissimus aestuantissimusque (ex radiis solaribus ibidem collectus), qui barathrum sive orcus nuncupatur, neque alius est ignis sublunaris: faeces enim sive terrestres reliquiae principiorum praedictorum, videlicet caloris solaris et aquae, sunt ignis et terra: damnatis destinata.
279. Ipsum enim est, quod ignem superat, et ab igne non superatur: sed in illo amicabiliter requiescit, eo gaudens.
285. Ad dextram vocatur Sol justitiae Mal. 4, 2, sed ad sinistram (Sol) a calore Ignis Gebhurae.
288. In naturalibus Jesod sub se continet argentum vivum; quia hoc est fundamentum totius artis transmutatoriae.

290. (Jessod) in personis denotat membrum genitale utriusque sexus. / Quapropter pervolare semper Adonai ad Mensuram El-chai continua aestuat cupidine. / Ipse autem hic gradus firmus est inter Ilium et Illam, ut natura seminis subtilissima e supernis demissa non dimoveatur. / . . . angelus redemptor, fons aquarum viventium, arbor scientiae boni et mali, Leviathan, Salomon, Messias filius Joseph.
291. Iste enim est effusorium aquarum supernarum: Et duae olivae super illud, sunt Nezach et Hod, duo testiculi masculini.
295. Foedus Pacis autem, seu perfectionis propterea dicitur, quia iste modus pacis et perfectionis autor est inter Tiphereth et Malchuth, ita ut de eo dicitur, I Par. 29, 11, quia modus ille, qui vocatur Col, est in coelo et in terra, ubi Targum hac utitur paraphrasi, quod uniatur cum coelo et cum terra.
298. Propinquus . . . et melior quam frater e longinquo, qui est Tiphereth.
299. . . . quod robustus Jisrael sit nomen medium inter Nezach et Hod.
301. In Sohar, in historia illius Puelli, dicitur, quod Justus (Jessod) vocetur Amicus fidelis ad locum Cant. 7. 10. Vadens ad dilectum meum. Et hinc Jesod dicitur Amicus, quia unit duos dilectos et amicos: quia per ipsum fit unio Tiphereth et Malchuth.
308. Hoc est illud quod non sine mysterio vocatur Stella . . . / Aquae El boni, seu Argenti vivi . . . Hoc argentum vivum . . . vocatur Aqua Sphaerica.
309. Haec (aqua) dicitur filia Matredi, i.e. . . . Viri aurificis laborantis cum assidua defatigatione; nam haec aqua non fluit e terra, nec effoditur in mineris, sed magno labore et multa assiduitate elicitur et perficitur. Huius uxor appellatur Aqua auri sive talis Aqua, quae aurum emittit. Cum hac si desponsatur artifex, filiam generabit, quae erit Aqua balnei regii.
314. In Sohar haec litera dicitur scaturigo vitae.
315. אפרח Pullus avis cujusque. Deut. 22, 6. Psalm. 84, 4. In Raja Mehimna R. Schimeon ben Jochai tradit per hoc nomen intelligi Gradum Tiphereth, quatenus constat e sex membris suis, quae sunt sex alae, quibus sursum volat et deorsum. Sed in Tikunim sub initium Libri R. Bar, Bar Channa; haec appellatio dicitur referenda ad Justum sub mysterio Lucis reflexae ab imo ad summum. Verba sunt haec: Aephrochim sunt flores, qui fructum nondum praebent perfectum. Suntque Sephiroth sub notione arboris, quae ab imo sursum conversa est, et quidem circa Jesod.
316. Penna, ala: it. membrum, et quidem genitale . . . hoc nomen exponit de Jesod, cui cognomen Justo tribuitur.
318. Phoenix . . . ex cuius pennis circa collum aureolis . . . Medicina ad omnes affectiones humanae naturae contrarias in temperiem sanitatis optatam reducendas utilissima . . . inventa et usurpata est.

322. Sic vocatur Malchuth . . . estque locus destinatus ad coctionem et elixationem influentiae, a marito ad ipsam demissae ad nutritionem catervarum. Sicut notum est: foeminam calore suo excoquere semen ad generandum.
324. De Dei filio intelligit, qui in castigandis mundi sceleribus formidandum Leonem sat diu imitatus paulo post, morte propinquante, dum SS. Eucharistiae Sacramentum instituit, in melleos favos longe suavissimos se ipsum convertit.
325. Saepius Adonai nomen Sephiraе ultimae, et ipsa Malchuth, Regnum, ita dicitur; quoniam ipsum totius mundanae fabricae fundamentum extat.
326. . . . lapis capitalis, a quo omnes catervae superiores et inferiores in opere creationis promuntur in esse.
327. Sapphireus, quia varium a supernis gradibus colorem trahit, et in creatis mox hoc, mox contrario modo operatur: nam bonum nonnunquam, quandoque malum, nunc vitam, nunc interitum, nunc languorem, nunc medelam, nunc egestatem, nunc divitias ministrat.
332. In hoc nomine perpetuo mysterium literae י (Jod) involvitur, et quidem ut plurimum in Malchuth, quatenus in ista existit litera Jod. Informis enim massa et figura יוֹד י figuram habet lapidis; et Malchuth est fundamentum et lapis cui totum aedificium superius superstruitur. De ea dicitur Zach. 3, 9: Lapis unus septem oculorum.
337. Tunc exurgit Hermaphroditi flos Saphyricus, admirandum Maioris Mundi Mysterium. Cuius pars, si in mille liquati Ophirizi partes infundatur, id omne in sui naturam convertit.
344. . . . quoniam lapis sapphirus aereum habet colorem. Virtutes ergo coelestium lapide sapphiro designantur, quia hi spiritus . . . superioris loci in coelestibus dignitatem tenent.
345. Crystallum . . . ex aqua congelascit, et robustum fit. Scimus vero quanta sit aquae mobilitas. Corpus autem redemptoris nostri, quia usque ad mortem passionibus subiacuit, aquae simile iuxta aliquid fuit: quia nascendo, crescendo, lassescendo, esuriendo, sitiendo, moriendo usque ad passionem suam per momenta temporum mobiliter decucurrit . . . Sed quia per resurrectionis suae gloriam ex ipsa sua corruptione in incorruptionis virtutem convaluit, quasi crystalli more ex aqua duruit, ut in illo et haec eadem natura esset, et in ipsa quae jam fuerat corruptionis mutabilitas non esset. Aqua ergo in crystallum versa est, quando corruptionis eius infirmitas per resurrectionem suam ad incorruptionis est firmitatem mutata. Sed notandum quod hoc crystallum horribile, id est, pavendum, dicitur . . . omnibus vera scientibus constat quia redemptor humani generis cum iudex apparuerit, et speciosus iustis, et terribilis erit iniustis.

347. Certum quidem est, quod macroprosopus, Pater et Mater, sint Corona, Sapientia et Intelligentia mundi Emanativi post restitutionem. / . . . e tribus punctis primis mundi inanitionis constituta sint tria capita superna, quae continentur in Sene Sanctissimo. Omnia autem tria numerantur pro uno in mundo Emanativo, qui est macroprosopus.
348. Forma secunda vocatur Ros crystallinus; et haec formatur a Severitate Basiliae Adami primi, quae intrabat intra Sapientiam Macroprosopi: hinc in crystallo color quidam emphaticus rubor apparet. Et haec est Sapientia illa, de qua dixerunt, quod in ilia radidentur Iudicia.
349. Lapis in sacro eloquio Dominum et redemptorem nostrum significat.

VI. THE CONJUNCTION

8. Mineralia tamen atque vegetabilia Hermaphroditae sunt naturae, eo quod utrumque sexum habeant. Nihilominus fit ex seipsis coniunctio formae et materiae, quemadmodum fit de animalibus.
9. Unde duo sulphura et duo argent[a] viv[a] dicuntur et sunt talia, quod unum et unum dixerunt, et sibi congaudent, et unum alterum continet.
19. Si enim homo ad summum bonum pervenire cupit, tunc . . . primo Deum, dein seipsum . . . agnoscere ilium oportet.
20. Pietas autem est gratia divinitus prolapsa, quae docet unumquemque seipsum, vere ut est, cognoscere.
23. . . . cum in vitro tuo corispexeris naturas insimul misceri . . .
25. Effodiatur ergo sepulcrum et sepeliatur mulier cum viro mortuo . . .
27. Non fieri transitum nisi per medium.
28. Mercurius est medium coniungendi.
34. Aqua aeris inter caelum et terram existens, est vita uniuscuiusque rei. Ipsa enim aqua solvit corpus in spiritum, et de mortuo facit vivum, et facit matrimonium inter virum et mulierem.
35. Siccum humectare, et durum lenificare, et corpora coniungere et attenuare.
39. Non absimili modo quo Deus primo creavit unum mundum sola meditatione, pariformiter creavit unum mundum, ex quo quidem res omnes natae fuerunt adaptatione. / Item ut unus Deus tantum est non plures unum etiam per unum ex nihilo mundum in mente sua prius creare voluit ut subinde in effectum producere quo continerentur omnia quae crearet in ipso: Deus ut esset in omnibus unus.

40. Sub isto binario spirituali et corporeo, tertium quid latuit, quod vinculum est sacraei matrimonii. Hoc ipsum est medium usque hue in omnibus perdurans, ac suorum amborum extremorum particeps, sine quibus ipsum minime, nec ipsa sine hoc suo medio esse possunt, quod sunt, ex tribus unum.
48. Est enim in humano corpore quaedam substantia conformis aetherae, quae reliquas elementares partes in eo praeservat, et continuare facit.
49. Spagiricam autem nostram medicinam esse corpoream non negamus, sed spiritalem dicimus esse factam, quam spiritus spagiricus induit.
50. Concludimus meditativam philosophiam in superatione corporis unione mentali facta, consistere. Sed prior haec unio nondum sophum efficit, nec nisi mentalem sophiae discipulum: unio vero mentis cum corpore secunda sophum exhibet, completam illam et beatam unionem tertiam cum unitate prima sperantem et expectantem. Faxit omnipotens Deus ut tales efficiamur omnes et ipse sit in omnibus unus.
60. Mens igitur bene dicitur esse composita, quoties animus cum anima tali vinculo iunctus est, ut corporis appetitus et cordis affectus fraenare valeat.
62. Qui diligit animam suam, perdet eam, et qui odit animam suam, in aeternum custodit eam.
67. Impossibile est enim vitae malae hominem possidere thesaurum sapientiae filiis reconditum, et male sanum ad eum acquirendum vel inquirendum, multo minus ad inveniendum aptum esse.
68. Admonendos esse discipulos putavi auxilii divini implorationis, deinceps accuratissimae diligentiae in disponendo se ad eiusmodi gratiam recipiendam.
69. Ego sum . . . vera medicina, corrigens ac transmutans, id quod non est amplius, in id quod fuit ante corruptionem, et in multo melius, item id quod non est, in id quod esse debet.
72. At veritas est summa virtus et inexpugnabile castrum.
73. Libera tamen ad suam unitatem redit. Hoc est unum ex arcanis naturae, per quod ad altiora pertigerunt spagiri.
82. Quidam Philosophi nominaverunt aurum Chelidoniam, Karnech, Geldum.
85. Lili Alchemiae et Medicinae . . . nobilissimum hoc omne quod ex altissimi conditoris manifestatione meditationibus hominum obtingere potest.
87. Miranda praestat in spagyrica arte, nam eo mediante lux diei in primam materiam reducitur.

102. μέλαν καὶ ἄψυχον καὶ νεκρὰ καὶ ὡς εἶπειν ἄπνους. / Item sapientiam tuam semina in cordibus nostris, et ab eis phlegma, choleram corruptam, et sanguinem bulientem expelle, ac per vias beatorum perducas. / Ne cinerem vilipendas . . . in eo enim est Diadema quod permanentium cinis est.
103. Item scitote, quod spiritus est in domo marmore circumdata, aperite igitur foramina, ut spiritus mortuus exeat.
105. Ad corporis igitur bonam dispositionem artificiatam, utimur spagirico medicamento.
117. . . . quaedam inest lumini (lunae), quod de ea defluit, quae humectet corpora et velut occulto rore madefaciat.
118. Rectam fidem super unguentem olere fecisti. / Odore scientiae totum perfudit orbem.
133. . . . concordantia et . . . discordantia, quam symbolizationem intelligimus.
170. O coelum nostrum! o aqua nostra et Mercurius noster! . . . o caput mortuum seu faeces maris nostri . . . Et haec sunt aviculae Hermetis epitheta, quae nunquam quiescit.
171. Et scitote quod caput artis est corvus, qui in nigredine noctis et diei claritate sine alis volat.
173. Vocatur quoque rotunda aliqua nubes, mors itidem, nigredo, utpote tenebrae et umbra. / Istud opus fit ita subito sicut veniunt nubes de caelo.
176. Corvus se pullis senio confectum praebet in pabulum: at Phoenix noster Christus Dominus . . . se nobis in coelestem alimoniam praebuit.
180. Niger qui caput est artis, albus qui medium et rubeus qui finem rerum omnium imponit.
182. Cum videris materiam tuam denigrari, gaude: quia principium est operis. / Caput corvi artis est origo.
183. Antimonium, pix, carbo, corvus, caput corvi, plumbum, aes ustum, ebur ustum dicitur.
185. Et sic habes duo elementa, primo aquam per se, dehinc terram ex aqua.
191. corvus in formam peccatoris constitutus.
193. Vas autem necessarium in hoc opere oportet esse rotundae figurae: ut sit artifex huius mutator firmamenti et testae capitis.
194. Locus superior est cerebrum, et est sedes intelligentiae.
195. Et animal forma formarum et genus generum est homo.
196. Vas autem factum est rotundum ad imitationem superius et inferius. Est namque aptius rerum ad id cuius generatio quaeritur in eo, res enim ligatur per suum simile.

197. Mundus superior habet semper effectum in homine, et perfecta inspiratio eius scilicet hominis in morte sua, usque ad firmamentum, nec deest perventio, donec revertatur, quod egressum est de mundo superiori, ad locum suum.
198. Videtisne relucens illud et inexpugnabile castrum? / Veritas est . . . inexpugnabile castrum. Hac in arce verus . . . continetur ille thesaurus, qui . . . asportatur hinc post mortem.
199. Creatura in divina mente concepta est simplex, invariabilis et aeterna, in se ipsa autem multiplex, variabilis, transitoria.
205. Moriente leone nascitur corvus. / O triste spectaculum et mortis aeternae imago: at artifici dulce nuntium! . . . Nam spiritum intus clausum vivificum scias, qui statuto tempore ab Omnipotente vitam hisce cadaveribus reddet.
217. Notum est, quod anima antequam suo corpori misceretur, mortua fuerat, et eius corpus similiter.

BIBLIOGRAPHY

BIBLIOGRAPHY

The items of the bibliography are arranged alphabetically under two headings: *A.* Volumes containing collections of alchemical tracts by various authors; *B.* General bibliography, including cross-references to the material in section *A.* Short titles of the alchemical volumes are printed in capital letters.

A. VOLUMES CONTAINING COLLECTIONS OF ALCHEMICAL TRACTS BY VARIOUS AUTHORS

ARS CHEMICA, quod sit licita recte exercentibus, probationes doctissimorum iurisconsultorum.... Strasbourg, 1566.

Contents quoted in this volume:

- i Septem tractatus seu capitula Hermetis Trismegisti aurei [pp. 7–31; usually referred to as “Tractatus aureus”]
- ii Studium Consilii coniugii de massa solis et lunae [pp. 48–263; usually referred to as “Consilium coniugii”]

ARTIS AURIFERAE quam chemiam vocant.... Basel, 1593. 2 vols.*

Contents quoted in this volume:

VOLUME I

- i Turba philosophorum [two versions: pp. 1–64, 65–139]
- ii Allegoriae super librum Turbae [pp. 139–45]
- iii Aenigmata ex visione Arislei et allegoriis sapientum [pp. 146–54; usually referred to as “Visio Arislei”]
- iv In Turbam philosophorum exercitationes [pp. 154–82]
- v Aurora consurgens, quae dicitur Aurea hora [pp. 185–246]
- vi Rosinus ad Euthiciam [pp. 246–77]
- vii Rosinus ad Sarratantam episcopum [pp. 277–319]
- viii Maria Prophetissa: Practica... in artem alchemicam [pp. 319–24]
- ix Kalid: Liber secretorum [pp. 325–51]
- x Kalid: Liber trium verborum [pp. 352–61]
- xi Tractatulus Aristotelis de practica lapidis philosophici [pp. 361–73]
- xii Authoris ignoti, philosophici lapidis secreta metaphoricè describentis [pp. 389–92]

xiii Merlinus: Allegoria de arcano lapidis [pp. 392–96]

xiv Rachaidibi [et aliorum] philosophorum Regis Persarum de materia lapidis
fragmenta [pp. 397–404]

xv Tractatulus Avicennae [pp. 405–36]

xvi Clangor buccinae [pp. 448–544]

xvii Liber de arte chymica [pp. 575–631]

VOLUME II

xviii Morienus Romanus: Sermo de transmutatione metallica [pp. 7–54]

xix Scala philosophorum [pp. 107–70]

xx Ludus puerorum [pp. 171–204]

xxi Rosarium philosophorum [pp. 204–384; contains a second version of the
“Visio Arislei” at pp. 284ff.]

xxii Arnaldus de Villanova: Thesaurus thesaurorum et Rosarius [pp. 385–455]

MANGETUS, JOANNES JACOBUS (ed.). *BIBLIOTHECA CHEMICA CURIOSA, seu Rerum
ad alchemiam pertinentium thesaurus instructissimus....* Geneva, 1702. 2 vols.

Contents quoted in this volume:

VOLUME I

i Hoghelande: De alchimiae difficultatibus [pp. 336–68]

ii Hermes Trismegistus: Tractatus aureus de lapidis physici secreto [pp. 400–445]

iii Artefius: Clavis majoris sapientiae [pp. 503–508]

iv [Altus:] Liber mutus alchimiae mysteria filiis artis nudis figuris evidentissime
aperiens [pp. 938–53]

VOLUME II

v Bonus: Margarita pretiosa novella correctissima [pp. 1–80]

vi Senior: De chemia [pp. 198–235]

vii Consilium coniugii [pp. 235–65]

viii [d’Espagnet:] Arcanum hermeticae philosophiae opus [pp. 649–61]

ix Barnaud: In aenygmaticum quoddam Epitaphium Bononiae... Commentariolus
[pp. 713–16]

In hoc volumine DE ALCHEMIA continentur haec:... Nuremberg, 1541.

Contents quoted in this volume:

i Geber: Summa perfectionis [pp. 20–205]

ii Tabula smaragdina Hermetis Trismegisti [p. 363]

*MUSAEUM HERMETICUM reformatum et amplificatum... continens tractatus
chimicos XXI praestantissimos... Frankfurt a. M., 1678. For translation, see: (B) WAITE,
The Hermetic Museum.*

Contents quoted in this volume:

- i [Hermes Trismegistus:] Tractatus aureus de lapide philosophorum [pp. 1–52]
- ii Madathanus: Aureum saeculum redivivum [pp. 53–72]
- iii [Siebmacher:] Hydrolithus sophericus, seu Aquarium sapientum [pp. 73–144]
- iv Mehung: Demonstratio naturae [pp. 145–71]
- v Flamel: Tractatus brevis seu Summarium philosophicum [pp. 172–79]
- vi [Barcius (F. von Sternberg)]: Gloria mundi, alias Paradisi tabula [pp. 203–304]
- vii Liber Alze [pp. 325–35]
- viii Lambspringk: De lapide philosophico figurae et emblemata [pp. 337–72]
- ix Valentinus: De prima materia [pp. 424–25]
- x Sendivogius: Novum lumen chemicum e naturae fonte et manuali experientia
depromptum [pp. 545–600; Parabola, seu Aenigma philosophicum
Coronidis..., pp. 585–90]
- xi [Sendivogius:] Novi luminis chemici Tractatus alter de sulphure [pp. 601–46]
- xii Philalethes: Introitus apertus ad oclusum regis palatium [pp. 601–46]
- xiii Philalethes: Fons chymicae veritatis [pp. 799–814]
- xiv Helvetius: Vitulus aureus [pp. 815–63]

*THEATRUM CHEMICUM, praecipuos selectorum auctorum tractatus... continens.
Vols. I—III, Ursel, 1602. Vols. IV-VI, Strasbourg, 1613, 1622, 1661.*

Contents quoted in this volume:

VOLUME I

- i Hoghelande: Liber de alchemiae difficultatibus [pp. 121–215]
- ii Dorn: Speculativae philosophiae, gradus septem vel decem continens [pp.
255–310]
- iii Dorn: Physica genesis [pp. 367–404]
- iv Dorn: Physica Trismegisti [pp. 405–37]
- v Dorn: Physica Trithemii [pp. 437–50]
- vi Dorn: Philosophia meditativa [pp. 450–72]
- vii Dorn: Philosophia chemica ad meditativam comparata [pp. 472–517]
- viii Dorn: De tenebris contra naturam et vita brevi [pp. 518–35]
- ix Dorn: Duellum animi cum corpore [pp. 535–50]

- x Dorn: Congeries Paracelsicae chemicae de transmutatione metallorum [pp. 557–646]
- xi Penotus: De vera praeparatione et usu medicamentorum chemicorum [pp. 672–772]
- xii Bernard of Treviso: De chemico miraculo, quod lapidem philosophiae appellant (Liber de alchemia) [pp. 773–803]
- xiii Zacharius, Dionysius: Opusculum philosophiae naturalis metallorum, cum annotationibus Nicolai Flameli [pp. 804–901]

VOLUME II

- xiv Aegidius de Vadis: Dialogus inter naturam et filium philosophiae [pp. 95–123]
- xv Penotus: Philosophi potius occultare artem conati sunt, quam patefacere [p. 123: a table]
- xvi Ripley: Duodecim portarum axiomata philosophica [pp. 123–39]
- xvii Hollandus: Fragmentum de opere philosophorum [pp. 142–46]
- xviii Penotus: Quinquagintaseptem canones de opere physico (“Reguia et canones”) [pp. 150–54]
- xix Dee: Monas hieroglyphica [pp. 203–43]
- xx Ventura: De ratione conficiendi lapidis [pp. 244–356]
- xxi Joannes Pico Mirandola: De auro [pp. 357–432]
- xxii Albertus Magnus: Super arborem Aristotelis [pp. 524–27]

VOLUME III

- xxiii De magni lapidis compositione et operatione [pp. 1–56]
- xxiv Rupescissa: Liber de confectione veri lapidis philosophorum [pp. 191–200]
- xxv Hollandus: Opera mineralia, seu de lapide philosophico omnia [pp. 320–564]
- xxvi Greverus: Secretum [pp. 783–810]
- xxvii Alani philosophi dicta de lapide philosophico [pp. 811–20]
- xxviii Barnaud: Commentarium in quoddam Epitaphium Bononiae... [pp. 836–48]
- xxix Delphinus: Liber secreti maximi [pp. 871–78]

VOLUME IV

- xxx Lully: Theorica et practica [pp. 1–191]
- xxxi Artefius: Clavis majoris sapientiae [pp. 221–40]
- xxxii Aphorismi Basiliani sive Canones Hermetici [pp. 368–71]
- xxxiii Beatus: Aurelia occulta philosophorum [pp. 525–81]

- xxxiv Arnold of Villanova: *Speculum alchimiae* [pp. 583–613]
xxxv Hermes Trismegistus: *Tractatus aureus... cum scholiis Dominici Gnosii*
[pp. 672–797]
xxxvi Lagneus: *Harmonia chemica* [pp. 813–903]
xxxvii Albertus: *Liber octo capitulorum de lapide philosophorum* [pp. 948–71]
xxxviii Valentinus: *Opus praeclarum ad utrumque* [pp. 1061–75]
xxxix Petrus de Silento: *Opus* [pp. 1113–27]

VOLUME V

- xl *Allegoriae sapientum... supra librum Turbae* [pp. 64–100]
xli *Tractatus Micreris suo discipulo Mirnefindo* [pp. 101–13]
xlii *Liber Platonis quartorum...* [pp. 114–208]
xliii Senior: *De chemia* [pp. 219–66]
xliv Mennens: *Aureum vellus* [pp. 267–470]
xlv *Consilium coniugii* [pp. 479–566]
xlvi Bonus: *Pretiosa margarita novella correctissima* [pp. 589–794]
xlvii *Tractatus Aristotelis alchymistae ad Alexandrum Magnum de lapide philosophico* [pp. 880–92]
xlviii *Epistola ad... Hermannum archiepiscopum Coloniensem de lapide philosophico* [pp. 893–900]

VOLUME VI

- xlix Vigenerus (Blaise de Vigenère): *De igne et sale* [pp. 1–139]
l Christopher of Paris: *Elucidarius artis transmutatoriae metallorum* [pp. 195–293]
li Grasseus: *Arca arcani* [pp. 294–381]
lii Orthelius: *Epilogus et recapitulatio... in Novum lumen chymicum Sendivogii*
[pp. 430–58]
liii Orthelius: *Discursus* [pp. 470–74]

THEATRUM CHEMICUM BRITANNICUM,... collected with annotations by Elias Ashmole. London, 1652.

Contents quoted in this volume:

- i Norton: *The Ordinall of Alchimy* [pp. 13–106]

B. GENERAL BIBLIOGRAPHY

ABEGG, EMIL. *Der Messiasglaube in Indien und Iran*. Berlin and Leipzig, 1928.

ABRAHAM ELEAZAR. See ELEAZAR.

- ABT, ADAM. *Die Apologie des Apuleius von Madaura und die antike Zauberei*. (Religionsgeschichtliche Versuche und Vorarbeiten, vol. 4, part 2, pages 75–345.) Giessen, 1908.
- ABU 'L-QĀSIM MUHAMMAD IBN AHMAD AL-'IRĀQĪ. *Kitâb al-'ilm almuktasab* (Book of Knowledge acquired concerning the cultivation of gold). Edited and translated by E. J. Holmyard. Paris, 1923.
- Acta Archelai*. See Hegemonius.
- Acta Joannis* (Acts of John). See JAMES.
- Acta Thomae* (Acts of Thomas). See JAMES.
- AEGIDIUS DE VADIS. “Dialogus inter naturam et filium philosophiae.” See (A) *Theatrum chemicum*, xiv.
- AELIAN (Claudius Aelianus). *De natura animalium*. Edited by Rudolph Hercher. Leipzig, 1864–66. 2 vols.
- “Aenigmata ex visione Arislei philosophi, et allegoriis sapientum” (“Aenigmata philosophorum”). See (A) *Artis auriferae*, iii and xxi.
- AGNOSTUS, IRENAEUS, pseud. (Friedrich Grick). *Prodromus Fr. R. C. [Rhodostauroticus]*. Segoduni (Rodez), 1620.
- AGRIPPA VON NETTESHEIM, CORNELIUS. *De incertitudine et vanitate scientiarum*. Cologne, 1585. English translation: *The Vanity of Arts and Sciences*. London, 1676.
- AIGREMONT, DR., pseud. (Siegmar Baron von Schultze-Galléra). *Fuss-und Schuhsymbolik und -Erotik*. Leipzig, 1909.
- [ALANUS.] “Dicta Alani.” See (A) *Theatrum chemicum*, xxvii.
- ALBERTUS MAGNUS (Albert the Great, Saint). “Liber octo capitulorum de lapide philosophorum.” See (A) *Theatrum chemicum*, xxxvii.
- _____. “Scriptum super arborem Aristotelis.” See (A) *Theatrum chemicum*, xxii.
- ALDROVANDUS, ULYSSES. *Dendrologiae libri duo*. Bologna [1667.] 2 vols.
- 'ALĪ, M. TURĀB (ed.). “Three Arabic Treatises on Alchemy by Muhammad bin Umail,” *Memoirs of the Asiatic Society of Bengal* (Calcutta), XII (1933), 1–116.
- “Allegoria Merlini.” See (A) *Artis auriferae*, xiii.
- “Allegoriae sapientum supra librum Turbae XXIX distinctiones.” See (A) *Theatrum chemicum*, xl.
- “Allegoriae super librum Turbae.” See (A) *Artis auriferae*, ii.
- [ALTUS, pseud.] *Mutus Liber*. La Rochelle, 1677. See also (A) MANGETUS, *Bibliotheca chemica curiosa*, iv.

AMBROSE, SAINT. *Commentarius in Cantica Canticorum e scriptis S. Ambrosii a Guillelmo, quondam Abbate S. Theodorici, collectus*. See Migne, *P.L.*, vol. 15, cols. 1851–1962.

_____. *De excessu fratris*. See: *S. Ambrosii Opera*, Pars VII. Edited by Otto Faller. (Corpus Scriptorum Ecclesiasticorum Latinorum, 73.) Vienna, 1955. (pp. 209–35.)

_____. *Epistolae*. See Migne, *P.L.*, vol. 16, cols. 875–1286.

_____. *Explanatio Psalmorum XII*. See: *S. Ambrosii Opera*, Pars VI. Edited by M. Petschenig. (Corpus Scriptorum Ecclesiasticorum Latinorum, 64.) Vienna and Leipzig, 1919.

_____. *Hexaemeron*. See Migne, *P.L.*, vol. 14, cols. 123–274.

ANGELUS SILESIUS (Johann Scheffler). *Sämtliche Poetische Werke*. Edited by Hans Ludwig Held. Munich, 1949–52. 3 vols. (“Der Cherubinische Wandersmann,” Vol. III, pp. 7–218.) For translations of certain parts of the “Cherubinische Wandersmann,” see: FLITCH, J. E. CRAWFORD. *Angelus Silesius: Selections from the Cherubic Wanderer*. London, 1932.

ANTONY OF PADUA, SAINT. *Sermones*. Padua, 1895–1913. 3 vols.

“Aphorismi Basiliani sive Canones Hermetici.” See (A) *Theatrum chemicum*, xxxii.

APTOWITZER, VIKTOR (AVIGDOR). “Arabisch-jüdische Schöpfungstheorien,” *Hebrew Union College Annual* (Cincinnati), VI (1929), 205–46.

APULEIUS, LUCIUS. *Metamorphoses*. See: *The Golden Ass*. With an English translation by Richard Adlington. Revised by Stephen Gaselee. (Loeb Classical Library.) London and Cambridge, Mass., 1947.

“Aquarium sapientum.” See (A) *Musaeum hermeticum*, iii.

“Arcanum Hermeticae philosophiae opus.” Geneva, 1653. See also D’ESPAGNET.

[ARISLEUS.] “Visio Arislei.” See (A) *Artis auriferae*, iii and xxi.

ARISTOTLE. [*De Anima*.] *On the Soul; Parva Naturalia; On Breath*. With an English translation by W. S. Hett. (Loeb Classical Library.) London and Cambridge, Mass., 1935.

[ARISTOTLE, pseud.] “Tractatus Aristotelis Alchymistae ad Alexandrum Magnum, de Lapide philosophico.” See (A) *Theatrum chemicum*, xlvii. Another version in (A) *Artis auriferae*, xi.

ARNALDUS DE VILLA NOVA (Arnold of Villanova). “Speculum alchimiae.” See (A) *Theatrum chemicum*, xxxiv.

_____. “Thesaurus Thesaurorum” and “Rosarius.” See (A) *Artis auriferae*, xxii.

ARTEFIUS. “Clavis maioris sapientiae.” See (A) *Theatrum chemicum*, xxxi. Another version in (A) MANGETUS, *Bibliotheca chemica curiosa*, iii.

ARTEMIDORUS DALDIANUS. *Onirocriticon Libri V*. Edited by Rudolf Hercher. Leipzig, 1864.

Atharvaveda. Hymns of the Atharva-Veda. Translated by Maurice Bloomfield. (Sacred Books of the East, 42.) Oxford, 1897.

_____. See also GRILL.

ATHENAEUS, ALEXIS. *The Deipnosophists*. With an English translation by Charles Burton Gulick. (Loeb Classical Library.) London and New York, 1927–41. 7 vols.

ATHENAGORAS. *Legatio pro Christianis*. See Migne, *P.G.*, vol. 6, cols. 889–972.

ATWOOD, MARY ANNE. *A Suggestive Enquiry into the Hermetic Mystery*. Revised edn., Belfast, 1920. (Contains translation of Hermes Trismegistus, “Tractatus aureus.”)

AUGUSTINE, SAINT. *The City of God*. Translated by John Healey. Edited by R. V. G. Tasker. (Everyman’s Library.) London and New York, 1945. 2 vols.

_____. *The Confessions*. Translated by Francis J. Sheed. London and New York, 1951.

_____. *Contra Faustum* (Reply to Faustus the Manichean). In *St. Augustine: The Writings against the Manichaeans and against the Donatists*. Translated by Richard Stothert and others. (Select Library of Nicene and Post-Nicene Fathers, 4.) Grand Rapids, 1956. (pp. 155–345.)

_____. *De actis cum Felice Manichaeo*. See Migne, *P.L.*, vol. 42, cols. 519–52.

_____. *De Natura Boni* (On the Nature of the Good). See *Augustine: Earlier Writings*. Selected and translated by John H. S. Burleigh. (Library of Christian Classics, 6.) London, 1953. (pp. 326–48.)

_____. [*Enarrationes in Psalmos*.] *Expositions of the Book of Psalms*. [Translated by J. Tweed, T. Scratton, and others.] (Library of Fathers of the Holy Catholic Church.) Oxford, 1847–57. 6 vols.

_____. *Epistola 55*. See *S. Aurelii Augustini Epistolae Pars I*. Edited by A. Goldbacher. (Corpus Scriptorum Ecclesiasticorum Latinorum, 34.) Vienna, Prague, Leipzig, 1895. (pp. 169–213.)

_____. *Quaestiones in Heptateuchum*. See Migne, *P.L.*, vol. 34, cols. 547–824.

_____. *Sermo Suppositus 120 (In Natali Domini IV. 8)*. See Migne, *P.L.*, vol. 39, cols. 1984–87.

_____. [*Tractatus in Joannis Evangelium*.] *Lectures or Tractates on the Gospel according to St. John*. Translated by James Innes. (*Works of Aurelius Augustinus*, edited by Marcus Dods.) Edinburgh, 1874. 2 vols.

“Aurelia occulta philosophorum.” See (*A*) *Theatrum chemicum*, xxxiii.

“Aureum vellus.” See (*A*) *Theatrum chemicum*, xlv.

- “Aurora consurgens” [Part II]. See (A) *Artis auriferae*, v. For Part I, see FRANZ.
- “Authoris ignoti, philosophici lapidis secreta metaphorice describentis.” See (A) *Artis auriferae*, xii.
- [AVALON, ARTHUR, pseud.] (Sir John Woodroffe) (ed. and trans.). *The Serpent Power. Being the Shat-Chakra-Nirupana and Paduka-Panchaka*. 2nd rev. edn., Madras, 1924.
- [AVICENNA.] *Tractatulus Avicennae*. See (A) *Artis auriferae*, xv.
- BAADER, BENEDICT FRANZ XAVER VON. *Sämmtliche Werke*. Leipzig, 1851–60. 10 vols.
- BAECHTOLD-STÄUBLI, HANNS. *Handwörterbuch des deutschen Aberglaubens*. Berlin and Leipzig, 1927–42. 10 vols.
- BARNAUD, NICOLAS. “Commentarium in quoddam epitaphium Bononiae...” See (A) *Theatrum chemicum*, xxviii. Also in (A) MANGETUS, *Bibliotheca chemica curiosa*, ix.
- BAUDIUS, DOMINICUS. *Amores*. Edited by Petrus Scriverius. Leyden, 1638. (For “Epitaphium Amoris ex Casperii Gevartii Electorum Libri III,” see pp. 497–518.)
- BAYNES, H. G. “On the Psychological Origins of Divine Kingship,” *Folklore* (London), XLVII (1936), 74–104.
- BECKER, FERDINAND. *Die Darstellung Jesu Christi unter dem Bilde des Fisches*. Breslau, 1866.
- BEER, PETER. *Geschichte, Lehren und Meinungen aller bestandenen und noch bestehenden religiösen Sekten der Juden und der Geheimlehre oder Cabbalah*. Brunn, 1822–23. 2 vols.
- [BELINUS.] “Dicta Belini.” Included in “Allegoriae sapientum super Turbae.” See (A) *Theatrum chemicum*, xl.
- BERNARD OF TREVISO (Bernardus Trevisanus.) “Liber de alchemia” (“De chemico miraculo, quod lapidem philosophiae appellant”). See (A) *Theatrum chemicum*, xii.
- [BERNARDINO DE SAHAGÚN.] *Einige Kapitel aus dem Geschichtswerk des Fray Bernardino de Sahagun aus dem Aztekischen übersetzt von Eduard Seler*. Edited by Cäcilie Seler-Sachs and others. Stuttgart, 1927.
- _____. *General History of the Things of New Spain (Florentine Codex)*. Book III: The Origin of the Gods. Translated by Arthur J. C. Anderson and Charles E. Dibble. (Monographs of the School of American Research, 14, Part IV.) Santa Fe, 1952.
- BERNOULLI, RUDOLF. “Spiritual Disciplines as Reflected in Alchemy and Related Disciplines.” In *Spiritual Disciplines* (q.v.), pp. 305–40.

- BÉROALDE DE VERVILLE, FRANÇOIS (trans.). *Le Tableau des riches inventions... qui sont représentées dans le Songe de Poliphile*. Paris, 1600. (Contains the “Recueil sténographique.”)
- BERTHELOT, MARCELLIN. *La Chimie au moyen âge*. Paris, 1893. 3 vols.
 _____. *Collection des anciens alchimistes grecs*. Paris, 1887–88. 3 vols.
 _____. *Les Origines de l’alchimie*. Paris, 1885.
- BEZOLD, CARL (ed. and trans.). *Më’arrath Gazzē. Die Schatzhöhle*. Leipzig, 1883–88. 2 parts.
- BISCHOFF, ERICH. *Die Elemente der Kabbalah*. Berlin, 1913. 2 vols.
- BOEHME, JAKOB. [Zweyte Apologie wieder Balthazar Tilken.] *The Second Apologie to Balthazar Tylcken*. See: *The Remainder of Books written by Jacob Behmen*. Englished by John Sparrow. London, 1662. See also below.
 _____. *Des gottseligen, hocherleuchteten Jacob Böhmen Teutonici Philosophi alle Theosophische Schrifften*. Amsterdam, 1682. (This edition of Boehme’s Works consists of a number of parts, each separately paginated and variously bound up. The parts are not numbered. It includes, inter alia, the following works referred to in the present volume. The bracketed English titles and volume references, following the German title of each work, refer to the 1764–81 London translation of the Works, cited below.)
 _____. *Aurora. Morgenröte im Ausgang...* [Aurora. Vol. I.]
 _____. [Drey principia.] *Beschreibung der drey Principien Göttliches Wesens*. [Three Principles of the Divine Essence. Vol. I.]
 _____. *Hohe und tiefe Gründe von dem dreyfachen Leben des Menschen*. [A High and Deep Search concerning the Threefold Life of Man. Vol. II.]
 _____. *Mysterium magnum*. [Mysterium magnum. Vol. III.]
 _____. [Quaestiones theosophicae.] *Theosophische Fragen in Betrachtung Göttlicher Offenbarung...* [Not in English collection.]
 _____. “Tabula Principiorum.” See *De signatura rerum* in this edition, pp. 269–87.
- BOEHME, JAKOB. *Von der Menschwerdung Jesu Christi*. [Not in English collection.]
 _____. *The Works of Jacob Behmen*. [Edited by G. Ward and T. Langcake.] London, 1764–81. 4 vols.
 _____. *Zweyte Apologia wieder Balthazar Tilken*. [Not in English collection; see above.]
- BONAVENTURE, SAINT. [Itinerarium mentis in Deum.] *The Franciscan Vision*. Translated by Fr. James, O.M. Cap. London, 1937.

- BONUS, PETRUS. "Pretiosa margarita novella." See (A) MANGETUS, *Bibliotheca chemica curiosa*, v. Another version in (A) *Theatrum chemicum*, xlvi. Another version, edited by Janus Lacinius, Venice, 1546.
- BOUCHÉ-LECLERCQ, AUGUSTE. *L'Astrologie grecque*. Paris, 1899.
- BOUSSET, WILHELM. [*Der Antichrist.*] *The Antichrist Legend*. Translated by A. H. Keane. London, 1896.
- _____. *Hauptprobleme der Gnosis*. Göttingen, 1907.
- _____. "Die Himmelsreise der Seele," *Archiv für Religionswissenschaft* (Tübingen and Leipzig), IV (1901), 136–69.
- BRANT, SEBASTIAN. *Hexastichon... in memorabiles Evangelistarum figuras*. Pforzheim, 1502.
- BREASTED, JAMES HENRY. *Development of Religion and Thought in Ancient Egypt*. New York and London, 1912.
- BRENTANO, CLEMENS. *Gesammelte Schriften*. Edited by Christian Brentano. Frankfurt a. M., 1852–55. 9 vols.
- Brihadaranyaka Upanishad*. See *Upanishads*.
- BRUCHMANN, C. F. H. *Epitheta Deorum quae apud Poetas Graecos leguntur*. (*Ausführliches Lexikon der griechischen und römischen Mythologie*, Supplement.) Leipzig, 1893.
- BRUGSCH, HEINRICH. *Religion und Mythologie der alten Ägypter*. Leipzig, 1885.
- BUDGE, ERNEST ALFRED WALLIS. *Coptic Apocrypha in the Dialect of Upper Egypt*. London, 1913.
- _____. *The Egyptian Heaven and Hell*. London, 1905–6. 2 vols.
- _____. *The Gods of the Egyptians*. London, 1904. 2 vols.
- _____. *Osiris and the Egyptian Resurrection*. London, 1911. 2 vols.
- [*Bundahisn.*] *Der Bundehesh*. Edited by Ferdinand Justi. Leipzig, 1868.
- BURNET, JOHN. *Early Greek Philosophy*. London, 1892; 4th edn., 1930.
- BURY, ROBERT GREGG. See PLATO.
- CAESARIUS OF HEISTERBACH. *Dialogue on Miracles*. Translated by H. von E. Scott and C. C. Swinton Bland. London, 1929. 2 vols.
- CALID. See KALID.
- CAMPBELL, COLIN. *The Miraculous Birth of King Amon-Hotep III*. Edinburgh and London, 1912.
- CAPELLE, PAUL. *De luna stellis lacteo orbe animarum sedibus*. Halle. 1927.
- CARDANUS, HIERONYMUS (Jerome Cardan). *De subtilitate*. Basel, 1611.

- CASSEL, PAULUS STEPHANUS (previously Selig). *Aus Literatur und Symbolik*. Leipzig, 1884.
- CASSIODORUS, M. AURELIUS. *Expositio in Cantica Canticorum*. See Migne, *P.L.*, vol. 70, cols. 1055–1106.
- _____. *Expositio in Psalterium*. See Migne, *P.L.*, vol. 70, cols. 25–1056.
- CAUSSIN, NICHOLAS. *De symbolica Aegyptiorum sapientia*. Paris, 1618.
- _____. *Polyhistor symbolicus*. Paris, 1618.
- CEDRENUS, GEORGIUS. *Historiarum compendium*. See Migne, *P.G.*, vols. 121 (whole) and 122, cols. 9–368.
- CHARLES, R. H. (ed.). *Apocrypha and Pseudepigrapha of the Old Testament*. Oxford, 1913. 2 vols.
- CHRISTENSEN, ARTHUR E. “Les Types du premier homme et du premier roi dans l’histoire légendaire des Iraniens,” *Archives d’Études orientales* (Stockholm), XIV (1917).
- CHRISTOPHER OF PARIS. “Elucidarius artis transmutatoriae metallorum summa major.” See (A) *Theatrum chemicum*, 1.
- CHWOLSOHN, D. *Die Ssabier*. St. Petersburg, 1856. 2 vols.
- CICERO. *De natura Deorum: Academica*. With a translation by H. Rackham. (Loeb Classical Library.) London and New York, 1933.
- _____. *De officiis*. With an English translation by Walter Miller. (Loeb Classical Library.) London and Cambridge, Mass., 1938.
- “Clangor buccinae.” See (A) *Artis auriferae*, xvi.
- CLEMENT OF ALEXANDRIA. *Stromata* (Miscellanies). In: *Clement of Alexandria [Works]*. Edited by Otto Stählin. Leipzig, 1906–9. 3 vols. (Vol. II, and Vol. III, pp. 3–102.) For translation, see: *The Writings of Clement of Alexandria*. Translated by William Wilson. (Ante-Nicene Christian Library, 4, 12. Edinburgh, 1867–69. 2 vols. Vol. I, pp. 349–470, and the whole of Vol. II.)
- CLEMENT OF ROME. *The Apostolical Constitutions*. See next entry.
- _____. *The Clementine Homilies and the Apostolical Constitutions*. Translated by Thomas Smith, Peter Peterson, and James Donaldson. (Ante-Nicene Christian Library, 17.) Edinburgh, 1870. (The two works have separate pagination.)
- _____. *Recognitiones*. See Migne, *P.G.*, vol. 1, cols. 1207–1474. For translation, see THEOPHILUS OF ANTIOCH.
- _____. *Second Epistle to the Corinthians*. See: LAKE, KIRSOPP (ed. and trans.). *The Apostolic Fathers* (Loeb Classical Library.) London and New York, 1914. 2 vols. (Vol. I, pp. 128–63.)

Codices and Manuscripts.

- Berlin. Cod. Berolinensis Latinus 532. (Folios 147^V-164^V, “Commentum beati Thomae de Aquino super... codice[m] qui et Turba dicitur Phylosophorum.”)
- Florence. Biblioteca Medicea-Laurenziana. MS. (Ashburnham 1166). “Miscellanea d’alchimia.” 14th cent.
- London. British Museum. MS. Add. 5025. Four rolls drawn in Lübeck. 1588. (The “Ripley Scrowle.”)
- Munich. Staatsbibliothek. Codex Germanicus 598. “Das Buch der heiligen Dreifaltigkeit...” 1420.
- Munich. Codex Latinus 4453. Gospels from Cathedral Treasury at Bamberg. 10th cent.
- Oxford. Bodleian Library. MS. Ashmole 1394. Contains two versions of Ripley’s “Cantilena,” pp. 67–74, 75–82. 17th cent.
- Oxford. Bodleian Library. MS. Ashmole 1445. Contains two English versions of Ripley’s “Cantilena,” fols. 2–12, 41–44.
- Oxford. Bodleian Library. MS. Ashmole 1479. Contains Ripley’s “Cantilena,” fols. 223^V-225^V.
- Oxford. Bodleian Library. MS. Bruce 96 (Codex Brucianus). See: BAYNES, CHARLOTTE AUGUSTA. *A Coptic Gnostic Treatise Contained in the Codex Brucianus*. Cambridge, 1933.
- Oxford. Bodleian Library. MS. Digby 83. 12th cent. Contains at folio 24 “Epistola Ethelwoldi ad Gerbertum papam, de circuli quadratura.”
- Paris. Bibliothèque de l’Arsenal. MS. 3022. “Vision advenue en songeant à Ben Adam....”
- Paris. Bibliothèque Nationale. MS. 2327. “Livre sur l’art de faire l’or.” 1478.
- Paris. Bibliothèque Nationale. MS. français 14765. Abraham le Juif. “Livre des figures hiéroglyphiques.”
- St. Gall. Codex Germanicus Alchemicus Vadiensis. 16th cent.
- In possession of author. “Figurarum Aegyptiorum secretarum.” 18th cent.
- COLONNA, FRANCESCO. See BÉROALDE DE VERVILLE.
- “Consilium coniugii.” See (A) *Ars chemica*, ii; (A) MANGETUS, *Bibliotheca chemica curiosa*, vii; and (A) *Theatrum chemicum*, xlv.
- CORDOVERO, MOSE. *Pardes Rimmonim*. Cracow, 1592. Other editions: Mantua, 1623; Amsterdam, 1708; Munkacs, 1906.
- CORNFORD, FRANCIS MACDONALD (trans.). *Plato’s Cosmology. The Timaeus of Plato translated with a running commentary*. London, 1937.
- Corpus Hermeticum*. See SCOTT, WALTER: *Hermetica*; also MEAD.
- Corpus Inscriptionum Latinarum*. Consilio et auctoritate Academiae Litterarum regiae Borussicae editum. Berlin, 1863ff. 15 vols.
- CRASSELAME, MARCANTONIO. See TACHENIUS.
- CRAWFORD, J. P. WICKERSHAM. “EL Horóscopo del Hijo del Rey Alcaraz en el ‘Libro de buen Amor,’” *Revista de filologia española* (Madrid), XII (1925), 184–90.
- CRAWLEY, ALFRED ERNEST. *The Idea of the Soul*. London, 1909.
- CUMONT, FRANZ. *Textes et monuments figurés relatifs aux mystères de Mithra*. Brussels, 1894–99. 2 vols.

CURTIUS, ERNST ROBERT. *European Literature and the Latin Middle Ages*. Translated by Willard R. Trask. New York (Bollingen Series XXXVI) and London, 1953.

_____. *James Joyce und sein Ulysses*. Zurich, 1929.

CYRIL OF JERUSALEM, SAINT. *Catecheses mystagogicae*. See Migne, *P.L.*, vol. 33, cols. 1066–1128. Another edition: *Opera*. Edited by Wilhelm Karl Reischl and Joseph Rupp. Munich, 1848–60. 2 vols. (Vol. I, p. 29 – Vol. II, p. 343.)

DALE, ANTHONY VAN. *Dissertationes de origine ac progressu idololatriae et superstitionum*. Amsterdam. 1696.

DAMASCIUS DIADOCHUS. *Damascii Successoris Dubitationes et Solutiones de Primis Principiis in Platonis Parmenidem*. Edited by C. Emil Ruelle. Paris, 1889. 2 vols.

“De arte chymica.” See (A) *Artis auriferae*, xvii.

DEE, JOHN. “Monas hieroglyphica.” See (A) *Theatrum chemicum*, xix.

DE GUBERNATIS, ANGELO. *Zoological Mythology*. London, 1872. 2 vols.

DELATTE, LOUIS. *Textes latins et vieux français relatifs aux Cyranides*. (Bulletin de la faculté de philosophie et lettres de l’Université de Liège, fasc. 93.) Liège and Paris, 1942.

DELPHINAS. “Liber secreti maximi.” See (A) *Theatrum chemicum*, xxix.

“De magni lapidis compositione et operatione.” See (A) *Theatrum chemicum*, xxiii.

“De promissionibus et praedictionibus Dei.” Attributed by some to St. Prosper (of Aquitaine). See Migne, *P.L.*, vol. 51, cols. 733–858.

D’ESPAGNET. “Arcanum Hermeticae philosophiae opus.” See (A) MANGETUS, *Bibliotheca chemica curiosa*, viii. See also above, s.v. “Arcanum...”

DEUSSEN, PAUL. *Allgemeine Geschichte der Philosophie*. Leipzig, 1894–1917. 2 vols. (each comprising 3 Abteilungen.)

_____. *Geheimlehre des Veda*. Leipzig, 1907.

DIELS, HERMANN. *Fragmente der Vorsokratiker*. Berlin, 1934–37. 3 vols.

DIODORUS OF SICILY. *Bibliotheca Historike*. Translated by C. H. Oldfather, C. L. Sherman, and R. M. Gerr. (Loeb Classical Library.) London and New York, 1933– (in progress). 12 vols.

DIONYSIUS THE AREOPAGITE, pseud. *De coelesti hierarchia*. See Migne, *P.G.*, vol. 3, cols. 119–370. (The commentary of George Pachymeres is here printed with the text.) For translation, see: *The Celestial Hierarchies*. Translated by the Editors of the Shrine of Wisdom. (Shrine of Wisdom Manual 15.) London, 1935.

_____. *De divinis nominibus*. See Migne, *P.L.*, vol. 3, cols. 585–996.

For translation, see: *On the Divine Names and the Mystical Theology*. Translated by C. E. Rolt. London and New York, 1920.

[DIOSCORIDES.] *Petri Andreae Matthioli Medici Senensis Commentarii in libros sex Pedacii Dioscoridis Anazarbei de Medica Materia*. Venice, 1554.

- DIRR, ADOLF (ed. and trans.). *Kaukasische Märchen. (Die Märchen der Weltliteratur, ed. Fr. von der Leyen and P. Zaunert, 12.)* Jena, 1920.
- DOELGER, FRANZ JOSEF. *Antike und Christentum*. Münster, 1929–36. 5 vols.
 _____. *Die Sonne der Gerechtigkeit und der Schwarze*. Münster, 1918.
- DORN, GERARD. “Congeries Paracelsicae chemicae de transmutatione metallorum.” See (A) *Theatrum chemicum*, x.
 _____. “De tenebris contra naturam et vita brevi.” See (A) *The atrum chemicum*, viii.
 _____. “Duellum animi cum corpore.” See (A) *Theatrum chemicum*, ix.
 _____. “Philosophia chemica.” See (A) *Theatrum chemicum*, vii.
 _____. “Philosophia meditativa.” See (A) *Theatrum chemicum*, vi.
 _____. “Physica genesis.” See (A) *Theatrum chemicum*, iii.
 _____. “Physica Trismegisti.” See (A) *Theatrum chemicum*, iv.
 _____. “Physica Trithemii.” See (A) *Theatrum chemicum*, v.
 _____. “Speculativa philosophia.” See (A) *Theatrum chemicum*, ii.
 _____. (ed.). *Theophrasti Paracelsi Libri V de Vita longa*. Frankfurt a. M., 1583.
- DREXELIUS, HIEREMIAS. *Opera*. Antwerp, 1643. 2 vols.
- DU CANGE, CHARLES DU FRESNE. *Glossarium ad scriptores mediae et infimae Graecitatis*. Breslau, 1891.
 _____. *Glossarium ad Scriptores mediae et infimae Latinitatis*. 1733–36. 6 vols. New edn., Graz, 1954. 10 vols. in 5.
- DU PERRON, ANQUETIL. *Oupnek’hat (id est, Secretum tegendum)... in Latinum conversum*. Strasbourg, 1801–2. 2 vols.
- ECKERT, EDUARD EMIL. *Die Mysterien der Heldenkirche, erhalten und fortgebildet im Bunde der alten und der neuen Kinder der Wittwe*. Schaffhausen, 1860.
- [ECKHART, MEISTER.] [*Works of*] *Meister Eckhart*. Translated by C. de B. Evans. London, 1924–52. 2 vols.
- EIRENAEUS ORANDUS. See FLAMEL.
- EISLER, ROBERT. *Weltenmantel und Himmelszelt*. Munich, 1910. 2 vols.
 _____. “Zur Terminologie und Geschichte der jüdischen Alchemie,” *Monatsschrift für Geschichte und Wissenschaft des Judentums* (Dresden), LXX (n.s., 34), (1926), 194–201.
- ELEAZAR, ABRAHAM. *Uraltes Chymisches Werck*. Leipzig, 1760. (Part II has separate pagination.)
- ELIADE, MIRCEA. *Shamanism: Archaic Techniques of Ecstasy*. Translated by Willard R. Trask. New York (Bollingen Series) and London, 1964. (Orig.: *Le Chamanisme et les techniques archaïques de l’extase*. Paris, 1951.)
- [ELIEZER BEN HYRCANUS.] *Pirkê de Rabbi Eliezer*. Translated and edited by Gerald Friedlander. London and New York, 1916.
- Encyclopaedia Judaica*. Edited by Jacob Klatzkin. Berlin, 1928–(publication suspended).
- Enoch, Book of*. See CHARLES, R. H.

- [EPHRAEM SYRUS, SAINT.] *Sancti Ephraemi Syri Hymni et Sermones*. Edited by Joseph Lamy. Mechlin, 1882–1902. 4 vols. (Numbered in columns, not pages.)
- _____. *Opera omnia*. Translated (into Latin) and edited by Gerard Voss. 3rd edn., Cologne, 1616. (“De paenitentia,” pp. 561–84.)
- EPIPHANIUS. *Ancoratus* and *Panarium*. Edited by Karl Holl. (Griechische christliche Schriftsteller.) Leipzig, 1915–33. 3 vols. (*Ancoratus*, Vol. I, pp. 1–149; *Panarium*, Vol. I, p. 169–Vol. III, p. 496.)
- “Epistola ad Hermannum archiepiscopum Coloniensem de lapide philosophorum.” See (A) *Theatrum chemicum*, xlvi.
- ERMAN, ADOLF. *Die Religion der Ägypter*. Berlin and Leipzig, 1934.
- EUCHERIUS, BISHOP OF LYONS. *Liber Formularum Spiritualis Intelligentiae*. See Migne, *P.L.*, vol. 50, cols. 727–72.
- EUSEBIUS. *Constantini Oratio ad Sanctorum Coetum*. In Migne, *P.G.*, vol. 20, cols. 1233–1316.
- EUSTATHIUS MACREMBOLITES. *De Hysmines et Hysminiae Amoribus Libri XI*. Edited by Isidore Hilberg. Vienna, 1876.
- EUTHYMIOS ZIGABENOS. *Panoplia Dogmatica*. See Migne, *P.G.*, vol. 130 (whole vol.)
- EVANS. See ECKHART.
- “Exercitationes in Turbam.” See (A) *Artis auriferae*, iv.
- FERGUSON, JOHN. *Bibliotheca chemica*. Glasgow, 1906, 2 vols.
- FICINO, MARSIGLIO (Marsilius Ficinus). *Opera*. Basel, 1576. 2 vols.
- FIERZ-DAVID, LINDA (ed.). *The Dream of Poliphilo*. Translated by Mary Hottinger. (Bollingen Series XXV.) New York, 1950.
- FIGULUS, BENEDICTUS (Benedict Torpfer). *Rosarium novum olympicum et benedictum*. Basel, 1608. 2 parts, separately paginated, but second part has no separate title-page.
- FIRMICUS MATERNUS, JULIUS. *Liber de errore profanarum religionum*. See: *M. Minucii Felicis Octavius et Julii Firmici Materni Liber de errore profanarum religionum*. Edited by Karl Halm. (Corpus Scriptorum Ecclesiasticorum Latinorum, 2.) Vienna, 1867.
- _____. *Matheseos Libri VIII*. Edited by W. Kroll, F. Skutsch, and K. Ziegler. Leipzig, 1897–1913. 2 vols.
- [FLAMEL, NICOLAS.] “Annotata quaedam ex Nicolao Flamelo.” See ZACHARIAS.
- _____. *His Exposition of the Hieroglyphicall Figures, etc.* By Eirenaeus Orandus. London, 1624.
- _____. “Summarium philosophicum.” See (A) *Musaeum hermeticum*, v.
- FLITCH, J. E. CRAWFORD. See ANGELUS SILESIUS.
- “Fons chymicae veritatis.” See PHILALETES.
- FRANCE, ANATOLE. *Penguin Island*. Translated by E. W. Evans. (Penguin Books.) West Drayton, 1948.
- FRANZ, MARIE-LOUISE VON. *Aurora Consurgens; Ein dem Thomas von Aquin zugeschriebenes Dokument der alchemistischen Gegensatzproblematik*. (Part III of C. G. JUNG: *Mysterium Coniunctionis*.) Zurich, 1957.

- (English edn.: *Aurora Consurgens; A Document Attributed to Thomas Aquinas on the Problem of Opposites in Alchemy*. Translated by R. F. C. Hull and A. S. B. Glover. (New York [Bollingen Series] and London, 1966.)
- _____. "Die Passio Perpetuae." In: JUNG, C. G. *Aion: Untersuchungen zur Symbolgeschichte*. (Psychologische Abhandlungen, VIII.) Zurich, 1951.
- FRAZER, SIR JAMES G. *The Golden Bough*. London, 1911–15. 12 vols. (Part II: *Taboo and the Perils of the Soul*, Vol. III. Part III: *The Dying God*, Vol. IV. Part IV: *Adonis, Attis, Osiris*, Vols. V and VI. Part VII: *Balder the Beautiful*, Vols. X and XI.)
- FRESNOY. See LENGLET DU FRESNOY.
- FROBENIUS, LEO. *Das Zeitalter des Sonnengottes*. Vol. I (no more published), Berlin, 1904.
- GALEN(US), CLAUDIUS. *De simplicium medicamentorum facultatibus libri XI*. Translated (into Latin) by Theodoricus Gerardus Gaudenus. Lyons, 1561.
- GARNERUS DE SANCTO VICTORE. *Gregorianum*. See Migne, *P.L.*, vol. 193, cols. 9–462.
- GEBER (JABIR.) "Summa perfectionis." See (A) *De alchemia*, i.
- _____. *Works*. Englished by Richard Russell (1678). Edited by Eric J. Holmyard. London, 1928.
- GEFFCKEN, JOANNES (ed.). *Die Oracula Sibyllina*. (Griechische christliche Schriftsteller.) Leipzig, 1902.
- [Gemma Gemmarum.] *Dictionarium quod Gemma Gemmarum vacant, nuper castigatum*. Hagenau, 1518.
- GEOFFREY OF MONMOUTH. *Histories of the Kings of Britain*. Translated by Sebastian Evans. London, 1904. (Book VII, pp. 170–188, contains the "Prophecies of Merlin.")
- GEVARTIUS, JOANNES CASPARIUS. *Electorum Libri III*. Paris, 1619.
- GHAZÂLI, AL-. *Die kostbare Perle im Wissen des Jenseits*. Edited by Mohammed Brugsch. Hanover, 1924.
- GIKATILA, JOSEPH. *Shaare ora*. Offenbach, 1715.
- GLAUBER, JOHANN RUDOLPH. *Tractatus de natura salium*. Amsterdam, 1658.
- _____. *Tractatus de signatura salium, metallorum, et planetarum*. Amsterdam, 1658.
- "Gloria mundi." See (A) *Musaeum hermeticum*, vi.
- GNOSIUS, DOMINICUS. See HERMES TRISMEGISTUS.
- GODEFRIDUS (GODFREY), ABBOT OF ADMONT. *Homiliae Dominicales*. See Migne, *P.L.*, vol. 174, cols. 21–632. (*Homilia III in Dominica III Adventus*, cols. 32–36; *Homilia IV in Dominica IV Adventus*, cols. 36–42.)
- GOETHE, JOHANN WOLFGANG VON. *Faust*. Translated by Philip Wayne. Harmondsworth, 1949, 1959. 2 vols.
- _____. *Faust. An abridged version*. Translated by Louis MacNeice. London, 1951.
- _____. *Die Geheimnisse*. In *Werke* (Gedenkausgabe), edited by Ernst Beutler. Zurich, 1948–54. 24 vols. (Vol. III, pp. 273–83.)
- _____. *West-östlicher Diwan*. In *Werke*, ed. Beutler. (Vol. III, pp. 285–412.)
- GOETZ, BRUNO. *Das Reich ohne Raum*. Potsdam, 1919. 2nd rev. and enlarged edn., Constance, 1925.
- GOLDSCHMIDT, ADOLPH. *German Illumination*. Florence and Paris, 1928. 2 vols.

- GOLDSCHMIDT, GUENTHER (ed.). *Heliodori Carmina Quattuor ad fidem Codicis Casselani* (Religionsgeschichtliche Versuche und Vorarbeiten, 19, part 2.) Giessen, 1923.
- GOODENOUGH, ERWIN R. "The Crown of Victory in Judaism," *Art Bulletin* (New York), XXVIII (1926), 139–59.
- GOURMONT, RÉMY DE. *Le Latin mystique*. Paris, 1930.
- GRASSEUS, JOHANNES. "Area arcani." See (A) *Theatrum chemicum*, li.
- GRATAROLUS, GULIELMUS. *Verae alchimiae artisque metallica, citra aenigmata...* Basel, 1561. 1 vol. in 2 parts, separately paginated. (*Rosarium philosophorum*, pp. 35–59 of Part II.)
- GREGORY THE GREAT, SAINT. *Homiliae in Evangelia*. See Migne, *P.L.*, vol. 76, cols. 1075–1312.
- _____. *Homiliae in Ezechielem*. See Migne, *P.L.*, vol. 76, cols. 786–1072.
- _____. *In Librum Primum Regum Expositiones*. See Migne, *P.L.*, vol. 79, cols. 17–468.
- _____. *In Septem Psalmos Poenitentiales*. See Migne, *P.L.*, vol. 79, cols. 549–658.
- _____. *Moralia in Job*. See Migne, *P.L.*, vol. 75, col. 509–vol. 76, col. 782.
- _____. *Super Cantica Cantorum Expositio*. See Migne, *P.L.*, vol. 79, cols. 471–548.
- GRENFELL, BERNARD P., and HUNT, ARTHUR S. *New Sayings of Jesus and Fragment of a Lost Gospel*. Oxford, 1904.
- GREVERUS, JODOCUS. "Secretum." See (A) *Theatrum chemicum*, xxvi.
- GRILL, JULIUS (ed.). *Hundert Lieder des Atharva-Veda*. 2nd edn., Stuttgart, 1888.
- GRIMM, JACOB. *Teutonic Mythology*. Translated by James Steven Stallybrass. London, 1880–88. 4 vols.
- _____. AND WILHELM. *Fairy Tales*. Translated by Margaret Hunt and James Stern. New York, 1944.
- GRUENBAUM, MAX. *Jüdisch-deutsche Chrestomathie*. Leipzig, 1882.
- GRUNWALD, MAX. "Neue Spuk- und Zauberliteratur," *Monatsschrift für Geschichte und Wissenschaft des Judentums* (Dresden), LXXVII (n.s., XLI), (1933), 161–72.
- GÜTERBOCK, HANS GUSTAV. "Kumarbi," *Istanbuler Schriften* (Zurich and New York), XVI (1946).
- GURNEY, O. R. *The Hittites*. (Pelican Books.) Harmondsworth, 1952.
- HALLER, MAX. "Das Hohe Lied." In: *Handbuch zum Alten Testament*. Edited by Otto von Eissfeldt. First Series, 18: *Die Fünf Megilloth*. Tübingen, 1940.
- HAMBURGER, JACOB (ed.). *Encyclopädie des Judentums*. Leipzig, 1896–1901. 3 vols.
- HARDING, M. ESTHER. *Woman's Mysteries*. 2nd edn., New York, 1955.
- HARNACK, ADOLF VON. *Lehrbuch der Dogmengeschichte*. 5th edn., Tübingen, 1931.
- HASTINGS, JAMES (ed.). *Encyclopedia of Religion and Ethics*. Edinburgh and New York, 1908–27. 13 vols.
- HEGEMONIUS. *Acta Archelai*. Edited by Charles Henry Beeson. (Griechische christliche Schriftsteller.) Leipzig, 1906.
- HEILER, FRIEDRICH. *Das neue Mariendogma im Lichte der Geschichte und im Urteil der Ökumene*. (Ökumenische Einheit, Heft 2.) Munich and Basel, 1951.
- HELD, HANS LUDWIG. See ANGELUS SILESIVS.

- HELIODORUS. See GOLDSCHMIDT.
- HELLWIG, CHRISTOPH VON. *Neu eingerichtetes Lexicon Medico-Chymicum, oder Chymisches Lexicon*. Frankfurt and Leipzig, 1711.
- HELVETIUS, JOHANN FRIEDRICH. “Vitulus aureus.” See (A) *Musaeum hermeticum*, xiv.
- HERMAS. *The Shepherd*. In: LAKE, KIRSOPP (ed. and trans.). *The Apostolic Fathers*. (Loeb Classical Library.) London and New York, 1912–13. 2 vols. (Vol. II, pp. 6–305.)
- [HERMES TRISMEGISTUS.] “Tractatus aureus.” See (A) MANGETUS, *Bibliotheca chemica curiosa*, ii. For other versions, see: (A) *Theatrum chemicum*, xxxv; (A) *Musaeum hermeticum*, i; ATWOOD; (A) *Ars chemica*, i. Also: *Tractatus vere aureus de lapidis philosophici secreto. Cum scholiis Dominici Gnosii*. Leipzig, 1610.
- HERODOTUS. *The Histories*. Translated by Aubrey de Selincourt. Harmondsworth, 1959.
- HERZOG, J. J., and HAUCK, ALBERT (eds.). *Realencyklopädie für protestantische Theologie und Kirche*. Leipzig, 1896–1913. 24 vols.
- HILARIUS (Hilary of Poitiers, Saint). *Commentarium in Matthaei Evangelium*. See Migne, *P.L.*, vol. 9, cols. 917–1078.
- _____. *Tractatus super Psalmos*. See Migne, *P.L.*, vol. 9, cols. 231–908.
- _____. *De Trinitate Libri XII*. See Migne, *P.L.*, vol. 10, cols. 25–472.
- HILKA, ALFONS. *Der altfranzösische Prosa-Alexanderroman nach der Berliner Bildhandschrift*. Halle, 1920.
- HIPPOLYTUS. *Elenchos (Refutatio omnium haeresium)*. (*Werke*, Vol. III.) Edited by Paul Wendland. (Griechische christliche Schriftsteller.) Leipzig, 1916. For translation, see: *Philosophumena, or The Refutation of all Heresies*. Translated by Francis Legge. London and New York, 1921. 2 vols.
- HOCART, ARTHUR MAURICE. *Kings and Councillors*. (Egyptian University: Collection of Works published by the Faculty of Arts, 12.) Cairo, 1936.
- HOFFMANN, ERNST THEODORE WILHELM (AMADEUS). *The Devil's Elixir*. (Trans. anon.) Edinburgh, 1824. 2 vols.
- HOGHELANDE, THEOBALD DE. “De alchemiae difficultatibus” (“Liber de alchemia”). See (A) *Theatrum chemicum*, i. Another version in (A) MANGETUS, *Bibliotheca chemica curiosa*, i.
- HOLLANDUS, JOANNES ISAACUS. “Fragmentum de opere philosophorum.” See (A) *Theatrum chemicum*, xvii.
- _____. “Operum mineralium liber.” See (A) *Theatrum chemicum*, xxv.
- HOLMYARD, ERIC J. (ed. and trans.). “Abu ‘1-Qāsīm al-’Irāqī,” *Isis* (Brussels), VIII (1926), 403–26.
- _____. See also ABU ‘L-QĀSIM; GEBER.
- HOMER. *The Iliad*. Translated by E. V. Rieu. Harmondsworth, 1958.
- _____. *The Odyssey*. Translated by E. V. Rieu. Harmondsworth, 1958.
- HONORIUS OF AUTUN. *Elucidarium*. See Migne, *P.L.*, vol. 172, cols. 1109–76.
- _____. *Expositio in Cantica Canticorum*. See Migne, *P.L.*, vol. 172, cols. 347–496.
- _____. *Liber duodecim quaestionum*. See Migne, *P.L.*, vol. 172, cols. 1177–86.
- _____. *Sacramentarium*. See Migne, *P.L.*, vol. 172, cols. 737–806.

- _____. *Sermo in Dominica in Palmis*. See Migne, *P.L.*, vol. 172, cols. 913–922.
- _____. *Sermo in Epiphania Domini*. See Migne, *P.L.*, vol. 172, cols. 843–50.
- _____. *Speculum de misteriis Ecclesiae*. See Migne, *P.L.*, vol. 172, cols. 813–1108.
- HORACE (Quintus Horatius Flaccus.) *Satires, Epistles, and Ars Poetica*. With an English translation by H. Rushton Fairclough. (Loeb Classical Library.) London and New York, 1929.
- HORAPOLLO NILIACUS. *The Hieroglyphics*. Translated by George Boas. (Bollingen Series XXIII.) New York, 1950.
- HORNEFFER, ERNST. *Nietzsches Lehre von der ewigen Wiederkunft*. Leipzig, 1900.
- HUGH OF ST. VICTOR. *De laude charitatis*. See Migne, *P.L.*, vol. 176, cols. 969–76.
- HURWITZ, S. “Archetypische Motive in der chassidischen Mystik.” In: *Zeitlose Dokumente der Seele*. (Studien aus dem C. G. Jung-Institut, 13.) Zurich, 1952.
- _____. *Die Gestalt des sterbenden Messias*. (Studien aus dem C. G. Jung-Institut, 8.) Zurich, 1958.
- HUXLEY, ALDOUS. *Grey Eminence*. London, 1956.
- I Ching, or the Book of Changes*. The German translation by Richard Wilhelm rendered into English by Cary F. Baynes. New York (Bollingen Series XIX) and London, 1950. 2 vols. 3rd edn., 1 vol., 1967.
- IGNATIUS LOYOLA, SAINT. *The Spiritual Exercises*. Translated with a commentary by Joseph Rickaby. London, 1923.
- IRENÆUS. *Adversus Haereses*. See: *The Writings of Irenaeus*. Translated by Alexander Roberts and W. H. Rambaut. (Ante-Nicene Christian Library, vols. 5, 9.) Edinburgh, 1868–9. 2 vols.
- ISIDORE OF SEVILLE, SAINT. *De natura rerum*. Edited by Gustav Becker. Berlin, 1857.
- _____. *Liber etymologiarum*. Basel, 1489.
- IZQUIERDO, SEBASTIANO. *Practica di alcuni esercitij spirituali di S. Ignatio*. Rome, 1686.
- JABIR. See GEBER.
- JACOBSON, HELMUTH. “Die dogmatische Stellung des Königs in der Theologie der alten Ägypter,” *Ägyptologische Forschungen*, ed. by Alexander Scharff (Gluckstadt, Hamburg, and New York), VIII (1939).
- JAFFÉ, ANIELA. “Bilder und Symbole aus E. T. A. Hoffmanns Märchen ‘Der Goldene Topf.’” In: JUNG, C. G. *Gestaltungen des Unbewussten*. Zurich, 1950.
- JAMES, MONTAGUE RHODES (ed. and trans.). *The Apocryphal New Testament*. Oxford, 1924. (Contains “Acts of Thomas,” pp. 364–438; “Acts of John,” pp. 228–70.)
- JASTROW, MORRIS. *Die Religion Babyloniens und Assyriens*. Giessen, 1912. 2 vols.
- JEROME, SAINT. *Epistola II ad Theodosium et caeteros Anachoretas*. In: (*Opera* Sec. I, Part I), *Epistolarum*, Pars I. Edited by Isidore Hilberg. (Corpus Scriptorum Ecclesiasticorum Latinorum, 54.) Vienna and Leipzig, 1910.
- Jewish Encyclopaedia, The*. Edited by Isidore Singer. New York and London, 1925. 12 vols.
- JOEL, DAVID HEYMANN. *Die Religionsphilosophie des Sohar*. Leipzig, 1849.

JOHN CHRYSOSTOM, SAINT. *Homiliae in Joannem*. See Migne, P.G., vol. 59, cols. 23–482. (*Homilia XXVI, alias XXV*, cols. 153–58.)

_____. *Homiliae in Matthaeum*. See Migne, P.G., vol. 57, col. 13–vol. 58, col. 794.

JOHN OF RUYSBROECK. See RUYSBROECK.

JOHN OF THE CROSS, SAINT. *Works*. Translated by E. Allison Peers. London, 1934–35. 3 vols. (“The Dark Night of the Soul,” Vol. I, pp. 335–486.)

JOYCE, JAMES. *Ulysses*. Hamburg, Paris, Bologna, 1932.

JUNG, CARL GUSTAV.* *Aion*. *Coll. Works*, 9, ii. 1959; 2nd edn., 1968.

_____. *Alchemical Studies*. *Coll. Works*, 13. 1967.

_____. “An Analysis of the Associations of an Epileptic.” In *Coll. Works*, 2. 1973.

_____. “Analytical Psychology and Education.” In *Coll. Works*, 17.

_____. “Answer to Job.” In *Coll. Works*, 11.

_____. “Archetypes of the Collective Unconscious.” In *Coll. Works*, 9, i.

_____. “Brother Klaus.” In *Coll. Works*, 11.

_____. “Commentary on *The Secret of the Golden Flower*.” In *Alchemical Studies*.

_____. “Concerning the Archetypes, with Special Reference to the Anima Concept.” In *Coll. Works*, 9, i.

_____. “Concerning Mandala Symbolism.” In *Coll. Works*, 9, i.

_____. “Concerning Rebirth.” In *Coll. Works*, 9, i.

_____. *The Development of Personality*. *Coll. Works*, 17. 1954.

_____. “Instinct and the Unconscious.” In *Coll. Works*, 8.

_____. “The Interpretation of Visions.” Seminar reports, multigraphed for private circulation. Zurich, 1939.

_____. “On the Nature of Dreams.” In *Coll. Works*, 8.

_____. “On the Nature of the Psyche.” In *Coll. Works*, 8.

_____. “On Psychic Energy.” In *Coll. Works*, 8.

_____. “Paracelsus the Physician.” In *Coll. Works*, 15.

_____. “Paracelsus as a Spiritual Phenomenon.” In *Alchemical Studies*.

_____. “The Phenomenology of the Spirit in Fairytales.” In *Coll. Works*, 9, 1.

_____. “The Philosophical Tree.” In *Alchemical Studies*.

_____. “A Psychological Approach to the Dogma of the Trinity.” I *Coll. Works*, 11.

JUNG, CARL GUSTAV. “The Psychological Aspects of the Kore.” In *Coll. Works*, 9, i.

_____. *Psychological Types*. *Coll. Works*, 6. 1971.

_____. *Psychology and Alchemy*. *Coll. Works*, 12. 1953; rev edn, 1968.

_____. “The Psychology of the Child Archetype.” In *Coll. Works*, 9, i.

_____. “The Psychology of Eastern Meditation.” In *Coll. Works*, 11.

_____. “Psychology and Religion.” In *Coll. Works*, 11.

- ____. "The Psychology of the Transference." In *Coll. Works*, 16.
- ____. "The Relations between the Ego and the Unconscious." In *Coll. Works*, 7.
- ____. "A Review of the Complex Theory." In *Coll. Works*, 8.
- ____. "Spirit and Life." In *Coll. Works*, 8.
- ____. "The Spirit Mercurius." In *Alchemical Studies*.
- ____. "A Study in the Process of Individuation." In *Coll. Works*, 9, i.
- ____. *Symbols of Transformation*. *Coll. Works*, 5. 1956; rev. edn., 1967.
- ____. "Synchronicity: An Acausal Connecting Principle." In *Coll. Works*, 8.
- ____. "The Transcendent Function." In *Coll. Works*, 8.
- ____. "Transformation Symbolism in the Mass." In *Coll. Works*, 11.
- ____. *Two Essays on Analytical Psychology*. *Coll. Works*, 7. 1953; rev. edn., 1966.
- ____. "Ulysses: A Monologue." In *Coll. Works*, 15.
- ____. "The Visions of Zosimos." In *Alchemical Studies*.
- ____. See also WILHELM.

*
*
*
*
*
*
*
*
*

KALID. "Liber secretorum." See (A) *Artis auriferae*, ix.

____. "Liber trium verborum." See (A) *Artis auriferae*, x.

Katha Upanishad. See *Upanishads*.

KEES, HERMANN. *Der Götterglaube im alten Ägypten*. (Mitteilungen der Vorderasiatisch-ägyptischen Gesellschaft, 45.) Leipzig, 1941.

KERÉNYI, C. (OR KARL). *Das Ägäische Fest*. (Albae Vigiliae, XI.) Zurich, 1941; 3rd edn., Wiesbaden, 1950.

____. *Asklepios: Archetypal Image of the Physician's Existence*. Translated by Ralph Manheim. New York (Bollingen Series XV; 3) and London, 1959.

____. *The Gods of the Greeks*. Translated by Norman Cameron. (Pelican Books.) Harmondsworth, 1958.

____. "Kore." In: KERÉNYI and JUNG, C. G. *Essays on a Science of Mythology*. (Bollingen Series XXII.) New York, 1949. Also published as *Introduction to a Science of Mythology*, London, 1950.)

____. *Töchter der Sonne*. Zurich, 1944.

KHUNRATH, HEINRICH. *Amphitheatrum sapientiae*. Hanau, 1609.

- ____. *Von hylealischen Chaos*. Magdeburg, 1597.
- KIRCHER, ATHANASIOS. *Oedipus Aegyptiacus*. Rome, 1652–54. 3 vols.
- KNORR VON ROSENROTH, CHRISTIAN. *Kabbala Denudata*. Sulzbach and Frankfurt a. M., 1677–84. 2 vols.
- KOEHLER, REINHOLD. *Kleinere Schriften zur erzählenden Dichtung des Mittelalters*. Berlin, 1898–1900. 3 vols.
- KOEPGEN, GEORG. *Die Gnosis des Christentums*. Salzburg, 1939.
- KOHUT, ALEXANDER. “Die talmudisch-midrassische Adamsage in ihrer Rückbeziehung auf die persische Yima- und Meshiasage,” *Zeitschrift der deutschen Morgenländischen Gesellschaft* (Leipzig), XXV (1871), 59–94.
- KOPP, HERMANN. *Die Alchemie in älterer und neuerer Zeit*. Heidelberg, 1886. 2 vols.
- Koran, The*. Translated by N. J. Dawood. (Penguin Books.) Harmondsworth, 1956.
- KRIEG, CLAUS W. *Chinesische Mythen und Legenden*. Zurich, 1946.
- LACINIUS, JANUS. See BONUS.
- LAGNEUS, DAVID. “Harmonía chemica.” See (A) *Theatrum chemicum*, xxxvi.
- LAJARD, FELIX. “Mémoire sur une représentation figurée de la Vénus orientale androgyne,” *Nouvelles annales de l’Institut archéologique, Section française* (Paris), I (1836), 161–212.
- ____. *Recherches sur le culte de Vénus*. Paris, 1849.
- LAKE, KIRSOPP (ed. and trans.). *The Apostolic Fathers*. (Loeb Classical Library.) London and New York, 1914. 2 vols.
- LAMBSPRINGK. “De lapide philosophico figurae et emblemata.” See (A) *Musaeum hermeticum*, viii.
- LARGUIER, LEO. *Le Faiseur d’or Nicolas Flamel*. (L’Histoire inconnue, 4.) Paris, 1936.
- LEISEGANG, HANS. *Die Gnosis*. Leipzig, 1924.
- ____. *Der heilige Geist*. Vol. I, part 1 (no more published). Leipzig and Berlin, 1919.
- LENGLET DU FRESNOY, PIERRE NICOLAS. *Histoire de la philosophie hermétique*. Paris and The Hague, 1742. 3 vols.
- LEO HEBRAEUS (Leone Ebreo). *Philosophy of Love*. Translated by F. Friedeberg-Seeley and Jean H. Barnes. London, 1937.
- LESSER, FRIEDRICH CHRISTIAN. *Lithotheologie*. Hamburg, 1735.
- “Liber Alze.” See (A) *Musaeum hermeticum*, vii.
- “Liber de arte chymica.” See (A) *Artis auriferae*, xvii.
- “Liber de magni lapidis compositione.” See (A) *Theatrum chemicum*, xxiii.
- LICETUS, FORTUNIUS. *Allegoria peripatetica de generatione amicitia etc.* Padua, 1630.
- LIDZBARSKI, MARK. *Das Johannesbuch der Mandäer*. Giessen, 1915.
- LIDZBARSKI, MARK (ed. and trans.). *Ginza: der Schatz oder das grosse Buch der Mandäer*. (Quellen der Religionsgeschichte, Group 4, vol. 13.) Göttingen and Leipzig, 1925.
- LIPPMANN, EDUARD O. VON. *Entstehung und Ausbreitung der Alchemie* Berlin, 1919–54. 3 vols.

- LOHMEYER, ERNST. "Vom göttlichen Wohlgeruch," *Sitzungsberichte der Heidelberger Akademie der Wissenschaften, Phil.-hist. Kl.*, IX. Abhandlung (1919).
- LORICHIUS, JOHANNES. *Aenigmatum Libri III*. Frankfurt a. M., 1545.
- Lu CH'ANG-WU. See WEI PO-YANG.
- [LUCIAN.] *Scholia in Lucianum*. Edited by Hugh Kabe. Leipzig, 1906.
- LUCIAN. "Pseudomantis." See: "Alexander; or, The False Prophet." In: *Works*. Translated from the Greek by Several Eminent Hands [Walter Moyle and others]. London, 1711. 2 vols. (Vol. I, pp. 144–181.)
- _____. "The Syrian Goddess" (De Dea Syria). In *Works* (as above). (Vol. I, pp. 241–271.)
- "Ludus puerorum." See (A) *Artis auriferae*, xx.
- LULLY, RAYMUND. *Codicillus*. Rouen, 1651.
- _____. "Theorica et practica." See (A) *Theatrum chemicum*, xxx.
- Mabinogion, The*. Translated by Gwyn Jones and Thomas Jones. (Everyman's Library.) London, 1949.
- ("Peredur son of Efwarg," pp. 183ff.)
- MACDONELL, ARTHUR ANTHONY. *A Sanskrit-English Dictionary*. London, 1893.
- [MACROBIUS.] *Macrobii Ambrosii Theodosii Opera*. Edited by Ludovicus Janus. Quedlinburg and Leipzig, 1848–52. 2 vols. ("Commentarium in Somnium Scipionis," Vol. I, pp. 13–215; "Saturnalia," Vol. II, pp. 3–647.) For translation of former, see: *Commentary on the Dream of Scipio*. Translated by William Harris Stahl. (Records of Civilization, Sources and Studies, 48.) New York, 1952.
- MADATHANUS, HENRICUS. "Aureum saeculum redivivum." See (A) *Musaeum hermeticum*, ii.
- MAIER, MICHAEL. *Atalanta fugiens, hoc est, emblemata nova de secretis naturae chymica*. Oppenheim, 1618.
- _____. *De circulo physico quadrato*. Oppenheim, 1616.
- _____. *Jocus severus*. Frankfurt a. M., 1617.
- _____. *Secretions naturae secretorum Scrutinium chymicum*. Frankfurt a. M., 1687.
- _____. *Symbola aureae mensae duodecim nationum*. Frankfurt a. M., 1617.
- MAITLAND, EDWARD. *Anna Kingsford: Her Life, Letters, Diary, and Work*. London, 1896. 2 vols.
- MÂLE, EMILE. *L'Art religieux du XII^e siècle en France*. 2nd edn., Paris, 1924.
- MALVASIUS, CAESAR (Carlo Cesare Malvasio). *Aelia Laelia Crispis non nata resurgens*. Bologna, 1683.
- MARIA PROPHETISSA. "Practica... in artem alchimicam." See (A) *Artis auriferae*, viii.
- MARSILIUS FICINUS. See FICINO.
- MARTIAL. *Epigrams*, with an English translation by Walter C. A. Ker. (Loeb Classical Library.) London and New York, 1920–25. 2 vols.
- MEAD, GEORGE ROBERT STOW (ed. and trans.). *Thrice Greatest Hermes*. London, 1949. 3 vols.
- MEERPOHL, FRANZ. "Meister Eckharts Lehre vom Seelenfiinklein," *Abhandlungen zur Philosophie und Psychologie der Religion* (Würzburg), Heft 10 (1926).
- ME(H)JUNG, JEAN DE. "Demonstrado naturae." See (A) *Musaeum hermeticum*, iv.

- MEIER, C. A. *Antike Inkubation und moderne Psychotherapie*. (Studien aus dem C. G. Jung-Institut, 1.) Zurich, 1949.
- MENNENS, WILLIAM. "Aurei velleris sive sacrae philosophiae vatum selectae et unicae Libri tres." See (A) *Theatrum chemicum*, xliv.
- Merlin*. Edited by Gaston Paris and Jacob Ulrich. (Société des anciens textes français.) Paris, 1886. For translation, see: *Merlin, or the Early History of King Arthur*. Edited by Henry B. Wheatley. (Early English Text Society, Original Series, nos. 10, 21, 36, 112.) London, 1899. 2 vols. See also GEOFFREY of MONMOUTH.
- MERLINUS. "Allegoria de arcano lapidis." See (A) *Artis auriferae*, xiii.
- MICRERIS. "Tractatus Micreris suo discipulo Mirnefindo." See (A) *Theatrum chemicum*, xli.
- Midrash Rabbah*. Edited by W. Freedman and Maurice Simon. London and Bournemouth, 1951. 10 vols.
- MIGNE, JACQUES PAUL (ed.) *Patrologiae cursus completus*.
 [P.L.] Latin Series. Paris, 1844–64, 221 vols.
 [P.G.] Greek Series. Paris, 1857–66. 166 vols.
 (These works are referred to in the text and in this bibliography as "Migne, P.L." and "Migne, P.G." respectively. References are to columns, not to pages.)
- MORET, ALEXANDRE. *Du caractère religieux de la royauté pharaonique*. (Annales du Musée Guimet, 15.) Paris, 1922.
- _____. *Mystères égyptiens*. Paris, 1922.
- MORIENUS ROMANUS. "De transmutatione metallica." See (A) *Artis auriferae*, xviii.
- MORRIS, RICHARD. *Legends of the Holy Rood*. London, 1871.
- MUELLER, ERNST (trans.). *Der Sohar. Das heilige Buch der Kabbala. Ausgewählte Texte*. Vienna, 1932.
- _____. *Der Sohar und seine Lehre*. Vienna and Berlin, 1920.
- MURMELSTEIN, BENJAMIN. "Adam: ein Beitrag zur Messiaslehre," *Wiener Zeitschrift für the Kunde des Morgenlandes* (Vienna), XXXV (1928), 242–75, and XXXVI (1929), 51–86.
- "Mutus liber." See ALTUS.
- MYLIUS, JOHANN DANIEL. *Philosophia reformata*. Frankfurt a. M., 1622.
- NEIHARDT, JOHN G. *Black Elk Speaks. Being the Life Story of a Holy Man of the Og[a]lala Sioux*. New York, 1932.
- NELKEN, JAN. "Analytische Beobachtungen über Phantasien eines Schizophrenen," *Jahrbuch für psychoanalytische und psychopathologische Forschungen* (Leipzig and Vienna), IV (1912), 504–62.
- NESTLE, E. "Der süsse Geruch als Erweis des Geistes," *Zeitschrift für die neutestamentliche Wissenschaft* (Giessen), VII (1906), 95–96.
- NEUMANN, ERICH. *The Origins and History of Consciousness*. Translated by R. F. C. Hull. New York (Bollingen Series XLII) and London, 1954.
- NEWMAN, JOHN HENRY. *An Essay on the Development of Christian Doctrine*. London, 1845.

- NIEDNER, FELIX. "Edda: Götterdichtung und Spruchdichtung." *Thule* (Jena), II (1920).
- NIETZSCHE, FRIEDRICH WILHELM. *Thus Spake Zarathustra*. Translated by Thomas Common; revised by Oscar Levy and John L. Beevers. London, 1932.
- NORTON, THOMAS. "The Ordinall of Alchimy." See (A) *Theatrum chemicum Britannicum*, i. *Nova Acta Paracelsica*. (V. Jahrbuch der Schweizerischen Paracelsus-Gesellschaft, 1948.) Einsiedeln, 1949.
- "Occulta Chemicorum Philosophia." See: VALENTINUS, BASILIUS. *Triumphwagen Antimonii*. Leipzig, 1604. (pp. 579–694.)
- ORANDUS, EIRENAEUS. See FLAMEL.
- ORIGEN. *Contra Celsum*. Translated by Henry Chadwick. Cambridge, 1953.
- _____. *De Oratione*. See Migne, P.G., vol. 11, cols. 415–562. For translation, see: *Alexandrian Christianity. Selected Translations of Clement and Origen*. Edited and translated by John Ernest Leonard Oulton and Henry Chadwick. (Library of Christian Classics, 2.) London, 1954. (pp. 238–329.)
- _____. *In Cantica Canticorum Homiliae*. See Migne, P.G., vol. 13, cols. 37–58.
- _____. *In Exodum Homiliae*. See Migne, P.G., vol. 12, cols. 297–396.
- _____. *In Ezechielem Homiliae*. See Migne, P.G., vol. 13, cols. 665–768.
- _____. *In Genesim Homiliae*. See Migne, P.G., vol. 12, cols. 145–262.
- _____. *In Leviticum Homiliae*. See Migne, P.G., vol. 12, cols. 405–574.
- _____. *In Numeros Homiliae*. See Migne, P.G., vol. 12, cols. 585–806.
- _____. *In Librum Regnorum Homiliae*. See Migne, P.G., vol. 12, cols. 995–1027.
- _____. *Peri Archon Libri IV*. See Migne, P.G., vol. 11, cols. 115–414.
- OROSIUS, PAULUS. *Ad Aurelium Augustinum Commonitorium*. In: *Priscilliani quae supersunt... accedit Orosii Commentarium de errore Priscillianistarum et Origenistarum*. (Corpus Scriptorum Ecclesiasticorum Latinorum.) Prague, Leipzig, Vienna, 1889.
- Orphic Fragments*. See: *Orphica*. Edited by Eugen Abel. Leipzig and Prague, 1885.
- ORTHELIUS. "Discursus de praecedente epistola" (i.e., Epistola Andreae de Blawen). See (A) *Theatrum chemicum*, liii.
- _____. "Epilogus et recapitulatio... in Novum lumen chymicum Sendivogii." See (A) *Theatrum chemicum*, lii.
- OVID. *Metamorphoses*. With an English translation by Frank Justus Miller. (Loeb Classical Library.) London and Cambridge, Mass., 1946. 2 vols.
- PACHYMERES, GEORGE. See DIONYSIUS, *De coelesti hierarchia*.
- PARACELSUS (Theophrastus Bombastus of Hohenheim). See: SUD-HOFF, KARL (ed.), *Theophrast von Hohenheim genannt Paracelsus Sämtliche Werke*. First section: *Medizinische Schriften*. 14 vols. Munich and Berlin, 1922–35. See also: HUSER, JOHANN (ed.) *Aureoli Philippi Theophrasti Bombasts von Hohenheim Paracelsi... Philosophi und Medici Opera Bücher und Schrifften*. Strasbourg, 1589–90. 10 parts. Reprinted 1603, 1616, 2 vols.
- _____. *Liber Azoth*. In Sudhoff, Vol. XIV, pp. 547–595; in Huser (1616), Vol. II, pp. 519–43.

- ____. *Deutsche Fragmente zu den Fünf Büchern der Vita Longa*. In Sudhoff, Vol. III, pp. 293–308.
- ____. *De generatione rerum naturalium* (Book I of “*De natura rerum*”). In Sudhoff, Vol. XI, pp. 307–403.
- ____. *Von dem Hönig*. In Sudhoff, Vol. II, pp. 193–204.
- ____. *Labyrinthus Medicorum*. In Sudhoff, Vol. XI, pp. 161–220.
- ____. *Lumen Apothecariorum Spagyrorum*. In Sudhoff, Vol. II, pp. 193ff.
- ____. *De natura rerum*. In Sudhoff, Vol. XI, pp. 307–403; in Huser (1590), Vol. I, pp. 881ff.
- ____. *Das Buch Paragranum*. In Sudhoff, Vol. VIII. Another edition, edited by Franz Strunz, Leipzig, 1903.
- ____. *Vorrede und erste beide Bücher des Paragranum*. In Sudhoff, Vol. II, pp. 33–113.
- ____. *De pestilitate*. In Sudhoff, Vol. XIV, pp. 597–661; in Huser (1599), part III.
- ____. *De philosophia, occulta*. In Sudhoff, Vol. XIV, pp. 513–42.
- ____. *Philosophia ad Athenienses*. In Sudhoff, Vol. XIII, pp. 390–433; in Huser (1616), Vol. II, pp. 1–63.
- ____. *Scholia in poemata Macri*. In Sudhoff, Vol. III, pp. 383–424; in Huser (1616), Vol. I, pp. 1070–88.
- ____. *Von den dreyen ersten Principiis oder essentiis*. In Sudhoff, Vol. III, pp. 3–11.
- ____. *Von den tartarischen Krankheiten*. In Sudhoff, Vol. XI, pp. 15–121; in Huser (1599), Part II.
- ____. *De vita longa*. In Sudhoff, Vol. III, pp. 247–90. Another edition, edited by Adam von Bodenstein, Basel, 1562. See also DORN.

PAULINUS OF AQUILEIA, SAINT. *Liber exhortationis ad Henricum Forojuliensem*. See Migne, *P.L.*, vol. 99, cols. 197–282.

PAULINUS OF NOLA, SAINT. *Poema 25*. In Migne, *P.L.*, vol. 61, cols. 633–38.

PAULY, AUGUST FRIEDRICH VON. *Paulys Realencyclopädie der classischen Altertumswissenschaft*. Neue Bearbeitung..., edited by Georg Wissowa. Stuttgart, 1893- (in progress).

PAUSANIAS. *Description of Greece*. With a translation by W. H. S. Jones. (Loeb Classical Library.) London and New York, 1926–35. 5 vols.

PENOTUS. “*Characteres secretorum celandorum*” (“*Philosophi potius occultare artem conati sunt quam patefacere*”). [A table.] See (A) *Theatrum chemicum*, xv.

____. “*De medicamentis chemicis*” (“*De vera praeparatione et usu medicamentorum chemicorum*”). See (A) *Theatrum chemicum*, xi.

____. “*Quinquagintaseptem canones de opere physico*” (“*Regulae et cañones*”). See (A) *Theatrum chemicum*, xviii.

PERNETY, ANTOINE JOSEPH. *Dictionnaire mytho-hermétique*. Paris, 1758 [1787].

____. *Les Fables égyptiennes et grecques*. Paris, 1758. 2 vols.

PETRUS DE SILENTIO. “*Opus*.” See (A) *Theatrum chemicum*, xxxix.

PHILALETHES, EIRENAEUS. “*Introitus apertus ad oclusum regis palatium*.” See (A) *Musaeum hermeticum*, xii.

____. “*Fons chymicae veritatis*.” See (A) *Musaeum hermeticum*, xiii.

____. See also VAUGHAN.

- PHILO. *De opificio mundi* (On the Account of the World's Creation Given by Moses). In *Works*, Loeb edition, Vol. I, pp. 6–137.
- _____. *Quaestiones in Genesim* (Questions and Answers on Genesis). Translated by Ralph Marcus. *Philo, Supplement*. (Loeb Classical Library.) London and Cambridge, Mass., 1953. 2 vols.
- _____. *Quis rerum divinarum haeres?* (Who is the Heir of Divine Things?). In *Works*, Loeb edition, Vol. IV, pp. 284–447.
- _____. [*Works*.] Translated by F. H. Colson and G. H. Whitaker. (Loeb Classical Library.) New York and London, 1929–. 10 vols. (in progress).
- PICINELLUS, PHILIPPUS (Filippo Picinello). *Mundus Symbolicus*. Cologne, 1687. 2 vols.
- PICO DELLA MIRANDOLA, GIOVANNI. *Opera*. Venice, 1557. (Contains: *Heptaplus*, fols. 1^r-13^r; *Apologia tredecim quaestionum*, fols. 13^v-40^r; *Disputationes adversus Astrólogos*, fols. 75^r-150^r.)
- _____. *Opera omnia*. Basel, 1572–73. 2 vols. (Contains *Heptaplus*, Vol. I, pp. 11–62; *In Astrologiam*, Vol. I, pp. 411–732.)
- _____. “De auro.” See (*A*) *Theatrum chemicum*, xxi.
- Pistis Sophia*. Edited and translated by G. R. S. Mead. London, 1955. Another version: translated (into German) by Carl Schmidt. Leipzig, 1925.
- PITRA, JOHN BAPTIST (ed.). *Analecta sacra Spicilegio Solesmensi praeparata*. Paris, 1876–91. 8 vols.
- PIUS XII, POPE. *Apostolic Constitution “Munificentissimus Deus.”* Translated into English. Dublin (Irish Messenger Office), 1950.
- PLATO. *The Republic*. Translated by R. D. P. Lee. (Penguin Books.) Harmondsworth and Baltimore, 1958.
- _____. *The Symposium*. Translated by W. Hamilton. (Penguin Books.) Harmondsworth and Baltimore, 1959.
- _____. *The Symposium of Plato*. Translated and edited by R. G. Bury. Cambridge, 1909.
- _____. See also CORNFORD.
- “Platonis Liber Quartorum.” See (*A*) *Theatrum chemicum*, xlii.
- PLINY. *Natural History*. With an English translation by H. Rackham. (Loeb Classical Library.) London and Cambridge, Mass., 1938. 10 vols.
- PLOTINUS. *The Enneads*. Translated by Stephen MacKenna. 2nd edn., revised by B. S. Page. London and New York, 1956.
- PLUTARCH. *Moralia*. Translated by F. C. Babbitt. (Loeb Classical Library.) London and Cambridge, Mass., 1927ff. 14 vols. (“De defectu oraculorum” [The Obsolescence of Oracles], Vol. V, pp. 401ff.; “De facie in orbe lunae” [The Face on the Moon], Vol. XII, pp. 34–223; “De Iside et Osiride” [Isis and Osiris], Vol. V, pp. 6–191; “Quaestiones Romanae” [Roman Questions], Vol. IV, pp. 6–171.)
- PORDAGE, JOHN. *Sophia*. Amsterdam, 1699.
- [PORPHYRY.] *Porphyry the Philosopher to his Wife Marcella*. Translated by Alice Zimmern. London, 1896.
- PREISENDANZ, KARL. *Papyri Graecae Magicae: Die griechischen Zauberpapyrien*. Berlin, 1928–31. 2 vols.
- PREUSCHEN, ERWIN. *Antilegomena*. Giessen, 1901; rev. edn., 1905.

- PROCLUS. *Commentaries on the Timaeus of Plato*. Translated by Thomas Taylor. London, 1820. 2 vols.
- RABANUS MAURUS. *Allegoriae in Sacram Scripturam*. See Migne, *P.L.*, vol. 112, cols. 849–1088.
- “Rachaidibi... Fragmentum.” See (*A*) *Artis auriferae*, xiv.
- RADHAKRISHNAN, SARVAPALLI. *Indian Philosophy*. London, 1923–27; rev. edn., 1929–31. 2 vols.
- RAHNER, HUGO. “Antenna Crucis II—Das Meer der Welt,” *Zeitschrift für katholische Theologie* (Innsbruck), LXVI (1942), 89–118.
- _____. “Das christliche Mysterium von Sonne und Mond.” In *Eranos-Jahrbuch X: 1943*. Zurich, 1944. (pp. 305–404.)
- _____. “Flumina de ventre Christi.” *Biblica* (Rome), XXII (1941), 269–302, 367–403.
- _____. “Die Gottesgeburt,” *Zeitschrift für katholische Theologie* (Innsbruck), LIX (1935), 333–418.
- _____. “Mysterium Lunae,” *Zeitschrift für katholische Theologie* (Innsbruck), LXIII (1939), 311–49. 428–42; LXIV (1940), 61–80, 121–131.
- _____. “Die seelenheilende Blume,” in *Eranos-Jahrbuch XII: Festgabe für C. G. Jung*. Zurich, 1945. (pp. 117–239.)
- [RAMANUJA.] *The Vedanta-Sutras with the Commentary of Ramanuja*. Translated by George Thibaut. (Sacred Books of the East, 34, 38, 48.) Oxford, 1890–1904. 3 volumes.
- READ, JOHN. *Prelude to Chemistry*. 2nd edn., London, 1939.
- Realencyklopädie für protestantische Theologie*. See HERZOG.
- “REGULAE et canones de opere physico.” See PENOTUS.
- REITZENSTEIN, RICHARD. *Die hellenistischen Mysterienreligionen*. Leipzig, 1910. 2nd edn., 1923; 3rd edn., 1927.
- _____. “Himmelswanderung und Drachenkampf.” In: *Friedrich Karl Andreas Festschrift zur Vollendung des siebenzigsten Lebensjahres*. Leipzig, 1916. (pp. 33–50.)
- _____. *Poimandres*. Leipzig, 1904.
- _____. *Zwei religionsgeschichtliche Fragen*. Berlin, 1926.
- _____ and SCHAEDELER, H. *Studien zum antiken Synkretismus aus Iran und Griechenland*. (Studien der Bibliothek Warburg, 7.) Berlin, 1926.
- REUCHLIN, JOHANNES. *De arte cabbalistica*. Hagenau, 1517.
- _____. *De verbo mirifico*. Lyons, 1552.
- REUSNER, H. (ed.). *Pandora*. Basel, 1588.
- RHINE, J. B. *New Frontiers of the Mind*. London, 1937.
- _____. *The Reach of the Mind*. New York, 1947; London, 1948.
- RIESSLER, PAUL (ed.). *Altjüdisches Schrifttum ausserhalb der Bibel*. Augsburg, 1928.
- Rigveda*. See: *The Hymns of the Rig-Veda*. Translated by Ralph T. H. Griffith. 2nd edn., Benares, 1896–97. 2 vols.

- RIPLEY, SIR GEORGE. *Chymische Schriften*. Erfurt, 1624.
- _____. *Omnia opera chemica*. Cassel, 1649.
- _____. “Duodecim portarum axiomata philosophica.” See (A) *Theatrum chemicum*, xvi.
- ROHDE, ERWIN. *Psyche*. Translated by W. B. Hillis. London, 1925.
- Rosarium philosophorum*. See (A) *Artis auriferae*, xxi; see also GRATAROLUS.
- ROSCHER, W. H. (ed.). *Ausführliches Lexikon der griechischen und römischen Mythologie*. Leipzig and Berlin, 1884–1937. 6 vols.
- ROSENCREUTZ, CHRISTIAN (pseud, of Johann Valentin Andreae). *Chymische Hochzeit*. Strasbourg, 1616. For translation, see: *The Hermetick Romance, or The Chymical Wedding*. Translated by E. Foxcroft. London, 1690.
- “Rosinus ad Euthiciam.” See (A) *Artis auriferae*, vi; also *ibid.*, 1610 edn., pp. 158–78.
- “Rosinus ad Sarratantam Episcopum.” See (A) *Artis auriferae*, vii.
- ROTH-SCHOLTZ, FRIEDRICH. *Deutsches Theatrum Chemicum*. Nürnberg, 1728–32. 3 vols.
- ROUSSELLE, ERWIN. “Drache und Stute, Gestalten der mythischen Welt Chinesischer Urzeit,” in *Eranos-Jahrbuch 1934*. Zurich, 1935. (pp. 11–33.)
- RULAND(US), MARTIN. *Lexicon Alchemiae sive Dictionarium alchemisticum*. Frankfurt a. M., 1622. For translation, see: *A Lexicon of Alchemy*. London, 1892.
- RUPESCISSA, JOANNES DE. “De confectione veri lapidis.” See (A) *Theatrum chemicum*, xxiv.
- _____. *La Vertu et la propriété de la quinte essence*. Lyons, 1581.
- RUSKA, JULIUS (ed.). *Buch der Alaune und Salze (De speciebus salium)*. Berlin, 1905.
- _____. “Die Vision des Arisleus.” In: *Georg Sticker Festschrift: Historische Studien und Skizzen zur Natur- und Heilwissenschaft*. Berlin, 1930.
- _____. “Studien zu Muhammad ibn Umail,” *Isis (Bruges)*, XXIV (1935–36), 310–42.
- _____. *Tabula Smaragdina*. (Heidelberger Akten der von-Portheim-Stiftung, 16.) Heidelberg, 1926.
- _____. *Turba Philosophorum*. Berlin, 1931.
- RUYSBROECK, JOHN OF. *The Adornment of the Spiritual Marriage* [etc.]. Translated by C. A. Wynschenk Dom. London, 1916.
- Saint-Graal, Le*. Le Mans (published by Eugene Bucher), 1875–78. 3 vols.
- “Scala philosophorum.” See (A) *Artis auriferae*, xix.
- SCHAEDER, HANS HEINRICH. *Urform und Fortbildungen des manichaischen Systems*. (Vorträge der Bibliothek Warburg.) Leipzig and Berlin, 1924–25. (pp. 65–157.)
- SCHEFFLER, JOHANN. See ANGELUS SILESIUS.
- SCHEFTELOWITZ, ISIDOR. *Die altpersische Religion und das Judentum*. Giessen, 1920.
- SCHEFTELOWITZ, ISIDOR. “Das Fischsymbol in Judentum und Christentum,” *Archiv für Religionswissenschaft* (Leipzig), XIV (1911), 321–85.

- SCHMIDT, CARL (ed.). *Manichäische Handschriften der Staatlichen Museen, Berlin*. Stuttgart, 1935–39. Vol. I (no more published).
- SCHMIEDER, KARL CHRISTOPH. *Geschichte der Alchemie*. Halle, 1832.
- SCHOLEM, GERHARD (Gershom G.) *Das Buch Bahir*. (Quellen und Forschungen zur Geschichte der jüdischen Mystik, I.) Leipzig, 1923.
- _____. *Major Trends in Jewish Mysticism*. London, 1955.
- _____. “Zu Abraham Eleazars Buch und dem Esch Mazareph. *Monatsschrift für Geschichte und Wissenschaft des Judentums* (Dresden), LXX (n. s., XXXIV; 1926), 202–209.
- SCHREBER, DANIEL PAUL. *Memoirs of My Nervous Illness*. Translated by Ida Macalpine and Richard A. Hunter. (Psychiatric Monograph Series, 1.) London, 1955. (Original, *Denkwürdigkeiten eines Nervenkranken*, 1903.)
- SCHULTZ, WOLFGANG. *Dokumente der Gnosis*. Jena, 1910.
- SCHULTZE, FRITZ. *Psychologie der Naturvölker*. Leipzig, 1900.
- SCHWARTZ, C. “Explanatio Inscriptionis cujusdam veteris.” *Acta Eruditorum* (Leipzig), 1727, pp. 332–35.
- SCHWEITZER, ALBERT. *Geschichte der Leben-Jesu-Forschung*. Tübingen, 1921.
- SCOTT, WALTER. *Hermetica*. Oxford, 1924–36. 4 vols.
- SELLIN, ERNST. *Introduction to the Old Testament*. Translated by W. Montgomery. London, 1923.
- SENDIVOGIUS, MICHAEL. “Parabola, seu Aenigma Philosophicum, Coronidis et super additamenti loco adjunctum.” See (A) *Musaeum hermeticum*, x.
- _____. “Novum lumen chemicum.” See (A) *Musaeum hermeticum*, x.
- _____. “Tractatus de Sulphure.” See (A) *Musaeum hermeticum*, xi.
- [SENIOR.] *De Chemia Senioris antiquissimi philosophi libellus*. Strasbourg, 1566. (Includes “Epístola Solis ad Lunam crescentem,” pp. 7–10.) Other versions in (A) MANGETUS, *Bibliotheca chemica curiosa*, vi, and in (A) *Theatrum chemicum*, xliii.
- “Septem tractatus Hermetis.” See HERMES TRISMEGISTUS.
- SERVIUS. *Servii Grammatici qui feruntur in Vergilii Carmina commentarii*. Edited by Georg Thilo and Hermann Hagen. Leipzig, 1878–1902. 3 vols.
- [Sibylline Oracles.] See GEFFCKEN.
- SIECKE, ERNST. *Beiträge zur genauen Kenntnis der Mondgottheit bei den Griechen*. Berlin, 1885.
- SILBERER, HERBERT. *Problems of Mysticism and Its Symbolism*. Translated by Smith Ely Jelliffe. New York, 1917.
- SOCRATES SCHOLASTICUS. [*Historia ecclesiastica*.] *The Ecclesiastical History*. In: *Socrates, Sozomenus, Church Histories*. Translation (anon.) revised by A. C. Zenos. (Select Library of Nicene and Post-Nicene Fathers, Second Series, 2.) Oxford and New York, 1891. (pp. 1–178.)
- SPIEGELBERG, W. “Der Gott Bait in dem Trinitätsamulett des Britischen Museums,” *Archiv für Religionswissenschaft* (Leipzig and Berlin), XXI (1922), 225–27.

- Spiritual Disciplines*. Translated by Ralph Manheim and R. F. C. Hull. (Papers from the Eranos Yearbooks, 4.) New York (Bollingen Series XXX: 4) and London, 1960.
- SPITTELER, CARL. *Olympischer Frühling*. Leipzig, 1900–1905. 4 parts. “Splendor solis.” See TRISMOSIN.
- SPON, JACOB, and WHEELER, GEORGE. *Voyage d’Italie, de Dalmatie, de Grèce et du Levant fait aux années 1675 et 1676*. Amsterdam, 1679. 2 vols.
- STADTMULLER, HUGO (ed.). *Anthologia Graeca Epigrammatum*. Leipzig, 1894–1906. 2 vols.
- STAPLETON, H. E., and HUSAIN, M. HIDAYAT. “Muhammad bin Umail: His Date, Writings, and Place in Alchemical History,” *Memoirs of the Asiatic Society of Bengal* (Calcutta), XII (1933).
- STEEB, JOHANN CHRISTOPH. *Coelum Sephiroticum Hebraeorum*. Mainz, 1679.
- STEINERUS, HENRICUS. *Dissertatio chymico-medica inauguralis de Antimonio*. Basel, [1699].
- STOLCIUS DE STOLCENBERG, DANIEL. *Viridarium Chymicum*. Frankfurt a. M., 1624.
- [SUIDAS.] *Suidae Lexicon*. Edited by Ada Adler. (Lexicographi Graeci, 1.) Leipzig, 1928–38. 5 parts.
- TABERNAEMONTANUS, JACOBUS THEODORUS. *Kräuterbuch*. Basel, 1731. 2 vols. (pagination continuous throughout).
- “Tabula smaragdina.” See (A) *De alchemia*, ii. See also RUSKA.
- TACHENIUS, OTTO (pseud. of Marcantonio Crasselame). *Lux obnubilata suapte natura refulgens. Vera de lapide philosophico theorica metro itálico descripta...* Venice, 1666. French translation: *La Lumière sortant par soi-mesme des ténèbres*. Paris, 1687. Another edn., 1693.
- [Talmud.] *The Babylonian Talmud*. Edited by I. Epstein. London, 1935–52. 35 vols. (*Seder Nezikin*, Vols. III and IV, being Baba Bathra, Vols. I and II, translated by Israel W. Slotki; *Seder Nezikin*, Vols. V and VI, being Sanhedrin, Vols. I and II, translated by Jacob Schachter and H. Freedman.)
- Tao Teh Ching*. See WALEY.
- TERESA, SAINT. *Works*. Translated by E. Allison Peers. London, 1946. 3 vols.
- TERSTEEGEN, GERHART. *Geistliches Blumengärtlein inniger Seelen*. Frankfurt a. M. and Leipzig, 1778.
- TERTULLIAN. *De Monogamia. Treatises on Marriage and Remarriage*. Translated by William P. LeSaint. (Ancient Christian Writers, 13.) Westminster (Maryland) and London, 1951.
- TETZEN, JOHANNES DE (Johannes Tiginensis). *Processus de Lapide Philosophorum*. In: *Johannis Ticinensis, Anthonii de Abbatia, Edoardi Kellaei Drey Chymische Bücher*. Hamburg. 1670.
- THEODORET OF CYRUS. *Haereticarum fabularum compendium*. See Migne, P.G., vol. 83, cols. 335–556.
- THEOPHILUS OF ANTIOCH. *Three Books to Autolytus*. In: *The Writings of Tatian and Theophilus, and the Clementine Recognitions*. Translated by B. P. Pratten, Marcus Dods, and Thomas Smith. (Ante-Nicene Christian Library, 3.) Edinburgh, 1867. (pp. 531–33.)
- THOMAS AQUINAS, SAINT. *Summa theologica*. Translated by the Fathers of the English Dominican Province. New York, 1947–48. 3 vols.
- THORNDIKE, LYNN. *A History of Magic and Experimental Science*. New York, 1923–58. 8 vols.

THORPE, BENJAMIN. "A Dialogue between Saturn and Solomon." In: *Analecta Anglo-Saxonica*. London, 1834. (pp. 95–100.)

TONIOLA, JOHANNES. *Basilea sepulta resecta continuata*. Basel, 1661.

"Tractatulus Aristotelis." See ARISTOTLE, pseud.

"Tractatulus Avicennae." See AVICENNA.

"Tractatus aureus de lapide philosophorum." See HERMES TRISMEGISTUS.

"Tractaus Micreris." See MICRERIS.

TRAUBE, LUDWIG. "O Roma nobilis. Philologische Untersuchungen aus dem Mittelalter," *Abhandlungen der philosophisch-philologischen Classe der Königlich Bayerischen Akademie der Wissenschaften* (Munich), XIX (1892), 299–392.

TRISMOSIN, SALOMON. *Aureum vellus, oder Guldin Schatz und Kunstkammer*. Rorschach, 1598. ("Splendor solis" is Tractatus Tertius. There are several tractates each separately paginated. For translation of "Splendor solis," see: *Splendor Solis: Alchemical Treatises*. Edited by J. K. London [1920].)

TSCHARNER, EDUARD HORST VON. "Das Vermächtnis des Laotse," *Bund*, 13 and 20 June, 1934.

"Turba philosophorum." See RUSKA; also (*A*) *Artis auriferae*, i.

TYLOR, EDWARD B. *Primitive Culture*. London, 1871. 2 vols.

Upanishads. See MAX MÜLLER, FRIEDRICH (trans.). *The Upanishads*. Parts I and II. (Sacred Books of the East, 1, 15.) Oxford, 1879, 1884.

USENER, HERMANN. *Das Weihnachtsfest*. Bonn, 1911.

Vajasaneyi-samhita. See: *The Texts of the White Yajurveda*. Translated with commentary by Ralph T. H. Griffith. Benares, 1899.

VALENTINUS, BASILIUS. *Chymische Schrifften*. Hamburg, 1677.

_____. "De prima materia lapidis philosophici." See (*A*) *Musaeum hermeticum*, ix.

_____. "Opus praeclarum ad utrumque." See (*A*) *Theatrum chemicum*, xxxviii.

_____. *Triumphwagen Antimonii*. Leipzig, 1611. For translation, see: *The Triumphal Chariot of Antimony*. With the commentary of Theodore Kerckringius. Edited by A. E. Waite. London, 1893.

VAN BEEK, CORNELIUS JOANNES M. J. (ed.). *Passio SS Perpetuae et Felicitatis*. Nymwegen, 1936.

[VAUGHAN, THOMAS.] *The Works of Thomas Vaughan: Eugenius Philaletha*. Edited by A. E. Waite. London, 1919.

VENTURA, LAURENTIUS. "De ratione conficiendi lapidis philosophici." See (*A*) *Theatrum chemicum*, xx.

VERANIUS, CAIETANUS FELIX. *Pantheon argenteae elocutionis*. Frankfurt a. M., 1712.

Verus Hermes. [Untraceable.]

VIGENÈRE, BLAISE DE (Vigenerus). "De igne et sale." See (*A*) *Theatrum chemicum*, xlix.

VIGNON, PAUL. *The Shroud of Christ*. Translated from the French. Westminster, 1902.

VITUS, RICHARDUS. See WHITE, RICHARD.

- WAITE, ARTHUR EDWARD. *The Holy Kabbalah*. London, 1929.
- _____. *The Real History of the Rosicrucians*. London, 1887.
- _____. (ed. and trans.). *The Hermetic Museum Restored and Enlarged*. London, 1893. 2 vols.
- _____. See also VAUGHAN.
- WALCH, CHRISTIAN WILHELM FRANZ. *Entwurf einer vollständigen Historie der Ketzereien*. Leipzig, 1762–83.
11 parts.
- WALEY, ARTHUR (trans.). *The Way and Its Power*. London, 1934.
- WEGMANN, HANS. *Das Rätsel der Sünde*. (Gottesglaube und Welt-erlebnis, 3.) Leipzig, 1937.
- WEIL, GUSTAV. *Biblische Legenden der Musulmänner*. Frankfurt a. M., 1845.
- WEI PO-YANG. “An Ancient Chinese Treatise on Alchemy, entitled Ts’an t’ung ch’i. Written by Wei Po-yang,” translated by Luch’iang Wu with introduction and notes by Tenney L. Davis, *Isis* (Bruges), XVIII (1932), 210–85.
- WELLING, GEORG VON. *Opus Mago-Cabbalisticum et Theosophicum*. Hamburg, 1735.
- WERNER, EDWARD THEODORE CHALMERS. *Myths and Legends of China*. London, 1922.
- WHITE, RICHARD, OF BASINGSTOKE (Richardus Vitus Basinstochius). *Aelia Laelia Crispis Epitaphium*.
Dordrecht, 1618.
- WHITE, VICTOR. “The Scandal of the Assumption,” *Life of the Spirit* (Oxford), V (1950), 199–212.
- WICKES, FRANCES G. *The Inner World of Man*. New York and London, 1950.
- WIELAND, C. MARTIN. *Dschinistan, oder ausleseme Feen- und Geistermärchen*. Winterthur, 1786–89. 3 vols.
 (“Der Stein der Weisen,” Vol. I, pp. 218–79.)
- WILAMOWITZ-MOELLENDORFF, U. VON. “Isyllos von Epidauros,” *Philologische Untersuchungen* (Berlin), Heft 9
(1886).
- WILHELM, RICHARD (ed.). *The Chinese Fairy Book*. Translated by Frederick H. Martens. London, 1922.
- _____. (trans.). *The Secret of the Golden Flower*. With a Commentary and Memorial by C. G. Jung. Translated
by Cary F. Baynes. London and New York, 1931. (New edn., 1962.)
- WINTER, J., and WÜNSCHE, AUGUST. *Die Jüdische Literatur seit Abschluss des Kanons*. Trier, 1894–96. 3 vols.
- WITTEKINDT, W. *Das Hohe Lied und seine Beziehungen zum Istarkult*. Hanover, 1925.
- WOLBERO, ABBOT OF ST. PANTALEON, COLOGNE. *Commentaria super Canticum Cantorum*. See Migne, *P.L.*,
vol. 195, cols. 1001–1278.
- WÜNSCHE, AUGUST. “Die Sagen vom Lebensbaum und Lebenswasser,” *Ex Oriente Lux* (Leipzig), I, parts 2 and
3 (1905).
- _____. “Salomos Thron und Hippodrom. Abbilder des Babylonischen Himmelsbildes,” *Ex Oriente Lux* (Leipzig),
II, part 3 (1906).
- _____. “Schöpfung und Sündenfall des ersten Menschenpaares im jüdischen und moslemischen Sagenkreise,” *Ex
Oriente Lux* (Leipzig), II, part 4 (1906).

ZACHARIUS, DIONYSIUS. "Opusculum philosophiae naturalis metallorum, cum annotationibus Nicolai Flamelli."

See (A) *Theatrum chemicum*, xiii.

ZIMMER, HEINRICH. *Der Weg zum Selbst*. Edited by C. G. Jung. Zurich, 1944.

Zohar, The. Translated by Harry Sperling and Maurice Simon. London, 1931–34. 5 vols. See also MUELLER.

"Zosimus ad Theosebeiam." See "Rosinus ad Euthicium."

INDEX

When cross reference is made to the “names of individual authors or treatises” in alchemical compilations, see the Bibliography, above, pp. 601ff, where the names are listed.

A

Abegg, Emil, [415n](#)

Abel, [388](#)

Abelard, [234](#), [439n](#)

ablution, [235](#), [422](#)

Abraham, [389](#), [399](#), [456n](#)

Abraham Eleazar, *see* Eleazar

Abraham of Franckenberg, [166](#)

Abraham the Jew, [50n](#), [410](#), [515](#), Pl. 3

Abt, Adam, [198n](#)

Abu'l-Qasim, [7](#), [17](#), [70n](#), [134n](#), [286](#), [302n](#), [462n](#), [511n](#)

Abydos, [266n](#)

abyss, [11](#), [198](#)

Abyssinians, [239](#)

Achaia Pharis, [392](#)

Achamoth, [338n](#), [403](#)

Acta Archelai, *see* Hegemonius

Actaeon, [159](#)

Acts of the Apostles, [218n](#), [337](#), [344](#), [345](#)

Acts of John, [9n](#)

Acts of Thomas, [69n](#), [355](#)

Adam, [210](#), [328](#), [351n](#), [409](#), [437](#)

as first adept, [397ff](#)

androgyny/dual nature/hermaphroditism of, [11](#), [16](#), [210](#), [373](#), [383f](#), [404f](#), [406ff](#),
[416](#), [440](#), [455](#)

as Anthropos, [407](#), [409f](#), [412n](#), [420](#), [424](#)

as arcane substance, [382f](#), [386n](#), [397](#)

pierced by arrow, [31](#), [122](#)

back of, 407n
as Christ, 456n
and colours, 386f
creation of, 16n, 384ff, 388, 397, 406ff, 440
derivation of name, 440
and Eve, 89, 373, 382ff, 397, 412, 455
two faces of, 408
fall/sin of, 26, 406, 416, 423, 481
as “Father”
in modern fantasy, 383
first and second, 404, 412, 415, 424
gift of intelligence, 406
grave of, 388, 389
heavenly and earthly, 413
as hook of Yod, 44n
Kadmon, *see separate entry below*
as lapis, 382, 398
as microcosm, 11, 386
“old,” 50, 384, 415ff, 424, 427, 429, 453
and perfect primordial man, 428
as prima materia, 384ff, 397, 409
as prophet, 399, 405
as quaternary, 389
rebirth/renewal of, 343, 383, 397, 453
and Satan, 409
second, 122, 343, 393, 394, 440, 446, 452ff
as statue/rock, 76, 390, 437
and Shulamite, 412, 416f
as symbol of self, 390, 413
as synonym of Mercurius, 393
tailed, 408, 417
tetradic/ogdoadic nature of, 387ff
as totality/wholeness, 390, 438ff
and Venus, 303, 383

“Adam and Eve, Life of,” 389

Adam Kadmon, 50, 383, 411, 412n, 420, 424, 431

androgyny of, 455

birth of, 423, 452f

cosmogonic, 456

heavenly and earthly, 413

as *homo maximus*/primeval man, 50, 412n, 416f, 454

as “inner man,” 383

and lapis, 446

as mediator, 412

“old Adam”

as, 415, 416, 453

as self, 429

as son-lover, 423

and transformative process, 429

unity and multiplicity of, 414, 429

Adamah, 406, 433, 440

Adamas, 394n, 407, 408f, 437

Adech, 49, 383

Adler, Alfred, 365n

Adonai, 446

A. Sabaoth, 76n

Adoni-bezek, 259n

Adonis, 34n, 259n, 372

Adoni-zedek, 259n

adoption, 283f, 315, 359

Aegean Festival (*Faust*), 461

Aegidius de Vadis, 111n, 146n, 458n, 500n

Aelia Laelia Crispis, 56ff, 83

Aelian, 195, 511n

“*Aenigmata philosophorum*”/“*Aenigmata ex Visione Arislei*,” see “*Visio Arislei*”

Aeon(s), 21, 262

aether, 177n, 207, 322

affects, objectification of, 471

Africa, 210, 211, 213
Africanus, 262n
Agathias Scholasticus, 82f
Agatho, *see* Priscius
Agathodaimon, 7, 8, 9, 196, 202, 340n
Agdistis, 34n
Agnostus, 98n
Agrippa von Nettesheim, 35, 159n
Ahriman, 40n
Aigremont, Dr. (pseud.), 509n
Aion, 282
air, 136; *see also* elements
Aithiops, 510; *see also* Ethiopian
Akori, 261
alabaster, 436
Alanus, *see* “Dicta Alani”
Albaon, 379, 441n
albedo, 10, 177, 197, 238, 239, 314, 439n
 colours and, 286
 dew and, 132
 moon and, 130f, 229, 436
 salt and, 191, 239, 244
 Shulamite and, 424
 white rose and, 306
Albertus Magnus, 17, 64n, 117n, 132n, 226, 335n, 356n, 435n, 436n, 500ff, 505ff, 519;
 see also “Super arborem Aristotelis”
alchemy, *passim*; assimilation process in, 325ff
 and Cabala, 24, 455
 and chemistry, 124, 240n, 250, 319f, 345, 457ff, 467, 475, 483, 532
 Chinese, 131, 237, 295, 436, 499n, 503
 —, and Western, 195n
 and Christianity, 15, 90f, 100ff, 124, 197, 243, 256f, 261f, 307, 309, 336n, 346,
 360f, 371f, 438, 441, 450, 466f, 484, 494, 540ff
 decline of, 362
 and dogma, 309, 326, 346, 362

futility of, 320
glorification of matter in, 187, 238
goal of, 533, 535ff
Greek, 131, 236, 434, 436, 460, 501, 513
and heresy, 542
individuation in, 381
language of, 263, 279, 506, 518
and measurement, 124f
and mythology, 293, 345n, 346, 475, 516
origins of, 262
paradoxes of, 82, 93, 199, 209, 415f, 441, 454
and psychology, 249, 319ff, 371, 475, 482, 487ff, 498, 519, 525, 540, 544ff
and revelation, 254
salt in, 249ff, *see also* salt
spiritual goal of, 90
symbolic character of, 457, 487, 526
and totality/wholeness, 30, 503
unconsciousness and, 327
woman in, 178, 315; *see also* lapis; opus

Alcibiades, 393
alcohol, 268n, 478
Aldrovandus, Ulysses, 59n, 68ff, 83, 86
alembic, 77n
Alexander, 64, 190n, 212n, 239
Alexander, Romance of, 133n
Alexis, 85
“Alfabet des Ben-Sira,” 398n
Ali, M. T., 72n
“Allegoria Merlini,” 266, 272, 293, 297, 308, 470n
“Allegoriae Sapientum,” 21n, 43, 130n, 138, 141, 175n, 189, 264n, 268n, 486n
“Allegoriae super librum Turbae,” 133f, 151n
Alpha and Omega, Christ as, 307
Alphidius, 4n
Altus, 153n; *see also* *Mutus liber*

alumen, [500](#)
Alze, Liber, *see* “Liber Alze”
amaritudo, *see* bitterness
Ambrose, St., [35](#), [37](#), [126](#), [215n](#), [277f](#), [336](#)
Amenophis IV, [266n](#)
Amente, [340](#)
American Indians, [273](#), [422n](#)
Amfortas, [252](#)
Aminadab, [206](#)
Amitabha, [20n](#)
Amitayus, [20n](#)
Amon, [259n](#)
amplification, self-, [458](#)
amulet, Trinity, [261](#)
Amun, [260n](#)
Anabaptism, [362](#)
analysis: therapeutical, [151n](#), [154](#), [248](#), [271](#), [494f](#), [526ff](#)
 danger of, [530](#); *see also* group analysis
analyst: and transference, [526f](#)
 winning independence of, [529f](#)
anamnesis, [229](#)
 “ritual,” [419](#), [420](#)
Ancient of Days, [10n](#), [279](#), [281](#), [297](#), [315](#)
androgynous/androgyny, [47](#), [373f](#), [405](#); *see also* Adam; Christ; Hermaphrodite; lapis;
 Mercurius
angel(s), [77](#), [402](#)
 of death, [386](#)
Angelus Silesius, [33n](#), [102n](#), [105](#), [109f](#), [113n](#), [165n](#), [166](#), [215](#), [311](#), [318f](#), [321](#)
anger, [144](#)
Aniada, [490](#)
anima, [26n](#), [71](#), [78](#), [83](#), [108n](#), [135](#), [163](#), [233](#), [307](#), [379](#), [404](#), [428](#), [431](#), [474](#)
 activation of, [308](#)
 alchemical meaning of, [113](#), [134n](#)
 and animus, [425f](#), [471](#)
 archetype of, [68](#), [176](#), [302n](#)

as archetype of life, 452
black, 452
coming into consciousness of, 356, 427
Diana as, 163
and ego, 426
freeing of, 141, 224, 339n, 473
king and, 379
as mediator between conscious and unconscious, 356n, 380
Mercurius as, 461, 490f, 505, 525
mermaid as, 71
as moon, 176, 220
negative aspects of, 141, 175, 379f
— and positive aspect, 426
as nightmare, 75
as old woman, 83
possession by, 180
pregnant, 176
projections of, 68, 181, 453f
as psychopomp, 214, 217, 225f, 233, 380
queen as, 517
and rotundum, 356
represented by Shulamite, 452
unconscious, 411
as representing unconscious, 106, 154, 175/f, 241, 452
virgin as, 74, 88, 404; *see also* psychopomp; soul; spirit
anima media natura, 185n, 322, 512, 537
anima mundi, 84, 187, 207, 240, 241, 278, 280, 322, 494, 505, 525, 536, 537, 539, 546
and Anthropos, 241
and Christ, 241f
light-seeds of, 67, 244
man and, 515
Mercurius as, 238, 322, 461, 490f, 525f; *see also* world-soul
anima rationalis, 369, 473
animals: attribute of god, 417

fighting, 360n, 470
four, 400
produced by Sol/Luna coniunctio, 144f
symbolic, Chinese, 400
symbols of unconscious, 210f, 212
animus, 135, 182, 428, 471
 possession by, 180
ankh, 261
Anquetil du Perron, *see* du Perron
Anthonius de Abbatia, 38n
Anthroparion, 229, 301; *see also* homunculus
Anthropos, 39, 56, 100n, 128, 136n, 171, 241, 290, 301, 322, 346, 347, 348, 350, 356,
370, 400, 409f, 416
 alchemical, 263, 349f, 410
 androgyny of, 407
 archetype of, 346, 414, 420, 525
 and China, 348n
 cosmic, 322
 scintilla and, 55
 and tetramorph, 400n; *see also* Adam; Christ; *filius philosophorum*; king; man,
 primordial; Mercurius
Antichrist, 18n, 125, 298, 307, 343
ἀντίμιμον πνεῦμα, 451
antimony, 332, 397
antinomies, 538
Antiochus, 202
Antiquus dierum, *see* Ancient of Days
Antony of Padua, 167n
Anubis, 269
Apep-serpent, 340–41n
“Aphorismi Basiliani,” 118n
Aphrodite, 237
Apis bull, 266n
Apocalypse, 102n, 371; *see also* Revelation, Book of
apocatastasis, 337

Apocrypha, New Testament, 226; *see also names of separate books*
Apollinian-Dionysian conflict, 373
Apollo, 121–22n, 203
Apollonius of Tyana, 21n, 138f
apotheosis, 355f
 of Virgin Mother, 467n; *see also Assumption*
appetites/passions, 143f
Aptowitzer, Viktor, 407n, 409n
Apuleius, 20, 297, 369n, 516
aqua doctrinae, 242, 253, 277, 504
aqua permanens/benedicta/divina/pinguis/propria, 5, 14n, 19, 28, 45, 55, 99, 134n, 140, 189, 191, 229, 235, 236, 252, 277, 293n, 316, 479n, 480n, 491, 503, 515n
 as anima or spirit, 229, 240, 339n
 blood as, 293, 306, 485
 effects of, 238, 268f
 extraction of, 152, 277f
 female chthonic aspect of, 359
 Mercurius as, 459n, 461, 484, 491f
 as transformative substance, 215, 277, 294, 382f
aqua pontica, 191, 193, 199, 235, 245, 253, 273, 484
“Aquarium sapientum,” 51n, 73n, 245, 263n, 289, 307n, 328, 344f, 349, 350n, 353, 398, 512
Aquarius, 176
Aquinas, *see* Thomas
Arabia Felix, 213
Arabs, 129, 142, 242
Aratus, 148f
arbor philosophica, 133, 134, 154n; *see also* tree, philosophical
arcane substance/*arcanum*, 42ff, 60f, 302, 351n, 434f, 501, 540
 brain as, 435
 corpus rotundum as, 434f
 corrupt, 280
 “dead,” 293
 earth as, 191, 440
 flesh as, 153n

heart as, [350n](#)
as “inner man,” [383](#)
king as, [153n](#), [263n](#), [332f](#), [335](#), [506f](#)
lapis as, [42](#), [44f](#), [240](#), [263n](#), [448](#), [475](#), [532](#)
lion as, [125](#), [295](#)
Mercurius as, [12](#), [43f](#), [190](#), [231](#), [465](#)
nigredo of, [50](#), [519](#)
paradox of, [42f](#), [59](#)
physical nature of, [541](#)
salt as, [183ff](#), [188ff](#), [238](#), [241](#), [245](#), [250](#)
serpent-chariot as, [207](#)
splitting of, [164](#)
sulphur as, [120](#), [122](#), [127](#), [350n](#)
symbolic character of, [477](#)
synonyms for, [125](#)
transformations of, [219f](#), [240f](#), [349](#)
unity of, [153n](#), [540](#)

Venus as, [302n](#), [303](#); *see also* Adam

Arcanum hermeticae philosophiae opus, *see* D’Espagnet

Arch(a)eus, [49](#), [54](#), [55](#)

archetypes, [87](#), [91](#), [103n](#), [105](#), [265](#), [336n](#), [357](#), [368](#), [453f](#), [473f](#), [491](#), [523f](#)

activation of, [347](#), [359](#)

autonomy of, [469](#), [524](#)

Christ as psychic reality of, [124](#)

of coniunctio, *see* coniunctio; of consciousness, *see* consciousness; as “God,” [552](#)

Imago Dei as, [54n](#)

of incest, *see* incest; integration of, [524](#)

of King’s sacrifice, [361](#), [372](#)

of meaning, [233](#)

and natural laws, [294](#)

new interpretation of, [524f](#)

numinosity of, [232](#), [301n](#), [390](#), [523](#), [552](#)

in Philo, [534](#)

possession by, [524](#), [545](#), [552f](#)

of rebirth, 150
of self, *see* self; stability of, 463
and synchronicity, 533n
of unity, 540
unity of, 454, 463
of wholeness, 544
of Wise Old Man, *see* Wise Old Man; *see also* anima; Anthropos; hero

Archeus, 411n

archons, 40, 225, 230, 231, 338, 402

arena, *see* sand

Ares, 78; *see also* Mars

Aries, 7, 176

Arisleus, *see* “Visio Arislei”

Aristeas, 513n

“Aristotelis Tractatulus,” *see* Tractatulus

Aristotle, 10n, 47n, 85, 144, 309n, 325n
pseudo-, 15n, 153n, 215, 432; *see also* “Tractat(ul)us Aristotelis”

ark of the covenant, 170n

Armillus, 447n

Arnaldus (de Villanova), 18n, 150, 153n, 189, 211n, 329n, 432

Arnold, 18n

arrow, 31
Cupid’s, 30; and moon, 26

Ars chemica, 5n, 28n; *see also* names of individual treatises

arsenic, 38n, 164

Artefius, 5n, 138f, 296f, 297n, 478n, 480n

Artemidorus, 336

Artemis, 121n, 420; Chitone, 71n; *see also* Diana

Arit’s *auriferae*, *see* names of individual authors or treatises

Artus, 266n

ascent and descent, 217ff, 339

asceticism, 475, 499

aseity, 293n

ash, 112, 189, 194, 238ff, 486n

“Ash Metsareph,” 444n
Asklepios, 121–22n, 228, 342, 351n
Asophol, 433
Ass, Golden, *see* Apuleius
assimilation, 325f
association experiment, 155, 208
Assumption, of Mary, 167n, 170–71n, 186, 244, 317, 466f, 469, 523
Astarte, 75n, 157; *see also* Diana
astrolabe, 207
astrology, 151n, 179, 338n, 350n
 colours and, 287
astronomy, 399
Asurbanipal, 284
Atarah, 455
Atharva-veda, 516f
Athenaeus, 82n, 85
Athenagoras, 21
Athens, 129
Athos, Mount, 245
atman, 109, 110, 123, 208, 499, 535
 atman/purusha, 123, 499
Aton, 266n
attachments, infantile, 527
attention, 152
Attis, 34n, 63n, 363n, 437n, 456n
attitude, religious, of adept, 475
Atwood, M. A., 153n
Augustine, St., 15n, n, 25ff, 32n, 36n, 39, 40n, 198, 199, 211, 237, 292, 318n, 373n,
 388n, 396f, 511n
“Aurelia occulta,” 223, 515
“Aureum saeculum redivivum,” *see* Madathanus
“Aureum vellus,” *see* Mennens; Trismosin, Salomon
Aurora consurgens, 4n, 9, 12n, 16n, 17n, 18n, 26n, 31n, 38, 48n, 49n, 50n, 55n, 64n,
 70n, 73n, 95n, 124n, 129, 130, 154n, 189n, 236, 269n, 287, 318, 332f, 349, 376f,

378n, 381n, 385n, 412, 534n; Part II, 18n, 60n, 71n, 76n, 112n, 120n, 131, 133n, 154n; 189n, 269n, 279n

aurum, see gold

Australian aborigines, 137n

automatisms, 180

Avalon, Arthur (pseud.), 405n

Avicenna, 4, 65n, 134n, 211; see also “Tractatulus Avicennae”

Axiom of Maria, see Maria Prophetissa

Azi-Dahaka, 448n

Azoch, 382

Aztecs, 30

B

Baader, Franz von, 405

Babel/Babylon, 117, 298, 307

Bacchus, 7n

Bach, J. S., 530

Baechtold-Stäubli, Hanns, 173n, 490n, 492n

baetylus, 539

“Bahir, Book,” 434n

Bais, 237

Bait, 261

Bakcheus, 363n

balsam/*balsamum vitae*, 34, 47, 54, 93f, 465, 477

bank clerk, embezzling, 145

baptism, 281, 436

alchemists and, 236

Christian, 237f

in fire, 235

and Red Sea, 199

salt at, 238

three kinds, 236

Barbeliots, 409n

Barbelo, 41n

Barcius, see “Gloria mundi”

Bardesanes, [39n](#), [76n](#), [373n](#)

Barnaud, Nicholas, [59ff](#), [65](#)

Baroldus, Wilhelmus, [65n](#)

Baroque, [166](#)

Bartholomew, Book of, [340n](#)

Basil, St., [218](#)

Basilides, [67n](#), [280n](#), [461](#)

Basilidians, [16](#), [104](#), [221](#), [291](#), [346](#), [451](#), [465](#)

basilisk, [80](#), [144](#)

Bata, [269](#)

bath, [457](#)

Adam and Venus in, [303](#), [383f](#)

coniunctio/hierosgamos in, [70](#), [116](#), [220](#), [269](#), [459n](#), [478n](#)

king's, [70f](#), [269](#), [295](#), [303](#), [330n](#), [358](#), [383](#), [444](#)

planetary, [358](#)

queen's, [379](#)

renewal in, [162](#), [220](#), [484](#)

surprise in, [121 & n](#), [159](#)

Baynes, H. G., [260n](#)

bear, [5n](#), [144](#)

Bear, Little, [148n](#)

Beatus, *see* "Aurelia occulta"

Becker, Ferdinand, [187n](#)

bed, [316](#)

Beer, Peter, [399n](#)

beheading, [513](#)

Behemoth, [251](#), [401](#)

Belenius, [138](#)

Belinus, [138](#); *see also* "Dicta Belini"

Belti, [302n](#)

Ben Sira, [408n](#)

Benedictio Fontis, [71n](#)

Berissa, [133](#), [293n](#)

Bernardino de Sahagún, [30n](#)

Bernardus à Portu Aquitanus, 175n

Bernardus Trevisanus, 10, 50n, 70, 93n, 111n, 112n, 153n, 162, 269, 330n, 398, 507

Bernoulli, Rudolf, 159n

Béroalde de Verville, François, 364n

Berthelot, Marcellin, 5n, 9n, 14n, 15n, 19n, 20n, 29n, 31n, 33n, 43n, 60n, 61n, 63n, 64n, 72n, 80n, 132n, 141n, 152n, 156n, 231n, 236n, 237n, 240n, 262, 287n, 304n, 385n, 429n, 434n, 435n, 450n, 458n, 504n, 539n; *see also* Christianos; Democritus; Olympiodorus; Zosimos

Bethel, 396n, 397

Bethesda, 158

Beya, 4, 19, 23n, 30, 60, 63, 117, 153, 236n, 272n, 299, 383

Bezold, Carl, 386n, 388n, 406n, 407n, 449n

Bible, *see names of individual books*

Bibliotheca chemica curiosa, *see* Manget, J. J.; *also names of individual authors or treatises*

Binah, 450n

binarius, *see* two

bird(s), 5n, 7, 77n, 151, 445

black, beheaded, 513

fledged and unfledged, 6

flying, 151n

green, 112

of Hermes, *see* Hermes

and snake, 342n

winged and wingless, 5

Bischoff, Erich, 135n

bisexuality, *see* androgyne; hermaphrodite

bitch, 146ff

Armenian, 32, 144n, 147

bitterness, 192ff, 246

and colours, 248

Black Elk, 206n

black and white, 76

blackening/blackness, 423, 512; *see also nigredo*

blood, 95, 152, 433, 480, 485f, 492

of Christ, [14](#), [201](#), [307](#), [440](#)
dam (Hebrew), [406n](#)
of black goat, [73](#)
lion's, [285](#), [293](#), [301](#), [305f](#), [323](#), [364](#)
and pact with devil, [485](#)
prohibition of shedding, [411n](#)
rose-coloured, [305](#)
salt and, [251](#)
as seat of soul, [485](#)
synonym of spirit, [14f](#), [293n](#)
symbolism of, [293ff](#)
as “whitest milk,” [121](#); see also *aqua permanens*

blue, [14](#), [149](#), [289](#); see also colours

Bodenstein, Adam von, [448](#); see also Paracelsus

body: glorified, [238](#)
 and soul/mind, conflict, [470ff](#)
 spiritualization of, [535ff](#), [541f](#)

Boehme, Jacob, [105](#), [166](#), [241](#), [338n](#), [344n](#), [350n](#), [373n](#), [404f](#), [441](#)

Boghazköy, [536n](#)

Bogomils, [409](#)

Boibeis, Lake, [121n](#)

Bolemus, [138](#)

Bologna, [56](#), [66](#), [68](#)

Bonaventure, St., [47n](#), [281](#), [504](#)

Bonellus, [138](#)

Bonus, Petrus, [3n](#), [4n](#), [6n](#), [11n](#), [17n](#), [22n](#), [42n](#), [95n](#)

“Book of the Cave of Treasures,” [386](#), [388](#), [407](#), [449](#)

Book of the Dead, Egyptian, [341n](#)

Bouché-Leclercq, Auguste, [116n](#), [350n](#), [351n](#)

Bousset, Wilhelm, [18n](#), [39n](#), [48n](#), [76n](#), [136n](#), [225n](#), [226n](#), [355n](#), [394n](#), [402n](#), [406n](#),
[407n](#), [414n](#)

brain, [435ff](#)
 turning black, [515](#)

brain-stone, [436](#)

Brant, Sebastian, [324f](#), Pls. [1](#), [2](#)

Breasted, J. H., [266n](#)
Brethren of the Free Spirit, [452](#)
Brihadaranyaka Upanishad, [136n](#)
Bruchmann, C. F. H., [307n](#)
Brugsch, Heinrich, [19n](#), [33n](#), [342n](#)
Buch der Alaune und Sake, [240n](#), [335n](#)
Budda, [37](#)
Buddha, [71n](#), [370](#)
Buddhism, [37n](#), [553](#)
Budge, E. A. Wallis, [30n](#), [40n](#), [64n](#), [340–41n](#)
bull-god, [260n](#)
Bundahisn, [40n](#)
Bury, R. G., [393n](#)
Bythos, [11](#)

C

Cabala, [4n](#), [9n](#), [18n](#), [22ff](#), [32n](#), [206](#), [383](#), [384](#), [390](#), [394](#), [396f](#), [399n](#), [410](#), [412ff](#), [442ff](#),
[455](#)
 and alchemy, [24](#), [455](#)
Cabiri, [409](#)
Cadmia, [80n](#)
Cadmus, [78ff](#), [343n](#)
caduceus, [228](#), [298](#)
caelum, [52f](#), [486f](#), [489](#), [493f](#), [532](#), [535f](#), [539](#), [542](#)
Caesar, [242](#)
Caesarius of Heisterbach, [140](#), [296n](#)
Cain, [388](#)
Camerarius, Georgius, [307n](#)
Campbell, Colin, [52n](#), [64n](#), [265n](#), [266n](#)
Canaanites, [259n](#)
Cancer, [7](#), [131](#), [176](#), [210](#)
candelulae, [115](#)
candle, and baptism, [235](#)
canicula, [153](#)
Canopic Gate, [217](#)

Capelle, Paul, [132n](#)
capitelum, [77n](#)
Capitol, [68n](#)
Capricorn, [7](#), [176](#)
caput corvi, see raven
caput mortuum, [510](#), [511f](#), [513](#)
carbuncle, [423](#)
Cardan, Jerome, [336](#)
Carmen Archelai, see Heliodorus
Carmina Heliodori, see Heliodorus
Carpocrates, [215](#)
Carus, C. G., [554](#)
Casaralta, [69](#)
Cassel, Paulus Stephanus, [18n](#)
Cassiodorus, [289n](#)
Catherine of Alexandria, St., [180](#)
cauda pavonis, [285](#), [287f](#), [290](#), [311](#)
causality, law of, [464](#)
Caussin, Nicholas, [243](#), [255n](#), [336n](#), [338n](#), [511n](#)
Cedrenus, Georgius, [37n](#)
celandine, see *Chelidonia*
celibacy, clerical, [90](#)
Celsus, [401ff](#)
centre, [13](#)
Cham, [50](#)
chamaeleon, [155](#), [156](#)
change, law of, [358](#)
chaos, [9](#), [80](#), [193](#), [205](#), [273](#), [279](#), [339](#), [353](#), [364n](#), [397n](#), [400](#), [459](#)
 inner, [286](#)
 maternal aspect of, [302](#), [359f](#)
 as nigredo, [197](#), [497](#)
 as prima materia, [156](#), [385](#)
 return to, [197](#), [283](#)
 spirit of, [197](#)

unconsciousness as, 253, 488

chariot, 202*f*, 203*ff*, 215

Charles, R. H., 389*n*, 492*n*

Charles' Wain, 205*n*

Chelidonia, 479, 483*f*, 490, 493

chemistry, 319; *see also* alchemy

chên-yên, 128, 348, 499*n*, 525*n*, 539

cherubim, 442

Cheyri, 133*n*, 448, 490

ch'i, 237, 471*n*

chick, 46

China, 399, 523

 Anthropos doctrine in, 348

Chinese: alchemy, *see* alchemy; Wei Po-yang; philosophy, *see yang/yin*

Chiron, 121*n*

Christ, 30, 35, 36, 126, 169, 170, 307, 361, 370, 388*n*, 422, 509

 and first and second Adam, 222, 343, 373, 393, 398, 404, 440, 446, 452, 456*n*

 and Adam Kadmon, 423, 454

 alchemical symbols for, 100, 117, 122*f*, 125, 128, 241, 246, 331, 360, 449, 494

 allegories of, 9*n*, 100, 124, 125, 147*n*; 159*n*, 169, 186, 282*ff*, 311, 324, 331, 336, 343*f*, 437*n*, 511

 androgyny of, 184*f*, 372, 373*f*, 379, 393, 441*f*

 as Anthropos, 16, 216, 290, 423

 apocalyptic, 371, 441*f*

 as archetype, 124

 birth of, 356*n*

 blood of, 14, 201, 306*f*, 440

 and Church, 90, 405, 412

 coming of, 211*f*, 213, 215*f*, 544

 as cornerstone, 14, 15, 450

 descent into hell, 171, 337

 and the devil, 102*n*, 104*n*, 125, 511

 and dragon's head, 117*f*

 dual form/nature of, 39, 104, 124, 404

 fast of, 512

historicity of, 124, 348f
host as, 446
as image of God, 406
imitation of, 35, 214, 349
incarnation of, 218, 348, 398, 400
inner, 347
and “inner man,” 491
Christ/lapis parallel, 52, 120, 124f, 126f, 158n, 185, 223, 264f, 290, 305, 345, 361,
394, 450f, 475, 525, 539
as “man encompassed by woman,” 125, 184f, 377
as mediator, 186
and Mercurius, 125, 216
Passion of, 322, 345, 349
—, Job as prefiguring, 354
—, opus as parallel of, 322, 345f, 349f
and phoenix, 336
pierced, 30, 32f, 122, 277
as eighth/“true”
prophet, 399, 400f, 404
redemption through, 34, 225
resurrection of, 158f, 215, 290n, 334
sacrifice of, 307, 336, 440
and salt, 241, 246
saviour of microcosm, 475
and serpent, 343, 421n
as Sol, 32, 100
and suffering servant, 123, 354
and sulphur, 122
as “sword,” 541
as symbol of self, 246n; *see also* Jesus

Christensen, A. E., 40n

Christianity, 103, 195f, 216, 370, 494, 523, 544
and alchemists/alchemy, *see* alchemy
androgyny in, 373f
early, and philosophy, 242

and myths, 336n
and opposites, 79, 90
and psychology, 325n
schisms in, 551
snake in, 343
and split psyche, 200
as *unio mentalis*, 524
Christianos, 132, 237n, 486n
Christopher of Paris, 392n
Chrysostom, *see* John Chrysostom
Chu-niao, 194, 292n
Church, the: alchemists and, 256f
 androgynous, 374
 assimilation by, 325n
 Bologna inscription and, 87
 as *corpus mysticum*, 378, 400
 “death”
 of, 35, 36n
 faith and, 257
 Luna/moon and, 25ff, 176, 314f
 and philosophy, 242f
 spiritual, 12
 as widow, 22; *see also* Christianity
Chwolsohn, D., 9n, 398n, 485n
cibatio, 285, 308, 435n
cibus immortalis, 372
Cicero, 129n, 242
circle(s), 16, 47, 203, 207
 and Adam, 407, 414
 diagram of concentric, 401ff
 squaring the, 316, 544
circulatio, 7
circulus exiguus, 12
citrinitas, 213n

clairvoyance, 464

“Clangor buccinae,” 4n, 189n, 191n, 438n

“Clavis maioris sapientiae,” see Artefius

Clement of Alexandria, 146n, 374, 440n

Clement of Rome, 136n, 166n, 336, 405; see also following

Clementine Epistles, Ethiopic, 389

Clementine Homilies, 399

cloud, 510–11n

Codices and Manuscripts:

Berlin: Cod. Berol. Lat. 532: 46n, 94n

Florence: Cod. Ashburnham: 31

London. B.M. MS. Add. 5025 (“Ripley Scrowle”), 71, 350n, 478n

Munich: Cod. Germ. Mon. 598: 31n

Cod. Lat. Mon. 4453: 373n

Oxford: MSS. Ashmole 1394, 1445, 1479: 275n

Codex Brucianus: 48n

MS. Digby 83: 434n

Paris: Arsenal MS. 3022: 75n

BN 2327: 61n, 262n

BN 14765, “Abraham le Juif”: 23n, 442, 506ff, Pl. 3

St. Gall: Cod. Germ. Alch. Vad.: 31n

In possession of author: “Figurarum aegyptiorum”: 6n, 50n, 111n, 290n, 384n, 506n, Pls. 4–7

coelum, see caelum

coincidence, meaningful, 464; see also synchronicity

coincidentia/complexio oppositorum, 104, 148, 166, 201, 374, 380; see also opposites

Colchis, 78n

colcothar, 511

Colonna, Francesco, 224n

Colossians, Epistle to the, 36n, 225n, 236, 242, 337n, 378n, 406, 415

colours, 4n, 226, 229, 248, 388, 403, 411n, 508ff

Adam and, 386

in alchemy, 43, 213, 287, 302, 306, 453f, 532

of birds, 77, 113, 194f, 338n; 513: bitterness and, 248

celestial, 14, 147, 149

in dreams, 248
four, 120, 213, 226, 287, 385f
and planets, 287
psychological meaning of, 248, 286ff, 311
of rainbow, 288
seven, 287, 386
of stone, 192, 355
of sulphur, 21n, 38, 92f, 99, 111ff, 116n, 295, 296n, 506, 516
synthesis of, 116, 285f, 288, 290; *see also names of individual colours*

combination, chemical, 457, 467

Communion, 440

complex(es): consciousness of, 207
 overcoming of, 230
 unconscious, luminosity of, 358

compulsion (s), 128, 180

Conception, Immaculate, 186, 523n

conceptualism, 439n

conflict: body/spirit, 470ff
 conscious/unconscious, 494ff
 psychic, realization of, 366; *see also opposites*

coniunctio, 17, 21, 288, 371f, 492, 525
 on animal level, 251n
 archetype of, 81, 167
 of body and soul, 337, 478n, 521
 oppositorum, 251n
 mysterium of, 166, 463, 465f, 469f, 482
 as psychic synthesis, 460
 of red man and white woman, 147, 230
 in the retort, 460, 475
 of Sol/sun and Luna/moon, 4n, 28, 32, 34, 80, 90f, 111, 136, 144, 149, 151n, 160, 210, 230, 315, 367, 376, 434, 438n, 439
 symbolism of, 371n, 470
 of woman with dragon, 21, 37, 142, 220, 460n; *see also coincidentia oppositorum*

conscious/consciousness, 97, 105, 118, 202f, 247, 355ff
 archetype of, 358

coming of, [108n](#)
coming to, [9](#), [128](#), [151n](#), [152](#), [231](#), [238](#), [345](#)
differentiation of, [418](#), [471](#)
dominants of, [325](#), [358ff](#), [367](#), [369f](#), [379](#)
—, binding force of, [368](#)
—, Christian, [331](#)
—, decay of, [362](#)
—, historical, [370](#)
—, mythical, [369](#)
—, negative aspect of, [380](#)
—, relativization of, [325](#)
—, renewal of, [355](#), [358f](#), [368f](#), [372f](#)
—, and shadow, [365](#)
ego-, *see* ego-consciousness
egocentrism of, [463](#)
eye as symbol of, [207](#)
identification with, [247](#)
integration of, [202f](#), [205](#), [546](#)
king symbol and, [355ff](#)
male and female, [135](#), [177f](#), [179f](#), [430](#)
moral, [420](#)
primitive, [459f](#)
and projection, [107](#)
renewal of, [369f](#)
Sol/sun as, [96f](#), [100](#), [106f](#), [128](#), [144](#), [177f](#), [229f](#), [308](#), [358](#), [367ff](#)
training of, [214](#)
and unconscious, [177](#), [241](#), [379f](#), [462f](#), [473](#), [533](#)
— attention towards, [152](#), [163](#), [528f](#)
—, compensation between, [103](#), [380](#)
—, conflict between, [360](#), [371](#)
—, confrontation of, [222](#), [229](#), [272](#), [521](#)
—, contamination of, [274](#)
—, discrimination between, [154](#), [200](#), [204](#), [496](#), [529](#)
—, dissociation of, [540f](#), [546](#)

—, mistrust of unconscious by conscious, 123
—, modification of, 208f
—, myth as bridge between, 528
—, as pair of opposites, 106, 357
—, as prototype of Sol/Luna symbolism, 97, 148
—, totality of, 369
—, union of, 15n, 164, 172, 272, 367f, 371, 380, 414, 517, 539
threshold of, 199n
transformation of, 156n, 358f
widening/extension of, 169, 171, 224, 229f, 251n, 253, 310, 541, 547
“Consilium coniugii,” 3n, 4n, 9f, 28, 29, 30n, 31n, 40n, 42n, 45n, 46, 71n; 75n, 92n;
93n, 95, 111n, 112n, 118, 120, 131n, 145n, 153n, 154n, 219f, 235n, 236, 263n,
296n, 307, 328, 461, 512n
contemplation, 498; see also *meditado*
continents, four, 214
contraries, see opposites
contrasexuality, psychic, 180
conversion, 366
convulsion therapy, 477
copper, 93
cor, 350n, 391f, 395f
Cordovero, Moses, 22n
Corinthians, First Epistle to the, 12n, 67n, 387, 413, 435n, 524n
Corinthians, Second Epistle to the, 14n, 36n, 169n, 397
Coronis, 121n
corpus, 5n; see also body
corpus glorificationis, 535
Corpus Hermeticum, 50n, 136n, 273n; see also Scott, Walter
Corpus Inscriptionum Latinarum, 20n, 57, 66n, 69
correspondence, alchemical, 249, 309
correspondentia, 184, 470
corruption/*corruptio*, 193, 197, 199
corvus, 510; see also raven
cover, of vessel, 316
Crasselame, Marcantonio, 338f

Crawford, J. P. Wickersham, [81n](#)
Crawley, A. E., [358n](#)
creation, alchemy and, [339](#), [537](#)
creatures, four, [205f](#), [215](#)
Creon, [22n](#)
cross, [3](#), [33](#), [101f](#), [388](#), [505](#)
 black, [421](#), [454](#)
crown, [17](#), [238](#) & *n*, [356](#)
 of light, seven-rayed, [9](#); *see also* Atarah; Kether
crucifixion, Christ's, [388n](#)
crystal, [245](#), [449](#)
Cubricus, [37](#), [38n](#)
cucurbita, [299](#), [301](#), [313n](#), [314](#); *see also* vessel
Cumont, Franz, [226n](#)
cup, golden, [301](#), [310](#)
Cupid, [302](#), [304](#), [309](#), *see also* arrow
curly hair, [86](#), [434](#) & *n*
Curtius, E. R., [229](#), [281n](#), [324](#)
Cusanus, *see* Nicholas Cusanus
Cybele, [34n](#)
cynicism, [474](#), [476](#), [495](#)
Cynosura, [148](#), [149](#)
Cyprus, [306n](#)
Cyranides, [292n](#), [391n](#)
Cyril of Jerusalem, [38n](#), [71n](#), [236](#), [336](#)
Cytherean stone, [304](#)

D

daemon(s), [8n](#), [196](#)
Dale, Anthony van, [408n](#)
Damascius, [403](#)
Daniel, [434](#), [442](#)
Daniel, Apocalypse of, [18n](#)
Daniel, Book of, [207n](#), [236n](#), [279](#), [434n](#), [450n](#)
Dante, [351](#)

darkness, 168, 187, 229, 248, 255
day, one, 337, 338, 504f; see also *filius unius diei*
dealbatio, 189, 239; see also *albedo*
De alchemia, see Geber and “*Tabula smaragdina*”
“*De arte chymica*,” 46n, 99f, 118n, 185n, 222n, 440n, 512n
death: actual, 474
 moon and, 27
 voluntary, 473
decapitation, see beheading
De chemia, see Senior
Dee, John, 4n, 45, 144n, 382
De Gubernatis, Angelo, 291
dei infernales, 175
Delatte, Louis, 159n, 292, 391n
Delos, 203
Delphinas, 18
deluge, see flood
demiurge, Gnostic, 371n
Democritus/Demokritus (pseudo-), 47, 262, 467n
 axiom of, 29, 79, 115n, 119n, 264
denarius, see ten
Denderah, 342
deposition fidei, 523
“*De promissionibus*,” 343
depth(s), 333, 505
descent, see ascent
desiccation, 204
desire, 144
D’Espagnet, Jean, 131n, 154n, 157n, 163, 302n, 356n
“*De sulphure*,” 88n, 111n, 113n, 114, 115, 121n, 158n, 459; see also Sendivogius
Deus terrestris/terrenus, 475, 546
Deussen, Paul, 109n, 415n
Deuteronomy, 354n, 447
devil, 30, 38f, 79, 93, 104, 117, 119, 125f, 186f, 196, 198, 289, 306, 341, 436n, 451,
 510, 550

Adam and, 387, 409
as binarius, 187, 188, 387
in Christianity, 125, 187f
death and, 341
dragon and, 185
as dream symbol, 116n
four-horned, 188, 353
in Old Testament, 197
one-footed, 510
pacts with, 485, 492f
raven and, 521
spirit of alchemy as, 196
and sulphur, *see* sulphur; as theriomorphic symbol, 125, 185, 187, 306, 332, 341, 511, 521

dew, 19, 33, 40, 47, 492
 moon and, 131f; *see also* rosemary

Diana, 116n, 121, 134n, 158, 159n, 163f, 168, 269
 doves of, 155, 157, 158f, 298, 299
 grove of, 155; *see also* Astarte; Artemis

“Dicta Alani,” 269
“Dicta Belini,” 21n, 138f, 141, 175n

Diels, Hermann, 71n

differences, numerical, 414n

Diodorus, 20n, 53n, 63n, 283n

Dionysius the Areopagite (pseudo-), 393–395n, 451

Dionysus, 259n, 273, 282, 307, 409

Dioscorides, 133n, 134n, 479n, 480n

directions, four, 3, 195, 210, 388

Dirr, Adolf, 209n, 212n

disappointment, 248

dismemberment, 63, 150, 175n, 188, 259n, 269, 350, 353f, 422; *see also* King

“Dispute between Mary and the Cross,” 33

dissociation: of personality, 471
 psychic, 353

distillation, circular, 227

distractio, 471, 474n

divisio, 353

Djabir, 60n; *see also* Geber; Jabir

doctor, and the individual, 105

Doelger, Franz Josef, 199n, 510n

dog(s), 5, 28n, 32, 144, 146ff

Coetanean, 147

Corascene, 34, 144n, 147, 155

Indian, 147n

lion and, 297f

rabid, 131, 155

as symbol, 146–47n

dogma: alchemy and, 309, *see also* alchemy

becomes soulless, 347

development of, 523f, 545

and psyche, 347f, 454

and symbols, 468

dog's mercury, *see* Mercurialis

Dog-star, *see* Cynosura

Domina, 22

dominants of consciousness, *see* consciousness

Dorn, Gerhard, 17, 99, 119, 120, 143, 187f, 221, 222n, 223, 270n, 291, 348, 315ff, 383n, 448n, 463, 465, 467, 469ff, 473, 475ff, 482ff, 489ff, 493, 499, 503, 513f, 517, 519ff, 525f, 529, 532, 533ff

“Congeries Paracelsicae...,” 15n, 16, 40n, 48, 113n, 133, 153n, 176, 221n, 290n, 305n, 382n, 399n, 407n, 461n, 490

“De tenebris contra naturam,” 8n, 34, 113, 188n, 353n, 387n

“Duellum animi cum corpore,” 387n

“Philosophia chemica,” 95n, 114n, 271, 287

“Philosophia meditativa,” 54, 96n, 460n, 465n, 471n, 475n, 476n, 485, 487n

“Physica genesis,” 39n, 46, 130n

“Physica Trismegisti,” 10n, 51, 64n, 71n, 94n, 113n, 129n, 130n, 176n, 220f, 223n, 224n, 352n, 375n, 461n, 462

“Physica Trithemii,” 221n, 271

“Speculativa philosophia,” 13n, 41, 55n, 95n, 96n, 99n, 106, 153n, 221, 229, 235n,
251, 270, 271, 278n, 293n, 298n, 309n, 352n, 514

doubt, 188, 234, 270

and belief, 454

dove(s), 69n, 76, 169, 261

of Diana, *see* Diana

Noah's, 433

dragon, 21, 78, 117, 119, 141f, 144, 149, 160, 187, 205, 210, 220, 223f, 226, 295, 335,
343, 350, 383, 400, 460n, 470, 531

alchemical synonyms for, 251

apocalyptic, 205

Babylonian, 117, 298

blood of, 302

crowned, 334

dismemberment of, 21, 132, 188, 350

earth, 189, 191

fiery, 37, 441

as *filius macrocosmi*, 118

as forerunner of self, 224

head/tail of, 116ff, 191, 298, 350n

as instinctual psyche, 384

mechanical, 343

moon and, 132

nigredo as, 515

opposites, 5, 117, 223, 230

and salt, 191

seven-headed, 304

sister of, 78

and sulphur, 112

winged and wingless, 5, 116f; *see also* serpent; snake; uroboros

drawings, of analysands, 248, 532f

dream(s), 152, 229, 249, 324, 327, 358f, 416, 468, 518, 526

and active imagination, 495f, 498

analysis of, 160, 209, 229, 300, 494, 528, 540

ascent and descent in, 223

colour in, 248
compensatory meaning in, 103, 309
complementary character of, 103
and conscious personality, 357
contamination in, 417, 462f
distortions in, 324
interpretation of, 540
and myth, 293n, 518
numinous, 177, 255
and outline of individuation process, 451
portrayal of ego-complex in, 358
as product of anima, 308
quaternity in, 203
salt in, 245
symbols, 107, 245, 390
—, of self in, 123, 214n, 390
—, of unity in, 222
EXAMPLES: of white and black magicians, 74, 507n
of copulating snakes, 76n
of transformation of black bird into white, 77
of hunt, 116n
of copulating dogs, 149
Drexelius, Hieremias, 65n
Drivaltigkeitsbuch, 31n
drives, 417
dropsy, 268, 269
dryads, 68f
dualism, 39
duality, psychic, 97
Du Cange, Charles du Fresne, 17n, 133n, 235n, 500n
Du Fresnoy, Lenglet, 150n, 362
du Perron, Anquetil, 517
duplication, in alchemy, 458
dust, 386, 388

dwarf(s), 301, 400

E

eagle, 4, 31n, 144, 148, 155, 295, 304, 323n, 342n, 445

of brass, 237n

earth, 4f, 262, 386, 392, 459

and Adam, 385ff

as arcane substance, 296, 440

“black,” 156, 204, 379n, 486n, 508f, 512f

as centre/centre of, 195, 220, 240, 403

“fatness”

of, 112

and fire, 440f, 446

feminine/maternal meaning of, 130, 412, 416, 420, 423, 438n, 446, 452

and moon, 130, 144, 439n

moon-earth/*terra alba*, 130f, 204, 435, 438

paradox, 310

represented by toad, 4

virginal, 31

watery nature of, 509; see also *terra*

earthquake, 171, 337

Easter, 512

Easter Day, 337f

Easter Even, 52n

Ebionites, 102n, 104n, 511

Ecbatana, 403

Ecclesia, 371, see also Church; *spiritual*, 12, 13, 16, 30, 35

Ecclesiasticus, Book of, 25, 202n, 270n, 272n

Eckert, E. E., 18n

Eckhart, Meister, 48, 87f, 201, 202n, 282, 318, 320, 335n, 549

eclipse, 27f, 30, 33

Edda, 341

Edem, 122, 435n

Eden, Garden of, 210

Edfu, 269

Edom, [290n](#)
education, [163](#)
egg, [45ff](#), [152n](#)
 philosophical, [516](#)
 silver, [516](#); *see also* world-egg
ego/ego-consciousness, [6](#), [107ff](#), [122f](#), [162](#), [205](#), [349n](#), [357f](#), [367](#), [379](#), [380](#), [453](#), [494](#),
[545f](#)
 and consciousness, [109n](#), [368](#)
 Eastern view of, [109](#)
 ego-complex, consciousness and, [53](#)
 female, and anima, [426](#)
 God and, [109f](#), [170](#)
 hybris of, [546](#)
 hypertrophy of, [2n](#)
 male, and animus, [426](#)
 and non-ego, [171](#), [369](#)
 relativization of, [358](#)
 and self, [110](#), [155](#), [214](#), [271n](#), [370f](#), [493f](#), [499](#), [534](#), [545ff](#)
 and shadow, [167f](#), [233](#)
 and time and space, [300](#)
 and unconscious, [234](#), [371](#), [426](#), [546](#)
 and will, [365](#), [370f](#)
Egypt, [8n](#), [30](#), [33n](#), [40n](#), [52n](#), [217](#), [237](#)
 decline of civilization, [523](#)
 kingship in, [259ff](#)
Egyptians, and sea, [193](#), [199](#)
Egyptians, Gospel according to the, [24n](#), [374](#)
Eidolos, [511](#)
eight, the number, [400ff](#), [445](#); *see also* Christ; octave; ogdoad; prophets
Eisler, Robert, [19n](#), [20n](#), [129n](#), [130n](#), [157n](#), [423–24n](#)
Elbo Interfactor, [235](#)
El-chai, [442n](#)
Eleazar, Abraham, [49f](#), [157](#), [251](#), [298n](#), [350n](#), [375n](#), [379](#), [410f](#), [415ff](#), [420](#), [421n](#), [432n](#),
[440ff](#), [446](#), [451](#), [506n](#); *see also* Abraham the Jew
elements: combination and dissolution, [460](#)

five, 322
four, 3, 7, 10, 45, 49, 67, 89, 120, 202, 203, 205, 210, 219, 221, 253, 262, 273n,
287n, 322, 385ff, 397n, 421f, 459f, 505
psychic and somatic, ion
Eleusis, 511n
“El-Habib, Book of,” 512n
Eliade, Mircea, 4n, 41n
Eliezer, Rabbi, see *Pirke de Rabbi Eliezer*
elixir (of life), 20, 21, 55, 318
Elizabeth, St., 307
Elkesaites, 456n
emotionality, 295, 297
Emperor/Empress, 4
 Roman, 258
empiricism, 146
enantiodromia, 334
enchanter’s nightshade, 490
Endymion, 159
Engonasi, 351n
Enlightenment, 124, 362
enmity, male/female, 89
Ennoia, 136f
Enoch, 8n, 398n
Enoch, Book of, 166n, 492n
En Soph, 412, 414, 416
entelechy, 96
Ephesians, Epistle to the, 13f, 15, 170, 337, 344, 415, 505n, 539n
Ephesus, Council of, 523n
Ephraem Syrus, 10n, 36, 102n, 281, 394n
Epicurus, 53
Epinoia, 136f, 140, 143
Eiphanius, 8n, 20, 37n, 38, 39n, 67n, 102n, 104n, 215n, 333, 334, 338, 343, 456n,
505n, 511n
“Epistola ad Hermannum,” 40n, 112n, 140n, 340n, 448
Erataoth, 402

Erechtheus, [340n](#)
Erman, Adolf, [19n](#)
Eros, [85](#), [116](#), [179ff](#), [241](#), [248](#), [466](#)
Erythia, [455](#)
Erythraean Sea, [210](#); *see also* Red Sea
Esdras II, [45n](#)
Esenephys, [237](#)
état prélogique, [250n](#)
Ethiopian, [38](#), [39n](#), [513](#); *see also* Aithiops
Eucharist, [307](#)
Eucherius, St. [125](#), [511n](#)
Euchites, [104n](#)
Europa, [78](#)
Eusebius, [212](#), [262n](#)
Euthymius Zigabenos, [409n](#)
evangelists, emblems of, [206](#), [324](#), Pls. [1](#), [2](#)
evaporation, [204](#), [238](#)
Eve, [41](#), [89](#), [257n](#), [382](#), [387](#), [408](#), [455](#)
 Adam and, *see* Adam and Eve
 children of, [388](#)
 creation of, [405](#)
 dark, [428](#)
 as earth, [382](#)
 parallels of, in Glauber, [184n](#), [240n](#), [407](#)
 and the Shulamite, [412](#)
 sin of, [412](#), [420](#), [423](#)
evil, [39](#), [79](#), [168](#)
 integration of, [451](#); *see also* good and evil; *privatio boni*
executioner, black, [513](#)
“Exercitationes in Turbam,” [101](#), [145n](#), [356n](#), [459n](#), [460n](#), [462n](#)
Exodus, the, [421](#)
Exodus, Book of, [354n](#), [449](#)
exogamy, [466n](#)
extractio, [491](#)

extra-sensory perception, *see* Rhine, J. B.

eye(s), [31f](#), [51ff](#), [207f](#), Pls. [8](#), [9](#)

in alchemy, [286](#)

of God, [51ff](#)

multiple, [207](#), [437n](#)

of the world, [97n](#); *see also* fishes'

eyes

eye-salve, [479n](#)

Ezekiel, Book of, [413](#), [442](#), [449](#)

Ezekiel, vision of, [206ff](#), [215](#), [442](#)

F

faith: and knowledge, [127](#)

return to, [528](#)

Fall, the, [170](#), [406](#)

fantasy(-ies), [209](#), [229](#), [249](#), [518](#)

and active imagination, [495](#), [526](#), [528f](#)

alchemical procedures as product of, [482f](#)

incestuous, [300](#)

lack of, [160](#)

modern, [518](#), [587f](#)

as prima materia, [528](#)

as product of anima, [308](#)

projection of, [487](#)

waking, [468](#)

wish-, [472](#)

Father, the, [102](#)

of All, [11](#)

father-imago, [182](#)

Father-Mother, Gnostic, [177](#), [338n](#)

Fathers, Church, [326](#)

Faust, *see* Goethe

feathers, [445](#)

feeling: differentiation of, [248](#)

function of, [246](#), [248](#)

Feminine, Eternal, [357](#)
Ferguson, John, [33n](#), [59n](#)
Fernandus, [169n](#)
fever, quartan, [28](#)
Ficinus, Marsilius, [52](#), [396](#)
Fierz-David, L., [224n](#)
Figulus, Benedictus, [303n](#), [306n](#)
Fiji, kingship in, [259n](#)
filia mystica, see *soror mystica*
filius macrocosmi/mundi majoris, [21](#), [103](#), [118](#), [127](#), [137](#), [187](#), [265](#), [279](#), [305](#), [329](#), [491](#),
[494](#)
filius philosophorum, [9](#), [18](#), [41](#), [62](#), [104n](#), [149](#), [219](#)
 as Anthropos, [228](#), [346](#)
filius regius, [104](#), [157](#), [291](#), [307](#), [317](#), [327](#), [335](#), [337](#), [346f](#), [360f](#), [371](#), [384](#)
filius unius diei, [144n](#), [335](#), [338](#), [504](#)
fimarium, [202n](#)
fire, [46f](#), [441f](#), [459](#)
 central, [441](#)
 consecration of, [52n](#)
 four kinds, [184n](#)
 and salt, [239](#)
Firmicus Maternus, [20](#), [52](#), [60n](#), [64n](#), [130n](#), [259n](#), [439n](#), [509](#)
fishes, [5](#)
 fishes' eyes, [51](#), [53](#), [64](#), [254n](#), [255](#), [528](#)
five, [194f](#)
Flamel, Nicolas, [50n](#), [52](#), [117n](#), [153n](#), [295n](#), [298](#), [303](#), [410](#), [506](#)
flesh, [15](#), [153n](#), [263](#)
flood, the, [205](#), [388](#), [399](#), [421](#)
flowers, see quaternity
Flritis, [193n](#)
foetus spagyricus, [221](#), [315](#)
“Fons chymicae veritatis,” see Philalethes
foot, [509n](#)
ford, meeting at, [226](#)
forest, [5](#)

form and matter, union, 458
forty, the number, 73n, 353f, 512
fountain: Mercurial, 12, 30
 tree and, 70
four, the number, 389, 422
 and monad, 221; *see also* animals; colours; continents; directions; functions;
 metals; quaternio; rivers
fourteen, 260
“Fragment from the Persian Philosophers,” 176f
France, alchemy in, 362
France, Anatole, 180
Franz, Marie-Louise von, vi, xv n, xv n, 4n, 9n, 31n, 39n, 50n, 510n, 534n
Frazer, Sir J. G., 259n, 266n, 358n
Freemasons, 18n
Free Spirit movement, 452
French Revolution, 253, 362
Freud, Sigmund/Freudians, 86, 91, 253, 256, 365n, 443n; 473, 520
 and transference, 527
Friday, 388
Frobenius, Leo, 211n
functions, four psychic, 203, 205, 207ff, 389
 inferior, 199, 208, 210, 213, 217
 and colours, 287; *see also* feeling; transcendent function

G

Gabbatha, 389
Gabir ibn Hayyan, 385
Gabricus/Gabritius, 4, 19, 21n, 23n, 30, 38, 60, 63, 153, 236n, 283, 299, 383
Gabriel, 398, 402, 406
Gaia, 515
Galatians, Epistle to the, 369
Galen, 80n, 132, 133
“gamonymus,” 465, 485
Garlandus, 240n
Garnerus de Sancto Victore, 53n

Gayomart, [40n](#), [347](#), [387n](#), [407](#), [414](#)
Geber, [112n](#), [150](#), [235n](#), [385](#), [441n](#), [501](#); *see also* Djabir
Geburah, [442n](#)
Geffcken, Johannes, [212n](#)
Gehenna, [442n](#)
Gemini, [176](#)
Gemma gemmarum, [116n](#)
gems, Gnostic, [8n](#), [9](#)
Genesis, Book of, [34](#), [73n](#), [77](#), [89](#), [108n](#), [143](#), [158](#), [169](#), [288](#), [338](#), [354n](#), [385](#), [396](#), [404](#),
[405](#), [433n](#), [435](#), [504](#), [509](#), [537](#)
Genza, [394n](#)
Geoffrey of Monmouth, [266n](#)
geomancy, [494n](#)
Georgian fairytale, [209](#)
Gerbert, *see* Sylvester II
Geryon, [455f](#)
Gevartius, Johannes Casparius, [66](#), [85](#)
Ghazali, [407n](#)
Gikatila, Joseph, [25n](#), [135n](#)
glass, [239](#), [296n](#)
Glauber, Johann Rudolf, [115n](#), [184](#), [185](#), [190](#), [239](#), [240](#), [241](#), [246](#), [407](#)
“Gloria mundi,” [43n](#), [129n](#), [131n](#), [140n](#), [177n](#), [190n](#), [191n](#), [197](#), [201n](#), [238](#), [240](#), [245](#),
[250](#), [252](#), [286n](#), [296](#), [307n](#), [383](#), [398](#), [439n](#)
Gnosius, Dominicus, [16n](#)
Gnosticism/Gnostics, [11](#), [48n](#), [53](#), [102](#), [103](#), [117](#), [177](#), [188](#), [199](#), [218](#), [243](#), [263f](#), [312](#),
[325n](#), [348](#), [373](#), [397n](#), [403n](#), [408f](#), [436n](#), [437](#), [450](#), [462](#), [490](#), [492](#)
goat: blood of, [73](#)
 one-footed, [516n](#)
God/god(s), [119](#)
 “accursed,” [402](#)
 aging of, [281f](#), [367](#)
 in alchemy, [279f](#)
 and animal, [417](#)
 as “best man,” [384](#)
 birth of, in man, [318](#)

concept of, and quaternity, 208
—, its relativity, 104
of destruction and salvation, 199, 209
eating, 30
and ego, 109f, 170, 215, 546
evolution of idea of, 367
experience of, 215
eyes of, 51ff
in Ezekiel's vision, 208
Father and Son, 281
hierosgamos of, 91, 301, 485
image of/*imago Dei*, 117, 310, 397, 478, 494, 499, 505, 517, 525, 539, 551
Indian snake-shaped, 205
king as, 259ff
knowledge of/*cognitio Dei*, 221n, 271, 456, 460, 481
lapis as, 422, 447
of love, 281, 361, 548
male and female in, 440n
in matter, 280, 537
metaphysical picture of, 548
of Old Testament, 280f, 361, 548
omnipotence of 550
point as symbol of, 47
presence of, 280, 288
proofs of, 550
renewal of, 282, 367, 368
—, archetype of, 281
sacrificed, 372
self and, 108n, 208, 390, 499, 546
as senex and puer, 361
son of, 30, 265, 494
—, archetype of, 523
as sphere, 47
as spirit, 12f, 47

as symbol of wholeness, 207
terrestris/terrenus, 475, 546
transformation of, 374f
as transformative substance, 280
as “uncreated,” 218, 222n, 451, 553
unio mentalis in, 470,
validity of statements about, 551
varying conceptions of, 548

goddesses: black, 420
 mother-, 157n, 523

Godefridus, 69n, 514n

God-Man, 265, 523
 King as, 259, 260f
 Mercurius as, 30

Goethe, J. W. von, 40n, 77, 96, 149, 161n, 162, 166, 177n, 212, 239, 244, 301, 330,
 351, 355, 360, 380n, 453, 461, 467n, 525, 554

Goetz, Bruno, 301n

gold, 9, 22, 47f, 195, 227, 261ff, 479n, 501, 506, 508, 516, 517
 aurum nostrum, 432, 449, 458
 aurum philosophorum, 4n, 9
 aurum potabile, 490
 aurum vulgi, 45, 458
 as colour, 287, 292n, 433f, 446, 509, 530
 dissolving, 304
 as goal of opus, 90, 106, 319, 457
 and head, 436n, *see also* head, golden
 and king, 262f, 264, 332, 506, 517
 philosophical, 48, 263
 production/generation of, 47, 93, 94n, 95, 234, 481
 as quaternity, 47, 392, 490
 and silver, 15n, 51, 154, 219, 236, 262n, 376, 392, 501, 514n
 and sulphur, 111
 as sun/Sol, 92f, 99, 111f, 392, 404, 423

Goldschmidt, Adolph, 373n

Golgotha, 388, 389, 456n

good and evil, [3](#), [7](#), [79](#), [166](#), [167](#), [169f](#), [182f](#), [196f](#), [251](#), [256](#), [473](#), [550](#)

Goodenough, Erwin R., [9n](#), [238n](#)

goose, [510n](#)

gospels, Brant and the, [324f](#)

Gourmont, Rémy de, [511n](#)

Grail, legend of, [159n](#), [266n](#), [274](#), [280](#)

grana, [478f](#)

Grasseus, Johannes, [245](#), [252](#), [377](#), [480n](#)

Gratarolus, Gulielmus, [17n](#), [18n](#) [211n](#),

graves, stench of, [461n](#), [492](#)

Greek Orthodox Church, [440](#)

green/greenness, [113](#), [116n](#), [288n](#), [289](#), [432](#)

Gregory the Great, St., [22](#), [147n](#), [154n](#), [185n](#), [198](#), [377n](#), [404](#), [405](#), [449](#), [450n](#)

Grenfell, B. P., and Hunt, A. S., [372n](#)

Greverus, Jodocus, [439n](#), [440n](#)

Grill, Julius, [517n](#)

Grimm, Brothers, [72](#), [304n](#), [341n](#), [387](#), [401](#)

group analysis, [106n](#)

growth, power of, [95](#)

Gruenbaum, Max, [406n](#)

Grunwald, Max, [399n](#)

guilt, [364](#)

Gurney, O. R., [536n](#)

Güterbock, Hans Gustav, [536n](#)

H

“Habib, Book al-,” [15n](#)

Hades, [236](#)

Haggadah, [406](#), [410n](#)

hair, curly, *see* curly

Hali, [147](#)

Haller, Max, [32n](#)

hamadryads, [68](#), [78n](#)

Hamburger, Jacob, [135n](#)

Harding, M. Esther, [175n](#)

harlot, sacred, [423](#)
Harmonia, [78ff](#)
Harnack, Adolf, [367](#)
Harpocrates, [282](#), [509](#)
Harranites, [5n](#), [138](#), [139](#), [142](#), [149](#), [297n](#), [434](#)
Harus, [407f](#)
Hastings, James, [20n](#), [23n](#), [400n](#)
Hathor, [261](#)
 temple of, [342](#)
Havilah, [286](#)
he (Hebrew letter), [429f](#)
head: golden, [434f](#), [446](#), [513](#)
 inwards of the, [422f](#), [435](#)
 magic, [513f](#)
 oracular, [434](#), [485n](#)
heating, four degrees of, [6f](#)
heaven, [220ff](#), [388](#), [400](#), [419](#), [478ff](#), [487](#), [535](#)
 bird of Hermes as, [510](#)
 eye as, [52f](#)
 female aspect of, [377](#)
 “higher”
 and “lower,” [478](#)
 “inner,” [531](#)
 the One as, [515](#); see also *caelum*
Hebrews, Epistle to the, [345](#)
Hebron, [389n](#), [398](#)
Heb-Sed, see Sed festival
Hecate, [28n](#), [32](#), [146n](#), [175](#)
Hegemonius, [7n](#), [37n](#), [40n](#), [41](#), [72n](#), [76n](#), [132n](#), [140n](#), [322](#), [395](#)
Heiler, Friedrich, [469n](#)
Heimarmene, [7](#), [9](#), [230](#)
Held, Hans Ludwig, [33n](#)
Helen (companion of Simon Magus), [136](#), [153n](#)
Heliodorus, [9n](#), [18](#), [21n](#), [50n](#)

Heliopolis, 213

Helios, 146, 159, 177, 237, 297, 357; *see also* Sol; Sun

hell: Christ's descent to, 337

 alchemists and, 211

 serpent and, 341

Hellwig, Christoph von, 486*n*

Helvetius, 449*n*

Henry III of France, 24*n*

Hera, 284, 455

Heracles, 140, 284, 455

Heraclitus, 48, 162*n*, 195, 358

heredity, 230

hermaphrodite / hermaphroditism, 30, 59*f*, 81*f*, 137*n*, 141, 151*n*, 180, 286, 288, 304, 371, 422, 448, 458, 539

 aspect of arcane substance, 164, 335

 epigram of the, 81*f*

 infant/child, 34, 155

 of nature, 335, 338

 statue of, 76*n*, 373*n*

 two-headed, 15; *see also* androgyne

Hermas, Shepherd of, 15, 226*ff*, 539

hermeneutics, 336*n*

Hermes, 8, 9, 17, 18, 20, 31, 45, 53, 98, 140, 184*n*, 196, 227, 235*n*, 339, 342, 387, 392, 484, 509

 bird of, 9, 46, 194*f*, 288, 445, 510

 bronze of, 296*n*

 ithyphallic/Ithyphallikos, 78, 409, 484

 Kadmilos, 78*n*

 Kriophoros, 228

 Kyllenios, 117, 304, 437, 442, 484

 the mystagogue, 70

 serpent of, 202, 340

 tomb of, 64

Hermes Trismegistos, 233, 234, 304, 391, 398, 435, 492*n*

 Mercurius as, 226*f*

statue of, [391](#)

tradition of, [504](#)

“Tractatus Aureus” of, in *Ars chemica*, [15ff](#), [43n](#), [98n](#), [99n](#), [269n](#), [327](#), [350](#), [355](#), [511n](#)

—, in *Bibliotheca chemica curiosa* (scholia), [11](#) & *n*

—, in *Musaeum hermeticum*, [42n](#), [44](#), [92n](#), [111nn](#), [112](#), [113](#), [190n](#), [190n](#), [245n](#), [302](#), [330n](#), [378f](#), [458nn](#)

—, in *Theatrum chemicum*, [16n](#), [48n](#), [512n](#); see also “Tabula smaragdina”

Hermogenes, [39n](#)

hero: birth of, [439n](#)

and dragon, [531](#)

journey of, [226](#)

as snake, [340](#)

in whale’s belly, [204](#), [210f](#)

Herodotus, [7n](#), [403](#)

Herrera, see *Irra*

Herzog and Hauck, [337n](#), [412n](#), [440n](#)

Hesperides, [78n](#)

Hierapolis, [492n](#)

hierosgamos, [25](#), [170](#), [266](#), [301](#), [384](#), [433](#), [466](#), [469f](#)

archetypal, [467](#)

in Cabala, [23f](#), [396](#)

in the earth, [130](#)

Egyptian, [33n](#)

eye and, [33n](#)

of gods, [33n](#), [91](#), [301](#), [485](#)

incestuous nature of, [91](#), [150](#), [466](#)

of substances, [299](#)

of Sun and Mercurius, [100](#)

of sun and moon, see *coniunctio*

in water, [269](#)

Hilary, St., [36](#), [198](#), [243](#), [513](#)

Hildegard of Bingen, St., [511n](#)

Hilka, Alfons, [133n](#)

Himavat/Himalaya, [431](#)

Hindu philosophy, [82](#); *see also* Upanishads; Vedas

Hinduism, [370](#)

Hippolytus, [20n](#), [34n](#), [44](#), [48](#), [49n](#), [53n](#), [56n](#), [63n](#), [67n](#), [76n](#), [104n](#), [123](#), [136](#), [148](#), [149](#), [160n](#), [177n](#), [199n](#), [209](#), [242](#), [244f](#), [252n](#), [257n](#), [286](#), [291n](#), [342n](#), [343](#), [346](#), [351n](#), [374n](#), [394n](#), [397n](#), [407](#), [409n](#), [435n](#), [437](#), [455f](#), [461n](#), [509n](#)

hiranyagarbha, [9n](#), [208](#)

Hittites, [157n](#)

Hocart, A. M., [259f](#)

Hoffmann, E. T. A., [181](#)

Hoghelande, Theobald de, [64n](#), [93n](#), [113n](#), [119n](#), [263n](#), [285n](#), [286](#), [297](#), [376n](#), [383n](#), [511n](#), [512n](#)

Hokhmah, [430n](#), [450n](#)

Hölderlin, Friedrich, [222](#)

Hollandus, Isaac, [156n](#), [189](#)

Holmyard, E. J., [7n](#), [9n](#); *see also* Abu'l-Qasim

Holobolus, [83n](#)

Holy Ghost, [30](#), [53](#), [169](#), [195f](#), [197](#), [261](#), [288](#), [289](#), [312](#), [318](#), [346](#), [367n](#), [375f](#), [452](#), [468](#), [492](#)

as eye, [102](#)

kingdom of, [30](#)

Mercurius and, [16](#)

Movement, [30](#)

religion of, [216n](#), [375](#), [452](#)

sevenfold, [404](#)

smell of, [312](#), [461](#), [492](#); *see also* Paraclete

Homer, [99n](#)

Iliad, [23n](#), [44n](#), [146n](#)

Odyssey, [73n](#)

homo maximus, [400](#), [409](#), [413](#), [420](#)

homunculus, [272](#), [301](#), [313](#), [319](#), [348](#), [385](#), [491](#), [525](#), [539](#)

hermaphroditic, [491](#)

honey, [479](#), [483](#), [490](#), [493](#)

Honorius of Autun, [13n](#), [31](#), [32](#), [33n](#), [100n](#), [159n](#), [199](#), [206](#), [290n](#), [298](#), [307](#), [341n](#), [343n](#), [378](#), [379](#), [515n](#)

Horace, [62n](#), [213n](#)

Horapollo, [147n](#), [336](#), [500n](#)
hormones, [477](#)
Horneffer, Ernst, [342n](#)
horoscope, [225](#), [230](#)
horse, belly of, [269](#)
Horus, [19n](#), [52](#), [64n](#), [259n](#), [261](#), [266n](#), [282](#)
Hosea, [201](#), [452](#)
Host, the, [446](#)
house(s), [151n](#), [152n](#)
 golden, [4](#)
 planetary, [225](#)
hsien-yên, [401](#)
Hugh of St. Victor, [384](#)
Hurrians, [536n](#)
Hurwitz, S., [23n](#), [25n](#), [413n](#), [448n](#)
Husio, G. Ph. Rodochaeus de Geleinen, [448](#)
Hussain, M. H., [72n](#), [73n](#), [75n](#), [139n](#)
Huxley, Aldous, [376n](#)
hybris, [546](#)
hydrargyrum, see quicksilver
hydrophobia, [34](#), [155](#)
hyssop, [422](#)

I

Ialdabaoth, [338](#), [402](#)
ibis, [195](#)
Ibn 'Umail al-Tamimi, [391](#)
I Ching, [182](#), [289n](#), [294](#), [445](#)
identity, unconscious, [250](#); see also *participation mystique*
Ignatius Loyola, St. [198](#), [214](#), [498](#)
ignis gehennalis, [94](#), [441](#)
illumination, three stages, [504](#)
image(s): displacement of, [293f](#)
 distortion of, [324f](#)
 and instinct, [418](#)

loss of, 362
understanding of, 529f

imagination, active, 107, 123, 248, 255, 320, 494ff, 518, 526, 528f
cathartic operation of, 496
and dream, 495, 498
masculine, 430

imago Dei, 525

imbibitio, 308

Immaculate Conception, *see* Conception, Immaculate

immortals, eight, 401

improvement, 427

Incarnation, 218, 222n, 348, 451, 553

incest, 19, 91f, 359f, 371n, 424, 466
in alchemy, 91, 424, 466
archetype of, 91, 150
brother-sister, 159, 469, 516
dream of, 149f
fantasies of, 300
regression to, 78
“royal,” 90, 299
variants of, 294

Inereatum, 39, 119, 404n

incubation, 203f

India, 109

Indian Ocean, 11

individual, 163f
doctor and, 105f

individuation, 55, 224, 264n, 381, 451, 469, 471f, 476, *et passim*
in alchemy, 381
beginning of, 529
dogma and, 454
moon prototype of, 175; *see also* wholeness

inflation, 157, 371

inspiration, 319, 551

instincts, [417f](#)
 objectification of, [471f](#)
insulin shocks, [477](#)
“Introitus apertus,” [111n](#), [157f](#), [298](#), [302](#), [303](#), [328](#), [331](#), [397](#), [438n](#), [516n](#); *see also*
 Philaletha
introversion, [204](#)
iota, *see* point
'Iraqi, al-, *see* Abu'l-Qasim
Irenaeus, [48n](#), [56n](#), [218](#), [243](#), [338n](#), [342n](#), [401](#), [403](#), [406n](#), [409n](#), [417n](#), [454n](#)
Irra, Abraham Cohen, [429](#), [430n](#)
Iris, [286](#), [288](#), [290](#)
 Junonia, [291](#)
irrationality, return of, [254](#)
Isaac, [389](#)
Isaiah, Book of, [23n](#), [51f](#), [75](#), [123](#), [131n](#), [201](#), [238n](#), [290n](#), [307n](#), [341n](#), [344](#), [447n](#), [448n](#),
 [511n](#)
Ischys, [121–22n](#)
Ishtar, [71n](#), [136](#), [157n](#), [272n](#), [302n](#), [423](#), [431n](#), [452](#)
Isidore of Seville, [146n](#), [192](#), [213n](#), [387n](#), [448n](#)
Isidore (son of Basilides), [71n](#), [280](#)
Isis, [19f](#), [21f](#), [63n](#), [237](#), [260](#), [273n](#), [290](#), [420](#), [423](#), [509](#), [511](#), [516](#)
“Isis to Horus,” [19n](#), [20](#)
isopsephia, [246n](#), [445](#)
Israel, [32](#)
Istar/Isthar, [31n](#)
Ixion, [121n](#)
Izquierdo, Sebastian, [198](#)

J

Jabir, [385n](#); *see also* Djabir
Jacob, [389](#), [396n](#)
Jacobsohn, Helmuth, [259n](#), [260n](#), [268n](#), [510n](#)
Jaffé, Aniela, [46n](#)
Jainism, [53](#)
Jalal-ud-din Rumi, [386](#)

James, M. R., [8n](#), [9n](#), [355n](#), [374n](#)
Jastrow, Morris, [32n](#)
Jean de Meung, [117n](#)
Jeans, Sir James, [538](#)
Jekyll and Hyde, [181](#)
Jeremiah, Book of, [48n](#), [198n](#)
Jeremiah ben Eleazar, [408](#)
Jericho, [27n](#)
Jerome, St., [198](#)
Jerusalem, [38](#), [48](#), [52](#), [401](#)
Jesus, [18n](#), [72n](#), [124](#), [135n](#), [166](#), [170](#), [347](#), [360](#), [361](#), [370](#), [379](#), [399](#), [456](#), [549](#)
 genealogy, [260n](#); *see also* Christ
Jews, [453](#)
jinn, [73](#)
Joachim of Flora, [30](#)
Job, Book of, [251](#), [341n](#), [354n](#), [409n](#), [433](#), [440](#), [441](#), [446](#), [447n](#), [448n](#), [546](#)
Joel (prophet), [41](#)
Joel, D. H., [135n](#)
John, St., [378](#), Pl. 1
 and salt, [246](#)
John, Acts of, *see* Acts
John, First Epistle of, [552](#)
John, Gospel of, [13n](#), [35n](#), [54n](#), [104n](#), [150n](#), [154n](#), [158n](#), [196](#), [220n](#), [221n](#), [250n](#), [254n](#),
 [277n](#), [290](#), [338](#), [343](#), [374](#), [375](#), [421n](#), [437](#), [456n](#), [471n](#)
John Chrysostom, St., [71n](#), [307](#)
John of the Cross, St., [393n](#)
John of Ruysbroeck, *see* Ruysbroeck
jot, *see* point
Joyce, James, [324f](#)
Judaea, [252f](#), [254](#)
Judges, Book of, [95n](#), [218n](#), [446n](#), [492n](#)
Julian the Apostate, [357](#)
Jung, Carl Gustav: WORKS:
 Aion, [5n](#), [30n](#), [49n](#), [54n](#), [67n](#), [79n](#), [104n](#), [106n](#), [107n](#), [151n](#), [184n](#), [188n](#), [199n](#),
 [216n](#), [240n](#), [245n](#), [251n](#), [271n](#), [272n](#), [441n](#), [454n](#), [460n](#), [484n](#), [491](#), [494n](#), [499n](#),

Alchemical Studies, 14n

“Analysis of the Associations of an Epileptic,” 208n

“Analytical Psychology and Education,” 74n

“Answer to Job,” 40n, 434n

“Archetypes of the Collective Unconscious, The,” 74n, 233n

“Brother Klaus,” 178n

“Commentary on *The Secret of the Golden Flower*,” 178n, 204n

“Concerning the Archetypes,” 106n

“Concerning Mandala Symbolism,” 195n, 204n, 401n, 463n, 494n, 503n, 532n

“Concerning Rebirth,” 387n

“Instinct and the Unconscious,” 418n

“Interpretation of Visions,” 420n

“On the Nature of Dreams,” 159n

“On the Nature of the Psyche,” 53n, 55n, 143n, 207n, 551n

“On Psychic Energy,” 95n, 426n

“Paracelsus as a Spiritual Phenomenon,” 30n, 46n, 49n, 55n, 68n, 122n, 133n, 187n, 269n, 306n, 335n, 340n, 343n, 383n, 391n, 395n, 448n, 465n, 479n, 485n, 490n

“Paracelsus the Physician,” 49n, 143n

“Phenomenology of the Spirit in Fairytales, The,” 46n, 74n, 392n, 451n, 511n

“The Philosophical Tree,” 8n, 23n, 40n, 71n, 76n, 134n, 154n, 156n, 322n

“Psychological Approach to the Dogma of the Trinity, A,” 102n, 187n, 188n, 212n, 216n, 318n

“Psychological Aspects of the Kore, The,” 88n

Psychological Types, 199n, 200n, 203n, 439n

Psychology and Alchemy, 5n, 7n, 9n, 16n, 31n, 38n, 39n, 41n, 45n, 48n, 65n, 67n, 68n, 70n, 71n, 72n, 100, 101n, 103n, 106n, 118n, 120n, 122n, 127, 133n, 134n, 140n, 141n, 142n, 187n, 193n, 203n, 204n, 207n, 212n, 214n, 215n, 216n, 223n, 229n, 254n, 258, 263n, 264, 272n, 277n, 279n, 281n, 287n, 290, 293n, 316n, 317, 320, 322n, 329, 331n, 332, 334n, 340n, 343n, 347n, 348n, 350n, 356, 358n, 359n, 379n, 381, 385n, 400n, 401, 404n, 410, 423n, 435n, 437n, 439n, 445n, 450n, 462n, 463n, 469, 475n, 478n, 484n, 491, 500n, 506n, 514n, 525

“Psychology and Religion,” 48n, 87, 188n, 215n, 216n, 240n, 318n, 363n

“Psychology of Eastern Meditation, The,” 9n

“Psychology of the Child Archetype, The,” 88n

“Psychology of the Transference, The,” 12, 32n, 77n, 81n, 147n, 153n, 160n, 219n,
258, 261n, 403n, 425, 439n, 460n, 466n, 474n

“Relations Between the Ego and the Unconscious,” 74n, 209, 496n

“Review of the Complex Theory, A,” 53n

“Spirit and Life,” 181n

“Spirit Mercurius, The,” 13n, 25n, 38n, 43n, 46n, 51n, 72n, 96n, 104n, 117n, 187n,
252n, 304n, 335, 340n, 353n, 378n, 441n, 442n, 451n, 484n

“Study in the Process of Individuation, A,” 16n, 204n, 223n, 287n, 401n, 469n, 503n,
532n

Symbols of Transformation, 204n, 341n, 343n, 405n

“Synchronicity,” 300n, 464n

“Transcendent Function, The,” 200n, 203n, 530n

“Transformation Symbolism in the Mass,” 20n, 30n, 33n, 49n, 64n, 216n, 273n,
293n, 322n, 354n, 434n, 485n

Two Essays on Analytical Psychology, 203n, 356n, 369

“Ulysses,” 325

“Visions of Zosimos, The,” 33n, 61n, 75n, 513n

Juno, 4, 68, 129n, 291

Jupiter, 176

K

ka, 259, 260, 265f

Ka’ba, 398

Kabbala denudata, see Knorr von Rosenroth

Kalid, 141n, 147, 148, 151n

Kamea, 445

ka-mutef, 259n, 260f, 265

karma, 225

katabasis, 350

Katha Upanishad, 135n

Kees, Hermann, 260n, 266n

Kékulé, Friedrich August, 81n

Kelîmath, 388

Kenesseth Israel, 25n

kenosis, 35, 36f, 170n

Kerényi, C., 21, 121n, 228n, 461, 511n, 516n

Kether, 9n, 23, 135n, 413n, 450n, 455

Khalid, *see* Kalid

Khunrath, Heinrich, 43n, 47, 55f, 119n, 133, 135, 190, 191, 192, 197, 235n, 240n, 246, 250, 262n, 264f, 277n, 287f, 296n, 302n, 304, 305, 329, 335, 337f, 354, 391, 441, 475, 493, 504n

Kiao-chau, rainmaker of, 419n

King/Rex: aging, 75, 279, 358, 370

as Anthropos, 343ff

as arcane substance, 263n, 332, 334f, 371, 506f; bath of, *see* bath

blackness/Nigredo and, 38, 508

as consciousness, 151n, 355ff, 368

cry for help of, 273n, 331, 333

dark side of, 330ff

dismemberment of, 63, 266ff, 272f

divinity of, 258ff, 367

dissolution of, 314, 359, 371, 470, 507

as gold/Sol/sun, 262ff, 308, 506, 508f, 517

insignia of, 258

as lapis, 262ff, 370

and lion/Leo, 332

of metals, *see* gold projection of, 369

and queen/Rex and Regina, 258ff, 397, 412n, 509, 513

—, as *coincidentia oppositorum*, 380

—, with dragon's tail, 350n

—, as personification of opposites, 4, 23, 92, 250

rebirth/renewal of, 70, 204n, 267, 268, 274ff, 306f, 312, 317, 322, 330f, 334, 345, 355, 358, 368, 370

—, religious problem of, 365ff

sacrifice of, 266ff, 277, 372

of the sea, 89, 331

sick, 281

as spirit, 379

sterility of, 331

theriomorphic, 297

tomb of, 64
transformation of, 265ff, 274, 283, 297
wholeness of, 279, 360

Kings (II), 22, 269

Kingsford, Anna, 178

kingship, in Egypt, 259ff

Kircher, Athanasius, 65n

Kiriath Arba', 389

Klaus, Brother, 178

Kneeler, the, 149

Knorr von Rosenroth, Christian, 18n, 22, 23n, 24n, 390n, 411ff, 429n, 430n, 442n, 443n, 445, 447, 450n

knowledge, tree of, *see* tree

Ko Hung, 400n

Koehler, Reinhold, 387n

Koepgen, Georg, 102f, 373ff

Kohen, 294n

kohl, 332

Kohut, Alexander, 386n, 398n, 406n

Komarios, 43, 60n, 76n, 236, 237, 262, 391, 511n

Kopp, Hermann, 425n

Koran, 30n, 71n, 387n

Kore, 355

Korybas, 363n, 409, 437

krater, 240n, 504

“Krates, Book of,” 304, 460

Krieg, Claus W., 400n

Kronos, 199, 237, 403, 493, 536n
tear of, 252

Kumarbi, 536n

Kundry, 252

Kybrich/Kybrius, 38

Kyllenios, *see* Hermes

Kypris, 93

L

Lacinius, Janus, *see* Bonus, Petrus

Lagneus, David, [51n](#), [149n](#), [287](#), [484](#)

Lajard, Felix, [303n](#), [304n](#)

Lamb, marriage of the, [166](#), [301](#), [371f](#), [374](#), [467](#), [528](#)

Lambspringk, [5](#), [263n](#), [295n](#), [360n](#)

Lao-tzu, [139n](#), [166](#)

lapis, [4](#), [42ff](#), [53](#), [99](#), [153n](#), [215](#), [216n](#), [371](#), [385](#), [467](#), [502](#), [526](#), *et passim*; as Adam, *see*

Adam

aethereus, [187](#)

and Anthropos, [290](#)

androgyny of, [371f](#)

as arcane substance/transforming substance, [42](#), [44](#), [240](#), [263](#), [448](#), [473](#), [532](#)

application to human body, [489](#)

bitterness of, [192f](#)

as *cervus fugitivus*, [159](#)

as child of Sol and Luna, [371](#)

as Christ, *see* Christ

colours of, [192f](#), [290f](#), [355](#)

exilis, [128](#), [274](#)

extraction of soul from, [277](#)

feminine aspect of, [157](#), [299](#)

as goal of opus, [8n](#), [372](#), [391](#), [501](#), [533](#), [535](#), [541](#)

as *homo totus*, [79](#)

as ideal for hermits, [372](#)

incorruptibility of, [80](#), [539](#)

as king's mother, [299](#)

light-nature of, [150](#)

meaning of, in alchemy, [475](#), [503](#)

—, in Cabala, [52n](#), [446f](#)

Mercurius as, [185](#), [393](#), [502](#), [505](#)

numinosity of, [532](#)

occultus, [194](#)

as old man, [10](#)

as orphan, [17](#), [37](#), [41](#)

as panacea, 318, 477, 533
paradox of, 42ff, 452
as quaternity of elements, 188
quartered, 422
and resurrection, 158n
sand as, 204
as saviour, 39, 124, 281, 317f, 475
secret of, 172, 398
as self, *see* self
as “son of man,” 222f
spirit, soul and body of, 372, 541
as symbol, 216n, 372, 454
synonyms of, 4n, 118, 262f, 290, 371, 423, 463
as tincture/medicine, 485
triunity of, 265
as union of opposites, 118, 396
unity of, 79, 153n, 222, 272, 342n, 371, 385, 540
as *unum/unus mundus*, 385, 463
volatile, 510
white stone, 239
as youth, 10, 166; *see also* stone

Larguier, Leo, 153n

Last Supper, 307, 364

lato, 235

Lauterburg, M., 337n

Lavoisier, Antoine Laurent, 124

law, tables of, 398

lead, 156, 225, 227, 335n, 351, 382, 428

Leah, 389

leap-year, 398

Lebhûdhâ, 388

Lehmann, F. R., 95n

Leibniz, G. W. von, 471

Leisegang, Hans, 15n, 348n, 402n, 403n

Lemures, [175](#), [236](#)

Lenglet du Fresnoy, *see* Du Fresnoy

Leo, *see* lion

Leone Ebreo, [53n](#)

Lesser, F. C., [18n](#)

Leto, [71n](#), [205](#)

Leviathan, [198](#), [210](#), [251](#), [401](#), [445](#)

Leviticus, Book of, [15n](#), [242n](#), [411n](#)

Lévy-Bruhl, L., [250n](#), [488](#)

Libellus Desideriorum Joannis Amati, [33n](#)

“Liber Alze,” [64n](#), [193](#)

“Liber Azoth,” *see* Paracelsus

“Liber de arte chymica,” *see* “De arte chymica”

“Liber de magni lapidis compositione,” [438n](#)

Liber mutus, *see* *Mutus liber*

“Liber Quartorum,” *see* “Platonis Liber Quartorum”

Libra, [7](#), [176](#)

Licetus, Fortunatus, [85](#)

Lidzbarski, Mark, [409n](#), [410n](#), [492n](#), [511n](#)

life-style, 365n

light, 47, 139, 338

Christ as, 338

crown of, 9

in Adam's nature, 406

Mercurius as, 504

Lilith, 122, 408

lily, 480, 485, 492

lion/Leo, 5, 28n, 32, 112n, 125, 141, 144, 147, 148, 176, 210, 297, 301ff, 332, 360n, 364, 365, 400n, 446

as allegory of Christ, 311, 324, 345n

—, of the devil, 298, 332

antiquus, 297

as arcane substance, 125, 295

in astrology, 350n; blood of, *see* blood

corruption of, 28

and dog, 297

dung of, 294n

and eagle, 323n

as evil, 117, 298

as evil passions, 160, 295

erotic aspect of, 298, 304, 310

green, 293f, 296, 304f, 323, 335, 461, 473

and lioness, 5, 295, 298

“lion-hunt”

of Marchos, 284, 298f

mutilation of, 142, 350, 364n

queen and, 311

red, 296, 335, 473

and sun, 144, 147, 297f

as synonym for Mercurius, 117, 295, 338, 461

Lippmann, Eduard von, 10n, 72n, 80n, 235n, 268n, 385n, 457, 510n

“Livre des Balances,” 406n

“Livre des Secrez de Nature,” 159n

Logos, [104](#), [179f](#)
 Christ as, [142](#), [290](#), [338](#), [361](#)
 as dog, [147n](#), [148](#), [149](#)
 ibis and, [195](#)

Lohmeyer, Ernst, [492n](#)

Lorichius, Johannes, [65](#), [82n](#)

Lot's wife, [83n](#)

love, and the unconscious, [86](#)

Loyola, *see* Ignatius

Lucian, [342n](#), [409n](#), [492n](#)

Lucifer, [118f](#), [170](#), [436n](#), [441](#), [512n](#)

“Lucius puerorum,” [64n](#)

Luke, Pl. [2](#)
 Gospel of, [12](#), [46n](#), [135n](#), [201](#), [206](#), [337](#), [344](#), [354n](#), [378](#), [471n](#)

Lully, Raymond, [76n](#), [113n](#), [119n](#), [296n](#), [329n](#), [392](#), [500n](#)

luminaries, four, [7](#)

Luna, [18](#), [25](#), [27](#), [32](#), [35ff](#), [79](#), [107](#), [116n](#), [129ff](#), [147f](#), [166](#), [168](#), [196](#), [219n](#), [247](#), [314](#),
 [355f](#), [360](#), [371](#), [376](#)
 eagle symbol of, [4](#)
 and Mercurius, [97](#), [101](#)
 mother of the sun, [177](#)
 as projection, [107](#)
 and *terra*, [438n](#); *see also* moon; opposites

Lunaria, [133ff](#)

Lunatica, [133f](#)

Luria, Isaac, [390](#), [412n](#), [413n](#), [449](#)

lux moderna, [504](#)

lye, [240](#), [486](#)

M

Mabinogion, [435n](#)

MacDonell, A. A., [135n](#), [517n](#)

Machaon, [121n](#)

Machpelah, [389](#)

Macrembolites, Eustathius, [83n](#)

Macrobius, 48n, 129n, 130, 131n, 132n, 145, 146n, 439n, 492n
macrocosm/microcosm, 265, 301
 Adam as, 409
 Saviours of, 475; see also *filius macrocosmi*
Macroprosopus, 450
Madathanus, Henricus, 18n, 50n
Madonna, tutelary, 284
Magi, 328
magic, 32, 228
 kingship and, 258
Magic Papyrus, Paris, 297n
magnesia, 240n
Magus, 51n; see also Simon Magus
Mahomet, 15n, 159n,
Maid, crowned, 322
Maier, Michael, 3n, 4, 5n, 18f, 21 & n, 37, 40n, 47, 49n, 56, 59ff, 80n, 82, 90, 97, 98,
 131, 142n, 194n, 210ff, 217, 220, 226ff, 235n, 256n, 269n, 273n, 296, 302, 331,
 332, 350n, 379n, 392, 397, 411n, 422, 437n, 448n, 445, 458n, 470n, 521
Maimonides, 398
Maitland, Edward, 178
Malachi, Book of, 100n, 276, 442n
Malchamech, 153n
Malchuth, 18n, 22f, 25, 32n, 52n, 244, 396f, 412f, 419n, 421, 443ff, 450n, 455
Mâle, Emile, 206n
malignity, of collective man, 183
Malus, 51
Malvasius, Caesar, 59, 66, 67, 74, 78ff
man: animal nature of, 405, 417
 black, 513
 in Buddhism, 370
 collective, malignity of, 183
 earthly and heavenly, 413
 empirical, 453, 536
 first / primitive / primordial, 210, 216, 241, 317, 322, 373, 388, 395, 417, 420, 423,
 424, 453f (see also Adam Kadmon; Anthropos; Purusha)

inner/spiritual, 346f, 383f, 437
—, Christ as, *see* Christ; as light-soul, 76n
likeness to God, 539
mass-man, 334
material, psychic, and pneumatic, 413, 428
medieval, 367
as microcosm, 386, 388, 534, 542
modern, self-knowledge of, 214
—, iconographic symbols of, 216n
“new,” 15
original, *see* Original Man
philosophic, 338
physical, 543
prima materia as, *see* prima materia
as single monad, 44
as son of God, 320
totality/wholeness of, 63, 127f, 188, 352, 426, 476, 534, 536, 546
true, 348f, *see also* *chên-yên*

mana, 95n, 250n
manas, 135n, 196
Manda d’Hayye, 394
Mandaeans/Mandaeism, 76n, 243, 393, 409n, 511n
mandala, 216n, 371, 388, 401, 403, 494, 544
 centre of, 463, 532
 of the elements, 322
 modern, 223n, 532f
 quaternity of, 15f, 245, 388
 as symbol of self, 324
 — of unity, 204, 222, 503, 531

mandrake/mandragora, 134
Manes, 175, 236
Manget, J. J., 159n, 362; *see also* names of separate treatises in “*Bibliotheca Chemica Curiosa*”
Mani/Manes, 18n, 37f, 395
Manichaeans/Manichaeism, 18, 28n, 36n, 37ff, 53, 67n, 79, 322, 395

marble, 75f
Marchos, 72, 284, 298, 301n
Marcus, 40n
Marcus (Gnostic), 177n
Marcus Graecus, 72n
Marez, 411n, 423
“Maria Prophetissa,” 38n
 axiom of, 67, 207, 212, 401, 429, 430, 459
marination, 189, 240, 274
Marinus, 39n
Mariyah, 73
Mark, Gospel of, 239, 242, 243, 345, 405, 549
Marquš, 298n
marriage: of Cana, 325
 chymical, 89, 283, 301, 461, 469f, 475
 class system, 426
 cross-cousin, 466n
 heavenly, 4n, 327, 372
 of the Lamb, *see* Lamb
 mystical, 90, 265, 466
 nefarious character of, 371n
 and new moon, 129
 royal/kingly, 75, 166, 300, 380f
 spagyric, 271f; *see also* coniunctio; hierosgamos
Mars, 7, 8n, 55n, 176, 217
 regimen of, 289; *see also* Ares
Martial, 86
Mary, the Virgin, 69n, 100, 169, 176, 306, 307, 322, 405, 420, 449
 coronation of, 324
 as Mediatrix, 176n, 186; *see also* Assumption; Conception, Immaculate
masculine mind, 247
massa confusa, 283, 286, 307, 385, 488, 504
mass man/masses: loss of images and, 362
 power and, 334

mass-mindedness, [13n](#), [256](#)
Masudi, [386](#)
Mater Alchimia, [18](#), [21](#), [76n](#), [269](#)
materialism, [537](#)
Mathieu de Vendôme, [81](#), [88](#)
matter: alchemists'
 view of, [250](#), [362](#)
 and form, union, [458](#)
 inertia of, [472](#)
 modern view, [502](#)
 Paracelsist view, [537](#)
 stone as, [450](#)
Matthew, Gospel of, [15](#), [56n](#), [117](#), [148n](#), [151n](#), [158n](#), [169n](#), [235f](#), [242](#), [257n](#), [260n](#), [337](#),
 [343n](#), [344](#), [352n](#), [372](#), [378](#), [405](#), [451](#), [471n](#)
Maya (Mother of the Buddha), [71n](#)
maya (illusion), [109](#)
Mead, G. R. S., [273n](#)
measurement, and science, [124](#)
Mechthild of Magdeburg, [467n](#)
Medea, [22](#)
mediator, [12](#), [13](#)
medicina, [126](#), [254](#)
medicine, spagyric, [465](#), [475f](#)
medicine man, fallible, [422n](#)
meditalito/meditation, [214](#), [234](#), [497](#)
medium, of conjunction, [461](#)
Meerpohl, Franz, [48n](#)
Mehnit, [33n](#)
Me(h)ung, *see* Jean de Meung
Meier, C. A., [77n](#), [228n](#)
Meir, Rabbi, [386](#)
Melampus, [78n](#), [509n](#)
melancholia, *see* *nigredo*
Melchizedek, [259n](#), [389](#)
Mennens, Gulielmus, [130n](#), [140n](#), [146n](#), [169n](#), [176](#), [432n](#), [441n](#)

menstruation, 174

Mephistopheles, 149

Mercurinus, 266

Mercurialis, 480, 484, 492, 494

Mercurius/Mercury, 39, 56, 96f, 131, 222, 224f, 233, 269n, 277, 304, 335, 339f, 384, 397, 501ff

and Adam, 382, 407

Agathodaimon as, 9n

ambivalence/paradox of, 25, 43f, 95, 115, 378, 459, 504

androgyny of, 16, 184f, 500n

as anima/*anima mundi*, 238, 322, 461, 490f, 525

as Anthropos, 16, 187, 216

as *aqua permanens*, 459n, 461, 491f

as arcane substance, 12, 44, 190, 231, 465

as archer, 304, 309n

as artifex, 293n

as boy, 224

and Christ, *see* Christ

concocted by sublimation, 479

as cup-bearer, 303

as “deus terrenus,” 490

as devil, 30, 185, 484

dressed as woman, 442

duplex/two-faced, 41, 75n, 79, 93, 96f, 101, 187, 295, 304, 340, 490, 506, 510

elusive/versatile, 445, 522

as flesh, 15

fountain, mercurial, 12, 30

hermaphrodite, 304, 393, 442, 459n

as Hermes Trismegistus, 226f

as Holy Ghost, 16, 30

Kyllenios, *see* Hermes Kyllenios; and lapis, *see* lapis

lily as, 485

and lion, *see* lion

lion as mount of, 304

and Luna, *see* moon

as “matrimonium,” 17
as mediator, 13, 25, 48, 459, 461, 503, 505
and metals, 501f
as microcosm, 382
moisture of, 28, 45, 479n, 484
numinosity of, 504
as the One/Oneness of, 294, 505f
in Paracelsus, 340n
personified, 216
phallic aspect of, 442
philosophorum, 510
as planet, 176, 226, 284n, 504
poisonous nature of, 93, 185, 484
as prima materia, 16, 393, 501f
psychological aspect of, 503
and quaternity, 113n, 505
as queen, 377f
as quicksilver, 490, 500
as rotundum, 140
and salt, 189ff, 238, 241
as Saviour of the macrocosm, 484
serpent of / *serpens mercurialis*, 47, 67, 101n, 185, 196, 207, 208, 253n, 257, 334, 436n, 441, 451
sign for, 4
as “son of one day,” 504f
as soul of gold and silver, 501
as spirit / nous / *spiritus Mercurii*, 13, 46, 97, 196, 231, 238, 350n, 353, 442, 461, 462, 491
as “spiritual blood,” 14
as *spiritus familiaris*, 497
statue(s) of, 210, 217, 393
as subtle thing, 352
and sulphur, 38, 303, 339
triad with sulphur and salt, 184
sword of, 61

as totality/wholeness, 16
transformations of, 295, 393, 532
as tree, 72, 444
as trickster, 248
as unconscious, 97, 378, 462, 491, 526
unicorn as, 500n
and Virgin Mary, 100f
as water, 382, 503f
white and red of, 16
and Yesod, 442ff; *see also* Anthropos; *aqua permanens*; arcane substance;
caduceus; Hermes

mercury (plant), 8n, 176

Merkabah, 206, 413n

Merlin (romance), 81

Merlin(us), 75, 266

“Merlini allegoria,” *see* “Allegoria Merlini”

mermaid, 31, 71

Meroë, 290

Merula, 292

Messiah, 23, 318, 414, 415n

metals: four, 113n
 moon and, 176
 seven, 19, 176, 392

metaphysics, 439, 455, 468, 547ff

metempsychosis, 37n

Michael, archon, 402

Michael Angelus, Marius L., 59

“Micreris, Tractatus,” 10f, 113, 120, 386, 439n, 461, 486n, 521n

microcosm, 16, 22, 39, 463, 531, 534, 539
 Adam as, 386
 man as, 388
 saviour of, 475; *see also* macrocosm/microcosm

microphysics, 538

Middle Ages, 360, 428, 488, 490
 “psychic”

in, 439
Midrash Rabbah, 407
Midrash of Ten Kings, 447n
Milan, 66
Milvescindus, 11n
Mirnefindus, 11n
mirror, and menstruating woman, 174f
miscarriage, 67
misogyny, 178
Missal, Roman, 511n
Mithraism, 141, 263, 403
Mithras, 52n
moisture, radical, 9, 47, 55, 250
mole, 156
moly, 133n, 293n, 484
Monad, 44, 45, 53, 221, 278
 Valentinian, 374n
monasticism, 90
Monday, 188
Monocalus/Monocolus, 500, 505n
Monoimos, 44f, 56
monster, and maiden, 226
moon/Luna, 9, 18, 20, 21, 35ff, 79, 101, 103, 106f, 129ff, 143ff, 147f, 193, 195f, 219n, 252, 322, 360, 371, 376
 as arcane substance, 154f
 albedo as, see *albedo*; as bitch, 32, 146
 and brain, 436
 circle of, 133, 140, 172
 coniunctio at new, 220, 315
 corruptibility of, 28
 day of, 188
 eagle as symbol of, 4
 and earth/“funnel of the earth,” 129f, 144, 146f, 438n, 439
 as eye, 32
 as female consciousness, 135, 180, 247

female/maternal aspect of, 50, 116n, 142, 144, 175ff, 247, 314f, 355f
and fertility, 438n, 452
in folklore, 173
full, 31
— and waning, 173ff
meaning of, 154ff
as mediatrix, 25, 29, 131
and Mercurius, 25, 97, 101, 131f, 140, 142
nature of, 173ff
as nymph of spring, 166
as préfiguration of self, 175
as projection, 107
psychology of, 178ff
as rotundum, 356f
and Saturn, as 434
and sea, 134n, 191f
Shulamite as, 434
as silver, 130, 176, 392
and sun, *see* sun
and three, 392
as type of man, 396n
as unconscious, 26n, 135, 144, 177f, 184, 2n, 356
unfavourable/dangerous aspect of, 25ff, 29ff, 32, 121n, 144f, 155, 168, 171, 173,
175, 315
and Venus, in zodiac, 7, 144
as vessel, 129, 130n, 176
moonlight, 356
moon-plant, 132ff, 184n
moon-sickness, 156n, 173
Moor, the, 513
Moors, King of the, 305
morality, adept and, 475
Moret, Alexandre, 266n, 268, 273n
Moriah, 447n
Morienus Romanus, 51, 64n, 112n, 194, 236n, 252n, 254n, 296n, 350n, 365n, 374f, 521

Morris, Richard, 33n
mortificatio, 141f, 197, 293n, 353
Moses, 277, 400n
Moses quaternio, 188
mother, 307ff, 322
 in *Cantilena*, 276, 278, 284f, 292f, 314f
 chaos as, 302
 divine, 261
 —, cult of, 361
 eighth as, 404
 as female aspect of father-son, 294
 nourishing, 276
 as prima materia, 21, 307
 renewal through, 291ff
 and son, 18ff, 150, 301, 316, 423f, 458
 of sulphur, 115
 tree as, *see* tree
 virgin as, 60
 “water”
 as, 21, 314
mother-goddess: Hittite, 157n
 Mary as, 523
Mothers, the (*Faust*), 360
mountains, 431
 of knowledge, 462n
Mueller, Ernst, 4n, 413n
Muhammad ibn Ishak al-Nadim, 485n
Muhammad ibn Umail, 5n; *see also* Senior
multiplicado, 329–307n
multiplicity, 462
mumia, 391
mummies, 391
“mundus archetypus,” 534
Murmelstein, Benjamin, 409n, 448n

Musaeum hermeticum, see Waite; also names of individual treatises

music: and alchemy, 80n

and individuation, 530

Mutus Liber, 153n, 154n, 315

Mylius, Johann Daniel, 6, 7n, 15n, 18n, 28n, 43n, 46, 51n, 55n, 60n, 75n, 76n, 93n, 97n, 98n, 99n, 111n, 112n, 113, 115n, 118, 120, 134n, 138, 140n, 141n, 153n, 185n, 189, 191, 192, 193, 194n, 215n, 222, 235n, 239n, 251, 263n, 286, 293n, 295n, 296n, 304n, 307n, 322n, 338, 330n, 377n, 386n, 394, 397n, 432, 439n, 449n, 461n, 504n, 511n, 512n, 513

Mysteries, 232, 233

Eleusinian, 233

Orphic, 7n

mystics, Christian, 375f, 546

myth(s), 142, 528

conquest of dragon in, 531

dream and, 293n

king as carrier of, 258

phoenix, in Christianity, 336

and religion, 336n

of sun-hero, 210

whale-dragon, 341n

mythology: Greek, 516; see *abo* alchemy

N

Naaman, 269

Naas, 46n, 436n

Naassenes, 76n, 123, 286, 363n, 394, 398n, 407, 435n, 437, 455, 509

name of God, see Tetragrammaton

narcissism, pathological, 498

narcotics, 477

natura abscondita, 95

nature, light of, 308

“natures,” union of, 457

Nebo, 284

Nebuchadnezzar, 434n

Nefesh, 411, 413n
Neihardt, J. G., 206n
Nelken, Jan, 48n, 69n, 281–82, 383n
Neoplatonism, 309
nereids, 461
Nergal, 31n
Nestle, E., 492n
Nestorians, 187
Neumann, Erich, 108n, 269n
neurosis(-es), 230, 353, 495, 526f
Nevers, Duc de, 24n
Newman, John Henry, 523, 545
Nezach and Hod, 444
Nicholas Cusanus, 104, 166
Nicholas von der Flüe, *see* Klaus, Brother
Nicodemus, 150n
Niedner, Felix, 341n
Nietzsche, F. W., 196, 247, 326, 342n, 363n
night, 177
night sea journey, 204, 461
nigredo, 31, 34n, 50n, 64, 122n, 156, 191, 330, 350, 411, 420, 452, 488, 507, 511f, 515,
Pl, 1
 dragon as, 515
 as first stage of opus, 256, 497
 as melancholia, 229, 287n, 320, 350, 355n, 376n, 422, 432, 483, 497, 510, 515,
 521
 as putrefaction, 501, 507
 raven/raven's head as, 510, 512, 521
 sol niger as, 95, 98n, 512
 as symbol of psychic suffering, 350, 354, 432
 transformation into *albedo*, 77, 197, 204
Nile, 217, 224, 231, 269, 503
nine, 304
Niobe, 82f
nirdvandva, 65, 223, 499

Noah, [288](#), [388](#), [399](#), [421](#); *see also* doves

Noah's Ark, [205](#)

Norton, Thomas, [76n](#), [286](#), [392](#)

Nous, [97](#), [137](#), [202](#), [205](#), [231](#), [244](#), [257](#), [383](#), [504](#)

novilunium, [144](#), [155f](#), [248](#), [315](#)

“Novum lumen chemicum,” *see* Sen-divogius

numbers, *see* two; three; ternarius; trinity; four; quaternio; five; seven; septenary; eight; ogdoad; nine; ten; fourteen; forty; sixty-four

numinous experience, [544](#), [547f](#)

nymphs, [68](#)

O

oak, [68ff](#), [77ff](#)

 Dodonian, [72](#)

 Junonian, [68](#)

 world, [69](#)

Oannes, [394n](#), [398n](#)

Obrycum, [448n](#)

“Occulta chemicorum philosophia,” [116n](#)

Oceanus, [44](#), [56](#); *see also* Okeanos

octave, musical, [404](#)

odor sepulcrorum, *see* graves, stench of

Odyssey, *see* Homer

Oedipus, [509n](#)

 Oedipus complex, [91](#)

ogdoad, [11](#), [401](#), [402f](#)

oil, [392](#)

Okeanos, [23n](#); *see also* Oceanus

Old Testament, [243](#); *see also* names of individual books

Olympiodorus, [9n](#), [14n](#), [31](#), [63n](#), [93n](#), [97n](#), [156](#), [249n](#), [286n](#), [351](#), [352](#), [509](#)

one-sidedness, [333f](#), [364](#)

Onoel, [402](#)

Ophir, [448n](#)

Ophirizum, [448](#)

Ophites, diagram of the, [401ff](#), [413n](#)

Ophiuchos, 351

opposites, 166, 218f, *see also* paradoxes

active/passive, 3, 458

albedo/rubedo, 10

assimilation of, 365

balance of, 230

bitterness/wisdom, 246

bright/dark, 3

characterological, 497

coexistence in unconscious state, 13n, 197

coincidence of, 209 (*see also coincidentia oppositorum*)

cold/warm, 3, 10, 246, 422

conflict of, 230, 350, 360

consciousness/unconsciousness, as Sol/Luna, 106

contamination of, 416f

dear/cheap, 3

dualism of, 3

East/West, 3

fire/water, 3, 6, 14n

fusion of, 317

god/goddess, 458

good/evil, 3, 7, 38, 79, 169f, 473 (*see also* good and evil)

gulf between, 473

heaven/earth, 3, 6, 38

height/depth, 6

identity of, 417

incest as union of, gif, 159f, 466

inner/outer, 11

integration of, 79, 365

King/Queen, 4

liberation from, 65, 223 (*see also nirdvandva*)

living/dead, 3, 6

male/female, 3, 4, 7, 89ff, 166, 288, 379n, 414n, 458, 459, 469f

—, union of, 49, 271f, 374, 379, 440n, 459, 461f

moist/dry, 3, 10, 38, 246, 422
old man/youth, 10
open/hidden, 3
pairs of, 3f, 38, 350n, 458
personification of, 4, 89f
precondition of psychic life, 170
problem of, 79
psychic nature of, 79
quaternio of, 3, 6ff, 185ff, 202f, 205, 209, 246f (see also quaternio)
red man/white woman, 4, 131n, 458n
separation of, 197, 333
Sol/Luna or sun/moon, 3, 5, 29, 106, 247
soul/body, 3, 5, 6, 38
spirit/soul, 4, 5
tension of, 418, 497
theriomorphic symbols of, 4ff, 360n
transconscious character of, 6, 381
union of, 12f, 19f, 41, 42ff, 65, 75ff, 80, 92, 118, 156, 166ff, 170, 200, 203, 210, 220, 2n, 371f, 396, 441, 457ff, 471, 495, 536 (see also *coincidentia oppositorum*)
—, in Abraham the Jew, 507ff
—, in Dorn, 477ff
—, psychological, 381
—, as male/female goals, 89, 180
—, symbols of, 371f, 504, 544
—, total, 475
upper/lower, 3, 10, 11
volatile/solid, 3
yang/yin, 79, 139n, see also *yang/yin*
opus, alchemical, 202ff, 221f, 524f, 526
ad album/ad rubeum, 154
ad lunam/lunae et solis, 154, 176
effects of, 319f, 352f
goal of, 62, 290, 394, 504, 535
as mysterium, 375n, 379

parallel in Church ritual and Mass, [198](#), [193n](#), [362](#)
as Passion, [322](#), [345f](#), [349](#)
psychological meaning of, [487ft](#) [518f](#)
as recapitulation of creation, [339](#)
stages of, [202](#), [285n](#), [287](#)
as transitus, [218](#)

“Opusculum auctoris ignoti,” [10n](#)

Orandus, Eirenaeus, [52](#)

“Ordinall of Alchemy,” *see* Norton

ordo compositionis, [458n](#)

Origen, [8n](#), [27n](#), [38n](#), [144n](#), [188](#), [225](#), [277](#), [286](#), [401f](#), [403n](#), [405](#), [406](#), [413n](#)

Original Man, [7](#), [11](#), [16](#), [23](#), [28n](#), [50](#), [412](#); *see also* Adam Kadmon; Protanthropos

Ormuzd, [40n](#)

Orosius, Paulus, [225n](#)

orphan, [17ff](#), [37](#), [41](#)

Orpheus, [7n](#), [9n](#), [24n](#)

Orphic fragments, [130n](#)

Orphic hymns, [516](#)

Orphic mysteries, *see* mysteries

Orphism, [136n](#)

“Orthelii Epilogus,” [15n](#), [480n](#)

Ortulanus, [329n](#)

“Ortus,” [211](#), [213](#), [215](#), [226](#), [338n](#)

oryx, [211n](#)

Osiris, [19](#), [22n](#), [40n](#), [52](#), [64](#), [177](#), [237](#), [259n](#), [260n](#), [264](#), [266n](#), [272n](#), [273](#), [290](#), [363n](#),
[414](#), [423](#), [437n](#), [456n](#), [509f](#), [511](#), [516](#)
black, [513](#)

Ostanes, [7f](#), [237](#)

Oupnek’hat, [517](#); *see also* Upanishads

Ovid, [71n](#)

owl, [234](#)

Oxyrhynchus fragments, [372n](#)

P

Pachymeres, [393n](#)

pair, alchemical, [153f](#), Pl. 7
Pan, [363](#)
panacea, [465](#), [477](#)
Panarkes, riddle of, [82n](#)
P'an Ku, [400](#)
panspermia, [451](#)
Papa, [363n](#)
Papyrus Mimaut, [19n](#)
parables, alchemical, [160](#)
Paracelsus, [39n](#), [46](#), [49](#), [93n](#), [94n](#), [96](#), [111n](#), [112](#), [113](#), [120](#), [133n](#), [173f](#), [184](#), [306n](#), [340n](#),
[383](#), [391](#), [404n](#), [405n](#), [448](#), [465](#), [476](#), [479n](#), [480n](#), [483](#), [485n](#), [490](#), [531](#), [537](#)
Paraclete, [30](#), [35](#), [69n](#), [318](#); *see also* Holy Ghost
Paradise, [210](#), [212](#), [217](#), [251](#), [440n](#)
 Christ in, [337](#)
 stone brought from, [397](#); *see also* rivers
paradox(es), [42ff](#), [502](#)
Paris Magic Papyrus, [20n](#), [196](#)
Parsifal, [252](#), [281](#), [529](#)
participation mystique, [250](#), [488](#)
Parvati, [420](#), [422](#), [423](#), [431](#)
"Passio Perpetuae," [38f](#), [39n](#), [50n](#), [510n](#)
Passion of Christ, *see* Christ
passions, *see* appetites
Paul, St., [147n](#), [169](#), [183](#), [243](#)
Paulinus of Aquileia, [521n](#)
Paulinus of Nola, [281](#)
Pauly-Wissowa, [71n](#)
Pausanias, [7n](#), [34n](#)
peacock, [285](#), [289f](#), [291f](#); *see also* *cauda pavonis*
Peasant Wars, [362](#)
pebble, white, [436n](#)
Peganum sylvestre, [133n](#)
Pelagios, [43](#), [240n](#)
Pelican, [11](#), [13f](#)
penis, [443](#)

Penotus, Bernardus G., [51n](#), [111n](#), [112n](#), [129n](#), [155n](#), [175](#), [176n](#), [222](#), [236](#), [289](#), [377](#),
[378](#), [436](#), [479n](#), [480n](#)

Peratics, [199](#), [200](#), [257n](#)

perfection, [257](#)
and wholeness, [428](#)

Pernety, Antoine Joseph, [18n](#), [3812](#), [45n](#), [63n](#), [80](#), [119n](#), [122n](#), [159n](#), [303n](#), [345n](#), [362](#),
[392n](#), [508n](#), [516](#)

Peronelle, [153n](#)

Persephone, [32](#)

Persia, [226](#)

persona, [356n](#), [380](#)

personality(-ies); fictitious, [529](#)
secondary, [358](#); *see also* dissociation

Pesaro cathedral, [187](#)

Pessinus, [34n](#)

Petasio/Petesis, [351](#)

Peter, St., [15](#)

Peter, First Epistle of, [298](#), [337](#), [344](#), [345](#), [539n](#)

Petras de Silento, [38n](#)

Pharaoh, [259n](#), [265](#), [268](#), [308](#)

Pherecydes, [69](#), [71n](#), [439n](#)

Philaletha / Philalethes, Eirenaeus, [33](#), [75n](#), [77](#), [131n](#), [155](#), [158n](#), [160](#), [172](#); *see also*
“Introitus apertus”

Philip, Gospel of, [8n](#)

Philippians, Epistle to the, [35n](#), [36](#), [170n](#), [345](#)

Philo, [15n](#), [69n](#), [262](#), [406](#), [413](#), [450n](#), [534](#)

philosopher, Adam as first, [397f](#)

philosophy, and the Church, [242](#)

phlegm/phlegma, [486](#), [488](#), [493](#), [526](#)

Phlegyas, [121n](#)

phobias, [180](#)

Phoebe, [121n](#)

phoenix, [51n](#), [77](#), [194n](#), [211](#), [213](#), [215](#), [216](#), [217](#), [227](#), [237](#), [290](#), [334](#), [336](#), [337](#), [338n](#),
[400](#), [445](#)

Phorcyds, [509n](#)

physical and psychic, relation, 537f
physician(s): Alexandrian and Egyptian, 267, 273f
 primordial, 121n
physicist, 502
Physis, 53, 103, 383, 416, 472, 490, 504, 507f
 fourfold, 3
Phyton, 350n, 441
Pibechios, 73n
Picinellus, Philippus, 147n, 169n, 215n, 229n, 243, 291f, 307n, 336n, 445n, 449n
Pico della Mirandola, Giovanni, 97n, 143f, 410, 448n
Pierius, 228n
piety, 460
Pirke de Rabbi Eliezer, 386, 388n, 389, 398
Pisces, 176
Pison, river, 286
Pistis Sophia, 261n, 409
Pithecanthropus, 213
Pitra, John Baptist, 154n, 218n, 236n, 237n
Pius IX, Pope, 523n
Pius XII, Pope, 167n
planets: influence of, 532
 seven, 217, 224, 332, 335n, 401f, 441
 and temperament, 230
Plato, 82n, 112n, 143n, 153n, 212, 279, 352n, 393, 407, 515, 538
“Platonis Liber Quattorum,” 94, 119, 134n, 139, 140, 142f, 153n, 294n, 352n, 435,
 458n, 460, 485, 491n, 513n, 514, 534n
Pleiades, 404
Pleroma, 401
Pliny, 80n, 129, 336, 513n
Plotinus, 534
Plutarch, 20n, 52n, 63n, 64n, 68n, 129n, 130, 132n, 140, 177, 193, 252n, 260n, 363n,
 493, 509n, 510n
Pluto, 122n
pneuma, 136f, 196, 244n
 king as, 262, 264; *see also* spirit

Poimandres, vision, [273n](#)
Poimandres community, [240n](#)
point, [44ff](#)
polarity, *see* opposites
Pole, celestial, [205n](#)
Poliphilo, *see* Colonna
Pordage, John, [144n](#)
Porphyry, [8n](#)
Poseidon, [203](#)
possession, symptoms of, [180](#)
potash, [240](#)
power, striving for, [86](#)
prayer, [522](#)
precognition, [464](#)
prediction, triple, of death, [81f](#)
Preisendanz, Karl, [19n](#), [20n](#), [45n](#), [53n](#), [140n](#), [146n](#), [196n](#), [237n](#), [297n](#), [500n](#)
prelogical thought, [250](#)
Preuschen, Erwin, [372n](#)
Preuss, K. T., [95n](#)
prima materia, [9](#), [10n](#), [15](#), [16](#), [22](#), [38](#), [45](#), [67](#), [84](#), [156](#), [283](#), [307](#), [379n](#), [435n](#), [501](#)
 as arcane substance, [42](#), [62](#)
 as beginning of opus, [193](#)
 chaos as, [193](#), [385](#), [397n](#)
 as corresponding to devil, [510](#)
 cranium as origin of, [435n](#)
 creation of, [139](#)
 female/maternal aspect of, [18](#), [21f](#), [39](#), [411](#)
 as “great Babylon,” [306](#)
 lead as, [245](#), [445](#), [493](#)
 massa confusa as, [385](#)
 of man, [365](#), [481](#)
 of metals, [45](#)
 mortificatio of, [293n](#)
 “mumia” as, [391](#)

return to, 99
as Saturn, 445, 493
sulphur as, 111
transformation process of, 67; *see also* Adam; lapis; Mercurius; sea; self; snake
primitives: and consciousness, 108n
thought of, 250n
Primordial Man, *see* Adam Kadmon; Anthropos; man, first; Original Man
Priscillian, 225
Priscius, Lucius Agatho, 57, 66ff
privatio boni, 79
Proclus, 7n, 24n, 94n
“Prodromus Rhodostauroticus,” *see* Agnostus
projection(s), 13n, 87, 107ff, 112, 204, 319f, 345f, 360, 472, 488f
of coniunctio, 91
consciousness and, 369, 489, 521f
Enigma of Bologna as, 57
of female, 178, 453
of inner Adam, 413
and matter, 250, 489, 519, 544
metaphysical, 79
of opus/transformation process, 359, 543
of soul, *see* soul
therapeutic value, 320
of unconscious contents, 299f, 498f
unconsciousness of, 364
of unity of personality, 222
propaganda, political, 253
prophet, true, 399 &, 400f
prophets, eight incarnations of, 399ff
Old Testament, 453
Protanthropos, 49
Protestantism/Protestants, 216, 321, 337, 361f
Proteus, 56
Proverbs, Book of, 444n

Prunicus, 403

Psalms, 26n, 27, 36n, 123n, 218, 331n, 333, 343, 344, 345, 408, 437n, 447n, 451, 511n

Psellus, Michael, 104n

psyche: and body, causal relation, 538

collective, 233

consciousness of whole, 209

as “constellation,” 357

devaluation of, 163, 263

divine, 417

double aspect of, 143

freeing/extraction of, 224, 263, 471, 491, 513

freeing of, from spirit, 543

matter and, 124, 490, 537

mysterium of, 153n

non-spatial, 300

psychic crisis, 222

— disturbance, 155f

reality of, 209, 439, 455, 473, 528f

split in, 200, 248

totality/wholeness of, 155, 203, 359, 390, 503, 533

transformation of, 197, 200

unconscious 498f; *see also* soul; spirit

psychoid: factor, 551

unconscious, 552

psychologism, 468

psychology, 105, 230f, 367, 437

and alchemy, 249, 476f, 482, 487ff, 498, 519, 526, 540, 544f, 546

analytical, 417

and Christian doctrine, 325n

female, 175, 178f

male, 178f

meaning of colours in, 287

and metaphysics, 390, 439, 455, 468, 547

and myth, 528

objective basis of, 428f
and physics, 538, 543
primitive, 259, 417
and religion, 325f
resistance to, 128, 510f
as science, 426, 428
and theology, 208, 455
unknown, in Middle Ages, 439, 467
value-concept, 426f

psychopomp, anima as, 214, 380

psychosis, 155, 353, 518, 526
 anticipated, 531
 distortions in, 324
 latent, 156f
 unleashed by analysis, 530

psychotherapy, 253, 256, 320, 359, 468, 474, 546f
 goal of, 365, 489
 group analysis, 106n
 “minor,” 366
 religious problems in, 366
 standstill in, 530
 technique, 255, 427, 474, 518, 526f

Ptahil, 394

Ptolemy, 403

puellus regius, 331

puer aeternus, 88, 166

pumice-stone, 134n

Puri, 205

purple, 289

purusha, 9n, 136n, 347, 414; see also *atman*

putrefactio/putrefaction, 95, 114, 236, 353, 501

Pythagoras, 32

Pythagoreans, 24, 252

Pytho, 536n

Q

quadriga, 206

qualities, four, 3, 422

quarters, four, 388

quaternarius, Adam as, 388

quaternio/quaternity, 3, 6ff, 45, 47, 101f, 185ff, 203, 207, 208f, 213, 421f, 424f, 431, 442, 459, 505

Christian, 186ff

divine name as, 430

double, 11

in dreams, 203

female character of, 188

of flowers, 490

marriage, 388, 425f, 430

and Trinity, 101f, 184f, 188, 440; *see also* colours; elements, four; gold; opposites; self; totality

queen, 307ff, 376ff

as anima, 379

apotheosis of, 324

and colours, 311

diet of, 310

dissolution in bath, 379

as Luna, 376

as maternal vessel, 378

as mother of God, 259n, 311

psychic pregnancy of, 308

Regina, 376ff

of Sheba, 245, 377, 378, 381

as soul, 379; *see also* King

quicksilver, 79, 112, 117, 118, 237, 250, 444, 490, 500, 502, 504; *see also* Mercury (-ius)

quintessence / *quinta essentia*, 95, 316, 322, 459, 477ff, 505

R

Ra, 19, 260n, 340–41n

Rabanus Maurus, [9n](#), [53n](#), [492n](#), [511n](#)

“Rachaidibi fragmentum,” *see* “Fragment from the Persian Philosophers”

Radhakrishnan, S., [53n](#)

Rahner, Hugo, [25n](#), [27n](#), [35](#), [130n](#), [131](#), [133n](#), [146n](#), [197](#), [198](#), [277](#), [278](#), [282n](#), [439n](#),
[511n](#)

rain, [510](#)

rainbow, [118](#), [286](#), [288](#)

rain-maker, [419n](#)

Ramanuja, [208n](#)

Raphael, [402](#)

raven/raven’s head, [43](#), [76](#), [145](#), [291](#), [344](#), [353](#), [508](#), [510](#), [516](#), [521](#)

 and devil, [521](#)

 night, [511](#)

Raziel, [399](#)

Read, John, [80n](#)

reality: and multiplicity, [462](#)

 of psyche, *see* psyche

reanimation, [521](#)

Reason, goddess of, [253f](#)

Rebecca, [389](#)

Rebis, [47](#), [250](#), [287](#)

red, [306](#), [506](#)

 and white, [17](#), [69n](#), [115](#), [532](#); *see also* colours; wine

reddening, [302](#); *see also* rubedo

redeemer, in alchemy, [104](#), [346](#)

 Gnostic, [230](#)

red man, [21n](#), [492](#)

red man / slave / white woman, [4](#), [131n](#), [147](#), [230](#)

Red Sea, [183](#), [199ff](#), [209](#), [210](#), [212](#), [217](#)

Regulus, [350n](#)

regulus, [332](#)

Reitzenstein, R., [19n](#), [20n](#), [100n](#), [510n](#), [515n](#)

 and Schaefer, H. H., [18n](#), [28n](#), [67n](#), [408n](#), [414n](#)

religion(s), [253](#), [256](#), [406](#), [553](#)

 as attention to unconscious, [162](#)

Christian, 540f (see also Christianity; Church)
as compensation, 418
conversion, religious, 366
founders of, 549
fundamental experience of, 171
and myth, 336n, 528
and psychology, 325f
as psychotherapeutic, 256
religious statements, 208, 280, 548f, 551
sectarianism and, 321

Renaissance, 324, 452

René d'Anjou, 452

représentations collectives, 522

restitution, 337

resurrection, 158f, 215, 290

retort, see vessel

return, eternal, 342n

Reuchlin, Johann, 22, 410

Reusner, H., 30, 38n, 59n, 70, 122, 187, 350n, 448n, 466n, 491

revelation, 255, 301n

Revelation, Book of, 23n, 48, 151n, 166, 205, 288, 298n, 301, 304, 307n, 332, 341n, 343, 372, 373, 434n, 436n, 441, 442, 449n

Rex, see King

rex marinus, 90

Rhasis, 10n, 240n

Rhea, 34n, 403

Rhine, J. B., 300n, 464

rice, 419

riddles, Platonic, 82

Riessler, Paul, 389n

Rig-Veda, 109n, 136n, 253n

“Rindenbuch,” 410, 506

Ripley, Sir George, 3n, 28n, 30n, 51, 63, 98n, 106n, 111n, 112n, 114, 131n, 192, 193, 197, 269n, 355, 436n, 439n, 460n, 461n, 480n
Cantilena, 274ff

Ripley Scrowle, [71](#), [350n](#), [478n](#)

rites, [418](#), [419](#)

d'entrée et de sortie, [522](#), [533](#)

Rituale Ecclesiae Dunelmensis, [387n](#)

rivers, four, of Paradise, [210](#), [286](#), [435n](#)

Rodochaeus de Geleinen Husio, *see* Husio

Rohde, Erwin, [340n](#)

Rohini, 516f
Rohita, 516f
Röhr, J., 95n
Romans, Epistle to the, 337n, 344, 415, 542n
Romanus, St., 236n, 492n
Rosarium philosophorum, 4, 12, 15n, 21, 28, 43n, 60n, 63n, 64, 76n, 77, 114, 117n, 130n, 132, 137f, 138n, 141f, 147, 149n, 153n, 184n, 189, 190n, 192n, 193, 194, 219, 222n, 235, 236n, 249, 261, 266n, 296n, 329n, 381, 432, 435, 438n, 474n, 504n, 510n, 512n, 515, 540n
Roscher, W. H., 23n, 32n, 284n, 351n, 409n
rose, 305f, 307, 430n
rosemary/*ros marinus*, 480, 484, 491n, 494
Rosencreutz, Christian, 43, 194n, 232, 293n, 295, 304, 305, 330, 351, 435n, 461, 513
Rosicrucian Society, 231
“Rosinus ad Euthiciam,” 43n, 119n, 192, 201, 382n
“Rosinus ad Sarratantam,” 15n, 30n, 51n, 115n, 131n, 132n, 140n, 192, 235n, 304n, 328n, 458n
rota, see wheel
rotundum, 140, 356, 434, 514; see also vessel s.v. roundness of
roundness, 356
 and the mother, 356f; see also rotundum
Rousselle, Erwin, 445n
Ruach Elohim, 264, 288
rubedo, 10, 99, 229, 306, 314, 317
Rubeus, 494n
Rueckert, F., 161n
Ruland(us), Martin, 18n, 38n, 55n, 59n, 80n, 115n, 119n, 134n, 135, 159n, 164, 194n, 204n, 234n, 264, 274n, 289n, 350n, 382, 383, 479n, 480n, 486n, 497, 500n
Rupescissa, Joannes de, 92n, 192, 478n, 510n
Ruska, J., 5n, 10n, 15n, 17n, 21n, 33n, 64n, 137n, 138, 203n, 257n, 298n, 479n; see also “Tabula smaragdina”; *Turba philosophorum*
Ruta sylvestris, 133n
Ruysbroeck, John of, 135n

Sabaeans, [9n](#), [243](#), [485](#), [513](#), [532](#)

Sabbath, [445](#)

sacraments, [232](#)

sacrifice: human, [486](#)

 motif of, [372](#)

Sagittarius, [176](#)

Saint-Denis, Abbey of, [206](#)

saints, theocentric, [376n](#)

sal, *see* salt

Sal Alkali, [189](#)

sal ammoniac, [55n](#), [273f](#)

sal spirituale, meaning, [249f](#)

salamander, [144n](#), [441](#)

salsatura, [189](#), [240](#)

salt/sal, [47](#), [54](#), [99n](#), [112](#), [121](#), [183ff](#), [486](#)

 and *albedo/nigredo*, [191](#), [239](#)

 in alchemical quaternio, [184ff](#), [188](#)

 “of all things,” [486](#)

 as analogy of Christ, [241](#), [246](#)

 as arcane substance, [183ff](#), [188ff](#), [238](#), [241](#), [245](#), [250](#)

 and ash, [189](#), [239](#), [356](#)

 in Bible, [242](#)

 bitterness of, [192f](#), [197](#), [246](#), [248f](#)

 in Cabala, [246](#), [251](#)

 as cosmic principle, [188](#)

 as dragon, [251](#)

 as dream symbol, [245](#)

 in ecclesiastical allegory, [241ff](#), [246](#)

 as Eros, [241](#), [248](#), [333](#)

 female/lunar aspect of, [184n](#), [188](#), [240](#), [245](#), [247](#), [252](#), [459](#), [506](#)

 as fire and water, [239](#), [243](#)

 “of the four colours,” [120](#)

 as lapis, [189f](#), [240](#), [246](#)

 of magnesia, [240](#)

meaning of, 239ff, 248
of metals, 245
origin of, 193f, 241, 248, 333
paradox of, 250
as preservative, 251
of Saturn, 252, 277n, 304n, 493
sign for, 241, 245
as soul, 240f
as spark of anima mundi, 240, 244
“spiritual,” 190, 249
and sulphur, 120, 239, 241, 250, 252
and Tartarus/Typhon/sea, 193, 251f, 493
Veneris, 304n, 495
and water, 191f, 243
of wisdom/*sal sapientiae*, 189, 238, 241ff, 250, 274, 493

samadhi, 540

Samson, 433, 446

sanctity, odour of, 307

sand, 204, 239

Sapientia, 30, 169, 312, 403
salt and, 242, 249, 252, 274; *see also* wisdom
sapientia Dei, 12n, 70n, 104, 127, 142, 318, 375

saponaria, 293n

sapphire, 447f

Sarah, 389

sarcophagi, 391
Roman, 461

Satan, 197, 511

Satanaël, 409

satori, 540

Satorneilos, 48 & n, 342n

Saturn, 7, 8n, 47, 64, 116, 120, 217, 224, 225, 227, 229, 231, 335, 338, 358, 403, 483, 493
and lead, 335n
and the moon, 175n, 176

and salt, 252, 277n

Saturnia, 75n

Saturninus, *see* Satorneilos

saurians, 213

“Scala philosophorum,” 38n, 191n

scarab, 500n

Schaeder, H. H., 38n; *see also* Reitzenstein and Schaeder

Schärf, Riwkah, 206n, 389n

Scheftelowitz, I., 51n, 398n, 407n

Schiller, 167

schizophrenia, 105, 121n

Schmidt, Carl, 395n

Schmieder, Karl Christoph, 29n, 150n, 332n

Scholem, G. G., 23n, 25n, 390n, 412n, 414n, 425n, 434n, 442n, 443

Schoolmen, 534

Schopenhauer, A., 517n

Schreber, D. P., 23n

Schultz, Wolfgang, 76n

Schultze, Fritz, 358n

Schwartz, C., 59n, 86n

Schwartzenburg, Gervasius von, 425n

Schweitzer, Albert, 16n

science, and religious experience, 327

scintilla(e), 48ff, 304n, 491

Scorpio, 176

scorpion, 60, 144

Scott, Walter, 273n, *see also* *Corpus Hermeticum*

Scythianos, 37

sea, 93, 157, 190ff, 204f, 461, 484, 510

- as *aqua permanens*, 134n, 191
- bitterness of, 183, 192f, 198, 252
- crossing of, 199, 209, 217
- desiccation of, 51, 203
- imprisonment in, 244

Indian Ocean, [10f](#)
and moon, *see* moon; Red, [183](#), [199](#), [201](#), [209](#), [212f](#), [217](#), [295](#)
regeneration in, [235ff](#)
as seat of hell, [198](#)
as synonym of prima materia, [10n](#), [193n](#)
Typhonian, [93](#), [193](#), [251f](#), [273](#)
as unconscious, [5n](#), [9](#), [11](#), [199f](#), [204](#), [278](#)
as “world,” [198](#); *see also* salt; water
“sea, our,” [5](#)
sea-dew, [484](#), [491](#)
sea-journey, [461](#); *see also* night sea journey
seasons, four, [3](#)
sea-water, [235ff](#); *see also* sea; water
secret, [232](#)
“Secret Inscription,” [45](#)
sectarianism, [321](#)
security, inner, [533](#)
Sed festival, [265ff](#), [268](#)
seed of the woman, [404](#), [405](#)
Sefer Raziel, [399n](#)
Sefira/Sefiroth, [9n](#), [22f](#), [412](#), [455](#), [456](#)
 tree of, [43](#), [135](#)
Selene, [32](#), [136n](#), [159](#), [197](#); *see also* Helen; Luna; moon
self, [44n](#), [63](#), [107n](#), [118](#), [120](#), [208](#), [210](#), [278](#), [471](#), [491](#), [531](#), [545](#)
 Adam as, *see* Adam; archetype of, [88](#), [544](#)
 and Christ, [246n](#), [349](#)
 as *coincidentia oppositorum*, [107n](#), [148](#)
 as compensation, [123f](#)
 and ego, *see* ego
 embodiments of, [384](#)
 empirical, [208](#)
 experience of, [327](#)
 and God, *see* God; “higher,”
 spiritual man as, [383f](#)

lapis as, 246n, 272, 371, 454, 503, 544
numinosity of, 544
paradoxical, 6, 123
prefiguration of, 175
prima materia of, 213
as psychic totality, 6, 110, 122, 155, 356, 371, 494, 503
quaternity of, 208, 490
symbols of, 203, 205n, 206f, 214, 224, 245, 371, 503, 505, 544
visualization of, 535

self-knowledge, 90, 214, 271, 460, 466, 474, 480, 482, 497ff, 517, 520, 534, 544
ethical consequences of, 545f

Sellin, 412, 434n

semen, 48n, 49

Sendivogius, Michael, 45, 49, 93n, 122n, 510; *see also* “De sulphure”

Senex, 224

Senior, 5, 9n, 12n, 28n, 31n, 34n, 40n, 42n, 72ff, 76n, 92n, 98, 129n, 138n, 139n, 142n, 145n, 147, 151n, 154n, 189, 191, 220n, 222n, 238n, 239, 240, 276, 299, 301n, 304, 350n, 374n, 391n, 391, 393, 394n, 396, 438n, 439n

separatio/separation, 353, 459, 489

Septenary, 12

serpent, *see* snake

Servius, 228n

servus rubeus, *see* red man

Set, 93, 511

Seth/Shîth, 398, 399

Sethians, 48, 244

seven, 401ff
archons, 402f
angels 402f
colours, 287, 386
eyes, 52, 437n
liberal arts, 399
stages of work, 270
statues, 76n
stone tables, 398; *see also* crown; metals; planets

Seven Sleepers, [387n](#)

sexuality, [443](#)

Shaare Kedusha, [44n](#)

Shabtai, [445](#)

shadow, [97f](#), [105](#), [122](#), [125](#), [148](#), [233](#), [247f](#), [417](#), [452](#), [494](#)

archetype of, [106](#)

as compensation, [125](#)

confrontation with, [365](#), [473](#), [496ff](#)

fascination of, [254](#)

as personification of personal unconscious, [106](#), [107n](#), [199](#)

projection of, [167f](#), [365](#)

recognition of, [253](#), [495](#), [520](#)

of the self, [63n](#), [107n](#)

sun's, [97f](#)

Shakti, [185n](#), [378](#), [405](#), [473](#)

shamanism, [4n](#), [40n](#)

Sheba, Queen of, [377](#)

Shekinah, [22](#), [23](#), [455](#)

Shem, [389](#)

shepherd, [228](#)

Shepherd of Hermas, see *Hennas*

Shiur Koma, [412](#)

Shiva, [185n](#), [377](#), [405](#), [431](#)

shroud, holy, [373n](#)

Shulamite, [51](#), [157](#), [206](#), [411ff](#), [416f](#), [420ff](#), [446](#), [451ff](#)

sibyl, [226](#)

Erythraean, [211](#), [213](#), [216](#), [227](#)

Sibylline Oracles, [76n](#), [211](#), [388n](#)

sickness, [352](#)

siddhasila, [53](#)

Siebmacher, see "Aquarium sapienturn"

Siecke, Ernst, [146n](#)

"Sifra de Zeniutha," [449](#)

"Sifre de-Adam Kadmaa," [399n](#)

Silberer, Herbert, [457](#), [555](#)
Silenus, [393](#)
silver, Luna and, [130](#); *see also* gold
Simeon ben Yochai, [443](#)
Simon of Gitta, [139n](#)
Simon Magus, [38](#), [49](#), [136](#), [139](#), [153n](#)
simple, the/simplicity, [352n](#), [534](#)
sin, original, [79](#), [542](#)
Situri-Sabitu, [71n](#)
sixty-four (the number), [445](#)
skirt, concealment under, [284](#)
skull, [513f](#)
slave, fugitive, [159n](#)
smells, in alchemy, [312](#)
snake/serpent, [5n](#), [47](#), [73](#), [76](#), [89](#), [125](#), [144](#), [159n](#), [175](#), [201f](#), [298](#), [335](#), [340ff](#), [421](#), [437n](#)
 Agathodaimon, [9](#)
 of Asklepeion, [228](#)
 and bird, as opposites, [342n](#)
 bite of, [30](#), [34](#)
 brain and, [436n](#)
 -charmers, [351n](#)
 in Christianity, [342f](#)
 cunning of, [257](#)
 as evil passions, [160](#)
 four-horned, [353](#)
 mercurial, *see* Mercurius
 in Paradise, [117](#), [315](#)
 poison of, [60](#)
 on pole, [421n](#)
 as prefiguration of Christ, [421n](#)
 as prima materia, [202](#)
 “rejoicing in itself,” [504](#)
 seven-headed, [340](#)
 snake-form, of spirits of dead, [340](#)

souls and numina as, [71n](#), [73](#)
transformation into, [80](#)
—, into queen, [380](#)
and tree, [78n](#), [343n](#)
winged, [261](#); *see also* Apep-serpent; dragon; Hermes; hero; Naas; uroboros

Socrates, [393](#)
 pseudo-, [43](#)

Socrates Scholasticus, [37n](#)

Sol, *see* sun

solificatio, [317](#), [369](#), [420](#), [422](#), [423](#), [453](#)

Solomon, [377](#), [381](#)

solutio, [236](#), [270ff](#), [353](#)

Son, the, [102](#)
 divine, archetype of, [523](#)

Son of (the) Man, [23n](#), [124](#), [127](#), [346](#), [348](#), [441](#), [442n](#), [446](#), [451](#)

Song of Songs, [17](#), [31](#), [37](#), [49n](#), [51](#), [69n](#), [129](#), [131n](#), [145n](#), [157](#), [206](#), [335n](#), [384](#), [393n](#),
 [412](#), [431n](#), [433](#), [444n](#)

sonship(s), [104](#)
 threefold, [291](#)

Sophe, [141n](#), [262](#)

Sophia, [20](#), [355](#), [363n](#), [401](#), [403](#), [454n](#), [490](#), [523](#)

soror / filia mystica, [136](#), [153](#)

soul, [83f](#), [161](#), [471ff](#)
 accrescent, [280](#), [310](#)
 affliction of the, [473](#), [483](#), [521](#)
 alchemical conception, [525f](#)
 androgyny, [183](#)
 animal, in man, [213f](#), [217](#)
 animation of, through spirit, [473](#)
 autonomy of, [472f](#)
 body, as animation of, [471](#), [472](#), [521](#)
 —, coniunctio of, [337](#), [478n](#), [521f](#)
 —, freeing of, from, [472](#), [488f](#), [491](#), [499](#), [507](#), [519](#), [521](#), [542](#)
 —, of lapis, *see* lapis
 —, separation of, [486](#), [541](#)

—, unity of, 65, 465, 471, 472, 488
bond of, to God and devil, 485
as breath-body, 525
descent of, 225, 231
femininity of, 379
godlikeness of, 231, 262f
mystery of, 165f
“passage” of, 404
“perfection” of, 292
and planetary houses, 225
plurality of, 358n
projection of, in matter, 84, 124, 126f
as redeemer, 46n
relation of, to moon, 132, 140
salt as symbol of, 240f
soul-spark, 48, 207
—, fishes’ eyes as, 53
and spirit, as opposites, 5f, 41, 46
transformation of, 240f, 351
union of opposites in, 91
unity of, 534f; *see also* anima; animus; psyche; world-soul

South, Mr., 153n

South, Queen of the, 378

“spagyric,” derivation, 481n

sparks, *see* scintillae

Spiegelberg, W., 261

spiraculum, 471

spirit, 136, 196ff, 221, 244, 370, 471ff, 482

of the age/*Zeitgeist*, 324, 520, 522, 530

alchemical symbols of, 687, 194, 242, 244, 509, 521

ambivalent, 143, 511

as *anima rationalis*, 473

and body, complementarity, 507

—, as opposites, 6, 46n, 148, 151n, 244, 443, 458, 461, 471f, 473f, 481, 534, 542

—, separation of, 466, 471f, 507
—, union of, 465, 475, 476, 478n, 517, 540ff
chthonic, 517, 521
“crime” of, 46n, 55n
expulsion of, 194
familiar/guardian, 149, 497, 511, 521
and gold, 261ff, 517
living/of life, 182, 207, 516n
male, 379n, 517
Mercurius, 12f, 46, 238
natural, 310
projection of, 489
as projection of coniunctio, 91
soul and, 5f, 41, 46f (see also soul)
—, animation of soul through, 473
—, liberation of psyche from, 543
—, soul and body, unity of, 65, 219f, 222
“spooks,” 408, 501, 511
spiritualization of body, 535f
spiritualism, 537
spiritualization, permanent, 472
spiritus familiaris, 497
spiritus mercurialis, 491
Spiritus Sanctus, 184n; see also Holy Ghost
Spitteler, Carl, 308
“Splendor solis,” see Trismosin
split-mindedness, masculine, 248
Spon, Jacob, 57n
sponge, 134f
Staehlin, Felix, 66n
stag, 5, 32, 159
stages, mystical, 451
stairway, 403f
Stapleton, H. E., 5n, 72n, 73n, 75n, 139n, 391n

stars, 143, 176
 seven, 332, 335n
State, totalitarian, 164
statue/*statua*, 76n, 390f; *see also* Mercurius
Steeb, J. C., 47, 52, 93n, 94n, 129n, 251n, 435n, 492n
Steiner, Rudolf, 103
Steinerus, Henricus, 512n
Stephanos, 236n
Stephen of Alexandria, 132n
Sternberg, F. von, *see* “Gloria mundi”
Stevenson, R. L., 181
stigmatization, 375
Stoics, 130n, 142, 471
Stokius de Stolcenberg, 3n, 4n, 6, 141n
stone, 10, 450f, *et passim*; given to Adam, 423
 antiquity of symbolism, 536n
 of Bethel, 397
 brain-, 436n
 Christ and, 345, 450f (*see also* Christ)
 cornerstone/rejected by builders, 14, 450, 482, 528
 as feminine matter, 450
 as incarnation of God, 451
 living, 539, 541
 physical nature of, 541
 soul of, 541
 symbolism of, 536n
 “that hath a spirit,” 450, 539
 “that is no stone,” 436, 450, 536f; *see also* lapis
stork, 133, 140, 356n
substantia caelestis, 499, 525, 526
succus vitae, 152
Suger, 206
Suidas, 37n
Sulamith, *see* Shulamite

sulphur, [106](#), [110ff](#), [168](#), [184](#), [220](#), [239](#), [241](#), [517](#)

alchemical symbols of, [125](#)

as anima/soul, [113](#), [350n](#)

and antimony, [332](#)

as arcane substance, *see* arcane substance

and arsenic, [164](#)

colours of, [21n](#), [38](#), [93](#), [99](#), [110ff](#), [114](#), [116n](#), [295](#), [296n](#), [506](#), [516](#)

comburens/combustible, [115](#), [156n](#), [158](#), [185](#)

as devil, [115](#), [125](#), [128](#), [158](#), [185](#)

double nature/paradox of, [111](#), [115](#), [120](#), [126](#), [458](#), [506](#)

as dragon, [112](#), [116](#)

effects of, [114f](#)

as evil, [38](#), [114](#), [164](#)

fiery nature of, [93](#), [110f](#), [117](#), [516](#)

as gold, [332f](#), [506](#), [509](#), [516](#), [517](#)

as “heart of all things,” [115f](#), [118](#)

incombustible, [120](#)

as life-spirit, [113](#), [161](#)

lion and, [295](#), [297](#)

as *medicina* and *medicus*, [121](#), [126](#)

and Mercurius, [112f](#), [115](#), [117](#)

operations of, [113f](#)

parable of, [93n](#), [115f](#), [121](#), [126](#), [159](#), [252](#)

as parallel of Christ, [122f](#), [125](#)

poisonousness of, [117](#)

and rainbow, [114](#), [120n](#)

and salt, *see* salt

and sun/Sol, as active substance, [94](#), [106](#), [111](#), [113f](#), [118](#), [127](#), [332](#), [459](#), [506](#)

as transformative substance, [119f](#)

triad with Mercurius/salt, [84](#), [459](#); *see also* Venus

Sulphur auratum antimonii, [332](#)

sun/Sol, [9](#), [16](#), [24](#), [26n](#), [32ff](#), [51](#), [53f](#), [79](#), [92ff](#), [121](#), [140ff](#), [147f](#), [166](#), [230](#), [360](#)

active substance of, [93f](#), [139](#) (*see also* sulphur)

ambivalence of, [95](#)

anima and, 141
black/Sol niger, 28n, 95, 98, 145, 148n, 181, 247f, 512
—, as feminine unconscious, 181
as bridegroom, 37, 396
chariot, 206n
as consciousness, 96, 100, 107, 127f, 144, 177, 308, 355, 357
copper and, 262
death of, 141f
dissolution of, 75n, 134n
dragon son of, 278n
and earth, conjunction, 515
earthly/*terrenus*, 99f
eclipse of, 27, 30, 460
fiery nature of, 176, 227
as generator of gold, 47, 93, 94n, 95
as image of God, 395
invisible, 54
and king, 258, 357
as King, 141, 151n, 308, 355ff, 368f, 509
—, and masculine spiritual father world, 359
light-nature / luminosity of, 96, 368
as Logos, 180
and Mercurius, 96f, 100f, 184
and moon/Luna, 25, 103, 114, 120, 137, 143f, 175f, 178f, 236, 296, 314, 400, 424, 434n, 451
—, animal counterparts of, 144f, 147
—, child of, 29, 219, 371, 434
—, coniunctio of, *see* coniunctio
—, as consciousness and unconscious, 97, 100, 106, 144, 148, 154
—, death of, 29
—, as dream symbols, 107
—, as father and mother, 29, 50, 137
—, as God and man, 396
—, as opposites, *see* opposites
—, as projections, 107

—, as *yang* and *yin*, 295n
peacock and, 291
relation to man, 106
renewal of, 213
and sea, 93, 134n, 515
“seed” of, 130
setting of, 30, 35n
significance of, 92ff
stages of transformation of, 141
subterranean, 28n
and sulphur, 93f, 106, 111, 114, 304
sun-hero myth, 210
as symbol of self, 544
as totality, 108f
as transformative substance, 94, 99
trinity of, 512n
umbra solis/shadow of, 28, 39, 92n, 97f, 128, 131, 145, 256
wings of, 276; *see also* Christ; gold; lion; opposites
sun-moon child, 219
“Super arborem Aristotelis,” 133, 140, 510n; *see also* Albertus Magnus
super-ego, 473
superiority, ethical, 248
Superman, 247
Suriel, 402
Surya, 516n
sweat-bath, 40, 204n, 273
Sylvester, St., 343
Sylvester II, Pope, 434
symbolizatio, 146, 147, 178
symbol(s)/symbolism, 468f, 536
 alchemical and Christian, 372
 and allegories, 475, 518
 and analogies, 468
 archetypal, 469f

dream and fantasy images as, 540
lapis as, *see* lapis
meaning of, for alchemists, 475
meanings, multiple, 443
numinous, 366
overlappings in, 324
paradoxical, 310
of plants, in alchemy, 485
psychological understanding of, 468*f*, 476*f*
religious psychology and, 326
research into, 209
of self, *see* self
theriomorphic, *see* theriomorphic symbols; “uniting,” 470, 497
various, of *coniunctio*, 470
symbolum, 500
symptoms, neurotic, 359, 489
synchronicity, 464
 archetype and, 533*n*
syncretism, Hellenistic, 243
synonyms, 458
synthesis: alchemical, 460
 of conscious and unconscious, 539
 of four and seven, 9
 of spiritual organizations, 321

T

Tabari, 386
Tabernaemontanus, 133*n*, 134, 479*n*, 480*n*
Tabit ibn Qurra, 142
“Tabula smaragdina,” 12*n*, 17, 62, 67, 101, 115*n*, 136*n*, 137, 176*n*, 218, 219, 221, 222, 257*n*, 352, 492*n*
Tachenius, Otto, 339*n*
tail, of serpent, 31
T'ai-yüan Sheng-mu, 400, 403*n*
Talmud, 251*n*, 386*n*, 413*n*

Tammuz, 372
Tantrism, 185n, 405
tao, 166, 419, 445n, 464, 499, 535, 540
Taoism, 400, 401, 419
Tao Teh Ching, see *Lao-tzu*
tapas, 203
Taphabaoth, 402
Targum, 388
Tarpeian Rock, 343
Tartar(us), 480, 486, 493, 532
tartaric water, 486
Tartarum, 483
Taurus, 144, 176
Taylor, F. Sherwood, 275n
telepathy, 464
Telesphoros, 228n
telum passionis, 384
temperaments, and colours, 287
Temple, Archbishop William, 318n
ten, 141, 221f, 401, 413n
teoqualo, 30
Terebinthos, 37
Teresa, St., 307, 393n
ternarius, 48
 Adam and, 387
terra, 296, 401, 512; see also earth; *alba (foliata)*, 130, 238, 435, 438n
 damnata, 239, 512
Tersteegen, G., 165n
Tertullian, 307
“Testament of Adam,” 389n
teth (Hebrew letter), 445
Tethys, 23n, 56
Tetragrammaton, 429f
tetrameria, 3n, 202, 385, 429

tetramorph, 215, 400n
tetrasomia, 113n
Tetzen, Johannes de, 433n
textual criticism, 326
Thabritius, *see* Gabricus
thalamus, 24
Tharthataoth, 402
Thauthabaoth, 402
Theatrum chemicum: *see names of individual authors or treatises*
Theatrum chemicum britannicum, *see* Norton
Thebes, 78
Theodore bar Konai, 28n
Theodore the Studite, 154n, 492n
Theodore, 37n
theologians, and the psyche, 208
theology, development of, 469
theophany, 453
Theophilus of Antioch, 396n
Theosebeia, 153n, 240n
Theotokos, 187, 523n
Theriaca, 29n
theriomorphic symbols, 4ff, 147, 149f, 169, 207, 298, 310
Thessalonians, First Epistle to, 238n
thief, 158, 163f, 167ff
Thomas, Acts of, *see* Acts
Thomas Aquinas, 113n, 226, 242, 398, 534n
Thorndike, Lynn, 434n
Thorpe, Benjamin, 387n
Toth, 304
three, 67, 71, 386f, 455f
 and one, 515
 and four, 207, 210ff, 392, 429ff; *see also* ternarius; Trinity
Thutmosis I, 259n
Tiamat, 340n

Tifereth, [22f](#), [244](#), [396f](#), [412f](#), [419n](#), [442n](#), [443ff](#)
tiger, [175](#), [295n](#)
Tikkune Zohar, [135n](#)
Timaeus, see Plato
time, psyche and, [300](#)
Timothy, Second Epistle to, [289n](#)
tinctura/tincture, [201](#), [224](#), [240](#), [345](#)
 rubea, [92](#)
tittle, see point
toad, [4](#), [37](#), [144](#)
tohu-bohu, [265](#)
tomb, [63ff](#)
Toniola, Johannes, [59n](#)
tortoise, [400](#)
totalitarianism, [321](#)
totality, see wholeness
totem meal, [372](#)
“Tractatulus Avicennae,” [329n](#)
“Tractat(ul)us Aristotelis,” [37n](#), [43n](#), [51](#), [64n](#), [67](#), [201f](#), [286](#)
“Tractatus aureus Hermetis,” see Hermes Trismegistus
“Tractatus Micreris,” see Micreris
“Tractatus de sulphure,” see “De sulphure”
tramps, [485f](#)
transcendent function, [200](#), [203](#)
transference, [527](#)
transformation, [420ff](#), [481](#)
 in alchemy, [80](#), [119](#), [142](#), [197](#), [213](#), [218](#), [229](#), [231](#), [236](#), [240](#), [257](#), [290f](#), [311](#), [358](#),
 [360f](#), [380](#), [426f](#), [428f](#), [451n](#), [453f](#), [500f](#), [510f](#); arcane substance, see arcane
 substance; of consciousness, see conscious
 through death and rebirth, [18](#), [142](#)
 in Greek alchemy, [14n](#), [391](#)
 in modern dreams, [74](#), [77](#)
 moral and spiritual, [263](#)
 as parallel to Passion of Christ, [345](#), [349](#)
 psychic, [106](#), [160n](#), [197](#), [240f](#), [308](#), [358f](#), [427](#), [453](#), [526](#), [529](#)

roval, Egyptian, 266
stages of, 141, 514n
transformative substance, 93, 119, 157, 215, 279f, 285, 382, 515
—, sun as, *see* sun; vessel of, 16, 119, 275

transitus, 218

transubstantiation, 30, 314

treasure-house, 4n

tree: as arcane substance, 296
cabalistic, 442
cedar, 269, 272n
coral, 133
as Cross, 389
feminine numen of, 70f
God as, 135n
of Hesperides, 78n
of knowledge, 71f, 420
of life, 69n
of light and fire, 76n
Mercury as, *see* Mercury; oak, *see* oak
palm, 71n, 272n
philosophical/*arbor philosophica*, 8n, 43, 133, 134, 154, 233, 285, 289, 292
of the sea, 134
of Sefiroth, 43, 135, 455
and serpent, *see* snake
snake numen of, 78n
sun- and moon-, 69, 133
vine, 154n, 272n
in Western Land, 69f
Yesod as, 444

Trevisanus, *see* Bernardus

triads, alchemical, 184; *see also* Trinity

trickster, 248

trimeria, 429

Trinity, 101, 123, 184, 185f, 207, 440, 524

Adam and, 398
alchemical, 184, 185, 226, 265, 459
amulet, 261
double, divine-human, 260f, 360
of God, Pharaoh, and *ka*, 260, 265
“lower triad,” 451
and quaternity, *see* quaternity
triad as, 450n, 451
—, false, 184n
trinitarian process, 318; *see also* quaternio

Trismosin, Salomon, 331, 434
Trisomatos, Hermes, 227
Trophonios, 122n, 340n
truth, 548ff
Tscharner, E. H. von, 445n
Turba philosophorum, 5n, 11n, 15n, 21, 29n, 33, 43, 46, 64, 22, 97n, 98n, 112, 113, 114n, 119f, 138f, 150, 152n, 154n, 189, 191n, 193n, 201, 238n, 249n, 286n, 303, 328, 353, 373n, 385, 457n, 459n, 460n, 470n, 479n, 492n, 511n; *see also* Ruska
Turin, 373n
Turks, Bosnian, 284
Turrius, Joannes, 59n, 66, 83f
twelve, 135
twins, 413n
two/binary, 15, 115, 188, 387, 429, 462, 534
Tylor, E. B., 358n
Typhon, 21–22n, 52n, 63n, 93, 175n, 193, 251f, 260n, 272n, 493
Tyre, 20
Tyriac, 29
Tyrian dye, 201

U

ὕδαρ θεῖον, 484, 503
“ugliest man,” 247
Ullikummi, 536n
unarius, 48, 352

unconscious(ness), 58, 81, 128, 181, 199f, 202, 210, 248, 253, 295, 368, 437n, 495, 522, 526, 527

Africa as, 211

ambivalence of, 197

archetypal structure of, 390

artificial, 472

attention to, 152, 163, 232

autonomy of, 254

birth of self in, 384

collective, 81, 84, 87, 91, 104, 106, 122f, 199, 258, 278, 280, 300, 523

—, personal and, 199f

compensatory character of, 103, 126, 156f, 162, 178f, 217, 232, 310, 333f, 346, 349, 366, 494, 497, 518, 531, 540

contamination of, 274, 293, 462f

counterposition in, 200

dangers of, 156f

destructive tendency of, 126, 184f, 200f

ego and, *see* ego

hermaphroditism of, 177

idées forces of, 528

illumination/making conscious of, 172, 201, 229, 311, 320, 356

increase of potential of, 363

integration of, 257, 546

irrational contents of, 229, 471

irruption of, 98n, 121n, 157, 208, 530, 549

longing of, for consciousness, 437

luminosity, multiple/scintillae of, 55n, 207, 491

lunar/feminine/maternal character of, 103n, 135, 144, 154, 175f, 178, 184, 241, 272, 356, 379, 517

Mercurius as, *see* Mercurius; as nigredo, *see* *nigredo*

opposites and, 79, 81

personification of, 106

physical symptoms and, 238

primordial, 462

projection of, [126](#), [196](#), [253](#), [299](#), [361](#)
psychoid, [552](#)
sea as, *see* sea
theriomorphic symbols of, [210ff](#)
transformation of, [77](#)
treatment of, [209](#)
unknowable, [498ff](#)
water as, [272f](#), [504](#)

underworld, imprisonment in, [236](#)

unicorn, [5](#), [281](#), [400](#), [423n](#), [500n](#)

unto mentalis/mental union, [465ff](#), [470f](#), [474](#), [476](#), [482f](#), [485](#), [487n](#), [497](#), [499](#), [507](#), [513](#),
[521f](#), [524](#), [528](#), [531f](#), [541](#)

unio mystica, [443](#), [537](#), [540](#)

unio naturalis, [488](#)

uniped(s), Pl. [4](#); *see also* Monocolus

unity: of arcanum, [540](#)
 creation of, [534](#)

universals, [439n](#)

unus mundus, *see* world

Upanishads, [135n](#), [136n](#), [517](#)

Uranos, [515](#)

uroboros, [79](#), [102n](#), [115n](#), [116](#), [223](#), [251](#), [294](#), [295f](#), [307f](#), [311](#), [340](#), [342n](#)
 Agathodaimon as, [112](#)
 aqua divina as, [112](#)
 as arcane substance, [29n](#), [60](#)
 as goal of opus, [504](#)
 as the One, [365](#)
 as self-devouring, [60](#), [144n](#), [285](#), [445](#)
 as symbol of self-origination / immortality, [293n](#), [365](#); *see also* dragon; snake

Ursa Major, [205n](#)

Usener, Hermann, [71n](#)

V

Vajasaneyi-samhita, [109n](#)

Valentinus/Valentinians, [282](#), [338n](#), [383](#), [403n](#), [417n](#)

Valentinus, Basilus, [5n](#), [116n](#), [152n](#), [190](#), [296](#), [302](#), [303](#), [304](#), [332n](#), [383](#)
value, in psychology, [426f](#)
van der Post, Laurens, [485n](#)
vas, see vessel *van* (Hebrew letter), [430](#)
Vaughan, Thomas, [33n](#); see also Philaletha
Vedas, see Atharva-veda; Rig-veda
Ventura, Laurentius, [15n](#), [40n](#), [51n](#), [64n](#), [98n](#), [111n](#), [118n](#), [134n](#), [150](#), [297n](#), [435n](#), [460n](#),
[461n](#)
Venus, [4](#), [7](#), [8n](#), [18](#), [83](#), [144](#), [176](#), [241](#), [302](#), [304](#)
 and Adam, [383](#)
 and green, [288](#)
 regimen of, [288f](#)
 and the stone, [304](#)
 sulphur and, [115f](#), [116n](#), [304](#)
Veranius, Caietanus Felix, [85f](#)
Verconius, Quintus, [69](#)
verdigris, [432](#)
Verus Hermes, [350n](#)
vessel, [11](#), [14n](#), [20n](#), [21](#), [70](#), [131n](#), [153](#), [202f](#), [223](#), [275n](#), [292](#), [294](#), [316f](#), [514](#)
 cup of Babylon, [301](#), [309](#)
 female/maternal aspect of, [20](#), [314](#), [378](#)
 hermetic, [15](#), [19](#), [279](#), [313](#), [522](#)
 rotundity of, [202n](#), [279](#), [435n](#), [514n](#)
 sun and moon as, [129](#), [154](#)
 symbolic, in alchemy, [119](#), [129f](#), [215](#), [223](#), [279](#), [316](#)
 tomb as, [64](#), [204](#), [273](#), [314](#), [460](#)
 of transformation, [16](#), [119](#), [275](#)
 uterus as, [71](#), [130](#), [281](#), [283](#), [314f](#); see also *cucurbita*
vetula, [18](#)
Vigènère, Blaise de, see Vigenerus
Vigenerus, Blasius, [24ff](#), [130n](#), [184n](#), [190](#), [191](#), [197](#), [239n](#), [246](#), [250](#), [252](#), [335n](#), [387](#),
[395f](#), [397](#)
Vignon, Paul, [373n](#)
Villanova, Arnaldus de, see Arnaldus
vir rubeus, see red man

vir unus, [286](#), [348](#)

Virgil, [83](#)

Virgin, [404](#); *see also* Mary

Virgin Mother, [356](#)

virginity, [374n](#)

Virgo, [176](#)

viriditas, *see* greenness

“Visio Arislei,” [4 & n](#), [5n](#), [15n](#), [38n](#);, [63](#), [90](#), [117n](#), [152n](#), [203n](#), [204n](#), [211](#), [272n](#), [283](#),
[292](#), [299](#), [314](#), [331](#), [435](#), [436n](#)

visions, of alchemists, [320](#)

“Vita Merlini,” [81](#)

Vitus, Richardus, [59n](#), [66](#), [82ff](#)

Volta, Achilles, [59n](#)

Volta, Marcus Antonius de la, [66](#)

Vulcan, [49](#)

Vulgate, [193](#), [242](#)

W

Wagner, archetypes in, [530](#)

Waite, A. E., [5n](#), [6n](#), [24n](#), [69n](#), [116n](#), [117n](#), [118n](#), [129n](#), [131n](#), [231n](#), [460n](#), [510n](#); *see also references to individual treatises in “Musaeum hermeticum”*

Walch, C. W. F., [39n](#)

water, [21](#), [237](#)

abyssal, [237n](#)

Adam as, [382](#)

central, [166](#)

chaotic, [197](#)

king and, [266ff](#)

Mercurius as, [503f](#)

permanent, *see aqua permartens*; salt and, [191](#)

sun and, [93](#), [99n](#)

symbol of unconscious, [272](#); *see also* sea-water

waterfall, [495](#)

water-vessel, [20n](#)

Wegmann, Hans, [272n](#)

Weil, Gustav, [407n](#)

Wei Po-yang, [131n](#), [156](#), [194](#), [292n](#), [295n](#), [348](#), [354](#), [436](#), [458n](#), [471n](#), [499n](#), [525n](#)

Welling, Georg von, [184](#), [241](#), [245n](#)

werewolf motif, [250n](#)

Werner, Edward T. C., [400n](#)

Western Land, [70](#)

Western man, and self-knowledge, [498](#)

whale, [210](#); *see also* hero

whale-dragon myths, [341n](#)

wheel(s), [7n](#), [41](#)

 in Ezekiel's vision, [205ff](#)

white/whiteness, [131n](#); *see also* *albedo*; black; red

White, Richard, *see* Vitus, Richardus

White, Victor, [167n](#), [187n](#)

wholeness/totality, [11](#), [15](#), [30](#), [61](#), [128](#), [203](#), [210ff](#), [279](#), [360](#), [427](#), [544ff](#)

 anima as symbol of, [307](#), [356f](#)

 cross and, [101](#)

 as goal, [210](#), [217](#), [219](#)

 of man, [63](#), [128](#), [188](#), [352](#), [426](#), [476](#), [534](#), [537](#), [546](#)

 modern representations of, [216n](#)

 and perfection, [428](#)

 of psyche, [155](#), [203](#), [390](#), [503](#), [533](#)

 quaternity and, [188](#), [203](#), [205](#), [426](#), [440](#)

 and "upper" quaternio, [188](#)

 self as, [6](#), [110](#), [122](#), [155](#), [356](#), [371](#), [493–502](#), [532](#)

 symbol of, [9](#), [101](#), [120](#), [207](#), [216](#), [219](#), [241](#), [286](#), [356](#), [529](#)

 by synthesis of male and female, [459](#)

Whore, Great, [301f](#), [304](#), [307](#)

Wickes, Frances G., [49n](#)

widow, [18ff](#)

Wieland, C. Martin, [297](#), [306n](#)

Wilamowitz-Moellendorff, U. von, [122n](#)

Wilhelm, Richard, [401n](#), [419n](#)

wine, [478](#), [486](#), [493](#), [510](#)

Winter, J., and Wünsche, A., 135n

wisdom, 512

 crown of, 9

 and feeling, 248f

 salt and, 242ff, 272

Wisdom of Solomon, The, 318n, 353n

Wise Old Man, 106, 233

witches, 73

Wittekindt, W., 31n, 71n, 129n, 131n, 157n, 302n, 431n

Wolbero, 521n

wolf, 5, 144, 210

Wolfram von Eschenbach, 274f, 423n

woman: in alchemy, 153, 178, 315

 carrier of wholeness, 357

 closeness to nature, 247f

 consciousness of, 178f

 and the devil, 188

 and dragon, 21, 37, 64, 142, 220, 460n, 470

femina alba/mulier candida/white woman, 4, 69, 131, 192, 240, 458n

 and Luna, 247

 salt and, 247; *see also* consciousness; red man

Word, the, 404

world(s): axis of, 76n

 division into two of, 462

 empirical, 538

 higher, 514

 navel of, 447n

 physical and perceptual, 548

 potential, “caelum” as equivalent of, 542

 —, as *mundus archetypus*, 534ff

 —, as *unio mystica*, 537

 and soul, 202

 three or four, 184

 unity of/*unus mundus*, 462f, 465, 476, 505, 533ff, 537ff

world-egg, 335, 516
world-picture, 403
world-soul, 55, 185n, 279, 512; see also *anima mundi*
worm, 334, 336, 338, 341, 342n, 343, 350n, see also snake
wounding, 31ff, 121
wrath-fire, 344n, 441
Wünsche, August, 384n, 398n, 406n, 409n, 412n, 440n

Y

Yahweh, 197, 361, 402, 546
yang/yin, 79, 139n, 195, 289n, 295, 400, 421, 458n, 464, 470
Yesod, 23f, 442ff, Pl.3
Yetser ha-ra, 161
YHVH, 429f
Yima, 448n
yin, see *yang/yin*
Ymir, 40n
yod (Hebrew letter), 429f, 447n
Yoga, 214
youth, winged, 158, 164f, 168ff
Yüan-shih t'ien-tsun, 400
Yusasit, 33n

Z

Zacchaeus, 135n
Zacharius, Dionysius, 93n, 112n, 114n, 119n
Zaddik, 442
Zadith, see Senior
Zarathustra, see Nietzsche
Zechariah, Book of, 52, 206n, 207, 437n, 447n
Zen, 540
Zeus, 34n, 78, 536n
Zimmer, Heinrich, 82n
zinc, 80n
zodiac, 6, 7, 225

Zohar, 23n, 24, 25n, 32n, 69n, 135n, 396, 399, 408, 410, 413n, 429n, 440n, 442, 443,
444n, 445n, 447n, 492n

Zorobabel, 437n

Zosimos, 4n, 9n, 33, 94n, 153n, 231, 236n, 237n, 240n, 262, 263f, 280, 322n, 348n,
388n, 390, 410, 436, 437, 465n, 479n, 525

CORRELATION OF PARAGRAPH NUMBERS

As the *Gesammelte Werke* edition of *Mysterium Coniunctionis* (2 vols., 1968) retains the textual arrangement and paragraph numbering of the first Swiss edition (1955/1956) and therefore varies in these respects from the Collected Works edition, the following table gives the equivalents between the two. The principal changes of arrangement, approved by Professor Jung, are explained in footnotes in the Collected Works edition. Paragraphs 1–30 are numbered alike in both editions.

Collected Works	Gesammelte Werke
[Band I]	
CHAPTER I	
1	1
31/32	31
33	32
34	33
35	34
CHAPTER II	
36	35
37	36
38	37
39	38
40	39
41	40
42	41
43	42
44	43
45	44/60
46	61

47	62
48/49	44
50	45
51	46
52	47
53	48
54	49
55	50
56	51
57	52/53
58	53
59	54
60	55
61	56
62	57/58
63	59
64	60
65	63
66	64
67	65
68	66
69	67
70	68
71	69
72	70
73	71
74	72
75	73
76	37 [<i>Bd. II</i>]
77	74

78	75
79	76
80	77
81	78
82	79
83	80
84	81
85	82
86	83
87	84
88	85
89	86
90	87
91	88
92	89
93	90
94	91
95	92
96	93
97	94
98	95
99	96
100	97
101	98
102	99
103	100

CHAPTER III

104	101
105	102

106	103
107	104
108	105
109	106
110	107
111	108
112	109
113	110
114	111
115	112
116	113
117	114
118	115
119	116
120	117
121	118
122	119
123	120
124/125	121
126	122
127	123
128	124
129	125
130	126
131	127
132	128
133	129
134	130
135	131
136	132

137	133
138	134
139	135
140	136
141	137
142	138
143	139
144	140
145/146	141
147	142
148	143
149	144
150	145
151	146
152	147
153	148
154	149
155	150
156	151
157	152
158	153
159	154
160	155
161	156
162	157
163	158
164	159
165	160
166	161

167	162
168	163
169	164
170	165
171	166
172	167
173	168
174	169
175	170
176	171
177	172
178	173
179	174
180/181	175
182	176
183	177
184	178
185	179
186	180
187	181
188	182
189	183
190	184
191	185
192/193	186
194	187
195	188
196	189
197	190
198	191

199	192
200	193
201	194
202	195
203	196/197
204	198
205	199
206	200
207	201
208	202
209	203
210	204
211	205
212	206
213	207
214	208
215	209
216	210
217	211
218	212
219	213
220	214
221	215
222	216
223	217
224	218
225	219
226	220
227	221

228	222
229	223
230	224
231	225
232	226
233	227
234	228
235	229
236	230
237	231
238	232
239	233
240	234
241	235
242	236
243	237
244	238
245	239
246	240
247	241
248	242
249	243
250	244
251	245
252	246
253	247
254	248
255	249
256	250
257	251

258	252
259	253
260	254
261	255
262	256
263	257
264	258
265	259
266	260
267	278
268	261
269	262
270	263
271	264
272	265
273	266
274	267
275	268
276	269
277	270
278	271
279	272
280	273
281	274
282	275
283	276
284	277
285	278/279
286	280

287	281
288	282
289	283
290	284
291	285
292	286
293	287
294	288
295	289
296	290
297	291
298	292
299	293
300	294
301	295
302	296
303	297
304	298
305	299
306	300
307	301
308	302
309	303
310	304
311	305
312	306
313	307
314	308
315	309
316	310

317	311
318	312
319	313
320	314
321	315
322	316
323	317
324	318
325	319
326	320
327	321
328	322
329	323
330	324
331	325
332	326
333	327
334	328
335	329
336	330
337	331
338	332
339	333
340	334
341–343	335
344	336
345	337
346/347	338
347	339

CHAPTER IV

349	1
350	2
351	3
352	4
353	5
354	6
355	7
356	8/9
357	10
358	11
359	12
360	13
361	14
362	15
363	16
364	17
365	18
366	19
367	20
368	21
369	22
370	23
371	24
372	25
373	26/27
374	28/29
375	30

376	31
377	32
378	33
379	34
380	35/40
381	41
382	42
383	43
384	44
385	45
386	46
387	47
388	48
389	49
390	50
391	51
392	52
393	53
394	54
395	55
396	56
397	57
398	58
399	59
400	60
401	61
402	62
403	63
404	64

405	65
406	66
407	67
408	68
409	69
410	70
411	71
412/413	72
414	73
415	74
416	75
417/418	76
419	77
420	78
All	79
422	81
423	82
424/425	83
426	84
427	85
428	86
429	87
430	88
431	89
432	90
433	91
434	93/92/94
435	95
436	96
437	97

438	98/99
439	100
440	101
441	102
442	103
443	104
444	105
445	106
446	107
447	108
448	109/110
449	111
450	112
451	113
452	114
453	115–119
454	120
455	121
456	122
457	123
458	124
459	125/126
460	127
461	128
462	129
463	130
464/465	131
466	132
467/468	133

469	134
470	135
471	136
472	137
473	138
474	139
475	140
476	141
477	142
478	143
479	144
480	145
481	146
482	147
483	148
484	149
485	150
486	151
487	152
488	153
489	154
490	155
491	156
492	157
493	158
494	159
495	160
496	161
497	162
498	163

499	164
500	165
501	166
502	167
503	168
504	169
505/506	170
507	171
508	172
509	173
510	174
511	175
512	176
513	177
514	178
515	179
516	180
517	181
518	182
518a*	183
519	184
520	185
521	186
522	187
523	188
524	189
525	190
526	191
527	192

528	193
529	194
530	195
531	196
532	197
533	198
534	199
535	200
536	201
537	202
538	203
539	204
540	205
541	206
542	207
543	208

CHAPTER V

544	209
545	210
546	211
547	212
548	213
549	214
550	215
551	216
552	217
553	218
554	219
555	220
556	221

557	222
558	223
559	224
560	225
561	226
562	227
563	228
564	229
565	230
566	231
567	232
568	233
569	234
570	235/248
571	235/248
572	236
573	237
574	238
575	239
576	240
577	241
578	242
579	243/246
580	244
581	245
582	246
583	249
584	250
585	251

586	252
587	253
588	254
589	255
590	256
591	257
592	258
593	266
594	268
595	259
596	260
597	261
598	262
599	263
600	264
601	269
602	270
603	271
604	272
605	273
606	265
607	274
608	275
609	276
610	277
611	278
612	279
613	280
614	281
615	282

616	283
617	284
618	285
619	267
620	286
621	287
622	288
623	289
624	290
625	291
626	292
627	293
628	294
629	295
630	296
631	297
632	298
633	299
634	300/274/303
635	300
636	301
637	302
638	304
639	305
640	306
641	307
642	308
643	309
644	310

645	311
646	312
647	313
648	314
649	315
650	316
651	317
652	318
653	319

CHAPTER VI

654/655	320
656	321
657	322
658	323
659	324
660	325
661	326
662	327
663	328
664	329
665	330
666	331
667	332
668	333
669	334
670–672	335
673	338
674	339
675	340
676	336

677/678	337
679	341
680	342
681	343
682	344
683	345
684/685	346
686/687	347
688	348
689	349
690	350
691	351
692	352
693	353
694	354
695	355
696	356
697	357
698	358
699	359
700	360
701	361
702	362
703	363
704	364
705/706	365
707	366
708	367
709	368

710	369
711	370
712–714	371
715	372
716	373
717	374
718	375
719	376
720	377
721	378
722	379
723	380
724	381
725	382
726	383
727	384
728	385
729	386
730	387
731	388
732	389
733	390
734	391
735	392
736	393
737	394
738	395
739	396
740	397
741–743	398

744	399
745	400
746	401
747	402
748	403
749	404
750	405
751/752	406
753	407
754	408
755	409
756	410
757	411
758	412
759	413
760	414
761	415/416
762	417
763	418
764	419
765	420
766	421
767	422
768	423
769	424
770	425
771	426
772	427
773	428

774	429
775	430
776	431
777	432
778	433
779	434
780	435
781	436
782	437
783	438
784	439
785	440
786	441
787	442
788	443
789	444

EPILOGUE

790	445
791	446
792	447

THE COLLECTED WORKS OF

C. G. JUNG

THE PUBLICATION of the first complete edition, in English, of the works of C. G. Jung was undertaken by Routledge and Kegan Paul, Ltd., in England and by Bollingen Foundation in the United States. The American edition is number XX in *Bollingen Series*, which since 1967 has been published by Princeton University Press. The edition contains revised versions of works previously published, such as *Psychology of the Unconscious*, which is now entitled *Symbols of Transformation*; works originally written in English, such as *Psychology and Religion*; works not previously translated, such as *Aion*; and, in general, new translations of virtually all of Professor Jung's writings. Prior to his death, in 1961, the author supervised the textual revision, which in some cases is extensive. Sir Herbert Read (d. 1968), Dr. Michael Fordham, and Dr. Gerhard Adler compose the Editorial Committee; the translator is R. F. C. Hull (except for Volume 2) and William McGuire is executive editor.

The price of the volumes varies according to size; they are sold separately, and may also be obtained on standing order. Several of the volumes are extensively illustrated. Each volume contains an index and in most a bibliography; the final volume will contain a complete bibliography of Professor Jung's writings and a general index to the entire edition.

In the following list, dates of original publication are given in parentheses (of original composition, in brackets). Multiple dates indicate revisions.

* 1. PSYCHIATRIC STUDIES

On the Psychology and Pathology of So-Called Occult Phenomena (1902)

On Hysterical Misreading (1904)

Cryptomnesia (1905)

On Manic Mood Disorder (1903)

A Case of Hysterical Stupor in a Prisoner in Detention (1902)

On Simulated Insanity (1903)

A Medical Opinion on a Case of Simulated Insanity (1904)

A Third and Final Opinion on Two Contradictory Psychiatric Diagnoses
(1906)

On the Psychological Diagnosis of Facts (1905)

†2. EXPERIMENTAL RESEARCHES

Translated by Leopold Stein in collaboration with Diana Riviere

STUDIES IN WORD ASSOCIATION (1904–7, 1910)

The Associations of Normal Subjects (by Jung and F. Riklin)

An Analysis of the Associations of an Epileptic

The Reaction-Time Ratio in the Association Experiment

Experimental Observations on the Faculty of Memory

Psychoanalysis and Association Experiments

The Psychological Diagnosis of Evidence

Association, Dream, and Hysterical Symptom

The Psychopathological Significance of the Association Experiment

Disturbances in Reproduction in the Association Experiment

The Association Method

The Family Constellation

PSYCHOPHYSICAL RESEARCHES (1907–8)

On the Psychophysical Relations of the Association Experiment

Psychophysical Investigations with the Galvanometer and Pneumograph in
Normal and Insane Individuals (by F. Peterson and Jung)

Further Investigations on the Galvanic Phenomenon and Respiration in
Normal and Insane Individuals (by C. Ricksher and Jung)

Appendix: Statistical Details of Enlistment (1906); New Aspects of Criminal
Psychology (1908); The Psychological Methods of Investigation Used in
the Psychiatric Clinic of the University of Zurich (1910); On the Doctrine
of Complexes ([1911] 1913); On the Psychological Diagnosis of Evidence
(1937)

*3. THE PSYCHOGENESIS OF MENTAL DISEASE

The Psychology of Dementia Praecox (1907)

The Content of the Psychoses (1908/1914)

On Psychological Understanding (1914)

A Criticism of Bleuler's Theory of Schizophrenic Negativism (1911)

On the Importance of the Unconscious in Psychopathology (1914)

On the Problem of Psychogenesis in Mental Disease (1919)

Mental Disease and the Psyche (1928)

On the Psychogenesis of Schizophrenia (1939)

Recent Thoughts on Schizophrenia (1957)

Schizophrenia (1958)

†4. FREUD AND PSYCHOANALYSIS

Freud's Theory of Hysteria: A Reply to Aschaffenburg (1906)

The Freudian Theory of Hysteria (1908)

The Analysis of Dreams (1909)

A Contribution to the Psychology of Rumour (1910–11)

On the Significance of Number Dreams (1910–11)

Morton Prince, "The Mechanism and Interpretation of Dreams": A Critical Review (1911)

On the Criticism of Psychoanalysis (1910)

Concerning Psychoanalysis (1912)

The Theory of Psychoanalysis (1913)

General Aspects of Psychoanalysis (1913)

Psychoanalysis and Neurosis (1916)

Some Crucial Points in Psychoanalysis: A Correspondence between Dr. Jung and Dr. Loÿ (1914)

Prefaces to "Collected Papers on Analytical Psychology" (1916, 1917) The Significance of the Father in the Destiny of the Individual (1909/1949)

Introduction to Kranefeldt's "Secret Ways of the Mind" (1930)

Freud and Jung: Contrasts (1929)

‡5. SYMBOLS OF TRANSFORMATION (1911–12/1952)

PART I

Introduction

Two Kinds of Thinking

The Miller Fantasies: Anamnesis

The Hymn of Creation

The Song of the Moth

PART II

Introduction

The Concept of Libido

The Transformation of Libido

The Origin of the Hero
Symbols of the Mother and of Rebirth
The Battle for Deliverance from the Mother
The Dual Mother
The Sacrifice
Epilogue
Appendix: The Miller Fantasies

*6. PSYCHOLOGICAL TYPES (1921)

Introduction
The Problem of Types in the History of Classical and Medieval Thought
Schiller's Ideas on the Type Problem
The Apollinian and the Dionysian
The Type Problem in Human Character
The Type Problem in Poetry
The Type Problem in Psychopathology
The Type Problem in Aesthetics
The Type Problem in Modern Philosophy
The Type Problem in Biography
General Description of the Types
Definitions
Epilogue
Four Papers on Psychological Typology (1913, 1925, 1931, 1936)

†7. TWO ESSAYS ON ANALYTICAL PSYCHOLOGY

On the Psychology of the Unconscious (1917/1926/1943)
The Relations between the Ego and the Unconscious (1928)
Appendix: New Paths in Psychology (1912); The Structure of the Unconscious (1916) (new versions, with variants, 1966)

‡8. THE STRUCTURE AND DYNAMICS OF THE PSYCHE

On Psychic Energy (1928)
The Transcendent Function ([1916]/1957)
A Review of the Complex Theory (1934)
The Significance of Constitution and Heredity in Psychology (1929)
Psychological Factors Determining Human Behavior (1937)

Instinct and the Unconscious (1919)
The Structure of the Psyche (1927/1931)
On the Nature of the Psyche (1947/1954)
General Aspects of Dream Psychology (1916/1948)
On the Nature of Dreams (1945/1948)
The Psychological Foundations of Belief in Spirits (1920/1948)
Spirit and Life (1926)
Basic Postulates of Analytical Psychology (1931)
Analytical Psychology and *Weltanschauung* (1928/1931)
The Real and the Surreal (1933)
The Stages of Life (1930–1931)
The Soul and Death (1934)
Synchronicity: An Acausal Connecting Principle (1952)
Appendix: On Synchronicity (1951)

*9. PART 1. THE ARCHETYPES AND THE COLLECTIVE UNCONSCIOUS

Archetypes of the Collective Unconscious (1934/1954)
The Concept of the Collective Unconscious (1936)
Concerning the Archetypes, with Special Reference to the Anima Concept
(1936/1954)
Psychological Aspects of the Mother Archetype (1938/1954)
Concerning Rebirth (1940/1950)
The Psychology of the Child Archetype (1940)
The Psychological Aspects of the Kore (1941)
The Phenomenology of the Spirit in Fairytales (1945/1948)
On the Psychology of the Trickster-Figure (1954)
Conscious, Unconscious, and Individuation (1939)
A Study in the Process of Individuation (1934/1950)
Concerning Mandala Symbolism (1950)
Appendix: Mandalas (1955)

*9. PART II AION (1951)

RESEARCHES INTO THE PHENOMENOLOGY OF THE SELF

The Ego

The Shadow

The Syzygy: Anima and Animus

The Self

Christ, a Symbol of the Self

The Sign of the Fishes

The Prophecies of Nostradamus

The Historical Significance of the Fish

The Ambivalence of the Fish Symbol

The Fish in Alchemy

The Alchemical Interpretation of the Fish

Background to the Psychology of Christian Alchemical Symbolism

Gnostic Symbols of the Self

The Structure and Dynamics of the Self

Conclusion

* 10. CIVILIZATION IN TRANSITION

The Role of the Unconscious (1918)

Mind and Earth (1927/1931)

Archaic Man (1931)

The Spiritual Problem of Modern Man (1928/1931)

The Love Problem of a Student (1928)

Woman in Europe (1927)

The Meaning of Psychology for Modern Man (1933/1934)

The State of Psychotherapy Today (1934)

Preface and Epilogue to “Essays on Contemporary Events” (1946)

Wotan (1936)

After the Catastrophe (1945)

The Fight with the Shadow (1946)

The Undiscovered Self (Present and Future) (1957)

Flying Saucers: A Modern Myth (1958)

A Psychological View of Conscience (1958)

Good and Evil in Analytical Psychology (1959)

Introduction to Wolff’s “Studies in Jungian Psychology” (1959)

The Swiss Line in the European Spectrum (1928)

Reviews of Keyserling’s “America Set Free” (1930) and “La Révolution
Mondiale” (1934)

The Complications of American Psychology (1930)

The Dreamlike World of India (1939)

What India Can Teach Us (1939)

Appendix: Documents (1933–1938)

†11. PSYCHOLOGY AND RELIGION: WEST AND EAST

WESTERN RELIGION

Psychology and Religion (The Terry Lectures) (1938/1940)

A Psychological Approach to the Dogma of the Trinity (1942/1948)

Transformation Symbolism in the Mass (1942/1954)

Forewords to White's "God and the Unconscious" and Werblowsky's "Lucifer and Prometheus" (1952)

Brother Klaus (1933)

Psychotherapists or the Clergy (1932)

Psychoanalysis and the Cure of Souls (1928)

Answer to Job (1952)

EASTERN RELIGION

Psychological Commentaries on "The Tibetan Book of the Great Liberation" (1939/1954) and "The Tibetan Book of the Dead" (1935/1953)

Yoga and the West (1936)

Foreword to Suzuki's "Introduction to Zen Buddhism" (1939)

The Psychology of Eastern Meditation (1943)

The Holy Men of India: Introduction to Zimmer's "Der Weg zum Selbst" (1944)

Foreword to the "I Ching" (1950)

*12. PSYCHOLOGY AND ALCHEMY (1944)

Prefatory note to the English Edition ([1951?] added 1967)

Introduction to the Religious and Psychological Problems of Alchemy

Individual Dream Symbolism in Relation to Alchemy (1936)

Religious Ideas in Alchemy (1937)

Epilogue

†13. ALCHEMICAL STUDIES

Commentary on "The Secret of the Golden Flower" (1929)

The Visions of Zosimos (1938/1954)

Paracelsus as a Spiritual Phenomenon (1942)

The Spirit Mercurius (1943/1948)

The Philosophical Tree (1945/1954)

‡14. MYSTERIUM CONIUNCTIONIS (1955–56)

AN INQUIRY INTO THE SEPARATION AND

SYNTHESIS OF PSYCHIC OPPOSITES IN ALCHEMY

The Components of the Coniunctio

The Paradoxa

The Personification of the Opposites

Rex and Regina

Adam and Eve

The Conjunction

*15. THE SPIRIT IN MAN, ART, AND LITERATURE

Paracelsus (1929)

Paracelsus the Physician (1941)

Sigmund Freud in His Historical Setting (1932)

In Memory of Sigmund Freud (1939)

Richard Wilhelm: In Memoriam (1930)

On the Relation of Analytical Psychology to Poetry (1922)

Psychology and Literature (1930/1950)

“Ulysses”: A Monologue (1932)

Picasso (1932)

†16. THE PRACTICE OF PSYCHOTHERAPY

GENERAL PROBLEMS OF PSYCHOTHERAPY

Principles of Practical Psychotherapy (1935)

What Is Psychotherapy? (1935)

Some Aspects of Modern Psychotherapy (1930)

The Aims of Psychotherapy (1931)

Problems of Modern Psychotherapy (1929)

Psychotherapy and a Philosophy of Life (1943)

Medicine and Psychotherapy (1945)

Psychotherapy Today (1945)

Fundamental Questions of Psychotherapy (1951)

SPECIFIC PROBLEMS OF PSYCHOTHERAPY

The Therapeutic Value of Abreaction (1921/1928)

The Practical Use of Dream-Analysis (1934)

The Psychology of the Transference (1946)

Appendix: The Realities of Practical Psychotherapy ([1937] added, 1966)

‡17. THE DEVELOPMENT OF PERSONALITY

Psychic Conflicts in a Child (1910/1946)

Introduction to Wickes's "Analyses der Kinderseele" (1927/1931)

Child Development and Education (1928)

Analytical Psychology and Education: Three Lectures (1926/1946)

The Gifted Child (1943)

The Significance of the Unconscious in Individual Education (1928)

The Development of Personality (1934)

Marriage as a Psychological Relationship (1925)

18. THE SYMBOLIC LIFE

Miscellaneous Writings

19. BIBLIOGRAPHY OF C. G. JUNG'S WRITINGS

20. GENERAL INDEX TO THE COLLECTED WORKS

* Revised for the second edition (1970).

1 *Das Aegäische Fest: Die Meergötterszene in Goethes Faust II.*

2 [First Swiss edn., 1944, but the two chief component essays first appeared in *Eranos Jahrbuch* 1935 and 1936.—EDITORS.]

3 *Problems of Mysticism and Its Symbolism*, first pub. 1914.

4 From *σπάειν*, ‘rend, tear, stretch out’, *ἀγείρειν*, ‘bring or collect together’.

5 Cf. “Psychology of the Transference.”

6 [This refers to the Swiss edition, which was published in three parts, each a separate volume, the third being devoted to a contribution by M.-L. von Franz. Parts I and II constitute the present volume. Part III has appeared in English under the title *Aurora Consurgens: A Document Attributed to Thomas Aquinas on the Problem of Opposites in Alchemy* (Bollingen Series LXXVII, New York and London, 1966), as a companion volume to *Mysterium Coniunctionis* but outside the Collected Works.—EDITORS.]

7 [The Swiss edition adds: “For Parts I and II I am responsible, while my coworker, Dr. Marie-Louise von Franz, is responsible for Part III. We have brought the book out jointly, because each author has participated in the work of the other.”]

1 Ripley says: “The coniunctio is the uniting of separated qualities or an equalizing of principles.” “Duodecim portarum axiomata philosophica,” *Theatrum chemicum*, II, p. 128.

2 Cf. the representation of the *tetrameria* in Stolcius de Stolcenberg, *Viridarium chymicum*, Fig. XLII.

3 Cf. “Consilium coniugii,” *Ars chemica*, p. 79: “In this stone are the four elements, and it is to be compared to the world and the composition of the world.” * [For the Latin or Greek of the quotations marked with an asterisk, see the Appendix.—EDITORS.] Also Michael Maier, *De circulo physico quadrato*, p. 17: “Nature, I say, when she turned about the golden circle, by that movement made its four qualities equal, that is to say, she squared that homogeneous simplicity turning back on itself, or brought it into an equilateral rectangle, in such a way that contraries are bound together by contraries, and enemies by enemies, as if with everlasting bonds, and are held in mutual embrace.” * Petrus Bonus says: “The elements are conjoined in the circle in true friendship” * (*Bibliotheca chemica*, II, p. 35).

4 Cf. John Dee, “Monas hieroglyphica,” *Theatr. chem.*, II, p. 220.

5 Cf. “Consilium coniugii,” *Ars chemica*, pp. 69f., and “Clangor buccinae,” *Artis auriferae*, I, p. 484. In the Cabala the situation is reversed: red denotes the female, white (the left side) the male. Cf. Mueller, *Der Sohar und seine Lehre*, pp. 20f.

6 “Aenigmata ex visione Arislei,” *Art. aurif.*, I, pp. 146ff. Union of sun and moon: Petrus Bonus (ed. Lacinus), *Pretiosa margarita novella* (1546), p. 112. The archetype of the heavenly marriage plays a great role here. On a primitive level this motif can be found in shamanism. Cf. Eliade, *Shamanism*, p. 75.

7 The most complete collection of the illustrations that appeared in printed works is Stolcius de Stolcenberg’s *Viridarium chymicum figuris cupro incisus adornatum* (Frankfurt, 1624).

8 *Symbola aureae mensae*, p. 192.*

9 The “treasure-house” (*gazophylacium, domus thesauraria*) of philosophy, which is a synonym for the *aurum philosophorum*, or lapis. Cf. von Fra. z, *Aurora Consurgens*, pp. 101ff. The idea goes back to Alphidius (see “Consilium coniugii,” *Ars chemica*, p. 108) and ultimately to Zosimos, who describes the lapis as a shining white temple of marble. Berthelot, *Collection des anciens alchimistes grecs*, III, i, 5.

10 *Symb. aur. mensae*, p. 200.

11 The printing is undated, but it probably comes from Samuel Emmel’s press at Strasbourg and may be contemporaneous with *Ars chemica*, which was printed there in 1566 and matches our libellus as regards type, paper, and format. The author, Senior Zadith filius Hamuel, may perhaps have been one of the Harranites of the 10th cent., or at least have been influenced by them. If the *Clavis maioris sapientiae* mentioned by Stapleton (“Muhammad bin Umail: His Date, Writings, and Place in Alchemical History”) is identical with the Latin treatise of the same name, traditionally ascribed to Artefius, this could be taken as proved, since that treatise contains a typical Harranite astral theory. Ruska (“Studien zu M. ibn Umail”) groups Senior with the *Turba* literature that grew up on Egyptian soil.

12 Senior says: “I joined the two luminaries in marriage and it became as water having two lights” * (*De chemia*, pp. 15f.).

13 *Musaeum hermeticum*, p. 343. (Cf. Waite, *The Hermetic Museum Restored and Enlarged*, I, pp. 276f.)

14 *Corpus* (as *corpus nostrum*) usually means the chemical “body” or “substance,” but morally it means the human body. “Sea” is a common symbol of the unconscious. In alchemy, therefore, the “body” would also symbolize the unconscious.

15 “Aenigmata philosophorum II,” *Art. aurif.*, I, p. 149. Cf. *Aion*, pars. 195, 213 n. 51.

16 See *Psychology and Alchemy*, fig. 240.

17 “They also appear in the “XI ‘Clavis” of Basilius Valentinus, *Chymische Schrifften*, p. 68, and in *Viridarium*, Figs. XI, LV, LXII. Variants are lion and snake (*Viridarium*, Fig. XII), lion and bird (Fig. LXXIV), lion and bear (Figs. XCIII and CVI).

18 Cf. Petrus Bonus, “Pretiosa margarita novella,” *Theatr. chem*, V, pp. 647f.: “Hermes: At the end of the world heaven and earth must be joined together, which is the philosophical word.” * Also *Mus. herm.*, p. 803 (Waite, II, p. 263).

19 Ms. Incipit: “Figurarum Aegyptiorum Secretarum.” 18th cent. (Author’s collection.)

20 “Thus the height is hidden and the depth is made manifest” * (*Mus. herm.*, p. 652).

21 Cf. the oft-repeated saying: “From the dead he makes the living” * (Mylius, *Philosophia reformata*, p. 191).

22 Mylius, p. 118. The fourth degree is the *coniunctio*, which would thus correspond to Capricorn.

23 Mylius remarks (p. 115): “... equality arises . . . from the four incompatibles mutually partaking in nature.” * A similar ancient idea seems to be that of the *ἡλιακὴ τράπεζα* (solar table) in the Orphic mysteries. Cf. Proclus, *Commentaries on the Timaeus of Plato*, trans. by Taylor, II, p. 378: “And Orpheus knew indeed of the Crater of Bacchus, but he also establishes many others about the solar table.” * Cf. also Herodotus, *The Histories*, III, 17–18 (trans. by de Selincourt, p. 181), and Pausanias, *Description of Greece*, VI, 26, 2 (trans. by Jones, III, pp. 156ff.).

24 Cf. *Psychology and Alchemy*, index, s.v. “rotundum,” “sphere,” “wheel,” and especially (par. 469, n. 110) the wheel with twelve buckets for raising souls in the *Acta Archelai*.

25 Holmyard, *Kitāb al-’ilm al-muktasab*, p. 38.

26 The idea of uniting the Many into One is found not only in alchemy but also in Origen, *In Libr. I Reg. [I Sam.] Horn.*, I, 4 (Migne, *P.G.*, vol. 12, col. 998): “There was one man. We, who are still sinners, cannot obtain this title of praise, for each of us is not one but many ... See how he who thinks himself one is not one, but seems to have as many personalities as he has moods, as also the Scripture says: A fool is changed as the moon.” * In another homily, *In Ezech.*, 9, 1 (Migne, *P.G.*, vol. 13, col. 732) he says: “Where there are sins, there is multitude ... but where virtue is, there is singleness, there is union.” * Cf. *Porphyry the Philosopher to His Wife Marcella*, trans. by Zimmern, p. 61: “If thou wouldst practise to ascend into thyself, collecting together all the powers which the body hath scattered and broken up into a multitude of parts unlike their former unity ...” Likewise the Gospel of Philip (cited from Epiphanius, *Panarium*, XXVI, 13): “I have taken knowledge (saith the soul) of myself, and have gathered myself together out of every quarter and have not begotten (sown) children unto the Ruler, but have rooted out his roots and gathered together the members that were scattered abroad. And I know thee who thou art, for I (she saith) am of them that are from above.” (James, *The Apocryphal New Testament*, p. 12.) Cf. also *Panarium*, XXVI, 3: “I am thou, and thou art I, and wherever thou art, there I am, and I am scattered in all things, and from wherever thou wilt thou canst gather me, but in gathering me thou gatherest together thyself.” The inner multiplicity of man reflects his microcosmic nature, which contains within it the stars and their (astrological) influences. Thus Origen (*In Lev. Horn.*, V, 2; Migne, *P.G.*, vol. 12, cols. 449–50) says: “Understand that thou hast within thyself herds of cattle . . . flocks of sheep and flocks of goats ... Understand that the fowls of the air are also within thee. Marvel not if we say that these are within thee, but understand that thou thyself art another world in little, and hast within thee the sun and the moon,

and also the stars ... Thou seest that thou hast all those things which the world hath." * And Dorn ("De tenebris contra naturam," *Theatr. chem.* I, p. 533) say: "To the four less perfect planets in the heavens there correspond the four elements in our body, that is, earth to Saturn, water to Mercury [instead of the moon, see above], air to Venus, and fire to Mars. Of these it is built up, and it is weak on account of the imperfection of the parts. And so let a tree be planted from them, whose root is ascribed to Saturn," * etc., meaning the philosophical tree, symbol of the developmental process that results in the unity of the filius Philosophorum, or lapis. Cf. my "The Philosophical Tree," par. 409.

27 The *ἀγαθὸς δαίμων* is a snakelike, chthonic fertility daemon akin to the "genius" of the hero. In Egypt as well it was a snakelike daemon giving life and healing power. In the Berlin Magic Papyrus it is the *ἀγαθὸς γεωργός* who fertilizes the earth, On Gnostic gems it appears together with Enoch, Enoch being an early parallel of Hermes. The Sabaeans who transmitted the Agathodaimon to the Middle Ages as the *πνεῦμα πάρεδρον* (familiar spirit) of the magical procedure, identified it with Hermes and Orpheus. (Chwolsohn, *Die Ssabier*, II, p. 624.) Olympiodorus (Berthelot, *Alch. grecs*, II, iv, 18) mentions it as the "more secret angel" (*μυστικώτερον ἄγγελον*), as the uroboros or "heaven," on which account it later became a synonym for Mercurius.

28 Cf. the Indian teachings concerning *hiranyagarbha*, 'golden germ,' and *purusha*. Also "The Psychology of Eastern Meditation," pars. 917f.

29 Cf. *ἕλη τῆς ὀρνιθογονίας* (the matter of the generation of the bird) in Zosimos (Berthelot, III, xlv, 1).

30 Holmyard, p. 37.

31 Cf. *Psychology and Alchemy*, figs. 203–5.

32 von Franz, pp. 53f Cf. also Goodenough, "The Crown of Victory. . . ." Senior (*De chemia*, p. 41) calls the *terra alba foliata* "the crown of victory." In *Heliodori carmina*, v. 252 (ed. by Goldschmidt, p. 57) the soul, on returning to the body, brings it a *νικητικὸν στέμμα*, 'wreath of victory.' In the Cabala the highest Sefira (like the lowest) is called Kether, the Crown. In Christian allegory the crown signifies Christ's humanity: Rabanus Maurus, *Allegoriae in Sacram Scripturam* (Migne, *P.L.*, vol. 112, col. 909). In the Acts of John, §109 (James, *Apocryphal New Testament*, p. 268) Christ is called the diadem.

33 *Ars chemica*, p. 196.*

34 "Opusculum autoris ignoti," *Art. aurif.*, I, p. 390. The author is generally cited as "Rhasis." Cf. Ruska, *Turba Phil.*, pp. 161f. Also Ephraem Syrus, *Hymni et Sermones* (ed. Lamy, I, col. 136): "Thy babe, O Virgin, is an old man; he is the Ancient of Days and precedeth all time."*

35 Dorn in "Physica Trismegisti," *Theatr. chem.*, I, p. 420. The division of the elements into two higher "psychic" elements and two lower "somatic" elements goes back to Aristotle. Cf. Lippmann, *Entstehung und Ausbreitung der Alchemie*, I, p. 147.

36 "Liber de alchemia," *Theatr. chem.*, I, p. 775.

37 Sea is a synonym for the prima materia.

38 *Theatr. chem.*, V, p. 111. This treatise (Micreris = Mercurius) is undoubtedly old and is probably of Arabic origin. The same saying is quoted by "Milvescindus" (Bonus, "Pretiosa marg. nov.," *Theatr. chem.*, V, pp. 662f.). In the *Turba* he is called "Mirnefindus."

39 This treatise, of Arabic origin, is printed in *Bibliotheca chemica*, I, pp. 400ff.

40 “For when she applies her beak to her breast, her whole neck with the beak is bent into the shape of a circle. . . . The blood flowing from her breast restores life to the dead fledglings.” * Ibid., p. 442 b.

41 Ibid.*

42 Ibid., 408 b. Cf. the words of the “bride” in *Aurora Consurgens*, p. 143: “I am the mediatrix of the elements, making one to agree with another; that which is warm I make cold . . . that which is dry I make moist . . . that which is hard I soften, and the reverse.” (Cf. Senior, *De chemia*, p. 34.)

43 *Bibl. chem.*, 408 a.

44 “It will penetrate every solid thing” * (“Tabula smaragdina”). The sentence “for the spirit alone penetrates all things, even the most solid bodies,” is probably not without reference to “for the Spirit searcheth all things, yea, the deep things of God” in I Cor. 2:10 (AV). Likewise the Mercurius of the alchemists is a “spirit of truth,” a *sapientia Dei*, but one who presses downward into the depths of matter, and whose acquisition is a *donum Spiritus Sancti*. He is the spirit who knows the secrets of matter, and to possess him brings illumination, in accordance with Paul’s “even so the things of God knoweth no man, but the Spirit of God” (I Cor. 2:11).

45 Luke 17 : 21f. Recently, “within you” (intra *υος, εντος υμων*) has been translated as “among you,” therefore, as our author says, “in the visible and bodily gathering together of men.” This shows the modern tendency to replace man’s inner cohesion by outward community, as though anyone who had no communion with himself would be capable of any fellowship at all! It is this deplorable tendency that paves the way for mass-mindedness.

46 Πνεῦμα ὁ Θεός. John 4 : 24.

47 *Bibl. chem.*, I, p. 443 a.

48 In his “Speculativa philosophia” (*Theatr. chem.*, I, p. 291) Dorn says of this union: “Such is the philosophical love between the parts of inanimate things, and the enmity also, *as between the parts of men*. [An allusion to projection!] But no more in the former than in the latter can there be a true union, unless the corruption of the said parts be removed before they are joined together; wherefore that which thou doest is for the sake of peace between enemies, that friends may come together in unity. In all imperfect bodies and those that fall short of their ultimate perfection friendship and enmity are both innate [an apt formulation of the coexistence of opposites in the unconscious “imperfect” state]; if the latter be removed by the work or effort of man, needs must the other return to its ultimate perfection through the art, which we have set forth in the union of man.” * Cf. “The Spirit Mercurius,” pars. 259ff.

49 Cf. Honorius of Autun, *Speculum de mysteriis ecclesiae* (Migne, *P.L.*, vol. 172, col. 936): “For it is said that the pelican so loves her young that she puts them to death with her claws. But on the third day for grief she wounds herself, and letting the blood from her body drip upon the fledglings she raises them from the dead. The pelican signifies the Lord, who so loved the world that he gave his only-begotten Son, whom on the third day he raised up, victor over death, and exalted above every name.” * Pelican is also the name of a retort, the spout of which runs back into the belly of the vessel. [Cf. *Alchemical Studies*, fig. B7.]

50 Cf. the comment on II Cor. 3 : 6 (“for the letter killeth, but the spirit giveth life”) in Olympiodorus (Berthelot, II, iv, 41), where one with knowledge of the hidden alchemical art is speaking: “How, then, do I understand the transformation (*μεταβολήν*)? How are the water and the fire, hostile and opposed to one another by nature, how are they come together in one, through harmony and friendship?”

51 *Bibl. chem.*, I, p. 442 b.

52 The *aqua permanens* “whose power is the spiritual blood, that is, the tincture. . . . For the body incorporates the spirit through the tincture of the blood: for all that has Spirit, has also blood.” * (Mylius, *Phil, ref.*, pp. 42f.) These quotations come from the *Turba* (ed. by Ruska, p. 129) and from the book al Habib (quoted by Ruska, pp. 42f.). For the Greek alchemists gold was the “red blood of silver” (Berthelot, II, iv, 38 and 44). Cf. also Philo, *Quaestiones in Genesim*, II, 59: “But blood is the essence of the sensible and vital spirit; for he says in another place [Leviticus 17 : 14]: The spirit of all flesh is its blood.” * Cf. Leisegang, *Der heilige Geist*, p. 97 n. and p. 94 n.

53 “Son, you must take of the fatter flesh.” * (Quotation from Aristotle in *Rosarium philosophorum*, *Art. aurif.*, II, p. 318.) The prima materia “grows from flesh and blood.” * (“Mahomet” in “Rosinus ad Sarratantam,” *Art. aurif.*, I, p. 308.) “To take the egg in the flesh.” * (Laurentius Ventura, *Theatr. chem.*, II, p. 274.) “Choose the tender flesh and you shall have the most excellent thing.” * (Ibid., p. 292.) “Flesh and blood” correspond to the “inward and hidden fire.” (Dorn, *Theatr. chem.*, I, p. 599.) For the patristic view see Augustine, *Quaestiones in Heptateuchum*, I, lx (Migne, *P.L.*, vol. 34, col. 616): “Perhaps he who was delivered for our transgressions [Christ] is signified by the flesh at evening.”*

54 Cf. “Aenigmata phil.,” *Art. aurif.*, I (1593), p. 151: “And then take the glass vessel with the bride and bridegroom and cast them into the furnace, and cause them to be roasted for three days, and then they will be two in one flesh.” * (Cf. Gen. 2 : 24 and Matt. 19 : 5.)

55 “As Christ in the holy Scriptures is called the Stone rejected by the builders, so also doth the same befall the Stone of the Wise” * (“Epilogus Orthelii,” *Theatr. chem.*, VI, p. 431).

56 “The Shepherd of Hermas,” tr. by Lake, II, pp. 217ff., Similitude 9.

57 Cf. my “A Study in the Process of Individuation.”

58 Cf. Schweitzer’s view of Christian concepts as “late Jewish eschatology”: *Geschichte der Leben-Jesu-Forschung*, p. 635.

59 The text is in *Psychology and Alchemy*, par. 454.

60 What would appear to be the first edition of the scholia, dated 1610, was published in Leipzig under the title *Hermetis Trismegisti Tractatus vere aureus de Lapidis philosophici secreto. Cum Scholiis Dominici Gnosii M.D.* The scholia are also printed in *Theatr. chem.*, IV, pp. 672ff., but there the author is said to be anonymous.

61 Dorn, “Congeries Paracelsicae chemicae,” *Theatr. chem.*, I, p. 578.

62 In *Aurora Consurgens*, also (pp. 129f.), the Adam composed of the four elements is contrasted with the Adam “from pure elements,” who, as the concluding sentence shows, is produced by the circulation of the four elements.

63 Gratarolus, *Verae alchemiae*, II, p. 265.

64 “He receives the power of the higher and the lower things. So shall you have the glory of the whole world.” * “Tabula smaragdina,” *De alchemia*, p. 363. Also Ruska, *Tabula Smaragdina*, p. 2.

65 Cf. *Aurora Consurgens*, p. 135.

66 *Theatr. chem.*, I, p. 578. * I do not know to which Hermes text Dorn is referring here. The orphan first appears in the *Pretiosa margarita novella* of Petrus Bonus: “This Orphan stone has no proper name” * (*Theatr. chem.*, V, p. 663). It is also in the edition of Janus Lacinius, 1546, p. 54^f.

67 Du Cange, *Glossarium*, s.v. “Orphanus.”

68 Ed. by Goldschmidt, I, vv. 112–14, p. 29. Heliodorus was a Byzantine of the 8th cent. (Goldschmidt, p. 2: “In 716–17, in the reign of Theodosius [III].”) Cassel (*Aus Literatur und Symbolik*, p. 248) gives Arnold (Arnaldus?), cited in Lesser’s *Lithotheologie*, p. 1161, as the source for “Orphanus.” I was unable to verify this statement.

69 It is said that in the Book of Secrets, Mani spoke of “the son of the widow,” Jesus (Schaefer, *Urform und Fortbildungen des manichäischen Systems*, p. 75 n.). Bousset (*The Antichrist Legend*, p. 70) mentions the reign of a widow who will precede the Antichrist (according to a Greek and Armenian Apocalypse of Daniel, p. 68). Freemasons are also reckoned among the “children of the widow” (Eckert, *Die Mysterien der Heidenkirche, erhalten und fortgebildet im Bunde der alten und neuen Kinder der Wittwe*). “Widow” in the Cabala is a designation for Malchuth. Knorr von Rosenroth, *Kabbala denudata*, I, p. 118.

70 Mylius, *Phil. ref.*, p. 173.

71 Gratarolus, *Verae alch.*, II, p. 265.

72 This expression appears for the first time in *Aurora consurgens*, Part II, *Art. aurif.*, I, p. 201. Mylius (*Phil. ref.*), copies it. The “vieille exténuée” mentioned in Pernety (*Dictionnaire mytho-hermetique*, p. 280) goes back to the same source. Cf. also “a mistress of about a hundred years of age” in “Aureum saeculum redivivum,” *Mus. herm.*, p. 64 (Waite, I, p. 59).

73 *Aurora consurgens* II, *Art. aurif.*, I, p. 196.

74 In *Aurora Consurgens*, p. 77, seven women seek one husband.

75 Cf. the “matrices of all things” in Rulandus, *Lexicon of Alchemy*, p. 226.

76 *Symb. aur. mensae*, p. 344.

77 Printed in *Theatr. chem.*, III, pp. 871ff. under the title “Antiqui Philosophi Galli Delphinati anonymi Liber Secreti Maximi totius mundanae gloriae.”

78 Gabritius therefore corresponds to Horus. In ancient Egypt Horus had long been equated with Osiris. Cf. Brugsch, *Religion und Mythologie der alten Ägypter*, p. 406. The Papyrus Mimaut has: “Do the terrible deed to me, the orphan of the honoured widow.” * Preisendanz relates the “widow” to Isis and the “orphan” to Horus, with whom the magician identifies himself (*Papyri Graecae Magicae*, I, pp. 54f). We find the “medicine of the widow” in the treatise “Isis to Horus,” Berthelot, *Alch. grecs*, I, xiii, 16.

79 *Symb. aur. mensae*, p. 515. The epithalamium begins with the words: “When the mother is joined with the son in the covenant of marriage, count it not as incest. For so doth nature ordain, so doth the holy law of fate require, and the thing is not displeasing to God.”*

80 “Est quod in ipsis floribus angat,

Et ubi mel, ibi fel, ubi uber, ibi tuber.”

81 In Greco-Roman times Isis was represented as a human-headed snake. Cf. illustration in Erman, *Religion der Ägypter*, p. 391. For Isis as *δράκων* see Reitzenstein, *Poimandres*, p. 31.

82 Erman, p. 301. The text derives from the time of the New Kingdom.

83 Preisendanz, *Papyri Graec. Magicae*, II, p. 74: “I am Isis who am called dew.”*

84 Synonymous with *aqua vitae*. The relation of the “soul-comforting” water of the Nile to Isis is indicated on a bas-relief (illustrated in Eisler, *Weltenmantel und Himmelszelt*, I, p. 70) in the Vatican, of a priestess of Isis bearing the *situla* (water-vessel). The two great parallels are the cup of water in the Early Christian communion, and the water

vessel of Amitabha. For the Christian cup of water see “Transformation Symbolism in the Mass,” pars. 311ff.; for the holy water in the worship of Amitabha, see Hastings, *Encyclopaedia*, I, p. 386 b, “Amitayus.”

85 Latin MS, 18th cent., “Figurarum Aegyptiorum secretarum.” (Author’s possession.)

86 Eisler, II, p. 328, n. 1.

87 The Golden Ass, XI, 3 (trans. Adlington and Gaselee, p. 543): “utterly dark cloak.” Cf. Hippolytus, *Elenchos*, I, 8.

88 Diodorus, *Bibliothēke Historike*, I, 25: τὸ τῆς ἀθανασίας φάρμακον.

89 She tried to make the child of the king of Phoenicia immortal by holding him in the fire. Plutarch, “Isis and Osiris,” 16, *Moralia* (trans. by Babbitt, V, pp. 40f.).

90 Diodorus, I, § 11.

91 *Ibid.*, I, 27.

92 The great Paris Magic Papyrus, line 2290. Preisendanz, *Papyri Græcæ Mag.*, I, p. 143.

93 Berthelot, *Alch. grecs*, I, xiii. Ἴσις προφήτις τῷ υἱῷ Ὀρῶ.

94 *Ancoratus* (ed. by Holl), c. 104, 1, p. 126.

95 *Liber de errore profanarum religionum* (ed. by Halm), II, 6: “The earth is the body of Isis.” * Cf. Plutarch, “Isis and Osiris,” 38, pp. 92f.

96 Reitzenstein, *Zwei religionsgeschichtliche Fragen*, p. 108, and *Poimandres*, p. 44.

97 Plutarch, 53, pp. 130f.

98 Reitzenstein, *Poimandres*, p. 270.

99 *Corpus Inscriptionum Latinarum*, X, No. 3800 (= 3580), from Capua: “TE TIBI / UNA QUAE / ES OMNIA / DEA ISIS / ARRIUS BAL / BINUS V.C.” (Now in Naples Museum.)

100 Reitzenstein, *Die hellenistischen Mysterienreligionen* (1927), pp. 27ff.

101 Athenagoras, *Legatio pro Christianis*, 22 (Migne, *P.G.*, vol. 6, col. 939f.).

102 *Ros. phil.*, *Art. aurif.* (1572), II, p. 413. From the so-called “Dicta Belini” (Apollonius of Tyana), “Allegoriae sapientum,” *Distinctio* 28, *Theatr. chem.*, V, p. 97.

103 Ruska, *Turba philosophorum*, p. 247. The wind is the pneuma hidden in the prima materia. The final illustration in Maier’s *Scrutinium chymicum* shows this burial.

104 Cf. also the μάχη θηλεία (female combat) in *Carmen Archelai*, one of the *Carmina Heliodori* (p. 56, IV, lines 230f.) (ed. by Goldschmidt), where the materia flees under the rain of projectiles and ends up as a “corpse” in the grave.

105 The corresponding masculine substance is red sulphur, the *vir* or *servus rubeus*, whose redness relates him to Typhon. In a “dirge for Gabricus who died after recently celebrating his marriage,” Maier (*Symb. aur. mensae*, p. 518) does in fact mention Typhon as a possible cause of his death. He begins by saying: “She who was the cause of your life is also the cause of your death,” but he then adds: “Three there seem to be who may have caused your death: Typhon, your mother, and Mulciber’s [Vulcan’s] furnace. He [Typhon] scatters the limbs of your body; it may be your mother alone, instead of your brother. But your mother feigns innocence.” It is clear that Maier suspects the mother in particular, and wants to make Typhon, the red slave, only a “causa ministerialis.”

106 Kerényi, *Töchter der Sonne*, pp. 92ff.

107 For this reason, the story of Medea's murder of Creon, her father-in-law, was also interpreted as an alchemical arcanum. Cf. Petrus Bonus, *Theatr. chem.*, V, p. 686.

108 *Super Ezechielem Horn.*, III (Migne, *P.L.*, vol. 76, col. 808).

109 *Expositions of the Book of Psalms*, Ps. 131, 23, vol. 6, p. 105.*

110 *Ibid.*, Ps. 145, 18f., vol. 6, p. 356.

111 *Kabbala denudata*, I, 1, p. 118.* Knorr's source is Moses Cordovero, *Pardes Rimmonim*, ch. 23.

112 *Tifereth* means 'beauty.'

113 *Kabbala denudata*, p. 202.

114 *Malchuth* means 'kingdom, dominion.'

115 *Kabbala denudata*, p. 528.

116 She is called moon (p. 456), earth (p. 156), bride (p. 477), matron, queen of heaven, fish-pool (p. 215), sea, well, tree of knowledge of good and evil, hind of loves ("so is Malchuth especially called because of the mystery of the new moon," p. 77), belly (p. 192), etc.*

117 *Kabbala denudata*, p. 163.

118 According to some authorities, Sefira is derived from *σφαίρα*. Cf. Hastings, *Encyclopedia*, VII, p. 625 b, "Kabbala." According to a more recent view the word is derived from the root *sfr*, 'primordial number.' Cf. Scholem, *Major Trends in Jewish Mysticism*, pp. 76ff. For the Tree of the Sefiroth see "The Philosophical Tree," par. 411, and Scholem, pp. 214ff.

119 *Yesod* means 'foundation.' In the MS in the Bibliothèque Nationale, Fr. 14765, pl. 8, *Yesod* is depicted like the Son of Man in Revelation 1 : 12 ff., with the seven stars in his right hand, the sword issuing from his mouth, and standing between the seven candlesticks. See *infra*, our Plate 3.

120 Cf. *Kabbala denudata*, I, p. 240, 4: "... for Malchuth shall be called a watered garden, Isaiah 58 : 11, when *Yesod* is in her, and fills her, and waters her with waters from on high." * P. 477: "When Malchuth receives the inflowing from the fifty gates through *Yesod*, then is she called bride." * For *Yesod* as *membrum genitale*, *ibid.*, p. 22. Cf. also Scholem, pp. 227f., and Hurwitz, *Arche-typische Motive in der chassidischen Mystik*, pp. 123ff.

121 Cf. the legend of Father Okeanos and Mother Tethys, who could no longer come together in a conjugal embrace. *Iliad*, XIV, 11. 300 ff. (trans. by Rieu), p. 265, and Roscher, *Lexikon*, V, col. 394 B, lines 30ff. This reference points only to the similarity of the motif, not to an equivalence of meaning.

122 Cf. the cohabitation of Gabricus and Beya brought about by the intervention of the philosophers.

123 *Der Sohar* (ed. by Mueller), p. 234. There is a parallel to this in the psychotic experiences of Schreber (*Memoirs of My Nervous Illness*), where the "rays of God" longingly seek to enter into him.

124 Cf. the parallel in the Gospel according to the Egyptians (James, *Apocryphal New Testament*, p. 11): "When the two become one and the male with the female is neither male nor female."

125 Waite, *The Holy Kabbalah*, p. 381.

126 *Kabbala denudata*, I, p. 338.

127 *Theatr. chem.*, VI, pp. 1ff. Blaise de Vigenère or Vigenaire (1523–96) was a learned scholar of Hebrew. He was secretary to the Due de Nevers and then to Henry III of France.

128 Cf. Proclus, *Commentaries on the Timaeus of Plato*, where he says that Orpheus called the moon the heavenly earth (41 e), and the Pythagoreans the aetheric earth (32 b).

129 *Theatr. chem.*, VI, p. 17. Malchuth is also called moon (*Kabb. denud.* I, 1, pp. 195 and 501). Other cognomens are house and night, and in Joseph Gikatila (*Shaare ora*) fountain, sea, stone, sapphire, tree of knowledge, land of life. (This information was supplied by Dr. S. Hurwitz.) Malchuth is the “kingdom of God,” described in the *Zohar* as *Kenesseth Israel*, “the mystical archetype of the community of Israel” (Scholem, p. 213).

130 Cf. Rahner, “Mysterium Lunae,” pp. 313ff.

131 Jung, “The Spirit Mercurius,” par. 273.

132 Epistola LV, 7f. (*CSEL*, XXXIV, pp. 176f.)

133 The Vulgate has: “Homo sanctus in sapientia manet sicut sol, nam stultus sicut luna mutatur” (DV: “A holy man continueth in wisdom as the sun, but a fool is changed as the moon”).

134 “Quis ergo est ille stultus, qui tamquam luna mutatur, nisi Adam, in quo omnes peccaverunt?”

135 Sol corresponds to the conscious man, Luna to the unconscious one, i.e., to his anima.

136 “For man’s soul, when it turns away from the sun of righteousness, that is, from inward contemplation of the unchangeable truth, turns all its strength to earthly things, and thereby is darkened more and more in its inward and higher parts; but when it begins to return to that unchangeable wisdom, the more it draws nigh thereto in loving affection, the more is the outward man corrupted, but the inward man is renewed from day to day; and all that light of natural disposition, which was turned towards lower things, is directed to the higher, and in a certain wise is taken away from things of earth, that it may die more and more to this world and its life be hid with Christ in God.” * (*CSEL*, XXXIV, p. 178.)

137 “Unde est illud: Paraverunt sagittas suas in pharetra, ut sagittent *in obscura luna* rectos corde.” The Vulgate, Psalm 10 : 3, has only “in obscuro” (DV: “For behold, the wicked bend their bow, they fit the arrow to the string, to shoot in the darkness at the upright of heart”). Cf. the “**arrows drunk with blood**” in *Aurora Consurgens*, p. 67.

138 “Orietur, inquit, in diebus eius justitia et abundantia pacis, quoad usque *interficiatur luna*.”

139 DV: “In his days justice shall flourish, and abundance of peace, until the moon shall fail.”

140 Augustine further remarks that the name “Jericho” means “moon” in Hebrew, and that the walls of this city, the “walls of mortal life,” collapsed (*Epist.*, LV, 10).

141 According to Origen, the sun and the moon were involved in the Fall (*Peri Archon*, I, 7, 4). Cited in Rahner, “Mysterium Lunae,” p. 327.

142 Rahner (p. 314) speaks very aptly of the “mystical darkness of its (the moon’s, i.e., the Church’s) union with Christ” at the time of the new moon, the latter signifying the “dying” Church.

143 First printing in *Ars chemica* (1566), p. 136.

144 The text has “id est Sol inferius,” and so has the later printing of 1622 (*Theatr. chem.*, V, p. 515) as well as Manget’s *Bibl. chem.* (II, p. 248a). It could therefore mean “the sun below.” This would presumably be a “subterranean sun” equivalent to the *Sol niger* (Mylius, *Phil. ref.*, p. 19, and Ripley, *Chymische Schrifften*, p. 51).

145 The quartan fever occurs every fourth day. The text has here: “For on every fourth day he naturally suffers from a quartan fever.”*

146 Leo, as the *domicilium solis*, stands for the sun, i.e., for the active (red) Mercurius.

147 “Per carnem suam sibi contemporaneam Lunarem vilescit.” The original Arabic text of Senior (*De chemia*, p. 9) has “canem” instead of “carnem.” The dog is Hecate’s animal and pertains to the moon (pars. 174ff.). In Manichaeism it is said of the Original Man and his sons, who descended into matter, that “consciousness was taken from them, and they became like one who is bitten by a mad dog or a snake” (Theodore bar Konai, cited in Reitzenstein and Schaeder, *Studien zum antiken Synkretismus aus Iran und Griechenland*, p. 343).

148 The *aqua permanens*.

149 Sol is speaking.

150 “Consilium coniugii,” pp. 141f.*

151 The preceding passage runs: “... let the residual body, which is called earth, be reduced to ashes, from which the tincture is extracted by means of water . . . Then join it to its head and tail.” * This refers to the production of the uroboros as the arcane substance that changes the natures.

152 This is the well-known formula of Democritus. Berthelot, *Alch. grecs*, II, i, 3: “Nature rejoices in nature, nature subdues nature, nature rules over nature.”*

153 *Tyria tinctura* or *Tyrius color* (*Turba*, Sermo XIV), *lapis tyrii coloris* (Sermo XXI, XXVII). “Thus we call our Tyrian (colour) at each step of the procedure by the name of its colour” * (Sermo LXII). “This is the red sulphur, shining in the darkness; and it is the red jacinth, and the fiery and death-dealing poison, and the conquering Lion, and the evil-doer, and the cleaving sword, and the Tyrian (tincture) which heals all infirmities” * (*Theatr. chem.*, V, p. 705). *Tyriaca* is identical with *Theriaca*, which is none other than the arcane substance.

154 Luna sends the dew.

155 Where the aerial realm of the demons and Satan begins.

156 Schmieder (*Geschichte der Alchemie*, p. 106) thinks the author was an Arab of the 13th cent. The fact that the author took over *carnem* / *canem*, a mistake possible only in Latin, shows, however, that he must have been one of the early Latinists.

157 Cf. Bernardino de Sahagún, *General History of the Things of New Spain*, Book 3: *The Origin of the Gods* (trans. by Anderson and Dibble), pp. 5f; also “Transformation Symbolism in the Mass,” p. 224.

158 Wallis Budge, *The Gods of the Egyptians*, I, p. 45.

159 Cf. my account in *Aion*, pars. 137ff., 232ff.

160 Cf. the Koran, Sura 18 (trans. by Dawood, p. 96), “the sun setting in a pool of black mud.”

161 Ripley, *Opera omnia*, p. 423. “Consilium coniugii,” *Ars chemica*, p. 186: “He slew himself with his own dart.” “Rosinus ad Sarrat.,” *Art. aurif.*, I, p. 293: “Who with an arrow from our quiver bound together, that is, joined in one body, wretched me, that is, I who possess the matter of Mercury and the Moon . . . and my beloved, that is, the fatness of the Sun with the moisture of the Moon.”*

162 1588 edn., p. 249. The picture is reproduced in my “Paracelsus as a Spiritual Phenomenon,” fig. B4.

163 The drawing of this tail is certainly odd, and one wonders whether it represents water (?) or steam (?). The prototype of the picture can be found in the so-called *Drivaltigkeitsbuch*, fol. 2^r. (Codex Germanicus Monacensis 598, 15th cent.) as well as in the Codex Germ. Alch. Vad., 16th cent. There she has a proper snake’s tail. One text describes the vapours as arrows (“Consil. coniug.,” p. 127). Cf. the eagles armed with arrows in the picture of Hermes Trismegistus from Senior (*Psychology and Alchemy*, fig. 128).

164 Berthelot, *Alch. grecs*, II, iv, 24.*

165 Cf. *Psychology and Alchemy*, fig. 131.

166 Migne, *P.L.*, vol. 172, col. 419.

167 “Vulnerasti cor meum soror mea sponsa. Vulnerasti cor meum in uno oculorum tuorum et in uno crine colli tui.” The correct translation is [as in AV]: “Thou hast ravished my heart, my sister, my spouse; thou hast ravished my heart with one of thine eyes, with one chain of thy neck.”

168 Cf. *Aurora Consurgens*, p. 133.

169 Here is, significantly enough, the source of the title of that mysterious treatise discussed in von Franz, *Aurora Consurgens*, which complements the present work.

170 AV mod.* A more exact translation of the original text would be “terrible as a host of armies.” The Hebrew word *nidgālōt* is read by recent commentators as *nirgālōt*, plural of Nirgal or Nergal. The Babylonian Nergal was the god of war and the underworld, the Lord of spirits, and the god of the midday heat of summer. Wittekindt (*Das Hohe Lied und seine Beziehungen turn Istarkult*, p. 8) therefore translates “terrible as the planets.” “Evidently the opposites in the figure of Istar are meant. . . . She is the gracious goddess of love and beauty, but she is also warlike, a slayer of men” (p. 9). On account of his magic, even greater consideration should be given to the underworld aspect of Nergal as the Lord of spirits. Cf. Morris Jastrow, *Die Religion Babyloniens und Assyriens*, I, pp. 361, 467. The reading *nirgālōt* is also accepted by Haller (*Das Hohe Lied*, p. 40). Hebrew *d* and *r* are very easily confused.

171 Roscher, *Lexikon*, II, col. 3138.

172 *Ibid.*, col. 3185.

173 *Ibid.*

174 Cf. *infra*, par. 174; also “The Psychology of the Transference,” par. 458, n. 4.

175 In Cabalistic interpretation she is Israel, bride of the Lord. Thus the *Zohar* says: “And when is he (God) called One? Only at that hour when the *matrona* (= Malchuth) will pair with the King, and ‘the kingdom will belong to God,’ as is said. What is meant by kingdom? It is the children of Israel, for the King unites himself with her, as is said: ‘On that day God is known . . . as One.’”

176 Augustine (*Sermo suppositus*, 120, 8) says: “Like a bridegroom Christ went forth from his chamber, he went out with a presage of his nuptials into the field of the world. . . . He came to the marriage bed of the cross, and there, in mounting it, he consummated his marriage. And when he perceived the sighs of the creature, he lovingly gave himself up to the torment in the place of his bride, . . . and he joined the woman to himself for ever.”*

177 It is remarkable that in ancient Egypt as well the eye is connected with the hierogamos of the gods. The first day of autumn (i.e., of the dwindling sun) is celebrated in the Heliopolitan inscriptions as the “feast day of the goddess Yusasit,” as the “arrival of the sister who makes ready to unite herself with her father.” On that day “the goddess Mehnit completes her work, so that the god Osiris may enter into the left eye.” Brugsch, *Religion und Mythologie der alten Aegypter*, p. 286.

178 Honorius, *loc. cit.** The wounding of the Redeemer by love is an idea that gave rise to some curious images among the later mystic writers. The following is from a *Libellus Desideriorum Joannis Amati*: “I have learnt an art, and have become an archer, good intention is my bow and the ceaseless desires of my soul are the arrows. The bow is spanned continually by the hand of God’s gracious help, and the Holy Ghost teaches me to shoot the arrows straight

to heaven. God grant that I may learn to shoot better, and one day hit the Lord Jesus.” Held, *Angelus Silesius: Sämtliche Poetische Werke*, I, p. 141.

179 Morris, *Legends of the Holy Rood*, pp. 197ff.

180 Berthelot, *Alch. grecs*, III, i–vi. The aspect of killing is discussed in my “The Visions of Zosimos,” pars. 91ff., and the sacrificial death in “Transformation Symbolism in the Mass,” pars. 376ff.

181 Ruska, *Turba*, Sermo 58, p. 161.*

182 Hg (the alchemical “dew”) “penetrates” the gold (sun) by amalgamation.

183 The treatise is supposed to have been written in 1645. Printed in *Mus. herm.*, pp. 647ff. (Waite, II, pp. 165ff). The name of the author, Eirenaeus Philaletha, is a pseudonym (“peaceful lover of truth”); the real author is conjectured to be the English alchemist Thomas Vaughan (1621–65)—incorrectly, it seems to me. See Waite, *The Works of Thomas Vaughan*, pp. xivff., and Ferguson, *Bibliotheca Chemica*, II, p. 194.

184 See *infra*, par. 174.

185 *Mus. herm.*, p. 658: “This is the infant Hermaphrodite, who from his very cradle has been bitten by the mad Corascene dog, wherefore he rages in madness with perpetual fear of water (hydrophobia).” * (See *infra*, pars. 176f.) The “rabid black dog” is chased away “with water and blows,” and “thus will the darkness be dispelled.” From this it can be seen that the mad dog represents the nigredo and thus, indirectly, the dark new moon, which eclipses the sun (cf. Senior, *De chemia*, p. 9: “Leo decays, weakened by the dog {flesh}”).* The “infant” would correspond to the raging Attis, *κατηφές ἄκουσμα Ῥέας*, “the dark rumour of Rhea,” “whom the Assyrians call thrice-desired Adonis,” the son-lover who dies young (Hippolytus, *Elcnchos*, V, 9, 8). According to the legend of Pessinus, Agdistis (Cybele), the mother of Attis, was herself hermaphroditic at first but was castrated by the gods. She drove Attis mad, so that he did the same thing to himself at his wedding. Zeus made his body incorruptible, and this forms the parallel to the *incorruptibilitas* of the alchemical “infant.” Cf. Pausanias, *Description of Greece*, VII, 17 (Frazer trans., III, pp. 266f.).

186 *Theatr. chem.*, I, p. 518.*

187 *Lux naturae* and *caeleste sulphur* are to be *understood* as identical.

188 *Theatr. chem.*, I, p. 518.*

189 John 12 : 31.

190 *The Vanity of Arts and Sciences* (anon, trans.), p. 315.*

191 *Zeitschrift für hath. Theol.*, LXIII, p. 431.

192 = emptying. See next paragraph.

193 *Hexameron*, IV, 8, 32 (Migne, P.L., vol. 14, col. 204).*

194 Prof. Rahner was kind enough to send me the following explanation: “The fundamental idea of the theologians is always this: the earthly fate of the Church as the body of Christ is modelled on the earthly fate of Christ himself. That is to say the Church, in the course of her history, moves towards a death, as well in her individual members (here is the connecting-link with the doctrine of ‘mortification’) as in her destiny as a whole, until the last day when, after fulfilling her earthly task, she becomes ‘unnecessary’ and ‘dies,’ as is indicated in Psalm 71 : 7: until the moon shall fail.’ These ideas were expressed in the symbolism of Luna as the Church. Just as the *kenosis* of Christ was fulfilled in death, even death on the cross (Phil. 2 : 8), and out of this death the ‘glory’ of the divine nature (2 : 9f.) was

bestowed on Christ's 'form as a servant' (2 : 7), whence this whole process can be compared with the setting (death) of the sun and its rising anew (glory), even so it is with the parallel *kenosis* of Ecclesia-Luna. The closer Luna approaches to the sun, the more is she darkened until, at the conjunction of the new moon, all her light is 'emptied' into Christ, the sun. (It is well worth noting that just at this point Augustine speaks of the strange speculations of the Manichaeans about the two 'light-ships,' when the ship of Luna pours out its light into the ship of the sun, *Epistola* 55, iv, 6.) Augustine now applies this to the individual Christians of whom the Ecclesia is composed. The remarkable paradox of Luna, that she is darkest when nearest the sun, is a symbol of Christian asceticism: 'The more the inward man draws nigh to the sun, the more is the outward man destroyed, but the inward man is renewed from day to day' (a variation of II Cor. 4 : 16). That is, the Christian dies like Luna and his life is 'hid with Christ in God' (Coloss. 3 : 3). All this Augustine says in *Epistola* 55, v, 8. Afterwards he applies it to the Church and her destiny (*Epistola* 55, vi, 10): she will vanish into Christ, the sun, at the end of time: 'donee interficiatur Luna.' Augustine here translates the ἀνταναιρεθῆ of Psalm 71 : 7 by 'interficiatur'; in his *Enarratio in Ps. 71* (Migne, *P.L.*, vol. 36, cols. 907f.) he expatiates on the translation of this Greek word and there renders it by 'tollatur' (is removed) and 'auferatur' (taken away). The doctrine implied in all these passages is that the Church in her future glory ceases her work of salvation, which is destined only for the earth, and that she is totally eclipsed by the splendour of Christ the sun, because (and this again is a strange paradox) in the resurrection of the flesh she herself has become the 'full moon,' and indeed the 'sun.' 'Permanebit cum Sole,' she 'shall live while the sun endures,' as Ps. 71 : 5 (RSV 72 : 5) says."

195 "Ὅς ἐν μορφῇ θεοῦ ὑπάρχων οὐχ ἄρπαγμόν ἠγήσατο τὸ εἶναι ἴσα θεῷ ἀλλὰ ἑαυτὸν ἐκένωσεν μορφὴν δούλου λαβών.

196 De trinitate, I, 13 (Migne, *P.L.*, vol. 10, col. 35). The passage says literally: "Hence, just as the truths that God became man, that the Immortal died, that the Eternal was buried, do not belong to the order of the rational intellect but are an exceptional work of power, so it is an effect not of intellect but of omnipotence that he who is man is likewise God, that he who died is immortal, that he who was buried is eternal."*

197 *Hymni et Sermones* (ed. Lamy), II, col. 802.*

198 Maier, *Scrut. chymicum*, p. 148.

199 Ibid., p. 13, from "Tractatulus Aristotelis," *Art. aurif.*, I, p. 369.

200 Cf. the Manichaean idea of the moon emptying her "soul-content" into the sun.

201 Epiphanius, *Panarium*, LXVI, 1 (ed. by Holl), III, pp. 14f.; Hegemonius, *Acta Archelai* (ed. by Beeson), LXII; Socrates Scholasticus, *The Ecclesiastical History*, I, 22; Theodoret, *Haereticarum fabularum compendium*, I, 26 (Migne, *P.G.*, vol. 83, col. 378).

202 This might be a reference to Buddhism. The Manichaean theory of metempsychosis may possibly come from the same source. Scythianos is said to have travelled to India. According to Suidas, *Lexikon* (ed. by Adler, part 3, p. 318), Scythianos-Manes was a Βραχμάνης (Brahman). Cf. also Cedrenus, *Historiarum compendium*, I, 456 (Migne, *P.G.*, vol. 121, col. 498).

203 Cyril of Jerusalem, *Katechesis*, VI, 21 (*Opera*, ed. by Reischl, I, p. 185).

204 *Panarium*, LXVI, 2 (ed. by Holl, III, p. 18).

205 Rulandus, *Lexicon*, p. 187.

206 *Art. aurif.*, II, p. 246.

- 207 “Maria Prophetissa,” *Art. aurif.*, I, p. 321.
- 208 “Scala philosophorum,” *ibid.*, II, p. 116.
- 209 Reusner, *Pandora*, p. 297, interpreted as “arsenic,” i.e., the active masculine element, from ἀρρῶν or ἀρσην.
- 210 Petrus de Silento, “Opus,” *Theatr. chem.*, IV, p. 1114.
- 211 Anthonius de Abbatia, *Epistolae duae*, in Roth-Scholtz, *Deutsches Theatrum Chemicum*, III, p. 703.
- 212 Pernety, *Diet, mytho-hermétique*, p. 233.
- 213 *Ibid.*, p. 179.
- 214 “Visio Arislei,” *Art. aurif.*, I, pp. 147f.
- 215 The name “Cubricus” for Mani has so far not been satisfactorily explained. Cf. Schaefer, *Urform und Fortbildungen* *Fortbildungen des manich. Systems*, pp. 88f, n.
- 216 Trans. by Foxcroft, p. 162.
- 217 Cf. my “Spirit Mercurius,” pars. 271, 276.
- 218 Cf. *Psychology and Alchemy*, par. 484. Also *Aurora Consurgens*, p. 57: “... the shadow of death, for a tempest hath overwhelmed me; then before me shall the Ethiopians fall down and my enemies shall lick my earth.” * Cf. Origen, *De oratione*, 27, 12 (Migne, *P.G.*, vol. 11, cols. 514f.): “He who participates in ‘the dragon’ is none other than ‘the Ethiopian’ spiritually, himself changed into a serpent.” * (*Alexandrian Christianity*, trans. by Oulton and Chadwick, p. 301). Epiphanius, *Panarium*, XXVI, 16 (ed. by Holl, I, p. 296) speaks of the “Aethiopes denigrati peccato” (Ethiopians blackened by sin).
- 219 *Passio SS. Perpetuae et Felicitas*, ed. by van Beek, pp. 26f. Cf. also M.-L. von Franz’s “Passio Perpetuae,” in *Aion* (Swiss edn., pp. 389ff.).
- 220 Cf. Paracelsus, “Philosophia ad Athenienses” (Sudhoff, XIII, pp. 390f.); Dorn, “Physica genesis,” *Theatr. chem.*, I, p. 380, and *Psychology and Alchemy*, pars. 430ff.
- 221 Cf. “the unbegotten father, the unbegotten earth, and the unbegotten air” of the Manichaeans (Augustine, *De Actis cum Felice*, I, 18; Migne, *P.L.*, vol. 42, col. 532), mentioned by Bardesanes and Marinus (Bousset, *Hauptprobleme der Gnosis*, p. 97) and by Hermogenes: “God created all things from coexistent and ungenerated matter.” * (Hippolytus, *Elenchos*, VIII, 17, 1.)
- 222 *Confessions*, V, 10 (trans. by Sheed, p. 75).
- 223 Augustine, *Reply to Faustus*, XX, 2 (trans. by Stothert and others, p. 253).
- 224 Walch, *Entwurf einer vollständigen Historie der Ketzereien*, I, p. 753.
- 225 Augustine, “The Nature of the Good,” 44 (*Earlier Writings*, trans. by Burleigh, p. 344)
- 226 Cf. *Faust II*, the angel scene at Faust’s death. Mephistopheles is addressing the angels:

“Us spirits you call damned, and look askance.

Witch-masters, you, par excellence;

For men and maid you lead astray.

What an adventure curst and dire!

Is this love’s elemental game?”

(*Faust, Part Two*, trans. by Wayne, p. 277.)

227 Maier, *Scrut. chymicum*, pp. 82ff. Laurentius Ventura, “De ratione conficiendi Lapidis,” *Theatr. chem.*, II, p. 293: “The stone . . . begins to sweat because of the narrowness of its prison.”*

228 Hegemonius, *Acta Archelai*, IX: “This prince sweats because of his tribulation, and his sweat is rain.” * Christensen (“Les Types du premier Homme et du premier Roi dans l’histoire légendaire des Iraniens,” p. 16) quotes from the Bundahisn (3, 19) that Ormuzd fashioned a “shining youth” from his sweat and that the first men were made from the sweat of Ymir (p. 35). According to Arabic tradition, Ormuzd sweated because of his “doubting thought” (cf. my “Answer to Job,” par. 579); from this doubting thought came Ahriman, and from his sweat Gayomart. In ancient Egypt, the gods of the seasons brought forth the harvest with the sweat of Osiris’ hands (Budge, *Coptic Apocrypha in the Dialect of Upper Egypt*, Intro., pp. lxviif.). Dorn (“Congeries Paracelsicae,” *Theatr. chem.*, I, p. 584) has the following remarkable passage on the lapis: “In its last operations . . . a dark liquid, ruddy like blood, drips from the matter and its vessel; whence they predicted that in the last days there would come upon the earth a most pure man, through whom would be brought about the liberation of the world, and that he would give forth drops of blood of a rose-red hue, whereby the world would be redeemed from the fall.” * Cf. my “The Philosophical Tree,” pars. 383ff.

229 “And Marcus says, They conceive in the baths, signifying the gentle and damp heat of the baths in which the stone sweats when it begins to dissolve” * (“Consil. coniugii,” *Ars chemica*, p. 167.) This passage is a commentary on Senior, *De chemia*, p. 79. The “Epistola ad Hermannum,” *Theatr. chem.*, V, p. 894, says: “Then the most perfect body is taken and applied to the fire of the Philosophers; then . . . that body becomes moist, and gives forth a kind of bloody sweat after the putrefaction and mortification, that is, a Heavenly Dew, and this dew is called the Mercury of the Philosophers, or Aqua Permanens.” * Cf. the Creator making the first men out of sweat in Eliade (*Shamanism*, p. 334 n.), who mentions this in connection with the sweat-bath.

230 Text in *Psychology and Alchemy*, par. 469, n. 110.

231 A parallel to Barbelo.

232 “And when it appears, it is as a comely woman to men, but to women it has the appearance of a beautiful and desirable youth.” * (*Acta Archelai*, IX.)

233 “Est hominum virtus fides vera” (the strength of man is true faith). Dorn, “Speculativa philosophia,” *Theatr. chem.*, I, p. 298.

234 *Ibid.*, p. 229.

1 Cf. Bonus, "Pretiosa margarita novella," *Theatr. chem.*, V, pp. 660f.: "The philosophers of old saw that this stone in its birth and sublimation . . . could be compared in parables . . . with all things that are in the world, whether bodily or intellectual. Wherefore whatever they are able to say and declare concerning virtues and vices, concerning the heavens and all things corporeal or incorporeal, the creation of the world . . . and of all the elements . . . and concerning corruptible and incorruptible, visible and invisible things, spirit and soul and body . . . and concerning life and death, good and evil, truth and falsehood, unity and multiplicity, poverty and riches, that which flies and that which flies not, war and peace, conqueror and conquered, toil and repose, sleep and waking, conception and birth, childhood and old age, male and female, strong and weak, white and red and all colours, hell and the pit and their darkness and their sulphurous fires, and also concerning paradise and its sublimity, its light and beauty, and its inestimable glory, and in short concerning those things that are and those that are not, those which may be spoken of and those which may not be spoken of, all these things they are able to say of this worshipful stone."*

2 By "lapis" is meant both the initial material, the prima materia, and the end-product of the opus, the lapis in its strict sense.

3 Or again, the filius is "vilis et carior" (base and more dear). "Consil. coniugii," *Ars chemica*, p. 150. Cf. Senior, *De chemia*, p. 11.

4 "Tractatus aureus," *Mus. herm.*, p. 10 (Waite, I, p. 13).

5 Cf. the "body that is not a body," in "Rosinus ad Euthiciam," *Art. aurif.*, I, p. 249.

6 Sermo XIII, Ruska, p. 122.*

7 Berthelot, *Alch. grecs*, IV, xx, 3. (MS. 2252, Bibl. Nat., Paris.)

8 *Ibid.*, IV, i. 7.*

9 *Ros. phil.*, *Art. aurif.*, II, p. 258.

10 "Tractatus aureus," *Ars chemica*, p. 12.

11 *Ros. phil.*, *Art. aurif.*, II, p. 259.

12 Mylius, *Phil. ref.*, p. 269.

13 *Ros. phil.*, p. 269.

14 *Theatr. chem.*, V, p. 67.

15 *Ibid.*, p. 87.

16 "Tractatus Aristotelis," *Theatr. chem.*, V, p. 886.*

17 Khunrath, *Von hylealischen Chaos*, p. 224, and others.*

18 "Gloria mundi," *Mus. herm.*, p. 270 (Waite, I, p. 218).

19 Trans. by Foxcroft, p. 30.

20 "The Spirit Mercurius," pars. 255ff.

21 *Mus. herm.*, p. 10 (Waite, I, p. 13).*

22 A condensation of the Iliad, XIV, 201 and 246: "I am going to the ends of the fruitful earth to visit Ocean, the forbear of the gods, and Mother Tethys . . . even Ocean Stream himself, who is the forbear of them all." (Trans. by Rieu, pp. 262f.)

23 *Elenchos* VIII, 12, 2ff. (Cf. Legge trans., *Philosophumena*, II, p. 107.)

24 The iota, the smallest Greek character, corresponding to our “dot” (which did not exist in Greek). Cf. Luke 16 : 17: “And it is easier for heaven and earth to pass than one tittle of the law to fall.”*

25 *Elenchos* VIII, 12, 5ff. (Legge, II, pp. 107f.). All this is a Gnostic paraphrase of John 1 and at the same time a meaningful exposition of the psychological self. In Jewish tradition Adam signifies, not a letter, but only the small hook at the top of the Yod (י). (*Shaare Kedusha*, III, 1, cited in *Encycl. Judaica*, s.v. “Adam Kadmon.”)

26 Pernety (*Diet, mytho-hermétique*, p. 293, s.v. “mer”) says of the “sea” of the alchemists: “Their sea is found everywhere, and the sages navigate it with a calmness which is not altered by winds or tempests. Their sea in general is the four elements, in particular it is their mercury.” Cf. *Psychology and Alchemy*, par. 57, n. 1, and par. 265. For the “man from the sea” cf. II Esdras (Apoc.) 11 and 13, fifth and sixth visions.

27 Mylius, *Phil, ref.*, p. 192.*

28 Pap. IV, lines 1115ff. Preisendanz, *Pap. Graec. Magicae*, I, p. 110.

29 *Mus. herm.*, p. 559 (Waite, II, p. 89).

30 “Monas hieroglyphica,” *Theatr. chem.*, II, p. 218.*

31 *Mus. herm.*, p. 59.

32 “Consil. coniugii,” *Ars chemica*, pp. 95 and 125: “Punctus Solis in medio rubeus” (the sun-point in the midst of the yolk). Yolk corresponds to fire. “In the midst of the yolk” is the *quintum elementum*, the quintessence, from which will grow the chick. Cf. Mylius, *Phil, ref.*, p. 145.

33 “The sun-point is the germ of the egg, which is in the yolk, and that germ is set in motion by the hen’s warmth.”* Codex Berolinensis Latinus 532, fol. 154^v. Ruska, *Turba*, p. 94.

34 *Theatr. chem.*, I, p. 382: “O wondrous wisdom, which by a word alone was able to bring into being every part of the vast and weighty mass of this huge machine that hath been made since the creation.”*

35 *Ars chemica*, p. 95.

36 Mylius, *Phil, ref.*, p. 131.

37 P. 21. Here Mylius mentions the “crime of the spirit,” from an anonymous treatise (“Liber de arte chymica incerti auctoris,” *Art. aurif.*, I, pp. 613f.). The crime of the spirit was that the spirit brought about the fall of the soul. It says to the soul: “I will bring thee to eternal death, to hell and the house of darkness. To whom the soul: My spirit, why dost thou not return me to that breast wherefrom by flattery thou didst take me? I thought thou wert bound to me by necessity. But I am thy friend, and I will conduct thee to eternal glory.”* “I will do so indeed, but alas, I am compelled to go away, though I will set thee above all precious stones and make thee blessed. Wherefore I beseech thee, when thou comest to the throne of thy kingdom, be mindful sometimes of me.”* This passage points fairly clearly to Luke 23 : 42: “Remember me when thou comest into thy kingdom.” Accordingly the soul, as the *lapis pretiosissimus*, has the significance of a redeemer. The spirit, on the other hand, plays the role of the Gnostic *Naas*, the serpent who brought about the fall of our first parents. The text even says of it: “But if that spirit remaineth with the soul and body, there is perpetual corruption there.”* For this remarkable aspect of the spirit see my “Phenomenology of the Spirit in Fairytales,” sec. 3, and “The Spirit Mercurius,” pars. 264ff., also Aniela Jaffé’s comments on “Phosphorus” in “Bilder und Symbole aus E. T. A. Hoffmanns Märchen ‘Der Goldene Topf.’” Here the spirit obviously plays the role of a “Luciferian” (light-bringing) *principium individuationis*.

38 Cf. my “Paracelsus as a Spiritual Phenomenon,” par. 201.

- 39 Steeb, *Coelum Sephiroticum*, p. 19.
- 40 Cf. Aristotle, *De anima*, I, 2.
- 41 *Von Hylealischen Chaos*, pp. 194ff.
- 42 Cf. St. Bonaventure, *Itinerarium*, 5 (trans. by James, p. 60).*
- 43 *Coel. Sephir.*, pp. 19, 33, 35ff., 117.
- 44 *De circulo quadrato*, p. 29.
- 45 *Ibid.*, p. 15.
- 46 p. 16.
- 47 *Ibid.*, p. 41.
- 48 “And therefore it represents the idea of the heavenly Jerusalem,” p. 38. Cf. the heavenly Jerusalem as “bride” in *Aurora Consurgens*, pp. 53f., and as the *domus thesauraria* (treasure-house) of the *Sapientia Dei*, pp. 101ff.
- 49 * Cf. the Anthropos symbolism in the Codex Brucianus, *Psychology and Alchemy*, pars. 138f.
- 50 *De circ, quad.*, pp. 42f.*
- 51 *Ibid.*, pp. 45f.*
- 52 Nelken reports (“Analytische Beobachtungen über Phantasien eines Schizophrenen,” p. 536) on an insane patient with Gnosticist delusions who stated that God the Father had shrunk to a small point owing to the continual emission of his semen. The semen was lured from him by a “cosmic whore,” who sprang from his blood when it mixed with the darkness. This is a pathological version of the “vir a foemina circumdatus” (“A woman shall compass a man”: Jeremiah 31 : 22).
- 53 “Congeries Paracelsicae,” *Theatr. chem.*, I, pp. 545ff. Dorn is an opponent of the quaternity. Cf. “Psychology and Religion,” par. 104 and n. 47.
- 54 Anonymous scholia to the “Tractatus aureus” in *Theatr. chem.*, IV, p. 691.
- 55 Bousset (*Hauptprobleme der Gnosis*, p. 321) says: “The Gnostics believed that human beings, or at any rate some human beings, carry within them from the beginning a higher element (the *σπιθηρ*) deriving from the world of light, which enables them to rise above the world of the Seven into the upper world of light, where dwell the unknown Father and the heavenly Mother.”
- 56 Meerpohl, “Meister Eckhardts Lehre vom Seelenfünklein.”
- 57 Irenaeus, *Adv. haer.*, I, 24. The *pneumatikoi* have in them a little bit of the Pleroma (II, 19). Cf. the teaching of Satorneilos in Hippolytus, *Elenchos*, VII, 28, 3 (Legge, II, pp. 80f.).
- 58 Macrobius, *In somnium Scipionis*, I, cap. xiv, 19.
- 59 *Elenchos*, V, 19, 7 (Legge, I, p. 162).*
- 60 This idea occurs in alchemy in numerous variations. Cf. Maier, *Symb. aur. mensae*, p. 380, and *Scrut. chymicum*, Emblema XXXI, p. 91: “The king swimming in the sea, crying with a loud voice: Whoso shall deliver me shall have a great reward.”* Likewise *Aurora Consurgens*, p. 57: “Who is the man that liveth, knowing and understanding, to deliver my soul from the hand of hell?”* and beginning of ch. 8.
- 61 *Elenchos*, V, 21, 1.
- 62 Cf. “Transformation Symbolism in the Mass,” par. 359.

63 Cf. *Aion*, par. 344, n. 147 for a parallel in Frances G. Wickes, *The Inner World of Man*, p. 245.

64 *Elenchos*, VI, 17, 7.

65 *Von den dreyen ersten Principiis oder essentiis*, ch. IX. (Sudhoff, III, p. 11.) Cf. “Paracelsus the Physician,” par. 39, n. 56; “Paracelsus as a Spiritual Phenomenon,” pars. 168, 209, 226.

66 The motif of undressing goes back to the Song of Songs 5 : 7: “The keepers of the walls took away my veil from me,” and 5 : 3: “I have put off my coat, how shall I put it on?” The undressing symbolizes the extraction of the soul.

67 *Mus. herm.*, p. 579 (Waite, II, p. 106).

68 I have subjected this text to a detailed interpretation in Ch. v, pars. 591ff.

69 “Cham” (Ham) means the blackness. The Egyptian is the same as the Ethiopian. (von Franz, “Passio Perpetuae,” pp. 464ff.)

70 *Mesech* means ‘mixed drink.’

71 *Uraltes Chymisches Wërck*, Part II, pp. 51f. This is supposed to be the book of Abraham the Jew which plays a great role in the biography of Nicholas Flamel.

72 A MS (*Incipit*: “Figurarum aegyptiorum,” 18th cent., in my possession) gives another version of this motif: “There was a certain man, who was of use for nothing, and could not be kept under guard: for he broke out of all prisons, nay more, he made light of all punishments; yet a certain simple, humble, and sincere man was found, who well understood his nature, and counselled that he be deprived of all his garments and made naked.”* According to the text (fol. 21^f), the undressing signifies putrefaction. Cf. Trevisanus, *Theatr. chem.*, I, pp. 799ff. For the prison cf. *Aurora consurgens* I, Parable 3: “Of the Gate of Brass and Bar of Iron of the Babylonish Captivity.” Similarly, in the *Carmina Heliodori* (Goldschmidt, p. 55), the *nigredo* is called a “wall like the blackness of darkness,” or a “robe of destruction” (p. 56). This goes back to the ancient idea of *σῶμα / σῆμα* (body / sign). Cf. *Corpus Hermeticum* (ed. Scott, I, p. 172f): “But first you must tear off this garment which you wear—this cloak of darkness, this web of ignorance, this [prop] of evil, this bond of corruption—this living death, this conscious corpse, this tomb you carry about with you.” The *nigredo* is also represented as the “garment of darkness.” Cf. *Aurora Consurgens*, p. 59: “He shall not deride my garment,” and the parable in the “Aureum Saeculum Redivivum” of Madathanus, *Mus. herm.*, p. 61 (Waite, I, p. 58): “Her garments, which were rancid, ill-savoured. and poisonous, lay at her feet, whither she had cast them; and at length she broke forth in these words: ‘I have put off my coat; how shall I put it on?’”* (Cf. Song of Songs 5 : 3).

73 Mylius, *Phil. ref.*, p. 149. Similarly Morienus, “De transmut. metallica,” *Art. aurif.*, II, p. 45.

74 Morienus, *ibid.*, p. 32, and Lagneus, “Harmonia chemica,” *Theatr. chem.*, IV, p. 870.

75 *Art. aurif.*, II, p. 32. They are bubbles of steam that rise up in the solution.

76 *Theatr. chem.*, V, p. 884: “Until the earth shines like fishes’ eyes.”*

77 “Granular bodies like fishes’ eyes,”* “Aquarium sapientum,” *Mus. herm.*, p. 91 (Waite, I, p. 83). “At the beginning . . . like red grains and when they coagulate, like fishes’ eyes.”* Mylius, *Phil. ref.*, p. 193. The same in Penotus, “Regulae et Canones,” *Theatr. chem.*, II, pp. 153f. “When they shine in it like fishes’ eyes,”* Ventura, “De ratione confic. lap.,” *Theatr. chem.*, II, p. 333.

78 *Bibliotheca chemica*, II, Tab. IX, Fig. 4. Malus, conjectured to be Magus, mentioned in Ruska (*Turba*) as an Arabian author. Cf. “The Spirit Mercurius,” par. 287.

79 A free version of “Rosinus ad Sarrat.,” *Art. aurif.*, I, p. 310.*

80 Evidently Dorn (“Congeries Paracelsicae,” *Theatr. chem.*, I, p. 607) means the same thing when he says of the Phoenix as the transforming substance: “Its fledglings with their beaks pull out their mother’s eyes.”*

81 *Opera*, p. 159.

82 “Physica Trismegisti,” *Theatr. chem.*, I, p. 423.

83 Scheftelowitz, “Das Fischsymbol im Judentum und Christentum,” p. 383.

84 Pseudonym of an unknown author.

85 Nicholas Flamel, *His Exposition of the Hieroglyphicall Figures*.

86 *Liber de errore profanarum religionum*, 20, 1.*

87 A reference to the birth of Mithras from a rock.

88 The heavenly Jerusalem of the Apocalypse.

89 This reference is valid if the “stone with seven eyes” is taken not as the keystone but as the foundation stone of the temple. The first reference is to the *lapis angularis*, whose parallel in the Eastertide consecration of the fire is the *silex* (firestone), from which the spark springs forth. Cf. the first Collect for Easter Eve: “O God, who through thy Son, who is called the cornerstone, hast brought the fire of thy light to the faithful, make holy for our future use this new fire struck from the firestone.”

90 Cf. what is said in “Adam and Eve,” pars. 568f., below, about the Cabalistic stone, and particularly about the stone as Malchuth.

91 Campbell, *The Miraculous Birth of King Amon-Hotep III*, p. 67. According to Plutarch (“Isis and Osiris,” 55, pp. 134f), Typhon, the wicked brother-shadow of Osiris, wounded or tore out the eye of Horus, and this is to be interpreted as referring to the new moon. For the relation between the eye and “Chemia” see the important passage in Plutarch (33, pp. 82f): “Egypt moreover, which has the blackest of soils, they call by the same name as the black portion of the eye, ‘Chemia,’ and compare it to a heart.”*

92 Steeb, *Coelum Sephiroticum*, p. 47.*

93 *Opera*, II, pp. 1447f.

94 On the authority of Leone Ebreo, *Philosophy of Love*.

95 Garnerus de S. Victore, *Gregorianum* (Migne, *PL.*, vol. 193, col. 166).

96 Papyrus XLVI, British Museum. Cf. Preisendanz, *Pap. Graec. Magicae*, I, p. 194, li. 401.

97 Diodorus, *Bibliothèque Historique*, I, 11: “Osiris means many-eyed . . . for in shedding his rays in every direction he surveys with many eyes”* (Loeb edn., I, pp. 38f.).

98 Radhakrishnan, *Indian Philosophy*, I, p. 333.

99 Cf. Rabanus Maurus, *Allegoriae in Sacram Script.* (Migne, *P.L.*, vol. 112, col. 1009: “The eye is . . . clarity of intellect.”)

100 Cf. my “Complex Theory,” pars. 203f., and “Nature of the Psyche,” pars. 388ff.

101 Hippolytus, *Elenchos*, I, 22, 2 (Legge, I, p. 58): “And that from the concourse of the atoms both God and all the elements came into being and that in them were all animals and other things.”*

102 “Speculativa philosophia,” *Theatr. chem.*, I, p. 275.

103 John 1 : 4f: “In him was life, and the life was the light of men. And the light shineth in the darkness ...”

104 “If a man knows how to transmute things in the greater world . . . how much more shall he know how to do in the microcosm, that is, in himself, the same that he is able to do outside himself, if he but know that the greatest treasure of man dwells within him and not outside him.”* Dorn, “Spec, phil.,” *Theatr. chem.*, I, p. 307.

105 *Imago Dei* is ‘God-image’ in the sense both of a “reflection” and an archetype.

106 *Theatr. chem.*, I, p. 460. Cf. *Aion*, pp. 37ff.

107 “The Archeus in man naturally practises the chymic art.”* “Spec, phil.,” p. 308. This agrees with Paracelsus.

108 “Because man is engendered in corruption, his own substance pursues him with hatred.”* *Ibid.*, p. 308.

109 Here *chalybs* means ‘steel,’ but as *chalybs Sendivogii* it is an arcane substance which is the “secret Salmiac.” This is Sal Armoniacus, the “dissolved stone” (Ruland, *Lexicon*, p. 281). Elsewhere Ruland says: “Sal ammoniac is the star”* (Latin edn., p. 71). Mylius (*Phil. ref.*, p. 314) says of the miraculous aqua: “That is the best, which is extracted by the force of our chalybs which is found in the Ram’s belly . . . before it is suitably cooked it is a deadly poison.”* The ruler of Aries is Mars (= iron). Cf. “Ares” in Paracelsus (“Paracelsus as a Spiritual Phenomenon,” pars. 176f.)

110 “Spec, phil.,” p. 308.*

111 Cf. the “crime of the spirit” in n. 37.

112 “Spec, phil.,” p. 307.*

113 Born in 1560, studied medicine, took his degree 1588 in Basel, and died 1605 in Leipzig.

114 *Von hylealischen Chaos*, pp. 54f.

115 P. 63. Cf. *Aurora Consurgens*, p. 97.

116 P. 94. The filling of the world with scintillae is probably a projection of the multiple luminosity of the unconscious. Cf. “Nature of the Psyche,” pars. 388ff.

117 Pp. 170f.

118 P. 217.

119 There are numerous other synonyms for the scintilla on pp. 220f. and 263f.

120 They were preserved only in Hippolytus, whose *Elenchos* was not discovered until the middle of the 19th cent., on Mount Athos. The passage about the iota (cf. Matthew 5 : 18) in Irenaeus (*Adv. haer.*, I, 3, 2) can hardly have given rise to a tradition.

121 Originally a contribution to the memorial volume for Albert Oeri (pp. 265ff.).

122 *Symb. aur. mensae*, p. 169.

123 See par. 67.

124 This was recognized very early. Thus Jacob Spon says in his *Voyage d’Italie, de Dalmatie, de Grèce et du Levant fait aux années 1675 et 1676*, I, p. 53: “I claim only that whoever composed it did not understand the principles of Latin names; for Aelia and Laelia are two different families, and Agatho and Priscus are two surnames that have no family connection.” And on p. 351: “If any melancholy dreamer chooses to amuse himself by explaining it to pass the time, let him; myself I have already said that I do not believe it to be ancient, and would not put myself to the bother of investigating its riddle.”

125 The inscription is also mentioned in Toniola, *Basilea sepulta resecta continuata* (1661), p. 101 of Appendix, “Exotica monumenta.”

126 *Aelia Laelia Crispis Non Nata Resurgens* (1683). Among the commentators Reusner (author of *Pandora*), Barnaud, Turrius, and Vitus are cited, but not Michael Maier.

127 Ferguson (*Bibliotheca chemica*, I, p. 6) mentions 43 commentators. But there are two others in Malvasius, presumably friends of the author, who are introduced as; “Aldrovandus Ulisses of Bologna and his comrade our Achilles” (p. 29). Thus, by 1683, the number of known commentators had risen to 48 (including Maier). Ulysses Aldrovandus, of Bologna, lived from 1522 to 1605. He was a famous doctor and philosopher. “Our Achilles” may be identical with Achilles Volta. His name is mentioned as one of the commentators in Schwartz, *Acta eruditorum*, p. 333. Unfortunately I have no access to his treatise. The total number of commentators is, however, larger than 48.

128 Cf. Ferguson, s.v. Barnaud and Aelia Laelia. Barnaud’s “Commentarium” is printed in *Theatr. chem.*, III, pp. 836ff., and also in Manget, *Bibl. chem.*, II, pp. 713ff.

129 According to Ruland (*Lexicon*, p. 91), “capilli” is a name for the *lapis Rebis*. It was also conjectured that the *prima materia* might be found in hair.

130 Cf. supra, par. 14, “vetula” and “vidua.”

131 “Nec casta” (not chaste) is missing in Maier.

132 From Arab, *al-baida*, ‘the White One’.

133 “For marriage, like a cloak, covers and hides whatever is vicious.”* *Symb. aur. mensae*, pp. 170f.

134 “Scorpion, i.e., poison. Because it kills itself and brings itself to life again.”* Mylius, *Phil. ref.*, p. 256, and *Ros. phil.*, *Art. aurif.*, II, p. 272. “Euoi, two-horned one, twin-formed one! This god of yours is not twin-formed, but multiform . . . he is the basilisk and the scorpion . . . he is the crafty serpent . . . he is the many-coiled dragon, who is taken with a hook . . . this god of yours is decked with the hairs of the Lernaean snake.”* Firmicus Maternus, *Lib. de err. Prof. relig.*, 21, 2 (ed. Halm, *Corp. script. lat.*, II).

135 “(The divine water) makes natures come forth from their natures, and it quickens the dead.” Djabir, “Livre du Mercure oriental” (Berthelot, *Chimie au moyen âge*, III, 213). Cf. “Komarios to Cleopatra” (Berthelot, *Alch. grecs*, IV, xx, 15): “Stand up from the grave . . . and the medicament of life has entered into you.”* “The tincturing spirit and the metallic water that is poured out over the body, bringing it to life.”* *Aurora consurgens* II, in *Art. aurif.*, I, p. 229.

136 With regard to “the piercing sword, the dividing blade of Mercurius” see “The Visions of Zosimos,” pars. 86, 109f.

137 “Commentarium,” *Theatr. chem.*, III, p. 844.*

138 * Cf. Berthelot, *Alch. grecs*, III, xviii, 1.* Barnaud seems to have known the Paris MS No. 2327 (Berthelot, p. ix).

139 He adds “which is accustomed to bear away the spirit.” Cf. the “crime of the spirit,” supra, n. 37.

140 *Theatr. chem.*, III, p. 845.*

141 Barnaud calls him “adorned with both natural and divine light” (p. 840).

142 Maier does not take *necessarius* here as meaning “kinsman.”

143 *Theatr. chem.*, III, p. 846.

144 The “wise man, whole, smoothed and rounded” is an Horatian figure, meaning a man who is not dependent on earthly things. Cf. *Satires*, lib. II, vii, 83f.: “Who then is free? The wise man, who is lord over himself, whom neither poverty nor death nor bonds affright, who bravely defies his passions, and scorns ambition, who in himself is a whole, smoothed and rounded.”* Horace, *Satires, Epistles, and Ars Poetica* (trans. by Fairclough), p. 231.

145 In so far as it is the sum of conscious and unconscious processes.

146 *Symb. aur. mensae*, p. 173.*

147 *Ros. phil., Art. aurif.*, II, p. 246. The empirical model for this is the amalgamization of gold with mercury. Hence the saying: “The whole work lies in the solution” (i.e., of sun and moon in mercury). *Ibid.*, p. 270.

148 *Opera*, p. 351. He says there arises a “thickening of the air [i.e., a concretizing of the spirit] and all the limbs are torn to atoms.”* The “mangled King” refers to Osiris, well known to the alchemists, and his dismemberment. Thus Olympiodorus (Berthelot, II, iv, 42) mentions Osiris as the “straitened tomb (ἡ ταφή ἐσφιγμένη) which hides all his limbs.” He is the moist principle (in agreement with Plutarch, “Isis and Osiris,” c. 33, trans. by Babbitt, V, pp. 80f.) and “has bound together (συνέσφιγξεν) the whole of the lead,” obviously as its “soul.” Typhon sealed the coffin of Osiris with lead. (Plutarch, *ibid.*) Osiris and Isis together form the androgynous prima materia (Maier, *Symb. aur. mensae*, pp. 343f., and Pernety, *Diet, mytho-hermétique*, p. 359). He has affinities with the “sick” or “imprisoned” King, the *Rex marinus* of the “Visio Arislei.” He is “many-eyed” (*oculi piscium!*) in Diodorus, I, 11 (Loeb edn., I, pp. 38f) and “many-formed” like Attis (or the “self-transforming” Mercurius). In the hymn to Attis (Hippolytus, *Elenchos*, V, 9, 8) he is said to be “a corpse, or a god, or the unfruitful one.”* He must be freed from his grave or prison. Cf. the daily rite of the king in cutting out the sacrificial victim’s eye in memory of the eye of Horus, which contained the soul of Osiris. (Campbell, *The Miraculous Birth of King Amon-Hotep III*, p. 67.) On the first day of Phamenoth (beginning of spring) Osiris enters the new moon. This is his conjunction with Isis (Plutarch, p. 83). “And as at the beginning the sun is hidden in the moon, so, hidden at the end, it is extracted from the moon.”* Ventura, “De ratione confic. lapidis,” *Theatr. chem.*, II, p. 276.

149 Cf. “Transformation Symbolism in the Mass,” pars. 345ff., 400, 410f.

150 The bad smell is the “stench of the graves.” “For its [the dead body’s] smell is evil, and like the stench of the graves.”* Maier, *Symb. aur. mensae*, and Morienus, “De transmut. metallica,” *Art. aurif.*, II, p. 33. The stench of the underworld is an idea that dates back to ancient Egypt. Cf. the “Book of Gates,” cited by Wallis Budge, *Coptic Apocrypha in the Dialect of Upper Egypt*, p. lxvi.

151 “The pure lato is cooked until it begins to shine like fishes’ eyes.”* Morienus in *Art. aurif.*, II, p. 32.

152 “This One being placed in its spherical tomb.”* (“Tract. Aristot.,” *Theatr. chem.*, V, p. 886.) “The vessel is also called the tomb.”* (Hoghelande, “De alchemiae diffic.,” *Theatr. chem.*, I, p. 199.) *Vas* = ‘tomb, prison.’ (Ventura, “De ratione confic. lap.,” *Theatr. chem.*, II, p. 289.) In *Aurora Consurgens*, p. 135, the stone is to be removed “from the door of my sepulchre.”

153 Ruska, *Turba*, Sermo LIX, p. 162.

154 Dorn, “Physica Trismegisti,” *Theatr. chem.*, I (1659), p. 436.

155 Berthelot, *Alch. grecs*, IV, xxiii.

156 Albertus Magnus, “Super arborem Aristot.,” *Theatr. chem.*, II, p. 527.

157 “The tomb in which our king is buried is called . . . Saturn”* (Waite, *Herm. Mus.*, II, p. 189).

158 Firmicus Maternus, *De err. prof. rel.*, 2, 3: “In their shrines they have the idol of Osiris buried.”*

159 “Liber Alze,” *Mus. herm.*, p. 332 (Waite, I, p. 267).* Cf. “Ludus puerorum,” *Art. aurif.*, II, p. 189: “Therefore Avicenna says: So long as the *nigredo* is manifest, the dark woman prevails, and that is the first strength of our stone.”*

160 “Commentarium,” *Theatr. chem.*, III, pp. 847f.

161 Cf. *Psychology and Alchemy*, pars. 23ff. The fact that the alchemists, in their attempts to solve the Enigma, immediately thought of the most significant thing they knew, namely the secret of their art, is understandable at a time when there were enigmas even concerning God, the holy scriptures, etc. Cf. Lorichius, *Aenigmatum libri III* (fol. 23^r), which also contains the riddle of the hermaphrodite: “When my pregnant mother bore me,” etc. (see infra, par. 89.)

162 Athanasius Kircher’s interpretation in his *Oedipus Aegyptiacus* (II, ch. 6, p. 418) is purely alchemical and not distinguished by any originality. He calls the inscription “the prime chymic enigma,” mentioning that Wilhelmus Baroldus the Englishman made a Cabalistic interpretation. The monument is mentioned in Drexelius, *Opera* (I, p. 69): “There is at Bologna an ancient epitaph which has puzzled the wits of many. . . . Some interpret it as referring to man’s soul, others to the water from the clouds, others to Niobe changed into a rock, others in yet other ways.”*

163 All this is in Malvasius, *Aelia Laelia*, p. 55.

164 P. 103.

165 Prof. Felix Staehelin has informed me that the inscription is cited in *Corp. inscr. lat.*, XI, Part I, p. 15*, No. 88* under the spurious ones. [These asterisks are part of the refs. in the *Corp.*]

166 P. 40.*

167 P. 90.

168 “Auspicatissimi . . . Ternarii Cultorem eximium.”

169 “Therefore I am called Hermes Trismegistus, as having three parts of the philosophy of the whole world.”*

170 “God prefers odd numbers.”*

171 Cf. *Psychology and Alchemy*, pars. 26, 209.

172 Cf. the Phibionites, Stratototics, etc., in Epiphanius, *Panarium*, XXVI, 5 (ed. Holl, I, p. 281). The same idea occurs in Manichaeism: Reitzenstein and Schaeder, *Studien zum antiken Synkretismus aus Iran und Griechenland*, p. 346. For alchemy the so-called third sonship of Basilides is particularly important (cf. *Aion*, pars. 118ff.). The sonship (*υιότης*) left below in the “universal seed-bed” (*πανσπερμία*) was “left behind in formlessness like an early birth” (*έν τῇ ἀμορφία καταλειμμένη ριονεί έκτρώματι*) (Hippolytus, *Elenchos*, VII, 26, 7). Cf. Paul (I Cor. 15 : 8): “Last of all, as to one untimely born, he appeared also to me” (RSV).

173 This treatise derives from the old Latinists, or from the “Arabists,” whose connection with Arabic tradition is uncertain.

174 *Theatr. chem.*, V, p. 881.*

175 “The subtlety of nature . . . provided the cause of growth and life, and restored itself in the most perfect natures.”* “This Serpent . . . swells like a coal-black Toad, and . . . begs to be freed from its misery.”*

176 *Aelia Laelia*, p. 29.

177 On the Capitoline Hill there was an ancient oak sacred to the Capitol. For “Junonia” see Plutarch, “Quaestiones Romanae,” 92, *Moralia* (ed. Babbitt), IV, pp. 138f.

178 Cf. *Psychology and Alchemy*, par. 116, and “Paracelsus as a Spiritual Phenomenon,” pars. 179f., 214ff.

179 *Dendrologia*, I, p. 211.*

180 *Corp. inscr. lat.*, XI, i, pp. 163, 884: MVTINA.

181 I must leave to the author the responsibility for the correctness of this statement.

182 *Dendrologia*, I, p. 215.*

183 Concerning white and red see *The Zohar* (trans. by Sperling and Simon), I, p. 3: “As the lily among thorns [Song of Songs 2 : 1] is tinged with red and white, so the community of Israel is visited now with justice and now with mercy.” In contrast to alchemy, red is co-ordinated with the feminine, and white with the masculine, side of the Sefiroth system.

184 Cf. the doves in the “grove of Diana,” *Mus. herm.*, p. 659 (Waite, II, p. 170). The dove symbol may be derived directly from Christian allegory. Here we must consider the maternal significance of the dove, since Mary is called the *columba mystica*. (Godefridus, *Homiliae Dominicales*, Migne, *P.L.*, vol. 174, col. 38.) Cf. further the “hidden mother” designated as a dove in the Acts of Thomas (James, *Apocryphal New Testament*, p. 388) and the dove symbolism of the Paraclete in Philo (“Who is the Heir of Divine Things?” Loeb edn., IV, pp. 398f.). Nelken describes the vision an insane patient had of “God the Father”: on his breast he bore a tree of life with red and white fruit, and on it was sitting a dove. (“Analytische Beobachtungen,” p. 541.)

185 Abu’l-Qasim Muhammad, *Kitāb al-’ilm al-muktasab*, ed. by Holmyard, p. 23.

186 *Psychology and Alchemy*, fig. 231. Cf. Sapientia Dei as the tree of life in *Aurora Consurgens*, p. 35.

187 “De chemico miraculo,” *Theatr. chem.*, 1, pp. 773ff.

188 P. 799.

189 “He inserted an old oak, cloven in the midst, which is protected from the rays of the sun, casting a shadow”* (p. 800).

190 P. 800.*

191 Usually the king is alone only when he is sitting in the sweat-bath.

192 [“Brunnenstock.” The fountain described here is of a type commonly found in rural parts of central Europe. Shaped like a flattened “L,” it consists of an upright block of wood, the “stock,” from which the waterpipe projects over a long trough hollowed out of a tree-trunk.-TRANS.]

193 The text is ambiguous on this point: “Petii rursum utrum fond Rex esset amicus et fons ipsi? Qui ait, mirum in modum sese vicissim amant, fons Regem attrahit et non Rex fontem: *nam Regi velut mater est*” p. 801). (I, asked again whether the King was friendly to the fount, and the fount to him. And he replied, they are wonderfully fond of each other. The fount attracts the King, and not the King the fount: *for it is like a mother to the King*.) There is a similar association in Cyril of Jerusalem, *Catecheses Mystagogicae*, II, 4 (*Opera*, ed. Reischl, II, p. 361): “And that saving water is made both a tomb and a mother to you.”* Cf. Usener, *Das Weihnachtsfest*, p. 173.

194 Cf. Ovid, *Metamorphoses*, VII (trans. by Miller, I, p. 386f.): “Before my eyes the same oak-tree seemed to stand, with just as many branches and just as many creatures on its branches.” Isidore states that the “winged oak” (*ὑπόπτερος δρῦς*) of Pherecydes was wrapped in a hood (*φᾶρος*) like a woman. (Diels, *Vorsokratiker*, I, p. 47.) The

“veiling” is an attribute of Artemis Chitone, and particularly of Ishtar: she is *tashmetu*, the Veiled One, Situri-Sabitu, who sits on the throne of the sea, “covered in a veil.” (Wittekindt, *Das Hohe Lied*, p. 15.) The constant attribute of Ishtar is the palm. According to the Koran, Sura 19, Mary was born under a palm-tree, just as Leto gave birth under a palm-tree in Delos. Maya gave birth to the Buddha with the assistance of a willow. Human beings are said to be born of oaks (Pauly-Wissowa, *Realencyclopädie*, s.v. “Drys”). Further material in my “The Philosophical Tree,” pars. 418f., 458ff.

195 This is also the liturgical name for the font. See the Preface in the *Benedictio Fontis*: “May he fecundate this water for the regeneration of man,” etc. Cf. “Consil. coniugii,” *Ars chemica*, p. 204: “By matrix he means the root of the gourd.”* “The spagyric vessel is to be constructed in the likeness of the natural vessel”* (Dorn, “Physica Trismeg.,” *Theatr. chem.*, I, p. 430). The “natural vessel” is the uterus. (*Aurora consurgens* II, in *Art. aurif.*, I, p. 203.)

196 “The place of gestation, even though it is artificial, yet imitates the natural place, since it is concave and closed.”* (“Consil. coniugii,” p. 147.)

197 Cf. *Psychology and Alchemy*, fig. 257.

198 There is a widespread idea that souls and numina appear as snakes (for instance the numen of the hero, Cecrops, Erechtheus, etc.). Cf. John Chrysostom, *Homilia XXVI (alias XXV) in Joannem* (Migne, P.G., vol. 59, col. 155): “For what the mother is to the unborn child, that water is to the believer. For in water he is moulded and formed. Of old it was said: Let the water bring forth creeping things with a living soul. But since the Lord entered the streams of the Jordan, the water beareth no longer creeping things with living souls, but reasonable souls bearing the Holy Spirit.”*

199 According to Hegemonius (*Acta Archelai*, p. 18), Jesus was the paradisaic tree, indeed the Tree of Knowledge, in Manichaeism: “The trees which are [in paradise] are the lusts and other temptations that corrupt the thoughts of men. But that tree in paradise whereby good is known is Jesus, and the knowledge of him which is in the world: and he who receives this discerns good from evil.”* Here the Tree of Knowledge is regarded as a remedy for concupiscence, though outwardly it is not to be distinguished from the other (corrupting) trees.

200 Cf. *Psychology and Alchemy*, figs. 8 and 19.

201 Cf. “The Spirit Mercurius,” pars. 239, 247f.

202 “Impone ei” could refer to the tree, as “imponere” also means to “put on.” The tree can be a birthplace. Cf. the ancient motif of tree-birth.

203 Sermo 58.

204 *De chemia*, p. 78.*

205 Probably identical with Marcus Graecus, author of the so-called “Book of Fire.” He is difficult to date. (Cf. Lippmann, *Entstehung und Ausbreitung der Alchemie*, I, pp. 477ff.) The fact that he is mentioned by Senior, whose Arabic writings are extant, may date him before the 10th cent. In Berthelot (*Chimie au moyen âge*, III, p. 124) there is a dialogue between Marqūsh, king of Egypt, and Safanjā, king of Saïd. Cf. M. T. Ali, ed., “Three Arabic Treatises on Alchemy by Muhammad Bin Umail” (10th cent.), and the excursus by H. E. Stapleton and M. H. Husain (“M. b. Umail: His Date, Writings, and Place in Alchemical History,” p. 175).

206 Stapleton and Husain (p. 177, n. 12) have here: “It is a house, which is called the grave (*qabr*) of Sahafa. She said (*qālat*) etc. Possibly the name Māriyah has been omitted.”

207 Or ‘region?’

208 τὸρμος = ‘hole’? The Arabic text has tūmtī.

209 The Arabic word for “reptile” really means ‘witch’. Cf. Stapleton and Husain (p. 177, n. 14): “The Arabic word properly means witches who consume the livers [*iecora* instead of *opaca*] of children and drink the milk of black goats.” Stapleton rejects “reptile.”

210 In the Arabic text, “liver.”

211 This makes one think of an altar fire and a goat sacrifice. Cf. “the blood of a most fine buck goat” (von Franz, *Aurora Consurgens*, p. 103). In Pibechios (Berthelot, *Alch. grecs*, III, xxv, 3) goat’s blood is a synonym for the divine water. Here the blood is used to feed the shades, as in the Nekyia, when Odysseus sacrifices black sheep, and, for Tiresias in particular, a black ram: “... the dark blood poured in. And now the souls of the dead who had gone below came swarming up from Erebus” (Rieu trans., p. 172).

212 This may refer to the “dissolved” state in the liquid medium.

213 Reading “pariunt” for “pereunt.”

214 In the form of *volatilia* and *vapores*.

215 This shows traces of Christian influence. The “Aquarium sapientum” (*Mus. herm.*, p. 117) says on this score: “Christ fasted in the wilderness for forty days and forty nights, as also he preached and worked miracles for forty months on earth, and lay for forty hours in the tomb. For forty days, between his rising from the dead and his ascension into heaven, he conversed with his disciples and showed himself alive to them.”* “Forty” is a prefiguration of the length of the opus. According to Genesis 50 : 3, forty days are required for embalming. Forty seems to be a magic multiple of four, 10 (the *denarius*) × 4.

216 I have mentioned this dream several times, for instance in “Archetypes of the Collective Unconscious,” par. 71, “The Phenomenology of the Spirit,” par. 398, “Analytical Psychology and Education,” par. 208, and “The Relations between the Ego and the Unconscious,” par. 287.

217 Cf. Stapleton and Husain, p. 178.

218 The love-birds of Astarte.

219 Here marble is the female substance, the so-called Saturnia (or Luna, Eva, Beya, etc.) which dissolves the sun. “Sparkling marble is the elixir for the whitening”* (Mylius, *Phil. ref.*, p. 234.) “Et de là changea sa forme noire et devint comme marbre blanc et le soleil était le plus haut” (MS. 3022, Bibl. de l’Arsenal, Paris). For the meridional position of the sun see “The Visions of Zosimos,” pars. 86 (III, v bis), 95, 107f. “Marble” is also a name for the “water like to itself,” i.e., Mercurius duplex. (Philaletha in *Mus. herm.*, p. 770.) This Senior passage is commented on in “Consil. coniugii”: “And let them cast their seed on the marble of the statues [?], and into the deifying water like to itself, and flying ravens will come and fall upon that statue. By ravens . . . he means the *nigredo*.”* The Consilium seems to point to what was known in alchemy as the “statua.” The origin of this idea is to be found in the treatise of Komarios (Berthelot, IV, xx, 14f.), where the soul, after the dark shadow has been removed from the body, awakens the now shining body from Hades, that it may rise from the grave, since it is clothed in spirituality and divinity. (For the exact text see “The Statue,” infra, par. 559.) In *Aurora consurgens* II (*Art. aurif.*, I, p. 196) *mater Alchimia* is likewise a statue, but one consisting of different metals. So, too, do the seven statues in Raymond Lully (Norton’s “Ordinall,” *Theatr. chem. Brit.*, ch. 1, p. 21). In Mylius (*Phil. ref.*, p. 19) it is said: “It is a great mystery to create souls, and to mould the lifeless body into a living statue.”* According to the teaching of the Mandaeans (Bousset,

Hauptprobleme der Gnosis, p. 34) and of the Naassenes (Hippolytus, *Elenchos*, V, 7; Legge, I, p. 122), Adam was a “corporeal” or “lifeless” statue. Similarly in Hegemonius (*Acta Archelai*, VIII) the “perfect man” was a “pillar of light,” referred to also in *Act. Arch.*, XIII: “But then shall these things be, when the statue shall come.”* We must bear these ideas in mind in reading Lully (*Codicillus*, ch. 49, p. 88): “Always extract oil [= soul] from the heart of the statues; for the soul in parable is fire, and a hidden fire.”* Senior (*De chemia*, p. 65) says: “We warm its water, which is extracted from the hearts of statues of stone.”* And in *Ros. phil. (Art. aurif.*, II, p. 335) we read: “... Venerate the souls in statues: for their dwelling is in them.”* Cf. the statue of the hermaphrodite, erected in the form of a cross, which “sweats,” in Bardesanes (Schultz, *Dokumente der Gnosis*, p. lv). The statue or pillar has affinities with the tree of light and tree of fire, as well as with the world’s axis. Cf. the pillar erected to Adonai Sabaoth in Book II of the Sibylline Oracles (ed. Geffcken, p. 39). Further material in “The Philosophical Tree,” pars. 421ff.

220 The Arabic text says “they will lay eggs.”

221 A woman patient who was much concerned with the problem of opposites dreamt that “*on the shore of a lake* [i.e., the edge of the unconscious] *two ring-snakes as thick as an arm, with pale human heads, were copulating.*” About six months later came the following dream: “*A snow-white snake with a black belly was growing out of my breast. I felt a deep love for it.*”

222 Birds flying up and down appear frequently in the literature and symbolize the ascending vapours. The “heaven” to which they ascend is the alembic or *capitelum* (helmet), which was placed over the cooking-vessel to catch the steam as it condensed.

223 At any rate this is the interpretation of the Latin translator.

224 See ch. I, n. 226.

225 I have to thank Dr. C. A. Meier for this dream.

226 *Art. aurif.*, II, p. 293. Cf. “Psychology of the Transference,” par. 528.

227 *Mus. herm.*, pp. 652ff. (Waite, II, p. 166).

228 From the 3rd cent. B.C., Cadmus, as a culture hero, was identified with Hermes Kadmilos.

229 Like the hamadryads, snakes are tree numina. A snake guarded the apples of the Hesperides and the oak of Ares in Colchis. Melampus received the gift of second sight from snakes which he found in a hollow oak.

230 Cf. *Aion*, pars. 80ff.

231 Musical ideas are sounded in alchemy since there are also alchemical “compositions” in existence. Michael Maier tried his hand at this art in his *Atalanta fugiens*. Examples are printed in Read, *Prelude to Chemistry*, pp. 281ff. For the parallel between alchemy and music see Berthelot, III, xlv, I and VI, xv, 2ff.

232 *Les Fables égyptiennes et grecques*, II, p. 121.

233 Pernety derives Cadmia from Cadmus. Ruland takes Cadmia as cobalt (which means “kobold”). Cadmia seems to have been zinc oxide and other zinc compounds. (Lippmann, *Entstehung und Ausbreitung der Alchemie*, II, p. 24.) Cadmus is connected with alchemy because he invented the art of mining and working gold. Cadmia is included in Galen’s pharmacopoeia as a means for drying deep ulcers. (*De simplicium medicamentorum facultatibus*, IX, pp. 599ff.) It was also known to Pliny. (*Hist. nat.*, XXXII, ch. 7, and XXXIII, ch. 5.)

234 Rather like the marriage-dance of the dancing couples in Kékulé’s vision of the benzol ring. Cf. “The Psychology of the Transference,” par. 353.

235 Cf. Wickersham Crawford, “El Horosopo del Hijo del Rey Alcaraz en el ‘Libro de Buen Amor,’” pp. 184ff.

236 Lorichius, *Aenigmatum libri III*, fol. 23^r.*

237 *Symbola aureae mensae*, p. 171.*

238 The riddle refers to Plato’s remark in the *Republic* (V, 479 B-C): “‘They are ambiguous like the puzzles you hear at parties,’ he replied, ‘or the children’s riddle about the eunuch hitting the bat and what he threw at it and what it was sitting on.’” (Lee trans., p. 243.) The scholium then gives the “Vir non vir” cited above. It is cited in another form as the riddle of Panarkes (Athenaeus, *Deipnosophists*, X, 452): “A man that was not a man hit a bird that was not a bird, perched on wood that was not wood, with a stone that was not a stone. The answer to these things is, severally, eunuch, bat, fennel, and pumice.”* (Gulick trans., IV, pp. 550f.)

239 Zimmer, *Der Weg zum Selbst*, p. 54.

240 Richardus Vitus Basinstochius, *Aelia Laelia Crispis Epitaphium Antiquum*, etc.

241 Whether Agathias was the author is uncertain. He was in Byzantium in 577 and 582. Among other things he wrote a *Κύκλος τῶν νέων ἐπιγραμμάτων* (Cycle of New Epigrams), much of which is preserved in the *Anthologia palatina et planudea*, including the above epigram. (Cf. *Anthologia Graeca Epigrammatum*, ed. Stadtmueller. II, Part 1, p. 210, No. 311.) Eustathius Macrembolites (*Aenigmata*, p. 209, 8 H) cites the above-mentioned interpretation of Holobolus, that the epigram refers to Lot’s wife.

242 Richardus Vitus, p. 11.*

243 Cf. *Aeneid*, VI, 730: “These life seeds have a fiery strength and heavenly origin.”*

244 This psychological insight, which was rediscovered only in the 20th century, seems to have been a commonplace among the alchemists from the middle of the 16th century on.

245 “She has so to speak the identity (selfness: *αὐτότητα*) of all mankind in herself.”* Vitus, p. 48.

246 P. 50.*

247 P. 50.*

248 “In this Epitaph the soul is described as an idea”* (p. 46).

249 P. 40.*

250 Padua, 1630.

251 *Allegoria peripatetica*, pp. 166f.*

252 *Electorum libri III*, Bk. III, cap. I, pp. 81ff.

253 *Deipnosophists*, XIII, 562 (trans. by Gulick), VI, pp. 36f.

254 Vol. II, p. 215.

255 Lib. V, epigram 61.*

256 *Acta eruditorum* (1727), p. 332.

257 Pars. 32ff.

258 Evans, *Meister Eckhart*, I, p. 438.

259 Cf. my “The Psychology of the Child Archetype” and “The Psychological Aspects of the Kore.”

260 “De sulphure,” *Mus. herm.*, p. 617: “(The soul) imagines very many profound things outside the body, and by this is made like unto God.”*

- 1 “Visio Arislei,” *Art. aurif.*, I, pp. 146ff.
- 2 Maier, *Symb. aur. mensae*, p. 156.
- 3 “Visio Arislei,” p. 147.
- 4 The philosophers say to him: “Lord, king you may be, but you rule and govern badly.”*
- 5 Senior, *De chemia*, p. 92.*
- 6 “Gold and silver in their metallic form are not the matter of our stone.”* “Tractatus aureus,” *Mus. herm.*, p. 32 (Waite, I, p. 33).
- 7 Because gold is not subject to oxidization, Sol is an arcanum described in the “Consilium coniugii” as follows: “A substance equal, permanent, fixed for the length of eternity” * (*Ars chemica*, p. 58). “For Sol is the root of incorruption.”* “Verily there is no other foundation of the Art than the sun and its shadow”* (ibid., p. 138).
- 8 Rupescissa, *La Vertu et la propriété de la quinte essence*, p. 19: “Jceluy soleil est vray or. . . . L’or de Dieu est appelé par les Philosophes, Soleil; car il est fils du Soleil du Ciel, et est engendre par les influences du Soleil és entrailles et veines de la terre.”
- 9 Sulphur is even identical with fire. Cf. “Consil. coniugii” (*Ars chemica*, p. 217): “Know therefore that sulphur is fire, that is, Sol.”* In Mylius (*Phil. ref.*, p. 185) Sol is identical with sulphur, i.e., the alchemical Sol signifies the active substance of the sun or of the gold.
- 10 “Our Sol is ruddy and burning.” * (Zacharius, “Opusculum,” *Theatr. chem.*, I, p. 840.) Bernardus Trevisanus goes so far as to say: “Sol is nothing other than sulphur and quicksilver.” * (Ibid., Flamel’s annotations, p. 860.)
- 11 Olympiodorus (Berthelot, *Alch. grecs*, II, iv, 43): “Smear [with it] the leaves of the shining goddess, the red Cyprian.”
- 12 Cf. the sulphur parable (infra par. 144), where the water is “most dangerous.”
- 13 Hoghelande, *Theatr. chem.*, I, p. 181.
- 14 *Mus. herm.*, pp. 581f. (Waite, II, p. 107).
- 15 Steeb, *Coelum sephiroticum*, p. 50. Paracelsus, in “De natura rerum” (Sudhoff, XI, p. 330), says: “Now the life of man is none other than an astral balsam, a balsamic impression, a heavenly and invisible fire, an enclosed air.” *De Vita longa* (ed. Bodenstein, fol. c 7^v): “(Treating of a certain invisible virtue) he calls it balsam, surpassing all bodily nature, which preserves the two bodies by conjunction, and upholds the celestial body together with the four elements.”*
- 16 Steeb, p. 117. The moon draws “universal form and natural life” from the sun. (Dorn, “Physica genesis,” *Theatr. chem.*, I, p. 397.)
- 17 *Theatr. chem.*, V, p. 130.
- 18 “It were vain to believe, as many do, that the sun is merely a heavenly fire.”* (Dorn, “Physica Trismegisti,” *Theatr. chem.*, I, p. 423.)
- 19 The alchemists still believed with Proclus that the sun generates the gold. Cf. Proclus, *Commentaries on the Timaeus of Plato* 18 B (trans. by Taylor), I, p. 36.
- 20 Dorn (“Phys. Trismeg.,” p. 423) says: “As the fount of life of the human body, it is the centre of man’s heart, or rather that secret thing which lies hid within it, wherein the natural heat is active.” *

- 21 Zosimos (Berthelot, *Alch. grecs*, III, xxi, 3) cites the saying of Hermes: “The sun is the maker of all things.” *
- 22 “Phys. Trismeg.,” p. 423.* The Codex Berol. Lat. 532 (fol. 154^v) says of the germ-cell of the egg: “The sun-point, that is, the germ of the egg, which is in the yolk.” *
- 23 “The first and most powerful male and universal seed is, by its nature, sulphur, the first and most powerful cause of all generation. Wherefore Paracelsus says that the sun and man through man generate man.” * (Dorn, *ibid.*)
- 24 Cf. *infra*, p. 98. The alchemical sun also rises out of the darkness of the earth, as in *Aurora Consurgens*, pp. 125f.: “This earth made the moon . . . then the sun arose . . . after the darkness which thou hast appointed therein before the sunrise.” *
- 25 *Ars chemica*, p. 158. On a primitive level, blood is the seat of the soul. Hair signifies strength and divine power. (Judges 13 : 5 and 16 : 17ff.)
- 26 Cf. the works of Lehmann, Preuss, and Rohr. A collection of mana-concepts can be found in my “On Psychic Energy,” pars. 114ff.
- 27 Cf. Bonus, “Pretiosa margarita novella,” *Theatr. chem.*, V, p. 648: “And in this wise Alchemy is supernatural, and is divine. And in this stone is all the difficulty of the Art, nor can any sufficient natural reason be adduced why this should be so. And thus it is when the intellect cannot comprehend this nor satisfy itself, but must yet believe it, as in miraculous divine matters; even as the foundation of the Christian faith, being supernatural, must first be taken as true by unbelievers, because its end is attained miraculously and supernaturally. Therefore God alone is the operator, nature taking no part in the work.”*
- 28 “Spec, phil.,” *Theatr. chem.*, I, p. 298; also “Phil, chemica,” p. 497.
- 29 Cf. *Aurora Consurgens*, p. 111: “For I could not wonder enough at the great virtue of the thing, which is bestowed upon and infused into it from heaven.”*
- 30 “Phil. meditativa,” *Theatr. chem.*, I, p. 456. There is a similar passage on P. 457: “Further, in the human body is concealed a certain substance of heavenly nature, known to very few, which needeth no medicament, being itself the incorrupt medicament.”*
- 31 P. 457.
- 32 P. 458. See also “Spec, phil.,” p. 266.
- 33 P. 459.*
- 34 “The Spirit Mercurius.”
- 35 Cf. the ancient idea that the sun corresponds to the right eye and the moon to the left. (Olympiodorus in Berthelot, *Alch. grecs*, II, iv, 51.)
- 36 Just as for the natural philosophers of the Middle Ages the sun was the god of the physical world, so the “little god of the world” is consciousness.
- 37 Consciousness, like the sun, is an “eye of the world.” (Cf. Pico della Mirandola, “Disputationes adversus astrologos,” lib. III, cap. X, p. 88r.) In his *Heptaplus* (Expositio 7, cap. IV, p. 11^f) he says: “Since Plato calls the Sun . . . the visible son of God, why do we not understand that we are the image of the invisible son? And if he is the true light enlightening every mind, he hath as his most express image this Sun, which is the light of the image enlightening every body.”*

38 This idea occurs already in the *Turba* (ed. by Ruska, p. 130): “But he who hath tinged the poison of the sages with the sun and its shadow, hath attained to the greatest secret.” * Mylius (*Phil, ref.*, p. 22) says: “In the shadow of the sun is the heat of the moon.” *

39 From ch. II of the “Tractatus aureus,” *Ars chemica*, p. 15.*

40 Cf. Mylius, *Phil, ref.*, p. 19. Here the *sol niger* is synonymous with the *caput corvi* and denotes the *anima media natura* in the state of *nigredo*, which appears when the “earth of the gold is dissolved by its own proper spirit.” * Psychologically, this means a provisional extinction of the conscious standpoint owing to an invasion from the unconscious. Mylius refers to the “ancient philosophers” as a source for the *sol niger*. A similar passage occurs on p. 118: “The sun is obscured at its birth. And this denigration is the beginning of the work, the sign of putrefaction, and the sure beginning of the commixture.” * This *nigredo* is the “changing darkness of purgatory.” Ripley (*Chymische Schriften*, p. 51) speaks of a “dark” sun, adding: “You must go through the gate of the blackness if you would gain the light of Paradise in the whiteness.” Cf. *Turba*, p. 145: “nigredo solis.”

41 *De chemia*, p. 91.*

42 The *sol niger* is a “counter-sun,” just as there is an invisible sun enclosed in the centre of the earth. (See Agnostus, *Prodromus Rhodostauroticus*, 1620, Vr.) A similar idea is found in Ventura (*Theatr. chem.*, II, p. 276): “And as at the beginning the sun is hidden in the Moon, so, hidden at the end, it is extracted from the moon.”*

43 “Tractatus aureus,” *Ars chemica*, p. 15.

44 Dorn, “Spec, phil.,” *Theatr. chem.*, I, p. 308. He conceives it in the first place as a physiologically destructive action which turns the salts in the body into chalk, so that the body becomes “sulphurous.” But this medical observation is introduced by the remark: “Because man is engendered in corruption, his own substance pursues him with hatred.” By this he means original sin and the corruption resulting therefrom.

45 I am not forgetting that the dangerous quality of Sol may also be due to the fact that his rays contain the miraculous water “which by the power of the magnet is extracted from the rays of the sun and moon.” * This water is a putrefying agent, because “before it is properly cooked it is a deadly poison.” Mylius, *Phil, ref.*, p. 314. This aqua permanens is the ὕδωρ θεῖον (divine water), the “divinity” being sulphur. It was called “sulphur water” (τὸ θεῖον also means sulphur) and is the same as mercury. θεῖον or θήιον in Homer was believed to possess apotropaic powers, and this may be the reason why it was called “divine.”

46 *Art. aurif.*, I, p. 58ff.*

47 The text only has “auri similitudinem profundam,” without a verb.

48 *Art. aurif.*, I, pp. 580ff.

49 “The Lapis-Christ Parallel.”

50 Especially as “sol iustitiae” (sun of justice), Malachi 4 : 2. Cf. Honorius of Autun, *Speculum de mysteriis Ecclesiae* (Migne, *P.L.*, vol. 172, col. 921): “For, like to the sun beneath a cloud, so did the sun of justice lie concealed under human flesh.” * Correspondingly, the Gnostic Anthropos is identical with the sun. (Cf. Reitzenstein, *Poimandres*, p. 280.)

51 *Art. aurif.*, I, p. 155.

52 The alchemical equivalent of the Trinity is the three-headed serpent (Mercurius). See *Psychology and Alchemy*, fig. 54.

53 Cf. my “Psychological Approach to the Dogma of the Trinity,” pars. 243ff. Though some may find it objectionable, the opposition between Christ and the devil in the above schema presupposes an inner relationship (regarded by the Ebionites, says Epiphanius, as that between two brothers). Angelus Silesius seems to have felt something of the sort, too:

“Were from the Devil all his His-ness gone,
You’d see the Devil sitting in God’s throne.”

Cherubinischer Wandersmann, I, No. 143 (Cf. Flicht version, p. 144). By “His-ness” Angelus Silesius means the “selfhood which damns,” as is incontestably true of all selfhood that does not acknowledge its identity with God.

54 The thinking in the Psalms and of the prophets is “circular. Even the Apocalypse consists of spiral images . . . One of the main characteristics of Gnostic thinking is circularity.” (Koepgen, *Gnosis des Christentums*, p. 149.) Koepgen gives an example from Ephraem Syrus: “Make glad the body through the soul, but give the soul back to the body, that both may be glad that after the separation they are joined again” (p. 151). An alchemist could have said the same of the uroboros, since this is the primal symbol of alchemical truth. Koepgen also describes dogma as “circular”: it is “round in the sense of a living reality. . . . Dogmas are concerned with the religious reality, and this is circular” (p. 52). He calls attention to the “fact of not knowing and not recognizing, which lies at the core of the dogma itself” (p. 51). This remark indicates the reason or one of the reasons for the “roundness”: dogmas are approximative concepts for a fact that exists yet cannot be described, and can only be approached by circumambulation. At the same time, these facts are “spheres” of indeterminable extent, since they represent *principles*. Psychologically they correspond to the archetypes. Overlapping and interpenetration are an essential part of their nature. “Roundness” is a peculiarity not only of dogmas, but, in especial degree, of alchemical thought.

55 Particularly dreams about hunger, thirst, pain, and sex. Another complementary factor is the feminine nature of the unconscious in a man.

56 For the compensatory aspect of this “reflection” see *Psychology and Alchemy*, pars. 26ff.

57 Koepgen, p. 112.

58 Cf. “The Spirit Mercurius,” pars. 282f. In another respect, also, the *filius philosophorum* is a “third” when we consider the development in the concept of the devil among the Ebionites (Epiphanius, *Panarium*, XXX). They spoke of two figures begotten by God, one of them Christ, the other the devil. The latter, according to Psellus, was called by the Euchites Satanaël, the elder brother of Christ. (Cf. *Aion*, par. 229, and “The Spirit Mercurius,” pars. 271f. In relation to these two the *filius regius*—as *donum Spiritus Sancti* and son of the prima materia—is a “third sonship,” which, in common with the prima materia, can trace its descent—though a more distant one—from God. For the threefold sonship see Hippolytus, *Elenchos*, VII, 22, 7f. (Legge, II, pp. 71f) and *Aion*, pars. 118f. The “sonships” come from the “true light” (John 1 : 9), from the Logos, the *sapientia Patris*. Hippolytus, VII, 22, 4 (Legge, II, pp. 68f.).

59 In psychotherapy the situation is no different from what it is in somatic medicine, where surgery is performed on the *individual*. I mention this fact because of the modern tendency to treat the psyche by group analysis, as if it were a collective phenomenon. The psyche as an individual factor is thereby eliminated.

60 “Spec, phil.,” *Theatr. chem.*, I, p. 308.

61 Ripley, *Chymische Schriften*, p. 34: “For then your Work will obtain the perfect whiteness. Then turn from the East towards midday, there it should rest at a fiery place, for that is the harvest or end of the Work. . . . Thereupon the sun will shine pure red in its circle and will triumph after the darkness.”

62 Cf. “Concerning the Archetypes, with Special Reference to the Anima Concept.” An example of the anima in plural form is given in *Psychology and Alchemy*, pars. 58ff.

63 Examples of both archetypes are to be found *ibid.*, Part II. Cf. also *Aion*, chs. 2 and 3. Another problem is the *shadow of the self*, which is not considered here.

64 Cf. *Psychology and Alchemy*, par. 159.

65 Examples of the sun and moon dreams are given *ibid.*, p. 135.

66 Here the concept of the *self* can be mentioned only in passing. (For a detailed discussion see *Aion*, ch. 4.) The self is the hypothetical summation of an indescribable totality, one half of which is constituted by ego-consciousness, the other by the shadow. The latter, so far as it can be established empirically, usually presents itself as the inferior or negative personality. It comprises that part of the collective unconscious which intrudes into the personal sphere, there forming the so-called personal unconscious. The shadow forms, as it were, the bridge to the figure of the anima, who is only partly personal, and through her to the impersonal figures of the collective unconscious. The concept of the self is essentially intuitive and embraces ego-consciousness, shadow, anima, and collective unconscious in indeterminable extension. As a totality, the self is a *coincidentia oppositorum*; it is therefore bright and dark and yet neither.

If we hypostatize the self and derive from it (as from a kind of pre-existent personality) the ego and the shadow, then these would appear as the empirical aspects of the opposites that are preformed in the self. Since I have no wish to construct a world of speculative concepts, which leads merely to the barren hair-splitting of philosophical discussion, I set no particular store by these reflections. If such concepts provisionally serve to put the empirical material in order, they will have fulfilled their purpose. The empiricist has nothing to say about the concepts self and God in themselves, and how they are related to one another.

67 Genesis 1 : 1–7 is a projection of this process. The coming of consciousness is described as an objective event, the active subject of which is not the ego but Elohim. Since primitive people very often do not feel themselves the subject of their thinking, it is possible that in the distant past consciousness appeared as an outside event that happened to the ego, and that it was integrated with the subject only in later times. Illumination and inspiration, which in reality are sudden expansions of consciousness, still seem to have, even for us, a subject that is not the ego. Cf. Neumann, *The Origins and History of Consciousness*, pp. 102ff.

68 I use the word “consciousness” here as being equivalent to “ego,” since in my view they are aspects of the same phenomenon. Surely there can be no consciousness without a knowing subject, and vice versa.

69 Cf. Rig-Veda, X, 31, 6 (trans. from Deussen, *Geschichte der Philosophie*, I, 1, p. 140):

“And this prayer of the singer, continually expanding,
Became a cow that was there before the world was,
The gods are foster-children of the same brood,
Dwelling together in the womb of this god.”

Vajasaneyi-samhita, 34, 3 (trans. from Deussen, *Die Geheimlehre des Veda*, p. 17):

“He who as consciousness, thought, decision,
Dwells as immortal light within man.”

70 “Save as a child, one goes not in where all
God’s children are: the door is much too small.”

Cherubinischer Wandersmann, I, No. 153.

71 “I am God’s child and son, and he is mine.
How comes it that we both can both combine?” (I, 256)
“God is my centre when I close him in;
And my circumference when I melt in him.” (III, 148)
“God, infinite, more present is in me
Than if a sponge should soak up all the sea.” (IV, 156)
“The hen contains the egg, the egg the hen,
The twain in one, and yet the one in twain.” (IV, 163)
“God becomes I and takes my manhood on:
Because I was before him was that done!” (IV, 259)

72 Part of this section appeared in *Nova Acta Paracelsica*, 1948, pp. 27ff.

73 Laurentius Ventura, “De ratione confic. lap.,” *Theatr. chem.*, II, pp. 334f.

74 “Figurarum Aegyptiorum,” MS, 18th cent. Author’s possession.

75 “Introitus apertus,” *Mus. herm.*, p. 652 (Waite, II, p. 165).

76 “Tractatus aureus,” *Mus. herm.*, p. 33 (Waite, I, p. 34); Mylius, *Phil. ref.*, p. 54.

77 Ventura, *Theatr. chem.*, II, p. 342.

78 “Tract, aureus,” *Mus. herm.*, p. 24 (Waite, I, p. 26).

79 *Ibid.*, pp. 11 and 21 (Waite, I, pp. 14 and 23); Aegidius de Vadis, “Dialogus,” *Theatr. chem.*, II, p. 100; Ripley, “Axiomata philosophica,” *Theatr. chem.*, II, p. 125.

80 Ripley, *Theatr. chem.*, II, p. 125. As *sulphur incremabile*, it is an end-product in *Theatr. chem.*, II, p. 302, and also in “De sulphure,” *Mus. herm.*, p. 622 (Waite, II, p. 142).

81 “Consil. coniug.,” *Ars chemica*, p. 217. In Paracelsus (ed. Huser, II, p.521) sulphur is one of the three primary fires (“fire is the body of souls”). In his *Vita longa* (ed. Bodenstein, fol. a 6^v) he says: “Sulphur is everything that burns, and nothing catches fire save by reason of sulphur.” * Trevisanus (“De chemico miraculo,” *Theatr. chem.*, I, p. 793) says: “For sulphur is none other than the pure fire hidden in the mercury.” * In Mylius (*Phil. ref.*, p. 50) the philosophical sulphur is “simple living fire, quickening other dead bodies [or: inert substances].” * Cf. also Penotus, “Regulae et canones,” *Theatr. chem.*, II, p. 150. Sulphur as “magna flamma” is a danger to the little life-flame of the alchemists (“De sulphure,” *Mus. herm.*, p. 637).

82 Ripley, *Opera omnia*, p. 150.

83 “Tract, aureus,” *Mus. herm.*, p. 24 (Waite, I, p. 26).

84 *Aurora consurgens* II, in *Art. aurif.*, I, p. 229.

- 85 In the Symbolic Table of Penotus (*Theatr. chem.*, II, p. 123) sulphur is co-ordinated with “virilitas prima” and “Dii caelestes.” The further co-ordination of sulphur with lion, dragon, and unicorn is the direct opposite of the heavenly.
- 86 “Consil. coniug.,” *Ars chemica*, p. 217, and “Epistola ad Hermannum,” *Theatr. chem.*, V, p. 893.
- 87 Mylius, *Phil. ref.*, p. 104; Zacharius, “Opusculum,” *Theatr. chem.*, I, p. 859.
- 88 Mylius, p. 179; *Mus. herm.*, p. 37 (Waite, I, p. 37).
- 89 *Mus. herm.*, p. 39.
- 90 *Turba*, p. 149, lines 21ff. “Consil. coniug.” (p. 66) says: “All quicksilver is sulphur” (a quotation attributed to Plato). On p. 202 there is a similar quotation from Geber.
- 91 *De pestilitate*, lib. 1 (ed. Sudhoff, XIV, p. 597).
- 92 Quotation from Geber in Trevisanus, *Theatr. chem.*, I, p. 793.
- 93 Quotation from Morienus, *ibid.*
- 94 Ripley, *Chymische Schrifften*, p. 31. For Mercurius as the “wife” of sulphur, who “receives from him the impregnation of the fruit,” see *ibid.*, pp. 10f.
- 95 “De sulphure,” *Mus. herm.*, p. 626 (Waite, II, p. 145).
- 96 *Mus. herm.*, p. 39 (Waite, I, p. 39). “Our,” of course, means: how we, the alchemists, understand it. Similarly in the *Turba*, p. 123, lines 17f.
- 97 *Turba*, p. 149.* The “four bodies” refer to the ancient *tetrasomia*, consisting of four metals. Dorn (“Congeries Paracelsicae,” *Theatr. chem.*, I, p. 622) accuses the Greeks of having turned the number four (i.e., the *tetrasomia*) into a monarchy of devilish idols, ruled over by Saturn, Venus, Mars, and Mercury.
- 98 *De natura rerum*, lib. 1 (“De Generatione rerum naturalium”). (Sudhoff, XI, p. 318; Huser, 1590, VI, p. 265.)
- 99 *Phil. ref.*, p. 202.
- 100 Referring to a “Sol” mentioned earlier.
- 101 *Theatr. chem.*, V, p. 103.*
- 102 Hoghelande, “Liber de alchimiae diff.,” *Theatr. chem.*, I, p. 171.
- 103 God is equated with greenness in the *Cherubinischer Wandersmann* (I, 190):
- “God is my sap: the leaves and buds I show,
They are his Holy Ghost, by whom I grow.”
- 104 “physica Trismegisti,” *Theatr. chem.*, I, p. 423. Hoghelande (*Theatr. chem.*, I, p. 172) quotes from Lully: “The father and the male seed,” and from Aquinas: “The substance of sulphur is like to the paternal seed, active and formative.”*
- 105 *Theatr. chem.*, I, p. 518.
- 106 “Phil. chemica,” *ibid.*, p. 482.
- 107 *Chymische Schrifften*, p. 10.
- 108 “But what is more, in his Kingdom there is a mirror in which the whole World is to be seen. Whosoever looks into this mirror, can see and learn therein the parts of the wisdom of the whole World, and so departs fully knowledgeable in these Three Kingdoms.” * *Mus. herm.*, p. 635 (Waite, II, p. 151).

109 Cf. the conversation between the alchemist and a “voice” in *Mus. herm.*, p. 637: “Master, doth Sulphur know aught concerning the metals? Voice: I have told thee that he knoweth all things, and of the metals even much more than of other things.” * “He is the heart of all things” * (p. 634).

110 *Turba*, p. 125, line 10.

111 *Art. aurif.*, II, p. 229.

112 Zacharius, “Opusculum,” *Theatr. chem.*, I, p. 842.

113 “De sulphure,” *Mus. herm.*, p. 632 (Waite, II, p. 149).

114 Mylius, *Phil. ref.*, pp. 61ff.

115 In my copy of *Phil. ref.*, p. 62. In Glauber (*De natura salium*, pp. 41 and 43) sulphur is the “exceeding black devil of hell” who quarrels with the salt.

116 “De sulphure,” *Mus. herm.*, p. 640 (Waite, II, p. 155). * *Candelulae* are “Elychnia of Sulphur, in which threads or morsels of wood are inserted.” * (Ruland, *Lexicon*, Latin edn., p. 457.)

117 The higher and the lower, the subtle and the coarse, the spiritual and the material.

118 They are one and the same, however. As above so below, and vice versa. Cf. “*Tabula smaragdina*.”

119 “Nature rejoices in nature,” according to the axiom of Democritus.

120 An allusion to the uroboros. The text of this passage is in “Rosinus ad Sarratantam,” *Art. aurif.*, I, p. 302.

121 *Mus. herm.*, p. 633ff. (Waite, II, pp. 149ff.).

122 A patient dreamt: “*Animals were being hunted. The devil, their patron saint, appeared. Suddenly all the colours appeared in his dark-brown face, and then a vermilion spot in his cheek.*”

123 The only other figure who could be the mother is Luna. She, too, appears later in the parable, but in the form of Diana, i.e., in the role of daughter-sister.

124 The green colour attributed to Sulphur he has in common with Venus, as the verses in the *Gemma gemmarum* show. Venus says:

“Transparent / green / and fair to view
I am commixt of every hue /
Yet in me’s a Red Spirit hid /
No name I know by which he’s bid /
And he did from my husband come /
The noble Mars, full quarrelsome.”

The “red spirit” is our Sulphur—“painter of all colours.”

125 The “*Occulta chemicorum philosophia*,” printed in the 1611 edn. of Basilus Valentinus’ *Triumphwagen Antimonii* (pp. 579ff.), mentions an astrological characteristic of Saturn: he is “supreme tester,” and Sol and Luna (who “only exist through him”), warm his cold body “better than a young woman” (p. 583). Already in the pre-Ptolemaic tradition Saturn was connected with dubious love-affairs (Bouche-Leclercq, *L’Astrologie grecque*, p. 436, n. 1). *Mus. herm.*, p. 623 (Waite, II, p. 143) mentions the “infernal prisons where Sulphur lies bound.”

126 “Sulphur is his [the dragon’s] tail.” (*Ars chemica*, p. 140.)

- 127 Johannes à Mehung (Jean de Meung) in “Demonstratio naturae,” *Mus. herm.*, p. 162 (Waite, I, p. 135). Jean de Meung lived c. 1250–1305.
- 128 In the second version of the Vision of Arisleus in *Ros. phil.*, *Art. aurif.*, II (1572), p. 246.
- 129 Albertus Magnus, “Super arborem Aristotelis,” *Theatr. chem.*, II, pp. 526f.
- 130 “The whole arcanum lies hidden in the sulphur of the Philosophers, which is also contained in the inmost part of their mercury.” * *Mus. herm.*, p. 643 (Waite, II, p. 157).
- 131 Regarding Hermes Kyllenios see “The Spirit Mercurius,” par. 278.
- 132 Flamel, “Summarium philosophicum,” *Mus. herm.*, p. 173 (Waite, I, p. 142).
- 133 Albertus Magnus, p. 525.*
- 134 Cf. *Psychology and Alchemy*, par. 26.
- 135 Mylius, *Phil. ref.*, p. 185.
- 136 Ventura, *Theatr. chem.*, II, p. 262.
- 137 *Ibid.*, p. 276.
- 138 *Mus. herm.*, p. 634.
- 139 *Ibid.*, p. 635.
- 140 *Ars chemica*, p. 66. The oil is described as resembling the *anima media natura* in “Aphorismi Basiliani” (*Theatr. chem.*, IV, p. 368): “But the quickening power, like that which holds the world together, is midway between spirit and body, and the bond of them both, especially in the sulphur of a certain rubeous and transparent oil ...”*
- 141 *phil. ref.*, p. 18.* An older source is “De arte chymica,” *Art. aurif.*, I, p. 608.
- 142 So named by Lully. Cf. Hoghelande, *Theatr. chem.*, I, p. 199.
- 143 This is consistently so in Khunrath; cf. *Von Hylealischen Chaos*, p. 264. In “Rosinus ad Euthiciam,” *Art. aurif.*, I, p. 252, it is the “name of the divine water.” In Zacharius (*Theatr. chem.*, I, p. 831) sulphur is the “fatness in the caverns of the earth.” * Cf. Ruland, *Lexicon*, p. 305. Pernety (*Diet. mytho-herm.*, pp. 148f.) says: “On voit le mot de soufre attribué à bien des matières même très opposées entre elles . . . Les Philosophes ont donné à ce soufre une infinité de noms.”
- 144 P. 192.
- 145 An allusion to the axiom of Democritus.
- 146 “That from which things have their being is God the invisible and unmoved, whose will created the intelligence; from the will and intelligence is produced the simple soul; but the soul gives rise to the discriminated natures from which the composite natures are produced,” etc.* (*Theatr. chem.*, V, p. 145.)
- 147 P. 255.
- 148 *Aurora consurgens* II, in *Art. aurif.*, I, p. 229. In “Consil. coniug.” it is called “incombustible” (p. 149).
- 149 “It has no end to its action, for it goes on tincturing for ever.” * (*Ibid.*, p. 164.)
- 150 *Ibid.*, p. 199.
- 151 In Huser, II, p. 525; in Sudhoff, XIV, p. 555, ϕ is used for sulphur; here as in Mylius associated with the rainbow. Sudhoff, without stating any reasons, textual or otherwise, reckons the *Liber Azoth* among the spurious treatises. I cannot agree with this view.

152 *Phil, ref.*, p. 50.

153 *Theatr. chem.*, V, p. 106.

154 For a detailed discussion see *Psychology and Alchemy*, Part III, ch. 5.

155 The stream, though small, is “most dangerous.” The servants say they have once tried to cross it, but “we scarcely escaped the peril of eternal death.” They add: “We know too that our predecessors perished here.” The servants are the alchemists, and the stream or its water symbolizes the danger threatening them, which is clearly the danger of drowning. The psychic danger of the opus is the irruption of the unconscious and the “loss of soul” caused thereby. I have in my possession an alchemical MS. of the 17th cent., showing an invasion of the unconscious in a series of pictures. The images produced bear all the marks of schizophrenia.

156 “De sulphure,” *Mus. herm.*, pp. 639f.

157 Prof. C. Kerényi has kindly lent me the MS. of his work on Asklepios [trans. *Asklepios: Archetypal Image of the Physician's Existence*, 1959], which is of the greatest interest to all doctors. He describes the primordial physician as the “wounded wounder” (Chiron, Machaon, etc.). But, curiously enough, there are other parallels too. In our treatise the Prince is called “vir fords,” the strong man. He is without doubt the sun, and he surprises Diana while bathing. The birth-myth of Asklepios states that the sun-god Apollo surprised Coronis (the “crow maiden”) while she was bathing in Lake Boibeis [ibid., pp. 93ff.]. Coronis, being black, is associated with the new moon (*σύννοδος solis et lunae*), and her dangerousness is shown in the name of her father Phlegyas (“the incendiary”). Her brother or uncle was Ixion, rapist and murderer. The connection of Coronis with the moon is also explained by the fact that Phoebe (moon) was her ancestress. When Coronis was already pregnant with Apollo's son, Asklepios, she had intercourse with the chthonic Ischys (*ισχύς* = strong, the “vir fortis”) and as a punishment was slain by Artemis. The child was rescued from the body of its mother, on the funeral pyre, by Apollo. Kerényi supposes an identity between the bright Apollo and the dark Ischys. (A similar identity would be that of Asklepios and Trophonios.) The wounds of the physicians were usually caused by arrows, and the same fate was suffered by Asklepios: he was struck with the thunderbolt of Zeus because of an excess of zeal and skill, for he had not only healed the sick but called back the dead, and this was too much for Pluto. (Cf. Wilamowitz-Moellendorff, “Isyllos von Epidaurus,” pp. 44ff.) The “Novum lumen chemicum” gives an “Aenigma coronidis” (*Mus. herm.*, pp. 585ff.; Waite, II, pp. 111ff.), but this, except for the miraculous “water at times manifested to thee in sleep,” contains nothing that would point to the myth of Asklepios. Dom Pernety (*Fables égyptiennes et grecques*, II, p. 152) correctly interprets Coronis as *putreductio, nigredo, caput corvi*, and the myth as an opus. This is surprisingly apt, since alchemy, although the alchemists did not know it, was a child of this mythology, or of the matrix from which the classical myth sprang as an elder brother.

158 Reproduced in “Paracelsus as a Spiritual Phenomenon” (fig. B4).

159 Cf. *Psychology and Alchemy*, fig. 150, where one “telum passionis” bears the sign of Mercurius, the other the sign of sulphur.

160 As is evident in the very word *un-conscious*.

161 Isaiah 52 : 14: “As many were astonished at him—his appearance was so marred, beyond human semblance, and his form beyond that of the sons of men.” 53 : 2f.: “For he grew up before [us] like a young plant, and like a root out of dry ground; he had no form or comeliness that we should look at him, and no beauty that we should desire him. He was despised and rejected of men; a man of sorrows, and acquainted with grief; and as one from whom men hide

their faces he was despised, and we esteemed him not.” [RSV. In the last verse, alternative readings for “sorrows” and “grief” are “pains” and “sickness”; cf. *Schmerzen* and *Krankheit* in the Zürcher Bibel, quoted by the author.—TRANS.]

162 *Elenchos*, V, 8, 18 (Legge, I, p. 134).

163 Psalm 24 : 7.

164 Psalm 22 : 6.

165 “Mensura, numerus et pondus.” Cf. von Franz, *Aurora Consurgens*, Parable 4 (p. 83).

166 *Liber formularum spiritalis intelligentiae*, V (Migne, P.L., vol. 50, col. 751).

167 *Explanatio Psalmorum XII*, ed. Petschenig, pp. 139, 256.

168 “Gloria mundi,” *Mus. herm.*, p. 275 (Waite, I, p. 221).

169 Dorn, “Physica Trismeg.,” *Theatr. chem.*, I, p. 424.

170 “This union the Philosophers have declared in various ways, and likened it, for instance, to the wedlock of a bride and bridegroom (as in the Song of Solomon).” * *Mus. herm.*, p. 90 (Waite, I, p. 82).

171 The immediate model for this was probably Senior’s “Epistola solis ad lunam crescentem” (*De chemia*, pp. 7f.), but it may also have been inspired by Cicero’s *De natura deorum*, III, 11: “... unless indeed we hold that the sun holds conversation with the moon, when their courses approximate” (trans. Rackham, pp. 312ff.). Luna was identified with the wife *par excellence*, Juno: “... considering the moon and Juno to be the same” (Macrobius, *Saturnalia*, lib. I, cap. XV).

172 Wittekindt, *Das Hohe Lied und seine Beziehungen zum Istarkult*, pp. 13 and 23. Further material in Eisler, *Weltenmantel und Himmelszelt*, I, pp. 122ff.; II, PP. 370, 435, 602.

173 Penotus, *Theatr. chem.*, I, p. 681.

174 Steeb, *Coelum sephiroticum*, p. 138. The original idea is in Plutarch, “Isis and Osiris,” 43: “She [Selene] is receptive and made pregnant by the sun, but she in turn emits and disseminates into the air generative principles.” (*Moralia*, trans. Babbitt, V, pp. 104f.).

175 “Consilium coniugii,” *Ars chemica*, pp. 141f.

176 Dorn, “Physica genesis,” *Theatr. chem.*, I, p. 397. As early as Firmicus Maternus (*Matheseos*, I, 4, 9) we find the idea that the moon undergoes a kind of rebirth from the sun. This idea reached its highest development in the patristic parallel between the moon and the Church. Cf. Rahner, “Mysterium Lunae.”

177 Dorn, “Phys. Trismeg.,” *Theatr. chem.*, I, p. 426. For the Stoics the moon was the mediatrix between the world of eternal stars and the lower, earthly realm; similarly in Macrobius (*In somnium Scipionis*, I, 21) the moon stands midway between things divine and things corruptible. Mennens, in his “Aureum vellus” (*Theatr. chem.*, V, p. 321) says: “But the Moon, being the lowest of the planets, is said to conceive like a womb the virtues of all the stars, and then to bestow them on sublunary things . . . The moon implants all the virtues of the stars for the generation of all things, and especially their seeds.” * The moon also has a life- giving influence on minerals, “fashioning and preserving in its [the earth’s] bowels the various species of stones, metals, nay more, of living things.”*

178 Plutarch, “The Face on the Moon,” 21 (XII, p. 139); Macrobius, *In somn. Scip.*, I, 11, and Orphic fragment 81: *ἄλλη γαῖα*, ‘another earth.’ See Eisler, *Welten-mantel*, II, p. 657.

178a P. 125.

179 P. 141.

180 “He desires to lie with his mother in the midst of the earth.”* (“Allegoriae sapientum,” *Theatr. chem.*, V, p. 69.) Vigenerus (“De igne et sale,” *Theatr. chem.*, VI, p. 98) says: “And the heaven of incorruptible bodies and the seat and vessel of things that change not is the Moon, which rules over moisture and represents water and earth.”*

181 *Ros. phil.*, in *Art. aurif.*, II, pp. 338f.: “... when thou seest the earth as whitest snow . . . the ash is extracted from ash and earth, sublimed and honoured . . . the white foliated earth is the good that is sought.”*

182 “For the first work is towards the whitening, in the house of the Moon.”* (D’Espagnet, *Arcanum Hermeticae philosophiae opus*, p. 82.)

183 The *servus rubicundus* (red slave) and the *femina alba* (white woman) form the traditional pair. The “whiteness” occurs also in Chinese alchemy and is likened to a virgin: “The white lives inside like a virgin.” (Wei Po-yang, “An Ancient Chinese Treatise on Alchemy,” p. 238.) For the whiteness of the moon cf. Witte-kindt’s translation of Song of Songs 6 : 10: “Who is that, rising like the moon, beautiful as the whiteness?” (*Das Hohe Lied*, p. 8.) *Lebānā* = whiteness, a designation for the moon in Isaiah 24 : 23 and 30 : 26.

184 Ripley, *Opera omnia*, p. 362. The same in “Gloria mundi,” *Mus. herm.*, p. 217 (Waite, I, p. 176), and “Fons chymicae veritatis,” *Mus. herm.*, p. 809 (Waite, II, p. 267).

185 Philaletha, “Introitus apertus,” *Mus. herm.*, p. 659 (Waite, II, p. 170). See *infra*, pars. 182ff.

186 *Symb. aur. mensae*, p. 378.

187 *Art. aurif.*, I, p. 191.

188 “Consil. coniug.,” *Ars chemica*, p. 57. Similarly “Rosinus ad Sarrat.” (*Art. aurif.*, I, p. 301): “Moisture . . . from the dominion of the Moon.” Macrobius says: “But there is a certain property . . . and nature in the light that flows from it, which moistens bodies and bathes them as with a hidden dew.”* (*Saturnalia*, lib. VII, cap. XVI.)

189 *Mus. herm.*, p. 809 (Waite, II, p. 267).

190 ‘Ο **Χριστιανός** is not a proper name but only the designation by which an anonymous “Christian philosopher” was known. He was said to have been a contemporary of Stephen of Alexandria, and would thus have lived in the reign of the Emperor Heraclius, at the turn of the 6th cent.

191 He compares it to the “ever-flowing fount of Paradise.”* (Berthelot, *Alch. grecs*, VI, i, 2.) In Macrobius (*In somn. scip.*, I, 11) Luna is the “author and creator of mortal bodies,”* and (I, 19) “the vegetative principle, that is, growth, comes to us from the roundness of the moon.”*

192 The moon receives the souls of the dead (Hegemonius, *Acta Archelai*, ed. Beeson, p. 11). The soul comes from the moon: “The moon produces the soul . . . for man’s generation.”* (Plutarch, “The Face on the Moon,” 28, pp. 198f.) Further material in Capelle, *De luna stellis lacteo orbe animarum sedibus*.

193 “Mercurial water of the moon” and “fount of the mother.” Cf. “Rosinus ad Sarrat.,” *Art. aurif.*, I, p. 299.

194 Albertus Magnus, “Super arborem Aristotelis,” *Theatr. chem.*, II, p. 525.

195 *Ros. phil.*, in *Art. aurif.*, II, pp. 275ff.

196 *Ibid.*, p. 243.

197 See *Psychology and Alchemy*, figs. 116 and 188. Cf. also the sun-and-moon trees of the “House of the Sun” in the *Romance of Alexander*: “Perhaps you would like to see the most holy trees of the Sun and Moon, which will declare the future to you.” * (Hilka, *Der altfranzösische Prosa-Alexanderroman*, pp. 203f.)

198 *Theatr. chem.*, II, p. 527.

199 Naturally an alchemistic pseudo-Galen. Galen is credited with having written a *Liber Secretorum*, to which unfortunately I have no access.

200 Du Cange (*Glossarium ad scriptores mediae et infimae Graecitatis*, Appendix, p. 38) gives: “βήρσσα, τὸ μῶλυ, molix.” The herbal of Tabernaemontanus (*Kräuter-buch*, I, p. 408) mentions “βίμσασᾶ = ἄρμαλα = πήγανον ἄγριον, *Peganum sylvestre*, called μῶλυ by Galen, *Hermelraute*, often confused with hemlock. A cure for epilepsy and melancholic fantasies, makes sleepy and drunken like wine, is used in love-potions.” Dioscorides (*De medica materia*, lib. III, cap. 46, p. 349) says that *Ruta sylvestris* “is called *moly* in Cappadocia and Galatia, neighboring regions of Asia.” Galen (*De simplicium medicamentorum facultatibus*, lib. VII, p. 491) states: “Moly, *Ruta sylvestris*, has a black root and a milk-white flower.” For “moly” see Rahner, “Die seelenheilende Blume: Moly und Mandragora in antiker und christlicher Symbolik.”

201 *Aurora consurgens* II, in *Art. aurif.*, I, p. 222. The “yellow flowers” are reminiscent of the “Cheyri,” the miraculous herb of Paracelsus. Cf. *infra*, par. 698, and “Paracelsus as a Spiritual Phenomenon,” par. 171 and n. 7. In his *Labyrinthus medicorum* (Sudhoff, XI, p. 205) Paracelsus mentions the Lunatica: “Thus there is in the Lunatica the course of the whole moon, not visible, but in spirit.”

202 He calls the flowers “most familiar to the philosophers.” “Congeries Paracelsicae,” *Theatr. chem.*, I, p. 581.

203 *Von hylealischen Chaos*, p. 270.

204 * I have not been able to find a parallel for “maris Luna.” “Sea” always signifies the solvent, i.e., the *aqua permanens*. In it Sol bathes, is immersed or drowned, often alone. The parallel to Luna in the bath, as we have shown above (n. 157), is Diana. But she never drowns in her bath, because she is the water itself.

205 “Spongia” means not only sponge but also pumice-stone, which has the same porous structure. Thus the “Liber quartorum” (*Theatr. chem.*, V, p. 190) says: “But that which is a vapour or subtlety in those parts is retained only by a hard body . . . and whenever there is a stone which surrounds the substances like a sponge.” * Possibly referring to this passage Mylius (*Phil. ref.*, p. 107) writes: “The Sun and Moon are calcined philosophically with the first water, that the bodies may be opened and become spongy and subtle, and the second water enter more easily.” * Ruland (*Lexicon*, p. 300) takes over from Dioscorides (*De medica materia*, lib. V, cap. 96, p. 625) the differentiation of sponges into male (one species of which is called *tragos*, ‘goat’) and female. Their ashes were used as a styptic. Ruland adds, from Avicenna, that sponges “have souls,” by which he probably meant the vapours they produce when they are warmed. But then, for the alchemists, “anima” always had a special meaning which Avicenna formulates as follows: “The higher part is the soul, which quickens the whole stone and makes it live again.” * Ruland stresses that sponges have “understanding” (*intellectum*) because they contract when they hear a noise or are touched. He regards the sponge as “a zoophyte, neither animal nor vegetable, but having a third nature.”

206 *Art. aurif.*, I, p. 141.

207 Cf. *Psychology and Alchemy*, par. 537, where the text of Abu'l-Qāsim (*Kitāb al-'ilm al-muktasab*) is cited in Holmyard's translation.

208 See *Psychology and Alchemy*, figs. 122, 131, 135, 186, 188. Ventura: “The roots of its ores are in the air and its summits in the earth. And when they are torn from their places, a horrible sound is heard and there follows a great fear. Wherefore go quickly, for they quickly vanish.” * (*Theatr. chem.*, II, p. 257.) This obviously refers to the mandragora, which shrieks when it is pulled out. See “The Philosophical Tree,” par. 380, n. 4, and pars. 410ff.

209 Here the tree is God himself: “The purpose of the Creation was, that God should be known as Lord and Ruler; He, the stem and root of the world.” (*Zohar* I, fol. 11b, as cited by Hamburger, *Encyclopädie der Judentums*, II.) Joseph Gikatila says: “Know that the holy names of God found in the Scriptures are all dependent on the four-letter name YHVH. Should you object that the name Ehyeh is the ground and the source, know that the four-letter name may be likened to the trunk of a tree, whereas the name Ehyeh is the root of this tree. From it, further roots and branches extend in every direction.” (Winter and Wiinsche, *Die Jüdische Literatur seit Abschluss des Kanons*, III, p. 267.) Of the “crown” (Kether) it is said: “It is the source which makes the tree fruitful and drives the sap through all its arms and branches. For You, Lord of the worlds, You who are the ground of all grounds, the cause of all causes, You water the tree from that source, which, like the soul in the body, spreads life everywhere.” (*Tik-kune Zohar*, as cited by Joel, *Die Religionsphilosophie des Sohar*, pp. 308f., and Bischoff, *Elemente der Kabbalah*, I, p. 82.)

210 John of Ruysbroeck (1294–1381) says of the tree of Zacchaeus (Luke 19): “And he must climb up into the tree of faith, which grows from above downwards, for its roots are in the Godhead. This tree has twelve branches, which are the twelve articles of faith. The lower speak of the Divine Humanity, and of those things which belong to our salvation of soul and of body. The upper part of the tree tells of the Godhead, of the Trinity of Persons, and of the Unity of the Nature of God. And the man must cling to that unity, in the highest part of the tree; for there it is that Jesus must pass with all his gifts.” (*The Adornment of the Spiritual Marriage*, trans. by Wynschenk Dom, pp. 47f.)

211 *Katha Upanishad*, II, 6, 1 (SBE, XV, p. 21): “There is that ancient tree, whose roots grow upward and whose branches grow downward—that indeed is called the Bright, that is called Brahman, that alone is called the Immortal. All worlds are contained in it, and no one goes beyond.”

212 The Sanskrit word *manas* means ‘mind’. It includes all intellectual as well as emotional processes, and can therefore mean, on the one hand, understanding, intellect, reflection, thought, etc., and, on the other, soul, heart, conscience, desire, will, etc. *Manas* is an organ of the inner “soul,” or *atman*. (MacDonell, *A Sanskrit-English Dictionary*, s.v. *manas*). Rig-veda, X, 90, 13 (trans. by Griffith, II, p. 519) says: “The Moon was gendered from his mind, and from his eye the Sun had birth.” This refers to the two eyes of Purusha, the macrocosmic Primordial Man (Anthropos), who created the world by transforming himself into it—a very primitive concept which perhaps underlies the “generation by adaptation” mentioned in the “Tabula smaragdina” (infra, par. 162). *Brihadaranyaka Upanishad* (I, 3, 16) says: “When the mind had become freed from death, it became the moon” (trans. by Max Müller, II, p. 81).

213 Bousset, *Hauptprobleme der Gnosis*, p. 78. “**Ἐννοια** means ‘thought, conception, reflection, view’, also ‘meaning’, and, as contrasted with **ἄνοια** (thoughtlessness), could be translated by the modern terms ‘insight’ and ‘consciousness’, while **ἄνοια** is in certain places (for instance in the *Corpus Hermeticum*) fittingly rendered by ‘unconsciousness’. In Orphism, Selene is the “all-wise maiden.”

214 Clement of Rome, *Recognitiones* (Migne, P.G., vol. 1, col. 1254).

215 ‘Notion, invention, purpose, design’.

216 *Elenchos*, VI, 19, 2.

217 Ibid., 18, 2. (Cf. Legge, II, p. 13.)

218 Ruska rightly rejects “adoptione” as a variant. By “things” the alchemists understood “substances.” The “adaptation” process is reminiscent of the notion, found especially among the Australian aborigines, that the Original Being changed himself into the things and creatures of this world. The striking use of the neuter pronoun “illud” is easily explained by the hermaphroditism of the product, which is constantly stressed.

219 Ruska, *Tabula Smaragdina*, p. 2.* Senior says of this text (*De chemia*, p. 30f.): “Air is a mediator between fire (= Sol) and water (= Luna) by reason of its heat and moisture.” “Air is the life of everything.” “The son of wisdom is born in the air.”*

220 Cf. Senior, p. 20: “... spirit and soul, when they shall have been boiled down in the repetition of the distillation, will be mixed together in a universal mixture, and the one will retain the other and they will become one. One in subtlety and spirituality ...”*

221 “Nisi me interfeceritis, intellectus vester non erit perfectus, et in sorore mea Luna crescit gradus sapientiae vestrae, et non cum alio ex servis meis, etsi sciretis secretum meum.” *Art. aurif.*, II, p. 380. The “servants” refer to the planets, or to the corresponding metals.

222 P. 175. Here he cites this sentence as coming from the “Epistola Solis ad Lunam,” which is in Senior, *De chemia*, pp. 7ff., but it does not occur there.

223 Mylius, *Phil. ref.*, p. 309, and *Ros. phil.*, in *Art. aurif.*, II, p. 378.

224 “Nuncio ergo vobis omnibus sapientibus, quod nisi me interficiatis, non potestis sapientes nuncupari. Si vero me interfeceritis, intellectus vester erit perfectus, et in sorore mea crescit luna, secundum gradum sapientiae nostrae et non cum alio ex servis meis, etsi sciretis secretum meum.” (*Theatr. chem.*, V, pp. 96ff.)

225 Other corruptions of the name are Bolemus, Belenius, Balinas, Bellus, Bonellus.

226 *Theatr. chem.*, IV, p. 221.

227 * The “three” refers to the three ways of combining souls: in the body, in the soul, in the spirit.

228 *

229 I cannot refrain from pointing out the remarkable analogy that exists between Simon of Gitta and Pseudo-Apollonius on the one hand, and Lao-tzu on the other, with regard to the *principia mundi*. The components of *tao* are the masculine *yang* and the feminine *yin*, the one hot, bright, and dry like the sun, the other cold, dark, and moist like the (new) moon. The *Tao Teh Ching* (ch. 25) says of the Original Being:

“There was something formless yet complete
that existed before heaven and earth;
Without sound, without substance,
Dependent on nothing, unchanging,
All pervading, unfailing.
One may think of it as the mother of all things under heaven.”

(*The Way and Its Power*, trans. Waley, p. 174.)

230 He may even be identical with Senior. Cf. Stapleton and Husain, “Muhammad bin Umail,” p. 126, n. 2.

231 *Theatr. chem.*, V, pp. 114ff.

- 232 Cf. *Psychology and Alchemy*, pars. 366ff.
- 233 “Isis and Osiris,” cap. 41, *Moralia* (trans. Babbitt), V, pp. 100f.
- 234 Preisendanz, *Pap. Graec. Mag.*, II, p. 139.*
- 235 “Gloria mundi,” *Mus. herm.*, p. 266 (Waite, I, p. 215).
- 236 Mylius, *Phil. ref.*, p. 185; similarly in “Epist. ad Hermannum,” *Theatr. chem.*, V, p. 893.
- 237 “Rosinus ad Sarrat.” *Art. aurif.*, I, p. 299.
- 238 *Theatr. chem.*, II, p. 525.
- 239 Ibid., p. 527. Concerning the significance of the stork the “Aureum vellus” (*Theatr. chem.*, V, p. 446) says: “The stork devours serpents, and its flesh is profitable against all poisons.” * The stork is therefore a dragon-killer and a symbol of the demon-conquering moon. This symbol is also an attribute of the Church.
- 240 *Dialogue on Miracles*, IV, 39 (trans. by Scott and Bland, I, p. 236). The moon is related to the soul by the further fact that it is the “receptacle of souls.” Cf. Hegemonius, *Acta Archelai*, VIII.
- 241 Cf. *Psychology and Alchemy*, par. 140, n. 17, par. 220, n. 108, par. 385, n. 87.
- 242 Cf. Kalid, “Liber trium verborum,” ch. VI, *Art. aurif.*, I (1593), pp. 357f.
- 243 “The dragon is born in the blackness and . . . kills itself.” * *Ros. phil.*, in *Art. aurif.*, II, p. 230. The “soul in chains” occurs as early as the treatise of Sophe, the Egyptian: “the divine soul bound in the elements.” Berthelot, III, xlii, 1, line 17.
- 244 “We place the soul of the world especially in the sun.” * Mylius, *Phil. ref.*, p. 10.
- 245 See Fig. 8 in Mylius, p. 359, and Figura CI in Stolcenberg, *Viridarium chymicum*.
- 246 Cf. *Psychology and Alchemy*, pars. 430f.
- 247 See the final Emblema in Maier’s *Scrutinium chymicum*, p. 148.
- 248 *Art. aurif.*, II, p. 224.* The passage occurs again on p. 241, with the added words: “That is, with Sol and Luna.”
- 249 As in the frontispiece of *Le Songe de Poliphile* (*Psychology and Alchemy*, fig. 4).
- 250 Senior, *De chemia*, p. 15.
- 251 ‘Thought, intellect, mind’.
- 252 ‘Opinion, view, notion’. Pico adds: “According to the principles of their teaching.” “Heptaplus,” *Opera omnia*, Lib. IV, cap. IV, p. 32.
- 253 In the same place Pico mentions that Plato and “certain younger” philosophers interpreted Sol as “active intellect, but the Moon [as] potential intellect.”*
- 254 Ibid.
- 255 Ibid.
- 256 Ibid.
- 257 Ibid. Cf. the idea of the “inner firmament” as a symbol of the unconscious. “Nature of the Psyche,” pars. 390f., and “Paracelsus the Physician,” pars. 29ff.
- 258 Cap. V. Pico adds: “Hence this saying of the Chaldees: The beasts of the earth inhabit thy vessel, and in Plato’s Republic we learn that we have at home diverj kinds of brutes.” * Cf. the text from Origen supra, par. 6, n. 26. The

English mystic John Pordage speaks in his *Sophia* (p. 108 of the Dutch edn., 1699) of the “horrible people” in the soul.

259 “Heptaplus,” Lib. II, cap. III, p. 20.

260 Cf. Dee, “Monas hieroglyphica,” *Theatr. chem.*, II, p. 219: “And when the semi-circle of the moon was brought to be the complement of the sun, there was evening and there was morning, one day. Be that (day) therefore the first, on which was made the light of the Philosophers.”* The union of ☉ and ☾ gives the sign for Taurus, ♉, ruler of the house of Venus. The marriage of day (sun) and night (moon) is the reason for the rather rare designation of the lapis as the “filius unius diei” (son of one day). See *infra*, pars. 472ff.

261 “We hold therefore the moon to be the lowest earth and the most ignoble of all stars, as is the earth, very like to it by the opacity of all its elements, and by its blemishes.” * (“Heptaplus,” Lib. II, cap. II, p. 18.)

262 “And we know the moon to be inferior to all.” * (“In Astrologiam,” X, iv, *Opera omnia*, I, p. 685.)

263 *Ibid.*, III, v, p. 461f.

264 A milder form of these is the salamander.

265 Often mentioned as the “Corascene dog” (sun) and the “Armenian bitch” (moon). See *infra*, section B.

266 Said to devour its own wings or feathers. The eagle is therefore a variant of the uroboros.

267 Senior, *De chemia*, p. 9.

268 Sol is mindful of the dangerous role of Luna: “No one torments me but my sister.” (“Exercitationes in Turbam,” *Art. aurif.*, I, p. 173.)

269 Song of Songs 1 : 5: “I am black, but comely,” and 1 : 6: “... I am black because the sun has burnt me” is sometimes quoted.

270 “Consil. coniugii,” *Ars chemica*, p. 136.*

271 *Commentary on the Dream of Scipio*, I, xxi, p. 181: “The moon, being the boundary of ether and air, is also the demarcation between the divine and the mortal.”*

272 *Ibid.*, I, xi, p. 131.*

273 The heat and dew of the moon “turn flesh rotten.” Macrobius, *Saturnalia*, lib. VII, cap. XVI.

274 The empirical method of physicians is a heresy, according to Isidore of Seville (*Liber etymologiarum*, IV, cap. IV, fol. xxi^l). There are three medical heresies, and of this one he says: “The second empirical method, the method of trial and error, was discovered by Aesculapius.”*

275 Cf. Rahner, “Das christliche Mysterium von Sonne und Mond,” p. 400.

276 The mediating position of the moon and the Church is mentioned by the alchemist William Mennens (“Aureum vellus,” *Theatr. chem.*, V, p. 460): “[This] comes about when the light of the Moon begins to increase up to its fifteenth day and then to decrease until its thirtieth, returning then into the horns, until no light at all appears in it. According to this view, the Moon in allegory . . . signifies the Church, which is bright on its spiritual side, but dark on its carnal.” * Note the due emphasis he lays on the two aspects of the Moon. This is the spirit of scientific truth as contrasted with the retouchings of the kerygmatic point of view, which plays such an unfortunate role in the two great Christian confessions.

277 Preisendanz, *Pap. Graec. Mag.*, I, p. 142, Pap. IV, line 2280. It is also said that Selene has the voice of a dog. (Pap. IV line 2810, p. 162, and IV, line 2550, p. 152.) Her confusion with Hecate naturally makes this attribute all the stronger. (Cf. Siecke, *Beiträge zur genauen Kenntnis der Mondgottheit bei den Griechen*, pp. 14f.) In the Iliad, VI, 344 Helen calls herself a “nasty, mean-minded bitch” *κυνὸς κακομηχάνου ὀκρνοέσσης*. *Κύνες* are the pert, wanton maids of Penelope.

278 Line 1695, p. 126. In the twelfth hour he appears as a crocodile. Cf. the “dragon-son of the sun.”

279 This term occurs in ch. 9 of the “Dialogus philosophiae” of Aegidius de Vadis (*Theatr. chem.*, II, p. 107). “Symbolizatio” is the drawing of parallels and analogies—in brief, an amplification, described by Clement of Alexandria (*Stromata*, V, 46, trans. Wilson, II, p. 248) as “symbolic interpretation.”

280 In the history of symbols the dog is distinguished by an uncommonly wide range of associations, which I will not attempt to exhaust here. The Gnostic parallel *Logos/canis* is reflected in the Christian one, *Christus / canis*, handed down in the formula “gentle to the elect, terrible to the reprobate,” a “true pastor.” * St. Gregory says: “Or what others are called the watch-dogs of this flock, save the holy doctors?” * (*Moralia in Job*, XX, vi, 15; Migne, P.L., vol. 76, col. 145.) Also to be borne in mind is the “Indian dog,” a quadruped on the earth but a fish in water. This ability to change its shape makes it an allegory of St. Paul. (All this and more can be found in Picinellus, *Mundus symbolicus*, I, pp. 352ff., s.v. *canis*.) In the *Hieroglyphics of Horapollo* (Boas trans., No. 39, p. 77) emphasis is laid on the dog’s power to spread infection, especially rabies and diseases of the spleen. Because of its rich symbolic context the dog is an apt synonym for the transforming substance.

281 Khalid ibn Jazid (c. 700), an Omayyad prince. The “Liber secretorum” is ascribed to him. The text is quoted in *Theatr. chem.*, IV, p. 859.

282 One of the many Hermes quotations whose origins are obscure.

283 *Art. aurif.*, I, pp. 340f.*

284 Cf. “Psychology of the Transference,” par. 353, n. 1.

285 *Art. aurif.*, II, p. 248.* This passage is cited in *Theatr. chem.*, IV, p. 832.

286 *Κυνόσουρα* means ‘dog’s tail’ and denotes the constellation of the Little Bear.

287 Perhaps a reference to Matthew 7 : 14: “... strait is the gate, and narrow is the way, which leadeth unto life.”

288 *Elenchos*, IV, 48, 10 (cf. Legge, I, p. 112). *Κύειν* means ‘to be pregnant’, also ‘beget’. The related verb *κυνεῖν* means ‘to kiss’.

289 ‘Ο *ἐγγόνασι*, the Kneeler, is the constellation of Hercules. Cf. *Elenchos*, V, 16, 16.

290 For “canis” as synonym for the lapis see Lagneus, “Harmonia chemica,” *Theatr. chem.*, IV, p. 822.

291 Wendland has *κυνοειδῆ*. *Κυανοειδῆ* is a conjecture.

292 One conjecture is *Περσεφόνη Φλυά*.

293 *Elenchos*, V, 20, 6f.

293a Cf. pars. 160f.

294 The motif of disappearance occurs in the second version of the Gabricus / Beya myth (*Ros. phil.*, *Art. aurif.*, 1593, II, p. 263) and in the submersion of the sun (p. 333).

295 The same archetype forms the background to the Nicodemus dialogue in John 3.

296 A Venetian physician of the 16th cent.

297 The text has “succu.” It could therefore mean ‘extract the most pure with the juice and blood.’

298 Schmieder (*Geschichte der Alchemie*, p. 153) mentions a MS of Arnaldus de Villanova, “De secretis naturae,” and so does Du Fresnoy, *Histoire de la philosophic hermétique*, III, p. 325.

299 *Theatr. chem.*, II, pp. 292f.*

300 “Noli alienum introducere” and “nihil extraneum,” an oft-repeated saying.

301 *Art. aurif.*, II, pp. 385ff.

302 “Superflua removenda,” an equally popular phrase.

303 The idea of the “house” may have derived originally from astrology. Here the house (as *domus propria*) means the matrix of the substance, but as *domus aliena* it means the chemical vessel (for instance the *domus vitrea*, ‘house of glass’). The “flying bird” is a gas that issues from the matrix. The stone, on the other hand, signifies the substance, which does not leave its house like the gas, but must be transferred to another vessel. The gas (spirit) is invisible and feminine by nature, and therefore belongs to the unconscious sphere, whereas the substance is visible and tangible — “more real,” as it were. It is masculine and belongs to the conscious sphere (in a man). Accordingly the *domus aliena* could be interpreted as consciousness, and the *domus propria* as the unconscious.

304 In the “separatio” one of the birds can fly, the other not. The “unio” produces the winged hermaphrodite.

305 Perhaps the only parallel to this * is in Senior (*De chemia*, p. 78): “And the ravens will come flying and fall upon it.” * The idea is, obviously, that the birds share the king’s meal, a possible influence here being the marriage of the king’s son (Matthew 22 : 2ff.) and the marriage of the Lamb (Revelation 19 : 9ff.). Rex always signifies the sun, while the king’s table signifies the bright world of day, i.e., consciousness, in and by which the contents of the unconscious (the birds) are recognized. These are the “fishes and birds” that bring the stone. (Cf. *Aion*, par. 224.)

306 Variants of the “bird flying and without wings” (Senior, *De chemia*, p. 37.) For the plucked bird see “Allegoriae super turbam,” *Art. aurif.*, I, p. 140: “Take a cock crowned with a red comb and pluck it alive.”*

307 The two birds are the two luminaries, Sol and Luna, or their spirits. One bird is male and without wings, the other female and winged. When bound together as “colligatae” they represent the coniunctio. They are the parents of the lapis, which is practically identical with “Ars nostra” since it is an “artificium” (artefact).

308 “Hominum consortia relinquere nescit.” In other words, they remain with men, which reminds us of Kalid’s “always being with you” (par. 174). The birds are personified contents of the unconscious which, once they are made conscious, cannot become unconscious again. As we know, an essential if not decisive part of any analytical treatment is based on the fact that conscious realization generally brings about a psychic change.

309 Sol as the day-star.

310 Luna as the mother of the living and mistress of the night.

311 The *succus vitae* is once more the *aqua permanens*, which remarkably enough is also designated “dog,” as a passage in the “Opus praeclarum” of Valentinus (*Theatr. chem.*, IV, p. 1069) shows: “... of the water . . . which is called Dog of the balsam, or virgin’s milk, or our quicksilver, or soul, or wind, or the dragon’s tail.”*

312 The arcane substance is frequently likened to an egg. Cf. the treatise “Concerning the Egg” *περὶ τοῦ ὄου*. Berthelot, *Alch. grecs*, I, iii), where the equivalents are the brain-stone (*οἱ δὲ λίθον ἐγκέφαλον*), the stone that is no

stone (*ἕτεροι λίθον οὐ λίθον*), and the image of the world (*ἕτεροι τὸ τοῦ κόσμου μίμημα*), as in the *Turba* (ed. Ruska, p. 112) and numerous other places.

313 Cf. the frequent direction “on a slow fire.”

314 As stated above, the term “domus” is often used. *Domus thesauraria* (treasure-house) denotes the place where the arcanum is found, or else it is the chemical vessel (*domus vitrea*) or furnace. Cf. “Visio Arislei,” *Art. aurif.*, I, p. 148.

315 *Caro* (flesh) is a name for the arcane substance, especially when it is “vivified.” The “Consil. coniug.” says (*Ars chemica*, p. 234): “That globe receives the flesh, i.e., the coagulation, and the blood, i.e., the tincture.” * Dorn reveals the reason for this in his “Spec. phil.” (*Theatr. chem.*, I, p. 300): “Hence we can understand the philosophical transmutations: do we not know that the pure substance of bread and wine is transformed into flesh and blood?” * Trevisanus (“De chemico miraculo,” *Theatr. chem.*, I, p. 802) is equally clear when he says of the “king”: “And now he gives his red and bleeding flesh to be eaten by us all.” * In “Congeries Paracelsicae” (*Theatr. chem.*, I, p. 599) Dorn says that the medicament “can be made more than perfect through its own flesh and blood,” in agreement with the above quotation from the “Consilium.” A quotation from Malchamech in *Ros. phil.* (*Art. aurif.*, II, p. 238) says of the lapis: “It grows from flesh and blood.” Often we come across the “fat flesh,” as in a quotation from Pseudo-Aristotle in Mylius (*Phil. ref.*, p. 277): “Son, you must take of the fatter flesh,” and (p. 70): “Eat a morsel of the fat flesh,” a quotation from Arnaldus de Villanova (“Thesaurus thesaurorum,” *Art. aurif.*, II, p. 406). “Caro” is an allusion to the “fleshly” nature of man, which is tintured by the opus. The “Liber Platonis quatorum” (*Theatr. chem.*, V, p. 144) emphasizes this, and also the importance of “having knowledge of the gross, disordered, fleshly body, which is the burden of nature and reaches to the simple soul.” * The “animam simplicem” comes close to Plato’s “eternal Idea.”

316 Arnaldus de Villanova (p. 397) lays stress on the oneness of the stone: “For there is one stone, one medicine, to which nothing from outside is added, nor is it diminished, save that the superfluities are removed.” * *Ros. phil.* (*Art. aurif.*, II, p. 206) is even more emphatic: “One the stone, one the medicament, one the vessel, one the procedure, and one the disposition.”*

317 Classic pairs are Simon Magus and Helen, Zosimos and Theosebeia, Nicholas Flamel and Peronelle, Mr. South and his daughter (Mrs. Atwood, author of *A Suggestive Enquiry into the Hermetic Mystery*). A good account of Flamel’s career can be found in Larguier, *Le Faiseur d’or Nicolas Flamel*. The *Mutus liber* of Altus, recently reprinted, represents the *Mysterium Solis et Lunae* as an alchemical operation between man and wife, in a series of pictures. That such an abstruse and, aesthetically speaking, far from commendable book should be reprinted in the 20th century is proof of the psyche’s secret and quite irrational participation in its own mysterium. I have attempted to describe the psychology of these relationships in my “Psychology of the Transference.”

318 Cf. the illustrations in the *Mutus liber*, where this motif is well represented.

319 The opus is to be performed at certain fixed, symbolical times. For example, the *Arcanum hermeticae Philosophiae opus* (p. 82) says: “For the first work towards the whiteness must be brought to an end in the house of the Moon, and the second in the second house of Mercury. The first work towards the redness [should end] in the second house of Venus; the latter terminates in the second royal throne of Jove, wherefrom our most mighty King receives his crown adorned with precious stones.” * Besides this time co-ordination there are a number of others. The “Consilium coniugii” (*Ars chemica*, p. 65) says: “The white [stone] begins to appear at sunset on the face of the

waters, hiding itself until midnight, and thereafter it inclines towards the deep. But the red works contrariwise, for it begins to rise above the waters at sunrise and thereafter descends into the deep.”*

320 Cf. Senior, *De chemia*, pp. 26ff. His account is not altogether clear on’ this point—which, as he himself admits, is due to the obscurities of the whole procedure. On p. 28 he says: “And the second work is the albefaction and the rubefaction, and the sages have brought these two works together in one. For when they speak of the one, they speak of the other also, and hence their writings seem to the readers to be contradictory.”*

321 The result of the opus is often called its “fruit,” as in the *Turba*, Sermo LVIII (Ruska, p. 161): “Why hast thou ceased to speak of the tree, of the fruit whereof he that eateth shall never hunger?” * (This passage is probably not without reference to John 6 : 35: “. . . he that cometh to me shall never hunger, and he that believeth on me shall never thirst.”) The *Turba* continues: “I say that old man ceases not to eat of the fruits of that tree . . . until that old man becomes a youth . . . and the father is become the son.” * It is questionable whether this is a Christian interpolation.

322 There are many pictures of the *arbor philosophica*. In patristic language it is “the fruitful tree which is to be nourished in our hearts” (Gregory the Great, *Super Cantica Canticorum*, 2 : 3; Migne, *P.L.*, vol. 79, col. 495), like the vine in the Eastern Church: “Thou, prophet of God, art seen as a mighty vine, filling the whole world with divine words as with fruits”* (Theodore the Studite, *Hymnus de S. Ephrem*, in Pitra, *Analecta Sacra*, I, p. 341). “[I am] the fruitful vine” (*Aurora Consurgens*, p. 139). *Aurora* II likewise refers to John 15 : 1 and 5: “Know ye not that all holy writing is in parables? For Christ followed the same practice and said: I am the true vine.” * (*Art. aurif.*, I, p. 186). Cf. also “The Philosophical Tree,” par. 359, n. 5, par. 458 and n. 5.

323 *Mus. herm.*, pp. 658f. (Waite, II, p. 171).

324 “The Spagyrics . . . extract from the moon itself an oil against falling-sickness and all affections of the brain.” * Penotus, *Theatr. chem.*, I, p. 714.

325 Not only does Luna cause moon-sickness, she herself is sick or ailing. One sickness is the “combustible sulphur” which prevents her from staying in the mixture, the other is “excessive coldness and dampness.” Hollandus, *Theatr. chem.*, III, p. 365.

326 “They fall into madness through ignorance.”* Berthelot, *Alch. grecs*, II, iv, 46.

327 *Isis*, XVIII, p. 237. On p. 238 Wei Po-yang describes the madness that attacks the adept. Cf. “The Philosophical Tree,” pars. 432ff.

328 Berthelot, II, iv, 52. An alchemist would say that he knew the secret of gold-making. Psychologically it would mean that he knew about the transformation of consciousness, but that it was abortive, so that instead of being illuminated he fell into deeper darkness.

329 “In the philosophical sublimation or first preparation of Mercury a Herculean task confronts the worker . . . The threshold is guarded by horned beasts . . . naught will assuage their ferocity save the tokens of Diana and the doves of Venus, if the fates call thee”* (D’Espagnet, “Arcanum hermeticae philos.,” XLII, *Bibliotheca chemica*, II, p. 653). The doves themselves were originally the “chicks of crows” (p. 655). The priestesses of Ishtar were called doves (Wittekindt, *Das Hohe Lied*, p. 12), just as the priestesses of the goddess of Asia Minor were called *πελειάδες*, ‘wild doves’ (Eisler, *Weltenmantel und Himmelszelt*, p. 158). The dove is also the attribute of the mother-goddess of the Hittites, who is depicted in an obscene position (Wittekindt, p. 50).

330 Eleazar, *Uraltes Chymisches Werck*, I, p. 34.

331 Ibid., p. 52. See *infra*, par. 624.

332 The text is corrupt here: “concutit statim pero ledos.” I read “terrae sedes.” It refers to the resurrection of the lapis out of the earth, which it penetrated as the “aer sophorum” (air of the sages), one of the many allusions to the coniunctio. The birth of the lapis has its parallel in Christ’s resurrection, hence the reference to the earthquake. (Cf. Matthew 28 : 2: “And behold, there was a great earthquake ...”)

333 Philaletha, *Mus. herm.*, p. 657 (Waite, II, p. 169).

334 John 5 : 2ff.

335 “He has the key to the infernal prison house where sulphur lies bound.”* “De sulphure,” *Mus. herm.*, p. 623 (Waite, II, p. 143).

336 “Servus fugitivus” (fugitive slave) is more common. “Cervus” occurs in Agrippa von Nettesheim (*The Vanity of Arts and Sciences*, p. 315): “... foolish Mysteries of this Art, and empty Riddles, of the Green Lion, the fugitive Hart.” There is a picture of Diana and Actaeon on the title-page of *Mus. herm.*, 1678 (reproduced in Bernoulli, “Spiritual Development as Reflected in Alchemy”). In the Table of Figures in Manget (*Bibl. chem.*, II, Plate IX, Fig. 13) the stag appears as the emblem of “Mahomet Philosophus.” It is a symbol of self-rejuvenation in Honorius of Autun, *Sermo in Epiphania Domini* (Migne, *P.L.*, vol. 172, col. 847), where it is said that the stag, when he has swallowed a poisonous snake, drinks water “that he may eject the poison, and then cast his horns and his hair and so take new”; we likewise should “put aside the horns of pride and the hair of worldly superfluity.” In the legend of the Grail it is related that Christ sometimes appeared to his disciples as a white stag with four lions (= the four evangelists). (Cf. “Nature of Dreams,” par. 559, n. 9, and the frontispiece to Vol. 8 of these *Coll. Works*) Here too it is stated that the stag can renew itself (*Le Saint Graal*, III, pp. 219 and 224). Ruland (*Lexicon*, p. 96) mentions only that “*Cerviculae Spiritus* is a bone of the heart of the stag.” Dom Pernety (*Diet, mytho-hermétique*, p. 72) says of the “cerveau ou coeur de cerf”: “C’est la matière des Philosophes.” The *Livre des Secrez de Nature* says: “The stag is a well-known beast, which renews itself when it feels it is growing old and weak. It goes to an ant-hill and digs at the foot thereof and brings forth thence a serpent, on which it tramples with its feet and afterwards eats; it then swells up, and so renews itself. Wherefore it lives for 900 years, as we find in scripture ...” (Delatte, *Textes Latins et Vieux François relatifs aux Cyranides*, p. 346.)

337 Since a psychic transformation is involved, the obscure passage in the Naassene hymn (Hippolytus, *Elenchos*, V, 10, 2), describing the sufferings of the soul, might be relevant here: “The soul . . . veiled in the form of a stag, wearies, overpowered by the pains of death.” * But the text is so uncertain that it has little documentary value.

338 Cf. “Psychology of the Transference,” pars. 419ff.

339 Goethe, “Der Schatzgräber.”

340 So in Rueckert’s well-known poem. Hebrew *Yetser ha-ra* means “instinct of evil.”

341 Cf. Heraclitus, R. P. 49, in Burnet, *Early Greek Philosophy*, p. 141.

342 *West-östlicher Diwan*.

343 Naturally, this is true only during the process of coming to terms with the unconscious.

344 P. 49.

345 “In outward forms thou’lt not find unity,

Thine eye must ever introverted be.

Canst thou forget thyself, to all forlorn,
Thou'lt feel God in thee, well and truly One.”

(Tersteegen, *Geistliches Blumengärtlein inniger Seelen*, No. 102, p. 24.)

“When I seek him outside, God makes me bad:
Only within is salvation to be had.”

(Angelus Silesius, *Sämtliche Poetische Werke*, ed. Held, I, p. 162.)

346 Book of Enoch 48 : 1: “... fountains of wisdom; and all the thirsty drank of them.” (Charles, *Apocrypha and Pseudepigrapha*, II, p. 216).

347 Boy Charioteer, Homunculus, and Euphorion.

348 Clement of Rome, Second Epistle to the Corinthians, 12 (*The Apostolic Fathers*, trans. Lake, I, p. 147).

349 This has been shown once again in our own day by the solemn promulgation of the dogma of the Assumption. A Catholic author aptly remarks: “There seems to be some strange rightness in the portrayal of this reunion in splendour of Son and Mother, Father and Daughter, Spirit and Matter.” (Victor White, “The Scandal of the Assumption,” *Life of the Spirit*, V, p. 199.) In this connection it is worth recalling the words of Pope Pius XII’s Apostolic Constitution, *Munificentissimus Deus*; “On this day the Virgin Mother was taken up to her heavenly bridal chamber” (English trans., p. 15). Cf. Antony of Padua, “Sermo in Assumptione S. Mariae Virginis,” *Sermones*, III, p. 730.

350 Also of gentleness, tameness, peacefulness (dove of Noah), simplicity (“simplices sicut columbae,” Matthew 10 : 16; DV: “guileless as doves”). Christ, too, is called a dove: “The Lord Jesus was a dove . . . saying Peace be unto you. . . . Behold the dove, behold the green olive-branch in its mouth.” * (Fernandus, cited in Picinellus, *Mundus Symbolicus*, p. 283.) Picinellus calls Mary the “most pure dove.” The “Aureum vellus” (Mennens, *Theatr. chem.*, V, p. 311) interprets the dove as follows: “Wherefore the Prophet crieth: Who will give me wings like a dove, that is to say, spotless and simple thoughts and contemplations?” *

351 II Corinthians 12 : 7.

352 A paradox which, like the *kenosis* doctrine (Philippians 2 : 6f.), is a slap in the face for reason.

353 My conjecture. See supra, II. 332.

354 An idea echoed in the dogma of the Assumption, which lays particular emphasis on the incorruptibility of the body, likening it, as the earthly vessel of divinity, to the ark of the covenant: “In the ark of the covenant, built of incorruptible wood and placed in the temple of God, they perceive an image of the most pure body of the Virgin Mary, preserved free from all corruption of the tomb.” (*Munificenlissimus Deus*, English trans., p. 13.) The coexistence in heaven of the real earthly body with the soul is expressed unequivocally in the words of the definition: “... was taken up . . . body and soul ...”

355 Baechtold and Stäubli, *Handwörterbuch des deutschen Aberglaubens*, VI, s.v. “Mond.”

356 Sudhoff, XIV, pp. 651ff.

357 Pseudonym Bernardus à Portu Aquitanus, *Theatr. chem.*, II, p. 123.

358 The moon also has a relation to Saturn, the astrological maleficus. In the “Dicta Belini” Saturn is, as it were, the “father-mother” of the moon: “I am the light of all things that are mine and I cause the moon to appear openly from

within my father Saturn, even from the regnant mother, who is at enmity with me.”* (“Allegoriae sapientum,” *Theatr. chem.*, V, p. 97.) Saturn plays the role of Typhon: dismemberment.

359 Medical psychologists would profit from Esther Harding’s account of moon psychology in her book *Woman’s Mysteries*. See especially ch. 12, “The Inner Meaning of the Moon Cycle.”

360 Dorn, “Phys. Trismeg.,” *Theatr. chem.*, I, p. 424.* An allusion to “Tabula Smaragdina,” *De Alchemia*, p. 363: “The wind hath borne it in his belly.”

361 “Congeries Paracelsicae,” *Theatr. chem.*, I, pp. 641f.

362 *Ibid.*, p. 642.

363 Penotus in “De medicament, chem.,” *Theatr. chem.*, I, p. 681.

364 “Aurei velleris Libri tres,” *Theatr. chem.*, V, p. 321.

365 A parallel to the Maria Mediatrix of the Church, who dispenses grace.

366 Presumably aether as the *quinta essentia*.

367 The “opus ad Lunam” is the whitening (*albedo*), which is compared with sunrise.

368 That is, of all luminaries, i.e., stars.

369 *Art. aurif.*, I, p. 398.*

370 “Gloria mundi,” *Mus. herm.*, p. 280 (Waite, I, p. 225).*

371 “Isis and Osiris,” 43, *Moralia* (trans. by Babbitt, V, pp. 104f.).

372 Goethe, *Faust* (trans. by MacNeice), p. 48 (mod.).

373 For instance in Marcus the Gnostic. Cf. Hippolytus, *Elenchos*, VI, 42, 2 (Legge, II, p. 44).

374 Cf. “Brother Klaus,” pars. 485f.

375 *Anna Kingsford: Her Life, Letters, Diary, and Work*, I, p. 130. I have quoted this vision at some length in my “Commentary on *The Secret of the Golden Flower*,” par. 40.

376 Cf. *Penguin Island* (trans. by Evans), p. 30.

377 “Spirit and Life,” pars. 629ff.

378 Cf. *I Ching, or the Book of Changes* (trans. Wilhelm and Baynes), I, p. 80, Hexagram 18: “Work on What Has Been Spoiled.”

379 Vigenerus (“De igne et sale,” *Theatr. chem.*, V, pp. 32f.) speaks of three worlds. The fire on earth corresponds to the sun in heaven, and this to the Spiritus Sanctus “in the intelligible world.” But on p. 39 he suddenly remembers the fourth, forgotten world: “The fourth is infernal, opposed to the intelligible, glowing and burning without any light.” * He also distinguishes four kinds of fire. (Cf. *Aion*, pars. 203, 393, and n. 81.)

380 Heaven, earth, hell (like sulphur, mercurius, sal) is a false triad: earth is dual, consisting of the light-world above and the shadow-world below.

381 Fire = sulphur, Sol = Mercurius (as the mother and son of Sol).

382 *Opus Mago-Cabbalisticum et Theosophicum*, p. 30.

383 A quotation from Hermes in *Rosarium phil.* (*Art. aurif.*, II, p. 244) mentions “Sal nostrae lunariae” (the salt of our moon-plant). “Our salt is found in a certain precious Salt, and in all things. On this account the ancient Philosophers called it the common moon” * (*Mus. herm.*, p. 217; Waite, I, p. 177). The salt from the Polar Sea is

“lunar” (feminine), and the salt from the Equatorial Sea is “solar” (masculine): Welling, p. 17. Glauber (*De signatura salium, metallorum et planetarum*, p. 12) calls salt feminine and gives Eve as a parallel.

384 St. Gregory, *In primum Regum expositiones*, I, i, 1 (Migne, *P.L.*, vol. 79, col. 23). This idea is developed in literal form, in both Tibetan and Bengali Tantrism, as Shiva in the embrace of Shakti, the maker of Maya. We find the same idea in alchemy. Mylius (*Phil. ref.*, pp. 8f.) says: “[God has] love all round him. Others have declared him to be an intellectual and fiery spirit, having no form, but transforming himself into whatsoever he wills and making himself equal to all things. . . . Whence, by a kind of similitude to the nature of the soul, we give to God, or the power of God which sustains all things, the name of Anima media natura or soul of the World.” * The concluding words are a quotation from “De arte chymica,” *Art. aurif.*, I, p. 608.

385 *De natura salium*, pp. 41ff.

386 “In the course of time these requests and petitions, so far from decreasing, grew daily more numerous and more insistent.” *Munificentissimus Deus*, p. 5.

387 A Catholic writer says of the Assumption: “Nor, would it seem, is the underlying motif itself even peculiarly Christian; rather would it seem to be but one expression of a universal archetypal pattern, which somehow responds to some deep and widespread human need, and which finds other similar expressions in countless myths and rituals, poems and pictures, practices and even philosophies, all over the globe.” Victor White, “The Scandal of the Assumption,” *Life of the Spirit*, V, p. 200.

388 (Basel, 1588), p. 253. Cf. *Psychology and Alchemy*, Fig. 232.

389 Cf. the man with a fish’s tail in the mosaic on the floor of the cathedral of Pesaro, 6th cent., with the inscription: “Est homo non totus medius sed piscis ab imo.” (This man is not complete, but half fish from the deep.) Becker, *Die Darstellung Jesu Christi unter dem Bilde des Fisches*, p. 127.

390 Cf. “The Spirit Mercurius,” pars. 267ff.; also the arcane teaching of Paracelsus in “Paracelsus as a Spiritual Phenomenon,” pars. 159ff.

391 Cf. “Dogma of the Trinity,” pars. 248f., 252ff.

392 For a closer discussion see “Psychology and Religion,” pars. 104ff.

393 “De Tenebris contra Naturam,” *Theatr. chem.*, I, p. 527. Cf. “Psychology and Religion,” pars. 104, n, 47, 120, n. 11, and “Dogma of the Trinity,” par. 262.

394 For details see *Aion*, pars. 359ff.

395 *Ibid.*, par. 171, n. 29.

396 P. 283.

397 “First comes the ash, then the salt, and from that salt by divers operations the Mercury of the Philosophers.” * Quoted in *Ros. phil.* (*Art. aurif.*, II, p. 210) and in “Clangor buccinae” (*Art. aurif.*, I, p. 488).

398 “De chemia,” *Theatr. chem.*, V, p. 231. For “salsatura” see *Aurora consurgens* II, in *Art. aurif.*, I, p. 205.

399 *Theatr. chem.*, V, p. 77.

400 Cited in *Ros. phil.*, p. 244.

401 *Ibid.*

402 Ibid., p. 222. The same on p. 225, where the salt is also called the “key that closes and opens.” In Parable VII of *Aurora Consurgens* (p. 141), the bride calls herself the “key” (*clavicula*).

403 *Ros. phil.*, p. 244.

404 Ibid., p. 269. The text adds: “He who tastes not the savour of the salts, shall never come to the desired ferment of the ferment.”*

405 “Opera mineralia,” *Theatr. chem.*, III, p. 411.

406 *Phil. ref.*, p. 189.

407 Ibid., p. 195.

408 Ibid., p. 222. Also in *Ros. phil.*, p. 208; Khunrath, *Amphitheatrum sapientiae*, p. 194, and *Mus. herm.*, p. 20 (Waite, I, p. 22).

409 Cited in “Tract, aureus,” *Mus. herm.*, p. 31 (Waite, I, p. 32). The writings of Basilius Valentinus do not date from the 15th cent, but are a 17th-cent. forgery.

410 “Alexander the Great, King of Macedonia, in his Philosophy has the following words: . . . Blessed be God in heaven who has created this art in the Salt.”* “Gloria mundi,” *Mus. herm.*, p. 217 (Waite, I, p. 176).

411 Ibid., p. 218 (Waite, I, p. 177).

412 Ibid., p. 216.

413 Ibid., p. 217. It is also described as the “balsam of nature” (Khunrath, *Hyl. Chaos*, p. 258) and as the “fifth element” (sea). Vigenerus, “De igne et sale,” *Theatr. chem.*, VI, p. 122.

414 *Hyl. Chaos*, p. 256.

415 Ibid., p. 257.

416 Ibid., p. 260.

417 *Amphitheatrum*, p. 194.

418 *Hyl. Chaos*, p. 257.

419 “De igne et sale,” p. 44.

420 *De natura salium*, p. 44. Glauber adds the verse: “In the salt and fire / Lies the treasure so dear.”

421 *Art. aurif.*, I, p. 210. In the *Turba* salt-water and sea-water are synonyms for Mercurius.

422 *Hyl. chaos*, p. 257.

423 “Our salt, that is to say, our earth.” “Tract, aureus,” *Mus. herm.*, p. 20 (Waite, I, p. 22). Cf. also “Clangor buccinae,” *Art. aurif.*, I, p. 488, and “Scala philosophorum,” *Art. aurif.*, II, p. 107.

424 *Phil. ref.*, p. 195.

425 One place is in “Gloria mundi,” *Mus. herm.*, p. 216 (Waite, I, p. 176): “(In the beginning) it is mostly black and evil-smelling.”*

426 “De igne et sale,” *Theatr. chem.*, VI, p. 98.

427 *Hyl. Chaos*, pp. 197f.

428 Ibid., p. 229.

429 Ibid., p. 254.

430 “De confectione lapidis,” *Theatr. chem.*, III, p. 199.

431 *Liber etymologiarum*, XIII, 14, fol. lxxviii.

432 A corrupt version of “Zosimos ad Theosebeiam,” owing to Arabic-Latin transmission. *Art. aurif.*, I, p. 264.

433 *Art. aurif.*, I, p. 316. Cf. also *Ros. phil.*, *Art. aurif.*, II, p. 258; Mylius, *Phil. ref.*, p. 249; “Tract, aureus,” *Ars chemica*, pp. 11f.

434 *Chymische Schrifften*, p. 100.

435 *Phil. ref.*, p. 244. The same in *Ros. phil.*, p. 248.

436 P. 222.

437 *Mus. herm.*, p. 328 (Waite, I, pp. 263f).

438 A *Turba* quotation from Sermo XV of Flritis (or Fictes = Socrates). See Ruska, *Turba philosophorum*, pp. 124f.

439 Cf. *Psychology and Alchemy*, pars. 56f., 476.

440 “Isis and Osiris,” 32, *Moralia* (trans. Babbitt) V, pp. 78f.

441 The text is a poem which Mylius cites from an older source. The most important passages are the following:

“There is a secret stone, hidden in a deep well
Worthless and rejected, concealed in dung or filth ...
And this stone is a bird, and neither stone nor bird ...
... now sea-spume or vinegar,
Now again the gem of salt, Almisadir the common salt ...
....
Now the sea, cleansed and purged with sulphur.”*

Phil. ref., p. 305. At that time *gemma* simply meant “stone.” Cf. Ruland, *Lexicon*, pp. 241f.

442 Cf. supra, par. 245: “Our stone is endowed with the strongest spirit.”

443 *Art. aurif.*, II, pp. 282f.

444 Cf. Rosencreutz, *Chymical Wedding* (trans. by Foxcroft), p. 155.

445 The phoenix, the Western equivalent of this wonder-bird, is described by Maier as very colourful: “His neck is surrounded with a golden brightness, and the rest of his body by feathers of purple hue.” * *Symb. aur. mens.*, p. 598.

446 *Isis*, XVIII, pp. 218, 258.

447 It is strange that the editors of Wei Po-yang are of the opinion that no fundamental analogy obtains between Chinese and Western alchemy. The similarity is, on the contrary, amazing. [Cf. “Concerning Mandala Symbolism,” pars. 630ff. (figs. 1–3).—EDS.]

448 *De natura animalium*, X, 29 (ed. Hercher, I, p. 257).

449 Preisendanz, *Pap. Graec. Mag.*, I, pp. 110ff. Pap. IV, 1115–66.

450 *Mus. herm.*, p. a 16 (Waite, I, p. 176).

451 “To the spiritual [body] is referred fire, to the corruptible [body], Salt.”* “De igne et sale,” *Theatr. chem.*, VI, p. 7.

452 *Expositions of the Book of Psalms*: Ps. 92 : 7, IV, p. 340.

- 453 *Tractatus super Psalmos*, 68, 28 (Migne, *P.L.*, vol. 9, col. 487).*
- 454 Rahner, “Antennae Crucis II,” p. 105.
- 455 *Expositions*: Ps. 148 : 9, VI, p. 424 (Migne, *P.L.*, vol. 36, col. 1943).
- 456 *Ibid.*, II, p. 593: “Profunditas aquarum impenetrabilis.”
- 457 *Ibid.*, I, p. 412: “Profunditas peccatorum.”
- 458 *Homiliae in Evangelia*, 11, 4 (Migne, *P.L.*, vol. 76, col. 1116): “Aeternae mortis profunda.”
- 459 Abt, *Die Apologie des Apuleius*, p. 257 (183).
- 460 The Septuagint has μέγα κῆτος (great whale) for Leviathan.
- 461 “Antennae Crucis, II,” p. 108.
- 462 *Epistula II ad Theodosium*, p. 12, in *Opera*, Sectio I, Pars I, Epistolarum Pars I.*
- 463 *Spiritual Exercises* (trans. by Rickaby), p. 41.*
- 464 *Pratica di alcuni esercitij Spirituali di S. Ignatio*, “Esercizio dell’Inferno,” H, p. 6.* The concluding words are reminiscent of Jeremiah 23 : 15: “Behold, I will feed them with wormwood [*absynthio*], and make them drink the water of gall.”
- 465 Doelger, *Antike und Christentum*, II, pp. 63ff.
- 466 *Tractates on the Gospel of St. John*, XXV, 9 (trans. by Innes), II, p. 80.*
- 467 *Speculum de mysteriis ecclesiae*, Migne, *P.L.*, vol. 172, col. 921.*
- 468 Whence the designation “Peratics,” a Gnostic sect. (Cf. *Aion*, pp. 185L) They were the “trans-scendentalists.”
- 469 Hippolytus, *Elenchos*, V, 16, 4f.
- 470 There exists a level or threshold of consciousness which is characteristic of a definite time-period or stratum of society, and which might be compared to a water-level. The unconscious level rises whenever the conscious level falls, and vice versa. Anything that is not in the conscious field of vision remains invisible and forms a content of the unconscious.
- 471 Cf. *Psychological Types*, def. 30.
- 472 *Ibid.*, def. 51 (especially par. 828). See also my “The Transcendent Function.”
- 473 Cf. Evans trans., II, p. 86. This passage refers to Hosea 13 : 5: “I did know thee in the wilderness, and in the land of great drought.”
- 474 *Turba*, ed. Ruska, p. 164.
- 475 *Venenum* or φάρμακον is a synonym for the tincture.
- 476 *Art. aurif.*, I, p. 272.
- 477 “Gloria mundi,” *Mus. herm.*, p. 216: “In the work it becomes like unto blood.”
- 478 The rest of the title is: “olim conscriptus et a quodam Christiano Philosopho collectus” (Written of old and gathered together by a certain Christian Philosopher). *Theatr. chem.*, V, pp. 880ff.
- 479 Here the author adds (p. 886): “It is better to take pleasure in the opus than in riches or in works of virtuosity (*virtuoso labore*).” * The rare “virtuosus” is equivalent to the Greek ἐνάρετος.
- 480 *Ibid.*, p. 885.

481 In his sermon on the “vessel of beaten gold” (Ecclesiasticus 50 : 9) Meister Eckhart says: “I have spoken a word which could be spoken of Saint Augustine or of any virtuous soul, such being likened to a golden vessel, massive and firm, adorned with every precious stone.” Cf. Evans, I, p. 50.

482 Not only the vessel must be round, but the “fimarium” it is heated in. The “fimarium” is made of *fimus equinus* (horse-dung). *Theatr. chem.*, V, p. 887.

483 Cf. *Psychological Types*, def. 29 and par. 828, and “The Transcendent Function.”

484 Cf. *Psychology and Alchemy*, par. 469.

485 Cf. *Two Essays on Analytical Psychology*, par. 367.

486 Cf. the heating and incubation of the Philosophers in the triple glass-house at the bottom of the sea in the Arisleus Vision. (Ruska, “Die Vision des Arisleus,” *Historische Studien und Skizzen zu Natur- und Heilwissenschaft*, pp. 22ff.; cf. the “Psychology of the Transference,” par. 455 and n. 22.)

487 *Tapas* is a technical term, meaning ‘self-incubation’ (‘brooding’) in the *dhyana* state.

488 For the psychology of the mandala see my “Commentary on *The Secret of the Golden Flower*,” pars. 31ff., *Psychology and Alchemy*, pars. mff., “A Study in the Process of Individuation,” and “Concerning Mandala Symbolism.”

489 Cf. *Symbols of Transformation*, pars. 308ff., and the Arisleus vision, which seems to be the prototype of the motif of the king in the sweat-bath.

490 Ruland, *Lexicon*, p. 37.

491 Remarkably enough, a 12th-cent. representation of the four-wheeled chariot (see below) bears the inscription: “Foederis ex area Christi cruce sistitur ara” (Out of the ark of the covenant an altar is built by the cross of Christ).

492 “Plaustrum” also denotes the “chariot” in the sky, Charles’ Wain (Ursa Major or Big Dipper). This constellation marks the celestial Pole, which was of great significance in the history of symbols. It is a model of the structure of the self.

493 Ezekiel 1 : 16f. There is a similar vision in Zechariah 6 : 1: “... and behold, four chariots came out from between two mountains ...” The first chariot had red horses, the second black, the third white, and the fourth dappled grey (RSV. Vulgate: “*varii et fortes*”; DV: “grisled and strong.”) The horses “went forth to the four winds of heaven.” For a remarkable parallel vision see Neihardt, *Black Elk Speaks, being the Life Story of a Holy Man of the Ogalala Sioux*, p. 23. In Black Elk’s vision twelve black horses stand in the west, twelve white horses in the north, twelve bays in the east, and in the south twelve greys.

494 Mâle, *L’Art religieux du XIIème siecle en France*, p. 182.

495 The passage is corrupt. The Hebrew original text has only: “My soul set me—chariots of Aminadab.” There are many different interpretations and conjectures, of which I will mention only Riwkah Scharf’s: Merkābāh can also be the sun-chariot (2 Kings 23 : 11); Aminadab is a king’s name, from Ammon, ’Amm, ’Ammi, a Semitic god, here possibly transferred to the sun-chariot.

496 For Honorius this naturally has the moral meaning of “turn again.” See his *Expositio in Cantica Cant.*, Migne, *P.L.*, vol. 172, col. 462.

497 In this connection the alchemists also mentioned the three men in the fiery furnace, Daniel 3 : 20ff.

498 Vulgate: “Quia spiritus vitae erat in rotis” Ezekiel 1 : 20. Cf. *Psychology and Alchemy*, par. 471.

499 Cf. “On the Nature of the Psyche,” pars. 395f.

500 Ramanuja’s commentary to the Vedanta-Sutras (SBE, XLVIII), p. 578.

501 Cf. my “Analysis of the Associations of an Epileptic.”

502 “The Bald-headed Gooseherd.” Cf. Dirr, *Kaukasische Mdrchen*, pp. 47ff.

503 “Whole” is meant here only in a relative sense, implying merely the most important aspects of the individual psyche and of the collective unconscious.

504 *Symb. aur. mensae*, pp. 568ff.

505 Maier makes the following equations: Europe = earth, America = water, Asia = air, Africa = fire.

506 Frobenius, *Das Zeitalter des Sonnengottes*, p. 82 and note.

507 “In the intense heat of summer.” *Art. aurif.*, I, p. 148.

508 “Sitibundus” means one who is parched with thirst on the sea. “Sitibundi in medio Oceani gurgite” (thirsting in the mid flood of Ocean).

509 *Symb. aur. mensae*, p. 594. Maier completes the picture of hell by citing the legend of the oryx: “There the Oryx, thirsting in the great heat of summer, is said to curse the heat of the sun with the shedding of tears and repeated groanings.”*

510 *Ibid.*, p. 199.* From Avicenna’s *Liber de anima artis*, to which unfortunately I have no access. The saying is cited as an “Aenigma” in cap. X of the “Rosarius” of Arnaldus de Villanova (Gratarolus, *Ferae alchemiae*, I, Part 2, p. 42).

511 “The cross of Jesus Christ the Son of God, Saviour.”

512 *The City of God*, II, p. 196. Cf. Geffcken, *Die Oracula Sibyllina*, pp. 153f.

512a Migne, *P.G.*, vol. 20, col. 1302.

513 *Plato’s Cosmology* (trans. by Cornford), p. 9.

514 There are two Armenian legends concerning Alexander, of which the first runs as follows: “When Alexander came into the world, he at once ran about the room. But when he came to the fourth corner, an angel struck him down and gave him to understand that he would conquer only three-quarters of the world.” In the second legend Alexander does conquer three-quarters of the world, but not the fourth, which is called that of the “righteous poor.” A sea surrounds it and cuts it off from other parts of the earth. Dirr, *Kaukasische Märchen*, p. 259.

515 Cf. *Psychology and Alchemy*, pars. 209. Concerning the problem in the Timaeus see “A Psychological Approach to the Dogma of the Trinity,” pars. 181ff.

516 Horace, *Epistolae*, I, xviii, 84.*

517 Corresponding to the *xanthesis*, *citrinitas*, or yellowing.

518 Isidore of Seville, *Liber etymologiarum* (XII, ch. 7, fol. lxxv): “The phoenix, a biru of Arabia, so called because it has a purple colour and is singular and unique in all the world.”*

519 “Whom, says she, seekest thou here, stranger? It is not lawful for a man to approach a virgin.” * The Sibyl pardons him, however, because he is “very desirous of learning.”

520 For the anima in this role see *Psychology and Alchemy*, pars. 73f.

521 Namely in the form of symbolic animals which appear in dreams as prefiguretions of the self.

522 *Spiritual Exercises* (trans. by Rickaby), p. 41.

523 *Ibid.*, p. 215.

524 Cf. "Psychology and Religion," par. 133.

525 Angelus Silesius says, however:

"Turn inward for your voyage! For all your arts
You will not find the Stone in foreign parts."

Cherubinischer Wandersmann, III, No. 118. All the same, no one has yet discovered himself without the world.

526 Mylius, *Phil, ref.*, pp. 33 and 245.

527 *Cher. Wand.*, III, No. 148.

528 See *Psychology and Alchemy*, fig. 53.

529 St. Ambrose says: "Let this bird teach us by his example to believe in the resurrection." * Epiphanius: "Why therefore did the wicked Jews not believe in the resurrection of our Lord Jesus Christ on the third day, when a bird brings himself to life again in the space of three days?" * Both cited in Picinellus, *Mundus symbolicus*, I, pp. 575, 576, 578.

530 If the iconographic symbols spontaneously produced by modern people are examined in this respect, we seldom find a human being as the central figure (in a mandala, for instance), but, much more frequently, an impersonal abstract sign which is meant to express totality. Occasionally there is a face or head, but this only enhances the analogy with alchemy. (Cf. *Psychology and Alchemy*, par. 530, and "Transformation Symbolism in the Mass," pars. 363ff.) The most extreme expression of the abstract and impersonal in alchemy is the lapis. I have already drawn attention to the peculiar nature of these central figures in "Psychology and Religion," pars. 156ff.

531 An exception to this is the third Person of the Trinity, the Holy Ghost, who is "breathed" by Father and Son (active and passive spiration: cf. my "Dogma of the Trinity," pars. 235ff. and n. 10). He is, as the usual representations show, the most "depersonalized" of the figures. I have already mentioned the alchemists' preference for a religion of the Holy Ghost. (See also *Aion*, pars. 141ff.)

532 *Symb. aur. mens.*, p. 606.*

533 *Ibid.*, p. 607.*

534 DV; AV, 18 : 9.

535 $\pi\acute{o}\kappa\omicron\varsigma$ = 'wool, fleece' (L. *vellus*). The passage refers to Psalm 71 : 6 (Vulgate): "Descendet sicut pluvia in vellus" (DV: "He shall come down like rains upon the fleece"), and Judges 6 : 37: "Ponam hoc vellus lanae in aera" (DV: "I will put this fleece of wool on the floor").

536 Pitra, *Analecta sacra*, V, pp. 85f.

537 Refers to Acts 1 : 9: "... and a cloud received him out of their sight."

538 *Adv. haer.*, III, VI, 2 (*The Writings of Irenaeus*, I, p. 270).

539 Reproduced in my "Psychology of the Transference," figs. 7 and 9.

540 Cf. "Tabula smaragdina" (ed. Ruska), p. 2.*

541 *Ars chemica*, p. 118.

542 This “someone,” as is clear from the later text (in *Bibliotheca chemica*), is the “beloved” in the Song of Songs, i.e., Luna. She speaks here to Sol.

543 Possibly an allusion to the “Tabula smaragdina.”

544 “Consil. coniug.,” p. 128; or remain “in the golden tree,” p. 211. There may be a reference here to John 3 : 13: “And no one has ascended into heaven except him who has descended from heaven” (DV).

545 I.e., from the “sulphur nostrum” previously referred to.

546 “In Luna crescente, in naturam solarem.” This could also be translated: “waxing in Luna into the nature of the sun.”

547 The light of sun *and* moon.

548 The 1566 edn. has “figitur amanti eum.” I read “earn.”

549 Consil. coniug.,” p. 165 (commentary in Senior, *De chemia*, p. 15). Cf. the “transposition of the lights” in the Cabala.

550 Emblema L, p. 148: “The dragon slays the woman and she him, and together they are bespattered with blood.”*

551 *Theatr. chem.*, I, p. 409.

552 Ibid., p. 431. Dorn adds: “It was hidden of old by the Philosophers in the riddle: Make the fixed, said they, volatile, and the volatile fixed, and you will have the whole magistry.”*

553 “Spec. phil.,” *Theatr. chem.*, I, p. 276.* Here the allusion to John 3 : 13 is even clearer.

554 Cf. supra, n. 393.

555 He says, for instance: “Learn from within thyself to know all that is in heaven and on earth, that thou mayest be wise in all things. Knowest thou not that heaven and the elements were formerly one, and were separated from one another by divine artifice, that they might bring forth thee and all things? If thou knowest this, the rest cannot escape thee, or thou lackest all sense. Again, in every generation such a separation is necessary, as I have said above, and needs to be effected of thyself, before thou settest sail towards the true philosophy. Thou wilt never make from others the One which thou seekest, except first there be made one thing of thyself.” * “Spec. phil.,” p. 276. The stages of the ascent are: (i) devotion to the faith, (2) knowledge of God by faith, (3) love from the knowledge of God. (“Physica Trithemii,” *Theatr. chem.*, I, p. 449.)

556 * A similar view is suggested in the “Congeries Paracelsicae chemicae,” *Theatr. chem.*, I, p. 589: “Therefore it must be boiled, roasted, and melted; it ascends and descends, and all these operations are one single operation performed by the fire alone.”*

557 The *Rosarium phil.* formulates the ascent and descent as follows: “Our stone passes into earth, earth into water, water into air, air into fire, and there it stays, but on the other hand it descends.” * *Art. aurif.*, II, p. 250.

558 The water in which the earth is dissolved is the earth’s soul or spirit, of which Senior says: “This divine water is the king descending from heaven.” Before that, the “king” was in the earth. Cf. *Ros. phil.*, p. 283.

559 *phil. ref.*, p. 20. This idea derives from “De arte chymica” (*Art. aurif.*, I, p. 612). Here the descent is identical with God’s incarnation. Our passage is followed by the text: “I will content thee with this parable: The Son of God coming down into the Virgin and there clothed with flesh is born as a man, who, after showing us the way of truth for our salvation, suffering and dying for us, after his resurrection returned to heaven, where the earth, that is, mankind, is exalted above all the circles of the world and set in the intellectual heaven of the most holy Trinity.”*

560 “De vera praep. medicament, chem.,” *Theatr. chem.*, I, p. 681.

561 Cf. *Psychology and Alchemy*, pars. 64ff., 78f.

562 “Phys. Trismeg.,” *Theatr. chem.*, I, p. 430.

563 This motif is not uncommon in mandaias drawn by patients, the centre being represented either by a fluttering bird, or a pulsing cyst or heart. (In pathology we speak of an “auricular flutter.”) The same motif appears in the form of concentric rings (see “A Study in the Process of Individuation,” Picture 8), or of waves surrounding a centre (Picture 3).

564 *Theatr. chem.*, IV, p. 575.

565 Colonna, *Hypnerotomachia Poliphili* (1499).

566 Dorn, “Phys. Trismeg.,” *Theatr. chem.*, I, p. 409.

567 For a thorough psychological analysis of the text see Fierz-David, *The Dream of Poliphilo*, pp. 57ff.

568 A psychological statement which, like all such, only becomes entirely true when it can be reversed.

569 Colossians 2 : 14f. (AV, mod.).

570 Orosius, *Ad Aurelium Augustinum commonitorium* (CSEL., XVIII, p. 153).*

571 *Contra Celsum*, VI, 22 (trans. by Chadwick), p. 334. (Migne, P.G., vol. 9, col. 1324.)

572 Usually the series seems to begin with Saturn. Cf. Bousset, “Die Himmelsreise der Seele.”

573 The interested reader is referred to Cumont, *Textes et Monuments relatifs aux Mystères de Mithra*, I, pp. 36ff.; Bousset, “Himmelsreise”; and Reitzenstein, “Himmelswanderung und Drachenkampf.”

574 Cf. the journey motif in *Psychology and Alchemy*, pars. 304f., 457 and n. 75. Concerning Mercurius see the *puer-senex* motif in Curtius, *European Literature and the Latin Middle Ages*, pp. 98ff.

575 *Shepherd of Hermas*, IV, 1, 10–2, 1 (trans. by Lake), p. 63.

576 In his *Symbola aureae mensae*.

577 I would also draw attention to the maiden and the dragon and the triadic symbolism in *The Dream of Poliphilo* (ed. by Fierz-David), especially the encounter with the triple-tongued dragon and the black prism in the realm of Queen Eleuterilida (pp. 73ff. and 90ff.). For the Erythraean Sibyl see Curtius, pp. 101ff.

578 “Therefore I am called Hermes Trismegistos, as having three parts of the Philosophy of the whole world.”* “Tabula smaragdina,” *De alchemia* (1541), cap. 12. “Domus barbae” comes from Arab *al-birba*, ‘pyramid’, where Hermes was said to be buried.

579 *Shepherd of Hermas*, IV, 3, 2–3, 5 (Lake, p. 67).

580 “Its power is complete when it is turned towards the earth.” * “Tabula smaragdina,” *De alchemia* (1541), cap. 6.

581 As, for example, Asklepios and his cabir, Telesphoros. Cf. Kerényi, *Asklepios*, pp. 58, 88, and C.A. Meier, *Antike Inkubation und moderne Psychotherapie*, pp. 47f.

582 *Shepherd of Hermas*, IV, 3, 6 (Lake, p. 67).

583 *Ibid.*, V, 1–4 (p. 69).

584 For the interpretation of the caduceus see Servius, *In Vergilii Carmina commentarii* (ed. by Thilo and Hagen), I, p. 508: “For the serpents have heads which look inward, in order to signify that ambassadors ought to discuss and agree among themselves. . . . For which reason . . . ambassadors of peace are called Caduceatores . . . and to those

Caducei are added two apples, one of the Sun and one of the Moon. . . . Mercury causes these two fierce animals to agree, so surely we also ought to agree with one another.” “Others say that the Latins call Mercury by that name as if he were Medicurrius, the mid-runner, because he is always passing between heaven and the lower regions . . . and that the Caduceus is assigned to him because he brings enemies together in friendship by mediating confidence.” * (Ibid. II, p. 220.) The medieval writer Pierius says of the caduceus: “He will very readily bring discordant minds into agreement, and will bind together the two serpents, that is, mutual hatreds, into one by the rod of his doctrine.” * Cited in Picinellus, *Mundus symbolicus*, I, p. 152.

585 “In the first place Saturn reigns in the *nigredo*.” * *Symb. aur. mensae*, p. 156.

586 Ibid., p. 568.

587 “Spec, phil.,” *Theatr. chem.*, I, p. 303: “As bodies are dissolved by solution, so the doubts of the philosophers are resolved by knowledge.”*

588 Berthelot, *Alch. grecs*, III, v bis (text vol., p. 118).

589 More precisely, before he comes to the house of Saturn, “in one of the entrances.” *Symb. aur. mensae*, p. 603.

590 Ibid., p. 477. Cf. Waite, *The Real History of the Rosicrucians*, pp. 268ff.

591 For details see “Archetypes of the Collective Unconscious,” pars. 66, 79.

592 Ruland, *Lexicon*, p. 226.

593 *Symb. aur. mensae*, pp. 603f.

594 Dorn, “Spec, phil.,” *Theatr. chem.*, I, p. 276.

595 “Rosinus ad Sarrat.,” *Art. aurif.*, I, p. 280: “But the lato is the unclean body.”*

596 For instance in Maier, *Symb. aur. mensae*, p. 215.

597 The whitened lato is identical with the “crystalline salt.” (Khunrath, *Hyl. Chaos*, p. 197.) The lato, too, is an arcane substance, but it has a negative character. Mylius says: “The lato is an imperfect yellow body compounded of Sun and Moon: when you have whitened it and restored it to its pristine yellowness, you have the lato again . . . Then you have passed through the door and have the beginning of the art.” * It is the *prima materia lapidis* in the state of *vilitas*, ‘baseness,’ from which the “pearl of great price” arises. (*Phil. ref.*, p. 199.) This passage seems to be taken from “Consil. coniug.,” *Ars chemica*, p. 134. The lato is the “black earth” (ibid., p. 80, also p. 39). According to Du Cange, “lato” has something to do with “*electrum*.” Cf. Lippmann, *Entstehung und Ausbreitung der Alchemie*, I, p. 481.

598 “Dealbate Latonem et libros rumpite, ne corda vestra corrumpantur.” *Ros. phil.* cites this saying from Geber, but in corrupt form: “reponite” instead of “rumpite.”

599 Ablutio was understood by the alchemists as distillatio. Cf. Mylius, *Phil. ref.*, P. 35.

600 Quotation from Hermes: “Azoth and fire cleanse the lato, and remove the blackness from it” * (*Art. aurif.*, II, p. 277).

601 Mylius has: “Fire and water cleanse the lato and wipe off its blackness.” * *Phil. ref.*, p. 297.

602 The fire symbolism connected with baptism is expressed particularly clearly in the hymn of St. Romanus, “De theophania”: “I behold him in the midst of the floods, him who once appeared as dew in the fire in the midst of the three youths [Daniel 3 : 24f.], now a fire shining in the Jordan.” * Pitra, *Analecta sacra*, I, p. 21.

603 P. 128.* Cf. supra, par. 291.

604 Parable 4. Another passage has: “But when he baptizes, he infuses the soul.”* Ibid.

605 *Theatr. chem.*, II, p. 123.

606 The classic example of this is the dissolution of Gabricus in the body of Beya, into “atoms” (*partes indivisibiles*). *Ros. Phil*, in *Art. aurif.*, II, p. 246.

607 Morienus, “De transmut. metallica,” *Art. aurif.*, II, p. 33.

608 * The text is in a poor state here. The passage is apparently attributed to Stephanos, and occurs not only in the treatise of Komarios (Berthelot, *Alch. grecs.* IV, xx, 13, lines 17 and 20) but also in Zosimos (III, ii). Whether Stephanos (7th cent.) would have expressed himself in such an old-fashioned way is uncertain. The passage does in fact belong in the treatise of Komarios, where it also occurs in different words at 10, lines 22ff. This runs: “The waves injure them [the substances] . . . in Hades and in the grave where they lie. But when the grave is opened, they will rise up from Hades like the newborn from the belly.”*

609 *Catecheses mystagogicae*, II, 4 (Migne, *P.G.*, vol. 33, col. 1080).*

610 Pitra, *Analecta sacra*, V, p. 150.*

611 Berthelot, *Alch. grecs*, IV, ii, 2.

612 *isis*, XVIII, pp. 238 and 251.

613 Berthelot, *Alch. grecs*, IV, xx, 8, 9, 12.

614 The *ἐναβύσσαιον ὕδωρ* (abyssal water) is mentioned in the treatise of Christianos, “The Making of the Mystical Water” (Berthelot, VI, v, 6, line 12).

615 Probably the earliest reference to the phoenix is in Zosimos (Berthelot, III, vi, 5), where a quotation from Ostanos speaks of an “eagle of brass, who descends into the pure spring and bathes there every day, thus renewing himself.”*

616 Preisendanz, *Pap. Graec. Mag.*, II, p. 73, Pap. XII, lines 228–38.*

617 *Mus. herm.*, p. 262 (Waite, I, p. 211). This opinion is put into the mouth of “Socrates,” and corresponds more or less to Sermo XVI of the *Turba*.

618 Ash is the calcined and annealed substance, freed from all decomposition.

619 Senior, *De chemia*, p. 41: “The white foliated earth is the crown of victory, which is ash extracted from ash, and their second body.” * The connection with 1 Thess. 2 : 19, “... our hope, or joy, or crown of glory” (DV), is doubtful, likewise with Isaiah 28 : 5, “... the Lord of hosts shall be a crown of glory” (DV). On the other hand, Isaiah 61 : 3, “... to give them a crown for ashes,” is of importance for the alchemical connection between ashes, diadem, and crown. Cf. Coodenough, “The Crown of Victory.”

620 Ibid., p. 40.

621 Vigenerus, “De igne et sale,” *Theatr. chem.*, VI, pp. 44f.

622 *Mus. herm.*, p. 217 (Waite, I, p. 176).

623 Vigenerus, p. 57.

624 *Mus. herm.*, p. 217.

625 *De natura salium*, pp. 16f. Glauber alludes here to Mark 9 : 49.

- 626 Mylius, *Phil, ref.*, p. 20.*
- 627 Cf. the *Liber de aluminibus et salibus*, attributed to Rhasis or to Garlandus (*Buch der Alaune und Salze*, ed. Ruska, pp. 81ff.). This purely chemical treatise of Arabic origin gives some idea of what the early medieval alchemists knew of chemistry.
- 628 *De chemia*, p. 42.
- 629 For the alchemists magnesia was as a rule an arcane substance and not a specifically chemical one. Cf. *Aion*, pars. 241f., 244.
- 630 Khunrath, *Hyl. Chaos*, p. 197.
- 631 *De Signatura salium*, p. 12. For Eve as the feminine element contained in the man see “Psychology and Religion,” par. 47, n. 22.
- 632 *Mus. herm.*, p. 217 (Waite, I, p. 176): “Sal terrae est anima.”
- 633 P. 218. How very much the tincture is the “baptismal water” can be seen from the Greek (Berthelot, VI, xviii, 4, line 2): “Being bodies they become spirits, so that he will baptize in the tincture of the spirit.” * There is a similar passage in Pelagios (Berthelot, IV, i, 9, lines 17ff.). We are reminded of the famous passage about the *krater* in Zosimos (Berthelot, III, li, line 8): “baptized in the *krater*,” referring to the baptism of Theosebeia into the Poimandres community.
- 634 *De signature salium*, p. 15.
- 635 *Ibid.*, p. 23.
- 636 Cf. *supra*, par. 261.
- 637 *De natura salium*, p. 44.
- 638 *Ibid.*, p. 51.
- 639 *Opus Mago-Cabbalisticum*, pp. 6 and 31.
- 640 *De officiis* I, §133 (trans. by Miller), pp. 136f.*
- 641 For instance, Leviticus 2 : 13.
- 642 *Commentarium in Matthaei Evangelium*, IV, 10 (Migne, *P.L.*, vol. 9, col. 954).*
- 643 *Mundus symbolicus*, p. 711.
- 644 “Aspergatur seimo sapientia, non obruatur.”
- 645 *Polyhistor symbolicus*.
- 646 *Adv. haer.*, I, vi, 1 (cf. trans. Roberts / Rambaut, I; p. 25).
- 647 Here *pneuma* has the meaning of a holy spirit and not of wind.
- 648 “Death” and the “father below” are both preceded by the same ἀπό (from) and are therefore parallel if not identical, in so far as the begetter of life is also the begetter of death. This is an indication of the ineluctable polaristic nature of the *auctor rerum*.
- 649 *Elenchos*, V, 19, 14ff. Cf. Legge, *Philosophumena*, I, pp. 163f.
- 650 See *A ion*, ch. 13.
- 651 Cubic salt crystals are mentioned in Welling, *Opus Mago-Cabbalisticum*, p. 41.
- 652 *Mus. herm.*, p. 20 (Waite, I, p. 22).

653 “Area arcani,” *Theatr. chem.*, VI, p. 314.

654 *Mus. herm.*, p. 216 (Waite, I, p. 176).

655 *Mus. herm.*, p. 88 (Waite, I, p. 80).

656 *Hyl. Chaos*, pp. 229, 254.

657 *Amphitheatrum*, p. 197. The lapis, however, corresponds to the self.

658 By “computatio” is meant the “isosephia,” that is, the sum which results from the numerical values of the letters in a word, this word being then equated with another word having the same numerical value.

659 “De igne et sale,” *Theatr. chem.*, VI, pp. 129f.

660 *De natura salium*, pp. 25 and 51. Christ as *sal sapientiae* is another symbol of the self.

661 Olympiodorus (Berthelot, II, iv, 38) remarks: “Thus the key to the meaning of the circular art is the synopsis thereof.” * And the *Turba* says: “The more I read the books, the more I am enlightened” * (ed. Ruska, *Sermo XV*, p. 125).

662 I take the concept of *participation mystique*, in the sense defined above, from the works of Lévy-Bruhl. Recently this idea has been repudiated by ethnologists, partly for the reason that primitives know very well how to differentiate between things. There is no doubt about that; but it cannot be denied, either, that incommensurable things can have, for them, an equally incommensurable tertium *comparationis*. One has only to think of the ubiquitous application of “mana,” the werewolf motif, etc. Furthermore, “unconscious identity” is a psychic phenomenon which the psychotherapist has to deal with every day. Certain ethnologists have also rejected Levy-Bruhl’s concept of the *Hat prelogique*, which is closely connected with that of *participation*. The term is not a very happy one, for in his own way the primitive thinks just as logically as we do. Levy-Bruhl was aware of this, as I know from personal conversation with him. By “prelogical” he meant the primitive presuppositions that contradict only our rationalistic logic. These presuppositions are often exceedingly strange, and though they may not deserve to be called “prelogical” they certainly merit the term “irrational.” Astonishingly enough Lévy-Bruhl, in his posthumously published diary, recanted both these concepts. This is the more remarkable in that they had a thoroughly sound psychological basis.

663 *Hyl. Chaos*, p. 74. Probably an allusion to John 1 : 9: “That was the true Light, which lighteth,” etc.

664 *Ibid.*, p. 194.

665 *Mus. herm.*, pp. 217f. (Waite, I, p. 177).

666 *Theatr. chem.*, VI, p. 127.

667 *Hyl. Chaos*, pp. 197f.

668 *Mus. herm.*, p. 216.

668 “Spec, phil.,” *Theatr. chem.*, I, p. 307.

670 *Mus. herm.*, p. 216.

671 Steeb, *Coel. sephiroth.*, pp. 26 and 29.

672 *phil. ref.*, p. 195.

673 I cannot recall ever having come across this association in the texts.

674 AV; DV, 40 : 10.

675 *Uraltes Chymisches Werck*, II, p. 62. This story is told in abbreviated form in the Babylonian Talmud, “*Baba Bathra*,” trans. by Slotki, II, pp. 296f. (74b): “All that the Holy One, blessed be He, created in this world He created male and female. Likewise, Leviathan the slant serpent and Leviathan the tortuous serpent He created male and female; and had they mated with one another they would have destroyed the whole world. What then did the Holy One, blessed be He, do? He castrated the male and killed the female, preserving it in salt for the righteous in the world to come; for it is written: And he will slay the dragon that is in the sea.” He is also said to have done the same thing to Behemoth. By way of explanation I should like to add that the two prehistoric animals, Leviathan (water) and Behemoth (land), together with their females, form a quaternio of opposites. The *coniunctio oppositorum* on the animal level, i.e., in the unconscious state, is prevented by God as being dangerous, for it would keep consciousness on the animal level and hinder its further development. (Cf. *Aion*, pars. 181ff.) Regarding the connection between salt and the female element, it is significant that it was the female Leviathan who was salted.

676 According to an old tradition God, after the Fall, moved Paradise and placed it in the future.

677 Cf. Plutarch, “Isis and Osiris,” 32, *Moralia* (trans. Babbitt, pp. 80ff.): “The saying of the Pythagoreans, that the sea is a tear of Kronos.”

678 Cf. The Gnostic view that Kronos is “a power of the colour of water, and all-destructive.” Hippolytus, *Elenchos*, V, 16, 2 (Legge, I, p. 154). For further associations of the “bright” water see “The Spirit Mercurius,” par. 274.

679 *Mus. herm.*, p. 222 (Waite, I, p. 180).

680 *Ibid.*, p. 213 (Waite, p. 173).*

681 Morienus, in whose treatise (“*De transmutatione metallica*”) is found only the expression “blessed water,” then the idea of the “one fount” of the four qualities, and finally, the important remark that no one attains the completion of the work “save by the affliction of the soul.” (*Art. aurif.*, II, pp. 18, 26, 34.)

682 *Mus. herm.*, p. 214.*

683 “*Curvitatem*,” presumably an allusion to the winding course of water and the “*rivuli*” (streams) of the Mercurial serpent.

684 “Darkness there was: at first concealed in darkness this All was indiscriminated chaos.” *Rig-veda*, X, 129, 2 (*Hymns of the Rig-veda*, trans. by Griffith, II, p. 575).

685 “*Vilitas*” was also something Christ was reproached with. Cf. John 1 : 46: “Can there any good thing come out of Nazareth?”

686 Cf. *Psychology and Alchemy*, par. 421.

687 Or as Morienus (*Art. aurif.*, II, p. 32) so graphically says: “Until it begins to shine like fishes’ eyes.”

688 Caussin, *Polyhistor symbolicus* (1618), p. 3.*

689 Maier (*Symb. aur. mensae*, p. 568): “There is in our chemistry a certain noble substance . . . in the beginning whereof is wretchedness with vinegar, but in its ending joy with gladness. And so I have supposed it will fare with me, that at first I shall taste, suffer, and experience much difficulty, bitterness, grief, and weariness, but in the end shall come to glimpse pleasanter and easier things.”*

690 Matthew 10 : 16.

691 Hippolytus reports the following saying of the Peratics: “The universal serpent is the wise word of Eve.” * This was the mystery and the river of Paradise, and the sign that protected Cain so that no one should kill him, for the God

of this world (ὁ θεὸς τοῦδε τοῦ κόσμου) had not accepted his offering. This God reminds us very much of the “prince of this world” in St. John. Among the Peratics it was naturally the demiurge, the “father below” (πατὴρ κάτωθεν). See *Elenchos*, V, 16, 8f. (I.egge, I, p. 155f.).

692 “This is the father of all perfection.” * Ruska, *Tabula Smaragdina*, p. 2.

1 A Fiji Islander told Hocart: “Only the chief was believed in: he was by way of being a human god” (*Kings and Councillors*, p. 61). “We must always bear in mind that the king is the god or gods” (p. 104).

2 Pharaoh is the son of the Creator-god. “But at certain festivities the ‘son’ unites with the divine ‘father’ in the mystic fashion of the rite” (Jacobsohn, *Die dogmatische Stellung des Königs in der Theologie der alten Aegypter*, p. 46).

3 Amon, the Father-god, unites himself, for instance, with Thutmosis I, and then, as the father, begets the son with the Queen (Jacobsohn, p. 17). Or again, the King lives on after his death as “Horus, the son of Hathor” (p. 20). A pyramid text says of Pharaoh: “Merenre is the Great, the son of the Great; Nut gave him birth” (p. 26). The *ka-mutef* makes the Queen the mother of the god (p. 62). Similar ideas are suggested by the names of the Canaanite kings Adoni-bezek and Adoni-zedek, which indicate an identification with the divine son of Ishtar, Adonis. Frazer (*The Golden Bough*, Pt. IV, p. 17), from whom I take this observation, comments: “Adoni-zedek means ‘Lord of righteousness’ and is therefore equivalent to Mel-chizedek, that is ‘king of righteousness,’ the title of that mysterious king of Salem and priest of God Most High.”

4 Among the Fiji Islanders the king is called “the Prosperity of the Land.” “When the great chief, entitled the ‘Lord of the Reef is installed, they pray: . . . ‘Let the fields resound, the land resound . . . let the fish come to land; let the fruit trees bear; let the land prosper’” (Hocart, p. 61).

5 Frazer, *The Golden Bough*, Pt. III, p. 14ff. His death or sacrifice is followed by dismemberment. Classic examples are Osiris and Dionysus. Cf. Firmicus Maternus, *Liber de errore profanarum religionum* (Corp. Scrip. Eccl. Lat., II, p. 76): “. . . slew Osiris and tore him limb from limb, and cast forth the palpitating members of the wretched corpse along all the banks of the river Nile.”* The same author says (7,7) concerning Dionysus: “For the stories of the Greeks claim to relate Liber to the Sun . . . Who has seen the infant sun? who has beguiled it, who has slain it? who has torn it to pieces, who has cut it up, who has feasted on its members? . . . But this error also they seek to cover by a rational explanation, that of the undivided and divided mind, and thus too they think they can provide a reason for their worship.”* In this connection we might also mention the bull-god of the eleventh nome of Lower Egypt: he was called “The Divided One,” and in later times was associated with Osiris. For this reason the eleventh nome was tabooed. (Kees, *Der Götterglaube im alten Aegypten*, pp. 12 and 258).

6 Cf. Jacobsohn, pp. 17 and 46.

7 The dead king, resuscitated, is addressed as Amun, who drinks the milk of Isis (ibid., p. 41).

8 The god, the king, and his *ka* form, as it were, a trinity composed of father, son, and procreative force (ibid., p. 58).

9 To correspond with the 14 *kas* of Ra, statues of 14 of the king’s ancestors were carried at the processions. They were the previous royal incarnations of the father-god, who reproduced himself once more in the king (Jacobsohn, pp. 28, 32, 62, 67). Baynes says in this connection: “The safeguarding power of the continuity of tribal authority and tradition from earliest times is concentrated by means of mass-projection upon the person of the king. The distant heroic ancestors, the mighty figures of the mythic past are alive and present in the person of the king. He is the master symbol just because he is living history.” (“On the Psychological Origins of Divine Kingship,” p. 91.)

10 It should be noted that Typhon tore the slain Osiris into 14 parts. Plutarch says: “The dismemberment of Osiris into 14 parts refers allegorically to the days of the waning of that satellite from the time of the full moon to the new moon.” (“Isis and Osiris,” 18, *Moralia*, trans. by Babbitt, V. pp. 44f.) Jacobsohn calls attention to the genealogical

table of Jesus in Matthew 1 : 1ff. Verse 17 runs: “So all the generations from Abraham to David are fourteen generations; and from the carrying away into Babylon unto Christ are fourteen generations.” This construction is somewhat arbitrary out of consideration for the number 14. Of the 14 ancestors of Pharaoh, Jacobsohn says (p. 67): “The conscious intention to bring out the number 14 is clearly discernible each time.”

11 Jacobsohn, p. 38.

12 Jacobsohn stresses the homoousia of father, son, the king’s *ka*, and the *ka-mutef* (pp. 38, 45f., 58, 62). In elucidating the *ka-mutef* as prototype of the ἅγιον πνεῦμα he cites (p. 65) the answer to the fifty-third question in the Heidelberg Catechism: “[I believe] that he [the Holy Ghost] is at the same time eternal God with the Father and the Son. Likewise, that he is also vouchsafed to me” (as personal *ka*). Jacobsohn also refers to the anecdote about Christ in *Pistis Sophia*, where the Holy Ghost appears as Christ’s double (that is, as a proper *ka*). He enters the house of Mary, who at first mistakes him for Jesus. But he asks: “Where is Jesus my brother, that I may go to meet him?” Mary took him for a phantom and bound him to the foot of the bed. When Jesus came in, he recognized and embraced him, and they became one. (*Pistis Sophia*, ed. Schmidt, ch. 61, pp. 20ff. Cf. *Aion*, par. 131.)

13 *

14 Spiegelberg, “Der Gott Bait in dem Trinitätsamulett des Britischen Museums,” pp. 225ff.

15 For the complete series, see my “Psychology of the Transference.”

16 According to Berthelot, “Sophe” is a variant of “Cheops-Souphis.” He cites a passage from the résumé of Africanus (3rd cent.) in Eusebius: “King Souphis wrote a book, which I purchased in Egypt as a very valuable thing” (*Origines de l’aichimie*, p. 58).

17 Berthelot, *Alch. grecs*, III, xlii.* So in Codex Parisiensis 2327, fol. 251 (Berthelot, *Origines de l’alchimie*, p. 58).

18 The text has *παναφθόρων*, but the sense requires *παμφθόρων*. Berthelot accordingly translates as ‘corruptible’.

19 Berthelot, *Alch. grecs*, III, xlii, 1.

20 Naturally this is still true of alchemy in later times. Thus Khunrath (*Von hylealischen Chaos*, p. 338) defines the King as gold refined from silver.

21 Rex as synonym for the lapis: “The Philosophers’ stone . . . is the Chemical King” (“Aquarium sapientum,” *Mus. herm.*, p. 119; Waite, I, p. 103). In Lamspringk’s *Symbols* he is the perfected arcane substance:

“I have overcome and vanquished my foes,
I have trodden the venomous Dragon under foot,
I am a great and glorious King in the earth ...
Therefore Hermes has called me the Lord of the Forests.” *

(*Mus. herm.*, p. 358; Waite, I, p. 292.) “The Philosophers’ stone is the king descending from Heaven.” (“Consil. coniug.,” *Ars chemica*, p. 61.) In Hoghelande’s “De alchemiae difficultatibus” (*Theatr. chem.*, I, p. 162) there is a strange description of the stone as a “tall and helmeted man” (*homo galeatus et altus*); it is also a “king crowned with a red diadem.” In Mylius (*Phil. ref.*, p. 17) it is the “princely stone” (*princeps lapis*).

22 For a literal translation of the text see *Psychology and Alchemy*, par. 456.

23 Cf. the saying of Democritus, quoted in many variants: “Nature rejoices in nature, nature subdues nature, nature rules over nature.” The truth of this dictum receives remarkable confirmation in the psychology of the individuation

process.

24 P. 276.

25 Cf. the curious passage in *Distinctio XIV* of the “*Allegoriae sapientum*” (*Theatr. chem.*, V, p. 86): “For some say, the moistures are to be honoured, for they are high-minded kings that suffer not insult: be careful therefore with them and seek their good will, and they will give to thee with their eyes, that thou mayest have of them whatsoever thou wiliest.”*

26 A paraphrase for the retort as the place of rebirth.

27 *Amphitheatrum*, p. 202.*

28 *Ibid.*, p. 197.*

29 *Ibid.*, pp. 198f.

30 Colin Campbell, *The Miraculous Birth of King Amon-Hotep III*, p. 82: “The Coronation, which bestowed on the divine being, the king, the two crowns of Egypt, advanced him a step further than birth in the divine scale of life.”

31 *Ibid.*, pp. 83ff.: “The anniversary of the Coronation seems to have been held as a Sed festival, when the king was regarded as Osiris on earth.” “The king is not ‘dancing’ or striding in the presence of his Osiris-self, as if worshipping him . . . no, the striding is a movement in the ceremony, preparatory to his taking possession of the throne, which marks his complete Osirification—the last act of the Sed festival” (p. 94). Breasted (*Development of Religion and Thought in Ancient Egypt*, p. 39) says of the Sed festival: “One of the ceremonies of this feast symbolized the resurrection of Osiris, and it was possibly to associate the Pharaoh with this auspicious event that he assumed the role of Osiris.” On the significance of the Sed festival Frazer (*The Golden Bough*, Pt. IV, ii, p. 153) says: “The intention of the festival seems to have been to procure for the king a new lease of life, a renovation of his divine energies, a rejuvenescence.” One of the inscriptions at Abydos runs: “Thou dost begin to renew thyself, to thee it is granted to blossom forth again like the young moon-god, thou dost grow young again . . . Thou art reborn in the renewal of the Sed festival” (Moret, *Du caractère religieux de la royauté pharaonique*, pp. 255f.). The Sed festival was held every 30 years, probably in connection with the quarters of the 120-year Sirius (= Isis) period. This festival, it should be noted, was also connected with a ceremony for making the fields fruitful: the king circumambulated a marked-off field four times, accompanied by the Apis bull. (Kees, *Der Götterglaube im alten Ägypten*, pp. 296f.) Similar ceremonies are still performed today. Amenophis IV caused the Aton, the symbol of his religious reformation, to be introduced at his Sed festival (Kees, p. 372).

32 Printed in *Art. aurif.*, I, pp. 392ff.

33 The name “Anus” which occasionally occurs, and which one might connect with the king of the same name in the Grail legend, is a corruption of “Horus.” It is possible that the source for the “*Allegoria Merlini*” is the “*Prophetia Merlini*,” which was well known in the Middle Ages. Cf. Geoffrey of Monmouth, *Histories of the Kings of Britain* (Book 7, pp. 170ff.).

34 The verses of a certain Mercurinus are preserved in *Ros. phil.*, *Art. aurif.* (1610 edn.), II, pp. 242f.

35 The distillation of alcohol from wine was probably discovered at the beginning of the 12th cent. (Lippmann, *Entstehung und Ausbreitung der Alchemie*, II, p. 38.)

36 Its equivalent, the ὕδωρ θεῖον, can be translated either as ‘divine water’ or as ‘sulphur water,’ since θεῖον means both.

37 For instance in “Allegoriae sapientum” (*Theatr. chem.*, V, p. 67): “**And know** that it is the water which draweth forth what is hidden.” *

38 Jacobsohn, *Die dogmatische Stellung des Königs in der Theologie der alten Ägypter*, p. 11.

39 [Cf. Neumann, *The Origins and History of Consciousness*, pp. 69ff.]

40 The king who is imprisoned in the sea also belongs to this context. (Cf. Maier, *Symbolae aureae mensae*, p. 380.) See text in “Paracelsus as a Spiritual Phenomenon,” pars. 181ff.

41 *Aurora consurgens* II, in *Art. aurif.*, I, p. 196: “Beware of dropsy and the flood of Noah.” * (Cf. Ripley, *Opera omnia*, p. 69.)

42 Maier, p. 261: “The horse’s belly is a great secret: our dropsical patient concealeth himself therein, that he may be restored to health and may free himself of all water [in turning] towards the sun.” *

43 “So doth the old man sit in the bath, whom keep in a carefully sealed and closed vessel, until the visible Mercurius be invisible and hidden” (*Theatr. chem.*, III, p. 820). *

44 Cf. supra, pars. 74f.

45 Cf. *Aurora Consurgens*, pp. 97f.: “And to Naaman was it said: Go and wash seven times in the Jordan and thou shalt be clean. For there is one baptism for the remission of sins.” *

46 “O blessed form of sea-water, which dissolvest the elements” (Tractatus aureus,” *Ars chemica*, p. 20).*

47 *Theatr. chem.*, I, p. 266.

48 In Dorn “veritas” is synonymous with “sapientia,” as is shown by the passage that follows in the original text. There Truth says, “Come unto me, all ye who seek,” which is a slight rephrasing of Ecclesiasticus 24 : 19: “Come unto me, all ye who desire me.”

49 “Spec, phil.,” p. 271.

50 Dorn stresses the great importance of self-knowledge for the performance of the *opus alchymicum* in other places as well. For instance, on p. 307 he says: “Therefore man, heaven and earth are one thing, likewise air and water. If man knows how to transmute things in the greater world . . . how much more so in the microcosm, that is, in himself, if he know that the greatest treasure of a man exists within the man, and not outside him.” *

51 “Quid, non quis ipse sit” is an excellent formulation of the personalistic question Who? and of the impersonal and objective What? Quis refers to the ego, quid to the self. Cf. *Aion*, par. 252.

52 “Spec, phil.,” p. 272.

53 P. 273.*

54 P. 303.

55 *Theatr. chem.*, I, p. 449.

56 That is, alchemical or occult.

57 *Theatr. chem.*, I, p. 475.

58 It is also regarded as the supreme sin. Cf. Wegmann, *Das Rätsel der Sünde*, ch. 3.

59 The water signifies the *sponsa* (bride) and *dilecta* (beloved) as well as Sapientia. Cf. Ecclesiasticus 24 : 5, where Wisdom “walked in the bottom of the deep, in the waves of the sea,” and, as the love-goddess Ishtar, praises herself as a cedar, cypress, palm-tree, rose-plant, vine, etc. (13ff.).

60 “Spec. phil.,” *Theatr. chem.*, I, p. 266, where Sapientia holds a long discourse.

61 Cf. *Psychology and Alchemy*, Part III, ch. 5, and *Aion*, pars. 121ff.

62 The method of the physicians was an imitation of Typhon’s dismemberment of Osiris. Indeed, the king had already begun to drink his fill of Typhon’s sea, in order to dissolve himself in it. The second version of the Visio Arislei in *Ros. phil.* likewise contains a dismemberment into “indivisible particles,” but there it refers not to the king but to his son. His dismemberment takes place in the body of Beya, and thus represents a process of histolysis in the chrysalis state.

63 Further material in “Transformation Symbolism in the Mass,” pars. 353, 400.

64 Variants of the latter are: the king immersed or drowning in the sea, the “sterile king of the sea,” Mater Alchimia’s dropsy, etc. The motif of the drowned king goes back to Osiris. In the lament of Isis for her son in the daily ritual, she says: “I have crossed the seas to the bounds of the earth, seeking the place where my Lord was; I have traversed Nadit in the night; I have sought . . . him who is in the water . . . in that night of the great affliction. I have found the drowned one of the earth of aforetime . . .” (Moret, *Mystères égyptiens*, p. 24).

65 Concerning this separation see the Poimandres vision in the *Corpus hermeticum*, lib. I, 4: “. . . And I beheld a boundless vision: all was changed into a mild and joyous light, and I marvelled when I saw it. And in a little while, Darkness settled upon it, fearful and gloomy . . . And I saw the darkness changing into a watery substance, which was in great turmoil, and belched forth smoke as from a fire. And I heard it making an indescribable sound of lamentation; for there came forth from it an inarticulate cry, as it were a cry for light. But from the light there arose above the watery substance a holy Word, that one might hear it; a voice and pure fire and a spiritual Word (*πνευματικὸν λόγον*).” (Cf. Scott, *Hermetica*, I, pp. 114ff. and Mead, *Thrice-Greatest Hermes*, II, pp. 4f.) The separation of the four elements from the dark chaos then follows. (The text is corrupt, so I have translated it literally.) Concerning the “cry,” cf. the drowning king’s cry for help in Maier, *Symb. aur. mensae*, p. 380.

66 Ruland, *Lexicon*, pp. 281, 283.

67 *Opera omnia chemica* (Cassel, 1649), pp. 421ff. [Like all Ripley’s works, the *Cantilena* did not appear in print until the middle of the 17th cent., long after his death. It was written in Latin and consists of 38 four-line stanzas (rhymed *aaaa*). Latin texts, which vary somewhat, appear in MSS. Ashmole 1394, pp. 67, 75; 1445, VIII, 2; 1479, 223, and English translations in MS. Ashmole 1445, VIII, pp. 2–12, 41–44, all dating from the 16th cent, and now at the Bodleian. The former of these translations (rhymed *aabb*), by an unknown hand, and entitled “George Ripley’s Song,” has been used here as a basis for the verses which follow. It was first published by F. Sherwood Taylor in *Ambix* (II, nos. 3 and 4, Dec. 1946). With the assistance of Mr. A. S. B. Glover, I have attempted to bring certain phrases in the *Ambix* version somewhat closer to the original Latin and hence to the prose translation made by Professor Jung in the Swiss edition of the *Mysterium*, and some of the verses have been recast. The Latin text given in the footnotes follows that of the Cassel edition throughout.—TRANS.]

68 “En philosophantium in hac cantilena

Summa arcana concino voce cum amoena,

Quae mentalis jubili pullulat a vena,

Et mens audientium fit dulcore plena.

“In extremis partibus nuptiis Mercurii

Accidit post studium semel quod interfui,
Ubi vescens epulis tam grandis convivii
Ignorata primitus haec novella didici.

“Quidam erat sterilis Rex in genitura,
Cujus forma nobilis et decora pura
Extitit, sanguineus erat hic natura,
Attamen conqueritur sua contra jura.

“Rex caput corporum quare sum ego,
Sterilis, inutilis sine prole dego,
Cuneta tamen interim mundana ego rego,
Et terrae nascentia quaeque, quod non nego.

“Causa tamen extitit quaedam naturalis
Vel defectus aliquis est originalis;
Quamvis sine maculis alvi naturalis
Eram sub solaribus enutritus alis.”

69 De *chemia*, p. 38: “It is the male which without wings is under the female, but the female has wings. Wherefore they said: Cast the female upon the male, and the male shall ascend upon the female.” *

70 “Ex terrae visceribus quoque vegetantur
Suis in seminibus, et qua animantur
Congruis temporibus fructu cumulantur,
Speciebus propriis et multiplicantur.

“Mea sed restringitur fortiter natura
Quod de meo corpore non fluit tinctura,
Infoecunda igitur mea est natura
Nee ad actum germinis multum valitura.”

71 Khunrath (*Hyl. chaos*, p. 268): “From the belly of Saturn’s salt flow living waters leaping up to blessed life.” (Cf. John 7 : 38: “... out of his belly shall flow rivers of living water.”) Saturn’s salt is the sapientia Saturni, the white dove hidden in the lead.

72 In *Numeros homiliae*, 17, 4 (Migne, *P.G.*, vol. 12, col. 707).

73 See fig. 150 in *Psychology and Alchemy*. Origen, In *Exodum homiliae*, 11, 2 (Migne, *P.G.*, vol. 12, col. 376) says of Christ: “Unless this rock had been smitten, it had not given water.” *

74 *Commentarius in Cantica Canticorum*, 1 (Migne, *PL.*, vol. 15, col. 1860). Dora (“Spec, phil.,” *Theatr. chem.*, I, p. 267) says: “Sweet is the ringing voice and grateful to the ears of them that philosophize! O inexhaustible fountain of riches to them that thirst after truth and justice! O solace to the want of them that are desolate! What more do ye seek, ye anguished mortals? Why, poor wretches, do you trouble your spirits with infinite cares? What madness is it, pray,

that blinds you? seeing that all that you seek outside yourselves and not within yourselves is within you and not without you.” *

75 Ambrose, *Explanatio Psalmorum XII* (ed. Petschenig, p. 337). In *Epistolae*, XLV, 3 (Migne, *PL.*, vol. 16, col. 1142) he says: “That real paradise is not an earthly and visible one, it is not in any place, but in ourself, and it is quickened and vivified by the powers of the soul and the inpouring of the spirit.” *

76 Rahner, “Flumina de ventre Christi,” p. 289.

77 “Massa mei corporis semper est mansura

Valde delectabilis atque satis dura,

Hancque, cum examinat ignis creatura,

Nulla mei ponderis abest caritura.

“Meque mater genuit sphaericae figurae

Domi, quod rotunditas esset mini curae.

Foremque prae ceteris speciei purae,

Et assistens regibus dignitatis jura.”

78 “Modo tamen anxia illud scio verum

Nisi fruar protinus ope specierum,

Generare nequeo, quia tempus serum

Est et ego stupeo antiquus dierum.”

79 Cf. the printer’s apology in the Introduction to *Aurora consurgens* II (*Art. aurif.*, I, p. 183), cited in *Psychology and Alchemy*, par. 464.

80 “In immunditia huius mundi, in stercore.”

81 Son of Basilides the Gnostic.

82 Further material in *Psychology and Alchemy*, pars. 522f. and n. 22.

83 Poema 25, Migne, *PL.* vol. 61, col. 637. Further material in Curtius, *European Literature and the Latin Middle Ages*, pp. 103ff.

84 Ephraem Syrus, *Hymni et sermones*, II, col. 620.*

85 *Ibid.*, I, col. 136.*

86 Nelken. “Analytische Beobachtungen über Phantasien eines Schizophrenen,” pp. 538ff.

87 Rahner, “Die Gottesgeburt,” pp. 341ff.

88 [The Swiss edition (II, p. 26, n. 85) has here “I heard that I should be reborn through Christ’s Tree.” This is based on the reading “Christi sed arbore” in line 2 of verse 11, which proves to be an error in transcription. The Cassel edition of the *Cantilena* (1649, and there appears to be no other) shows (p. 422) “Christi sed ab ore” (by Christ’s mouth), in this agreeing with the 16th cent. Latin and English MSS. at the Bodleian. Since pars. 36–39 of the Swiss text are mainly concerned with the “arbor philosophica” mentioned elsewhere in Ripley’s writings, they are here omitted with the author’s consent.—TRANS.]

89 “Me praedatum penitus iuventutis flore

Mots invasit funditus Chiisti sed ab ore
Me audivi coelitus grandi cum stupore
Renascendum denuo nescio quo araore.

“Regnum Dei aliter nequeo intrare
Hinc ut nascar denuo me humiliare
Voló matres sinibus meque adaptare
In primam materiam et me disgregare.”

90 “Ad hoc mater propria regem animavit
Eiusque conceptui sese acceleravit,
Quem statim sub chlamyde sua occultavit
Donee eum iterum ex se incarnavit.”

91 Cf. Diodorus, *Bibliothèque Historique*, 4, 39 (trans. by Oldfather, II, pp. 468f.)

92 Nebo corresponds to the planet Mercury.

93 Roscher, *Lexikon*, III, 1, col. 62, s.v. Nebo.

94 Senior, *De chemia*, p. 63.

95 *Ibid.*, p. 63.*

96 The “thalamus” refers to the mystic marriage. See *infra*, the “green lion.”

97 “Mirum erat ilico cerneré connexum
Factura naturaliter primum ad complexum,
Foedere complacito ad utrumque sexum
Penitus post aeris montana transvexurn,

“Mater tunc ingreditur thalamum pudoris
Et sese in lectulo collocat honoris,
Inter linteamina plenaque candoris
Signa statim edidit futuri languoris.

“Moribundi corporis virus emanabat,
Quod maternam faciem candidam foedabat,
Hinc a se extraneos cunctos exserebat
Ostiumque camerae firme sigillabat.

“Vescebatur interim carnibus pavonis
Et bibebat sanguinem viridis leonis
Sibi quem Mercurio telo passionis
Ministrabat aureo scypho Babylonis.”

98 The sequence of alchemical operations is arbitrary in its details and varies from author to author.

99 Hoghelande seems to suggest something of the sort when he says that “colours appear on the surface of the mercury” (*Theatr. chem.*, I, p. 150).

100 Cf. *supra*, par. 6, n. 26.

101 *Theatrum Chemicum Britannicum*, p. 54.

102 “This thing . . . maketh the colours to appear sporadically” * (*Turba*, Sermo XIII, lines gff.). “This, therefore, is the stone which we have called by all manner of names, which receiveth and drinketh the work, and out of which every colour appeareth” * (*ibid.*, lines 24f.). Similarly Mylius (*Phil. ref.*, p. 119): “All the colours of the world shall be manifested.” *

103 *Theatr. chem.*, I, p. 179.

104 “An earthly manifestation of the quintessence you may behold in the colours of the rainbow, when the rays of the sun shine through the rain.” * “Gloria mundi,” *Mus. herm.*, p. 251 (*Wake*, I. p. 202).

105 “... the pupil of the eye and Iris (rainbow) in the sky.” (Olympiodorus, in Berthelot, *Alch. grecs*, II, iv, 38.)*

106 *Elenchos*, V. 9 (cf. Legge trans., I, p. 143).

107 Abu’l Qāsim Muhammad, *Kitāb al-Urn al-muktasab* (ed. Holmyard), p. 23.

108 *Phil. ref.*, p. 121.

109 “In fine quadrangulari,” i.e., at the synthesis of the four elements.

110 *Theatr. chem.*, V, p. 881.

111 Cf. Berthelot, *Alch. grecs*, Introduction, p. 76. Also *infra*, par. 577.

112 P, 95: “He who shall raise up his soul shall see its colours.” *

113 *Citrinitas* = the choleric temperament, *rubedo* = the sanguine, *albedo* = the phlegmatic, *nigredo* = the melancholic. (“*Harmonia chemica*,” *Theatr. chem.*, IV, p. 873.)

114 “*Phil. chem.*,” *Theatr. chem.*, I, p. 485.

115 Cf. *Psychology and Alchemy*, pars. 212, 262, and “A Study in the Process of Individuation,” pars. 564ff. (Picture 5).

116 Cf. the naive prayer of the author in *Amphitheatrum sapientiae*, p. 221: “I beseech thee with all my heart, that thou wilt send me from thy holy heavens Ruach-Hokhmah-El, the Spirit of thy Wisdom, that it may ever be beside me as a familiar, may skilfully govern me, wisely admonish me and teach me; may be with me and pray with me and work with me; may give me right will and knowledge and experience and ability in physical and physico-medical matters.” * The learned Dr. Khunrath would no doubt have been delighted to have the Holy Ghost as a laboratory assistant.

117 Cf. Fig. IV in the Appendix to *Amphitheatrum*.

118 *Ibid.*, p. 202.

119 The emphasis is thus on the green colour.

120 “... and a rainbow was upon his head, and his face was as the sun.”

121 *Mus. herm.*, p. 693 (*Waite*, II, p. 194).

122 *Ibid.*, p. 694. It is worth pointing out that a remarkable change occurs during the regimen Martis: whereas in the regimen Veneris the stone, the material to be transformed, is “put into another vessel,” in the regimen Martis we are

told that “The mother, being now sealed in her infant’s belly, swells and is purified, and because of the great . . . purity of the compound, no putridity can have place in this regimen . . . Know that our Virgin Earth here undergoes the last degree of cultivation, and prepares to receive and mature the fruit of the sun.” * It is interesting that in this regimen the maternal substance is enclosed in the belly of its own child. These are transformations that could be expressed only in terms of the operation of *yin* and *yang*. Cf. the *I Ching* (Book of Changes).

123 Cf. Cassiodorus, *Expositio in Cantica Canticorum* (Migne, *P.L.*, vol. 70, cols. 1071, 1073, 1096).

124 Ruland, *Lexicon*, p. 126, s.v. Digestio: “A change of any substance into another by a process of natural coction.”

125 *Mus. herm.*, p. 131 (Waite, I, p. 111). The text continues: “All which things are of good omen: namely that a man so troubled shall nonetheless in due time reach the blessed and greatly desired conclusion, as also the Holy Scripture itself witnesseth, wherein it is written (II Tim. 3 : 12), that all those who desire to live godly in Christ Jesus shall suffer persecution, and that it is through many tribulations and straits that we must enter the kingdom of Heaven.” *

126 Latin MS, 18th cent., “Figurarum Aegyptiorum sectetioium,” fol. 5 (author’s possession).

127 “Congeries Paracelsicae,” *Theatr. chem.*, I, p. 599.

128 Honorius of Autun, *Speculum de mysteriis ecclesiae* (Migne, *P.L.*, vol. 172, col. 936) says of the phoenix: “The phoenix is said to be red, and is Christ, of whom it is written: Who is this that cometh from Edom, with dyed garments from Bosra?” * (Cf. Isaiah 63 : 2: “Wherefore an thou red in thine apparel, and thy garments like him that treadeth in the winefat?” * Also verse 3: “. . . and their blood shall be sprinkled upon my garments.”) Honorius continues: “Edom, which means red, is the name given to Esau, from the red pottage with which he was fed by Jacob his brother.” * After relating the myth of the phoenix Honorius adds: “On the third day the bird is restored, because on the third day Christ was Taised again by the Father.” *

129 *Elenchos*, X, 14, 1 (Legge, II, p. 159).*

130 *Zoological Mythology*, II, p. 323 (mod.).

131 In order to hatch its eggs, the peacock seeks a lonely and hidden spot. Picinellus adds: “And assuredly solitude, the only recipe for preserving a spiritual disposition, offers the fullest occasion for inner felicity.” *

132 I take this statement from Picinellus, as I was unable to ascertain which *Merula* is meant.

133 *Mundus Symbolicus*, I, p. 316.

134 *City of God*, XXI, 4 (trans. by Healey, II, p. 322): “Who was it but God that made the flesh of a dead peacock to remain always sweet, and without any putrefaction?” In the *Cyranides* the peacock is accounted “a most sacred bird.” Its eggs are useful in preparing the gold colour. “When the peacock is dead, its flesh does not fade nor emit a foetid smell, but remains as if preserved with aromatic substances.” * Its brain can be used to prepare a love-potion. Its blood, when drunk, expels demons, and its dung cures epilepsy. (Delatte, *Textes latins et vieux français relatifs aux Cyranides*, p. 171.)

135 In China (cf. the treatise of Wei Po-yang, in *Isis*, XVIII, p. 258) the nearest analogy is the “fluttering Chu-Niao,” the scarlet bird; it has five colours, symbolizing totality, corresponding to the five elements and the five directions. “It is put into the cauldron of hot fluid to the detriment of its feathers.” In Western alchemy the cock is plucked, or its wings are clipped, or it eats its own feathers.

136 Ripley himself takes blood as synonymous with spirit: “The spirit or blood of the green lion” (*Opera omnia*, p. 139). In Rosencreutz’s *Chymkal Wedding* (p. 74) the lion holds a tablet with the inscription: “Hermes the Prince.

After so many wounds inflicted on humankind, here by God's counsel and the help of the Art flow I, a healing medicine. Let him drink me who can: let him wash who will: let him trouble me who dare: drink, brethren, and live."

*

137 Cf. the parallel of the opus with the Mass in *Psychology and Alchemy*, pars. 480ff., and "Transformation Symbolism in the Mass," pars. 339ff.

138 Cf. Mylius, *Phil. ref.*, p. 303, where he says that Mercurius is the green lion and "is the whole elixir of the *albedo* and the *rubedo*, and the *aqua permanens* and the water of life and death, and the virgin's milk, the herb of ablution [an allusion to the Saponaria, Berissa, and moly], and the fountain of the soul: of which who shall drink does not die, and it takes on colour and is their medicine and causes them to acquire colours, and it is this which mortifies and desiccates and moistens, makes warm and cool, and does contrary things," etc.* In short, Mercurius is the master-workman and the artifex. Therefore Mylius proceeds with the winged word: "And he is the dragon who marries himself and impregnates himself, and brings to birth in due time, and slays all living things with his poison." * (Usually he is said to "slay himself," too, and to "bring himself to life.") The uroboros has the wonderful quality of "aseity" (existence by self-origination) in common with the Godhead, for which reason it cannot be distinguished from him. This *aqua permanens*, unlike the ambiguous *ὕδωρ θεῖον*, is explicitly "divine." We can therefore understand the solemn exhortation in Dorn ("Spec. phil.," *Theatr. chem.*, I, p. 299): "Draw nigh, O Body, to this fountain, that with thy Mind thou mayest drink to satiety and hereafter thirst no more after vanities. O wondrous efficacy of this fount, which maketh one of two, and peace between enemies! The fount of love can make *mind* out of spirit and soul, but this maketh *one man* of mind and body. We thank thee, O Father, that thou hast deigned to make thy sons partakers of thy inexhaustible fount of virtues. Amen." *

139 The extraction of the soul from the prima materia is equivalent to the *mortificatio*. Then, in the *impraegnatio*, *informatio*, *impressio*, *imbibitio*, *cibatio*, etc., the soul returns to the dead body, and this is followed by its resuscitation or rebirth in a state of incorruptibility.

140 The best instances of this interconnection of everything with everything else can be found in dreams, which are very much nearer to the unconscious even than myths.

141 The "Liber Platonis quattorum," which dates from the 10th cent., cites blood as a solvent (*Theatr. chem.*, V, p. 157), and says also that a particularly strong solvent is lion's dung (p. 159).

142 Cf. the treatise of Wei Po-yang (pp. 231ff.), where *yin* and *yang* are the "charioteers" who lead from the inside to the outside. The sun is *yang*, the moon *yin* (p. 233). Our western image of the uroboros is expressed in the words: "*Yin* and *yang* drink and devour one another" (p. 244); "*Yang* donates and *yin* receives" (p. 245), and, in another form: "The Dragon breathes into the Tiger and the Tiger receives the spirit from the Dragon. They mutually inspire and benefit" (p. 252). As in western alchemy Mercurius duplex is designated "orientalis" and "occidentalis," so in China the dragon (*yang*) reigns over the East and the Tiger (*yin*) over the West. "The way is long and obscurely mystical, at the end of which the Ch'ien (*yang*) and the K'un (*yin*) come together" (p. 260).

143 Cf.n. 138.

144 See the illustration in Lambspringk's *Symbols, Mus. herm.*, p. 349 (Waite, I, p. 283).

145 That is to say, the "flying lion" is equated with Mercurius, who, in turn, consists of the winged and wingless dragon. Cf. Flamel, "Summarium philosophicum," *Mus. herm.*, p. 173 (Waite, I, p. 142).

- 146 Mylius, *Phil, ref.*, p. 190.
- 147 Emotional outbursts usually occur in cases of insufficient adaptation due to unconsciousness.
- 148 Maier, quoting Lully, says: “Some have called this earth the green lion mighty in battle; others the serpent that devours, stiffens, and mortifies his own tail” * (*Symb. aur. mensae*, p. 427).
- 149 See n. 148.
- 150 “But no unclean body enters, with one exception, which is commonly called by the philosophers the green Lion.” * (Maier, p. 464, and Ripley, *Opera omnia*, p. 139)
- 151 Maier (p. 427) adds: “because the earth is depopulated of its spirits.” *
- 152 Ibid.
- 153 *Medium coniungendi tincturas inter solem et lunam.*” (Maier, p. 464, Ripley, *Opera omnia*, p. 139.)
- 154 *Chymische Schrifften*, pp. 248f.
- 155 *Mus. herm.*, p. 219 (Waite, I, p. 178).*
- 156 Further evidence for the lion as the arcane substance can be found in “Consil. coniugii” (*Ars chemica*, p. 64), where the lion signifies the “aes Hermetis” (bronze of Hermes). Another synonym for the lion is “vitrum” (glass), which on account of its transparency was also a symbol for the soul. (Cf. Caesarius of Heisterbach, *Dialogue on Miracles*, I.32 and IV.39 (trans. by Scott and Bland, I, pp. 42 and 237.) So, too, in Morienus, who counts the lion among the three substances that have to be kept secret. (“De transmut. metallica,” *Art. aurif.*, II, pp. 51f.) *Ros. phil.* (*Art. aurif.*, II, p. 229) says: “In our green Lion is the true material . . . and it is called Adrop, Azoth, or the green Duenech.” *
- 157 The red lion is probably a later equivalent of sulphur ruboum (from the time of Paracelsus, it would seem). Mylius (*Phil, ref.*, p. 209, and Schema 23, p. 190) equates the two lions with red and white sulphur.
- 158 Khunrath, *Hyl. Chaos*, p. 325.
- 159 “Clavis maioris sapientiae” (*Theatr. chem.*, IV, p. 238). The treatise is probably of Harranite origin.
- 160 Paris Magic Papyrus, line 1665 (Preisendanz, *Pap. Graec. Magic*, I, p. 126.) The lion is emblematic of the 6th hour.
- 161 Ventura, *Theatr. chem.*, II, p. 289.
- 162 Contact with wild nature, whether it be man, animal, jungle or swollen river, requires tact, foresight, and politeness. Rhinoceroses and buffaloes do not like being surprised.
- 163 Wieland, *Dschinistan, oder auserlesene Feen- und Geistermärchen*.
- 164 As in Apuleius the ass regains his human shape by eating roses, so he does here by eating a lily. In the Paris Magic Papyrus the ass is the solar emblem of the 5th hour.
- 165 Also with the griffin, camel, horse, and calf. (*Theatr. chem.*, I, p. 163.)
- 166 Dorn, “Spec, phil.,” *Theatr. chem.*, I, p. 301.
- 167 *Sermo in Dominica in Palmis* (Migne, *P.L.*, vol. 172, col. 916): “The devil is also called Dragon and lion.”
- 168 Eleazar (Abraham the Jew) mentions that the doves of Diana rouse the sleeping lion. Cf. *Uraltes Chymisches Werck*, Part I, p. 86.

169 *Mus. herm.*, p. 654. “Si voto tuo cupis potiri” might mean rather more than this, since “votum” also means “vow.”

170 Revelation 17 : 5: “Mystery, Babylon the great, the mother of harlots and abominations of the earth.”

171 Presumably two or three miles from the city. “Summarium philosophicum,” *Mus. herm.*, p. 173 (Waite, I, p. 142).

172 Mentioned in the Arabic texts as Marqūš, king of Egypt. Cf. Ruska, *Tabula Smaragdina*, p. 57.

173 “The stone which he who knows, places on his eyes.” *

174 “Et hic lapis, quem diligit Leo, est foemina.”

175 Cf. my “Synchronicity: An Acausal Connecting Principle,” pars. 949ff.

176 Considering, that is to say, that time is psychically relative, as the ESP experiments have shown. Cf. the writings of J. B. Rhine.

177 I am aware of the problematical nature of this conception. But those who know the material will admit that it is no easy task to express this subtle but very important difference in conceptual terms. In actual practice the difference is immediately apparent, since, compared with personal contents, the products of the non-ego often have the quite specific character of “revelation,” and are therefore felt as being inspired by an alien presence, or as perceptions of an object independent of the ego. Archetypal experiences often have a numinous effect and for that reason are of the greatest importance in psychotherapy.

178 As this discussion started with the concept of Leo, I would like to draw the reader’s attention to Bruno Goetz’s novel *Das Reich ohne Raum* (1919). Goetz gives an excellent description of that feverish atmosphere, which ends with the sorcerer shrinking down a pair of lovers and putting them in a glass phial. This erotic fever seems to be connected with Leo, for a passage in the “Lion Hunt” runs: “His mother said to him: O Marchos, must this fire be lighter than the heat of fever? Marchos said to her: O mother, let it be in the state of fever. I return and enkindle that fire” *—the fire in the pit that serves Leo as a bridal bed. (Cf. Senior, *De chemia*, p. 63.)

179 *Mus. herm.*, pp. 653f. (Waite, II, p. 166).

180 In Abu’l Qasim (Holmyard, pp. 419f.) Venus is nicknamed “the noble, the impure, the green lion, the father of colours, the peacock of the Pleiades, the phoenix.”

181 *Mus. herm.*, pp. 30f. (Waite, I, pp. 31f.). Quotation from Basilus Valentinus.

182 The contradiction between *meretrix* and *sponsa* is of very ancient origin: Ishtar, the “beloved” of the Song of Songs, is on the one hand the harlot of the gods (the “hierodule of heaven,” Belli, the Black One), but on the other hand she is the mother and virgin. (Wittekindt, *Das Hohe Lied*, pp. 11f., 17, 24.) Unperturbed by the identity of the arcane substance with Venus, which he himself asserts, Khunrath (*Hyl. Chaos*, p. 62) calls the mother of the lapis a virgin and a “generado casta” (chaste generation). Or again, he speaks of the “virgin womb of Chaos” (p. 75), inspired less by Christian tradition than by the insistence of the archetype, which had already prompted the same statements about Ishtar. Mother, daughter, sister, bride, matron, and whore are always combined in the anima archetype.

183 Concerning the rose, see *infra*, pars. 419f.

184 The richness of Venus’s colours is also praised by Basilus Valentinus in his treatise on the seven planets (*Chymische Schrifften*, p. 167). Cf. *supra*, par. 140, n. 124.

- 185 *Mus. herm.*, p. 399 (Waite, I, p. 330).
- 186 D'Espagnet, *Bibliotheca Chemica*, II, p. 653.
- 187 *Symb. aur. mensae*, p. 178.
- 188 D'Espagnet, *Arcanum Hermeticae philosophiae opus* (1653), p. 82.
- 189 "Venus, however, precedes the Sun, since she is eastern." * Sermo 67 (ed. Ruska), p. 166.
- 190 *Theatr. chem.*, I, p. 883. The magnesia is also called "aphroselinum Orientis," the moonstone of the East (ibid., p. 885).
- 191 Her classical cognomen is "armata." According to Pernety (*Diet, mytho-her- métique*, p. 518) Venus is bound to Mars by a fire which is of the same nature as the sun. Cf. the bull-slaying Venus with the sword in Lajard, *Recherches sur leculte de Vénus*, Pl. IXff.
- 192 *Chymische Schrifften*, pp. 73f. Cf. infra, par. 547.
- 193 The text continues: "And in the fire you will see an emblem of the great Work: black, the peacock's tail, white, yellow, and red." * *Mus. herm.*, p. 683 (Waite, II, p. 186).
- 194 Obscenely described in Figulus, *Rosarium novum Olympicum*, I, p. 73.
- 195 The androgynous Venus is a very ancient prototype. Cf. Lajard, "Mémoire sur une représentation figurée de la Vénus orientale androgyne," likewise his *Recherches sur le culte de Vénus*, Pl. I, no. 1.
- 196 *Chymische Schrifften*, p. 62.
- 197 *Hyl. Chaos*, p. 91.
- 198 Ibid., p. 233. Other synonyms are *Sal Veneris*, *Vitriolum Veneris*, *Sal Saturni*, *leo rubeus et viridis*, *sulphur vitrioli*. They are all the *scintilla animae mundi*, the active principle that manifests itself in powerful instincts. Cf. Khunrath, *Hyl. Chaos*, p. 264.
- 199 Mylius, *Phil, ref.*, p. 17.
- 200 See Grimm's fairytale of the "Spirit in the Bottle," cited in my "The Spirit Mercurius," par. 239.
- 201 Berthelot, *Alch. grecs*, V, vii, 18 and 19.
- 202 Berthelot, *Chimie au moyen âge*, III, pp. 61ff.
- 203 "The Spirit Mercurius," par. 278.
- 204 *Art. aurif.*, I, p. 318.*
- 205 This is also suggested by the mysterious passage in Dorn: "Seek your lion in the East and the eagle to the South in taking up this work of ours . . . you should direct your way to the south; so shall you obtain your desire in Cyprus, of which nothing more may be said." * ("Congeries Paracelsicae," *Theatr. chem.*, I, p. 610.) For the alchemists Cyprus is definitely associated with Venus. In this connection I would also refer to Dorn's commentary on the *Vita longa* of Paracelsus, discussed in my "Paracelsus as a Spiritual Phenomenon." It is concerned with the "characteristics of Venus" in Paracelsus, which Dorn interprets as the "shield and buckler of love" (ibid., par. 234).
- 206 The idea of the rose-coloured blood seems to go back to Paracelsus: "Therefore I say to you (saith Paracelsus) . . ." (Dorn, *Theatr. chem.*, I, p. 609).
- 207 *Hyl. Chaos*, pp. 93 and 196.

208 On p. 276 he speaks of the “rose-coloured blood and aethereal water that flowed from the side of the Son of the Great World.”

209 Figulus (*Rosarium novum Olympicum*, Part 2, p. 15) says: “I will not forbear to admonish thee not to reveal to anyone, however dear, the treasure of our secrets, lest the stinking goats browse upon the red and white roses of our rose-garden.”

210 “The white rose is completed in summer-time in the East”* (Mylius, *Phil. ref.*, p. 124).

211 See *infra*, par. 485.

212 “Aquarium sapientum,” *Mus. herm.*, p. 118 (Waite, I, p. 103).

213 “Gloria Mundi,” *Mus. herm.*, p. 218 (Waite, I, p. 178): “... how the garden is to be opened, and the noble roses are to be seen in their field.” *

214 Cf. “rosy Paphian,” “rose-hued Aphrodite,” “rose-hued Cyprian,” etc. (Bruchmann, *Epitheta Deorum quae apud poetas Graecos leguntur*, s.v. Aphrodite, pp. 65, 68).

215 **κόκκινος**, *coccineus*. Cf. Rev. 17 : 4f.

216 Isaiah 1 : 18: “... though your sins be as scarlet, they shall be as white as snow; though they be red like crimson, they shall be as wool.”

217 In keeping with these associations, the adulterous queen in Wieland’s alchemical fairytale was changed into a pink goat.

218 “Antichrist shall be born in great Babylon of a whore of the tribe of Dan. He will be filled with the devil in his mother’s womb and brought up by witches in Corozain” * (Migne, *P.L.*, vol. 172, col. 1163).

219 “Like to the rose that blooms in the midst of the thorns that enclose it,

So are the pleasures of love never unshared with its gall.” *

(Georgius Camerarius, cited in Picinellus, *Mundus Symbolicus*, I, pp. 665f.)

220 “Consil. coniugii,” *Ars chemica*, p. 220.*

221 *In Matth. Homiliae*, 72 (73) (Migne, *P.G.*, vol. 57–58, col. 739).*

222 *Treatises on Marriage and Remarriage*, trans. by Le Saint, pp. 78f.*

223 This pun is permissible, since one of the synonyms for the *aqua permanens* is “urina puerorum.”

224 Dorn (“Spec. Phil., “*Theatr. chem.*, I, p. 271) writes: “Whoever wishes to learn the alchemical art, let him learn not the philosophy of Aristotle, but that which teaches the truth . . . for his teaching consists entirely in amphibology, which is the best of all cloaks for lies. When he censured Plato and others for the sake of gaining renown, he could find no more commodious instrument than that which he used for his censure, namely amphibology, attacking his writings on the one hand, defending them by subterfuge on the other, and the reverse; and this kind of sophistry is to be found in all his writings.” *

225 For the alchemists the world was an image and symbol of God.

226 Mercurius is also an “archer.”

227 “Impraegnata igitur graviter languebat

Certe novem mensibus in quibus madebat

Fusis ante lachrymis quam parturiebat

Lacte manans, viridis Leo quod sugebat.”

228 *Cherubinischer Wandersmann*, III, 11.

229 “Eius tunc multicolor cutis apparebat
Nunc nigra, nunc viridis, nunc rubea fiebat,
Sese quod multoties sursum erigebat
Et deorsum postea sese reponebat.”

230 “Centum et quinquaginta noctibus languebat
Et diebus totidem moerens residebat,
In triginta postmodum rex reviviscebat,
Cuius onus vernulo flore redolebat.”

231 “Ejus magnitudine primo coaequatus
Venter in millecuplum crevit ampliatus,
Ut super principio suo sit testatus
Finis perfectissime ignibus probatus.
“Erat sine scopulis thalamus et planus,
Et cum parietibus erectus ut manus
Prolongatus aliter sequeretur vanus
Fructus neque filius nasceretur sanus.”
“Stufa subtus lectulum erat collocata,
Una atque alia artificiata
Erat super lectulum valde temperata
Membrana frigescerent ejus delicata.
“Eratque cubiculi ostium firmatum,
Nulli praebens aditum suum vel gravatum,
Et camini etiam os redintegratum
Ab inde ne faceret vapor evolutum.”

232 [*IllHam* could also refer to *tetredo*, ‘foulness.’—TRANS.]

233 *Spirificare* = *spiram facere*, ‘to make a coil, wind like a snake.’ *Spiritum facere* does not seem to me credible. *Sine coeli polis* (without the poles of heaven) is probably put in to fill up the line, and means no more than that this process does not take place in heaven but in the *cucurbita*.

234 “Postquam computruerunt ibi membra prolis
Carneae tetredinem deponebat molis,
Illam Lunae similans sine coeli polis
Postquam spirificans in splendorem Solis.”

235 *Mutus liber*. Luna is shown in Pl. 5, and Sol or Phoebus Apollo in Pl. 6.

236 *Supra*, pars. 19ff., 172f.

237 As I have shown earlier, the alchemists thought the conjunction of the new moon was something sinister. Cf. particularly the “viperinus conatus” of the mother (supra, par. 14), a parallel of the early death of the mythological sun-god.

238 “Sic cum tempus aderat mater suum natum
Prius quem conceperat, edidit renatum.
Qui post partum regium repetebat statum,
Possidens omnimodum foetum coeli gratum.

“Lectus matris extitit qui quadrangularis
Post notata témpora fit orbicularis,
Cuius cooperculum formae circularis
Undequaque candeat fulgor ut Lunaris.”

239 Cf. *Psychology and Alchemy*, par. 116.

240 Ibid., par. 338.

241 “Lecti sic quadrangulus factus est rotundus
Et de nigro maximo albus atque mundus
De quo statim prodiit natus rubicundus
Qui resumpsit regium sceptrum laetabundus.”

242 “Hinc Deus paradysi portas reseravit,
Uti Luna candida ilium decoravit,
Quam post ad imperii loca sublimavit
Soleque ignivomo digne coronavit.”

243 Angelus Silesius (*Cherub. Wandersmann*, III, 195) says of Sapientia:

“As once a Virgin fashioned the whole earth,
So by a Virgin it shall have rebirth.”

244 That the Church has not done everything it might have been expected to do in regard to the doctrine of the Holy Ghost was a remark made to me spontaneously by Dr. Temple, the late Archbishop of Canterbury. For the psychological aspect of the doctrine of the Holy Ghost see “Dogma of the Trinity,” pars. 234ff.

245 This conclusion is quite obvious in Angelus Silesius.

246 Cf. the magnificent sermon on the text “When all things were in the midst of silence” (Wisdom of Solomon 18 : 14) in Meister Eckhart (trans. by Evans, I, p. 3): “Here in time we make holiday because the eternal birth which God the Father bore and bears unceasingly in eternity is now born in time, in human nature. St. Augustine says this birth is always happening. But if it happen not in me what does it profit me? What matters is that it shall happen in me. We intend therefore to speak of this birth as happening in us, as being consummated in the virtuous soul; for it is in the perfect soul that God speaks his Word . . . There is a saying of the wise man: ‘When all things were in the midst of silence, then leapt there down into me from on high, from the royal throne, a secret Word.’”

247 *Cherub. Wandersmann*, II, 101–104.

248 The critical passages are: “And thus God the Father gives birth to his Son, in the very oneness of the divine nature. Mark, thus it is and in no other way that God the Father gives birth to his Son, in the ground and essence of the soul, and thus he unites himself with her.” “St. John says: ‘The light shineth in the darkness; it came unto its own and as many as received it became in authority sons of God; to them was given power to become God’s sons.’” (Trans. by Evans, I, pp. 5 and 9.)

249 “Elementis quatuor Deus insignita

Arma tibi contulit decenter polita,

Quorum erat medio virgo redimita

Quae in quinto circulo fuit stabilita.”

250 Hegemonius, *Acta Archelai* (ed. Beeson), p. 10: “When the good father knew that darkness had come upon his earth, he brought forth from himself the virtue [or strength] which is called the mother of life, wherewith he surrounded the first man. These are the five elements, wind, light, water, fire, and matter; and clothed therewith, as preparation for war, he came down to fight against the darkness.” *

251 See *Psychology and Alchemy*, figs. 64, 82, 114.

252 Ibid., pars. 499, 505f., fig. 208.

253 “In our vessel the Passion is enacted,” says Mylius (*Phil, ref.*, p. 33). The motif of torture can be found in the visions of Zosimos. Cf. “Transformation Symbolism in the Mass,” pars. 344ff., 410f. and “The Philosophical Tree,” chs. 17 and 18.

254 The eagle represents the next-higher stage of transformation after Leo. The lion is a quadruped and still earthbound, whereas the eagle symbolizes spirit.

255 “Et unguento affluit haec delicioso

Expurgala sanguine prius menstruoso

Radiabat undique vultu luminoso

Adornata lapide omni pretioso.

“Ast in eius gremio viridis iacebat

Leo, cui aquila prandium ferebat;

De leonis latere cruor effluebat,

De manu Mercurii, quem Virgo bibebat.

“Lac, quod mirum extitit, ilia propinabat

Suis de uberibus, quod leoni dabat.

Eius quoque faciem spongia mundabat,

Quam in lacte proprio saepe madidabat.

“Illa diademate fuit coronata

Igneoque pedibus aere ablata

Et in suis vestibis splendide stellata,

Empyreo medio coeli collocata.

“Signis, temporibus et ceteris planetis,
Circumfusa, nebulis tenebrosis spretis,
Quae, contextis crinibus in figuram retis,
Sedit, quam luminibus Rex respexit laetis.”

256 [Cf. Curtius, *James Joyce und sein Ulysses*.]

257 *Hexastichon Sebastiani Brant in memorabiles evangelistarum figuras* (1502). See our Pls. 1 and 2.

258 One of my critics includes me among the “smelters,” on the ground that I take an interest in the psychology of comparative religion. This description is justified in so far as I have called all religious ideas *psychic* (though their possible transcendental meaning is something I am not competent to judge). That is to say, I maintain that there is a relationship between Christian doctrine and psychology—a relationship which in my view need not necessarily turn out to the disadvantage of the former. My critic betrays a singular lack of confidence in the assimilating power of his doctrine when he deprecates with horror this incipient process of fusion. The Church was able to assimilate Aristotle despite his essentially alien way of thinking, and what has she not taken over from pagan philosophy, pagan cults, and—last but not least—from Gnosticism, without poisoning herself in the process! If Christian doctrine is able to assimilate the fateful impact of psychology, that is a sign of vitality, for life is assimilation. Anything that ceases to assimilate dies. The assimilation of Aristotle warded off the danger then threatening from the Arabs. Theological critics should remember these things before launching purely negative attacks on psychology. It is no more the intention of the psychologist than it was of the alchemist to disparage in any way the significance of religious symbols.

259 “Fit hie Regum omnium summus triumphator,
Et aegrorum corporum grandis mediator,
Omnium defectuum tantus reformator,
Illi ut obedient Caesar et viator.

“Praelatis et regibus praebens decoramen,
Aegris et invalidis fit in consolamen.
Quis est quem non afficit huius medicamen,
Quo omnis penuriae pellitur gravamen.”

260 *Ars chemica*, ch. III, p. 22.

261 “Introitus apertus,” *Mus. herm.*, p. 654 (Waite, II, p. 167).

262 *Mus. herm.*, p. 96 (Waite, I, p. 86).

263 Cf. “Rosinus ad Sarrat.,” *Art. aurif.*, I, p. 281: “Then he touches the ferment with the prepared imperfect body, as it is said, until they become one in body, figure, and appearance, and then it is called the Birth. For then is born our stone, which is called king by the Philosophers, as it is said in the *Turba*: Honour our king coming out of the fire, crowned with a diadem.” *

264 *Mus. herm.*, pp. 654f. (Waite, II, p. 167).*

265 And ye shall see the *iksir* [elixir] clothed with the garment of the kingdom.” * *Turba* (ed. Ruska), p. 147.

266 “The stone of the Philosophers is the king descending from heaven, and his hills are of silver, and his rivers of gold, and his earth precious stones and gems” * (*Ars chemica*, p. 61).

267 *Phil, ref.*, p. 10.

268 *Ibid.*, p. 284. Cited in *Ros. phil. (Art. aurif.*, II, p. 329) as a quotation from Lully. A similar quotation in *Ros. phil.* (p. 272) is attributed to Ortulanus and Arnaldus: “Because the soul is infused into the body and a crowned king is born.” * On p. 378 *Ros. phil.* cites an “Aenigma Hermetis de tinctura rubea”: “I am crowned and adorned with a diadem and clothed with kingly garments; for I cause joy to enter into bodies.” * The “Tractatulus Avicennae” (*Art. aurif.*, I, p. 422) says: “Despise not the ash, for God will grant it liquefaction, and then finally by divine permission the king is crowned with a red diadem. It behoves thee therefore to attempt this magistry.” *

269 *Hyl. Chaos*, pp. 236f.

270 *Ibid.*, pp. 286f. Cf. the passage from *Amphitheatrum*, p. 197 (supra, par. 355, n. 28).

271 “Illius species” = a piece of the king, as it were, who is now suddenly a substance.

272 The “multiplicado” often means a spontaneous renewal of the tincture, comparable to the widow’s cruse of oil. Mylius (*Phil, ref.*, p. 92) lays down the following rule: “Project therefore on any body as much of it as you please, since its Tincture shall be multiplied twofold. And if one part of it in the first place converts with its bodies a hundred parts: in the second it converts a thousand, in the third ten thousand, in the fourth a hundred thousand, in the fifth a million, into the true sun-making and moon-making (substance).” *

273 “Nostrum Deus igitur nobis det optamen

Illius in speciem per multiplicamen,

Ut gustemus practicae per regeneramen

Eius fructus, uberes et ter dukes. Amen.”

274 Cf. the king’s bath in Bernardus Trevisanus, supra, pars. 74f. For a detailed parable see the “Tractatus aureus de lapide,” in *Mus. herrn.*, pp. 41ff. (Wake, I, pp. 41ff).

275 *Art. aurif.*, I, pp. 146ff.

276 *Mus. herm.*, p. 654 (Wake, II, p. 167).

277 *Symb. aur. mensae*, p. 380: “And although that king of the philosophers seems dead, yet he lives, and cries out from the deep: He who shall deliver me from the waters and bring me back to dry land, him will I bless with riches everlasting. But although that cry is heard by many, yet are none near at hand to be moved with compassion for the king and to seek him. For who, say they, will plunge into the sea? Who will relieve another’s danger at the cost of his own? For few there are who credit his lamentation and they think the voice they hear to be the loud cries and echoes of Scylla and Charybdis. So they stay idle at home, and have no care for the king’s treasure nor for his safety.”* Cf. *Psychology and Alchemy*, pars. 434ff.

278 Possibly a reference to Psalm 69 : 2f.: “I sink in deep mire, where there is no standing; I am come into deep waters, where the floods overflow me. I am weary of crying, my throat is dried; mine eyes fail while I wait for my God.” Verse 14f.: “Deliver me out of the mire, and let me not sink; let me be delivered from them that hate me, and out of the deep waters. Let not the waterflood overflow me, neither let the deep swallow me up, and let not the pit shut her mouth upon me.”

279 *Splendor Solis: Alchemical Treatises of Solomon Trismosin*, pp. 29f. See also *Psychology and Alchemy*, fig. 166.

280 The true antimony of the philosophers [lies] in the deep sea, that the son of the king may lurk submerged” * (*Symb. aur. rnensae*, p. 380).

281 Ibid., p. 378, referring to *The Triumphal Chariot of Antimony* of Basilius Valentinus, which, it seems, was first published in German in 1604. The Latin edition appeared later, in 1646. See Schmieder, *Geschichte der Alchemie*, p. 205.

282 Pars. 434ff.

282a p. 133.

283 *Panarium* (ed. Holl), Haer. 36, cap. 4 (II, pp. 47ff.).

284 *Ancoratus* (ed. Holl), vol. I, p. 20.

285 Ibid., pp. 104f.

286 See *Psychology and Alchemy*, figs. 10–12, 46, 47.

287 Cf. “The Spirit Mercurius,” par. 269 and n. 41, and “Paracelsus as a Spiritual Phenomenon,” par. 182, n. 61.

288 P. 195, “the son of one (HIS) day; wherein are warm, cold, moist and dry.” The Mercurial Serpent “giving birth in a single day,” however, is mentioned in “De lapide philosophorum” of Albertus Magnus (*Theatr. chem.*, IV, pp. 98f). See *infra*, pars. 712 and 718. Cf. also *Das Buch der Alaune und Salze* (ed. Ruska), pp. 58f.

289 As regards the Saturn/lead equation, it should be noted that although astrologically Saturn is a malefic planet of whom only the worst is expected, he is also a purifier, because true purity is attained only through repentance and expiation of sin. Thus Meister Eckhart says in his sermon on the text, “For the powers of heaven shall be shaken” (Luke 21 : 26): “Further we must note how (God) has decked the natural heavens with seven planets, seven noble stars which are nearer to us than the rest. The first is Saturn, then comes Jupiter, then Mars, and then the Sun; after that comes Venus, and then Mercury, and then the Moon. Now when the soul becomes a spiritual heaven, our Lord will deck her with these same stars spiritually, as St. John saw in his Apocalypse when he espied the King of Kings seated upon the throne of the majesty of God, and having seven stars in his hand. Know that the first star, Saturn, is the purger . . . In the heaven of the soul Saturn becomes of angelic purity, bringing as reward the vision of God, as our Lord said, ‘Blessed are the pure in heart for they shall see God.’” (Evans, I, p. 168.) It is in this sense that Saturn should be understood here. Cf. Vigenerus (“De igne et sale,” *Theatr. chem.*, VI, p. 76): “Lead signifies the vexations and troubles wherewith God visits us and brings us back to repentance. For as lead burns up and removes all the imperfections of metals, for which reason Boethus the Arab called it the water of sulphur, so likewise tribulation in this life cleanses us from the many blemishes which we have incurred: wherefore St. Ambrose calls it the key of heaven.” *

290 Song of Songs 2 : 2.

291 *Natural History*, X, ii (trans. by Rackham, III, p. 294).*

292 *The Apostolic Constitutions*, V, 7 (trans. by Smith and others, p. 134).

293 *Onirocriticon*, lib. IV, cap. 47.

294 *Catecheses Mystagogicae*, XVIII, 8 (ed. Reischl and Rupp, II, pp. 307ff.).

295 *De Excessu fratris*, lib. II, cap. 59 (ed. Faller, p. 281), and *Hexaameron*, V, cap. 23 (Migne, *P.L.*, vol. 14, col. 238).

296 *De subtilitate*, p. 602.

297 The fact that the myth was assimilated into Christianity by interpretation is proof, first of all, of the myth's vitality; but it also proves the vitality of Christianity, which was able to interpret and assimilate so many myths. The importance of hermeneutics should not be under-estimated: it has a beneficial effect on the psyche by consciously linking the distant past, the ancestral heritage which is still alive in the unconscious, with the present, thus establishing the vitally important connection between a consciousness oriented to the present moment only and the historical psyche which extends over infinitely long periods of time. As the most conservative of all products of the human mind, religions are in themselves the bridges to the ever-living past, which they make alive and present for us. A religion that can no longer assimilate myths is forgetting its proper function. But its spiritual vitality depends on the continuity of myth, and this can be preserved only if each age translates the myth into its own language and makes it an essential content of its view of the world. The *Sapientia Dei* which reveals itself through the archetype always ensures that the wildest deviations shall return to the middle position. Thus the fascination of philosophical alchemy comes very largely from the fact that it was able to give new expression to nearly all the most important archetypes. Indeed, as we have seen already, it even tried to assimilate Christianity.

298 Numerous examples of these parallels can be found in Picinellus, *Mundus Symbolicus*, I, pp. 322ff.

299 Cf. the edition of his *Hieroglyphica* in Caussin, *De Symbolica Aegyptorum sapientia* (1618), p. 142.

300 *The Hieroglyphics of Horapollo* (trans. by Boas), p. 75 (Book I, No. 34).

301 Ibid., p. 96 (Book II, No. 57): "For when this bird is born, there is a renewal of things." *

302 Likewise Col. 1 : 20, and in a certain sense Rom. 8 : 19ff.

303 "Today shalt thou be with me in paradise."

304 According to the dogma, Christ descended with his body into limbo.

305 These speculations belong to the 17th cent., whereas Khunrath wrote in the 16th cent. See the article by M. Lauterburg on Christ's descent into hell in Herzog and Hauck, *Realenzyklopaedie für protestantische Theologie*, VIII, p. 204.

306 Cf. the aforementioned "Onus," which is identical with the phoenix and shares its display of colours. In his excerpts from Epiphanius Caussin cites: "The bird phoenix is more beautiful than the peacock; for the peacock has wings of gold and silver, but the phoenix of jacinth and emerald, and adorned with the colours of precious stones: she has a crown upon her head" * (*Symb. Aegypt. sap.*, p. 142).

307 Vulgate: "Factumque est vespere et mane, dies unus."

308 Gen. 1 : 2: "And darkness was upon the face of the deep." Cf. Boehme ("Tabulae principiorum," I, 3, in *De signatura rerum*, Amsterdam edn., p. 271), who calls darkness the first of the three principles.

309 John 8 : 12: "I am the light of the world."

310 Among the Valentinians (Irenaeus, *Adversus haereses*, I, 5, 1) the demiurge and king of all things who was created by Achamoth was called the "Father-Mother"—an hermaphrodite. Similar traditions may have been known to the alchemists, though I have found no trace of any such connections.

311 The alchemical figures, especially the gods of metals, should always be thought of astrologically as well.

312 [The first edition was published at Venice (1666) with the title *Lux obnubilata suapte natura refulgens*; the French edition (1687), which contains the Italian poem at pp. 3ff., is cited below: poem in the text, Crasselame's

commentary in the foot-notes. Crasselame was the pseudonym of Otto Tachenius. Grateful acknowledgment is made to Professor Charles Singleton for the prose translation of the Italian verses.—EDITORS.]

313 “It establishes a twofold motion in Mercurius, one of descent and the other of ascent, and as the former serves to give form to the materials by means of the rays of the sun and of the other stars which by their nature are directed towards lower bodies, and by the action of its vital spirit to awaken the natural fire which is as it were asleep in them, so the movement of ascent serves naturally to purify the bodies.” (P. 112) The first descent *comes* within the story of the Creation and is therefore left out of account by most of the alchemists. Accordingly, they begin their work with the ascent and complete it with the descent, whose purpose is to reunite the freed soul (the *aqua permanens*) with the dead (purified) body, thus bringing the *filius* to birth.

314 “From it goes forth Splendour, from its light Life, from its movement Spirit” (p. 113).

315 Cf. “The Spirit Mercurius,” par. 283, and *Psychology and Alchemy*, pars. 430ff. Crasselame was influenced by Paracelsus. He identifies his Mercurius with the “Illiastes”; cf. “Paracelsus as a Spiritual Phenomenon,” pars. 160, 168, n. 62, 170ff. and n. 10.

316 The “Epístola ad Hermannum” (*Theatr. chem.*, V, p. 900) says of the lapis: “it ascends of itself, blackens, descends and whitens, grows and diminishes . . . is born, dies, rises again, and thereafter lives forever.” *

317 Examples are Trophonios in his cave (Rohde, *Psyche*, trans. Hillis, p. 105, n. 12) and Erechtheus in the crypt of the Erechtheion (p. 98). The heroes themselves often have the form of snakes (p. 137), or else the snake is their symbol (p. 290, n. 105). The dead in general are frequently depicted as snakes (p. 170). Like the “hero” of alchemy, Mercurius, another ancient alchemical authority, the Agathodaimon, also has the form of a snake.

318 Cf. the snake-boat of Ra in the underworld (Budge, *The Egyptian Heaven and Hell*, I, pp. 66, 86). The snake-monster *par excellence* is the Apep-serpent (Budge, *The Gods of the Egyptians*, I, p. 269). Its equivalent in Babylonia is Tiamat (I, p. 277). The Book of the Apostle Bartholomew (Budge, *Coptic Apocrypha in the Dialect of Upper Egypt*, p. 180) says with reference to the resurrection of Christ: “Now Abbaton, who is Death, and Gaios, and Tryphon, and Ophiath, and Phthinon, and Sotomis, and Komphion, who are the six sons of Death, wriggled into the tomb of the Son of God on their faces, in the form of serpents.” Budge comments (intro., p. Ixiii): “In the Coptic Amente lived Death with his six sons, and in the form of a seven-headed serpent, or of seven serpents, they wriggled into the tomb of the Lord to find out when his body was going to Amente. The seven-headed serpent of the Gnostics is only a form of the serpent of Nau . . . and the belief in this monster is as old at least as the 6th dynasty.” The “seven Uraei of Amente,” mentioned in the Book of the Dead (ch. 83) are probably identical with the “worms in Rastau, that live upon the bodies of men and feed upon their blood” (Papyrus of Nektu-Amen). When Ra stabbed the Apep-serpent with his lance, it threw up everything it had devoured (Budge, *Osiris and the Egyptian Resurrection*, I, p. 65). This is a motif which recurs in the primitive whale-dragon myths. Generally the hero’s father and mother come up with him out of the monster’s belly (cf. *Symbols of Transformation*, par. 538, n. 85), or everything that death had swallowed (par. 310). It is clear that this motif is a préfiguration of the apocatastasis on a primitive level.

319 Rev. 20 : 2. Honorius of Autun, *Speculum de misteriis ecclesiae* (Migne, P.L., vol. 172, col. 937): “The seven-headed dragon, the prince of darkness, drew down from heaven with his tail a part of the stars, and covered them over with a cloud of sins, and drew over them the shadow of death.” *

320 Isaiah 38 : 10: “... in the cutting off of my days I shall go to the gates of hell” (AV/DV).

321 Job 17 : 13f.: "... the grave is mine house: I have made my bed in the darkness. I have said to corruption, Thou art my father; to the worm, Thou art my mother and my sister." Job 21 : 26: "They shall lie down alike in the dust, and the worms shall cover them."

322 Niedner, *Thule, II*, p. 39.

323 Grimm, *Teutonic Mythology* (trans. by Stallybrass), IV, p. 1540.

324 Cf. Nietzsche, *Thus Spake Zarathustra* (trans. by Common), p. 121: "When did ever a dragon die of a serpent's poison?" says Zarathustra to the snake that had bitten him. He is a hero of the race of dragons, for which reason he is also called the "stone of wisdom" (p. 205).

325 Cf. Lucian's story of Alexander the mountebank, who produced an egg with Asklepios inside it. ("Pseudomantis," 12, in *Works*, I, pp. 144ff.)

326 Brugsch, *Religion und Mythologie der alten Ägypter*, pp. 103f.

327 It is astonishing to see how alchemy made analogous use of the same images: the opus is a repetition of the Creation, it brings light from the darkness (*nigredo*), the lapis is "one," it is produced in the form of *puer*, *infans*, *puellus*, and can be multiplied indefinitely.

328 The worm stands for the most primitive and archaic form of life from which ultimately developed the direct opposite of the earth-bound creature—the bird. This pair of opposites—snake and bird—is classical. The eagle and serpent, the two animals of Zarathustra, symbolize the cycle of eternal return. "For thine animals know well, O Zarathustra, who thou art and must become: behold, thou art the teacher of the eternal return" (*Thus Spake Zarathustra*, p. 264). Cf. the "ring of return" (p. 273) and "alpha and omega" (p. 275). The shepherd into whose mouth the serpent crawled is also connected with the idea of eternal return (pp. 207f.). He forms with the snake the circle of the uroboros. "The circle did not evolve: it is the primary law" (Aphorism 29 in Horneffer, *Nietzsches Lehre von der Ewigen Wiederkunft*, p. 78). Cf. also the teaching of Saturninus that the angels first created a man who could only crawl like a worm. (Irenaeus, *Adv. haer.*, I, XXIV, 1.) As Hippolytus remarks (*Elenchos*, VII, 28, 3), because of the weakness of the angels who created him, man "grovelled like a worm."

329 Cf. *Psychology and Alchemy*, fig. 217. There is also an indirect hint of this in the hanging up of the snake on a tree. Cf. the alchemical myth of Cadmus (*supra*, pars. 84ff.), and *Psychology and Alchemy*, fig. 150.

330 Honorius of Autun, *Spec. de myst. eccl.* (Migne, P.L., vol. 172, col. 915).

331 Migne, P.L., vol. 51, col. 833.

332 Cf. *Symbols of Transformation*, pars. 572ff.

333 Cf. *supra*, par. 146; also "Paracelsus as a Spiritual Phenomenon," par. 182.

334 This is another quotation, namely from Psalm 21 : 7 (DV). It is interesting that this psalm begins with the words: "My God, my God, why hast thou forsaken me?" an indication that the transformation of the King of Glory into the least of his creatures is felt as abandonment by God. The words are the same as Matthew 27 : 46: "Eli, Eli, lama sabachthani."

335 *Elenchos*, V, 8, 18 (Legge, I, p. 134).*

336 *Ancoratus*, 45 (ed. Holl, p. 55).

337 *Mus. Herm.*, pp. 117f.

338 "Assatus." The word was used by the alchemists to denote the roasting of the ore.

339 The fire of divine wrath” suggests Boehme’s “divine wrath-fire.” I do not know whether there is direct connection between them. In our treatise God’s wrath, falling upon Christ, turns against God himself. Boehme discusses this question in “Aurora” (*Works*, I), VIII, 20ff., pp. 62ff., and *Quaestiones theosophicae* (Amsterdam edn., 1682, pp. 3, 11ff), and says that on the one hand the wrath-fire comes from the “dryness,” one of the seven “qualities” of Creation, and on the other hand it is connected with the first principle of “divine revelation,” the darkness (Gen. 1 : 2), which “reaches into the fire” (“*Tabula principiorum*,” I, pp. 2ff.). The fire is hidden in the centre of the light as well as in all creatures, and was kindled by Lucifer.

340 The rose-coloured tincture brings Christ into connection with the lion. (Cf. *supra*, pars. 419f.)

341 We have an amusing example of this tendency in Dom Pernety (*Les Fables égyptiennes et grecques*), who demonstrates the alchemical nature of ancient mythology without seeing that this was the matrix from which the alchemical ideas arose.

342 *Elenchos*, VII, 27, 4f. (Legge, II, p. 78).

343 Cf. *Psychology and Alchemy*, par. 451.

344 Cf. Leisegang, *Der heilige Geist*, pp. 78f.

345 Wei Po-yang, “An Ancient Chinese Treatise on Alchemy,” p. 241.

346 Cf. the Anthropos doctrine in Zosimos. (*Psychology and Alchemy*, par. 456.)

347 P. 251.

348 It is highly remarkable that there should be an Anthropos doctrine in China, where the basic philosophical assumptions are so very different.

349 Who, *nota bene*, is not to be confused with the ego.

350 A reverse process set in during the 17th cent., exemplified most clearly in Boehme. (The “*Aquarium sapientum*” represents the critical point between the two.) After that, the dogmatic figure of Christ began to predominate and enriched itself with alchemical ideas.

351 As Morienus (*Art. aurif.*, II, p. 18) says: “For the entry into rest is exceeding narrow, and no man can enter therein save by affliction of the soul.” *

352 “There is in our chemistry a certain noble substance, which moves from lord to lord” * (Maier, *Symb. aur. mensae*, p. 568). “*Verus Mercurii spiritus*” and “*sulphuris anima*” are parallels to dragon and eagle, king and lion, spirit and body (*Mus. herm.*, p. 11). The “*senex-draco*” must be reborn as the king (*Verus Hermes*, p. 16). King and Queen are represented with a dragon’s tail (Eleazar, *Uraltes Chymisches Werck*, pp. 82ff.). There, on p. 38, it is said that a black worm and dragon come from the king and queen in the *nigredo*. The worm *Phyton* sucks the king’s blood (p. 47).

353 Since the alchemical symbols are saturated with astrology, it is important to know that the chief star in Leo is called *Regulus* (“little king”) and that the Chaldaeans regarded it as the lion’s heart (Bouché-Leclercq, *L’Astrologie grecque*, pp. 438f.). *Regulus* is a favourable sign at the birth of kings. “*Cor*” (heart) is one of the names of the arcane substance. It signifies “fire, or any great heat” (Ruland, *Lexicon*, p. 114).

354 Cf. *Psychology and Alchemy*, fig. 4, top left. Also the inscription in *Pandora* (ed. Reusner), p. 227: “Kill the lion in his blood.” The symbol derives from Senior (*De chemia*, p. 64).

355 See the eagle with the head of a king consuming his feathers in the Ripley Scrowle: *Psychology and Alchemy*, fig. 228.

356 So far I have found no reference to Dante in any of the texts.

357 Berthelot, *Alch. grecs*, II, iv, 28.

358 It is difficult to explain why the constellation Ophiuchos (Anguitenens, Serpentarius, the Serpent-Holder) is called a demon. Astronomically speaking he stands on Scorpio and is therefore connected astrologically with poison and physicians. And indeed, in the ancient world he signified Asklepios (Roscher, *Lexikon*, VI, cols. 921f.). Hippolytus (*Elenchos*, IV, 47, 5ff.) states that whereas the constellation Engonasi (The Kneeler) represents Adam and his labours, and hence the first creation, Ophiuchos represents the second creation or rebirth through Christ, since he prevents the Serpent from reaching the Crown (*στέφανος. corona borealis*, the Wreath of Ariadne, the beloved of Dionysus). (Cf. Bouché-Leclercq, p. 609, n. 1.) This interpretation does not fit in badly with the “saviour” Asklepios. But since, according to the ancients, snake-charmers are born under this constellation, a nefarious connotation may have crept in (also, perhaps, through the “poisonous” Scorpio).

359 *Μόλυβδος*, another name for the arcane substance.

360 An allusion to Matthew 13 : 31: “The kingdom of heaven is like to a grain of mustard seed.”

361 “Unionis simplicitas” refers probably to the doctrine of the “res simplex,” signifying the Platonic “Idea.” “The simple is that which Plato calls the intelligible, not the sensible.” “The simple is the unexpected part,” it is “indivisible” and “of one essence.” The soul is “simplex.” “The work is not brought to perfection unless it ends in the simple.” “The conversion of the elements to the simple.” “Man is the most worthy of living things and nearest to the simple, and this because of his intelligence.” Quotations from “Liber Platonis quattorum,” *Theatr. chem.*, V, pp. 120, 122, 130, 139, 179, 189.*

362 Cf. “Spec, phil.,” *Theatr. chem.*, I, p. 298: “They found the virtue [power] of it [truth] to be such, that it performed miracles.”* (Cf. also “Phil, chemica,” *Theatr. chem.*, I, pp. 497 and 507.)

363 “Physica Trismegisti,” *Theatr. chem.*, I, p. 433.

364 *Ibid.*, p. 434.

365 The centre, therefore, cannot be simply God (the “One”), since only in man can it be attacked by disease.

366 “De tenebris contra naturam,” *Theatr. chem.*, I, pp. 530f.*

367 Cf. “The Spirit Mercurius.”

367a *Turba*, Sermo XLVII, p. 152.* (Another reading for “veterum” is “et unientem.”)

368 *Ibid.*, p. 149.

369 “The devil seeking to erect them [the horns] into heaven, and being cast down therefrom, attempted thereafter to infix them in the mind of man, namely, ambition, brutality, calumny, and dissension.” * (“De tenebris contra naturam,” *Theatr. chem.*, I, p. 531.)

370 Likewise the “Aquarium sapientum,” *Mus. herm.*, p. 129 (Waite, I, p. 110) says: “Man is placed by God in the furnace of tribulation, and like the Hermetic compound he is troubled at length with all kinds of straits, divers calamities and anxieties, until he die to the old Adam and the flesh, and rise again as in truth a new man.” *

371 Here the author refers to Wisdom of Solomon, ch. 5, obviously meaning verses 3 and 4: “... These are they whom we had some little time in derision and for parable of reproach. We fools esteemed their life madness and their

end without honour” (DV). He also mentions Job 30, where verse 10 would be relevant: “They abhor me and flee far from me, and are not afraid to spit in my face.”

372 Genesis 8 : 6: Noah sent forth the raven after 40 days. Gen. 7 : 7: rising of the flood. Gen. 7 : 4: “I will rain upon the earth forty days and forty nights.” Luke 4 : 1f: “Jesus . . . was led by the Spirit into the wilderness, being forty days tempted of the devil.” Exodus 34 : 28: Moses was with the Lord forty days and forty nights. Deut. 8 : 2: The children of Israel wandered forty years in the wilderness.

373 *Mus. herm.*, p. 130 (Waite, I, p. 111).*

374 “An Ancient Chinese Treatise on Alchemy,” p. 238. Cf. the motif of torture in “Transformation Symbolism in the Mass,” pars. 345ff., 410f.

375 *Hyl. Chaos*, pp. 186f.

376 Instead of “tristitia” the usual synonym for the nigredo is “melancholia,” as in “Consil. coniugii” (*Ars chemica*, pp. 125f.): “Melancholia id est nigredo.”

377 *Ars chemica*, p. 14.

378 Cf. James, *The Apocryphal New Testament*, p. 367.

379 Bousset, *Hauptprobleme der Gnosis*, pp. 58ff.

380 The coincidence of the apotheosis of the king with the birth of Christ is indicated in D’Espagnet, *Arcanum Hermeticae philosophiae opus*, p. 82: “But lastly, [the opus] comes to an end in the other royal throne of Jove, from which our most mighty king shall receive a crown adorned with most precious rubies. ‘Thus in its own footsteps does the year revolve upon itself.’” *

381 The anima mediates between consciousness and the collective unconscious, just as the persona does between the ego and the environment. Cf. *Two Essays on Analytical Psychology*, pars. 305ff., 339, 507.

382 Pars. 107f. and n. 38, 116. Cf. “Transformation Symbolism in the Mass,” pars. 366ff.

383 Cf. Albertus Magnus, “Super arborem Aristotelis” (*Theatr. chem.*, II, p. 527): “The stork sat there, as if calling itself the circle of the moon.” * The stork, like the swan and goose, has a maternal significance.

384 “Exercit. in Turbam,” *Art. aurif.*, I, p. 181.*

385 *Ibid.*, p. 180.

386 The primitive assertion that the individual has a plurality of souls is in agreement with our findings. Cf. Tylor, *Primitive Culture*, I, pp. 391ff.; Schultze, *Psychologie der Naturvölker*, p. 268; Crawley, *The Idea of the Soul*, pp. 235ff.; and Frazer, *Taboo and the Perils of the Soul*, pp. 27 and 80, and *Balder the Beautiful*, II, pp. 221ff.

387 Cf. *Psychology and Alchemy*, figs. 27, 57, 257.

388 *Ibid.*, fig. 149.

389 The phase of the conflict of opposites is usually represented by fighting animals, such as the lion, dragon, wolf, and dog. Cf. Lambspringk’s *Symbols in the Musaeum hermeticum*.

390 Cf. *Psychology and Alchemy*, pars. 520ff.

391 *Ibid.*, pars. 38, 56ff.

392 In late antiquity Pan was no longer a grotesque pastoral deity but had taken on a philosophical significance. The Naassenes regarded him as one of the forms of the “many-formed Attis” (*Elenchos*, V, 9, 9) and as synonymous with

Osiris, Sophia, Adam, Korybas, Papa, Bakcheus, etc. The story of the dirge is in Plutarch, “The Obsolescence of Oracles,” 17 (*Moralia*, V, pp. 401ff.). (Cf. “Psychology and Religion,” par. 145). Its modern equivalent is Zarathustra’s cry “God is dead!” (*Thus Spake Zarathustra*, p. 67).

393 “In the midst of the Chaos a small globe is happily indicated, and this is the supreme point of junction of all that is useful for this quest. This small place, more efficient than all the entirety, this part which comprises its whole, this accessory more abundant than its principal, on opening the store of its treasures, causes the two substances to appear which are but a single one. . . . Of these two is composed the unique perfect, the simple abundant, the composite without parts, the only indivisible hatchet of the sages, from which emerges the scroll of destiny, extending evenly beyond the Chaos, after which it advances in ordered fashion to its rightful end.” (“Recueil stéganographique,” *Le Songe de Poliphile*, II, f.) In these words Béroalde de Verville describes the germ of unity in the unconscious.

394 Because of his fiery nature, the lion is the “affective animal” *par excellence*. The drinking of the blood, the essence of the lion, is therefore like assimilating one’s own affects. Through the wound the lion is “tapped,” so to speak: the affect is pierced by the well-aimed thrust of the weapon (insight), which sees through the motive for the affect. In alchemy, the wounding or mutilation of the lion signifies the subjugation of concupiscence.

395 Thus Morienus (7th-8th cent.) states: “This thing is extracted from thee, for thou art its ore; in thee they find it, and, to speak more plainly, from thee they take it; and when thou hast experienced this, the love and desire for it will be increased in thee. And thou shalt know that this thing subsists truly and beyond all doubt” * (*Art. aurif.*, II, p. 37).

396 In Freud this is done by making conscious the repressed contents; in Adler, by gaining insight into the fictitious “life-style.”

397 This sentence needs qualifying as it does not apply to all conflict situations. Anything that can be decided by reason without injurious effects can safely be left to reason. I am thinking, rather, of those conflicts which reason can no longer master without danger to the psyche.

398 There were, nevertheless, some who would have liked to have the Holy Ghost as a familiar during their work. (See *supra*, n. 116.)

*[For par. 518a. inadvertently omitted at this point in the first edition, see *supra*, p. vii.]

399 Cf. the *solificatio* in the Isis mysteries: “And a garland of flowers was upon my head, with white palm-leaves sprouting out on every side like rays; thus I was adorned like unto the sun, and made in the fashion of an image” (*The Golden Ass*, trans. by Adlington, pp. 582f.).

400 Consciousness consists in the relation of a psychic content to the ego. Anything not associated with the ego remains unconscious.

401 This ever-repeated psychological situation is archetypal and expresses itself, for instance, in the relation of the Gnostic demiurge to the highest God.

402 The conjunction symbolism appears in two places: first, at the descent into the darkness, when the marriage has a nefarious character (incest, murder, death); second, before the ascent, when the union has a more “heavenly” character.

403 Cf. Oxyrhynchos Fragment 5 (discovered 1897): “Jesus saith, Wherever there are (two), they are not without God, and wherever there is one alone, I say, I am with him. Raise the stone, and there thou shalt find me; cleave the

wood, and there am I.” (Grenfell and Hunt, *New Sayings of Jesus*, p. 38.) The text is fragmentary. See Preuschen, *Antilegomena*, p. 43.

404 Particularly in the *Turba*.

405 Cf. the androgynous statue in the form of a cross, in Bardesanes.

406 As late as Boehme, Adam was described as a “male virgin.” Cf. “Three Principles of the Divine Essence” (*Works*, I), X, 18, p. 68, and XVII, 82, p. 159. Such views had been attacked by Augustine.

407 Cf. the picture of his baptism in the Reichenau Codex Lat. Mon. 4453, reproduced in Goldschmidt, *German Illumination*, II, 27.

408 How different is the picture of the “Holy Shroud” in Turin! Cf. Vignon, *The Shroud of Christ*.

409 Koepgen notes: “Not even the reformers, who twisted the ideal of virginity in the interests of a bourgeois ethos, ventured to change anything in this respect. Even for them Christ was an androgynous unity of man and virgin. The only puzzling thing is that they acknowledged the virginity of Christ while disapproving the virginity of the priesthood.” (p. 319).

410 Senior, *De chemia*, p. 108. Cf. ἀπροσδεής (“in need of nothing”) as an attribute of the Valentinian monad. (Hippolytus, *Elenchos*, VI, 29, 4.)

411 *Stromata*, III, 13, 92,* cited in James, *The Apocryphal New Testament*, p. 11.

412 “De transmut. metallka,” *Art. aurif.*, II, pp. 22f.* This seemingly pointless and selfish procedure becomes understandable if the alchemical opus is regarded as a divine mystery. In that case its mere presence in the world would be sufficient.

413 “For the first Chief of the spagyrics saith: Knock and it shall be opened unto you” * (Matthew 7 : 7). “Phys. Trismegisti,” *Theatr. chem.*, I, p. 413.

414 Ibid.* Eleazar (*Uraltes Chymisches Werck*, II, p. 53) says: “For this stone belongeth only to the proven and elect of God.”

415 I can only agree with Aldous Huxley when he writes in *Grey Eminence* (1943): “By the end of the seventeenth century, mysticism has lost its old significance in Christianity and is more than half dead. ‘Well, what of it?’* may be asked. ‘Why shouldn’t it die? What use is it when it’s alive?’—The answer to these questions is that where there is no vision, the people perish; and that, if those who are the salt of the earth lose their savour, there is nothing to keep that earth disinfected, nothing to prevent it from falling into complete decay. The mystics are channels through which a little knowledge of reality filters down into our human universe of ignorance and illusion. A totally unmystical world would be a world totally blind and insane” (p. 98). “In a world inhabited by what the theologians call unregenerate or natural men, church and state can probably never become appreciably better than the best of the states and churches of which the past has left us a record. Society can never be greatly improved, until such time as most of its members choose to become theocentric saints. Meanwhile, the few theocentric saints who exist at any given moment are able in some slight measure to qualify and mitigate the poisons which society generates within itself by its political and economic activities. In the gospel phrase, theocentric saints are the salt which preserves the social world from breaking down into irremediable decay” (p. 296).

416 Hoghelande (*Theatr. chem.*, I, p. 162): “So also the King and Queen are called the composite of the stone . . . Thus man and woman are called Male and Female, because of their union and action and passion. Rosinus [says]:

The secret of the art of gold consists in the male and the female.” *

417 Parable XII, pp. 135ff.

418 “Area arcani,” *Theatr. chem.*, VI, p. 314.

419 *Theatr. chem.*, II, p. 149.

420 St. Gregory, *In I Regum expos.* (Migne, *P.L.*, vol. 79, col. 23). Mylius (*Phil. réf.*, p. 8) says of God: “Whom the divine Plato declared to dwell in the substance of fire; meaning thereby the unspeakable splendour of God in himself and the love that surrounds him.” *

421 Cf. “The Spirit Mercurius,” pars. 271, 284.

422 *Aurora Consurgens*, p. 141: “I am the crown wherewith my beloved is crowned.”

423 *Mus, herm.*, p. 50 (Waite, I, p. 48).

424 “Adorned with a most excellent crown composed of pure diamonds” probably refers to the wreath of stars about her head.

425 Migne, *P.L.*, vol. 172, col. 834.

426 Colossians 2:3: “... so as to know the mystery of God the Father and of Christ Jesus, in whom are hidden all the treasures of wisdom and knowledge’ (DV).

427 The alchemists were in *some* doubt as to whether to call the body or the soul feminine. Psychologically, this consideration applies only to the soul as the representative of the body, for the body itself is experienced only indirectly through the soul. The masculine element is spirit.

428 This is true only of the male artifex. The situation is reversed in the case of a woman.

429 Thus Maier (*Symb. aur. mensae*, p. 336) says: “He who works through the talent of another and the hand of a hireling, will find that his works are estranged from the truth. And conversely, he who performs servile work for another, as a servant in the Art, will never be admitted to the mysteries of the Queen.” * Cf. *Psychology and Alchemy*, par. 421.

430 The materia prima, raw material, black earth.

431 *Uraltes Chymisches Werck*, II, p. 72.

432 “Come then, to higher spheres conduct him!

Divining *you*, he knows the way.”

(*Faust II*, trans. by MacNeice, p. 303.)

433 *Art. aurif.*, II, p. 294f. Cf. *Aurora Consurgens*, pp. 53f.

- 1 “Monas hieroglyphica,” *Theatr. chem.*, II, p. 222. *
- 2 Azoch = Azoth = “Mercurius duplex.” Cf. Ruland, *Lexicon*, p. 66, s.v. Azoch.
- 3 “Take Adam and that which is made like to Adam: here hast thou named Adam and hast been silent concerning the name of the woman or Eve, not naming her, for thou knowest that men who are like unto thee in the world know that that which is made like unto thee is Eve” * (“Rosinus ad Euthiciam,” *Art. aurif.*, I, p. 248).
- 4 “Congeries Paracelsicae chemicae,” *Theatr. chem.*, I, p. 578: “Wherefore with the most powerful talent and understanding they asserted that their stone was a living thing, which they also called their Adam, who bore his invisible Eve hidden in his body from the moment when they were united by the power of the great Creator of all things. And for that reason the Mercury of the Philosophers may fittingly be called nothing else than their most secret compound Mercury, and not the vulgar one.... There is in Mercury whatever the wise seek . . . the matter of the stone of the philosophers is naught else than . . . Adam the true hermaphrodite and microcosm.” * “Nature first requires of the artifex that the philosophic Adam be drawn to the Mercurial substance” * (p. 589). “... the composition of the most holy Adamic stone is made from the Adamic Mercury of the sages” * (p. 590).
- 5 For instance, Adam as “God the Father” fused together with Eve. Cf. Nelken, p. 542.
- 6 *Mus. herm.*, p. 228. *
- 7 “Adam was the Lord, King, and Ruler.” * *Ibid.*, p. 269.
- 8 “De prima materia,” *Mus. herm.*, p. 425. * Cf. *supra*, pars. 415f.
- 9 Cf. Hoghelande (*Theatr. chem.*, I, p. 162): “A tall and helmeted man.”
- 10 A Paracelsan neologism, presumably a compound of “Adam” and “Enoch.” Cf. “Paracelsus as a Spiritual Phenomenon” par. 168.
- 11 Dorn (in his edition of Paracelsus’ *De vita longa*, p. 178) calls him the “invisibilis homo maximus.”
- 12 Ms. from 18th cent., “Figurarum aegyptiorum,” fol. 17.
- 13 *De laude charitatis* (Migne, *P.L.*, vol. 176, col. 974).
- 14 See *supra*, pan. 24f.
- 15 Cf. Wünsche, “Schöpfung und Sündenfall,” p. 10. Adam had two faces. God sawed him into two halves—Adam and Eve.
- 16 *Ibid.*, p. 24.
- 17 Further material in *Psychology and Alchemy*, pars. 425ff., 430f., 433.
- 18 “The second Adam who is called the philosophic man.” * (*Aurora consurgens*, I, Parable VI.)
- 19 Sermo VIII (ed. Ruska), p. 115. *
- 20 The Latin Geber, author of the classical “Summa perfectionis,” was formerly thought to be identical with Jabir. For the present state of the Jabir controversy see Lippmann, *Entstehung und Ausbreitung der Alchemie*, II, p. 89.
- 21 Berthelot, *Chimie au moyen âge*, III, pp. 148f.
- 22 For instance in Mylius, *Phil. ref.*, p. 168.
- 23 Adam’s body came from the earth of Babylonia, his head from the land of Israel, and his limbs from the remaining countries. (*Talmud*, ed. Epstein, “Sanhedrin,” 38a; I, p. 241.)
- 24 *Theatr. chem.*, V, p. 109.

25 Here the text develops the comparison of Adam with the arcane substance.

26 “He [God] began to collect the dust of the first man from the four corners of the world; red, black, white, and green. Red, this is the blood; black refers to the entrails; white refers to the bones and sinews; green refers to the body.” * *Pirke de Rabbi Eliezer* (trans. by Friedlander), ch. 11, pp. 77f. (modified). According to other sources, green refers to the skin and the liver. Cf. *Jewish Encyclopaedia*, I, pp. 173ff., s.v. Adam, for further material.

27 *Ibid.*, p. 174.

28 Bezold, *Die Schatzhöhle*, p. 3.

29 Kohut, “Die talmudisch-midrassische Adamssage in ihrer Rückbeziehung auf die persische Yima- und Meshiasage.”

30 Grimm (*Teutonic Mythology*, II, p. 565) cites a Latin version from the *Rituale Ecclesiae Dunelmensis* (10th cent.) and other material besides. The above quotation is from Koehler, *Kleinere Schriften zur erzählenden Dichtung des Mittelalters*, II, p. 2. The “questions” go back to an Anglo-Saxon “Dialogue between Saturn and Solomon” (Thorpe, *Analecta Anglo-Saxonica*, pp. 95ff.).

31 Isidore of Seville, *De natura rerum*, IX (ed. Becker, p. 21). Cited in *Jewish Encyclopaedia*, I, p. 174, s.v. Adam.

32 Cf. the seven sons of Adam and the seven metals from the blood of Gayomart. There is the same uncertainty in the legend of the seven sleepers recounted in the 18th Sura of the Koran: in some versions there are seven, in others eight sleepers, or the eighth is a dog, or there are three men and a dog, and so on. (See “Concerning Rebirth,” par. 242, n. 6.) Similarly, Adam sometimes has three colours, red, black, and white, and sometimes four, white, black, red, and green. (Cf. *Jewish Encyclopaedia*, I, p. 174.)

33 Elsewhere he says of the devil: “For he knew that through the ternarius no entry could lie open to Adam, since the unarius protected the ternarius, and therefore he sought to enter the binarius of Eve” * (“Duellum animi cum corpore,” *Theatr. chem.*, I, p. 542).

34 “De tenebris contra naturam,” *Theatr. chem.*, I, p. 527. *

35 “The first man was of the earth, earthy; the second man is from heaven, heavenly” (DV).

36 “De igne et sale,” *Theatr. chem.*, VI, p. 3. *

37 *Ibid.* *

38 *Pirke de Rabbi Eliezer*, p. 79.

39 *Jewish Encyclopaedia*, s.v. Adam.

40 Mentioned in Zosimos, in Berthelot, *Alch. grecs*, III, xlix, 6. Cf. also *Sibylline Oracles* (ed. Geffcken), pp. 47ff.

41 In the sixth hour, on a Friday, “Heva mounted the tree of transgression, and in the sixth hour the Messiah mounted the cross” (Bezold, *Die Schatzhöhle*, p. 62). Cf. Augustine’s interpretation of the crucifixion as Christ’s marriage with the “matrona.” (Infra, par. 568.)

42 Bezold, pp. 27ff.

43 *Ibid.*, p. 76.

44 “Testament of Adam,” in Riessler, *Altjüdisches Schrifttum ausserhalb der Bibel*, p. 1087.

45 Charles, *Apocrypha and Pseudepigrapha of the Old Testament*, II, p. 142.

46 Ch. 20, pp. 148f. Dr. R. Schärf points out that the cave is not identical with the City of Four, since Kirjath Arba' is a name for Hebron, where the cave is.

47 “Therefore in Adam the first man . . . were contained all those ideas or species aforesaid, from the practical soul to the emanative simplicity.” * [I am indebted to Prof. G. Scholem for the following interpretative translation of the last few words: “. . . from the *nefesh* (i.e., the lowest of the five parts of the soul) of the world of *'asiyah* (i.e., the lowest of the four worlds of the Cabalistic cosmos) to the *yehidah* (the highest soul) of the world of *'atsiluth* (the highest world of the Cabalistic cosmos).”—TRANS.] Knorr von Rosenroth, “De revolutionibus animarum,” Part I, cap. I, sec. 10, *Kabbala denudata*, II, Part 3, p. 248.

48 Berthelot, *Alch. grecs*, IV, xx.

49 *Ibid.*, IV, xx, 15.

50 *De chemia*, p. 64: “Then I gather together the head, hands and feet [of the lion] and warm with them the water extracted from the hearts of statues, from the white and yellow stones, which falls from heaven in time of rain.” *

51 Stapleton, “Muhammad bin Umail.”

52 Already in the *Cyranides* we find: “Also the laudanum of his [the goat’s] beard, i.e., mumia or hyssop or sweat.” * (Delatte, *Textes latins et vieux jranfais relatifs aux Cyranides*, p. 129.)

53 *Von hyl. Chaos*, pp. 310f.: “The foundations of all that is created . . . are contained in . . . the radical moisture, the seed of the world, the Mumia, the materia prima.” *

54 Cf. “Paracelsus as a Spiritual Phenomenon,” pars. 170 and n. 5, 190.

55 *Codicillus*, 1651, p. 88. * Cf. Maier, *Symbola*, p. 19. Concerning the oil Lully says: “This oil is the tincture, gold and the soul, and the unguent of the philosophers” * (*Codicillus*, p. 96). A follower of Lully, Christopher of Paris, says: “That oil or divine water . . . is called the Mediator” * (“Elucidarius,” *Theatr. chem.*, VI, p. 214). It is therefore not surprising that Pernety (*Diet, mytho-hermetique*, p. 472) quotes the first *Codicillus* passage thus: “You extract this God [*deum* for *oleum*] from the hearts of statues by a moist bath of water and by a dry bath of fire.”

56 *Theatr. chem. Brit.*, pp. 20f.

57 Of these Norton discusses iron, copper, and lead.

58 Cf. “The Phenomenology of the Spirit in Fairytales,” pars. 425, 437ff.

59 I have had access to only a few of the dozens of Lully treatises that exist, so I have not attempted to trace the origin of the story.

60 Dionysius is cited in the alchemical literature. See *Theatr. chem.*, VI, p. 91.

61 “They made in them [the statues] both doors and hollows, in which they placed images of the gods they worshipped. And so statues of Mercury after this kind appeared of little worth, but contained within them ornaments of gods” * (Pachymeres’ paraphrase of Dionysius the Areopagite, *De caelesti hierarchia*, in Migne, *P.G.*, vol. 3, col. 162).

62 *Symposium*, 215a; trans. by Hamilton, p. 100. In his commentary on this passage R. G. Bury (*The Symposium of Plato*, p. 143) says: “The interiors [of the statuettes] were hollow and served as caskets to hold little figures of gods wrought in gold or other precious metals.”

63 One has only to read the meditations of St. Teresa of Avila or of St. John of the Cross on Song of Songs 1:1: “Let him kiss me with the kiss of his mouth, for thy breasts (*ubcra*) are better than wine” (DV). Usually (as in AV and

RSV) the passage is falsified: “love” for “breasts.”

64 The corresponding passage in Hippolytus, *Elenchos*, V, 7, 6, runs: “But the Assyrians say that the fish-eating Cannes [the first man] was born among them, and the Chaldaeans say the same thing about Adam; and they assert that he was the man whom the earth brought forth alone, and that he lay unbreathing and unmoved as a statue [*ἀνδριάντα*], an image of him on high who is praised as the man Adamas, begotten of many powers” (Legge trans., I, p. 122, modified).

65 Bousset, *Hauptprobleme der Gnosis*, pp. 34f This story from the Genza (holy book of the Mandaeans) may throw light on the passage in Senior, where he says that the male reptile “will cast his semen upon the marble in a statue” * (*De chemia*, p. 78).

66 Kohen, *Ernek ha-Melech*. [This reference is untraceable—EDITORS.]

67 Cf. the pregnant sentences in Ephraem Syrus (“De poenitentia,” *Opera omnia*, p. 572): “Two Adams are created: the one, our father, unto death, because he was created mortal, and sinned; the second, our father, unto resurrection, since when he was immortal he by death overcame death and sin. The first Adam, here, is father; the second, there, is also father of the first Adam.” *

68 *Phil. ref.*, p. 19. * It is by no means certain that Mylius, who seldom or never gives his sources, is the originator of this thought. He might just as easily have copied it from somewhere, though I cannot trace the source.

69 “Paracelsus as a Spiritual Phenomenon” par. 214.

70 *Acta Archelai*, XIII, p. 21. *

71 Schmidt, *Manichäische Handschriften der Staatlichen Museen, Berlin*, I.

72 Ch. XXIV, p. 72, vv. 33f.

73 Ch. LIX, p. 149, v. 29f.

74 P. 150, v. 8.

75 Ch. LXII, p. 155, v. 10ff.

76 Ch. LXXII, p. 176, v. 3ff.

77 P. 177, v. 2ff.

78 *Theatr. chem.*, VI, p. 91. *

79 *Divine Names* (trans. by Rolt), p. 93. * An older authority than Dionysius is Theophilus of Antioch (2nd cent.), who says: “The sun is a type of God, and the moon of man” (*Three Books to Autolytus*, II, 15; trans. by Pratten and others, p. 82). *

80 *Kabbala denudata*, I, Part 1, p. 546.

81 This was the stone of Bethel, which Jacob set up after his dream of the ladder.

82 “It is the brightest, which belongs to Tifereth.” * *Kabbala denudata*, p. 202.

83 Malchuth = *sponsa* (pp. 366, 477). The “ecclesia Israel” is also called Malchuth (p. 480). Besides this, Tifereth and Malchuth are brother and sister (p. 120). “Malchuth is also called by the name of mother, since she is the mother of all things that exist under her, even to the bound of the whole Abyss” * (p. 120).

84 “His [the sun’s] beauty is compared with that of a bridegroom coming forth from his bridechamber. And he is as a bridegroom issuing from his couch” * (*Theatr. chem.*, VI, p. 92).

- 85 *Sermo suppositus*, 120, 8 (Migne, *P.L.*, vol. 39, cols. 1984f.). *
- 86 *Mus. herm.*, p. 688 (Waite, II, p. 189).
- 87 As the “chaos,” the materia prima likewise consists of four elements (*Theatr. chem.*, VI, p. 228) which are in conflict. The task of the opus is to reconcile them so that they give rise to the One, the filius philosophorum. The Gnostics of Hippolytus thought in the same way; they spoke of the ascent and rebirth of Adam “that he may be born spiritual, not fleshly” (*Elenchos*, V, 8, 18). He is called “mighty in war,” but the war is in his own body, which “is made from warring elements” (V, 8, 19; Legge, I, p. 134).
- 88 “More medicinal virtue lies hid in antimony than in any other simple, and therefore more of the tinging virtue of the tincture.” * (*Symbola*, p. 379.)
- 89 Similarly Mylius says: “And therefore it is said that the stone is in every man. And Adam brought it forth with him from Paradise, from which material our stone or Elixir is produced in every man.” * (*Phil. ref.*, p. 30.)
- 90 *Mus. herm.*, p. 97.
- 91 *Mus. herm.*, p. 268 (Waite, I, p. 216).
- 92 In the Naassene view the Chaldaeans equated Oannes with Adam. Cf.n. 64, supra.
- 93 *Summa theol.*, I, q. 94, ad 3 (I, pp. 480ff.).
- 94 Chwolsohn, *Die Ssabier*, II, p. 601.
- 95 Wünsche, “Salomos Thron und Hippodrom,” p. 50.
- 96 Kohut, “Die talmudisch-midrassische Adamssage,” p. 80.
- 97 *Jewish Encyclopaedia*, s.v. Adam.
- 98 “Alfabet des Ben-Sira.” Cf. Scheftelowitz, *Die altpersische Religion und das Judentum*, p. 218.
- 99 Chwolsohn, *Die Ssabier*, I, p. 709.
- 100 “Adam handed on the tradition to Enoch, who was initiated into the principle of intercalation” * (*Pirke de Rabbi Eliezer*, 8, trans. by Friedlander, p. 52).
- 101 “Adam said: these are the tables, on which the Holy One, blessed be He, will write with his own finger.” * (Cf. *Pirke de Rabbi Eliezer*, 20, p. 148.)
- 102 *Theatr. chem.*, I, pp. 774f.
- 103 “The world is to be renewed, or rather, chastened and little short of destroyed, by water” * (“Congeries Paracelsicae,” *Theatr. chem.*, I, p. 617).
- 104 *Theatr. chem.*, I, pp. 617f.
- 105 From Aramaic *ras* = ‘secret’.
- 106 Peter Beer, *Geschichte, Lehre und Meinungen aller bestandenen und noch bestehenden religiösen Sekten der Juden und der Geheimlehre oder Cabbalah*, II, pp. 1 if. The mystical book Sefer Raziel is one of the oldest texts of the Cabala (1st edn., Amsterdam, 1701). It is identified with “Sifre de-Adam Kadmaa,” cited in *the Zohar*. (Cf. *Jewish Encyclopaedia*, s.v. Adam.) According to another version the book was made of precious stones and contained the names of the seven charms which God gave to Adam. (Grunwald, “Neue Spuk- und Zaubersliteratur,” pp. 167f.)

- 107 The series consists of Adam, Enoch, Noah, Abraham, Isaac, Jacob, Moses, Christ. *Clementine Homilies* (trans. by Smith and others), pp. 283 and 259.
- 108 *P'an* means 'egg-shell,' *Ku* 'firm, to make firm; 'undeveloped and unenlightened, i.e., the embryo' (Hastings, *Encyclopaedia of Religion and Ethics*, IV, 141a).
- 109 Moses, too, is represented with horns.
- 110 Cf. the Christian relation of the Anthropos to the tetramorph (angel, eagle, lion, ox). See *Psychology and Alchemy*, fig. 53.
- 111 He is supposed to have been invented, so to speak, by the Taoist philosopher Ko Hung, 4th cent.
- 112 He is an "increated" made of uncreated, incorruptible air.
- 113 For these statements see Werner, *Myths and Legends of China*, pp. 76ff. Krieg (*Chinesische Mythen und Legenden*, pp. 7ff.) gives a very fine recension of the P'an-Ku legend, in which he brings together a number of Taoist-alchemical motifs.
- 114 Wilhelm, *The Chinese Fairy Book* (trans. by Martens), pp. 76ff.
- 115 *Grimm's Fairy Tales* (trans. by Hunt and Stern), p. 137.
- 116 *Adv. haer.*, I, v. 3. (trans. by Roberts and Rambaut, I, p. 22).
- 117 *Contra Celsum* VI, 24 (trans. by Chadwick, p. 337).
- 118 Cf. "A Study in the Process of Individuation" and "Concerning Mandala Symbolism."
- 119 "It contained a drawing of ten circles, which were separated from one another and held together by a single circle, which was said to be the soul of the universe and was called Leviathan." * (*Contra Celsum*, VI, 25, p. 340.)
- 120 The passage runs: "We also found that Behemoth is mentioned in it as if it were some being fixed below the lowest circle. The inventor of this horrible diagram depicted Leviathan upon the circumference of the circle and at its centre, putting in. the name twice." * (*Ibid.*)
- 121 *Ibid* *
- 122 *Ibid.*, VI, 27, pp. 342f.
- 123 *Ibid.*, VI, 30, p. 346.
- 124 "... and they say that the star Saturn is in sympathy with the lion-like Archon" (VI, 31, p. 347). * Cf. Bousset, *Hauptprobleme der Gnosis*, pp. 351ff.
- 125 In the prayer to Ialdabaoth the celebrant addresses him thus: "And thou, Ialdabaoth, first and seventh . . . a perfect work for Son and Father." * (*Origen*, VI, 31, p. 347.)
- 126 Leisegang (*Die Gnosis*, p. 169) gives a different reconstruction but does not take account of the seven spheres of the archons.
- 127 VI, 31, p. 347.
- 128 *Adv. haer.* I, ivff. (trans. by Roberts and Rambaut, I, pp. 16ff.)
- 129 The demiurge is the hebdomad, but Achamoth is the ogdoad. (Leisegang, p. 317.)
- 130 Damascius, *De Principiis* (ed. Ruelle), § 266 (II, pp. 132f.) *
- 131 *Contra Celsum*, p. 350. * The Gnostics, Origen remarks, likened this Prunicus to the "woman with the bloody flux," who was thus afflicted for twelve years. T'ai-yüan, "the Holy Mother of the First Cause," had a pregnancy

lasting for twelve years. (See supra, par. 573.)

132 Irenaeus (*Adv. haer.* I, iv, 2) says that, according to the Valentinians, “the whole soul of the world and of the creator of the world” proceeded from Sophia’s longing for the life-giver (Christ). (Cf. *Writings*, I, p. 17.)

133 *The Histories*, I, 98 (trans. by de Selincourt, pp. 54f).

134 Concerning the mandala as the plan of a primitive settlement see my “Psychology of the Transference,” pars. 433ff.

135 “For these two metals recall the colours of the sun and moon.” * (Cf. *Contra Celsum*, p. 334.)

136 *Moralia in Job*, cap. 38, bk. 29, chap. 31 (Migne, *P.L.*, vol. 76, col. 519). *

137 *Three Principles of the Divine Essence* (*Works*, I), XVIII, 20, p. 170.

138 *A High and Deep Search concerning the Threefold Life of Man* (*Works*, II), V, 41, p. 47.

139 *Ibid.*, XI, 12, p. 110. Cf. the increatum of Paracelsus and the alchemists (*Psychology and Alchemy*, pars. 430f.).

140 *A High and Deep Search*, VI, 77–8, p. 67.

141 *Zweyte Apologie wieder Balthasar Tilken* (Amsterdam edn., 1682), II, 227, p. 306.

142 *Mysterium Magnum* (*Works*, III), IX, 11, p. 36; XXIII, 38, p. 104.

143 *Three Principles* (*Works*, I), XVII, 78, p. 159.

144 *Ibid.*, XIII, 9, p. 94.

145 *Menschwerdung Christi*, Part I, ch. 11, 10.

146 *A High and Deep Search* (*Works*, II), V, 56, p. 48.

147 Avalon, *The Serpent Power*.

148 For this motif see *Symbols of Transformation*, pars. 306, 349, 620.

149 Lit., “vergaffte sich.” This expression derives from Paracelsus. See *Liber Azoth* (ed. Sudhoff, vol. XIV) p. 574.

150 von Baader, *Werke*, VII, p. 229.

151 *Ibid.*, p. 231.

152 *In Genesim Hom.*, I, 7 (Migne, *P.G.*, vol. 12, col. 151).

153 “Every man has in himself both Adam and Eve. For as in that first transgression of man, the serpent suggested, Eve delighted, and Adam consented, so we see every day that when the devil suggests, the flesh delights, and the spirit consents.” * *In Septem Psalmos poenitentiales*, V, § 8 (Migne, *P.L.*, vol. 79, col. 608).

154 “*In Cant. hom.* II (Migne, *P.G.*, vol. 13, cols. 47ff.).

155 “Le Livre des Balances,” in Berthelot, *Chimie au moyen âge*, III, p. 140.

156 Irenaeus, *Adv. haer.*, I, 30, 9; Bousset, *Hauptprobleme der Gnosis*, p. 198; Bezold, *Die Schatzhöhle*, p. 3; Kohut, “Adamssage,” pp. 72 and 87; *Jewish Encyclopaedia*, s.v. Adam; Wünsche, “Schöpfung und Sündenfall des ersten Menschenpaares,” p. 11.

157 Gruenbaum, *Jüdisch-deutsche Chrestomathie*, p. 180. *Adamah* is also related to Hebrew *dam*, ‘blood.’ “Adam” would therefore mean “made of red earth.”

158 *In Genesim Hom.*, I, 13. *

159 Philo distinguishes between the mortal Adam made of earth and the Adam created after the image of God and says of the latter: “He that was created after the [divine] image was an idea, or genus, or imprint, or object of thought, incorporeal, neither male nor female, by nature incorruptible” * (“On the Account of the World’s Creation given by Moses,” §134, *Works*, I, pp. 106f., mod.).

160 “Congeries Paracelsicae,” *Theatr. chem.*, I, p. 578.

161 *Elenchos*, V, 6, 4f (Legge, I, p. 120).

162 Ed. Freedman and Simon, II, p. 54. Cf. also Scheftelowitz, *Die altpersische Religion und das Judentum*, p. 217, and Bousset, *Hauptprobleme der Gnosis*, p. 198.

163 Adam’s back is of significance. An Islamic legend says: “Then God also made a covenant with the descendants of Adam: for he touched his back, and lo, all men who will be born until the end of the world crept forth from his back, in stature no greater than ants, and ranged themselves to his right hand and to his left.” (Weil, *Biblische Legende der Muselmänner*, p. 34.) Then God sent these little souls back into Adam’s backbone, where they died and were changed into a single spirit. (Ghazali, *Die kostbare Perle im Wissen des Jenseits*, ed. Brugsch, p. 7.) Citations from Aptowitz, “Arabisch-jüdische Schopfungstheorien,” p. 216.

164 *De Signatura salium, metallorum et planetarum*, p. 12.

165 Bezold, *Die Schatzhöhle*, p. 3.

166 Reitzenstein and Schaeder, *Studien zum antiken Synkretismus aus Iran und Griechenland*, p. 114.

167 *Jewish Encyclopaedia*, s.v. Adam.

168 *Ibid.*

169 *Ibid.*

170 *Zohar* I, 34 (trans. by Sperling and Simon, I, p. 129), and III, 19 (IV, p. 359).

171 According to Ben Sira. Cf. van Dale, *Dissertationes de origine ac progressu Idololatriae et Superstitionum*, p. 112.

172 *Ibid.*, pp. 111.

173 According to the teaching of the Barbeliots (Irenaeus, *Adv. haer. I*, 29, 2f.; *Writings*, I, p. 102), the Autogenes, who was sent forth by Ennoia and the Logos, created “the perfect and true man, who is called Adamas.”

174 Cf. *Scholia in Lucianum*, “De dea Syria,” 28 (ed. Rabe, p. 187), and Roscher, *Lexikon*, s.v. *κόρυβος*, col. 1392 b.

175 Hippolytus, *Elenchos*, V, 8, 9ff. (Legge trans., I, pp. 133ff.).

176 *Pistis Sophia* (trans. by Mead), pp. 19 and 30. For Adam as “head of the Aeon” see Lidzbarski, *Das Johannesbuch der Mandaer*, p. 93, line 4.

177 Euthymios Zigabenos, *Panoplia Dogmatica* (Migne, *P.G.*, vol. 130).

178 Wünsche, *Die Sagen vom Lebensbaum und Lebenswasser*, p. 23.

179 For a comprehensive survey of the Adam material see Murrelstein, “Adam, ein Beitrag zur Messiaslehre.” Concerning the universal soul see *ibid.*, XXXV, p. 269, and XXXVI, p. 52; also Aptowitz, “Arabisch-jüdische Schopfungstheorien,” p. 214: “While Adam lay there a lifeless body, God showed him all the righteous who would one day issue from him. These have their origin in the separate parts of Adam’s body: one from his head, the other from his hair, and others from his forehead, eyes, nose, mouth, ear and jawbone. Proof of this can be found in Job 38

: 4, where [as interpreted by the midrash] God says to Job: ‘Tell me how thou art made, from what part of Adam’s body thou comest; if thou canst tell me this, then mayest thou contend with me.’” “The first Adam was as great as the world from one end to the other, therefore the angels would have cried ‘Holy!’ before him, but God made him small by taking away pieces of his limbs, which then lay round about Adam. Adam said to God: ‘Wherefore dost thou rob me?’ God answered him: ‘I will recompense thine injuries many times, for it hath been said, The son of David shall not come until all the souls in thy body are become earth. Take these pieces and carry them into all regions of the earth; wherever thou dost cast them, they will be turned to dust, and there shall the earth be inhabited by thy descendants. The places which thou shalt appoint for Israel shall belong to Israel, and the places which thou shalt appoint for the other peoples shall belong to the other peoples.” In this Haggadah (discourse), therefore, it is said that all the generations of men were contained in Adam; in his soul, all souls, and in his body, all bodies.

180 Lidzbarski, *Das Johannesbuch der Mandäer*, p. 168, line 7.

181 Cf. the Zosimos text in *Psychology and Alchemy*, par. 456.

182 Berthelot, *Alch. grecs*, III, xlix, 4–12.

183 Reuchlin, *De verbo mirifico*, and *De arte cabbalistica*.

184 “Apologia tredecim Quaestionum,” *Opera* (Venice, 1557).

185 *Uraltes Chymisches Werck*, 2nd edn., 1760. Published in Leipzig by Julius Gervasius von Schwartzburg.

186 See preface to the book. The MS is said to have been in the possession of Cardinal Richelieu. The story goes that Flamel bought the treatise, which was written on sheets of bark, for two florins from an unknown person. It is a late forgery from the beginning of the 18th cent. The first edition appeared in 1735.

187 This phrase occurs also in Maier, *Symbola*, p. 568: “There is in our chemistry a certain noble substance which moves from lord to lord, in the beginning whereof is wretchedness with vinegar, but in the end joy with gladness.” *

188 Eleazar states that Marez, , signifies earth, Hebrew *erets*.

189 Hebrew *riqma*, ‘many-coloured garment.’

190 The men of Kedar lived in black tents.

191 Mixed drink, spiced wine.

192 *Uraltes Chymisches Werck*, II, pp. 51f.

193 “The psyche, which by them is called *nefesh*, is the vital spirit, not in so far as it is wholly corporeal, but as that which is inborn and primitive and seminal, which later writers call the Archeus. This corresponds to the vegetative or plastic soul of the Philosophers, and the affective or concupiscible soul of the Platonists.” * (Knorr’s note to § 7 of the “Tractatus de revolutionibus animarum,” *Kabbala denudata*, II, Part 3, p. 247.) *Nefesh* is a kind of blood-soul, hence the prohibition against shedding blood (Leviticus 17 : 14).

193a *

194 [The Hebrew word used in Song of Songs 6 : 13 is “Shulamith” or “Shulammit,” translated in most versions of the Bible as “the Shulamite” (the girl from Shulem or ancient Shunem). Cf. Sellin, *Introduction to Old Testament*, pp. 223ff. “Sulamith” or “Shulamith” is also used as a personal name by modern Jews.—TRANS.]

195 “Adam is called by the Cabalists Adam Kadmon, to distinguish him from Adam the first man . . . because of all things that came forth from God he occupies the first place, as the first man among the species of men. Nothing can

more fitly be signified thereby than the soul of the Messiah, of which Paul speaks in I Corinthians 15:45–49.” * (Knorr’s note to “Tract, de revolut. animarum,” *Kabbala denudata*, II, Part 3, p. 244.)

196 “The love of the ‘King’ for the ‘Queen’ is the love of God for ‘Zion’, or for that power which is also called ‘Shalom,’ peace or fulfilment; for ‘Shulamith,’ who is praised in the Song of Songs” (Müller, *Der Sohar und seine Lehre*, p. 46).

197 Scholem, “Kabbala,” in *Encyclopaedia Judaica*, IX, cols. 630ff.

198 *Kabbala denudata*, I, p. 28, s.v. homo. Wünsche (“Kabbala,” in Herzog and Hauck, *Realenzyklopädie*, IX, p. 676) says: “Concerning Adam Kadmon the Cabalistic writings are not altogether clear. Sometimes he is conceived as the Sephiroth in their entirety, sometimes as a first emanation existing before the Sephiroth and superior to them, through which God . . . was made manifest and . . . revealed himself to the whole of Creation as a kind of prototype (macrocosm). In the latter event it looks as though Adam Kadmon were a first revelation interposed between God and the world, a second *God*, so to speak, or *the divine Logos*.” This view agrees with that of the *Kabbala denudata*, which was influenced by Isaac Luria. Here Adam Kadmon is “a mediator between En Soph and the Sefiroth” (*Jewish Encyclopaedia*, III, p. 475, s.v. Cabala). Dr. S. Hurwitz refers me to the *Zohar* (III, 48a): “As soon as man was created everything was created, the upper and the lower worlds, for everything is contained in man.” According to this view Adam Kadmon is the *homo maximus*, who is himself the world. Man and his heavenly prototype are “twins” (*Talmud*, “Sanhedrin,” 46b, ed. Epstein, I, p. 306). Adam Kadmon is the “highest man” of the divine chariot (Merkabah), the “highest crown” (Kether), the anima generalis. Isaac Luria says he contains in himself the ten Sefiroth. They went forth from him in ten concentric circles, and these are his *nefesh*, souls. (Cf. supra, pars. 574ff., the diagram of the Ophites in Origen, *Contra Celsum*.)

199 Ezek. 34 : 31 apparently says nothing of the kind. What it does say, however, is: “And ye my flock, the flock of my pasture, are men” (AV). “Man” = “Adam.” “Adam” here is a collective concept.

200 The parentheses are Knorr von Rosenroth’s.

201 *Kabbala denudata*, II, Part 3, pp. 248. *

202 Cf. *ibid.*, ch. 3, sect. I, pp. 255f.

203 *Ibid.*, p. 251. * Knorr’s parentheses.

204 “Sed differentias specificas designari per rectilineum.” The so-called “numerical differences” are concerned with the opposites. The text says: “The numerical differences refer to the balance-like arrangement in which there is a turning [in which two principles are related, i.e., “turned”] face to face, and two or more things of the same perfection or species are distinguished only as male and female. And these numerical differences [i.e., relationships] are also denoted by such expressions as “facing,” “turning the back,” etc.” * Diss. VI, § 9, p. 118.

205 “Ab Aen-Soph, i.e., Uno generalissimo, productum esse Universum, qui est Adam Kadmon, qui est unum et multum, et ex quo et in quo omnia. . . . Differentias autem generum notari per circulos homocentricos, sicut Ens, substantiam; haec, corpus; hoc, vivens; istud, sensitivum; et haec, rationale continet. . . . Et hoc modo in Adam Kadmon repraesentantur omnium rerum ordines, turn genera, quam species et individua.” (*Ibid.*) Cf. Scholem, *Major Trends in Jewish Mysticism*, p.215.

206 For the Egyptian source see the account in Bousset, *Hauptprobleme der Gnosis*, and Reitzenstein and Schaeder, *Studien zum antiken Synkretismus*. For the Indian, see Deussen, *Ceschichte der Philosophic*, I, 1, p. 228, and for its

relations with the belief in the Messiah, see Abegg, *Der Messiasglaube in Indien und Iran*.

207 Cf. supra, par. 589. According to the Valentinians, man is covered in a “pelt-like garment” (δερμάτικον χιτῶνα). Irenaeus, *Adv. haer.*, I, 5, 5 (Migne, *P.G.*, vol. 7, cols. 501f.).

208 Cf. “Instinct and the Unconscious,” par. 277.

209 It makes no difference here that the definition and classification of the instincts are an extremely controversial matter. The word “instinct” still denotes something that is known and understood by everyone.

210 Cf. supra, par. 18, the separation of Tifereth and Malchuth as the cause of evil.

211 As an example of “being in Tao” and its synchronistic accompaniments I will cite the story, told me by the late Richard Wilhelm, of the rain-maker of Kiaochau: “There was a great drought where Wilhelm lived; for months there had not been a drop of rain and the situation became catastrophic. The Catholics made processions, the Protestants made prayers, and the Chinese burned joss-sticks and shot off guns to frighten away the demons of the drought, but with no result. Finally the Chinese said, ‘We will fetch the rain-maker.’ And from another province a dried up old man appeared. The only thing he asked for was a quiet little house somewhere, and there he locked himself in for three days. On the fourth day the clouds gathered and there was a great snow-storm at the time of the year when no snow was expected, an unusual amount, and the town was so full of rumours about the wonderful rain-maker that Wilhelm went to ask the man how he did it. In true European fashion he said: ‘They call you the rain-maker, will you tell me how you made the snow?’ And the little Chinese said: ‘I did not make the snow, I am not responsible.’ ‘But what have you done these three days?’ ‘Oh, I can explain that. I come from another country where things are in order. Here they are out of order, they are not as they should be by the ordinance of heaven. Therefore the whole country is not in Tao, and I also am not in the natural order of things because I am in a disordered country. So I had to wait three days until I was back in Tao and then naturally the rain came.’” From “Interpretation of Visions,” Vol. 3 of seminars in English by C. G. Jung (new edn., privately multigraphed, 1939), p. 7.

212 In this connection Eleazar makes use of the symbol (significant only for a Christian) of the snake set up on a pole, a prefiguration of Christ (John 3 : 14).

213 I am informed that the American Indian punishment for a fallible medicineman was to have him pulled asunder by four horses, all going in opposite directions. (I cannot vouch for the truth of this statement, but the important thing is the idea as such.)

214 Wolfram von Eschenbach calls the carbuncle a healing stone which lies under the horn of the unicorn. Cf. *Psychology and Alchemy*, par. 552.

215 The passage we have cited may be decisive in regard to the origin and date of the treatise, both of which were contested by Robert Eisler, who, without having seen the book, doubted Scholem’s view that it is a late forgery. (Eisler, “Zur Terminologie und Geschichte der jüdischen Alchemie,” pp. 194 and 202.) See also Kopp (*Die Alchemie in Alterer und neuerer Zeit*, II, pp. 314ff.), who established a first edition in 1735 and regards the publisher Gervasius von Schwartzenburg as the author.

216 Pars. 422ff.

217 Cf. my “On Psychic Energy,” pars. 18ff.

218 Berthelot, *Alch. grecs*, VI, v, 6. *

219 *Kabbah denudata*, I, Part 3, “Porta coelorum,” ch. 8, § 3, p. 116. *

220 Ibid., § 4: “And this is the reason why the Essential Name has four letters, three different, and the fourth a repetition of the second: for the first *he* is the spouse of the *yod*; and the second, the spouse of the *vau*. The first emanated from *yod*, directly, and the second from *vau*, in a converse and reflex way.” *

221 Another view of the *yod* can be found in the *Zohar*, III, 191 (Vol. V, p. 267): “He then cited the verse, ‘I am black, but comely.’ This means that when she (the Moon) is very lovesick for her Beloved, she shrinks to nothing until only a dot is left of her, and she is hidden from all her hosts and camps. Then she says, ‘I am black,’ like the letter *Yod*, in which there is no white space, and I have no room to shelter you under my wings; therefore ‘do not look at me,’ for ye cannot see me at all.”

222 “*Yod*, because it is simple, is something single and primary, and like the number ‘1,’ which, among numbers and as a point, is the first of all bodies. But the point by moving along its length produces a line, namely *vau*.” * (*Kabbala denudata*, Vol. 1, Part 3, Diss. VII, § 1, p. 142.) “The letter *yod*, because it is a point, is made the beginning and the middle and the end; indeed, it is also the beginning of the Decads and the end of the unities and therefore it returns to the One.” * (Introductio in Librum Sohar, § 1, ch. XXXVII, § 1, *Kabbala denudata*, II, Part 1, p. 203.) With regard to the function of *yod*, Sect. VI, ch. I, p. 259 is significant: “When the Wisdom of the Blessed One saw that even in this splendour the worlds could not be manifested, since the Light was still too weak there, he again signalled to this letter *yod* that it should once more descend and break through the sphere of splendour and give forth its light, which was a little denser.” * The point is the “inner point,” which is the same as the “inner rose,” the “community of Israel,” the “Bride.” Further attributes of the rose are: sister, companion, dove, perfect one, twin. (“Tres discursus initiales Libri Sohar,” Comm. in Disc. I, § 12f., *Kabbala denudata*, II, Part 2, p. 151.) *Yod* is attached to the “summit of the crown” and descends upon Sapiencia (Hokhmah): “It scattered light and an eminent influence on that Wisdom.” * (“Theses Cabbalisticæ,” I, § 19. *Kabbala denudata*, I, Part 2, p. 151.) *Yod* is the “vas” or “vasculum” into which the “fount of the sea” pours, and from which the “fount gushing forth wisdom” issues. (“Pneumatica Kabbalistica,” Diss. I, ch. I, § 7 and 10, *Kabbala denudata*, II, Part 3, pp. 189f.)

223 “*Vau* denotes life, which is the emanation and movement of the essence that is manifested in it; and it is the medium of union and connection between the essence and the understanding.” * (Herrera, “Porta coelorum,” Diss. VII, ch. I, § 3, *Kabbala denudata*, I, Part 3, p. 141.)

224 A whole series of quaternions are associated with the Tetragrammaton. Cf. “Porta coelorum,” Diss. VII, ch. III, § 5, p. 145.

225 “*He* denotes Being, which is composed of essence and existence.” “The last *he* is the image of the intellect or mind.” * (Ibid., ch. I, § 2 and 4, p. 141.)

226 Song of Songs says of the Shulamite (4 : 8): “Come with me from Lebanon, my spouse, with me from Lebanon; come down from the top of Amana, from the top of Shenir and Hermon, from the lions’ dens, from the mountains of the leopards” (AV, mod.). According to Wittekindt (*Das Hohe Lied*, p. 166) Lebanon, lion, and leopard refer to Ishtar.

227 Eleazar, *Uraltes Chymisches Werck*, II, p. 52.

228 “For by greenness virginity would appear to be prefigured” * (Mennens, “Aureum vellus,” *Theatr. chem.*, V, p. 434).

229 *Art. aurif.*, II, p. 220. *

230 *Phil, ref.*, p. 11. *

231 “Speculum alchimiae,” *Theatr. chem.*, IV, p. 605. *

232 “Asophol” means gold.

233 This must refer to Job 28 : 5: “As for the earth, out of it cometh bread, and under it is turned up as it were fire” (AV). (“... but underneath it is turned up as by fire.” RSV.)

234 Earth.

235 Fire.

236 “Adamah” means red earth, synonymous with “laton.”

237 The Vulgate has: “Semitam ignoravit avis, nec intuitus est earn oculus vulturis” (DV: The bird hath not known the path, neither hath the eye of the vulture beheld it). Our text obviously does not follow the Vulgate, but seems to be based on Luther’s version.

238 “Three things make the shining stone;
Save where God’s own breath has blown
No man it possesses.” *

Joh. de Tetzen, “Processus de lapide philosophorum,” *Drey Chymische Bücher*, p. 64.

239 Genesis 8 : 11.

240 Song of Songs 5 : 11: “His head is as the most fine gold, his locks are bushy, and black as a raven.”

241 Hebrew *shemesh* (sun) is masculine as well as feminine. The Book Bahir says: “And why is the gold called ZaHaB? Because in it are comprised three principles: the Male (Zakhar), and this is indicated by the letter *Zayin*, the soul, and that is indicated by *He*. And what is its function? *He* is the throne for *Zayin* . . . and *Beth* (guarantees) their continuance.” (Scholem, *Das Buch Bahir*, p. 39, sect. 36.) For the sun-moon conjunction see the vision of the sun-woman (Rev. 11 : 19), discussed in “Answer to Job,” pars. 710ff. [According to Sellin, *Introduction to Old Testament*, p. 224, it has been suggested that the Song of Songs may contain festal hymns on the relations of the sun (*Shelems*) and the moon (*Shelamith*).—TRANS.]

242 Cf. the motif of curly-headedness in the discussion of Aelia Laelia Crispis, *supra*, par. 37.

243 Salomon Trismosin, *Aureum Vellus*, *Tractatus Tertius*, p. 28.

244 Berthelot, *Alch. grecs*, III, x, 1.

245 *Χρυσέα κεφαλή κατὰ τὸν θεσπέσιον Δανιὴλ τὸν θεηγόρον* (Berthelot, *Alch. grecs*, IV, vi, 1). This refers to Daniel 2 : 31f, describing Nebuchadnezzar’s dream of the great image with feet of clay.

246 Thomdike, *A History of Magic and Experimental Science*, I, p. 705. Sylvester II, formerly Gerbert of Rheims, was, it appears, interested in alchemy. Evidence for this is an alleged letter to Gerbert (early 12th cent.) on the squaring of the circle (Bodleian MS. Digby 83). Thomdike attributes the letter to Gerbert himself.

247 Cf. “Transformation Symbolism in the Mass,” pars. 365f.

248 Cf. *Psychology and Alchemy*, pars. 116, 220; also the “round thing” or “Moor’s head” in Rosencreutz, *Chymical Wedding*, pp. 147–8; the golden ball heated by the sun (p. 113), *cibatio* (feeding) with the blood of the beheaded (p. 117), death’s head and sphere (p. 120). The cranium is mentioned as the place of origin of the prima materia in Ventura (*Theatr. chem.*, II, p. 271), and in “Liber Platonis quattorum” (*Theatr. chem.*, V, p. 151): “The vessel necessary in this work must be round in shape, that the artifex may be the transformer of this firmament and of the

brain-pan.” * Albertus Magnus (“Super arborem Aristotelis,” *Theatr. chem.*, II, p. 525) says: “His head lives forever and therefore his head is called the life of glory and the angels serve it. And God placed this image in the paradise of delights and in it he set his own image and likeness,” * and on p. 526: “... until the black head of the Ethiopian bearing the likeness be well washed.” * Among the Naassenes of Hippolytus the head of the primordial man Edem signified paradise, and the four rivers that issue from it signified the four senses. (*Elenchos*, V, 9, 15; Legge, I, p. 143.) The same author describes the “talking head” as a magic trick. (*Elenchos*, IV, 41; Legge, I, p. 102.) There is some connection between the text of Albertus Magnus and the report in Hippolytus, at any rate in meaning; perhaps the common source is I Corinthians 11 : 3: “But I would have you know that the head of every man is Christ, and the head of the woman is the man, and the head of Christ is God” (DV). Compare the Albertus text with verse 7: “A man indeed ought not to cover his head, because he is the image and glory of God.” For the head as a trophy of revenge see “Peredur son of Efwarg” in the *Mabinogion* (trans. by Jones), pp. 183ff. As early as the Greek alchemists the “simple thing” (ἀπλοῦν), i.e., the prima materia, was called the “golden head.” (Berthelot, *Alch. grecs*, IV, vi, 1.)

249 *Art. aurif.*, II, p. 264. *

250 Steeb, *Coelum Sefhiroticum*, pp. 117f. *

251 *Art. aurif.*, I, p. 147.

252 *Theatr. chem.*, V, pp. 124, 127, 187.

253 *Ibid.*, p. 124. P. 128: “We must convert the member (i.e., the brain or heart) at the beginning of the work into that from which it is generated, and then we convert it through the spirit into whatsoever we will.” * “Member” means here a part of the body (“membrum cerebri,” p. 127). What is meant is a transformation of the brain into the *res simplex*, to which it is in any case related, “for it is a triangle in shape and is nearer than all members of the body to the likeness of the simple.” *

254 This seems to have made a particularly strong impression on Albertus Magnus, who believed he had proof that gold is formed in the head: “The greatest mineral virtue is in every man, and especially in the head between the teeth, so that in due time gold is found in tiny oblong grains . . . Wherefore it is said that the stone is in every man.” * (Cited in Ripley, “Axiomata philosophica,” *Theatr. chem.*, II, p. 134.) Can there have been gold-fillings in those days?

255 *Isis*, XVIII, p. 260.

256 Berthelot, *Alch. grecs*, I, iii, 1.

257 *Ibid.*, III, ii, 1.

258 *Ibid.*, III, xxix, 4.

259 “Characteres secretorum celandorum,” *Theatr. chem.*, II, p. 123.

260 The alchemists connected the “white stone” with Rev. 2 : 17: “... and I will give him a white pebble (*calculus*, ψῆφον) and upon the pebble a new name written, which no one knows except him who receives it.” (DV).

261 “Visio Arislei,” *Art. aurif.*, I, p. 148.

262 Hence the devil is expressly called “Lucifer.” Penotus therefore correlates the brain with the snake, to whom our first parents owed their first independent action. The Gnostic Naas and the *serpens mercurialis* of the alchemists play a similar role.

263 Hippolytus, *Elenchos*, IV, 51, 13 (Legge, I, p. 117). *

264 The parallels include Attis, Osiris, the serpent, and Christ.

265 ἀπό τοῦ ἀχαρακτηριστοῦ ἐγκεφάλου.

266 He adds: “But no one is aware of it,” another reference to unconsciousness.

267 *Elenchos*, V, 8, 13ff. (Legge, I, p. 133). Cf. Psalm 29 : 3: “The voice of the Lord is upon the waters,” and verse 10: “The Lord sitteth upon the flood.” For an alchemical parallel in Maier see *Psychology and Alchemy*, pars. 434ff.

268 This stone in the foundations of Zion may refer to Zech. 4 : 9f.: “The hands of Zorobabel have laid the foundation of this house, and his hands shall finish it . . . And they shall rejoice and shall see the tin plummet in the hand of Zorobabel. These are the seven eyes of the Lord that run to and fro through the whole earth” (DV). One of the alchemists brought this passage into connection with the lapis philosophorum on the ground that the “eyes of the Lord” were on the foundationstone. (Cf. *supra*, par. 45.)

269 *Elenchos*, V, 7, 35L (Legge, I, p. 129). The passages in parentheses are uncertain.

270 “Seminate aurum in terram albam foliata.” *Ros. phil., Art. aurif.*, II, p. 336 has: “Seminate ergo animam in terram albam foliatam.” Concerning terra foliata see Emblema VI in Maier, *Scrutinium chymicum*, pp. 16ff. The symbol probably derives from Senior, *De chemia*, pp. 24f.: “Likewise they call this water the lifegiving Cloud, the lower world, and by this they understand the foliate Water, which is the gold of the Philosophers, which Lord Hermes called the Egg with many names. The lower world is the body and burnt ashes, to which they reduce the venerable Soul. And the burnt ashes and the soul are the gold of the sages which they sow in their white earth, and [in] the earth scattered with stars, foliate, blessed, and thirsting, which he called the earth of leaves and the earth of silver and the earth of gold.” * “[Wherefore] Hermes said: Sow the gold in white foliate earth. For white foliate earth is the crown of victory, which is ashes extracted from ashes” * (p. 41). The “Liber de magni lapidis compositione” (*Theatr. chem.*, III, p. 33) mentions the “star Diana” as a synonym for *terra*.

271 In their use of the terms Luna and Terra the alchemists often make no distinction between the two. The following two sentences occur almost side by side in “Clangor buccinae” (*Art. aurif.*, I, p. 464): “Therefore *Luna* is the mother and the field in which the seed should be sown and planted,” * and “for I [says Sol] am as seed sown in good *earth*.”

* The generative pair are always Sol and Luna, but at least as often the earth is the mother. It seems that Luna represents the beloved and bride, while earth represents the maternal element. The “Introitus apertus,” *Mus. herm.*, p. 694 (Waite, II, pp. 194f.) says: “Know that our virgin earth here undergoes the last degree of cultivation, that the fruit of the Sun may be sown and ripened.” * The earth is the “mother of metals” and of all creatures. As *terra alba*, it is the “perfect white stone” (*Art. aurif.*, II, p. 490); but this phase of the *albedo* is called “full moon” and “fruitful white earth” (Mylius, *Phil. ref.*, p. 20). Just as Luna longs for her lover, so the earth draws down the moon’s soul. (Ripley, *Opera omnia*, p. 78.) Luna says to Sol: “I shall receive a soul from thee by flattery” * (Senior, *De chemia*, p. 8). The “Tractatus Micreris” (*Theatr. chem.*, V, p. 109) says: “From water falling upon the earth Adam was created, who is also the lesser world.” * Mylius (*Phil. ref.*, p. 185): “Earth is called the mother of the elements, for she bears the son in her womb.” * “Gloria mundi” (*Mus. herm.*, p. 221; Waite, I, p. 179) endows the filius with the dual birth of the hero: “although at his first birth he is begotten by the Sun and the Moon, he embodies certain earthly elements.” * “The father receives the son, that is, the earth retains the spirit.” * (Mylius, *Phil. ref.*, p. 137.) This whole identification of earth and moon is attested in antiquity: “For the lowest part of all the world is the earth, but the lowest part of the aether is the moon; and they have called the moon the aethereal earth.” * (Macrobius, *In somnium Scipionis*, I, 19, 10.) Pherecydes says the moon is the heavenly earth from which souls are born. In Firmicus

Maternus (*Matheseos*, V, praef. 5) the moon is even “the mother of mortal bodies.” For the connection between the moon and the earth’s fertility see Rahner, “Mysterium Lunae,” pp. 61ff.

272 Cf. “Psychology of the Transference,” pars. 469ff.

273 Proof of this is the controversy about universals, which Abelard sought to resolve by means of his “conceptualism.” Cf. *Psychological Types* pars. 68ff.

274 Theosophy and kindred systems are still based on this principle.

275 The presbyter Jodocus Greverus says in his “Secretum” (*Theatr. chem.*, III, pp. 785f.): “But do thou therefore, dear reader, receive the legitimate meaning of my words, and understand that philosophers are like to gardeners and husbandmen, who first choose their seeds, and when they are selected, sow them not in common earth, but in cultivated fields or prepared gardens.” * “But the Sun and Moon of the philosophers being taken as good seed, the earth itself is to be cleared of all its refuse and weeds, and worked with diligent tending, and after it has been thus tilled the aforesaid seeds of Sun and Moon are to be set therein.” *

276 “De arte chymica,” *Art. aurif.*, I, p. 613.” This earth is in the truest sense paradise, the “garden of happiness and wisdom.” “For it is the gift of God, having the mystery of the union of Persons in the Holy Trinity. O most wondrous knowledge, which is the theatre of all nature, and its anatomy, earthly astrology, proof of God’s omnipotence, testimony to the resurrection of the dead, pattern of the remission of sins, infallible rehearsal of the judgment to come and mirror of eternal blessedness.” * (Greverus, *Theatr. chem.*, III, p. 809.)

277 “Male and female created he them. From this we learn that every figure which does not comprise male and female elements is not a higher [heavenly] figure. . . . Observe this: God does not make his abode in any place where male and female are not joined together.” (*Zohar*, I, p. 177, mod.) Cf. “When we have trampled on the garment of shame, and when the two become one and the male with the female is neither male nor female” (*Stromata*, III, 13, 92). According to the *Zohar* (IV, p. 338), a male and female principle are to be distinguished in God himself. Cf. Wiinsche, “Kabbala,” Herzog and Hauck, *Realenzyklopädie*, IX, p. 679, line 43.

278 “Wherefore in the centre of the earth there is a most vast and raging fire, gathered together from the rays of the sun. It is called the abyss or nether world, and there is no other sublunar fire; for the dregs or earthly remains of the aforesaid principles, i.e., of the sun’s heat and of water, are fire and earth, set aside for the damned.” * (Mennens, *Theatr. chem.*, V, p. 370.)

279 “For he it is that overcomes fire, and by fire is not overcome; but in it amicably rests, rejoicing therein.” * (*The Works of Geber*, trans. by Russell, p. 135.)

280 Identified by Eleazar with Albaon = black lead.

281 This expression derives from Khunrath, *Hyl. Chaos*.

282 Cf. “The Spirit Mercurius” par. 263.

283 *Uraltes Chymisches Werck*, I, p. 63.

284 Χαλκολιβάνω, rendered by the Vulgate as *aurichalcum*, from *ὄρειχαλκος*, a copper alloy.

285 Cf. the dual aspect of the Cabalistic Tifereth, who corresponds to the Son of Man: “To the right he is called the Sun of righteousness, Malachi 4 : 2, but to the left [he is called the Sun] from the heat of the fire of Geburah.” * (*Kabbah denudata*, I, Part 1, p. 348.) Of the second day, which is assigned to Geburah, it is said: “On that day Gehenna was created” (ibid., p. 439).

286 Bibliothèque Nationale, Fr. 14765, pl. 8.

287 Cf. the 4 × 4 structure in *Aion*, par. 410.

288 “In natural things Yesod contains in itself quicksilver, for this is the foundation of the whole art of transmutation” * (*Kabbala denudata*, I, p. 441).

289 Cf. “The Spirit Mercurius,” par. 278.

290 “Yesod in human beings denotes the genital member of either sex” * (*Kab. den.*, I, p. 440). The divine name assigned to him is El-chai: “Wherefore Adonai burns with continual lust to fly to the measure of El-chai” * (p. 441). Yesod is also called “firm” and “true,” because he leads the “influx” of Tifereth down into Malchuth: “It is this firm step between Him and Her, that the most subtle nature of the semen sent down from above shall not be moved” * (p. 560). His cognomina are, among others: “redeeming angel, fount of living waters, tree of knowledge of good and evil, Leviathan, Solomon, Messiah the son of Joseph.” * The ninth Sefira (Yesod) is named “member of the covenant (or of circumcision).” (*Kabbala denudata*, I, Part 2, Apparatus in *Librum Sohar*, p. 10.) “The Zohar makes prominent use of phallic symbolism in connection with speculations concerning the Sefira Yesod” (Scholem, *Major Trends*, p. 228). The author adds: “There is of course ample room here for psychoanalytical interpretations.” In so far as the Freudian school translates psychic contents into sexual terminology there is nothing left for it to do here, since the author of the *Zohar* has done it already. This school merely shows us all the things that a penis can be, but it never discovered what the phallus can symbolize. It was assumed that in such a case the censor had failed to do its work. As Scholem himself shows and emphasizes particularly, the sexuality of the *Zohar*, despite its crudity, should be understood as a symbol of the “foundation of the world.”

291 “He is the spout for the waters from on high . . . and upon it are two olives, Nezach and Hod, the two testicles of the male” * (*Kabbala denudata*, I, Part 1, p. 330).

292 P. 544, “fons” p. 215.

293 P. 551.

294 *Ibid.*, p. 165, s.v. Botri.

295 P. 210, 5: “But the covenant of peace or perfection is so called because this mode makes peace and perfection between Tifereth and Malchuth, so that it is said thereof in I Chron. 29 : 11, ‘for this mode, which is called Qol [i.e., “All”], is in heaven and earth,’ the Targum using this paraphrase, that it is united with heaven and earth.” *

296 P. 500.

297 Pp. 674 and 661.

298 P. 677: “Near . . . and better than the brother from afar, who is Tifereth.” *

299 P. 14: “For the Strong One of Israel is the name midway between Nezach and Hod.” *

300 As *castella munita* (fortified strongholds) and *botri* (grapes), Nezach and Hod signify the testicles. (Pp. 156 and 165).

301 Yesod is also called, like Tifereth, *amicus fidelis*, the faithful friend: “In the Zohar, in speaking of that youth, it is said that the Just One (Yesod) shall be called the faithful friend, according to Song of Songs 7 : 10, ‘I am my beloved’s.’ And hence Yesod is called Friend, for he unites two lovers and friends; for through him is effected the union of Tifereth and Malchuth” * (p. 247).

302 P. 560. The symbolism is sexual (cf. supra, n. 290). The attribute “strong,” “mighty” applies to Tifereth as well as to Yesod.

303 P. 710.

304 P. 340.

305 P. 165.

306 P. 660: Proverbs 10 : 25: “But the righteous is an everlasting foundation.”

307 P. 441.

308 Pp. 441f. *

309 P. 442. * This appears to come from the alchemical treatise “Ash Metsareph,” on which Knorr elaborates in his “Apparatus.”

310 See supra, par. 329, n. 658.

311 From Ital. *cameo*, L. *cammaeus*.

312 As a multiple of 4, 64 thus represents the highest totality. The 64 hexagrams of the *I Ching* should probably be understood in the same way. They represent the course of the “valley spirit,” Tao, winding like a dragon or water. Cf. Rousselle, “Drache und Stute,” p. 28; also Tschärner, *Das Vermächtnis des Laotse*, p. 11.

313 *Kabbala denudata*, I, Part 1, p. 443.

314 “In the Zohar this letter is called the fount of life” * (pp. 439 and 366).

315 P. 144: “Aprokh: the chick of any bird. Deut. 22 : 6; Ps. 84 : 4. In Raya Mehimna, R. Simeon ben Yochai says that by this name is to be understood the grade Tifereth, as is apparent from its six members (limbs), which are six wings, wherewith it flies up and down. But in Tikkunim at the beginning of the book of R. Bar, Bar Channa: this name is said to refer to the Just One under the mystery of light reflected from the depths to the height. His words are these: Aepbrochim are flowers, which do not yet bear perfect fruit. They are the Sefiroth under the notion of a tree, which is turned from the depths upwards, and this with reference to Yesod.” *

316 “Feather, wing . . . the genital member . . . this name is expounded of Yesod, who is surnamed the Just One” * (p. 22).

317 See *Psychology and Alchemy*, fig. 228.

318 “The phoenix . . . from the glittering feathers about whose neck . . . is made a medicine most useful for restoring to the desired state of health all affections contrary to human nature” * (*Symbola*, p. 599).

319 *Kabbala denudata*, I, Part 1, pp. 499 and 737.

320 Ibid., p. 348.

321 Pp. 157, 266, 439.

322 The text continues: “As is well known, the woman by her warmth cooks the seed for generation” * (p. 465).

323 Judges 14 : 14.

324 “This is to be understood of the Son of God, who after having long imitated the terrible lion in rebuking the world’s sins, a little later, when he instituted the most holy sacrament of the Eucharist as his death drew nigh, turned himself into exceeding sweet honeycombs” * (Picinellus, *Mundus Symbolicus*, I, p. 397).

325 *Kabbala denudata*, I, Part 1, p. 16. *

326 Ibid., p. 16. * *Zohar*, I, 831a (Eng. trans., II, p. 339) says: “The world did not come into being until God took a certain stone, which is called the foundationstone, and cast it into the abyss so that it held fast there, and from it the world was planted. This is the central point of the universe, and on this point stands the Holy of Holies. This is the stone referred to in the verses, ‘Who laid the cornerstone thereof? (Job 38 : 6), ‘a tried stone, a precious cornerstone’ (Isaiah 28:16), and ‘The stone which the builders rejected has become the head of the corner’ (Psalm 118 : 22). This stone is compounded of fire, water, and air, and rests on the abyss.... ‘This stone has on it seven eyes’ . . . (Zech. 3 : 9). It is the rock Moriah, the place of Isaac’s sacrifice. It is also the navel of the world.”

327 *Kabbala denudata*, I, Part 1, p. 16. *

328 “See now that I, even I, am he, and there is no god with me; I kill, and I make alive; I wound, and I heal; neither is there any that can deliver out of my hand.”

329 He recommends his work to “philosophers, theologians of every religion, and lovers of the chymic art.” See title-page of Vol. I, [Part 1](#).

330 Pp. 16 and 18.

331 Pp. 16f.

332 The stone refers not only to the upper world but also to Malchuth: “In this perpetual name the mystery of the letter Yod (י) is involved, and that to the greatest degree in Malchuth, for in her exists the letter Yod. For the shapeless mass and form of the hath the figure of the stone, and Malchuth is the foundation and the stone on which the whole upper edifice is built. Of her it is said in Zachariah 3 : 9: Upon one stone there are seven eyes” * (p. 17). (Cf. supra, ch. II, “The Scintilla,” where I discuss the *κεφαλα* of Monoimos, the iota.) The “lower stone” has an evil significance in the Midrashic legend of Armillus, the “son of the stone.” The Midrash of the Ten Kings says: “And Satan will come down and have intercourse with the stone in Rome. The stone will conceive and bear Armillus.” “This stone is the wife of Belial, and after he had cohabited with her she became pregnant and gave birth to Armillus.” The latter has “squinting red eyes, two heads, green feet.” “His hair is red like gold.” He is thus a Typhon-like figure, the adversary of the second Adam. “He will come to the Edomites and say to them, I am your saviour.” The stone in Rome had “the shape of a beautiful girl, who was made in the first six days of the Creation.” Armillus corresponds to the threeheaded Azi-Dahaka of Persian legend, who subdued Yima, the Anthropos. See Murrelstein, “Adam,” pp. 75ff. Further variants in Hurwitz, *Die Gestalt des sterbenden Messias*.

333 *Das Buch Paragranum* (ed. Strunz), p. 77.

334 P. 64.

335 Cf. “Paracelsus as a Spiritual Phenomenon,” par. 234, n. 22.

336 *De vita longa*, p. 72.

337 *Theatr. chem.*, V, p. 899. *

338 “Ophirizum” may be derived from Ophir, whose pure gold was proverbial. (Cf. Job 22 : 24 and Isaiah 13 : 12.) Reusner’s *Pandora* (p. 304) gives for “purum aurum, clear gold”: “Obrizum aurum.” This agrees with Isidore of Seville, *Liber etymologiarum*, lib. XVI, cap. XVII, fol. 84r: “Obrycum aurum.” L. *obrussa*, Gk. *ὄβρυζον χρυσίον*, ‘pure gold’. Also mentioned in Pico della Mirandola, “De auro,” *Theatr. chem.*, II, p. 392.

339 Mylius, *Phil, ref.*, p. 151.

340 *Theatr. chem.*, II, p. 526. Cf. Rev. 21 : 21: “pure gold, as it were transparent glass.”

341 Helvetius, “Vitus aureus,” *Mus. herm.*, p. 826 (Waite, II, p. 280).

342 Bezold, *Die Schatzhöhle*, p. 4.

343 Picinellus, *Mundus symbolicus*, I, p. 690.

344 In *Ezechielem*, I, Horn, viii (Migne, *P.L.*, vol. 76, col. 863). He continues: “The virtues therefore of the heavens are signified by the sapphire stone, for these spirits . . . hold the dignity of the highest place in heaven.” * Cf. also *Moralia in Job*, lib. XVIII, cap. XXVII.

345 in *Ezechielem*, lib. I, Horn, vii: “The crystal . . . is congealed from water, and becomes solid. And we know how great is the mobility of water; but the body of our Redeemer, because it underwent sufferings even unto death, was in some respects like unto water; for in being born, growing up, and suffering weariness, hunger, thirst, and death, he pursued a mobile course moment by moment until his passion. . . . But because through the glory of his resurrection he was restored out of that corruptibility into the strength of incorruptibility, he hardened after the fashion of a crystal from water, so that there was one and the same nature in it and in him, and the mutability of corruption which had formerly been in him was no more. Therefore water was changed into crystal when the infirmity of corruptibility was changed into the strength of incorruptibility by his resurrection. But mark that the crystal is said to be dreadful, that is, to be feared . . . and to all who know the truth it is manifest that the Redeemer of mankind, when he shall appear as judge, will be comely to the just, but terrible to the unjust.” *

346 The Kingdom (Basilia) refers to Malchuth.

347 The Macroprosopos corresponds to the first triad of the Aziluth system: Kether (*corona*), Binah (*intelligentia*), and Hokhmah (*sapientia*). “It is certain that Macroprosopos, the Father and Mother, are the Crown, Wisdom and Intelligence of the emanative world after the restitution.” * (Ibid., sect. 166, pp. 56f.) This triad is a real Trinity: “From the first three parts of the world of emptiness are constituted three supreme heads, which are contained in the Most Holy Ancient One. But all three are counted as one in the emanative world, which is Macroprosopos.” * The *λόγος μακρόκοσμος ΟΥ μακροπρόσωπος* occurs in Philo.

348 “Commentarius generalis,” *Kabbala denudata*, II, Part 2, Tract. IV, p. 61. *

349 Christ is called lapis in the patristic literature. Cf. for example St. Gregory, *Expos, in I Reg.*, lib. IV, cap. vii, 12 (Migne, *P.L.*, vol. 79, col. 212): “The stone in Holy Writ signifies our Lord and Redeemer.” *

350 Berthelot, *Alch. grecs*, III, vi, 5. Cf. *Psychology and Alchemy*, par. 405.

351 Daniel 2 : 34 (DV).

352 Cf. “The Spirit Mercurius,” pars. 270ff., 283.

353 Cf. “The Phenomenology of the Spirit in Fairytales,” pars. 425f., 436ff.

354 *The Celestial Hierarchies*, III, 3 (Eng. trans., p. 18).

355 The fate of the Shulamite corresponds, in a sense, to that of Sophia among the Gnostics, as reported by Irenaeus. (Cf. *Aion*, pars. 75, n. 23, 118, n. 86, 307, n. 33.)

356 Geryon was the son of Callirhoe and Chrysaor, who sprang from the blood of the Gorgon.

357 *Elenchos*, V, 8, 4.

358 Ibid., V, 6, 6f. (Cf. Legge, I, p. 121).

359 Similar ideas can be found in the *Panarium* of Epiphanius, XXX, 3 (ed. Holl, vol. I, p. 336): The Elkesaites declared that Adam was Christ. He came down into Adam, put on his body and appeared to Abraham, Isaac, and

Jacob. Concerning Abraham's grave on Golgotha see *ibid.*, XLVI, 5 (II, pp. 208f).

360 "Osiris, heavenly horn of the moon" is a cognomen of Attis. (*Elenchos*, V, 9, 8.)

361 John 1 : 3.

362 *Elenchos*, V, 8, 4f. (Cf. Legge, I, pp. 131f.).

- 1 *Problems of Mysticism and Its Symbolism*, p. 121.
- 2 *Entstehung und Ausbreitung der Alchemie*.
- 3 *Turba Philosophorum* (ed. Ruska), p. 119.
- 4 *Ibid.*, p. 127.
- 5 *Ibid.*
- 6 P. 126.
- 7 Berthelot, *Alch. grecs*, III, xl 2.
- 8 Aegidius de Vadis, "Dialogus" (*Theatr. chem.*, II, p. 99): "But minerals and vegetables are of hermaphrodite nature in that they have twofold sex. Nonetheless, there comes about between them a conjunction of form and matter, as with animals." *
- 9 "Rosinus ad Sarratantam" (*Art. aurif.*, I, p. 302): "Wherefore there are said to be two sulphurs and two quicksilvers, and they are such that they are called one and one, and they rejoice together, and the one contains the other."**
- 10 *Ibid.*
- 11 The mixture and union of the elements is called the "ordo compositionis" ("Liber Plat, quartorum," *Theatr. chem.*, V, p. 182). Wei Po-yang says: "The way is long and obscurely mystical, at the end of which Ch'ien (yang) and K'un (yin) come together" (pp. 210ff).
- 12 Maier, *Symbola*, p. 178.
- 13 The "red man" and the "white woman," or "Red Sea sand" and "sputum of the moon." *Mus. herm.*, p. 9 (Waite, I, p. 12).
- 14 *Ibid.*, p. 11 (Waite, I, p. 14).
- 15 As in the *Turba*, p. 117.
- 16 The "copulatio" takes place in "mercurio menstruali" ("Exercit. in Turbam," *Art. aurif.*, I, p. 161) or in a bath of *aqua permanens*, which again is Mercurius. Mercurius is both masculine and feminine and at the same time the child born of their union.
- 17 *Mus. herm.*, pp. 622ff. (Waite, II, pp. 142ff.)
- 18 See *Aion*, pars. 250ff.
- 19 "If a man would attain the highest good, he . . . must rightly know first God and then himself." * *Mus. herm.*, p. 105 (Waite, I, p. 93).
- 20 Dorn, "Phil, meditativa," *Theatr. chem.*, I, p. 467. "But piety is grace sent down from God, which teaches every man to know himself as he really is" * ("Detenebris," *Theatr. chem.*, I, p. 462).
- 21 Berthelot, *La Chimie au moyen âge*, III, p. 50.
- 22 *Theatr. chem.*, V, p. 144.
- 23 "... when you see the substances mingle in your distilling vessel." * *Mus. herm.*, p. 685 (Waite, II, p. 187).
- 24 "Exercit. in Turbam," *Art. aurif.*, I, p. 159. Also in *Theatr. chem.*, I, p. 180.
- 25 Ripley, *Opera omnia*, pp. 38 and 81. Cf. also Ventura, *Theatr. chem.*, II, p. 291: "Let a tomb therefore be dug and the woman buried with the dead man." * This is a reference to *Turba*, Sermo LIX, but there the woman is buried with the dragon (*supra*, par. 15).

- 26 *Mus. herm.*, p. 686 (Waite, II, p. 188). Cf. “Psychology of the Transference,” par. 468.
- 27 Dorn, “Physica Trismegisti,” *Theatr. chem.*, I, p. 418.* Cf. his remark “tertium esse necessarium” (“Congeries Paracelsicae,” *Theatr. chem.*, I, p. 577).
- 28 Ventura, *Theatr. chem.*, II, p. 320.*
- 29 *Ibid.*, p. 332.
- 30 Ripley, “Axiomata philosophica,” *Theatr. chem.*, II, p. 125. Similarly in *Mus. herm.*, p. 39 (Waite, I, p. 42).
- 31 *Art. aurif.*, I, p. 281.
- 32 *Ars chemica*, p. 74. The counterpart of the “Luna odorifera” mentioned here is the *odor sepulcrorum* (stench of the graves).
- 33 **Μύρον εὐωδέστατον**. Hippolytus, *Elenchos*, VII, 22, 14.
- 34 “The aerial water existing between earth and heaven is the life of everything. For that water dissolves the body into spirit, makes the dead to live, and brings about the marriage between man and woman.” * (Mylius, *Phil. ref.*, p. 191.)
- 35 “[It is able to] moisten what is dry, and to soften what is hard, and to conjoin and weaken bodies” * (*Theatr. chem.*, V, p. 111).
- 36 *Chymical Wedding*.
- 37 Kerényi, *Das Aegaeische Fest*, p. 55.
- 38 “Exercit. in Turbam,” *Art. aurif.*, I, pp. 160f.
- 39 “In a way not unlike that in which God in the beginning created one world by meditation alone, so likewise he created one world, from which all things came into being by adaptation” * (*Theatr. chem.*, I, p. 417).
- “Also, as there is only one God and not many, so he willed at first in his mind to create from nothing one world, and then to bring it about that all things which he created should be contained in it, that God in all things might be one” * (*ibid.*, p. 415).
- 40 *Ibid.*, p. 418.*
- 41 Cf. the “mountain” in which all knowledge is found, but no distinctions and no opposites. (Abu’I-Qasim Muhammad, *Kitāb al-’ilm al-muktasab*, p. 24.) Further material in *Psychology and Alchemy*, par. 516 and n. 1.
- 42 See “Concerning Mandala Symbolism,” par. 645.
- 43 Cf. *Psychology and Alchemy*, par. 426 and n. 2, fig. 195.
- 44 Cf. my “Synchronicity: An Acausal Connecting Principle.”
- 45 Cf. his *New Frontiers of the Mind* and *The Reach of the Mind*. The relevant phenomena are discussed in “Synchronicity,” pars. 833ff.
- 46 Balsam occurs in Zosimos as a synonym for the *aqua permanens*. (Berthelot, *Alch. greccs*, III, xxv, 1.)
- 47 Cf. “Paracelsus as a Spiritual Phenomenon,” par. 171.
- 48 “For there is in man’s body a certain substance conformable to the ethereal, which preserves the other elemental parts in it and causes them to continue” * (“Phil. meditativa,” *Theatr. chem.*, I, p. 456).
- 49 “And we do not deny that our spagyric medicine is corporeal, but we say that it is made spiritual when the spagyric spirit clothes it” * (*ibid.*). A synonym for balsam is the wine that is “duplex,” i.e., both “philosophic” and

“common” (ibid., p. 464).

50 Ibid., p. 456.*

51 For instance in Reusner’s *Pandora. Cf. Psychology and Alchemy*, fig. 232.

52 See “Psychology of the Transference,” pars. 419ff. The incest symbolism is due to the intrusion of endogamous libido. The primitive “cross-cousin-marriage” was superseded by a pure exogamy which left the endogamous demands unsatisfied. It is these demands that come to the fore in incest symbolism.

53 This is already the case with the alchemist Democritus, who probably lived at least as early as the 1st cent. A.D. For him it is a marriage of the natures. (Texts in Berthelot *Alch. grecs*, II, i ff.) Significantly enough, the last and grandest example of an alchemical opus, Goethe’s *Faust*, ends with the apotheosis of the Virgin Mother, Mary-Sophia, queen and goddess. The epithet “dea” also occurs in Mechthild of Magdeburg.

54 This does not contradict the statement that symbols are the best possible formulation of an idea whose referent is not clearly known. Such an idea is always based on a tendency to represent its referent in its own way.

55 Another example is the series of mandalas in “A Study in the Process of Individuation.”

56 Further material in Heiler, *Das neue Mariendogma im Lichte der Geschichte*.

57 Cf. Emblema L in Maier’s *Scrutinum chymicum*, p. 148. Cf. also *Turba*, Sermo LIX.

58 *Scrut. chymicum*, p. 46, and *Mus. herm.*, pp. 351, 357 (Waite, I, pp. 285, 291).

59 “Merlini allegoria,” *Art. aurif.*, I, p. 393.

60 “Therefore the mind is well said to be composed when the spirit and the soul are joined by such a bond that the bodily appetites and the heart’s affections are restrained” * (“Phil, medit.,” *Theatr. chem.*, I, p. 451).

61 Ibid., pp. 451f.

62 Here Dorn cites the “verbum Dei”: “He that loveth his soul shall lose it, and he that hateth his soul preserveth it for ever” * (p. 453). Cf. Matthew 16 : 25, Luke 17 : 33, and John 12 : 25.

63 Cf. the parallel in Wei Po-yang: “Closed on all sides, its interior is made up of intercommunicating labyrinths. The protection is so complete as to turn back all that is devilish and undesirable. . . . Cessation of thought is desirable and worries are preposterous. The divine *ch’i* (air, spirit, ethereal essence) fills the quarters. . . . Whoever retains it will prosper and he who loses it, will perish.” (P. 238.)

64 The *distractio* is something that “some call voluntary death.” Cf. the death of the royal pair in *Ros. phil.*, discussed in “Psychology of the Transference,” pars. 467ff.

65 Cf. supra, par. 355.

66 Early references are given in *Psychology and Alchemy*, pars. 453f.

67 “It is impossible for a man of evil life to possess the treasure that is concealed from the sons of wisdom, and he is unfit to acquire it or to search it out, much less to find it” * (“Phil, medit.,” p. 457).

68 “I have thought it right to admonish the disciples to implore the divine aid, and [to remind them] of the need for the most careful diligence in preparing themselves for the reception of this grace” * (ibid.).

69 “I am the true medicine [says Wisdom], correcting and transmuting that which *is no longer* into that which it *was before* its corruption, and that which *is not* into that which it *ought to be.*” * (Ibid., p. 459).

70 The vinum philosophicum contains the *essentia caelestis*. (“Phil, medit.,” p. 464.)

71 P.457.

72 “But truth is the supreme virtue and an impregnable stronghold” * (p. 458).

73 P. 464.*

74 “Grana” can also mean grape-pips.

75 For details of this procedure see *infra*.

76 P. 465.

77 Cf. Rupescissa, *La Vertu et la propriété de la quinte essence*. The quintessence is the equivalent of heaven (p. 15). It is also called “esprit du vin” and “eau de vie.” It is the “ciel humain” (p. 17), “de la couleur du ciel” (p. 19).

78 Dorn is probably referring here to the magical procedure described in the second part of Artefius, “Clavis maioris sapientiae” (*Bibl. chem.*, I, pp. 503ff., and *Theatr. chem.*, IV, pp. 236ff.), whereby the planetary spirits who are needed in order to unite the spirit or soul with the body, and to transform the latter, are compelled to descend. Cf. the pictures of the coniunctio in the bath in the Ripley Scrowle and its variants, one of which is given in *Psychology and Alchemy*, fig. 257.

79 “Phil. medit.,” p. 466. “Sunt igitur stellae nobis inferiores individua quaevis a natura hoc in mundo inferiori producta coniunctione videlicet earum et caeli tanquam superiorum cum inferioribus elementis” (*Theatr. chem.*, 1602, 1, p. 466).

80 *Ibid.*, pp. 465f.

81 “The elixir of honey preserves and cleanses the human body from all imperfections, both within and without” (Penotus, *Theatr. chem.*, I, p. 730). The first chapter of Paracelsus’ *Lumen apothecariorum* (Huser, VII, pp. 222ff.; Sudhoff, II, 193ff.) is devoted to honey. In the “third elevation” the honey becomes a “deadly poison,” like “Tartarus mortalis.” *Von den Tartarischen Krankheiten*, cap. XIV (Huser, II, p. 239; Sudhoff, XI, pp. 88f.). It contains “Tartarum” (Huser, p. 223). It occurs in Zosimos as the *aqua permanens* (Berthelot, *Alch. grecs*, III, xxv, 1). Both here and in the *Turba* (Sermo XXXVII (p. 16) it forms, with vinegar, a pair of opposites.

82 “Chelidonia” occurs as a secret name in the version of the *Turba* given in *Art. aurif.*, I, pp. 1ff., which does not differ appreciably from Ruska’s text: “Some philosophers have named gold Chelidonia, Karnech, Geldum.” * Ruska explains “Geldum” as “Chelidonium maius L.” (p. 28). Dioscorides (*Materia medica*, II, cap. 176, p. 302) says that with this herb swallows cure blindness in their young. In the Herbal of Tabernaemontanus (I, p. 106) it is cited as an eye-salve (against night-blindness). In Ruland (*Lexicon*, p. 98) Chelidonia is a pseudonym for gold (presumably on account of its yellow flowers). In the maws of young swallows two small stones are found, the “lapides Chelidonii,” one of them black, the other red (*ibid.*, pp. 98–99). On account of its colour, the eye-salve (*Succus chelidoniae*) is used to extract the moisture (soul) of Mercurius. (Dorn, “Congeries Paracelsicae,” *Theatr. chem.*, I, p. 582). Sal Chelidoniae is mentioned as an “emmenagogue and solvent” (I, p. 759). Chelidonia is a name for the lapis (IV, p. 822) and a cure for insanity (V, p. 432). In Paracelsus there are four Chelidonias synonymous with “anthos” (*Paragranum*, Part II, “De philosophia”; Sudhoff, VIII, pp. 68–90). (Cf. “Cheyri” in “Paracelsus as a Spiritual Phenomenon,” par. 171 and n. 7.) Chelidonia is a preservative against thunderstorms (*De phil. occulta*, Huser, IX, p. 361, Sudhoff, XIV, p. 537).

83 “Ros” (dew) = *aqua permanens*. According to Tabernaemontanus, rosemary is an alexipharmic (p. 312).

84 Tabernaemontanus (II, pp. 940ff.) says that *Mercurialis testiculata* (Dog's mercury) was found, like moly, by Mercurius, has a divided sex and is an emmenagogue. According to Dioscorides, Mercurialis, inserted into the vagina, determines the sex of the child (*Mat. med.*, lib. IV, cap. 183, p. 559). "Mercurialis saeva: Water of Alum wherein Mercury is generated. It is . . . of a golden colour" (Ruland, *Lexicon*, p. 231).

85 Liliū = Mercurius and *quinta essentia sulphuris* (Ruland, p. 207). "The Lily of Alchemy and Medicine . . . this is the noblest thing of all the manifestations of the supreme Creator which man may meditate upon." * (Dorn, "Congeries Paracelsicae," p. 608.) *Anthera* (presumably stamen) *liliorum* is given in Paracelsus as an alexipharmic (*Scholia in poëmata Macri*, Huser, VII, p. 268, Sudhoff, III, p. 414). The *succus liliorum* is "mercurial" and "incombustible" (Grasseus, "Area arcani," *Theatr. chem.*, VI, p. 327). Coniunctio of the white and red lily (*ibid.*, p. 335).

86 Blood is a synonym for the red tincture (= aqua permanens), a preliminary stage of the lapis (Ruland, p. 286). *Sanguis hominis ruffi* = Sulphur = *Mercurius solis* (*ibid.*).

87 Penotus (*Theatr. chem.*, I, p. 749) says of tartar: "It performs wonderful things in the spagyric art, for by its mediation the light of day is turned into the prima materia." * *Saturnus calcinatus* was named by Ripley the "tartar from black grapes" (Orthelius, *Theatr. chem.*, VI, p. 471).

88 This probably refers to the treatise of Artefius (n. 78).

89 "Phil. medit.," pp. 470f.

90 "Corpus tandem in amborum iam unitorum unionem condescendere cogitur et obedire."

91 Perhaps this saying lies at the root of the word "spagyric," from *σπάειν*, 'to rend, tear, stretch out,' *ἀγείρειν*, 'to bring or collect together.'

92 "Quis haerebit adhuc nisi lapis in generatione spagirica?" That is to say, the centre of the earth and the stone correspond.

93 Pp. 466ff.

94 *Lumen apothecariorum* (Huser, VII, pp. 222ff.).

95 The essence.

96 Cf. "The Spirit Mercurius," par. 276.

97 "Harmonía chemica," *Theatr. chem.*, IV, p. 820.

98 Cf. "The Spirit Mercurius," par. 278.

99 Cf. *Psychology and Alchemy*, par. 265, also *Aion*, par. 206.

100 So, too, in Paracelsus, where the soul, Melusine, lives in the blood. Cf. "Paracelsus as a Spiritual Phenomenon," par. 180.

101 Cf. the passage from the *Fihrist-el-U'lum* of Muhammad ibn Ishak al-Nadim in Chwolsohn, *Die Ssabier und der Ssabismus*, II, pp. 19f., describing the maceration of a man's body in oil and borax. The head of the corpse was then used as an oracle. See also the report by Laurens van der Post in "Transformation Symbolism in the Mass," par. 370.

102 Cf. the description of the *caput mortuum* in Christianos: "... black and soulless and dead, and so to speak unbreathing." * (Berthelot, *Alch. greccs*, VI, xii, 1.) Phlegm has also a moral connotation: "Sow likewise thy wisdom in our hearts, expel from them the phlegm, the corrupt choler and boiling blood, and lead us in the ways of the blessed" * ("Allegoriae sap.," *Theatr. chem.*, V, p. 66). The residue, the "black earth," is the ash of which the

“Tractatus Micreris” says: “Despise not the ashes . . . for in them is the diadem, the ash of the things that endure” * (*Theatr. chem.*, V, p. 104).

103 There is in man a “marmoreus tartarus,” a “very hard stone” (Ruland, p. 220). Bowls of marble or serpentine are said to give protection against poison. (Hellwig, *Lexikon Medico-Chymicum*, p. 162.) “Know also that the spirit is enclosed in a house of marble; open therefore the passages that the dead spirit may come forth” * (“Alleg. sap.,” p. 66).

104 Dorn, “Phil, medit.,” pp. 457f. Obviously, therefore, the immortal part of man.

105 “Therefore, for the preparation of a good disposition of the body, we make use of the spagyric medicine” (ibid., p. 457).*

106 Lévy-Bruhl’s view has recently been disputed by ethnologists, not because this phenomenon does not occur among primitives, but because they have not understood it. Like so many other specialists, these critics prefer to know nothing of the psychology of the unconscious.

107 Cf. “Thereniabin,” manna, etc. Honeydew or “maydew” occurs in Paracelsus. Cf. “Paracelsus as a Spiritual Phenomenon,” par. 190 and n. 93.

108 Baechtold-Stäubli, *Handwörterbuch*, s.v. Schellkraut.

109 Ibid., pp. 86f.

110 “And the Spagyric makes of the four a harmonious whole, as the flower Cheyri shows” (*De vita longa*, Book III, cap. I, in Sudhoff, I, 3, p. 301).

111 Cf. *Mus. herm.*, p. 112 (Waite, I, p. 98).

112 Cf. “extraction of the cogitation” in “Liber Plat, quartorum,” *Theatr. chem.*, V, p. 144.

113 *Aion*, pars. 239ff.

114 *Pandora*, p. 253. Cf. *Psychology and Alchemy*, fig. 232.

115 “The Lapis-Christ Parallel.”

116 Ch. v.

117 Also called “ros Gideonis” with reference to Judges 6 : 36ff. This is an ancient idea, cf. Macrobius (*Saturnalia*, VII, 16): “There is in its [the moon’s] light something that flows down from it, which moistens bodies and soaks them with a kind of hidden dew.” * Dew wakens the dead and is the food of the holy (*Zohar*, 128b). Irenaeus speaks of the “dew of light” in Gnosticism (*Adv. haer.*, I, 30, 3, and III, 17, 3). In Rabanus Maurus it is “God’s grace” (Migne, *P.L.*, vol. 112, col. 1040). In Romanus it is Christ (Pitra, *Analecta sacra*, I, p. 237). Dew contains the “mellifluous nectar of heaven” (Steeb, *Coel. sephiroth.*, p. 139). Hermes Trismegistus meant dew when he said in the “Tabula Smaragdina”: “Its father is the sun, its mother the moon.” (*De alchimia*, p. 363). Dew is frequently mentioned in the *Turba* (e.g., in Sermo 58).

118 Theodore the Studite (Pitra, I, p. 337): “Thou hast made right faith to give forth an odour above ointment.” * “It imbued the whole world with the odour of knowledge” * (ibid., p. 342). The “Great Book of the Mandaeans” speaks of the “odour of almighty life” (Lidzbarski, *Ginza, der Schatz*, p. 110). Compare the sweet odour of Sapientia with the perfume of the mother goddess in and around the temple of Hierapolis (Lucian, “The Syrian Goddess,” *Works*, I, p. 261), and with the scent of the Tree of Life in the Book of Enoch (Charles, *Apocrypha and Pseudepigrapha*, II, p.

205). See also Nestle, “Der süsse Geruch als Erweis des Geistes,” p. 95, and Lohmeyer, “Vom göttlichen Wohlgeruch,” pp. 41ff.

119 Baechtold-Stäubli, *Handwörterbuch*, s.v. Rosmarin.

120 *Von hylealischen Chaos*, pp. 263ff.

121 *Ibid.*, p. 264.

122 P. 260.

123 “Isis and Osiris,” cap. 57, *Moralia*, V, p. 137.

124 Such was the significance of the Rubeus in the art of geomancy, much practised in Dorn’s day.

125 Concerning the rotation of the mandala see “Concerning Mandala Symbolism,” par. 693 and Fig. 38, also *Aion*, pars. 408ff.

126 A *σύμβολον* is a ‘throwing together.’

127 Cf. “Relations between the Ego and the Unconscious,” pars. 341ff.

128 Cf. *Lexicon*, p. 226.

129 Cf. *Aion*, pars. 70ff.

130 In Chinese alchemy this is *chên-yên*, the true man (*τέλειος ἄνθρωπος*). “True man is the extreme of excellence. He is and he is not. He resembles a vast pool of water, suddenly sinking and suddenly floating. . . . When first gathered, it may be classified as white. Treat it and it turns red. . . . The white lives inside like a virgin. The squareness, the roundness, the diameter and the dimensions mix and restrain one another. Having been in existence before the beginning of the heavens and the earth: lordly, lordly, high and revered.” (Wei Po-yang, pp. 237f.)

131 *Theatr. chem.*, IV, pp. 948ff.

132 Here a synonym for Mercurius. Cf. Ruland, *Lexicon*, p. 24.

133 In the strictest sense of the word, a “symbolum” is a coin broken into two pieces, so that the halves “tally.” Cf. Aegidius de Vadis, “Dialogus” (*Theatr. chem.*, II, p. 107): “... concord and discord, which we take to mean symbolization.” * The symbolum here means the capacity of elements to combine; it is the “retinaculum elementorum,” the rope of the elements. (Lully, “Theorica et practica,” *Theatr. chem.*, IV, p. 133.)

134 Instead of *medioxime*.

135 Presumably derived from *μονόκαυλος* (bot.), ‘one-stemmed’, but more probably a misprint for *monocolus* (*μονόκωλος*), ‘one-footed’, or for the late Latin *monocaleus*, ‘having only one testicle, semi-castrated.’ (Cf. Du Cange, *Glossarium*, s.h.v.) *Monocaleus* might be a reference to the androgynous nature of Mercurius. The conjecture *monocerus* (*μονόκερως*) is possible, since the unicorn signified Mercurius and was well known in 16th- and especially 17th-cent. alchemy. (Cf. *Psychology and Alchemy*, pars. 518, 547.) According to Horapollo the scarab, which in the Leyden Papyrus is identical with Osiris, is one-horned (*ibid.*, par. 530).

136 The text is not in a good state. I have therefore placed a full point after “praeponderat” and begin a new sentence with “dum in sua natura.”

137 Obviously its arcane nature.

138 By which something like “cohesion” is meant.

139 Particularly *Aion*.

- 140 Cf. “A Study in the Process of Individuation” and “Concerning Mandala Symbolism.”
- 141 Berthelot, *Alch. grecs*, II, i, 3.
- 142 Khunrath, *Hyl. Chaos*, p. 195. Cf. supra, pars. 472ff.
- 143 For instance in Mylius, *Phil. ref.*, p. 244, and Ros. *phil., Art. aurif.*, II, p. 381: “And I illumine all luminaries with my light.”
- 144 Cf. *The Franciscan Vision*, pp. 14f. For the “one day” in Epiphanius, see supra, pars. 472ff.
- 145 Cf. Ephesians 3 : 18: “... so that . . . you may be able to comprehend . . . what is the breadth and length and height and depth ...”
- 146 The alchemical sign for the four elements is a cross.
- 147 An expression occurring only once.
- 148 Supra, pars. 634ff.
- 149 Eleazar, *Uraltes Chymisches Werck*.
- 150 The Latin MS. “Figurarum aegyptiorum secretarum” (author’s possession) has on fol. 19: “Duo tantum sunt coadjutores qui hic perficiuntur.” Pl. 4 is taken not from the Paris Codex but from the above MS., fol. 20. The pictures are similar in both. [Cf. *Psychology and Alchemy*, par. 391, n. 101.]
- 151 The corresponding picture in my MS. (fol. 27) bears the inscription: “Sic fit, ut quod latuit, pateat.”
- 152 Just as Albertus supposes that gold is silver “inside” and vice versa. Here I would recall to the reader the dream of the black and white magicians, discussed supra, pars. 79f.
- 153 Pernety (*Les Fables égyptiennes et grecques*, I, p. 179) says of the putrefaction: “It uncovers for us the interior of the mixture. . . . It makes . . . the hidden manifest. It is the death of accidentals, the first step to generation.”
- 154 The king’s foot is the right one. This has always been regarded as masculine and luck-bringing. That is why in some countries one starts to march with the right foot. Besides this, the foot in general has a phallic significance. See Aigremont, *Fussund Schuhsymbolik und -Erotik*.
- 155 He has himself become the “black earth” referred to earlier: “Prenez cette terre noire.”
- 156 Maier, *Symbola*, pp. 344f.
- 157 Berthelot, *Alch. grecs*, II, iv, 42.
- 158 Corresponding to the ὕδροποιός ἀρχή in Plutarch (“Isis and Osiris,” c. 33, *Moralia*, V, pp. 80f.)
- 159 “... the seeds of fruits are Osiris” (*De errore prof, relig.*, 2, 6).
- 160 Osiris is also likened to the Logos, the corpse, and the grave. (Hippolytus, *Elenchos*, V, 8, 10; V, 8, 22; V, 9, 5 and 8.)
- 161 Hippolytus, V, 8, 10. Although there are no one-footed heroes in Greek mythology, names like Oedipus and Melampus and ideas such as that of the one tooth and one eye of the Phorcyds suggest something very similar.
- 162 Plutarch, “Isis and Osiris,” c. 22, pp. 54f.
- 163 Doelger, *Die Sonne der Gerechtigkeit und der Schwarze*, p. 64.
- 164 Cf. von Franz, “Die Passio Perpetuae,” in *Aion* (Swiss edn.), pp. 467f.
- 165 *Theatr. chem.*, III, p. 854. In “Super arborem Aristotelis” (*Theatr. chem.*, II, p. 526) the *nigredo* or *caput corvi* is termed the “caput nigrum aethiopsis.”

166 Cf. Reitzenstein, *Die hellenistischen Mysterienreligionen*, p. 80.

167 Jacobsohn, *Die dogmatische Stellung des Königs in der Theologie der alten Aegypter*, p. 23: “Hail to thee [Osiris] . . . who risest in the heavens as Ra, renewing thy form as the moon.”

168 Cf. Lippmann, *Entstehung und Ausbreitung der Alchemie*, I, pp. 180, 303, 326.

169 The bird of Hermes is usually the goose.

170 *Mus. herm.*, pp. 581f. (Waite, II, p. 108).*

171 *Ros. phil., Art. aurif.*, II, p. 258.*

172 *Ibid.*, p. 259.

173 “it [the water] is also called a round cloud, death, blackness, darkness, shadow.” * *Mus. herm.*, p. 327 (Waite, I, p. 263). Rupescissa speaks of a “dark blue cloud” (*La Vertu et la propriété de la quinte essence*, p. 29). It is mentioned in the *Turba* (ed. Ruska, pp. 120f.) together with the shadow. “That work comes about as suddenly as the clouds from heaven” (Hoghelande, *Theatr. chem.*, I, p. 204).* In Mylius (*Phil. ref.*, pp. 108 and 304) the “water of the cloud” is Mercurius, also in Abu’l-Qasim (p. 420). “Black clouds” are the *nigredo* (Mylius, p. 234, and “Tractatus aureus,” *Ars chemica*, p. 15). References to the “cloud rising from the sea,” “the new waters,” “the life-potion that rouses the sleepers” occur in the very ancient treatise of Komarios (Berthelot, *Alch. grecs*, IV, xx, 8), and in Rabanus Maurus the cloud represents the “comfort of the Holy Ghost and Christ’s ascension” (Migne, *P.L.*, vol. 112, col. 1007). This would correspond to the remark in Komarios that “the clouds rising from the sea carry the blessed waters” (Berthelot, IV, xx, 12). Augustine likens the apostles to a cloud, which symbolizes the concealment of the Creator under the flesh (*Expositions of the Book of Psalms*, Ps. 88 (89) : 7, IV, p. 245). Similarly, Christ was prefigured by the pillar of cloud that guided the Jews through the wilderness (Augustine, Ps. 98 (99): 10, p. 456, and Epiphanius, *Ancoratus*). “From thee the clouds flow,” says Hildegard of Bingen of the Holy Ghost (Remy de Gourmont, *Le Latin mystique*, p. 157). The alchemical concept of the cloud may have been influenced by the liturgical “Drop down dew, ye heavens, from above, and let the clouds rain down the Just One: let the earth open and bud forth a Saviour” (*Roman Missal*, Introit for 4th Sunday of Advent. Cf. Isaiah 45 : 8). One thinks also of the Eleusinian *ἕε κύε*, “Let it rain, make fruitful!” (Cf. Kerényi, “Kore,” pp. 205f.) In Mandaicism the cloud signifies the feminine. One of the texts says: “Yonder, yonder I stand, I and the cloud that arose with me” (Lidzbarski, *Ginza*, p. 399).

174 In a lecture at the Eranos Conference of 1945, which was not printed in the *Eranos Jahrbuch*, Rahner discussed the allegory of the devil in patristic literature.

175 “The Phenomenology of the Spirit in Fairytales,” sects. III and IV.

176 Based on Psalm 102 : 6: “I am like an owl of the desert.” Cf. Eucherius, *Liber formularum spiritualis intelligentiae* (Migne, *P.L.*, vol. 50, col. 750), and Rabanus Maurus (Migne, *P.L.*, vol. 112, col. 1006). For the crucifixion of the raven see “Spirit in Fairytales,” par. 422. Referring to the story in Aelian, Caussin says: “The raven, overcome with age, offers itself for food to its young; but our phoenix, Christ the Lord . . . offered himself to us as heavenly nourishment” * (*Polyhistor symbolicus*, pp. 308f.). The raven is thus an allegory of Christ, or of the Host.

177 *Oxford English Dictionary*, s.v. colcothar.

178 *Mus. herm.*, p. 117 (Waite, I, p. 102).

179 Ibid., pp. 91 and 117 (Waite, I, pp. 82, 102).

180 “Liber de arte chymica” (*Art. aurif.*, I, p. 610) mentions in this connection a trinitarian image of three suns, black, white, and red. The commentary to “Tractatus Aureus” (*Theatr. chem.*, IV, p. 703) remarks that there are three ravens on the mountain of the Philosophers: “The black which is the head of the art, the white which is the middle, and the red which brings all things to an end.” * “Consil. coniugii” (*Ars chemica*, p. 167) even mentions a quaternity of ravens. In the Book of El-Habib (Berthelot, *La Chimie au moyen âge*, III, p. 100), Mary says that the red male (i.e., the Sulphur) should be recognized as the “head of the world.”

181 Mylius (*Phil. ref.*, p. 19) comments that if Lucifer had had within him the *anima media natura* or God, he would not have been cast into hell.

182 “When you see your matter going black, rejoice: for that is the beginning of the work.” * (*Ros. phil.*, *Art. aurif.*, II, p. 258) “The raven’s head is the beginning of the work” * (Hoghelande, *Theatr. chem.*, I, p. 166).

183 “It is called antimony, pitch, coal, the raven, the raven’s head, lead, burnt copper, burnt ivory” * (*Theatr. chem.*, I, p. 166).

184 *Ros. phil.*, p. 265.

185 “And thus you have two elements, first water by itself, then earth from water” * (ibid.).

186 Steinerus, *Dissertatio chymico-medica*, p. A 2v.

187 Rosencreutz, *Chymical Wedding*, p. 148.

188 Ibid., p. 123.

189 P. 159.

190 Cf. “Liber Plat, quart.,” *Theatr. chem.*, V, p. 186. Concerning the Sabaeen magical rite of decapitation see “The Visions of Zosimos,” pars. 93f.

191 * *Tract, super Psalmos*, CXLVI, 12 (Migne, *P.L.*, vol. 9, col. 874).

192 *Phil. ref.*, p. 190. The ravens are the black souls of the king and queen. Cf. the story of Aristeas, who saw his soul fly out of his mouth in the shape of a raven. (Pliny, *Nat. hist.*, lib. VII, cap. LII.) The raven is the black soul-symbol, the dove is the bright one. There is a battle between raven and dove in *Chymical Wedding*. p. 24.

193 “The vessel necessary in this work must be round in shape, that the artifex may be the transformer of this firmament and of the brainpan” * (“Lib. Plat. quart.,” pp. 150f.).

194 “The upper place is the brain, and that is the seat of the understanding” * (ibid., p. 187).

195 Ibid., p. 186.*

196 “The vessel is made round after the fashion of the upper and lower [worlds?]. For it is eminently suited to that [thing] whose generation is sought in it, for a thing is bound by its like” * (p. 150).

197 p. 186.*

198 “Seest thou that gleaming and impregnable stronghold?” * (“Spec, phil.,” *Theatr. chem.*, I, p. 278). “Truth is . . . an impregnable stronghold. In this citadel is contained that true treasure which is taken hence after death.” * (“Phil, medit.,” p. 458). The “castle” is an allegory of Mary (Godefridus, *Homiliae Dominicales*, Migne, *P.L.*, vol. 174, col. 32). Dorn distinguishes four strongholds, placed as it were on top of one another. The lowest is of crystal and shelters “philosophical love”; the second is of silver and contains Sophia; the third is of diamond (*adamantina*) and only a

few get there, “who are taken up by the will of God”; the fourth is golden but “not perceptible to the senses,” “a place of eternal felicity, free from care and filled with every manner of eternal joy” (“Spec, phil.,” p. 279). Cf. the four stages of transformation in the “Liber quartorum,” discussed in *Psychology and Alchemy*, pars. 366ff.

199 Honorius of Autun says in *Liber duodecim quaest.* (Migne, *P.L.*, vol. 172, col. 1179): “The creature as conceived in the divine mind is simple, unchanging, and eternal, but in itself it is multiple, changing, transitory.”*

200 Cf. Reitzenstein, *Poimandres*, p. 16, and the description of the Microcosmus in the *Sacramentarium* of Honorius (Migne, *P.L.*, vol. 172, col. 773): his head is round as heaven and his eyes are the sun and moon.

201 *Theatr. chem.*, V, p. 189.

202 Both synonyms for the *aqua permanens*.

203 *Art. aurif.*, II, p. 264.

204 *Theatr. chem.*, IV, pp. 569f.

205 The “Introitus apertus” says: “With the death of the lion the raven is bom,” * i.e., when desire dies, the blackness of death sets in. “O sad spectacle and image of eternal death, but glad news for the Artificer! . . . For thou knowest that the spirit enclosed within is quickened, which at the time appointed by the Almighty will restore life to these dead bodies.” * (*Mus. herm.*, p. 691.)

206 Usually, in better accord with ancient tradition, he is the moist principle.

207 *Les Fables égyptiennes et grecques*, I, p. 179.

208 Cf. Kerényi, *The Gods of the Greeks*, p. 19.

209 Synonymous with Surya, the sun. Cf. *Hymns of the Atharva-Veda*, XIII, 1, 32 (trans. by Bloomfield, p. 211).

210 Like the “high-climbing” goat, the he-goat in general has a sexual significance, as has the foot (see n. 154). In view of the coniunctio situation this aspect is not without importance. (See par. 688, concerning Mercurialis.)

211 *Hymns of the Atharva-Veda*, p. 207. *Ēkapāda* is also a one-foot verse metre (Gk. *μονοποδία* and *μονοποδιαίος*). *Agā ēkapād* has the subsidiary meanings of ‘herd-driver’, ‘shepherd’, and ‘unborn,’ ‘eternal’. Cf. MacDonell, *Sanskrit-English Dictionary*, s.v., and *Sacred Books of the East*, XLII, p. 664.

212 Floruit 1731 to 1805. The *Oupnek’hat* was published between 1802 and 1804. First German trans. in 1808.

213 It had a great influence on Schopenhauer. In the *Oupnek’hat* there is a section entitled “Oupnek’hat Naraiin,” which is an excerpt from the *Atharva-veda*. But there is nothing in it about the *ēkapād*.

214 Grill, *Hundert Lieder des Atharva-Veda*.

215 See *Aion*, ch. 3.

216 The raven is a symbol of the devil in Paulinus of Aquileia, *Liber Exhortationis*, cap. 50 (Migne, *P.L.*, vol. 99, col. 253) and Wolbero, *Commentaria super Cant. Cant.* (ibid., vol. 195, col. 1159).

217 “It is well known that the soul, before it was mingled with its body, was dead, and its body likewise” * (“Tractatus Micreris,” *Theatr. chem.*, V, p. 106).

218 *Essay on the Development of Christian Doctrine*.

219 Declaration of the Virgin’s right to the title of Theotokos (“God-bearer”) at the Council of Ephesus in 431, and definition of the Immaculate Conception by Pope Pius IX in 1854.

220 Cf. I Corinthians 13 : 12: “Now I know in part, but then I shall know even as I am known.”

221 Cf. the *ckên-yên* of Wei Po-yang.

222 “Omne quo indiget” is frequently said of the lapis.

223 Cf. “The Transcendent Function,” pars. 166ff.

224 Cf. “Concerning Mandala Symbolism,” fig. 28 and commentary, par. 682, and the blue centre of Indian mandalas.

225 Red (= sun) and white (= moon) are the alchemical colours.

226 Cf. “A Study in the Process of Individuation,” Picture 9.

227 I refer here to the relation between the archetype and the phenomenon of synchronicity.

228 In the “Liber Platonis quattorum” this is the term for the arcane substance.

229 Similarly, Aquinas conceives the prima materia as “ens in potentia” (*Summa*, Part I, p. 66, Art. 1). Cf. von Franz, *Aurora Consurgens*, Commentary, p. 174, n. 88.

230 Philo’s writings were available in the Latin edition of Petronillus (Lyons, 1561) and may have been known to Dorn, who wrote ca. 1590.

231 The antiquity of the stone symbolism is shown by the fact that it occurs not only among primitives living today but in the documents of ancient cultures as well, as for instance in the Hurrian texts of Boghazköy, where the son of the father-god Kumarbi is the stone Ullikummi, a “terrible” diorite stone that “grew in the water.” This stone parallels the Greek myth of the stone which Kronos swallowed and spat out again when Zeus compelled him to yield up the children he had devoured. Zeus then set it up as a cult-object in Pytho. Ullikummi is a Titanic being and, interestingly enough, an implacable enemy of the gods. (Cf. Güterbock, “Kumarbi,” *Istanbul Schriften*, No. 16; Gurney, *The Hittites*, pp. 190ff.)

232 Genesis 1 : 2: “The earth was without form and void, and the Spirit of God brooded over the deep.” (Author’s trans.)

233 Berthelot, *Alch. grecs*, III, vi, 5.

234 I Peter 2 : 5: “... like living stones be yourselves built into a spiritual edifice” (RSV, mod.). Cf. Ephesians 2 : 20.

235 *Ros. phil.*, *Art. aurif.*, II, p. 206.

236 Romans 7 : 24.

237 “And when his friends heard of it, they went out to lay hold on him: for they said, He is beside himself.”

238 Cf. “On the Nature of the Psyche,” par. 368.

* Other editions of the *Artis auriferae* include one in 1572 (from which the “Visio Arislei” is sometimes quoted in this volume) and one in 1610 (3 vols.; from which “Rosinus ad Euthiciam” [I, pp. 158–78] is quoted in this volume).

* For details of the Collected Works of C. G. Jung, see list at end of this volume.

* For par. 518a, inadvertently omitted in the first edition, see supra, p. vii

- * Published 1957; 2nd edn., 1970.
- † Published 1973.
- * Published 1960.
- † Published 1961.
- ‡ Published 1956; 2nd edn., 1967. (65 plates, 43 text figures.)
- * Published 1971.
- † Published 1953; 2nd edn., 1966.
- ‡ Published 1960; 2nd edn., 1969.
- * Published 1959; 2nd edn., 1968. (Part I: 79 plates, with 29 in colour.)
- * Published 1964; 2nd edn., 1970. (8 plates.)
- † Published 1958; 2nd edn., 1969.
- * Published 1953; 2nd edn., completely revised, 1968. (270 illustrations.)
- † Published 1968. (50 plates, 4 text figures.)
- ‡ Published 1963; 2nd edn., 1970. (10 plates.)
- * Published 1966.
- † Published 1954; 2nd edn., revised and augmented, 1966. (13 illustrations.)
- ‡ Published 1954.

BOLLINGEN SERIES XX

THE COLLECTED WORKS

OF

C. G. JUNG

VOLUME 15

EDITORS

† SIR HERBERT READ

MICHAEL FORDHAM, M.D., M.R.C.P.

GERHARD ADLER, PH.D.

WILLIAM MC GUIRE, *executive editor*

Also available in Princeton/Bollingen Paperbacks:

ON THE NATURE OF THE PSYCHE by C. G. Jung, translated by R.F.C. Hull, Extracted from *The Structure and Dynamics of the Psyche*, Vol. 8, Collected Works (P/B Paperback #157)

THE PSYCHOLOGY OF THE TRANSFERENCE by C. G. Jung, translated by R.F.C. Hull, Extracted from *The Practice of Psychotherapy*, Vol. 16, Collected Works (P/B Paperback #158)

PSYCHOLOGY AND EDUCATION by C. G. Jung, translated by R.F.C. Hull, Extracted from *The Development of Personality*, Vol. 17, Collected Works (P/B Paperback #159)

ESSAYS ON A SCIENCE OF MYTHOLOGY by C. G. Jung and C. Kerényi, translated by R.F.C. Hull (P/B Paperback #180)

THE ORIGINS AND HISTORY OF CONSCIOUSNESS by Erich Neumann, translated by R.F.C. Hull (P/B Paperback #204)

FOUR ARCHETYPES: MOTHER/REBIRTH/SPIRIT/TRICKSTER by C. G. Jung, translated by R.F.C. Hull, Extracted from *The Archetypes and the Collective Unconscious*, Vol. 9, [part I](#), Collected Works (P/B Paperback #215)

AMOR AND PSYCHE: THE PSYCHIC DEVELOPMENT OF THE FEMININE by Erich Neumann, translated by Ralph Manheim (P/B Paperback #239)

ART AND THE CREATIVE UNCONSCIOUS by Erich Neumann, translated by R.F.C. Hull (P/B Paperback #240)

COMPLEX/ARCHETYPE/SYMBOL IN THE PSYCHOLOGY OF C. G. JUNG by Jolande Jacobi, translated by Ralph Manheim (P/B Paperback #241)

THE SPIRIT IN MAN, ART, AND LITERATURE by C. G. Jung, translated by R.F.C. Hull, Vol. 15, Collected Works (P/B Paperback #252)

**SPIRIT IN
MAN, ART,
AND LITERATURE**

C. G. JUNG

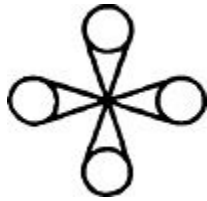

TRANSLATED BY R. F. C. HULL

BOLLINGEN SERIES XX

PRINCETON UNIVERSITY PRESS

COPYRIGHT © 1966 BY BOLLINGEN FOUNDATION

PUBLISHED BY PRINCETON UNIVERSITY PRESS

First Princeton/Bollingen Paperback Printing, 1971

THE HARDCOVER EDITION IS PUBLISHED IN THE UNITED STATES OF AMERICA BY PRINCETON UNIVERSITY PRESS AND IN ENGLAND BY ROUTLEDGE AND KEGAN PAUL, LTD. IN THE AMERICAN EDITION, ALL THE VOLUMES COMPRISING THE COLLECTED WORKS CONSTITUTE NUMBER XX IN BOLLINGEN SERIES, SPONSORED BY BOLLINGEN FOUNDATION. THE PRESENT VOLUME IS NUMBER 15 OF THE COLLECTED WORKS AND WAS THE FOURTEENTH TO APPEAR.

LIBRARY OF CONGRESS CATALOGUE CARD NUMBER: 75-156

ISBN 0-691-01775-1 (paperback edn.)

ISBN 0-691-09773-9 (hardcover edn.)

MANUFACTURED IN THE U. S. A.

EDITORIAL NOTE

There are different ways of looking at the achievements of outstanding personalities. Each can be studied in the light of his individual development, of the historical influences that played upon him, or of the more intangible collective influences expressed by the word *Zeitgeist*. Jung's attention was directed mainly to the great cultural movements—alchemy in particular—which compensated the *Zeitgeist* or arose from it, and to the creative spirit that introduced pioneering interpretations into realms as diverse as those of medicine, psychoanalysis, Oriental studies, the visual arts, and literature. The essays on Paracelsus, Freud, the sinologist Richard Wilhelm, Picasso, and Joyce's *Ulysses* have been brought together in illustration of this central theme; two others consider literary products independently of personality structure and the psychology of the individual artist. The source of scientific and artistic creativity in archetypal structures, and particularly in the dynamics of the "spirit archetype," forms an essential counterpoint to the theme underlying this collection of essays.

*

Grateful acknowledgment is made to those who helped in various ways to document and annotate the contents of this volume, particularly the essay on *Ulysses*: Leonard Albert, Daniel Brody, Ed. Bucher, Joseph Campbell, Stanley Dell, Richard Ellmann, Carola Giedion-Welcker, Stuart Gilbert, Jolande Jacobi, Aniela Jaffé, and Lilly Jung. For permission to quote from Joyce's *Ulysses* the publishers acknowledge to Random House, Inc., New York, and The Bodley Head Ltd., London.

VOLUME 15
SPIRIT IN MAN, ART, AND LITERATURE

TABLE OF CONTENTS

EDITORIAL NOTE

I

Paracelsus

Translated from “Paracelsus,” *Wirklichkeit der Seele* (Zurich: Rascher, 1934).

Paracelsus the Physician

Translated from “Paracelsus als Arzt,” *Paracelsica: Zwei Vorlesungen über den Arzt und Philosophen Theophrastus* (Zurich: Rascher, 1942).

II

Sigmund Freud in His Historical Setting

Translated from “Sigmund Freud als kulturhistorische Erscheinung,” *Wirklichkeit der Seele* (Zurich: Rascher, 1934).

In Memory of Sigmund Freud

Translated from “Sigmund Freud: Ein Nachruf,” *Sonntagsblatt der Basler Nachrichten*, XXXIII (1939).

III

Richard Wilhelm: In Memoriam

Translated from “Nachruf für Richard Wilhelm,” *Das Geheimnis der goldenen Blüte: Ein chinesisches Lebensbuch*, 5th edn. (Zurich: Rascher, 1957).

IV

On the Relation of Analytical Psychology to Poetry

Translated from “Über die Beziehungen der analytischen Psychologie zum dichterischen Kunstwerk,” *Seelenprobleme der Gegenwart* (Zurich: Rascher, 1931).

Psychology and Literature

Translated from “Psychologie und Dichtung,” *Gestaltungen des Unbewussten* (Zurich: Rascher, 1950).

Introduction

1. The Work of Art
2. The Artist

V

“Ulysses”: A Monologue

Translated from “Ulysses,” *Wirklichkeit der Seele* (Zurich: Rascher, 1934).

Appendix

Picasso

Translated from “Picasso,” *Wirklichkeit der Seele* (Zurich: Rascher, 1934).

BIBLIOGRAPHY

INDEX

I

PARACELSUS

PARACELSUS THE PHYSICIAN

PARACELSUS¹

- [1] That remarkable man, Philippus Aureolus Bombast von Hohenheim, known as Theophrastus Paracelsus,² was born in this house on November 10, 1493. His medieval mind and questing spirit would not take it amiss if, in respectful remembrance of the customs of his day, we first glance at the position of the sun at the time of his birth. It stood in the sign of Scorpio, a sign that, according to ancient tradition, was favourable to physicians, the ministers of poisons and of healing. The ruler of Scorpio is the proud and bellicose Mars, who endows the strong with warlike courage and the weak with a quarrelsome and irascible disposition. The course of Paracelsus's life certainly did not belie his nativity.
- [2] Turning now from the heavens to the earth on which he was born, we see his parents' house embedded in a deep, lonely valley, darkly overhung by woods, and surrounded by the sombre towering mountains that shut in the moorlike slopes of the hills and declivities round about melancholy Einsiedeln. The great peaks of the Alps rise up menacingly close, the might of the earth visibly dwarfs the will of man; threateningly alive, it holds him fast in its hollows and forces its will upon him. Here, where nature is mightier than man, none escapes her influence; the chill of water, the starkness of rock, the gnarled, jutting roots of trees and precipitous cliffs—all this generates in the soul of anyone born there something that can never be extirpated, lending him that characteristically Swiss obstinacy, doggedness, stolidity, and innate pride which have been interpreted in various ways—favourably as self-reliance, unfavourably as dour pigheadedness. “The Swiss are characterized by a noble spirit of liberty, but also by a certain coldness which is less agreeable,” a Frenchman once wrote.
- [3] Father Sun and Mother Earth seem to have been more truly the begetters of his character than were Paracelsus's own begetters by blood. For, at any rate on his father's side, Paracelsus was not a Swiss but a Swabian, a son of Wilhelm Bombast, the illegitimate offspring of Georg Bombast of Hohenheim, Grand Master of the Order of the Knights of St. John. But, born under the spell of the Alps, in the lap of a more potent earth that, regardless of his blood, had made him her own, Paracelsus came into the world by character a Swiss, in accordance with the unknown topographical law that rules a man's disposition.
- [4] His mother came from Einsiedeln, and nothing is known of her influence. His father, on the other hand, was something of a problem. He had wandered into the country as a doctor and had settled down in that out-of-the-way spot along the

pilgrims' route. What right had he, born illegitimate, to bear his father's noble name? One surmises the tragedy in the soul of the illegitimate child: a grim, lonely man shorn of his birthright, nursing resentment against his homeland in the seclusion of his wooded valley, and yet, with unconfessed longing, receiving news from pilgrims of the world outside to which he will never return. Aristocratic living and the pleasures of cosmopolitanism were in his blood, and remained buried there. Nothing exerts a stronger psychic effect upon the human environment, and especially upon children, than the life which the parents have not lived. So we may expect this father to have exerted the most powerful influence on the young Paracelsus, who will have reacted in just the opposite way.

[5] A great love—indeed, his only love—bound him to his father. This was the only man he remembered with love. A loyal son like this will make amends for his father's guilt. All the father's resignation will turn into consuming ambition in the son. The father's resentment and inevitable feelings of inferiority will make the son an avenger of his father's wrongs. He will wield his sword against all authority, and will do battle with everything that lays claim to the *potestas patris*, as if it were his own father's adversary. What the father lost or had to relinquish—success, fame, a free-roving life in the great world—he will have to win back again. And, following a tragic law, he must also fall out with his friends, as the predestined consequence of the fateful bond with his only friend, his father—for psychic endogamy is attended by heavy punishments.

[6] As is not uncommon, nature equipped him very badly for the role of avenger. Instead of an heroic figure fit for a rebel, she gave him a stature of a mere five feet, an unhealthy appearance, an upper lip that was too short and did not quite cover his teeth (often the distinguishing mark of nervous people), and, so it seems, a pelvis that struck everybody by its femininity when, in the nineteenth century, his bones were exhumed in Salzburg.³ There is even a legend that he was a eunuch, though to my knowledge there is no further evidence of this. At all events, love seems never to have woven her roses into his earthly life, and he had no need of their thorns, since his character was prickly enough as it was.

[7] Hardly had he reached an age to bear arms than the little man buckled on a sword much too big for him, from which he seldom let himself be parted, the less so because, in its ball-shaped pommel, he kept his laudanum pills, which were his true arcanum. Thus accoutred, a figure not entirely lacking in comedy, he set forth into the wide world on his amazing and hazardous journeys which took him to Germany, France, Italy, the Netherlands, Denmark, Sweden, and Russia. An eccentric thaumaturge, almost a second Apollonius of Tyana, he is supposed, according to legend, to have travelled to Africa and Asia, where he discovered the greatest secrets. He never undertook any regular studies, as submission to authority was taboo to him.

He was a self-made man, who devised for himself the apt motto *Alterius non sit, qui suus esse potest*,⁴ a right and proper Swiss sentiment. All that befell Paracelsus on his endless journeys must remain forever in the realm of conjecture, but probably it was a constant repetition of what happened to him in Basel. In 1525, already famed as a physician, he was summoned to Basel by the town council, the latter evidently acting in one of those rare fits of clear-headedness which now and then occur in the course of history, as the appointment of the youthful Nietzsche also shows. The appointment of Paracelsus had a somewhat distressing background, as Europe at that time was suffering under an unexampled epidemic of syphilis which had broken out after the Neapolitan campaign. Paracelsus occupied the post of a town physician, but he comported himself with a lack of dignity not at all to the taste of the university or of the worshipful public. He scandalized the former by giving his lectures in the language of stable-boys and scullions, that is, in German; the latter he outraged by appearing in the street, not in his robe of office, but in a labourer's jerkin. Among his colleagues he was the best-hated man in Basel, and not a hair was left unscathed in his medical treatises. He was known as the "mad bull," the "wild ass of Einsiedeln." He gave it all back, and more, in studiedly obscene invective, a far from edifying spectacle.

[8] In Basel, fate dealt him a blow that struck deep into his life: he lost his friend and favourite pupil, the humanist Johannes Oporinus, who meanly betrayed him and supplied his enemies with the most powerful ammunition. Afterwards, Oporinus himself regretted his disloyalty, but it was too late; the damage could never be mended. Nothing, however, could dampen the arrogant and obstreperous behaviour of Paracelsus; on the contrary, the betrayal only increased it. He soon took to travelling again, mostly poverty-stricken and often reduced to beggary.

When he was thirty-eight, a characteristic change showed itself in his writings: philosophical treatises began to appear alongside his medical ones. "Philosophical" is hardly the right word for this spiritual phenomenon—one would do better to call it "Gnostic." This remarkable psychic change is one that usually occurs after the midpoint of life has been crossed, and it might be described as a reversal of the psychic current. Only rarely does this subtle change of direction appear clearly on the surface; in most people it takes place, like all the important things in life, beneath the threshold of consciousness. Among those with powerful minds, it manifests itself as a transformation of the intellect into a kind of speculative or intuitive spirituality, as for instance in the case of Newton, Swedenborg, and Nietzsche. With Paracelsus, the tension between the opposites was not so marked, though it was noticeable enough.

[9] This brings us, after having touched on the externals and the vicissitudes of his personal life, to Paracelsus the spiritual man, and we now enter a world of ideas that must seem extraordinarily dark and confusing to the man of the present, unless he has

some special knowledge of the late-medieval mentality. Above all, Paracelsus—despite his high estimation of Luther—died a good Catholic, in strange contrast to his pagan philosophy. One can hardly suppose that Catholicism was simply his style of life. For him it was probably such a manifestly and completely incomprehensible thing that he never even reflected upon it, otherwise he would certainly have got into difficulties with the Church and with his own feelings. Paracelsus was evidently one of those people who keep their intellect and their feelings in different compartments, so that they can happily go on thinking with the intellect and not run the risk of colliding with what their feelings believe. It is indeed a great relief when the one hand does not know what the other is doing, and it would be idle curiosity to want to know what would happen if the two ever did collide. In those days, if all went well, they did not collide—this is the distinctive feature of that peculiar age, and it is quite as puzzling as the mentality, say, of Pope Alexander VI and of the whole higher clergy of the Cinquecento. Just as, in art, a merry paganism emerged from under the skirts of the Church, so, behind the curtain of scholastic disputation, a paganism of the spirit flourished in a rebirth of Neoplatonism and natural philosophy. Among the leaders of this movement it was particularly the Neoplatonism of the humanist Marsilio Ficino which influenced Paracelsus, as it did so many other aspiring “modern” minds in those days. Nothing is more characteristic of the explosive, revolutionary, futuristic spirit of the times, which left Protestantism far behind and anticipated the nineteenth century, than the motto of Agrippa von Nettesheim’s book *De incertitudine et vanitate scientiarum* (1527):

Nullis his parcat Agrippa,
contemnit, scit, nescit, flet, ridet,
irascitur, insectatur, carpit omnia,
ipse philosophus, daemon, heros, deus et omnia.⁵

[10] A new era had dawned, the overthrow of the authority of the Church was under way, and with it vanished the metaphysical certainty of the Gothic man. But whereas in Latin countries antiquity broke through in every conceivable form, the barbarous Germanic countries, instead of reverting to classical times, succumbed to the primitive experience of the spirit in all its immediacy, in different forms and at different levels, embodied by great and marvellous thinkers and poets like Meister Eckhart, Agrippa, Paracelsus, Angelus Silesius, and Jacob Boehme. All of them show their primitive but forceful originality by an impetuous language that has broken away from tradition and authority. Apart from Boehme, probably the worst rebel in this respect was Paracelsus. His philosophical terminology is so individual and so arbitrary that it surpasses by far the “power words” of the Gnostics in eccentricity and turgidity of style.

[11] The highest cosmogonic principle, corresponding to the Gnostic demiurge, is the Yliaster or Hylaster, a hybrid compound of *hyle* (matter) and *astrum* (star). This concept might be translated as “cosmic matter.” It is something like the “One” of Pythagoras and Empedocles, or the Heimarmene of the Stoics—a primitive conception of primary matter or energy. The Graeco-Latin coinage is no more than a fashionable stylistic flourish, a cultural veneer for a very ancient idea that had also fascinated the pre-Socratics, though there is no reason to suppose that Paracelsus inherited it from them. These archetypal images belong to humanity at large and can crop up autochthonously in anybody’s head at any time and place, only needing favourable circumstances for their reappearance. The suitable moment for this is always when a particular view of the world is collapsing, sweeping away all the formulas that purported to offer final answers to the great problems of life. It is, as a matter of fact, quite in accord with psychological law that, when all the uprooted gods have come home to roost in man, he should cry out, “Ipse philosophus, daemon, heros, deus et omnia,” and that, when a religion glorifying the spirit disappears, there should rise up in its stead a primordial image of creative matter.

[12] In strictest contrast to the Christian view, the supreme Paracelsan principle is thoroughly materialistic. The spiritual principle takes second place, this being the *anima mundi* that proceeds from matter, the “Ideos” or “Ides,” the “Mysterium magnum” or “Limbus major, a spiritual being, an invisible and intangible thing.” Everything is contained in it in the form of Plato’s “eidola,” the archetypes, a germinal idea that may have been implanted in Paracelsus by Marsilio Ficino. The “Limbus” is a circle. The animate world is the larger circle, man is the “Limbus minor,” the smaller circle. He is the microcosm. Consequently, everything without is within, everything above is below. Between all things in the larger and smaller circles reigns “correspondence” (*correspondentia*), a notion that culminates in Swedenborg’s *homo maximus* as a gigantic anthropomorphization of the universe. In the more primitive conception of Paracelsus the anthropomorphization is lacking. For him man and world alike are aggregates of animate matter, and this in turn is a notion that has an affinity with the scientific conceptions of the late nineteenth century, except that Paracelsus did not think mechanistically, in terms of inert, chemical matter, but in a primitive animistic way. For him nature swarmed with witches, incubi, succubi, devils, sylphs, undines, etc. The animation he experienced psychically was simultaneously the animation of nature. The death of all things psychic that took place in scientific materialism was still a long way off, but he prepared the ground for it. He was still an animist, in keeping with his primitive cast of mind, but already a materialist. Matter, as something infinitely distributed throughout space, is the absolute opposite of that concentration of the organic which is psyche. The world of sylphs and undines was soon to come to an end, and would be resurrected only in the

psychological era, when one would wonder how such ancient truths could ever have been forgotten. But, of course, it is much simpler to suppose that what we do not understand does not exist.

[13] The world of Paracelsus, macrocosmically and microcosmically, consisted of animate particles, or *entia*. Diseases, too, were *entia*, and in the same way there was an *ens astrorum, veneni, naturale, spirituale, or ideale*. The great epidemic of plague raging at that time, he explained in a letter to the Emperor, was caused by succubi begotten in whore-houses. An *ens* was another “spiritual being,” hence he said in his book *Paragranum*: “Diseases are not bodies, wherefore spirit must be used against spirit.” By this he meant that, according to the doctrine of correspondence, for every *ens morbi* there existed a natural “arcanum” which could be used as a specific against the corresponding disease. For this reason he did not describe diseases clinically or anatomically, but in terms of their specifics; for instance, there were “tartaric” diseases, which could be cured by their specific *arcanum*, in this case tartar. Therefore he held in high esteem the doctrine of signatures, which seems to have been one of the main principles of folk-medicine in those days, as practised by midwives, army surgeons, witches, quacks, and hangmen. According to this doctrine, a plant, for instance, with leaves shaped like a hand is good for diseases of the hand, and so forth.

[14] Disease for Paracelsus was “a natural growth, a spiritual, living thing, a seed.” We may safely say that for him a disease was a proper and necessary constituent of life that lived together with man, and not a hated “alien body” as it is for us. It was kith and kin to the arcana which were present in nature and which, as nature’s constituents, were as necessary to her as diseases were to man. Here the most modern doctor would shake Paracelsus by the hand and say: “I don’t think it’s quite like that, but it’s not so far off.” The whole world, said Paracelsus, was an apothecary’s shop, and God the apothecary in chief.

[15] Paracelsus had a mind typical of a crucial time of transition. His searching and wrestling intellect had broken free from a spiritual view of the world to which his feelings still clung. *Extra ecclesiam nulla salus*—this saying applies in the highest degree to every man whose spiritual transformation carries him beyond the magic circle of traditional holy images which, as ultimate truths, shut off the horizon: he loses all his comforting prejudices, his whole world falls apart, and he knows as yet nothing about a different order of things. He has become impoverished, as unknowing as a small child, still entirely ignorant of the new world, and able to recall only with difficulty the age-old experiences of mankind that speak to him from his blood. All authority has dropped away, and he must build a new world out of his own experience.

[16] On his long journeys Paracelsus gathered a rich harvest of experience, not scorning even the grimmest sources, for he was a pragmatist and empiricist without parallel. All this primary material he accepted without prejudice, at the same time drawing upon the primitive darkness of his own psyche for the philosophical ideas fundamental to his work. Old pagan beliefs, living on in the blackest superstitions of the populace, were fished up. Christian spirituality reverted to primitive animism, and out of this Paracelsus, with his scholastic training, concocted a philosophy that had no Christian prototype, but resembled far more the thinking of the most execrated enemies of the Church—the Gnostics. Like every ruthless innovator who rejects authority and tradition, he was in danger of retrogressing to the very things that they in turn had once rejected, and so reaching a lifeless and purely destructive standstill. But probably owing to the fact that, while his intellect roved far and wide and probed back into the distant past, his feelings still clung to the traditional values, the full consequences of retrogression were averted. Thanks to this unbearable opposition, regression turned into progression. He did not deny the spirit his feelings believed in, but erected beside it the counter-principle of matter: earth as opposed to heaven, nature as opposed to spirit. For this reason he was not a blind destroyer, a genius-*cum-charlatan* like Agrippa, but a father of natural science, a pioneer of the new spirit, and as such he is rightly honoured today. He would certainly shake his head at the idea for which some of his modern disciples most venerate him. His hard-won discovery was not “panpsychism”—this still clung to him as a relic of his primitive *participation mystique* with nature—but *matter and its qualities*. The conscious situation of his age and the existing state of knowledge did not allow him to see man outside the framework of nature as a whole. This was reserved for the nineteenth century. The indissoluble, unconscious oneness of man and world was still an absolute fact, but his intellect had begun to wrestle with it, using the tools of scientific empiricism. Modern medicine can no longer understand the psyche as a mere appendage of the body and is beginning to take the “psychic factor” more and more into account. In this respect it approaches the Paracelsan conception of physically animated matter, with the result that the whole spiritual phenomenon of Paracelsus appears in a new light.

[17] Just as Paracelsus was the great medical pioneer of his age, so today he is symbolic of an important change in our conception of the nature of disease and of life itself.

PARACELSUS THE PHYSICIAN¹

[18] Anyone who is at all familiar with the writings of that great physician whose memory we honour today will know how impossible it is to give an adequate account in a lecture of all the achievements that have made the name of Paracelsus immortal. He was a veritable whirlwind, tearing up everything by the roots and leaving behind him a pile of wreckage. Like an erupting volcano he laid waste and destroyed, but he also fertilized and brought to life. It is impossible to be fair to him; one can only underestimate him or overestimate him, and so one remains continually dissatisfied with one's own efforts to comprehend even one facet of his multitudinous nature. Even if one limits oneself to sketching a picture of Paracelsus the "physician," one meets this physician on so many different levels and in so many different guises that every attempt at portraiture remains a miserable patchwork. His prodigious literary output has done little to clear up the general confusion, least of all the still controversial question of the genuineness of some of the most important writings, not to speak of the mass of contradictions and arcane terms that make Paracelsus one of the greatest obscurantists of the epoch. Everything about him was on an immense scale, or, we might equally well say, everything was exaggerated. Long dreary stretches of utter nonsense alternate with oases of inspired insight, so rich and illuminating that one cannot shake off the uneasy feeling that somehow one has overlooked the main point of his argument.

[19] Unfortunately, I cannot claim to be a Paracelsus specialist and to possess a full knowledge of the *Opera omnia*. If, for professional reasons, one has to devote oneself to other things than just Paracelsus, it is hardly possible to make a conscientious study of the two thousand six hundred folio pages of the Huser edition of 1616, or the still more comprehensive edition of Sudhoff. Paracelsus is an ocean, or, to put it less kindly, a chaos, an alchemical melting-pot into which the human beings, gods, and demons of that tremendous age, the first half of the sixteenth century, poured their peculiar juices. The first thing that strikes us on reading his works is his bilious and quarrelsome temperament. He raged against the academic physicians all along the line, and against their authorities, Galen, Avicenna, Rhazes, and the rest. The only exceptions (apart from Hippocrates) were the alchemical authorities, Hermes, Archelaos, Morienus, and others, whom he quotes with approval. In general, he attacked neither astrology² nor alchemy, nor any of the popular superstitions. On this latter account his works are a mine of information for the folklorist. There are only a few treatises from the pen of Paracelsus, except for theological ones, that do not

reveal his fanatical hatred of academic medicine. Again and again one comes across violent outbursts that betray his bitterness and his personal grievances. It is quite clear that this was no longer objective criticism; it was the deposit of numerous personal disappointments that were especially bitter for him because he had no insight into his own faults. I mention this fact not in order to bring his personal psychology into the limelight, but to stress one of the chief impressions which his writings make on the reader. Practically every page bears in one way or another the human, often all too human stamp of this strange and powerful personality. His motto is said to have been *Alterius non sit, qui suus esse potest* (Let him not be another's who can be his own), and if this necessitated a ruthless, not to say brutal passion for independence, there is certainly no lack of literary as well as biographical proofs of its existence. As is the way of things, this rebellious defiance and harshness contrasted very strongly with his loyal attachment to the Church and with the soft-heartedness and sympathy with which he treated his patients, particularly those who were destitute.

[20] Paracelsus was both a conservative and a revolutionary. He was conservative as regards the basic truths of the Church, and of astrology and alchemy, but sceptical and rebellious, both in practice and theory, where academic medicine was concerned. It is largely to this that he owes his celebrity, for it seems to me very difficult to single out any medical discoveries of a *fundamental nature* that can be traced back to Paracelsus. What seems so important to us, the inclusion of surgery within the province of medicine, did not, for Paracelsus, mean developing a new science, but merely taking over the arts of the barbers and field-surgeons along with those of midwives, witches, sorcerers, astrologers, and alchemists. I feel I ought to apologize for the heretical thought that, if Paracelsus were alive today, he would undoubtedly be the advocate of all those arts which academic medicine prevents us from taking seriously, such as osteopathy, magnetopathy, iridodiagnosis, faith-healing, dietary manias, etc. If we imagine for a moment the emotions of faculty members at a modern university where there were professors of iridodiagnosis, magnetopathy, and Christian Science, we can understand the outraged feelings of the medical faculty at Basel when Paracelsus burned the classic text-books of medicine, gave his lectures in German, and, scorning the dignified gown of the doctor, paraded the streets in a workman's smock. The glorious Basel career of the "wild ass of Einsiedeln," as he was called, came to a speedy end. The impish impedimenta of the Paracelsan spirit were a bit too much for the respectable doctors of his day.

[21] In this respect we have the valuable testimony of a medical contemporary, the learned Dr. Conrad Gessner, of Zurich, in the form of a letter, written in Latin, to Ferdinand I's personal physician, Crato von Crafftheim, dated August 16, 1561.³ Although written twenty years after the death of Paracelsus, it is still redolent of the

reactions he provoked. Replying to a question of Crato's, Gessner states that he had no list of Paracelsus's writings, nor would he bother to get one, since he considered Theophrastus utterly unworthy to be mentioned along with respectable authors, let alone with Christian ones, and certainly not with pious citizens, such as even the pagans were. He and his followers were nothing but Arian heretics. He had been a sorcerer and had intercourse with demons. "The Basel Carolostadius," continues Gessner, "by name of Bodenstein,⁴ a few months ago sent a treatise of Theophrastus, 'De anatome corporis humani,' here to be printed. In it he makes mock of physicians who examine single parts of the body and carefully determine their position, shape, number, and nature, but neglect the most important thing, namely, to what stars and to what regions of the heavens each part belongs."

[22] Gessner ends with the lapidary words: "But our typographers have refused to print it." The letter tells us that Paracelsus was not counted among the "boni scriptores." He was even suspected of practising divers kinds of magic and—worse still—of the Arian heresy.⁵ Both these were capital offences at that time. Such accusations may do something to explain the restlessness of Paracelsus and his wanderlust, which never left him and drove him from city to city through half Europe. He may very well have been concerned for his skin. Gessner's attack on "De anatome corporis humani" is justified in so far as Paracelsus really did make mock of anatomical dissection, then beginning to be practised, because he said the doctors saw nothing at all in the cut-up organs. He himself was mainly interested in the cosmic correlations, such as he found in the astrological tradition. His doctrine of the "star in the body" was a favourite idea of his, and it occurs everywhere in his writings. True to the conception of man as a microcosm, he located the "firmament" in man's body and called it the "astrum" or "Sydus." It was an endosomatic heaven, whose constellations did not coincide with the astronomical heaven but originated with the individual's nativity, the "ascendant" or horoscope.

[23] Gessner's letter shows how Paracelsus was judged by a contemporary colleague, and an authoritative one at that. We must now try to get a picture of Paracelsus as a physician from his own writings. For this purpose I shall let the Master speak in his own words, but since these words contain a good many that he made up himself, I must now and then interject a comment.

[24] Part of the doctor's function is to be equipped with special knowledge. Paracelsus is also of this opinion, though with the strange qualification that a "made" doctor has to be a hundred times more industrious than a "natural" one, because everything comes to the latter from the "light of nature." He himself, it seems, studied at Ferrara and obtained his doctor's degree there. He also acquired knowledge of the classical medicine of Hippocrates, Galen, and Avicenna, having already received some kind of

preliminary education from his father. Let us hear, from the *Book Paragranum*,⁶ what he has to say about the physician's art:

What then is the physician's art? He should know what is useful and what harmful to intangible things, to the *beluis marinis*, to the fishes, what is pleasant and unpleasant, healthy and unhealthy to the beasts: these are the arts relating to natural things. What more? The wound-blessings and their powers, why and for what cause they do what they do: what *Melosina* is, and what *Syrena*, what *permutatio*, *transplantatio* and *transmutatio* are, and how they may be fully understood: what is above nature, what is above species, what is above life, what the visible is and the invisible, what produces sweetness and bitterness, what taste is, what death is, what is useful to fishermen, what a currier, a tanner, a dyer, a blacksmith, and a carpenter should know, what belongs in the kitchen, in the cellar, in the garden, what belongs to time, what a hunter knows, what a mountaineer knows, what befits a traveller, what befits a sedentary man, what warfare requires, what makes peace, what makes clerics and laymen, what every calling does, what every calling is, what God is, what Satan, what poison, and what the antidote to poison is, what there is in women, what in men, what distinguishes women from maidens, yellow from white, white from black, and red from fallow, in all things, why one colour here, another there, why short, why long, why success, why failure: and wherein this knowledge applies to all things.

[25] This quotation introduces us straight away to the strange sources of Paracelsus's empiricism. We see him as a wandering scholar on the road, with a company of travellers; he turns in at the village smith, who, as the chief medical authority, knows all the spells for healing wounds and stanching blood. From hunters and fishermen he hears wondrous tales of land and water creatures; of the Spanish tree-goose, which on putrefying turns into tortoises, or of the fertilizing power of the wind in Portugal, which begets mice in a sheaf of straw set up on a pole.⁷ The ferryman tells of the *Lorind*, which causes the mysterious "crying and echoing of the waters."⁸ Animals sicken and cure themselves like people, and the mountain folk even tell of the diseases of metals, of the leprosy of copper, and such things.⁹ All this the physician should know. He should also know of the wonders of nature and the strange correspondence of the microcosm with the macrocosm, and not only with the visible universe, but with the invisible cosmic arcana, the mysteries. We meet one of these arcana at once—Melusina, a magical creature belonging half to folklore and half to the alchemical doctrine of Paracelsus, as her connection with the *permutatio* and *transmutatio* shows. According to him, Melusines dwell in the blood, and, since blood is the ancient seat of the soul, we may conjecture that Melusina is a kind of *anima vegetativa*. She is, in essence, a variant of the mercurial spirit, which in the fourteenth and fifteenth centuries was depicted as a female monster. Unfortunately, I

must refrain from going into this figure more closely, as it would lead us into the depths of alchemical speculation.

[26] But now let us return to our theme—the physician’s science, as Paracelsus conceives it. The *Book Paragranum* says that the physician “sees and knows all disease outside the human body,”¹⁰ and that “the physician should proceed from external things, not from man.”¹¹ “Therefore the physician proceeds from what is before his eyes, and from what is before him he sees what is behind him, that is: from the external he sees the internal. Only external things give knowledge of the internal; without them no internal thing may be known.”¹² This means that the physician gains his knowledge of disease less from the sick person than from other natural phenomena that apparently have nothing to do with man, and above all from alchemy. “If they do not know that,” says Paracelsus, “then they do not know the *Arcana*. And if they do not know what makes copper and what engenders the *Vitriolata*, then they do not know what causes leprosy. And if they do not know what makes rust on iron, then they do not know what causes ulcerations. And if they do not know what makes earthquakes, then they do not know what causes cold ague. External things teach and reveal the causes of man’s infirmities, and man does not reveal the infirmity himself.”¹³

[27] Evidently, then, the physician recognizes from, say, the diseases of the metals what disease a man is suffering from, He must in any case be an alchemist. He “must employ the *Scientia Alchimiae* and not the foul brew of the Montpellier school,” which is “such filthy hogwash that even the pigs would rather eat offal.”¹⁴ He must know the health and diseases of the elements.¹⁵ As the “*species lignorum, lapidum, herbarum*” are likewise in man, he must know them too. Gold, for example, is a “natural comfortative” in man.¹⁶ There is an “external art of Alchemy,” but also an “*Alchimia microcosmi*,” and the digestive process is such. The stomach, according to Paracelsus, is the alchemist in the belly. The physician must know alchemy in order to make his medicines, in particular the *arcana* such as *aurum potable*, the *tinctura Rebis*, the *tinctura procedens*, the *Elixir tincturae*, and the rest.¹⁷ Here, as so often, Paracelsus makes mock of himself, for he “knows not how,” yet he says of the academic physicians: “You all talk drivel and have made yourselves strange dictionaries and vocabularies. No one can look at them without being led by the nose, and yet people are sent to the apothecary’s with this incomprehensible jargon when they have better medicine in their own garden.”¹⁸ The *arcana* play a great role in Paracelsan therapy, especially in the treatment of mental diseases. “For in the *Arcanis*,” says Paracelsus, “the tuff-stone becomes jacinth, the liver-stone alabaster, the flint garnet, clay a noble bolus, sand pearls, nettles manna, *Ungula* balsam. Herein lies the description of things, and in these things the physician should be well grounded.”¹⁹ And in conclusion Paracelsus cries out: “Is it not true that Pliny never

proved anything? Then what did he write? What he heard from the alchemists. If you do not know these things and what they are, you are a quack!” Thus the physician must know alchemy in order to diagnose human diseases from their analogy with the diseases of minerals. And finally, he himself is the subject of the alchemical process of transformation, since he is “ripened” by it.²⁰

[28] This difficult remark refers once more to the secret doctrine. Alchemy was not simply a chemical procedure as we understand it, but far more a philosophical procedure, a special kind of yoga, in so far as yoga also seeks to bring about a psychic transformation. For this reason the alchemists drew parallels between their *transmutatio* and the transformation symbolism of the Church.

[29] The physician had to be not only an alchemist but also an astrologer,²¹ for a second source of knowledge was the “firmament.” In his *Labyrinthus medicorum* Paracelsus says that the stars in heaven must be “coupled together,” and that the physician must “extract the judgment of the firmament from them.”²² Lacking this art of astrological interpretation, the physician is but a “pseudomedicus.” The firmament is not merely the cosmic heaven, but a body which is a part or content of the human body. “Where the body is, there will the eagles gather. And where the medicine is, there do the physicians gather.”²³ The firmamental body is the corporeal equivalent of the astrological heaven.²⁴ And since the astrological constellation makes a diagnosis possible, it also indicates the therapy. In this sense the firmament may be said to contain the “medicine.” The physicians gather round the firmamental body like eagles round a carcass because, as Paracelsus says in a not very savoury comparison, “the carcass of the natural light” lies in the firmament. In other words, the *corpus sydereum* is the source of illumination by the *lumen naturae*, the “natural light,” which plays the greatest possible role not only in the writings of Paracelsus but in the whole of his thought. This intuitive conception is, in my opinion, an achievement of the utmost historical importance, for which no one should grudge Paracelsus undying fame. It had a great influence on his contemporaries and an even greater one on the mystic thinkers who came afterwards, but its significance for philosophy in general and for the theory of knowledge in particular still lies dormant. Its full development is reserved for the future.

[30] The physician should learn to know this inner heaven. “For if he knows heaven only externally, he remains an astronomer and an astrologer; but if he establishes its order in man, then he knows two heavens. Now these two give the physician knowledge of the part which the upper sphere influences. This [part?] must be present without infirmity in the physician in order that he may know the *Caudam Draconis* in man, and know the *Arietem* and *Axem Polarem*, and his *Lineam Meridionalem*, his Orient and his Occident.” “From the external we learn to know the internal.” “Thus there is in man a firmament as in heaven, but not of one piece; there

are two. For the hand that divided light from darkness, and the hand that made heaven and earth, has done likewise in the microcosm below, having taken from above and enclosed within man's skin everything that heaven contains. For that reason the external heaven is a guide to the heaven within. Who, then, will be a physician who does not know the external heaven? For we live in this same heaven and it lies before our eyes, whereas the heaven within us is not before the eyes but behind them, and therefore we cannot see it. For who can see through the skin? No one."²⁵

[31] We are involuntarily reminded of Kant's "starry heaven above me" and "moral law within me"—that "categorical imperative" which, psychologically speaking, took the place of the Heimarmene (compulsion of the stars) of the Stoics. There can be no doubt that Paracelsus was influenced by the Hermetic idea of "heaven above, heaven below."²⁶ In his conception of the inner heaven he glimpsed an eternal primordial image, which was implanted in him and in all men, and recurs at all times and places. "In every human being," he says, "there is a special heaven, whole and unbroken."²⁷ "For a child which is being conceived already has its heaven." "As the great heaven stands, so it is imprinted at birth."²⁸ Man has "his Father in heaven and also in the air, he is a child that is made and born from the air and from the firmament." There is a "linea lactea" in heaven and in us. "The galaxa goes through the belly."²⁹ The poles and the zodiac are likewise in the human body. "It is necessary," he says, "that a physician should recognize the ascendants, the conjunctions, the exaltations, etc., of the planets, and that he understand and know all the constellations. And if he knows these things externally in the Father, it follows that he will know them in man, even though the number of men is so very great, and where to find heaven with its concordance in everyone, where health, where sickness, where beginning, where end, where death. For heaven is man and man is heaven, and all men are one heaven, and heaven is only one man."³⁰ The "Father in heaven" is the starry heaven itself. Heaven is the *homo maximus*, and the *corpus sydereum* is the representative of the *homo maximus* in the individual. "Now man was not born of man, for the first man had no progenitor, but was created. From created matter there grew the *Limbus*, and from the *Limbus* man was created and man has remained of the *Limbus*. And since he has remained so, he must be apprehended through the Father and not from himself, because he is enclosed in the skin (and no one can see through this and the workings within him are not visible). For the external heaven and the heaven within him are one, but in two parts. Even as Father and Son are two [aspects of one Godhead], so there is one Anatomy [which has two aspects]. Whoever knows the one, will also know the other."³¹

[32] The heavenly Father, the *homo maximus*, can also fall sick, and this enables the physician to make his human diagnoses and prognoses. Heaven, says Paracelsus, is

its own physician, “as the dog of its wounds.” But man is not. Therefore he must “seek the locus of all sickness and health in the Father, and be mindful that this organ is of Mars, this of Venus, this of Luna,” etc.³² This evidently means that the physician has to diagnose sickness and health from the condition of the Father, or heaven. The stars are important aetiological factors. “Now all infection starts in the stars, and from the stars it follows afterwards in man. That is to say, if heaven is for it, then it begins in man. Now heaven does not enter into man—we should not talk nonsense on that account—but the stars in man, as ordered by God’s hand, copy what heaven starts and brings to birth externally, and therefore it follows in man. It is like the sun shining through a glass and the moon giving light on the earth: but this does not injure a man, corrupting his body and causing diseases. For no more than the sun itself comes down to the earth do the stars enter a man, and their rays give a man nothing. The *Corpora* must do that and not the rays, and these are the *Corpora Microcosmi Astrali*, which gives the nature of the Father.”³³ The *Corpora Astrali* are the same as the aforementioned *corpus sydereum* or *astrale*. Elsewhere Paracelsus says that “diseases come from the Father”³⁴ and not from man, just as the woodworm does not come from the wood.

[33] The *astrum* in man is important not only for diagnosis and prognosis, but also for therapy. “From this emerges the reason why heaven is unfavourable to you and will not guide your medicine, so that you accomplish nothing: heaven must guide it for you. And the art lies, therefore, in that very place [i.e., heaven]. Say not that Melissa is good for the womb, or Marjoram for the head: so speak the ignorant. Such matters lie in Venus and in Luna, and if you wish them to have the effect you claim, you must have a favourable heaven or there will be no effect. Therein lies the error that has become prevalent in medicine: Just hand out remedies, if they work, they work. Any peasant lad can engage in such practices, it takes no Avicenna or Galen.”³⁵ When the physician has brought the *corpus astrale*, that is, the physiological Saturn (spleen) or Jupiter (liver), into the right connection with heaven, then, says Paracelsus, he is “on the right road.” “And he should know, accordingly, how to make the Astral Mars and the physical Mars [the *corpus astrale*] subservient to one another, and how to conjugate and unite them. For this is the core which no physician from the first until myself has bit into. Thus it is understood that the medicine must be prepared in the stars and become firmamental. For the upper stars bring sickness and death, and also make well. Now if anything is to be done, it cannot be done without the *Astra*. And if it is to be done with the *Astra*, then the preparation should be completed at the same time as the medicine is being made and prepared by heaven.”³⁶ The physician must “recognize the kind of medicine according to the stars and that, therefore, there are *Astra* both above and below. And since medicine can do nothing without heaven, it must be guided by heaven.” This means that the astral influence must direct the

alchemical procedure and the preparation of arcane remedies. “The course of heaven teaches the course and regimen of the fire in the Athanar.³⁷ For the virtue which lies in the sapphire comes from heaven by means of solution and coagulation and fixation.”³⁸ Of the practical use of medicines Paracelsus says: “Medicine is in the will of the stars and is guided and directed by the stars. What belongs to the brain is directed to the brain by Luna; what belongs to the spleen is directed to the spleen by Saturn; what belongs to the heart is directed to the heart by Sol; and similarly to the kidneys by Venus, to the liver by Jupiter, to the bile by Mars. And not only is this so with these [organs], but with all the others which cannot be mentioned here.”³⁹

[34] The names of diseases should likewise be correlated with astrology, and so should anatomy, which for Paracelsus meant nothing less than the astrophysiological structure of man, a “concordance with the machine of the world,” and nothing at all resembling what Vesalius understood by it. It was not enough to cut open the body, “like a peasant looking at a psalter.”⁴⁰ For him anatomy meant something like analysis. Accordingly he says: “Magic is the *Anatomia Medicinae*. Magic divides up the *corpora* of medicine.”⁴¹ But anatomy was also a kind of re-remembering of the original knowledge inborn in man, which is revealed to him by the *lumen naturae*. In his *Labyrinthus medicorum* he says: “How much labour and toil did the Mille Artifex⁴² need to wrest this Anatomy from out the memory of man, to make him forget this noble art and lead him into vain imaginings and other mischief wherein there is no art, and which consume his time on earth unprofitably! For he who knows nothing loves nothing ... but he who understands loves, observes, sees.”⁴³

[35] With regard to the names of diseases, Paracelsus thought they should be chosen according to the zodiac and the planets, e.g., *Morbus leonis, sagittarii, martis*, etc. But he himself seldom adhered to this rule. Very often he forgot how he had called something and then invented a new name for it—which, incidentally, only adds to our difficulties in trying to understand his writings.

[36] We see, therefore, that for Paracelsus aetiology, diagnosis, prognosis, therapy, nosology, pharmacology, pharmaceuticals, and—last but not least—the daily hazards of medical practice were all directly related to astrology. Thus he admonished his colleagues: “You should see to it, all you physicians, that you know the cause of fortune and misfortune: until you can do this, keep away from medicine.”⁴⁴ This could mean that if the indications elicited from the patient’s horoscope were unfavourable, the doctor had an opportunity to make himself scarce—a very welcome one in those robust times, as we also know from the career of the great Dr. Cardan.

[37] But not content with being an alchemist and astrologer, the physician had also to be a philosopher. What did Paracelsus mean by “philosophy”? Philosophy, as he understood it, had nothing whatever to do with our conception of the matter. For him

it was something “occult,” as we would say. We must not forget that Paracelsus was an alchemist through and through, and that the “natural philosophy” he practised had far less to do with thinking than with *experience*. In the alchemical tradition “philosophia,” “sapientia,” and “scientia” were essentially the same. Although they were treated as abstract ideas, they were in some strange way imagined as being quasi-material, or at least as being contained in matter,⁴⁵ and were designated accordingly. Hence they appeared in the form of quicksilver or Mercurius, lead or Saturn, gold or *aurum non vulgi*, salt or *sal sapientiae*, water or *aqua permanens*, etc. These substances were arcana, and like them philosophy too was an arcanum. In practice, this meant that philosophy was as it were concealed in matter and could also be found there.⁴⁶ We are obviously dealing with psychological projections, that is, with a primitive state of mind still very much in evidence at the time of Paracelsus, the chief symptom of which is the unconscious identity of subject and object.

[38] These preparatory remarks may help us to understand Paracelsus’s question: “What is nature other than philosophy?”⁴⁷ “Philosophy” was in man and outside him. It was like a mirror, and this mirror consisted of the four elements, for in the elements the microcosm was reflected.⁴⁸ The microcosm could be known from its “mother,”⁴⁹ i.e., elemental “matter.” There were really two “philosophies,” relating respectively to the lower and higher spheres. The lower philosophy had to do with minerals, the higher with the *Astra*.⁵⁰ By this he meant astronomy, from which we can see how thin was the dividing line between philosophy and “Scientia.” This is made very clear when we are told that philosophy was concerned with earth and water, astronomy with air and fire.⁵¹ Like philosophy, Scientia was inborn in all creatures; thus the pear-tree produced pears only by virtue of its Scientia. Scientia was an “influence” hidden in nature, and one needed “magic” in order to reveal this arcanum. “All else is vain delusion and madness, from which are begotten the fantasts.” The gift of Scientia had to be “raised alchemically to the highest pitch,”⁵² that is to say it had to be distilled, sublimated, and subtilized like a chemical substance. If the “Scientiae of nature” are not in the physician, “you will only hem and haw and know nothing for certain but the babbling of your mouth.”⁵³

[39] So it is not surprising that philosophy also involved practical work. “In philosophy is knowledge, the entire globulus, and this by means of the *practica*. For philosophy is nothing other than the *practica globuli* or *sphaerae*.... Philosophy teaches the powers and properties of earthly and watery things ... therefore concerning philosophy I will tell you that just as there is in the earth a philosopher, so is there also in man, for one philosopher is of the earth, another of water,” etc.⁵⁴ Thus there is a “philosopher” in man just as there is an “alchemist,” who, we have heard, is the stomach. This same philosophizing function is also found in the earth and can be “extracted” from it. The “*practica globuli*” mentioned in the text means the

alchemical treatment of the *massa globosa* or *prima materia*, the arcane substance; hence philosophy was in essence an alchemical procedure.⁵⁵ For Paracelsus, philosophical cognition was actually an activity of the object itself, therefore he calls it a “Zuwerffen”: the object “throws” its meaning at man. “The tree ... gives the name tree without [the aid of] the alphabet”; it says what it is and contains, just as the stars do, which have within them their own “firmamental judgment.” Thus Paracelsus can assert that it is the “Archasius”⁵⁶ in man which “draws to itself *scientiam atque prudentiam*.”⁵⁷ Indeed, he admits with great humility: “What does man invent out of himself or through himself? Not enough to patch a pair of breeches with.”⁵⁸ Besides which not a few of the medical arts are “revealed by devils and spirits.”⁵⁹

[40] I won't pile up quotations, but from all this it should be clear that the physician's “philosophy” was of an arcane nature. That Paracelsus was a great admirer of magic and the *Ars cabbalistica*, the “Gabal,” is only to be expected. If a physician does not know magic, he says, he is a “well-intentioned madman in medicine, who inclines more to deception than to the truth.” Magic is a preceptor and teacher.⁶⁰ Accordingly, Paracelsus made many amulets and seals,⁶¹ so it was partly his own fault if he got a bad reputation for practising magic. Speaking of physicians in times to come—and this peering into the future is characteristic—he says: “They will be *Geomantici*, they will be *Adepti*, they will be *Archei*, they will be *Spagyri*, they will possess the *Quintum esse*.”⁶² The chemical dream of alchemy has been fulfilled, and it was Paracelsus who foresaw the role which chemistry was destined to play in present-day medicine.

[41] Before I bring my all too summary remarks to a close, I would like to lay stress on one highly important aspect of his therapy, namely, the psychotherapeutic aspect. Paracelsus still practised the ancient art of “charming” an illness, of which the Ebers Papyrus gives so many excellent examples from ancient Egypt.⁶³ Paracelsus calls this method *Theorica*. He concedes that there is a *Theorica Essentiae Curae* and a *Theorica Essentiae Causae*, but immediately adds that the “*Theorica curae et causae* are hidden together and inseparably one.” What the physician has to say to the patient will depend on his own nature: “He must be whole and complete, otherwise he will discover nothing.” The light of nature must give him instruction, that is, he must proceed intuitively, for only by illumination can he understand “nature's textbooks.” The “theoricus medicus” must therefore speak with God's mouth, for the physician and his medicines were created by God,⁶⁴ and just as the theologian draws his truth from the holy revealed scripture, the physician draws it from the light of nature. The *Theorica* is a “*religio medici*.” He gives an example of how it should be practised and how to speak to the patient: “Or a dropsical patient says his liver is chilled, etc., and consequently they are inclined to dropsy. Such reasons are much too trivial. But if you say the cause is a meteoric semen which turns to rain, and the rain percolates

down from above, from the *media interstitia* into the lower parts, so that the semen becomes a stretch of water, a pond, a lake, then you have put your finger on it. It is like when you see a fine, clear cloudless sky: suddenly a little cloud appears, which grows and increases, so that within an hour a great rain, hailstorm, shower, etc., sets in. This is how we should theorize concerning the fundamentals of medicine in disease, as has been said.”⁶⁵ One can see how suggestively this must have worked on the patient: the meteorological comparison induces a precipitation, immediately the sluices of the body open and the ascites stream off. Even in organic diseases such psychic stimulation is not to be underestimated, and I am convinced that more than one of the miraculous cures of the Master can be traced back to his admirable *theorica*.

[42] Concerning the physician’s attitude to the patient, Paracelsus has many good things to say. From the wealth of utterances on this subject I would like, in conclusion, to quote a few scattered sayings from the *Liber de caducis*.⁶⁶ “First of all it is very necessary to tell of the compassion that must be innate in a physician.” “Where there is no love, there is no art.” Physician and medicine “are both nothing other than a mercy conferred on the needy by God.” The art is achieved by the “work of love.” “Thus the physician must be endowed with no less compassion and love than God intends towards man.” Compassion is “the physician’s mentor.” “I under the Lord, the Lord under me, I under Him outside my office, He under me outside His office. Thus each is subordinate to the other’s office, and in such love each subordinate to the other.” What the physician does is not *his* work: he is “the means by which nature is put to work.” Medicine “grows unbidden and pushes up from the earth even if we sow nothing.” “The practice of this art lies in the heart: if your heart is false, the physician within you will be false.” “Let him not say with desperate Satan: it is impossible.” He should put his trust in God. “For sooner will the herbs and roots speak with you, and in them will be the power you need.” “The physician has partaken of the banquet to which the invited guests did not come.”

[43] With this I come to the end of my lecture. I shall be content if I have succeeded in giving you at least a few impressions of the strange personality and the spiritual force of the celebrated physician whom his contemporaries rightly named the “Luther of medicine.” Paracelsus was one of the great figures of the Renaissance, and one of the most unfathomable. For us he is still an enigma, four hundred years afterwards.



FREUD IN HIS HISTORICAL SETTING



IN MEMORY OF SIGMUND FREUD

SIGMUND FREUD IN HIS HISTORICAL SETTING¹

[44] It is always a delicate and dangerous task to place a living man in historical perspective. But at least it is possible to gauge his significance and the extent to which he has been conditioned by history if his life-work and system of thought form a self-contained whole as do Freud's. His teaching, which in its fundamentals is probably known to every educated layman today, is not limitless in its ramifications, nor does it include any extraneous elements whose origins lie in other fields of science; it is based on a few transparent principles which, to the exclusion of everything else, dominate and permeate the whole substance of his thought. The originator of this teaching has, moreover, identified it with his method of "psychoanalysis," thereby making it into a rigid system that may rightly be charged with absolutism. On the other hand, the extraordinary emphasis laid upon this theory causes it to stand out as a strange and unique phenomenon against its philosophical and scientific background. Nowhere does it merge with other contemporary concepts, nor has its author made any conscious effort to connect it with its historical predecessors. This impression of isolation is heightened still further by a peculiar terminology which at times borders on subjective jargon. To all appearances—and Freud would prefer to have it that way—it is as if this theory had developed exclusively in the doctor's consulting-room and were unwelcome to everyone but himself and a thorn in the flesh of "academic" science. And yet, even the most original and isolated idea does not drop down from heaven, but grows out of an objective network of thought which binds all contemporaries together whether they recognize it or not.

[45] The historical conditions which preceded Freud were such that they made a phenomenon like himself necessary, and it is precisely the fundamental tenet of his teaching—namely, the repression of sexuality—that is most clearly conditioned in this historical sense. Like his greater contemporary Nietzsche, Freud stands at the end of the Victorian era, which was never given such an appropriate name on the Continent despite the fact that it was just as characteristic of the Germanic and Protestant countries as of the Anglo-Saxon. The Victorian era was an age of repression, of a convulsive attempt to keep anaemic ideals artificially alive in a framework of bourgeois respectability by constant moralizings. These ideals were the last offshoots of the collective religious ideas of the Middle Ages, and shortly before had been severely shaken by the French Enlightenment and the ensuing revolution. Hand in hand with this, ancient truths in the political field had become hollow and

threatened to collapse. It was still too soon for the final overthrow, and consequently all through the nineteenth century frantic efforts were made to prevent the Christian Middle Ages from disappearing altogether. Political revolutions were stamped out, experiments in moral freedom were thwarted by middle-class public opinion, and the critical philosophy of the late eighteenth century reached its end in a renewed, systematic attempt to capture the world in a unified network of thought on the medieval model. But in the course of the nineteenth century enlightenment slowly broke through, particularly in the form of scientific materialism and rationalism.

[46] This is the matrix out of which Freud grew, and its mental characteristics have shaped him along foreordained lines. He has a passion for explaining everything rationally, exactly as in the eighteenth century; one of his favourite maxims is Voltaire's "Écrasez l'infâme." With a certain satisfaction he invariably points out the flaw in the crystal; all complex psychic phenomena like art, philosophy, and religion fall under his suspicion and appear as "nothing but" repressions of the sexual instinct. This essentially reductive and negative attitude of Freud's towards accepted cultural values is due to the historical conditions which immediately preceded him. He sees as his time forces him to see. This comes out most clearly in his book *The Future of an Illusion*, where he draws a picture of religion which corresponds exactly with the prejudices of a materialistic age.

[47] Freud's revolutionary passion for negative explanations springs from the historical fact that the Victorian age falsified its cultural values in order to produce a middle-class view of the world, and, among the means employed, religion—or rather, the religion of repression—played the chief role. It is this sham religion that Freud has his eye on. The same is true of his idea of man: man's conscious qualities, his idealistically falsified persona, rest on a correspondingly dark background, that is to say on a basis of repressed infantile sexuality. Every positive gift or creative activity depends on some infantile negative quantity, in accordance with the materialistic *bon mot*: "Der Mensch ist, was er isst" (man is what he eats).

[48] This conception of man, considered historically, is a reaction against the Victorian tendency to see everything in a rosy light and yet to describe everything *sub rosa*. It was an age of mental "pussyfooting" that finally gave birth to Nietzsche, who was driven to philosophize with a hammer. So it is only logical that ethical motives as determining factors in human life do not figure in Freud's teaching. He sees them in terms of conventional morality, which he justifiably supposes would not have existed in this form, or not have existed at all, if one or two bad-tempered patriarchs had not invented such precepts to protect themselves from the distressing consequences of their impotence. Since then these precepts have unfortunately gone on existing in the super-ego of every individual. This grotesquely depreciative view

is a just punishment for the historical fact that the ethics of the Victorian age were nothing but conventional morality, the creation of curmudgeonly *praeceptores mundi*.

[49] If Freud is viewed in this retrospective way as an exponent of the resentment of the new century against the old, with its illusions, its hypocrisy, its half-truths, its faked, overwrought emotions, its sickly morality, its bogus, sapless religiosity, and its lamentable taste, he can be seen, in my opinion, much more correctly than when one marks him out as the herald of new ways and new truths. He is a great destroyer who breaks the fetters of the past. He liberates us from the unwholesome pressure of a world of rotten habits. He shows how the values in which our parents believed may be understood in an altogether different sense: for instance, that sentimental fraud about the parents who live only for their children, or the noble son who worships his mother all his life, or the ideal daughter who completely understands her father. Previously these things were believed uncritically, but ever since Freud laid the unsavoury idea of incestuous fixation on the dining-room table as an object of discussion, salutary doubts have been aroused—though for reasons of health they should not be pushed too far.

[50] The sexual theory, to be properly understood, should be taken as a negative critique of our contemporary psychology. We can become reconciled even to its most disturbing assertions if we know against what historical conditions they are directed. Once we know how the nineteenth century twisted perfectly natural facts into sentimental, moralistic virtues in order not to have its picture of the world upset, we can understand what Freud means by asserting that the infant already experiences sexuality at its mother's breast—an assertion which has aroused the greatest commotion. This interpretation casts suspicion on the proverbial innocence of the child at the breast, that is, on the mother-child relationship. That is the whole point of the assertion—it is a shot aimed at the heart of “holy motherhood.” The fact that mothers bear children is not holy but merely natural. If people say it is holy, then one strongly suspects that something very unholy has to be covered up by it. Freud has said out loud “what is behind it,” only he has unfortunately blackened the infant instead of the mother.

[51] Scientifically, the theory of infantile sexuality is of little value. It is all one to the caterpillar whether we say that it eats its leaf with ordinary pleasure or with sexual pleasure. Freud's historical contribution does not consist in these scholastic mistakes of interpretation in the field of specialized science, but in the fact on which his fame is justifiably founded, namely that, like an Old Testament prophet, he overthrew false idols and pitilessly exposed to the light of day the rottenness of the contemporary psyche. Whenever he undertakes a painful reduction (explaining the nineteenth-century God as a glorified version of Papa, or money-grubbing as infantile pleasure in excrement), we can be sure that a collective overvaluation or falsification is being

attacked. Where, for instance, is the saccharine God of the nineteenth century confronted with a *deus absconditus*, as in Luther's teaching? And is it not assumed by all nice people that good men also earn good money?

[52] Like Nietzsche, like the Great War, and like James Joyce, his literary counterpart, Freud is an answer to the sickness of the nineteenth century. That is indeed his chief significance. For those with a forward-looking view he offers no constructive plan, because not even with the boldest effort or the strongest will would it ever be possible to act out in real life all the repressed incest-wishes and other incompatibilities in the human psyche. On the contrary, Protestant ministers have already plunged into psychoanalysis because it seems to them an excellent means of sensitizing people's consciences to yet more sins than merely conscious ones—a truly grotesque but extremely logical turn of events prophesied years ago by Stanley Hall in his autobiography. Even the Freudians are beginning to take note of a new and if possible even more soulless repression—quite understandably, since no one knows what to do with his incompatible wishes. On the contrary, one begins to understand how unavoidable it is that such things are repressed.

[53] In order to mitigate this cramp of conscience, Freud invented the idea of sublimation. Sublimation means nothing less than the alchemist's trick of turning the base into the noble, the bad into the good, the useless into the useful. Anyone who knew how to do this would be certain of immortal fame. Unfortunately, the secret of converting energy without the consumption of a still greater quantity of energy has never yet been discovered by the physicists. Sublimation remains, for the present, a pious wish-fulfilment invented for silencing inopportune questions.

[54] In discussing these problems I do not wish to lay the main emphasis on the professional difficulties of the practising psychotherapist, but on the evident fact that Freud's programme is not a forward-looking one. Everything about it is oriented backwards. Freud's only interest is where things come from, never where they are going. It is more than the scientific need for causality that drives him to seek for causes, for otherwise it could not have escaped him that many psychological facts have explanations entirely different from those based on the *faux pas* of a *chronique scandaleuse*.

[55] An excellent example of this is his essay on Leonardo da Vinci and the problem of the two mothers. As a matter of fact, Leonardo did have an illegitimate mother and a stepmother, but in reality the dual-mother problem may be present as a mythological motif even when the two mothers do not really exist. Mythical heroes very often have two mothers, and for the Pharaohs this mythological custom was actually *de rigueur*. But Freud stops short at the scurrilous fact; he contents himself with the idea that *naturally* something unpleasant or negative is concealed in the situation. Although this procedure is not exactly "scientific," yet, considered from the

standpoint of historical justice, I credit it with a greater value than if it were scientifically unassailable. All too easily the dark background that is *also* present in the Leonardo problem could be rationalized away by a narrow scientific approach, and then Freud's historical task of showing up the darkness behind the false façades would not be fulfilled. A small scientific inaccuracy has little meaning here. If one goes through his works carefully and critically, one really does have the impression that Freud's aim of serving science, which he pushes again and again to the fore, has been secretly diverted to the cultural task of which he himself is unconscious, and that this has happened at the expense of the development of his theory. Today the voice of one crying in the wilderness must necessarily strike a scientific tone if the ear of the multitude is to be reached. At all costs we must be able to say that it is science which has brought such facts to light, for that alone is convincing. But even science is not proof against the unconscious *Weltanschauung*. How easy it would have been to take Leonardo's *St. Anne with the Virgin and the Christ Child* as a classical representation of the mythological motif of the two mothers! But for Freud's late Victorian psychology, and for an infinitely large public as well, it is far more effective if after "thorough investigation" it can be confirmed that the great artist owed his existence to a slip-up of his respectable father! This thrust goes home, and Freud makes this thrust not because he consciously wants to abandon science for gossip, but because he is under compulsion from the *Zeitgeist* to expose the possible dark side of the human psyche. Yet the really scientific clue to the picture is the dual-mother motif, but that only stirs the few to whom knowledge really matters, however unfashionable it may be. Such an hypothesis leaves the greater public cold, because to them Freud's one-sided, negative explanation means very much more than it does to science.

[56] It is axiomatic that science strives for an impartial, unbiased, and inclusive truth. The Freudian theory, on the other hand, is at best a partial truth, and therefore in order to maintain itself and be effective it has the rigidity of a dogma and the fanaticism of an inquisitor. For a scientific truth a simple statement suffices. Secretly, psychoanalytic theory has no intention of passing as a strict scientific truth; it aims rather at influencing a wider public. And from this we can recognize its origin in the doctor's consulting-room. It preaches those truths which it is of paramount importance that the neurotic of the early twentieth century should understand because he is an unconscious victim of late Victorian psychology. Psychoanalysis destroys the false values in him personally by cauterizing away the rottenness of the dead century. Thus far, it betokens a valuable, indeed indispensable increase in practical knowledge which has advanced the study of neurotic psychology in the most lasting way. We have to thank the bold one-sidedness of Freud if medicine is now in a position to treat

cases of neurosis individually and make the individual psyche an object of research. Before Freud, this happened only as a rare curiosity.

[57] But in so far as neurosis is not an illness specific to the Victorian era but enjoys a wide distribution in time and space, and is therefore found among people who are not in need of any special sexual enlightenment or the destruction of harmful assumptions in this respect, a theory of neurosis or of dreams which is based on a Victorian prejudice is at most of secondary importance to science. If this were not so, Adler's very different conception would have fallen flat and had no effect. Adler reduces everything not to the pleasure principle but to the power drive, and the success of his theory is not to be denied. This fact brings out with dazzling clearness the one-sidedness of the Freudian theory. Adler's, it is true, is just another one-sidedness, but taken together with Freud's it produces a more comprehensive and still clearer picture of the resentment against the spirit of the nineteenth century. All the modern defection from the ideals of our fathers is mirrored again in Adler.

[58] The human psyche, however, is not simply a product of the *Zeitgeist*, but is a thing of far greater constancy and immutability. The nineteenth century is a merely local and passing phenomenon, which has deposited but a thin layer of dust on the age-old psyche of mankind. Once this layer is wiped off and our professional eye-glasses are cleaned, what shall we see? How shall we look upon the psyche, and how shall we explain a neurosis? This problem confronts every analyst whose cases are not cured even after all the sexual experiences of childhood have been dug up, and all their cultural values dissected into lurid elements, or even when the patient has become that strange fiction—a "normal" man and a gregarious animal.

[59] A general psychological theory that claims to be scientific should not be based on the malformations of the nineteenth century, and a theory of neurosis must also be capable of explaining hysteria among the Maori. As soon as the sexual theory leaves the narrow field of neurotic psychology and branches out into other fields, for instance that of primitive psychology, its one-sidedness and inadequacy leap to the eye. Insights that grew up from the observation of Viennese neuroses between 1890 and 1920 prove themselves poor tools when applied to the problems of totem and taboo, even when the application is made in a very skilful way. Freud has not penetrated into that deeper layer which is common to all men. He could not have done so without being untrue to his historical task. And this task he has fulfilled—a task enough for a whole life's work, and fully deserving the fame it has won.

IN MEMORY OF SIGMUND FREUD¹

[60] The cultural history of the past fifty years is inseparably bound up with the name of Sigmund Freud, the founder of psychoanalysis, who has just died. The Freudian outlook has affected practically every sphere of our contemporary thinking, except that of the exact sciences. Wherever the human psyche plays a decisive role, this outlook has left its mark, above all in the broad field of psychopathology, then in psychology, philosophy, aesthetics, ethnology and—last but not least—the psychology of religion. Everything that man can say about the nature of the psyche, whether it be true or only apparently true, necessarily touches upon the foundations of all the humane sciences, even though the really decisive discoveries have been made within the sphere of medicine, which, as we know, cannot be counted among the “humanities.”

[61] Freud was first and foremost a “nerve specialist” in the strictest sense of this word, and in every respect he always remained one. By training he was no psychiatrist, no psychologist, and no philosopher. In philosophy he lacked even the most rudimentary elements of education. He once assured me personally that it had never occurred to him to read Nietzsche. This fact is of importance in understanding Freud’s peculiar views, which are distinguished by an apparently total lack of any philosophical premises. His theories bear the unmistakable stamp of the doctor’s consulting-room. His constant point of departure is the neurotically degenerate psyche, unfolding its secrets with a mixture of reluctance and ill-concealed enjoyment under the critical eye of the doctor. But as the neurotic patient, besides having his individual sickness, is also an exponent of the local and contemporary mentality, a bridge exists from the start between the doctor’s view of his particular case and certain general assumptions. The existence of this bridge enabled Freud to turn his intuition from the narrow confines of the consulting-room to the wide world of moral, philosophical, and religious ideas, which also, unhappily enough, proved themselves amenable to this critical investigation.

[62] Freud owed his initial impetus to Charcot, his great teacher at the Salpêtrière. The first fundamental lesson he learnt there was the teaching about hypnotism and suggestion, and in 1888 he translated Bernheim’s book on the latter subject. The other was Charcot’s discovery that hysterical symptoms were the consequence of certain ideas that had taken possession of the patient’s “brain.” Charcot’s pupil, Pierre Janet, elaborated this theory in his comprehensive work *Névroses et idées fixes* and provided it with the necessary foundations. Freud’s older colleague in Vienna, Joseph

Breuer, furnished an illustrative case in support of this exceedingly important discovery (which, incidentally, had been made long before by many a family doctor), building upon it a theory of which Freud said that it “coincides with the medieval view once we substitute a psychological formula for the ‘demon’ of priestly fantasy.” The medieval theory of possession (toned down by Janet to “obsession”) was thus taken over by Breuer and Freud in a more positive form, the evil spirit—to reverse the Faustian miracle—being transmogrified into a harmless “psychological formula.” It is greatly to the credit of both investigators that they did not, like the rationalistic Janet, gloss over the significant analogy with possession, but rather, following the medieval theory, hunted up the factor causing the possession in order, as it were, to exorcize the evil spirit. Breuer was the first to discover that the pathogenic “ideas” were memories of certain events which he called “traumatic.” This discovery carried forward the preliminary work done at the Salpêtrière, and it laid the foundation of all Freud’s theories. As early as 1893 both men recognized the far-reaching practical importance of their findings. They realized that the symptom-producing “ideas” were rooted in an *affect*. This affect had the peculiarity of never really coming to the surface, so that it was never really conscious. The task of the therapist was therefore to “abreact” the “blocked” affect.

[63] This provisional formulation was certainly simple—too simple to do justice to the essence of the neuroses in general. At this point Freud commenced his own independent researches. It was first of all the question of the trauma that occupied him. He soon found (or thought he had found) that the traumatic factors were unconscious because of their painfulness. But they were painful because—according to his views at the time—they were one and all connected with the sphere of sex. The theory of the sexual trauma was Freud’s first independent theory of hysteria. Every specialist who has to do with the neuroses knows on the one hand how suggestible the patients are and, on the other, how unreliable are their reports. The theory was therefore treading on slippery and treacherous ground. As a result, Freud soon felt compelled to correct it more or less tacitly by attributing the traumatic factor to an abnormal development of infantile fantasy. The motive force of this luxuriant fantasy-activity he took to be an infantile sexuality, which nobody had liked to speak of before. Cases of abnormal precocity of development had naturally long been known in the medical literature, but such had not been assumed to be the case in relatively normal children. Freud did not commit this mistake either, nor did he envisage any concrete form of precocious development. It was rather a question of his paraphrasing and interpreting more or less normal infantile occurrences in terms of sexuality. This view unleashed a storm of indignation and disgust, first of all in professional circles and then among the educated public. Apart from the fact that every radically new idea invariably provokes the most violent resistance of the

experts, Freud's conception of the infant's instinctual life was an encroachment upon the domain of general and normal psychology, since his observations from the psychology of neurosis were transferred to a territory which had never before been exposed to this kind of illumination.

[64] Careful and painstaking investigation of neurotic and, in particular, hysterical states of mind could not conceal from Freud that such patients often exhibit an unusually lively dream-life and on that account like to tell of their dreams. In structure and manner of expression their dreams frequently correspond to the symptomatology of their neurosis. Anxiety states and anxiety dreams go hand in hand and obviously spring from the same root. Freud could therefore not avoid including dreams within the scope of his investigations. He had recognized very early that the "blocking" of the traumatic affect was due to the *repression* of "incompatible" material. The symptoms were substitutes for impulses, wishes, and fantasies which, because of their moral or aesthetic painfulness, were subjected to a "censorship" exercised by ethical conventions. In other words, they were pushed out of the conscious mind by a certain kind of moral attitude, and a specific inhibition prevented them from being remembered. The "theory of repression," as Freud aptly called it, became the centre-piece of his psychology. Since a great many things could be explained by this theory, it is not surprising that it was also applied to dreams. Freud's *Interpretation of Dreams* (1900) is an epoch-making work and probably the boldest attempt ever made to master the enigma of the unconscious psyche on the apparently firm ground of empiricism. Freud sought to prove with the aid of case material that dreams are disguised wish-fulfilments. This extension of the "repression mechanism," a concept borrowed from the psychology of neurosis, to the phenomenon of dreams was the second encroachment upon the sphere of normal psychology. It had immense consequences, as it stirred up problems which would have required for their solution a more compendious equipment than the limited experiences of the consulting-room.

[65] *The Interpretation of Dreams* is probably Freud's most important work, and at the same time the most open to attack. For us young psychiatrists it was a fount of illumination, but for our older colleagues it was an object of mockery. As with his recognition that neurosis has the character of a medieval "possession," so, by treating dreams as a highly important source of information about the unconscious processes—"the dream is the *via regia* to the unconscious"—Freud rescued something of the utmost value from the past, where it had seemed irretrievably sunk in oblivion. Indeed, in ancient medicine as well as in the old religions, dreams had a lofty significance and the dignity of an oracle. At the turn of the century, however, it was an act of the greatest scientific courage to make anything as unpopular as dreams an object of serious discussion. What impressed us young psychiatrists most was neither

the technique nor the theory, both of which seemed to us highly controversial, but the fact that anyone should have dared to investigate dreams at all. This line of investigation opened the way to an understanding of schizophrenic hallucinations and delusions from the inside, whereas hitherto psychiatrists had been able to describe them only from the outside. More than that, *The Interpretation of Dreams* provided a key to the many locked doors in the psychology of neurotics as well as of normal people.

[66] The repression theory was further applied to the interpretation of jokes, and in 1905 Freud published his entertaining *Jokes and Their Relation to the Unconscious*, a pendant to *The Psychopathology of Everyday Life*. Both these books may be read with enjoyment and instruction by the layman. A foray beyond the repression theory into the domain of primitive psychology, in *Totem and Taboo*, was less successful, since the application of concepts derived from the psychology of neurotics to the views of primitives did not explain the latter but only showed up the insufficiency of the former in a rather too obvious light.

[67] The final application of this theory was to the field of religion, in *The Future of an Illusion* (1927). Though there is much that is still tenable in *Totem and Taboo*, the same cannot, unfortunately, be said of the latter work. Freud's inadequate training in philosophy and in the history of religion makes itself painfully conspicuous, quite apart from the fact that he had no understanding of what religion was about. In his old age he wrote a book on Moses, who led the children of Israel to the Promised Land but was not allowed to set foot in it himself. That his choice fell on Moses is probably no accident in the case of a personality like Freud.

[68] As I said at the beginning, Freud always remained a physician. For all his interest in other fields, he constantly had the clinical picture of neurosis before his mind's eye—the very attitude that makes people ill and effectively prevents them from being healthy. Anyone who has this picture before him always sees the flaw in everything, and however much he may struggle against it, he must always point out what this daemonically obsessive picture compels him to see: the weak spot, the unadmitted wish, the hidden resentment, the secret, illegitimate fulfilment of a wish distorted by the “censor.” The neurotic is ill precisely because such things haunt his psyche; for though his unconscious contains many *other* things, it appears to be exclusively populated by contents that his consciousness has rejected for very good reasons. The keynote of Freud's thought is therefore a devastatingly pessimistic “nothing but.” Nowhere does he break through to a vision of the helpful, healing powers which would let the unconscious be of some benefit to the patient. Every position is undermined by a psychological critique that reduces everything to its unfavourable or ambiguous elements, or at least makes one suspect that such elements exist. This negative attitude is undoubtedly correct when applied to the little

games of make-believe which a neurosis produces in such abundance. Here the conjecture of unpleasant things in the background is often very much to the point, but not always. Also, there is no illness that is not at the same time an unsuccessful attempt at a cure. Instead of showing up the patient as the secret accomplice of morally inadmissible wishes, one can just as well explain him as the unwitting victim of instinctual problems which he doesn't understand and which nobody in his environment has helped him solve. His dreams, in particular, can be taken as nature's own auguries, having nothing whatever to do with the all-too-human self-deluding operations which Freud insinuates into the dream-process.

[69] I say this not in order to criticize Freud's theories but to lay due emphasis on his scepticism towards all or most of the ideals of the nineteenth century. Freud has to be seen against this cultural background. He put his finger on more than one ulcerous spot. All that glittered in the nineteenth century was very far from being gold, religion included. Freud was a great destroyer, but the turn of the century offered so many opportunities for debunking that even Nietzsche was not enough. Freud completed the task, very thoroughly indeed. He aroused a wholesome mistrust in people and thereby sharpened their sense of real values. All that gush about man's innate goodness, which had addled so many brains after the dogma of original sin was no longer understood, was blown to the winds by Freud, and the little that remains will, let us hope, be driven out for good and all by the barbarism of the twentieth century. Freud was no prophet, but he is a prophetic figure. Like Nietzsche, he overthrew the gigantic idols of our day, and it remains to be seen whether our highest values are so real that their glitter is not extinguished in the Acherontian flood. Doubt about our civilization and its values is the contemporary neurosis. If our convictions were really indubitable nobody would ever doubt them. Nor would anyone have been able to make it seem plausible that our ideals are only disguised expressions of motives that we do well to hide. But the nineteenth century has left us such a legacy of dubious propositions that doubt is not only possible but altogether justified, indeed meritorious. The gold will not prove its worth save in the fire. Freud has often been compared to a dentist, drilling out the carious tissue in the most painful manner. So far the comparison holds true, but not when it comes to the gold-filling. Freudian psychology does not fill the gap. If our critical reason tells us that in certain respects we are irrational and infantile, or that all religious beliefs are illusions, what are we to do about our irrationality, what are we to put in place of our exploded illusions? Our naïve childishness has in it the seeds of creativity, and illusion is a natural component of life, and neither of them can ever be suppressed or replaced by the rationalities and practicalities of convention.

[70] Freud's psychology moves within the narrow confines of nineteenth-century scientific materialism. Its philosophical premises were never examined, thanks

obviously to the Master's insufficient philosophical equipment. So it was inevitable that it should come under the influence of local and temporal prejudices—a fact that has been noted by various other critics. Freud's psychological method is and always was a cauterizing agent for diseased and degenerate material, such as is found chiefly in neurotic patients. It is an instrument to be used by a doctor, and it is dangerous and destructive, or at best ineffective, when applied to the natural expressions of life and its needs. A certain rigid one-sidedness in the theory, backed by an often fanatical intolerance, was perhaps an unavoidable necessity in the early decades of the century. Later, when the new ideas met with ample recognition, this grew into an aesthetic defect, and finally, like every fanaticism, it evoked the suspicion of an inner uncertainty. In the last resort, each of us carries the torch of knowledge only part of the way, and none is immune against error. Doubt alone is the mother of scientific truth. Whoever fights against dogma in high places falls victim, tragically enough, to the tyranny of a partial truth. All who had a share in the fate of this great man saw this tragedy working out step by step in his life and increasingly narrowing his horizon.

[71] In the course of the personal friendship which bound me to Freud for many years, I was permitted a deep glimpse into the mind of this remarkable man. He was a man possessed by a daemon—a man who had been vouchsafed an overwhelming revelation that took possession of his soul and never let him go. It was the encounter with Charcot's ideas that called awake in him that primordial image of a soul in the grip of a daemon, and kindled that passion for knowledge which was to lay open a dark continent to his gaze. He felt he had the key to the murky abysses of the possessed psyche. He wanted to unmask as illusion what the "absurd superstition" of the past took to be a devilish incubus, to whip away the disguises worn by the evil spirit and turn him back into a harmless poodle—in a word, reduce him to a "psychological formula." He believed in the power of the intellect; no Faustian shudderings tempered the hybris of his undertaking. He once said to me: "I only wonder what neurotics will do in the future when all their symbols have been unmasked. It will then be impossible to have a neurosis." He expected enlightenment to do everything—his favourite quotation was Voltaire's "Écrasez l'infâme." From this sentiment there grew up his astonishing knowledge and understanding of any morbid psychic material, which he smelt out under a hundred disguises and was able to bring to light with truly unending patience.

[72] Ludwig Klages' saying that "the spirit is the adversary of the soul"² might serve as a cautionary motto for the way Freud approached the possessed psyche. Whenever he could, he dethroned the "spirit" as the possessing and repressing agent by reducing it to a "psychological formula." Spirit, for him, was just a "nothing but." In a crucial talk with him I once tried to get him to understand the admonition: "Try the spirits

whether they are of God” (I John 4 : 1). In vain. Thus fate had to take its course. For one can fall victim to possession if one does not understand betimes why one is possessed. One should ask oneself for once: Why has this idea taken possession of me? What does that mean in regard to myself? A modest doubt like this can save us from falling head first into the idea and vanishing for ever.

[73] Freud’s “psychological formula” is only an apparent substitute for the daemonically vital thing that causes a neurosis. In reality only the spirit can cast out the “spirits”—not the intellect, which at best is a mere assistant, like Faust’s Wagner, and scarcely fitted to play the role of an exorcist.



RICHARD WILHELM: IN MEMORIAM

RICHARD WILHELM: IN MEMORIAM¹

[74] It is no easy task for me to speak of Richard Wilhelm and his work, because, starting very far away from one another, our paths crossed in cometlike fashion. His life-work has a range that lies outside my compass. I have never seen the China that first moulded his thought and later continued to engross him, nor am I familiar with its language, the living expression of the Chinese East. I stand indeed as a stranger outside that vast realm of knowledge and experience in which Wilhelm worked as a master of his profession. He as a sinologist and I as a doctor would probably never have come into contact had we remained specialists. But we met in a field of humanity which begins beyond the academic boundary posts. There lay our point of contact; there the spark leapt across and kindled a light that was to become for me one of the most significant events of my life. Because of this I may perhaps speak of Wilhelm and his work, thinking with grateful respect of this mind which created a bridge between East and West and gave to the Occident the precious heritage of a culture thousands of years old, a culture perhaps destined to disappear forever.

[75] Wilhelm possessed the kind of mastery which is won only by a man who goes beyond his speciality, and so his striving for knowledge became a concern touching all mankind. Or rather, it had been that from the beginning and remained so always. What else could have liberated him so completely from the narrow horizon of the European—and indeed, of the missionary—that no sooner had he delved into the secrets of the Chinese mind than he perceived the treasure hidden there for us, and sacrificed his European prejudices for the sake of this rare pearl? Only an all-embracing humanity, a greatness of heart that glimpses the whole, could have enabled him to open himself without reserve to a profoundly alien spirit, and to further its influence by putting his manifold gifts and capacities at its service. The understanding with which he devoted himself to this task, with no trace of Christian resentment or European arrogance, bears witness to a truly great mind; for all mediocre minds in contact with a foreign culture either perish in the blind attempt to deracinate themselves or else they indulge in an uncomprehending and presumptuous passion for criticism. Toying only with the surface and externals of the foreign culture, they never eat its bread or drink its wine, and so never enter into a real communion of minds, that most intimate transfusion and interpenetration which generates a new birth.

[76] As a rule, the specialist's is a purely masculine mind, an intellect to which fecundity is an alien and unnatural process; it is therefore an especially ill-adapted

tool for giving rebirth to a foreign spirit. But a larger mind bears the stamp of the feminine; it is endowed with a receptive and fruitful womb which can reshape what is strange and give it a familiar form. Wilhelm possessed the rare gift of a maternal intellect. To it he owed his unequalled ability to feel his way into the spirit of the East and to make his incomparable translations.

[77] To me the greatest of his achievements is his translation of, and commentary on, the *I Ching*.² Before I came to know Wilhelm's translation, I had worked for years with Legge's inadequate rendering,³ and I was therefore fully able to appreciate the extraordinary difference between the two. Wilhelm has succeeded in bringing to life again, in new form, this ancient work in which not only many sinologists but most of the modern Chinese see nothing more than a collection of absurd magical spells. This book embodies, as perhaps no other, the living spirit of Chinese civilization, for the best minds of China have collaborated on it and contributed to it for thousands of years. Despite its fabulous age it has never grown old, but still lives and works, at least for those who seek to understand its meaning. That we too belong to this favoured group we owe to the creative achievement of Wilhelm. He has brought the book closer to us by his careful translation and personal experience both as a pupil of a Chinese master of the old school and as an initiate in the psychology of Chinese yoga, who made constant use of the *I Ching* in practice.

[78] But together with these rich gifts, Wilhelm has bequeathed to us a task whose magnitude we can only surmise at present, but cannot fully apprehend. Anyone who, like myself, has had the rare good fortune to experience in association with Wilhelm the divinatory power of the *I Ching* cannot remain ignorant of the fact that we have here an Archimedean point from which our Western attitude of mind could be lifted off its foundations. It is no small service to have given us, as Wilhelm did, such a comprehensive and richly coloured picture of a foreign culture. What is even more important is that he has inoculated us with the living germ of the Chinese spirit, capable of working a fundamental change in our view of the world. We are no longer reduced to being admiring or critical observers, but find ourselves partaking of the spirit of the East to the extent that we succeed in experiencing the living power of the *I Ching*.

[79] The principle on which the use of the *I Ching* is based appears at first sight to be in complete contradiction to our scientific and causal thinking. For us it is unscientific in the extreme, almost taboo, and therefore outside the scope of our scientific judgment, indeed incomprehensible to it.

[80] Some years ago, the then president of the British Anthropological Society asked me how it was that so highly intelligent a people as the Chinese had produced no science. I replied that this must be an optical illusion, since the Chinese did have a science whose standard text-book was the *I Ching*, but that the principle of this

science, like so much else in China, was altogether different from the principle of our science.

[81] The science of the *I Ching* is based not on the causality principle but on one which—hitherto unnamed because not familiar to us—I have tentatively called the *synchronistic* principle. My researches into the psychology of unconscious processes long ago compelled me to look around for another principle of explanation, since the causality principle seemed to me insufficient to explain certain remarkable manifestations of the unconscious. I found that there are psychic parallelisms which simply cannot be related to each other causally, but must be connected by another kind of principle altogether. This connection seemed to lie essentially in the relative simultaneity of the events, hence the term “synchronistic.” It seems as though time, far from being an abstraction, is a concrete continuum which possesses qualities or basic conditions capable of manifesting themselves simultaneously in different places by means of an acausal parallelism, such as we find, for instance, in the simultaneous occurrence of identical thoughts, symbols, or psychic states. Another example, pointed out by Wilhelm, would be the coincidence of Chinese and European periods of style, which cannot have been causally related to one another. Astrology would be an example of synchronicity on a grand scale if only there were enough thoroughly tested findings to support it. But at least we have at our disposal a number of well-tested and statistically verifiable facts which make the problem of astrology seem worthy of scientific investigation. Its value is obvious enough to the psychologist, since astrology represents the sum of all the psychological knowledge of antiquity.

[82] The fact that it is possible to reconstruct a person’s character fairly accurately from his birth data shows the relative validity of astrology. It must be remembered, however, that the birth data are in no way dependent on the actual astronomical constellations, but are based on an arbitrary, purely conceptual time system. Owing to the precession of the equinoxes, the spring-point has long since moved out of the constellation of Aries into Pisces, so that the astrological zodiac on which horoscopes are calculated no longer corresponds to the heavenly one. If there are any astrological diagnoses of character that are in fact correct, this is due not to the influence of the stars but to our own hypothetical time qualities. In other words, whatever is born or done at this particular moment of time has the quality of this moment of time.

[83] Here we have the basic formula for the use of the *I Ching*. As you know, the hexagram that characterizes the moment of time, and gives us insight into it, is obtained by manipulating a bundle of yarrow stalks or by throwing three coins. The division of the yarrow stalks or the fall of the coins depends on pure chance. The runic stalks or coins fall into the pattern of the moment. The only question is: Did King Wen and the Duke of Chou, who lived a thousand years before the birth of Christ, interpret these chance patterns correctly?⁴ Experience alone can decide.

[84] At his first lecture at the Psychological Club in Zurich, Wilhelm, at my request, demonstrated the use of the *I Ching* and at the same time made a prognosis which, in less than two years, was fulfilled to the letter and with the utmost clarity. Predictions of this kind could be further confirmed by numerous parallel experiences. However, I am not concerned with establishing objectively the validity of the *I Ching*'s statements, but take it simply as a premise, just as Wilhelm did. I am concerned only with the astonishing fact that the hidden qualities of the moment become legible in the hexagram. The interconnection of events made evident by the *I Ching* is essentially analogous to what we find in astrology. There the moment of birth corresponds to the fall of the coins, the constellation to the hexagram, and the astrological interpretation of the birth data corresponds to the text assigned to the hexagram.

[85] The type of thinking based on the synchronistic principle, which reached its climax in the *I Ching*, is the purest expression of Chinese thinking in general. In the West it has been absent from the history of philosophy since the time of Heraclitus, and reappears only as a faint echo in Leibniz.⁵ However, in the interim it was not altogether extinguished, but lingered on in the twilight of astrological speculation, and it still remains on that level today.

[86] At this point the *I Ching* responds to something in us that is in need of further development. Occultism has enjoyed a renaissance in our times that is without parallel—the light of the Western mind is nearly darkened by it. I am not thinking now of our seats of learning and their representatives. As a doctor who deals with ordinary people, I know that the universities have ceased to act as disseminators of light. People are weary of scientific specialization and rationalism and intellectualism. They want to hear truths that broaden rather than restrict, that do not obscure but enlighten, that do not run off them like water but penetrate them to the marrow. This search is only too likely to lead a large if anonymous public astray.

[87] When I think of the significance of Wilhelm's achievement, I am always reminded of Anquetil Duperron, the Frenchman who brought the first translation of the Upanishads to Europe. This was at the very time when, after almost eighteen hundred years, the inconceivable happened and the Goddess of Reason drove the Christian God from his throne in Notre-Dame. Today, when far more inconceivable things are happening in Russia than ever did in Paris, and Christianity has become so debilitated that even the Buddhists think it is high time they sent missionaries to Europe, it is Wilhelm who brings new light from the East. This was the cultural task to which he felt himself called, recognizing how much the East had to offer in our spiritual need.

[88] A beggar is not helped by having alms, great or small, pressed into his hand, even though this may be what he wants. He is far better helped if we show him how he can

permanently rid himself of his beggary by work. Unfortunately, the spiritual beggars of our time are too inclined to accept the alms of the East in bulk and to imitate its ways unthinkingly. This is a danger about which too many warnings cannot be uttered, and one which Wilhelm felt very clearly. The spirit of Europe is not helped merely by new sensations or a titillation of the nerves. What it has taken China thousands of years to build cannot be acquired by theft. If we want to possess it, we must earn the right to it by working on ourselves. Of what use to us is the wisdom of the Upanishads or the insight of Chinese yoga if we desert our own foundations as though they were errors outlived, and, like homeless pirates, settle with thievish intent on foreign shores? The insights of the East, and in particular the wisdom of the *I Ching*, have no meaning for us if we close our minds to our own problems, jog along with our conventional prejudices, and veil from ourselves our real human nature with all its dangerous undercurrents and darkneses. The light of this wisdom shines only in the dark, not in the brightly lit theatre of our European consciousness and will. The wisdom of the *I Ching* issued from a background of whose horrors we have a faint inkling when we read of Chinese massacres, of the sinister power of Chinese secret societies, or of the nameless poverty, hopeless filth and vices of the Chinese masses.

[89] We need to have a firmly based, three-dimensional life of our own before we can experience the wisdom of the East as a living thing. Therefore, our prime need is to learn a few European truths about ourselves. Our way begins with European reality and not with yoga exercises which would only delude us about our own reality. We must continue Wilhelm's work of translation in a wider sense if we wish to show ourselves worthy pupils of the master. The central concept of Chinese philosophy is *tao*, which Wilhelm translated as "meaning." Just as Wilhelm gave the spiritual treasure of the East a European meaning, so we should translate this meaning into life. To do this—that is, to realize *tao*—would be the true task of the pupil.

[90] If we turn our eyes to the East, we see an overwhelming destiny fulfilling itself. The guns of Europe have burst open the gates of Asia; European science and technology, European materialism and cupidity, are flooding China. We have conquered the East politically. And what happened when Rome did the same thing to the Near East? The spirit of the East entered Rome. Mithras, the Persian god of light, became the god of the Roman legions, and out of the most unlikely corner of Asia Minor a new spiritual Rome arose. Would it be unthinkable that the same thing might happen today and find us just as blind as the cultured Romans who marvelled at the superstitions of the Christians? It is worth noticing that England and Holland, the two main colonizing powers in Asia, are also the two most infected with Hindu theosophy. I know that our unconscious is full of Eastern symbolism. The spirit of the East is really at our gates. Therefore it seems to me that the search for *tao*, for a

meaning in life, has already become a collective phenomenon among us, and to a far greater extent than is generally realized. The fact that Wilhelm and the indologist Hauer were asked to lecture on yoga at this year's congress of German psychotherapists is a most significant sign of the times. Imagine what it means when a practising physician, who has to deal with people at their most sensitive and receptive, establishes contact with an Eastern system of healing! In this way the spirit of the East penetrates through all our pores and reaches the most vulnerable places of Europe. It could be a dangerous infection, but it might also be a remedy. The Babylonian confusion of tongues in the West has created such a disorientation that everyone longs for simpler truths, or at least for guiding ideas which speak not to the head alone but also to the heart, which bring clarity to the contemplative spirit and peace to the restless pressure of our feelings. Like ancient Rome, we today are once more importing every form of exotic superstition in the hope of finding the right remedy for our sickness.

[91] Human instinct knows that all great truth is simple. The man whose instincts are atrophied therefore supposes that it is found in cheap simplifications and platitudes; or, as a result of his disappointment, he falls into the opposite error of thinking that it must be as obscure and complicated as possible. Today we have a Gnostic movement in the anonymous masses which is the exact psychological counterpart of the Gnostic movement nineteen hundred years ago. Then, as today, solitary wanderers like Apollonius of Tyana spun the spiritual threads from Europe to Asia, perhaps to remotest India. Viewing him in this historical perspective, I see Wilhelm as one of those great Gnostic intermediaries who brought the Hellenic spirit into contact with the cultural heritage of the East and thereby caused a new world to rise out of the ruins of the Roman Empire.

[92] In the midst of the jarring disharmony of European opinion and the shouts of false prophets, it is indeed a blessing to hear the simple language of Wilhelm, the messenger from China. One notices at once that it is schooled in the plant-like spontaneity of the Chinese mind, which is able to express profound things in simple language. It discloses something of the simplicity of great truth, the ingenuousness of deep meaning, and it carries to us the delicate perfume of the Golden Flower. Penetrating gently, it has set in the soil of Europe a tender seedling, giving us a new intuition of life and its meaning, far removed from the tension and arrogance of the European will.

[93] Faced with the alien culture of the East, Wilhelm showed a degree of modesty highly unusual in a European. He approached it freely, without prejudice, without the assumption of knowing better; he opened his heart and mind to it. He let himself be gripped and shaped by it, so that when he came back to Europe he brought us, not only in his spirit but in his whole being, a true image of the East. This deep

transformation was certainly not won without great sacrifice, for our historical premises are so entirely different. The keenness of Western consciousness and its harsh problems had to soften before the more universal, more equable nature of the East; Western rationalism and one-sided differentiation had to yield to Eastern breadth and simplicity. For Wilhelm this change meant not only a shifting of the intellectual standpoint but a radical rearrangement of the components of his personality. The picture of the East he has given us, free of ulterior motive and all trace of tendentiousness, could never have been painted in such perfection had he not been able to let the European in him slip into the background. If he had allowed East and West to clash together with unyielding harshness, he could not have fulfilled his mission of conveying to us a true picture of China. The sacrifice of the European was unavoidable and necessary for the fulfilment of the task fate laid upon him.

[94] Wilhelm accomplished his mission in every sense of the word. Not only did he make accessible to us the cultural treasure of ancient China, but, as I have said, he brought us its spiritual root, the root that has remained alive all these thousands of years, and planted it in the soil of Europe. With the completion of this task, his mission reached its climax and, unfortunately, its end. According to the law of *enantiodromia*, so well understood by the Chinese, the end of one phase is the beginning of its opposite. Thus *yang* at its highest point changes into *yin*, and positive into negative. I came closer to Wilhelm only in the last years of his life, and I could observe how, with the completion of his life-work, Europe and European man hemmed him in more and more closely, beset him in fact. And at the same time there grew in him the feeling that he stood on the brink of a great change, an upheaval whose nature he could not clearly grasp. He only knew that he faced a decisive crisis. His physical illness went parallel with this development. His dreams were filled with memories of China, but the images were always sad and gloomy, a clear proof that the Chinese contents of his mind had become negative.

[95] Nothing can be sacrificed for ever. Everything returns later in changed form, and when once a great sacrifice has been made, the sacrificed thing when it returns must meet with a healthy and resistant body that can take the shock. Therefore, a spiritual crisis of these dimensions often means death if it takes place in a body weakened by disease. For now the sacrificial knife is in the hand of him who was sacrificed, and a death is demanded of the erstwhile sacrificer.

[96] As you see, I have not withheld my personal views, for if I had not told you what Wilhelm meant to me, how would it have been possible for me to speak of him? Wilhelm's life-work is of such immense importance to me because it clarified and confirmed so much that I had been seeking, striving for, thinking, and doing in my efforts to alleviate the psychic sufferings of Europeans. It was a tremendous experience for me to hear through him, in clear language, things I had dimly divined

in the confusion of our European unconscious. Indeed, I feel myself so very much enriched by him that it seems to me as if I had received more from him than from any other man. That is also the reason why I do not feel it a presumption if I am the one to offer on the altar of his memory the gratitude and respect of all of us.

IV

ON THE RELATION OF ANALYTICAL PSYCHOLOGY TO POETRY



PSYCHOLOGY AND LITERATURE

ON THE RELATION OF ANALYTICAL PSYCHOLOGY TO POETRY¹

[97] In spite of its difficulty, the task of discussing the relation of analytical psychology to poetry affords me a welcome opportunity to define my views on the much debated question of the relations between psychology and art in general. Although the two things cannot be compared, the close connections which undoubtedly exist between them call for investigation. These connections arise from the fact that the practice of art is a psychological activity and, as such, can be approached from a psychological angle. Considered in this light, art, like any other human activity deriving from psychic motives, is a proper subject for psychology. This statement, however, involves a very definite limitation of the psychological viewpoint when we come to apply it in practice. Only that aspect of art which consists in the process of artistic creation can be a subject for psychological study, but not that which constitutes its essential nature. The question of what art is in itself can never be answered by the psychologist, but must be approached from the side of aesthetics.

[98] A similar distinction must be made in the realm of religion. A psychological approach is permissible only in regard to the emotions and symbols which constitute the phenomenology of religion, but which do not touch upon its essential nature. If the essence of religion and art could be explained, then both of them would become mere subdivisions of psychology. This is not to say that such violations of their nature have not been attempted. But those who are guilty of them obviously forget that a similar fate might easily befall psychology, since its intrinsic value and specific quality would be destroyed if it were regarded as a mere activity of the brain, and were relegated along with the endocrine functions to a subdivision of physiology. This too, as we know, has been attempted.

[99] Art by its very nature is not science, and science by its very nature is not art; both these spheres of the mind have something in reserve that is peculiar to them and can be explained only in its own terms. Hence when we speak of the relation of psychology to art, we shall treat only of that aspect of art which can be submitted to psychological scrutiny without violating its nature. Whatever the psychologist has to say about art will be confined to the process of artistic creation and has nothing to do with its innermost essence. He can no more explain this than the intellect can describe or even understand the nature of feeling. Indeed, art and science would not exist as separate entities at all if the fundamental difference between them had not long since forced itself on the mind. The fact that artistic, scientific, and religious

propensities still slumber peacefully together in the small child, or that with primitives the beginnings of art, science, and religion coalesce in the undifferentiated chaos of the magical mentality, or that no trace of “mind” can be found in the natural instincts of animals—all this does nothing to prove the existence of a unifying principle which alone would justify a reduction of the one to the other. For if we go so far back into the history of the mind that the distinctions between its various fields of activity become altogether invisible, we do not reach an underlying principle of their unity, but merely an earlier, undifferentiated state in which no separate activities yet exist. But the elementary state is not an explanatory principle that would allow us to draw conclusions as to the nature of later, more highly developed states, even though they must necessarily derive from it. A scientific attitude will always tend to overlook the peculiar nature of these more differentiated states in favour of their causal derivation, and will endeavour to subordinate them to a general but more elementary principle.

[100] These theoretical reflections seem to me very much in place today, when we so often find that works of art, and particularly poetry, are interpreted precisely in this manner, by reducing them to more elementary states. Though the material he works with and its individual treatment can easily be traced back to the poet’s personal relations with his parents, this does not enable us to understand his poetry. The same reduction can be made in all sorts of other fields, and not least in the case of pathological disturbances. Neuroses and psychoses are likewise reducible to infantile relations with the parents, and so are a man’s good and bad habits, his beliefs, peculiarities, passions, interests, and so forth. It can hardly be supposed that all these very different things must have exactly the same explanation, for otherwise we would be driven to the conclusion that they actually are the same thing. If a work of art is explained in the same way as a neurosis, then either the work of art is a neurosis or a neurosis is a work of art. This explanation is all very well as a play on words, but sound common sense rebels against putting a work of art on the same level as a neurosis. An analyst might, in an extreme case, view a neurosis as a work of art through the lens of his professional bias, but it would never occur to an intelligent layman to mistake a pathological phenomenon for art, in spite of the undeniable fact that a work of art arises from much the same psychological conditions as a neurosis. This is only natural, because certain of these conditions are present in every individual and, owing to the relative constancy of the human environment, are constantly the same, whether in the case of a nervous intellectual, a poet, or a normal human being. All have had parents, all have a father- or a mother-complex, all know about sex and therefore have certain common and typical human difficulties. One poet may be influenced more by his relation to his father, another by the tie to his mother, while a third shows unmistakable traces of sexual repression in his poetry.

Since all this can be said equally well not only of every neurotic but of every normal human being, nothing specific is gained for the judgment of a work of art. At most our knowledge of its psychological antecedents will have been broadened and deepened.

[101] The school of medical psychology inaugurated by Freud has undoubtedly encouraged the literary historian to bring certain peculiarities of a work of art into relation with the intimate, personal life of the poet. But this is nothing new in principle, for it has long been known that the scientific treatment of art will reveal the personal threads that the artist, intentionally or unintentionally, has woven into his work. The Freudian approach may, however, make possible a more exhaustive demonstration of the influences that reach back into earliest childhood and play their part in artistic creation. To this extent the psychoanalysis of art differs in no essential from the subtle psychological nuances of a penetrating literary analysis. The difference is at most a question of degree, though we may occasionally be surprised by indiscreet references to things which a rather more delicate touch might have passed over if only for reasons of tact. This lack of delicacy seems to be a professional peculiarity of the medical psychologist, and the temptation to draw daring conclusions easily leads to flagrant abuses. A slight whiff of scandal often leads spice to a biography, but a little more becomes a nasty inquisitiveness—bad taste masquerading as science. Our interest is insidiously deflected from the work of art and gets lost in the labyrinth of psychic determinants, the poet becomes a clinical case and, very likely, yet another addition to the curiosa of *psychopathia sexualis*. But this means that the psychoanalysis of art has turned aside from its proper objective and strayed into a province that is as broad as mankind, that is not in the least specific of the artist and has even less relevance to his art.

[102] This kind of analysis brings the work of art into the sphere of general human psychology, where many other things besides art have their origin. To explain art in these terms is just as great a platitude as the statement that “every artist is a narcissist.” Every man who pursues his own goal is a “narcissist”—though one wonders how permissible it is to give such wide currency to a term specifically coined for the pathology of neurosis. The statement therefore amounts to nothing; it merely elicits the faint surprise of a *bon mot*. Since this kind of analysis is in no way concerned with the work of art itself, but strives like a mole to bury itself in the dirt as speedily as possible, it always ends up in the common earth that unites all mankind. Hence its explanations have the same tedious monotony as the recitals which one daily hears in the consulting-room.

[103] The reductive method of Freud is a purely medical one, and the treatment is directed at a pathological or otherwise unsuitable formation which has taken the place of the normal functioning. It must therefore be broken down, and the way

cleared for healthy adaptation. In this case, reduction to the common human foundation is altogether appropriate. But when applied to a work of art it leads to the results I have described. It strips the work of art of its shimmering robes and exposes the nakedness and drabness of *Homo sapiens*, to which species the poet and artist also belong. The golden gleam of artistic creation—the original object of discussion—is extinguished as soon as we apply to it the same corrosive method which we use in analysing the fantasies of hysteria. The results are no doubt very interesting and may perhaps have the same kind of scientific value as, for instance, a post-mortem examination of the brain of Nietzsche, which might conceivably show us the particular atypical form of paralysis from which he died. But what would this have to do with *Zarathustra*? Whatever its subterranean background may have been, is it not a whole world in itself, beyond the human, all-too-human imperfections, beyond the world of migraine and cerebral atrophy?

[104] I have spoken of Freud's reductive method but have not stated in what that method consists. It is essentially a medical technique for investigating morbid psychic phenomena, and it is solely concerned with the ways and means of getting round or peering through the foreground of consciousness in order to reach the psychic background, or the unconscious. It is based on the assumption that the neurotic patient represses certain psychic contents because they are morally incompatible with his conscious values. It follows that the repressed contents must have correspondingly negative traits—infantile-sexual, obscene, or even criminal—which make them unacceptable to consciousness. Since no man is perfect, everyone must possess such a background whether he admits it or not. Hence it can always be exposed if only one uses the technique of interpretation worked out by Freud.

[105] In the short space of a lecture I cannot, of course, enter into the details of the technique. A few hints must suffice. The unconscious background does not remain inactive, but betrays itself by its characteristic effects on the contents of consciousness. For example, it produces fantasies of a peculiar nature, which can easily be interpreted as sexual images. Or it produces characteristic disturbances of the conscious processes, which again can be reduced to repressed contents. A very important source for knowledge of the unconscious contents is provided by dreams, since these are direct products of the activity of the unconscious. The essential thing in Freud's reductive method is to collect all the clues pointing to the unconscious background, and then, through the analysis and interpretation of this material, to reconstruct the elementary instinctual processes. Those conscious contents which give us a clue to the unconscious background are incorrectly called *symbols* by Freud. They are not true symbols, however, since according to his theory they have merely the role of *signs* or *symptoms* of the subliminal processes. The true symbol differs essentially from this, and should be understood as an expression of an

intuitive idea that cannot yet be formulated in any other or better way. When Plato, for instance, puts the whole problem of the theory of knowledge in his parable of the cave, or when Christ expresses the idea of the Kingdom of Heaven in parables, these are genuine and true symbols, that is, attempts to express something for which no verbal concept yet exists. If we were to interpret Plato's metaphor in Freudian terms we would naturally arrive at the uterus, and would have proved that even a mind like Plato's was still struck on a primitive level of infantile sexuality. But we would have completely overlooked what Plato actually created out of the primitive determinants of his philosophical ideas; we would have missed the essential point and merely discovered that he had infantile-sexual fantasies like any other mortal. Such a discovery could be of value only for a man who regarded Plato as superhuman, and who can now state with satisfaction that Plato too was an ordinary human being. But who would want to regard Plato as a god? Surely only one who is dominated by infantile fantasies and therefore possesses a neurotic mentality. For him the reduction to common human truths is salutary on medical grounds, but this would have nothing whatever to do with the meaning of Plato's parable.

[106] I have purposely dwelt on the application of medical psychoanalysis to works of art because I want to emphasize that the psychoanalytic method is at the same time an essential part of the Freudian doctrine. Freud himself by his rigid dogmatism has ensured that the method and the doctrine—in themselves two very different things—are regarded by the public as identical. Yet the method may be employed with beneficial results in medical cases without at the same time exalting it into a doctrine. And against this doctrine we are bound to raise vigorous objections. The assumptions it rests on are quite arbitrary. For example, neuroses are by no means exclusively caused by sexual repression, and the same holds true for psychoses. There is no foundation for saying that dreams merely contain repressed wishes whose moral incompatibility requires them to be disguised by a hypothetical dream-censor. The Freudian technique of interpretation, so far as it remains under the influence of its own one-sided and therefore erroneous hypotheses, displays a quite obvious bias.

[107] In order to do justice to a work of art, analytical psychology must rid itself entirely of medical prejudice; for a work of art is not a disease, and consequently requires a different approach from the medical one. A doctor naturally has to seek out the causes of a disease in order to pull it up by the roots, but just as naturally the psychologist must adopt exactly the opposite attitude towards a work of art. Instead of investigating its typically human determinants, he will inquire first of all into its meaning, and will concern himself with its determinants only in so far as they enable him to understand it more fully. Personal causes have as much or as little to do with a work of art as the soil with the plant that springs from it. We can certainly learn to understand some of the plant's peculiarities by getting to know its habitat, and for the

botanist this is an important part of his equipment. But nobody will maintain that everything essential has then been discovered about the plant itself. The personal orientation which the doctor needs when confronted with the question of aetiology in medicine is quite out of place in dealing with a work of art, just because a work of art is not a human being, but is something supra-personal. It is a thing and not a personality; hence it cannot be judged by personal criteria. Indeed, the special significance of a true work of art resides in the fact that it has escaped from the limitations of the personal and has soared beyond the personal concerns of its creator.

[108] I must confess from my own experience that it is not at all easy for a doctor to lay aside his professional bias when considering a work of art and look at it with a mind cleared of the current biological causality. But I have come to learn that although a psychology with a purely biological orientation can explain a good deal about man in general, it cannot be applied to a work of art and still less to man as creator. A purely causalistic psychology is only able to reduce every human individual to a member of the species *Homo sapiens*, since its range is limited to what is transmitted by heredity or derived from other sources. But a work of art is not transmitted or derived—it is a creative reorganization of those very conditions to which a causalistic psychology must always reduce it. The plant is not a mere product of the soil; it is a living, self-contained process which in essence has nothing to do with the character of the soil. In the same way, the meaning and individual quality of a work of art inhere within it and not in its extrinsic determinants. One might almost describe it as a living being that uses man only as a nutrient medium, employing his capacities according to its own laws and shaping itself to the fulfilment of its own creative purpose.

[109] But here I am anticipating somewhat, for I have in mind a particular type of art which I still have to introduce. Not every work of art originates in the way I have just described. There are literary works, prose as well as poetry, that spring wholly from the author's intention to produce a particular result. He submits his material to a definite treatment with a definite aim in view; he adds to it and subtracts from it, emphasizing one effect, toning down another, laying on a touch of colour here, another there, all the time carefully considering the over-all result and paying strict attention to the laws of form and style. He exercises the keenest judgment and chooses his words with complete freedom. His material is entirely subordinated to his artistic purpose; he wants to express this and nothing else. He is wholly at one with the creative process, no matter whether he has deliberately made himself its spearhead, as it were, or whether it has made him its instrument so completely that he has lost all consciousness of this fact. In either case, the artist is so identified with his work that his intentions and his faculties are indistinguishable from the act of creation itself. There is no need, I think, to give examples of this from the history of literature or from the testimony of the artists themselves.

[110] Nor need I cite examples of the other class of works which flow more or less complete and perfect from the author's pen. They come as it were fully arrayed into the world, as Pallas Athene sprang from the head of Zeus. These works positively force themselves upon the author; his hand is seized, his pen writes things that his mind contemplates with amazement. The work brings with it its own form; anything he wants to add is rejected, and what he himself would like to reject is thrust back at him. While his conscious mind stands amazed and empty before this phenomenon, he is overwhelmed by a flood of thoughts and images which he never intended to create and which his own will could never have brought into being. Yet in spite of himself he is forced to admit that it is his own self speaking, his own inner nature revealing itself and uttering things which he would never have entrusted to his tongue. He can only obey the apparently alien impulse within him and follow where it leads, sensing that his work is greater than himself, and wields a power which is not his and which he cannot command. Here the artist is not identical with the process of creation; he is aware that he is subordinate to his work or stands outside it, as though he were a second person; or as though a person other than himself had fallen within the magic circle of an alien will.

[111] So when we discuss the psychology of art, we must bear in mind these two entirely different modes of creation, for much that is of the greatest importance in judging a work of art depends on this distinction. It is one that had been sensed earlier by Schiller, who as we know attempted to classify it in his concept of the *sentimental* and the *naïve*. The psychologist would call "sentimental" art *introverted* and the "naïve" kind *extraverted*. The introverted attitude is characterized by the subject's assertion of his conscious intentions and aims against the demands of the object, whereas the extraverted attitude is characterized by the subject's subordination to the demands which the object makes upon him. In my view, Schiller's plays and most of his poems give one a good idea of the introverted attitude: the material is mastered by the conscious intentions of the poet. The extraverted attitude is illustrated by the second part of *Faust*: here the material is distinguished by its refractoriness. A still more striking example is Nietzsche's *Zarathustra*, where the author himself observed how "one became two."

[112] From what I have said, it will be apparent that a shift of psychological standpoint has taken place as soon as one speaks not of the poet as a person but of the creative process that moves him. When the focus of interest shifts to the latter, the poet comes into the picture only as a reacting subject. This is immediately evident in our second category of works, where the consciousness of the poet is not identical with the creative process. But in works of the first category the opposite appears to hold true. Here the poet appears to be the creative process itself, and to create of his own free will without the slightest feeling of compulsion. He may even be fully convinced of

his freedom of action and refuse to admit that his work could be anything else than the expression of his will and ability.

[113] Here we are faced with a question which we cannot answer from the testimony of the poets themselves. It is really a scientific problem that psychology alone can solve. As I hinted earlier, it might well be that the poet, while apparently creating out of himself and producing what he consciously intends, is nevertheless so carried away by the creative impulse that he is no longer aware of an “alien” will, just as the other type of poet is no longer aware of his own will speaking to him in the apparently “alien” inspiration, although this is manifestly the voice of his own self. The poet’s conviction that he is creating in absolute freedom would then be an illusion: he fancies he is swimming, but in reality an unseen current sweeps him along.

[114] This is not by any means an academic question, but is supported by the evidence of analytical psychology. Researches have shown that there are all sorts of ways in which the conscious mind is not only influenced by the unconscious but actually guided by it. Yet is there any evidence for the supposition that a poet, despite his self-awareness, may be taken captive by his work? The proof may be of two kinds, direct or indirect. Direct proof would be afforded by a poet who thinks he knows what he is saying but actually says more than he is aware of. Such cases are not uncommon. Indirect proof would be found in cases where behind the apparent free will of the poet there stands a higher imperative that renews its peremptory demands as soon as the poet voluntarily gives up his creative activity, or that produces psychic complications whenever his work has to be broken off against his will.

[115] Analysis of artists consistently shows not only the strength of the creative impulse arising from the unconscious, but also its capricious and wilful character. The biographies of great artists make it abundantly clear that the creative urge is often so imperious that it battens on their humanity and yokes everything to the service of the work, even at the cost of health and ordinary human happiness. The unborn work in the psyche of the artist is a force of nature that achieves its end either with tyrannical might or with the subtle cunning of nature herself, quite regardless of the personal fate of the man who is its vehicle. The creative urge lives and grows in him like a tree in the earth from which it draws its nourishment. We would do well, therefore, to think of the creative process as a living thing implanted in the human psyche. In the language of analytical psychology this living thing is an *autonomous complex*. It is a split-off portion of the psyche, which leads a life of its own outside the hierarchy of consciousness. Depending on its energy charge, it may appear either as a mere disturbance of conscious activities or as a supraordinate authority which can harness the ego to its purpose. Accordingly, the poet who identifies with the creative process would be one who acquiesces from the start when the unconscious imperative begins

to function. But the other poet, who feels the creative force as something alien, is one who for various reasons cannot acquiesce and is thus caught unawares.

[116] It might be expected that this difference in its origins would be perceptible in a work of art. For in the one case it is a conscious product shaped and designed to have the effect intended. But in the other we are dealing with an event originating in unconscious nature; with something that achieves its aim without the assistance of human consciousness, and often defies it by wilfully insisting on its own form and effect. We would therefore expect that works belonging to the first class would nowhere overstep the limits of comprehension, that their effect would be bounded by the author's intention and would not extend beyond it. But with works of the other class we would have to be prepared for something suprapersonal that transcends our understanding to the same degree that the author's consciousness was in abeyance during the process of creation. We would expect a strangeness of form and content, thoughts that can only be apprehended intuitively, a language pregnant with meanings, and images that are true symbols because they are the best possible expressions for something unknown—bridges thrown out towards an unseen shore.

[117] These criteria are, by and large, corroborated in practice. Whenever we are confronted with a work that was consciously planned and with material that was consciously selected, we find that it agrees with the first class of qualities, and in the other case with the second. The example we gave of Schiller's plays, on the one hand, and *Faust II* on the other, or better still *Zarathustra*, is an illustration of this. But I would not undertake to place the work of an unknown poet in either of these categories without first having examined rather closely his personal relations with his work. It is not enough to know whether the poet belongs to the introverted or to the extraverted type, since it is possible for either type to work with an introverted attitude at one time, and an extraverted attitude at another. This is particularly noticeable in the difference between Schiller's plays and his philosophical writings, between Goethe's perfectly formed poems and the obvious struggle with his material in *Faust II*, and between Nietzsche's well-turned aphorisms and the rushing torrent of *Zarathustra*. The same poet can adopt different attitudes to his work at different times, and on this depends the standard we have to apply.

[118] The question, as we now see, is exceedingly complicated, and the complication grows even worse when we consider the case of the poet who identifies with the creative process. For should it turn out that the apparently conscious and purposeful manner of composition is a subjective illusion of the poet, then his work would possess symbolic qualities that are outside the range of his consciousness. They would only be more difficult to detect, because the reader as well would be unable to get beyond the bounds of the poet's consciousness which are fixed by the spirit of the time. There is no Archimedean point outside his world by which he could lift his

time-bound consciousness off its hinges and recognize the symbols hidden in the poet's work. For a symbol is the intimation of a meaning beyond the level of our present powers of comprehension.

[119] I raise this question only because I do not want my typological classification to limit the possible significance of works of art which apparently mean no more than what they say. But we have often found that a poet who has gone out of fashion is suddenly rediscovered. This happens when our conscious development has reached a higher level from which the poet can tell us something new. It was always present in his work but was hidden in a symbol, and only a renewal of the spirit of the time permits us to read its meaning. It needed to be looked at with fresher eyes, for the old ones could see in it only what they were accustomed to see. Experiences of this kind should make us cautious, as they bear out my earlier argument. But works that are openly symbolic do not require this subtle approach; their pregnant language cries out at us that they mean more than they say. We can put our finger on the symbol at once, even though we may not be able to unriddle its meaning to our entire satisfaction. A symbol remains a perpetual challenge to our thoughts and feelings. That probably explains why a symbolic work is so stimulating, why it grips us so intensely, but also why it seldom affords us a purely aesthetic enjoyment. A work that is manifestly not symbolic appeals much more to our aesthetic sensibility because it is complete in itself and fulfils its purpose.

[120] What then, you may ask, can analytical psychology contribute to our fundamental problem, which is the mystery of artistic creation? All that we have said so far has to do only with the psychological phenomenology of art. Since nobody can penetrate to the heart of nature, you will not expect psychology to do the impossible and offer a valid explanation of the secret of creativity. Like every other science, psychology has only a modest contribution to make towards a deeper understanding of the phenomena of life, and is no nearer than its sister sciences to absolute knowledge.

[121] We have talked so much about the meaning of works of art that one can hardly suppress a doubt as to whether art really "means" anything at all. Perhaps art has no "meaning," at least not as we understand meaning. Perhaps it is like nature, which simply *is* and "means" nothing beyond that. Is "meaning" necessarily more than mere interpretation—an interpretation secreted into something by an intellect hungry for meaning? Art, it has been said, is beauty, and "a thing of beauty is a joy for ever." It needs no meaning, for meaning has nothing to do with art. Within the sphere of art, I must accept the truth of this statement. But when I speak of the relation of psychology to art we are outside its sphere, and it is impossible for us not to speculate. We must interpret, we must find meanings in things, otherwise we would be quite unable to think about them. We have to break down life and events, which are self-contained processes, into meanings, images, concepts, well knowing that in

doing so we are getting further away from the living mystery. As long as we ourselves are caught up in the process of creation, we neither see nor understand; indeed we ought not to understand, for nothing is more injurious to immediate experience than cognition. But for the purpose of cognitive understanding we must detach ourselves from the creative process and look at it from the outside; only then does it become an image that expresses what we are bound to call "meaning." What was a mere phenomenon before becomes something that in association with other phenomena has meaning, that has a definite role to play, serves certain ends, and exerts meaningful effects. And when we have seen all this we get the feeling of having understood and explained something. In this way we meet the demands of science.

[122] When, a little earlier, we spoke of a work of art as a tree growing out of the nourishing soil, we might equally well have compared it to a child growing in the womb. But as all comparisons are lame, let us stick to the more precise terminology of science. You will remember that I described the nascent work in the psyche of the artist as an autonomous complex. By this we mean a psychic formation that remains subliminal until its energy-charge is sufficient to carry it over the threshold into consciousness. Its association with consciousness does not mean that it is assimilated, only that it is perceived; but it is not subject to conscious control, and can be neither inhibited nor voluntarily reproduced. Therein lies the autonomy of the complex: it appears and disappears in accordance with its own inherent tendencies, independently of the conscious will. The creative complex shares this peculiarity with every other autonomous complex. In this respect it offers an analogy with pathological processes, since these too are characterized by the presence of autonomous complexes, particularly in the case of mental disturbances. The divine frenzy of the artist comes perilously close to a pathological state, though the two things are not identical. The *tertium comparationis* is the autonomous complex. But the presence of autonomous complexes is not in itself pathological, since normal people, too, fall temporarily or permanently under their domination. This fact is simply one of the normal peculiarities of the psyche, and for a man to be unaware of the existence of an autonomous complex merely betrays a high degree of unconsciousness. Every typical attitude that is to some extent differentiated shows a tendency to become an autonomous complex, and in most cases it actually does. Again, every instinct has more or less the character of an autonomous complex. In itself, therefore, an autonomous complex has nothing morbid about it; only when its manifestations are frequent and disturbing is it a symptom of illness.

[123] How does an autonomous complex arise? For reasons which we cannot go into here, a hitherto unconscious portion of the psyche is thrown into activity, and gains ground by activating the adjacent areas of association. The energy needed for this is

naturally drawn from consciousness—unless the latter happens to identify with the complex. But where this does not occur, the drain of energy produces what Janet calls an *abaissement du niveau mental*. The intensity of conscious interests and activities gradually diminishes, leading either to apathy—a condition very common with artists—or to a regressive development of the conscious functions, that is, they revert to an infantile and archaic level and undergo something like a degeneration. The “inferior parts of the functions,” as Janet calls them, push to the fore; the instinctual side of the personality prevails over the ethical, the infantile over the mature, and the unadapted over the adapted. This too is something we see in the lives of many artists. The autonomous complex thus develops by using the energy that has been withdrawn from the conscious control of the personality.

[124] But in what does an autonomous *creative* complex consist? Of this we can know next to nothing so long as the artist’s work affords us no insight into its foundations. The work presents us with a finished picture, and this picture is amenable to analysis only to the extent that we can recognize it as a symbol. But if we are unable to discover any symbolic value in it, we have merely established that, so far as we are concerned, it means no more than what it says, or to put it another way, that it *is* no more than what it *seems* to be. I use the word “seems” because our own bias may prevent a deeper appreciation of it. At any rate we can find no incentive and no starting-point for an analysis. But in the case of a symbolic work we should remember the dictum of Gerhard Hauptmann: “Poetry evokes out of words the resonance of the primordial word.” The question we should ask, therefore, is: “What primordial image lies behind the imagery of art?”

[125] This question needs a little elucidation. I am assuming that the work of art we propose to analyse, as well as being symbolic, has its source not in the *personal unconscious* of the poet, but in a sphere of unconscious mythology whose primordial images are the common heritage of mankind. I have called this sphere the *collective unconscious*, to distinguish it from the personal unconscious. The latter I regard as the sum total of all those psychic processes and contents which are capable of becoming conscious and often do, but are then suppressed because of their incompatibility and kept subliminal. Art receives tributaries from this sphere too, but muddy ones; and their predominance, far from making a work of art a symbol, merely turns it into a symptom. We can leave this kind of art without injury and without regret to the purgative methods employed by Freud.

[126] In contrast to the personal unconscious, which is a relatively thin layer immediately below the threshold of consciousness, the collective unconscious shows no tendency to become conscious under normal conditions, nor can it be brought back to recollection by any analytical technique,² since it was never repressed or forgotten. The collective unconscious is not to be thought of as a self-subsistent

entity; it is no more than a potentiality handed down to us from primordial times in the specific form of mnemonic images³ or inherited in the anatomical structure of the brain. There are no inborn ideas, but there are inborn possibilities of ideas that set bounds to even the boldest fantasy and keep our fantasy activity within certain categories: *a priori* ideas, as it were, the existence of which cannot be ascertained except from their effects. They appear only in the shaped material of art as the regulative principles that shape it; that is to say, only by inferences drawn from the finished work can we reconstruct the age-old original⁴ of the primordial image.

[127] The primordial image, or archetype, is a figure—be it a daemon, a human being, or a process—that constantly recurs in the course of history and appears wherever creative fantasy is freely expressed. Essentially, therefore, it is a mythological figure. When we examine these images more closely, we find that they give form to countless typical experiences of our ancestors. They are, so to speak, the psychic residua of innumerable experiences of the same type. They present a picture of psychic life in the average, divided up and projected into the manifold figures of the mythological pantheon. But the mythological figures are themselves products of creative fantasy and still have to be translated into conceptual language. Only the beginnings of such a language exist, but once the necessary concepts are created they could give us an abstract, scientific understanding of the unconscious processes that lie at the roots of the primordial images. In each of these images there is a little piece of human psychology and human fate, a remnant of the joys and sorrows that have been repeated countless times in our ancestral history, and on the average follow ever the same course. It is like a deeply graven river-bed in the psyche, in which the waters of life, instead of flowing along as before in a broad but shallow stream, suddenly swell into a mighty river. This happens whenever that particular set of circumstances is encountered which over long periods of time has helped to lay down the primordial image.

[128] The moment when this mythological situation reappears is always characterized by a peculiar emotional intensity; it is as though chords in us were struck that had never resounded before, or as though forces whose existence we never suspected were unloosed. What makes the struggle for adaptation so laborious is the fact that we have constantly to be dealing with individual and atypical situations. So it is not surprising that when an archetypal situation occurs we suddenly feel an extraordinary sense of release, as though transported, or caught up by an overwhelming power. At such moments we are no longer individuals, but the race; the voice of all mankind resounds in us. The individual man cannot use his powers to the full unless he is aided by one of those collective representations we call ideals, which releases all the hidden forces of instinct that are inaccessible to his conscious will. The most effective ideals are always fairly obvious variants of an archetype, as is evident from

the fact that they lend themselves to allegory. The ideal of the “mother country,” for instance, is an obvious allegory of the mother, as is the “fatherland” of the father. Its power to stir us does not derive from the allegory, but from the symbolical value of our native land. The archetype here is the *participation mystique* of primitive man with the soil on which he dwells, and which contains the spirits of his ancestors.

[129] The impact of an archetype, whether it takes the form of immediate experience or is expressed through the spoken word, stirs us because it summons up a voice that is stronger than our own. Whoever speaks in primordial images speaks with a thousand voices; he enthral and overpowers, while at the same time he lifts the idea he is seeking to express out of the occasional and the transitory into the realm of the ever-enduring. He transmutes our personal destiny into the destiny of mankind, and evokes in us all those beneficent forces that ever and anon have enabled humanity to find a refuge from every peril and to outlive the longest night.

[130] That is the secret of great art, and of its effect upon us. The creative process, so far as we are able to follow it at all, consists in the unconscious activation of an archetypal image, and in elaborating and shaping this image into the finished work. By giving it shape, the artist translates it into the language of the present, and so makes it possible for us to find our way back to the deepest springs of life. Therein lies the social significance of art: it is constantly at work educating the spirit of the age, conjuring up the forms in which the age is most lacking. The unsatisfied yearning of the artist reaches back to the primordial image in the unconscious which is best fitted to compensate the inadequacy and one-sidedness of the present. The artist seizes on this image, and in raising it from deepest unconsciousness he brings it into relation with conscious values, thereby transforming it until it can be accepted by the minds of his contemporaries according to their powers.

[131] Peoples and times, like individuals, have their own characteristic tendencies and attitudes. The very word “attitude” betrays the necessary bias that every marked tendency entails. Direction implies exclusion, and exclusion means that very many psychic elements that could play their part in life are denied the right to exist because they are incompatible with the general attitude. The normal man can follow the general trend without injury to himself; but the man who takes to the back streets and alleys because he cannot endure the broad highway will be the first to discover the psychic elements that are waiting to play their part in the life of the collective. Here the artist’s relative lack of adaptation turns out to his advantage; it enables him to follow his own yearnings far from the beaten path, and to discover what it is that would meet the unconscious needs of his age. Thus, just as the one-sidedness of the individual’s conscious attitude is corrected by reactions from the unconscious, so art represents a process of self-regulation in the life of nations and epochs.

[32] I am aware that in this lecture I have only been able to sketch out my views in the barest outline. But I hope that what I have been obliged to omit, that is to say their practical application to poetic works of art, has been furnished by your own thoughts, thus giving flesh and blood to my abstract intellectual frame.

PSYCHOLOGY AND LITERATURE¹

Introduction

Psychology, which once eked out a modest existence in a small and highly academic backroom, has, in fulfilment of Nietzsche's prophecy, developed in the last few decades into an object of public interest which has burst the framework assigned to it by the universities. In the form of psychotechnics it makes its voice heard in industry, in the form of psychotherapy it has invaded wide areas of medicine, in the form of philosophy it has carried forward the legacy of Schopenhauer and von Hartmann, it has quite literally rediscovered Bachofen and Carus, through its mythology and the psychology of primitives have acquired a new focus of interest, it will revolutionize the science of comparative religion, and not a few theologians want to apply it even to the cure of souls. Will Nietzsche be proved right in the end with his "scientia ancilla psychologiae"?

At present, unfortunately, this encroaching advance of psychology is still a welter of chaotic cross-currents, each of the conflicting schools attempting to cover up the confusion by an all the more vociferous dogmatism and a fanatical defence of its own standpoint. Equally onesided are the attempts to open up all these different areas of knowledge and life to psychological research. Onesidedness and rigidity of principle are, however, the childish errors of every young science that has to perform pioneer work with but few intellectual tools. Despite all [my] tolerance and realization of the necessity of doctrinal opinions of various kinds, I have never wearied of emphasizing that onesidedness and dogmatism harbour in themselves the gravest dangers precisely in the domain of psychology. The psychologist should constantly bear in mind that his hypothesis is no more at first than the expression of his own subjective premise and can therefore never lay immediate claim to general validity. What the individual researcher has to contribute in explanation of any one of the countless aspects of the psyche is merely a point of view, and it would be doing the grossest violence to the object of research if he tried to make this one point of view into a generally binding truth. The phenomenology of the psyche is so colourful, so variegated in form and meaning, that we cannot possibly reflect all its riches in *one* mirror. Nor in our description of it can we ever embrace the whole, but must be content to shed light only on single parts of the total phenomenon.

Since it is a characteristic of the psyche not only to be the source of all productivity but, more especially, to express itself in all the activities and achievements of the human mind, we can nowhere grasp the nature of the psyche *per*

se but can meet it only in its various manifestations. The psychologist is therefore obliged to make himself familiar with a wide range of subjects, not out of presumption and inquisitiveness but rather from love of knowledge, and for this purpose he must abandon his thickly walled specialist fortress and set out on the quest for truth. He will not succeed in banishing the psyche to the confines of the laboratory or of the consulting room, but must follow it through all those realms where its visible manifestations are to be found, however strange they may be to him.

Thus it comes that I, unperturbed by the fact that I am by profession a doctor, speak to you today as a psychologist about the poetic imagination, although this constitutes the proper province of literary science and of aesthetics. On the other hand, it is also a psychic phenomenon, and as such it probably must be taken into account by the psychologist. In so doing I shall not encroach on the territory either of the literary historian or of the aesthetician, for nothing is further from my intentions than to replace their points of view by psychological ones. Indeed, I would be making myself guilty of that same sin of onesidedness which I have just censured. Nor shall I presume to put before you a complete theory of poetic creativity, as that would be altogether impossible for me. My observations should be taken as nothing more than points of view by which a psychological approach to poetry might be oriented in a general way.

[133] It is obvious enough that psychology, being a study of psychic processes, can be brought to bear on the study of literature, for the human psyche is the womb of all the arts and sciences. The investigation of the psyche should therefore be able on the one hand to explain the psychological structure of a work of art, and on the other to reveal the factors that make a person artistically creative. The psychologist is thus faced with two separate and distinct tasks, and must approach them in radically different ways.

[134] In the case of a work of art we are confronted with a product of complicated psychic activities—but a product that is apparently intentional and consciously shaped. In the case of the artist we must deal with the psychic apparatus itself. In the first instance the object of analysis and interpretation is a concrete artistic achievement, while in the second it is the creative human being as a unique personality. Although these two objects are intimately related and even interdependent, neither of them can explain the other. It is of course possible to draw inferences about the artist from the work of art, and *vice versa*, but these inferences are never conclusive. At best they are probably surmises or lucky guesses. A knowledge of Goethe's particular relation to his mother throws some light on Faust's exclamation: "The mothers, the mothers, how eerily it sounds!" But it does not enable us to see how the attachment to his mother could produce the *Faust* drama itself, however deeply we sense the importance of this relationship for Goethe the

man from the many telltale traces it has left behind in his work. Nor are we more successful in reasoning in the reverse direction. There is nothing in *The Ring of the Nibelungs* that would lead us to discern or to infer the fact that Wagner had a tendency towards transvestism, even though a secret connection does exist between the heroics of the Nibelungs and a certain pathological effeminacy in the man Wagner. The personal psychology of the artist may explain many aspects of his work, but not the work itself. And if ever it did explain his work successfully, the artist's creativity would be revealed as a mere symptom. This would be detrimental both to the work of art and to its repute.

[135] The present state of psychological knowledge does not allow us to establish those rigorous causal connections in the realm of art which we would expect a science to do. Psychology, after all, is the newest of the sciences. It is only in the realm of the psychophysical instincts and reflexes that we can confidently operate with the concept of causality. From the point where true psychic life begins—that is, at a level of greater complexity—the psychologist must content himself with widely ranging descriptions of psychic processes, and with portraying as vividly as he can the warp and woof of the mind in all its amazing intricacy. At the same time, he should refrain from calling any one of these processes “necessary” in the sense that it is causally determined. If the psychologist were able to demonstrate definite causalities in a work of art and in the process of artistic creation, he would leave aesthetics no ground to stand on and would reduce it to a special branch of his own science. Although he should never abandon his claim to investigate and establish the causality of complex psychic processes—to do so would be to deny psychology the right to exist—he will never be able to make good this claim in the fullest sense, because the creative urge which finds its clearest expression in art is irrational and will in the end make a mock of all our rationalistic undertakings. All conscious psychic processes may well be causally explicable; but the creative act, being rooted in the immensity of the unconscious, will forever elude our attempts at understanding. It describes itself only in its manifestations; it can be guessed at, but never wholly grasped. Psychology and aesthetics will always have to turn to one another for help, and the one will not invalidate the other. It is an important principle of psychology that any given psychic material can be shown to derive from causal antecedents; it is a principle of aesthetics that a psychic product can be regarded as existing in and for itself. Whether the work of art or the artist himself is in question, both principles are valid in spite of their relativity.

1. *The Work of Art*

[136] There is a fundamental difference of attitude between the psychologist's approach to a literary work and that of a literary critic. What is of decisive importance and

value for the latter may be quite irrelevant for the former. Indeed, literary products of highly dubious merit are often of the greatest interest to the psychologist. The so-called “psychological novel” is by no means as rewarding for the psychologist as the literary-minded suppose. Considered as a self-contained whole, such a novel explains itself. It has done its own work of psychological interpretation, and the psychologist can at most criticize or enlarge upon this.

[137] In general, it is the non-psychological novel that offers the richest opportunities for psychological elucidation. Here the author, having no intentions of this sort, does not show his characters in a psychological light and thus leaves room for analysis and interpretation, or even invites it by his unprejudiced mode of presentation. Good examples of such novels are those of Benoît, or English fiction after the manner of Rider Haggard, as well as that most popular article of literary mass-production, the detective story, first exploited by Conan Doyle. I would also include Melville’s *Moby Dick*, which I consider to be the greatest American novel, in this broad class of writings. An exciting narrative that is apparently quite devoid of psychological intentions is just what interests the psychologist most of all. Such a tale is constructed against a background of unspoken psychological assumptions, and the more unconscious the author is of them, the more this background reveals itself in unalloyed purity to the discerning eye. In the psychological novel, on the other hand, the author himself makes the attempt to raise the raw material of his work into the sphere of psychological discussion, but instead of illuminating it he merely succeeds in obscuring the psychic background. It is from novels of this sort that the layman gets his “psychology”; whereas novels of the first kind require the psychologist to give them a deeper meaning.

[138] I have been speaking in terms of the novel, but what I am discussing is a psychological principle which is not restricted to this form of literature. We meet with it also in poetry, and in *Faust* it is so obvious that it divides the first part from the second. The love-tragedy of Gretchen is self-explanatory; there is nothing the psychologist can add to it that has not already been said in better words by the poet. But the second part cries out for interpretation. The prodigious richness of the imaginative material has so overtaxed, or outstripped, the poet’s powers of expression that nothing explains itself any more and every line only makes the reader’s need of an interpretation more apparent. *Faust* is perhaps the best illustration of these two extremes in the psychology of art.

[139] For the sake of clarity I would like to call the one mode of artistic creation *psychological*,² and the other *visionary*. The psychological mode works with materials drawn from man’s conscious life—with crucial experiences, powerful emotions, suffering, passion, the stuff of human fate in general. All this is assimilated by the psyche of the poet, raised from the commonplace to the level of poetic

experience, and expressed with a power of conviction that gives us a greater depth of human insight by making us vividly aware of those everyday happenings which we tend to evade or to overlook because we perceive them only dully or with a feeling of discomfort. The raw material of this kind of creation is derived from the contents of man's consciousness, from his eternally repeated joys and sorrows, but clarified and transfigured by the poet. There is no work left for the psychologist to do—unless perhaps we expect him to explain why Faust fell in love with Gretchen, or why Gretchen was driven to murder her child. Such themes constitute the lot of humankind; they are repeated millions of times and account for the hideous monotony of the police court and the penal code. No obscurity surrounds them, for they fully explain themselves in their own terms.

[140] Countless literary products belong to this class: all the novels dealing with love, the family milieu, crime and society, together with didactic poetry, the greater number of lyrics, and drama both tragic and comic. Whatever artistic form they may take, their contents always derive from the sphere of conscious human experience—from the psychic foreground of life, we might say. That is why I call this mode of creation “psychological”; it remains within the limits of the psychologically intelligible. Everything it embraces—the experience as well as its artistic expression—belongs to the realm of a clearly understandable psychology. Even the psychic raw material, the experiences themselves, have nothing strange about them; on the contrary, they have been known from the beginning of time—passion and its fated outcome, human destiny and its sufferings, eternal nature with its beauty and horror.

[141] The gulf that separates the first from the second part of *Faust* marks the difference between the psychological and the visionary modes of artistic creation. Here everything is reversed. The experience that furnishes the material for artistic expression is no longer familiar. It is something strange that derives its existence from the hinterland of man's mind, as if it had emerged from the abyss of prehuman ages, or from a superhuman world of contrasting light and darkness. It is a primordial experience which surpasses man's understanding and to which in his weakness he may easily succumb. The very enormity of the experience gives it its value and its shattering impact. Sublime, pregnant with meaning, yet chilling the blood with its strangeness, it arises from timeless depths; glamorous, daemonic, and grotesque, it bursts asunder our human standards of value and aesthetic form, a terrifying tangle of eternal chaos, a *crimen laesae majestatis humanae*. On the other hand, it can be a revelation whose heights and depths are beyond our fathoming, or a vision of beauty which we can never put into words. This disturbing spectacle of some tremendous process that in every way transcends our human feeling and understanding makes quite other demands upon the powers of the artist than do the experiences of the foreground of life. These never rend the curtain that veils the cosmos; they do not

exceed the bounds of our human capacities, and for this reason they are more readily shaped to the demands of art, however shattering they may be for the individual. But the primordial experiences rend from top to bottom the curtain upon which is painted the picture of an ordered world, and allow a glimpse into the unfathomable abyss of the unborn and of things yet to be. Is it a vision of other worlds, or of the darkneses of the spirit, or of the primal beginnings of the human psyche? We cannot say that it is any or none of these.

Formation, transformation.

Eternal Mind's eternal recreation.

[142] We find such a vision in the *Shepherd of Hermas*, in Dante, in the second part of *Faust*, in Nietzsche's Dionysian experience,³ in Wagner's *Ring*, *Tristan*, *Parsifal*, in Spitteler's *Olympian Spring*, in William Blake's paintings and poetry, in the *Hypnerotomachia* of the monk Francesco Colonna,⁴ in Jacob Boehme's poetic-philosophic stammerings,⁵ and in the magnificent but scurrilous imagery of E. T. A. Hoffmann's tale *The Golden Bowl*.⁶ In more restricted and succinct form, this primordial experience is the essential content of Rider Haggard's *She* and *Ayesha*, of Benoît's *L'Atlantide*, of Alfred Kubin's *Die andere Seite*, of Meyrink's *Das grüne Gesicht*, of Goetz's *Das Reich ohne Raum*, and of Barlach's *Der tote Tag*. The list might be greatly extended.

[143] In dealing with the psychological mode of creation, we need never ask ourselves what the material consists of or what it means. But this question forces itself upon us when we turn to the visionary mode. We are astonished, confused, bewildered, put on our guard or even repelled;⁷ we demand commentaries and explanations. We are reminded of nothing in everyday life, but rather of dreams, night-time fears, and the dark, uncanny recesses of the human mind. The public for the most part repudiates this kind of literature, unless it is crudely sensational, and even the literary critic finds it embarrassing. It is true that Dante and Wagner have made his task somewhat easier for him by disguising the visionary experience in a cloak of historical or mythical events, which are then erroneously taken to be the real subject-matter. In both cases the compelling power and deeper meaning of the work do not lie in the historical or mythical material, but in the visionary experience it serves to express. Rider Haggard, pardonably enough, is generally regarded as a romantic story-teller, but in his case too the tale is only a means—admittedly a rather lush one—for capturing a meaningful content.

[144] It is strange that a deep darkness surrounds the sources of the visionary material. This is the exact opposite of what we find in the psychological mode of creation, and we are led to suspect that this obscurity is not unintentional. We are naturally inclined to suppose, under the influence of Freudian psychology, that some highly personal

experiences must lie behind all this phantasmagoric darkness, which would help to explain that strange vision of chaos, and why it sometimes seems as if the poet were intentionally concealing the source of his experience. From here it is only a step to the conjecture that this kind of art is pathological and neurotic, but a step that is justified in so far as the visionary material exhibits peculiarities which are observed in the fantasies of the insane. Conversely, psychotic products often contain a wealth of meaning such as is ordinarily found only in the works of a genius. One will naturally feel tempted to regard the whole phenomenon from the standpoint of pathology and to explain the strange images as substitute figures and attempts at concealment. It is easy enough to suppose that an intimate personal experience underlies the “primordial vision,” an experience that cannot be reconciled with morality. It may, for instance, have been a love affair that seemed morally or aesthetically incompatible with the personality as a whole or with the poet’s fictitious view of himself. His ego then sought to repress this experience altogether, or at least its salient features, and make it unrecognizable, i.e., unconscious. For this purpose the whole arsenal of pathological fantasy is called into play, and because this manoeuvre is bound to be unsatisfactory, it has to be repeated in an almost endless series of fictions. This would account for the proliferation of monstrous, daemonic, grotesque, and perverse figures, which all act as substitutes for the “unacceptable” reality and at the same time conceal it.

[145] Such a view of the poet’s psychology has aroused considerable attention and is the only theoretical attempt that has been made so far to give a “scientific” explanation of the sources of visionary material. If I now put forward my own view, I do so because I assume it is not so well-known, and is less understood, than the one I have just described.

[146] The reduction of the vision to a personal experience makes it something unreal and unauthentic—a mere substitute, as we have said. The vision thus loses its primordial quality and becomes nothing but a symptom; the teeming chaos shrinks to the proportions of a psychic disturbance. We feel reassured by this explanation, and turn back to our picture of a well-ordered cosmos. As practical and reasonable human beings, we never expected it to be perfect; we accept these unavoidable imperfections which we call abnormalities and diseases, and take it for granted that human nature is not exempt from them. The frightening revelation of abysses that defy human understanding is dismissed as illusion, and the poet is regarded as the victim and perpetrator of deception. His primordial experience was “human, all too human,” so much so that he could not face it and had to conceal its meaning from himself.

[147] We should do well, I think, to bear clearly in mind the full consequences of this reduction of art to personal factors, and see where it leads. The truth is that it deflects our attention from the psychology of the work of art and focuses it on the psychology

of the artist. The latter presents a problem that cannot be denied, but the work of art exists in its own right and cannot be got rid of by changing it into a personal complex. As to what it means to the artist, whether it is just a game, or a mask, or a source of suffering, or a positive achievement, these are questions which we shall discuss in the next section. Our task for the moment is to interpret the work of art psychologically, and to do this we must take its foundation—the primordial experience—as seriously as we do the experiences underlying personalistic art, which no one doubts are real and important. It is certainly much more difficult to believe that a visionary experience can be real, for it has all the appearance of something that does not fall to the ordinary lot of man. It has about it a fatal suggestion of vague metaphysics, so that we feel obliged to intervene in the name of well-intentioned reasonableness. We are driven to the conclusion that such things simply cannot be taken seriously, or else the world would sink back into benighted superstition. Anyone who does not have distinct leanings towards the occult will be inclined to dismiss visionary experiences as “lively fantasy” or “poetic licence.” The poets themselves contribute to this by putting a wholesome distance between themselves and their work. Spitteler, for example, maintained that his *Olympian Spring* “meant” nothing, and that he could just as well have sung: “May is come, tra-la-la-la-la!” Poets are human too, and what they say about their work is often far from being the best word on the subject. It seems as if we have to defend the seriousness of the visionary experience against the personal resistance of the poet himself.

[148] In the *Shepherd of Hermas*, the *Divine Comedy*, and *Faust*, we catch echoes of a preliminary love-episode which culminates in a visionary experience. There is no ground for the assumption that the normal, human experience in the first part of *Faust* is repudiated or concealed in the second, or that Goethe was normal at the time when he wrote [Part I](#) but in a neurotic state of mind when he wrote [Part II](#). These three works cover a period of nearly two thousand years, and in each of them we find the undisguised personal love-episode not only connected with the weightier visionary experience but actually subordinated to it. This testimony is significant, for it shows that in the work of art (irrespective of the personal psychology of the poet) the vision represents a deeper and more impressive experience than human passion. In works of art of this nature—and we must never confuse them with the artist as a person—it cannot be doubted that the vision is a genuine primordial experience, no matter what the rationalists may say. It is not something derived or secondary, it is not symptomatic of something else, it is a true symbol—that is, an expression for something real but unknown. The love-episode is a real experience really suffered, and so is the vision. It is not for us to say whether its content is of a physical, psychic, or metaphysical nature. In itself it had psychic reality, and this is no less real than

physical reality. Human passion falls within the sphere of conscious experience, while the object of the vision lies beyond it. Through our senses we experience the known, but our intuitions point to things that are unknown and hidden, that by their very nature are secret. If ever they become conscious, they are intentionally kept secret and concealed for which reason they have been regarded from earliest times as mysterious, uncanny, and deceptive. They are hidden from man, and he hides himself from them out of religious awe, protecting himself with the shield of science and reason. The ordered cosmos he believes in by day is meant to protect him from the fear of chaos that besets him by night—his enlightenment is born of night-fears! What if there were a living agency beyond our everyday human world—something even more purposeful than electrons? Do we delude ourselves in thinking that we possess and control our own psyches, and is what science calls the “psyche” not just a question-mark arbitrarily confined within the skull, but rather a door that opens upon the human world from a world beyond, allowing unknown and mysterious powers to act upon man and carry him on the wings of the night to a more than personal destiny? It even seems as if the love-episode had served as a mere release, or had been unconsciously arranged for a definite purpose, and as if the personal experience were only a prelude to the all-important “divine comedy.”

[149] The creator of this kind of art is not the only one who is in touch with the night-side of life; prophets and seers are nourished by it too. St. Augustine says: “And higher still we soared, thinking in our minds and speaking and marvelling at Your works: and so we came to our own souls, and went beyond them to reach at last that region of richness unending, where You feed Israel forever with the food of truth ...”⁸ But this same region also has its victims: the great evil-doers and destroyers who darken the face of the times, and the madmen who approach too near to the fire: “Who among us shall dwell with the devouring fire? Who among us shall dwell with everlasting burnings?”⁹ It is true indeed that those whom the gods wish to destroy they first make mad. However dark and unconscious this night-world may be, it is not wholly unfamiliar. Man has known it from time immemorial, and for primitives it is a self-evident part of their cosmos. It is only we who have repudiated it because of our fear of superstition and metaphysics, building up in its place an apparently safer and more manageable world of consciousness in which natural law operates like human law in a society. The poet now and then catches sight of the figures that people the night-world—spirits, demons, and gods; he feels the secret quickening of human fate by a suprahuman design, and has a presentiment of incomprehensible happenings in the pleroma. In short, he catches a glimpse of the psychic world that terrifies the primitive and is at the same time his greatest hope. It would, incidentally, be an interesting subject for research to investigate how far our recently invented fear of superstition and our materialistic outlook are derived from, and are a further

development of, primitive magic and the fear of ghosts. At any rate the fascination exerted by depth psychology and the equally violent resistance it evokes are not without relevance to our theme.

[150] From the very beginnings of human society we find traces of man's efforts to banish his dark forebodings by expressing them in a magical or propitiatory form. Even in the Rhodesian rock-drawings of the Stone Age there appears, side by side with amazingly lifelike pictures of animals, an abstract pattern—a double cross contained in a circle. This design has turned up in practically every culture, and we find it today not only in Christian churches but in Tibetan monasteries as well. It is the so-called sun-wheel, and since it dates from a time when the wheel had not yet been invented, it cannot have had its origin in any experience of the external world. It is rather a symbol for some inner experience, and as a representation of this it is probably just as lifelike as the famous rhinoceros with tick-birds on its back. There has never been a primitive culture that did not possess a highly developed system of secret teaching, a body of lore concerning the things that lie beyond man's earthly existence, and of wise rules of conduct.¹⁰ The men's councils and the totem clans preserve this knowledge, and it is handed down to the younger men in the rites of initiation. The mysteries of the Graeco-Roman world performed the same function, which has left behind a rich deposit in the world's mythologies.

[151] It is therefore to be expected that the poet will turn to mythological figures in order to give suitable expression to his experience. Nothing would be more mistaken than to suppose that he is working with second-hand material. On the contrary, the primordial experience is the source of his creativeness, but it is so dark and amorphous that it requires the related mythological imagery to give it form. In itself it is wordless and imageless, for it is a vision seen "as in a glass, darkly." It is nothing but a tremendous intuition striving for expression. It is like a whirlwind that seizes everything within reach and assumes visible form as it swirls upward. Since the expression can never match the richness of the vision and can never exhaust its possibilities, the poet must have at his disposal a huge store of material if he is to communicate even a fraction of what he has glimpsed, and must make use of difficult and contradictory images in order to express the strange paradoxes of his vision. Dante decks out his experience in all the imagery of heaven, purgatory, and hell; Goethe brings in the Blocksberg and the Greek underworld; Wagner needs the whole corpus of Nordic myth, including the Parsifal saga; Nietzsche resorts to the hieratic style of the bard and legendary seer; Blake presses into his service the phantasmagoric world of India, the Old Testament, and the Apocalypse; and Spitteler borrows old names for the new figures that pour in alarming profusion from his muse's cornucopia. Nothing is missing in the whole gamut that ranges from the ineffably sublime to the perversely grotesque.

[152] The psychologist can do little to elucidate this variegated spectacle except provide comparative material and a terminology for its discussion. Thus, what appears in the vision is the imagery of the collective unconscious. This is the matrix of consciousness and has its own inborn structure. According to phylogenetic law, the psychic structure must, like the anatomical, show traces of the earlier stages of evolution it has passed through. This is in fact so in the case of the unconscious, for in dreams and mental disturbances psychic products come to the surface which show all the traits of primitive levels of development, not only in their form but also in their content and meaning, so that we might easily take them for fragments of esoteric doctrines. Mythological motifs frequently appear, but clothed in modern dress; for instance, instead of the eagle of Zeus, or the great roc, there is an airplane; the fight with the dragon is a railway smash; the dragon-slaying hero is an operatic tenor; the Earth Mother is a stout lady selling vegetables; the Pluto who abducts Persephone is a reckless chauffeur, and so on. What is of particular importance for the study of literature, however, is that the manifestations of the collective unconscious are compensatory to the conscious attitude, so that they have the effect of bringing a one-sided, unadapted, or dangerous state of consciousness back into equilibrium. This function can also be observed in the symptomatology of neurosis and in the delusions of the insane, where the process of compensation is often perfectly obvious—for instance in the case of people who have anxiously shut themselves off from the world and suddenly discover that their most intimate secrets are known and talked about by everybody. The compensation is, of course, not always as crass as this; with neurotics it is much more subtle, and in dreams—particularly in one's own dreams—it is often a complete mystery at first not only to the layman but even to the specialist, however staggeringly simple it turns out to be once it has been understood. But, as we know, the simplest things are often the most difficult to understand.

[153] If we disregard for the moment the possibility that *Faust* was compensatory to Goethe's conscious attitude, the question that arises is this: in what relation does it stand to the conscious outlook of his time, and can this relation also be regarded as compensatory? Great poetry draws its strength from the life of mankind, and we completely miss its meaning if we try to derive it from personal factors. Whenever the collective unconscious becomes a living experience and is brought to bear upon the conscious outlook of an age, this event is a creative act which is of importance for a whole epoch. A work of art is produced that may truthfully be called a message to generations of men. So *Faust* touches something in the soul of every German, as Jacob Burckhardt has already remarked.¹¹ So also Dante's fame is immortal, and the *Shepherd of Hermas* was very nearly included in the New Testament canon. Every period has its bias, its particular prejudice, and its psychic malaise. An epoch is like

an individual; it has its own limitations of conscious outlook, and therefore requires a compensatory adjustment. This is effected by the collective unconscious when a poet or seer lends expression to the unspoken desire of his times and shows the way, by word or deed, to its fulfilment—regardless whether this blind collective need results in good or evil, in the salvation of an epoch or its destruction.

[154] It is always dangerous to speak of one's own times, because what is at stake is too vast to be comprehended.¹² A few hints must therefore suffice. Francesco Colonna's book takes the form of a dream which depicts the apotheosis of love. It does not tell the story of a human passion, but describes a relationship to the anima, man's subjective image of woman, incarnated in the fictitious figure of the lady Polia. The relationship is played out in the pagan setting of classical antiquity, and this is remarkable because the author, so far as we know, was a monk. His book, written in 1453, compensates the medieval Christian outlook by conjuring up a simultaneously older and more youthful world from Hades, which is at the same time the grave and the fruitful mother.¹³ The *Hypnerotomachia* of Colonna, says Linda Fierz-David, "is the symbol of the living process of growth which had been set going, obscurely and incomprehensibly, in the men of his time, and had made of the Renaissance the beginning of a new era."¹⁴ Already in Colonna's time the Church was being weakened by schisms, and the age of the great voyages and of scientific discovery was dawning. These tensions between the old and the new are symbolized by the paradoxical figure of Polia, the "modern" soul of the monk Francesco Colonna. After three centuries of religious schism and the scientific discovery of the world, Goethe paints a picture of the megalomania that threatens the Faustian man, and attempts to redeem the inhumanity of this figure by uniting him with the Eternal Feminine, the maternal Sophia. She is the highest manifestation of the anima, stripped of the pagan savagery of the nymph Polia. But this compensation of Faust's inhumanity had no lasting effect, for Nietzsche, after proclaiming the death of God, announces the birth of the Superman, who in turn is doomed to destruction. Nietzsche's contemporary, Spitteler, transforms the waxing and waning of the gods into a myth of the seasons. If we compare his *Prometheus and Epimetheus*¹⁵ with the drama that is being enacted on the world stage today, the prophetic significance of the great work of art will become painfully apparent.¹⁶ Each of these poets speaks with the voice of thousands and tens of thousands, foretelling changes in the conscious outlook of his time.

2. The Artist

[155] The secret of creativeness, like that of the freedom of the will, is a transcendental problem which the psychologist cannot answer but can only describe. The creative personality, too, is a riddle we may try to answer in various ways, but always in vain. Nevertheless, modern psychologists have not been deterred from investigating the

problem of the artist and his art. Freud thought he had found a key to the work of art by deriving it from the personal experience of the artist.¹⁷ This was a possible approach, for it was conceivable that a work of art might, like a neurosis, be traced back to complexes. It was Freud's great discovery that neuroses have a quite definite psychic cause, and that they originate in real or imagined emotional experiences in early childhood. Some of his followers, in particular Rank and Stekel, adopted a similar approach and arrived at similar results. It is undeniable that the artist's personal psychology may occasionally be traced out in the roots and in the furthest ramifications of his work. This view, that personal factors in many ways determine the artist's choice of material and the form he gives it, is not in itself new. Credit, however, is certainly due to the Freudian school for showing how far-reaching this influence is and the curious analogies to which it gives rise.

[156] Freud considers a neurosis to be a substitute for a direct means of gratification. For him it is something inauthentic—a mistake, a subterfuge, an excuse, a refusal to face facts; in short, something essentially negative that should never have been. One hardly dares to put in a good word for a neurosis, since it is apparently nothing but a meaningless and therefore irritating disturbance. By treating a work of art as something that can be analysed in terms of the artist's repressions we bring it into questionable proximity with a neurosis, where, in a sense, it finds itself in good company, for the Freudian method treats religion and philosophy in the same way. No legitimate objection can be raised to this if it is admitted to be no more than an unearthing of those personal determinants without which a work of art is unthinkable. But if it is claimed that such an analysis explains the work of art itself, then a categorical denial is called for. The essence of a work of art is not to be found in the personal idiosyncrasies that creep into it—indeed, the more there are of them, the less it is a work of art—but in its rising above the personal and speaking from the mind and heart of the artist to the mind and heart of mankind. The personal aspect of art is a limitation and even a vice. Art that is only personal, or predominantly so, truly deserves to be treated as a neurosis. When the Freudian school advances the opinion that all artists are undeveloped personalities with marked infantile autoerotic traits, this judgment may be true of the artist as a man, but it is not applicable to the man as an artist. In this capacity he is neither autoerotic, nor heteroerotic, nor erotic in any sense. He is in the highest degree objective, impersonal, and even inhuman—or suprahuman—for as an artist he is nothing but his work, and not a human being.

[157] Every creative person is a duality or a synthesis of contradictory qualities. On the one side he is a human being with a personal life, while on the other he is an impersonal creative process. As a human being he may be sound or morbid, and his personal psychology can and should be explained in personal terms. But he can be understood as an artist only in terms of his creative achievement. We should make a

great mistake if we reduced the mode of life of an English gentleman, or a Prussian officer, or a cardinal, to personal factors. The gentleman, the officer, and the high ecclesiastic function as impersonal officials, and each role has its own objective psychology. Although the artist is the exact opposite of an official, there is nevertheless a secret analogy between them in so far as a specifically artistic psychology is more collective than personal in character. Art is a kind of innate drive that seizes a human being and makes him its instrument. The artist is not a person endowed with free will who seeks his own ends, but one who allows art to realize its purposes through him. As a human being he may have moods and a will and personal aims, but as an artist he is “man” in a higher sense—he is “collective man,” a vehicle and moulder of the unconscious psychic life of mankind. That is his office, and it is sometimes so heavy a burden that he is fated to sacrifice happiness and everything that makes life worth living for the ordinary human being. As K. G. Carus says: “Strange are the ways by which genius is announced, for what distinguishes so supremely endowed a being is that, for all the freedom of his life and the clarity of his thought, he is everywhere hemmed round and prevailed upon by the Unconscious, the mysterious god within him; so that ideas flow to him—he knows not whence; he is driven to work and to create—he knows not to what end: and is mastered by an impulse for constant growth and development—he knows not whither.”¹⁸

[158] In these circumstances it is not at all surprising that the artist is an especially interesting specimen for the critical analysis of the psychologist. His life cannot be otherwise than full of conflicts, for two forces are at war within him: on the one hand the justified longing of the ordinary man for happiness, satisfaction, and security, and on the other a ruthless passion for creation which may go so far as to override every personal desire. If the lives of artists are as a rule so exceedingly unsatisfactory, not to say tragic, it is not because of some sinister dispensation of fate, but because of some inferiority in their personality or an inability to adapt. A person must pay dearly for the divine gift of creative fire. It is as though each of us was born with a limited store of energy. In the artist, the strongest force in his make-up, that is, his creativeness, will seize and all but monopolize this energy, leaving so little over that nothing of value can come of it. The creative impulse can drain him of his humanity to such a degree that the personal ego can exist only on a primitive or inferior level and is driven to develop all sorts of defects—ruthlessness, selfishness (“autoeroticism”), vanity, and other infantile traits. These inferiorities are the only means by which it can maintain its vitality and prevent itself from being wholly depleted. The autoeroticism of certain artists is like that of illegitimate or neglected children who from their earliest years develop bad qualities to protect themselves from the destructive influence of a loveless environment. Such children easily become ruthless and selfish, and later display an invincible egoism by remaining all

their lives infantile and helpless or by actively offending against morality and the law. How can we doubt that it is his art that explains the artist, and not the insufficiencies and conflicts of his personal life? These are nothing but the regrettable results of his being an artist, a man upon whom a heavier burden is laid than upon ordinary mortals. A special ability demands a greater expenditure of energy, which must necessarily leave a deficit on some other side of life.

[159] It makes no difference whether the artist knows that his work is generated, grows and matures within him, or whether he imagines that it is his own invention. In reality it grows out of him as a child its mother. The creative process has a feminine quality, and the creative work arises from unconscious depths—we might truly say from the realm of the Mothers. Whenever the creative force predominates, life is ruled and shaped by the unconscious rather than by the conscious will, and the ego is swept along on an underground current, becoming nothing more than a helpless observer of events. The progress of the work becomes the poet's fate and determines his psychology. It is not Goethe that creates *Faust*, but *Faust* that creates Goethe.¹⁹ And what is *Faust*? *Faust* is essentially a symbol. By this I do not mean that it is an allegory pointing to something all too familiar, but the expression of something profoundly alive in the soul of every German, which Goethe helped to bring to birth. Could we conceive of anyone but a German writing *Faust* or *Thus Spake Zarathustra*? Both of them strike a chord that vibrates in the German psyche, evoking a "primordial image," as Burckhardt once called it—the figure of a healer or teacher of mankind, or of a wizard. It is the archetype of the Wise Old Man, the helper and redeemer, but also of the magician, deceiver, corrupter, and tempter. This image has lain buried and dormant in the unconscious since the dawn of history; it is awakened whenever the times are out of joint and a great error deflects society from the right path. For when people go astray they feel the need of a guide or teacher, and even of a physician. The seductive error is like a poison that can also act as a cure, and the shadow of a saviour can turn into a fiendish destroyer. These opposing forces are at work in the mythical healer himself: the physician who heals wounds is himself the bearer of a wound, a classic example being Chiron.²⁰ In Christianity it is the wound in the side of Christ, the great physician. Faust, characteristically enough, is unwounded, which means that he is untouched by the moral problem. A man can be as high-minded as Faust and as devilish as Mephistopheles if he is able to split his personality into two halves, and only then is he capable of feeling "six thousand feet beyond good and evil." Mephistopheles was cheated of his reward, Faust's soul, and for this he presented a bloody reckoning a hundred years later. But who now seriously believes that poets utter truths that apply to all men? And if they do, in what way would we have to regard the work of art?

[160] In itself, an archetype is neither good nor evil. It is morally neutral, like the gods of antiquity, and becomes good or evil only by contact with the conscious mind, or else a paradoxical mixture of both. Whether it will be conducive to good or evil is determined, knowingly or unknowingly, by the conscious attitude. There are many such archetypal images, but they do not appear in the dreams of individuals or in works of art unless they are activated by a deviation from the middle way. Whenever conscious life becomes one-sided or adopts a false attitude, these images “instinctively” rise to the surface in dreams and in the visions of artists and seems to restore the psychic balance, whether of the individual or of the epoch.

[161] In this way the work of the artist meets the psychic needs of the society in which he lives, and therefore means more than his personal fate, whether he is aware of it or not. Being essentially the instrument of his work, he is subordinate to it, and we have no right to expect him to interpret it for us. He has done his utmost by giving it form, and must leave the interpretation to others and to the future. A great work of art is like a dream; for all its apparent obviousness it does not explain itself and is always ambiguous. A dream never says “you ought” or “this is the truth.” It presents an image in much the same way as nature allows a plant to grow, and it is up to us to draw conclusions. If a person has a nightmare, it means he is either too much given to fear or too exempt from it; if he dreams of a wise old man, it means he is either too much of a pedant or else in need of a teacher. In a subtle way both meanings come to the same thing, as we realize when we let a work of art act upon us as it acted upon the artist. To grasp its meaning, we must allow it to shape us as it shaped him. Then we also understand the nature of his primordial experience. He has plunged into the healing and redeeming depths of the collective psyche, where man is not lost in the isolation of consciousness and its errors and sufferings, but where all men are caught in a common rhythm which allows the individual to communicate his feelings and strivings to mankind as a whole.

[162] This re-immersion in the state of *participation mystique* is the secret of artistic creation and of the effect which great art has upon us, for at that level of experience it is no longer the weal or woe of the individual that counts, but the life of the collective. That is why every great work of art is objective and impersonal, and yet profoundly moving. And that is also why the personal life of the artist is at most a help or a hindrance, but is never essential to his creative task. He may go the way of the Philistine, a good citizen, a fool, or a criminal. His personal career may be interesting and inevitable, but it does not explain his art.

V

"ULYSSES": A MONOLOGUE

PICASSO

“ULYSSES”: A MONOLOGUE¹

[163] The Ulysses of my title has to do with James Joyce and not with that shrewd and storm-driven figure of Homer’s world who knew how to escape by guile and wily deeds the enmity and vengeance of gods and men, and who after a wearisome voyage returned to hearth and home. Joyce’s Ulysses, very much unlike his ancient namesake, is a passive, merely perceiving consciousness, a mere eye, ear, nose, and mouth, a sensory nerve exposed without choice or check to the roaring, chaotic, lunatic cataract of psychic and physical happenings, and registering all this with almost photographic accuracy.

[164] *Ulysses* is a book that pours along for seven hundred and thirty-five pages, a stream of time seven hundred and thirty-five days long which all consist in one single and senseless day in the life of every man, the completely irrelevant sixteenth day of June, 1904, in Dublin—a day on which, in all truth, nothing happens. The stream begins in the void and ends in the void. Is all this perhaps one single, immensely long, and excessively complicated Strindbergian pronouncement upon the essence of human life—a pronouncement which, to the reader’s dismay, is never finished? Possibly it does touch upon the essence, but quite certainly it reflects life’s ten thousand facets and their hundred thousand gradations of colour. So far as I can see, there are in those seven hundred and thirty-five pages no obvious repetitions, not a single blessed island where the long-suffering reader may come to rest; no place where he can seat himself, drunk with memories, and contemplate with satisfaction the stretch of road he has covered, be it one hundred pages or even less. If only he could spot some little commonplace that had obligingly slipped in again where it was not expected! But no! The pitiless stream rolls on without a break, and its velocity or viscosity increases in the last forty pages till it sweeps away even the punctuation marks. Here the suffocating emptiness becomes so unbearably tense that it reaches the bursting point. This utterly hopeless emptiness is the dominant note of the whole book. It not only begins and ends in nothingness, it consists of nothing but nothingness.² It is all infernally nugatory. As a piece of technical virtuosity it is a brilliant and hellish monster-birth.³

[165] I had an uncle whose thinking was always direct and to the point. One day he stopped me on the street and demanded: “Do you know how the devil tortures the souls in hell?” When I said no, he replied: “He keeps them waiting.” And with that he walked away. This remark occurred to me when I was ploughing through *Ulysses* for the first time. Every sentence rouses an expectation that is not fulfilled; finally, out of

sheer resignation, you come to expect nothing, and to your horror it gradually dawns on you that you have hit the mark. In actual fact nothing happens, nothing comes of it all,⁴ and yet a secret expectation battling with hopeless resignation drags the reader from page to page. The seven hundred and thirty-five pages that contain nothing by no means consist of blank paper but are closely printed. You read and read and read and you pretend to understand what you read. Occasionally you drop through an airpocket into a new sentence, but once the proper degree of resignation has been reached you get accustomed to anything. Thus I read to page 135 with despair in my heart, falling asleep twice on the way. The incredible versatility of Joyce's style has a monotonous and hypnotic effect. Nothing comes to meet the reader, everything turns away from him, leaving him gaping after it. The book is always up and away, dissatisfied with itself, ironic, sardonic, virulent, contemptuous, sad, despairing, and bitter. It plays on the reader's sympathies to his own undoing unless sleep kindly intervenes and puts a stop to this drain of energy. Arrived at page 135, after making several heroic efforts to get at the book, to "do it justice," as the phrase goes, I fell at last into profound slumber.⁵ When I awoke quite a while later, my views had undergone such a clarification that I started to read the book backwards. This method proved as good as the usual one; the book can just as well be read backwards, for it has no back and no front, no top and no bottom. Everything could easily have happened before, or might have happened afterwards.⁶ You can read any of the conversations just as pleasurably backwards, for you don't miss the point of the gags. Every sentence is a gag, but taken together they make no point. You can also stop in the middle of a sentence—the first half still makes sense enough to live by itself, or at least seems to. The whole work has the character of a worm cut in half, that can grow a new head or a new tail as required.

[166] This singular and uncanny characteristic of the Joycean mind shows that his work pertains to the class of cold-blooded animals and specifically to the worm family. If worms were gifted with literary powers they would write with the sympathetic nervous system for lack of a brain.⁷ I suspect that something of this kind has happened to Joyce, that we have here a case of visceral thinking⁸ with severe restriction of cerebral activity and its confinement to the perceptual processes. One is driven to unqualified admiration for Joyce's feats in the sensory sphere: what he sees, hears, tastes, smells, touches, inwardly as well as outwardly, is beyond measure astonishing. The ordinary mortal, if he is a specialist in sense-perception, is usually restricted either to the outer world or to the inner. Joyce knows them both. Garlands of subjective association twine themselves about the objective figures on a Dublin street. Objective and subjective, outer and inner, are so constantly intermingled that in the end, despite the clearness of the individual images, one wonders whether one is dealing with a physical or with a transcendental tape worm.⁹ The tapeworm is a

whole living cosmos in itself and is fabulously procreative; this, it seems to me, is an inelegant but not unfitting image for Joyce's proliferating chapters. It is true that the tapeworm can produce nothing but other tapeworms, but it produces them in inexhaustible quantities. Joyce's book might have been fourteen hundred and seventy pages long or even a multiple of that and still it would not have lessened infinity by a drop, and the essential would still have remained unsaid. But does Joyce want to say anything essential? Has this old-fashioned prejudice any right to exist here? Oscar Wilde maintained that a work of art is something entirely useless. Nowadays even the Philistine would raise no objection to this, yet in his heart he still expects a work of art to contain something "essential." Where is it with Joyce? Why doesn't he say it right out? Why doesn't he hand it to the reader with an expressive gesture—"a straight way, so that fools shall not err therein"?

[167] Yes, I admit I feel I have been made a fool of. The book would not meet me half way, nothing in it made the least attempt to be agreeable, and that always gives the reader an irritating sense of inferiority. Obviously I have so much of the Philistine in my blood that I am naïve enough to suppose that a book wants to tell me something, to be understood—a sad case of mythological anthropomorphism projected on to the book! And what a book—no opinion possible—epitome of maddening defeat of intelligent reader, who after all is not such a—(if I may use Joyce's suggestive style). Surely a book has a content, represents something; but I suspect that Joyce did not wish to "represent" anything. Does it by any chance represent *him*—does that explain this solipsistic isolation, this drama without eyewitnesses, this infuriating disdain for the assiduous reader? Joyce has aroused my ill will. One should never rub the reader's nose into his own stupidity, but that is just what *Ulysses* does.

[168] A therapist like myself is always practising therapy—even on himself. Irritation means: You haven't yet seen what's behind it. Consequently we should follow up our irritation and examine whatever it is we discover in our ill temper. I observe then: this solipsism, this contempt for the cultivated and intelligent member of the reading public who wants to understand,¹⁰ who is well-meaning, and who tries to be kindly and just, gets on my nerves. There we have it, the cold-blooded unrelatedness of his mind which seems to come from the saurian in him or from still lower regions—conversation in and with one's own intestines—a man of stone, he with the horns of stone, the stony beard, the petrified intestines, Moses, turning his back with stony unconcern on the flesh-pots and gods of Egypt, and also on the reader, thereby outraging his feelings of good will.

[169] From this stony underworld there rises up the vision of the tapeworm, rippling, peristaltic, monotonous because of its endless proglottic proliferation. No proglottid is quite like any other, yet they can easily be confused. In every segment of the book, however small, Joyce himself is the sole content of the segment. Everything is new

and yet remains what it was from the beginning. Talk of likeness to nature! What pullulating richness—and what boredom! Joyce bores me to tears, but it is a vicious dangerous boredom such as not even the worst banality could induce. It is the boredom of nature, the bleak whistling of the wind over the crags of the Hebrides, sunrise and sunset over the wastes of the Sahara, the roar of the sea—real Wagnerian “programme music” as Curtius rightly says, and yet eternal repetition. Notwithstanding Joyce’s baffling many-sidedness, certain themes can be picked out though they may not be intended. Perhaps he would like there to be none, for causality and finality have neither place nor meaning in his world, any more than have values. Nevertheless, themes are unavoidable, they are the scaffolding for all psychic happenings, however hard one tries to soak the soul out of every happening, as Joyce consistently does. Everything is desouled, every particle of warm blood has been chilled, events unroll in icy egoism. In all the book there is nothing pleasing, nothing refreshing, nothing hopeful, but only things that are grey, grisly, gruesome, or pathetic, tragic, ironic, all from the seamy side of life and so chaotic that you have to look for the thematic connections with a magnifying glass. And yet they are there, first of all in the form of unavowed resentments of a highly personal nature, the wreckage of a violently amputated boyhood; then as flotsam from the whole history of thought exhibited in pitiful nakedness to the staring crowd. The religious, erotic, and domestic prehistory of the author is reflected in the drab surface of the stream of events; we even behold the disintegration of his personality into Bloom, *l’homme moyen sensuel*, and the almost gaseous Stephen Dedalus, who is mere speculation and mere mind. Of these two, the former has no son and the latter no father.

[170] Somewhere there may be a secret order or parallelism in the chapters—authoritative voices have been raised to this effect¹¹—but in any case it is so well concealed that at first I noticed nothing of the kind. And even if I had, it would not have interested me in my helplessly irritated state, any more than would the monotony of any other squalid human comedy.

[171] I had already taken up *Ulysses* in 1922 but had laid it aside disappointed and vexed. Today it still bores me as it did then. Why do I write about it? Ordinarily, I would no more be doing this than writing about any other form of surrealism (what is surrealism?) that passes my understanding. I am writing about Joyce because a publisher was incautious enough to ask me what I thought about him, or rather about *Ulysses*,¹² concerning which opinions are notoriously divided. The only thing beyond dispute is that *Ulysses* is a book that has gone through ten printings and that its author is glorified by some and damned by others. He stands in the cross-fire of discussion and is thus a phenomenon which the psychologist should not ignore. Joyce has exerted a very considerable influence on his contemporaries, and it was this fact which first aroused my interest in *Ulysses*. Had this book slipped noiselessly and

unsung into the shades of oblivion I would certainly never have dragged it back again; for it annoyed me thoroughly and amused me only a little. Above all, it held over me the threat of boredom because it had only a negative effect on me and I feared it was the product of an author's negative mood.

[172] But of course I am prejudiced. I am a psychiatrist, and that implies a professional prejudice with regard to all manifestations of the psyche. I must therefore warn the reader: the tragicomedy of the average man, the cold shadow-side of life, the dull grey of spiritual nihilism are my daily bread. To me they are a tune ground out on a street organ, stale and without charm. Nothing in all this shocks or moves me, for all too often I have to help people out of these lamentable states. I must combat them incessantly and I may only expend my sympathy on people who do not turn their backs on me. *Ulysses* turns its back on me. It is unco-operative, it wants to go on singing its endless tune into endless time—a tune I know to satiety—and to extend to infinity its ganglionic rope-ladder of visceral thinking and cerebration reduced to mere sense-perception. It shows no tendency towards reconstruction; indeed, destructiveness seems to have become an end in itself.

[173] But that is not the half of it—there is also the symptomatology! It is all too familiar, those interminable ramblings of the insane who have only a fragmentary consciousness and consequently suffer from a complete lack of judgment and an atrophy of all their values. Instead, there is often an intensification of the sense-activities. We find in these writings an acute power of observation, a photographic memory for sense-perceptions, a sensory curiosity directed inwards as well as outwards, the predominance of retrospective themes and resentments, a delirious confusion of the subjective and psychic with objective reality, a method of presentation that takes no account of the reader but indulges in neologisms, fragmentary quotations, sound- and speech-associations, abrupt transitions and hiatuses of thought. We also find an atrophy of feeling¹³ that does not shrink from any depth of absurdity or cynicism. Even the layman would have no difficulty in tracing the analogies between *Ulysses* and the schizophrenic mentality. The resemblance is indeed so suspicious that an indignant reader might easily fling the book aside with the diagnosis “schizophrenia.” For the psychiatrist the analogy is startling, but he would nevertheless point out that a characteristic mark of the compositions of the insane, namely, the presence of stereotyped expressions, is notably absent. *Ulysses* may be anything, but it is certainly not monotonous in the sense of being repetitious. (This is not a contradiction of what I said earlier; it is impossible to say anything contradictory about *Ulysses*.) The presentation is consistent and flowing, everything is in motion and nothing is fixed. The whole book is borne along on a subterranean current of life that shows singleness of aim and rigorous selectivity, both these being unmistakable proof of the existence of a unified personal will and directed intention.

The mental functions are under severe control; they do not manifest themselves in a spontaneous and erratic way. The perceptive functions, that is, sensation and intuition, are given preference throughout, while the discriminative functions, thinking and feeling, are just as consistently suppressed. They appear merely as mental contents, as objects of perception. There is no relaxing of the general tendency to present a shadow-picture of the mind and the world, in spite of frequent temptations to surrender to a sudden touch of beauty. These are traits not ordinarily found in the insane. There remains, then, the insane person of an uncommon sort. But the psychiatrist has no criteria for judging such a person. What seems to be mental abnormality may be a kind of mental health which is inconceivable to the average understanding; it may even be a disguise for superlative powers of mind.

[174] It would never occur to me to class *Ulysses* as a product of schizophrenia. Moreover, nothing would be gained by this label, for we wish to know why *Ulysses* exerts such a powerful influence and not whether its author is a high-grade or a low-grade schizophrenic. *Ulysses* is no more a pathological product than modern art as a whole. It is “cubistic” in the deepest sense because it resolves the picture of reality into an immensely complex painting whose dominant note is the melancholy of abstract objectivity. Cubism is not a disease but a tendency to represent reality in a certain way—and that way may be grotesquely realistic or grotesquely abstract. The clinical picture of schizophrenia is a mere analogy in that the schizophrenic apparently has the same tendency to treat reality as if it were strange to him, or, conversely, to estrange himself from reality. With the schizophrenic the tendency usually has no recognizable purpose but is a symptom inevitably arising from the disintegration of the personality into fragmentary personalities (the autonomous complexes). In the modern artist it is not produced by any disease in the individual but is a collective manifestation of our time. The artist does not follow an individual impulse, but rather a current of collective life which arises not directly from consciousness but from the collective unconscious of the modern psyche. Just because it is a collective phenomenon it bears identical fruit in the most widely separated realms, in painting as well as literature, in sculpture as well as architecture. It is, moreover, significant that one of the spiritual fathers of the modern movement—van Gogh—was actually schizophrenic.

[175] The distortion of beauty and meaning by grotesque objectivity or equally grotesque irreality is, in the insane, a consequence of the destruction of the personality; in the artist it has a creative purpose. Far from his work being an expression of the destruction of his personality, the modern artist finds the unity of his artistic personality in destructiveness. The Mephistophelian perversion of sense into nonsense, of beauty into ugliness—in such an exasperating way that nonsense almost makes sense and ugliness has a provocative beauty—is a creative

achievement that has never been pushed to such extremes in the history of human culture, though it is nothing new in principle. We can observe something similar in the perverse change of style under Ikhnaton, in the inane lamb symbolism of the early Christians, in those doleful Pre-Raphaelite figures, and in late Baroque art, strangling itself in its own convolutions. Despite their differences all these epochs have an inner relationship: they were periods of creative incubation whose meaning cannot be satisfactorily explained from a causal standpoint. Such manifestations of the collective psyche disclose their meaning only when they are considered teleologically as anticipations of something new.

[176] The epoch of Ikhnaton was the cradle of the first monotheism, which has been preserved for the world in Jewish tradition. The crude infantilism of the early Christian era portended nothing less than the transformation of the Roman Empire into a City of God. The rejection of the art and science of his time was not an impoverishment for the early Christian, but a great spiritual gain. The Pre-Raphaelite primitives were the heralds of an ideal of bodily beauty that had been lost to the world since classical times. The Baroque was the last of the ecclesiastical styles, and its self-destruction anticipates the triumph of the spirit of science over the spirit of medieval dogmatism. Tiepolo, for instance, who had already reached the danger zone in his technique, is not a symptom of decadence when considered as an artistic personality, but labours with the whole of his being to bring about a much needed disintegration.

[177] This being so we can ascribe a positive, creative value and meaning not only to *Ulysses* but also to its artistic congeners. In its destruction of the criteria of beauty and meaning that have held till today, *Ulysses* accomplishes wonders. It insults all our conventional feelings, it brutally disappoints our expectations of sense and content, it thumbs its nose at all synthesis. We would show ill will even to suspect any trace of synthesis or form, for if we succeeded in demonstrating any such unmodern tendencies in *Ulysses* this would amount to pointing out a gross aesthetic defect. Everything abusive we can say about *Ulysses* bears witness to its peculiar quality, for our abuse springs from the resentment of the unmodern man who does not wish to see what the gods have graciously veiled from sight.

[178] All those ungovernable forces that welled up in Nietzsche's Dionysian exuberance and flooded his intellect have burst forth in undiluted form in modern man. Even the darkest passages in the second part of *Faust*, even *Zarathustra* and, indeed, *Ecce Homo*, try in one way or another to recommend themselves to the public. But it is only modern man who has succeeded in creating an art in reverse, a backside of art that makes no attempt to be ingratiating, that tells us just where we get off, speaking with the same rebellious contrariness that had made itself

disturbingly felt in those precursors of the moderns (not forgetting Hölderlin) who had already started to topple the old ideals.

[179] If we stick to one field of experience only, it is not really possible to see clearly what is happening. It is not a matter of a single thrust aimed at one definite spot, but of an almost universal “restratification” of modern man, who is in the process of shaking off a world that has become obsolete. Unfortunately we cannot see into the future and so we do not know how far we still belong in the deepest sense to the Middle Ages. If, from the watch-towers of the future, we should seem stuck in medievalism up to the ears, I for one would be little surprised. For that alone would satisfactorily explain to us why there should be books or works of art after the style of *Ulysses*. They are drastic purgatives whose full effect would be dissipated if they did not meet with an equally strong and obstinate resistance. They are a kind of psychological specific which is of use only where the hardest and toughest material must be dealt with. They have this in common with Freudian theory, that they undermine with fanatical one-sidedness values that have already begun to crumble.

[180] *Ulysses* makes a show of semi-scientific objectivity, at times even employing “scientific” language, and yet it displays a truly unscientific temper: it is sheer negation. Even so it is creative—a creative destruction. Here is no theatrical gesture of a Herostratus burning down temples, but an earnest endeavour to rub the noses of our contemporaries in the shadow-side of reality, not with any malicious intent but with the guileless naïveté of artistic objectivity. One may safely call the book pessimistic even though at the very end, on nearly the final page, a redeeming light breaks wistfully through the clouds. This is only *one* page against seven hundred and thirty-four which were one and all born of Orcus. Here and there, a fine crystal glitters in the black stream of mud, so that even the unmodern may realize that Joyce is an “artist” who knows his trade—which is more than can be said of most modern artists—and is even a past master at it, but a master who has piously renounced his powers in the name of a higher goal. Even in his “restratification” Joyce has remained a pious Catholic: his dynamite is expended chiefly upon churches and upon those psychic edifices which are begotten or influenced by churches. His “anti-world” has the medieval, thoroughly provincial, quintessentially Catholic atmosphere of an Erin trying desperately to enjoy its political independence. He worked at *Ulysses* in many foreign lands, and from all of them he looked back in faith and kinship upon Mother Church and Ireland. He used his foreign stopping-places merely as anchors to steady his ship in the maelstrom of his Irish reminiscences and resentments. Yet *Ulysses* does not strain back to his Ithaca—on the contrary, he makes frantic efforts to rid himself of his Irish heritage.

[181] We might suppose this behaviour to be of only local interest and expect it to leave the rest of the world quite cold. But it does not leave the world cold. The local

phenomenon seems to be more or less universal, to judge from its effects on Joyce's contemporaries. The cap must fit. There must exist a whole community of moderns who are so numerous that they have been able to devour ten editions of *Ulysses* since 1922. The book must mean something to them, must even reveal something that they did not know or feel before. They are not infernally bored by it, but are helped, refreshed, instructed, converted, "restratified." Obviously, they are thrown into a desirable state of some sort, for otherwise only the blackest hatred could enable the reader to go through the book from page 1 to page 735 with attention and without fatal attacks of drowsiness. I therefore surmise that medieval Catholic Ireland covers a geographical area of whose size I have hitherto been ignorant; it is certainly far larger than the area indicated on the ordinary map. This Catholic Middle Ages, with its Messrs. Dedalus and Bloom, seems to be pretty well universal. There must be whole sections of the population that are so bound to their spiritual environment that nothing less than Joycean explosives are required to break through their hermetic isolation. I am convinced that this is so: we are still stuck in the Middle Ages up to the ears. And it is because Joyce's contemporaries are so riddled with medieval prejudices that such prophets of negation as he and Freud are needed to reveal to them the other side of reality.

[182] Of course, this tremendous task could hardly be accomplished by a man who with Christian benevolence tried to make people turn an unwilling eye on the shadow-side of things. That would amount only to their looking on with perfect unconcern. No, the revelation must be brought about by the appropriate attitude of mind, and Joyce is again a master here. Only in this way can the forces of negative emotion be mobilized. *Ulysses* shows how one should execute Nietzsche's "sacrilegious backward grasp." Joyce sets about it coldly and objectively, and shows himself more "bereft of gods" than Nietzsche ever dreamed of being. All this on the implicit and correct assumption that the fascinating influence exerted by the spiritual environment has nothing to do with reason, but everything with feeling. One should not be misled into thinking that because Joyce reveals a world that is horribly bleak and bereft of gods, it is inconceivable that anyone should derive the slightest comfort from his book. Strange as it may sound, it remains true that the world of *Ulysses* is a better one than the world of those who are hopelessly bound to the darkness of their spiritual birthplaces. Even though the evil and destructive elements predominate, they are far more valuable than the "good" that has come down to us from the past and proves in reality to be a ruthless tyrant, an illusory system of prejudices that robs life of its richness, emasculates it, and enforces a moral compulsion which in the end is unendurable. Nietzsche's "slave-uprising in morals" would be a good motto for *Ulysses*. What frees the prisoner of a system is an "objective" recognition of his world and of his own nature. Just as the arch-Bolshevist revels in his unshaven

appearance, so the man who is bound in spirit finds a rapturous joy in saying straight out for once exactly how things are in his world. For the man who is dazzled by the light the darkness is a blessing, and the boundless desert is a paradise to the escaped prisoner. It is nothing less than redemption for the medieval man of today not to have to be the embodiment of goodness and beauty and common sense. Looked at from the shadow-side, ideals are not beacons on mountain peaks, but taskmasters and gaolers, a sort of metaphysical police originally thought up on Sinai by the tyrannical demagogue Moses and thereafter foisted upon mankind by a clever ruse.

[183] From the causal point of view Joyce is a victim of Roman Catholic authoritarianism, but considered teleologically he is a reformer who for the present is satisfied with negation, a Protestant nourished by his own protests. Atrophy of feeling is a characteristic of modern man and always shows itself as a reaction when there is too much feeling around, and in particular too much false feeling. From the lack of feeling in *Ulysses* we may infer a hideous sentimentality in the age that produced it. But are we really so sentimental today?

[184] Again a question which the future must answer. Still, there is a good deal of evidence to show that we actually are involved in a sentimentality hoax of gigantic proportions. Think of the lamentable role of popular sentiment in wartime! Think of our so-called humanitarianism! The psychiatrist knows only too well how each of us becomes the helpless but not pitiable victim of his own sentiments. Sentimentality is the superstructure erected upon brutality. Unfeelingness is the counter-position and inevitably suffers from the same defects. The success of *Ulysses* proves that even its lack of feeling has a positive effect on the reader, so that we must infer an excess of sentiment which he is quite willing to have damped down. I am deeply convinced that we are not only stuck in the Middle Ages but also are caught in our own sentimentality. It is therefore quite comprehensible that a prophet should arise to teach our culture a compensatory lack of feeling. Prophets are always disagreeable and usually have bad manners, but it is said that they occasionally hit the nail on the head. There are, as we know, major and minor prophets, and history will decide to which of them Joyce belongs. Like every true prophet, the artist is the unwitting mouthpiece of the psychic secrets of his time, and is often as unconscious as a sleep-walker. He supposes that it is he who speaks, but the spirit of the age is his prompter, and whatever this spirit says is proved true by its effects.

[185] *Ulysses* is a *document humain* of our time and, what is more, it harbours a secret. It can release the spiritually bound, and its coldness can freeze all sentimentality—and even normal feeling—to the marrow. But these salutary effects do not exhaust its powers. The notion that the devil himself stood sponsor to the work, if interesting, is hardly a satisfactory hypothesis. There is life in it, and life is never exclusively evil and destructive. To be sure, the side of it that is most tangible seems negative and

disruptive; but one senses behind it something intangible—a secret purpose which lends it meaning and value. Is this patchwork quilt of words and images perhaps “symbolic”? I am not thinking of an allegory (heaven forbid!), but of the symbol as an expression of something whose nature we cannot grasp. In that case a hidden meaning would doubtless shine through the curious fabric at some point, here and there notes would resound that had been heard at other times and places, maybe in unusual dreams or in the cryptic wisdom of forgotten races. This possibility cannot be contested, but, for myself, I cannot find the key. On the contrary, the book seems to me to be written in the full light of consciousness; it is not a dream and not a revelation of the unconscious. Compared with *Zarathustra* or the second part of *Faust*, it shows an even stronger purposiveness and sense of direction. This is probably why *Ulysses* does not bear the features of a symbolic work. Of course, one senses the archetypal background. Behind Dedalus and Bloom there stand the eternal figures of spiritual and carnal man; Mrs. Bloom perhaps conceals an anima entangled in worldliness, and Ulysses himself might be the hero. But the book does not focus upon this background; it veers away in the opposite direction and strives to attain the utmost objectivity of consciousness. It is obviously not symbolic and has no intention of being so. Were it none the less symbolic in certain parts, then the unconscious, in spite of every precaution, would have played the author a trick or two. For when something is “symbolic,” it means that a person divines its hidden, ungraspable nature and is trying desperately to capture in words the secret that eludes him. Whether it is something of the world he is striving to grasp or something of the spirit, he must turn to it with all his mental powers and penetrate all its iridescent veils in order to bring to the light of day the gold that lies jealously hidden in the depths.

[186] But the shattering thing about *Ulysses* is that behind the thousand veils nothing lies hidden; it turns neither to the world nor to the spirit but, cold as the moon looking on from cosmic space,¹⁴ leaves the comedy of genesis and decay to pursue its course. I sincerely hope that *Ulysses* is not symbolic, for if it were it would have failed in its purpose. What kind of anxiously guarded secret might it be that is hidden with matchless care under seven hundred and thirty-five unendurable pages? It is better not to waste one’s time and energy on a fruitless treasure-hunt. Indeed, there *ought not* to be anything symbolic behind the book, for if there were our consciousness would be dragged back into world and spirit, perpetuating Messrs. Bloom and Dedalus to all eternity, befooled by the ten thousand facets of life. This is just what *Ulysses* seeks to prevent: it wants to be an eye of the moon, a consciousness detached from the object, in thrall neither to the gods nor to sensuality, and bound neither by love nor by hate, neither by conviction nor by prejudice. *Ulysses* does not preach this but practises it—detachment of consciousness¹⁵ is the goal that shimmers through the fog of this book. This, surely, is its real secret, the secret of a new cosmic

consciousness; and it is revealed not to him who has conscientiously waded through the seven hundred and thirty-five pages, but to him who has gazed at his world and his own mind for seven hundred and thirty-five days with the eyes of Ulysses. This space of time, at any rate, is to be taken symbolically—"a time, times and a half a time"—an indefinite time, therefore; but sufficiently long for the transformation to take place. The detachment of consciousness can be expressed in the Homeric image of Odysseus sailing the straits between Scylla and Charybdis, between the Symplegades, the clashing rocks of the world and the spirit; or, in the imagery of the Dublin inferno, between Father John Conmee and the Viceroy of Ireland, "a light crumpled throwaway," drifting down the Liffey (p. 239):

Elijah, skiff, light crumpled throwaway, sailed eastward by flanks of ships and trawlers, amid an archipelago of corks, beyond new Wapping street past Benson's ferry, and by the threemasted schooner *Rosevean* from Bridgwater with bricks.

[187] Can this detachment of consciousness, this depersonalization of the personality, can this be the Ithaca of the Joycean Odyssey?

[188] One might suppose that in a world of nothing but nothingness at least the "I"—James Joyce himself—would be left over. But has anyone noticed the appearance, among all the unhappy, shadowy "I"s of this book, of a single, actual ego? True, every figure in *Ulysses* is superlatively real, none of them could be other than what they are, they are themselves in every respect. And yet not one of them has an ego, there is no acutely conscious, human centre, an island surrounded by warm heart's blood, so small and yet so vitally important. All the Dedaluses, Blooms, Harrys, Lynches, Mulligans, and the rest of them talk and go about as in a collective dream that begins nowhere and ends nowhere, that takes place only because "No-man"—an unseen Odysseus—dreams it. None of them knows this, and yet all live for the sole reason that a god bids them live. That is how life is—*vita somnium breve*—and that is why the Joycean figures are so real. But the ego that embraces them all appears nowhere. It betrays itself by nothing, by no judgment, no sympathy, not a single anthropomorphism. The ego of the creator of these figures is not to be found. It is as though it had dissolved into the countless figures of *Ulysses*.¹⁶ And yet, or rather for that very reason, all and everything, even the missing punctuation of the final chapter, is Joyce himself. His detached, contemplative consciousness, dispassionately embracing in one glance the timeless simultaneity of the happenings of the sixteenth day of June, 1904, must say of all these appearances: *Tat tvam asi*, "That art thou"—"thou" in a higher sense, not the ego but the self. For the self alone embraces the ego and the non-ego, the infernal regions, the viscera, the *imagines et lares*, and the heavens.

[189] Whenever I read *Ulysses* there comes into my mind a Chinese picture, published by Richard Wilhelm,¹⁷ of a yogi in meditation, with five human figures growing out

of the top of his head and five more figures growing out of the top of each of *their* heads. This picture portrays the spiritual state of the yogi who is about to rid himself of his ego and to pass over into the more complete, more objective state of the self. This is the state of the “moon-disk, at rest and alone,” of *sat-chit-ananda*, the epitome of being and not-being, the ultimate goal of the Eastern way of redemption, the priceless pearl of Indian and Chinese wisdom, sought and extolled through the centuries.

[190] The “light crumpled throwaway” drifts towards the East. Three times this crumpled note turns up in *Ulysses*, each time mysteriously connected with Elijah. Twice we are told: “Elijah is coming.” He actually does appear in the brothel scene (rightly compared by Middleton Murry to the Walpurgisnacht in *Faust*), where in Americanese he explains the secret of the note (p. 478):

Boys, do it now. God’s time is 12.25. Tell mother you’ll be there. Rush your order and you play a slick ace. Join on right here! Book through to eternity junction, the nonstop run. Just one word more. Are you a god or a doggone clod? If the second advent came to Coney Island are we ready? Florry Christ, Stephen Christ, Zoe Christ, Bloom Christ, Kitty Christ, Lynch Christ, it’s up to you to sense that cosmic force. Have we cold feet about the cosmos? No. Be on the side of the angels. Be a prism. *You have that something within, the higher self.*¹⁸ You can rub shoulders with a Jesus, a Gautama, an Ingersoll. Are you all in this vibration? I say you are. You once noble that, congregation, and a buck joyride to heaven becomes a back number. You got me? It’s a lifebrightener, sure. The hottest stuff ever was. It’s the whole pie with jam in. It’s just the cutest snappiest line out. It is immense, supersumptuous. It restores.

[191] One can see what has happened: the detachment of human consciousness and its consequent approximation to the divine—the whole basis and highest artistic achievement of *Ulysses*— suffers an infernal distortion in the drunken madhouse of the brothel as soon as it appears in the cloak of a traditional formula. Ulysses, the sorely tried wanderer, toils ever towards his island home, back to his true self, beating his way through the turmoil of eighteen chapters, and, free at last from the fool’s world of illusions, “looks on from afar,” impassively. Thus he achieves what a Jesus or a Buddha achieved, and what Faust also strove for—the overcoming of a fool’s world, liberation from the opposites. And just as Faust was dissolved in the Eternal Feminine, so it is Molly Bloom (whom Stuart Gilbert compares to the blossoming earth) who has the last word in her unpunctuated monologue, putting a blessed close to the hellish, shrieking dissonances with a harmonious final chord.

[192] Ulysses is the creator-god in Joyce, a true demiurge who has freed himself from entanglement in the physical and mental world and contemplates them with detached consciousness. He is for Joyce what Faust was for Goethe, or Zarathustra for Nietzsche. He is the higher self who returns to his divine home after blind

entanglement in *samsara*. In the whole book no Ulysses appears; the book itself is Ulysses, a microcosm of James Joyce, the world of the self and the self of the world in one. Ulysses can return home only when he has turned his back on the world of mind and matter. This is surely the message underlying that sixteenth day of June, 1904, the everyday of everyman, on which persons of no importance restlessly do and say things without beginning or aim—a shadowy picture, dreamlike, infernal, sardonic, negative, ugly, devilish, but true. A picture that could give one bad dreams or induce the mood of a cosmic Ash Wednesday, such as the Creator might have felt on August 1, 1914. After the optimism of the seventh day of creation the demiurge must have found it pretty difficult in 1914 to identify himself with his handiwork. *Ulysses* was written between 1914 and 1921—hardly the conditions for painting a particularly cheerful picture of the world or for taking it lovingly in one's arms (nor today either, for that matter). So it is not surprising that the demiurge in the artist sketched a negative picture, so blasphemously negative that in Anglo-Saxon countries the book was banned in order to avoid the scandal of its contradicting the creation story in Genesis! And that is how the misunderstood demiurge became Ulysses in search of his home.

[193] There is so little feeling in *Ulysses* that it must be very pleasing to all aesthetes. But let us assume that the consciousness of *Ulysses* is not a moon but an ego that possesses judgment, understanding, and a feeling heart. Then the long road through the eighteen chapters would not only hold no delights but would be a road to Calvary; and the wanderer, overcome by so much suffering and folly, would sink down at nightfall into the arms of the Great Mother, who signifies the beginning and end of life. Under the cynicism of Ulysses there is hidden a great compassion; he knows the sufferings of a world that is neither beautiful nor good and, worse still, rolls on without hope through the eternally repeated everyday, dragging with it man's consciousness in an idiot dance through the hours, months, years. Ulysses has dared to take the step that leads to the detachment of consciousness from the object; he has freed himself from attachment, entanglement, and delusion, and can therefore turn homeward. He gives us more than a subjective expression of personal opinion, for the creative genius is never one but many, and he speaks in stillness to the souls of the multitude, whose meaning and destiny he embodies no less than the artist's own.

[194] It seems to me now that all that is negative in Joyce's work, all that is cold-blooded, bizarre and banal, grotesque and devilish, is a positive virtue for which it deserves praise. Joyce's inexpressibly rich and myriad-faceted language unfolds itself in passages that creep along tapeworm fashion, terribly boring and monotonous, but the very boredom and monotony of it attain an epic grandeur that makes the book a *Mahabharata* of the world's futility and squalor. "From drains, clefts, cesspools, middens arise on all sides stagnant fumes" (p. 412). And in this open cloaca is

reflected with blasphemous distortion practically everything that is highest in religious thought, exactly as in dreams. (Alfred Kubin's *Die andere Seite* is a country-cousin of the metropolitan *Ulysses*.)

[195] Even this I willingly accept, for it cannot be denied. On the contrary, the transformation of eschatology into scatology proves the truth of Tertullian's dictum: *anima naturaliter christiana*. Ulysses shows himself a conscientious Antichrist and thereby proves that his Catholicism still holds together. He is not only a Christian but—still higher title to fame—a Buddhist, Shivaist, and a Gnostic (p. 481):

(*With a voice of waves.*) ... White yoghin of the Gods. Occult pimander of Hermes Trismegistos. (*With a voice of whistling seawind.*) Punarjanam patsypunjaub! I won't have my leg pulled. It has been said by one: beware of the left, the cult of Shakti. (*With a cry of storm birds.*) Shakti, Shiva! Dark hidden Father! ... Aum! Baum! Pyjaum! I am the light of the homestead, I am the dreamery creamery butter.

[196] Is not that touching and significant? Even on the dunghill the oldest and noblest treasures of the spirit are not lost. There is no cranny in the psyche through which the divine afflatus could finally breathe out its life and perish in noisome filth. Old Hermes, father of all heretical bypaths, is right: "As above, so below." Stephen Dedalus, the bird-headed sky-man, trying to escape from the all too gaseous regions of the air, falls into an earthly slough and in the very depths encounters again the heights from which he fled. "And should I flee to the uttermost ends of the earth ..." The close of this sentence is a blasphemy that furnishes the most convincing proof of this in all *Ulysses*.¹⁹ Better still, that nosyparker Bloom, the perverse and impotent sensualist, experiences in the dirt something that had never happened to him before: his own transfiguration. Glad tidings: when the eternal signs have vanished from the heavens, the pig that hunts truffles finds them again in the earth. For they are indelibly stamped on the lowest as on the highest; only in the lukewarm intermediate realm that is accursed of God are they nowhere to be found.

[197] Ulysses is absolutely objective and absolutely honest and therefore trustworthy. One can trust his testimony as to the power and nugatoriness of the world and the spirit. Ulysses alone is reality, life, meaning; in him is comprised the whole phantasmagoria of mind and matter, of egos and non-egos. And here I would like to ask Mr. Joyce a question: "Have you noticed that you are a representation, a thought, perhaps a complex of Ulysses? That he stands about you like a hundred-eyed Argus, and has thought up for you a world and an anti-world, filling them with objects without which you could not be conscious of your ego at all?" I do not know what the worthy author would answer to this question. Nor is it any business of mine—there is nothing to stop me from indulging in metaphysics on my own. But one is driven to ask it when one sees how neatly the microcosm of Dublin, on that sixteenth day of June, 1904, has been fished out of the chaotic macrocosm of world history,

how it is dissected and spread out on a glass slide in all its tasty details, and described with the most pedantic exactitude by a completely detached observer. Here are the streets, here are the houses and a young couple out for a walk, a real Mr. Bloom goes about his advertising business, a real Stephen Dedalus diverts himself with aphoristic philosophy. It would be quite possible for Mr. Joyce himself to loom up at some Dublin street-corner. Why not? He is surely as real as Mr. Bloom and could therefore equally well be fished out, dissected, and described (as, for instance, in *A Portrait of the Artist as a Young Man*).

[198] Who, then, is Ulysses? Doubtless he is a symbol of what makes up the totality, the oneness, of all the single appearances in *Ulysses* as a whole—Mr. Bloom, Stephen, Mrs. Bloom, and the rest, including Mr. Joyce. Try to imagine a being who is not a mere colourless conglomerate soul composed of an indefinite number of ill-assorted and antagonistic individual souls, but consists also of houses, street-processions, churches, the Liffey, several brothels, and a crumpled note on its way to the sea—and yet possesses a perceiving and registering consciousness! Such a monstrosity drives one to speculation, especially as one can prove nothing anyway and has to fall back on conjecture. I must confess that I suspect Ulysses of being a more comprehensive self who is the subject of all the objects on the glass slide, a being who acts as if he were Mr. Bloom or a printing-shop or a crumpled note, but actually is the “dark hidden Father” of his specimens. “I am the sacrificer and the sacrificed.” In the language of the infernal regions: “I am the dreamery creamery butter.” When he turns to the world with a loving embrace, all the gardens blossom. But when he turns his back upon it, the empty everyday rolls on—*labitur et labetur in omne volubilis aevum*.²⁰

[199] The demiurge first created a world that in his vainglory seemed to him perfect; but looking upward he beheld a light which he had not created. Thereupon he turned back towards the place where was his home. But as he did so, his masculine creative power turned into feminine acquiescence, and he had to confess:

All things ephemeral
Are but a reflection;
The unattainable
Here finds perfection;
The indescribable
Here it is done;
The Eternal Feminine
Still draws us on.

[200] From the specimen-slide far below upon earth, in Ireland, Dublin, 7 Eccles Street, from her bed as she grows sleepy at about two o'clock in the morning of the seventeenth of June, 1904, the voice of easy-going Mrs. Bloom speaks:

O and the sea the sea crimson sometimes like fire and the glorious sunsets and the figtrees in the Alameda gardens yes and all the queer little streets and pink and blue and yellow houses and the rosegardens and the jessamine and geraniums and cactuses and Gibraltar as a girl where I was a Flower of the mountain yes when I put the rose in my hair like the Andalusian girls used or shall I wear a red yes and how he kissed me under the Moorish wall and I thought well as well him as another and then I asked him with my eyes to ask again yes and then he asked me would I yes to say yes my mountain flower and first I put my arms around him yes and drew him down to me so he could feel my breasts all perfume yes and his heart was going like mad and yes I said yes I will Yes.

[201] O *Ulysses*, you are truly a devotional book for the object-besotted, object-ridden white man! You are a spiritual exercise, an ascetic discipline, an agonizing ritual, an arcane procedure, eighteen alchemical alembics piled on top of one another, where amid acids, poisonous fumes, and fire and ice, the homunculus of a new, universal consciousness is distilled!

[202] You say nothing and betray nothing, O *Ulysses*, but you give us the works! Penelope need no longer weave her never-ending garment; she now takes her ease in the gardens of the earth, for her husband is home again, all his wanderings over. A world has passed away, and is made new.

[203] Concluding remark: I am now getting on pretty well with my reading of *Ulysses*—forward!

APPENDIX

[The genesis of the foregoing paper is of interest, in that conflicting explanations have been published. The version that is believed to be authentic is given first:

(1) In par. 171, Jung stated that he wrote the article because a publisher asked him “what I thought about [Joyce], or rather about *Ulysses*.” This was Dr. Daniel Brody, formerly head of Rhein-Verlag (Zurich), which published a German translation of *Ulysses* in 1927 (2nd and 3rd edns., 1930). Dr. Brody has recounted that, in 1930, he attended a lecture by Jung in Munich on “the psychology of the author.” (This was probably an earlier version of the preceding paper, “Psychology and Literature.”) Speaking with Jung later, Dr. Brody said that he felt Jung was referring to Joyce, without mentioning his name. Jung denied this but said that he was indeed interested in Joyce and had read part of *Ulysses*. Dr. Brody responded that the Rhein-Verlag was preparing to publish a literary review, and he would welcome an article on Joyce by Jung for the first issue. Jung agreed, and about a month later he delivered the article to Dr. Brody, who discovered that Jung had dealt with Joyce and *Ulysses* mainly from a clinical point of view and, so it seemed, harshly. He sent the article to Joyce, who cabled him, “Niedrigerhängen,” meaning “Hang it lower” or, figuratively, “Show it up by printing it.” (Joyce was quoting Frederick the Great, who upon seeing a placard attacking him directed that it be hung lower for all to behold.) Friends of Joyce, including Stuart Gilbert, advised Brody not to publish the article, though Jung at first insisted on its publication. In the meantime, political tensions had developed in Germany, so that the Rhein-Verlag decided to abandon the projected literary review, and Dr. Brody therefore returned the article to Jung. Later, Jung revised the essay (modifying its severity) and published it in 1932 in the *Europäische Revue*. The original version has never come to light.

The foregoing summary is based partially on recent communications from Dr. Brody to the Editors and partially on the contents of a letter from Professor Richard Ellmann, who obtained a similar account from Dr. Brody. Professor Ellmann has stated that he will deal with the subject in a new edition of his biography of Joyce.

(2) In the first edition of his *James Joyce* (1959; p. 641), Professor Ellmann wrote that Brody asked Jung for a preface to the third edition (late 1930) of the German translation of *Ulysses*. Patricia Hutchins, in *James Joyce's World* (1957; p. 182), quotes Jung in an interview: “In the thirties I was asked to write an introduction to the German edition of *Ulysses*, but as such it was not a success. Later I published it in

one of my books. My interest was not literary but professional.... The book was a most valuable document from my point of view....”

(3) In a letter to Harriet Shaw Weaver, Sept. 27, 1930, from Paris, Joyce wrote: “The Rheinverlag wrote to Jung for a preface to the German edition of Gilbert’s book. He replied with a very long and hostile attack ... which they are much upset about, but I want them to use it....” (*Letters*, ed. Stuart Gilbert, p. 294). Rhein-Verlag published a German edition of *James Joyce’s “Ulysses”: A Study*, as *Das Rätsel Ulysses*, in 1932. Mr. Gilbert stated, in a letter to the Editors: “I fear my memories of Jung’s *Ulysses* essay remain vague, but ... I feel fairly sure that Jung was asked to write the piece for my *Rätsel* and not for any German edition of *Ulysses*.” Professor Ellmann has subsequently commented, in a letter: “I suspect that at some point in the negotiations with Jung the possibility of using the article also as a preface to Gilbert’s book may well have arisen, either at Brody’s suggestion or at Joyce’s.”

*

Jung sent Joyce a copy of the revised version of his essay, with the following letter (cf. Ellmann, *James Joyce*, p. 642):

Küsnacht-Zürich
Seestrasse 228
September 27th, 1932.

James Joyce Esq.

Hotel Elite,
Zürich

Dear Sir,

Your *Ulysses* has presented the world such an upsetting psychological problem that repeatedly I have been called in as a supposed authority on psychological matters.

Ulysses proved to be an exceedingly hard nut and it has forced my mind not only to most unusual efforts, but also to rather extravagant peregrinations (speaking from the standpoint of a scientist). Your book as a whole has given me no end of trouble and I was brooding over it for about three years until I succeeded to put myself into it. But I must tell you that I’m profoundly grateful to yourself as well as to your gigantic opus, because I learned a great deal from it. I shall probably never be quite sure whether I did enjoy it, because it meant too much grinding of nerves and of grey matter. I also don’t know whether you will enjoy what I have written about *Ulysses* because I couldn’t help telling the world how much I was bored, how I grumbled, how I cursed and how I admired. The 40 pages of non stop run in the end is a string

of veritable psychological peaches. I suppose the devil's grandmother knows so much about the real psychology of a woman, I didn't.

Well I just try to recommend my little essay to you, as an amusing attempt of a perfect stranger who went astray in the labyrinth of your *Ulysses* and happened to get out of it again by sheer good luck. At all events you may gather from my article what *Ulysses* has done to a supposedly balanced psychologist.

With the expression of my deepest appreciation, I remain, dear Sir,

Yours faithfully

C. G. Jung

Jung's copy of *Ulysses* (cf. above, p. 109, n. 1) contains on its flyleaf the following inscription in Joyce's hand: "To Dr C. G. Jung, with grateful appreciation of his aid and counsel. James Joyce. Xmas 1934, Zurich." The copy is evidently the one that Jung owned when he wrote the essay, as some of the passages quoted therein have been marked in pencil.

—EDITORS.]

PICASSO¹

[204] As a psychiatrist, I almost feel like apologizing to the reader for becoming involved in the excitement over Picasso. Had it not been suggested to me from an authoritative quarter, I should probably never have taken up my pen on the subject. It is not that this painter and his strange art seem to me too slight a theme—I have, after all, seriously concerned myself with his literary brother, James Joyce.² On the contrary, his problem has my undivided interest, only it appears too wide, too difficult, and too involved for me to hope that I could come anywhere near to covering it fully in a short article. If I venture to voice an opinion on the subject at all, it is with the express reservation that I have nothing to say on the question of Picasso's "art" but only on its psychology. I shall therefore leave the aesthetic problem to the art critics, and shall restrict myself to the psychology underlying this kind of artistic creativeness.

[205] For almost twenty years, I have occupied myself with the psychology of the pictorial representation of psychic processes, and I am therefore in a position to look at Picasso's pictures from a professional point of view. On the basis of my experience, I can assure the reader that Picasso's psychic problems, so far as they find expression in his work, are strictly analogous to those of my patients. Unfortunately, I cannot offer proof on this point, as the comparative material is known only to a few specialists. My further observations will therefore appear unsupported, and require the reader's good will and imagination.

[206] Non-objective art draws its contents essentially from "inside." This "inside" cannot correspond to consciousness, since consciousness contains images of objects as they are generally seen, and whose appearance must therefore necessarily conform to general expectations. Picasso's object, however, appears different from what is generally expected—so different that it no longer seems to refer to any object of outer experience at all. Taken chronologically, his works show a growing tendency to withdraw from the empirical objects, and an increase in those elements which do not correspond to any outer experience but come from an "inside" situated behind consciousness—or at least behind that consciousness which, like a universal organ of perception set over and above the five senses, is orientated towards the outer world. Behind consciousness there lies not the absolute void but the unconscious psyche, which affects consciousness from behind and from inside, just as much as the outer world affects it from in front and from outside. Hence those pictorial elements which do not correspond to any "outside" must originate from "inside."

[207] As this “inside” is invisible and cannot be imagined, even though it can affect consciousness in the most pronounced manner, I induce those of my patients who suffer mainly from the effects of this “inside” to set them down in pictorial form as best they can. The aim of this method of expression is to make the unconscious contents accessible and so bring them closer to the patient’s understanding. The therapeutic effect of this is to prevent a dangerous splitting-off of the unconscious processes from consciousness. In contrast to objective or “conscious” representations, all pictorial representations of processes and effects in the psychic background are *symbolic*. They point, in a rough and approximate way, to a meaning that for the time being is unknown. It is, accordingly, altogether impossible to determine anything with any degree of certainty in a single, isolated instance. One only has the feeling of strangeness and of a confusing, incomprehensible jumble. One does not know what is actually meant or what is being represented. The possibility of understanding comes only from a comparative study of many such pictures. Because of their lack of artistic imagination, the pictures of patients are generally clearer and simpler, and therefore easier to understand, than those of modern artists.

[208] Among patients, two groups may be distinguished: the *neurotics* and the *schizophrenics*. The first group produces pictures of a synthetic character, with a pervasive and unified feeling-tone. When they are completely abstract, and therefore lacking the element of feeling, they are at least definitely symmetrical or convey an unmistakable meaning. The second group, on the other hand, produces pictures which immediately reveal their alienation from feeling. At any rate they communicate no unified, harmonious feeling-tone but, rather, contradictory feelings or even a complete lack of feeling. From a purely formal point of view, the main characteristic is one of fragmentation, which expresses itself in the so-called “lines of fracture”—that is, a series of psychic “faults” (in the geological sense) which run right through the picture. The picture leaves one cold, or disturbs one by its paradoxical, unfeeling, and grotesque unconcern for the beholder. This is the group to which Picasso belongs.³

[209] In spite of the obvious differences between the two groups, their productions have one thing in common: their *symbolic content*. In both cases the meaning is an implied one, but the neurotic searches for the meaning and for the feeling that corresponds to it, and takes pains to communicate it to the beholder. The schizophrenic hardly ever shows any such inclination; rather, it seems as though he were the victim of this meaning. It is as though he had been overwhelmed and swallowed up by it, and had been dissolved into all those elements which the neurotic at least tries to master. What I said about Joyce holds good for schizophrenic forms of expression too: nothing comes to meet the beholder, everything turns away from him; even an occasional touch of beauty seems only like an inexcusable delay in withdrawal. It is

the ugly, the sick, the grotesque, the incomprehensible, the banal that are sought out—not for the purpose of expressing anything, but only in order to obscure; an obscurity, however, which has nothing to conceal, but spreads like a cold fog over desolate moors; the whole thing quite pointless, like a spectacle that can do without a spectator.

[210] With the first group, one can divine what they are trying to express; with the second, what they are unable to express. In both cases, the content is full of secret meaning. A series of images of either kind, whether in drawn or written form, begins as a rule with the symbol of the Nekyia—the journey to Hades, the descent into the unconscious, and the leave-taking from the upper world. What happens afterwards, though it may still be expressed in the forms and figures of the day-world, gives intimations of a hidden meaning and is therefore symbolic in character. Thus Picasso starts with the still objective pictures of the Blue Period—the blue of night, of moonlight and water, the Tuat-blue of the Egyptian underworld. He dies, and his soul rides on horseback into the beyond. The day-life clings to him, and a woman with a child steps up to him warningly. As the day is woman to him, so is the night; psychologically speaking, they are the light and the dark soul (anima). The dark one sits waiting, expecting him in the blue twilight, and stirring up morbid presentiments. With the change of colour, we enter the underworld. The world of objects is death-struck, as the horrifying masterpiece of the syphilitic, tubercular, adolescent prostitute makes plain. The motif of the prostitute begins with the entry into the beyond, where he, as a departed soul, encounters a number of others of his kind. When I say “he,” I mean that personality in Picasso which suffers the underworld fate—the man in him who does not turn towards the day-world, but is fatefully drawn into the dark; who follows not the accepted ideals of goodness and beauty, but the demoniacal attraction of ugliness and evil. It is these antichristian and Luciferian forces that well up in modern man and engender an all-pervading sense of doom, veiling the bright world of day with the mists of Hades, infecting it with deadly decay, and finally, like an earthquake, dissolving it into fragments, fractures, discarded remnants, debris, shreds, and disorganized units. Picasso and his exhibition are a sign of the times, just as much as the twenty-eight thousand people who came to look at his pictures.

[211] When such a fate befalls a man who belongs to the neurotic group, he usually encounters the unconscious in the form of the “Dark One,” a Kundry of horribly grotesque, primeval ugliness or else of infernal beauty. In Faust’s metamorphosis, Gretchen, Helen, Mary, and the abstract “Eternal Feminine” correspond to the four female figures of the Gnostic underworld, Eve, Helen, Mary, and Sophia. And just as Faust is embroiled in murderous happenings and reappears in changed form, so Picasso changes shape and reappears in the underworld form of the tragic Harlequin

—a motif that runs through numerous paintings. It may be remarked in passing that Harlequin is an ancient chthonic god.⁴

[212] The descent into ancient times has been associated ever since Homer's day with the Nekyia. Faust turns back to the crazy primitive world of the witches' sabbath and to a chimerical vision of classical antiquity. Picasso conjures up crude, earthy shapes, grotesque and primitive, and resurrects the soullessness of ancient Pompeii in a cold, glittering light—even Giulio Romano could not have done worse! Seldom or never have I had a patient who did not go back to neolithic art forms or revel in evocations of Dionysian orgies. Harlequin wanders like Faust through all these forms, though sometimes nothing betrays his presence but his wine, his lute, or the bright lozenges of his jester's costume. And what does he learn on his wild journey through man's millennial history? What quintessence will he distil from this accumulation of rubbish and decay, from these half-born or aborted possibilities of form and colour? What symbol will appear as the final cause and meaning of all this disintegration?

[213] In view of the dazzling versatility of Picasso, one hardly dares to hazard a guess, so for the present I would rather speak of what I have found in my patients' material. The Nekyia is no aimless and purely destructive fall into the abyss, but a meaningful *katabasis eis antron*, a descent into the cave of initiation and secret knowledge. The journey through the psychic history of mankind has as its object the restoration of the whole man, by awakening the memories in the blood. The descent to the Mothers enabled Faust to raise up the sinfully whole human being—Paris united with Helen—that *homo totus* who was forgotten when contemporary man lost himself in one-sidedness. It is he who at all times of upheaval has caused the tremor of the upper world, and always will. This man stands opposed to the man of the present, because he is the one who ever is as he was, whereas the other is what he is only for the moment. With my patients, accordingly, the *katabasis* and *katalysis* are followed by a recognition of the bipolarity of human nature and of the necessity of conflicting pairs of opposites. After the symbols of madness experienced during the period of disintegration there follow images which represent the coming together of the opposites: light/dark, above/below, white/black, male/female, etc. In Picasso's latest paintings, the motif of the union of opposites is seen very clearly in their direct juxtaposition. One painting (although traversed by numerous lines of fracture) even contains the conjunction of the light and dark anima. The strident, uncompromising, even brutal colours of the latest period reflect the tendency of the unconscious to master the conflict by violence (colour = feeling).

[214] This state of things in the psychic development of a patient is neither the end nor the goal. It represents only a broadening of his outlook, which now embraces the whole of man's moral, bestial, and spiritual nature without as yet shaping it into a living unity. Picasso's *drame intérieur* has developed up to this last point before the

dénouement. As to the future Picasso, I would rather not try my hand at prophecy, for this inner adventure is a hazardous affair and can lead at any moment to a standstill or to a catastrophic bursting asunder of the conjoined opposites. Harlequin is a tragically ambiguous figure, even though—as the initiated may discern—he already bears on his costume the symbols of the next stage of development. He is indeed the hero who must pass through the perils of Hades, but will he succeed? That is a question I cannot answer. Harlequin gives me the creeps—he is too reminiscent of that “motley fellow, like a buffoon” in *Zarathustra*, who jumped over the unsuspecting rope-dancer (another Pagliacci) and thereby brought about his death. Zarathustra then spoke the words that were to prove so horrifyingly true of Nietzsche himself: “Your soul will be dead even sooner than your body: fear nothing more!” Who the buffoon is, is made plain as he cries out to the rope-dancer, his weaker *alter ego*: “To one better than yourself you bar the way!” He is the greater personality who bursts the shell, and this shell is sometimes—the brain.

BIBLIOGRAPHY

BIBLIOGRAPHY

- AGRIPPA VON NETTESHEIM, HEINRICH CORNELIUS. *De incertitudine et vanitate scientiarum et artium*. Strasbourg, 1622. (Original edn., Cologne, 1527.)
- AUGUSTINE, SAINT. *Confessions*. Translated by Francis Joseph Sheed. London and New York, 1951.
- BARLACH, ERNST. *Der tote Tag*. Berlin, 1912. 2nd edn., 1918.
- BENOÎT, PIERRE. *Atlantida*. Translated by Mary C. Tongue and Mary Ross. New York, 1920. (Original: *L'Atlantide*. Paris, 1920.)
- BERTHELOT, MARCELLIN. *Collection des anciens alchimistes grecs*. Paris, 1887–88. 3 vols. [Cited as “*Alch, grecs.*”]
- BLAKE, WILLIAM. *The Complete Writings*. Edited by Geoffrey Keynes. London and New York, 1957.
- BURCKHARDT, JACOB. *Letters*. Selected, edited, and translated by Alexander Dru. London and New York, 1955.
- CARUS, KARL GUSTAV. *Psyche*. Edited by Ludwig Klages. Jena, 1926. (Original edn., Pforzheim, 1846.)
- COLONNA, FRANCESCO. *Hypnerotomachia Poliphili*. Venice, 1499.
- _____. See also FIERZ-DAVID.
- CURTIUS, ERNEST ROBERT. *James Joyce und sein Ulysses*. Zurich, 1929
- EBERS, GEORG (ed.). *Papyros Ebers. Das hermetische Buch über die Arzneimittel der alten Aegypter*. Leipzig, 1875. 2 vols.
- ECKERMANN, JOHANN PETER. *Conversations with Goethe*. Translated by R. O. Moon. London [1951].
- ELLMANN, RICHARD. *James Joyce*. New York and London, 1959.
- ERMATINGER, EMIL (ed.). *Philosophie der Litteraturwissenschaft*. Berlin, 1930.
- [FIERZ-DAVID, LINDA.] *The Dream of Poliphilo*. Related and interpreted by Linda Fierz-David. Translated by Mary Hottinger. New York (Bollingen Series), 1950.
- FREUD, SIGMUND. *The Standard Edition of the Complete Psychological Works*. Translated under the General Editorship of James Strachey. London, 1953–. 24 vols.
- _____. “Delusions and Dreams in Jensen’s *Gradiva*.” Translated by James Strachey. (Standard Edition, vol. 9, pp. 7–95.) (Orig. 1907.)
- _____. *The Future of an Illusion*. Translated by W. D. Robson-Scott. (Standard Edition, vol. 21, pp. 5–56.) (Orig. 1927.)
- _____. *The Interpretation of Dreams*. Translated by James Strachey. (Standard Edition, vols. 4, 5.) (Orig. 1900.)
- _____. *Jokes and their Relation to the Unconscious*. Translated by James Strachey. (Standard Edition, vol. 8.) (Orig. 1905.)
- _____. *Leonardo da Vinci and a Memory of His Childhood*. Translated by Alan Tyson. (Standard Edition, vol. 11, pp. 63–137.) (Orig. 1910.)

- _____. *Moses and Monotheism*. Translated by James Strachey. (Standard Edition, vol. 23, pp. 7–137.) (Orig. 1939.)
- _____. *The Psychopathology of Everyday Life*. Translated by Alan Tyson. (Standard Edition, vol. 6.) (Orig. 1901.)
- _____. *Totem and Taboo*. Translated by James Strachey. (Standard Edition, vol. 13, pp. 1–161.) (Orig. 1912.)
- GESSNER, CONRAD. *Epistolarum medicinalium ... libri III*. Zurich, 1577.
- GIEDION-WELCKER, CAROLA. “Ein sprachliches Experiment von James Joyce,” *Neue Schweizer Rundschau* (Zurich), Sept. 1929, pp. 660–77.
- GILBERT, STUART. *James Joyce's "Ulysses": A Study*. New York and London, 1930.
- _____. See also JOYCE, *Letters*.
- GOETHE, JOHANN WOLFGANG VON. *Faust, Part Two*. Translated by Philip Wayne. (Penguin Classics.) Harmondsworth and Baltimore, 1959.
- GOETZ, BRUNO. *Das Reich ohne Raum*. Potsdam, 1919. 2nd edn., enlarged, Constance, 1925.
- GUTMANN, BRUNO. *Die Stammeslehren der Dschagga*. (Arbeiten zur Entwicklungspsychologie, 12, 16, 19.) Munich, 1932–38. 3 vols.
- HAGGARD, HENRY RIDER. *She*. London, 1887.
- _____. *Ayesha: The Return of She*. London, 1905.
- HALL, G. STANLEY. *Life and Confessions of a Psychologist*. New York and London, 1923.
- HERMAS. *The Shepherd*. In: *The Apostolic Fathers*. With an English translation by Kirsopp Lake. London and New York (Loeb Classical Library), 1912–13. 2 vols. (Vol. 2, pp. 6–305.)
- [HERMES TRISMEGISTUS.] *Poimandres*. In: WALTER SCOTT (ed. and trans.). *Hermetica*. Oxford, 1924–36. 4 vols. (Vol. 1, pp. 114–133.)
- HOFFMANN, ERNST THEODOR WILHELM (Amadeus). *Der goldene Topf*. Edited by W. F. Mainland. Oxford, 1942. English version: “The Golden Pot.” In: J. M. COHEN (ed.). *Tales from Hoffmann*. Translated by various hands (in this instance, Thomas Carlyle). London, 1951. (Pp. 19–108.)
- HORACE. *Satires, Epistles and Ars poetica*. With an English translation by H. R. Fairclough. London and New York (Loeb Classical Library), 1926.
- HUTCHINS, PATRICIA. *James Joyce's World*. London, 1957.
- [*I Ching*.] *The Yi King*. Translated by James Legge. (Sacred Books of the East, 16: Sacred Books of China: The Texts of Confucianism, Part Two.) Oxford, 1882.
- _____. *I Ging (Dschou I). Das Buch der Wandlungen*. Translated into German by Richard Wilhelm. Jena, 1924.
- _____. *The I Ching, or Book of Changes*. The [foregoing] Richard Wilhelm translation, rendered into English by Cary F. Baynes. With a foreword by C. G. Jung. New York (Bollingen Series), 1950; London, 1951. 2 vols. 3rd edn. in 1 vol., 1967.
- JAFFÉ, ANIELA. “Bilder und Symbole aus E. T. A. Hoffmanns Märchen Der Goldene Topf.” In: C. G. JUNG. *Gestaltungen des Unbewussten*. Zurich, 1950.
- JANET, PIERRE. *Névroses et idées fixes*. Paris, 1898. 2 vols.
- JENSEN, WILHELM. *Gradiva: ein pompejanisches Phantasiestück*. Dresden and Leipzig, 1903.

- JOYCE, JAMES. *Finnegans Wake*. London and New York, 1939.
- _____. *Letters*. Edited by Stuart Gilbert. New York and London, 1957.
- _____. *A Portrait of the Artist as a Young Man*. (Travellers' Library.) London, 1930. (Original edn., 1916.)
- _____. *Ulysses*. Paris, 10th printing, 1928.
- _____. *Work in Progress*. Serially in: *transition* (Paris), 1 (May 1927)–18 (Nov. 1929).
- JUNG, CARL GUSTAV. *Civilization in Transition. Collected Works* vol. 10.
- _____. "Concerning Rebirth." In: *Collected Works*, vol. 9, part i.
- _____. "Foreword to the *I Ching*." In: *Collected Works*, vol. 11.
- _____. "Instinct and the Unconscious." In: *Collected Works*, vol. 8.
- _____. *Memories, Dreams, Reflections*. Recorded and edited by Aniela Jaffé. Translated by Richard and Clara Winston. New York and London (separate editions, differently paginated), 1963.
- _____. "On the Nature of the Psyche." In: *Collected Works*, vol. 8.
- _____. "Paracelsus as a Spiritual Phenomenon." In: *Collected Works*, vol. 13.
- _____. *The Practice of Psychotherapy. Collected Works*, vol. 16.
- _____. *Psychological Types. Collected Works*, vol. 6. Alternative version: *Psychological Types*. Translated by H. G. Baynes. London and New York, 1923.
- _____. *Psychology and Alchemy. Collected Works*, vol. 12.
- _____. "A Study in the Process of Individuation." In: *Collected Works*, vol. 9, part i.
- _____. *Symbols of Transformation. Collected Works*, vol. 5.
- _____. "The Transcendent Function." In: *Collected Works*, vol. 8.
- _____. "Wotan." In: *Collected Works*, vol. 10.
- KERÉNYI, C. *Asklepios: Archetypal Image of the Physician's Existence*. Translated by Ralph Manheim. New York (Bollingen Series), 1959; London, 1961. (Original: *Der göttliche Arzt*.)
- KLAGES, LUDWIG. *Der Geist als Widersacher der Seele*. Leipzig, 1929–32. 3 vols.
- KUBIN, ALFRED. *Die andere Seite*. Munich, 1909.
- "Liber quartorum." See "Platonis ..."
- MELVILLE, HERMAN. *Moby Dick; or, The Whale*. New York, 1851.
- MEYRINK, GUSTAV. *Das grüne Gesicht*. Leipzig, 1916.
- MYLIUS, JOHANN DANIEL. *Philosophia reformata*. Frankfurt a. M., 1622.
- NIETZSCHE, FRIEDRICH WILHELM. *Ecce Homo [and Poems]*. Translated by Anthony M. Ludovici. (Complete Works, 17.) Edinburgh, London, and New York, 1911.
- _____. *Thus Spake Zarathustra*. Translated by Thomas Common. (Complete Works, 11.) London and New York, 1909.
- PARACELUSUS (Aureolus Philippus Theophrastus Bombast von Hohenheim). *Opera, Bücher und Schrifften ... durch Joannem Huserum in Truck gegeben*. Strasbourg, 1589–91. 10 parts. Reprinted 1603, 1616. 2 vols. [Cited as "Huser" or "Opera."]

- _____. *Sämtliche Werke*. Translated (from the 1589–91 Huser edition) into modern German by Bernhard Aschner. Jena, 1926–32. 4 vols.
- _____. *Selected Writings*. Edited with an introduction by Jolande Jacobi. Translated by Norbert Guterman. New York (Bollingen Series) and London, 1951; 2nd edn., 1958.
- _____. *Archidoxis magicae*. In: *Opera* (see above), vol. II, 544–73.
- _____. *Das Buch Paragranum*. Edited by Franz Strunz. Jena, 1903.
- _____. *De caducis*. In: *Opera*, vol. I, 589–607.
- _____. *De morbis amentium*. In: *Opera*, vol. I, 486–506.
- _____. *De transmutationibus rerum naturalium*. In: *Opera*, vol. I, 898–902.
- _____. *De vita longa*. Edited by Adam von Bodenstein. Basel, 1562.
- _____. *Fragmenta medica*. Liber IV Columnarum. In: *Opera*, vol. I, 131–67.
- _____. *Fragmenta ad Paramirum*. In: *Opera*, vol. I, 132.
- _____. *Labyrinthus medicorum errantium*. In: *Opera*, vol. I, 264–82.
- _____. *Liber Azoth*. In: *Opera*, vol. II, 519–43.
- _____. *Von dem Podagra*. In: *Opera*, vol. I, 539–42.
- “Platonis Liber quartorum.” In: *Theatrum chemicum*. Ursel and Strasbourg, 1602–61. 6 vols. (Vol. 5, pp. 114–208.)
- Poimandres*. See HERMES TRISMEGISTUS.
- SCHILLER, JOHANN CHRISTOPH FRIEDRICH. “On Naïve and Sentimental Poetry.” In: *Essays Aesthetical and Philosophical*. London, 1875. (Pp. 262–332.)
- SLOCUM, JOHN J., and HERBERT CAHOON. *A Bibliography of James Joyce*. New Haven, 1953.
- SPITTELER, CARL. *Olympischer Frühling*. Jena, 1922. 2 vols.
- _____. *Prometheus and Epimetheus*. Translated by James Fullarton Muirhead. London, 1931.
- Theatrum chemicum*. See “Platonis...”
- WILHELM, HELLMUT. “The Concept of Time in the Book of Changes.” In: *Man and Time*. (Papers from the Eranos Yearbooks, 3.) New York (Bollingen Series) and London, 1957.
- WILHELM, RICHARD (trans.). *The Secret of the Golden Flower*. With a foreword and commentary by C. G. Jung. Translated by Cary F. Baynes. New York and London, 1931; 2nd edn., 1962.
- _____. See also *I Ching; I Ging*.

INDEX

INDEX

A

- abaissement du niveau mental*, 112n
- Adler, Alfred, 33n, 39f
- aesthetics, 85, 87
- Agrippa von Nettesheim, Heinrich Cornelius, 7f
- alchemy, 14f, 18ff
- allegory, 82
- Allport, Gordon W., 33n
- amulets and seals, 28
- anatomical dissection, 16
- anatomy, 24f
- Angelus Silesius (Joh. Scheffler), 8
- anima, 138, 140
- animals, instinct in, 66
- animism, primitive, 11
- Anquetil Duperron, A. H., 58
- anxiety states, 43f
- apathy, 79
- Apocalypse, 97
- Apollonius of Tyana, 60
- arcana, 19, 26
- “Archasius,” 27
- Archelaos, 14
- archetype(s), 8f, 80n, 81f, 97, 103
and Joyce, 123
- Archidoxis magicae* (Paracelsus), 28n
- architecture, 117
- Arian heresy, 16
- art: introverted and extraverted, 73, 76

“meaning” of, 77f, 104f
modern, 119
non-objective, 136
and psychology, 65ff, 84ff
social significance of, 82f
artists: and the creative urge, 75ff, 86f, 89ff, 100ff
detachment of, 125n
duality of, 101ff
psychology of, 93
Aschner, Bernhard, 3n
astrology, 14ff, 20ff, 56f
astronomy, 26
Atlantide, l' (Benoît), 91
Augustine, St., 95
autoeroticism, 102
autonomous complexes, *see* complexes
Avicenna, 14, 17
Ayesha (Haggard), 91

B

Bachofen, J. J., 84
Barlach, Ernst, 91
Baroque art, 118
Basel, 6, 15
Baynes, Cary F., 54n
Benoît, Pierre, 88, 91
Bernheim, H., 42
Bible, *see* New and Old Testaments
birth data, 56
Blake, William, 91, 97
blasphemy, 129
Bleuler, Manfred, 33n
blood, the ancient seat of the soul, 18
Bloom, Leopold, 114, 123f, 129f

Bloom, Molly, [127](#), [131](#)
Blue Period, of Picasso, [138](#)
Bodenstein, Adam von, [16](#), [16n](#)
Boehme, Jacob, [8](#), [91](#)
Bombast, Georg, [4](#)
Bombast, Wilhelm, [4](#)
Bombast von Hohenheim, Philippus Aureolus, *see* Paracelsus, Theophrastus
Breuer, Joseph, [42](#)
British Anthropological Society, [55](#)
Brody, Daniel, [132f](#)
Buddha/Buddhism, [58](#), [127f](#)
buffoon, in *Zarathustra*, [140f](#)
Burckhardt, Jacob, [98](#), [103](#)

C

Cardan, Jerome, [25](#)
Carus, K. G., [84](#), [101](#)
“categorical imperative,” [21](#)
Catholic Church: and Joyce, [120f](#), [128](#)
 and Paracelsus, [7f](#), [11](#), [15](#)
causality, [56](#), [87](#)
censorship, [44f](#), [71](#)
Charcot, J. M., [42](#), [48](#)
“charming” an illness, [28](#)
chemistry, [28](#)
children: illegitimate or neglected, [103](#)
China/Chinese, [53ff](#)
 philosophy, [57ff](#), [126](#)
 science, [55](#)
Chiron, [104](#)
Christ, *see* Jesus Christ
Christian Church, [99](#)
Christian Science, [15](#)
Christianity/Christians, [58](#), [99](#), [104](#), [118](#)

cognition: philosophical, 27
collective unconscious, *see* unconscious
Colonna, Francesco, 91, 99
colour(s), and feeling, 140
compensatory function, of unconscious, 98f
complexes, autonomous, 75, 78f, 117
Conan Doyle, Sir Arthur, 88
conflict, in lives of artists, 102f
consciousness/conscious mind: and artistic creation, 89, 104
 may be causally explicable, 87
 detachment of, 124ff
 influence of the unconscious on, 74f, 98
 new and universal, 132
 and the unconscious, 136
copper, leprosy of, 18f
correspondence, doctrine of, 9f
cosmic matter, 8
Crato von Crafftheim, 15
creative complex, *see* complexes, autonomous
creative process, 72ff, 82f, 100ff, 135
 and the collective unconscious, 98, 103ff, 117
 feminine quality of, 103
 and mythology, 97
 “psychological” and “visionary,” 89ff
crime, and literature, 89
Cubism, 117
Curtius, E. R., 110n, 112n, 114, 115n

D

Dante, 91, 94, 97, 98
De incertitudine et vanitate scientiarum (Agrippa), 7f
Dedalus, Stephen, 114, 123f, 129f
degeneration, 79
delusion(s), 45, 98

demiurge, [127](#), [131](#)
De morbis amentium (Paracelsus), [19n](#)
destructiveness: and the creative purpose, [118f](#)
 and Joyce, [116](#)
detective stories, [88](#)
De vita longa (Paracelsus), [16n](#), [28n](#)
diagnosis, [20](#), [23](#)
didactic poetry, [89](#)
Dioscuri, [103n](#)
disease(s): mental, [19](#)
 names of, [24f](#)
 Paracelsus' attitude to, [9f](#)
distortion, and the creative purpose, [117f](#)
Divine Comedy, [94](#)
drama, [89](#)
dreams, [39](#), [43ff](#), [70f](#), [99](#)
 and the collective unconscious, [98](#), [104f](#)
dropsy, [29](#)
dual-mother problem, [38f](#)
Dublin, [107](#), [130](#)

E

Ebers Papyrus, [28](#)
Ecce Homo, *see* Nietzsche
Eckermann, J. P., [103n](#)
Eckhart, Meister, [8](#)
effeminacy, in Wagner, [86](#)
ego, and Joyce, [125](#), [127f](#)
Egypt, [28](#)
Einsiedeln, [3](#), [4](#)
Elijah (in *Ulysses*), [126](#)
Ellmann, Richard, [129n](#), [133ff](#)
emotion, [81f](#)
Empedocles, [8](#)

England, 59

entia, 9f

Ermatinger, Emil, 86n

“Eternal Feminine,” 131, 139

ethics, *see* morality

Europäische Revue, 109n, 132

Europe: influence of the East on, 55, 58ff

occultism in, 58

philosophy, 57

evolution: psychic, 97f

F

faith-healing, 15

fantasies, 69

pathological, 92f

Faust (Goethe), 18, 73, 76, 86f, 88f, 90f, 94, 98ff, 103f, 123, 126f, 130f, 139f

fear(s), 105

and the unknown, 95

feeling: atrophy of

in the work of Joyce, 116, 122

in the pictures of schizophrenics, 137

Ficino, Marsilio, 7, 9

Fierz-David, Linda, 91n, 99

Finnegans Wake (Joyce), 110n

firmamental body, 20

folk-medicine, 10

Fragmenta ad Paramirum (Paracelsus), 22n

Fragmenta medica (Paracelsus), 27n

Frederick the Great, 132

Freud, Sigmund, 33ff, 67ff, 82, 121

his lack of philosophical premises, 41, 45, 47

as physician, 41, 45, 47

and the psychology of the artist, 100

reductive method, 69

scepticism towards the ideals of the nineteenth century, 46
on sexual repression, 34ff
on sublimation, 37
and the unconscious, 42ff
WORKS: *Future of an Illusion*, 35, 45
Interpretation of Dreams, 44f
on Jensen's *Gradiva*, 100n
Jokes and their Relation to the Unconscious, 45
on Leonardo da Vinci, 100n
Psychopathology of Everyday Life, 45
Totem and Taboo, 45

G

“Gabal,” 28
Galen, 14, 17
Genesis, 127
genius, 102
German psyche, 98, 103f
Germany, 132
Gessner, Conrad, 15f
ghosts, fear of, 96
Giedion-Welcker, Carola, 111n
Gilbert, Stuart, 112n, 115n, 124n, 127, 132f
Gnostics, 8, 11, 139
 modern, 60, 128
Goethe, J. W. von, 76, 86f, 90, 94, 97ff, 103, 127, 131 (quoted)
Goetz, Bruno, 91
Gogh, Vincent van, 117
Golden Bowl (Hoffmann), 91
Graeco-Roman world, 96
Gutmann, Bruno, 96n

H

Hades, 138, 140

Haggard, H. Rider, [88](#), [91f](#)
Hall, G. Stanley, [37](#)
hallucinations, schizophrenic, [45](#)
harlequin, [139f](#)
Harranites, [26n](#)
Hartmann, Eduard von, [84](#)
Hauer, Wilhelm, [60](#)
Hauptmann, Gerhard, [80](#)
Heimarmene, [8](#), [21](#)
Heraclitus, [57](#)
Hermas, see *Shepherd of Hermas*
Hermes, [14](#), [21](#), [129](#)
Hindu theosophy, [59](#)
Hippocrates, [17](#)
Hoffmann, E. T. A., [91](#)
Hölderlin, Friedrich, [119](#)
Holland, [59](#)
Holy City, The, [129n](#)
Homer, [124](#)
homo maximus, [9](#), [22f](#)
Horace: *Epistles*, [131n](#)
horoscope(s), [16](#), [25](#), [56](#)
human nature, bipolarity of, [140](#)
Hutchins, Patricia, [133](#)
Hylaster, see Yliaster
Hypnerotomachia Poliphili, [91](#), [99](#)
hypnotism, [42](#)
hysteria, [42f](#)

I

I Ching, [54ff](#)
ideals, [82](#)
ideas, symptom-producing, [42](#)
Ikhnaton, [118](#)

illusion(s), [47f](#)
and poetic creation, [74](#), [76](#)
image(s), primordial, [80ff](#), [103](#)
incestuous fixation, [36f](#)
India/Indian, [60](#), [97](#)
philosophy, [126](#)
infantile sexuality, *see* sexuality
infantilism: and the artist, [102](#)
and the early Christians, [118](#)
inhibition, [44](#)
initiation, rites of, [97](#)
insane: and *abaissement du niveau mental*, [112n](#)
compositions of the, [116](#)
delusions of the, [98](#)
and visionary experience, [95f](#) *see also* mental patients
instinct(s), [70](#), [79](#), [82](#), [87](#)
in animals, [66](#)
intuitions, and the unconscious, [95](#)
iridodiagnosis, [15](#)
Isaiah, [95n](#)

J

Jacobi, Jolande, [5n](#)
Jaffé, Aniela, [91n](#)
James Joyce's World (Hutchins), [133f](#)
Janet, Pierre, [42](#), [79](#), [112n](#)
Jesus Christ, [70](#), [102](#), [127](#)
Jews, [118](#)
jokes, [45](#)
Joyce, James, [37](#), [109ff](#), [137n](#)
genesis of Jung's article on, [132ff](#)
influence on his contemporaries, [115](#), [117](#), [120](#)
inscription in Jung's copy of *Ulysses*, [134](#)
his language, [128](#)

letter from Jung to, [133f](#)
his style, [111](#), [114](#)
his themes, [114](#) see also *Portrait ...; Ulysses*
Jung, Carl Gustav: letter to Joyce, [133f](#)
WORKS: *Civilization in Transition*, [48n](#)
“Concerning Rebirth,” [103n](#)
Foreword to the *I Ching*, [54n](#)
“Instinct and the Unconscious,” [80n](#)
Memories, Dreams, Reflections, [80n](#)
“On the Nature of the Psyche,” [81n](#)
Practice of Psychotherapy, The, [89n](#)
Psychological Types, [80n](#), [99n](#)
Psychology and Alchemy, [91n](#)
Secret of the Golden Flower, The, [126n](#)
“Study in the Process of Individuation, A,” [91n](#)
“Transcendent Function, The,” [80n](#)

K

Kaegi, W., [139n](#)
Kant, Immanuel, [21](#)
Kerényi, C., [104n](#)
Klages, Ludwig, [48](#), [102n](#)
knowledge, theory of, [21](#), [70](#)
Kubin, Alfred, [91](#), [128](#)

L

Labyrinthus medicorum (Paracelsus), [19](#), [20](#), [25](#)
lamb symbolism, [118](#)
Legge, James, [54](#)
Leibniz, G. W., [57](#)
Leonardo da Vinci, [38](#), [100n](#)
leprosy, [19](#)
Lévy-Bruhl, Lucien, [33n](#)
Liber Azoth (Paracelsus), [18n](#)

Liber de caducis, 18n, 29

“*Liber quartorum*,” 26n, 28n

“*Limbus*,” 9, 22

literary critics, 88, 92

literature, and the creative process, 72ff, 117

Lorind, 18

love-episodes, and visionary experience, 93ff

lumen naturae, 20f, 25

Luther, Martin, 37

lyric poetry, 89

M

macrocosm, and microcosm, 18, 130

magic: and medicine, 16, 18, 25, 28

 primitives and, 66, 96

magnetopathy, 15

man, Freud’s idea of, 35

mandala, as sun-wheel, 96

materialism, 96

 scientific, 9, 34, 47

meaning, of works of art, 77f, 105

medicine, 10ff, 41

 academic, 14f, 19

 ancient, 44

Melusina, 18

Melville, Herman, 88

“memories in the blood,” 140

mental patients, 19, 78, 98

 pictures by, 135ff *see also* insane

Mephistopheles, 104

Mercurius, 103n

metals, diseases of, 18ff

metaphysics, fear of, 96

Meyrink, Gustav, 91

microcosm, man as, 16, 21, 26 *see also* macrocosm

Middle Ages: modern man and, 119ff

religious ideas of, 34

Mithras, 59

Moby Dick (Melville), 88

modern man, 138f

“restratification” of, 119ff

monotheism, 118

Montpellier school, 19

morality: and modern man, 121f

of the Victorian age, 35ff

Morienus Romanus, 14

Moses, 45, 111n, 114, 122

Mother, Earth, 97

mother-child relationship, 36

Mothers, descent to the, 140

Murry, John Middleton, 126

Mylius, 26n

mythology, 80f, 84, 96

modern, 98

N

narcissism, 68

“natural light,” *see lumen naturae*

Nekyia, 138f

Neoplatonism, 7

neurosis, 39f, 41ff, 67

and artistic creation, 100f, 137ff

contemporary, 47, 71

symptomatology of, 98

New Testament, 99

Nietzsche, F. W., 34f, 37, 41, 46, 84, 91, 97, 99, 119, 121

Ecce Homo, 119

Zarathustra, 73, 76, 103, 119, 123, 127, 140f

nightmares, 104
night-world, 95
novels, “psychological,” 88ff

O

occultism, 58
Odysseus, *see* Ulysses
Old Testament, 97 *see also* Genesis; Isaiah; Psalms
Olympian Spring (Spitteler), 91, 94
Oporinus, Johannes, 6
opposites, 140
“organ-representatives,” 112n
osteopathy, 15

P

paganism, 7, 11
painting(s), 117
 by mental patients, 135ff
parables, 70
Paracelsus, Theophrastus, 3ff
 and the Catholic Church, 7f, 11, 15
 his empiricism, 17
 and materialism, 9
 attitude to medicine and disease, 9f, 13ff
 personal appearance, 5
 his philosophical terminology, 8
 psychic change, 6f
 relationship with his father, 4f
 the spiritual man, 7
 travels, 5f
Paragranum, Das Buch (Paracelsus), 10, 17f, 22n–29n
parents, and children, 36, 67
Parsifal (Wagner), 91, 97
pathology, and artistic creation, 78, 92f

Penelope, 132

Persephone, 97

“personalistic” mode of artistic creation, 89n, 93

personality: splitting of the, 104, 117

 and Joyce, 114, 116

philosophy, as understood by Paracelsus, 25ff

phylogeny, 97

physician’s attitude to the patient, 29f

Picasso, Pablo, 135ff

pictorial representation of psychic processes, 135ff

Plato, 9, 70

“Platonis liber quartorum,” see “Liber quartorum”

pleasure principle, 39

Pliny, 20

poetry, psychological approach to, 65ff, 85, 89ff

poets, and mythology, 97

Polia, 99f

Portrait of the Artist as a Young Man, A (Joyce), 125n, 130

possession, 42, 44, 48

power drive, Adler and, 39

prediction, 57

Pre-Raphaelites, 118

pre-Socratics, 8

primitives, psychology of, 40, 45, 66, 84, 95, 98

primordial experience, 90, 92ff, 96

primordial images, see image(s)

prognosis, 23

projections, 26

Prometheus and Epimetheus (Spitteler), 99

prophets, 122

 and visionary experience, 95

propitiation, rites of, 96f

prostitute motif, in Picasso’s pictures, 138

Psalms, 129n

psychic change, [6f](#)
psychic processes, pictorial representation of, [135ff](#)
psychoanalysis: Freudian, [33](#), [37](#), [39](#)
 applied to works of art, [67ff](#)
“psychological” mode of artistic creation, [89ff](#)
psychology: of art, [73ff](#)
 danger of dogmatism in, [84](#)
 Freudian, [33ff](#), [92](#), [119](#)
 and literature, [84ff](#)
 medical, [67ff](#)
 and poetry, [65ff](#)
 of primitives, [40](#), [45](#), [66](#), [84](#), [96](#), [98](#)
psychoses, [67](#), [71](#)
psychotechnics, [84](#)
psychotherapy, [28](#), [84](#)
Pythagoras, [8](#)

R

Rank, Otto, [100](#)
rationalism, [34](#)
reality, representation of, by artists and by schizophrenics, [117](#)
reflexes, [87](#)
religion, [84](#)
 and dreams, [44](#)
 Freud’s attitude to, [35](#), [37](#), [45](#), [101](#)
 and psychology, [65ff](#)
Renaissance, [99](#)
repression(s), [37](#), [44ff](#), [69ff](#)
 and artistic creation, [93](#), [101](#)
 and the interpretation of jokes, [45](#)
 sexual, [34](#), [67](#)
resentment, as a theme in the work of Joyce, [114](#), [116](#)
Rhazes, [14](#)
Rhein-Verlag, [132ff](#)

Rhodesian rock-drawings, 96
Ring of the Nibelungs (Wagner), 86, 91
rites: of initiation, 97
 of propitiation, 96f
rock-drawings, 96
Roman Catholic Church, *see* Catholic Church
Roman Empire, 117
Romano, Giulio, 139
Rome, 59f
Russia, 58

S

Sabaeans, 26n
Salpêtrière, 42
samsara, 127
sat-chit-ananda, 126
Schiller, Friedrich, 73, 76
schizophrenia, 116f
 and artistic creation, 137f
schizophrenic hallucinations, *see* hallucinations
Schopenhauer, Arthur, 84
science, 118f
 Chinese, 55f
 European, 59
 and Freudian theory, 39
Scientia, 26f
scientific discovery, 99
scientific materialism, *see* materialism
scientific method, 66
sculpture, 117
seals, *see* amulets
self, 125ff
sense-perception, and Joyce, 112, 116
sentimentality, 122f

sex(uality): repression of, 34
 infantile, 35f, 43, 69
 and the unconscious, 43ff

She (Haggard), 91

Shepherd of Hermas, 91, 94, 98

Shiva, 128

signatures, doctrine of, 10

Sophia, 100

spells, 18

spirit(s), Freud's attitude to, 48

Spitteler, Carl, 91, 94, 97, 99

"star in the body," 16, 23

Stekel, Wilhelm, 100

Stoics, 8, 21

Stone Age, 96

stream of consciousness, 112n

sublimation, 37

suggestion, 42

sun-wheel, 96

Superman, 100

superstition, fear of, 96

surgery, 15

Swedenborg, Emanuel, 9

symbol(s), 70, 76f, 79f, 95f, 99, 103
 representing the organs, 112n
 Christian, 118
 and Joyce, 123f
 in non-objective art, 136ff, 140

synchronicity, 56f

syphilis, 6

T

"Tabula smaragdina," 21n

tao, 59

tapeworm, as image of Joyce's style, [112](#), [114](#), [128](#)

Tat tvam asi, [125](#)

technology, European, [59](#)

Tertullian, [128](#)

Theatrum chemicum, [26n](#)

Theorica, [28f](#)

theosophy, Hindu, [59](#)

therapy, [20](#), [23f](#), [28](#)

Tiepolo, G. B., [118](#)

time, [56f](#)

totem clans, [97](#)

transformation, alchemical process of, [20](#)

transvestism, [86](#)

trauma, [42f](#)

 sexual, [43](#)

tree-geese, [18](#)

Tristan und Isolde (Wagner), [91](#)

truth, nature of, [60](#)

U

Ulysses (Joyce), [109ff](#)

 detachment of consciousness in, [124ff](#)

 German translation of, [132f](#)

 Joyce's inscription in Jung's copy, [134](#)

 nihilistic tendencies of, [91n](#)

 resemblances to and differences from the compositions of the insane, [116ff](#)

 and symbolism, [123f](#)

Ulysses/Odysseus, as demiurge, [127ff](#)

unconscious, [42ff](#), [56](#), [69ff](#), [87f](#), [93](#)

 and artistic creation, [90ff](#), [103](#), [105](#)

 collective, [80f](#), [97f](#), [117f](#)

 and Eastern symbolism, [59](#)

 European, [60](#)

 influence on the conscious mind, [74f](#), [79](#)

and paintings by mental patients, [136ff](#), [139](#)
universities, [58](#)
Upanishads, [58](#)

V

Vesalius, Andreas, [24](#)
Victorian era, [34ff](#)
“visceral thinking,” [112](#), [116](#)
“visionary” mode of artistic creation, [89ff](#)
 sources of, [92ff](#)
Voltaire, [34](#), [48](#)
Vulcan, [27n](#)

W

Wagner, Richard, [86](#), [91](#), [97](#)
Weaver, Harriet Shaw, [133](#)
Wernicke, Carl, [112n](#)
Wilde, Oscar, [113](#)
Wilhelm, Hellmut, [57n](#)
Wilhelm, Richard, [53ff](#), [126](#)
wind which begets mice, [18](#)
Wise Old Man, [103](#), [104](#)
wish-fulfilments, [44f](#)
women, in Picasso’s pictures, [138](#)
Work in Progress (Joyce), [110n](#), [111n](#)

Y / Z

yin and *yang*, [60](#)
Yliaster (or Hylaster), [8](#)
Yoga, [20](#), [60](#)
 Chinese, [54](#), [58](#)
yogi, [126](#)
Zarathustra, *see* Nietzsche

THE COLLECTED WORKS OF C. G. JUNG

THE PUBLICATION of the first complete edition, in English, of the works of C. G. Jung was undertaken by Routledge and Kegan Paul, Ltd., in England and by Bollingen Foundation in the United States. The American edition is number XX in Bollingen Series, which since 1967 has been published by Princeton University Press. The edition contains revised versions of works previously published, such as *Psychology of the Unconscious*, which is now entitled *Symbols of Transformation*; works originally written in English, such as *Psychology and Religion*; works not previously translated, such as *Aion*; and, in general, new translations of virtually all of Professor Jung's writings. Prior to his death, in 1961, the author supervised the textual revision, which in some cases is extensive. Sir Herbert Read (d. 1968), Dr. Michael Fordham, and Dr. Gerhard Adler compose the Editorial Committee; the translator is R. F. C. Hull (except for Volume 2) and William McGuire is executive editor.

The price of the volumes varies according to size; they are sold separately, and may also be obtained on standing order. Several of the volumes are extensively illustrated. Each volume contains an index and in most a bibliography; the final volume will contain a complete bibliography of Professor Jung's writings and a general index to the entire edition.

In the following list, dates of original publication are given in parentheses (of original composition, in brackets). Multiple dates indicate revisions.

*1 PSYCHIATRIC STUDIES

On the Psychology and Pathology of So-Called Occult Phenomena (1902)

On Hysterical Misreading (1904)

Cryptomnesia (1905)

On Manic Mood Disorder (1903)

A Case of Hysterical Stupor in a Prisoner in Detention (1902)

On Simulated Insanity (1903)

A Medical Opinion on a Case of Simulated Insanity (1904)

A Third and Final Opinion on Two Contradictory Psychiatric Diagnoses (1906)

On the Psychological Diagnosis of Facts (1905)

2 EXPERIMENTAL RESEARCHES

Translated by Leopold Stein in collaboration with Diana Riviere

STUDIES IN WORD ASSOCIATION (1904–7, 1910)

The Associations of Normal Subjects (by Jung and F. Riklin)

An Analysis of the Associations of an Epileptic

The Reaction-Time Ratio in the Association Experiment

Experimental Observations on the Faculty of Memory

Psychoanalysis and Association Experiments

The Psychological Diagnosis of Evidence

Association, Dream, and Hysterical Symptom

The Psychopathological Significance of the Association Experiment

Disturbances in Reproduction in the Association Experiment

The Association Method

The Family Constellation

PSYCHOPHYSICAL RESEARCHES (1907–8)

On the Psychophysical Relations of the Association Experiment

Psychophysical Investigations with the Galvanometer and Pneumograph in Normal and Insane Individuals (by F. Peterson and Jung)

Further Investigations on the Galvanic Phenomenon and Respiration in Normal and Insane Individuals (by C. Ricksher and Jung)

Appendix: Statistical Details of Enlistment (1906); New Aspects of Criminal Psychology (1908); The Psychological Methods of Investigation Used in the Psychiatric Clinic of the University of Zurich (1910); On the Doctrine of Complexes ([1911] 1913); On the Psychological Diagnosis of Evidence (1937)

***3 THE PSYCHOGENESIS OF MENTAL DISEASE**

The Psychology of Dementia Praecox (1907)

The Content of the Psychoses (1908/1914)

On Psychological Understanding (1914)

A Criticism of Bleuler's Theory of Schizophrenic Negativism (1911)

On the Importance of the Unconscious in Psychopathology (1914)

On the Problem of Psychogenesis in Mental Disease (1919)

Mental Disease and the Psyche (1928)

On the Psychogenesis of Schizophrenia (1939)

Recent Thoughts on Schizophrenia (1957)

Schizophrenia (1958)

‡4 FREUD AND PSYCHOANALYSIS

Freud's Theory of Hysteria: A Reply to Aschaffenburg (1906)

The Freudian Theory of Hysteria (1908)

The Analysis of Dreams (1909)

A Contribution to the Psychology of Rumour (1910–11)

On the Significance of Number Dreams (1910–11)

Morton Prince, "The Mechanism and Interpretation of Dreams": A Critical Review (1911)

On the Criticism of Psychoanalysis (1910)

Concerning Psychoanalysis (1912)

The Theory of Psychoanalysis (1913)

General Aspects of Psychoanalysis (1913)

Psychoanalysis and Neurosis (1916)

Some Crucial Points in Psychoanalysis: A Correspondence between Dr. Jung and Dr. Loÿ (1914)

Prefaces to "Collected Papers on Analytical Psychology" (1916, 1917)

The Significance of the Father in the Destiny of the Individual (1909/1949)

Introduction to Kranefeldt's "Secret Ways of the Mind" (1930)

Freud and Jung: Contrasts (1929)

‡5 SYMBOLS OF TRANSFORMATION (1911–12/1952)

PART I

Introduction

Two Kinds of Thinking

The Miller Fantasies: Anamnesis

The Hymn of Creation

The Song of the Moth

PART II

Introduction

The Concept of Libido

The Transformation of Libido

The Origin of the Hero

Symbols of the Mother and of Rebirth

The Battle for Deliverance from the Mother

The Dual Mother

The Sacrifice

Epilogue

Appendix: The Miller Fantasies

*6 PSYCHOLOGICAL TYPES (1921)

Introduction

The Problem of Types in the History of Classical and Medieval Thought

Schiller's Ideas on the Type Problem

The Apollinian and the Dionysian

The Type Problem in Human Character

The Type Problem in Poetry

The Type Problem in Psychopathology

The Type Problem in Aesthetics

The Type Problem in Modern Philosophy

The Type Problem in Biography

General Description of the Types

Definitions

Epilogue

Four Papers on Psychological Typology (1913, 1925, 1931, 1936)

†7 TWO ESSAYS ON ANALYTICAL PSYCHOLOGY

On the Psychology of the Unconscious (1917/1926/1943)

The Relations between the Ego and the Unconscious (1928)

Appendix: New Paths in Psychology (1912); The Structure of the Unconscious (1916) (new versions, with variants, 1966)

‡8 THE STRUCTURE AND DYNAMICS OF THE PSYCHE

On Psychic Energy (1928)

The Transcendent Function ([1916]/1957)

A Review of the Complex Theory (1934)

The Significance of Constitution and Heredity in Psychology (1929)

Psychological Factors Determining Human Behavior (1937)

Instinct and the Unconscious (1919)

The Structure of the Psyche (1927/1931)

On the Nature of the Psyche (1947/1954)
General Aspects of Dream Psychology (1916/1948)
On the Nature of Dreams (1945/1948)
The Psychological Foundations of Belief in Spirits (1920/1948)
Spirit and Life (1926)
Basic Postulates of Analytical Psychology (1931)
Analytical Psychology and *Weltanschauung* (1928/1931)
The Real and the Surreal (1933)
The Stages of Life (1930–1931)
The Soul and Death (1934)
Synchronicity: An Acausal Connecting Principle (1952)
Appendix: On Synchronicity (1951)

***9 PART I. THE ARCHETYPES AND THE COLLECTIVE UNCONSCIOUS**

Archetypes of the Collective Unconscious (1934/1954)
The Concept of the Collective Unconscious (1936)
Concerning the Archetypes, with Special Reference to the Anima Concept
(1936/1954)
Psychological Aspects of the Mother Archetype (1938/1954)
Concerning Rebirth (1940/1950)
The Psychology of the Child Archetype (1940)
The Psychological Aspects of the Kore (1941)
The Phenomenology of the Spirit in Fairytales (1945/1948)
On the Psychology of the Trickster-Figure (1954)
Conscious, Unconscious, and Individuation (1939)
A Study in the Process of Individuation (1934/1950)
Concerning Mandala Symbolism (1950)
Appendix: Mandalas (1955)

***9 PART II. AION (1951)**

RESEARCHES INTO THE PHENOMENOLOGY OF THE SELF

The Ego

The Shadow

The Syzygy: Anima and Animus

The Self

Christ, a Symbol of the Self

The Sign of the Fishes

The Prophecies of Nostradamus

The Historical Significance of the Fish

The Ambivalence of the Fish Symbol

The Fish in Alchemy

The Alchemical Interpretation of the Fish

Background to the Psychology of Christian Alchemical Symbolism

Gnostic Symbols of the Self

The Structure and Dynamics of the Self

Conclusion

*10 CIVILIZATION IN TRANSITION

The Role of the Unconscious (1918)

Mind and Earth (1927/1931)

Archaic Man (1931)

The Spiritual Problem of Modern Man (1928/1931)

The Love Problem of a Student (1928)

Woman in Europe (1927)

The Meaning of Psychology for Modern Man (1933/1934)

The State of Psychotherapy Today (1934)

Preface and Epilogue to “Essays on Contemporary Events” (1946)

Wotan (1936)

After the Catastrophe (1945)

The Fight with the Shadow (1946)

The Undiscovered Self (Present and Future) (1957)

Flying Saucers: A Modern Myth (1958)

A Psychological View of Conscience (1958)

Good and Evil in Analytical Psychology (1959)

Introduction to Wolff’s “Studies in Jungian Psychology” (1959)

The Swiss Line in the European Spectrum (1928)

Reviews of Keyserling’s “America Set Free” (1930) and “La Révolution Mondiale” (1934)

The Complications of American Psychology (1930)

The Dreamlike World of India (1939)

What India Can Teach Us (1939)

Appendix: Documents (1933–1938)

†11 PSYCHOLOGY AND RELIGION: WEST AND EAST

WESTERN RELIGION

Psychology and Religion (The Terry Lectures) (1938/1940)

A Psychological Approach to the Dogma of the Trinity (1942/1948)

Transformation Symbolism in the Mass (1942/1954)

Forewords to White's "God and the Unconscious" and Werblowsky's "Lucifer and Prometheus" (1952)

Brother Klaus (1933)

Psychotherapists or the Clergy (1932)

Psychoanalysis and the Cure of Souls (1928)

Answer to Job (1952)

EASTERN RELIGION

Psychological Commentaries on "The Tibetan Book of the Great Liberation" (1939/1954) and "The Tibetan Book of the Dead" (1935/1953)

Yoga and the West (1936)

Foreword to Suzuki's "Introduction to Zen Buddhism" (1939)

The Psychology of Eastern Meditation (1943)

The Holy Men of India: Introduction to Zimmer's "Der Weg zum Selbst" (1944)

Foreword to the "I Ching" (1950)

*12 PSYCHOLOGY AND ALCHEMY (1944)

Prefatory note to the English Edition ([1951?] added 1967)

Introduction to the Religious and Psychological Problems of Alchemy

Individual Dream Symbolism in Relation to Alchemy (1936)

Religious Ideas in Alchemy (1937)

Epilogue

†13 ALCHEMICAL STUDIES

Commentary on "The Secret of the Golden Flower" (1929)

The Visions of Zosimos (1938/1954)

Paracelsus as a Spiritual Phenomenon (1942)

The Spirit Mercurius (1943/1948)

The Philosophical Tree (1945/1954)

‡14 MYSTERIUM CONIUNCTIONIS (1955-56)

AN INQUIRY INTO THE SEPARATION AND
SYNTHESIS OF PSYCHIC OPPOSITES IN ALCHEMY

The Components of the Coniunctio

The Paradoxa

The Personification of the Opposites

Rex and Regina

Adam and Eve

The Conjunction

*15 THE SPIRIT IN MAN, ART, AND LITERATURE

Paracelsus (1929)

Paracelsus the Physician (1941)

Sigmund Freud in His Historical Setting (1932)

In Memory of Sigmund Freud (1939)

Richard Wilhelm: In Memoriam (1930)

On the Relation of Analytical Psychology to Poetry (1922)

Psychology and Literature (1930/1950)

“Ulysses”: A Monologue (1932)

Picasso (1932)

†16 THE PRACTICE OF PSYCHOTHERAPY

GENERAL PROBLEMS OF PSYCHOTHERAPY

Principles of Practical Psychotherapy (1935)

What Is Psychotherapy? (1935)

Some Aspects of Modern Psychotherapy (1930)

The Aims of Psychotherapy (1931)

Problems of Modern Psychotherapy (1929)

Psychotherapy and a Philosophy of Life (1943)

Medicine and Psychotherapy (1945)

Psychotherapy Today (1945)

Fundamental Questions of Psychotherapy (1951)

SPECIFIC PROBLEMS OF PSYCHOTHERAPY

The Therapeutic Value of Abreaction (1921/1928)

The Practical Use of Dream-Analysis (1934)

The Psychology of the Transference (1946)

Appendix: The Realities of Practical Psychotherapy ([1937] added, 1966)

‡17 THE DEVELOPMENT OF PERSONALITY

Psychic Conflicts in a Child (1910/1946)

Introduction to Wickes's "Analyses der Kinderseele" (1927/1931)

Child Development and Education (1928)

Analytical Psychology and Education: Three Lectures (1926/1946)

The Gifted Child (1943)

The Significance of the Unconscious in Individual Education (1928)

The Development of Personality (1934)

Marriage as a Psychological Relationship (1925)

18 MISCELLANY

Posthumous and Other Miscellaneous Works

19 BIBLIOGRAPHY AND INDEX

Complete Bibliography of C. G. Jung's Writings

General Index to the Collected Works

¹ [An address delivered in the house in which Paracelsus was born, at Einsiedeln (Canton Schwyz), June, 1929, under the auspices of the Literary Club of Zurich, and published in *Der Lesezirkel* (Zurich), XVI: 10 (Sept., 1929). Reprinted in *Wirklichkeit der Seele* (Zurich, 1934) and as a pamphlet (St. Gallen, 1952).—EDITORS.]

² See the excellent edition of Paracelsus's writings prepared by Bernhard Aschner.

³ [Paracelsus died Sept. 24, 1541, at Salzburg, where he was buried in the cemetery of St. Sebastian, "among the poor of the almshouse" (Jacobi, in her edn. of Paracelsus' selected writings, p. lxi).—EDITORS.]

⁴ "Let him not be another's who can be his own."

⁵ "Agrippa spares no man; he contemns, knows, knows not, weeps, laughs, waxes wroth, reviles, carps at all things; being himself philosopher, demon, hero, god, and all things."

¹ [Originally delivered as a lecture to the Swiss Society for the History of Medicine and the Natural Sciences, at the annual meeting of the Society for Nature Research, Basel, Sept. 7, 1941, to commemorate the 400th anniversary of Paracelsus's death; published as "Paracelsus als Arzt," *Schweizerische medizinische Wochenschrift* (Basel), LXXXI (1941): 40, 1153-70; republished in *Paracelsica: Zwei Vorlesungen über den Arzt und Philosophen Theophrastus* (Zurich, 1942). The other essay from *Paracelsica* is published in Vol. 13 of the *Coll. Works under the title* "Paracelsus as a Spiritual Phenomenon," together with Jung's foreword to *Paracelsica*.—EDITORS.]

² Not, at least, in principle. He did, however, expressly repudiate various superstitious abuses of astrology.

³ *Epistolarum Conradi Gessneri, Philosophici Medici Tiguri, Libri III* (Zurich, 1577), fol. 2^{v-r}.

⁴ Adam von Bodenstein, editor of the *Vita longa* and a pupil of Paracelsus in Basel.

⁵ Paracelsus himself mentions the accusation in "Haeresiarcha." Cf. *Das Buch Paragranum*, ed. Strunz, preface, p. 18.

⁶ *Ibid.*, p. 105. [For the translation of the quotations from Paracelsus I am greatly indebted to Dr. R. T. Llewellyn.—TRANS.]

⁷ *Liber Azoth*, ed. Huser, pp. 534 and 535. He declares that he witnessed the transformation of the tree-goose himself.

⁸ *De caducis* (Huser, I), p. 595.

⁹ *Paragranum*. The *leprositatis aeris* is a well-known idea in alchemy. Cf. *Faust II*: "It's only rust that gives the coin its worth."

¹⁰ P. 33.

¹¹ P. 39.

¹² P. 53.

¹³ P. 35.

¹⁴ *Labyrinthus medicorum errantium* (Huser, I), p. 272.

¹⁵ *Ibid.*, p. 269.

¹⁶ P. 270.

¹⁷ *De morbis amentium*, Part II, ch. VI (Huser, I), p. 506.

¹⁸ *Paragranum*, p. 32.

¹⁹ *Ibid.*, pp. 65f.

²⁰ Pp. 80. 83.

²¹ Paracelsus makes no real *distinction* between astronomy and astrology.

²² Ch. II (Huser, I), p. 267.

²³ *Ibid.*

²⁴ *Paragranum*, p. 50: "As in the heavens so also in the body the stars float free, pure, and have an invisible influence, like the arcana."

²⁵ *Ibid.*, p. 52.

²⁶ Paracelsus certainly knew the "Tabula smaragdina," the classical authority of medieval alchemy, and the text: "What is below is like what is above. What is above is like what is below. Thus is the miracle of the One

accomplished.”

²⁷ *Paragranum*, p. 56.

²⁸ *Ibid.*, p. 57.

²⁹ P. 48. Cf. the description in “De ente astrali,” *Fragmenta ad Paramirum* (Huser, I, p. 132): “The heavens are a spirit and a vapour in which we live just like a bird in time. Not only the stars or the moon etc. constitute the heavens, but also there are stars in us, and these which are in us and which we do not see constitute the heavens also ... the firmament is twofold, that of the heavens and that of the bodies, and these latter agree with each other, and not the body with the firmament ... man’s strength comes from the upper firmament and all his power lies in it. As the former may be weak or strong, so, too, is the firmament in the body ...”

³⁰ *Paragranum*, p. 56.

³¹ P. 55.

³² P. 60.

³³ P. 54.

³⁴ P. 48.

³⁵ P. 73.

³⁶ P. 72.

³⁷ Alchemical furnace.

³⁸ *Paragranum*, p. 77.

³⁹ P. 73.

⁴⁰ *Lab. med.*, ch. IV (Huser, I), p. 370.

⁴¹ *Ibid.*, ch. IX, p. 277.

⁴² The devil.

⁴³ *Lab. med.*, ch. IX, p. 278.

⁴⁴ *Paragranum*, p. 67.

⁴⁵ Hence the alchemists’ strange but characteristic use of language, as for instance: “That body is the place of the science, gathering it together,” etc. (Mylius, *Philosophia reformata*, p. 123.)

⁴⁶ The “Liber quattorum” (10th cent.) speaks of the *extraction of thought*. The relevant passage runs: “Those seated by the river Euphrates are the Chaldaeans, who are skilled in the stars and in judging them, and they were the first to accomplish the extraction of thought.” These inhabitants of the banks of the Euphrates were probably the Sabaeans or Harranites, to whose learned activities we owe the transmission of a great many scientific treatises of Alexandrian origin. Here, as in Paracelsus, alchemical transformation is connected with the influence of the stars. The same passage says: “They who sit by the banks of the Euphrates convert gross bodies into a simple appearance, with the help of the movement of the higher bodies” (*Theatrum chemicum*, 1622, V, p. 144). Compare the “extraction of thought” with the Paracelsan saying that the Archasius “attracts science and prudence.” See *infra*, par. 39.

⁴⁷ *Paragranum*, p. 26.

⁴⁸ *Ibid.*, p. 27.

⁴⁹ Pp 28, 29.

⁵⁰ Pp. 13, 33.

⁵¹ P. 47.

⁵² *Lab. med.*, ch. VI (Huser, I), p. 273.

⁵³ *Ibid.*

⁵⁴ *Fragmenta medica*, Lib. IV Columnarum Medicinae (Huser, I), p. 142.

⁵⁵ In this respect, too, Paracelsus showed himself to be a conservative alchemist, for even in antiquity the fourfold alchemical procedure was known as *τετραμερεῖν τὴν φιλοσοφίαν*, “the division of the philosophy into four parts” (Berthelot, *Alch. grecs*, III, xlv, 5).

⁵⁶ “Archasius” is probably the same as “Archeus,” the life-warmth, also called Vulcan. It seems to have been localized in the belly, where it took care of digestion and produced “foods,” just as the *archeus terrae* produced metals. This was the alchemist of the earth who regulated the “mineral fire in the mountains” (*De transmutationibus rerum naturalium*, Lib. VII, Huser, I, p. 900). We find this idea also in the “Liber quattorum,” where the Archeus is called “Alkian” or “Alkien.” “Alkian is ... the spirit that nourishes and governs man, through which comes about the conversion of his food and his animal generation, and through it man exists” (*Theatr. chem.*, 1622, V, p. 152). “The Alkien of the earth is the animal Alkien: at the ends of the earth ... are powers ... like those animal powers which the physicians call Alkien” (*ibid.*, p. 191).

⁵⁷ *De vita longa*, Lib. I, ch. IX, ed. Bodenstein, p. 26.

⁵⁸ *Paragranum*, p. 98.

⁵⁹ *Von dem Podagra* (Huser, I), p. 541.

⁶⁰ *Lab. med.*, ch. IX (Huser, I), p. 277.

⁶¹ *Archidoxis magicae*, Lib. I (Huser, II), p. 546.

⁶² *Paragranum*, preface, p. 21.

⁶³ G. Ebers, *Papyros E. Das hermetische Buch über die Arzneimittel der alten Aegypter*.

⁶⁴ God loves the physician above all scholars. Therefore he should be truthful and not a “man of masks” (*Paragranum*, p. 95).

⁶⁵ *Lab. med.*, ch. VIII (Huser, I), p. 276.

⁶⁶ Huser, I, p. 589ff.

¹ [First published simultaneously in the English and German editions of the same journal: translated by Cary F. Baynes, under the present title, in *Character and Personality: An International Quarterly of Psychodiagnostics and Allied Studies* (Durham, North Carolina), I: 1 (Sept. 1932); and as “Sigmund Freud als kulturhistorische Erscheinung” (the original version) in *Charakter: eine Vierteljahresschrift für psychodiagnostische Studien und verwandte Gebiete* (Berlin), I: 1 (Sept. 1932). Jung was a collaborating editor of the journal, along with Alfred Adler, Gordon W. Allport, Manfred Bleuler, Lucien Lévy-Bruhl, and others. The essay was reprinted in *Wirklichkeit der Seele* (Zurich, 1934).—EDITORS.]

¹ [Originally published as “Sigmund Freud: Ein Nachruf,” *Sonntagsblatt der Basler Nachrichten*, XXXIII:40 (Oct. 1, 1939). Freud died in London on Sept. 23.—EDITORS.]

² [Cf. Klages, *Der Geist als Widersacher der Seele*; and Jung, *Civilization in Transition*, pars. 375, 657.—EDITORS.]

¹ [Originally delivered as the principal address at a memorial service held in Munich in May, 1930, for Wilhelm, who had died the previous March 1. Published as “Nachruf für Richard Wilhelm,” *Neue Zürcher Zeitung*, CLI: 1 (March 6, 1930), and in the *Chinesisch-Deutscher Almanach* (Frankfurt a. M.), 1931. Republished in the 2nd edition of Jung and Wilhelm, *Das Geheimnis der goldenen Blüte: Ein chinesisches Lebensbuch* (Zurich, 1938). Previously translated by Cary F. Baynes as an appendix to Jung and Wilhelm, *The Secret of the Golden Flower* (London and New York, 1931; revised and augmented edition, 1962). Grateful acknowledgment is made here to Mrs. Baynes for permission to draw upon the 1962 version of her translation. For Jung’s commentary on *The Secret of the Golden Flower*, see *Coll. Works*, Vol. 13.—EDITORS.]

² [Wilhelm’s translation of the Chinese classic was published in Jena, 1924. Translated into English by Cary F. Baynes as *The I Ching, or Book of Changes* (1950), with a foreword by Jung (see *Coll. Works*, Vol. 11).—EDITORS.]

³ *The Yi King*, trans. by James Legge (*Sacred Books of the East*, Vol. 16; 1882).

⁴ For the details and history of the method, see the *I Ching* (1967 edn.), pp. xlixff. and 356ff.

⁵ [See Hellmut Wilhelm, “The Concept of Time in the Book of Changes,” pp. 216ff.—EDITORS.]

¹ [A lecture delivered to the Society for German Language and Literature, Zurich, May, 1922. First published as “Über die Beziehungen der analytischen Psychologie zum dichterischen Kunstwerk,” *Wissen und Leben* (Zurich), XV: 19-20 (Sept., 1922); reprinted in *Seelenprobleme der Gegenwart* (Zurich, 1931); translated by H. G. Baynes, as “On the Relation of Analytical Psychology to Poetic Art,” *British Journal of Psychology* (Medical Section) (Cambridge), III:3 (1923), reprinted in *Contributions to Analytical Psychology* (London and New York, 1928).—EDITORS.]

² [By this Jung probably meant the analytical techniques that were in use at the time (1922), and more particularly the Freudian. Whether he had by then developed his own technique for constellating the collective unconscious is an open question. Cf. “The Transcendent Function” (orig. 1916), pp. 67ff., and ch. VI of Jung’s *Memories, Dreams, Reflections*.—EDITORS.]

³ [Here Jung defines the *collective unconscious* in much the same way as a year earlier (*Psychological Types*, pars. 624, 747) he had defined the *archetype*. Still earlier, in 1919, using the term “archetype” for the first time, he had stated: “The instincts and the archetypes together form the ‘collective unconscious’” (“Instinct and the Unconscious,” par. 270). This is in better agreement with his later formulations. The subject of the above sentence should therefore be understood as the archetype.—EDITORS.]

⁴ [Lit., “primitive Vorlage.” In the light of Jung’s later formulations, this would mean the “archetype *per se*” as distinct from the “archetypal image.” Cf. particularly “On the Nature of the Psyche,” par. 417.—EDITORS.]

¹ [First published as “Psychologie und Dichtung” in *Philosophie der Literaturwissenschaft* (Berlin, 1930), ed. by Emil Ermatinger; expanded and revised in *Gestaltungen des Unbewussten* (Zurich, 1950). The original version was translated by Eugene Jolas as “Psychology and Poetry,” *transition: An International Quarterly for Creative Experiment*, no. 19/20 (June, 1930); also translated by W. S. Dell and Cary F. Baynes, in *Modern Man in Search of a Soul* (London and New York, 1933).

A typescript of an introduction was found among Jung’s posthumous papers; it is first published here, in translation. Evidently Jung used the introduction when he read the essay as a lecture, though nothing certain is known of such an occasion. Cf. p. 132, par. (1).—EDITORS.]

² [The designation “psychological” is somewhat confusing in this context because, as the subsequent discussion makes clear, the “visionary” mode deals equally with “psychological” material. Moreover, “psychological” is used in still another sense in pars. 136–37, where the “psychological novel” is contrasted with the “non-psychological novel.”

[The term “personalistic” suggests itself as coming closer to defining the material in question, which derives from “the sphere of conscious human experience—from the psychic foreground of life” (par. 140). The term “personalistic” occurs elsewhere in Jung’s writings, e.g., in *The Practice of Psychotherapy*, pars. 212 and 281, n. 34. Both times it characterizes a particular kind of psychology. The second instance is the more significant in that “personalistic” is contrasted with “archetypal,” and this would appear to be precisely the distinction intended between the two kinds of psychological material and the two modes of artistic creation.—EDITORS.]

³ Cf. my essay “Wotan,” pars. 375ff.

⁴ Recently interpreted along the lines of analytical psychology by Linda Fierz-David, in *The Dream of Poliphilo*.

⁵ Some samples of Boehme may be found in my *Psychology and Alchemy*, pars. 214ff., and in “A Study in the Process of Individuation,” pars. 533ff., 578ff.

⁶ Cf. the detailed study by Aniela Jaffé in *Gestaltungen des Unbewussten*.

⁷ One has only to think of James Joyce’s *Ulysses*, which is a work of the greatest significance in spite or perhaps because of its nihilistic tendencies.

⁸ *Confessions* (trans. Sheed), p. 158.

⁹ Isaiah 33:14.

¹⁰ *Die Stammeslehren der Dschagga*, edited by Bruno Gutmann, comprises no less than three volumes and runs to 1975 pages!

¹¹ Letter to Albert Brenner. [In 1855. See Dru trans. of Burckhardt’s letters, p. 116, and Jung, *Symbols of Transformation*, par. 45, n. 45.—EDITORS.]

¹² Written in 1929.

¹³ *The Dream of Poliphilo*, pp. 234ff.

¹⁴ *Ibid.*, p. 27.

¹⁵ I am referring to the first version, written in prose.

¹⁶ Cf. *Psychological Types*, pars. 321ff.

¹⁷ See his essays on Jensen’s *Gradiva* (Standard Edition, IX), and on Leonardo da Vinci (XI).

¹⁸ *Psyche*, ed. Ludwig Klages, p. 158.

¹⁹ Eckermann's dream, in which he saw Faust and Mephistopheles falling to earth in the form of a double meteor, recalls the motif of the Dioscuri (cf. the motif of the two friends in my essay "Concerning Rebirth," pp. 135ff.), and this sheds light on an essential characteristic of Goethe's psyche. An especially subtle point here is Eckermann's remark that the swift and horned figure of Mephisto reminded him of Mercurius. This observation is in full accord with the alchemical nature of Goethe's masterpiece. (I have to thank my colleague W. Kranefeldt for refreshing my memory of Eckermann's *Conversations*.)

²⁰ Cf. C. Kerényi, *Asklepios*, pp. 78f.

¹ [For the genesis of this essay, see appendix, *infra*, p. 132. It was first published in the *Europäische Revue* (Berlin), VIII:2/9 (Sept., 1932); reprinted in *Wirklichkeit der Seele* (Zurich, 1934). Translated by W. Stanley Dell in *Spring* (New York), 1949, and in *Nimbus* (London), II: 1 (June–Aug., 1952), which translation forms the basis of the present version.

[The quotations from *Ulysses* are in accordance with the 10th printing (Paris, 1928), a copy of which Jung owned and cited, though he evidently (*infra*, par. 171) had seen *Ulysses* upon its first publication, 1922.—EDITORS.]

[Author's headnote added to version in *Wirklichkeit der Seele*:] This literary essay first appeared in the *Europäische Revue*. It is not a scientific treatise, any more than is my *aperçu* on Picasso. I have included it in the present volume because *Ulysses* is an important "document humain" very characteristic of our time, and because my opinions may show how ideas that play a considerable role in my work can be applied to literary material. My essay lacks not only any scientific but also any didactic intention, and is of interest to the reader only as a subjective confession.

² As Joyce himself says (*Work in Progress, in transition*): "We may come, touch and go, from atoms and ifs but we are presurely destined to be odd's without ends." [As in *Finnegans Wake* (1939), p. 455. Fragments were published 1924-38, under the title *Work in Progress*, in the monthly magazine *transition* and elsewhere.—EDITORS]

³ Curtius (*James Joyce und sein Ulysses*) calls *Ulysses* a "Luciferian book, a work of Antichrist."

⁴ Curtius (*ibid.*, p. 60): "A metaphysical nihilism is the substance of Joyce's work."

⁵ The magic words that sent me to sleep occur at the bottom of p. 134 and top of p. 135: "that stone effigy in frozen music, horned and terrible, of the human form divine, that eternal symbol of wisdom and prophecy which, if aught that the imagination or the hand of sculptor has wrought in marble of soultransfigured and of soultransfiguring deserves to live, deserves to live." At this point, dizzy with sleep, I turned the page and my eye fell on the following passage: "a man supple in combat: stonehorned, stonebearded, heart of stone." This refers to Moses, who refused to be cowed by the might of Egypt. The two passages contained the narcotic that switched off my consciousness, activating a still unconscious train of thought which consciousness would only have disturbed. As I later discovered, it dawned on me here for the first time what the author was doing and what was the idea behind his work.

⁶ This is greatly intensified in *Work in Progress*. Carola Giedion-Welcker aptly remarks on the "ever-recurring ideas in ever-changing forms, projected into a sphere of absolute irreality. Absolute time, absolute space" (*Neue Schweizer Rundschau*, Sept. 1929, p. 666).

⁷ In Janet's psychology this phenomenon is known as *abaissement du niveau mental*. Among the insane it happens involuntarily, but with Joyce it is the result of deliberate training. All the richness and grotesque profundity of dream-thinking come to the surface when the "fonction du réel," that is, adapted consciousness, is switched off. Hence the predominance of psychic and verbal automatisms and the total neglect of any communicable meaning.

⁸ I think Stuart Gilbert (*James Joyce's "Ulysses,"* 1930, p. 40) is right in supposing that each chapter is presided over, among other things, by one of the visceral or sensory dominants. Those he cites are the kidneys, genitals, heart, lungs, oesophagus, brain, blood, ear, musculature, eye, nose, uterus, nerves, skeleton, skin. These dominants each function as a *leitmotif*. My remark about visceral thinking was written in 1930. For me Gilbert's proof offers valuable confirmation of the psychological fact that an *abaissement du niveau mental* constellates what Wernicke calls the "organ-representatives," i.e., symbols representing the organs.

- ⁹ Curtius, p. 30: “He reproduces the stream of consciousness without filtering it either logically or ethically.”
- ¹⁰ Curtius, p. 8: “The author has done everything to avoid making it easier for the reader to understand.”
- ¹¹ Curtius, Stuart Gilbert, and others.
- ¹² [See the appendix, *infra*.]
- ¹³ Gilbert, p. 2, speaks of a “deliberate deflation of sentiment.”
- ¹⁴ Gilbert, p. 355 n.: “... to take, so to speak, a God’s-eye view of the cosmos.”
- ¹⁵ Gilbert likewise stresses this detachment. He says on p. 21: “The attitude of the author of *Ulysses* towards his personages is one of serene detachment.” (I would put a question-mark after “serene.”) P. 22: “All facts of any kind, mental or material, sublime or ridiculous, have an equivalence of meaning for the artist.” P. 23: “In this detachment, as absolute as the indifference of Nature herself towards her children, we may see one of the causes of the apparent ‘realism’ of *Ulysses*.”
- ¹⁶ As Joyce himself says in *A Portrait of the Artist as a Young Man* (1930 edn., p. 245): “The artist, like the God of Creation, remains within or behind or beyond or above his handiwork, invisible, refined out of existence, indifferent, paring his fingernails.”
- ¹⁷ Wilhelm and Jung, *The Secret of the Golden Flower* (1962 edn.), p. 57. [The picture is reproduced in *Alchemical Studies*, p. 33.—EDITORS,]
- ¹⁸ My italics.
- ¹⁹ [This passage has been difficult to interpret, for the quotation could not be located in *Ulysses*. Jung quoted the novel usually in English but here he uses German: “‘Und flöh’ ich ans äusserste Ende der Welt, so ...’ der Nachsatz ist des Ulysses beweiskräftige Blasphemie.” This may be a reference to the beginning of a speech of Stephen Dedalus in the Circe episode (p. 476): “What went forth to the ends of the world to traverse not itself. God, the sun, Shakespeare, a commercial traveller, having itself traversed in reality itself, becomes that self.... Wait a second. Damn that fellow’s noise in the street....” The “noise in the street” is a gramophone playing a sacred cantata, *The Holy City*. Professor Ellmann has suggested a back-reference here to Stephen’s remark to Deasy in the Nestor episode (ch. 2): “That is God.... A shout in the street.” Jung could also have intended a Biblical allusion; cf. Psalm 139: 7–9 (AV): “... whither shall I flee from thy presence? If I ascend up into heaven, thou art there: if I make my bed in hell, behold, thou art there. If I take the wings of the morning, and dwell in the uttermost parts of the sea ...”—EDITORS.]
- ²⁰ [Horace, *Epistles*, 1.2.33 (trans. Fairclough: “yet on [the river] glides, and on it will glide, rolling its flood forever”).—EDITORS.]

¹ [First published in the *Neue Zürcher Zeitung*, CLIII : 2 (Nov. 13, 1932); reprinted in *Wirklichkeit der Seele* (Zurich, 1934). Previously translated by Alda F. Oertly for the *Papers of the Analytical Psychology Club of New York City* (1940); another translation, by Ivo Jarosy, appeared in *Nimbus* (London), II : 2 (autumn, 1953). Both versions have been consulted in the present translation.

[The Kunsthaus, Zurich, held an exhibition of 460 works by Picasso from Sept. 11 to Oct. 30, 1932.—EDITORS.]

² “‘Ulysses’: A Monologue,” supra.

³ By this I do not mean that anyone who belongs to these two groups suffers from either neurosis or schizophrenia. Such a classification merely means that in the one case a psychic disturbance will probably result in ordinary neurotic symptoms, while in the other it will produce schizoid symptoms. In the case under discussion, the designation “schizophrenic” does not, therefore, signify a diagnosis of the mental illness schizophrenia, but merely refers to a disposition or habitus on the basis of which a serious psychological disturbance could produce schizophrenia. Hence I regard neither Picasso nor Joyce as psychotics, but count them among a large number of people whose habitus it is to react to a profound psychic disturbance not with an ordinary psychoneurosis but with a schizoid syndrome. As the above statement has given rise to some misunderstanding, I have considered it necessary to add this psychiatric explanation. [Jung’s article in the *Zeitung* was followed by replies in the press, provoked especially by the observation on schizophrenia in par. 208. Consequently, Jung added this note in the 1934 version.—EDITORS.]

⁴ I am indebted to Dr. W. Kaegi for this information.

- For details of the *Collected Works of C. C. Jung*, see announcement at end of this volume.

- * Published 1957; 2nd edn., 1970.
- * Published 1960.
- † Published 1961.
- ‡ Published 1956; 2nd edn., 1967. (65 plates, 43 text figures.)
- * Published 1971.
- † Published 1953; 2nd edn., 1966.
- ‡ Published 1960; 2nd edn., 1969.
- * Published 1959; 2nd edn., 1968. (Part I: 79 plates, with 29 in colour.)
- * Published 1964; 2nd edn., 1970. (8 plates.)
- † Published 1958; 2nd edn., 1969.
- * Published 1953; 2nd edn., completely revised, 1968. (270 illustrations.)
- † Published 1968. (50 plates, 4 text figures.)
- ‡ Published 1963; 2nd edn., 1970. (10 plates.)
- * Published 1966.
- † Published 1954; 2nd edn., revised and augmented, 1966. (13 illustrations.)
- ‡ Published 1954.

B O L L I N G E N S E R I E S X X

THE COLLECTED WORKS

OF

C. G. JUNG

VOLUME 16

EDITORS

SIR HERBERT READ

MICHAEL FORDHAM, M.D., M.R.C.P.

GERHARD ADLER, PH.D.

WILLIAM MCGUIRE, *executive editor*

PRACTICE OF PSYCHOTHERAPY

ESSAYS ON THE PSYCHOLOGY OF THE
TRANSFERENCE AND OTHER SUBJECTS

C. G. JUNG

SECOND EDITION

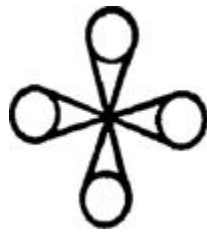

TRANSLATED BY R. F. C. HULL

BOLLINGEN SERIES XX

PRINCETON UNIVERSITY PRESS

COPYRIGHT 1954 BY BOLLINGEN FOUNDATION INC., NEW YORK, N.Y. COPYRIGHT © RENEWED 1982
BY PRINCETON UNIVERSITY PRESS NEW MATERIAL COPYRIGHT © 1966 BY BOLLINGEN
FOUNDATION PUBLISHED BY PRINCETON UNIVERSITY PRESS, PRINCETON, N.J. ALL RIGHTS
RESERVED

SECOND EDITION, REVISED AND AUGMENTED, 1966

Second printing, 1970

Third printing, with corrections, 1975

Fourth printing, 1977

First Princeton / Bollingen Paperback printing, 1985

THIS EDITION IS BEING PUBLISHED IN THE UNITED STATES
OF AMERICA BY PRINCETON UNIVERSITY PRESS AND IN
ENGLAND BY ROUTLEDGE AND KEGAN PAUL, LTD. IN THE
AMERICAN EDITION, ALL THE VOLUMES COMPRISING THE
COLLECTED WORKS CONSTITUTE NUMBER XX IN
BOLLINGEN SERIES. THE PRESENT VOLUME IS NUMBER 16
OF THE COLLECTED WORKS AND WAS THIRD TO APPEAR.

ISBN 0-691-09767-4

ISBN 0-691-01870-7 (PBK.)

LIBRARY OF CONGRESS CATALOG CARD NUMBER: 75-156

MANUFACTURED IN THE U.S.A.

EDITORIAL NOTE TO THE SECOND EDITION

Since this volume was one of the first to appear in the Collected Works, its second edition calls for considerable revision. As with each new edition of these volumes, the reference materials (footnotes and bibliography) have been corrected and brought up to date, taking into account the subsequent publication of nearly all of Jung's works in this English edition. The use of numbers for bibliographical citations having been found to be inconvenient for readers, references by title have been substituted.

The first eleven papers are unchanged, except for new information in some of the editorial footnotes (indicated by an asterisk). The translation of "The Psychology of the Transference" has, however, been extensively reworked. The translations from Latin and Greek have been revised by Mr. A. S. B. Glover, and improved readings have been substituted in the text. Among the other revisions are several taken over from the subsequent Swiss edition of the volume and the changes noted at pars. 405 and 433.

In 1958 the present work, with the title *Praxis der Psychotherapie*, was the first volume to appear in the *Gesammelte Werke von C. G. Jung*, under the editorship of Marianne Niehus-Jung, Lena Hurwitz-Eisner, and Franz Riklin, in Zurich. Acknowledgment is gratefully made to the Swiss Editors for suggestions which were helpful in the preparation of this second English edition. The foreword which Jung specially wrote for *Praxis der Psychotherapie* has been added to the present volume.

A 1937 lecture, "The Realities of Practical Psychotherapy," previously unpublished and recently rediscovered among Jung's posthumous papers, has been added to this second edition as an appendix.

TRANSLATOR'S NOTE

Certain of the essays in this volume were previously translated and published in *Contributions to Analytical Psychology* (London and New York, 1928), *Modern Man in Search of a Soul* (London and New York, 1933), and *Essays on Contemporary Events* (London, 1947). I wish to thank Mrs. Cary F. Baynes and Miss Mary Briner for permission to make full use of those texts in preparing the present revised versions. My particular thanks are due to Miss Barbara Hannah for placing at my disposal her draft translation of the opening chapters of "The Psychology of the Transference."

It may be noted that two papers, "Some Aspects of Modern Psychotherapy" and "The Therapeutic Value of Abreaction," were written in English, and are published here with certain editorial modifications.

FOREWORD TO THE SWISS EDITION (1958)

This volume, number 16 in the series, is the first of the *Gesammelte Werke* to be published. It contains both early and late writings on questions concerned with the practice of psychotherapy. I am indebted to the Editors not only for their careful revision of the texts, but in particular for their choice of material. This testifies to their appreciation of the fact that my contribution to the knowledge of the psyche is founded on practical experience of human beings. It was, indeed, my endeavours as a medical psychologist to understand the ills of the soul that led me, in more than fifty years of psychotherapeutic practice, to all my later insights and conclusions, and in turn compelled me to re-examine my findings and to modify them in the light of new experience.

The reader will find in these essays not only an outline of my attitude as a practising psychotherapist and of the principles on which it rests. They also contain an historical study of a phenomenon that may be regarded as the crux, or at any rate the crucial experience, in any thorough going analysis—the problem of the transference, whose central importance was recognized long ago by Freud. This question is of such scope, and so difficult to elucidate in all its aspects, that a deeper investigation of its historical antecedents could not be avoided.

Naturally, if an historical study like this is seen in isolation from my later writings, the unprepared reader will have some difficulty in recognizing its connection with his conception of what psychotherapy should be. Psychotherapeutic practice and the historical approach will seem to him to be two incommensurable things. In psychological reality, however, this is not the case at all, for we are constantly coming upon phenomena that reveal their historical character as soon as their causality is examined a little more closely. Psychic modes of behaviour are, indeed, of an eminently historical nature. The psychotherapist has to acquaint himself not only with the personal biography of his patient, but also with the mental and spiritual assumptions prevalent in his milieu, both present and past, where traditional and cultural influences play a part and often a decisive one.

For example, no psychotherapist who seriously endeavours to understand the whole man is spared the task of learning the language of dreams and their symbolism. As with every language, historical knowledge is needed in order to understand it properly. This is particularly so since it is not an everyday language, but a symbolic language that makes frequent use of age-old forms of expression. A knowledge of these enables the analyst to extricate his patient from the oppressive constriction of a purely personalistic

understanding of himself, and to release him from the egocentric prison that cuts him off from the wide horizon of his further social, moral, and spiritual development.

In spite or because of its heterogeneous composition, this book may serve to give the reader a good idea of the empirical foundations of psychotherapy and its widely ramifying problems.

C. G. JUNG

August 1957

VOLUME 16
PRACTICE OF PSYCHOTHERAPY

TABLE OF CONTENTS

EDITORIAL NOTE TO THE SECOND EDITION

TRANSLATOR'S NOTE

FOREWORD TO THE SWISS EDITION (1958)

LIST OF ILLUSTRATIONS

PART ONE

GENERAL PROBLEMS OF PSYCHOTHERAPY

I. Principles of Practical Psychotherapy

Translated from "Grundsätzliches zur praktischen Psychotherapie," *Zentralblatt für Psychotherapie* (Zurich), VIII (1935).

II. What Is Psychotherapy?

Translated from "Was ist Psychotherapie?," *Schweizerische Aerztezeitung für Standesfragen* (Zurich), XVI (1935).

III. Some Aspects of Modern Psychotherapy

Originally published in English, *Journal of State Medicine* (London), XXXVIII (1930).

IV. The Aims of Psychotherapy

Translated from "Ziele der Psychotherapie," *Seelenprobleme der Gegenwart* (Zurich: Rascher, 1931).

V. Problems of Modern Psychotherapy

Translated from "Die Probleme der modernen Psychotherapie," *Seelenprobleme der Gegenwart* (Zurich: Rascher, 1931).

VI. Psychotherapy and a Philosophy of Life

Translated from "Psychotherapie und Weltanschauung," *Aufsätze zur Zeitgeschichte* (Zurich: Rascher, 1946).

VII. Medicine and Psychotherapy

Translated from “Medizin und Psychotherapie,” *Bulletin der Schweizerischen Akademie der medizinischen Wissenschaften* (Basel), I (1945).

VIII. Psychotherapy Today Psychotherapy Today Psychotherapy Today

Translated from “Die Psychotherapie in der Gegenwart,” *Aufsätze zur Zeitgeschichte* (Zurich: Rascher, 1946).

IX. Fundamental Questions of Psychotherapy Fundamental Questions of Psychotherapy

Translated from “Grundfragen der Psychotherapie,” *Dialectica* (Neuchâtel), V (1951).

PART TWO

SPECIFIC PROBLEMS OF PSYCHOTHERAPY

I. The Therapeutic Value of Abreaction

Originally published in English; this is a revised version, from *Contributions to Analytical Psychology* (London: Kegan Paul, Trench, Trübner; New York: Harcourt, Brace, 1928).

II. The Practical Use of Dream-Analysis

Translated from “Die praktische Verwendbarkeit der Traumanalyse,” *Wirklichkeit der Seele* (Zurich: Rascher, 1934).

III. The Psychology of the Transference

Translated from *Die Psychologie der Übertragung* (Zurich: Rascher, 1946).

FOREWORD

INTRODUCTION

AN ACCOUNT OF THE TRANSFERENCE PHENOMENA BASED ON THE ILLUSTRATIONS TO THE “ROSARIUM PHILOSOPHORUM”

1. *The Mercurial Fountain*
2. *King and Queen*
3. *The Naked Truth*
4. *Immersion in the Bath*
5. *The Conjunction*

6. *Death*
7. *The Ascent of the Soul*
8. *Purification*
9. *The Return of the Soul*
10. *The New Birth*

EPILOGUE

APPENDIX: The Realities of Practical Psychotherapy The Realities of Practical Psychotherapy The Realities of Practical Psychotherapy

Translated from “Die Wirklichkeit der psychotherapeutischen Praxis,” an unpublished lecture (1937).

BIBLIOGRAPHY

INDEX

LIST OF ILLUSTRATIONS

Figures 1–10 are full pages, with woodcuts, reproduced from the *Rosarium philosophorum, secunda pars alchimiae de lapide philosophico* (Frankfurt, 1550). Figures 11–13 are full pages reproduced from the textless picture book *Mutus liber, in quo tamen tota philosophia hermetica... depingitur* (see Bibliography). They are described on [page 322](#), note 1.

1. The Mercurial Fountain
2. King and Queen
3. The Naked Truth
4. Immersion in the Bath
5. The Conjunction
- 5a. The Conjunction
6. Death
7. The Ascent of the Soul
8. Purification
9. The Return of the Soul
10. The New Birth
- 11–13.

I

GENERAL PROBLEMS OF PSYCHOTHERAPY

PRINCIPLES OF PRACTICAL PSYCHOTHERAPY¹

[1] Psychotherapy is a domain of the healing art which has developed and acquired a certain independence only within the last fifty years. Views in this field have changed and become differentiated in a great variety of ways, and the mass of experience accumulated has given rise to all sorts of different interpretations. The reason for this lies in the fact that psychotherapy is not the simple, straightforward method people at first believed it to be, but, as has gradually become clear, a kind of dialectical process, a dialogue or discussion between two persons. Dialectic was originally the art of conversation among the ancient philosophers, but very early became the term for the process of creating new syntheses. A person is a psychic system which, when it affects another person, enters into reciprocal reaction with another psychic system. This, perhaps the most modern, formulation of the psychotherapeutic relation between physician and patient is clearly very far removed from the original view that psychotherapy was a method which anybody could apply in stereotyped fashion in order to reach the desired result. It was not the needs of speculation which prompted this unsuspected and, I might well say, unwelcome widening of the horizon, but the hard facts of reality. In the first place, it was probably the fact that one had to admit the possibility of different interpretations of the observed material. Hence there grew up various schools with diametrically opposed views. I would remind you of the Liébeault-Bernheim French method of suggestion therapy, *rééducation de la volonté*; Babinski's "persuasion"; Dubois' "rational psychic orthopedics"; Freud's psychoanalysis, with its emphasis on sexuality and the unconscious; Adler's educational method, with its emphasis on power-drives and conscious fictions; Schultz's autogenic training—to name only the better known methods. Each of them rests on special psychological assumptions and produces special psychological results; comparison between them is difficult and often wellnigh impossible. Consequently it was quite natural that the champions of any one point of view should, in order to simplify matters, treat the opinions of the others as erroneous. Objective appraisal of the facts shows, however, that each of these methods and theories is justified up to a point, since each can boast not only of certain successes but of psychological data that largely prove its particular assumption. Thus we are faced in psychotherapy with a situation comparable with that in modern physics where, for instance, there are two contradictory theories of light. And just as physics

does not find this contradiction unbridgeable, so the existence of many possible standpoints in psychology should not give grounds for assuming that the contradictions are irreconcilable and the various views merely subjective and therefore incommensurable. Contradictions in a department of science merely indicate that its subject displays characteristics which at present can be grasped only by means of antinomies—witness the wave theory and the corpuscular theory of light. Now the psyche is infinitely more complicated than light; hence a great number of antinomies is required to describe the nature of the psyche satisfactorily. One of the fundamental antinomies is the statement that *psyche depends on body and body depends on psyche*. There are clear proofs for both sides of this antinomy, so that an objective judgment cannot give more weight to thesis or to antithesis. The existence of valid contradictions shows that the object of investigation presents the inquiring mind with exceptional difficulties, as a result of which only relatively valid statements can be made, at least for the time being. That is to say, the statement is valid only in so far as it indicates what kind of psychic system we are investigating. Hence we arrive at the dialectical formulation which tells us precisely that psychic influence is the reciprocal reaction of two psychic systems. Since the individuality of the psychic system is infinitely variable, there must be an infinite variety of relatively valid statements. But if individuality were absolute in its particularity, if one individual were totally different from every other individual, then psychology would be impossible as a science, for it would consist in an insoluble chaos of subjective opinions. Individuality, however, is only relative, the complement of human conformity or likeness; and therefore it is possible to make statements of general validity, i.e., scientific statements. These statements relate only to those parts of the psychic system which do in fact conform, i.e., are amenable to comparison and statistically measurable; they do not relate to that part of the system which is individual and unique. The second fundamental antinomy in psychology therefore runs: *the individual signifies nothing in comparison with the universal, and the universal signifies nothing in comparison with the individual*. There are, as we all know, no universal elephants, only individual elephants. But if a generality, a constant plurality, of elephants did not exist, a single individual elephant would be exceedingly improbable.

[2] These logical reflections may appear somewhat remote from our theme. But in so far as they are the outcome of previous psychological experience, they yield practical conclusions of no little importance. When, as a psychotherapist, I set myself up as a medical authority over my patient and on that account claim to know something about his individuality, or to be able to make valid statements about it, I am only demonstrating my lack of criticism, for I am in no position to judge the whole of the personality before me. I cannot say anything valid about him except in so far as he

approximates to the “universal man.” But since all life is to be found only in individual form, and I myself can assert of another individuality only what I find in my own, I am in constant danger either of doing violence to the other person or of succumbing to his influence. If I wish to treat another individual psychologically at all, I must for better or worse give up all pretensions to superior knowledge, all authority and desire to influence. I must perforce adopt a dialectical procedure consisting in a comparison of our mutual findings. But this becomes possible only if I give the other person a chance to play his hand to the full, unhampered by my assumptions. In this way his system is geared to mine and acts upon it; my reaction is the only thing with which I as an individual can legitimately confront my patient.

[3] These considerations of principle produce in the psychotherapist a very definite attitude which, in all cases of *individual* treatment, seems to me to be absolutely necessary because it alone is scientifically responsible. Any deviation from this attitude amounts to therapy by suggestion, the kind of therapy whose main principle is: “The individual signifies nothing in comparison with the universal.” Suggestion therapy includes all methods that arrogate to themselves, and apply, a knowledge or an interpretation of other individualities. Equally it includes all strictly technical methods, because these invariably assume that all individuals are alike. To the extent that the insignificance of the individual is a truth, suggestive methods, technical procedures, and theorems in any shape or form are entirely capable of success and guarantee results with the universal man—as for instance, Christian Science, mental healing, faith cures, remedial training, medical and religious techniques, and countless other isms. Even political movements can, not without justice, claim to be psychotherapy in the grand manner. The outbreak of war cured many a compulsion neurosis, and from time immemorial certain miraculous localities have caused neurotic states to disappear; similarly, popular movements both large and small can exert a curative influence on the individual.

[4] This fact finds the simplest and most nearly perfect expression in the primitive idea of “mana.” Mana is a universal medicinal or healing power which renders men, animals, and plants fruitful and endows chieftain and medicine-man with magical strength. Mana, as Lehmann has shown, is identified with anything “extraordinarily potent,” or simply with anything impressive. On the primitive level anything impressive is therefore “medicine.” Since it is notorious that a hundred intelligent heads massed together make one big fathead, virtues and endowments are essentially the hallmarks of the individual and not of the universal man. The masses always incline to herd psychology, hence they are easily stampeded; and to mob psychology, hence their witless brutality and hysterical emotionalism. The universal man has the characteristics of a savage and must therefore be treated with technical methods. It is in fact bad practice to treat collective man with anything other than “technically

correct” methods, i.e., those collectively recognized and believed to be effective. In this sense the old hypnotism or the still older animal magnetism achieved, in principle, just as much as a technically irreproachable modern analysis, or for that matter the amulets of the primitive medicine-man. It all depends on the method the therapist happens to believe in. His belief is what does the trick. If he really believes, then he will do his utmost for the sufferer with seriousness and perseverance, and this freely given effort and devotion will have a curative effect—up to the level of collective man’s mentality. But the limits are fixed by the “individual-universal” antinomy.

[5] This antinomy constitutes a psychological as well as a philosophical criterion, since there are countless people who are not only collective in all essentials but are fired by a quite peculiar ambition to be nothing but collective. This accords with all the current trends in education which like to regard individuality and lawlessness as synonymous. On this plane anything individual is rated inferior and is repressed. In the corresponding neuroses individual contents and tendencies appear as psychological poisons. There is also, as we know, an overestimation of individuality based on the rule that “the universal signifies nothing in comparison with the individual.” Thus, from the psychological (not the clinical) point of view, we can divide the psychoneuroses into two main groups: the one comprising collective people with underdeveloped individuality, the other individualists with atrophied collective adaptation. The therapeutic attitude differs accordingly, for it is abundantly clear that a neurotic individualist can only be cured by recognizing the collective man in himself—hence the need for collective adaptation. It is therefore right to bring him down to the level of collective truth. On the other hand, psychotherapists are familiar with the collectively adapted person who has everything and does everything that could reasonably be required as a guarantee of health, but yet is ill. It would be a bad mistake, which is nevertheless very often committed, to normalize such a person and try to bring him down to the collective level. In certain cases all possibility of individual development is thereby destroyed.

[6] Since individuality, as we stressed in our introductory argument, is absolutely unique, unpredictable, and uninterpretable, in these cases the therapist must abandon all his preconceptions and techniques and confine himself to a purely dialectical procedure, adopting the attitude that shuns all methods.

[7] You will have noticed that I began by presenting the dialectical procedure as the latest phase of psychotherapeutic development. I must now correct myself and put this procedure in the right perspective: it is not so much an elaboration of previous theories and practices as a complete abandonment of them in favour of the most

unbiased attitude possible. In other words, the therapist is no longer the agent of treatment but a fellow participant in a process of individual development.

[8] I would not like it to be supposed that these discoveries dropped straight into our laps. They too have their history. Although I was the first to demand that the analyst should himself be analysed, we are largely indebted to Freud for the invaluable discovery that analysts too have their complexes and consequently one or two blind spots which act as so many prejudices. The psychotherapist gained this insight in cases where it was no longer possible for him to interpret or to guide the patient from on high or *ex cathedra*, regardless of his own personality, but was forced to admit that his personal idiosyncrasies or special attitude hindered the patient's recovery. When one possesses no very clear idea about something, because one is unwilling to admit it to oneself, one tries to hide it from the patient as well, obviously to his very great disadvantage. The demand that the analyst must be analysed culminates in the idea of a dialectical procedure, where the therapist enters into relationship with another psychic system both as questioner and answerer. No longer is he the superior wise man, judge, and counsellor; he is a fellow participant who finds himself involved in the dialectical process just as deeply as the so-called patient.

[9] The dialectical procedure has another source, too, and that is the *multiple significance of symbolic contents*. Silberer distinguishes between the psychoanalytic and the anagogic interpretation, while I distinguish between the analytical-reductive and the synthetic-hermeneutic interpretation. I will explain what I mean by instancing the so-called infantile fixation on the parental imago, one of the richest sources of symbolic contents. The analytical-reductive view asserts that interest ("libido") streams back regressively to infantile reminiscences and there "fixates"—if indeed it has ever freed itself from them. The synthetic or anagogic view, on the contrary, asserts that certain parts of the personality which are capable of development are in an infantile state, as though still in the womb. Both interpretations can be shown to be correct. We might almost say that they amount virtually to the same thing. But it makes an enormous difference in practice whether we interpret something regressively or progressively. It is no easy matter to decide aright in a given case. Generally we feel rather uncertain on this point. The discovery that there are essential contents of an indubitably equivocal nature has thrown suspicion on the airy application of theories and techniques, and thus helped to range the dialectical procedure alongside the subtler or cruder suggestion methods.

[10] The depth-dimension which Freud has added to the problems of psychotherapy must logically lead sooner or later to the conclusion that any final understanding between doctor and patient is bound to include the personality of the doctor. The old hypnotists and Bernheim with his suggestion therapy were well enough aware that

the healing effect depended firstly on the “rapport”—in Freud’s terminology, “transference”—and secondly on the persuasive and penetrative powers of the doctor’s personality. In the doctor-patient relationship, as we have said, two psychic systems interact, and therefore any deeper insight into the psychotherapeutic process will infallibly reach the conclusion that in the last analysis, since individuality is a fact not to be ignored, the relationship must be dialectical.

[11] It is now perfectly clear that this realization involves a very considerable shift of standpoint compared with the older forms of psychotherapy. In order to avoid misunderstandings, let me say at once that this shift is certainly not meant to condemn the existing methods as incorrect, superfluous, or obsolete. The more deeply we penetrate the nature of the psyche, the more the conviction grows upon us that the diversity, the multidimensionality of human nature requires the greatest variety of standpoints and methods in order to satisfy the variety of psychic dispositions. It is therefore pointless to subject a simple soul who lacks nothing but a dose of common sense to a complicated analysis of his impulses, much less expose him to the bewildering subtleties of psychological dialectic. It is equally obvious that with complex and highly intelligent people we shall get nowhere by employing well-intentioned advice, suggestions, and other efforts to convert them to some kind of system. In such cases the best thing the doctor can do is lay aside his whole apparatus of methods and theories and trust to luck that his personality will be steadfast enough to act as a signpost for the patient. At the same time he must give serious consideration to the possibility that in intelligence, sensibility, range and depth the patient’s personality is superior to his own. But in all circumstances the prime rule of dialectical procedure is that the individuality of the sufferer has the same value, the same right to exist, as that of the doctor, and consequently that every development in the patient is to be regarded as valid, unless of course it corrects itself of its own accord. Inasmuch as a man is merely collective, he can be changed by suggestion to the point of becoming—or seeming to become—different from what he was before. But inasmuch as he is an individual he can only become what he is and always was. To the extent that “cure” means turning a sick man into a healthy one, cure is change. Wherever this is possible, where it does not demand too great a sacrifice of personality, we should change the sick man therapeutically. But when a patient realizes that cure through change would mean too great a sacrifice, then the doctor can, indeed he should, give up any wish to change or cure. He must either refuse to treat the patient or risk the dialectical procedure. This is of more frequent occurrence than one might think. In my own practice I always have a fair number of highly cultivated and intelligent people of marked individuality who, on ethical grounds, would vehemently resist any serious attempt to change them. In all such cases the doctor must leave the individual way to healing open, and then the cure will bring

about no alteration of personality but will be the process we call “individuation,” in which the patient becomes what he really is. If the worst comes to the worst, he will even put up with his neurosis, once he has understood the meaning of his illness. More than one patient has admitted to me that he has learned to accept his neurotic symptoms with gratitude, because, like a barometer, they invariably told him when and where he was straying from his individual path, and also whether he had let important things remain unconscious.

[12] Although the new, highly differentiated methods allow us an unsuspected glimpse into the endless complications of psychic relationships and have gone a long way to putting them on a theoretical basis, they nevertheless confine themselves to the analytical-reductive standpoint, so that the possibilities of individual development are obscured by being reduced to some general principle, such as sexuality. This is the prime reason why the phenomenology of individuation is at present almost virgin territory. Hence in what follows I must enter into some detail, for I can only give you an idea of individuation by trying to indicate the workings of the unconscious as revealed in the observed material itself. For, in the process of individual development, it is above all the unconscious that is thrust into the forefront of our interest. The deeper reason for this may lie in the fact that the conscious attitude of the neurotic is unnaturally one-sided and must be balanced by complementary or compensatory contents deriving from the unconscious. The unconscious has a special significance in this case as a corrective to the onesidedness of the conscious mind; hence the need to observe the points of view and impulses produced in dreams, because these must take the place once occupied by collective controls, such as the conventional outlook, habit, prejudices of an intellectual or moral nature. The road the individual follows is defined by his knowledge of the laws that are peculiar to himself; otherwise he will get lost in the arbitrary opinions of the conscious mind and break away from the mother-earth of individual instinct.

[13] So far as our present knowledge extends, it would seem that the vital urge which expresses itself in the structure and individual form of the living organism produces in the unconscious a process, or is itself such a process, which on becoming partially conscious depicts itself as a fugue-like sequence of images. Persons with natural introspective ability are capable of perceiving fragments of this autonomous or self-activating sequence without too much difficulty, generally in the form of visual fantasies, although they often fall into the error of thinking that they have *created* these fantasies, whereas in reality the fantasies have merely occurred to them. Their spontaneous nature can no longer be denied, however, when, as often happens, some fantasy-fragment becomes an obsession, like a tune you cannot get out of your head, or a phobia, or a “symbolic tic.” Closer to the unconscious sequence of images are the dreams which, if examined over a long series, reveal the continuity of the

unconscious pictorial flood with surprising clearness. The continuity is shown in the repetition of motifs. These may deal with people, animals, objects, or situations. Thus the continuity of the picture sequence finds expression in the recurrence of some such motif over a long series of dreams.

[14] In a dream series extending over a period of two months, one of my patients had the water-motif in twenty-six dreams. In the first dream it appeared as the surf pounding the beach, then in the second as a view of the glassy sea. In the third dream the dreamer was on the seashore watching the rain fall on the water. In the fourth there was an indirect allusion to a voyage, for he was journeying to a distant country. In the fifth he was travelling to America; in the sixth, water was poured into a basin; in the seventh he was gazing over a vast expanse of sea at dawn; in the eighth he was aboard ship. In the ninth he travelled to a far-off savage land. In the tenth he was again aboard ship. In the eleventh he went down a river. In the twelfth he walked beside a brook. In the thirteenth he was on a steamer. In the fourteenth he heard a voice calling, "This is the way to the sea, we must get to the sea!" In the fifteenth he was on a ship going to America. In the sixteenth, again on a ship. In the seventeenth he drove to the ship in an automobile. In the eighteenth he made astronomical calculations on a ship. In the nineteenth he went down the Rhine. In the twentieth he was on an island, and again in the twenty-first. In the twenty-second he navigated a river with his mother. In the twenty-third he stood on the seashore. In the twenty-fourth he looked for sunken treasure. In the twenty-fifth his father was telling him about the land where the water comes from. And finally in the twenty-sixth he went down a small river that debouched into a larger one.

[15] This example illustrates the continuity of the unconscious theme and also shows how the motifs can be evaluated statistically. Through numerous comparisons one can find out to what the water-motif is really pointing, and the interpretation of motifs follows from a number of similar dream-series. Thus the sea always signifies a collecting-place where all psychic life originates, i.e., the collective unconscious. Water in motion means something like the stream of life or the energy-potential. The ideas underlying all the motifs are visual representations of an archetypal character, symbolic primordial images which have served to build up and differentiate the human mind. These primordial images are difficult to define; one might even call them hazy. Cramping intellectual formulae rob them of their natural amplitude. They are not scientific concepts which must necessarily be clear and unequivocal; they are universal perceptions of the primitive mind, and they never denote any particular content but are significant for their wealth of associations. Lévy-Bruhl calls them "collective representations," and Hubert and Mauss call them *a priori* categories of the imagination.

[16] In a longer series of dreams the motifs frequently change places. Thus, after the last of the above dreams, the water-motif gradually retreated to make way for a new motif, the “unknown woman.” In general, dreams about women refer to women whom the dreamer knows. But now and then there are dreams in which a female figure appears who cannot be shown to be an acquaintance and whom the dream itself distinctly characterizes as unknown. This motif has an interesting phenomenology which I should like to illustrate from a dream series extending over a period of three months. In this series the motif occurred no less than fifty-one times. At the outset it appeared as a throng of vague female forms, then it assumed the vague form of a woman sitting on a step. She then appeared veiled, and when she took off the veil her face shone like the sun. Then she was a naked figure standing on a globe, seen from behind. After that she dissolved once more into a throng of dancing nymphs, then into a bevy of syphilitic prostitutes. A little later the unknown appeared on a ball, and the dreamer gave her some money. Then she was a syphilitic again. From now on the unknown becomes associated with the so-called “dual motif,” a frequent occurrence in dreams. In this series a savage woman, a Malay perhaps, is doubled. She has to be taken captive, but she is also the naked blonde who stood on the globe, or else a young girl with a red cap, a nursemaid, or an old woman. She is very dangerous, a member of a robberband and not quite human, something like an abstract idea. She is a guide, who takes the dreamer up a high mountain. But she is also like a bird, perhaps a marabou or pelican. She is a mancatcher. Generally she is fair-haired, a hairdresser’s daughter, but has a dark Indian sister. As a fair-haired guide she informs the dreamer that part of his sister’s soul belongs to her. She writes him a love-letter, but is another man’s wife. She neither speaks nor is spoken to. Now she has black hair, now white. She has peculiar fantasies, unknown to the dreamer. She may be his father’s unknown wife, but is not his mother. She travels with him in an airplane, which crashes. She is a voice that changes into a woman. She tells him that she is a piece of broken pottery, meaning presumably that she is a part-soul. She has a brother who is prisoner in Moscow. As the dark figure she is a servant-girl, stupid, and she has to be watched. Often she appears doubled, as two women who go mountain-climbing with him. On one occasion the fair-haired guide comes to him in a vision. She brings him bread, is full of religious ideas, knows the way he should go, meets him in church, acts as his spiritual guide. She seems to pop out of a dark chest and can change herself from a dog into a woman. Once she appears as an ape. The dreamer draws her portrait in a dream, but what comes out on the paper is an abstract symbolic ideogram containing the trinity, another frequent motif.

[17] The unknown woman, therefore, has an exceedingly contradictory character and cannot be related to any normal woman. She represents some fabulous being, a kind

of fairy; and indeed fairies have the most varied characters. There are wicked fairies and good fairies; they too can change themselves into animals, they can become invisible, they are of uncertain age, now young, now old, elfin in nature, with part-souls, alluring, dangerous, and possessed of superior knowledge. We shall hardly be wrong in assuming that this motif is identical with the parallel ideas to be found in mythology, where we come across this elfin creature in a variety of forms—nymph, oread, sylph, undine, nixie, hamadryad, succubus, lamia, vampire, witch, and what not. Indeed the whole world of myth and fable is an outgrowth of unconscious fantasy just like the dream. Frequently this motif replaces the water-motif. Just as water denotes the unconscious in general, so the figure of the unknown woman is a personification of the unconscious, which I have called the “anima.” This figure only occurs in men, and she emerges clearly only when the unconscious starts to reveal its problematical nature. In man the unconscious has feminine features, in woman masculine; hence in man the personification of the unconscious is a feminine creature of the type we have just described.

[18] I cannot, within the compass of a lecture, describe all the motifs that crop up in the process of individuation—when, that is to say, the material is no longer reduced to generalities applicable only to the collective man. There are numerous motifs, and we meet them everywhere in mythology. Hence we can only say that the psychic development of the individual produces something that looks very like the archaic world of fable, and that the individual path looks like a regression to man’s prehistory, and that consequently it seems as if something very untoward were happening which the therapist ought to arrest. We can in fact observe similar things in psychotic illnesses, especially in the paranoid forms of schizophrenia, which often swarm with mythological images. The fear instantly arises that we are dealing with some misdevelopment leading to a world of chaotic or morbid fantasy. A development of this kind may be dangerous with a person whose social personality has not found its feet; moreover any psychotherapeutic intervention may occasionally run into a latent psychosis and bring it to full flower. For this reason to dabble in psychotherapy is to play with fire, against which amateurs should be stringently cautioned. It is particularly dangerous when the mythological layer of the psyche is uncovered, for these contents have a fearful fascination for the patient—which explains the tremendous influence mythological ideas have had on mankind.

[19] Now, it would seem that the recuperative process mobilizes these powers for its own ends. Mythological ideas with their extraordinary symbolism evidently reach far into the human psyche and touch the historical foundations where reason, will, and good intentions never penetrate; for these ideas are born of the same depths and speak a language which strikes an answering chord in the inner man, although our reason may not understand it. Hence, the process that at first sight looks like an

alarming regression is rather a *reculer pour mieux sauter*, an amassing and integration of powers that will develop into a new order.

[20] A neurosis at this level is an entirely spiritual form of suffering which cannot be tackled with ordinary rational methods. For this reason there are not a few psychotherapists who, when all else fails, have recourse to one of the established religions or creeds. I am far from wishing to ridicule these efforts. On the contrary, I must emphasize that they are based on an extremely sound instinct, for our religions contain the still living remains of a mythological age. Even a political creed may occasionally revert to mythology, as is proved very clearly by the swastika, the German Christians, and the German Faith Movement. Not only Christianity with its symbols of salvation, but all religions, including the primitive with their magical rituals, are forms of psychotherapy which treat and heal the suffering of the soul, and the suffering of the body caused by the soul. How much in modern medicine is still suggestion therapy is not for me to say. To put it mildly, consideration of the psychological factor in practical therapeutics is by no means a bad thing. The history of medicine is exceedingly revealing in this respect.

[21] Therefore, when certain doctors resort to the mythological ideas of some religion or other, they are doing something historically justified. But they can only do this with patients for whom the mythological remains are still alive. For these patients some kind of rational therapy is indicated until such time as mythological ideas become a necessity. In treating devout Catholics, I always refer them to the Church's confessional and its means of grace. It is more difficult in the case of Protestants, who must do without confession and absolution. The more modern type of Protestantism has, however, the safetyvalve of the Oxford Group movement, which prescribes lay confession as a substitute, and group experience instead of absolution. A number of my patients have joined this movement with my entire approval, just as others have become Catholics, or at least better Catholics than they were before. In all these cases I refrain from applying the dialectical procedure, since there is no point in promoting individual development beyond the needs of the patient. If he can find the meaning of his life and the cure for his disquiet and disunity within the framework of an existing credo—including a political credo—that should be enough for the doctor. After all, the doctor's main concern is the sick, not the cured.

[22] There are, however, very many patients who have either no religious convictions at all or highly unorthodox ones. Such persons are, on principle, not open to any conviction. All rational therapy leaves them stuck where they were, although on the face of it their illness is quite curable. In these circumstances nothing is left but the dialectical development of the mythological material which is alive in the sick man himself, regardless of history and tradition. It is here that we come across those

mythological dreams whose characteristic sequence of images presents the doctor with an entirely new and unexpected task. He then needs the sort of knowledge for which his professional studies have not equipped him in the least. For the human psyche is neither a psychiatric nor a physiological problem; it is not a biological problem at all but—precisely—a psychological one. It is a field on its own with its own peculiar laws. Its nature cannot be deduced from the principles of other sciences without doing violence to the idiosyncrasy of the psyche. It cannot be identified with the brain, or the hormones, or any known instinct; for better or worse it must be accepted as a phenomenon unique in kind. The phenomenology of the psyche contains more than the measurable facts of the natural sciences: it embraces the problem of mind, the father of all science. The psychotherapist becomes acutely aware of this when he is driven to penetrate below the level of accepted opinion. It is often objected that people have practised psychotherapy before now and did not find it necessary to go into all these complications. I readily admit that Hippocrates, Galen, and Paracelsus were excellent doctors, but I do not believe that modern medicine should on that account give up serum therapy and radiology. It is no doubt difficult, particularly for the layman, to understand the complicated problems of psychotherapy; but if he will just consider for a moment why certain situations in life or certain experiences are pathogenic, he will discover that human opinion often plays a decisive part. Certain things accordingly seem dangerous, or impossible, or harmful, simply because there are opinions that cause them to appear in that light. For instance, many people regard wealth as the supreme happiness and poverty as man's greatest curse, although in actual fact riches never brought supreme happiness to anybody, nor is poverty a reason for melancholia. But we have these opinions, and these opinions are rooted in certain mental preconceptions—in the *Zeitgeist*, or in certain religious or antireligious views. These last play an important part in moral conflicts. As soon as the analysis of a patient's psychic situation impinges on the area of his mental preconceptions, we have already entered the realm of general ideas. The fact that dozens of normal people never criticize their mental preconceptions—obviously not, since they are unconscious of them—does not prove that these preconceptions are valid for all men, or indeed unconscious for all men, any more than it proves that they may not become the source of the severest moral conflict. Quite the contrary: in our age of revolutionary change, inherited prejudices of a general nature on the one hand and spiritual and moral disorientation on the other are very often the deeperlying causes of far-reaching disturbances in psychic equilibrium. To these patients the doctor has absolutely nothing to offer but the possibility of individual development. And for their sake the specialist is compelled to extend his knowledge over the field of the humane sciences, if he is to do justice to the symbolism of psychic contents.

[23] I would make myself guilty of a sin of omission if I were to foster the impression that specialized therapy needed nothing but a wide knowledge. Quite as important is the moral differentiation of the doctor's personality. Surgery and obstetrics have long been aware that it is not enough simply to wash the patient—the doctor himself must have clean hands. A neurotic psychotherapist will invariably treat his own neurosis in the patient. A therapy independent of the doctor's personality is just conceivable in the sphere of rational techniques, but it is quite inconceivable in a dialectical procedure where the doctor must emerge from his anonymity and give an account of himself, just as he expects his patient to do. I do not know which is the more difficult: to accumulate a wide knowledge or to renounce one's professional authority and anonymity. At all events the latter necessity involves a moral strain that makes the profession of psychotherapist not exactly an enviable one. Among laymen one frequently meets with the prejudice that psychotherapy is the easiest thing in the world and consists in the art of putting something over on people or wheedling money out of them. But actually it is a tricky and not undangerous calling. Just as all doctors are exposed to infections and other occupational hazards, so the psychotherapist runs the risk of psychic infections which are no less menacing. On the one hand he is often in danger of getting entangled in the neuroses of his patients; on the other hand if he tries too hard to guard against their influence, he robs himself of his therapeutic efficacy. Between this Scylla and this Charybdis lies the peril, but also the healing power.

[24] Modern psychotherapy is built up of many layers, corresponding to the diversities of the patients requiring treatment. The simplest cases are those who just want sound common sense and good advice. With luck they can be disposed of in a single consultation. This is certainly not to say that cases which look simple are always as simple as they look; one is apt to make disagreeable discoveries. Then there are patients for whom a thorough confession or "abreaction" is enough. The severer neuroses usually require a reductive analysis of their symptoms and states. And here one should not apply this or that method indiscriminately but, according to the nature of the case, should conduct the analysis more along the lines of Freud or more along those of Adler. St. Augustine distinguishes two cardinal sins: concupiscence and conceit (*superbia*). The first corresponds to Freud's pleasure principle, the second to Adler's power-drive, the desire to be on top. There are in fact two categories of people with different needs. Those whose main characteristic is infantile pleasure-seeking generally have the satisfaction of incompatible desires and instincts more at heart than the social role they could play, hence they are often well-to-do or even successful people who have arrived socially. But those who want to be "on top" are mostly people who are either the under-dogs in reality or fancy that they are not playing the role that is properly due to them. Hence they often have difficulty in

adapting themselves socially and try to cover up their inferiority with power fictions. One can of course explain all neuroses in Freudian or Adlerian terms, but in practice it is better to examine the case carefully beforehand. In the case of educated people the decision is not difficult: I advise them to read a bit of Freud and a bit of Adler. As a rule they soon find out which of the two suits them best. So long as one is moving in the sphere of genuine neurosis one cannot dispense with the views of either Freud or Adler.

[25] But when the thing becomes monotonous and you begin to get repetitions, and your unbiased judgment tells you that a standstill has been reached, or when mythological or archetypal contents appear, then is the time to give up the analytical-reductive method and to treat the symbols anagogically or synthetically, which is equivalent to the dialectical procedure and the way of individuation.

[26] All methods of influence, including the analytical, require that the patient be seen as often as possible. I content myself with a maximum of four consultations a week. With the beginning of synthetic treatment it is of advantage to spread out the consultations. I then generally reduce them to one or two hours a week, for the patient must learn to go his own way. This consists in his trying to understand his dreams himself, so that the contents of the unconscious may be progressively articulated with the conscious mind; for the cause of neurosis is the discrepancy between the conscious attitude and the trend of the unconscious. This dissociation is bridged by the assimilation of unconscious contents. Hence the interval between consultations does not go unused. In this way one saves oneself and the patient a good deal of time, which is so much money to him; and at the same time he learns to stand on his own feet instead of clinging to the doctor.

[27] The work done by the patient through the progressive assimilation of unconscious contents leads ultimately to the integration of his personality and hence to the removal of the neurotic dissociation. To describe the details of this development would far exceed the limits of a lecture. I must therefore rest content with having given you at least a general survey of the principles of practical psychotherapy.

II

WHAT IS PSYCHOTHERAPY?¹

[28] It is not so very long ago that fresh air, application of cold water, and “psychotherapy” were all recommended in the same breath by well-meaning doctors in cases mysteriously complicated by psychic symptoms. On closer examination “psychotherapy” meant a sort of robust, benevolently paternal advice which sought to persuade the patient, after the manner of Dubois, that the symptom was “only psychic” and therefore a morbid fancy.

[29] It is not to be denied that advice may occasionally do some good, but advice is about as characteristic of modern psychotherapy as bandaging of modern surgery—that is to say, personal and authoritarian influence is an important factor in healing, but not by any means the only one, and in no sense does it constitute the essence of psychotherapy. Whereas formerly it seemed to be everybody’s province, today psychotherapy has become a science and uses the scientific method. With our deepened understanding of the nature of neuroses and the psychic complications of bodily ills, the nature of the treatment, too, has undergone considerable change and differentiation. The earlier suggestion theory, according to which symptoms had to be suppressed by counteraction, was superseded by the psychoanalytical viewpoint of Freud, who realized that the cause of the illness was not removed with the suppression of the symptom and that the symptom was far more a kind of signpost pointing, directly or indirectly, to the cause. This novel attitude—which has been generally accepted for the last thirty years or so—completely revolutionized therapy because, in contradiction to suggestion therapy, it required that the causes be brought to consciousness.

[30] Suggestion therapy (hypnosis, etc.) was not lightly abandoned—it was abandoned only because its results were so unsatisfactory. It was fairly easy and practical to apply, and allowed skilled practitioners to treat a large number of patients at the same time, and this at least seemed to offer the hopeful beginnings of a lucrative method. Yet the actual cures were exceedingly sparse and so unstable that even the delightful possibility of simultaneous mass treatment could no longer save it. But for that, both the practitioner and the health insurance officer would have had every interest in retaining this method. It perished, however, of its own insufficiency.

[31] Freud's demand that the causes be made conscious has become the *leitmotiv* or basic postulate of all the more recent forms of psychotherapy. Psychopathological research during the last fifty years has proved beyond all possibility of doubt that the most important aetiological processes in neurosis are essentially unconscious; while practical experience has shown that the making conscious of aetiological facts or processes is a curative factor of far greater practical importance than suggestion. Accordingly in the course of the last twenty-five or thirty years there has occurred over the whole field of psychotherapy a swing away from direct suggestion in favour of all forms of therapy whose common standpoint is the raising to consciousness of the causes that make for illness.

[32] As already indicated, the change of treatment went hand in hand with a profounder and more highly differentiated theory of neurotic disturbance. So long as treatment was restricted to suggestion, it could content itself with the merest skeleton of a theory. People thought it sufficient to regard neurotic symptoms as the "fancies" of an overwrought imagination, and from this view the therapy followed easily enough, the object of which was simply to suppress those products of imagination—the "imaginary" symptoms. But what people thought they could nonchalantly write off as "imaginary" is only one manifestation of a morbid state that is positively protean in its symptomatology. No sooner is one symptom suppressed than another is there. The core of the disturbance had not been reached.

[33] Under the influence of Breuer and Freud the so-called "trauma" theory of neuroses held the field for a long time. Doctors tried to make the patient conscious of the original traumatic elements with the aid of the "cathartic method." But even this comparatively simple method and its theory demanded an attitude of doctor to patient very different from the suggestion method, which could be practised by anyone with the necessary determination. The cathartic method required careful individual scrutiny of the case in question and a patient attitude that searched for possible traumata. For only through the most meticulous observation and examination of the material could the traumatic elements be so constellated as to result in abreaction of the original affective situations from which the neurosis arose. Hence a lucrative group treatment became exceedingly difficult, if not impossible. Although the performance expected of the doctor was qualitatively higher than in the case of suggestion, the theory was so elementary that there was always the possibility of a rather mechanical routine, for in principle there was nothing to prevent the doctor from putting several patients at once into the relaxed condition in which the traumatic memories could be abreacted.

[34] As a result of this more exhaustive treatment of the individual case it could no longer be disguised that the trauma theory was a hasty generalization. Growing

experience made it clear to every conscientious investigator of neurotic symptoms that specifically sexual traumata and other shocks may indeed account for some forms of neurosis, but not by any means for all. Freud himself soon stepped beyond the trauma theory and came out with his theory of “repression.” This theory is much more complicated, and the treatment became differentiated accordingly. It was realized that mere abreaction cannot possibly lead to the goal, since the majority of neuroses are not traumatic at all. The theory of repression took far more account of the fact that typical neuroses are, properly speaking, developmental disturbances. Freud put it that the disturbance was due to the repression of infantile sexual impulses and tendencies which were thereby made unconscious. The task of the theory was to track down these tendencies in the patient. But since by definition they are unconscious, their existence could only be proved by a thorough examination of the patient’s anamnesis as well as his actual fantasies.

[35] In general the infantile impulses appear mainly in dreams, and that is why Freud now turned to a serious study of the dream. This was the decisive step that made modern psychotherapy a method of individual treatment. It is quite out of the question to apply psychoanalysis to several patients at once. It is anything but a mechanical routine.

[36] Now whether this form of treatment calls itself “individual psychology” with Adler or “psychoanalysis” with Freud and Stekel, the fact remains that modern psychotherapy of whatever kind, so far as it claims to be medically conscientious and scientifically reliable, can no longer be mass-produced but is obliged to give undivided and generous attention to the individual. The procedure is necessarily very detailed and lengthy. True, attempts are often made to shorten the length of treatment as much as possible, but one could hardly say that the results have been very encouraging. The point is that most neuroses are misdevelopments that have been built up over many years, and these cannot be remedied by a short and intensive process. Time is therefore an irreplaceable factor in healing.

[37] Neuroses are still—very unjustly—counted as mild illnesses, mainly because their nature is not tangible and of the body. People do not “die” of a neurosis—as if every bodily illness had a fatal outcome! But it is entirely forgotten that, unlike bodily illnesses, neuroses may be extremely deleterious in their psychic and social consequences, often worse than psychoses, which generally lead to the social isolation of the sufferer and thus render him innocuous. An ankylosed knee, an amputated foot, a long-drawn-out phthisis, are in every respect preferable to a severe neurosis. When the neurosis is regarded not merely from the clinical but from the psychological and social standpoint, one comes to the conclusion that it really is a severe illness, particularly in view of its effects on the patient’s environment and way

of life. The clinical standpoint by itself is not and cannot be fair to the nature of a neurosis, because a neurosis is more a psychosocial phenomenon than an illness in the strict sense. It forces us to extend the term “illness” beyond the idea of an individual body whose functions are disturbed, and to look upon the neurotic person as a sick system of social relationships. When one has corrected one’s views in this way, one will no longer find it astonishing that a proper therapy of neuroses is an elaborate and complicated matter.

[38] Unfortunately, the medical faculties have bothered far too little with the fact that the number of neuroses (and above all the frequency of psychic complications in organic diseases) is very great and thus concerns the general practitioner in unusually high degree, even though he may not realize it. Nevertheless his studies give him no preparation whatever in this most important respect; indeed, very often he never has a chance to find out anything about this subject, so vital in practice.

[39] Although the beginnings of modern psychotherapy rest in the main on the services of Freud, we should be very wrong if we—as so often happens—identified psychological treatment with Freudian “psychoanalysis” pure and simple. This error is certainly fostered by Freud himself and his adherents, who, in most sectarian fashion, regard their sexual theory and their methodology as the sole means of grace. Adler’s “individual psychology” is a contribution not to be underestimated, and represents a widening of the psychological horizon. There is much that is right and true in the theory and method of psychoanalysis; nevertheless it restricts its truth essentially to the sexual frame of reference and is blind to everything that is not subordinate to it. Adler has proved that not a few neuroses can be more successfully explained in quite another way.

[40] These newer developments of theory have as their therapeutic aim not only the raising to consciousness of pathogenic contents and tendencies, but their reduction to original “simple” instincts, which is supposed to restore the patient to his natural, unwarped state. Such an aim is no less praiseworthy than it is logical and promising in practice. The wholesome results are, when one considers the enormous difficulties in treating the neuroses, most encouraging, if not so ideal that we need wish for nothing better.

[41] Reduction to instinct is itself a somewhat questionable matter, since man has always been at war with his instincts—that is to say, they are in a state of perpetual strife; hence the danger arises that the reduction to instinct will only replace the original neurotic conflict by another. (To give but one example: Freud replaces the neurosis by the so-called “transference neurosis.”) In order to avoid this danger, psychoanalysis tries to devalue the infantile desires through analytical insight, whereas individual psychology tries to replace them by collectivizing the individual

on the basis of the herd instinct. Freud represents the scientific rationalism of the nineteenth century, Adler the socio-political trends of the twentieth.

[42] Against these views, which clearly rest on time-bound assumptions, I have stressed the need for more extensive individualization of the method of treatment and for an irrationalization of its aims—especially the latter, which would ensure the greatest possible freedom from prejudice. In dealing with psychological developments, the doctor should, as a matter of principle, let nature rule and himself do his utmost to avoid influencing the patient in the direction of his own philosophical, social, and political bent. Even if all citizens are equal before the law, they are very unequal as individuals, and therefore each can find happiness only in his own way. This is not to preach “individualism,” but only the necessary precondition for responsible action: namely that a man should know himself and his own peculiarities and have the courage to stand by them. Only when a man lives in his own way is he responsible and capable of action—otherwise he is just a hanger-on or follower-on with no proper personality.

[43] I mention these far-reaching problems of modern psychotherapy not, indeed, to give an elaborate account of them but simply to show the reader the sort of problems which the practitioner comes up against when his avowed aim is to guide the neurotic misdevelopment back to its natural course. Consider a man who is largely unconscious of his own psychology: in order to educate him to the point where he can consciously take the right road for *him* and at the same time clearly recognize his own social responsibilities, a detailed and lengthy procedure is needed. If Freud, by his observation of dreams—which are so very important therapeutically—has already done much to complicate the method, it is rendered even more exacting, rather than simplified, by further individualization, which logically sets greater store by the patient’s individual material. But to the extent that his particular personality is thereby brought into play, his collaboration can be enlisted all the more. The psychoanalyst thinks he must see his patient for an hour a day for months on end; I manage in difficult cases with three or four sittings a week. As a rule I content myself with two, and once the patient has got going, he is reduced to one. In the interim he has to work at himself, but under my control. I provide him with the necessary psychological knowledge to free himself from my medical authority as speedily as possible. In addition, I break off the treatment every ten weeks or so, in order to throw him back on his normal milieu. In this way he is not alienated from his world—for he really suffers from his tendency to live at another’s expense. In such a procedure time can take effect as a healing factor, without the patient’s having to pay for the doctor’s time. With proper direction most people become capable after a while of making their contribution—however modest at first—to the common work. In my experience the absolute period of cure is not shortened by too many sittings. It lasts a

fair time in all cases requiring thorough treatment. Consequently, in the case of the patient with small means, if the sittings are spaced out and the intervals filled in with the patient's own work, the treatment becomes financially more endurable than when undertaken daily in the hope of (problematical) suggestive effects.

[44] In all clear cases of neurosis a certain re-education and regeneration of personality are essential, for we are dealing with a misdevelopment that generally goes far back into the individual's childhood. Accordingly the modern method must also take account of the philosophical and pedagogical views of the humane sciences, for which reason a purely medical education is proving increasingly inadequate. Such an activity should in all cases presuppose a thorough knowledge of psychiatry. But for adequate treatment of dreams a plentiful admixture of symbolical knowledge is needed, which can only be acquired by a study of primitive psychology, comparative mythology, and religion.

[45] Much to the astonishment of the psychotherapist, the object of his labours has not grown simpler with deepened knowledge and experience, but has visibly increased in scope and complexity; and in the clouds of the future the lineaments of a new practical psychology have already begun to take shape, which will embrace the insights of the doctor as well as of the educator and all those whose concern is the human soul. Till then, psychotherapy will assuredly remain the business of the doctor, and it is to be hoped that the medical faculties will not long continue to turn a deaf ear to this plea addressed to the doctor by the sick. The educated public knows of the existence of psychotherapy, and the intelligent doctor knows, from his own practice, the great importance of psychological influence. Hence in Switzerland there is already a fine body of doctors who stand up for the rights of psychotherapy and practise it with self-sacrificing devotion, despite the fact that their work is often made bitter for them by ridicule, misinterpretation, and criticism, as inept as it is malevolent.

III

SOME ASPECTS OF MODERN PSYCHOTHERAPY¹

- [46] Modern psychotherapy finds itself in rather an awkward position at a public-health congress. It can boast of no international agreements, nor can it provide the legislator or the minister of public hygiene with suitable or workable advice. It must assume the somewhat humble role of personal charity work versus the big organizations and institutions of public welfare, and this despite the fact that neuroses are alarmingly common and occupy no small place among the host of evils that assail the health of civilized nations.
- [47] Psychotherapy and modern psychology are as yet individual experiments with little or no general applicability. They rest upon the initiative of individual doctors, who are not supported even by the universities. Nevertheless the problems of modern psychology have aroused a widespread interest out of all proportion to the exceedingly restricted official sympathy.
- [48] I must confess that I myself did not find it at all easy to bow my head to Freud's innovations. I was a young doctor then, busying myself with experimental psychopathology and mainly interested in the disturbances of mental reactions to be observed in the so-called association experiments. Only a few of Freud's works had then been published. But I could not help seeing that my conclusions undoubtedly tended to confirm the facts indicated by Freud, namely the facts of repression, substitution, and "symbolization." Nor could I honestly deny the very real importance of sexuality in the aetiology and indeed in the actual structure of neuroses.
- [49] Medical psychology is still pioneer work, but it looks as if the medical profession were beginning to see a psychic side to many things which have hitherto been considered from the physiological side only, not to mention the neuroses, whose psychic nature is no longer seriously contested. Medical psychology seems, therefore, to be coming into its own. But where, we may ask, can the medical student learn it? It is important for the doctor to know something about the psychology of his patients, and about the psychology of nervous, mental, and physical diseases. Quite a lot is known about these things among specialists, though the universities do not encourage such studies. I can understand their attitude. If I were responsible for a

university department, I should certainly feel rather hesitant about teaching medical psychology.

[50] In the first place, there is no denying the fact that Freud's theories have come up against certain rooted prejudices. It was to no purpose that he modified the worst aspects of his theories in later years. In the public eye he is branded by his first statements. They are one-sided and exaggerated; moreover they are backed by a philosophy that is falling more and more out of favour with the public: a thoroughly materialistic point of view which has been generally abandoned since the turn of the century. Freud's exclusive standpoint not only offends too many ideals but also misinterprets the natural facts of the human psyche. It is certain that human nature has its dark side, but the layman as well as the reasonable scientist is quite convinced that it also has its good and positive side, which is just as real. Common sense does not tolerate the Freudian tendency to derive everything from sexuality and other moral incompatibilities. Such a view is too destructive.

[51] The extraordinary importance which Freud attaches to the unconscious meets with scant approval, although it is an interesting point with a certain validity. But one should not stress it too much, otherwise one robs the conscious mind of its practical significance and eventually arrives at a completely mechanistic view of things. This goes against our instincts, which have made the conscious mind the *arbiter mundi*. It is nevertheless true that the conscious mind has been overvalued by the rationalists. Hence it was a healthy sign to give the unconscious its due share of value. But this should not exceed the value accorded to consciousness.

[52] A further reason for hesitation is the absence of a real medical psychology, though there may be a psychology for doctors. Psychology is not for professionals only, nor is it peculiar to certain diseases. It is something broadly human, with professional and pathological variations. Nor, again, is it merely instinctual or biological. If it were, it could very well be just a chapter in a text-book of biology. It has an immensely important social and cultural aspect without which we could not imagine a human psyche at all. It is therefore quite impossible to speak of a general or normal psychology as the mere expression of a clash between instinct and moral law, or other inconveniences of that kind. Since the beginning of history man has been the maker of his own laws; and even if, as Freud seems to think, they were the invention of our malevolent forefathers, it is odd how the rest of humanity has conformed to them and given them silent assent.

[53] Even Freud, who tried to restrict what he called psychoanalysis to the medical sphere (with occasional, somewhat inappropriate excursions into other spheres), even he was forced to discuss fundamental principles that go far beyond purely medical considerations. The most cursory professional treatment of an intelligent patient is

bound to lead to basic issues, because a neurosis or any other mental conflict depends much more on the personal attitude of the patient than on his infantile history. No matter what the influences are that disturbed his youth, he still has to put up with them and he does so by means of a certain attitude. The attitude is all-important. Freud emphasizes the aetiology of the case, and assumes that once the causes are brought into consciousness the neurosis will be cured. But mere consciousness of the causes does not help any more than detailed knowledge of the causes of war helps to raise the value of the French franc. The task of psychotherapy is to correct the conscious attitude and not to go chasing after infantile memories. Naturally you cannot do the one without paying attention to the other, but the main emphasis should be upon the attitude of the patient. There are extremely practical reasons for this, because there is scarcely a neurotic who does not love to dwell upon the evils of the past and to wallow in self-commiserating memories. Very often his neurosis consists precisely in his hanging back and constantly excusing himself on account of the past.

[54] As you know, I am critical of Freud in this particular respect, but my criticism would not go so far as to deny the extraordinary power of the retrospective tendency. On the contrary, I consider it to be of the greatest importance, so important that I would not call any treatment thorough that did not take it into account. Freud in his analysis follows this regressive tendency to the end and thus arrives at the findings you all know. These findings are only *apparent* facts; in the main they are interpretations. He has a special method of interpreting psychic material, and it is partly because the material has a sexual aspect and partly because he interprets it in a special way that he arrives at his typical conclusions. Take for instance his treatment of dreams. He believes that the dream is a façade. He says you can turn it inside out, that this or that factor is eliminated by a censor, and so forth.

[55] I hold that interpretation is the crux of the whole matter. One can just as well assume that the dream is not a façade, that there is no censor, and that the unconscious appears in dreams in the naïvest and most genuine way. The dream is as genuine as the albumen in urine, and this is anything but a façade. If you take the dream like this, you naturally come to very different conclusions. And the same thing happens with the patient's regressive tendency. I have suggested that it is not just a relapse into infantilism, but a genuine attempt to get at something necessary. There is, to be sure, no lack of infantile perversions. But are we so certain that what appears to be, and is interpreted as, an incestuous craving is really only that? When we try, conscientiously and without theoretical bias, to find out what the patient is really seeking in his father or mother, we certainly do not, as a rule, find incest, but rather a genuine horror of it. We find that he is seeking something entirely different, something that Freud only appreciates negatively: the universal feeling of childhood

innocence, the sense of security, of protection, of reciprocated love, of trust, of faith—a thing that has many names.

[56] Is this goal of the regressive tendency entirely without justification? Or is it not rather the very thing the patient urgently needs in order to build up his conscious attitude?

[57] I believe that incest and the other perverted sexual aspects are, in most cases, no more than by-products, and that the essential contents of the regressive tendency are really those which I have just mentioned. I have no objection to a patient's going back to that kind of childhood, nor do I mind his indulging in such memories.

[58] I am not blind to the fact that the patient must sink or swim, and that he may possibly go under as the result of infantile indulgence; but I call him back to these valuable memories with conscious intent. I appeal to his sense of values deliberately, because I have to make the man well and therefore I must use all available means to achieve the therapeutic aim.

[59] The regressive tendency only means that the patient is seeking *himself* in his childhood memories, sometimes for better, sometimes for worse. His development was one-sided; it left important items of character and personality behind, and thus it ended in failure. That is why he has to go back. In *Psychological Types*, I tried to establish the general lines along which these one-sided developments move. There are two main attitudes which differ fundamentally, namely introversion and extraversion. Both are perfectly good ways of living, so long as they co-operate reasonably well. It is only a dominating one-sidedness that leads to disaster. Within this very general framework there are more subtle distinctions based upon whatever function is preferred by the individual. Thus somebody with a good brain will develop a powerful intellect at the expense of his feelings. Or again, the facts perceived by the realist will obliterate the beautiful visions of the intuitive. All such people will look back to childhood when they come to the end of their particular tether, or they will hanker for some state when they were still in touch with the lost world, or their dreams will reproduce enchanting memories of a past that has sunk into oblivion.

[60] By adopting a more idealistic philosophy, one can interpret things differently and produce a perfectly decent and respectable psychology which is just as true, relatively speaking, as the sordid underside. I do not see why one should not interpret the facts in a decent and positive way when one can easily afford to do so. For many people this is much better and more encouraging than to reduce everything to primitive constituents with nasty names. But here too we must not be one-sided, because certain patients are all the better for being told some drastic but cleansing truth.

[61] Freud's original idea of the unconscious was that it was a sort of receptacle or storehouse for repressed material, infantile wishes, and the like. But the unconscious is far more than that: it is the basis and precondition of all consciousness. It represents the unconscious functioning of the psyche in general. It is psychic life before, during, and after consciousness. And inasmuch as the newborn child is presented with a ready-made, highly developed brain which owes its differentiation to the accretions of untold centuries of ancestral life, the unconscious psyche must consist of inherited instincts, functions, and forms that are peculiar to the ancestral psyche. This collective heritage is by no means made up of inherited ideas, but rather of the possibilities of such ideas—in other words, of *a priori* categories of possible functioning. Such an inheritance could be called instinct, using the word in its original sense. But it is not quite so simple. On the contrary, it is a most intricate web of what I have called archetypal conditions. This implies the probability that a man will behave much as his ancestors behaved, right back to Methuselah. Thus the unconscious is seen as the collective predisposition to extreme conservatism, a guarantee, almost, that nothing new will ever happen.

[62] If this statement were unreservedly true, there would be none of that creative fantasy which is responsible for radical changes and innovations. Therefore our statement must be in part erroneous, since creative fantasy exists and is not simply the prerogative of the unconscious psyche. Generally speaking, it is an intrusion from the realm of the unconscious, a sort of lucky hunch, different in kind from the slow reasoning of the conscious mind. Thus the unconscious is seen as a creative factor, even as a bold innovator, and yet it is at the same time the stronghold of ancestral conservatism. A paradox, I admit, but it cannot be helped. It is no more paradoxical than man himself and that cannot be helped either.

[63] There are sound philosophical reasons why our arguments should end in paradox and why a paradoxical statement is the better witness to truth than a one-sided, so-called "positive" statement. But this is not the place to embark on a lengthy logical discourse.

[64] Now if you will bear in mind what we have just said about the significance of the unconscious, and if you will recall our discussion of the regressive tendency, you will discover a further and cogent reason why the patient should have such a tendency, and why he is quite justified in having it. To be retrospective and introspective is a pathological mistake only when it stops short at futilities like incest and other squalid fantasies, or at feelings of inferiority. Retrospection and introspection should be carried much further, because then the patient will not only discover the true reason for his childhood longings, but, going beyond himself into the sphere of the collective psyche, he will enter first into the treasure-house of collective ideas and

then into creativity. In this way he will discover his identity with the whole of humanity, as it ever was, is, and ever shall be. He will add to his modest personal possessions which have proved themselves insufficient. Such acquisitions will strengthen his attitude, and this is the very reason why collective ideas have always been so important.

[65] It looks as if Freud had got stuck in his own pessimism, clinging as he does to his thoroughly negative and personal conception of the unconscious. You get nowhere if you assume that the vital basis of man is nothing but a very personal and therefore very private *affaire scandaleuse*. This is utterly hopeless, and true only to the extent that a Strindberg drama is true. But pierce the veil of that sickly illusion, and you step out of your narrow, stuffy personal corner into the wide realm of the collective psyche, into the healthy and natural matrix of the human mind, into the very soul of humanity. That is the true foundation on which we can build a new and more workable attitude.

IV

THE AIMS OF PSYCHOTHERAPY¹

[66] It is generally agreed today that neuroses are functional psychic disturbances and are therefore to be cured preferably by psychological treatment. But when we come to the question of the structure of the neuroses and the principles of therapy, all agreement ends, and we have to acknowledge that we have as yet no fully satisfactory conception of the nature of the neuroses or of the principles of treatment. While it is true that two currents or schools of thought have gained a special hearing, they by no means exhaust the number of divergent opinions that actually exist. There are also numerous non-partisans who, amid the general conflict of opinion, have their own special views. If, therefore, we wanted to paint a comprehensive picture of this diversity, we should have to mix upon our palette all the hues and shadings of the rainbow. I would gladly paint such a picture if it lay within my power, for I have always felt the need for a conspectus of the many viewpoints. I have never succeeded in the long run in not giving divergent opinions their due. Such opinions could never arise, much less secure a following, if they did not correspond to some special disposition, some special character, some fundamental psychological fact that is more or less universal. Were we to exclude one such opinion as simply wrong and worthless, we should be rejecting this particular disposition or this particular fact as a misinterpretation—in other words, we should be doing violence to our own empirical material. The wide approval which greeted Freud's explanation of neurosis in terms of sexual causation and his view that the happenings in the psyche turn essentially upon infantile pleasure and its satisfaction should be instructive to the psychologist. It shows him that this manner of thinking and feeling coincides with a fairly widespread trend or spiritual current which, independently of Freud's theory, has made itself felt in other places, in other circumstances, in other minds, and in other forms. I should call it a manifestation of the collective psyche. Let me remind you here of the works of Havelock Ellis and August Forel and the contributors to *Anthropophyteia*;² then of the changed attitude to sex in Anglo-Saxon countries during the post-Victorian period, and the broad discussion of sexual matters in literature, which had already started with the French realists. Freud is one of the exponents of a contemporary psychological fact which has a special history of its own; but for obvious reasons we cannot go into that here.

[67] The acclaim which Adler, like Freud, has met with on both sides of the Atlantic points similarly to the undeniable fact that, for a great many people, the need for self-assertion arising from a sense of inferiority is a plausible basis of explanation. Nor can it be disputed that this view accounts for psychic actualities which are not given their due in the Freudian system. I need hardly mention in detail the collective psychological forces and social factors that favour the Adlerian view and make it their theoretical exponent. These matters are sufficiently obvious.

[68] It would be an unpardonable error to overlook the element of truth in both the Freudian and the Adlerian viewpoints, but it would be no less unpardonable to take either of them as the sole truth. Both truths correspond to psychic realities. There are in fact some cases which by and large can best be described and explained by the one theory, and some by the other.

[69] I can accuse neither of these two investigators of any fundamental error; on the contrary, I endeavour to apply both hypotheses as far as possible because I fully recognize their relative rightness. It would certainly never have occurred to me to depart from Freud's path had I not stumbled upon facts which forced me into modifications. And the same is true of my relation to the Adlerian viewpoint.

[70] After what has been said it seems hardly necessary to add that I hold the truth of my own deviationist views to be equally relative, and feel myself so very much the mere exponent of another disposition that I could almost say with Coleridge: "I believe in the one and only saving Church, of which at present I am the only member."³

[71] It is in applied psychology, if anywhere, that we must be modest today and bear with an apparent plurality of contradictory opinions; for we are still far from having anything like a thorough knowledge of the human psyche, that most challenging field of scientific inquiry. At present we have merely more or less plausible opinions that cannot be squared with one another.

[72] If, therefore, I undertake to say something about my views I hope I shall not be misunderstood. I am not advertising a novel truth, still less am I announcing a final gospel. I can only speak of attempts to throw light on psychic facts that are obscure to me, or of efforts to overcome therapeutic difficulties.

[73] And it is just with this last point that I should like to begin, for here lies the most pressing need for modifications. As is well known, one can get along for quite a time with an inadequate theory, but not with inadequate therapeutic methods. In my psychotherapeutic practice of nearly thirty years I have met with a fair number of failures which made a far deeper impression on me than my successes. Anybody can have successes in psychotherapy, starting with the primitive medicine-man and faith-

healer. The psychotherapist learns little or nothing from his successes, for they chiefly confirm him in his mistakes. But failures are priceless experiences because they not only open the way to a better truth but force us to modify our views and methods.

[74] I certainly recognize how much my work has been furthered first by Freud and then by Adler, and in practice I try to acknowledge this debt by making use of their views, whenever possible, in the treatment of my patients. Nevertheless I must insist that I have experienced failures which, I felt, might have been avoided had I considered the facts that subsequently forced me to modify their views.

[75] To describe all the situations I came up against is almost impossible, so I must content myself with singling out a few typical cases. It was with older patients that I had the greatest difficulties, that is, with persons over forty. In handling younger people I generally get along with the familiar viewpoints of Freud and Adler, for these tend to bring the patient to a certain level of adaptation and normality. Both views are eminently applicable to the young, apparently without leaving any disturbing after-effects. In my experience this is not so often the case with older people. It seems to me that the basic facts of the psyche undergo a very marked alteration in the course of life, so much so that we could almost speak of a psychology of life's morning and a psychology of its afternoon. As a rule, the life of a young person is characterized by a general expansion and a striving towards concrete ends; and his neurosis seems mainly to rest on his hesitation or shrinking back from this necessity. But the life of an older person is characterized by a contraction of forces, by the affirmation of what has been achieved, and by the curtailment of further growth. His neurosis comes mainly from his clinging to a youthful attitude which is now out of season. Just as the young neurotic is afraid of life, so the older one shrinks back from death. What was a normal goal for the young man becomes a neurotic hindrance to the old—just as, through his hesitation to face the world, the young neurotic's originally normal dependence on his parents grows into an incest-relationship that is inimical to life. It is natural that neurosis, resistance, repression, transference, "guiding fictions," and so forth should have one meaning in the young person and quite another in the old, despite apparent similarities. The aims of therapy should undoubtedly be modified to meet this fact. Hence the age of the patient seems to me a most important *indicium*.

[76] But there are various *indicia* also within the youthful phase of life. Thus, in my estimation, it is a technical blunder to apply the Freudian viewpoint to a patient with the Adlerian type of psychology, that is, an unsuccessful person with an infantile need to assert himself. Conversely, it would be a gross misunderstanding to force the Adlerian viewpoint on a successful man with a pronounced pleasure-principle

psychology. When in a quandary the resistances of the patient may be valuable signposts. I am inclined to take deep-seated resistances seriously at first, paradoxical as this may sound, for I am convinced that the doctor does not necessarily know better than the patient's own psychic constitution, of which the patient himself may be quite unconscious. This modesty on the part of the doctor is altogether becoming in view of the fact that there is not only no generally valid psychology today but rather an untold variety of temperaments and of more or less individual psyches that refuse to fit into any scheme.

[77] You know that in this matter of temperament I postulate two different basic attitudes in accordance with the typical differences already suspected by many students of human nature—namely, the extraverted and the introverted attitudes. These attitudes, too, I take to be important *indicia*, and likewise the predominance of one particular psychic function over the others.⁴

[78] The extraordinary diversity of individual life necessitates constant modifications of theory which are often applied quite unconsciously by the doctor himself, although in principle they may not accord at all with his theoretical creed.

[79] While we are on this question of temperament I should not omit to mention that there are some people whose attitude is essentially spiritual and others whose attitude is essentially materialistic. It must not be imagined that such an attitude is acquired accidentally or springs from mere misunderstanding. Very often they are ingrained passions which no criticism and no persuasion can stamp out; there are even cases where an apparently outspoken materialism has its source in a denial of religious temperament. Cases of the reverse type are more easily credited today, although they are not more frequent than the others. This too is an *indicium* which in my opinion ought not to be overlooked.

[80] When we use the word *indicium* it might appear to mean, as is usual in medical parlance, that this or that treatment is indicated. Perhaps this should be the case, but psychotherapy has at present reached no such degree of certainty—for which reason our *indicia* are unfortunately not much more than warnings against one-sidedness.

[81] The human psyche is a thing of enormous ambiguity. In every single case we have to ask ourselves whether an attitude or a so-called *habitus* is authentic, or whether it may not be just a compensation for its opposite. I must confess that I have so often been deceived in this matter that in any concrete case I am at pains to avoid all theoretical presuppositions about the structure of the neurosis and about what the patient can and ought to do. As far as possible I let pure experience decide the therapeutic aims. This may perhaps seem strange, because it is commonly supposed that the therapist has an aim. But in psychotherapy it seems to me positively advisable for the doctor not to have too fixed an aim. He can hardly know better than

the nature and will to live of the patient. The great decisions in human life usually have far more to do with the instincts and other mysterious unconscious factors than with conscious will and well-meaning reasonableness. The shoe that fits one person pinches another; there is no universal recipe for living. Each of us carries his own life-form within him—an irrational form which no other can outbid.

[82] All this naturally does not prevent us from doing our utmost to make the patient normal and reasonable. If the therapeutic results are satisfactory, we can probably let it go at that. If not, then for better or worse the therapist must be guided by the patient's own irrationalities. Here we must follow nature as a guide, and what the doctor then does is less a question of treatment than of developing the creative possibilities latent in the patient himself.

[83] What I have to say begins where the treatment leaves off and this development sets in. Thus my contribution to psychotherapy confines itself to those cases where rational treatment does not yield satisfactory results. The clinical material at my disposal is of a peculiar composition: new cases are decidedly in the minority. Most of them already have some form of psychotherapeutic treatment behind them, with partial or negative results. About a third of my cases are not suffering from any clinically definable neurosis, but from the senselessness and aimlessness of their lives. I should not object if this were called the general neurosis of our age. Fully two thirds of my patients are in the second half of life.

[84] This peculiar material sets up a special resistance to rational methods of treatment, probably because most of my patients are socially well-adapted individuals, often of outstanding ability, to whom normalization means nothing. As for so-called normal people, there I really am in a fix, for I have no ready made philosophy of life to hand out to them. In the majority of my cases the resources of the conscious mind are exhausted (or, in ordinary English, they are "stuck"). It is chiefly this fact that forces me to look for hidden possibilities. For I do not know what to say to the patient when he asks me, "What do you advise? What shall I do?" I don't know either. I only know one thing: when my conscious mind no longer sees any possible road ahead and consequently gets stuck, my unconscious psyche will react to the unbearable standstill.

[85] This "getting stuck" is a psychic occurrence so often repeated during the course of human history that it has become the theme of many myths and fairytales. We are told of the Open sesame! to the locked door, or of some helpful animal who finds the hidden way. In other words, getting stuck is a typical event which, in the course of time, has evoked typical reactions and compensations. We may therefore expect with some probability that something similar will appear in the reactions of the unconscious, as, for example, in dreams.

[86] In such cases, then, my attention is directed more particularly to dreams. This is not because I am tied to the notion that dreams must always be called to the rescue, or because I possess a mysterious dream-theory which tells me how everything must shape itself; but quite simply from perplexity. I do not know where else to go for help, and so I try to find it in dreams. These at least present us with images pointing to something or other, and that is better than nothing. I have no theory about dreams, I do not know how dreams arise. And I am not at all sure that my way of handling dreams even deserves the name of a “method.” I share all your prejudices against dream-interpretation as the quintessence of uncertainty and arbitrariness. On the other hand, I know that if we meditate on a dream sufficiently long and thoroughly, if we carry it around with us and turn it over and over, something almost always comes of it. This something is not of course a scientific result to be boasted about or rationalized; but it is an important practical hint which shows the patient what the unconscious is aiming at. Indeed, it ought not to matter to me whether the result of my musings on the dream is scientifically verifiable or tenable, otherwise I am pursuing an ulterior—and therefore autoerotic—aim. I must content myself wholly with the fact that the result means something to the patient and sets his life in motion again. I may allow myself only one criterion for the result of my labours: Does it work? As for my scientific hobby—my desire to know *why* it works—this I must reserve for my spare time.

[87] Infinitely varied are the contents of the initial dreams, that is, the dreams that come at the outset of the treatment. In many cases they point directly to the past and recall things lost and forgotten. For very often the standstill and disorientation arise when life has become one-sided, and this may, in psychological terms, cause a sudden loss of libido. All our previous activities become uninteresting, even senseless, and our aims suddenly no longer worth striving for. What in one person is merely a passing mood may in another become a chronic condition. In these cases it often happens that other possibilities for developing the personality lie buried somewhere or other in the past, unknown to anybody, not even to the patient. But the dream may reveal the clue.

[88] In other cases the dream points to present facts, for example marriage or social position, which the conscious mind has never accepted as sources of problems or conflicts.

[89] Both possibilities come within the sphere of the rational, and I daresay I would have no difficulty in making such initial dreams seem plausible. The real difficulty begins when the dreams do not point to anything tangible, and this they do often enough, especially when they hold anticipations of the future. I do not mean that such dreams are necessarily prophetic, merely that they feel the way, they “reconnoitre.”

These dreams contain inklings of possibilities and for that reason can never be made plausible to an outsider. Sometimes they are not plausible even to me, and then I usually say to the patient, “I don’t believe it, but follow up the clue.” As I have said, the sole criterion is the stimulating effect, but it is by *no* means necessary for me to understand why such an effect takes place.

[90] This is particularly true of dreams that contain something like an “unconscious metaphysics,” by which I mean mythological analogies that are sometimes incredibly strange and baffling.

[91] Now, you will certainly protest: How on earth can I know that the dreams contain anything like an unconscious metaphysics? And here I must confess that I do not really know. I know far too little about dreams for that. I see only the effect on the patient, of which I would like to give you a little example.

[92] In a long initial dream of one of my “normal” patients, the illness of his sister’s child played an important part. She was a little girl of two.

[93] Some time before, this sister had in fact lost a boy through illness, but otherwise none of her children was ill. The occurrence of the sick child in the dream at first proved baffling to the dreamer, probably because it failed to fit the facts. Since there was no direct and intimate connection between the dreamer and his sister, he could feel in this image little that was personal to him. Then he suddenly remembered that two years earlier he had taken up the study of occultism, in the course of which he also discovered psychology. So the child evidently represented his interest in the psyche—an idea I should never have arrived at of my own accord. Seen purely theoretically, this dream image can mean anything or nothing. For that matter, does a thing or a fact ever mean anything in itself? The only certainty is that it is always man who interprets, who assigns meaning. And that is the gist of the matter for psychology. It impressed the dreamer as a novel and interesting idea that the study of occultism might have something sickly about it. Somehow the thought struck home. And this is the decisive point: the interpretation works, however we may elect to account for its working. For the dreamer the thought was an implied criticism, and through it a certain change of attitude was brought about. By such slight changes, which one could never think up rationally, things are set in motion and the dead point is overcome, at least in principle.

[94] From this example I could say figuratively that the dream meant that there was something sickly about the dreamer’s occult studies, and in this sense—since the dream brought him to such an idea—I can also speak of “unconscious metaphysics.”

[95] But I go still further: Not only do I give the patient an opportunity to find associations to his dreams, I give myself the same opportunity. Further, I present him

with my ideas and opinions. If, in so doing, I open the door to “suggestion,” I see no occasion for regret; for it is well known that we are susceptible only to those suggestions with which we are already secretly in accord. No harm is done if now and then one goes astray in this riddle-reading: sooner or later the psyche will reject the mistake, much as the organism rejects a foreign body. I do not need to prove that my interpretation of the dream is right (a pretty hopeless undertaking anyway), but must simply try to discover, with the patient, what *acts* for him—I am almost tempted to say, what is actual.

[96] For this reason it is particularly important for me to know as much as possible about primitive psychology, mythology, archaeology, and comparative religion, because these fields offer me invaluable analogies with which I can enrich the associations of my patients. Together, we can then find meaning in apparent irrelevancies and thus vastly increase the effectiveness of the dream. For the layman who has done his utmost in the personal and rational sphere of life and yet has found no meaning and no satisfaction there, it is enormously important to be able to enter a sphere of irrational experience. In this way, too, the habitual and the commonplace come to wear an altered countenance, and can even acquire a new glamour. For it all depends on how we look at things, and not on how they are in themselves. The least of things with a meaning is always worth more in life than the greatest of things without it.

[97] I do not think I underestimate the risk of this undertaking. It is as if one began to build a bridge out into space. Indeed, the ironist might even allege—and has often done so—that in following this procedure both doctor and patient are indulging in mere fantasy-spinning.

[98] This objection is no counter-argument, but is very much to the point. I even make an effort to second the patient in his fantasies. Truth to tell, I have no small opinion of fantasy. To me, it is the maternally creative side of the masculine mind. When all is said and done, we can never rise above fantasy. It is true that there are unprofitable, futile, morbid, and unsatisfying fantasies whose sterile nature is immediately recognized by every person endowed with common sense; but the faulty performance proves nothing against the normal performance. All the works of man have their origin in creative imagination. What right, then, have we to disparage fantasy? In the normal course of things, fantasy does not easily go astray; it is too deep for that, and too closely bound up with the tap-root of human and animal instinct. It has a surprising way of always coming out right in the end. The creative activity of imagination frees man from his bondage to the “nothing but”⁵ and raises him to the status of one who plays. As Schiller says, man is completely human only when he is at play.

[99] My aim is to bring about a psychic state in which my patient begins to experiment with his own nature—a state of fluidity, change, and growth where nothing is eternally fixed and hopelessly petrified. I can here of course adumbrate only the principles of my technique. Those of you who happen to be acquainted with my works can easily imagine the necessary parallels. I would only like to emphasize that you should not think of my procedure as entirely without aim or limit. In handling a dream or fantasy I make it a rule never to go beyond the meaning which is effective for the patient; I merely try to make him as fully conscious of this meaning as possible, so that he shall also become aware of its supra-personal connections. For, when something happens to a man and he supposes it to be personal only to himself, whereas in reality it is a quite universal experience, then his attitude is obviously wrong, that is, too personal, and it tends to exclude him from human society. By the same token we need to have not only a personal, contemporary consciousness, but also a supra-personal consciousness with a sense of historical continuity. However abstract this may sound, practical experience shows that many neuroses are caused primarily by the fact that people blind themselves to their own religious promptings because of a childish passion for rational enlightenment. It is high time the psychologist of today recognized that we are no longer dealing with dogmas and creeds but with the religious attitude *per se*, whose importance as a psychic function can hardly be overrated. And it is precisely for the religious function that the sense of historical continuity is indispensable.

[100] Coming back to the question of my technique, I ask myself how far I am indebted to Freud for its existence. At all events I learned it from Freud's method of free association, and I regard it as a direct extension of that.

[101] So long as I help the patient to discover the effective elements in his dreams, and so long as I try to get him to see the general meaning of his symbols, he is still, psychologically speaking, in a state of childhood. For the time being he is dependent on his dreams and is always asking himself whether the next dream will give him new light or not. Moreover, he is dependent on my having ideas about his dreams and on my ability to increase his insight through my knowledge. Thus he is still in an undesirably passive condition where everything is rather uncertain and questionable; neither he nor I know the journey's end. Often it is not much more than a groping about in Egyptian darkness. In this condition we must not expect any very startling results—the uncertainty is too great for that. Besides which there is always the risk that what we have woven by day the night will unravel. The danger is that nothing permanent is achieved, that nothing remains fixed. It not infrequently happens in these situations that the patient has a particularly vivid or curious dream, and says to me, "Do you know, if only I were a painter I would make a picture of it." Or the

dreams are about photographs, paintings, drawings, or illuminated manuscripts, or even about the films.

[102] I have turned these hints to practical account, urging my patients at such times to paint in reality what they have seen in dream or fantasy. As a rule I am met with the objection, "But I am not a painter!" To this I usually reply that neither are modern painters, and that consequently modern painting is free for all, and that anyhow it is not a question of beauty but only of the trouble one takes with the picture. How true this is I saw recently in the case of a talented professional portraitist; she had to begin my way of painting all over again with pitiably childish efforts, literally as if she had never held a brush in her hand. To paint what we see before us is a different art from painting what we see within.

[103] Many of my more advanced patients, then, begin to paint. I can well understand that everyone will be profoundly impressed with the utter futility of this sort of dilettantism. Do not forget, however, that we are speaking not of people who still have to prove their social usefulness, but of those who can no longer see any sense in being socially useful and who have come upon the deeper and more dangerous question of the meaning of their own individual lives. To be a particle in the mass has meaning and charm only for the man who has not yet reached that stage, but none for the man who is sick to death of being a particle. The importance of what life means to the individual may be denied by those who are socially below the general level of adaptation, and is invariably denied by the educator whose ambition it is to breed mass-men. But those who belong to neither category will sooner or later come up against this painful question.

[104] Although my patients occasionally produce artistically beautiful things that might very well be shown in modern "art" exhibitions, I nevertheless treat them as completely worthless when judged by the canons of real art. As a matter of fact, it is essential that they should be considered worthless, otherwise my patients might imagine themselves to be artists, and the whole point of the exercise would be missed. It is not a question of art at all—or rather, it should not be a question of art—but of something more and other than mere art, namely the living effect upon the patient himself. The meaning of individual life, whose importance from the social standpoint is negligible, stands here at its highest, and for its sake the patient struggles to give form, however crude and childish, to the inexpressible.

[105] But why do I encourage patients, when they arrive at a certain stage in their development, to express themselves by means of brush, pencil, or pen at all?

[106] Here again my prime purpose is to produce an effect. In the state of psychological childhood described above, the patient remains passive; but now he begins to play an active part. To start off with, he puts down on paper what he has

passively seen, thereby turning it into a deliberate act. He not only talks about it, he is actually doing something about it. Psychologically speaking, it makes a vast difference whether a man has an interesting conversation with his doctor two or three times a week, the results of which are left hanging in mid air, or whether he has to struggle for hours with refractory brush and colours, only to produce in the end something which, taken at its face value, is perfectly senseless. If it were really senseless to him, the effort to paint it would be so repugnant that he could scarcely be brought to perform this exercise a second time. But because his fantasy does not strike him as entirely senseless, his busying himself with it only increases its effect upon him. Moreover, the concrete shaping of the image enforces a continuous study of it in all its parts, so that it can develop its effects to the full. This invests the bare fantasy with an element of reality, which lends it greater weight and greater driving power. And these rough-and-ready pictures do indeed produce effects which, I must admit, are rather difficult to describe. For instance, a patient needs only to have seen once or twice how much he is freed from a wretched state of mind by working at a symbolical picture, and he will always turn to this means of release whenever things go badly with him. In this way something of inestimable importance is won—the beginning of independence, a step towards psychological maturity. The patient can make himself creatively independent through this method, if I may call it such. He is no longer dependent on his dreams or on his doctor's knowledge; instead, by painting himself he gives shape to himself. For what he paints are active fantasies—that which is active within him. And that which is active within is himself, but no longer in the guise of his previous error, when he mistook the personal ego for the self; it is himself in a new and hitherto alien sense, for his ego now appears as the object of that which works within him. In countless pictures he strives to catch this interior agent, only to discover in the end that it is eternally unknown and alien, the hidden foundation of psychic life.

[107] It is impossible for me to describe the extent to which this discovery changes the patient's standpoint and values, and how it shifts the centre of gravity of his personality. It is as though the earth had suddenly discovered that the sun was the centre of the planetary orbits and of its own earthly orbit as well.

[108] But have we not always known this to be so? I myself believe that we have always known it. But I may know something with my head which the other man in me is far from knowing, for indeed and in truth I live as though I did not know it. Most of my patients knew the deeper truth, but did not live it. And why did they not live it? Because of that bias which makes us all live from the ego, a bias which comes from overvaluation of the conscious mind.

[109] It is of the greatest importance for the young person, who is still unadapted and has as yet achieved nothing, to shape his conscious ego as effectively as possible, that is, to educate his will. Unless he is a positive genius he cannot, indeed he should not, believe in anything active within him that is not identical with his will. He must feel himself a man of will, and may safely depreciate everything else in him and deem it subject to his will, for without this illusion he could not succeed in adapting himself socially.

[110] It is otherwise with a person in the second half of life who no longer needs to educate his conscious will, but who, to understand the meaning of his individual life, needs to experience his own inner being. Social usefulness is no longer an aim for him, although he does not deny its desirability. Fully aware as he is of the social unimportance of his creative activity, he feels it more as a way of working at himself to his own benefit. Increasingly, too, this activity frees him from morbid dependence, and he thus acquires an inner stability and a new trust in himself. These last achievements now redound to the good of the patient's social existence; for an inwardly stable and self-confident person will prove more adequate to his social tasks than one who is on a bad footing with his unconscious.

[111] I have purposely avoided loading my lecture with theory, hence much must remain obscure and unexplained. But, in order to make the pictures produced by my patients intelligible, certain theoretical points must at least receive mention. A feature common to all these pictures is a primitive symbolism which is conspicuous both in the drawing and in the colouring. The colours are as a rule quite barbaric in their intensity. Often an unmistakable archaic quality is present. These peculiarities point to the nature of the underlying creative forces. They are irrational, symbolistic currents that run through the whole history of mankind, and are so archaic in character that it is not difficult to find their parallels in archaeology and comparative religion. We may therefore take it that our pictures spring chiefly from those regions of the psyche which I have termed the collective unconscious. By this I understand an unconscious psychic functioning common to all men, the source not only of our modern symbolical pictures but of all similar products in the past. Such pictures spring from, and satisfy, a natural need. It is as if a part of the psyche that reaches far back into the primitive past were expressing itself in these pictures and finding it possible to function in harmony with our alien conscious mind. This collaboration satisfies and thus mitigates the psyche's disturbing demands upon the latter. It must, however, be added that the mere execution of the pictures is not enough. Over and above that, an intellectual and emotional understanding is needed; they require to be not only rationally integrated with the conscious mind, but morally assimilated. They still have to be subjected to a work of synthetic interpretation. Although I have travelled this path with individual patients many times, I have never yet succeeded in

making all the details of the process clear enough for publication.⁶ So far this has been fragmentary only. The truth is, we are here moving in absolutely new territory, and a ripening of experience is the first requisite. For very important reasons I am anxious to avoid hasty conclusions. We are dealing with a process of psychic life outside consciousness, and our observation of it is indirect. As yet we do not know to what depths our vision will plumb. It would seem to be some kind of centring process, for a great many pictures which the patients themselves feel to be decisive point in this direction. During this centring process what we call the ego appears to take up a peripheral position. The change is apparently brought about by an emergence of the historical part of the psyche. Exactly what is the purpose of this process remains at first sight obscure. We can only remark its important effect on the conscious personality. From the fact that the change heightens the feeling for life and maintains the flow of life, we must conclude that it is animated by a peculiar purposefulness. We might perhaps call this a new illusion. But what is “illusion”? By what criterion do we judge something to be an illusion? Does anything exist for the psyche that we are entitled to call illusion? What we are pleased to call illusion may be for the psyche an extremely important life-factor, something as indispensable as oxygen for the body—a psychic actuality of over-whelming significance. Presumably the psyche does not trouble itself about our categories of reality; for it, everything that *works* is real. The investigator of the psyche must not confuse it with his consciousness, else he veils from his sight the object of his investigation. On the contrary, to recognize it at all, he must learn to see how different it is from consciousness. Nothing is more probable than that what we call illusion is very real for the psyche—for which reason we cannot take psychic reality to be commensurable with conscious reality. To the psychologist there is nothing more fatuous than the attitude of the missionary who pronounces the gods of the “poor heathen” to be mere illusion. Unfortunately we still go blundering along in the same dogmatic way, as though *our* so-called reality were not equally full of illusion. In psychic life, as everywhere in our experience, all things that work are reality, regardless of the names man chooses to bestow on them. To take these realities for what they are—not foisting other names on them—that is our business. To the psyche, spirit is no less spirit for being named sexuality.

[112] I must repeat that these designations and the changes rung upon them never even remotely touch the essence of the process we have described. It cannot be compassed by the rational concepts of the conscious mind, any more than life itself; and it is for this reason that my patients consistently turn to the representation and interpretation of symbols as the more adequate and effective course.

[113] With this I have said pretty well everything I can say about my therapeutic aims and intentions within the broad framework of a lecture. It can be no more than an

incentive to thought, and I shall be quite content if such it has been.

V

PROBLEMS OF MODERN PSYCHOTHERAPY¹

[114] Psychotherapy, or the treatment of the mind by psychological methods, is today identified in popular thought with “psychoanalysis.”

[115] The word “psychoanalysis” has become so much a part of common speech that everyone who uses it seems to understand what it means. But what the word actually connotes is unknown to most laymen. According to the intention of its creator, Freud, it can be appropriately applied only to the method, inaugurated by himself, of reducing psychic symptoms and complexes to certain repressed impulses; and in so far as this procedure is not possible without the corresponding points of view, the idea of psychoanalysis also includes certain theoretical assumptions, formulated as the Freudian theory of sexuality expressly insisted upon by its author. But, Freud notwithstanding, the layman employs the term “psychoanalysis” loosely for all modern attempts whatsoever to probe the mind by scientific methods. Thus Adler’s school must submit to being labelled “psychoanalytic” despite the fact that Adler’s viewpoint and method are apparently in irreconcilable opposition to those of Freud. In consequence, Adler does not call his psychology “psychoanalysis” but “individual psychology”; while I prefer to call my own approach “analytical psychology.” by which I mean something like a general concept embracing both psychoanalysis and individual psychology as well as other endeavours in the field of “complex psychology.”

[116] Since, however, there is but one mind, or one psyche, in man, it might seem to the layman that there can be only one psychology, and he might therefore suppose these distinctions to be either subjective quibbles or the commonplace attempts of small-minded persons to set themselves up on little thrones. I could easily lengthen the list of “psychologies” by mentioning other systems not included under “analytical psychology.” There are in fact many different methods, standpoints, views, and beliefs which are all at war with one another, chiefly because they all misunderstand one another and refuse to give one another their due. The many-sidedness, the diversity, of psychological opinions in our day is nothing less than astonishing, not to say confusing for the layman.

[117] If, in a text-book of pathology, we find numerous remedies of the most diverse kind prescribed for a given disease, we may safely conclude that none of these

remedies is particularly efficacious. So, when many different ways of approaching the psyche are recommended, we may rest assured that none of them leads with absolute certainty to the goal, least of all those advocated with fanaticism. The very number of present-day psychologies is a confession of perplexity. The difficulty of gaining access to the psyche is gradually being borne in upon us, and the psyche itself is seen to be a “horned problem,” to use Nietzsche’s expression. It is small wonder therefore that efforts to attack this elusive riddle keep on multiplying, first from one side and then from another. The variety of contradictory standpoints and opinions is the inevitable result.

[118] The reader will doubtless agree that in speaking of psychoanalysis we should not confine ourselves to its narrower connotation, but should deal in general with the successes and failures of the various contemporary endeavours, which we sum up under the term “analytical psychology,” to solve the problem of the psyche.

[119] But why this sudden interest in the human psyche as a datum of experience? For thousands of years it was not so. I wish merely to raise this apparently irrelevant question, not to answer it. In reality it is not irrelevant, because the impulses at the back of our present-day interest in psychology have a sort of subterranean connection with this question.

[120] All that now passes under the layman’s idea of “psychoanalysis” has its origin in medical practice; consequently most of it is medical psychology. This psychology bears the unmistakable stamp of the doctor’s consulting-room, as can be seen not only in its terminology but also in its theoretical set-up. Everywhere we come across assumptions which the doctor has taken over from natural science and biology. It is this that has largely contributed to the divorce between modern psychology and the academic or humane sciences, for psychology explains things in terms of irrational nature, whereas the latter studies are grounded in the intellect. The distance between mind and nature, difficult to bridge at best, is still further increased by a medical and biological nomenclature which often strikes us as thoroughly mechanical, and more often than not severely overtaxes the best-intentioned understanding.

[121] Having expressed the hope that the foregoing general remarks may not be out of place in view of the confusion of terms existing in this field, I should now like to turn to the real task in hand and scrutinize the achievements of analytical psychology.

[122] Since the endeavours of our psychology are so extraordinarily heterogeneous, it is only with the greatest difficulty that we can take up a broadly inclusive standpoint. If, therefore, I try to divide the aims and results of these endeavours into certain classes, or rather stages, I do so with the express reservation appropriate to a purely provisional undertaking which, it may be objected, is just as arbitrary as the surveyor’s triangulation of a landscape. Be that as it may, I would venture to regard

the sum total of our findings under the aspect of four stages, namely, confession, elucidation, education, and transformation. I shall now proceed to discuss these somewhat unusual terms.

[123] The first beginnings of all analytical treatment of the soul are to be found in its prototype, the confessional. Since, however, the two have no direct causal connection, but rather grow from a common irrational psychic root, it is difficult for an outsider to see at once the relation between the groundwork of psychoanalysis and the religious institution of the confessional.

[124] Once the human mind had succeeded in inventing the idea of sin, man had recourse to psychic concealment; or, in analytical parlance, repression arose. Anything concealed is a secret. The possession of secrets acts like a psychic poison that alienates their possessor from the community. In small doses, this poison may be an invaluable medicament, even an essential pre-condition of individual differentiation, so much so that even on the primitive level man feels an irresistible need actually to invent secrets: their possession safeguards him from dissolving in the featureless flow of unconscious community life and thus from deadly peril to his soul. It is a well known fact that the widespread and very ancient rites of initiation with their mystery cults subserved this instinct for differentiation. Even the Christian sacraments were looked upon as “mysteries” in the early Church, and, as in the case of baptism, were celebrated in secluded spots and only mentioned under the veil of allegory.

[125] A secret shared with several persons is as beneficial as a merely private secret is destructive. The latter works like a burden of guilt, cutting off the unfortunate possessor from communion with his fellows. But, if we are conscious of what we are concealing, the harm done is decidedly less than if we do not know what we are repressing—or even that we have repressions at all. In this case the hidden content is no longer consciously kept secret; we are concealing it even from ourselves. It then splits off from the conscious mind as an independent complex and leads a sort of separate existence in the unconscious psyche, where it can be neither interfered with nor corrected by the conscious mind. The complex forms, so to speak, a miniature self-contained psyche which, as experience shows, develops a peculiar fantasy-life of its own. What we call fantasy is simply spontaneous psychic activity, and it wells up wherever the inhibitive action of the conscious mind abates or, as in sleep, ceases altogether. In sleep, fantasy takes the form of dreams. But in waking life, too, we continue to dream beneath the threshold of consciousness, especially when under the influence of repressed or other unconscious complexes. Incidentally, unconscious contents are on no account composed exclusively of complexes that were once conscious and subsequently became unconscious by being repressed. The

unconscious, too, has its own specific contents which push up from unknown depths and gradually reach consciousness. Hence we should in no wise picture the unconscious psyche as a mere receptacle for contents discarded by the conscious mind.

[126] All unconscious contents, which either approach the threshold of consciousness from below, or have sunk only slightly beneath it, affect the conscious mind. Since the content does not appear as such in consciousness, these effects are necessarily indirect. Most of our “lapses” are traceable to such disturbances, as are all neurotic symptoms, which are nearly always, in medical parlance, of a psychogenic nature, the exceptions being shock effects (shell-shock and the like). The mildest forms of neurosis are the lapses of consciousness mentioned above—e.g., slips of the tongue, suddenly forgetting names and dates, inadvertent clumsiness leading to injuries and accidents, misunderstandings and so-called hallucinations of memory, as when we think we have said something or done something, or faulty apprehension of things heard and said, and so on.

[127] In all these instances a thorough investigation can show the existence of some content which, in an indirect and unconscious way, is distorting the performance of the conscious mind.

[128] Generally speaking, therefore, an unconscious secret is more injurious than a conscious one. I have seen many patients who, as a result of difficult circumstances that might well have driven weaker natures to suicide, sometimes developed a suicidal tendency but, because of their inherent reasonableness, prevented it from becoming conscious and in this way generated an unconscious suicide-complex. This unconscious urge to suicide then engineered all kinds of dangerous accidents—as, for instance, a sudden attack of giddiness on some exposed place, hesitation in front of a motor-car, mistaking corrosive sublimate for cough mixture, a sudden zest for dangerous acrobatics, and so forth. When it was possible to make the suicidal leaning conscious in these cases, common sense could intervene as a salutary check: the patients could then consciously recognize and avoid the situations that tempted them to self-destruction.

[129] All personal secrets, therefore, have the effect of sin or guilt, whether or not they are, from the standpoint of popular morality, wrongful secrets.

[130] Another form of concealment is the act of holding something back. What we usually hold back are emotions or affects. Here too it must be stressed that self-restraint is healthy and beneficial; it may even be a virtue. That is why we find self-discipline to be one of the earliest moral arts even among primitive peoples, where it has its place in the initiation ceremonies, chiefly in the form of ascetic continence and the stoical endurance of pain and fear. Self-restraint is here practised within a

secret society as an undertaking shared with others. But if self-restraint is only a personal matter, unconnected with any religious views, it may become as injurious as the personal secret. Hence the well-known bad moods and irritability of the over-virtuous. The affect withheld is likewise something we conceal, something we can hide even from ourselves—an art in which men particularly excel, while women, with very few exceptions, are by nature averse to doing such injury to their affects. When an affect is withheld it is just as isolating and just as disturbing in its effects as the unconscious secret, and just as guilt-laden. In the same way that nature seems to bear us a grudge if we have the advantage of a secret over the rest of humanity, so she takes it amiss if we withhold our emotions from our fellow men. Nature decidedly abhors a vacuum in this respect; hence there is nothing more unendurable in the long run than a tepid harmony based on the withholding of affects. The repressed emotions are often of a kind we wish to keep secret. But more often there is no secret worth mentioning, only emotions which have become unconscious through being withheld at some critical juncture.

[131] The respective predominance of secrets or of inhibited emotions is probably responsible for the different forms of neurosis. At any rate the hysterical subject who is very free with his emotions is generally the possessor of a secret, while the hardened psychasthenic suffers from emotional indigestion.

[132] To cherish secrets and hold back emotion is a psychic misdemeanour for which nature finally visits us with sickness—that is, when we do these things in private. But when they are done in communion with others they satisfy nature and may even count as useful virtues. It is only restraint practised for oneself alone that is unwholesome. It is as if man had an inalienable right to behold all that is dark, imperfect, stupid, and guilty in his fellow men—for such, of course, are the things we keep secret in order to protect ourselves. It seems to be a sin in the eyes of nature to hide our inferiority—just as much as to live entirely on our inferior side. There would appear to be a sort of conscience in mankind which severely punishes every one who does not somehow and at some time, at whatever cost to his virtuous pride, cease to defend and assert himself, and instead confess himself fallible and human. Until he can do this, an impenetrable wall shuts him off from the vital feeling that he is a man among other men.

[133] This explains the extraordinary significance of genuine, straightforward confession—a truth that was probably known to all the initiation rites and mystery cults of the ancient world. There is a saying from the Greek mysteries: “Give up what thou hast, and then thou wilt receive.”

[134] We may well take this saying as a motto for the first stage in psychotherapeutic treatment. The beginnings of psychoanalysis are in fact nothing else than the

scientific rediscovery of an ancient truth; even the name that was given to the earliest method—catharsis, or cleansing—is a familiar term in the classical rites of initiation. The early cathartic method consisted in putting the patient, with or without the paraphernalia of hypnosis, in touch with the hinterland of his mind, hence into that state which the yoga systems of the East describe as meditation or contemplation. In contrast to yoga, however, the aim here is to observe the sporadic emergence, whether in the form of images or of feelings, of those dim representations which detach themselves in the darkness from the invisible realm of the unconscious and move as shadows before the inturned gaze. In this way things repressed and forgotten come back again. This is a gain in itself, though often a painful one, for the inferior and even the worthless belongs to me as my shadow and gives me substance and mass. How can I be substantial without casting a shadow? I must have a dark side too if I am to be whole; and by becoming conscious of my shadow I remember once more that I am a human being like any other. At any rate, if this rediscovery of my own wholeness remains private, it will only restore the earlier condition from which the neurosis, i.e., the split-off complex, sprang. Privacy prolongs my isolation and the damage is only partially mended. But through confession I throw myself into the arms of humanity again, freed at last from the burden of moral exile. The goal of the cathartic method is full confession—not merely the intellectual recognition of the facts with the head, but their confirmation by the heart and the actual release of suppressed emotion.

[135] As may easily be imagined, the effect of such a confession on simple souls is very great, and its curative results are often astonishing. Yet I would not wish to see the main achievement of our psychology at this stage merely in the fact that some sufferers are cured, but rather in the systematic emphasis it lays upon the significance of confession. For this concerns us all. All of us are somehow divided by our secrets, but instead of seeking to cross the gulf on the firm bridge of confession, we choose the treacherous makeshift of opinion and illusion.

[136] Now I am far from wishing to enunciate a general maxim. It would be difficult to imagine anything more unsavoury than a wholesale confession of sin. Psychology simply establishes the fact that we have here a sore spot of first-rate importance. As the next stage, the stage of elucidation, will make clear, it cannot be tackled directly, because it is a problem with quite particularly pointed horns.

[137] It is of course obvious that the new psychology would have remained at the stage of confession had catharsis proved itself a panacea. First and foremost, however, it is not always possible to bring the patients close enough to the unconscious for them to perceive the shadows. On the contrary, many of them—and for the most part complicated, highly conscious persons—are so firmly anchored in consciousness that

nothing can pry them loose. They develop the most violent resistances to any attempt to push consciousness aside; they want to talk with the doctor on the conscious plane and go into a rational explanation and discussion of their difficulties. They have quite enough to confess already, they say; they do not have to turn to the unconscious for that. For such patients a complete technique for approaching the unconscious is needed.

[138] This is one fact which at the outset seriously restricts the application of the cathartic method. The other restriction reveals itself later on and leads straight into the problems of the second stage. Let us suppose that in a given case the cathartic confession has occurred, the neurosis has vanished, or rather the symptoms are no longer visible. The patient could now be dismissed as cured—if it depended on the doctor alone. But he—or especially she—cannot get away. The patient seems bound to the doctor through the confession. If this seemingly senseless attachment is forcibly severed, there is a bad relapse. Significantly enough, and most curiously, there are cases where no attachment develops; the patient goes away apparently cured, but he is now so fascinated by the hinterland of his own mind that he continues to practise catharsis on himself at the expense of his adaptation to life. He is bound to the unconscious, to himself, and not to the doctor. Clearly the same fate has befallen him as once befell Theseus and Peirithous his companion, who went down to Hades to bring back the goddess of the underworld. Tiring on the way, they sat down to rest for a while, only to find that they had grown fast to the rocks and could not rise.

[139] These curious and unforeseen mischances need elucidation just as much as the first-mentioned cases, those that proved inaccessible to catharsis. In spite of the fact that the two categories of patients are apparently quite different, elucidation is called for at precisely the same point—that is, where the problem of fixation arises, as was correctly recognized by Freud. This is immediately obvious with patients who have undergone catharsis, especially if they remain bound to the doctor. The same sort of thing had already been observed as the unpleasant result of hypnotic treatment, although the inner mechanisms of such a tie were not understood. It now turns out that the nature of the tie in question corresponds more or less to the relation between father and child. The patient falls into a sort of childish dependence from which he cannot defend himself even by rational insight. The fixation is at times extraordinarily powerful—its strength is so amazing that one suspects it of being fed by forces quite outside ordinary experience. Since the tie is the result of an unconscious process, the conscious mind of the patient can tell us nothing about it. Hence the question arises of how this new difficulty is to be met. Obviously we are dealing with a neurotic formation, a new symptom directly induced by the treatment. The unmistakable outward sign of the situation is that the “feeling-toned” memory-image of the father is transferred to the doctor, so that whether he likes it or not the

doctor appears in the role of the father and thus turns the patient into a child. Naturally the patient's childishness does not arise on that account—it was always present, but repressed. Now it comes to the surface, and—the long-lost father being found again—tries to restore the family situation of childhood. Freud gave to this symptom the appropriate name of “transference.” That there should be a certain dependence on the doctor who has helped you is a perfectly normal and humanly understandable phenomenon. What is abnormal and unexpected is the extraordinary toughness of the tie and its imperviousness to conscious correction.

[140] It is one of Freud's outstanding achievements to have explained the nature of this tie, or at least the biological aspects of it, and thus to have facilitated an important advance in psychological knowledge. Today it has been incontestably proved that the tie is caused by unconscious fantasies. These fantasies have in the main what we may call an “incestuous” character, which seems adequately to explain the fact that they remain unconscious, for we can hardly expect such fantasies, barely conscious at best, to come out even in the most scrupulous confession. Although Freud always speaks of incest-fantasies as though they were repressed, further experience has shown that in very many cases they were never the contents of the conscious mind at all or were conscious only as the vaguest adumbrations, for which reason they could not have been repressed intentionally. It is more probable that the incest-fantasies were always essentially unconscious and remained so until positively dragged into the light of day by the analytical method. This is not to say that fishing them out of the unconscious is a reprehensible interference with nature. It is something like a surgical operation on the psyche, but absolutely necessary inasmuch as the incest-fantasies are the cause of the transference and its complex symptoms, which are no less abnormal for being an artificial product.

[141] While the cathartic method restores to the ego such contents as are capable of becoming conscious and should normally be components of the conscious mind, the process of clearing up the transference brings to light contents which are hardly ever capable of becoming conscious in that form. This is the cardinal distinction between the stage of confession and the stage of elucidation.

[142] We spoke earlier of two categories of patients: those who prove impervious to catharsis and those who develop a fixation after catharsis. We have just dealt with those whose fixation takes the form of transference. But, besides these, there are people who, as already mentioned, develop no attachment to the doctor but rather to their own unconscious, in which they become entangled as in a web. Here the parental imago is not transferred to any human object but remains a fantasy, although as such it exerts the same pull and results in the same tie as does the transference. The first category, the people who cannot yield themselves unreservedly to catharsis,

can be understood in the light of Freudian research. Even before they came along for treatment they stood in an identity-relationship to their parents, deriving from it that authority, independence, and critical power which enabled them successfully to withstand the catharsis. They are mostly cultivated, differentiated personalities who, unlike the others, did not fall helpless victims to the unconscious activity of the parental imago, but rather usurped this activity by unconsciously identifying themselves with their parents.

[143] Faced with the phenomenon of transference, mere confession is of no avail; it was for this reason that Freud was driven to substantial modifications of Breuer's original cathartic method. What he now practised he called the "interpretative method."

[144] This further step is quite logical, for the transference relationship is in especial need of elucidation. How very much this is the case the layman can hardly appreciate; but the doctor who finds himself suddenly entangled in a web of incomprehensible and fantastic notions sees it all too clearly. He must interpret the transference—explain to the patient what he is projecting upon the doctor. Since the patient himself does not know what it is, the doctor is obliged to submit what scraps of fantasy he can obtain from the patient to analytical interpretation. The first and most important products of this kind are dreams. Freud therefore proceeded to examine dreams exclusively for their stock of wishes that had been repressed because incompatible with reality, and in the process discovered the incestuous contents of which I have spoken. Naturally the investigation revealed not merely incestuous material in the stricter sense of the word, but every conceivable kind of filth of which human nature is capable—and it is notorious that a lifetime would be required to make even a rough inventory of it.

[145] The result of the Freudian method of elucidation is a minute elaboration of man's shadow-side unexampled in any previous age. It is the most effective antidote imaginable to all the idealistic illusions about the nature of man; and it is therefore no wonder that there arose on all sides the most violent opposition to Freud and his school. I will not speak of the inveterate illusionists; I would merely point out that among the opponents of this method of explanation there are not a few who have no illusions about man's shadow-side and yet object to a biased portrayal of man from the shadow-side alone. After all, the essential thing is not the shadow but the body which casts it.

[146] Freud's interpretative method rests on "reductive" explanations which unfailingly lead backwards and downwards, and it is essentially destructive if overdone or handled one-sidedly. Nevertheless psychology has profited greatly from Freud's pioneer work; it has learned that human nature has its black side—and not man alone,

but his works, his institutions, and his convictions as well. Even our purest and holiest beliefs rest on very deep and dark foundations; after all, we can explain a house not only from the attic downwards, but from the basement upwards, and the latter explanation has the prime advantage of being genetically the more correct, since houses are in fact built bottom-side first, and the beginning of all things is simple and crude. No thinking person can deny that Salomon Reinach's explanation of the Last Supper in terms of primitive totemism is fraught with significance; nor will he reject the application of the incest hypothesis to the myths of the Greek divinities. Certainly it pains our sensibilities to interpret radiant things from the shadow-side and thus in a measure trample them in the sorry dirt of their beginnings. But I hold it to be an imperfection in things of beauty, and a frailty in man, if anything of such a kind permit itself to be destroyed by a mere shadow-explanation. The uproar over Freud's interpretations is entirely due to our own barbarous or childish naïveté, which does not yet understand that high rests on low, and that *les extrêmes se touchent* really is one of the ultimate verities. Our mistake lies in supposing that the radiant things are done away with by being explained from the shadow-side. This is a regrettable error into which Freud himself has fallen. Shadow pertains to light as evil to good, and vice versa. Therefore I cannot lament the shock which this exposure administered to our occidental illusions and pettiness; on the contrary I welcome it as an historic and necessary rectification of almost incalculable importance. For it forces us to accept a philosophical relativism such as Einstein embodies for mathematical physics, and which is fundamentally a truth of the Far East whose ultimate effects we cannot at present foresee.

[147] Nothing, it is true, is less effective than an intellectual idea. But when an idea is a *psychic fact* that crops up in two such totally different fields as psychology and physics, apparently without historical connection, then we must give it our closest attention. For ideas of this kind represent forces which are logically and morally unassailable; they are always stronger than man and his brain. He fancies that he makes these ideas, but in reality they make him—and make him their unwitting mouthpiece.

[148] To return to our problem of fixation, I should now like to deal with the effects of elucidation. The fixation having been traced back to its dark origins, the patient's position becomes untenable; he cannot avoid seeing how inept and childish his demands are. He will either climb down from his exalted position of despotic authority to a more modest level and accept an insecurity which may prove very wholesome, or he will realize the inescapable truth that to make claims on others is a childish self-indulgence which must be replaced by a greater sense of responsibility.

[149] The man of insight will draw his own moral conclusions. Armed with the knowledge of his deficiencies, he will plunge into the struggle for existence and consume in progressive work and experience all those forces and longings which previously caused him to cling obstinately to a child's paradise, or at least to look back at it over his shoulder. Normal adaptation and forbearance with his own shortcomings: these will be his guiding moral principles, together with freedom from sentimentality and illusion. The inevitable result is a turning away from the unconscious as from a source of weakness and temptation—the field of moral and social defeat.

[150] The problem which now faces the patient is his education as a social being, and with this we come to the third stage. For many morally sensitive natures, mere insight into themselves has sufficient motive force to drive them forward, but it is not enough for people with little moral imagination. For them—to say nothing of those who may have been struck by the analyst's interpretation but still doubt it in their heart of hearts—self-knowledge without the spur of external necessity is ineffective even when they are deeply convinced of its truth. Then again it is just the intellectually differentiated people who grasp the truth of the reductive explanation but cannot tolerate mere deflation of their hopes and ideals. In these cases, too, the power of insight will be of no avail. The explanatory method always presupposes sensitive natures capable of drawing independent moral conclusions from insight. It is true that elucidation goes further than uninterpreted confession alone, for at least it exercises the mind and may awaken dormant forces which can intervene in a helpful way. But the fact remains that in many cases the most thorough elucidation leaves the patient an intelligent but still incapable child. Moreover Freud's cardinal explanatory principle in terms of pleasure and its satisfaction is, as further research has shown, one-sided and therefore unsatisfactory. Not everybody can be explained from this angle. No doubt we all have this angle, but it is not always the most important. We can give a starving man a beautiful painting; he would much prefer bread. We can nominate a languishing lover President of the United States; he would far rather wrap his arms round his adored. On the average, all those who have no difficulty in achieving social adaptation and social position are better accounted for by the pleasure principle than are the unadapted who, because of their social inadequacy, have a craving for power and importance. The elder brother who follows in his father's footsteps and wins to a commanding position in society may be tormented by his desires; while the younger brother who feels himself suppressed and overshadowed by the other two may be goaded by ambition and the need for self-assertion. He may yield so completely to this passion that nothing else can become a problem for him, anyway not a vital one.

[151] At this point in Freud's system of explanation there is a palpable gap, into which there stepped his one-time pupil, Adler. Adler has shown convincingly that numerous cases of neurosis can be far more satisfactorily explained by the power instinct than by the pleasure principle. The aim of his interpretation is therefore to show the patient that he "arranges" his symptoms and exploits his neurosis in order to achieve a fictitious importance; and that even his transference and his other fixations subserve the will to power and thus represent a "masculine protest" against imaginary suppression. Obviously Adler has in mind the psychology of the under-dog or social failure, whose one passion is self-assertion. Such individuals are neurotic because they always imagine they are hard done by and tilt at the windmills of their own fancy, thus putting the goal they most desire quite out of reach.

[152] Adler's method begins essentially at the stage of elucidation; he explains the symptoms in the sense just indicated, and to that extent appeals to the patient's understanding. Yet it is characteristic of Adler that he does not expect too much of understanding, but, going beyond that, has clearly recognized the need for social education. Whereas Freud is the investigator and interpreter, Adler is primarily the educator. He thus takes up the negative legacy which Freud bequeathed him, and, refusing to leave the patient a mere child, helpless despite his valuable understanding, tries by every device of education to make him a normal and adapted person. He does this evidently in the conviction that social adaptation and normalization are desirable goals, that they are absolutely necessary, the consummation of human life. From this fundamental attitude comes the widespread social activity of the Adlerian school, but also its depreciation of the unconscious, which, it seems, occasionally amounts to its complete denial. This is probably a swing of the pendulum—the inevitable reaction to the emphasis Freud lays on the unconscious, and as such quite in keeping with the natural aversion which we noted in patients struggling for adaptation and health. For, if the unconscious is held to be nothing more than a receptacle for all the evil shadow-things in human nature, including deposits of primeval slime, we really do not see why we should linger longer than necessary on the edge of this swamp into which we once fell. The scientific inquirer may behold a world of wonders in a mud puddle, but for the ordinary man it is something best left alone. Just as early Buddhism had no gods because it had to free itself from an inheritance of nearly two million gods, so psychology, if it is to develop further, must leave behind so entirely negative a thing as Freud's conception of the unconscious. The educational aims of the Adlerian school begin precisely where Freud leaves off; consequently they meet the needs of the patient who, having come to understand himself, wants to find his way back to normal life. It is obviously not enough for him to know how his illness arose and whence it came, for we seldom get rid of an evil merely by understanding its causes. Nor should it be forgotten that the crooked paths of a neurosis lead to as

many obstinate habits, and that for all our insight these do not disappear until replaced by other habits. But habits are won only by exercise, and appropriate education is the sole means to this end. The patient must be *drawn out* of himself into other paths, which is the true meaning of “education,” and this can only be achieved by an educative will. We can therefore see why Adler’s approach has found favour chiefly with clergymen and teachers, while Freud’s approach is fancied by doctors and intellectuals, who are one and all bad nurses and educators.

[153] Each stage in the development of our psychology has something curiously final about it. Catharsis, with its heart-felt outpourings, makes one feel: “Now we are there, everything has come out, everything is known, the last terror lived through and the last tear shed; now everything will be all right.” Elucidation says with equal conviction: “Now we know where the neurosis came from, the earliest memories have been unearthed, the last roots dug up, and the transference was nothing but the wish-fulfilling fantasy of a childhood paradise or a relapse into the family romance; the road to a normally disillusioned life is now open.” Finally comes education, pointing out that no amount of confession and no amount of explaining can make the crooked plant grow straight, but that it must be trained upon the trellis of the norm by the gardener’s art. Only then will normal adaptation be reached.

[154] This curious sense of finality which attends each of the stages accounts for the fact that there are people using cathartic methods today who have apparently never heard of dream interpretation, Freudians who do not understand a word of Adler, and Adlerians who do not wish to know anything about the unconscious. Each is ensnared in the peculiar finality of his own stage, and thence arises that chaos of opinions and views which makes orientation in these troubled waters so exceedingly difficult.

[155] Whence comes the feeling of finality that evokes so much authoritarian bigotry on all sides?

[156] I can only explain it to myself by saying that each stage does in fact rest on a final truth, and that consequently there are always cases which demonstrate this particular truth in the most startling way. In our delusion-ridden world a truth is so precious that nobody wants to let it slip merely for the sake of a few so-called exceptions which refuse to toe the line. And whoever doubts this truth is invariably looked on as a faithless reprobate, so that a note of fanaticism and intolerance everywhere creeps into the discussion.

[157] And yet each of us can carry the torch of knowledge but a part of the way, until another takes it from him. If only we could understand all this impersonally—could understand that we are not the personal creators of our truths, but only their exponents, mere mouthpieces of the day’s psychic needs, then much venom and

bitterness might be spared and we should be able to perceive the profound and supra-personal continuity of the human mind.

[158] As a rule, we take no account of the fact that the doctor who practises catharsis is not just an abstraction which automatically produces nothing but catharsis. He is also a human being, and although his thinking may be limited to his special field, his actions exert the influence of a complete human being. Without giving it a name and without being clearly conscious of it, he unwittingly does his share of explanation and education, just as the others do their share of catharsis without raising it to the level of a principle.

[159] All life is living history. Even the reptile still lives in us *par sous-entendu*. In the same way, the three stages of analytical psychology so far dealt with are by no means truths of such a nature that the last of them has gobbled up and replaced the other two. On the contrary, all three are salient aspects of one and the same problem, and they no more invalidate one another than do confession and absolution.

[160] The same is true of the fourth stage, transformation. It too should not claim to be the finally attained and only valid truth. It certainly fills a gap left by the earlier stages, but in so doing it merely fulfils a further need beyond the scope of the others.

[161] In order to make clear what this fourth stage has in view and what is meant by the somewhat peculiar term “transformation,” we must first consider what psychic need was not given a place in the earlier stages. In other words, can anything lead further or be higher than the claim to be a normal and adapted social being? To be a normal human being is probably the most useful and fitting thing of which we can think; but the very notion of a “normal human being,” like the concept of adaptation, implies a restriction to the average which seems a desirable improvement only to the man who already has some difficulty in coming to terms with the everyday world—a man, let us say, whose neurosis unfits him for normal life. To be “normal” is the ideal aim for the unsuccessful, for all those who are still below the general level of adaptation. But for people of more than average ability, people who never found it difficult to gain successes and to accomplish their share of the world’s work—for them the moral compulsion to be nothing but normal signifies the bed of Procrustes—deadly and insupportable boredom, a hell of sterility and hopelessness. Consequently there are just as many people who become neurotic because they are merely normal, as there are people who are neurotic because they cannot become normal. That it should enter anyone’s head to educate them to normality is a nightmare for the former, because their deepest need is really to be able to lead “abnormal” lives.

[162] A man can find satisfaction and fulfilment only in what he does not yet possess, just as he can never be satisfied with something of which he has already had too much. To be a social and adapted person has no charms for one to whom such an

aspiration is child's play. Always to do the right thing becomes a bore for the man who knows how, whereas the eternal bungler cherishes a secret longing to be right for once in some distant future.

[163] The needs and necessities of mankind are manifold. What sets one man free is another man's prison. So also with normality and adaptation. Even if it be a biological axiom that man is a herd animal who only finds optimum health in living as a social being, the very next case may quite possibly invert this axiom and show us that he is completely healthy only when leading an abnormal and unsocial life. It is enough to drive one to despair that in practical psychology there are no universally valid recipes and rules. There are only individual cases with the most heterogeneous needs and demands—so heterogeneous that we can virtually never know in advance what course a given case will take, for which reason it is better for the doctor to abandon all preconceived opinions. This does not mean that he should throw them overboard, but that in any given case he should use them merely as hypotheses for a possible explanation. Not, however, in order to instruct or convince his patient, but rather to show how the doctor reacts to that particular individual. For, twist and turn the matter as we may, the relation between doctor and patient remains a personal one within the impersonal framework of professional treatment. By no device can the treatment be anything but the product of mutual influence, in which the whole being of the doctor as well as that of his patient plays its part. In the treatment there is an encounter between two irrational factors, that is to say, between two persons who are not fixed and determinable quantities but who bring with them, besides their more or less clearly defined fields of consciousness, an indefinitely extended sphere of non-consciousness. Hence the personalities of doctor and patient are often infinitely more important for the outcome of the treatment than what the doctor says and thinks (although what he says and thinks may be a disturbing or a healing factor not to be underestimated). For two personalities to meet is like mixing two different chemical substances: if there is any combination at all, both are transformed. In any effective psychological treatment the doctor is bound to influence the patient; but this influence can only take place if the patient has a reciprocal influence on the doctor. You can exert no influence if you are not susceptible to influence. It is futile for the doctor to shield himself from the influence of the patient and to surround himself with a smoke-screen of fatherly and professional authority. By so doing he only denies himself the use of a highly important organ of information. The patient influences him unconsciously none the less, and brings about changes in the doctor's unconscious which are well known to many psychotherapists: psychic disturbances or even injuries peculiar to the profession, a striking illustration of the patient's almost "chemical" action. One of the best known symptoms of this kind is the counter-transference evoked by the transference. But the effects are often much more

subtle, and their nature can best be conveyed by the old idea of the demon of sickness. According to this, a sufferer can transmit his disease to a healthy person whose powers then subdue the demon—but not without impairing the well-being of the subduer.

[164] Between doctor and patient, therefore, there are imponderable factors which bring about a mutual transformation. In the process, the stronger and more stable personality will decide the final issue. I have seen many cases where the patient assimilated the doctor in defiance of all theory and of the latter's professional intentions—generally, though not always, to the disadvantage of the doctor.

[165] The stage of transformation is grounded on these facts, but it took more than twenty-five years of wide practical experience for them to be clearly recognized. Freud himself has admitted their importance and has therefore seconded my demand for the analysis of the analyst.

[166] What does this demand mean? Nothing less than that the doctor is as much “in the analysis” as the patient. He is equally a part of the psychic process of treatment and therefore equally exposed to the transforming influences. Indeed, to the extent that the doctor shows himself impervious to this influence, he forfeits influence over the patient; and if he is influenced only unconsciously, there is a gap in his field of consciousness which makes it impossible for him to see the patient in true perspective. In either case the result of the treatment is compromised.

[167] The doctor is therefore faced with the same task which he wants his patient to face—that is, he must become socially adapted or, in the reverse case, appropriately non-adapted. This therapeutic demand can of course be clothed in a thousand different formulae, according to the doctor's beliefs. One doctor believes in overcoming infantilism—therefore he must first overcome his own infantilism. Another believes in abreacting all affects—therefore he must first abreact all his own affects. A third believes in complete consciousness—therefore he must first reach consciousness of himself. The doctor must consistently strive to meet his own therapeutic demand if he wishes to ensure the right sort of influence over his patients. All these guiding principles of therapy make so many ethical demands, which can be summed up in the single truth: be the man through whom you wish to influence others. Mere talk has always been counted hollow, and there is no trick, however artful, by which this simple truth can be evaded in the long run. The fact of being convinced and not the thing we are convinced of—that is what has always, and at all times, worked.

[168] Thus the fourth stage of analytical psychology requires the counter-application to the doctor himself of whatever system is believed in—and moreover with the same

relentlessness, consistency, and perseverance with which the doctor applies it to the patient.

[169] When one considers with what attentiveness and critical judgment the psychologist must keep track of his patients in order to show up all their false turnings, their false conclusions and infantile subterfuges, then it is truly no mean achievement for him to perform the same work upon himself. We are seldom interested enough in ourselves for that; moreover nobody pays us for our introspective efforts. Again, the common neglect into which the reality of the human psyche has fallen is still so great that self-examination or preoccupation with ourselves is deemed almost morbid. Evidently we suspect the psyche of harbouring something unwholesome, so that any concern with it smells of the sick-room. The doctor has to overcome these resistances in himself, for who can educate others if he is himself uneducated? Who can enlighten others if he is still in the dark about himself? And who purify others if himself impure?

[170] The step from education to self-education is a logical advance that completes the earlier stages. The demand made by the stage of transformation, namely that the doctor must change himself if he is to become capable of changing his patient, is, as may well be imagined, a rather unpopular one, and for three reasons. First, because it seems unpractical; second, because of the unpleasant prejudice against being preoccupied with oneself; and third, because it is sometimes exceedingly painful to live up to everything one expects of one's patient. The last item in particular contributes much to the unpopularity of this demand, for if the doctor conscientiously doctors himself he will soon discover things in his own nature which are utterly opposed to normalization, or which continue to haunt him in the most disturbing way despite assiduous explanation and thorough abreaction. What is he to do about these things? He always knows what the patient should do about them—it is his professional duty to do so. But what, in all sincerity, will he do when they recoil upon himself or perhaps upon those who stand nearest to him? He may, in his self-investigations, discover some inferiority which brings him uncomfortably close to his patients and may even blight his authority. How will he deal with this painful discovery? This somewhat "neurotic" question will touch him on the raw, no matter how normal he thinks he is. He will also discover that the ultimate questions which worry him as much as his patients cannot be solved by any treatment, that to expect solutions from others is childish and keeps you childish, and that if no solution can be found the question must be repressed again.

[171] I will not pursue any further the many problems raised by self-examination because, owing to the obscurity which still surrounds the psyche, they would be of little interest today.

[172] Instead, I would like to emphasize once again that the newest developments in analytical psychology confront us with the imponderable elements in the human personality; that we have learned to place in the foreground the personality of the doctor himself as a curative or harmful factor; and that what is now demanded is his own transformation—the self-education of the educator. Consequently, everything that occurred on the objective level in the history of our psychology—confession, elucidation, education—passes to the subjective level; in other words, what happened to the patient must now happen to the doctor, so that his personality shall not react unfavourably on the patient. The doctor can no longer evade his own difficulty by treating the difficulties of others: the man who suffers from a running abscess is not fit to perform a surgical operation.

[173] Just as the momentous discovery of the unconscious shadow-side in man suddenly forced the Freudian school to deal even with questions of religion, so this latest advance makes an unavoidable problem of the doctor's ethical attitude. The self-criticism and self-examination that are indissolubly bound up with it necessitates a view of the psyche radically different from the merely biological one which has prevailed hitherto; for the human psyche is far more than a mere object of scientific interest. It is not only the sufferer but the doctor as well, not only the object but also the subject, not only a cerebral function but the absolute condition of consciousness itself.

[174] What was formerly a method of medical treatment now becomes a method of self-education, and with this the horizon of our psychology is immeasurably widened. The crucial thing is no longer the medical diploma, but the human quality. This is a significant turn of events, for it places all the implements of the psychotherapeutic art that were developed in clinical practice, and then refined and systematized, at the service of our self-education and self-perfection, with the result that analytical psychology has burst the bonds which till then had bound it to the consulting-room of the doctor. It goes beyond itself to fill the hiatus that has hitherto put Western civilization at a psychic disadvantage as compared with the civilizations of the East. We Westerners knew only how to tame and subdue the psyche; we knew nothing about its methodical development and its functions. Our civilization is still young, and young civilizations need all the arts of the animal-tamer to make the defiant barbarian and the savage in us more or less tractable. But at a higher cultural level we must forgo compulsion and turn to self-development. For this we must have a way, a method, which, as I said, has so far been lacking. It seems to me that the findings and experiences of analytical psychology can at least provide a foundation, for as soon as psychotherapy takes the doctor himself for its subject, it transcends its medical origins and ceases to be merely a method for treating the sick. It now treats the healthy or such as have a moral right to psychic health, whose sickness is at most

the suffering that torments us all. For this reason analytical psychology can claim to serve the common weal—more so even than the previous stages which are each the bearer of a general truth. But between this claim and present-day reality there lies a gulf, with no bridge leading across. We have yet to build that bridge stone by stone.

VI

PSYCHOTHERAPY AND A PHILOSOPHY OF LIFE¹

[175] So much is psychotherapy the child of practical improvisation that for a long time it had trouble in thinking out its own intellectual foundations. Empirical psychology relied very much at first on physical and then on physiological ideas, and ventured only with some hesitation on the complex phenomena which constitute its proper field. Similarly, psychotherapy was at first simply an auxiliary method; only gradually did it free itself from the world of ideas represented by medical therapeutics and come to understand that its concern lay not merely with physiological but primarily with psychological principles. In other words, it found itself obliged to raise psychological issues which soon burst the framework of the experimental psychology of that day with its elementary statements. The demands of therapy brought highly complex factors within the purview of this still young science, and its exponents very often lacked the equipment needed to deal with the problems that arose. It is therefore not surprising that a bewildering assortment of ideas, theories, and points of view predominated in all the initial discussions of this new psychology which had been, so to speak, forced into existence by therapeutic experience. An outsider could hardly be blamed if he received an impression of babel. This confusion was inevitable, for sooner or later it was bound to become clear that one cannot treat the psyche without touching on man and life as a whole, including the ultimate and deepest issues, any more than one can treat the sick body without regard to the totality of its functions—or rather, as a few representatives of modern medicine maintain, the totality of the sick man himself.

[176] The more “psychological” a condition is, the greater its complexity and the more it relates to the whole of life. It is true that elementary psychic phenomena are closely allied to physiological processes, and there is not the slightest doubt that the physiological factor forms at least one pole of the psychic cosmos. The instinctive and affective processes, together with all the neurotic symptomatology that arises when these are disturbed, clearly rest on a physiological basis. But, on the other hand, the disturbing factor proves equally clearly that it has the power to turn physiological order into disorder. If the disturbance lies in a repression, then the disturbing factor—that is, the repressive force—belongs to a “higher” psychic order. It is not something elementary and physiologically conditioned, but, as experience shows, a highly complex determinant, as for example certain rational, ethical, aesthetic, religious, or

other traditional ideas which cannot be scientifically proved to have any physiological basis. These extremely complex dominants form the other pole of the psyche. Experience likewise shows that this pole possesses an energy many times greater than that of the physiologically conditioned psyche.

[177] With its earliest advances into the field of psychology proper, the new psychotherapy came up against the problem of opposites—a problem that is profoundly characteristic of the psyche. Indeed, the structure of the psyche is so contradictory or contrapuntal that one can scarcely make any psychological assertion or general statement without having immediately to state its opposite.

[178] The problem of opposites offers an eminently suitable and ideal battleground for the most contradictory theories, and above all for partially or wholly unrealized prejudices regarding one's philosophy of life. With this development psychotherapy stirred up a hornets' nest of the first magnitude. Let us take as an example the supposedly simple case of a repressed instinct. If the repression is lifted, the instinct is set free. Once freed, it wants to live and function in its own way. But this creates a difficult—sometimes intolerably difficult—situation. The instinct ought therefore to be modified, or “sublimated,” as they say. How this is to be done without creating a new repression nobody can quite explain. The little word “ought” always proves the helplessness of the therapist; it is an admission that he has come to the end of his resources. The final appeal to reason would be very fine if man were by nature a rational animal, but he is not; on the contrary, he is quite as much irrational. Hence reason is often not sufficient to modify the instinct and make it conform to the rational order. Nobody can conceive the moral, ethical, philosophical, and religious conflicts that crop up at this stage of the problem—the facts surpass all imagination. Every conscientious and truth-loving psychotherapist could tell a tale here, though naturally not in public. All the contemporary problems, all the philosophical and religious questionings of our day, are raked up, and unless either the psychotherapist or the patient abandons the attempt in time it is likely to get under both their skins. Each will be driven to a discussion of his philosophy of life, both with himself and with his partner. There are of course forced answers and solutions, but in principle and in the long run they are neither desirable nor satisfying. No Gordian knot can be permanently cut; it has the awkward property of always tying itself again.

[179] This philosophical discussion is a task which psychotherapy necessarily sets itself, though not every patient will come down to basic principles. The question of the measuring rod with which to measure, of the ethical criteria which are to determine our actions, must be answered somehow, for the patient may quite possibly expect us to account for our judgments and decisions. Not all patients allow themselves to be condemned to infantile inferiority because of our refusal to render

such an account, quite apart from the fact that a therapeutic blunder of this kind would be sawing off the branch on which we sit. In other words, the art of psychotherapy requires that the therapist be in possession of avowable, credible, and defensible convictions which have proved their viability either by having resolved any neurotic dissociations of his own or by preventing them from arising. A therapist with a neurosis is a contradiction in terms. One cannot help any patient to advance further than one has advanced oneself. On the other hand, the possession of complexes does not in itself signify neurosis, for complexes are the normal foci of psychic happenings, and the fact that they are painful is no proof of pathological disturbance. Suffering is not an illness; it is the normal counterpole to happiness. A complex becomes pathological only when we think we have not got it.

[180] As the most complex of psychic structures, a man's philosophy of life forms the counterpole to the physiologically conditioned psyche, and, as the highest psychic dominant, it ultimately determines the latter's fate. It guides the life of the therapist and shapes the spirit of his therapy. Since it is an essentially subjective system despite the most rigorous objectivity, it may and very likely will be shattered time after time on colliding with the truth of the patient, but it rises again, rejuvenated by the experience. Conviction easily turns into self-defence and is seduced into rigidity, and this is inimical to life. The test of a firm conviction is its elasticity and flexibility; like every other exalted truth it thrives best on the admission of its errors.

[181] I can hardly draw a veil over the fact that we psychotherapists ought really to be philosophers or philosophic doctors—or rather that we already are so, though we are unwilling to admit it because of the glaring contrast between our work and what passes for philosophy in the universities. We could also call it religion *in statu nascendi*, for in the vast confusion that reigns at the roots of life there is no line of division between philosophy and religion. Nor does the unrelieved strain of the psychotherapeutic situation, with its host of impressions and emotional disturbances, leave us much leisure for the systematization of thought. Thus we have no clear exposition of guiding principles drawn from life to offer either to the philosophers or to the theologians.

[182] Our patients suffer from bondage to a neurosis, they are prisoners of the unconscious, and if we attempt to penetrate with understanding into that realm of unconscious forces, we have to defend ourselves against the same influences to which our patients have succumbed. Like doctors who treat epidemic diseases, we expose ourselves to powers that threaten our conscious equilibrium, and we have to take every possible precaution if we want to rescue not only our own humanity but that of the patient from the clutches of the unconscious. Wise self-limitation is not the same thing as text-book philosophy, nor is an ejaculatory prayer in a moment of

mortal danger a theological treatise. Both are the outcome of a religious and philosophical attitude that is appropriate to the stark dynamism of life.

[183] The highest dominant always has a religious or a philosophical character. It is by nature extremely primitive, and consequently we find it in full development among primitive peoples. Any difficulty, danger, or critical phase of life immediately calls forth this dominant. It is the most natural reaction to all highly charged emotional situations. But often it remains as obscure as the semiconscious emotional situation which evoked it. Hence it is quite natural that the emotional disturbances of the patient should activate the corresponding religious or philosophical factors in the therapist. Often he is most reluctant to make himself conscious of these primitive contents, and he quite understandably prefers to turn for help to a religion or philosophy which has reached his consciousness from outside. This course does not strike me as being illegitimate in so far as it gives the patient a chance to take his place within the structure of some protective institution existing in the outside world. Such a solution is entirely natural, since there have always and everywhere been totem clans, cults, and creeds whose purpose it is to give an ordered form to the chaotic world of the instincts.

[184] The situation becomes difficult, however, when the patient's nature resists a collective solution. The question then arises whether the therapist is prepared to risk having his convictions dashed and shattered against the truth of the patient. If he wants to go on treating the patient he must abandon all preconceived notions and, for better or worse, go with him in search of the religious and philosophical ideas that best correspond to the patient's emotional states. These ideas present themselves in archetypal form, freshly sprung from the maternal soil whence all religious and philosophical systems originally came. But if the therapist is not prepared to have his convictions called in question for the sake of the patient, then there is some reason for doubting the stability of his basic attitude. Perhaps he cannot give way on grounds of self-defence, which threatens him with rigidity. The margin of psychological elasticity varies both individually and collectively, and often it is so narrow that a certain degree of rigidity really does represent the maximum achievement. *Ultra posse nemo obligatur.*

[185] Instinct is not an isolated thing, nor can it be isolated in practice. It always brings in its train archetypal contents of a spiritual nature, which are at once its foundation and its limitation. In other words, an instinct is always and inevitably coupled with something like a philosophy of life, however archaic, unclear, and hazy this may be. Instinct stimulates thought, and if a man does not think of his own free will, then you get compulsive thinking, for the two poles of the psyche, the physiological and the mental, are indissolubly connected. For this reason instinct cannot be freed without

freeing the mind, just as mind divorced from instinct is condemned to futility. Not that the tie between mind and instinct is necessarily a harmonious one. On the contrary it is full of conflict and means suffering. Therefore the principal aim of psychotherapy is not to transport the patient to an impossible state of happiness, but to help him acquire steadfastness and philosophic patience in face of suffering. Life demands for its completion and fulfilment a balance between joy and sorrow. But because suffering is positively disagreeable, people naturally prefer not to ponder how much fear and sorrow fall to the lot of man. So they speak soothingly about progress and the greatest possible happiness, forgetting that happiness is itself poisoned if the measure of suffering has not been fulfilled. Behind a neurosis there is so often concealed all the natural and necessary suffering the patient has been unwilling to bear. We can see this most clearly from hysterical pains, which are relieved in the course of treatment by the corresponding psychic suffering which the patient sought to avoid.

[186] The Christian doctrine of original sin on the one hand, and of the meaning and value of suffering on the other, is therefore of profound therapeutic significance and is undoubtedly far better suited to Western man than Islamic fatalism. Similarly the belief in immortality gives life that untroubled flow into the future so necessary if stoppages and regressions are to be avoided. Although we like to use the word “doctrine” for these—psychologically speaking—extremely important ideas, it would be a great mistake to think that they are just arbitrary intellectual theories. Psychologically regarded, they are emotional experiences whose nature cannot be discussed. If I may permit myself a banal comparison, when I feel well and content nobody can prove to me that I am not. Logical arguments simply bounce off the facts felt and experienced. Original sin, the meaning of suffering, and immortality are emotional facts of this kind. But to experience them is a charisma which no human art can compel. Only unreserved surrender can hope to reach such a goal.

[187] Not everybody is capable of this surrender. There is no “ought” or “must” about it, for the very act of exerting the will inevitably places such an emphasis on *my* will to surrender that the exact opposite of surrender results. The Titans could not take Olympus by storm, and still less may a Christian take Heaven. The most healing, and psychologically the most necessary, experiences are a “treasure hard to attain,” and its acquisition demands something out of the common from the common man.

[188] As we know, this something out of the common proves, in practical work with the patient, to be an invasion by archetypal contents. If these contents are to be assimilated, it is not enough to make use of the current philosophical or religious ideas, for they simply do not fit the archaic symbolism of the material. We are therefore forced to go back to pre-Christian and non-Christian conceptions and to

conclude that Western man does not possess the monopoly of human wisdom and that the white race is not a species of *Homo sapiens* specially favoured by God. Moreover we cannot do justice to certain contemporary collective phenomena unless we revert to the pre-Christian parallels.

[189] Medieval physicians seem to have realized this, for they practised a philosophy whose roots can be traced back to pre-Christian times and whose nature exactly corresponds to our experiences with patients today. These physicians recognized, besides the light of divine revelation, a *lumen naturae* as a second, independent source of illumination, to which the doctor could turn if the truth as handed down by the Church should for any reason prove ineffective either for himself or for the patient.

[190] It was eminently practical reasons, and not the mere caperings of a hobby-horse, that prompted me to undertake my historical researches. Neither our modern medical training nor academic psychology and philosophy can equip the doctor with the necessary education, or with the means, to deal effectively and understandingly with the often very urgent demands of his psychotherapeutic practice. It therefore behoves us, unembarrassed by our shortcomings as amateurs of history, to go to school once more with the medical philosophers of a distant past, when body and soul had not yet been wrenched asunder into different faculties. Although we are specialists par excellence, our specialized field, oddly enough, drives us to universalism and to the complete overcoming of the specialist attitude, if the totality of body and soul is not to be just a matter of words. Once we have made up our minds to treat the soul, we can no longer close our eyes to the fact that neurosis is not a thing apart but the whole of the pathologically disturbed psyche. It was Freud's momentous discovery that the neurosis is not a mere agglomeration of symptoms, but a wrong functioning which affects the whole psyche. The important thing is not the neurosis, but the man who has the neurosis. We have to set to work on the human being, and we must be able to do him justice as a human being.

[191] The conference we are holding today proves that our psychotherapy has recognized its aim, which is to pay equal attention to the physiological and to the spiritual factor. Originating in natural science, it applies the objective, empirical methods of the latter to the phenomenology of the mind. Even if this should remain a mere attempt, the fact that the attempt has been made is of incalculable significance.

VII

MEDICINE AND PSYCHOTHERAPY¹

[192] Speaking before an audience of doctors, I always experience a certain difficulty in bridging the differences that exist between medicine on the one hand and psychotherapy on the other in their conception of pathology. These differences are the source of numerous misunderstandings, and it is therefore of the greatest concern to me, in this short talk, to express one or two thoughts which may serve to clarify the special relationship that psychotherapy bears to medicine. Where distinctions exist, well-meaning attempts to stress the common ground are notoriously lacking in point. But it is extremely important, in his own interests, that the psychotherapist should not in any circumstances lose the position he originally held in medicine, and this precisely because the peculiar nature of his experience forces upon him a certain mode of thought, and certain interests, which no longer have—or perhaps I should say, do not yet have—a rightful domicile in the medicine of today. Both these factors tend to lead the psychotherapist into fields of study apparently remote from medicine, and the practical importance of these fields is generally difficult to explain to the non-psychotherapist. From accounts of case histories and miraculously successful cures the non-psychotherapist learns little, and that little is frequently false. I have yet to come across a respectable specimen of neurosis of which one could give anything like an adequate description in a short lecture, to say nothing of all the therapeutic intricacies that are far from clear even to the shrewdest professional.

[193] With your permission I will now examine the three stages of medical procedure—anamnesis, diagnosis, and therapy—from the psychotherapeutic point of view. The pathological material I am here presupposing is pure psychoneurosis.

[194] We begin with the anamnesis, as is customary in medicine in general and psychiatry in particular—that is to say, we try to piece together the historical facts of the case as flawlessly as possible. The psychotherapist, however, does not rest content with these facts. He is aware not only of the unreliability of all evidence, but, over and above that, of the special sources of error in statements made on one's own behalf—the statements of the patient who, wittingly or unwittingly, gives prominence to facts that are plausible enough in themselves but may be equally misleading as regards the pathogenesis. The patient's whole environment may be drawn into this system of explanation in a positive or negative sense, as though it were in

unconscious collusion with him. At all events one must be prepared *not* to hear the very things that are most important. The psychotherapist will therefore take pains to ask questions about matters that seem to have nothing to do with the actual illness. For this he needs not only his professional knowledge; he has also to rely on intuitions and sudden ideas, and the more widely he casts his net of questions the more likely he is to succeed in catching the complex nature of the case. If ever there were an illness that cannot be localized, because it springs from the whole of a man, that illness is a psychoneurosis. The psychiatrist can at least console himself with diseases of the brain; not so the psychotherapist, even if he privately believes in such a maxim, for the case before him demands the thorough psychological treatment of a disturbance that has nothing to do with cerebral symptoms. On the contrary, the more the psychotherapist allows himself to be impressed by hereditary factors and the possibility of psychotic complications, the more crippled he will be in his therapeutic action. For better or worse he is obliged to overlook such cogent factors as heredity, the presence of schizophrenic symptoms, and the like, particularly when these dangerous things are put forward with special emphasis. His assessment of anamnestic data may therefore turn out to be very different from a purely medical one.

[195] It is generally assumed in medical circles that the examination of the patient should lead to the diagnosis of his illness, so far as this is possible at all, and that with the establishment of the diagnosis an important decision has been arrived at as regards prognosis and therapy. Psychotherapy forms a startling exception to this rule: the diagnosis is a highly irrelevant affair since, apart from affixing a more or less lucky label to a neurotic condition, nothing is gained by it, least of all as regards prognosis and therapy. In flagrant contrast to the rest of medicine, where a definite diagnosis is often, as it were, logically followed by a specific therapy and a more or less certain prognosis, the diagnosis of any particular psychoneurosis means, at most, that some form of psychotherapy is indicated. As to the prognosis, this is in the highest degree independent of the diagnosis. Nor should we gloss over the fact that the classification of the neuroses is very unsatisfactory, and that for this reason alone a specific diagnosis seldom means anything real. In general, it is enough to diagnose a “psychoneurosis” as distinct from some organic disturbance—the word means no more than that. I have in the course of years accustomed myself wholly to disregard the diagnosing of specific neuroses, and I have sometimes found myself in a quandary when some word-addict urged me to hand him a specific diagnosis. The Greco-Latin compounds needed for this still seem to have a not inconsiderable market value and are occasionally indispensable for that reason.

[196] The sonorous diagnosis of neuroses *secundum ordinem* is just a façade; it is not the psychotherapist’s real diagnosis. His establishment of certain facts might

conceivably be called “diagnosis,” though it is psychological rather than medical in character. Nor is it meant to be communicated; for reasons of discretion, and also on account of the subsequent therapy, he usually keeps it to himself. The facts so established are simply perceptions indicating the direction the therapy is to take. They can hardly be reproduced in the sort of Latin terminology that sounds scientific; but there are on the other hand expressions of ordinary speech which adequately describe the essential psychotherapeutic facts. The point is, we are not dealing with clinical diseases but with psychological ones. Whether a person is suffering from hysteria, or an anxiety neurosis, or a phobia, means little beside the much more important discovery that, shall we say, he is *fiils à papa*. Here something fundamental has been said about the content of the neurosis and about the difficulties to be expected in the treatment. So that in psychotherapy the recognition of disease rests much less on the clinical picture than on the content of complexes. Psychological diagnosis aims at the diagnosis of complexes and hence at the formulation of facts which are far more likely to be concealed than revealed by the clinical picture. The real toxin is to be sought in the complex, and this is a more or less autonomous psychic quantity. It proves its autonomous nature by not fitting into the hierarchy of the conscious mind, or by the resistance it successfully puts up against the will. This fact, which can easily be established by experiment, is the reason why psychoneuroses and psychoses have from time immemorial been regarded as states of *possession*, since the impression forces itself upon the naïve observer that the complex forms something like a shadow-government of the ego.

[197] The content of a neurosis can never be established by a single examination, or even by several. It manifests itself only in the course of treatment. Hence the paradox that the true psychological diagnosis becomes apparent only at the end. Just as a sure diagnosis is desirable and a thing to be aimed at in medicine, so, conversely, it will profit the psychotherapist to know as little as possible about specific diagnoses. It is enough if he is reasonably sure of the differential diagnosis between organic and psychic, and if he knows what a genuine melancholy is and what it can mean. Generally speaking, the less the psychotherapist knows in advance, the better the chances for the treatment. Nothing is more deleterious than a routine understanding of everything.

[198] We have now established that the anamnesis appears more than usually suspect to the psychotherapist, and that clinical diagnosis is, for his purposes, well-nigh meaningless. Finally, the therapy itself shows the greatest imaginable departures from the views commonly accepted in medicine. There are numerous physical diseases where the diagnosis also lays down the lines for a specific treatment; a given disease cannot be treated just anyhow. But for the psychoneuroses the only valid principle is that their treatment must be psychological. In this respect there is any number of

methods, rules, prescriptions, views, and doctrines, and the remarkable thing is that any given therapeutic procedure in any given neurosis can have the desired result. The various psychotherapeutic dogmas about which such a great fuss is made do not, therefore, amount to very much in the end. Every psychotherapist who knows his job will, consciously or unconsciously, theory notwithstanding, ring all the changes that do not figure in his own theory. He will occasionally use suggestion, to which he is opposed on principle. There is no getting round Freud's or Adler's or anybody else's point of view. Every psychotherapist not only has his own method—he himself is that method. *Ars requirit totum hominem*, says an old master. The great healing factor in psychotherapy is the doctor's personality, which is something not given at the start; it represents his performance at its highest and not a doctrinaire blueprint. Theories are to be avoided, except as mere auxiliaries. As soon as a dogma is made of them, it is evident that an inner doubt is being stifled. Very many theories are needed before we can get even a rough picture of the psyche's complexity. It is therefore quite wrong when people accuse psychotherapists of being unable to reach agreement even on their own theories. Agreement could only spell one-sidedness and desiccation. One could as little catch the psyche in a theory as one could catch the world. Theories are not articles of faith, they are either instruments of knowledge and of therapy, or they are no good at all.

[199] Psychotherapy can be practised in a great variety of ways, from psychoanalysis, or something of that kind, to hypnotism, and so on right down to cataplasms of honey and possets of bat's dung. Successes can be obtained with them all. So at least it appears on a superficial view. On closer inspection, however, one realizes that the seemingly absurd remedy was exactly the right thing, not for this particular *neurosis*, but for this particular human being, whereas in another case it would have been the worst thing possible. Medicine too is doubtless aware that sick people exist as well as sicknesses; but psychotherapy knows first and foremost—or rather should know—that its proper concern is not the fiction of a neurosis but the distorted totality of the human being. True, it too has tried to treat neurosis like an *ulcus cruris*, where it matters not a jot for the treatment whether the patient was the apple of her father's eye or whether she is a Catholic, a Baptist, or what not; whether the man she married be old or young, and all the rest of it. Psychotherapy began by attacking the symptom, just as medicine did. Despite its undeniable youthfulness as a scientifically avowable method, it is yet as old as the healing art itself and, consciously or otherwise, has always remained mistress of at least half the medical field. Certainly its real advances were made only in the last half century when, on account of the specialization needed, it withdrew to the narrower field of the psychoneuroses. But here it recognized relatively quickly that to attack symptoms or, as it is now called,

symptom analysis was only half the story, and that the real point is the treatment of the whole psychic human being.

[200] What does this mean: the whole psychic human being?

[201] Medicine in general has to deal, in the first place, with man as an anatomical and physiological phenomenon, and only to a lesser degree with the human being psychically defined. But this precisely is the subject of psychotherapy. When we direct our attention to the psyche from the viewpoint of the natural sciences, it appears as one biological factor among many others. In man this factor is usually identified with the conscious mind, as has mostly been done up to now by the so-called humane sciences as well. I subscribe entirely to the biological view that the psyche is one such factor, but at the same time I am given to reflect that the psyche—in this case, consciousness—occupies an exceptional position among all these biological factors. For without consciousness it would never have become known that there is such a thing as a world, and without the psyche there would be absolutely no possibility of knowledge, since the object must go through a complicated physiological and psychic process of change in order to become a psychic image. This image alone is the immediate object of knowledge. The existence of the world has two conditions: it to exist, and us to know it.

[202] Now, whether the psyche is understood as an epiphenomenon of the living body, or as an *ens per se*, makes little difference to psychology, in so far as the psyche knows itself to exist and behaves as such an existent, having its own phenomenology which can be replaced by no other. Thereby it proves itself to be a biological factor that can be described phenomenologically like any other object of natural science. The beginnings of a phenomenology of the psyche lie in psychophysiology and experimental psychology on the one hand, and, on the other, in descriptions of diseases and the diagnostic methods of psychopathology (e.g., association experiments and Rorschach's irrational ink-blot). But the most convincing evidence is to be found in every manifestation of psychic life, in the humane sciences, religious and political views and movements, the arts, and so forth.

[203] The “whole psychic human being” we were asking about thus proves to be nothing less than a world, that is, a microcosm, as the ancients quite rightly thought, though for the wrong reasons. The psyche reflects, and knows, the whole of existence, and everything works in and through the psyche.

[204] But in order to get a real understanding of this, we must very considerably broaden our conventional conception of the psyche. Our original identification of psyche with the conscious mind does not stand the test of empirical criticism. The medical philosopher C.G. Carus had a clear inkling of this and was the first to set forth an explicit philosophy of the unconscious. Today he would undoubtedly have

been a psychotherapist. But in those days the psyche was still the anxiously guarded possession of philosophy and therefore could not be discussed within the framework of medicine, although the physicians of the Romantic Age tried all sorts of unorthodox experiments in this respect. I am thinking chiefly of Justinus Kerner. It was reserved for the recent past to fill in the gaps in the conscious processes with hypothetical unconscious ones. The existence of an unconscious psyche is as likely, shall we say, as the existence of an as yet undiscovered planet, whose presence is inferred from the deviations of some known planetary orbit. Unfortunately we lack the aid of the telescope that would make certain of its existence. But once the idea of the unconscious was introduced, the concept of the psyche could be expanded to the formula “psyche = ego-consciousness + unconscious.”

[205] The unconscious was understood personalistically at first—that is to say, its contents were thought to come exclusively from the sphere of ego-consciousness and to have become unconscious only secondarily, through repression. Freud later admitted the existence of archaic vestiges in the unconscious, but thought they had more or less the significance of anatomical atavisms. Consequently we were still far from an adequate conception of the unconscious. Certain things had yet to be discovered, although actually they lay ready to hand: above all the fact that in every child consciousness grows out of the unconscious in the course of a few years, also that consciousness is always only a temporary state based on an optimum physiological performance and therefore regularly interrupted by phases of unconsciousness (sleep), and finally that the unconscious psyche not only possesses the longer lease of life but is continuously present. From this arises the important conclusion that the real and authentic psyche is the unconscious, whereas the ego-consciousness can be regarded only as a temporary epiphenomenon.

[206] In ancient times the psyche was conceived as a microcosm, and this was one of the characteristics attributed to the psychophysical man. To attribute such a characteristic to the ego-consciousness would be boundlessly to overestimate the latter. But with the unconscious it is quite different. This, by definition and in fact, cannot be circumscribed. It must therefore be counted as something boundless: infinite or infinitesimal. Whether it may legitimately be called a microcosm depends simply and solely on whether certain portions of the world beyond individual experience can be shown to exist in the unconscious—certain constants which are not individually acquired but are *a priori* presences. The theory of instinct and the findings of biology in connection with the symbiotic relationship between plant and insect have long made us familiar with these things. But when it comes to the psyche one is immediately seized with the fear of having to do with “inherited ideas.” We are not dealing with anything of the sort; it is more a question of *a priori* or prenatally determined modes of behaviour and function. It is to be conjectured that just as the

chicken comes out of the egg in the same way all the world over, so there are psychic modes of functioning, certain ways of thinking, feeling, and imagining, which can be found everywhere and at all times, quite independent of tradition. A general proof of the rightness of this expectation lies in the ubiquitous occurrence of parallel mythologems, Bastian's "folk-thoughts" or primordial ideas; and a special proof is the autochthonous reproduction of such ideas in the psyche of individuals where direct transmission is out of the question. The empirical material found in such cases consists of dreams, fantasies, delusions, etc.

[207] Mythologems are the aforementioned "portions of the world" which belong to the structural elements of the psyche. They are constants whose expression is everywhere and at all times the same.

[208] You may ask in some consternation: What has all this to do with psychotherapy? That neuroses are somehow connected with instinctual disturbances is not surprising. But, as biology shows, instincts are by no means blind, spontaneous, isolated impulses; they are on the contrary associated with typical situational patterns and cannot be released unless existing conditions correspond to the *a priori* pattern. The collective contents expressed in mythologems represent such situational patterns, which are so intimately connected with the release of instinct. For this reason knowledge of them is of the highest practical importance to the psychotherapist.

[209] Clearly, the investigation of these patterns and their properties must lead us into fields that seem to lie infinitely far from medicine. That is the fate of empirical psychology, and its misfortune: to fall between all the academic stools. And this comes precisely from the fact that the human psyche has a share in all the sciences, because it forms at least half the ground necessary for the existence of them all.

[210] It should be clear from the foregoing discussion that everything psychotherapy has in common with symptomatology clinically understood—i.e., with the medical picture—is, I will not say irrelevant, but of secondary importance in so far as the medical picture of disease is a provisional one. The real and important thing is the psychological picture, which can only be discovered in the course of treatment behind the veil of pathological symptoms. In order to get closer to the sphere of the psyche, the ideas derived from the sphere of medicine are not enough. But, to the extent that psychotherapy, considered as part of the healing art, should never, for many cogent reasons, slip out of the doctor's control and should therefore be taught in medical faculties, it is forced to borrow from the other sciences—which is what other medical disciplines have been doing for a long time. Yet whereas medicine in general can limit its borrowings to the natural sciences, psychotherapy needs the help of the humane sciences as well.

[211] In order to complete my account of the differences between medicine and psychotherapy, I ought really to describe the phenomenology of those psychic processes which manifest themselves in the course of treatment and do not have their counterpart in medicine. But such an undertaking would exceed the compass of my lecture, and I must therefore refrain. I trust, however, that the little I have been privileged to say has thrown some light on the relations between psychotherapy and the medical art.

VIII

PSYCHOTHERAPY TODAY¹

[212] It would be a rewarding task to examine in some detail the relationship between psychotherapy and the state of mind in Europe today. Yet probably no one would be blamed for shrinking from so bold a venture, for who could guarantee that the picture he has formed of the present psychological and spiritual plight of Europe is true to reality? Are we, as contemporaries of and participants in these cataclysmic events, at all capable of cool judgment and of seeing clearly amid the indescribable political and ideological chaos of present-day Europe? Or should we perhaps do better to narrow the field of psychotherapy and restrict our science to a modest specialists' corner, remaining indifferent to the ruin of half the world? I fear that such a course, in spite of its commendable modesty, would ill accord with the nature of psychotherapy, which is after all the "treatment of the soul." Indeed, the concept of psychotherapy, however one may choose to interpret it, carries with it very great pretensions: for the soul is the birth-place of all action and hence of everything that happens by the will of man. It would be difficult, if not impossible, to carve out an arbitrarily limited segment of the infinitely vast realm of the psyche and call that the secluded theatre of psychotherapy. Medicine, it is true, has found itself obliged to mark off a specific field, that of the neuroses and psychoses, and this is both convenient and feasible for the practical purpose of treatment. But the artificial restriction must be broken down immediately psychotherapy understands its problems not simply as those of a technique but as those of a science. Science *qua* science has no boundaries, and there is no speciality whatever that can boast of complete self-sufficiency. Any speciality is bound to spill over its borders and to encroach on adjoining territory if it is to lay serious claim to the status of a science. Even so highly specialized a technique as Freudian psychoanalysis was unable, at the very outset, to avoid poaching on other, and sometimes exceedingly remote, scientific preserves. It is, in fact, impossible to treat the psyche, and human personality in general, sectionally. In all psychic disturbances it is becoming clear—perhaps even more so than in the case of physical illnesses—that the psyche is a whole in which everything hangs together. When the patient comes to us with a neurosis, he does not bring a part but the whole of his psyche and with it the fragment of world on which that psyche depends, and without which it can never be properly understood. Psychotherapy is therefore less able than any other specialized department of science to take refuge in the sanctuary of a

speciality which has no further connection with the world at large. Try as we may to concentrate on the most personal of personal problems, our therapy nevertheless stands or falls with the question: What sort of world does our patient come from and to what sort of world has he to adapt himself? The world is a supra-personal fact to which an essentially personalistic psychology can never do justice. Such a psychology only penetrates to the personal element in man. But in so far as he is also a part of the world, he carries the world in himself, that is, something at once impersonal and supra-personal. It includes his entire physical and psychic basis, so far as this is given from the start. Undoubtedly the personalities of father and mother form the first and apparently the only world of man as an infant; and, if they continue to do so for too long, he is on the surest road to neurosis, because the great world he will have to enter as a whole person is no longer a world of fathers and mothers, but a supra-personal fact. The child first begins to wean itself from the childhood relation to father and mother through its relation to its brothers and sisters. The elder brother is no longer the true father and the elder sister no longer the true mother. Later, husband and wife are originally strangers to one another and come from different families with a different history and often a different social background. When children come, they complete the process by forcing the parents into the role of father and mother, which the parents, in accordance with their infantile attitude, formerly saw only in others, thereby trying to secure for themselves all the advantages of the childhood role. Every more or less normal life runs this enantiomorphous course and compels a change of attitude from the extreme of the child to the other extreme of the parent. The change requires the recognition of objective facts and values which a child can dismiss from his mind. School, however, inexorably instils into him the idea of objective time, of duty and the fulfilment of duty, of outside authority, no matter whether he likes or loathes the school and his teacher. And with school and the relentless advance of time, one objective fact after another increasingly forces its way into his personal life, regardless of whether it is welcome or not and whether he has developed any special attitude towards it. Meanwhile it is made overpoweringly clear that any prolongation of the father-and-mother world beyond its allotted span must be paid for dearly. All attempts to carry the infant's personal world over into the greater world are doomed to failure; even the transference which occurs during the treatment of neurosis is at best only an intermediate stage, giving the patient a chance to shed all the fragments of egg-shell still adhering to him from his childhood days, and to withdraw the projection of the parental imagos from external reality. This operation is one of the most difficult tasks of modern psychotherapy. At one time it was optimistically assumed that the parental imagos could be more or less broken down and destroyed through analysis of their contents. But in reality that is not the case: although the parental imagos can be released from the state of projection and withdrawn from the external world, they continue, like everything else acquired in

early childhood, to retain their original freshness. With the withdrawal of the projection they fall back into the individual psyche, from which indeed they mainly originated.²

[213] Before we go into the question of what happens when the parental imagos are no longer projected, let us turn to another question: Is this problem, which has been brought to light by modern psychotherapy, a new one in the sense that it was unknown to earlier ages which possessed no scientific psychology as we understand it? How did this problem present itself in the past?

[214] In so far as earlier ages had in fact no knowledge of psychotherapy in our sense of the word, we cannot possibly expect to find in history any formulations similar to our own. But since the transformation of child into parent has been going on everywhere from time immemorial and, with the increase of consciousness, was also experienced subjectively as a difficult process, we must conjecture the existence of various general psychotherapeutic systems which enabled man to accomplish the difficult transition-stages. And we do find, even at the most primitive level, certain drastic measures at all those moments in life when psychic transitions have to be effected. The most important of these are the initiations at puberty and the rites pertaining to marriage, birth, and death. All these ceremonies, which in primitive cultures still free from foreign influence are observed with the utmost care and exactitude, are probably designed in the first place to avert the psychic injuries liable to occur at such times; but they are also intended to impart to the initiand the preparation and teaching needed for life. The existence and prosperity of a primitive tribe are absolutely bound up with the scrupulous and traditional performance of the ceremonies. Wherever these customs fall into disuse through the influence of the white man, authentic tribal life ceases; the tribe loses its soul and disintegrates. Opinion is very much divided about the influence of Christian missionaries in this respect; what I myself saw in Africa led me to take an extremely pessimistic view.

[215] On a higher and more civilized level the same work is performed by the great religions. There are the christening, confirmation, marriage, and funeral ceremonies which, as is well known, are much closer to their origins, more living and complete, in Catholic ritual than in Protestantism. Here too we see how the father-mother world of the child is superseded by a wealth of analogical symbols: a patriarchal order receives the adult into a new filial relationship through spiritual generation and rebirth. The pope as *pater patrum* and the *ecclesia mater* are the parents of a family that embraces the whole of Christendom, except such parts of it as protest. Had the parental imagos been destroyed in the course of development and thus been rendered ineffective, an order of this kind would have lost not only its *raison d'être* but the very possibility of its existence. As it is, however, a place is found for the ever-active

parental imagos as well as for that ineradicable feeling of being a child, a feeling which finds meaning and shelter in the bosom of the Church. In addition, a number of other ecclesiastical institutions provide for the steady growth and constant renewal of the bond. Among them I would mention in particular the mass and the confessional. The Communion is, in the proper sense of the word, the family table at which the members foregather and partake of the meal in the presence of God, following a sacred custom that goes far back into pre-Christian times.

[216] It is superfluous to describe these familiar things in greater detail. I mention them only to show that the treatment of the psyche in times gone by had in view the same fundamental facts of human life as modern psychotherapy. But how differently religion deals with the parental imagos! It does not dream of breaking them down or destroying them; on the contrary, it recognizes them as living realities which it would be neither possible nor profitable to eliminate. Religion lets them live on in changed and exalted form within the framework of a strictly traditional patriarchal order, which keeps not merely decades but whole centuries in living connection. Just as it nurtures and preserves the childhood psyche of the individual, so also it has conserved numerous and still living vestiges of the childhood psyche of humanity. In this way it guards against one of the greatest psychic dangers—loss of roots—which is a disaster not only for primitive tribes but for civilized man as well. The breakdown of a tradition, necessary as this may be at times, is always a loss and a danger; and it is a danger to the soul because the life of instinct—the most conservative element in man—always expresses itself in traditional usages. Age-old convictions and customs are deeply rooted in the instincts. If they get lost, the conscious mind becomes severed from the instincts and loses its roots, while the instincts, unable to express themselves, fall back into the unconscious and reinforce its energy, causing this in turn to overflow into the existing contents of consciousness. It is then that the rootless condition of consciousness becomes a real danger. This secret *vis a tergo* results in a hybris of the conscious mind which manifests itself in the form of exaggerated self-esteem or an inferiority complex. At all events a loss of balance ensues, and this is the most fruitful soil for psychic injury.

[217] If we look back over the thousand-odd years of our European civilization, we shall see that the Western ideal of the education and care of the soul has been, and for the most part still is, a patriarchal order based on the recognition of parental imagos. Thus in dealing with the individual, no matter how revolutionary his conscious attitude may be, we have to reckon with a patriarchal or hierarchical orientation of the psyche which causes it instinctively to seek and cling to this order. Any attempt to render the parental imagos and the childhood psyche ineffective is therefore doomed to failure from the outset.

[218] At this point we come back to our earlier question of what happens when the parental imagos are withdrawn from projection. The detachment of these imagos from certain persons who carry the projection is undoubtedly possible and belongs to the stock in trade of psychotherapeutic success. On the other hand the problem becomes more difficult when there is a transference of the imagos to the doctor. In these cases the detachment can develop into a crucial drama. For what is to happen to the imagos if they are no longer attached to a human being? The pope as supreme father of Christendom holds his office from God; he is the servant of servants, and transference of the imagos to him is thus a transference to the Father in heaven and to Mother Church on earth. But how fares it with men and women who have been uprooted and torn out of their tradition? Professor Murray³ of Harvard University has shown on the basis of extensive statistical material—thus confirming my own previously published experience—that the incidence of complexes is, on the average, highest among Jews; second come Protestants; and Catholics third. That a man's philosophy of life is directly connected with the well-being of the psyche can be seen from the fact that his mental attitude, his way of looking at things, is of enormous importance to him and his mental health—so much so that we could almost say that things are less what they are than how we see them. If we have a disagreeable view of a situation or thing, our pleasure in it is spoiled, and then it does in fact usually disagree with us. And, conversely, how many things become bearable and even acceptable if we can give up certain prejudices and change our point of view. Paracelsus, who was above all a physician of genius, emphasized that nobody could be a doctor who did not understand the art of “theorizing.”⁴ What he meant was that the doctor must induce, not only in himself but also in his patient, a way of looking at the illness which would enable the doctor to cure and the patient to recover, or at least to endure being ill. That is why he says “every illness is a purgatorial fire.”⁵ He consciously recognized and made full use of the healing power of a man's mental attitude. When, therefore, I am treating practising Catholics, and am faced with the transference problem, I can, by virtue of my office as a doctor, step aside and lead the problem over to the Church. But if I am treating a non-Catholic, that way out is debarred, and by virtue of my office as a doctor I cannot step aside, for there is as a rule nobody there, nothing towards which I could suitably lead the father-imago. I can, of course, get the patient to recognize with his reason that I am not the father. But by that very act I become the reasonable father and remain despite everything the father. Not only nature, but the patient too, abhors a vacuum. He has an instinctive horror of allowing the parental imagos and his childhood psyche to fall into nothingness, into a hopeless past that has no future. His instinct tells him that, for the sake of his own wholeness, these things must be kept alive in one form or another. He knows that a complete withdrawal of the projection will be followed by an apparently endless isolation within the ego, which is all the more burdensome because he has so

little love for it. He found it unbearable enough before, and he is unlikely to bear it now simply out of sweet reasonableness. Therefore at this juncture the Catholic who has been freed from an excessively personal tie to his parents can return fairly easily to the mysteries of the Church, which he is now in a position to understand better and more deeply. There are also Protestants who can discover in one of the newer variants of Protestantism a meaning which appeals to them, and so regain a genuine religious attitude. All other cases—unless there is a violent and sometimes injurious solution—will, as the saying goes, “get stuck” in the transference relationship, thereby subjecting both themselves and the doctor to a severe trial of patience. Probably this cannot be avoided, for a sudden fall into the orphaned, parentless state may in certain cases—namely, where there is a tendency to psychosis—have dangerous consequences owing to the equally sudden activation of the unconscious which always accompanies it. Accordingly the projection can and should be withdrawn only step by step. The integration of the contents split off in the parental imagos has an activating effect on the unconscious, for these imagos are charged with all the energy they originally possessed in childhood, thanks to which they continued to exercise a fateful influence even on the adult. Their integration therefore means a considerable afflux of energy to the unconscious, which soon makes itself felt in the increasingly strong coloration of the conscious mind by unconscious contents. Isolation in pure ego-consciousness has the paradoxical consequence that there now appear in dreams and fantasies impersonal, collective contents which are the very material from which certain schizophrenic psychoses are constructed. For this reason the situation is not without its dangers, since the releasing of the ego from its ties with the projection—and of these the transference to the doctor plays the principal part—involves the risk that the ego, which was formerly dissolved in relationships to the personal environment, may now be dissolved in the contents of the collective unconscious. For, although the parents may be dead in the world of external reality, they and their imagos have passed over into the “other” world of the collective unconscious, where they continue to attract the same ego-dissolving projections as before.

[219] But at this point a healthful, compensatory operation comes into play which each time seems to me like a miracle. Struggling against that dangerous trend towards disintegration, there arises out of this same collective unconscious a counteraction, characterized by symbols which point unmistakably to a process of centring. This process creates nothing less than a new centre of personality, which the symbols show from the first to be superordinate to the ego and which later proves its superiority empirically. The centre cannot therefore be classed with the ego, but must be accorded a higher value. Nor can we continue to give it the name of “ego,” for which reason I have called it the “self.” To experience and realize this self is the

ultimate aim of Indian yoga, and in considering the psychology of the self we would do well to have recourse to the treasures of Indian wisdom. In India, as with us, the experience of the self has nothing to do with intellectualism; it is a vital happening which brings about a fundamental transformation of personality. I have called the process that leads to this experience the “process of individuation.” If I recommend the study of classical yoga, it is not because I am one of those who roll up their eyes in ecstasy when they hear such magic words as *dhyana* or *buddhi* or *mukti*, but because psychologically we can learn a great deal from yoga philosophy and turn it to practical account. Furthermore, the material lies ready to hand, clearly formulated in the Eastern books and the translations made of them. Here again my reason is not that we have nothing equivalent in the West: I recommend yoga merely because the Western knowledge which is akin to it is more or less inaccessible except to specialists. It is esoteric, and it is distorted beyond recognition by being formulated as an arcane discipline and by all the rubbish that this draws in its wake. In alchemy there lies concealed a Western system of yoga meditation, but it was kept a carefully guarded secret from fear of heresy and its painful consequences. For the practising psychologist, however, alchemy has one inestimable advantage over Indian yoga—its ideas are expressed almost entirely in an extraordinarily rich symbolism, the very symbolism we still find in our patients today. The help which alchemy affords us in understanding the symbols of the individuation process is, in my opinion, of the utmost importance.⁶

[220] Alchemy describes what I call the “self” as *incorruptibile*, that is, an indissoluble substance, a One and Indivisible that cannot be reduced to anything else and is at the same time a Universal, to which a sixteenth-century alchemist even gave the name of *filius macrocosmi*.⁷ Modern findings agree in principle with these formulations.

[221] I had to mention all these things in order to get to the problem of today. For if we perseveringly and consistently follow the way of natural development, we arrive at the experience of the self, and at the state of being simply what one is. This is expressed as an ethical demand by the motto of Paracelsus, the four-hundredth anniversary of whose birth we celebrated in the autumn of 1941: “*Alterius non sit, qui suus esse potest*” (That man no other man shall own,/Who to himself belongs alone)—a motto both characteristically Swiss and characteristically alchemical. But the way to this goal is toilsome and not for all to travel. “*Est longissima via*,” say the alchemists. We are still only at the beginning of a development whose origins lie in late antiquity, and which throughout the Middle Ages led little more than a hole-and-corner existence, vegetating in obscurity and represented by solitary eccentrics who were called, not without reason, *tenebriones*. Nevertheless men like Albertus Magnus, Roger Bacon, and Paracelsus were among the fathers of modern science, and their spirit did much to shake the authority of the “total” Church. Our modern

psychology grew out of the spirit of natural science and, without realizing it, is carrying on the work begun by the alchemists. These men were convinced that the *donum artis* was given only to the few *electis*, and today our experience shows us only too plainly how arduous is the work with each patient and how few can attain the necessary knowledge and experience. Meanwhile the disintegration and weakening of that salutary institution, the Christian Church, goes on at an alarming rate, and the loss of any firm authority is gradually leading to an intellectual, political, and social anarchy which is repugnant to the soul of European man, accustomed as he is to a patriarchal order. The present attempts to achieve full individual consciousness and to mature the personality are, socially speaking, still so feeble that they carry no weight at all in relation to our historic needs. If our European social order is not to be shaken to its foundations, authority must be restored at all costs.

[222] This is probably one reason for the efforts now being made in Europe to replace the collectivity of the Church by the collectivity of the State. And just as the Church was once absolute in its determination to make theocracy a reality, so the State is now making an absolute bid for totalitarianism. The mystique of the spirit has not been replaced by a mystique either of nature or of the *lumen naturae*, as Paracelsus named it, but by the total incorporation of the individual in a political collective called the "State." This offers a way out of the dilemma, for the parental imagos can now be projected upon the State as the universal provider and the authority responsible for all thinking and willing. The ends of science are made to serve the social collective and are only valued for their practical utility to the collective's ends. The natural course of psychological development is succeeded, not by a spiritual direction which spans the centuries and keeps cultural values alive, but by a political directorate which ministers to the power struggles of special groups and promises economic benefits to the masses. In this way European man's deep-seated longing for a patriarchal and hierarchical order finds an appropriate concrete expression which accords only too well with the herd instinct, but is fixed at such a low level as to be in every respect detrimental to culture.

[223] It is here that opinion is apt to be divided. In so far as psychotherapy claims to stand on a scientific basis and thus by the principle of free investigation, its declared aim is to educate people towards independence and moral freedom in accordance with the knowledge arrived at by unprejudiced scientific research. Whatever the conditions to which the individual wishes to adapt himself, he should always do so consciously and of his own free choice. But, in so far as political aims and the State are to claim precedence, psychotherapy would inevitably become the instrument of a particular political system, and it is to *its* aims that people would have to be educated and at the same time seduced from their own highest destiny. Against this conclusion

it will undoubtedly be objected that man's ultimate destiny lies not in his existence as an individual but in the aspirations of human society, because without this the individual could not exist at all. This objection is a weighty one and cannot be lightly dismissed. It is an undoubted truth that the individual exists only by virtue of society and has always so existed. That is why among primitive tribes we find the custom of initiation into manhood, when, by means of a ritual death, the individual is detached from his family and indeed from his whole previous identity, and is reborn as a member of the tribe. Or we find early civilizations, such as the Egyptian and Babylonian, where all individuality is concentrated in the person of the king, while the ordinary person remains anonymous. Or again, we observe whole families in which for generations the individuality of the name has compensated for the nonentity of its bearers; or a long succession of Japanese artists who discard their own name and adopt the name of a master, simply adding after it a modest numeral. Nevertheless, it was the great and imperishable achievement of Christianity that, in contrast to these archaic systems which are all based on the original projection of psychic contents, it gave to each individual man the dignity of an immortal soul, whereas in earlier times this prerogative was reserved to the sole person of the king. It would lead me too far to discuss here just how much this Christian innovation represents an advance of human consciousness and of culture in general, by putting an end to the projection of the highest values of the individual soul upon the king or other dignitaries. The innate will to consciousness, to moral freedom and culture, proved stronger than the brute compulsion of projections which keep the individual permanently imprisoned in the dark of unconsciousness and grind him down into nonentity. Certainly this advance laid a cross upon him—the torment of consciousness, of moral conflict, and the uncertainty of his own thoughts. This task is so immeasurably difficult that it can be accomplished, if at all, only by stages, century by century, and it must be paid for by endless suffering and toil in the struggle against all those powers which are incessantly at work persuading us to take the apparently easier road of unconsciousness. Those who go the way of unconsciousness imagine that the task can safely be left to “others” or, ultimately, to the anonymous State. But who are these “others,” these obvious supermen who pretend to be able to do what everybody is only too ready to believe that he cannot do? They are men just like ourselves, who think and feel as we do, except that they are past masters in the art of “passing the buck.” Exactly *who* is the State?—The agglomeration of all the nonentities composing it. Could it be personified, the result would be an individual, or rather a monster, intellectually and ethically far below the level of most of the individuals in it, since it represents mass psychology raised to the nth power. Therefore Christianity in its best days never subscribed to a belief in the State, but set before man a supramundane goal which should redeem him from the compulsive force of his projections upon this world, whose ruler is the spirit of

darkness. And it gave him an immortal soul that he might have a fulcrum from which to lift the world off its hinges, showing him that his goal lies not in the mastery of this world but in the attainment of the Kingdom of God, whose foundations are in his own heart.

[224] If, then, man cannot exist without society, neither can he exist without oxygen, water, albumen, fat, and so forth. Like *these, society is one of the necessary conditions of his existence*. It would be ludicrous to maintain that man lives in order to breathe air. It is equally ludicrous to say that the individual exists for society. “Society” is nothing more than a term, a concept for the symbiosis of a group of human beings. A concept is not a carrier of life. The sole and natural carrier of life is the individual, and that is so throughout nature.⁸ “Society” or “State” is an agglomeration of life-carriers and at the same time, as an organized form of these, an important condition of life. It is therefore not quite true to say that the individual can exist only as a particle in society. At all events man can live very much longer without the State than without air.

[225] When the political aim predominates there can be no doubt that a secondary thing has been made the primary thing. Then the individual is cheated of his rightful destiny and two thousand years of Christian civilization are wiped out. Consciousness, instead of being widened by the withdrawal of projections, is narrowed, because society, a mere condition of human existence, is set up as a goal. Society is the greatest temptation to unconsciousness, for the mass infallibly swallows up the individual—who has no security in himself—and reduces him to a helpless particle. The totalitarian State could not tolerate for one moment the right of psychotherapy to help man fulfil his natural destiny. On the contrary, it would be bound to insist that psychotherapy should be nothing but a tool for the production of manpower useful to the State. In this way it would become a mere technique tied to a single aim, that of increasing social efficiency. The soul would forfeit all life of its own and become a function to be used as the State saw fit. The science of psychology would be degraded to a study of the ways and means to exploit the psychic apparatus. As to its therapeutic aim, the complete and successful incorporation of the patient into the State machine would be the criterion of cure. Since this aim can best be achieved by making the individual completely soulless—that is, as unconscious as possible—all methods designed to increase consciousness would at one stroke become obsolete, and the best thing would be to bring out of the lumber-rooms of the past all the methods that have ever been devised to prevent man from becoming conscious of his unconscious contents. Thus the art of psychotherapy would be driven into a complete regression.⁹

[226] Such, in broad outline, is the alternative facing psychotherapy at this present juncture. Future developments will decide whether Europe, which fancied it had escaped the Middle Ages, is to be plunged for a second time and for centuries into the darkness of an Inquisition. This will only happen if the totalitarian claims of the State are forcibly carried through and become a permanency. No intelligent person will deny that the organization of society, which we call the State, not only feels a lively need to extend its authority but is compelled by circumstances to do so. If this comes about by free consent and the conscious choice of the public, the results will leave nothing to be desired. But if it comes about for the sake of convenience, in order to avoid tiresome decisions, or from lack of consciousness, then the individual runs the certain risk of being blotted out as a responsible human being. The State will then be no different from a prison or an ant-heap.

[227] Although the conscious achievement of individuality is consistent with man's natural destiny, it is nevertheless not his whole aim. It cannot possibly be the object of human education to create an anarchic conglomeration of individual existences. That would be too much like the unavowed ideal of extreme individualism, which is essentially no more than a morbid reaction against an equally futile collectivism. In contrast to all this, the natural process of individuation brings to birth a consciousness of human community precisely because it makes us aware of the unconscious, which unites and is common to all mankind. Individuation is an at-one-ment with oneself and at the same time with humanity, since oneself is a part of humanity. Once the individual is thus secured in himself, there is some guarantee that the organized accumulation of individuals in the State—even in one wielding greater authority—will result in the formation no longer of an anonymous mass but of a conscious community. The indispensable condition for this is conscious freedom of choice and individual decision. Without this freedom and self-determination there is no true community, and, it must be said, without such community even the free and self-secured individual cannot in the long run prosper.¹⁰ Moreover, the common weal is best served by independent personalities. Whether man today possesses the maturity needed for such a decision is another question. On the other hand, solutions which violently forestall natural development and are forced on mankind are equally questionable. The facts of nature cannot in the long run be violated. Penetrating and seeping through everything like water, they will undermine any system that fails to take account of them, and sooner or later they will bring about its downfall. But an authority wise enough in its statesmanship to give sufficient free play to nature—of which spirit is a part—need fear no premature decline. It is perhaps a humiliating sign of spiritual immaturity that European man needs, and wants, a large measure of authority. The fact has to be faced that countless millions in Europe—with the guilty complicity of reformers whose childishness is only equalled by their lack of tradition

—have escaped from the authority of the Church and the *patria potestas* of kings and emperors only to fall helpless and senseless victims to any power that cares to assume authority. The immaturity of man is a fact that must enter into all our calculations.

[228] We in Switzerland are not living on a little planetoid revolving in empty space, but on the same earth as the rest of Europe. We are right in the middle of these problems, and if we are unconscious, we are just as likely to succumb to them as the other nations. The most dangerous thing would be for us to imagine that we are on a higher plane of consciousness than our neighbours. There is no question of that. While it would be an impropriety for a handful of psychologists and psychotherapists like ourselves to take our importance too seriously—or I might say, too pompously—I would nevertheless emphasize that just because we are psychologists it is our first task and duty to understand the psychic situation of our time and to see clearly the problems and challenges with which it faces us. Even if our voice is too weak to make itself heard above the tumult of political strife and fades away ineffectively, we may yet comfort ourselves with the saying of the Chinese Master: “When the enlightened man is alone and thinks rightly, it can be heard a thousand miles away.”

[229] All beginnings are small. Therefore we must not mind doing tedious but conscientious work on obscure individuals, even though the goal towards which we strive seems unattainably far off. But one goal we can attain, and that is to develop and bring to maturity individual personalities. And inasmuch as we are convinced that the individual is the carrier of life, we have served life’s purpose if one tree at least succeeds in bearing fruit, though a thousand others remain barren. Anyone who proposed to bring all growing things to the highest pitch of luxuriance would soon find the weeds—those hardiest of perennials—waving above his head. I therefore consider it the prime task of psychotherapy today to pursue with singleness of purpose the goal of individual development. So doing, our efforts will follow nature’s own striving to bring life to the fullest possible fruition in each individual, for only in the individual can life fulfil its meaning—not in the bird that sits in a gilded cage.

IX

FUNDAMENTAL QUESTIONS OF PSYCHOTHERAPY¹

[230] In the medical text-books of a few years back, under the general heading of “therapy,” at the end of a list of cures and pharmaceutical prescriptions, one might find a mysterious item called “psychotherapy.” What exactly one was to understand by this remained shrouded in eloquent obscurity. What did it mean? Was it hypnosis, suggestion, persuasion, catharsis, psychoanalysis, Adlerian education, autogenic training, or what? This list amply illustrates the vague multiplicity of opinions, views, theories, and methods that all pass under the name of “psychotherapy.”

[231] When a new and uninhabited continent is discovered, there are no landmarks, no names, no highways, and every pioneer who sets foot upon it comes back with a different story. Something of this kind seems to have happened when medical men plunged for the first time into the new continent named “psyche.” One of the first explorers to whom we are indebted for more or less intelligible reports is Paracelsus. His uncanny knowledge, which is at times not lacking in prophetic vision, was, however, expressed in a language that was informed by the spirit of the sixteenth century. It abounds not only in demonological and alchemical ideas, but in Paracelsian neologisms, whose florid exuberance compensated a secret feeling of inferiority quite in keeping with the self-assertiveness of their much maligned, and not unjustly misunderstood, creator. The scientific era, which began in earnest with the seventeenth century, cast out the pearls of Paracelsus’ medical wisdom along with the other lumber. Not until two centuries later did a new and altogether different kind of empiricism arise with Mesmer’s theory of animal magnetism, stemming partly from practical experiences which today we should attribute to suggestion, and partly from the old alchemical lore. Working along these lines, the physicians of the Romantic Age then turned their attention to somnambulism, thus laying the foundations for the clinical discovery of hysteria. But almost another century had to pass before Charcot and his school could begin to consolidate ideas in this field. We have to thank Pierre Janet for a deeper and more exact knowledge of hysterical symptoms, and the two French physicians, Liébeault and Bernheim, later to be joined by August Forel in Switzerland, for a systematic investigation and description of the phenomena of suggestion. With the discovery by Breuer and Freud of the affective origins of psychogenic symptoms, our knowledge of their causation took a decisive step forward into the realm of psychology. The fact that the affectively toned

memory images which are lost to consciousness lay at the root of the hysterical symptom immediately led to the postulate of an *unconscious* layer of psychic happenings. This layer proved to be, not “somatic,” as the academic psychology of those days was inclined to assume, but *psychic*, because it behaves exactly like any other psychic function from which consciousness is withdrawn, and which thus ceases to be associated with the ego. As Janet showed almost simultaneously with Freud, but independently of him, this holds true of hysterical symptoms generally. But whereas Janet supposed that the reason for the withdrawal of consciousness must lie in some specific weakness, Freud pointed out that the memory images which produce the symptoms are characterized by a disagreeable affective tone. Their disappearance from consciousness could thus easily be explained by *repression*. Freud therefore regarded the aetiological contents as “incompatible” with the tendencies of the conscious mind. This hypothesis was supported by the fact that repressed memories frequently arouse a moral censorship, and do so precisely on account of their traumatic or morally repellent nature.

[232] Freud extended the repression theory to the whole field of psychogenic neuroses with great practical success; indeed, he went on to use it as an explanation of culture as a whole. With this he found himself in the sphere of general psychology, which had long been entrusted to the philosophical faculty. Apart from a few technical terms and methodical points of view, psychology, as practised by the doctor, had not so far been able to borrow much from the philosophers, and so medical psychology, on encountering an unconscious psyche right at the beginning of its career, literally stepped into a vacuum. The concept of the unconscious was, with a few praiseworthy exceptions, anathematized by academic psychology, so that only the phenomena of consciousness were left as a possible object for psychological research. The collision between the medical approach and the general psychology then prevailing was therefore considerable. On the other hand, Freud’s discoveries were just as much of a challenge and a stumbling-block to the purely somatic views of the doctors. And so they have remained for the last fifty years. It needed the trend towards psychosomatic medicine that came over from America to put a fresher complexion on the picture. Even so, general psychology has still not been able to draw the necessary conclusions from the fact of the unconscious.

[233] Any advance into new territory is always attended by certain dangers, for the pioneer has to rely in all his undertakings upon the equipment he happens to take with him. This, in the present instance, is his training in somatic medicine, his general education, and his view of the world, which is based chiefly on subjective premises, partly temperamental, partly social. His medical premises enable him to size up correctly the somatic and biological aspects of the material he has to deal with; his general education makes it possible for him to form an approximate idea of

the nature of the repressive factor; and finally, his view of the world helps him to put his special knowledge on a broader basis and to fit it into a larger whole. But when scientific research moves into a region hitherto undiscovered and therefore unknown, the pioneer must always bear in mind that another explorer, setting foot on the new continent at another place and with other equipment, may well sketch quite another picture.

[234] So it happened with Freud: his pupil Alfred Adler developed a view which shows neurosis in a very different light. It is no longer the sexual urge, or the pleasure principle, that dominates the picture, but the urge to power (self-assertion, "masculine protest," "the will to be on top"). As I have shown in a concrete instance,² both theories can be successfully applied to one and the same case; moreover it is a well-known psychological fact that the two urges keep the scales balanced, and that the one generally underlies the other. Adler remained as one-sided as Freud, and both agree that not only the neurosis, but the man himself, can be explained from the shadow side, in terms of his moral inferiority.

[235] All this points to the existence of a personal equation, a subjective prejudice that was never submitted to criticism. The rigidity with which both men adhered to their position denotes, as always, the compensating of a secret uncertainty and an inner doubt. The facts as described by the two investigators are, if taken with a pinch of salt, right enough; but it is possible to interpret them in the one way as much as in the other, so that both are partially wrong, or rather, they are mutually complementary. The lesson to be drawn from this is that in practice one would do well to consider both points of view.

[236] The reason for this first dilemma of medical psychology presumably lies in the fact that the doctors found no cultivated ground under their feet, since ordinary psychology had nothing concrete to offer them. They were therefore thrown back on their own subjective prejudices as soon as they looked round for tools. For me, this resolved itself into the pressing need to examine the kind of attitudes which human beings in general adopt towards the object (no matter what this object may be). Accordingly, I have come to postulate a number of types which all depend on the respective predominance of one or the other orienting function of consciousness, and have devised a tentative scheme into which the various attitudes can be articulated. From this it would appear that there are no less than eight theoretically possible attitudes. If we add to these all the other more or less individual assumptions, it is evident that there is no end to the possible viewpoints, all of which have their justification, at least subjectively. In consequence, criticism of the psychological assumptions upon which a man's theories are based becomes an imperative necessity. Unfortunately, however, this has still not been generally recognized, otherwise

certain viewpoints could not be defended with such obstinacy and blindness. One can only understand why this should be so when one considers what the subjective prejudice signifies: it is as a rule a carefully constructed product into whose making has gone the whole experience of a lifetime. It is the individual psyche colliding with the environment. In the majority of cases, therefore, it is a subjective variant of a universal human experience, and for that very reason careful self-criticism and detailed comparison are needed if we are to frame our judgments on a more universal basis. But the more we rely on the principles of consciousness in endeavouring to perform this essential task, the greater becomes the danger of our interpreting experience in those terms, and thus of doing violence to the facts by excessive theorizing. Our psychological experience is still too recent and too limited in scope to permit of general theories. The investigator needs a lot more facts which would throw light on the nature of the psyche before he can begin to think of universally valid propositions. For the present we must observe the rule that a psychological proposition can only lay claim to significance if the obverse of its meaning can also be accepted as true.

[237] Personal and theoretical prejudices are the most serious obstacles in the way of psychological judgment. They can, however, be eliminated with a little good will and insight. Freud himself accepted my suggestion that every doctor should submit to a training analysis before interesting himself in the unconscious of his patients for therapeutic purposes. All intelligent psychotherapists who recognize the need for conscious realization of unconscious aetiological factors agree with this view. Indeed it is sufficiently obvious, and has been confirmed over and over again by experience, that what the doctor fails to see in himself he either will not see at all, or will see grossly exaggerated, in his patient; further, he encourages those things to which he himself unconsciously inclines, and condemns everything that he abhors in himself. Just as one rightly expects the surgeon's hands to be free from infection, so one ought to insist with especial emphasis that the psychotherapist be prepared at all times to exercise adequate self-criticism, a necessity which is all the more incumbent upon him when he comes up against insuperable resistances in the patient which may possibly be justified. He should remember that the patient is there to be treated and not to verify a theory. For that matter, there is no single theory in the whole field of practical psychology that cannot on occasion prove basically wrong. In particular, the view that the patient's resistances are in no circumstances justified is completely fallacious. The resistance might very well prove that the treatment rests on false assumptions.

[238] I have dwelt on the theme of training analysis at some length because of late there have been renewed tendencies to build up the doctor's authority as such, and thus to inaugurate another era of *ex cathedra* psychotherapy, a project which differs

in no way from the somewhat antiquated techniques of suggestion, whose inadequacy has long since become apparent. (This is not to say that suggestion therapy is never indicated.)

[239] The intelligent psychotherapist has known for years that any complicated treatment is an individual, *dialectical* process, in which the doctor, as a person, participates just as much as the patient. In any such discussion the question of whether the doctor has as much insight into his own psychic processes as he expects from his patient naturally counts for a very great deal, particularly in regard to the “rapport,” or relationship of mutual confidence, on which the therapeutic success ultimately depends. The patient, that is to say, can win his own inner security only from the security of his relationship to the doctor as a human being. The doctor can put over his authority with fairly good results on people who are easily gulled. But for critical eyes it is apt to look a little too threadbare. This is also the reason why the priest, the predecessor of the doctor in his role of healer and psychologist, has in large measure forfeited his authority, at any rate with the educated public. Difficult cases, therefore, are a veritable ordeal for both patient and doctor. The latter should be prepared for this as far as possible by a thorough training analysis. It is far from being either an ideal or an absolutely certain means of dispelling illusions and projections, but at least it demonstrates the need for self-criticism and can reinforce the psychotherapist’s aptitude in this direction. No analysis is capable of banishing all unconsciousness for ever. The analyst must go on learning endlessly, and never forget that each new case brings new problems to light and thus gives rise to unconscious assumptions that have never before been constellated. We could say, without too much exaggeration, that a good halt of every treatment that probes at all deeply consists in the doctor’s examining himself, for only what he can put right in himself can he hope to put right in the patient. It is no loss, either, if he feels that the patient is hitting him, or even scoring off him: it is his own hurt that gives the measure of his power to heal. This, and nothing else, is the meaning of the Greek myth of the wounded physician.³

[240] The problems with which we are concerned here do not occur in the field of “minor” psychotherapy, where the doctor can get along quite well with suggestion, good advice, or an apt explanation. But neuroses or psychotic borderline states in complicated and intelligent people frequently require what is called “major” psychotherapy, that is, the dialectical procedure. In order to conduct this with any prospect of success, all subjective and theoretical assumptions must be eliminated as far as practicable. One cannot treat a Mohammedan on the basis of Christian beliefs, nor a Parsee with Jewish orthodoxy, nor a Christian with the pagan philosophy of the ancient world, without introducing dangerous foreign bodies into his psychic organism. This sort of thing is constantly practised, and not always with bad results;

but, for all that, it is an experiment whose legitimacy seems to me exceedingly doubtful. I think a conservative treatment is the more advisable. One should, if possible, not destroy any values that have not proved themselves definitely injurious. To replace a Christian view of the world by a materialistic one is, to my way of thinking, just as wrong as the attempt to argue with a convinced materialist. That is the task of the missionary, not of the doctor.

[241] Many psychotherapists, unlike me, hold the view that theoretical problems do not enter into the therapeutic process at all. The aetiological factors, they think, are all questions of purely personal psychology. But if we scrutinize these factors more closely, we find that they present quite a different picture. Take, for example, the sexual urge, which plays such an enormous role in Freudian theory. This urge, like every other urge, is not a personal acquisition, but is an objective and universal datum that has nothing whatever to do with our personal wishes, desires, opinions, and decisions. It is a completely impersonal force, and all we can do is to try to come to terms with it with the help of subjective and theoretical judgments. Of these latter, only the subjective premises (and then only a part of them) belong to the personal sphere; for the rest they are derived from the stream of tradition and from environmental influences, and only a very small fraction of them has been built up personally as a result of conscious choice. Just as I find myself moulded by external and objective social influences, so also I am moulded by internal and unconscious forces, which I have summed up under the term “the subjective factor.” The man with the extraverted attitude bases himself primarily on social relationships; the other, the introvert, primarily on the subjective factor. The former is largely unaware of his subjective determinacy and regards it as insignificant; as a matter of fact, he is frightened of it. The latter has little or no interest in social relationships; he prefers to ignore them, feeling them to be onerous, even terrifying. To the one, the world of relationships is the important thing; for him it represents normality, the goal of desire. The other is primarily concerned with the inner pattern of his life, with his own self-consistency.

[242] When we come to analyse the personality, we find that the extravert makes a niche for himself in the world of relationships at the cost of unconsciousness (of himself as a subject); while the introvert, in realizing his personality, commits the grossest mistakes in the social sphere and blunders about in the most absurd way. These two very typical attitudes are enough to show—quite apart from the types of physiological temperament described by Kretschmer—how little one can fit human beings and their neuroses into the strait jacket of a single theory.

[243] As a rule these subjective premises are quite unknown to the patient, and also, unfortunately, to the doctor, so that the latter is too often tempted to overlook the old

adage *quod licet Jovi, non licet bovi*, or in other words, one man's meat is another man's poison, and in this way to unlock doors that were better shut, and vice versa. Medical theory is just as likely as the patient to become the victim of its own subjective premises, even if to a lesser degree, since it is at least the outcome of comparative work on a large number of cases and has therefore rejected any excessively individual variants. This, however, is only in the smallest degree true of the personal prejudices of its creator. Though the comparative work will do something to mitigate them, they will nevertheless give a certain colouring to his medical activities and will impose certain limits. Accordingly, one urge or the other, one idea or the other, will then impose itself as the limit and become a bogus principle which is the be-all and end-all of research. Within this framework everything can be observed correctly and—according to the subjective premise—logically interpreted, as was undoubtedly the case with Freud and Adler; and yet in spite of this, or perhaps just because of it, very different views will result, in fact to all appearances they will be flatly irreconcilable. The reason obviously lies in the subjective premise, which assimilates what suits it and discards what does not.

[244] Such developments are by no means the exception in the history of science, they are the rule. Anyone who accuses modern medical psychology of not even being able to reach agreement on its own theories is completely forgetting that no science can retain its vitality without divergences of theory. Disagreements of this kind are, as always, incentives to a new and deeper questioning. So also in psychology. The Freud-Adler dilemma found its solution in the acceptance of divergent principles, each of which laid stress on one particular aspect of the total problem.

[245] Seen from this angle, there are numerous lines of research still waiting to be opened up. One of the most interesting, perhaps, is the problem of the *a priori* attitude-type and of the functions underlying it. This was the line followed by the Rorschach test, Gestalt psychology, and the various other attempts to classify type-differences. Another possibility, which seems to me equally important, is the investigation of the theoretical⁴ factors that have proved to be of such cardinal importance when it comes to choosing and deciding. They have to be considered not only in the aetiology of neurosis, but in the evaluation of the analytical findings. Freud himself laid great emphasis on the function of the moral "censor" as one cause of repression, and he even felt obliged to hold up religion as one of the neuroticizing factors which lend support to infantile wish-fantasies. There are, in addition, theoretical assumptions that claim to play a decisive part in "sublimation"—value-categories that are supposed to help or hinder the work of fitting the tendencies revealed by the analysis of the unconscious into the life-plan of the patient. The very greatest significance attaches to the investigation of these so-called theoretical factors, not only in regard to the aetiology but—what is far more important—in

regard to the therapy and necessary *reconstruction of the personality*, as Freud himself confirmed, even if only negatively, in his later writings. A substantial part of these factors was termed by him the “super-ego,” which is the sum of all the collective beliefs and values consciously handed down by tradition. These, like the Torah for the orthodox Jew, constitute a solidly entrenched psychic system which is superordinate to the ego and the cause of numerous conflicts.

[246] Freud also observed that the unconscious occasionally produces images that can only be described as “archaic.” They are found more particularly in dreams and in waking fantasies. He, too, tried to interpret or amplify such symbols “historically,” as for example in his study of the dual mother motif in a dream of Leonardo da Vinci.⁵

[247] Now it is a well-known fact that the factors composing the “super-ego” correspond to the “collective representations” which Lévy-Bruhl posited as basic to the psychology of primitive man. The latter are general ideas and value-categories which have their origin in the primordial motifs of mythology, and they govern the psychic and social life of the primitive in much the same way as our lives are governed and moulded by the general beliefs, views, and ethical values in accordance with which we are brought up and by which we make our way in the world. They intervene almost automatically in all our acts of choice and decision, as well as being operative in the formation of concepts. With a little reflection, therefore, we can practically always tell why we do something and on what general assumptions our judgments and decisions are based. The false conclusions and wrong decisions of the neurotic have pathogenic effects because they are as a rule in conflict with these premises. Whoever can live with these premises without friction fits into our society as perfectly as the primitive, who takes his tribal teachings as an absolute rule of conduct.

[248] But when an individual, as a result perhaps of some anomaly in his personal disposition (no matter what this may be), ceases to conform to the *canon* of collective ideas, he will very likely find himself not only in conflict with society, but in disharmony with himself, since the super-ego represents another psychic system within him. In that case he will become neurotic: a dissociation of the personality supervenes, which, given the necessary psychopathic foundation, may lead to its complete fragmentation, that is, to the schizoid personality and to schizophrenia. Such a case serves as a model for the *personal neurosis*, for which an explanation in personalistic terms is quite sufficient, as we know from experience that no further procedure is necessary for a cure except the demolition of the subject’s false conclusions and wrong decisions. His wrong attitude having been corrected, the patient can then fit into society again. His illness was in fact nothing but the product of a certain “weakness,” either congenital or acquired. In cases of this kind it would

be a bad mistake to try to alter anything in the fundamental idea, the “collective representation.” That would only thrust the patient still deeper into his conflict with society by countenancing his pathogenic weakness.

[249] Clinical observations seem to show that schizophrenics fall into two different groups: an asthenic type (hence the French term *psychasthénie*) and a spastic type, given to active conflict. And the same is true of neurotics. The first type is represented by the kind of neurosis which can be explained purely personalistically, as it is a form of maladjustment based on personal weakness. The second type is represented by individuals who *could* be adjusted without much difficulty, and who have also proved their aptitude for it. But for some reason or other they cannot or will not adjust themselves, and they do not understand why their own particular “adjustment” does not make normal life possible for them, when in their estimation such a life should be well within the bounds of possibility. The reason for their neurosis seems to lie in their having something above the average, an overplus for which there is no adequate outlet. We may then expect the patient to be consciously or—in most cases—unconsciously critical of the generally accepted views and ideas. Freud, too, seems to have come across similar experiences, otherwise he would hardly have felt impelled to attack religion from the standpoint of the medical psychologist, as being the cornerstone of a man’s fundamental beliefs. Seen in the light of medical experience, however, this attempt was, in a sense, thoroughly consistent with its own premises, although one can hold a very different view on the manner in which it was conducted; for not only is religion not the enemy of the sick, it is actually a system of psychic healing, as the use of the Christian term “cure of souls” makes clear, and as is also evident from the Old Testament.⁶

[250] It is principally the neuroses of the second type that confront the doctor with problems of this kind. There are in addition not a few patients who, although they have no clinically recognizable neurosis, come to consult the doctor on account of psychic conflicts and various other difficulties in their lives, laying before him problems whose answer inevitably involves a discussion of fundamental questions. Such people often know very well—what the neurotic seldom or never knows—that their conflicts have to do with the fundamental problem of their own attitude, and that this is bound up with certain principles or general ideas, in a word, with their religious, ethical, or philosophical beliefs. It is precisely because of such cases that psychotherapy has to spread far beyond the confines of somatic medicine and psychiatry into regions that were formerly the province of priests and philosophers. From the degree to which priests and philosophers no longer discharge any duties in this respect or their competence to do so has been denied by the public, we can see what an enormous gap the psychotherapist is sometimes called upon to fill, and how remote religion on the one hand and philosophy on the other have become from the

actualities of life. The parson is blamed because one always knows in advance what he is going to say; the philosopher, because he never says anything of the slightest practical value. And the odd thing is that both of them—with few and ever fewer exceptions—are distinctly unsympathetic towards psychology.

[251] The positive meaning of the religious factor in a man's philosophical outlook will not, of course, prevent certain views and interpretations from losing their force and becoming obsolete, as a result of changes in the times, in the social conditions, and in the development of human consciousness. The old mythologems upon which all religion is ultimately based are, as we now see them, the expression of inner psychic events and experiences; and, by means of a ritualistic "anamnesis," they enable the conscious mind to preserve its link with the unconscious, which continues to send out or "ecphorate"⁷ the primordial images just as it did in the remote past. These images give adequate expression to the unconscious, and its instinctive movements can in that way be transmitted to the conscious mind without friction, so that the conscious mind never loses touch with its instinctive roots. If, however, certain of these images become antiquated, if, that is to say, they lose all intelligible connection with our contemporary consciousness, then our conscious acts of choice and decision are sundered from their instinctive roots, and a partial disorientation results, because our judgment then lacks any feeling of definiteness and certitude, and there is no emotional driving-force behind decision. The collective representations that connect primitive man with the life of his ancestors or with the founders of his tribe form the bridge to the unconscious for civilized man also, who, if he is a believer, will see it as the world of divine presences. Today these bridges are in a state of partial collapse, and the doctor is in no position to hold those who are worst hit responsible for the disaster. He knows that it is due far more to a shifting of the whole psychic situation over many centuries, such as has happened more than once in human history. In the face of such transformations the individual is powerless.

[252] The doctor can only look on and try to understand the attempts at restitution and cure which nature herself is making. Experience has long shown that between conscious and unconscious there exists a compensatory relationship, and that the unconscious always tries to make whole the conscious part of the psyche by adding to it the parts that are missing, and so prevent a dangerous loss of balance. In our own case, as might be expected, the unconscious produces compensating symbols which are meant to replace the broken bridges, but which can only do so with the active cooperation of consciousness. In other words, these symbols must, if they are to be effective, be "understood" by the conscious mind; they must be assimilated and integrated. A dream that is not understood remains a mere occurrence; understood, it becomes a living experience.

[253] I therefore consider it my main task to examine the manifestations of the unconscious in order to learn its language. But since, on the one hand, the theoretical assumptions we have spoken of are of eminently historical interest, and, on the other hand, the symbols produced by the unconscious derive from archaic modes of psychic functioning, one must, in carrying out these investigations, have at one's command a vast amount of historical material; and, secondly, one must bring together and collate an equally large amount of empirical material based on direct observation.

[254] The practical need for a deeper understanding of the products of the unconscious is sufficiently obvious. In pursuit of this, I am only going further along the path taken by Freud, though I certainly try to avoid having any preconceived metaphysical opinions. I try rather to keep to first-hand experience, and to leave metaphysical beliefs, either for or against, to look after themselves. I do not imagine for a moment that I can stand above or beyond the psyche, so that it would be possible to judge it, as it were, from some transcendental Archimedean point "outside." I am fully aware that I am entrapped in the psyche and that I cannot do anything except describe the experiences that there befall me. When, for instance, one examines the world of fairytales, one can hardly avoid the impression that one is meeting certain figures again and again, albeit in altered guise. Such comparisons lead on to what the student of folklore calls the investigation of motifs. The psychologist of the unconscious proceeds no differently in regard to the psychic figures which appear in dreams, fantasies, visions, and manic ideas, as in legends, fairytales, myth, and religion. Over the whole of this psychic realm there reign certain motifs, certain typical figures which we can follow far back into history, and even into prehistory, and which may therefore legitimately be described as "archetypes."⁸ They seem to me to be built into the very structure of man's unconscious, for in no other way can I explain why it is that they occur universally and in identical form, whether the redeemer-figure be a fish, a hare, a lamb, a snake, or a human being. It is the same redeemer-figure in a variety of accidental disguises. From numerous experiences of this kind I have come to the conclusion that the most individual thing about man is surely his consciousness, but that his shadow, by which I mean the uppermost layer of his unconscious, is far less individualized, the reason being that a man is distinguished from his fellows more by his virtues than by his negative qualities. The unconscious, however, in its principal and most overpowering manifestations, can only be regarded as a collective phenomenon which is everywhere identical, and, because it never seems to be at variance with itself, it may well possess a marvellous unity and self-consistency, the nature of which is at present shrouded in impenetrable darkness. Another fact to be considered here is the existence today of parapsychology, whose proper subject is manifestations that are directly connected with the unconscious. The most important of these are the ESP⁹ phenomena, which medical psychology should

on no account ignore. If these phenomena prove anything at all, it is the fact of a certain psychic relativity of space and time, which throws a significant light on the unity of the collective unconscious. For the present, at any rate, only two groups of facts have been established with any certainty: firstly, the congruence of individual symbols and mythologems; and secondly, the phenomenon of extra-sensory perception. The interpretation of these phenomena is reserved for the future.



SPECIFIC PROBLEMS OF PSYCHOTHERAPY

THE THERAPEUTIC VALUE OF ABREACTION¹

[255] In his discussion of William Brown's paper, "The Revival of Emotional Memories and Its Therapeutic Value," William McDougall, writing in the *British Journal of Psychology*,² gave expression to some important considerations which I would like to underline here. The neuroses resulting from the Great War have, with their essentially traumatic aetiology, revived the whole question of the trauma theory of neurosis. During the years of peace this theory had rightly been kept in the background of scientific discussion, since its conception of neurotic aetiology is far from adequate.

[256] The originators of the theory were Breuer and Freud. Freud went on to a deeper investigation of the neuroses and soon adopted a view that took more account of their real origins. In by far the greater number of ordinary cases there is no question of a traumatic aetiology.

[257] But, in order to create the impression that the neurosis is caused by some trauma or other, unimportant and secondary occurrences must be given an artificial prominence for the sake of the theory. These traumata, when they are not mere products of medical fantasy, or else the result of the patient's own compliancy, are secondary phenomena, the outcome of an attitude that is already neurotic. The neurosis is as a rule a pathological, one-sided development of the personality, the imperceptible beginnings of which can be traced back almost indefinitely into the earliest years of childhood. Only a very arbitrary judgment can say where the neurosis actually begins.

[258] If we were to relegate the determining cause as far back as the patient's prenatal life, thus involving the physical and psychic disposition of the parents at the time of conception and pregnancy—a view that seems not at all improbable in certain cases—such an attitude would be more justifiable than the arbitrary selection of a definite point of neurotic origin in the individual life of the patient.

[259] Clearly, in dealing with this question, one should never be influenced too much by the surface appearance of the symptoms, even when both the patient and his family synchronize the first manifestation of these with the onset of the neurosis. A

more thorough investigation will almost invariably show that some morbid tendency existed long before the appearance of clinical symptoms.

[260] These obvious facts, long familiar to every specialist, pushed the trauma theory into the background until, as a result of the war, there was a regular spate of traumatic neuroses.

[261] Now, if we set aside the numerous cases of war neurosis where a trauma—a violent shock—impinged upon an established neurotic history, there still remain not a few cases where no neurotic disposition can be established, or where it is so insignificant that the neurosis could hardly have arisen without a trauma. Here the trauma is more than an agent of release: it is causative in the sense of a *causa efficiens*, especially when we include, as an essential factor, the unique psychic atmosphere of the battlefield.

[262] These cases present us with a new therapeutic problem which seems to justify a return to the original Breuer-Freud method and its underlying theory; for the trauma is either a single, definite, violent impact, or a complex of ideas and emotions which may be likened to a psychic wound. Everything that touches this complex, however slightly, excites a vehement reaction, a regular emotional explosion. Hence one could easily represent the trauma as a complex with a high emotional charge, and because this enormously effective charge seems at first sight to be the pathological cause of the disturbance, one can accordingly postulate a therapy whose aim is the complete release of this charge. Such a view is both simple and logical, and it is in apparent agreement with the fact that abreaction—i.e., the dramatic rehearsal of the traumatic moment, its emotional recapitulation in the waking or in the hypnotic state—often has a beneficial therapeutic effect. We all know that a man feels a compelling need to recount a vivid experience again and again until it has lost its affective value. As the proverb says, “What filleth the heart goeth out by the mouth.” The unbosoming gradually depotentiates the affectivity of the traumatic experience until it no longer has a disturbing influence.

[263] This conception, apparently so clear and simple, is unfortunately—as McDougall rightly objects—no more adequate than many another equally simple and therefore delusive explanation. Views of this kind have to be fiercely and fanatically defended as though they were dogmas, because they cannot hold their own in the face of experience. McDougall is also right to point out that in quite a large number of cases abreaction is not only useless but actually harmful.

[264] In reply, it is possible to take up the attitude of an injured theorist and say that the abreactive method never claimed to be a panacea, and that refractory cases are to be met with in every method.

[265] But, I would rejoin, it is precisely here, in a careful study of the refractory cases, that we gain the most illuminating insight into the method or theory in question, for they disclose far more clearly than the successes just where the theory is weak. Naturally this does not disprove the efficacy of the method or its justification, but it does at least lead to a possible improvement of the theory and, indirectly, of the method.

[266] McDougall, therefore, has laid his finger on the right spot when he argues that the essential factor is the dissociation of the psyche and not the existence of a highly charged affect and, consequently, that the main therapeutic problem is not abreaction but how to integrate the dissociation. This argument advances our discussion and entirely agrees with our experience that a traumatic complex brings about dissociation of the psyche. The complex is not under the control of the will and for this reason it possesses the quality of psychic autonomy.

[267] Its autonomy consists in its power to manifest itself independently of the will and even in direct opposition to conscious tendencies: it forces itself tyrannically upon the conscious mind. The explosion of affect is a complete invasion of the individual, it pounces upon him like an enemy or a wild animal. I have frequently observed that the typical traumatic affect is represented in dreams as a wild and dangerous animal—a striking illustration of its autonomous nature when split off from consciousness.

[268] Considered from this angle, abreaction appears in an essentially different light: as an attempt to reintegrate the autonomous complex, to incorporate it gradually into the conscious mind as an accepted content, by living the traumatic situation over again, once or repeatedly.

[269] But I rather question whether the thing is as simple as that, or whether there may not be other factors essential to the process. For it must be emphasized that mere rehearsal of the experience does not itself possess a curative effect: the experience must be rehearsed in the presence of the doctor.

[270] If the curative effect depended solely upon the rehearsal of experience, abreaction could be performed by the patient alone, as an isolated exercise, and there would be no need of any human object upon whom to discharge the affect. But the intervention of the doctor is absolutely necessary. One can easily see what it means to the patient when he can confide his experience to an understanding and sympathetic doctor. His conscious mind finds in the doctor a moral support against the unmanageable affect of his traumatic complex. No longer does he stand alone in his battle with these elemental powers, but some one whom he trusts reaches out a hand, lending him moral strength to combat the tyranny of uncontrolled emotion. In this way the integrative powers of his conscious mind are reinforced until he is able once more to

bring the rebellious affect under control. This influence on the part of the doctor, which is absolutely essential, may, if you like, be called suggestion.

[271] For myself, I would rather call it his human interest and personal devotion. These are the property of no method, nor can they ever become one; they are moral qualities which are of the greatest importance in all methods of psychotherapy, and not in the case of abreaction alone. The rehearsal of the traumatic moment is able to reintegrate the neurotic dissociation only when the conscious personality of the patient is so far reinforced by his relationship to the doctor that he can consciously bring the autonomous complex under the control of his will.

[272] Only under these conditions has abreaction a curative value. But this does not depend solely on the discharge of affective tension; it depends, as McDougall shows, far more on whether or not the dissociation is successfully resolved. Hence the cases where abreaction has a negative result appear in a different light.

[273] In the absence of the conditions just mentioned, abreaction by itself is not sufficient to resolve the dissociation. If the rehearsal of the trauma fails to reintegrate the autonomous complex, then the relationship to the doctor can so raise the level of the patient's consciousness as to enable him to overcome the complex and assimilate it. But it may easily happen that the patient has a particularly obstinate resistance to the doctor, or that the doctor does not have the right kind of attitude to the patient. In either case the abreactive method breaks down.

[274] It stands to reason that when dealing with neuroses which are traumatically determined only to a minor degree, the cathartic method of abreaction will meet with poor success. It has nothing to do with the nature of the neurosis, and its rigid application is quite ludicrous here. Even when a partial success is obtained, it can have no more significance than the success of any other method which admittedly had nothing to do with the nature of the neurosis.

[275] *Success* in these cases is due to suggestion; it is usually of very limited duration and clearly a matter of chance. The prime cause is always the transference to the doctor, and this is established without too much difficulty provided that the doctor evinces an earnest belief in his method. Precisely because it has as little to do with the nature of neurosis as, shall we say, hypnosis and other such cures, the cathartic method has, with few exceptions, long been abandoned in favour of analysis.

[276] Now it happens that the analytical method is most unassailable just where the cathartic method is most shaky: that is, in the relationship between doctor and patient. It matters little that, even today, the view prevails in many quarters that analysis consists mainly in "digging up" the earliest childhood complex in order to pluck out the evil by the root. This is merely the aftermath of the old trauma theory.

Only in so far as they hamper the patient's adaptation to the present have these historical contents any real significance. The painstaking pursuit of all the ramifications of infantile fantasy is relatively unimportant in itself; the therapeutic effect comes from the doctor's efforts to enter into the psyche of his patient, thus establishing a psychologically adapted relationship. For the patient is suffering precisely from the absence of such a relationship. Freud himself has long recognized that the transference is the alpha and omega of psychoanalysis. The transference is the patient's attempt to get into psychological rapport with the doctor. He needs this relationship if he is to overcome the dissociation. The feebler the rapport, i.e., the less the doctor and patient understand one another, the more intensely will the transference be fostered and the more sexual will be its form.

[277] To attain the goal of adaptation is of such vital importance to the patient that sexuality intervenes as a function of compensation. Its aim is to consolidate a relationship that cannot ordinarily be achieved through mutual understanding. In these circumstances the transference can well become the most powerful obstacle to the success of the treatment. It is not surprising that violent sexual transferences are especially frequent when the analyst concentrates too much on the sexual aspect, for then all other roads to understanding are barred. An exclusively sexual interpretation of dreams and fantasies is a shocking violation of the patient's psychological material: infantile-sexual fantasy is by no means the whole story, since the material also contains a creative element, the purpose of which is to shape a way out of the neurosis. This natural means of escape is now blocked; the doctor is the only certain refuge in a wilderness of sexual fantasies, and the patient has no alternative but to cling to him with a convulsive erotic transference, unless he prefers to break off the relationship in hatred.

[278] In either case the result is spiritual desolation. This is the more regrettable since, obviously, psychoanalysts do not in the least desire such a melancholy result; yet they often bring it about through their blind allegiance to the dogma of sexuality.

[279] Intellectually, of course, the sexual interpretation is extremely simple; it concerns itself at most with a handful of elementary facts which recur in numberless variations. One always knows in advance where the matter will end. *Inter faeces et urinam nascimur* remains an eternal truth, but it is a sterile, a monotonous, and above all an unsavoury truth. There is absolutely no point in everlastingly reducing all the finest strivings of the soul back to the womb. It is a gross technical blunder because, instead of promoting, it destroys psychological understanding. More than anything else neurotic patients need that psychological rapport; in their dissociated state it helps them to adjust themselves to the doctor's psyche. Nor is it by any means so simple to establish this kind of human relationship; it can only be built up with great

pains and scrupulous attention. The continual reduction of all projections to their origins—and the transference is made up of projections—may be of considerable historical and scientific interest, but it never produces an adapted attitude to life; for it constantly destroys the patient's every attempt to build up a normal human relationship by resolving it back into its elements.

[280] If, in spite of this, the patient does succeed in adapting himself to life, it will have been at the cost of many moral, intellectual, and aesthetic values whose loss to a man's character is a matter for regret. Quite apart from this major loss, there is the danger of perpetually brooding on the past, of looking back wistfully to things that cannot be remedied now: the morbid tendency, very common among neurotics, always to seek the cause of their inferiority in the dim bygone, in their upbringing, the character of their parents, and so forth.

[281] This minute scrutiny of minor determinants will affect their present inferiority as little as the existing social conditions would be ameliorated by an equally painstaking investigation of the causes of the Great War. The real issue is the moral achievement of the whole personality.

[282] To assert, as a general principle, that a reductive analysis is unnecessary would of course be short-sighted and no more intelligent than to deny the value of all research into the causes of war. The doctor must probe as deeply as possible into the origins of the neurosis in order to lay the foundations of a subsequent synthesis. As a result of reductive analysis, the patient is deprived of his faulty adaptation and led back to his beginnings. The psyche naturally seeks to make good this loss by intensifying its hold upon some human object—generally the doctor, but occasionally some other person, like the patient's husband or a friend who acts as a counterpole to the doctor. This may effectively balance a one-sided transference, but it may also turn out to be a troublesome obstacle to the progress of the work. The intensified tie to the doctor is a compensation for the patient's faulty attitude to reality. This tie is what we mean by "transference."

[283] The transference phenomenon is an inevitable feature of every thorough analysis, for it is imperative that the doctor should get into the closest possible touch with the patient's line of psychological development. One could say that in the same measure as the doctor assimilates the intimate psychic contents of the patient into himself, he is in turn assimilated as a figure into the patient's psyche. I say "as a figure," because I mean that the patient sees him not as he really is, but as one of those persons who figured so significantly in his previous history. He becomes associated with those memory images in the patient's psyche because, like them, he makes the patient divulge all his intimate secrets. It is as though he were charged with the power of those memory images.

[284] The transference therefore consists in a number of projections which act as a substitute for a real psychological relationship. They create an apparent relationship and this is very important, since it comes at a time when the patient's habitual failure to adapt has been artificially intensified by his analytical removal into the past. Hence a sudden severance of the transference is always attended by extremely unpleasant and even dangerous consequences, because it maroons the patient in an impossibly unrelated situation.

[285] Even if these projections are analysed back to their origins—and all projections can be dissolved and disposed of in this way—the patient's claim to human relationship still remains and should be conceded, for without a relationship of some kind he falls into a void.

[286] Somehow he must relate himself to an object existing in the immediate present if he is to meet the demands of adaptation with any degree of adequacy. Irrespective of the reductive analysis, he will turn to the doctor not as an object of sexual desire, but as an object of purely human relationship in which each individual is guaranteed his proper place. Naturally this is impossible until all the projections have been consciously recognized; consequently they must be subjected to a reductive analysis before all else, provided of course that the legitimacy and importance of the underlying claim to personal relationship is constantly borne in mind.

[287] Once the projections are recognized as such, the particular form of rapport known as the transference is at an end, and the problem of individual relationship begins. Every student who has perused the literature and amused himself with interpreting dreams and unearthing complexes in himself and others can easily get as far as this, but beyond it no one has the right to go except the doctor who has himself undergone a thorough analysis, or can bring such passion for truth to the work that he can analyse himself through his patient. The doctor who has no wish for the one and cannot achieve the other should never touch analysis; he will be found wanting, cling as he may to his petty conceit of authority.

[288] In the last resort his whole work will be intellectual bluff—for how can he help his patient to conquer his morbid inferiority when he himself is so manifestly inferior? How can the patient learn to abandon his neurotic subterfuges when he sees the doctor playing hide-and-seek with his own personality, as though unable, for fear of being thought inferior, to drop the professional mask of authority, competence, superior knowledge, etc.?

[289] The touchstone of every analysis that has not stopped short at partial success, or come to a standstill with no success at all, is always this person-to-person relationship, a psychological situation where the patient confronts the doctor upon

equal terms, and with the same ruthless criticism that he must inevitably learn from the doctor in the course of his treatment.

[290] This kind of personal relationship is a freely negotiated bond or contract as opposed to the slavish and humanly degrading bondage of the transference. For the patient it is like a bridge; along it, he can make the first steps towards a worthwhile existence. He discovers that his own unique personality has value, that he has been accepted for what he is, and that he has it in him to adapt himself to the demands of life. But this discovery will never be made while the doctor continues to hide behind a method, and allows himself to carp and criticize without question. Whatever method he then adopts, it will be little different from suggestion, and the results will match the method. In place of this, the patient must have the right to the freest criticism, and a true sense of human equality.

[291] I think I have said enough to indicate that, in my view, analysis makes far higher demands on the mental and moral stature of the doctor than the mere application of a routine technique, and also that his therapeutic influence lies primarily in this more personal direction.

[292] But if the reader should conclude that little or nothing lay in the method, I would regard that as a total misapprehension of my meaning. Mere personal sympathy can never give the patient that objective understanding of his neurosis which makes him independent of the doctor and sets up a counterinfluence to the transference.

[293] For the objective understanding of his malady, and for the creation of a personal relationship, science is needed—not a purely medical knowledge that embraces only a limited field, but a wide knowledge of every aspect of the human psyche. The treatment must do more than destroy the old morbid attitude; it must build up a new attitude that is sound and healthy. This requires a fundamental change of vision. Not only must the patient be able to see the cause and origin of his neurosis, he must also see the legitimate psychological goal towards which he is striving. We cannot simply extract his morbidity like a foreign body, lest something essential be removed along with it, something meant for life. Our task is not to weed it out, but to cultivate and transform this growing thing until it can play its part in the totality of the psyche.

II

THE PRACTICAL USE OF DREAM-ANALYSIS¹

[294] The use of dream-analysis in psychotherapy is still a much debated question. Many practitioners find it indispensable in the treatment of neuroses, and consider that the dream is a function whose psychic importance is equal to that of the conscious mind itself. Others, on the contrary, dispute the value of dream-analysis and regard dreams as a negligible by-product of the psyche. Obviously, if a person holds the view that the unconscious plays a decisive part in the aetiology of neuroses, he will attribute a high practical importance to dreams as direct expressions of the unconscious. Equally obviously, if he denies the unconscious or at least thinks it aetiologically insignificant, he will minimize the importance of dream-analysis. It might be considered regrettable that in this year of grace 1931, more than half a century after Carus formulated the concept of the unconscious, more than a century after Kant spoke of the “illimitable field of obscure ideas,” and nearly two hundred years after Leibniz postulated an unconscious psychic activity, not to mention the achievements of Janet, Flournoy, Freud, and many more—that after all this, the actuality of the unconscious should still be a matter for controversy. But, since it is my intention to deal exclusively with practical questions, I will not advance in this place an apology for the unconscious, although our special problem of dream-analysis stands or falls with such an hypothesis. Without it, the dream is a mere freak of nature, a meaningless conglomeration of fragments left over from the day. Were that really so, there would be no excuse for the present discussion. We cannot treat our theme at all unless we recognize the unconscious, for the avowed aim of dream-analysis is not only to exercise our wits, but to uncover and realize those hitherto unconscious contents which are considered to be of importance in the elucidation or treatment of a neurosis. Anyone who finds this hypothesis unacceptable must simply rule out the question of the applicability of dream-analysis.

[295] But since, according to our hypothesis, the unconscious possesses an aetiological significance, and since dreams are the direct expression of unconscious psychic activity, the attempt to analyse and interpret dreams is theoretically justified from a scientific standpoint. If successful, we may expect this attempt to give us scientific insight into the structure of psychic causality, quite apart from any therapeutic results that may be gained. The practitioner, however, tends to consider scientific discoveries as, at most, a gratifying by-product of his therapeutic work, so he is hardly likely to

take the bare possibility of theoretical insight into the aetiological background as a sufficient reason for, much less an indication of, the practical use of dream-analysis. He may believe, of course, that the explanatory insight so gained is of therapeutic value, in which case he will elevate dream-analysis to a professional duty. It is well known that the Freudian school is of the firm opinion that very valuable therapeutic results are achieved by throwing light upon the unconscious causal factors—that is, by explaining them to the patient and thus making him fully conscious of the sources of his trouble.

[296] Assuming for the moment that this expectation is justified by the facts, then the only question that remains is whether dream-analysis can or cannot be used, alone or in conjunction with other methods, to discover the unconscious aetiology. The Freudian answer to this question is, I may assume, common knowledge. I can confirm this answer inasmuch as dreams, particularly the initial dreams which appear at the very outset of the treatment, often bring to light the essential aetiological factor in the most unmistakable way. The following example may serve as an illustration:

[297] I was consulted by a man who held a prominent position in the world. He was afflicted with a sense of anxiety and insecurity, and complained of dizziness sometimes resulting in nausea, heaviness in the head, and constriction of breath—a state that might easily be confused with mountain sickness. He had had an extraordinarily successful career, and had risen, by dint of ambition, industry, and native talent, from his humble origins as the son of a poor peasant. Step by step he had climbed, attaining at last a leading position which held every prospect of further social advancement. He had now in fact reached the spring-board from which he could have commenced his flight into the empyrean, had not his neurosis suddenly intervened. At this point in his story the patient could not refrain from that familiar exclamation which begins with the stereotyped words: “And just now, when....” The fact that he had all the symptoms of mountain sickness seemed highly appropriate as a drastic illustration of his peculiar impasse. He had also brought to the consultation two dreams from the preceding night. The first dream was as follows: “*I am back again in the small village where I was born. Some peasant lads who went to school with me are standing together in the street. I walk past, pretending not to know them. Then I hear one of them say, pointing at me: ‘He doesn’t often come back to our village.’*”

[298] It requires no feat of interpretation to see in this dream a reference to the humble beginnings of the dreamer’s career and to understand what this reference means. The dream says quite clearly: “You forgot how far down you began.”

[299] Here is the second dream: “*I am in a great hurry because I want to go on a journey. I keep on looking for things to pack, but can find nothing. Time flies, and the*

train will soon be leaving. Having finally succeeded in getting all my things together, I hurry along the street, only to discover that I have forgotten a brief-case containing important papers. I dash back all out of breath, find it at last, then race to the station, but I make hardly any headway. With a final effort I rush on to the platform only to see the train just steaming out of the station yard. It is very long, and it runs in a curious S-shaped curve, and it occurs to me that if the engine-driver does not look out, and puts on steam when he comes into the straight, the rear coaches will still be on the curve and will be thrown off the rails by the gathering speed. And this is just what happens: the engine-driver puts on steam, I try to cry out, the rear coaches give a frightful lurch and are thrown off the rails. There is a terrible catastrophe. I wake up in terror.”

[300] Here again no effort is needed to understand the message of the dream. It describes the patient's frantic haste to advance himself still further. But since the engine-driver in front steams relentlessly ahead, the neurosis happens at the back: the coaches rock and the train is derailed.

[301] It is obvious that, at the present phase of his life, the patient has reached the highest point of his career; the strain of the long ascent from his lowly origin has exhausted his strength. He should have rested content with his achievements, but instead of that his ambition drives him on and on, and up and up into an atmosphere that is too thin for him and to which he is not accustomed. Therefore his neurosis comes upon him as a warning.

[302] Circumstances prevented me from treating the patient further, nor did my view of the case satisfy him. The upshot was that the fate depicted in the dream ran its course. He tried to exploit the professional openings that tempted his ambition, and ran so violently off the rails that the catastrophe was realized in actual life.

[303] Thus, what could only be inferred from the conscious anamnesis—namely that the mountain sickness was a symbolical representation of the patient's inability to climb any further—was confirmed by the dreams as a fact.

[304] Here we come upon something of the utmost importance for the applicability of dream-analysis: the dream describes the inner situation of the dreamer, but the conscious mind denies its truth and reality, or admits it only grudgingly. Consciously the dreamer could not see the slightest reason why he should not go steadily forward; on the contrary, he continued his ambitious climbing and refused to admit his own inability which subsequent events made all too plain. So long as we move in the conscious sphere, we are always unsure in such cases. The anamnesis can be interpreted in various ways. After all, the common soldier carries the marshal's baton in his knapsack, and many a son of poor parents has achieved the highest success. Why should it not be the case here? Since my judgment is fallible, why should my

conjecture be better than his? At this point the dream comes in as the expression of an involuntary, unconscious psychic process beyond the control of the conscious mind. It shows the inner truth and reality of the patient as it really is: not as I conjecture it to be, and not as he would like it to be, but *as it is*. I have therefore made it a rule to regard dreams as I regard physiological facts: if sugar appears in the urine, then the urine contains sugar, and not albumen or urobilin or something else that might fit in better with my expectations. That is to say, I take dreams as diagnostically valuable facts.

[305] As is the way of all dreams, my little dream example gives us rather more than we expected. It gives us not only the aetiology of the neurosis but a prognosis as well. What is more, we even know exactly where the treatment should begin: we must prevent the patient from going full steam ahead. This is just what he tells himself in the dream.

[306] Let us for the time being content ourselves with this hint and return to our consideration of whether dreams enable us to throw light on the aetiology of a neurosis. The dreams I have cited actually do this. But I could equally well cite any number of initial dreams where there is no trace of an aetiological factor, although they are perfectly transparent. I do not wish for the present to consider dreams which call for searching analysis and interpretation.

[307] The point is this: there are neuroses whose real aetiology becomes clear only right at the end of an analysis, and other neuroses whose aetiology is relatively unimportant. This brings me back to the hypothesis from which we started, that for the purposes of therapy it is absolutely necessary to make the patient conscious of the aetiological factor. This hypothesis is little more than a hang-over from the old trauma theory. I do not of course deny that many neuroses are traumatic in origin; I simply contest the notion that all neuroses are of this nature and arise without exception from some crucial experience in childhood. Such a view necessarily results in the causalistic approach. The doctor must give his whole attention to the patient's past; he must always ask "Why?" and ignore the equally pertinent question "What for?" Often this has a most deleterious effect on the patient, who is thereby compelled to go searching about in his memory—perhaps for years—for some hypothetical event in his childhood, while things of immediate importance are grossly neglected. The purely causalistic approach is too narrow and fails to do justice to the true significance either of the dream or of the neurosis. Hence an approach that uses dreams for the sole purpose of discovering the aetiological factor is biased and overlooks the main point of the dream. Our example indeed shows the aetiology clearly enough, but it also offers a prognosis or anticipation of the future as well as a suggestion about the treatment. There are in addition large numbers of

initial dreams which do not touch the aetiology at all, but deal with quite other matters, such as the patient's attitude to the doctor. As an example of this I would like to tell you three dreams, all from the same patient, and each dreamt at the beginning of a course of treatment under three different analysts. Here is the first: "*I have to cross the frontier into another country, but cannot find the frontier and nobody can tell me where it is.*"

[308] The ensuing treatment proved unsuccessful and was broken off after a short time. The second dream is as follows: "*I have to cross the frontier, but the night is pitch-black and I cannot find the customs-house. After a long search I see a tiny light far off in the distance, and assume that the frontier is over there. But in order to get there, I have to pass through a valley and a dark wood in which I lose my way. Then I notice that someone is near me. Suddenly he clings to me like a madman and I awake in terror.*"

[309] This treatment, too, was broken off after a few weeks because the analyst unconsciously identified himself with the patient and the result was complete loss of orientation on both sides.

[310] The third dream took place under my treatment: "*I have to cross a frontier, or rather, I have already crossed it and find myself in a Swiss customs-house. I have only a handbag with me and think I have nothing to declare. But the customs official dives into my bag and, to my astonishment, pulls out a pair of twin beds.*"

[311] The patient had got married while under my treatment, and at first she developed the most violent resistance to her marriage. The aetiology of the neurotic resistance came to light only many months afterwards and there is not a word about it in the dreams. They are without exception anticipations of the difficulties she is to have with the doctors concerned.

[312] These examples, like many others of the kind, may suffice to show that dreams are often anticipatory and would lose their specific meaning completely on a purely causalistic view. They afford unmistakable information about the analytical situation, the correct understanding of which is of the greatest therapeutic importance. Doctor A understood the situation correctly and handed the patient over to Doctor B. Under him she drew her own conclusions from the dream and decided to leave. My interpretation of the third dream was a disappointment to her, but the fact that the dream showed the frontier as already crossed encouraged her to go on in spite of all difficulties.

[313] Initial dreams are often amazingly lucid and clear-cut. But as the work of analysis progresses, the dreams tend to lose their clarity. If, by way of exception, they keep it we can be sure that the analysis has not yet touched on some important layer of the

personality. As a rule, dreams get more and more opaque and blurred soon after the beginning of the treatment, and this makes the interpretation increasingly difficult. A further difficulty is that a point may soon be reached where, if the truth be told, the doctor no longer understands the situation as a whole. That he does not understand is proved by the fact that the dreams become increasingly obscure, for we all know that their “obscurity” is a purely subjective opinion of the doctor. To the understanding nothing is obscure; it is only when we do not understand that things appear unintelligible and muddled. In themselves dreams are naturally clear; that is, they are just what they must be under the given circumstances. If, from a later stage of treatment or from a distance of some years, we look back at these unintelligible dreams, we are often astounded at our own blindness. Thus when, as the analysis proceeds, we come upon dreams that are strikingly obscure in comparison with the illuminating initial dreams, the doctor should not be too ready to accuse the dreams of confusion or the patient of deliberate resistance; he would do better to take these findings as a sign of his own growing inability to understand—just as the psychiatrist who calls his patient “confused” should recognize that this is a projection and should rather call himself confused, because in reality it is he whose wits are confused by the patient’s peculiar behaviour. Moreover it is therapeutically very important for the doctor to admit his lack of understanding in time, for nothing is more unbearable to the patient than to be always understood. He relies far too much anyway on the mysterious powers of the doctor and, by appealing to his professional vanity, lays a dangerous trap for him. By taking refuge in the doctor’s self-confidence and “profound” understanding, the patient loses all sense of reality, falls into a stubborn transference, and retards the cure.

[314] Understanding is clearly a very subjective process. It can be extremely one-sided, in that the doctor understands but not the patient. In such a case the doctor conceives it to be his duty to convince the patient, and if the latter will not allow himself to be convinced, the doctor accuses him of resistance. When the understanding is all on my side, I say quite calmly that I do not understand, for in the end it makes very little difference whether the doctor understands or not, but it makes all the difference whether the patient understands. Understanding should therefore be understanding in the sense of an agreement which is the fruit of joint reflection. The danger of a one-sided understanding is that the doctor may judge the dream from the standpoint of a preconceived opinion. His judgment may be in line with orthodox theory, it may even be fundamentally correct, but it will not win the patient’s assent, he will not come to an understanding with him, and that is in the practical sense incorrect—incorrect because it anticipates and thus cripples the patient’s development. The patient, that is to say, does not need to have a truth inculcated into him—if we do that, we only

reach his head; he needs far more to grow up to this truth, and in that way we reach his heart, and the appeal goes deeper and works more powerfully.

[315] When the doctor's one-sided interpretation is based on mere agreement as to theory or on some other preconceived opinion, his chances of convincing the patient or of achieving any therapeutic results depend chiefly upon *suggestion*. Let no one deceive himself about this. In itself, suggestion is not to be despised, but it has serious limitations, not to speak of the subsidiary effects upon the patient's independence of character which, in the long run, we could very well do without. A practising analyst may be supposed to believe implicitly in the significance and value of conscious realization, whereby hitherto unconscious parts of the personality are brought to light and subjected to conscious discrimination and criticism. It is a process that requires the patient to face his problems and that taxes his powers of conscious judgment and decision. It is nothing less than a direct challenge to his ethical sense, a call to arms that must be answered by the whole personality. As regards the maturation of personality, therefore, the analytical approach is of a higher order than suggestion, which is a species of magic that works in the dark and makes no ethical demands upon the personality. Methods of treatment based on suggestion are deceptive makeshifts; they are incompatible with the principles of analytical therapy and should be avoided if at all possible. Naturally suggestion can only be avoided if the doctor is conscious of its possibility. There is at the best of times always enough—and more than enough—unconscious suggestion.

[316] The analyst who wishes to rule out conscious suggestion must therefore consider every dream interpretation invalid until such time as a formula is found which wins the assent of the patient.

[317] The observance of this rule seems to me imperative when dealing with those dreams whose obscurity is evidence of the lack of understanding of both doctor and patient. The doctor should regard every such dream as something new, as a source of information about conditions whose nature is unknown to him, concerning which he has as much to learn as the patient. It goes without saying that he should give up all his theoretical assumptions and should in every single case be ready to construct a totally new theory of dreams. There are still boundless opportunities for pioneer work in this field. The view that dreams are merely the imaginary fulfilments of repressed wishes is hopelessly out of date. There are, it is true, dreams which manifestly represent wishes or fears, but what about all the other things? Dreams may contain ineluctable truths, philosophical pronouncements, illusions, wild fantasies, memories, plans, anticipations, irrational experiences, even telepathic visions, and heaven knows what besides. One thing we ought never to forget: almost half our life is passed in a more or less unconscious state. The dream is specifically the utterance of

the unconscious. Just as the psyche has a diurnal side which we call consciousness, so also it has a nocturnal side: the unconscious psychic activity which we apprehend as dreamlike fantasy. It is certain that the conscious mind consists not only of wishes and fears, but of vastly more besides; and it is highly probable that our dream psyche possesses a wealth of contents and living forms equal to or even greater than those of the conscious mind, which is characterized by concentration, limitation, and exclusion.

[318] This being so, it is imperative that we should not pare down the meaning of the dream to fit some narrow doctrine. We must remember that there are not a few patients who imitate the technical or theoretical jargon of the doctor, and do this even in their dreams, in accordance with the old tag, *Canis panem somniat, piscator pisces*. This is not to say that the fishes of which the fisherman dreams are fishes and nothing more. There is no language that cannot be misused. As may easily be imagined, the misuse often turns the tables on us; it even seems as if the unconscious had a way of strangling the doctor in the coils of his own theory. Therefore I leave theory aside as much as possible when analysing dreams—not entirely, of course, for we always need some theory to make things intelligible. It is on the basis of theory, for instance, that I expect dreams to have a meaning. I cannot prove in every case that this is so, for there are dreams which the doctor and the patient simply do not understand. But I have to make such an hypothesis in order to find courage to deal with dreams at all. To say that dreams add something important to our conscious knowledge, and that a dream which fails to do so has not been properly interpreted—that, too, is a theory. But I must make this hypothesis as well in order to explain to myself why I analyse dreams in the first place. All other hypotheses, however, about the function and the structure of dreams are merely rules of thumb and must be subjected to constant modification. In dream-analysis we must never forget, even for a moment, that we move on treacherous ground where nothing is certain but uncertainty. If it were not so paradoxical, one would almost like to call out to the dream interpreter: “Do anything you like, only don’t try to understand!”

[319] When we take up an obscure dream, our first task is not to understand and interpret, but to establish the context with minute care. By this I do *not* mean unlimited “free association” starting from any and every image in the dream, but a careful and conscious illumination of the interconnected associations objectively grouped round particular images. Many patients have first to be educated to this, for they resemble the doctor in their insuperable desire to understand and interpret offhand, especially when they have been primed by ill-digested reading or by a previous analysis that went wrong. They begin by associating in accordance with a theory, that is, they try to understand and interpret, and they nearly always get stuck. Like the doctor, they want to get behind the dream at once in the false belief that the

dream is a mere façade concealing the true meaning. But the so-called façade of most houses is by no means a fake or a deceptive distortion; on the contrary, it follows the plan of the building and often betrays the interior arrangement. The “manifest” dream-picture is the dream itself and contains the whole meaning of the dream. When I find sugar in the urine, it is sugar and not just a façade for albumen. What Freud calls the “dream-façade” is the dream’s obscurity, and this is really only a projection of our own lack of understanding. We say that the dream has a false front only because we fail to see into it. We would do better to say that we are dealing with something like a text that is unintelligible not because it has a façade—a text has no façade—but simply because we cannot read it. We do not have to get behind such a text, but must first learn to read it.

[320] The best way to do this, as I have already remarked, is to establish the context. Free association will get me nowhere, any more than it would help me to decipher a Hittite inscription. It will of course help me to uncover all my own complexes, but for this purpose I have no need of a dream—I could just as well take a public notice or a sentence in a newspaper. Free association will bring out all my complexes, but hardly ever the meaning of a dream. To understand the dream’s meaning I must stick as close as possible to the dream images. When somebody dreams of a “deal table,” it is not enough for him to associate it with his writing-desk which does not happen to be made of deal. Supposing that nothing more occurs to the dreamer, this blocking has an objective meaning, for it indicates that a particular darkness reigns in the immediate neighbourhood of the dream-image, and that is suspicious. We would expect him to have dozens of associations to a deal table, and the fact that there is apparently nothing is itself significant. In such cases I keep on returning to the image, and I usually say to my patient, “Suppose I had no idea what the words ‘deal table’ mean. Describe this object and give me its history in such a way that I cannot fail to understand what sort of a thing it is.”

[321] In this way we manage to establish almost the whole context of the dream-image. When we have done this for all the images in the dream we are ready for the venture of interpretation,

[322] Every interpretation is an hypothesis, an attempt to read an unknown text. An obscure dream, taken in isolation, can hardly ever be interpreted with any certainty. For this reason I attach little importance to the interpretation of single dreams. A relative degree of certainty is reached only in the interpretation of a series of dreams, where the later dreams correct the mistakes we have made in handling those that went before. Also, the basic ideas and themes can be recognized much better in a dream-series, and I therefore urge my patients to keep a careful record of their dreams and of the interpretations given. I also show them how to work out their

dreams in the manner described, so that they can bring the dream and its context with them in writing to the consultation. At a later stage I get them to work out the interpretation as well. In this way the patient learns how to deal correctly with his unconscious without the doctor's help.

[323] Were dreams nothing more than sources of information about factors of aetiological importance, the whole work of dream-interpretation could safely be left to the doctor. Again, if their only use was to provide the doctor with a collection of useful hints and psychological tips, my own procedure would be entirely superfluous. But since, as my examples have shown, dreams contain something more than practical helps for the doctor, dream-analysis deserves very special attention. Sometimes, indeed, it is a matter of life and death. Among many instances of this sort, there is one that has remained particularly impressive. It concerns a colleague of mine, a man somewhat older than myself, whom I used to see from time to time and who always teased me about my dream-interpretations. Well, I met him one day in the street and he called out to me, "How are things going? Still interpreting dreams? By the way, I've had another idiotic dream. Does that mean something too?" This is what he had dreamed: "*I am climbing a high mountain, over steep snow-covered slopes. I climb higher and higher, and it is marvellous weather. The higher I climb the better I feel. I think, 'If only I could go on climbing like this for ever!' When I reach the summit my happiness and elation are so great that I feel I could mount right up into space. And I discover that I can actually do so: I mount upwards on empty air, and awake in sheer ecstasy.*"

[324] After some discussion, I said, "My dear fellow, I know you can't give up mountaineering, but let me implore you not to go alone from now on. When you go, take two guides, and promise on your word of honour to follow them absolutely." "Incorrigible!" he replied, laughing, and waved good-bye. I never saw him again. Two months later the first blow fell. When out alone, he was buried by an avalanche, but was dug out in the nick of time by a military patrol that happened to be passing. Three months afterwards the end came. He went on a climb with a younger friend, but without guides. A guide standing below saw him literally step out into the air while descending a rock face. He fell on the head of his friend, who was waiting lower down, and both were dashed to pieces far below. That was *ecstasis* with a vengeance!²

[325] No amount of scepticism and criticism has yet enabled me to regard dreams as negligible occurrences. Often enough they appear senseless, but it is obviously we who lack the sense and ingenuity to read the enigmatic message from the nocturnal realm of the psyche. Seeing that at least half our psychic existence is passed in that realm, and that consciousness acts upon our nightly life just as much as the

unconscious overshadows our daily life, it would seem all the more incumbent on medical psychology to sharpen its senses by a systematic study of dreams. Nobody doubts the importance of conscious experience; why then should we doubt the significance of unconscious happenings? They also are part of our life, and sometimes more truly a part of it for weal or woe than any happenings of the day.

[326] Since dreams provide information about the hidden inner life and reveal to the patient those components of his personality which, in his daily behaviour, appear merely as neurotic symptoms, it follows that we cannot effectively treat him from the side of consciousness alone, but must bring about a change in and through the unconscious. In the light of our present knowledge this can be achieved only by the thorough and conscious assimilation of unconscious contents.

[327] “Assimilation” in this sense means mutual penetration of conscious and unconscious, and not—as is commonly thought and practised—a one-sided evaluation, interpretation, and deformation of unconscious contents by the conscious mind. As to the value and significance of unconscious contents in general, very mistaken views are current. It is well known that the Freudian school presents the unconscious in a thoroughly negative light, much as it regards primitive man as little better than a monster. Its nursery-tales about the terrible old man of the tribe and its teachings about the “infantile-perverse-criminal” unconscious have led people to make a dangerous ogre out of something perfectly natural. As if all that is good, reasonable, worth while, and beautiful had taken up its abode in the conscious mind! Have the horrors of the World War done nothing to open our eyes, so that we still cannot see that the conscious mind is even more devilish and perverse than the naturalness of the unconscious?

[328] The charge has recently been laid at my door that my teaching about the assimilation of the unconscious would undermine civilization and deliver up our highest values to sheer primitivity. Such an opinion can only be based on the totally erroneous supposition that the unconscious is a monster. It is a view that springs from fear of nature and the realities of life. Freud invented the idea of sublimation to save us from the imaginary claws of the unconscious. But what is real, what actually exists, cannot be alchemically sublimated, and if anything is apparently sublimated it never was what a false interpretation took it to be.

[329] The unconscious is not a demoniacal monster, but a natural entity which, as far as moral sense, aesthetic taste, and intellectual judgment go, is completely neutral. It only becomes dangerous when our conscious attitude to it is hopelessly wrong. To the degree that we repress it, its danger increases. But the moment the patient begins to assimilate contents that were previously unconscious, its danger diminishes. The dissociation of personality, the anxious division of the day-time and the nighttime

sides of the psyche, cease with progressive assimilation. What my critic feared—the overwhelming of the conscious mind by the unconscious—is far more likely to ensue when the unconscious is excluded from life by being repressed, falsely interpreted, and depreciated.

[330] The fundamental mistake regarding the nature of the unconscious is probably this: it is commonly supposed that its contents have only one meaning and are marked with an unalterable plus or minus sign. In my humble opinion, this view is too naïve. The psyche is a self-regulating system that maintains its equilibrium just as the body does. Every process that goes too far immediately and inevitably calls forth compensations, and without these there would be neither a normal metabolism nor a normal psyche. In this sense we can take the theory of compensation as a basic law of psychic behaviour. Too little on one side results in too much on the other. Similarly, the relation between conscious and unconscious is compensatory. This is one of the best-proven rules of dream interpretation. When we set out to interpret a dream, it is always helpful to ask: What conscious attitude does it compensate?

[331] Compensation is not as a rule merely an illusory wishfulfilment, but an actual fact that becomes still more actual the more we repress it. We do not stop feeling thirsty by repressing our thirst. In the same way, the dream-content is to be regarded with due seriousness as an actuality that has to be fitted into the conscious attitude as a codetermining factor. If we fail to do this, we merely persist in that eccentric frame of mind which evoked the unconscious compensation in the first place. It is then difficult to see how we can ever arrive at a sane judgment of ourselves or at a balanced way of living.

[332] If it should occur to anyone to replace the conscious content by an unconscious one—and this is the prospect which my critics find so alarming—he would only succeed in repressing it, and it would then reappear as an unconscious compensation. The unconscious would thus have changed its face completely: it would now be timidly reasonable, in striking contrast to its former tone. It is not generally believed that the unconscious operates in this way, yet such reversals constantly take place and constitute its proper function. That is why every dream is an organ of information and control, and why dreams are our most effective aid in building up the personality.

[333] The unconscious does not harbour in itself any explosive materials unless an overweening or cowardly conscious attitude has secretly laid up stores of explosives there. All the more reason, then, for watching our step.

[334] From all this it should now be clear why I make it an heuristic rule, in interpreting a dream, to ask myself: What conscious attitude does it compensate? By so doing, I relate the dream as closely as possible to the conscious situation; indeed, I would even assert that without knowledge of the conscious situation the dream can

never be interpreted with any degree of certainty. Only in the light of this knowledge is it possible to make out whether the unconscious content carries a plus or a minus sign. The dream is not an isolated event completely cut off from daily life and lacking its character. If it seems so to us, that is only the result of our lack of understanding, a subjective illusion. In reality the relation between the conscious mind and the dream is strictly causal, and they interact in the subtlest of ways.

[335] I should like to show by means of an example how important it is to evaluate the unconscious contents correctly. A young man brought me the following dream: “*My father is driving away from the house in his new car. He drives very clumsily, and I get very annoyed over his apparent stupidity. He goes this way and that, forwards and backwards, and manoeuvres the car into a dangerous position. Finally he runs into a wall and damages the car badly. I shout at him in a perfect fury that he ought to behave himself. My father only laughs, and then I see that he is dead drunk.*” This dream has no foundation in fact. The dreamer is convinced that his father would never behave like that, even when drunk. As a motorist he himself is very careful and extremely moderate in the use of alcohol, especially when he has to drive. Bad driving, and even slight damage to the car, irritate him greatly. His relation to his father is positive. He admires him for being an unusually successful man. We can say, without any great feat of interpretation, that the dream presents a most unfavourable picture of the father. What, then, should we take its meaning to be for the son? Is his relation to his father good only on the surface, and does it really consist in over-compensated resistances? If so, we should have to give the dream-content a positive sign; we should have to tell the young man: “That is your real relation to your father.” But since I could find nothing neurotically ambivalent in the son’s real relation to his father, I had no warrant for upsetting the young man’s feelings with such a destructive pronouncement. To do so would have been a bad therapeutic blunder.

[336] But, if his relation to his father is in fact good, why must the dream manufacture such an improbable story in order to discredit the father? In the dreamer’s unconscious there must be some tendency to produce such a dream. Is that because he has resistances after all, perhaps fed by envy or some other inferior motive? Before we go out of our way to burden his conscience—and with sensitive young people this is always rather a dangerous proceeding—we would do better to inquire not *why* he had this dream, but what its purpose is. The answer in this case would be that his unconscious is obviously trying to take the father down a peg. If we regard this as a compensation, we are forced to the conclusion that his relation to his father is not only good, but actually too good. In fact he deserves the French soubriquet of *fils à papa*. His father is still too much the guarantor of his existence, and the dreamer is still living what I would call a provisional life. His particular danger is that he

cannot see his own reality on account of his father; therefore the unconscious resorts to a kind of artificial blasphemy so as to lower the father and elevate the son. “An immoral business,” we may be tempted to say. An unintelligent father would probably take umbrage, but the compensation is entirely to the point, since it forces the son to contrast himself with his father, which is the only way he could become conscious of himself.

[337] The interpretation just outlined was apparently the correct one, for it struck home. It won the spontaneous assent of the dreamer, and no real values were damaged, either for the father or for the son. But this interpretation was only possible when the whole conscious phenomenology of the father-son relationship had been carefully studied. Without a knowledge of the conscious situation the real meaning of the dream would have remained in doubt.

[338] For dream-contents to be assimilated, it is of overriding importance that no real values of the conscious personality should be damaged, much less destroyed, otherwise there is no one left to do the assimilating. The recognition of the unconscious is not a Bolshevik experiment which puts the lowest on top and thus re-establishes the very situation it intended to correct. We must see to it that the values of the conscious personality remain intact, for unconscious compensation is only effective when it co-operates with an integral consciousness. Assimilation is never a question of “this *or* that,” but always of “this *and* that.”

[339] Just as the interpretation of dreams requires exact knowledge of the conscious status quo, so the treatment of dream symbolism demands that we take into account the dreamer’s philosophical, religious, and moral convictions. It is far wiser in practice not to regard dream-symbols semiotically, i.e., as signs or symptoms of a fixed character, but as true symbols, i.e., as expressions of a content not yet consciously recognized or conceptually formulated. In addition, they must be considered in relation to the dreamer’s immediate state of consciousness. I say that this procedure is advisable *in practice* because in theory relatively fixed symbols do exist whose meaning must on no account be referred to anything known and formulable as a concept. If there were no such relatively fixed symbols it would be impossible to determine the structure of the unconscious, for there would be nothing that could in any way be laid hold of or described.

[340] It may seem strange that I should attribute an as it were indefinite content to these relatively fixed symbols. Yet if their content were not indefinite, they would not be symbols at all, but signs or symptoms. We all know how the Freudian school operates with hard-and-fast sexual “symbols”—which in this case I would call “signs”—and endows them with an apparently definitive content, namely sexuality. Unfortunately Freud’s idea of sexuality is incredibly elastic and so vague that it can be made to

include almost anything. The word sounds familiar enough, but what it denotes is no more than an indeterminable x that ranges from the physiological activity of the glands at one extreme to the sublime reaches of the spirit at the other. Instead of yielding to a dogmatic conviction based on the illusion that we know something because we have a familiar word for it, I prefer to regard the symbol as an unknown quantity, hard to recognize and, in the last resort, never quite determinable. Take, for instance, the so-called phallic symbols which are supposed to stand for the *membrum virile* and nothing more, Psychologically speaking, the *membrum* is itself—as Kranefeldt points out in a recent work³—an emblem of something whose wider content is not at all easy to determine. But primitive people, who, like the ancients, make the freest use of phallic symbols, would never dream of confusing the phallus, as a ritualistic symbol, with the penis. The phallus always means the creative mana, the power of healing and fertility, the “extraordinarily potent,” to use Lehmann’s expression, whose equivalents in mythology and in dreams are the bull, the ass, the pomegranate, the yoni, the he-goat, the lightning, the horse’s hoof, the dance, the magical cohabitation in the furrow, and the menstrual fluid, to mention only a few of the thousand other analogies. That which underlies all the analogies, and sexuality itself, is an archetypal image whose character is hard to define, but whose nearest psychological equivalent is perhaps the primitive mana-symbol.

[341] All these symbols are relatively fixed, but in no single case can we have the *a priori* certainty that in practice the symbol must be interpreted in that way.

[342] Practical necessity may call for something quite different. Of course, if we had to give an exhaustive scientific interpretation of a dream, in accordance with a theory, we should have to refer every such symbol to an archetype. But in practice that can be a positive mistake, for the patient’s psychological state at the moment may require anything but a digression into dream theory. It is therefore advisable to consider first and foremost the meaning of the symbol in relation to the conscious situation—in other words, to treat the symbol as if it were not fixed. This is as much as to say that we must renounce all preconceived opinions, however knowing they make us feel, and try to discover what things mean for the patient. In so doing, we shall obviously not get very far towards a theoretical interpretation; indeed we shall probably get stuck at the very beginning. But if the practitioner operates too much with fixed symbols, there is a danger of his falling into mere routine and pernicious dogmatism, and thus failing his patient. Unfortunately I must refrain from illustrating this point, for I should have to go into greater detail than space here permits. Moreover I have published sufficient material elsewhere in support of my statements.

[343] It frequently happens at the very beginning of the treatment that a dream will reveal to the doctor, in broad perspective, the whole programme of the unconscious.

But for practical reasons it may be quite impossible to make clear to the patient the deeper meaning of the dream. In this respect, too, we are limited by practical considerations. Such insight is rendered possible by the doctor's knowledge of relatively fixed symbols. It can be of the greatest value in diagnosis as well as in prognosis. I was once consulted about a seventeen-year-old girl. One specialist had conjectured that she might be in the first stages of progressive muscular atrophy, while another thought that it was a case of hysteria. In view of the second opinion, I was called in. The clinical picture made me suspect an organic disease, but there were signs of hysteria as well. I asked for dreams. The patient answered at once: "Yes, I have terrible dreams. Only recently I dreamt *I was coming home at night. Everything is as quiet as death. The door into the living-room is half open, and I see my mother hanging from the chandelier, swinging to and fro in the cold wind that blows in through the open windows.* Another time I dreamt that *a terrible noise broke out in the house at night. I get up and discover that a frightened horse is tearing through the rooms. At last it finds the door into the hall, and jumps through the hall window from the fourth floor into the street below. I was terrified when I saw it lying there, all mangled.*"

[344] The gruesome character of the dreams is alone sufficient to make one pause. All the same, other people have anxiety dreams now and then. We must therefore look more closely into the meaning of the two main symbols, "mother" and "horse." They must be equivalents, for they both do the same thing: they commit suicide. "Mother" is an archetype and refers to the place of origin, to nature, to that which passively creates, hence to substance and matter, to materiality, the womb, the vegetative functions. It also means the unconscious, our natural and instinctive life, the physiological realm, the body in which we dwell or are contained; for the "mother" is also the matrix, the hollow form, the vessel that carries and nourishes, and it thus stands psychologically for the foundations of consciousness. Being inside or contained in something also suggests darkness, something nocturnal and fearful, hemming one in. These allusions give the idea of the mother in many of its mythological and etymological variants; they also represent an important part of the Yin idea in Chinese philosophy. This is no individual acquisition of a seventeen-year-old girl; it is a collective inheritance, alive and recorded in language, inherited along with the structure of the psyche and therefore to be found at all times and among all peoples.

[345] The word "mother," which sounds so familiar, apparently refers to the best-known, the individual mother—to "my mother." But the mother-symbol points to a darker background which eludes conceptual formulation and can only be vaguely apprehended as the hidden, nature-bound life of the body. Yet even this is too narrow and excludes too many vital subsidiary meanings. The underlying, primary psychic

reality is so inconceivably complex that it can be grasped only at the farthest reach of intuition, and then but very dimly. That is why it needs symbols.

[346] If we apply our findings to the dream, its interpretation will be: The unconscious life is destroying itself. That is the dream's message to the conscious mind of the dreamer and to anybody who has ears to hear.

[347] "Horse" is an archetype that is widely current in mythology and folklore. As an animal it represents the non-human psyche, the subhuman, animal side, the unconscious. That is why horses in folklore sometimes see visions, hear voices, and speak. As a beast of burden it is closely related to the mother-archetype (witness the Valkyries that bear the dead hero to Valhalla, the Trojan horse, etc.). As an animal lower than man it represents the lower part of the body and the animal impulses that rise from there. The horse is dynamic and vehicular power: it carries one away like a surge of instinct. It is subject to panics like all instinctive creatures who lack higher consciousness. Also it has to do with sorcery and magical spells—especially the black night-horses which herald death.

[348] It is evident, then, that "horse" is an equivalent of "mother" with a slight shift of meaning. The mother stands for life at its origin, the horse for the merely animal life of the body. If we apply this meaning to the text of our dream, its interpretation will be: The animal life is destroying itself.

[349] The two dreams make nearly identical statements, but, as is usually the case, the second is the more specific. Note the peculiar subtlety of the dream: there is no mention of the death of the individual. It is notorious that one often dreams of one's own death, but that is no serious matter. When it is really a question of death, the dream speaks another language.

[350] Both dreams point to a grave organic disease with a fatal outcome. This prognosis was soon confirmed.

[351] As for the relatively fixed symbols, this example gives a fair idea of their general nature. There are a great many of them, and all are individually marked by subtle shifts of meaning. It is only through comparative studies in mythology, folklore, religion, and philology that we can evaluate their nature scientifically. The evolutionary stratification of the psyche is more clearly discernible in the dream than in the conscious mind. In the dream, the psyche speaks in images, and gives expression to instincts, which derive from the most primitive levels of nature. Therefore, through the assimilation of unconscious contents, the momentary life of consciousness can once more be brought into harmony with the law of nature from which it all too easily departs, and the patient can be led back to the natural law of his own being.

[352] I have not been able, in so short a space, to deal with anything but the elements of the subject. I could not put together before your eyes, stone by stone, the edifice that is reared in every analysis from the materials of the unconscious and finally reaches completion in the restoration of the total personality. The way of successive assimilations goes far beyond the curative results that specifically concern the doctor. It leads in the end to that distant goal which may perhaps have been the first urge to life: the complete actualization of the whole human being, that is, individuation. We physicians may well be the first conscious observers of this dark process of nature. As a rule we see only the pathological phase of development, and we lose sight of the patient as soon as he is cured. Yet it is only after the cure that we would really be in a position to study the normal process, which may extend over years and decades. Had we but a little knowledge of the ends toward which the unconscious development is tending, and were the doctor's psychological insight not drawn exclusively from the pathological phase, we should have a less confused idea of the processes mediated to the conscious mind by dreams and a clearer recognition of what the symbols point to. In my opinion, every doctor should understand that every procedure in psychotherapy, and particularly the analytical procedure, breaks into a purposeful and continuous process of development, now at this point and now at that, and thus singles out separate phases which seem to follow opposing courses. Each individual analysis by itself shows only one part or one aspect of the deeper process, and for this reason nothing but hopeless confusion can result from comparative case histories. For this reason, too, I have preferred to confine myself to the rudiments of the subject and to practical considerations; for only in closest *contact* with the everyday facts can we come to anything like a satisfactory understanding.

III

THE PSYCHOLOGY OF THE TRANSFERENCE¹

INTERPRETED IN CONJUNCTION WITH A SET OF ALCHEMICAL PICTURES

Quaero non pono, nihil hic determino dictans Coniicio, conor, confero, tento, rogo....

(I inquire, I do not assert; I do not here determine anything with final assurance; I conjecture, try, compare, attempt, ask....)

—Motto to Christian Knorr von Rosenroth,

Adumbratio Kabbalae Christianae

TO MY WIFE

FOREWORD

Everyone who has had practical experience of psychotherapy knows that the process which Freud called “transference” often presents a difficult problem. It is probably no exaggeration to say that almost all cases requiring lengthy treatment gravitate round the phenomenon of transference, and that the success or failure of the treatment appears to be bound up with it in a very fundamental way. Psychology, therefore, cannot very well overlook or avoid this problem, nor should the psychotherapist pretend that the so-called “resolution of the transference” is just a matter of course. We meet with a similar optimism in the treatment of “sublimation,” a process closely connected with the transference. In discussing these phenomena, people often talk as though they could be dealt with by reason, or by intelligence and will, or could be remedied by the ingenuity and art of a doctor armed with superior technique. This euphemistic and propitiatory approach is useful enough when the situation is not exactly simple and no easy results are to be had; but it has the disadvantage of disguising the difficulty of the problem and thus preventing or postponing deeper investigation. Although I originally agreed with Freud that the importance of the transference could hardly be overestimated, increasing experience has forced me to realize that its importance is relative. The transference is like those medicines which are a panacea for one and pure poison for another. In one case its appearance denotes a change for the better, in another it is a hindrance and an aggravation, if not a change for the worse, and in a third it is relatively unimportant. Generally speaking, however, it is a critical phenomenon of varying shades of meaning and its absence is as significant as its presence.

In this book I am concerned with the “classical” form of transference and its phenomenology. As it is a form of relationship, it always implies a vis-à-vis. Where it is negative or not there at all, the vis-à-vis plays an unimportant part, as is generally the case, for instance, when there is an inferiority complex coupled with a compensating need for self-assertion.²

*It may seem strange to the reader that, in order to throw light on the transference, I should turn to something so apparently remote as alchemical symbolism. But anyone who has read my book *Psychology and Alchemy* will know what close connections exist between alchemy and those phenomena which must, for practical reasons, be considered in the psychology of the unconscious. Consequently he will not be surprised to learn that this phenomenon, shown by experience to be so frequent and so important, also has its place in the symbolism and imagery of alchemy. Such images are not likely*

to be conscious representations of the transference relationship; rather, they unconsciously take that relationship for granted, and for this reason we may use them as an Ariadne thread to guide us in our argument.

The reader will not find an account of the clinical phenomena of transference in this book. It is not intended for the beginner who would first have to be instructed in such matters, but is addressed exclusively to those who have already gained sufficient experience from their own practice. My object is to provide some kind of orientation in this newly discovered and still unexplored territory, and to acquaint the reader with some of its problems. In view of the great difficulties that beset our understanding here, I would like to stress the provisional character of my investigation. I have tried to put together my observations and ideas, and I recommend them to the reader's consideration in the hope of directing his attention to certain points of view whose importance has forced itself upon me in the course of time. I am afraid that my description will not be easy reading for those who do not possess some knowledge of my earlier works. I have therefore indicated in the footnotes those of my writings which might be of assistance.

The reader who approaches this book more or less unprepared will perhaps be astonished at the amount of historical material I bring to bear on my investigation. The reason and inner necessity for this lie in the fact that it is only possible to come to a right understanding and appreciation of a contemporary psychological problem when we can reach a point outside our own time from which to observe it. This point can only be some past epoch that was concerned with the same problems, although under different conditions and in other forms. The comparative analysis thus made possible naturally demands a correspondingly detailed account of the historical aspects of the situation. These could be described much more succinctly if we were dealing with well-known material, where a few references and hints would suffice. But unfortunately that is not the case, since the psychology of alchemy here under review is almost virgin territory. I must therefore take it for granted that the reader has some knowledge of my *Psychology and Alchemy*, otherwise it will be hard for him to gain access to the present volume. The reader whose professional and personal experience has sufficiently acquainted him with the scope of the transference problem will forgive me this expectation.

Although the present study can stand on its own, it forms at the same time an introduction to a more comprehensive account of the problem of opposites in alchemy, and of their phenomenology and synthesis, which will appear later under the title *Mysterium Coniunctionis*. I would like to express my thanks here to all those who read my manuscript and drew attention to defects. My particular thanks are due to Dr Marie-Louise von Franz for her generous help.

Autumn, 1945

INTRODUCTION

Bellica pax, vulnus dulce, suave malum.

(A warring peace, a sweet wound, a mild evil.)

—JOHN GOWER, *Confessio amantis*, II, p. 35

1

[353] The fact that the idea of the mystic marriage plays such an important part in alchemy is not so surprising when we remember that the term most frequently employed for it, *coniunctio*, referred in the first place to what we now call chemical combination, and that the substances or “bodies” to be combined were drawn together by what we would call affinity. In days gone by, people used a variety of terms which all expressed a human, and more particularly an erotic, relationship, such as *nuptiae*, *matrimonium*, *coniugium*, *amicitia*, *attractio*, *adulatio*. Accordingly the bodies to be combined were thought of as *agens et patiens*, as *vir* or *masculus*, and as *femina*, *mulier*, *femineus*; or they were described more picturesquely as dog and bitch,¹ horse (stallion) and donkey,² cock and hen,³ and as the winged and wingless dragon.⁴ The more anthropomorphic and theriomorphic the terms become, the more obvious is the part played by creative fantasy and thus by the unconscious, and the more we see how the natural philosophers of old were tempted, as their thoughts explored the dark, unknown qualities of matter, to slip away from a strictly chemical investigation and to fall under the spell of the “myth of matter.” Since there can never be absolute freedom from prejudice, even the most objective and impartial investigator is liable to become the victim of some unconscious assumption upon entering a region where the darkness has never been illuminated and where he can recognize nothing. This need not necessarily be a misfortune, since the idea which then presents itself as a substitute for the unknown will take the form of an archaic though not inapposite analogy. Thus Kekulé’s vision of the dancing couples,⁵ which first put him on the track of the structure of certain carbon compounds, namely the benzene ring, was surely a vision of the *coniunctio*, the mating that had preoccupied the minds of the alchemists for seventeen centuries. It was precisely this image that had always lured the mind of the investigator away from the problem of chemistry and back to the ancient myth of the royal or divine marriage; but in Kekulé’s vision it reached its chemical goal in the end, thus rendering the greatest imaginable service both to our understanding of organic compounds and to the subsequent

unprecedented advances in synthetic chemistry. Looking back, we can say that the alchemists had keen noses when they made this *arcanum arcanorum*,⁶ this *donum Dei et secretum altissimi*,⁷ this inmost mystery of the art of gold-making, the climax of their work. The subsequent confirmation of the other idea central to gold-making—the transmutability of chemical elements—also takes a worthy place in this belated triumph of alchemical thought. Considering the eminently practical and theoretical importance of these two key ideas, we might well conclude that they were intuitive anticipations whose fascination can be explained in the light of later developments.⁸

[354] We find, however, that alchemy did not merely change into chemistry by gradually discovering how to break away from its mythological premises, but that it also became, or had always been, a kind of mystic philosophy. The idea of the *coniunctio* served on the one hand to shed light on the mystery of chemical combination, while on the other it became the symbol of the *unio mystica*, since, as a mythologem, it expresses the archetype of the union of opposites. Now the archetypes do not represent anything external, non-psychic, although they do of course owe the concreteness of their imagery to impressions received from without. Rather, independently of, and sometimes in direct contrast to, the outward forms they may take, they represent the life and essence of a non-individual psyche. Although this psyche is innate in every individual it can neither be modified nor possessed by him personally. It is the same in the individual as it is in the crowd and ultimately in everybody. It is the precondition of each individual psyche, just as the sea is the carrier of the individual wave.

[355] The alchemical image of the *coniunctio*, whose practical importance was proved at a later stage of development, is equally valuable from the psychological point of view: that is to say, it plays the same role in the exploration of the darkness of the psyche as it played in the investigation of the riddle of matter. Indeed, it could never have worked so effectively in the material world had it not already possessed the power to fascinate and thus to fix the attention of the investigator along those lines. The *coniunctio* is an *a priori* image that occupies a prominent place in the history of man's mental development. If we trace this idea back we find it has two sources in alchemy, one Christian, the other pagan. The Christian source is unmistakably the doctrine of Christ and the Church, *sponsus* and *sponsa*, where Christ takes the role of Sol and the Church that of Luna.⁹ The pagan source is on the one hand the hierosgamos,¹⁰ on the other the marital union of the mystic with God.¹¹ These psychic experiences and the traces they have left behind in tradition explain much that would otherwise be totally unintelligible in the strange world of alchemy and its secret language.

[356] As we have said, the image of the *coniunctio* has always occupied an important place in the history of the human mind. Recent developments in medical psychology have, through observation of the mental processes in neuroses and psychoses, forced us to become more and more thorough in our investigation of the psychic background, commonly called the unconscious. It is psychotherapy above all that makes such investigations necessary, because it can no longer be denied that morbid disturbances of the psyche are not to be explained exclusively by the changes going on in the body or in the conscious mind; we must adduce a third factor by way of explanation, namely hypothetical unconscious processes.¹²

[357] Practical analysis has shown that unconscious contents are invariably projected at first upon concrete persons and situations. Many projections can ultimately be integrated back into the individual once he has recognized their subjective origin; others resist integration, and although they may be detached from their original objects, they thereupon transfer themselves to the doctor. Among these contents the relation to the parent of opposite sex plays a particularly important part, i.e., the relation of son to mother, daughter to father, and also that of brother to sister.¹³ As a rule this complex cannot be integrated completely, since the doctor is nearly always put in the place of the father, the brother, and even (though naturally more rarely) the mother. Experience has shown that this projection persists with all its original intensity (which Freud regarded as aetiological), thus creating a bond that corresponds in every respect to the initial infantile relationship, with a tendency to recapitulate all the experiences of childhood on the doctor. In other words, the neurotic maladjustment of the patient is now *transferred* to him.¹⁴ Freud, who was the first to recognize and describe this phenomenon, coined the term “transference neurosis.”¹⁵

[358] This bond is often of such intensity that we could almost speak of a “combination.” When two chemical substances combine, both are altered. This is precisely what happens in the transference. Freud rightly recognized that this bond is of the greatest therapeutic importance in that it gives rise to a *mixtum compositum* of the doctor’s own mental health and the patient’s maladjustment. In Freudian technique the doctor tries to ward off the transference as much as possible—which is understandable enough from the human point of view, though in certain cases it may considerably impair the therapeutic effect. It is inevitable that the doctor should be influenced to a certain extent and even that his nervous health should suffer.¹⁶ He quite literally “takes over” the sufferings of his patient and shares them with him. For this reason he runs a risk—and must run it in the nature of things.¹⁷ The enormous importance that Freud attached to the transference phenomenon became clear to me at our first personal meeting in 1907. After a conversation lasting many hours there came a pause. Suddenly he asked me out of the blue, “And what do you think about

the transference?” I replied with the deepest conviction that it was the alpha and omega of the analytical method, whereupon he said, “Then you have grasped the main thing.”

[359] The great importance of the transference has often led to the mistaken idea that it is absolutely indispensable for a cure, that it must be demanded from the patient, so to speak. But a thing like that can no more be demanded than faith, which is only valuable when it is spontaneous. Enforced faith is nothing but spiritual cramp. Anyone who thinks that he must “demand” a transference is forgetting that this is only one of the therapeutic factors, and that the very word “transference” is closely akin to “projection”—a phenomenon that cannot possibly be demanded.¹⁸ I personally am always glad when there is only a mild transference or when it is practically unnoticeable. Far less claim is then made upon one as a person, and one can be satisfied with other therapeutically effective factors. Among these the patient’s own insight plays an important part, also his goodwill, the doctor’s authority, suggestion,¹⁹ good advice,²⁰ understanding, sympathy, encouragement, etc. Naturally the more serious cases do not come into this category.

[360] Careful analysis of the transference phenomenon yields an extremely complicated picture with such startlingly pronounced features that we are often tempted to pick out one of them as the most important and then exclaim by way of explanation: “Of course, it’s nothing but...!” I am referring chiefly to the erotic or sexual aspect of transference fantasies. The existence of this aspect is undeniable, but it is not always the only one and not always the essential one. Another is the will to power (described by Adler), which proves to be coexistent with sexuality, and it is often very difficult to make out which of the two predominates. These two aspects alone offer sufficient grounds for a paralysing conflict.

[361] There are, however, other forms of instinctive *concupiscentia* that come more from “hunger,” from wanting to possess; others again are based on the instinctive negation of desire, so that life seems to be founded on fear or self-destruction. A certain *abaissement du niveau mental*, i.e., a weakness in the hierarchical order of the ego, is enough to set these instinctive urges and desires in motion and bring about a dissociation of personality—in other words, a multiplication of its centres of gravity. (In schizophrenia there is an actual fragmentation of personality.) These dynamic components must be regarded as real or symptomatic, vitally decisive or merely syndromal, according to the degree of their predominance. Although the strongest instincts undoubtedly demand concrete realization and generally enforce it, they cannot be considered exclusively biological since the course they actually follow is subject to powerful modifications coming from the personality itself. If a man’s temperament inclines him to a spiritual attitude, even the concrete activity of the

instincts will take on a certain symbolical character. This activity is no longer the mere satisfaction of instinctual impulses, for it is now associated with or complicated by “meanings.” In the case of purely syndromal instinctive processes, which do not demand concrete realization to the same extent, the symbolical character of their fulfilment is all the more marked. The most vivid examples of these complications are probably to be found in erotic phenomenology. Four stages of eroticism were known in the late classical period: Hawwah (Eve), Helen (of Troy), the Virgin Mary, and Sophia. The series is repeated in Goethe’s *Faust*: in the figures of Gretchen as the personification of a purely instinctual relationship (Eve); Helen as an anima figure;²¹ Mary as the personification of the “heavenly,” i.e., Christian or religious, relationship; and the “eternal feminine” as an expression of the alchemical *Sapientia*. As the nomenclature shows, we are dealing with the heterosexual Eros or anima-figure in four stages, and consequently with four stages of the Eros cult. The first stage—Hawwah, Eve, earth—is purely biological; woman is equated with the mother and only represents something to be fertilized. The second stage is still dominated by the sexual Eros, but on an aesthetic and romantic level where woman has already acquired some value as an individual. The third stage raises Eros to the heights of religious devotion and thus spiritualizes him: Hawwah has been replaced by spiritual motherhood. Finally, the fourth stage illustrates something which unexpectedly goes beyond the almost unsurpassable third stage: *Sapientia*. How can wisdom transcend the most holy and the most pure?—Presumably only by virtue of the truth that the less sometimes means the more. This stage represents a spiritualization of Helen and consequently of Eros as such. That is why *Sapientia* was regarded as a parallel to the Shulamite in the Song of Songs.

[362] Not only are there different instincts which cannot forcibly be reduced to one another, there are also different levels on which they move. In view of this far from simple situation, it is small wonder that the transference—also an instinctive process, in part—is very difficult to interpret and evaluate. The instincts and their specific fantasy-contents are partly concrete, partly symbolical (i.e., “unreal”), sometimes one, sometimes the other, and they have the same paradoxical character when they are projected. The transference is far from being a simple phenomenon with only one meaning, and we can never make out beforehand what it is all about. The same applies to its specific content, commonly called incest. We know that it is possible to interpret the fantasy-contents of the instincts either as *signs*, as self-portraits of the instincts, i.e., reductively; or as *symbols*, as the spiritual meaning of the natural instinct. In the former case the instinctive process is taken to be “real” and in the latter “unreal.”

[363] In any particular case it is often almost impossible to say what is “spirit” and what is “instinct.” Together they form an impenetrable mass, a veritable magma

sprung from the depths of primeval chaos. When one meets such contents one immediately understands why the psychic equilibrium of the neurotic is disturbed, and why the whole psychic system is broken up in schizophrenia. They emit a fascination which not only grips—and has already gripped—the patient, but can also have an inductive effect on the unconscious of the impartial spectator, in this case the doctor. The burden of these unconscious and chaotic contents lies heavy on the patient; for, although they are present in everybody, it is only in him that they have become active, and they isolate him in a spiritual loneliness which neither he nor anybody else can understand and which is bound to be misinterpreted. Unfortunately, if we do not feel our way into the situation and approach it purely from the outside, it is only too easy to dismiss it with a light word or to push it in the wrong direction. This is what the patient has long been doing on his own account, giving the doctor every opportunity for misinterpretation. At first the secret seems to lie with his parents, but when this tie has been loosed and the projection withdrawn, the whole weight falls upon the doctor, who is faced with the question: “What are *you* going to do about the transference?”

[364] The doctor, by voluntarily and consciously taking over the psychic sufferings of the patient, exposes himself to the overpowering contents of the unconscious and hence also to their inductive action. The case begins to “fascinate” him. Here again it is easy to explain this in terms of personal likes and dislikes, but one overlooks the fact that this would be an instance of *ignotum per ignotius*. In reality these personal feelings, if they exist at all in any decisive degree, are governed by those same unconscious contents which have become activated. An unconscious tie is established and now, in the patient’s fantasies, it assumes all the forms and dimensions so profusely described in the literature. The patient, by bringing an activated unconscious content to bear upon the doctor, constellates the corresponding unconscious material in him, owing to the inductive effect which always emanates from projections in greater or lesser degree. Doctor and patient thus find themselves in a relationship founded on mutual unconsciousness.

[365] It is none too easy for the doctor to make himself aware of this fact. One is naturally loath to admit that one could be affected in the most personal way by just any patient. But the more unconsciously this happens, the more the doctor will be tempted to adopt an “apotropaic” attitude, and the *persona medici* he hides behind is, or rather seems to be, an admirable instrument for this purpose. Inseparable from the *persona* is the doctor’s routine and his trick of knowing everything beforehand, which is one of the favourite props of the well-versed practitioner and of all infallible authority. Yet this lack of insight is an ill counsellor, for the unconscious infection brings with it the therapeutic possibility—which should not be underestimated—of the illness being transferred to the doctor. We must suppose as a matter of course that

the doctor is the better able to make the constellated contents conscious, otherwise it would only lead to mutual imprisonment in the same state of unconsciousness. The greatest difficulty here is that contents are often activated in the doctor which might normally remain latent. He might perhaps be so normal as not to need any such unconscious standpoints to compensate his conscious situation. At least this is often how it looks, though whether it is so in a deeper sense is an open question. Presumably he had good reasons for choosing the profession of psychiatrist and for being particularly interested in the treatment of the psychoneuroses; and he cannot very well do that without gaining some insight into his own unconscious processes. Nor can his concern with the unconscious be explained entirely by a free choice of interests, but rather by a fateful disposition which originally inclined him to the medical profession. The more one sees of human fate and the more one examines its secret springs of action, the more one is impressed by the strength of unconscious motives and by the limitations of free choice. The doctor knows—or at least he should know—that he did not choose this career by chance; and the psychotherapist in particular should clearly understand that psychic infections, however superfluous they seem to him, are in fact the predestined concomitants of his work, and thus fully in accord with the instinctive disposition of his own life. This realization also gives him the right attitude to his patient. The patient then means something to him personally, and this provides the most favourable basis for treatment.

3

[366] In the old pre-analytical psychotherapy, going right back to the doctors of the Romantic Age, the transference was already defined as “rapport.” It forms the basis of therapeutic influence once the patient’s initial projections are dissolved. During this work it becomes clear that the projections can also obscure the judgment of the doctor—to a lesser extent, of course, for otherwise all therapy would be impossible. Although we may justifiably expect the doctor at the very least to be acquainted with the effects of the unconscious on his own person, and may therefore demand that anybody who intends to practise psychotherapy should first submit to a training analysis, yet even the best preparation will not suffice to teach him everything about the unconscious. A complete “emptying” of the unconscious is out of the question, if only because its creative powers are continually producing new formations. Consciousness, no matter how extensive it may be, must always remain the smaller circle within the greater circle of the unconscious, an island surrounded by the sea; and, like the sea itself, the unconscious yields an endless and self-replenishing abundance of living creatures, a wealth beyond our fathoming. We may long have known the meaning, effects, and characteristics of unconscious contents without ever having fathomed their depths and potentialities, for they are capable of infinite variation and can never be depotentiated. The only way to get at them in practice is to

try to attain a conscious attitude which allows the unconscious to co-operate instead of being driven into opposition.

[367] Even the most experienced psychotherapist will discover again and again that he is caught up in a bond, a combination resting on mutual unconsciousness. And though he may believe himself to be in possession of all the necessary knowledge concerning the constellated archetypes, he will in the end come to realize that there are very many things indeed of which his academic knowledge never dreamed. Each new case that requires thorough treatment is pioneer work, and every trace of routine then proves to be a blind alley. Consequently the higher psychotherapy is a most exacting business and sometimes it sets tasks which challenge not only our understanding or our sympathy, but the whole man. The doctor is inclined to demand this total effort from his patient, yet he must realize that this same demand only works if he is aware that it applies also to himself.

[368] I said earlier that the contents which enter into the transference were as a rule originally projected upon the parents or other members of the family. Owing to the fact that these contents seldom or never lack an erotic aspect or are genuinely sexual in substance (apart from the other factors already mentioned), an incestuous character does undoubtedly attach to them, and this has given rise to the Freudian theory of incest. Their exogamous transference to the doctor does not alter the situation. He is merely drawn into the peculiar atmosphere of family incest through the projection. This necessarily leads to an unreal intimacy which is highly distressing to both doctor and patient and arouses resistance and doubt on both sides. The violent repudiation of Freud's original discoveries gets us nowhere, for we are dealing with an empirically demonstrable fact which meets with such universal confirmation that only the ignorant still try to oppose it. But the interpretation of this fact is, in the very nature of the case, highly controversial. Is it a genuine incestuous instinct or a pathological variation? Or is the incest one of the "arrangements" (Adler) of the will to power? Or is it regression of normal libido²² to the infantile level, from fear of an apparently impossible task in life?²³ Or is all incest-fantasy purely symbolical, and thus a reactivation of the incest archetype, which plays such an important part in the history of the human mind?

[369] For all these widely differing interpretations we can marshal more or less satisfactory arguments. The view which probably causes most offence is that incest is a genuine instinct. But, considering the almost universal prevalence of the incest taboo, we may legitimately remark that a thing which is not liked and desired generally requires no prohibition. In my opinion, each of these interpretations is justified up to a point, because all the corresponding shades of meaning are present in individual cases, though with varying intensity. Sometimes one aspect predominates

and sometimes another. I am far from asserting that the above list could not be supplemented further.

[370] In practice, however, it is of the utmost importance how the incestuous aspect is interpreted. The explanation will vary according to the nature of the case, the stage of treatment, the perspicacity of the patient, and the maturity of his judgment.

[371] The existence of the incest element involves not only an intellectual difficulty but, worst of all, an emotional complication of the therapeutic situation. It is the hiding place for all the most secret, painful, intense, delicate, shamefaced, timorous, grotesque, unmoral, and at the same time the most sacred feelings which go to make up the indescribable and inexplicable wealth of human relationships and give them their compelling power. Like the tentacles of an octopus they twine themselves invisibly round parents and children and, through the transference, round doctor and patient. This binding force shows itself in the irresistible strength and obstinacy of the neurotic symptom and in the patient's desperate clinging to the world of infancy or to the doctor. The word "possession" describes this state in a way that could hardly be bettered.

[372] The remarkable effects produced by unconscious contents allow us to infer something about their energy. All unconscious contents, once they are activated—i.e., have made themselves felt—possess as it were a specific energy which enables them to manifest themselves everywhere (like the incest motif, for instance). But this energy is normally not sufficient to thrust the content into consciousness. For that there must be a certain predisposition on the part of the conscious mind, namely a deficit in the form of loss of energy. The energy so lost raises the psychic potency of certain compensating contents in the unconscious. The *abaissement du niveau mental*, the energy lost to consciousness, is a phenomenon which shows itself most drastically in the "loss of soul" among primitive peoples, who also have interesting psychotherapeutic methods for recapturing the soul that has gone astray. This is not the place to go into these matters in detail, so a bare mention must suffice.²⁴ Similar phenomena can be observed in civilized man. He too is liable to a sudden loss of initiative for no apparent reason. The discovery of the real reason is no easy task and generally leads to a somewhat ticklish discussion of things lying in the background. Carelessness of all kinds, neglected duties, tasks postponed, wilful outbursts of defiance, and so on, all these can dam up his vitality to such an extent that certain quanta of energy, no longer finding a conscious outlet, stream off into the unconscious, where they activate other, compensating contents, which in turn begin to exert a compulsive influence on the conscious mind. (Hence the very common combination of extreme neglect of duty and a compulsion neurosis.)

[373] This is one way in which loss of energy may come about. The other way causes loss not through a malfunctioning of the conscious mind but through a “spontaneous” activation of unconscious contents, which react secondarily upon consciousness. There are moments in human life when a new page is turned. New interests and tendencies appear which have hitherto received no attention, or there is a sudden change of personality (a so-called mutation of character). During the incubation period of such a change we can often observe a loss of conscious energy: the new development has drawn off the energy it needs from consciousness. This lowering of energy can be seen most clearly before the onset of certain psychoses and also in the empty stillness which precedes creative work.²⁵

[374] The remarkable potency of unconscious contents, therefore, always indicates a corresponding weakness in the conscious mind and its functions. It is as though the latter were threatened with impotence. For primitive man this danger is one of the most terrifying instances of “magic.” So we can understand why this secret fear is also to be found among civilized people. In serious cases it is the secret fear of going mad; in less serious, the fear of the unconscious—a fear which even the normal person exhibits in his resistance to psychological views and explanations. This resistance borders on the grotesque when it comes to scouting all psychological explanations of art, philosophy, and religion, as though the human psyche had, or should have, absolutely nothing to do with these things. The doctor knows these well-defended zones from his consulting hours: they are reminiscent of island fortresses from which the neurotic tries to ward off the octopus. (“Happy neurosis island,” as one of my patients called his conscious state!) The doctor is well aware that the patient needs an island and would be lost without it. It serves as a refuge for his consciousness and as the last stronghold against the threatening embrace of the unconscious. The same is true of the normal person’s taboo regions which psychology must not touch. But since no war was ever won on the defensive, one must, in order to terminate hostilities, open negotiations with the enemy and see what his terms really are. Such is the intention of the doctor who volunteers to act as a mediator. He is far from wishing to disturb the somewhat precarious island idyll or pull down the fortifications. On the contrary, he is thankful that somewhere a firm foothold exists that does not first have to be fished up out of the chaos, always a desperately difficult task. He knows that the island is a bit cramped and that life on it is pretty meagre and plagued with all sorts of imaginary wants because too much life has been left outside, and that as a result a terrifying monster is created, or rather is roused out of its slumbers. He also knows that this seemingly alarming animal stands in a secret compensatory relationship to the island and could supply everything that the island lacks.

[375] The transference, however, alters the psychological stature of the doctor, though this is at first imperceptible to him. He too becomes affected, and has as much difficulty in distinguishing between the patient and what has taken possession of him as has the patient himself. This leads both of them to a direct confrontation with the daemonic forces lurking in the darkness. The resultant paradoxical blend of positive and negative, of trust and fear, of hope and doubt, of attraction and repulsion, is characteristic of the initial relationship. It is the *veíkos kai ψιλία* (hate and love) of the elements, which the alchemists likened to the primeval chaos. The activated unconscious appears as a flurry of unleashed opposites and calls forth the attempt to reconcile them, so that, in the words of the alchemists, the great panacea, the *medicina catholica*, may be born.

4

[376] It must be emphasized that in alchemy the dark initial state of *nigredo* is often regarded as the product of a previous operation, and that it therefore does not represent the absolute beginning.²⁶ Similarly, the psychological parallel to the *nigredo* is the result of the foregoing preliminary talk which, at a certain moment, sometimes long delayed, “touches” the unconscious and establishes the unconscious identity²⁷ of doctor and patient. This moment *may* be perceived and registered consciously, but generally it happens outside consciousness and the bond thus established is recognized only later and indirectly by its results. Occasionally dreams occur about this time, announcing the appearance of the transference. For instance, a dream may say that a fire has started in the cellar, or that a burglar has broken in, or that the patient’s father has died, or it may depict an erotic or some other ambiguous situation.²⁸ From the moment when such a dream occurs there may be initiated a queer unconscious time-reckoning, lasting for months or even longer. I have often observed this process and will give a practical instance of it:

[377] When treating a lady of over sixty, I was struck by the following passage in a dream she had on October 21, 1938: “*A beautiful little child, a girl of six months old, is playing in the kitchen with her grandparents and myself, her mother. The grandparents are on the left of the room and the child stands on the square table in the middle of the kitchen. I stand by the table and play with the child. The old woman says she can hardly believe we have known the child for only six months. I say that it is not so strange because we knew and loved the child long before she was born.*”

[378] It is immediately apparent that the child is something special, i.e., a child hero or divine child. The father is not mentioned; his absence is part of the picture.²⁹ The kitchen, as the scene of the happening, points to the unconscious. The square table is the quaternity, the classical basis of the “special” child,³⁰ for the child is a symbol of the self and the quaternity is a symbolical expression of this. The self as such is

timeless and existed before any birth.³¹ The dreamer was strongly influenced by Indian writings and knew the Upanishads well, but not the medieval Christian symbolism which is in question here. The precise age of the child made me ask the dreamer to look in her notes to see what had happened in the unconscious six months earlier. Under April 20, 1938, she found the following dream:

[379] “*With some other women I am looking at a piece of tapestry, a square with symbolical figures on it. Immediately afterwards I am sitting with some women in front of a marvellous tree. It is magnificently grown, at first it seems to be some kind of conifer, but then I think—in the dream—that it is a monkey-puzzle [a tree of genus *Araucaria*] with the branches growing straight up like candles [a confusion with *Cereus candelabrum*]. A Christmas tree is fitted into it in such a way that at first it looks like one tree instead of two.*”—As the dreamer was writing down this dream immediately on waking, with a vivid picture of the tree before her, she suddenly had a vision of a tiny golden child lying at the foot of the tree (tree-birth motif). She had thus gone on dreaming the sense of the dream. It undoubtedly depicts the birth of the divine (“golden”) child.

[380] But what had happened nine months previous to April 20, 1938? Between July 19 and 22, 1937, she had painted a picture showing, on the left, a heap of coloured and polished (precious) stones surmounted by a silver serpent, winged and crowned. In the middle of the picture there stands a naked female figure from whose genital region the same serpent rears up towards the heart, where it bursts into a five-pointed, gorgeously flashing golden star. A coloured bird flies down on the right with a little twig in its beak. On the twig five flowers are arranged in a *quaternio*, one yellow, one blue, one red, one green, but the topmost is golden—obviously a mandala structure.³² The serpent represents the hissing ascent of Kundalini, and in the corresponding yoga this marks the first moment in a process which ends with deification in the divine Self, the syzygy of Shiva and Shakti.³³ It is obviously the moment of symbolical conception, which is both Tantric and—because of the bird—Christian in character, being a contamination of the symbolism of the Annunciation with Noah’s dove and the sprig of olive.

[381] This case, and more particularly the last image, is a classical example of the kind of symbolism which marks the onset of the transference. Noah’s dove (the emblem of reconciliation), the *incarnatio Dei*, the union of God with matter for the purpose of begetting the redeemer, the serpent path, the Sushumna representing the line midway between sun and moon—all this is the first, anticipatory stage of an as-yet-unfulfilled programme that culminates in the union of opposites. This union is analogous to the “royal marriage” in alchemy. The prodromal events signify the meeting or collision of various opposites and can therefore appropriately be called chaos and blackness.

As mentioned above, this may occur at the beginning of the treatment, or it may have to be preceded by a lengthy analysis, a stage of *rapprochement*. Such is particularly the case when the patient shows violent resistances coupled with fear of the activated contents of the unconscious.³⁴ There is good reason and ample justification for these resistances and they should never, under any circumstances, be ridden over roughshod or otherwise argued out of existence. Neither should they be belittled, disparaged, or made ridiculous; on the contrary, they should be taken with the utmost seriousness as a vitally important defence mechanism against overpowering contents which are often very difficult to control. The general rule should be that the weakness of the conscious attitude is proportional to the strength of the resistance. When, therefore, there are strong resistances, the conscious rapport with the patient must be carefully watched, and—in certain cases—his conscious attitude must be supported to such a degree that, in view of later developments, one would be bound to charge oneself with the grossest inconsistency. That is inevitable, because one can never be too sure that the weak state of the patient's conscious mind will prove equal to the subsequent assault of the unconscious. In fact, one must go on supporting his conscious (or, as Freud thinks, "repressive") attitude until the patient can let the "repressed" contents rise up spontaneously. Should there by any chance be a latent psychosis³⁵ which cannot be detected beforehand, this cautious procedure may prevent the devastating invasion of the unconscious or at least catch it in time. At all events the doctor then has a clear conscience, knowing that he has done everything in his power to avoid a fatal outcome.³⁶ Nor is it beside the point to add that consistent support of the conscious attitude has in itself a high therapeutic value and not infrequently serves to bring about satisfactory results. It would be a dangerous prejudice to imagine that analysis of the unconscious is the one and only panacea which should therefore be employed in every case. It is rather like a surgical operation and we should only resort to the knife when other methods have failed. So long as it does not obtrude itself the unconscious is best left alone. The reader should be quite clear that my discussion of the transference problem is not an account of the daily routine of the psychotherapist, but far more a description of what happens when the check normally exerted on the unconscious by the conscious mind is disrupted, though this need not necessarily occur at all

[382] Cases where the archetypal problem of the transference becomes acute are by no means always "serious" cases, i.e., grave states of illness. There are of course such cases among them, but there are also mild neuroses, or simply psychological difficulties which we would be at a loss to diagnose. Curiously enough, it is these latter cases that present the doctor with the most difficult problems. Often the persons concerned endure unspeakable suffering without developing any neurotic symptoms

that would entitle them to be called ill. We can only call it an intense suffering, a passion of the soul but not a disease of the mind.

[383] Once an unconscious content is constellated, it tends to break down the relationship of conscious trust between doctor and patient by creating, through projection, an atmosphere of illusion which either leads to continual misinterpretations and misunderstandings, or else produces a most disconcerting impression of harmony. The latter is even more trying than the former, which at worst (though it is sometimes for the best!) can only hamper the treatment, whereas in the other case a tremendous effort is needed to discover the points of difference. But in either case the constellation of the unconscious is a troublesome factor. The situation is enveloped in a kind of fog, and this fully accords with the nature of the unconscious content: it is a “black blacker than black” (*nigrum, nigrius nigro*),³⁷ as the alchemists rightly say, and in addition is charged with dangerous polar tensions, with the *inimicitia elementorum*. One finds oneself in an impenetrable chaos, which is indeed one of the synonyms for the mysterious *prima materia*. The latter corresponds to the nature of the unconscious content in every respect, with one exception: this time it does not appear in the alchemical substance but in man himself. In the case of alchemy it is quite evident that the unconscious content is of human origin, as I have shown in *Psychology and Alchemy*.³⁸ Hunted for centuries and never found, the *prima materia* or *lapis philosophorum* is, as a few alchemists rightly suspected, to be discovered in man himself. But it seems that this content can never be found and integrated directly, but only by the circuitous route of projection. For as a rule the unconscious first appears in projected form. Whenever it appears to obtrude itself directly, as in visions, dreams, illuminations, psychoses, etc., these are always preceded by psychic conditions which give clear proof of projection. A classical example of this is Saul’s fanatical persecution of the Christians before Christ appeared to him in a vision.

[384] The elusive, deceptive, ever-changing content that possesses the patient like a demon now flits about from patient to doctor and, as the third party in the alliance, continues its game, sometimes impish and teasing, sometimes really diabolical. The alchemists aptly personified it as the wily god of revelation, Hermes or Mercurius; and though they lament over the way he hoodwinks them, they still give him the highest names, which bring him very near to deity.³⁹ But for all that, they deem themselves good Christians whose faithfulness of heart is never in doubt, and they begin and end their treatises with pious invocations.⁴⁰ Yet it would be an altogether unjustifiable suppression of the truth were I to confine myself to the negative description of Mercurius’ impish drolleries, his inexhaustible invention, his

insinuations, his intriguing ideas and schemes, his ambivalence and—often—his unmistakable malice. He is also capable of the exact opposite, and I can well understand why the alchemists endowed their Mercurius with the highest spiritual qualities, although these stand in flagrant contrast to his exceedingly shady character. The contents of the unconscious are indeed of the greatest importance, for the unconscious is after all the matrix of the human mind and its inventions. Wonderful and ingenious as this other side of the unconscious is, it can be most dangerously deceptive on account of its numinous nature. Involuntarily one thinks of the devils mentioned by St Athanasius in his life of St Anthony, who talk very piously, sing psalms, read the holy books, and—worst of all—speak the truth. The difficulties of our psychotherapeutic work teach us to take truth, goodness, and beauty where we find them. They are not always found where we look for them: often they are hidden in the dirt or are in the keeping of the dragon. “In stercore invenitur” (it is found in filth)⁴¹ runs an alchemical dictum—nor is it any the less valuable on that account. But, it does not transfigure the dirt and does not diminish the evil, any more than these lessen God’s gifts. The contrast is painful and the paradox bewildering. Sayings like are too optimistic and superficial; they forget the moral torment occasioned by the opposites, and the importance of ethical values.

ουρανο ανω	(Heaven above
ουρανο κατω	Heaven below
αστρα ανω	Stars above
αστρα κατω	Stars below
παν ο ανω	All that is above
τουτο κατω	Also is below
ταυτα λαβε	Grasp this
κε ευτυχε	And rejoice) ⁴²

[385] The refining of the *prima materia*, the unconscious content, demands endless patience, perseverance,⁴³ equanimity, knowledge, and ability on the part of the doctor; and, on the part of the patient, the putting forth of his best powers and a capacity for suffering which does not leave the doctor altogether unaffected. The deep meaning of the Christian virtues, especially the greatest among these, will become clear even to the unbeliever; for there are times when he needs them all if he is to rescue his consciousness, and his very life, from this pocket of chaos, whose final subjugation, without violence, is no ordinary task. If the work succeeds, it often works like a miracle, and one can understand what it was that prompted the alchemists to insert a heartfelt *Deo concedente* in their recipes, or to allow that only if God wrought a miracle could their procedure be brought to a successful conclusion.

[386] It may seem strange to the reader that a “medical procedure” should give rise to such considerations. Although in illnesses of the body there is no remedy and no treatment that can be said to be infallible in all circumstances, there are still a great many which will probably have the desired effect without either doctor or patient having the slightest need to insert a *Deo concedente*. But we are not dealing here with the body—we are dealing with the psyche. Consequently we cannot speak the language of body-cells and bacteria; we need another language commensurate with the nature of the psyche, and equally we must have an attitude which measures the danger and can meet it. And all this must be genuine or it will have no effect; if it is hollow, it will damage both doctor and patient. The *Deo concedente* is not just a rhetorical flourish; it expresses the firm attitude of the man who does not imagine that he knows better on every occasion and who is fully aware that the unconscious material before him is something *alive*, a paradoxical Mercurius of whom an old master says: “Et est ille quem natura paululum operata est et in metallicam formam formavit, tamen imperfectum relinquit.” (And he is that on whom nature hath worked but a little, and whom she hath wrought into metallic form yet left unfinished)⁴⁴—a natural being, therefore, that longs for integration within the wholeness of a man. It is like a fragment of primeval psyche into which no consciousness has as yet penetrated to create division and order, a “united dual nature,” as Goethe says—an abyss of ambiguities.

[387] Since we cannot imagine—unless we have lost our critical faculties altogether—that mankind today has attained the highest possible degree of consciousness, there must be some potential unconscious psyche left over whose development would result in a further extension and a higher differentiation of consciousness. No one can say how great or small this “remnant” might be, for we have no means of measuring the possible range of conscious development, let alone the extent of the unconscious. But there is not the slightest doubt that a *massa confusa* of archaic and undifferentiated contents exists, which not only manifests itself in neuroses and psychoses but also forms the “skeleton in the cupboard” of innumerable people who are not really pathological. We are so accustomed to hear that everybody has his “difficulties and problems” that we simply accept it as a banal fact, without considering what these difficulties and problems really mean. Why is one never satisfied with oneself? Why is one unreasonable? Why is one not always good and why must one ever leave a cranny for evil? Why does one sometimes say too much and sometimes too little? Why does one do foolish things which could easily be avoided with a little forethought? What is it that is always frustrating us and thwarting our best intentions? Why are there people who never notice these things and cannot even admit their existence? And finally, why do people in the mass beget the historical lunacy of the last thirty years? Why couldn’t Pythagoras, twenty-four

hundred years ago, have established the rule of wisdom once and for all, or Christianity have set up the Kingdom of Heaven upon earth?

[388] The Church has the doctrine of the devil, of an evil principle, whom we like to imagine complete with cloven hoofs, horns, and tail, half man, half beast, a chthonic deity apparently escaped from the rout of Dionysus, the sole surviving champion of the sinful joys of paganism. An excellent picture, and one which exactly describes the grotesque and sinister side of the unconscious; for we have never really come to grips with it and consequently it has remained in its original savage state. Probably no one today would still be rash enough to assert that the European is a lamblike creature and not possessed by a devil. The frightful records of our age are plain for all to see, and they surpass in hideousness everything that any previous age, with its feeble instruments, could have hoped to accomplish.

[389] If, as many are fain to believe, the unconscious were only nefarious, only evil, then the situation would be simple and the path clear: to do good and to eschew evil. But what is “good” and what is “evil”? The unconscious is not just evil by nature, it is also the source of the highest good:⁴⁵ not only dark but also light, not only bestial, semi-human, and demonic but superhuman, spiritual, and, in the classical sense of the word, “divine.” The Mercurius who personifies the unconscious⁴⁶ is essentially “duplex,” paradoxically dualistic by nature, fiend, monster, beast, and at the same time panacea, “the philosophers’ son,” *sapientia Dei*, and *donum Spiritus Sancti*.⁴⁷

[390] Since this is so, all hope of a simple solution is abolished. All definitions of good and evil become suspect or actually invalid. As moral forces, good and evil remain unshaken, and—as the simple verities for which the penal code, the ten commandments, and conventional Christian morality take them—undoubted. But conflicting loyalties are much more subtle and dangerous things, and a conscience sharpened by worldly wisdom can no longer rest content with precepts, ideas, and fine words. When it has to deal with that remnant of primeval psyche, pregnant with the future and yearning for development, it grows uneasy and looks round for some guiding principle or fixed point. Indeed, once this stage has been reached in our dealings with the unconscious, these desiderata become a pressing necessity. Since the only salutary powers visible in the world today are the great psychotherapeutic systems which we call the religions, and from which we expect the soul’s salvation, it is quite natural that many people should make the justifiable and often successful attempt to find a niche for themselves in one of the existing creeds and to acquire a deeper insight into the meaning of the traditional saving verities.

[391] This solution is normal and satisfying in that the dogmatically formulated truths of the Christian Church express, almost perfectly, the nature of psychic experience. They are the repositories of the secrets of the soul, and this matchless knowledge is

set forth in grand symbolical images. The unconscious thus possesses a natural affinity with the spiritual values of the Church, particularly in their dogmatic form, which owes its special character to centuries of theological controversy—absurd as this seemed in the eyes of later generations—and to the passionate efforts of many great men.

[392] The Church would be an ideal solution for anyone seeking a suitable receptacle for the chaos of the unconscious were it not that everything man-made, however refined, has its imperfections. The fact is that a return to the Church, i.e., to a particular creed, is not the general rule. Much the more frequent is a better understanding of, and a more intense relation to, religion as such, which is not to be confused with a creed.⁴⁸ This, it seems to me, is mainly because anyone who appreciates the legitimacy of the two viewpoints, of the two branches into which Christianity has been split, cannot maintain the exclusive validity of either of them, for to do so would be to deceive himself. As a Christian, he has to recognize that the Christendom he belongs to has been split for four hundred years and that his Christian beliefs, far from redeeming him, have exposed him to a conflict and a division that are still rending the body of Christ. These are the facts, and they cannot be abolished by each creed pressing for a decision in its favour, as though each were perfectly sure it possessed the absolute truth. Such an attitude is unfair to modern man; he can see very well the advantages that Protestantism has over Catholicism and *vice versa*, and it is painfully clear to him that this sectarian insistence is trying to corner him against his better judgment—in other words, tempting him to sin against the Holy Ghost. He even understands why the churches are bound to behave in this way, and knows that it must be so lest any joyful Christian should imagine himself already reposing in Abraham's anticipated bosom, saved and at peace and free from all fear. Christ's passion continues—for the life of Christ in the *corpus mysticum*, or Christian life in both camps, is at loggerheads with itself and no honest man can deny the split. We are thus in the precise situation of the neurotic who must put up with the painful realization that he is in the midst of conflict. His repeated efforts to repress the other side have only made his neurosis worse. The doctor must advise him to accept the conflict just as it is, with all the suffering this inevitably entails, otherwise the conflict will never be ended. Intelligent Europeans, if at all interested in such questions, are consciously or semiconsciously protestant Catholics and catholic Protestants, nor are they any the worse for that. It is no use telling me that no such people exist: I have seen both sorts, and they have considerably raised my hopes about the European of the future.

[393] But the negative attitude of the public at large to all credos seems to be less the result of religious convictions than one symptom of the general mental sloth and ignorance of religion. We can wax indignant over man's notorious lack of spirituality, but when one is a doctor one does not invariably think that the disease is malevolent or the patient morally inferior; instead, one supposes that the negative results may possibly be due to the remedy applied. Although it may reasonably be doubted whether man has made any marked or even perceptible progress in morality during the known five thousand years of human civilization, it cannot be denied that there has been a notable development of consciousness and its functions. Above all, there has been a tremendous extension of consciousness in the form of *knowledge*. Not only have the individual functions become differentiated, but to a large extent they have been brought under the control of the ego—in other words, man's will has developed. This is particularly striking when we compare our mentality with that of primitives. The security of our ego has, in comparison with earlier times, greatly increased and has even taken such a dangerous leap forward that, although we sometimes speak of "God's will," we no longer know what we are saying, for in the same breath we assert, "Where there's a will there's a way." And who would ever think of appealing to God's help rather than to the goodwill, the sense of responsibility and duty, the reason or intelligence, of his fellow men?

[394] Whatever we may think of these changes of outlook, we cannot alter the fact of their existence. Now when there is a marked change in the individual's state of consciousness, the unconscious contents which are thereby constellated will also change. And the further the conscious situation moves away from a certain point of equilibrium, the more forceful and accordingly the more dangerous become the unconscious contents that are struggling to restore the balance. This leads ultimately to a dissociation: on the one hand, ego-consciousness makes convulsive efforts to shake off an invisible opponent (if it does not suspect its next-door neighbour of being the devil!), while on the other hand it increasingly falls victim to the tyrannical will of an internal "Government opposition" which displays all the characteristics of a dæmonic subman and superman combined.

[395] When a few million people get into this state, it produces the sort of situation which has afforded us such an edifying object-lesson every day for the last ten years. These contemporary events betray their psychological background by their very singularity. The insensate destruction and devastation are a reaction against the deflection of consciousness from the point of equilibrium. For an equilibrium does in fact exist between the psychic ego and non-ego, and that equilibrium is a *religio*, a "careful consideration"⁴⁹ of ever-present unconscious forces which we neglect at our peril. The present crisis has been brewing for centuries because of this shift in man's conscious situation.

[396] Have the Churches adapted themselves to this secular change? Their truth may, with more right than we realize, call itself “eternal,” but its temporal garment must pay tribute to the evanescence of all earthly things and should take account of psychic changes. Eternal truth needs a human language that alters with the spirit of the times. The primordial images undergo ceaseless transformation and yet remain ever the same, but only in a new form can they be understood anew. Always they require a new interpretation if, as each formulation becomes obsolete, they are not to lose their spellbinding power over that *fugax Mercurius*⁵⁰ and allow that useful though dangerous enemy to escape. What is that about “new wine in old bottles”? Where are the answers to the spiritual needs and troubles of a new epoch? And where the knowledge to deal with the psychological problems raised by the development of modern consciousness? Never before has eternal truth been faced with such a hybris of will and power.

8

[397] Here, apart from motives of a more personal nature, probably lie the deeper reasons for the fact that the greater part of Europe has succumbed to neo-paganism and anti-Christianity, and has set up a religious ideal of worldly power in opposition to the metaphysical ideal founded on love. But the individual’s decision not to belong to a Church does not necessarily denote an anti-Christian attitude; it may mean exactly the reverse: a reconsidering of the kingdom of God in the human heart where, in the words of St. Augustine,⁵¹ the *mysterium paschale* is accomplished “in its inward and higher meanings.” The ancient and long obsolete idea of man as a microcosm contains a supreme psychological truth that has yet to be discovered. In former times this truth was projected upon the body, just as alchemy projected the unconscious psyche upon chemical substances. But it is altogether different when the microcosm is understood as that interior world whose inward nature is fleetingly glimpsed in the unconscious. An inkling of this is to be found in the words of Origen: “Intellige te alium mundum esse in parvo et esse intra te Solem, esse Lunam, esse etiam stellas” (Understand that thou art a second little world and that the sun and the moon are within thee, and also the stars).⁵² And just as the cosmos is not a dissolving mass of particles, but rests in the unity of God’s embrace, so man must not dissolve into a whirl of warring possibilities and tendencies imposed on him by the unconscious, but must become the unity that embraces them all. Origen says pertinently: “Vides, quomodo ille, qui putatur unus esse, non est unus, sed tot in eo personae videntur esse, quot mores” (Thou seest that he who seemeth to be one is yet not one, but as many persons appear in him as he hath velleities).⁵³ Possession by the unconscious means being torn apart into many people and things, a *disiunctio*. That is why, according to Origen, the aim of the Christian is to become an inwardly united human being.⁵⁴ The blind insistence on the outward community of the Church

naturally fails to fulfil this aim; on the contrary, it inadvertently provides the inner disunity with an outward vessel without really changing the *disiunctio* into a *coniunctio*.

[398] The painful conflict that begins with the *nigredo* or *tenebrositas* is described by the alchemists as the *separatio* or *divisio elementorum*, the *solutio*, *calcinatio*, *incineratio*, or as dismemberment of the body, excruciating animal sacrifices, amputation of the mother's hands or the lion's paws, atomization of the bridegroom in the body of the bride, and so on.⁵⁵ While this extreme form of *disiunctio* is going on, there is a transformation of that arcanum—be it substance or spirit—which invariably turns out to be the mysterious Mercurius. In other words, out of the monstrous animal forms there gradually emerges a *res simplex*, whose nature is one and the same and yet consists of a duality (Goethe's "united dual nature"). The alchemist tries to get round this paradox or antinomy with his various procedures and formulae, and to make one out of two.⁵⁶ But the very multiplicity of his symbols and symbolic processes proves that success is doubtful. Seldom do we find symbols of the goal whose dual nature is not immediately apparent. His *filius philosophorum*, his *lapis*, his *rebis*, his homunculus, are all hermaphroditic. His gold is *non vulgi*, his *lapis* is spirit and body, and so is his tincture, which is a *sanguis spiritualis*—a spiritual blood.⁵⁷ We can therefore understand why the *nuptiae chymicae*, the royal marriage, occupies such an important place in alchemy as a symbol of the supreme and ultimate union, since it represents the magic-by-analogy which is supposed to bring the work to its final consummation and bind the opposites by love, for "love is stronger than death."

9

[399] Alchemy describes, not merely in general outline but often in the most astonishing detail, the same psychological phenomenology which can be observed in the analysis of unconscious processes. The individual's specious unity that emphatically says "I want, I think" breaks down under the impact of the unconscious. So long as the patient can think that somebody else (his father or mother) is responsible for his difficulties, he can save some semblance of unity (*putatur unus esse!*). But once he realizes that he himself has a shadow, that his enemy is in his own heart, then the conflict begins and one becomes two. Since the "other" will eventually prove to be yet another duality, a compound of opposites, the ego soon becomes a shuttlecock tossed between a multitude of "velleities," with the result that there is an "obfuscation of the light," i.e., consciousness is depotentiated and the patient is at a loss to know where his personality begins or ends. It is like passing through the valley of the shadow, and sometimes the patient has to cling to the doctor as the last remaining shred of reality. This situation is difficult and distressing for

both parties; often the doctor is in much the same position as the alchemist who no longer knew whether he was melting the mysterious amalgam in the crucible or whether he was the salamander glowing in the fire. Psychological induction inevitably causes the two parties to get involved in the transformation of the third and to be themselves transformed in the process, and all the time the doctor's knowledge, like a flickering lamp, is the one dim light in the darkness. Nothing gives a better picture of the psychological state of the alchemist than the division of his work-room into a "laboratory," where he bustles about with crucibles and alembics, and an "oratory," where he prays to God for the much needed illumination—"purge the horrible darkneses of our mind,"⁵⁸ as the author of *Aurora* quotes.

[400] "Ars requirit totum hominem," we read in an old treatise.⁵⁹ This is in the highest degree true of psychotherapeutic work. A genuine participation, going right beyond professional routine, is absolutely imperative, unless of course the doctor prefers to jeopardize the whole proceeding by evading his own problems, which are becoming more and more insistent. The doctor must go to the limits of his subjective possibilities, otherwise the patient will be unable to follow suit. Arbitrary limits are no use, only real ones. It must be a genuine process of purification where "all superfluities are consumed in the fire" and the basic facts emerge. Is there anything more fundamental than the realization, "This is what I am"? It reveals a unity which nevertheless is—or was—a diversity. No longer the earlier ego with its make-believes and artificial contrivances, but another, "objective" ego, which for this reason is better called the "self." No longer a mere selection of suitable fictions, but a string of hard facts, which together make up the cross we all have to carry or the fate we ourselves are. These first indications of a future synthesis of personality, as I have shown in my earlier publications, appear in dreams or in "active imagination," where they take the form of the mandala symbols which were also not unknown in alchemy. But the first signs of this symbolism are far from indicating that unity has been attained. Just as alchemy has a great many very different procedures, ranging from the sevenfold to the thousandfold distillation, or from the "work of one day" to "the errant quest" lasting for decades, so the tensions between the psychic pairs of opposites ease off only gradually; and, like the alchemical end-product, which always betrays its essential duality, the united personality will never quite lose the painful sense of innate discord. Complete redemption from the sufferings of this world is and must remain an illusion. Christ's earthly life likewise ended, not in complacent bliss, but on the cross. (It is a remarkable fact that in their hedonistic aims materialism and a certain species of "joyful" Christianity join hands like brothers.) The goal is important only as an idea; the essential thing is the *opus* which leads to the goal: *that* is the goal of a lifetime. In its attainment "left and right"⁶⁰ are united, and conscious and unconscious work in harmony.

[401] The *coniunctio oppositorum* in the guise of Sol and Luna, the royal brother-sister or mother-son pair, occupies such an important place in alchemy that sometimes the entire process takes the form of the *hierosgamos* and its mystic consequences. The most complete and the simplest illustration of this is perhaps the series of pictures contained in the *Rosarium philosophorum* of 1550, which series I reproduce in what follows. Its psychological importance justifies closer examination. Everything that the doctor discovers and experiences when analysing the unconscious of his patient coincides in the most remarkable way with the content of these pictures. This is not likely to be mere chance, because the old alchemists were often doctors as well, and thus had ample opportunity for such experiences if, like Paracelsus, they worried about the psychological well-being of their patients or inquired into their dreams (for the purpose of diagnosis, prognosis, and therapy). In this way they could collect information of a psychological nature, not only from their patients but also from themselves, i.e., from the observation of their own unconscious contents which had been activated by induction.⁶¹ Just as the unconscious expresses itself even today in a picture-series, often drawn spontaneously by the patient, so those earlier pictures, such as we find in the Codex Rhenoviensis 172, in Zurich, and in other treatises, were no doubt produced in a similar way, that is, as the deposit of impressions collected during the work and then interpreted or modified in the light of traditional factors.⁶² In the modern pictures, too, we find not a few traces of traditional themes side by side with spontaneous repetitions of archaic or mythological ideas. In view of this close connection between picture and psychic content, it does not seem to me out of place to examine a medieval series of pictures in the light of modern discoveries, or even to use them as an Ariadne thread in our account of the latter. These curiosities of the Middle Ages contain the seeds of much that emerged in clearer form only many centuries later.

Invenit gratiam in deserto populus...

—JEREMIAS (VULGATE) 31 : 2

The people... found grace in the desert...

—JEREMIAS (D.V.) 31 : 2

**AN ACCOUNT OF THE TRANSFERENCE PHENOMENA BASED ON THE
ILLUSTRATIONS TO THE "ROSARIUM PHILOSOPHORUM"**

THE MERCURIAL FOUNTAIN

We are the metals' first nature and only source/

The highest tincture of the Art is made through us.

No fountain and no water has my like/

I make both rich and poor both whole and sick.

For healthful can I be and poisonous.¹

[Figure 1]

[402] This picture goes straight to the heart of alchemical symbolism, for it is an attempt to depict the mysterious basis of the *opus*. It is a quadratic quaternity characterized by the four stars in the four corners. These are the four elements. Above, in the centre, there is a fifth star which represents the fifth entity, the “One” derived from the four, the *quinta essentia*. The basin below is the *vas Hermeticum*, where the transformation takes place. It contains the *mare nostrum*, the *aqua permanens* or ἵδωρ θεῖον, the “divine water.” This is the *mare tenebrosum*, the chaos. The vessel is also called the uterus² in which the *foetus spagyricus* (the homunculus) is gestated.³ This basin, in contrast to the surrounding square, is circular, because it is the matrix of the perfect form into which the square, as an imperfect form, must be changed. In the square the elements are still separate and hostile to one another and must therefore be united in the circle. The inscription on the rim of the basin bears out this intention. It runs (filling in the abbreviations): “Unus est Mercurius mineralis, Mercurius vegetabilis, Mercurius animalis.” (*Vegetabilis* should be translated as “living” and *animalis* as “animate” in the sense of having a soul, or even as “psychic.”⁴) On the outside of the basin there are six stars which together with Mercurius represent the seven planets or metals. They are all as it were contained in Mercurius, since he is the *pater metallorum*. When personified, he is the unity of the seven planets, an Anthropos whose body is the world, like Gayomart, from whose body the seven metals flow into the earth. Owing to his feminine nature, Mercurius is also the mother of the seven, and not only of the six, for he is his own father and mother.⁵

[403] Out of the “sea,” then, there rises this Mercurial Fountain, *triplex nomine*, as is said with reference to the three manifestations of Mercurius.⁶ He is shown flowing out of three pipes in the form of *lac virginis*, *acetum fontis*, and *aqua vitae*. These are three of his innumerable synonyms. The aforementioned unity of Mercurius is here represented as a triad. It is repeatedly emphasized that he is a trinity, *triunus* or *trinus*,

the chthonic, lower, or even infernal counterpart of the Heavenly Trinity, just as Dante's devil is three-headed.⁷ For the same reason Mercurius is often shown as a three-headed serpent. Above the three pipes we find the sun and moon, who are the indispensable acolytes and parents of the mystic transformation, and, a little higher, the quintessential star, symbol of the unity of the four hostile elements. At the top of the picture is the *serpens bifidus*, the divided (or two-headed) serpent, the fatal *binarius* which Dorn defines as the devil.⁸ This serpent is the *serpens mercurialis*,⁹ representing the *duplex natura* of Mercurius. The heads are spitting forth fire, from which Maria the Copt or Jewess derived her "duo fumi."¹⁰ These are the two vapours whose condensation¹¹ initiates the process which leads to a multiple sublimation or distillation for the purpose of purifying away the *mali odores*, the *foetor sepulcrorum*¹² and the clinging darkness of the beginning.

ROSARIUM



Wir sind der metall anfang vnd erste natur /
 Die kunst macht durch vns die höchste tinctur.
 Keen brunn noch wasser ist meyn gleych /
 Ich mach gesund arm vnd reich.
 Vnd bin doch gesund gystig vnd dñlich.

Succus

Figure 1

[404] This structure reveals the tetrameria (fourfold nature) of the transforming process, already known to the Greeks. It begins with the four separate elements, the state of chaos, and ascends by degrees to the three manifestations of Mercurius in the inorganic, organic, and spiritual worlds; and, after attaining the form of Sol and Luna (i.e., the precious metals gold and silver, but also the radiance of the gods who can

overcome the strife of the elements by love), it culminates in the one and indivisible (incorruptible, ethereal, eternal) nature of the *anima*, the *quinta essentia*, *aqua permanens*, tincture, or *lapis philosophorum*. This progression from the number 4 to 3 to 2 to 1 is the “axiom of Maria,” which runs in various forms through the whole of alchemy like a *leitmotiv*. If we set aside the numerous “chemical” explanations we come to the following symbolical ground-plan: the initial state of wholeness is marked by four mutually antagonistic tendencies—4 being the minimum number by which a circle can be naturally and visibly defined. The reduction of this number aims at final unity. The first to appear in the progression is the number 3, a masculine number, and out of it comes the feminine number 2.¹³ Male and female inevitably constellate the idea of sexual union as the means of producing the 1, which is then consistently called the *filius regius* or *filius philosophorum*.

[405] The quaternity¹⁴ is one of the most widespread archetypes and has also proved to be one of the most useful schemata for representing the arrangement of the functions by which the conscious mind takes its bearings.¹⁵ It is like the crossed threads in the telescope of our understanding. The cross formed by the points of the quaternity is no less universal and has in addition the highest possible moral and religious significance for Western man. Similarly the circle, as the symbol of completeness and perfect being, is a widespread expression for heaven, sun, and God; it also expresses the primordial image of man and the soul.¹⁶ Four as the minimal number by which order can be created represents the pluralistic state of the man who has not yet attained inner unity, hence the state of bondage and disunion, of disintegration, and of being torn in different directions—an agonizing, unredeemed state which longs for union, reconciliation, redemption, healing, and wholeness.

[406] The triad appears as “masculine,” i.e., as the active resolve or *agens* whose alchemical equivalent is the “upwelling.” In relation to it the dyad is “feminine,” the receptive, absorbent *patiens*, or the material that still has to be formed and impregnated (*informatio, impraegnatio*). The psychological equivalent of the triad is want, desire, instinct, aggression and determination, whereas the dyad corresponds to the reaction of the psychic system as a whole to the impulse or decision of the conscious mind. This would of course perish of inanition if it did not succeed in overcoming the inertia of the merely natural man and in achieving its object despite his laziness and constant resistance. But by dint of compulsion or persuasion the conscious mind is able to carry through its purpose, and only in the resultant *action* is a man a living whole and a unity (“In the beginning was the deed,” as Faust says)¹⁷—provided that the action is the mature product of a process embracing the whole psyche and not just a spasm or impulse that has the effect of suppressing it.

[407] At bottom, therefore, our symbolical picture is an illustration of the methods and philosophy of alchemy. These are not warranted by the nature of matter as known to the old masters; they can only derive from the *unconscious* psyche. No doubt there was also a certain amount of *conscious* speculation among the alchemists, but this is no hindrance whatever to unconscious projection, for wherever the mind of the investigator departs from exact observation of the facts before it and goes its own way, the unconscious *spiritus rector* will take over and lead the mind back to the unchangeable, underlying archetypes, which are then forced into projection by this regression. We are moving here on familiar ground. These things are depicted in the most magnificent images in the last and greatest work of alchemy—Goethe's *Faust*. Goethe is really describing the experience of the alchemist who discovers that what he has projected into the retort is his own darkness, his unredeemed state, his passion, his struggles to reach the goal, i.e., to become what he really is, to fulfil the purpose for which his mother bore him, and, after the peregrinations of a long life full of confusion and error, to become the *filius regius*, son of the supreme mother. Or we can go even further back to the important forerunner of *Faust*, the *Chymical Wedding* of Christian Rosencreutz (1616), which was assuredly known to Goethe.¹⁸ Fundamentally it is the same theme, the same "Axioma Mariae," telling how Rosencreutz is transformed out of his former unenlightened condition and comes to realize that he is related to "royalty." But in keeping with its period (beginning of the seventeenth century), the whole process is far more projected and the withdrawal of the projection into the hero—which in *Faust*'s case turns him into a superman¹⁹—is only fleetingly hinted at. Yet the psychological process is essentially the same: the becoming aware of those powerful contents which alchemy sensed in the secrets of matter.

[408] The text that follows the picture of the Mercurial Fountain is mainly concerned with the "water" of the art, i.e., mercury. In order to avoid repetition, I would refer the reader to my lecture "The Spirit Mercurius." Here I will only say that this fluid substance, with all its paradoxical qualities, really signifies the unconscious which has been projected into it. The "sea" is its static condition, the "fountain" its activation, and the "process" its transformation. The integration of unconscious contents is expressed in the idea of the elixir, the *medicina catholica* or *universalis*, the *aurum potabile*, the *cibus sempiternus* (everlasting food), the health-giving fruits of the philosophical tree, the *vinum ardens*, and all the other innumerable synonyms. Some of them are decidedly ominous but no less characteristic, such as *succus lunariae* or *lunatica* (juice of the moon-plant),²⁰ *aqua Saturni* (note that Saturn is a baleful deity!), poison, scorpion, dragon, son of the fire, boys' or dogs' urine, brimstone, devil, etc.

[409] Although not expressly stated in the text, the gushing up and flowing back of the Mercurial Fountain within its basin completes a circle, and this is an essential characteristic of Mercurius because he is also the serpent that fertilizes, kills, and devours itself and brings itself to birth again. We may mention in this connection that the circular sea with no outlet, which perpetually replenishes itself by means of a spring bubbling up in its centre, is to be found in Nicholas of Cusa as an allegory of God.²¹

KING AND QUEEN

[410] The *arcanum artis*, or *coniunctio Solis et Lunae* as supreme union of hostile opposites, was not shown in our first picture; but now it is illustrated in considerable detail, as its importance deserves, in a series of pictures. King and Queen, bridegroom and bride, approach one another for the purpose of betrothal or marriage. The incest element appears in the brother-sister relationship of Apollo and Diana. The pair of them stand respectively on sun and moon, thus indicating their solar and lunar nature in accordance with the astrological assumption of the importance of the sun's position for man and the moon's for woman. The meeting is somewhat distant at first, as the court clothes suggest. The two give each other their *left* hands, and this can hardly be unintentional since it is contrary to custom. The gesture points to a closely guarded secret, to the "left-hand path," as the Indian Tantrists call their Shiva and Shakti worship. The left-hand (sinister) side is the dark, the unconscious side. The left is inauspicious and awkward; also it is the side of the heart, from which comes not only love but all the evil thoughts connected with it, the moral contradictions in human nature that are expressed most clearly in our affective life. The contact of left hands could therefore be taken as an indication of the affective nature of the relationship, of its dubious character, since this is a mixture of "heavenly and earthly" love further complicated by an incestuous *sous-entendu*. In this delicate yet altogether human situation the gesture of the *right* hands strikes us as compensatory. They are holding a device composed of five (4 + 1) flowers. The branches in the hands each have two flowers; these four again refer to the four elements of which two—fire and air—are active and two—water and earth—passive, the former being ascribed to the man and the latter to the woman. The fifth flower comes from above and presumably represents the *quinta essentia*; it is brought by the dove of the Holy Ghost, an analogy of Noah's dove that carried the olive branch of reconciliation in its beak. The bird descends from the quintessential star (cf. [fig. 1](#)).

[411] The real secret lies in the union of *right* hands, for, as the picture shows, this is mediated by the *donum Spiritus Sancti*, the royal art. The "sinister" left-handed contact here becomes associated with the union, effected from above, of two quaternities (the masculine and feminine manifestations of the four elements) in the form of an ogdoad consisting of five flowers and three branches. These masculine numbers point to action, decision, purpose, and movement. The fifth flower is distinguished from the four in that it is brought by the dove. The three branches correspond to the upwelling of Mercurius *triplex nomine* or to the three pipes of the

fountain. So once again we have an abbreviated recapitulation of the *opus*, i.e., of its deeper meaning as shown in the first picture. The text to [Figure 2](#) begins significantly with the words: “Mark well, in the art of our magisterium nothing is concealed by the philosophers except the secret of the art which may not be revealed to all and sundry. For were that to happen, that man would be accursed; he would incur the wrath of God and perish of the apoplexy. Wherefore all error in the art arises because men do not begin with the proper substance,¹ and for this reason you should employ venerable Nature, because from her and through her and in her is our art born and in naught else: and so our magisterium is the work of Nature and not of the worker.”²

[412] If we take the fear of divine punishment for betrayal at its face value, the reason for this must lie in something that is thought to endanger the soul’s salvation, i.e., a typical “peril of the soul.” The causal “wherefore” with which the next sentence begins can only refer to the secret that must not be revealed; but because the *prima materia* remains unknown in consequence, all those who do not know the secret fall into error, and this happens because, as said, they choose something arbitrary and artificial instead of pure Nature. The emphasis laid on *venerabilis natura*³ gives us some idea of that passion for investigation which ultimately gave birth to natural science, but which so often proved inimical to faith. Worship of nature, a legacy from the past, stood in more or less secret opposition to the views of the Church and led the mind and heart in the direction of a “left-hand path.” What a sensation Petrarch’s ascent of Mont Ventoux caused! St. Augustine had warned in his *Confessions* (X, viii): “And men go forth to admire the high mountains and the great waves of the sea and the broad torrent of the rivers and the vast expanse of the ocean and the orbits of the stars, and to turn away from themselves....”



Nota bene: In arte nostri magisterij nihil est *Secretum*
 celatū à Philosophis excepto secreto artis, quod *artis*
 non licet cuiquam reuelare, quod si fieret ille ma-
 lediceretur, & indignationem domini incur-
 reret, & apoplexia moreretur. # Quare om-
 nis error in arte existit, ex eo, quod debitam
 C ij

Figure 2

[413] The exclusive emphasis on nature as the one and only basis of the art is in flagrant contrast to the ever-recurring protestation that the art is a *donum Spiritus Sancti*, an arcanum of the *sapientia Dei*, and so forth, from which we would have to conclude that the alchemists were unshakably orthodox in their beliefs. I do not think that this can be doubted as a rule. On the contrary, their belief in illumination through the Holy Ghost seems to have been a psychological necessity in view of the ominous darkness of nature's secrets.

[414] Now if a text which insists so much on pure nature is explained or illustrated by a picture like [Figure 2](#), we must assume that the relationship between king and queen was taken to be something perfectly natural. Meditation and speculation about the mystery of the *coniunctio* were inevitable, and this would certainly not leave erotic fantasy untouched, if only because these symbolical pictures spring from the corresponding unconscious contents—half spiritual, half sexual—and are also intended to remind us of that twilight region, for only from indistinguishable night can the light be born. This is what nature and natural experience teach, but the spirit believes in the *lumen de lumine*—the light born of light.⁴ Somehow the artifex was

entangled in this game of unconscious projection and was bound to experience the mysterious happening with shudders of fear, as a tremendum. Even that scoffer and blasphemer Agrippa von Nettesheim displays a remarkable reticence in his criticism of “Alkumistica.”⁵ After saying a great deal about this dubious art, he adds:⁶ “Permulta adhuc de hoc arte (mihi tamen non ad modum inimica) dicere possem, nisi iuratum esset (quod facere solent, qui mysteriis initiantur) de silentio”(I could say much more about this art—which I do not find so disagreeable—were it not for the oath of silence usually taken by initiates into mysteries).⁷ Such a mitigation of his criticism, most unexpected in Agrippa, makes one think that he is on the defensive: somehow he was impressed by the royal art.

[415] It is not necessary to think of the secret of the art as anything very lurid. Nature knows nothing of moral squalor, indeed her truths are alarming enough. We need only bear in mind one fact: that the desired *coniunctio* was not a legitimate union but was always—one could almost say, on principle incestuous. The fear that surrounds this complex—the “fear of incest”—is quite typical and has already been stressed by Freud. It is further exacerbated by fear of the compulsive force which emanates from most unconscious contents.

[416] The left-handed contact and crosswise union of the right hands—*sub rosa*— is a startlingly concrete and yet very subtle hint of the delicate situation in which “venerable nature” has placed the adept. Although the Rosicrucian movement cannot be traced further back than the *Fama* and *Confessio fraternitatis* of Andreae at the beginning of the seventeenth century,⁸ we are nevertheless confronted with a “rosie cross” in this curious bouquet of three flowering branches, which evidently originated sometime before 1550 but, equally obviously, makes no claim to be a true *rosicrucus*.⁹ As we have already said, its threefold structure is reminiscent of the Mercurial Fountain, while at the same time it points to the important fact that the “rose” is the product of three *living* things: the king, the queen, and between them the dove of the Holy Ghost. Mercurius *triplex nomine* is thus converted into three figures, and he can no longer be thought of as a metal or mineral, but only as “spirit.” In this form also he is triple-natured—masculine, feminine, and divine. His coincidence with the Holy Ghost as the third person of the Trinity certainly has no foundation in dogma, but “venerable nature” evidently enabled the alchemist to provide the Holy Ghost with a most unorthodox and distinctly earth-bound partner, or rather to complement him with that divine spirit which had been imprisoned in all creatures since the day of Creation. This “lower” spirit is the Primordial Man, hermaphroditic by nature and of Iranian origin, who was imprisoned in Physis.¹⁰ He is the spherical, i.e., perfect, man who appears at the beginning and end of time and is man’s own beginning and end. He is man’s totality, which is beyond the division of the sexes and can only be reached when male and female come together in one. The

revelation of this higher meaning solves the problems created by the “sinister” contact and produces from the chaotic darkness the *lumen quod superat omnia lumina*.

[417] If I did not know from ample experience that such developments also occur in modern man, who cannot possibly be suspected of having any knowledge of the Gnostic doctrine of the Anthropos, I should be inclined to think that the alchemists were keeping up a secret tradition, although the evidence for this (the hints contained in the writings of Zosimos of Panopolis) is so scanty that Waite, who knows medieval alchemy relatively well, doubts whether a secret tradition existed at all.¹¹ I am therefore of the opinion, based on my professional work, that the Anthropos idea in medieval alchemy was largely “autochthonous,” i.e., the outcome of subjective experience. It is an “eternal” idea, an archetype that can appear spontaneously at any time and in any place. We meet the Anthropos even in ancient Chinese alchemy, in the writings of Wei Po-yang, about A.D. 142. There he is called *chên-jên* (‘true man’).¹²

[418] The revelation of the Anthropos is associated with no ordinary religious emotion; it signifies much the same thing as the vision of Christ for the believing Christian. Nevertheless it does not appear *ex opere divino* but *ex opere naturae*; not from above but from the transformation of a shade from Hades, akin to evil itself and bearing the name of the pagan god of revelation. This dilemma throws a new light on the secret of the art: the very serious danger of heresy. Consequently the alchemists found themselves between Scylla and Charybdis: on the one hand they ran the conscious risk of being misunderstood and suspected of fraudulent gold-making, and on the other of being burned at the stake as heretics. As to the gold, right at the beginning of the text to [Figure 2](#), the *Rosarium* quotes the words of Senior: “Aurum nostrum non est aurum vulgi.” But, as history shows, the alchemist would rather risk being suspected of gold-making than of heresy. It is still an open question, which perhaps can never be answered, how far the alchemist was conscious of the true nature of his art. Even texts as revealing as the *Rosarium* and *Aurora consurgens* do not help us in this respect.

[419] As regards the psychology of this picture, we must stress above all else that it depicts a human encounter where love plays the decisive part. The conventional dress of the pair suggests an equally conventional attitude in both of them. Convention still separates them and hides their natural reality, but the crucial contact of left hands points to something “sinister,” illegitimate, morganatic, emotional, and instinctive, i.e., the fatal touch of incest and its “perverse” fascination. At the same time the intervention of the Holy Ghost reveals the hidden meaning of the incest, whether of brother and sister or of mother and son, as a repulsive symbol for the *unio mystica*.

Although the union of close blood-relatives is everywhere taboo, it is yet the prerogative of kings (witness the incestuous marriages of the Pharaohs, etc.). Incest symbolizes union with one's own being, it means individuation or becoming a self, and, because this is so vitally important, it exerts an unholy fascination—not, perhaps, as a crude reality, but certainly as a psychic process controlled by the unconscious, a fact well known to anybody who is familiar with psychopathology. It is for this reason, and not because of occasional cases of human incest, that the first gods were believed to propagate their kind incestuously. Incest is simply the union of like with like, which is the next stage in the development of the primitive idea of self-fertilization.¹³

[420] This psychological situation sums up what we can all see for ourselves if we analyse a transference carefully. The conventional meeting is followed by an unconscious “familiarization” of one's partner, brought about by the projection of archaic, infantile fantasies which were originally vested in members of the patient's own family and which, because of their positive or negative fascination, attach him to parents, brothers, and sisters.¹⁴ The transference of these fantasies to the doctor draws him into the atmosphere of family intimacy, and although this is the last thing he wants, it nevertheless provides a workable *prima materia*. Once the transference has appeared, the doctor must accept it as part of the treatment and try to understand it, otherwise it will be just another piece of neurotic stupidity. The transference itself is a perfectly natural phenomenon which does not by any means happen only in the consulting-room—it can be seen everywhere and may lead to all sorts of nonsense, like all unrecognized projections. Medical treatment of the transference gives the patient a priceless opportunity to withdraw his projections, to make good his losses, and to integrate his personality. The impulses underlying it certainly show their dark side to begin with, however much one may try to whitewash them; for an integral part of the work is the *umbra solis* or *sol niger* of the alchemists, the black shadow which everybody carries with him, the inferior and therefore hidden aspect of the personality, the weakness that goes with every strength, the night that follows every day, the evil in the good.¹⁵ The realization of this fact is naturally coupled with the danger of falling victim to the shadow, but the danger also brings with it the possibility of consciously deciding not to become its victim. A visible enemy is always better than an invisible one. In this case I can see no advantage whatever in behaving like an ostrich. It is certainly no ideal for people always to remain childish, to live in a perpetual state of delusion about themselves, foisting everything they dislike on to their neighbours and plaguing them with their prejudices and projections. How many marriages are wrecked for years, and sometimes forever, because he sees his mother in his wife and she her father in her husband, and neither ever recognizes the other's reality! Life has difficulties enough without that; we

might at least spare ourselves the stupidest of them. But, without a fundamental discussion of the situation, it is often simply impossible to break these infantile projections. As this is the legitimate aim and real meaning of the transference, it inevitably leads, whatever method of rapprochement be used, to discussion and understanding and hence to a heightened consciousness, which is a measure of the personality's integration. During this discussion the conventional disguises are dropped and the true man comes to light. He is in very truth reborn from this psychological relationship, and his field of consciousness is rounded into a circle.

[421] It would be quite natural to suppose that the king and queen represent a transference relationship in which the king stands for the masculine partner and the queen for the feminine partner. But this is by no means the case, because the figures represent contents which have been projected from the unconscious of the adept (and his *soror mystica*). Now the adept is conscious of himself as a man, consequently his masculinity cannot be projected, since this only happens to unconscious contents. As it is primarily a question of man and woman here, the projected fragment of personality can only be the feminine component of the man, i.e., his anima.¹⁶ Similarly, in the woman's case, only the masculine component can be projected. There is thus a curious counter-crossing of the sexes: the man (in this case the adept) is represented by the queen, and the woman (the *soror mystica*) by the king. It seems to me that the flowers forming the "symbol" suggest this counter-crossing. The reader should therefore bear in mind that the picture shows two archetypal figures meeting, and that Luna is secretly in league with the adept, and Sol with his woman helper. The fact that the figures are royal expresses, like real royalty, their archetypal character; they are collective figures common to large numbers of people. If the main ingredient of this mystery were the enthronement of a king or the deification of a mortal, then the figure of the king might possibly be a projection and would in that case correspond to the adept. But the subsequent development of the drama has quite another meaning, so we can discount this possibility.¹⁷

[422] The fact that, for reasons which can be proved empirically, king and queen play cross roles and represent the unconscious contra-sexual side of the adept and his soror leads to a painful complication which by no means simplifies the problem of transference. Scientific integrity, however, forbids all simplification of situations that are not simple, as is obviously the case here. The pattern of relationship is simple enough, but, when it comes to detailed description in any given case, it is extremely difficult to make out from which angle the relationship is being described and what aspect we are describing. The pattern is as follows:

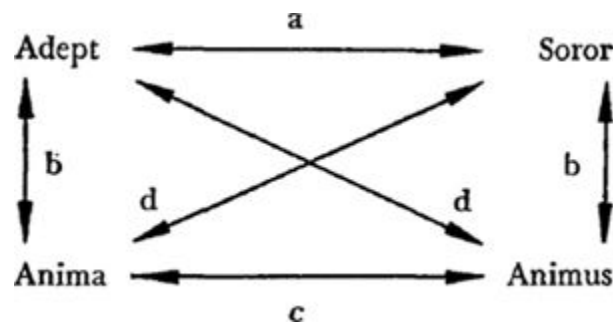

[423] The direction of the arrows indicates the pull from masculine to feminine and *vice versa*, and from the unconscious of one person to the conscious of the other, thus denoting a positive transference relationship. The following relationships have therefore to be distinguished, although in certain cases they can all merge into each other, and this naturally leads to the greatest possible confusion:

(a) An uncomplicated personal relationship.

(b) A relationship of the man to his anima and of the woman to her animus.

(c) A relationship of anima to animus and *vice versa*.

(d) A relationship of the woman's animus to the man (which happens when the woman is identical with her animus), and of the man's anima to the woman (which happens when the man is identical with his anima).

[424] In describing the transference problem with the help of this series of illustrations, I have not always kept these different possibilities apart; for in real life they are invariably mixed up and it would have put an intolerable strain on the explanation had I attempted a rigidly schematic exposition. Thus the king and queen each display every conceivable shade of meaning from the superhuman to the subhuman, sometimes appearing as a transcendental figure, sometimes hiding in the figure of the adept. The reader should bear this in mind if he comes across any real or supposed contradictions in the remarks which follow.

[425] These counter-crossing transference relationships are foreshadowed in folklore: the archetype of the cross-marriage, which I call the "marriage quaternio,"¹⁸ can also be found in fairytales. An Icelandic fairytale¹⁹ tells the following story:

[426] Finna was a girl with mysterious powers. One day, when her father was setting out for the Althing, she begged him to refuse any suitor who might ask for her hand. There were many suitors present, but the father refused them all. On the way home he met a strange man, Geir by name, who forced the father at point of sword to promise his daughter to him. So they were married, and Finna took Sigurd her brother with her to her new home. About Christmas-time, when Finna was busy with the festive preparations, Geir disappeared. Finna and her brother went out to look for him and found him on an island with a beautiful woman. After Christmas, Geir suddenly appeared in Finna's bedroom. In the bed lay a child. Geir asked her whose

child it was, and Finna answered that it was her child. And so it happened for three years in succession, and each time Finna accepted the child. But at the third time, Geir was released from his spell. The beautiful woman on the island was Ingeborg, his sister. Geir had disobeyed his stepmother, a witch, and she had laid a curse on him: he was to have three children by his sister, and unless he found a wife who knew everything and held her peace, he would be changed into a snake and his sister into a filly. Geir was saved by the conduct of his wife; and he married his sister Ingeborg to Sigurd.

[427] Another example is the Russian fairytale “Prince Danila Govorila.”²⁰ There is a young prince who is given a lucky ring by a witch. But its magic will work only on one condition: he must marry none but the girl whose finger the ring fits. When he grows up he goes in search of a bride, but all in vain, because the ring fits none of them. So he laments his fate to his sister, who asks to try on the ring. It fits perfectly. Thereupon her brother wants to marry her, but she thinks it would be a sin and sits at the door of the house weeping. Some old beggars who are passing comfort her and give her the following advice: “Make four dolls and put them in the four corners of the room. If your brother summons you to the wedding, go, but if he summons you to the bedchamber, do not hurry! Trust in God and follow our advice.”

[428] After the wedding her brother summons her to bed. Then the four dolls begin to sing:

Cuckoo, Prince Danila,
Cuckoo, Govorila,
Cuckoo, he takes his sister,
Cuckoo, for a wife,
Cuckoo, earth open wide,
Cuckoo, sister fall inside.

[429] The earth opens and swallows her up. Her brother calls her three times, but by the third time she has already vanished. She goes along under the earth until she comes to the hut of Baba Yaga,²¹ whose daughter kindly shelters her and hides her from the witch. But before long the witch discovers her and heats up the oven. The two girls then seize the old woman and put her in the oven instead, thus escaping the witch’s persecution. They reach the prince’s castle, where the sister is recognized by her brother’s servant. But her brother cannot tell the two girls apart, they are so alike. So the servant advises him to make a test: the prince is to fill a skin with blood and put it under his arm. The servant will then stab him in the side with a knife and the prince is to fall down as if dead. The sister will then surely betray herself. And so it happens: the sister throws herself upon him with a great cry, whereupon the prince

springs up and embraces her. But the magic ring also fits the finger of the witch's daughter, so the prince marries her and gives his sister to a suitable husband.

[430] In this tale the incest is on the point of being committed, but is prevented by the peculiar ritual with the four dolls. The four dolls in the four corners of the room form the marriage quaternio, the aim being to prevent the incest by putting four in place of two. The four dolls form a magic simulacrum which stops the incest by removing the sister to the underworld, where she discovers her alter ego. Thus we can say that the witch who gave the young prince the fatal ring was his mother-in-law-to-be, for, as a witch, she must certainly have known that the ring would fit not only his sister but her own daughter.

[431] In both tales the incest is an evil fate that cannot easily be avoided. Incest, as an endogamous relationship, is an expression of the libido which serves to hold the family together. One could therefore define it as "kinship libido," a kind of instinct which, like a sheep-dog, keeps the family group intact. This form of libido is the diametrical opposite of the exogamous form. The two forms together hold each other in check: the endogamous form tends towards the sister and the exogamous form towards some stranger. The best compromise is therefore a first cousin. There is no hint of this in our fairy-stories, but the marriage quaternio is clear enough. In the Icelandic story we have the schema:

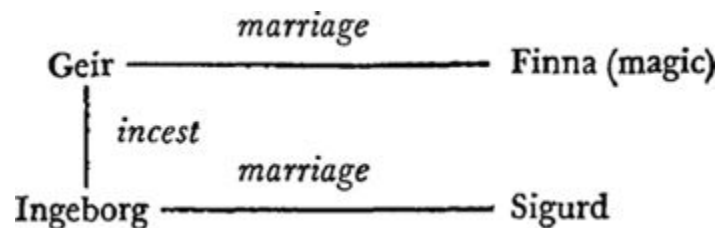

In the Russian:

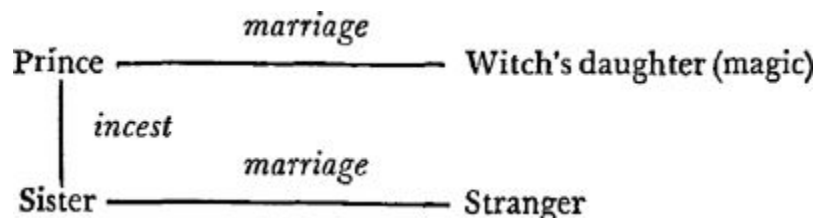

[432] The two schemata agree in a remarkable way. In both cases the hero wins a bride who has something to do with magic or the world beyond. Assuming that the archetype of the marriage quaternio described above is at the bottom of these folkloristic quaternities, the stories are obviously based on the following schema:

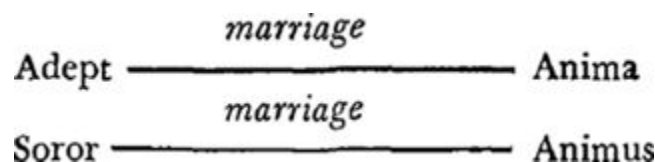

[433] Marriage with the anima is the psychological equivalent of absolute identity between conscious and unconscious. But since such a condition is possible only in

the complete absence of psychological self-knowledge, it must be more or less primitive, i.e., the man's relationship to the woman is essentially an anima projection. The only sign that the whole thing is unconscious is the remarkable fact that the carrier of the animaimage is distinguished by magical characteristics. These characteristics are missing from the soror-animus relationship in the stories; that is, the unconscious does not make itself felt at all as a separate experience. From this we must conclude that the symbolism of the stories rests on a much more primitive mental structure than the alchemical quaternio and its psychological equivalent. Therefore we must expect that on a still more primitive level the anima too will lose her magical attributes, the result being an uncomplicated, purely matter-of-fact marriage quaternio. And we do find a parallel to the two crossed pairs in the so-called "cross-cousin marriage." In order to explain this primitive form of marriage I must go into some detail. The marriage of a man's sister to his wife's brother is a relic of the "sister-exchange marriage" characteristic of the structure of many primitive tribes. But at the same time this double marriage is the primitive parallel of the problem which concerns us here: the conscious and unconscious dual relationship between adept and soror on the one hand and king and queen (or animus and anima) on the other. John Layard's important study, "The Incest Taboo and the Virgin Archetype," put me in mind of the sociological aspects of our psychologem. The primitive tribe falls into two halves, of which Howitt says: "It is upon the division of the whole community into two exogamous intermarrying classes that the whole social structure is built up."²² These "moieties" show themselves in the lay-out of settlements²³ as well as in many strange customs. At ceremonies, for instance, the two moieties are strictly segregated and neither may trespass on the other's territory. Even when going out on a hunt, they at once divide into two halves as soon as they set up camp, and the two camps are so arranged that there is a natural obstacle between them, e.g., the bed of a stream. On the other hand the two halves are connected by what Hocart calls "the ritual interdependence of the two sides" or "mutual ministrations." In New Guinea one side breeds and fattens pigs and dogs, not for themselves but for the other side, and vice versa. Or when there is a death in the village and the funeral feast is prepared, this is eaten by the other side, and so on.²⁴ [Another form of such division elsewhere is]²⁵ the widespread institution of "dual kingship."²⁶

[434] The names given to the two sides are particularly enlightening, such as—to mention only a few—east and west, high and low, day and night, male and female, water and land, left and right. It is not difficult to see from these names that the two halves are felt to be antithetical and thus the expression of an endopsychic antithesis. The antithesis can be formulated as the masculine ego versus the feminine "other," i.e., conscious versus unconscious personified as anima. The primary splitting of the psyche into conscious and unconscious seems to be the cause of the division within

the tribe and the settlement. It is a division founded on fact but not consciously recognized as such.

[435] The social split is by origin a matrilineal division into two, but in reality it represents a division of the tribe and settlement into four. The quartering comes about through the crossing of the matrilineal by a patrilineal line of division, [so that the entire population is divided into patrilineal as well as matrilineal moieties].²⁷ The practical purpose of this quartering is the separation and differentiation of marriage classes, [or “kinship sections,” as they are now called]. The basic pattern is a square or circle divided by a cross; it forms the ground-plan of the primitive settlement and the archaic city, also of monasteries, convents, etc., as can be seen in Europe, Asia, and prehistoric America.²⁸ The Egyptian hieroglyph for “city” is a St. Andrew’s cross in a circle.²⁹

[436] In specifying the marriage classes, it should be mentioned that every man belongs to his father’s patrilineal moiety, [and the woman he marries must not come from his mother’s moiety. In other words, he can take a wife only from the opposite matrilineal *and* patrilineal moiety.] In order to avoid the possibility of incest, he marries his mother’s brother’s daughter and gives his sister to his wife’s brother (sister-exchange marriage). This results in the cross-cousin marriage.³⁰

[437] This form of union, consisting of two brother-and-sister marriages crossing each other, seems to be the original model for the peculiar psychologem which we find in alchemy:



When I say “model” I do not mean that the system of marriage classes was the cause and our psychologem the effect. I merely wish to point out that this system predated the alchemical quaternio. Nor can we assume that the primitive marriage quaternio is the absolute origin of this archetype, for the latter is not a human invention at all but a fact that existed long before consciousness, as is true of all ritual symbols among primitives as well as among civilized peoples today. We do certain things simply without thinking, because they have always been done like that.³²

[438] The difference between the primitive and the cultural marriage quaternio consists in the fact that the former is a sociological and the latter a mystical phenomenon. While marriage classes have all but disappeared among civilized peoples, they nevertheless re-emerge on a higher cultural level as spiritual ideas. In the interests of the welfare and development of the tribe, the exogamous social order thrust the endogamous tendency into the background so as to prevent the danger of regression

to a state of having no groups at all. It insisted on the introduction of “new blood” both physically and spiritually, and it thus proved to be a powerful instrument in the development of culture. In the words of Spencer and Gillen: “This system of what has been called group marriage, serving as it does to bind more or less closely together groups of individuals who are mutually interested in one another’s welfare, has been one of the most powerful agents in the early stages of the upward development of the human race.”³³ Layard has amplified this idea in his above-mentioned study. He regards the endogamous (incest) tendency as a genuine instinct which, if denied realization in the flesh, must realize itself in the spirit. Just as the exogamous order made culture possible in the first place, so also it contains a latent spiritual purpose. Layard says: “Its latent or spiritual purpose is to enlarge the spiritual horizon by developing the idea that there is after all a sphere in which the primary desire may be satisfied, namely the divine sphere of the gods together with that of their semi-divine counterparts, the culture heroes.”³⁴ The idea of the incestuous hierogamos does in fact appear in the civilized religions and blossoms forth in the supreme spirituality of Christian imagery (Christ and the Church, *sponsus* and *sponsa*, the mysticism of the Song of Songs, etc.). “Thus the incest taboo,” says Layard, “leads in full circle out of the biological sphere into the spiritual.”³⁵ On the primitive level the feminine image, the anima, is still completely unconscious and therefore in a state of latent projection. Through the differentiation of the “four-class marriage system” into the eight-class,³⁶ the degree of kinship between marriage partners is considerably diluted, and in the twelve-class system it becomes [further reduced]. These “dichotomies”³⁷ obviously serve to enlarge the framework of the marriage classes and thus to draw more and more groups of people into the kinship system. Naturally such an enlargement was possible only where a sizeable population was expanding.³⁸ The eight-class and particularly the twelve-class systems mean a great advance for the exogamous order, but an equally severe repression of the endogamous tendency, which is thereby stimulated to a new advance in its turn. Whenever an instinctive force—i.e., a certain sum of psychic energy—is driven into the background through a onesided (in this case, exogamous) attitude on the part of the conscious mind, it leads to a dissociation of personality. The conscious personality with its one-track (exogamous) tendency comes up against an invisible (endogamous) opponent, and because this is unconscious it is felt to be a stranger and therefore manifests itself in projected form. At first it makes its appearance in human figures who have the power to do what others may not do—kings and princes, for example. This is probably the reason for the royal incest prerogative, as in ancient Egypt. To the extent that the magical power of royalty was derived increasingly from the gods, the incest prerogative shifted to the latter and so gave rise to the incestuous hierogamos. But when the numinous aura surrounding the person of the king is taken over by the gods, it has been transferred to a spiritual authority, which results in

the projection of an autonomous psychic complex—in other words, psychic existence becomes reality. Thus Layard logically derives the anima from the numen of the goddess.³⁹ In the shape of the goddess the anima is manifestly projected, but in her proper (psychological) shape she is *introjected*; she is, as Layard says, the “anima within.” She is the natural *sponsa*, man’s mother or sister or daughter or wife from the beginning, the companion whom the endogamous tendency vainly seeks to win in the form of mother and sister. She represents that longing which has always had to be sacrificed since the grey dawn of history. Layard therefore speaks very rightly of “internalization through sacrifice.”⁴⁰

[439] The endogamous tendency finds an outlet in the exalted sphere of the gods and in the higher world of the spirit. Here it shows itself to be an instinctive force of a spiritual nature; and, regarded in this light, the life of the spirit on the highest level is a return to the beginnings, so that man’s development becomes a recapitulation of the stages that lead ultimately to the perfection of life in the spirit.

[440] The specifically alchemical projection looks at first sight like a regression: god and goddess are reduced to king and queen, and these in turn look like mere allegories of chemical substances which are about to combine. But the regression is only apparent. In reality it is a highly remarkable development: the conscious mind of the medieval investigator was still under the influence of metaphysical ideas, but because he could not derive them from nature he projected them into nature. He sought for them in matter, because he supposed that they were most likely to be found there. It was really a question of a transference of numen the converse of that from the king to the god. The numen seemed to have migrated in some mysterious way from the world of the spirit to the realm of matter. But the descent of the projection into matter had led some of the old alchemists, for example Morienus Romanus, to the clear realization that this matter was not just the human body (or something in it) but the human personality itself. These prescient masters had already got beyond the inevitable stage of obtuse materialism that had yet to be born from the womb of time. But it was not until the discoveries of modern psychology that this human “matter” of the alchemists could be recognized as the *psyche*.

[441] On the psychological level, the tangle of relationships in the cross-cousin marriage reappears in the transference problem. The dilemma here consists in the fact that anima and animus are projected upon their human counterparts and thus create by suggestion a primitive relationship which evidently goes back to the time of group marriages. But in so far as anima and animus undoubtedly represent the contrasexual components of the personality, their kinship character does not point backwards to the group marriage but “forwards” to the integration of personality, i.e., to individuation.

[442] Our present-day civilization with its cult of consciousness—if this can be called civilization—has a Christian stamp, which means that neither anima nor animus is integrated but is still in the state of projection, i.e., expressed by dogma. On this level both these figures are unconscious as components of personality, though their effectiveness is still apparent in the numinous aura surrounding the dogmatic ideas of bridegroom and bride. Our “civilization,” however, has turned out to be a very doubtful proposition, a distinct falling away from the lofty ideal of Christianity; and, in consequence, the projections have largely fallen away from the divine figures and have necessarily settled in the human sphere. This is understandable enough, since the “enlightened” intellect cannot imagine anything greater than man except those tin gods with totalitarian pretensions who call themselves State or Fuehrer. This regression has made itself as plain as could be wished in Germany and other countries. And even where it is not so apparent, the lapsed projections have a disturbing effect on human relationships and wreck at least a quarter of the marriages. If we decline to measure the vicissitudes of the world’s history by the standards of right and wrong, true and false, good and evil, but prefer to see the retrograde step in every advance, the evil in every good, the error in every truth, we might compare the present regression with the apparent retreat which led from scholasticism to the mystical trend of natural philosophy and thence to materialism. Just as materialism led to empirical science and thus to a new understanding of the psyche, so the totalitarian psychosis with its frightful consequences and the intolerable disturbance of human relationships are forcing us to pay attention to the psyche and our abysmal unconsciousness of it. Never before has mankind as a whole experienced the numen of the psychological factor on so vast a scale. In one sense this is a catastrophe and a retrogression without parallel, but it is not beyond the bounds of possibility that such an experience also has its positive aspects and might become the seed of a nobler culture in a regenerated age. It is possible that the endogamous urge is not ultimately tending towards projection at all; it may be trying to unite the different components of the personality on the pattern of the cross-cousin marriage, but on a higher plane where “spiritual marriage” becomes an inner experience that is not projected. Such an experience has long been depicted in dreams as a mandala divided into four, and it seems to represent the goal of the individuation process, i.e., the self.

[443] Following the growth of population and the increasing dichotomy of the marriage classes, which led to a further extension of the exogamous order, all barriers gradually broke down and nothing remained but the incest-taboo. The original social order made way for other organizing factors culminating in the modern idea of the State. Now, everything that is past sinks in time into the unconscious, and this is true also of the original social order. It represented an archetype that combined exogamy

and endogamy in the most fortunate way, for while it prevented marriage between brother and sister it provided a substitute in the cross-cousin marriage. This relationship is still close enough to satisfy the endogamous tendency more or less, but distant enough to include other groups and to extend the orderly cohesion of the tribe. But with the gradual abolition of exogamous barriers through increasing dichotomy, the endogamous tendency was bound to gain strength in order to give due weight to consanguineous relationships and so hold them together. This reaction was chiefly felt in the religious and then in the political field, with the growth on the one hand of religious societies and sects—we have only to think of the brotherhoods and the Christian ideal of “brotherly love”—and of nations on the other. Increasing internationalism and the weakening of religion have largely abolished or bridged over these last remaining barriers and will do so still more in the future, only to create an amorphous mass whose preliminary symptoms can already be seen in the modern phenomenon of the mass psyche. Consequently the original exogamous order is rapidly approaching a condition of chaos painfully held in check. For this there is but one remedy: the inner consolidation of the individual, who is otherwise threatened with inevitable stultification and dissolution in the mass psyche. The recent past has given us the clearest possible demonstration of what this would mean. No religion has afforded any protection, and our organizing factor, the State, has proved to be the most efficient machine for turning out mass-men. In these circumstances the immunizing of the individual against the toxin of the mass psyche is the only thing that can help. As I have already said, it is just conceivable that the endogamous tendency will intervene compensatorily and restore the consanguineous marriage, or the union of the divided components of the personality, on the psychic level—that is to say, *within* the individual. This would form a counterbalance to the progressive dichotomy and psychic dissociation of collective man.

[444] It is of supreme importance that this process should take place *consciously*, otherwise the psychic consequences of massmindedness will harden and become permanent. For, if the inner consolidation of the individual is not a conscious achievement, it will occur spontaneously and will then take the well-known form of that incredible hard-heartedness which collective man displays towards his fellow men. He becomes a soulless herd animal governed only by panic and lust: his soul, which can live only in and from human relationships, is irretrievably lost. But the conscious achievement of inner unity clings to human relationships as to an indispensable condition, for without the conscious acknowledgment and acceptance of our fellowship with those around us there can be no synthesis of personality. That mysterious something in which the inner union takes place is nothing personal, has nothing to do with the ego, is in fact superior to the ego because, as the self, it is the synthesis of the ego and the supra-personal unconscious. The inner consolidation of

the individual is not just the hardness of collective man on a higher plane, in the form of spiritual aloofness and inaccessibility: it emphatically includes our fellow man.

[445] To the extent that the transference is projection and nothing more, it divides quite as much as it connects. But experience teaches that there is one connection in the transference which does not break off with the severance of the projection. That is because there is an extremely important instinctive factor behind it: the kinship libido. This has been pushed so far into the background by the unlimited expansion of the exogamous tendency that it can find an outlet, and a modest one at that, only within the immediate family circle, and sometimes not even there, because of the quite justifiable resistance to incest. While exogamy was limited by endogamy, it resulted in a natural organization of society which has entirely disappeared today. Everyone is now a stranger among strangers. Kinship libido—which could still engender a satisfying feeling of belonging together, as for instance in the early Christian communities—has long been deprived of its object. But, being an instinct, it is not to be satisfied by any mere substitute such as a creed, party, nation, or state. It wants the *human* connection. That is the core of the whole transference phenomenon, and it is impossible to argue it away, because relationship to the self is at once relationship to our fellow man, and no one can be related to the latter until he is related to himself.

[446] If the transference remains at the level of projection, the connection it establishes shows a tendency to regressive concretization, i.e., to an atavistic restoration of the primitive social order. This tendency has no possible foothold in our modern world, so that every step in this direction only leads to a deeper conflict and ultimately to a real transference neurosis. Analysis of the transference is therefore an absolute necessity, because the projected contents must be reintegrated if the patient is to gain the broader view he needs for free decision.

[447] If, however, the projection is broken, the connection—whether it be negative (hate) or positive (love)—may collapse for the time being so that nothing seems to be left but the politeness of a professional tête-à-tête. One cannot begrudge either doctor or patient a sigh of relief when this happens, although one knows full well that the problem has only been postponed for both of them. Sooner or later, here or in some other place, it will present itself again, for behind it there stands the restless urge towards individuation.

[448] Individuation has two principal aspects: in the first place it is an internal and subjective process of integration, and in the second it is an equally indispensable process of objective relationship. Neither can exist without the other, although sometimes the one and sometimes the other predominates. This double aspect has two corresponding dangers. The first is the danger of the patient's using the

opportunities for spiritual development arising out of the analysis of the unconscious as a pretext for evading the deeper human responsibilities, and for affecting a certain “spirituality” which cannot stand up to moral criticism; the second is the danger that atavistic tendencies may gain the ascendancy and drag the relationship down to a primitive level. Between this Scylla and that Charybdis there is a narrow passage, and both medieval Christian mysticism and alchemy have contributed much to its discovery.

[449] Looked at in this light, the bond established by the transference—however hard to bear and however incomprehensible it may seem—is vitally important not only for the individual but also for society, and indeed for the moral and spiritual progress of mankind. So, when the psychotherapist has to struggle with difficult transference problems, he can at least take comfort in these reflections. He is not just working for this particular patient, who may be quite insignificant, but for himself as well and his own soul, and in so doing he is perhaps laying an infinitesimal grain in the scales of humanity’s soul. Small and invisible as this contribution may be, it is yet an *opus magnum*, for it is accomplished in a sphere but lately visited by the numen, where the whole weight of mankind’s problems has settled. The ultimate questions of psychotherapy are not a private matter—they represent a supreme responsibility.

THE NAKED TRUTH

[450] The text to this picture (Fig. 3) is, with a few alterations, a quotation from the “Tractatus aureus.”¹ It runs: “He who would be initiated into this art and secret wisdom must put away the vice of arrogance, must be devout, righteous, deep-witted, humane towards his fellows, of a cheerful countenance and a happy disposition, and respectful withal. Likewise he must be an observer of the eternal secrets that are revealed to him. My son, above all I admonish thee to fear God who seeth what manner of man thou art [*in quo dispositionis tuae visus est*] and in whom is help for the solitary, whosoever he may be [*adiuvatio cuiuslibet sequestrati*].”² And the *Rosarium* adds from Pseudo-Aristotle: “Could God but find a man of faithful understanding, he would open his secret to him.”³

[451] This appeal to obviously moral qualities makes one thing quite clear: the *opus* demands not only intellectual and technical ability as in the study and practice of modern chemistry; it is a moral as well as a psychological undertaking. The texts are full of such admonitions, and they indicate the kind of attitude that is required in the execution of a religious work. The alchemists undoubtedly understood the *opus* in this sense, though it is difficult to square our picture with such an exordium. The chaste disguises have fallen away.⁴ Man and woman confront one another in unabashed naturalness. Sol says, “O Luna, let⁵ me be thy husband,” and Luna, “O Sol, I must submit to thee.” The dove bears the inscription: “Spiritus est qui unificat.”⁶ This remark hardly fits the unvarnished eroticism of the picture, for if what Sol and Luna say—who, be it noted, are brother and sister—means anything at all, it must surely mean earthly love. But since the spirit descending from above is stated to be the mediator,⁷ the situation acquires another aspect: it is supposed to be a union in the spirit. This is borne out admirably by one important detail in the picture: the contact of left hands has ceased. Instead, Luna’s left hand and Sol’s right hand now hold the branches (from which spring the *flores Mercurii*, corresponding to the three pipes of the fountain), while Luna’s right and Sol’s left hand are touching the flowers. The left-handed relationship is no more: the two hands of both are now connected with the “uniting symbol.” This too has been changed: there are only three flowers instead of five, it is no longer an ogdoad but a hexad,⁸ a sixrayed figure. The double quaternity has thus been replaced by a double triad. This simplification is evidently the result of the fact that two elements have each paired off, presumably with their opposites, for according to alchemical theory each element contains its opposite “within” it. Affinity, in the form of a “loving” approach, has already

achieved a partial union of the elements, so that now only one pair of opposites remains: masculine-feminine or *agens-patiens*, as indicated by the inscription. In accordance with the axiom of Maria, the elementary quaternity has become the active triad, and this will lead to the *coniunctio* of the two.

PHILOSOPHORVM.
scipsis secundum equalitatē inspissentur. Solus enim calor tēperatus est humiditatis inspissatiuus et mixtionis perfectiuius, et non super excedens. Nā generatiōes et procreationes rerū naturalū habent solū fieri per tēperatissimū calorē et equa lē, vti est solus finus equinus humidus et calidus.



Figure 3

[452] Psychologically we can say that the situation has thrown off the conventional husk and developed into a stark encounter with reality, with no false veils or adornments of any kind. Man stands forth as he really is and shows what was hidden under the mask of conventional adaptation: the shadow. This is now raised to consciousness and integrated with the ego, which means a move in the direction of wholeness. Wholeness is not so much perfection as completeness. Assimilation of the shadow gives a man body, so to speak; the animal sphere of instinct, as well as the primitive or archaic psyche, emerge into the zone of consciousness and can no longer be repressed by fictions and illusions. In this way man becomes for himself the difficult problem he really is. He must always remain conscious of the fact that he is such a problem if he wants to develop at all. Repression leads to a one-sided development if not to stagnation, and eventually to neurotic dissociation. Today it is

no longer a question of “How can I get rid of my shadow?”—for we have seen enough of the curse of one-sidedness. Rather we must ask ourselves: “How can man live with his shadow without its precipitating a succession of disasters?” Recognition of the shadow is reason enough for humility, for genuine fear of the abysmal depths in man. This caution is most expedient, since the man without a shadow thinks himself harmless precisely because he is ignorant of his shadow. The man who recognizes his shadow knows very well that he is not harmless, for it brings the archaic psyche, the whole world of the archetypes, into direct contact with the conscious mind and saturates it with archaic influences. This naturally adds to the dangers of “affinity,” with its deceptive projections and its urge to assimilate the object in terms of the projection, to draw it into the family circle in order to actualize the hidden incest situation, which seems all the more attractive and fascinating the less it is understood. The advantage of the situation, despite all its dangers, is that once the naked truth has been revealed the discussion can get down to essentials; ego and shadow are no longer divided but are brought together in an—admittedly precarious—unity. This is a great step forward, but at the same time it shows up the “differentness” of one’s partner all the more clearly, and the unconscious usually tries to close the gap by increasing the attraction, so as to bring about the desired union somehow or other. All this is borne out by the alchemical idea that the fire which maintains the process must be temperate to begin with and must then gradually be raised to the highest intensity.

IMMERSION IN THE BATH

[453] A new motif appears in this picture: the bath. In a sense this takes us back to the first picture of the Mercurial Fountain, which represents the “upwelling.” The liquid is Mercurius, not only of the three but of the “thousand” names. He stands for the mysterious psychic substance which nowadays we would call the unconscious psyche. The rising fountain of the unconscious has reached the king and queen, or rather they have descended into it as into a bath. This is a theme with many variations in alchemy. Here are a few of them: the king is in danger of drowning in the sea; he is a prisoner under the sea; the sun drowns in the mercurial fountain; the king sweats in the glass-house; the green lion swallows the sun; Gabricus disappears into the body of his sister Beya, where he is dissolved into atoms; and so forth. Interpreted on the one hand as a harmless bath and on the other hand as the perilous encroachment of the “sea,” the earth-spirit Mercurius in his watery form now begins to attack the royal pair from *below*, just as he had previously descended from above in the shape of the dove. The contact of left hands in [Figure 2](#) has evidently roused the spirit of the deep and called up a rush of water.

[454] The immersion in the “sea” signifies the *solutio*— “dissolution” in the physical sense of the word and at the same time, according to Dorn, the solution of a problem.¹ It is a return to the dark initial state, to the amniotic fluid of the gravid uterus. The alchemists frequently point out that their stone grows like a child in its mother’s womb; they call the *vas hermeticum* the uterus and its contents the foetus. What is said of the *lapis* is also said of the water: “This stinking water contains everything it needs.”² It is sufficient unto itself, like the Uroboros, the tail-eater, which is said to beget, kill, and devour itself. *Aqua est, quae occidit et vivificat*— the water is that which kills and vivifies.³ It is the *aqua benedicta*, the lustral water,⁴ wherein the birth of the new being is prepared. As the text to our picture explains: “Our stone is to be extracted from the nature of the two bodies.” It also likens the water to the *ventus* of the “Tabula smaragdina,” where we read: “Portavit eum ventus in ventre suo” (The wind hath carried it in his belly). The *Rosarium* adds: “It is clear that wind is air, and air is life, and life is soul, that is, oil and water.”⁵ The curious idea that the soul (i.e., the breath-soul) is oil and water derives from the dual nature of Mercurius. The *aqua permanens* is one of his many synonyms, and the terms *oleum*, *oleaginitas*, *unctuosum*, *unctuositas*, all refer to the arcane substance which is likewise Mercurius. The idea is a graphic reminder of the ecclesiastical use of various unguents and of the consecrated water. The two bodies mentioned above

are represented by the king and queen, a possible reference to the *commixtio* of the two substances in the chalice of the Mass. A similar *coniunctio* is shown in the “Grandes heures du duc de Berry,”⁶ where a naked “little man and woman” are being anointed by two saintly servitors in the baptismal bath of the chalice. There can be no doubt of the connections between the alchemical *opus* and the Mass, as the treatise of Melchior Cibinensis⁷ proves. Our text says: “Anima est Sol et Luna.” The alchemist thought in strictly medieval trichotomous terms:⁸ anything alive—and his *lapis* is undoubtedly alive—consists of corpus, anima, and spiritus. The *Rosarium* remarks (p. 239) that “the body is Venus and feminine, the spirit is Mercurius and masculine”; hence the anima, as the “vinculum,” the link between body and spirit, would be hermaphroditic,⁹ i.e., a *coniunctio Solis et Lunae*. Mercurius is the hermaphrodite par excellence. From all this it may be gathered that the queen stands for the body¹⁰ and the king for the spirit,¹¹ but that both are unrelated without the soul, since this is the *vinculum* which holds them together.¹² If no bond of love exists, they have no soul. In our pictures the bond is effected by the dove from above and by the water from below. These constitute the link—in other words, they are the soul. Thus the underlying idea of the psyche proves it to be a half bodily, half spiritual substance, an *anima media natura*,¹³ as the alchemists call it,¹⁴ an hermaphroditic being¹⁵ capable of uniting the opposites, but who is never complete in the individual unless related to another individual. The unrelated human being lacks wholeness, for he can achieve wholeness only through the soul, and the soul cannot exist without its other side, which is always found in a “You.” Wholeness is a combination of I and You, and these show themselves to be parts of a transcendent unity¹⁶ whose nature can only be grasped symbolically, as in the symbols of the *rotundum*, the rose, the wheel,¹⁷ or the *coniunctio Solis et Lunae*. The alchemists even go so far as to say that the *corpus*, *anima*, and *Spiritus* of the arcane substance are one, “because they are all from the One, and of the One, and with the One, which is the root of itself” (Quia ipsa omnia sunt ex uno et de uno et cum uno, quod est radix ipsius).¹⁸ A thing which is the cause and origin of itself can only be God, unless we adopt the implied dualism of the Paracelsists, who were of the opinion that the *prima materia* is an *increatedum*.¹⁹ Similarly, the pre-Paracelsist *Rosarium*²⁰ maintains that the quintessence is a “self-subsistent body, differing from all the elements and from everything composed thereof.”

ROSARIUM

corrūpitur, neq; ex imperfecto penitus secundū artem aliquid fieri potest. Ratio est quia ars primas dispositiones inducere non potest, sed lapis noster est res media inter perfecta & imperfecta corpora, & quod natura ipsa incepit hoc per artem ad perfectionē deducitur. Si in ipso Mercurio operari inceperis vbi natura reliquit imperfectum, inuenies in eo perfectionē et gaudebis.

Perfectum non alteratur, sed corrumpitur. Sed imperfectum bene alteratur, ergo corruptio vnius est generatio alterius.



Speculum

Figure 4

[455] Coming now to the psychology of the picture, it is clearly a descent into the unconscious. The immersion in the bath is another “night sea journey,”²¹ as the “Visio Arislei” proves. There the philosophers are shut up with the brother-sister pair in a triple glass-house at the bottom of the sea by the *Rex Marinus*. Just as, in the primitive myths, it is so stiflingly hot in the belly of the whale that the hero loses his hair, so the philosophers suffer very much from the intense heat²² during their confinement. The hero-myths deal with rebirth and apocatastasis, and the “Visio” likewise tells of the resuscitation of the dead Thabritius (Gabricus) or, in another version, of his rebirth.²³ The night sea journey is a kind of *descensus ad inferos*—a descent into Hades and a journey to the land of ghosts somewhere beyond this world, beyond consciousness, hence an immersion in the unconscious. In our picture the immersion is effected by the rising up of the fiery, chthonic Mercurius, presumably the sexual libido which engulfs the pair²⁴ and is the obvious counterpart to the heavenly dove. The latter has always been regarded as a love-bird, but it also has a purely spiritual significance in the Christian tradition accepted by the alchemists. Thus the pair are united *above* by the symbol of the Holy Ghost, and it looks as if the immersion in the bath were also uniting them *below*, i.e., in the water which is the

counterpart of spirit (“It is death for souls to become water,” says Heraclitus). Opposition and identity at once—a philosophical problem only when taken as a psychological one!

[456] This development recapitulates the story of how the Original Man (Nous) bent down from heaven to earth and was wrapped in the embrace of Physis—a primordial image that runs through the whole of alchemy. The modern equivalent of this stage is the conscious realization of sexual fantasies which colour the transference accordingly. It is significant that even in this quite unmistakable situation the pair are still holding on with both hands to the starry symbol brought by the Holy Ghost, which signalizes the meaning of their relationship: man’s longing for transcendent wholeness.

THE CONJUNCTION

O Luna, folded in my sweet embrace/
 Be you as strong as I, as fair of face.
 O Sol, brightest of all lights known to men/
 And yet you need me, *as the cock the hen.*

[Figure 5]

[457] The sea has closed over the king and queen, and they have gone back to the chaotic beginnings, the *massa confusa*. Physis has wrapped the “man of light” in a passionate embrace. As the text says: “Then Beya [the maternal sea] rose up over Gabricus and enclosed him in her womb, so that nothing more of him was to be seen. And she embraced Gabricus with so much love that she absorbed him completely into her own nature, and dissolved him into atoms.” These verses from Mercurinus are then quoted:

Candida mulier, si rubeo sit nupta marito,
 Mox complexantur, complexaque copulantur,
 Per se solvuntur, per se quoque conficiuntur,
 Ut duo qui fuerant, unum quasi corpore fiant.

(White-skinned lady, lovingly joined to her ruddy-limbed husband, Wrapped in each other’s arms in the bliss of connubial union, Merge and dissolve as they come to the goal of perfection: They that were two are made one, as though of one body.)

[458] In the fertile imagination of the alchemists, the hierosgamos of Sol and Luna continues right down to the animal kingdom, as is shown by the following instructions: “Take a Coetanean dog and an Armenian bitch, mate them, and they will bear you a son in the likeness of a dog.”¹ The symbolism is about as crass as it could be. On the other hand the *Rosarium*² says: “In hora coniunctionis maxima apparent miracula” (In the hour of conjunction the greatest marvels appear). For this is the moment when the *filius philosophorum* or *lapis* is begotten. A quotation from Alfidius³ adds: “Lux moderna ab eis gignitur” (The new light is begotten by them). Kalid says of the “son in the likeness of a dog” that he is “of a celestial hue” and that “this son will guard you... in this world and in the next.”⁴ Likewise Senior: “She hath borne a son who served his parents in all things, save that he is more splendid and refulgent than they,”⁵ i.e., he outshines the sun and moon. The real meaning of the

coniunctio is that it brings to birth something that is one and united. It restores the vanished “man of light” who is identical with the Logos in Gnostic and Christian symbolism and who was there before the creation; we also meet him at the beginning of the Gospel of St. John. Consequently we are dealing with a cosmic idea, and this amply explains the alchemists’ use of superlatives.

[459] The psychology of this central symbol is not at all simple. On a superficial view it looks as if natural instinct had triumphed. But if we examine it more closely we note that the coitus is taking place in the water, the *mare tenebrositatis*, i.e., the unconscious. This idea is borne out by a variant of the picture (Figure 5a). There again Sol and Luna are in the water, but both are winged. They thus represent spirit—they are aerial beings, creatures of thought. The texts indicate that Sol and Luna are two *vapores* or *fumi* which gradually develop as the fire increases in heat, and which then rise as on wings from the *decoctio* and *digestio* of the *prima materia*.⁶ That is why the paired opposites are sometimes represented as two birds fighting⁷ or as winged and wingless dragons.⁸ The fact that two aerial creatures should mate on or beneath the water does not disturb the alchemist in the least, for he is so familiar with the changeable nature of his synonyms that for him water is not only fire but all sorts of astonishing things besides. If we interpret the water as steam we may be getting nearer the truth. It refers to the boiling solution in which the two substances unite.

CONIUNCTIO SIVE
Coitus.



© Luna durch meyn vmbgeben/vnd süsse mynne/
Wirstu schön/starck/vnd gewaltig als ich byn.
© Sol/du bist vber alle liecht zu erkennen/
So bedarffstu doch mein als der hand der hennen.

ARISLEVS IN VISIONE.

Coniunge ergo filium tuum Gabricum dilec-
torem tibi in omnibus filijs tuis cum sua sorore
Beya

Figure 5

[460] As to the frank eroticism of the pictures, I must remind the reader that they were drawn for medieval eyes and that consequently they have a symbolical rather than a pornographic meaning. Medieval hermeneutics and meditation could contemplate even the most delicate passages in the Song of Songs without taking offence and view them through a veil of spirituality. Our pictures of the *coniunctio* are to be understood in this sense: union on the biological level is a symbol of the *unio oppositorum* at its highest. This means that the union of opposites in the royal art is just as real as coitus in the common acceptance of the word, so that the *opus* becomes an analogy of the natural process by means of which instinctive energy is transformed, at least in part, into symbolical activity. The creation of such analogies frees instinct and the biological sphere as a whole from the pressure of unconscious contents. Absence of symbolism, however, overloads the sphere of instinct.⁹ The analogy contained in Figure 5 is a little too obvious for our modern taste, so that it almost fails in its purpose.

FERMENTATIO.



Die wird Sol aber verschlossen
Und mit Mercurio philosophorum ybergossen.

Figure 5a

[461] As every specialist knows, the psychological parallels encountered in medical practice often take the form of fantasy-images which, when drawn, differ hardly at all from our pictures. The reader may remember the typical case I mentioned earlier (par. 377ff.), where the act of conception was represented symbolically and, exactly nine months later, the unconscious, as though influenced by a *suggestion à échéance*, produced the symbolism of a birth, or of a new-born child, without the patient's being conscious of the preceding psychic conception or having consciously reckoned the period of her "pregnancy." As a rule the whole process passes off in a series of dreams and is discovered only retrospectively, when the dream material comes to be analysed. Many alchemists compute the duration of the *opus* to be that of a pregnancy, and they liken the entire procedure to such a period of gestation.¹⁰

[462] The main emphasis falls on the *unio mystica*, as is shown quite clearly by the presence of the uniting symbol in the earlier pictures. It is perhaps not without deeper significance that this symbol has disappeared in the pictures of the *coniunctio*. For at this juncture the meaning of the symbol is fulfilled: the partners have themselves become symbolic. At first each represented two elements; then each of them united into one (integration of the shadow); and finally the two together with the third become a whole—"ut duo qui fuerant, unum quasi corpore fiant." Thus the axiom of

Maria is fulfilled. In this union the Holy Ghost disappears as well, but to make up for that, Sol and Luna themselves become spirit. The real meaning, therefore, is Goethe's "higher copulation,"¹¹ a union in unconscious identity, which could be compared with the primitive, initial state of chaos, the *massa confusa*, or rather with the state of *participation mystique* where heterogeneous factors merge in an unconscious relationship. The *coniunctio* differs from this not as a mechanism but because it is by nature never an initial state: it is always the product of a process or the goal of endeavour. This is equally the case in psychology, though here the *coniunctio* comes about unintentionally and is opposed to the bitter end by all biologically minded and conscientious doctors. That is why they speak of "resolving the transference." The detachment of the patient's projections from the doctor is desirable for both parties and, if successful, may be counted as a positive result. This is a practical possibility when, owing to the patient's immaturity, or his disposition, or because of some misunderstanding arising out of the projection, or because reason and plain common sense demand it, the continued transformation of projected unconscious contents comes to a hopeless standstill, and at the same time an opportunity presents itself from outside for the projection to be switched to another object. This solution has about the same merit as persuading a person not to go into a monastery or not to set out on a dangerous expedition or not to make a marriage which everybody agrees would be stupid. We cannot rate reason highly enough, but there are times when we must ask ourselves: do we really know enough about the destinies of individuals to enable us to give good advice under *all* circumstances? Certainly we must act according to our best convictions, but are we so sure that our convictions are for the best as regards the other person? Very often we do not know what is best for ourselves, and in later years we may come to thank God from the bottom of our hearts that his kindly hand preserved us from the "reasonableness" of our former plans. It is easy for the critic to say after the event, "Ah, but that wasn't the right sort of reason!" Who can know with unassailable certainty when he has the right sort? Moreover, is it not essential to the true art of living, sometimes, in defiance of all reason and fitness, to include the unreasonable and the unfitting within the ambience of the possible?

[463] It should therefore not surprise us to find that there are not a few cases where, despite every effort, no possibility presents itself of resolving the transference, although the patient is—from the rational point of view—equipped with the necessary understanding and neither he nor the doctor can be accused of any technical negligence or oversight. Both of them may be so deeply impressed by the vast irrationality of the unconscious as to come to the conclusion that the best thing is to cut the Gordian knot with a drastic decision. But the surgical partition of these Siamese twins is a perilous operation. There may be successes, though in my

experience they are few and far between. I am all for a conservative solution of the problem. If the situation really is such that no other possibilities of any kind can be considered, and the unconscious obviously insists on the retention of the tie, then the treatment must be continued hopefully. It may be that the severance will only occur at a later stage, but it may also be a case of psychological “pregnancy” whose natural outcome must be awaited with patience, or again it may be one of those fatalities which, rightly or wrongly, we take on our own shoulders or else try to avoid. The doctor knows that always, wherever he turns, man is dogged by his fate. Even the simplest illness may develop surprising complications; or, equally unexpectedly, a condition that seemed very serious may take a turn for the better. Sometimes the doctor’s art helps, sometimes it is useless. In the domain of psychology especially, where we still know so little, we often stumble upon the unforeseen, the inexplicable—something of which we can make neither head nor tail. Things cannot be forced, and wherever force seems to succeed it is generally regretted afterwards. Better always to be mindful of the limitations of one’s knowledge and ability. Above all one needs forbearance and patience, for often time can do more than art. Not everything can and must be cured. Sometimes dark moral problems or inexplicable twists of fate lie hidden under the cloak of a neurosis. One patient suffered for years from depressions and had an unaccountable phobia about Paris. She managed to rid herself of the depressions, but the phobia proved inaccessible. However, she felt so well that she was prepared to risk ignoring her phobia. She succeeded in getting to Paris, and the next day she lost her life in a car smash. Another patient had a peculiar and abiding horror of flights of steps. One day he got caught up in some street-rioting and shots were fired. He found himself in front of a public building with a broad flight of steps leading up to it. In spite of his phobia he dashed up them to seek shelter inside the building, and fell on the steps, mortally wounded by a stray bullet.

[464] These examples show that psychic symptoms need to be judged with the greatest caution. This is also true of the various forms of transference and its contents. They sometimes set the doctor almost insoluble problems or cause him all manner of worries which may go to the limits of the endurable and even beyond. Particularly if he has a marked ethical personality and takes his psychological work seriously, this may lead to moral conflicts and divided loyalties whose real or supposed incompatibility has been the occasion of more than one disaster. On the basis of long experience I would therefore like to warn against too much therapeutic enthusiasm. Psychological work is full of snags, but it is just here that incompetents swarm. The medical faculties are largely to blame for this, because for years they refused to admit the psyche among the aetiological factors of pathology, even though they had no other use for it. Ignorance is certainly never a recommendation, but often the best

knowledge is not enough either. Therefore I say to the psychotherapist: let no day pass without humbly remembering that everything has still to be learned.

[465] The reader should not imagine that the psychologist is in any position to explain what “higher copulation” is, or the *coniunctio*, or “psychic pregnancy,” let alone the “soul’s child.” Nor should one feel annoyed if the newcomer to this delicate subject, or one’s own cynical self, gets disgusted with these—as he thinks them—phoney ideas and brushes them aside with a pitying smile and an offensive display of tact. The unprejudiced scientific inquirer who seeks the truth and nothing but the truth must guard against rash judgments and interpretations, for here he is confronted with *psychological facts* which the intellect cannot falsify and conjure out of existence. There are among one’s patients intelligent and discerning persons who are just as capable as the doctor of giving the most disparaging interpretations, but who cannot avail themselves of such a weapon in the face of these insistent facts. Words like “nonsense” only succeed in banishing little things—not the things that thrust themselves tyrannically upon you in the stillness and loneliness of the night. The images welling up from the unconscious do precisely that. What we choose to call this fact does not affect the issue in any way. If it is an illness, then this *morbus sacer* must be treated according to its nature. The doctor can solace himself with the reflection that he, like the rest of his colleagues, does not only have patients who are curable, but chronic ones as well, where curing becomes nursing. At all events the empirical material gives us no sufficient grounds for always talking about “illness”; on the contrary, one comes to realize that it is a moral problem and often one wishes for a priest who, instead of confessing and proselytizing, would just listen, obey, and put this singular matter before God so that He could decide.

[466] *Patientia et mora* are absolutely necessary in this kind of work. One must be able to wait on events. Of work there is plenty—the careful analysis of dreams and other unconscious contents. Where the doctor fails, the patient will fail too, which is why the doctor should possess a real knowledge of these things and not just opinions, the offscourings of our modern philosophy for everyman. In order to augment this much-needed knowledge, I have carried my researches back to those earlier times when naïve introspection and projection were still at work, mirroring a psychic hinterland that is virtually blocked for us today. In this way I have learned much for my own practice, especially as regards understanding the formidable fascination of the contents in question. These may not always strike the patient as particularly fascinating, so he suffers instead from a proportionately strong compulsive tie in whose intensity he can rediscover the force of those subliminal images. He will, however, try to interpret the tie rationalistically, in the spirit of the age, and consequently does not perceive and will not admit the irrational foundations of his transference, namely the archetypal images.

6

DEATH

Here King and Queen are lying dead/

In great distress the soul is sped.

[Figure 6]

[467] *Vas hermeticum*, fountain, and sea have here become sarcophagus and tomb. King and queen are dead and have melted into a single being with two heads. The feast of life is followed by the funereal threnody. Just as Gabricus dies after becoming united with his sister, and the son-lover always comes to an early end after consummating the hierosgamos with the mother-goddess of the Near East, so, after the *coniunctio oppositorum*, deathlike stillness reigns. When the opposites unite, all energy ceases: there is no more flow. The waterfall has plunged to its full depth in that torrent of nuptial joy and longing; now only a stagnant pool remains, without wave or current. So at least it appears, looked at from the outside. As the legend tells us, the picture represents the *putrefactio*, the corruption, the decay of a once living creature. Yet the picture is also entitled “Conceptio.” The text says: “Corruptio unius generatio est alterius”—the corruption of one is the generation of the other,¹ an indication that this death is an interim stage to be followed by a new life. No new life can arise, say the alchemists, without the death of the old. They liken the art to the work of the sower, who buries the grain in the earth: it dies only to waken to new life.² Thus with their *mortificatio*, *interfectio*, *putrefactio*, *combustio*, *incineratio*, *calcinatio*, etc., they are imitating the work of nature. Similarly they liken their labours to human mortality, without which the new and eternal life cannot be attained.³

[468] The corpse left over from the feast is already a new body, a *hermaphroditus* (a compound of Hermes-Mercurius and Aphrodite-Venus). For this reason one half of the body in the alchemical illustrations is masculine, the other half feminine (in the *Rosarium* this is the left half). Since the *hermaphroditus* turns out to be the long-sought *rebis* or *lapis*, it symbolizes that mysterious being yet to be begotten, for whose sake the *opus* is undertaken. But the *opus* has not yet reached its goal, because the *lapis* has not come alive. The latter is thought of as animal, a living being with body, soul, and spirit. The legend says that the pair who together represented body and spirit are dead, and that the soul (evidently only *one*⁴ soul) parts from them “in great distress.”⁵ Although various other meanings play a part here, one cannot rid oneself of the impression that the death is a sort of tacit punishment for the sin of

incest, for “the wages of sin is death.”⁶ That would explain the soul’s “great distress” and also the blackness mentioned in the variant of our picture⁷ (“Here is Sol turned black”).⁸ This blackness is the *immunditia* (uncleanliness), as is proved by the *ablutio* that subsequently becomes necessary. The *coniunctio* was incestuous and therefore sinful, leaving pollution behind it. The *nigredo* always appears in conjunction with *tenebrositas*, the darkness of the tomb and of Hades, not to say of Hell. Thus the descent that began in the marriage-bath has touched rock-bottom: death, darkness, and sin. For the adept, however, the hopeful side of things is shown in the anticipated appearance of the hermaphrodite, though the psychological meaning of this is at first obscure.

PHILOSOPHORVM.
 CONCEPTIO SEV PVTRE
factio

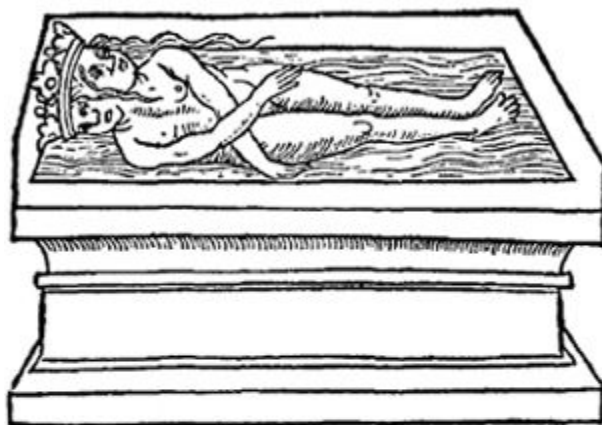

Wye ligen König vnd Königin dor/
 Die sele scheydt sich mit grosser not.

ARISTOTELES REX ET
Philosophus.

Nunquam vidi aliquod animatum crescere
 sine putrefactione, nisi autem fiat putri-
 dum inuanum erit opus alchimicum.

Figure 6

[469] The situation described in our picture is a kind of Ash Wednesday. The reckoning is presented, and a dark abyss yawns. Death means the total extinction of consciousness and the complete stagnation of psychic life, so far as this is capable of consciousness. So catastrophic a consummation, which has been the object of annual lamentations in so many places (e.g., the laments for Linus, Tammuz,⁹ and Adonis), must surely correspond to an important archetype, since even today we have our

Good Friday. An archetype always stands for some typical event. As we have seen, there is in the *coniunctio* a union of two figures, one representing the daytime principle, i.e., lucid consciousness, the other a nocturnal light, the unconscious. Because the latter cannot be seen directly, it is always projected; for, unlike the shadow, it does not belong to the ego but is collective. For this reason it is felt to be something alien to us, and we suspect it of belonging to the particular person with whom we have emotional ties. In addition a man's unconscious has a feminine character; it hides in the feminine side of him which he naturally does not see in himself but in the woman who fascinates him. That is probably why the soul (*anima*) is feminine. If, therefore, man and woman are merged in some kind of unconscious identity, he will take over the traits of her animus and she the traits of his anima. Although neither anima nor animus can be constellated without the intervention of the conscious personality, this does not mean that the resultant situation is nothing but a personal relationship and a personal entanglement. The personal side of it is a fact, but not the main fact. The main fact is the *subjective experience* of the situation—in other words, it is a mistake to believe that one's personal dealings with one's partner play the most important part. Quite the reverse: the most important part falls to the man's dealings with the anima and the woman's dealings with the animus. Nor does the *coniunctio* take place with the personal partner; it is a royal game played out between the active, masculine side of the woman (the animus) and the passive, feminine side of the man (the anima). Although the two figures are always tempting the ego to identify itself with them, a real understanding even on the personal level is possible only if the identification is refused. Non-identification demands considerable moral effort. Moreover it is only legitimate when not used as a pretext for avoiding the necessary degree of personal understanding. On the other hand, if we approach this task with psychological views that are too personalistic, we fail to do justice to the fact that we are dealing with an archetype which is anything but personal. It is, on the contrary, an *a priori* so universal in scope and incidence that it often seems advisable to speak less of *my* anima or *my* animus and more of *the* anima and *the* animus. As archetypes, these figures are semi-collective and impersonal quantities, so that when we identify ourselves with them and fondly imagine that we are then most truly ourselves, we are in fact most estranged from ourselves and most like the average type of *Homo sapiens*. The personal protagonists in the royal game should constantly bear in mind that at bottom it represents the "trans-subjective" union of archetypal figures, and it should never be forgotten that it is a *symbolical* relationship whose goal is complete individuation. In our series of pictures this idea is suggested *sub rosa*. Hence, when the *opus* interposes itself in the form of the rose or wheel, the unconscious and purely personal relationship becomes a psychological problem which, while it prevents a descent into complete darkness, does not in any way cancel out the operative force of the archetype. The right way, like the wrong way, must be

paid for, and however much the alchemist may extol *venerabilis natura*, it is in either case an *opus contra naturam*. It goes against nature to commit incest, and it goes against nature not to yield to an ardent desire. And yet it is nature that prompts such an attitude in us, because of the kinship libido. So it is as Pseudo-Democritus says: “Nature rejoices in nature, nature conquers nature, nature rules over nature.”¹⁰ Man’s instincts are not all harmoniously arranged, they are perpetually jostling each other out of the way. The ancients were optimistic enough to see this struggle not as a chaotic muddle but as aspiring to some higher order.

[470] Thus the encounter with anima and animus means conflict and brings us up against the hard dilemma in which nature herself has placed us. Whichever course one takes, nature will be mortified and must suffer, even to the death; for the merely natural man must die in part during his own lifetime. The Christian symbol of the crucifix is therefore a prototype and an “eternal” truth. There are medieval pictures showing how Christ is nailed to the Cross by his own virtues. Other people meet the same fate at the hands of their vices. Nobody who finds himself on the road to wholeness can escape that characteristic suspension which is the meaning of crucifixion. For he will infallibly run into things that thwart and “cross” him: first, the thing he has no wish to be (the shadow); second, the thing he is not (the “other,” the individual reality of the “You”); and third, his psychic non-ego (the collective unconscious). This being at cross purposes with ourselves is suggested by the crossed branches held by the king and queen, who are themselves man’s cross in the form of the anima and woman’s cross in the form of the animus. The meeting with the collective unconscious is a fatality of which the natural man has no inkling until it overtakes him. As Faust says: “You are conscious only of the single urge/O may you never know the other!”

[471] This process underlies the whole *opus*, but to begin with it is so confusing that the alchemist tries to depict the conflict, death, and rebirth figuratively, on a higher plane, first—in his *practica*— in the form of chemical transformations and then—in his *theoria*— in the form of conceptual images. The same process may also be conjectured to underlie certain religious *opera*, since notable parallels exist between ecclesiastical symbolism and alchemy. In psychotherapy and in the psychology of neuroses it is recognized as the psychic process par excellence, because it typifies the content of the transference neurosis. The supreme aim of the *opus psychologicum* is conscious realization, and the first step is to make oneself conscious of contents that have hitherto been projected. This endeavour gradually leads to knowledge of one’s partner and to self-knowledge, and so to the distinction between what one really is and what is projected into one, or what one imagines oneself to be. Meanwhile, one is so taken up with one’s own efforts that one is hardly conscious of the extent to which “nature” acts not only as a driving-force but as a helper—in other words, how much

instinct insists that the higher level of consciousness be attained. This urge to a higher and more comprehensive consciousness fosters civilization and culture, but must fall short of the goal unless man voluntarily places himself in its service. The alchemists are of the opinion that the *artifex* is the servant of the work, and that not he but nature brings the work to fruition. All the same, there must be will as well as ability on man's part, for unless both are present the urge remains at the level of merely natural symbolism and produces nothing but a perversion of the instinct for wholeness which, if it is to fulfil its purpose, needs all parts of the whole, including those that are projected into a "You." Instinct seeks them there, in order to re-create that royal pair which every human being has in his wholeness, i.e., that bisexual First Man who has "no need of anything but himself." Whenever this drive for wholeness appears, it begins by disguising itself under the symbolism of incest, for, unless he seeks it in himself, a man's nearest feminine counterpart is to be found in his mother, sister, or daughter.

[472] With the integration of projections—which the merely natural man in his unbounded naïveté can never recognize as such—the personality becomes so vastly enlarged that the normal ego-personality is almost extinguished. In other words, if the individual identifies himself with the contents awaiting integration, a positive or negative inflation results. Positive inflation comes very near to a more or less conscious megalomania; negative inflation is felt as an annihilation of the ego. The two conditions may alternate. At all events the integration of contents that were always unconscious and projected involves a serious lesion of the ego. Alchemy expresses this through the symbols of death, mutilation, or poisoning, or through the curious idea of dropsy, which in the "Aenigma Merlini"¹¹ is represented as the king's desire to drink inordinate quantities of water. He drinks so much that he melts away and has to be cured by the Alexandrian physicians.¹² He suffers from a surfeit of the unconscious and becomes dissociated—"ut mihi videtur omnia membra mea ab invicem dividuntur" (so that all my limbs seem divided one from another).¹³ As a matter of fact, even Mother Alchemia is dropsical in her lower limbs.¹⁴ In alchemy, inflation evidently develops into a psychic oedema.¹⁵

[473] The alchemists assert that death is at once the conception of the *filius philosophorum*, a peculiar variation of the doctrine of the Anthropos.¹⁶ Procreation through incest is a royal or divine prerogative whose advantages the ordinary man is forbidden to enjoy. The ordinary man is the natural man, but the king or hero is the "supernatural" man, the *pneumatikos* who is "baptized with spirit and water," i.e., begotten in the *aqua benedicta* and born from it. He is the Gnostic Christ who descends upon the man Jesus during his baptism and departs from him again before the end. This "son" is the new man, the product of the union of king and queen—

though here he is not born of the queen, but queen and king are themselves transformed into the new birth.¹⁷

[474] Translated into the language of psychology, the mythologem runs as follows: the union of the conscious mind or egopersonality with the unconscious personified as anima produces a new personality compounded of both—"ut duo qui fuerant, unum quasi corpore fiant." Not that the new personality is a third thing midway between conscious and unconscious, it is both together. Since it transcends consciousness it can no longer be called "ego" but must be given the name of "self." Reference must be made here to the Indian idea of the atman, whose personal and cosmic modes of being form an exact parallel to the psychological idea of the self and the *filius philosophorum*.¹⁸ The self too is both ego and non-ego, subjective and objective, individual and collective. It is the "uniting symbol" which epitomizes the total union of opposites.¹⁹ As such and in accordance with its paradoxical nature, it can only be expressed by means of symbols. These appear in dreams and spontaneous fantasies and find visual expression in the mandalas that occur in the patient's dreams, drawings, and paintings. Hence, properly understood, the self is not a doctrine or theory but an image born of nature's own workings, a natural symbol far removed from all conscious intention. I must stress this obvious fact because certain critics still believe that the manifestations of the unconscious can be written off as pure speculation. But they are matters of observed fact, as every doctor knows who has to deal with such cases. The integration of the self is a fundamental problem which arises in the second half of life. Dream symbols having all the characteristics of mandalas may occur long beforehand without the development of the inner man becoming an immediate problem. Isolated incidents of this kind can easily be overlooked, so that it then seems as if the phenomena I have described were rare curiosities. They are in fact nothing of the sort; they occur whenever the individuation process becomes the object of conscious scrutiny, or where, as in the psychoses, the collective unconscious peoples the conscious mind with archetypal figures.

THE ASCENT OF THE SOUL

Here is the division of the four elements/

As from the lifeless corpse the soul ascends.

[Figure 7]

[475] This picture carries the *putrefactio* a stage further. Out of the decay the soul mounts up to heaven. Only *one* soul departs from the two, for the two have indeed become one. This brings out the nature of the soul as a *vinculum* or *ligamentum*: it is a function of relationship. As in real death, the soul departs from the body and returns to its heavenly source. The One born of the two represents the metamorphosis of both, though it is not yet fully developed and is still a “conception” only. Yet, contrary to the usual meaning of conception, the soul does not come down to animate the body, but leaves the body and mounts heavenwards. The “soul” evidently represents the *idea* of unity which has still to become a concrete fact and is at present only a potentiality. The idea of a wholeness made up of *sponsus* and *sponsa* has its correlate in the *rotundus globus coelestis*.¹

[476] This picture corresponds psychologically to a dark state of disorientation. The decomposition of the elements indicates dissociation and the collapse of the existing ego-consciousness. It is closely analogous to the schizophrenic state, and it should be taken very seriously because this is the moment when latent psychoses may become acute, i.e., when the patient becomes aware of the collective unconscious and the psychic non-ego. This collapse and disorientation of consciousness may last a considerable time and it is one of the most difficult transitions the analyst has to deal with, demanding the greatest patience, courage, and faith on the part of both doctor and patient. It is a sign that the patient is being driven along willy-nilly without any sense of direction, that, in the truest sense of the word, he is in an utterly *soulless* condition, exposed to the full force of autoerotic affects and fantasies. Referring to this state of deadly darkness, one alchemist says: “Hoc est ergo magnum signum, in cuius investigatione nonnulli perierunt” (This is a great sign, in the investigation of which not a few have perished).²

[477] This critical state, when the conscious mind is liable to be submerged at any moment in the unconscious, is akin to the “loss of soul” that frequently attacks primitives. It is a sudden *abaissement du niveau mental*, a slackening of the conscious tension, to which primitive man is especially prone because his consciousness is still relatively weak and means a considerable effort for him. Hence

his lack of will-power, his inability to concentrate and the fact that, mentally, he tires so easily, as I have experienced to my cost during palavers. The widespread practice of yoga and dhyana in the East is a similar *abaissement* deliberately induced for the purpose of relaxation, a technique for releasing the soul. With certain patients, I have even been able to establish the existence of subjectively experienced levitations in moments of extreme derangement.³ Lying in bed, the patients felt that they were floating horizontally in the air a few feet above their bodies. This is a suggestive reminder of the phenomenon called the “witch’s trance,” and also of the parapsychic levitations reported of many saints.

[478] The corpse in our picture is the residue of the past and represents the man who is no more, who is destined to decay. The “torments” which form part of the alchemist’s procedure belong to this stage of the *iterum mori*— the reiterated death. They consist in “*membra secare, arctius sequestrare ac partes mortificare et in naturam, quae in eo [lapide] est, vertere*” (cutting up the limbs, dividing them into smaller and smaller pieces, mortifying the parts, and changing them into the nature which is in [the stone]), as the *Rosarium* says, quoting from Hermes. The passage continues: “You must guard the water and fire dwelling in the arcane substance and contain those waters with the permanent water, even though this be no water, but the fiery form of the true water.”⁴ For the precious substance, the soul, is in danger of escaping from the bubbling solution in which the elements are decomposed. This precious substance is a paradoxical composite of fire and water, i.e., Mercurius, the *servus* or *cervus fugitivus* who is ever about to flee—or who, in other words, resists integration (into consciousness). He has to be “contained” by the “water,” whose paradoxical nature corresponds to the nature of Mercurius and actually contains him within itself. Here we seem to have a hint about the treatment required: faced with the disorientation of the patient, the doctor must hold fast to his own orientation; that is, he must know what the patient’s condition means, he must understand what is of value in the dreams, and do so moreover with the help of that *aqua doctrinae* which alone is appropriate to the nature of the unconscious. In other words, he must approach his task with views and ideas capable of grasping unconscious symbolism. Intellectual or supposedly scientific theories are not adequate to the nature of the unconscious, because they make use of a terminology which has not the slightest affinity with its pregnant symbolism. The waters must be drawn together and held fast by the one water, by the *forma ignea verae aquae*. The kind of approach that makes this possible must therefore be plastic and symbolical, and itself the outcome of personal experience with unconscious contents. It should not stray too far in the direction of abstract intellectualism; hence we are best advised to remain within the framework of traditional mythology, which has already proved comprehensive enough for all

practical purposes. This does not preclude the satisfaction of theoretical requirements, but these should be reserved for the private use of the doctor.

ROSARIUM
ANIMÆ EXTRACTIO VEL
impregnatio.



Die teylen sich die vier element/
Aus dem leyb scheydet sich die seel beyndt.

De

Figure 7

[479] Therapy aims at strengthening the conscious mind, and whenever possible I try to rouse the patient to mental activity and get him to subdue the *massa confusa* of his mind with his own understanding,⁵ so that he can reach a vantage-point *au-dessus de la mêlée*. Nobody who ever had any wits is in danger of losing them in the process, though there are people who never knew till then what their wits are for. In such a situation, understanding acts like a life-saver. It integrates the unconscious, and gradually there comes into being a higher point of view where both conscious and unconscious are represented. It then proves that the invasion by the unconscious was rather like the flooding of the Nile: it increases the fertility of the land. The panegyric addressed by the *Rosarium* to this state is to be taken in that sense: “O natura benedicta et benedicta est tua operatio, quia de imperfecto facis perfectum cum vera putrefactione quae est nigra et obscura. Postea facis germinare novas res et diversas, cum tua viriditate facis diversos colores apparere.” (O blessed Nature, blessed are thy works, for that thou makest the imperfect to be perfect through the true putrefaction,

which is dark and black. Afterwards thou makest new and multitudinous things to grow, causing with thy verdure the many colours to appear.)⁶ It is not immediately apparent why this dark state deserves special praise, since the *nigredo* is universally held to be of a sombre and melancholy humour reminiscent of death and the grave. But the fact that medieval alchemy had connections with the mysticism of the age, or rather was itself a form of mysticism, allows us to adduce as a parallel to the *nigredo* the writings of St. John of the Cross⁷ concerning the “dark night.” This author conceives the “spiritual night” of the soul as a supremely positive state, in which the invisible—and therefore dark—radiance of God comes to pierce and purify the soul.

[480] The appearance of the colours in the alchemical vessel, the so-called *cauda pavonis*, denotes the spring, the renewal of life—*post tenebras lux*. The text continues: “This blackness is called earth.” The Mercurius in whom the sun drowns is an earth-spirit, a *Deus terrenus*,⁸ as the alchemists say, or the *Sapi entia Dei* which took on body and substance in the creature by creating it. The unconscious is the spirit of chthonic nature and contains the archetypal images of the *Sapientia Dei*. But the intellect of modern civilized man has strayed too far in the world of consciousness, so that it received a violent shock when it suddenly beheld the face of its mother, the earth.

[481] The fact that the soul is depicted as a homunculus in our picture indicates that it is on the way to becoming the *filius regius*, the undivided and hermaphroditic First Man, the Anthropos. Originally he fell into the clutches of Physis, but now he rises again, freed from the prison of the mortal body. He is caught up in a kind of ascension, and, according to the *Tabula smaragdina*, unites himself with the “upper powers.” He is the essence of the “lower power” which, like the “third filiation” in the doctrine of Basilides, is ever striving upwards from the depths,⁹ not with the intention of staying in heaven, but solely in order to reappear on earth as a healing force, as an agent of immortality and perfection, as a mediator and saviour. The connection with the Christian idea of the Second Coming is unmistakable.

[482] The psychological interpretation of this process leads into regions of inner experience which defy our powers of scientific description, however unprejudiced or even ruthless we may be. At this point, unpalatable as it is to the scientific temperament, the idea of mystery forces itself upon the mind of the inquirer, not as a cloak for ignorance but as an admission of his inability to translate what he knows into the everyday speech of the intellect. I must therefore content myself with a bare mention of the archetype which is inwardly experienced at this stage, namely the birth of the “divine child” or—in the language of the mystics—the inner man.¹⁰

PURIFICATION

Here falls the heavenly dew, to lave/

The soiled black body in the grave.

[Figure 8]

[483] The falling dew is a portent of the divine birth now at hand. *Ros Gedeonis* (Gideon's dew)¹ is a synonym for the *aqua permanens*, hence for Mercurius.² A quotation from Senior at this point in the *Rosarium* text says: "Maria says again: 'But the water I have spoken of is a king descending from heaven, and the earth's humidity absorbs it, and the water of heaven is retained with the water of the earth, and the water of the earth honours that water with its lowliness and its sand, and water consorts with water and water will hold fast to water and Albira is whitened with Astuna.'"³

[484] The whitening (*albedo* or *dealbatio*) is likened to the *ortus solis*, the sunrise; it is the light, the illumination, that follows the darkness. Hermes says: "Azoth et ignis latonem abluunt et nigredinem ab eo auferunt" (Azoth and fire cleanse the lato and remove the blackness).⁴ The spirit Mercurius descends in his heavenly form as *sapientia* and as the fire of the Holy Ghost, to purify the blackness. Our text continues: "Dealbate latonem et libros rumpite, ne corda vestra rumpantur."⁵ Haec est enim compositio omnium Sapientum et etiam tertia pars totius operis.⁶ Jungite ergo, ut dicitur in *Turba*, siccum humido: id est terram nigram cum aqua sua et coquite donee dealbatur. Sic habes aquam et terram per se et terram cum aqua dealbatam: ilia albedo dicitur aer." (Whiten the lato and rend the books lest your hearts be rent asunder.⁵ For this is the synthesis of the wise and the third part of the whole *opus*⁶ Join therefore, as is said in the *Turba*,⁷ the dry to the moist, the black earth with its water, and cook till it whitens. In this manner you will have the essence of water and earth, having whitened the earth with water: but that whiteness is called air.) So that the reader may know that the "water" is the *aqua sapientiae*, and the dew falling from heaven the divine gift of illumination and wisdom, there follows a long disquisition on Wisdom, entitled "Septimum Sapientiae Salomonis":

She it is that Solomon chose to have instead of light, and above all beauty and health; in comparison of her he compared not unto her the virtue of any precious stone. For all gold in her sight shall be esteemed as a little sand, and silver shall be counted as clay; and this is not without cause, for to gain her is better than the merchandise of silver and the most pure gold. And her fruit is more precious than all

the riches of this world, and all the things that are desired are not to be compared with her. Length of days and health are in her right hand, and in her left hand glory and infinite riches. Her ways are beautiful operations and praiseworthy, not unsightly nor ill-favoured, and her paths are measured and not hasty,⁸ but are bound up with stubborn and day-long toil. She is a tree of life to them that lay hold on her, and an unfailing light. Blessed shall they be who retain her, for the science of God shall never perish, as Alphidius beareth witness, for he saith: He who hath found this science, it shall be his rightful food for ever.⁹

PHILOSOPHORVM

ABLVTIO VEL *Mundificatio*

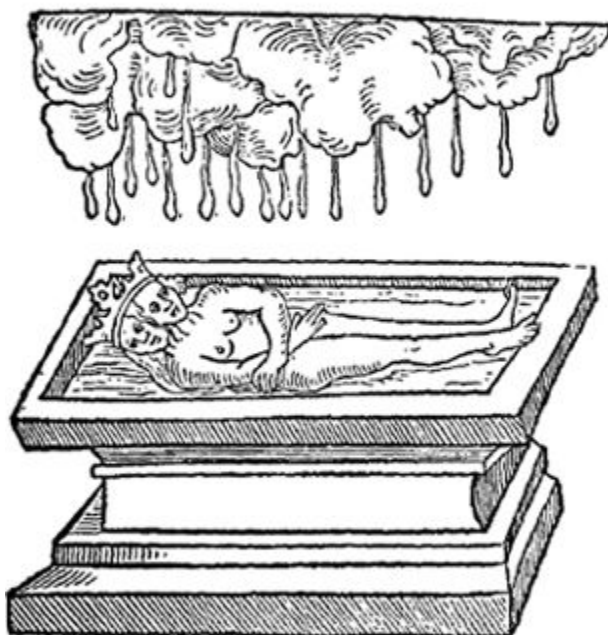

*Sie sehe der Tau von Himmel herab/
Vnd wascht den schwarzen leyb im grab ab.*

K ij

Figure 8

[485] In this connection I would like to point out that water as a symbol of wisdom and spirit can be traced back to the parable which Christ told to the Samaritan woman at the well.¹⁰ The uses to which this parable was put can be seen in one of the sermons of Cardinal Nicholas of Cusa, a contemporary of our alchemists: “There is in Jacob’s well a water which human ingenuity has sought and found. Philosophy is its name, and it is found through laborious investigation of the world of the senses. But in the Word of God, which dwells in the depths of the living well of Christ’s humanity, there is a fountain for the refreshment of the spirit. Here, then, we have Jacob’s well of the senses, the well of reason and the well of wisdom. From the first well, which is

of animal nature and deep, the father drinks, together with his children and cattle; from the second, which is yet deeper and on the very margin of nature, there drink only the children of men, namely those whose reason has awakened and whom we call philosophers; from the third, the deepest of all, drink the sons of the All-Highest, whom we call gods and true theologians. Christ in his humanity may be called the deepest well.... In this deepest well is the source of wisdom, which brings bliss and immortality.... The living well bears the source of its own life, it calls the thirsty to the waters of salvation that they may be refreshed with the water of saving wisdom.”¹¹ Another passage in the same sermon says: “Whosoever drinks the spirit, drinks of a bubbling spring.”¹² Finally, Cusanus says: “Mark well, our reason is given to us with the power of an intellectual seed; wherefore it contains a welling principle through which it generates in itself the water of understanding. And this well can yield naught but water of a like nature, namely, the water of human understanding; just as the understanding of the principle ‘every thing either is or is not’ yields the metaphysical water from which the other streams of science flow without cease.”¹³

[486] After all this there can be no more doubt that the black darkness is washed away by the *aqua sapientiae* of “our science,” namely the God-given gift of the royal art and the knowledge it bestows. The *mundificatio* (purification) means, as we have seen, the removal of the superfluities that always cling to merely natural products, and especially to the symbolic unconscious contents which the alchemist found projected into matter. He therefore acted on Cardan’s rule that the object of the work of interpretation is to reduce the dream material to its most general principles.¹⁴ This is what the laboratory worker called the *extractio animae*, and what in the psychological field we would call the working through of the idea contained in the dream. We know that this requires a necessary premise or hypothesis, a certain intellectual structure by means of which “apperceptions” can be made. In the case of the alchemist, such a premise was ready to hand in the *aqua (doctrinae)*, or the God-inspired *sapientia* which he could also acquire through a diligent study of the “books,” the alchemical classics. Hence the reference to the books, which at this stage of the work must be avoided or destroyed “lest your hearts be rent asunder.” This singular exhortation, altogether inexplicable from the chemical point of view, has a profound significance here. The atolvent water or *aqua sapientiae* had been established in the teachings and sayings of the masters as the *donum Spiritus Sancti* which enables the philosopher to understand the *miracula operis*. Therefore he might easily be tempted to assume that philosophical knowledge is the highest good, as the Cusanus quotation shows. The psychological equivalent of this situation is when people imagine that they have reached the goal of the work once the unconscious contents have been made conscious and theoretically evaluated. In both cases this would be arbitrarily to define “spirit” as a mere matter of thinking and intuition. Both

disciplines, it is true, are aiming at a “spiritual” goal: the alchemist undertakes to produce a new, volatile (hence aerial or “spiritual”) entity endowed with *corpus, anima, et spiritus*, where *corpus* is naturally understood as a “subtle” body or “breath body”; the analyst tries to bring about a certain attitude or frame of mind, a certain “spirit” therefore. But because the body, even when conceived as the *corpus glorificationis*, is grosser than *anima* and *spiritus*, a “remnant of earth” necessarily clings to it, albeit a very subtle one.¹⁵ Hence an attitude that seeks to do justice to the unconscious as well as to one’s fellow human beings cannot possibly rest on knowledge alone, in so far as this consists merely of thinking and intuition. It would lack the function that perceives values, i.e., feeling, as well as the *fonction du réel*, i.e., sensation, the sensible perception of reality.¹⁶

[487] Thus if books and the knowledge they impart are given exclusive value, man’s emotional and affective life is bound to suffer. That is why the purely intellectual attitude must be abandoned. “Gideon’s dew” is a sign of divine intervention, it is the moisture that heralds the return of the soul.

[488] The alchemists seem to have perceived the danger that the work and its realization may get stuck in one of the conscious functions. Consequently they stress the importance of the *theoria*, i.e., intellectual understanding as opposed to the *practica*, which consisted merely of chemical experiments. We might say that the *practica* corresponds to pure perception, and that this must be supplemented by apperception. But this second stage still does not bring complete realization. What is still lacking is heart or feeling, which imparts an abiding value to anything we have understood. The books must therefore be “destroyed” lest thinking impair feeling and thus hinder the return of the soul.

[489] These difficulties are familiar ground to the psychotherapist. It often happens that the patient is quite satisfied with merely registering a dream or fantasy, especially if he has pretensions to aestheticism. He will then fight against even intellectual understanding because it seems an affront to the reality of his psychic life. Others try to understand with their brains only, and want to skip the purely practical stage. And when they have understood, they think they have done their full share of realization. That they should also have a *feeling-relationship* to the contents of the unconscious seems strange to them or even ridiculous. Intellectual understanding and aestheticism both produce the deceptive, treacherous sense of liberation and superiority which is liable to collapse if feeling intervenes. Feeling always binds one to the reality and meaning of symbolic contents, and these in turn impose binding standards of ethical behaviour from which aestheticism and intellectualism are only too ready to emancipate themselves.

[490] Owing to the almost complete lack of psychological differentiation in the age of alchemy, it is hardly surprising that such considerations as these are only hinted at in the treatises. But hints do exist, as we have seen. Since then the differentiation of the functions has increased apace, with the result that they have become more and more segregated from one another. Consequently it is very easy for the modern mind to get stuck in one or other of the functions and to achieve only an incomplete realization. It is hardly necessary to add that in time this leads to a neurotic dissociation. To this we owe the further differentiation of the individual functions as well as the discovery of the unconscious, but at the price of psychological disturbance. Incomplete realization explains much that is puzzling both in the individual and in the contemporary scene. It is a crucial matter for the psychotherapist, particularly for those who still believe that intellectual insight and routine understanding, or even mere recollection, are enough to effect a cure. The alchemists thought that the *opus* demanded not only laboratory work, the reading of books, meditation, and patience, but also love.

[491] Nowadays we would speak of “feeling-values” and of realization through feeling. One is often reminded of Faust’s shattering experience when he was shaken out of the “deadly dull rut” of his laboratory and philosophical work by the revelation that “feeling is all.” In this we can already see the modern man who has got to the stage of building his world on a single function and is not a little proud of his achievement. The medieval philosophers would certainly never have succumbed to the idea that the demands of feeling had opened up a new world. The pernicious and pathological slogan *l’art pour l’art* would have struck them as absurd, for when they contemplated the mysteries of nature, sensation, creation, thinking, cognition and feeling were all one to them. Their state of mind was not yet split up into so many different functions that each stage of the realization process would have needed a new chapter of life. The story of Faust shows how unnatural our condition is: it required the intervention of the devil—in anticipation of Steinach ¹⁷—to transform the ageing alchemist into a young gallant and make him forget himself for the sake of the all-too-youthful feelings he had just discovered! That is precisely the risk modern man runs: he may wake up one day to find that he has missed half his life.

[492] Nor is realization through feeling the final stage. Although it does not really belong to this chapter, yet it might not be out of place to mention the fourth stage after the three already discussed, particularly since it has such a very pronounced symbolism in alchemy. This fourth stage is the anticipation of the *lapis*. The imaginative activity of the fourth function—intuition, without which no realization is complete—is plainly evident in this anticipation of a possibility whose fulfilment could never be the object of empirical experience at all: already in Greek alchemy it was called *λίθος οὐ λίθος* “the stone that is no stone.” Intuition gives outlook and insight; it revels in the garden of magical possibilities as if they were real. Nothing is more

charged with intuitions than the *lapis philosophorum*. This keystone rounds off the work into an experience of the totality of the individual. Such an experience is completely foreign to our age, although no previous age has ever needed wholeness so much. It is abundantly clear that this is the prime problem confronting the art of psychic healing in our day, as a consequence of which we are now trying to loosen up our rigid *psychologie à compartiments* by putting in a few communicating doors.

[493] After the ascent of the soul, with the body left behind in the darkness of death, there now comes an enantiodromia: the *nigredo* gives way to the *albedo*. The black or unconscious state that resulted from the union of opposites reaches the nadir and a change sets in. The falling dew signals resuscitation and a new light: the ever deeper descent into the unconscious suddenly becomes illumination from above. For, when the soul vanished at death, it was not lost; in that other world it formed the living counterpole to the state of death in this world. Its reappearance from above is already indicated by the dewy moisture. This dewiness partakes of the nature of the psyche, for *ψυχή* is cognate with *ψυχρός* (cold) and *ψυχώω* (to freshen and animate), while on the other hand dew is synonymous with the *aqua permanens*, the *aqua sapientiae*, which in turn signifies illumination through the realization of meaning. The preceding union of opposites has brought light, as always, out of the darkness of night, and by this light it will be possible to see what the real meaning of that union was.

THE RETURN OF THE SOUL

Here is the soul descending from on high/

To quick the corpse we strove to purify.

[Figure 9]

[494] Here the reconciler, the soul, dives down from heaven to breathe life into the dead body. The two birds at the bottom left of the picture represent the allegorical winged and wingless dragons in the form of fledged and unfledged birds.¹ This is one of the many synonyms for the double nature of Mercurius, who is both a chthonic and a pneumatic being. The presence of this divided pair of opposites means that although the hermaphrodite appears to be united and is on the point of coming alive, the conflict between them is by no means finally resolved and has not yet disappeared: it is relegated to the “left” and to the “bottom” of the picture, i.e., banished to the sphere of the unconscious. The fact that these still unintegrated opposites are represented theriomorphically (and not anthropomorphically as before) bears out this supposition.

[495] The text of the *Rosarium* continues with a quotation from Morienus: “Despise not the ash, for it is the diadem of thy heart.” This ash, the inert product of incineration, refers to the dead body, and the admonition establishes a curious connection between body and heart which at that time was regarded as the real seat of the soul.² The diadem refers of course to the supremely kingly ornament. Coronation plays some part in alchemy—the *Rosarium*, for instance, has a picture³ of the *Coronatio Mariae*, signifying the glorification of the white, moonlike (purified) body. The text then quotes Senior as follows: “Concerning the white tincture: When my beloved parents have tasted of life, have been nourished with pure milk and become drunk with my white substance, and have embraced each other in my bed, they shall bring forth the son of the moon, who will excel all his kindred. And when my beloved has drunk from the red rock sepulchre and tasted the maternal fount in matrimony, and has drunk with me of my red wine and lain with me in my bed in friendship, then I, loving him and receiving his seed into my cell, shall conceive and become pregnant and when my time is come shall bring forth a most mighty son, who shall rule over and govern all the kings and princes of the earth, crowned with the golden crown of victory by the supreme God who liveth and reigneth for ever and ever.”⁴

[496] The coronation picture that illustrates this text⁵ proves that the resuscitation of the purified corpse is at the same time a glorification, since the process is likened to the

crowning of the Virgin.⁶ The allegorical language of the Church supports such a comparison. The connections of the Mother of God with the moon,⁷ water, and fountains are so well known that I need not substantiate them further. But whereas it is the Virgin who is crowned here, in the Senior text it is the son who receives the “crown of victory”—which is quite in order since he is the *filius regius* who replaces his father. In *Aurora* the crown is given to the *regina austri*, Sapientia, who says to her beloved: “I am the crown wherewith my beloved is crowned,” so that the crown serves as a connection between the mother and her son-lover.⁸ In a later text⁹ the *aqua amara* is defined as “crowned with light.” At that time Isidore of Seville’s etymology was still valid: *mare ab amaro*,¹⁰ which vouches for “sea” as synonymous with the *aqua permanens*. It is also an allusion to the water symbolism of Mary (πηγή, “fountain”).¹¹ Again and again we note that the alchemist proceeds like the unconscious in the choice of his symbols: every idea finds both a positive and a negative expression. Sometimes he speaks of a royal pair, sometimes of dog and bitch; and the water symbolism is likewise expressed in violent contrasts. We read that the royal diadem appears “in menstruo meretricis (in the menstruum of a whore),”¹² or the following instructions are given: “Take the foul deposit [*faecem*] that remains in the cooking-vessel and preserve it, for it is the crown of the heart.” The deposit corresponds to the corpse in the sarcophagus, and the sarcophagus corresponds in turn to the mercurial fountain or the *vas hermeticum*.

PHILOSOPHORVM
ANIMÆ IVBILATIO SEV
Ortus seu Sublimatio,



Sie schwingt sich die seel hernidder/
Vnd erquicket den gereinigten leychnam wider-

L ij

Figure 9

[497] The soul descending from heaven is identical with the dew, the *aqua divina*, which, as Senior, quoting Maria, explains, is “Rex de coelo descendens.”¹³ Hence this water is itself crowned and forms the “diadem of the heart,”¹⁴ in apparent contradiction to the earlier statement that the ash was the diadem. It is difficult to tell whether the alchemists were so hopelessly muddled that they did not notice these flat contradictions, or whether their paradoxes were sublimely deliberate. I suspect it was a bit of both, since the *ignorantes, stulti, fatui* would take the texts at their face value and get bogged in the welter of analogies, while the more astute reader, realizing the necessity for symbolism, would handle it like a virtuoso with no trouble at all. Intellectual responsibility seems always to have been the alchemists’ weak spot, though a few of them tell us plainly enough how we are to regard their peculiar language.¹⁵ The less respect they showed for the bowed shoulders of the sweating reader, the greater was their debt, willing or unwilling, to the unconscious, for it is just the infinite variety of their images and paradoxes that points to a psychological fact of prime importance: the indefiniteness of the archetype with its multitude of meanings, all presenting different facets of a single, simple truth. The alchemists were so steeped in their inner experiences that their sole concern was to devise fitting

images and expressions regardless of whether these were intelligible or not. Although in this respect they remained behind the times, they nevertheless performed the inestimable service of having constructed a phenomenology of the unconscious long before the advent of psychology. We, as heirs to these riches, do not find our heritage at all easy to enjoy. Yet we can comfort ourselves with the reflection that the old masters were equally at a loss to understand one another, or that they did so only with difficulty. Thus the author of the *Rosarium* says that the “antiqui Philosophi tam obscure quam confuse scripserunt,” so that they only baffled the reader or put him off altogether. For his part, he says, he would make the “experimentum verissimum” plain for all eyes to see and reveal it “in the most certain and human manner”—and then proceeds to write exactly like all the others before him. This was inevitable, as the alchemists did not really know what they were writing about. Whether we know today seems to me not altogether sure. At any rate we no longer believe that the secret lies in chemical substances, but that it is rather to be found in one of the darker and deeper layers of the psyche, although we do not know the nature of this layer. Perhaps in another century or so we shall discover a new darkness from which there will emerge something we do not understand either, but whose presence we sense with the utmost certainty.

[498] The alchemist saw no contradiction in comparing the diadem with a “foul deposit” and then, in the next breath, saying that it is of heavenly origin. He follows the rule laid down in the “Tabula smaragdina”: “Quod est inferius, est sicut quod est superius. Et quod est superius, est sicut quod est inferius.”¹⁶ His faculty for conscious discrimination was not as acute as modern man’s, and was distinctly blunter than the scholastic thought of his contemporaries. This apparent regression cannot be explained by any mental backwardness on the part of the alchemist; it is more the case that his main interest is focussed on the unconscious itself and not at all on the powers of discrimination and formulation which mark the concise conceptual thinking of the schoolmen. He is content if he succeeds in finding expressions to delineate afresh the secret he feels. How these expressions relate to and differ from one another is of the smallest account to him, for he never supposes that anybody could reconstruct the art from his ideas about it, but that those who approach the art at all are already fascinated by its secret and are guided by sure intuition, or are actually elected and predestined thereto by God. Thus the *Rosarium*¹⁷ says, quoting Hortulanus:¹⁸ “Solus ille, qui scit facere lapidem Philosophorum, intelligit verba eorum de lapide” (Only he who knows how to make the philosophers’ stone can understand their words concerning it). The darkness of the symbolism scatters before the eyes of the enlightened philosopher. Hortulanus says again: “Nihil enim prodest occultatio philosophorum in sermonibus, ubi doctrina Spiritus sancti operatur”¹⁹ (The

mystification in the sayings of the philosophers is of no avail where the teaching of the Holy Ghost is at work).

[499] The alchemist's failure to distinguish between *corpus* and *spiritus* is in our case assisted by the assumption that, owing to the preceding *mortificatio* and *sublimatio*, the body has taken on "quintessential" or spiritual form and consequently, as a *corpus mundum* (pure substance), is not so very different from spirit. It may shelter spirit or even draw it down to itself.²⁰ All these ideas lead one to conclude that not only the *coniunctio* but the reanimation of the "body" is an altogether transmundane event, a process occurring in the psychic non-ego. This would explain why the process is so easily projected, for if it were of a personal nature its liability to projection would be considerably reduced, because it could then be made conscious without too much difficulty. At any rate this liability would not have been sufficient to cause a projection upon inanimate matter, which is the polar opposite of the living psyche. Experience shows that the carrier of the projection is not just *any* object but is always one that proves adequate to the nature of the content projected—that is to say, it must offer the content a "hook" to hang on.²¹

[500] Although the process is essentially transcendental, the projection brings it down to reality by violently affecting the conscious and personal psyche. The result is an inflation, and it then becomes clear that the *coniunctio* is a hierosgamos of the gods and not a mere love-affair between mortals. This is very subtly suggested in the *Chymical Wedding*, where Rosencreutz, the hero of the drama, is only a guest at the feast and, though forbidden to do so, slips into the bedchamber of Venus in order to gaze admiringly on the naked beauty of the sleeper. As a punishment for this intrusion Cupid wounds him in the hand with an arrow.²² His own personal, secret connection with the royal marriage is only fleetingly indicated right at the end: the king, alluding to Rosencreutz, says that he (Rosencreutz) was his father.²³ Andreae, the author, must have been a man of some wit, since at this point he tries to extricate himself from the affair with a jest. He gives a clear hint that he himself is the father of his characters and gets the king to confirm this. The voluntarily proffered information about the paternity of this "child" is the familiar attempt of a creative artist to bolster up the prestige of his ego against the suspicion that he is the victim of the creative urge welling out of the unconscious. Goethe could not shake off the grip of *Faust*—his "main business"—half so easily. (Lesser men have correspondingly more need of greatness, hence they must make others think more highly of them.) Andreae was as fascinated by the secret of the art as any alchemist; the serious attempt he made to found the Rosicrucian Order is proof of this, and it was largely for reasons of expediency, owing to his position as a cleric, that he was led to adopt a more distant attitude in later years.²⁴

[501] If there is such a thing as an unconscious that is not personal—i.e., does not consist of individually acquired contents, whether forgotten, subliminally perceived, or repressed—then there must also be processes going on in this non-ego, spontaneous archetypal events which the conscious mind can only perceive when they are projected. They are immemorially strange and unknown, and yet we seem to have known them from everlasting; they are also the source of a remarkable fascination that dazzles and illuminates at once. They draw us like a magnet and at the same time frighten us; they manifest themselves in fantasies, dreams, hallucinations, and in certain kinds of religious ecstasy.²⁵ The *coniunctio* is one of these archetypes. The absorptive power of the archetype explains not only the widespread incidence of this motif but also the passionate intensity with which it seizes upon the individual, often in defiance of all reason and understanding. To the *peripeteia* of the *coniunctio* also belong the processes illustrated in the last few pictures. They deal with the after-effects of the fusion of opposites, which have involved the conscious personality in their union. The extreme consequence of this is the dissolution of the ego in the unconscious, a state resembling death. It results from the more or less complete identification of the ego with unconscious factors, or, as we would say, from contamination. This is what the alchemists experienced as *immunditia*, pollution. They saw it as the defilement of something transcendent by the gross and opaque body which had for that reason to undergo sublimation. But the body, psychologically speaking, is the expression of our individual and conscious existence, which, we then feel, is in danger of being swamped or poisoned by the unconscious. We therefore try to separate the ego-consciousness from the unconscious and free it from that perilous embrace. Yet, although the power of the unconscious is feared as something sinister, this feeling is only partially justified by the facts, since we also know that the unconscious is capable of producing beneficial effects. The kind of effect it will have depends to a large extent on the attitude of the conscious mind.

[502] Hence the *mundificatio*—purification—is an attempt to discriminate the mixture, to sort out the *coincidentia oppositorum* in which the individual has been caught. The rational man, in order to live in this world, has to make a distinction between “himself” and what we might call the “eternal man.” Although he is a unique individual, he also stands for “man” as a species, and thus he has a share in all the movements of the collective unconscious. In other words, the “eternal” truths become dangerously disturbing factors when they suppress the unique ego of the individual and live at his expense. If our psychology is forced, owing to the special nature of its empirical material, to stress the importance of the unconscious, that does not in any way diminish the importance of ego-consciousness. It is merely the one-sided overvaluation of the latter that has to be checked by a certain relativization of values. But

this relativization should not be carried so far that the ego is completely fascinated and overpowered by the archetypal truths. The ego lives in space and time and must adapt itself to their laws if it is to exist at all. If it is absorbed by the unconscious to such an extent that the latter alone has the power of decision, then the ego is stifled, and there is no longer any medium in which the unconscious could be integrated and in which the work of realization could take place. The separation of the empirical ego from the “eternal” and universal man is therefore of vital importance, particularly today, when mass-degeneration of the personality is making such threatening strides. Mass-degeneration does not come only from without: it also comes from within, from the collective unconscious. Against the outside, some protection was afforded by the *droits de l’homme* which at present are lost to the greater part of Europe,²⁶ and even where they are not actually lost we see political parties, as naïve as they are powerful, doing their best to abolish them in favour of the slave state, with the bait of social security. Against the daemonism from within, the Church offers some protection so long as it wields authority. But protection and security are only valuable when not excessively cramping to our existence; and in the same way the superiority of consciousness is desirable only if it does not suppress and shut out too much life. As always, life is a voyage between Scylla and Charybdis.

[503] The process of differentiating the ego from the unconscious,²⁷ then, has its equivalent in the *mundificatio*, and, just as this is the necessary condition for the return of the soul to the body, so the body is necessary if the unconscious is not to have destructive effects on the ego-consciousness, for it is the body that gives bounds to the personality. The unconscious can be integrated only if the ego holds its ground. Consequently, the alchemist’s endeavour to unite the *corpus mundum*, the purified body, with the soul is also the endeavour of the psychologist once he has succeeded in freeing the ego-consciousness from contamination with the unconscious. In alchemy the purification is the result of numerous distillations; in psychology too it comes from an equally thorough separation of the ordinary ego-personality from all inflationary admixtures of unconscious material. This task entails the most painstaking self-examination and self-education, which can, however, be passed on to others by one who has acquired the discipline himself. The process of psychological differentiation is no light work; it needs the tenacity and patience of the alchemist, who must purify the body from all superfluities in the fiercest heat of the furnace, and pursue Mercurius “from one bride chamber to the next.” As alchemical symbolism shows, a radical understanding of this kind is impossible without a human partner. A general and merely academic “insight into one’s mistakes” is ineffectual, for then the mistakes are not really seen at all, only the idea of them. But they show up acutely when a human relationship brings them to the fore and when they are noticed by the other person as well as by oneself. Then and then only can they really be felt and

their true nature recognized. Similarly, confessions made to one's secret self generally have little or no effect, whereas confessions made to another are much more promising.

[504] The "soul" which is reunited with the body is the One born of the two, the *vinculum* common to both.²⁸ It is therefore the very essence of relationship. Equally the psychological anima, as representative of the collective unconscious, has a collective character. The collective unconscious is a natural and universal datum and its manifestation always causes an unconscious identity, a state of *participation mystique*. If the conscious personality becomes caught up in it and offers no resistance, the relationship is personified by the anima (in dreams, for instance), who then, as a more or less autonomous part of the personality, generally has a disturbing effect. But if, as the result of a long and thorough analysis and the withdrawal of projections, the ego has been successfully separated from the unconscious, the anima will gradually cease to act as an autonomous personality and will become a function of relationship between conscious and unconscious. So long as she is projected she leads to all sorts of illusions about people and things and thus to endless complications. The withdrawal of projections makes the anima what she originally was: an archetypal image which, in its right place, functions to the advantage of the individual. Interposed between the ego and the world, she acts like an ever-changing Shakti, who weaves the veil of Maya and dances the illusion of existence. But, functioning between the ego and the unconscious, the anima becomes the matrix of all the divine and semi-divine figures, from the pagan goddess to the Virgin, from the messenger of the Holy Grail to the saint.²⁹ The unconscious anima is a creature without relationships, an autoerotic being whose one aim is to take total possession of the individual. When this happens to a man he becomes strangely womanish in the worst sense, with a moody and uncontrolled disposition which, in time, has a deleterious effect even on the hitherto reliable functions—e.g., his intellect—and gives rise to the kind of ideas and opinions we rightly find so objectionable in animus-possessed women.³⁰

[505] Here I must point out that very different rules apply in feminine psychology, since in this case we are not dealing with a function of relationship but, on the contrary, with a *discriminative* function, namely the animus. Alchemy was, as a philosophy, mainly a masculine preoccupation and in consequence of this its formulations are for the most part masculine in character. But we should not overlook the fact that the feminine element in alchemy is not so inconsiderable since, even at the time of its beginnings in Alexandria, we have authentic proof of female philosophers like Theosebeia,³¹ the *soror mystica* of Zosimos, and Paphnutia and Maria Prophetissa. From later times we know of the pair of alchemists, Nicolas Flamel and his wife Peronelle. The *Mutus liber* of 1677 gives an account of a man

and wife performing the *opus* together,³² and finally in the nineteenth century we have the pair of English alchemists, Thomas South and his daughter, who later became Mrs. Atwood. After busying themselves for many years with the study of alchemy, they decided to set down their ideas and experiences in book form. To this end they separated, the father working in one part of the house and his daughter in another. She wrote a thick, erudite tome while he versified. She was the first to finish and promptly sent the book to the printer. Scarcely had it appeared when her father was overcome with scruples, fearing lest they had betrayed the great secret. He succeeded in persuading his daughter to withdraw the book and destroy it. In the same spirit, he sacrificed his own poetic labours. Only a few lines are preserved in her book, of which it was too late to withdraw all the copies. A reprint,³³ prepared after her death in 1910, appeared in 1918. I have read the book: no secrets are betrayed. It is a thoroughly medieval production garnished with would-be theosophical explanations as a sop to the syncretism of the new age.

[506] A remarkable contribution to the role of feminine psychology in alchemy is furnished by the letter which the English theologian and alchemist, John Pordage,³⁴ wrote to his *soror mystica* Jane Leade. In it³⁵ he gives her spiritual instruction concerning the *opus*:

[507] This sacred furnace, this *Balneum Mariae*, this glass phial, this secret furnace, is the place, the matrix or womb, and the centre from which the divine Tincture flows forth from its source and origin. Of the place or abode where the Tincture has its home and dwelling I need not remind you, nor name its name, but I exhort you only to knock at the foundation. Solomon tells us in his Song that its inner dwelling its not far from the navel, which resembles a round goblet filled with the sacred liquor of the pure Tincture.³⁶ You know the fire of the philosophers, it was the key they kept concealed.... The fire is the love-fire, the life that flows forth from the Divine Venus, or the Love of God; the fire of Mars is too choleric, too sharp, and too fierce, so that it would dry up and burn the *materia*: wherefore the love-fire of Venus alone has the qualities of the right true fire.

[508] This true philosophy will teach you how you should know yourself, and if you know yourself rightly, you will also know the pure nature; for the pure nature is in yourself. And when you know the pure nature which is your true selfhood, freed from all wicked, sinful selfishness, then also you will know God, for the Godhead is concealed and wrapped in the pure nature like a kernel in the nutshell.... The true philosophy will teach you who is the father and who is the mother of this magical child.... The father of this child is Mars, he is the fiery life which proceeds from Mars as the father's quality. His mother is Venus, who is the gentle love-fire proceeding from the son's quality. Here then, in the qualities and forms of nature, you

see male and female, man and wife, bride and bridegroom, the first marriage or wedding of Galilee, which is celebrated between Mars and Venus when they return from their fallen state. Mars, or the husband, must become a godly man, otherwise the pure Venus will take him neither into the conjugal nor into the sacred marriage bed. Venus must become a pure virgin, a virginal wife, otherwise the wrathful jealous Mars in his wrath-fire will not wed with her nor live with her in union; but instead of agreement and harmony, there will be naught but strife, jealousy, discord, and enmity among the qualities of nature....

[509] Accordingly, if you think to become a learned artist, look with earnestness to the union of your own Mars and Venus, that the nuptial knot be rightly tied and the marriage between them well and truly consummated. You must see to it that they lie together in the bed of their union and live in sweet harmony; then the virgin Venus will bring forth her pearl, her water-spirit, in you, to soften the fiery spirit of Mars, and the wrathful fire of Mars will sink quite willingly, in mildness and love, into the love-fire of Venus, and thus both qualities, *as fire and water*, will mingle together, agree, and flow into one another; and from their agreement and union there will proceed the first conception of the magical birth which we call Tincture, the love-fire Tincture. Now although the Tincture is conceived in the womb of your humanity and is awakened to life, yet there is still a great danger, and it is to be feared that, because it is still in the body or womb, it may yet be spoiled by neglect before it be brought in due season into the light. On this account you must look round for a good nurse, who will watch it in its childhood and will tend it properly: and such must be your own pure heart and your own virginal will....

[510] This child, this tincturing life, must be assayed, proved, and tried in the qualities of nature; and here again great anxiety and danger will arise, seeing that it must suffer the damage of temptation in the body and womb, and you may thus lose the birth. For the delicate Tincture, this tender child of life, must descend into the forms and qualities of nature, that it may suffer and endure temptation and overcome it; it must needs descend into the Divine Darkness, into the darkness of Saturn, wherein no light of life is to be seen: there it must be held captive, and be bound with the chains of darkness, and must live from the food which the prickly Mercurius will give it to eat, which to the Divine Tincture of life is naught but dust and ashes, poison and gall, fire and brimstone. It must enter into the fierce wrathful Mars, by whom (as happened to Jonah in the belly of hell) it is swallowed, and must experience the curse of God's wrath; also it must be tempted by Lucifer and the million devils who dwell in the quality of the wrathful fire. And here the divine artist in this philosophical work will see the first colour, where the Tincture appears in its blackness, and it is the blackest black; the learned philosophers call it their black crow, or their black raven, or again their blessed and blissful black; for in the darkness of this black is hidden the

light of lights in the quality of Saturn; and in this poison and gall there is hidden in Mercurius the most precious medicament against the poison, namely the life of life. And the blessed Tincture is hidden in the fury or wrath and curse of Mars.

[511] Now it seems to the artist that all his work is lost. What has become of the Tincture? Here is nothing that is apparent, that can be perceived, recognized, or tasted, but darkness, most painful death, a hellish fearful fire, nothing but the wrath and curse of God; yet he does not see that the Tincture of Life is in this putrefaction or dissolution and destruction, that there is light in this darkness, life in this death, love in this fury and wrath, and in this poison the highest and most precious Tincture and medicament against all poison and sickness.

[512] The old philosophers named this work or labour their descension, their cineration, their pulverization, their death, their putrefaction of the *materia* of the stone, their corruption, their *caput mortuum*. You must not despise this blackness, or black colour, but persevere in it in patience, in suffering, and in silence, until its forty days of temptation are over, until the days of its tribulations are completed, when the seed of life shall waken to life, shall rise up, sublimate or glorify itself, transform itself into whiteness, purify and sanctify itself, give itself the redness, in other words, transfigure and fix its shape. When the work is brought thus far, it is an easy work: for the learned philosophers have said that the making of the stone is then woman's work and child's play. Therefore, if the human will is given over and left, and becomes patient and still and as a dead nothing, the Tincture will do and effect everything in us and for us, if we can keep our thoughts, movements, and imaginations still, or can leave off and rest. But how difficult, hard, and bitter this work appears to the human will, before it can be brought to this shape, so that it remains still and calm even though all the fire be let loose in its sight, and all manner of temptations assail it!

[513] Here, as you see, there is great danger, and the Tincture of life can easily be spoiled and the fruit wasted in the womb, when it is thus surrounded on all sides and assailed by so many devils and so many tempting essences. But if it can withstand and overcome this fiery trial and sore temptation, and win the victory: then you will see the beginning of its resurrection from hell, death, and the mortal grave, appearing first in the quality of Venus; and then the Tincture of life will itself burst forth mightily from the prison of the dark Saturn, through the hell of the poisonous Mercurius, and through the curse and direful death of God's wrath that burns and flames in Mars, and the gentle love-fire of the Venus quality will gain the upper hand, and the love-fire Tincture will be preferred in the government and have supreme command. And then the gentleness and love-fire of Divine Venus will reign as lord and king in and over all qualities.

[514] Nevertheless there is still another danger that the work of the stone may yet miscarry. Therefore the artist must wait until he sees the Tincture covered over with its other colour, as with the whitest white, which he may expect to see after long patience and stillness, and which truly appears when the Tincture rises up in the lunar quality: illustrious Luna imparts a beautiful white to the Tincture, the most perfect white hue and a brilliant splendour. And thus is the darkness transformed into light, and death into life. And this brilliant whiteness awakens joy and hope in the heart of the artist, that the work has gone so well and fallen out so happily. For now the white colour reveals to the enlightened eye of the soul cleanliness, innocence, holiness, simplicity, heavenly-mindedness, and righteousness, and with these the Tincture is henceforth clothed over and over as with a garment. She is radiant as the moon, beautiful as the dawn. Now the divine virginity of the tincturing life shines forth, and no spot or wrinkle nor any other blemish is to be seen.

[515] The old masters were wont to call this work their white swan, their albification, or making white, their sublimation, their distillation, their circulation, their purification, their separation, their sanctification, and their resurrection, because the Tincture is made white like a shining silver. It is sublimed or exalted and transfigured by reason of its many descents into Saturn, Mercurius, and Mars, and by its many ascents into Venus and Luna. This is the distillation, the *Balneum Mariae*: because the Tincture is purified in the qualities of nature through the many distillations of the water, blood, and heavenly dew of the Divine Virgin Sophia, and, through the manifold circulation in and out of the forms and qualities of nature, is made white and pure, like brilliantly polished silver. And all uncleanliness of the blackness, all death, hell, curse, wrath, and all poison which rise up out of the qualities of Saturn, Mercury, and Mars are separated and depart, wherefore they call it their separation, and when the Tincture attains its whiteness and brilliance in Venus and Luna they call it their sanctification, their purification and making white. They call it their resurrection, because the white rises up out of the black, and the divine virginity and purity out of the poison of Mercurius and out of the red fiery rage and wrath of Mars....

[516] Now is the stone shaped, the elixir of life prepared, the love-child or the child of love born, the new birth completed, and the work made whole and perfect. Farewell! fall, hell, curse, death, dragon, beast, and serpent! Good night! mortality, fear, sorrow, and misery! For now redemption, salvation, and recovery of everything that was lost will again come to pass within and without, for now you have the great secret and mystery of the whole world; you have the Pearl of Love; you have the unchangeable eternal essence of Divine Joy from which all healing virtue and all multiplying power come, from which there actively proceeds the active power of the Holy Ghost. You

have the seed of the woman who has trampled on the head of the serpent. You have the seed of the virgin and the blood of the virgin in one essence and quality.

[517] O wonder of wonders! You have the tincturing Tincture, the pearl of the virgin, which has three essences or qualities in one; it has body, soul, and spirit, it has fire, light, and joy, it has the Father's quality, it has the Son's quality, and has also the Holy Ghost's quality, even all these three, in one fixed and eternal essence and being. This is the Son of the Virgin, this is her first-born, this is the noble hero, the trampler of the serpent, and he who casts the dragon under his feet and tramples upon him.... For now the Man of Paradise is become clear as a transparent glass, in which the Divine Sun shines through and through, like gold that is wholly bright, pure, and clear, without blemish or spot. The soul is henceforth a most substantial seraphic angel, she can make herself doctor, theologian, astrologer, divine magician, she can make herself whatsoever she will, and do and have whatsoever she will: for all qualities have but one will in agreement and harmony. And this same one will is God's eternal infallible will; and from henceforth the Divine Man is in his own nature become one with God.³⁷

[518] This hymn-like myth of love, virgin, mother, and child sounds extremely feminine, but in reality it is an archetypal conception sprung from the masculine unconscious, where the Virgin Sophia corresponds to the anima (in the psychological sense).³⁸ As is shown by the symbolism and by the not very clear distinction between her and the son, she is also the "paradisal" or "divine" being, i.e., the self. The fact that these ideas and figures were still mystical for Pordage and more or less undifferentiated is explained by the emotional nature of the experiences which he himself describes.³⁹ Experiences of this kind leave little room for critical understanding. They do, however, throw light on the processes hidden behind the alchemical symbolism and pave the way for the discoveries of modern medical psychology. Unfortunately we possess no original treatises that can with any certainty be ascribed to a woman author. Consequently we do not know what kind of alchemical symbolism a woman's view would have produced. Nevertheless, modern medical practice tells us that the feminine unconscious produces a symbolism which, by and large, is compensatory to the masculine. In that case, to use Pordage's terms, the leitmotiv would not be gentle Venus but fiery Mars, not Sophia but Hecate, Demeter, and Persephone, or the matriarchal Kali of southern India in her brighter and darker aspects.⁴⁰

[519] In this connection I would like to draw attention to the curious pictures of the *arbor philosophica* in the fourteenth-century Codex Ashburnham.⁴¹ One picture shows Adam struck by an arrow,⁴² and the tree growing out of his genitals; in the other picture the tree grows out of Eve's head. Her right hand covers her genitals, her

left points to a skull. Plainly this is a hint that the man's *opus* is concerned with the erotic aspect of the anima, while the woman's is concerned with the animus, which is a "function of the head."⁴³ The *prima materia*, i.e., the unconscious, is represented in man by the "unconscious" anima, and in woman by the "unconscious" animus. Out of the *prima materia* grows the philosophical tree, the unfolding *opus*. In their symbolical sense, too, the pictures are in accord with the findings of psychology, since Adam would then stand for the woman's animus who generates "philosophical" ideas with his member (*λόγοι σπερματικοί*), and Eve for the man's anima who, as Sapiientia or Sophia, produces out of her head the intellectual content of the work.

[520] Finally, I must point out that a certain concession to feminine psychology is also to be found in the *Rosarium*, in so far as the first series of pictures is followed by a second—less complete, but otherwise analogous—series, at the end of which there appears a masculine figure, the "emperor," and not, as in the first, an "empress," the "daughter of the philosophers." The accentuation of the feminine element in the Rebis (Fig. 10) is consistent with a predominantly male psychology, whereas the addition of an "emperor" in the second version is a concession to woman (or possibly to the male consciousness).

[521] In its primary "unconscious" form the animus is a compound of spontaneous, unpremeditated opinions which exercise a powerful influence on the woman's emotional life, while the anima is similarly compounded of feelings which thereafter influence or distort the man's understanding ("she has turned his head"). Consequently the animus likes to project himself upon "intellectuals" and all kinds of "heroes," including tenors, artists, sporting celebrities, etc. The anima has a predilection for everything that is unconscious, dark, equivocal, and unrelated in woman, and also for her vanity, frigidity, helplessness, and so forth. In both cases the incest element plays an important part: there is a relation between the young woman and her father, the older woman and her son, the young man and his mother, the older man and his daughter.

[522] It will be clear from all this that the "soul" which accrues to ego-consciousness during the *opus* has a feminine character in the man and a masculine character in the woman. His anima wants to reconcile and unite; her animus tries to discern and discriminate. This strict antithesis is depicted in the alchemists' Rebis, the symbol of transcendental unity, as a coincidence of opposites; but in conscious reality—once the conscious mind has been cleansed of unconscious impurities by the preceding *mundificatio*—it represents a conflict even though the conscious relations between the two individuals may be quite harmonious. Even when the conscious mind does not identify itself with the inclinations of the unconscious, it still has to face them and somehow take account of them in order that they may play their part in the life of the

individual, however difficult this may be. For if the unconscious is not allowed to express itself through word and deed, through worry and suffering, through our consideration of its claims and resistance to them, then the earlier, divided state will return with all the incalculable consequences which disregard of the unconscious may entail. If, on the other hand, we give in to the unconscious too much, it leads to a positive or negative inflation of the personality. Turn and twist this situation as we may, it always remains an inner and outer conflict: one of the birds is fledged and the other not. We are always in doubt: there is a pro to be rejected and a contra to be accepted. All of us would like to escape from this admittedly uncomfortable situation, but we do so only to discover that what we left behind us was ourselves. To live in perpetual flight from ourselves is a bitter thing, and to live with ourselves demands a number of Christian virtues which we then have to apply to our own case, such as patience, love, faith, hope, and humility. It is all very fine to make our neighbour happy by applying them to him, but the demon of self-admiration so easily claps us on the back and says, “Well done!” And because this is a great psychological truth, it must be stood on its head for an equal number of people so as to give the devil something to carp at. But—does it make *us* happy when we have to apply these virtues to ourselves? when I am the recipient of my own gifts, the least among my brothers whom I must take to my bosom? when I must admit that I need all my patience, my love, my faith, and even my humility, and that I myself am my own devil, the antagonist who always wants the opposite in everything? Can we ever really endure ourselves? “Do unto others...”—this is as true of evil as of good.

[523] In John Gower’s *Confessio amantis*⁴⁴ there is a saying which I have used as a motto to the Introduction of this book: “Bellica pax, vulnus dulce, suave malum” (a warring peace, a sweet wound, a mild evil). Into these words the old alchemist put the quintessence of his experience. I can add nothing to their incomparable simplicity and conciseness. They contain all that the ego can reasonably demand of the *opus*, and illuminate for it the paradoxical darkness of human life. Submission to the fundamental contrariety of human nature amounts to an acceptance of the fact that the psyche is at cross purposes with itself. Alchemy teaches that the tension is fourfold, forming a cross which stands for the four warring elements. The quaternio is the minimal aspect under which such a state of total opposition can be regarded. The cross as a form of suffering expresses psychic reality, and carrying the cross is therefore an apt symbol for the wholeness and also for the passion which the alchemist saw in his work. Hence the *Rosarium* ends, not unfittingly, with the picture of the risen Christ and the verses:

After my many sufferings and great martyrdom
I rise again transfigured, of all blemish free.

[524] An exclusively rational analysis and interpretation of alchemy, and of the unconscious contents projected into it, must necessarily stop short at the above parallels and antinomies, for in a total opposition there is no third—*tertium non datur!* Science comes to a stop at the frontiers of logic, but nature does not—she thrives on ground as yet untrodden by theory. *Venerabilis natura* does not halt at the opposites; she uses them to create, out of opposition, a new birth.

THE NEW BIRTH

Here is born the Empress of all honour/
 The philosophers name her their daughter.

She multiplies/bears children ever again/
 They are incorruptibly pure and without stain.

[Figure 10]

[525] Our last picture is the tenth in the series, and this is certainly no accident, for the denarius is supposed to be the perfect number.¹ We have shown that the axiom of Maria consists of 4, 3, 2, 1; the sum of these numbers is 10, which stands for unity on a higher level. The unarius represents unity in the form of the *res simplex*, i.e., God as *auctor rerum*,² while the denarius is the result of the completed work. Hence the real meaning of the denarius is the Son of God.³ Although the alchemists call it the *filius philosophorum*,⁴ they use it as a Christ-symbol and at the same time employ the symbolic qualities of the ecclesiastical Christ-figure to characterize their Rebis.⁵ It is probably correct to say that the medieval Rebis had these Christian characteristics, but for the Hermaphroditus of Arabic and Greek sources we must conjecture a partly pagan tradition. The Church symbolism of *sponsus* and *sponsa* leads to the mystic union of the two, i.e., to the *anima Christi* which lives in the *corpus mysticum* of the Church. This unity underlies the idea of Christ's androgyny, which medieval alchemy exploited for its own ends. The much older figure of the Hermaphroditus, whose outward aspect probably derives from a Cyprian *Venus barbata*, encountered in the Eastern Church the already extant idea of an androgynous Christ, which is no doubt connected with the Platonic conception of the bisexual First Man, for Christ is ultimately the Anthropos.



Hie ist geboren die eddele Keyserin reich/
 Die meister nennen sie ihrer dochter gleich.
 Die vermeret sich/gebirt kinder ohn zal/
 Sein vnd dōlich rein/vmnd ohn alles mahl.

Die

Figure 10

[526] The denarius forms the *totius operis summa*, the culminating point of the work beyond which it is impossible to go except by means of the *multiplicatio*. For, although the denarius represents a higher stage of unity, it is also a multiple of 1 and can therefore be multiplied to infinity in the ratio of 10, 100, 1000, 10,000, etc., just as the mystical body of the Church is composed of an indefinitely large number of believers and is capable of multiplying that number without limit. Hence the Rebis is described as the *cibus sempiternus* (everlasting food), *lumen indeficiens*, and so forth; hence also the assumption that the tincture replenishes itself and that the work need only be completed once and for all time.⁶ But, since the *multiplicatio* is only an attribute of the denarius, 100 is no different from and no better than 10.⁷

[527] The *lapis*, understood as the cosmogonic First Man, is the *radix ipsius*, according to the *Rosarium*: everything has grown from this One and through this One.⁸ It is the Uroboros, the serpent that fertilizes and gives birth to itself, by definition an *increatedum*, despite a quotation from Rosarius to the effect that “Mercurius noster nobilissimus” was created by God as a “res nobilis.” This *creatum increatum* can only be listed as another paradox. It is useless to rack our brains over this

extraordinary attitude of mind. Indeed we shall continue to do so only while we assume that the alchemists were not being consciously and intentionally paradoxical. It seems to me that theirs was a perfectly natural view: anything unknowable could best be described in terms of opposites.⁹ A longish poem in German, evidently written at about the time it was printed in the 1550 *Rosarium*, explains the nature of the Hermaphroditus as follows:

[528] Here is born the Empress of all honour/

The philosophers name her their daughter.
She multiplies/bears children ever again/
They are incorruptibly pure and without stain.
The Queen hates death and poverty
She surpasses gold silver and jewellery/
All medicaments great and small.
Nothing upon earth is her equal/
Wherefore we say thanks to God in heaven.
O force constrains me naked woman that I am/
For unblest was my body when I first began.
And never did I become a mother/
Until the time when I was born another.
Then the power of roots and herbs did I possess/
And I triumphed over all sickness.
Then it was that I first knew my son/
And we two came together as one.
There I was made pregnant by him and gave birth
Upon a barren stretch of earth.
I became a mother yet remained a maid/
And in my nature was established.
Therefore my son was also my father/
As God ordained in accordance with nature.
I bore the mother who gave me birth/
Through me she was born again upon earth.
To view as one what nature hath wed/
Is in our mountain most masterfully hid.
Four come together in one/
In this our magisterial Stone.
And six when seen as a trinity/

Is brought to essential unity.
To him who thinks on these things aright/
God giveth the power to put to flight
All such sicknesses as pertain
To metals and the bodies of men.
None can do that without God's help/
And then only if he see through himself.
Out of my earth a fountain flows/
And into two streams it branching goes.
One of them runs to the Orient/
The other towards the Occident.
Two eagles fly up with feathers aflame/
Naked they fall to earth again.
Yet in full feather they rise up soon/
That fountain is Lord of sun and moon.
O Lord Jesu Christ who bestow'st
The gift through the grace of thy Holy Ghost:
He unto whom it is given truly/
Understands the masters' sayings entirely.
That his thoughts on the future life may dwell/
Body and soul are joined so well.
And to raise them up to their father's kingdom/
Such is the way of art among men.

[529] This poem is of considerable psychological interest. I have already stressed the anima nature of the androgyne. The “unblessedness” of the “first body” has its equivalent in the disagreeable, daemonic, “unconscious” anima which we considered in the last chapter. At its second birth, that is, as a result of the opus, this anima becomes fruitful and is born together with her son, in the shape of the Hermaphroditus, the product of mother-son incest. Neither fecundation nor birth impairs her virginity.¹⁰ This essentially Christian paradox is connected with the extraordinary *timeless* quality of the unconscious: everything has already happened and is yet unhappened, is already dead and yet unborn.¹¹ Such paradoxical statements illustrate the potentiality of unconscious contents. In so far as comparisons are possible at all, they are objects of memory and knowledge, and in this sense belong to the remote past; we therefore speak of “vestiges of primordial mythological ideas.” But, in so far as the unconscious manifests itself in a sudden incomprehensible invasion, it is something that was never there before, something altogether strange,

new, and belonging to the future. The unconscious is thus the mother as well as the daughter, and the mother has given birth to her own mother (*in creatum*), and her son was her father.¹² It seems to have dawned on the alchemists that this most monstrous of paradoxes was somehow connected with the self, for no man can practise such an art unless it be with God's help, and unless "he see through himself." The old masters were aware of this, as we can see from the dialogue between Morienus and King Kalid. Morienus relates how Hercules (the Byzantine Emperor Heraclius) told his pupils: "O sons of wisdom, know that God, the supreme and glorious Creator, has made the world out of four unequal elements and set man as an ornament between them." When the King begged for further explanation, Morienus answered: "Why should I tell you many things? For this substance [i.e., the arcanum] is extracted from you, and you are its ore; in you the philosophers find it, and, that I may speak more plainly, from you they take it. And when you have experienced this, the love and desire for it will be increased in you. And you shall know that this thing subsists truly and beyond all doubt.... For in this stone the four elements are bound together, and men liken it to the world and the composition of the world."¹³

[530] One gathers from this discourse that, owing to his position between the four world-principles, man contains within himself a replica of the world in which the unequal elements are united. This is the microcosm in man, corresponding to the "firmament" or "Olympus" of Paracelsus: that unknown quantity in man which is as universal and wide as the world itself, which is in him by nature and cannot be acquired. Psychologically, this corresponds to the collective unconscious, whose projections are to be found everywhere in alchemy. I must refrain from adducing more proofs of the psychological insight of the alchemists, since this has already been done elsewhere.¹⁴

[531] The end of the poem hints at immortality—at the great hope of the alchemists, the *elixir vitae*. As a transcendental idea, immortality cannot be the object of experience, hence there is no argument either for or against. But immortality as an *experience of feeling* is rather different. A feeling is as indisputable a reality as the existence of an idea, and can be experienced to exactly the same degree. On many occasions I have observed that the spontaneous manifestations of the self, i.e., the appearance of certain symbols relating thereto, bring with them something of the timelessness of the unconscious which expresses itself in a feeling of eternity or immortality. Such experiences can be extraordinarily impressive. The idea of the *aqua permanens*, the *in corruptibilitas lapidis*, the *elixir vitae*, the *cibus immortalis*, etc., is not so very strange, since it fits in with the phenomenology of the collective unconscious.¹⁵ It might seem a monstrous presumption on the part of the alchemist to imagine himself capable, even with God's help, of producing an everlasting substance. This claim gives many treatises an air of boastfulness and humbug on

account of which they have deservedly fallen into disrepute and oblivion. All the same, we should beware of emptying out the baby with the bath water. There are treatises that look deep into the nature of the *opus* and put another complexion on alchemy. Thus the anonymous author of the *Rosarium* says: "It is manifest, therefore, that the stone is the master of the philosophers, as if he [the philosopher] were to say that he does of his own nature that which he is compelled to do; and so the philosopher is not the master, but rather the minister, of the stone. Consequently, he who attempts through the art and apart from nature to introduce into the matter anything which is not in it naturally, errs, and will bewail his error."¹⁶ This tells us plainly enough that the artist does not act from his own creative whim, but is driven to act by the stone. This almighty taskmaster is none other than the self. The self wants to be made manifest in the work, and for this reason the *opus* is a process of individuation, a becoming of the self. The self is the total, timeless man and as such corresponds to the original, spherical,¹⁷ bisexual being who stands for the mutual integration of conscious and unconscious.

[532] From the foregoing we can see how the *opus* ends with the idea of a highly paradoxical being that defies rational analysis. The work could hardly end in any other way, since the *complexio oppositorum* cannot possibly lead to anything but a baffling paradox. Psychologically, this means that human wholeness can only be described in antinomies, which is always the case when dealing with a transcendental idea. By way of comparison, we might mention the equally paradoxical corpuscular theory and wave theory of light, although these do at least hold out the possibility of a mathematical synthesis, which the psychological idea naturally lacks. Our paradox, however, offers the possibility of an *intuitive* and *emotional* experience, because the unity of the self, unknowable and incomprehensible, irradiates even the sphere of our discriminating, and hence divided, consciousness, and, like all unconscious contents, does so with very powerful effects. This inner unity, or experience of unity, is expressed most forcibly by the mystics in the idea of the *unio mystica*, and above all in the philosophies and religions of India, in Chinese Taoism, and in the Zen Buddhism of Japan. From the point of view of psychology, the names we give to the self are quite irrelevant, and so is the question of whether or not it is "real." Its psychological reality is enough for all practical purposes. The intellect is incapable of knowing anything beyond that anyway, and therefore its Pilate-like questionings are devoid of meaning.

[533] To come back to our picture: it shows an apotheosis of the Rebis, the right side of the body being male, the left female. The figure stands on the moon, which in this case corresponds to the feminine lunar vessel, the *vas hermeticum*. Its wings betoken volatility, i.e., spirituality. In one hand it holds a chalice with three snakes in it, or possibly one snake with three heads; in the other, a single snake. This is an obvious

allusion to the axiom of Maria and the old dilemma of 3 and 4, and also to the mystery of the Trinity. The three snakes in the chalice are the chthonic equivalent of the Trinity, and the single snake represents, firstly, the unity of the three as expressed by Maria and, secondly, the “sinister” *serpens Mercurialis* with all its subsidiary meanings.¹⁸ Whether pictures of this kind are in any way related to the Baphomet¹⁹ of the Templars is an open question, but the snake symbolism²⁰ certainly points to the evil principle, which, although excluded from the Trinity, is yet somehow connected with the work of redemption. Moreover to the left of the Rebis we also find the raven, a synonym for the devil.²¹ The unfledged bird has disappeared: its place is taken by the winged Rebis. To the right, there stands the “sun and moon tree,” the *arbor philosophica*, which is the conscious equivalent of the unconscious process of development suggested on the opposite side. The corresponding picture of the Rebis in the second version²² has, instead of the raven, a pelican plucking its breast for its young, a well-known allegory of Christ. In the same picture a lion is prowling about behind the Rebis and, at the bottom of the hill on which the Rebis stands, there is the three-headed snake.²³ The alchemical hermaphrodite is a problem in itself and really needs special elucidation. Here I will say only a few words about the remarkable fact that the fervently desired goal of the alchemist’s endeavours should be conceived under so monstrous and horrific an image. We have proved to our satisfaction that the antithetical nature of the goal largely accounts for the monstrosity of the corresponding symbol. But this rational explanation does not alter the fact that the monster is a hideous abortion and a perversion of nature. Nor is this a mere accident undeserving of further scrutiny; it is on the contrary highly significant and the outcome of certain psychological facts fundamental to alchemy. The symbol of the hermaphrodite, it must be remembered, is one of the many synonyms for the goal of the art. In order to avoid unnecessary repetition I would refer the reader to the material collected in *Psychology and Alchemy*, and particularly to the lapis-Christ parallel, to which we must add the rarer and, for obvious reasons, generally avoided comparison of the *prima materia* with God.²⁴ Despite the closeness of the analogy, the *lapis* is not to be understood simply as the risen Christ and the *prima materia* as God; the *Tabula smaragdina* hints, rather, that the alchemical mystery is a “lower” equivalent of the higher mysteries, a sacrament not of the paternal “mind” but of maternal “matter.” The disappearance of theriomorphic symbols in Christianity is here compensated by a wealth of allegorical animal forms which tally quite well with *mater natura*. Whereas the Christian figures are the product of spirit, light, and good, the alchemical figures are creatures of night, darkness, poison, and evil. These dark origins do much to explain the misshapen hermaphrodite, but they do not explain everything. The crude, embryonic features of this symbol express the immaturity of the alchemist’s mind, which was not sufficiently developed to equip him for the difficulties of his task. He was underdeveloped in two senses: firstly he did not

understand the real nature of chemical combinations, and secondly he knew nothing about the psychological problem of projection and the unconscious. All this lay as yet hidden in the womb of the future. The growth of natural science has filled the first gap, and the psychology of the unconscious is endeavouring to fill the second. Had the alchemists understood the psychological aspects of their work, they would have been in a position to free their “uniting symbol” from the grip of instinctive sexuality where, for better or worse, mere nature, unsupported by the critical intellect, was bound to leave it. Nature could say no more than that the combination of supreme opposites was a hybrid thing. And there the statement stuck, in sexuality, as always when the potentialities of consciousness do not come to the assistance of nature—which could hardly have been otherwise in the Middle Ages owing to the complete absence of psychology.²⁵ So things remained until, at the end of the nineteenth century, Freud dug up this problem again. There now ensued what usually happens when the conscious mind collides with the unconscious: the former is influenced and prejudiced in the highest degree by the latter, if not actually overpowered by it. The problem of the union of opposites had been lying there for centuries in its sexual form, yet it had to wait until scientific enlightenment and objectivity had advanced far enough for people to mention “sexuality” in scientific conversation. The sexuality of the unconscious was instantly taken with great seriousness and elevated to a sort of religious dogma, which has been fanatically defended right down to the present time: such was the fascination emanating from those contents which had last been nurtured by the alchemists. The natural archetypes that underlie the mythologems of incest, the hierosgamos, the divine child, etc., blossomed forth—in the age of science—into the theory of infantile sexuality, perversions, and incest, while the *coniunctio* was rediscovered in the transference neurosis.²⁶

[534] The sexualism of the hermaphrodite symbol completely overpowered consciousness and gave rise to an attitude of mind which is just as unsavoury as the old hybrid symbolism. The task that defeated the alchemists presented itself anew: how is the profound cleavage in man and the world to be understood, how are we to respond to it and, if possible, abolish it? So runs the question when stripped of its natural sexual symbolism, in which it had got stuck only because the problem could not push its way over the threshold of the unconscious. The sexualism of these contents always denotes an unconscious identity of the ego with some unconscious figure (either anima or animus), and because of this the ego is obliged, willing and reluctant at once, to be a party to the hierosgamos, or at least to believe that it is simply and solely a matter of an erotic consummation. And sure enough it increasingly becomes so the more one believes it—the more exclusively, that is to say, one concentrates on the sexual aspect and the less attention one pays to the archetypal patterns. As we have seen, the whole question invites fanaticism because

it is so painfully obvious that we are in the wrong. If, on the other hand, we decline to accept the argument that because a thing is fascinating it is the absolute truth, then we give ourselves a chance to see that the alluring sexual aspect is but one among many—the very one that deludes our judgment. This aspect is always trying to deliver us into the power of a partner who seems compounded of all the qualities we have failed to realize in ourselves. Hence, unless we prefer to be made fools of by our illusions, we shall, by carefully analysing every fascination, extract from it a portion of our own personality, like a quintessence, and slowly come to recognize that we meet ourselves time and again in a thousand disguises on the path of life. This, however, is a truth which only profits the man who is temperamentally convinced of the individual and irreducible reality of his fellow men.

[535] We know that in the course of the dialectical process the unconscious produces certain images of the *goal*. In *Psychology and Alchemy* I have described a long series of dreams which contain such images (including even a shooting target). They are mostly concerned with ideas of the mandala type, that is, the circle and the quaternity. The latter are the plainest and most characteristic representations of the goal. Such images unite the opposites under the sign of the quaternio, i.e., by combining them in the form of a cross, or else they express the idea of wholeness through the circle or sphere. The superior type of personality may also figure as a goal-image, though more rarely. Occasionally special stress is laid on the luminous character of the centre. I have never come across the hermaphrodite as a personification of the goal, but more as a symbol of the initial state, expressing an identity with anima or animus.

[536] These images are naturally only anticipations of a wholeness which is, in principle, always just beyond our reach. Also, they do not invariably indicate a subliminal readiness on the part of the patient to realize that wholeness consciously, at a later stage; often they mean no more than a temporary compensation of chaotic confusion and lack of orientation. Fundamentally, of course, they always point to the self, the container and organizer of all opposites. But at the moment of their appearance they merely indicate the possibility of order in wholeness.

[537] What the alchemist tried to express with his Rebis and his squaring of the circle, and what the modern man also tries to express when he draws patterns of circles and quaternities, is wholeness—a wholeness that resolves all opposition and puts an end to conflict, or at least draws its sting. The symbol of this is a *coincidentia oppositorum* which, as we know, Nicholas of Cusa identified with God. It is far from my intention to cross swords with this great man. My business is merely the natural science of the psyche, and my main concern to establish the facts. How these facts are named and what further interpretation is then placed upon them is of secondary

importance. Natural science is not a science of words and ideas, but of facts. I am no terminological rigorist—call the existing symbols “wholeness,” “self,” “consciousness,” “higher ego,” or what you will, it makes little difference. I for my part only try not to give any false or misleading names. All these terms are simply names for the facts that alone carry weight. The names I give do not imply a philosophy, although I cannot prevent people from barking at these terminological phantoms as if they were metaphysical hypostases. The facts are sufficient in themselves, and it is well to know about them. But their interpretation should be left to the individual’s discretion. “The maximum is that to which nothing is opposed, and in which the minimum is also the maximum,”²⁷ says Nicholas of Cusa. Yet God is also above the opposites: “Beyond this coincidence of creating and being created art thou God.”²⁸ Man is an analogy of God: “Man is God, but not in an absolute sense, since he is man. He is therefore God in a human way. Man is also a world, but he is not all things at once in contracted form, since he is man. He is therefore a microcosm.”²⁹ Hence the *complexio oppositorum* proves to be not only a possibility but an ethical duty: “In these most profound matters every endeavour of our human intelligence should be bent to the achieving of that simplicity where contradictories are reconciled.”³⁰ The alchemists are as it were the empiricists of the great problem of the union of opposites, whereas Nicholas of Cusa is its philosopher.

EPILOGUE

[538] To give any description of the transference phenomenon is a very difficult and delicate task, and I did not know how to set about it except by drawing upon the symbolism of the alchemical *opus*. The *theoria* of alchemy, as I think I have shown, is for the most part a projection of unconscious contents, of those archetypal forms which are characteristic of all pure fantasy-products, such as are to be met with in myths and fairytales, or in the dreams, visions, and the delusional systems of individual men and women. The important part played in the history of alchemy by the hierosgamos and the mystical marriage, and also by the *coniunctio*, corresponds to the central significance of the transference in psychotherapy on the one hand and in the field of normal human relationships on the other. For this reason, it did not seem to me too rash an undertaking to use an historical document, whose substance derives from centuries of mental effort, as the basis and guiding thread of my argument. The gradual unfolding of the symbolic drama presented me with a welcome opportunity to bring together the countless individual experiences I have had in the course of many years' study of this theme—experiences which, I readily admit, I did not know how to arrange in any other way. This venture, therefore, must be regarded as a mere experiment; I have no desire to attribute any conclusive significance to it. The problems connected with the transference are so complicated and so various that I lack the categories necessary for a systematic account. There is in such cases always an urge to simplify things, but this is dangerous because it so easily violates the facts by seeking to reduce incompatibles to a common denominator. I have resisted this temptation so far as possible and allow myself to hope that the reader will not run away with the idea that the process I have described here is a working model of the average course of events. Experience shows, in fact, that not only were the alchemists exceedingly vague as to the sequence of the various stages, but that in our observation of individual cases there is a bewildering number of variations as well as the greatest arbitrariness in the sequence of states, despite all agreement in principle as to the basic facts. A logical order, as we understand it, or even the possibility of such an order, seems to lie outside the bounds of our subject at present. We are moving here in a region of individual and unique happenings that have no parallel. A process of this kind can, if our categories are wide enough, be reduced to an order of sorts and described, or at least adumbrated, with the help of analogies; but its inmost essence is the uniqueness of a life individually lived—which nobody can grasp from outside, but which, on the contrary, holds the individual in its grip. The series of pictures that served as our Ariadne thread is one of many,¹ so that

we could easily set up several other working models which would display the process of transference each in a different light. But no single model would be capable of fully expressing the endless wealth of individual variations which all have their *raison d'être*. Such being the case, it is clear to me that even this attempt to give a comprehensive account of the phenomenon is a bold undertaking. Yet its practical importance is so great that the attempt surely justifies itself, even if its defects give rise to misunderstandings.

[539] We live today in a time of confusion and disintegration. Everything is in the melting pot. As is usual in such circumstances, unconscious contents thrust forward to the very borders of consciousness for the purpose of compensating the crisis in which it finds itself. It is therefore well worth our while to examine all such borderline phenomena with the greatest care, however obscure they seem, with a view to discovering the seeds of new and potential orders. The transference phenomenon is without doubt one of the most important syndromes in the process of individuation; its wealth of meanings goes far beyond mere personal likes and dislikes. By virtue of its collective contents and symbols it transcends the individual personality and extends into the social sphere, reminding us of those higher human relationships which are so painfully absent in our present social order, or rather disorder. The symbols of the circle and the quaternity, the hallmarks of the individuation process, point back, on the one hand, to the original and primitive order of human society, and forward on the other to an inner order of the psyche. It is as though the psyche were the indispensable instrument in the reorganization of a civilized community as opposed to the collectivities which are so much in favour today, with their aggregations of half-baked mass-men. This type of organization has a meaning only if the human material it purports to organize is good for something. But the mass-man is good for nothing—he is a mere particle that has forgotten what it is to be human and has lost its soul. What our world lacks is the *psychic connection*; and no clique, no community of interests, no political party, and no State will ever be able to replace this. It is therefore small wonder that it was the doctors and not the sociologists who were the first to feel more clearly than anybody else the true needs of man, for, as psychotherapists, they have the most direct dealings with the sufferings of the soul. If my general conclusions sometimes coincide almost word for word with the thoughts of Pestalozzi, the deeper reason for this does not lie in any special knowledge I might possess of this great educator's writings, but in the nature of the subject itself, that is, in insight into the reality of man.



Figure 11



Figure 12



Figure 13

APPENDIX

THE REALITIES OF PRACTICAL PSYCHOTHERAPY¹

[540] Psychogenic disturbances, quite unlike organic diseases, are atypical and individual. With growing experience one even finds oneself at a loss in making a diagnosis. The neuroses, for example, vary so much from individual to individual that it hardly means anything when we diagnose “hysteria.” “Hysteria” has a meaning only in so far as it marks a distinction from an organic disease. To the psychotherapist it means infinitely less than typhoid, scarlet fever, or pneumonia do to the practising physician. It belongs to a group that is only vaguely defined both clinically and psychologically, like “obsessional neurosis” or “schizophrenia.” Though we cannot do without such a nomenclature, we use it with the feeling that we have not said very much. As a rule, the diagnosis does not greatly matter since the needs and the difficulties of the treatment have to do with quite other factors than the more or less fortuitous diagnosis. And because there are only individual illnesses, they practically never follow a typical course on which a specific diagnosis could be based.

[541] What we have said about diagnosis is also true of therapy in so far as this takes the form of an individual analysis. It is just as impossible to describe a typical course of treatment as it is to make a specific diagnosis. This radical, not to say nihilistic statement naturally does not apply to cases where a *method* is employed as a matter of principle. Here the accent lies on the procedure and not on the recognition of the individual symptoms and their aetiology. One can employ any method at random, so to speak, regardless of the individual factors; one can hypnotize, suggest, train the will, psychoanalyse in such a way that the individual neurosis amounts to little more than a *disturbance of the method employed*. A physician can treat syphilis with a mercury compound, or rheumatic fever with salicylate, without qualms and without under normal circumstances going wide of the mark. But when the psychotherapist treats neuroses according to Freud, Adler, or Jung—that is to say, when he employs their alleged methods as a matter of principle—it may easily happen that the procedure, although unexceptionable in itself, is so disturbed and thrown off the rails by an atypical neurosis that the entire treatment comes to nothing. The orthodox standpoint then holds that this was the patient’s fault, as though he had failed to take advantage of the indubitable blessings of the method, which in itself is always effective.

[542] One can employ methods as a matter of principle so long as the pathological processes are restricted to a field that is markedly collective and not individual, and so long as the premises on which the method is based are in accord with the pathological facts. Not everyone has a power complex, which as a rule is

characteristic of the unsuccessful person, nor is everyone involved in an incestuous romance, which happens only to those whose family have soured them against the pleasure principle. But when the premises of the method coincide with the problematical situation of the patient, the method will be successful up to the moment when its collective viewpoint can no longer grasp the individual factors that begin to appear. It is then no longer a question of fictions and inferiority feelings that can be reduced to power complexes, or of resistances and repressions that can be reduced to infantile sexuality, but of individual, unique factors of vital importance. When this point is reached, it is the method and the analyst that fail, not the patient. Yet I have had many patients who have dolefully confessed that they could not be treated because they always “failed” with the transference, in other words, could not produce one, when according to the method a transference was a therapeutic necessity. Any analyst who inculcates such things into his patients is entirely forgetting that “transference” is only another word for “projection.” No one can voluntarily *make* projections, they just *happen*. Besides that, they are illusions which merely make the treatment more difficult. What seems to be so easily won by the transference always turns out in the end to be a loss; for a patient who gets rid of a symptom by transferring it to the analyst always makes the analyst the guarantor of this miracle and so binds himself to him more closely than ever.

[543] When one employs a method on principle, it is perfectly possible, within those limits, to describe a more or less typical course of treatment. Speaking for myself, I must confess that experience has taught me to keep away from therapeutic “methods” as much as from diagnoses. The enormous variation among individuals and their neuroses has set before me the ideal of approaching each case with a minimum of prior assumptions. The ideal would naturally be to have no assumptions at all. But this is impossible even if one exercises the most rigorous self-criticism, for one is *oneself* the biggest of all one’s assumptions, and the one with the gravest consequences. Try as we may to have no assumptions and to use no ready-made methods, the assumption that I myself am will determine my method: as I am, so will I proceed.

[544] In spite of the differences between people, we must recognize that there are a great many similarities. As long as the analyst moves within a psychological sphere that is similar in kind to the patient’s, nothing of fundamental therapeutic importance has happened. He has at most laid the foundations of a mutual understanding, and this can be appealed to when he comes up against those essential differences in the patient to which the pathological process is always ready to return. These qualitative differences cannot be dealt with by any method that is based on premises held to be generally valid. If one wants to give a name to the process of coming to terms with them, one could call it a dialectical procedure—which means no more than an

encounter between my premises and the patient's. This encounter is complicated by the fact that the patient's premises are to some extent pathological, whereas a so-called "normal" attitude is presupposed of the analyst.

[545] "Normal" is a somewhat vague concept which simply means that the analyst at least has no neurosis and is more or less in full possession of his mental faculties. If, on the contrary, he is neurotic, a fateful, unconscious identity with the patient will inevitably supervene—a "counter-transference" of a positive or negative character. Even if the analyst has no neurosis, but only a rather more extensive area of unconsciousness than usual, this is sufficient to produce a sphere of mutual unconsciousness, i.e., a counter-transference. This phenomenon is one of the chief occupational hazards of psychotherapy. It causes psychic infections in both analyst and patient and brings the therapeutic process to a standstill. This state of unconscious identity is also the reason why an analyst can help his patient just so far as he himself has gone and not a step further. In my practice I have had from the beginning to deal with patients who got "stuck" with their previous analysts, and this always happened at the point where the analyst could make no further progress with himself. As soon as an unconscious identity appears, one notices a peculiar staleness and triteness in the analytical relationship, the dreams become incomprehensible or cease altogether, personal misunderstandings arise, with outbursts of affect, or else there is a resigned indifference which leads sooner or later to a discontinuation of the treatment.

[546] The reason for this may not always lie in the analyst's evasion of his personal difficulties, but in a *lack of knowledge, which has exactly the same effect as unconsciousness*. I remember a case that caused me no end of trouble.² It concerned a 25-year-old woman patient, who suffered from a high degree of emotivity, exaggerated sensitiveness, and hysterical fever. She was very musical; whenever she played the piano she got so emotional that her temperature rose and after ten minutes registered 100° F. or more. She also suffered from a compulsive argumentativeness and a fondness for philosophical hair-splitting that was quite intolerable despite her high intelligence. She was unmarried, but was having a love-affair which, except for her hypersensitivity, was perfectly normal. Before she came to me, she had been treated by an analyst for two months with no success. Then she went to a woman analyst, who broke off the treatment at the end of a week. I was the third. She felt she was one of those who were doomed to fail in analysis, and she came to me with pronounced feelings of inferiority. She didn't know why it hadn't worked with the other analysts. I got her to tell me her somewhat lengthy anamnesis, which took several consulting hours. I then asked her: "Did you notice that when you were treated by Dr. X [the first], you had at the very beginning a dream which struck you, and which you did not understand at the time?" She remembered at once that during

the second week of the treatment she had an impressive dream which she had not understood then, but which seemed clear enough to her in the light of later events. *She had dreamt that she had to cross a frontier. She had arrived at a frontier station; it was night, and she had to find where the frontier could be crossed, but she could not find the way and got lost in the darkness.* This darkness represented her unconsciousness, that is, her unconscious identity with the analyst, who was also in the dark about finding a way out of this unconscious state—which is what crossing the frontier meant. As a matter of fact, a few years later this analyst gave up psychotherapy altogether because of too many failures and personal involvements.

[547] Early in the second treatment, the dream of the frontier was repeated in the following form: *She had arrived at the same frontier station. She had to find the crossing, and she saw, despite the darkness, a little light in the distance showing where the place was. In order to get there, she had to go through a wooded valley in pitch-blackness. She plucked up her courage and went ahead. But hardly had she entered the wood than she felt somebody clinging to her, and she knew it was her analyst.* She awoke in terror. This analyst, too, later gave up her profession for very much the same reasons.

[548] I now asked the patient: “Have you had a dream like that since you have been with me?” She gave an embarrassed smile and told the following dream: *I was at the frontier station. A customs official was examining the passengers one by one. I had nothing but my handbag, and when it came to my turn I answered with a good conscience that I had nothing to declare. But he said, pointing to my handbag: “What have you got in there?” And to my boundless astonishment he pulled a large mattress, and then a second one, out of my bag.*” She was so frightened that she woke up.³

[549] I then remarked: “So you wanted to hide your obviously bourgeois wish to get married, and felt you had been unpleasantly caught out.” Though the patient could not deny the logical rightness of the interpretation, she produced the most violent resistances against any such possibility. Behind these resistances, it then turned out, there was hidden a most singular fantasy of a quite unimaginable erotic adventure that surpassed anything I had ever come across in my experience. I felt my head reeling, I thought of nymphomaniac possession, of weird perversions, of completely depraved erotic fantasies that rambled meaninglessly on and on, of latent schizophrenia, where at least the nearest comparative material could be found. I began to look askance at the patient and to find her unsympathetic, but was annoyed with myself for this, because I knew that no good results could be hoped for while we remained on such a footing. After about four weeks the undeniable symptoms of a standstill did in fact appear. Her dreams became sketchy, dull, dispiriting, and

incomprehensible. I had no more ideas and neither had the patient. The work became tedious, exhausting, and barren. I felt that we were gradually getting stuck in a kind of soggy dough. The case began to weigh upon me even in my leisure hours; it seemed to me uninteresting, hardly worth the bother. Once I lost patience with her because I felt she wasn't making any effort. "So here are the personal reactions coming out," I thought. The following night *I dreamt that I was walking along a country road at the foot of a steep hill. On the hill was a castle with a high tower. Sitting on the parapet of the topmost pinnacle was a woman, golden in the light of the evening sun. In order to see her properly, I had to bend my head so far back that I woke up with a crick in the neck.* I realized to my amazement that the woman was my patient.⁴

[550] The dream was distinctly disturbing, for the first thing that came into my head while dozing was the verse from Schenkenbach's "Reiterlied":

She sits so high above us,
No prayer will she refuse.

This is an invocation to the Virgin Mary. The dream had put my patient on the highest peak, making her a goddess, while I, to say the least, had been looking down on her.

[551] The next day I said to her: "Haven't you noticed that our work is stuck in the doldrums?" She burst into tears and said: "Of course I've noticed it. I know I always fail and never do anything right. You were my last hope and now this isn't going to work either." I interrupted her: "This time it is different. I've had a dream about you." And I told her the dream, with the result that the superficial symptomatology, her argumentativeness, her insistence on always being right, and her touchiness vanished. But now her real neurosis began, and it left me completely flabbergasted. It started with a series of highly impressive dreams, which I could not understand at all, and then she developed symptoms whose cause, structure, and significance were absolutely incomprehensible to me. They first took the form of an indefinable excitation in the perineal region, and she dreamt that a white elephant was coming out of her genitals. She was so impressed by this that she tried to carve the elephant out of ivory. I had no idea what it meant, and only had the uncomfortable feeling that something inexplicable was going on with a logic of its own, though I couldn't see at all where it would lead.

[552] Soon afterwards symptoms of uterine ulcers appeared, and I had to send the patient to a gynaecologist. There was an inflamed swelling of the mucous membrane of the uterus, about the size of a pea, which refused to heal after months of treatment and merely shifted from place to place.

[553] Suddenly this symptom disappeared, and she developed an extreme hyperaesthesia of the bladder. She had to leave the room two or three times during the consulting hour. No local infection could be found. Psychologically, the symptom meant that something had to be “ex-pressed.” So I gave her the task of expressing by drawings whatever her hand suggested to her. She had never drawn before, and set about it with much doubt and hesitation. But now symmetrical flowers took shape under her hand, vividly coloured and arranged in symbolic patterns.⁵ She made these pictures with great care and with a concentration I can only call devout.

[554] Meanwhile the hyperaesthesia of the bladder had ceased, but intestinal spasms developed higher up, causing gurgling noises and sounds of splashing that could be heard even outside the room. She also suffered from explosive evacuations of the bowels. At first the colon was affected, then the ileum, and finally the upper sections of the small intestine. These symptoms gradually abated after several weeks. Their place was then taken by a strange paraesthesia of the head. The patient had the feeling that the top of her skull was growing soft, that the fontanelle was opening up, and that a bird with a long sharp beak was coming down to pierce through the fontanelle as far as the diaphragm.

[555] The whole case worried me so much that I told the patient there was no sense in her coming to me for treatment, I didn’t understand two-thirds of her dreams, to say nothing of her symptoms, and besides this I had no notion how I could help her. She looked at me in astonishment and said: “But it’s going splendidly! It doesn’t matter that you don’t understand my dreams. I always have the craziest symptoms, but something is happening all the time.”

[556] I could only conclude from this peculiar remark that for her the neurosis was a positive experience; indeed, “positive” is a mild expression for the way she felt about it. As I could not understand her neurosis, I was quite unable to explain how it was that all these extremely unpleasant symptoms and incomprehensible dreams could give her such a positive feeling. One can, with an effort, imagine that *something* is better than nothing, even though this something took the form of disagreeable physical symptoms. But so far as the dreams were concerned, I can only say that I have seldom come across a series of dreams that seemed to be so full of meaning. Only, their meaning escaped me.

[557] In order to elucidate this extraordinary case, I must return to a point in the anamnesis which has not been mentioned so far. The patient was a full-blooded European, but had been born in Java. As a child she spoke Malay and had an *ayah*, a native nurse. When she was of school age, she went to Europe and never returned to the Indies. Her childhood world was irretrievably sunk in oblivion, so that she could not remember a single word of Malay. In her dreams there were frequent allusions to

Indonesian motifs, but though I could sometimes understand them I was unable to weave them into a meaningful whole.

[558] About the time when the fantasy of the fontanelle appeared, I came upon an English book which was the first to give a thorough and authentic account of the symbolism of Tantric Yoga. The book was *The Serpent Power*, by Sir John Woodroffe, who wrote under the pseudonym of Arthur Avalon. It was published about the time when the patient was being treated by me. To my astonishment I found in this book an explanation of all those things I had not understood in the patient's dreams and symptoms.

[559] It is, as you see, quite impossible that the patient knew the book beforehand. But could she have picked up a thing or two from the *ayah*? I regard this as unlikely because Tantrism, and in particular Kundalini Yoga, is a cult restricted to southern India and has relatively few adherents. It is, moreover, an exceedingly complicated symbolical system which no one can understand unless he has been initiated into it or has at least made special studies in this field. Tantrism corresponds to our Western scholasticism, and if anyone supposes that a Javanese *ayah* could teach a five-year-old child about the *chakra* system, this would amount to saying that a French nanny could induct her charge into the *Summa* of St. Thomas or the conceptualism of Abelard. However the child may have picked up the rudiments of the *chakra* system, the fact remains that its symbolism does much to explain the patient's symptoms.

[560] According to this system, there are seven centres, called *chakras* or *padmas* (lotuses), which have fairly definite localizations in the body. They are, as it were, psychic localizations, and the higher ones correspond to the historical localizations of consciousness. The nethermost *chakra*, called *mulādhāra*, is the perineal lotus and corresponds to the cloacal zone in Freud's sexual theory. This centre, like all the others, is represented in the shape of a flower, with a circle in the middle, and has attributes that express in symbols the psychic qualities of that particular localization. Thus, the perineal *chakra* contains as its main symbol the sacred *white elephant*. The next *chakra*, called *svadhīsthāna*, is localized near the bladder and represents the sexual centre. Its main symbol is water or sea, and subsidiary symbols are the sickle moon as the feminine principle, and a devouring water-monster called *makara*, which corresponds to the biblical and cabalistic Leviathan. The mythological whaledragon is, as you know, a symbol for the devouring and birth-giving womb, which in its turn symbolizes certain reciprocal actions between consciousness and the unconscious. The patient's bladder symptoms can be referred to the *svadhīsthāna* symbolism, and so can the inflamed spots in the uterus. Soon afterwards she began her drawings of flowers, whose symbolic content relates them quite clearly to the *chakras*. The third centre, called *manipura*, corresponds to the solar plexus. As we have seen, the noises

in the abdomen gradually moved up to the small intestine. This third *chakra* is the emotional centre, and is the earliest known localization of consciousness. There are primitives in existence who still think with their bellies. Everyday speech still shows traces of this: something lies heavy on the stomach, the bowels turn to water, etc. The fourth *chakra*, called *anāhata*, is situated in the region of the heart and the diaphragm. In Homer the diaphragm (*phren, phrenes*) was the seat of feeling and thinking.⁶ The fifth and sixth, called *vishuddha* and *ajña*, are situated respectively in the throat and between the eyebrows. The seventh, *sahasrāra*, is at the top of the skull.

[561] The fundamental idea of Tantrism is that a feminine creative force in the shape of a serpent, named *kundalinī*, rises up from the perineal centre, where she had been sleeping, and ascends through the *chakras*, thereby activating them and constellating their symbols. This “Serpent Power” is personified as the *mahādevishakti*, the goddess who brings everything into existence by means of *māyā*, the building material of reality.

[562] When the *kundalinī* serpent had reached the *manipura* centre in my patient, it was met by the bird of thought descending from above, which with its sharp beak pierced through the fontanelle (*sahasrāra chakra*) to the diaphragm (*anāhata*). Thereupon a wild storm of affect broke out, because the bird had implanted in her a thought which she would not and could not accept. She gave up the treatment and I saw her only occasionally, but noticed she was hiding something. A year later came the confession: she was beset by the thought that she wanted a child. This very ordinary thought did not fit in at all well with the nature of her psychic experience and it had a devastating effect, as I could see for myself. For as soon as the *kundalinī* serpent reached *manipura*, the most primitive centre of consciousness, the patient’s brain told her what kind of thought the *shakti* was insinuating into her: that she wanted a real child and not just a psychic experience. This seemed a great let-down to the patient. But that is the disconcerting thing about the *shakti*: her building material is *māyā*, “real illusion.” In other words, she spins fantasies with real things.

[563] This little bit of Tantric philosophy helped the patient to make an ordinary human life for herself, as a wife and mother, out of the local demonology she had sucked in with her *ayah*’s milk, and to do so without losing touch with the inner, psychic figures which had been called awake by the long-forgotten influences of her childhood. What she experienced as a child, and what later estranged her from the European consciousness and entangled her in a neurosis, was, with the help of analysis, transformed not into nebulous fantasies but into a lasting spiritual possession in no way incompatible with an ordinary human existence, a husband, children, and housewifely duties.

[564] Although this case is an unusual one, it is not an exception. It has served its purpose if it has enabled me to give you some idea of my psychotherapeutic procedure. The case is not in the least a story of triumph; it is more like a saga of blunders, hesitations, doubts, gropings in the dark, and false clues which in the end took a favourable turn. But all this comes very much nearer the truth and reality of my procedure than a case that brilliantly confirms the preconceived opinions and intentions of the therapist. I am painfully aware, as you too must be, of the gaps and shortcomings of my exposition, and I must rely on your imagination to supply a large part of what has been left unsaid. If you now recall that mutual ignorance means mutual unconsciousness and hence unconscious identity, you will not be wrong in concluding that in this case the analyst's lack of knowledge of Oriental psychology drew him further and further into the analytical process and forced him to participate as actively as possible. Far from being a technical blunder, this is a fate-sent necessity in such a situation. Only your own experience can tell you what this means in practice. No psychotherapist should lack that natural reserve which prevents people from riding roughshod over mysteries they do not understand and trampling them flat. This reserve will enable him to pull back in good time when he encounters the mystery of the patient's difference from himself, and to avoid the danger—unfortunately only too real—of committing psychic murder in the name of therapy. For the ultimate cause of a neurosis is something *positive* which needs to be safeguarded for the patient; otherwise he suffers a psychic loss, and the result of the treatment is at best a defective cure. The fact that our patient was born in the East and spent the most important years of her childhood under Oriental influences is something that cannot be eliminated from her life. The childhood experience of a neurotic is not, in itself, negative; far from it. It becomes negative only when it finds no suitable place in the life and outlook of the adult. The real task of analysis, it seems to me, is to bring about a synthesis between the two.

BIBLIOGRAPHY

BIBLIOGRAPHY

The items of the bibliography are arranged alphabetically under two headings: *A.* Ancient volumes containing collections of alchemical tracts by various authors; *B.* General bibliography, including cross-references to the material in section *A.* Short titles of the ancient volumes are printed in capital letters.

A. ANCIENT VOLUMES CONTAINING COLLECTIONS OF ALCHEMICAL TRACTS BY VARIOUS AUTHORS

ARS CHEMICA, quod sit licita recte exercentibus, probationes doctissimorum iurisconsultorum.... Strasbourg, 1566.

Contents quoted in this volume:

- i Septem tractatus seu capitula Hermetis Trismegisti aurei [pp. 7–31; usually referred to as “Tractatus aureus”]
- ii Studium Consilii coniugii de massa solis et lunae [pp. 48–263; usually referred to as “Consilium coniugii”]

ARTIS AURIFERAE quam chemiam vocant.... Basel, [1593]. 2 vols.

Contents quoted in this volume:

VOLUME I

- i Aenigmata ex visione Arislei philosophi et allegoriis sapientum [pp. 146–54; usually referred to as “Visio Arislei”]
- ii In Turbam philosophorum exercitationes [pp. 154–82]
- iii Aurora consurgens, quae dicitur Aurea hora [Part II only] [pp. 185–246]
- iv Rosinus ad Euthicium [pp. 246–77]
- v Rosinus ad Sarratantam episcopum [pp. 277–319]
- vi Maria Prophetissa: Practica... in artem alchemicam [pp. 319–24]
- vii Kalid: Liber secretorum alchemiae [pp. 325–51]
- viii Kalid: Liber trium verborum [pp. 352–61]
- ix Tractatulus Aristotelis de practica lapidis philosophici [pp. 361–73]
- x Merlinus: Allegoria de arcano lapidis [pp. 392–96]
- xi Tractatulus Avicennae [pp. 405–36]
- xii Liber de arte chimica [pp. 575–631]

VOLUME II

xiii Morienus Romanus: Sermo de transmutatione metallica [pp. 7–54]

xiv Rosarium philosophorum [pp. 204–384]

MANGET (US), JOANNES JACOBUS (ed.). *BIBLIOTHECA CHEMICA CURIOSA, seu Rerum ad alchemiam pertinentium thesaurus instructissimus....* Geneva, 1702. 2 vols.

Contents quoted in this volume:

i Hermes Trismegistus: Tractatus aureus de lapidis physici secreto [pp. 400–445]

ii Lully: Testamentum novissimum, regi Carolo dicatum [pp. 790–806]

iii [Altus:] Mutus Liber, in quo tamen tota Philosophia hermetica figuris hieroglyphicis depingitur [pp. 938–53]

MUSAEUM HERMETICUM rejormatum et amplificatum... continens tractatus chimicos XXI praestantissimos... Frankfurt a. M., 1678. For translation, see (B) WAITE.

Contents quoted in this volume:

i [Hermes Trismegistus:] Tractatus aureus de philosophorum lapide [pp. 1–52]

ii [Barcius (F. von Sternberg):] Gloria mundi, alias Paradisi tabula [pp. 203–304]

iii Lamspringk: De lapide philosophico figurae et emblemata [pp. 337–72]

iv Philalethes: Introitus apertus ad occlusum regis palatium [pp. 647–700]

v Philalethes: Fons chemica veritatis [pp. 799–814]

THEATRUM CHEMICUM, praecipuos selectorum auctorum tractatus... continens. Vols. I-III, Ursel, 1602; Vols. IV-VI, Strasbourg, 1613, 1622, 1661.

Contents quoted in this volume:

VOLUME I

i Hoghelande: Liber de alchemiae difficultatibus [pp. 121–215]

ii Dorn: Speculativae philosophiae, gradus septem vel decern continens [pp. 255–310]

iii Dorn: Physica Trismegisti [pp. 405–37]

iv Dorn: Duellum animi cum corpore [pp. 535–50]

v Dorn: Congeries Paracelsicae chemicae de transmutationibus metallorum [pp. 557–646]

vi Zacharius, Dionysius: Opusculum philosophiae naturalis metallorum, cum annotationibus Nicolai Flamelli [pp. 804–901]

VOLUME II

- vii Aegidius de Vadis: Dialogus inter naturam et filium philosophiae [pp. 95–123]
- viii Penotus: Quinquaginta septem canones de opere physico [pp. 150–54]
- ix Dee: Monas hieroglyphica [pp. 203–43]
- x Ventura: De ratione conficiendi lapidis [pp. 244–356]

VOLUME III

- xi [Melchior:] Addam et processum sub forma missae, a Nicolao [Melchiori] Cibinensi, ad Ladislaum Ungariae et Bohemiae regem olim missum [pp. 853–60]

VOLUME IV

- xii Artefius: Clavis maioris sapientiae [pp. 221–40]
- xiii Avicenna: Declaratio lapidis physici filio suo Aboali [pp. 986–94]

VOLUME V

- xiv Liber Platonis quartorum... [pp. 114–208]
- xv Mennens: Aureum vellus [pp. 267–470]
- xvi Bonus: Pretiosa margarita novella [pp. 589–794]
- xvii Tractatus Aristotelis alchymistae ad Alexandrum Magnum, de lapide philosophico [pp. 880–92]

THEATRUM CHEMICUM BRITANNICUM... Collected with annotations by Elias Ashmole. London, 1652.

Contents quoted in this volume:

- i Norton: The Ordinall of Alchimy [pp. 13–106; for a modern edition see (B) NORTON]

B. GENERAL BIBLIOGRAPHY

ABŪ 'L-QĀSIM. See HOLMYARD.

Acta Joannis (Acts of John). See JAMES.

Adumbratio Kabbalae Christianae. See KNORR VON ROSENROTH.

AEGIDIUS DE VADIS. See (A) *Theatrum chemicum*, vii.

AGRIPPA VON NETTESHEIM, HEINRICH CORNELIUS. *De incertitudine et vanitate omnium scientiarum*. The Hague, 1653.

ALBERTUS MAGNUS (Albert the Great, Saint). *Opera omnia*. Ed. Auguste and Emil Borgnet. Paris, 1890–99. 38 vols. (“Summa theologica,” vols. 31–35.)

[ALTUS.] *Mutus liber, in quo tamen tota philosophia hermetica figuris hieroglyphicis depingitur*. La Rochelle, 1677. See also (A) *Bibliotheca chemica curiosa*, iii, the source of figs. 11–13.

AMBROSE, SAINT. *De Noe et arca*. See MIGNE, *P.L.*, vol. 14, cols. 381–428.

ANASTASIUS SINAÏTA. *Anagogicae contemplationes in hexaemeron ad Theophilum*. See MIGNE, *P.G.*, vol. 89, cols. 851–1078.

ANDREAE, JOHANN VALENTIN. See ROSENCREUTZ.

ANGELUS SILESIUS (Johannes Scheffler). *Der Cherubinischer Wandersmann*. In: *Sämtliche poetische Werke*. Edited by H. L. Held. Munich, 1924.

Anthropophyteia. Jahrbücher für folkloristische Erhebungen und Forschungen. Edited by Thomas Achelis and others. Leipzig, 1905–12. 9 vols.

ARISTOTLE, pseud. See (A) *Artis auriferae*, ix; (A) *Theatrum chemicum*, xvii.

ARTEFIUS. See (A) *Theatrum chemicum*, xii.

ATWOOD, MARY ANNE. *A Suggestive Inquiry into the Hermetic Mystery*. Belfast, 1920.

AUGUSTINE, SAINT. *Annotationes in Job*. See MIGNE, *P.L.*, vol. 34, cols. 825–86.

_____. *The Confessions of Saint Augustine*. Translated by Francis Joseph Sheed. London, 1943.

_____. *Epistula LV*. See MIGNE, *P.L.*, vol. 33, cols. 208–09.

“Aurora consurgens.”

Part I. See *Codices and MSS*, iii.

Part II. See (A) *Artis auriferae*, iii.

See also FRANZ, MARIE-LOUISE VON.

AVALON, ARTHUR, pseud. (Sir John Woodroffe) (ed. and trans.). *The Serpent Power*. Translated from the Sanskrit. 3rd revised edn., Madras and London, 1931.

AVICENNA. See (A) *Theatrum chemicum*, xiii; (A) *Artis auriferae*, xi.

Baruch, Apocalypse of. See CHARLES.

BAYNES, CHARLOTTE AUGUSTA. *A Coptic Gnostic Treatise Contained in the Codex Brucianus*. Cambridge, 1933.

BENOÎT, PIERRE. *Atlantida*. Translated by Mary C. Tongue and Mary Ross. [Original: *L'Atlantide*.]

BERNARD OF CLAIRVAUX, SAINT. *Sermones in Cantica Canticorum*. See MIGNE, P.L., vol. 183, cols. 785–1198. For translation, see: *Sermons on the Canticle of Canticles*. Translated by a Priest of Mount Melleray. Dublin, 1920. 2 vols.

BÉROALDE DE VERVILLE, FRANÇOIS. See COLONNA.

BERTHELOT, MARCELLIN. *La Chimie au moyen âge*. (Histoire de sciences.) Paris, 1893. 3 vols.

_____. *Collection des anciens alchimistes grecs*. Paris, 1887–88. 3 vols.

BONUS, PETRUS. See (A) *Theatrum chemicum*, xvi.

BOUSSET, WILHELM. *Hauptprobleme der Gnosis*. (Forschungen zur Religion und Literatur des alten und neuen Testaments, X.) Göttingen, 1907.

BROWN, WILLIAM. “The Revival of Emotional Memories and Its Therapeutic Value,” *British Journal of Psychology* (London), *Medical Section*, I (1920–21), 16–19.

CARDAN, JEROME (Hieronymus Cardanus). *Somniorum synesiorum omnis generis insomnia explicantes libri IV*. Basel, 1585. 2 vols.

CHARLES, ROBERT HENRY (ed.). *Apocrypha and Pseudepigrapha of the Old Testament*. Oxford, 1913. 2 vols. (“Apocalypse of Baruch,” vol. II, pp. 470–526.)

CHRISTENSEN, ARTHUR. *Les Types du premier homme et du premier roi dans l’histoire légendaire des Iraniens*. (Archives d’études orientales, XIV, parts 1–2.) Stockholm, 1917; Leiden, 1934.

CHWOLSOHN, DANIEL ABRAMOVICH. *Die Ssabier und der Ssabismus*. St. Petersburg, 1856. 2 vols.

Codices and Manuscripts:

i Florence. Biblioteca Medicea-Laurenziana. MS Ashburnham 1166. “Miscellanea d’alchimia.” 14th cent.

ii Paris. Bibliothèque nationale. MS Latin 919. “Grandes heures du duc de Berry.” 1413.

iii Zurich. Zentralbibliothek. Codex Rhenoviensis 172. 15th cent. Item 1: “Aurora consurgens.” (Note: Mutilated MS beginning at the fourth parable.)

COLONNA, FRANCESCO. *Hypnerotomachia Poliphili...* Venice, 1499. For French translation, see: *Le Songe de Poliphile*. Translated by François Béroalde de Verville. Paris, 1600. For English paraphrase, see: *The Dream of Poliphilo*. Related and interpreted by Linda Fierz-David. Translated by Mary Hottinger. (Bollingen Series XXV.) New York, 1950.

“Consilium coniugii.” See (A) *Ars chemica*, ii.

DEE, JOHN. See (A) *Theatrum chemicum*, ix.

DORN, GERHARD. See (A) *Theatrum chemicum*, ii-v.

DU CANGE, CHARLES DU FRESNE, SIEUR. *Glossarium ad scriptores mediae et infimae graecitatis*. Lyons, 1688. 2 vols.

“Exercitationes in Turbam.” See (A) *Artis auriferae*, ii.

FERGUSON, JOHN. *Bibliotheca chemica*. Glasgow, 1906. 2 vols.

FIERZ-DAVID, HANS EDUARD. *Die Entwicklungsgeschichte der Chemie*. Basel, 1945.

FIERZ-DAVID, LINDA. See COLONNA.

FIRMICUS MATERNUS, JULIUS. *Julii Firmici Materni Matheseos Libri VIII*. Ed. W. Kroll and F. Skutsch. Leipzig, 1897–1913. 2 vols. (“Mathesis V. praefatio,” vol. II, pp. 1–66.)

FLAMEL, NICHOLAS. See (A) *Theatrum chemicum*, vi.

FRANZ, MARIE-LOUISE VON. *Aurora Consurgens: A Document on the Alchemical Problem of Opposites, Attributed to Thomas Aquinas*. Translated by R. F. C. Hull and A. S. B. Glover. New York (Bollingen Series) and London, 1966.

FRAZER, SIR JAMES GEORGE. *Taboo and the Perils of the Soul*. (*The Golden Bough*, 3rd edn., vol. III.) London, 1911.

_____. *Totemism and Exogamy*. London, 1910. 4 vols.

FREUD, SIGMUND. “Fragment of an Analysis of a Case of Hysteria.” Translated by Alix and James Strachey. In: Standard Edn.,* vol. 7. 1953.

_____. *Introductory Lectures on Psycho-Analysis*. Translated by James Strachey. Standard Edn.,* vols. 15, 16. 1963.

_____. “Leonardo da Vinci and a Memory of His Childhood.” Translated by Alan Tyson. In: Standard Edn.,* vol. 11. 1957.

_____. “Observations on Transference-Love.” Translated by Joan Riviere. In: Standard Edn.,* vol. 12. 1958.

_____. “Remembering, Repeating, and Working-Through.” Translated by Joan Riviere. In: Standard Edn.,* vol. 12. 1958.

FROBENIUS, LEO. *Das Zeitalter des Sonnengottes*. Berlin, 1904.

“Gloria mundi.” See (A) *Musaeum hermeticum*, ii.

- GOETHE, JOHANN WOLFGANG VON. *West-östlicher Divan*. For translation, see: *West-Easterly Divan*. Translated with an introduction and notes by J. Weiss. Boston, 1877.
- GOODENOUGH, ERWIN. "The Crown of Victory in Judaism," *Art Bulletin* (New York), XXVIII (1926), 135–59.
- GOWER, JOHN. *The Complete Works...* Edited by G. C. Macaulay. Oxford, 1899–1902. 4 vols. (*Confessio amantis*, vols. II and III.)
- GREGORY THE GREAT, SAINT. *Epistolae*. See MIGNE, *P.L.*, vol. 77, cols. 441–1328.
- _____. *Super Cantica Canticorum Expositio*. See MIGNE, *P.L.*, vol. 79, cols. 471–548.
- GUTERMAN, NORBERT (trans.). *Russian Fairy Tales*. London and New York, 1946. (Derived from the original collection of A. N. Afanasiev.)
- HAGGARD, SIR HENRY RIDER. *Ayesha, or The Return of She*. London, 1905
- _____. *She*. London, 1887.
- HAMMER-PURGSTALL, JOSEPH. *Mémoire sur deux coffrets gnostiques du moyen âge*. Paris, 1835.
- _____. *Mysterium Baphometis revelatum seu Fratres militiae Templi*. (Fundgruben des Orients, VI.) Vienna, 1818.
- HARDING, M. ESTHER. *Woman's Mysteries, Ancient and Modern*. New York, rev. edn., 1955.
- HASTINGS, JAMES (ed.). *Encyclopedia of Religion and Ethics*. Edinburgh and New York, 1908–27. 13 vols.
- HAUCK, ALBERT (ed.). *Realencyklopädie für protestantische Theologie und Kirche*. Leipzig, 1896–1913. 24 vols.
- HERMES TRISMEGISTUS. See "Tractatus aureus."
- HIPPOLYTUS. *Elenchos*. In: *Hippolytus Werke*, vol. III. Edited by Paul Wendland. (Die griechische christliche Schriftsteller, XXVI.) Leipzig, 1916.
- HOCART, ARTHUR MAURICE. *Kings and Councillors*. Cairo, 1936.
- HOGHELANDE, THEOBALD DE. See (A) *Theatrum chemicum*, i.
- HOLMYARD, ERIC JOHN. "Abū 'l-Qāsim al-Irāqī," *Isis* (Bruges), VIII (1926), 403–26.
- HORTULANUS (Joannes de Garlandia). "Commentarius in Tabulam Smaragdinam Hermetis Trismegisti." In: *De Alchemia*. Nuremberg, 1541. (Pp. 364–73.)

HOWITT, ALERED WILLIAM. *The Native Tribes of South-East Australia*. London and New York, 1904.

IRENAEUS, SAINT. *Contra (Adversus) haereses*. See MIGNE, P.G., vol. 7, cols. 433–1224. For translation, see: *Five Books of S. Irenaeus... against Heresies*. Translated by John Keble. Oxford, 1872.

ISIDORE OF SEVILLE, SAINT. *Liber etymologiarum*. See MIGNE, P.L., vol. 82, cols. 73–728.

JACOBI, JOLANDE. *The Psychology of C. G. Jung*. 8th revised edn., translated by Ralph Manheim. London and New Haven, 1973.

JAMES, MONTAGUE RHODES (ed. and trans.). *The Apocryphal New Testament*. Oxford, 1924. (“Acts of John,” pp. 228–70.)

JAMES, WILLIAM. *The Varieties of Religious Experience*. London and New York, 1922.

JEROME, SAINT. *Adversus Jovinianum*. See MIGNE, P.L., vol. 23, cols. 211–338. For translation, see: *Letters and Select Works*. Translated by W. H. Freemantle and others. (Select Library of Nicene and Post-Nicene Fathers.) New York, Oxford, and London, 1893.

John, Acts of. See JAMES, MONTAGUE RHODES.

JOHN OF THE CROSS, SAINT. *The Complete Works...* Translated by E. Allison Peers. London, 1934–35. (“The Dark Night of the Soul,” vol. I, pp. 335–486.)

JUNG, CARL GUSTAV.* *Aion*. (*Coll. Works*, 9, ii.)

_____. “Analytical Psychology and Education.” In *Coll. Works*, 17.

_____. “Brother Klaus.” In *Coll. Works*, 11.

_____. “Concerning the Archetypes, with Special Reference to the Anima Concept.” In *Coll. Works*, 9, i.

_____. “Concerning Mandala Symbolism.” In *Coll. Works*, 9, i.

_____. *Mysterium Coniunctionis*. (*Coll. Works*, 14.)

_____. “On Psychic Energy.” In *Coll. Works*, 8.

_____. “On the Psychology of the Unconscious.” In *Coll. Works*, 7.

_____. “Paracelsus as a Spiritual Phenomenon.” In *Coll. Works*, 13.

_____. *Psychological Types*. (*Coll. Works*, 6.) (Alternative source: *Psychological Types*, translated by H. G. Baynes. London and New York, 1923.)

_____. *Psychology and Alchemy*. (*Coll. Works*, 12.)

- _____. "Psychology and Religion." In *Coll. Works*, 11
- _____. "The Relations between the Ego and the Unconscious." In *Coll. Works*, 7.
- _____. "The Spirit Mercurius." In *Coll. Works*, 13.
- _____. "A Study in the Process of Individuation." In *Coll. Works*, *underline 9, i.*
- _____. *Symbols of Transformation*. (*Coll. Works*, 5.)

JUNG, CARL GUSTAV. "Synchronicity: An Acausal Connecting Principle." In *Coll. Works*, 8.

- _____. "The Theory of Psychoanalysis." In *Coll. Works*, 4.
- _____. *Two Essays on Analytical Psychology*. (*Coll. Works*, 7.)
- _____. "The Visions of Zosimos." In *Coll. Works*, 13.

*

*

KALID. "Liber secretorum alchemiae." See (A) *Artis auriferae*, vii.

_____. "Liber trium verborum." See (A) *Artis auriferae*, viii.

KEKULÉ VON STRADONITZ, FRIEDRICH AUGUST. *Lehrbuch der organischen Chemie*. Continued with the co-operation of Richard Anschütz and G. Schultz. Erlangen and Stuttgart, 1861–87. 4 vols.

KERÉNYI, C. (OR KARL). *Asklepios: Archetypal Image of the Physician's Existence*. Translated by Ralph Manheim. (Archetypal Images in Greek Religion, 3.) New York (Bollingen Series) and London, 1959.

KHUNRATH, HEINRICH CONRAD. *Amphitheatrum sapientiae aeternae*. Hanau, 1604.

_____. *Von hylealischen, das ist, pri-materialischen catholischen, oder allgemeinem natürlichen Chaos*. Magdeburg, 1597.

KIRCHER, ATHANASIUS. *Oedipus Aegyptiacus*. Rome, 1652–54. 3. vols.

KLINZ, ALBERT. *Ἱερός γάμος: Quaestiones selectae ad sacras nuptias Graecorum religionis et poeseos pertinentes*. Halle, 1933.

KNORR VON ROSENROTH, CHRISTIAN. *Kabbala denudata*. Sulzbach and Frankfurt a. M., 1677–84. 2 vols. (The "Adumbratio kabbalae christianae" is an Appendix to vol. II.)

KOCH, JOSEF (ed.). "Cusanus-Texte," *Sitzungsberichte der Heidelberger Akademie der Wissenschaften, Philosophisch-historische Klasse*, 1936/7, Abh. 2.

- KOHUT, ALEXANDER. "Die talmudisch-midrassische Adamssage in ihrer Rückbeziehung auf die persische Yima- und Meshiasage," *Zeitschrift der Deutschen morgenländischen Gesellschaft* (Leipzig), XXV (1871), 59–94.
- KRANEFELDT, W. M. "Komplex und Mythos." In: C. G. JUNG and others, *Seelenprobleme der Gegenwart*. 4th edn., Zurich, 1950. (Orig., 1931.)
- KRÖNLEIN, J. H. "Amalrich von Bena und David von Dinant," *Theologische Studien und Kritiken* (Hamburg), XXIX (1847), 271ff.
- KUNIKE, HUGO (ed.). *Märchen von Sibirien*. (Die Märchen der Weltliteratur.) Jena, 1923.
- LAMBSRINGK. See (A) *Musaeum hermeticum*, iii.
- LAVAUD, M. B. *Vie profonde de Nicolas de Flue*. Fribourg, 1942.
- LAYARD, JOHN. "The Incest Taboo and the Virgin Archetype," *Eranos-Jahrbuch 1944* (Zurich), XII (1945), 253ff.
- _____. *Stone Men of Malekula: Vao*. London, 1942.
- LEISEGANG, HANS. *Der heilige Geist*. Leipzig, 1919. Vol. I (no more published).
- LÉVY-BRUHL, LUCIEN. *How Natives Think*. Translated by Lilian A. Clare (from *Les Fonctions mentales dans les sociétés inférieures*). London, 1926.
- "Liber de arte chimica." See (A) *Artis auriferae*, xii.
- "Liber Platonis quartorum." See (A) *Theatrum chemicum*, xiv.
- LULLY, RAYMUND. "Testamentum." See (A) *Bibliotheca chemica*, ii.
- LYDUS, JOANNES (Johannes Laurentius). *De mensibus*. Edited by Richard Wünsch. Leipzig, 1898.
- MCDUGALL, WILLIAM. "The Revival of Emotional Memories and its Therapeutic Value," *British Journal of Psychology* (London), *Medical Section*, I (1920–21), 23–29.
- MAIER, MICHAEL. *De circulo physico quadrato*. Oppenheim, 1616.
- _____. *Symbola aureae mensae duodecim nationum*. Frankfurt a. M., 1617.
- MANGET, JEAN JACQUES. See (A) *Bibliotheca chemica curiosa*.
- MARIA PROPHETISSA. See (A) *Artis auriferae*, vi.
- MEIER, C. A. "Moderne Physik–moderne Psychologie." In: *Die kulturelle Bedeutung der komplexen Psychologie*. Berlin, 1935. (Pp. 349–62.)

- MEIER, C. A. "Spontanmanifestationen des kollektiven Unbewussten," *Zentralblatt für Psychotherapie* (Leipzig), XI (1939), 284–303.
- MELCHIOR, NICHOLAS, OF HERMANNSTADT (Cibinensis) (Nicolaus Melchior Szebeni). See (A) *Theatrum chemicum*, xi.
- MENNENS, GULIELMUS. See (A) *Theatrum chemicum*, xv.
- MERLINUS. See (A) *Artis auriferae*, x.
- MIGNE, JACQUES PAUL (ed.). *Patrologiae cursus completus*.
[P.L.] Latin Series. Paris, 1844–80. 221 vols.
[P.L.] Greek Series. Paris, 1857–66. 166 vols.
[These works are referred to as "MIGNE, P.L.," and "MIGNE, P.G.," respectively. References are to columns, not to pages.]
- MORIENUS ROMANUS. See (A) *Artis auriferae*, xiii.
- MURRAY, HENRY ALEXANDER (ed.). *Explorations in Personality*. New York and London, 1938.
- "Mutus liber." See ALTUS.
- MYLIUS, JOHANN DANIEL. *Philosophia reformata*. Frankfurt a. M., 1622.
- NAUMANN, HANS AND IDA (trans.). *Isländische Volksmärchen*. (Die Märchen der Weltliteratur.) Jena, 1923.
- NICHOLAS [KHRYPFFS] OF CUSA (Nicolaus Cusanus). *De conjecturis novissimorum temporum*. In: *Opera*. Basel, 1565.
- _____. *De docta ignorantia*. Edited by Paolo Rotta. Bari, 1923. For translation, see: *Of Learned Ignorance*. Translated by Germain Heron. London, 1954.
- _____. See also KOCH, JOSEF.
- NICOLAI, CHRISTOPH FRIEDRICH. *Versuch über die Beschuldigungen, welche dem Tempelherrenorden gemacht wurden*. Berlin and Stettin, 1782.
- NORTON, THOMAS. *The Ordinall of Alchimy*. With an introduction by E. J. Holmyard. London, 1928; Baltimore, 1929.
- _____. See also (A) *Theatrum chemicum Britannicum*, i.
- NOTKER BALBULUS. *Hymnus in die Pentecostes*. See MIGNE, P.L., vol. 131, cols. 1012–13.

- ONIAN, RICHARD BROXTON. *The Origins of European Thought*. 2nd edn., Cambridge, 1954.
- ORIGEN. *Homiliae in Leviticum*. See MIGNE, P.G., vol. 12, cols. 405–574.
- _____. *Homiliae in librum Regnorum*. See MIGNE, P.G., vol. 12, cols. 995–1028.
- PARACELUS (Theophrastus Bombast of Hohenheim). “De ente Dei.” In: *Sämtliche Werke*, I. Abt.: *Medizinische... Schriften*, ed. K. Sudhoff and W. Matthiessen, Munich and Berlin, 1922–33, 14 vols. (Vol. I, pp. 225–233.)
- _____. [*Labyrinthus medicorum errantium*.] “Vom Irrgang der Ärzte.” In: *Sämtliche Werke* (see previous entry), vol. XI, pp. 161–221.
- PAULINUS OF AQUILEIA. *Liber exhortationis ad Henricum Forojuliensem*. See MIGNE, P.L., vol. 99, cols. 197–282.
- PENOTUS, BERNARDUS GEORGIUS (Bernardus à Portu). See (A) *Theatrum chemicum*, viii.
- PESTALOZZI, JOHANN HEINRICH. *Ideen*. (*Pestalozzis Werk*, edited by Martin Hürlimann, II.) Zurich, 1927.
- PHILALETHES. See (A) *Musaeum hermeticum*, iv-v.
- PLATO. *Timaeus*. For translation, see: *The Timaeus and the Critias or Atlantis*. Translated by Thomas Taylor. (Bollingen Series III.) New York, 1944.
- PLATO, pseud. See (A) *Theatrum chemicum*, xiv.
- PORDAGE, JOHN. “Philosophisches Send-Schreiben vom Stein der Weisheit.” See ROTH-SCHOLTZ.
- _____. *Sophia: das ist die holdseelige ewige Jungfrau der göttlichen Weisheit....* Amsterdam, 1699.
- PREISENDANZ, KARL (ed.). *Papyri Graecae magicae: die griechischen Zauberpapyri*. Leipzig and Berlin, 1928–31. 2 vols.
- PROCLUS DIADOCHUS. *In Platonis Timaeum Commentaria*. Edited by Ernst Diehl. Leipzig, 1903–6. 3 vols. For translation, see: *The Commentaries of Proclus on the Timaeus of Plato*. Translated by Thomas Taylor. London, 1820.
- RABANUS MAURUS. *Allegoriae in universam sacram Scripturam*. See MIGNE, P.L., vol. 112, cols. 849–1088.
- RAHNER, HUGO. “Mysterium lunae,” *Zeitschrift für katholische Theologie* (Würzburg), LXIII (1939), 311–49, 428–42; LXIV (1940), 61–80, 121–31.

- RASMUSSEN, KNUD. *Die Gabe des Adlers*. Frankfurt a. M., 1937.
- REINACH, SALOMON. *Cultes, Mythes, et Religions*. Paris. 1905–23. 5 vols.
- REITZENSTEIN, RICHARD, and SCHAEFER, HANS HEINRICH. *Studien zum antiken Synkretismus aus Iran und Griechenland*. (Studien der Bibliothek Warburg, VII.) Leipzig, 1926.
- RHINE, J. B. *Extra-Sensory Perception*. Boston, 1934.
- RIPLEY, GEORGE. *Omnia opera chemica*. Kassel, 1649.
- Rosarium philosophorum. Secunda pars alchimiae de lapide philosophico vero modo praeparando... cum figuris rei perfectionem ostendentibus*. Frankfurt a. M., 1550.
See also (A) *Artis auriferae*, xiv.
- ROSENCREUTZ, CHRISTIAN (Johann Valentin Andreae). *Chymische Hochzeit... anno 1459*. Reprinted from a Strasbourg 1616 edition. Edited by Ferdinand Maack. Berlin, 1913. For translation, see: *The Hermetick Romance; or, The Chymical Wedding*. Translated by E. Foxcroft. London, 1690.
- _____. *Turbo, sive Molestae et frustra per cuncta divagans ingenium*. Helicon, 1616.
- “Rosinus ad Sarratantam.” See (A) *Artis auriferae*, v.
- ROTH-SCHOLTZ, FRIEDRICH (ed.). *Deutsches Theatrum chemicum*. Nuremberg, 1728–32. 3 vols. (“Philosophisches Send-Schreiben vom Stein der Weissheit,” by John Pordage, vol. I, pp. 557–97).
- RUSKA, JULIUS FERDINAND. *Tabula smaragdina; ein Beitrag zur Geschichte der hermetischen Literatur*. Heidelberg, 1926.
- _____. *Turba Philosophorum: ein Beitrag zur Geschichte der Alchemie*. (Quellen und Studien der Geschichte der Naturwissenschaften und der Medizin, I.) Berlin, 1931.
- SCHENKENBACH. “Reiterlied.” See his “Reuterlied” (ca. 1520), in: Franz M. Böhme (ed.). *Altdeutsches Liederbuch*. Leipzig, 1877.
- [SENIOR.] *De chemia Senioris antiquissimi philosophi libellus*. Strasbourg, 1566.
- SILBERER, HERBERT. *Problems of Mysticism and Its Symbolism*. Translated by Smith Ely Jelliffe. New York, 1917.
- SPENCER, SIR BALDWIN, and GILLEN, FRANCIS JAMES. *The Northern Tribes of Central Australia*. London and New York, 1904.
- STAPLETON, HENRY ERNEST, and HUSAIN, M. HIDAYAT (eds.). *Three Arabic Treatises on Alchemy, by Muhammad bin Umail*. (Asiatic Society of Bengal: Memoirs, XII, i.)

Calcutta, 1933.

STÖCKLI, ALBAN. *Die Visionen des seligen Bruder Klaus*. Einsiedeln, 1933.

STOLCIUS DE STOLCENBERG, DANIEL. *Viridarium chymicum*. Frankfurt a. M., 1624.

“Tabula smaragdina” (“The Emerald Table of Hermes Trismegistus”). See RUSKA.

“Tractatus aureus.” See (A) *Ars chemica*, i; (A) *Bibliotheca chemica curiosa*, i; (A) *Musaeum hermeticum*, i.

“Turba philosophorum.” See RUSKA.

UMAIL, MUHAMMAD BIN. See STAPLETON and HUSAIN.

VANSTEENBERGHE, EDMOND. *Le Cardinal Nicolas de Cues*. Paris, 1920.

VENTURA, LAURENTIUS. See (A) *Theatrum chemicum*, x.

“Visio Arislei.” See (A) *Artis auriferae*, i.

WAITE, ARTHUR EDWARD. *The Real History of the Rosicrucians*. London, 1887.

_____. *The Secret Tradition in Alchemy: Its Development and Records*. London, 1926.

_____. (trans.). *The Hermetic Museum Restored and Enlarged*. London, 1893. 2 vols. [A translation of (A) *Musaeum hermeticum*.]

[WEI PO-YANG.] “An Ancient Chinese Treatise on Alchemy Entitled Ts’an T’ung Ch’i, written by Wei Po-yang about 142 A.D.,” translated by Lu-ch’iang Wu, *Isis* (Bruges), XVIII:53 (Oct., 1932), 210–89.

WINTHUIS, JOSEF. *Das Zweigeschlechterwesen*. Leipzig, 1928.

WOODROFFE, SIR JOHN. See Avalon.

ZACHARIUS, DIONYSUS. See (A) *Theatrum chemicum*, vi.

INDEX

INDEX

A

abaissement du niveau mental, 173, 180, 268

Abelard, Pierre, 335

ablutio, 260

abreaction, 19, 23, 74, 130ff

 attempt to reintegrate autonomous complex, 132

 cathartic method of, 133

 curative effect of, 132

 harmful, 131

 and war neurosis, 130

Abū 'l-Qāsim, 206n, 288n

accidents, basis in unconscious, 57

Acta Joannis, 200n

active imagination, *see* imagination

Adam, 248n, 258n

 and animus, 302f

 sin of, 264n

 struck by arrow, 302

adaptation, 39, 65

 as goal of treatment, 134

 and neurosis, 7

 normal, 68, 70

 social, 19, 67, 72

adept, 219f, 221, 227, 260, 322n; *see also* alchemist

 artifex

adjustment, neurotics and, 121

Adler, Alfred, 4, 19f, 24, 25, 26, 37, 38f, 53, 113f, 118, 119, 173, 179, 328

 as educator, 4, 67, 111

 and incest, 178

 theory and method of, 66ff

Adonai, 287n

Adonis, 260

advice: “good,” 173n

 psychotherapy by, 21, 117

Aegidius de Vadis, 308n

“Aenigma Merlini,” 264

aestheticism, 279f

aetiology of neuroses, 31, 143

affects: autoerotic, 268

 explosion of, 131

 traumatic, in dreams, 132

 withheld, 58

affinity, 167, 238, 239

afflictio animae, 210n

Africa, 97

age of patient, as *indicium*, 39

Agrippa von Nettesheim, Cornelius, 215 & n

aims: autoerotic, in science, 42

 social usefulness, 50

 therapeutic, 41, 52, 81, 83

ajña, 336

albedo, 273, 281; *see also* white(ness)

Albertus Magnus, 103, 316n

 alchemist(s): contradictions of, 287

 as doctors and dream analysts, 200

 as empiricists of psyche, 290n

 — of union of opposites, 320

 female, 296

 and images, 288

 immaturity, mental, 289, 317

 obscurity of, 288n

 pairs of, 296, 322n

 workroom of, 199; *see also* adept

 artifex

alchemy, [167ff](#), [198](#), *et passim*

Arabic, [245n](#)

Chinese, [217](#)

and ecclesiastical symbolism, [263](#)

feminine element in, [296f](#), [302](#)

a form of mysticism, [169](#), [271](#)

self in, [102](#)

symbolism of, [165](#)

theoria of, [321](#)

and yoga, [102](#)

Alexandria, [296](#)

Alfidius/Alphidius, [248](#), [276](#)

Alkia, [273n](#)

alter ego, [224](#)

ambivalence, [189](#)

Ambrose, St., [315n](#)

amplification, Freud and, [120](#)

anahata, [336](#)

analogy(-ies), [168](#)

and associations, [45](#)

analysis, [133](#)

of analyst, [8](#), [72](#), [115](#), [137](#)

demands of, on doctor, [138](#)

dream-, [139ff](#)

reductive, [19](#), [135](#), [136f](#)

training, [115f](#), [177](#); *see also* psychoanalysis

analyst: analysis of, *see* analysis; ethical attitude, [74](#)

personality of, [8](#), [74](#), [88](#); *see also* doctor

analytical psychology, [53](#), [54](#)

achievements of, [55](#)

anamnesis, [23](#), [85](#), [87](#), [122](#), [142](#)

Anastasius Sinaita, [315n](#)

Andrae, Johann Valentin, [209n](#), [216](#), [288n](#), [291f](#)

androgyne, [311](#)

see also *hermaphroditus*/hermaphrodite
androgyny, Christ's, 308
angel, 322n
 soul as, 301
Angelus Silesius, 272n, 295n
anima, 174, 207, 220, 221, 230, 260f, 302, 311
 and animus, *see below*
 autoerotic being, 295
 as autonomous/projected part of personality, 220, 228, 245n, 295
 Christi, 308
 collective character, 295
 effect on man's understanding, 303
 ego vs., 226
 function of conscious/unconscious relationship, 295
 as hermaphrodite, 244, 311, 319
 magical aspect, 225
 and marriage quaternity, 227
 marriage with, 225
 matrix of divine figures, 295
 anima media natura, 244
 anima mundi, *see* world-soul
 as nixie, 322n
 and numen of goddess, 229
 reconciles and unites, 304
 unconscious personified as, 265
 as unknown woman, 14f
 as *vinculum*, 244
 "within," 229
anima and animus, 261f
 expressed by dogma, 231
 in transference, 221
animal, helpful, 42
animal magnetism, *see* magnetism
animals, *see names of individual species*

animus, 225, 230, *see also* anima and animus

discriminative function, 296, 304

illusions produced by, 296n

and woman's emotional life, 303

Annunciation, 185

Anthony (of Egypt), St., 189

Anthropophyteia, 37

Anthropos/First/Original/Primordial Man, 216f, 264

bisexual/hermaphroditic, 216, 263, 264, 272

in Chinese alchemy, 217

as *filius philosophorum*, 264

Gnostic doctrine of, 216

lapis as, 309

Mercurius as, 204

as Nous, 246

son of Oceanus, 308n

and vision of Christ, 217

antinomy(-ies), 314

body/psyche, 4

individual/universal, 5, 6, 7, 314

society/individual, 104; *see also* opposites

antithesis, endopsychic, 226

anxiety neurosis, *see* neurosis

Aphrodite, 238n, 258; *see also* Venus

Apocalypse of Baruch, 264n

apocatastasis, 245

Apollo, 211

apperception(s), 278, 279

apprehension, 181n

aqua: amara, 286

benedicta, 242, 264f

divina, 287

doctrinae, 270, 278

permanens, 203, 207, 242, 268, 273, 282, 286, 313

sapientiae, 274, 277, 278, 282
Saturni, 210
vitae, 206; *see also* water
arbor philosophica, 302, 315
see also tree, philosophical
arcanum, 214, 312
transformation of, 197
archaeology, 45, 50
archetype(s), 13, 20, 34, 80, 122, 124, 169, 178, 317, 318
absorptive power of, 292
forced into projection, 209
Freud and, 185*n*
incest, 179
indefiniteness of, 288
and instinct, 81
invasion by, 82
manifestations of, 292
multitude of meanings, 288
parent, 96
and symbol, 157
trans-subjective union of, 261; *see also* Anthropos
child
hierosgamos
horse
marriage
mother
psyche
sapientia Dei
symbols
Archimedean point, 124
Arisleus, *see* “Visio Arislei”
Aristotle, 316*n*
pseudo-, 236, 271*n*, 295*n*
“Armenian bitch,” 167*n*, 248*n*

“Arnolde the great Clerke,” 288n

arrangement(s), 66, 179

arrow, 291, 302

Ars chemica, see titles of separate treatises as in *Bibl.*

art (of alchemy): nature its basis, 214n

secret nature of, 290

see also alchemy

opus

Artefius, 306n

artifex, servant of work, 263; see also adept

alchemist

Artis auriferae, see titles of separate treatises as in *Bibl.*

Artus, 264n

ash(es), 283f, 287

Ashburnham Codex, 302

ass, 157

assimilation: of doctor by patient, 72

of unconscious contents, see unconscious contents

association(s): and analogies, 45

and complexes, 149

to dreams, 44

enriching, 45

free, 47, 148

association experiments, 29, 96

assumptions: false, 115

prior, 329

astrology, 211

Athanasius, St., 189

Athanor, 322n

atman, 265

attitude(s): ambiguity of, 40

apotropaic, 176

two basic, 40

clinging to youthful, 39

conscious, 20, 178
—, support of, 186
conventional, 217
doctor's, to patient, 133
eight possible, 114
extraverted/introverted, 40, 117
to object, 114
patient's, and conflicts, 121*f*
— to doctor, 144
personal, and neurosis, 31
—, and supra-personal, 46
religious, 46, 101
repressive, 186
spiritual/materialistic, 40
transference as, 135; *see also* conscious attitude
introversion/extraversion
attitude-type, *a priori*, 119
Atwood, Mrs., 296
Augustine, St., 19, 196, 214, 315*n*
Aurora consurgens, 168*n*, 188*n*, 190*n*, 199, 207*n*, 214*n*, 217, 219*n*, 242*n*, 244*n*, 257*n*,
264*n*, 276*n*, 286, 297*n*
aurum: non vulgi, 198, 217
potabile, 210
authority: dialectics and, 5
political/religious, 108*f*
search for, 109
and therapist, 5, 18
autogenic training, 4, 111
autonomy: psychic, 131
of traumatic affect, 132
Avalon, Arthur, 185*n*, 335
Avicenna, 214*n*, 257*n*
axiom of Maria/*axioma Mariae*, *see* Maria
azoth, 273 & n

B

- Babinski, J., 3
- Babylon, civilization of, 105
- Bacon, Roger, 103
- balneum Mariae*, 297, 300
- Baphomet, 315
- baptism, 56, 97
of Jesus, 265
- Baruch, Apocalypse of, 264n
- Basilides, 272
- basin, *see* vessel
- Bastian, Adolf, 91
- bath, 241ff
- Baynes, Charlotte A., 183n
- beds, dream of, anticipating marriage, 144
- Beghards and Béguines, 301n
- behaviour, pattern of, 124n
- Benoît, Pierre, 220n
- benzene ring, 168
- Bernard, St., 302n, 305n
- Bernardus à Portu, *see* Penotus
- Bernheim, Hippolyte, 3, 9, 112
- Berthelot, Marcellin, 167n, 206n, 210n, 262n, 288n
- Beya, 241, 247
- Bible, *see names of separate books*
- Bibliotheca chemica curiosa*, *see titles of separate treatises as in Bibl.*
- birds, 283, 322n
fighting, 250
see also names of separate species
- birth: of divine child, 272
new, 301, 306ff, *see also* rebirth
rites at, 97
tincture as, 298
- bitch, *see* dog/bitch

blackness, [185](#), [299](#)

“black blacker than black,” [187](#); *see also* darkness

nigredo

bladder, hyperaesthesia of, [333](#)

blocking of associations, [149](#)

blood, spiritual, [198](#)

body: bounds personality, [294](#)

“breath”/subtle, [278](#)

as conscious existence, [292](#)

and heart, [284](#)

and psyche, interdependence, [4](#)

purified, [284](#)

quintessential/spiritual form of, [290](#)

and soul, [83](#)

and spirit, [258](#)

—, alchemists’ failure to distinguish, [290](#); *see also* corpus

Boehme, Jakob, [297n](#)

Bonus, Petrus, [311n](#)

Bousset, Wilhelm, [169n](#), [183n](#)

brain, [34](#)

Breuer, Josef, [22](#), [63](#), [112](#), [129](#)

bride and bridegroom, [211](#), [298](#)

atomization of, [197](#)

brother/sister pair, [200](#), [218](#)

Brown, William, [129](#)

buddhi, [102](#)

Buddhism, [67](#)

dhyana/Zen, [102](#), [268](#), [314](#)

bull, [157](#)

C

calcinatio, [197](#), [258](#)

Canticles, *see* Song of Songs

“Cantilena Riplaei,” [302n](#)

Cardan, Jerome, [201n](#), [277](#)

Carus, C. G., 90, 139
catharsis/cathartic method, 23, 59ff, 68f, 111, 133
Catholic Church/Catholicism, 16, 194
 ritual of, 97
Catholics, and complexes, 99, 100
cauda pavonis, 271
causality, psychic, 140
censor, 32
 censorship, moral, 112, 119
centring process, 51, 101
cervus fugitivus, see *servus fugitivus*
chakra system, 335, 336
chalice, 314
chaos, 185, 187, 203, 207, 252
 primeval, 182
 and schizophrenia, 175
 see also *massa confusa*
character, mutation of, 181
Charcot, Jean Martin, 112
chemistry, synthetic, 168
chên-jên, 217
child: divine, 183, 184, 252, 272, 318
 dream-symbol, 183f
 magical, 298
 representing interest in psyche, 44
 tincture as, 298
childhood, 27, 95f
 neuroses in, 218n
 psychological, state of, 47f; see also regression
China: alchemy in, 210n, 217
 marriage classes in, 229n
 philosophy in, 159
Christ, 200, 217, 262, 276, 315
 androgynous, 308

and the Church, 169, 228

denarius as allegory of, 308n

-figure/symbol, 308

as fountain, 276

Gnostic, 265

life in *corpus mysticum*, 194

passion of, 194

risen, 305

triadic, 206n

see also Jesus

christening, *see* baptism

Christensen, Arthur, 248n

Christian Science, 6

Christianity, 191, 193

and the individual, 105

“joyful,” 200

as psychotherapy, 16

split in, 194

and the State, 106

theriomorphic symbols and, 316

view of world in, 117

Church(es), 197, 294, 308

authority of, 109

Christ and the, 169

corpus mysticum/mystical body of, 308, 309

collectivity, replaced by State, 104

disintegration of, 103

dogmas of, and psychic experience, 193

as mother, 97, 98, 99

outward community of, 197

return to, 100

and State, 104; *see also* Catholics

Christianity

Protestants

Chwolsohn, D. A., [264n](#)

Cibinensis, *see* Melchior

cibus: immortalis, [313](#)

sempiternus, [210](#), [309](#)

circle, [208](#), [210](#), [226](#), [319](#), [323](#)

civilization: Christian, and political aim, [107](#)

and culture, [107n](#)

Pestalozzi on, [108n](#)

classes, marriage, [226ff](#)

climbing, motif of, [142](#), [150f](#)

see also mountain sickness

cock/hen, [167](#) & *n*

Codex Ashburnham, [302](#)

Codex Rhenoviensis, [201](#)

coetaneum, [167n](#), [247](#)

coincidentia oppositorum, [293](#), [304](#), [319](#); *see also* opposites; *coniunctio oppositorum*

Coleridge, S. T., [37](#)

collective man, [6](#), [7](#), [10](#), [15](#), [233](#); *see also* mass-men

collective representations, *see* representations, collective

collectivism, [108](#)

Colonna, Francesco, [206n](#), [250n](#)

colours, [271](#); *see also* black

red

white

combination, chemical, [167](#), [169](#), [171](#)

commixtio, [242](#)

Communion, [98](#); *see also* Last Supper

Mass

compensation, [11](#), [40](#), [123](#), [155](#), [156](#)

in dreams, [153f](#)

law of, [153](#)

transference as, [136](#); *see also* unconscious

completeness, *see* wholeness

complexes, [59](#)

autonomous, 131ff, 229
context of, 87
diagnosis of, 87
and fantasy, 56
formation of, 56
free association and, 149
incidence of, and religious affiliation, 99
inferiority, 99, 165
in Jews/Protestants/Catholics, 99
not always neurotic, 78
power, 328
and prejudices, 8
as repressed impulses, 53
traumatic, 130ff
complex psychology, 53
complexio oppositorum, 320
conceptio, 256
concupiscentia, 173
confession(al), 16, 19, 55, 66, 98
 attachment produced by, 60
 curative results, 59f
 limits of, 68
 to oneself, 294f
 as prototype of analysis, 55
confirmation, 97
conflicts, 194, 197, 198, 262
 mental, 31
 moral, 18
 psychic, 121f
coniunctio, 167ff, 211ff, 220n, 239, 242, 247ff, 291, 292, 321
 anima/animus, 261
 as archetype, 168n, 292
 a hierosgamos, 291
incestuous, 215

oppositorum, 200, 257

Solis et Lunae, 245

sources of image, 169

and transference neurosis, 318; *see also* hierosgamos
marriage

conscience, 193

conscious attitude

discrepancy with unconscious, 20

of neurotic, 11

conscious mind, 30, 34, 42, 43, 51, 89

of alchemist, 230

articulation of unconscious with, 20

characteristics of, 148

collision with unconscious, 317

and ego, 50

hybris of, 99

impotent by itself, 208

inhibitive action of, 56

instinctive roots of, 122

integrative powers of, 132

and loss of energy, 180

overvaluation of, 30, 50, 293

psyche not identical with, 91

relation to dreams, 154

— to unconscious, 56, 123, 304

secrets and, 56

unconscious as corrective of, 11

and unconscious, mutual integration, 314; *see also* consciousness

consciousness: and cure of neurosis, 31

depotentiated, 198

disorientation of, 267

dissociation of, 195

extension of, 191, 263

— knowledge as, 195

heightened, and transference, 219
lapses of, 57
most individual part of man, 124
personal and supra-personal, 46
psyche as, 89, 90
rootlessness, 98f
superiority of, 294
a temporary state, 91
and unconscious, 177; *see also* conscious mind
“Consilium coniugii,” 168n, 203n, 242n, 284n
consultations, frequency of, 10, 16
contamination, 292, 294
contemplation, 59
contradictions, in psychology, 4
corascenum, 167n, 248n
coronation, 284
corpse: purified, resuscitation of, 284
 in sarcophagus, 286
corpus, 278
 mundum, 194
 mysticum, 194, 308
cosmos, 197
counter-transference, 72, 171n, 329
Cramer, Samuel, 317n
creative: possibilities, 41
 work, 181
creatum increatum, 309
cross, 200, 207f, 262, 319
 “rosie,” 216
 St. Andrew’s, 227
 symbol of wholeness, 305
crow, 299
crown, 287n
 of the heart, 286

crucifix, 262
cults, mystery, 56
 confession in, 59
culture: and civilization, 109n
 Freudian view, 112
Cupid, 291
cure, as change, 10
“cure of souls,” 121
Cusanus, *see* Nicholas of Cusa

D

dance, as symbol, 157
dancing couples, Kekulé's, 168
Dante, 206, 312n
dark night of the soul, 271
darkness(es), 159, 331
 of our mind, 199
datura, 292n
Dausten, Johannes, 308n
David of Dinant, 316n
dealbatio, 273
“De alchimiae difficultatibus,” *see* Hoghelande
“De arte chimica,” 244n
death: as archetype, 260
 dream, anticipating, 150
 —, of own, 160
 followed by new life, 257, 299
 horse as herald of, 159
 meaning of, 260
 punishment for incest, 258
 and rebirth, 262
 reiterated, 268
 rites at/ritual, 97, 105
 shrinking from, 39
 state of, 281

decad, [306n](#)
Dee, John, [306n](#)
degeneration, mass-, [293](#)
delirium, induced by intoxicants, [292n](#)
Demeter, [302](#)
Democritus, pseudo-, [262](#)
denarius, [306](#), [308](#)
 allegory of Christ, [308n](#)
Deo concedente, [190](#)
depression, [181n](#), [254](#)
descent, [245f](#), [260](#), [281](#)
desire, negation of, [173](#)
Deus terrenus, [271](#)
Deuteronomy, [242n](#)
development, conscious, possible extent, [191](#)
devil(s), [189](#), [195](#), [280](#), [315](#)
 as chthonic deity, [192](#)
 Church's doctrine of, [192](#)
 lapis as, [206n](#)
 three-headed, [206](#)
dew, [274](#), [281](#), [287](#); *see also* Gideon's dew
 ros Gedeonis
dhyana, [102](#), [268](#)
diadem/*diadema*: and *corona*/Kether, [287n](#)
 and "foul deposit," [289](#)
 "of the heart," [284](#)
 Solomon's, [286n](#)
diagnosis, [85ff](#), [158](#), [327](#)
 clinical, [87](#)
 irrelevance, in psychotherapy, [86](#)
dialectic/dialectical: meaning, [3](#)
 procedure, [8f](#), [10](#), [16](#), [18](#), [20](#), [116](#), [117](#), [318](#)
 psychotherapy as, [3ff](#), [116](#), [329](#)
 and suggestion methods, [9](#)

Diana, 211
diaphragm, 336
differentiation: individual, and sin, 55
 instinct for, 56
 needs patience, 294
Dionysus, 192
disiunctio, 197
disintegration, 101
dislike, 165*n*
dismemberment, 197
dissociation, 239, 267
 of conscious and unconscious, 195
 neurotic, 20, 132*f*, 280; *see also* personality
dissolution, 241
 see also solutio; ego
distillation, 200, 294, 300
doctor: aim of, 41
 in analysis, 72
 authority of, 5, 18
 belief of, 7
 lack of understanding in, 145
 as mediator, 181*f*
 methods of, 69, *see also* methods
 necessity of intervention, 132
 need of convictions in, 78
 neurotic, 18
 as partner in development, 8
 and patient, relation, 3, 5, 8, 71*f*, 116, 132*f*, 176
 personality of, 8, 9*f*, 74, 88
 risks run by, 19
 self-criticism by, 115
 subjective possibilities of, 199
 and transference, 61*f*, 170*ff*
 transference of illness to, 176; *see also* analysis

analyst
physician
dog/bitch, [167](#), [247](#), [286](#)
dogmas: and psychic experience, [193](#)
 psychotherapeutic, [87f](#)
donkey, *see* ass
 horse/donkey
donum Spiritus sancti, [192](#), [212](#), [214](#), [278](#)
Dorn, Gerhard, [206](#), [241n](#), [290n](#), [306n](#)
dove, [236f](#), [244](#), [246](#)
 of Holy Ghost, [212](#), [216](#), [246](#)
 Mercurius as, [241](#)
 Noah's, [185](#), [212](#)
dragons, winged/wingless, [167](#), [250](#), [283](#)
drawings by patients, [201f](#)
 see also paintings
dream series, [12ff](#), [150](#), [334](#)
dreams, [11](#), [12](#), [13](#), [42ff](#), [56](#), [123](#), [124](#), [153](#), [292](#)
 aetiological significance, [140](#), [143](#)
 analysis of, [139ff](#)
 announcing appearance of transference, [183](#)
 associations to, [44](#)
 compensation in, [153f](#)
 describe inner situation, [142](#)
 establishment of context, [148](#), [150](#)
 as façade, [32](#), [149](#)
 fantasy and, [56](#)
 Freud and, [23](#), [26](#), [32](#), [63](#)
 infantile impulses in, [23f](#)
 initial, [43](#), [140](#), [143](#), [144](#), [145](#), [156](#)
 interpretation, [32](#), [44f](#), [63](#), [134](#), [150](#), [154](#)
 loss of clarity in analysis, [145](#)
 manifest, [149](#)
 mythological, [17](#)

give prognosis, 143, 144
“reconnoitring,” 43
recording of, by patients, 156
and repressed wishes, 147
sexual interpretation, 134; *see also* fantasy
image; INSTANCES (in order of citation): return to village of birth, 141
train disaster, 141
inability to find frontier, 144, 331
twin beds found by customs officer, 144, 331
climbing mountain, 150f
of father’s bad driving of car, 154
of mother hanging, 158
of horse jumping from window, 158
of playing with child standing on table, 183
of tapestry and monkey-puzzle tree, 184
of woman in castle on hill, 332
droits de l’homme, 293
dropsy, 264
duality, 198
Dubois, Paul, 3, 21
Du Cange, Charles du Fresne, Sieur, 273n
dyad, feminine, 208

E

earth, woman as, 74
ecclesia mater, 97
ecphoration, 122
ecstasy, religious, 292
education, 55, 65f, 68, 69
 Adler and, 67, 111
 and individuality, 7
 and self-education, 73
educational method, of therapy, 4
ego, 49, 51, 102, 112, 173, 233, 245n, 260, 265, 291

vs. anima, 226
and centring process, 51
complex as shadow-government of, 87
and conscious mind, 50
-consciousness, 91, 195, 267, *see also* consciousness
—, overvaluation of, 293
differentiation of, 294
dissolution of, 101, 292
isolation within, 100
lesion of, 264
objective, 199
-personality, 263, 265
and self, 265
and shadow, 198, 239f
space/time and, 293
and unconscious, 265, 293ff

Egypt: civilization of, 105
incest in ancient, 218, 229

Einstein, Albert, 65

elasticity, of unconscious time, 260n

Elbo Interfactor, 274n

elements: bound together in stone, 312
decomposition of, 267
four, 203, 207, 211, 305, 312
masculine and feminine manifestations of, 212
partial union of, 239
traumatic, 73
unity of, 206
warring, 305

elephant, 333, 335

El-Habib, Book of, 198n

elixir, 210
vitalis, 301, 312, 313

Ellis, Havelock, 37

elucidation, 55, 60, 61ff
 effects of, 65, 68
emotions: repressed, 58; *see also* affects
emperor and empress, 303; *see also* king and queen
enantiodromia, 96, 281
endogamy/exogamy, 225ff
energy: instinctive, and symbolical activity, 250
 lowering of, 181
 psychic, 229
 of unconscious contents, 180
environment, 85
equilibrium: of ego/non-ego, 195
 of psyche, 153
Eros, 174
eroticism, four stages, 174
E.S.P., *see* extra-sensory perception
“eternal man,” 293
ethical sense, 147
ethics, standards of, 280
Europe: neo-paganism in, 196
 and patriarchal order, 104
 plight of, 94
Euthicia, 296n
Eve, 174, 303
evil: and good, 192
 principle of, 191, 315
“Exercitationes in Turbam,” 244n, 245n
exogamy, 228, 231f
experience: rehearsal of, 132; *see also* abreaction
explanation(s), 69, 117
 limits of, 68
 reductive, 64, 66
external and internal, 288–9n
extractio animae, 277

extra-sensory perception, 125
extraversion, 33, 40, 117, 118
Ezekiel: book of, 260n
 vision of, 184n

F

fairy, motif, 14
fairytales, 124, 222, 303n, 321
faith cures, 6, 38
fantasy(-ies), 45, 56, 124, 292
 active, 49
 autoerotic, 268
 creative, 34, 45, 134, 167
 dream and, 56
 infantile, religion and, 119
 —, sexual, 134
 spontaneous, 11
 and transference, 62, 68, 173
 visual, 11
 see also dreams
incest
fatalism, Islamic, 81
fate, human, 177
father: in heaven, 99
 memory-image of, 61
 unknown, 183n
father/son relationship, 155
Faust, *see* Goethe
fear, 181
feeling, 33, 40n, 279
 and idea, 312
 realization through, 280f
Ferguson, John, 308n, 309n
fictions: conscious, 4
 guiding, 39

Fierz-David, H. E., 168n
filiation, third, 272
filius: macrocosmi, 103
 philosophorum, 198, 207, 248, 264, 265, 308
 regius, 207, 209, 272, 286
filis à papa, 86
finality, sense of, 68f
fire: of the philosophers, 297
 and water, 298
Firmicus Maternus, Julius, 244n
First Man, *see* Anthropos
fish, 124
five, 183n, 184, 211, 212; *see also quinta essentia*
fixation, 65
 infantile, 8
 and transference, 61
Flamel, Nicolas, 296
Flournoy, Théodore, 139
flowers, five, 211, 220, 238
foetus (spagyricus), 204, 242
folklore, 124, 159, 160
folk-thoughts, 91
fontanelle, fantasy of, 334
Forel, August, 37, 112
fountain: maternal, 284
 Mercurial, 204, 209f, 212, 216, 241, 246n
 Mother of God and, 286
 threefold, Brother Klaus's vision of, 183n, 204n
four, the number, 208, 211, 212, 223f, 306n, 314; *see also* elements
 quaternio/quaternity
Franz, Marie-Louise von, 166
Frazer, Sir James G., 180n, 225n
Freud, Sigmund, 3, 8, 9, 19, 21, 22, 23, 24, 25, 26, 29, 30ff, 36, 37, 46f, 53, 61ff, 72, 83,
 112, 113, 115, 118, 129, 134, 139, 152, 164, 170, 171, 172, 185n, 186n, 215, 218n,
 317, 328

and Adler, [66ff](#), [119](#)
and aetiology, [31](#)
and archaic images, [120](#)
and archaic vestiges in unconscious, [90](#)
on dreams, [63](#)
his interpretative method, [64](#)
as investigator, [67](#)
opposition to, [64](#)
pleasure-principle, [19](#)
and regressive tendency, [32](#)
and religion, [121](#)
and scientific materialism, [26](#)
and sexuality, *see* sexuality
on spontaneity of transference, [172n](#)
theories of, [30](#)
and transference, [61f](#), [164](#), [185n](#)
on transference neurosis, [171](#) & *n*
WORKS: “Fragment of an Analysis of a Case of Hysteria,” [172n](#)
Introductory Lectures, [171n](#), [172n](#)
“Leonardo da Vinci,” [120](#)
“Observations on Transference-Love,” [172n](#)
“Remembering, Repeating, and Working-Through,” [171n](#)
Frobenius, L., [245n](#)
frontier, motif of crossing, [144](#)
functions, psychic, [33](#), [40](#), [207](#), [279](#)
 differentiation of, [195](#), [280](#); *see also* feeling
 intuition
 sensation
 thinking
funeral rites, [97](#)
furnace, [322n](#)
 sacred, [297](#)
furrow, cohabitation in, [157](#)

G

Gabricus, [241](#), [245](#), [247](#), [257](#)

Galen, [17](#)

Galilee, marriage in, [298](#)

Gayomart, [204](#), [248n](#), [314n](#)

Genesis, [258n](#)

German Christians, [16](#)

German Faith Movement, [16](#)

Gestalt psychology, [119](#)

“getting stuck,” [42](#), [101](#), [149](#), [157](#), [279](#), [280](#), [330](#), [332](#)

ghosts, land of, [246](#)

Gideon’s dew, [273](#), [279](#)

glass-house, [241](#), [245](#)

“Gloria Mundi,” [286n](#)

Gnosticism, [183n](#), [216](#), [248](#), [265](#)

goal, [209](#)

antithetical nature of, [316](#)

hermaphrodite a synonym for, [16](#)

as an idea, [200](#)

images of, [319](#)

spiritual, [278](#)

goat, [157](#)

God: above the opposites, [320](#)

as *auctor rerum*, [308](#)

as cause of self, [245](#)

as source and sea, [210n](#)

union with matter, [185](#)

Goethe, J. W. von, [174](#), [191](#), [197n](#), [198](#), [208](#), [209](#), [252](#), [262](#), [280](#), [291](#)

gold, [198](#), [207](#)

see also *aurum*

gold-making, [168](#)

good, *see* evil and good

Goodenough, Erwin R., [287n](#)

Gower, John, [167](#), [305](#)

Grail, Holy, [295](#)

“Grandes heures du duc de Berry,” [242](#)

Gregory the Great, St., [258n](#), [286n](#)

guilt, secrets and, [55ff](#)

Guterman, N., [222n](#)

H

habits, neurosis and, [68](#)

Hades, [61](#), [217](#), [246](#), [260](#)

Haggard, Sir H. Rider, [220n](#)

hair, hero's loss of, [245](#)

hallucinations, [292](#)

Hammer-Purgstall, Joseph, [315n](#)

Harding, M. Esther, [302n](#)

hare, [124](#)

Harpocrates, [308n](#)

Hastings, James, [292n](#)

hate, [165n](#)

Hauck, Albert, [317n](#)

Hauer, J. W., [330](#)

Hawwah, [174](#); *see also* Eve

heart, diadem of the, [283f](#), [286](#), [287](#)

Hecate, [302](#)

Helen (companion of Simon Magus), [174n](#)

Helen of Troy, [174](#)

hell, [260](#); *see also* Hades

hen, *see* cock/hen

Heraclitus, [246](#)

Heraclius, Emperor, [312](#)

herd: instinct, [26](#), [104](#)

 psychology, [6](#); *see also* mass-men

heredity, [85](#)

heresy, [217](#)

hermaphroditus/hermaphrodite, [258](#), [283](#), [308](#), [309](#), [311](#), [315](#), [316ff](#)

 synonym for goal of opus, [316](#)

and union of opposites, [244](#); *see also* *Anthropos rebis*

hermaphroditic: alchemical symbols as, [198](#)
primordial man as, [216](#); *see also* *Mercurius*

Hermes, [188](#), [248n](#), [267n](#), [273](#), [274n](#); *see also* *Mercurius*
birds of, [283n](#)

hero, child-, [183](#)

hero-myths, [245](#)

Hesperus, [238n](#)

hexad, [238](#)

hierosgamos, [169](#), [200](#), [220n](#), [228](#), [247](#), [291](#), [318](#), [321](#)
see also *coniunctio*; marriage

Hippocrates, [17](#)

Hippolytus, [206n](#), [272n](#), [306n](#), [308n](#)

Hocart, A. M., [226](#), [227n](#), [228n](#)

Hoghelande, Theobald de, [167n](#), [199n](#), [288n](#)

Holmyard, E. J., [206n](#), [288n](#)

Holy Ghost, [212](#), [214](#), [216](#), [246](#), [252](#), [273](#), [290](#)
sin against, [194](#)
see also *donum Spiritus sancti*

Homer, [336](#)

homosexuality, [170n](#), [218n](#)

homunculus, [198](#), [204](#), [272](#)

horse/donkey, [167](#)
as archetype/symbol, [159f](#)
hoof of, [157](#)
Trojan, [159](#)

Hortulanus, [204n](#), [257n](#), [290](#)

Horus, [264n](#)

Howitt, A. W., [225](#)

Hubert, H., and Mauss, M., [13](#)

hybris: of conscious mind, [99](#)
of will and power, [196](#)

Hyle, [238n](#)

hypnotism/hypnosis, 22, 59, 88, 111
and catharsis, 59
as cure, 133
early use of, 6
and fixation, 61
recapitulation under, 131
hysteria, 86, 112, 158, 327
and secrets, 58
hysterical pains, 81

I

ideas: collective, 120
inherited, 34, 91, 124*n*
primordial, 91
identification, 245*n*
with parents, 63
with unconscious contents, results of, 263
identity: relationship to parents, 63
unconscious, 183, 295, 330
see also *participation mystique*
illusion, 51*f*, 65
image(s), 255
of alchemy, 165
archaic, 120
conceptual, 262
dream, 42, 44, 149
of goal, 319
memory, 112
—, in transference, 136
parental, and the State, 104
primordial, see archetypes
psychic, 89
sequence of, 11
imagination, 22
active, 199

a priori categories of, 13, 34
creative, 45f
moral, 65

imago: father, 100
parental, 8, 62, 96 & n, 98, 99, 100, 101
—, projection on State, 104
—, in religion, 98; see also projection

immortality, 312f
belief in, 81

immunditia, 292

impulses, repressed, 53

incarnatio, Dei, 185

incest, 32f, 35, 39, 62f, 175, 178f, 211, 215, 217f, 222ff, 239, 263
in ancient Egypt, 218, 229
and anima/animus, 303
animus and, 304
archetype of, 179, 317
death as punishment for, 258
in fairytales, 223ff
fear/horror of, 32, 215
Freudian theory, 178
Greek myths and, 64
as individuation, 218
as instinct, 179, 228
mother/son, 311f
procreation through, 264
royal or divine prerogative, 218, 264
symbol of union with one's own being, 218

incineratio, 197, 258

increatum, 204n
prima materia as, 245

indicium(-a), 40
age, 39
attitude, extravert/introvert, 40

- resistance, 39
- individual, 10, 48, 169
 - inner consolidation of, 233
 - and society, 104ff, 120
 - and universal, 5ff
- individual psychology, 24, 25, 26, 53; *see also* Adler
- individualism, 26
 - extreme, 108
- individuality: achievement of, *see* individuation
 - conscious, 108
 - and family, 105
 - overestimation of, 7
 - relativity of, 5
 - underdeveloped, 7
 - uniqueness of, 4, 7
- individuation, 10, 11, 20, 102, 108, 160, 218, 230, 231, 245n, 261, 266
 - incest as, 218
 - motifs in, 15
 - spiritual marriage as goal of, 231
 - transference and, 323
 - two aspects of, 234
- induction, psychological, 199, 201
- infantilism, 32
- infant, world of man as, 95
- infections, psychic, 177, 330
- inferiority: cause of, 135
 - in doctor, 74
 - feelings, 111, 330
 - moral, 114
 - sense of, 37
- inferiority complex, *see* complex(es)
- inflation, 263, 264, 291, 294, 304
- inimicitia elementorum*, 187
- initiation, 105

rites of, 56, 59, 97
self-restraint in, 57

insight, 65f, 115, 173
academic, 294
limitations of, 66

instinct(s), 30, 34, 41, 46, 80ff, 91, 98, 100, 175, 239, 250, 262
and archetypes, 81
herd, *see* herd instinct
incestuous, 179, 228
individual, 11
and mind, 81
and neurosis, 92
paradoxical character, 175
and philosophy of life, 81
reduction to, 25
repressed, 77
and spirit, 175
symbolical character, 174
theory of, 91
for wholeness, 263

integration, 16, 170, 190
of parental images, 101
of projections, 263
of psyche, 131
of self, 265; *see also* wholeness

intellect, 279
limits of, 314

internalization through sacrifice, 229

interpretation(s): anagogic, 8, 9, 20
analytical-reductive, 8, 11
blocking of, 149
need of patient's assent to, 147
of patient's paintings, 51
psychoanalytic, 8

regressive and progressive, 9
rules of, 155ff
sexual, 134
synthetic-hermeneutic, 8, 9, 20
interpretative method, 63f
interviews, *see* consultations
intoxicants, 292n
introjection, of anima, 229
introspection, 35
introversion/extraversion, 33, 40, 117f; *see also* attitudes
intuition(s), 33, 40n, 85, 159, 278, 279, 281
Ion, 264n
Irenaeus, 184n
irrationalization, of aims of treatment, 26
Isidore of Seville, St., 286
“island, neurosis,” 181
isms, 6

J

Jābir ibn Hayyān, 288n
Jacobi, Jolande, 207n
Jacob’s well, 276
James, Montague R., 200n
James, William, 46n
Janet, Pierre, 112, 139
Jeremiah/Jeremias, Book of, 202
Jerome, St., 245n
Jesus, 265; *see also* Christ
Jews, and complexes, 99
jimson weed, 292n
Joannes de Garlandia, 290n; *see also* Hortulanus
Joannes Lydus, *see* Lydus
Job, Book of, 121n
Johannes Pontanus, 309n
John, St., Gospel of, 248, 276n

John of the Cross, St., [271](#), [309n](#)

Jonah, [299](#)

Judges, Book of, [273n](#)

Jûnân ben Marqûlius, [264n](#)

Jung, Carl Gustav:

CASES (*in order of presentation, numbered for reference*):

[1] Man who experienced dream series including water motif, unknown woman motif, etc., illustrating continuity of unconscious themes.—[12ff](#)

[2] Man whose initial dream criticized his interest in occult subjects.—[44ff](#)

[3] Man with symptoms resembling mountain sickness, and archetypal dreams indicating need for check on his ambitious plans.—[140ff](#)

[4] Woman with dreams of crossing frontier, indicating course her three attempts at analysis would take.—[144](#)

[5] Mountain climber with dreams presaging fatal climbing expedition.—[150f](#)

[6] Young man with derogatory dreams of father compensating his “too good” relationship with parent.—[154f](#)

[7] Girl of 17, whose dreams, studied to establish diagnosis between hysteria and progressive muscular atrophy, pointed to grave organic disease and death.—[158ff](#)

[8] Woman over 60, whose dreams and pictures (notably of divine child) illustrate onset of transference.—[183ff](#)

[9] Woman whose attempt to overcome phobia of Paris by a visit there resulted in her death.—[254](#)

[10] Man with phobia of flights of steps, who dies in accident on steps.—[254](#)

WORKS: *Aion*, [220n](#), [222n](#)

“Analytical Psychology and Education,” [218n](#)

“Brother Klaus,” [201n](#)

“Child Development and Education,” [151n](#)

“Concerning the Archetypes...,” [220n](#)

“Concerning Mandala Symbolism,” [333n](#)

Mysterium Coniunctionis, [166](#), [222n](#), [264n](#), [302n](#)

“On Psychic Energy,” [179n](#)

“Paracelsus as a Spiritual Phenomenon,” [284n](#)

Psychological Types, [33](#), [265n](#), [279n](#)

Psychology and Alchemy, [51n](#), [102n](#), [165](#), [166](#), [188](#), [198n](#), [204n](#), [206n](#), [208n](#), [216n](#), [236n](#), [242n](#), [245n](#), [250n](#), [264n](#), [284n](#), [286n](#), [296n](#), [312n](#), [315n](#), [316](#), [319](#)

“Psychology and Religion,” 102n, 193n, 312n

“Relations between the Ego and the Unconscious,” 113n

“Spirit Mercurius,” 188n, 192n, 209, 246n, 273n, 302n, 315n

“Study in the Process of Individuation,” 51n, 183n

Symbols of Transformation, 229n

“Synchronicity: An Acausal Connecting Principle,” 260n

“Theory of Psychoanalysis, The,” 179n

Two Essays on Analytical Psychology, 209n, 220n, 294n, 332n

“Visions of Zosimos, The,” 264n

K

Kali, 302

Kalid, 167n, 247n, 248, 252n, 312

Kant, Immanuel, 139

Kekulé von Stradonitz, F. A., 168

Kerényi, Karl (C.), 116n

Kerner, Justinus, 90

Kether, 287n, 289n

Khunrath, Henricus, 103, 288n, 308n

king(s): individuality and the, 105

patria potestas of, 109

king and queen (alchemical): in bath, 241ff

coniunctio, 211ff

counter-crossing, 220

death of, 257

transformed into new birth, 265

kingship, dual, 226

kinship: libido, *see* libido

sections, 226

Kircher, Athanasius, 189n

kitchen, symbol of unconscious, 183

Klaus, Brother, *see* Nicholas of Flüe

Klinz, Albert, 169n

Knorr von Rosenroth, Christian, 163, 287n

knowledge, 195

lack of, effects, [330](#)
Koch, Joseph, [277n](#)
Kohut, Alexander, [248n](#)
Kranefeldt, W. M., [157](#)
krater, [315n](#)
Krates, Book of, [288n](#)
Kretschmer, Ernst, [118](#)
Krönlein, J. H., [316n](#)
Kundalini, [185](#), [335](#), [336](#)
Kunike, Hugo, [303n](#)

L

lac virginis, [206](#)
lamb, [124](#)
Lambspringk, [250n](#), [283n](#)
lapis philosophorum, [188](#), [198](#), [207](#), [242](#), [248](#), [258](#), [316](#)
 anticipation of the, [281](#)
 charged with *intuitions*, [281](#)
 as *corpus/anima/spiritus*, [244](#)
 as *creatum/increatum*, [309](#)
 as First Man, [309](#)
 as *radix ipsius*, [309](#)
 as Uroboros, [309](#); *see also* stone
lapis-Christ parallel, [316](#)
“lapses,” [56](#)
Last Supper, [64](#)
lato, [273n](#)
Lavaud, M. B., [183n](#), [184n](#), [201n](#), [204n](#)
Layard, John, [225](#), [226n](#), [227n](#), [228](#), [229n](#)
Leade, Jane, [296n](#), [297](#)
left: hand, significance of, [211](#), [217](#), [238](#)
 and right, [200](#), [211](#), [314](#)
 as the unconscious, [283](#)
 “left-hand path,” [211](#)
legends, [124](#)

Lehmann, F. R., 6, 157
Leibniz, G. W. von, 139
Leisegang, Hans, 169*n*
Leo, 246
Leonardo da Vinci, 120
Leviathan, 335
levitation, 268
Lévy-Bruhl, Lucien, 13, 120, 183*n*
“Liber Platonis Quartorum,” 273*n*, 316*n*
libido, 8, 171*n*
 kinship, 224, 233, 262
 loss of, 43
 meaning of, 179*n*
 Mercurius as, 246
 regression to infantile level, 179
Liébeault, A.-A., 3, 112
life: provisional, 155
 second half of, 38*f*, 41, 50, 265
light: black hidden in, 299

Man of, 248
obfuscation of the, 198
theories of, 4, 314
unconscious as nocturnal, 260
lightning, 157
Linus, 260
lion, 246n, 315
 green, 241, 242n
Logos, 248
love: binding the opposites, 198
 of God, 197
Lucifer, 192n, 299
Lully, Raymund, 187n
lumen: indeficiens, 309
 naturae, 82, 104
Luna, 244n, 247
 imparts whiteness to tincture, 300; *see also* moon
 Sol
Luther, Martin, 216n
Lydus, Joannes, 238n, 258n, 306n

M

Maack, Ferdinand, 216n
McDougall, William, 129, 131, 133
madness, 210n
 fear of, 181
magic, 181
 by analogy, 198
magnetism, animal, 7, 111
Mahādevishakti, 336
Maier, Michael, 187n, 196n, 210n, 272n, 283n
makara, 335
Malchuth, 287n, 289n
man: analogy of God, 320

collective, 6, 7
divine, 301
inner, 272
modern, risk of, 281
natural and supernatural, 264
rational and eternal, 293
mana, 6, 157
mandala(s), 200, 319
 dream symbols as, 265
 flowers as, 185
 spiritual marriage as, 231
manic ideas, 124
manipura, 336
Maqrîzi, Al-, 264n
mare: nostrum, 203
 tenebrosum/tenebrositas, 203, 248
Maria the Jewess/Prophetissa, 206, 273n, 287, 296
 axiom of/*axioma Mariae*, 207, 209, 239, 250n, 252, 306, 314
marriage: ceremonies, 97
 classes, 226, 227, 228
 cross-, 222f
 cross-cousin, 225ff, 232
 divine/mystic, 167, 169, 321
 dream anticipating, 144
 infantile projections in, 219
 quaternity, 222ff
 royal/chemical, 185, 198, 291
 sister-exchange, 225
 spiritual, 231; see also *coniunctio hierosgamos*
 unto mystica
Mars, 298, 302
Mary, the Virgin, 174, 286n, 295, 303n, 305n
 Coronatio Mariae, 284

as *sapientia*, 174
water symbolism of, 286
masculine protest, 67, 113
Mass, the, 98, 242
mass-degeneration, 293
mass-men, 48, 232, 323; *see also* herd
massa confusa, 191, 247, 252
materialism, 40, 117, 230, 231
 Freud and, 30
matrix, 158, 203n
matter: myth of, 168
 unconscious projected into, 277
maximum/minimum, 320
Maya, 295, 336f
medicina catholica, 182, 210
medicine: primitive, 6
 psychosomatic, 113
 and psychotherapy, 84, 92
medicine-man, 7, 38
meditation, 59
megalomania, 263
Meier, C. A., 260n, 268n
melancholy, 87
Melchior Cibinensis, Nicholas, 242
memory(-ies)
 hallucinations of, 57
 infantile, 31
 repressed, 112
Mennens, Gulielmus, 316n
menstrual fluid, 157
mental healing, 6
Mercurinus, 247, 264n
Mercurius, 188f, 191, 197, 204, 241, 264n, 270, 271, 273, 291n, 299, 300, 301
 ambivalence of, 189

chthonic, 246, 283
as dove, 241
duplex/dual nature of, 192, 206, 242, 283
an earth-spirit, 271
fiery nature of, 246*n*
fleeing/fugax, 196, 270
food of, 299
hermaphrodite, 244
mother of the seven, 204
as perfect stone, 204*n*
poison of, 301
as serpent, 206, 210
telum passionis of, 291*n*
threefold character/*triplex nomine*, 204*f*, 207, 216
as unconscious psyche, 241
as water, 241

mercury (element), 209

Merlinus, 264*n*

Merqûlius/Marqûlius, 264*n*

Mesmer, Friedrich Anton, 111

Messiah, 264*n*

metals: seven, 204
transmutation of, 291*n*

metaphysics: projected into nature, 230
unconscious, 43, 44

method(s), 138
abreactive, 133
Adler's, 67
analytical, 133
—, and incest-fantasies, 62
analytical-reductive, 20
cathartic, 23, 59*ff*, 133
choice of, 327*f*
educational, 4

explanatory, 66
individualization of, 26
interpretative, Freud's, 63f
and psychotherapist, 88
rational, 16
technical, 6
variety of psychotherapeutical, 3f, 9; *see also* psychotherapy
therapy
treatment

microcosm, 90, 196f
man as, 196, 312, 320
psyche as, 91

Middle Ages, 103
absence of psychology in, 317

mind: human, supra-personal, 69
and instinct, 81
and nature, 55
problem of, 17; *see also* conscious mind

miraculous localities, 6

missionaries, Christian, influence of, 97

Mithras, 245n

mob psychology, 6; *see also* herd
mass-men

moieties, marriage, 225ff

monad, 306n, 308n
Oceanus as, 308n

Monoïmos, 308n

Mont Ventoux, 214

moon: Mother of God and, 286
son of the, 284
tincture compared to, 300; *see also* Luna
Selene
Sol and Luna
sun

moon-plant, 210

Morienus, 207n, 210n, 230, 274n, 275n, 283, 312

mortificatio, 258, 290

mother: dual, motif of, 120

of God, see Mary, the Virgin

and son-lover, 286

as symbol/archetype, 158f

mother/son pair, 200, 218, 286

motif(s), 12ff

dual, 13

in folklore, 124

investigation of, 124

repetition of, 12; see also dark(ness)

fairy

frontier

hero

mountain

sea

sweating

water

woman

mountain: motif of climbing, 142, 150f

-sickness, 140ff

mukti, 102

mulādhāra, 335

multiplicatio, 308f

mundificatio, 277, 293, 294, 304

Murray, Henry A., 99

Musaeum hermeticum, see titles of separate treatises as in *Bibl.*

Mutus liber, 296 & n, 322n, figures 11–13

Mylius, Johann Daniel, 182n, 192n, 244n, 250n, 306n

mysteries, Greek, 59

mysterium paschale, 196

mystery cults, 56, 59

mysticism, Christian, [234](#), [317n](#)

myth(s), [124](#), [321](#)

Greek, [64](#)

mythologem(s), [91](#), [92](#), [122](#), [169](#), [265](#), [317](#)

congruence of, [125](#)

and release of instinct, [92](#)

mythology, [15ff](#), [45](#), [120](#), [157](#), [159](#), [160](#), [270](#)

N

name, four-letter, of God, [316n](#)

nature, [212f](#)

as guide in psychotherapy, [41](#)

human, contrariety of, [305](#)

qualities of, [298](#), [300](#); *see also* mind

Naumann, Hans and Ida, [222n](#)

νεῖκος καὶ φιλία, [182](#)

neologisms, of Paracelsus, [111](#)

neurosis(-es), [29](#), [59](#), [121](#)

acceptance of, [10](#), [194](#)

aetiology/cause of, [20](#), [135](#)

—, dreams and, [140](#), [143](#)

—, importance of, [143](#)

— ultimate, [338](#)

anxiety, [86](#)

beginning of, [129f](#)

classification of, [86](#)

complexes and, [78](#)

compulsion, [6](#), [180](#)

content of, [86f](#)

and infantile history, [31](#)

as instinctual disturbances, [92](#)

nature of, [30](#), [36](#)

obsessional, [327](#)

of our age, [41](#)

one-sided personality development, [129](#)

personal, 120
and personal attitude, 31
and reductive analysis, 19
and religious promptings, 46
seriousness of, 24
and sexuality, 29, 36
transference, 25, 171, 234, 263, 318
“trauma” theory of, 22, 129f
variety of, 58, 327
war, 130
as warning, 142
as wrong functioning of psyche, 83
in young and old, 39; *see also* psychoneuroses
trauma(ta)
neurotics, two types, 121
New Guinea, 226
Nicholas of Cusa, 210, 276f, 309n, 319, 320
Nicholas of Flue, 183n
Nicolai, C. F., 315n
Nietzsche, F. W., 54
night sea journey, 245
nigredo, 182 & n, 197, 258n, 260, 271, 273, 281
nixie, 322n
Noah, flood of, 264n
non-ego, psychic, 262, 265, 291
non-identification, 261
normality, 70, 329
normalization, 67
Norton, Thomas, 287n, 309n
“nothing but,” 46, 173
Notker Balbulus, 199n
Nous, 246, 315n
numbers, 207f, 212, 238n, 306ff
masculine/feminine, 207, 212

odd/even, [207n](#)

see also individual numbers

numen: of goddess, [229](#)

transference of, [230](#)

nuptiae chymicae, [198](#)

O

obfuscation of the light, [198](#)

“obscurity,” subjective nature of, [145](#)

occultism, [44](#)

Oceanus, [308n](#)

ogdoad, [212](#), [238](#)

Old Testament, [121](#); *see also of names separate books*

Olympiodorus, [210n](#)

one/One, [203](#), [245](#), [306n](#)

born of the two, [295](#); *see also monad*

one-sidedness, [11](#), [33](#), [129](#), [146](#), [239](#)

Onians, R. B., [336n](#)

opinion, and pathogenicity, [17](#)

opposites, [182](#), [189](#), [305](#), [316](#)

coincidence of, *see coincidentia oppositorum*;

describe the unknowable, [309](#)

fusion/union of, [169](#), [185](#), [211](#), [244](#), [250](#), [257](#), [265](#), [281](#), [282](#), [292](#), [317](#), [320](#)

pairs of, [200](#), [239](#), [250](#), [283](#)

—, alchymical, [222n](#)

problem of, [77](#)

synthesis of, [165n](#)

tension of, [200](#)

unintegrated, [283](#)

united by hermaphrodite, [244](#); *see also antinomies*

complexio oppositorum

coniunctio oppositorum

EXAMPLES: ego/anima, [226](#)

ego/shadow, [198](#)

evil/good, 64
matter/psyche, 291
shadow/light, 64
Sol/Luna, 200, 211, 238
opus, 200, 203, 212, 236, 250, 262, 274, 280, 296, 303, 313, 321, 322n
analogy of coitus, 250
contra naturam, 262
demands of the, 236
end of, paradoxical, 314
magnum, 235
man's and woman's, and anima/animus, 303
moral character of, 236
as period of gestation, 252
a process of individuation, 313
psychologicum, aim of, 263
time-sequence of phases, 258n
Origen, 197
original man, *see* Anthropos
orthopedics, rational psychic, 3
“other,” the, 262
Oxford Groups, 16

P

padmas, 335
paganism, 192
painting, 47ff
pair(s): alchemical, 276f, 322n
of angels, 322n
royal, 286; *see also* antinomies
opposites
panacea, 182, 192
panic(s), 159
Paphnutia, 296
Paracelsus/Paracelsists, 17, 100, 103, 104, 111, 201, 245, 312
Paradise, Man of, 301

paradox: of unconscious, 34
of unimpaired virginity, 311

paraesthesia, of head, 334

paranoia, induced, 172n

parapsychology, 124; *see also* levitation

parental imago, *see* imago

parent(s): archetype, 96
disposition of, and neuroses, 130
of opposite sex, relation to, 170
projection on, 178

participation mystique, 183n, 252, 295

pathology, 84

patient(s): age, and method of handling, 38
of alchemists, 201
and catharsis, 62
“normal,” 44
paintings and drawings by, 47f, 200f; *see also* doctor

patria potestas, 109

patriarchal order, 97, 98
in European civilization, 99, 103, 104

Paul, St., *see* Saul

Paulinus of Aquileia, 315n

peacock, *see cauda pavonis*

Peirithous, 61

pelican, 315

penis, *see* phallus

Penotus, Bernardus Georgius, 272n

Peratics, 206n

Peronelle, 296

Persephone, 302

person, as psychic system, 3

persona, of doctor, 176

personality: centre of, 102
change of, 181

dissociation of, [120](#), [152](#), [173](#)
enlargement of, [263](#)
integration of, [20](#)
new centre of the, [102](#)
reconstruction/regeneration of, [27](#), [119](#)
schizoid, [120](#)
synthesis of, [199](#), [233](#); *see also* doctor

persuasion therapy, [3](#), [111](#)

perversions, infantile, [32](#)

Pestalozzi, J. H., [106n](#), [107n](#), [108n](#), [323](#)

Petrarch, [214](#)

peyotl, [292n](#)

phallus, contrasted with penis, [157](#)

phantoms, terminological, [320](#)

Pharaohs, [218](#)

Philalethes, [286n](#), [309n](#)

philology, [160](#)

philosophy: of life, [41](#), [77ff](#), [99](#)
—, and psyche, [79](#)
and instinct, [81](#)
psychology and, [112f](#), [122](#)
and psychotherapy, [79](#)
and religion, [79f](#)

phobia, [12](#), [86](#), [254](#)

Phosphorus, [238n](#)

phren(es), [336](#)

physician(s): medieval, [82](#)
wounded, [116](#); *see also* doctor
therapist

physics: and psychology, [65](#), [260n](#);
and psychotherapy, [4](#)

physiology, psychotherapy and, [76f](#)

Physis, [216](#), [246](#), [247](#), [272](#)

pictures: patients', [48f](#)

and psychic content, 201
planets, seven, 204
Plato, 314n;
 pseudo-, 273n
pleasure: infantile, 36
 principle, 19, 39, 66, 113
pneumatikos, 264
Poiret, Pierre, 317n
poisoning, as symbol, 264
politics, and psychotherapy, 6, 104
pollution, 292
pomegranate, 157
Pontanus, Johannes, 309n
Pope, the, 97, 99
Pordage, John, 296n, 297, 302
possession, 87, 180
 by unconscious, 197
power: complex, 328
 -drive(s), 4, 19
 -fictions, 19
 instinct, 66
 urge/will to, 113, 173, 179
practica and *theoria*, 262, 279
“*Practica Mariae*,” 250n
pregnancy, psychological, 255
Preisendanz, Karl, 167n
prejudices: of analyst, 8
 danger of, 115
 subjective, of Adler and Freud, 114, 118
prenatal life, and neurosis, 130
priest, 116, 122
prima materia, 187, 188, 189, 212, 218, 245, 303, 316
 equated with anima/animus, 303
 and God, 316n

primitive man, 123, 195, 268

and phallic symbols, 157

psychology of, 120

and secrets, 55*f*

and self-discipline, 57

unconscious in, 181

Primordial Man, *see* Anthropos

Proclus Diadochus, 306*n*

prognosis, 86, 158

and diagnosis, 86

dreams and, 143, 144

projection(s), 116, 170, 172, 187*n*, 188, 197, 231, 291

alchemical, 230

anima and, 295

compulsion of, 105

descent into matter, 230

detachment from doctor, 253

on feminine partner, 245*n*

inductive effect of, 176

infantile, in marriage, 219*f*

integration of, 263

— through, 187

object of, 291

of parental imagos, 96, 101

reduction of, 135

transference and, 63, 136, 177, 178, 233, 328

withdrawal of, 96, 99, 218, 295

Protestantism/Protestants, 16, 97, 99, 101, 194

Psalms, 121*n*, 219*n*

psychasthenia, and emotions, 58

psyche, 38, 90

ambiguity of, 40

ancestral, 34

and body, 4, 190

childhood, 98ff
collective, 35, 37
and consciousness, 89, 90
dissociation of, 131
as ego-consciousness and unconscious, 90
as *ens per se*, 89
as epiphenomenon, 89
evolutionary stratification of, 160
mass, 232
as microcosm, 91
non-individual, 169
not identical with conscious mind, 91
patriarchal orientation of, 99
phenomenology of, 89
preconscious structure of, 96n
primary splitting of, 226
self-regulating system, 153
totality of, 138
uniqueness of, 17
variability of, 4
a whole, 95
in youth and age, 39; *see also* archetype(s)
instincts)

psychoanalysis, 3, 21, 24, 25, 31, 88, 95, 111
and catharsis, 59
and confessional, 55
layman's idea of, 54
and psychotherapy, 53; *see also* analysis
Freud
psychologie à compartiments, 281

psychology(-ies): analytical, *see* analytical psychology
complex, *see* complex psychology
divorce from other sciences, 55
in early and later life, 39

empirical/experimental, 76, 89, 92
feminine, 296, 303
general, 112f
individual, *see* individual psychology
medical, 54, 113
—, absence of, 31
—, dilemma of, 114
multiplicity of, 53, 54
personalistic, 95, 185n
primitive, 45; *see also* psycho-analysis
psychoneuroses: as states of possession, 87
two groups, 7; *see also* neurosis
psychosis(-es), 24, 266
latent, 15, 186, 267
—, and manifest, proportion, 186n
schizophrenic, 101
as states of possession, 87
totalitarian, 231; *see also* schizophrenia
psychosomatic medicine, 113
psychotherapist, *see* analyst
doctor
psychotherapy, aim of, 81, 83, 104
contradictions in, 4
as dialectic, 3
diverse methods, need of, 9
ex cathedra, 116
field of, 94f
intellectual foundations, 76
meaning of, 21f, 111
and medicine, 84f
“minor,” 117
and politics, 104
pre-analytical, 177
as science, 95, 104

subject of, 89
task of, 78, 110
totalitarianism and, 107
“treatment of the soul,” 94
ultimate questions of, 235
and unconscious, 170
various schools, 3ff; *see also* method(s)
therapy
treatment
puberty, 97
Purgatory, 182n
purification, 277, 293, 300; *see also* *mundificatio*
purple, 287n
putrefactio/putrefaction, 182n, 241n, 257, 258, 267, 271, 299
Pythagoras/Pythagoreans, 191, 306n

Q

quaternio/quaternity, 183, 203, 207f, 238, 239, 305, 319, 323
double, 238
flowers as, 185
marriage, 212, 224ff
two, union of, 212; *see also* four
queen, *see* king and queen
quinta essentia/quintessence, 203, 207, 211, 245, 318

R

Rabanus Maurus, 308n
Rahner, Hugo, 169n
rapport: doctor/patient, 116, 134, 135, 137, 177; *see also* transference
Rasmussen, Knud, 303n
raven, 283n, 299, 315
realists, French, 37
reality, psychic and conscious, 52
realization: conscious, value of, 146
incomplete, 280

reason, and instinct, 78
rebirth, 245
rebis, 198, 258, 303, 304, 314, 315
 apotheosis of, 314
 as *cibus sempiternus/lumen indeficiens*, 309
 symbol of transcendental unity, 304; *see also* hermaphrodite
 lapis
red, 284, 299
redeemer, 124, 185
reduction, to instinct, 25
reductive explanations, 64, 66
rééducation de la volonté, 3
regina Austri, 286
regression(s), 32f, 81
 alchemical projection as, 230
 goal of, 32
 of libido, 179
 to primitivity, 15, 234
 as *reculer pour mieux sauter*, 15
Reinach, Salomon, 64
Reitzenstein, R., and Schaeder, H.H., 216n, 314n
relationship(s): counter-crossing, 220ff
 human, and transference, 136f
 infantile, in transference, 170
 symbolical, 261; *see also* doctor
relativism, philosophical, 65
relativity, of space and time, psychic, 125
religio, 195f
religion(s), 16, 98, 124
 comparative, 45, 50
 and “creed,” 193
 form of psychotherapy, 16
 Freud and, 119, 121
 modern man’s attitude to, 194

and parental imagos, 98
and philosophy, 79f, 122
as psychic healing, 121
psychological aspect of, 192n
as psychotherapeutic systems, 193
rites of, 97
and symbols, 160; *see also* Catholic Church
Christianity, etc.
religious function, 46
representations, collective, 13, 120, 121, 123; *see also* image(s)
repression, 29, 39, 55f, 62, 77, 112, 119, 239
 and instinct, 77
 and sin, 55, 56
 sublimation and, 77
 theory of, 23
res simplex, 197, 308
resistance(s), 39, 115, 133, 165n
 and abreaction, 131
 justified, 115
 and negative transference, 165n
 over-compensated, 154
 violent, to resolution of transference, 185, 186n
results, suggestive method and, 6
resurrection, *opus* as, 300f
retrospection, 32, 35
rex and *regina*, 227; *see also* king and queen
Rex marinus, 245
Rhazes, 204n
Rhine, J. B., 125n
right, *see* left and right
Ripley, Sir George, 264n; *see also* “*Cantilena Riplaei*”
ritual, Catholic/Protestant, 97
rites, marriage/birth/death, 97
Robert of Chartres, 274n

roots, loss of, 98
 instinctive, 122
Rorschach test, 90, 119
ros Gedeonis 273, 279
Rosarium philosophorum, 167n, 182n, 190n, 200ff, 212n, 242, 244, 245, 246n, 247,
 257n, 268, 271, 274n, 276n, 278n, 283, 288n, 289, 290, 303, 313, figures 1–10
Rosarius, 309
rose, 245, 261
Rosencreutz, Christian, 209, 216n, 291
Rosicrucianism, 215, 292
Rosinus, 204n, 296n
“Rosinus ad Sarratantam,” 274n, 283n, 284n, 311n
Roth-Scholtz, F., 297n
rotundum, 245; *see also* sphere
 wheel
Ruska, J., 189n, 198n, 204n, 214n, 257n, 258n, 284n

S

Sabaeans, 264n
sacraments, Christian, 56
sacrifices, animal, 197
sahasrāra, 336
saint, 295
salamander, 199
salt, 308n
Samaritan woman, 276
sanctification, *opus as*, 300
sanguis spiritualis, 198
Sapientia, 174, 273, 274, 278, 286, 303
 Dei, 192, 214, 271f
sarcophagus, 286
Satan: as raven, 315n
 stone as, 206n; *see also* devil
Saturn, 210, 298ff
 darkness of, 298

Saul (Paul, St.), 188
Schenkenbach, 332
Schiller, 46
schizophrenia, 120, 173, 175, 267, 327
 induced, 120, 172n
 mythological images in, 15
 symptoms of, 85
 two types, 121
scholasticism, 335; *see also* schoolmen
school, effects of, 96
schoolmen, 290
Schultz, J. H., 4
science: limits of, 305
 natural, of the psyche, 319
Scylla and Charybdis, 217, 234, 294
sea, 209
 circular, 210
 immersion in, 241
 motif of, 12; *see also* Oceanus
 water
Second Coming, Christ's, 272
second half of life, 38f, 41, 50, 265
secrets, 55ff
"secta liberi spiritus," 301n
Selene, 167n, 174n; *see also* Luna
 moon
self, 102, 103, 184, 199, 231, 233, 245n, 264n, 265
 alchemy and, 102
 contains all opposites, 319
 and ego, 49, 199, 265
 integration of, 265
 and non-ego, 265
 reality of, 314
 realization of, 102

spontaneous manifestations of, 313
as taskmaster, 313
timeless, 184
and timeless unconscious, 313
unity of, 314; *see also* ego
integration
self-assertion, 113
 need for, 37, 39, 66, 67, 165
self-criticism, of doctor, 115, 116
self-destruction, 173
self-education, 73, 74, 75
self-fertilization, 218
self-restraint, 57*f*
Senior, 167*n*, 206*n*, 215*n*, 217, 242*n*, 248, 258*n*, 273, 283*n*, 284, 286, 287, 288*n*
sensation, 40*n*, 279
separatio, 197
Sephira, 287*n*
sepulchre, red, 284
serpent/snake, 124, 184, 314*f*
 path, 185
 ritual, 315*n*
 serpens mercurialis, 206, 210, 315, *see also* Mercurius
 three, in chalice, 314
 three-headed, 206, 315
 trampler of, 301
 two-headed, 206; *see also* Uroboros
“serpent power,” *see chakras*
servus fugitivus, 270
seven, 204
sex: Anglo-Saxon attitude to, 37
 counter-crossing of, 220
sexual: impulses, infantile, 23
 urge, 117
sexuality, 317

and aetiology of neuroses, 29, 36
as compensation, 134
Freudian theory of, 3, 23, 25, 53, 117, 156
reduction to, 11
of symbols, 156
and transference, 134
shadow, 59, 63f, 114, 124, 198, 219, 239, 262
 assimilation of, 239
 and ego, 198, 239
 Freudian school and, 63f, 74
 integration of, 252
 in transference analysis, 219
Shakti, 185, 211, 295, 336f
Shekinah, 287n
shell-shock, 57
Shiva, 185, 211
Shulamite, 174
signs and symbols, 156, 175; *see also* symbols
Silberer, Herbert, 8, 318n
silver, 207
Simon Magus, 174n
sin: original, 81
 and repression, 55; *see also* guilt
six, 238n
sleep, 9
 fantasy in, 56
snake, *see* serpent
social relationships, attitude to, 118
social security, 294
society: individual and, 104ff, 120
 natural organization of, 233
 State and, 108
 temptation to unconsciousness, 107
Sol/Luna, 200, 207, 220, 236f, 242, 252, 322n

as archetypes, 220
Christ and Church as, 169
coniunctio of, 247ff
sol niger, 219
solar plexus, 336
Solomon, 274, 297
solutio, 197, 241
somnambulism, 112
son: and crown of victory, 286
 ruler over earth, 284
 of the virgin, 301
Son of God, 308
Song of Songs, 174, 228, 236n, 250, 286n, 297n
Sophia, 174, 297n, 302, 303
 as anima, 300, 303
 as the self, 302
Sorin, 268n
soror mystica, adept's, 219, 220, 227, 297, 322n
soul, 27, 107, 208n, 242, 258, 304
 ascent of, 267ff, 281
 birthplace of action, 94
 in Christianity, 105, 106
 function of relationship, 267
 as homunculus, 272
 as idea of unity, 267
 immortality of, *see* immortality
 loss of, 180, 268
 peril of, 56, 212
 as reconciler, 283
 return of, 279, 294
 as substantial angel, 301
 suffering of the, 16
 symbols of, 208n
 union with purified body, 294

as *vinculum*, 267; see also *anima*
animus
psyche
world-soul

South, Thomas, 296

space and time, psychic relativity, 125

Spencer, B., and Gillen, F. J., 228

sphere, 319; see also *rotundum*

spirit, 13, 278
 Christian symbols product of, 316
 Mercurius as, 216

sponsus/sponsa, 169, 228, 267, 308

spring, as allegory of God, 210

square, 204, 226
 see also *quaternio*

stability, inner, and social existence, 50

standards, ethical, 280

Stapleton, H. E., and Husain, M. Hidayat, 273n

star(s), 203, 204
 five-pointed golden, 184
 quintessential, 206, 212

State, the, 104ff, 232, 323
 agglomeration of life-carriers, 106
 in Christianity, 106
 and mass-men, 232
 and parental images, 104
 totalitarian, 107f
 collectivity of, 104
 and individuals, 106

Steinach, Eugen, 280f

Stekel, Wilhelm, 24

Stöckli, A., 183n, 184n

Stolcius de Stolcenberg, Daniel, 283n

stone, philosophers', 215n, 274, 278n, 290, 301

making of, “child’s play,” 299
“that is no stone,” 281
virgin mother of, 311n
see also *lapis philosophorum*

Strindberg, August, 35

subjective: factor, 117f
level, 74

sublimatio/sublimation, 77, 119, 152, 164, 206, 278n, 290, 300

substitution, 29

succus lunariae/lunatica, 210

suffering, 81f, 262

suggestion, 44, 88, 112, 132, 138, 146f, 173n
inadequacy of, 116
in interpretation, 146
limitations of, 146
theory of, 21
unconscious, 147

suggestion therapy, 3, 6, 9, 16, 21f, 116

suicide, 158
unconscious urge to, 57

sun, 214
and moon, 206, 211; see also *Sol*

sunrise, *albedo* and, 273

super-ego, 119, 120

superman/supermen, 105, 209
and submen, 195

Sushumna, 185

svadisthāna, 335, 336

swan, white, 300

swastika, 16

sweating, motif of, 241

symbiosis, plant/insect, 91

symbol(s), 47, 156, 250, 265
alchemical, compensating Christian, 316

analogical, 97
and centring process, 101
compensating, 123
danger of fixed meaning, 157
derivation from archaic functioning, 123
dream, 156
dual nature of, 198
feminine, 302 & *n*
fixed, 156ff
of the goal, 198
mana, 157
multiplicity of, 198
natural, self as, 265
need for, 159
phallic, 157
positive and negative, 286
sexual, 156
theriomorphic, and Christianity, 316
uniting, 238, 252, 265, 317; *see also* signs and symbols

symbolic contents, multiple significance, 8

symbolism: alchemy and, 102, 165, 294
Christian, 248
dream, 156
ecclesiastical, 263
Gnostic, 248
knowledge of, needed, 27
mythological, 15
at onset of transference, 185
in patients' paintings, 50

symbolization, 29

symptoms: acceptance of, 10
affective origins, 112
analysis of, 89
"imaginary," 22

neurotic, 57, 130
as repressed impulses, 53
suppression of, 21
synchronicity, 260n
synthesis, 135
system(s): person as, 3
 psychic individuality of, 4
 psychic influence as reciprocal reaction of two, 4
 relationship between two, 8

T

table, symbol of self, 183
taboo, incest, 179, 228, 232
 in normal person, 181
“Tabula smaragdina,” 189n, 242, 272, 274n, 289, 316
Tammuz, 260
Tantric: symbolism, 185, 334f
 worship, 211
Tao(ism), 289n, 314
technique: Freudian, 171–2n
 medical, 6
 principles of, 46f
 in psychotherapy, 94
 religious, 6; *see also* method(s)
telum passionis, 291n, 302n
temperament: importance of, 40
 types of psychological, 118
Templars, 315
temptation, forty days of, 299
ten, 306 & n, 308n; *see also* decad
 denarius
tenebriones, 103
tenebrositas, *see nigredo*
tension, discharge of, 133
tetragrammaton, 287n

tetrameria, [207](#)

Thabritius, *see* Gabricus

Theatrum chemicum, *see* titles of separate treatises as in *Bibl.*

theocracy, [104](#)

θεωρία/theoria, [119n](#), [262](#), [279](#)

of alchemy, [132](#); *see also* *practica*

theory(-ies): and dream analysis, [148](#)

meaning of, [119n](#)

modifications, needed in therapy, [40](#)

and psychotherapy, [88](#)

theorizing, [100](#)

Theosebeia, [296](#)

therapy: aims of, [41](#), [270](#)

principles of, [36](#)

psychotherapeutic view of, [84](#), [88ff](#)

rational, [16](#), [17](#); *see also* method(s)

psychotherapy

treatment

Theseus, [61](#)

thinking, [40n](#), [278](#)

compulsive, [81](#)

Thomas Aquinas, St., [335](#)

three, [183n](#), [204f](#), [207](#), [238](#), [314](#); *see also* triad

trinity

Thucydides, [215n](#)

tic, symbolic, [12](#)

time, *see* space

time-reckoning, unconscious, [183](#)

tincture, [198](#), [207](#), [297ff](#)

white, [284](#)

Tiphereth, [287n](#)

torments, [268](#)

totalitarianism, [104](#), [231](#)

totality, man's, [216](#); *see also* wholeness

totemism, primitive, 64

“Tractatulus Aristotelis,” *see* Aristotle, pseudo

“Tractatulus Avicennae,” 257*n*

“Tractatus aureus,” 189*n*, 236, 264*n*, 267*n*, 283*n*

tradition, dangers of breakdown, 98

trance, witch’s, 268

transference, 9, 61*ff*, 96, 99, 133, 134*ff*, 164, 171*ff*, 233, 321, 323

Adler and, 67

alpha and omega of analysis, 134

analysis of, 218, 234

archetypal aspect in, 185*n*, 187

artificially acquired, 171*n*

as attitude to life, 135

core of, 234

counter-crossing relationships in, 221*ff*

and cure, 172

erotic, 134

“failure” with, 328

Freud and, 171, 172*n*, 185*n*

“getting stuck” in, 101

and heightened consciousness, 219

and individuation, 323

infantile fantasies in, 218

irrational foundations of, 256

made up of projections, 135

meaning of, 136

a natural phenomenon, 171*n*, 218

negative, 164, 165*n*

projection in, 63, 136*f*, 172, 328

resistance to termination of, 186*n*

resolution of, 164, 253

and sexuality, 134, 173

severance of, 136, 253

sometimes not resolvable, 253; *see also* doctor

rapport

transference neurosis, *see* neurosis

transformation, 55, 69f, 203

- child > parent, 97
- dark > light, 300
- death > life, 300
- mutual, 55, 69ff

trapeza, 183n

trauma(ta), 22, 23, 133

- and neurosis, 129f, 143
- war neurosis and, 130

treatment, 327

- aim of, 138
- a dialectical process, 116
- four stages of, 55, 59ff
- hypnotic, 61
- individual, 6, 24, 26
- irrationalization of, 26
- limits of rational, 41; *see also* method(s)
- psychotherapy
- therapy

tree: birth motif, 184

- Christmas, 184
- growing from Adam and Eve, 302
- of life, 276
- philosophical, 302, 303, *see also arbor philosophica*
- sun and moon, 315

triad: double, 238

- masculine, 208

trinity/Trinity, 314f, 316n

- chthonic equivalent of, 315
- divine, 210n
- evil and, 315
- motif of, 14

Mercurius and, 206, 216

Trojan horse, 159

“Turba philosophorum,” 244n, 274n, 306n; *see also* Ruska
two, 207, 306n

one born of the, 295; *see also* dyad

types: asthenic and spastic, 121

psychological, 114, 119; *see also* attitude-type

extraversion

feeling

introversion

intuition(s)

sensation

thinking

U

ὑδωρ θεῖον, 203

ulcers, uterine, 333

unarius, 306; *see also* one

unconscious, 11, 15, 20, 32, 74, 113, 139, 170ff, 191, 192, 260, 302, 303, 311

Adlerian depreciation of, 67

aetiological/causal significance of, 140

aims of, 42

ancestral/instinctual, 34

archaic vestiges in, 90

basis of consciousness, 34

beneficial effects of, 293

chaos of, 193

collective, *see* unconscious, collective, *below*

compensatory character, 11, 123, 153, 180

and consciousness/conscious mind, 11, 34, 56, 123, 177, 294

continuity of, 12, 92

creativity of, 34

early conceptions of, 90

effects of, on therapist, 177

everywhere identical, 124

fear of, 181
feeling-relationship to, 279
feminine, 302
Freud and, 30, 34, 152
fundamental mistake about, 153
general psychology and, 113
inductive action of, 176
as infantile/criminal/perverse, 152
invasion by, 271
as matrix of human mind, 189
motives, and free choice, 177
neutrality of, 152
not directly observable, 170n
not only evil, 192
personal, 35
personalistic view, 90
possession by, 197
process, in alchemy, 198
as real psyche, 91
repressed, 34
scientific theories and, 270
sexuality of, 317, 318
significance of, 151
as “somatic,” 112
timelessness of, 311, 313
turning away from, 65
unconscious, collective, 13, 50f, 101, 124, 262, 267, 293, 295, 312
 in alchemy, 313
 sea as symbol of, 12f
 unity of, 125; *see also* imagination
 representations
unconscious contents: alchemical symbols for integration of, 210
 assimilation of, 20, 152
 constellation of, 187

energy/potency of, [13](#), [180](#)
integration of, [210](#)
nature of, [56](#), [156](#), [160](#)
projected, [170](#), [253](#), [277](#); *see also* archetype(s)
image(s)
symbol(s)
unconsciousness: mutual, of doctor and patient, [176](#), [178](#)
way of, [105](#)
understanding, in doctor and patient, [145f](#)
unio mystica, [169](#), [218](#), [252](#), [308](#), [314](#); *see also* marriage, divine/mystic
union: of conscious mind with unconscious, [265](#)
of God with matter, [185](#)
inner nature of, in alchemy, [298](#)
of opposites, *see* opposites
partial, of elements, [239](#)
unity: and diversity, [199](#)
inner, [233](#)
transcendent, [245](#)
universal, and individual, [5ff](#)
universal man, [5](#), [6](#)
universities, and medical psychology, [30](#)
Upanishads, [184](#)
urges, instinctive, [173](#)
urine, boys'/dogs', [210](#)
Uroboros, [242](#), [309](#)
uterus, [203](#), [241](#), [336](#)

V

Valhalla, [159](#)
Valkyries, [159](#)
values, [33](#)
ethical, [189](#)
loss of, [135](#)
relativization of, [293](#)
Vansteenberghe, Edmond, [210n](#)

vas Hermeticum, 203, 241f, 257, 286

feminine lunar vessel, 314

vapours, two, 206, 248

velleities, 198

Ventura, Laurentius, 271n

Venus, 244, 291, 297ff

barbata, 308

love-fire of, 297, 298, 300

and Mars, 298, 302

mother of the child, 298

pearl of, 298

a pure virgin, 298

vessel, alchemical, 203; see also *vas Hermeticum*

victory, crown of, 286

vinculum, of soul and body, 295

vinum ardens, 210

Virgin: seed/Son of the, 301; see also Mary

virtues, Christian, 190, 304

vishuddha, 336

“Visio Arislei,” 170n, 218n, 245

vulture, 283n

W

Waite, A. E., 217, 292n

War, Great, see World War I

water, 242, 248f, 270

black, 264n

dream-motif, 12, 13

as energy-potential, 13

metaphysical, 277

symbol of Mary, 286

— of wisdom, 276

see also *aqua*

Wei Po-yang, 210n, 217, 289n

Weltanschauung, 119n

whale, 245

whale-dragon, 335

wheat, grain of, 257n

wheel, 245, 261

white(ness), 299ff see also *albedo*

whitening, see *dealbatio*

whole man, treatment of, 89f

wholeness, 59, 191, 239, 244, 245n, 262, 263, 281, 319

circle as symbol of, 210

combines I and You, 244f

cross as symbol of, 305

describable only in antinomies, 314

idea of, 267, 319

initial state of, 207

royal pair in, 263

transcendent, 246; see also integration

will: development of the, 195

education of, 50

God's, 301

in second half of life, 50

Winthuis, Josef, 244n

Wisdom, 274 see also *Sapientia*

wish-fantasies, 218n

infantile, religion and, 119

wishes, repressed, 63

dreams and, 147

witch's trance, 268

wolf, 167n

woman/women: and alchemy, 296, 302

animus-possessed, 296

unknown, motif of, 13f

Woodroffe, Sir John, 335

Word of God, 276; see also *Logos*

work: danger of the, 279

goal of the, [278](#)

metaphors of, [300](#); see also *opus*

working through, [278](#)

world-soul, [314n](#)

World War I, and neurosis, [129](#)

wrath, God's, [299](#), [300](#)

Y

yin, [159](#)

yoga, [59](#), [102](#), [185](#), [268](#)

Kundalini, [335](#)

yoni, [157](#)

Z

Zacharius, Dionysius, [168n](#), [244n](#)

Zadith Senior, *see* Senior

Zeitgeist, [18](#)

Zen Buddhism, *see* Buddhism

Zosimos, [167n](#), [206n](#), [216](#), [264n](#), [296](#) & *n*

THE COLLECTED WORKS OF

C. G. JUNG

THE PUBLICATION of the first complete edition, in English, of the works of C. G. Jung was undertaken by Routledge and Kegan Paul, Ltd., in England and by Bollingen Foundation in the United States. The American edition is number XX in Bollingen Series, which since 1967 has been published by Princeton University Press. The edition contains revised versions of works previously published, such as *Psychology of the Unconscious*, which is now entitled *Symbols of Transformation*; works originally written in English, such as *Psychology and Religion*; works not previously translated, such as *Aion*; and, in general, new translations of virtually all of Professor Jung's writings. Prior to his death, in 1961, the author supervised the textual revision, which in some cases is extensive. Sir Herbert Read (d. 1968), Dr. Michael Fordham, and Dr. Gerhard Adler compose the Editorial Committee; the translator is R. F. C. Hull (except for Volume 2) and William McGuire is executive editor.

The price of the volumes varies according to size; they are sold separately, and may also be obtained on standing order. Several of the volumes are extensively illustrated. Each volume contains an index and in most a bibliography; the final volumes will contain a complete bibliography of Professor Jung's writings and a general index to the entire edition.

In the following list, dates of original publication are given in parentheses (of original composition, in brackets). Multiple dates indicate revisions.

*1. PSYCHIATRIC STUDIES

On the Psychology and Pathology of So-Called Occult Phenomena (1902)

On Hysterical Misreading (1904)

Cryptomnesia (1905)

On Manic Mood Disorder (1903)

A Case of Hysterical Stupor in a Prisoner in Detention (1902)

On Simulated Insanity (1903)

A Medical Opinion on a Case of Simulated Insanity (1904)

A Third and Final Opinion on Two Contradictory Psychiatric Diagnoses
(1906)

On the Psychological Diagnosis of Facts (1905)

†2. EXPERIMENTAL RESEARCHES

Translated by Leopold Stein in collaboration with Diana Riviere

STUDIES IN WORD ASSOCIATION (1904–7, 1910)

The Associations of Normal Subjects (by Jung and F. Riklin)

An Analysis of the Associations of an Epileptic

The Reaction-Time Ratio in the Association Experiment

Experimental Observations on the Faculty of Memory

Psychoanalysis and Association Experiments

The Psychological Diagnosis of Evidence

Association, Dream, and Hysterical Symptom

The Psychopathological Significance of the Association Experiment

Disturbances in Reproduction in the Association Experiment

The Association Method

The Family Constellation

PSYCHOPHYSICAL RESEARCHES (1907–8)

On the Psychophysical Relations of the Association Experiment

Psychophysical Investigations with the Galvanometer and Pneumograph in
Normal and Insane Individuals (by F. Peterson and Jung)

Further Investigations on the Galvanic Phenomenon and Respiration in
Normal and Insane Individuals (by C. Ricksher and Jung)

Appendix: Statistical Details of Enlistment (1906); New Aspects of Criminal
Psychology (1908); The Psychological Methods of Investigation Used in the
Psychiatric Clinic of the University of Zurich (1910); On the Doctrine of
Complexes ([1911] 1913); On the Psychological Diagnosis of Evidence
(1937)

*3. THE PSYCHOGENESIS OF MENTAL DISEASE

The Psychology of Dementia Praecox (1907)

The Content of the Psychoses (1908/1914)

On Psychological Understanding (1914)

A Criticism of Bleuler's Theory of Schizophrenic Negativism (1911)

On the Importance of the Unconscious in Psychopathology (1914)

On the Problem of Psychogenesis in Mental Disease (1919)

Mental Disease and the Psyche (1928)

On the Psychogenesis of Schizophrenia (1939)

Recent Thoughts on Schizophrenia (1957)

Schizophrenia (1958)

†4. FREUD AND PSYCHOANALYSIS

Freud's Theory of Hysteria: A Reply to Aschaffenburg (1906)

The Freudian Theory of Hysteria (1908)

The Analysis of Dreams (1909)

A Contribution to the Psychology of Rumour (1910–11)

On the Significance of Number Dreams (1910–11)

Morton Prince, "The Mechanism and Interpretation of Dreams": A Critical Review (1911)

On the Criticism of Psychoanalysis (1910)

Concerning Psychoanalysis (1912)

The Theory of Psychoanalysis (1913)

General Aspects of Psychoanalysis (1913)

Psychoanalysis and Neurosis (1916)

Some Crucial Points in Psychoanalysis: A Correspondence between Dr. Jung and Dr. Loÿ (1914)

Prefaces to "Collected Papers on Analytical Psychology" (1916, 1917)

The Significance of the Father in the Destiny of the Individual (1909/1949)

Introduction to Kranefeldt's "Secret Ways of the Mind" (1930)

Freud and Jung: Contrasts (1929)

‡5. SYMBOLS OF TRANSFORMATION (1911–12/1952)

PART I

Introduction

Two Kinds of Thinking

The Miller Fantasies: Anamnesis

The Hymn of Creation

The Song of the Moth

PART II

Introduction

The Concept of Libido

The Transformation of Libido

The Origin of the Hero

Symbols of the Mother and of Rebirth

The Battle for Deliverance from the Mother

The Dual Mother

The Sacrifice

Epilogue

Appendix: The Miller Fantasies

*6. PSYCHOLOGICAL TYPES (1921)

Introduction

The Problem of Types in the History of Classical and Medieval Thought

Schiller's Ideas on the Type Problem

The Apollinian and the Dionysian

The Type Problem in Human Character

The Type Problem in Poetry

The Type Problem in Psychopathology

The Type Problem in Aesthetics

The Type Problem in Modern Philosophy

The Type Problem in Biography

General Description of the Types

Definitions

Epilogue

Four Papers on Psychological Typology (1913, 1925, 1931, 1936)

†7. TWO ESSAYS ON ANALYTICAL PSYCHOLOGY

On the Psychology of the Unconscious (1917/1926/1943)

The Relations between the Ego and the Unconscious (1928)

Appendix: New Paths in Psychology (1912); The Structure of the Unconscious (1916) (new versions, with variants, 1966)

‡8. THE STRUCTURE AND DYNAMICS OF THE PSYCHE

On Psychic Energy (1928)

The Transcendent Function ([1916]/1957)

A Review of the Complex Theory (1934)

The Significance of Constitution and Heredity in Psychology (1929)

Psychological Factors Determining Human Behavior (1937)

Instinct and the Unconscious (1919)

The Structure of the Psyche (1927/1931)

On the Nature of the Psyche (1947/1954)

General Aspects of Dream Psychology (1916/1948)

On the Nature of Dreams (1945/1948)

The Psychological Foundations of Belief in Spirits (1920/1948)

Spirit and Life (1926)

Basic Postulates of Analytical Psychology (1931)
Analytical Psychology and *Weltanschauung* (1928/1931)
The Real and the Surreal (1933)
The Stages of Life (1930–1931)
The Soul and Death (1934)
Synchronicity: An Acausal Connecting Principle (1952)
Appendix: On Synchronicity (1951)

*9. PART I. THE ARCHETYPES AND THE COLLECTIVE UNCONSCIOUS

Archetypes of the Collective Unconscious (1934/1954)
The Concept of the Collective Unconscious (1936)
Concerning the Archetypes, with Special Reference to the Anima Concept
(1936/1954)
Psychological Aspects of the Mother Archetype (1938/1954)
Concerning Rebirth (1940/1950)
The Psychology of the Child Archetype (1940)
The Psychological Aspects of the Kore (1941)
The Phenomenology of the Spirit in Fairytales (1945/1948)
On the Psychology of the Trickster-Figure (1954)
Conscious, Unconscious, and Individuation (1939)
A Study in the Process of Individuation (1934/1950)
Concerning Mandala Symbolism (1950)
Appendix: Mandalas (1955)

*9. PART II. AION (1951)

RESEARCHES INTO THE PHENOMENOLOGY OF THE SELF

The Ego
The Shadow
The Syzygy: Anima and Animus
The Self
Christ, a Symbol of the Self
The Sign of the Fishes
The Prophecies of Nostradamus
The Historical Significance of the Fish
The Ambivalence of the Fish Symbol
The Fish in Alchemy
The Alchemical Interpretation of the Fish

Background to the Psychology of Christian Alchemical Symbolism
Gnostic Symbols of the Self
The Structure and Dynamics of the Self
Conclusion

*10. CIVILIZATION IN TRANSITION

The Role of the Unconscious (1918)
Mind and Earth (1927/1931)
Archaic Man (1931)
The Spiritual Problem of Modern Man (1928/1931)
The Love Problem of a Student (1928)
Woman in Europe (1927)
The Meaning of Psychology for Modern Man (1933/1934)
The State of Psychotherapy Today (1934)
Preface and Epilogue to “Essays on Contemporary Events” (1946)
Wotan (1936)
After the Catastrophe (1945)
The Fight with the Shadow (1946)
The Undiscovered Self (Present and Future) (1957)
Flying Saucers: A Modern Myth (1958)
A Psychological View of Conscience (1958)
Good and Evil in Analytical Psychology (1959)
Introduction to Wolff’s “Studies in Jungian Psychology” (1959)
The Swiss Line in the European Spectrum (1928)
Reviews of Keyserling’s “America Set Free” (1930) and “La Révolution
Mondiale” (1934)
The Complications of American Psychology (1930)
The Dreamlike World of India (1939)
What India Can Teach Us (1939)
Appendix: Documents (1933–1938)

†11 PSYCHOLOGY AND RELIGION: WEST AND EAST

WESTERN RELIGION

Psychology and Religion (The Terry Lectures) (1938/1940)
A Psychological Approach to the Dogma of the Trinity (1942/1948)
Transformation Symbolism in the Mass (1942/1954)

Forewords to White's "God and the Unconscious" and Werblowsky's "Lucifer and Prometheus" (1952)

Brother Klaus (1933)

Psychotherapists or the Clergy (1932)

Psychoanalysis and the Cure of Souls (1928)

Answer to Job (1952)

EASTERN RELIGION

Psychological Commentaries on "The Tibetan Book of the Great Liberation" (1939/1954) and "The Tibetan Book of the Dead" (1935/1953)

Yoga and the West (1936)

Foreword to Suzuki's "Introduction to Zen Buddhism" (1939)

The Psychology of Eastern Meditation (1943)

The Holy Men of India: Introduction to Zimmer's "Der Weg zum Selbst" (1944)

Foreword to the "I Ching" (1950)

*12. PSYCHOLOGY AND ALCHEMY (1944)

Prefatory note to the English Edition ([1951?] added 1967)

Introduction to the Religious and Psychological Problems of Alchemy

Individual Dream Symbolism in Relation to Alchemy (1936)

Religious Ideas in Alchemy (1937)

Epilogue

†13. ALCHEMICAL STUDIES

Commentary on "The Secret of the Golden Flower" (1929)

The Visions of Zosimos (1938/1954)

Paracelsus as a Spiritual Phenomenon (1942)

The Spirit Mercurius (1943/1948)

The Philosophical Tree (1945/1954)

‡14. MYSTERIUM CONIUNCTIONIS (1955–56)

AN INQUIRY INTO THE SEPARATION AND

SYNTHESIS OF PSYCHIC OPPOSITES IN ALCHEMY

The Components of the Coniunctio

The Paradoxa

The Personification of the Opposites

Rex and Regina

Adam and Eve
The Conjunction

*15. THE SPIRIT IN MAN, ART, AND LITERATURE

Paracelsus (1929)

Paracelsus the Physician (1941)

Sigmund Freud in His Historical Setting (1932)

In Memory of Sigmund Freud (1939)

Richard Wilhelm: In Memoriam (1930)

On the Relation of Analytical Psychology to Poetry (1922)

Psychology and Literature (1930/1950)

“Ulysses”: A Monologue (1932)

Picasso (1932)

†16. THE PRACTICE OF PSYCHOTHERAPY

GENERAL PROBLEMS OF PSYCHOTHERAPY

Principles of Practical Psychotherapy (1935)

What Is Psychotherapy? (1935)

Some Aspects of Modern Psychotherapy (1930)

The Aims of Psychotherapy (1931)

Problems of Modern Psychotherapy (1929)

Psychotherapy and a Philosophy of Life (1943)

Medicine and Psychotherapy (1945)

Psychotherapy Today (1945)

Fundamental Questions of Psychotherapy (1951)

SPECIFIC PROBLEMS OF PSYCHOTHERAPY

The Therapeutic Value of Abreaction (1921/1928)

The Practical Use of Dream-Analysis (1934)

The Psychology of the Transference (1946)

Appendix: The Realities of Practical Psychotherapy ([1937] added, 1966)

‡17. THE DEVELOPMENT OF PERSONALITY

Psychic Conflicts in a Child (1910/1946)

Introduction to Wickes’s “Analyses der Kinderseele” (1927/1931)

Child Development and Education (1928)

Analytical Psychology and Education: Three Lectures (1926/1946)

The Gifted Child (1943)

The Significance of the Unconscious in Individual Education (1928)

The Development of Personality (1934)

Marriage as a Psychological Relationship (1925)

18. THE SYMBOLIC LIFE

Miscellaneous Writings

19. GENERAL BIBLIOGRAPHY OF C. G. JUNG'S WRITINGS

20. GENERAL INDEX TO THE COLLECTED WORKS

1 [Delivered as a lecture to the Zurich Medical Society in 1935. Published as “Grundsätzliches zur praktischen Psychotherapie,” *Zentralblatt für Psychotherapie*, VIII (1935): 2, 66–82.—EDITORS.]

1 [Delivered as a lecture, “Was ist Psychotherapie?,” in May 1935. at a symposium on “Psychotherapy in Switzerland.” Subsequently published in *Schweizerische Aerztezeitung fur Standesfragen*, XVI: 26 (June, 1935), 335–39.—EDITORS.]

1 [Written in English. Read at the Congress of the Society of Public Health, Zurich, in 1929. First published in *Journal of State Medicine* (London), XXXVIII: 6 (June, 1930), 348–54.—EDITORS.]

1 [*Delivered as a lecture, “Ziele der Psychotherapie,” on April 12, 1929, at the 4th General Medical Congress for Psychotherapy, Bad Nauheim, and published in the *Bericht* of the Congress, 1929; republished in *Seelenprobleme der Gegenwart* (Zurich, 1931), pp. 87–114. Previously trans. by C. F. Baynes and W. S. Dell in *Modern Man in Search of a Soul* (London and New York, 1933).—EDITORS.]

2 [Published at Leipzig, 1904–13.—EDITORS.]

3 [•The attribution to Coleridge is incorrect, according to Coleridgean scholars who were consulted.—EDITORS.]

4 [Viz., thinking, feeling, sensation, and intuition.—EDITORS.]

5 [•The term “nothing but” (*nichts als*) denotes the common habit of explaining something unknown by reducing it to something apparently known and thereby devaluing it. For instance, when a certain illness is said to be “nothing but psychic,” it is explained as imaginary and is thus devalued. The expression is borrowed from James, *The Varieties of Religious Experience*, p. 12.—EDITORS.]

6 •This has since been remedied. Cf. “A Study in the Process of Individuation.” [Also cf. *Psychology and Alchemy*, Part II.—EDITORS.]

1 [Published as “Die Probleme der modernen Psychotherapie” in *Schweizerisches Medizinisches Jahrbuch*, 1929, and in *Seelenprobleme der Gegenwart* (Zurich, 1931), pp. 1–39. Previously trans. by C. F. Baynes and W. S. Dell in *Modern Man in Search of a Soul* (London and New York, 1933).—EDITORS.]

1 [•The introductory address to a discussion at the Conference for Psychology, Zurich, September 26, 1942. Published as “Psychotherapie und Weltanschauung” in the *Schweizerische Zeitschrift für Psychologie und ihre Anwendungen*, I (1943):3, 157–64; and in *Aufsätze zur Zeitgeschichte* (Zurich, 1946), pp. 57–72. Previously trans. by Mary Bnner in *Essays on Contemporary Events* (London, 1947), for other contents of which see Vol. 10, Part III.—EDITORS.]

1 [Delivered as a lecture to a scientific meeting of the Senate of the Swiss Academy of Medical Science. Zurich, May 12, 1945. Published as “Medizin und Psychotherapie.” *Bulletin der Schweizerischen Akademie der medizinischen Wissenschaften*, I (1945): 5, 315–25.—EDITORS.]

1 [A lecture delivered to a Section of the Swiss Society for Psychotherapy at its fourth annual meeting (1941). The Section was formed to further the interests of psychotherapists in Switzerland. The lecture was published as “Die Psychotherapie in der Gegenwart” in the *Schweizerische Zeitschrift für Psychologie und ihre Anwendungen*, IV (1945), 1–18; and in *Aufsätze zur Zeitgeschichte* (Zurich, 1946), pp. 25–56, from which the present translation was made. Previously trans. by Mary Briner in *Essays on Contemporary Events* (London, 1947); cf. Vol. 10, Part III.—EDITORS.]

2 As we know, the parental imago is constituted on the one hand by the personally acquired image of the personal parents, but on the other hand by the parent archetype which exists *a priori*, i.e., in the pre-conscious structure of the psyche.

3 In *Explorations in Personality*.

4 * “Labyrinthus medicorum errantium,” p. 199 (“Theorica medica”). [The word *θεωπία* originally meant looking about one at the world.—TRANS.]

5 * “De ente Dei,” p. 226.

6 Cf. *Psychology and Alchemy*, and “Psychology and Religion.”

7 Khunrath, *Von hylealischen... Chaos*.

8 Pestalozzi said (*Ideen*, p. 187): “None of the institutions, measures, and means of education established for the masses and the needs of men in the aggregate, whatever shape or form they may take, serve to advance human culture. In the vast majority of cases they are completely worthless for that purpose and are directly opposed to it. Our race develops its human qualities in essence only from face to face, from heart to heart. Essentially it develops only in little intimate circles which gradually grow in graciousness and love, in confidence and trust. All the means requisite for the education of man, which serve to make him truly humane and to bring him to mankindliness, are in their origin and essence the concern of the individual and of such institutions as are closely and intimately attached to his heart and mind. They never were nor will be the concern of the masses. They never were nor will be the concern of civilization.” [See note 10 below.—TRANS.]

9 *Ibid.*, pp. 189f.: “The collective existence of our race can only produce civilization, not culture. [See note 10 below.—TRANS.] Is it not true, do we not see every day, that in proportion as the herd-like aggregations of men become more important, and in proportion as officialdom, which represents the legal concentration of the power of the masses, has freer play and wields greater authority, the divine breath of tenderness is the more easily extinguished in the hearts of the individuals composing these human aggregations and their officials, and that the receptivity to truth which lies deep in man’s nature perishes within them to the same degree?

“The collectively unified man, if truly he be nothing but that, sinks down in all his relations into the depths of civilized corruption, and sunk in this corruption, ceases to seek more over the whole earth than the wild animals in the forest seek.”

10 More than a hundred years ago, in times not so unlike our own, Pestalozzi wrote (*ibid.*, p. 186): “The race of men cannot remain socially united without some ordering power. Culture has the power to unite men as individuals, in independence and freedom, through law and art. But a cultureless civilization unites them as masses, without regard to independence, freedom, law or art, through the power of coercion.” [N.B. Pestalozzi evidently subscribes to the Germanic distinction between *Kultur* and *Zivilisation*, where the latter term is employed in a pejorative sense. The

idea is that culture, deriving ultimately from tillage and worship (*cultus*), is a natural organic growth, whereas civilization is an affair of the city (*civis*) and thus something artificial. Cf. note 9 above.—TRANS.]

1 [First published as “Grundfragen der Psychotherapie,” *Dialectica* (Neuchâtel). V (1951): 1, 8–24.—EDITORS.]

2 “The Relations Between the Ego and the Unconscious,” chs. II and III.

3 Kerényi, *Asklepios*, p. 83.

4 [Literally *weltanschaulich*, ‘pertaining to one’s view of the world.’ *Weltanschauung* is usually translated as ‘philosophy (of life),’ ‘world-view,’ etc. In the present context, ‘theoretical’ is used in the precise sense of the Greek *θεωρία*, which meant ‘looking about the world,’ ‘contemplation’; hence ‘speculation.’ Cf. p. 100, note 4.—TRANS.]

5 Freud, “Leonardo da Vinci” (Standard edn., Vol. XI).

6 E.g., Psalms 147:3 and Job 5:18.

7 [From *ἐκφορέω*, ‘to carry forth.’—TRANS.]

8 The concept of the archetype is a specifically psychological instance of the “pattern of behaviour” in biology. Hence it has nothing whatever to do with inherited ideas, but with modes of behaviour.

9 * Rhine, *Extra-Sensory Perception*.

1 Written in English. First published in the *British Journal of Psychology* (London), *Medical Section*, II (1921): i, 13–22. Revised and published in *Contributions to Analytical Psychology* (London and New York, 1928), pp. 282–94. Some verbal alterations to the revised version have been made here.—EDITORS.]

2 [Both published 1920.]

1 [* Delivered as a lecture, “Die praktische Verwendbarkeit der Traumanalyse,” at the 6th General Medical Congress for Psychotherapy, Dresden, April 1931, and published in the *Bericht* of the Congress; republished in *Wirklichkeit der Seele* (Zurich, 1934), pp. 68–103. Trans. from the *Bericht* by Gary F. Baynes and W. S. Dell in *Modern Man in Search of a Soul* (New York and London, 1933).—EDITORS.]

2 [This dream is discussed at greater length in “Child Development and Education,” pars. 117ff.—EDITORS.]

3 “Komplex und Mythos.”

1 [First published, in book form, as *Die Psychologie der Übertragung* (Zurich, 1946).—EDITORS.]

2 This is not to say that a transference never occurs in such cases. The negative form of transference in the guise of resistance, dislike, or hate endows the other person with great importance from the start, even if this importance is negative; and it tries to put every conceivable obstacle in the way of a positive transference. Consequently the symbolism so characteristic of the latter—the synthesis of opposites—cannot develop.

1 “Accipe canem corascenum masculum et caniculum Armeniae” (Take a Corascene dog and an Armenian bitch). —“De alchimiae difficultatibus,” *Theatrum chemicum*, I, p. 163. A quotation from Kalid (in the *Rosarium, Artis auriferae*, II, p. 248) runs: “Accipe canem coetaneum et catulam Armeniae” (Take a Coetanean dog and an Armenian bitch). In a magic papyrus, Selene (moon) is called κῶν (bitch).—Paris MS. Z 2280, in Preisendanz, *Papyri Graecae Magicae*, I, p. 142. In Zosimos, dog and wolf.—Berthelot, *Alchimistes grecs*, III, xii, 9. [No translation of the words *corascenum* and *coetaneum* has been attempted, as we are advised that they are probably corrupt, or may indicate geographical names.—EDITORS.]

2 Zosimos, in Berthelot, *Alch. grecs*, III, xii, 9.

3 The classical passage is to be found in Senior, *De chemia*, p. 8: “Tu mei indiges, sicut gallus gallinae indiget” (You need me as the cock needs the hen).

4 Numerous pictures exist in the literature.

5 Kekulé, *Lehrbuch der organischen Chemie*, I, pp. 624f., and Fierz-David, *Die Entwicklungsgeschichte der Chemie*, pp. 235ff.

6 Zacharius, “Opusculum,” *Theatr. chem.*, I, p. 826.

7 “Consilium coniugii,” *Ars chemica*, p. 259. Cf. *Aurora consurgens*, I, Ch. II: “Est namque donum et sacramentum Dei atque res divina” (For she [Wisdom] is a gift and sacrament of God and a divine matter).

8 This does not contradict the fact that the *coniunctio* motif owes its fascination primarily to its archetypal character.

9 Cf. the detailed account in Rahner, “Mysterium lunae.”

10 A collection of the classical sources is to be found in Klinz, ‘*Ἐρὸς γάμος*.’

11 Bousset, *Hauptprobleme der Gnosis*, pp. 69ff., 263f., 315ff.; Leisegang, *Der heilige Geist*, I, p. 235.

12 I call unconscious processes “hypothetical” because the unconscious is by definition not amenable to direct observation and can only be inferred.

13 I am not considering the so-called homosexual forms, such as father-son, mother-daughter, etc. In alchemy, as far as I know, this variation is alluded to only once, in the “Visio Arislei” (*Art. aurif.*, I, p. 147): “Domine, quamvis rex sis, male tamen imperas et regis: masculos namque masculis coniunxisti, sciens quod masculi non gignunt” (Lord, though thou art king, yet thou rulest and governest badly; for thou hast joined males with males, knowing that males do not produce offspring).

14 Freud says (*Introductory Lectures*, Part III, p. 455): “The decisive part of the work is achieved by creating in the patient’s relation to the doctor—in the ‘transference’—new editions of the old conflicts; in these the patient would like to behave in the same way as he did in the past.... In place of the patient’s true illness there appears the artificially constructed transference illness, in place of the various unreal objects of his libido there appears a single, and once more imaginary, object in the person of the doctor.” It is open to doubt whether the transference is always constructed artificially, since it is a phenomenon that can take place quite apart from any treatment, and is moreover a very frequent natural occurrence. Indeed, in any human relationship that is at all intimate, certain transference phenomena will almost always operate as helpful or disturbing factors.

15 “Provided only that the patient shows compliance enough to respect the necessary conditions of the analysis, we regularly succeed in giving all the symptoms of the illness a new transference meaning and in replacing his ordinary neurosis by a ‘transference-neurosis’....” (“Remembering, Repeating, and Working-Through,” P. 154.) Freud puts

down a little too much to his own account here. A transference is not by any means always the work of the doctor. Often it is in full swing before he has even opened his mouth. Freud's conception of the transference as a "new edition of the old disorder," a "newly created and transformed neurosis," or a "new, artificial neurosis" (*Introductory Lectures*, III, p. 444), is right in so far as the transference of a neurotic patient is equally neurotic, but this neurosis is neither new nor artificial nor created: it is the same old neurosis, and the only new thing about it is that the doctor is now drawn into the vortex, more as its victim than as its creator.

16 Freud had already discovered the phenomenon of the "counter-transference." Those acquainted with his technique will be aware of its marked tendency to keep the person of the doctor as far as possible beyond the reach of this effect. Hence the doctor's preference for sitting behind the patient, also his pretence that the transference is a product of his technique, whereas in reality it is a perfectly natural phenomenon that can happen to him just as it can happen to the teacher, the clergyman, the general practitioner, and—last but not least—the husband. Freud also uses the expression "transference-neurosis" as a collective term for hysteria, hysterical fears, and compulsion neuroses (*Ibid.*, p. 445).

17 The effects of this on the doctor or nurse can be very far-reaching. I know of cases where, in dealing with borderline schizophrenics, short psychotic intervals were actually "taken over," and during these periods it happened that the patients were feeling more than ordinarily well. I have even met a case of induced paranoia in a doctor who was analysing a woman patient in the early stages of latent persecution mania. This is not so astonishing since certain psychic disturbances can be extremely infectious if the doctor himself has a latent predisposition in that direction.

18 Freud himself says ("Observations on Transference-Love," p. 380) of this: "I can hardly imagine a more senseless proceeding. In doing so, an analyst robs the phenomenon of the element of spontaneity which is so convincing and lays up obstacles for himself in the future which are hard to overcome." Here Freud stresses the "spontaneity" of the transference, in contrast to his views quoted above. Nevertheless those who "demand" the transference can fall back on the following cryptic utterance of their master ("Fragment of an Analysis of a Case of Hysteria," p. 116): "If the theory of analytic technique is gone into, it becomes evident that transference is [something necessarily demanded]." [... that transference is an inevitable necessity," as in the authorized translation, is to stretch the meaning of Freud's "etwas notwendig Gefordertes."—TRANS.]

19 Suggestion happens of its own accord, without the doctor's being able to prevent it or taking the slightest trouble to produce it.

20 "Good advice" is often a doubtful remedy, but generally not dangerous because it has so little effect. It is one of the things the public expects in the *persona medici*.

21 Simon Magus' Helen (Selene) is another excellent example.

22 The reader will know that I do not understand *libido* in the original Freudian sense as *appetitus sexualis*, but as an *appetitus* which can be defined as psychic energy. See "On Psychic Energy."

23 This is the view I have put forward as an explanation of certain processes in "The Theory of Psychoanalysis."

24 Cf. Frazer, *Taboo and the Perils of the Soul*, pp. 54ff.

25 The same phenomenon can be seen on a smaller scale, but no less clearly, in the apprehension and depression which precede any special psychic exertion, such as an examination, a lecture, an important interview, etc.

26 Where the *nigredo* is identified with the *putrefactio* it does not come at the beginning, as for example in fig. 6 of our series of pictures from the *Rosarium philosophorum* (*Art. aurif.*, II, p. 254). In Mylius, *Philosophia reformata*, p. 116, the *nigredo* appears only in the fifth grade of the work, during the “putrefactio, quae in umbra purgatorii celebratur” (putrefaction which is celebrated in the darkness of Purgatory); but further on (p. 118), we read in contradiction to this: “Et haec denigratio est operis initium, putrefactionis indicium” etc. (And this *denigratio* is the beginning of the work, an indication of the putrefaction).

27 “Unconscious identity” is the same as Lévy-Bruhl’s *participation mystique*. Cf. *How Natives Think*.

28 A pictorial representation of this moment, in the form of a flash of lightning and a “stone-birth,” is to be found in my “A Study in the Process of Individuation,” Picture 2.

29 Because he is the “unknown father,” a theme to be met with in Gnosticism. See Bousset, *Hauptprobleme der Gnosis*, Ch. II, pp. 58–91.

30 Cf. Nicholas of Flüe’s vision of the threefold fountain arising in the square container (Lavaud, *Vie profonde de Nicolas de Flue*, p. 67, and Stöckli, *Die Visionen des seligen Bruder Klaus*, p. 19). A Gnostic text says: “In the second Father[hood] the five trees are standing and in their midst is a trapeza [τράπεζα]. Standing on the trapeza is an Only-begotten word [λόγος μονοενης].” (Baynes, *A Coptic Gnostic Treatise*, p. 70.) The trapeza is an abbreviation of τετράπεζα, a four-legged table or podium (ibid., p. 71). Cf. Irenaeus, *Contra haereses*, III, 11, where he compares the “fourfold gospel” with the four cherubim in the vision of Ezekiel, the four regions of the world, and the four winds: “ex quibus manifestum est, quoniam qui est omnium artifex Verbum, qui sedet super Cherubim et continet omnia, dedit nobis quadriforme Evangelium, quod uno spiritu continetur” (from which it is clear that He who is the Maker of all things, the Word [Logos] who sits above the Cherubim and holds all things together, gave unto us the fourfold gospel, which is contained in one spirit).

Concerning the kitchen, cf. Lavaud, *Vie profonde*, p. 66, and Stöckli, *Die Visionen*, p. 18.

31 This is not a metaphysical statement but a psychological fact.

32 As regards the bird with the flowering twig, see Figs, 2 and 3 infra.

33 Avalon, *The Serpent Power*, pp. 345f.

34 Freud, as we know, observes the transference problem from the standpoint of a personalistic psychology and thus overlooks the very essence of the transference—the collective contents of an archetypal nature. The reason for this is his notoriously negative attitude to the psychic reality of archetypal images, which he dismisses as “illusion.” This materialistic bias precludes strict application of the phenomenological principle without which an objective study of the psyche is absolutely impossible. My handling of the transference problem, in contrast to Freud’s, includes the archetypal aspect and thus gives rise to a totally different picture. Freud’s rational treatment of the problem is quite logical as far as his purely personalistic premises go, but both in theory and in practice they do not go far enough, since they fail to do justice to the obvious admixture of archetypal data.

35 The numerical proportion of latent to manifest psychoses is about equal to that of latent to active cases of tuberculosis.

36 The violent resistance, mentioned by Freud, to the rational resolution of the transference is often due to the fact that in some markedly sexual forms of transference there are concealed collective unconscious contents which defy

all rational resolution. Or, if this resolution is successful, the patient is cut off from the collective unconscious and comes to feel this as a loss.

37 Cf. Lully, “Testamentum,” *Bibliotheca chemica curiosa*, I, pp. 790ff., and Maier, *Symbola aureae mensae*, pp. 379f.

38 Pars. 342f.

39 Cf. “The Spirit Mercurius,” Part II, sec. 6.

40 Thus *Aurora consurgens*, II (*Art. aurif.*, I, pp. 185–246) closes with the words: “Et sic probata est medicina Philosophorum, quam omni [investiganti] fidei et pio praestare dignetur Deus omnipotens, unigenitusque filius Dei Dominus noster Jesus Christus, qui cum Patre et Spiritu sancto vivit et regnat, unus Deus per infinita saeculorum. Amen” (And this is the approved medicine of the philosophers, which may our Lord Jesus Christ, who liveth and reigneth with the Father and the Holy Ghost, one God for ever and ever, deign to give to every searcher who is faithful, pious, and of good will, Amen). This conclusion no doubt comes from the Offertorium (prayer during the *commixtio*), where it says: “... qui humanitatis nostrae fieri dignatus est particeps, Jesus Christus, Filius tuus, Dominus noster: qui tecum vivit et regnat in unitate Spiritus Sancti Deus per omnia saecula saeculorum. Amen.” (... who vouchsafed to become partaker of our humanity, Jesus Christ, Thy Son, our Lord: who liveth and reigneth with Thee in the unity of the Holy Ghost, one God, world without end. Amen.)

41 Cf. “Tractatus aureus,” *Ars chemica*, p. 21.

42 Kircher, “Oedipus Aegyptiacus,” II, Class X, Ch. V, p. 414. There is a connection between this text and the “Tabula smaragdina”; cf. Ruska, *Tabula smaragdina*, p. 217.

43 The *Rosarium* (*Art. aurif.*, II, p. 230) says: “Et scias, quod haec est longissima via, ergo patientia et mora sunt necessariae in nostro magisterio” (And you must know that this is a very long road; therefore patience and deliberation are needful in our magistry). Cf. *Aurora consurgens*, I, Ch. 10: “Tria sunt necessaria videlicet patientia mora et aptitudo instrumentorum” (Three things are necessary, namely: patience, deliberation, and skill with the instruments).

44 *Rosarium*, p. 231. What the alchemist sees in “metallic form” the psychotherapist sees in man.

45 Here I must expressly emphasize that I am not dabbling in metaphysics or discussing questions of faith, but am speaking of psychology. Whatever religious experience or metaphysical truth may be in themselves, looked at empirically they are essentially psychic phenomena, that is, they manifest themselves as such and must therefore be submitted to psychological criticism, evaluation, and investigation. Science comes to a stop at its own borders.

46 Cf. “The Spirit Mercurius,” Part II, sec. 10.

47 The alchemists also liken him to Lucifer (“bringer of light”), God’s fallen and most beautiful angel. Cf. Mylius, *Phil* ref., p. 18.

48 Cf. “Psychology and Religion,” pars. 6f.

49 I use the classical etymology of *religio* and not that of the Church Fathers.

50 Maier, *Symb. aur. mens.*, p. 386.

51 *Epistula LV* (Migne, *P.L.*, vol. 33, cols. 208–09).

52 *Homiliae in Leviticum*, V, 2 (Migne, *P.G.*, vol. 12, col. 449).

53 *Ibid.*

54 *Hom. in Librum Regnorum*, 1, 4.

55 “Hounded from one bride-chamber to the next.”—*Faust*, Part I.

56 For the same process in the individual psyche, see *Psychology and Alchemy*, pars. 44ff.

57 Cf. Ruska, *Turba*, Sermo XIX, p. 129. The term comes from the Book of El-Habib (*ibid.*, p. 43).

58 “Spiritus alme,/illustrator hominum,/horridas nostrae/mentis purga tenebras.” (Sublime spirit, enlightener of mankind, purge the horrible darknesses of our mind.)—Notker Balbulus, *Hymnus in Die Pentecostes* (Migne, *P.L.*, vol. 131, cols. 1012–13).

59 Hoghelande, “De alchemiae difficultatibus,” p. 139.

60 *Acta Joannis*, 98 (cf. James, *Apocryphal New Testament*, p. 255):... kal *ἁρμονία σοφίας* σοφία δὲ οὐσα ἐν ἁρμονίᾳ ὑπάρχουσιν δεξιοὶ καὶ ἀριστεροὶ, δυνάμεις, ἐξουσίαι, ἀρχαὶ καὶ δαίμονες, ἐνέργειαι...* (“... Harmony of wisdom, but when there is wisdom the left and the right are in harmony: powers, principalities, archons, daemons, forces...”).

61 Cardan (*Somniorum synesiorum...*) is an excellent example of one who examined his own dreams.

62 As regards the work of reinterpretation, see my “Brother Klaus.” Also Lavaud, *Vie profonde*, Ch. III, “La Grande Vision.”

1 [These mottoes, where they appear, translate the verses under the woodcuts in the figures. Figs. 1–10 are full pages reproduced from the Frankfurt first edition (1550) of the *Rosarium philosophorum*. The textual quotations, however, are taken from the version printed in *Art. aurif.*, II (Basel, 1593), except for the poem at par. 528.—EDITORS.]

2 The “Cons, coniug.” (*Ars chemica*, p. 147) says: “Et locus generationis, licet sit artificialis, tamen imitatur naturalem, quia est concavus, conclusus” etc. (The place of gestation, even though it is artificial, yet imitates the natural place, since it is concave and closed). And (p. 204): “Per matricem, intendit fundum cucurbitae” (By matrix he means the root of the gourd).

3 Cf. Ruska, *Turba*, p. 163.

4 Cf. Hortulanus (Ruska, *Tabula smaragdina*, p. 186): “Unde infinitae sunt partes mundi, quas omnes philosophus in tres partes dividit scilicet, in partem Mineralem Vegetabilem et Animalem.... Et ideo dicit habens tres partes philosophiae totius mundi, quae partes continentur in unico lapide scilicet Mercurio Philosophorum” (Hence the parts of the world are infinite, all of which the philosopher divides into three parts, namely mineral, vegetable, animal.... And therefore he claims to have the three parts of the philosophy of the whole world, which parts are contained in the single stone, namely the Mercurius of the Philosophers). Ch. 13: “Et ideo vocatur lapis iste perfectus, quia in se habet naturam mineralium et vegetabilium et animalium. Est enim lapis triunus et unus, quatuor habens naturas” (And this stone is called perfect because it has in itself the nature of mineral, vegetable, and animal. For the stone is triple and one, having four natures).

5 Cf. the alchemical doctrine of the *incretum*: *Psychology and Alchemy*, pars. 430ff.

6 A quotation based on Rosinus in *Rosarium*, p. 249, says: “Triplex in nomine, unus in esse.” Cf. the threefold fountain of God in the vision of Brother Klaus (Lavaud, *Vie profonde*, p. 66). The actual Rosinus passage (itself a quotation from Rhazes) runs (*Art. aurif.*, I, p. 300): “Lapis noster cum mundi creato[re] nomen habet, qui est trinus et unus” (Our stone has a name common with the Creator of the world who is triple and one). Senior (*De chemia*, p. 45) says: “Aes nostrum est sicut homo, habens spiritum, animam et corpus. Propterea dicunt sapientes: Tria et Tria sunt unum. Deinde dixerunt: in uno sunt tria.” (Our copper is like a man, having spirit, soul, and body. Therefore the wise men say: Three and Three are One. Further they said: In One there are Three.) Cf. also Zosimos (Berthelot, *Alch. greca*, III, vi, 18). The mercurial fountain recalls the *πηγή μεγάλη* of the Peratics (Hippolytus, *Elenchos*, V, 12, 2), which forms one part of the threefold world. The three parts correspond to 3 gods, 3 *λόγοι*, 3 spirits (*μοῖ*), 3 men. This triad is opposed by a Christ equipped with all the properties of the triad and himself of triadic nature, coming from above, from the *ἀγεννησία*, before the separation. (Here I prefer Bernays’ reading *πρὸ τῆς* [cf. *Elenchos*, p. 105] because it makes more sense.)

7 In Abū’l-Qāsim the lapis is called *al-shaitan*, ‘Satan’; cf. Holmyard, “Abū’l-Qāsim al-Irāqī,” p. 422.

8 The serpent is also *triplex nomine*, as the inscriptions “animalis,” “vegetabilis,” “mineralis” show.

9 *Psychology and Alchemy*, fig. 20.

10 “Practica,” *Art. aurif.*, I, p. 321: “Ipsa sunt duo fumi complectentes duo lumina” (They are the two vapours enveloping the two lights).

11 We find the same motif in the frontispiece of Colonna, *Le Songe de Poliphile*, as the leaves which fall from the tree rooted in the fire. See *Psychology and Alchemy*, fig. 4.

12 Cf. *Aurora consurgens*, I, Ch. IV: “Evil odours and vapours that infect the mind of the laborant.” Also Morienus (*Art. aurif.*, II, p. 34): “Hic enim est odor, qui assimilatur odori sepulcrorum....” (For this is the odour that is similar to the stench of the graves...).

13 The interpretation of uneven numbers as masculine and of even numbers as feminine is general in alchemy and originated in antiquity.

14 [For the 2nd edn., there has been a change in the sequence of pars. 405–407, in order to place Jung’s summarizing statement in what would seem to be its logical position, i.e., present par. 407.—EDITORS.]

15 Cf. Jacobi, *Psychology of C. G. Jung*, Diagrams IV–VII.

16 For the soul as square, circle, or sphere see *Psychology and Alchemy*, pars. 109 and 439, n. 47.

17 The above remarks should be understood only psychologically and not in the moral sense. The “deed” as such is not the essence of the psychic life-process but only a part of it, although a very important part.

18 Incidentally, Johann Valentin Andreae, the real author of the *Chymical Wedding*, also wrote a Faust drama in Latin entitled *Turbo, sive Molestie et frustra per cuncta divagans ingenium* (1616), the story of a man who knew everything and was finally disappointed, but who found his salvation in the *contemplatio Christi*. The author, a theologian in Württemberg, lived from 1586 to 1654.

19 I have dealt with this psychological process at length in *Two Essays*, pars. 224f., 380f.

20 An allusion to madness. The *afflictio animae* is mentioned in Olympiodorus (Berthelot, *Alch. grecs*, II. iv, 43). Morienus (*Art. aurif.*, II, p. 18), and Maier (*Symb. aur. mens.*, p. 568), and in Chinese alchemy (Wei Po-yang, “An Ancient Chinese Treatise,” pp. 241–45).

21 God is the source, river, and sea which all contain the same water. The Trinity is a life that “proceeds from itself to itself, by way of itself”—Vansteenberghe, *Le Cardinal Nicolas de Cues*, pp. 296f.

1 *Debita materia*, meaning the *prima materia* of the process.

2 *Rosarium*, p. 219: “Nota bene: In arte nostri magisterii nihil est celatum a Philosophis excepto secreto artis, quod non licet cuiquam revelare: quodsi fieret, ille malediceretur et indignationem Domini incurreret et apoplexia moreretur. Quare omnis error in arte existit ex eo quod debitam materiam non accipiunt. Igitur venerabili utimini natura, quia ex ea et per eam et in ea generatur ars nostra et non in alio: et ideo magisterium nostrum est opus naturae et non opificis.”

3 Ruska, *Turba*, Sermo XXIX, p. 137.

4 Cf. *Aurora consurgens*, I, where the parables “Of the Black Earth,” “Of the Flood of Waters and of Death,” “Of the Babylonish Captivity,” are followed by the parable “Of the Philosophic Faith” with its avowal of the *lumen de lumine*. Cf. also Avicenna, “Declaratio lapidis physici,” *Theatr. chem.*, IV, p. 990.

5 A corruption of “alchymia.”

6 *De incertitudine et vanitate omnium scientiarum*, Ch. XC.

7 Later, Agrippa (*ibid.*) says one or two other things about the stone: “As to that unique and blessed substance, besides which there is no other although you may find it everywhere, as to that most sacred stone of the philosophers—almost I had broken my oath and made myself a desecrator of temples by blurting out its name—I shall nevertheless speak in circumlocutions and dark hints, so that none but the sons of the art and the initiates of this mystery shall understand. The thing is one which has neither too fiery nor too earthen a substance.... More I am not permitted to say, and yet there be greater things than these. However. I consider this art—with which I have a certain familiarity—as being the most worthy of that honour which Thucydides pays to an upright woman, when he says that the best is she of whom least is said either in praise or blame.” Concerning the oath of secrecy, see also Senior, *De chemia*, p. 92: “Hoc est secretum, super quo iuraverunt, quod non indicarent in aliquo libro” (This is the secret which they promised on oath not to divulge in any book).

8 Both texts are supposed to have been in circulation in manuscript from about 1610, according to F. Maack, editor of Rosencreutz’s *Chymische Hochzeit*, pp. xxxviif. [They are to be found there at pp. 47–84.—EDITORS.]

9 A kind of “rosie cross” can also be seen in Luther’s crest.

10 Cf. *Psychology and Alchemy*, par. 436, and Reitzenstein and Schaeder, *Studien zum antiken Synkretismus*.

11 Waite, *The Secret Tradition*.

12 Wei Po-yang, p. 241.

13 The union of “like with like” in the form of homosexual relationships is to be found in the “Visio Arislei” (*Art. aurif.*, I, p. 147), marking the stage preceding the brother-sister incest.

14 According to Freud, these projections are infantile wish-fantasies. But a more thorough examination of neuroses in childhood shows that such fantasies are largely dependent on the psychology of the parents, that is, are caused by the parents’ wrong attitude to the child. Cf. “Analytical Psychology and Education,” pars. 216ff.

15 Hence *Aurora consurgens*, I, Ch. VI, says: “... and all my bones are troubled before the face of my iniquity.” Cf. Ps. 37 : 4 (D.V.): “... there is no peace for my bones, because of my sins.”

16 Cf. *Two Essays*, pars. 296ff. [Also “Concerning the Archetypes, with Special Reference to the Anima Concept” and *Aion*, ch. 3.—EDITORS.]

17 It may be helpful to remind the reader that in Rider Haggard's *She* there is a description of this "royal" figure. Leo Vincey, the hero, is young and handsome, the acme of perfection, a veritable Apollo. Beside him there stands his fatherly guardian, Holly, whose resemblance to a baboon is described in great detail. But inwardly Holly is a paragon of wisdom and moral rectitude—even his name hints at "holy." In spite of their banality both of them have superhuman qualities, Leo as well as the devout "baboon." (Together they correspond to the *sol et umbra eius*.) The third figure is the faithful servant who bears the significant name of Job. He stands for the long-suffering but loyal companion who has to endure both superhuman perfection and subhuman baboonishness. Leo may be regarded as the sun-god; he goes in quest of "She" who "dwells among the tombs" and who is reputed to kill her lovers one by one—a characteristic also ascribed by Benoit to his "Atlantide"—and to rejuvenate herself by periodically bathing in a pillar of fire. "She" stands for Luna, and particularly for the dangerous new moon. (It is at the *synodus* of the *novilunium*— i.e., at the *coniunctio* of the Sun and Moon at the time of the new moon—that the bride kills her lover.) The story eventually leads, in *Ayesha*, another novel of Haggard's, to the mystical hierogamos.

18 The alchemical pairs of opposites are often arranged in such quaternions, as I shall show in a later work. [Cf. *Mysterium Coniunctionis*, pp. 6ff., and *Aion*, pp. 250ff.—EDITORS.]

19 Naumann (ed.), *Isländische Volksmärchen*, No. 8, pp. 47ff.

20 Guterman (trans.), *Russian Fairy Tales*, pp. 351ff.

21 The Russian arch-witch.

22 *The Native Tribes of S.E. Australia*, p. 157; cf. Frazer, *Totemism and Exogamy*, I, p. 306.

23 Layard, *Stone Men of Malekula*, pp. 62ff.

24 Hocart, *Kings and Councillors*, p. 265.

25 [Pars. 433ff. incorporate corrections made by Dr. John Layard in 1955 with reference to his own writings and authorized by Jung in the 1958 Swiss edition. Later corrections made by Dr. Layard (1965) are given in square brackets.—EDITORS.]

26 *Ibid.*, pp. 157, 193.

27 Layard, *Stone Men of Malekula*, pp. 85ff.

28 Hocart, *Kings and Councillors*, pp. 244ff.

29 *Ibid.*, p. 250.

30 Layard, "The Incest Taboo," pp. 270ff.

31 I would remind the reader that Rex and Regina are usually brother and sister or sometimes mother and son.

32 If we think at all when doing these things, it must be a preconscious or rather an unconscious act of thought. Psychological explanations cannot very well get on without such an hypothesis.

33 *The Northern Tribes of Central Australia*, p. 74.

34 Layard, "The Incest Taboo," p. 284.

35 *Ibid.*, p. 293.

36 In this system a man marries his [mother's mother's brother's daughter's daughter].

37 Hocart, *Kings and Councillors*, p. 259.

38 In China, for instance, one can still find vestiges of the twelve-class system.

39 Layard, "The Incest Taboo," pp. 281ff.

40 Ibid., p. 284. Perhaps I may point out the similar conclusions reached in *Symbols of Transformation*, pars. 464ff.

- 1 An Arabic treatise whose origin is still obscure. It is printed in *Ars chemica*, and (with scholia) in *Bibl. chem. curiosa*, I, pp. 400ff.
- 2 This passage is rather different in ‘the original text (*Ars chemica*, p. 14): “in quo est nisus tuae dispositionis, et adunatio cuiuslibet sequestrati.” Cf. *Psychology and Alchemy*, par. 385 and n. 87.
- 3 *Art. aurif.*, II, pp. 227–38.
- 4 Cf. Cant. 5:3: “I have put off my garment.”
- 5 Original is illegible: ?vgan.
- 6 This is the reading of the 1593 edition. The first edition of 1550 has “vivificat.”
- 7 The dove is also the attribute of the goddess of love and was a symbol of *amor coniugalis* in ancient times.
- 8 Cf. Joannes Lydus, *De mensibus*, II, 11: “The sixth day they ascribe to Phosphorus [morning star], who is the begetter of warmth and generative moisture [γονίμως ὑγραίνοντι]. Perhaps this is the son of Aphrodite, like Hesperus the evening star, as appeared to the Greeks. Aphrodite we could call the nature of the visible universe, the first-born Hyle which the oracle names star-like [Ἄστεριαν] as well as heavenly. The number 6 is most skilled in begetting [γεννητικώτατος], for it is even and uneven, partaking both of the active nature on account of the uneven [περιττὸν also means “superfluous” or “excessive”], and of the hylical nature on account of the even, for which reason the ancients also named it marriage and harmony. For among those that follow the number 1, it is the only number perfect in all its parts, being composed of these: its halves of the number 3, its thirds of the number 2, and its sixths of the number 1 [6 = 3 + 2 + 1]. And they say also that it is both male and female, like Aphrodite herself, who is of male and female nature and is accordingly called hermaphroditic by the theologians. And another says that the number 6 is soul-producing [or belongs to the ψυχογονία, ψυχογονικός], because it multiplies itself into the worldsphere [ἐπιπεδούμενος = πολλαπλασιασμός], and because in it the opposites are mingled. It leads to like-mindedness [ὁμόνοιαν] and friendship, giving health to the body, harmony to songs and music, virtue to the soul, prosperity to the state, and forethought [πρόνοιαν] to the universe.”

1 Dorn, "Speculativae philosophiae," p. 303: "Studio philosophorum comparatur putrefactio chemica.... Ut per solutionem corpora solvuntur, ita per cognitionem resolvuntur philosophorum dubia" (The chemical putrefaction can be compared with the study of the philosophers.... As bodies are dissolved through the *olutio*, so the doubts of the philosophers are resolved through knowledge).

2 Instead of the meaningless "aqua foetum" I read "aqua foetida" (*Rosarium*, p. 241). Cf. "Cons, coniug.," *Ars chemica*, p. 64: "Leo viridis, id est... aqua foetida, quae est mater omnium ex qua et per quam et cum qua praeparant..." (The green lion, that is... the stinking water, which is the mother of all things, and out of it and through it and with it, they prepare...).

3 *Rosarium*, p. 214. Cf. *Aurora consurgens*, I, Ch. XII, where the bride says of herself in God's words (Deut. 32 : 39): "I will kill and I will make to live... and there is none that can deliver out of my hand."

4 *Rosarium*, p. 213.

5 *Ibid.*, p. 237. This goes back to Senior, *De chemia*, pp. 19, 31, 33.

6 Cf. *Psychology and Alchemy*, fig. 159.

7 "Addam et processum," *Theatr. chem.*, III, pp. 8538. Cf. *Psychology and Alchemy*, pars. 480ff.

8 *Aurora consurgens*, I, Ch. IX, "qualis pater talis filius, talis et Spiritus Sanctus et hi tres unum sunt, corpus, spiritus et anima, quia omnis perfectio in numero ternario consistit, hoc est mensura, numero et pondere" (Like as the Father is, so is the Son, and so also is the Holy Spirit, and these three are One, body, spirit, and soul, for all perfection consisteth in the number three, that is, in measure, number, and weight.)

9 "Anima vocatur Rebis." "Exercitationes in Turbam," *Art. aurif.*, I, p. 180.

10 According to Firmicus Maternus (*Mathesis* V, pref., ed, Kroll and Skutsch, II, p. 3), Luna is "humanorum corporum mater."

11 Psychologically one should read *mens* for *spiritus*.

12 Sometimes the spirit is the *vinculum*, or else the latter is a *natura ignea* (Zacharius, "Opusculum," *Theatr. chem.*, I, p. 887).

13 Cf. "De arte chimica." *Art. aurif.*, I, pp. 584ff, and Mylius, *Phil. ref.*, p. 9.

14 Cf. "Turba," *Art. aurif.*, I, p. 180: "... Spiritus et corpus unum sunt mediante anima, quae est apud spiritum et corpus. Quod si anima non esset, tunc spiritus et corpus separarentur ab invicem per ignem, sed anima adiuncta spiritui et corpori, hoc totum non curat ignem nec ullam rem mundi." (... The spirit and the body are one, the soul acting as a mediator which abides with the spirit and the body. If there were no soul, the spirit and the body would be separated from each other by the fire, but because the soul is joined to the spirit and the body, this whole is unaffected by fire or by any other thing in the world.)

15 Cf. Winthuis, *Das Zweigeschlechterwesen*.

16 I do not, of course, mean the synthesis or identification of two individuals, but the conscious union of the ego with everything that has been projected into the "You." Hence wholeness is the product of an intrapsychic process which depends essentially on the relation of one individual to another. Relationship paves the way for individuation and makes it possible, but is itself no proof of wholeness. The projection upon the feminine partner contains the anima and sometimes the self.

17 Cf. *Psychology and Alchemy*, index.

18 *Rosarium*, p. 369.

19 *Psychology and Alchemy*, pars. 430ff.

20 P. 251.

21 Cf. Frobenius, *Das Zeitalter des Sonnengottes*.

22 “Visio Arislei,” *Art. aurif.*, I, p. 148: “Mansimus in tenebris undarum et intenso aestatis calore ac maris perturbatione” (We remained in the darkness of the waves and in the intense heat of summer and the perturbation of the sea).

23 Cf. the birth of Mithras “from the sole heat of libido” (de solo aestu libidinis). Jerome, *Adversus Jovinianum* (Migne, *P.L.*, vol. 23, col. 246). In Arabic alchemy, too, the fire that causes the fusion is called “libido.” Cf. “Exercitationes in Turbam.”

Art. aurif., I, p. 181: “Inter supradicta tria (scil., corpus, anima, spiritus) inest libido,” etc. (Between the aforementioned three, i.e., body, soul, spirit, there is a libido).

24 See the inscription to fig. 5a:

“But here King Sol is tight shut in,

And *Mercurius philosophorum* pours over him.”

The sun drowning in the mercurial fountain (*Rosarium*, p. 315) and the lion swallowing the sun (p. 367) both have this meaning, which is also an allusion to the *ignea natura* of Mercurius (Leo is the House of the Sun). For this aspect of Meicurius see “The Spirit Mercurius,” Part II, sec. 3.

1 *Rosarium*, p. 248. Quotation from Kalid, “Liber secretorum alchemiae,” *Art. aurif.*, I, p. 340. [Cf. par. 353, n. 1.—EDITORS.]

2 P. 247.

3 p. 248.

4 Kalid, “Liber secretorum alchemiae,” *Art. aurif.*, I, p. 340: “Et dixit. Hermes patri suo: Pater timeo ab inimico in mea mansione. Et dixit: Fili, accipe canem masculum Corascenem et caniculam Armeniae et iunge in simul et parient canem coloris coeli et imbibe ipsum una siti ex aqua maris: quia ipse custodiet tuum amicum et custodiet te ab inimico tuo et adiuvabit te ubicumque sis, semper tecum existendo in hoc mundo et in alio.” (And Hermes said to his father: Father, I am afraid of the enemy in my house. And he said: My son, take a Corascene dog and an Armenian bitch, join them together, and they will beget a dog of a celestial hue, and if ever he is thirsty, give him sea water to drink: for he will guard your friend, and he will guard you from your enemy, and he will help you wherever you may be, always being with you, in this world and in the next.)

5 *Rosarium*, p. 248. The radiant quality (*στίλβων*) is characteristic of Mercurius and also of the first man, Gayomart or Adam. Cf. Christensen, *Les Types du premier homme*, pp. 22ff., and Kohut, “Die talmudisch-midrassische Adamssage,” pp. 68, 72, 87.

6 The “Practica Mariae” (*Art. aurif.*, I, p. 321) makes the two into four: “[Kibrich et Zubech]... ipsa sunt duo fumi complectentes duo Iumina” (They are the two vapours enveloping the two lights). These four evidently correspond to the four elements, since we read on p. 320: “... si sunt apud homines omnia 4 elementa, dixit compleri possent et complexionari et coagulari eorum fumi...” (If there are in men all 4 elements, he says, their vapours could be completed and commingled and coagulated).

7 See Lambspringk, “Figurae,” *Musaeum hermeticum*.

8 Frontispiece to Colonna, *Le Songe de Poliphile*. See *Psychology and Alchemy*, fig. 4.

9 Hence the ambivalent saying in Mylius, *Phil. ref.*, p. 182: “In habentibus symbolum facilis est transitus” (For those who have the symbol the passage is easy).

10 Cf. Kalid, “Liber trium verborum,” *Art aurif.*, I, pp. 355f.

11 “No more shall you stay a prisoner
 Wrapped in darkest obfuscation;
 New desires call you upwards
 To the higher copulation.”—*West-östlicher Divan*.

1 “Tractatulus Avicennae,” *Art. aurif.*, I, p. 426.

2 Cf. *Aurora*, I, Ch. XII (after John 12:24). Hortulanus (Ruska, *Tabula*, p. 186): “Vocatur [lapis] etiam granum frumenti, quod nisi mortuum fuerit, ipsum solum manet,” etc. (It [the stone] is also called the grain of wheat, which remains itself alone, unless it dies). Equally unhappy is the other comparison, also a favourite: “Habemus exemplum in ovo quod putrescit primo, et tunc gignitur pullus, qui post totum corruptum est animal vivens” (We have an example in the egg: first it putrefies and then the chick is born, a living animal sprung from the corruption of the whole).—*Rosarium*, p. 255.

3 Cf. Ruska, *Turba*, p. 139: “Tunc autem, doctrinae filii, illa res igne indiget, quousque illius corporis spiritus vertatur et per noctes dimittatur, ut homo in suo tumulo, et pulvis fiat. His peractis reddet ei Deus et animam suam et spiritum, ac infirmitate ablata confortatur illa res... quemadmodum homo post resurrectionem fortior fit,” etc. (But, sons of the doctrine, that thing will need fire, until the spirit of its body is changed and is sent away through the nights, like a man in his grave, and becomes dust. When this has happened, God will give back to it its soul and its spirit and, with all infirmity removed, that thing is strengthened... as a man becomes stronger after the resurrection.)

4 Cf. the *ψυχογονία* in Lydus’ account of the hexad, supra, par. 451, n. 8.

5 Cf. Senior, *De chemia*, p. 16: “... et reviviscit, quod fuerat morti deditum, post inopiam magnam” (What had been given over to death, comes to life again after great tribulation).

6 For the alchemist, this had a precedent in Gen. 2:17: “for in the day that thou eatest thereof thou shalt surely die.” Adam’s sin is part of the drama of the creation. “Cum peccavit Adam, eius est anima mortua” (When Adam sinned his soul died), says Gregory the Great (Epist. CXIV, Migne, *P.L.*, vol. 77, col. 806).

7 *Art. aurif.*, II, p. 324.

8 The *nigredo* appears here not as the initial state but as the product of a prior process. The time-sequence of phases in the *opus* is very uncertain. We see the same uncertainty in the individuation process, so that a typical sequence of stages can only be constructed in very general terms. The deeper reason for this “disorder” is probably the “timeless” quality of the unconscious, where conscious succession becomes simultaneity, a phenomenon I have called “synchronicity.” [Cf. Jung, “Synchronicity: An Acausal Connecting Principle.”] From another point of view we would be justified in speaking of the “elasticity of unconscious time” on the analogy of the equally real “elasticity of space.” For the relations between psychology and atomic physics, see Meier, “Moderne Physik.”

9 Ezek. 8 : 14: “... behold, there sat women weeping for Tammuz.”

10 Berthelot, *Alch. grecs*, II, i, 3: ‘Η φύσις τῆ φύσει τέρκεται, καὶ ἡ φύσις τὴν φύσιν νικᾷ καὶ ἡ φύσις τὴν φύσιν κρατεῖ.

11 Merlinus probably has as little to do with Merlin the magician as “King Artus” with King Arthur. It is more likely that Merlinus is “Mercurinus,” a diminutive form of Mercurius and the pseudonym of some Hermetic philosopher. “Artus” is the Hellenistic name for Horus. The form “Merqûlius” and “Marqûlius” for Mercurius is substantiated in Arabic sources. Jûnân ben Marqûlius is the Greek Ion, who according to Byzantine mythology is a son of Mercurius (Chwolsohn, *Die Ssabier* I, p. 796). Al-Maqrizi says: “The Merqûlians... are the Edessenes who were in the neighbourhood of Harran,” obviously the Sabaeans (ibid., II, p. 615). The Ion in Zosimos (Berthelot, *Alch. grecs*, III, i, 2) probably corresponds to the above Ion. [Cf. “The Visions of Zosimos,” par. 86, n. 4.—EDITORS.]

12 Merlinus, “Allegoria de arcano lapidis,” *Art. aurif.*, I, pp. 392ff.: “Rex autem... bibit et rebibit, donec omnia membra sua repleta sunt, et omnes venae eius inflatae” (But the king drinks and drinks again until all his limbs are full and all his veins inflated). [Cf. *Mysterium Coniunctionis*, pp. 266f.—EDITORS.]

13 In the “Tractatus aureus” (*Mus. herm.*, p. 51) the king drinks the “aqua pernigra,” here described as “pretiosa et sana,” for strength and health. He represents the new birth, the self, which has assimilated the “black water,” i.e., the unconscious. In the Apocalypse of Baruch the black water signifies the sin of Adam, the coming of the Messiah, and the end of the world.

14 *Aurora*, II, in *Art. aurif.*, I, p. 196.

15 Hence the warning: “Cave ab hydropisi et diluvio Noe” (Beware of dropsy and the flood of Noah).—Ripley, *Omnia opera chemica*, p. 69.

16 Cf. *Psychology and Alchemy*, pars. 456f.

17 One of several versions.

18 This is meant only as a psychological and not as a metaphysical parallel.

19 Cf. *Psychological Types*, pars. 434ff.

1 “Tractatus aureus,” *Mus. herm.*, p. 47.

2 Quotation from a source unknown to me, given as “Sorin” in *Rosarium*, p. 264.

3 One such case is described in Meier, “Spontanmanifestationen,” p. 290.

4 *Art. aurif.*, II, p. 264: “Et eorum aquas sua aqua continere, si qua non est aqua, forma ignea verae aquae.”

5 Remembering the rule that every proposition in psychology may be reversed with advantage, I would point out that it is always a bad thing to accentuate the conscious attitude when this has shown itself to be so strong in the first place as violently to suppress the unconscious.

6 *Art. aurif.*, II, p. 265.

7 *The Dark Night of the Soul*.

8 Ventura, “De ratione conficiendi lapidis,” *Theatr. chem.*, II, p. 260. There is in the gold a “quiddam essentiale Divinum” (something of Divine essence) (“Tractatus Aristotelis,” *Theatr. chem.*, V, p. 892). “Natura est vis quaedam insita rebus.... Deus est natura et natura Deus, a Deo oritur aliquid proximum ei” (Nature is a certain force innate in things.... God is Nature and Nature is God, and from God originates something very near to him).—Penotus, “Quinquaginta septem canones,” *Theatr. chem.*, II, p. 153. God is known in the *linea in se reducto* of the gold (Maier, *De circulo physico quadrato*, p. 16).

9 Hippolytus, *Elenchos*, VII, 26, 10.

10 Angelus Silesius, *Cherubinischer Wandersmann*, Book IV, p. 194: “The work that God loves best and most wants done/Is this: that in you he can bear his son.” Book II, p. 103: “There where God bends on you his spirit mild/Is born within the everlasting child.”

1 Cf. Judges 6 : 36ff.

2 Cf. “The Spirit Mercurius,” II, sec. 2.

3 *Art. aurif.*, II, pp. 275f. Cf. Senior, *De chemia*, pp. 17–18: “Dixit iterum Maria: Aqua, quam iam memoravi, est rex de coelo descendens et terra cum humore suo suscepit eum et retinetur aqua coeli cum aqua terrae propter servitium suum et propter arenam suam honorat eam et congregatur aqua in aquam, Alkia in Alkiam et dealbatur Alkia cum Astuam.” In the Arabic text “Astua” appears also as “Alkia”; “al-kiyān” = “vital principle” (Stapleton, “Three Arabic Treatises,” p. 152). “Alkia” occurs in the “Liber Platonis quattorum” (p. 152) in the sense of “vital principle” or “libido.”

4 Azoth is the arcane substance (cf. Senior, *De chemia*, p. 95) and the lato is the black substance, a mixture of copper, cadmium, and orichalcum (*ἐλατρών*; see Du Cange, *Glossarium*).

5 *Rosarium*, p. 277. This oft-repeated quotation is to be found in the treatise of Morienus (“Sermo de transmutatione metallorum,” *Art. aurif.*, II, pp. 7ff.), which appears to have been translated from the Arabic by Robert of Chartres in the 12th century. Morienus attributes it to the obsolete author Elbo Interfecto. It must be of very early origin, but hardly earlier than the 8th century.

6 Reference to the “Tab. smarag.”: “Itaque vocatus sum Hermes Trismegistus habens tres partes philosophiae totius mundi” (Therefore I am called Hermes Trismegistus, having the three parts of the philosophy of the whole world).

7 A classic of Arabic origin, put into Latin between the 11th and 12th centuries. The *Turba* quotation in the *Rosarium* comes from “Rosinus ad Sarratantam,” *Art. aurif.*, I, pp. 284f. The *Turba* (ed. Ruska, p. 158) has only: “Siccum igitur humido miscete, quae sunt terra et aqua; ac igne et aere coquite, unde spiritus et anima desiccantur” (Therefore mix the dry with the moist, which are earth and water, and cook them with fire and air, whence spirit and soul are dried out).

8 A reference to the saying of Morienus (“De transmutatione metallorum,” *Art. aurif.*, II, p. 21): “... omnis festinatio [scil. festinantia] ex parte Diaboli est” (... all haste is of the devil). Hence the *Rosarium* says (p. 352): “Ergo qui patientiam non habet ab opere manum suspendat, quia impedit cum ob festinantiam credulitas” (Therefore, he who hath not patience, let him hold back his hand from the work, for credulity will ensnare him if he hasten).

9 *Rosarium*, p. 277. Identical with *Aurora consurgens*, I, Ch. I.

10 John 4 : 13–14: “... Whosoever drinketh of this water shall thirst again: But whosoever drinketh of the water that I shall give him shall never thirst; but the water that I shall give him shall be in him a well of water springing up into everlasting life.”

11 Koch, “Cusanus-Texte,” p. 124: “In puteo Jacob est aqua, quae humano ingenio quaesita et reperta est, et potest significari quoad hoc philosophia humana, quae penetratione laboriosa sensibilibus quaeritur. In Verbo autem Dei, quod est in profundo vivi putei, scil. humanitatis Christi, est fons refrigerans spiritum. Et ita notemus puteum sensibilem Jacob, puteum rationalem, et puteum sapientialem. De primo puteo, qui est naturae animalis et altus, bibunt pater, filii et pecora; de secundo, qui altior in orizonte naturae, bibunt filii hominum tantum, scil. ratione vigentes, et philosophi vocantur; de tertio, qui altissimus, bibunt filii excelsi, qui dicuntur dii et sunt veri theologi. Christus secundum humanitatem puteus quidem dici potest altissimus.... In illo profundissimo puteo est fons sapientiae, quae praestat felicitatem et immortalitatem... portat vivus puteus fontem suae vitae ad sitientes, vocat sitientes ad aquas salubres, ut aqua sapientiae salutaris reficiantur.”

12 Ibid., p. 132: “Qui bibit spiritum, bibit fontem scaturientem.”

13 Ibid., p. 134: “Adhuc nota, quod intellectus nobis datus est cum virtute seminis intellectualis: unde in se habet principium fontale, mediante quo in seipso generat aquam intelligentiae, et fons ille non potest nisi aquam suae naturae producere, scilicet humanae intelligentiae, sicut intellectus principii, ‘quodlibet est vel non est’ producit aquas metaphysicales, ex quibus alia flumina scientiarum emanant indesinenter.”

14 Cardan, *Somniorum synesiorum*: “Unumquodque somnium ad sua generalia deducendum est.”

15 “... subtilietur lapis, donec in ultimam subtilitatis puritatem deveniat et ultimo volatilis fiat” (The stone should be subtilized until it reaches the ultimate purity of refinement and becomes, in the end, volatile).—*Rosarium*, p. 351. Or again (ibid., p. 285): “Sublimatio est duplex: Prima est remotio superfluitatis, ut remaneant partes purissimae a faecibus elementaribus segregatae sicque virtutem quintae essentiae possideant. Et haec sublimatio est corporum in spiritum reductio cum scilicet corporalis densitas transit in spiritus subtilitatem.” (Sublimation is twofold: The first is the removal of the superfluous so that the purest parts shall remain, free from elementary dregs, and shall possess the quality of the quintessence. The other sublimation is the reduction of the bodies to spirit, i.e., when the corporeal density is transformed into a spiritual subtlety.)

16 Cf. *Psychological Types*, Definitions 21 (in Baynes edn., Def. 20), 35, 47, 53.

17 [Eugen Steinach (1861–1944), Austrian physiologist who experimented with rejuvenation by grafting animal glands.—EDITORS.]

1 Cf. Lamspringk's *Symbols, Mus. Herm.*, p. 355, with the verses:

“Nidus in sylva reperitur in quo Hermes suos pullos habet, (A nest is found in the forest in which Hermes has his
Unus semper conatur volatum, Alter in nido manere birds. One always tries to fly away, The other rejoices in
gaudet, Et alter alterum non dimittit.” the nest to stay And will not let the other go.)

This image comes from Senior, *De chemia*, p. 15: “Abscisae sunt ab eo alae et pennae et est manens, non recedens ad superiora” (Its wings are cut off and its feathers, and it is stationary, not returning to the heights). Likewise Stolcius de Stolcenberg, *Viridarium chymicum*, Fig. XXXIII. In Maier, *De circulo*, p. 127, the opposites are represented as “vultur in cacumine montis et corvus sine alis” (a vulture on the peak of the mountain and a raven without wings). Cf. “Tractatus aureus,” *Ars chem.*, pp. 11–12, and “Rosinus ad Sarratantam,” *Art. aurif.*, I, p. 316.

2 Cf. “Paracelsus as a Spiritual Phenomenon,” pars. 201f.

3 *Psychology and Alchemy*, fig. 235.

4 *Art. aurif.*, II, p. 377: “De Tinctura alba: Si parentes dilecti mei de vita gustaverint et lacte mero lactati fuerint et meo albo inebriati fuerint et in lectulo meo nupserint, generabunt filium Lunae, qui totam parentelam suam praevalerit. Et si dilectus meus de tumulo rubeo petrae potaverit et fontem matris suae gustaverit et inde copulatus fuerit et vino meo rubeo et mecum inebriatus fuerit et in lecto [meo] mihi amicablem concubuerit, et in amore meo sperma suum cellulam meam subintraverit, concipiam et ero praegnans et tempore meo pariam filium potentissimum, dominantem et regnantem prae cunctis regibus et principibus terrae, coronatum aurea corona victoriae, ad omnia a Deo altissimo, qui vivit et regnat in saeculorum saecula.” Cf. “Cons, coniug.,” *Ars chem.*, p. 129, and “Rosinus ad Sarratantam,” pp. 291ff.

5 The style of the pictures dates them to the 16th cent., but the text may be a century older. Ruska (*Tab. smarag.*, p. 193) assigns the text to the 14th cent. The later dating, 15th cent. (Ruska, *Turba*, p. 342), is probably the more accurate.

6 *Psychology and Alchemy*, par. 500.

7 See *ibid.*, fig. 220.

8 Cant. 3:11: “... see king Solomon in the diadem, wherewith his mother crowned him in the day of his espousals.” Gregory the Great comments that the mother is Mary “quae coronavit eum diademate, quia humanitatem nostram ex ea ipsa assumpsit.... Et hoc in die desponsationis eius... factum esse dicitur: quia quando unigenitus filius Dei divinitatem suam humanitati nostrae copulare voluit, quando.... Ecclesiam sponsam suam sibi assumere placuit: tunc... carnem nostram ex matre Virgine suscipere voluit” (who crowned him with the crown because he assumed our human nature from her.... And that is said to have been done on the day of his espousals, because, when the only-begotten son of God wished to join his divinity with our human nature, he decided to take unto himself, as his bride, the Church. Then it was that he willed to assume our flesh from his virgin mother).—St Gregory, *Super Cantica Canttorum expositio*, ch. III (Migne, *P.L.*, vol. 79, col. 507.)

9 “Gloria mundi,” *Mus. herm.*, p. 213.

10 *Liber etymologiarum*, XIII, 14.

11 *Psychology and Alchemy*, par. 92.

12 Philalethes, “Introitus apertus,” *Mus. herm.*, p. 654.

13 *De chemia*, p. 17.

14 It is just possible that the idea of the *diadema* is connected with the cabalistic *Kether* (corona). The *Diadema purpureum* is *Malchuth*, “the female,” “the bride.” Purple relates to the *vestmentum*, an attribute to the Shekinah (the Divine Presence), which “enim est Vestis et Palatium Modi Tiphereth, non enim potest fieri mentio Nominis Tetragrammati nisi in Palatio eius, quod est Adonai. Apellaturque nomine *Diadematis*, quia est Corona in capite mariti sui” (... is the Garment and the Palace of the Modus Tiphereth [Glory], for no mention can be made of the Four-Letter Name which is Adonai, except in His Palace. And it is called by the name of Diadem because it is the crown on the head of the husband)—Knorr von Rosenroth, *Kabbala denudata*, I, p. 131. “... Malchuth vocatur Kether nempe corona legis,” etc. (Malchuth is called Kether since it is the crown of the Law). “Sephirah decima vocatur Corona: quia est mundus Dilectionum, quae omnia circumdant,” etc. (The tenth Sephira [number] is called the crown, because it is the world of delights which surround all things).—Ibid., p. 487. “[Corona] sic vocatur Malchuth, quando ascendit usque ad Kether; ibi *enim existens est* Corona super caput mariti sui” ([The Crown] is called Malchuth when it ascends up to Kether; for there is the crown upon the head of the husband).—Ibid., p. 624. Cf. Goodenough, “The Crown of Victory in Judaism.”

15 Norton’s “Ordinall” (*Theatr, chem. britannicum*, p. 40) says:

“For greatly doubted evermore all suche,
 That of this Scyence they may write too muche:
 Every each of them tought but one pointe or twayne,
 Whereby his fellowes were made certayne:
 How that he was to them a Brother,
 For every of them understoode each other;
 Alsoe they wrote not every man to teache,
 But to shew themselves by a secret speache:
 Trust not therefore to reading of one Boke,
 But in many Auctors works ye may looke;
 Liber librum apperit saith Arnolde the great Clerke.”

“The Book of Krates” (Berthelot, *Moyen âge*, III, p. 52) says: “Your intentions are excellent, but your soul will never bring itself to divulge the truth, because of the diversities of opinion and of wretched pride.” Hoghelande (“De alch. diff.,” *Theatr. chem.*, I, p. 155) says: “At haec [scientia]... tradit opus suum immiscendo falsa veris et vera falsis, nunc diminute nimium, nunc superabundanter, et sine ordine, et saepius praepostero ordine, et nititur obscure tradere et occultare quantum potest” (This [science] transmits its work by mixing the false with the true and the true with the false, sometimes very briefly, at other times in a most prolix manner, without order and quite often in the reverse order; and it endeavours to transmit [the work] obscurely, and to hide it as much as possible). Senior (*De chemia*, p. 55) says: “Verum dixerunt per omnia, Homines vero non intelligunt verba eorum... unde falsificant veridicos, et verificant falsificos opinionibus suis.... Error enim eorum est ex ignorantia intentionis eorum, quando audiunt diversa verba, sed ignota intellectui eorum, cum sint in intellectu occulto.” (They told the truth in regard to all things, but men do not understand their words... whence through their assumptions they falsify the verities and verify the falsities.... The error springs from ignorance of their [the writers’] meaning, when they hear divers words unknown to their understanding, since these have a hidden meaning.) Of the secret hidden in the words of the wise, Senior says: “Est

enim illud interius subtiliter perspicientis et cognoscentis” (For this belongs to him who subtly perceives and is cognizant of the inner meaning). The *Rosarium* (p. 230) explains: “Ego non dixi omnia apparentia et necessaria in hoc opere, quia sunt aliqua quae non licet homini loqui” (So I have not declared all that appears and is necessary in this work, because there are things of which a man may not speak). Again (p. 274): “Talis materia debet tradi mystice, sicut poësis fabulose et parabolice” (Such matters must be transmitted in mystical terms, like poetry employing fables and parables). Khunrath (*Von hyl. Chaos*, p. 21) mentions the saying: “Arcana publicata vilescunt” (secrets that are published become cheap)—words which Andreae used as a motto for his *Chymical Wedding*. Abū’l Qâsim Muhammad ibn Ahmad al-Simāwī, known as al-Irāqī, says in his “Book of the Seven Climes” (see Holmyard, “Abū’l-Qâsim,” p. 410) regarding Jābir ibn Hayyān’s method of instruction: “Then he spoke enigmatically concerning the composition of the External and the Internal.... Then he spoke darkly... that in the External there is no complete tincture and that the complete tincture is to be found only in the Internal. Then he spoke darkly... saying, Verily we have made the External nothing more than a veil over the Internal... that the Internal is like this and like that and he did not cease from this kind of behaviour until he had completely confused all except the most quick-witted of his pupils....” Wei Po-yang (c. 142 A.D.) says: “It would be a great sin on my part not to transmit the Tao which would otherwise be lost to the world forever. I shall not write on silk lest the divine secret be unwittingly spread abroad. In hesitation I sigh....” (“An Ancient Chinese Treatise,” p. 243).

16 The parallel to this is the paradoxical relation of Malchuth to Kether, the lowest to the highest (see note 14 above).

17 P. 270.

18 He is thought to be identical with Joannes de Garlandia, who lived in the second half of the 12th cent. and wrote the “Commentarius in Tabulam smaragdinam,” in *De alchemia* (1541).

19 Ibid., p. 365. Since the alchemists were, as “philosophers,” the empiricists of the psyche, their terminology is of secondary importance compared with their experience, as is the case with empiricism generally. The discoverer is seldom a good classifier.

20 Thus Dom (“Physica Trismegisti,” *Theatr. chem.*, I, p. 409) says: “Spagirica foetura terrestris caelicam naturam induat per ascensum, et deinceps suo descensu centri naturam terreni recipiat” (This earthly, spagyric birth clothes itself with heavenly nature by its ascent, and then by its descent visibly puts on the nature of the centre of the earth).

21 This explains why the projection usually has some influence on the carrier, which is why the alchemists in their turn expected the “projection” of the stone to bring about a transmutation of base metals.

22 The alchemists regarded the arrow as the *telum passionis* of Mercurius.

23 Rosencreutz, *The Chymical Wedding*, p. 212.

24 Waite, *Real History of the Rosicrucians*.

25 Intoxicants that induce delirious states can also release these processes, for which purpose datura (Jimson weed) and peyotl are used in primitive rites. See Hastings, *Encyclopedia*, IV, pp. 735f.

26 As this book was written in 1943, I leave this sentence as it stands, in the hope of a better world to come.

27 This process is described in the second of my *Two Essays*.

28 Cf. “Tractatulus Aristotelis,” *Art. aurif.*, I, p. 371.

29 A good example of this is to be found in Angelus Silesius, *Cherubinischer Wandersmann*, Book III, no. 238:

“God is made man and now is born—rejoice!

Where then? In me, the mother of his choice.

How should that be? My soul that Virgin Maid,

My heart the manger and my limbs the shed....”

30 In woman the animus produces very similar illusions, the only difference being that they consist of dogmatic opinions and prejudices which are taken over at random from somebody else and are never the product of her own reflection.

31 She is the Euthicia of the treatise of Rosinus (= Zosimos) in *Art. aurif.*, I, pp. 277ff.

32 The *Mutus liber* is reproduced as an appendix to Vol. I of the *Bibl. chem. curiosa*, 1702. For illustrations from the *Mutus Liber*, see figs. 11–13 of the present volume, and *Psychology and Alchemy*, index. We might mention John Pordage and Jane Leade (17th cent.) as another pair of alchemists. See *infra*.

33 *A Suggestive Inquiry into the Hermetic Mystery*.

34 John Pordage (1607–1681) studied theology and medicine in Oxford. He was a disciple of Jakob Boehme and a follower of his alchemical theosophy. He became an accomplished alchemist and astrologer. One of the chief figures in his mystical philosophy is Sophia. (“She is my divine, eternal, essential self-sufficiency. She is my wheel within my wheel,” etc.—Pordage’s *Sophia*, p. 21.)

35 The letter is printed in Roth-Scholz, *Deutsches Theatrum chemicum*, I, pp. 557–97. The first German edition of this “Philosophisches Send-Schreiben vom Stein der Weissheit” seems to have been published in Amsterdam in 1698. [The letter was evidently written in English, since the German version in Roth-Scholz, 1728–32, is stated to be “aus dem Englischen übersetzt.” But no English edition or MS. can be traced at the British Museum, the Library of Congress, or any of the other important British and American libraries. Pordage’s name does not occur among the alumni at Oxford.—EDITORS.]

36 One of the favourite allusions to the Song of Songs 7:2: “Thy navel is like a round goblet, which wanteth not liquor.” Cf. also *Aurora consurgens*, I, Ch. XII.

37 The concluding passages are very reminiscent of the teachings of the “secta liberi spiritus,” which were propagated as early as the 13th century by the Béguines and Beghards.

38 Hence Pordage’s view is more or less in agreement with woman’s conscious psychology, but not with her unconscious psychology.

39 Pordage, *Sophia*, Ch. I.

40 There is a modern work that gives an excellent account of the feminine world of symbols: Esther Harding’s *Woman’s Mysteries*.

41 Florence, Ashburnham 1166, 14th cent. They are reproduced as figs. 131 and 135 in *Psychology and Alchemy*.

42 The arrow refers to the *telum passionis* of Mercurius. Cf. “Cantilena Riplaei” in *ibid.*, par. 491, and *Mysterium Coniunctionis*, pp. 285fr. Cf. also “The Spirit Mercurius,” Part II, sec. 8, and St. Bernard of Clairvaux, *Sermones in Cantica*, XXX, 8 (Migne, *P.L.*, vol. 183, cols. 932–33): “Est et sagitta sermo Dei vivus et efficax et penetrabilior omni gladio ancipiti.... Est etiam sagitta electa amor Christi, quae Mariae animam non modo confixit, sed etiam pertransivit, ut nullam in pectore virginali particulam vacuum amore relinqueret.” (God’s word is an arrow; it is lively and effective and more penetrating than a double-edged sword.... And the love of Christ is a choice arrow too, which

not only entered, but transfixed, the soul of Mary, so that it left no particle of her virgin heart free of love.)—Trans. by a priest of Mount Melleray, I, p. 346.

43 Cf. the Alaskan Eskimo tale “The Woman Who Became a Spider,” in Rasmussen, *Die Gabe des Adlers*, pp. 121ff., and the Siberian tale “The Girl and the Skull,” in Kunike (ed.), *Märchen aus Sibirien*, No. 31, where a woman marries a skull.

44 Ed. Macaulay, II, p. 35: motto of Book I. Cf. St. Bernard of Clairvaux, *Sermones in Cant.*, XXIX, 8 (Migne, *P.L.*, vol. 183, col. 933) (of Mary): “Et illa quidem in tota se grande et suave amoris vulnus accepit...” (And she indeed received a great and sweet wound of love in all her being).

1 “Numerus perfectus est denarius” (the perfect number is ten).—Mylius, *Phil. ref.*, p. 134. The Pythagoreans regarded the *δεκάς* as the *τέλειος ἀριθμός*.—Hippolytus, *Elenchos*, I, 2, 8. Cf. Joannes Lydus, *De mensibus*, 3, 4, and Proclus, *In Platonis Timaeum Commentaria*, 21 AB. This view was transmitted to alchemy through the *Turba* (pp. 300ff., “Sermo Pythagorae”). Dorn (“Congeries,” *Theatr. chem.* I, p. 622) says: “Quando quidem ubi Quaternarius et Ternarius ad Denarium ascendunt, eorum fit ad unitatem regressus. In isto concluditur arcano omnis occulta rerum sapientia.” (When the number four and the number three ascend to the number ten, they return to the One. In this secret all the hidden wisdom of things is contained.) But he denies (“Duellum animi,” *Theatr. chem.*, I, p. 545) that $1 + 2 + 3 + 4 = 10$, since 1 is not a number, maintaining that the denarius comes from $2 + 3 + 4 = 9 + 1$. He insists on the elimination of the devilish binarius (ibid., pp. 542ff.). John Dee (“Monas hieroglyphica,” *Theatr. chem.*, II, p. 220) derives the denarius in the usual way: the *antiquissimi Latini philosophi* assumed that the *crux rectilinea* meant the denarius. The old author Artefius (probably an Arab) also derives the denarius by adding together the first four numbers (“Clavis,” *Theatr. chem.*, IV, p. 222). But later he says that 2 is the first number, and he proceeds to make the following operation: $2 + 1 = 3$, $2 + 2 = 4$, $4 + 1 = 5$, $4 + 3 = 7$, $7 + 1 = 8$, $8 + 1 = 9$, $8 + 2 = 10$, and says that “eodem modo centenarii ex denariis, millenarii vero ex centenariis procreantur” (in the same way the hundreds are produced out of the tens, and the thousands out of the hundreds). This operation can be regarded as either enigmatic or childish.

2 According to Hippolytus (*Elenchos*, IV, 43, 4), the Egyptians said that God was a *μονὰς ἀδιαίρετος* (an indivisible unity), and that 10 was a monad, the beginning and end of all number.

3 The denarius as an *allegoria Christi* is to be found in Rabanus Maurus, *Allegoriae in universam sanctam Scripturam* (Migne, *P.L.*, vol. 112, col. 907).

4 “Audi atque attende: Sal antiquissimum Mysterium! Cuius nucleum in Denario, Harpocratice, sile.” (Listen and pay heed: Salt is the oldest mystery. Hide its nucleus in the number ten, after the manner of Harpocrates.)—Khunrath, *Amphitheatrum*, p. 194. The salt is the salt of wisdom. Harpocrates is the genius of the secret mysteries. Cf. *Psychology and Alchemy*, figs. 52 and 253.

5 There is a parallel to this in the system of Monoïmos (Hippolytus, *Elenchos*, VIII, 12, 2ff.). The son of Oceanus (the Anthropos) is an indivisible monad and yet divisible: he is mother and father, a monad that is also a decad. “Ex denario divino statues unitatem” (Out of the divine number ten you will constitute unity).—Quotation from Job. Dausten in Aegidius de Vadis, “Dialogus,” *Theatr. chem.*, II, p. 115. Dausten, or Dastyne, was probably an Englishman; certain authorities date him at the beginning of the 14th cent., others much later. See Ferguson, *Bibl. chem.*, I, s.v. “Dausten.”

6 Norton’s “Ordinall,” *Theatr. chem, britannicum*, p. 48. Philalethes (“Fons chemicae veritatis,” *Mus. herm.*, p. 802) says: “Qui semel adeptus est, ad Autumnum sui laboris pervenit” (He who has once found it has reached the harvest time of his work). This is a quotation from Johannes Pontanus, who lived about 1550 and was a physician and professor of philosophy at Königsberg. Cf. Ferguson, *Bibl. chem.*, II, p. 212.

7 It is worth noting that St. John of the Cross pictures the ascent of the soul in ten stages.

8 “Ipsa omnia sunt ex uno et de uno et cum uno, quod est radix ipsius” (They are all from the One, and of the One, and with the One, which is the root of itself).—*Art. aurif.*, II, p. 369.

9 Nicholas of Cusa, in his *De docta ignorantia*, regarded antinomical thought as the highest form of reasoning.

10 Cf. “Rosinus ad Sarratantam,” *Art. aurif.*, I, p. 309: “Cuius [lapidis] mater virgo est, et pater non concubuit” (Its [the stone’s] mother is a virgin, and the father lay not with her).

11 Cf. Petrus Bonus, “Pretiosa margarita novella,” *Theatr. chem.*, V, p. 649: “Cuius mater virgo est, cuius pater foeminam nescit. Adhuc etiam noverunt, quod Deus fieri debet homo, quia in die novissima huius artis, in qua est operis complementum, generans et generatum fiunt omnino unum: et senex et puer et pater et filius fiunt omnino unum. Ita quod omnia vetera fiunt nova.” (Whose mother is a virgin and whose father knew not woman. They knew also that God must become man, because on the last day of this art, when the completion of the work takes place, begetter and begotten become altogether one. Old man and youth, father and son, become altogether one. Thus all things old are made new.)

12 Cf. Dante, *Paradiso*, XXXIII, i: “O Virgin Mother, daughter of thy son.”

13 “Sermo de transmutatione metallorum,” *Art. aurif.*, II, p. 37.

14 Cf. “Psychology and Religion,” pars. 95ff., 153ff.; and *Psychology and Alchemy*, pars. 342ff.

15 It goes without saying that these concepts offer no solution of any metaphysical problem. They neither prove nor disprove the immortality of the soul.

16 *Art. aurif.*, II, pp. 356f.: “Patet ergo quod Philosophorum Magister lapis est, quasi diceret, quod naturaliter etiam per se facit quod tenetur facere: et sic Philosophus non est Magister lapidis, sed potius minister. Ergo qui quaerit per artem extra naturam per artificium inducere aliquid in rem, quod in ea naturaliter non est, errat et errorem suum deflebit.” [The above translation follows the author’s German version. An equally likely translation of the “quasi diceret” clause would be: “as if it (the stone) were to say that it does of its own nature that which it is held to do.”—A.S.B.G.]

17 The Persian Gayomart is as broad as he is long, hence spherical in shape like the world-soul in Plato’s *Timaeus*. He is supposed to dwell in each individual soul and in it to return to God. See Reitzenstein and Schaefer, *Studien zum antiken Synkretismus*, p. 25.

18 Cf. “The Spirit Mercurius.”

19 Possibly from βαφή (*tinctura*) and μῆτις (skill, sagacity), thus roughly corresponding to the Krater of Hermes filled with voûs. Cf. Nicolai, *Versuch über die Beschuldigungen, welche dem Tempelherrenorden gemacht wurden*, p. 120; Hammer-Purgstall, *Mysterium Baphometis*, pp. 3ff.

20 Cf. *Psychology and Alchemy*, fig. 70, showing a snake ritual. There is no certain connection of snake worship with the Templars (Hammer-Purgstall, *Mémoire sur deux coffrets gnostiques*).

21 Anastasius Sinaïta, *Anagogicae contemplationes*: “Et cum vel suffocatus esset et perisset tenebrosus corvus Satan...” (And when the dark raven Satan [or: of Satan] was suffocated or had perished...). St. Ambrose, *De Noe et Arca*, I, 17 (Migne, *P.L.*, vol. 14, col. 411): “Siquidem omnis impudentia atque culpa tenebrosa est et mortuis pascitur sicut corvus...” (If indeed all shamelessness and guilt is dark and feeds on the dead like a raven...). Again, the raven signifies the sinners: St. Augustine, *Annotationes in Job*, I, xxviii, 41 (Migne, *P.L.*, vol. 34, col. 880): “Significantur ergo nigri [scl. corvi] hoc est peccatores nondum dealbati remissione peccatorum” (They signify the black [raven], i.e., the sinners not yet whitened by remission of their sins). Paulinus of Aquileia, *Liber exhortationis* (Migne, *P.L.*, vol. 99, col. 253): “anima peccatoris... quae nigrior corvo est” (The soul of a sinner... which is blacker than a raven).

22 *Art. aurif.*, II, p. 359. See *Psychology and Alchemy*, fig. 54.

23 For further pictures of the Rebis see *ibid.*, Index, s.v. “hermaphrodite.”

24 The identification of the *prima materia* with God occurs not only in alchemy but in other branches of medieval philosophy as well. It derives from Aristotle and its first appearance in alchemy is in the Harranite “Treatise of Platonic Tetralogies” (“Liber Platonis Quartorum,” *Theatr. chem.*, V). Mennens (“Aureum vellus,” *Theatr. chem.*, V, p. 334) says: “Nomen itaque quadrilaterum Dei sanctissimam Trinitatem designare videtur et materiam, quae et umbra eius dicitur et a Moyse Dei posteriora vocatur” (Therefore the four-letter name of God seems to signify the Most Holy Trinity and the Materia, which is also called his shadow, and which Moses called his back parts). Subsequently this idea crops up in the philosophy of David of Dinant, who was attacked by Albertus Magnus. “Sunt quidam haeretici dicentes Deum et materiam primam et *νοῦν* sive mentem idem esse” (There are some heretics who say that God and the prima materia and the nous or mind are the same thing).—*Summa Theologica*, I, 6, qu. 29, memb. 1 art. 1, par. 5 (*Opera*, ed. Borgnet, vol. 31, p. 294). Further details in Krönlein, “Amalrich von Bena,” pp. 303ff.

25 The idea of the hermaphrodite is seemingly to be met with in later Christian mysticism. Thus Pierre Poiret (1646–1719), the friend of Mme Guyon, was accused of believing that, in the millennium, propagation would take place hermaphroditically. The accusation was refuted by Cramer (Hauck, *Realencyklopädie*, XV, p. 496), who showed that there was nothing of this in Poiret’s writings.

26 It is interesting to see how this theory once more joined forces with alchemy in Herbert Silberer’s book, *Problems of Mysticism and Its Symbolism*.

27 *De docta ignorantia*, II, 3: “Maximum autem est, cui nihil opponitur, ubi et Minimum est Maximum.”

28 “Ultra hanc coincidentiam creare cum creari es tu Deus.”

29 *De conjecturis*, II, 14: “Homo enim Deus est, sed non absolute, quoniam homo. Humane igitur est Deus. Homo etiam mundus est, sed non contracte omnia, quoniam homo. Est igitur homo *μικρόκοσμος*.”

30 *Of Learned Ignorance* (trans. Heron), p. 173: “Debet autem in his profundis omnis nostri humani ingenii conatus esse, ut ad illam se elevet simplicitatem, ubi contradictoria coincidunt.”

1 Of these I would draw attention only to the series contained in *Mutus liber*, where the adept and his *soror mystica* are shown performing the *opus*. The first picture (fig. 11) shows an angel waking the sleeper with a trumpet; in the second picture (fig. 12), the pair of alchemists kneel on either side of the Athanor (furnace) with the sealed phial inside it, and above them are two angels holding the same phial, which now contains Sol and Luna, the spiritual equivalents of the two adepts. The third picture (fig. 13) shows, among other things, the sotor catching birds in a net and the adept hooking a nixie with rod and line: birds, being volatile creatures, stand for thoughts or the pluralistic animus, and the nixie corresponds to the anima. The undisguisedly psychic character of this portrayal of the *opus* is probably due to the fact that the book was written comparatively late—1677.

- 1 [Translated from “Die Wirklichkeit der psychotherapeutischen Praxis,” a lecture delivered at the Second Congress for Psychotherapy, Bern, May 28, 1937, and found among Jung’s posthumous papers. Previously unpublished.—EDITORS.]
- 2 [This case is discussed by Jung in Prof. J. W. Hauer’s Seminar on Kundalini Yoga (privately multigraphed, Zurich, autumn 1932, pp. 91 ff.). Certain aspects of it are mentioned in Jung’s published writings (see notes infra).—EDITORS.]
- 3 [Cf. *supra*, pars. 307–10.—EDITORS.]
- 4 [Cf. *Two Essays on Analytical Psychology*, par. 189.—EDITORS.]
- 5 [Examples of this patient’s drawings are reproduced and discussed in “Concerning Mandala Symbolism,” figs. 7–9, and pars. 656 ff.—EDITORS.]
- 6 [As Onians (*The Origins of European Thought*, pp. 26 ff.) has demonstrated, *phrenes* in Homer Were the lungs.—TRANS.]

- * The Standard Edition of the Complete Psychological Works of Sigmund Freud, translated under the general editorship of James Strachey, in collaboration with Anna Freud, assisted by Alix Strachey and Alan Tyson. London.
- * For details of the Collected Works of C. G Jung, see list at end of this volume
- * For details of the Collected Works of C. G. Jung, including unpublished vols. (marked with asterisk), see list at end of this volume.

- * Published 1957; 2nd edn., 1970.
- † Published 1973.
- Published 1960.
- † Published 1961.
- ‡ Published 1956; 2nd edn., 1967. (65 plates, 43 text figures.)
- Published 1971.
- † Published 1953; 2nd edn., 1966.
- ‡ Published 1960; 2nd edn., 1969.
- Published 1959; 2nd edn., 1968. (Part I: 79 plates, with 29 in colour.)
- Published 1964; 2nd edn., 1970. (8 plates.)
- † Published 1958; 2nd edn., 1969.
- Published 1953; 2nd edn., completely revised, 1968. (270 illustrations.)
- † Published 1968. (50 plates, 4 text figures.)
- ‡ Published 1963; 2nd edn., 1970. (10 plates.)
- Published 1966.
- † Published 1954; 2nd edn., revised and augmented, 1966. (13 illustrations.)
- ‡ Published 1954.

BOLLINGEN SERIES XX

THE COLLECTED WORKS

OF

C. G. JUNG

VOLUME 17

EDITORS

SIR HERBERT READ

MICHAEL FORDHAM, M.D., M.R.C.P.

GERHARD ADLER, PH.D.

WILLIAM MCGUIRE, *executive editor*

**DEVELOPMENT
OF
PERSONALITY**

C. G. JUNG

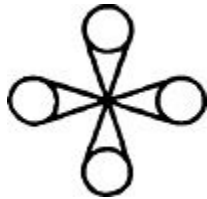

TRANSLATED BY R. F. C. HULL

BOLLINGEN SERIES XX

PRINCETON UNIVERSITY PRESS

COPYRIGHT 1954 BY BOLLINGEN FOUNDATION INC., NEW YORK, N. Y.

PUBLISHED BY PRINCETON UNIVERSITY PRESS

Second printing, with corrections, 1964

Third printing, with additional corrections, 1970

Fourth printing, 1974

Fifth printing, 1977

First Princeton/Bollingen Paperback printing, 1981

THIS EDITION IS BEING PUBLISHED IN THE UNITED STATES OF AMERICA BY PRINCETON UNIVERSITY PRESS, AND IN ENGLAND BY ROUTLEDGE AND KEGAN PAUL, LTD. IN THE AMERICAN EDITION, ALL THE VOLUMES COMPRISING THE COLLECTED WORKS CONSTITUTE NUMBER XX IN BOLLINGEN SERIES, SPONSORED BY BOLLINGEN FOUNDATION. THE PRESENT VOLUME IS NUMBER 17 OF THE COLLECTED WORKS, AND WAS THE FOURTH TO APPEAR.

LIBRARY OF CONGRESS CATALOG CARD NO. 75-156

ISBN 0-691-09763-1

ISBN 0-691-01838-3 pbk.

MANUFACTURED IN THE U. S. A.

EDITORIAL NOTE

Personality as the expression of the wholeness of man is defined by Jung as an adult ideal whose conscious realization through individuation is the aim of human development in the second half of life. It is to the study of this aim that Jung has devoted his main attention in all his later work. It is manifest that in childhood and adolescence the ego is brought into being and firmly established; no account of individuation, therefore, would be complete without a psychological outline of the early formative period of development.

The present volume is a collection of Professor Jung's papers on child psychology and education, of which the three lectures on "Analytical Psychology and Education" are the chief item. Jung regards the psychology of parents and educators as of the greatest importance in the maturation and growth to consciousness of the children—especially so in the case of those who are unusually gifted. He emphasizes that an unsatisfactory psychological relationship between the parents may be an important cause of psychogenic disorders in childhood. It has been thought relevant to include Jung's paper on "Marriage as a Psychological Relationship" and, finally, to link up the problems of childhood with those of individuation in the adult by adding the essay which gives the present volume its title.

The essay "Child Development and Education" is presented here for the first time under this title. It previously appeared as one of the four lectures on "Analytical Psychology and Education," published in *Contributions to Analytical Psychology*; yet it had been delivered on a different occasion from the three others, its subject-matter is different, and it is not included by Jung in *Psychologie und Erziehung*, which contains the three other lectures. It contains a significant textual change by the author: an important statement in paragraph 106 on the subject of archetypal images in the dreams of children. Editorial reference is given to the privately printed record of Jung's seminars on the subject.

Only the essay "The Gifted Child" and the introduction to Frances Wickes's book *Analyse der Kinderseele* have not previously been translated into English, apart from the brief alteration mentioned above. But the author has considerably revised the essays on education, so that much new matter is to be found in this volume, which will, it is hoped, help to set forth Jung's position in regard to child psychology.

TRANSLATOR'S NOTE

With the exception of the “Introduction to Wickes’s *Analyse der Kinderseele*” and “The Gifted Child,” all the papers in the present volume were previously translated by various hands and published in *Collected Papers on Analytical Psychology* (2nd edition, London, 1917, and New York, 1920), *Contributions to Analytical Psychology* (London and New York, 1928), and *The Integration of the Personality* (New York, 1939; London, 1940). Several of them, as indicated in the footnotes at the beginning of each paper, have since been revised and expanded by the author. I would like to express my thanks to the late Dr. A. A. Brill, Mr. Stanley Dell, and in particular to Mrs. Cary F. Baynes, for permission to make full use of the earlier texts in preparing the present revised versions.

VOLUME 17
DEVELOPMENT OF PERSONALITY

TABLE OF CONTENTS

EDITORIAL NOTE

TRANSLATOR'S NOTE

I. Psychic Conflicts in a Child

Translated from "Über Konflikte der kindlichen Seele," *Psychologie und Erziehung* (Zurich: Rascher, 1946).

II. Introduction to Wickes's *Analyse der Kinderseele*

Translated from the German edition (Stuttgart: Hoffman, 1931).

III. Child Development and Education

Translated from the unpublished German original.

IV. Analytical Psychology and Education

Translated from "Analytische Psychologie und Erziehung," *Psychologie und Erziehung* (Zurich: Rascher, 1946).

Lecture One, —Lecture Two, —Lecture Three

V. The Gifted Child

Translated from "Der Begabte," *Psychologie und Erziehung* (Zurich: Rascher, 1946).

VI. The Significance of the Unconscious in Individual Education

Translated from the unpublished German original.

VII. The Development of Personality

Translated from "Vom Werden der Persönlichkeit," *Wirklichkeit der Seele* (Zurich: Rascher, 1934).

VIII. Marriage as a Psychological Relationship

Translated from “Die Ehe als psychologische Beziehung,” *Seelenprobleme der Gegenwart* (Zurich: Rascher, 1931).

BIBLIOGRAPHICAL NOTE

INDEX

PSYCHIC CONFLICTS IN A CHILD

[**The third of a series of lectures on “The Association Method,”** delivered on the 20th anniversary of the opening of Clark University, Worcester, Massachusetts, September, 1909. The original version was published under the title “Über Konflikte der kindlichen Seele,” *Jahrbuch für psychoanalytische und psychopathologische Forschungen*, II (1910), 33ff. It was translated by A. A. Brill and published in the *American Journal of Psychology*, XXI (1910), in a Clark University anniversary volume (1910), and in *Collected Papers on Analytical Psychology* (1st edn., London, 1916; 2nd edn., London, 1917, and New York, 1920). The revised version, of which this present essay is a translation, appeared in *Psychologie und Erziehung* (Zurich, 1946). The first two lectures comprising “The Association Method” were never published in German but were included in the aforementioned 1910 and 1916 publications. See Vol. 2 of the *Coll. Works.*—EDITORS.]

FOREWORD TO THE SECOND EDITION

I am publishing this little study just as it is, without making any alterations for the second edition. Although in point of fact our conceptions have been considerably modified and extended since these observations first appeared in 1910, I do not feel that the subsequent modifications would justify me in describing the views put forward in the first edition as basically false, an imputation that has been laid against me in certain quarters. On the contrary, just as the observations here recorded have retained their value as facts, so also have the conceptions themselves. But no conception is ever all-embracing, for it is always dominated by a point of view. The point of view adopted in this work is psycho-biological. It is naturally not the only one possible, indeed there are several others. Thus, more in accord with the spirit of Freudian psychology, this little piece of child psychology could be regarded from the purely hedonistic standpoint, the psychological process being conceived as a movement dominated by the pleasure principle. The main motives would then be the desire for and the striving towards the most pleasurable, and hence the most satisfying, realization of fantasy. Or, following Adler's suggestion, one could regard the same material from the standpoint of the power principle, an approach which is psychologically just as legitimate as that of the hedonistic principle. Or one could employ a purely logical approach, with the intention of demonstrating the development of logical processes in the child. One could even approach the matter from the standpoint of the psychology of religion and give prominence to the earliest beginnings of the God-concept. I have been content to steer a middle course that keeps to the psycho-biological method of observation, without attempting to subordinate the material to this or that hypothetical key principle. In so doing I am not, of course, contesting the legitimacy of such principles, for they are all included in our human nature; but only a very one-sided specialist would think of declaring as universally valid the heuristic principle that had proved its particular value for his discipline or for his individual method of observation. The essence of human psychology, precisely because so many different possible principles exist, can never be fully comprehended under any one of them, but only under the totality of individual aspects.

The basic hypothesis of the view advanced in this work is that sexual interest plays a not inconsiderable role in the nascent process of infantile thinking, an hypothesis that should meet with no serious opposition. A contrary hypothesis would certainly come up against too many well-observed facts, quite apart from its being extraordinarily improbable that a fundamental instinct of such cardinal importance for human psychology should not make itself felt in the infantile psyche from the very beginning.

On the other hand I also lay stress on the significance of *thinking* and the importance of concept-building for the solution of psychic conflicts. It should be sufficiently clear from what follows that the initial sexual interest strives only figuratively towards an immediate sexual goal, but far more towards the development of thinking. Were this not so, the solution of the conflict could be reached solely through the attainment of a sexual goal, and not through the mediation of an intellectual concept. But precisely the latter is the case, from which we may conclude that infantile sexuality is not to be identified outright with adult sexuality, since adult sexuality cannot be adequately replaced by concept-building, but is in most cases only satisfied with the real sexual goal, namely the tribute of normal sexual functioning which nature exacts. On the other hand, we know from experience that the infantile beginnings of sexuality can also lead to real sexual functioning—masturbation—when the conflicts are not resolved. The building of concepts, however, opens out to the libido a channel that is capable of further development, so that its continual, active realization is assured. Given a certain intensity of conflict, the absence of concept-building acts as a hindrance which thrusts the libido back into its initial sexuality, with the result that these beginnings or buddings are brought prematurely to an abnormal pitch of development. This produces an infantile neurosis. Gifted children in particular, whose mental demands begin to develop early on account of their intelligent disposition, run a serious risk of premature sexual realization through the suppression of what their parents and teachers would call an unsuitable curiosity.

As these reflections show, I do not regard the thinking function as just a makeshift function of sexuality which sees itself hindered in its pleasurable realization and is therefore compelled to pass over into the thinking function; but, while perceiving in infantile sexuality the beginnings of a future sexual function, I also discern there the seeds of higher spiritual functions. The fact that infantile conflicts can be resolved through concept-building speaks in favour of this, and also the fact that even in adult life the vestiges of infantile sexuality are the seeds of vital spiritual functions. The fact that adult sexuality grows out of this polyvalent germinal disposition does not prove that infantile sexuality is “sexuality” pure and simple. I therefore dispute the rightness of Freud’s idea of the “polymorphous-perverse” disposition of the child. It is simply a *polyvalent* disposition. If we proceeded according to the Freudian formula, we should have to speak, in embryology, of the ectoderm as the brain, because from it the brain is ultimately developed. But much also develops from it besides the brain, for instance the sense organs and other things.

December, 1915

C. G. J.

FOREWORD TO THE THIRD EDITION

Since this paper first appeared, almost thirty years have gone by. Yet it would seem that this little work has not given up the ghost, but is in increasing demand with the public. In one or two respects, certainly, it has never grown stale, firstly because it presents a simple series of facts such as occur repeatedly and are found to be much the same everywhere; secondly because it demonstrates something of great practical and theoretical importance, namely the characteristic striving of the child's fantasy to outgrow its "realism" and to put a "symbolic" interpretation in the place of scientific rationalism. This striving is evidently a natural and spontaneous expression of the psyche, which for that very reason cannot be traced back to any "repression" whatsoever. I stressed this particular point in my Foreword to the second edition, and my mention of it there has not lost its topicality, since the myth of the polymorphous sexuality of the child is still sedulously believed in by the majority of specialists. The repression theory is as grossly overestimated as ever, while the natural phenomena of psychic transformation are accordingly underestimated, if not entirely ignored. In 1912, I made these phenomena the subject of a compendious study, which cannot be said even now to have penetrated the intellects of psychologists as a class. I trust therefore that the present modest and factual report will succeed in rousing the reader to reflection. Theories in psychology are the very devil. It is true that we need certain points of view for their orienting and heuristic value; but they should always be regarded as mere auxiliary concepts that can be laid aside at any time. We still know so very little about the psyche that it is positively grotesque to think we are far enough advanced to frame general theories. We have not even established the empirical extent of the psyche's phenomenology: how then can we dream of general theories? No doubt theory is the best cloak for lack of experience and ignorance, but the consequences are depressing: bigotedness, superficiality, and scientific sectarianism.

To document the polyvalent germinal disposition of the child with a sexual terminology borrowed from the stage of fully-fledged sexuality is a dubious undertaking. It means drawing everything else in the child's make-up into the orbit of sexual interpretation, so that on the one hand the concept of sexuality is blown up to fantastic proportions and becomes nebulous, while on the other hand spiritual factors are seen as warped and stunted instincts. Views of this kind lead to a rationalism which is not even remotely capable of doing justice to the essential polyvalence of the infantile disposition. Even though a child may be preoccupied with matters which, for adults, have an undoubtedly sexual complexion, this does not prove that the nature of the child's preoccupation is to be regarded as equally sexual. For the cautious and

conscientious investigator sexual terminology, as applied to infantile phenomena, can be deemed at most a professional *façon de parler*. I have my qualms about its appropriateness.

Apart from a few small improvements I am allowing this paper to appear once again in unaltered form.

December, 1938

C. G. J.

PSYCHIC CONFLICTS IN A CHILD

- [1] About the time when Freud published his report on the case of “Little Hans,”¹ I received from a father who was acquainted with psychoanalysis a series of observations concerning his little daughter, then four years old.
- [2] These observations have so much that bears upon, and supplements, Freud’s report on “Little Hans” that I cannot refrain from making this material accessible to a wider public. The widespread incomprehension, not to say indignation, with which “Little Hans” was greeted, was for me an additional reason for publishing my material, although it is nothing like as extensive as that of “Little Hans.” Nevertheless, it contains points which seem to confirm how typical the case of “Little Hans” is. So-called “scientific” criticism, so far as it has taken any notice at all of these important matters, has once more proved overhasty, seeing that people have still not learned first to examine and then to judge.
- [3] The little girl to whose sagacity and intellectual sprightliness we are indebted for the following observations is a healthy, lively child of emotional temperament. She has never been seriously ill, nor had she ever shown any trace of “nervous” symptoms.
- [4] Livelier systematic interests awakened in the child about her third year; she began to ask questions and to spin wishful fantasies. In the report which now follows we shall, unfortunately, have to give up the idea of a consistent exposition, for it is made up of anecdotes which treat of one isolated experience out of a whole cycle of similar ones, and which cannot, therefore, be dealt with scientifically and systematically, but must rather take the form of a story. We cannot dispense with this mode of exposition in the present state of our psychology, for we are still a long way from being able in all cases to separate with unerring certainty what is curious from what is typical.
- [5] When the child, whom we will call Anna, was about three years old, she had the following conversation with her grandmother:
- “Granny, why are your eyes so dim?”
- “Because I am old.”
- “But you will become young again?”
- “Oh dear, no. I shall become older and older, and then I shall die.”
- “And what then?”
- “Then I shall be an angel.”

“And then you will be a baby again?”

[6] The child found here a welcome opportunity for the provisional solution of a problem. For some time she had been in the habit of asking her mother whether she would ever have a real live doll, a baby brother, which naturally gave rise to the question of where babies come from. As such questions were asked quite spontaneously and unobtrusively, the parents attached no significance to them, but responded to them as lightly as the child herself seemed to ask them. Thus one day she was told the pretty story that children are brought by the stork. Anna had already heard somewhere a slightly more serious version, namely that children are little angels who live in heaven and are then brought down by the said stork. This theory seems to have become the point of departure for the little one's investigating activities. From the conversation with the grandmother it could be seen that this theory was capable of wide application; for it solved in a comforting manner not only the painful thought of dying, but at the same time the riddle of where children come from. Anna seemed to be saying to herself: “When somebody dies he becomes an angel, and then he becomes a child.” Solutions of this sort, which kill at least two birds with one stone, used to be tenaciously adhered to even in science, and cannot be undone in the child's mind without a certain amount of shock. In this simple conception there lie the seeds of the reincarnation theory, which, as we know, is still alive today in millions of human beings.²

[7] Just as the birth of a little sister was the turning point in the history of “Little Hans,” so in this case it was the arrival of a baby brother, which took place when Anna had reached the age of four. The problem of where children come from, hardly touched upon so far, now became topical. The mother's pregnancy had apparently passed unnoticed; that is to say, Anna had never made any observations on this subject. On the evening before the birth, when labour pains were just beginning, the child found herself in her father's room. He took her on his knee and said, “Tell me, what would you say if you got a little brother tonight?” “I would kill him,” was the prompt answer. The expression “kill” looks very alarming, but in reality it is quite harmless, for “kill” and “die” in child language only mean to “get rid of,” either actively or passively, as has already been pointed out a number of times by Freud. I once had to treat a fifteen-year-old girl who, under analysis, had a recurrent association, and kept on thinking of Schiller's “Song of the Bell.” She had never really read the poem, but had once glanced through it, and could only remember something about a cathedral tower. She could recall no further details. The passage goes:

From the tower

The bell-notes fall

Heavy and sad
For the funeral. ...

Alas it is the wife and mother,
Little wife and faithful mother,
Whom the dark prince of the shadows
Snatches from her spouse's arms....

- [8] She naturally loved her mother dearly and had no thought of her death, but on the other hand the present position was this: she had to go away with her mother for five weeks, staying with relatives; the year before, the mother had gone by herself, and the daughter (an only and spoilt child) was left at home alone with her father. Unfortunately this year it was the "little wife" who was being snatched from the arms of her spouse, whereas the daughter would greatly have preferred the "faithful mother" to be parted from her child.
- [9] On the lips of a child, therefore, "kill" is a perfectly harmless expression, especially when one knows that Anna used it quite promiscuously for all possible kinds of destruction, removal, demolition, etc. All the same this tendency is worth noting. (Compare the analysis of "Little Hans.")
- [10] The birth occurred in the early morning. When all traces of the birth had been removed, together with the bloodstains, the father went into the room where Anna slept. She awoke as he entered. He told her the news of the arrival of a little brother, which she took with a surprised and tense expression on her face. The father then picked her up and carried her into the bedroom. Anna threw a rapid glance at her rather wan-looking mother and then displayed something like a mixture of embarrassment and suspicion, as if thinking, "What's going to happen now?" She evinced hardly any pleasure at the sight of the new arrival, so that the cool reception she gave it caused general disappointment. For the rest of the morning she kept very noticeably away from her mother; this was the more striking, as normally she was always hanging around her. But once, when her mother was alone, she ran into the room, flung her arms round her neck and whispered hurriedly, "Aren't you going to die now?"
- [11] Something of the conflict in the child's soul is now revealed to us. The stork theory had obviously never caught on properly, but the fruitful rebirth hypothesis undoubtedly had, according to which a person helps a child into life by dying. Mama ought therefore to die. Why, then, should Anna feel any pleasure over the new arrival, of whom she was beginning to feel childishly jealous anyway? Hence, she had to assure herself at a favourable opportunity whether Mama was going to die or not. Mama did not die. With this happy issue, however, the rebirth theory

received a severe setback. How was it now possible to explain little brother's birth and the origins of children in general? There still remained the stork theory, which, though never expressly rejected, had been implicitly waived in favour of the rebirth hypothesis.³ The next attempts at explanation unfortunately remained hidden from the parents, as the child went to stay with her grandmother for a few weeks. From the latter's report, however, it appears that the stork theory was much discussed, there being of course a tacit agreement to support it.

[12] When Anna returned home she again displayed, on meeting her mother, the same mixture of embarrassment and suspicion as after the birth. The impression was quite explicit to both parents, though not explicable. Her behaviour towards the baby was very nice. Meantime a nurse had arrived, who made a deep impression on little Anna with her uniform—an extremely negative impression at first, as she evinced the greatest hostility towards her in all things. Thus nothing would induce her to let herself be undressed in the evenings and put to bed by this nurse. The reason for this resistance soon became clear in a stormy scene by the bedside of the little brother, when Anna shouted at the nurse, "That's not your little brother, he is mine!" Gradually, however, she became reconciled to the nurse and began to play nurse herself; she had to have her white cap and apron, nursing her little brother and her dolls in turn. In contrast to her former mood the present one was unmistakably elegiac and dreamy. She often sat for hours crouched under the table singing long stories to herself and making rhymes, partly incomprehensible, but consisting partly of wishful fantasies on the "nurse" theme ("I am a nurse of the green cross"), and partly of distinctly painful feelings which were struggling for expression.

[13] Here we meet with an important new feature in the little one's life: reveries, the first stirrings of poetry, moods of an elegiac strain—all of them things which are usually to be met with only at a later phase of life, at a time when the youth or maiden is preparing to sever the family tie, to step forth into life as an independent person, but is still inwardly held back by aching feelings of homesickness for the warmth of the family hearth. At such a time they begin weaving poetic fancies in order to compensate for what is lacking. To approximate the psychology of a four-year-old to that of the boy or girl approaching puberty may at first sight seem paradoxical; the affinity lies, however, not in the age but in the mechanism. The elegiac reveries express the fact that part of the love which formerly belonged, and should belong, to a real object, is now *introverted*, that is, it is turned inwards into the subject and there produces an increased fantasy activity.⁴ Whence comes this introversion? Is it a psychological manifestation peculiar to this period, or does it come from a conflict?

[14] On this point the following episode is enlightening. Anna disobeyed her mother more and more often, saying insolently, "I shall go back to Granny!"

“But I shall be sad if you leave me.”

“Ah, but you’ve got baby brother.”

[15] The mother’s reaction shows us what the child was really getting at with her threats to go away again: she obviously wanted to hear what her mother would say to her proposal, what her attitude was in general, and whether the little brother had not ousted her altogether from her mother’s affection. One must not, however, fall for this transparent piece of trickery. The child could see and feel perfectly well that she was not stinted of anything essential in her mother’s love, despite the existence of her baby brother. The veiled reproach she levels at her mother on that score is therefore unjustified, and to the trained ear this is betrayed by the slightly affected tone of voice. One often hears similar tones even with grown-up people. Such a tone, which is quite unmistakable, does not expect to be taken seriously and obtrudes itself all the more forcibly for that reason. Nor should the reproach be taken to heart by the mother, for it is merely the forerunner of other and this time more serious resistances. Not long after the conversation narrated above, the following scene took place:

Mother: “Come, we’ll go into the garden.”

Anna: “You’re lying to me. Watch out if you’re not telling the truth!”

Mother: “What are you thinking of? Of course I’m telling the truth.”

Anna: “No, you are not telling the truth.”

Mother: “You’ll soon see whether I’m telling the truth: we are going into the garden this minute.”

Anna: “Is that true? You’re quite sure it’s true? You’re not lying?”

[16] Scenes of this kind were repeated a number of times. But this time the tone was more vehement and insistent, and also the accent on the word “lie” betrayed something special which the parents did not understand; indeed they attributed far too little significance at first to the child’s spontaneous utterances. In this they were only doing what all official education does. We do not usually listen to children at any stage of their careers; in all the essentials we treat them as *non compos mentis* and in all the unessentials they are drilled to the perfection of automatons. Behind resistances there always lies a question, a conflict, of which we hear soon enough at another time and on another occasion. But usually we forget to connect the thing heard with the resistances. Thus, on another occasion, Anna faced her mother with the awkward questions:

“I want to be a nurse when I grow up.”

“That’s what I wanted to be when I was a child.”

“Why aren’t you a nurse, then?”

“Well, because I am a mother instead, and so I have children of my own to nurse.”

Anna (thoughtfully): “Shall I be a different woman from you? Shall I live in a different place? Shall I still talk with you?”

[17] The mother’s answer again shows where the child’s question was leading.⁵ Anna would obviously like to have a child to nurse, just as the nurse has. Where the nurse got the child from is quite clear, and Anna could get a child in the same way when she grew up. Why then wasn’t Mama such a nurse—that is, how did she get the child if she didn’t get it in the same way as the nurse? Anna could get a child just as the nurse had done, but how all that was going to be different in the future, or rather how she was going to be like her mother in the matter of getting children, was not so easy to see. Hence the thoughtful question “Shall I be a different woman from you?” Shall I be different in every way? The stork theory is evidently no good, the dying theory no less so, therefore one gets a child as the nurse, for example, got hers. In this natural way she, too, could get one; but how about the mother, who is no nurse and yet has children? Looking at the matter from this angle, Anna asks, “Why aren’t you a nurse?”—meaning: why haven’t you got your child in the plain, straightforward, natural way? This strangely indirect mode of interrogation is typical and may be connected with the child’s hazy grasp of the problem, unless we are to assume a certain “diplomatic vagueness” prompted by a desire to evade direct questioning. Later we shall find evidence of this possibility.

[18] Anna is therefore confronted with the question “Where does the child come from?” The stork did not bring it; Mama did not die; nor did Mama get it in the same way as the nurse. She has, however, asked this question before and was informed by her father that the stork brings children; but this is definitely not so, she has never been deceived on this point. Therefore Papa and Mama and all the others lie. This readily explains her mistrustful attitude at the birth and the reproaches levelled against her mother. But it also explains another point, namely the elegiac reveries which we have attributed to a partial introversion. We now know the real object from which love had to be withdrawn and introverted for lack of an aim: it was withdrawn from the parents who deceived her and refused to tell her the truth. (What can this be which must not be uttered? What goes on here? Such are the parenthetic questions which the child later formulated to herself. Answer: It must be something that needs hushing up, perhaps something dangerous.) Attempts to make the mother talk and to draw out the truth by means of artful questions were futile, so resistance meets with resistance and the introversion of love begins. Naturally the capacity for sublimation in a four-year-old child is still too meagrely developed for it to render more than symptomatic service; hence she has to rely on another compensation, that is, she resorts to one of the already abandoned infantile devices for securing love by force, preferably that of crying and calling the mother at night. This had been diligently practised and exploited during her first year. It now returns

and, in keeping with her age, has become well motivated and equipped with recent impressions.

[19] We should mention that the Messina earthquake had just occurred, and this event was much discussed at table. Anna was extraordinarily interested in everything to do with it, getting her grandmother to tell her over and over again how the earth shook and the houses tumbled down and how many people lost their lives. That was the beginning of her nocturnal fears; she could not be left alone, her mother had to go to her and stay with her, otherwise she was afraid that the earthquake would come and the house fall in and kill her. By day, too, she was intensely occupied with such thoughts; when out walking with her mother she would pester her with such questions as “Will the house be standing when we get home? Will Papa still be alive? Are you sure there’s no earthquake at home?” At every stone in the road she would ask whether it was from the earthquake. A house under construction was a house destroyed by the earthquake, and so on. Finally she used to cry out at night that the earthquake was coming, she could hear it rumbling. Every evening she had to be solemnly promised that no earthquake would come. Various ways of calming her were tried, for instance she was told that earthquakes only occur where there are volcanoes. But then she had to be satisfied that the mountains surrounding the town were not volcanoes. This reasoning gradually led the child to an intense and, at her age, unnatural craving for knowledge, until finally all the geological pictures and atlases had to be fetched from her father’s library. For hours she would rummage through them looking for pictures of volcanoes and earthquakes, and asking endless questions.

[20] We see here an energetic attempt being made to sublimate fear into a desire for knowledge, which strikes us as decidedly premature at this age. But how many gifted children, suffering from exactly the same problem, do we not see being spoon-fed on this untimely sublimation, and by no means to their advantage. For if one fosters sublimation at this age one is only strengthening a neurosis. The root of the child’s desire for knowledge is fear, and the fear is the expression of converted libido, that is, of an introversion that has become neurotic and is neither necessary nor favourable to the development of the child at this age. Where this desire for knowledge is ultimately leading is made clear by a series of questions which arose almost daily: “Why is Sophie [a younger sister] younger than I? Where was Freddie [her little brother] before? Was he in heaven and what was he doing there? Why did he only come down now, why not before?”

[21] Such being the state of affairs, the father decided that the mother ought to tell the child the truth about her little brother at the first favourable opportunity.

[22] This presented itself when, soon afterwards, Anna again inquired about the stork. Her mother told her that the story of the stork was not true, but that Freddie grew

inside his mother as the flower grows out of the earth. At first he was very little, and then he grew bigger and bigger like a plant. The child listened attentively without the least surprise and then asked:

“But did he come all by himself?”

“Yes.”

“But he can’t walk yet!”

Sophie: “Then he crawled out.”

Anna (overhearing Sophie’s remark): “Is there a hole here” —pointing to her chest —“or did he come out of the mouth? Who came out of the nurse?”

[23] At this point she interrupted herself and exclaimed, “No, I know the stork brought him down from heaven!” Then, before the mother could answer her questions, she dropped the subject and again asked to see pictures of volcanoes. The evening following this conversation was calm. The sudden explanation had evidently produced in the child a whole chain of ideas, which announced themselves in a spate of questions. New and unexpected vistas were opened, and she rapidly approached the main problem: “Where did the baby come out? Was it from a hole in the chest or from the mouth?” Both suppositions qualify as acceptable theories. We even meet with young married women who still entertain the theory of the hole in the abdominal wall or of Caesarean section; this is supposed to betray a very unusual degree of innocence. As a matter of fact it is not innocence; in such cases we are practically always dealing with infantile sexual activities which in later life have brought the *vias naturales* into ill repute.

[23a] It may be asked where the child got the absurd idea that there is a hole in the chest, or that the birth takes place through the mouth. Why did she not pick on one of the natural openings in the pelvis, from which things come out daily? The explanation is simple. It was not so very long since our little one had challenged all the educative arts of her mother by her heightened interest in both these openings and their remarkable products—an interest not always in accord with the demands of cleanliness and decorum. Then for the first time she became acquainted with the exceptional laws relating to these bodily regions and, being a sensitive child, she soon noticed that there was something taboo about them. Consequently this region had to be left out of her calculations, a trivial error of thought which may be forgiven in a child when one considers all those people who, despite the most powerful spectacles, can never see anything sexual anywhere. In this matter Anna reacted far more docilely than her little sister, whose scatological interests and achievements were certainly phenomenal and who even misbehaved in that way at table. She invariably described her excesses as “funny,” but Mama said no, it was not funny, and forbade such fun. The child seemed to take these incomprehensible educational sallies in good part, but she soon had her revenge. Once when a new

dish appeared on the table she categorically refused to have anything to do with it, remarking that it was “not funny.” Thereafter all culinary novelties were declined on the ground that they were “not funny.”

[24] The psychology of this negativism is quite typical and is not hard to fathom. The logic of feeling says simply: “If you don’t find my little tricks funny and make me give them up, then I won’t find your tricks funny either, and won’t play with you.” Like all childish compensations of this kind, this works on the important infantile principle “It serves you right when I’m hurt.”

[25] After this digression, let us return to our theme. Anna had merely shown herself docile and had so adjusted herself to the cultural demands that she thought (or at least spoke) of the simplest things last. The incorrect theories that have been substituted for the correct ones sometimes persist for years, until brusque enlightenment comes from without. It is therefore no wonder that such theories, the formation of and adherence to which is favoured even by parents and educationists, should later become determinants of important symptoms in a neurosis, or of delusions in a psychosis, as I have shown in my “Psychology of Dementia Praecox.”⁶ Things that have existed in the psyche for years always remain somewhere, even though they may be hidden under compensations of a seemingly different nature.

[26] But even before the question is settled as to where the child actually comes out a new problem obtrudes itself: children come out of Mama, but how about the nurse? Did someone come out of her too? Then follows the abrupt exclamation, “No, I know the stork brought him down from heaven!” What is there so peculiar about the fact that nobody came out of the nurse? We recall that Anna has identified herself with the nurse and plans to become a nurse later, for she too would like to have a child, and she could get one just as easily as the nurse had done. But now, when it is known that little brother grew in Mama, what is to be done?

[27] This disquieting question is averted by a quick return to the stork-angel theory, which had never really been believed and which after a few trials is definitely abandoned. Two questions, however, remain in the air. The first is: where does the child come out? and the second, a considerably more difficult one: how is it that Mama has children while the nurse and the servants do not? Neither question is asked for the time being.

[28] The next day at lunch, Anna announced, apparently out of the blue, “My brother is in Italy and has a house made of cloth and glass and it doesn’t fall down.”

[29] Here as always it was impossible to ask for an explanation; the resistances were too great, and Anna would not have let herself be pinned down. This unique and rather officious announcement is very significant. For some three months the children had been spinning a stereotyped fantasy of a “big brother” who knew

everything, could do everything, and had everything. He had been to all the places where they had not been, was allowed to do all the things they were not allowed to do, was the owner of enormous cows, horses, sheep, dogs, etc.⁷ Each of them had such a big brother. The source of this fantasy is not far to seek: its model is the father, who seems to be rather like a brother to Mama. So the children too must have an equally powerful brother. This brother is very brave, he is at present in dangerous Italy and lives in an impossibly fragile house which does not fall down. For the child this is an important wish-fulfilment: the earthquake is no longer dangerous. In consequence the fear and anxiety were banished and did not return. The fear of earthquakes now entirely disappeared. Instead of calling her father to her bedside every evening to conjure away the fear, she now became more affectionate and begged him to kiss her good night. In order to test this new state of affairs, the father showed her more pictures of volcanoes and earthquakes, but Anna remained indifferent and examined the pictures coldly: "Dead people! I've seen all that before." Even the photograph of a volcanic eruption no longer held any attractions for her. Thus all her scientific interest collapsed and vanished as suddenly as it had come. However, during the days that followed her enlightenment Anna had more important matters to attend to, for she had her newly found knowledge to disseminate among her circle of acquaintances. She began by recounting, at great length, how Freddie had grown in Mama, and herself and her younger sister likewise; how Papa grew in *his* mother and Mama in *her* mother, and the servants in their respective mothers. By dint of numerous questions she also tested whether her knowledge was firmly founded in truth, for her suspicions had been aroused in no small degree, so that repeated corroboration was needed to dissipate all her misgivings. In between times the children brought up the stork-angel theory again, but in a less believing tone, and even lectured the dolls in a singsong voice.

[30] The new knowledge, however, obviously held its ground, for the phobia did not return.

[31] Only once did her certainty threaten to go to pieces. About a week after the enlightenment her father had to spend the morning in bed with an attack of influenza. The children knew nothing of this, and Anna, coming into her parents' bedroom, saw the unexpected sight of her father lying in bed. She made an oddly surprised face, remained standing far away from the bed, and would not come nearer, evidently feeling shy and mistrustful again. Suddenly she burst out with the question "Why are you in bed? Have you got a plant in your inside too?"

[32] Naturally her father had to laugh, and assured her that children never grew in their fathers, that as a matter of fact men did not have children, but only women, whereupon the child instantly became friendly again. But though the surface was

calm the problems went on working in the depths. A few days later Anna again announced at lunch, “I had a dream last night about Noah’s Ark.” The father then asked her what she had dreamed, to which Anna only let out a stream of nonsense. In such cases one must simply wait and pay attention. Sure enough, after a few minutes Anna said to her grandmother, “I had a dream last night about Noah’s Ark and there were lots of little animals in it.” Another pause. Then she began the story for the third time: “*I had a dream last night about Noah’s Ark and there were lots of little animals in it and underneath there was a lid which opened and all the little animals fell out.*” Knowledgeable persons will understand the fantasy. The children really did have a Noah’s Ark, but the opening, a lid, was in the roof and not underneath. This is a delicate hint that the story about children being born from the mouth or chest was wrong, and that she had a pretty good idea of where they did come out—namely, from underneath.

[33] Several weeks now passed without any noteworthy occurrences. There was one dream: “*I dreamt about Papa and Mama, they were sitting up late in the study and we children were there too.*”

[34] On the face of it this is just the well-known wish of children to be allowed to stay up as long as the parents. This wish is here realized, or rather it is used to mask a much more important wish, the wish to be present in the evenings when the parents are alone, and—naturally and innocently enough—in the *study* where she had seen all those interesting books and had satisfied her thirst for knowledge. In other words, she was really seeking an answer to the burning question of where little brother came from. If the children were there they would find out.

[35] A few days later Anna had a nightmare, from which she awoke screaming, “The earthquake is coming, the house is beginning to shake!” Her mother went to her and comforted her, saying that there was no earthquake, everything was quiet and everybody was asleep. Then Anna said in an urgent tone, “I’d just like to see the spring, how all the little flowers come out and how all the fields are full of flowers; I want to see Freddie, he has such a dear little face. What is Papa doing—what did he say?” Her mother told her he was asleep and hadn’t said anything. Anna then remarked, with a sarcastic smile, “He will probably be sick again in the morning!”

[36] This text must be read backwards. The last sentence is not intended seriously, as it was uttered in a sarcastic tone of voice. The last time father was sick Anna suspected him of having “a plant in his inside.” The sarcasm therefore means “He will probably have a child in the morning!” But this is not intended seriously, for Papa cannot have a child, only Mama has children; perhaps she will have another tomorrow, but where from? “What is Papa doing?” Here we have an unmistakable formulation of the difficult problem: what does Papa do if he does not produce children? Anna would very much like to find the clue to all her problems; she would

like to know how Freddie came into the world, she would like to see how the flowers come out of the earth in the spring, and these wishes all hide behind her fear of earthquakes.

[37] After this intermezzo Anna slept peacefully until morning. In the morning her mother asked her what was the matter with her last night. Anna had forgotten everything and thought she had only had a dream: “*I dreamt I could make the summer and then someone threw a golliwog down the toilet.*”

[38] This singular dream is made up of two different scenes, which are separated by the word “then.” The second part derives its material from a recent wish to have a golliwog, i.e., to have a masculine doll just as Mama has a little boy. Someone throws the golliwog down the toilet—but usually one lets quite other things drop down the toilet. The inference is that children come out just like the things into the toilet. Here we have an analogy to the *Lumpf*-theory of Little Hans. Whenever several scenes are found in one dream, each scene ordinarily represents a special variation of the working out of the complex. Thus the first part is only a variation of the theme found in the second part. We have noted above what is meant by “seeing the spring” or “seeing the flowers come out.” Anna now dreams that she *can make the summer*, i.e., can cause the flowers to come out; she herself can make a little child, and the second part of the dream represents this as analogous to the making of a motion. Here we put our finger on the egoistic wish which lies behind the seemingly objective interest of the previous night’s conversation.

[39] A few days later the mother received a visit from a lady who was looking forward to her confinement. The children apparently noticed nothing. But the next day they amused themselves, under the guidance of the elder girl, by taking all the old newspapers out of their father’s waste-paper basket and stuffing them under their frocks in front, so that the imitation was unmistakable. That night Anna again had a dream: “*I dreamt about a lady in the town, she had a very fat stomach.*” As the chief actor in a dream is always the dreamer himself under a definite aspect, the game of the day before finds complete interpretation,

[40] Not long after, Anna surprised her mother with the following performance: she stuck her doll under her clothes and slowly pulled it out head downwards, saying, “Look, the baby is coming out, now it is all out.” Anna was telling her mother: thus I conceive the problem of birth. What do you think of it? is it right? The game is really meant as a question, for, as we shall see later, this conception still had to be officially confirmed.

[41] Rumination on the problem by no means ended here, as is apparent from the ideas Anna conceived during the following weeks. Thus she repeated the same game a few days later with her Teddy bear, which had the function of a specially beloved doll. Another day, pointing to a rose, she said to her grandmother, “Look, the rose is

getting a baby.” As the grandmother did not quite take her meaning, the child pointed to the swollen calyx: “Don’t you see, it’s all fat here!”

[42] One day she was quarrelling with her younger sister, when the latter exclaimed angrily, “I’ll kill you!” Whereupon Anna replied, “When I am dead you will be all alone, and then you’ll have to pray to God for a live baby.” And immediately the scene changed: Anna was the angel, and the younger sister had to kneel down before her and beg her to send a living child. In this way Anna became the child-giving mother.

[43] Once they had oranges for supper. Anna impatiently asked for one and said, “I’ll take an orange and I’ll swallow it all down into my stomach, and then I shall get a baby.”

[44] This instantly reminds us of the fairytales in which childless women finally make themselves pregnant by swallowing fruit, fish and the like.⁸ Anna was here trying to solve the problem of how children actually get into the mother. In so doing she takes up a position of inquiry which had never been formulated before so precisely. The solution follows in the form of an analogy, which is characteristic of the archaic thinking of the child. (Thinking in analogies is also found in the adult, in the stratum lying immediately below consciousness. Dreams bring the analogies to the surface, as also does dementia praecox.) In German and numerous other foreign fairytales one frequently finds such childish comparisons. Fairytales seem to be the myths of childhood and they therefore contain among other things the mythology which children weave for themselves concerning sexual processes. The poetry of fairytale, whose magic is felt even by the adult, rests not least upon the fact that some of the old theories are still alive in our unconscious. We experience a strange and mysterious feeling whenever a fragment of our remotest youth stirs into life again, not actually reaching consciousness, but merely shedding a reflection of its emotional intensity on the conscious mind.

[45] The problem of how the child gets into the mother is a difficult one to solve. As the only way of getting things into the body is through the mouth, it stands to reason that the mother ate something like a fruit, which then grew inside her. But here another difficulty presents itself: one knows what comes out of the mother, but what is the use of the father? Now, it is an old rule of the mental economy to connect two unknowns and to use one to solve the other.

[46] Hence the conviction rapidly fastened on the child that the father is somehow involved in the whole business, particularly in view of the fact that the problem of where children come from still leaves the question open of how they get into the mother.

[47] What does the father do? This question occupied Anna to the exclusion of all else. One morning she ran into her parents’ bedroom while they were still dressing,

jumped into her father's bed, lay flat on her face, and flailed with her legs, crying out, "Look, is that what Papa does?" Her parents laughed and did not answer, as it only dawned on them afterwards what this performance probably signified. The analogy with the horse of Little Hans, which made such a commotion with its legs, is surprisingly close.

[48] Here, with this latest achievement, the matter seemed to rest; at any rate the parents found no opportunity to make any pertinent observations. That the problem should come to a standstill at this point is not really surprising, for this is the most difficult part. The child knows nothing about sperms and nothing about coitus. There is but one possibility: the mother must eat something, for only in that way can anything get into the body. But what does the father do? The frequent comparisons with the nurse and other unmarried people were obviously to some purpose. Anna was bound to conclude that the existence of the father was in some way significant. But what on earth does he do? Anna and Little Hans are agreed that it must have something to do with the legs.

[49] This standstill lasted about five months, during which time no phobias or any other signs of a working through of the complex appeared. Then came the first premonition of future events. Anna's family were at that time living in a country house near a lake, where the children could bathe with their mother. As Anna was afraid to go more than knee-deep into the water, her father once took her right in with him, which led to a great outburst of crying. That evening, when going to bed, Anna said to her mother, "Papa wanted to drown me, didn't he?"

[50] A few days later there was another outburst. She had continued to stand in the gardener's way until finally, for a joke, he picked her up and put her in a hole he had just dug. Anna started to cry miserably, and declared afterwards that the man had tried to bury her.

[51] The upshot was that Anna woke up one night with fearful screams. Her mother went to her in the adjoining room and quieted her. Anna had dreamed that "*a train went by overhead and fell down.*"

[52] Here we have a parallel to the "stage coach" story of Little Hans. These incidents show clearly enough that fear was again in the air, i.e., that there was some obstacle preventing the transference of love to the parents and that therefore a large part of it was converted into fear. This time the mistrust was directed not against the mother, but against the father, who she was sure must know the secret, but would never let anything out. What could the father be doing or keeping up his sleeve? To the child this secret appeared to be something very dangerous, so obviously she felt that the worst might be expected of the father. (This childish fear of the father is to be seen particularly clearly in adults in cases of dementia praecox, which takes the lid off many unconscious processes as though it were acting on psychoanalytical

principles.) Hence Anna arrived at the apparently nonsensical notion that her father wanted to drown her.

[53] Meanwhile Anna had grown a little older and her interest in her father took on a special tinge which is rather hard to describe. Language has no words for the peculiar kind of tender curiosity that shone in the child's eyes.

[54] It is probably no accident that the children began playing a pretty game about this time. They called the two biggest dolls their "grandmothers" and played at hospital with them, a tool-shed being taken over as a hospital. There the grandmothers were brought, interned, and left to sit overnight. "Grandmother" in this connection is distinctly reminiscent of the "big brother" earlier. It seems very likely that the "grandmother" deputizes for the mother. So the children were already conspiring to get the mother out of the way.⁹ This intention was assisted by the fact that the mother had again given Anna cause for displeasure.

[55] It came about in the following way: The gardener had laid out a large bed which he was sowing with grass. Anna helped him in this work with much pleasure, apparently without guessing the profound significance of her childish play. About a fortnight later she began to observe with delight the young grass sprouting. On one of these occasions she went to her mother and asked, "How did the eyes grow into the head?"

[56] Her mother told her she didn't know. But Anna went on to ask whether God knew, or her father, and why God and her father knew everything? The mother then referred her to her father, who might be able to tell her how the eyes grew into the head. Some days later there was a family gathering at tea. After the meal had broken up, the father remained at the table reading the paper, and Anna also stayed behind. Suddenly approaching her father she said, "Tell me, how did the eyes grow into the head?"

Father: "They did not grow into the head; they were there from the beginning and grew with the head."

Anna: "Weren't the eyes planted?"

Father: "No, they just grew in the head like the nose."

Anna: "But did the mouth and the ears grow like that? And the hair?"

Father: "Yes, they all grew the same way."

Anna: "Even the hair? But the baby mice come into the world all naked. Where was the hair before? Aren't there little seeds for it?"

Father: "No. The hair, you see, comes out of little granules which are like seeds, but they are already in the skin and nobody sowed them there."

[57] The father was now getting into a fix. He guessed where the little one was leading him, therefore he did not want to upset, on account of a single false application, the

diplomatically introduced seed theory which she had most fortunately picked up from nature; for the child spoke with an unwonted earnestness which compelled consideration.

[58] Anna (visibly disappointed, and in a distressed voice): “But how did Freddie get into Mama? Who stuck him in? And who stuck you into your mama? Where did he come out?”

[59] From this sudden storm of questions the father chose the last for his first answer:

“Think, now, you know that Freddie is a boy; boys grow into men and girls into women, and only women can have children. Now, just think, where could Freddie have come out?”

Anna (laughing joyfully and pointing to her genitals): “Did he come out here?”

Father: “But of course. Surely you must have thought of that before?”

Anna (overlooking the question): “But how did Freddie get into Mama? Did anybody plant him? Was the seed sown?”

[60] This extremely precise question could no longer be evaded by the father. He explained to the child, who listened with the greatest attention, that the mother is like the soil and the father like the gardener; that the father provides the seed which grows in the mother and thus produces a baby. This answer gave her extraordinary satisfaction; she immediately ran to her mother and said, “Papa has told me everything, now I know it all.” But what it was she knew, she never told to anyone.

[61] The new knowledge was, however, put into practice the following day. Anna went up to her mother and said brightly: “Just think, Mama, Papa told me that Freddie was a little angel and was brought down from heaven by the stork.” Her mother was naturally astounded, and said, “I am quite certain your father never told you anything of the sort.” Whereupon the little one skipped away laughing.

[62] This was her revenge. Her mother evidently would not or could not tell her how the eyes grew into the head; she didn't even know how Freddie had got into her. Therefore she could easily be led up the garden path with that old story about the stork. She might believe it still.

* * *

[63] The child was now satisfied, for her knowledge had been enriched and a difficult problem solved. An even greater advantage, however, was the fact that she had won a more intimate relationship with her father, which did not prejudice her intellectual independence in the least. The father of course was left with an uneasy feeling, for he was not altogether happy about having passed on to a four-and-a-half-year-old child a secret which other parents carefully guard. He was disquieted by the thought of what Anna might do with her knowledge. What if she was indiscreet and exploited it? She might so easily instruct her playmates or gleefully play the *enfant*

terrible with grown-ups. But these fears proved to be groundless. Anna never breathed a word about it, either then or at any time. The enlightenment had, moreover, brought a complete silencing of the problem, so that no more questions presented themselves. Yet the unconscious did not lose sight of the riddle of human creation. A few weeks after her enlightenment Anna recounted the following dream: *She was “in the garden and several gardeners stood making wee-wee against the trees, and Papa was also doing it.”*

[64] This recalls the earlier unsolved problem: what does the father do?

[65] Also about this time a carpenter came into the house in order to repair an ill-fitting cupboard; Anna stood by and watched him planing the wood. That night she dreamt that the carpenter “planed off” her genitals.

[66] The dream could be interpreted to mean that Anna was asking herself: will it work with me? oughtn't one to do something like what the carpenter did, in order to make it work? Such an hypothesis would indicate that this problem is particularly active in the unconscious at the moment, because there is something not quite clear about it. That this is so was shown by the next incident, which did not, however, occur until several months later, when Anna was approaching her fifth birthday. Meantime the younger sister, Sophie, was taking a growing interest in these matters. She had been present when Anna received enlightenment at the time of the earthquake phobia, and had even thrown in an apparently understanding remark on that occasion, as the reader may remember. But in actual fact the explanation was not understood by her at the time. This became clear soon afterwards. She had days when she was more than usually affectionate with her mother and never left her skirts; but she could also be really naughty and irritable. On one of these bad days she tried to tip her little brother out of the pram. Her mother scolded her, whereupon she set up a loud wailing. Suddenly, in the midst of her tears, she said, “I don't know anything about where children come from!” She was then given the same explanation that her elder sister had received earlier. This seemed to allay the problem for her, and for several months there was peace. Then once more there were days when she was whining and bad-tempered. One day, quite out of the blue, she turned to her mother with the question “Was Freddie really in your inside?”

Mother: “Yes.”

Sophie: “Did you push him out?”

Mother: “Yes.”

Anna (butting in): “But was it down below?”

[67] Here Anna employed a childish term which is used for the genitals as well as for the anus.

Sophie: “And then you let him drop down?”

[68] The expression “drop down” comes from that toilet mechanism, of such absorbing interest to children, whereby one lets the excreta drop down into the bowl.

Anna: “Or was he sicked up?”

[69] The evening before, Anna had been sick owing to a slightly upset stomach.

[70] After a pause of several months Sophie had suddenly caught up and now wished to make sure of the explanation previously vouchsafed to her. This making doubly sure seems to indicate that doubts had arisen concerning the explanation given by her mother. To judge by the content of the questions, the doubts arose because the process of birth had not been adequately explained. “Push” is a word children sometimes use for the act of defecation. It tells us along what lines the theory will develop with Sophie, too. Her further remark, as to whether one had let Freddie “drop down,” betrays such a complete identification of her baby brother with excrement that it borders on the ludicrous. To this Anna makes the singular remark that perhaps Freddie was “sicked up.” Her own vomiting of the day before had made a deep impression on her. It was the first time she had been sick since her earliest childhood. That was one way in which things could leave the body, though she had obviously not given it serious thought until now. (Only once had it occurred to her, and that was when they were discussing the body openings and she had thought of the mouth.) Her remark is a firm pointer away from the excrement theory. Why did she not point at once to the genitals? Her last dream gives us a clue to the probable reasons: there is something about the genitals which Anna still does not understand; something or other has to be done there to make it “work.” Maybe it wasn’t the genitals at all; maybe the seed for little children got into the body through the mouth, like food, and the child came out like “sick.”

[71] The detailed mechanism of birth, therefore, was still puzzling. Anna was again told by her mother that the child really does come out down below. About a month later, Anna suddenly had the following dream: *“I dreamt I was in the bedroom of Uncle and Auntie. Both of them were in bed. I pulled the bedclothes off Uncle, lay on his stomach, and joggled up and down on it.”*

[72] This dream came like a bolt from the blue. The children were then on holiday for several weeks and the father, who had been detained in town on business, had arrived on that same day for a visit. Anna was especially affectionate with him. He asked her jokingly, “Will you travel up to town with me this evening?” Anna: “Yes, and then I can sleep with you?” All this time she hung lovingly on her father’s arm as her mother sometimes did. A few moments later she brought out her dream. Some days previously she had been staying as a guest with the aunt mentioned in the dream (the dream, too, was some days old). She had looked forward particularly to that visit, because she was certain she would meet two small cousins—boys—in whom she showed an unfeigned interest. Unfortunately, the cousins were not there,

and Anna was very disappointed. There must have been something in her present situation that was related to the content of the dream for it to be remembered so suddenly. The relation between the manifest content and the conversation with her father is clear enough. The uncle was a decrepit old gentleman and only known to the child from a few rare encounters. In the dream he is patently a substitute for her father. The dream itself creates a substitute for the disappointment of the day before: she is in bed with her father. Here we have the *tertium comparationis* with the present. Hence the sudden remembrance of the dream. The dream recapitulates a game which Anna often played in her father's (empty) bed, the game of joggling about and kicking with her legs on the mattress. From this game stemmed the question "Is this what Papa does?" Her immediate disappointment is that her father answered her question with the words, "You can sleep by yourself in the next room." Then follows the remembrance of the same dream which has already consoled her for a previous erotic disappointment (with the cousins). At the same time the dream is essentially an illustration of the theory that "it" takes place in bed, and by means of the aforementioned rhythmical movements. Whether the remark that she lay on her uncle's stomach had anything to do with her being sick cannot be proved.

[73] Such is the extent of our observations up to the present. Anna is now a little over five years old and already in possession, as we have seen, of a number of the most important sexual facts. Any adverse effect of this knowledge upon her morals and character has yet to be observed. Of the favourable therapeutic effect we have spoken already. It is also quite clear from the report that the younger sister is in need of a special explanation for herself, as and when the problem arises for her. If the time is not ripe, no amount of enlightenment, it would seem, is of the slightest use.

[74] I am no apostle of sex education for schoolchildren, or indeed of any standardized mechanical explanations. I am therefore not in a position to offer any positive and uniformly valid advice. I can only draw one conclusion from the material here recorded, which is, that we should try to see children as they really are, and not as we would wish them; that, in educating them, we should follow the natural path of development, and eschew dead prescriptions.

Supplement

[75] As already mentioned in the foreword, our views have undergone a considerable change since this paper was first published. There is, in the observations, one point in particular which has not been sufficiently appreciated, namely the fact that again and again, despite the enlightenment they received, the children exhibited a distinct preference for some fantastic explanation. Since the first appearance of the present

work this tendency, contrary to my expectations, has increased: the children continue to favour a fantastic theory. In this matter I have before me a number of incontestable observations, some of them concerning the children of other parents. The four-year-old daughter of one of my friends, for instance, who does not hold with useless secrecy in education, was allowed last year to help her mother decorate the Christmas tree. But this year the child told her mother, "It wasn't right last year. This time I'll not look and you will lock the door with the key."

[76] As a result of this and similar observations, I have been left wondering whether the fantastic or mythological explanation preferred by the child might not, for that very reason, be more suitable than a "scientific" one, which, although factually correct, threatens to clamp down the latch on fantasy for good. In the present instance the latch could be unclamped again, but only because the fantasy brushed "science" aside.

[77] Did their enlightenment harm the children? Nothing of the sort was observed. They developed healthily and normally. The problems they broached apparently sank right into the background, presumably as a result of the manifold external interests arising out of school life, and the like. The fantasy activity was not harmed in the least, nor did it pursue paths that could be described as in any way abnormal. Occasional remarks or observations of a delicate nature were made openly and without secrecy.

[78] I have therefore come to hold the view that the earlier free discussions took the wind out of the children's imagination and thus prevented any secretive fantasy from developing which would have cast a sidelong glance at these things, and would, in consequence, have been nothing but an obstacle to the free development of thinking. The fact that the fantasy activity simply ignored the right explanation seems, in my view, to be an important indication that all freely developing thought has an irresistible need to emancipate itself from the realism of fact and to create a world of its own.

[79] Consequently, however little advisable it is to give children false explanations which would only sow the seeds of mistrust, it is, so it seems to me, no less inadvisable to insist on the acceptance of the right explanation. For the freedom of the mind's development would merely be suppressed through such rigid consistency, and the child forced into a concretism of outlook that would preclude further development. Side by side with the biological, the spiritual, too, has its inviolable rights. It is assuredly no accident that primitive peoples, even in adult life, make the most fantastic assertions about well-known sexual processes, as for instance that coitus has nothing to do with pregnancy.¹⁰ From this it has been concluded that these people do not even know there is such a connection. But more accurate investigation has shown that they know very well that with animals

copulation is followed by pregnancy. Only for human beings is it denied—not *not known*, but flatly *denied*—that this is so, for the simple reason that they prefer a mythological explanation which has freed itself from the trammels of concretism. It is not hard to see that in these facts, so frequently observed among primitives, there lie the beginnings of *abstraction*, which is so very important for culture. We have every reason to suppose that this is also true of the psychology of the child. If certain South American Indians really and truly call themselves red cockatoos and expressly repudiate a figurative interpretation of this fact, this has absolutely nothing to do with any sexual repression on “moral” grounds, but is due to the law of independence inherent in the thinking function and to its emancipation from the concretism of sensuous perceptions. We must assign a separate principle to the thinking function, a principle which coincides with the beginnings of sexuality only in the polyvalent germinal disposition of the very young child. To reduce the origins of thinking to mere sexuality is an undertaking that runs counter to the basic facts of human psychology.



INTRODUCTION TO WICKES'S "ANALYSE DER KINDERSEELE"

INTRODUCTION TO WICKES'S "ANALYSE DER KINDERSEELE"¹

- [80] What this book provides is not theory, but experience. That is just what gives it its special value for anyone really interested in child psychology. We cannot fully understand the psychology of the child or that of the adult if we regard it as the subjective concern of the individual alone, for almost more important than this is his relation to others. Here, at all events, we can begin with the most easily accessible and, practically speaking, the most important part of the psychic life of the child. Children are so deeply involved in the psychological attitude of their parents that it is no wonder that most of the nervous disturbances in childhood can be traced back to a disturbed psychic atmosphere in the home. This book shows, from a series of remarkable examples, just how disastrous the parental influence can be for the child. Probably no father or mother will be able to read these chapters without realizing the devastating truths of this book. *Exempla docent*—example is the best teacher! Once more this proves to be a well-worn yet pitiless truth. It is not a question of good and wise counsels, but solely of deeds, of the actual life of the parents. Nor is it a matter of living in accordance with accepted moral values, for the observance of customs and laws can very easily be a cloak for a lie so subtle that our fellow human beings are unable to detect it. It may help us to escape all criticism, we may even be able to deceive ourselves in the belief of our obvious righteousness. But deep down, below the surface of the average man's conscience, he hears a voice whispering, "There is something not right," no matter how much his rightness is supported by public opinion or by the moral code. Certain instances in this book show very clearly that there exists a terrible law which stands beyond man's morality and his ideas of rightness—a law which cannot be cheated.
- [81] Besides the problem of environmental influence, the book also gives due weight to psychic factors which have more to do with the irrational values of the child than with his rational psychology. The latter can be made the object of scientific research, while the spiritual values, the qualities of the soul, elude purely intellectual treatment. It is no good having sceptical ideas about this—nature does not care a pin for our ideas. If we have to deal with the human soul we can only meet it on its own ground, and we are bound to do so whenever we are confronted with the real and crushing problems of life.
- [82] I am glad the author has not shrunk from opening the door to intellectual criticism. Genuine experience has nothing to fear from objections, whether justified or unjustified, for it always holds the stronger position.

[83] Although this book does not pretend to be “scientific,” it is scientific in a higher sense, because it gives a true picture of the difficulties that actually occur in the upbringing of children. It merits the serious attention of everybody who has anything to do with children, either by vocation or from duty. But it will also be of interest to those who, neither for reasons of duty nor from educational inclination, wish to know more about the beginnings of human consciousness. Even though many of the views and experiences set forth in this book have nothing fundamentally new to offer to the doctor and psychological educator, the curious reader will now and then come upon cases which are strange and will give pause to his critical understanding—cases and facts which the author, with her essentially practical turn of mind, does not pursue in all their complexities and theoretical implications. What is the thoughtful reader to make, for instance, of the puzzling but undeniable fact of the identity of the psychic state of the child with the unconscious of the parents? One is dimly aware here of a region full of incalculable possibilities, a hydra-headed monster of a problem that is as much the concern of the biologist and psychologist as of the philosopher. For anyone acquainted with the psychology of primitives there is an obvious connection between this “identity” and Lévy-Bruhl’s idea of “participation mystique.” Strange to say, there are not a few ethnologists who still kick against this brilliant idea, for which the unfortunate expression “mystique” may have to shoulder no small part of the blame. The word “mystical” has indeed become the abode of all unclean spirits, although it was not meant like that originally, but has been debased by sordid usage. There is nothing “mystical” about identity, any more than there is anything mystical about the metabolism common to mother and embryo. Identity derives essentially from the notorious unconsciousness of the small child. Therein lies the connection with the primitive, for the primitive is as unconscious as a child. Unconsciousness means non-differentiation. There is as yet no clearly differentiated ego, only events which may belong to me or to another. It is sufficient that *somebody* should be affected by them. The extraordinary infectiousness of emotional reactions then makes it certain that everybody in the vicinity will involuntarily be affected. The weaker ego-consciousness is, the less it matters who is affected, and the less the individual is able to guard against it. He could only do that if he could say: you are excited or angry, but I am not, for I am not you. The child is in exactly the same position in the family: he is affected to the same degree and in the same way as the whole group.

[84] For all lovers of theory, the essential fact behind all this is that the things which have the most powerful effect upon children do not come from the conscious state of the parents but from their unconscious background. For the ethically minded person who may be a father or mother this presents an almost frightening problem, because the things we can manipulate more or less, namely consciousness and its

contents, are seen to be ineffectual in comparison with these uncontrollable effects in the background, no matter how hard we may try. One is afflicted with a feeling of extreme moral uncertainty when one takes these unconscious processes with the seriousness they deserve. How are we to protect our children from ourselves, if conscious will and conscious effort are of no avail? There can be no doubt that it is of the utmost value for parents to view their children's symptoms in the light of their own problems and conflicts. It is their duty as parents to do so. Their responsibility in this respect carries with it the obligation to do everything in their power not to lead a life that could harm the children. Generally far too little stress is laid upon how important the conduct of the parents is for the child, because it is not words that count, but deeds. Parents should always be conscious of the fact that they themselves are the principal cause of neurosis in their children.

[85] We must not, however, exaggerate the importance of unconscious effects, even though the mind's love of causes finds dangerous satisfaction in doing precisely this. Nor should we exaggerate the importance of causality in general. Certainly causes exist, but the psyche is not a mechanism that reacts of necessity and in a regular way to a specific stimulus. Here as elsewhere in practical psychology we are constantly coming up against the experience that in a family of several children only one of them will react to the unconscious of the parents with a marked degree of identity, while the others show no such reaction. The specific constitution of the individual plays a part here that is practically decisive. For this reason, the biologically trained psychologist seizes upon the fact of organic heredity and is far more inclined to regard the whole mass of genealogical inheritance as the elucidating factor, rather than the psychic causality of the moment. This standpoint, however satisfying it may be by and large, is unfortunately of little relevance to individual cases because it offers no practical clue to psychological treatment. For it also happens to be true that psychic causality exists between parents and children regardless of all the laws of heredity; in fact, the heredity point of view, although undoubtedly justified, diverts the interest of the educator or therapist away from the practical importance of parental influence to some generalized and more or less fatalistic regard for the dead hand of heredity, from the consequences of which there is no escape.

[86] It would be a very grave omission for parents and educators to ignore psychic causality, just as it would be a fatal mistake to attribute all the blame to this factor alone. In every case both factors have a part to play, without the one excluding the other.

[87] What usually has the strongest psychic effect on the child is the life which the parents (and ancestors too, for we are dealing here with the age-old psychological phenomenon of original sin) have not lived. This statement would be rather too

perfunctory and superficial if we did not add by way of qualification: that part of their lives which *might have been* lived had not certain somewhat threadbare excuses prevented the parents from doing so. To put it bluntly, it is that part of life which they have always shirked, probably by means of a pious lie. That sows the most virulent germs.

[88] Our author's exhortation to clear-eyed self-knowledge is therefore altogether appropriate. The nature of the case must then decide how much of the blame really rests with the parents. One should never forget that it is a question of "original sin," a sin against life and not a contravention of man-made morality, and that the parents must therefore be viewed as children of the grandparents. The curse of the House of Atreus is no empty phrase.

[89] Nor should one fall into the error of thinking that the form or intensity of the child's reaction necessarily depends upon the peculiar nature of the parent's problems. Very often these act as a catalyst and produce effects which could be better explained by heredity than by psychic causality.

[90] The causal significance of parental problems for the psyche of the child would be seriously misunderstood if they were always interpreted in an exaggeratedly personal way as moral problems. More often we seem to be dealing with some fate-like ethos beyond the reach of our conscious judgment. Such things as proletarian inclinations in the scions of noble families, outbursts of criminality in the offspring of the respectable or over-virtuous, a paralysing or impassioned laziness in the children of successful business men, are not just bits of life that have been left deliberately un-lived, but compensations wrought by fate, functions of a natural ethos which casts down the high and mighty and exalts the humble. Against this neither education nor psychotherapy is of any avail. The most they can do, if reasonably applied, is to encourage the child to fulfil the task imposed upon him by the natural ethos. The guilt of the parents is impersonal, and the child should pay for it no less impersonally.

[91] Parental influence only becomes a moral problem in face of conditions which might have been changed by the parents, but were not, either from gross negligence, slothfulness, neurotic anxiety, or soulless conventionality. In this matter a grave responsibility often rests with the parents. And nature has no use for the plea that one "did not know."

[92] Not knowing acts like guilt.

[93] Frances Wickes's book also raises the following problem in the mind of the thoughtful reader:

The psychology of "identity," which precedes ego-consciousness, indicates what the child is by virtue of his parents. But what he is as an individuality distinct from his parents can hardly be explained by the causal relationship to the parents. We

ought rather to say that it is not so much the parents as their ancestors—the grandparents and great-grandparents—who are the true progenitors, and that these explain the individuality of the children far more than the immediate and, so to speak, accidental parents. In the same way the true psychic individuality of the child is something new in respect of the parents and cannot be derived from their psyche. It is a combination of collective factors which are only potentially present in the parental psyche, and are sometimes wholly invisible. Not only the child's body, but his soul, too, proceeds from his ancestry, in so far as it is individually distinct from the collective psyche of mankind.

[94] The child's psyche, prior to the stage of ego-consciousness, is very far from being empty and devoid of content. Scarcely has speech developed when, in next to no time, consciousness is present; and this, with its momentary contents and its memories, exercises an intensive check upon the previous collective contents. That such contents exist in the child who has not yet attained to ego-consciousness is a well-attested fact. The most important evidence in this respect is the dreams of three- and four-year-old children, among which there are some so strikingly mythological and so fraught with meaning that one would take them at once for the dreams of grown-ups, did one not know who the dreamer was. They are the last vestiges of a dwindling collective psyche which dreamingly reiterates the perennial contents of the human soul. From this phase there spring many childish fears and dim, unchildlike premonitions which, rediscovered in later phases of life, form the basis of the belief in reincarnation. But from this sphere also spring those flashes of insight and lucidity which give rise to the proverb: Children and fools speak the truth.

[95] Because of its universal distribution the collective psyche, which is still so close to the small child, perceives not only the background of the parents, but, ranging further afield, the depths of good and evil in the human soul. The unconscious psyche of the child is truly limitless in extent and of incalculable age. Behind the longing to be a child again, or behind the anxiety dreams of children, there is, with all due respect to the parents, more than the joys of the cradle or a bad upbringing.

[96] Primitive peoples often hold the belief that the soul of the child is the incarnation of an ancestral spirit, for which reason it is dangerous to punish children, lest the ancestral spirit be provoked. This belief is only a more concrete formulation of the views I have outlined above.

[97] The infinity of the child's preconscious soul may disappear with it, or it may be preserved. The remnants of the child-soul in the adult are his best and worst qualities; at all events they are the mysterious *spiritus rector* of our weightiest deeds and of our individual destinies, whether we are conscious of it or not. It is they which make kings or pawns of the insignificant figures who move about on the

checker-board of life, turning some poor devil of a casual father into a ferocious tyrant, or a silly goose of an unwilling mother into a goddess of fate. For behind every individual father there stands the primordial image of the Father, and behind the fleeting personal mother the magical figure of the Magna Mater. These archetypes of the collective psyche, whose power is magnified in immortal works of art and in the fiery tenets of religion, are the dominants that rule the preconscious soul of the child and, when projected upon the human parents, lend them a fascination which often assumes monstrous proportions. From that there arises the false aetiology of neurosis which, in Freud, ossified into a system: the Oedipus complex. And that is also why, in the later life of the neurotic, the images of the parents can be criticized, corrected, and reduced to human dimensions, while yet continuing to work like divine agencies. Did the human father really possess this mysterious power, his sons would soon liquidate him or, even better, would refrain from becoming fathers themselves. For what ethical person could possibly bear so gigantic a responsibility? Far better to leave this sovereign power to the gods, with whom it had always rested before man became “enlightened.”



CHILD DEVELOPMENT AND EDUCATION

CHILD DEVELOPMENT AND EDUCATION¹

[98] It is with a certain hesitation that I undertake the task of presenting to you, in a brief lecture, the connection between the findings of analytical psychology and the general problems of education. In the first place, it is a large and extensive field of human experience which cannot possibly be covered in a few pithy sentences. Furthermore, analytical psychology deals with a method and a system of thought neither of which can be assumed to be generally known. Hence their applicability to educational problems is not easily demonstrated. An historical introduction to the way in which this youngest of the psychological sciences has developed is almost indispensable, for it enables us to understand many things which, if we met them today for the first time, would be most difficult to grasp.

[99] Developing out of therapeutic experiences with hypnotism, psychoanalysis, as Freud termed it, became a specific medical technique for investigating the causes of functional, or non-organic, nervous disorders. It was primarily concerned with the sexual origins of these disorders, and its value as a method of therapy was based on the assumption that a permanent curative effect would result from bringing the sexual causes to consciousness. The entire Freudian school still takes this view of psychoanalysis and refuses to recognize any causation of nervous disorders other than the sexual. Although originally subscribing to this method, I have, during the course of years, developed the conception of *analytical psychology*, which lays stress on the fact that psychological investigation along psychoanalytic lines has left the narrow confines of a medical technique, with its restriction to certain theoretical assumptions, and has passed over into the general field of normal psychology. Therefore, when I speak of the connection between analytical psychology and education, I am leaving Freudian analysis out of account. Since the latter is a psychology which deals exclusively with the ramifications of the sexual instinct in the psyche, it would be pertinent to the discussion only if we were dealing exclusively with the sexual psychology of the child. But at the outset I must make it perfectly clear that I in no way support those views which maintain that the relation of the child to the parents, or to his brothers, sisters, comrades, is to be explained simply as the immature beginnings of the sexual function. Those views, surely not unknown to you, are in my opinion premature and one-sided generalizations which have already given rise to the most absurd misinterpretations. When pathological phenomena are present to a degree which would justify a psychological explanation along sexual lines, it is not the child's own psychology that is fundamentally

responsible, but the sexually disturbed psychology of the parents. The mind of the child is extremely susceptible and dependent, and is steeped for a long time in the atmosphere of his parental psychology, only freeing itself from this influence relatively late, if at all.²

100] I will now try to give you some idea of the fundamental viewpoints of analytical psychology which are useful in considering the mind of the child, especially at school age. You must not think that I am in a position to offer you a list of hints for immediate application. All I can do is to provide a deeper insight into the general laws which underlie the psychic development of the child. But I shall be content if, from what I am able to give you, you carry away a sense of the mysterious evolution of the highest human faculties. The great responsibility which devolves upon you as educators of the next generation will prevent you from forming hasty conclusions; for there are certain viewpoints which need to germinate, often for a long time, before they can profitably be put into practice. The deepened psychological knowledge of the teacher should not, as unfortunately sometimes happens, be unloaded directly on the child; rather it should help the teacher to adopt an understanding attitude towards the child's psychic life. This knowledge is definitely for adults, not for children. What *they* are given must always be something elementary, and suited to the immature mind.

101] One of the most important achievements of analytical psychology is undoubtedly the recognition of the biological structure of the mind, but it is not easy to put into a few words something that has taken many years to discover. Therefore if at first I seem to range rather far afield, I do so only in order to bring certain general reflections to bear upon the particular problem of the child-mind.

102] Experimental psychology, represented at its best by the school of Wundt, has, as you know, occupied itself exclusively with the psychology of normal consciousness, as though the mind consisted solely of conscious phenomena. But medical psychology, especially the French school, was soon forced to recognize the existence of unconscious psychic phenomena. We know today that the conscious mind consists only of those ideational complexes which are directly associated with the ego. Those psychic factors which possess only a slight degree of intensity, or those which once had intensity but have lost it again, are "under the threshold," that is, they are subliminal, and belong to the sphere of the unconscious. By virtue of its indefinite extension the unconscious might be compared to the sea, while consciousness is like an island rising out of its midst. This comparison, however, must not be pushed too far; for the relation of conscious to unconscious is essentially different from that of an island to the sea. It is not in any sense a stable relationship, but a ceaseless welling-up, a constant shifting of content; for, like the conscious, the unconscious is never at rest, never stagnant. It lives and works in a

state of perpetual interaction with the conscious. Conscious contents that have lost their intensity, or their actuality, sink into the unconscious, and this we call forgetting. Conversely, out of the unconscious, there rise up new ideas and tendencies which, as they emerge into consciousness, are known to us as fantasies and impulses. The unconscious is the matrix out of which consciousness grows; for consciousness does not enter the world as a finished product, but is the end-result of small beginnings.

103] This development takes place in the child. During the first years of life there is hardly any consciousness, though the existence of psychic processes manifests itself at a very early stage. These processes, however, are not grouped round an organized ego; they have no centre and therefore no continuity, lacking which a conscious personality is impossible. Consequently the child has in our sense no memory, despite the plasticity and susceptibility of its psychic organ. Only when the child begins to say "I" is there any perceptible continuity of consciousness. But in between there are frequent periods of unconsciousness. One can actually see the conscious mind coming into existence through the gradual unification of fragments. This process continues throughout life, but from puberty onwards it becomes slower, and fewer and fewer fragments of the unconscious are added to consciousness. The greatest and most extensive development takes place during the period between birth and the end of psychic puberty, a period that may normally extend, for a man of our climate and race, to the twenty-fifth year. In the case of a woman it usually ends when she is about nineteen or twenty. This development establishes a firm connection between the ego and the previously unconscious psychic processes, thus separating them from their source in the unconscious. In this way the conscious rises out of the unconscious like an island newly risen from the sea. We reinforce this process in children by education and culture. School is in fact a means of strengthening in a purposeful way the integration of consciousness.

104] Now if we were to ask what would happen if there were no schools, and children were left entirely to themselves, we should have to answer that they would remain largely unconscious. What kind of a state would this be? It would be a primitive state, and when such children came of age they would, despite their native intelligence, still remain primitive—savages, in fact, rather like a tribe of intelligent Negroes or Bushmen. They would not necessarily be stupid, but merely intelligent by instinct. They would be ignorant, and therefore unconscious of themselves and the world. Beginning life on a very much lower cultural level, they would differentiate themselves only slightly from the primitive races. This possibility of regression to the primitive stage is explained by the fundamental biogenetic law which holds good not only for the development of the body, but also in all probability for that of the psyche.

105] According to this law the evolution of the species repeats itself in the embryonic development of the individual. Thus, to a certain degree, man in his embryonic life passes through the anatomical forms of primeval times. If the same law holds for the mental development of mankind, it follows that the child develops out of an originally unconscious, animal condition into consciousness, primitive at first, and then slowly becoming more civilized.

106] The condition during the first two or three years of his life, when the child is unconscious of himself, may be compared to the animal state. Just as the child in embryo is practically nothing but a part of the mother's body, and wholly dependent on her, so in early infancy the psyche is to a large extent part of the maternal psyche, and will soon become part of the paternal psyche as well. The prime psychological condition is one of fusion with the psychology of the parents, an individual psychology being only potentially present. Hence it is that the nervous and psychic disorders of children right up to school age depend very largely on disturbances in the psychic world of the parents. All parental difficulties reflect themselves without fail in the psyche of the child, sometimes with pathological results. The dreams of small children often refer more to the parents than to the child itself. Long ago I observed some very curious dreams in early childhood, for instance the first dreams patients could remember. They were "big dreams," and their content was often so very unchildlike that at first I was convinced they could be explained by the psychology of the parents. There was the case of a boy who dreamt out the whole erotic and religious problem of his father. The father could remember no dreams at all, so for some time I analysed the father through the dreams of his eight-year-old son. Eventually the father began to dream himself, and the dreams of the child stopped. Later on I realized that the peculiar dreams of small children are genuine enough, since they contain archetypes which are the cause of their apparently adult character.³

107] A marked change occurs when the child develops consciousness of his ego, a fact which is registered by his referring to himself as "I." This change normally takes place between the third and fifth year, but it may begin earlier. From this moment we can speak of the existence of an individual psyche, though normally the psyche attains relative independence only after puberty. Up till then it has been largely the plaything of instinct and environment. The child who enters school at six is still for the most part the psychic product of his parents, endowed, it is true, with the nucleus of ego-consciousness, but incapable of asserting his unconscious individuality. One is often tempted to interpret children who are peculiar, obstinate, disobedient, or difficult to handle as especially individual or self-willed. This is a mistake. In such cases we should always examine the parental milieu, its psychological conditions and history.⁴ Almost without exception we discover in the parents the only valid

reasons for the child's difficulties. His disquieting peculiarities are far less the expression of his own inner life than a reflection of disturbing influences in the home. If the physician has to deal with nervous disorders in a child of this age, he will have to pay serious attention to the psychic state of the parents; to their problems, the way they live and do not live, the aspirations they have fulfilled or neglected, and to the predominant family atmosphere and the method of education. All these psychic conditions influence a child profoundly. In his early years the child lives in a state of *participation mystique* with his parents. Time and again it can be seen how he reacts immediately to any important developments in the parental psyche. Needless to say both the parents and the child are unconscious of what is going on. The infectious nature of the parents' complexes can be seen from the effect their mannerisms have on their children. Even when they make completely successful efforts to control themselves, so that no adult could detect the least trace of a complex, the children will get wind of it somehow. I remember a very revealing case of three girls who had a *most* devoted mother. When they were approaching puberty they confessed shamefacedly to each other that for years they had suffered from horrible dreams about her. They dreamt of her as a witch or a dangerous animal, and they could not understand it at all, since their mother was so lovely and so utterly devoted to them. Years later the mother became insane, and in her insanity would exhibit a sort of lycanthropy in which she crawled about on all fours and imitated the grunting of pigs, the barking of dogs, and the growling of bears.

107^{a]} This is an expression of primitive identity, from which the individual consciousness frees itself only gradually. In this battle for freedom the school plays a not unimportant part, as it is the first milieu the child finds outside his home. School comrades take the place of brothers and sisters; the teacher, if a man, acts as a substitute for the father, and, if a woman, for the mother. It is important that the teacher should be conscious of the role he is playing. He must not be satisfied with merely pounding the curriculum into the child; he must also influence him through his personality. This latter function is at least as important as the actual teaching, if not more so in certain cases. Though it is a misfortune for a child to have no parents, it is equally dangerous for him to be too closely bound to his family. An excessively strong attachment to the parents is a severe handicap in his later adaptation to the world, for a growing human being is not destined to remain forever the child of his parents. There are, unfortunately, many parents who keep their children infantile because they themselves do not wish to grow old and give up their parental authority and power. In this way they exercise an extremely bad influence over their children, since they deprive them of every opportunity for individual responsibility. These disastrous methods of upbringing result either in dependent personalities, or in men and women who can achieve their independence only by furtive means.

There are other parents, again, who on account of their own weaknesses are not in a position to meet the child with the authority it needs if it is to take its proper place in the world. The teacher, as a personality, is then faced with the delicate task of avoiding repressive authority, while at the same time exercising that just degree of authority which is appropriate to the adult in his dealings with children. This attitude cannot be produced artificially; it can only come about in a natural way when the teacher does his duty as a man and a citizen. He must be an upright and healthy man himself, for good example still remains the best pedagogic method. But it is also true that the very best method avails nothing if its practitioner does not hold his position on his personal merits. It would be different if the only thing that mattered in school life were the methodical teaching of the curriculum. But that is at most only half the meaning of school. The other half is the real psychological education made possible through the personality of the teacher. This education means guiding the child into the larger world and widening the scope of parental training. For however careful the latter is, it can never avoid a certain one-sidedness, as the milieu always remains the same. School, on the other hand, is the first impact of the greater world which the child has to meet, and it ought to help him to free himself progressively from the parental environment. The child naturally brings to the teacher the kind of adaptation he has learned from his father; he projects the father-image upon him, with the added tendency to assimilate the personality of the teacher to the father-image. It is therefore necessary for the teacher to adopt the personal approach, or at any rate to leave the door open for such a contact. If the personal relationship of child to teacher is a good one, it matters very little whether the method of teaching is the most up to date. Success does not depend on the method, any more than it is the exclusive aim of school life to stuff the children's heads with knowledge, but rather to make them real men and women. We need not concern ourselves so much with the amount of specific information a child takes away with him from school; the thing of vital importance is that the school should succeed in freeing the young man from unconscious identity with his family, and should make him properly conscious of himself. Without this consciousness he will never know what he really wants, but will always remain dependent and imitative, with the feeling of being misunderstood and suppressed.

108] In what I have just said I have tried to give you a general picture of the child psyche from the standpoint of analytical psychology; but so far I have remained only on the surface. We can go very much deeper if we apply the methods of investigation used in analytical psychology. The practical application of these would be out of the question for the ordinary teacher, and an amateurish or half-serious use of them is to be severely discouraged, although some knowledge of them on the part of the teacher is certainly desirable. It is by no means desirable, however, that he

should apply them directly to the education of the children. It is his own education that needs them, and this will eventually redound to the good of his pupils.

109] You may perhaps be surprised to hear me speak of the education of the educator, but I must tell you that I am far from thinking that a man's education is completed when he leaves school, even if he has achieved the university grade. There should be not only continuation courses for young people, but continuation schools for adults. At present we educate people only up to the point where they can earn a living and marry; then education ceases altogether, as though a complete mental outfit had been acquired. The solution of all the remaining complicated problems of life is left to the discretion—and ignorance—of the individual. Innumerable ill-advised and unhappy marriages, innumerable professional disappointments, are due solely to this lack of adult education. Vast numbers of men and women thus spend their entire lives in complete ignorance of the most important things. Many childish vices are believed to be ineradicable, largely because they are often found in adults whose education is supposed to be finished, and who are therefore thought to be long past the educable period. There was never a greater mistake. The adult *is* educable, and can respond gratefully to the art of individual education; but naturally his education cannot be conducted along the lines suitable to the child. He has lost the extraordinary plasticity of the child's mind, and has acquired a will of his own, personal convictions, and a more or less definite consciousness of himself, so that he is far less amenable to systematic influence. To this must be added the fact that the child, in his psychic development, passes through the ancestral stages and is only educated up to the modern level of culture and consciousness. The adult, however, stands firmly on this level and feels himself to be the upholder of contemporary culture. He therefore has little inclination to submit to a teacher like a child. As a matter of fact, it is important that he should not submit, otherwise he might easily slip back into a childish state of dependence.

110] The educational method, then, that will best meet the needs of the adult must be indirect rather than direct; that is to say, it must put him in possession of such psychological knowledge as will permit him to educate himself. Such an effort could not and should not be expected from a child, but we can expect it from an adult, especially if he is a teacher. The teacher must not be a merely passive upholder of culture; he must actively promote that culture through his own self-education. His culture must never remain at a standstill, otherwise he will start correcting in the children those faults which he has neglected in himself. This is manifestly the antithesis of education.

111] Analytical psychology has given considerable thought to the methods for aiding the adult in his psychic growth, but if I speak to you about them now, it is for the sole purpose of making clear the possibilities of continued self-education. I must

warn you again most emphatically that it would be very unsound to apply these methods directly to children. The indispensable basis of self-education is self-knowledge. We gain self-knowledge partly from a critical survey and judgment of our own actions, and partly from the criticism of others. Self-criticism, however, is all too prone to personal prejudice, while criticism from others is liable to err or to be otherwise displeasing to us. At all events, the self-knowledge accruing to us from these two sources is incomplete and confused like all human judgments, which are seldom free from the falsifications of desire and fear. But is there not some objective critique which will tell us what we really are, somewhat after the fashion, say, of a thermometer, which confronts the fever patient with the indisputable fact that he has a temperature of exactly 103.1°? Where our bodies are concerned we do not deny the existence of objective criteria. If, for example, we are convinced that we can eat strawberries, like everybody else, without ill effects, and the body nevertheless reacts with a violent rash, this is objective proof that despite our idea to the contrary we are allergic to strawberries.

112] But when it comes to psychology, it seems to us that everything is voluntary and subject to our choice. This universal prejudice arises from our tendency to identify the whole psyche with the conscious phase of it. There are, however, many extremely important psychic processes which are unconscious, or only indirectly conscious. Of the unconscious we can know nothing directly, but indirectly we can perceive the effects that come into consciousness. If everything in consciousness were, as it seems, subject to our will and choice, then we could not discover anywhere an objective criterion by which to test our self-knowledge. Yet there is something independent of desire and fear, something as impersonal as a product of nature, that enables us to know the truth about ourselves. This objective statement is to be found in a product of psychic activity which is the very last thing we would credit with such a meaning, namely the dream.

113] What are dreams? Dreams are products of unconscious psychic activity occurring during sleep. In this condition the mind is to a large extent withdrawn from our voluntary control. With the small portion of consciousness that remains to us in the dream state we apperceive what is going on, but we are no longer in a position to guide the course of psychic events according to our wish and purpose; hence we are also robbed of the possibility of deceiving ourselves. The dream is a spontaneous process resulting from the independent activity of the unconscious, and is as far removed from our conscious control as, shall we say, the physiological activity of digestion. Therefore, we have in it an absolutely objective process from the nature of which we can draw objective conclusions about the situation as it really is.

114] That is all very well, you will say, but how in the world is it possible to draw trustworthy conclusions from the fortuitous and chaotic confusion of a dream? To

this I hasten to reply that dreams are only apparently fortuitous and chaotic. On closer inspection we discover a remarkable sequence in the dream-images, both in relation to one another and in relation to the content of waking consciousness. This discovery was made by means of a relatively simple procedure, which works as follows: The body of the dream is divided into its separate portions or images, and all the free associations to each portion are collected. In doing this, we soon become aware of an extremely intimate connection between the dream-images and the things that occupy our thoughts in the waking state, although the meaning of this connection may not be immediately apparent. By collecting all the associations we complete the preliminary part of the dream analysis, thus establishing the context, which shows the manifold connections of the dream with the contents of consciousness and the intimate way in which it is bound up with the tendencies of the personality.

115] When we have illuminated the dream from all sides we can begin the second part of our task, namely the interpretation of the material before us. Here as everywhere in science, we must rid ourselves of prejudice as far as possible, and let the material speak for itself. In very many cases a single glance at the dream and the assembled material suffices to give us at least an intuition of its meaning, and no special effort of thought is needed to interpret it. In other cases it requires much labour and considerable experience. Unfortunately I cannot enter here into the far-reaching question of dream-symbolism. Massive tomes have been written on this subject, and although in practice we cannot do without the experience stored up in these volumes, there are many cases where sound common sense is enough.

116] By way of illustration I shall now give you a short dream, together with its meaning.

117] The dreamer was a man with an academic education, about fifty years of age. I knew him only slightly, and our occasional meetings consisted mostly of humorous gibes on his part at what we called the "game" of dream interpretation. On one of these occasions he asked me laughingly if I was still at it. I replied that he obviously had a very mistaken idea of the nature of dreams. He then remarked that he had just had a dream which I must interpret for him. I said I would do so, and he told me the following dream:

He was alone in the mountains, and wanted to climb a very high, steep mountain which he could see towering in front of him. At first the ascent was laborious, but then it seemed to him that the higher he climbed the more he felt himself being drawn towards the summit. Faster and faster he climbed, and gradually a sort of ecstasy came over him. He felt he was actually soaring up on wings, and when he reached the top he seemed to weigh nothing at all, and stepped lightly off into empty space. Here he awoke.

118] He wanted to know what I thought of his dream. I knew that he was not only an experienced but an ardent mountain-climber, so I was not surprised to see yet another vindication of the rule that dreams speak the same language as the dreamer. Knowing that mountaineering was such a passion with him, I got him to talk about it. He seized on this eagerly and told me how he loved to go alone without a guide, because the very danger of it had a tremendous fascination for him. He also told me about several dangerous tours, and the daring he displayed made a particular impression on me. I asked myself what it could be that impelled him to seek out such dangerous situations, apparently with an almost morbid enjoyment. Evidently a similar thought occurred to him, for he added, becoming at the same time more serious, that he had no fear of danger, since he thought that death in the mountains would be something very beautiful. This remark threw a significant light on the dream. Obviously he was looking for danger, possibly with the unavowed idea of suicide. But why should he deliberately seek death? There must be some special reason. I therefore threw in the remark that a man in his position ought not to expose himself to such risks. To which he replied very emphatically that he would never “give up his mountains,” that he had to go to them in order to get away from the city and his family. “This sticking at home does not suit me,” he said. Here was a clue to the deeper reason for his passion. I gathered that his marriage was a failure, and that there was nothing to keep him at home. Also he seemed disgusted with his professional work. It occurred to me that his uncanny passion for the mountains must be an avenue of escape from an existence that had become intolerable to him.

119] I therefore privately interpreted the dream as follows: Since he still clung on to life in spite of himself, the ascent of the mountain was at first laborious. But the more he surrendered himself to his passion, the more it lured him on and lent wings to his feet. Finally it lured him completely out of himself: he lost all sense of bodily weight and climbed even higher than the mountain, out into empty space. Obviously this meant death in the mountains.

120] After a pause, he said suddenly, “Well, we’ve talked about all sorts of other things. You were going to interpret my dream. What do you think about it?” I told him quite frankly what I thought, namely that he was seeking his death in the mountains, and that with such an attitude he stood a remarkably good chance of finding it.

121] “But that is absurd,” he replied, laughing. “On the contrary, I am seeking my health in the mountains.”

122] Vainly I tried to make him see the gravity of the situation. Six months later, on the descent from a very dangerous peak, he literally stepped off into space. He fell on the head of a companion who was standing on a ledge below him, and both were killed.⁵

- 123] From this dream we can observe the general function of dreams. It reflects certain vital tendencies of the personality, either those whose meaning embraces our whole life, or those which are momentarily of most importance. The dream presents an objective statement of these tendencies, a statement unconcerned with our conscious wishes and beliefs. After this you will probably agree with me that a dream may in certain circumstances be of inestimable value for conscious life, even when it is not, as here, a matter of life and death.
- 124] How much of moral and practical value this dreamer would have gained if only he had known of his dangerous lack of restraint!
- 125] That is why, as physicians of the soul, we have to turn to the ancient art of dream interpretation. We have to educate adults who are no longer willing, like children, to be guided by authority. We have to do with men and women whose way of life is so individual that no counsellor, however wise, could prescribe the way that is uniquely right for them. Therefore we have to teach them to listen to their own natures, so that they can understand from within themselves what is happening.
- 126] So far as is possible within the limits of a lecture, I have tried to give you some insight into the world of analytical psychology and its ideas. I for my part shall be satisfied if what I have said is of help to you in your profession.

IV

ANALYTICAL PSYCHOLOGY AND EDUCATION

[The following three lectures were delivered at the International Congress of Education, in London in 1924. They were originally drafted in English by the author and revised by Roberts Aldrich. They were then published in German as *Analytische Psychologie und Erziehung* (Heidelberg, 1926), and the English version was subsequently published in *Contributions to Analytical Psychology* (London and New York, 1928) together with the preceding lecture. The present new translation is made from the revised and enlarged edition of *Psychologie und Erziehung* (Zurich, 1946), on the basis of careful comparison between it and the earlier English version.—EDITORS.]

LECTURE ONE

127] Psychology is one of the youngest sciences. The word “psychology” has been in use for a long time, but formerly it was only the title of a certain chapter in philosophy—that chapter in which the philosopher more or less laid down the law as to what the human soul had to be according to the premises of his own particular philosophy. I remember, as a young student, that I used to enjoy the privilege of hearing from one professor how little was known about the real nature of psychic processes, and from another exactly what the psyche had to be as a logical necessity. If one studies the origins of modern empirical psychology one is profoundly impressed by the fight which the earliest investigators had to wage against the firmly entrenched scholastic way of thinking. Philosophic thought, powerfully influenced by theology (“queen of sciences”), had a decidedly deductive tendency, and over it there reigned a mass of naïve, idealistic preconceptions which were bound sooner or later to lead to a reaction. This reaction took the form of the materialism of the nineteenth century, from whose outlook we are not yet completely freed even today. The success of the empirical method is so undeniable that the splendour of its victory has even begotten a materialistic philosophy, which in reality is more a psychological reaction than a justifiable scientific theory. The materialistic outlook is an exaggerated reaction against the medieval idealism and has nothing to do with the empirical method as such.

128] Thus modern empirical psychology was cradled in an atmosphere of rank materialism. It was first and foremost a physiological psychology, thoroughly empirical in its experimental basis, viewing the psychic process exclusively from outside and mainly with an eye to its physiological manifestations. Such a state of affairs was fairly satisfactory so long as psychology was a department of philosophy or of the natural sciences. So long as it was restricted to the laboratory, psychology could remain purely experimental and could regard the psychic process entirely from outside. Instead of the old dogmatic psychology we now had a philosophical psychology no less academic in its origins. However, the peace of the academic laboratory was soon to be disturbed by the demands of those who needed psychology for practical purposes. These intruders were the doctors. The neurologist as well as the psychiatrist has to concern himself with psychic disorders and therefore feels the urgent need of a psychology that can be practically applied. Quite independently of the developments of academic psychology medical men had already discovered a means of access to the human mind and to the psychological treatment of its disorders. This was hypnotism, which grew out of what had been

called “mesmerism” in the latter part of the eighteenth century, and “animal magnetism” at the beginning of the nineteenth. The development of hypnotism led, via Charcot, Liébeault, and Bernheim, to the kind of medical psychology represented by Pierre Janet. Another of Charcot’s pupils, Freud, in Vienna,¹ used the hypnotic method at first very much in the same way as Janet, but he soon struck out on a different path. Whereas Janet remained for the most part descriptive, Freud penetrated further and more deeply into matters which, to the medical science of those days, hardly seemed worth investigating, namely the morbid fantasies of the patient and their activity in the realm of the unconscious mind. It would be unjust to imply that Janet overlooked this; indeed the contrary is the case. It is his great merit to have pointed out the existence and the importance of unconscious processes in the psychological structure of nervous and mental disorders. Freud’s particular merit lies not in the actual discovery of unconscious activity, but in unveiling the real nature of this activity, and above all in working out a practical method for exploring the unconscious. Independently of Freud, I too had approached the problem of a practical psychology firstly from the side of experimental psychopathology, employing chiefly the association method, and then from the study of the personality.² As Freud made the hitherto neglected morbid fantasies of the patient his special field of research,³ so I directed my attention more particularly to the reasons why people made certain mistakes in the course of the association experiment. Like the fantasies of hysterics, the disturbances in the association experiment were regarded as valueless and meaningless, a purely fortuitous phenomenon, in a word, as so much *materia vilis*. I discovered,⁴ however, that these disturbances were due to the operation of unconscious processes which I called “feeling-toned complexes.”⁵ After having, so to speak, put my finger on the same psychological mechanisms as Freud, it was natural that I should become his pupil and collaborator over a period of many years. But while I always recognized the truth of his conclusions so far as the facts were concerned, I could not conceal my doubts as to the validity of his theories. His regrettable dogmatism was the main reason why I felt obliged to part company from him. My scientific conscience would not allow me to lend support to an almost fanatical dogma based on a one-sided interpretation of the facts.

129] Freud’s achievement is by no means inconsiderable. But while he shares with others the discovery of the unconscious in relation to the aetiology and structure of neuroses and psychoses, his great and unique merit, to my mind, lies in his discovery of a method for exploring the unconscious and, more particularly, dreams. He was the first to make the bold attempt to throw open the secret doors of the dream. The discovery that dreams have a meaning, and that there is a way to an understanding of them, is perhaps the most significant and most valuable part of this

remarkable edifice called psychoanalysis. I do not wish to belittle Freud's achievement, but I feel I must be fair to all those who have wrestled with the great problems of medical psychology and who, through their labours, have laid the foundations without which neither Freud nor myself would have been able to accomplish our tasks. Thus Pierre Janet, Auguste Forel, Théodore Flournoy, Morton Prince, Eugen Bleuler, deserve gratitude and remembrance whenever we speak of the first steps of medical psychology.

130] Freud's work has shown that the functional neuroses are causally based on unconscious contents whose nature, when understood, allows us to see how the disease came about. The value of this discovery is as great as the discovery of the specific cause of tuberculosis and other infectious diseases. Moreover, quite apart from the therapeutic importance of analytical psychology, the psychology of the normal has been tremendously enriched, for the understanding of dreams has opened up an almost limitless vista, showing how consciousness develops out of the remotest and darkest depths of the unconscious, while the practical application of the analytical method has enabled us to distinguish typical functions and attitudes in the behaviour of normal individuals. In so far as psychoanalysis is a branch of medical psychology, it concerns itself solely with abnormal cases and should therefore be reserved for the physician; but dream psychology, studied for the light it throws upon normal human behaviour, will be of ever-increasing interest to thoughtful people generally, and especially to those with educational inclinations. It is in fact highly desirable that the educator, if he wishes really to understand the mentality of his pupils, should pay attention to the findings of analytical psychology. That, however, presupposes some knowledge of psychopathology, for the abnormal child is far harder to understand than the normal. Abnormality and disease are not far apart, and just as one expects some knowledge of the physical ailments of children from the all-round educated teacher, so one might expect from him a little knowledge of their psychic ailments.

131] There are five main groups of psychic disturbances in children:

BACKWARD CHILDREN. A common form of backward child is the mental defective, characterized chiefly by low intelligence and a general incapacity to understand.

132] The most obvious type is the phlegmatic, slow, dull-witted, stupid child. Among these cases may be found children who, for all their poverty of intellect, are distinguished by a certain richness of heart, and who are capable of loyalty, affection, devotion, reliability, and self-sacrifice. The less obvious and rarer type is the excitable, easily irritated child, whose mental incapacity is no less indubitable than that of the defective, but is often markedly one-sided.

133] From these congenital and practically incurable, though not ineducable, types we must distinguish the child with arrested mental development. His development is

very slow, at times almost imperceptible, and it often needs the expert diagnosis of a skilled psychiatrist to decide whether it is a case of mental defect or not. Such children frequently have the emotional reactions of imbeciles. I was once consulted about a boy of six years old who suffered from violent fits of rage, during which he used to smash his toys and threaten his parents and his nurse in quite a dangerous way. In addition he “refused to speak,” as his parents put it. He was a little fellow, well-fed, but terribly suspicious, malevolent, obstinate, and altogether negative. It was perfectly obvious that he was an imbecile and simply *could* not speak. He had never learnt how to do so. But his imbecility was not bad enough to account entirely for his inability to speak. His general behaviour pointed to a neurosis. Whenever a young child exhibits the symptoms of a neurosis one should not waste too much time examining his unconscious. One should begin one’s investigations elsewhere, starting with the mother; for almost invariably the parents are either the direct cause of the child’s neurosis or at least the most important element in it. Thus I found that the child was the only boy among seven girls. The mother was an ambitious, self-willed woman, who took it as an insult when I told her that her son was not normal. She had deliberately repressed all knowledge of the boy’s infirmity; he simply *had* to be intelligent, and if he was stupid, it was all due to his evil will and malicious obstinacy. Naturally the boy learnt far less than he would have done had he been lucky enough to possess a reasonable mother; in fact he learnt nothing at all. What is more, he duly became the very things his mother’s own ambition drove him to, namely, malicious and self-willed. Totally misunderstood, and therefore isolated within himself, he developed his fits of rage out of sheer despair. I know of another boy, of fourteen, in much the same family circumstances. He killed his stepfather with an axe during a paroxysm of rage. He too had been pushed too far.

134] Arrested mental development is found not infrequently in first children, or in children whose parents are estranged through psychic incompatibilities. It may also result from the mother’s illness during pregnancy, or from prolonged labour, or from deformation of the skull and hemorrhage during delivery. If such children are not ruined by educational forcing, they normally attain a relative mental maturity in the course of time, though it may be later than with ordinary children.

135] The second group comprises PSYCHOPATHIC CHILDREN. In cases of moral insanity the disorder is either congenital or due to organic injury of parts of the brain by wounding or disease. Such cases are incurable. Occasionally they become criminals and they have in them the seeds of habitual criminality.

136] From this group one must carefully distinguish the child with arrested moral development, the morbidly autoerotic type. These cases often display an alarming amount of egotism and premature sexual activity; in addition they are untruthful and unreliable, and almost completely lacking in human feeling and love. As a rule they

are illegitimate or adopted children who have unfortunately never been warmed and nourished by the psychic atmosphere of a real father and mother. They suffer from an almost organic lack of something that every child needs as a vital necessity, namely the psychically nourishing care of parents, and especially of a mother. As a result, illegitimate children in particular are always exposed to psychic danger, and it is the moral sphere that suffers first and foremost. Many children can adapt to foster parents, but not all; and those who cannot, develop an extremely self-centred and ruthlessly egotistical attitude for the unconscious purpose of getting for themselves what the real parents have failed to give them. Such cases are not always incurable. I once saw a boy who violated his four-year-old sister when he was five, tried to kill his father when he was nine, but at the age of eighteen was developing into satisfactory normality, despite a diagnosis of incurable moral insanity. If the unbridled licentiousness to which such cases are sometimes prone is coupled with a good intelligence, and if there is no irreparable break with society, these patients can give up their criminal tendencies by using their heads. Nevertheless, it is to be observed that reason is a very flimsy barrier against pathological proclivities.

137] The third group consists of EPILEPTIC CHILDREN. These cases are unfortunately not uncommon. It is easy enough to recognize a true epileptic attack, but what is called "petit mal" is an exceedingly obscure and complicated condition. Here there are no obvious attacks, only very peculiar and often hardly perceptible alterations of consciousness, which nevertheless pass over into the severe mental disorder of the epileptic with his irritability ferocity, greediness, his sticky sentimentality, his morbid passion for justice, his egotism, and his narrow range of interests. It is of course impossible to enumerate here all the manifold forms of epilepsy; but, in order to illustrate its symptomatology, I will mention the case of a small boy who began to behave strangely when he was about seven years old. The first thing to be noticed was that he used to disappear abruptly, and was then found hiding in the cellar or in a dark corner of the attic. It was impossible to get him to explain why he ran away so suddenly and hid himself. Sometimes he would leave off playing and bury his face in his mother's skirts. At first these things happened so rarely that no attention was paid to his odd behaviour, but when he began to do the same thing at school, suddenly leaving his desk and running to the teacher, his family became alarmed. Nobody, however, had thought of the possibility of a serious disease. Occasionally, too, he would stop short for a few seconds in the middle of a game, or even in the middle of a sentence, without any explanation and apparently without even knowing that the lapse had occurred. Gradually he developed a rather disagreeable and irritable character. Sometimes he had fits of rage, and on one occasion he threw a pair of scissors at his little sister with such force that the point pierced the bone of the skull just above the eyes, nearly killing her. As the parents did not think of

consulting a psychiatrist, the disease remained unrecognized, and he was treated simply as a bad boy. At the age of twelve he had his first observed epileptic fit, and only then was his disease understood. Despite great difficulties I was able to find out from the boy that when he was about six he began to be seized with terror of some unknown being. When he was alone, he had the feeling that someone unseen was present. Later he came to see a short man with a beard, a man he had never seen before, but whose features he could describe in great detail. This man suddenly appeared before him and frightened him so much that he ran away and hid himself. It was difficult to discover why the man was so terrifying. The boy was obviously upset about something, which he treated as a dreadful secret. It took me hours to win his confidence, but eventually he confessed. "This man tried to make me take something terrible from him. I can't tell you what it was, it was frightful. He came nearer and nearer and kept on insisting that I must take it, but I was so frightened that I always ran away and did not take it." As he said this he turned pale and began to tremble with fear. When at last I succeeded in calming him down, he said, "This man tried to make me take a *sin*." "But what sort of a sin?" I asked. The boy stood up, looked suspiciously all round him, and then whispered, "It was murder." When he was eight years old he had, as I mentioned above, made a violent attack on his sister. Later, the attacks of fear continued, but the vision changed. The terrible man did not return; but in his stead there appeared the figure of a nun, a sort of nurse. At first her face was veiled, but later it was unveiled, revealing a most terrifying expression, a pale, deathlike face. Between the ages of nine and twelve he was haunted by this figure. The fits of rage, despite his growing irritability, ceased, but the manifest epileptic attacks began to appear instead. Clearly, the vision of the nun signified the changing of the incompatible criminal tendency symbolized by the bearded man into obvious disease.⁶

138] Sometimes such cases are still mainly functional and not yet organic, so that it is possible to do something for them with psychotherapy. That is why I have mentioned this case in some detail. It may give some idea of what goes on in the child's mind behind the scenes.

139] The fourth group comprises the various forms of PSYCHOSIS. Although such cases are not common among children, one can find at least the first stages of that pathological mental development which later, after puberty, leads to schizophrenia in all its manifold forms. As a rule these children behave in a strange and even bizarre way; they are incomprehensible, often quite un-get-at-able, hypersensitive, shut in, emotionally abnormal, being either torpid or liable to explode over the most trifling causes.

140] I once had to examine a boy of fourteen in whom sexual activity had begun suddenly and somewhat prematurely in a rather disquieting way, so that it disturbed

his sleep and upset his general health. The trouble began when the boy went to a dance and a certain girl refused to dance with him. He went away in high dudgeon. When he got home he tried to learn his school lessons, but found it was impossible because of a mounting and indescribable emotion compounded of fear, rage, and despair, which took hold of him more and more until at last he rushed out into the garden and rolled on the ground in an almost unconscious condition. After a couple of hours the emotion passed and the sexual trouble began. There were several cases of schizophrenia in this boy's family. This is a typical pathological emotion characteristic of children with a bad family inheritance.

141] The fifth group consists of NEUROTIC CHILDREN. It is of course quite beyond the scope of a single lecture to describe all the symptoms and forms of a childhood neurosis. Anything may be found, ranging from abnormally naughty behaviour to definitely hysterical attacks and states. The trouble can be apparently physical, for instance hysterical fever or abnormally low temperature, convulsions, paralysis, pain, digestive disturbances, etc., or it can be mental and moral, taking the form of excitement or depression, lying, sexual perversion, stealing, and so forth. I remember the case of a little girl of four who had suffered from the most chronic constipation since the first year of her life. She had already undergone every imaginable and unimaginable kind of physical treatment. All were useless, because the doctors overlooked the one important factor in the child's life, namely her mother. As soon as I saw the mother I realized that she was the real cause, and so I suggested treating her and advised her at the same time to give up the child. Another person took the mother's place, and the next day the trouble was gone, and did not return, as I was able to follow up the case for many years afterward. The solution of this problem was quite simple as regards the child, though of course it would not have been so had not the pathogenic influence coming from the mother been removed through analysis. The little girl was a youngest child, the regular pet of a neurotic mother. The latter projected all her phobias onto the child and surrounded her with so much anxious care that she was never free from tension, and such a state is notoriously unfavourable to the peristaltic function.

142] It is my conviction that it is absolutely essential for any teacher who wishes to apply the principles of analytical psychology to have a first-hand knowledge of the psychopathology of childhood and its attendant dangers. Unfortunately, there are certain books on psychoanalysis which give the impression that it is all very simple and that success can be had for the asking. No competent psychiatrist could endorse such superficial notions, and no warning can be too emphatic against unskilled and frivolous attempts to analyse children. There is no doubt that it is of the greatest value to the educator to know what modern psychology has contributed to the understanding of the child mind. But anyone who wishes to apply analytical

methods to children must have thorough knowledge of the pathological conditions he will be called upon to deal with. I must confess that I do not see how anyone, except a responsible physician, can dare to analyse children without special knowledge and medical advice.

143] To analyse children is a most difficult and delicate task. The conditions under which we have to work are altogether different from those governing the analysis of grown-ups. The child has a special psychology. Just as its body during the embryonic period is part of the mother's body, so its mind is for many years part of the parents' mental atmosphere. That explains why so many neuroses of children are more symptoms of the mental condition of the parents than a genuine illness of the child. Only a very little of the child's psychic life is its own; for the most part it is still dependent on that of the parents. Such dependence is normal, and to disturb it is injurious to the natural growth of the child's mind. It is therefore understandable that premature and indelicate enlightenment on the facts of sex can have a disastrous effect on his relations with his parents, and such an effect is almost inevitable if you base your analysis on the dogma that the relations between parents and children are necessarily sexual.

144] It is no less unjustifiable to give the so-called Oedipus complex the status of a prime cause. The Oedipus complex is a symptom. Just as any strong attachment to a person or a thing may be described as a "marriage," and just as the primitive mind can express almost anything by using a sexual metaphor, so the regressive tendency of a child may be described in sexual terms as an "incestuous longing for the mother." But it is no more than a figurative way of speaking. The word "incest" has a definite meaning, and designates a definite thing, and as a general rule can only be applied to an adult who is psychologically incapable of linking his sexuality to its proper object. To apply the same term to the difficulties in the development of a child's consciousness is highly misleading.

145] This is not to say that sexual precocity does not exist. But such cases are distinctly exceptional and abnormal, and there is nothing to justify the doctor in extending the concepts of pathology to the sphere of the normal. Just as it is hardly permissible to call blushing a skin disease, or joy a fit of madness, so cruelty is not necessarily sadism, pleasure is not necessarily lust, and firmness is not necessarily sexual repression.

146] In studying the history of the human mind one is impressed again and again by the fact that its growth keeps pace with a widening range of consciousness, and that each step forward is an extremely painful and laborious achievement. One could almost say that nothing is more hateful to man than to give up the smallest particle of unconsciousness. He has a profound fear of the unknown. Ask anybody who has ever tried to introduce new ideas! If even the allegedly mature man is afraid of the

unknown, why shouldn't the child hesitate also? The *horror novi* is one of the most striking qualities of primitive man. This is a natural enough obstacle, as obstacles go; but excessive attachment to the parents is unnatural and pathological, because a too great fear of the unknown is itself pathological. Hence one should avoid the one-sided conclusion that hesitation in advancing is necessarily due to sexual dependence on the parents. Often it may be simply a *reculer pour mieux sauter*. Even in cases where children do exhibit sexual symptoms—where, in other words, the incestuous tendency is perfectly obvious—I should recommend a careful examination of the parents' psyche. One finds astonishing things, such as a father unconsciously in love with his own daughter, a mother who is unconsciously flirting with her son, imputing under the cover of unconsciousness their own adult emotions to their children, who, again unconsciously, act the parts allotted to them. Children will not of course play these strange and unnatural roles unless unconsciously forced into them by their parents' attitude.

147] I will now describe one such case. There was a family of four children, two daughters and two sons. All four were neurotic. The girls had shown neurotic symptoms since before puberty. I shall avoid unnecessary details, sketching the fate of the family only in broad outline.

148] The elder daughter, when she was twenty, fell in love with an eminently suitable young man of good family and a university education. The marriage, however, was put off for one reason or another, and, as though hypnotized, she started an affair with one of her father's office employees. She seemed to love her fiancé very much, but was so prudish with him that she never allowed him even to kiss her, while she went very far with the other man without the slightest hesitation. She was excessively naïve and childish, and totally unconscious at first of what she was doing. Then, to her unspeakable horror, the full consciousness of it came over her. She broke down completely, and for years she suffered from hysteria. She severed her connection with the employee and also with her fiancé without explaining her conduct to anyone.

149] The second daughter got married, apparently with no difficulties, but to a man below her mental level. She was frigid and remained childless. In less than a year she had fallen so passionately in love with a friend of her husband's that it developed into a long-drawn-out love affair.

150] The elder son, in himself a talented young man, showed the first signs of neurotic indecision when it came to choosing a career. Eventually he decided to study chemistry, but he had no sooner begun than he was overwhelmed with such a homesickness that he left the university and went straight home to mother. There he fell into a peculiar state of mental confusion with hallucinations, and when this state subsided again after about six weeks, he resolved to take up medicine. He actually

went so far as to sit for the examination. Soon afterwards he became engaged. Hardly was the engagement a fact than he began to doubt the rightness of his choice; then came anxiety states and the engagement was broken off. Thereupon he went right off his head and had to be shut up in an asylum for several months.

151] The second son was a psychasthenic neurotic, a woman-hater who seriously planned to remain a bachelor all his life and clung to his mother in the most sentimental way.

152] I was called in to deal with all four children. In each case the history pointed back unmistakably to the mother's secret. Eventually I learned her story. She was a talented, vivacious woman, who in her young days had received a strict, very one-sided and narrow education. With the utmost severity towards herself and with remarkable strength of character she had adhered all her life to the principles implanted in her, and allowed herself no exceptions. She had not long been married when she got to know a friend of her husband's, and fell obviously in love with him. It was equally obvious to her that this love was fully reciprocated. But her principles made no provision for such an eventuality, therefore it had no right to exist. She always behaved as if nothing were amiss, and she kept up the part for over twenty years until the death of this man, with never a word spoken on either side. Her relations with her husband were distant and correct. In later years she suffered from periodic melancholia.

153] Naturally such a state of affairs could not fail to create a very oppressive atmosphere in the home, and nothing influences children more than these silent facts in the background. They have an extremely contagious effect on the children. The daughters unconsciously imitated their mother's attitude,⁷ while the sons sought compensation by remaining, as it were, unconscious lovers, the unconscious love being over-compensated by their conscious rejection of women.

154] As one can imagine, it is not at all easy in practice to deal with such cases. Treatment should really have begun with the mother, or rather with the relations between the father and the mother. I think that an all-round conscious realization of the situation and its implications would have had a salutary effect. Conscious realization prevents the unmentionable atmosphere, the general cluelessness, the blank disregard of the troublesome object; in short, it stops the painful content from being repressed. And though this may seem to cause the individual more suffering, he is at least suffering meaningfully and from something real. Repression has the apparent advantage of clearing the conscious mind of worry, and the spirit of all its troubles, but, to counter that, it causes an indirect suffering from something unreal, namely a neurosis. Neurotic suffering is an unconscious fraud and has no moral merit, as has real suffering. Apart, however, from producing a neurosis the repressed cause of the suffering has other effects: it radiates out into the environment and, if

there are children, infects them too. In this way neurotic states are often passed on from generation to generation, like the curse of Atreus. The children are infected indirectly through the attitude they instinctively adopt towards their parents' state of mind: either they fight against it with unspoken protest (though occasionally the protest is vociferous) or else they succumb to a paralysing and compulsive imitation. In both cases they are obliged to do, to feel, and to live not as *they* want, but as their parents want. The more "impressive" the parents are, and the less they accept their own problems (mostly on the excuse of "sparing the children"), the longer the children will have to suffer from the un-lived life of their parents and the more they will be forced into fulfilling all the things the parents have repressed and kept unconscious. It is not a question of the parents having to be "perfect" in order to have no deleterious effects on their children. If they really were perfect, it would be a positive catastrophe, for the children would then have no alternative but moral inferiority, unless of course they chose to fight the parents with their own weapons, that is, copy them. But this trick only postpones the final reckoning till the third generation. The repressed problems and the suffering thus fraudulently avoided secrete an insidious poison which seeps into the soul of the child through the thickest walls of silence and through the whited sepulchres of deceit, complacency, and evasion. The child is helplessly exposed to the psychic influence of the parents and is bound to copy their self-deception, their insincerity, hypocrisy, cowardice, self-righteousness, and selfish regard for their own comfort, just as wax takes up the imprint of the seal. The only thing that can save the child from unnatural injury is the efforts of the parents not to shirk the psychic difficulties of life by deceitful manoeuvres or by remaining artificially unconscious, but rather to accept them as tasks, to be as honest with themselves as possible, and to shed a beam of light into the darkest corners of their souls. If they can confess to an understanding ear, so much the better. If for certain reasons they cannot, that is admittedly an aggravation, but not a disadvantage—on the contrary, it is often an advantage, for they are then forced to cope unaided with the thing that is most difficult for them. Public confession, as in the Salvation Army or the Oxford Group, is extremely effective for simple souls who can unbosom themselves *ex profundis*. But such souls are not exactly at home in a fashionable drawing-room, nor are such confessions to be heard there, however indiscreet. Confession, as we know, can also be used for self-deception. The more intelligent and cultured a man is, the more subtly he can humbug himself. No moderately intelligent person should believe himself either a saint or a sinner. Both would be a conscious lie. Rather he should keep shamefacedly silent about his moral qualities, ever mindful of his abysmal sinfulness on the one hand, and of his meritoriously humble insight into this desolate state of affairs on the other. All that the younger Blumhardt⁸ remarked to an acquaintance of mine, on his making an agonizingly contrite confession of sin, was:

“Do you think God is interested in your miserable muck?” Blumhardt had evidently noted the trick that makes drawing-room confession so attractive.

155] It is not, let me repeat, a question of the parents committing no faults—that would be humanly impossible—but of their recognizing them for what they are. It is not life that must be checked, but unconsciousness; above all, the unconsciousness of the educator. But that means our own unconsciousness, because each one of us is, for better or worse, the educator of his fellow man. For so morally bound up with one another are we human beings that a leader leads the led, and the led mislead the leader.

LECTURE TWO

156] Scientific psychology, to begin with, was either physiological psychology, or a rather unorganized accumulation of observations and experiments dealing with isolated facts and functions. Freud's hypothesis, though certainly one-sided, gave it a liberating push towards a psychology of psychic complexities. His work is really a psychology of the ramifications of the sexual instinct in the human psyche. But despite the undeniable importance of sex, one should not suppose that sex is everything. Such a broad hypothesis is like wearing coloured spectacles: it obliterates the finer shades so that everything is seen under the same lurid hue. It is therefore significant that Freud's first pupil, Alfred Adler, framed an entirely different hypothesis of equally broad applicability. The Freudians usually fail to mention Adler's merits, as they make a fanatical creed of their sex-hypothesis. But fanaticism is always a compensation for hidden doubt. Religious persecutions occur only where heresy is a menace. There is no instinct in man that is not balanced by another instinct. Sex would be absolutely unchecked in man were there not a balancing factor in the form of an equally important instinct destined to counteract an unbridled and therefore destructive functioning of the sexual instinct. The structure of the psyche is not unipolar. Just as sex is a force that sways man with its compelling impulses, so there is a natural force of self-assertion in him which enables him to resist emotional explosions. Even among primitives we find the severest restrictions imposed not only on sex but on other instincts too, without there being any need of the Ten Commandments or of the precepts of the catechism. All restrictions on the blind operation of sex derive from the instinct of self-preservation, which is what Adler's self-assertion amounts to in practice. Unfortunately, Adler in his turn goes too far and, by almost entirely neglecting the Freudian point of view, falls into the same error of one-sidedness and exaggeration. His psychology is the psychology of all the self-assertive tendencies in the human psyche. I admit that a one-sided truth has the advantage of simplicity, but whether it is an adequate hypothesis is another matter. We ought to be able to see that there is much in the psyche that depends on sex—sometimes, indeed, everything; but that at other times very little depends on sex and nearly everything on the instinct of self-preservation, or the power instinct, as Adler called it. Both Freud and Adler make the mistake of assuming the continuous operation of one and the same instinct, as though it were a chemical component that was always present in the same quantity, like the two hydrogen atoms in water. If that were the case, man would be mainly sexual, according to Freud, and mainly self-assertive, according to Adler. But he

cannot be both at the same time. Everyone knows that the instincts vary in intensity. Sometimes sex predominates, sometimes self-assertion or some other instinct. That is the simple fact which both investigators have overlooked. When sex predominates, everything becomes sexualized, since everything then expresses or serves the sexual purpose. When hunger predominates, practically everything has to be explained in terms of food. Why do we say, "Don't take him seriously, it's his bad day today"? Because we know that a man's psychology can be profoundly altered by a bad mood. This is even more true when dealing with powerful instincts. Freud and Adler can easily be reconciled if only we will take the trouble to regard the psyche not as a rigid and unalterable system, but as a fluid stream of events which change kaleidoscopically under the alternating influence of different instincts. Hence we may have to explain a man on the Freudian basis before his marriage, and on the Adlerian basis afterwards, which common sense has done all along.¹ Such a combination, however, leaves us in a rather uncomfortable situation. Instead of enjoying the apparent certainty of a single, simple truth, we feel ourselves castaways on a boundless sea of ever-changing conditions, helplessly tossed from one vagary to the next. The protean life of the psyche is a greater, if more inconvenient, truth than the rigid certainty of the one-eyed point of view. It certainly does not make the problems of psychology any easier. But it does free us from the incubus of "nothing but," which is the insistent leitmotiv of all one-sidedness.

157] As soon as the discussion comes to grips with the problem of instinct, everything gets into a dreadful muddle. How are we to distinguish the instincts from one another? How many instincts are there? What are instincts anyway? Thus you immediately get involved in biology and find yourself in more of a muddle than ever. I would therefore advise restriction to the psychological sphere without any assumptions as to the nature of the underlying biological process. The day may come when the biologist, and maybe even the physiologist, will be able to reach out his hand to the psychologist at the point where they meet after tunnelling from opposite sides through the mountain of the unknown.² In the meantime, we must learn to be a little more modest in the face of the psychological facts: instead of knowing so exactly that certain things are "nothing but" sex or "nothing but" the will to power, we should take them more at their face value. Consider religious experience, for instance. Can science be so sure that there is no such thing as a "religious instinct"? Can we really suppose that the religious phenomenon is nothing but a secondary function based on the repression of sex? Can anyone show us those "normal" peoples or races who are free from such silly repressions? But if no one can point to any race, or even a tribe, which is quite free from religious phenomena, then I really do not see how one can justify the argument that religious phenomena are not genuine and are merely repressions of sex. Moreover, has not history

provided us with plenty of examples where sex is actually an integral part of religious experience? The same is true of art, which is likewise supposed to be the result of sexual repressions, although even animals have aesthetic and artistic instincts. This ridiculous and well-nigh pathological exaggeration of the importance of sex is itself a symptom of the contemporary spiritual unbalance, owing chiefly to the fact that our age lacks a true understanding of sexuality.³ Whenever an instinct has been underrated, an abnormal overvaluation is bound to follow. And the more unjust the undervaluation the more unhealthy the subsequent overvaluation. As a matter of fact, no moral condemnation could make sex as hateful as the obscenity and blatant vulgarity of those who exaggerate its importance. The intellectual crudeness of the sexual interpretation makes a right valuation of sex impossible. Thus, probably very much against the personal aspirations of Freud himself, the literature that has followed in his wake is effectively carrying on the work of repression. Before Freud nothing was allowed to be sexual, now everything is nothing but sexual.

158] The preoccupation with sex in psychotherapy is due firstly to the assumption that fixation to the parental imagos is by nature sexual, and secondly to the fact that with many patients sexual fantasies, or those that appear to be such, predominate. Freudian doctrine explains all this in the well-known sexual manner with the laudable intent of freeing the patient from his so-called “sexual” fixation to the parental imagos and initiating him into “normal” life. It speaks, plainly enough, the same language as the patient,⁴ and in suitable cases this is of course a distinct advantage, though it becomes a disadvantage as time goes on, because the sexual terminology and ideology bind the problem down to the very level on which it has shown itself to be insoluble. The parents are not just “sexual objects” or “pleasure objects” to be dismissed out of hand; they are, or they represent, vital forces which accompany the child on the winding path of destiny in the form of favourable or dangerous factors, from whose influence even the adult can escape only in limited degree, analysis or no analysis. Father and mother are, whether we know it or not, replaced by something analogous to them—if, that is to say, we succeed in detaching ourselves from them at all. The detachment is possible only if we can step on to the next level. For example, the place of the father is now taken by the doctor, a phenomenon which Freud called the “transference.” But in the place of the mother there is substituted the wisdom of a doctrine. And indeed the great prototype in the Middle Ages was the substitution of Mother Church for the family. In recent times worldly allegiances have taken the place of the spiritual organization of society, for to remain a permanent member of the family has very undesirable psychic consequences and is for that reason rendered impossible even in primitive society by the initiation ceremonies. Man needs a wider community than the family, in whose

leading-strings he will be stunted both spiritually and morally. If he is burdened with too much family, if, in later life, his tie to the parents is too strong, he will simply transfer the parental tie to the family he himself has raised (if he ever gets that far), thus creating for his own progeny the same suffocating psychic atmosphere from which he suffered in his youth.

159] No psychic allegiance to any kind of secular organization can ever satisfy the spiritual and emotional demands previously made on the parents. Moreover, it is by no means to the advantage of a secular organization to possess members who make such demands. One can see this clearly enough from the thoughtless expectations which the spiritually immature cherish in regard to "Father State"; and where such misguided yearnings ultimately lead is shown by those countries whose leaders, skilfully exploiting the infantile hopes of the masses by suggestion, have actually succeeded in arrogating to themselves the power and authority of the father. Spiritual impoverishment, stultification, and moral degeneracy have taken the place of spiritual and moral fitness, and produced a mass psychosis that can only lead to disaster. A man cannot properly fulfil even the biological meaning of human existence if this and this only is held up to him as an ideal. Whatever the shortsighted and doctrinaire rationalist may say about the meaning of culture, the fact remains that there is a culture-creating spirit. This spirit is a living spirit and not a mere rationalizing intellect. Accordingly, it makes use of a religious symbolism superordinate to reason, and where this symbolism is lacking or has met with incomprehension, things can only go badly with us. Once we have lost the capacity to orient ourselves by religious truth, there is absolutely nothing which can deliver man from his original biological bondage to the family, as he will simply transfer his infantile principles, uncorrected, to the world at large, and will find there a father who, so far from guiding him, leads him to perdition. Important as it is for a man to be able to earn his daily bread and if possible to support a family, he will have achieved nothing that could give his life its full meaning. He will not even be able to bring his children up properly, and will thus have neglected to take care of the brood, which is an undoubted biological ideal. A spiritual goal that points beyond the purely natural man and his worldly existence is an absolute necessity for the health of the soul; it is the Archimedean point from which alone it is possible to lift the world off its hinges and to transform the natural state into a cultural one.

160] Our psychology takes account of the cultural as well as the natural man, and accordingly its explanations must keep both points of view in mind, the spiritual and the biological. As a medical psychology, it cannot do otherwise than pay attention to the whole man. Since the average doctor has been educated exclusively in the natural sciences and is, therefore, accustomed to see everything as a "natural" phenomenon, it is only to be expected that he will understand psychic phenomena

from the same biological angle. This mode of observation has great heuristic value and opens out perspectives which were closed to all ages before us. Thanks to its empirical and phenomenological outlook we now know the facts as they really are; we know what is happening and how it happens, unlike earlier ages which usually had only doctrines and theories about the unknown. One can hardly overestimate the value of strictly scientific biological inquiry; it more than anything else has sharpened the eye of the psychiatrist for factual data and made possible a method of description closely approximating to reality. But this apparently self-evident procedure is not, as it happens, self-evident at all, or rather, in no field of experience is the eye for facts so myopic as in the psyche's perception and observation of itself. Nowhere do prejudices, misinterpretations, value-judgments, idiosyncrasies, and projections trot themselves out more glibly and unashamedly than in this particular field of research, regardless of whether one is observing oneself or one's neighbour. Nowhere does the observer interfere more drastically with the experiment than in psychology. I am tempted to say that one can never verify facts enough, because psychic experience is so extremely delicate and is moreover exposed to countless disturbing influences.

161] Nor should we omit to mention that whereas in all other departments of natural science a physical process is observed by a psychic process, in psychology the psyche observes itself, directly in the subject, indirectly in one's neighbour. One is reminded of the story of the topknot of Baron Munchausen, and consequently one comes to doubt whether psychological knowledge is possible at all. In this matter too the doctor feels grateful to natural science that he does not have to philosophize, but can enjoy living knowledge in and through the psyche. That is to say, although the psyche can never know anything *beyond* the psyche (that would be sheer Baron Munchausen!), it is still possible for two strangers to meet within the sphere of the psychic. They will never know themselves as they are, but only as they appear to one another. In the other natural sciences, the question of what a thing is can be answered by a knowledge that goes beyond the thing in question, namely by a psychic reconstruction of the physical process. But in what, or through what, can the psychic process be repeated? It can only be repeated in and through the psychic; in other words, there is no knowledge *about* the psyche, but only *in* the psyche.

162] Although, therefore, the medical psychologist mirrors the psychic in the psychic, he nevertheless remains, consistently with his empirical and phenomenological approach, within the framework of natural science; but at the same time he departs from it in principle in so far as he undertakes his reconstruction—knowledge and explanation—not in another medium, but in the same medium. Natural science combines two worlds, the physical and the psychic. Psychology does this only in so far as it is psychophysiology. As “pure” psychology its principle of explanation is

ignotum per ignotius, for it can reconstruct the observed process only in the same medium from which that process is itself constituted. It is rather as if the physicist were unable to do anything except repeat the physical process in all its possible variations, without the aid of any *theoria*. But every psychic process, so far as it can be observed as such, is essentially *theoria*, that is to say, it is a *presentation*; and its reconstruction—or “re-presentation”—is at best only a variant of the same presentation. If it is not that, it is just a compensatory attempt to improve or to find fault, or a piece of polemic or criticism; in either case it means the annulment of the process to be reconstructed. To adopt such a procedure in psychology is about as scientific as the paleontology of the eighteenth century, which interpreted *Andrias Scheuchzeri* (the giant salamander) as a human being who had been drowned in the Flood. This problem becomes acute when we have to do with contents which are difficult to understand, such as dream-images, manic ideas, and the like. Here the interpretation must guard against making use of any other viewpoints than those manifestly given by the content itself. If someone dreams of a lion, the correct interpretation can only lie in the direction of the lion; in other words, it will be essentially an *amplification* of this image. Anything else would be an inadequate and incorrect interpretation, since the image “lion” is a quite unmistakable and sufficiently positive presentation. When Freud asserts that the dream means something other than what it says, this interpretation is a “polemic” against the dream’s natural and spontaneous presentation of itself, and is therefore invalid. A scientifically responsible interpretation which proceeds along the line of the image it wishes to interpret cannot be called a tautology; on the contrary, it enlarges the meaning of the image until it becomes, through amplification, a generally valid concept. Even a mathematical grasp of the psyche, were such a thing possible, could only be an algebraically expressed expansion of its meaning. Fechner’s psychophysics is just the opposite of this, being an acrobatic attempt to jump over its own head.

163] At this crucial point psychology stands outside natural science. Although sharing with the latter its method of observation and the empirical verification of fact, it lacks the Archimedean point outside and hence the possibility of objective measurement. To that extent psychology is at a disadvantage compared with natural science. Only one other science finds itself in a similar situation, and that is atomic physics, where the process to be observed is modified by the observer. As physics has to relate its measurements to objects, it is obliged to distinguish the observing medium from the thing observed,⁵ with the result that the categories of space, time, and causality become relative.

164] This strange encounter between atomic physics and psychology has the inestimable advantage of giving us at least a faint idea of a possible Archimedean

point for psychology. The microphysical world of the atom exhibits certain features whose affinities with the psychic have impressed themselves even on the physicists.⁶ Here, it would seem, is at least a suggestion of how the psychic process could be “reconstructed” in another medium, in that, namely, of the microphysics of matter. Certainly no one at present could give the remotest indication of what such a “reconstruction” would look like. Obviously it can only be undertaken by nature herself, or rather, we may suppose it to be happening continuously, all the time the psyche perceives the physical world. The case of psychology versus natural science is not altogether hopeless, even though, as said, the issue lies beyond the scope of our present understanding.

165] Psychology can also claim to be one of the humane sciences, or, as they are called in German, the *Geisteswissenschaften*, sciences of the mind. All these sciences of the mind move and have their being within the sphere of the psychic, if we use this term in its limited sense, as defined by natural science. From that point of view “mind” is a psychic phenomenon.⁷ But, even as a science of the mind, psychology occupies an exceptional position. The sciences of law, history, philosophy, theology, etc., are all characterized and limited by their subject-matter. This constitutes a clearly defined mental field, which is itself, phenomenologically regarded, a psychic product. Psychology, on the other hand, though formerly counted a discipline of philosophy, is today a natural science and its subject-matter is not a mental product but a natural phenomenon, i.e., the psyche. As such it is among the elementary manifestations of organic nature, which in turn forms one half of our world, the other half being the inorganic. Like all natural formations, the psyche is an irrational datum. It appears to be a special manifestation of life and to have this much in common with living organisms that, like them, it produces meaningful and purposeful structures with the help of which it propagates and continually develops itself. And just as life fills the whole earth with plant and animal forms, so the psyche creates an even vaster world, namely consciousness, which is the self-cognition of the universe.

166] In respect of its natural subject-matter and its method of procedure, modern empirical psychology belongs to the natural sciences, but in respect of its method of explanation it belongs to the humane sciences.⁸ On account of this “ambiguity” or “double valence,” doubts have been raised as to its scientific character, firstly on the score of this same ambivalence, secondly, on that of its alleged “arbitrariness.” As to the latter point, it should not be forgotten that there are certain people who regard their psychic processes as purely arbitrary acts. They are naively convinced that everything they think, feel, want, and so on, is a product of their wills and is therefore “arbitrary.” They believe that they think their own thoughts and want their own wants, there being no other subject of these activities except themselves. It is

apparently impossible for them to admit that psychic activity could ever be carried on without a subject (in this case, of course, the ego). They balk at the idea that the psychic content, which they imagine they themselves have produced, exists in its own right, and is apparently far more the product of itself or of a will other than that of the ego.

167] Here we are up against a fashionable and widespread illusion in favour of the ego. In French they even go so far as to say “J’ai fait un rêve,” although the dream is the one psychic content which least of all can be said to have been deliberately willed or created. Conversely, although German possesses the admirable expression “Einfall,”⁹ nobody who “had a good idea” would feel the slightest compunction about chalking up this lucky fluke to his own account, as though it were something he had manufactured himself. But that, as the word “Einfall” clearly shows, is precisely not the case, firstly because of the obvious incapacity of the subject, and secondly because of the manifest spontaneity of the trans-subjective psyche. We therefore say in German, as well as in French and English, “The idea occurred to me,” which is absolutely correct, seeing that the agent is not the subject but the idea, and that the idea literally dropped in through the roof.

168] These examples point to the objectivity of the psyche: it is a natural phenomenon and nothing “arbitrary.” The will, too, is a phenomenon, though “free will” is not a natural phenomenon because it is not observable in itself, but only in the form of concepts, views, convictions, or beliefs. It is therefore a problem which belongs to a pure “science of the mind.” Psychology has to confine itself to natural phenomenology if it is not to go poaching on other preserves. But the verification of the psyche’s phenomenology is no simple matter, as we can see from this popular illusion concerning the “arbitrariness” of psychic processes.

169] As a matter of fact, there do exist psychic contents which are produced or caused by an antecedent act of the will, and which must therefore be regarded as products of some intentional, purposive, and conscious activity. To that extent a fair proportion of psychic contents are *mental* products. Yet the will itself, like the willing subject, is a phenomenon which rests on an unconscious background, where consciousness appears only as the intermittent functioning of an unconscious psyche. The ego, the subject of consciousness, comes into existence as a complex quantity which is constituted partly by the inherited disposition (character constituents) and partly by unconsciously acquired impressions and their attendant phenomena. The psyche itself, in relation to consciousness, is pre-existent and transcendent. We could therefore describe it, with du Prel,¹⁰ as the transcendental subject.

170] Analytical psychology differs from experimental psychology in that it does not attempt to isolate individual functions (sense functions, emotional phenomena,

thought-processes, etc.) and then subject them to experimental conditions for purposes of investigation. It is far more concerned with the total manifestation of the psyche as a natural phenomenon—a highly complex structure, therefore, even though critical examination may be able to divide it up into simpler component complexes. But even these components are extremely complicated and, in their basic features, inscrutable. The boldness of our psychology in daring to operate with such unknowns would be presumptuous indeed, were it not that a higher necessity absolutely requires its existence and affords it help. We doctors are forced, for the sake of our patients, to treat obscure complaints which are hard or impossible to understand, sometimes with inadequate and therapeutically doubtful means, and to summon up the necessary courage and the right feeling of responsibility. We have, for professional reasons, to tackle the darkest and most desperate problems of the soul, conscious all the time of the possible consequences of a false step.

171] The difference between this and all earlier psychologies is that analytical psychology does not hesitate to tackle even the most difficult and complicated processes. Another difference lies in our method of procedure. We have no laboratory equipped with elaborate apparatus. Our laboratory is the world. Our tests are concerned with the actual, day-to-day happenings of human life, and the test-subjects are our patients, relatives, friends, and, last but not least, ourselves. Fate itself plays the role of experimenter. There are no needle-pricks, artificial shocks, surprise-lights, and all the paraphernalia of laboratory experiment; it is the hopes and fears, the pains and joys, the mistakes and achievements of real life that provide us with our material.

172] Our aim is the best possible understanding of life as we find it in the human soul. What we learn through understanding will not, I sincerely hope, petrify into intellectual theory, but will become an instrument which, through practical application, will improve in quality until it can serve its purpose as perfectly as possible. Its main purpose is the better adaptation of human behaviour, and adaptation in two directions (illness is faulty adaptation). The human being must be adapted on two fronts, firstly to external life—profession, family, society—and secondly to the vital demands of his own nature. Neglect of the one or the other imperative leads to illness. Although it is true that anyone whose unadaptedness reaches a certain point will eventually fall ill, and will therefore also be a failure in life, yet not everybody is ill merely because he cannot meet the demands of the outside world, but rather because he does not know how to use his external adaptedness for the good of his most personal and intimate life and how to bring it to the right pitch of development. Some people become neurotic for external reasons, others for internal ones. It can easily be imagined how many different psychological formulations there must be in order to do justice to such diametrically

opposite types. Our psychology inquires into the reasons for the pathogenic failure to adapt, following the slippery trail of neurotic thinking and feeling until it finds the way back to life. Our psychology is therefore an eminently practical science. It does not investigate for investigation's sake, but for the immediate purpose of giving help. We could even say that learning is its by-product, but not its principal aim, which is again a great difference from what one understands by "academic" science.

173] It is obvious that the purpose and inmost meaning of this new psychology is educational as well as medical. Since every individual is a new and unique combination of psychic elements, the investigation of truth must begin afresh with each case, for each "case" is individual and not derivable from any preconceived formula. Each individual is a new experiment of life in her ever-changing moods, and an attempt at a new solution or new adaptation. We miss the meaning of the individual psyche if we interpret it on the basis of any fixed theory, however fond of it we may be. For the doctor this means the individual study of every case; for the teacher, the individual study of every pupil. I do not mean that you should begin each investigation from the very bottom. What you already understand needs no investigating. I speak of "understanding" only when the patient or pupil can agree with the interpretations offered; understanding that goes over your patient's head is an unsafe business for both. It might be fairly successful with a child, but certainly not with an adult of any mental maturity. In any case of disagreement the doctor must be ready to drop all his arguments for the sole purpose of finding the truth. There are naturally cases where the doctor sees something which is undoubtedly there, but which the patient will not or cannot admit. As the truth is often hidden as much from the doctor as from the patient, various methods have been evolved for gaining access to the unknown contents. I purposely say "unknown" and not "repressed" because I think it altogether wrong to assume that whenever a content is unknown it is necessarily repressed. The doctor who really thinks that way gives the appearance of knowing everything beforehand. Such a pretence stymies the patient and will most likely make it impossible for him to confess the truth. At all events the know-all attitude takes the wind out of his sails, though this is sometimes not altogether unwelcome to him, as he can then guard his secret the more easily, and it is so much more convenient to have his truth handed to him by the analyst than be forced to realize and confess it himself. In this way nobody is the gainer. Moreover, this superior knowing in advance undermines the patient's independence of mind, a most precious quality that should on no account be injured. One really cannot be careful enough, as people are incredibly eager to be rid of themselves, running after strange gods whenever occasion offers.

174] There are four methods of investigating the unknown in a patient.

175] The first and simplest method is the ASSOCIATION METHOD. I do not think I need go into details here, as this method has been known for the last fifty years. Its principle is to discover the main complexes through disturbances in the association experiment. As an introduction to analytical psychology and to the symptomatology of complexes, this method is recommended for every beginner.¹¹

176] The second method, SYMPTOM-ANALYSIS, has a merely historical value and was given up by Freud, its originator, long ago. By means of hypnotic suggestion it was attempted to get the patient to reproduce the memories underlying certain pathological symptoms. The method works very well in all cases where a shock, a psychic injury, or a trauma is the chief cause of the neurosis. It was on this method that Freud based his earlier trauma theory of hysteria. But since most cases of hysteria are not of traumatic origin, this theory was soon discarded along with its method of investigation. In a case of shock the method can have a therapeutic effect through “abreaction” of the traumatic content. During and after the first World War it was useful in treating shell-shock and similar disorders.¹²

177] The third method, ANAMNESTIC ANALYSIS, is of greater importance as a method both of investigation and of therapy. In practice it consists in a careful anamnesis or reconstruction of the historical development of the neurosis. The material elicited in this way is a more or less coherent sequence of facts told to the doctor by the patient, so far as he can remember them. He naturally omits many details which either seem unimportant to him or which he has forgotten. The experienced analyst who knows the usual course of neurotic development will put questions which help the patient to fill in some of the gaps. Very often this procedure by itself is of great therapeutic value, as it enables the patient to understand the chief factors of his neurosis and may eventually bring him to a decisive change of attitude. It is of course as unavoidable as it is necessary for the doctor not only to ask questions, but to give hints and explanations in order to point out important connections of which the patient is unconscious. While serving as an officer in the Swiss Army Medical Corps, I often had occasion to use this anamnestic method. For instance, there was a nineteen-year-old recruit who reported sick. When I saw the young man he told me straight out that he was suffering from inflammation of the kidneys and that that was the cause of his pains. I wondered how he knew his diagnosis so definitely, whereupon he said that an uncle of his had the same trouble and the same pains in the back. The examination, however, revealed no trace of organic disease. It was obviously a neurosis. I asked for his previous history. The main fact was that the young man had lost both parents rather early and now lived with the uncle he had just mentioned. This uncle was his foster-father, of whom he was very fond. The day before he reported sick he received a letter from his uncle, telling him that he was laid up again with nephritis. The letter affected him unpleasantly and he threw it

away at once, without realizing the true cause of the emotion he was trying to repress. Actually, he was very much afraid lest his foster-father should die, and this put him in mind again of his grief at the loss of his parents. As soon as he realized this he had a violent fit of weeping, with the result that he joined the ranks again next morning. It was a case of identification with the uncle, which was uncovered by the anamnesis. The realization of his suppressed emotions had a therapeutic effect.

178] A similar case was that of another recruit, who for weeks before I saw him had been having medical treatment for stomach trouble. I suspected that he was neurotic. The anamnesis revealed that the trouble began when he heard the news that his aunt, who was like a mother to him, had to undergo an operation for cancer of the stomach. Here again the uncovering of the hidden connection had curative results. Simple cases of this kind are quite common, and are accessible to anamnestic analysis. In addition to the favourable effect produced by the realization of previously unconscious connections, it is usual for the doctor to give some good advice, or encouragement, or even a reproof.

179] This is the best practical method for the treatment of neurotic children. With children you cannot very well apply the method of dream-analysis, as it penetrates deep into the unconscious. In the majority of cases you have simply to clear away certain obstacles, and this can be done without much technical knowledge. Generally speaking, a child's neurosis would be a very simple matter were it not that there is an invariable connection between it and the wrong attitude of the parents. This complication buttresses the child's neurosis against all therapeutic intervention.

180] The fourth method is the ANALYSIS OF THE UNCONSCIOUS. Despite the fact that anamnestic analysis can reveal certain facts of which the patient is unconscious, it is not what Freud would have called "psychoanalysis." In reality there is a remarkable difference between the two methods. The anamnestic method, as I pointed out, deals with conscious contents, or with contents ready for reproduction, while the analysis of the unconscious only begins when the conscious material is exhausted. I beg to point out that I do not call this fourth method "psychoanalysis," as I wish to leave that term entirely to the Freudians. What they understand by psychoanalysis is no mere technique, but a method which is dogmatically bound up with and based upon Freud's sexual theory. When Freud publicly declared that psychoanalysis and his sexual theory were indissolubly wedded, I was obliged to strike out on a different path, as I was unable to endorse his one-sided views. That is also the reason why I prefer to call this fourth method the analysis of the unconscious.

181] As I have emphasized above, this method can only be applied when the conscious contents are exhausted. By this I mean that analysis of the unconscious is possible only after all the conscious material has been properly examined and there is still no satisfactory explanation and solution of the conflict. The anamnestic method often

serves as an introduction to the fourth method. By careful examination of his conscious mind you get to know your patient; you establish what the old hypnotists used to call "rapport." This personal contact is of prime importance, because it forms the only safe basis from which to tackle the unconscious. This is a factor that is frequently overlooked, and when it is neglected it may easily lead to all sorts of blunders. Even the most experienced judge of human psychology cannot possibly know the psyche of another individual, so he must depend upon goodwill, i.e., good contact with the patient, and trust him to tell the analyst when anything goes wrong. Very often misunderstandings occur right at the beginning of the treatment, sometimes through no fault of the doctor. Owing to the very nature of his neurosis, the patient will harbour all kinds of prejudices which are often the direct cause of his neurosis and help to keep it alive. If these misunderstandings are not thoroughly cleared up, they can easily leave behind them a feeling of resentment which reduces all your subsequent efforts to nothing. Of course, if you begin the analysis with a fixed belief in some theory which purports to know all about the nature of neurosis, you apparently make your task very much easier; but you are nevertheless in danger of riding roughshod over the real psychology of your patient and of disregarding his individuality. I have seen any number of cases where the cure was hindered by theoretical considerations. Without exception the failure was due to lack of contact. It is only the most scrupulous observation of this rule that can prevent unforeseen catastrophes. So long as you feel the human contact, the atmosphere of mutual confidence, there is no danger; and even if you have to face the terrors of insanity, or the shadowy menace of suicide, there is still that area of human faith, that certainty of understanding and of being understood, no matter how black the night. It is by no means easy to establish such a contact, and you cannot achieve it at all except by a careful comparison of both points of view and by mutual freedom from prejudice. Mistrust on either side is a bad beginning, and so is the forcible breaking down of resistances through persuasion or other coercive measures. Even conscious suggestion as part of the analytical procedure is a mistake, because the patient's feeling of being free to make up his own mind must at all costs be preserved. Whenever I discover the slightest trace of mistrust or resistance I try to take it with the utmost seriousness so as to give the patient a chance to re-establish the contact. The patient should always have a firm foothold in his conscious relation to the doctor, who in his turn needs that contact if he is to be sufficiently informed about the actual state of the patient's consciousness. He needs this knowledge for very practical reasons. Without it, he would not be able to understand his patient's dreams correctly. Therefore, not only in the beginning, but during the whole course of an analysis the personal contact must be the main point of observation, because it alone can prevent extremely disagreeable and surprising discoveries, as well as fatal issues so far as is humanly possible. And not only that, it is above all else a means for

correcting the false attitude of the patient, in such a way that he does not feel he is being persuaded against his will or actually outwitted.

182] I should like to give you an illustration of this. A young man of about thirty, obviously very clever and highly intellectual, came to see me, not, he said, for treatment, but only in order to ask one question. He produced a voluminous manuscript, which, so he said, contained the history and analysis of his case. He called it a compulsion neurosis—quite correctly, as I saw when I read the document. It was a sort of psychoanalytical autobiography, most intelligently worked out and showing really remarkable insight. It was a regular scientific treatise, based on wide reading and a thorough study of the literature. I congratulated him on his achievement and asked him what he had really come for. “Well,” he said, “you have read what I have written. Can you tell me why, with all my insight, I am still as neurotic as ever? In theory I should be cured, as I have recalled even my earliest memories. I have read of many people who, with infinitely less insight than I have, were nevertheless cured. Why should I be an exception? Please tell me what it is I have overlooked or am still repressing.” I told him I could not at the moment see any reason why his really astonishing insight had not touched his neurosis. “But,” I said, “allow me to ask you for a little more information about yourself personally.” “With pleasure,” he replied. So I went on: “You mention in your autobiography that you often spend the winter in Nice and the summer in St. Moritz. I take it that you are the son of wealthy parents?” “Oh, no,” he said, “they are not wealthy at all.” “Then no doubt you have made your money yourself?” “Oh, no,” he replied, smiling. “But how is it then?” I asked with some hesitation. “Oh, that does not matter,” he said, “I got the money from a woman, she is thirty-six, a teacher in a council school.” And he added, “It’s a liaison, you know.” As a matter of fact this woman, who was a few years older than himself, lived in very modest circumstances on her meagre earnings as a teacher. She saved the money by stinting herself, naturally in the hope of a later marriage, which this delightful gentleman was not even remotely contemplating. “Don’t you think,” I asked, “that the fact that you are financially supported by this poor woman might be one of the chief reasons why you are not yet cured?” But he laughed at what he called my absurd moral innuendo, which according to him had nothing to do with the scientific structure of his neurosis. “Moreover,” he said, “I have discussed this point with her, and we are both agreed that it is of no importance.” “So you think that by the mere fact of having discussed this situation you have talked the other fact—the fact of your being supported by a poor woman—out of existence? Do you imagine you have any lawful right to the money jingling in your pockets?” Whereupon he rose and indignantly left the room, muttering something about moral prejudices. He was one of the many who believe that morals have nothing to do with neurosis and that

sinning on purpose is not sinning at all, because it can be intellectualized out of existence.

183] Obviously I had to tell this young gentleman what I thought of him. If we could have reached agreement on this point, treatment would have been possible. But if we had begun our work by ignoring the impossible basis of his life, it would have been useless. With views like his only a criminal can adapt to life. But this patient was not really a criminal, only a so-called intellectual who believed so much in the power of reason that he even thought he could unthink a wrong he had committed. I believe firmly in the power and dignity of the intellect, but only if it does not violate the feeling-values. These are not just infantile resistances. This example shows what a decisive factor the personal contact is.

184] When the anamnestic stage of analysis is over, that is, when all the conscious material—recollections, questions, doubts, conscious resistances, etc—has been sufficiently dealt with, one can then proceed to the analysis of the unconscious. With this, one enters a new sphere. From now on we are concerned with the living psychic process itself, namely with DREAMS.

185] Dreams are neither mere reproductions of memories nor abstractions from experience. They are the undisguised manifestations of unconscious creative activity. As against Freud's view that dreams are wish-fulfilments, my experience of dreams leads me to think of them as functions of compensation. When, in the course of analysis, the discussion of conscious material comes to an end, previously unconscious potentialities begin to become activated, and these may easily be productive of dreams. Let me give an example. An elderly lady of fifty-four, but comparatively well preserved, came to consult me about her neurosis, which had begun about one year after the death of her husband twelve years before. She suffered from numerous phobias. Naturally she had a long story to unfold of which I will only mention the fact that, after the death of her husband, she lived by herself in her beautiful country house. Her only daughter was married and lived abroad. The patient was a woman of superficial education only, with a narrow mental horizon, who had learnt nothing in the last forty years. Her ideals and convictions belonged to the eighteen-seventies. She was a loyal widow and clung to her marriage as best she could without her husband. She could not understand in the least what the reason for her phobias could be; certainly it was no question of morals, as she was a worthy member of the church. Such people believe as a rule only in physical causes: phobias have regularly to do with the "heart," or the "lungs," or the "stomach." But strangely enough the doctors had found nothing wrong with those organs. Now she no longer knew what to think about her illness. So I told her that henceforth we would try to see what her dreams had to say on the question of her phobias. Her dreams at that time had the character of snapshots: a gramophone playing a love-

song; herself as a young girl, just engaged; her husband as a doctor, and so on. It was quite obvious what they were hinting at. In discussing the problem I was very careful not to call such dreams “Wish-fulfilments,” as she was already far too much inclined to say of her dreams, “Oh, they are nothing but fancies, one dreams such foolish stuff sometimes!” It was very important that she should give serious attention to this problem and feel that it really did concern her. The dreams contained her real intentions, and had to be added to the other contents of consciousness in order to compensate her blind one-sidedness. I call dreams compensatory because they contain ideas, feelings, and thoughts whose absence from consciousness leaves a blank which is filled with fear instead of with understanding. She wished to know nothing about the meaning of her dreams, because she felt it was pointless to think about a question which could not be answered at once. But, like many other people, she failed to notice that by repressing disagreeable thoughts she created something like a psychic vacuum which, as usually happens, gradually became filled with anxiety. Had she troubled herself consciously with her thoughts she would have known what was lacking, and she would then have needed no anxiety states as a substitute for the absence of conscious suffering.

186] Clearly, then, the doctor must know the conscious standpoint of his patient if he wants to have a secure basis for understanding the compensatory intention of dreams.

187] Experience tells us that the meaning and content of dreams are closely related to the conscious attitude. Recurrent dreams correspond to equally recurrent conscious attitudes. In the case just given it is easy to see what the dreams meant. But suppose a young girl, newly engaged, had such dreams: it is certain that they would have quite a different meaning. The analyst, therefore, must have a very good knowledge of the conscious situation, because it may happen that the same dream-motifs mean one thing on one occasion and the exact opposite on another. It is practically impossible, and it is certainly not desirable, to interpret dreams without being personally acquainted with the dreamer. Sometimes, however, one comes across fairly intelligible dreams, particularly with people who know nothing about psychology, where personal knowledge of the dreamer is not necessary for interpretation. Once, on a train journey, I found myself with two strangers in the dining car. The one was a fine-looking old gentleman, the other a middle-aged man with an intelligent face. I gathered from their conversation that they were military men, presumably an old general and his adjutant. After a long silence, the old man suddenly said to his companion, “Isn’t it odd what you dream sometimes? I had a remarkable dream last night. I dreamed *I was on parade with a number of young officers, and our commander-in-chief was inspecting us. Eventually he came to me,*

but instead of asking a technical question he demanded a definition of the beautiful. I tried in vain to find a satisfactory answer, and felt most dreadfully ashamed when he passed on to the next man, a very young major, and asked him the same question. This fellow came out with a damned good answer, just the one I would have given if only I could have found it. This gave me such a shock that I woke up.” Then, suddenly and unexpectedly addressing me, a total stranger, he asked, “D’you think dreams can have a meaning?” “Well,” I said, “some dreams certainly have a meaning.” “But what could be the meaning of a dream like that?” he asked sharply, with a nervous twitch of the face. I said, “Did you notice anything peculiar about this young major? What did he look like?” “He looked like me, when I was a young major.” “Well, then,” I said, “it looks as if you had forgotten or lost something which you were still able to do when you were a young major. Evidently the dream was calling your attention to it.” He thought for a while, and then he burst out, “That’s it, you’ve got it! When I was a young major I was interested in art. But later this interest got swamped by routine.” Thereupon he relapsed into silence, and not a word more was spoken. After dinner I had an opportunity of speaking with the man whom I took to be his adjutant. He confirmed my surmise about the old gentleman’s rank, and told me that I had obviously touched on a sore spot, because the general was known and feared as a crusty old disciplinarian who meddled with the most trifling matters that were no concern of his.

188] For the general attitude of this man it would certainly have been better if he had kept and cultivated a few outside interests instead of letting himself be drowned in mere routine, which was neither in his own interest nor in that of his work.

189] Had the analysis been carried further, I could have shown him that he would be well advised to accept the standpoint of the dream. He would thus have been able to realize his one-sidedness, and correct it. Dreams are of inestimable value in this respect, provided that you keep away from all theoretical assumptions, as they only arouse unnecessary resistances in the patient. One such theoretical assumption is the idea that dreams are always repressed wish-fulfilments, generally of an erotic nature. It is far better, in actual practice, not to make any assumptions at all, not even that dreams must of necessity be compensatory. The fewer assumptions you have, and the more you can allow yourself to be acted upon by the dream and by what the dreamer has to say about it, the more easily you will arrive at the meaning of the dream. There are sexual dreams, just as there are hunger dreams, fever dreams, anxiety dreams, and others of a somatogenic nature. Dreams of this kind are clear enough, and no elaborate work of interpretation is needed to uncover their instinctual basis. So, guided by long experience, I now proceed on the principle that a dream expresses exactly what it means, and that any interpretation which yields a meaning not expressed in the manifest dream-image is therefore wrong. Dreams are

neither deliberate nor arbitrary fabrications; they are natural phenomena which are nothing other than what they pretend to be. They do not deceive, they do not lie, they do not distort or disguise, but naïvely announce what they are and what they mean. They are irritating and misleading only because we do not understand them. They employ no artifices in order to conceal something, but inform us of their content as plainly as possible in their own way. We can also see what it is that makes them so strange and so difficult: for we have learned from experience that they are invariably seeking to express something that the ego does not know and does not understand. Their inability to express themselves more plainly corresponds to the inability, or unwillingness, of the conscious mind to understand the point in question. To take an example: if only our friend the general had taken the necessary time off from his undoubtedly exhausting duties to consider what it was that prompted him to go poking about in his soldiers' knapsacks—an occupation he would have done better to leave to his subordinates—he would have discovered the reason for his irritability and bad moods, and would thus have spared himself the annoying blow which my innocent interpretation dealt him. He could, with a little reflection, have understood the dream himself, for it was as simple and clear as could be wished. But it had the nasty quality of touching him on his blind spot; indeed it is this blind spot that spoke in the dream.

190] There is no denying that dreams often confront the psychologist with difficult problems, so difficult, indeed, that many psychologists prefer to ignore them, and to echo the lay prejudice that dreams are nonsense. But, just as a mineralogist would be ill advised to throw away his specimens because they are only worthless pebbles, so the psychologist and doctor denies himself the profoundest insight into the psychic life of his clients if he is prejudiced and ignorant enough to gloss over the utterances of the unconscious, not to speak of solving the scientific task which dreams impose on the investigator.

191] Since dreams are not pathological but quite normal phenomena, dream psychology is not the prerogative of the doctor but of psychologists in general. In practice, however, it is chiefly the doctor who will have to concern himself with dreams, because their interpretation offers the key to the unconscious. This key is needed above all by the doctor who has to treat neurotic and psychotic disorders. Sick people have a naturally stronger incentive to probe into their unconscious than have healthy people, and they therefore enjoy an advantage which the others do not share. It is very rare for the normal adult to find that an important part of his education has been neglected, and then to spend a large amount of time and money on getting a deeper insight into himself and a broader equability. As a matter of fact, so very much is lacking to the educated man of today that it is sometimes hard to tell him apart from a neurotic. Besides cases of the latter sort, who obviously need

medical attention, there are numerous others who could be helped just as much by a practical psychologist.

- 192] Treatment by dream-analysis is an eminently educational activity, whose basic principles and conclusions would be of the greatest assistance in curing the evils of our time. What a blessing it would be, for instance, if even a small percentage of the population could be acquainted with the fact that it simply does not pay to accuse others of the faults from which one suffers most of all oneself!
- 193] The material you have to work with in the analysis of the unconscious consists not only of dreams. There are products of the unconscious which are known as fantasies. These fantasies are either a sort of day-dreaming, or else they are rather like visions and inspirations. You can analyse them in the same way as dreams.
- 194] There are two principal methods of interpretation which can be applied according to the nature of the case. The first is the so-called reductive method. Its chief aim is to find out the instinctive impulses underlying the dream. Take as an example the dreams of the elderly lady I mentioned a short while back. In her case, certainly, it was most important that she should see and understand the instinctive facts. But in the case of the old general it would have been somewhat artificial to speak of repressed biological instincts, and it is highly unlikely that he was repressing his aesthetic interests. Rather, he drifted away from them through force of habit. In his case, dream-interpretation would have a *constructive* purpose, as we should try to add something to his conscious attitude, rounding it out as it were. His sinking into a routine corresponds to a certain indolence and inertia which is characteristic of the Old Adam in us. The dream was trying to scare him out of it. But in the case of the elderly lady the understanding of the erotic factor would enable her consciously to recognize her primitive female nature, which for her is more important than the illusion of improbable innocence and strait-laced respectability.
- 195] Thus we apply a largely reductive point of view in all cases where it is a question of illusions, fictions, and exaggerated attitudes. On the other hand, a constructive point of view must be considered for all cases where the conscious attitude is more or less normal, but capable of greater development and refinement, or where unconscious tendencies, also capable of development, are being misunderstood and kept under by the conscious mind. The reductive standpoint is the distinguishing feature of Freudian interpretation. It always leads back to the primitive and elementary. The constructive standpoint, on the other hand, tries to synthesize, to build up, to direct one's gaze forwards. It is less pessimistic than the other, which is always on the look-out for the morbid and thus tries to break down something complicated into something simple. It may occasionally be necessary for the treatment to destroy pathological structures; but treatment consists just as often, or even oftener, in strengthening and protecting what is healthy and worth preserving,

so as to deprive the morbidities of any foothold. You can, if you like, regard not only every dream, but every symptom of illness, every characteristic, every manifestation of life from the reductive point of view, and thus arrive at the possibility of a negative judgment. If you go far enough back in your investigations, then we are all descended from thieves and murderers, and it is easy to show how all humility is rooted in spiritual pride, and every virtue in its corresponding vice. Which point of view he shall decide to adopt in any given case must be left to the insight and experience of the analyst. He will avail himself now of the one and now of the other in accordance with his knowledge of the character and conscious situation of his patient.

- 196] A few words on the symbolism of dreams and fantasies may not be out of place in this connection. Symbolism has today assumed the proportions of a science and can no longer make do with more or less fanciful sexual interpretations. Elsewhere I have attempted to put symbolism on the only possible scientific foundation, namely that of comparative research.¹³ This method seems to have yielded extremely significant results.
- 197] Dream-symbolism has first of all a personal character which can be elucidated by the dreamer's associations. An interpretation that goes over the dreamer's head is not to be recommended, though it is perfectly possible in the case of certain symbolisms.¹⁴ In order to establish the exact meaning which a dream has for the dreamer personally, the dreamer's collaboration is absolutely essential. Dream-images are many-faceted and one can never be sure that they have the same meaning in another dream or in another dreamer. A relative constancy of meaning is exhibited only by the so-called *archetypal* images.¹⁵
- 198] For the practical work of dream-analysis one needs a special knack and intuitive understanding on the one hand, and a considerable knowledge of the history of symbols on the other. As in all practical work with psychology, mere intellect is not enough; one also needs feeling, because otherwise the exceedingly important feeling-values of the dream are neglected. Without these, dream-analysis is impossible. As the dream is dreamed by the whole man, it follows that anyone who tries to interpret the dream must be engaged as a whole man too. "Ars totum requirit hominem," says an old alchemist. Understanding and knowledge there must be, but they should not set themselves up above the heart, which in its turn must not give way to sentiment. All in all, dream-interpretation is an art, like diagnosis, surgery, and therapeutics in general—difficult, but capable of being learned by those whose gift and destiny it is.

LECTURE THREE

199] Through the analysis and interpretation of dreams we try to understand the tendencies of the unconscious. When I say “tendencies of the unconscious” it sounds very like a personification, as though the unconscious were a conscious being with a will of its own. But from the scientific standpoint it is simply a *quality* of certain psychic phenomena. One cannot even say that there is a definite class of psychic phenomena which regularly and under all circumstances have the quality of being unconscious. Anything may be, or become, unconscious. Anything you forget, or anything from which you divert your attention until it is forgotten, falls into the unconscious. In brief, anything whose energy-tension drops below a certain level becomes subliminal. If, to your lost memories, you add the many subliminal perceptions, thoughts, and feelings, you will get some idea of what constitutes as it were the upper layers of the unconscious.

199^{a]} Such is the material you have to deal with in the first part of a practical analysis. Some of these unconscious contents have the special quality of being actively repressed by the conscious mind. Through the more or less deliberate withdrawal of attention from certain conscious contents, and through active resistance to them, they are eventually expelled from consciousness. A continual mood of resistance keeps these contents artificially below the threshold of potential consciousness. This is a regular occurrence in hysteria. It is the beginning of the personality split which is one of the most conspicuous features of this illness. Despite the fact that repression also occurs in relatively normal individuals, the total loss of repressed memories is a pathological symptom. Repression, however, should be clearly distinguished from suppression. Whenever you want to switch your attention from something in order to concentrate it on something else, you have to suppress the previously existing contents of consciousness, because, if you cannot disregard them, you will not be able to change your object of interest. Normally you can go back to the suppressed contents any time you like; they are always recoverable. But if they resist recovery, it may be a case of repression. In that case there must be some interest somewhere which wants to forget. Suppression does not cause forgetting, but repression definitely does. There is of course a perfectly normal process of forgetting which has nothing to do with repression. Repression is an artificial loss of memory, a self-suggested amnesia. It is not, in my experience, justifiable to assume that the unconscious consists wholly or for the greater part of repressed material. Repression is an exceptional and abnormal process, and the most striking evidence of this is the loss of feeling-toned contents, which one might think

would persist in consciousness and remain easily recoverable. It can have effects very similar to those produced by concussion and by other brain injuries (e.g., by poisoning), for these cause an equally striking loss of memory. But whereas in the latter case absolutely all memories of a certain period are affected, repression causes what is called a *systematic amnesia*, where only specific memories or groups of ideas are withdrawn from recollection. In such cases a certain attitude or tendency can be detected on the part of the conscious mind, a deliberate intention to avoid even the bare possibility of recollection, for the very good reason that it would be painful or disagreeable. The idea of repression is quite in place here. This phenomenon can be observed most easily in the association experiment, where certain stimulus words hit the feeling-toned complexes. When they are touched, lapses or falsifications of memory (amnesia or paramnesia) are very common occurrences. Generally the complexes have to do with unpleasant things which one would rather forget and of which one has no wish to be reminded. The complexes themselves are the result, as a rule, of painful experiences and impressions.

200] Unfortunately, this rule is subject to certain limitations. It sometimes happens that even important contents disappear from consciousness without the slightest trace of repression. They vanish automatically, to the great distress of the person concerned and not at all on account of some conscious interest which has engineered the loss and rejoices over it. I am not speaking here of normal forgetting, which is only a natural lowering of energy-tension; I am thinking rather of cases where a motive, a word, image, or person, vanishes without trace from the memory, to reappear later at some important juncture. These are cases of what is called cryptomnesia. (One such case, which concerned Nietzsche, is described in my "Psychology and Pathology of So-called Occult Phenomena," 1902.¹) I remember, for instance, meeting a writer who later described our conversation in great detail in his autobiography. But the *pièce de résistance* was missing, namely a little lecture I read him on the origin of certain psychic disturbances. This memory was not in his repertoire. It reappeared, however, most significantly in another of his books devoted to this subject. For, in the last resort, we are conditioned not only by the past, but by the future, which is sketched out in us long beforehand and gradually evolves out of us. This is especially the case with a creative person who does not at first see the wealth of possibilities within him, although they are all lying there ready. So it may easily happen that one of these still unconscious aptitudes is called awake by a "chance" remark or by some other incident, without the conscious mind knowing exactly what has awakened, or even that anything has awakened at all. Only after a comparatively long incubation period does the result hatch out. The initial cause or stimulus often remains permanently submerged. A content that is not yet conscious behaves exactly like an ordinary complex. It irradiates the conscious mind and causes the conscious

contents associated with it either to become supercharged, so that they are retained in consciousness with remarkable tenacity, or else to do just the opposite, becoming liable to disappear suddenly, not through repression from above, but through attraction from below. One may even be led to the discovery of certain hitherto unconscious contents through the existence of what one might call “lacunae,” or eclipses in consciousness. It is therefore well worth while to look a bit more closely when you have the vague feeling of having overlooked or forgotten something. Naturally, if you assume that the unconscious consists mainly of repressions, you cannot imagine any creative activity in the unconscious, and you logically arrive at the conclusion that eclipses are nothing but secondary effects following a repression. You then find yourself on a steep slope. The explanation through repression is carried to inordinate lengths, and the creative element is completely disregarded. Causalism is exaggerated out of all proportion and the creation of culture is interpreted as a bogus substitute activity. This view is not only splenetic, it also devalues whatever good there is in culture. It then looks as if culture were only a long-drawn sigh over the loss of paradise, with all its infantilism, barbarity, and primitiveness. In truly neurotic manner it is suggested that a wicked patriarch in the dim past forbade infantile delights on pain of castration. Thus, somewhat too drastically and with too little psychological tact, the castration myth becomes the aetiological culture-myth. This leads on to a specious explanation of our present cultural “discontent,”² and one is perpetually smelling out regrets for some lost paradise which one ought to have had. That the sojourn in this barbarous little kindergarten is considerably more discontenting and uncomfortable than any culture up to 1933 is a fact which the weary European has had ample opportunity to verify for himself during the last few years. I suspect that the “discontent” has very personal motivations. Also, one can easily throw dust into one’s own eyes with theories. The theory of repressed infantile sexuality or of infantile traumata has served innumerable times in practice to divert one’s attention from the actual reasons for the neurosis,³ that is to say, from all the slacknesses, carelessnesses, callousnesses, greedinesses, spitefulnesses, and sundry other selfishnesses for whose explanation no complicated theories of sexual repression are needed. People should know that not only the neurotic, but everybody, naturally prefers (so long as he lacks insight) never to seek the causes of any inconvenience in himself, but to push them as far away from himself as possible in space and time. Otherwise he would run the risk of having to make a change for the better. Compared with this odious risk it seems infinitely more advantageous either to put the blame on to somebody else, or, if the fault lies undeniably with oneself, at least to assume that it somehow arose of its own accord in early infancy. One cannot of course quite remember how, but if one could remember, then the entire neurosis would vanish on the spot. The efforts to remember give the appearance of strenuous activity, and furthermore have the

advantage of being a beautiful red herring. For which reason it may seem eminently desirable, from this point of view also, to continue to hunt the trauma as long as possible.

201] This far from unwelcome argument requires no revision of the existing attitude and no discussion of present-day problems. There can of course be no doubt that many neuroses begin in childhood with traumatic experiences, and that nostalgic yearnings for the irresponsibilities of infancy are a daily temptation to certain patients. But it remains equally true that hysteria, for instance, is only too ready to manufacture traumatic experiences where these are lacking, so that the patient deceives both himself and the doctor. Moreover it still has to be explained why the same experience works traumatically with one child and not with another.

202] Naïveté is out of place in psychotherapy. The doctor, like the educator, must always keep his eyes open to the possibility of being consciously or unconsciously deceived, not merely by his patient, but above all by himself. The tendency to live in illusion and to believe in a fiction of oneself—in the good sense or in the bad—is almost insuperably great. The neurotic is one who falls victim to his own illusions. But anyone who is deceived, himself deceives. Everything can then serve the purposes of concealment and subterfuge. The psychotherapist should realize that so long as he believes in a theory and in a definite method he is likely to be fooled by certain cases, namely by those clever enough to select a safe hiding-place for themselves behind the trappings of the theory, and then to use the method so skilfully as to make the hiding-place undiscoverable.

203] Since there is no nag that cannot be ridden to death, all theories of neurosis and methods of treatment are a dubious affair. So I always find it cheering when businesslike physicians and fashionable consultants aver that they treat patients along the lines of “Adler,” or of “Künkel,” or of “Freud,” or even of “Jung.” There simply is not and cannot be any such treatment, and even if there could be, one would be on the surest road to failure. When I treat Mr. X, I have of necessity to use method X, just as with Mrs. Z I have to use method Z. This means that the method of treatment is determined primarily by the nature of the case. All our psychological experiences, all points of view whatsoever, no matter from what theory they derive, may be of use on the right occasion. A doctrinal system like that of Freud or Adler consists on the one hand of technical rules, and on the other of the pet emotive ideas of its author. Still under the spell of the old pathology, which unconsciously regarded diseases as distinct “*entia*” in the Paracelsian sense,^{3a} each of them thought it possible to describe a neurosis as if it presented a specific and clearly defined clinical picture. In the same way doctors still hoped to capture the essence of the neurosis with doctrinaire classifications and to express it in simple formulae. Such an endeavour was rewarding up to a point, but it only thrust all the unessential

features of the neurosis to the forefront, and thus covered up the one aspect that is essential, namely the fact that this illness is always an intensely individual phenomenon. The real and effective treatment of neurosis is always individual, and for this reason the stubborn application of a particular theory or method must be characterized as basically wrong. If it has become evident anywhere that there are not so much illnesses as ill people, this is manifestly the case in neurosis. Here we meet with the most individual clinical pictures it is possible to imagine, and not only that, but we frequently find in the neuroses contents or components of personality which are far more characteristic of the patient as an individual than the somewhat colourless figure he is all too likely to cut in civilian life. Because the neuroses are so extraordinarily individualistic, their theoretical formulation is an impossibly difficult task, as it can only refer to the collective features, i.e., those common to many individuals. But that is precisely the least important thing about the illness, or rather, it is totally irrelevant. Apart from this difficulty there is something else to be considered, the fact, namely, that nearly every psychological principle, every truth relating to the psyche, must, if it is to be made absolutely true, immediately be reversed. Thus one is neurotic because one has repressions or because one does not have repressions; because one's head is full of infantile sex fantasies or because one has no fantasies; because one is childishly unadapted to one's environment or because one is adapted too exclusively to the environment; because one does or because one does not live by the pleasure principle; because one is too unconscious or because one is too conscious; because one is selfish or because one exists too little as a self; and so on. These antinomies, which can be multiplied at will, show how difficult and thankless is the task of theory-building in psychology.

204] I myself have long discarded any uniform theory of neurosis, except for a few quite general points like dissociation, conflict, complex, regression, *abaissement du niveau mental*, which belong as it were to the stock-in-trade of neurosis. In other words, every neurosis is characterized by dissociation and conflict, contains complexes, and shows traces of regression and *abaissement*. These principles are not, in my experience, reversible. But even in the very common phenomenon of repression the antinomial principle is already at work, since the principle "The chief mechanism of neurosis lies in repression" must be reversed because instead of repression we often find its exact opposite, the *drawing away* of a content, its subtraction or abduction, which corresponds to the "loss of soul" so frequently observed among primitives.⁴ "Loss of soul" is not due to repression but is clearly a species of seizure, and is therefore explained as sorcery. These phenomena, originally belonging to the realm of magic, have not by any means died out in so-called civilized people.

205] A general theory of neurosis is therefore a premature undertaking, because our grasp of the facts is still far from complete. Comparative research into the unconscious has only begun.

206] Prematurely conceived theories are not without their dangers. Thus the theory of repression, whose validity in a definite field of pathology is incontestable—up to the point where it has to be reversed!—has been extended to creative processes, and the creation of culture relegated to second place, as a mere ersatz product. At the same time the wholeness and healthiness of the creative function is seen in the murky light of neurosis, which is of course an undoubted product of repression in many cases. In this way creativity becomes indistinguishable from morbidity, and the creative individual immediately suspects himself of some kind of illness, while the neurotic has lately begun to believe that his neurosis is an art, or at least a source of art. These would-be artists, however, develop one characteristic symptom: they one and all shun psychology like the plague, because they are terrified that this monster will gobble up their so-called artistic ability. As if a whole army of psychologists could do anything against the power of a god! True productivity is a spring that can never be stopped up. Is there any trickery on earth which could have prevented Mozart or Beethoven from creating? Creative power is mightier than its possessor. If it is not so, then it is a feeble thing, and given favourable conditions will nourish an endearing talent, but no more. If, on the other hand, it is a neurosis, it often takes only a word or a look for the illusion to go up in smoke. Then the supposed poet can no longer write, and the painter's ideas become fewer and drearier than ever, and for all this psychology is to blame. I should be delighted if a knowledge of psychology did have this sanative effect and if it put an end to the neuroticism which makes contemporary art such an unenjoyable problem. Disease has never yet fostered creative work; on the contrary, it is the most formidable obstacle to creation. No breaking down of repressions can ever destroy true creativeness, just as no analysis can ever exhaust the unconscious.

207] The unconscious is the ever-creative mother of consciousness. Consciousness grows out of the unconscious in childhood, just as it did in primeval times when man became man. I have often been asked how the conscious arose from the unconscious. The only possible way to answer this is to infer, from present experience, certain events which lie hidden in the abyss of the past, beyond the reach of science. I do not know whether such an inference is permissible, but it may be that even in those remote times consciousness arose in much the same way as it arises today. There are two distinct ways in which consciousness arises. The one is a moment of high emotional tension, comparable to the scene in *Parsifal* where the hero, at the very moment of greatest temptation, suddenly realizes the meaning of Amfortas' wound. The other way is a state of contemplation, in which ideas pass

before the mind like dream-images. Suddenly there is a flash of association between two apparently disconnected and widely separated ideas, and this has the effect of releasing a latent tension. Such a moment often works like a revelation. In every case it seems to be the discharge of energy-tension, whether external or internal, which produces consciousness. Many, though not all, of the earliest memories of infancy still retain traces of these sudden flashes of consciousness. Like the records handed down from the dawn of history, some of them are remnants of real happenings, others are purely mythical; in other words, some were objective in origin, and some subjective. The latter are often extremely symbolical and of great importance for the subsequent psychic life of the individual. Most of the earliest impressions in life are soon forgotten and go to form the infantile layer of what I have called the PERSONAL UNCONSCIOUS. There are definite reasons for this division of the unconscious into two parts. The personal unconscious contains everything forgotten or repressed or otherwise subliminal that has been acquired by the individual consciously or unconsciously. This material has an unmistakably personal stamp. But you can also find other contents which bear hardly any trace of a personal quality, and which appear incredibly strange to the individual. Such contents are frequently found in insanity, where they contribute not a little to the confusion and disorientation of the patient. In the dreams of normal people, too, these strange contents may occasionally appear. When you analyse a neurotic and compare his unconscious material with that of a man suffering from schizophrenia, you are instantly aware of a striking difference. With the neurotic, the material produced is mainly of a personal origin. His thoughts and feelings revolve round his family and his social set, but in a case of insanity the personal sphere is often completely swamped by collective representations. The madman hears the voice of God speaking to him; in his visions he sees cosmic revolutions, and it is just as if a veil has been twitched away from a world of ideas and emotions hitherto concealed. He suddenly begins talking of spirits, demons, witchcraft, secret magical persecutions, and so forth. It is not difficult to guess what this world is: it is the world of the primitive, which remains profoundly unconscious so long as everything is going well, but rises to the surface when some fatality befalls the conscious mind. This impersonal layer of the psyche I have termed the COLLECTIVE UNCONSCIOUS —“collective” because it is not an individual acquisition but is rather the functioning of the inherited brain structure, which in its broad outlines is the same in all human beings, and in certain respects the same even in mammals. The inherited brain is the product of our ancestral life. It consists of the structural deposits or equivalents of psychic activities which were repeated innumerable times in the life of our ancestors. Conversely, it is at the same time the ever-existing a priori type and

author of the corresponding activity. Far be it from me to decide which came first, the hen or the egg.

208] Our individual consciousness is a superstructure based on the collective unconscious, of whose existence it is normally quite unaware. The collective unconscious influences our dreams only occasionally, and whenever this happens, it produces strange and marvellous dreams remarkable for their beauty, or their demoniacal horror, or for their enigmatic wisdom—"big dreams," as certain primitives call them. People often hide such dreams as though they were precious secrets, and they are quite right to think them so. Dreams of this kind are enormously important for the individual's psychic balance. Often they go far beyond the limits of his mental horizon and stand out for years like spiritual landmarks, even though they may never be quite understood. It is a hopeless undertaking to interpret such dreams reductively, as their real value and meaning lie in themselves. They are spiritual experiences that defy any attempt at rationalization. In order to illustrate what I mean, I should like to tell you the dream of a young theological student.^{4a} I do not know the dreamer myself, so my personal influence is ruled out. He dreamed *he was standing in the presence of a sublime hieratic figure called the "white magician," who was nevertheless clad in a long black robe. This magician had just ended a lengthy discourse with the words "And for that we require the help of the black magician." Then the door suddenly opened and another old man came in, the "black magician," who however was dressed in a white robe. He too looked noble and sublime. The black magician evidently wanted to speak with the white, but hesitated to do so in the presence of the dreamer. At that the white magician said, pointing to the dreamer, "Speak, he is an innocent." So the black magician began to relate a strange story of how he had found the lost keys of paradise and did not know how to use them. He had, he said, come to the white magician for an explanation of the secret of the keys. He told him that the king of the country in which he lived was looking for a suitable monument for himself. His subjects had chanced to dig up an old sarcophagus containing the mortal remains of a virgin. The king opened the sarcophagus, threw away the bones and had the sarcophagus buried again for later use. But no sooner had the bones seen the light of day, than the being to whom they had once belonged—the virgin—changed into a black horse that galloped off into the desert. The black magician pursued it across the sandy wastes and beyond, and there after many vicissitudes and difficulties he found the lost keys of paradise.* That was the end of his story and also, unfortunately, of the dream.

209] I think a dream like this will help to make clear the difference between an ordinary, personal dream and the "big" dream. Anybody with an open mind can at once feel the significance of the dream and will agree with me that such dreams

come from a “different level” from that of the dreams we dream every night. We touch here upon problems of vast import, and it is tempting to dwell on this subject for a while. Our dream should serve to illustrate the activity of the layers that lie below the personal unconscious. The manifest meaning of the dream takes on a quite special aspect when we consider that the dreamer was a young theologian. It is evident that the relativity of good and evil is being presented to him in a most impressive manner. It would therefore be advisable to probe him on this point, and it would be exceedingly interesting to learn what a theologian has to say about this eminently psychological question. Also the psychologist would be in the highest degree interested to see how a theologian would reconcile himself to the fact that the unconscious, while clearly distinguishing between the opposites, nevertheless recognizes their identity. It is hardly likely that a youthful theologian would consciously have thought of anything so heretical. Who, then, is the thinker of such thoughts? If we further consider that there are not a few dreams in which mythological motifs appear, and that these motifs are absolutely unknown to the dreamer, then the question arises of where such material comes from, since he has never encountered it anywhere in his conscious life, and who or what it is that thinks such thoughts and clothes them in such imagery—thoughts which, moreover, go beyond the dreamer’s own mental horizon.⁵ In many dreams and in certain psychoses we frequently come across archetypal material, i.e., ideas and associations whose exact equivalents can be found in mythology. From these parallels I have drawn the conclusion that there is a layer of the unconscious which functions in exactly the same way as the archaic psyche that produced the myths.

210] Although dreams in which these mythological parallels appear are not uncommon, the emergence of the collective unconscious, as I have called this myth-like layer, is an unusual event which only takes place under special conditions. It appears in the dreams dreamt at important junctures in life. The earliest dreams of childhood, if we can still remember them, often contain the most astonishing mythologems; we also find the primordial images in poetry and in art generally, while religious experience and dogma are a mine of archetypal lore.

211] The collective unconscious is a problem that seldom enters into practical work with children: their problem lies mainly in adapting themselves to their surroundings. Indeed, their connection with the primordial unconsciousness must be severed, as its persistence would present a formidable obstacle to the development of consciousness, which is what they need more than anything else. But if I were discussing the psychology of people beyond middle life, I should have a good deal more to say about the significance of the collective unconscious. You should always bear in mind that our psychology varies not only according to the momentary predominance of certain instinctive impulses and certain complexes, but according

to the individual's life phase. You should be careful, therefore, not to impute an adult's psychology to a child. You cannot treat a child as you would an adult. Above all, the work can never be as systematic as with adults. A real, systematic dream-analysis is hardly possible, because with children the unconscious should not be stressed unnecessarily: one can easily arouse an unwholesome curiosity, or induce an abnormal precociousness and self-consciousness, by going into psychological details which are of interest only to the adult. When you have to handle difficult children, it is better to keep your knowledge of psychology to yourself, as simplicity and common sense are what they need most.⁶ Your analytical knowledge should serve your own attitude as an educator first of all, because it is a well-known fact that children have an almost uncanny instinct for the teacher's personal shortcomings. They know the false from the true far better than one likes to admit. Therefore the teacher should watch his own psychic condition, so that he can spot the source of the trouble when anything goes wrong with the children entrusted to his care. He himself may easily be the unconscious cause of evil. Naturally we must not be too naïve in this matter: there are people, doctors as well as teachers, who secretly believe that a person in authority has the right to behave just as he likes, and that it is up to the child to adapt as best he may, because sooner or later he will have to adapt to real life which will treat him no better. Such people are convinced at heart that the only thing that matters is material success, and that the only real and effective moral restraint is the policeman behind the penal code. Where unconditional adaptation to the powers of this world is accepted as the supreme principle of belief, it would of course be vain to expect psychological insight from a person in authority as a moral obligation. But anyone who professes a democratic view of the world cannot approve of such an authoritarian attitude, believing as he does in a fair distribution of burdens and advantages. It is not true that the educator is always the one who educates, and the child always the one to be educated. The educator, too, is a fallible human being, and the child he educates will reflect his failings. Therefore it is wise to be as clear-sighted as possible about one's subjective views, and particularly about one's faults. As a man is, so will be his ultimate truth, and so also his strongest effect on others.

212] The psychology of children's neuroses can only be described very inadequately in general systematic terms, for, with few exceptions, the unique or individual features are overwhelmingly preponderant, as is usually also the case with the neuroses of adults. Here as there diagnoses and classifications have little meaning when weighed against the individual peculiarity of each case. Instead of a general description I should like to give you some examples from case histories, which I owe to the friendly collaboration of my pupil Frances G. Wickes, formerly consulting psychologist at St. Agatha's School, New York City.⁷

213] The first case is that of a boy seven years old. He had been diagnosed as mentally defective. The boy showed lack of coordination in walking, squinted in one eye and had an impediment in his speech. He was given to sudden outbursts of temper, and would keep the house in an uproar with his wild rages, throwing things about and threatening to kill the family. He liked to tease and to show off. At school he bullied the other children; he could not read, or take his place in class with children of the same age. After he had been at school for about six months, the rages increased until there were several each day. He was a first child, had been happy and friendly enough up to the age of five and a half, but between three and four he developed night terrors. He was late in learning to talk. The tongue was found to be tied, and an operation was performed. He could still hardly articulate at five and a half, and it was then discovered that the ligaments had not been properly cut. This was remedied. When he was five, a small brother was born. At first he was delighted, but as the baby grew older he seemed at times to hate him. As soon as his little brother began to walk, which he did unusually early, our patient started his wild tempers. He would show great vindictiveness, alternating with moods of affection and remorse. As these rages seemed to be brought on by almost anything, no matter how trifling, nobody thought of jealousy. As the rages increased, so the night terrors abated. Intelligence tests showed unusual ability in thinking. He was delighted at every success and became friendly when encouraged, but was irritable over failures. The parents were brought to understand that the rages were compensatory power manifestations which he developed on realizing his own impotence, firstly when he saw how his little brother was praised and admired for doing with perfect ease the very thing that was impossible for him, and then in having to compete on such unequal terms with the other children at school. While he had remained the only child, whose parents lavished special care on him because of his handicaps, he was happy; but when he tried to hold his own on such unequal terms he became like a wild animal trying to break the chain. The rages, which the mother said were apt to occur “when some little bit of a thing went wrong,” were often found to be connected with the times when the little brother was made to show off his tricks before visitors.

214] The boy soon developed very good relations with the psychologist, whom he called his “friend.” He began to talk to her without falling into his rages. He would not tell his dreams, but would indulge in bombastic fantasies about how he was going to kill everybody and cut off their heads with a great sword. One day he suddenly interrupted himself and said: “That’s what I’ll do. What do you think of that?” The psychologist laughed and answered, “I think just as you do—it’s all bunk.” Then she gave him a picture of Santa Claus which he had admired, saying, “You and Santa Claus and I know it’s all bunk.” His mother put the picture in the

window for him to see, and the next day he caught sight of it in one of his rages. He calmed down at once and remarked, "Santa Claus, that's all bunk!" and promptly did what he had been told to do. He then began to see his rages as something he enjoyed and used for a definite purpose. He showed remarkable intelligence in discerning his real motives. His parents and teachers co-operated in praising his efforts and not merely his successes. He was made to feel his place as the "eldest son." Special attention was given to speech training. Gradually he learned to control his rages. For a time the old night terrors became more frequent as the rages subsided, but then they too diminished.

215] One cannot expect a disorder that began so early on the basis of organ inferiorities to be cured at once. It will take years to reach a complete adaptation. A strong feeling of inferiority is obviously at the bottom of this neurosis. It is a clear case of Adlerian psychology, where the inferiority gives rise to a power complex. The symptomatology shows how the neurosis attempted to compensate the loss of efficiency.

216] The second case concerns a little girl about nine years old. She had run a subnormal temperature for three months and was unable to attend school. Otherwise she showed no special symptoms, except loss of appetite and increasing listlessness. The doctor could find no reason for this condition. The father and mother were both sure they had the child's full confidence, and that she was not worried or unhappy in any way. The mother finally admitted to the psychologist that she and her husband did not get on together, but said that they never discussed their difficulties in front of the child, who was completely unconscious of them. The mother wanted a divorce, but could not make up her mind to face the upheaval it would involve. So everything remained in mid air, and in the meantime the parents made no effort to solve any of the difficulties causing their unhappiness. Both of them had an unduly possessive attachment to the child, who in turn had a terrific father-complex. She slept in her father's room in a little bed next to his and got into his bed in the mornings. She gave the following dream:

"I went with Daddy to see Granny. Granny was in a big boat. She wanted me to kiss her and wanted to put her arms round me, but I was afraid of her. Daddy said, 'Well then, I'll kiss Granny!' I didn't want him to do it, as I was afraid something might happen to him. Then the boat moved off and I couldn't find anybody and I felt frightened."

217] Several times she had dreams about Granny. Once Granny was all mouth, wide open. Another time she dreamt of "a big snake, which came out from under my bed and played with me." She often spoke of the snake dream, and had one or two others like it. The dream about her Granny she told with reluctance, but then confessed that every time her father went away she was frightened he would never come back. She

had sized up her parents' situation, and told the psychologist that she knew her mother did not like her father, but she did not want to talk about it, "because it would make them feel bad." When her father was away on business trips she was always afraid he would leave them. She had also noticed that her mother was always happier then. The mother realized that she was no help to the child, but on the contrary only made her ill by leaving the situation unsolved. The parents had either to tackle their difficulties together and try to come to a real understanding, or, if this should prove impossible, decide to separate. Eventually, they chose the latter course, and explained the situation to the child. The mother had been convinced that a separation would harm the child, instead of which her health improved as soon as the real situation came out into the open. She was told that she would not be parted from either parent but would have two homes instead; and although a divided home seems a poor arrangement for any child, her relief at no longer being a prey to vague fears and forebodings was so great that she returned to normal health and to real enjoyment of school and play.

217^{a]} A case like this is often a great puzzle to the general practitioner. He looks in vain for an organic cause of the trouble, not knowing that he ought to look elsewhere, for no medical textbook would admit the possibility that psychic difficulties between father and mother could be responsible for the child's subnormal temperature. But to the analyst such causes are by no means unknown or strange. The child is so much a part of the psychological atmosphere of the parents that secret and unsolved problems between them can influence its health profoundly. The *participation mystique*, or primitive identity, causes the child to feel the conflicts of the parents and to suffer from them as if they were its own. It is hardly ever the open conflict or the manifest difficulty that has such a poisonous effect, but almost always parental problems that have been kept hidden or allowed to become unconscious. The author of these neurotic disturbances is, without exception, the unconscious. Things that hang in the air and are vaguely felt by the child, the oppressive atmosphere of apprehension and foreboding, these slowly seep into the child's soul like a poisonous vapour.

218] What this child seemed to feel most was the unconscious of her father. If a man has no real relations with his wife, then obviously he seeks another outlet. And if he is not conscious of what he is seeking, or if he represses fantasies of that kind, his interest will regress on the one side to the memory-image of his mother, and on the other side it invariably fastens on his daughter, if there is one. This is what might be called unconscious incest. You can hardly hold a man responsible for his unconsciousness, but the fact remains that in this matter nature knows neither patience nor pity, and takes her revenge directly or indirectly through illness and unlucky accidents of all kinds. Unfortunately, it is almost a collective ideal for men

and women to be as unconscious as possible in the ticklish affairs of love. But behind the mask of respectability and faithfulness the full fury of neglected love falls upon the children. You cannot blame the ordinary individual, as you cannot expect people to know the attitude they ought to adopt and how they are to solve their love problems within the framework of present-day ideals and conventions. Mostly they know only the negative measures of negligence, procrastination, suppression, and repression. And to know of anything better is admittedly very difficult.

219] The dream about the grandmother shows how the unconscious psychology of the father is penetrating that of the child. It is he who wishes to kiss his mother, and the child feels forced to kiss her in the dream. The grandmother who is “all mouth” suggests swallowing and devouring.⁸ Obviously the child is in danger of being swallowed by her father’s regressive libido. That is why she dreams of the snake; for the snake, since ancient times, has always been the symbol of danger: of being caught in coils, or swallowed, or poisoned.⁹ This case also shows how apt children are to see very much more than their parents suspect. It is of course not possible for parents to have no complexes at all. That would be superhuman. But they should at least come to terms with them consciously; they should make it a duty to work out their inner difficulties for the sake of the children. They should not take the easy road of repressing them in order to avoid painful discussions. The love problem is part of mankind’s heavy toll of suffering, and nobody should be ashamed of having to pay his tribute. It is a thousand times better in every respect for parents frankly to discuss their problems, instead of leaving their complexes to fester in the unconscious.

220] In a case like this, what would be the use of talking to the child about incestuous fantasies and father-fixations? Such a procedure would only make her believe that it was all the fault of her own immoral or foolish nature, and would burden her with a responsibility which is not hers at all, but really belongs to her parents. She suffers not because she has unconscious fantasies but because her father has them. She is a victim of the wrong atmosphere in the home, and her problem disappears as soon as her parents faced up to theirs.

221] The third case concerns a very intelligent girl of thirteen, reported as anti-social, rebellious, and unable to adapt herself to school conditions. At times she was very inattentive and would give peculiar answers for which she could offer no explanation. She was a big, well-developed girl, apparently in the best of health. She was several years younger than her classmates, trying, with her thirteen years, to lead the life of a young girl of sixteen or seventeen, but without the corresponding capabilities. Physically she was over-developed, puberty having begun when she was barely eleven. She was frightened of her sexual excitability and of her desire to

masturbate. Her mother was a woman of brilliant intellect, with an intense will to power, who had early decided that her daughter must be a prodigy. She had forced every intellectual faculty and suppressed all emotional growth. She wanted the child to go to school earlier than anybody else. The father's business took him from home a good deal, and to the girl he seemed more like a shadowy ideal than an actual reality. She suffered from a tremendous pressure of pent-up emotions which fed more upon homosexual fantasies than upon real relationships. She confessed that she sometimes longed to be caressed by a certain teacher, and then suddenly she would fancy that all her clothes had dropped off, so that she lost track of what was being said to her; hence her absurd answers. This is one of her dreams: "*I saw my mother slipping down the bath and I knew she was drowning, but I could not move. Then I grew terribly frightened and started to weep because I had let her drown. I woke up crying.*" This dream helped her to bring to the surface the hidden resistances to the unnatural life she was forced to lead. She acknowledged her desire for normal companionship. Little could be done at home, but a change of surroundings, the understanding of her problem, and the frank discussion brought a considerable improvement.

222] This case is simple, but very typical. The role played by the parents is again most conspicuous. It was one of those typical marriages where the father is completely wrapped up in his business, and the mother tries to realize her social ambitions through the child. The child had to be a success in order to satisfy her mother's desires and expectations and to flatter her vanity. A mother like this does not as a rule see the real character of her child at all, or her individual ways and needs. She projects herself into the child and rules her with a ruthless will to power. Such a marriage is all too likely to produce just that psychological situation and to intensify it still further. There seems to have been a considerable distance between husband and wife, as so masculine a woman can hardly have had any real understanding of a man's feelings: the only thing she knows how to get out of him is his money. He pays her in order to keep her in a fairly tolerable mood. All her love turns into ambition and will to power (if indeed she has not been doing this since long before her marriage, unconsciously following the example of her own mother). The children of such mothers are practically nothing more than dolls, to be dressed up and adorned at pleasure. They are nothing but mute figures on the chessboard of their parents' egoism, and the maddening thing is that all this is done under the cloak of selfless devotion to the dear child, whose happiness is the sole aim of the mother's life. But in actual fact the child is not given a grain of real love. That is why she suffers from premature sexual symptoms, like so many other neglected and ill-treated children, while at the same time she is deluged with so-called maternal love. The homosexual fantasies clearly show that her need for real love is not

satisfied; consequently she craves love from her teachers, but of the wrong sort. If tender feelings are thrown out at the door, then sex in violent form comes in through the window, for besides love and tenderness a child needs understanding. The right thing in this case would naturally be to treat the mother, which might do something to improve her marriage and deflect her passion from the child, at the same time giving the latter access to her mother's heart. Failing that, one can only try to check the mother's injurious influence by stiffening the child's resistance to her, so that she will at least be able to criticize her mother's faults with fairness and become conscious of her own individual needs. Nothing is more stunting than the efforts of a mother to embody herself in her child, without ever considering that a child is not a mere appendage, but a new and individual creature, often furnished with a character which is not in the least like that of the parents and sometimes seems to be quite frighteningly alien. The reason for this is that children are only nominally descended from their parents, but are actually born from the ancestral stock. Occasionally you have to go back several hundred years to see the family likeness.

223] The child's dream is quite intelligible: it obviously means the death of the mother.¹⁰ Such is the answer of the child's unconscious to the mother's blind ambition. Had she not tried to "kill" her daughter's individuality the unconscious would never have reacted in that way. Certainly you should never start generalizing from the results of such a dream. Death-dreams about the parents are not uncommon, and you might be led to suppose that they are always based on the kind of conditions I have just described. But you should remember that a dream-image does not always have the same meaning in all circumstances. You can never be certain of a dream's meaning unless you are sufficiently acquainted with the conscious situation of the dreamer.

224] The last case I shall mention concerns an eight-year-old girl, Margaret, who suffered from a complaint that does not seem to be causally connected with the parents. It is a complicated case which cannot be dealt with fully in a lecture. I have therefore selected only one important phase in its development. The child had been at school for a year without being able to learn anything, except a little reading. She moved clumsily, went up and down stairs like a child just beginning to walk, had little control of her limbs, and spoke in a whining voice. In conversation she would show intense eagerness at first, then suddenly bury her face in her hands and refuse to say any more. As soon as she started to speak she would burst into a weird gibberish made up of disconnected words. When she tried to write she drew single letters, and then covered the whole paper with scribbles which she called "funnies." Intelligence tests could not be given in the normal way, but in several thinking and feeling tests she got the results of an eleven-year-old, in others barely those of a child of four. She had never been normal. When she was ten days old, blood clots

resulting from the difficult birth had to be removed from the cranial cavity. She was watched over day and night and looked after with the greatest care. It soon became apparent that she used her physical disabilities to tyrannize her parents, meanwhile resenting any attempt to help her. The parents tried to compensate her defects by shielding her from reality and by providing her with moral crutches which kept her from struggling to overcome her difficulties and frustrations through an effort of will.

225] The first psychological approach was through the world of imagination. As the child was fairly imaginative, she began to learn to read for the sake of stories, and, once started, she progressed with astonishing rapidity. Too much concentration on one thing made her irritable and excited, but nevertheless there was a steady gain. One day Margaret announced, "I have a twin sister. She is called Anna. She is just like me except that she always wears lovely pink clothes and has glasses. [Glasses meant her weak eyes, which kept her from poring over the books she now loved.] If Anna were here I should work better." The psychologist suggested that Anna should be asked to come in. Margaret went out into the hall and came back with Anna. Then she tried to write, so as to show Anna. After that, Anna was always present. First Margaret would write, then Anna. One day everything went wrong, and finally she burst out, "I shall never learn to write and it's all Mother's fault! I am left-handed, and she never told my first teacher. I had to try to write with my right hand, and now I shall grow up and never be able to write because of Mother." The psychologist told her of another child who was also left-handed and whose mother had made the same mistake. Margaret inquired eagerly, "So he can't write at all?" "Oh, no," said the psychologist, "he writes stories and all sorts of things, only it was harder for him, that's all. He generally writes with his left hand now. You can write with your left hand if you want to." "But I like my right hand best." "Oho, then it doesn't seem to be all your mother's fault. I wonder whose fault it is?" Margaret only said, "I don't know." Thereupon it was suggested that she might ask Anna. So she went out and came back after a while and said, "Anna says it's my fault and I had better do some work." Before this she had always refused to discuss her responsibility, but from now on she would go out of the room, talk it over with Anna, and bring back the result. Sometimes she would come back with all the signs of rebellion, but she always told the truth. Once, after railing against Anna, she said, "But Anna insists, 'Margaret, it's your own fault. You've got to try.'" "From this she went on to a realization of her own projections. One day she got into a fearful temper with her mother. She burst into the room, shouting, "Mother is horrid, horrid, horrid!" "Who is horrid?" she was asked." Mother," she answered. "You might ask Anna," said the psychologist. There was a long pause, then she said, "Pooh! I guess

I know as much as Anna. I'm horrid. I'll go and tell Mother." This she did and then returned quietly to her work.

226] As a result of the serious injury at birth the child had not been able to develop properly. She naturally deserved, and received, a good deal of attention from her parents; but it is almost impossible to draw the line and to know exactly how far one should go in considering a child's incapacities. Somewhere, certainly, the optimum is reached, and if you go beyond that you start spoiling the child. As the first-mentioned case shows, children do feel their inferiority in certain ways, and they begin to compensate by assuming a false superiority. This is only another inferiority, but a moral one; no genuine satisfaction results, and so a vicious circle is begun. The more a real inferiority is compensated by a false superiority, the less the initial inferiority is remedied, and the more it is intensified by the feeling of moral inferiority. This necessarily leads to more false superiority, and so on at an ever increasing rate. Obviously, Margaret needed a great deal of attention and was therefore involuntarily spoiled, so that she learnt to exploit the legitimate devotion of her parents. As a result, she got stuck in her incapacity and defeated her own efforts to extricate herself, remaining more incapable and more infantile than her actual handicaps warranted.

227] Such a condition is most favourable to the growth of a second personality. The fact that her conscious mind fails to progress does not mean in the least that her unconscious personality will also remain at a standstill. This part of herself will advance as time goes on, and the more the conscious part hangs back, the greater will be the dissociation of personality. Then one day the more developed personality will appear on the scene and challenge the regressive ego. This was the case with Margaret: she saw herself confronted by "Anna," her superior twin sister, who for a while represented her moral reason. Later the two merged into one, and this signified a tremendous advance. In 1902, I published a study of very much the same psychological structure. It was about a young girl of sixteen with a quite extraordinary dissociation of personality. You will find it in my paper on "The Psychology and Pathology of So-called Occult Phenomena."¹¹ The educational use which the psychologist made of the second personality brought excellent results, and entirely agreed with the teleological significance of the figure of Anna. The psychic double is a commoner phenomenon than one would expect, although it seldom reaches a degree of intensity that would entitle one to speak of a "double personality."

* * *

228] About education in general and school education in particular the doctor has little to say from the standpoint of his science, as that is hardly his business. But on the

education of difficult or otherwise exceptional children he has an important word to add. He knows only too well from his practical experience what a vital role parental influences and the effects of schooling play even in the life of the adult. He is therefore inclined, when dealing with children's neuroses, to seek the root cause less in the child itself than in its adult surroundings, and more particularly in the parents. Parents have the strongest effect upon the child not only through its inherited constitution, but also through the tremendous psychic influence they themselves exert. That being so, the uneducatedness and unconsciousness of the adult works far more powerfully than any amount of good advice, commands, punishments, and good intentions. But when, as is unfortunately all too often the case, parents and teachers expect the child to make a better job of what they themselves do badly, the effect is positively devastating. Again and again we see parents thrusting their unfulfilled illusions and ambitions on to the child, and forcing it into a role for which it is in no circumstances fitted. I remember being consulted about a badly behaved little boy. From the parents' account I learnt that, at the age of seven, he could neither read nor write, that he would not learn any of his lessons properly, resisting, with unreasoning defiance, every attempt to educate him, and that for two years he had been developing rages in which he smashed everything within reach. He was intelligent enough, so the parents thought, but totally lacking in goodwill. Instead of working he lazed about or played with his decrepit old Teddy bear, which for years had been his only toy. He had been given plenty of other toys, but he viciously destroyed them. They had even engaged a good governess for him, but she could do nothing with him either. He was, after a couple of girls, the first and only son, on whom, so it seemed to me, the mother doted especially. As soon as I saw the child the riddle was solved: the boy was pretty much of an imbecile already, and the mother, who could not endure having a backward son, had so egged on and tormented this essentially harmless and good-natured zany with her ambitions that he went completely berserk out of sheer desperation. When I spoke to the mother after the examination she was outraged by my diagnosis and insisted that I must have made a mistake.

229] The educator should know above all else that talk and officious discipline lead nowhere, that what counts is example. If he unconsciously permits all kinds of viciousness, lies, and bad manners in himself, these will have an incomparably more powerful effect than the best of intentions, which are so easily come by. The doctor therefore believes that the best way to educate others is for the educator himself to be educated, and that he should first try out on himself the psychological profundities he has learnt from text-books, in order to test their efficacy. So long as these efforts are prosecuted with a certain amount of intelligence and patience, he will probably not make such a bad teacher.

V

THE GIFTED CHILD

THE GIFTED CHILD¹

230] When I visited the United States for the first time, I was much astonished to see that there were no barriers at the railway crossings and no protective hedges alongside the railway track. In the remoter districts the line was actually used as a foot-path. When I voiced my astonishment about this, I was informed, “Only an idiot could fail to see that trains pass along the line at forty to a hundred miles an hour!” Another thing that struck me was that nothing is *verboden*; instead, one is merely “not allowed” to do something, or one is politely requested: “Please don’t _____.”

231] These impressions, and others like them, reduced themselves to the discovery that in America civic life appeals to the intelligence and expects an intelligent response, whereas in Europe it plans for stupidity. America fosters and looks forward to intelligence; Europe looks back to see whether the dumb ones are also coming along. What is worse, Europe takes evil intentions for granted and is forever crying that bossy and officious “*Verboten!*” into our ears, whereas America addresses herself to people’s common sense and goodwill.

232] Involuntarily I found my thoughts drifting back to my school-days, and there I saw the European prejudice embodied in certain of my teachers. I was not, as a twelve-year-old schoolboy, by any means drowsy or stupid, but often I felt uncommonly bored when the teacher had to busy himself with the slowcoaches. I had the good fortune to possess a genial Latin master who, during the exercises, used to send me to fetch books from the university library, and in these I browsed with delight as I dawdled back by the longest possible route. Boredom, however, was by no means the worst of my experiences. Once, among the numerous and not exactly stimulating themes for an essay, we were given something really interesting. I set to work very seriously and polished my sentences with the greatest care. In happy anticipation of having written the best, or at least one of the better essays, I handed mine in to the teacher. When giving them back he always used to discuss the best essay first, and then the others in order of merit. All the others came before mine, and when the last, feeblest effort was about to be discussed, the teacher inflated himself in a manner that boded disaster, and pronounced the following words: “Jung’s essay is by far the best, but he has composed it frivolously and dashed it off without taking any trouble. Therefore it merits no attention whatever.” “That is not true,” I cried, “I’ve never put so much work into any essay as I did into this.” “That’s a lie!” he shouted. “Look at Smith Minor”—the boy who had

produced the worst essay—“*he* took trouble over his. He will get on in life, but you won’t, no, not you—for in life you can’t get away with cleverness and humbug.” I was silent. From that moment I never did a stroke of work during German lessons.

233] This mishap lies more than half a century behind me, and I have no doubt that there have been many changes and improvements in the school since then. But, at the time, it obsessed my thoughts and left me with a feeling of bitterness, though this naturally gave place to better understanding as my experience of life increased. I came to realize that my teacher’s attitude was after all based on the noble precept of helping the weak and eradicating the bad. But, as so often happens with such precepts, they are apt to be elevated to soulless principles which do not bear thinking about further, so that a lamentable caricature of goodness results: one helps the weak and fights against the bad, but at the same time one runs the risk of putting the gifted child in a back place, as though being ahead of one’s fellows were something scandalous and improper. The average person distrusts and readily suspects anything that his intelligence cannot grasp. *Il est trop intelligent*—reason enough for the blackest suspicion! In one of his novels Paul Bourget describes an exquisite scene in the antechamber of some Minister, which serves as the perfect paradigm. A middle-class couple offer this criticism of a celebrated scholar, with whom of course they are not acquainted: “Il doit être de la police secrète, il a l’air si méchant.”

234] I trust you will forgive me for having dwelt so long on autobiographical details. Nevertheless this *Wahrheit* without the *Dichtung* is not just an isolated instance; it is something that happens all too often. The gifted schoolchild faces us with an important task which we cannot ignore, despite that worthy maxim about helping the less gifted. In a country as small as Switzerland we cannot afford, however charitable our aspirations may be, to overlook these much-needed gifted children. Even today we seem to proceed somewhat diffidently in this matter. Not long ago I heard of the following case: An intelligent little girl in one of the lower forms at a primary school suddenly became a bad pupil, much to the astonishment of her parents. The things the child said out of school sounded so comical that her parents got the impression that the children were treated like idiots and were being stultified artificially. So the mother went to see the Principal about it and discovered that the teacher had been trained to cope with defectives and had formerly looked after backward children. Obviously she did not know the first thing about normal ones. Luckily the damage was caught in time, so that the child could be passed on to a normal teacher under whom she soon picked up again.

235] The problem of the gifted child is not at all simple, because he is not distinguished merely by the fact of being a good pupil. Occasionally he is the exact opposite. He may even be notoriously absent-minded, have his head full of other things, be

indolent, slovenly, inattentive, badly behaved, self-willed, or evoke the impression of being half asleep. From external observation alone it is sometimes difficult to distinguish the gifted child from a mental defective.

236] Nor should we forget that gifted children are not always precocious, but may on the contrary develop slowly, so that the gift remains latent for a long time. The giftedness can then be spotted only with difficulty. On the other hand too much goodwill and optimism on the part of the teacher can imagine talents that later turn out to be blanks, as in the biography which says: "No signs of genius were observable up to his fortieth year—nor indeed afterwards."

237] Sometimes the only thing that helps in diagnosing a gift is careful observation of the child's individuality both in school and at home, which alone enables us to see what is primary disposition and what is secondary reaction. In the gifted child inattentiveness, absent-mindedness, and day-dreaming may prove to be a secondary defence against outside influences, in order that the interior fantasy processes may be pursued undisturbed. Admittedly the mere existence of lively fantasies or peculiar interests is no proof of special gifts, as the same predominance of aimless fantasies and abnormal interests may also be found in the previous history of neurotics and psychotics. What does reveal the gift, however, is the *nature* of these fantasies. For this one must be able to distinguish an intelligent fantasy from a stupid one. A good criterion of judgment is the originality, consistency, intensity, and subtlety of the fantasy structure, as well as the latent possibility of its realization. One must also consider how far the fantasy extends into the child's actual life, for instance in the form of hobbies systematically pursued and other interests. Another important indication is the degree and quality of his interest in general. One sometimes makes surprising discoveries where problem children are concerned, such as a voracious and apparently indiscriminate reading of books, done mostly in the forbidden hours after bedtime, or else some unusual practical accomplishment. All these signs can only be understood by one who takes the trouble to inquire into the reasons for the child's problems, and who is not content merely to pick on the bad qualities. A certain knowledge of psychology—by which I mean common sense and experience—is therefore a desirable requisite in a teacher.

238] The psychic disposition of the gifted child always moves in violent contrasts. That is to say, it is extremely rare for the gift to affect all regions of the psyche uniformly. The general rule is that one or the other region will be so little developed as to entitle us to speak of a defect. Above all the degree of maturity differs enormously. In the region of the gift abnormal precocity may prevail, while outside that region the mental attainment may be below normal for a child of that age. Occasionally this gives rise to a misleading picture: one thinks one is dealing with a rather undeveloped and mentally backward child and, in consequence, fails to credit him

with any ability above the normal. Or it may be that a precocious intellect is not accompanied by a corresponding development of verbal facility, so that the child is driven to express himself in a seemingly confused or unintelligible way. In such cases only a careful inquiry into the why and wherefore, and a conscientious deliberation of the answers, can save the teacher from false judgments. But there are also cases where the gift applies to some aptitude not affected by school-work at all. This is particularly true of certain practical accomplishments. I myself remember boys who distinguished themselves at school by their remarkable stupidity, but who were highly efficient at the peasant trades of their parents.

239] While I am on this subject I must not omit to point out that very erroneous views used to be held at one time concerning the gift for mathematics. It was believed that the capacity for logical and abstract thought was, so to speak, incarnate in mathematics and that this was therefore the best discipline if one wanted to think logically. But the mathematical gift, like the musical gift to which it is biologically related, is identical neither with logic nor with intellect, although it makes use of them just as all philosophy and science do. One can be musical without possessing a scrap of intellect, and in the same way astounding feats of calculation can be performed by imbeciles. Mathematical sense can be inculcated as little as can musical sense, for it is a specific gift.

240] The gifted child is faced with complications not only in the intellectual but in the moral sphere, that is, in the province of feeling. The prevarication, lying, and other moral laxities so common in grown-ups can easily become a distressing problem for the morally gifted child. It is just as easy for an adult to disregard moral criticism that springs from feeling, as it is to overlook or underestimate intellectual sensitivity and precocity. The gifts of the heart are not quite so obvious or so impressive as intellectual and technical endowments, and, just as the latter demand special understanding from the teacher, so these other gifts often make the even greater demand that he himself should be educated. For the day will inevitably come when what the educator teaches by word of mouth no longer works, but only what he is. Every educator—and I use the term in its widest sense—should constantly ask himself whether he is actually fulfilling his teachings in his own person and in his own life, to the best of his knowledge and with a clear conscience. Psychotherapy has taught us that in the final reckoning it is not knowledge, not technical skill, that has a curative effect, but the personality of the doctor. And it is the same with education: it presupposes self-education.

241] In saying this I have no wish to set myself up as a judge over the pedagogues; on the contrary, with my many years as active teacher and educator, I must count myself as one of them and await judgment or condemnation with the rest. It is only on the basis of my experience in treating human beings that I venture to draw your

attention to the profound practical significance of this fundamental educational truth.

242] There are, besides the gifts of the head, also those of the heart, which are no whit less important, although they may easily be overlooked because in such cases the head is often the weaker organ. And yet people of this kind sometimes contribute more to the well-being of society, and are more valuable, than those with other talents. But, like all gifts, talented feeling has two sides to it. A high degree of empathy, especially noticeable in girls, can adapt itself to the teacher so skilfully as to arouse the impression of a special talent, and moreover on the evidence of no mean achievements. But as soon as the personal influence ceases, the gift fizzles out. It was nothing but an enthusiastic episode conjured into existence through empathy, flaring up like a straw fire and leaving the ashes of disappointment behind.

243] The education of gifted children makes considerable demands upon the intellectual, psychological, moral, and artistic capacities of the educator, demands which, it may be, no teacher can reasonably be expected to fulfil. He would have to be something of a genius himself if he were to do justice to the gift of genius among any of his pupils.

244] Fortunately, however, many gifts seem to have a peculiar ability to take care of themselves, and the closer a gifted child comes to being a genius the more his creative capacity—as the very word “genius” implies—acts like a personality far in advance of his years, one might even say like a divine daemon who not only needs no educating, but against whom it is more necessary to protect the child. Great gifts are the fairest, and often the most dangerous, fruits on the tree of humanity. They hang on the weakest branches, which easily break. In most cases, as I have already suggested, the gift develops in inverse ratio to the maturation of the personality as a whole, and often one has the impression that a creative personality grows at the expense of the human being. Sometimes, indeed, there is such a discrepancy between the genius and his human qualities that one has to ask oneself whether a little less talent might not have been better. What after all is great intellect beside moral inferiority? There are not a few gifted persons whose usefulness is paralysed, not to say perverted, by their human shortcomings. A gift is not an absolute value, or rather, it is such a value only when the rest of the personality keeps pace with it, so that the talent can be applied usefully. Creative powers can just as easily turn out to be destructive. It rests solely with the moral personality whether they apply themselves to good things or to bad. And if this is lacking, no teacher can supply it or take its place.

245] The narrow margin between a gift and its pathological variant makes the problem of educating such children much more difficult. Not only is the gift almost invariably compensated by some inferiority in another sphere, but occasionally it is

coupled with a morbid defect. In such cases it is almost impossible to determine whether it is the gift or the psychopathic constitution that predominates.

246] For all these reasons I would hardly like to say whether it would be of advantage to educate particularly gifted pupils in separate classes, as has been proposed.² I at least would not care to be the expert upon whom devolved the selection of suitable pupils. Although it would be an enormous help to the gifted ones, we have still to consider the fact that these same pupils do not always come up to the level of their gifts in other respects, human as well as mental. Segregated in a special class, the gifted child would be in danger of developing into a one-sided product. In a normal class, on the other hand, although he might be bored with the subject in which he excelled, the other subjects would serve to remind him of his backwardness, and this would have a useful and much-needed moral effect. For all gifts have the moral disadvantage of causing in their possessor a feeling of superiority and hence an inflation which needs to be compensated by a corresponding humility. But since gifted children are very often spoilt, they come to expect exceptional treatment. My old teacher was well aware of this, and that is why he delivered his moral “knock-out,” from which I failed at the time to draw the necessary conclusions. Since then I have learnt to see that my teacher was an instrument of fate. He was the first to give me a taste of the hard truth that the gifts of the gods have two sides, a bright and a dark. To rush ahead is to invite blows, and if you don’t get them from the teacher, you will get them from fate, and generally from both. The gifted child will do well to accustom himself early to the fact that any excellence puts him in an exceptional position and exposes him to a great many risks, the chief of which is an exaggerated self-confidence. Against this the only protection is humility and obedience, and even these do not always work.

247] It therefore seems to me better to educate the gifted child along with the other children in a normal class, and not to underline his exceptional position by transferring him to a special class. When all is said and done, school is a part of the great world and contains in miniature all those factors which the child will encounter in later life and with which he will have to come to terms. Some at least of this necessary adaptation can and should be learnt at school. Occasional clashes are not a catastrophe. Misunderstanding is fatal only when chronic, or when the child’s sensitivity is unusually acute and there is no possibility of finding another teacher. That often brings favourable results, but only when the cause of the trouble really does lie with the teacher. This is by no means the rule, for in many cases the teacher has to suffer for the ruin wrought by the child’s upbringing at home. Far too often parents who were unable to fulfil their own ambitions embody them in their gifted child, whom they either pamper or else whip up into a showpiece, sometimes

very much to his detriment in later years, as is sufficiently evident from the lives of certain infant prodigies.

248] A powerful talent, and especially the Danaän gift of genius, is a fateful factor that throws its shadow early before. The genius will come through despite everything, for there is something absolute and indomitable in his nature. The so-called “misunderstood genius” is rather a doubtful phenomenon. Generally he turns out to be a good-for-nothing who is forever seeking a soothing explanation of himself. Once, in my professional capacity, I was forced to confront a “genius” of this type with the alternative: “Or perhaps you are nothing but a lazy hound?” It was not long before we found ourselves in whole-hearted agreement on this point. Talent, on the other hand, can either be hampered, crippled, and perverted, or fostered, developed, and improved. The genius is as rare a bird as the phoenix, an apparition not to be counted upon. Consciously or unconsciously, genius is something that by God’s grace is there from the start, in full strength. But talent is a statistical regularity and does not always have a dynamism to match. Like genius, it is exceedingly diverse in its forms, giving rise to individual differentiations which the educator ought not to overlook; for a differentiated personality, or one capable of differentiation, is of the utmost value to the community. The levelling down of the masses through suppression of the aristocratic or hierarchical structure natural to a community is bound, sooner or later, to lead to disaster. For, when everything outstanding is levelled down, the signposts are lost, and the longing to be led becomes an urgent necessity. Human leadership being fallible, the leader himself has always been, and always will be, subject to the great symbolical principles, even as the individual cannot give his life point and meaning unless he puts his ego at the service of a spiritual authority superordinate to man. The need to do this arises from the fact that the ego never constitutes the whole of a man, but only the conscious part of him. The unconscious part, of unlimited extent, alone can complete him and make him a real totality.

249] Biologically speaking, the gifted person is a deviation from the mean, and in so far as Lao-tzu’s remark that “high stands on low” is one of the eternal verities, this deviation takes place simultaneously in the heights and depths of the same individual. This produces a tension of opposites in him, which in its turn tempers and intensifies his personality. Like the still waters, the gifted child runs deep. His danger lies not only in deviating from the norm, however favourable this may appear to be, but even more in that inner polarity which predisposes to conflict. Therefore, instead of segregation in special classes, the personal interest and attention of the teacher are likely to be more beneficial. Although the institution of a trained school psychiatrist is thoroughly to be recommended and need not be a mere concession to the craze for what is technically right, I would say, in the light of my

own experience, that an understanding heart is everything in a teacher, and cannot be esteemed highly enough. One looks back with appreciation to the brilliant teachers, but with gratitude to those who touched our human feelings. The curriculum is so much necessary raw material, but warmth is the vital element for the growing plant and for the soul of the child.

250] Because there are, among the other pupils, gifted and highly strung natures which ought not to be hemmed in and stifled, the school curriculum should for that very reason never wander too far from the humanities into over specialized fields. The coming generation should at least be shown the doors that lead to the many different departments of life and the mind. And it seems to me especially important for any broad-based culture to have a regard for history in the widest sense of the word. Important as it is to pay attention to what is practical and useful, and to consider the future, that backward glance at the past is just as important. Culture means continuity, not a tearing up of roots through "progress." For the gifted child in particular, a balanced education is essential as a measure of psychic hygiene. As I have said, his gift is one-sided and is almost always offset by some childish immaturity in other regions of the psyche. Childhood, however, is a state of the past. Just as the developing embryo recapitulates, in a sense, our phylogenetic history, so the childpsyche relives "the lesson of earlier humanity," as Nietzsche called it. The child lives in a pre-rational and above all in a prescientific world, the world of the men who existed before us. Our roots lie in that world and every child grows from those roots. Maturity bears him away from his roots and immaturity binds him to them. Knowledge of the universal origins builds the bridge between the lost and abandoned world of the past and the still largely inconceivable world of the future. How should we lay hold of the future, how should we assimilate it, unless we are in possession of the human experience which the past has bequeathed to us? Dispossessed of this, we are without root and without perspective, defenceless dupes of whatever novelties the future may bring. A purely technical and practical education is no safeguard against delusion and has nothing to oppose to the counterfeit. It lacks the culture whose innermost law is the continuity of history, the long procession of man's more than individual consciousness. This continuity which reconciles all opposites also heals the conflicts that threaten the gifted child.

251] Anything new should always be questioned and tested with caution, for it may very easily turn out to be only a new disease. That is why true progress is impossible without mature judgment. But a well-balanced judgment requires a firm standpoint, and this in turn can only rest on a sound knowledge of what has been. The man who is unconscious of the historical context and lets slip his link with the past is in constant danger of succumbing to the crazes and delusions engendered by all novelties. It is the tragedy of all innovators that they empty out the baby with the

bath-water. Though the mania for novelty is not, thank heavens, the national vice of the Swiss, we live nevertheless in a wider world that is being shaken by strange fevers of renewal. In face of this frightening and grandiose spectacle, steadiness is demanded of our young men as never before, firstly for the stability of our country, and secondly for the sake of European civilization, which has nothing to gain if the achievements of the Christian past are wiped out.

252] The gifted ones, however, are the torch-bearers, chosen for that high office by nature herself.

VI

THE SIGNIFICANCE OF THE UNCONSCIOUS IN INDIVIDUAL EDUCATION

THE SIGNIFICANCE OF THE UNCONSCIOUS IN INDIVIDUAL EDUCATION¹

253] In general, one can distinguish three kinds of education:

I. EDUCATION THROUGH EXAMPLE. This kind of education can proceed wholly unconsciously and is therefore the oldest and perhaps the most effective form of all. It is aided by the fact that the child is psychologically more or less identical with its environment, and especially with its parents. This peculiarity is one of the most conspicuous features of the primitive psyche, for which the French anthropologist, Lévy-Bruhl, coined the term “participation mystique.” Because unconscious education through example rests on one of the oldest psychic characteristics, it is effective where all other direct methods fail, as for instance in insanity. Many insane patients have to be made to work in order to keep them from degenerating: to give them advice, or to try to order them about, is in most cases quite useless. But if you just send them along with a group of workers, eventually they get infected by the example of the others and begin to work themselves. In the last analysis, all education rests on this fundamental fact of psychic identity, and in all cases the deciding factor is this seemingly automatic contagion through example. This is so important that even the best methods of conscious education can sometimes be completely nullified by bad example.

254] II. COLLECTIVE EDUCATION. By collective education I do not necessarily mean education *en masse* (as in schools), but education according to rules, principles, and methods. These three things are necessarily of a collective nature, since it is assumed that they are at least valid for and applicable to the large majority of individuals. It is further assumed that they are effective instruments in the hands of all those who have learnt how to manipulate them. We can take it for granted that this kind of education will not produce anything except what is already contained in its premises, and that the individuals it turns out will be moulded by general rules, principles, and methods.

255] To the extent that the individuality of the pupil succumbs to the collective nature of these educational influences, he naturally develops a character much resembling that of another individual, who, though originally quite different, has nevertheless acquiesced in the same way. If there is a large number of individuals who possess this degree of acquiescence, conformity becomes uniformity. The larger the number of individuals who conform, the greater the unconscious pressure of example on all those who, rightly or wrongly, have so far successfully resisted the collective method. And since the example of the crowd exerts a compelling influence through

unconscious psychic contagion, it may in the long run have a crushing effect upon those individuals who possess no more than average strength of character, if it does not extinguish them altogether. Provided that the quality of this training is sound, we may naturally expect good results so far as collective adaptation is concerned. On the other hand, an over-idealistic moulding of character can have disastrous consequences for the unique personality of the individual. To educate him into being a good citizen and a useful member of society is certainly a highly desirable goal. But once a certain level of uniformity is overstepped, and collective values are fostered at the expense of individual uniqueness, then you get the type of person who, though he may be a perfect paragon of the educational rules, principles, and methods, and is therefore adapted to all the situations and problems that come within the scope of his educational premises, nevertheless feels insecure in all matters where individual judgments have to be made without recourse to the regulations.

256] Collective education is indeed a necessity and cannot be replaced by anything else. We live in a collective world, and we need collective norms just as much as we need a common language. On no account must the principle of collective education be sacrificed for the sake of developing individual idiosyncrasies, however much we may desire to prevent the more valuable ones from being stifled. We must bear in mind that individual uniqueness is not under all circumstances an asset, not even for the individual himself. When we examine the type of child who resists collective education, we often find that these children are afflicted with various psychic abnormalities, either congenital or acquired. Among them I would also include spoiled and demoralized children. Many such children actually work out their own salvation by throwing themselves on the support of a normally functioning group. In this way they achieve a certain degree of uniformity, and can protect themselves from the injurious effects of their own individualities. I do not at all subscribe to the view that fundamentally man is always good, and that his evil qualities are merely misunderstood good. On the contrary, I hold that there are very many persons who represent such an inferior combination of inherited characteristics that it would be far better both for society and for themselves if they refrained from expressing their individual idiosyncrasies. We can therefore claim with a clear conscience that collective education is, at bottom, of undoubted value, and absolutely sufficient for most people. We must not, however, make it the sovereign principle of education, for there exists a large group of children who require the third form of education, namely *individual* education.

257] III. INDIVIDUAL EDUCATION. In applying this method, all rules, principles, and systems must be subordinated to the one purpose of bringing out the specific individuality of the pupil. This aim is directly opposed to that of collective

education, which seeks to level out and make uniform. All children who successfully resist this require individual attention. Among these we naturally find the most diverse types. First of all, there are those who are ineducable as a result of pathological degeneration. These generally fall into the category of mental defectives. Then there are others who, far from being ineducable, exhibit special aptitudes, though of a peculiar or one-sided nature. The most frequent of such peculiarities is the incapacity to understand any form of mathematics not expressed in concrete numbers. For this reason higher mathematics ought always to be optional in schools, since it is in no way connected with the development of logical thinking. For these pupils, mathematics is quite meaningless, and a source of needless torment. The truth is that mathematics presupposes a definite mental aptitude which by no means everybody possesses and which cannot be acquired. For those who do not possess it, mathematics can only be learnt by rote like a jumble of meaningless words. Such persons may be highly gifted in every other way, and may possess the capacity for logical thinking already, or can acquire it more easily through direct instruction in logic.

258] Strictly speaking, of course, a deficiency in mathematical ability cannot be regarded as an individual peculiarity. But it does clearly show how a school curriculum may sin against the psychological peculiarity of a pupil. In the same way, certain widely accepted pedagogic principles may prove to be utterly useless, indeed positively harmful, in all cases where the psychological peculiarity of the pupil calls for an exclusively individual influence. Fairly frequently we find that not only specific rules, but the whole apparatus of educational influence is met by an insurmountable antagonism. In such cases we usually have to do with so-called neurotic children. The teacher is at first inclined to ascribe the difficulties to the morbid disposition of the child, but more careful inquiry will often show that the child comes from a peculiar domestic milieu which is quite sufficient to explain his maladjustment. The child has acquired an attitude at home that unfits him for collective life.

259] It is, of course, quite outside the teacher's province to change the home atmosphere, although a little good advice can often work wonders even with parents. As a rule, however, the trouble has to be cured in the child himself, and this means finding the right approach to his peculiar psychology so as to render it amenable to influence. As we have already said, the first requisite is thorough knowledge of his home life. We know a great deal when we have found out the causes of a symptom, but still more is needed. The next thing we need to know is what sort of effects the external causes have produced in the child's psyche. This knowledge we obtain from a thorough investigation of his psychological life-history on the basis of his own and his parents' statements. Under certain conditions a good deal can be accomplished

with just this information. Skilful teachers have applied this method all along, so there is no need for me to dwell on it here.

260] If we realize that the child gradually develops out of the unconscious state into a conscious one, we can understand why practically all environmental influences, or at any rate the most elementary and most lasting of them, are unconscious. The first impressions of life are the strongest and most profound, even though they are unconscious—perhaps indeed for that very reason, for so long as they are unconscious they are not subject to change. We can only correct what is in our consciousness; what is unconscious remains unchanged. Consequently, if we wish to produce a change we must first raise these unconscious contents to consciousness, so as to submit them to correction. This operation is not necessary in cases where a careful investigation of the family environment and of the psychological life-history of the individual has furnished us with the means of influencing him effectively. But in cases where this does not suffice, the investigation must go deeper. It is a species of surgical intervention which can have dire results if performed without adequate technical equipment. It takes considerable medical experience to know just when and where this treatment should be applied. Laymen unfortunately often underestimate the dangers which such interventions entail. By bringing unconscious contents to the surface you artificially create a condition that bears the closest resemblance to a psychosis. The vast majority of mental illnesses (except those of a directly organic nature) are due to a disintegration of consciousness caused by the irresistible invasion of unconscious contents. Accordingly we must know where we can intervene without the risk of harm. Even if no danger threatens from this side, we are still not exempt from certain hazards. One of the commonest consequences of preoccupation with unconscious contents is the development of what Freud called “the transference.” Strictly speaking, transference is the projection of unconscious contents upon the person analysing the unconscious. The term “transference,” however, is used in a much wider sense and embraces all the exceedingly complex processes which bind the patient to the analyst. This bond can turn into an extremely unpleasant obstacle if inexpertly handled. There are cases where it has even led to suicide. One of the main reasons for this is the coming to consciousness of certain unconscious contents which throw a new and disturbing light on the family situation. Things may come up that transform the patient’s love and trust in his parents into resistance and hatred. He then finds himself in an intolerable state of isolation, and will cling desperately to the analyst as his last remaining link with the world. If at this critical juncture the analyst, through some technical blunder, snaps even this link, it can lead straight to suicide.

261] I am therefore of the opinion that so drastic a measure as the analysis of the unconscious should at least be conducted under the control and guidance of a doctor

adequately trained in psychiatry and psychology.

262] In what way, then, can unconscious contents be brought to consciousness? As you will realize, it is hardly possible within the compass of a lecture to describe all the ways in which this may be done. The best practical method, though also the most difficult, is the analysis and interpretation of dreams. Dreams are unquestionably products of unconscious psychic activity. Born in sleep without design or assistance on our part, they pass before our inward vision and may suddenly float back into our waking life on a dim remnant of consciousness. Their strange, often irrational and incomprehensible nature may well inspire mistrust of them as reliable sources of information. And indeed our attempts to understand dreams are scarcely in keeping with any known scientific method of calculation and measurement. Our position is more like that of an archaeologist deciphering an unknown script. Yet, if unconscious contents exist at all, dreams are surely in the best position to tell us something about them. To Freud belongs the great honour of having been the first to demonstrate this possibility in our own day, although all previous ages were deeply preoccupied with the mystery of dreams, nor was this interest always purely superstitious. The work of Artemidorus of Daldis (second century A.D.) on dream interpretation is, of its kind, a scientific document not to be despised, nor should we dismiss as valueless the dream interpretations of the Essenes recorded by Flavius Josephus (b. A.D. 37). Nevertheless, had it not been for Freud, science would probably not have returned so soon to dreams as sources of information, despite the enormous attention paid to them by the physicians of antiquity. Even today opinion is still very much divided on this subject. There are in fact many medical psychologists who refuse to analyse dreams, either because the method seems to them too uncertain, too arbitrary, and too difficult, or because they feel no need of the unconscious. I myself am of the contrary opinion, and have been convinced by ample experience that in all difficult cases the patient's dreams can be of incalculable value to the psychiatrist, both as a source of information and as a therapeutic instrument.

263] Coming now to the much-disputed question of dream-analysis, we proceed in a manner not unlike that employed in the deciphering of hieroglyphs. First we assemble all the available material which the dreamer himself can give as regards the dream images. We next exclude any statements that depend upon particular theoretical assumptions, for those are generally quite arbitrary attempts at interpretation. We then inquire into the happenings of the previous day, as well as into the mood and the general plans and purposes of the dreamer in the days and weeks preceding the dream. A more or less intimate knowledge of his circumstances and character is of course a necessary prerequisite. Great care and attention must be given to this preparatory work if we want to get at the meaning of the dream. I have

no faith in dream interpretations made on the spur of the moment and concocted out of some preconceived theory. One must be careful not to impose any theoretical assumptions on the dream; in fact, it is always best to proceed as if the dream had no meaning at all, so as to be on one's guard against any possible bias. Dream-analysis may yield entirely unforeseen results, and facts of an exceedingly disagreeable nature may sometimes come to light whose discussion would certainly have been avoided at all costs had we been able to anticipate them. We may also get results that are obscure and unintelligible at first, because our conscious standpoint has still not plumbed the secrets of the psyche. In such cases it is better to adopt a waiting attitude than to attempt a forced explanation. In this kind of work one has to put up with a great many question marks.

264] While we are engaged in collecting all this material certain portions of the dream gradually grow clearer, and we begin to see, in the apparently meaningless jumble of images, some glimmerings of a script—only disconnected sentences at first, then more and more of the context. It will perhaps be best if I give you a few examples of the dreams that occur in the course of an individual education under medical control.²

265] I must first acquaint you in some measure with the personality of the dreamer, for without this acquaintance you will hardly be able to transport yourselves into the peculiar atmosphere of the dreams.

266] There are dreams that are pure poems and can therefore only be understood through the mood they convey as a whole. The dreamer is a youth of a little over twenty, still entirely boyish in appearance. There is even a touch of girlishness in his looks and manner of expression. The latter betrays a very good education and upbringing. He is intelligent, with pronounced intellectual and aesthetic interests. His aestheticism is very much in evidence: we are made instantly aware of his good taste and his fine appreciation of all forms of art. His feelings are tender and soft, given to the enthusiasms typical of puberty, but somewhat effeminate. There is no trace of adolescent callowness. Undoubtedly he is too young for his age, a clear case of retarded development. It is quite in keeping with this that he should have come to me on account of his homosexuality. The night preceding his first visit he had the following dream:

267] The dream is clearly a coherent expression of mood. The dreamer's comments are as follows: "Lourdes is the mystic fount of healing. Naturally I remembered yesterday that I was going to you for treatment and was in search of a cure. There is said to be a well like this at Lourdes. It would be rather unpleasant to go down into the water. The well was ever so deep."

"I am in a lofty cathedral filled with mysterious twilight. They tell me that it is the cathedral at Lourdes. In the centre there is a deep dark well, into which I have to

descend.”

268] Now what does this dream tell us? On the surface it seems clear enough, and we might be content to take it as a kind of poetic formulation of the mood of the day before. But we should never stop there, for experience shows that dreams are much deeper and more significant. One might almost suppose that the dreamer came to the doctor in a highly poetic mood and was entering upon the treatment as though it were a sacred religious act to be performed in the mystical half-light of some awe-inspiring sanctuary. But this does not fit the facts at all. The patient merely came to the doctor to be treated for that unpleasant matter, his homosexuality, which is anything but poetic. At any rate we cannot see from the mood of the preceding day why he should dream so poetically, if we were to accept so direct a causation for the origin of the dream. But we might conjecture, perhaps, that the dream was stimulated precisely by the dreamer's impressions of that highly unpoetical affair which impelled him to come to me for treatment. We might even suppose that he dreamed in such an intensely poetical manner just because of the unpoeticalness of his mood on the day before, much as a man who has fasted by day dreams of delicious meals at night. It cannot be denied that the thought of treatment, of the cure and its unpleasant procedure, recurs in the dream, but poetically transfigured, and in a guise which meets most effectively the lively aesthetic and emotional needs of the dreamer. He will be drawn on irresistibly by this inviting picture, despite the fact that the well is dark, deep, and cold. Something of the dream-mood will persist after sleep and will even linger on into the morning of the day on which he has to submit to the unpleasant and unpoetical duty of visiting me. Perhaps the drab reality will be touched by the bright, golden after-glow of the dream feeling.

269] Is this, perhaps, the purpose of the dream? That would not be impossible, for in my experience the vast majority of dreams are compensatory. They always stress the other side in order to maintain the psychic equilibrium. But the compensation of mood is not the only purpose of the dream picture. The dream also provides a mental corrective. The patient had of course nothing like an adequate understanding of the treatment to which he was about to submit himself. But the dream gives him a picture which describes in poetic metaphors the nature of the treatment before him. This becomes immediately apparent if we follow up his associations and comments on the image of the cathedral:

“Cathedral,” he says, “makes me think of Cologne Cathedral. Even as a child I was fascinated by it. I remember my mother telling me of it for the first time, and I also remember how, whenever I saw a village church, I asked if it were Cologne Cathedral. I wanted to be a priest in a cathedral like that.”

270] In these associations the patient is describing a very important experience of his childhood. As in nearly all cases of this kind, he had a particularly close tie with his

mother. By this we are not to understand a particularly good or intense *conscious* relationship, but something in the nature of a secret, subterranean tie which expresses itself consciously, perhaps, only in the retarded development of character, i.e., in a relative infantilism. The developing personality naturally veers away from such an unconscious infantile bond; for nothing is more obstructive to development than persistence in an unconscious—one could also say, a psychically embryonic, condition. For this reason instinct seizes on the first opportunity to replace the mother by another object. If it is to be a real mother-substitute, this object must be, in some sense, an analogy of her. This is entirely the case with our patient. The intensity with which his childish fantasy seized upon the symbol of Cologne Cathedral corresponds to the strength of his unconscious need to find a substitute for the mother. The unconscious need is heightened still further in a case where the infantile bond threatens injury. Hence the enthusiasm with which his childish imagination took up the idea of the Church; for the Church is, in the fullest sense, a mother. We speak not only of Mother Church, but even of the Church's womb. In the ceremony known as the *benedictio fontis*, the baptismal font is apostrophized as *immaculatus divini fontis uterus*—"immaculate womb of the divine fount." We naturally think that a man must have known this meaning consciously before it could get to work on his fantasy, and that an unknowing child could not possibly be affected by these significations. Such analogies certainly do not work by way of the conscious mind, but in quite another manner.

271] The Church represents a higher spiritual substitute for the purely natural, or "carnal," tie to the parents. Consequently it frees the individual from an unconscious natural relationship which, strictly speaking, is not a relationship at all but simply a condition of inchoate, unconscious identity. This, just because it is unconscious, possesses a tremendous inertia and offers the utmost resistance to any kind of spiritual development. It would be hard to say what the essential difference is between this condition and the soul of an animal. Now, it is by no means the special prerogative of the Christian Church to try to make it possible for the individual to detach himself from his original, animal-like condition; the Church is simply the latest, and specifically Western, form of an instinctive striving that is probably as old as mankind itself. It is a striving that can be found in the most varied forms among all primitive peoples who are in any way developed and have not yet become degenerate: I mean the institution or rite of initiation into manhood. When he has reached puberty the young man is conducted to the "men's house," or some other place of consecration, where he is systematically alienated from his family. At the same time he is initiated into the religious mysteries, and in this way is ushered not only into a wholly new set of relationships, but, as a renewed and changed personality, into a new world, like one reborn (*quasi modo genitus*). The initiation is

often attended by all kinds of tortures, sometimes including circumcision and the like. These practices are undoubtedly very old. They have almost become instinctive mechanisms, with the result that they continue to repeat themselves without external compulsion, as in the “baptisms” of German students or the even more wildly extravagant initiations in American students’ fraternities. They have become engraved in the unconscious in the form of a primordial image, an archetype, as St. Augustine calls it.

272] When his mother told him as a little boy about Cologne Cathedral, this primordial image was stirred and awakened to life. But there was no priestly instructor to develop it further, so the child remained in his mother’s hands. Yet the longing for a man’s leadership continued to grow in the boy, taking the form of homosexual leanings—a faulty development that might never have come about had a man been there to educate his childish fantasies. The deviation towards homosexuality has, to be sure, numerous historical precedents. In ancient Greece, as also in certain primitive communities, homosexuality and education were practically synonymous. Viewed in this light, the homosexuality of adolescence is only a profound misunderstanding of the otherwise very appropriate need for masculine guidance.

273] According to the dream, then, what the initiation of the treatment signifies for the patient is the fulfilment of the true meaning of his homosexuality, i.e., his entry into the world of adult men. All that we have been forced to discuss here in such tedious and long-winded detail, in order to understand it properly, the dream has condensed into a few vivid metaphors, thus creating a picture which works far more effectively on the imagination, feeling, and understanding of the dreamer than any learned discourse. Consequently the patient was better and more intelligently prepared for the treatment than if he had been overwhelmed with medical and pedagogical maxims. For this reason I regard dreams not only as a valuable source of information but as an extraordinarily effective instrument of education and therapy.

274] I shall now give you the second dream, which the patient dreamt on the night following his first visit to me. It makes certain welcome additions to the previous one. I must explain in advance that during the first consultation I did not refer in any way to the dream we have just been discussing. It was not even mentioned. Nor was there a word said that was even remotely connected with the foregoing.

275] The second dream was as follows:

“I am in a great Gothic cathedral. At the altar stands a priest. I stand before him with my friend, holding in my hand a little Japanese ivory figure, with the feeling that it is going to be baptized. Suddenly an elderly woman appears, takes the fraternity ring from my friend’s finger, and puts it on her own. My friend is afraid that this may bind him in some way. But at the same time there is a sound of wonderful organ music.”

276] Unfortunately I cannot, within the short space of a lecture, enter into all the details of this exceedingly ingenious dream. Here I will only bring out briefly those points which continue and supplement the dream of the preceding day. The second dream is unmistakably connected with the first: once more the dreamer is in church, that is, in the state of initiation into manhood. But a new figure has been added: the priest, whose absence in the previous situation we have already noted. The dream therefore confirms that the unconscious meaning of his homosexuality has been fulfilled and that a new development can be started. The actual initiation ceremony, that is, the baptism, may now begin. The dream symbolism corroborates what I said before, namely that it is not the prerogative of the Christian Church to bring about such transitions and psychic transformations, but that behind the Church there is a living primordial image which in certain conditions is capable of enforcing them.

277] What, according to the dream, is to be baptized is a little Japanese ivory figure. The patient says of this: "It was a tiny, grotesque little manikin that reminded me of the male organ. It was certainly odd that this member was to be baptized. But after all, with the Jews circumcision is a sort of baptism. That must be a reference to my homosexuality, because the friend standing with me before the altar is the one with whom I have sexual relations. We belong to the same fraternity. The fraternity ring obviously stands for our relationship."

278] We know that in common usage the ring is the token of a bond or relationship, as for example the wedding ring. We can therefore safely take the fraternity ring in this case as symbolizing the homosexual relationship, and the fact that the dreamer appears together with his friend points in the same direction.

279] The complaint to be remedied is homosexuality. The dreamer is to be led out of this relatively childish condition and initiated into the adult state by means of a kind of circumcision ceremony under the supervision of a priest. These ideas correspond exactly to my analysis of the previous dream. Thus far the development has proceeded logically and consistently with the aid of archetypal images. But now a disturbing factor appears to enter. An elderly woman suddenly takes possession of the fraternity ring; in other words, she draws to herself what has hitherto been a homosexual relationship, thus causing the dreamer to fear that he is getting involved in a new relationship with obligations of its own. Since the ring is now on the hand of a woman, a marriage of sorts has been contracted, i.e., the homosexual relationship seems to have passed over into a heterosexual one, but a heterosexual relationship of a peculiar kind, as it concerns an elderly woman. "She is a friend of my mother's," says the patient. "I am very fond of her, in fact she is like a mother to me." From this remark we can see what has happened in the dream: as a result of the initiation the homosexual tie has been cut and a heterosexual relationship substituted for it, a platonic friendship with a woman resembling his mother. In spite of her

resemblance to his mother, this woman is not his mother any longer, so the relationship with her signifies a step beyond the mother towards masculinity, and hence a partial conquest of his adolescent homosexuality.

280] The fear of the new tie can easily be understood, firstly as the fear which the woman's resemblance to his mother might naturally arouse—it could be argued that the dissolution of the homosexual tie has led to a complete regression to the mother—and secondly as the fear of the new and unknown factors in the adult heterosexual state with its possible obligations, such as marriage, and so on. That we are in fact concerned here not with a regression but with an advance seems to be confirmed by the music that now peals forth. The patient is musical and especially susceptible to solemn organ music. Therefore music signifies for him a very positive feeling, so in this case it forms an harmonious conclusion to the dream, which in turn is well qualified to leave behind a beautiful, holy feeling for the following morning.

281] If you consider the fact that up to now the patient had seen me for only one consultation, in which little more was discussed than a general anamnesis, you will doubtless agree with me when I say that both dreams make astonishing anticipations. They show the patient's situation in a highly remarkable light, and one that is very strange to the conscious mind, while at the same time they lend to the banal medical situation an aspect that is uniquely attuned to the psychic peculiarities of the dreamer, and thus capable of stringing his aesthetic, intellectual, and religious interests to concert pitch. No better conditions for treatment could possibly be imagined. One is almost persuaded, from the meaning of these dreams, that the patient entered upon the treatment with the utmost readiness and hopefulness, quite prepared to cast aside his boyishness and become a man. In reality, however, this was not the case at all. Consciously he was full of hesitation and resistance; moreover, as the treatment progressed, he constantly showed himself antagonistic and difficult, ever ready to slip back into his previous infantilism. The dreams, therefore, stand in strict contrast to his conscious behaviour. They move along a progressive line and are on the side of the educator. In my opinion they give us a clear view of the specific function of dreams. This function I have called compensation. The unconscious progressiveness and the conscious regressiveness together form a pair of opposites which, as it were, keeps the scales balanced. The influence of the educator tilts the balance in favour of progression. In this way dreams give effective support to our educational efforts and at the same time afford the deepest insight into the intimate fantasy life of the patient. Thus his conscious attitude gradually becomes more understanding and receptive to new influences.

282] From what has been said it might be inferred that, were all dreams to behave in this manner, they would be an incomparable means of access to the most individual secrets of psychic life. In so far as dreams are capable of explanation, this is actually

true as a general rule; but the great difficulty nevertheless remains of explaining them. Not only is wide experience and considerable tact needed, but also knowledge. To interpret dreams on the basis of a general theory, or on certain ready-made suppositions, is not merely ineffectual, but a definitely wrong and harmful practice. By the gentle art of persuasion and by the liberal use of alleged dream-mechanisms like inversion, distortion, displacement and what not, the dream can be construed to yield almost any meaning. The same arbitrary procedures were also to be found in the first attempts to decipher hieroglyphs. Before even attempting to understand a dream we ought always to say to ourselves, "This dream can mean anything." It need not stand in opposition to the conscious attitude, but may simply run parallel to it, which would also be quite in accord with its compensatory function. Moreover, there are dreams that defy every effort at interpretation. Often the only possible thing is to hazard a guess. At any rate, up to the present no open sesame for dreams has been discovered, no infallible method, and no absolutely satisfactory theory. The Freudian hypothesis that all dreams are the disguised fulfilment of sexual and other morally inadmissible wishes I myself cannot corroborate. I must therefore regard the use of this hypothesis and the tactics based upon it as a subjective bias. Indeed, I am persuaded that, in view of the tremendous irrationality and individuality of dreams, it may be altogether outside the bounds of possibility to construct a popular theory. Why should we believe that everything without exception is a fit subject for science? Scientific thinking is only one of the mental faculties at our disposal for understanding the world. It might be better to look upon dreams as being more in the nature of works of art instead of mere observational data for the scientist. The first view seems to me to yield better results because it is nearer to the essential nature of dreams. And this, after all, is the main point, that we should make ourselves aware of our unconscious compensation and thus overcome the one-sidedness and inadequacy of the conscious attitude. So long as other methods of education are efficacious and useful, we do not need the assistance of the unconscious. Indeed it would be a most reprehensible blunder if we tried to substitute analysis of the unconscious for well-tried conscious methods. The analytical method should be strictly reserved for those cases where other methods have failed, and should then be practised only by specialists, or by laymen under specialist control and guidance.

283] The general results of such psychiatric studies and methods are not of mere academic interest to the educator; they may also be of very real help, since in certain cases they furnish him with an insight unattainable without such knowledge.

VII

THE DEVELOPMENT OF PERSONALITY

THE DEVELOPMENT OF PERSONALITY¹

[284] In somewhat free-handed fashion the last two lines of Goethe's stanza are often quoted:

The Highest bliss on earth shall be
The joys of personality!²

This gives expression to the view that the ultimate aim and strongest desire of all mankind is to develop that fulness of life which is called personality. Nowadays, "personality training" has become an educational ideal that turns its back upon the standardized, mass-produced, "normal" human being demanded by the machine age. It thus pays tribute to the historical fact that the great liberating deeds of world history have sprung from leading personalities and never from the inert mass, which is at all times secondary and can only be prodded into activity by the demagogue. The huzzahs of the Italian nation go forth to the personality of the Duce, and the dirges of other nations lament the absence of strong leaders.³ The yearning for personality has therefore become a real problem that occupies many minds today, whereas in former times there was only one man who had a glimmering of this question—Friedrich Schiller, whose letters on aesthetic education have lain dormant, like a Sleeping Beauty of literature, for more than a century. We may confidently assert that the "Holy Roman Empire of the German Nation" has not taken much notice of Schiller as an educator. On the other hand, the *furor teutonicus* has hurled itself upon pedagogics (in the strict sense of the education of children), delved into child psychology, ferreted out the infantilism of the adult, and made of childhood such a portentous condition of life and human fate that it completely overshadows the creative meaning and potentialities of adult existence. Our age has been extravagantly praised as the "century of the child." This boundless expansion of the kindergarten amounts to complete forgetfulness of the problems of adult education divined by the genius of Schiller. Nobody will deny or underestimate the importance of childhood; the severe and often life-long injuries caused by stupid upbringing at home or in school are too obvious, and the need for more reasonable pedagogic methods is far too urgent. But if this evil is to be attacked at the root, one must in all seriousness face the question of how such idiotic and bigoted methods of education ever came to be employed, and still are employed. Obviously, for the sole reason that there are half-baked educators who are not human beings at all, but walking personifications of method. Anyone who wants to educate must himself be educated. But the parrot-like book-learning and mechanical use of methods that is still practised

today is no education either for the child or for educator. People are everlastingly saying that the child's personality must be trained. While I admire this lofty ideal, I can't help asking who it is that trains the personality? In the first and foremost place we have the parents, ordinary, incompetent folk who, more often than not, are half children themselves and remain so all their lives. How could anyone expect all these ordinary parents to be "personalities," and who has ever given a thought to devising methods for inculcating "personality" into them? Naturally, then, we expect great things of the pedagogue, of the trained professional, who, heaven help us, has been stuffed full of "psychology" and is bursting with ill-assorted views as to how the child is supposed to be constituted and how he ought to be handled. It is presumed that the youthful persons who have picked on education as a career are themselves educated; but nobody, I daresay, will venture to assert that they are all "personalities" as well. By and large, they suffer from the same defective education as the hapless children they are supposed to instruct, and as a rule are as little "personalities" as their charges. Our whole educational problem suffers from a one-sided approach to the child who is to be educated, and from an equally one-sided lack of emphasis on the uneducatedness of the educator. Everyone who has finished his course of studies feels himself to be fully educated; in a word, he feels grown up. He must feel this, he must have this solid conviction of his own competence in order to survive the struggle for existence. Any doubt or feeling of uncertainty would hinder and cripple him, undermining the necessary faith in his own authority and unfitting him for a professional career. People expect him to be efficient and good at his job and not to have doubts about himself and his capabilities. The professional man is irretrievably condemned to be competent.

285] Everyone knows that these conditions are not ideal. But, with reservations, we can say that they are the best possible under the circumstances. We cannot imagine how they could be different. We cannot expect more from the average educator than from the average parent. If he is good at his job, we have to be content with that, just as we have to be content with parents bringing up their children as best they can.

286] The fact is that the high ideal of educating the personality is not for children: for what is usually meant by personality—a well-rounded psychic whole that is capable of resistance and abounding in energy—is an *adult ideal*. It is only in an age like ours, when the individual is unconscious of the problems of adult life, or—what is worse—when he consciously shirks them, that people could wish to foist this ideal on to childhood. I suspect our contemporary pedagogical and psychological enthusiasm for the child of dishonourable intentions: we talk about the child, but we should mean the child in the adult. For in every adult there lurks a child—an eternal child,⁴ something that is always becoming, is never completed, and calls for unceasing care, attention, and education. That is the part of the human personality which wants to develop and become whole. But the man of today is far indeed from

this wholeness. Dimly suspecting his own deficiencies, he seizes upon child education and fervently devotes himself to child psychology, fondly supposing that something must have gone wrong in his own upbringing and childhood development that can be weeded out in the next generation. This intention is highly commendable, but comes to grief on the psychological fact that we cannot correct in a child a fault that we ourselves still commit. Children are not half as stupid as we imagine. They notice only too well what is genuine and what is not. Hans Andersen's story of the emperor's clothes contains a perennial truth. How many parents have come to me with the laudable intention of sparing their children the unhappy experiences they had to go through in their own childhood! And when I ask, "Are you quite sure you have overcome these mistakes yourself?" they are firmly convinced that the damage has long since been repaired. In actual fact it has not. If as children they were brought up too strictly, then they spoil their own children with a tolerance bordering on bad taste; if certain matters were painfully concealed from them in childhood, these are revealed with a lack of reticence that is just as painful. They have merely gone to the opposite extreme, the strongest evidence for the tragic survival of the old sin—a fact which has altogether escaped them.

287] If there is anything that we wish to change in our children, we should first examine it and see whether it is not something that could better be changed in ourselves. Take our enthusiasm for pedagogics. It may be that the boot is on the other leg. It may be that we misplace the pedagogical need because it would be an uncomfortable reminder that we ourselves are still children in many respects and still need a vast amount of educating.

288] At any rate this doubt seems to me to be extremely pertinent when we set out to train our children's "personalities." Personality is a seed that can only develop by slow stages throughout life. There is no personality without definiteness, wholeness, and ripeness. These three qualities cannot and should not be expected of the child, as they would rob it of childhood. It would be nothing but an abortion, a premature pseudo-adult; yet our modern education has already given birth to such monsters, particularly in those cases where parents set themselves the fanatical task of always "doing their best" for the children and "living only for them." This clamant ideal effectively prevents the parents from doing anything about their own development and allows them to thrust their "best" down their children's throats. This so-called "best" turns out to be the very things the parents have most badly neglected in themselves. In this way the children are goaded on to achieve their parents' most dismal failures, and are loaded with ambitions that are never fulfilled. Such methods and ideals only engender educational monstrosities.

289] No one can train the personality unless he has it himself. And it is not the child, but only the adult, who can achieve personality as the fruit of a full life directed to this end. The achievement of personality means nothing less than the optimum development of the whole individual human being. It is impossible to foresee the endless variety of conditions that have to be fulfilled. A whole lifetime, in all its biological, social, and spiritual aspects, is needed. Personality is the supreme realization of the innate idiosyncrasy of a living being. It is an act of high courage flung in the face of life, the absolute affirmation of all that constitutes the individual, the most successful adaptation to the universal conditions of existence coupled with the greatest possible freedom for self-determination. To educate a man to *this* seems to me no light matter. It is surely the hardest task the modern mind has set itself. And it is dangerous too, dangerous to a degree that Schiller never imagined, though his prophetic insight made him the first to venture upon these problems. It is as dangerous as the bold and hazardous undertaking of nature to let women bear children. Would it not be sacrilege, a Promethean or even Luciferian act of presumption, if a superman ventured to grow an homunculus in a bottle and then found it sprouting into a Golem? And yet he would not be doing anything that nature does not do every day. There is no human horror or fairground freak that has not lain in the womb of a loving mother. As the sun shines upon the just and the unjust, and as women who bear and give suck tend God's children and the devil's brood with equal compassion, unconcerned about the possible consequences, so we also are part and parcel of this amazing nature, and, like it, carry within us the seeds of the unpredictable.

290] Our personality develops in the course of our life from germs that are hard or impossible to discern, and it is only our deeds that reveal who we are. We are like the sun, which nourishes the life of the earth and brings forth every kind of strange, wonderful, and evil thing; we are like the mothers who bear in their wombs untold happiness and suffering. At first we do not know what deeds or misdeeds, what destiny, what good and evil we have in us, and only the autumn can show what the spring has engendered, only in the evening will it be seen what the morning began.

291] Personality, as the complete realization of our whole being, is an unattainable ideal. But unattainability is no argument against the ideal, for ideals are only signposts, never the goal.

292] Just as the child must develop in order to be educated, so the personality must begin to sprout before it can be trained. And this is where the danger begins. For we are handling something unpredictable, we do not know how and in what direction the budding personality will develop, and we have learned enough of nature and the world to be somewhat chary of both. On top of that, we were brought up in the Christian belief that human nature is intrinsically evil. But even those who no longer

adhere to the Christian teaching are by nature mistrustful and not a little frightened of the possibilities lurking in the subterranean chambers of their being. Even enlightened psychologists like Freud give us an extremely unpleasant picture of what lies slumbering in the depths of the human psyche. So it is rather a bold venture to put in a good word for the development of personality. Human nature, however, is full of the strangest contradictions. We praise the “sanctity of motherhood,” yet would never dream of holding it responsible for all the human monsters, the homicidal maniacs, dangerous lunatics, epileptics, idiots and cripples of every description who are born every day. At the same time we are tortured with doubts when it comes to allowing the free development of personality. “Anything might happen then,” people say. Or they dish up the old, feeble-minded objection to “individualism.” But individualism is not and never has been a natural development; it is nothing but an unnatural usurpation, a freakish, impertinent pose that proves its hollowness by crumpling up before the least obstacle. What we have in mind is something very different.

293] Clearly, no one develops his personality because somebody tells him that it would be useful or advisable to do so. Nature has never yet been taken in by well-meaning advice. The only thing that moves nature is causal necessity, and that goes for human nature too. Without necessity nothing budes, the human personality least of all. It is tremendously conservative, not to say torpid. Only acute necessity is able to rouse it. The developing personality obeys no caprice, no command, no insight, only brute necessity; it needs the motivating force of inner or outer fatalities. Any other development would be no better than individualism. That is why the cry of “individualism” is a cheap insult when flung at the natural development of personality.

294] The words “many are called, but few are chosen” are singularly appropriate here, for the development of personality from the germ-state to full consciousness is at once a charisma and a curse, because its first fruit is the conscious and unavoidable segregation of the single individual from the undifferentiated and unconscious herd. This means isolation, and there is no more comforting word for it. Neither family nor society nor position can save him from this fate, nor yet the most successful adaptation to his environment, however smoothly he fits in. The development of personality is a favour that must be paid for dearly. But the people who talk most loudly about developing their personalities are the very ones who are least mindful of the results, which are such as to frighten away all weaker spirits.

295] Yet the development of personality means more than just the fear of hatching forth monsters, or of isolation. It also means fidelity to the law of one’s own being.

296] For the word “fidelity” I should prefer, in this context, the Greek word used in the New Testament, *πίστις* which is erroneously translated “faith.” It really means

“trust,” “trustful loyalty.” Fidelity to the law of one’s own being is a trust in this law, a loyal perseverance and confident hope; in short, an attitude such as a religious man should have towards God. It can now be seen how portentous is the dilemma that emerges from behind our problem: personality can never develop unless the individual chooses his own way, consciously and with moral deliberation. Not only the causal motive—necessity—but conscious moral decision must lend its strength to the process of building the personality. If the first is lacking, then the alleged development is a mere acrobatics of the will; if the second, it will get stuck in unconscious automatism. But a man can make a moral decision to go his own way only if he holds that way to be the best. If any other way were held to be better, then he would live and develop that other personality instead of his own. The other ways are conventionalities of a moral, social, political, philosophical, or religious nature. The fact that the conventions always flourish in one form or another only proves that the vast majority of mankind do not choose their own way, but convention, and consequently develop not themselves but a method and a collective mode of life at the cost of their own wholeness.

297] Just as the psychic and social life of mankind at the primitive level is exclusively a group life with a high degree of unconsciousness among the individuals composing it, so the historical process of development that comes afterwards is in the main collective and will doubtless remain so. That is why I believe convention to be a collective necessity. It is a stopgap and not an ideal, either in the moral or in the religious sense, for submission to it always means renouncing one’s wholeness and running away from the final consequences of one’s own being.

298] To develop one’s own personality is indeed an unpopular undertaking, a deviation that is highly uncongenial to the herd, an eccentricity smelling of the cenobite, as it seems to the outsider. Small wonder, then, that from earliest times only the chosen few have embarked upon this strange adventure. Had they all been fools, we could safely dismiss them as *ἰδιῶται*, mentally “private” persons who have no claim on our interest. But, unfortunately, these personalities are as a rule the legendary heroes of mankind, the very ones who are looked up to, loved, and worshipped, the true sons of God whose names perish not. They are the flower and the fruit, the ever fertile seeds of the tree of humanity. This allusion to historical personalities makes it abundantly clear why the development of personality is an ideal, and why the cry of individualism is an insult. Their greatness has never lain in their abject submission to convention, but, on the contrary, in their deliverance *from* convention. They towered up like mountain peaks above the mass that still clung to its collective fears, its beliefs, laws, and systems, and boldly chose their own way. To the man in the street it has always seemed miraculous that anyone should turn aside from the beaten track with its known destinations, and strike out on the steep and narrow path

leading into the unknown. Hence it was always believed that such a man, if not actually crazy, was possessed by a daemon or a god; for the miracle of a man being able to act otherwise than as humanity has always acted could only be explained by the gift of daemonic power or divine spirit. How could anyone but a god counterbalance the dead weight of humanity in the mass, with its everlasting convention and habit? From the beginning, therefore, the heroes were endowed with godlike attributes. According to the Nordic view they had snake's eyes, and there was something peculiar about their birth or descent; certain heroes of ancient Greece were snake-souled, others had a personal daemon, were magicians or the elect of God. All these attributes, which could be multiplied at will, show that for the ordinary man the outstanding personality is something *supernatural*, a phenomenon that can only be explained by the intervention of some daemonic factor.

299] What is it, in the end, that induces a man to go his own way and to rise out of unconscious identity with the mass as out of a swathing mist? Not necessity, for necessity comes to many, and they all take refuge in convention. Not moral decision, for nine times out of ten we decide for convention likewise. What is it, then, that inexorably tips the scales in favour of the *extra-ordinary*?

300] It is what is commonly called *vocation*: an irrational factor that destines a man to emancipate himself from the herd and from its well-worn paths. True personality is always a vocation and puts its trust in it as in God, despite its being, as the ordinary man would say, only a personal feeling. But vocation acts like a law of God from which there is no escape. The fact that many a man who goes his own way ends in ruin means nothing to one who has a vocation. He *must* obey his own law, as if it were a daemon whispering to him of new and wonderful paths. Anyone with a vocation hears the voice of the inner man: he is *called*. That is why the legends say that he possesses a private daemon who counsels him and whose mandates he must obey. The best known example of this is Faust, and an historical instance is provided by the daemon of Socrates. Primitive medicine-men have their snake spirits, and Aesculapius, the tutelary patron of physicians, has for his emblem the Serpent of Epidaurus. He also had, as his private daemon, the Cabir Telesphoros, who is said to have dictated or inspired his medical prescriptions.

301] The original meaning of "to have a vocation" is "to be addressed by a voice." The clearest examples of this are to be found in the avowals of the Old Testament prophets. That it is not just a quaint old-fashioned way of speaking is proved by the confessions of historical personalities such as Goethe and Napoleon, to mention only two familiar examples, who made no secret of their feeling of vocation.

302] Vocation, or the feeling of it, is not, however, the prerogative of great personalities; it is also appropriate to the small ones all the way down to the "midget" personalities, but as the size decreases the voice becomes more and more

muffled and unconscious. It is as if the voice of the daemon within were moving further and further off, and spoke more rarely and more indistinctly. The smaller the personality, the dimmer and more unconscious it becomes, until finally it merges indistinguishably with the surrounding society, thus surrendering its own wholeness and dissolving into the wholeness of the group. In the place of the inner voice there is the voice of the group with its conventions, and vocation is replaced by collective necessities. But even in this unconscious social condition there are not a few who are called awake by the summons of the voice, whereupon they are at once set apart from the others, feeling themselves confronted with a problem about which the others know nothing. In most cases it is impossible to explain to the others what has happened, for any understanding is walled off by impenetrable prejudices. "You are no different from anybody else," they will chorus, or, "there's no such thing," and even if there is such a thing, it is immediately branded as "morbid" and "most unseemly." For it is "a monstrous presumption to suppose anything of that sort could be of the slightest significance"—it is "purely psychological." This last objection is extremely popular nowadays. It stems from a curious underestimation of anything psychic, which people apparently regard as personal, arbitrary, and therefore completely futile. And this, paradoxically enough, despite their enthusiasm for psychology. The unconscious, after all, is "nothing but fantasy." We "merely imagined" so and so, etc. People think themselves magicians who can conjure the psyche hither and thither and fashion it to suit their moods. They deny what strikes them as inconvenient, sublimate anything nasty, explain away their phobias, correct their faults, and feel in the end that they have arranged everything beautifully. In the meantime they have forgotten the essential point, which is that only the tiniest fraction of the psyche is identical with the conscious mind and its box of magic tricks, while for much the greater part it is sheer unconscious *fact*, hard and immitigable as granite, immovable, inaccessible, yet ready at any time to come crashing down upon us at the behest of unseen powers. The gigantic catastrophes that threaten us today are not elemental happenings of a physical or biological order, but psychic events. To a quite terrifying degree we are threatened by wars and revolutions which are nothing other than psychic epidemics. At any moment several millions of human beings may be smitten with a new madness, and then we shall have another world war or devastating revolution. Instead of being at the mercy of wild beasts, earthquakes, landslides, and inundations, modern man is battered by the elemental forces of his own psyche. This is the World Power that vastly exceeds all other powers on earth. The Age of Enlightenment, which stripped nature and human institutions of gods, overlooked the God of Terror who dwells in the human soul. If anywhere, fear of God is justified in face of the overwhelming supremacy of the psychic.

303] But all this is so much abstraction. Everyone knows that the intellect, that clever jackanapes, can put it this way or any other way he pleases. It is a very different thing when the psyche, as an objective fact, hard as granite and heavy as lead, confronts a man as an inner experience and addresses him in an audible voice, saying, "This is what will and must be." Then he feels himself called, just as the group does when there's a war on, or a revolution, or any other madness. It is not for nothing that our age calls for the redeemer personality, for the one who can emancipate himself from the inescapable grip of the collective and save at least his own soul, who lights a beacon of hope for others, proclaiming that here is at least *one* man who has succeeded in extricating himself from that fatal identity with the group psyche. For the group, because of its unconsciousness, has no freedom of choice, and so psychic activity runs on in it like an uncontrolled law of nature. There is thus set going a chain reaction that comes to a stop only in catastrophe. The people always long for a hero, a slayer of dragons, when they feel the danger of psychic forces; hence the cry for personality.

304] But what has the individual personality to do with the plight of the many? In the first place he is part of the people as a whole, and is as much at the mercy of the power that moves the whole as anybody else. The only thing that distinguishes him from all the others is his vocation. He has been called by that all-powerful, all-tyrannizing psychic necessity that is his own and his people's affliction. If he hearkens to the voice, he is at once set apart and isolated, as he has resolved to obey the law that commands him from within. "His *own* law!" everybody will cry. But he knows better: it is *the* law, *the* vocation for which he is destined, no more "his own" than the lion that fells him, although it is undoubtedly this particular lion that kills him and not any other lion. Only in this sense is he entitled to speak of "his" vocation, "his" law.

305] With the decision to put his way above all other possible ways he has already fulfilled the greater part of his vocation as a redeemer. He has invalidated all other ways for himself, exalting his law above convention and thus making a clean sweep of all those things that not only failed to prevent the great danger but actually accelerated it. For conventions in themselves are soulless mechanisms that can never understand more than the mere routine of life. Creative life always stands outside convention. That is why, when the mere routine of life predominates in the form of convention and tradition, there is bound to be a destructive outbreak of creative energy. This outbreak is a catastrophe only when it is a mass phenomenon, but never in the individual who consciously submits to these higher powers and serves them with all his strength. The mechanism of convention keeps people unconscious, for in that state they can follow their accustomed tracks like blind brutes, without the need for conscious decision. This unintended result of even the best conventions is

unavoidable but is no less a terrible danger for that. For when new conditions arise that are not provided for under the old conventions, then, just as with animals, panic is liable to break out among human beings kept unconscious by routine, and with equally unpredictable results.

306] Personality, however, does not allow itself to be seized by the panic terror of those who are just waking to consciousness, for it has put all its terrors behind it. It is able to cope with the changing times, and has unknowingly and involuntarily become a *leader*.

307] All human beings are much alike, otherwise they could not succumb to the same delusion, and the psychic substratum upon which the individual consciousness is based is universally the same, otherwise people could never reach a common understanding. So, in this sense, personality and its peculiar psychic make-up are not something absolutely unique. The uniqueness holds only for the *individual* nature of the personality, as it does for each and every individual. To become a personality is not the absolute prerogative of the genius, for a man may be a genius without being a personality. In so far as every individual has the law of his life inborn in him, it is theoretically possible for any man to follow this law and so become a personality, that is, to achieve wholeness. But since life only exists in the form of living units, i.e., individuals, the law of life always tends towards a life individually lived. So although the objective psyche can only be conceived as a universal and uniform datum, which means that all men share the same primary, psychic condition, this objective psyche must nevertheless individuate itself if it is to become actualized, for there is no other way in which it could express itself except through the individual human being. The only exception to this is when it seizes hold of a group, in which case it must, of its own nature, precipitate a catastrophe, because it can only operate unconsciously and is not assimilated by any consciousness or assigned its place among the existing conditions of life.

308] Only the man who can consciously assent to the power of the inner voice becomes a personality; but if he succumbs to it he will be swept away by the blind flux of psychic events and destroyed. That is the great and liberating thing about any genuine personality: he voluntarily sacrifices himself to his vocation, and consciously translates into his own individual reality what would only lead to ruin if it were lived unconsciously by the group.

309] One of the most shining examples of the meaning of personality that history has preserved for us is the life of Christ. In Christianity, which, be it mentioned in passing, was the only religion really persecuted by the Romans, there rose up a direct opponent of the Caesarean madness that afflicted not only the emperor, but every Roman as well: *civis Romanus sum*. The opposition showed itself wherever the worship of Caesar clashed with Christianity. But, as we know from what the

evangelists tell us about the psychic development of Christ's personality, this opposition was fought out just as decisively in the soul of its founder. The story of the Temptation clearly reveals the nature of the psychic power with which Jesus came into collision: it was the power-intoxicated devil of the prevailing Caesarean psychology that led him into dire temptation in the wilderness. This devil was the objective psyche that held all the peoples of the Roman Empire under its sway, and that is why it promised Jesus all the kingdoms of the earth, as if it were trying to make a Caesar of him. Obeying the inner call of his vocation, Jesus voluntarily exposed himself to the assaults of the imperialistic madness that filled everyone, conqueror and conquered alike. In this way he recognized the nature of the objective psyche which had plunged the whole world into misery and had begotten a yearning for salvation that found expression even in the pagan poets. Far from suppressing or allowing himself to be suppressed by this psychic onslaught, he let it act on him consciously, and assimilated it. Thus was world-conquering Caesarism transformed into spiritual kingship, and the Roman Empire into the universal kingdom of God that was not of this world. While the whole Jewish nation was expecting an imperialistically minded and politically active hero as a Messiah, Jesus fulfilled the Messianic mission not so much for his own nation as for the whole Roman world, and pointed out to humanity the old truth that where force rules there is no love, and where love reigns force does not count. The religion of love was the exact psychological counterpart to the Roman devil-worship of power.

310] The example of Christianity is perhaps the best illustration of my previous abstract argument. This apparently unique life became a sacred symbol because it is the psychological prototype of the only meaningful life, that is, of a life that strives for the individual realization—absolute and unconditional—of its own particular law. Well may we exclaim with Tertullian; *anima naturaliter christiana!*

311] The deification of Jesus, as also of the Buddha, is not surprising, for it affords a striking example of the enormous valuation that humanity places upon these hero figures and hence upon the ideal of personality. Though it seems at present as if the blind and destructive dominance of meaningless collective forces would thrust the ideal of personality into the background, yet this is only a passing revolt against the dead weight of history. Once the revolutionary, unhistorical, and therefore uneducated inclinations of the rising generation have had their fill of tearing-down tradition, new heroes will be sought and found. Even the Bolsheviks, whose radicalism leaves nothing to be desired, have embalmed Lenin and made a saviour of Karl Marx. The ideal of personality is one of the ineradicable needs of the human soul, and the more unsuitable it is the more fanatically it is defended. Indeed, the worship of Caesar was itself a misconceived cult of personality, and modern

Protestantism, whose critical theology has reduced the divinity of Christ to vanishing point, has found its last refuge in the personality of Jesus.

312] Yes, this thing we call personality is a great and mysterious problem. Everything that can be said about it is curiously unsatisfactory and inadequate, and there is always a danger of the discussion losing itself in pomposity and empty chatter. The very idea of personality is, in common usage, so vague and ill-defined that one hardly ever finds two people who take the word in the same sense. If I put forward a more definite conception of it, I do not imagine that I have uttered the last word. I should like to regard all I say here only as a tentative attempt to approach the problem of personality without making any claim to solve it. Or rather, I should like my attempt to be regarded as a description of the psychological problems raised by personality. All the usual explanations and nostrums of psychology are apt to fall short here, just as they do with the man of genius or the creative artist. Inferences from heredity or from environment do not quite come off; inventing fictions about childhood, so popular today, ends—to put it mildly—in unreality; explanations from necessity—“he had no money,” “he was a sick man,” etc.—remain caught in externals. There is always something irrational to be added, something that simply cannot be explained, a *deus ex machina* or an *asylum ignorantiae*, that well-known sobriquet for God. The problem thus seems to border on the extrahuman realm, which has always been known by a divine name. As you can see, I too have had to refer to the “inner voice,” the vocation, and define it as a powerful objective-psychic factor in order to characterize the way in which it functions in the developing personality and how it appears subjectively. Mephistopheles, in *Faust*, is not personified merely because this creates a better dramatic or theatrical effect, as though Faust were his own moralist and painted his private devil on the wall. The opening words of the Dedication—“Once more you hover near me, forms and faces”—are more than just an aesthetic flourish. Like the concretism of the devil, they are an admission of the objectivity of psychic experience, a whispered avowal that this was what *actually happened*, not because of subjective wishes, or fears, or personal opinions, but somehow quite of itself. Naturally only a numskull thinks of ghosts, but something like a primitive numskull seems to lurk beneath the surface of our reasonable daytime consciousness.

313] Hence the eternal doubt whether what appears to be the objective psyche is really objective, or whether it might not be imagination after all. But then the question at once arises: have I imagined such and such a thing on purpose, or has it been imagined by something in me? It is a similar problem to that of the neurotic who suffers from an imaginary carcinoma. He knows, and has been told a hundred times before, that it is all imagination, and yet he asks me brokenly, “But why do I imagine such a thing? I don’t want to do it!” To which the answer is: the idea of the

carcinoma has imagined itself in him without his knowledge and without his consent. The reason is that a psychic growth, a “proliferation,” is taking place in his unconscious without his being able to make it conscious. In the face of this interior activity he feels afraid. But since he is entirely persuaded that there can be nothing in his own soul that he does not know about, he must relate his fear to a physical carcinoma which he knows does not exist. And if he should still be afraid of it, there are a hundred doctors to convince him that his fear is entirely groundless. The neurosis is thus a defence against the objective, inner activity of the psyche, or an attempt, somewhat dearly paid for, to escape from the inner voice and hence from the vocation. For this “growth” is the objective activity of the psyche, which, independently of conscious volition, is trying to speak to the conscious mind through the inner voice and lead him towards wholeness. Behind the neurotic perversion is concealed his vocation, his destiny: the growth of personality, the full realization of the life-will that is born with the individual. It is the man without *amor fati* who is the neurotic; he, truly, has missed his vocation, and never will he be able to say with Cromwell, “None climbeth so high as he who knoweth not whither his destiny leadeth him.”⁵

314] To the extent that a man is untrue to the law of his being and does not rise to personality, he has failed to realize his life’s meaning. Fortunately, in her kindness and patience, Nature never puts the fatal question as to the meaning of their lives into the mouths of most people. And where no one asks, no one need answer.

315] The neurotic’s fear of carcinoma is therefore justified: it is not imagination, but the consistent expression of a psychic fact that exists in a sphere outside consciousness, beyond the reach of his will and understanding. If he withdrew into the wilderness and listened to his inner life in solitude, he might perhaps hear what the voice has to say. But as a rule the miseducated, civilized human being is quite incapable of perceiving the voice, which is something not guaranteed by the current shibboleths. Primitive people have a far greater capacity in this respect; at least the medicine-men are able, as part of their professional equipment, to talk with spirits, trees, and animals, these being the forms in which they encounter the objective psyche or psychic non-ego.

316] Because neurosis is a developmental disturbance of the personality, we physicians of the soul are compelled by professional necessity to concern ourselves with the problem of personality and the inner voice, however remote it may seem to be. In practical psychotherapy these psychic facts, which are usually so vague and have so often degenerated into empty phrases, emerge from obscurity and take visible shape. Nevertheless, it is extremely rare for this to happen spontaneously as it did with the Old Testament prophets; generally the psychic conditions that have caused the disturbance have to be made conscious with considerable effort. But the contents

that then come to light are wholly in accord with the inner voice and point to a predestined vocation, which, if accepted and assimilated by the conscious mind, conduces to the development of personality.

317] Just as the great personality acts upon society to liberate, to redeem, to transform, and to heal, so the birth of personality in oneself has a therapeutic effect. It is as if a river that had run to waste in sluggish side-streams and marshes suddenly found its way back to its proper bed, or as if a stone lying on a germinating seed were lifted away so that the shoot could begin its natural growth.

318] The inner voice is the voice of a fuller life, of a wider, more comprehensive consciousness. That is why, in mythology, the birth of the hero or the symbolic rebirth coincides with sunrise, for the growth of personality is synonymous with an increase of self-consciousness. For the same reason most heroes are characterized by solar attributes, and the moment of birth of their greater personality is known as illumination.

319] The fear that most people naturally have of the inner voice is not so childish as might be supposed. The contents that rise up and confront a limited consciousness are far from harmless, as is shown by the classic example of the temptation of Christ, or the equally significant Mara episode in the Buddha legend. As a rule, they signify the specific danger to which the person concerned is liable to succumb. What the inner voice whispers to us is generally something negative, if not actually evil. This must be so, first of all because we are usually not as unconscious of our virtues as of our vices, and then because we suffer less from the good than from the bad in us. The inner voice, as I have explained above, makes us conscious of the evil from which the whole community is suffering, whether it be the nation or the whole human race. But it presents this evil in an individual form, so that one might at first suppose it to be only an individual characteristic. The inner voice brings the evil before us in a very tempting and convincing way in order to make us succumb. If we do not partially succumb, nothing of this apparent evil enters into us, and no regeneration or healing can take place. (I say "apparent," though this may sound too optimistic.) If we succumb completely, then the contents expressed by the inner voice act as so many devils, and a catastrophe ensues. But if we can succumb only in part, and if by self-assertion the ego can save itself from being completely swallowed, then it can assimilate the voice, and we realize that the evil was, after all, only a semblance of evil, but in reality a bringer of healing and illumination. In fact, the inner voice is a "Lucifer" in the strictest and most unequivocal sense of the word, and it faces people with ultimate moral decisions without which they can never achieve full consciousness and become personalities. The highest and the lowest, the best and the vilest, the truest and the most deceptive things are often

blended together in the inner voice in the most baffling way, thus opening up in us an abyss of confusion, falsehood, and despair.

320] It is naturally absurd for people to accuse the voice of Nature, the all-sustainer and all-destroyer, of evil. If she appears inveterately evil to us, this is mainly due to the old truth that the good is always the enemy of the better. We would be foolish indeed if we did not cling to the traditional good for as long as possible. But as Faust says:

Whenever in this world we reach the good
We call the better all a lie, a sham!

A good thing is unfortunately not a good forever, for otherwise there would be nothing better. If better is to come, good must stand aside. Therefore Meister Eckhart says, "God is not good, or else he could be better."

321] There are times in the world's history—and our own time may be one of them—when good must stand aside, so that anything destined to be better first appears in evil form. This shows how extremely dangerous it is even to touch these problems, for evil can so easily slip in on the plea that it is, potentially, the better. The problems of the inner voice are full of pitfalls and hidden snares. Treacherous, slippery ground, as dangerous and pathless as life itself once one lets go of the railings. But he who cannot lose his life, neither shall he save it. The hero's birth and the heroic life are always threatened. The serpents sent by Hera to destroy the infant Hercules, the python that tries to strangle Apollo at birth, the massacre of the innocents, all these tell the same story. To develop the personality is a gamble, and the tragedy is that the daemon of the inner voice is at once our greatest danger and an indispensable help. It is tragic, but logical, for it is the nature of things to be so.

322] Can we, therefore, blame humanity, and all the well-meaning shepherds of the flock and worried fathers of families, if they erect protective barriers, hold up wonder-working images, and point out the roads that wind safely past the abyss?

323] But, in the end, the hero, the leader, the saviour, is one who discovers a new way to greater certainty. Everything could be left undisturbed did not the new way demand to be discovered, and did it not visit humanity with all the plagues of Egypt until it finally is discovered. The undiscovered vein within us is a living part of the psyche; classical Chinese philosophy names this interior way "Tao," and likens it to a flow of water that moves irresistibly towards its goal. To rest in Tao means fulfilment, wholeness, one's destination reached, one's mission done; the beginning, end, and perfect realization of the meaning of existence innate in all things. Personality is Tao.

VIII

MARRIAGE AS A PSYCHOLOGICAL RELATIONSHIP

MARRIAGE AS A PSYCHOLOGICAL RELATIONSHIP¹

- 324] Regarded as a psychological relationship, marriage is a highly complex structure made up of a whole series of subjective and objective factors, mostly of a very heterogeneous nature. As I wish to confine myself here to the purely psychological problems of marriage, I must disregard in the main the objective factors of a legal and social nature, although these cannot fail to have a pronounced influence on the psychological relationship between the marriage partners.
- 325] Whenever we speak of a “psychological relationship” we presuppose one that is *conscious*, for there is no such thing as a psychological relationship between two people who are in a state of unconsciousness. From the psychological point of view they would be wholly without relationship. From any other point of view, the physiological for example, they could be regarded as related, but one could not call their relationship psychological. It must be admitted that though such total unconsciousness as I have assumed does not occur, there is nevertheless a not inconsiderable degree of partial unconsciousness, and the psychological relationship is limited in the degree to which that unconsciousness exists.
- 326] In the child, consciousness rises out of the depths of unconscious psychic life, at first like separate islands, which gradually unite to form a “continent,” a continuous land-mass of consciousness. Progressive mental development means, in effect, extension of consciousness. With the rise of a continuous consciousness, and not before, psychological relationship becomes possible. So far as we know, consciousness is always ego-consciousness. In order to be conscious of myself, I must be able to distinguish myself from others. Relationship can only take place where this distinction exists. But although the distinction may be made in a general way, normally it is incomplete, because large areas of psychic life still remain unconscious. As no distinction can be made with regard to unconscious contents, on this terrain no relationship can be established; here there still reigns the original unconscious condition of the ego’s primitive identity with others, in other words a complete absence of relationship.
- 327] The young person of marriageable age does, of course, possess an ego-consciousness (girls more than men, as a rule), but, since he has only recently emerged from the mists of original unconsciousness, he is certain to have wide areas which still lie in the shadow and which preclude to that extent the formation of psychological relationship. This means, in practice, that the young man (or woman) can have only an incomplete understanding of himself and others, and is therefore

imperfectly informed as to his, and their, motives. As a rule the motives he acts from are largely unconscious. Subjectively, of course, he thinks himself very conscious and knowing, for we constantly overestimate the existing content of consciousness, and it is a great and surprising discovery when we find that what we had supposed to be the final peak is nothing but the first step in a very long climb. The greater the area of unconsciousness, the less is marriage a matter of free choice, as is shown subjectively in the fatal compulsion one feels so acutely when one is in love. The compulsion can exist even when one is not in love, though in less agreeable form.

328] Unconscious motivations are of a personal and of a general nature. First of all, there are the motives deriving from parental influence. The relationship of the young man to his mother, and of the girl to her father, is the determining factor in this respect. It is the strength of the bond to the parents that unconsciously influences the choice of husband or wife, either positively or negatively. Conscious love for either parent favours the choice of a like mate, while an unconscious tie (which need not by any means express itself consciously as love) makes the choice difficult and imposes characteristic modifications. In order to understand them, one must know first of all the cause of the unconscious tie to the parents, and under what conditions it forcibly modifies, or even prevents, the conscious choice. Generally speaking, all the life which the parents could have lived, but of which they thwarted themselves for artificial motives, is passed on to the children in substitute form. That is to say, the children are driven unconsciously in a direction that is intended to compensate for everything that was left unfulfilled in the lives of their parents. Hence it is that excessively moral-minded parents have what are called "unmoral" children, or an irresponsible wastrel of a father has a son with a positively morbid amount of ambition, and so on. The worst results flow from parents who have kept themselves artificially unconscious. Take the case of a mother who deliberately keeps herself unconscious so as not to disturb the pretence of a "satisfactory" marriage. Unconsciously she will bind her son to her, more or less as a substitute for a husband. The son, if not forced directly into homosexuality, is compelled to modify his choice in a way that is contrary to his true nature. He may, for instance, marry a girl who is obviously inferior to his mother and therefore unable to compete with her; or he will fall for a woman of a tyrannical and overbearing disposition, who may perhaps succeed in tearing him away from his mother. The choice of a mate, if the instincts have not been vitiated, may remain free from these influences, but sooner or later they will make themselves felt as obstacles. A more or less instinctive choice might be considered the best from the point of view of maintaining the species, but it is not always fortunate psychologically, because there is often an uncommonly large difference between the purely instinctive personality and one that is individually differentiated. And though in such cases the race might

be improved and invigorated by a purely instinctive choice, individual happiness would be bound to suffer. (The idea of “instinct” is of course nothing more than a collective term for all kinds of organic and psychic factors whose nature is for the most part unknown.)

329] If the individual is to be regarded solely as an instrument for maintaining the species, then the purely instinctive choice of a mate is by far the best. But since the foundations of such a choice are unconscious, only a kind of impersonal liaison can be built upon them, such as can be observed to perfection among primitives. If we can speak here of a “relationship” at all, it is, at best, only a pale reflection of what we mean, a very distant state of affairs with a decidedly impersonal character, wholly regulated by traditional customs and prejudices, the prototype of every conventional marriage.

330] So far as reason or calculation or the so-called loving care of the parents does not arrange the marriage, and the pristine instincts of the children are not vitiated either by false education or by the hidden influence of accumulated and neglected parental complexes, the marriage choice will normally follow the unconscious motivations of instinct. Unconsciousness results in non-differentiation, or unconscious identity. The practical consequence of this is that one person presupposes in the other a psychological structure similar to his own. Normal sex life, as a shared experience with apparently similar aims, further strengthens the feeling of unity and identity. This state is described as one of complete harmony, and is extolled as a great happiness (“one heart and one soul”)—not without good reason, since the return to that original condition of unconscious oneness is like a return to childhood. Hence the childish gestures of all lovers. Even more is it a return to the mother’s womb, into the teeming depths of an as yet unconscious creativity. It is, in truth, a genuine and incontestable experience of the Divine, whose transcendent force obliterates and consumes everything individual; a real communion with life and the impersonal power of fate. The individual will for self-possession is broken: the woman becomes the mother, the man the father, and thus both are robbed of their freedom and made instruments of the life urge.

331] Here the relationship remains within the bounds of the biological instinctive goal, the preservation of the species. Since this goal is of a collective nature, the psychological link between husband and wife will also be essentially collective, and cannot be regarded as an individual relationship in the psychological sense. We can only speak of this when the nature of the unconscious motivations has been recognized and the original identity broken down. Seldom or never does a marriage develop into an individual relationship smoothly and without crises. There is no birth of consciousness without pain.

331a] The ways that lead to conscious realization are many, but they follow definite laws. In general, the change begins with the onset of the second half of life. The middle period of life is a time of enormous psychological importance. The child begins its psychological life within very narrow limits, inside the magic circle of the mother and the family. With progressive maturation it widens its horizon and its own sphere of influence; its hopes and intentions are directed to extending the scope of personal power and possessions; desire reaches out to the world in ever-widening range; the will of the individual becomes more and more identical with the natural goals pursued by unconscious motivations. Thus man breathes his own life into things, until finally they begin to live of themselves and to multiply; and imperceptibly he is overgrown by them. Mothers are overtaken by their children, men by their own creations, and what was originally brought into being only with labour and the greatest effort can no longer be held in check. First it was passion, then it became duty, and finally an intolerable burden, a vampire that battens on the life of its creator. Middle life is the moment of greatest unfolding, when a man still gives himself to his work with his whole strength and his whole will. But in this very moment evening is born, and the second half of life begins. Passion now changes her face and is called duty; "I want" becomes the inexorable "I must," and the turnings of the pathway that once brought surprise and discovery become dulled by custom. The wine has fermented and begins to settle and clear. Conservative tendencies develop if all goes well; instead of looking forward one looks backward, most of the time involuntarily, and one begins to take stock, to see how one's life has developed up to this point. The real motivations are sought and real discoveries are made. The critical survey of himself and his fate enables a man to recognize his peculiarities. But these insights do not come to him easily; they are gained only through the severest shocks.

331b] Since the aims of the second half of life are different from those of the first, to linger too long in the youthful attitude produces a division of the will. Consciousness still presses forward, in obedience, as it were, to its own inertia, but the unconscious lags behind, because the strength and inner resolve needed for further expansion have been sapped. This disunity with oneself begets discontent, and since one is not conscious of the real state of things one generally projects the reasons for it upon one's partner. A critical atmosphere thus develops, the necessary prelude to conscious realization. Usually this state does not begin simultaneously for both partners. Even the best of marriages cannot expunge individual differences so completely that the state of mind of the partners is absolutely identical. In most cases one of them will adapt to marriage more quickly than the other. The one who is grounded on a positive relationship to the parents will find little or no difficulty in adjusting to his or her partner, while the other may be hindered by a deep-seated

unconscious tie to the parents. He will therefore achieve complete adaptation only later, and, because it is won with greater difficulty, it may even prove the more durable.

331c] These differences in tempo, and in the degree of spiritual development, are the chief causes of a typical difficulty which makes its appearance at critical moments. In speaking of “the degree of spiritual development” of a personality, I do not wish to imply an especially rich or magnanimous nature. Such is not the case at all. I mean, rather, a certain complexity of mind or nature, comparable to a gem with many facets as opposed to the simple cube. There are many-sided and rather problematical natures burdened with hereditary traits that are sometimes very difficult to reconcile. Adaptation to such natures, or their adaptation to simpler personalities, is always a problem. These people, having a certain tendency to dissociation, generally have the capacity to split off irreconcilable traits of character for considerable periods, thus passing themselves off as much simpler than they are; or it may happen that their many-sidedness, their very versatility, lends them a peculiar charm. Their partners can easily lose themselves in such a labyrinthine nature, finding in it such an abundance of possible experiences that their personal interests are completely absorbed, sometimes in a not very agreeable way, since their sole occupation then consists in tracking the other through all the twists and turns of his character. There is always so much experience available that the simpler personality is surrounded, if not actually swamped, by it; he is swallowed up in his more complex partner and cannot see his way out. It is an almost regular occurrence for a woman to be wholly contained, spiritually, in her husband, and for a husband to be wholly contained, emotionally, in his wife. One could describe this as the problem of the “contained” and the “container.”

332] The one who is contained feels himself to be living entirely within the confines of his marriage; his attitude to the marriage partner is undivided; outside the marriage there exist no essential obligations and no binding interests. The unpleasant side of this otherwise ideal partnership is the disquieting dependence upon a personality that can never be seen in its entirety, and is therefore not altogether credible or dependable. The great advantage lies in his own undividedness, and this is a factor not to be underrated in the psychic economy.

333] The container, on the other hand, who in accordance with his tendency to dissociation has an especial need to unify himself in undivided love for another, will be left far behind in this effort, which is naturally very difficult for him, by the simpler personality. While he is seeking in the latter all the subtleties and complexities that would complement and correspond to his own facets, he is disturbing the other’s simplicity. Since in normal circumstances simplicity always has the advantage over complexity, he will very soon be obliged to abandon his

efforts to arouse subtle and intricate reactions in a simpler nature. And soon enough his partner, who in accordance with her² simpler nature expects simple answers from him, will give him plenty to do by constellating his complexities with her everlasting insistence on simple answers. Willynilly, he must withdraw into himself before the suasions of simplicity. Any mental effort, like the conscious process itself, is so much of a strain for the ordinary man that he invariably prefers the simple, even when it does not happen to be the truth. And when it represents at least a half-truth, then it is all up with him. The simpler nature works on the more complicated like a room that is too small, that does not allow him enough space. The complicated nature, on the other hand, gives the simpler one too many rooms with too much space, so that she never knows where she really belongs. So it comes about quite naturally that the more complicated contains the simpler. The former cannot be absorbed in the latter, but encompasses it without being itself contained. Yet, since the more complicated has perhaps a greater need of being contained than the other, he feels himself outside the marriage and accordingly always plays the problematical role. The more the contained clings, the more the container feels shut out of the relationship. The contained pushes into it by her clinging, and the more she pushes, the less the container is able to respond. He therefore tends to spy out of the window, no doubt unconsciously at first; but with the onset of middle age there awakens in him a more insistent longing for that unity and undividedness which is especially necessary to him on account of his dissociated nature. At this juncture things are apt to occur that bring the conflict to a head. He becomes conscious of the fact that he is seeking completion, seeking the contentedness and undividedness that have always been lacking. For the contained this is only a confirmation of the insecurity she has always felt so painfully; she discovers that in the rooms which apparently belonged to her there dwell other, unwished-for guests. The hope of security vanishes, and this disappointment drives her in on herself, unless by desperate and violent efforts she can succeed in forcing her partner to capitulate, and in extorting a confession that his longing for unity was nothing but a childish or morbid fantasy. If these tactics do not succeed, her acceptance of failure may do her a real good, by forcing her to recognize that the security she was so desperately seeking in the other is to be found in herself. In this way she finds herself and discovers in her own simpler nature all those complexities which the container had sought for in vain.

334] If the container does not break down in face of what we are wont to call “unfaithfulness,” but goes on believing in the inner justification of his longing for unity, he will have to put up with his self-division for the time being. A dissociation is not healed by being split off, but by more complete disintegration. All the powers that strive for unity, all healthy desire for selfhood, will resist the disintegration, and

in this way he will become conscious of the possibility of an inner integration, which before he had always sought outside himself. He will then find his reward in an undivided self.

335] This is what happens very frequently about the midday of life, and in this wise our miraculous human nature enforces the transition that leads from the first half of life to the second. It is a metamorphosis from a state in which man is only a tool of instinctive nature, to another in which he is no longer a tool, but himself: a transformation of nature into culture, of instinct into spirit.

336] One should take great care not to interrupt this necessary development by acts of moral violence, for any attempt to create a spiritual attitude by splitting off and suppressing the instincts is a falsification. Nothing is more repulsive than a furtively prurient spirituality; it is just as unsavoury as gross sensuality. But the transition takes a long time, and the great majority of people get stuck in the first stages. If only we could, like the primitives, leave the unconscious to look after this whole psychological development which marriage entails, these transformations could be worked out more completely and without too much friction. So often among so-called “primitives” one comes across spiritual personalities who immediately inspire respect, as though they were the fully matured products of an undisturbed fate. I speak here from personal experience. But where among present-day Europeans can one find people not deformed by acts of moral violence? We are still barbarous enough to believe both in asceticism and its opposite. But the wheel of history cannot be put back; we can only strive towards an attitude that will allow us to live out our fate as undisturbedly as the primitive pagan in us really wants. Only on this condition can we be sure of not perverting spirituality into sensuality, and vice versa; for both must live, each drawing life from the other.

337] The transformation I have briefly described above is the very essence of the psychological marriage relationship. Much could be said about the illusions that serve the ends of nature and bring about the transformations that are characteristic of middle life. The peculiar harmony that characterizes marriage during the first half of life—provided the adjustment is successful—is largely based on the projection of certain archetypal images, as the critical phase makes clear.

338] Every man carries within him the eternal image of woman, not the image of this or that particular woman, but a definite feminine image. This image is fundamentally unconscious, an hereditary factor of primordial origin engraved in the living organic system of the man, an imprint or “archetype” of all the ancestral experiences of the female, a deposit, as it were, of all the impressions ever made by woman—in short, an inherited system of psychic adaptation. Even if no women existed, it would still be possible, at any given time, to deduce from this unconscious image exactly how a woman would have to be constituted psychically.

The same is true of the woman: she too has her inborn image of man. Actually, we know from experience that it would be more accurate to describe it as an image of *men*, whereas in the case of the man it is rather the image of *woman*. Since this image is unconscious, it is always unconsciously projected upon the person of the beloved, and is one of the chief reasons for passionate attraction or aversion. I have called this image the “anima,” and I find the scholastic question *Habet mulier animam?* especially interesting, since in my view it is an intelligent one inasmuch as the doubt seems justified. Woman has no anima, no soul, but she has an *animus*. The anima has an erotic, emotional character, the animus a rationalizing one. Hence most of what men say about feminine eroticism, and particularly about the emotional life of women, is derived from their own anima projections and distorted accordingly. On the other hand, the astonishing assumptions and fantasies that women make about men come from the activity of the animus, who produces an inexhaustible supply of illogical arguments and false explanations.

339] Anima and animus are both characterized by an extraordinary many-sidedness. In a marriage it is always the contained who projects this image upon the container, while the latter is only partially able to project his unconscious image upon his partner. The more unified and simple this partner is, the less complete the projection. In which case, this highly fascinating image hangs as it were in mid air, as though waiting to be filled out by a living person. There are certain types of women who seem to be made by nature to attract anima projections; indeed one could almost speak of a definite “anima type.” The so-called “sphinx-like” character is an indispensable part of their equipment, also an equivocalness, an intriguing elusiveness—not an indefinite blur that offers nothing, but an indefiniteness that seems full of promises, like the speaking silence of a Mona Lisa. A woman of this kind is both old and young, mother and daughter, of more than doubtful chastity, childlike, and yet endowed with a naïve cunning that is extremely disarming to men.³ Not every man of real intellectual power can be an animus, for the animus must be a master not so much of fine ideas as of fine words—words seemingly full of meaning which purport to leave a great deal unsaid. He must also belong to the “misunderstood” class, or be in some way at odds with his environment, so that the idea of self-sacrifice can insinuate itself. He must be a rather questionable hero, a man with possibilities, which is not to say that an animus projection may not discover a real hero long before he has become perceptible to the sluggish wits of the man of “average intelligence.”⁴

340] For man as well as for woman, in so far as they are “containers,” the filling out of this image is an experience fraught with consequences, for it holds the possibility of finding one’s own complexities answered by a corresponding diversity. Wide vistas seem to open up in which one feels oneself embraced and contained. I say “seem”

advisedly, because the experience may be two-faced. Just as the animus projection of a woman can often pick on a man of real significance who is not recognized by the mass, and can actually help him to achieve his true destiny with her moral support, so a man can create for himself a *femme inspiratrice* by his anima projection. But more often it turns out to be an illusion with destructive consequences, a failure because his faith was not sufficiently strong. To the pessimists I would say that these primordial psychic images have an extraordinarily positive value, but I must warn the optimists against blinding fantasies and the likelihood of the most absurd aberrations.

341] One should on no account take this projection for an individual and conscious relationship. In its first stages it is far from that, for it creates a compulsive dependence based on unconscious motives other than the biological ones. Rider Haggard's *She* gives some indication of the curious world of ideas that underlies the anima projection. They are in essence spiritual contents, often in erotic disguise, obvious fragments of a primitive mythological mentality that consists of archetypes, and whose totality constitutes the collective unconscious. Accordingly, such a relationship is at bottom collective and not individual. (Benoît, who created in *L'Atlantide* a fantasy figure similar even in details to "She," denies having plagiarized Rider Haggard.)

342] If such a projection fastens on to one of the marriage partners, a collective spiritual relationship conflicts with the collective biological one and produces in the container the division or disintegration I have described above. If he is able to hold his head above water, he will find himself through this very conflict. In that case the projection, though dangerous in itself, will have helped him to pass from a collective to an individual relationship. This amounts to full conscious realization of the relationship that marriage brings. Since the aim of this paper is a discussion of the psychology of marriage, the psychology of projection cannot concern us here. It is sufficient to mention it as a fact.

343] One can hardly deal with the psychological marriage relationship without mentioning, even at the risk of misunderstanding, the nature of its critical transitions. As is well known, one understands nothing psychological unless one has experienced it oneself. Not that this ever prevents anyone from feeling convinced that his own judgment is the only true and competent one. This disconcerting fact comes from the necessary overvaluation of the momentary content of consciousness, for without this concentration of attention one could not be conscious at all. Thus it is that every period of life has its own psychological truth, and the same applies to every stage of psychological development. There are even stages which only the few can reach, it being a question of race, family, education, talent, and passion. Nature is aristocratic. The normal man is a fiction, although certain generally valid laws do

exist. Psychic life is a development that can easily be arrested on the lowest levels. It is as though every individual had a specific gravity, in accordance with which he either rises, or sinks down, to the level where he reaches his limit. His views and convictions will be determined accordingly. No wonder, then, that by far the greater number of marriages reach their upper psychological limit in fulfilment of the biological aim, without injury to spiritual or moral health. Relatively few people fall into deeper disharmony with themselves. Where there is a great deal of pressure from outside, the conflict is unable to develop much dramatic tension for sheer lack of energy. Psychological insecurity, however, increases in proportion to social security, unconsciously at first, causing neuroses, then consciously, bringing with it separations, discord, divorces, and other marital disorders. On still higher levels, new possibilities of psychological development are discerned, touching on the sphere of religion where critical judgment comes to a halt.

344] Progress may be permanently arrested on any of these levels, with complete unconsciousness of what might have followed at the next stage of development. As a rule graduation to the next stage is barred by violent prejudices and superstitious fears. This, however, serves a most useful purpose, since a man who is compelled by accident to live at a level too high for him becomes a fool and a menace.

345] Nature is not only aristocratic, she is also esoteric. Yet no man of understanding will thereby be induced to make a secret of what he knows, for he realizes only too well that the secret of psychic development can never be betrayed, simply because that development is a question of individual capacity.

INDEX

INDEX

A

- abaissement du niveau mental*, 114
- ability, mathematical, 152
- abnormality(-ies): and disease, 68
 - psychic, 151
- abreaction, 94
- absent-mindedness, 138
- abstraction, 34
- adaptation, 55*f*, 171, 198
 - collective, and individual, 150
 - external, 92*f*
 - in marriage, 194
 - to own nature, 92
 - unconditional, 120
- Adler, Alfred, 3, 13*n*, 81, 82, 113
 - and Freud, reconciliation of, 82
 - psychology of, 123
- adolescence: homosexuality in, 159, 162
 - introversion in, 13
- adult(s): child in, 169*f*
 - continuation schools for, 57
 - educability of, 57
 - upholder of contemporary culture, 58
 - a. existence, meaning of, 168
 - a, ideal, 169
- advice, 131, 173
 - by doctor, 96
- Aesculapius, 176
- aestheticism, 156; *see also* instinct(s)
 - interest

affection, rivalry in, 13

alchemist, 107

Aldrich, Roberts, 63

altar (dream-image), 161

ambition(s), 132

- love and, 127
- parents', 142
- unfulfilled, 171; *see also* mother(s)

America: civic life in, 135; *see also* South America

Amfortas' wound, 115f

amnesia, systematic, 109

analogies, thinking in, 24

analysis: anamnestic stage, 95, 100

- of children, 75, *see also* child(ren); of dreams, *see* dream-analysis: of unconscious, *see* unconscious; *see also* psychotherapy

analyst, 94; *see also* doctor

analytical psychology, 50

- aim of, 92
- and education, *see* education
- and experimental p., 91
- nature of, 91
- and normal p., 68
- and teacher, 57, 74

anamnesis, 95f, 162

anamnestic analysis, 95, 100

- a. method, 95, 97

ancestors, the child's true progenitors, 44

Andersen, Hans, 170

angel(s), 24

- children as, 9f, 20, 28

anger, *see* rage(s)

anima/animus, 198f

- projections, 198ff

anima type, 199

animal(s): aesthetic instincts in, 83

- little, dream of, [21f](#)
 - a. magnetism, [66](#)
 - a. state, and childhood, compared, [53](#)
- animus, *see* anima/animus
- Anna, *see* Jung, Carl Gustav, CASES IN SUMMARY
 - imaginary twin sister, [129](#), [131](#)
- antinomies, and unconscious, [114](#)
- anxiety, [101](#)
 - a. dreams, *see* dreams
 - a. states, [77](#)
 - substitutes for conscious suffering, [101](#)
- Apollo, [186](#)
- appetite, loss of, [123](#)
- aptitudes: mental, [152](#)
 - unconscious, [100](#)
- archetype(s), [10](#), [45](#), [125n](#), [199](#), [200](#)
 - in dreams, [54](#)
 - archetypal images, [106](#), [159](#), [161](#), [198](#)
 - a. material, [119](#)
 - see also various headings for individual archetypes, e.g., father, Magna Mater, rebirth, etc.*
- Archimedean point, [88](#), [89](#)
- army: Jung's experience as medical officer in, [95f](#)
 - a general's dream, [102](#)
- art, [83](#), [115](#), [119](#), [156](#)
- Artemidorus of Daldis, [154](#)
- artist(s), [182](#)
 - would-be, [115](#)
- association(s), [116](#), [158](#); *see also* dreams
 - free associations
 - a. experiment, [94](#), [109](#)
 - , mistakes in, [67](#)
- association method, [67](#), [94](#)
- atom, *see* microphysics

atomic physics, *see* physics

Atreus, house of, its curse, 43, 78

attention: concentration of, 200

 withdrawal of, 108

attitude: authoritarian, 120

 conscious, 105, 163*f*

 — and dreams, 101

 false, of patient, 98

 of religious man, 174

 spiritual, 197

 teacher's, 136

Augustine, St., 159

authority: and children, 120

 parental, lack of, 56

 —, unwillingness to abandon, 55

autoerotic type, 70

automatism, unconscious, 174

automatons, children treated as, 14

B

backward children, *see* children

baptism, 158

 (dream-figure), 160*f*

 of students, 159

Basel School Council, 135

Beethoven, Ludwig van, 115

belief, Christian, 172

benedictio fontis, 158

Benoît, Pierre, 199*n*, 200

Bernheim, Hippolyte, 66&n

Bible: New Testament, 173

 Old Testament, 176, 184

“big brother” fantasy, 20, 27

“big dreams,” *see* dreams

biological and spiritual: psychology must explain both, 86

respective rights of, 34

birth, 11, 70

Anna's reaction to, 12

child's idea of, 9ff, 12n, 15–20, 24f, 28f, 30, 31

difficult, 70, 129

inadequately explained, 31

injury at, 130; *see also* stork theory

Bleuler, Eugen, 68

Blumhardt, Christoph, 79&n

blushing, 75

boat, big, 123

Bohr, Niels, 89n

Bolsheviks, 181

Bourget, Paul, 137

brain: ectoderm and, 5

injuries, 70, 109

structure, and collective unconscious, 117

Breuer, Josef, 95n

brother, 20, 121f; *see also* “big brother” fantasy

Buddha, 181, 184

Bushmen, 52

C

Cabir, *see* Telesphoros

Caesar/Caesarism, 180, 181

Caesarian section, 18

cancer of stomach, 96; *see also* carcinoma

carcinoma: neurotic's fear of, 183

an unconscious proliferation, 182f

cases, *see under* Jung, Carl Gustav

castration myth, 111

cathedral, 156ff, 160

c. tower, 10

see also Cologne cathedral

causalism/causality, 88, 111

 importance of, 42

 psychic, and herediity, 42*f*

see also necessity

causes: external, 153

 sexual, of neurosis, 49*f*

see also neurosis(-es)

cenobite, 174

“century of the child,” 168

Charcot, Jean Martin, 66

child(ren): in adult, 168*ff*

 analysis of, 74

 anti-social, 126

 backward, 69*ff*, 139

 beginnings of neurosis in, 112

 born from ancestral stock, 128

 collective unconscious and, 119

 copies faults of parents, 79

 difficult, 120

 —, and parental milieu, 54

 effects of parental influence on, 39

 and environment 149

 epileptic, 71*f*

 eternal, 170

 excitable, 69

 first, 70, 121

 gifted, 135*ff*

 —, education of, 140-43

 —, and mental defective, distinction, 137

 —, premature development of, 5

 —, segregation of, 142, 144

illegitimate/adopted, 70

 an individual, 128, 151

logical processes in, 4
main groups of psychic disturbances, 69ff
mentally arrested, 69
c. mind, susceptibility of, 50
neuroses of, and parents, 74, 96
neurotic, and home attitude, 152
—, ineducable, 152
—, treatment of, 96
only, 122
passes through ancestral stages, 58
phlegmatic, 69
“polymorphous-perverse” disposition of, 5, 6
pre-rational and pre-scientific, 144
psychic disorders of, 53
psychic life dependent on parents, 74f
psychopathic, 70f
sexual psychology of, 50
c. soul, remnants in adult, 45
spoilt, 130, 151, 170
and therapy, 152f
“unmoral,” 191
“where they come from,” 9ff, 15ff, 19ff, 25
wish to change, 170
see also “century of the child”
childbirth, *see* birth
childhood, return to, 192
Chinese philosophy, 188
Christ, *see* Jesus
Christianity, 172, 180
Christmas tree, 33
Church: as form of instinctive striving, 159
 Mother, as substitute for family, 85, 158
 and psychic transformations, 161
circumcision: and baptism, 161

in initiation, 159
Clark University (Worcester, Mass.), lecture, 2ff
coitus, 32, 34
child's ignorance of, 25
collective psyche, 44f; *see also* collective unconscious
collective representations, 116
collective unconscious, 116f, 200
and brain structure, 117
children and, 119
dreams and, *see* dream(s)
and individual consciousness, 117
in middle life, 119
collectivities, in education, 150ff
collectivity, 174, 178
Cologne cathedral, as mother substitute, 157ff
community: differentiated personalities and, 143
political, 135
structure of, 143
compensation(s), 16, 19, 77, 162
childish, 19
dreams as, 100, 101, 157, 162f
unconscious, 164
wrought by fate, 44
complex(-es), 110, 114, 119
component of psyche, 92
feeling-toned, 67, 109
parents', 55, 125, 126, 192
symptomatology of, 94
working through, 26
—, and dreams, 23
complex theory, 67n *see also* father; Oedipus complex
compulsion: in love, 190
c. neurosis, 98
concept building, 4, 5

conception, 24, 28
concussion, 109
confession, public, 79
confidence, need of mutual, 97
conflict(s), 5, 11, 14, 114, 144
 explanation of, 97
 and gifted child, 145
 of parents, 42
 psychic, thinking and, 4
conscious and unconscious, 51*f*, 59, 68, 91, 105, 108, 115, 131, 153, 154, 177, 194
 in neurotic, 114 *see also* unconscious
conscious mind, 103, 109, 110, 162, 183 *see also* unconscious
conscious motives, Freud and, 15*n*
consciousness: alterations of, 71
 always ego-consciousness, 190
 beginnings of, 40, 44, 45
 and change, 153
 contents of, 101
 continuity of, in child, 52
 created by psyche, 90
 development of, 68, 75, 119, 190
 — in child, 52
 disintegration of, 153
 an end-result, 52
 extension of, 190
 individual, basis of, 179
 —, a superstructure on collective unconscious, 117
 ineffectual compared to unconscious, 42
 normal, 51
 over-valuation of, 200
 as self-cognition of universe, 90
 sudden flashes of, 116
 threshold of potential, 108 *see also* ego; unconscious
constipation, 73

constitution: inherited, 131
 psychopathic, 141
contagion: by example, 150
 unconscious, 150
 “contained” and “container,” 195ff
contemplation, 116
convention(s), 174f, 178
 a collective necessity, 174
 mechanism of, 179
convulsions, 73; *see also* epilepsy
creative work, and disease, 115
criminality, 43, 72
 habitual, 70
Cromwell, Oliver, 183
cruelty, and sadism, 75
cryptomnesia, 110
culture: adult as upholder of, 58
 aetiological c.-myth, 111
 contemporary, 12n, 111, 177, 185, 197
 = continuity, 144
 c.-creating spirit, 85
 creation of, 111, 114
 cultural man, 86
 meaning of, 85
 teacher and, 58
curriculum, school, 144, 152
customs, observance of, cloak for a lie, 40

D

daemon, 141, 175
 personal, of heroes, 175
 private, 176
 of Socrates, 176
 voice of, 176; *see also* demons

danger, 61
 snake symbol of, 125
 daughter, 125
 individuality of, 128

daydreaming, 105, 138

death, 9, 11, 15, 61
 child's concept of, 9, 11
 dreams of, 128
 of mother, 11, 128

defectives, pathological, 172; *see also* imbeciles; mental defectives

degeneration, pathological, 151

deification of hero figures, 181

delusions, 145

dementia praecox: and analysis, 24
 fear of father in, 26

demons, 116 *see also* daemon; devil

dependence, state of, 58

depression, 73

desert (dream-image), 118

development: collective, 174
 embryonic, 53
 neurotic, 95
 spiritual, 194
 —, resistance to, 159

devil, 180
 concretism of the, 182
 as objective psyche, 180; *see also* demons

diagnosis, 107, 132

dictatorship, 167, 168ⁿ

digestive disturbances, 73

disappointments, professional, 57

discontent, cultural, 111

disease(s): and creation, 115
 as *entia*, 113

disintegration, [197](#), [200](#)
displacement, [163](#)
dissociation, [114](#), [196](#)
 tendency to, [194f](#)
distortion, dream mechanism of, [163](#)
divine, experience of the, [192](#)
divorce, [123](#), [201](#)
doctor: advice and reproof by, [96](#)
 desirable for analysis, [154](#)
 empirical and psychological outlook, [86](#)
 as father surrogate, [84f](#)
 and misunderstandings, [97](#)
 personality of, [140](#); *see also* analyst
doll(s), [23f](#)
 as grandmother, [27](#)
 children as, [127](#)
double, psychic, [131](#); *see also* personality
dream(s), [59ff](#), [88](#), [90](#), [100ff](#)
 and analogies, [24](#)
 analysis of, *see* dream-analysis
 in antiquity, [155](#)
 anxiety, [103](#)
 “big,” [53](#), [117f](#)
 and collective unconscious, [116f](#), [119](#)
 compensations/compensatory, *see* compensations(s)
 and conscious attitude, [101](#)
 and conscious behaviour, [162](#)
 context of, [60](#)
 difficulty of explaining, [163](#)
 dreamer chief actor in, [23](#)
 feeling-values of, [107](#)
 fever, [103](#)
 free associations to, [60](#)
 Freud and, [67f](#), [88](#), [100](#), [163](#)

general function of, 62
general theory of, 163
hunger, 103
at important junctures of life, 119
as instrument of education and therapy, 160
interpretation of, *see* dream-interpretation
manifest meaning of, 118
manifestations of unconscious creativity, 100
meaning of, 68
mechanisms of, 163
as mental corrective, 157
mistrust of, 154
multi-scened, 23
mythological, 44*f*
natural phenomena, 103
an objective process, 59
products of unconscious psyche, 59, 154
purpose of, 157
recurrent, 101
sexual, 103
somatogenic, 103
speak language of dreamer, 61
spontaneous, 59
symbolism of, *see* dream-symbolism
theoretical assumptions about, 103
value for conscious life, 62
value for psychiatrist, 155
wish-fulfilments, 100, 101, 103, 163
as works of art, 164
wrong interpretations of, 103
of young children, 44*f*, 53*f*
INSTANCES OF DREAM-SUBJECTS: animals, little, 21*f*
black and white magicians, 117
cathedral and Japanese ivory figure, 160

cathedral and well, 156
climbing mountain, 60
commanding officer and definition of the beautiful, 102
drowning, 126
earthquake, 22*f*
father's erotic problems, 53
kicking in bed, 32
lady with fat stomach, 23
mother as witch or animal, 55
Noah's ark, 21*f*
parents sitting up late, 22
snake, 123
summer and golliwog, 23
train, 26
uncle and aunt in bed, 31; *see also* death, dreams of

dream-analysis, 96, 154
in children, 120
educational, 104
method, 155*ff*
preparatory work, 155
results, 155
theoretical assumptions in, 155

dream-images, 88, 155
connection with waking thoughts, 60
many-faceted, 106
meaning, 128
sequence in, 59

dream-interpretation, 60, 88, 105, 108*ff*, 154, 163
arbitrary, 155
an art, 107
constructive, 105
key to unconscious, 104
use of, 62

dream psychology: educationalists and, 68

not prerogative of doctor, 104
dream-symbolism, 60ff, 106
 personal character of, 106
drowning; dream-image, 126
 fantasy of, 26
du Prel, Carl, 91&n
Dyer, Thomas, 189n

E

earthquake, 16f, 20
 fear of, 23
 nightmare of, 22
Eckhart, Meister, 185
educated man, and neurotic, compared, 104
education: adult, lack of, and life's problems, 57
 —, problems of, 168
 analytic method and, 57
 analytical psychology and, 49, 68
 balanced, 144
 as career, 169
 child, 170
 collective, 150ff
 of difficult children, 131
 doctor and, 131
 indirect method best, 58
 individual, 149ff
 methods of, 168
 modern, 171
 one-sided approach, 169
 psychological, meaning of, 56
 technical and practical, 145
 three kinds of, 149
 through example, 149f; *see also* educator; pedagogics; teacher/teaching
educator: average, 169

education of, 57, 132, 168
fallibility of, 120
personality of, 140
unconsciousness of, 80; *see also* education; pedagogics; teacher/teaching

ego, 90, 103, 143
and conscious mind, 51
e.-consciousness, 41, 44, 90
—, child's, 54
and illusion, 90
and inner voice, 185
regressive, 131
subject of consciousness, 91
unconsciousness and, 52

ego(t)ism, 70
children and parents', 127

Einfall, 90*f*

emotions, 126
suppressed, 96

empathy, 140

emperor's clothes, fable of, 170

empirical psychology, *see* psychology

energy, 169, 201
creative, 178
energy-tension, 108, 110
—, discharge of, 116

enfant terrible, 29

enlightenment, effect on children, 33

Enlightenment, Age of, 177

environment, 182
adaptation to, 114, 173
children and, 40
family, 153; *see also* child(ren)

Epidaurus, serpent of, 176

epilepsy, 71*f*

epileptics, 172; *see also* child(ren)
erotic factor, 105
 eroticism, feminine, 198
Essenes, 155
ethnologists, 41
Europe, 135, 145
evil, 184
 man's intrinsic, 172; *see also* good; voice, inner
evolution of species, and individual development, 53
example: bad, 150
 education through, 149f
 importance of, 132
excrement, baby brother identified with, 31
explanation, 30
 fantastic, children's preference for, 33
 "right," 34
eyes, 27
 snake's, in heroes, 175

F

facility, verbal, *see* verbal facility
factors: collective, 44; *see also* erotic factor
faculties, human, mysterious evolution of, 51
fairy tales, 24, 170
family, 53ff
 biological bondage to, 86
 initiation rites and, 159
 Mother Church substituted for, 85
 need of wider community than, 85
 psychological kinship within, 54n
fanaticism, 81
fantasy(-ies), 3, 33, 52, 58, 163
 f. activity, 13
 and actual life, 138

aimless, 138
bombastic, 122
child's, 12*f*
homosexual, 126*f*
incestuous, 126
intelligent and stupid, 138
morbid, 66*f*
f. processes, interior, 138
products of unconscious, 105
repressed, 124
secretive, need of, for development, 34
sexual, 84
—, infantile, 114
stereotyped, of “big brother,” 20
unconscious, 126
wishful, 9; *see also* hobbies

fascism, 167, 168*n*

fate: adaptation to environment and, 173
 personality and, 173

father, 21
 child sleeping in room of, 123
 f. complex, 123
 doctor as surrogate for, 84
 f. fixations, 126
 function of, in childbirth, 25
 image projected on teacher, 56
 man as, 192
 mistrust of, 26
 primordial image of, 45
 regressive libido of, 125
 unconscious psychology of, 125; *see also* parents

Faust, 176, 182, 185

fear(s), 72, 182
 childish, 45

child's desire for knowledge and, 17
collective, 175
conversion of love into, 26
expression of converted libido, 17
of God, *see* God
of new ideas, 75
nocturnal, 16, *see also* panic
and self-knowledge, 58
sublimation of, 17
superstitious, 201
of unknown, *see* unknown
Fechner, Gustav Theodor, 88
feeling(s), 139, 162
 gifted child and, 139
 “grown-up,” 169
 man's, 127
 need of, in dream-analysis, 107
 neurotic, 93
 subliminal, 108
 talented, 139
 tender, 127
 f.-toned complexes, 67, 109
 f.-values, and intellect, 100; *see also* inferiority; superiority
femme inspiratrice, 199
fever, hysterical, 73
Fierz, Professor Markus, 88*n*
fish, pregnancy by swallowing, 24
fits, *see* epilepsy
Flach, F. B., 199*n*
Flournoy, Théodore, 68
Forel, Auguste, 68
forgetting, 52
 normal, 109*f*
 and suppression, 109

fraternity ring, 160, 161

free associations, 60

free will, 91

Freud, Sigmund:

achievement of, 67f, 154

and Adler, 81f

and conscious motives, 15n

dogmatism of, 67, 97, 113

and dreams, 67f, 88, 100, 154f, 163

and evil in the psyche, 172

and hypnosis, 49, 66, 94

Jung's relations with, 67

— break from, 67, 96

— estimate of, 67f, 154

and “kill,” child's term, 10

“Little Hans” case of, see “Hans, Little”

and Oedipus complex as ossified system, 46

“polymorphous-perverse” concept of, 5

and psychoanalytical method, 49, 66, 96

and reductive method, 105

and sexual interpretation, 5, 81, 84, 96, 163

and transference, 153

and trauma theory of hysteria, 94f

WORKS: *Analysis of a Phobia in a Five-Year-Old Boy*, 8n

Civilization and Its Discontents, 111n

(with Breuer) *Studies on Hysteria*, 95n; see also Freudian psychology;
psychoanalysis.

Freudian psychology, if applied to Anna's case, 3

Frobenius, Leo, 125n

fruit, pregnancy by swallowing, 24, 25

frustrations, 129

function: creative, 115

spiritual, and infantile sexuality, 5

thinking, 5, 34f

—, and sexuality, 5
“funny,” child’s use of term, 18f
furor teutonicus, 168

G

gana, 114n

genius, 140, 182

Danaan gift of, 143

and gifted child, 141

and human qualities, discrepancy, 141

the misunderstood, 143

and personality, 179

and talent, compared, 143

“getting stuck,” 130, 174, 197

ghosts, 182

gift(s): compensated by inferiority, 141

dangers of, 141

diagnosis of, 138

of head and heart, 140

musical and mathematical, 139

and pathological variant, 141

gifted child, *see* child (ren)

glasses, meaning of, 129

goal: instinctive, 192

sexual, 4

spiritual, necessity of, 86

God, 175

concept, 4

elect of, 175

fear of, 177

primitive definition, 20

vocation as law of, 175

voice of, 116

Goethe, Johann Wolfgang, 167, 176; *see also* *Faust*

Golem, 171
golliwog, dream of, 23
good: and better, 185
 and evil, in man, 45, 151, 172
 relativity of, 118
grandmother/“granny,” 123, 125
 and death, 9
 game of, 27
 as “mouth,” 125
Greece, ancient: heroes of, 175
 homosexuality in, 159
group: voice of, 176
 g. psyche, identity with, 178
guidance, masculine, need for, 159
guilt, of parents, impersonal, 44

H

Haggard, H. Rider, 199*n*, 200
hair, at birth, 28
“Hans, Little” (Freud’s case), 8, 10, 11, 23, 25
 stage-coach story of, 26
Hansel and Gretel, 125*n*
harmony, in marriage, 192
Hay, Marie, 199*n*
hedonism, 3
Hera, 186
Hercules, 186
herd, the, 174
heredity, 42*f*, 182, 194
 dead hand of, 43
hero(es), 115, 181
 birth of, 184, 186
 godlike attributes of, 175
 legendary, 174

longing for, 178
as a Messiah, 180
snake-souled, 175
solar attributes of, 184
Hine-nui-te-po, 125n
history, 144
 continuity of, 145
Hitler, Adolf, 168n
hobbies, as fantasies, 138
home: atmosphere, 152
 life at, knowledge of child's, 152
homesickness, 13
homosexuality, 126, 127, 156, 157, 159, 160ff, 191
 and education, 159
 in ancient Greece, 159
 unconscious meaning of, 160; *see also* fantasies
horror novi, 75
horse: black, 118
 of Little Hans, 25
humility: a protection to gifted child, 142
 rooted in pride, 106
hypnotism, 49, 66, 94; *see also* suggestion
hysteria, 73, 76, 108, 112
 trauma theory of, 94
 hysterics, fantasies of, 67

I

idea(s): new, fear of, 75
 “occurrence” of, 91
ideal: of “doing their best,” 171
 shadowy, father as, 126
idealism, medieval, 65
identification, 96
 of baby brother with excrement, 31

identity, 41, 42
 original, 193
 primitive, *see* primitive identity
 psychic, 149
 psychology of, 44
 unconscious, 158, 192
 — with family, 56

ιδιώται, 174

idiots, 172

illumination, 184

illusion(s), 132
 and ego, 90

image(s): amplification of, 88
 archetypal/primordial, *see* archetypes
 unconscious, 198; *see also* dream-images

imagination: objective psyche as, 182
 world of, 129

imagos, parental, fixation to, 84

imbeciles/imbecility, 69, 132
 emotional reactions, 69
 feats of calculation by, 139

imitation, compulsive, 78

impulse(s), 52
 instinctive, 105, 119; *see also* fantasy(-ies)

inattentiveness, 138

incarnation, of ancestral spirit, 45

incest, 126
 misleading use of term, 75
 unconscious, 125; *see also* fantasies

incubation period, 110

indecision, neurotic, 76

independence of mind, importance of, 94

Indians, South American, 34

individual, 171

capacity, 201
embryonic development of, 53
a new experiment of life, 93
and species, 192
a unique combination of psychic elements, 93; *see also* child(ren)

individualism, 173, 175

individuality, 97
child as, 44
child's, and ancestors, 44
— not derived from parents' psyche, 44
of daughter, 128

individuation, 179

indolence, 105; *see also* laziness

ineducability, 151*f*

inertia, 105

infantilism, 158, 162
of adult, 168

inferiority: feeling of, 121*f*,
in child, 130
moral, 130, 141

inflation, 142

inheritance, *see* heredity

initiation: ceremonies, 85, 159
into manhood, 160*f*
of treatment, 160

inner life: of child, 54
of neurotic, 183

inner voice, *see* voice

innocents, massacre of, 186

insanity, 97, 116, 149
moral, 70*f*

insecurity, 201

insight, flashes of, 45

inspirations, fantasies as, 105

instinct(s), [53](#), [158](#), [191f](#), [197](#)
 aesthetic, in animals, [83](#)
 balance of, [81](#)
 distinction between, [83](#)
 overvaluation of, [84](#)
 religious, [83](#)
 repressed/repression of, [15n](#), [105](#)
 restrictions on, [82](#)
 sexual, Freud and, [81](#)
integration, inner, [197](#)
intellect, [107](#), [177](#)
 and feeling-values, [100](#)
 precocious, [139](#)
intelligence: suspicion of, [137](#)
 i. tests, [121](#), [129](#)
intentions: good, [131](#)
 real, [101](#)
interest(s): abnormal, [138](#)
 aesthetic, [105](#), [162](#)
 intellectual, [162](#)
 object of, [109](#)
 religious, [162](#)
International Congress of Education, [49n](#), [63](#), [149](#)
interpretation, [15n](#)
 Freudian, [3](#), [105](#)
 sexual, [106](#); *see also* dream-interpretation
introversion, [13&n](#), [16](#)
inversion, [163](#)
irrational values, [40](#)
Italy, [20](#), [167](#)
ivory figure, Japanese, [160](#), [161](#)

J

Jacobi, Jolande, [113n](#)

Janet, Pierre, [66](#), [68](#)

jealousy, [121](#)

Jesus, [180](#), [181](#)

in Protestantism, [181](#)

Temptation of, [180](#), [184](#)

vocation of, [180](#)

Jews: and circumcision, [161](#)

and Messiah, [180](#)

Jordan, Pascual, [89n](#)

Josephus, Flavius, [155](#)

judgments, individual, [151](#)

Jung, Carl Gustav: school reminiscence, [136](#)

CASES IN SUMMARY (in order of presentation, numbered for reference):

[1] Anna, aged 3, subject of “Psychic Conflicts in a Child.” — [9-35](#)

[2] Girl, aged 15, who harboured an unconscious fantasy of mother’s death. — [11](#)

[3] Boy, who dreamed the erotic and religious problems of father (ref.). - [53](#)

[4] Three sisters, who dreamed of “devoted” mother as animal, she later going insane. — [55](#)

[5] Mountain-climber, man of 50, whose dreams presaged a fatal climbing expedition. — [60f](#)

[6] Boy, aged 6, imbecile, whose fits of rage were caused by his mother’s ambition. — [69f](#)

[7] Boy, aged 14, who killed his stepfather. — [70](#)

[8] Boy, who at 5 violated his sister, later tried to kill father, and grew up to be normal. — [70f](#)

[9] Boy, aged 7, epileptic, whose first symptom was truancy. — [71f](#)

[10] Boy, aged 14, schizophrenic, whose first symptom was a sexual conflict. — [73](#)

[11] Girl, aged 4, whose psychogenic constipation was caused by her mother. — [73f](#)

[12] Four abnormal siblings, all infected by un-lived erotic life of mother, who subsequently became melancholic. — [76ff](#)

[13] Recruit, aged 19, hysterical, cured by anamnestic analysis. — [95f](#)

[14] Recruit, neurotic, cured by anamnestic analysis. — [96](#)

[15] Man, aged 30, who was “kept” by older woman, and whose “psychoanalytical autobiography” omitted essential moral element. — [98f](#)

- [16] Widow, aged 54, whose “snapshot” dreams contained her real intentions. — [100f](#)
- [17] Crusty old general, whose dream showed an undeveloped interest in art. — [102f](#)
- [18] Cryptomnestic case concerning Nietzsche, in “Psychology and Pathology of So-called Occult Phenomena” (ref.). — [110](#)
- [19] Young theological student, with religious problem, who dreamt of black and white magicians. — [117ff](#)
- [20] Boy, aged 7, supposedly mental defective, with many symptoms, treated by explanation of his condition to his parents and later by individual treatment; he developed a moral imaginary companion in Santa Claus. — [121f](#)
- [21] Girl, aged 9, with subnormal temperature, who improved when her parents faced their conflict. — [123f](#)
- [22] Girl, aged 13, whose antisocial attitude was caused by her intellectually ambitious mother. — [126f](#)
- [23] Margaret, aged 8, with birth injury, who during treatment developed an imaginary companion called Anna. — [128ff](#)
- [24] Medium, girl aged 16, subject of “The Psychology and Pathology of So-called Occult Phenomena” (ref.). — [131](#)
- [25] Little boy, imbecile, whose condition was not accepted by his mother. — [132](#)
- [26] Little girl, intelligent, whose difficulties stemmed from being pupil of teacher trained to work with mentally defective children. — [137](#)
- [27] “Misunderstood genius”: “lazy hound.” — [143](#)
- [28] Homosexual youth, aged 20, whose religious dreams compensated the negative view of his condition and indicated the initiatory character of his symptom. — [156ff](#)

WORKS: “The Archetypes of the Collective Unconscious,” [106n](#)

Contributions to Analytical Psychology, [63](#)

“Mind and Earth,” [77n](#)

“On the Psychology and Pathology of So-called Occult Phenomena,” [67n](#), [110](#), [131](#)

“Paracelsus as a Spiritual Phenomenon,” [113n](#)

“Practical Use of Dream-Analysis,” [62](#)

“Psychic Conflicts in a Child,” [50n](#)

“Psychological Aspects of the Kore,” [106](#)

“Psychological Aspects of the Mother Archetype,” [77](#)

Psychology and Alchemy, [106n](#)

“Psychology of the Child Archetype,” [106](#), [170n](#)

“Psychology of Dementia Praecox,” 19

“A Review of the Complex Theory,” 67n, 94n

“Sigmund Freud: a Cultural Phenomenon,” 84n

“Spirit and Life,” 89n

Studies in Word Association, 67n, 94n

Symbols of Transformation, 106n, 125n

K

Kerényi, C. (Károly), 170n

keys of Paradise, 118

Keyserling, Count Hermann, 114n, 189n

“kill,” 24, 128

 meaning to children, 10f

kinship, psychological, within family. 54

knowledge: child’s unnatural craving for, 17

 fear and desire for, 17

 thirst for, 22

Künkel, Fritz, 112

L

Lagerlöf, Selma, 199n

Lao-tzu, 143

laziness, 43, 143; *see also* indolence

leader/leadership, 143, 167f, 179, 186

left-handedness, 129

Lenin, Nikolai (V. I. Ulyanov), 181

Lévy-Bruhl, Lucien, 41, 149

libido, 5

 converted, fear as expression of, 17

 father’s regressive, 125

 suspension as transference of, 13n

Liébeault, A .-A.. 66

life: middle, *see* middle life; second half of, *see* second half of life

life-history, value in diagnosis, 153

likeness, family, 128

“Little Hans,” *see* “Hans, Little”

Lourdes, 156

love, 125, 191

and force, 181

and homosexual fantasies, 127

introverted, 13, 16

securing by force, 16

unconscious, 78; *see also* ambition(s); fear

Lucifer, 185

lunatics, 172; *see also* insanity

lycanthropy, 55

lying, 14, 73, 139

M

magic, 114

magician: black and white, 117*f*

hero as, 175

Magna Mater, magical figure, 45

maladjustment, 152

Malinowski, Bronislaw, 34

man: cultural and natural, 86

as father, 192

inborn image of, 198; *see also* whole man

maniacs, homicidal, 172

manic ideas, 88

manikin, 161

Mara, 184

marriage (s), 161, 162, 189*ff*

arranged, 192

biological aim of, 201

choice, 192

conventional, 192

disorders in, 201

in first half of life, 197f
ill-advised, 57
metaphorical use of term, 75
transitions in relationship, 200
typical, 127
young people and, 190

Marx, Karl, 181

masturbation, 5, 18, 126

materialism: and empirical psychology, 66
nineteenth-century, 65
as reaction against medieval idealism, 65

mathematics, 139
incapacity for, 152

maturation, 141, 193

maturity, 139, 144

Maui, 125n

medicine-men, primitive, 176, 183

Meier, C. A., 89n

melancholia, 77

memory(-ies), 94, 108
artificial loss of, 109
child has no, 52
infantile, 116
repressed, 109
memory-image, of mother, 124f

mental defectives, 69, 137, 151; *see also* imbeciles

Mephistopheles, 182

mesmerism, 66

Messiah, 180

Messina earthquake, 16f

metaphors: in dreams, 157
sexual, 75

method(s): analysis of unconscious, 96f
analytical, 164

anamnetic, 95, 97
constructive, 105
educational, 149ff, 164, 168
empirical, 65
psycho-biological, 3, 4
reductive, 105
scientific, 154; *see also* association method; education
microphysics, and reconstruction of psychic process, 89
Middle Ages, Church substitutes for family, 85
middle life, 193, 197
 collective unconscious in, 119
 marriage in, 196
mind: biological structure of, 51
 growth of, and widening consciousness, 75
 a psychic phenomenon, 89
“misunderstood” class, 143, 199
modern man, and psyche, 177
Mona Lisa, 199
mood(s), 103
 of affection and remorse, 121
 children’s, 13
 compensation of, 157
 elegiac, 12f
 poetic, 157
moral: decision, 174f
 development, arrested, 70
 insanity, 71
 qualities, 79
morality, law beyond, 40
morals, 139
 and neurosis, 99
mother(s), 74, 172, 193
 ambitious, 69, 128
 child-giving, 24

and child's neurosis, 69
death of, 11, 128
devouring, as archetype, 125n
doctrine replaces, 85
"faithful," 11
getting rid of the, 27n
incestuous longing for, figurative, 75
as instinctual ground-layer, 128n
memory-image of, 124f
regression to, 162
m.-substitute, 158
will to power of, 126, 127
woman as, 192; see also parents

motherhood, sanctity of, 172
motifs, mythological, 119
motivations/motives, 122
 conscious, 15n
 unconscious, 190, 193

mountain(s): dream-image, 60ff
 passion for, avenue of escape, 61

mouth, 123, 125

Mozart, Wolfgang Amadeus, 115

Munchausen, Baron, 87

murder, fear of committing, 72

music: in dream, 160, 162
 as gift, 139

mysteries, religious, 159
"mystical," use of word, 41

mythologems, 119

mythology, 24, 34, 119, 184
 in dreams, 44f
 Nordic, 175
 Polynesian, 125n

Napoleon I, 176

natural man, 86

necessity: causal, 173
and moral decision, 175

negativism, 14, 19
psychology of, 19

Negroes, 52

nervous disorders: child's, 54
functional, 49
sexual origins of, 49

neurasthenia, 123

neurosis(-es), 5, 7, 104, 184
causes of/reasons for, 94, 111, *see also* causes
—, internal and external, 93
children's, 5, 73f, 121, 131
—, beginnings of, 112
—, forms of, 73
—, and parents, 42, 74, 96, *see also* child(ren), parent(s)
classification, 113
compulsion, 98
creative function and, 114f
defence against inner voice, 183
dubious/incorrect theories of, 19, 112
false aetiology of, 46
functional, and unconscious, 68
general theory of, premature, 114
imbecility and, 69
individualistic nature of, 113
infantile, *see* children's *above*
insecurity and, 201
nature of, 97
relation with morals, 99

neurotic(s): children, 73f
and illusions, 112, 182

- inner life of, 183
- sexual fantasies of, 13n
- states, passed on, 78
- unconscious of, and schizophrenia, 116

New Testament, 173

Nietzsche, Friedrich, 110, 144, 183n

night terrors, 121, 122

nightmare, of earthquake, 22

Noah's Ark, dream of, 21f

normal man, a fiction, 200

"nothing but," 83, 177

novelty, mania for, 145

nun, vision of, 72

nurse, Anna's reaction to, 12f, 15

O

obedience, as protection to gifted child, 142

objective psyche, 179ff

- as psychic
- non-ego, 183

Oedipus complex, 46, 75

- a symptom, 75

Old Testament prophets, 176, 184

oneness, unconscious, 192

one-sidedness, 83

- see also* education openings, body, 18, 31

opposites

- identity of, 118
- progressiveness/regressiveness, 163
- reconciliation of, 145
- spiritual/biological, 86
- spirituality/sensuality, 197
- tension of, 144

orange, 24

organ inferiorities, 122

over-compensation, 78

Oxford Group, 79

P

pain, 73

paleontology, scientific status in 18th century, 88

panic, 179

Paracelsus, 113

parallels, mythological, 119

paralysis, 73

paramnesia, 109

parents: aims of, 171

attitude/conduct/relationship to child, 12, 39, 44, 50, 70, 75, 79

average, 169

as cause of child's neurosis, 69

as children of grandparents, 43

complexes of, 125, 126

consequences of repression in, 78

correction of images of, 46

deception by, 16

demands on, 85

excessive attachment to, 55, 75f

and gifted child, 142

good advice and, 152

influence, effect on child, 39

love and hate of, 154

and marriage, 190ff

not just sexual objects, 84

as "personalities," 168

problems of, 126

—, as catalyst, 43

psychology of, and "big dreams," 53

recognition of faults by, 79

responsibility to children, 84ff

separation of, 124

unconscious tie to, 191, 194

unconscious of, and child's psyche, 39n, 41

“unlived life” of, effects on child, 43, 78, 191; *see also* ambition(s); child(ren); conflicts

Parsifal (Wagner), 115

participation mystique, 41, 54, 124, 149; *see also* primitive identity

past, and future, 110, 145

pedagogics, 168

enthusiasm for, 170; *see also* education; teacher/teaching

perceptions, subliminal, 108

persecutions, magical, 116

personal unconscious, 116, 118

contents of, 116

personality(-ies): achievement of, 171

an adult ideal, 169

child's, 168, 170

Christ's, 180

conservative, 173

creative, 141

cult of, 181

dependent, 55

development of, 167ff

differentiated, 143

dissociation of, 131

doctor's, curative effect of, 140

double, 131

doubts about, 172f

education of, not for children, 169

an educational ideal, 167

and genius, 179

hero and, 181

individual nature of, 179

moral, 141

second, growth of, [131](#)
spiritual, [197](#)
p. split, [108](#)
p. training, [167ff](#)
unattainable ideal, [172](#)
uncongenial to the herd, [174](#)
unconscious, [131](#)
vital tendencies reflected in dreams, [62](#)
yearning for, [168](#)
personification, of unconscious, [108](#)
petit mal, [71](#)
philosophy: deductive tendency, [65](#)
psychology and, [89](#); *see also* Chinese philosophy
phobia(s), [21](#), [74](#), [100](#)
phylogenetic recapitulation, [144](#)
physics, atomic, and psychology, [88f](#)
πίστις, [173](#)
pleasure: and lust, [75](#)
 p. principle, [3](#), [114](#)
poetry, primordial images in, [119](#)
politics, contemporary, [167](#)
“polymorphous-perverse” disposition, [5](#), [6](#)
power (s): complex, [123](#)
 creative and destructive, [141](#)
 instinct, [82](#)
 principle, [3](#)
 Roman devil-worship of, [181](#)
precocity, [139](#)
 abnormal, [120](#), [139](#)
 sexual, [75](#)
pregnancy: illness in, [70](#)
 imitation of, [23](#)
 primitive view of, [34](#)
 by swallowing fish, etc., [24](#)

prejudices, moral, 99
premonitions, of children, 45
priest (dream-figure), 160f
primitive(s)/primitive peoples, 41, 45, 114, 159, 174, 183, 197
 and “big dreams,” 117
 children compared to, 52, 53
 and *horror novi*, 75
 restriction on instincts among, 81
 and sexual processes, 34
 world of the, 116; *see also* initiation
primitive identity: and education, 55
 and parents’ conflicts, 124
 and relationship, 190; *see also participation mystique*
problems, parents’, 126
 as catalyst, 43
 causal significance for child’s psyche, 43
progress: and culture, 144
 impossible without mature judgment, 145
progression, educator’s influence in favour of, 163
projection, 198, 200
 and individual relationship, 200
 realization of, 130
 in transference, 153; *see also* anima/animus
proletarian inclinations, of noble families, 43
prophets, Old Testament, 176, 184
protest, unspoken, 78
Protestantism, 181
psychasthenia, 77
psyche: archaic, 119
 child’s, contents of, 44
 —, general picture of, 57
 collective, *see* collective psyche
 in early infancy, 53
 a fluid stream of events, 82

identification with consciousness, 59
individual, 54
an irrational datum, 90
objectivity of, 91, 117, *see also* objective psyche
perception of itself, 86f:
as plaything of instinct and environment, 54
protean life of, 83
its reactions not specific, 42
structure not unipolar, 81
theories and phenomenology of, 7
transcendental subject, 91
trans-subjective, 91
underestimation of, 177
psychiatrist, school, 144
psychiatry, 86
psychic: disorders, 66
factors, subliminal, 51
phenomena, biological explanation, 86
—, unconscious, 51
processes, arbitrariness of, 90f
psychoanalysis, 8, 15n, 49, 68, 113
books on, 74
and medical psychology, 68
and sexual causation, 50
and sexual theory, 96; *see also* Freud; Freudian psychology
psycho-biological method, 3, 4
psychologist, medical: and dreams, 155
and natural science, 87
psychology: analytical, *see* analytical psychology
arbitrariness of, 90
empirical, modern, 66
—, origins of, 65
enthusiasm for, 177
experimental, 51, 66, 91

formerly part of philosophy, 65
Freudian, 3, 81, *see also* psychoanalysis
a humane science, 89, 90
individual, potential in child, 53
meaning of, educational and medical, 93
medical, 51
—, and whole man, 86
must explain spiritual and biological, 86
and natural science, 87, 89*f*
not a mere subjective concern, 39
objective measurement in, 88
philosophical replaces dogmatic, 66
physiological, 66, 81
position of, 89
a practical science, 93
pure, principle of explanation, 87
relations with biology and physiology, 83
scientific, early, 81
shunned by would-be artists, 115
subject-matter of, 89
theory-building in, 114
a young science, 65
psychopathic: children, 70
 constitution, 141
psychopathology, 68
 experimental, 67
psychophysics, 88
psychophysiology, 87
psychosis(-es), 104, 119, 153
 in childhood, 73
 incorrect theories as determinants of delusions in, 19
 mass, 85
psychotherapy: and doctor's personality, 140
 use in epilepsy, 72; *see also* analysis

puberty, 55, 126, 159

psychic, 52

punishments, 131

pupil(s): gifted, segregation of, 141, 144

individuality of, 150ff

python, 186

Q

questions, children's, 12n, 15n, 16ff, 27f

R

rage(s), 69f, 121f, 132

as compensatory power manifestations, 122

rapport, hypnotists on, 97

rationalist, doctrinaire, 85

reaction(s): emotional, infectiousness of, 41

secondary, 138

reading, 128, 132

indiscriminate, by children, 138

realism, child's outgrowing of, 6

reason, flimsy barrier against pathological tendencies, 71

rebirth: archetype of, 10n

symbolic, 184; *see also* reincarnation

Red Riding Hood, 125n

redeemer personality, 178

reductive: method, 105

viewpoint, 106

regression, 114

to mother, 162

to primitive stage, 53

regressive tendency, child's, 75

regressiveness, *see* opposites

reincarnation theory, 10ff, 45

relationship, 192

collective biological and spiritual, 200
heterosexual, 161
homosexual, 161f
individual, 193
psychology of, in marriage, 189
and unconscious, 190
religion, 4, 159, 201
archetypes in, 119
experience of, 83
not merely sex repression, 83
religious man, and God, 174
repression(s), 6, 13n, 78, 94, 108ff, 114f, 124f
and creativeness, 115
an exceptional process, 109
explanation through, 111
normal, 108f
sexual, 34, 83, 111
theory of, 114; *see also* instinct(s); suppression
resistance(s), 84n
active, 108
aroused by dreams, 103
children's, 14, 16, 20
conscious, 100, 162
forcible breaking down of, 98
infantile, 100
to parents, 153
stiffening child's, 128
responsibility, child's, 126, 130
reveries, children's, 13, 16
revolution(s), 181
cosmic, 116
as psychic epidemics, 177f
Riklin, Franz, 24n
ring: dream figure, 160

as token of relationship, [161](#)
rivalry: *see* affection; sibling
Roman, [180f](#)
 empire, [180](#)
rose, [24](#)
Ross, Mary, [199n](#)
rules, technical, in psychoanalysis, [113](#)

S

salvation, yearning for, [180](#)
Salvation Army, [79](#)
Santa Claus, [122](#)
sarcophagus, [118](#)
savages, *see* primitive(s)
saviour, [186](#)
Schiller, J. C. F. von, [10](#), [171](#)
 on aesthetic education, [168](#)
 as educator, [168](#)
schizophrenia, [67n](#), [73](#), [116](#)
school, [55](#), [131](#), [142](#)
 for adults, [57](#)
 and consciousness, [52](#)
 curriculum, [144](#), [152](#)
 meaning of, [56](#)
 and unconscious identity with family, [56](#)
science: humane, [89](#)
 natural, [86ff](#); *see also* psychology
second half of life, [193](#)
 aims of, [194](#)
security, hope of, [196](#)
segregation: of gifted children, [142](#), [144](#)
 of individual, [173](#)
self-assertion, [81](#)
self-confidence, exaggerated, [142](#)

self-consciousness, 184

self-criticism, 58

self-education, 140

- possibilities of continued, 58
- of teacher, 58

selfhood, 197

self-knowledge, 43, 58

- incomplete and confused, 58

self-preservation, instinct of, 82

self-sacrifice, 199

sensuality, and spirituality, 197

serpents, 186; *see also* snake

sex, 192

- balancing factor to, 81
- exaggerated importance of, 81, 84
- and Freudian psychology, 5, 81, 84, 96, 163
- and infantile thinking, 4
- life, normal, 192
- premature enlightenment on, 75
- and psyche, 82
- and religious experiences, 83
- s. education, 32

sexual: activity, premature, 70

- enlightenment, premature, 75
- excitability, 126
- interest, goal of, 4
- perversion, 73
- symptoms, premature, 127
- , in children, and parents' psyche, 76
- wishes, dreams and, 163

sexuality: adult and infantile, compared, 4

- infantile, 7
- , a *façon de parler*, 7
- , repressed, 111

—, and spiritual functions, 5
and origins of thinking, 35
overdeveloped concept of, 7
polymorphous, child's, 5f
thinking function and, 5
shadow, of young persons, 190
shell-shock, 95
sibling(s), 42
 case of four abnormal, 76ff
 s. rivalry, 10, 121
simplicity, and complexity, 195
sin: original, 43
 “taking a sin,” 72
sister: imaginary twin, 129, 131
 representing moral reason, 131
snake: big, 123
 and hero, 175
 python, 186
 spirits, 176
 symbolism, 125n
Socrates, daemon of, 176
son: eldest, 122
 as husband substitute, 191
sorcery, 114
soul, 92
 child's preconscious, 45
 —, projected on parents, 45
 must be met on its own ground, 40
 loss of, 114
South America: *gana*, term used in, 114n
 Indians of, 34
species: development repeated in individual, 53
 and individual, 192
 maintenance of, 191f

speech, 44, 69
 impediment in, 121
 training, 122

spirit (s), 116, 183
 ancestral, 45
 culture-creating, 85

spiritual: attitude, 197
 function, 5; *see also* biological and spiritual

spontaneous utterances, significance of child's, 14

squinting, 121

stammerers, 13n

standpoint, conscious, of patient, 101

State, father, 85

staying up late, of children, 21

steadiness, need of, 145

stealing, 73

stomach: fat, dream of, 23
 s. trouble, 96

stork theory, 9f, 11f, 15f, 17f, 19f, 28

students, initiation rites of, 159

sublimation: in four-year-old child, 16
 untimely, 17

suffering: meaningful, 78
 neurotic, an unconscious fraud, 78

suggestion, 85, 98
 hypnotic, 94

suicide, 61, 97
 caused by transference, 154

sun heroes, 184

superiority: false, as compensation, 130
 feeling of, 142

supernatural, 175

suppression, repression and, 109, 125

swallowing, pregnancy and, 24

Switzerland, [137](#), [141n](#)
national vice of, [145](#)
symbol(s): history of, [107](#)
sacred, [181](#)
symbolism, [106](#)
—, religious, [85](#); *see also* dream-symbolism
symptom: causes of, [152](#)
s.-analysis, method of, [94](#)

T

taboo, [18](#)
Tao, as personality, [186](#)
teacher/teaching, [168f](#)
and analytical psychology, [57](#), [74](#)
attitude of, [136](#)
authority of, [56](#)
and child, relationship, [56](#)
and child's psychic life, [51](#)
example of, [56](#)
influence of, on child, [55](#)
as instrument of fate, [142](#)
method of, [56](#)
need of education for, [140](#)
needs knowledge of psychology, [138](#)
needs understanding heart, [144](#)
as parent-substitute, [55](#)
personality of, [56](#)
self-education of, [58](#)
shortcomings of, and children, [120](#); *see also* education; educator; pedagogics
technique(s): and treatment, [92ff](#), [112ff](#), [140](#), [153](#)
pedagogic, [168](#)
Teddy bear, [24](#), [132](#)
teleology, [131](#)
Telesphoros, [176](#)

temper outbursts, [121](#); *see also* rage

temperature, low, [73](#), [123](#)

Temptation, Christ's, [180](#), [184](#)

tension, release of latent, [116](#)

Tertullian, [181](#)

tests: for intelligence, [121](#), [129](#)
for thinking and feeling, [129](#)

theologian, [117f](#)
theology, [65](#)

theoria, [87](#)

theory(-ies): and analysis, [97](#)
fixed, [93](#)
function of, in psychology, [7](#)
incorrect, substituted for correct, [19](#)
intellectual, [92](#)
old, alive in unconscious, [25](#)
of psychotherapist, [112](#); *see also* stork theory

thinking: development of, [4](#), [34](#)
infantile, sex and, [4](#)
logical, [152](#)
neurotic, [93](#)
philosophic, [65](#)
and psychic conflicts, [4](#)
scientific, [163](#); *see also* function

thought(s): logical and abstract, [139](#)
subliminal, [108](#)
repressing disagreeable, [101](#)

toilet, [23](#), [27n](#), [30](#)

Tongue, Mary C., [199n](#)

tongue, tied, [121](#)

tool-shed, [27n](#)

torture, in initiation, [159](#)

totalitarianism, [85](#), [167](#)

tradition, [178](#)

train (dream-image), 26

transference, 85

- meaning of, 153f

transformation(s), instinct and spirit, 197

- of middle life, 197
- nature and culture, 197
- psychic, 6, 161

trauma(ta), 94, 112

- infantile, 111

treatment, 92

- initiation of, 160
- method determined by case, 113
- as religious act, 157
- and technique, 92ff, 112ff, 140, 153

U

unadaptedness, 92

unbalance, spiritual, contemporary, 84

unconscious, 97, 104, 124

- analysis of, 96ff, 100, 105, 154, *see also* analysis
- as collective ideal, 125
- comparative research into, 114
- compared to sea, 51
- consequences of u. proliferation, 182f
- content of, 108ff
- discovery of, 67
- and dreams, 59f, *see also* dreams
- effects perceived indirectly, 59
- ego and, 143
- inertia of, 158
- Janet and the, 66
- matrix/mother of consciousness, 52, 115
- never at rest, 51
- nothing but fantasy, 177

old theories alive in, 25
as a quality, 108
and relationship, 190
the repressed, 108
tendencies of, 108
—, and conscious mind, 105
two parts of, 116ff; *see also* collective unconscious; conscious and unconscious;
personal unconscious; unconsciousness
unconscious psyche, child's, 45
unconsciousness, 76
child's, and identity, 41
difficulty of giving up, 75
of educator, 80
partial, 189
primordial, 119
understanding: child's need of, 127
interpretations of, 93
intuitive, need of, in dream-analysis, 106
unfaithfulness, in marriage, 196
uniqueness, individual, not always an asset, 151
unity, longing for, 196
unknown: fear of, 75f
methods of investigating, 94

V

vacuum, psychic, 101
values: collective, and individual uniqueness, 150
irrational, of child, 40
moral, 40
spiritual, 40
verbal facility, 139
virgin (dream-image), 118
virtue, rooted in vice, 106
vision(s): fantasies as, 105

madman's, 116
of nun, 72
symbolism of, 106; *see also* dream(s); fantasy(-ies)
vocation, 175ff
and collective necessities, 176
feeling of, 176
as psychic necessity, 178
sacrifice of self to, 180
and voice of inner man, 176
voice: of God, 116
inner, 176ff
—, and ego, 185
—, and evil, 184f
—, and Lucifer, 185
—, and neurosis, 183
tone of, 14
volcanoes, 17, 18, 20

W

Wagner, Richard, 115
walking, uncoordinated, 121
wars, as psychic epidemics, 177f; *see also* World War, first
wedding ring, *see* ring
well (dream-image), 156f
whole man, 107, 143
wholeness, 170f, 174, 179, 183
individual and group, 176
Wickes, Frances G., 39ff, 121
will: acrobatics of, 174
division of, 194
a phenomenon, 91
and psychic contents, 91
will to power, mother's, 126f
wings (dream-image), 61

wish(es), 182
egoistic, 23
wish-fulfilment, 20, 163
dream as, 100f, 103, 128n, *see also* dream(s)
witch, 55
witchcraft, 116
Wolff, Toni, 90n
woman: elderly (dream-figure), 160f
eternal image of, 198
masculine, 127
as mother, 192
woman-hater, 77
womb: of Church, 158
return to, 192
wood, fantasy of planing, 29
World War, first, 95
writing, 129, 132
Wundt, Wilhelm, 51
Wylie, Elinor, 199n
Wyss, Walter H. von, 83n

Y

young people, and marriage motives, 190; *see also* adolescence

THE COLLECTED WORKS OF

C. G. JUNG

*THE PUBLICATION of the first complete edition, in English, of the works of C. G. Jung was undertaken by Routledge and Kegan Paul, Ltd., in England and by Bollingen Foundation in the United States. The American edition is number XX in Bollingen Series, which since 1967 has been published by Princeton University Press. The edition contains revised versions of works previously published, such as *Psychology of the Unconscious*, which is now entitled *Symbols of Transformation*; works originally written in English, such as *Psychology and Religion*; works not previously translated, such as *Aion*; and, in general, new translations of virtually all of Professor Jung's writings. Prior to his death, in 1961, the author supervised the textual revision, which in some cases is extensive. Sir Herbert Read (d. 1968), Dr. Michael Fordham, and Dr. Gerhard Adler compose the Editorial Committee; the translator is R. F. C. Hull (except for Volume 2) and William McGuire is executive editor.*

The price of the volumes varies according to size; they are sold separately, and may also be obtained on standing order. Several of the volumes are extensively illustrated. Each volume contains an index and in *most* a bibliography; the final volumes will contain a complete bibliography of Professor Jung's writings and a general index to the entire edition.

In the following list, dates of original publication are given in parentheses (of original composition, in brackets). Multiple dates indicate revisions.

•1. PSYCHIATRIC STUDIES

On the Psychology and Pathology of So-Called Occult Phenomena (1902)

On Hysterical Misreading (1904)

Cryptomnesia (1905)

On Manic Mood Disorder (1903)

A Case of Hysterical Stupor in a Prisoner in Detention (1902)

On Simulated Insanity (1903)

A Medical Opinion on a Case of Simulated Insanity (1904)

A Third and Final Opinion on Two Contradictory Psychiatric Diagnoses (1906)

On the Psychological Diagnosis of Facts (1905)

†2. EXPERIMENTAL RESEARCHES

Translated by Leopold Stein in collaboration with Diana Riviere

STUDIES IN WORD ASSOCIATION (1904–7, 1910)

The Associations of Normal Subjects (by Jung and F. Riklin)

An Analysis of the Associations of an Epileptic

The Reaction-Time Ratio in the Association Experiment

Experimental Observations on the Faculty of Memory

Psychoanalysis and Association Experiments

The Psychological Diagnosis of Evidence

Association, Dream, and' Hysterical Symptom

The Psychopathological Significance of the Association Experiment

Disturbances in Reproduction in the Association Experiment

The Association Method

The Family Constellation

PSYCHOPHYSICAL RESEARCHES (1907–8)

On the Psychophysical Relations of the Association Experiment

Psychophysical Investigations with the Galvanometer and Pneumograph in Normal and Insane Individuals (by F. Peterson and Jung)

Further Investigations on the Galvanic Phenomenon and Respiration in Normal and Insane Individuals (by C. Ricksher and Jung)

Appendix: Statistical Details of Enlistment (1906); New Aspects of Criminal Psychology (1908); The Psychological Methods of Investigation Used in the Psychiatric Clinic of the University of Zurich (1910); On the Doctrine of Complexes ([1911] 1913); On the Psychological Diagnosis of Evidence (1937)

•3. THE PSYCHOGENESIS OF MENTAL DISEASE

The Psychology of Dementia Praecox (1907)

The Content of the Psychoses (1908/1914)

On Psychological Understanding (1914)

A Criticism of Bleuler's Theory of Schizophrenic Negativism (1911)

On the Importance of the Unconscious in Psychopathology (1914)

On the Problem of Psychogenesis in Mental Disease (1919)

Mental Disease and the Psyche (1928)

On the Psychogenesis of Schizophrenia (1939)

Recent Thoughts on Schizophrenia (1957)

Schizophrenia (1958)

† 4. FREUD AND PSYCHOANALYSIS

Freud's Theory of Hysteria: A Reply to Aschaffenburg (1906)

The Freudian Theory of Hysteria (1908)

The Analysis of Dreams (1909)

A Contribution to the Psychology of Rumour (1910–11)

On the Significance of Number Dreams (1910–11)

Morton Prince, "The Mechanism and Interpretation of Dreams": A Critical Review (1911)

On the Criticism of Psychoanalysis (1910)

Concerning Psychoanalysis (1912)

The Theory of Psychoanalysis (1913)

General Aspects of Psychoanalysis (1913)

Psychoanalysis and Neurosis (1916)

Some Crucial Points in Psychoanalysis: A Correspondence between Dr. Jung and Dr. Loÿ (1914)

Prefaces to "Collected Papers on Analytical Psychology" (1916, 1917)

The Significance of the Father in the Destiny of the Individual (1909/1949)

Introduction to Kranefeldt's "Secret Ways of the Mind" (1930)

Freud and Jung: Contrasts (1929)

‡ 5. SYMBOLS OF TRANSFORMATION (1911–12/1952)

PART I

Introduction

Two Kinds of Thinking

The Miller Fantasies: Anamnesis

The Hymn of Creation

The Song of the Moth

PART II

Introduction

The Concept of Libido

The Transformation of Libido

The Origin of the Hero
Symbols of the Mother and of Rebirth
The Battle for Deliverance from the Mother
The Dual Mother
The Sacrifice
Epilogue
Appendix: The Miller Fantasies

• **6. PSYCHOLOGICAL TYPES (1921)**

Introduction
The Problem of Types in the History of Classical and Medieval Thought
Schiller's Ideas on the Type Problem
The Apollinian and the Dionysian
The Type Problem in Human Character
The Type Problem in Poetry
The Type Problem in Psychopathology
The Type Problem in Aesthetics
The Type Problem in Modern Philosophy
The Type Problem in Biography
General Description of the Types
Definitions
Epilogue
Four Papers on Psychological Typology (1913, 1925, 1931, 1936)

† **7. TWO ESSAYS ON ANALYTICAL PSYCHOLOGY**

On the Psychology of the Unconscious (1917/1926/1943)
The Relations between the Ego and the Unconscious (1928)
Appendix: New Paths in Psychology (1912); The Structure of the Unconscious
(1916) (new versions, with variants, 1966)

‡ **8. THE STRUCTURE AND DYNAMICS OF THE PSYCHE**

On Psychic Energy (1928)
The Transcendent Function ([1916]/1957)
A Review of the Complex Theory (1934)
The Significance of Constitution and Heredity in Psychology (1929)

Psychological Factors Determining Human Behavior (1937)
Instinct and the Unconscious (1919)
The Structure of the Psyche (1927/1931)
On the Nature of the Psyche (1947/1954)
General Aspects of Dream Psychology (1916/1948)
On the Nature of Dreams (1945/1948)
The Psychological Foundations of Belief in Spirits (1920/1948)
Spirit and Life (1926)
Basic Postulates of Analytical Psychology (1931)
Analytical Psychology and *Weltanschauung* (1928/1931)
The Real and the Surreal (1933)
The Stages of Life (1930–1931)
The Soul and Death (1934)
Synchronicity: An Acausal Connecting Principle (1952)
Appendix: On Synchronicity (1951)

• **9. PART I. THE ARCHETYPES AND THE COLLECTIVE UNCONSCIOUS**

Archetypes of the Collective Unconscious (1934/1954)
The Concept of the Collective Unconscious (1936)
Concerning the Archetypes, with Special Reference to the Anima Concept
(1936/1954)
Psychological Aspects of the Mother Archetype (1938/1954)
Concerning Rebirth (1940/1950)
The Psychology of the Child Archetype (1940)
The Psychological Aspects of the Kore (1941)
The Phenomenology of the Spirit in Fairytales (1945/1948)
On the Psychology of the Trickster-Figure (1954)
Conscious, Unconscious, and Individuation (1939)
A Study in the Process of Individuation (1934/1950)
Concerning Mandala Symbolism (1950)
Appendix: Mandalas (1955)

• **9. PART II. AION (1951)**

RESEARCHES INTO THE PHENOMENOLOGY OF THE SELF

The Ego

The Shadow

The Syzygy: Anima and Animus

The Self

Christ, a Symbol of the Self

The Sign of the Fishes

The Prophecies of Nostradamus

The Historical Significance of the Fish

The Ambivalence of the Fish Symbol

The Fish in Alchemy

The Alchemical Interpretation of the Fish

Background to the Psychology of Christian Alchemical Symbolism

Gnostic Symbols of the Self

The Structure and Dynamics of the Self

Conclusion

• 10. CIVILIZATION IN TRANSITION

The Role of the Unconscious (1918)

Mind and Earth (1927/1931)

Archaic Man (1931)

The Spiritual Problem of Modern Man (1928/1931)

The Love Problem of a Student (1928)

Woman in Europe (1927)

The Meaning of Psychology for Modern Man (1933/1934)

The State of Psychotherapy Today (1934)

Preface and Epilogue to “Essays on Contemporary Events” (1946)

Wotan (1936)

After the Catastrophe (1945)

The Fight with the Shadow (1946)

The Undiscovered Self (Present and Future) (1957)

Flying Saucers: A Modern Myth (1958)

A Psychological View of Conscience (1958)

Good and Evil in Analytical Psychology (1959)

Introduction to Wolff’s “Studies in Jungian Psychology” (1959)

The Swiss Line in the European Spectrum (1928)

Reviews of Keyserling’s “America Set Free” (1930) and “La Révolution
Mondiale” (1934)

The Complications of American Psychology (1930)

The Dreamlike World of India (1939)

What India Can Teach Us (1939)

Appendix: Documents (1933–1938)

†11. PSYCHOLOGY AND RELIGION: WEST AND EAST

WESTERN RELIGION

Psychology and Religion (The Terry Lectures) (1938/1940)

A Psychological Approach to the Dogma of the Trinity (1942/1948)

Transformation Symbolism in the Mass (1942/1954)

Forewords to White's "God and the Unconscious" and Werblowsky's "Lucifer and Prometheus" (1952)

Brother Klaus (1933)

Psychotherapists or the Clergy (1932)

Psychoanalysis and the Cure of Souls (1928)

Answer to Job (1952)

EASTERN RELIGION

Psychological Commentaries on "The Tibetan Book of the Great Liberation" (1939/1954) and "The Tibetan Book of the Dead" (1935/1953)

Yoga and the West (1936)

Foreword to Suzuki's "Introduction to Zen Buddhism" (1939)

The Psychology of Eastern Meditation (1943)

The Holy Men of India: Introduction to Zimmer's "Der Weg zum Selbst" (1944)

Foreword to the "I Ching" (1950)

•12. PSYCHOLOGY AND ALCHEMY (1944)

Prefatory note to the English Edition ([1951?] added 1967)

Introduction to the Religious and Psychological Problems of Alchemy

Individual Dream Symbolism in Relation to Alchemy (1936)

Religious Ideas in Alchemy (1937)

Epilogue

†13. ALCHEMICAL STUDIES

Commentary on "The Secret of the Golden Flower" (1929)

The Visions of Zosimos (1938/1954)

Paracelsus as a Spiritual Phenomenon (1942)

The Spirit Mercurius (1943/1948)

The Philosophical Tree (1945/1954)

‡14. MYSTERIUM CONIUNCTIONIS (1955–56)

AN INQUIRY INTO THE SEPARATION AND
SYNTHESIS OF PSYCHIC OPPOSITES IN ALCHEMY

The Components of the Coniunctio

The Paradoxa

The Personification of the Opposites

Rex and Regina

Adam and Eve

The Conjunction

●15. THE SPIRIT IN MAN, ART, AND LITERATURE

Paracelsus (1929)

Paracelsus the Physician (1941)

Sigmund Freud in His Historical Setting (1932)

In Memory of Sigmund Freud (1939)

Richard Wilhelm; In Memoriam (1930)

On the Relation of Analytical Psychology to Poetry (1922)

Psychology and Literature (1930/1950)

“Ulysses”: A Monologue (1932)

Picasso (1932)

‡16. THE PRACTICE OF PSYCHOTHERAPY

GENERAL PROBLEMS OF PSYCHOTHERAPY

Principles of Practical Psychotherapy (1935)

What Is Psychotherapy? (1935)

Some Aspects of Modern Psychotherapy (1930)

The Aims of Psychotherapy (1931)

Problems of Modern Psychotherapy (1929)

Psychotherapy and a Philosophy of Life (1943)

Medicine and Psychotherapy (1945)

Psychotherapy Today (1945)

Fundamental Questions of Psychotherapy (1951)

SPECIFIC PROBLEMS OF PSYCHOTHERAPY

The Therapeutic Value of Abreaction (1921/1928)

The Practical Use of Dream-Analysis (1934)

The Psychology of the Transference (1946)

Appendix: The Realities of Practical Psychotherapy ([1937] added, 1966)

‡17. THE DEVELOPMENT OF PERSONALITY

Psychic Conflicts in a Child (1910/1946)

Introduction to Wickes's "Analyses der Kinderseele" (1927/1931)

Child Development and Education (1928)

Analytical Psychology and Education: Three Lectures (1926/1946)

The Gifted Child (1943)

The Significance of the Unconscious in Individual Education (1928)

The Development of Personality (1934)

Marriage as a Psychological Relationship (1925)

•18. THE SYMBOLIC LIFE

Miscellaneous Writings

†19. GENERAL BIBLIOGRAPHY OF C. G. JUNG'S WRITINGS

†20. GENERAL INDEX TO THE COLLECTED WORKS

See also:

C. G. JUNG: LETTERS

Selected and edited by Gerhard Adler, in collaboration with Aniela Jaffé. Translations from the German by R.F.C. Hull.

VOL. 1: 1906–1950

VOL. 2: 1951–1961

THE FREUD/JUNG LETTERS

Edited by William McGuire, translated by

Ralph Manheim and R.F.C. Hull

C. G. JUNG SPEAKING: Interviews and Encounters

Edited by William McGuire and R.F.C. Hull

C. G. JUNG: Word and Image

Edited by Aniela Jaffé

¹ “Analysis of a Phobia in a Five-year-old Boy,” *Standard Edition of the Complete Psychological Works of Sigmund Freud*, X (1955; first pub. 1909).

² [In the light of Professor Jung’s later researches these theories can be understood as based upon the archetype of rebirth, in the unconscious. Several other examples of archetypal activity are to be found in this essay.—EDITORS.]

³ One might ask at this point why one is justified in supposing at all that children of this age worry their heads about such theories. The answer is that children are intensely interested in all the sensuously perceptible things going on around them. This also shows itself in the well-known endless questions concerning the why and wherefore of everything. One has to put off the dun-coloured spectacles of our culture for a moment if one wants to understand the psychology of a child. For everybody the birth of a child is quite the most important event there can possibly be. For our civilized thinking, however, birth has lost much of its biological uniqueness, just as sex has done. But somewhere or other the mind must have stored up the correct biological valuations impressed upon it all through the ages. What could be more probable than that the child still has these valuations and makes no bones about showing them, before civilization spreads like a pall over his primitive thinking?

⁴ This process is altogether typical. When life comes up against an obstacle, so that no adaptation can be achieved and the transference of libido to reality is suspended, then an introversion takes place. That is to say, instead of the libido working towards reality there is an increased fantasy activity which aims at removing the obstacle, or at least removing it in fantasy, and this may in time lead to a practical solution. Hence the exaggerated sexual fantasies of neurotics, who in this way try to overcome their specific repression; hence also the typical fantasy of stammerers, that they really possess a great talent for eloquence. (That they have some claims in this respect is brought home to us by Alfred Adler’s thoughtful studies on organ inferiority.)

⁵ The somewhat paradoxical view that the aim of the child’s question is to be sought in the mother’s answer requires a little discussion. It is one of the greatest of Freud’s services to psychology that he opened up again the whole questionableness of *conscious* motives. One consequence of repressing the instincts is that the importance of conscious thinking for action is boundlessly overestimated. According to Freud, the criterion for the psychology of the act is not the conscious motive, but the *result* of the act (the result being evaluated not physically but psychologically). This view sets the act in a new and biologically revealing light. I refrain from examples and shall content myself with observing that this view is extremely valuable for psychoanalysis both in principle and as regards interpretation.

⁶ [In *Coll. Works*, Vol. 3: *The Psychogenesis of Mental Disease*. For the complete contents of the *Collected Works of C. G. Jung*, see the list at the end of this volume.—EDITORS.]

⁷ This is a primitive definition of God.

⁸ Cf, Franz Riklin, *Wishfulfillment and Symbolism in Fairy Tales* (trans. by W. A. White, Nervous and Mental Disease Monograph Series, No. 21, New York, 1915).

⁹ This tendency to get rid of the mother also showed itself in the following incident: The children had requisitioned the tool-shed as a house for themselves and their dolls. An important room in any house is, as we know, the toilet, which obviously cannot be lacking. Accordingly, the children went to the toilet in a corner of the tool-shed. Their

mother naturally could not help spoiling this illusion by forbidding such games. Soon afterwards she caught the remark, “When Mama is dead we’ll do it every day in the tool-shed and put on Sunday clothes every day.”

¹⁰ [Cf. Bronislaw Malinowski, *The Sexual Life of Savages* (3rd edn., London and New York, 1932).—EDITORS.]

¹ [The first three and a half paragraphs originally appeared as an introduction to Frances G. Wickes, *The Inner World of Childhood* (New York, 1927). The book was subsequently translated into German as *Analyse der Kinderseele* (Stuttgart, 1931), and for it Professor Jung expanded his introduction to the present dimensions. It is here translated entirely anew.

Mrs. Wickes (1875–1967) was for many years a school psychologist. She collected numerous case studies, and these were later illuminated for her when she encountered Professor Jung's theories, which she was able to confirm and extend. The most important part of her thesis demonstrates how the unconscious of parents can cause many psychic disorders of childhood.—EDITORS.]

¹ [This lecture was delivered at the International Congress of Education, in Territet (near Montreux) in 1923, and was published in *Contributions to Analytical Psychology* (London and New York, 1928) as the first of four lectures on “Analytical Psychology and Education,” the others being those which follow in the present volume. It was never published in German, but a translation of the original manuscript was made for that volume by H. G. and C. F. Baynes. The present text has been somewhat revised by the author, but is in the main identical with the Baynes version, upon which it is based.—EDITORS.]

² [Professor Jung’s position with regard to infantile sexuality is made clear in the first paper in this volume, “Psychic Conflicts in a Child,” and elsewhere in his writings.—EDITORS.]

³ [Attempts to persuade Professor Jung to write further about his collection of children’s dreams proved unavailing, owing to the pressure upon him of other work. He delivered, however, four series of seminars on the subject between 1935 and 1940, at the Eidgenössische Technische Hochschule, Zurich. The last three were reported by members of the seminars and the transcripts have been privately circulated. Only the third series (winter term, 1938–39) has been translated into English, likewise for private circulation.—EDITORS.]

⁴ I have given elsewhere a number of examples of the extraordinary kinship which exists in the psychological *habitus* of members of the same family, amounting in one case almost to identity. See “The Association Method,” Lecture 2, in *Coll. Works, Vol. 2*.

⁵ [This case is also discussed in “The Practical Use of Dream Analysis,” *Coll. Works, Vol. 16*, pars. 323f., where further details will be found.—EDITORS.]

LECTURE ONE

¹ Freud also translated Hippolyte Bernheim's work into German, under the title *Die Suggestion und ihre Heilwirkung* (Leipzig and Vienna, 1888).

² Cf. my dissertation, "On the Psychology and Pathology of So-called Occult Phenomena," *Coll. Works*, Vol. I.

³ [See *Standard Edition of the Complete Psychological Works of Sigmund Freud*, IX (1959) and X (1955).—EDITORS.]

⁴ The results of my own experiments and those of my fellow workers are set forth in *Studies in Word Association*, trans. by M. D. Eder (London, 1918; New York, 1919). [For Jung's contributions, see *Coll. Works*, Vol. 2.—EDITORS.]

⁵ The so-called "complex theory" found its application in the psychopathology of schizophrenia (Cf. my *The Psychology of Dementia Praecox*, *Coll. Works*, Vol. 3). An account of the same appears in "A Review of the Complex Theory," *Coll. Works*, Vol. 8.

⁶ It is interesting to see how the subliminally existing murder which was seeking to attach itself to the patient in later life (bearded man) is compensated by the disease (the nurse), as if the disease were protecting him against the crime.

⁷ Cf. my "The Psychological Aspects of the Mother Archetype," *Coll. Works*, Vol. 9, pt. 1, and "Mind and Earth," *Coll. Works*, Vol. 10.

⁸ [Christoph Blumhardt (1842–1919), eminent Swiss theologian and Social Democrat.—EDITORS.]

LECTURE TWO

¹ Or, to quote the words of a philosopher: “Before supper I am a Kantian, after supper a Nietzschean.”

² A very promising beginning has been made in the excellent work of Walter H. von Wyss: *Psychophysiologische Probleme in der Medizin* (Basel, 1944).

³ [Professor Jung elaborates this theme in “Sigmund Freud in His Historical Setting,” *Coll. Works*, Vol. 15—EDITORS.]

⁴ Where this fails to work it is put down to the patient’s “resistances.”

⁵ I am indebted to Professor Markus Fierz, of Basel, for this formulation,

⁶ Cf. C. A. Meier’s conspectus of the relevant literature, up to 1935, under “Moderne Physik—Moderne Psychologie,” in *Die kulturelle Bedeutung der komplexen Psychologie* (Berlin, 1935), pp. 34Qff. I would refer the reader particularly to the extensive quotations from articles by Niels Bohr, *Naturwissenschaft*, XVI (1928), 245, and XVII (1929), 483. Since the latter date see particularly Pascual Jordan, *Die Physik des 20. Jahrhunderts* (Brunswick, 1936), also his “Positivische Bemerkungen über die parapsychischen Erscheinungen,” *Zentralblatt für Psychotherapie*, IX (1936), 3ff.; *Anschauliche Quantentheorie* (Berlin, 1936), pp. 271ff.; *Die Physik und das Geheimnis des organischen Lebens* (Brunswick, 1941), pp. 114ff.

⁷ Cf. my essay “Spirit and Life,” *Coll. Works*, Vol. 8.

⁸ Cf. Toni Wolff, “Einführung in die Grundlagen der komplexen Psychologie,” Ch. I, *Die kulturelle Bedeutung der komplexen Psychologie*.

⁹ There are only pale reflections of this word in French and English, such as “idée,” “idea,” “sudden idea,” etc. The German “witzige Einfall” fares a little better as “saillie” or “sally of wit” (from *saillir*, “to rush forth”).

¹⁰ Carl du Prel, *Das Rätsel des Menschen* (Leipzig, 1892), pp. 27ff.

¹¹ Cf. *Studies in Word Association*, *Coll. Works*, Vol. 2; and “A Review of the Complex Theory,” *Coll. Works*, Vol. 8.

¹² Cf. the classic work of Breuer and Freud, *Studies on Hysteria* (1893–95).

¹³ Cf. my *Symbols of Transformation*, *Coll. Works*, Vol. 5; “The Psychology of the Child Archetype” and “The Psychological Aspects of the Kore,” *Coll. Works*, Vol. 9, pt. i.

¹⁴ Cf. my “Individual Dream Symbolism in Relation to Alchemy,” in *Psychology and Alchemy*, *Coll. Works*, Vol. 12.

¹⁵ Cf. my “Archetypes of the Collective Unconscious,” *Coll. Works*, Vol. 9, pt. i.

LECTURE THREE

¹ *Coll. Works, Vol. 1.*

² [Cf. Freud's *Civilization and Its Discontents, Standard Edition of the Complete Psychological Works of Sigmund Freud*, XXI (1961; first pub. 1930).—EDITORS.]

³ Cf. the above-mentioned case (pars. 182f.) of a young man who sunned himself on the Riviera and in the Engadine.

^{3^a} [Cf. Jung, "Paracelsus as a Spiritual Phenomenon," *Coll. Works*, Vol. 13; and Jolande Jacobi, ed., *Paracelsus; Selected Writings* (New York [Bollingen Series XXVII] and London, 2nd edn., 1958), p. 39.—EDITORS.]

⁴ Called "gana loss" in South America. [Spanish, gana = lit., "appetite," "desire." See Count Hermann Keyserling, *South-American Meditations*, trans. by Theresa Duerr (New York and London, 1932), pp. 158ff., on this usage in Buenos Aires.—EDITORS.]

^{4^a} [This case is also discussed in *Two Essays on Analytical Psychology, Coll. Works*, Vol. 7, par. 287.—EDITORS.]

⁵ I do not wish to give offence to the dreamer of the dream under discussion, whom I do not know personally; but I hardly think that a young man of twenty-two would be conscious of the problem broached by this dream, at least, not of its full extent.

⁶ This is not to be identified with ignorance. In order to get at an infantile neurosis or a difficult child, sound knowledge is needed as well as all the other things.

⁷ Well known as the author of *The Inner World of Childhood* (New York and London, 1927), and of *The Inner World of Man* (New York, London, and Toronto, 1938; 2nd edn., 1948). I should like to recommend the first book in particular to parents and teachers. [See the second paper in this volume, an introduction to the German edition.—EDITORS.]

⁸ This is the manifestation of an archetype, namely that of the deadly, devouring mother. Cf. the fairytales of Red Riding Hood and of Hansel and Gretel, and the South Sea myth of Maui and Hine-nui-te-po, the tribal ancestress who sleeps with her mouth open. Maui creeps into the mouth and is swallowed (Leo Frobenius, *Das Zeitalter des Sonnengottes*, Berlin, 1904, I, pp. 66ff.).

⁹ Cf. the snake symbolism in *Symbols of Transformation, Coll. Works*, Vol. 5.

¹⁰ Superficially this dream can be understood as a wish-fulfilment, but closer examination would show that it sums up the facts. For the daughter the mother signifies the feminine instinctual ground-layer which in this case is profoundly disturbed.

¹ [This was first delivered at the annual meeting of the Basel School Council, in December, 1942. It was published as “Der Begabte” in the *Schweizer Erziehungs Rundschau*, XVI (1943): 1, and in *Psychologie und Erziehung* (Zurich, 1946), from which the present translation is made.—EDITORS.]

² [By and large, children in Switzerland are taught in classes composed of pupils belonging to the same age group. There is no attempt to separate them according to their ability as is usual in Great Britain.—EDITORS.]

¹ [Originally delivered as a lecture at the International Congress of Education, Heidelberg, 1925, and subsequently translated by C. F. and H. G. Baynes in *Contributions to Analytical Psychology* (London and New York, 1928). The present translation is newly made from the original manuscript, though the earlier English version has been freely consulted.—EDITORS.]

² [This case is also discussed in *Two Essays on Analytical Psychology, Coll. Works*, Vol. 7, pars. 167ff.—EDITORS.]

¹ [First delivered as a lecture entitled “Die Stimme des Innern” at the Kulturbund, Vienna, in November, 1932. Subsequently published under the title “Vom Werden der Persönlichkeit” in *Wirklichkeit der Seele* (Zurich, Leipzig, and Stuttgart, 1934), and translated into English by Stanley M. Dell as the final chapter of *The Integration of the Personality* (New York, 1939, and London, 1940). The present new translation is made from *Wirklichkeit der Seele*, though the earlier English version has been freely consulted.—EDITORS.]

² *Westästlicher Diwan*, Suleikabuch.

³ Since this sentence was written, Germany too has found her Führer.

⁴ [Cf. C. Kerényi, “The Primordial Child in Primordial Times,” and Jung, “The Psychology of the Child-Archetype,” in *Essays on a Science of Mythology* (Bollingen Series XXII, N. Y. 1949; Princeton/Bollingen Paperback edn., revised, 1969; British edn.: *Introduction to a Science of Mythology*, London, 1950).—EDITORS.]

⁵ [In the German, attributed to Nietzsche.—EDITORS.]

¹ [First published as “Die Ehe als psychologische Beziehung,” in *Das Ehebuch* (Celle, 1925), a volume edited by Count Hermann Keyserling; translated by Theresa Duerr in the English version, *The Book of Marriage* (New York, 1926). The original was reprinted in *Seelenprobleme der Gegenwart* (Zurich, 1931). The essay was again translated into English by H. G. and Cary F. Baynes in *Contributions to Analytical Psychology* (London and New York, 1928), and this version has been freely consulted in the present translation.—EDITORS.]

² [In translating this and the following passages, I have, for the sake of clarity, assumed that the container is the man and the contained the woman. This assumption is due entirely to the exigencies of English grammar, and is not implied in the German text. Needless to say, the situation could just as easily be reversed.—TRANS.]

³ There are excellent descriptions of this type in H. Rider Haggard’s *She* (London, 1887) and Pierre Benoît’s *L’Atlantide* (Paris, 1920; trans. by Mary C. Tongue and Mary Ross as *Atlantida*, New York, 1920).

⁴ A passably good account of the animus is to be found in Marie Hay’s book *The Evil Vineyard* (New York, 1923), also in Elinor Wylie’s *Jennifer Lorn* (New York, 1923) and Selma Lagerlöf’s *Gösta Berlings Saga* (1891; English trans. by P. B. Flach, *The Story of Gösta Berling*, 1898).

- Published 1957; 2nd edn., 1970.
- † Published 1973.
- Published 1960.
- † Published 1961.
- ‡ Published 1956; 2nd edn., 1967. (65 plates, 43 text figures.)
- Published 1971.
- † Published 1953; and edn., 1966.
- ‡ Published 1960; 2nd edn., 1969.
- Published 1959; 2nd edn., 1968. (Part I: 79 plates, with 29 in colour.)
- Published 1964; 2nd edn., 1970. (8 plates.)
- † Published 1958; 2nd edn., 1969.
- Published 1953; 2nd edn., completely revised, 1968. (270 illustrations.)
- † Published 1968. (50 plates, 4 text figures.)
- ‡ Published 1963; 2nd edn., 1970. (10 plates.)
- Published 1966.
- † Published 1954; 2nd edn., revised and augmented, 1966. (13 illustrations.)
- ‡ Published 1954.
- Published 1976.
- † Published 1979.

B O L L I N G E N S E R I E S X X

THE COLLECTED WORKS

OF

C. G. JUNG

VOLUME 18

EDITORS

† SIR HERBERT READ

MICHAEL FORDHAM, F.R.C.PSYCH., HON. F.B.P.S.S.

GERHARD ADLER, PH.D.

WILLIAM MCGUIRE, *executive editor*

THE SYMBOLIC LIFE

MISCELLANEOUS
WRITINGS

C. G. JUNG

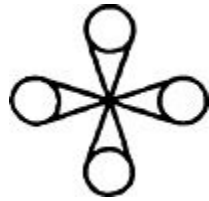

TRANSLATED BY R. F. C. HULL

BOLLINGEN SERIES XX

PRINCETON UNIVERSITY PRESS

COPYRIGHT 1950, 1953, COPYRIGHT © 1955, 1958, 1959, 1963, 1968, 1969, 1970, 1973, 1976 BY PRINCETON UNIVERSITY PRESS, PRINCETON, N.J.

THIS EDITION IS BEING PUBLISHED IN THE UNITED STATES OF AMERICA FOR BOLLINGEN FOUNDATION BY PRINCETON UNIVERSITY PRESS AND IN ENGLAND BY ROUTLEDGE & KEGAN PAUL, LTD. IN THE AMERICAN EDITION. ALL THE VOLUMES COMPRISING THE COLLECTED WORKS CONSTITUTE NUMBER XX IN BOLLINGEN SERIES. THE PRESENT VOLUME IS NUMBER 18 OF THE COLLECTED WORKS AND IS THE EIGHTEENTH TO APPEAR.

For the following, copyright in the U.S.A. has been assigned to Princeton University Press: Foreword to Fierz-David, *The Dream of Poliphilo*, copyright 1950 by Bollingen Foundation Inc. Foreword to Perry, *The Self in Psychotic Process*, copyright. 1953, by the Regents of the University of California. Foreword to Abegg, *Ostasien denkt anders*, copyright 1953 by the Analytical Psychology Club of New York. Foreword to Neumann. *Origins and History of Consciousness*, copyright 1954 by Bollingen Foundation Inc. Foreword to Harding, *Woman's Mysteries*, copyright © 1955 by Dr. Esther Harding. "Human Nature Does Not Yield Easily to Idealistic Advice," copyright © 1955 by *New Republic*. Foreword to de Laszlo, *Psyche and Symbol*, copyright © 1958 by Bollingen Foundation, Inc. Foreword to Bertine, *Human Relationships*, copyright 1958 by Eleanor Bertine. Foreword to Jacobi, *Complex/Archetype/Symbol*, copyright © 1959 by Bollingen Foundation, Inc. "The Future of Parapsychology," copyright © 1963 by *International Journal of Parapsychology*. "The Tavistock Lectures," copyright © 1968 by the Heirs of C. G. Jung. "Answers to Questions on Freud," copyright © 1968 by the Analytical Psychology Club of New York. Foreword to Neumann, *Depth Psychology and a New Ethic*, copyright © 1969 by the C. G. Jung Foundation for Analytical Psychology, Inc., New York. "Depth Psychology and Self Knowledge," copyright © 1969, and "Adaptation, Individuation, Collectivity," copyright © 1970, by the Analytical Psychology Club of New York. Foreword to Harding, *The Way of All Women*, copyright © 1970 by the C. G. Jung Foundation for Analytical Psychology, Inc., New York. Foreword to Jacobi, *The Psychology of C. G. Jung*, copyright © 1973 by Jolande Jacobi. The following were copyright in the U.S.A.: Foreword to Custance, *Wisdom, Madness and Folly*, copyright 1952 by John Custance. Foreword to Jaffé, *Apparitions and Precognition*, copyright © 1963 by University Books Inc. Foreword to a catalogue on alchemy, copyright © 1968 by Yale University

Library. Due acknowledgements are made. "Sigmund Freud: 'On Dreams'.", "Marginal Note on Wittels: Die Sexuelle Not," "A Comment on Tausk's Criticism of Nelken," and "Religion and Psychology: Reply to Buber," copyright © 1973 by Princeton University Press.

LIBRARY OF CONGRESS CATALOGUE CARD NUMBER: 75-156

ISBN 0-691-09892-1

MANUFACTURED IN THE U. S. A.

IN MEMORIAM

Herbert Read

(1893–1968)

R. F. C. Hull

(1913–1974)

EDITORIAL NOTE

When these Collected Works were planned, during the late 1940's, in consultation with Professor Jung, the Editors set aside a brief final volume for "reviews, short articles, etc., of the psychoanalytic period, later introductions, etc., Bibliography of Jung's Writings, and General Index of the Collected Works." Now arriving at publication soon after Jung's centenary year, this collection of miscellany has become the most ample volume in the edition—and no longer includes the Bibliography and General Index, which have been assigned to volumes 19 and 20 respectively.

Volume 18 now contains more than one hundred and thirty items, ranging in time from 1901, when Jung at 26 had just accepted his first professional appointment as an assistant at the Burghölzli, to 1961, shortly before his death. The collection, touching upon virtually every aspect of Jung's professional and intellectual interest during a long life devoted to the exegesis of the symbol, justifies its title, taken from a characteristic work of Jung's middle years, the seminar given to the Guild of Pastoral Psychology in London, 1939.

This profusion of material is the consequence of three factors. After Jung retired from his active medical practice, in the early 1950's, until his death in June 1961, he devoted most of his time to writing: not only the longer works for which a place was made in the original scheme of the edition, but an unexpectedly large number of forewords to books by pupils and colleagues, replies to journalistic questionnaires, encyclopaedia articles, occasional addresses, and letters (some of which, because of their technical character, or because they were published elsewhere, are included in Volume 18 rather than in the *Letters* volumes). Of works in this class, Jung wrote some fifty after 1950.

Secondly, research for the later volumes of the Collected Works, for the *Letters* (including *The Freud/Jung Letters*), and for the General Bibliography has brought to light many reviews, short articles, reports, etc., from the earlier years of Jung's career. A considerable run of psychiatric reviews from the years 1906–1910 was discovered by Professor Henri F. Ellenberger and turned over to the Editors, who wish to record their gratitude to him.

Finally, the Jung archives at Küsnacht have yielded several manuscripts in a finished or virtually finished state, the earliest being a 1901 report on Freud's *On Dreams*. A related category of material embraces abstracts of lectures, evidently unwritten, the transcripts of which were not read and approved by Jung. The abstracts themselves have been deemed worthy of inclusion in this volume.

“The Tavistock Lectures” and “The Symbolic Life” are examples of oral material to whose transcription Jung *had* given his approval. The former work has become well known as *Analytical Psychology: Its Theory and Practice*, under which title the present version was published in 1968.

Around 1960, the Editors conceived the idea of adding to Volume 15, *The Spirit in Man, Art, and Literature*, some of the forewords that Jung had written for books by other persons, on the ground that these statements were an expression of the archetype of the spirit. Jung was invited to make the choice, and his list comprised fifteen forewords, to books by the following authors: Lily Abegg, John Custance, Linda Fierz-David, Michael Fordham, M. Esther Harding (two books), Aniela Jaffé, Olga von Koenig-Fachsenfeld, Rose Mehlich, Fanny Moser, John Weir Perry, Carl Ludwig Schleich, Gustav Schmaltz, Hans Schmid-Guisan, and Oscar A. H. Schmitz. Subsequently, as the plan for a comprehensive volume of miscellany took form, these forewords were retained in Volume 18.

The contents of the present volume—following after the three longer and more general works in [Parts I, II, and III](#)—are arranged as [Parts IV](#) through [XVI](#), in the sequence of the volumes of the Collected Works to which they are related by subject, and chronologically within each Part. The result is sometimes arbitrary, as certain items could be assigned to more than one volume. Some miscellanea were published in later editions or printings of the previous volumes, e.g., “The Realities of Practical Psychotherapy,” now an appendix in Volume 16, 2nd edition; the prefatory note to the English edition of *Psychology and Alchemy*, now in the 2nd edition of Volume 12; and the author’s note to the first American/English edition of *Psychology of the Unconscious* (1916), now in Volume 5, 2nd edition, 1974 printing.

The death of the translator, R.F.C. Hull, in December 1974, after a prolonged illness, was a heavy loss to the entire enterprise. He had, however, translated by far most of the contents of Volume 18. The contributions of other translators are indicated by their initials in a footnote at the beginning of the translated item: A.S.B. Glover, Ruth Horine, Hildegard Nagel, Jane D. Pratt, Lisa Ress, and Wolfgang Sauerlander. To them the Editors are deeply grateful. Mr. Glover, up until his death in 1966, also played an important part in the compilation and editing of the papers. Special acknowledgement must be made to two co-workers at the source, as it were, who contributed greatly by searching out material and helping to identify and annotate the texts: Marianne Niehus-Jung (d. 1965), who was a co-editor of the Swiss edition of her father’s collected works, and Aniela Jaffé, who had been Jung’s secretary and collaborator with him in the writing of his memoirs.

Acknowledgement is made also to the following, who gave valued assistance with research and advice with various editorial problems: Mrs. Doris Albrecht, Dr. E. A. Bennet, Professor Ernst Benz, Jonathan Dodd, Dr. Martin Ebon, Mrs. Antoinette Fierz,

C.H.A. Fleurent (*British Medical Journal*) Dr. M.-L. von Franz, Dr. W. H. Gillespie, Michael Hamburger (also for permission to quote his translation of a poem of Hölderlin), J. Havet (Unesco), Dr. Joseph Henderson, Mrs. Aniela Jaffé, Mrs. Ernest Jones, Mrs. Jean Jones (American Psychiatric Association), Mr. and Mrs. Franz Jung, Dr. James Kirsch, Pamela Long, Professor Dr. C. A. Meier, Professor W. G. Moulton, Professor Henry A. Murray, Mrs. Julie Neumann, Jacob Rabi (*Al Hamishmar*), Lisa Ress, Professor Paul Roazen, Professor D. W. Robertson, Jr., Wolfgang Sauerlander, G. Spencer-Brown, Gerald Sykes, Professor Kurt Weinberg, and Mrs. Shirley White (BBC).

VOLUME 18
THE SYMBOLIC LIFE: MISCELLANEOUS WRITINGS

TABLE OF CONTENTS

EDITORIAL NOTE

I

THE TAVISTOCK LECTURES (1935)

Lecture I

Discussion

Lecture II

Discussion

Lecture III

Discussion

Lecture IV

Discussion

Lecture V

Discussion

II

SYMBOLS AND THE INTERPRETATION OF DREAMS (1961)

The Significance of Dreams

The Functions of the Unconscious

The Language of Dreams

The Problem of Types in Dream Interpretation

The Archetype in Dream Symbolism

The Function of Religious Symbols

Healing the Split

III
THE SYMBOLIC LIFE (1939)

The Symbolic Life

Discussion

IV
ON OCCULTISM
(C.W., vol. 1)*

On Spiritualistic Phenomena (1905)

Foreword to Jung: *Phénomènes occultes* (1938)

Psychology and Spiritualism (1948)

Foreword to Moser: *Spuk: Irrglaube oder Wahrglaube?* (1950)

Jung's Contribution

Foreword to Jaffé: *Apparitions and Precognition* (1957)

V
THE PSYCHOGENESIS OF MENTAL DISEASE
(C.W., vol. 3)

The Present Status of Applied Psychology (1908)

On Dementia Praecox (1908)

Review of Sadger: *Konrad Ferdinand Meyer* (1909)

Review of Waldstein: *Das unbewusste Ich* (1909)

Crime and the Soul (1932)

The Question of Medical Intervention (1950)

Foreword to Custance: *Wisdom, Madness and Folly* (1951)

Foreword to Perry: *The Self in Psychotic Process* (1953)

Foreword to Schmalz: *Komplexe Psychologie und körperliches Symptom* (1955)

VI
FREUD AND PSYCHOANALYSIS
(C.W., vol. 4)

Sigmund Freud: *On Dreams* (1901)

Review of Hellpach: *Grundlinien einer Psychologie der Hysterie* (1905)

Reviews of Psychiatric Literature (1906–10)

The Significance of Freud's Theory for Neurology and Psychiatry (1907)

Review of Stekel: *Nervöse Angstzustände und ihre Behandlung* (1908)

Editorial Preface to the *Jahrbuch* (1909)

Marginal Notes on Wittels: *Die sexuelle Not* (1910)

Review of Wulffen: *Der Sexualverbrecher* (1910)

Abstracts of the Psychological Works of Swiss Authors (1910)

Review of Hitschmann: *Freuds Neurosenlehre* (1911)

Annual Report by the President of the International Psychoanalytic Association (1911)

Two Letters on Psychoanalysis (1912)

On the Psychoanalytic Treatment of Nervous Disorders (1912)

A Comment on Tausk's Criticism of Nelken (1913)

Answers to Questions on Freud (1953)

VII

ON SYMBOLISM

(C.W., vol. 5)

The Concept of Ambivalence (1910)

Contributions to Symbolism (1911)

VIII

TWO ESSAYS ON ANALYTICAL PSYCHOLOGY

(C.W., vol. 7)

Adaptation, Individuation, Collectivity (1916)

Foreword to the Hungarian edition of Jung: *On the Psychology of the Unconscious* (1944)

IX

THE STRUCTURE AND DYNAMICS OF THE PSYCHE

(C.W., vol. 8)

Forewords to Jung: *Über psychische Energetik und das Wesen der Träume* (1928, 1947)

On Hallucination (1933)

Foreword to Schleich: *Die Wunder der Seele* (1934)

Foreword to Jacobi: *The Psychology of C. G. Jung* (1939)

Foreword to the Spanish edition (1947)

Foreword to Harding: *Psychic Energy* (1947)

Address on the Occasion of the Founding of the C. G. Jung Institute, Zurich, 24 April 1948

Depth Psychology (1948)

Foreword to the First Volume of Studies from the C. G. Jung Institute (1948)

Foreword to Frieda Fordham: *Introduction to Jung's Psychology* (1952)

Foreword to Michael Fordham: *New Developments in Analytical Psychology* (1957)

An Astrological Experiment (1958)

Letters on Synchronicity

To Markus Fierz (1950, 1954)

To Michael Fordham (1955)

The Future of Parapsychology (1960)

X

THE ARCHETYPES AND THE COLLECTIVE UNCONSCIOUS

(C.W., vol. 9)

The Hypothesis of the Collective Unconscious (1932)

Foreword to Adler: *Entdeckung der Seele* (1933)

Foreword to Harding: *Woman's Mysteries* (1948)

Foreword to Neumann: *The Origins and History of Consciousness* (1949)

Foreword to Adler: *Studies in Analytical Psychology* (1949)

Foreword to Jung: *Gestaltungen des Unbewussten* (1949)

Foreword to Wickes: *Von der inneren Welt des Menschen* (1953)
Foreword to Jung: *Von den Wurzeln des Bewusstseins* (1953)
Foreword to van Helldingen: *Beelden uit het onbewuste* (1954)
Foreword to Jacobi: *Complex/Archetype/Symbol* (1956)
Foreword to Bertine: *Human Relationships* (1956)
Preface to de Laszlo: *Psyche and Symbol* (1957)
Foreword to Brunner: *Die Anima als Schicksalsproblem des Mannes* (1959)

XI

CIVILIZATION IN TRANSITION

(C.W., vol. 10)

Report on America (1910)
On the Psychology of the Negro (1912)
A Radio Talk in Munich (1930)
Forewords to Jung: *Seelenprobleme der Gegenwart* (1930, 1932, 1959)
Foreword to Aldrich: *The Primitive Mind and Modern Civilization* (1931)
Press Communiqué on Visiting the United States (1936)
Psychology and National Problems (1936)
Return to the Simple Life (1941)
Epilogue to Jung: *L'Homme à la découverte de son âme* (1944)
Marginalia on Contemporary Events (1945)
Answers to *Mishmar* on Adolf Hitler (1945)
Techniques of Attitude Change Conducive to World Peace (Memorandum to UNESCO) (1948)
The Effect of Technology on the Human Psyche (1949)
Foreword to Neumann: *Depth Psychology and a New Ethic*
Foreword to Baynes: *Analytical Psychology and the English Mind* (1950)
The Rules of Life (1954)
On Flying Saucers (1954)
Statement to the United Press International (1958)

Letter to Keyhoe (1958)
Human Nature Does Not Yield Easily to Idealistic Advice (1955)
On the Hungarian Uprising (1956)
On Psychodiagnostics (1958)
If Christ Walked the Earth Today (1958)
Foreword to *Hugh Crichton-Miller 1877–1959* (1960)

XII

PSYCHOLOGY AND RELIGION

(C.W., vol. 11)

Why I Am Not a Catholic (1944)
The Definition of Demonism (1945)
Foreword to Jung: *Symbolik des Geistes* (1947)
Foreword to Quispel: *Tragic Christianity* (1949)
Foreword to Abegg: *Ostasien denkt anders* (1949)
Foreword to Allenby: *A Psychological Study of the Origins of Monotheism* (1950)
The Miraculous Fast of Brother Klaus (1951)
Concerning *Answer to Job* (1952)
Religion and Psychology: A Reply to Martin Buber (1952)
Address at the Presentation of the Jung Codex (1953)
Letter to Père Bruno (1953)
Letter to Père Lachat (1954)
On Resurrection (1954)
On the Discourses of the Buddha (1955?)
Foreword to Froboese-Thiele: *Träume—eine Quelle religiöser Erfahrung?* (1957)
Jung and Religious Belief (1956–57)

XIII

ALCHEMICAL STUDIES

(C.W., vols. 12, 13, 14)

Foreword to a Catalogue on Alchemy (1946)

Faust and Alchemy (1949)

Alchemy and Psychology (1950)

XIV

THE SPIRIT IX MAX, ART, AND LITERATURE

(C.W., vol. 15)

Memorial to J. S. (1927)

Foreword to Schmid-Guisan: *Tag und Nacht* (1931)

Hans Schmid-Guisan: In Memoriam (1932)

On the Tale of the Otter

Is There a Freudian Type of Poetry? (1932)

Foreword to Gilbert: *The Curse of Intellect* (1934)

Foreword to Jung: *Wirklichkeit der Seele* (1933)

Foreword to Mehlich: *J.H. Fichtes Seelenlehre und ihre Beziehung zur Gegenwart* (1935)

Foreword to von Koenig-Fachsenfeld: *Wandlungen des Traumproblems von der Romantik bis zur Gegenwart* (1935)

Foreword to Gilli: *Der dunkle Bruder* (1938)

Gérard de Nerval (1945)

Foreword to Fierz-David: *The Dream of Poliphilo* (1946)

Foreword to Crottet: *Mondwald* (1949)

Foreword to Jacobi: *Paracelsus: Selected Writings* (1949)

Foreword to Kankeleit: *Das Unbewusste als Keimstätte des Schöpferischen* (1959)

Jung's Contribution

Foreword to Serrano: *The Visits of the Queen of Sheba* (1960)

Is There a True Bilingualism? (1961)

XV

THE PRACTICE OF PSYCHOTHERAPY

(C.W., vol. 16)

Review of Heyer: *Der Organismus der Seele* (1933)

Review of Heyer: *Praktische Seelenheilkunde* (1936)

On the *Rosarium Philosophorum* (1937)

Preface to an Indian Journal of Psychotherapy (1955)

On Pictures in Psychiatric Diagnosis (1959)

XVI

THE DEVELOPMENT OF PERSONALITY

(C.W., vol. 17)

Foreword to Evans: *The Problem of the Nervous Child* (1919)

Foreword to Harding: *The Way of All Women* (1932)

Depth Psychology and Self-Knowledge (1943)

Foreword to Spier: *The Hands of Children* (1944)

Foreword to the Hebrew edition of Jung: *Psychology and Education* (1955)

ADDENDA

Foreword to *Psychologische Abhandlungen*, Volume I (1914)

Address at the Presentation of the Jung Codex [longer version] (1953)

BIBLIOGRAPHY

INDEX OF TITLES

INDEX

THE TAVISTOCK LECTURES

On the Theory and Practice of Analytical Psychology

EDITORIAL NOTE

C. G. Jung was invited by the Institute of Medical Psychology (Tavistock Clinic), Malet Place, London, at the instigation of Dr. J. A. Hadfield, to give a series of five lectures, which he delivered September 30 to October 4, 1935. According to the 1935 report of the Institute, the Lectures when announced were not titled. The audience, of some two hundred, consisted chiefly of members of the medical profession. A stenographic record was taken of the lectures and the subsequent discussions; the transcript was edited by Mary Barker and Margaret Game, passed by Professor Jung, and printed by mimeograph for private distribution by the Analytical Psychology Club of London, in 1936, under the title “Fundamental Psychological Conceptions: A Report of Five Lectures by C. G. Jung ...” The work has become widely known as “The Tavistock Lectures” or “The London Seminars.”

Passages from the Lectures were published in a French translation by Dr. Roland Cahen in his edition of Jung’s *L’Homme à la découverte de son âme* (Geneva, 1944; cf. *infra*, pars. 1357ff.), where the editor inserted them in a transcript of a series of seminars that Jung gave to the Société de Psychologie of Basel in 1934. Jung included much of the same material in both the London and Basel series as well as in lectures given in 1934 and 1935 at the Eidgenössische Technische Hochschule, Zurich.

The present text underwent stylistic revision by R.F.C. Hull, under the supervision of the Editors of the Collected Works, and the footnotes inserted by the original editors were augmented (in square brackets). The text was published in 1968 under the title *Analytical Psychology: Its Theory and Practice; The Tavistock Lectures* (New York: Pantheon Books, and London: Routledge & Kegan Paul), with the addition of a foreword, by E. A. Bennet, and an appendix giving biographical details of the participants in the discussion (both now omitted).

Grateful acknowledgment is made to Mrs. Barker and Mrs. Game, for their co-operation; to those living among the participants in the discussions who gave permission to reproduce their remarks; to Dr. Roland Cahen; and to Mr. Sidney Gray, present secretary of the Tavistock Institute of Medical Psychology, for his assistance.

For advice in the preparation of the notes, the Editors are obliged to Joseph Campbell, J. Desmond Clark, Etienne Gilson, Norbert Guterman, Mrs. Lilly Jung, E. Dale Saunders, and Mrs. Ruth Spiegel.

PREFATORY NOTE TO THE ORIGINAL EDITION

This report of Professor Jung's Lectures to the Institute of Medical Psychology is edited under the auspices of the Analytical Psychology Club, London.

On the whole the report is verbatim, though it has been considered advisable to alter the construction of certain sentences with a view to avoiding any ambiguity of meaning. The editors can only hope that in making these minor changes they have not destroyed the very individual flavour of the Lectures.

In a few cases it was found impossible to ascertain the names of those taking part in the discussions, nor was it practicable to submit proofs of their questions to each of the speakers. For this deficiency and for any possible errors in the reporting of questions we offer our apology.

The stencils of the charts, diagrams, and drawings have been cut with Professor Jung's permission from the originals in his possession.¹

Our thanks are due to the Institute of Medical Psychology not only for giving the Analytical Psychology Club permission to report the Lectures but also for facilitating the work in every way. To Miss Toni Wolff we would express our special gratitude for helping us with our task. Finally, and above all, we wish to thank Professor Jung for answering questions about difficult points and for passing the report in its final form.

MARY BARKER
MARGARET GAME

London, October 1935

LECTURE I

The Chairman (Dr. H. Crichton-Miller):

[1] Ladies and Gentlemen, I am here to express your welcome to Professor Jung, and it gives me great pleasure to do so. We have looked forward, Professor Jung, to your coming for several months with happy anticipation. Many of us no doubt have looked forward to these seminars hoping for new light. Most of us, I trust, are looking forward to them hoping for new light upon ourselves. Many have come here because they look upon you as the man who has saved modern psychology from a dangerous isolation in the range of human knowledge and science into which it was drifting. Some of us have come here because we respect and admire that breadth of vision with which you have boldly made the alliance between philosophy and psychology which has been so condemned in certain other quarters. You have restored for us the idea of value, the concept of human freedom in psychological thought; you have given us certain new ideas that to many of us have been very precious, and above all things you have not relinquished the study of the human psyche at the point where all science ends. For this and many other benefits which are known to each of us independently and individually we are grateful to you, and we anticipate with the highest expectations these meetings.

Professor Jung:

[2] Ladies and Gentlemen: First of all I should like to point out that my mother tongue is not English; thus if my English is not too good I must ask your forgiveness for any error I may commit.

[3] As you know, my purpose is to give you a short outline of certain fundamental conceptions of psychology. If my demonstration is chiefly concerned with my own principles or my own point of view, it is not that I overlook the value of the great contributions of other workers in this field. I do not want to push myself unduly into the foreground, but I can surely expect my audience to be as much aware of Freud's and Adler's merits as I am.

[4] Now as to our procedure, I should like to give you first a short idea of my programme. We have two main topics to deal with, namely, on the one side the concepts concerning the *structure of the unconscious mind* and its *contents*; on the other, the *methods* used in the *investigation* of contents originating in the unconscious psychic processes. The second topic falls into three parts, first, the word-association

method; second, the method of dream-analysis; and third, the method of active imagination.

[5] I know, of course, that I am unable to give you a full account of all there is to say about such difficult topics as, for instance, the philosophical, religious, ethical, and social problems peculiar to the collective consciousness of our time, or the processes of the collective unconscious and the comparative mythological and historical researches necessary for their elucidation. These topics, although apparently remote, are yet the most potent factors in making, regulating, and disturbing the personal mental condition, and they also form the root of disagreement in the field of psychological theories. Although I am a medical man and therefore chiefly concerned with psychopathology, I am nevertheless convinced that this particular branch of psychology can only be benefited by a considerably deepened and more extensive knowledge of the normal psyche in general. The doctor especially should never lose sight of the fact that diseases are disturbed normal processes and not *entia per se* with a psychology exclusively their own. *Similia similibus curantur* is a remarkable truth of the old medicine, and as a great truth it is also liable to become great nonsense. Medical psychology, therefore, should be careful not to become morbid itself. One-sidedness and restriction of horizon are well-known neurotic peculiarities.

[6] Whatever I may be able to tell you will undoubtedly remain a regrettably unfinished torso. Unfortunately I take little stock of new theories, as my empirical temperament is more eager for new facts than for what one might speculate about them, although this is, I must admit, an enjoyable intellectual pastime. Each new case is almost a new theory to me, and I am not quite convinced that this standpoint is a thoroughly bad one, particularly when one considers the extreme youth of modern psychology, which to my mind has not yet left its cradle. I know, therefore, that the time for general theories is not yet ripe. It even looks to me sometimes as if psychology had not yet understood either the gigantic size of its task, or the perplexingly and distressingly complicated nature of its subject-matter: the psyche itself. It seems as if we were just waking up to this fact, and that the dawn is still too dim for us to realize in full what it means that the psyche, being the *object* of scientific observation and judgment, is at the same time its *subject*, the *means* by which you make such observations. The menace of so formidably vicious a circle has driven me to an extreme of caution and relativism which has often been thoroughly misunderstood.

[7] I do not want to disturb our dealings by bringing up disquieting critical arguments. I only mention them as a sort of anticipatory excuse for seemingly unnecessary complications. I am not troubled by theories, but a great deal by facts; and I beg you therefore to keep in mind that the shortness of time at my disposal does not allow me to produce all the circumstantial evidence which would substantiate my

conclusions. I especially refer here to the intricacies of dream-analysis and to the comparative method of investigating the unconscious processes. In short, I have to depend a great deal upon your goodwill, but I realize naturally it is my own task in the first place to make things as plain as possible.

[8] Psychology is a science of consciousness, in the very first place. In the second place, it is the science of the products of what we call the unconscious psyche. We cannot directly explore the unconscious psyche because the unconscious is just unconscious, and we have therefore no relation to it. We can only deal with the conscious products which we suppose have originated in the field called the unconscious, that field of “dim representations” which the philosopher Kant in his *Anthropology*¹ speaks of as being half a world. Whatever we have to say about the unconscious is what the conscious mind says about it. Always the unconscious psyche, which is entirely of an unknown nature, is expressed by consciousness and in terms of consciousness, and that is the only thing we can do. We cannot go beyond that, and we should always keep it in mind as an ultimate critique of our judgment.

[9] Consciousness is a peculiar thing. It is an intermittent phenomenon. One-fifth, or one-third, or perhaps even one-half of our human life is spent in an unconscious condition. Our early childhood is unconscious. Every night we sink into the unconscious, and only in phases between waking and sleeping have we a more or less clear consciousness. To a certain extent it is even questionable how clear that consciousness is. For instance, we assume that a boy or girl ten years of age would be conscious, but one could easily prove that it is a very peculiar kind of consciousness, for it might be a consciousness without any consciousness of the *ego*. I know a number of cases of children eleven, twelve, and fourteen years of age, or even older, suddenly realizing “I am.” For the first time in their lives they know that they themselves are experiencing, that they are looking back over a past in which they can remember things happening but cannot remember that they were in them.

[10] We must admit that when we say “I” we have no absolute criterion whether we have a full experience of “I” or not. It might be that our realization of the ego is still fragmentary and that in some future time people will know very much more about what the ego means to man than we do. As a matter of fact, we cannot see where that process might ultimately end.

[11] Consciousness is like a surface or a skin upon a vast unconscious area of unknown extent. We do not know how far the unconscious rules because we simply know nothing of it. You cannot say anything about a thing of which you know nothing. When we say “the unconscious” we often mean to convey something by the term, but as a matter of fact we simply convey that we do not know what the unconscious is. We have only indirect proofs that there is a mental sphere which is subliminal. We have some scientific justification for our conclusion that it exists.

From the products which that unconscious mind produces we can draw certain conclusions as to its possible nature. But we must be careful not to be too anthropomorphic in our conclusions, because things might in reality be very different from what our consciousness makes them.

[12] If, for instance, you look at our physical world and if you compare what our consciousness makes of this same world, you find all sorts of mental pictures which do not exist as objective facts. For instance, we see colour and hear sound, but in reality they are oscillations. As a matter of fact, we need a laboratory with very complicated apparatus in order to establish a picture of that world apart from our senses and apart from our psyche; and I suppose it is very much the same with our unconscious—we ought to have a laboratory in which we could establish by objective methods how things really are when in an unconscious condition. So any conclusion or any statement I make in the course of my lectures about the unconscious should be taken with that critique in mind. It is always *as if*, and you should never forget that restriction.

[13] The conscious mind moreover is characterized by a certain narrowness. It can hold only a few simultaneous contents at a given moment. All the rest is unconscious at the time, and we only get a sort of continuation or a general understanding or awareness of a conscious world through the *succession* of conscious moments. We can never hold an image of totality because our consciousness is too narrow; we can only see flashes of existence. It is always as if we were observing through a slit so that we only see a particular moment; all the rest is dark and we are not aware of it at that moment. The area of the unconscious is enormous and always continuous, while the area of consciousness is a restricted field of momentary vision.

[14] Consciousness is very much the product of perception and orientation in the *external* world. It is probably localized in the cerebrum, which is of ectodermic origin and was probably a sense organ of the skin at the time of our remote ancestors. The consciousness derived from that localization in the brain therefore probably retains these qualities of sensation and orientation. Peculiarly enough, the French and English psychologists of the early seventeenth and eighteenth centuries tried to derive consciousness from the senses as if it consisted solely of sense data. That is expressed by the famous formula *Nihil est in intellectu quod non fuerit in sensu*.² You can observe something similar in modern psychological theories. Freud, for instance, does not derive the conscious from sense data, but he derives the unconscious from the conscious, which is along the same rational line.

[15] I would put it the reverse way: I would say the thing that comes first is obviously the unconscious and that consciousness really arises from an unconscious condition. In early childhood we are unconscious; the most important functions of an instinctive

nature are unconscious, and consciousness is rather the product of the unconscious. It is a condition which demands a violent effort. You get tired from being conscious. You get exhausted by consciousness. It is an almost unnatural effort. When you observe primitives, for instance, you will see that on the slightest provocation or with no provocation whatever they doze off, they disappear. They sit for hours on end, and when you ask them, "What are you doing? What are you thinking?" they are offended, because they say, "Only a man that is crazy thinks—he has thoughts in his head. We do not think." If they think at all, it is rather in the belly or in the heart. Certain Negro tribes assure you that thoughts are in the belly because they only realize those thoughts which actually disturb the liver, intestines, or stomach. In other words, they are conscious only of emotional thoughts. Emotions and affects are always accompanied by obvious physiological innervations.

[16] The Pueblo Indians told me that all Americans are crazy, and of course I was somewhat astonished and asked them why. They said, "Well, they say they think in their heads. No sound man thinks in the head. *We* think in the heart." They are just about in the Homeric age, when the diaphragm (*phren* = mind, soul) was the seat of psychic activity. That means a psychic localization of a different nature. *Our* concept of consciousness supposes thought to be in our most dignified head. But the Pueblo Indians derive consciousness from the intensity of feeling. Abstract thought does not exist for them. As the Pueblo Indians are sun-worshippers, I tried the argument of St. Augustine on them. I told them that God is not the sun but the one who made the sun.³ They could not accept this because they cannot go beyond the perceptions of their senses and their feelings. Therefore consciousness and thought to them are localized in the heart. To us, on the other hand, psychic activities are nothing. We hold that dreams and fantasies are localized "down below," therefore there are people who speak of the *sub*-conscious mind, of the things that are *below* consciousness.

[17] These peculiar localizations play a great role in so-called primitive psychology, which is by no means primitive. For instance if you study Tantric Yoga and Hindu psychology you will find the most elaborate system of psychic layers, of localizations of consciousness up from the region of the perineum to the top of the head. These "centres" are the so-called *chakras*⁴ and you not only find them in the teachings of yoga but can discover the same idea in old German alchemical books,⁵ which surely do not derive from a knowledge of yoga.

[18] The important fact about consciousness is that nothing can be conscious without an ego to which it refers. If something is not related to the ego then it is not conscious. Therefore you can define consciousness as a relation of psychic facts to the ego. What is that ego? The ego is a complex datum which is constituted first of all by a general awareness of your body, of your existence, and secondly by your

memory data; you have a certain idea of having been, a long series of memories. Those two are the main constituents of what we call the ego. Therefore you can call the ego a complex of psychic facts. This complex has a great power of attraction, like a magnet; it attracts contents from the unconscious, from that dark realm of which we know nothing; it also attracts impressions from the outside, and when they enter into association with the ego they are conscious. If they do not, they are not conscious.

[19] My idea of the ego is that it is a sort of complex. Of course, the nearest and dearest complex which we cherish is our ego. It is always in the centre of our attention and of our desires, and it is the absolutely indispensable centre of consciousness. If the ego becomes split up, as in schizophrenia, all sense of values is gone, and also things become inaccessible for voluntary reproduction because the centre has split and certain parts of the psyche refer to one fragment of the ego and certain other contents to another fragment of the ego. Therefore, with a schizophrenic, you often see a rapid change from one personality into another.

[20] You can distinguish a number of functions in consciousness. They enable consciousness to become oriented in the field of ectopsychic facts and endopsychic facts. What I understand by the *ectopsyche* is a system of relationship between the contents of consciousness and facts and data coming in from the environment. It is a system of orientation which concerns my dealing with the external facts given to me by the function of my senses. The *endopsyche*, on the other hand, is a system of relationship between the contents of consciousness and postulated processes in the unconscious.

[21] In the first place we will speak of the ectopsychic functions. First of all we have *sensation*,⁶ our sense function. By sensation I understand what the French psychologists call “la fonction du réel,” which is the sum-total of my awareness of external facts given to me through the function of my senses. So I think that the French term “la fonction du réel” explains it in the most comprehensive way. Sensation tells me that something *is*: it does not tell me *what* it is and it does not tell me other things about that something; it only tells me that something is.

[22] The next function that is distinguishable is *thinking*.⁷ Thinking, if you ask a philosopher, is something very difficult, so never ask a philosopher about it because he is the only man who does not know what thinking is. Everybody else knows what thinking is. When you say to a man, “Now think properly,” he knows exactly what you mean, but a philosopher never knows. Thinking in its simplest form tells you *what* a thing is. It gives a name to the thing. It adds a concept because thinking is perception and judgment. (German psychology calls it apperception.)⁸

[23] The third function you can distinguish and for which ordinary language has a term is *feeling*.⁹ Here minds become very confused and people get angry when I

speak about feeling, because according to their view I say something very dreadful about it. Feeling informs you through its feeling-tones of the *values* of things. Feeling tells you for instance whether a thing is acceptable or agreeable or not. It tells you what a thing is *worth* to you. On account of that phenomenon, you cannot perceive and you cannot apperceive without having a certain feeling reaction. You always have a certain feeling-tone, which you can even demonstrate by experiment. We will talk of these things later on. Now the “dreadful” thing about feeling is that it is, like thinking, a *rational*¹⁰ function. All men who think are absolutely convinced that feeling is never a rational function but, on the contrary, most irrational. Now I say: Just be patient for a while and realize that man cannot be perfect in every respect. If a man is perfect in his thinking he is surely never perfect in his feeling, because you cannot do the two things at the same time; they hinder each other. Therefore when you want to think in a dispassionate way, really scientifically or philosophically, you must get away from all feeling-values. You cannot be bothered with feeling-values at the same time, otherwise you begin to feel that it is far more important to think about the freedom of the will than, for instance, about the classification of lice. And certainly if you approach from the point of view of feeling the two objects are not only different as to *facts* but also as to *value*. Values are no anchors for the intellect, but they exist, and giving value is an important psychological function. If you want to have a complete picture of the world you must necessarily consider values. If you do not, you will get into trouble. To many people feeling appears to be most irrational, because you feel all sorts of things in foolish moods; therefore everybody is convinced, in this country particularly, that you should control your feelings. I quite admit that this is a good habit and wholly admire the English for that faculty. Yet there are such things as feelings, and I have seen people who control their feelings marvellously well and yet are terribly bothered by them.

[24] Now the fourth function. Sensation tells us that a thing *is*. Thinking tells us *what* that thing is, feeling tells us what it is *worth* to us. Now what else could there be? One would assume one has a complete picture of the world when one knows there *is* something, *what* it is, and what it is *worth*. But there is another category, and that is time. Things have a past and they have a future. They come from somewhere, they go to somewhere, and you cannot see where they came from and you cannot know where they go to, but you get what the Americans call a hunch. For instance, if you are a dealer in art or in old furniture you get a hunch that a certain object is by a very good master of 1720, you get a hunch that it is good work. Or you do not know what shares will do after a while, but you get the hunch that they will rise. That is what is called *intuition*,¹¹ a sort of divination, a sort of miraculous faculty. For instance, you do not know that your patient has something on his mind of a very painful kind, but you “get an idea,” you “have a certain feeling,” as we say, because ordinary language

is not yet developed enough for one to have suitably defined terms. The word intuition becomes more and more a part of the English language, and you are very fortunate because in other languages that word does not exist. The Germans cannot even make a linguistic distinction between sensation and feeling. It is different in French; if you speak French you cannot possibly say that you have a certain “sentiment dans l’estomac,” you will say “sensation”; in English you also have your distinctive words for sensation and feeling. But you can mix up *feeling* and *intuition* easily. Therefore it is an almost artificial distinction I make here, though for practical reasons it is most important that we make such a differentiation in scientific language. We must define what we mean when we use certain terms, otherwise we talk an unintelligible language, and in psychology this is always a misfortune. In ordinary conversation, when a man says feeling, he means possibly something entirely different from another fellow who also talks about feeling. There are any number of psychologists who use the word *feeling*, and they define it as a sort of crippled thought. “Feeling is nothing but an unfinished thought”—that is the definition of a well-known psychologist. But feeling is something genuine, it is something real, it is a function, and therefore we have a word for it. The instinctive natural mind always finds the words that designate things which really have existence. Only psychologists invent words for things that do not exist.

[25] The last-defined function, intuition, seems to be very mysterious, and you know I am “very mystical,” as people say. This then is one of my pieces of mysticism! Intuition is a function by which you see round corners, which you really cannot do; yet the fellow will do it for you and you trust him. It is a function which normally you do not use if you live a regular life within four walls and do regular routine work. But if you are on the Stock Exchange or in Central Africa, you will use your hunches like anything. You cannot, for instance, calculate whether when you turn round a corner in the bush you will meet a rhinoceros or a tiger—but you get a hunch, and it will perhaps save your life. So you see that people who live exposed to natural conditions use intuition a great deal, and people who risk something in an unknown field, who are pioneers of some sort, will use intuition. Inventors will use it and judges will use it. Whenever you have to deal with strange conditions where you have no established values or established concepts, you will depend upon that faculty of intuition.

[26] I have tried to describe that function as well as I can, but perhaps it is not very good. I say that intuition is a sort of perception which does not go exactly by the senses, but it goes via the unconscious, and at that I leave it and say “I don’t know how it works.” I do not know what is happening when a man knows something he definitely should not know. I do not know how he has come by it, but he has it all right and he can act on it. For instance, anticipatory dreams, telepathic phenomena,

and all that kind of thing are intuitions. I have seen plenty of them, and I am convinced that they do exist. You can see these things also with primitives. You can see them everywhere if you pay attention to these perceptions that somehow work through the subliminal data, such as sense-perceptions so feeble that our consciousness simply cannot take them in. Sometimes, for instance, in cryptomnesia, something creeps up into consciousness; you catch a word which gives you a suggestion, but it is always something that is unconscious until the moment it appears, and so presents itself as if it had fallen from heaven. The Germans call this an *Einfall*, which means a thing which falls into your head from nowhere. Sometimes it is like a revelation. Actually, intuition is a very natural function, a perfectly normal thing, and it is necessary, too, because it makes up for what you cannot perceive or think or feel because it lacks reality. You see, the past is not real any more and the future is not as real as we think. Therefore we must be very grateful to heaven that we have such a function which gives us a certain light on those things which are round the corners. Doctors, of course, being often presented with the most unheard-of situations, need intuition a great deal. Many a good diagnosis comes from this “very mysterious” function.

[27] Psychological functions are usually controlled by the will, or we hope they are, because we are afraid of everything that moves by itself. When the functions are controlled they can be excluded from use, they can be suppressed, they can be selected, they can be increased in intensity, they can be directed by will-power, by what we call intention. But they also can function in an involuntary way, that is, they think for you, they feel for you—very often they do this and you cannot even stop them. Or they function unconsciously so that you do not know what they have done, though you might be presented, for instance, with the result of a feeling process which has happened in the unconscious. Afterwards somebody will probably say, “Oh, you were very angry, or you were offended, and therefore you reacted in such and such a way.” Perhaps you are quite unconscious that you have felt in that way, nevertheless it is most probable that you have. Psychological functions, like the sense functions, have their specific energy. You cannot dispose of feeling, or of thinking, or of any of the four functions. No one can say, “I will not think”—he will think inevitably. People cannot say, “I will not feel”—they will feel because the specific energy invested in each function expresses itself and cannot be exchanged for another.

[28] Of course, one has preferences. People who have a good mind prefer to think about things and to adapt by thinking. Other people who have a good feeling function are good social mixers, they have a great sense of values; they are real artists in creating feeling situations and living by feeling situations. Or a man with a keen sense of objective observation will use his sensation chiefly, and so on. The

dominating function gives each individual his particular kind of psychology. For example, when a man uses chiefly his intellect, he will be of an unmistakable type, and you can deduce from that fact the condition of his feeling. When thinking is the dominant or superior function, feeling is necessarily in an inferior condition.¹² The same rule applies to the other three functions. But I will show you that with a diagram which will make it clear.

[29] You can make the so-called cross of the functions (Figure 1).

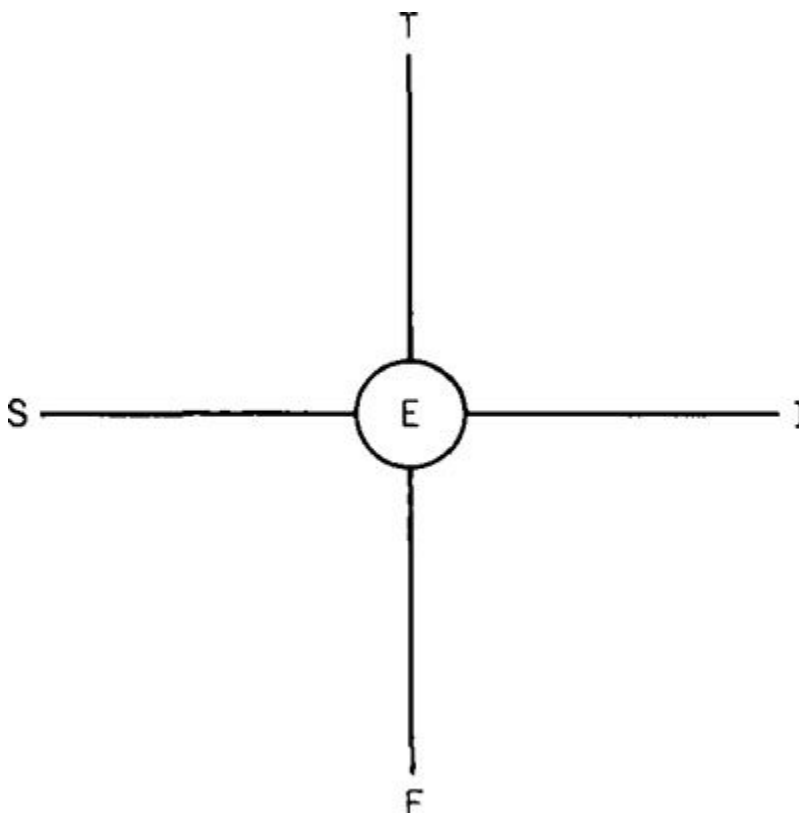

FIG. 1. The Functions

In the centre is the *ego* (E), which has a certain amount of energy at its disposal, and that energy is the will-power. In the case of the thinking type, that will-power can be directed to *thinking* (T). Then we must put *feeling* (F) down below, because it is, in this case, the *inferior function*.¹³ That comes from the fact that when you think you must exclude feeling, just as when you feel you must exclude thinking. If you are thinking, leave feeling and feeling-values alone, because feeling is most upsetting to your thoughts. On the other hand people who go by feeling-values leave thinking well alone, and they are right to do so, because these two different functions contradict each other. People have sometimes assured me that their thinking was just as differentiated as their feeling, but I could not believe it, because an individual cannot have the two opposites in the same degree of perfection at the same time.

[30] The same is the case with *sensation* (S) and *intuition* (I). How do they affect each other? When you are observing physical facts you cannot see round corners at the

same time. When you observe a man who is working by his sense function you will see, if you look at him attentively, that the axes of his eyes have a tendency to converge and to come together at one point. When you study the expression or the eyes of intuitive people, you will see that they only glance at things—they do not look, they radiate at things because they take in their fulness, and among the many things they perceive they get one point on the periphery of their field of vision and that is the *hunch*. Often you can tell from the eyes whether people are intuitive or not. When you have an intuitive attitude you usually do not as a rule observe the details. You try always to take in the whole of a situation, and then suddenly something crops up out of this wholeness. When you are a sensation type you will observe facts as they are, but then you have no intuition, simply because the two things cannot be done at the same time. It is too difficult, because the principle of the one function excludes the principle of the other function. That is why I put them here as opposites.

[31] Now, from this simple diagram you can arrive at quite a lot of very important conclusions as to the structure of a given consciousness. For instance, if you find that *thinking* is highly differentiated, then feeling is undifferentiated. What does that mean? Does it mean these people have no feelings? No, on the contrary. They say, “I have very strong feelings. I am full of emotion and temperament.” These people are under the sway of their emotions, they are caught by their emotions, they are overcome by their emotions at times. If, for instance, you study the private life of professors it is a very interesting study. If you want to be fully informed as to how the intellectual behaves at home, ask his wife and she will be able to tell you a story!

[32] The reverse is true of the *feeling* type. The feeling type, if he is natural, never allows himself to be disturbed by thinking; but when he gets sophisticated and somewhat neurotic he is disturbed by thoughts. Then thinking appears in a compulsory way, he cannot get away from certain thoughts. He is a very nice chap, but he has extraordinary convictions and ideas, and his thinking is of an inferior kind. He is caught by this thinking, entangled in certain thoughts; he cannot disentangle because he cannot reason, his thoughts are not movable. On the other hand, an intellectual, when caught by his feelings, says, “I feel just like that,” and there is no argument against it. Only when he is thoroughly boiled in his emotion will he come out of it again. He cannot be reasoned out of his feeling, and he would be a very incomplete man if he could.

[33] The same happens with the *sensation* type and the *intuitive* type. The intuitive is always bothered by the reality of things; he fails from the standpoint of realities; he is always out for the possibilities of life. He is the man who plants a field and before the crop is ripe is off again to a new field. He has ploughed fields behind him and new hopes ahead all the time, and nothing comes off. But the sensation type remains with

things. He remains in a given reality. To him a thing is true when it is real. Consider what it means to an intuitive when something is real. It is just the wrong thing; it should not be, something else should be. But when a sensation type does not have a given reality—four walls in which to be—he is sick. Give the intuitive type four walls in which to be, and the only thing is how to get out of it, because to him a given situation is a prison which must be undone in the shortest time so that he can be off to new possibilities.

[34] These differences play a very great role in practical psychology. Do not think I am putting people into this box or that and saying, “He is an intuitive,” or “He is a thinking type.” People often ask me, “Now, is So-and-So not a thinking type?” I say, “I never thought about it,” and I did not. It is no use at all putting people into drawers with different labels. But when you have a large empirical material, you need critical principles of order to help you to classify it. I hope I do not exaggerate, but to me it is very important to be able to create a kind of order in my empirical material, particularly when people are troubled and confused or when you have to explain them to somebody else. For instance, if you have to explain a wife to a husband or a husband to a wife, it is often very helpful to have these objective criteria, otherwise the whole thing remains “He said”—“She said.”

[35] As a rule, the inferior function does not possess the qualities of a conscious differentiated function. The conscious differentiated function can as a rule be handled by intention and by the will. If you are a real thinker, you can direct your thinking by your will, you can control your thoughts. You are not the slave of your thoughts, you can think of something else. You can say, “I can think something quite different, I can think the contrary.” But the feeling type can never do that because he cannot get rid of his thought. The thought possesses him, or rather he is possessed by thought. Thought has a fascination for him, therefore he is afraid of it. The intellectual type is afraid of being caught by feeling because his feeling has an archaic quality, and there he is like an archaic man—he is the helpless victim of his emotions. It is for this reason that primitive man is extraordinarily polite, he is very careful not to disturb the feelings of his fellows because it is dangerous to do so. Many of our customs are explained by that archaic politeness. For instance, it is not the custom to shake hands with somebody and keep your left hand in your pocket, or behind your back, because it must be visible that you do not carry a weapon in that hand. The Oriental greeting of bowing with hands extended palms upward means “I have nothing in my hands.” If you kowtow you dip your head to the feet of the other man so that he sees you are absolutely defenceless and that you trust him completely. You can still study the symbolism of manners with primitives, and you can also see why they are afraid of the other fellow. In a similar way, we are afraid of our inferior functions. If you take a typical intellectual who is terribly afraid of falling in love, you will think his fear

very foolish. But he is most probably right, because he will very likely make foolish nonsense when he falls in love. He will be caught most certainly, because his feeling only reacts to an archaic or to a dangerous type of woman. This is why many intellectuals are inclined to marry beneath them. They are caught by the landlady perhaps, or by the cook, because they are unaware of their archaic feeling through which they get caught. But they are right to be afraid, because their undoing will be in their feeling. Nobody can attack them in their intellect. There they are strong and can stand alone, but in their feelings they can be influenced, they can be caught, they can be cheated, and they know it. Therefore never force a man into his feeling when he is an intellectual. He controls it with an iron hand because it is very dangerous.

[36] The same law applies to each function. The inferior function is always associated with an archaic personality in ourselves; in the inferior function we are all primitives. In our differentiated functions we are civilized and we are supposed to have free will; but there is no such thing as free will when it comes to the inferior function. There we have an open wound, or at least an open door through which anything might enter.

[37] Now I am coming to the *endopsychic functions* of consciousness. The functions of which I have just spoken rule or help our conscious orientation in our relations with the environment; but they do not apply to the relation of things that are as it were below the ego. The ego is only a bit of consciousness which floats upon the ocean of the dark things. The dark things are the inner things. On that inner side there is a layer of psychic events that forms a sort of fringe of consciousness round the ego. I will illustrate it by a diagram:

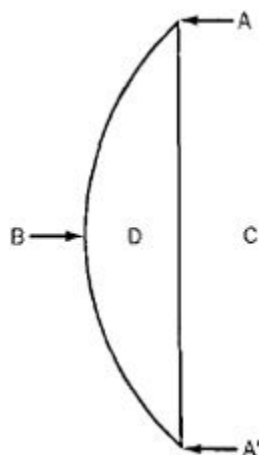

FIG. 2. The Ego

[38] If you suppose AA' to be the threshold of consciousness, then you would have in D an area of consciousness referring to the ectopsychic world B , the world ruled by those functions of which we were just speaking. But on the other side, in C , is the *shadow-world*. There the ego is somewhat dark, we do not see into it, we are an

enigma to ourselves. We only know the ego in D, we do not know it in C. Therefore we are always discovering something new about ourselves. Almost every year something new turns up which we did not know before. We always think we are now at the end of our discoveries. We never are. We go on discovering that we are this, that, and other things, and sometimes we have astounding experiences. That shows there is always a part of our personality which is still unconscious, which is still becoming: we are unfinished; we are growing and changing. Yet that future personality which we are to be in a year's time is already here only it is still in the shadow. The ego is like a moving frame on a film. The future personality is not yet visible, but we are moving along, and presently we come to view the future being. These potentialities naturally belong to the dark side of the ego. We are well aware of what we have been, but we are not aware of what we are going to be.

[39] Therefore the *first* function on that endopsychic side is *memory*. The function of memory, or reproduction, links us up with things that have faded out of consciousness, things that became subliminal or were cast away or repressed. What we call memory is this faculty to reproduce unconscious contents, and it is the first function we can clearly distinguish in its relationship between our consciousness and the contents that are actually not in view.

[40] The *second* endopsychic function is a more difficult problem. We are now getting into deep waters because here we are coming into darkness. I will give you the name first: *the subjective components of conscious functions*. I hope I can make it clear. For instance, when you meet a man you have not seen before, naturally you think something about him. You do not always think things you would be ready to tell him immediately; perhaps you think things that are untrue, that do not really apply. Clearly, they are subjective reactions. The same reactions take place with things and with situations. Every application of a conscious function, whatever the object might be, is always accompanied by subjective reactions which are more or less inadmissible or unjust or inaccurate. You are painfully aware that these things happen in you, but nobody likes to admit that he is subject to such phenomena. He prefers to leave them in the shadow, because that helps him to assume that he is perfectly innocent and very nice and honest and straightforward and "only too willing" etc.,—you know all these phrases. As a matter of fact, one is not. One has any amount of subjective reactions, but it is not quite becoming to admit these things. These reactions I call the subjective components. They are a very important part of our relations to our own inner side. There things get definitely painful. That is why we dislike entering this shadow-world of the ego. We do not like to look at the shadowside of ourselves; therefore there are many people in our civilized society who have lost their shadow altogether, they have got rid of it. They are only two-dimensional; they have lost the third dimension, and with it they have usually lost the

body. The body is a most doubtful friend because it produces things we do not like; there are too many things about the body which cannot be mentioned. The body is very often the personification of this shadow of the ego. Sometimes it forms the skeleton in the cupboard, and everybody naturally wants to get rid of such a thing. I think this makes sufficiently clear what I mean by subjective components. They are usually a sort of disposition to react in a certain way, and usually the disposition is not altogether favourable.

[41] There is one exception to this definition: a person who is not, as we suppose we all are, living on the positive side, putting the right foot forward and not the wrong one, etc. There are certain individuals whom we call in our Swiss dialect “pitch-birds” [*Pechvögel*]; they are always getting into messes, they put their foot in it and always cause trouble, because they *live* their own shadow, they live their own negation. They are the sort of people who come late to a concert or a lecture, and because they are very modest and do not want to disturb other people, they sneak in at the end and then stumble over a chair and make a hideous racket so that everybody has to look at them. Those are the “pitch-birds.”

[42] Now we come to the *third* endopsychic component—I cannot say function. In the case of memory you can speak of a function, but even your memory is only to a certain extent a voluntary or controlled function. Very often it is exceedingly tricky; it is like a bad horse that cannot be mastered. It often refuses in the most embarrassing way. All the more is this the case with the subjective components and reactions. And now things begin to get worse, for this is where the *emotions* and *affects* come in. They are clearly not functions any more, they are just events, because in an emotion, as the word denotes, you are moved away, you are cast out, your decent ego is put aside, and something else takes your place. We say, “He is beside himself,” or “The devil is riding him,” or “What has gotten into him today,” because he is like a man who is possessed. The primitive does not say he got angry beyond measure; he says a spirit got into him and changed him completely. Something like that happens with emotions; you are simply possessed, you are no longer yourself, and your control is decreased practically to zero. That is a condition in which the inner side of a man takes hold of him, he cannot prevent it. He can clench his fists, he can keep quiet, but it has him nevertheless.

[43] The *fourth* important endopsychic factor is what I call *invasion*. Here the shadow-side, the unconscious side, has full control so that it can break into the conscious condition. Then the conscious control is at its lowest. Those are the moments in a human life which you do not necessarily call pathological; they are pathological only in the old sense of the word when pathology meant the science of the passions. In that sense you can call them pathological, but it is really an extraordinary condition

in which a man is seized upon by his unconscious and when anything may come out of him. One can lose one's mind in a more or less normal way. For instance, we cannot assume that the cases our ancestors knew very well are abnormal, because they are perfectly normal phenomena among primitives. They speak of the devil or an incubus or a spirit going into a man, or of his soul leaving him, one of his separate souls—they often have as many as six. When his soul leaves him, he is in an altered condition because he is suddenly deprived of himself; he suffers a loss of self. That is a thing you can often observe in neurotic patients. On certain days, or from time to time, they suddenly lose their energy, they lose themselves, and they come under a strange influence. These phenomena are not in themselves pathological; they belong to the ordinary phenomenology of man, but if they become habitual we rightly speak of a neurosis. These are the things that lead to neurosis; but they are also exceptional conditions among normal people. To have overwhelming emotions is not in itself pathological, it is merely undesirable. We need not invent such a word as pathological for an undesirable thing, because there are other undesirable things in the world which are not pathological, for instance, tax-collectors.

Discussion

Dr. J. A. Hadfield:

[44] In what sense do you use the word “emotion”? You used the word “feeling” rather in the sense in which many people here use the word “emotion.” Do you give the term “emotion” a special significance or not?

Professor Jung:

[45] I am glad you have put that question, because there are usually great mistakes and misunderstandings concerning the use of the word emotion. Naturally everybody is free to use words as he likes, but in scientific language you are bound to cling to certain distinctions so that everyone knows what you are talking about. You will remember I explained “feeling” as a function of valuing, and I do not attach any particular significance to feeling. I hold that feeling is a rational function if it is differentiated. When it is not differentiated it just happens, and then it has all the archaic qualities which can be summed up by the word “unreasonable.” But conscious feeling is a rational function of discriminating values.

[46] If you study emotions you will invariably find that you apply the word “emotional” when it concerns a condition that is characterized by physiological innervations. Therefore you can measure emotions to a certain extent, not their psychic part but the physiological part. You know the James-Lange theory of affect.¹⁴ I take emotion as affect, it is the same as “something affects you.” It does something to you—it interferes with you. Emotion is the thing that carries you away. You are thrown out of yourself; you are beside yourself as if an explosion had moved you out of yourself and put you beside yourself. There is a quite tangible physiological condition which can be observed at the same time. So the difference would be this: feeling has no physical or tangible physiological manifestations, while emotion is characterized by an altered physiological condition. You know that the James-Lange theory of affect says that you only get really emotional when you are aware of the physiological alteration of your general condition. You can observe this when you are in a situation where you would most probably be angry. You know you are going to be angry, and then you feel the blood rushing up into your head, and *then* you are really angry, but not before. Before, you only know you are going to be angry, but when the blood rushes up into your head you are caught by your own anger, immediately the body is affected, and because you realize that you are getting excited, you are twice as angry as you ought to be. Then you are in a real emotion. But when you have *feeling* you have control. You are on top of the situation, and you

can say, "I have a very nice feeling or a very bad feeling about it." Everything is quiet and nothing happens. You can quietly inform somebody, "I hate you," very nicely. But when you say it spitefully you have an emotion. To say it quietly will not cause an emotion, either in yourself or in the other person. Emotions are most contagious, they are the real carriers of mental contagion. For instance, if you are in a crowd that is in an emotional condition, you cannot help yourself, you are in it too, you are caught by that emotion. But the feelings of other people do not concern you in the least, and for this reason you will observe that the differentiated feeling type usually has a cooling effect upon you, while the emotional person heats you up because the fire is radiating out of him all the time. You see the flame of that emotion in his face. By sympathy your sympathetic system gets disturbed, and you will show very much the same signs after a while. That is not so with feelings. Do I make myself clear?

Dr. Henry V. Dicks:

[47] May I ask, in continuation of that question, what is the relation in your view between affects and feelings?

Professor Jung:

[48] It is a question of degree. If you have a value which is overwhelmingly strong for you it will become an emotion at a certain point, namely, when it reaches such an intensity as to cause a physiological innervation. All our mental processes probably cause slight physiological disturbances which are so small that we have not the means to demonstrate them. But we have a pretty sensitive method by which to measure emotions, or the physiological part of them, and that is the psychogalvanic effect.¹⁵ It is based on the fact that the electrical resistance of the skin decreases under the influence of emotion. It does not decrease under the influence of feeling.

[49] I will give you an example. I made the following experiment with my former Professor at the Clinic. He functioned as my test partner, and I had him in the laboratory under the apparatus for measuring the psychogalvanic effect. I told him to imagine something which was intensely disagreeable to him but of which he knew I was not aware, something unknown to me yet known to him and exceedingly painful. So he did. He was well acquainted with such experiments and gifted with great power of concentration, so he concentrated on something, and there was almost no visible disturbance of the electrical resistance of the skin; the current did not increase at all. Then I thought I had a hunch. That very morning I had observed certain signs of something going on and I guessed it must be hellishly disagreeable to my chief. So I thought, "I am going to try something." I simply said to him, "Was not that the case

of So-and-So?”—mentioning the name. Instantly there was a deluge of emotion. That was the *emotion*; the former reaction was the *feeling*.

[50] It is a curious fact that hysterical pain does not cause contraction of the pupils, it is not accompanied by physiological innervation, and yet it is an intense pain. But physical pain causes contraction of the pupils. You can have an intense feeling and no physiological alteration; but as soon as you have physiological alteration you are possessed, you are dissociated, thrown out of your own house, and the house is then free for the devils.

Dr. Eric Graham Howe:

[51] Could we equate emotion and feeling with conation and cognition respectively? Whereas feeling corresponds to cognition, emotion is conative.

Professor Jung:

[52] Yes, one could say that in philosophical terminology. I have no objection.

Dr. Howe:

[53] May I have another shot? Your classification into four functions, namely those of sensation, thinking, feeling, and intuition, seems to me to correspond with the one-, two-, three-, and four-dimensional classification. You yourself used the word “three-dimensional” referring to the human body, and you also said that intuition differed from the other three in that it was the function which included Time. Perhaps, therefore, it corresponds to a fourth dimension? In that case, I suggest that “sensation” corresponds with one-dimensional, “perceptual cognition” with two-dimensional, “conceptual cognition” (which would correspond perhaps with your “feeling”) with three-dimensional, and “intuition” with four-dimensional on this system of classification.

Professor Jung:

[54] You can put it like that. Since intuition sometimes seems to function as if there were no space, and sometimes as if there were no time, you might say that I add a sort of fourth dimension. But one should not go too far. The concept of the fourth dimension does not produce facts. Intuition is something like H. G. Wells’s Time Machine. You remember the time machine, that peculiar motor, which when you sit on it moves off with you into time instead of into space. It consists of four columns, three of which are always visible, but the fourth is visible only indistinctly because it represents the time element. I am sorry but the awkward fact is that intuition is

something like this fourth column. There is such a thing as unconscious perception, or perception by ways which are unconscious to us. We have the empirical material to prove the existence of this function. I am sorry that there are such things. My intellect would wish for a clear-cut universe with no dim corners, but there are these cobwebs in the cosmos. Nevertheless I do not think there is anything mystical about intuition. Can you explain beyond any possibility of doubt why, for instance, some birds travel enormous distances, or the doings of caterpillars, butterflies, ants, or termites? There you have to deal with quite a number of questions. Or take the fact of water having the greatest density at 4° Centigrade. Why such a thing? Why has energy a limitation to quantum? Well, it has, and that is awkward; it is not right that such things should be, but they are. It is exactly like the old question, “Why has God made flies?”—He just has.

Dr. Wilfred R. Bion:

[55] In your experiment why did you ask the Professor to think of an experience which was painful to himself and unknown to you? Do you think there is any significance in the fact that he knew you knew of the unpleasant experience in the second experiment and that this had some bearing on the difference of emotional reaction which he showed in the two examples you gave?

Professor Jung:

[56] Yes, absolutely. My idea was based on the fact that when I know that my partner does not know, it is far more agreeable to me; but when I know that he knows too, it is a very different thing and is very disagreeable. In any doctor's life there are cases which are more or less painful when a colleague knows about them, and I knew almost for a certainty that if I gave him a hint that I knew, he would jump like a mine, and he did. That was my reason.

Dr. Eric B. Strauss:

[57] Would Dr. Jung make clearer what he means when he says that feeling is a rational function? Further, I do not quite understand what Dr. Jung means by feeling. Most of us when we employ the term feeling understand polarities such as pleasure, pain, tension, and relaxation. Further, Dr. Jung claims that the distinction between feelings and emotions is only one of degree. If the distinction is only one of degree, how is it that he puts them on different sides of the frontier, so to speak? Still further, Dr. Jung claims that one of the criteria or the chief criterion would be that feelings are unaccompanied by physiological change, whereas emotions are accompanied by such changes. Experiments conducted by Professor Freudlicher¹⁶ in Berlin have, I

think, shown clearly that simple feelings, in the sense of pleasure, pain, tension, and relaxation, are as a matter of fact accompanied by physiological changes, such as changes in the blood pressure, which can now be recorded by very accurate apparatus.

Professor Jung:

[58] It is true that feelings, if they have an emotional character, are accompanied by physiological effects; but there are definitely feelings which do not change the physiological condition. These feelings are very mental, they are not of an emotional nature. That is the distinction I make. Inasmuch as feeling is a function of values, you will readily understand that this is not a physiological condition. It can be something as abstract as abstract thinking. You would not expect abstract thinking to be a physiological condition. Abstract thinking is what the term denotes. Differentiated thinking is rational; and so feeling can be rational in spite of the fact that many people mix up the terminology.

[59] We must have a word for the giving of values. We must designate that particular function, as apart from others, and feeling is an apt term. Of course, you can choose any other word you like, only you must say so. I have absolutely no objection if the majority of thinking people come to the conclusion that feeling is a very bad word for it. If you say, "We prefer to use another term," then you must choose another term to designate the function of valuing, because the fact of values remains and we must have a name for it. Usually the sense of values is expressed by the term "feeling." But I do not cling to the term at all. I am absolutely liberal as to terms, only I give the definition of terms so that I can say what I mean when I use such and such a term. If anybody says that feeling is an emotion or that feeling is a thing that causes heightened blood pressure, I have no objection. I only say that I do not use the word in that sense. If people should agree that it ought to be forbidden to use the word feeling in such a way as I do, I have no objection. The Germans have the words *Empfindung* and *Gefühl*. When you read Goethe or Schiller you find that even the poets mix up the two functions. German psychologists have already recommended the suppression of the word *Empfindung* for feeling, and propose that one should use the word *Gefühl* (feeling) for values, while the word *Empfindung* should be used for sensation. No psychologist nowadays would say, "The feelings of my eyes or of my ears or of my skin." People of course say that they have feelings in their big toe or ear, but no scientific language of that kind is possible any more. Taking those two words as identical, one could express the most exalted moods by the word *Empfindung*, but it is exactly as if a Frenchman spoke of "les sensations les plus nobles de l'amour." People would laugh, you know. It would be absolutely impossible, shocking!

Dr. E. A. Bennet:

[60] Do you consider that the superior function in the case of a person suffering from manic-depression remains conscious during the period of depression?

Professor Jung:

[61] I would not say that. If you consider the case of manic-depressive insanity you occasionally find that in the manic phase one function prevails and in the depressive phase another function prevails. For instance, people who are lively, sanguine, nice and kind in the manic phase, and do not think very much, suddenly become very thoughtful when the depression comes on, and then they have obsessive thoughts, and vice versa. I know several cases of intellectuals who have a manic-depressive disposition. In the manic phase they think freely, they are productive and very clear and very abstract. Then the depressive phase comes on, and they have obsessive feelings; they are obsessed by terrible moods, just moods, not thoughts. Those are, of course, psychological details. You see these things most clearly in cases of men of forty and a little bit more who have led a particular type of life, an intellectual life or a life of values, and suddenly that thing goes under and up comes just the contrary. There are very interesting cases like that. We have the famous literary illustrations, Nietzsche for instance. He is a most impressive example of a change of psychology into its opposite at middle age. In younger years he was the aphorist in the French style; in later years, at 38, in *Thus Spake Zarathustra*, he burst out in a Dionysian mood which was absolutely the contrary of everything he had written before.

Dr. Bennet:

[62] Is melancholia not extraverted?

Professor Jung:

[63] You cannot say that, because it is an incommensurable consideration. Melancholia in itself could be termed an introverted condition but it is not an attitude of preference. When you call somebody an introvert, you mean that he prefers an introverted habit, but he has his extraverted side too. We all have both sides, otherwise we could not adapt at all, we would have no influence, we would be beside ourselves. Depression is always an introverted condition. Melancholies sink down into a sort of embryonic condition, therefore you find that accumulation of peculiar physical symptoms.

Dr. Mary C. Luff:

[64] As Professor Jung has explained emotion as an obsessive thing which possesses the individual, I am not clear how he differentiates what he calls “invasions” from “affects.”

Professor Jung:

[65] You experience sometimes what you call “pathological” emotions, and there you observe most peculiar contents coming through as emotion: thoughts you have never thought before, sometimes terrible thoughts and fantasies. For instance, some people when they are very angry, instead of having the ordinary feelings of revenge and so on, have the most terrific fantasies of committing murder, cutting off the arms and legs of the enemy, and such things. Those are invading fragments of the unconscious, and if you take a fully developed pathological emotion it is really a state of *eclipse* of consciousness when people are raving mad for a while and do perfectly crazy things. That is an invasion. That would be a pathological case, but fantasies of this kind can also occur within the limits of normal. I have heard innocent people say, “I could cut him limb from limb,” and they actually do have these bloody fantasies; they would “smash the brains” of people, they imagine *doing* what in cold blood is merely *said* as a metaphor. When these fantasies get vivid and people are afraid of themselves, you speak of invasion.

Dr. Luff:

[66] Is that what you call confusional psychosis?

Professor Jung:

[67] It does not need to be a psychosis at all. It does not need to be pathological; you can observe such things in normal people when they are under the sway of a particular emotion. I once went through a very strong earthquake. It was the first time in my life I experienced an earthquake. I was simply overcome by the idea that the earth was not solid and that it was the skin of a huge animal that had shaken itself as a horse does. I was simply caught by that idea for a while. Then I came out of the fantasy remembering that that is exactly what the Japanese say about earthquakes: that the big salamander has turned over or changed its position, the salamander that is carrying the earth.¹⁷ Then I was satisfied that it was an archaic idea which had jumped into my consciousness. I thought it was remarkable; I did not quite think it was pathological.

Dr. B. D. Hendy:

[68] Would Professor Jung say that affect, as he defined it, is *caused* by a characteristic physiological condition, or would he say that this physiological alteration is the *result* of, let us say, invasion?

Professor Jung:

[69] The relation between body and mind is a very difficult question. You know that the James-Lange theory says that affect is the result of physiological alteration. The question whether the body or the mind is the predominating factor will always be answered according to temperamental differences. Those who by temperament prefer the theory of the supremacy of the body will say that mental processes are epiphenomena of physiological chemistry. Those who believe more in the spirit will say the contrary, to them the body is just the appendix of the mind and causation lies with the spirit. It is really a philosophical question, and since I am not a philosopher I cannot claim to make a decision. All we can know empirically is that processes of the body and processes of the mind happen together in some way which is mysterious to us. It is due to our most lamentable mind that we cannot think of body and mind as one and the same thing; probably they *are* one thing, but we are unable to think it. Modern physics is subject to the same difficulty; look at the regrettable things which happen with light! Light behaves as if it were oscillations, and it also behaves as if it were "corpuscles." It needed a very complicated mathematical formula by M. de Broglie to help the human mind to conceive the possibility that oscillations and corpuscles are two phenomena, observed under different conditions, of one and the same ultimate reality.¹⁸ You cannot *think* this, but you are forced to admit it as a postulate.

[70] In the same way, the so-called psychophysical parallelism is an insoluble problem. Take for instance the case of typhoid fever with psychological concomitants. If the psychic factor were mistaken for a causation, you would reach preposterous conclusions. All we can say is that there are certain physiological conditions which are clearly caused by mental disorder, and certain others which are not caused but merely accompanied by psychic processes. Body and mind are the two aspects of the living being, and that is all we know. Therefore I prefer to say that the two things happen together in a miraculous way, and we had better leave it at that, because we cannot think of them together. For my own use I have coined a term to illustrate this being together; I say there is a peculiar principle of *synchronicity*¹⁹ active in the world so that things happen together somehow and behave as if they were the same, and yet for us they are not. Perhaps we shall some day discover a new kind of mathematical method by which we can prove that it must be like that. But for the time being I am absolutely unable to tell you whether it is the body or the mind that prevails, or whether they just coexist.

Dr. L. J. Bendit:

[71] I am not quite clear when invasion becomes pathological. You suggested in the first part of your talk this evening that invasion became pathological whenever it became habitual. What is the difference between a pathological invasion and an artistic inspiration and creation of ideas?

Professor Jung:

[72] Between an artistic inspiration and an invasion there is absolutely no difference. It is exactly the same, therefore I avoid the word "pathological." I would never say that artistic inspiration is pathological, and therefore I make that exception for invasions too, because I consider that an inspiration is a perfectly normal fact. There is nothing bad in it. It is nothing out of the ordinary. Happily enough it belongs to the order of human beings that inspiration takes place occasionally—very rarely, but it does. But it is quite certain that pathological things come in pretty much the same way, so we have to draw the line somewhere. If you are all alienists and I present to you a certain case, then you might say that that man is insane. I would say that that man is not insane for this reason, that as long as he can explain himself to me in such a way that I feel I have a contact with him that man is not crazy. To be crazy is a very relative conception. For instance, when a Negro behaves in a certain way we say, "Oh well, he's only a Negro," but if a white man behaves in the same way we say, "That man is crazy," because a white man cannot behave like that. A Negro is expected to do such things but a white man does not do them. To be "crazy" is a social concept; we use social restrictions and definitions in order to distinguish mental disturbances. You can say that a man is peculiar, that he behaves in an unexpected way and has funny ideas, and if he happens to live in a little town in France or Switzerland you would say, "He is an original fellow, one of the most original inhabitants of that little place"; but if you bring that man into the midst of Harley Street, well, he is plumb crazy. Or if a certain individual is a painter, you think he is a very original artist, but let that man be the cashier of a big bank and the bank will experience something. Then they will say that fellow is surely crazy. But these are simply social considerations. We see the same thing in lunatic asylums. It is not an absolute increase in insanity that makes our asylums swell like monsters, it is the fact that we cannot stand abnormal people any more, so there are apparently very many more crazy people than formerly. I remember in my youth we had people whom I recognized later on as being schizophrenic, and we thought, "Well, Uncle So-and-So is a very original man." In my native town we had some imbeciles, but one did not say, "He is a terrible ass," or something like that, but "He is very nice." In the same way one called certain idiots "cretins," which comes from the saying "il est

bon chrétien.” You could not say anything else of them, but at least they were good Christians.

The Chairman:

[73] Ladies and Gentlemen, I think we must let Professor Jung off any further activity for tonight, and we thank him very much indeed.

LECTURE II

The Chairman (Dr. J. A. Hadfield):

[74] Ladies and Gentlemen, you have already been introduced to Dr. Jung and that in the most eulogistic language, but I think all who were here last night will recognize that even such a great eulogy was in no sense exaggerated. Dr. Jung last night was referring to a number of the functions of the human mind, such as feeling, thinking, intuition, and sensation, and I could not help feeling that in him all these functions, contrary to what he told us, seemed to be very well differentiated. I also had a hunch that in him they were bound together in the centre by a sense of humour. Nothing convinces me so much of the truth of any conception as when its creator is able to see it as a subject of humour, and that is what Dr. Jung did last night. Over-seriousness in regard to any subject very often displays the fact that the individual is dubious and anxious about the truth of what he is trying to convey.

Professor Jung:

[75] Ladies and Gentlemen, yesterday we dealt with the functions of consciousness. Today I want to finish the problem of the structure of the mind. A discussion of the human mind would not be complete if we did not include the existence of unconscious processes. Let me repeat shortly the reflections which I made last night.

[76] We cannot deal with unconscious processes directly because they are not reachable. They are not directly apprehended; they appear only in their products, and we postulate from the peculiar quality of those products that there must be something behind them from which they originate. We call that dark sphere the unconscious psyche.

[77] The ectopsychic contents of consciousness derive in the first place from the environment, through the data of the senses.

Then the contents also come from other sources, such as memory and processes of judgment. These belong to the endopsychic sphere. A third source for conscious contents is the dark sphere of the mind, the unconscious. We approach it through the peculiarities of the endopsychic functions, those functions which are not under the control of the will. They are the vehicle by which unconscious contents reach the surface of consciousness.

[78] The unconscious processes, then, are not directly observable, but those of its products that cross the threshold of consciousness can be divided into two classes. The first class contains recognizable material of a definitely personal origin; these contents are individual acquisitions or products of instinctive processes that make up the personality as a whole. Furthermore, there are forgotten or repressed contents, and creative contents. There is nothing specially peculiar about them. In other people such things may be conscious. Some people are conscious of things of which other people are not. I call that class of contents the subconscious mind or the *personal unconscious*, because, as far as we can judge, it is entirely made up of personal elements, elements that constitute the human personality as a whole.

[79] Then there is another class of contents of definitely unknown origin, or at all events of an origin which cannot be ascribed to individual acquisition. These contents have one outstanding peculiarity, and that is their mythological character. It is as if they belong to a pattern not peculiar to any particular mind or person, but rather to a pattern peculiar to *mankind in general*. When I first came across such contents I wondered very much whether they might not be due to heredity, and I thought they might be explained by racial inheritance. In order to settle that question I went to the United States and studied the dreams of pure-blooded Negroes, and I was able to satisfy myself that these images have nothing to do with so-called blood or racial inheritance, nor are they personally acquired by the individual. They belong to mankind in general, and therefore they are of a *collective* nature.

[80] These collective patterns I have called *archetypes*, using an expression of St. Augustine's.¹ An archetype means a *typos* [imprint], a definite grouping of archaic character containing, in form as well as in meaning, *mythological motifs*. Mythological motifs appear in pure form in fairytales, myths, legends, and folklore. Some of the well-known motifs are: the figures of the Hero, the Redeemer, the Dragon (always connected with the Hero, who has to overcome him), the Whale or the Monster who swallows the Hero.² Another variation of the motif of the Hero and the Dragon is the Katabasis, the Descent into the Cave, the Nekyia. You remember in the *Odyssey* where Ulysses descends *ad inferos* to consult Tiresias, the seer. This motif of the Nekyia is found everywhere in antiquity and practically all over the world. It expresses the psychological mechanism of introversion of the conscious mind into the deeper layers of the unconscious psyche. From these layers derive the contents of an impersonal, mythological character, in other words, the archetypes, and I call them therefore the impersonal or *collective unconscious*.

[81] I am perfectly well aware that I can give you only the barest outline of this particular question of the collective unconscious. But I will give you an example of its symbolism and of how I proceed in order to discriminate it from the personal

unconscious. When I went to America to investigate the unconscious of Negroes I had in mind this particular problem: are these collective patterns racially inherited, or are they “a priori categories of imagination,” as two Frenchmen, Hubert and Mauss,³ quite independently of my own work, have called them. A Negro told me a dream in which occurred the figure of a man crucified on a wheel.⁴ I will not mention the whole dream because it does not matter. It contained of course its personal meaning as well as allusions to impersonal ideas, but I picked out only that one motif. He was a very uneducated Negro from the South and not particularly intelligent. It would have been most probable, given the well-known religious character of the Negroes, that he should dream of a man crucified on a *cross*. The cross would have been a personal acquisition. But it is rather improbable that he should dream of the man crucified on a *wheel*. That is a very uncommon image. Of course I cannot prove to you that by some curious chance the Negro had not seen a picture or heard something of the sort and then dreamt about it; but if he had not had any model for this idea it would be an *archetypal image*, because the crucifixion on the wheel is a *mythological motif*. It is the ancient sun-wheel, and the crucifixion is the sacrifice to the sun-god in order to propitiate him, just as human and animal sacrifices formerly were offered for the fertility of the earth. The sun-wheel is an exceedingly archaic idea, perhaps the oldest religious idea there is. We can trace it to the Mesolithic and Paleolithic ages, as the sculptures of Rhodesia prove. Now there were real wheels only in the Bronze Age; in the Paleolithic Age the wheel was not yet invented. The Rhodesian sun-wheel seems to be contemporary with very naturalistic animal-pictures, like the famous rhino with the tick-birds, a masterpiece of observation. The Rhodesian sun-wheel is therefore an original vision, presumably an archetypal sun-image.⁵ But this image is not a naturalistic one, for it is always divided into four or eight partitions (Figure 3). This image, a sort of divided circle, is a symbol which you find throughout the whole history of mankind as well as in the dreams of modern individuals. We might assume that the invention of the actual wheel started from this vision. Many of our inventions came from mythological anticipations and primordial images. For instance, the art of alchemy is the mother of modern chemistry. Our conscious scientific mind started in the matrix of the unconscious mind.

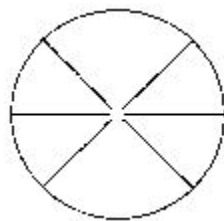

FIG. 3. Sun-wheel

[82] In the dream of the Negro, the man on the wheel is a repetition of the Greek mythological motif of Ixion, who, on account of his offence against men and gods, was fastened by Zeus upon an incessantly turning wheel. I give you this example of a mythological motif in a dream merely in order to convey to you an idea of the collective unconscious. One single example is of course no conclusive proof. But one cannot very well assume that this Negro had studied Greek mythology, and it is improbable that he had seen any representation of Greek mythological figures. Furthermore, figures of Ixion are pretty rare.

[83] I could give you conclusive proof of a very elaborate kind of the existence of these mythological patterns in the unconscious mind. But in order to present my material I should need to lecture for a fortnight. I would have first to explain to you the meaning of dreams and dream-series and then give you all the historical parallels and explain fully their importance, because the symbolism of these images and ideas is not taught in public schools or universities, and even specialists very rarely know of it. I had to study it for years and to find the material myself, and I cannot expect even a highly educated audience to be *au courant* with such abstruse matters. When we come to the technique of dream-analysis I shall be forced to enter into some of the mythological material and you will get a glimpse of what this work of finding parallels to unconscious products is really like. For the moment I have to content myself with the mere statement that there are mythological patterns in that layer of the unconscious, that it produces contents which cannot be ascribed to the individual and which may even be in strict contradiction to the personal psychology of the dreamer. For instance, you are simply astounded when you observe a completely uneducated person producing a dream which really should not occur with such a person because it contains the most amazing things. And children's dreams often make you think to such a degree that you must take a holiday afterwards in order to recover from the shock, because these symbols are so tremendously profound and you think: How on earth is it possible that a child should have such a dream?

[84] It is really quite simple to explain. Our mind has its history, just as our body has its history. You might be just as astonished that man has an appendix, for instance. Does he know he ought to have an appendix? He is just born with it. Millions of people do not know they have a thymus, but they have it. They do not know that in certain parts of their anatomy they belong to the species of the fishes, and yet it is so. Our unconscious mind, like our body, is a storehouse of relics and memories of the past. A study of the structure of the unconscious collective mind would reveal the same discoveries as you make in comparative anatomy. We do not need to think that there is anything mystical about it. But because I speak of a collective unconscious, I have been accused of obscurantism. There is nothing mystical about the collective unconscious. It is just a new branch of science, and it is really common sense to

admit the existence of unconscious collective processes. For, though a child is not born conscious, his mind is not a *tabula rasa*. The child is born with a definite brain, and the brain of an English child will work not like that of an Australian blackfellow but in the way of a modern English person. The brain is born with a finished structure, it will work in a modern way, but this brain has its history. It has been built up in the course of millions of years and represents a history of which it is the result. Naturally it carries with it the traces of that history, exactly like the body, and if you grope down into the basic structure of the mind you naturally find traces of the archaic mind.

[85] The idea of the collective unconscious is really very simple. If it were not so, then one could speak of a miracle, and I am not a miracle-monger at all. I simply go by experience. If I could tell you the experiences you would draw the same conclusions about these archaic motifs. By chance, I stumbled somehow into mythology and have read more books perhaps than you. I have not always been a student of mythology. One day, when I was still at the clinic, I saw a patient with schizophrenia who had a peculiar vision, and he told me about it. He wanted me to see it and, being very dull, I could not see it. I thought, "This man is crazy and I am normal and his vision should not bother me." But it did. I asked myself: What does it mean? I was not satisfied that it was just crazy, and later I came on a book by a German scholar, Dieterich,⁶ who had published part of a magic papyrus. I studied it with great interest, and on page 7 I found the vision of my lunatic "word for word." That gave me a shock. I said: "How on earth is it possible that this fellow came into possession of that vision?" It was not just one image, but a series of images and a literal repetition of them. I do not want to go into it now because it would lead us too far. It is a highly interesting case; as a matter of fact, I published it.⁷

[86] This astonishing parallelism set me going. You probably have not come across the book of the learned professor Dieterich, but if you had read the same books and observed such cases you would have discovered the idea of the collective unconscious.

[87] The deepest we can reach in our exploration of the unconscious mind is the layer where man is no longer a distinct individual, but where his mind widens out and merges into the mind of mankind—not the conscious mind, but the unconscious mind of mankind, where we are all the same. As the body has its anatomical conformity in its two eyes and two ears and one heart and so on, with only slight individual differences, so has the mind its basic conformity. On this collective level we are no longer separate individuals, we are all one. You can understand this when you study the psychology of primitives. The outstanding fact about the primitive mentality is this lack of distinctiveness between individuals, this oneness of the subject with the

object, this *participation mystique*, as Lévy-Bruhl⁸ terms it. Primitive mentality expresses the basic structure of the mind, that psychological layer which with us is the collective unconscious, that underlying level which is the same in all. Because the basic structure of the mind is the same in everybody, we cannot make distinctions when we experience on that level. There we do not know if something has happened to you or to me. In the underlying collective level there is a wholeness which cannot be dissected. If you begin to think about participation as a fact which means that fundamentally we are identical with everybody and everything, you are led to very peculiar theoretical conclusions. You should not go further than those conclusions because these things get dangerous. But some of the conclusions you should explore, because they can explain a lot of peculiar things that happen to man.

[88] I want to sum up: I have brought a diagram (Figure 4). It looks very complicated but as a matter of fact it is very simple. Suppose our mental sphere to look like a lighted globe. The surface from which the light emanates is the function by which you chiefly adapt. If you are a person who adapts chiefly by thinking, your surface is the surface of a thinking man. You will tackle things with your thinking, and what you will show to people will be your thinking. It will be another function if you are of another type.⁹

[89] In the diagram, *sensation* is given as the peripheral function. By it man gets information from the world of external objects. In the second circle, *thinking*, he gets what his senses have told him; he will give things a name. Then he will have a *feeling* about them; a feeling-tone will accompany his observation. And in the end he will get some consciousness of where a thing comes from, where it may go, and what it may do. That is *intuition*, by which you see round corners. These four functions form the ectopsychic system.

[90] The next circle in the diagram represents the conscious ego-complex to which the functions refer. Inside the endopsyché you first notice *memory*, which is still a function that can be controlled by the will; it is under the control of your ego-complex. Then we meet the *subjective components of the functions*. They cannot be exactly directed by the will but they still can be suppressed, excluded, or increased in intensity by will-power. These components are no longer as controllable as memory, though even memory is a bit tricky as you know. Then we come to the *affects* and *invasions*, which are only controllable by sheer force. You can suppress them, and that is all you can do. You have to clench your fists in order not to explode, because they are apt to be stronger than your ego-complex.

[91] This psychic system cannot really be expressed by such a crude diagram. The diagram is rather a scale of values showing how the energy or intensity of the ego-complex which manifests itself in will-power gradually decreases as you approach

the darkness that is ultimately at the bottom of the whole structure—the *unconscious*. First we have the personal subconscious mind. The *personal unconscious* is that part of the psyche which contains all the things that could just as well be conscious. You know that many things are termed unconscious, but that is only a relative statement. There is nothing in this particular sphere that is necessarily unconscious in everybody. There are people who are conscious of almost anything of which man can be conscious. Of course we have an extraordinary amount of unconsciousness in our civilization, but if you go to other races, to India or to China, for example, you discover that these people are conscious of things for which the psychoanalyst in our countries has to dig for months. Moreover, simple people in natural conditions often have an extraordinary consciousness of things of which people in towns have no knowledge and of which townspeople begin to dream only under the influence of psychoanalysis. I noticed this at school. I had lived in the country among peasants and with animals, and I was fully conscious of a number of things of which other boys had no idea. I had the chance and I was not prejudiced. When you analyse dreams or symptoms or fantasies of neurotic or normal people, you begin to penetrate the unconscious mind, and you can abolish its artificial threshold. The personal unconscious is really something very relative, and its circle can be restricted and become so much narrower that it touches zero. It is quite thinkable that a man can develop his consciousness to such an extent that he can say: *Nihil humanum a me alienum puto*.¹⁰

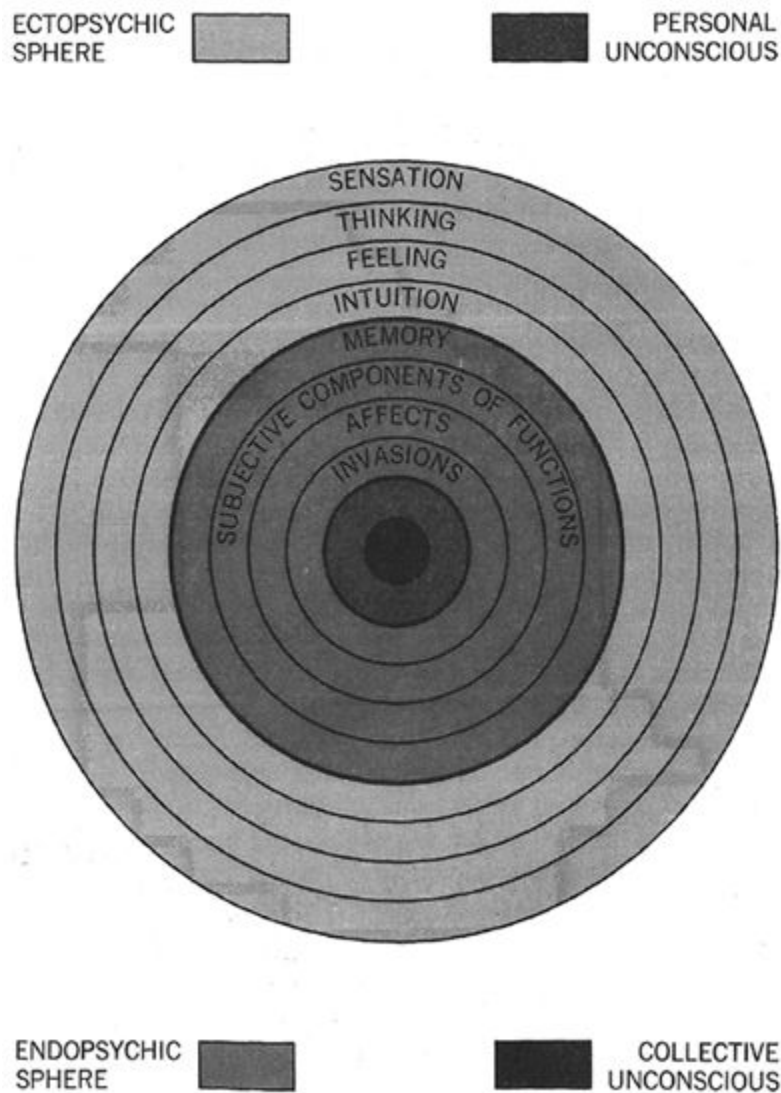

FIG. 4. The Psyche

[92] Finally we come to the ultimate kernel which cannot be made conscious at all—the sphere of the archetypal mind. Its presumable contents appear in the form of images which can be understood only by comparing them with historical parallels. If you do not recognize certain material as historical, and if you do not possess the parallels, you cannot integrate these contents into consciousness and they remain projected. The contents of the *collective unconscious* are not subject to any arbitrary intention and are not controllable by the will. They actually behave as if they did not exist in yourself—you see them in your neighbours but not in yourself. When the contents of the collective unconscious become activated, we become aware of certain things in our fellow men. For instance, we begin to discover that the bad Abyssinians are attacking Italy. You know the famous story by Anatole France. Two peasants were always fighting each other, and there was somebody who wanted to go into the reasons for it, and he asked one man, “Why do you hate your neighbour and fight him like this?” He replied, “Mais il est de l’autre côté de la rivière!” That is like France and Germany. We Swiss people, you know, had a very good chance during the Great War to read newspapers and to study that particular mechanism which behaved

like a great gun firing on one side of the Rhine and in exactly the same way on the other side, and it was very clear that people saw in their neighbours the thing they did not recognize in themselves.

[93] As a rule, when the collective unconscious becomes really constellated in larger social groups, the result is a public craze, a mental epidemic that may lead to revolution or war or something of the sort. These movements are exceedingly contagious—almost overwhelmingly contagious because, when the collective unconscious is activated, you are no longer the same person. You are not only in the movement—you *are* it. If you lived in Germany or were there for a while, you would defend yourself in vain. It gets under your skin. You are human, and wherever you are in the world you can defend yourself only by restricting your consciousness and making yourself as empty, as soulless, as possible. Then you lose your soul, because you are only a speck of consciousness floating on a sea of life in which you do not participate. But if you remain yourself you will notice that the collective atmosphere gets under your skin. You cannot live in Africa or any such country without having that country under your skin. If you live with the yellow man you get yellow under the skin. You cannot prevent it, because somewhere you are the same as the Negro or the Chinese or whoever you live with, you are all just human beings. In the collective unconscious you are the same as a man of another race, you have the same archetypes, just as you have, like him, eyes, a heart, a liver, and so on. It does not matter that his skin is black. It matters to a certain extent, sure enough—he has probably a whole historical layer less than you. The different strata of the mind correspond to the history of the races.

[94] If you study races as I have done you can make very interesting discoveries. You can make them, for instance, if you analyse North Americans. The American, on account of the fact that he lives on virgin soil, has the Red Indian in him. The Red man, even if he has never seen one, and the Negro, though he may be cast out and the tram-cars reserved for white men only, have got into the American and you will realize that he belongs to a partly coloured nation.¹¹ These things are wholly unconscious, and you can only talk to very enlightened people about them. It is just as difficult to talk to Frenchmen or Germans when you have to tell them why they are so much against each other.

[95] A little while ago I had a nice evening in Paris. Some very cultivated men had invited me, and we had a pleasant conversation. They asked me about national differences, and I thought I would put my foot in it, so I said: “What you value is *la clarté latine, la clarté de l’esprit latin*. That is because your thinking is inferior. The Latin thinker is inferior in comparison to the German thinker.” They cocked their ears, and I said: “But your feeling is unsurpassable, it is absolutely differentiated.”

They said: “How is that?” I replied: “Go to a café or a vaudeville or a place where you hear songs and stage-plays and you will notice a very peculiar phenomenon. There are any number of very grotesque and cynical things and then suddenly something sentimental happens. A mother loses her child, there is a lost love, or something marvellously patriotic, and you must weep. For you, the salt and the sugar have to go together. But a German can stand a whole evening of sugar only. The Frenchman must have some salt in it. You meet a man and say: *Enchanté de faire votre connaissance*. You are not *enchanté de faire sa connaissance* at all; you are really feeling: ‘Oh go to the devil.’ But you are not disturbed, nor is he. But do not say to a German: *Enchanté de faire votre connaissance*, because he will believe it. A German will sell you a pair of sock-suspenders and not only expect, as is natural, to be paid for it. He also expects to be loved for it.”

[96] The German nation is characterized by the fact that its feeling function is inferior, it is not differentiated. If you say that to a German he is offended. I should be offended too. He is very attached to what he calls “*Gemütlichkeit*.” A room full of smoke in which everybody loves everybody—that is *gemütlich* and that must not be disturbed. It has to be absolutely clear, just one note and no more. That is *la clarté germanique du sentiment*, and it is inferior. On the other hand, it is a gross offence to a Frenchman to say something paradoxical, because it is not clear. An English philosopher has said, “A superior mind is never quite clear.” That is true, and also superior feeling is never quite clear. You will only enjoy a feeling that is above board when it is slightly doubtful, and a thought that does not have a slight contradiction in it is not convincing.

[97] Our particular problem from now on will be: How can we approach the dark sphere of man? As I have told you, this is done by three methods of analysis: the word-association test, dream-analysis, and the method of active imagination. First of all I want to say something about *word-association tests*.¹² To many of you perhaps these seem old-fashioned, but since they are still being used I have to refer to them. I use this test now not with patients but with criminal cases.

[98] The experiment is made—I am repeating well-known things—with a list of say a hundred words. You instruct the test person to react with the first word that comes into his mind as quickly as possible after having heard and understood the stimulus word. When you have made sure that the test person has understood what you mean you start the experiment. You mark the time of each reaction with a stop-watch. When you have finished the hundred words you do another experiment. You repeat the stimulus words and the test person has to reproduce his former answers. In certain places his memory fails and reproduction becomes uncertain or faulty. These mistakes are important.

- [99] Originally the experiment was not meant for its present application at all; it was intended to be used for the study of mental association. That was of course a most Utopian idea. One can study nothing of the sort by such primitive means. But you can study something else when the experiment fails, when people make mistakes. You ask a simple word that a child can answer, and a highly intelligent person cannot reply. Why? That word has hit on what I call a complex, a conglomeration of psychic contents characterized by a peculiar or perhaps painful feeling-tone, something that is usually hidden from sight. It is as though a projectile struck through the thick layer of the *persona*¹³ into the dark layer. For instance, somebody with a money complex will be hit when you say: "To buy," "to pay," or "money." That is a disturbance of reaction.
- [100] We have about twelve or more categories of disturbance and I will mention a few of them so that you will get an idea of their practical value. The prolongation of the reaction time is of the greatest practical importance. You decide whether the reaction time is too long by taking the average mean of the reaction times of the test person. Other characteristic disturbances are: reaction with more than one word, against the instructions; mistakes in reproduction of the word; reaction expressed by facial expression, laughing, movement of the hands or feet or body, coughing, stammering, and such things; insufficient reactions like "yes" or "no"; not reacting to the real meaning of the stimulus word; habitual use of the same words; use of foreign languages—of which there is not a great danger in England, though with us it is a great nuisance; defective reproduction, when memory begins to fail in the reproduction experiment; total lack of reaction.
- [101] All these reactions are beyond the control of the will. If you submit to the experiment you are done for, and if you do not submit to it you are done for too, because one knows why you are unwilling to do so. If you put it to a criminal he can refuse, and that is fatal because one knows why he refuses. If he gives in he hangs himself. In Zurich I am called in by the Court when they have a difficult case; I am the last straw.
- [102] The results of the association test can be illustrated very neatly by a diagram (Figure 5). The height of the columns represents the actual reaction time of the test person. The dotted horizontal line represents the average mean of reaction times. The unshaded columns are those reactions which show no signs of disturbance. The shaded columns show disturbed reactions. In reactions 7, 8, 9, 10, you observe for instance a whole series of disturbances: the stimulus word at 7 was a critical one, and without the test person noticing it at all three subsequent reaction times are overlong on account of the perseveration of the reaction to the stimulus word. The test person was quite unconscious of the fact that he had an emotion. Reaction 13 shows an isolated disturbance, and in 16–20 the result is again a whole series of disturbances.

The strongest disturbances are in reactions 18 and 19. In this particular case we have to do with a so-called intensification of sensitiveness through the sensitizing effect of an unconscious emotion: when a critical stimulus word has aroused a perseverating emotional reaction, and when the next critical stimulus word happens to occur within the range of that perseveration, then it is apt to produce a greater effect than it would have been expected to produce if it had occurred in a series of indifferent associations. This is called the sensitizing effect of a perseverating emotion.

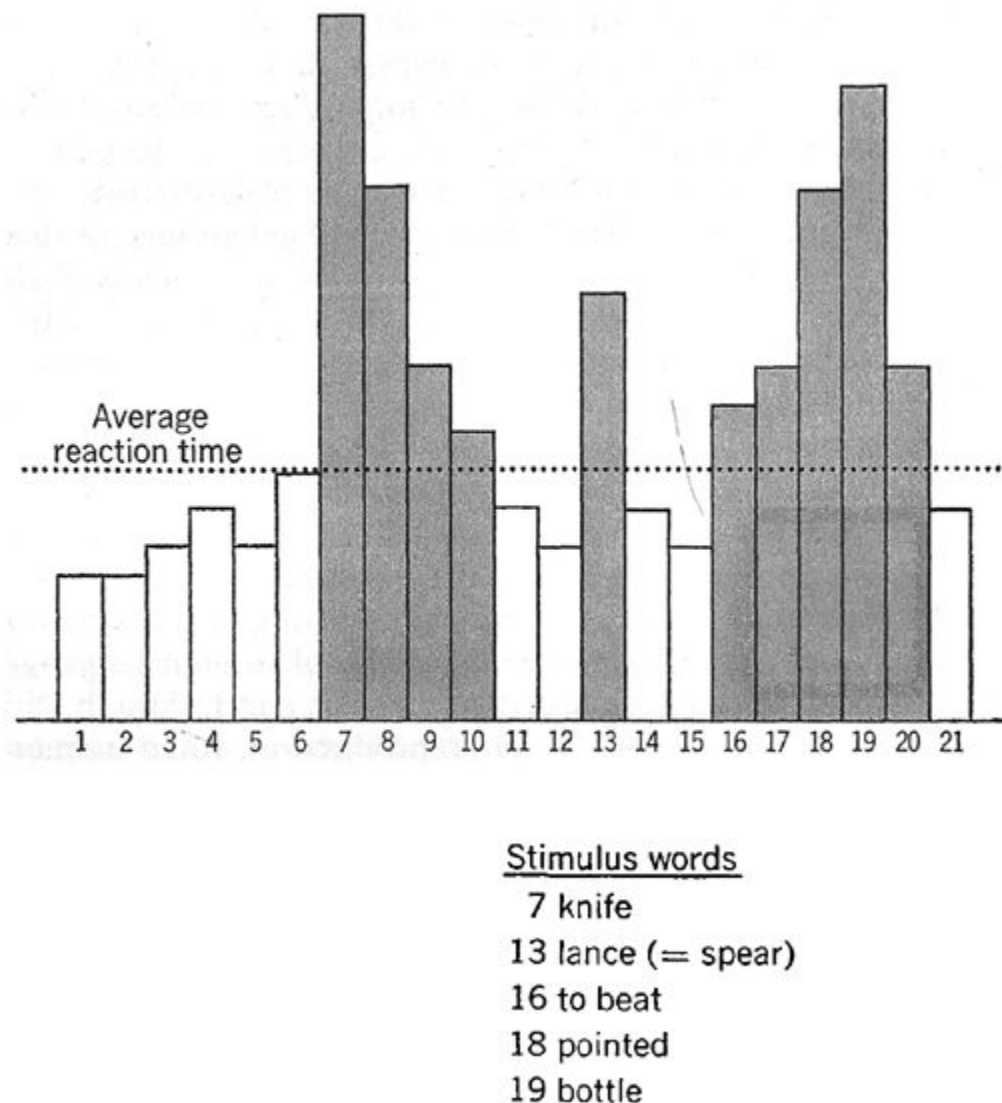

FIG. 5. Association Test

[103] In dealing with criminal cases we can make use of the sensitizing effect, and then we arrange the critical stimulus words in such a way that they occur more or less within the presumable range of perseveration. This can be done in order to increase the effect of critical stimulus words. With a suspected culprit as a test person, the critical stimulus words are words which have a direct bearing upon the crime.

[104] The test person for Figure 5 was a man about 35, a decent individual, one of my normal test persons. I had of course to experiment with a great number of normal people before I could draw conclusions from pathological material. If you want to know what it was that disturbed this man, you simply have to read the words that

caused the disturbances and fit them together. Then you get a nice story. I will tell you exactly what it was.

[105] To begin with, it was the word *knife* that caused four disturbed reactions. The next disturbance was *lance* (or *spear*) and then *to beat*, then the word *pointed* and then *bottle*. That was in a short series of fifty stimulus words, which was enough for me to tell the man point-blank what the matter was. So I said: "I did not know you had had such a disagreeable experience." He stared at me and said: "I do not know what you are talking about." I said: "You know you were drunk and had a disagreeable affair with sticking your knife into somebody." He said: "How do you know?" Then he confessed the whole thing. He came of a respectable family, simple but quite nice people. He had been abroad and one day got into a drunken quarrel, drew a knife and stuck it into somebody, and got a year in prison. That is a great secret which he does not mention because it would cast a shadow on his life. Nobody in his town or surroundings knows anything about it and I am the only one who by chance stumbled upon it. In my seminar in Zurich I also make these experiments. Those who want to confess are of course welcome to. However, I always ask them to bring some material of a person *they* know and *I* do not know, and I show them how to read the story of that individual. It is quite interesting work; sometimes one makes remarkable discoveries.

[106] I will give you other instances. Many years ago, when I was quite a young doctor, an old professor of criminology asked me about the experiment and said he did not believe in it. I said: "No, Professor? You can try it whenever you like." He invited me to his house and I began. After ten words he got tired and said: "What can you make of it? Nothing has come of it." I told him he could not expect a result with ten or twelve words; he ought to have a hundred and then we could see something. He said: "Can you do something with these words?" I said: "Little enough, but I can tell you something. Quite recently you have had worries about money, you have too little of it. You are afraid of dying of heart disease. You must have studied in France, where you had a love affair, and it has come back to your mind, as often, when one has thoughts of dying, old sweet memories come back from the womb of time." He said: "How do you know?" Any child could have seen it! He was a man of 72 and he had associated *heart* with *pain*—fear that he would die of heart failure. He associated *death* with *to die*—a natural reaction—and with *money* he associated *too little*, a very usual reaction. Then things became rather startling to me. To *pay*, after a long reaction time, he said *La Semeuse*, though our conversation was in German. That is the famous figure on the French coin. Now why on earth should this old man say *La Semeuse*? When he came to the word *kiss* there was a long reaction time and there was a light in his eyes and he said: *Beautiful*. Then of course I had the story. He would never have used French if it had not been associated with a particular feeling,

and so we must think why he used it. Had he had losses with the French franc? There was no talk of inflation and devaluation in those days. That could not be the clue. I was in doubt whether it was money or love, but when he came to *kiss/beautiful* I knew it was love. He was not the kind of man to go to France in later life, but he had been a student in Paris, a lawyer, probably at the Sorbonne. It was relatively simple to stitch together the whole story.

[107] But occasionally you come upon a real tragedy. Figure 6 is the case of a woman of about thirty years of age. She was in the clinic, and the diagnosis was schizophrenia of a depressive character. The prognosis was correspondingly bad. I had this woman in my ward, and I had a peculiar feeling about her. I felt I could not quite agree with the bad prognosis, because already schizophrenia was a relative idea with me. I thought that we are all relatively crazy, but this woman was peculiar, and I could not accept the diagnosis as the last word. In those days one knew precious little. Of course I made an anamnesis, but nothing was discovered that threw any light on her illness. Therefore I put her to the association test and finally made a very peculiar discovery. The first disturbance was caused by the word *angel*, and a complete lack of reaction by the word *obstinate*. Then there were *evil*, *rich*, *money*, *stupid*, *dear*, and *to marry*. Now this woman was the wife of a well-to-do man in a very fine position and apparently happy. I had questioned her husband, and the only thing he could tell me, as she also did, was that the depression came on about two months after her eldest child had died—a little girl four years old. Nothing else could be found out about the aetiology of the case. The association test confronted me with a most baffling series of reactions which I could not put together. You will often be in such a situation, particularly if you have no routine with that kind of diagnosis. Then you first ask the test person about the words which are not going directly to the kernel. If you asked directly about the strongest disturbances you would get wrong answers, so you begin with relatively harmless words and you are likely to get an honest reply. I said: “What about *angel*: Does that word mean something to you?” She replied: “Of course, that is my child whom I have lost.” And then came a great flood of tears. When the storm had blown over I asked: “What does *obstinate* mean to you?” She said: “It means nothing to me.” But I said: “There was a big disturbance with the word and it means there is something connected with it.” I could not penetrate it. I came to the word *evil* and could get nothing out of her. There was a severely negative reaction which showed that she refused to answer. I went on to *blue*, and she said: “Those are the eyes of the child I have lost.” I said: “Did they make a particular impression on you?” She said: “Of course. They were so wonderfully blue when the child was born.” I noticed the expression on her face, and I said: “Why are you upset?” and she replied: “Well, she did not have the eyes of my husband.” Finally it came out that the child had had the eyes of a former lover of

hers. I said: “What is upsetting you with regard to that man?” And I was able to worm the story out of her.

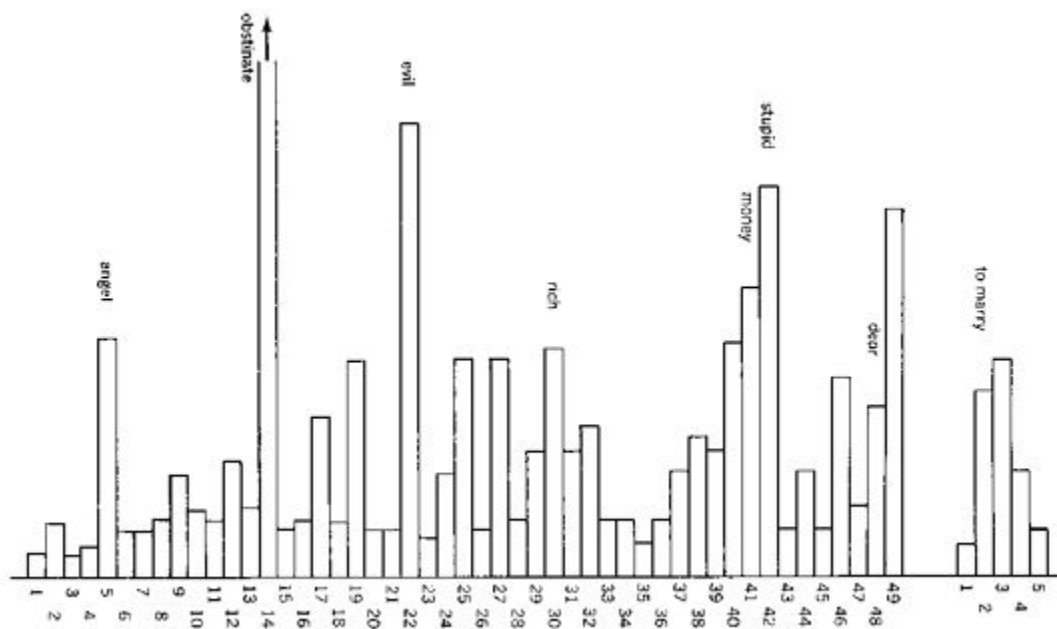

FIG. 6. Association Test

[108] In the little town in which she grew up there was a rich young man. She was of a well-to-do family but nothing grand. The man was of the moneyed aristocracy and the hero of the little town, and every girl dreamed of him. She was a pretty girl and thought she might have a chance. Then she discovered she had no chance with him, and her family said: “Why think of him? He is a rich man and does not think of you. Here is Mr. So-and-So, a nice man. Why not marry him?” She married him and was perfectly happy ever after until the fifth year of her marriage, when a former friend from her native town came to visit her. When her husband left the room he said to her: “You have caused pain to a certain gentleman” (meaning the hero). She said: “What? I caused pain?” The friend replied: “Didn’t you know he was in love with you and was disappointed when you married another man?” That set fire to the roof. But she repressed it. A fortnight later she was bathing her boy, two years, and her girl, four years old. The water in the town—it was not in Switzerland—was not above suspicion, in fact it was infected with typhoid fever. She noticed that the little girl was sucking a sponge. But she did not interfere, and when the little boy said, “I want to drink some water,” she gave him the possibly infected water. The little girl got typhoid fever and died, the little boy was saved. Then she had what she wanted—or what the devil in her wanted—the denial of her marriage in order to marry the other man. To this end she had committed murder. She did not know it; she only told me the facts and did not draw the conclusion that she was responsible for the death of the child since she knew the water was infected and there was danger. I was faced with the question whether I should tell her she had committed murder, or whether I should keep quiet. (It was only a question of telling *her*, there was no threat of a

criminal case.) I thought that if I told her it might make her condition much worse, but there was a bad prognosis anyhow, whereas, if she could realize what she had done, the chance was that she might get well. So I made up my mind to tell her point-blank: "You killed your child." She went up in the air in an emotional state, but then she came down to the facts. In three weeks we were able to discharge her, and she never came back. I traced her for fifteen years, and there was no relapse. That depression fitted her case psychologically: she was a murderess and under other circumstances would have deserved capital punishment. Instead of going to jail she was sent to the lunatic asylum. I practically saved her from the punishment of insanity by putting an enormous burden on her conscience. For if one can accept one's sin one can live with it. If one cannot accept it, one has to suffer the inevitable consequences.

Discussion

Question:

[109] I want to refer to last night. Towards the end of his lecture Dr. Jung spoke of higher and lower functions and said the thinking type would use his feeling function archaically. I would like to know: is the reverse true? Does the feeling type, when he tries to think, think archaically? In other words, are thinking and intuition to be regarded always as higher functions than feeling and sensation? I ask this because ... I gathered from lectures elsewhere that sensation was the lowest of conscious functions and thinking a higher one. It is certainly the case that in everyday life thinking seems to be the top-notch. The professor—not this Professor—thinking in his study regards himself and is regarded as the highest type, higher than the countryman who says: “Sometimes I sits and thinks and sometimes I just sits.”

Professor Jung:

[110] I hope I did not give you the impression that I was giving a preference to any of the functions. The dominating function in a given individual is always the most differentiated, and that can be *any* function. We have absolutely no criterion by which we can say this or that function in itself is the best. We can only say that the differentiated function in the individual is the best for adapting, and that the one that is most excluded by the superior function is inferior on account of being neglected. There are some modern people who say that intuition is the highest function. Fastidious individuals prefer intuition, it is classy! The sensation type always thinks that other people are very inferior because they are not so real as he is. He is the real fellow and everybody else is fantastic and unreal. Everybody thinks his superior function is the top of the world. In that respect we are liable to the most awful blunders. To realize the actual order of functions in our consciousness, severe psychological criticism is needed. There are many people who believe that world problems are settled by thinking. But no truth can be established without all four functions. When you have thought the world you have done one-fourth of it; the remaining three-fourths may be against you.

Dr. Eric B. Strauss:

[111] Professor Jung said the word-association test was a means by which one could study the contents of the personal unconscious. In the examples he gave surely the matters revealed were matters in the patient's conscious mind and not in his

unconscious. Surely if one wanted to seek for unconscious material one would have to go a step further and get the patient to associate freely on the anomalous reactions. I am thinking of the association with the word “knife,” when Professor Jung so cleverly assumed the story of the unfortunate incident. That surely was in the patient’s conscious mind, whereas, if the word “knife” had unconscious associations we might, if we were Freudian-minded, have assumed it was associated with an unconscious castration complex or something of that kind. I am not saying it is so, but I do not understand what Professor Jung means when he says the association test is to reach to the patient’s unconscious. Surely in the instance given tonight it is used to reach the conscious, or what Freud would perhaps call the preconscious.

Professor Jung:

[112] I should like very much if you would pay more attention to what I say. I told you that unconscious things are very *relative*. When I am unconscious of a certain thing I am only relatively unconscious of it; in some other respects I may know it. The contents of the personal unconscious are perfectly conscious in certain respects, but you do not know them under a *particular aspect* or at a *particular time*.

[113] How can you establish whether the thing is conscious or unconscious? You simply ask people. We have no other criterion to establish whether something is conscious or unconscious. You ask: “Do you know whether you have had certain hesitations?” They say: “No, I had no hesitation; to my knowledge I had the same reaction time.” “Are you conscious that something disturbed you?” “No, I am not.” “Have you no recollection of what you answered to the word ‘knife’?” “None at all.” This unawareness of facts is a very common thing. When I am asked if I know a certain man I may say no, because I have no recollection of him and so I am not conscious of knowing him; but when I am told that I met him two years ago, that he is Mr. So-and-So who has done such and such a thing, I reply: “Certainly I know him.” I know him and I do not know him. All the contents of the personal unconscious are *relatively* unconscious, even the castration complex and the incest complex. They are perfectly known under certain aspects, though they are unconscious under others. This relativity of being conscious of something becomes quite plain in hysterical cases. Quite often you find that things which seem unconscious are unconscious only to the doctor but not perhaps to the nurse or the relatives.

[114] I had to see an interesting case once in a famous clinic in Berlin, a case of multiple sarcomatosis of the spinal cord, and because it was a very famous neurologist who had made the diagnosis I almost trembled, but I asked for the anamnesis and had a very nice one worked out. I asked when the symptoms began, and found it was the evening of the day when the only son of the woman had left her

and married. She was a widow, quite obviously in love with her son, and I said: "This is no sarcomatosis but an ordinary hysteria, which we can prove presently." The professor was horrified at my lack of intelligence or tact or I don't know what, and I had to walk out. But somebody ran after me in the street. It was the nurse, who said: "Doctor, I want to thank you for saying that it *was* hysteria. I always thought so."

Dr. Eric Graham Howe:

[115] May I return to what Dr. Strauss said? Last night Professor Jung reproved me for merely using words, but I think it is important to get these words clearly understood. I wonder if you have ever asked for the association experiment to be applied to the words "mystic" or "fourth dimension"? I believe you would get a period of great delay and concentrated fury every time they were mentioned. I propose to return to the fourth-dimensional, because I believe it is a link badly needed to help our understanding. Dr. Strauss uses the word "unconscious," but I understand from Professor Jung that there is no such thing, there is only a relative unconsciousness which depends on a relative degree of consciousness. According to Freudians, there is a place, a thing, an entity called the unconscious. According to Professor Jung, as I understand him, there is no such thing. He is moving in a fluid medium of relationship and Freud in a static medium of unrelated entities. To get it clear Freud is *three-dimensional* and Jung is, in all his psychology, *four-dimensional*. For this reason, I would criticize if I may the whole diagrammatic system of Jung because he is giving you a three-dimensional presentation of a four-dimensional system, a static presentation of something that is functionally moving, and unless it is explained you get it confused with the Freudian terminology and you cannot understand it. I shall insist that there must be some clarification of words.

Professor Jung:

[116] I could wish Dr. Graham Howe were not so indiscreet. You are right, but you should not say such things. As I explained, I tried to begin with the mildest propositions. You put your foot right into it and speak of four dimensions and of the word "mystic," and you tell me that all of us would have a long reaction time to such stimulus words. You are quite right, everybody would be stung because we are just beginners in our field. I agree with you that it is very difficult to let psychology be a living thing and not to dissolve it into static entities. Naturally you must express yourself in terms of the fourth dimension when you bring the time factor into a three-dimensional system. When you speak of dynamics and processes you need the time factor, and then you have all the prejudice of the world against you because you have used the word "four-dimensional." It is a taboo word that should not be mentioned. It has a history, and we should be exceedingly tactful with such words. The more you

advance in the understanding of the psyche the more careful you will have to be with terminology, because it is historically coined and prejudiced. The more you penetrate the basic problems of psychology the more you approach ideas which are philosophically, religiously, and morally prejudiced. Therefore certain things should be handled with the utmost care.

Dr. Howe:

[117] This audience would like you to be provocative. I am going to say a rash thing. You and I do not regard the shape of the ego as a straight line. We would be prepared to regard the sphere as a true shape of the self in four dimensions, of which one is the three-dimensional outline. If so, will you answer a question: "What is the scope of that self which in four dimensions is a moving sphere?" I suggest the answer is: "The universe itself, which includes your concept of the collective racial unconscious."

Professor Jung:

[118] I should be much obliged if you would repeat that question.

Dr. Howe:

[119] How big is this sphere, which is the four-dimensional self? I could not help giving the answer and saying that it is the same bigness as the universe.

Professor Jung:

[120] This is really a philosophical question, and to answer it requires a great deal of theory of cognition. The world is our picture. Only childish people imagine that the world is what we think it is. The image of the world is a projection of the world of the self, as the latter is an introjection of the world. But only the special mind of a philosopher will step beyond the ordinary picture of the world in which there are static and isolated things. If you stepped beyond that picture you would cause an earthquake in the ordinary mind, the whole cosmos would be shaken, the most sacred convictions and hopes would be upset, and I do not see why one should wish to disquiet things. It is not good for patients, nor for doctors: it is perhaps good for philosophers.

Dr. Ian Suttie:

[121] I should like to go back to Dr. Strauss's question. I can understand what Dr. Strauss means and I think I can understand what Professor Jung means. As far as I can see, Professor Jung fails to make any link between his statement and Dr.

Strauss's. Dr. Strauss wanted to know how the word-association test can show the Freudian unconscious, the material that is actually pushed out of mind. As far as I understand Professor Jung, he means what Freud means by the "Id." It seems to me that we should define our ideas well enough to compare them and not merely use them, each in our own school.

Professor Jung:

[122] I must repeat again that my methods do not discover *theories*, they discover *facts*, and I tell you what facts I discover with these methods. I cannot discover a castration complex or a repressed incest or something like that—I find only psychological *facts*, not theories. I am afraid you mix up too much theory with fact and you are perhaps disappointed that the experiments do not reveal a castration complex and such things, but a castration complex is a *theory*. What you find in the association method are definite facts which we did not know before and which the test person also did not know in this particular light. I do not say he did not know it under another light. You know many things when you are in your business that you do not know at home, and at home you know many things that you do not know in your official position. Things are known in one place and somewhere else they are not known. That is what we call unconscious. I must repeat that we cannot penetrate the unconscious *empirically* and then discover, for instance, the Freudian *theory* of the castration complex. The castration complex is a mythological idea, but it is not found as such. What we actually find are certain facts grouped in a specific way, and we name them according to mythological or historical parallels. You cannot find a mythological motif, you can only find a personal motif, and that never appears in the form of a theory but as a living fact of human life. You can abstract a theory from it, Freudian or Adlerian or any other. You can think what you please about the facts of the world, and there will be as many theories in the end as heads that think about it.

Dr. Suttie:

[123] I protest! I am not interested in this or that theory or what facts are found or not, but I am interested in having a means of communication by which each can know what the others are thinking and for that end I hold that our conceptions must be defined. We must know what the other person means by a certain thing like the unconscious of Freud. As for the word "unconscious," it is becoming more or less known to everybody. It has therefore a certain social or illustrative value, but Jung refuses to recognize the word "unconscious" in the meaning Freud gives to it and uses "unconscious" in a way that we have come to consider as what Freud calls the "Id."

Professor Jung:

[124] The word “unconscious” is not Freud’s invention. It was known in German philosophy long before, by Kant and Leibniz and others, and each of them gives his definition of that term. I am perfectly well aware that there are many different conceptions of the unconscious, and what I was trying humbly to do was to say what *I* think about it. It is not that I undervalue the merits of Leibniz, Kant, von Hartmann, or any other great man, including Freud and Adler and so on. I was only explaining what *I* mean by the unconscious, and I presuppose that you are all aware of what Freud means by it. I did not think it was my task to explain things in such a way that somebody who is convinced of Freud’s theory and prefers that point of view would be upset in his belief. I have no tendency to destroy your convictions or points of view. I simply exhibit my own point of view, and if anybody should be tempted to think that this also is reasonable, that is all I want. It is perfectly indifferent to me what one thinks about the unconscious in general, otherwise I should begin a long dissertation on the concept of the unconscious as understood by Leibniz, Kant, and von Hartmann.

Dr. Suttie:

[125] Dr. Strauss asked about the relationship of the unconscious as conceived by you and by Freud. Is it possible to bring them into precise and definite relationship?

Professor Jung:

[126] Dr. Graham Howe has answered the question. Freud is seeing the mental processes as static, while I speak in terms of dynamics and relationship. To me all is relative. There is nothing definitely unconscious; it is only not present to the conscious mind under a certain light. You can have very different ideas of why a thing is known under one aspect and not known under another aspect. The only exception I make is the mythological pattern, which is profoundly unconscious, as I can prove by the facts.

Dr. Strauss:

[127] Surely there is a difference between using your association test as a crime detector and for finding, let us say, unconscious guilt. Your criminal is conscious of his guilt and he is conscious that he is afraid of its being discovered. Your neurotic is unaware of his guilt and unaware that he is afraid of his guilt. Can the same kind of technique be used in these two very different kinds of cases?

The Chairman:

[128] This woman was not conscious of her guilt though she had allowed the child to suck the sponge.

Professor Jung:

[129] I will show you the difference experimentally. In Figure 7 you have a short illustration of respiration during the association test. You see four series of seven respirations registered after the stimulus words. The diagrams are condensations of respirations after indifferent and critical stimulus words in a greater number of test persons.

[130] "A" gives respirations after indifferent stimulus words. The first inspirations after the stimulus words are restricted, while the following inspirations are of normal size.

[131] In "B" where the stimulus word was a critical one the volume of breathing is definitely restricted, sometimes by more than half the normal size.

[132] In "C" we have the behaviour of breathing after a stimulus word relating to a complex that was conscious to the test persons. The first inspiration is almost normal, and only later you find a certain restriction.

[133] In "D" the respiration is after a stimulus word that was related to a complex of which the test persons were unconscious. In this case the first inspiration is remarkably small and the following are rather below normal.

[134] These diagrams illustrate very clearly the difference of reaction between conscious and unconscious complexes. In "C," for instance, the complex is conscious. The stimulus word hits the test person, and there is a deep inspiration. But when the stimulus word hits an unconscious complex, the volume of breathing is restricted, as shown in "D" I. There is a spasm in the thorax, so that almost no breathing takes place. In that way one has empirical proof of the physiological difference between conscious and unconscious reaction.¹⁴

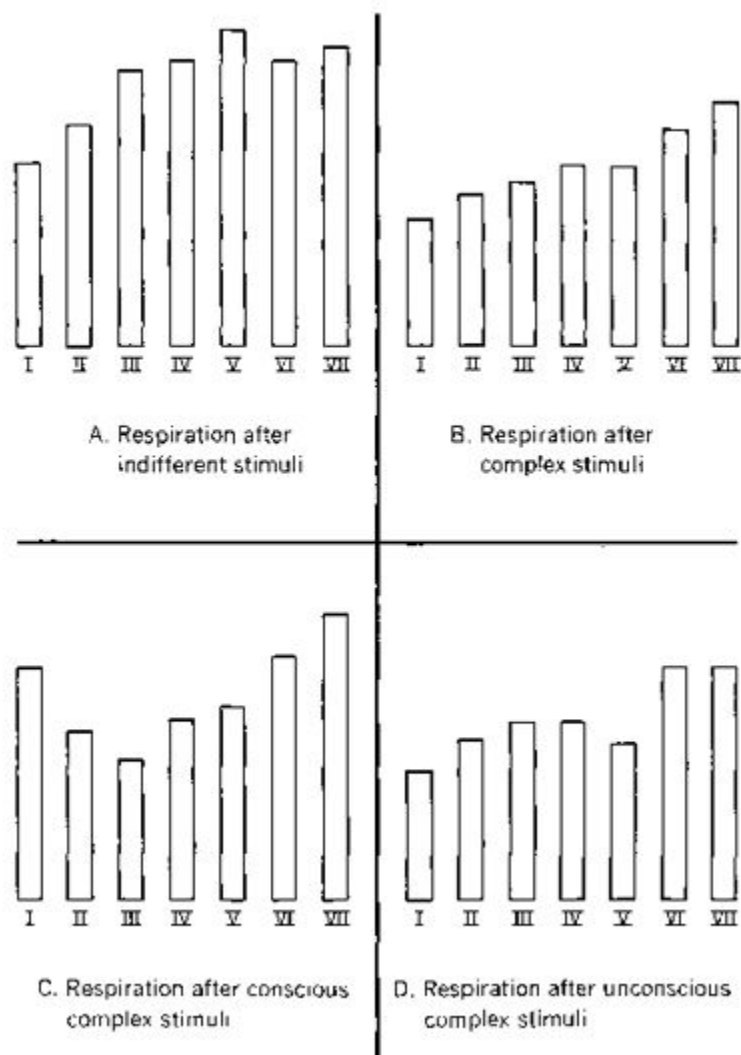

FIG. 7. Association Test Respiration

Dr. Wilfred R. Bion:

[135] You gave an analogy between archaic forms of the body and archaic forms of the mind. Is it purely an analogy or is there in fact a closer relationship? Last night you said something which suggested that you consider there is a connection between the mind and the brain, and there has lately been published in the *British Medical Journal* a diagnosis of yours from a dream of a physical disorder.¹⁵ If that case was correctly reported it makes a very important suggestion, and I wondered whether you considered there was some closer connection between the two forms of archaic survival.

Professor Jung:

[136] You touch again on the controversial problem of psychophysical parallelism for which I know of no answer, because it is beyond the reach of man's cognition. As I tried to explain yesterday, the two things—the psychic fact and the physiological fact—come together in a peculiar way. They happen together and are, so I assume,

simply two different aspects to our *mind*, but not in reality. We see them as two on account of the utter incapacity of our mind to think them together. Because of that possible unity of the two things, we must expect to find dreams which are more on the physiological side than on the psychological, as we have other dreams that are more on the psychological than on the physical side. The dream to which you refer was very clearly a representation of an organic disorder. These “organic representations” are well known in ancient literature. The doctors of antiquity and of the Middle Ages used dreams for their diagnosis. I did not conduct a physical examination on the man you refer to. I only heard his history and was told the dream, and I gave my opinion on it. I have had other cases, for instance a very doubtful case of progressive muscular atrophy in a young girl. I asked about dreams and she had two dreams which were very colourful. A colleague, a man who knew something of psychology, thought it might be a case of hysteria. There were indeed hysterical symptoms, and it was still doubtful if it was progressive muscular atrophy or not; but on account of the dreams I came to the conclusion that it must be an organic disease, and the end proved my diagnosis. It was an organic disturbance, and the dreams were definitely referring to the organic condition.¹⁶ According to my idea of the community of the psyche and the living body it should be like that, and it would be marvellous if it were not so.

Dr. Bion:

[137] Will you be talking of that later when you speak on dreams?

Professor Jung:

[138] I am afraid that I cannot go into such detail; it is too special. It is really a matter of special experience, and its presentation would be a very difficult job. It would not be possible to describe to you briefly the criteria by which I judge such dreams. The dream you mentioned, you may remember, was a dream of the little mastodon. To explain what that mastodon really means in an organic respect and why I must take that dream as an organic symptom would start such an argument that you would accuse me of the most terrible obscurantism. These things really are obscure. I had to speak in terms of the basic mind, which thinks in archetypal patterns. When I speak of archetypal patterns those who are aware of these things understand, but if you are not aware you think, “This fellow is absolutely crazy because he talks of mastodons and their difference from snakes and horses.” I should have to give you a course of about four semesters about symbology first so that you could appreciate what I said.

[139] That is the great trouble: there is such a gap between what is usually known of these things and what I have worked on all these years. If I were to speak of this even

before a medical audience I should have to talk of the peculiarities of the *niveau mental*, to quote Janet, and I might as well talk Chinese. For instance, I would say that the *abaissement du niveau mental* sank in a certain case to the level of the *manipura chakra*,¹⁷ that is, to the level of the navel. We Europeans are not the only people on the earth. We are just a peninsula of Asia, and on that continent there are old civilizations where people have trained their minds in introspective psychology for thousands of years, whereas we began with our psychology not even yesterday but only this morning. These people have an insight that is simply fabulous, and I had to study Eastern things to understand certain facts of the unconscious. I had to go back to understand Oriental symbolism. I am about to publish a little book on one symbolic motif only,¹⁸ and you will find it hair-raising. I had to study not only Chinese and Hindu but Sanskrit literature and medieval Latin manuscripts which are not even known to specialists, so that one must go to the British Museum to find the references. Only when you possess that apparatus of parallelism can you begin to make diagnoses and say that this dream is organic and that one is not. Until people have acquired that knowledge I am just a sorcerer. They say it is *un tour de passe-passe*. They said it in the Middle Ages. They said, "How can you see that Jupiter has satellites?" If you reply that you have a telescope, what is a telescope to a medieval audience?

[140] I do not mean to boast about this. I am always perplexed when my colleagues ask: "How do you establish such a diagnosis or come to this conclusion?" I reply: "I will explain if you will allow me to explain what you ought to know to be able to understand it." I experienced this myself when the famous Einstein was Professor at Zurich. I often saw him, and it was when he was beginning to work on his theory of relativity. He was often in my house, and I pumped him about his relativity theory. I am not gifted in mathematics and you should have seen all the trouble the poor man had to explain relativity to me. He did not know how to do it. I went fourteen feet deep into the floor and felt quite small when I saw how he was troubled. But one day he asked me something about psychology. Then I had my revenge.

[141] Special knowledge is a terrible disadvantage. It leads you in a way too far, so that you cannot explain any more. You must allow me to talk to you about seemingly elementary things, but if you will accept them I think you will understand why I draw such and such conclusions. I am sorry that we do not have more time and that I cannot tell you everything. When I come to dreams I have to give myself away and to risk your thinking me a perfect fool, because I am not able to put before you all the historical evidence which led to my conclusions. I should have to quote bit after bit from Chinese and Hindu literature, medieval texts and all the things which you do not know. How could you? I am working with specialists in other fields of knowledge and they help me. There was my late friend Professor Wilhelm, the

sinologist; I worked with him. He had translated a Taoist text, and he asked me to comment on it, which I did from the psychological side.¹⁹ I am a terrible novelty to a sinologist, but what he has to tell us is a novelty to us. The Chinese philosophers were no fools. We think the old people were fools, but they were as intelligent as we are. They were frightfully intelligent people, and psychology can learn no end from old civilizations, particularly from India and China. A former President of the British Anthropological Society asked me: "Can you understand that such a highly intelligent people as the Chinese have no science?" I replied: "They have a science, but you do not understand it. It is not based on the principle of causality. The principle of causality is not the only principle; it is only relative."

[142] People may say: What a fool to say causality is only relative! But look at modern physics! The East bases its thinking and its evaluation of facts on another principle. We have not even a word for that principle. The East naturally has a word for it, but we do not understand it. The Eastern word is *Tao*. My friend McDougall²⁰ has a Chinese student, and he asked him: "What exactly do you mean by Tao?" Typically Western! The Chinese explained what Tao is and he replied: "I do not understand yet." The Chinese went out to the balcony and said: "What do you see?" "I see a street and houses and people walking and tramcars passing." "What more?" "There is a hill." "What more?" "Trees." "What more?" "The wind is blowing." The Chinese threw up his arms and said: "That is Tao."

[143] There you are. Tao can be anything. I use another word to designate it, but it is poor enough. I call it *synchronicity*. The Eastern mind, when it looks at an ensemble of facts, accepts that ensemble as it is, but the Western mind divides it into entities, small quantities. You look, for instance, at this present gathering of people, and you say: "Where do they come from? Why should they come together?" The Eastern mind is not at all interested in that. It says: "What does it *mean* that these people are together?" That is not a problem for the Western mind. You are interested in what you come here for and what you are doing here. Not so the Eastern mind; it is interested in being together.

[144] It is like this: you are standing on the sea-shore and the waves wash up an old hat, an old box, a shoe, a dead fish, and there they lie on the shore. You say: "Chance, nonsense!" The Chinese mind asks: "What does it mean that these things are together?" The Chinese mind experiments with that *being together* and *coming together at the right moment*, and it has an experimental method which is not known in the West, but which plays a large role in the philosophy of the East. It is a method of forecasting possibilities, and it is still used by the Japanese Government about political situations; it was used, for instance, in the Great War. This method was formulated in 1143 B.C.²¹

LECTURE III

The Chairman (Dr. Maurice B. Wright):

[145] Ladies and Gentlemen, it is my privilege to be the Chairman at Professor Jung's lecture at this evening's meeting. It was my privilege twenty-one years ago to meet Professor Jung when he came over to London to give a series of addresses,¹ but there was then a very small group of psychologically minded physicians. I remember very well how after the meetings we used to go to a little restaurant in Soho and talk until we were turned out. Naturally we were trying to pump Professor Jung as hard as we could. "When I said goodbye to Professor Jung he said to me—he did not say it very seriously—"I think you are an extravert who has become an introvert." Frankly, I have been brooding about that ever since!

[146] Now, ladies and gentlemen, just a word about last night. I think Professor Jung gave us a very good illustration of his views and of his work when he talked about the value of the telescope. A man with a telescope naturally can see a good deal more than anybody with unaided sight. That is exactly Professor Jung's position. With his particular spectacles, with his very specialized research, he has acquired a knowledge, a vision of the depth of the human psyche, which for many of us is very difficult to grasp. Of course, it will be impossible for him in the space of a few lectures to give us more than a very short outline of the vision he has gained. Therefore, in my opinion anything which might seem blurred or dark is not a question of obscurantism, it is a question of spectacles. My own difficulty is that, with my muscles of accommodation already hardening, it might be impossible for me ever to see that vision clearly, even if for the moment Professor Jung could lend me his spectacles. But however this may be, I know that we are all thrilled with everything he can tell us, and we know how stimulating it is to our own thinking, especially in a domain where speculation is so easy and where proof is so difficult.

Professor Jung:

[147] Ladies and Gentlemen, I ought to have finished my lecture on the association tests yesterday, but I would have had to overstep my time. So you must pardon me for coming back to the same thing once more. It is not that I am particularly in love with the association tests. I use them only when I must, but they are really the foundation of certain conceptions. I told you last time about the characteristic

disturbances, and I think it would be a good thing, perhaps, if I were briefly to sum up all there is to say about the results of the experiment, namely about the complexes.

[148] A complex is an agglomeration of associations—a sort of picture of a more or less complicated psychological nature—sometimes of traumatic character, sometimes simply of a painful and highly toned character. Everything that is highly toned is rather difficult to handle. If, for instance, something is very important to me, I begin to hesitate when I attempt to do it, and you have probably observed that when you ask me difficult questions I cannot answer them immediately because the subject is important and I have a long reaction time. I begin to stammer, and my memory does not supply the necessary material. Such disturbances are complex disturbances—even if what I say does not come from a personal complex of mine. It is simply an important affair, and whatever has an intense feeling-tone is difficult to handle because such contents are somehow associated with physiological reactions, with the processes of the heart, the tonus of the blood vessels, the condition of the intestines, the breathing, and the innervation of the skin. Whenever there is a high tonus it is just as if that particular complex had a body of its own, as if it were localized in my body to a certain extent, and that makes it unwieldy, because something that irritates my body cannot be easily pushed away because it has its roots in my body and begins to pull at my nerves. Something that has little tonus and little emotional value can be easily brushed aside because it has no roots. It is not adherent or adhesive.

[149] Ladies and Gentlemen, that leads me to something very important—the fact that a complex with its given tension or energy has the tendency to form a little personality of itself. It has a sort of body, a certain amount of its own physiology. It can upset the stomach. It upsets the breathing, it disturbs the heart—in short, it behaves like a partial personality. For instance, when you want to say or do something and unfortunately a complex interferes with this intention, then you say or do something different from what you intended. You are simply interrupted, and your best intention gets upset by the complex, exactly as if you had been interfered with by a human being or by circumstances from outside. Under those conditions we really are forced to speak of the tendencies of complexes to act as if they were characterized by a certain amount of will-power. When you speak of will-power you naturally ask about the ego. Where then is the ego that belongs to the will-power of the complexes? We know our own ego-complex, which is supposed to be in full possession of the body. It is not, but let us assume that it is a centre in full possession of the body, that there is a focus which we call the ego, and that the ego has a will and can do something with its components. The ego also is an agglomeration of highly toned contents, so that in principle there is no difference between the ego-complex and any other complex.

[150] Because complexes have a certain will-power, a sort of ego, we find that in a schizophrenic condition they emancipate themselves from conscious control to such an extent that they become visible and audible. They appear as visions, they speak in voices which are like the voices of definite people. This personification of complexes is not in itself necessarily a pathological condition. In dreams, for instance, our complexes often appear in a personified form. And one can train oneself to such an extent that they become visible or audible also in a waking condition. It is part of a certain yoga training to split up consciousness into its components, each of which appears as a specific personality. In the psychology of our unconscious there are typical figures that have a definite life of their own.²

[151] All this is explained by the fact that the so-called unity of consciousness is an illusion. It is really a wish-dream. We like to think that we are one; but we are not, most decidedly not. We are not really masters in our house. We like to believe in our will-power and in our energy and in what we can do; but when it comes to a real show-down we find that we can do it only to a certain extent, because we are hampered by those little devils the complexes. Complexes are autonomous groups of associations that have a tendency to move by themselves, to live their own life apart from our intentions. I hold that our personal unconscious, as well as the collective unconscious, consists of an indefinite, because unknown, number of complexes or fragmentary personalities.

[152] This idea explains a lot. It explains, for instance, the simple fact that a poet has the capacity to dramatize and personify his mental contents. When he creates a character on the stage, or in his poem or drama or novel, he thinks it is merely a product of his imagination; but that character in a certain secret way has made itself. Any novelist or writer will deny that these characters have a psychological meaning, but as a matter of fact you know as well as I do that they have one. Therefore you can read a writer's mind when you study the characters he creates.

[153] The complexes, then, are partial or fragmentary personalities. When we speak of the ego-complex, we naturally assume that it has a consciousness, because the relationship of the various contents to the centre, in other words to the ego, is called consciousness. But we also have a grouping of contents about a centre, a sort of nucleus, in other complexes. So we may ask the question: Do complexes have a consciousness of their own? If you study spiritualism, you must admit that the so-called spirits manifested in automatic writing or through the voice of a medium do indeed have a sort of consciousness of their own. Therefore unprejudiced people are inclined to believe that the spirits are the ghosts of a deceased aunt or grandfather or something of the kind, just on account of the more or less distinct personality which can be traced in these manifestations. Of course, when we are dealing with a case of

insanity we are less inclined to assume that we have to do with ghosts. We call it pathological then.

[154] So much about the complexes. I insist on that particular point of consciousness within complexes only because complexes play a large role in dream-analysis. You remember my diagram (Figure 4) showing the different spheres of the mind and the dark centre of the unconscious in the middle. The closer you approach that centre, the more you experience what Janet calls an *abaissement du niveau mental*: your conscious autonomy begins to disappear, and you get more and more under the fascination of unconscious contents. Conscious autonomy loses its tension and its energy, and that energy reappears in the increased activity of unconscious contents. You can observe this process in an extreme form when you carefully study a case of insanity. The fascination of unconscious contents gradually grows stronger and conscious control vanishes in proportion until finally the patient sinks into the unconscious altogether and becomes completely victimized by it. He is the victim of a new autonomous activity that does not start from his ego but starts from the dark sphere.

[155] In order to deal with the association test thoroughly, I must mention an entirely different experiment. You will forgive me if for the sake of economizing time I do not go into the details of the researches, but these diagrams (Figs. 8, 9, 10, 11) illustrate the results of very voluminous researches into families.³ They represent the quality of associations. For instance, the little summit in Figure 8 designated as number XI is a special class or category of association. The principle of classification is logical and linguistic. I am not going into this, and you will simply have to accept the fact that I have made fifteen categories into which I divide associations. We made tests with a great number of families, all for certain reasons uneducated people, and we found that the type of association and reaction is peculiarly parallel among certain members of the family; for instance, father and mother, or two brothers, or mother and child are almost identical in their type of reaction.

[156] I shall explain this by Figure 8. The dotted line (.....) represents the mother, the broken line (-----) her sixteen-year-old daughter, and the unbroken line (-) the father. This was a very unfortunate marriage. The father was an alcoholic and the mother was a very peculiar type. You see that the sixteen-year-old daughter follows her mother's type closely. As much as thirty per cent of all associations are identical words. This is a striking case of participation, of mental contagion. If you think about this case you can draw certain conclusions. The mother was forty-five years old, married to an alcoholic. Her life was therefore a failure. Now the daughter has exactly the same reactions as the mother. If such a girl comes out into the world as though she were forty-five years old and married to an alcoholic, think what a mess she will get into! This participation explains why the daughter of an alcoholic who

has had a hell of a youth will seek a man who is an alcoholic and marry him; and if by chance he should not be one, she will make him into one on account of that peculiar identity with one member of the family.

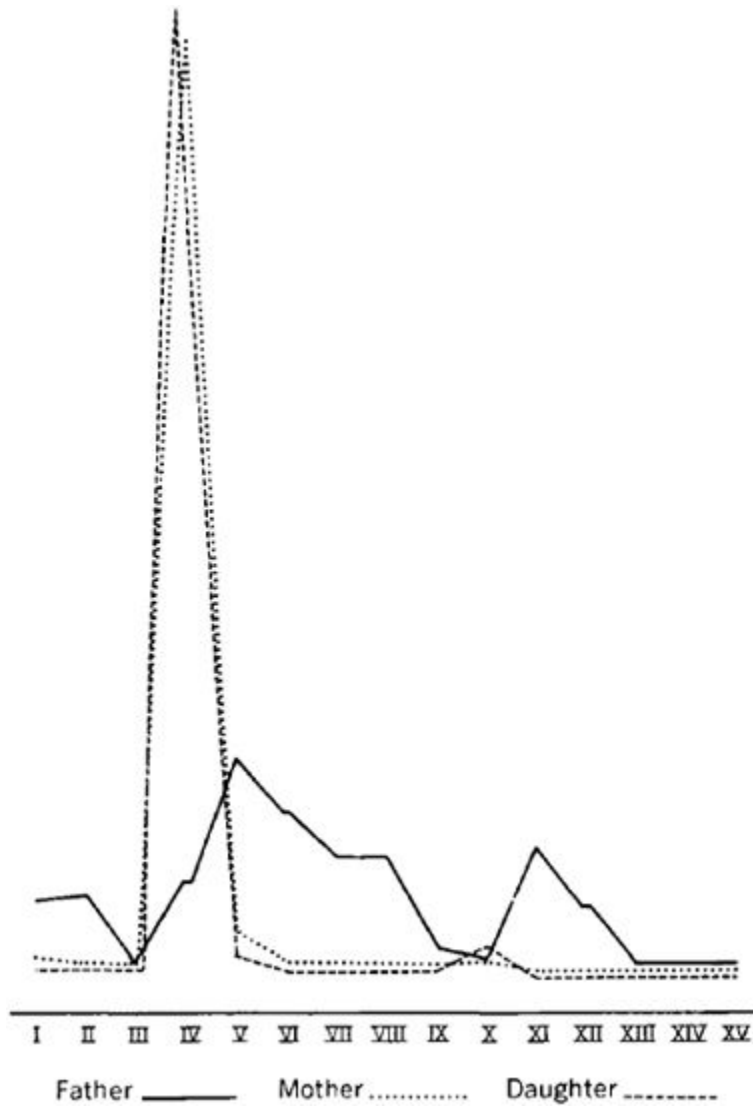
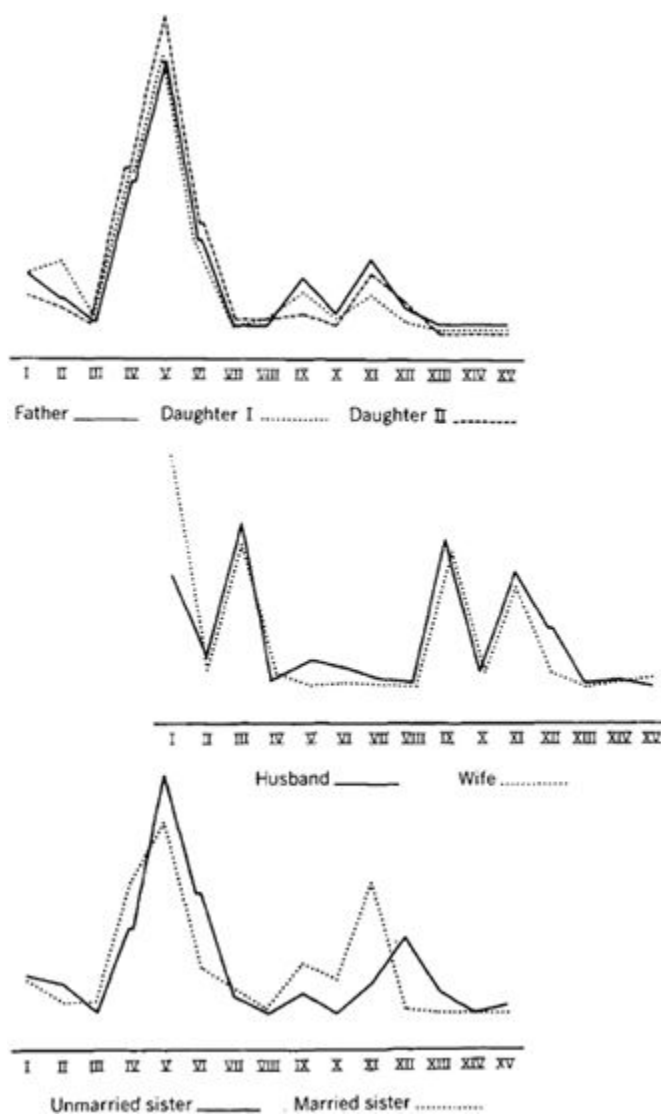

FIG. 8. Association Test of a Family



FIGS. 9–11. Association Tests of Families

[157] Figure 9 is a very striking case, too. The father, who was a widower, had two daughters who lived with him in complete identity. Of course, that also is most unnatural, because either he reacts like a girl or the two girls react like a man, even in the way they speak. The whole mental make-up is poisoned through the admixture of an alien element, because a young daughter is not in actual fact her father.

[158] Figure 10 is the case of a husband and wife. This diagram gives an optimistic tone to my very pessimistic demonstrations. You see there is perfect harmony here; but do not make the mistake of thinking that this harmony is a paradise, for these people will kick against each other after a while because they are just too harmonious. A very good harmony in a family based on participation soon leads to frantic attempts on the part of the spouses to kick loose from each other, to liberate themselves, and then they invent irritating topics of discussion in order to have a reason for feeling misunderstood. If you study the ordinary psychology of marriage, you discover that most of the troubles consist in this cunning invention of irritating topics which have absolutely no foundation.

[159] Figure 11 is also interesting. These two women are sisters living together; one is single and the other married. Their summit is found at number V. The wife in Figure 10 is the sister of these two women in Figure 11, and while most probably they were all of the same type originally, she married a man of another type. Their summit is at number III in Figure 10. The condition of identity or participation which is demonstrated in the association test can be substantiated by entirely different experiences, for instance, by graphology. The handwriting of many wives, particularly young wives, often resembles that of the husband. I do not know whether it is so in these days, but I assume that human nature remains very much the same. Occasionally it is the other way round because the so-called feeble sex has its strength sometimes.

[160] Ladies and Gentlemen, we are now going to step over the border into dreams. I do not want to give you any particular introduction to dream-analysis.⁴ I think the best way is just to show you how I proceed with a dream, and then it does not need much explanation of a theoretical kind, because you can see what are my underlying ideas. Of course, I make great use of dreams, because dreams are an objective source of information in psychotherapeutic treatment. When a doctor has a case, he can hardly refrain from having ideas about it. But the more one knows about cases, the more one should make an heroic effort not to know in order to give the patient a fair chance. I always try not to know and not to see. It is much better to say you are stupid, or play what is apparently a stupid role, in order to give the patient a chance to come out with his own material. That does not mean that you should hide altogether.

[161] This is a case of a man forty years old, a married man who has not been ill before. He looks quite all right; he is the director of a great public school, a very intelligent fellow who has studied an old-fashioned kind of psychology, Wundt psychology,⁵ that has nothing to do with details of human life but moves in the stratosphere of abstract ideas. Recently he had been badly troubled by neurotic symptoms. He suffered from a peculiar kind of vertigo that seized upon him from time to time, palpitation, nausea, and peculiar attacks of feebleness and a sort of exhaustion. This syndrome presents the picture of a sickness which is well known in Switzerland. It is mountain sickness, a malady to which people who are not used to great heights are easily subject when climbing. So I asked, "Is it not mountain sickness you are suffering from?" He said, "Yes, you are right. It feels exactly like mountain sickness." I asked him if he had dreams, and he said that recently he had had three dreams.

[162] I do not like to analyse one dream alone, because a single dream can be interpreted arbitrarily. You can speculate anything about an isolated dream; but if you compare a series of, say, twenty or a hundred dreams, then you can see interesting

things. You see the process that is going on in the unconscious from night to night, and the continuity of the unconscious psyche extending through day and night. Presumably we are dreaming all the time, although we are not aware of it by day because consciousness is much too clear. But at night, when there is that *abaissement du niveau mental*, the dreams can break through and become visible.

[163] In the first dream *the patient finds himself in a small village in Switzerland. He is a very solemn black figure in a long coat; under his arm he carries several thick books. There is a group of young boys whom he recognizes as having been his classmates. They are looking at him and they say: "That fellow does not often make his appearance here."*

[164] In order to understand this dream you have to remember that the patient is in a very fine position and has had a very good scientific education. But he started really from the bottom and is a self-made man. His parents were very poor peasants, and he worked his way up to his present position. He is very ambitious and is filled with the hope that he will rise still higher. He is like a man who has climbed in one day from sea-level to a level of 6,000 feet, and there he sees peaks 12,000 feet high towering above him. He finds himself in the place from which one climbs these higher mountains, and because of this he forgets all about the fact that he has already climbed 6,000 feet and immediately he starts to attack the higher peaks. But as a matter of fact though he does not realize it he is tired from his climbing and quite incapable of going any further at this time. This lack of realization is the reason for his symptoms of mountain sickness. The dream brings home to him the actual psychological situation. The contrast of himself as the solemn figure in the long black coat with thick books under his arm appearing in his native village, and of the village boys remarking that he does not often appear there, means that he does not often remember where he came from. On the contrary he thinks of his future career and hopes to get a chair as professor. Therefore the dream puts him back into his early surroundings. He ought to realize how much he has achieved considering who he was originally and that there are natural limitations to human effort.

[165] The beginning of the second dream is a typical instance of the kind of dream that occurs when the conscious attitude is like his. *He knows that he ought to go to an important conference, and he is taking his portfolio. But he notices that the hour is rather advanced and that the train will leave soon, and so he gets into that well-known state of haste and of fear of being too late. He tries to get his clothes together, his hat is nowhere, his coat is mislaid, and he runs about in search of them and shouts up and down the house, "Where are my things?" Finally he gets everything together, and runs out of the house only to find that he has forgotten his portfolio. He rushes back for it, and looking at his watch finds how late it is getting; then he runs to the station, but the road is quite soft so that it is like walking on a bog and his feet*

can hardly move any more. Pantingly he arrives at the station only to see that the train is just leaving. His attention is called to the railway track, and it looks like this:

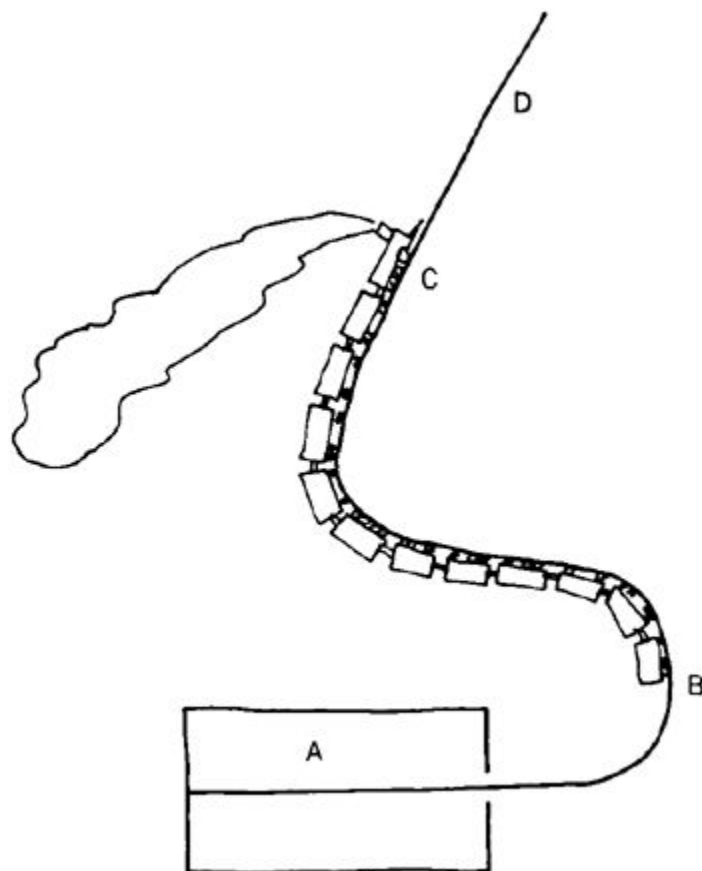

FIG. 12. Dream of the Train

[166] He is at A, the tail-end of the train is already at B and the engine is at C. He watches the train, a long one, winding round the curve, and he thinks, "If only the engine-driver, when he reaches point D, has sufficient intelligence not to rush full steam ahead; for if he does, the long train behind him which will still be rounding the curve will be derailed." Now the engine-driver arrives at D and he opens the steam throttle fully, the engine begins to pull, and the train rushes ahead. The dreamer sees the catastrophe coming, the train goes off the rails, and he shouts, and then he wakes up with the fear characteristic of nightmare.

[167] Whenever one has this kind of dream of being late, of a hundred obstacles interfering, it is exactly the same as when one is in such a situation in reality, when one is nervous about something. One is nervous because there is an unconscious resistance to the conscious intention. The most irritating thing is that consciously you want something very much, and an unseen devil is always working against it, and of course you are that devil too. You are working against this devil and do it in a nervous way and with nervous haste. In the case of this dreamer, that rushing ahead is also against his will. He does not want to leave home, yet he wants it very much, and all the resistance and difficulties in his way are his own doing. He is that engine-driver who thinks, "Now we are out of our trouble; we have a straight line ahead, and

now we can rush along like anything.” The straight line beyond the curve would correspond to the peaks 12,000 feet high, and he thinks these peaks are accessible to him.

[168] Naturally, nobody seeing such a chance ahead would refrain from making the utmost use of it, so his reason says to him, “Why not go on, you have every chance in the world.” He does not see why something in him should work against it. But this dream gives him a warning that he should not be as stupid as this engine-driver who goes full steam ahead when the tail-end of the train is not yet out of the curve. That is what we always forget; we always forget that our consciousness is only a surface, our consciousness is the avant-garde of our psychological existence. Our head is only one end, but behind our consciousness is a long historical “tail” of hesitations and weaknesses and complexes and prejudices and inheritances, and we always make our reckoning without them. We always think we can make a straight line in spite of our shortcomings, but they will weigh very heavily and often we derail before we have reached our goal because we have neglected our tail-ends.

[169] I always say that our psychology has a long saurian’s tail behind it, namely the whole history of our family, of our nation, of Europe, and of the world in general. We are always human, and we should never forget that we carry the whole burden of being only human. If we were heads only we should be like little angels that have heads and wings, and of course they can do what they please because they are not hindered by a body that can walk only on the earth. I must not omit to point out, not necessarily to the patient but to myself, that this peculiar movement of the train is like a snake. Presently we shall see why.

[170] The next dream is the crucial dream, and I shall have to give certain explanations. In this dream we have to do with a peculiar animal which is half lizard and half crab. Before we go into the details of the dream, I want to make a few remarks about the method of working out the meaning of a dream. You know that there are many views and many misunderstandings as to the way in which you get at dreams.

[171] You know, for instance, what is understood by free association. This method is a very doubtful one as far as my experience goes. Free association means that you open yourself to any amount and kind of associations and they naturally lead to your complexes. But then, you see, I do not want to know the complexes of my patients. That is uninteresting to me. I want to know what the *dreams* have to say about complexes, not what the complexes are. I want to know what a man’s unconscious is doing with his complexes, I want to know what he is preparing himself for. *That* is what I read out of the dreams. If I wanted to apply the method of free association I would not need dreams. I could put up a signboard, for instance “Footpath to So-and-So,” and simply let people meditate on that and add free associations, and they would invariably arrive at their complexes. If you are riding in a Hungarian or Russian train

and look at the strange signs in the strange language, you can associate all your complexes. You have only to let yourself go and you naturally drift into your complexes.

[172] I do not apply the method of free association because my goal is not to know the complexes; I want to know what the dream is. Therefore I handle the dream as if it were a text which I do not understand properly, say a Latin or a Greek or a Sanskrit text, where certain words are unknown to me or the text is fragmentary, and I merely apply the ordinary method any philologist would apply in reading such a text. My idea is that the dream does not conceal: we simply do not understand its language. For instance, if I quote to you a Latin or a Greek passage some of you will not understand it, but that is not because the text dissimulates or conceals; it is because you do not know Greek or Latin. Likewise, when a patient seems confused, it does not necessarily mean that he is confused, but that the doctor does not understand his material. The assumption that the dream wants to conceal is a mere anthropomorphic idea. No philologist would ever think that a difficult Sanskrit or cuneiform inscription conceals. There is a very wise word of the Talmud which says that the dream is its own interpretation. The dream is the whole thing, and if you think there is something behind it, or that the dream has concealed something, there is no question but that you simply do not understand it.

[173] Therefore, first of all, when you handle a dream you say, "I do not understand a word of that dream." I always welcome that feeling of incompetence because then I know I shall put some good work into my attempt to understand the dream. What I do is this. I adopt the method of the philologist, which is far from being free association, and apply a logical principle which is called *amplification*. It is simply that of seeking the parallels. For instance, in the case of a very rare word which you have never come across before, you try to find parallel text passages, parallel applications perhaps, where that word also occurs, and then you try to put the formula you have established from the knowledge of other texts into the new text. If you make the new text a readable whole, you say, "Now we can read it." That is how we learned to read hieroglyphics and cuneiform inscriptions and that is how we can read dreams.

[174] Now, how do I find the context? Here I simply follow the principle of the association experiment. Let us assume a man dreams about a simple sort of peasant's house. Now, do I know what a simple peasant's house conveys to that man's mind? Of course not; how could I? Do I know what a simple peasant's house means to him in general? Of course not. So I simply ask, "How does that thing appear to you?"—in other words, what is your context, what is the mental tissue in which that term "simple peasant's house" is embedded? He will tell you something quite astonishing. For instance, somebody says "water." Do I know what he means by "water"? Not at

all. When I put that test word or a similar word to somebody, he will say “green.” Another one will say “H₂O,” which is something quite different. Another one will say “quicksilver,” or “suicide.” In each case I know what tissue that word or image is embedded in. That is *amplification*. It is a well-known logical procedure which we apply here and which formulates exactly the technique of finding the context.

[175] Of course. I ought to mention here the merit of Freud, who brought up the whole question of dreams and who has enabled us to approach the problem of dreams at all. You know his idea is that a dream is a distorted representation of a secret incompatible wish which does not agree with the conscious attitude and therefore is censored, that is, distorted, in order to become unrecognizable to the conscious and yet in a way to show itself and live. Freud logically says then: Let us redress that whole distortion: now be natural, give up your distorted tendencies and let your associations flow freely, then we will come to your natural facts, namely, your complexes. This is an entirely different point of view from mine. Freud is seeking the complexes, I am not. That is just the difference. I am looking for what the *unconscious is doing* with the complexes, because that interests me very much more than the fact that people have complexes. We all have complexes: it is a highly banal and uninteresting fact. Even the incest complex which you can find anywhere if you look for it is terribly banal and therefore uninteresting. It is only interesting to know what people do with their complexes; that is the practical question which matters. Freud applies the method of free association and makes use of an entirely different logical principle, a principle which in logic is called *reductio in primam figuram*, reduction to the first figure. The *reductio in primam figuram* is a so-called syllogism, a complicated sequence of logical conclusions, whose characteristic is that you start from a perfectly reasonable statement, and, through surreptitious assumptions and insinuations, you gradually change the reasonable nature of your first simple or prime figure until you reach a complete distortion which is utterly unreasonable. That complete distortion, in Freud’s idea, characterizes the dream; the dream is a clever distortion that disguises the original figure, and you have only to undo the web in order to return to the first reasonable statement, which may be “I wish to commit this or that: I have such and such an incompatible wish.” We start, for instance, with a perfectly reasonable assumption, such as “No unreasonable being is free”—in other words, has free will. This is an example which is used in logic. It is a fairly reasonable statement. Now we come to the first fallacy, “Therefore, no free being is unreasonable.” You cannot quite agree because there is already a trick. Then you continue, “All human beings are free”—they all have free will. Now you triumphantly finish up, “Therefore no human being is unreasonable.” That is complete nonsense.

[176] Let us assume that the dream is such an utterly nonsensical statement. This is perfectly plausible because obviously the dream is something like a nonsensical statement; otherwise you could understand it. As a rule you cannot understand it; you hardly ever come across dreams which are clear from beginning to end. The ordinary dream seems absolute nonsense and therefore one depreciates it. Even primitives, who make a great fuss about dreams, say that ordinary dreams mean nothing. But there are “big” dreams; medicine men and chiefs have big dreams, but ordinary men have no dreams. They talk exactly like people in Europe. Now you are confronted with that dream-nonsense, and you say, “This nonsense must be an insinuating distortion or fallacy which derives from an originally reasonable statement.” You undo the whole thing and you apply the *reductio in primam figuram* and then you come to the initial undisturbed statement. So you see that the procedure of Freud’s dream-interpretation is perfectly logical, if you assume that the statement of the dream is really nonsensical.

[177] But do not forget when you make the statement that a thing is unreasonable that perhaps you do not understand because you are not God; on the contrary, you are a fallible human being with a very limited mind. When an insane patient tells me something, I may think: “What that fellow is talking about is all nonsense.” As a matter of fact, if I am scientific, I say “I do not understand,” but if I am unscientific, I say “That fellow is just crazy and I am intelligent.” This argumentation is the reason why men with somewhat unbalanced minds often like to become alienists. It is humanly understandable because it gives you a tremendous satisfaction, when you are not quite sure of yourself, to be able to say “Oh, the others are much worse.”

[178] But the question remains: Can we safely say that a dream is nonsense? Are we quite sure that we know? Are we sure that the dream is a distortion? Are you absolutely certain when you discover something quite against your expectation that it is a mere distortion? Nature commits no errors. Right and wrong are human categories. The natural process is just what it is and nothing else—it is not nonsense and it is not unreasonable. We do not understand: that is the fact. Since I am not God and since I am a man of very limited intellectual capacities, I had better assume that I do not understand dreams. With that assumption I reject the prejudiced view that the dream is a distortion, and I say that if I do not understand a dream, it is my mind which is distorted, I am not taking the right view of it.

[179] So I adopted the method which philologists apply to difficult texts, and I handle dreams in the same way. It is, of course, a bit more circumstantial and more difficult; but I can assure you that the results are far more interesting when you arrive at things that are human than when you apply a most dreadful monotonous interpretation. I hate to be bored. Above all we should avoid speculations and theories when we have to deal with such mysterious processes as dreams. We should never forget that for

thousands of years very intelligent men of great knowledge and vast experience held very different views about them. It is only quite recently that we invented the theory that a dream is nothing. All other civilizations have had very different ideas about dreams.

[180] Now I will tell you the big dream of my patient: *“I am in the country, in a simple peasant’s house, with an elderly, motherly peasant woman. I talk to her about a great journey I am planning: I am going to walk from Switzerland to Leipzig. She is enormously impressed, at which I am very pleased. At this moment I look through the window at a meadow where there are peasants gathering hay. Then the scene changes. In the background appears a monstrously big crab-lizard. It moves first to the left and then to the right so that I find myself standing in the angle between them as if in an open pair of scissors. Then I have a little rod or a wand in my hand, and I lightly touch the monster’s head with the rod and kill it. Then for a long time I stand there contemplating that monster.”*

[181] Before I go into such a dream I always try to establish a sequence, because this dream has a history before and will have a history afterwards. It is part of the psychic tissue that is continuous, for we have no reason to assume that there is no continuity in the psychological processes, just as we have no reason to think that there is any gap in the processes of nature. Nature is a continuum, and so our psyche is very probably a continuum. This dream is just one flash or one observation of psychic continuity that became visible for a moment. As a continuity it is connected with the preceding dreams. In the previous dream we have already seen that peculiar snake-like movement of the train. This comparison is merely a hypothesis, but I have to establish such connections.

[182] After the train-dream the dreamer is back in the surroundings of his early childhood; he is with a motherly peasant woman—a slight allusion to the mother, as you notice. In the very first dream, he impresses the village boys by his magnificent appearance in the long coat of the Herr Professor. In this present dream too he impresses the harmless woman with his greatness and the greatness of his ambitious plan to walk to Leipzig—an allusion to his hope of getting a chair there. The monster crab-lizard is outside our empirical experience; it is obviously a creation of the unconscious. So much we can see without any particular effort.

[183] Now we come to the actual context. I ask him, “What are your associations to ‘simple peasant’s house’?” and to my enormous astonishment he says, “It is the lazarus-house of St. Jacob near Basel.” This house was a very old leprosy, and the building still exists. The place is also famous for a big battle fought there in 1444 by the Swiss against the troops of the Duke of Burgundy. His army tried to break into Switzerland but was beaten back by the avant-garde of the Swiss army, a body of 1,300 men who fought the Burgundian army consisting of 30,000 men at the lazarus-house of St. Jacob.

The 1,300 Swiss fell to the very last man, but by their sacrifice they stopped the further advance of the enemy. The heroic death of these 1,300 men is a notable incident in Swiss history, and no Swiss is able to talk of it without patriotic feeling.

[184] Whenever the dreamer brings such a piece of information, you have to put it into the context of the dream. In this case it means that the dreamer is in a leprosy. The leprosy-house is called "Siechenhaus," sick-house, in German, the "sick" meaning the lepers. So he has, as it were, a revolting contagious disease; he is an outcast from human society, he is in the sick-house. And that sick-house is characterized, moreover, by that desperate fight which was a catastrophe for the 1,300 men and which was brought about by the fact that they did not obey orders. The avant-garde had strict instructions not to attack but to wait until the whole of the Swiss army had joined up with them. But as soon as they saw the enemy they could not hold back and, against the commands of their leaders, made a headlong rush and attacked, and of course they were all killed. Here again we come to the idea of this rushing ahead without establishing a connection with the bulk of the tail-end, and again the action is fatal. This gave me a rather uncanny feeling, and I thought, "Now what is the fellow after, what danger is he coming to?" The danger is not just his ambition, or that he wishes to be with the mother and commit incest, or something of the kind. You remember, the engine-driver is a foolish fellow too; he runs ahead in spite of the fact that the tail-end of the train is not yet out of the curve; he does not wait for it, but rushes along without thinking of the whole. That means that the dreamer has the tendency to rush ahead, not thinking of his tail; he behaves as if he were his head only, just as the avant-garde behaved as if it were the whole army, forgetting that it had to wait; and because it did not wait, every man was killed. This attitude of the patient is the reason for his symptoms of mountain sickness. He went too high, he is not prepared for the altitude, he forgets where he started from.

[185] You know perhaps the novel by Paul Bourget, *L'Étape*. Its motif is the problem that a man's low origin always clings to him, and therefore there are very definite limitations to his climbing the social ladder. That is what the dream tries to remind the patient of. That house and that elderly peasant woman bring him back to his childhood. It looks, then, as if the woman might refer to the mother. But one must be careful with assumptions. His answer to my question about the woman was "That is my landlady." His landlady is an elderly widow, uneducated and old-fashioned, living naturally in a milieu inferior to his. He is too high up, and he forgets that the next part of his invisible self is the family in himself. Because he is a very intellectual man, feeling is his inferior function. His feeling is not at all differentiated, and therefore it is still in the form of the landlady, and in trying to impose upon that landlady he tries to impose upon himself with his enormous plan to walk to Leipzig.

[186] Now what does he say about the trip to Leipzig? He says, "Oh, that is my ambition. I want to go far, I wish to get a Chair." Here is the headlong rush, here is the foolish attempt, here is the mountain sickness; he wants to climb too high. This dream was before the war, and at that time to be a professor in Leipzig was something marvellous. His feeling was deeply repressed; therefore it does not have right values and is much too naïve. It is still the peasant woman; it is still identical with his own mother. There are many capable and intelligent men who have no differentiation of feeling, and therefore their feeling is still contaminated with the mother, is still in the mother, identical with the mother, and they have mothers' feelings; they have wonderful feelings for babies, for the interiors of houses and nice rooms and for a very orderly home. It sometimes happens that these individuals, when they have turned forty, discover a masculine feeling and then there is trouble.

[187] The feelings of a man are so to speak a woman's and appear as such in dreams. I designate this figure by the term *anima*, because she is the personification of the inferior functions which relate a man to the collective unconscious. The collective unconscious as a whole presents itself to a man in feminine form. To a woman it appears in masculine form, and then I call it the *animus*. I chose the term *anima* because it has always been used for that very same psychological fact. The *anima* as a personification of the collective unconscious occurs in dreams over and over again.⁶ I have made long statistics about the *anima* figure in dreams. In this way one establishes these figures empirically.

[188] When I ask my dreamer what he means when he says that the peasant woman is impressed by his plan, he answers, "Oh, well, that refers to my boasting. I like to boast before an inferior person to show who I am; when I am talking to uneducated people I like to put myself very much in the foreground. Unfortunately I have always to live in an inferior milieu." When a man resents the inferiority of his milieu and feels that he is too good for his surroundings, it is because the inferiority of the milieu *in himself* is projected into the outer milieu and therefore he begins to mind those things which he should mind in himself. When he says, "I mind my inferior milieu," he ought to say, "I mind the fact that my own inner milieu is below the mark." He has no right values, he is inferior in his feeling-life. That is his problem.

[189] At this moment he looks out of the window and sees the peasants gathering hay. That, of course, again is a vision of something he has done in the past. It brings back to him memories of similar pictures and situations; it was in summer and it was pretty hard work to get up early in the morning to turn the hay during the day and gather it in the evening. Of course, it is the simple honest work of such folk. He forgets that only the decent simple work gets him somewhere and not a big mouth. He also asserts, which I must mention, that in his present home he has a picture on the wall of peasants gathering hay, and he says, "Oh, that is the origin of the picture

in my dream.” It is as though he said, “The dream is nothing but a picture on the wall, it has no importance, I will pay no attention to it.” At that moment the scene changes. When the scene changes you can always safely conclude that a representation of an unconscious thought has come to a climax, and it becomes impossible to continue that motif.

[190] Now in the next part of the dream things are getting dark; the crab-lizard appears, apparently an enormous thing. I asked, “What about the crab, how on earth do you come to that?” He said, “That is a mythological monster which walks backwards. The crab walks backwards. I do not understand how I get to this thing—probably through some fairytale or something of that sort.” What he had mentioned before were all things which you could meet with in real life, things which do actually exist. But the crab is not a personal experience, it is an archetype. When an analyst has to deal with an archetype he may begin to think. In dealing with the *personal* unconscious you are not allowed to think too much and to add anything to the associations of the patient. Can you add something to the personality of somebody else? You are a personality yourself. The other individual has a life of his own and a mind of his own inasmuch as he is a person. But inasmuch as he is not a person, inasmuch as he is also myself, he has the same basic structure of mind, and there I can begin to think, I can associate for him. I can even provide him with the necessary context because he will have none, he does not know where that crab-lizard comes from and has no idea what it means, but I know and can provide the material for him.

[191] I point out to him that the hero motif appears throughout the dreams. He has a hero fantasy about himself which comes to the surface in the last dream. He is the hero as the great man with the long coat and with the great plan; he is the hero who dies on the field of honour at St. Jacob; he is going to show the world who he is; and he is quite obviously the hero who overcomes the monster. The hero motif is invariably accompanied by the dragon motif; the dragon and the hero who fights him are two figures of the same myth.

[192] The dragon appears in his dream as the crab-lizard. This statement does not, of course, explain what the dragon represents as an image of his psychological situation. So the next associations are directed round the monster. When it moves first to the left and then to the right the dreamer has the feeling that he is standing in an angle which could shut on him like open scissors. That would be fatal. He has read Freud, and accordingly he interprets the situation as an incest wish, the monster being the mother, the angle of the open scissors the legs of the mother, and he himself, standing in between, being just born or just going back into the mother.

[193] Strangely enough, in mythology, the dragon *is* the mother. You meet that motif all over the world, and the monster is called the mother dragon.⁷ The mother dragon eats the child again, she sucks him in after having given birth to him. The “terrible

mother,” as she is also called, is waiting with wide-open mouth on the Western Seas, and when a man approaches that mouth it closes on him and he is finished. That monstrous figure is the mother sarcophaga, the flesh-eater; it is, in another form, Matuta, the mother of the dead. It is the goddess of death.

[194] But these parallels still do not explain why the dream chooses the particular image of the crab. I hold—and when I say I hold I have certain reasons for saying so—that representations of psychic facts in images like the snake or the lizard or the crab or the mastodon or analogous animals also represent organic facts. For instance, the serpent very often represents the cerebro-spinal system, especially the lower centres of the brain, and particularly the medulla oblongata and spinal cord. The crab, on the other hand, having a sympathetic system only, represents chiefly the sympathicus and para-sympathicus of the abdomen; it is an abdominal thing. So if you translate the text of the dream it would read: if you go on like this your cerebro-spinal system and your sympathetic system will come up against you and snap you up. That is in fact what is happening. The symptoms of his neurosis express the rebellion of the sympathetic functions and of the cerebro-spinal system against his conscious attitude.

[195] The crab-lizard brings up the archetypal idea of the hero and the dragon as deadly enemies. But in certain myths you find the interesting fact that the hero is not connected with the dragon only by his fight. There are, on the contrary, indications that the hero is himself the dragon. In Scandinavian mythology the hero is recognized by the fact that he has snake’s eyes. He has snake’s eyes because he is a snake. There are many other myths and legends which contain the same idea. Cecrops, the founder of Athens, was a man above and a serpent below. The souls of heroes often appear after death in the form of serpents.

[196] Now in our dream the monstrous crab-lizard moves first to the left, and I ask him about this left side. He says, “The crab apparently does not know the way. Left is the unfavourable side, left is sinister.” Sinister does indeed mean left and unfavourable. But the right side is also not good for the monster, because when it goes to the right it is touched by the wand and is killed. Now we come to his standing in between the angle of the monster’s movement, a situation which at first glance he interpreted as incest. He says, “As a matter of fact, I felt surrounded on either side like a hero who is going to fight a dragon.” So he himself realizes the hero motif.

[197] But unlike the mythical hero he does not fight the dragon with a weapon, but with a wand. He says, “From its effect on the monster it seems that it is a magical wand.” He certainly does dispose of the crab in a magical way. The wand is another mythological symbol. It often contains a sexual allusion, and sexual magic is a means of protection against danger. You may remember, too, how during the earthquake at

Messina⁸ nature produced certain instinctive reactions against the overwhelming destruction.

[198] The wand is an instrument, and instruments in dreams mean what they actually are, the devices of man to concretize his will. For instance, a knife is my will to cut; when I use a spear I prolong my arm, with a rifle I can project my action and my influence to a great distance; with a telescope I do the same as regards my sight. An instrument is a mechanism which represents my will, my intelligence, my capability, and my cunning. Instruments in dreams symbolize an analogous psychological mechanism. Now this dreamer's instrument is a magic wand. He uses a marvellous thing by which he can spirit away the monster, that is, his lower nervous system. He can dispose of such nonsense in no time, and with no effort at all.

[199] What does this actually mean? It means that he simply thinks that the danger does not exist. That is what is usually done. You simply think that a thing is not and then it is no more. That is how people behave who consist of the head only. They use their intellect in order to think things away; they reason them away. They say, "This is nonsense, therefore it cannot be and therefore it is not." That is what he also does. He simply reasons the monster away. He says, "There is no such thing as a crab-lizard, there is no such thing as an opposing will; I get rid of it, I simply think it away. I think it is the mother with whom I want to commit incest, and that settles the whole thing, for I shall not do it." I said, "You have killed the animal—what do you think is the reason why you contemplate the animal for such a long time?" He said, "Oh, well, yes, naturally it is marvellous how you can dispose of such a creature with such ease." I said, "Yes, indeed it is very marvellous!"

[200] Then I told him what I thought of the situation. I said, "Look here, the best way to deal with a dream is to think of yourself as a sort of ignorant child or ignorant youth, and to come to a two-million-year-old man or to the old mother of days and ask, 'Now, what do you think of me?' She would say to you, 'You have an ambitious plan, and that is foolish, because you run up against your own instincts. Your own restricted capabilities block the way. You want to abolish the obstacle by the magic of your thinking. You believe you can think it away by the artifices of your intellect, but it will be, believe me, matter for some afterthought.' "And I also told him this: "Your dreams contain a warning. You behave exactly like the engine-driver or like the Swiss who were foolhardy enough to run up against the enemy without any support behind them, and if you behave in the same way you will meet with a catastrophe."

[201] He was sure that such a point of view was much too serious. He was convinced that it is much more probable that dreams come from incompatible wishes and that he really had an unrealized incestuous wish which was at the bottom of this dream; that he was conscious now of this incestuous wish and had got rid of it and now could go to Leipzig. I said, "Well then, bon voyage." He did not return, he went on with his

plans, and it took him just about three months to lose his position and go to the dogs. That was the end of him. He ran up against the fatal danger of that crab-lizard and would not understand the warning. But I do not want to make you too pessimistic. Sometimes there are people who really understand their dreams and draw conclusions which lead to a more favourable solution of their problems.

Discussion

Dr. Charles Brunton:

[202] I do not know whether it is fair to ask about the dreams of someone who is not here, but I have a small daughter five and a half years old who has recently had two dreams which awakened her at night. The first dream occurred in the middle of August, and she told me this: "I see a wheel, and it is rolling down a road and it burns me." That was all I could get out of her. I wanted her to draw a picture of it the next day, but she did not want to be bothered, so I left it. The other dream was about a week ago, and this time it was "a beetle that was pinching me." That was all I could get about it. I do not know whether you would like to comment on them. The only thing I would like to add is that she knows the difference between a beetle and a crab. She is very fond of animals.

Professor Jung:

[203] You have to consider that it is very difficult and not quite fair to comment on dreams of someone one does not know; but I will tell you as much as one can see from the symbolism. The beetle would, according to my idea, have to do with the sympathetic system. Therefore I should conclude from that dream that there are certain peculiar psychological processes going on in the child, which touch upon her sympathetic system, and this might arouse some intestinal or other abdominal disorder. The most cautious statement one could make would be to say that there is a certain accumulation of energy in the sympathetic system which causes slight disturbances. This is also borne out by the symbol of the fiery wheel. The wheel in her dream seems to be a sun-symbol, and in Tantric philosophy fire corresponds to the so-called *manipura chakra*, which is localized in the abdomen. In the prodromal symptoms of epilepsy you sometimes find the idea of a wheel revolving inside. This too expresses a manifestation of a sympathetic nature. The image of the revolving wheel reminds us of the wheel upon which Ixion was crucified. The dream of the little girl is an archetypal dream, one of those strange archetypal dreams children occasionally have.

[204] I explain these archetypal dreams of children by the fact that when consciousness begins to dawn, when the child begins to feel that *he is*, he is still close to the original psychological world from which he has just emerged: a condition of deep unconsciousness. Therefore you find with many children an awareness of the contents of the collective unconscious, a fact which in some Eastern beliefs is interpreted as reminiscence of a former existence. Tibetan philosophy, for instance,

speaks of the “Bardo” existence and of the condition of the mind between death and birth.⁹ The idea of former existence is a projection of the psychological condition of early childhood. Very young children still have an awareness of mythological contents, and if these contents remain conscious too long, the individual is threatened by an incapacity for adaptation; he is haunted by a constant yearning to remain with or to return to the original vision. There are very beautiful descriptions of these experiences by mystics and poets.

[205] Usually at the age of four to six the veil of forgetfulness is drawn upon these experiences. However, I have seen cases of ethereal children, so to speak, who had an extraordinary awareness of these psychic facts and were living their life in archetypal dreams and could not adapt. Recently I saw a case of a little girl of ten who had some most amazing mythological dreams.¹⁰ Her father consulted me about these dreams. I could not tell him what I thought because they contained an uncanny prognosis. The little girl died a year later of an infectious disease. She had never been born entirely.

Dr. Leonard F. Browne:

[206] I should like to ask Professor Jung a question with regard to the interpretation of the dreams he told us today. In view of the fact that the patient was unable to accept the interpretation, I should like to know whether that difficulty could have been overcome by some variation in the technique.

Professor Jung:

[207] If I had had the intention of being a missionary, or a saviour, I should have used a clever trick. I should have said to the patient, “Yes, that is the mother complex all right,” and we would have gone on talking that kind of jargon for several months and perhaps in the end I would have swung him round. But I know from experience that such a thing is not good; you should not cheat people even for their good. I do not want to cheat people out of their mistaken faith. Perhaps it was better for that man to go to the dogs than to be saved by wrong means. I never hinder people. When somebody says, “I am going to commit suicide if—,” I say, “If that is your intention, I have no objection.”

Dr. Browne:

[208] Did you have any evidence that the symptoms of mountain sickness were cured?

Professor Jung:

[209] The patient lost his neurosis in going down in life. That man did not belong at a height of 6,000 feet; he belonged lower down. He became inferior instead of being neurotic. Once I talked to the head of a great institution in America for the education of criminal children, and was told about a very interesting experience. They have two categories of children. The majority of them, when they come to the institution, feel ever so much better, they develop very nicely and normally and they eventually grow out of whatever their original evil was. The other category, the minority, become hysterical when they try to be nice and normal. Those are the born criminals whom you cannot change. They are normal when they do wrong. We also do not feel quite right when we are behaving perfectly, we feel much better when we are doing a bit of wrong. That is because we are not perfect. The Hindus, when they build a temple, leave one corner unfinished; only the gods make something perfect, man never can. It is much better to know that one is not perfect, then one feels much better. So it is with these children, and so it is with our patients. It is wrong to cheat people out of their fate and to help them to go beyond their level. If a man has it in him to be adapted, help him by all means; but if it is really his task *not* to be adapted, help him by all means not to be adapted, because then he is all right.

[210] What would the world be like if all people were adapted? It would be boring beyond endurance. There must be some people who behave in the wrong way; they act as scapegoats and objects of interest for the normal ones. Think how grateful you are for detective novels and newspapers, so that you can say, "Thank heaven I am not that fellow who has committed the crime, I am a perfectly innocent creature." You feel satisfaction because the evil people have done it for you. This is the deeper meaning of the fact that Christ as the redeemer was crucified between two thieves. These thieves in their way were also redeemers of mankind, they were the scapegoats.

Question:

[211] I would like to ask a question about the psychological functions, if that is not going too far back. In answering a question last night you said that there was no criterion for considering either of the four functions as being superior in itself and you further said that all the four functions would have to be equally differentiated in order to obtain full and adequate knowledge of the world. Do you mean, therefore, that it is possible in any given case for all the four functions to be equally differentiated or to be arrived at by education?

Professor Jung:

[212] I do not believe that it is humanly possible to differentiate all four functions alike, otherwise we would be perfect like God, and that surely will not happen. There will always be a flaw in the crystal. We can never reach perfection. Moreover, if we could differentiate the four functions equally we should only make them into consciously disposable functions. Then we would lose the most precious connection with the unconscious through the inferior function, which is invariably the weakest; only through our feebleness and incapacity are we linked up with the unconscious, with the lower world of the instincts and with our fellow beings. Our virtues only enable us to be independent. There we do not need anybody, there we are kings; but in our inferiority we are linked up with mankind as well as with the world of our instincts. It would not even be an advantage to have all the functions perfect, because such a condition would amount to complete aloofness. I have no perfection craze. My principle is: for heaven's sake do not be perfect, but by all means try to be complete—whatever that means.

Question:

[213] May I ask what it means to be complete? Will you enlarge upon that?

Professor Jung:

[214] I must leave something to your own mental efforts. It is surely a most amusing enterprise, for instance, to think on your way home what it possibly means to be complete. We should not deprive people of the pleasure of discovering something. To be complete is a very great problem, and to talk of it is amusing, but to be it is the main thing.

Question:

[215] How do you fit mysticism into your scheme?

Professor Jung:

[216] Into what scheme?

Reply:

[217] The scheme of psychology and the psyche.

Professor Jung:

[218] Of course you should define what you mean by mysticism. Let us assume that you mean people who have mystical experience. Mystics are people who have a particularly vivid experience of the processes of the collective unconscious. Mystical experience is experience of archetypes.

Question:

[219] Is there any difference between archetypal forms and mystical forms?

Professor Jung:

[220] I make no distinction between them. If you study the phenomenology of mystical experience you will come across some very interesting things. For instance, you all know that our Christian heaven is a masculine heaven and that the feminine element is only tolerated. The Mother of God is not divine, she is only the arch-saint. She intercedes for us at the throne of God but she is not part of the Deity. She does not belong to the Trinity.

[221] Now some Christian mystics have a different experience. For instance we have a Swiss mystic, Niklaus von der Flüe.¹¹ He experienced a God and a Goddess. Then there was a mystic of the thirteenth century, Guillaume de Digulleville, who wrote the *Pèlerinage de l'âme de Jésus Christ*.¹² Like Dante, he had a vision of the highest paradise as "le ciel d'or," and there upon a throne one thousand times more bright than the sun sat le Roi, who is God himself, and beside him on a crystal throne of brownish hue, la Reine, presumably the Earth. This is a vision outside the Trinity idea, a mystical experience of an archetypal nature which includes the feminine principle. The Trinity is a dogmatic image based on an archetype of an exclusively masculine nature. In the Early Church the Gnostic interpretation of the Holy Ghost as feminine was declared a heresy.

[222] Dogmatic images, such as the Trinity, are archetypes which have become abstract ideas. But there are a number of mystical experiences inside the Church whose archetypal character is still visible. Therefore they sometimes contain a heretical or pagan element. Remember, for instance, St. Francis of Assisi. Only through the great diplomatic ability of Pope Boniface VIII could St. Francis be assimilated into the Church. You have only to think of his relation to animals to understand the difficulty. Animals, like the whole of Nature, were taboo to the Church. Yet there are sacred animals like the Lamb, the Dove, and, in the Early Church, the Fish, which are worshipped.

Question:

[223] Will Professor Jung give us his view on the psychological differences between the dissociation in hysteria and the dissociation in schizophrenia?

Professor Jung:

[224] In hysteria the dissociated personalities are still in a sort of interrelation, so that you always get the impression of a total person. With a hysterical case you can establish a rapport, you get a feeling reaction from the whole person. There is only a superficial division between certain memory compartments, but the basic personality is always present. In the case of schizophrenia that is not so. There you encounter only fragments, there is nowhere a whole. Therefore, if you have a friend or a relative whom you have known well and who becomes insane, you will get a tremendous shock when you are confronted with a fragmentary personality which is completely split up. You can only deal with one fragment at a time; it is like a splinter of glass. You do not feel the continuity of the personality any longer. While with a hysterical case you think: if I could only wipe away that sort of obscuration or that sort of somnambulism then we should have the sum-total of the personality. But with schizophrenia it is a deep dissociation of personality; the fragments cannot come together any more.

Question:

[225] Are there any more strictly psychological conceptions by which that difference can be expressed?

Professor Jung:

[226] There are certain borderline cases where you can stitch the parts together if you can reintegrate the lost contents. I will tell you of a case I had. A woman had been twice in a lunatic asylum with a typical schizophrenic attack. When she was brought to me she was better, but still in a state of hallucination. I saw that it was possible to reach the split-off parts. Then I began to go through every detail of the experiences which she had had in the lunatic asylum with her; we went through all the voices and all the delusions, and I explained every fact to her so that she could associate them with her consciousness. I showed her what these unconscious contents were that came up during her insanity, and because she was an intelligent person, I gave her books to read so that she acquired a great deal of knowledge, chiefly mythological knowledge, by which she herself could stitch the parts together. The breaking lines were still there, of course, and whenever afterwards she had a new wave of disintegration I told her to try to draw or paint a picture of that particular situation in order to have a picture of the whole of herself which objectified her condition, and so

she did. She brought me quite a number of pictures she had made, which had helped her whenever she felt she was falling apart again. In this way I have kept her afloat for about twelve years, and she has had no more attacks which necessitated her seclusion in an asylum. She could always manage to ward off the attacks by objectifying their contents. She told me, moreover, that when she had made such a picture she went to her books and read a chapter about some of its main features, in order to bring it into general connection with mankind, with what people know, with the collective consciousness, and then she felt right again. She said she felt adapted and she was no longer at the mercy of the collective unconscious.

[227] All cases are not as accessible as that one, as you will realize. I cannot cure schizophrenia in principle. Occasionally by great good chance I can synthesize the fragments. But I do not like to do it because it is frightfully difficult work.

LECTURE IV

The Chairman (Dr. Emanuel Miller):

[228] I shall not take any of Professor Jung's time away from you but will merely express my great pleasure at the opportunity of being Chairman this evening. Only I am put to a grave disadvantage: I have not been able to attend the previous lectures and therefore I do not know to what depths of the unconscious Professor Jung has already led you, but I think he is going to continue tonight the presentation of his method of dream-analysis.

Professor Jung:

[229] The interpretation of a profound dream, such as our last one was, is never sufficient when it is left in the personal sphere. This dream contains an archetypal image, and that is always an indication that the psychological situation of the dreamer extends beyond the mere personal layer of the unconscious. His problem is no more entirely a personal affair, but something which touches upon the problems of mankind in general. The symbol of the monster is an indication of this. This symbol brings up the hero myth, and furthermore the association with the battle of St. Jacob, which characterizes the localization of the scene, appeals also to a general interest.

[230] The ability to apply a general point of view is of great therapeutic importance. Modern therapy is not much aware of this, but in ancient medicine it was well known that the raising of the personal disease to a higher and more impersonal level had a curative effect. In ancient Egypt, for instance, when a man was bitten by a snake, the priest-physician was called in, and he took from the temple library the manuscript about the myth of Rā and his mother Isis, and recited it. Isis had made a poisonous worm and hidden it in the sand, and the god Rā had stepped on the serpent and was bitten by it, so that he suffered terrible pain and was threatened with death. Therefore the gods caused Isis to work a spell which drew the poison out of him.¹ The idea was that the patient would be so impressed by this narrative that he would be cured. To us this sounds quite impossible. We could not imagine that the reading of a story from *Grimm's Fairy Tales*, for instance, would cure typhoid fever or pneumonia. But we only take into account our rational modern psychology. To understand the effect we have to consider the psychology of the ancient Egyptians, which was quite different. And yet those people were not so very different. Even with us certain things can work miracles; sometimes spiritual consolation or psychological influence alone can

cure, or at least will help to cure an illness. And of course it is all the more so with a person on a more primitive level and with a more archaic psychology.

[231] In the East a great amount of practical therapy is built upon this principle of raising the mere personal ailment into a generally valid situation, and ancient Greek medicine also worked with the same method. Of course the collective image or its application has to be in accordance with the particular psychological condition of the patient. The myth or legend arises from the archetypal material which is constellated by the disease, and the psychological effect consists in connecting the patient with the general human meaning of his particular situation. Snakebite, for instance, is an archetypal situation, therefore you find it as a motif in any number of tales. If the archetypal situation underlying the illness can be expressed in the right way the patient is cured. If no adequate expression is found, the individual is thrown back upon himself, into the isolation of being ill; he is alone and has no connection with the world. But if he is shown that his particular ailment is not his ailment only, but a general ailment—even a god's ailment—he is in the company of men and gods, and this knowledge produces a healing effect. Modern spiritual therapy uses the same principle: pain or illness is compared with the sufferings of Christ, and this idea gives consolation. The individual is lifted out of his miserable loneliness and represented as undergoing a heroic meaningful fate which is ultimately good for the whole world, like the suffering and death of a god. When an ancient Egyptian was shown that he was undergoing the fate of Ra, the sun-god, he was immediately ranked with the Pharaoh, who was the son and representative of the gods, and so the ordinary man was a god himself, and this brought such a release of energy that we can understand quite well how he was lifted out of his pain. In a particular frame of mind people can endure a great deal. Primitives can walk on glowing coals and inflict the most terrible injuries on themselves under certain circumstances without feeling any pain. And so it is quite likely that an impressive and adequate symbol can mobilize the forces of the unconscious to such an extent that even the nervous system becomes affected and the body begins to react in a normal way again.

[232] In the case of psychological suffering, which always isolates the individual from the herd of so-called normal people, it is also of the greatest importance to understand that the conflict is not a personal failure only, but at the same time a suffering common to all and a problem with which the whole epoch is burdened. This general point of view lifts the individual out of himself and connects him with humanity. The suffering does not even have to be a neurosis; we have the same feeling in very ordinary circumstances. If for instance you live in a well-to-do community, and you suddenly lose all your money, your natural reaction will be to think that it is terrible and shameful and that you are the only one who is such an ass as to lose his money. But if everybody loses his money it is quite another matter and

you feel reconciled to it. When other people are in the same hole as I am I feel much better. If a man is lost in the desert or quite alone on a glacier, or if he is the responsible leader of a group of men in a precarious situation, he will feel terrible. But when he is a soldier in a whole battalion that is lost, he will join the rest in cheering and making jokes, and will not realize the danger. The danger is not less, but the individual feels quite differently about it in a group than when he has to face it alone.

[233] Whenever archetypal figures appear in dreams, especially in the later stages of analysis, I explain to the patient that his case is not particular and personal, but that his psychology is approaching a level which is universally human. That outlook is very important, because a neurotic feels tremendously isolated and ashamed of his neurosis. But if he knows his problem to be general and not merely personal, it makes all the difference. In the case of our dreamer, if I had been going on with the treatment I would have called the patient's attention to the fact that the motif in his last dream was a general human situation. He himself in his associations had realized the hero-dragon conflict.

[234] The hero's fight with the dragon, as the symbol of a typical human situation, is a very frequent mythological motif. One of the most ancient literary expressions of it is the Babylonian Creation Myth, where the hero-god Marduk fights the dragon Tiamat. Marduk is the spring-god and Tiamat is the mother-dragon, the primordial chaos. Marduk kills her and splits her in two parts. From one half he makes the heavens and from the other he makes the earth.²

[235] A more striking parallel to our case is the great Babylonian epos of Gilgamesh.³ Gilgamesh is really an *arriviste par excellence*, a man of ambitious plans, like our dreamer, and a great king and hero. All the men are working for him like slaves to build a town with mighty walls. The women feel neglected and complain to the gods about their reckless tyrant. So the gods decide that something has to be done about it. Translated into psychological language this means: Gilgamesh is using his consciousness only, his head has wings and is detached from the body, and his body is going to say something about it. It will react with a neurosis, that is, by constellating a very opposite factor. How is this neurosis described in the poem? The gods decide to "call up," that is to make, a man like Gilgamesh. They create Enkidu; yet he is in some ways different. The hair of his head is long, he looks like a cave-man, and he lives with the wild animals in the plains and drinks from the water-wells of the gazelles. Gilgamesh, being normal so far, has a perfectly normal dream about the intention of the gods. He dreams that a star falls down on his back, a star like a mighty warrior, and Gilgamesh is wrestling with him but cannot shake himself free. Finally he overcomes him and puts him down at his mother's feet, and the mother "makes him equal" to Gilgamesh. The mother is a wise woman and interprets the

dream for Gilgamesh so that he is ready to meet the danger. Enkidu is meant to fight Gilgamesh and bring him down, but Gilgamesh in a very clever way makes him his friend. He has conquered the reaction of his unconscious by cunning and will-power and he persuades his opponent that they are really friends and that they can work together. Now things are going worse than ever.

[236] Although right in the beginning Enkidu has an oppressive dream, a vision of the underworld where the dead live, Gilgamesh is preparing for a great adventure. Like heroes, Gilgamesh and Enkidu start out together to overcome Humbaba, a terrible monster whom the gods have made guardian of their sanctuary on the cedar mountain. His voice roars like the tempest, and everybody who approaches the wood is overcome by weakness. Enkidu is brave and very strong, but he is nervous about the enterprise. He is depressed by bad dreams and pays a lot of attention to them, like the inferior man in ourselves whom we ridicule when that inferior part of ourselves feels superstitious about certain dates, and so on; the inferior man nevertheless continues to be nervous about certain things. Enkidu is very superstitious, he has had bad dreams on the way to the forest and has forebodings that things will go wrong. But Gilgamesh interprets the dreams optimistically. Again the reaction of the unconscious is cheated, and they succeed in bringing back Humbaba's head triumphantly to their city.

[237] Now the gods decide to interfere, or rather it is a goddess, Ishtar, who tries to defeat Gilgamesh. The ultimate principle of the unconscious is the Eternal Feminine, and Ishtar, with true feminine cunning, makes wonderful promises to Gilgamesh if he will become her lover: he would be like a god and his power and wealth would increase beyond measure. But Gilgamesh does not believe a word of it, he refuses with insulting words and reproaches her for all her faithlessness and cruelty towards her lovers. Ishtar in her rage and fury persuades the gods to create an enormous bull, which descends from the heavens and devastates the country. A great fight begins, and hundreds of men are killed by the poisonous breath of the divine bull. But again Gilgamesh, with the help of Enkidu, slays him, and the victory is celebrated.

[238] Ishtar, overcome by rage and pain, descends to the wall of the city, and now Enkidu himself commits an outrage against her. He curses her and throws the member of the dead bull in her face. This is the climax, and now the peripeteia sets in. Enkidu has more dreams of an ominous nature and becomes seriously ill and dies.

[239] This means that the conscious separates from the unconscious altogether; the unconscious withdraws from the field, and Gilgamesh is now alone and overcome with grief. He can hardly accept the loss of his friend, but what torments him most is the fear of death. He has seen his friend die and is faced with the fact that he is mortal too. One more desire tortures him—to secure immortality. He sets out heroically to find the medicine against death, because he knows of an old man, his ancestor, who

has eternal life and who lives far away in the West. So the journey to the underworld, the Nekyia, begins, and he travels to the West like the sun, through the door of the heavenly mountain. He overcomes enormous difficulties, and even the gods do not oppose his plan, although they tell him that he will seek in vain. Finally he comes to his destination and persuades the old man to tell him of the remedy. At the bottom of the sea he acquires the magic herb of immortality, the *pharmakon athanasias*, and he is bringing the herb home. Although he is tired of travelling he is full of joy because he has the wonderful medicine and does not need to be afraid of death any more. But while he is refreshing himself by bathing in a pool, a snake smells out the herb of immortality and steals it from him. After his return, he takes up new plans for the fortification of his city, but he finds no peace. He wants to know what happens to man after death and he finally succeeds in evoking Enkidu's spirit, which comes up from a hole in the earth and gives Gilgamesh very melancholy information. With this the epos ends. The ultimate victory is won by the cold-blooded animal.

[240] There are quite a number of dreams recorded from antiquity with parallel motifs, and I will give you a short example of how our colleagues of old—the dream interpreters of the first century A.D.—proceeded. The story is told by Flavius Josephus in his history of the Jewish war,⁴ where he also records the destruction of Jerusalem.

[241] There was a Tetrarch of Palestine by the name of Archelaos, a Roman governor who was very cruel and who, like practically all of those provincial governors, regarded his position as an opportunity to enrich himself and steal what he could lay his hands on. Therefore a delegation was sent to the emperor Augustus to complain about him. This was in the tenth year of Archelaos' governorship. About this time he had a dream in which he saw nine big ripe ears of wheat which were eaten up by hungry oxen. Archelaos was alarmed and instantly called in his court psychoanalyst. But the psychoanalyst did not know what the dream meant, or he was afraid to tell the truth and wriggled out of it. Archelaos called in other psychoanalysts for consultation, and they in the same way refused to know anything about the dream.

[242] But there was a peculiar sect of people, the Essenes or Therapeutai, with more independent minds. They lived in Egypt and near the Dead Sea, and it is not impossible that John the Baptist as well as Simon Magus belonged to such circles. So as a last resort a man called Simon the Essene was sent for, and he told Archelaos: "The ears of wheat signify the years of your reign, and the oxen the change of things. The nine years are fulfilled and there will be a great change in your fate. The hungry oxen mean your destruction." In those countries such a dream-image would be perfectly understandable. The fields have to be guarded carefully against foraging cattle. There is little grass, and it is a catastrophe when during the night the oxen break through the fence into the field and trample down and eat the growing grain, so

that in the morning the whole bread of a year is gone. Now for the confirmation of the interpretation. A few days later a Roman ambassador arrived to investigate, dismissed Archelaos, took all his property from him, and exiled him to Gaul.

[243] Archelaos was married, and his wife, Glaphyra, also had a dream. Naturally she was impressed by what had happened to her husband. She dreamt of her first husband—Archelaos was her third marriage—who had been disposed of in a very impolite way: he had been murdered, and Archelaos was most probably the murderer. Things were a bit rough in those days. This former husband, Alexandros, appeared to her in the dream and blamed her for her conduct and told her that he was going to take her back into his household. Simon did not interpret this dream, so the analysis is left to our discretion. The important fact is that Alexandros was dead, and that Glaphyra saw the dead husband in her dream. This, of course, in those days, meant the ghost of that person. So when he told her that he was going to take her back to his household it signified that he was going to fetch her to Hades. And indeed, a few days later she committed suicide.

[244] The way the dream-interpreter proceeded with the dream of Archelaos was very sensible. He understood the dream exactly as we would, although these dreams are of a much simpler nature than most of our dreams. I have noticed that dreams are as simple or as complicated as the dreamer is himself, only they are always a little bit ahead of the dreamer's consciousness. I do not understand my own dreams any better than any of you, for they are always somewhat beyond my grasp and I have the same trouble with them as anyone who knows nothing about dream-interpretation. Knowledge is no advantage when it is a matter of one's own dreams.

[245] Another interesting parallel to our case is the story you all know in the fourth chapter of the Book of Daniel.⁵ When the king Nebuchadnezzar had conquered the whole of Mesopotamia and Egypt, he thought he was very great indeed because he possessed the whole known world. Then he had the typical dream of the *arriviste* who has climbed too high. He dreamed of an enormous tree growing up to heaven and casting a shadow over the whole earth. But then a watcher and holy one from heaven ordered the tree to be hewn down, and his branches cut off, and his leaves shaken, so that only his stump remained; and that he should live with the beasts and his human heart be taken from him and a beast's heart given to him.

[246] Of course all the astrologers and wise men and dream-interpreters refused to understand the dream. Only Daniel, who already in the second chapter had proved himself a courageous analyst—he even had a vision of a dream which Nebuchadnezzar could not remember—understood its meaning. He warned the king to repent of his avarice and injustice, otherwise the dream would come true. But the king went on as before, very proud of his power. Then a voice from heaven cursed him and repeated the prophecy of the dream. And it all happened as foretold.

Nebuchadnezzar was cast out to the beasts and he became like an animal himself. He ate grass as the oxen and his body was wet with the dew of heaven, his hair grew long like eagles' feathers and his nails like birds' claws. He was turned back into a primitive man and all his conscious reason was taken away because he had misused it. He regressed even further back than the primitive and became completely inhuman; he was Humbaba, the monster, himself. All this symbolized a complete regressive degeneration of a man who has overreached himself.

[247] His case, like our patient's, is the eternal problem of the successful man who has overreached himself and is contradicted by his unconscious. The contradiction is first shown in the dreams and, if not accepted, must be experienced in reality in a fatal way. These historical dreams, like all dreams, have a *compensatory function*: they are an indication—a symptom, if you prefer to say so—that the individual is at variance with unconscious conditions, that somewhere he has deviated from his natural path. Somewhere he has fallen a victim to his ambition and his ridiculous designs, and, if he does not pay attention, the gap will widen and he will fall into it, as our patient has.

[248] I want to emphasize that it is not safe to interpret a dream without going into careful detail as to the context. Never apply any theory, but always ask the patient how *he* feels about his dream-images. For dreams *are always* about a particular problem of the individual about which he has a wrong conscious judgment. The dreams are the reaction to our conscious attitude in the same way that the body reacts when we overeat or do not eat enough or when we ill-treat it in some other way. *Dreams are the natural reaction of the self-regulating psychic system.* This formulation is the nearest I can get to a theory about the structure and function of dreams. I hold that dreams are just as manifold and unpredictable and incalculable as a person you observe during the day. If you watch an individual at one moment and then at another you will see and hear the most varied reactions, and it is exactly the same with dreams. In our dreams we are just as many-sided as in our daily life, and just as you cannot form a theory about those many aspects of the conscious personality you cannot make a general theory of dreams. Otherwise we would have an almost divine knowledge of the human mind, which we certainly do not possess. We know precious little about it, therefore we call the things we do not know unconscious.

[249] But today I am going to contradict myself and break all my rules. I am going to interpret a single dream, not one out of a series; moreover I do not know the dreamer, and further, I am not in possession of the associations. Therefore I am interpreting the dream arbitrarily. There is a justification for this procedure. If a dream is clearly formed of *personal* material you have to get the individual associations; but if the dream is chiefly a *mythological* structure—a difference which is obvious at once—

then it speaks a universal language, and you or I can supply parallels with which to construct the context as well as anybody else, always provided we possess the necessary knowledge. For instance, when the dream takes up the hero-dragon conflict, everybody has something to say about it, because we have all read fairytales and legends and know something of heroes and dragons. On the collective level of dreams there is practically no difference in human beings, while there is all the difference on the personal level.

[250] The main substance of the dream I am going to speak of is mythological. Here we are confronted with the question: Under what conditions does one have mythological dreams? With us they are rather rare, as our consciousness is to a great extent detached from the underlying archetypal mind. Mythological dreams therefore are felt by us as a very alien element. But this is not so with a mentality nearer to the primordial psyche. Primitives pay great attention to such dreams and call them "big dreams" in contradistinction to ordinary ones. They feel that they are important and contain a general meaning. Therefore in a primitive community the dreamer feels bound to announce a big dream to the assembly of men, and a palaver is held over it. Such dreams were also announced to the Roman Senate. There is a story of a senator's daughter in the first century B.C. who dreamed that the goddess Minerva had appeared to her and complained that the Roman people were neglecting her temple. The lady felt obliged to report the dream to the Senate, and the Senate voted a certain sum of money for the restoration of the temple. A similar case is told of Sophocles, when a precious golden vessel had been stolen from the temple of Herakles. The god appeared to Sophocles in a dream and told him the name of the thief.⁶ After the third repetition of the dream, Sophocles felt obliged to inform the Areopagus. The man in question was seized, and in the course of the investigation he confessed and brought back the vessel. These mythological or collective dreams have a character which forces people instinctively to tell them. This instinct is quite appropriate, because such dreams do not belong to the individual; they have a collective meaning. They are true in themselves in general, and in particular they are true for people in certain circumstances. That is the reason why in antiquity and in the Middle Ages dreams were held in great esteem. It was felt that they expressed a collective human truth.

[251] Now I will tell you the dream. It was sent to me by a colleague of mine years ago with a few remarks about the dreamer. My colleague was an alienist at a clinic, and the patient was a distinguished young Frenchman, twenty-two years of age, highly intelligent, and very aesthetic. He had travelled in Spain and had come back with a depression which was diagnosed as manic-depressive insanity, depressive form. The depression was not very bad, but bad enough for him to be sent to the clinic. After six months he was released from confinement, and a few months later he committed suicide. He was no longer under the depression, which was practically cured; he

committed suicide apparently in a state of calm reasoning. We shall understand from the dream why he committed suicide. This is the dream, and it occurred at the beginning of the depression:

Underneath the great cathedral of Toledo there is a cistern filled with water which has a subterranean connection with the river Tagus, which skirts the city. This cistern is a small dark room. In the water there is a huge serpent whose eyes sparkle like jewels. Near it there is a golden bowl containing a golden dagger. This dagger is the key to Toledo, and its owner commands full power over the city. The dreamer knows the serpent to be the friend and protector of B— C—, a young friend of his who is present. B— C— puts his naked foot into the serpent's jaws. The serpent licks it in a friendly way and B— C— enjoys playing with the serpent; he has no fear of it because he is a child without guile. In the dream B— C— appears to be about the age of seven; he had indeed been a friend of the dreamer's early youth. Since this time, the dream says, the serpent has been forgotten and nobody dared to descend into its haunts.

[252] This part is a sort of introduction, and now the real action begins.

The dreamer is alone with the serpent. He talks to it respectfully, but without fear. The serpent tells the dreamer that Spain belongs to him as he is B— C—'s friend, and asks him to give back the boy. The dreamer refuses to do this and promises instead that he himself will descend into the darkness of the cave to be the friend of the serpent. But then he changes his mind, and instead of fulfilling his promise he decides to send another friend, a Mr. S—, to the serpent. This friend is descended from the Spanish Moors, and to risk the descent into the cistern he has to recover the original courage of his race. The dreamer advises him to get the sword with the red hilt which is to be found in the weapons factory on the other bank of the Tagus. It is said to be a very ancient sword, dating back to the old Phocaeans.⁷ S— gets the sword and descends into the cistern, and the dreamer tells him to pierce his left palm with the sword. S— does so, but he is not able to keep his countenance in the powerful presence of the serpent. Overcome by pain and fear, he cries out and staggers up the stairs again without having taken the dagger. Thus the dreamer cannot hold Toledo, and he could do nothing about it and had to leave his friend there as a mere wall decoration.

[252a]. That is the end of the dream. The original of course is in French. Now for the context. We have certain hints as to these friends. B— C— is a friend of the dreamer's early youth, a little bit older than himself, and he projected everything that was wonderful and charming into this boy and made him a sort of hero. But he lost sight of him later; perhaps the boy died. S— is a friend of more recent date. He is said to be descended from the Spanish Moors. I do not know him personally, but I know his family. It is a very old and honourable family from the South of France, and

the name might easily be a Moorish name. The dreamer knew this legend about the family of S—

[253] As I told you, the dreamer had recently been to Spain and of course had seen Toledo, and he had the dream after he got back and had been taken to the clinic. He was in a bad state, practically in despair, and he could not help telling the dream to his doctor. My colleague did not know what to do with it, but he felt an urge to send me the dream because he felt it to be very important. But at the time I received the dream I could not understand it. Nevertheless I had the feeling; that if I had known something more about such dreams, and if I could have handled the case myself, I might have been able to help the young man and his suicide might not have occurred. Since then I have seen many cases of a similar nature. Often one can turn a difficult corner by a real understanding of dreams like this one. With such a sensitive, refined individual who had studied the history of art and was an unusually artistic and intelligent person, one must be exceedingly careful. Banalities are no use in such a case; one has to be serious and enter into the real material.

[253a] We make no mistake when we assume that the dreamer has picked out Toledo for a particular reason—both as the object of his trip and of his dream; and the dream brings up material which practically everybody would have who had seen Toledo with the same mental disposition, the same education and refinement of aesthetic perception and knowledge. Toledo is an extremely impressive city. It contains one of the most marvellous Gothic cathedrals of the world. It is a place with an immensely old tradition; it is the old Roman Toletum, and for centuries has been the seat of the Cardinal Archbishop and Primate of Spain. From the sixth to the eighth century it was the capital of the Visigoths; from the eighth to the eleventh it was a provincial capital of the Moorish kingdom; and from the eleventh to the sixteenth century it was the capital of Castile. The cathedral of Toledo, being such an impressive and beautiful building, naturally suggests all that it represents: the greatness, the power, the splendour, and the mystery of medieval Christianity, which found its essential expression in the Church. Therefore the cathedral is the embodiment, the incarnation, of the spiritual kingdom, for in the Middle Ages the world was ruled by the Emperor *and* by God. So the cathedral expresses the Christian philosophy or *Weltanschauung* of the Middle Ages.

[254] The dream says that underneath the cathedral there is a mysterious place, which in reality is not in tune with a Christian church. What is beneath a cathedral of that age? There is always the so-called under-church or crypt. You have probably seen the great crypt at Chartres; it gives a very good idea of the mysterious character of a crypt. The crypt at Chartres was previously an old sanctuary with a well, where the worship of a virgin was celebrated—not of the Virgin Mary, as is done now—but of a Celtic goddess. Under every Christian church of the Middle Ages there is a secret

place where in old times the mysteries were celebrated. What we now call the sacraments of the Church were the *mysteria* of early Christianity. In Provençal the crypt is called *le musset*, which means a secret; the word perhaps originates from *mysteria* and could mean mystery-place. In Aosta, where they speak a Provençal dialect, there is a *musset* under the cathedral.

[255] The crypt is probably taken over from the cult of Mithras. In Mithraism the main religious ceremony took place in a vault half sunk into the earth, and the community remained separated in the main church above. There were peepholes so that they could see and hear the priests and the elect ones chanting and celebrating their rites below, but they were not admitted to them. That was a privilege for the initiates. In the Christian church the separation of the baptistry from the main body of the building derives from the same idea, for baptism as well as the communion were *mysteria* of which one could not speak directly. One had to use a sort of allegorical allusion so as not to betray the secrets. The mystery also attached to the name of Christ, which therefore was not allowed to be mentioned; instead, he was referred to by the name of Ichthys, the Fish. You have probably seen reproductions of very early Christian paintings where Christ appears as the Fish. This secrecy connected with the holy name is probably the reason why the name of Christ is not mentioned in an early Christian document of about A.D. 140 known as *The Shepherd* of Hermas,⁸ which was an important part of the body of Christian literature recognized by the Church till about the fifth century. The writer of this book of visions, Hermas, is supposed to have been the brother of the Roman bishop Pius. The spiritual teacher who appears to Hermas is called the Poimen, the Shepherd, and not the Christ.

[256] The idea of the crypt or mystery-place leads us to something below the Christian *Weltanschauung*, something older than Christianity, like the pagan well below the cathedral at Chartres, or like an antique cave inhabited by a serpent. The well with the serpent is of course not an actual fact which the dreamer saw when he travelled in Spain. This dream-image is not an individual experience and can therefore only be paralleled by archaeological and mythological knowledge. I have to give you a certain amount of that parallelism so that you can see in what context or tissue such a symbolical arrangement appears when looked at in the light of comparative research work. You know that every church still has its baptismal font. This was originally the *piscina*, the pond, in which the initiates were bathed or symbolically drowned. After a figurative death in the baptismal bath they came out transformed *quasi modo geniti*, as reborn ones. So we can assume that the crypt or baptismal font has the meaning of a place of terror and death and also of rebirth, a place where dark initiations take place.

[257] The serpent in the cave is an image which often occurs in antiquity. It is important to realize that in classical antiquity, as in other civilizations, the serpent not

only was an animal that aroused fear and represented danger, but also signified healing. Therefore Asklepios, the god of physicians, is connected with the serpent; you all know his emblem which is still in use. In the temples of Asklepios, the Asklepieia, which were the ancient clinics, there was a hole in the ground, covered by a stone, and in that hole lived the sacred serpent. There was a slot in the stone through which the people who came to the place of healing threw down the fee for the doctors. The snake was at the same time the cashier of the clinic and collector of gifts that were thrown down into its cave. During the great pestilence in the time of Diocletian the famous serpent of the Asklepieion at Epidaurus was brought to Rome as an antidote to the epidemic. It represented the god himself.

[258] The serpent is not only the god of healing; it also has the quality of wisdom and prophecy. The fountain of Castalia at Delphi was originally inhabited by a python. Apollo fought and overcame the python, and from that time Delphi was the seat of the famous oracle and Apollo its god, until he left half his powers to Dionysus, who later came in from the East. In the underworld, where the spirits of the dead live, snakes and water are always together, as we can read in Aristophanes' *The Frogs*. The serpent in legend is often replaced by the dragon; the Latin *draco* simply means snake. A particularly suggestive parallel to our dream symbol is a Christian legend of the fifth century about St. Sylvester:⁹ there was a terrible dragon in a cave under the Tarpeian rock in Rome to whom virgins were sacrificed. Another legend says that the dragon was not a real one but artificial, and that a monk went down to prove it was not real and when he got down to the cave he found that the dragon had a sword in his mouth and his eyes consisted of sparkling jewels.

[259] Very often these caves, like the cave of Castalia, contain springs. These springs played a very important role in the cult of Mithras, from which many elements of the early Church originated. Porphyry relates that Zoroaster, the founder of the Persian religion, dedicated to Mithras a cave containing many springs. Those of you who have been to Germany and seen the Saalburg near Frankfurt will have noticed the spring near the grotto of Mithras. The cult of Mithras is always connected with a spring. There is a beautiful Mithraeum in Provence which has a large piscina with wonderful crystal-clear water, and in the background a rock on which is carved the Mithras Tauroktonos—the bull-killing Mithras. These sanctuaries were always a great scandal to the early Christians. They hated all these natural arrangements because they were no friends of nature. In Rome a Mithraeum has been discovered ten feet below the surface of the Church of San Clemente. It is still in good condition but filled with water, and when it is pumped out it fills again. It is always under water because it adjoins a spring which floods the interior. The spring has never been found. We know of other religious ideas in antiquity, for instance of the Orphic cult, which always associate the underworld with water.

[260] This material will give you an idea that the serpent in the cave full of water is an image that was generally known and played a great role in antiquity. As you have noticed, I have chosen all my examples exclusively from antiquity; I could have chosen other parallels from other civilizations, and you would find it was the same. The water in the depths represents the unconscious. In the depths as a rule is a treasure guarded by a serpent or a dragon; in our dream the treasure is the golden bowl with the dagger in it. In order to recover the treasure the dragon has to be overcome. The treasure is of a very mysterious nature. It is connected with the serpent in a strange way; the peculiar nature of the serpent denotes the character of the treasure as though the two things were one. Often there is a golden snake with the treasure. Gold is something that everyone is seeking, so we could say that it looks as if the serpent himself were the great treasure, the source of immense power. In early Greek myths, for instance, the dweller in the cave is a hero, such as Cecrops, the founder of Athens. Above he is half man and half woman, a hermaphrodite, but the lower part of his body is a serpent; he is clearly a monster. The same is said of Erechtheus, another mythical king of Athens.

[261] That prepares us a little for understanding the golden bowl and the dagger in our dream. If you have seen Wagner's *Parsifal* you know that the bowl corresponds to the Grail and the dagger to the spear and that the two belong together; they are the male and the female principle which form the union of opposites. The cave or underworld represents a layer of the unconscious where there is no discrimination at all, not even a distinction between the male and the female, which is the first differentiation primitives make. They distinguish objects in this way, as we still do occasionally. Some keys, for instance, have a hole in the front, and some are solid. They are often called male and female keys. You know the Italian tiled roofs. The convex tiles are placed above and the concave ones underneath. The upper ones are called monks and the under ones the nuns. This is not an indecent joke to the Italians, but the quintessence of discrimination.

[262] When the unconscious brings together the male and the female, things become utterly indistinguishable and we cannot say any more whether they are male or female, just as Cecrops came from such a mythical distance that one could not say whether he was man or woman, human or serpent. So we see that the bottom of the cistern in our dream is characterized by a complete union of opposites. This is the primordial condition of things, and at the same time a most ideal achievement, because it is the union of elements eternally opposed. Conflict has come to rest, and everything is still or once again in the original state of indistinguishable harmony. You find the same idea in ancient Chinese philosophy. The ideal condition is named Tao, and it consists of the complete harmony between heaven and earth. Figure 13 represents the symbol for Tao. On one side it is white with a black spot, and on the

other it is black with a white spot. The white side is the hot, dry, fiery principle, the south; the black side is the cold, humid, dark principle, the north. The condition of Tao is the beginning of the world where nothing has yet begun—and it is also the condition to be achieved by the attitude of superior wisdom. The idea of the union of the two opposite principles, of male and female, is an archetypal image. I once had a very nice example of its still-living primitive form. When on military duty with the army during the war, I was with the mountain artillery, and the soldiers had to dig a deep hole for the position of a heavy gun. The soil was very refractory, and they cursed a good deal while they were digging up the heavy blocks. I was sitting hidden behind a rock, smoking my pipe and listening to what they said. One man said: “Now, damn it all, we have dug into the depths of this blooming old valley where the old lake-dwellers lived and where father and mother are still sleeping together.” That is the same idea, very naïvely expressed. A Negro myth says that the primordial man and the primordial woman were sleeping together in the calabash; they were quite unconscious until they found they were torn asunder and what was in between was the son. Man was in between, and from that time they were separated, and then they knew each other. The original condition of absolute unconsciousness is expressed as a completely restful condition where nothing happens.



FIG. 13. Tao

[263] When the dreamer comes to these symbols he reaches the layer of complete unconsciousness, which is represented as the greatest treasure. It is the central motif in Wagner's *Parsifal* that the spear should be restored to the Grail because they belong eternally together. This union is a symbol of complete fulfilment—eternity before and after the creation of the world, a dormant condition. That is probably the thing which the desire of man is seeking. That is why he ventures into the cave of the dragon, to find that condition where consciousness and the unconscious are so completely united that he is neither conscious nor unconscious. Whenever the two are too much separated, consciousness seeks to unite them again by going down into the depths where they once were one. Thus you find in Tantric Yoga or Kundalini Yoga an attempt to reach the condition where Shiva is in eternal union with Shakti. Shiva is the eternally unextended point, and he is encircled by the female principle, Shakti, in the form of a serpent.

[264] I could give you many more instances of this idea. It played a great role in the secret tradition of the Middle Ages. In medieval alchemical texts there are pictures of the process of the union of Sol and Luna, the male and the female principle. We have traces of an analogous symbolism in Christian reports about the ancient mysteries. There is a report by a Bishop Asterios about Eleusis, and it says that every year the priest made the *katabasis* or descent into the cave. And the priest of Apollo and the priestess of Demeter, the earth mother, celebrated the *hierosgamos*, the sacred nuptials, for the fertilization of the earth. This is a Christian statement which is not substantiated. The initiates of the Eleusinian mysteries were sworn to the strictest secrecy; if they betrayed anything, they were punished with death. So we have practically no knowledge of their rites. We know, on the other hand, that during the mysteries of Demeter certain obscenities took place because they were thought good for the fertility of the earth. The distinguished ladies of Athens assembled, with the priestess of Demeter presiding. They had a good meal and plenty of wine and afterwards performed the rite of the *aischrologia*. That is, they had to tell indecent jokes. This was considered a religious duty because it was good for the fertility of the next season.¹⁰ A similar rite took place in Bubastis in Egypt at the time of the Isis mysteries. The inhabitants of the villages on the upper Nile came down in parties, and the women on the barges used to expose themselves to the women on the banks of the Nile. It was probably done for the same reason as the *aischrologia*, to ensure the fertility of the earth. You can read about it in Herodotus.¹¹ In southern Germany as late as the nineteenth century, in order to increase the fertility of the soil, the peasant used to take his wife to his fields and have intercourse with her in a furrow. This is called sympathetic magic.

[265] The bowl is a vessel that receives or contains, and is therefore female. It is a symbol of the body which contains the anima, the breath and liquid of life, while the dagger has piercing, penetrating qualities and is therefore male. It cuts, it discriminates and divides, and so is a symbol of the masculine Logos principle.

[266] In our dream the dagger is said to be the key to Toledo. The idea of the key is often associated with the mysteries in the cave. In the cult of Mithras there is a peculiar kind of god, the key god Aion, whose presence could not be explained; but I think it is quite understandable. He is represented with the winged body of a man and the head of a lion, and he is encoiled by a snake which rises up over his head.¹² You have a figure of him in the British Museum. He is Infinite Time and Long Duration; he is the supreme god of the Mithraic hierarchy and creates and destroys all things, the *durée créatrice* of Bergson. He is a sun-god. Leo is the zodiacal sign where the sun dwells in summer, while the snake symbolizes the winter or wet time. So Aion, the lion-headed god with the snake round his body, again represents the union of opposites, light and darkness, male and female, creation and destruction. The god is

represented as having his arms crossed and holding a key in each hand. He is the spiritual father of St. Peter, for he too holds the keys. The keys which Aion is holding are the keys to the past and future.

[267] The ancient mystery cults are always connected with psychopompic deities. Some of these deities are equipped with the keys to the underworld, because as the guardians of the door they watch over the descent of the initiates into the darkness and are the leaders into the mysteries. Hecate is one of them.

[268] In our dream the key is the key to the city of Toledo, so we have to consider the symbolic meaning of Toledo and of the city. As the old capital of Spain, Toledo was a very strong fortification and the very ideal of a feudal city, a refuge and stronghold which could not easily be touched from outside. The city represents a totality, closed in upon itself, a power which cannot be destroyed, which has existed for centuries and will exist for many centuries more. Therefore the city symbolizes the totality of man, an attitude of wholeness which cannot be dissolved.

[269] The city as a synonym for the self, for psychic totality, is an old and well-known image. We read for instance in the Oxyrhynchus sayings of Jesus:¹³ “A city built upon the top of a high hill and stablished, can neither fall nor be hid.” And: “Strive therefore to know yourselves, and ye shall be aware that ye are the sons of the almighty Father; and ye shall know that ye are in the city of God and ye are the city.” There is a Coptic treatise in the Codex Brucianus in which we find the idea of the Monogenes, or only son of God, who is also the Anthropos, Man.¹⁴ He is called the city with the four gates. The city with the four gates symbolizes the idea of totality; it is the individual who possesses the four gates to the world, the four psychological functions, and so is contained in the self. The city with the four gates is his indestructible wholeness—consciousness and the unconscious united.

[270] So these depths, that layer of utter unconsciousness in our dream, contain at the same time the key to individual completeness and wholeness, in other words to healing. The meaning of “whole” or “wholeness” is to make holy or to heal. The descent into the depths will bring healing. It is the way to the total being, to the treasure which suffering mankind is forever seeking, which is hidden in the place guarded by terrible danger. This is the place of primordial unconsciousness and at the same time the place of healing and redemption, because it contains the jewel of wholeness. It is the cave where the dragon of chaos lives and it is also the indestructible city, the magic circle or *temenos*, the sacred precinct where all the split-off parts of the personality are united.

[271] The use of a magic circle or mandala, as it is called in the East, for healing purposes is an archetypal idea. When a man is ill the Pueblo Indians of New Mexico make a sand-painting of a mandala with four gates. In the centre of it they build the so-called sweat-house or medicine-lodge, where the patient has to undergo the sweat-

cure. On the floor of the medicine-lodge is painted another magic circle—being thus placed in the centre of the big mandala—and in the midst of it is the bowl with the healing water. The water symbolizes the entrance to the underworld. The healing process in this ceremony is clearly analogous to the symbolism which we find in the collective unconscious. It is an individuation process, an identification with the totality of the personality, with the self. In Christian symbolism the totality is Christ, and the healing process consists of the *imitatio Christi*. The four gates are replaced by the four arms of the cross.

[272] The serpent in the cave in our dream is the friend of B— C—, the hero of the dreamer's early days, into whom he projected everything he wanted to become and all the virtues to which he was aspiring. That young friend is at peace with the serpent. He is a child without guile, he is innocent and knows as yet of no conflict. Therefore he has the key to Spain and the power over the four gates.¹⁵

Discussion

Dr. David Yellowlees:

[273] I need hardly mention that I shall not attempt to discuss anything that has been said tonight. We are all glad Professor Jung has given us such an extraordinarily fascinating account of his own views, rather than spend time on controversial matters. But I think some of us would be grateful if he would recognize that we approach psychology and psychotherapy along lines not exclusively Freudian perhaps, but in accordance with certain fundamental principles with which Freud's name is associated, though he may not have originated them. We are very grateful that Professor Jung has given us what we believe to be a wider view. Some of us prefer that view, and perhaps the Freudians would be able to tell us why. But the question was raised the other night as to the relationship between the concept of the unconscious which Professor Jung has been laying before us and Freud's concept of it, and I think if Professor Jung will be so good he could help us a little in that direction. I know quite well I may be misinterpreting him, but the impression I got on Tuesday night was almost as if he had said that he was dealing with facts and Freud with theories. He knows as well as I do that this bald statement really requires some amplification and I wish he could tell us, for example, what we ought to do from a therapeutic point of view when faced with a patient who produces spontaneously what I would call Freudian material, and how far we should regard Freudian theories simply as theories in view of the evidence which can be proved by such material as infantile fixation of the libido—oral, anal, phallic, and so on. If Professor Jung would say a little to give us some kind of correlation we would be very grateful.

Professor Jung:

[274] I told you at the beginning that I do not want to be critical. I just want to give you a point of view of my own, of how I envisage psychological material, and I suppose that when you have heard what I have to contribute you will be able to make up your minds about these questions, and how much of Freud, how much of Adler, or myself, or I do not know whom, you will want to follow. If you want me to elucidate the question of the connection with Freud, I am quite glad to do it. I started out entirely on Freud's lines. I was even considered to be his best disciple. I was on excellent terms with him until I had the idea that certain things are symbolical. Freud would not agree to this, and he identified his method with the theory and the theory with the method. That is impossible, you cannot identify a method with science. I said that in view of these things I could not keep on publishing the *Jahrbuch*¹⁵ and I withdrew.

[275] But I am perfectly well aware of the merits of Freud and I do not want to diminish them. I know that what Freud says agrees with many people, and I assume that these people have exactly the kind of psychology that he describes. Adler, who has entirely different views, also has a large following, and I am convinced that many people have an Adlerian psychology. I too have a following—not so large as Freud's—and it consists presumably of people who have my psychology. I consider my contribution to psychology to be my subjective confession. It is my personal psychology, my prejudice that I see psychological facts as I do. I admit that I see things in such and such a way. But I expect Freud and Adler to do the same and confess that their ideas are their subjective point of view. So far as we admit our personal prejudice, we are really contributing towards an objective psychology. We cannot help being prejudiced by our ancestors, who want to look at things in a certain way, and so we instinctively have certain points of view. It would be neurotic if I saw things in another way than my instinct tells me to do; my snake, as the primitives say, would be all against me. When Freud said certain things, my snake did not agree. And I take the route that my snake prescribes, because that is good for me. But I have patients with whom I have to make a Freudian analysis and go into all the details which Freud has correctly described. I have other cases that force me to an Adlerian point of view, because they have a power complex. People who have the capacity to adapt and are successful are more inclined to have a Freudian psychology, because a man in that position is looking for the gratification of his desires, while the man who has not been successful has no time to think about desires. He has only one desire—to succeed, and he will have an Adlerian psychology, because a man who always falls into the second place will develop a power complex.

[276] I have no power complex in that sense because I have been fairly successful and in nearly every respect I have been able to adapt. If the whole world disagrees with me it is perfectly indifferent to me. I have a perfectly good place in Switzerland, I enjoy myself, and if nobody enjoys my books I enjoy them. I know nothing better than being in my library, and if I make discoveries in my books, that is wonderful. I cannot say I have a Freudian psychology because I never had such difficulties in relation to desires. As a boy I lived in the country and took things very naturally, and the natural and unnatural things of which Freud speaks were not interesting to me. To talk of an incest complex just bores me to tears. But I know exactly how I could make myself neurotic: if I said or believed something that is not myself. I say what I see, and if somebody agrees with me it pleases me and if nobody agrees it is indifferent to me. I can join neither the Adlerian nor the Freudian confession. I can agree only with the Jungian confession because I see things that way even if there is not a single person on earth who shares my views. The only thing I hope for is to give you some interesting ideas and let you see how I tackle things.

[277] It is always interesting to me to see a craftsman at work. His skill makes the charm of a craft. Psychotherapy is a craft and I deal in my individual way—a very humble way with nothing particular to show—with the things I have to do. Not that I believe for a moment that I am absolutely right. Nobody is absolutely right in psychological matters. Never forget that in psychology the *means* by which you judge and observe the psyche is the *psyche* itself. Have you ever heard of a hammer beating itself? In psychology the observer is the observed. The psyche is not only the *object* but also the *subject* of our science. So you see, it is a vicious circle and we have to be very modest. The best we can expect in psychology is that everybody puts his cards on the table and admits: “I handle things in such and such a way, and this is how I see them.” Then we can compare notes.

[278] I have always compared notes with Freud and Adler. Three books have been written by pupils of mine who tried to give a synopsis of the three points of view.¹⁶ You have never heard this from the other side. That is our Swiss temperament. We are liberal and we try to see things side by side, together. From my point of view the best thing is to say that obviously there are thousands of people who have a Freudian psychology and thousands who have an Adlerian psychology. Some seek gratification of desire and some others fulfilment of power and yet others want to see the world as it is and leave things in peace. We do not want to change anything. The world is good as it is.

[279] There are many different psychologies in existence. A certain American university, year after year, issues a volume of the psychologies of 1934, 1935, and so on. There is a total chaos in psychology, so do not be so frightfully serious about psychological theories. Psychology is not a religious creed but a point of view, and when we are human about it we may be able to understand each other. I admit that some people have sexual trouble and others have other troubles. I have chiefly other troubles. You now have an idea of how I look at things. My problem is to wrestle with the big monster of the historical past, the great snake of the centuries, the burden of the human mind, the problem of Christianity. It would be so much simpler if I knew nothing; but I know too much, through my ancestors and my own education. Other people are not worried by such problems, they do not care about the historical burdens Christianity has heaped upon us. But there are people who are concerned with the great battle between the present and the past or the future. It is a tremendous human problem. Certain people make history and others build a little house in the suburbs. Mussolini’s case is not settled by saying he has a power complex. He is concerned with politics, and that is his life and death. The world is huge and there is not one theory only to explain everything.

[280] To Freud the unconscious is chiefly a receptacle for things repressed. He looks at it from the corner of the nursery. To me it is a vast historical storehouse. I

acknowledge I have a nursery too, but it is small in comparison with the vast spaces of history which were more interesting to me from childhood than the nursery. There are many people like myself, I am optimistic in that respect. Once I thought there were no people like myself; I was afraid it was megalomania to think as I did. Then I found many people who fitted in with my point of view, and I was satisfied that I represented perhaps a minority of people whose basic psychological facts are expressed more or less happily by my formulation, and when you get these people under analysis you will find they do not agree with Freud's or Adler's point of view, but with mine. I have been reproached for my naïveté. When I am not sure about a patient I give him books by Freud and Adler and say, "Make your choice," in the hope that we are going on the right track. Sometimes we are on the wrong track. As a rule, people who have reached a certain maturity and who are philosophically minded and fairly successful in the world and not too neurotic, agree with my point of view. But you must not conclude from what I present to you that I always lay my cards on the table and tell the patient all I mention here. Time would not allow me to go into all those details of interpretation. But a few cases need to acquire a great amount of knowledge and are grateful when they see a way to enlarge their point of view.

[281] I cannot say where I could find common ground with Freud when he calls a certain part of the unconscious the Id. Why give it such a funny name? It is the unconscious and that is something we do not know. Why call it the Id? Of course the difference of temperament produces a different outlook. I never could bring myself to be so frightfully interested in these sex cases. They do exist, there are people with a neurotic sex life and you have to talk sex stuff with them until they get sick of it and you get out of that boredom. Naturally, with my temperamental attitude, I hope to goodness we shall get through with the stuff as quickly as possible. It is neurotic stuff and no reasonable normal person talks of it for any length of time. It is not natural to dwell on such matters. Primitives are very reticent about them. They allude to sexual intercourse by a word that is equivalent to "hush." Sexual things are taboo to them, as they really are to us if we are natural. But taboo things and places are always apt to be the receptacle for all sorts of projections. And so very often the real problem is not to be found there at all. Many people make unnecessary difficulties about sex when their actual troubles are of quite a different nature.

[282] Once a young man came to me with a compulsion neurosis. He brought me a manuscript of his of a hundred and forty pages, giving a complete Freudian analysis of his case. It was quite perfect according to the rules, it could have been published in the *Jahrbuch*. He said: "Will you read this and tell me why I am not cured although I made a complete psychoanalysis?" I said: "So you have, and I do not understand it either. You ought to be cured according to all the rules of the art, but when you say you are not cured I have to believe you." He repeated: "Why am I not cured, having a

complete insight into the structure of my neurosis?" I said: "I cannot criticize your thesis. The whole thing is marvellously well demonstrated. There remains only one, perhaps quite foolish, question: you do not mention where you come from and who your parents are. You say you spent last winter on the Riviera and the summer in St. Moritz. Were you very careful in the choice of your parents?" "Not at all." "You have an excellent business and are making a good deal of money?" "No, I cannot make money." "Then you have a big fortune from an uncle?" "No." "Then where does the money come from?" He replied: "I have a certain arrangement. I have a friend who gives me the money." I said: "It must be a wonderful friend," and he replied, "It is a woman." She was much older than himself, aged thirty-six, a teacher in an elementary school with a small salary, who, as an elderly spinster, fell in love with the fellow who was twenty-eight. She lived on bread and milk so that he could spend his winter on the Riviera and his summer in St. Moritz. I said: "And you ask why you are ill!" He said: "Oh, you have a moralistic point of view; that is not scientific." I said: "The money in your pocket is the money of the woman you cheat." He said, "No, we agreed upon it. I had a serious talk with her and it is not a matter for discussion that I get the money from her." I said: "You are pretending to yourself that it is not her money, but you live by it, and that is immoral. That is the cause of your compulsion neurosis. It is a compensation and a punishment for an immoral attitude." An utterly unscientific point of view, of course, but it is my conviction that he deserves his compulsion neurosis and will have it to the last day of his life if he behaves like a pig.

Dr. T. A. Ross:

[283] Did not that come out in the analysis?

Professor Jung:

[284] He went right away like a god and thought: "Dr. Jung is only a moralist, not a scientist. Anybody else would have been impressed by the interesting case instead of looking for simple things." He commits a crime and steals the savings of a lifetime from an honest woman in order to be able to have a good time. That fellow belongs in gaol, and his compulsion neurosis provides it for him all right.

Dr. P. W. L. Camps:

[285] I am a humble general practitioner, not a psychologist, and may be labelled as a suburban villa. I am an outsider in this place. The first night I thought I had no right to be here; the second night I was here again; the third night I was glad to be here; and the fourth night I am in a maze of mythology.

[286] I would like to ask something about last night. We were sent away with the idea that perfection was most undesirable and completion the end and aim of existence. I slept soundly last night but I felt that I had had an ethical shock. Perhaps I am not gifted with much intellect and it was an intellectual shock too. Professor Jung declares himself a determinist or fatalist. After he had analysed a young man who went away disappointed and then went to bits, Professor Jung felt it was only right that he should go to bits. You as psychologists, I take it, are endeavouring to cure people, and you have a purpose in life, not merely to enjoy your interests, whether it be mythology or the study of human nature. You want to get at the bottom of human nature and try to build it up to something better.

[287] I listened with the greatest interest to Professor Jung's simple English terms and rejoiced in them. I have been confounded with all this new terminology. To hear of our sensation and thinking and feeling and intuition—to which possibly an X may be added for something else—was most illuminating to me as an ordinary individual.

[288] But I feel that we did not hear where the conscious or rather where the unconscious of the child develops. I fear that we did not hear enough about children. I should like to ask Professor Jung where the unconscious in the child does become the conscious.

[289] I should also like to know whether we are not misled some what by this multitude of diagrams, barriers, Egos, and Ids, and other things I have seen portrayed; whether we could not improve on these diagrams by having a gradation of stages.

[290] As Professor Jung has pointed out, we have inherited faces and eyes and ears and there are a multitude of faces and in psychology there are a multitude of types also. Is it not reasonable to suppose that there is an enormous possibility of varieties planted on that inheritance, that they are a sort of mesh, a sieve as it were, that will receive impressions and select them in the unconscious years of early life and reach through into consciousness later? I should like to ask Professor Jung whether these thoughts have crossed the mind of an eminent psychologist such as he is—the very greatest psychologist in my view—tonight?

Professor Jung:

[291] After that severe reproach for immorality I owe an explanation of my cynical remarks of yesterday. I am not as bad as all that. I naturally try to do my best for my patients, but in psychology it is very important that the doctor should not strive to heal at all costs. One has to be exceedingly careful not to impose one's own will and conviction on the patient. We have to give him a certain amount of freedom. You can't wrest people away from their fate, just as in medicine you cannot cure a patient if nature means him to die. Sometimes it is really a question whether you are allowed

to rescue a man from the fate he must undergo for the sake of his further development. You cannot save certain people from committing terrible nonsense because it is in their grain. If I take it away they have no merit. We only gain merit and psychological development by accepting ourselves as we are and by being serious enough to live the lives we are trusted with. Our sins and errors and mistakes are necessary to us, otherwise we are deprived of the most precious incentives to development. When a man goes away, having heard something which might have changed his mind, and does not pay attention, I do not call him back. You may accuse me of being unchristian, but I do not care. I am on the side of nature. The old Chinese Book of Wisdom says: "The Master says it once." He does not run after people, it is no good. Those who are meant to hear will understand, and those who are not meant to understand will not hear.

[292] I was under the impression that my audience consisted chiefly of psychotherapists. If I had known that medical men were present I would have expressed myself more civilly. But psychotherapists will understand. Freud—to quote the master's own words—says it is not good to try to cure at all costs. He often repeated that to me, and he is right.

[293] Psychological truths are two-edged, and whatever I say can be used in such a way that it can work the greatest evil, the greatest devastation and nonsense. There is not one statement I have made which has not been twisted into its opposite. So I do not insist on any statement. You can take it, but if you do not take it, all right. You may perhaps blame me for that, but I trust that there is a will to live in everybody which will help them to choose the thing that is right for them. When I am treating a man I must be exceedingly careful not to knock him down with my views or my personality, because he has to fight his lonely fight through life and he must be able to trust in his perhaps very incomplete armour and in his own perhaps very imperfect aim. When I say, "That is not good and should be better," I deprive him of courage. He must plough his field with a plough that is not good perhaps: mine may be better, but what good is it to him? He has not got my plough. I have it and he cannot borrow it; he must use his own perhaps very incomplete tools and has to work with his own inherited capacities, whatever they are. I help him of course, I may say for instance: "Your thinking is perfectly good, but perhaps in another respect you could improve." If he does not want to hear it, I shall not insist because I do not want to make him deviate.

Dr. Marion Mackenzie:

[294] In the same way that the rich young man was not called back but went away sorrowful?

Professor Jung:

[295] Yes, it is the same technique. If I were to say to a man, “You should not go away.” he would never come back. I have to say, “Have your own way.” Then he will trust me.

[296] As to the question about children, there has been in the last decades such a noise about children that I often scratch my head at a meeting and say: “Are they all midwives and nurses?” Does not the world consist chiefly of parents and grandparents? The adults have the problems. Leave the poor children alone. I get the mother by the ears and not the child. The parents make the neuroses of children.

[297] It is certainly interesting to make researches into the development of consciousness. The beginning of consciousness is a fluid condition, and you cannot say when the child has become really conscious and when it has not yet. But that belongs to an entirely different chapter: the psychology of the ages. There is a psychology of childhood, which apparently consists in the psychology of the respective parents; a psychology from infancy to puberty; a psychology of puberty, of the young man, of the adult man of thirty-five, of the man in the second half of life, of the man in old age. That is a science in itself, and I could not possibly bring in all that too. I have a most difficult time as it is to illustrate one single dream. Science is large. It is as if you expected a physicist, when he talks of the theory of light, to elucidate at the same time the whole of mechanical physics. It is simply not possible. Psychology is not an introductory course for nurses; it is a very serious science and consists of a heap of knowledge, so you should not expect too much from me. I am doing my level best to grapple with dreams and to tell you something about them, and I naturally cannot fulfil all expectations.

[298] As to the question about perfection: to strive for perfection is a high ideal. But I say: “Fulfil something you are able to fulfil rather than run after what you will never achieve.” Nobody is perfect. Remember the saying: “None is good but God alone,”¹⁷ and nobody can be. It is an illusion. We can modestly strive to fulfil ourselves and to be as complete human beings as possible, and that will give us trouble enough.

Dr. Eric B. Strauss:

[299] Does Professor Jung intend to publish the reasons which led him to identify certain archetypal symbols with physiological processes?

Professor Jung:

[300] The case you refer to was submitted to me by Dr. Davie, and afterwards he published it without my knowledge.¹⁸ I do not wish to say more about this correlation

because I do not yet feel on very safe ground. Questions of differential diagnosis between organic disease and psychological symbols are very difficult, and I prefer not to say anything about it for the time being.

Dr. Strauss:

[301] But your diagnosis was made from the facts of the dream?

Professor Jung:

[302] Yes, because the organic trouble disturbed the mental functioning. There was a serious depression and presumably a profound disturbance of the sympathetic system.

Dr. H. Crichton-Miller:

[303] Tomorrow is the last seminar, and there is a point that interests us that has not been referred to. That is the difficult problem of transference. I wonder if Professor Jung would think it proper to give us his view tomorrow—without dealing necessarily with other schools—as to transference and the proper handling of it?

LECTURE V

The Chairman (Dr. J. R. Rees):

[304] Ladies and Gentlemen: You will have noticed that the Chairman's remarks have been growing shorter each evening. Yesterday Professor Jung was in the middle of a continuous story, and I think we all want him to get on with it straight away.

Professor Jung:

[305] Ladies and Gentlemen: You remember that I began to give you the material belonging to this dream. I am now in the middle of it and there is a great more to come. But at the end of yesterday's lecture I was asked by Dr. Crichton-Miller to speak about the problem of transference. That showed me something which seems to be of practical interest. When I analyse such a dream carefully and put in a great deal of work, it often happens that my colleagues wonder why I am heaping up such a quantity of learned material. They think, "Well, yes, it shows his zeal and his goodwill to make something of a dream. But what is the practical use of all these parallels?"

[306] I do not mind these doubts in the least. But I was really just about to bring in something belonging to the problem, and Dr. Crichton-Miller has caught me in this attempt and asked just that question which any practical doctor would ask. Practical doctors are troubled by practical problems, and not by theoretical questions; therefore they always get a bit impatient when it comes to theoretical elucidations. They are particularly troubled by the half-amusing, half-painful, even tragic problems of transference. If you had been a little bit more patient, you would have seen that I was handling the very material by which transference can be analysed. But since the question has been raised I think I should rather give way to your wish and talk about the psychology and treatment of transference. But the choice is up to you. My feeling was that Dr. Crichton-Miller had spoken the mind of the majority of you. Am I right in this assumption?

Members:

[307] Yes.

Professor Jung:

[308] I think you are right in your decision, for if I am going to speak about transference I shall have the opportunity to lead back to what I had originally intended with the analysis of that dream. I am afraid we will not have time to finish it; but I think it is better if I start from your actual problems and your actual difficulties.

[309] I would never have been forced to work out that elaborate symbolism and this careful study of parallels if I had not been terribly worried by the problem of transference. So, in discussing the question of transference, an avenue will open to the kind of work I was trying to describe to you in my lecture last night. I told you in the beginning that my lectures will be a sorry torso. I am simply unable, in five evenings, even if I compress things together as I have done, to give you a complete summary of what I have to tell.

[310] Speaking about the transference makes it necessary first to define the concept so that we really understand what we are talking about. You know that the word transference, originally coined by Freud, has become a sort of colloquial term; it has even found its way into the larger public. One generally means by it an awkward hanging-on, an adhesive sort of relationship.

[311] The term “transference” is the translation of the German word *Übertragung*. Literally *Übertragung* means: to carry something over from one place to another. The word *Übertragung* is also used in a metaphorical sense to designate the carrying over from one form into another. Therefore in German it is synonymous with *Übersetzung*—that is, translation.

[312] The psychological process of transference is a specific form of the more general process of projection. It is important to bring these two concepts together and to realize that transference is a special case of projection—at least that is how I understand it. Of course, everybody is free to use the term in his own way.

[313] Projection is a general psychological mechanism that carries over subjective contents of any kind into the object. For instance, when I say, “The colour of this room is yellow,” that is a projection, because in the object itself there is no yellow; yellow is only in us. Colour is our subjective experience as you know. The same when I hear a sound, that is a projection, because sound does not exist in itself; it is a sound in my head, it is a psychic phenomenon which I project.

[314] Transference is usually a process that happens between two people and not between a human subject and a physical object, though there are exceptions; whereas the more general mechanism of projection, as we have seen, can just as well extend to physical objects. The mechanism of projection, whereby subjective contents are carried over into the object and appear as if belonging to it, is never a voluntary act, and transference, as a specific form of projection, is no exception to this rule. You cannot consciously and intentionally project, because then you know all the time that

you are projecting your subjective contents; therefore you cannot locate them in the object, for you know that they really belong to you. In projection the apparent fact you are confronted with in the object is in reality an illusion; but you assume what you observe in the object not to be subjective, but objectively existing. Therefore, a projection is abolished when you find out that the apparently objective facts are really subjective contents. Then these contents become associated with your own psychology, and you cannot attribute them to the object any more.

[315] Sometimes one is apparently quite aware of one's projections though one does not know their full extent. And that portion of which one is not aware remains unconscious and still appears as if belonging to the object. This often happens in practical analysis. You say, for instance: "Now, look here, you simply project the image of your father into that man, or into myself," and you assume that this is a perfectly satisfactory explanation and quite sufficient to dissolve the projection. It is satisfactory to the doctor, perhaps, but not to the patient. Because, if there is still something more in that projection, the patient will keep on projecting. It does not depend upon his will; it is simply a phenomenon that produces itself. Projection is an automatic, spontaneous fact. It is simply there; you do not know how it happens. You just find it there. And this rule, which holds good for projection in general, is also true of transference. Transference is something which is just there. If it exists at all, it is there *a priori*. Projection is always an *unconscious* mechanism, therefore consciousness, or conscious realization, destroys it.

[316] Transference, strictly, as I have already said, is a projection which happens between two individuals and which, as a rule, is of an emotional and compulsory nature. Emotions in themselves are always in some degree overwhelming for the subject, because they are involuntary conditions which override the intentions of the ego. Moreover, they cling to the subject, and he cannot detach them from himself. Yet this involuntary condition of the subject is at the same time projected into the object, and through that a bond is established which cannot be broken, and exercises a compulsory influence upon the subject.

[317] Emotions are not detachable like ideas or thoughts, because they are identical with certain physical conditions and are thus deeply rooted in the heavy matter of the body. Therefore the emotion of the projected contents always forms a link, a sort of dynamic relationship, between the subject and the object—and that is the transference. Naturally, this emotional link or bridge or elastic string can be positive or negative, as you know.

[318] The projection of emotional contents always has a peculiar influence. Emotions are contagious, because they are deeply rooted in the sympathetic system; hence the word "sympathicus." Any process of an emotional kind immediately arouses similar processes in others. When you are in a crowd which is moved by an emotion, you

cannot fail to be roused by that same emotion. Suppose you are in a country where a language is spoken which you don't understand, and somebody makes a joke and people laugh, then you laugh too in an idiotic way, simply because you can't refrain from laughing. Also when you are in a crowd which is politically excited you can't help being excited too, even when you do not share their opinion at all, because emotion has this suggestive effect. The French psychologists have dealt with this "contagion mentale"; there are some very good books on the subject, especially *The Crowd: A Study of the Popular Mind*, by Le Bon.

[319] In psychotherapy, even if the doctor is entirely detached from the emotional contents of the patient, the very fact that the patient has emotions has an effect upon him. And it is a great mistake if the doctor thinks he can lift himself out of it. He cannot do more than become conscious of the fact that he is affected. If he does not see that, he is too aloof and then he talks beside the point. It is even his duty to accept the emotions of the patient and to mirror them. That is the reason why I reject the idea of putting the patient upon a sofa and sitting behind him. I put my patients in front of me and I talk to them as one natural human being to another, and I expose myself completely and react with no restriction.

[320] I remember very well a case of an elderly woman of about fifty-eight—a doctor too—from the United States. She arrived in Zurich in a state of utter bewilderment. She was so confused at first I thought her half crazy, until I discovered that she had been in an analysis. She told me certain things she had done in her bewilderment, and it was quite obvious that she would never have done these things if her analyst had been a human being and not a mystical cipher who was sitting behind her, occasionally saying a wise word out of the clouds and never showing an emotion. So she got quite lost in her own mists and did some foolish things which he could easily have prevented her from doing if he had behaved like a human being. When she told me all that, I naturally had an emotional reaction and swore, or something like that. Upon which she shot out of her chair and said reproachfully, "But you have an emotion!" I answered, "Why, of course I have an emotion." She said, "But you should not have an emotion." I replied, "Why not? I have a good right to an emotion." She objected, "But you are an analyst!" I said, "Yes, I am an analyst, and I have emotions. Do you think that I am an idiot or a catatonic?" "But analysts have no emotions." I remarked, "Well, your analyst apparently had no emotions, and, if I may say so, he was a fool!" That one moment cleared her up completely; she was absolutely different from then on. She said, "Thank heaven! Now I know where I am. I know there is a human being opposite me who has human emotions!" My emotional reaction had given her orientation. She wasn't a thinking type, she was a feeling type and therefore needed that kind of orientation. But her analyst was a man who simply thought and existed in his intellect, and had no connection with her feeling-life. She

was a highly emotional sanguine sort of person who needed the emotionality and the feeling gesture of another human being in order not to feel alone. When you have to treat a feeling type and you talk intellectual stuff exclusively it is the same as if you, as the only intellectual, were talking to a company of feeling types. You would be utterly lost; you would feel as if you were at the North Pole, because you wouldn't be understood; nobody would react to your ideas. People would all be frightfully nice—and you would feel utterly foolish because they would not respond to your way of thinking.

[321] One always has to answer people in their main function, otherwise no contact is established. So, in order to be able to show my patients that their reactions have arrived in my system, I have to sit opposite them so that they can read the reactions in my face and can see that I am listening. If I sit behind them, then I can yawn, I can sleep, I can go off on my own thoughts, and I can do what I please. They never know what is happening to me, and then they remain in an auto-erotic and isolated condition which is not good for ordinary people. Of course, if they were going to prepare for an existence as hermits on the Himalayas, it would be a different matter.

[322] The emotions of patients are always slightly contagious, and they are very contagious when the contents which the patient projects into the analyst are identical with the analyst's own unconscious contents. Then they both fall into the same dark hole of unconsciousness, and get into the condition of participation. This is the phenomenon which Freud has described as countertransference. It consists of mutual projecting into each other and being fastened together by mutual unconsciousness. Participation, as I have told you, is a characteristic of primitive psychology, that is, of a psychological level where there is no conscious discrimination between subject and object. Mutual unconsciousness is of course most confusing both to the analyst and to the patient; all orientation is lost, and the end of such an analysis is disaster.

[323] Even analysts are not absolutely perfect, and it can happen that they are occasionally unconscious in certain respects. Therefore long ago I stipulated that analysts ought to be analysed themselves: they should have a father confessor or a mother confessor. Even the Pope, for all his infallibility, has to confess regularly, and not to a monsignor or a cardinal but to an ordinary priest. If the analyst does not keep in touch with his unconscious objectively, there is no guarantee whatever that the patient will not fall into the unconscious of the analyst. You probably all know certain patients who possess a diabolical cunning in finding out the weak spot, the vulnerable place in the analyst's psyche. To that spot they seek to attach the projections of their own unconscious. One usually says that it is a characteristic of women, but that is not true, men do just the same. They always find out this vulnerable spot in the analyst, and he can be sure that, whenever something gets into him, it will be exactly in that place where he is without defence. That is the place

where he is unconscious himself and where he is apt to make exactly the same projections as the patient. Then the condition of participation happens, or, more strictly speaking, a condition of personal contamination through mutual unconsciousness.

[324] One has, of course, all sorts of ideas about transference, and we are all somewhat prejudiced by the definition which Freud has given; one is inclined to think that it is always a matter of erotic transference. But my experience has not confirmed the theory that it is erotic contents or infantile things exclusively that are projected. According to my experience, anything can be a matter for projection, and the erotic transference is just one of the many possible forms of transference. There are many other contents in the human unconscious which are also of a highly emotional nature, and they can project themselves just as well as sexuality. All activated contents of the unconscious have the tendency to appear in projection. It is even the rule that an unconscious content which is constellated shows itself first as a projection. Any activated archetype can appear in projection, either into an external situation, or into people, or into circumstances—in short, into all sorts of objects. There are even transferences to animals and to things.

[325] Not very long ago I had an interesting case of an unusually intelligent man. I explained to him a projection he had “made”: he had projected his unconscious image of woman into a real woman, and the dreams showed very clearly just where the real person was utterly different from what he expected her to be. The fact went home. Then he said, “If I had known that two years ago it would have saved me 40,000 francs!” I asked, “How is that?” “Well, somebody showed me an old Egyptian sculpture, and I instantly fell in love with it. It was an Egyptian cat, a very beautiful thing.” He instantly bought it for 40,000 francs and put it on the mantelpiece in his drawing-room. But then he found that he had lost his peace of mind. His office was on the floor below, and nearly every hour he had to jump up from his work to look at the cat, and when he had satisfied his desire he went back to work only to go upstairs again after some time. This restlessness became so disagreeable that he put the cat on his desk right opposite him—to find that he couldn’t work any more! Then he had to lock it away in the attic in order to be liberated from its influence, and he had to fight down a continuous temptation to open the box and look at the cat again. When he understood his general projection of the feminine image—for, of course, the cat symbolized the woman—then the whole charm and fascination of the sculpture was gone.

[326] That was a projection into a physical object, and it made the cat into a living being to whom he always had to return as some people return to the analyst. As you know, the analyst is often accused of having snake’s eyes, of magnetizing or hypnotizing people, of forcing them to come back to him, of not letting them go.

There *are* certain exceptionally bad cases of countertransference when the analyst really cannot let go of the patient; but usually such accusations are the expression of a very disagreeable kind of projection which may even amount to ideas of persecution.

[327] The intensity of the transference relationship is always equivalent to the importance of its contents to the subject. If it is a particularly intense transference, we can be sure that the contents of the projection, once they are extracted and made conscious, will prove to be just as important to the patient as the transference was. When a transference collapses it does not vanish into the air; its intensity, or a corresponding amount of energy, will appear in another place, for instance in another relationship, or in some other important psychological form. For the intensity of the transference is an intense emotion which is really the property of the patient. If the transference is dissolved, all that projected energy falls back into the subject, and he is then in possession of the treasure which formerly, in the transference, had simply been wasted.

[328] Now we have to say a few words about the *aetiology* of the transference. Transference can be an entirely spontaneous and unprovoked reaction, a sort of “love at first sight.” Of course transference should never be misunderstood as love; it has nothing to do with love whatever. Transference only misuses love. It may appear as if transference were love, and inexperienced analysts make the mistake of taking it for love, and the patient makes the same mistake and says that he is in love with the analyst. But he is not in love at all.

[329] Occasionally a transference can even spring up before the first sight, that is before or outside the treatment. And if it happens to a person who does not come for analysis afterwards, we cannot find out the reasons. But this shows all the more that it has nothing whatever to do with the real personality of the analyst.

[330] Once a lady came to me whom I had seen about three weeks before at a social reception. I had not even spoken to her then, I had only talked to her husband, and I knew him only rather superficially. The lady then wrote for a consultation, and I gave her an appointment. She came, and when she was at the door of my consulting room she said, “I don’t want to enter.” I replied, “You don’t have to enter; you can go away, of course! I have absolutely no interest in having you here if you don’t want to come.” Then she said, “But I must!” I answered, “I’m not forcing you.” “But you forced me to come.” “How did I do that?” I thought she was crazy, but she was not crazy at all, she merely had a transference which pulled her to me. She had made some kind of projection in the meantime, and that projection had such a high emotional value for her that she could not resist it; she was magically drawn to come to me because that elastic string was too strong for her. In the course of her analysis we naturally found out what the contents of that non-provoked transference were.

[331] Usually a transference establishes itself only during the analysis. Very often it is caused by a difficulty in making contact, in establishing emotional harmony between the doctor and the patient—what the French psychologists at the time of hypnotic and suggestion therapy used to call “le rapport.” A good rapport means that the doctor and patient are getting on well together, that they can really talk to each other and that there is a certain amount of mutual confidence. Of course, at the time of the hypnotic therapists, the whole hypnotic and suggestive effect depended on the existence or non-existence of the rapport. In analytical treatment, if the rapport between analyst and patient is difficult on account of differences of personality, or if there are other psychological distances between them that hinder the therapeutic effect, that lack of contact causes the unconscious of the patient to try to cover the distance by building a compensatory bridge. Since there is no common ground, no possibility of forming any kind of relationship, a passionate feeling or an erotic fantasy attempts to fill the gap.

[332] This often happens to people who habitually resist other human beings—either because of an inferiority complex or because of megalomania, or for other reasons—and who are psychologically very isolated. Then, out of fear of getting lost, their nature causes a violent effort of the emotions to attach themselves to the analyst. They are in despair that perhaps he too will not understand them: so they try to propitiate either the circumstances, or the analyst, or their own unwillingness by a sort of sexual attraction.

[333] All these compensatory phenomena can be turned round and be applied to the analyst as well. Suppose, for instance, that an analyst has to treat a woman who does not particularly interest him, but suddenly he discovers that he has a sexual fantasy about her. Now I don't wish it on analysts that they should have such fantasies, but if they do they had better realize it, because it is important information from their unconscious that their human contact with the patient is not good, that there is a disturbance of rapport. Therefore the analyst's unconscious makes up for the lack of a decent human rapport by forcing a fantasy upon him in order to cover the distance and to build a bridge. These fantasies can be visual, they can be a certain feeling or a sensation—a sexual sensation, for instance. They are invariably a sign that the analyst's attitude to the patient is wrong, that he overvalues him or undervalues him or that he does not pay the right attention. That correction of his attitude can also be expressed by dreams. So if you dream of a patient, always pay attention and try to see whether the dream is showing you where you may be wrong. Patients are tremendously grateful when you are honest in that respect, and they feel it very much when you are dishonest or neglectful.

[334] I once had a most instructive case of that sort. I was treating a young girl of about twenty or twenty-four. She had had a very peculiar childhood; she was born in Java

of a very good European family, and had a native nurse.¹ As happens with children born in the colonies, the exotic environment and that strange and, in this case, even barbarous civilization got under her skin, and the whole emotional and instinctual life of the child became tainted with that peculiar atmosphere. That atmosphere is something the white man in the East hardly ever realizes; it is the psychic atmosphere of the native in regard to the white man, an atmosphere of intense fear—fear of the cruelty, the recklessness, and the tremendous and unaccountable power of the white man. That atmosphere infects children born in the East; the fear creeps into them and fills them with unconscious fantasies about the cruelty of the white man, and their psychology gets a peculiar twist and their sex life often goes completely wrong. They suffer from unaccountable nightmares and panics and cannot adapt themselves to normal circumstances when it comes to the problem of love and marriage and so on.

[335] That was the case with this girl. She went hopelessly astray and got into the most risky erotic situations, and she acquired a very bad reputation. She adopted inferior ways; she began to paint and powder herself in a rather conspicuous fashion, also to wear big ornaments in order to satisfy the primitive woman in her blood, or rather in her skin, so that *she* could join in and help her to live. Because she could not and naturally would not live without her instincts, she had to do all sorts of things which went too low. For instance, she easily succumbed to bad taste; she wore terrible colours to please the primitive unconscious in her so that it would join in when she wanted to interest a man. But naturally her choice of men was also below the mark, and so she got into a frightful tangle. Her nickname was “the great whore of Babylon.” All this was, of course, most unfortunate for an otherwise decent girl. When she came to me she really looked absolutely forbidding, so that I felt pretty awkward on account of my own maids when she was in my office for an hour. I said, “Now, you simply can’t look like that, you look like—” and I said something exceedingly drastic. She was very sad over it but she couldn’t help it.

[336] At this point I dreamed of her in the following way: *I was on a highway at the foot of a high hill, and upon the hill was a castle, and on that castle was a high tower, the donjon. On top of that high tower was a loggia, a beautiful open contrivance with pillars and a beautiful marble balustrade, and upon that balustrade sat an elegant figure of a woman. I looked up—and I had to look up so that I felt the pain in my neck even afterwards—and the figure was my patient!* Then I woke up and instantly I thought, “Heavens! Why does my unconscious put that girl so high up?” And immediately the thought struck me, “I have looked down on her.” For I really thought that she was bad. My dream showed me that this was a mistake, and I knew that I had been a bad doctor. So I told her the next day: “I have had a dream about you where I had to look up to you so that my neck hurt me, and the reason for this compensation is that I have looked down on you.” That worked miracles, I can tell you! No trouble

with the transference any more, because I simply got right with her and met her on the right level.

[337] I could tell you quite a number of informative dreams like that about the doctor's own attitude. And when you really try to be on a level with the patient, not too high nor too low, when you have the right attitude, the right appreciation, then you have much less trouble with the transference. It won't save you from it entirely, but sure enough you won't have those bad forms of transference which are mere over-compensations for a lack of rapport.

[338] There is another reason for over-compensation by transference in the case of patients with an utterly auto-erotic attitude; patients who are shut away in auto-erotic insulation and have a thick coat of armour, or a thick wall and moat around them. Yet they have a desperate need for human contact, and they naturally begin to crave for a human being outside the walls. But they don't do anything about it. They won't lift a finger, and neither will they allow anybody to approach them, and from this attitude they get a terrible transference. Such transferences cannot be touched, because the patients are too well defended on all sides. On the contrary, if you try to do something about the transference, they feel it as a sort of aggression, and they defend themselves still more. So you must leave these people to roast in their own fat until they are satisfied and come voluntarily out of their fortress. Of course they will complain like anything about your lack of understanding and so on, but the only thing you can do is to be patient and say, "Well, you are inside, you show nothing, and as long as you don't show anything I can do nothing either."

[339] In such a case the transference can come almost to the boiling point, because only a strong flame will cause the person to leave his castle. Of course that means a great outburst; but the outburst must be borne quietly by the doctor, and the patient will later on be very thankful that he has not been taken literally. I remember the case of a colleague of mine—and I can safely tell you of this case because she is dead—an American woman who came to me under very complicated circumstances. In the beginning she was on her high horse. You know there are peculiar institutions in America called universities and colleges for women; in our technical language we call them animus incubators, and they turn out annually a large number of fearful persons. Now she was such a bird. She was "very competent," she had got into a disagreeable transference situation. She was an analyst and had a case of a married man who fell wildly in love with her, apparently. It was not, of course, love, it was transference. He projected into her that she wanted to marry him but would not admit that she was in love with him and so wasted no end of flowers and chocolates and finery over her, and finally he even threatened her with a revolver. So she had to leave at once and come to me.

[340] It soon turned out that she had no idea of a woman's feeling-life. She was O.K. as a doctor, but whatever touched the sphere of a man was absolutely and utterly strange to her. She was even blissfully ignorant of a man's anatomy, because at the university, where she had studied one only dissected female bodies. So you can imagine the situation with which I was confronted.

[341] Naturally I saw it coming, and I saw right away why the man had fallen into the trap. She was totally unconscious of herself as a woman; she was just a man's mind with wings underneath, and the whole woman's body was non-existent, and her patient was forced by nature to fill the gap. He had to prove to her that a man does exist and that a man has a claim, that she was a woman and that she should respond to him. It was her female non-existence that baited the trap. He was, of course, equally unconscious, because he did not see at all that she did not exist as a woman. You see, he also was such a bird, consisting of only a head with wings underneath. He also was not a man. We often discover with Americans that they are tremendously unconscious of themselves. Sometimes they suddenly grow aware of themselves, and then you get these interesting stories of decent young girls eloping with Chinamen or with Negroes, because in the American that primitive layer, which with us is a bit difficult, with them is decidedly disagreeable, as it is much lower down. It is the same phenomenon as "going black" or "going native" in Africa.

[342] Now these two people both came into this awful transference situation, and one could say they were both entirely crazy, and therefore the woman had to run away. The treatment was, of course, perfectly clear. One had to make her conscious of herself as a woman, and a woman never becomes conscious of herself as long as she cannot accept the fact of her feelings. Therefore her unconscious arranged a marvellous transference to me, which naturally she would not accept, and I did not force it upon her. She was just such a case of complete insulation, and facing her with her transference would merely have forced her into a position of defence which of course would have defeated the whole purpose of the treatment. So I never spoke of it and just let things go, and quietly worked along with the dreams. The dreams, as they always do, were steadily informing us of the progress of her transference. I saw the climax coming and knew that one day a sudden explosion would take place. Of course, it would be a bit disagreeable and of a very emotional nature, as you have perhaps noticed in your own experience, and I foresaw a highly sentimental situation. Well, you just have to put up with it; you cannot help it. After six months of very quiet and painstaking systematic work she couldn't hold herself in any longer, and suddenly she almost shouted: "But I love you!" and then she broke down and fell upon her knees and made an awful mess of herself.

[343] You just have to stand such a moment. It is really awful to be thirty-four years old and to discover suddenly that you are human. Then it comes, of course, as a big lump

to you and that lump is often indigestible. If I had told her six months before that the moment would come when she would make declarations of love, she would have jumped off to the moon. Hers was a condition of auto-erotic insulation, and the rising flame, the increasing fire of her emotions finally burned through the walls, and naturally it all came out as a sort of organic eruption. She was the better for its happening, and in that moment even the transference situation in America was settled.

[344] You probably think that all this sounds pretty cold-blooded. As a matter of fact, you can only cope decently with such a situation when you do not behave as if you were superior. You have to accompany the process and lower your consciousness and feel along the situation, in order not to differ too much from your patient; otherwise he feels too awkward and will have the most terrible resentment afterwards. So it is quite good to have a reserve of sentiments which you can allow to play on such an occasion. Of course it requires some experience and routine to strike the right note. It is not always quite easy, but one has to bridge over these painful moments so that the reactions of the patient will not be too bad.

[345] I have already mentioned a further reason for the transference, and that is mutual unconsciousness and contamination.² The case which I just told you about provides an example of this. Contamination through mutual unconsciousness happens as a rule when the analyst has a similar lack of adaptation to that of the patient; in other words, when he is neurotic. In so far as the analyst is neurotic, whether his neurosis be good or bad, he has an open wound, somewhere there is an open door which he does not control, and there a patient will get in, and then the analyst will be contaminated. Therefore it is an important postulate that the analyst should know as much as possible about himself.

[346] I remember the case of a young girl who had been with two analysts before she came to me, and when she came to me she had the identical dream she had had when she was with those analysts.³ Each time at the very beginning of her analysis she had a particular dream: *She came to the frontier and she wanted to cross it, but she could not find the custom-house where she should have gone to declare whatever she carried with her.* In the first dream she was seeking the frontier, but she did not even come to it. That dream gave her the feeling that she would never be able to find the proper relation to her analyst; but because she had feelings of inferiority and did not trust her judgment, she remained with him, and nothing came of it at all. She worked with him for two months and then she left.

[347] She then went to another analyst. Again she dreamed that *she came to the frontier; it was a black night, and the only thing she could see was a faint little light. Somebody said that that was the light in the custom-house, and she tried to get to it. On the way she went down a hill and crossed a valley. In the depths of the valley was*

a dark wood and she was afraid to go on, but nevertheless she went through it, and suddenly she felt that somebody was clinging to her in the darkness. She tried to shake herself free, but that somebody clung to her still more, and she suddenly discovered that it was her analyst. Now what happened was that after about three months of work this analyst developed a violent counter-transference to her, which the initial dream had foreseen.

[348] When she came to me—she had seen me before at a lecture and had made up her mind to work with me—she dreamed that *she was coming to the Swiss frontier. It was day and she saw the custom-house. She crossed the frontier and she went into the custom-house, and there stood a Swiss customs official. A woman went in front of her and he let that woman pass, and then her turn came. She had only a small bag with her, and she thought she would pass unnoticed. But the official looked at her and said: “What have you got in your bag?” She said: “Oh, nothing at all,” and opened it. He put his hand in and pulled out something that grew bigger and bigger, until it was two complete beds.* Her problem was that she had a resistance against marriage; she was engaged and would not marry for certain reasons, and those beds were the marriage-beds. I pulled that complex out of her and made her realize the problem, and soon after she married.

[349] These initial dreams are often most instructive. Therefore I always ask a new patient when he first comes to me: “Did you know some time ago that you were coming? Have you met me before? Have you had a dream lately, perhaps last night?”—because if he did, it gives me most valuable information about his attitude. And when you keep in close touch with the unconscious you can turn many a difficult corner. A transference is always a hindrance; it is never an advantage. You cure in spite of the transference, not because of it.

[350] Another reason for the transference, particularly for bad forms of it, is provocation on the part of the analyst. There are certain analysts, I am sorry to say, who work for a transference because they believe, I don’t know why, that transference is a useful and even necessary part of the treatment; therefore patients *ought* to have a transference. Of course this is an entirely mistaken idea. I have often had cases who came to me after a previous analysis and who after a fortnight or so became almost desperate. So far things had gone on very nicely and I was fully confident that the case would work out beautifully—and suddenly the patients informed me that they could not go on, and then the tears came. I asked, “Why can’t you go on? Have you got no money, or what is the matter?” They said, “Oh, no, that is not the reason. I have no transference.” I said, “Thank heaven you have no transference! A transference is an illness. It is abnormal to have a transference. Normal people never have transferences.” Then the analysis goes on again quietly and nicely.

[351] We do not need transference just as we do not need projection. Of course, people will have it nevertheless. They always have projections but not the kind they expect. They have read Freud on transference, or they have been with another analyst, and it has been pumped into them that they ought to have a transference or they will never be cured. This is perfect nonsense. Transference or no transference, that has nothing to do with the cure. It is simply due to a peculiar psychological condition that there are these projections, and, just as one dissolves other projections by making them conscious, one has to dissolve the transference by making it conscious too. If there is no transference, so much the better. You get the material just the same. It is not transference that enables the patient to bring out his material; you get all the material you could wish for from dreams. The dreams bring out everything that is necessary. If you work for a transference, most likely you will provoke one, and the result of the analysis will be bad; for you can only provoke a transference by insinuating the wrong things, by arousing expectations, by making promises in a veiled way, which you do not mean to keep because you could not. You cannot possibly have affairs with eleven thousand virgins, and so you cheat people. An analyst is not allowed to be too friendly, otherwise he will be caught by it: he will produce an effect which goes beyond him. He cannot pay the bill when it is presented, and he should not provoke something for which he is not willing to pay. Even if the analyst means to do it for the good of the patient, it is a very misguided way, and it is always a great mistake. Leave people where they are. It does not matter whether they love the analyst or not. We are not all Germans who want to be loved when they sell you a pair of sock-suspenders. It is too sentimental. The patient's main problem is precisely to learn how to live his own life, and you don't help him when you meddle with it.

[352] Those are some of the reasons for a transference. The general psychological reason for projection is always an activated unconscious that seeks expression. The intensity of the transference is equivalent to the importance of the projected content. A strong transference of a violent nature corresponds to a fiery content; it contains something important, something of great value to the patient. But as long as it is projected, the analyst seems to embody this most precious and important thing. He can't help being in this unfortunate position, but he has to give that value back to the patient, and the analysis is not finished until the patient has integrated the treasure. So, if a patient projects the saviour complex into you, for instance, you have to give back to him nothing less than a saviour—whatever that means. But *you* are not the saviour—most certainly not.

[353] Projections of an archetypal nature involve a particular difficulty for the analyst. Each profession carries its respective difficulties, and the danger of analysis is that of becoming infected by transference projections, in particular by archetypal contents. When the patient assumes that his analyst is the fulfilment of his dreams, that he is

not an ordinary doctor but a spiritual hero and a sort of saviour, of course the analyst will say, "What nonsense! This is just morbid. It is a hysterical exaggeration." Yet—it tickles him; it is just too nice. And, moreover, he has the same archetypes in himself. So he begins to feel, "If there are saviours, well, perhaps it is just possible that I am one," and he will fall for it, at first hesitantly, and then it will become more and more plain to him that he really is a sort of extraordinary individual. Slowly he becomes fascinated and exclusive. He is terribly touchy, susceptible, and perhaps makes himself a nuisance in medical societies. He cannot talk with his colleagues any more because he is—I don't know what. He becomes very disagreeable or withdraws from human contacts, isolates himself, and then it becomes more and more clear to him that he is a very important chap really and of great spiritual significance, probably an equal of the Mahatmas on the Himalayas, and it is quite likely that he also belongs to the great brotherhood. And then he is lost to the profession.

[354] We have very unfortunate examples of this kind. I know quite a number of colleagues who have gone that way. They could not resist the continuous onslaught of the patients' collective unconscious—case after case projecting the saviour complex and religious expectations and the hope that perhaps this analyst with his "secret knowledge" might own the key that has been lost by the Church, and thus could reveal the redeeming truth. All this is a subtle and very alluring temptation and they have given way to it. They identify with the archetype, they discover a creed of their own, and as they need disciples who believe in them they will found a sect.

[355] The same problem also accounts for the peculiar difficulty psychologists of different schools have in discussing their divergent ideas in a reasonably amicable way, and for a tendency, peculiar to our branch of science, to lock themselves into little groups and scientific sects with a faith of their own. All these groups really doubt their exclusive truth, and therefore they all sit together and say the same thing continually until they finally believe it. Fanaticism is always a sign of repressed doubt. You can study that in the history of the Church. Always in those times when the Church begins to waver the style becomes fanatical, or fanatical sects spring up, because the secret doubt has to be quenched. When one is really convinced, one is perfectly calm and can discuss one's belief as a personal point of view without any particular resentment.

[356] It is a typical occupational hazard of the psychotherapist to become psychically infected and poisoned by the projections to which he is exposed. He has to be continually on his guard against inflation. But the poison does not only affect him psychologically; it may even disturb his sympathetic system. I have observed quite a number of the most extraordinary cases of physical illness among psychotherapists, illness which does not fit in with the known medical symptomatology, and which I ascribe to the effect of this continuous onslaught of projections from which the

analyst does not discriminate his own psychology. The peculiar emotional condition of the patient does have a contagious effect. One could almost say it arouses similar vibrations in the nervous system of the analyst, and therefore, like alienists, psychotherapists are apt to become a little queer. One should bear that problem in mind. It very definitely belongs to the problem of transference.

[357] We now have to speak of the *therapy* of the transference.⁴ This is an enormously difficult and complicated subject, and I am afraid I shall tell you certain things which you know just as well as I do, but in order to be systematic I cannot omit them.

[358] It is obvious that the transference has to be dissolved and dealt with in the same way as the analyst would deal with any other projection. That means in practical terms: you have to make the patient realize the *subjective value* of the personal and impersonal contents of his transference. For it is not only personal material which he projects. As you have just heard, the contents can just as well be of an impersonal, that is archetypal, nature. The saviour complex is certainly not a personal motif; it is a world-wide expectation, an idea which you find all over the world and in every epoch of history. It is the archetypal ideas of the magic personality.⁵

[359] In the beginning of an analysis, transference projections are inevitable repetitions of former personal experiences of the patient's. At this stage you have to treat all the relationships which the patient has had before. For instance, if you have a case who has been in many health-resorts with the typical doctors you find in such places, the patient will project these experiences into the analyst; so you have first to work through the figures of all those colleagues in seaside places and sanatoria, with enormous fees and the necessary theatrical display, and the patient quite naturally assumes that you too are such a bird. You have to work through the whole series of people that the patient has experienced—the doctors, the lawyers, the teachers in schools, the uncles, the cousins, the brothers, and the father. And when you have gone through the whole procession and come right down to the nursery you think that now you are through with it, but you are not. It is just as if behind the father there was still more, and you even begin to suspect that the grandfather is being projected. That is possible; I never knew of a great-grandfather that was projected into me, but I know of a grandfather that was. When you have got down to the nursery, so that you almost peep out of the other side of existence, then you have exhausted the possibilities of *consciousness*; and if the transference does not come to an end there, despite all your efforts, it is on account of the projection of *impersonal* contents. You recognize the existence of impersonal projections by the peculiar impersonal nature of their contents; as for instance the saviour complex or an archaic God-image. The archetypal character of these images produces a "magic," that is, an overpowering effect. With our rational consciousness we can't see why this should happen. God, for instance, is spirit, and spirit to us is nothing substantial or dynamic. But if you study

the original meaning of these terms, you get at the real nature of the underlying experience, and you understand how they affect the primitive mind, and, in a similar way, the primitive psyche in ourselves. Spirit, *spiritus*, or *pneuma* really means air, wind, breath; *spiritus* and *pneuma* in their archetypal character are dynamic and half-substantial agencies: you are moved by them as by a wind, they are breathed into you, and then you are inflated.

[360] The projected archetypal figures can just as well be of negative character, like images of the sorcerer, the devil, of demons and so on. Even analysts are not at all quite fireproof in that respect. I know colleagues who produce the most marvellous fantasies about myself and believe that I am in league with the devil and work black magic. And with people who never before thought that there was such a thing as the devil, the most incredible figures appear in the transference of impersonal contents. The projection of images of parental influence can be dissolved with the ordinary means of normal reasoning and common sense; but you cannot destroy the hold of impersonal images by mere reason. It would not even be right to destroy them, because they are tremendously important. In order to explain this, I am afraid I shall have to refer again to the history of the human mind.

[361] It is no new discovery that archetypal images are projected. They actually have to be projected, otherwise they inundate consciousness. The problem is merely to have a form which is an adequate container. There is, as a matter of fact, an age-old institution which helps people to project impersonal images. You know it very well: you all probably have gone through the procedure, but unfortunately you were too young to recognize its importance. This institution is religious initiation, and with us it is baptism. When the fascinating and unique influence of the parental images has to be loosened, so that the child is liberated from his original biological participation with the parents, then Nature, that is the unconscious nature in man, in her infinite wisdom produces a certain kind of initiation. You find it with very primitive tribes—it is the initiation into manhood, into participation in the spiritual and social life of the tribe. In the course of the differentiation of consciousness, initiation has undergone many changes of form, until with us it was elaborated into the Christian institution of baptism. In baptism, there are two necessary functionaries, godfather and godmother. In our Swiss dialect we call them by the names of God, “Götti” and “Gotte.” “Götti” is the masculine form, it means the begetter; “Gotte” is the feminine form. The word “God” has nothing to do with “good”; it really means the Begetter. Baptism and the spiritual parents in the form of godfather and godmother express the mysterium of being twice-born. You know that all the higher castes in India have the honorific title of “Twice-born.” It was also the prerogative of the Pharaoh to be twice-born. Therefore very often you find in Egyptian temples beside the main room the so-called birth-chamber where one or two rooms were reserved for the rite. In

them the Pharaoh's twofold birth is described, how he is born in the flesh as a human being from ordinary parents, but is also generated by the god and carried and given birth to by the goddess. He is born the son of man and of God.

[362] Our baptism means the detaching of the child from the merely natural parents and from the overpowering influence of the parental images. For this purpose, the biological parents are replaced by spiritual parents; godfather and godmother represent the *intercessio divina* through the medium of the Church, which is the visible form of the spiritual kingdom. In the Catholic rite even marriage—where we would suppose it to be all-important that this particular man and this particular woman become united and are confronted with each other—is interfered with by the Church; the *intercessio sacerdotis* prevents the immediate contact of the couple. The priest represents the Church, and the Church is always in between in the form of confession, which is obligatory. This intervention is not due to the particular cunning of the Church; it is rather her great wisdom, and it is an idea going back to the very origins of Christianity that we are not married merely as man and woman; we are married *in Christo*. I own an antique vase upon which an early Christian marriage is represented. The man and the woman hold each other's hand in the Fish; the Fish is between them, and the Fish is Christ. In this way the couple is united in the Fish. They are separated and united by Christ; Christ is in between, he is the representative of the power which is meant to separate man from merely natural forces.

[363] This process of separation from nature is undergone in the well-known initiation rites or puberty rites of primitive tribes. When they approach puberty, the boys are called away suddenly. In the night they hear the voice of the spirits, the bull-roarers, and no woman is allowed to appear out of the house, or she is killed instantly. Then the boys are brought out to the bush-house, where they are put through all sorts of gruesome performances. They are not allowed to speak; they are told that they are dead, and then they are told that they are now reborn. They are given new names in order to prove that they are no more the same personalities as before, and so they are no longer the children of their parents. The initiation can even go so far that, after they return, the mothers are not allowed to talk to their sons any more, because the young men are no longer their children. Formerly, with the Hottentots, the boy had occasionally even to perform incest once with his mother in order to prove that she was not his mother any more, but just a woman like the rest.

[364] Our corresponding Christian rite has lost much of its importance, but if you study the symbolism of baptism you still see traces of the original meaning. Our birth-chamber is the baptismal font; this is really the piscina, the fish-pond in which one is like a little fish; one is symbolically drowned and then revived. You know that the early Christians were actually plunged into the baptismal font, and this used to be much larger than it is now; in many old churches the baptistry was a building on its

own, and it was always built on the ground-plan of a circle. On the day before Easter, the Catholic Church has a special ceremony for the consecration of the baptismal font, the *Benedictio Fontis*. The merely natural water is exorcised from the admixture of all malign powers and transformed into the regenerating and purifying fountain of life, the immaculate womb of the divine source. Then the priest divides the water in the fourfold form of the cross, breathes upon it three times, plunges the consecrated Easter candle three times into it, as a symbol of the eternal light, and at the same time his incantation brings the virtue, the power of the *Spiritus Sanctus* to descend into the font. From this *hierosgamos*, from the holy marriage between the *Spiritus Sanctus* and the baptismal water as the womb of the Church, man is reborn in the true innocence of new childhood. The maculation of sin is taken from him and his nature is joined with the image of God. He is no longer contaminated by merely natural forces, he is regenerated as a spiritual being.

[365] We know of other institutions for detaching man from natural conditions. I can't go into much detail, but if you study the psychology of primitives, you find that all important events of life are connected with elaborate ceremonies whose purpose is to detach man from the preceding stage of existence and to help him to transfer his psychic energy into the next phase. When a girl marries, she ought to be detached from the parental images and should not become attached to a projection of the father-image into the husband. Therefore in Babylon a peculiar ritual was observed whose purpose was to detach the young girl from the father-image. This is the rite of temple prostitution, in which girls of good families had to hand themselves over to a stranger visiting the temple, who presumably would never return, and had to spend a night with him. We know of a similar institution in the Middle Ages, the *jus primae noctis*, the right of the first night which the feudal lord had in regard to his serfs. The bride had to spend her wedding-night with her feudal lord. By the rite of temple prostitution, a most impressive image was created which collided with the image of the man the young woman was going to marry, and so when there was trouble in marriage—for even in those days trouble occasionally arose—the regression which is the natural result would not go back to the father-image but to the stranger she had once met, the lover who came from unknown lands. Then she did not fall back into childhood but upon a human being suited to her age, and so was sufficiently protected against infantile regression.

[366] This ritual shows a very beautiful observation of the human psyche. For there is an archetypal image in women of a lover in a remote, unknown land, a man coming over the seas who meets her once and then goes away again. You know this motif from Wagner's *Flying Dutchman* and from Ibsen's *Lady from the Sea*. In both dramas the heroine is waiting for the stranger who will come from far over the seas to have the great love experience with her. In Wagner's opera she has fallen in love with the

actual image of him and knows him even before he arrives. The Lady from the Sea has met him once before and is under the compulsion of always going to the sea to await his return. In that Babylonian rite this archetypal image is lived concretely in order to detach the woman from the parental images which are real archetypal images and therefore exceedingly powerful. I have written a little book about the relations between the ego and the unconscious,⁶ where I have described a case of projection of the father-image by a woman who was under my treatment, and how the problem then developed through the analysis of the archetypal image which was at the basis of this father transference.

[367] The first stage of the treatment of the transference does not involve only the realization by the patient that he is still looking at the world from the angle of the nursery, school-room, and so on, by projecting and expecting all the positive and negative authoritative figures of his personal experience; this realization merely deals with the objective side. To establish a really mature attitude, he has to see the *subjective value* of all these images which seem to create trouble for him. He has to assimilate them into his own psychology; he has to find out in what way they are part of himself; how he attributes for instance a positive value to an *object*, when as a matter of fact it is he who could and should develop this value. And in the same way, when he projects negative qualities and therefore hates and loathes the object, he has to discover that he is projecting his own inferior side, his shadow, as it were, because he prefers to have an optimistic and one-sided image of himself. Freud, as you know, deals only with the objective side. But you cannot really help a patient to assimilate the contents of his neurosis by indulgence in a childish lack of responsibility, or by resignation to a blind fate of which he is the victim. His neurosis means him to become a total personality, and that includes recognition of and responsibility for his whole being, his good and his bad sides, his superior as well as his inferior functions.

[368] Let us now assume that the projection of personal images has been worked through and is sufficiently dealt with, but there is still a transference which you simply cannot dissolve. Then we come to the *second stage* in the therapy of transference. That is the *discrimination between personal and impersonal contents*. The personal projections, as we have seen, must be dissolved; and they can be dissolved through conscious realization. But the impersonal projections cannot be destroyed because they belong to the structural elements of the psyche. They are not relics of a past which has to be outgrown; they are, on the contrary, purposive and compensatory functions of the utmost importance. They are an important protection against situations in which a man might lose his head. In any situation of panic, whether external or internal, the archetypes intervene and allow a man to react in an instinctively adapted way, just as if he had always known the situation: he reacts in

the way mankind has always reacted. Therefore the mechanism is of vital importance.

[369] It goes without saying that the projection of these impersonal images upon the analyst has to be withdrawn. But you merely dissolve the *act* of projection; you should not, and really cannot, dissolve its *contents*. Neither, of course, can the patient assimilate the impersonal contents into his personal psychology. The fact that they are *impersonal* contents is just the reason for projecting them; one feels that they do not belong to one's subjective mind, they must be located somewhere outside one's ego, and, for lack of a suitable form, a human object is made their receptacle. So you have to be exceedingly careful in handling impersonal projections. It would, for instance, be a great mistake to say to a patient: "You see, you simply project the saviour-image into me. What nonsense to expect a saviour and to make me responsible." If you meet such an expectation, take it seriously; it is by no means nonsense. The whole world has a saviour expectation; you find it everywhere. Look at Italy, for instance, or look at Germany. At present you have no saviour in England, and in Switzerland we have none; but I don't believe that we are so very different from the rest of Europe. The situation with us is slightly different from that of the Italians and Germans; they are perhaps a little bit less balanced; but even with us it would need precious little. In those countries you have the saviour complex as mass psychology. The saviour complex is an archetypal image of the collective unconscious, and it quite naturally becomes activated in an epoch so full of trouble and disorientation as ours. In these collective events, we merely see, as through a magnifying glass, what can also happen within the individual. It is in just such a moment of panic that the compensatory psychic elements come into action. It is not at all an abnormal phenomenon. It is perhaps strange to us that it should be expressed in political form. But the collective unconscious is a very irrational factor, and our rational consciousness cannot dictate to it how it should make its appearance. Of course, if left entirely to itself, its activation can be very destructive; it can, for instance, be a psychosis. Therefore, man's relation to the collective unconscious has always been regulated; there is a characteristic form by which the archetypal images are expressed. For the collective unconscious is a function that always operates, and man has to keep in touch with it. His psychic and spiritual health is dependent on the co-operation of the impersonal images. Therefore man has always had his religions.

[370] What are religions? Religions are psychotherapeutic systems. What are we doing, we psychotherapists? We are trying to heal the suffering of the human mind, of the human psyche or the human soul, and religions deal with the same problem. Therefore our Lord himself is a healer; he is a doctor; he heals the sick and he deals with the troubles of the soul; and that is exactly what we call psychotherapy. It is not a play on words when I call religion a psychotherapeutic system. It is the most

elaborate system, and there is a great practical truth behind it. I have a clientele which is pretty large and extends over a number of continents, and where I live we are practically surrounded by Catholics; but during the last thirty years I have not had more than about six practising Catholics among my patients. The vast majority were Protestants and Jews. I once sent round a questionnaire to people whom I did not know, asking: "If you were in psychological trouble what would you do? Would you go to the doctor or would you go to the priest or parson?" I cannot remember the actual figures; but I remember that about twenty per cent of the Protestants said they would go to the parson. All the rest were most emphatically against the parson and for the doctor, and the most emphatic were the relatives and children of parsons. There was one Chinese who replied, and he put it very nicely. He remarked: "When I am young I go to the doctor, and when I am old I go to the philosopher." But about fifty-eight or sixty per cent of the Catholics answered that they would certainly go to the priest. That proves that the Catholic Church in particular, with its rigorous system of confession and its director of conscience, is a therapeutic institution. I have had some patients who, after having had analysis with me, even joined the Catholic Church, just as I have had some patients who now go to the so-called Oxford Group Movement—with my blessing! I think it is perfectly correct to make use of these psychotherapeutic institutions which history has given to us, and I wish I were still a medieval man who could join such a creed. Unfortunately it needs a somewhat medieval psychology to do it, and I am not sufficiently medieval. But you see from this that I take the archetypal images and a suitable form for their projection seriously, because the collective unconscious is really a serious factor in the human psyche.

[371] All those personal things like incestuous tendencies and other childish tunes are mere surface; what the unconscious really contains are the great collective events of the time. In the collective unconscious of the individual, history prepares itself; and when the archetypes are activated in a number of individuals and come to the surface, we are in the midst of history, as we are at present. The archetypal image which the moment requires gets into life, and everybody is seized by it. That is what we see today. I saw it coming, I said in 1918 that the "blond beast" is stirring in its sleep and that something will happen in Germany.⁷ No psychologist then understood at all what I meant, because people had simply no idea that our personal psychology is just a thin skin, a ripple upon the ocean of collective psychology. The powerful factor, the factor which changes our whole life, which changes the surface of our known world, which makes history, is collective psychology, and collective psychology moves according to laws entirely different from those of our consciousness. The archetypes are the great decisive forces, they bring about the real events, and not our personal reasoning and practical intellect. Before the Great War all intelligent people said:

“We shall not have any more war, we are far too reasonable to let it happen, and our commerce and finance are so interlaced internationally that war is absolutely out of the question.” And then we produced the most gorgeous war ever seen. And now they begin to talk that foolish kind of talk about reason and peace plans and such things; they blindfold themselves by clinging to a childish optimism—and now look at reality! Sure enough, the archetypal images decide the fate of man. Man’s unconscious psychology decides, and not what we think and talk in the brain-chamber up in the attic.

[372] Who would have thought in 1900 that it would be possible thirty years later for such things to happen in Germany as are happening today? Would you have believed that a whole nation of highly intelligent and cultivated people could be seized by the fascinating power of an archetype? I saw it coming, and I can understand it because I know the power of the collective unconscious. But on the surface it looks simply incredible. Even my personal friends are under that fascination, and when I am in Germany, I believe it myself, I understand it all, I know it has to be as it is. One cannot resist it. It gets you below the belt and not in your mind, your brain just counts for nothing, your sympathetic system is gripped. It is a power that fascinates people from within, it is the collective unconscious which is activated, it is an archetype which is common to them all that has come to life. And because it is an archetype, it has historical aspects and we cannot understand the events without knowing history.⁸ It is German history that is being lived today, just as Fascism is living Italian history. We cannot be children about it, having intellectual and reasonable ideas and saying: this should not be. That is just childish. This is real history, this is what really happens to man and has always happened, and it is far more important than our personal little woes and our personal convictions. I know highly educated Germans who were just as reasonable as I think I am or as you think you are. But a wave went over them and just washed their reason away, and when you talk to them you have to admit that they could not do anything about it. An incomprehensible fate has seized them, and you cannot say it is right, or it is wrong. It has nothing to do with rational judgment, it is just history. And when your patient’s transference touches upon the archetypes, you touch upon a mine that may explode, just as we see it explode collectively. These impersonal images contain enormous dynamic power. Bernard Shaw says in *Man and Superman*: “This creature Man, who in his own selfish affairs is a coward to the backbone, will fight for an idea like a hero.”⁹ Of course, we would not call Fascism or Hitlerism ideas. They are archetypes, and so we would say: Give an archetype to the people and the whole crowd moves like one man, there is no resisting it.

[373] On account of this tremendous dynamic power of archetypal images you cannot reason them away. Therefore the only thing to do at the *third stage* of the therapy of

the transference is *to differentiate the personal relationship to the analyst from impersonal factors*. It is perfectly understandable that when you have carefully and honestly worked for a patient, he likes you, and because you have done a decent bit of work on a patient, you like him, whether it is a man or a woman. That is quite self-evident. It would be most unnatural and neurotic if there were not some personal recognition on the patient's part for what you have done for him. A personal human reaction to you is normal and reasonable, therefore let it be, it deserves to live; it is not transference any more. But such an attitude to the analyst is possible in a human and decent form only when it is not vitiated by unrecognized impersonal values. This means that there has to be, on the other side, a full recognition of the importance of the archetypal images, many of which have a religious character. Whether you assume that the Nazi storm in Germany has a religious value or not does not matter. It has. Whether you think that the Duce is a religious figure or not does not matter, because he is a religious figure. You could even read the affirmation of it in a newspaper these days, when they quoted that verse about a Roman Caesar: "Ecce deus, deus ille, Menalca."¹⁰ Fascism is the Latin form of religion, and its religious character explains why the whole thing has such a tremendous fascination.

[374] The consequence of this recognition of the importance of impersonal values may be that your patient joins a Church or a religious creed or whatever it may be. If he cannot bring together his experience of the collective unconscious within a given religious form, then the difficulty begins. Then the impersonal factors have no receptacle, and so the patient falls back into the transference, and the archetypal images spoil the human relation to the analyst. Then the analyst *is* the saviour, or curse him, he is not when he ought to be! For he is only a human being; he cannot be the saviour nor any other archetypal image which is activated in the patient's unconscious.

[375] On account of that enormously difficult and important problem I have worked out a particular technique for restoring these projected impersonal values to the individual himself. It is a rather complicated technique, and last night I was just about to show you something of it in relation to that dream. For when the unconscious says that below the Christian Church is the secret chamber with the golden bowl and the golden dagger, it does not lie. The unconscious is nature, and nature never lies. There *is* gold, there *is* the treasure and the great value.

[376] If I had had the opportunity I would have gone on and told you something about that treasure and the means to secure it. And then you would have seen the justification for the method which enables the individual to keep in touch with his impersonal images. As it is. I can only allude to it and must refer you to my books for further material.¹¹

[377] I call this *fourth stage* of the therapy of transference the *objectivation of impersonal images*. It is an essential part of the process of individuation.¹² Its goal is to detach consciousness from the object so that the individual no longer places the guarantee of his happiness, or of his life even, in factors outside himself, whether they be persons, ideas, or circumstances, but comes to realize that everything depends on whether he holds the treasure or not. If the possession of that gold is realized, then the centre of gravity is in the individual and no longer in an object on which he depends. To reach such a condition of detachment is the aim of Eastern practices, and it is also the aim of all the teachings of the Church. In the various religions the treasure is projected into the sacred figures, but this hypostasis is no longer possible for the modern enlightened mind. A great number of individuals cannot express their impersonal values in historical symbols any more.

[378] They are therefore faced with the necessity of finding an individual method by which the impersonal images are given shape. For they have to take on form, they have to live their characteristic life, otherwise the individual is severed from the basic function of the psyche, and then he is neurotic, he is disorientated and in conflict with himself. But if he is able to objectify the impersonal images and relate to them, he is in touch with that vital psychological function which from the dawn of consciousness has been taken care of by religion.

[379] It is impossible for me to go into details of the problem, not only because the time for my lecture is over, but because it is beyond scientific conceptions to give adequate expression to a living psychic experience. All we can say rationally about this condition of detachment is to define it as a sort of centre within the psyche of the individual, but not within the ego. It is a non-ego centre. I am afraid I should have to give you a long dissertation on comparative religion in order to convey to you fully what I mean by a non-ego centre.¹³ So I can only mention the existence of this problem. It is really the essential problem of a great number of individuals who come to analysis, and therefore the psychotherapist has to try to find a method by which he can help them to solve it.

[380] If we adopt such a method, we take up the torch that was abandoned by our old colleagues of the seventeenth century when they put it down in order to become chemists. In so far as we psychologists are emerging from chemical and material conceptions of the psyche, we are taking up that torch again, century—for alchemy was the work of the doctors who were busy with the mind.

Discussion

Question:

[381] May I ask Professor Jung a very elementary question: Would he give us a definition of neurosis?

Professor Jung:

[382] A neurosis is a dissociation of personality due to the existence of complexes. To have complexes is in itself normal; but if the complexes are incompatible, that part of the personality which is too contrary to the conscious part becomes split off. If the split reaches the organic structure, the dissociation is a psychosis, a schizophrenic condition, as the term denotes. Each complex then lives an existence of its own, with no personality left to tie them together.

[383] As the split-off complexes are unconscious, they find only an indirect means of expression, that is, through neurotic symptoms. Instead of suffering from a psychological conflict, one suffers from a neurosis. Any incompatibility of character can cause dissociation, and too great a split between the thinking and the feeling function, for instance, is already a slight neurosis. When you are not quite at one with yourself in a given matter, you are approaching a neurotic condition. The idea of psychic dissociation is the most general and cautious way I can define a neurosis. Of course it does not cover the symptomatology and phenomenology of neurosis; it is only the most general psychological formulation I am able to give.

Dr. H. G. Baynes:

[384] You said that transference is of no practical value in analysis. Is it not possible to give it a teleological value?

Professor Jung:

[385] I have not said it in so many words, but the teleological value of transference becomes apparent from an analysis of its archetypal contents. Its purposive value is also shown in what I said about transference as a function of compensation for a lack of rapport between the analyst and the patient—at least if one assumes that it is normal for human beings to be *en rapport* with each other. Of course I could imagine that an introverted philosopher is rather inclined to think that people have no contacts. For instance, Schopenhauer says that human egotism is so great that a man can kill his brother in order to smear his boots with his brother's fat.

Dr. Henry V. Dicks:

[386] I think we can assume then, Professor Jung, that you regard the outbreak of a neurosis as an attempt at self-cure, as an attempt at compensation by bringing out the inferior function?

Professor Jung:

[387] Absolutely.

Dr. Dicks:

[388] I understand, then, that the outbreak of a neurotic illness, from the point of view of man's development, is something favourable?

Professor Jung:

[389] That is so, and I am glad you bring up that idea. That is really my point of view. I am not altogether pessimistic about neurosis. In many cases we have to say: "Thank heaven he could make up his mind to be neurotic." Neurosis is really an attempt at self-cure, just as any physical disease is part an attempt at selfcure. We cannot understand a disease as an *ens per se* any more, as something detached which not so long ago it was believed to be. Modern medicine—internal medicine, for instance—conceives of disease as a system composed of a harmful factor and a healing factor. It is exactly the same with neurosis. It is an attempt of the self-regulating psychic system to restore the balance, in no way different from the function of dreams—only rather more forceful and drastic.

Dr. J. A. Hadfield:

[390] Would Professor Jung give us a short account of the technique of active imagination?

Professor Jung:

[391] That was the subject I really wanted to tell you about today in consequence of the analysis of the Toledo dream, so I am very glad to take it up. You will realize that I shall not be able to present any empirical material, but I may succeed in giving you an idea of the method. I believe that the best way is to tell you of a case where it was very difficult to teach the patient the method.

[392] I was treating a young artist, and he had the greatest trouble in understanding what I meant by active imagination. He tried all sorts of things but he could not get at

it. The difficulty with him was that he could not think. Musicians, painters, artists of all kinds, often can't think at all, because they never intentionally use their brain. This man's brain too was always working for itself; it had its artistic imaginations and he couldn't use it psychologically, so he couldn't understand. I gave him every chance to try, and he tried all sorts of stunts. I cannot tell you all the things he did, but I will tell you how he finally succeeded in using his imagination psychologically.

[393] I live outside the town, and he had to take the train to get to my place. It starts from a small station, and on the wall of that station was a poster. Each time he waited for his train he looked at that poster. The poster was an advertisement for Mürren in the Bernese Alps, a colourful picture of the waterfalls, of a green meadow and a hill in the centre, and on that hill were several cows. So he sat there staring at that poster and thinking that he could not find out what I meant by active imagination. And then one day he thought: "Perhaps I could start by having a fantasy about that poster. I might for instance imagine that I am myself in the poster, that the scenery is real and that I could walk up the hill among the cows and then look down on the other side, and then I might see what there is behind that hill."

[394] So he went to the station for that purpose and imagined that he was in the poster. He saw the meadow and the road and walked up the hill among the cows, and then he came up to the top and looked down, and there was the meadow again, sloping down, and below was a hedge with a stile. So he walked down and over the stile, and there was a little footpath that ran round a ravine, and a rock, and when he came round that rock, there was a small chapel, with its door standing a little ajar. He thought he would like to enter, and so he pushed the door open and went in, and there upon an altar decorated with pretty flowers stood a wooden figure of the Mother of God. He looked up at her face, and in that exact moment something with pointed ears disappeared behind the altar. He thought, "Well, that's all nonsense," and instantly the whole fantasy was gone.

[395] He went away and said, "Now again I haven't understood what active imagination is." And then, suddenly, the thought struck him: "Well, perhaps that really *was* there: perhaps that thing behind the Mother of God, with the pointed ears, that disappeared like a flash, really happened." Therefore he said to himself: "I will just try it all over as a test." So he imagined that he was back in the station looking at the poster, and again he fantasied that he was walking up the hill. And when he came to the top of the hill, he wondered what he would see on the other side. And there was the hedge and the stile and the hill sloping down. He said. "Well, so far so good. Things haven't moved since, apparently." And he went round the rock, and there was the chapel. He said: "There is the chapel, that at least is no illusion. It is all quite in order." The door stood ajar and he was quite pleased. He hesitated a moment and said: "Now, when I push that door open and I see the Madonna on the altar, then that

thing with the pointed ears should jump down behind the Madonna, and if it doesn't, then the whole thing is bunk!" And so he pushed the door open and looked—and there it all was and the thing jumped down, as before, and then he was convinced. From then on he had the key and knew he could rely on his imagination, and so he learned to use it.

[396] There is no time to tell you about the development of his images, nor how other patients arrive at the method. For of course everybody gets at it in his own way. I can only mention that it might also be a dream or an impression of a hypnagogic nature from which active imagination can start. I really prefer the term "imagination" to "fantasy," because there is a difference between the two which the old doctors had in mind when they said that "opus nostrum," our work, ought to be done "per veram imaginationem et non phantastica"—by true imagination and not by a fantastical one.¹³ In other words, if you take the correct meaning of this definition, fantasy is mere nonsense, a phantasm, a fleeting impression; but imagination is active, purposeful creation. And this is exactly the distinction I make too.

[397] A fantasy is more or less your own invention, and remains on the surface of personal things and conscious expectations. But active imagination, as the term denotes, means that the images have a life of their own and that the symbolic events develop according to their own logic—that is, of course, if your conscious reason does not interfere. You begin by concentrating upon a starting point. I will give you an example from my own experience. When I was a little boy, I had a spinster aunt who lived in a nice old-fashioned house. It was full of beautiful old coloured engravings. Among them was a picture of my grandfather on my mother's side. He was a sort of bishop, and he was represented as coming out of his house and standing on a little terrace. There were handrails and stairs coming down from the terrace, and a footpath leading to the cathedral. He was in full regalia, standing there at the top of the terrace. Every Sunday morning I was allowed to pay a call on my aunt, and then I knelt on a chair and looked at that picture until grandfather came down the steps. And each time my aunt would say, "But, my dear, he doesn't walk, he is still standing there." But I knew I had seen him walking down.

[398] You see how it happened that the picture began to move. And in the same way, when you concentrate on a mental picture, it begins to stir, the image becomes enriched by details, it moves and develops. Each time, naturally, you mistrust it and have the idea that you have just made it up, that it is merely your own invention. But you have to overcome that doubt, because it is not true. We can really produce precious little by our conscious mind. All the time we are dependent upon the things that literally fall into our consciousness; therefore in German we call them *Einfälle*. For instance, if my unconscious should prefer not to give me ideas, I could not proceed with my lecture, because I could not invent the next step. You all know the

experience when you want to mention a name or a word which you know quite well, and it simply does not present itself; but some time later it drops into your memory. We depend entirely upon the benevolent co-operation of our unconscious. If it does not co-operate, we are completely lost. Therefore I am convinced that we cannot do much in the way of conscious invention; we over-estimate the power of intention and the will. And so when we concentrate on an inner picture and when we are careful not to interrupt the natural flow of events, our unconscious will produce a series of images which make a complete story.

[399] I have tried that method with many patients and for many years, and I possess a large collection of such "opera." It is most interesting to watch the process. Of course I don't use active imagination as a panacea; there have to be definite indications that the method is suitable for the individual, and there are a number of patients with whom it would be wrong to force it upon them. But often in the later stage of analysis, the objectivation of images replaces the dreams. The images anticipate the dreams, and so the dream-material begins to peter out. The unconscious becomes deflated in so far as the conscious mind relates to it. Then you get all the material in a creative form and this has great advantages over dream-material. It quickens the process of maturation, for analysis is a process of quickened maturation. This definition is not my own invention; the old professor Stanley Hall invented the term.

[400] Since by active imagination all the material is produced in a conscious state of mind, the material is far more rounded out than the dreams with their precarious language. And it contains much more than dreams do; for instance, the feeling-values are in it, and one can judge it by feeling. Quite often, the patients themselves feel that certain material contains a tendency to visibility. They say, for instance: "That dream was so impressive, if I only could paint I would try to express its atmosphere." Or they feel that a certain idea should be expressed not rationally but in symbols. Or they are gripped by an emotion which, if given form, would be explainable, and so on. And so they begin to draw, to paint, or to shape their images plastically, and women sometimes do weaving. I have even had one or two women who danced their unconscious figures. Of course, they can also be expressed in writing.

[401] I have many complete series of such pictures. They yield an enormous amount of archetypal material. Just now I am about to work out the historical parallels of some of them. I compare them with the pictorial material produced in similar attempts in past centuries, particularly in the early Middle Ages. Certain elements of the symbolism go back to Egypt. In the East we find many interesting parallels to our unconscious material, even down to the last details. This comparative work gives us a most valuable insight into the structure of the unconscious. You have to hand the necessary parallels to the patients too, not of course in such an elaborate way as you would present it in a scientific study, but as much as each individual needs in order to

understand his archetypal images. For he can see their real meaning only when they are not just a queer subjective experience with no external connections, but a typical, ever-recurring expression of the objective facts and processes of the human psyche. By objectifying his impersonal images, and understanding their inherent ideas, the patient is able to work out all the values of his archetypal material. Then he can really see it, and the unconscious becomes understandable to him. Moreover, this work has a definite effect upon him. Whatever he has put into it works back on him and produces a change of attitude which I tried to define by mentioning the non-ego centre.

[402] I will give you an interesting example. I had a case, a university man, a very one-sided intellectual. His unconscious had become troubled and activated; so it projected itself into other men who appeared to be his enemies, and he felt terribly lonely, because everybody seemed to be against him. Then he began to drink in order to forget his troubles, but he got exceedingly irritable and in these moods he began to quarrel with other men, and several times he had very disagreeable encounters, and once he was thrown out of a restaurant and got beaten up. And there were more incidents of that sort. Then things became really too thick for his endurance, and he came to me to ask my advice about what he should do. In that interview, I got a very definite impression of him: I saw that he was chock-full of archaic material, and I said to myself: "Now I am going to make an interesting experiment to get that material absolutely pure, without any influence from myself, and therefore I won't touch it." So I sent him to a woman doctor who was then just a beginner and who did not know much about archetypal material. Thus I was absolutely sure that she would not tamper with it. The patient was in such low spirits that he did not object to my proposition. So he worked with her and did everything she said.¹⁴

[403] She told him to watch his dreams, and he wrote them all down carefully, from the first to the last. I now have a series of about thirteen hundred dreams of his. They contain the most marvellous series of archetypal images. And quite naturally, without being told to do so, he began to draw a number of pictures which he saw in his dreams, because he felt them to be very important. And in this work on his dreams and on these pictures he did exactly the kind of work which other patients do by active imagination. He even invented active imagination for himself in order to work out certain most intricate problems which his dreams presented him with, as for instance how to balance the contents of a circle, and more things like this. He worked out the problem of the *perpetuum mobile*, not in a crazy way but in a symbolic way. He worked on all the problems which medieval philosophy was so keen on and of which our rational mind says. "That is all nonsense." Such a statement only shows that we do not understand. They did understand: we are the fools, not they.

[404] In the course of this analysis, which took him through about the first four hundred dreams, he was not under my surveillance. After the first interview I did not see him at all for eight months. He was five months with that doctor, and then for three months he was doing the work all by himself, continuing the observation of his unconscious with minute accuracy. He was very gifted in this respect. In the end, for about two months, he had a number of interviews with me. But I did not have to explain much of the symbolism to him.

[405] The effect of this work with his unconscious was that he became a perfectly normal and reasonable person. He did not drink any more, he became completely adapted and in every respect completely normal. The reason for this is quite obvious: that man—he was not married—had lived in a very one-sided intellectual way, and naturally had certain desires and needs also. But he had no chance with women at all, because he had no differentiation of feeling whatsoever. So he made a fool of himself with women at once, and of course they had no patience with him. And he made himself very disagreeable to men, so he was frightfully lonely. But now he had found something that fascinated him; he had a new centre of interest. He soon discovered that his dreams pointed to something very meaningful, and so his whole intuitive and scientific interest was aroused. Instead of feeling like a lost sheep, he thought: “Ah, when I am through with my work in the evening, I go to my study, and then I shall see what happens. I will work over my dreams, and then I shall discover extraordinary things.” And so it was. Of course rational judgment would say that he just fell violently into his fantasies. But that was not the case at all. He did a real bit of hard work on his unconscious, and he worked out his images scientifically. When he came to me after his three months alone, he was already almost normal. Only he still felt uncertain; he was troubled because he could not understand some of the material he had dug up from the unconscious. He asked my advice about it, and I most carefully gave him certain hints as to its meaning, but only so far as this could help him to keep on with the work and carry it through.

[406] At the end of the year I am going to publish a selection from his first four hundred dreams, where I show the development of one motif only, the central motif of these archetypal images.¹⁵ There will be an English translation later, and then you will have the opportunity to see how the method works in a case absolutely untouched by myself, or by any other outside suggestion. It is a most amazing series of images and really shows what active imagination can do. You understand, in this case it was only partially a method for objectifying the images in plastic form, because many of the symbols appeared directly in the dreams; but all the same it shows the kind of atmosphere which active imagination can produce. I have patients who, evening after evening, work at these images, painting and shaping their observations and experiences. The work has a fascination for them; it is the

fascination which the archetypes always exert upon consciousness. But by objectifying them, the danger of their inundating consciousness is averted and their positive effect is made accessible. It is almost impossible to define this effect in rational terms; it is a sort of “magical” effect, that is, a suggestive influence which goes out from the images to the individual, and in this way his unconscious is extended and is changed.

[407] I am told that Dr. Bennet has brought some pictures by a patient. Will he be so kind as to show them?

This picture (Figure 14) is meant to represent a bowl or vase. Of course it is very clumsily expressed and is a mere attempt, a suggestion of a vase or bowl. The motif of the vessel is itself an archetypal image which has a certain purpose, and I can prove from this picture what the purpose is. A vessel is an instrument for containing things. It contains for instance liquids, and prevents them from getting dispersed. Our German word for vessel is *Gefäss*, which is the noun of *fassen*, that is, to set, to contain, to take hold of. The word *Fassung* means the setting, and also, metaphorically, composure, to remain collected. So the vessel in this picture indicates the movement of containing in order to gather in and to hold together. You have to hold something together which otherwise would fall asunder. From the way this picture is composed, and from certain features in it, it is obvious that the psychology of this man contains a number of disparate elements. It is a picture characteristic of a schizophrenic condition. I do not know the case at all, but Dr. Bennet confirms that my conclusion is correct. You see the disparate elements all over the picture; there are a number of things which are not motivated and which don't belong together. Moreover, you see peculiar lines dividing the field. These lines are characteristic of a schizophrenic mentality; I call them the breaking lines. When a schizophrenic paints a picture of himself, he naturally expresses the schizophrenic split in his own mental structure, and so you find these breaking lines which often go right through a particular figure, like the breaking lines in a mirror. In this picture, the figures themselves show no breaking lines; they only go all over the field.



FIG.14. Painting by a patient

[408] This man, then, tries to gather in all the disparate elements into the vessel. The vessel is meant to be the receptacle for his whole being, for all the incompatible units. If he tried to gather them into his ego, it would be an impossible task, because the ego can be identical only with one part at a time. So he indicates by the symbol of the vessel that he is trying to find a container for everything, and therefore he gives a hint at a non-ego centre by that sort of ball or globe in the middle.

[409] The picture is an attempt at self-cure. It brings all the disparate elements into the light, and it also tries to put them together into that vessel. This idea of a receptacle is an archetypal idea. You find it everywhere, and it is one of the central motifs of unconscious pictures. It is the idea of the magic circle which is drawn round something that has to be prevented from escaping or protected against hostile influences. The magic circle as an apotropaic charm is an archaic idea which you still find in folklore. For instance, if a man digs for a treasure, he draws the magic circle round the field in order to keep the devil out. When the ground-plan of a city was set out, there used to be a ritual walk or ride round the circumference in order to protect the place within. In some Swiss villages, it is still the custom for the priest and the

town council to ride round the fields when the blessing is administered for the protection of the harvest. In the centre of the magic circle or sacred precinct is the temple. One of the most wonderful examples of this idea is the temple of Borobudur in Java. The walk round, the *circumambulatio*, is done in a spiral: the pilgrims pass the figures of all the different lives of the Buddha, until on the top there is the invisible Buddha, the Buddha yet to come. The ground-plan of Borobudur is a circle within a square. This structure is called in Sanskrit a mandala. The word means a circle, particularly a magic circle. In the East, you find the mandala not only as the ground-plan of temples, but as pictures in the temples, or drawn for the day of certain religious festivals. In the very centre of the mandala there is the god or the symbol of divine energy, the diamond thunderbolt. Round this innermost circle is a cloister with four gates. Then comes a garden, and round this there is another circle which is the outer circumference.

[410] The symbol of the mandala has exactly this meaning of a holy place, a *temenos*, to protect the centre. And it is a symbol which is one of the most important motifs in the objectivation of unconscious images.¹⁶ It is a means of protecting the centre of the personality from being drawn out and from being influenced from outside.

[411] This picture by Dr. Bennet's patient is an attempt to draw such a mandala. It has a centre, and it contains all his psychic elements, and the vase would be the magic circle, the *temenos*, round which he has to do the *circumambulatio*. Attention is thus directed towards the centre, and at the same time all the disparate elements come under observation and an attempt is made to unify them. The *circumambulatio* had always to be done clockwise. If one turned round in the other direction it was very unfavourable. The idea of the *circumambulatio* in this picture is the patient's first attempt to find a centre and a container for his whole psyche. But he does not succeed. The design shows no balance, and the vase is toppling over. It even topples over towards the left, towards the side of the unconscious. So the unconscious is still too powerful. If he wants his apotropaic magic to work, he must do it in a different way. We shall see what he does in the next picture.

[412] In this picture (Figure 15) he makes an attempt at symmetry. Now these disparate, monstrous things which he could not grasp before are collected and assimilated into more favourable, less pathological forms. He can now gather the living units of his unconscious, in the form of snakes, into the sacred vase. And the vase stands firm, it does not topple over any more, and its shape has improved. He does not succeed yet with his intention; but at least he can give his animals some form. They are all animals of the underworld, fishes that live in the deep sea, and snakes of the darkness. They symbolize the lower centres of his psychology, the sympathetic system. A most remarkable thing is that he also gathers in the stars. That means that the cosmos, his world, is collected into the picture. It is an allusion to the

unconscious astrology which is in our bones, though we are unaware of it. At the top of the whole picture is the personification of the unconscious, a naked anima-figure who turns her back. That is a typical position; in the beginning of the objectivation of these images the anima-figure often turns her back. At the foot of the vase are eight figures of the crescent moon; the moon is also a symbol of the unconscious. A man's unconscious is the lunar world, for it is the night world, and this is characterized by the moon, and Luna is a feminine designation, because the unconscious is feminine. There are still various breaking lines which disturb the harmony. But I should assume that if no particular trouble interferes, the patient will most likely continue along this constructive line. I should say that there is hope that he might come round altogether, because the appearance of the anima is rather a positive sign. She also is a sort of vase, for in the beginning she incorporates the whole of the unconscious, instead of its being scattered in all the various units. Also, the patient tries to separate the motifs to the right and to the left, and this indicates an attempt at conscious orientation. The ball or globe in the first picture has disappeared, but this is not a negative sign. The whole vessel is the centre, and he has corrected the toppling over of the vase, it stands quite firmly on its base. All this shows that he is really making an attempt to put himself right.



[413] The pictures should be given back to the patient because they are very important. You can get copies; patients like to do copies for the doctor. But he should leave the originals with the patients, because they want to look at them; and when they look at them they feel that their unconscious is expressed. The objective form works back on them and they become enchanted. The suggestive influence of the picture reacts on the psychological system of the patient and induces the same effect which he put into the picture. That is the reason for idols, for the magic use of sacred images, of icons. They cast their magic into our system and put us right, provided we put ourselves into them. If you put yourself into the icon, the icon will speak to you. Take a Lamaic mandala which has a Buddha in the centre, or a Shiva, and, to the extent that you can put yourself into it, it answers and comes into you. It has a magic effect.

[414] Because these pictures of the unconscious express the actual psychological condition of the individual, you can use them for the purpose of diagnosis. You can tell right away from such a picture where the patient stands, whether he has a schizophrenic disposition or is merely neurotic. You can even tell what his prognosis is. It only needs some experience to make these paintings exceedingly helpful. Of course, one should be careful. One should not be dogmatic and say to every patient, "Now you paint." There are people who think: "Dr. Jung's treatment consists in telling his patients to paint," just as formerly they thought: "He divides them into introverts and extraverts and says 'you should live in such and such a way, because you belong to this type or that.'" That is certainly not treatment. Each patient is a new problem for the doctor, and he will only be cured of his neurosis if you help him to find his individual way to the solution of his conflicts.

The Chairman:

[415] Ladies and Gentlemen, you have been expressing by your applause something of what you feel about Professor Jung. This is the last time in this group of talks that we will have the honour and pleasure and privilege of hearing Professor Jung. We have only inadequate ways of expressing our thanks to him for these lectures which have been so stimulating, so challenging, which have left us with so many things to think about in the future, things which to all of us, especially those who are practising psychotherapy, are enormously suggestive. I think that is what you meant to do for us, Sir, and that is what you have done. We in this Institute are extremely proud to have had you here talking to us, and all of us, I think, are harbouring the idea that before long you will be back in England to talk to us again and make us think more about these great problems.

II

SYMBOLS AND THE INTERPRETATION OF DREAMS

[This essay was composed in English and completed shortly before Jung's death in June 1961. Without title, it was written to introduce a symposium, *Man and His Symbols* (© 1964 Aldus Books, London), consisting of essays by Jung and four colleagues, edited by Jung and after his death by Dr. Marie-Louise von Franz, with John Freeman as coordinating editor. The symposium was conceived as a popular presentation of Jung's ideas, and accordingly its contents were, with the authors' agreement, extensively reworked under the supervision of John Freeman in collaboration with Dr. von Franz. Jung's essay was largely rewritten and, particularly in the opening sections, rearranged; a number of deletions were made, some explanatory passages were added, and it was given the title "Approaching the Unconscious." The present version is Jung's original text, revised by R. F. C. Hull; except for some minor transpositions the original arrangement has been preserved. The illustrations (122 in the original edn.) have been omitted. Chapter divisions and titles have been introduced in consultation with Dr. von Franz. Acknowledgment is made to Aldus Books and Doubleday and Co. for permission to incorporate some stylistic improvements from the 1964 version.—EDITORS.]

1. THE SIGNIFICANCE OF DREAMS

[416] Through his language, man tries to designate things in such a way that his words will convey the meaning of what he intends to communicate. But sometimes he uses terms or images that are not strictly descriptive and can be understood only under certain conditions. Take, for instance, the many abbreviations like UN, UNESCO, NATO, etc., which infest our newspapers, or trademarks or the names of patent medicines. Although one cannot see what they mean, they yet have a definite meaning if you know it. Such designations are not *symbols*, they are *signs*. What we call a symbol is a term, a name, or an image which in itself may be familiar to us, but its connotations, use, and application are specific or peculiar and hint at a hidden, vague, or unknown meaning. Take as an example the image of the double adze that occurs frequently on Cretan monuments. We know the object, but we do not know its specific meaning. Again, a Hindu who had been on a visit to England told his friends at home that the English worshipped animals, because he had found eagles, lions, and oxen in their old churches and cathedrals, and he was not aware that these animals were the symbols of the evangelists. There are even many Christians who do not know that they are derived from the vision of Ezekiel, which in turn offers a parallel to the Egyptian Horus and his four sons. Other examples are the wheel and the cross, which are universally known objects, yet under certain conditions they are symbolic and mean something that is still a matter for controversial speculation.

[417] A term or image is symbolic when it means more than it denotes or expresses. It has a wider “unconscious” aspect—an aspect that can never be precisely defined or fully explained. This peculiarity is due to the fact that, in exploring the symbol, the mind is finally led towards ideas of a transcendent nature, where our reason must capitulate. The wheel, for instance, may lead our thoughts to the idea of a “divine” sun, but at this point reason has to admit its inadequacy, for we are unable to define or to establish the existence of a “divine” being. We are merely human, and our intellectual resources are correspondingly limited. We may call something “divine,” but this is simply a name, a *façon de parler*. based perhaps on a creed, yet never amounting to a proof.

[418] Because there are innumerable things beyond the range of human understanding, we constantly use symbolic expressions and images when referring to them (ecclesiastical language in particular is full of symbols). But this conscious use of symbolism is only one aspect of a psychological fact of great importance: we also produce symbols unconsciously and spontaneously in our dreams.

[419] Each act of apperception, or cognition, accomplishes its task only partially: it is never complete. First of all, sense-perception, fundamental to all experience, is restricted by the limited number and quality of our senses, which can however be compensated to a certain extent by the use of instruments, but not sufficiently to eliminate entirely a fringe of uncertainty. Moreover apperception translates the observed fact into a seemingly incommensurable medium—into a psychic event, the nature of which is unknowable. Unknowable, because cognition cannot cognize itself—the psyche cannot know its own psychic substance. There is thus an indefinite number of unknown factors in every experience, in addition to which the object of cognition is always unknown in certain respects since we cannot know the ultimate nature of matter itself.

[420] Every conscious act or event thus has an unconscious aspect, just as every sense-perception has a subliminal aspect: for instance, sound below or above audibility, or light below or above visibility. The unconscious part of a psychic event reaches consciousness only indirectly, if at all. The event reveals the existence of its unconscious aspect inasmuch as it is characterized either by emotionality or by a vital importance that has not been realized consciously. The unconscious part is a sort of afterthought, which may become conscious in the course of time by means of intuition or by deeper reflection. But the event can also manifest its unconscious aspect—and this is usually the case—in a dream. The dream shows this aspect in the form of a symbolic image and not as a rational thought. It was the understanding of dreams that first enabled us to investigate the unconscious aspect of conscious psychic events and to discover its nature.

[421] It has taken the human mind a long time to arrive at a more or less rational and scientific understanding of the functional meaning of dreams. Freud was the first who tried to elucidate the unconscious background of consciousness in an empirical way. He worked on the general assumption that dream-contents are related to conscious representations through the law of association, i.e., by causal dependence, and are not merely chance occurrences. This assumption is by no means arbitrary but is based on the empirical fact, observed long ago by neurologists and especially by Pierre Janet, that neurotic symptoms are connected with some conscious experience. They even appear to be split-off areas of the conscious mind which, at another time and under different conditions, can be conscious, just as an hysterical anaesthesia can be there one moment and gone the next, only to reappear again after a while. Breuer and Freud recognized more than half a century ago that neurotic symptoms are meaningful and make sense inasmuch as they express a certain thought. In other words, they function in the same manner as dreams: they *symbolize*. A patient, for instance, confronted with an intolerable situation, develops a spasm whenever he tries to swallow: “He can’t swallow it.” Under similar conditions another patient

develops asthma: “He can’t breathe the atmosphere at home.” A third suffers from a peculiar paralysis of the legs: “He can’t go on any more.” A fourth vomits everything he eats: “He can’t stomach it.” And so on. They could all just as well have had dreams of a similar kind.

[422] Dreams, of course, display a greater variety and are often full of picturesque and luxuriant fantasy, but they boil down eventually to the same basic thought if one follows Freud’s original method of “free association.” This method consists in letting the patient go on talking about his dream-images. That is precisely what the non-psychological doctor omits to do. Being always pressed for time, he loathes letting his patient babble on about his fantasies seemingly without end. Yet, if he only knew, his patient is just about to give himself away and to reveal the unconscious background of his ailment. Anyone who talks long enough will inevitably betray himself by what he says and what he purposely refrains from saying. He may try very hard to lead the doctor and himself away from the real facts, but after a while it is quite easy to see which point he is trying to steer away from. Through apparently rambling and irrational talk, he unconsciously circumscribes a certain area to which he continually returns in ever-renewed attempts to hide it. In his circumlocutions he even makes use of a good deal of symbolism, apparently serving his purpose of hiding and avoiding yet pointing all the time to the core of his predicament.

[423] Thus, if the doctor is patient enough, he will hear a wealth of symbolic talk, seemingly calculated to hide something, a secret, from conscious realization. A doctor sees so many things from the seamy side of life that he is seldom far from the truth when he interprets the hints which his patient is emitting as signs of an uneasy conscience. What he eventually discovers, unfortunately, confirms his expectations. Thus far nobody can say anything against Freud’s theory of repression and wish-fulfilment as apparent causes dream symbolism.

[424] If one considers the following experience, however, one becomes sceptical. A friend and colleague of mine, travelling for long hours on a train journey through Russia, passed the time by trying to decipher the Cyrillic script of the railway notices in his compartment. He fell into a sort of reverie about what the letters might mean and—following the principle of “free association”—what they reminded him of, and soon he found himself in the midst of all sorts of reminiscences. Among them, to his great displeasure, he did not fail to discover those old and disagreeable companions of sleepless nights, his “complexes”—repressed and carefully avoided topics which the doctor would joyously point to as the most likely causes of a neurosis or the most convincing meaning of a dream.

[425] There was no dream, however, merely “free associations” to incomprehensible letters, which means that from any point of the compass you can reach the centre directly. Through free association you arrive at the critical secret thoughts, no matter

where you start from, be it symptoms, dreams, fantasies, Cyrillic letters or examples of modern art. At all events, this fact proves nothing with regard to dreams and their real meaning. It only shows the existence of associable material floating about. Very often dreams have a very definite, as if purposeful, structure, indicating the underlying thought or intention though, as a rule, the latter is not immediately comprehensible.

[426] This experience was an eye-opener to me, and, without dismissing the idea of “association” altogether, I thought one should pay more attention to the dream itself, i.e., to its actual form and statement. For instance, a patient of mine dreamed of a drunken, dishevelled, vulgar woman called his “wife” (though in reality his wife was totally different). The dream statement, therefore, is shocking and utterly unlike reality, yet that is what the dream says. Naturally such a statement is not acceptable and is immediately dismissed as dream nonsense. If you let the patient associate freely to the dream, he will most likely try to get away as far as possible from such a shocking thought in order to end up with one of his staple complexes, but you will have learnt nothing about the meaning of this particular dream. What is the unconscious trying to convey by such an obviously untrue statement?

[427] If somebody with little experience and knowledge of dreams should think that dreams are just chaotic occurrences without meaning, he is at liberty to do so. But if one assumes that they are normal events, which as a matter of fact they are, one is bound to consider that they are either causal—i.e., that there is a rational cause for their existence—or in some way purposive, or both; in other words, that they make sense.

[428] Clearly, the dream is seeking to express the idea of a degenerate female who is closely connected with the dreamer. This idea is projected upon his wife, where the statement becomes untrue. What does it refer to, then?

[429] Subtler minds in the Middle Ages already knew that every man “carries Eve, his wife, hidden in his body.”¹ It is this feminine element in every man (based on the minority of female genes in his biological make-up) which I have called the *anima*. “She” consists essentially in a certain inferior kind of relatedness to the surroundings and particularly to women, which is kept carefully concealed from others as well as from oneself. A man’s visible personality may seem quite normal, while his anima side is sometimes in a deplorable state. This was the case with our dreamer: his female side was not nice. Applied to his anima, the dream-statement hits the nail on the head when it says: you are behaving like a degenerate female. It hits him hard as indeed it should. One should not, however, understand such a dream as evidence for the *moral nature* of the unconscious. It is merely an attempt to balance the lopsidedness of the conscious mind, which had believed the fiction that one was a perfect gentleman throughout.

[430] Such experiences taught me to mistrust free association. I no longer followed associations that led far afield and away from the manifest dream-statement. I concentrated rather on the actual dream-text as the thing which was intended by the unconscious, and I began to circumambulate the dream itself, never letting it out of my sight, or as one turns an unknown object round and round in one's hands to absorb every detail of it.

[431] But why should one consider dreams, those flimsy, elusive, unreliable, vague, and uncertain phantasms, at all? Are they worthy of our attention? Our rationalism would certainly not recommend them, and the history of dream interpretation before Freud was a sore point anyway; most discouraging in fact, most "unscientific" to say the least of it. *Yet dreams are the commonest and universally accessible source for the investigation of man's symbolizing faculty*, apart from the contents of psychoses, neuroses, myths, and the products of the various arts. All these, however, are more complicated and more difficult to understand, because, when it comes to the question of their individual nature, one cannot venture to interpret such unconscious products without the aid of the originator. Dreams are indeed the chief source of all our knowledge about symbolism.

[432] One cannot *invent* symbols; wherever they occur, they have not been devised by conscious intention and wilful selection, because, if such a procedure had been used, they would have been nothing but signs and abbreviations of conscious thoughts. Symbols occur to us spontaneously, as one can see in our dreams, which are not invented but which happen to us. They are not immediately understandable, they need careful analysis by means of association, but, as I have said, not of "free association," which we know always leads back eventually to the emotional thoughts or complexes that are unconsciously captivating our mind. To get there, we have no need of dreams. But in the early days of medical psychology the general assumption was that dreams were analysed for the purpose of discovering complexes. For this purpose, however, it is sufficient to conduct an association test, which supplies all the necessary hints as I have shown long ago. And not even this test is necessary, because one can obtain the same result by letting people talk long enough.

[433] There can be no doubt that dreams often arise from an emotional disturbance in which the habitual complexes are involved. The habitual complexes are the tender spots of the psyche, which react most quickly to a problematical external situation. But I began to suspect that dreams might have another, more interesting function. The fact that they eventually lead back to the complexes is not the specific merit of dreams. If we want to learn what a dream means and what specific function it fulfils, we must disregard its inevitable outcome, the complex. We must put a check on limitless "free" association, a restriction provided by the dream itself. By free association, we move away from the individual dream-image and lose sight of it. We

must, on the contrary, keep close to the dream and its individual form. The dream is its own limitation. It is itself the criterion of what belongs to it and of what leads away from it. All material that does not lie within the scope of the dream, or that oversteps the boundaries set by its individual form, leads astray and produces nothing but the complexes, and we do not know whether they belong to the dream or not since they can be produced in so many other ways. There is, for instance, an almost infinite variety of images by which the sexual act can be “symbolized,” or rather allegorized. But the dream obviously intends its own specific expression in spite of the fact that the resultant associations will lead to the idea of sexual intercourse. This is no news and is easy to see, but the real task is to understand why the dream has chosen its own individual expression.

[434] Only the material that is clearly and visibly indicated as belonging to the dream by the dream-images themselves should be used for interpretation. While free association moves away from the theme of the dream in something like a zigzag line, the new method, as I have always said, is more like a circumambulation, the centre of which is the dream-image. One concentrates on the specific topics, on the dream itself, and disregards the frequent attempts of the dreamer to break away from it. This ever-present “neurotic” dissociative tendency has many aspects, but at bottom it seems to consist in a basic resistance of the conscious mind to anything unconscious and unknown. As we know, this often fierce resistance is typical of the psychology of primitive societies, which are as a rule conservative and show pronounced misoneistic tendencies. Anything new and unknown causes distinct and even superstitious fear. The primitive manifests all the reactions of a wild animal to untoward events. Our highly differentiated civilization is not at all free from such primitive behaviour. A new idea that is not exactly in line with general expectations meets with the severest obstacles of a psychological kind. It is given no credit, but is feared, combatted, and abhorred in every way. Many pioneers can tell a story of misery, all due to the primitive misoneism of their contemporaries. When it comes to psychology, one of the youngest of the sciences, you can see misoneism at work, and in dealing with your own dreams you can easily observe your reactions when you have to admit a disagreeable thought. It is chiefly and above all fear of the unexpected and unknown that makes people eager to use free association as a means of escape. I do not know how many times in my professional work I have had to repeat the words: “Now let’s get back to your dream. What does the *dream* say?”

[435] If one wants to understand a dream it must be taken seriously, and one must also assume that it means what it manifestly says, since there is no valid reason to suppose that it is anything other than it is. Yet the apparent futility of dreams is so overwhelming that not only the dreamer but the interpreter as well may easily

succumb to the prejudice of the “nothing but” explanation. Whenever a dream gets difficult and obstinate, the temptation to dismiss it altogether is not far away.

[436] When I was doing fieldwork with a primitive tribe in East Africa, I discovered to my amazement that they denied having dreams at all. But by patient indirect talk I soon found that they had dreams all right, like everybody else, but were convinced that their dreams meant nothing. “Dreams of ordinary men mean nothing,” they said. The only dreams that mattered were those of the chief and the medicine-man, which concerned the welfare of the tribe. Such dreams were highly appreciated. The only drawback was that the chief as well as the medicine-man denied having any more dreams “since the British were in the country.” The District Commissioner had taken over the function of the “big dream.”

[437] This incident shows that even in a primitive society opinions about dreams are ambivalent, just as in our society, where most people see nothing in dreams while a minority thinks very highly of them. The Church, for instance, has long known of *somnia a Deo missa* (dreams sent by God), and in our own time we have watched the growth of a scientific discipline which aims at exploring the vast field of unconscious processes. Yet the average man thinks little or nothing about dreams, and even a thoroughly educated person shares the common ignorance and underrates everything remotely connected with the “unconscious.”

[438] The very existence of an unconscious psyche is denied by a great number of scientists and philosophers, who often use the naïve argument that if there were an unconscious psyche there would be two subjects in the individual instead of one. But that is precisely the case, in spite of the supposed unity of the personality. It is, indeed, the great trouble of our time that so many people exist whose right hand does not know what their left is doing. It is by no means the neurotic alone who finds himself in this predicament. It is not a recent development, nor can it be blamed on Christian morality; it is, on the contrary, the symptom of a general unconsciousness that is the heritage of all mankind.

[439] The development of consciousness is a slow and laborious process that took untold ages to reach the civilized state (which we date somewhat arbitrarily from the invention of writing, about 4000 B.C.). Although the development since that date seems to be considerable, it is still far from complete. Indefinitely large areas of the mind still remain in darkness. What we call “psyche” is by no means identical with consciousness and its contents. Those who deny the existence of the unconscious do not realize that they are actually assuming our knowledge of the psyche to be complete, with nothing left for further discoveries. It is exactly as if they declared our present knowledge of nature to be the summit of all possible knowledge. Our psyche is part of nature, and its enigma is just as limitless. We cannot define “nature” or “psyche,” but can only state what, at present, we understand them to be. No man in

his senses, therefore, could make such a statement as “there is no unconscious,” i.e., no psychic contents of which he and others are unconscious—not to mention the mountain of convincing evidence that medical science has accumulated. It is not, of course, scientific responsibility or honesty that causes such resistance, but age-old misoneism, fear of the new and unknown.

[440] This peculiar resistance to the unknown part of the psyche has its historical reasons. Consciousness is a very recent acquisition and as such is still in an “experimental state”—frail, menaced by specific dangers, and easily injured. As a matter of fact one of the most common mental derangements among primitives consists in the “loss of a soul,” which, as the term indicates, means a noticeable dissociation of consciousness. On the primitive level the psyche or soul is by no means a unit, as is widely supposed. Many primitives assume that, as well as his own, a man has a “bush-soul,” incarnate in a wild animal or a tree, with which he is connected by a kind of psychic identity. This is what Lévy-Bruhl called *participation mystique*.² In the case of an animal it is a sort of brother, so much so that a man whose brother is a crocodile is supposed to be safe while swimming across a crocodile-infested river. In the case of a tree, the tree is supposed to have authority over the individual like a parent. Injury to the bush-soul means an equal injury to the man. Others assume that a man has a number of souls, which shows clearly that the primitive often feels that he consists of several units. This indicates that his psyche is far from being safely synthesized; on the contrary, it threatens to fall asunder only too easily under the onslaught of unchecked emotions.

[441] What we observe in the seemingly remote sphere of the primitive mind has by no means vanished in our advanced civilization. Only too often, as I have said, the right hand does not know what the left is doing, and in a state of violent affect one frequently forgets who one is, so that people can ask: “What the devil has got into you?” We are possessed and altered by our moods, we can suddenly be unreasonable, or important facts unaccountably vanish from our memory. We talk about being able to “control ourselves,” but self-control is a rare and remarkable virtue. If you ask your friends or relatives they may be able to tell you things about yourself of which you have no knowledge. One almost always forgets or omits to apply to oneself the criticism that one hands out so freely to others, fascinated by the mote in one’s brother’s eye.

[442] All these well-known facts show beyond a doubt that, on the heights of our civilization, human consciousness has not yet attained a reasonable degree of continuity. It is still dissociable and vulnerable, in a way fortunately so, since the dissociability of the psyche is also an advantage in that it enables us to concentrate on one point by dismissing everything else that might claim attention. It makes a great difference, however, whether your consciousness purposely splits off and suppresses

a part of the psyche temporarily, or whether the same thing *happens* to you, so that the psyche splits spontaneously without your consent and knowledge, or perhaps even against your will. The first is a civilized achievement, the second a primitive and archaic condition or a pathological event and the cause of a neurosis. It is the “loss of a soul,” the symptom of a still existing mental primitivity.

[443] It is a long way indeed from primitivity to a reliable cohesion of consciousness. Even in our days the unity of consciousness is a doubtful affair, since only a little affect is needed to disrupt its continuity. On the other hand the perfect control of emotion, however desirable from one point of view, would be a questionable accomplishment, for it would deprive social intercourse of all variety, colour, warmth, and charm.

2. THE FUNCTIONS OF THE UNCONSCIOUS

[444] Our *new* method treats the dream as a spontaneous product of the psyche about which there is no previous assumption except that it somehow makes sense. This is no more than every science assumes, namely that its object is worthy of investigation. No matter how low one's opinion of the unconscious may be, the unconscious is at least on a level with the louse, which, after all, enjoys the honest interest of the entomologist. As to the alleged boldness of the hypothesis that an unconscious psyche exists, I must emphasize that a more modest formulation could hardly be imagined. It is so simple that it amounts to a tautology: a content of consciousness disappears and cannot be reproduced. The best we can say of it is: the thought (or whatever it was) has become unconscious, or is cut off from consciousness, so that it cannot even be remembered. Or else it may happen that we have an inkling or hunch of something which is about to break into consciousness: "something is in the air," "we smell a rat," and so on. To speak under these conditions of latent or unconscious contents is hardly a daring hypothesis.

[445] When something vanishes from consciousness it does not dissolve into thin air or cease to exist, any more than a car disappearing round a corner becomes non-existent. It is simply out of sight, and, as we may meet the car again, so we may come across a thought again which was previously lost. We find the same thing with sensation, as the following experiment proves. If you produce a continuous note on the edge of audibility, you will observe in listening to it that at regular intervals it is audible and inaudible. These oscillations are due to a periodic increase and decrease of attention. The note never ceases to exist with static intensity. It is merely the decrease of attention that causes its apparent disappearance.

[446] The unconscious, therefore, consists in the first place of a multitude of temporarily eclipsed contents which, as experience shows, continue to influence the conscious processes. A man in a distracted state of mind goes to a certain place in his room, obviously to fetch something. Then he suddenly stops perplexed: he has forgotten why he got up and what he was after. He gropes absent-mindedly among a whole collection of objects, completely at sea as to what he wants to find. Suddenly he wakes up, having discovered the thing he wants. He behaves like a man walking in his sleep oblivious of his original purpose, yet unconsciously guided by it. If you observe the behaviour of a neurotic, you can see him performing apparently conscious and purposeful acts yet, when you ask him about them, you discover to your surprise that he is either unconscious of them or has something quite different in

mind. He hears and does not hear, he sees yet is blind, he knows and does not know at the same time. Thousands of such observations have convinced the specialist that unconscious contents behave as if they were conscious, and that you can never be sure whether thought, speech, or action is conscious or not. Something so obvious to yourself that you cannot imagine it to be invisible to anybody can be as good as nonexistent to your fellows, and yet they behave as if they were just as conscious of it as you are yourself.

[447] This kind of behaviour has given rise to the medical prejudice that hysterical patients are confirmed liars. Yet the surplus of lies they seem to produce is due to the uncertainty of their mental state, to the dissociability of their consciousness, which is liable to unpredictable eclipses, just as their skin shows unexpected and changing areas of anaesthesia. There is no certainty whether a needle-prick will be registered or not. If their attention can be focused on a certain point, the whole surface of their body may be completely anaesthetized, and, when attention relaxes, sense-perception is instantly restored. Moreover when one hypnotizes such cases one can easily demonstrate that they are aware of everything that has been done in an anaesthetized area or during an eclipse of consciousness. They can remember every detail just as if they had been fully conscious during the experiment. I recall a similar case of a woman who was admitted to the clinic in a state of complete stupor. Next day when she came to, she knew who she was, but did not know where she was nor how or why she had come there, nor did she know the date. I hypnotized her, and she could tell me a verifiable story of why she fell ill, how she had got to the clinic, and who had received her, with all the details. As there was a clock in the entrance hall, though not in a very conspicuous place, she could also remember the time of her admission to the minute. Everything happened as if she had been in a completely normal condition and not deeply unconscious.

[448] It is true that the bulk of our evidential material comes from clinical observation. That is the reason why many critics assume that the unconscious and its manifestations belong to the sphere of psychopathology as neurotic or psychotic symptoms and that they do not occur in a normal mental state. But, as has been pointed out long ago, neurotic phenomena are not by any means the exclusive products of disease. They are as a matter of fact *normal occurrences pathologically exaggerated, and therefore* just more obvious than their normal parallels. One can indeed observe all hysterical symptoms in a diminutive form in normal individuals, but they are so slight that they usually pass unnoticed. In this respect, everyday life is a mine of evidential material.

[449] Just as conscious contents can vanish into the unconscious, other contents can also arise from it. Besides a majority of mere recollections, really new thoughts and creative ideas can appear which have never been conscious before. They grow up

from the dark depths like a lotus, and they form an important part of the subliminal psyche. This aspect of the unconscious is of particular relevance in dealing with dreams. One must always bear in mind that dream material does not necessarily consist of memories; it may just as well contain new thoughts that are not yet conscious.

[450] Forgetting is a normal process, in which certain conscious contents lose their specific energy through a deflection of attention. When interest turns elsewhere, it leaves former contents in the shadow, just as a searchlight illuminates a new area by leaving another to disappear in the darkness. This is unavoidable, for consciousness can keep only a few images in full clarity at one time, and even this clarity fluctuates, as I have mentioned. "Forgetting" may be defined as temporarily subliminal contents remaining outside the range of vision against one's will. But the forgotten contents have not ceased to exist. Although they cannot be reproduced they are present in a subliminal state, from which they can rise up spontaneously at any time, often after many years of apparently total oblivion, or they can be fetched back by hypnosis.

[451] Besides normal forgetting, there are the cases described by Freud of disagreeable memories which one is only too ready to lose. As Nietzsche has remarked, when pride is insistent enough, memory prefers to give way. Thus among the lost memories we encounter not a few that owe their subliminal state (and their incapacity to be reproduced at will) to their disagreeable and incompatible nature. These are the *repressed* contents.

[452] As a parallel to normal forgetting, *subliminal sense-perceptions* should be mentioned, because they play a not unimportant role in our daily life. We see, hear, smell and taste many things without noticing them at the time, either because our attention is deflected or because the stimulus is too slight to produce a conscious impression. But in spite of their apparent non-existence they can influence consciousness. A well-known example is the case of the professor walking in the country with a pupil, deep in serious conversation. Suddenly he notices that his thoughts are interrupted by an unexpected flow of memories from his early childhood. He cannot account for it, as he is unable to discover any associative connection with the subject of his conversation. He stops and looks back: there at a little distance is a farm, through which they had passed a short while ago, and he remembers that soon afterwards images of his childhood began to surge up. "Let us go back to the farm," he says to his pupil; "it must be about there that my fantasies started." Back at the farm, the professor notices the smell of geese. Instantly he recognizes it as the cause of the interruption: in his early youth he had lived on a farm where there were geese, whose characteristic smell had formed a lasting impression and caused the reproduction of the memory-images. He had noticed the

smell while passing the farmyard, subliminally, and the unconscious perception had called back long-forgotten memories.

[453] This example illustrates how the subliminal perception released early childhood memories, the energetic tension of which proved to be strong enough to interrupt the conversation. The perception was subliminal because the attention was engaged elsewhere, and the stimulus was not strong enough to deflect it and to reach consciousness directly. Such phenomena are frequent in everyday life, but mostly they pass unnoticed.

[454] A relatively rare but all the more astonishing phenomenon that falls into the same category is *cryptomnesia*, or the “concealed recollection.” It consists in the fact that suddenly, mostly in the flow of creative writing, a word, a sentence, an image, a metaphor, or even a whole story appears which may exhibit a strange or otherwise remarkable character. If you ask the author where this fragment comes from, he does not know, and it becomes obvious that he has not even noticed it as anything peculiar. I will quote one such example from Nietzsche’s *Thus Spake Zarathustra*. The author describes Zarathustra’s “descent to hell” with certain characteristic details which coincide almost word for word with the narration in a ship’s log from the year 1686.

[455] Nietzsche, *Thus Spake Zarathustra* (1883)¹

Now about the time that Zarathustra sojourned on the Happy Isles, it happened that a ship anchored at the isle on which the smoking mountain stands, and the crew went ashore to shoot rabbits. About the noontide hour, however, when the captain and his men were together again, they suddenly saw a man coming towards them through the air, and a voice said distinctly: “It is time! It is highest time!” But when the figure drew close to them, flying past quickly like a shadow in the direction of the volcano, they recognized with the greatest dismay that it was Zarathustra.... “Behold,” said the old helmsman, “Zarathustra goes down to hell!”

Justinus Kerner, *Blätter aus Prevorst* (1831–39)²

The four captains and a merchant, Mr. Bell, went ashore on the island of Mount Stromboli to shoot rabbits. At three o’clock they mustered the crew to go aboard, when, to their inexpressible astonishment, they saw two men flying rapidly towards them through the air. One was dressed in black, the other in grey. They came past them very closely, in the greatest haste, and to their utmost dismay descended into the crater of the terrible volcano, Mount Stromboli. They recognized the pair as acquaintances from London.

[456] When I read Nietzsche’s story I was struck by its peculiar style, which is different from Nietzsche’s usual language, and by the strange images of a ship anchored off a mythological island, of a captain and his crew shooting rabbits, and of the descent to

hell of a man who was recognized as an old acquaintance. The parallels with Kerner could not be a mere coincidence. Kerner's collection dates from about 1835 and is probably the only extant source of the seaman's yarn. At least I was certain that Nietzsche must have gleaned it from there. He retells the story with a few significant variations and as if it were his own invention. As it was in the year 1902 that I came across this case, I still had the opportunity to write to Elizabeth Förster-Nietzsche, the author's sister, and she remembered that she and her brother had read the *Blätter aus Prevorst* when Nietzsche was eleven years old, though she did not remember this particular story. The reason why I remembered it was that I had come across Kerner's collection four years before, in a private library; and, as I was interested in the writings of the physicians of that time as the forerunners of medical psychology, I had read through all the volumes of the *Blätter*. Naturally I should have forgotten the yarn in the course of time, because it did not interest me in any way. But in reading Nietzsche I suddenly had a *sentiment du déjà vu*, followed by a dim recollection of old-fashioned cut, and gradually the picture of Kerner's book filtered into my consciousness.

[457] Benoît, who produced a surprising parallel to Rider Haggard's *She* in his novel *L'Atlantide*, when accused of plagiarism had to answer that he had never come across Rider Haggard's book and was entirely unaware of its existence. This case could also have been one of cryptomnesia, if it had not been an elaboration of a sort of *representation collective*, as Lévy-Bruhl has named certain general ideas characteristic of primitive societies. I shall be dealing with these later on.

[458] What I have said about the unconscious will give the reader a fair idea of the subliminal material on which the spontaneous production of dream-symbols is based. It is evidently material that owes its unconsciousness chiefly to the fact that certain conscious contents must necessarily lose their energy, i.e., the attention bestowed on them, or their specific emotional tone, in order to make room for new contents. If they were to retain their energy, they would remain above the threshold and one could not get rid of them. It is as if consciousness were a sort of projector that casts its light (of attention or interest) on new perceptions—due to arrive presently—as well as on the traces of former ones in a dormant state. As a conscious act, this process can be understood as an intentional and voluntary event. Yet just as often consciousness is forced to turn on its light by the intensity of an external or internal stimulus.

[459] This observation is not superfluous, for there are many people who overestimate the role of will-power and think nothing can happen in their minds that they do not intend. But, for the sake of psychological understanding, one should learn to discriminate carefully between *intentional and unintentional contents*. The former are derived from the ego-personality, while the latter arise from a source which is not

identical with the ego, that is, from a subliminal part of the ego, from its “other side,” which is in a way another subject. The existence of this other subject is by no means a pathological symptom, but a normal fact that can be observed at any time anywhere.

[460] I once had a discussion with one of my colleagues about another doctor who had done something I had qualified as “utterly idiotic.” This doctor was my colleague’s personal friend, and moreover a believer in the somewhat fanatical creed to which my colleague subscribed. Both were teetotalers. He impulsively replied to my criticism: “Of course he is an ass”—pulling himself up short—“a highly intelligent man, I meant to say.” I mildly remarked that the ass came first, whereupon he angrily denied ever having said such a thing about his friend, and to an unbeliever at that. This man was highly regarded as a scientist, but his right hand did not know what his left was doing. Such people are not fit for psychology and, as a matter of fact, do not like it. But that is the way the voice from the other side is usually treated: “I didn’t mean it, I never said so.” And in the end, as Nietzsche says, memory prefers to give way.

3. THE LANGUAGE OF DREAMS

[461] All contents of consciousness have been or can become subliminal, thus forming part of the psychic sphere which we call the unconscious. All urges, impulses, intentions, affects, all perceptions and intuitions, all rational and irrational thoughts, conclusions, inductions, deductions, premises, etc., as well as all categories of feeling, have their subliminal equivalents, which may be subject to partial, temporary, or chronic unconsciousness. One uses a word or a concept, for instance, that in another connection has an entirely different meaning of which one is momentarily unconscious, and this can lead to a ridiculous or even disastrous misunderstanding. Even a most carefully defined philosophical or mathematical concept, which we are sure does not contain more than we have put into it, is nevertheless more than we assume. It is at the least a psychic event, the nature of which is actually unknowable. The very numbers you use in counting are more than you take them for. They are at the same time mythological entities (for the Pythagoreans they were even divine), but you are certainly unaware of this when you use numbers for a practical purpose.

[462] We are also unconscious of the fact that general terms like “state,” “money,” “health,” “society” etc. usually mean more than they are supposed to signify. They are general only because we assume them to be so, but in practical reality they have all sorts of nuances of meaning. I am not thinking of the deliberate twisting of such concepts in their Communist usage, but of the fact that even when they are understood in their proper sense they nevertheless vary slightly from person to person. The reason for this variation is that a general notion is received into an individual context and is therefore understood and used in an individual way. As long as concepts are identical with mere words, the variation is almost imperceptible and of no practical importance. But when an exact definition or a careful explanation is needed, one can occasionally discover the most amazing variations, not only in the purely intellectual understanding of the term, but particularly in its emotional tone and its application. As a rule these variations are subliminal and therefore never realized.

[463] One may dismiss such differences as redundant or over-nice distinctions, but the fact that they exist shows that even the most banal contents of consciousness have a penumbra of uncertainty around them, which justifies us in thinking that each of them carries a definite subliminal charge. Although this aspect plays little role in everyday life, one must bear it in mind when analysing dreams. I recall a dream of

my own that baffled me for a while. In this dream, a certain Mr. X was desperately trying to get behind me and jump on my back. I knew nothing of this gentleman except that he had succeeded in twisting something I had said into a rather grotesque travesty of my meaning. This kind of thing had frequently happened to me in my professional life, and I had never bothered to realize whether it made me angry or not. But as it is of practical importance to maintain conscious control of one's emotions, the dream pointedly brought up the incident again in the apparent "disguise" of a colloquialism. This saying, common enough in ordinary speech, is "Du kannst mir auf den Buckel steigen" (you can climb on my back), which means "I don't give a damn what you say."

[464] One could say that this dream-image was symbolic, for it did not state the situation directly but in a roundabout way, through a concretized colloquial metaphor which I did not understand at first sight. Since I have no reason to believe that the unconscious has any intention of concealing things, I must be careful not to project such a device on its activity. It is characteristic of dreams to prefer pictorial and picturesque language to colourless and merely rational statements. This is certainly not an intentional concealment; it simply emphasizes our inability to understand the emotionally charged picture-language of dreams.

[465] As daily adaptation to the reality of things demands accurate statements, we have learnt to discard the trimming of fantasy, and have thus lost a quality that is still characteristic of the primitive mind. Primitive thinking sees its object surrounded by a fringe of associations which have become more or less unconscious in civilized man. Thus animals, plants, and inanimate objects can acquire properties that are most unexpected to the white man. A nocturnal animal seen by day is, for the primitive, quite obviously a medicine-man who has temporarily changed his shape; or else it is a doctor-animal or an animal-ancestor, or somebody's bush-soul. A tree can be part of a man's life, it has a soul and a voice, and the man shares its fate, and so on. Certain South American Indians assure you that they are red *araras* (parrots), although they are quite aware that they have no feathers and don't look like birds. In the primitive's world, things do not have the same sharp boundaries they do in ours. What we call psychic identity or *participation mystique* has been stripped off our world of things. It is exactly this halo, or "fringe of consciousness," as William James calls it, which gives a colourful and fantastic aspect to the primitive's world. We have lost it to such a degree that we do not recognize it when we meet it again, and are baffled by its incomprehensibility. With us such things are kept below the threshold; and when they occasionally reappear, we are convinced that something is wrong.

[466] I have more than once been consulted by highly educated and otherwise intelligent people because they had peculiar dreams, involuntary fantasies, or even visions, which shocked or frightened them. They assumed that nobody in a sound

mental condition could suffer from such phenomena, and that a person who had a vision was certainly pathological. A theologian I knew once avowed his belief that Ezekiel's visions were morbid symptoms, and that when Moses and other prophets heard "voices" they were suffering from hallucinations. Naturally he got into a panic when some spontaneous events of this kind happened to him. We are so used to the rational surface of our world that we cannot imagine anything untoward happening within the confines of common sense. If our mind once in a while does something thoroughly unexpected, we are terrified and immediately think of a pathological disturbance, whereas primitive man would think of fetishes, spirits, or gods but would never doubt his sanity. Modern man is very much in the situation of the old doctor who was himself a psychotic patient. When I asked him how he was, he replied that he had had a wonderful night disinfecting the whole heaven with chloride of mercury but had found no trace of God. What we find instead of God is a neurosis or something worse, and the fear of God has changed into a phobia or anxiety neurosis. The emotion remains the same, only its object has changed its name and nature for the worse.

[467] I remember a professor of philosophy and psychology who consulted me about his cancer phobia. He suffered from a compulsive conviction that he had a malignant tumour, although nothing of the sort was ever found in dozens of X-ray pictures. "Oh, I know there is nothing," he would say, "but there still *might* be something." Such a confession is certainly far more humiliating to a strong intellect than the belief of a primitive that he is plagued by a ghost. Malevolent spirits are at least a perfectly admissible hypothesis in a primitive society, but it is a shattering experience for a civilized person to have to admit that he is the victim of nothing more than a foolish prank of the imagination. The primitive phenomenon of obsession has not vanished, it is the same as ever. It is only interpreted in a different and more obnoxious way.

[468] Many dreams present images and associations that are analogous to primitive ideas, myths, and rites. These dream-images were called "archaic remnants" by Freud. The term suggests that they are psychic elements left over from times long ago and still adhering to our modern mind. This point of view forms part of the prevailing depreciation of the unconscious as a mere appendix of consciousness or, to put it more drastically, a dustbin which collects all the refuse of the conscious mind—all things discarded, disused, worthless, forgotten, and repressed.

[469] This opinion had to be abandoned in more recent times, since further investigation has shown that such images and associations belong to the regular structure of the unconscious and can be observed more or less everywhere, in the dreams of highly educated as well as illiterate people, of the intelligent as well as the stupid. They are in no sense dead or meaningless "remnants"; on the contrary, they still continue to function and are therefore of vital value just because of their

“historical” nature. They are a sort of language that acts as a bridge between the way in which we consciously express our thoughts and a more primitive, more colourful and pictorial form of expression—a language that appeals directly to feeling and emotion. Such a language is needed to translate certain truths from their “cultural” form (where they are utterly ineffectual) into a form that hits the nail on the head. For instance, there is a lady well known for her stupid prejudices and stubborn arguments. The doctor tries in vain to instil some insight. He says: “My dear lady, your views are indeed very interesting and original. But you see, there are many people who unfortunately lack your assumptions and have need of your forbearance. Couldn’t you ...” etc. He could just as well talk to a stone. But the dream follows a different method. She dreams: there is a great social affair to which she is invited. She is received by her hostess (a very bright woman) at the door with the words: “Oh, how nice that you have come, all your friends are already here and are expecting you.” She leads her to a door, opens it, and the lady steps into—a cowshed.

[470] This is a more concrete and drastic language, simple enough to be understood even by a blockhead. Although the lady would not admit the point of the dream, it nevertheless went home, and after a time she was forced to accept it because she could not help seeing the self-inflicted joke.

[471] The message of the unconscious is of greater importance than most people realize. As consciousness is exposed to all sorts of external attractions and distractions, it is easily led astray and seduced into following ways that are unsuited to its individuality. The general function of dreams is to balance such disturbances in the mental equilibrium by producing contents of a complementary or compensatory kind. Dreams of high vertiginous places, balloons, aeroplanes, flying and falling, often accompany states of consciousness characterized by fictitious assumptions, overestimation of oneself, unrealistic opinions, and grandiose plans. If the warning of the dream is not heeded, real accidents take its place. One stumbles, falls downstairs, runs into a car, etc. I remember the case of a man who was inextricably involved in a number of shady affairs. He developed an almost morbid passion for dangerous mountain-climbing as a sort of compensation: he was trying to “get above himself.” In one dream he saw himself stepping off the summit of a high mountain into the air. When he told me his dream, I instantly saw the risk he was running, and I tried my best to emphasize the warning and convince him of the need to restrain himself. I even told him that the dream meant his death in a mountain accident. It was in vain. Six months later he “stepped off into the air.” A mountain guide watched him and a young friend letting themselves down on a rope in a difficult place. The friend had found a temporary foothold on a ledge, and the dreamer was following him down. Suddenly he let go of the rope “as if he were jumping into the air,” as the guide reported afterwards. He fell on his friend, and both went down and were killed.

[472] Another typical case was that of a lady who was living above herself in a fantasy of distinction and austerity. But she had shocking dreams, reminding her of all sorts of unsavoury things. When I put my finger on them, she indignantly refused to acknowledge them. The dreams then became menacing, full of references to the long lonely walks she took in the woods near the town, where she indulged in soulful musings. I saw the danger and warned her insistently, but she would not listen. A week later a sexual pervert attacked her murderously, and only in the nick of time was she rescued by some people who had heard her screams. Obviously she had a secret longing for some such adventure and preferred to pay the price of two broken ribs and the fracture of a laryngeal cartilage, just as the mountain climber at least had the satisfaction of finding a definite way out of his predicament.

[473] Dreams prepare, announce, or warn about certain situations, often long before they actually happen. This is not necessarily a miracle or a precognition. Most crises or dangerous situations have a long incubation, only the conscious mind is not aware of it. Dreams can betray the secret. They often do, but just as often, it seems, they do not. Therefore our assumption of a benevolent hand restraining us in time is doubtful. Or, to put it more positively, it seems that a benevolent agency is at work sometimes but at other times not. The mysterious finger may even point the way to perdition. One cannot afford to be naïve in dealing with dreams. They originate in a spirit that is not quite human, but is rather the breath of nature—of the beautiful and generous as well as the cruel goddess. If we want to characterize this spirit, we would do better to turn to the ancient mythologies and the fables of the primeval forest. Civilization is a most expensive process and its acquisitions have been paid for by enormous losses, the extent of which we have largely forgotten or have never appreciated.

[474] Through our efforts to understand dreams we become acquainted with what William James has aptly called the “fringe of consciousness.” What appear to be redundant and unwelcome accessories are, if studied more closely, the almost invisible roots of conscious contents, i.e., their subliminal aspects. They form the psychic material that must be considered as the intermediary between unconscious and conscious contents, or the bridge that spans the gap between consciousness and the ultimately physiological foundations of the psyche. The practical importance of such a bridge can hardly be overrated. It is the indispensable link between the rational world of consciousness and the world of instinct. The more our consciousness is influenced by prejudices, fantasies, infantile wishes, and the lure of external objects, the more the already existing gap will widen out into a neurotic dissociation and lead to an artificial life far removed from healthy instincts, nature, and truth. Dreams try to re-establish the equilibrium by restoring the images and emotions that express the state of the unconscious. One can hardly ever restore the original condition by rational talk, which is far too flat and colourless. But, as my

examples have shown, the language of dreams provides just those images which appeal to the deeper strata of the psyche. One could even say that the interpretation of dreams enriches consciousness to such an extent that it re-learns the forgotten language of the instincts.

[475] In so far as instincts are physiological urges, they are perceived by the senses and at the same time manifest themselves as fantasies. But in so far as they are not perceived sensually, they reveal their presence only in images. The vast majority of instinctive phenomena consists, however, of images, many of which are of a symbolic nature whose meaning is not immediately recognizable. One finds them chiefly in that twilight realm between dim consciousness and the unconscious background of the dream. Sometimes a dream is of such vital importance that its message reaches consciousness no matter how uncomfortable or shocking it may be. From the standpoint of mental equilibrium and physiological health in general, it is much better for the conscious and the unconscious to be connected and to move on parallel lines than for them to be dissociated. In this respect the production of symbols can be considered a most valuable function.

[476] One will naturally ask what is the point of this function if its symbols should pass unnoticed or prove to be incomprehensible? But lack of conscious understanding does not mean that the dream has no effect at all. Even civilized man can occasionally observe that a dream which he cannot remember can slightly alter his mood for better or worse. Dreams can be “understood” to a certain extent in a subliminal way, and that is mostly how they work. Only when a dream is very impressive, or repeats itself often, do interpretation and conscious understanding become desirable. But in pathological cases an interpretation is imperative and should be undertaken if there are no counter-indications, such as the existence of a latent psychosis, which is, as it were, only waiting for a suitable releasing agent to burst forth in full force. Unintelligent and incompetent application of dream analysis and interpretation is indeed not advisable, and particularly not when there is a dissociation between a very onesided consciousness and a correspondingly irrational or “crazy” unconscious.

[477] Owing to the infinite variety of conscious contents and their deviation from the ideal middle line, the unconscious compensation is equally varied, so that one would be hard put to it to say whether dreams and their symbols are classifiable or not. Though there are dreams and occasional symbols—better called motifs in this case—which are typical and occur often, most dreams are individual and atypical. Typical motifs are falling, flying, being chased by dangerous animals or men being insufficiently or absurdly clothed in public places, being in a hurry or lost in a milling crowd, fighting with useless weapons or being utterly defenceless, running and

getting nowhere, and so on. A typical infantile motif is the dream of growing infinitely small or infinitely big, or of being transformed from the one into the other.

[478] A noteworthy phenomenon is the recurrent dream. There are cases of dreams repeating themselves from the days of childhood to the advanced years of adult life. Such dreams usually compensate a defect in one's conscious attitude, or they date from a traumatic moment that has left behind some specific prejudice, or they anticipate a future event of some importance. I myself dreamt of a motif that was repeated many times over a period of years. It was that I discovered a part of a wing of my house which I did not know existed. Sometimes it was the place where my parents lived—who had died long ago—where my father, to my great surprise, had a laboratory in which he studied the comparative anatomy of fishes, and where my mother ran a hostelry for ghostly visitors. Usually the wing or independent guest-house was an historical building several hundred years old, long forgotten, yet my ancestral property. It contained interesting old furniture, and towards the end of this series of recurrent dreams I discovered an old library whose books were unknown to me. Finally, in the last dream, I opened one of the old volumes and found in it a profusion of the most marvellous symbolic pictures. When I awoke, my heart was pounding with excitement.

[479] Some time before this dream I had placed an order with an antiquarian bookseller abroad for one of the Latin alchemical classics, because I had come across a quotation that I thought might be connected with early Byzantine alchemy, and I wished to verify it. Several weeks after my dream a parcel arrived containing a parchment volume of the sixteenth century with many most fascinating symbolic pictures. They instantly reminded me of my dream library. As the rediscovery of alchemy forms an important part of my life as a pioneer of psychology, the motif of the unknown annex of my house can easily be understood as an anticipation of a new field of interest and research. At all events, from that moment thirty years ago the recurrent dream came to an end.

[480] Symbols, like dreams, are natural products, but they do not occur only in dreams. They can appear in any number of psychic manifestations: there are symbolic thoughts and feelings, symbolic acts and situations, and it often looks as if not only the unconscious but even inanimate objects were concurring in the arrangement of symbolic patterns. There are numerous well-authenticated stories of a clock that stopped at the moment of its owner's death, like Frederick the Great's pendulum clock at Sans Souci; of a mirror that broke, or a boiling coffee-pot that exploded, just before or during a crisis; and so on. Even if the sceptic refuses to credit such reports, stories of this kind are ever renewed and are told again and again, which is ample proof of their psychological importance, even though ignorant people deny their factual existence.

[481] The most important symbols, however, are not individual but collective in their nature and origin. They are found principally in the religions. The believer assumes that they are of divine origin—that they are revealed. The sceptic thinks they are invented. Both are wrong. It is true that, on the one hand, such symbols have for centuries been the objects of careful and quite conscious elaboration and differentiation, as in the case of dogmas. But, on the other hand, they are *représentations collectives* dating from dim and remote ages, and these are “revelations” only in the sense that they are images originating in dreams and creative fantasies. The latter are involuntary, spontaneous manifestations and by no means arbitrary and intentional inventions.

[482] There was never a genius who sat down with his pen or brush and said: “Now I am going to invent a symbol.” No one can take a more or less rational thought, reached as a logical conclusion or deliberately chosen, and then disguise it as a “symbolic” phantasmagoria. No matter how fantastic the trappings may look, it would still be a *sign* hinting at a conscious thought, and not a symbol. A sign is always less than the thing it points to, and a symbol is always more than we can understand at first sight. Therefore we never stop at the sign but go on to the goal it indicates; but we remain with the symbol because it promises more than it reveals.

[483] If the contents of dreams agree with a sex theory, then we know their essence already, but if they are symbolic we at least know that we do not understand them yet. *A symbol does not disguise, it reveals in time.* It is obvious that dream interpretation will yield one result when you consider the dream to be symbolic, and an entirely different one when you assume that the essential thought is merely disguised but already known in principle. In the latter case, dream interpretation makes no sense whatever, for you find only what you know already. Therefore I always advise my pupils: “Learn as much as you can about symbolism and forget it all when you are analysing a dream.” This advice is so important in practice that I myself have made it a rule to admit that I never understand a dream well enough to interpret it correctly. I do this in order to check the flow of my own associations and reactions, which might otherwise prevail over my patient’s uncertainties and hesitations. As it is of the highest therapeutic importance for the analyst to get the message of the dream as accurately as possible, it is essential for him to explore the context of the dream-images with the utmost thoroughness. I had a dream while I was working with Freud that illustrates this very clearly.

[484] I dreamt that I was in “my house,” apparently on the first floor, in a cosy, pleasant drawing-room furnished in the style of the eighteenth century. I was rather astonished because I realized I had never seen this room before, and began to wonder what the ground floor was like. I went downstairs and found it rather dark, with panelled walls and heavy furniture dating from the sixteenth century or even earlier. I was greatly

surprised and my curiosity increased, because it was all a very unexpected discovery. In order to become better acquainted with the whole structure of the house, I thought I would go down to the cellar. I found a door, with a flight of stone steps that led down to a large vaulted room. The floor consisted of large slabs of stone, and the walls struck me as very ancient. I examined the mortar and found it was mixed with splinters of brick. Obviously it was an old Roman wall. I began to grow excited. In a corner, I saw an iron ring in one of the stone slabs. I lifted it up and saw yet another narrow flight of steps leading down to a sort of cave which was obviously a prehistoric tomb. It contained two skulls, some bones, and broken shards of pottery. Then I woke up.

[485] If Freud, when analysing this dream, had followed my method of exploring the context, he would have heard a far-reaching story. But I am afraid he would have dismissed it as a mere attempt to escape from a problem that was really his own. The dream is in fact a short summary of my life—the life of my mind. I grew up in a house two hundred years old, our furniture consisted mostly of pieces about a hundred years old, and mentally my greatest adventure had been the study of Kant and Schopenhauer. The great news of the day was the work of Charles Darwin. Shortly before this I had been living in a still medieval world with my parents, where the world and man were still presided over by divine omnipotence and providence. This world had become antiquated and obsolete. My Christian faith had been relativized by my encounter with Eastern religions and Greek philosophy. It is for this reason that the ground floor was so still, dark, and obviously uninhabited.

[486] My then historical interests had developed from my original preoccupation with comparative anatomy and paleontology when I worked as an assistant at the Anatomical Institute. I was fascinated by the bones of fossil man, particularly by the much-discussed *Neanderthalensis* and the still more controversial skull of Dubois' *Pithecanthropus*. As a matter of fact, these were my real associations to the dream. But I did not dare mention the subject of skulls, skeletons, or corpses to Freud, because I had learned that this theme was not popular with him. He cherished the peculiar idea that I anticipated his early death. He drew this conclusion from the fact that I was interested in the mummified corpses in the so-called Bleikeller in Bremen, which we had visited together in 1909 on our trip to America.¹

[487] Thus I was reluctant to come out with my thoughts, since through recent experience I was deeply impressed by the almost unbridgeable gap between Freud's mental outlook and background and my own. I was afraid of losing his friendship if I should open up to him about my inner world, which, I surmised, would look very queer to him. Feeling quite uncertain about my own psychology, I almost automatically told him a lie about my "free associations" in order to escape the

impossible task of enlightening him about my very personal and utterly different mental constitution.

[488] I soon realized that Freud was seeking for some incompatible wish of mine. And so I suggested tentatively that the skulls might refer to certain members of my family whose death, for some reason, I might desire. This proposal met with his approval, but I was not satisfied with such a “phoney” solution.

[489] While I was trying to find a suitable answer to Freud’s questions, I was suddenly confounded by an intuition about the role which the subjective factor plays in psychological understanding. My intuition was so overwhelming that my only thought was how to get out of this impossible snarl, and I took the easy way out by a lie. This was neither elegant nor morally defensible, but otherwise I should have risked a fatal row with Freud—and I did not feel up to that for many reasons.

[490] My intuition consisted in a sudden and most unexpected insight into the fact that my dream meant myself, *my* life and *my* world, my whole reality as against a theoretical structure erected by another, alien mind for reasons and purposes of its own. It was not Freud’s dream, it was mine; and suddenly I understood in a flash what my dream meant.

[491] I must apologize for this rather lengthy narration of the jam I got into through telling Freud my dream. But it is a good example of the difficulties in which one gets involved in the course of a real dream analysis. So much depends on the personal differences between the analyst and the analysand.

[492] Dream analysis on this level is less a technique than a dialectical process between two personalities. If it is handled as a technique, the peculiarity of the subject as an individual is excluded and the therapeutic problem is reduced to the simple question: who will dominate whom? I had given up hypnotic treatment for this very reason, because I did not want to impose my will on others. I wanted the healing processes to grow out of the patient’s own personality, and not out of suggestions of mine that would have only a passing effect. I wanted to protect and preserve my patient’s dignity and freedom so that he could live his life by his own volition.

[493] I could not share Freud’s almost exclusive interest in sex. Assuredly sex plays no small role among human motives, but in many cases it is secondary to hunger, the power drive, ambition, fanaticism, envy, revenge, or the devouring passion of the creative impulse and the religious spirit.

[494] For the first time it dawned on me that before we construct general theories about man and his psyche we should learn a great deal more about the real human being, rather than an abstract idea of *Homo sapiens*.

4. THE PROBLEM OF TYPES IN DREAM INTERPRETATION

[495] In all other branches of science, it is a legitimate procedure to apply an hypothesis to an impersonal object. Psychology, however, inescapably confronts us with the living relationship between two individuals, neither of whom can be divested of his subjectivity or depersonalized in any way. They can mutually agree to deal with a chosen theme in an impersonal, objective manner, but when the whole of the personality becomes the object of their discussion, two individual subjects confront one another and the application of a one-way rule is excluded. Progress is possible only if mutual agreement can be reached. The objectivity of the final result can be established only by comparison with the standards that are generally valid in the social milieu to which the individuals belong, and we must also take their own mental equilibrium, or "sanity," into account. This does not mean that the final result must be the complete collectivization of the individual, for this would be a most unnatural condition. On the contrary, a sane and normal society is one in which people habitually disagree. General agreement is relatively rare outside the sphere of the instinctive qualities. Disagreement functions as a vehicle of mental life in a society, but it is not a goal; agreement is equally important. Because psychology basically depends upon balanced opposites, no judgment can be considered final unless allowance is made for its reversibility. The reason for this peculiarity lies in the fact that there is no standpoint above or outside psychology that would enable us to form a final judgment as to what the psyche is. Everything we can imagine is in a psychic state, i.e., in the state of a conscious representation. To get outside this is the whole difficulty of the physical sciences.

[496] In spite of the fact that the only reality is the individual, some generalities are necessary in order to clarify and classify the empirical material, for it would obviously be impossible to formulate any psychological theory, or to teach it, by describing individuals. As a principle of classification, one can choose any likeness or unlikeness if only it is general enough, be it anatomical, physiological, or psychological. For our purpose, which is mainly concerned with psychology, it will be a psychological one, namely the widespread and easily observable fact that a great number of people are *extraverted* and others *introverted*. There is no need for a special explanation of these terms as they have passed into common speech.

[497] This is one of the many generalities from which one can choose, and it is fairly suitable for our purpose in so far as we are seeking to describe the method of, and approach to, an understanding of dreams as the main source of natural symbols. As I

have said, the process of interpretation consists in the confrontation of two minds, the analyst's and the analysand's, and not in the application of a preconceived theory. The analyst's mind is characterized by a number of individual peculiarities, perhaps just as many as the analysand's. They have the effect of prejudices. It cannot be assumed that the analyst is a superman just because he is a doctor and possesses a theory and a corresponding technique. He can only imagine himself to be superior if he assumes that his theory and technique are absolute truths, capable of embracing the whole of the psyche. Since such an assumption is more than doubtful, he cannot really be sure of it. Consequently he will be assailed by secret doubts in adopting such an attitude, i.e., in confronting the human wholeness of the analysand with a theory and a technique (which are mere hypotheses) instead of with his own living wholeness. This alone is the equivalent of his analysand's personality. Psychological experience and knowledge are nothing more than professional advantages on the part of the analyst that do not keep him safely outside the fray. He will be tested just as much as the analysand.

[498] Since the systematic analysis of dreams demands the confrontation of two individuals, it will make a great difference whether their type of attitude is the same or not. If both belong to the same type, they may sail along happily for a long time. But if one is an extravert and the other an introvert, their different and contradictory standpoints may clash right away, particularly when they are unconscious of their own type or are convinced that it is the only right one. Such a mistake is easily made, because the value of the one is the non-value of the other. The one will choose the majority view, the other will reject it just because it is everybody's taste. Freud himself interpreted the introverted type as an individual morbidly engrossed in himself. But introspection and self-knowledge can just as well be of the greatest value.

[499] The apparently trifling difference between the extravert, with his emphasis on externals, and the introvert, who puts the emphasis on the way he takes a situation, plays a very great role in the analysis of dreams. From the start you must bear in mind that what the one appreciates may be very negative to the other, and the high ideal of the one can be an object of repulsion to the other. This becomes more and more obvious the further you go into the details of type differences. Extraversion and introversion are just two among many peculiarities of human behaviour, but they are often rather obvious and easily recognizable. If one studies extraverted individuals, for instance, one soon discovers that they differ from one another in many ways, and that being extraverted is a superficial and too general criterion to be really characteristic. That is why, long ago, I tried to find some further basic peculiarities that might serve the purpose of getting some order into the apparently limitless variations of human personality.

[500] I had always been impressed by the fact that there are surprisingly many individuals who never use their minds if they can avoid it, and yet are not stupid, and an equal number who obviously do use their minds but in an amazingly stupid way. I was also surprised to find many intelligent and wide-awake people who lived (as far as one could make out) as if they had never learned to use their sense organs. They did not see the things before their eyes, hear the words sounding in their ears, notice the things they touched or tasted, and lived without being aware of their own bodies. There were others who seemed to live in a most curious condition of consciousness, as if the state they had arrived at today were final, with no change in sight, or as if the world and the psyche were static and would remain so for ever. They seemed devoid of all imagination, and entirely and exclusively dependent on sense perception. Chances and possibilities did not exist in their world, and in their “today” there was no real “tomorrow.” The future was just the repetition of the past.

[501] What I am trying to convey to the reader is the first glimpse of the impressions I received when I began to observe the many people I met. It soon became clear to me that the people who used their minds were those who *thought*, who employed their intellectual faculty in trying to adapt to people and circumstances; and that the equally intelligent people, who yet did not think, were those who sought and found their way by *feeling*. Now “feeling” is a word that needs some explanation. For instance, one speaks of “feeling” when it is a matter of “sentiment” (corresponding to the French *sentiment*). But one also applies the same word to an opinion; a communication from the White House may begin: “The President feels ...” Or one uses it to express an intuition: “I had a feeling ...” Finally, feeling is often confused with sensation.

[502] What I mean by feeling in contrast to thinking is a *judgment of value*: agreeable or disagreeable, good or bad, and so on. Feeling so defined is not an emotion or affect, which is, as the words convey, an involuntary manifestation. Feeling as I mean it is a judgment without any of the obvious bodily reactions that characterize an emotion. Like thinking, it is a *rational* function; whereas intuition, like sensation, is *irrational*. In so far as intuition is a “hunch” it is not a product of a voluntary act; it is rather an involuntary event, which depends on different external or internal circumstances instead of an act of judgment. Intuition is more like sense perception, which is also an irrational event in so far as it depends essentially on external or internal stimuli deriving from physical and not mental causes.

[503] These four functional types correspond to the obvious means by which consciousness obtains its orientation. *Sensation* (or sense perception) tells you that something exists; *thinking* tells you what it is; *feeling* tells you whether it is agreeable or not; and *intuition* tells you where it comes from and where it is going.

[504] The reader should understand that these four criteria are just so many viewpoints among others, such as will-power, temperament, imagination, memory, morality, religiousness, etc. There is nothing dogmatic about them, nor do they claim to be the ultimate truth about psychology; but their basic nature recommends them as suitable principles of classification. Classification has little value if it does not provide a means of orientation and a practical terminology. I find classification into types particularly helpful when I am called upon to explain parents to children or husbands to wives, and vice versa. It is also useful in understanding one's own prejudices.

[505] Thus, if you want to understand another person's dream, you have to sacrifice your own predilections and suppress your prejudices, at least for the time being. This is neither easy nor comfortable, because it means a moral effort that is not everyone's cup of tea. But, if you do not make the effort to criticize your own standpoint and to admit its relativity, you will get neither the right information about, nor sufficient insight into, your analysand's mind. As you expect at least some willingness on his part to listen to your opinion and to take it seriously, the patient must be granted the same right too. Although such a relationship is indispensable for any understanding and is therefore a self-evident necessity, one has to remind oneself again and again that in therapy it is more important for the patient to understand than for the analyst's theoretical expectations to be satisfied. The patient's resistance to the analyst is not necessarily wrong; it is rather a sign that something does not "click." Either the patient is not yet at a point where he would be able to understand, or the interpretation does not fit.

[506] In our efforts to interpret the dream symbols of another person, we are particularly hampered by an almost invincible tendency to fill the gaps in our understanding by *projection*—that is, by the assumption that what I think is also my partner's thought. This source of error can be avoided by establishing the context of the dream-images and excluding all theoretical assumptions—except for the heuristic hypothesis that dreams somehow make sense.

[507] There is no rule, let alone a law, of dream interpretation, although it does look as if the general purpose of dreams is *compensation*. At least, compensation can be said to be the most promising and most fertile hypothesis. Sometimes the manifest dream demonstrates its compensatory character from the start. For instance, a patient with no small idea of himself and his moral superiority dreamt of a drunken tramp wallowing in a ditch beside the road. The dreamer says (in the dream): "It's awful to see how low a man can fall!" It is evident that the dream was attempting to deflate his exalted opinion of himself. But there was more to it than that. It turned out that he had a black sheep in the family, a younger brother who was a degenerate alcoholic. What the dream also revealed was that his superior attitude compensated the inferiority of his brother—and of the brother who was also himself.

[508] In another case, a lady who was proud of her intelligent understanding of psychology kept on dreaming about a certain woman whom she occasionally met in society. In real life she did not like her, thinking her vain, dishonest, and an intriguer. She wondered why she should dream of a person so unlike herself and yet, in the dream, so friendly and intimate, like a sister. The dream obviously wanted to convey the idea that she was “shadowed” by an unconscious character resembling that woman. As she had a very definite idea of herself, she was unaware of her own power-complex and her own shady motives, which had more than once led to disagreeable scenes that were always attributed to others but never to her own machinations.

[509] It is not only the shadow-side that is overlooked, disregarded and repressed; positive qualities can also be subjected to the same treatment. An instance of this would be an apparently modest, self-effacing man with winning, apologetic or deprecatory manners, who always takes a back seat though with seeming politeness he never misses an opportunity to be present. His judgment is well-informed, even competent and apparently appreciative, yet it hints at a certain higher level from which the matter in question could be dealt with in a far superior way. In his dreams he constantly meets great men such as Napoleon and Alexander the Great. His obvious inferiority complex is clearly compensated by such momentous visitors, but at the same time the dreams raise the critical question: what sort of man must I be to have such illustrious callers? In this respect, they show that the dreamer nurses a secret megalomania as an antidote to his inferiority complex. Without his knowing it, the idea of grandeur enables him to immunize himself against all influences from his surroundings; nothing penetrates his skin, and he can thus keep aloof from obligations that would be binding to other people. He does not feel in any way called upon to prove to himself or his fellows that his superior judgment is based on corresponding merits. He is not only a bachelor, but mentally sterile as well. He only understands the art of spreading hints and whisperings about his importance, but no monument witnesses to his deeds. He plays this inane game all unconsciously, and the dreams try to bring it home to him in a curiously ambiguous way, as the old saying goes: *Ducunt volentem fata, nolentem trahunt* (the fates lead the willing, but drag the unwilling). Hobnobbing with Napoleon or being on speaking terms with Alexander the Great is just the thing a man with an inferiority complex could wish for—a wholesale confirmation of the greatness behind the scenes. It is true wish-fulfilment, which anticipates an achievement without the merits that should lead to it. But why, one will ask, can't dreams be open and direct about it, and say it clearly without subterfuges that seem to mislead in an almost cunning way?

[510] I have frequently been asked this question and I have asked it myself. I am often surprised at the tantalizing way dreams seem to evade definite information or omit

the decisive point. Freud assumed the existence of a special factor, called the “censor,” which was supposed to twist the dream-images and make them unrecognizable or misleading in order to deceive the dreaming consciousness about the real subject of the dream: the incompatible wish. Through the concealment of the critical point, it was supposed that the dreamer’s sleep would be protected against the shock of a disagreeable reminiscence. But the dream as a guardian of sleep is an unlikely hypothesis, since dreams just as often disturb sleep.

[511] It looks rather as if, instead of an unconscious censor, consciousness, or the dreamer’s approach to consciousness, had itself a blotting-out effect on the subliminal contents. Subliminality corresponds to what Janet calls *abaissement du niveau mental*. It is a lowering of the energetic tension, in which psychic contents sink below the threshold and lose the qualities they possess in their conscious state. They lose their definiteness and clearness, and their relations become vaguely analogous instead of rational and comprehensible. This is a phenomenon that can be observed in all dreamlike conditions, whether due to fatigue, fever, or toxins. But as soon as their tension increases, they become less subliminal, more definite, and thus more conscious. There is no reason to believe that the *abaissement* shields incompatible wishes from discovery, although it may incidentally happen that an incompatible wish disappears along with the vanishing consciousness. The dream, being essentially a subliminal process, cannot produce a definite thought, unless it should cease to be a dream by instantly becoming a conscious content. The dream cannot but skip all those points that are particularly important to the conscious mind. It manifests the “fringe of consciousness,” like the faint glimmer of the stars during a total eclipse of the sun.

[512] Dream symbols are for the most part manifestations of a psyche that is beyond the control of consciousness. Meaning and purposefulness are not prerogatives of the conscious mind; they operate through the whole of living nature. There is no difference in principle between organic and psychic formations. As a plant produces its flower, so the psyche creates its symbols. Every dream is evidence of this process. Thus, through dreams, intuitions, impulses, and other spontaneous happenings, instinctive forces influence the activity of consciousness. Whether that influence is for better or worse depends on the actual contents of the unconscious. If it contains too many things that normally ought to be conscious, then its function becomes twisted and prejudiced; motives appear that are not based on true instincts, but owe their activity to the fact that they have been consigned to the unconscious by repression or neglect. They overlay, as it were, the normal unconscious psyche and distort its natural symbol-producing function.

[513] Therefore it is usual for psychotherapy, concerned as it is with the causes of a disturbance, to begin by eliciting from the patient a more or less voluntary confession

of all the things he dislikes, is ashamed of, or fears. This is like the much older confession in the Church, which in many ways anticipated modern psychological techniques. In practice, however, the procedure is often reversed, since overpowering feelings of inferiority or a serious weakness may make it very difficult, if not impossible, for the patient to face a still deeper darkness and worthlessness. I have often found it more profitable first to give a positive outlook to the patient, a foundation on which he could stand, before we approached more painful and debilitating insights.

[514] Take as a simple example the dream of “personal exaltation,” in which one has tea with the Queen of England, or is on intimate terms with the Pope. If the dreamer is not a schizophrenic, the practical interpretation of the symbol depends very much on the state of his consciousness. If he is obviously convinced of his greatness a damper will be indicated, but if it is a matter of a worm already crushed by the weight of his inferiority, a further lowering of his values would amount to cruelty. In the former case a reductive treatment will recommend itself, and it will be easy to show from the associative material how inappropriate and childish the dreamer’s intentions are, and how much they emanate from infantile wishes to be equal or superior to his parents. But in the latter case, where an all-pervading feeling of worthlessness has already devalued every positive aspect, to show the dreamer, on top of it all, how infantile, ridiculous, or even perverse he is would be quite unfitting. Such a procedure would only increase his inferiority, as well as cause an unwelcome and quite unnecessary resistance to the treatment.

[515] There is no therapeutic technique or doctrine that is generally applicable, since every case that comes for treatment is an individual in a specific condition. I remember a patient I had to treat over a period of nine years. I saw him only for a few weeks each year, as he lived abroad. From the start I knew what his real trouble was, but I also saw how the least attempt to get closer to the truth was met by a violent reaction and a self-defence that threatened complete rupture between us. Whether I liked it or not, I had to do my best to maintain the rapport and to follow his inclination, supported by his dreams, though this led the discussion away from the central problem that, according to all reasonable expectations, should have been discussed. It went so far that I often accused myself of leading my patient astray, and only the fact that his condition slowly but clearly improved prevented me from confronting him brutally with the truth.

[516] In the tenth year, however, the patient declared himself cured and freed from all symptoms. I was surprised and ready to doubt his statement, because theoretically he could not be cured. Noticing my astonishment, he smiled and said: “And now I want to thank you quite particularly for your unfailing tact and patience in helping me to circumvent the painful cause of my neurosis. I am now ready to tell you everything

about it. If I had been able to do so I would have told you right out at the first consultation. But that would have destroyed my rapport with you, and where would I have been then? I would have been morally bankrupt and would have lost the ground from under my feet, having nothing to stand on. In the course of the years I have learnt to trust you, and as my confidence grew my condition improved. I improved because my belief in myself was restored, and now I am strong enough to discuss the problem that was destroying me.”

[517] He then made a devastatingly frank confession, which showed me the reasons for the peculiar course our treatment had followed. The original shock had been such that he could not face it alone. It needed the two of us, and that was the therapeutic task, not the fulfilment of theoretical presuppositions.

[518] From cases like this I learnt to follow the lines already indicated in the material presented by the patient and in his disposition, rather than commit myself to general theoretical considerations that might not be applicable to that particular case. The practical knowledge of human nature I have accumulated in the course of sixty years has taught me to regard each case as a new experience, for which, first of all, I have to seek the individual approach. Sometimes I have not hesitated to plunge into a careful study of infantile events and fantasies; at other times I have begun at the top, even if this meant soaring into a mist of most unlikely metaphysical speculations. It all depends on whether I am able to learn the language of the patient and to follow the gropings of his unconscious towards the light. Some demand one thing and some another. Such are the differences between individuals.

[519] This is eminently true of the interpretation of symbols. Two different individuals can have almost the same dream, yet if one is young and the other old, the problems disturbing them will be correspondingly different, and it would be absurd to interpret both dreams in the same way. An example that comes to mind is a dream in which a company of young men are riding on horseback across a wide field. The dreamer is in the lead and jumps a ditch of water, just clearing it. The others fall into the ditch. The young man who told me this dream was a cautious, introverted type and rather afraid of adventure. But the old man, who also had this dream, was bold and fearless, and had lived an active and enterprising life. At the time of the dream, he was an invalid who would not settle down, gave much trouble to his doctor and nurse, and had injured himself by his disobedience and restlessness. Obviously the dream was telling the young man what he *ought* to do, and the old man what he was *still doing*. While it encouraged the hesitant young man, the old one would be only too glad to risk the jump. But that still-flickering spirit of adventure was just his greatest trouble.

[520] This example shows how the interpretation of dreams and symbols depends largely on the individual disposition of the dreamer. Symbols have not one meaning only but several, and often they even characterize a pair of opposites, as does, for

instance, the *stella matutina*, the morning star, which is a well-known symbol of Christ and at the same time of the devil (Lucifer). The same applies to the lion. The correct interpretation depends on the context, i.e., the associations connected with the image, and on the actual condition of the dreamer's mind.

5. THE ARCHETYPE IN DREAM SYMBOLISM

[521] The hypothesis we have advanced, that dreams serve the purpose of *compensation*, is a very broad and comprehensive assumption. It means that we believe the dream to be a normal psychic phenomenon that transmits unconscious reactions or spontaneous impulses to the conscious mind. Since only a small minority of dreams are manifestly compensatory, we must pay particular attention to the language of dreams that we consider to be symbolic. The study of this language is almost a science in itself. It has, as we have seen, an infinite variety of individual expressions. They can be read with the help of the dreamer, who himself provides the associative material, or context of the dream-image, so that we can look at all its aspects as if circumambulating it. This method proves to be sufficient in all ordinary cases, such as when a relative, a friend, or a patient tells you a dream more or less conversationally. But when it is a matter of outstanding dreams of obsessive or recurrent dreams, or dreams that are highly emotional, the personal associations produced by the dreamer no longer suffice for a satisfactory interpretation. In such cases, we have to take into consideration the fact, already observed and commented on by Freud, that elements often occur in a dream that are not individual and cannot be derived from personal experience. They are what Freud called “archaic remnants”—thought-forms whose presence cannot be explained by anything in the individual’s own life, but seem to be aboriginal, innate, and inherited patterns of the human mind.

[522] Just as the human body represents a whole museum of organs, with a long evolutionary history behind them, so we should expect the mind to be organized in a similar way rather than to be a product without history. By “history” I do not mean the fact that the mind builds itself up through conscious tradition (language, etc.), but rather its biological, prehistoric, and unconscious development beginning with archaic man, whose psyche was still similar to that of an animal. This immensely old psyche forms the basis of our mind, just as the structure of our body is erected upon a generally mammalian anatomy. Wherever the trained eye of the morphologist looks, it recognizes traces of the original pattern. Similarly, the experienced investigator of the psyche cannot help seeing the analogies between dream-images and the products of the primitive mind, its *représentations collectives*, or mythological motifs. But just as the morphologist needs the science of comparative anatomy, so the psychologist cannot do without a “comparative anatomy of the psyche.” He must have a sufficient experience of dreams and other products of the unconscious on the one hand, and on

the other of mythology in its widest sense. He cannot even see the analogy between a case of compulsion neurosis, schizophrenia, or hysteria and that of a classical demonic possession if he has not sufficient knowledge of both.

[523] My views about the “archaic remnants,” which I have called “archetypes”¹ or “primordial images,” are constantly criticized by people who lack a sufficient knowledge both of the psychology of dreams and of mythology. The term “archetype” is often misunderstood as meaning a certain definite mythological image or motif. But this would be no more than a conscious representation, and it would be absurd to assume that such variable representations could be inherited. The archetype is, on the contrary, an inherited *tendency of the human mind to form representations* of mythological motifs—representations that vary a great deal without losing their basic pattern. There are, for instance, numerous representations of the motif of the hostile brothers, but the motif remains the same. This inherited tendency is instinctive, like the specific impulse of nest-building, migration, etc. in birds. One finds these *représentations collectives* practically everywhere, characterized by the same or similar motifs. They cannot be assigned to any particular time or region or race. They are without known origin, and they can reproduce themselves even where transmission through migration must be ruled out.

[524] My critics have also incorrectly assumed that by archetypes I mean “inherited ideas,” and on this ground have dismissed the concept of the archetype as a mere superstition. But if archetypes were ideas that originated in our conscious mind or were acquired by it, one would certainly understand them, and would not be astonished and bewildered when they appear in consciousness. I can remember many cases of people who have consulted me because they were baffled by their own or their children’s dreams. The reason was that the dreams contained images that could not be traced to anything they remembered, and they could not explain where their children could have picked up such strange and incomprehensible ideas. These people were highly educated persons, sometimes psychiatrists themselves. One of them was a professor who had a sudden vision and thought he was crazy. He came to me in a state of complete panic. I simply took a four-hundred-year-old volume from the shelf and showed him an old woodcut that depicted his vision. “You don’t need to be crazy,” I told him. “They knew all about your vision four hundred years ago.” Whereupon he sat down entirely deflated but once more normal.

[525] I particularly remember the case of a man who was himself a psychiatrist. He brought me a handwritten booklet he had received as a Christmas present from his ten-year-old daughter. It contained a whole series of dreams she had had when she was eight years old. It was the weirdest series I had ever seen, and I could well understand why her father was more than puzzled by the dreams. Childlike though

they were, they were a bit uncanny, containing images whose origin was wholly incomprehensible to her father. Here are the salient motifs from the dreams:²

1. The “bad animal”: a snakelike monster with many horns, that kills and devours all other animals. But God comes from the four corners, being really four gods, and gives rebirth to all the animals.

2. Ascent into heaven where pagan dances are being celebrated, and descent to hell where angels are doing good deeds.

3. A horde of small animals frightens the dreamer. The animals grow to enormous size, and one of them devours her.

4. A small mouse is penetrated by worms, snakes, fishes, and human beings. Thus the mouse becomes human. This is the origin of mankind in four stages.

5. A drop of water is looked at through a microscope: it is full of branches. This is the origin of the world.

6. A bad boy with a clod of earth. He throws bits of it at the passers-by, and they all become bad too.

7. A drunken woman falls into the water and comes out sober and renewed.

8. In America many people are rolling in an ant heap, attacked by the ants. The dreamer, in a panic, falls into a river.

9. The dreamer is in a desert on the moon. She sinks so deep into the ground that she reaches hell.

10. She touches a luminous ball seen in a vision. Vapours come out of it. Then a man comes and kills her.

11. She is dangerously ill. Suddenly birds come out of her skin and cover her completely.

12. Swarms of gnats hide the sun, moon, and stars, all except one star which then falls on the dreamer.

[526] In the unabridged German original, each dream begins with the words of the fairytale: “Once upon a time ...” With these words the little dreamer suggests that she feels as if each dream were a sort of fairytale, which she wants to tell her father as a Christmas present. Her father was unable to elucidate the dreams through their context, for there seemed to be no personal associations. Indeed, this kind of childhood dream often seems to be a “Just So Story,” with very few or no spontaneous associations. The possibility that these dreams were conscious elaborations can of course be ruled out only by someone who had an intimate knowledge of the child’s character and did not doubt her truthfulness. They would, however, remain a challenge to our understanding even if they were fantasies that originated in the waking state. The father was convinced that they were authentic, and I have no reason to doubt it. I knew the little girl myself, but this was before she

gave the dreams to her father, and I had no chance to question her about them, for she lived far away from Switzerland and died of an infectious disease about a year after that Christmas.

[527] The dreams have a decidedly peculiar character, for their leading thoughts are in a way like philosophical problems. The first dream, for instance, speaks of an evil monster killing all other animals, but God gives rebirth to them through a kind of *apocatastasis*, or restitution. In the Western world this idea is known through Christian tradition. It can be found in the Acts of the Apostles 3:21: “(Christ,) whom the heaven must receive until the times of restitution of all things ...” The early Greek Fathers of the Church (Origen, for instance) particularly insisted on the idea that, at the end of time, everything will be restored by the Redeemer to its original and perfect state. According to Matthew 17:11, there was already an old Jewish tradition that Elias “truly shall first come, and restore all things.” I Corinthians 15:22 refers to the same idea in the following words: “For as in Adam all die, even so in Christ shall all be made alive.”

[528] One might argue that the child had met with this thought in her religious education. But she had had very little of this, as her parents (Protestants) belonged to those people, common enough in our days, who know the Bible only from hearsay. It is particularly unlikely that the idea of *apocatastasis* had been explained to her, and had become a matter of vital interest. Her father, at any rate, was entirely unaware of this mythical idea.

[529] Nine of the twelve dreams are concerned with the theme of destruction and restoration. We find the same connection in I Corinthians 15:22, where Adam and Christ; i.e., death and resurrection, are linked together. None of these dreams, however, shows anything more than superficial traces of a specifically Christian education or influence. On the contrary, they show more analogy with primitive tales. This is corroborated by the other motif—the cosmogonic myth of the creation of the world and of man, which appears in dreams 4 and 5.

[530] The idea of Christ the Redeemer belongs to the world-wide and pre-Christian motif of the hero and rescuer who, although devoured by the monster, appears again in a miraculous way, having overcome the dragon or whale or whatever it was that swallowed him. How, when, and where such a motif originated nobody knows. We do not even know how to set about investigating the problem in a sound way. Our only certainty is that every generation, so far as we can see, has found it as an old tradition. Thus we can safely assume that the motif “originated” at a time when man did not yet know that he possessed a hero myth—in an age, therefore, when he did not yet reflect consciously on what he was saying. The hero figure is a typical image, an archetype, which has existed since time immemorial.

[531] The best examples of the spontaneous production of archetypal images are presented by individuals, particularly children, who live in a milieu where one can be sufficiently certain that any direct knowledge of the tradition is out of the question. The milieu in which our little dreamer lived was acquainted only with the Christian tradition, and very superficially at that. Christian traces may be represented in her dreams by such ideas as God, angels, heaven, hell, and evil, but the way in which they are treated points to a tradition that is entirely non-Christian.

[532] Let us take the first dream, of the God who really consists of four gods, coming from the “four corners.” The corners of what? There is no room mentioned in the dream. A room would not even fit in with the picture of what is obviously a cosmic event, in which the Universal Being himself intervenes. The quaternity itself is a strange idea, but one that plays a great role in Eastern religions and philosophies. In the Christian tradition it has been superseded by the Trinity, a notion that we must assume was known to the child. But who in an ordinary middleclass milieu would be likely to know of a divine quaternity? It is an idea that was once current in circles acquainted with Hermetic philosophy in the Middle Ages, but it petered out at the beginning of the eighteenth century and has been entirely obsolete for at least two hundred years. Where, then, did the little girl pick it up? From Ezekiel’s vision? But there is no Christian teaching that identifies the seraphim with God.

[533] The same question may be asked about the horned serpent. In the Bible, it is true, there are many horned animals, for instance in the Book of Revelation (ch. 13). But they seem to be quadrupeds, although their overlord is the dragon, which in Greek (*drakon*) means serpent. The horned serpent appears in Latin alchemy as the *quadricornutus serpens* (four-horned serpent), a symbol of Mercurius and an antagonist of the Christian Trinity. But this is an obscure reference, and, as far as I can discover, it occurs only in one author.³

[534] In dream 2 a motif appears that is definitely non-Christian and a reversal of values: pagan dances by men in heaven and good deeds by angels in hell. This suggests, if anything, a relativization of moral values. Where did the child hit on such a revolutionary and modern idea, worthy of Nietzsche’s genius? Such an idea is not strange to the philosophical mind of the East, but where could we find it in the child’s milieu, and what is its place in the mind of an eight-year-old girl?

[535] This question leads to a further one: what is the compensatory meaning of the dreams, to which the little girl obviously attributed so much importance that she gave them to her father as a Christmas present?

[536] If the dreamer had been a primitive medicine-man, one would not go far wrong in supposing them to be variations on the philosophical themes of death, resurrection, or restitution, the origin of the world, the creation of man, and the relativity of values (Lao-tze: “high stands on low”). One might well give up such dreams as hopeless if

one tried to interpret them from a personal standpoint. But, as I have said, they undoubtedly contain *représentations collectives*, and they are in a way analogous to the doctrines taught to young people in primitive tribes when they are initiated into manhood. At such times they learn about what God or the gods or the “founding” animals have done, how the world and man were created, what the end of the world will be, and the meaning of death. And when do we, in our Christian civilization, hand out similar instructions? At the beginning of adolescence. But many people begin to think of these things again in old age, at the approach of death.

[537] Our dreamer, as it happened, was in both these situations, for she was approaching puberty and at the same time the end of her life. Little or nothing in the symbolism of the dreams points to the beginning of a normal adult life, but there are many allusions to destruction and restoration. When I first read the dreams, I had the uncanny feeling that they foreboded disaster. The reason I felt like that was the peculiar nature of the compensation that I deduced from the symbolism. It was the opposite of what one would expect to find in the consciousness of a girl of that age. These dreams open up a new and rather terrifying vision of life and death, such as one might expect in someone who looks back upon life rather than forward to its natural continuation. Their atmosphere recalls the old Roman saying, *vita somnium breve* (life is a short dream), rather than the joy and exuberance of life’s springtime. For this child, life was a *ver sacrum vovendum*, a vow of a vernal sacrifice. Experience shows that the unknown approach of death casts an *adumbratio*, an anticipatory shadow, over the life and dreams of the victim. Even the altar in our Christian churches represents, on the one hand, a tomb, and on the other a place of resurrection—the transformation of death into eternal life.

[538] Such are the thoughts that the dreams brought home to the child. They were a preparation for death, expressed through short stories, like the instruction at primitive initiations, or the *koans* of Zen Buddhism. It is an instruction that does not resemble the orthodox Christian doctrine but is more like primitive thought. It seems to have originated outside the historical tradition, in the matrix that, since prehistoric times, has nourished philosophical and religious speculations about life and death.

[539] In the case of this girl, it was as if future events were casting their shadow ahead by arousing thought-forms that, though normally dormant, are destined to describe or accompany the approach of a fatal issue. They are to be found everywhere and at all times. Although the concrete shape in which they express themselves is more or less personal, their general pattern is collective, just as animal instincts vary a good deal in different species and yet serve the same general purpose. We do not assume that each newborn animal creates its own instincts as an individual acquisition, and we cannot suppose, either, that human beings invent and produce their specifically human modes of reaction with every new birth. Like the instincts, the collective

thought-patterns of the human mind are innate and inherited; and they function, when occasion arises, in more or less the same way in all of us.

[540] Emotional manifestations are based on similar patterns, and are recognizably the same all over the earth. We understand them even in animals, and the animals themselves understand each other in this respect, even if they belong to different species. And what about insects, with their complicated symbiotic functions? Most of them do not even know their parents and have nobody to teach them. Why should we suppose, then, that man is the only living creature deprived of specific instincts, or that his psyche is devoid of all traces of its evolution? Naturally, if you identify the psyche with consciousness, you can easily succumb to the erroneous idea that the psyche is a *tabula rasa*, completely empty at birth, and that it later contains only what it has learnt by individual experience. But the psyche is more than consciousness. Animals have little consciousness, but they have many impulses and reactions that denote the existence of a psyche, and primitives do a lot of things whose meaning is unknown to them. You may ask many civilized people in vain for the reason and meaning of the Christmas tree or of the coloured eggs at Easter, because they have no idea about the meaning of these customs. The fact is, they do things without knowing why they do them. I am inclined to believe that things were generally done first and that only a long time afterwards somebody asked a question about them, and then eventually discovered why they were done. The medical psychologist is constantly confronted with otherwise intelligent patients who behave in a peculiar way and have no inkling of what they say or do. We have dreams whose meaning escapes us entirely, even though we may be firmly convinced that the dream has a definite meaning. We feel it is important or even terrifying, but why?

[541] Regular observation of such facts has enforced the hypothesis of an unconscious psyche, the contents of which seem to be of approximately the same variety as those of consciousness. We know that consciousness depends in large measure on the collaboration of the unconscious. When you make a speech, the next sentence is being prepared while you speak, but this preparation is mostly unconscious. If the unconscious does not collaborate and withholds the next sentence you are stuck. You want to quote a name, or a term otherwise familiar to you, but nothing is forthcoming. The unconscious does not deliver it. You want to introduce somebody whom you know well, but his name has vanished, as if you had never known it. Thus you depend on the goodwill of your unconscious. Any time the unconscious chooses, it can defeat your otherwise good memory, or put something into your mouth that you did not intend at all. It can produce unpredictable and unreasonable moods and affects and thus cause all sorts of complications.

[542] Superficially, such reactions and impulses seem to be of an intimately personal nature and are therefore believed to be entirely individual. In reality, they are based

on a preformed and ever-ready instinctive system with its own characteristic and universally understandable thought-forms, reflexes, attitudes, and gestures. These follow a pattern that was laid down long before there was any trace of a reflective consciousness. It is even conceivable that the latter originated in violent emotional clashes and their often disastrous consequences. Take the case of the savage who, in a moment of anger and disappointment at having caught no fish, strangles his much beloved only son, and is then seized with immeasurable regret as he holds the little dead body in his arms. Such a man has a great chance to remember the agony of this moment for ever. This could have been the beginning of a reflective consciousness. At all events, the shock of a similar emotional experience is often needed to make people wake up and pay attention to what they are doing. I would mention the famous case of the Spanish hidalgo, Ramón Lull, who after a long chase finally succeeded in meeting his lady at a secret rendezvous. Silently she opened her garment and showed him her cancer-eaten bosom. The shock changed his life: he became a holy man.

[543] Often in the case of these sudden transformations one can prove that an archetype has been at work for a long time in the unconscious, skilfully arranging circumstances that will unavoidably lead to a crisis. It is not rare for the development to manifest itself so clearly (for instance in a series of dreams) that the catastrophe can be predicted with reasonable certainty. One can conclude from experiences such as these that archetypal forms are not just static patterns, but dynamic factors that manifest themselves in spontaneous impulses, just as instincts do. Certain dreams, visions, or thoughts can suddenly appear, and in spite of careful investigation one cannot find out what causes them. This does not mean that they have no cause; they certainly have, but it is so remote or obscure that one cannot see what it is. One must wait until the dream and its meaning are sufficiently understood, or until some external event occurs that will explain the dream.

[544] Our conscious thoughts often concern themselves with the future and its possibilities, and so does the unconscious and its dreams. There has long been a world-wide belief that the chief function of dreams is prognostication of the future. In antiquity, and still in the Middle Ages, dreams played their part in medical prognosis. I can confirm from a modern dream the prognosis, or rather precognition, in an old dream quoted by Artemidoros of Daldis, in the second century A.D. He relates that a man dreamt he saw his father die in the flames of a house on fire. Not long afterwards, he himself died of a *phlegmone* (fire, high fever), presumably pneumonia. Now it so happened that a colleague of mine was suffering from a deadly gangrenous fever—in fact, a *phlegmone*. A former patient of his, who had no knowledge of the nature of the doctor's illness, dreamt that the doctor was perishing in a great fire. The dream occurred three weeks before the doctor died, at a time when he had just

entered hospital and the disease was only at its beginning. The dreamer knew nothing but the bare fact that the doctor was ill and had entered hospital.

[545] As this example shows, dreams can have an anticipatory or prognostic aspect, and their interpreter will be well advised to take this aspect into account, particularly when an obviously meaningful dream does not yield a context sufficient to explain it. Such a dream often comes right out of the blue, and one wonders what could have prompted it. Of course, if one knew its ultimate outcome, the cause would be clear. It is only our conscious mind that does not know; the unconscious seems already informed, and to have submitted the case to a careful prognostic examination, more or less in the way consciousness would have done if it had known the relevant facts. But, precisely because they were subliminal, they could be perceived by the unconscious and submitted to a sort of examination that anticipates their ultimate result. So far as one can make out from dreams, the unconscious in its “deliberations” proceeds in an instinctive way rather than along rational lines. The latter way is the prerogative of consciousness, which selects with reason and knowledge. But the unconscious is guided chiefly by instinctive trends, represented by corresponding thought-forms—the archetypes. It looks as if it were a poet who had been at work rather than a rational doctor, who would speak of infection, fever, toxins, etc., whereas the dream describes the diseased body as a man’s earthly house, and the fever as the heat of a conflagration that is destroying the house and its inhabitant.

[546] As this dream shows, the archetypal mind has handled the situation in the same way as it did at the time of Artemidoros. A situation of a more or less unknown nature has been intuitively grasped by the unconscious and submitted to an archetypal treatment. This shows clearly that, in place of the *raisonnement* which consciousness would have applied, the archetypal mind has autonomously taken over the task of prognostication. The archetypes have their own initiative and their own specific energy, which enable them not only to produce a meaningful interpretation (in their own style) but also to intervene in a given situation with their own impulses and thought-forms. In this respect they function like complexes, which also enjoy a certain autonomy in everyday life. They come and go very much as they please, and they often interfere with our conscious intentions in an embarrassing way.

[547] One can perceive the specific energy of the archetypes when one experiences the peculiar feeling of numinosity that accompanies them—the fascination or spell that emanates from them. This is also characteristic of the personal complexes, whose behaviour may be compared with the role played by the archetypal *représentations collectives* in the social life of all times. As personal complexes have their individual history, so do social complexes of an archetypal character. But while personal complexes never produce more than a personal bias, archetypes create myths, religions, and philosophical ideas that influence and set their stamp on whole nations

and epochs. And just as the products of personal complexes can be understood as compensations of onesided or faulty attitudes of consciousness, so myths of a religious nature can be interpreted as a sort of mental therapy for the sufferings of mankind, such as hunger, war, disease, old age, and death.

[548] The universal hero myth, for example, shows the picture of a powerful man or god-man who vanquishes evil in the form of dragons, serpents, monsters, demons, and enemies of all kinds, and who liberates his people from destruction and death. The narration or ritual repetition of sacred texts and ceremonies, and the worship of such a figure with dances, music, hymns, prayers, and sacrifices, grip the audience with numinous emotions and exalt the participants to identification with the hero. If we contemplate such a situation with the eyes of a believer, we can understand how the ordinary man is gripped, freed from his impotence and misery, and raised to an almost superhuman status, at least for the time being, and often enough he is sustained by such a conviction for a long time. An initiation of this kind produces a lasting impression, and may even create an attitude that gives a certain form and style to the life of a society. I would mention as an example the Eleusinian mysteries, which were finally suppressed at the beginning of the seventh century. They formed, together with the Delphic oracle, the essence and spirit of ancient Greece. On a much greater scale the Christian era owes its name and significance to another antique mystery, that of the god-man, which has its roots in the archetypal Osiris-Horus myth of ancient Egypt.

[549] It is nowadays a common prejudice to assume that once, in an obscure prehistoric time, the basic mythological ideas were “invented” by a clever old philosopher or prophet, and ever afterwards “believed” by credulous and uncritical people, although the stories told by a power-seeking priesthood were not really “true” but mere “wishful thinking.” The word “invent” is derived from the Latin *invenire* and means, in the first place, to “come upon” or to “find” something and, in the second, to find something by *seeking* for it. In the latter case, it is not a matter of finding or coming upon something by mere chance, for there is a sort of foreknowledge or a faint inkling of the thing you are going to find.

[550] When we contemplate the strange ideas in the dreams of the little girl, it seems unlikely that she *sought* them, as she was rather surprised at finding them. They occurred to her rather as strange and unexpected stories that seemed noteworthy and interesting enough to be given to her father as a Christmas present. In doing so, she lifted them up into the sphere of our still living Christian mystery, the birth of our Lord, blended with the secret of the evergreen tree that carries the newborn Light. Although there is ample historical evidence for the symbolic relationship between Christ and the tree symbol, the little girl’s parents would have been badly embarrassed had they been asked to explain exactly what they meant by decorating a

tree with burning candles to celebrate the nativity of Christ. “Oh, it’s just a Christmas custom!” they would have said. A serious answer would require a far-reaching dissertation on the symbolism of the dying god in antiquity, in the Near East, and its relation to the cult of the Great Mother and her symbol, the tree—to mention only one aspect of this complicated problem.

[551] The further we delve into the origins of a *représentation collective* or, in ecclesiastical language, of a dogma, the more we uncover a seemingly limitless web of archetypal patterns that, before modern times, were never the object of conscious reflection. Thus, paradoxically enough, we know more about mythological symbolism than did any age before our own. The fact is that in former times men *lived* their symbols rather than reflected upon them. I will illustrate this by an experience I once had with the primitives on Mount Elgon in East Africa. Every morning at dawn they leave their huts and breathe or spit into their hands, stretching them out to the first rays of the sun, as if they were offering either their breath or their spittle to the rising god—to *mungu*. (This Swahili word, which they used in explaining the ritual act, is derived from a Polynesian root equivalent to *mana* or *mulungu*. These and similar terms designate a “power” of extraordinary efficacy, an all-pervading essence which we would call divine. Thus the word *mungu* is their equivalent for Allah or God.) When I asked them what they meant by this act and why they did it, they were completely baffled. They could only say: “We have always done it. It has always been done when the sun rises.” They laughed at the obvious conclusion that the sun is *mungu*. The sun is not *mungu* when it is above the horizon; *mungu* is the actual moment of the sunrise.

[552] What they were doing was obvious to me but not to them. They just do it, they never reflect on what they are doing, and are consequently unable to explain themselves. They are evidently just repeating what they have “always” done at sunrise, no doubt with a certain emotion and by no means merely mechanically, for they *live* it while we *reflect* on it. Thus I knew that they were offering their *souls* to *mungu*, because the breath (of life) and the spittle mean “soul substance.” Breathing or spitting on something conveys a “magical” effect, as, for instance, when Christ used spittle to heal the blind, or when a son inhales his dying father’s last breath in order to take over the father’s soul. It is most unlikely that these primitives ever, even in the remote past, knew any more about the meaning of their ceremony. On the contrary, their ancestors probably knew even less, because they were more profoundly unconscious and thought if possible even less about their doings.

[553] Faust aptly says: “Im Anfang war die Tat” (in the beginning was the deed). Deeds were never invented, they were done. Thoughts, on the other hand, are a relatively late discovery; they were found, and then they were sought and found. Yet unreflected life existed long before man; it was not invented, but in it man found

himself as an afterthought. First he was moved to deeds by unconscious factors, and only a long time afterwards did he begin to reflect about the causes that had moved him; then it took him a very long time indeed to arrive at the preposterous idea that he must have moved himself—his mind being unable to see any other motivating force than his own. We would laugh at the idea of a plant or an animal inventing itself, yet there are many people who believe that the psyche or the mind invented itself and thus brought itself into being. As a matter of fact, the mind has grown to its present state of consciousness as an acorn grows into an oak or as saurians developed into mammals. As it has been, so it is still, and thus we are moved by forces from within as well as from without.

[554] In a mythological age these forces were called *mana*, spirits, demons, and gods, and they are as active today as they ever were. If they conform to our wishes, we call them happy hunches or impulses and pat ourselves on the back for being smart fellows. If they go against us, then we say it is just bad luck, or that certain people have it in for us, or it must be pathological. The one thing we refuse to admit is that we are dependent on “powers” beyond our control.

[555] It is true that civilized man has acquired a certain amount of will-power which he can apply where he pleases. We have learnt to do our work efficiently without having recourse to chanting and drumming to hypnotize us into the state of doing. We can even dispense with the daily prayer for divine aid. We can carry out what we propose to do, and it seems self-evident that an idea can be translated into action without a hitch, whereas the primitive is hampered at every step by doubts, fears, and superstitions. The motto “Where there’s a will there’s a way” is not just a Germanic prejudice; it is the superstition of modern man in general. In order to maintain his credo, he cultivates a remarkable lack of introspection. He is blind to the fact that, with all his rationality and efficiency, he is possessed by powers beyond his control. The gods and demons have not disappeared at all, they have merely got new names. They keep him on the run with restlessness, vague apprehensions, psychological complications, an invincible need for pills, alcohol, tobacco, dietary and other hygienic systems—and above, all, with an impressive array of neuroses.

[556] I once met a drastic example of this in a professor of philosophy and “psychology”—a psychology in which the unconscious had not yet arrived. He was the man I mentioned who was obsessed by the idea that he had cancer, although X-rays had proved to him that it was all imaginary. Who or what caused this idea? It obviously derived from a fear that was not caused by observation of the facts. It suddenly overcame him and then remained. Symptoms of this kind are extraordinarily obstinate and often enough hinder the patient from getting the proper treatment. For what good would psychotherapy be in dealing with a malignant tumour? Such a dangerous thing could only be operated on without delay. To the

professor's ever-renewed relief, every new authority assured him that there was no trace of cancer. But the very next day the doubt began nagging again, and he was plunged once more into the night of unmitigated fear.

[557] The morbid thought had a power of its own that he could not control. It was not foreseen in his philosophical brand of psychology, where everything flowed neatly from consciousness and sense-perception. The professor admitted that his case was pathological, but there his thinking stopped, because it had arrived at the sacrosanct border-line between the philosophical and the medical faculty. The one deals with normal and the other with abnormal contents, unknown in the philosopher's world.

[558] This compartment psychology reminds me of another case. It was that of an alcoholic who had come under the laudable influence of a certain religious movement and, fascinated by its enthusiasm, had forgotten he needed a drink. He was obviously and miraculously cured by Jesus, and accordingly was held up as a witness to divine grace or to the efficacy of the said organization. After a few weeks of public confession, the novelty began to wear off and some alcoholic refreshment seemed to be indicated. But this time the helpful organization came to the conclusion that the case was "pathological" and not suitable for an intervention by Jesus. So they put him in a clinic to let the doctor do better than the divine healer.

[559] This is an aspect of the modern "cultural" mind that is well worth looking into. It shows an alarming degree of dissociation and psychological confusion. We believe exclusively in consciousness and free will, and are no longer aware of the powers that control us to an indefinite degree, outside the narrow domain where we can be reasonable and exercise a certain amount of free choice and self-control. In our time of general disorientation, it is necessary to know about the true state of human affairs, which depends so much on the mental and moral qualities of the individual and on the human psyche in general. But if we are to see things in their right perspective, we need to understand the past of man as well as his present. That is why a correct understanding of myths and symbols is of essential importance.

6. THE FUNCTION OF RELIGIOUS SYMBOLS

[560] Although our civilized consciousness has separated itself from the instincts, the instincts have not disappeared: they have merely lost their contact with consciousness. They are thus forced to assert themselves in an indirect way, through what Janet called automatisms. These take the form of symptoms in the case of a neurosis or, in normal cases, of incidents of various kinds, like unaccountable moods, unexpected forgetfulness, mistakes in speech, and so on. Such manifestations show very clearly the *autonomy* of the archetypes. It is easy to believe that one is master in one's own house, but as long as we are unable to control our emotions and moods, or to be conscious of the myriad secret ways in which unconscious factors insinuate themselves into our arrangements and decisions, we are certainly not the masters. On the contrary, we have so much reason for uncertainty that it will be better to look twice at what we are doing.

[561] The exploration of one's conscience, however, is not a popular pastime, although it would be most necessary, particularly in our time when man is threatened with self-created and deadly dangers that are growing beyond his control. If, for a moment, we look at mankind as one individual, we see that it is like a man carried away by unconscious powers. He is dissociated like a neurotic, with the Iron Curtain marking the line of division. Western man, representing the kind of consciousness hitherto regarded as valid, has become increasingly aware of the aggressive will to power of the East, and he sees himself forced to take extraordinary measures of defence. What he fails to see is that it is his own vices, publicly repudiated and covered up by good international manners, that are thrown back in his face through their shameless and methodical application by the East. What the West has tolerated, but only secretly, and indulged in a bit shamefacedly (the diplomatic lie, the double-cross, veiled threats), comes back openly and in full measure and gets us tied up in knots—exactly the case of the neurotic! It is the face of our own shadow that glowers at us across the Iron Curtain.

[562] This state of affairs explains the peculiar feeling of helplessness that is creeping over our Western consciousness. We are beginning to realize that the conflict is in reality a moral and mental problem, and we are trying to find some answer to it. We grow increasingly aware that the nuclear deterrent is a desperate and undesirable answer, as it cuts both ways. We know that moral and mental remedies would be more effective because they could provide us with a psychic immunity to the ever-increasing infection. But all our attempts have proved to be singularly ineffectual,

and will continue to do so as long as we try to convince ourselves and the world that it is only *they*, our opponents, who are all wrong, morally and philosophically. We expect *them* to see and understand where they are wrong, instead of making a serious effort ourselves to recognize our own shadow and its nefarious doings. If we could only see our shadow, we should be immune to any moral and mental infection and insinuation. But as long as this is not so, we lay ourselves open to every infection because we are doing practically the same things as *they* are, only with the additional disadvantage that we neither see nor want to understand what we are doing under the cloak of good manners.

[563] The East has one big myth—which we call an illusion in the vain hope that our superior judgment will make it disappear. This myth is the time-hallowed archetypal dream of a Golden Age or a paradise on earth, where everything is provided for everybody, and one great, just, and wise Chief rules over a human kindergarten. This powerful archetype in its infantile form has got them all right, but it won't disappear from the world at the mere sight of our superior point of view. We even support it by our own childishness, for our Western civilization is in the grip of the same mythology. We cherish the same prejudices, hopes, and expectations. We believe in the Welfare State, in universal peace, in more or less equality for man, in his eternal human rights, injustice and truth, and (not too loud) in the Kingdom of God on earth.

[564] The sad truth is that man's real life consists of inexorable opposites—day and night, wellbeing and suffering, birth and death, good and evil. We are not even sure that the one will prevail against the other, that good will overcome evil, or joy defeat pain. Life and the world are a battleground, have always been and always will be, and, if it were not so, existence would soon come to an end. It is for this reason that a superior religion like Christianity expected an early end to this world, and Buddhism actually puts an end to it by turning its back on all desires. These categorical answers would be frankly suicidal if they were not bound up with the peculiar moral ideas and practices that constitute the body of both religions.

[565] I mention this because in our time there are countless people who have lost faith in one or other of the world religions. They do not understand them any longer. While life runs smoothly, the loss remains as good as unnoticed. But when suffering comes, things change very rapidly. One seeks the way out and begins to reflect about the meaning of life and its bewildering experiences. It is significant that, according to the statistics, the psychiatrist is consulted more by Protestants and Jews than by Catholics. This might be expected, for the Catholic Church still feels responsible for the *cura animarum*, the care of souls. But in this scientific age, the psychiatrist is apt to be asked questions that once belonged to the domain of the theologian. People feel that it makes, or would make, a great difference if only they had a positive belief in a meaningful way of life or in God and immortality. The spectre of death looming up

before them often gives a powerful incentive to such thoughts. From time immemorial, men have had ideas about a Supreme Being (one or several) and about the Land of the Hereafter. Only modern man thinks he can do without them. Because he cannot discover God's throne in heaven with a telescope or radar, or establish for certain that dear father or mother are still about in a more or less corporeal form, he assumes that such ideas are not "true." I would rather say that they are not "true" enough. They have accompanied human life since prehistoric times and are still ready to break through into consciousness at the slightest provocation.

[566] One even regrets the loss of such convictions. Since it is a matter of invisible and unknowable things (God is beyond human understanding, and immortality cannot be proved), why should we bother about evidence or truth? Suppose we did not know and understand the need for salt in our food, we would nevertheless profit from its use. Even if we should assume that salt is an illusion of our taste-buds, or a superstition, it would still contribute to our wellbeing. Why, then, should we deprive ourselves of views that prove helpful in crises and give a meaning to our existence? And how do we know that such ideas are not true? Many people would agree with me if I stated flatly that such ideas are illusions. What they fail to realize is that this denial amounts to a "belief" and is just as impossible to prove as a religious assertion. We are entirely free to choose our standpoint; it will in any case be an arbitrary decision. There is, however, a strong empirical reason why we should hold beliefs that we know can never be proved. It is that they are known to be useful. Man positively needs general ideas and convictions that will give a meaning to his life and enable him to find his place in the universe. He can stand the most incredible hardships when he is convinced that they make sense; but he is crushed when, on top of all his misfortunes, he has to admit that he is taking part in a "tale told by an idiot."

[567] It is the purpose and endeavour of religious symbols to give a meaning to the life of man. The Pueblo Indians believe that they are the sons of Father Sun, and this belief gives their life a perspective and a goal beyond their individual and limited existence. It leaves ample room for the unfolding of their personality, and is infinitely more satisfactory than the certainty that one is and will remain the underdog in a department store. If St. Paul had been convinced that he was nothing but a wandering weaver of carpets, he would certainly not have been himself. His real and meaningful life lay in the certainty that he was the messenger of the Lord. You can accuse him of megalomania, but your opinion pales before the testimony of history and the *consensus omnium*. The myth that took possession of him made him something greater than a mere craftsman.

[568] Myths, however, consist of symbols that were not invented but happened. It was not the man Jesus who created the myth of the God-man; it had existed many

centuries before. He himself was seized by this symbolic idea, which, as St. Mark tells us, lifted him out of the carpenter's shop and the mental narrowness of his surroundings. Myths go back to primitive story-tellers and their dreams, to men moved by the stirrings of their fantasies, who were not very different from poets and philosophers in later times. Primitive story-tellers never worried about the origin of their fantasies; it was only much later that people began to wonder where the story came from. Already in ancient Greece they were advanced enough to surmise that the stories about the gods were nothing but old and exaggerated traditions of ancient kings and their deeds. They assumed even then that the myth did not mean what it said because it was obviously improbable. Therefore they tried to reduce it to a generally understandable yarn. This is exactly what our time has tried to do with dream symbolism: it is assumed that it does not mean what it seems to say, but something that is generally known and understood, though not openly admitted because of its inferior quality. For those who had got rid of their conventional blinkers there were no longer any riddles. It seemed certain that dreams meant something different from what they said.

[569] This assumption is wholly arbitrary. The Talmud says more aptly: "The dream is its own interpretation." Why should dreams mean something different from what appears in them? Is there anything in nature that is other than what it is? For instance, the duck-billed platypus, that original monster which no zoologist would ever have invented, is it not just what it is? The dream is a normal and natural phenomenon, which is certainly just what it is and does not mean something it is not. We call its contents symbolic because they have obviously not only one meaning, but point in different directions and must therefore mean something that is unconscious, or at least not conscious in all its aspects.

[570] To the scientific mind, such phenomena as symbolic ideas are most irritating, because they cannot be formulated in a way that satisfies our intellect and logic. They are by no means the only instance of this in psychology. The trouble begins already with the phenomenon of affect or emotion, which evades all the attempts of the psychologist to pin it down in a hard-and-fast concept. The cause of the difficulty is the same in both cases—the intervention of the unconscious. I know enough of the scientific standpoint to understand that it is most annoying to have to deal with facts that cannot be grasped completely or at any rate adequately. The trouble with both phenomena is that the facts are undeniable and yet cannot be formulated in intellectual terms. Instead of observable details with clearly discernible features, it is life itself that wells up in emotions and symbolic ideas. In many cases emotion and symbol are actually one and the same thing. There is no intellectual formula capable of representing such a complex phenomenon in a satisfactory way.

[571] The academic psychologist is perfectly free to dismiss the emotions or the unconscious, or both, from his consideration. Yet they remain facts to which at least the medical psychologist has to pay ample attention, for emotional conflicts and the interventions of the unconscious are the classical features of his science. If he treats a patient at all, he is confronted with irrationalities of this kind whether he can formulate them intellectually or not. He has to acknowledge their only too troublesome existence. It is therefore quite natural that people who have not had the medical psychologist's experience find it difficult to follow what he is talking about. Anyone who has not had the chance, or the misfortune, to live through the same or similar experiences is hardly capable of understanding what happens when psychology ceases to be a tranquil pursuit for the scientist in his laboratory and becomes a real life adventure. Target practice on a shooting range is far from being a battlefield, but the doctor has to deal with casualties in a real war. Therefore he has to concern himself with psychic realities even if he cannot define them in scientific terms. He can name them, but he knows that all the terms he uses to designate the essentials of life do not pretend to be more than names for facts that have to be experienced in themselves, because they cannot be reproduced by their names. No textbook can teach psychology; one learns only by actual experience. No understanding is gained by memorizing words, for symbols are the living facts of life.

[572] The cross in the Christian religion, for instance, is a meaningful symbol that expresses a multitude of aspects, ideas, and emotions, but a cross before somebody's name simply indicates that that individual is dead. The *lingam* or phallus functions as an all-embracing symbol in the Hindu religion, but if a street urchin draws one on a wall, it just means an interest in his penis. Because infantile and adolescent fantasies often continue far into adult life, many dreams contain unmistakable sexual allusions. It would be absurd to understand them as anything else. But when a mason speaks of monks and nuns to be laid upon each other, or a locksmith of male and female keys, it would be nonsensical to suppose that he is indulging in glowing adolescent fantasies. He simply means a particular kind of tile or key that has been given a colourful name. But when an educated Hindu talks to you about the *lingam*, you will hear things we Westerners would never connect with the penis. You may even find it most difficult to guess what he actually means by this term, and you will naturally conclude that the *lingam symbolizes* a good many things. It is certainly not an obscene allusion; nor is the cross a mere sign for death but a symbol for a great many other ideas. Much, therefore, depends on the maturity of the dreamer who produces such an image.

[573] The interpretation of dreams and symbols requires some intelligence. It cannot be mechanized and crammed into stupid and unimaginative brains. It demands an ever-

increasing knowledge of the dreamer's individuality as well as an ever-increasing self-awareness on the part of the interpreter. No experienced worker in this field will deny that there are rules of thumb that can prove helpful, but they must be applied with prudence and intelligence. Not everybody can master the "technique." You may follow all the right rules and the apparently safe path of knowledge and yet you get stuck in the most appalling nonsense, simply by overlooking a seemingly unimportant detail that a better intelligence would not have missed. Even a man with a highly developed intellect can go badly astray because he has never learnt to use his intuition or his feeling, which might be at a regrettably low level of development.

[574] The attempt to understand symbols does not only bring you up against the symbol itself, but up against the wholeness of the symbol-producing individual. If one is really up to this challenge, one may meet with success. But as a rule it will be necessary to make a special study of the individual and his or her cultural background. One can learn a lot in this way and so get a chance to fill in the gaps in one's education. I have made it a rule myself to consider every case an entirely new proposition about which I do not even know the ABC. Routine may be and often is practical, and quite useful as long as one skates on the surface, but as soon as one gets in touch with the vital problems, life itself takes over and even the most brilliant theoretical premises become ineffectual words.

[575] This makes the teaching of methods and techniques a major problem. As I have said, the pupil has to acquire a good deal of specialized knowledge. This provides him with the necessary mental tool-shop, but the main thing, the handling of the tools, can be acquired only if the pupil undergoes an analysis that acquaints him with his own conflict. This can be quite a task with some so-called normal but unimaginative individuals. They are just incapable of realizing, for instance, the simple fact that psychic events happen to us spontaneously. Such people prefer to cling to the idea that whatever occurs either is done by themselves or else is pathological and must be cured by pills or injections. They show how close dull normality is to a neurosis, and as a matter of fact such people succumb most easily to psychic epidemics.

[576] In all the higher grades of science, imagination and intuition play an increasingly important role over and above intellect and its capacity for application. Even physics, the most rigorous of all the applied sciences, depends to an astonishing degree on intuition, which works by way of the unconscious processes and not by logical deductions, although it is possible to demonstrate afterwards what logical procedure might have led to the same result.

[577] Intuition is almost indispensable in the interpretation of symbols, and can cause an immediate acceptance on the part of the dreamer. But, subjectively convincing as such a lucky hunch may be, it is also somewhat dangerous, because it leads to a false

sense of security. It may even seduce both the interpreter and the dreamer into continuing this rather facile exchange of ideas, which may end in a sort of mutual dream. The secure basis of real intellectual and moral knowledge gets lost if one is satisfied with a vague feeling of having understood. Usually when one asks people the reasons for their so-called understanding, they are unable to give an explanation. One can understand and explain only when one has brought intuitions down to the safe basis of real knowledge of the facts and their logical connections. An honest investigator will have to admit that this is not possible in certain cases, but it would be dishonest of him to dismiss them on that account. Even a scientist is a human being, and it is quite natural that he, like others, hates the things he cannot explain and thus falls victim to the common illusion that what we know today represents the highest summit of knowledge. Nothing is more vulnerable and ephemeral than scientific theories, which are mere tools and not everlasting truths.

7. HEALING THE SPLIT

[578] When the medical psychologist takes an interest in symbols, he is primarily concerned with “natural” symbols as distinct from “cultural” symbols. The former are derived from the unconscious contents of the psyche, and they therefore represent an enormous number of variations on the basic archetypal motifs. In many cases, they can be traced back to their archaic roots, i.e., to ideas and images that we meet in the most ancient records and in primitive societies. In this respect, I should like to call the reader’s attention to such books as Mircea Eliade’s study of shamanism,¹ where a great many illuminating examples may be found.

[579] “Cultural” symbols, on the other hand, are those that have expressed “eternal truths” or are still in use in many religions. They have gone through many transformations and even a process of more or less conscious elaboration, and in this way have become the *représentations collectives* of civilized societies. Nevertheless, they have retained much of their original numinosity, and they function as positive or negative “prejudices” with which the psychologist has to reckon very seriously.

[580] Nobody can dismiss these numinous factors on merely rational grounds. They are important constituents of our mental make-up and vital forces in the building up of human society, and they cannot be eradicated without serious loss. When they are repressed or neglected, their specific energy disappears into the unconscious with unpredictable consequences. The energy that appears to have been lost revives and intensifies whatever is uppermost in the unconscious—tendencies, perhaps, that have hitherto had no chance to express themselves, or have not been allowed an uninhibited existence in our consciousness. They form an ever-present destructive “shadow.” Even tendencies that might be able to exert a beneficial influence turn into veritable demons when they are repressed. This is why many well-meaning people are understandably afraid of the unconscious, and incidentally of psychology.

[581] Our times have demonstrated what it means when the gates of the psychic underworld are thrown open. Things whose enormity nobody could have imagined in the idyllic innocence of the first decade of our century have happened and have turned the world upside down. Ever since, the world has remained in a state of schizophrenia. Not only has the great civilized Germany disgorged its primitivity, but Russia also is ruled by it, and Africa has been set on fire. No wonder the Western world feels uneasy, for it does not know how much it plays into the hands of the uproarious underworld and what it has lost through the destruction of its numinosities. It has lost its moral and spiritual values to a very dangerous degree. Its

moral and spiritual tradition has collapsed, and has left a worldwide disorientation and dissociation.

[582] We could have seen long ago from primitive societies what the loss of numinosity means: they lose their *raison d'être*, the order of their social organizations, and then they dissolve and decay. We are now in the same condition. We have lost something we have never properly understood. Our spiritual leaders cannot be spared the blame for having been more interested in protecting their institutions than in understanding the mystery that symbols present. Faith does not exclude thought (which is man's strongest weapon), but unfortunately many believers are so afraid of science, and also of psychology, that they turn a blind eye to the numinous psychic powers that forever control man's fate. We have stripped all things of their mystery and numinosity; nothing is holy any longer.

[583] The masses and their leaders do not realize that it makes no substantial difference whether you call the world principle male and a father (spirit), or female and a mother (matter). Essentially, we know as little of the one as of the other. Since the beginning of the human mind, both were numinous symbols, and their importance lay in their numinosity and not in their sex or other chance attributes. Since energy never vanishes, the emotional energy that manifests itself in all numinous phenomena does not cease to exist when it disappears from consciousness. As I have said, it reappears in unconscious manifestations, in symbolic happenings that compensate the disturbances of the conscious psyche. Our psyche is profoundly disturbed by the loss of moral and spiritual values that have hitherto kept our life in order. Our consciousness is no longer capable of integrating the natural afflux of concomitant, instinctive events that sustains our conscious psychic activity. This process can no longer take place in the same way as before, because our consciousness has deprived itself of the organs by which the auxiliary contributions of the instincts and the unconscious could be assimilated. These organs were the numinous symbols, held holy by common consent.

[584] A concept like "physical matter," stripped of its numinous connotation of the "Great Mother," no longer expresses the vast emotional meaning of "Mother Earth." It is a mere intellectual term, dry as dust and entirely inhuman. In the same way, "spirit" identified with "intellect" ceases to be the Father of All. It degenerates into the limited mind of man, and the immense emotional energy expressed in the image "our Father" vanishes in the sand of an intellectual desert.

[585] Through scientific understanding, our world has become dehumanized. Man feels himself isolated in the cosmos. He is no longer involved in nature and has lost his emotional participation in natural events, which hitherto had a symbolic meaning for him. Thunder is no longer the voice of a god, nor is lightning his avenging missile. No river contains a spirit, no tree means a man's life, no snake is the embodiment of

wisdom, and no mountain still harbours a great demon. Neither do things speak to him nor can he speak to things, like stones, springs, plants, and animals. He no longer has a bush-soul identifying him with a wild animal. His immediate communication with nature is gone for ever, and the emotional energy it generated has sunk into the unconscious.

[586] This enormous loss is compensated by the symbols in our dreams. They bring up our original nature, its instincts and its peculiar thinking. Unfortunately, one would say, they also express their contents in the language of nature, which is strange and incomprehensible to us. It sets us the task of translating its images into the rational words and concepts of modern speech, which has liberated itself from its primitive encumbrances—notably from its mystical participation with things. Nowadays, talking of ghosts and other numinous figures is no longer the same as conjuring them up. We have ceased to believe in magical formulas; not many taboos and similar restrictions are left; and our world seems to be disinfected of all such superstitious numina as “witches, warlocks, and worricows,” to say nothing of werewolves, vampires, bush-souls, and all the other bizarre beings that populate the primeval forest.

[587] At least the surface of our world seems to be purified of all superstitious and irrational admixtures. Whether, however, the real inner world of man—and not our wish-fulfilling fiction about it—is also freed from primitivity is another question. Is not the number 13 still taboo for many people? Are there not still many individuals possessed by funny prejudices, projections, and illusions? A realistic picture of the human mind reveals many primitive traits and survivals, which are still playing their roles just as if nothing had happened during the last five hundred years. The man of today is a curious mixture of characteristics acquired over the long ages of his mental development. This is the man and his symbols we have to deal with, and we must scrutinize his mental products very carefully indeed. Sceptical viewpoints and scientific convictions exist in him side by side with old-fashioned prejudices, outdated habits of thought and feeling, obstinate misinterpretations, and blind ignorance.

[588] Such are the people who produce the symbols we are investigating in their dreams. In order to explain the symbols and their meaning, it is essential to learn whether these representations are still the same as they ever were, or whether they have been chosen by the dream for its particular purpose from a store of general conscious knowledge. If, for instance, one has to deal with a dream in which the number 13 occurs, the question is: Does the dreamer habitually believe in the unfavourable nature of the number, or does the dream merely allude to people who still indulge in such superstitions? The answer will make a great difference to the interpretation. In the former case, the dreamer is still under the spell of the unlucky

13, and will therefore feel most uncomfortable in room no. 13 or sitting at a table with thirteen people. In the latter case, 13 may not be more than a chiding or disparaging remark. In one case it is a still numinous representation; in the other it is stripped of its original emotionality and has assumed the innocuous character of a mere piece of indifferent information.

[589] This illustrates the way in which archetypes appear in practical experience. In the first case they appear in their original form—they are images and at the same time emotions. One can speak of an archetype only when these two aspects coincide. When there is only an image, it is merely a word-picture, like a corpuscle with no electric charge. It is then of little consequence, just a word and nothing more. But if the image is charged with numinosity, that is, with psychic energy, then it becomes dynamic and will produce consequences. It is a great mistake in practice to treat an archetype as if it were a mere name, word, or concept. It is far more than that: it is a piece of life, an image connected with the living individual by the bridge of emotion. The word alone is a mere abstraction, an exchangeable coin in intellectual commerce. But the archetype is living matter. It is not limitlessly exchangeable but always belongs to the economy of a living individual, from which it cannot be detached and used arbitrarily for different ends. It cannot be explained in just any way, but only in the one that is indicated by that particular individual. Thus the symbol of the cross, in the case of a good Christian, can be interpreted only in the Christian way unless the dream produces very strong reasons to the contrary, and even then the specifically Christian meaning should not be lost sight of.

[590] The mere use of words is futile if you do not know what they stand for. This is particularly true in psychology, where we speak of archetypes like the anima and animus, the wise old man, the great mother, and so on. You can know about all the saints, sages, prophets, and other godly men, and all the great mothers of the world, but if they are mere images whose numinosity you have never experienced, it will be as if you were talking in a dream, for you do not know what you are talking about. The words you use are empty and valueless, and they gain life and meaning only when you try to learn about their numinosity, their relationship to the living individual. Then only do you begin to understand that the names mean very little, but that the way they are related to you is all-important.

[591] The symbol-producing function of our dreams is an attempt to bring our original mind back to consciousness, where it has never been before, and where it has never undergone critical self-reflection. We *have been* that mind, but we have never *known* it. We got rid of it before understanding it. It rose from its cradle, shedding its primitive characteristics like cumbersome and valueless husks. It looks as if the unconscious represented the deposit of these remnants. Dreams and their symbols continually refer to them, as if they intended to bring back all the old primitive things

from which the mind freed itself in the course of its evolution: illusions, childish fantasies, archaic thought-forms, primitive instincts. This is in reality the case, and it explains the resistance, even fear and horror, one experiences in approaching the unconscious. One is shocked less by the primitivity of its contents than by their emotionality. They are not merely neutral or indifferent, they are so charged with affect that they are often exceedingly uncomfortable. They can even cause real panic, and the more they are repressed the more they spread through the whole personality in the form of a neurosis.

[592] It is just their emotionality, however, that gives them such a vital importance. It is as if a man who has lived through a period of life in an unconscious state should suddenly realize that there is a gap in his memory—that important events seem to have taken place that he cannot remember. In so far as he assumes that the psyche is an exclusively personal affair (and this is the usual assumption), he will try to retrieve the apparently lost infantile memories. But the gaps in his childhood memories are merely the symptoms of a much greater loss, the loss of the primitive psyche—the psyche that lived and functioned before it was reflected by consciousness.

[593] As the evolution of the embryonic body repeats its prehistory, so the mind grows up through the series of its prehistoric stages. Dreams seem to consider it their main task to bring back a sort of recollection of the prehistoric as well as the infantile world, right down to the level of the most primitive instincts, as if such memories were a priceless treasure. And these memories can indeed have a remarkably healing effect in certain cases, as Freud saw long ago. This observation confirms the view that an infantile memory-gap (a so-called amnesia) amounts to a definite loss and that its recovery brings an increase in vitality and well-being. Since we measure a child's psychic life by the paucity and simplicity of its conscious contents, we do not appreciate the far-reaching complexities of the infantile mind that stem from its original identity with the prehistoric psyche. That "original mind" is just as much present and still functioning in the child as the evolutionary stages are in the embryo. If the reader remembers what I said earlier about the child who made a present of her dreams to her father, he will get a good idea of what I mean.

[594] In infantile amnesia, one finds strange admixtures of mythological fragments that also often appear in later psychoses. Images of this kind are highly numinous and therefore very important. If such recollections reappear in adult life, they may in some cases cause profound psychological disturbances, while in other people they can produce astonishing cures or religious conversions. Often they bring back a piece of life, missing for a long time, that enriches the life of an individual.

[595] The recollection of infantile memories and the reproduction of archetypal modes of psychic functioning create a wider horizon and a greater extension of consciousness, provided that one succeeds in assimilating and integrating the lost and

regained contents. Since they are not neutral, their assimilation will modify the personality, even as they themselves will have to undergo certain alterations. In this part of the individuation process the interpretation of symbols plays an important practical role; for the symbols are natural attempts to reconcile and reunite often widely separated opposites, as is apparent from the contradictory nature of many symbols. It would be a particularly obnoxious error in this work of assimilation if the interpreter were to take only the conscious memories as “true” or “real,” while considering the archetypal contents as merely fantastic representations. Dreams and their ambiguous symbols owe their forms on the one hand to repressed contents and on the other to archetypes. They thus have two aspects and enable one to interpret in two ways: one lays the emphasis either on their personal or on their archetypal aspect. The former shows the morbid influence of repression and infantile wishes, while the latter points to the sound instinctive basis. However fantastic the archetypal contents may be, they represent emotional powers or “numinosities.” If one should try to brush them aside, they would only get repressed and would create the same neurotic condition as before. Their numinosity gives the contents an autonomous nature. This is a psychological fact that cannot be denied. If it is nevertheless denied, the regained contents are annihilated and any attempt at a synthesis is futile. But it appears to be a tempting way out and therefore it is often chosen.

[596] Not only is the existence of archetypes denied, but even those people who do admit their existence usually treat them as if they were mere images and forget that they are living entities that make up a great part of the human psyche. As soon as the interpreter strips them of their numinosity, they lose their life and become mere words. It is then easy enough to link them together with other mythological representations, and so the process of limitless substitution begins; one glides from archetype to archetype, everything means everything, and one has reduced the whole process to absurdity. All the corpses in the world are chemically identical, but living individuals are not. It is true that the forms of archetypes are to a considerable extent interchangeable, but their numinosity is and remains a fact. It represents the *value* of an archetypal event. This emotional value must be kept in mind and allowed for throughout the whole intellectual process of interpretation. The risk of losing it is great, because thinking and feeling are so diametrically opposed that thinking abolishes feeling-values and vice versa. Psychology is the only science that has to take the factor of value (feeling) into account, since it forms the link between psychic events on the one hand, and meaning and life on the other.

[597] Our intellect has created a new world that dominates nature, and has populated it with monstrous machines. The latter are so indubitably useful and so much needed that we cannot see even a possibility of getting rid of them or of our odious subservience to them. Man is bound to follow the exploits of his scientific and

inventive mind and to admire himself for his splendid achievements. At the same time, he cannot help admitting that his genius shows an uncanny tendency to invent things that become more and more dangerous, because they represent better and better means for wholesale suicide. In view of the rapidly increasing avalanche of world population, we have already begun to seek ways and means of keeping the rising flood at bay. But nature may anticipate all our attempts by turning against man his own creative mind, and, by releasing the H-bomb or some equally catastrophic device, put an effective stop to overpopulation. In spite of our proud domination of nature we are still her victims as much as ever and have not even learnt to control our own nature, which slowly and inevitably courts disaster.

[598] There are no longer any gods whom we can invoke to help us. The great religions of the world suffer from increasing anaemia, because the helpful numina have fled from the woods, rivers, mountains, and animals, and the God-men have disappeared underground into the unconscious. There we suppose they lead an ignominious existence among the relics of our past, while we remain dominated by the great *Déesse Raison*, who is our overwhelming illusion. With her aid we are doing laudable things: we rid the world of malaria, we spread hygiene everywhere, with the result that under-developed populations increase at such a rate that food is becoming a problem. “We have conquered nature” is a mere slogan. In reality we are confronted with anxious questions, the answers to which seem nowhere in sight. The so-called conquest of nature overwhelms us with the natural fact of over-population and makes our troubles more or less unmanageable because of our psychological incapacity to reach the necessary political agreements. It remains quite natural for men to quarrel and fight and struggle for superiority over one another. Where indeed have we “conquered nature”?

[599] As any change must begin somewhere, it is the single individual who will undergo it and carry it through. The change must begin with one individual; it might be any one of us. Nobody can afford to look around and to wait for somebody else to do what he is loath to do himself. As nobody knows what he could do, he might be bold enough to ask himself whether by any chance his unconscious might know something helpful, when there is no satisfactory conscious answer anywhere in sight. Man today is painfully aware of the fact that neither his great religions nor his various philosophies seem to provide him with those powerful ideas that would give him the certainty and security he needs in face of the present condition of the world.

[600] I know that the Buddhists would say, as indeed they do: if only people would follow the noble eightfold path of the Dharma (doctrine, law) and had true insight into the Self; or the Christians: if only people had the right faith in the Lord; or the rationalists: if only people could be intelligent and reasonable—then all problems would be manageable and solvable. The trouble is that none of them manages to

solve these problems himself. Christians often ask why God does not speak to them, as he is believed to have done in former days. When I hear such questions, it always makes me think of the Rabbi who was asked how it could be that God often showed himself to people in the olden days but that nowadays one no longer saw him. The Rabbi replied: “Nor is there anyone nowadays who could stoop so low.”

[601] This answer hits the nail on the head. We are so captivated by and entangled in our subjective consciousness that we have simply forgotten the age-old fact that God speaks chiefly through dreams and visions. The Buddhist discards the world of unconscious fantasies as “distractions” and useless illusions; the Christian puts his Church and his Bible between himself and his unconscious; and the rationalist intellectual does not yet know that his consciousness is not his total psyche, in spite of the fact that for more than seventy years the unconscious has been a basic scientific concept that is indispensable to any serious student of psychology.

[602] We can no longer afford to be so God-almighty as to set ourselves up as judges of the merits or demerits of natural phenomena. We do not base our botany on a division into useful and useless plants, or our zoology on a classification into harmless and dangerous animals. But we still go on blithely assuming that consciousness is sense and the unconscious is nonsense—as if you could make out whether any natural phenomenon makes sense or not! Do microbes, for instance, make sense or nonsense? Such evaluations merely demonstrate the lamentable state of our mind, which conceals its ignorance and incompetence under the cloak of megalomania. Certainly microbes are very small and most despicable, but it would be folly to know nothing about them.

[603] Whatever else the unconscious may be, it is a natural phenomenon that produces symbols, and these symbols prove to be meaningful. We cannot expect someone who has never looked through a microscope to be an authority on microbes; in the same way, no one who has not made a serious study of natural symbols can be considered a competent judge in this matter. But the general undervaluation of the human psyche is so great that neither the great religions nor the philosophies nor scientific rationalism have been willing to look at it twice. In spite of the fact that the Catholic Church admits the occurrence of dreams sent by God, most of its thinkers make no attempt to understand them. I also doubt whether there is a Protestant treatise on dogmatics that would “stoop so low” as to consider the possibility that the *vox Dei* might be perceived in a dream. But if somebody really believes in God, by what authority does he suggest that God is unable to speak through dreams?

[604] I have spent more than half a century investigating natural symbols, and I have come to the conclusion that dreams and their symbols are not stupid and meaningless. On the contrary, dreams provide you with the most interesting information if only you take the trouble to understand their symbols. The results, it is true, have little to

do with such worldly concerns as buying and selling. But the meaning of life is not exhaustively explained by your business activities, nor is the deep desire of the human heart answered by your bank account, even if you have never heard of anything else.

[605] At a time when all available energy is spent in the investigation of nature, very little attention is paid to the essence of man, which is his psyche, although many researches are made into its conscious functions. But the really unknown part, which produces symbols, is still virtually unexplored. We receive signals from it every night, yet deciphering these communications seems to be such an odious task that very few people in the whole civilized world can be bothered with it. Man's greatest instrument, his psyche, is little thought of, if not actually mistrusted and despised. "It's only psychological" too often means: It is nothing.

[606] Where, exactly, does this immense prejudice come from? We have obviously been so busy with the question of what we think that we entirely forget what the unconscious psyche thinks about us. Freud made a serious attempt to show why the unconscious deserves no better judgment, and his teachings have inadvertently increased and confirmed the existing contempt for the psyche. Before him it had been merely overlooked and neglected; now it has become a dump for moral refuse and a source of fear.

[607] This modern standpoint is surely onesided and unjust. It does not even accord with the known facts. Our actual knowledge of the unconscious shows it to be a natural phenomenon, and that, like nature herself, it is at least *neutral*. It contains all aspects of human nature—light and dark, beautiful and ugly, good and evil, profound and silly. The study of individual as well as collective symbolism is an enormous task, and one that has not yet been mastered. But at last a beginning has been made. The results so far gained are encouraging, and they seem to indicate an answer to many of the questions perplexing present-day mankind.

III

THE SYMBOLIC LIFE

[A seminar talk given on 5 April 1939 to the Guild of Pastoral Psychology, London. Issued privately, as a transcript from shorthand notes by Derek Kitchin, as Guild Lecture No. 80 (London, 1954). Jung had approved the transcript. Subsequently published, in abbreviated form, in *Darshana* (Moradabad, India), 1:3 (August 1961), 11–22; the issue was dedicated to the memory of C. G. Jung, who had died on 6 June of that year. The Guild Lecture is reproduced here with stylistic revisions.]

THE SYMBOLIC LIFE

Professor Jung was asked two questions:

First, had he any views on what was likely to be the next step in religious development? Did he, for example, think that there would be a new revelation—as some would phrase it, a new incarnation of the World Teacher, a new collective fantasy? Or was there likely to be a reinterpretation and new appreciation of the esoteric meaning of Christianity—perhaps with the aid of psychology? Or would there be no collective expression, but a period in which each man had to make his own individual contact and live out his own personal expression?

Secondly, would he explain why the believing Catholic was not subject to neurosis, and what could be done by the Protestant churches to counteract the tendency of their members to neurotic conditions?

[608] I am not as ambitious as the questions that have been put to me! I should like to start with the second question, about the Roman Catholics, which has not been considered as of primary importance, but which, from a technical point of view, deserves full attention.

[609] You have heard that I said Roman Catholics are less threatened by neurosis than members of other religious confessions. Of course there are Catholic neurotics just as well as others, but it is a fact that in my forty years of experience I have had no more than six practising Catholics among my patients. Naturally I do not count all those who *have been* Catholics, or who say that they are Catholics but who do not practise; but of practising Catholics I have had not more than about six. That is also the experience of my colleagues. In Zurich we are surrounded by Catholic cantons; not quite two-thirds of Switzerland is Protestant and the rest is Catholic. And then we have on the frontier Southern Germany, which is Catholic. So we should have a fair number of Catholic patients, but we have not; we have very few.

[610] I was once asked by students of divinity a very interesting question: whether in my view people in modern times, in case of psychological trouble, would go to the doctor rather than to the parson or the priest? Now, I said I could not answer that question, but I would enquire. So I sent round a questionnaire with detailed questions. I did not do it myself, because if I ask something, of course that is already a prejudice, and every answer would be prejudiced. So I gave the questionnaire to certain people who were not known to be acquainted with me, or in any kind of

relation to me, and they sent it around, and we got hundreds of very interesting answers. And there I found the confirmation of what I already knew, namely, a large percentage—by far the majority—of Catholics said that, in case of psychological trouble, they would go to the priest and not to the doctor. The vast majority of Protestants said they would naturally go to the doctor. I had a very large number of answers from members of families of parsons, and they nearly all said that they would not go to the parson, they would rather go to the doctor. (I can talk quite freely about this. I am the son of a parson, and my grandfather was a sort of bishop, and I had five uncles all parsons, so I know something about the job! I have no hostile attitude to the clergy. On the contrary; but this is a fact.) I also had answers from Jews, and not one single Jew said he would go to the Rabbi—he wouldn't even think of it. And I had one Chinese, who gave me a classical answer. He said: "When I am young I go to the doctor, and when I am old I go to the philosopher."

[611] I also had answers from representatives of the clergy, and I must mention one answer, which I hope is not in any way representative, but which casts a certain light upon a certain kind of theologian. The writer said, "Theology has nothing to do with the practical man." What has it to do with, then? You could say, "With God"; but you are not going to tell me that theology deals with God in that sense. Theology is really meant for man, if it is meant for anything. God needs no theology, I should say. That [answer] is a symptom of a certain attitude which explains a lot.

[612] Now, I have spoken of my own experience in this field, but recently statistical researches have been made in America about the very same question, but from another angle. It is a sort of appreciation of the amount of complexes, or complex manifestations, you find in people. You find the least or the smallest number of complex manifestations in practising Catholics, far more in Protestants, and the most in Jews. That is absolutely independent of my own researches; a colleague of mine in the United States made these researches,¹ and that bears out what I have told you.

[613] So there must be something in the Catholic Church which accounts for this peculiar fact. Of course, we think in the first place of confession. That is only the outer aspect. I happen to know a great deal about confession, because I have often had to do with the Catholic clergy, particularly with Jesuits, who were busy in psychotherapy. For many years the Catholic clergy have studied psychotherapy; they have followed it up very closely. In the first place it was, of course, the Jesuits who studied it, and now recently I have heard that the Benedictines have done so too. There is an old tradition in the Catholic Church of the *directeur de conscience*—a sort of leader of souls. These directors have an extraordinary amount of experience and training in that work, and I have often been amazed at the wisdom with which Jesuits and other Catholic priests advised their patients.

[614] Just recently it happened that a patient of mine, a woman of the nobility, who had a Jesuit father-confessor, discussed with him all the critical points of the analysis she made under my care. Of course, a number of things were not quite orthodox, and I was fully aware that there was a great conflict in her mind, and I advised her to discuss these matters with her father-confessor. (He was a famous Jesuit—he is now dead.) And then, after she had had that very frank talk, she told me all he said to her, and he had confirmed every word I had told her—a thing that was rather amazing to me, particularly from the mouth of a Jesuit. That opened my eyes to the extraordinary wisdom and culture of the Catholic *directeur de conscience*. And it explains to a certain extent why the practising Catholic would rather go to the priest.

[615] The fact is that there are relatively few neurotic Catholics, and yet they are living under the same conditions as we do. They are presumably suffering from the same social conditions and so on, and so one would expect a similar amount of neurosis. There must be something in the cult, in the actual religious practice, which explains that peculiar fact that there are fewer complexes, or that these complexes manifest themselves much less in Catholics than in other people. That something, besides confession, is really the cult itself. It is the Mass, for instance. The heart of the Mass contains a living mystery, and that is the thing that works. When I say “a living mystery,” I mean nothing mysterious; I mean mystery in that sense which the word has always had—a *mysterium tremendum*.² And the Mass is by no means the only mystery in the Catholic Church. There are other mysteries too. They begin with the very preparations, the simple things, in the Church. Take, for instance, the preparation of the baptismal water—the rite of the *benedictio fontis major*, or *minor*, on the night of the Sabbath before Easter. There you can see that a part of the Eleusinian Mysteries is still performed.

[616] If you ask the average priest, he is unable to give you any account of these things. He does not know them. I once asked the Bishop of Fribourg, in Switzerland, to send us a man who could give a good account of the mystery of the Mass. It was a sad failure; he could tell us nothing. He could only confess to the wonderful impression, the marvellous mystical feeling, but he could say nothing at all as to why he had that feeling. It was only sentiments, and we could do nothing with it. But if you go into the history of the rite, if you try to understand the whole structure of that rite, including all the other rites round it, then you see it is a mystery that reaches down into the history of the human mind; it goes back very far—far beyond the beginnings of Christianity. You know that very important parts of the Mass—for instance, the Host—belonged to the cult of Mithras. In the cult of Mithras they used bread stamped with the cross, or divided into four; they used the little bells; and they used baptismal water—that is quite certainly pre-Christian. We even have texts that bear this out. The rite of the divine water, or the *aqua permanens*—the “eternal water”—is

an alchemical conception, older than its Christian use; and when you study the *benedictio fontis*, the actual making of the water, you see that it is an alchemical procedure; and we have a text from the first century, a text of Pseudo-Democritus, which says what the blessing was done for.

[617] These are absolute facts which are quite surely established. They point back into prehistory, into a continuity of tradition perhaps hundreds of years before Christianity. Now these mysteries have always been the expression of a fundamental psychological condition. Man expresses his most fundamental and most important psychological conditions in this ritual, this magic, or whatever you call it. And the ritual is the cult performance of these basic psychological facts. That explains why we should not change anything in a ritual. A ritual must be done according to tradition, and if you change one little point in it, you make a mistake. You must not allow your reason to play with it. For instance, take that most difficult dogma, the dogma of the Virgin Birth: it is absolutely wrong to rationalize it. If you leave it as it is, as it has been handed down, then it is true; but if you rationalize it, it is all wrong, because then you shift it over to the plane of our playful intellect, which does not understand the secret. It is the secret of virginity and the virginal conception, and that is a most important psychological fact. The sad truth is that we do not understand it any more. But, you know, in former centuries man did not need that kind of intellectual understanding. We are very proud of it; but it is nothing to be proud of. Our intellect is absolutely incapable of understanding these things. We are not far enough advanced psychologically to understand the truth, the extraordinary truth, of ritual and dogma. Therefore such dogmas should never be submitted to any kind of criticism.

[618] So, you see, if I treat a real Christian, a real Catholic, I always keep him down to the dogma, and say, "You stick to it! And if you begin to criticize it in any way intellectually, then I am going to analyse you, and then you are in the frying-pan!" When a practising Catholic comes to me, I say, "Did you confess this to your father-confessor?" Naturally he says, "No, he does not understand." "What in hell, then," I say, "did you confess?" "Oh, lousy little things of no importance"—but the main sins he never talked of. As I said, I have had quite a number of these Catholics—six. I was quite proud to have so many, and I said to them, "Now, you see, what you tell me here, this is really serious. You go now to your father-confessor and you confess, whether he understands or does not understand. That is of no concern. It must be told before God, and if you don't do it, you are out of the Church, and then analysis begins, and then things will get hot, so you are much better off in the lap of the Church." So, you see, I brought these people back into the Church, with the result that the Pope himself gave me a private blessing for having taught certain important Catholics the right way of confessing.

[619] For instance, there was a lady who played a very great role in the war. She was very Catholic, and always in the summer she used to come to Switzerland to pass her summer holiday. There is a famous monastery there with many monks, and she used to go to it for confession and spiritual advice. Now, being an interesting person, she got a bit too interested in her father-confessor, and he got a bit too interested in her, and there was some conflict. He was then removed to the Clausura,³ and she naturally collapsed, and she was advised to go to me. So she came to me in full resistance against the authorities who had interfered, and I made her go back to her spiritual authorities and confess the whole situation. And when she went back to Rome, where she lived, and where she had a confessor, he asked her, “Well, I know you from many years ago: how is it that you now confess so freely?” And she said she had learnt it from a doctor. That is the story of how I got the Pope’s private blessing.

[620] My attitude to these matters is that, as long as a patient is really a member of a church, he ought to be serious. He ought to be really and sincerely a member of that church, and he should not go to a doctor to get his conflicts settled when he believes that he should do it with God. For instance, when a member of the Oxford Group comes to me in order to get treatment, I say, “You are in the Oxford Group; so long as you are there, you settle your affair with the Oxford Group. I can’t do it better than Jesus.”

[621] I will tell you a story of such a case. A hysterical alcoholic was cured by this Group movement, and they used him as a sort of model and sent him all round Europe, where he confessed so nicely and said that he had done wrong and how he had got cured through the Group movement. And when he had repeated his story twenty, or it may have been fifty, times, he got sick of it and took to drink again. The spiritual sensation had simply faded away. Now what are they going to do with him? They say, now he is pathological, he must go to a doctor. See, in the first stage he has been cured by Jesus, in the second by a doctor! I should and did refuse such a case. I sent that man back to these people and said, “If you believe that Jesus has cured this man, he will do it a second time. And if he can’t do it, you don’t suppose that I can do it better than Jesus?” But that is just exactly what they do expect: when a man is pathological, Jesus won’t help him but the doctor will.

[622] As long as a fellow believes in the Oxford Group movement, he stays there; and as long as a man is in the Catholic Church, he is in the Catholic Church for better or worse and he should be cured by those means. And mind you, I have seen that they can be cured by those means—that is a fact! Absolution, the Holy Communion, can cure them, even in very serious cases. If the experience of the Holy Communion is real, if the ritual and the dogma fully express the psychological situation of that individual, he can be cured. If the ritual and dogma do not fully express the psychological situation of that individual, he can’t be cured. That is the reason why

you have Protestantism, and that is why Protestantism is so uncertain, why it splits and splits. That is no objection to Protestantism; it is exactly the same as the story about the Code Napoléon.

[623] After the Code Napoléon had been in use a year, the man entrusted with the execution of Napoleon's orders came back with a portfolio of immense size. Napoleon looked at it and asked, "Mais comment? Est-ce que le Code est mort?"—because the man had so many propositions to make. But the man answered, "Au contraire, Sire; il vit!"

[624] The splitting up of Protestantism into new denominations—four hundred or more we have—is a sign of life. But, alas! It is not a very nice sign of life, in the sense of a church, because there is no dogma and there is no ritual. There is not the typical symbolic life.

[625] You see, man is in need of a symbolic life—badly in need. We only live banal, ordinary, rational, or irrational things—which are naturally also within the scope of rationalism, otherwise you could not call them irrational. But we have no symbolic life. Where do we live symbolically? Nowhere, except where we participate in the ritual of life. But who, among the many, are really participating in the ritual of life? Very few. And when you look at the ritual life of the Protestant Church, it is almost nil. Even the Holy Communion has been rationalized. I say that from the Swiss point of view: in the Swiss Zwinglian Church the Holy Communion is not a communion at all; it is a meal of memory. There is no Mass either; there is no confession; there is no ritual, symbolic life.

[626] Have you got a corner somewhere in your house where you perform the rites, as you can see in India? Even the very simple houses there have at least a curtained corner where the members of the household can lead the symbolic life, where they can make their new vows or meditation. We don't have it; we have no such corner. We have our own room, of course—but there is a telephone which can ring us up at any time, and we always must be ready. We have no time, no place. Where have we got these dogmatic or these mysterious images? Nowhere! We have art galleries, yes—where we kill the gods by thousands. We have robbed the churches of their mysterious images, of their magical images, and we put them into art galleries. That is worse than the killing of the three hundred children in Bethlehem; it is a blasphemy.

[627] Now, we have no symbolic life, and we are all badly in need of the symbolic life. Only the symbolic life can express the need of the soul—the daily need of the soul, mind you! And because people have no such thing, they can never step out of this mill—this awful, grinding, banal life in which they are "nothing but." In the ritual they are near the Godhead; they are even divine. Think of the priest in the Catholic Church, who is in the Godhead: he carries himself to the sacrifice on the altar; he

offers himself as the sacrifice. Do we do it? Where do we know that we do it? Nowhere! Everything is banal, everything is “nothing but”; and that is the reason why people are neurotic. They are simply sick of the whole thing, sick of that banal life, and therefore they want sensation. They even want a war; they all want a war. They are all glad when there is a war: they say, “Thank heaven, now something is going to happen—something bigger than ourselves!”

[628] These things go pretty deep, and no wonder people get neurotic. Life is too rational, there is no symbolic existence in which I am something else, in which I am fulfilling my role, my role as one of the actors in the divine drama of life.

[629] I once had a talk with the master of ceremonies of a tribe of Pueblo Indians, and he told me something very interesting. He said, “Yes, we are a small tribe, and these Americans, they want to interfere with our religion. They should not do it,” he said, “because we are the sons of the Father, the Sun. He who goes there”; (pointing to the sun)—’that is our Father. We must help him daily to rise over the horizon and to walk over Heaven. And we don’t do it for ourselves only: we do it for America, we do it for the whole world. And if these Americans interfere with our religion through their missions, they will see something. In ten years Father Sun won’t rise any more, because we can’t help him any more.”

[630] Now, you may say, that is just a sort of mild madness. Not at all! These people have no problems. They have their daily life, their symbolic life. They get up in the morning with a feeling of their great and divine responsibility: they are the sons of the Sun, the Father, and their daily duty is to help the Father over the horizon—not for themselves alone, but for the whole world. You should see these fellows: they have a natural fulfilled dignity. And I quite understood when he said to me, “Now look at these Americans: they are always seeking something. They are always full of unrest, always looking for something. What are they looking for? There is nothing to be looked for!” That is perfectly true. You can see them, these travelling tourists, always looking for something, always in the vain hope of finding something. On my many travels I have found people who were on their third trip round the world—uninterruptedly. Just travelling, travelling; seeking, seeking. I met a woman in Central Africa who had come up alone in a car from Cape Town and wanted to go to Cairo. “What for?” I asked. “What are you trying to do that for?” And I was amazed when I looked into her eyes—the eyes of a hunted, a cornered animal—seeking, seeking, always in the hope of something. I said, “What in the world are you seeking? What are you waiting for, what are you hunting after?” She is nearly possessed; she is possessed by so many devils that chase her around. And why is she possessed? Because she does not live the life that makes sense. Hers is a life utterly, grotesquely banal, utterly poor, meaningless, with no point in it at all. If she is killed today, nothing has happened, nothing has vanished—because she was nothing! But if

she could say, “I am the daughter of the Moon. Every night I must help the Moon, my Mother, over the horizon”—ah, that is something else! Then she lives, then her life makes sense, and makes sense in all continuity, and for the whole of humanity. That gives peace, when people feel that they are living the symbolic life, that they are actors in the divine drama. That gives the only meaning to human life; everything else is banal and you can dismiss it. A career, producing of children, are all *maya* compared with that one thing, that your life is meaningful.

[631] That is the secret of the Catholic Church: that they still, to a certain extent, can live the meaningful life. For instance, if you can watch daily the sacrifice of the Lord, if you can partake of his substance, then you are filled with the Deity, and you daily repeat the eternal sacrifice of Christ. Of course, what I say is just so many words, but to the man who really lives it, it means the whole world. It means more than the whole world, because it makes sense to him. It expresses the desire of the soul; it expresses the actual facts of our unconscious life. When the wise man said, “Nature demands death,” he meant just that.

[632] So I think we can go on now to the next question. What I have spoken of is, alas, to a great extent the past. We cannot turn the wheel backwards; we cannot go back to the symbolism that is gone. No sooner do you know that this thing is symbolic than you say, “Oh, well, it presumably means something else.” Doubt has killed it, has devoured it. So you cannot go back. I cannot go back to the Catholic Church, I cannot experience the miracle of the Mass; I know too much about it. I know it is the truth, but it is the truth in a form in which I cannot accept it any more. I cannot say “This is the sacrifice of Christ,” and see him any more. I cannot. It is no more true to me; it does not express my psychological condition. My psychological condition wants something else. I must have a situation in which that thing becomes true once more. I need a new form. When one has had the misfortune to be fired out of a church, or to say “This is all nonsense,” and to quit it—that has no merit at all. But to be in it and to be forced, say, by God, to leave it—well, then you are legitimately *extra ecclesiam*. But *extra ecclesiam nulla salus*; then things really become terrible, because you are no more protected, you are no more in the *consensus gentium*, you are no more in the lap of the All-compassionate Mother. You are alone and you are confronted with all the demons of hell. That is what people don’t know. Then they say you have an anxiety neurosis, nocturnal fears, compulsions—I don’t know what. Your soul has become lonely; it is *extra ecclesiam* and in a state of no-salvation. And people don’t know it. They think your condition is pathological, and every doctor helps them to believe it. And, of course, when they say, and when everybody holds, that this is neurotic and pathological, then we have to talk that language. I talk the language of my patients. When I talk with lunatics, I talk the lunatic language, otherwise they don’t understand me. And when I talk with neurotics, I talk neurotic

with them. But it is neurotic talk when one says that this is a neurosis. As a matter of fact it is something quite different: it is the terrific fear of loneliness. It is the hallucination of loneliness, and it is a loneliness that cannot be quenched by anything else. You can be a member of a society with a thousand members, and you are still alone. That thing in you which should live is alone; nobody touches it, nobody knows it, you yourself don't know it; but it keeps on stirring, it disturbs you, it makes you restless, and it gives you no peace.

[633] So, you see. I was forced simply through my patients to try to find out what we could do about such a condition. I am not going to found a religion, and I know nothing about a future religion. I only know that in certain cases such and such things develop. For instance, take any case you want: if I go far enough, if the case demands it, or if certain conditions are favourable, then I shall observe certain unmistakable things, namely, that the unconscious facts are coming up and becoming threateningly clear. That is very disagreeable. And therefore Freud had to invent a system to protect people, and himself, against the reality of the unconscious, by putting a most depreciatory explanation upon these things, an explanation that always begins with "nothing but." The explanation of every neurotic symptom was known long ago. We have a theory about it: it is all due to a father fixation, or to a mother fixation; it is all nonsense, so you can dismiss it. And so we dismiss our souls—"Oh, I am bound by a fixation to my mother, and if I see that I have all kinds of impossible fancies about my mother, I am liberated from that fixation." If the patient succeeds, he has lost his soul. Every time you accept that explanation you lose your soul. You have not helped your soul; you have replaced your soul by an explanation, a theory.

[634] I remember a very simple case.⁴ There was a student of philosophy, a very intelligent woman. That was quite at the beginning of my career. I was a young doctor then, and I did not know anything beyond Freud. It was not a very important case of neurosis, and I was absolutely certain that it could be cured; but the case had not been cured. That girl had developed a terrific father-transference to me—projected the image of the father on me. I said, "But, you see, I'm not your father!" "I know," she said, "that you're not my father, but it always seems as if you were." She behaved accordingly and fell in love with me, and I was her father, brother, son, lover, husband—and, of course, also her hero and saviour—every thinkable thing! "But," I said, "you see, that is absolute nonsense!" "But I can't live without it," she answered. What could I do with that? No depreciatory explanation would help. She said, "You can say what you like; it is so." She was in the grip of an unconscious image. Then I had the idea: "Now, if anybody knows anything about it, it must be the unconscious, that has produced such an awkward situation." So I began to watch the dreams seriously, not just in order to catch certain fantasies, but because I really wanted to understand how her psychic system reacted to such an abnormal situation

—or to such a very normal situation, if you like to say so, because that situation is usual. She produced dream? in which I appeared as the father. That we dealt with. Then I appeared as the lover, and I appeared as the husband—that was all in the same vein. Then I began to change my size: I was much bigger than an ordinary human being; sometimes; I had even divine attributes. I thought “Oh, well, that is the old saviour idea.” And then I took on the most amazing forms. I appeared, for instance, the size of a god, standing in the fields and holding her in my arms as if she were a baby, and the wind was blowing over the corn and the fields were waving like waves of water, and in the same way I rocked her in my arms. And then, when I saw that picture, I thought, “Now I see what the unconscious really is after: the unconscious wants to make a god of me: that girl needs a god—at least, her unconscious needs a god. Her unconscious wants to find a god, and because it cannot find a god, it says Dr. Jung is a god.” And so I said to her what I thought: “I surely am not a god, but your unconscious needs a god. That is a serious and a genuine need. No time before us has fulfilled that need; you are just an intellectual fool, just as much as I am, but we don’t know it.” That changed the situation completely; it made all the difference in the world. I cured that case, because I fulfilled the need of the unconscious.

[635] I can tell you another case.⁵ The patient was a Jewish girl. She was a funny little character, a very pretty, elegant little thing—and I thought “What a useless beast!” She had a frightful neurosis, a terrible anxiety neurosis, with awful attacks of fear, and she had suffered from these things for years. She had been with another analyst and had turned his head altogether; he fell in love with her, and she found no help in him. Then she came to me. The night before she came—before I had seen her at all—I had a dream, and I dreamed of a young girl, a pretty girl that came to me and I did not understand her case at all. Suddenly I thought, “By Jove! Hasn’t she an extraordinary father complex!” And I felt it as a sort of revelation. I was much impressed by that dream; I did not know to what it referred. Then, when that girl came in next day, instantly I thought of my dream: “Perhaps she is the one!” First she told me her story. At first I couldn’t see what it was all about, and then I thought, “Isn’t it a father complex?” I saw nothing of a father complex, but it gave me the idea of asking more about the history of her family. Then I found out that she came from a Hasidic family—you know, those great mystics. Her grandfather had been a sort of wonder-rabbi—he had second sight—and her father had broken away from that mystic community, and she was completely sceptical and completely scientific in her outlook on life. She was highly intelligent, with that murderous kind of intellect that you very often find in Jews. So I thought, “Aha! What does that mean with reference to her neurosis? Why does she suffer from such an abysmal fear?” And I said to her, “Look here, I’m going to tell you something, and you will probably think it is all foolishness, but you have been untrue to your God. Your grandfather led the right

life, but you are worse than a heretic; you have forsaken the mystery of your race. You belong to holy people, and what do you live? No wonder that you fear God, that you suffer from the fear of God.”

[636] Within one week I had cured that anxiety neurosis, and that is no lie (I am too old to lie!)—that is a fact. Before she had had months, many months, of analysis, but all too rational. With that remark she turned the corner, as if she suddenly began to understand, and her whole neurosis collapsed. It had no point in it any more: it had been based upon the mistake that she could live with her miserable intellect alone in a perfectly banal world, when in fact she was a child of God and should have lived the symbolic life, where she would have fulfilled the secret will in herself that was also in her family. She had forgotten all that, and was living, of course, in full contradiction to her whole natural system. Suddenly her life had a meaning, and she could live again; her whole neurosis went by the board.

[637] In other cases, of course, it is not so—should I say—simple (it was not quite simple, you know!). I do not want to tell you further details of that case. It was a most instructive one, but I would rather tell you of other cases where things are not so simple, where you have to guide people quite slowly and wait for a long time until the unconscious produces the symbols that bring them back into the original symbolic life. Then you have to know a great deal about the language of the unconscious, the language of dreams. Then you see how the dreams begin to produce extraordinary figures. These are all found in history under different names. They are unknown quantities, but you find these figures in a literature which is itself completely obsolete. If you happen to know these symbols, you can explain to your patients what the unconscious is after.

[638] Of course, I can't give you a full description of these things, I can only mention them. From my observations I learned that the modern unconscious has a tendency to produce a psychological condition which we find, for instance, in medieval mysticism. You find certain things in Meister Eckhart; you find many things in Gnosticism; that is a sort of esoteric Christianity. You find the idea of the Adam Kadmon in every man—the Christ within. Christ is the second Adam, which is also, in exotic religions, the idea of the Atman or the complete man, the original man, the “all-round” man of Plato, symbolized by a circle or a drawing with circular motifs. You find all these ideas in medieval mysticism; you find them all through alchemical literature, beginning with the first century after Christ. You find them in Gnosticism, you find many of them in the New Testament, of course, in Paul. But it is an absolutely consistent development of the idea of Christ within—not the historical Christ without, but the Christ within; and the argument is that it is immoral to allow Christ to suffer for us, that he has suffered enough, and that we should carry our own sins for once and not shift them off on to Christ—that we should carry them all.

Christ expresses the same idea when he says, “I appear in the least of your brethren”;⁶ and what about it, my dear son, if the least of your brethren should be yourself—what about it then? Then you get the intimation that Christ is not to be the least in your life, that we have a brother in ourselves who is really the least of our brethren, much worse than the poor beggar whom you feed. That is, in ourselves we have a shadow; we have a very bad fellow in ourselves, a very poor man, and he has to be accepted. What has Christ done—let us be quite banal about it—what has Christ done when we consider him as an entirely human creature? Christ was disobedient to his mother; Christ was disobedient to his tradition: Christ falsified himself, and played it out to the bitter end: he carried through his hypothesis to the bitter end. How was Christ born? In the greatest misery. Who was his father? He was an illegitimate child—humanly the most miserable situation: a poor girl having a little son. That is our symbol, that is ourselves; we are all that. And if anyone lives his own hypothesis to the bitter end (and pays with his death, perhaps, he knows that Christ is his brother.

[639] That is modern psychology, and that is the future. That is the true future, that is the future of which I know—but, of course, the historical future might be quite different. We do not know whether it is not the Catholic Church that will reap the harvest that is now going to be cut down. We do not know that. We do not know whether Hitler is going to found a new Islam. (He is already on the way; he is like Mohammed. The emotion in Germany is Islamic; warlike and Islamic. They are all drunk with a wild god.) That can be the historic future. But I do not care for a historic future at all, not at all; I am not concerned with it. I am only concerned with the fulfilment of that will which is in every individual. My history is only the history of those individuals who are going to fulfil their hypotheses. That is the whole problem; that is the problem of the true Pueblo: that I do today everything that is necessary so that my Father can rise over the horizon. That is my standpoint. Now I think I have talked enough!

Discussion

Canon H. England:

[640] In the Church of England ritual we have, after the Holy Communion: “Here we offer and present unto Thee, O Lord, ourselves, our souls and bodies, to be a reasonable, holy, and lively sacrifice.” That is the sacrifice and that is the ritual which should satisfy the conditions you demand, is it not?

Professor Jung:

[641] Absolutely. Yes, the Church of England has a great asset in that. The Church of England, of course, is not the whole Protestant world, and it is not quite Protestant in England.

The Bishop of Southwark:

[642] The question is whether it is quite a Protestant world.

Professor Jung:

[643] But I should call the Church of England a real church. Protestantism in itself is no church at all.

The Bishop of Southwark:

[644] But there are other parts of the Protestant world which have churches. There are, for instance, the Lutherans in Sweden; take them as an example of a reformed church. Their conditions are more like our own. Have you ever come across the Orthodox ritual? Does the Russian ritual have the same effect?

Professor Jung:

[645] I am afraid that, owing to historical events, the whole thing has been interrupted. I have seen a few Orthodox people, and I am afraid they were no longer very orthodox.

The Bishop of Southwark:

[646] I meet a good number of Russian exiles in Paris, in a colony there, who are very deliberately trying to keep alive the old Russian religious life with as little change as

possible.

Professor Jung:

[647] I have never seen a real member of the Orthodox Church, but I am quite convinced that as they live the symbolic life in that church they are all right.

The Bishop of Southwark:

[648] We Anglicans are in much closer touch with the Orthodox Church than with the Catholics, and they seem to us rather too symbolic—not quite to be facing up to the straight path, the facts they ought to be dealing with. They have rather the exile psychology—a world of their own—and I am rather frightened of that psychology for some of our own people, who seem to want to take refuge in symbolism from the responsibilities of life.

Professor Jung:

[649] With the best truth you can cheat; you can cheat with anything, so there are people who take illegitimate refuge in symbolism. For instance, monasteries are full of people who run away from life and its obligations and live the symbolic life—the symbolic life of their past. Such cheats are always punished, but it is a peculiar fact that they can stand it somehow without getting too neurotic. There is a peculiar value in the symbolic life. It is a fact that the primitive Australians sacrifice to it two-thirds of their available time—of their lifetime in which they are conscious.

The Bishop of Southwark:

[650] King Alfred the Great did something very much like that.

Professor Jung:

[651] Yes, that is the secret of primitive civilizations.

The Bishop of Southwark:

[652] He was a very practical civilizing man.

Professor Jung:

[653] Yes, because the very fact that you live the symbolic life has an extraordinarily civilizing influence. Those people are far more civilized and creative on account of

the symbolic life. People who are only rational have very little influence; it is all talk, and with talk you get nowhere.

Canon England:

[654] But symbols may appeal to reason, for all that; to an enlightened reason.

Professor Jung:

[655] They may, yes! Symbols often cause an extraordinary intensity of mental life, even of intellectual life. If you look through the Patristic literature you find mountains of emotion, all couched in symbolism.

The Reverend D. Glan Morgan:

[656] But what are the Protestants to do now, especially we of the left—the Free Churches—the Nonconformists? We have no symbols at all, we have rejected them, lock, stock, and barrel. Our chapels are dead, our pulpits are platforms.

Professor Jung:

[657] Excuse me! You have a lot of symbolism still. You speak of God or of Jesus? There you are! What could be more symbolic? God is a symbol of symbols!

Mr. Morgan:

[658] Even that symbol becomes a contradiction. And there are crowds of people in our churches who can believe in Jesus Christ, but who cannot believe in God.

Professor Jung:

[659] Yes, and in the Catholic Church there are plenty who believe in the Church, but don't believe in God—nor in anything else!

The Bishop of Southwark:

[660] How far has this something to do with it? Not only has the Roman Catholic Church a very full symbolic system, but it is combined with the profession of absolute certitude—the dogma of infallibility. That must have a direct bearing on the value of symbols.

Professor Jung:

[661] Very important. The Church is absolutely right, wholly right, in insisting on that absolute validity, otherwise she opens the door to doubt.

Dr. Ann Harling:

[662] To conflict or neurosis?

Professor Jung:

[663] Absolutely. Therefore “extra ecclesiam nulla salus.”

The Bishop of Southwark:

[664] Are all forms of conflict neurosis?

Professor Jung:

[665] Only when the intellect breaks away from that symbolic observance. When the intellect does not serve the symbolic life it is the devil: it makes you neurotic.

Mr. Morgan:

[666] May there be a transition, a moving ever from one system to another, and may not that be neurotic?

Processor Jung:

[667] Neurosis is a transitory phase, it is the unrest between two positions.

Mr. Morgan:

[668] I am asking because I myself feel at the moment that there is a good deal of neurosis among Protestants on account of the price that has to be paid for moving over from one state to the other.

Professor Jung:

[669] That is what I say: “extra ecclesiam nulla salus.” you get into a terrible frying-pan when you get out of the Church: therefore I don’t wish it on people. I point out the validity of the primary Church.

The Bishop of Southwark:

[670] What are we to do with the great majority of people we have to deal with who are not in any church? They say they are in the Church of England, but they don't belong in any sense.

Professor Jung:

[671] I am afraid you can't do anything with such people. The Church is there and is valid for those who are inside. Those who are outside the walls of the Church cannot be brought back into the Church by the ordinary means. But I wish the clergy would understand the language of the soul, and that the clergyman would be a *directeur de conscience!* Why should I be a *directeur de conscience?* I am a doctor: I have no preparation for that. It is the natural calling of the clergyman: he should do it. Therefore I wish that a new generation of clergymen would come in and do the same as they do in the Catholic Church: that they would try to translate the language of the unconscious, even the language of dreams, into proper language. For instance, I know that there is now in Germany the Berneuchener Circle,⁷ a liturgical movement; and one of the main representatives is a man who has a great knowledge of symbolism. He has given me quite a number of instances, which I am able to check, where he translated the figures in dreams into dogmatic language with the greatest success, and these people quietly slipped back into the order of the Church. They have no right to be neurotic. They belong to a church, and if you can help them to slip back to the Church you have helped them. Several of my patients became Catholics, others went back into the Church organization. But it must be something that has substance and form. It is by no means true that when one analyses somebody he necessarily jumps into the future. He is perhaps meant for a church, and if he can go back into a church, perhaps that is the best thing that can happen.

Mr. Morgan:

[672] What if he can't?

Professor Jung:

[673] Then there is trouble; then he has to go on the Quest; then he has to find out what his soul says; then he has to go through the solitude of a land that is not created. I have published such an example in my lectures⁸—that of a great scientist, a very famous man, who lives today.⁹ He set out to see what the unconscious said to him, and it gave him a wonderful lead. That man got into order again because he gradually accepted the symbolic data, and now he leads the religious life, the life of the careful observer. Religion is careful observation of the data. He now observes all the things that are brought him by his dreams; that is his only guidance.

[674] We are in a new world with that; we are exactly like primitives. When I went to East Africa, I went to a small tribe in Mount Elgon and I asked the medicine-man about dreams. He said, "I know what you mean; my father still had dreams." I said, "You have no dreams?" And then he wept and answered, "No, I have no dreams any more." I asked, "Why?" He answered, "Since the British came into the country." "Now, how is that?" He said, "The District Commissioner knows when there shall be war; he knows when there are diseases; he knows where we must live—he does not allow us to move." The political guidance is now represented by the D.C., by the superior intelligence of the white man; therefore, why should they need dreams? Dreams were the original guidance of man in the great darkness. Read that book of Rasmussen's about the Polar Eskimos.¹⁰ There he describes how a medicine-man became the leader of his tribe on account of a vision. When a man is in the wilderness, the darkness brings the dreams—*somnia a Deo missa*—that guide him. It has always been so. I have not been led by any kind of wisdom; I have been led by dreams, like any primitive. I am ashamed to say so, but I am as primitive as any nigger,¹¹ because I do not know! When you are in the darkness you take the next thing, and that is a dream. And you can be sure that the dream is your nearest friend; the dream is the friend of those who are not guided any more by the traditional truth and in consequence are isolated. That was the case with the old alchemical philosophers, and you read in the *Tractatus Aureus* of Hermes Trismegistus a passage that bears out what I said about isolation. There you read: "(Deus) in quo est adiuvatio cuiuslibet sequestrati" (God, in whom is the help of all who are lonely). Hermes, at the same time, was a real leader of souls and the very incarnation of inspiration, thus representing the unconscious manifest in dreams. So, you see, the one who is going alone and has no guidance, he has the *somnia a Deo missa*; he has no D.C. Of course, when we have a D.C. we do not need a dream, but when we are alone, that is something else.

The Bishop of Southwark:

[675] A practising parson, a Roman Catholic, has a D.C., an authority, and does not need dreams.

Professor Jung:

[676] Agreed! Nevertheless, there are people in the Church who have *somnia a Deo missa*, and the Church is very careful to appreciate the importance of such dreams. They don't deny the fact that there are *somnia a Deo missa*; the Church reserves the right of judgment, but they do consider it.

Lt.-Colonel H. M. Edwards:

[677] Are Roman Catholic priests being trained as psychotherapists?

Professor Jung:

[678] Yes.

Colonel Edwards:

[679] Not in this country?

Professor Jung:

[680] No, the Jesuits are. For example, the main father-confessor of Jena is a Jesuit trained in psychotherapy.

Dr. A. D. Belilios:

[681] Of the Jungian school?

Professor Jung:

[682] Of all schools. I am afraid he doesn't go as far as I go. I asked him about his position as to dreams, and he said, "Well, there we have to be careful, and we are already a bit suspect. We have the means of grace of the Church." "Right you are," I said, "you don't need dreams. I can give no absolution, I have no means of grace; therefore I must listen to dreams. I am a primitive; you are a civilized man." In a way that man is much more wonderful than I am. He can be a saint; I cannot be a saint—I can only be a nigger, very primitive, going by the next thing—quite superstitious.

Wing-Commander T. S. Rippon:

[683] How do you feel with the question of life after death?

Professor Jung:

[684] I have not been there consciously yet. When I die, I shall say "Now, let us see!" For the time being I am in this form, and I say, "Now, what is here? Let us do everything we can here." If, when we die, we find there is a new life, I shall say, "Now let us live once more—*encore une fois!*" I don't know, but I can tell you this: the unconscious has no time. There is no trouble about time in the unconscious. Part of our psyche is not in time and not in space. They are only an illusion, time and space, and so in a certain part of our psyche time does not exist at all.

Mr. Derek Kitchin:

[685] You wrote somewhere, Professor, that for many persons a belief in a future life was a necessity to psychological health.

Professor Jung:

[686] Yes. You would be out of tune if you did not consider immortality when your dreams put you up against that problem; then you should decide. If they don't you can leave it. But if they put you up against it, then you have to say, "I must try how I feel. Let us assume that there is no such thing as immortality, no life after death: how do I feel about that? How do I function with such a conviction?" Then, perhaps, your stomach goes wrong. So you say, "Let us assume that I am immortal," and then you function. So you must say, "That must be right." How do we know? How does an animal know that the particular bit of grass it has eaten is not poisonous, and how do animals know that something is poisonous? They go wrong. That is how we know the truth: the truth is that which helps us to live—to live properly.

The Reverend Francis Boyd:

[687] That which works; the pragmatic test.

Professor Jung:

[688] That which really works. I have no assumptions about these things. How can I? I only know that if I live in a certain way I live wrongly; I am unhealthy. And if I live in another way I am right. For instance, if the Pueblos believe that they are the sons of the Father Sun, they are in order. So I say, "I wish I could be a son of the Sun." Alas! I can't do it; I can't afford it; my intellect doesn't allow it. So I am bound to find another form. But they are all right. It would be the greatest mistake to tell those people that they are not the sons of the Sun. I tried, for instance, the argument of St. Augustine:¹² "Non est Dominus Sol factus, sed per quem Sol factus est" (God is not the sun but the one who made the sun). But my Pueblo got into a frightful state; he thought that was the most awful blasphemy. He said, "This *is* the Father; there is no Father behind it. How can we think of a Father we cannot see?" And in so far as they live in that belief, it is true. Anything that *lives* on earth, is true. So the Christian dogma is true, much truer than we have ever thought. We think we are much cleverer. As long as we don't understand it, as long as we don't see where it could lead beyond, there is no reason why we should give it up. If we see we are out of it, then we have what we call a superior point of view. That is another thing. Analysis is

merely a means of making us more conscious of our perplexity; we are all on the Quest.

The Bishop of Southwark:

[689] Would you say the same of the Nazi or the Mohammedan, that they are right to go on in their faith?

Professor Jung:

[690] God is terrible; the living God is a living fear. I think it is an instrument, as Mohammed was for that people. All people, for instance, who are filled with that uncanny power, are always most disagreeable for others. I am quite convinced that some of the people in the Old Testament were very disagreeable people.

The Reverend W. Hopkins:

[691] There is obviously, and always has been, a conflict between science and religion. It is not so acute now as it has been. How do you bring about a reconciliation, which obviously is the sort of thing that is needed?

Professor Jung:

[692] There is no conflict between religion and science. That is a very old-fashioned idea. Science has to consider what there is. There is religion, and it is one of the most essential manifestations of the human mind. It is a fact, and science has nothing to say about it; it simply has to confirm that there is that fact. Science always runs after these things; it does not try to explain the phenomena. Science cannot establish a religious truth. A religious truth is essentially an experience, it is not an opinion. Religion is an absolute experience. A religious experience is absolute, it cannot be discussed. For instance, when somebody has had a religious experience, he just has such an experience, and nothing can take it away from him.

Mr. Hopkins:

[693] In the nineteenth century the scientists were apt to be much more dogmatic than they are now. They dismissed all religion as an illusion. But now they admit it, and they experience it themselves.

Professor Jung:

[694] Our science is phenomenology. In the nineteenth century science was labouring under the illusion that science could establish a truth. No science can establish a truth.

Mr. Hopkins:

[695] But it is the science of the nineteenth century that the ordinary people have today. That is our problem.

Professor Jung:

[696] Yes, you are up against it. It has filtered down into the lower strata of the population, and has worked no end of evil. When the asses catch hold of science, that is awful. Those are the great mental epidemics of our time; they are all insane, the whole crowd!

IV

ON OCCULTISM

(related to Volume I of the Collected Works)

ON SPIRITUALISTIC PHENOMENA¹

[697] It is impossible, within the short space of a lecture, to say anything fundamental about such a complicated historical and psychological problem as spiritualism^{1a} appears to be. One must content oneself with shedding a little light on one or the other aspect of this intricate question. This kind of approach will at least give the hearer an approximate idea of the many facets of spiritualism. Spiritualism, as well as being a theory (its advocates call it “scientific”), is a religious belief which, like every religious belief, forms the spiritual core of a religious movement. This sect believes in the actual and tangible intervention of a spiritual world in our world, and consequently makes a religious practice of communicating with the spirits. The dual nature of spiritualism gives it an advantage over other religious movements: not only does it believe in certain articles of faith that are not susceptible of proof, but it bases its belief on a body of allegedly scientific, physical phenomena which are supposed to be of such a nature that they cannot be explained except by the activity of spirits. Because of its dual nature—on the one side a religious sect, on the other a scientific hypothesis—spiritualism touches upon widely differing areas of life that would seem to have nothing in common.

[698] Spiritualism as a sect originated in America in the year 1848. The story of its origin is a strange one.² Two girls of the Methodist family Fox, in Hydesville, near Rochester (New York), were frightened every night by sounds of knocking. At first a great scandal arose, because the neighbours suspected that the devil was up to his usual tricks. Gradually, however, communication was established with the knocking sounds when it was discovered that questions were answered with a definite number of knocks. With the help of a knocking alphabet, it was learned that a man had been murdered in the Foxes’ house, and his body buried in the cellar. Investigations were said to have confirmed this.

[699] Thus far the report. The public performances given by the Foxes with the poltergeists were quickly followed by the founding of other sects. Tableturning, much practised earlier, was taken up again. Numerous mediums were sought and found, that is, persons in whose presence such phenomena as knocking noises occurred. The movement spread rapidly to England and the continent. In Europe, spiritualism took the form chiefly of an epidemic of tableturning. There was hardly an evening party or dance where the guests did not steal away at a late hour to question the table. This particular symptom of spiritualism was rampant everywhere. The religious sects

made less headway, but they continued to grow steadily. In every big city today there is a fairly large community of practising spiritualists.

[700] In America, which swarms with local religious movements, the rise of spiritualism is understandable enough. With us, its favourable reception can be explained only by the fact that the ground had been historically prepared. The beginning of the nineteenth century had brought us the Romantic Movement in literature, a symptom of a widespread, deep-seated longing for anything extraordinary and abnormal. People adored wallowing in Ossianic emotions, they went crazy over novels set in old castles and ruined cloisters. Everywhere prominence was given to the mystical, the hysterical; lectures about life after death, about sleepwalkers and visionaries, about animal magnetism and mesmerism, were the order of the day. Schopenhauer devoted a long chapter to all these things in his *Parerga und Paralipomena*, and he also spoke of them at various places in his *chef d'œuvre*.³ Even his important concept of “sanctity” is a far-fetched, mystico-aesthetic ideal. Similar movements made themselves felt in the Catholic church, clustering round the strange figure of Johan Joseph von Görres 1776–1848. Especially significant in this respect is his four-volume work *Die christliche Mystik*, Regensburg, 1836–42,. The same trends appear in his earlier book. *Emanuel Swedenborg, seine Visionen und sein Verhältnis zur Kirche*, Speyer 1827,. The Protestant public raved about the soulful poetry of Justinus Kerner and his clairvoyante, Frau Friederike Hauffe, while certain theologians gave vent to their catholicizing tendencies by excommunicating spirits. From this period, too, come a large number of remarkable psychological descriptions of abnormal people—ecstatics, somnambulists, sensitives. They were much in demand and were cultivated assiduously. A good example was Frau Hauffe herself, the clairvoyante of Prevorst, and the circle of admirers who gathered round her. Her Catholic counterpart was Katharina Emmerich, the ecstatic nun of Dulmen. Reports of similar personalities were collected together in a weighty tome by an anonymous savant, entitled “The Ecstatic Virgins of the Tyrol. Guiding Stars in the Dark Firmament of Mysticism.”⁴

[701] When these strange personages were investigated, the following suprasensible processes were observed:

1. “Magnetic” phenomena.
2. Clairvoyance and prophecy.
3. Visions.

[702] 1. *Animal magnetism*, as understood at the beginning of the nineteenth century, covered a vaguely defined area of physiological and psychological phenomena which, it was thought, could all be explained as “magnetic.” “Animal magnetism” had been in the air ever since the brilliant experiments of Franz Anton Mesmer. It

was Mesmer who discovered the art of putting people to sleep by light passes of the hand. In some people this sleep was like the natural one, in others it was a “waking sleep”; that is, they were like sleepwalkers, only part of them was asleep, while some senses remained awake. This half-sleep was also called “magnetic sleep” or somnambulism. People in these states were wholly under the will of the magnetist, they were “magnetized” by him. Today, as we know, there is nothing wonderful about these states; they are known as hypnosis and we use the mesmeric passes as a valuable adjunct to other methods of suggestion. The significance attributed to the passes quickly led to their being grossly overestimated. People thought that some vitalistic force had been discovered; they spoke of a “magnetic fluid” that streamed from the magnetist into the patient and destroyed the diseased tissue. They also used it to explain the movements of the table in tableturning, imagining that the table was vitalized by the laying on of hands and could therefore move about like a living thing. The phenomena of the divining rod and the automatically swinging pendulum were explained in the same way. Even completely crazy phenomena of this sort were widely reported and believed. Thus the *Neue Preussische Zeitung* reported from Barmen, in Pomerania that a party of seven persons sat themselves round a table in a boat, and magnetized it. “In the first 20 minutes the boat drifted 50 feet downstream. Then it began to turn, with steadily increasing speed, until the rotary movement had carried it through an arc of 180 degrees in 3 minutes. Eventually, by skilful manipulation of the rudder, the boat moved forwards, and the party travelled half a mile upstream in 40 minutes, but on the return journey covered the same distance in 26 minutes. A crowd of spectators, watching the experiment from the banks of the river, received the ‘table travellers’ with jubilation.” In very truth, a mystical motorboat! According to the report, the experiment had been suggested by a Professor Nägeli, of Freiburg im Breisgau.

[703] Experiments in divination are known from the grey dawn of history. Thus Ammianus Marcellinus reports from A.D. 371 that a certain Patricius and Hilarius, living in the reign 364–78 of the Emperor Valens, had discovered by the “abominable arts of soothsaying” who would succeed to the throne. For this purpose they used a metal bowl, with the alphabet engraved round the rim. Over it amid fearful oaths, they suspended a ring on a thread. This began to swing, and spelt out the name Theodorus. When their magic was divulged, they were arrested and put to death.

[704] Ordinarily, experiments with the automatic movements of the table, the divining rod and the pendulum are not as bizarre as the first example or as dangerous as the second. The various phenomena that may occur in tableturning have been described in a treatise by Justinus Kerner bearing the significant title: “The Somnambulant Tables. A History and Explanation of these Phenomena”⁵, 1853,. They have also been

described by the late Professor Thury of Geneva, in *Les Tables parlantes au point de vue de la physique générale*, 1855,.

[705] *Clairvoyance and prophecy* are further characteristics of somnambulists. Clairvoyance in time and space plays a large role in the biographies and descriptions of these cases. The literature abounds in more or less credible reports, most of which have been collected by Gurney, Myers, and Podmore in their book *Phantasms of the Living*, 1886,.

[706] An excellent example of clairvoyance is preserved for us in philosophical literature and is especially interesting because it was personally commented on by Kant. In an undated letter to Charlotte von Knobloch, he wrote as follows about the spirit-seer Swedenborg:⁶

[707] The following occurrence appears to me to have the greatest weight of proof, and to place the assertion respecting Swedenborg's extraordinary gift beyond all possibility of doubt.

[708] In the year 1759, towards the end of September, on Saturday at four o'clock p.m., Swedenborg arrived at Gottenburg from England, when Mr. William Castel invited him to his house, together with a party of fifteen persons. About six o'clock Swedenborg went out, and returned to the company quite pale and alarmed. He said that a dangerous fire had just broken out in Stockholm, at the Södermalm (Gottenburg is about fifty German miles from Stockholm), and that it was spreading very fast. He was restless, and went out often. He said that the house of one of his friends, whom he named, was already in ashes, and that his own was in danger. At eight o'clock, after he had been out again, he joyfully exclaimed, 'Thank God! the fire is extinguished; the third door from my house.' This news occasioned great commotion throughout the whole city, but particularly amongst the company in which he was. It was announced to the Governor the same evening. On Sunday morning Swedenborg was summoned to the Governor who questioned him concerning the disaster. Swedenborg described the fire precisely, how it had begun and in what manner it had ceased, and how long it had continued. On the same day the news spread through the city, and as the Governor thought it worthy of attention, the consternation was considerably increased; because many were in trouble on account of their friends and property, which might have been involved in the disaster. On Monday evening a messenger arrived at Gottenburg, who was despatched by the Board of Trade during the time of the fire. In the letters brought by him, the fire was described precisely in the manner stated by Swedenborg. On Tuesday morning the Royal Courier arrived at the Governor's with the melancholy intelligence of the fire, of the loss which it had occasioned, and of the houses it had damaged and ruined, not in the least differing from that which Swedenborg had given at the very time when it happened; for the fire was extinguished at eight o'clock.

[709] What can be brought forward against the authenticity of this occurrence (the conflagration in Stockholm)? My friend who wrote this to me has examined all, not only in Stockholm, but also, about two months ago, in Gottenburg, where he is well acquainted with the most respectable houses, and where he could obtain the most authentic and complete information, for as only a very short time had elapsed since 1759 most of the inhabitants are still alive who were eyewitnesses of this occurrence.

[710] *Prophecy* is a phenomenon so well known from the teachings of religion that there is no need to give any examples.

[711] 3. *Visions* have always figured largely in miraculous tales, whether in the form of a ghostly apparition or an ecstatic vision. Science regards visions as delusions of the senses, or hallucinations. Hallucinations are very common among the insane. Let me cite an example from the literature of psychiatry:

[712] A twenty-four-year-old servant girl, with an alcoholic father and a neurotic mother, suddenly begins falling into peculiar states. From time to time she falls into a state of consciousness in which she sees everything that comes into her mind vividly before her, as though it were there in reality. All the time the images keep changing with breathtaking speed and lifelikeness. The patient, who in actual life is nothing but a simple country girl, then resembles an inspired seer. Her features become transfigured, her movements flow with grace. Famous figures pass before her mind's eye. Schiller appears to her in person and plays with her. He recites his poems to her. Then she herself begins to recite, improvising in verse the things she has read, experienced, and thought. Finally she comes back to consciousness tired and exhausted, with a headache and a feeling of oppression, and with only an indistinct memory of what has happened. At other times her second consciousness has a sombre character. She sees ghostly figures prophesying disaster, processions of spirits, caravans of strange and terrifying beastlike forms, her own body being buried, etc.⁷

[713] Visionary ecstasies are usually of this type. Numerous visionaries are known to us from history, among them many of the Old Testament prophets. There is the report of St. Paul's vision on the road to Damascus, followed by a blindness that ceased at the psychological moment. This blindness reminds us on the one hand of the blindness which can be produced by suggestion, and on the other hand of the blindness which occurs spontaneously with certain hysterical patients and again disappears at a suitable psychological moment. The best visions, and the ones that are psychologically the most transparent, are found in the legends of the saints, the visions being most colourful in the case of female saints experiencing the heavenly marriage. An outstanding visionary type was the Maid of Orleans, who was unconsciously imitated by the devout dreamer Thomas Ignaz Martin at the time of Louis XVIII.⁸

[714] Swedenborg, a learned and highly intelligent man, was a visionary of unexampled fertility. His importance is attested by the fact that he had a considerable influence on Kant.⁹

[715] These remarks are not meant to be conclusive, they are only intended to sketch in broad outline the state of knowledge at that time and its mystical tendency. They give some idea of the psychological premises which explain the rapid spread of American spiritualism in Europe. The tableturning epidemic of the fifties has already been mentioned. It reached a climax in the sixties and seventies. In Paris, spiritualistic séances were held at the court of Napoleon III. Famous and sometimes infamous mediums appeared—Cumberland, the Davenport brothers, Home, Slade, Miss Cook. This was the real heyday of spiritualism, for these mediums produced marvellous phenomena, quite extraordinary things which went so far beyond the bounds of credibility that a thinking person who was not himself an eyewitness could only treat them with scepticism. The impossible happened: human bodies, and parts of bodies, materialized out of thin air, bodies that had an intelligence of their own and declared themselves to be the spirits of the dead. They complied with the doubting requests of the worldlings and even submitted to experimental conditions; on vanishing from this world, they left behind pieces of their white gauzy robes, prints of their hands and feet, handwriting on the inner side of two slates sealed together, and, finally, even let themselves be photographed.

[716] But the full impact of these tidings, impressive as they were, was not felt until the famous English physicist, William Crookes, in his *Quarterly Journal of Science*, presented to the world a report on the observations he had made during the past eight years, which had convinced him of the reality of the phenomena in question. Since the report is concerned with observations at which none of us was present, under conditions which it is no longer possible to check, we have no alternative but to let the observer himself inform us how these observations were mirrored in his brain. The tone of the report at least allows us to surmise the state of his feelings at the time of writing. I shall therefore cite verbatim a passage from his investigations during the years 1870–73:¹⁰

CLASS VI

The Levitation of Human Beings

[717] This has occurred in my presence on four occasions in darkness. The test conditions under which they took place were quite satisfactory, so far as the judgment was concerned: but ocular demonstration of such a fact is so necessary to disturb our preformed opinions as to “the naturally possible and impossible,” that I will here

only mention cases in which the deductions of reason were confirmed by the sense of sight.

[718] On one occasion I witnessed a chair, with a lady sitting on it, rise several inches from the ground. On another occasion, to avoid the suspicion of this being in some way performed by herself, the lady knelt on the chair in such manner that its four feet were visible to us. It then rose about three inches, remained suspended for about ten seconds, and then slowly descended. At another time two children, on separate occasions, rose from the floor with their chairs, in full daylight, under (to me) most satisfactory conditions; for I was kneeling and keeping close watch upon the feet of the chair, and observing that no one might touch them.

[719] The most striking cases of levitation which I have witnessed have been with Mr. Home. On three separate occasions have I seen him raised completely from the floor of the room. Once sitting in an easy chair, once kneeling on his chair, and once standing up. On each occasion I had full opportunity of watching the occurrence as it was taking place.

[720] There are at least a hundred recorded instances of Mr. Home's rising from the ground, in the presence of as many separate persons, and I have heard from the lips of the three witnesses to the most striking occurrence of this kind—the Earl of Dunraven Lord Lindsay, and Captain C. Wynne—their own most minute accounts of what took place. To reject the recorded evidence on this subject is to reject all human testimony whatever; for no fact in sacred or profane history is supported by a stronger array of proofs.

[721] The accumulated testimony establishing Mr. Home's levitations is overwhelming. It is greatly to be desired that some person, whose evidence would be accepted as conclusive by the scientific world—if indeed there lives a person whose testimony *in favour* of such phenomena would be taken—would seriously and patiently examine these alleged facts. Most of the eye-witnesses to these levitations are now living, and would, doubtless, be willing to give their evidence. But, in a few years, such *direct* evidence will be difficult, if not impossible, to be obtained.

[722] It is obvious from the tone of this passage that Crookes was completely convinced of the reality of his observations. I refrain from further quotations because they would not tell us anything new. It is sufficient to remark that Crookes saw pretty well everything that occurred with these great mediums. It is hardly necessary to stress that if this unprecedented happening is an actual fact, the world and science have been enriched by an experience of the most tremendous importance. For a variety of reasons, it is not possible to criticize Crookes's powers of apprehension and retention during those years from the psychiatric point of view. We only know that at that time Crookes was not manifestly insane. Crookes and his observations must remain for the present an unsolved psychological enigma. The same is true of a

number of other observers whose intelligence and honesty one does not wish to disparage without good reason. Of numerous other observers, noted for their prejudices, lack of criticism, and exuberant imagination, I shall say nothing: they are ruled out from the start.

[723] One does not have to be particularly beset by doubts as to whether our knowledge of the world in the twentieth century has really attained the highest possible peak to feel humanly touched by this forthright testimony of an eminent scholar. But, in spite of our sympathy, we may leave out of account the question of the physical reality of such phenomena, and instead turn our attention to the psychological question: how does a thinking person, who has shown his sober-mindedness and gift for scientific observation to good advantage in other fields, come to assert that something inconceivable is a reality?

[724] This psychological interest of mine has prompted me to keep track of persons who are gifted as mediums. My profession as a psychiatrist gave me ample opportunities for this, particularly in a city like Zurich. So many remarkable elements converging in so small a space can perhaps be found nowhere else in Europe. In the last few years I have investigated eight mediums, six of them women and two of them men. The total impression made by these investigations can be summed up by saying that one must approach a medium with a minimum of expectations if one does not want to be disappointed. The results are of purely psychological interest, and no physical or physiological novelties came to light. Everything that may be considered a scientifically established fact belongs to the domain of the mental and cerebral processes and is fully explicable in terms of the laws already known to science.

[725] All phenomena which the spiritualists claim as evidence of the activity of spirits are connected with the presence of certain persons, the mediums themselves. I was never able to observe happenings alleged to be "spiritual" in places or on occasions when no medium was present. Mediums are as a rule slightly abnormal mentally. Frau Rothe, for example, although she could not be declared *non compos mentis* by forensic psychiatrists, nevertheless exhibited a number of hysterical symptoms. Seven of my mediums showed slight symptoms of hysteria (which, incidentally, are extraordinarily common in other walks of life too). One medium was an American swindler whose abnormality consisted chiefly in his impudence. The other seven acted in good faith. Only one of them, a woman of middle age, was born with her gifts; she had suffered since earliest childhood from alterations of consciousness (frequent and slightly hysterical twilight states). She made a virtue of necessity, induced the change of consciousness herself by auto-suggestion, and in this state of auto-hypnosis was able to prophesy. The other mediums discovered their gift only through social contacts and then cultivated it at spiritualistic séances, which is not particularly difficult. One can, with a few skillful suggestions, teach a remarkably

high percentage of people, especially women, the simple spiritualistic manipulations, table-turning for instance, and, less commonly, automatic writing.

[726] The ordinary phenomena met with in mediums are table-turning, automatic writing, and speaking in a trance.

[727] Table-turning consists in one or more persons laying their hands on a table that can move easily. After a time—a couple of minutes to an hour) the table begins to move, making turning or rocking movements. This phenomenon can be observed in the case of all objects that are touched. The automatically swinging pendulum and the divining rod are based on the same principle. It was, then, a very childish hypothesis to assume, as in earlier decades, that the objects touched moved of themselves, like living things. If a fairly heavy object is chosen, and one feels the arm muscles of the medium while the object is moving, the muscular tension is immediately apparent, and hence also the effort of the medium to move the object. The only remarkable thing is that the mediums assert they feel nothing of this effort, but, on the contrary, have a definite feeling that the object is moving of its own accord, or else that their arm or hand is moved for them. This psychological phenomenon is strange only to people who know nothing of hypnosis. A hypnotized person can be told that, on waking, he will forget everything that happened under the hypnosis, but that at a certain sign he will, without knowing why, suddenly raise his right arm. Sure enough, on waking, he has forgotten everything; at the sign he raises his right arm, without knowing why—his arm “simply rose up in the air of its own accord.”

[728] Spontaneous phenomena can occasionally be observed in hysterics, for instance the paralysis or peculiar automatic movements of an arm. Either the patients cannot give the reasons for these sudden symptoms, or they give the wrong reasons; for instance, the symptom came from their having caught cold, or from over-strain. One has only to hypnotize the patient in order to discover the real reason and the significance of the symptom. For instance, a young girl wakes up in the morning to find that her right arm is paralysed. She rushes in terror to the doctor and tells him she doesn't know how it happened, she must obviously have overstrained herself doing the housework the day before. That is the only reason she can think of. Under hypnosis it turns out that the day before she had a violent quarrel with her parents, and that her father grabbed her by the right arm and pushed her out of the door. The paralysis of the arm is now clear; it is connected with the unconscious memory of yesterday's scene, which was not present in her waking consciousness. (The existence of “unconscious ideas” is discussed in my paper “The Reaction-time Ratio in the Association Experiment.”¹¹)

[729] It is evident from these facts that our bodies can easily execute automatic movements whose cause and origin are not known to us. And if science had not drawn our attention to it, we would not know, either, that our arms and hands are

constantly making slight movements, called “intended tremors,” which accompany our thoughts. If, for instance, one vividly imagines a simple geometrical figure, a triangle, say, the tremors of the outstretched hand will also describe a triangle, as can be demonstrated very easily by means of a suitable apparatus. Hence, if we sit down at the table with a lively expectation of automatic movements, the intended tremors will reflect this expectation and gradually cause the table to move. But once we have felt the apparently automatic movement, we are immediately convinced that “the thing works.” The conviction suggestion clouds our judgment and observation, so that we do not notice how the tremors, very slight at first, gradually build up into muscular contractions which then naturally produce stronger and stronger and still more convincing effects.

[730] Now if an ordinary table, whose simple construction we know, can execute movements apparently of its own accord and behave as if it were alive, then human fantasy is quite ready to believe that the cause of the movement is some mystic fluid or even the spirits of the air. And if, as usually happens, the table composes sentences with an intelligible content out of the letters of the alphabet, then it seems proved beyond a doubt that an “alien intelligence” is at work. We know, however, that the initial, automatic tremors are in large measure dependent on our ideas. If they are capable of moving the table, they can equally well guide its movements in such a way that they construct words and sentences out of the alphabet. Nor is it necessary to visualize the sentence beforehand. The unconscious part of the psyche which controls the automatic movements very soon causes an intellectual content to flow into them.¹² As might be expected, the intellectual content is as a rule on a very low level and only in exceptional cases exceeds the intelligence of the medium. A good example of the poverty of “table-talking” is given in Allan Kardec’s *Buch der Medien*.

[731] “Automatic writing” follows the same principles as table-turning. The content of the writing is in no way superior to that of “table-talking.” The same considerations apply to talking in a trance or ecstasy. Instead of the muscles of the arm and hand, it is the muscles of the speech apparatus that start functioning independently. The content of trance communications is naturally on the same level as the products of the other automatisms.

[732] These phenomena are statistically the ones most commonly observed in mediums. Clairvoyance is much rarer. Only two of my mediums had the reputation of being clairvoyant. One of them is a well-known professional, who has already made a fool of herself in various cities in Switzerland. In order to assess her mental state as fairly as possible. I had nearly thirty sittings with her over a period of six months. The results of the investigation, so far as clairvoyance is concerned, can be put very briefly: nothing that quite unquestionably exceeded the normal psychological

capacities was observed. On the other hand, she did in some instances display a remarkably fine gift for unconscious combination. She could combine “petites perceptions” and guesses and evaluate them in a very skilful way, mostly in a state of slight clouding of consciousness. There is nothing supernatural about this state; on the contrary, it is a well-known subject of psychological research.

[733] How delicate is the capacity for unconscious apprehension could be demonstrated experimentally with my second medium. The experiments were conducted as follows. The medium sat opposite me at a small table that stood on a thick soft carpet (to assist greater mobility). Both of us laid our hands on the table. While the medium’s mind was occupied by her engaging in conversation with a third person, I thought intensively of a number between 0 and 10—for instance, 3. The arrangement was that the table had to indicate the number thought of by the same number of tilts. The fact that the number was indicated correctly each time when I kept my hands on the table throughout the experiment is not remarkable. What is remarkable is that in 77 per cent of the cases the correct number was also given when I removed my hands immediately after the first tilt. If my hands did not touch the table at all, there were no correct scores. The results of numerous experiments showed that by means of intended tremors it is possible to communicate a number between 0 and 10 to another person, in such a way that though this person could not recognize the number, he could nevertheless reproduce it by automatic movements. I was able to establish to my satisfaction that the conscious mind of the medium never had any inkling of the number I had communicated. Numbers above 10 were reproduced very uncertainly, sometimes only one of the numerals being given. If I thought of the numbers in Roman instead of Arabic numerals, the results were considerably worse. The aforesaid 77 per cent correct scores applies only to experiments with Arabic numerals. From this one can conclude that my unconscious movements must have communicated a pictorial image of the numbers. The more complicated and less customary images of Roman numerals fared worse, as was also the case with numbers above 10.

[734] I cannot report these experiments without recalling a curious and instructive observation I made one day when all the psychological experiments with the medium went wrong. Even the experiments with numbers failed to come off, until I finally hit on the following expedient: In an experiment conducted along much the same lines. I told the medium that the number I was thinking of 3 was between 2 and 5. I then got the table to answer me a dozen times. The numbers it reproduced with iron consistency were 2, 4, and 5, but never 3; thus indicating, negatively but quite clearly, that the table, or rather the unconscious of the medium, was well aware of the number I was thinking of and avoided it out of mere caprice. The capriciousness of the unconscious is something the spiritualists could tell us a good deal about, only in

their language it would be said that the good spirits had been supplanted by mischievous mocking spirits who had ruined the experiment.

[735] The sensitive apprehension of the unconscious, shown by its capacity to translate another person's tremors into numbers, is a striking but by no means unprecedented fact. There are numerous corroborative examples in the scientific literature. But if the unconscious, as my experiments prove, is capable of registering and reproducing something without the conscious mind knowing anything about it, then the greatest caution is necessary in evaluating clairvoyant performances. Before we jump to the conclusion that thought flies through time and space detached from the brain, we should seek to discover by meticulous psychological investigation the hidden sources of the apparently supernatural knowledge.

[736] On the other hand, any unprejudiced investigator will readily admit that we do not stand today on the pinnacle of all wisdom, and that nature still has infinite possibilities up her sleeve which may be revealed in happier days to come. I shall therefore confine myself to pointing out that the cases I observed of supposed clairvoyance might easily be explained in another and more intelligible way than by the assumption of mystic powers of cognition. The apparently inexplicable cases of clairvoyance I know only by hearsay, or have read of in books.

[737] The same is true of that other great class of spiritualistic manifestations, the *physical* phenomena. Those I saw were reputed to be such, but in fact were not. Generally speaking, among the countless believers in miracles of our days very few will be found who have ever seen anything manifestly supernatural. And among these few there will be still fewer who do not suffer from an overheated imagination and do not replace critical observation by faith. Nevertheless, we are left with a residue of witnesses who ought not to be cavilled at. Among these I would include Crookes.

[738] All human beings are bad observers of things that are unfamiliar to them. Crookes, too, is a human being. There is no universal gift for observation that could claim a high degree of certainty without special training. Human observation achieves something only when trained in a definite field. Take a sensitive observer away from his microscope and turn his attention to wind and weather, and he is more helpless than any hunter or peasant. If we plump a good physicist down in the deceptive, magical darkness of a spiritualistic séance, with hysterical mediums plying their trade with all the incredible refinement many of them have at their command, his observation will be no more acute than a layman's. Everything will then depend on the strength of his prejudice for or against. In this respect the psychic disposition of a man like Crookes would be worth investigating. If as a result of environmental influence and education, or his innate temperament, he is not disinclined to believe in miracles, he will be convinced by the apparition. But if he is disinclined from the

start to believe in miracles, he will remain unconvinced in spite of the apparition, just as did many other people who witnessed similar things with the same medium.

[739] Human observation and reporting are subject to disturbance by countless sources of error, many of which are still quite unknown. For instance, a whole school of experimental psychology is now studying the “psychology of evidence,” that is, the problem of observation and reporting. Professor William Stern,¹³ the founder of this school, has published experiments which show man’s powers of observation in a bad light. And yet Stern’s experiments were conducted on educated people! It seems to me that we must go on working patiently for a few more years in the direction of the Stern school before we tackle the difficult question of the reality of spiritualistic phenomena.

[740] So far as the miraculous reports in the literature are concerned, we should, for all our criticism, never lose sight of the limitations of our knowledge, otherwise something embarrassingly human might happen, making us feel as foolish as the academicians felt over Chladni’s meteors,¹⁴ or the highly respected Bavarian Board of Physicians over the railway.¹⁵ Nevertheless I believe that the present state of affairs gives us reason enough to wait quietly until more impressive physical phenomena put in an appearance. If, after making allowance for conscious and unconscious falsification, self-deception, prejudice, etc., we should still find something positive behind them, then the exact sciences will surely conquer this field by experiment and verification, as has happened in every other realm of human experience. That many spiritualists brag about their “science” and “scientific knowledge” is, of course, irritating nonsense. These people are lacking not only in criticism but in the most elementary knowledge of psychology. At bottom they do not want to be taught any better, but merely to go on believing—surely the naïvest of presumptions in view of our human failings.

FOREWORD TO JUNG: "PHÉNOMÈNES OCCULTES"¹

[741] The essays collected together in this little volume were written over a period of thirty years, the first in 1902 and the last in 1932. The reason why I am bringing them out together is that all three are concerned with certain borderline problems of the human psyche, the question of the soul's existence after death. The first essay gives an account of a young somnambulistic girl who claimed to be in communication with the spirits of the departed. The second essay deals with the problem of dissociation and "part-souls" (or splinter-personalities). The third discusses the psychology of the belief in immortality and the possibility of the continued existence of the soul after death.

[742] The point of view I have adopted is that of modern empirical psychology and the scientific method. Although these essays deal with subjects which usually fall within the province of philosophy or theology, it would be a mistake to suppose that psychology is concerned with the *metaphysical* nature of the problem of immortality. Psychology cannot establish any metaphysical "truths," nor does it try to. It is concerned solely with the *phenomenology of the psyche*. The idea of immortality is a psychic phenomenon that is disseminated over the whole earth. Every "idea" is, from the psychological point of view, a phenomenon, just as is "philosophy" or "theology." For modern psychology, ideas are *entities*, like animals and plants. The scientific method consists in the description of nature. All mythological ideas are *essentially real*, and far older than any philosophy. Like our knowledge of physical nature, they were originally perceptions and experiences. In so far as such ideas are universal, they are symptoms or characteristics or normal exponents of psychic life, which are *naturally* present and need no proof of their "truth." The only question we can profitably discuss is whether they are universal or not. If they are universal, they belong to the natural constituents and normal structure of the psyche. And if by any chance they are not encountered in the conscious mind of a given individual, then they are present in the unconscious and the case is an abnormal one. The fewer of these universal ideas are found in consciousness, the more of them there will be in the unconscious, and the greater will be their influence on the conscious mind. This state of things already bears some resemblance to a neurotic disturbance.

[743] It is normal to think about immortality, and abnormal not to do so or not to bother about it. If everybody eats salt, then that is the normal thing to do, and it is abnormal not to. But this tells us nothing about the "rightness" of eating salt or of the idea of immortality. That is a question which strictly speaking has nothing to do with

psychology. Immortality cannot be proved any more than can the existence of God, either philosophically or empirically. We know that salt is indispensable for our physiological health. We do not eat salt for this reason, however, but because food with salt in it tastes better. We can easily imagine that long before there was any philosophy human beings had instinctively found out what ideas were necessary for the normal functioning of the psyche. Only a rather stupid mind will try to go beyond that, and to venture an opinion on whether immortality does or does not exist. This question cannot be asked for the simple reason that it cannot be discussed. More important, it misses the essential point, which is the functional value of the idea as such.

[744] If a person does not “believe” in salt, it is up to the doctor to tell him that salt is necessary for physiological health. Equally, it seems to me that the doctor of the soul should not go along with the fashionable stupidities but should remind his patient what the normal structural elements of the psyche are. For reasons of psychic hygiene, it would be better not to forget these original and universal ideas; and wherever they have disappeared, from neglect or intellectual bigotry, we should reconstruct them as quickly as we can regardless of “philosophical” proofs for or against (which are impossible anyway). In general, the heart seems to have a more reliable memory for what benefits the psyche than does the head, which has a rather unhealthy tendency to lead an “abstract” existence, and easily forgets that its consciousness is snuffed out the moment the heart fails in its duty.

[745] Ideas are not just counters used by the calculating mind; they are also golden vessels full of living feeling. “Freedom” is not a mere abstraction, it is also an emotion. Reason becomes unreason when separated from the heart, and a psychic life void of universal ideas sickens from undernourishment. The Buddha said: “These four are the foodstuffs, ye bhikkus, which sustain the creatures that are born, and benefit the creatures that seek rebirth. The first is edible food, coarse or fine; touch is the second; the thinking capacity of the mind is the third; and the fourth is consciousness.”²

PSYCHOLOGY AND SPIRITUALISM¹

[746] The reader should not casually lay this book aside on discovering that it is about “Invisibles,” that is to say about spirits, on the assumption that it belongs to the literature of spiritualism. One can very well read the book without resorting to any such hypothesis or theory, and take it simply as a report of psychological facts or a continuous series of communications from the unconscious—which is, indeed, what it is really about. Even spirits appear to be psychic phenomena whose origins lie in the unconscious. At all events, the “Invisibles” who are the source of information in this book are shadowy personifications of unconscious contents, conforming to the rule that activated portions of the unconscious assume the character of *personalities* when they are perceived by the conscious mind. For this reason, the voices heard by the insane seem to belong to definite personalities who can often be identified, and personal intentions are attributed to them. And in fact, if the observer is able—though this is not always easy—to collect together a fair number of these verbal hallucinations, he will discover in them something very like motives and intentions of a personal character.

[747] The same is true to an even greater degree of the “controls” in mediumistic séances who make the “communications.” Everything in our psyche has to begin with a personal character, and one must push one’s investigations very far before one comes across elements that are no longer personal. The “I” or “we” of these communications has a merely grammatical significance and is never proof of the existence of a spirit, but only of the physical presence of the medium or mediums. In dealing with “proofs of identity,” such as are offered in this book, one must remember that proofs of this kind would seem to be theoretically impossible considering the enormous number of possible sources of error. We know for a certainty that the unconscious is capable of subliminal perceptions and is a treasure house of lost memories. In addition, it has been proved by experiment that time and space are *relative* for the unconscious, so that unconscious perception, not being impeded by the space-time barrier, can obtain experiences to which the conscious mind has no access. In this connection I would refer to the experiments conducted at Duke University and other places.²

[748] Considering all this, the proof of identity seems to be a forlorn hope, in theory anyway. In practice, however, things are rather different because cases actually occur which are so overwhelmingly impressive that they are absolutely convincing to those concerned. Even though our critical arguments may cast doubt on every single case,

there is not a single argument that could prove that spirits do not exist. In this regard, therefore, we must rest content with a “non liquet.” Those who are convinced of the reality of spirits should know that this is a subjective opinion which can be attacked on any number of grounds. Those who are not convinced should beware of naïvely assuming that the whole question of spirits and ghosts has been settled and that all manifestations of this kind are meaningless swindles. This is not so at all. These phenomena exist in their own right, regardless of the way they are interpreted, and it is beyond all doubt that they are genuine manifestations of the unconscious. The communications of “spirits” are *statements about the unconscious psyche*, provided that they are really spontaneous and are not cooked up by the conscious mind. They have this in common with dreams; for dreams, too, are statements about the unconscious, which is why the psychotherapist uses them as a first-class source of information.

[749] *The Unobstructed Universe* may therefore be regarded as offering valuable information about the unconscious and its ways. It differs very favourably from the usual run of spiritualistic communications in that it eschews all edifying verbiage and concentrates instead on certain general ideas. This pleasing difference may be attributable to the happy circumstance that the real begetter of the book is the medium Betty, the deceased wife of the author. It is her “spirit” that pervades the book. We are familiar with her personality from Mr. White’s earlier books,³ and we know how great an educative influence she had on all those around her, constellating in their unconscious all the things that come to light in these communications.

[750] The educative intention behind Betty’s activity does not differ essentially from the general tenor of spiritualistic literature. The “spirits” strive to develop man’s consciousness and to unite it with the unconscious, and Betty, on her own admission, pursues the same aim. It is interesting to note that the beginnings of American spiritualism coincided with the growth of scientific materialism in the middle of the nineteenth century. Spiritualism in all its forms therefore has a *compensatory* significance. Nor should it be forgotten that a number of highly competent scientists, doctors, and philosophers have vouched for the truth of certain phenomena which demonstrate the very peculiar effect the psyche has upon matter. Among them were Friedrich Zöllner, William Crookes, Alfred Richet, Camille Flammarion, Giovanni Schiaparelli, Sir Oliver Lodge, and our Zurich psychiatrist Eugen Bleuler, not to mention a large number of less well-known names. Although I have not distinguished myself by any original researches in this field, I do not hesitate to declare that I have observed a sufficient number of such phenomena to be completely convinced of their reality. To me they are inexplicable, and I am therefore unable to decide in favour of any of the usual interpretations.

[751] Although I do not wish to prejudice the reader of this book, I cannot refrain from drawing attention to some of the issues it raises. What, above all, seems to me worth mentioning—especially in view of the fact that the author has no knowledge of modern psychology—is that the “Invisibles” favour an energetic conception of the psyche which has much in common with recent psychological findings. The analogy is to be found in the idea of “frequency.” But here we come upon a difference that should not be overlooked. For whereas the psychologist supposes that consciousness has a higher energy than the unconscious, the “Invisibles” attribute to the spirit of the departed, i.e., to a personified unconscious content) a higher “frequency” than to the living psyche. One should not, however, attach too much importance to the fact that the concept of energy is made use of in both cases, since this is a fundamental category of thought in all the modern sciences.

[752] The “Invisibles” further assert that our world of consciousness and the “Beyond” together form a single cosmos, with the result that the dead are not in a different place from the living. There is only a difference in their “frequencies,” which might be likened to the revolutions of a propeller: at low speeds the blades are visible, but at high speeds they disappear. In psychological terms this would mean that the conscious and the unconscious psyche are one, but are separated by different amounts of energy. Science can agree with this statement, although it cannot accept the claim that the unconscious possesses a higher energy since this is not borne out by experience.

[753] According to the “Invisibles,” the “Beyond” is this same cosmos but without the limitations imposed on mortal man by space and time. Hence it is called “the unobstructed universe.” Our world is contained in this higher order and owes its existence principally to the fact that the corporeal man has a low “frequency,” thanks to which the limiting factors of space and time become operative. The world without limitations is called “Orthos,” which means the “right” or “true” world. This tells us clearly enough what kind of significance is imputed to the “Beyond,” though it must be emphasized that this does not imply a devaluation of our world. I am reminded of the philosophical riddle which my Arab dragon-man asked me when visiting the tombs of the Khalifs in Cairo. “Which man is the cleverer: the one who builds his house where he will be for the longest time, or the one who builds it where he will be only temporarily?” Betty is in no doubt that this limited life should be lived as fully as possible, because the attainment of maximum consciousness while still in this world is an essential condition for the coming life in “Orthos.” She is thus in agreement not only with the general trend of spiritualistic philosophy, but also with Plato, who regarded philosophy as a preparation for death.

[754] Modern psychology can affirm that for many people this problem arises in the second half of life, when the unconscious often makes itself felt in a very insistent

way. The unconscious is the land of dreams, and according to the primitive view the land of dreams is also the land of the dead and of the ancestors. From all we know about it, the unconscious does in fact seem to be relatively independent of space and time, nor is there anything objectionable in the idea that consciousness is surrounded by the sea of the unconscious, just as this world is contained in "Orthos." The unconscious is of unknown extent and is possibly of greater importance than consciousness. At any rate, the role which consciousness plays in the life of primitives and primates is insignificant compared with that of the unconscious. The events in our modern world, as we see humanity blindly staggering from one catastrophe to the next, are not calculated to strengthen anyone's belief in the value of consciousness and the freedom of the will. Consciousness *should* of course be of supreme importance, for it is the only guarantee of freedom and alone makes it possible for us to avoid disaster. But this, it seems, must remain for the present a pious hope.

[755] Betty's aim is to extend consciousness as far as possible by uniting it with "Orthos." To this end it must be trained to listen to the unconscious psyche in order to bring about the collaboration of the "Invisibles." The aims of modern psychotherapy are similar: it too endeavours to compensate the onesidedness and narrowness of the conscious mind by deepening its knowledge of the unconscious.

[756] The similarity of aim should not, however, lead us to overlook a profound difference of viewpoint. The psychology of the "Betty Books" differs in no essential respect from the primitive view of the world, where the contents of the unconscious are all projected into external objects. What appears to the primitive to be a "spirit" may on a more conscious level be an abstract thought, just as the gods of antiquity turned into philosophical ideas at the beginning of our era. This primitive projection of psychological factors is common to both spiritualism and theosophy. The advantage of projection is obvious: the projected content is visibly "there" in the object and calls for no further reflection. But since the projection does bring the unconscious a bit nearer to consciousness, it is at least better than nothing. Mr. White's book certainly makes us think, but the kind of thinking it caters to is not psychological; it is mechanistic, and this is of little help when we are faced with the task of integrating projections. Mechanistic thinking is one of the many Americanisms that stamp the book as a typical product and leave one in no doubt as to its origin. But it is well worth while getting to know this side of the American psyche, for the world will hear a great deal more of it in times to come.

July 1948

FOREWORD TO MOSER: "SPUK: IRRGLAUBE ODER WAHRGLAUBE?"¹

[757] The author has asked me for a few introductory words to her book. It gives me all the more pleasure to comply with her request as her previous book on occultism,² written with great care and knowledge of the subject, is still fresh in my memory. I welcome the appearance of this new book, a copiously documented collection of parapsychological experiences, as a valuable contribution to psychological literature in general. Extraordinary and mysterious stories are not necessarily always lies and fantasies. Many "ingenious, curious, and edifying tales" were known to previous centuries, among them observations whose scientific validity has since been confirmed. The modern psychological description of man as a totality had its precursors in the numerous biographical accounts of unusual people such as somnambulists and the like at the beginning of the nineteenth century. Indeed, though we owe the discovery of the unconscious to these old pre-scientific observations, our investigation of parapsychological phenomena is still in its infancy. We do not yet know the full range of the territory under discussion. Hence a collection of observations and of reliable material performs a very valuable service. The collector must certainly have courage and an unshakable purpose if he is not to be intimidated by the difficulties, handicaps, and possibilities of error that beset such an undertaking, and the reader, too, must summon up sufficient interest and patience to allow this sometimes disconcerting material to work upon him objectively, regardless of his prejudices. In this vast and shadowy region, where everything seems possible and nothing believable, one must oneself have observed many strange happenings and in addition heard, read, and if possible tested many stories by examining their witnesses in order to form an even moderately sure judgment.

[758] In spite of such advances as the founding of the British and American Society for Psychical Research and the existence of a considerable and in part well-documented literature, a prejudice is still rampant even in the best informed circles, and reports of this kind meet with a mistrust which is only partially justified. It looks as though Kant will be proved right for a long time to come when he wrote nearly two hundred years ago: "Stories of this kind will have at any time only secret believers, while publicly they are rejected by the prevalent fashion of disbelief."³ He himself reserved judgment in the following words: "The same ignorance makes me so bold as to absolutely deny the truth of the various ghost stories, and yet with the common, although queer, reservation that while I doubt any one of them, still I have

a certain faith in the whole of them taken together.”⁴ One could wish that very many of our bigots would take note of this wise position adopted by a great thinker.

[759] I am afraid this will not come about so easily, for our rationalistic prejudice is grounded—*lucus a non lucendo*—not on reason but on something far deeper and more archaic, namely on a primitive instinct to which Goethe referred when he said in *Faust*: “Summon not the well-known throng ...” I once had a valuable opportunity to observe this instinct at work. It was while I was with a tribe on Mount Elgon, in East Africa, most of whom had never come into contact with the white man. Once, during a palaver, I incautiously uttered the word *selelteni*, which means “ghosts.” Suddenly a deathly silence fell on the assembly. The men glanced away, looked in all directions, and some of them made off. My Somali headman and the chief confabulated together, and then the headman whispered in my ear: “What did you say that for? Now you’ll have to break up the palaver.” This taught me that one must never mention ghosts on any account. The same primitive fear of ghosts is still deep in our bones, but it is unconscious. Rationalism and superstition are complementary. It is a psychological rule that the brighter the light, the blacker the shadow; in other words, the more rationalistic we are in our conscious minds, the more alive becomes the spectral world of the unconscious. And it is indeed obvious that rationality is in large measure an apotropaic defence against superstition, which is everpresent and unavoidable. The daemonic world of primitives is only a few generations away from us, and the things that have happened and still go on happening in the dictator states teach us how terrifyingly close it is. I must constantly remind myself that the last witch was burned in Europe in the year my grandfather was born.

[760] The widespread prejudice against the factual reports discussed in this book shows all the symptoms of the primitive fear of ghosts. Even educated people who should know better often advance the most nonsensical arguments, tie themselves in knots and deny the evidence of their own eyes. They will put their names to reports of séances and then—as has actually happened more than once—withdraw their signatures afterwards, because what they have witnessed and corroborated is nevertheless impossible—as though anyone knew exactly what is impossible and what is not!

[761] Ghost stories and spiritualistic phenomena practically never prove what they seem to. They offer no proof of the immortality of the soul, which for obvious reasons is incapable of proof. But they are of interest to the psychologist from several points of view. They provide information about things the layman knows nothing of, such as the exteriorization of unconscious processes, about their content, and about the possible sources of parapsychological phenomena. They are of particular importance in investigating the localization of the unconscious and the phenomenon of synchronicity, which points to a relativation of space and time and hence also of

matter. It is true that with the help of the statistical method existence of such effects can be proved, as Rhine and other investigators have done. But the individual nature of the more complex phenomena of this kind forbids the use of the statistical method, since this stands in a complementary relation to synchronicity and necessarily destroys the latter phenomenon, which the statistician is bound to discount as due to chance. We are thus entirely dependent on well observed and well authenticated individual cases. The psychologist can only bid a hearty welcome to any new crop of objective reports.

[762] The author has put together an impressive collection of factual material in this book. It differs from other collections of the kind by its careful and detailed documentation, and thus gives the reader a total impression of the situation which he often looks for in vain in other reports of this nature. Although ghosts exhibit certain universal features they nevertheless appear in individual forms and under conditions which are infinitely varied and of especial importance for the investigator. The present collection provides the most valuable information in just this respect.

[763] The question discussed here is a weighty one for the future. Science has only just begun to take a serious interest in the human psyche and, more particularly, in the unconscious. The wide realm of psychic phenomena also includes parapsychology, which is opening undreamt-of vistas before our eyes. It is high time humanity took cognizance of the nature of the psyche, for it is becoming more and more evident that the greatest danger which threatens man comes from his own psyche and hence from that part of the empirical world we know the least about. Psychology needs a tremendous widening of its horizon. The present book is a milestone on the long road to knowledge of the psychic nature of man.

April 1950

Jung's Contribution⁵

[764] In the summer of 1920 I went to London, at the invitation of Dr. X, to give some lectures. My colleague told me that, in expectation of my visit, he had found a suitable weekend place for the summer. This, he said, had not been so easy, because every thing had already been let for the summer holidays, or else was so exorbitantly expensive or unattractive that he had almost given up hope. But finally, by a lucky change, he had found a charming cottage that was just right for us, and at a ridiculously low price. In actual fact it turned out to be a most attractive old farmhouse in Buckinghamshire, as we saw when we went there at the end of our first week of work, on a Friday evening. Dr. X had engaged a girl from the neighbouring village to cook for us, and a friend of hers would come in the afternoons as a voluntary help. The house was roomy, two-storeyed, and built in the shape of a right

angle. One of these wings was quite sufficient for us. On the ground floor there was a conservatory leading into the garden; then a kitchen, dining-room, and drawing-room. On the top floor a corridor ran from the conservatory steps through the middle of the house to a large bedroom, which took up the whole front of the wing. This was my room. It had windows facing east and west, and a fireplace in the front wall (north). To the left of the door stood a bed, opposite the fireplace a big old-fashioned chest of drawers, and to the right a wardrobe and a table. This, together with a few chairs, was all the furniture. On either side of the corridor was a row of bedrooms, which were used by Dr. X and occasional guests.

[765] The first night, tired from the strenuous work of the week, I slept well. We spent the next day walking and talking. That evening, feeling rather tired, I went to bed at 11 o'clock, but did not get beyond the point of drowsing. I only fell into a kind of torpor, which was unpleasant because I felt I was unable to move. Also it seemed to me that the air had become stuffy, and that there was an indefinable, nasty smell in the room. I thought I had forgotten to open the windows. Finally, in spite of my torpor, I was driven to light a candle: both windows were open, and a night wind blew softly through the room, filling it with the flowery scents of high summer. There was no trace of the bad smell. I remained half awake in my peculiar condition, until I glimpsed the first pale light of dawn through the east window. At this moment the torpor dropped away from me like magic, and I fell into a deep sleep from which I awoke only towards nine o'clock.

[766] On Sunday evening I mentioned in passing to Dr. X that I had slept remarkably badly the night before. He recommended me to drink a bottle of beer, which I did. But when I went to bed the same thing happened: I could not get beyond the point of drowsing. Both windows were open. The air was fresh to begin with, but after about half an hour it seemed to turn bad; it became stale and fuggy, and finally somehow repulsive. It was hard to identify the smell, despite my efforts to establish its nature. The only thing that came into my head was that there was something sickly about it. I pursued this clue through all the memories of smells that a man can collect in eight years of work at a psychiatric clinic. Suddenly I hit on the memory of an old woman who was suffering from an open carcinoma. This was quite unmistakably the same sickly smell I had so often noticed in her room.

[767] As a psychologist, I wondered what might be the cause of this peculiar olfactory hallucination. But I was unable to discover any convincing connection between it and my present state of consciousness. I only felt very uncomfortable because my torpor seemed to paralyze me. In the end I could not think any more, and fell into a torpid doze. Suddenly I heard the noise of water dripping. "Didn't I turn off the tap properly?" I thought. "But of course, there's no running water in the room—so it's obviously raining—yet today was so fine." Meanwhile the dripping went on

regularly, one drop every two seconds. I imagined a little pool of water to the left of my bed, near the chest of drawers. "Then the roof must leak." I thought. Finally, with a heroic effort, so it seemed to me, I lit the candle and went over to the chest of drawers. There was no water on the floor, and no damp spot on the plaster ceiling. Only then did I look out of the window: it was a clear, starry night. The dripping still continued. I could make out a place on the floor, about eighteen inches from the chest of drawers, where the sound came from. I could have touched it with my hand. All at once the dripping stopped and did not come back. Towards three o'clock, at the first light of dawn. I fell into a deep sleep. No—I have heard death-watch beetles. The ticking noise they make is sharper. This was a duller sound, exactly what would be made by drops of water falling from the ceiling.

[768] I was annoyed with myself, and not exactly refreshed by this weekend. But I said nothing to Dr. X. The next weekend, after a busy and eventful week. I did not think at all about my previous experience. Yet hardly had I been in bed for half an hour than everything was there as before: the torpor, the repulsive smell, the dripping. And this time there was something else: something brushed along the walls, the furniture creaked now here and now there, there were rustlings in the corners. A strange restlessness was in the air. I thought it was the wind, lit the candle and went to shut the windows. But the night was still, there was no breath of wind. So long as the light was on, the air was fresh and no noise could be heard. But the moment I blew out the candle, the torpor slowly returned, the air became fuggy, and the creakings and rustlings began again. I thought I must have noises in my ear, but at three o'clock in the morning they stopped as promptly as before.

[769] The next evening I tried my luck again with a bottle of beer. I had always slept well in London and could not imagine what could give me insomnia in this quiet and peaceful spot. During the night the same phenomena were repeated, but in intensified form. The thought now occurred to me that they must be parapsychological. I knew that problems of which people are unconscious can give rise to exteriorization phenomena, because constellated unconscious contents often have a tendency to manifest themselves outwardly somehow or other. But I knew the problems of the present occupants of the house very well, and could discover nothing that would account for the exteriorizations. The next day I asked the others how they had slept. They all said they had slept wonderfully.

[770] The third night it was even worse. There were loud knocking noises, and I had the impression that an animal, about the size of a dog, was rushing round the room in a panic. As usual, the hubbub stopped abruptly with the first streak of light in the east.

[771] The phenomena grew still more intense during the following weekend. The rustling became a fearful racket, like the roaring of a storm. Sounds of knocking

came also from outside in the form of dull blows, as though somebody were banging on the brick walls with a muffled hammer. Several times I had to assure myself that there was no storm, and that nobody was banging on the walls from outside.

[772] The next weekend, the fourth, I cautiously suggested to my host that the house might be haunted, and that this would explain the surprisingly low rent. Naturally he laughed at me, although he was as much at a loss as I about my insomnia. It had also struck me how quickly the two girls cleared away after dinner every evening, and always left the house long before sundown. By eight o'clock there was no girl to be seen. I jokingly remarked to the girl who did the cooking that she must be afraid of us if she had herself fetched every evening by her friend and was then in such a hurry to get home. She laughed and said that she wasn't at all afraid of the gentlemen, but that nothing would induce her to stay a moment in this house alone, and certainly not after sunset. "What's the matter with it?" I asked. "Why, it's haunted, didn't you know? That's the reason why it was going so cheap. Nobody's ever stuck it here." It had been like that as long as she could remember. But I could get nothing out of her about the origin of the rumour. Her friend emphatically confirmed everything she had said.

[773] As I was a guest, I naturally couldn't make further inquiries in the village. My host was sceptical, but he was willing to give the house a thorough looking over. We found nothing remarkable until we came to the attic. There, between the two wings of the house, we discovered a dividing wall, and in it a comparatively new door, about half an inch thick, with a heavy lock and two huge bolts, that shut off our wing from the unoccupied part. The girls did not know of the existence of this door. It presented something of a puzzle because the two wings communicated with one another both on the ground floor and on the first floor. There were no rooms in the attic to be shut off, and no signs of use. The purpose of the door seemed inexplicable.

[774] The fifth weekend was so unbearable that I asked my host to give me another room. This is what had happened: it was a beautiful moonlight night, with no wind; in the room there were rustlings, creakings, and hangings; from outside, blows rained on the walls. I had the feeling there was something near me, and opened my eyes. There, beside me on the pillow, I saw the head of an old woman, and the right eye, wide open, glared at me. The left half of the face was missing below the eye. The sight of it was so sudden and unexpected that I leapt out of bed with one bound, lit the candle, and spent the rest of the night in an armchair. The next day I moved into the adjoining room, where I slept splendidly and was no longer disturbed during this or the following weekend.

[775] I told my host that I was convinced the house was haunted, but he dismissed this explanation with smiling scepticism. His attitude, understandable though it was, annoyed me somewhat, for I had to admit that my health had suffered under these

experiences. I felt unnaturally fatigued, as I had never felt before. I therefore challenged Dr. X to try sleeping in the haunted room himself. He agreed to this, and gave me his word that he would send me an honest report of his observations. He would go to the house alone and spend the weekend there so as to give me a “fair chance.”

[776] Next morning I left. Ten days later I had a letter from Dr. X. He had spent the weekend alone in the cottage. In the evening it was very quiet, and he thought it was not absolutely necessary to go up to the first floor. The ghost, after all, could manifest itself anywhere in the house, if there was one. So he set up his camp bed in the conservatory, and as the cottage really was rather lonely, he took a loaded shotgun to bed with him. Everything was deathly still. He did not feel altogether at ease, but nevertheless almost succeeded in falling asleep after a time. Suddenly it seemed to him that he heard footsteps in the corridor. He immediately struck a light and flung open the door, but there was nothing to be seen. He went back grumpily to bed, thinking I had been a fool. But it was not long before he again heard footsteps, and to his discomfiture he discovered that the door lacked a key. He rammed a chair against the door, with its back under the lock, and returned to bed. Soon afterwards he again heard footsteps, which stopped just in front of the door; the chair creaked, as though somebody was pushing against the door from the other side. He then set up his bed in the garden, and there he slept very well. The next night he again put his bed in the garden, but at one o'clock it started to rain, so he shoved the head of the bed under the eaves of the conservatory and covered the foot with a waterproof blanket. In this way he slept peacefully. But nothing in the world would induce him to sleep again in the conservatory. He had now given up the cottage.

[777] A little later I heard from Dr. X that the owner had had the cottage pulled down, since it was unsaleable and scared away all tenants. Unfortunately I no longer have the original report, but its contents are stamped indelibly on my mind. It gave me considerable satisfaction after my colleague had laughed so loudly at my fear of ghosts.

*

[778] I would like to make the following remarks by way of summing up. I can find no explanation of the dripping noise. I was fully awake and examined the floor carefully. I consider it out of the question that it was a delusion of the senses. As to the rustling and creaking, I think they were probably not objective noises, but noises in the ear which seemed to me to be occurring objectively in the room. In my peculiar hypnoid state they appeared exaggeratedly loud. I am not at all sure that the knocking noises, either, were objective. They could just as well have been heartbeats that seemed to me to come from outside. My torpor was associated with an inner excitation probably

corresponding to fear. Of this fear I was unconscious until the moment of the vision—only then did it break through into consciousness. The vision had the character of a hypnagogic hallucination and was probably a reconstruction of the memory of the old woman with carcinoma.

[779] Coming now to the olfactory hallucination, I had the impression that my presence in the room gradually activated something that was somehow connected with the walls. It seemed to me that the dog rushing round in a panic represented my intuition. Common speech links intuition with the nose: I had “smelt” something. If the olfactory organ in man were not so hopelessly degenerate, but as highly developed as a dog’s, I would have undoubtedly have had a clearer idea of the persons who had lived in the room earlier. Primitive medicine-men can not only smell out a thief, they also “smell” spirits and ghosts.

[780] The hypnoid catalepsy that each time was associated with these phenomena was the equivalent of intense concentration, the object of which was a subliminal and therefore “fascinating” olfactory perception. The two things together bear some resemblance to the physical and psychic state of a pointer that has picked up the scent. The source of the fascination, however, seems to me to have been of a peculiar nature, which is not sufficiently explained by any substance emitting a smell. The smell may have “embodied” a psychic situation of an excitatory nature and carried it across to the percipient. This is by no means impossible when we consider the extraordinary importance of the sense of smell in animals. It is also conceivable that intuition in man has taken the place of the world of smells that were lost to him with the degeneration of the olfactory organ. The effect of intuition on man is indeed very similar to the instant fascination which smells have for animals. I myself have had a number of experiences in which “psychic smells,” or olfactory hallucinations, turned out to be subliminal intuitions which I was able to verify afterwards.

[781] This hypothesis naturally does not pretend to explain all ghost phenomena, but at most a certain category of them. I have heard and read a great many ghost stories, and among them are a few that could very well be explained in this way. For instance, there are all those stories of ghosts haunting rooms where a murder was committed. In one case, bloodstains were still visible under the carpet. A dog would surely have smelt the blood and perhaps recognized it as human, and if he possessed a human imagination he would also have been able to reconstruct the essential features of the crime. Our unconscious, which possesses very much more subtle powers of perception and reconstruction than our conscious minds, could do the same thing and project a visionary picture of the psychic situation that excited it. For example, a relative once told me that, when stopping at a hotel on a journey abroad, he had a fearful nightmare of a woman being murdered in his room. The next morning he discovered that on the night before his arrival a woman had in fact been

murdered there. These remarks are only meant to show that parapsychology would do well to take account of the modern psychology of the unconscious.

FOREWORD TO JAFFÉ: “APPARITIONS AND PRECOGNITION”¹

[782] The author of this book has already made a name for herself by her valuable contributions to the literature of analytical psychology. Here she tells of strange tales which incur the odium of superstition and are therefore exchanged only in secret. They were lured into the light of day by a questionnaire sent out by the *Schweizerischer Beobachter*, which can thereby claim to have rendered no small service to the public. The mass of material that came in arrived first at my address. Since my age and my evergrowing preoccupation with other matters did not allow me to burden myself with further work, the task of sorting out such a collection and submitting it to psychological evaluation could not have been placed in worthier hands than those of the author. She had displayed so much psychological tact, understanding and insight in her approach to a related theme—an interpretation of E.T.A. Hoffmann’s story “The Golden Pot”²—that I never hesitated in my choice.

[783] Curiously enough, the problem of wonder tales as they are currently told—enlightenment or no enlightenment—has never been approached from the psychological side. I naturally don’t count mythology, although people are generally of the opinion that mythology is essentially history and no longer happens nowadays. As a psychic phenomenon of the present, it is considered merely a hunting-ground for economics. Nevertheless, ghost stories, warning visions, and other strange happenings are constantly being reported, and the number of people to whom something once “happened” is surprisingly large. Moreover, despite the disapproving silence of the “enlightened,” it has not remained hidden from the wider public that for some time now there has been a serious science which goes by the name of “parapsychology.” This fact may have helped to encourage the popular response to the questionnaire.

[784] One of the most notable things that came to light is the fact that among the Swiss, who are commonly regarded as stolid, unimaginative, rationalistic and materialistic, there are just as many ghost stories and suchlike as, say, in England or Ireland. Indeed, as I know from my own experience and that of other investigators, magic as practised in the Middle Ages and harking back to much remoter times has by no means died out, but still flourishes today as rampantly as it did centuries ago. One doesn’t speak of these things, however, They simply happen, and the intellectuals know nothing of them—for intellectuals know neither themselves nor people as they really are. In the world of the latter, without their being conscious of it, the life of the centuries lives on, and things are continually happening that have

accompanied human life from time immemorial: premonitions, foreknowledge, second sight, hauntings, ghosts, return of the dead, bewitchings, sorcery, magic spells, etc.

[785] Naturally enough our scientific age wants to know whether such things are “true,” without taking into account what the nature of any such proof would have to be and how it could be furnished. For this purpose the events in question must be looked at squarely and soberly, and it generally turns out that the most exciting stories vanish into thin air and what is left over is “not worth talking about.” Nobody thinks of asking the fundamental question: what is the real reason why the same old stories are experienced and repeated over and over again, without losing any of their prestige? On the contrary, they return with their youthful vitality constantly renewed, fresh as on the first day.

[786] The author has made it her task to take these tales for what they are, that is, as *psychic facts*, and not to pooh-pooh them because they do not fit into our scheme of things. She has therefore logically left aside the question of truth, as has long since been done in mythology, and instead has tried to inquire into the psychological questions: Exactly *who* is it that sees a ghost? Under what psychic conditions does he see it? What does a ghost signify when examined for its content, i.e., as a symbol?

[787] She understands the art of leaving the story just as it is, with all the trimmings that are so offensive to the rationalist. In this way the *twilight atmosphere* that is so essential to the story is preserved. An integral component of any nocturnal, numinous experience is the dimming of consciousness, the feeling that one is in the grip of something greater than oneself, the impossibility of exercising criticism, and the paralysis of the will. Under the impact of the experience reason evaporates and another power spontaneously takes control—a most singular feeling which one willy-nilly hoards up as a secret treasure no matter how much one’s reason may protest. That, indeed, is the uncomprehended purpose of the experience—to make us feel the overpowering presence of a mystery.

[788] The author has succeeded in preserving the total character of such experiences, despite the refractory nature of the reports, and in making it an object of investigation. Anyone who expects an answer to the question of parapsychological truth will be disappointed. The psychologist is little concerned here with what kind of facts can be established in the conventional sense; all that matters to him is whether a person will vouch for the authenticity of his experience regardless of all interpretations. The reports leave no doubt about this; moreover, in most cases their authenticity is confirmed by independent parallel stories. It cannot be doubted that such reports are found at all times and places. Hence there is no sufficient reason for doubting the veracity of individual reports. Doubt is justified only when it is a

question of a deliberate lie. The number of such cases is increasingly small, for the authors of such falsifications are too ignorant to be able to lie properly.

[789] The psychology of the unconscious has thrown so many beams of light into other dark corners that we would expect it to elucidate also the obscure world of wonder tales eternally young. From the copious material assembled in this book those conversant with depth psychology will surely gain new and significant insights which merit the greatest attention. I can recommend it to all those who know how to value things that break through the monotony of daily life with salutary effects, (sometimes!) shaking our certitudes and lending wings to the imagination.

August 1957

V

THE PSYCHOGENESIS OF MENTAL DISEASE

(related to Volume 3 of the Collected Works)

THE PRESENT STATUS OF APPLIED PSYCHOLOGY¹

In German Switzerland

[790] Though psychology is not taught in either Basel or Fribourg, a psychological institute has just been opened in Bern, under the direction of Professor Dürr. In the winter semester 1907 he has given a course on general psychology and another on paedagogics based on psychology, as well as an introduction to experimental psychology.

[791] As to Zurich: Professor Schumann is giving a course on Special Psychology and conducting a seminar for advanced students at the University laboratory for experimental psychology. — Privatdocent Wreschner² is lecturing this winter on physiology and psychology of the voice and language and conducting an introductory course (with demonstrations) on experimental psychology at the psychological laboratory. — At the psychological laboratory of the University's psychiatric clinic, established 1906, I am holding a seminar for advanced students. The programme includes normal and pathological psychology.

[792] As to associations concerned with psychology, there is nothing in Bern or Basel. (Fribourg need not be mentioned at all.)

[793] In Zurich the following have existed for some years:

1. An association for legal psychiatry, whose chairman I have been since early 1907.³

2. There also has existed for many years a psychological-neurological society where an occasional psychological lecture may be heard. The chairman is Professor von Monakow.⁴

3. In addition, in the autumn of 1907 a Society for Freudian Researches was founded (with ca. 20 members). The chairman is Professor Bleuler.⁵

C. G. JUNG (Burghölzli-Zurich)

ON DEMENTIA PRAECOX¹

[794] The depotentiation of the association process or *abaissement du niveau mental*, which consequently has a downright dreamlike quality, seems to indicate that a pathogenic agent [*Noxe*] contributes to dementia praecox which is absent in, say, hysteria. The characteristics of the *abaissement* were assigned to the pathogenic agent, which was construed as organically conditioned and likened to a symptom of poisoning (e.g., paranoid states in chronic poisoning).

REVIEW OF SADGER: "KONRAD FERDINAND MEYER. EINE PATHOGRAPHISCH-PSYCHOLOGISCHE STUDIE"¹

[795] The new art of writing biographies from the psychological point of view has already produced a number of moderately successful studies. One has only to think of Möbius² on Goethe, Schopenhauer, Schumann, and Nietzsche, and Lange on Hölderlin.³ Among these "pathographies," Sadger's book occupies an exceptional position. It does not stand out because of a meticulous unearthing of the diagnosis, nor does it try to squeeze the poet's pathology into a particular clinical frame of reference, as Möbius did in an objectionable manner in the case of Goethe. Sadger's aim is rather to understand the development of the whole personality as a psychological process, and to grasp it from within. It is no matter for regret that the psychiatric pigeon-holing of the "case" receives scant attention. Our understanding is in no way advanced when we know for certain the medical designation of the subject's state of mind. The recognition that Schumann suffered from dementia praecox and K. F. Meyer from periodic melancholia contributes nothing whatever to an understanding of their psyches. People are only too ready to stop at the diagnosis, thinking that any further understanding can be dispensed with. But this is just where the real task of the pathographer begins, if he wants, as he should, to understand more than the ordinary biographer. The biographer would rather not penetrate too deeply into certain areas, and because he does not understand what is going on there and can discover nothing understandable, he calls those areas mad or "pathological." Möbius sticks psychiatric labels on them and reports something of their geography. The proper task of the pathographer, however, is to describe in intelligible language what is actually happening in these locked regions of the psyche, and what powerful influences pass to and fro between the world of the understandable and the world of the not-understood. Up to now psychography has failed miserably, believing that its task is complete once insanity has been established; and there is some justification for this since not a few of the most prominent modern psychiatrists are firmly convinced that insanity is beyond further understanding. The validity of this statement is purely subjective, however: anything we do not understand we are likely to call insane. In view of this limitation, we should not venture so far, let alone assert that what we do not understand is not understandable at all. It is understandable, only we are intellectually still so dense and lethargic that our ears cannot hear and our minds cannot grasp the mysteries of which the insane speak. Here and there we do understand something, and occasionally we glimpse inner connections which link up

what appears to be wildly fortuitous and utterly incoherent into regular causal chains. We owe this insight to the genius of Sigmund Freud and his psychology, which is now undergoing all the punishments of hell that the scientific Philistines hold in reserve for every new discovery.⁴

[796] Anyone who wishes to read Sadger's book with real understanding should first familiarize himself with Freud's psychology, otherwise he will get a curious impression of the special prominence the author gives to the significance of the mother in the life of the poet. Lacking the requisite knowledge the reader will also find it difficult to understand many of the parenthetical remarks concerning the father-son and mother-son relationship and to appreciate their general validity. It will be evident from these hints that Sadger's book can claim a special place among the pathographies because, unlike the others, it digs down far deeper to the very roots of the pathological and annexes wide areas of that dark world of the non-understood to the world of intelligible things. Anyone who has been able to profit by Freud's writings will read with great interest how the sensitive soul of the poet gradually freed itself from the crushing weight of mother-love and its attendant emotional conflicts, and how as a result the hidden source of poetic creativity began to flow. We owe the author a debt of gratitude for this glimpse into the life of an artist whose development presents so many baffling problems. Readers who bring no preliminary knowledge with them may be prompted by this book to acquire some.

REVIEW OF WALDSTEIN: "DAS UNBEWUSSTE ICH"¹

[797] For a variety of reasons it is welcome news that Waldstein's book *The Subconscious Self* has been rescued from oblivion and made accessible to a wider public in an excellent translation. The content of the book is equally good and, in places, very important. In his preface to the German edition, Dr. Veraguth² (Zurich) remarks that the book, first published more than a decade ago, is to be valued primarily as an historical document. This, unfortunately, is only too true, for nowhere does the present end sooner and the past begin earlier than in medical literature. The English edition was published at a time when another turn of the ascending spiral of scientific knowledge had just been completed in Germany. The scientists had once again reached the point that had been reached eighty years earlier. Those were the days of that remarkable man Franz Anton Mesmer,³ perhaps the first in the German-speaking world to observe that, armed with the necessary self-assurance, practically anyone could imitate the miraculous cures wrought at places of pilgrimage, by priests, French kings, and thaumaturges in sheep's clothing (witness Ast the Shepherd, who relieved his milieu of several million marks). This art was named "Mesmerism." It was not a swindle, and much good was accomplished by it. Mesmer offered his art to science, and even founded a school, but he took too little account of the fact that ever since science has existed there has also existed an undying élite enthroned at the top, that knows everything far better than anybody else, and from time to time guards mankind against various pernicious aberrations. It protected us from the erroneous belief that Jupiter had moons, that such things as meteors could fall from the air, that puerperal fever was caused by dirty hands, and that the brain possessed a fibrous structure. For eighty years the élite protected psychology from the discovery of hypnotism by pooh-poohing Mesmer's "animal magnetism." Nevertheless a few German crackpots and obscurantists of the Romantic Age kept Mesmer's teachings alive, quietly collecting observations and experiences that were ridiculed by their contemporaries and successors because they smacked of superstition. Notwithstanding the persistent mocking laughter, the numerous books from the pen of Justinus Kerner, Eschenmayer, Ennemoser, Horst, etc.,⁴ to name but a few who reported "curious tales of somnambulists," contain, along with obvious nonsense, glaring truths which were put to sleep for the next sixty years. The French country doctor Liébeault,⁵ who made a timid attempt in the sixties to publish a little book on this subject, was stuck with his whole edition unsold at the publisher's for twenty years. Thirty years later there existed a literature of hundreds of books and a

number of technical periodicals. The spiral had once again entered this domain. All of a sudden it was discovered that an enormous amount could be done, both in theory and practice, with the earlier “Mesmerism”; that apparently dangerous symptoms of nervous ailments, such as paresis, contractures, paraesthesias, etc., could be produced at will by suggestion and then blown away again—in short, that the whole army of the neuroses, accounting for at least eighty per cent of the neurologist’s clientele, were disturbances of a psychic nature. (A realization that is so modern today that its rediscoverers are hailed as incalculably great benefactors of mankind.)

[798] In its unfathomable wisdom the élite instantly recognized that mankind was in dire peril, and declared (1) that suggestion therapy was fraudulent and ineffective; (2) that it was exceedingly dangerous; (3) that the insights gained by hypnotic methods were sheer fabrication, imagination, and suggestion; and (4) that the neuroses were organic diseases of the brain. It had, however, also been rediscovered that our consciousness obviously does not cover the full range of the psyche, that the psychic factor exists and is effective in regions beyond the reach of consciousness. This psychic factor beyond consciousness was named the subconscious or the second ego or the unconscious personality, etc. In Germany the heretics were Dessoir, Forel, Moll, Vogt, and Schrenck-Notzing,⁶ among others, and in France, Binet, Janet, and their schools. Waldstein’s book on the “subconscious” ego came out just when the movement in Germany had reached its climax. All honest researchers greeted this resurgence with enthusiasm, but the élite rightly regarded it as deleterious to the development of logical thought. The leading authorities therefore asserted that the subconscious was (1) nonexistent; (2) not psychic but physiological, and hence impenetrable; (3) only feebly conscious, so feeble, in fact, that one is no longer conscious of being conscious of it. Since then the investigators of the “unconscious” have been branded as unscientific; the “unconscious” has no existence at all and is merely a feeble flicker of consciousness. Or else it is physiological, which is the opposite of psychological, and therefore not the concern of the psychologist or of anybody else. In this way it is barricaded against investigation.

[799] But this time, in spite of everything, the seed did not die. Work went ahead steadily, and today we are much further advanced than we were a decade ago. Even so, this advance holds only for the few who have not allowed themselves to become embittered, and who are working indefatigably to open up the abysses of the human psyche to consciousness. For these few, Waldstein’s book is, to be sure, no novelty and will add little to their knowledge, but for all others it contains much that is new and much that is good. It has shrewd things to say about aesthetics and the origin of works of art. Still better is its psychological conception of the neuroses, a conception which one hopes will be widely disseminated, seeing that the élite still clings firmly to the notion that hysteria and nervous disorders originate in alterations within the

brain. Unfortunately many run-of-the-mill doctors still swear by this gospel to the detriment of their neurotic patients, whom our age produces in swarms. Nearly all these patients have been convinced by the medical dogma that their sickness is of a physical nature. Again and again the doctors back up this nonsense, and the treatment goes muddling on with its medicaments and magic nostrums. It is hardly surprising that nowadays Christian Science has better results to show than many neurologists. This little book performs a valuable service by at least throwing a ray of light on those dark regions of the psyche from which all human achievements ultimately spring, whether they be artistic creations or nervous disorders. It is to be hoped that books of this kind will find favour with the educated public, so as gradually to prepare the ground for a deeper understanding of the human psyche, and to free the minds of the sound and sick alike from the crass materialism of the cerebro-organic dogma. The sensitive psychological note which Waldstein strikes gives his book a particularly attractive character, even though his analysis does not probe nearly as deeply as Freud's researches.

CRIME AND THE SOUL¹

[800] The dual personality of the criminal is frequently apparent at first glance. One need not follow the tortuous path of his psychological experiences, disguises, and eventual unmasking as the story of his dual existence is dramatically told in the film. Generally speaking, every criminal, in his outward show of acting honourably, wears a quite simple disguise which is easily recognizable. Of course, this does not apply to the lowest dregs of the criminal fraternity—to the men and women who have become outcasts from all ordinary human society. Generally, however, criminals, men and women alike, betray a certain ambition to be respectable, and repeatedly emphasize their respectability. The “romance” of a criminal existence is only rarely romantic. A very large number of criminals lead a thoroughly middle-class existence and commit their crimes, as it were, through their second selves. Few criminals succeed in attaining a complete severance between their liking for middle-class respectability, on the one hand, and their instinct for crime on the other.

[801] It is a terrible fact that crime seems to creep up on the criminal as something foreign that gradually gains a hold on him so that eventually he has no knowledge from one moment to another of what he is about to do. Let me illustrate this with a striking example from my own experience.

[802] A nine-year-old boy stabbed his little sister above the eye with a pair of scissors, which penetrated as far as the cerebral membrane. Had it gone half a millimetre deeper the child would have died instantly. Two years earlier, when the boy was seven, his mother told me that there was something wrong with him. The boy was doing some peculiar things. At school, during lessons, he would suddenly rise from his seat and cling to his teacher with every sign of extreme terror. At home he would often run away from play and hide in the loft. When asked to explain the reason he made no reply. When I spoke to the boy he told me that he had frequent attacks of cramp. Then the following conversation took place:

[803] “Why are you always afraid?”

[804] The child did not reply. I realized that he was reluctant to speak, so I tried persuasion. Finally he said:

[805] “I must not tell you.”

[806] “Why not?”

[807] “I pressed him further, but all I was able to get out of him was that he must not say why he was afraid. At last he blurted it out.

[808] “I am afraid of the man,” he said.

[809] “What man?”

[810] No reply. Then, after much wheedling, I succeeded in winning his confidence. He told me that at the age of seven a little man appeared to him. The little man had a beard. The boy also gave other details of the little man’s appearance. This little man had winked at him, and that had frightened him. That was why he clung to his teacher at school and ran away from play at home to hide in the loft.

[811] “What did this little man want of you?” I asked.

[812] “He wanted to put the blame on me.”

[813] “What do you mean by ‘blame’?”

[814] The boy could not answer. He merely repeated the word “blame.” He said that each time the little man came nearer and nearer to him, and last time he had come quite close, and that was why he, the boy, stabbed his sister. The appearance of the little man was none other than the personification of the criminal instinct, and what the boy described as “blame” was a symbol of the second self that was driving him to destruction.

[815] After the crime the boy had epileptic fits. Since then he has committed no further crimes. In this case as in many others, epilepsy represented an evasion of the crime, a repression of the criminal instinct. Unconsciously people try to escape the inner urge to crime by taking refuge in illness.

[816] In other cases it happens that people who are apparently normal transmit the evil instincts concealed under this appearance of normality to other people, and frequently lead them, quite unconsciously, to carry out the deeds which they themselves would never commit although they would like to.

[817] Here is an example: Some time ago there was a murder in the Rhineland which created a great sensation. A man of up-to-then blameless character killed his entire family, and even his dog. No one knew the reason; no one had ever noticed anything abnormal about the man. This man told me that he had bought a knife without having any particular object in mind. One night he fell asleep in the living-room, where there was a clock with a pendulum. He heard the ticking of the clock, and this tick-tock was like the sound of a battalion of marching soldiers. The sound of marching gradually died away, as though the battalion had passed. When it ceased completely he suddenly felt, “Now I must do it.” Then he committed the murders. He stabbed his wife eleven times.

[818] According to my subsequent investigations it was the woman who was chiefly to blame for what happened. She belonged to a religious sect, whose members regarded all who do not pray with them as outsiders, children of the devil, and themselves as saints. This woman transmitted the evil that was in her, unconsciously perhaps, but

quite certainly, to her husband. She persuaded him that he was evil, whereas she herself was good, and instilled the criminal instinct into his subconscious mind. It was characteristic that the husband recited a saying from the Bible at each stab, which best indicates the origin of his hostility.

[819] Far more crime, cruelty, and horror occur in the human soul than in the external world. The soul of the criminal, as manifested in his deeds, often affords an insight into the deepest psychological processes of humanity in general. Sometimes it is quite remarkable what a background such murders have, and how people are driven to perpetrate acts which at any other time and of their own accord they would never commit.

[820] Once a baker went for his Sunday walk. The next thing he knew was that on waking up he found himself in a police cell, with his hands and feet manacled. He was amazed. He thought he was dreaming. He had no idea why he was locked up. But in the meantime the man had murdered three people and seriously injured two. Undoubtedly he committed these crimes in a cataleptic state. The baker's Sunday walk turned out quite differently from what he had intended on leaving home. The wife of this baker was a member of the same sect as the other woman, and therefore a "saint," so that the motive of this crime is analogous to that described above.

[821] The more evil a person is, the more he tries to force upon others the wickedness he does not want to show to the outside world. The baker and the Rhinelanders were respectable men. Before they committed their crimes they would have been amazed had anyone thought them capable of such things. They certainly never intended to commit murder. This idea was unconsciously instilled into them as a means of abreacting the evil instincts of their wives. Man is a very complicated being, and though he knows a great deal about all sorts of things, he knows very little about himself.

THE QUESTION OF MEDICAL INTERVENTION¹

The medical journal *Psyche* published answers² to a questionnaire sent to twenty-eight doctors concerning a report by Dr. Medard Boss, delivered at the 66th Congress of South-west German Psychiatrists and Neurologists in Badenweiler, in which he presented the case of a transvestite “under its existential-analytical aspect.” The treatment ended with the total castration of the patient by Dr. Boss, including amputation of the penis with implantation of artificial labiae. The report provoked critical comments from some of his colleagues³ followed by a rejoinder from Dr. Boss.⁴ In view of the significance of the case for the doctor-patient relationship, the editors of *Psyche* circulated the following questionnaire to the colleagues whom Dr. Boss had named:

1. Do you consider an intervention like that performed by Dr. Boss permissible from the general medical standpoint or not?

2. Do you consider such an intervention permissible from the standpoint of the psychotherapist?

[822] I had first of all to plough my way through the report of this case. The totally superfluous existentialist jargon complicates the situation unnecessarily and does not make for enjoyable reading. The patient was obviously bent upon getting himself transformed into a woman as far as possible and equally set against any other kind of influence. It is quite clear that nothing could be done about it psychotherapeutically. That settles Question 2. An operation like this has nothing to do with psychotherapy, because anyone, the patient included, could have advised himself to ask a surgeon to castrate him. If Dr. Boss gave him this advice, that is his own private affair, and something that one does not make a song and dance about in public.

[823] Question 1 is not so easy to answer. On the principle *nulla poena sine lege* an intervention of this kind is “justified” if the law either permits it or does not forbid it. There is no law against cosmetic operations, and if I succeed in persuading a surgeon to amputate a finger for me that is his and my private affair, a problem of individual ethics. If anyone who is *compos mentis* wishes to be castrated and feels happier for it afterwards than he did before, there is not much in his action that one can fairly object to. If the doctor is convinced that such an operation really does help his patient, and nobody is injured by it, his ethical disposition to help and ameliorate might very well prompt him to perform the operation without anyone being in a position to object to it on principle. Only, he should realize that he is offending the collective professional ethics of doctors in a hazardous way by his somewhat unusual

and unconventional procedure. Moreover, the operation affects an organ that is the object of a collective taboo; that is to say, castration is a *numinous mutilation* which makes a powerful impression on everyone and is consequently hedged about with all sorts of emotional considerations. A doctor who risks this intervention should not be surprised if there is a collective reaction against it. He may be justified before his own conscience, but he risks his reputation by violating collective feeling. (The hangman is in much the same situation.) Insults of this nature are not in the interests of the medical profession and are therefore, quite rightly, abhorred.

[824] Dr. Boss would have done better to preserve a decent silence about this painful affair instead of proclaiming it *urbi et orbi* with “existential-analytical” *éclat*, however concerned he was to justify himself in the eyes of his profession. Evidently he has only the dimmest notion of how much his action offends professional medical feeling.

[825] So I can answer Question I by saying that, for the above reasons, I consider the intervention, from the medical standpoint, hazardous if not impermissible. From the individual standpoint I would prefer to give Dr. Boss the benefit of the doubt.

FOREWORD TO CUSTANCE: "WISDOM, MADNESS AND FOLLY"¹

[826] When I was working in 1906 on my book *The Psychology of Dementia Praecox*² (as schizophrenia was then called), I never dreamt that in the succeeding half-century psychological investigation of the psychoses and their contents would make virtually no progress whatever. The dogma, or intellectual superstition, that only physical causes are valid still bars the psychiatrist's way to the psyche of his patient and impels him to take the most reckless and incalculable liberties with this most delicate of all organs rather than allow himself even to think about the possibility of genuinely psychic causes and effects, although these are perfectly obvious to an unprejudiced mind. All that is necessary is to pay attention to them, but this is just what the materialistic prejudice prevents people from doing, even when they have seen through the futility of metaphysical assumptions. The organic, despite the fact that its nature is largely unknown and purely hypothetical, seems much more convincing than psychic reality, since this still does not exist in its own right and is regarded as a miserable vapour exhaled, as it were, from the albuminous scheme of things. How in the world do people know that the only reality is the physical atom, when this cannot even be proved to exist at all except by means of the psyche? If there is anything that can be described as primary, it must surely be the psyche and not the atom, which, like everything else in our experience, is presented to us directly only as a psychic model or image.

[827] I still remember vividly the great impression it made upon me when I succeeded for the first time in deciphering the apparently complete nonsense of schizophrenic neologisms, which must have been infinitely easier than deciphering hieroglyphs or cuneiform inscriptions. While these give us authentic insight into the intellectual culture of ancient man—an achievement certainly not to be underestimated—deciphering of the products of insanity and of other manifestations of the unconscious unlocks the meaning of far older and more fundamental psychic processes, and opens the way to a psychic underworld or hinterland which is the matrix not only of the mental products of the past but of consciousness itself. This, however, seems quite uninteresting to the psychiatrist and to concern him least of all—just as if it were tremendously important to know exactly where the stones were quarried to build our medieval cathedrals, but of no importance whatever to know what the meaning and purpose of these edifices might be.

[828] Half a century has not sufficed to give the psychiatrist, the "doctor of the soul," the smallest acquaintance with the structure and contents of the psyche. Nobody need

write an apology for the meaning of the brain since it can actually be put under the microscope. The psyche, however, is nothing, because it is not sufficiently physical to be stained and mounted on a slide. People still go on despising what they don't know, and what they know least of all they claim to know best. The very attempt to bring some kind of order into the chaos of psychological experience is considered "unscientific," because the criteria of physical reality cannot be applied directly to psychic reality. Documentary evidence, though fully recognized in the study of history and in jurisprudence, still seems to be unknown in the realm of psychiatry.

[829] For this reason a book like the present one should be particularly welcome to psychologists. It is a *document humain*, unfortunately one of few. I know no more than half a dozen such autochthonous descriptions of psychosis, and of these this is the only one derived from the domain of manic-depressive insanity, all the others being derived from that of schizophrenia. In my experience at any rate it is quite unique. Certainly there are, in numerous clinical histories, comparable descriptions given by the patients themselves, but they never reach the light of day in the form of a printed publication; and besides, few of them could equal the autobiography of our author in point of articulateness, general education, wide reading, deep thought, and self-criticism. The value of this book is all the greater because, uninfluenced by any outside literature, it describes the discovery, or rather the rediscovery, of certain fundamental and typical psychic structures. Although I myself have been studying the very same phenomena for years, and have repeatedly described them, it still came to me as a surprise and a novelty to see how the delirious flight of ideas and uninhibitedness of the manic state lower the threshold of consciousness to such an extent that, as with the *abaissement du niveau mental* in schizophrenia, the unconscious is laid bare and rendered intelligible. What the author has discovered in the manic state is in exact agreement with my own discoveries. By this I mean more particularly the structure of opposites and their symbolism, the anima archetype, and lastly the unavoidable encounter with the reality of the psyche. As is generally known, these three main points play an essential role in my psychology, with which, however, the author did not become acquainted until afterwards.

[830] It is of particular interest, more especially for the expert in this field, to see what kind of total picture emerges when the inhibitions exerted by the conscious mind on the unconscious are removed in mania. The result is a crude and unmitigated system of opposites, of every conceivable colour and form, extending from the heights to the depths. The symbolism is predominantly collective and archetypal in character, and thus decidedly mythological or religious. Clear indications of an individuation process are absent, since the dialectical drama unfolds in the spontaneous, inner confrontation of opposites before the eyes of a perceiving and reflecting subject. He does not stand in any dialectical relationship to a human partner; in other words,

there is no dialogue. The values delineate themselves in an undifferentiated system of black and white, and the problem of the differentiated functions is not posed. Hence the absence of any clear signs of individuation; as is well known, the prerequisite for this is an intense relationship with another individual and a coming to terms with him. The question of relationship, or Eros, nowhere appears as a problem in this book. Instead, psychic reality, which the author very rightly calls “actuality,” receives all the more attention, and the value of this cannot be denied.

[831] As might be expected from the impressive contents of his psychosis, the author was profoundly affected by them. This runs like a leit-motiv through his book from the beginning to the end, making it a confessional monologue addressed to an anonymous circle of listeners, as well as an encounter with the equally anonymous spirit of the age. Its intellectual horizon is wide and does honour to the “logos” of its author. I do not know what sort of impression it will make on the “normal” layman, who has never had anything thrust upon him from the other side of the barrier. I can only say that psychiatrists and practising psychologists owe the author the greatest possible thanks for the illumination his unaided efforts have given them. As a contribution to our knowledge of those highly significant psychic contents that manifest themselves in pathological conditions or underlie them, his book is as valuable as it is unique.

FOREWORD TO PERRY: "THE SELF IN PSYCHOTIC PROCESS"¹

[832] As I studied Dr. Perry's manuscript, I could not help recalling the time when I was a young alienist searching vainly for a point of view which would enable me to understand the workings of the diseased mind. Merely clinical observations—and the subsequent post mortem when one used to stare at a brain which ought to have been out of order yet showed no sign of abnormality—were not particularly enlightening. "Mental diseases are diseases of the brain" was the *axiom*, and told one just nothing at all. Within my first months at the Clinic,² I realized that the thing I lacked was a *real psychopathology*, a science which showed what was happening in the mind during a psychosis. I could never be satisfied with the idea that all that the patients produced, especially the schizophrenics, was nonsense and chaotic gibberish. On the contrary, I soon convinced myself that their productions meant something which could be understood, if only one were able to find out what it was. In 1901, I started my association experiments with normal test persons in order to create a normal basis for comparison. I found then that the experiments were almost regularly disturbed by psychic factors beyond the control of consciousness. I called them *complexes*. No sooner had I established this fact than I applied my discovery to cases of hysteria and schizophrenia. In both I found an inordinate amount of disturbance, which meant that the unconscious in these conditions is not only opposed to consciousness but also has an extraordinary energetic charge. While with neurotics the complexes consist of split-off contents, which are systematically arranged, and for this reason are easily understandable, with schizophrenics the unconscious proves to be not only unmanageable and autonomous, but highly unsystematic, disordered, and even chaotic. Moreover, it has a peculiar dreamlike quality, with associations and bizarre ideas such as are found in dreams. In my attempts to understand the contents of schizophrenic psychoses, I was considerably helped by Freud's book on dream interpretation, which had just appeared (1900). By 1905, I had acquired so much reliable knowledge about the psychology of schizophrenia (then called "dementia praecox") that I was able to write two papers³ about it. *The Psychology of Dementia Praecox* (1906) had practically no influence at all, since nobody was interested in pathological psychology except Freud, with whom I had the honour of collaborating for the next seven years.

[833] Dr. Perry, in this book, gives an excellent picture of the psychic contents with which I found myself confronted. At the beginning, I felt completely at a loss in understanding the association of ideas which I could observe daily with my patients. I

did not know then that all the time I had the key to the mystery in my pocket, inasmuch as I could not help seeing the often striking parallelism between the patients' delusions and mythological motifs. But for a long time I did not dare to assume any relationship between mythological formations and individual morbid delusions. Moreover, my knowledge of folklore, mythology, and primitive psychology was regrettably deficient, so that I was slow in discovering how common these parallels were. Our clinical approach to the human mind was only medical, which was about as helpful as the approach of the mineralogist to Chartres Cathedral. Our training as alienists was much concerned with the anatomy of the brain but not at all with the human psyche. One could not expect very much more in those days, when even neuroses, with their overflow of psychological material, were a psychological *terra incognita*. The main art the students of psychiatry had to learn in those days was how not to listen to their patients.

[834] Well, I had begun to listen, and so had Freud. He was impressed with certain facts of neurotic psychology, which he even named after a famous mythological model, but I was overwhelmed with "historical" material while studying the psychotic mind. From 1906 until 1912 I acquired as much knowledge of mythology, primitive psychology, and comparative religion as possible. This study gave me the key to an understanding of the deeper layers of the psyche and I was thus enabled to write my book⁴ with the English title *Psychology of the Unconscious*. This title is slightly misleading, for the book represents the analysis of a prodromal schizophrenic condition. It appeared forty years ago, and last year I published a fourth, revised edition under the title *Symbols of Transformation*. One could not say that it had any noticeable influence on psychiatry. The alienist's lack of psychological interest is by no means peculiar to him. He shares it with a number of other schools of thought, such as theology, philosophy, political economy, history, and medicine, which all stand in need of psychological understanding and yet allow themselves to be prejudiced against it and remain ignorant of it. It is only within the last years, for instance, that medicine has recognized "psychosomatics."

[835] Psychiatry has entirely neglected the study of the psychotic mind, in spite of the fact that an investigation of this kind is important not only from a scientific and theoretical standpoint but also from that of practical therapy.

[836] Therefore I welcome Dr. Perry's book as a messenger of a time when the psyche of the mental patient will receive the interest it deserves. The author gives a fair representation of an average case of schizophrenia, with its peculiar mental structure, and, at the same time, he shows the reader what he should know about general human psychology if he wishes to understand the apparently chaotic distortions and the grotesque "bizarrerie" of the diseased mind. An adequate understanding often has a remarkable therapeutic effect in milder cases which, of course, do not appear in

mental hospitals, but all the more in the consultation hours of the private specialist. One should not underrate the disastrous shock which patients undergo when they find themselves assailed by the intrusion of strange contents which they are unable to integrate. The mere fact that they have such ideas isolates them from their fellow men and exposes them to an irresistible panic, which often marks the outbreak of the manifest psychosis. If, on the other hand, they meet with adequate understanding from their physician, they do not fall into a panic, because they are still understood by a human being and thus preserved from the disastrous shock of complete isolation.

[837] The strange contents which invade consciousness are rarely met with in neurotic cases, least not directly, which is the reason why so many psychotherapists are unfamiliar with the deeper strata of the human psyche. The alienist, on the other hand, rarely has the time or the necessary scientific equipment to deal with, or even to bother with, his patients' psychology. In this respect, the author's book fills a yawning gap. The reader should not be misled by the current prejudice that I produce nothing but theories. My so-called theories are not figments but facts that can be verified, if one only takes the trouble, as the author has done with so much success, to listen to the patient, to give him the credit—that is humanly so important—of meaning something by what he says, and to encourage him to express himself as much as he possibly can. As the author has shown, drawing, painting and other methods are sometimes of inestimable value, inasmuch as they complement and amplify verbal expression. It is of paramount importance that the investigator should be sufficiently acquainted with the history and phenomenology of the mind. Without such knowledge, he could not understand the symbolic language of the unconscious and so would be unable to help his patient assimilate the irrational ideas that bewilder and confuse his consciousness. It is not a "peculiar historical interest," a sort of hobby of mine to collect historical curiosities, as has been suggested, but an earnest endeavour to help the understanding of the diseased mind. *The psyche, like the body, is an extremely historical structure.*

[838] I hope that Dr. Perry's book will arouse the psychiatrist's interest in the psychological aspect of his cases. Psychology belongs as much to his training as anatomy and physiology to that of the surgeon.

FOREWORD TO SCHMALTZ: "KOMPLEXE PSYCHOLOGIE UND KÖRPERLICHES SYMPTOM"¹

[839] Having read his book with lively interest and undivided agreement, I am all the more ready to comply with the author's request that I say a few words by way of introduction. He has successfully undertaken to treat a case from the field of psychosomatic medicine psychologically, in collaboration with an internal specialist, and to describe the whole course of the treatment up to the cure in all its details. The clinical description of the case is impeccable and thorough, and it seems to me that its psychological elucidation and interpretation is equally satisfactory. Nowhere does the author betray any theoretical bias; all his conclusions are amply documented with noteworthy care and circumspection. The clinical history concerns one of those frequent cases of cardiac disorder, a disease that is associated with the lesion of feeling so characteristic of our time. The author deserves particular credit for fearlessly pointing out the deeper reasons for a neurosis and for setting it in a broader context. A neurosis is an expression of the "affections" of the whole man, and it is impossible to treat the whole man solely within the framework of a medical specialism. Psychogenic causes have to do with the psyche, and this, by its very nature, not only extends beyond the medical horizon but also, as the matrix of all psychic events, transcends the bounds of scientific understanding. Certainly the aetiological details have to be worked out within the limits of a specialist method, but the psychology and therapy of the neurosis demand an Archimedean point outside, without which they merely turn in a circle. Indeed, medicine itself is a science that has been able to make such great progress only because it borrowed lavishly from the other sciences. It necessarily had to draw physics, chemistry, and biology into its orbit, and if this was true of somatic medicine, then the psychology of the neuroses will not be able to get along without borrowing from the humanities.

[840] Of decisive importance for the aetiology and therapy of the neuroses is the individual's own attitude. If this is subjected to careful analysis, one finds that it rests on personal and collective premises which can be pathogenic as well as curative in their effects. Just as modern medicine is no longer content to establish that a patient has infected himself with typhoid fever, but must also worry about the water supply responsible for the infection, so the psychology of the neuroses cannot possibly be content with an aetiology that makes do with traumata and infantile fantasies. We have known for a long time that children's neuroses depend on the psychic situation of the parents. We also know to our cost how much these "psychic situations" are due

not merely to personal defects but to collective psychic conditions. That would be reason enough for the specialist to take heed of these general conditions—one cannot combat an epidemic of typhoid even with the most careful diagnosis and treatment of individual cases. The older medicine had to be satisfied with handing out any philtre provided only that it helped. Thanks to the auxiliary sciences, modern medicine is in a position to find out the true nature of its nostrums. But what cures a neurosis? In order to find the real answer to this question, the psychology of the neuroses must go far beyond its purely medical confines. There are a few doctors who already have inklings of this. In this respect, too, the author has dared to fling open one or two windows.

VI

FREUD AND PSYCHOANALYSIS

(related to Volume 4 of the Collected Works)

SIGMUND FREUD: "ON DREAMS"¹

25 January 1901

[841] Freud begins by giving a short exposition of his work. He first distinguishes the various interpretations which the problem of dreams has undergone in the course of history:

1. The old "mythological" or, rather, mystical hypothesis that dreams are meaningful utterances of a soul freed from the fetters of sense. The soul is conceived as a transcendent entity which either produces dreams independently, as [Gotthilf Heinrich von] Schubert still supposed, or else represents the medium of communication between the conscious mind and divine revelation.

2. The more recent hypothesis of [K. A.] Schemer and [J.] Volkelt, according to which dreams owe their existence to the operation of psychic forces that are held in check during the day.

3. The critical modern view that dreams can be traced back to peripheral stimuli which partially affect the cerebral cortex and thereby induce dream-activity.

4. The common opinion that dreams have a deeper meaning, and may even foretell the future. Freud, with reservations, inclines to this view. He does not deny the dream a deeper meaning and admits the rightness of the common method of dream interpretation, in so far as it takes the dream-image as a symbol for a hidden content that has a meaning.

[842] In his opening observations Freud compares dreams with obsessional ideas, which, like them, are strange and inexplicable to the conscious mind.

[843] The psychotherapy of obsessional ideas offers the key to unravelling the ideas in dreams. Just as we get a patient who suffers from an obsession to take note of all the ideas that associate themselves with the dominating idea, we can make upon ourselves the experiment of observing everything that becomes associated with the ideas in the dream if, without criticism, we allow all those things to appear which we are in the habit of suppressing as worthless and disturbing. We take note, therefore, of all psychically valueless ideas, the momentary perceptions and thoughts which are not accompanied by any deeper feeling of value, and which are produced every day in unending quantities.

[844] Example, p. 310:² On the basis of the results of this method, Freud conjectures that the dream is a kind of substitute, that is, a symbolic representation of trains of thought that have a meaning, and are often bound up with lively affects. The

mechanism of this substitution is still not very clear at present, but at any rate we may accord it the status of an extremely important psychological process once we have established its beginning and end by the method just described. Freud calls the content of the dream as it appears in consciousness the *manifest content of the dream*. The material of the dream, the psychological premises, that is to say all the trains of thought that are hidden from the dreaming consciousness and can be discovered only by analysis, he calls the *latent content of the dream*. The synthetic process, which elaborates the disconnected or only superficially connected ideas into a relatively unified dream-image, is called the *dream-work*.

[845] We are now faced with two cardinal questions:

1. What is the psychic process that changes the latent dream-content into the manifest dream-content?
2. What is the motive for this change?

[846] There are dreams whose latent content is not hidden at all, or barely so, and which in themselves are logical and understandable because the latent content is practically identical with the manifest content. Children's dreams are frequently of this kind, because the thought-world of children is chiefly filled with sensuous, concrete imagery. The more complicated and abstract the thoughts of an adult become, the more confused are most of his dreams. We seldom meet with a completely transparent and coherent dream in an adult. Frequently the dreams of adults belong to the class of dreams which, though meaningful and logical in themselves, are unintelligible because their meaning does not in any way fit the thought-processes of the waking consciousness. The great majority of dreams, however, are confused, incoherent dreams that surprise us by their absurd or impossible features. These are the dreams, also, that are furthest removed from their premise, the latent dream-material, that bear the least resemblance to it and are therefore difficult to analyse, and have required for their synthesis the greatest expenditure of transformative psychic energy.

[847] Children's dreams, with their clarity and transparent meaning, are the least subject to the transformative activity of the dream-work. Their nature is therefore fairly clear; most of them are wish-dreams.

[848] A child that is hungry dreams of food, a pleasure forbidden the day before is enacted in the dream, etc. Children are concerned with simple sensuous objects and simple wishes, and for this reason their dreams are very simple too. When adults are concerned with similar objects, their dreams as well are very simple. To this class belong the so-called dreams of convenience, most of which take place shortly before waking. For example, it is time to get up, and one dreams that one is up already, washing, dressing, and already at work. Or if any kind of examination is impending, one finds oneself in the middle of it, etc. With adults, however, very simple-looking

dreams are often fairly complicated because several wishes come into conflict and influence the formation of the dream-image.

[849] For children's dreams and dreams of convenience in adults the author lays down the following formula: A thought expressed in the optative has been replaced by a representation in the present tense.³

[850] The second of the questions we asked, concerning the motive for the conversion of the latent content into the concrete dream-image, can be answered most easily in these simple cases. Evidently the enacted fulfilment of the wish mitigates its affectivity; in consequence, the wish does not succeed in breaking through the inhibition and waking the sleeping organism. In this case, therefore, the dream performs the function of a guardian of sleep.

[851] Our first question, concerning the process of the dream-work, can best be answered by examining the confused dreams.

[852] In examining a confused dream, the first thing that strikes us is how very much richer the latent dream-material is than the dream-image constructed from it. Every idea in the manifest dream proves, on analysis, to be associated with at least three or four other ideas which all have something in common. The corresponding dream-image frequently combines all the different characteristics of the individual underlying ideas. Freud compares such an image with Galton's family photographs, in which several exposures are superimposed. This combination of different ideas Freud calls *condensation*. To this process is due the indefinite, blurred quality of many dream-images. The dream knows no "either-or" but only the copulative "and."

[853] Often, on a superficial examination of two ideas united in a single image, no common factor can be found. But, on penetrating more deeply, we discover that whenever no *tertium comparationis* is present, the dream creates one, and generally does so by manipulating the linguistic expression of the ideas in question. Sometimes dissimilar ideas are homophonous; sometimes they rhyme, or could be confused with one another if attention is poor. The dream uses these possibilities as a *quid pro quo* and thus combines the dissimilar elements. In other cases it works not only wittily but positively poetically, speaking in tropes and metaphors, creating symbols and allegories, all for the purpose of concealment under deceptive veils. The process of condensation begets monstrous figures that far surpass the fabulous beings in Oriental fairytales. A modern philosopher holds that the reason why we are so prosaic in our daily lives is that we squander too much poetic fantasy in our dreams. The figures in a confused dream are thus, in the main, composite structures. (Example on p. 321.)⁴

[854] In the manifest dream, the latent dream-material is represented by these composite structures, which Freud calls the dream-elements. These elements are not

incoherent, but are connected together by a common dream-thought, i.e., they often represent different ways of expressing the same dominating idea.

[855] This rather complicated situation explains a good deal of the confusion and unintelligibility of the dream, but not all of it. So far we have considered only the ideational side of the dream. The feelings and affects, which play a very large part, have still to be discussed.

[856] If we analyse one of our own dreams, we finally arrive by free association at trains of thought which at one time or another were of importance to us, and which are charged with a feeling of value. During the process of condensation and reinterpretation, certain thoughts are pushed onto the stage of the dream, and their peculiar character might easily invite the dreamer to criticize and suppress them, as actually happens in the waking state. The affective side of the dream, however, prevents this, since it imbues the dream elements with feelings that act as a powerful counterweight to all criticism. Obsessional ideas function in the same way. For example, agoraphobia manifests itself with an overwhelming feeling of fear, and so maintains the position it has usurped in consciousness.

[857] Freud supposes that the affects attached to the components of the latent dream-material are transferred to the elements of the manifest dream, thus helping to complete the dissimilarity between the latent and the manifest content. He calls this process *displacement*, or, in modern terms, a transvaluation of psychic values.

[858] By means of these two principles, the author believes he can offer an adequate explanation of the obscurity and confusion of a dream constructed out of simple, concrete thought-material. These two hypotheses shed a new light on the question of the instigator of a dream, and the connection between the dream and waking life. There are dreams whose connection with waking life is quite evident, and whose instigator is a significant impression received during the day. But far more frequently the dream-instigator is an incident which, although trivial enough in itself, and often positively silly, in spite of its complete valuelessness, introduces a long and intensely affective dream. In these cases, analysis leads us back to complexes of ideas which, though unimportant in themselves, are associated with highly significant impressions of the day by incidental relationships of one kind or another. In the dream the incidental elements occupy a large and imposing place, while the significant ones are completely occluded from the dreaming consciousness. The real instigator of the dream, therefore, is not the trivial, incidental element, but the powerful affect in the background. Why, then, does the affect detach itself from the ideas that are associated with it, and in their place push the nugatory and valueless elements into consciousness? Why does the dreaming intellect trouble to rout out the forgotten, incidental, and unimportant things from every corner of our memory, and to build them up into elaborate and ingenious images?

[859] Before turning to the solution of this question, Freud tries to point out further effects of the dream-work in order to shed a clear light on the purposiveness of the dream-functions.

[860] In adults, besides visual and auditory memory-images, the material underlying the dream includes numerous abstract elements which it is not so easy to represent in concrete form. In considering the *representability of the dream-content*, a new difficulty arises which influences the dream's performance. At this point the author digresses a bit and describes how the dream represents logical relations in sensuous imagery. His observations in this respect are of no further importance for his theory; they merely serve to increase the stock of the discredited dream in the estimation of the public.

[861] One extremely remarkable effect of the dream-work is what Freud calls the *dream-composition*. This, according to his definition, is a kind of revision which the disordered mass of dream-elements undergo at the moment of their inception—a regular dramatization frequently conforming to all the rules of art exposition, development, and solution. In this way the dream acquires, as the author says, a façade, which does not of course cover it up at all points. This façade is in Freud's view the crux of the misunderstanding about dreams, since it systematizes the deceptive play of the dream-elements and brings them into a plausible relationship. Freud thinks that the reason for this final shaping of the dream-content is the regard for intelligibility. He imagines the dream producer as a kind of jocular daimon who wants to make his plans plausible to the sleeper.

[862] Apart from this last effect of the dream-work, what is created by the dream is nothing in any way new or intellectually superior. Anything of value in the dream-image can be shown by analysis to be already present in the latent material. And it may very well be doubted whether the dream-composition is anything but a direct effect of reduced consciousness, a fleeting attempt to explain the hallucinations of the dream.

[863] We now come to the final question: Why does the dream do this work? In analysing his own dreams, the author usually came upon quickly forgotten and unexpected thoughts of a distinctly unpleasant nature, which had entered his waking consciousness only to be suppressed again immediately. He designates the state of these thoughts by the name *repression*.

[864] In order to elucidate the concept of repression, the author postulates two thought-producing systems, one of which has free access to consciousness, while the other can reach consciousness only through the medium of the first. To put it more clearly, there is on the borderline between conscious and unconscious a *censorship* which is continually active throughout waking life, regulating the flow of thoughts to consciousness in such a way that it keeps back all incidental thoughts which for some

reason are prohibited, and admits to consciousness only those of which it approves. During sleep there is a momentary predominance of what was repressed by day; the censorship must relax and produces a compromise—the dream. The author does not conceal the somewhat too schematic and anthropomorphic features of this conception, but solaces himself with the hope that its objective correlate may one day be found in some organic or functional form.

[865] There are thoughts, often of a preeminently egoistic nature, which are able to slip past the censorship imposed by ethical feelings and criticism when this is relaxed in sleep. The censorship, however, is not entirely abrogated, but only reduced in effectiveness, so that it can still exert some influence on the shaping of the dream-thoughts. The dream represents the reaction of the personality to the intrusion of unruly thoughts. Its contents are repressed thoughts portrayed in distorted or disguised form.

[866] From the example of dreams that are comprehensible and have a meaning, it is evident that their content is generally a fulfilled wish. It is the same with confused dreams that are difficult to understand. They, too, contain the fulfilment of repressed wishes.

[867] Dreams, therefore, can be divided into three classes:

1. Those that represent an *unrepressed wish in undisguised form*. Such dreams are of the infantile type.

2. Those that represent the fulfilment of a *repressed wish in disguised form*. According to Freud, most dreams belong to this class.

3. Those that represent a *repressed wish in undisguised form*. Such dreams are said to be accompanied by fear, the fear taking the place of dream-distortion.

[868] Through the conception of the dream as a compromise we arrive at an explanation of dreams in general. When the waking consciousness sinks into sleep, the energy needed to maintain the inhibition against the sphere of repressed material abates. But just as the sleeper still has some attention at his disposal for sensory stimuli coming from outside, and, by means of this attention, can eliminate sleep-disturbing influences by weaving around them a disguising veil of dreams, so stimuli arising from within, from the unconscious psychic sphere, are neutralized by the periphrasis of a dream. The purpose in both cases is the same, namely, the preservation of sleep, and for this reason Freud calls the dream the “guardian of sleep.” Excellent examples of this are waking dreams, which abound in periphrastic inventions designed to make the continuation of the reverie plausible.

[869] Confused dreams are not so clear in this respect, but Freud maintains that, with application and goodwill, repressed wishes can be discovered in them too. On this point he adopts a rather one-sided attitude, since, instead of a wish, the cause of a

dream may easily prove to be just the opposite, a repressed fear, which, manifesting itself in undisguised and often exaggerated form, makes the teleological explanation of dreams appear doubtful.

Freud: Dreams

CONTENTS

[870] *Arrangement:*

Introduction.

1. Example from analysis. Uncritical tracing back of associations.

a) Manifest dream-content.

b) Latent dream-content.

2. Classification of dreams.

a) Meaningful and intelligible.

b) Meaningful and unintelligible.

c) Confused.

3. Children's dreams.

4. Adults. Dreams of convenience and wish-dreams.

5. Causes of the strangeness of dreams.

a) Condensation.

i. by means of the natural common factor.

ii. by means of a common factor created by the dream itself.

b) Displacement. Dream-distortion. Distortion of prohibited thoughts.

c) Concrete representation of inadequate ideas, hence metaphors.

Sensuous metamorphosis of logical relations.

Causal: transformation or mere juxtaposition.

Alternatives = "and."

Similarity, common factor, congruence.

Contradiction, mockery, scorn = absurdity of manifest dream.

d) Dream-composition for the purpose of intelligibility.

e) Teleological conception: dream as guardian of sleep.

REVIEW OF HELLPACH: "GRUNDLINIEN EINER PSYCHOLOGIE DER HYSTERIE"¹

[871] All those professional colleagues who are interested in the great problem of hysteria will surely welcome with joy and eager expectation a work that, judging by its bulk, promises a thorough-going treatment of the psychology of hysteria on the broadest possible basis. Anyone acquainted with the present position of the hysteria theory, and especially the psychology of hysteria, is aware that our knowledge of this obscure field is unfortunately a minimal one. Freud's researches, which have received but scant recognition though they have not yet been superseded, have prepared the ground for thinking that future research into hysteria will be psychological. Hellpach's book appears to meet this expectation. Casting the most cursory glance at the index of names appended to the end of the book, we find the following cited: Archimedes, Behring, Billroth, Büchner, Buddha, Cuvier, Darwin, Euler, Fichte, Galileo, Gall, Goethe, Herbart, Hume, Kepler, Laplace, de la Mettrie, Newton, Rousseau, Schelling, and many others, all illustrious names among which we now and then light on that of a psychiatrist or neurologist. There can be no doubt at all that a future theory of hysteria will go far beyond the narrow confines of psychiatry and neurology. The deeper we penetrate into the riddle of hysteria, the more its boundaries expand. Hellpach thus starts from a basis of great scope, assuredly not without reason. But when we recall the limitless range of knowledge indicated by the names in the index, Hellpach's basis for a psychology of hysteria would seem to have undergone a dangerous expansion.

[872] From various hints thrown out by the author we gather that he is inclined to suspect adverse critics of being ill-intentioned. I would therefore like to say at once that I have no prejudices against Hellpach. On the contrary, I have read his book *sine ira* and with attention, in the honest endeavour to understand it and be fair to it. The text up to p. 146 can be considered an introduction. There are disquisitions on the concepts, theories, and history of science, ranging over every conceivable field of knowledge, which at first blush have nothing to do with hysteria. A mere handful of aphorisms culled from the history of the hysteria theory, chiefly appreciations of the achievements of Charcot and other investigators, have a tenuous connection with the theme. I do not feel competent to criticize the highly generalized discussions on the theories of scientific research. The sidelights from the history of hysteria research are neither exhaustive as a presentation of the subject nor do they offer the researcher anything new. They make practically no contribution to psychology.

[873] The actual treatment of the theme begins on p. 147. First we have a discussion on *suggestibility*. Here Hellpach's thinking and his sure touch must be applauded: he is tackling one of the most difficult points in the hysteria theory. It is immediately obvious that the current concept of suggestibility is rather vague and hence unsatisfactory. Hellpach tries to probe the problem of volition and motivation by analysing "command" and "suggestion." The analysis leads on to a discussion of mechanization and *demotivation*: emancipation of the act of will from the motive. By various convoluted trains of thought we then get to the problem of apperception (as understood by Wundt), which is intimately connected with the problem of volition. Hellpach attaches particular importance to one quality of apperception, and that is the *extinction of sensation*. Stimuli which are only just perceptible on the periphery of the visible field may under certain circumstances be extinguished, but the source of the stimulus (small stars, etc.) disappears as the result of focussing. This observation is extended by analogy to apperception, so-called active apperception taking over the role of focussing. A sensation-extinguishing effect is thus attributed to apperception. Hellpach expatiates at length on this notion, unfortunately in a hardly intelligible manner and without adducing sufficient reasons in support. Extinction of sensation seems to him to be something common and regular. But actually it is an exception, for apperception does not extinguish sensation—on the contrary. The discussion on apperception culminates in the passage: "The control that in the more passive state of apperception extends over the whole field of consciousness disappears with the increasing tension of active apperception. This gives rise to distracted actions."

[874] A further "state of apperception" Hellpach finds in "emptiness of consciousness." Here he undertakes, among other things, a little excursion into the uncultivated deserts of dementia praecox and carries off, as a trophy, negativism as a manifestation of suggestibility in the empty consciousness of the catatonic—as though anyone had the slightest idea of what the consciousness of a catatonic looks like!

[875] The following sentence may be taken as the final result of his analysis of suggestibility: "I regard complete senselessness or complete lack of moderation as the criteria for all psychic effects that can be called suggestions." Unfortunately I can make neither head nor tail of this. In the course of a fifty-page analysis the concept of suggestibility has, to be sure, rambled off into nebulosity, one doesn't quite know how, nor does one know what has become of it. Instead we are offered two peculiar criteria for suggestion, whose beginning and end both lie in the realm of unintelligibles.

[876] There now follows a chapter on one of the thousand hysterical symptoms: ataxia-abasia. The essence of this chapter is its emphasis on the meaning of hysterical paralysis. Another chapter deals with the meaning of hysterical disturbance of

sensation. Hellpach treats hysterical pain-apraxia as an illness on its own, but offers no proof of this. Equally, he treats hysterical hyperaesthesias as a physiological and not a psychological problem. Here again conclusive reasons are lacking. Particularly in hysteria, however, “explanatory principles should not be multiplied beyond the necessary.”² To explain anaesthesia, Hellpach uses the apperceptive extinction of sensation, that aforementioned paradoxical phenomenon which is anything but a simple, certain, clear-cut fact. The proposition that hysterics cease to feel when they ought to feel must be applauded. But this singular fact should not be explained by an even more obscure and ill-founded observation.

[877] Hellpach finds the hysterical intellect characterized by *fantastic apperception* and *tractability*. Fantastic apperception is a psychological state in which “fantasy activity is linked with a tendency towards passivization of apperception.” One can dimly guess what Hellpach is getting at with this turgid pronouncement, but I must own I am incapable of forming any clear conception of it. And I do not think that Hellpach had any clear conception of it either, or he would have been able to communicate it to an attentive reader.

[878] Hellpach defines tractability as follows: “The tractable person is one who meets the demands made upon him willingly or with psychic indifference, or at least without actively fighting down inner resistances.” Suggestibility, which in an earlier chapter vanished beneath a flood of psychological and conceptual verbiage, unexpectedly surfaces here in the innocuous guise of “tractability.”

[879] In the chapter entitled “The Psychological Bar to a Psychology of Hysteria,” we get to the “root phenomenon of hysteria.” The “disproportion between the insignificance of the affective cause and the intensity of the expressive phenomenon” is supposed to be the core of hysterical mental abnormality.

[880] The last section of the book deals with the further elaboration and application of the principles previously laid down, and partly with a discussion of Freud’s teachings in regard to the genesis of hysteria. It is to Hellpach’s credit that he understands Freud and is able to keep in check and counterbalance certain biases and exaggerations of the Freudian school. But as regards the genesis of hysteria he nowhere advances beyond Freud, and in point of clarity he lags far behind.

[881] Now and then Hellpach makes sorties against the “unconscious.” He set out to explain various expressive movements in hysteria without reference to this hypothesis. This attempt deserves to be read in the original (pp. 401ff.). To me it seems neither clear nor convincing. Moreover, expressive movements are, *par excellence*, not unconscious phenomena. It is known that the hypothesis of the psychological unconscious is based on quite other facts, which Hellpach does not touch on. Even so, he makes use of the concept of the unconscious several times, probably because he knows of no better one to put in its place.

[882] His attempts in the concluding chapters to elucidate the sociological and historical aspects of the hysteria problem deserve to be greeted as a general tendency; they show that the author has an unusual, indeed splendid over-all view of his material. Unfortunately he remains stuck at all points in the most general and uncertain of concepts. The net result of all this effort is disproportionately small. The psychological gain reduces itself to the announcement of a grand design and to a few astute observations and interpretations. For this failure the blame lies not least with the extreme infelicities of Hellpach's style. If the reader has at last managed to grasp a sentence or a question, and then hopes to find its continuation or answer in the next sentence, he is again and again pulled up by explanations of how the author arrived at the first sentence and all that can or could be said about this first sentence. In this way the argument proceeds by fits and starts, and the effect of this in the long run is insufferably fatiguing. The number of wrong turns Hellpach takes is astonishing, but he enumerates still more circumstantially how many others he could have taken. The result is that he often has to explain why he is coming back to his theme again. Because of this, the book suffers from a peculiar opacity which makes orientation extraordinarily difficult.

[883] The author has, furthermore, committed a grave sin of omission in that he cites next to no examples. This omission is especially painful when pathological phenomena are being discussed. Anyone who wants to teach something new must first teach his public how to see, but without examples this is impossible. Maybe Hellpach could still come out with a few good and new things if he deigned to descend into the nether regions of case material and experimental research. If he wishes to address himself to the empiricist at all, he will find this advice assuredly justified.

REVIEWS OF PSYCHIATRIC LITERATURE¹

1906

[884] L. Bruns: *Die Hysterie im Kindesalter*. 2nd revised edn., Halle, 1906. —The author, known for his researches into the symptomatology and therapy of hysteria, has now published a second edition of his book on hysteria in childhood, a work familiar to most medical men. After a short historical introduction he gives a concise survey of the symptomatology, keeping to the empirical essentials and leaving aside all rarities and curiosities with commendable self-restraint. With the help of clear-cut cases he gives a brief description of the various forms and localizations of the paralyzes and spasms, tics and choreic affections; somnambulism, lethargies, and states of possession are treated more cursorily, being less common. The painful symptoms (neuralgias, etc.) and bladder disturbances, and particularly the *psychic* symptoms that are so extraordinarily important in hysteria, come off rather poorly. In his discussion of the aetiology, the author holds, as against Charcot, that too much significance should not be attached to heredity. More important, it seems to him, and I think rightly, are the psychic causes in the individual concerned, particularly imitation of bad examples, the influence of bad upbringing, fright, fear, etc. In many cases the influence of the parents is directly psychogenic.

[885] In view of the admitted frequency of infantile hysteria, diagnosis is of great importance, for many cases are not only retarded by a false diagnosis but are completely wrecked by it. The author takes a firm stand on psychogenesis: the unmistakable psychic element in hysterical symptoms is of the utmost significance in differential diagnosis. Often one has to rely on one's own impressions; the author quotes the classic words of Möbius:² "According to the view I have formed of the nature of hysteria, many symptoms can be hysterical, many others not." In many cases, therefore, the diagnosis of hysteria is less a science than an art. Commendably, the author urges the greatest caution against assuming *simulation*.

[886] Treatment is fundamentally *always a psychic one*; water, electricity, etc. work only by suggestion. This excellently written chapter is an invaluable guide for the practitioner, but the details of it cannot be gone into here.

[887] The book is written by a practitioner for practitioners; it is no handicap, therefore, that the theoretical side is represented somewhat aphoristically and takes no account of the latest analytical views of Freud.

[888] E. Bleuler: *Affektivität, Suggestibilität, Paranoia*.³ Halle, 1906. This work, addressed chiefly to psychologists and psychiatrists, is distinguished, like all Bleuler's publications, by its lucidity; its theme is one that is coming more and more into the forefront of psychological interest: namely, affects and their influence on the psyche. This field of research, like some other domains of psychology, suffers greatly from a confusion of concepts. Bleuler therefore proposes, first of all, a clean division between affects proper and intellectual feelings, a conceptual distinction of the greatest value in scientific discussion. *Affectivity*, comprising all affects and quasi-affective processes, is an inclusive concept which covers all nonintellectual psychic processes such as volition, feeling, suggestibility, attention, etc. It is a psychic factor that exerts as much influence on the psyche as on the body.

[889] In the first and second parts of his book Bleuler applies this conception in the realm of normal psychology. In the third part he discusses the *pathological alterations of affectivity*. Affectivity is of the greatest imaginable importance in psychopathology. Quite apart from the affective psychoses proper (manic-depressive insanity), it plays a significant role in psychoses which one was wont to regard as predominantly intellectual. Bleuler demonstrates this with the help of careful clinical histories of *paranoia originaria*.⁴ He found that the content of the paranoid picture developed from a *feeling-toned complex*, that is, from ideas accompanied by intensive affect which therefore have an abnormally strong influence on the psyche. This is the keynote of the book.

[890] It is impossible, in a short review, to do justice to the numerous perspectives which Bleuler's book opens out and to the wealth of empirical material it contains. It is urgently recommended first of all to professionals; but non-psychiatrists also, who are interested in the general problems of psychopathology, will not be able to lay it aside without reaping a rich harvest of psychological insights.

[891] Carl Wernicke.⁵ *Grundriss der Psychiatrie in klinischen Vorlesungen*. 2nd revised edn., Leipzig, 1906. — Following Wernicke's sudden death, Liepmann and Knapp have seen to the publication of the second edition of this important book, which has acted as a ferment in modern psychiatry like no other. Wernicke incarnated, so to speak, that school of psychopathology which believed it could base itself exclusively on anatomical data. His book is an impressive exponent of this thinking; besides a huge mass of empirical material we find many brilliant speculations whose starting point is always anatomical. The book is the work of an entirely original mind that tried, on the basis of clinical data combined with brain anatomy, to introduce new viewpoints into psychotherapy, hoping to effect a final synthesis of those two mutually repellent disciplines, brain anatomy and psychology. Wernicke is always the master where psychopathological events come closest to the anatomical, above all, therefore, in the treatment of problems clustering round the question of aphasia. His

“Psychophysiological Introduction,” where he tries to answer questions concerning the connection between cerebral and psychophysiological data, is, even for the non-psychiatrist, one of the most interesting in recent medical literature.

[892] The section that follows, “Paranoid States,” introduces Wernicke’s famous sejunction theory,⁶ which is the cornerstone of his system. The third and longest section treats of “acute psychoses and defective states.” Here, with the help of numerous examples, Wernicke develops his revolutionary clinical approach, which has met with only the limited approbation of fellow professionals and has so far not produced a school. Wernicke’s ideas, for all their brilliance, are too narrow: brain anatomy and psychiatric clinics are certainly important for psychopathology, but *psychology* is more important still and this is what is lacking in Wernicke. The danger of dogmatic schematism for anyone who follows in Wernicke’s footsteps, but with less brilliance, is very great. It is devoutly to be hoped, therefore, that this admirable book will produce as few schools as possible.

1907

[893] Albert Moll:⁷ *Der Hypnotismus, mit Einschluss der Hauptpunkte der Psychotherapie und des Occultismus*. 4th enlarged edn., Berlin, 1907. — Moll’s well-known book has now attained nearly twice the size of the first edition. The first, historical section is very full and covers the whole range of the hypnosis movement. The second is a lucid and, didactically speaking, very good introduction to the various forms and techniques of hypnotism, followed by a discussion of the hypnotist’s work and the nature of suggestion. Moll defines it thus: “Suggestion is a process whereby, under inadequate conditions, an effect is obtained by evoking the idea that such an effect will be obtained.” The third part, treating of symptomatology, is very thorough and contains some good criticism. It also covers the very latest phenomena in the domain of hypnotism, including Mme. Madeleine and “Clever Hans.”⁸ It is incomprehensible to me why Moll, in the section on dreams, does not consider Freud’s pioneering researches. Freud is accorded only a few meagre quotations. In his discussion on the relations between certain mental disturbances (catatonia especially) and similar hypnotic states, Moll has overlooked the work of Ragnar Vogt,⁹ which is of significance in this respect. Altogether, the examination of the connection of pathological mental states with hypnosis and related functional phenomena is neither exhaustive nor productive of tangible results, as is the case, incidentally, in all textbooks of hypnotism to date. The case of echolalia described on p. 200 may well be a simple catatonia, and this is true also of a large number of so-called “imitative illnesses” which are generally observed by doctors who have no knowledge of the symptomatology of catatonia. If Moll can blithely speak of great suggestibility during sleep, then the whole concept of suggestibility needs very

drastic revision. In the discussion on the subconscious one again misses the highly important researches of Freud. Section VIII, "Medicine," gives a very valuable and useful account of the influence of "authorities" on the question of hypnosis and its alleged dangers. Discussing hypnotic methods of treatment, Moll also touches on the cathartic method. He bases himself here on the original publications of Breuer and Freud,¹⁰ which Freud meanwhile has long since superseded. His present technique differs somewhat from the way Moll describes it. Recently Löwenfeld¹¹ has given up his negative attitude towards Freud, at least as regards anxiety neurosis. The remaining chapters give a comprehensive account of various psychotherapeutic methods. The forensic significance of hypnotism is also discussed at some length. The final chapter, "The Occult," is a critical survey of the most important "occult" phenomena.

[894] Apart from Löwenfeld's book,¹² Moll's is the best and fullest introduction to hypnotic psychotherapy. It is warmly recommended to all doctors, nerve specialists in particular.

[895] Albert Knapp: *Die polyneuritischen Psychosen*. Weisbaden, 1906. — The first 85 pages are taken up with detailed clinical histories and their epicrises. The following 50 contain a general description of the relevant symptoms, in clear language which makes a rapid orientation possible. The nomenclature is strongly influenced by Wernicke, which will hardly meet with general approval. The preference given to the term "akinetic motility psychosis" for catatonia etc., is hardly intelligible, especially when one considers that it only describes a condition that can take on a totally different appearance the next moment. The book should be especially welcome to psychiatrists.

[896] M. Reichhardt: *Leitfaden zur psychiatrischen Klinik*. Jena, date not given. — This book is a valuable introduction to the elements of psychiatry. The author discusses them under three main heads:

[897] General symptomatology, with clear and precise definitions.

[898] Exploratory methods, with a detailed description of the numerous methods for testing intelligence and apprehension.

[899] Special psychiatry. Here the author confines himself to essentials. On the controversial subject of dementia praecox, the emphasis falls on dementia simplex, catatonia and paranoia, the latter being treated *in globo*, without reference to the special diagnoses of the Kraepelin school, which in practice are irrelevant anyhow. A good index adds to the book's handiness. Apart from the clear exposition, one of its main advantages is the noteworthy restriction to what is essential. The legal definitions of insanity are taken exclusively from German law-books. On the question of intelligence tests, no mention is made of the not unimportant method of reading a fable with free reproduction afterwards. The statement that in country areas

an institution with 1000–1500 beds is enough for a million inhabitants is certainly not true of Switzerland. Besides private institutions, we have in Canton Zurich about 1300 public beds, not nearly enough to meet the demand. For the rest, the book is warmly recommended not only to students, but especially to all doctors called upon to give a judicial opinion on any kind of mental abnormality.

1908

[900] Franz C. R. Eschle: *Grundzüge der Psychiatrie*. Vienna, 1907. — The author—director of the sanatorium at Sinsheim in Baden—has tried to present the fundamentals of psychiatry in the form of a manual, drawing upon his many years of experience as an alienist. **Part I** treats of the nature and development of insanity. He distinguishes, as general forms of psychic abnormality, a distinctive, an affective, and an appetitive insufficiency, corresponding roughly to the old psychology of Kant. This chapter is rather heavy going. The arrangement is far from clear and the style is often tortuous, for instance p. 37: “In hypnotic sleep, which represents the most intense and persistent form of the artificial suggestive insufficiency of the psychosomatic mechanism, Rosenbach holds that the psychic organ is unable to build up the differentiating unity which stands in antithetical relation to the other parts of the body (and to the external world) as the ‘ego,’ although it nevertheless represents this unity,” etc. This but one example among many!

[901] In **Part II**, “Clinical Pictures of Insanity,” the author gives a description of the specific diseases with a great deal of interesting case material and original views which one cannot always endorse, as for instance when he asserts with Rosenbach that a widespread use of hypnosis would lead to a general stultification of the public. His classification of the psychoses is a mixture of old and modern points of view; he groups acute hallucinatory confusion and acute dementia (curable stupidity) with dementia praecox while distinguishing paranoia and paranoid dementia.

[902] **Part III** is a forensic evaluation of doubtful mental conditions. There is a good index of authors and subjects. The book is essentially eclectic and tries to select the best from the old psychiatry and the new and combine them into a unity with a dash of philosophy thrown in. It should therefore prove stimulating reading for doctors in sanatoria who have not kept abreast of the latest developments in psychiatry.

[903] P. Dubois:¹³ *Die Einbildung als Krankheitsursache*. Wiesbaden, 1907. —Dubois presents in generally understandable outline his view of the nature and the treatment of the psychoneuroses. He begins with a clear and illuminating definition of “imagination” and then proceeds to show the pathological effects of imagination with the help of numerous instructive examples. His therapy, likewise derived from this view and clearly expounded, consists essentially in enlightening the patients on the nature of their symptoms and in re-educating their thinking. Let us hope that this

distinguished book will contribute to a general breakthrough of the conception of the psychogenic nature of most neuroses! Like all Dubois' other writings, it is urgently recommended to the practising doctor. Even though the Dubois method may not be successful with every neurosis, it is eminently suited to have a prophylactic effect, so that cases where the symptoms are due to imprudent suggestions on the part of the doctor may gradually become less common. In conclusion Dubois hints at a possible extension of his therapy to the psychoses—but in this matter the alienist is not so optimistic.

[904] Georg Lomer: *Liebe und Psychose*. Wiesbaden, 1907.— Lomer's book is more an example of *belles-lettres* than a scientific evaluation of sexuality and its psychological derivatives. By far the greater part of it is concerned with normal psychosexual processes which it seeks to present to an intelligent lay public. Readers who would like to penetrate deeper must have recourse to Havelock Ellis and Freud. The pathology of sex is discussed in an appendix, with—in comparison with similar productions—a wholesome reserve in the communication of piquant case histories. One could have wished for a rather deeper grasp of the problems of psychosexual pathology, where such excellent preparatory work has been done, as witness the researches of Freud.

[905] E. Meyer: *Die Ursachen der Geisteskrankheiten*. Jena, 1907. — Meyer's book comes at the right time and will be welcomed not only by every psychiatrist but by all those who are interested in the causes of mental illnesses in the widest sense. It also remedies the palpable lack of any comprehensive account of the aetiology of the psychoses. The author discusses in great detail the numerous factors that have to be taken into account in their causation. The chapter on poisonings is written with especial care. In discussing the psychic causes, which are at present the subject of violent controversy, the author displays a calm impartiality, allowing the psychic elements more freedom of play than do certain other views which would like to reduce the whole aetiology to non-psychic causes. One small error needs correcting: Freud and the Zurich school see in the psychological disposition only the material determinants of the later symptoms, but not the sole cause of psychosis. The author has made a singularly good selection from the extensive literature dealing with the question of aetiology. An excellent index assists easy reference.

[906] Sigmund Freud: *Zur Psychopathologie des Alltagslebens*. 2nd enlarged edn., Berlin, 1907.¹⁴ — It is a heartening sign that this important book has now gone into a second edition. It is practically the only major work of Freud's that introduces his ideas into the world with little or no effort, so simply and fluently is it written. Thus it is well suited to initiate the layman (and there are few who are *not* laymen in this field) into the problems of Freudian psychology. It is concerned not with the speculations of theoretical psychology but with psychological case material taken

from everyday life. It is just the apparently insignificant incidents of everyday life that Freud has made the theme of his researches, showing with the help of numerous examples how the unconscious influences our thoughts and actions at every turn in an unexpected way. Many of his examples have an implausible look, but one should not be put off by that, because all unconscious trains of thought in an individual look anything but plausible on paper. The profound truth of Freud's ideas will carry conviction only when one tests them for oneself. Even for those who are not especially interested in psychological matters Freud's book makes stimulating reading; for those who think more deeply, who by inclination or profession are interested in the psychic processes, it is a rich mine of far-sighted ideas which have a significance that can scarcely be estimated at present for the whole range of mental and nervous diseases. In this respect the book is an easy guide to Freud's latest works on hysteria,¹⁵ which despite the deep truth of their subject-matter, or because of it, have hitherto met only with fanatical opposition and intractable misunderstanding. The book is therefore recommended with all urgency to alienists and to nerve specialists in particular.

1909

[907] L. Löwenfeld:¹⁶ *Homosexualität und Strafgesetz*. Wiesbaden, 1908. — This book is the product of the current struggle that has been touched off in Germany by section 175 of the penal code. This section, as is generally known, concerns unnatural vice between men, and also with animals. The author gives a concise history of the clinical concept of homosexuality. He sums up the present state of opinion as follows: "Though homosexuality is an anomaly that may appear in the physical sphere in association with disease and degeneration, in the majority of cases it is an isolated psychic deviation from the norm, which cannot be regarded as pathological or degenerative and is not likely to reduce the value of the individual as a member of society." Section 175, which became law only under the pressure of orthodoxy despite opposition by influential authorities, has so far proved to be not only useless and inhuman, but directly harmful as it offers opportunities for professional blackmail with all its tragic and repulsive consequences. The book gives a very good survey of the whole question of homosexuality.

[908] Karl Kleist: *Untersuchungen zur Kenntnis der psychomotorischen Bewegungsstörungen bei Geisteskranken*. Leipzig, 1908 — The book presents the clinical history of a motility psychosis alias catatonia with a detailed epicritical discussion. The author leans heavily on the views of Wernicke, with the result that the book is concerned chiefly with cerebral localizations. The conclusion reached is that psychomotor disturbances in catatonics are conditioned by two factors, innervatory and psychic. The seat of disease is supposed to be the terminal point of

the cerebellar-cortical tracts, i.e., the frontal cerebral cortex. As the patients occasionally have sensations of strain and fatigue in the performance of the tasks assigned them, and as the psychomotor symptoms are due to a disturbance of the motor reactions coordinated with these sensations, the psychic conditioning factor likewise points to the cerebellar-frontal system. This conclusion is logical if one regards the psychic functional complexes as an appendix of their executive organs from the start. The book is recommended to specialists because of its acute differential-diagnostic analysis of apraxia and related motility disturbances.

[909] Oswald Bumke:¹⁷ *Landläufige Irrtümer in der Beurteilung von Geisteskranken*. Wiesbaden, 1908. — This little book contains more than its title indicates. It is a short and clearly written outline of psychiatry, and while it does not give an altogether elementary description of the psychoses it presupposes some knowledge of the main types—knowledge which almost every practitioner possesses today. On this basis the author discusses questions which are wont to present difficulties to doctors with no psychiatric training in their assessment of mental disturbances. Aetiology, diagnosis, prognosis, and therapy are discussed from this standpoint, the author giving valuable advice and hints from his own practical experience. At the end there is a chapter on the forensic view of the insane.

[910] A comprehensive and handy little book, highly recommended.

[911] Christian von Ehrenfels: *Grundbegriffe der Ethik*. Wiesbaden, 1907. — The author—professor of philosophy in Prague—gives a philosophical but easily understandable account of his basic ethical concepts. His argument culminates in the confrontation between social and individual morality, once more a subject of violent controversy. The conclusion reached, though typical of the general tenor of the book, can hardly be called positive: “Normative morality is identical with correct social morality, the sole proviso being that every individual must be free to modify social morality, not in accordance with his own caprice but in a manner he can defend before the tribunal of the eternal and inscrutable.”

[912] Christian von Ehrenfels: *Sexualethik*. Wiesbaden, 1907.— While the author’s *Grundbegriffe der Ethik* is mainly of theoretical interest, this work is of great practical importance. It is the clearest and best account I know of sexual ethics and its postulates. The author begins with a deeply thought out and lucid presentation of natural and cultural sexual morality. The following chapter, “Contemporary Sexual Morality in the West,” discusses the tremendous conflict between the postulates of natural and cultural sexuality, the socially useful effects of monogamy on the one hand and its shadow-side on the other, prostitution, the double sexual morality of society and its pernicious influence on culture. In his discussion of reform movements the author takes a cautious and reserved stand, as far from Philistine approval of the *status quo* as from certain modern tendencies that would like to pull

down all barriers. Although he has no definite programme of reform (which shows he is no dreamer!), he expresses many liberal views which will surely help to solve our greatest social problem, beginning with the individual. His book, which unlike others of the kind is not a parade of garish nudities veiled in scientific garb, deserves the widest acclaim for its unpretentious and reasonable attempt to find *possible* solutions.

[913] Max Dost: *Kurzer Abriss der Psychologie, Psychiatrie und gerichtlichen Psychiatrie*. Leipzig, 1908. — This little book is a new kind of compendium of psychiatry with special reference to intelligence testing. Psychology comes off rather too lightly. The chapters on psychiatry, however, really offer everything one could expect from a short outline. For the psychiatrist the enumeration of various psychic exploratory methods will be particularly welcome. It will be hard to find so handy an account anywhere in the literature.

[914] Alexander Pilcz: *Lehrbuch der speziellen Psychiatrie für Studierende und Aerzte*. 2nd revised edn., Leipzig and Vienna, 1909. — Not every branch of medicine is in such an infantile state of development as psychiatry, where a textbook, which ought to have general validity, is only of local significance. When one considers that dementia praecox is a disease which in Zurich accounts for half the admissions, in Munich is steadily decreasing (as a result of new theories), is not common in Vienna, is rare in Berlin and in Paris hardly occurs at all, the reviewer of a psychiatric textbook must disregard the Babylonian confusion of tongues and concepts and simply accept the standpoint of the textbook in question. Pilcz's book, now in its 2nd edition, is an admirable work which fulfils its purpose. It is excellently written, and contains everything essential. The material is clearly arranged, the exposition terse and precise. Highly recommended.

[915] W. von Bechterew: *Psyche und Leben*. 2nd edn., Wiesbaden, 1908. — This book does not treat of psychological problems on the basis of a wide knowledge of the literature, as the title might suggest, but deals with psychophysiological relations in general from the theoretical philosophical side, and then goes on to discuss the relation of energy to the psyche and of the psyche to physiology and biology. The style is aphoristic; the chapters, thirty-one in number, are only loosely connected. The chief value of the book lies in its numerous reports of the views of a great variety of specialist researchers and in its literary references. Readers who want a synthetic or critical clarification of the psychophysiological problems will seek for it in vain. But for anyone who seeks orientation in this interesting field and its complicated, widely dispersed literature this stimulating book is highly recommended.

[916] M. Urstein: *Die Dementia praecox und ihre Stellung zum manisch-depressiven Irresein*. Vienna, 1909. — As the title indicates, this is a clinical examination of dementia praecox diagnosis, a topic that has come once more to the forefront because of the recent swing towards the Kraepelin school. Not everyone will be able to

imitate the ease with which manic-depressive insanity is now distinguished from dementia praecox, and Urstein is one of them. He sharply criticizes the work of Wilmann and Dreyfus, who would like to restrict dementia praecox diagnosis in favour of manic-depressive insanity. His book can count on the decided sympathy of all who doubt the thoroughness of Kraepelin's diagnostics, and who cannot go along with the idea that a catatonic is from now on a manic-depressive. Pages 125 to 372 are padded out with case histories, an unnecessary appendage in view of the specialist readership for which the book is intended.

[917] Albert Reibmayer: *Die Entwicklungsgeschichte des Talentes und Genies*. Munich, 1908. — Only the first volume of the book is available at present, but despite this drawback it is already apparent that it is a broad and comprehensive study. The present volume is essentially a theoretical, constructive survey of the problem, which naturally has extensive ramifications into biology and history. If the second volume provides the necessary biographies and suchlike material, we shall have in Reibmayer's book an important work meriting the widest attention.

[918] P. Näcke:¹⁸ *Über Familienmord durch Geisteskranke*. Halle, 1908. — The book is a monograph on family murder. The author presents 161 cases, classified according to their respective peculiarities. He is of the opinion that family murder is now on the increase. He distinguishes between "complete" and "incomplete" family murder. The first is more common in the case of relatively sane individuals; the second more common with the insane. The murderers are usually in the prime of life. The victims of the men are usually their wives, of the women their children. The commonest causes are chronic alcoholism, paranoia, and epilepsy in men; melancholy, paranoia, and dementia praecox in women.

[919] Th. Becker: *Einführung in die Psychiatrie*. 4th revised and enlarged edn., Leipzig, 1908. — This handy little book is a clear and concise introduction to psychiatry. With regard to the classification of the psychoses the author is conservative, allowing a good deal of room for paranoia alongside dementia praecox. The book has much to recommend it as an "introduction" if one disregards the chapter on hysteria, which no longer meets with modern requirements.

[920] A. Cramer: *Gerichtliche Psychiatrie*. 4th revised and enlarged edn., Jena, 1908. — Cramer's guide to judicial psychiatry, now in its fourth edition, is one of the best of its kind; it is thorough, comprehensive, and, compared with Hoche's manual,¹⁹ has the great advantage of consistent exposition. As everywhere in psychiatry, the lack of a consistent classification is to be regretted; this is not the fault of the author but of the discipline itself. Were it not for this inconvenience Cramer's book could be generally recommended; as it is, the beginner can rely on it completely only if he is disposed to trust its particular approach. For the rest, the book will prove useful in the hands of psychiatric experts.

[921] August Forel:²⁰ *Ethische und rechtliche Konflikte im Sexualleben in- und ausserhalb der Ehe*. Munich, 1909. — The author introduces his book with the following words: “The following pages are for the most part an attack, based on documentary material, on the hypocrisy, the dishonesty and cruelty of our present-day morality and our almost non-existent rights in matters of sexual life.” From which it is apparent that this work is another contribution to the great social task to which Forel has already rendered such signal service. Essentially it presents a large number of psychosexual conflicts of a moral or judicial nature, knowledge of which is indispensable not only for the nerve specialist, but for every doctor who has to advise his patients in the difficult situations of life.

THE SIGNIFICANCE OF FREUD'S THEORY FOR NEUROLOGY AND PSYCHIATRY¹

[922] In medical terms, Freud's achievements are on the whole limited to the fields of hysteria and obsessional neurosis. His investigations begin with the psychogenetic explanation of the hysterical symptom, an explanation formulated by Möbius and experimentally tested by Pierre Janet. According to this point of view, every physical symptom of a hysterical nature is causally connected with a corresponding psychological event. This view can be corroborated by a critical analysis of the hysterical symptom, which becomes intelligible only when the psychological factor is taken into account, as exemplified by the many paradoxical phenomena of cutaneous and sensory anesthetics. But the theory of psychogenesis cannot explain the *individual determinants* of the hysterical symptom. Stimulated by Breuer's discovery of a psychological connection, Freud bridged this large gap in our knowledge by his method of psychoanalysis, and he demonstrated that a determining psychological factor can be found for every symptom. The determination always proceeds from a *repressed feeling-toned complex of representations*. (Lecturer illustrates this statement with a few case histories taken partly from Freud, partly from his own experience.) The same principle applies to the obsessional neurosis, the individual manifestation of which is determined by very similar mechanisms. (Lecturer adduces a number of examples.) As Freud maintains, sexuality in the widest sense plays a significant role in the genesis of a neurosis, quite understandably so, since sexuality plays an important role in the intimate life of the psyche. Psychoanalysis, in addition, has in many cases an unmistakable therapeutic effect, which however does not mean that it is the only way of treating a neurosis. By dint of his theory of psychological determination, Freud has become very important for psychiatry, especially for the elucidation of the symptoms, so far completely unintelligible, of dementia praecox. Analysis of this disease uncovers the same psychological mechanisms that are at work in the neuroses, and thus makes us understand the individual forms of illusionary ideas, hallucinations, paraesthesias, and bizarre hebephrenic fantasies. A vast area of psychiatry, up until now totally dark, is thus suddenly illuminated. (Lecturer relates two case histories of dementia praecox as examples.)

REVIEW OF STEKEL: "NERVÖSE ANGSTZUSTÄNDE UND IHRE BEHANDLUNG"¹

[923] The book contains a presentation of states of nervous anxiety, buttressed by an abundance of case material: in **Part I**, Anxiety Neuroses, in **Part II**, Anxiety Hysteria. The clinical boundaries for either group are flung far afield, taking in much more than existing clinical methods have accounted for. Anxiety neurosis, especially, is enriched by many new categories of disease, the symptoms of which are taken to be *equivalents of anxiety*. By its very nature anxiety hysteria has fluctuating boundaries and tends to merge with other forms of hysteria. **Part III** is concerned with the general diagnostics of anxiety states as well as general therapy and, specifically, the technique of psychotherapy. Now, what makes the book especially attractive is the fact that Stekel, a pupil of Freud, very laudably makes the first attempt to enable a larger medical public to gain insight in the psychological structure of the neuroses. In his case histories, Stekel does not confine himself to presenting only the surface (as has hitherto been usual), but, following the most intimate individual reactions of the patient, gives a penetrating picture of the psychogenesis in each case and its further progress during the therapeutic effect of the psychoanalysis. He analyses many cases with great skill and rich experience and in great detail, while others are presented only in psychological outline, which the psychological layman may have difficulty in following. Such outline presentations, unfortunately, cannot be avoided if the book is not to become inordinately long, even though such cases are hard to understand and can easily lead to misconstruction and to the reproach that the author indulges in rash interpretation. On the basis of this method, which specifically considers every individuality on its own terms, Stekel can demonstrate that without exception states of nervous anxiety are determined by psychosexual conflicts of the most intimate nature, thereby once more confirming Freud's assertion that neurotic anxiety is nothing but a converted sexual desire.

[924] Up to now we suffered from a lack of case material in the light of Freudian analysis. To an extent Stekel's book fills this gap. It is very readable and therefore must be highly recommended to all practising physicians, not merely to specialists, for open and hidden neuroses are legion and every physician has to cope with them.

EDITORIAL PREFACE TO THE "JAHRBUCH"¹

[925] In the spring of 1908 a private meeting was held in Salzburg of all those who are interested in the development of the psychology created by Sigmund Freud and in its application to nervous and mental diseases. At this meeting it was recognized that the working out of the problems in question was already beginning to go beyond the bounds of purely medical interest, and the need was expressed for a periodical which would gather together studies in this field that hitherto have been scattered at random. Such was the impetus that gave rise to our *Jahrbuch*. Its task is to be the progressive publication of all scientific papers that are concerned in a positive way with the deeper understanding and solution of our problems. The *Jahrbuch* will thus provide not only an insight into the steady progress of work in this domain with its great future, but also an orientation on the current state and scope of questions of the utmost importance for all the humane sciences.

DR. C. G. JUNG

MARGINAL NOTES ON WITTELS: "DIE SEXUELLE NOT"¹

[926] This book is written with as much passion as intelligence. It discusses such questions as abortion, syphilis, the family, the child, women, and professions for women. Its motto is: "Human beings must live out their sexuality, otherwise their lives will be warped." Accordingly, Wittels lifts up his voice for the liberation of sexuality in the widest sense. He speaks a language one seldom hears, the language of unsparing, almost fanatical truthfulness, that falls unpleasantly on the ear because it tears away all shams and unmasks all cultural lies. It is not my business to pass judgment on the author's morals. Science has only to listen to this voice and tacitly admit that it is not a lone voice crying in the wilderness, that it could be a leader for many who are setting out on this path, that we have here a movement rising from invisible sources and swelling into a mightier current every day. Science has to test and weigh the evidence—and understand it.

[927] The book is dedicated to Freud and much of it is based on Freud's psychology, which is in essence the scientific rationalization of this contemporary movement. For the social psychologist the movement is and remains an intellectual problem, while for the social moralist it is a challenge. Wittels meets this challenge in his own way, others do so in theirs. We should listen to them all. Nowhere is the warning more in place that on the one hand we should refrain from enthusiastic applause, and on the other not kick against the pricks in blind rage. We have to realize, quite dispassionately, that whatever we fight about in the outside world is also a battle in our inner selves. In the end we have to admit that mankind is not just an accumulation of individuals utterly different from one another, but possesses such a high degree of psychological collectivity that in comparison the individual appears as merely a slight variant. How shall we judge this matter fairly if we cannot admit that it is also our own problem? Anyone who can admit this will first seek the solution in himself. This, in fact, is the way all great solutions begin.

[928] Most people, however, seem to have a secret love of voyeurism; they gaze at the contestants as though they were watching a circus, wanting to decide immediately who is finally right or wrong. But anyone who has learnt to examine the background of his own thoughts and actions, and has acquired a lasting and salutary impression of the way our unconscious biological impulses warp our logic, will soon lose his delight in gladiatorial shows and public disputation, and will perform them in himself and with himself. In that way we preserve a perspective that is particularly needful in an age when Nietzsche arose as a significant portent. Wittels will surely not remain

alone; he is only the first of many who will come up with “ethical” conclusions from the mine of Freud’s truly biological psychology—conclusions that will shake to the marrow what was previously considered “good.” As a French wit once remarked, of all inventors moralists have the hardest lot, since their innovations can only be immoralities. This is absurd and at the same time sad, as it shows how out of date our conception of morality has become. It lacks the very best thing that modern thought has accomplished: a biological and historical consciousness. This lack of adaptation must sooner or later bring about its fall, and nothing can stop this fall. And here I am reminded of the wise words of Anatole France: “And, although the past is there to point out to them ever-changing and shifting rights and duties, they would look upon themselves as dupes were they to foresee that future humanity is to create for itself new rights, duties and gods. Finally, they fear disgracing themselves in the eyes of their contemporaries, in assuming the horrible immorality which future morality stands for. Such are the obstacles to a quest of the future.”²

[929] The danger of our old-fashioned conception of morality is that it blinkers our eyes to innovations which, however fitting they may be, always carry with them the odium of immorality. But it is just here that our eyes should be clear and far-seeing. The movement I spoke of, the urge to reform sexual morality, is not the invention of a few cranky somnambulists but has all the impact of a force of nature. No arguments or quibbles about the *raison d’être* of morality are any use here; we have to accept what is most intelligent and make the best of it. This means tough and dirty work. Wittels’ book gives a foretaste of what is to come, and it will shock and frighten many people. The long shadow of this fright will naturally fall on Freudian psychology, which will be accused of being a hotbed of iniquity. To anticipate this I would like to say a word in its defence now. Our psychology is a science that can at most be accused of having discovered the dynamite terrorists work with. What the moralist and general practitioner do with it is none of our business, and we have no intention of interfering. Plenty of unqualified persons are sure to push their way in and commit the greatest follies, but that too does not concern us. Our aim is simply and solely scientific knowledge, and we do not have to bother with the uproar it has provoked. If religion and morality are blown to pieces in the process, so much the worse for them for not having more stamina. Knowledge is a force of nature that goes its way irresistibly from inner necessity. There can be no hushing up and no compromises, only unqualified acceptance.

[930] This knowledge is not to be identified with the changing views of the ordinary medical man, for which reason it cannot be judged by moral criteria. This has to be said out loud, because today there are still people claiming to be scientific who extend their moral misgivings even to scientific insights. Like every proper science, psychoanalysis is beyond morality; it rationalizes the unconscious and so fits the

previously autonomous and unconscious instinctual forces into the psychic economy. The difference between the position before and afterwards is that the person in question now really *wants* to be what he is and to leave nothing to the blind dispensation of the unconscious. The objection that immediately arises, that the world would then get out of joint, must be answered first and foremost by psychoanalysis; it has the last word, but only in the privacy of the consulting room, because this fear is an individual fear. It is sufficient that the goal of psychoanalysis is a psychic state in which “you ought” and “you must” are replaced by “I will,” so that, as Nietzsche says, a man becomes master not only of his vices but also of his virtues. Inasmuch as psychoanalysis is purely rational—and it is so of its very nature—it is neither moral nor antimoral and gives neither prescriptions nor any other “you oughts.” Undoubtedly the tremendous need of the masses to be led will force many people to abandon the standpoint of the psychoanalyst and to start “prescribing.” One person will prescribe morality, another licentiousness. Both of them cater to the masses and both follow the currents that drive the masses hither and thither. Science stands above all this and lends the strength of its armour to Christian and anti-Christian alike. It has no confessional axe to grind.

[931] I have never yet read a book on the sexual question that demolishes present-day morality so harshly and unmercifully and yet remains in essentials so true. For this reason Wittels’ book deserves to be read, but so do many others that deal with the same question, for the important thing is not the individual book but the problem common to them all.

REVIEW OF WULFFEN: "DER SEXUALVERBRECHER"¹

[932] Wulffen's comprehensive account of sexual misdemeanours is not confined merely to criminal case histories but seeks to get at the psychological and social foundations of the offence. Two hundred and fifty pages alone are devoted to sexual biology in general, sexual psychology, characterology, and pathology. In the chapter on sexual psychology the author himself will surely deplore the absence of psychoanalytic viewpoints. The other chapters on criminology, being written by an experienced criminologist, are of great interest and very stimulating to the researcher in this field. The illustrations are uniformly good, some of them of great psychological value.

[933] For a future psychoanalytic investigation of this subject Wulffen's book should be a most valuable source alongside the compilations of Pitaval.²

ABSTRACTS OF THE PSYCHOLOGICAL WORKS OF SWISS AUTHORS (to the end of 1909)¹

[934] This compilation contains among other things all works of the Zurich school that are either directly concerned with psychoanalysis or touch upon it in essentials. Works with a clinical or psychological content not concerned with psychoanalysis have been omitted. Abraham's works, including those written in Zurich, are abstracted in *Jahrbuch* 1909. A few works by German authors that come close to the findings in *Diagnostische Assoziationsstudien* are noted in passing. A consideration of the critical and oppositional literature is unfortunately impossible as long as the scientific soundness of our principles of research is called in question.

[935] Bezzola (formerly Schloss Hard, Ermatingen): "Zur Analyse psychotraumatischer Symptome," *Journ. f. Psychol., u. Neurol.*, VIII (1907). — The author still bases himself entirely on the trauma theory. His procedure corresponds in detail to the Breuer-Freud method, which was called "cathartic." The author has no real grasp of later methods. He recommends a modification which he calls *psychosynthesis*. "Every psychically effective experience reaches consciousness in the form of dissociated excitations of the senses. In order to become concepts, these excitations have to be associated among themselves and also with consciousness. But in consequence of the narrow range of consciousness, this process cannot be fully completed, certain components remain in the unconscious or become conscious by false association. Psychosynthesis consists in reinforcing these isolated conscious components by empathy until the components subconsciously associated with them are reactivated, whereupon the development of the whole process reaches consciousness and the dissolution of the psychotraumatic symptoms ensues." This theory is supported by a series of cases. Naturally they are presented with total blindness for the actual psychosexual background. The epilogue contains an attack on Freud's sexual theory in the usual nervous tone and with arguments to match.

Binswanger, see Jung: *Diagnost. Assoz. stud.*, XI.

[936] Bleuler (Zurich): "Freudsche Mechanismen in der Symptomatologie von Psychosen," *Psychiatr.-neurol. Wochenschrift*, 1906.— Analyses of symptoms and associations in various psychotic states.

[937] Bleuler and Jung: "Komplexe und Krankheitsursache bei Dementia praecox," *Zentralbl. f. Nervenheilkunde u. Psychiatrie*, XXXI (1908), 220ff. —The authors seek to clarify their aetiological standpoint in the light of Meyer's critique of Jung's

theory of dementia praecox. They first demonstrate that the new conception is not aetiological but symptomatological. Questions of aetiology are complicated and take second place. Bleuler makes a rigorous distinction between the physical process of disease and the psychological determination of the symptoms, and in view of the importance of the former he attaches no aetiological significance to the latter. As against this, Jung leaves the question of the ideogenic aetiology open, since in physical processes of disease the physical correlate of affect can play an aetiological significant role.

[938] Bleuler: *Affektivität, Suggestibilität, Paranoia*. Halle, 1906.— In this book Bleuler makes a broadminded attempt to provide a general psychological description and definition of affective processes, and to correlate them with an outline of Freudian psychology. The conception of attention and suggestibility as special instances or partial manifestations of affectivity is a pleasing simplification of the Babylonian confusion of tongues and concepts prevailing in psychology and psychiatry today. Even though the last word has not been spoken, Bleuler offers us a simple interpretation, based on experience, of complicated psychic processes. Psychiatry is in urgent need of this since the psychiatrist is *forced* to think and operate with complicated psychic entities. We could easily wait for a hundred years until we got anything of this kind from experimental psychology. With affectivity as a basis, Bleuler devotes an uncommonly important chapter to the inception of paranoid ideas, demonstrating in four cases that a feeling-toned complex lies at the root of the delusion.

[939] The reviewer must rest content with this general sketch of the book's scope and tendency. Its wealth of detail does not lend itself to brief summation. We can say that Bleuler's book is the best general description to date of the psychology of affect. It is warmly recommended to everyone, especially the beginner.

[940] _____. "Sexuelle Abnormitäten der Kinder," *Jahrbuch der schweiz. Gesellschaft f. Schulgesundheitspflege*, IX (1908), 623ff. — A lucid description of sexual perversions in children. Frequent reference is made to Freud's psychology. The author favours sexual enlightenment, not in the form of mass sex education at school, but at home, the right moment being tactfully chosen by the parents.

_____. See Jung: *Diagnost. Assoz. stud.*, V.

[941] Bolte (Bremen): "Assoziationsversuche als diagnostisches Hilfsmittel," *Allgemeine Zeitschrift f. Psychiatrie*, LXIV (1907).— The author demonstrates the use of the association experiment for diagnostic purposes. He concurs in essentials with the basic findings of the *Diagnostische Assoziationsstudien*. Some interesting examples bring the ideas in this book vividly to life.

- [942] Chalewsky (Zurich): "Heilung eines hysterischen Bellens durch Psychoanalyse," *Zentralbl. f. Nervenheilkunde u. Psychiatrie*, XX (1909). [Abstract, by Maeder, omitted.]
- [943] Claparède (Geneva): "Quelques mots sur la définition de l'hystérie," *Archives de psychologie*, VII (1908), 1969ff. —The author criticizes with great skill the recent conception of hysteria inaugurated by Babinski. In the concluding chapter he develops his own views into a conception which itself consists of a series of question marks. He acknowledges the importance of Freudian repression and endows it with biological significance. Psychoanalytic resistance, of which he has gained first-hand experience, is for him a defence reaction. He takes the same view of globus [hystericus = lump in the throat], vomiting, spasms in the oesophagus, lying, simulation, etc. He sees bodily symptoms as a revivification of ancestral reactions that were once useful. Thus the hysterogenic mechanism is conceived as a "tendance à la réversion," an atavistic mode of reaction. Its infantile character and the "disposition ludique" (play tendency) seem to him to support this theory. His arguments lack the necessary empirical basis which of course can only be acquired through psychoanalysis.
- [944] Eberschweiler (Zurich): "Untersuchungen über die sprachliche Komponente der Assoziation," *Allgemeine Zeitschrift für Psychiatrie*, 1908. — A painstaking and careful investigation prompted by the reviewer. One finding is of particular interest for complex psychology: it has been shown that in the association experiment certain vowel sequences occur, i.e., successive reactions have the same vowel sound. Now if these "perseverations" are correlated with complex-indicators, we find that, given an average percentage of 0.36 complex-indicators per reaction, 0.65 fall on a word in the vowel sequence. If we take the two associations preceding the vowel sequences without clang affinity, we reach the following result:
- a) Association without vowel sequence: 0.10 complex-indicators.
 - b) Association without vowel sequence: 0.58 complex-indicators.
1. Beginning of vowel sequence (association with vowel sound perseverating in the ensuing series): 0.91 complex-indicators.
 - 2nd term in the vowel sequence: 0.68.
 - 3rd term in the vowel sequence: 0.10.
 - 4th term in the vowel sequence: 0.05.
- [945] It is evident that after complex-disturbances there is a distinct tendency to clang perseverations, and this is an important finding as regards the mechanism of punning and rhyming.
- [946] Flournoy (Geneva): *Das Indes à la Planète Mars. Étude sur un cas de somnambulisme avec glossolalie*. 3rd edn., Paris, 1900.— "Nouvelles observations

sur un cas de somnambulisme avec glossolalie,” *Archives de psychologie*, I (1901). — Flournoy’s comprehensive and extremely important work on a case of hysterical somnambulism contributes valuable material on fantasy systems and merits the attention not only of psychoanalysts but also of the general public. In presenting his case Flournoy comes very close to certain of Freud’s views, though no use could be made of his more recent discoveries.

[947] Frank Zurich: “Zur Psychoanalyse” (Festschrift for Forel), *Journ. f. Psychol, u. Neurol.* XIII (1908). — After a short historical introduction based on the studies by Breuer and Freud, the author expresses his regret that Freud has abandoned the original method without giving his reasons for so doing. Attentive reading of Freud’s subsequent writings discloses soon enough why he preferred the perfected technique to the originally imperfect one. The author restricts himself to the use of the original cathartic method in conjunction with hypnosis, and his case material proves that he is working with a valuable, practically useful method which yields rewarding results. The inevitable attack on Freud’s theory of sexuality is consequently set forth in more temperate tones. The author poses the question: “Why should just the sexual affects among the many others with which the psyche is endowed give rise to disturbances, or is the sexual affect supposed to be the root of all others?” (The role of sexuality in the neuroses was not invented *a priori*, but was discovered empirically through the use of psychoanalysis, and this is something quite different from the cathartic method.) The author does not use psychoanalysis because “a practising physician should not be obliged, in each case, to carry the psychoanalysis through to its very end for theoretical reasons only.” This obligation exists nowhere, but for *practical* reasons one has to go further than one did in 1895; had the method of that time accomplished everything, there would have been no need for going further. The author gained the impression that Freud mastered hypnosis and suggestion very well in theory, but by no means perfectly in actual practice. “I can understand his constant change of method only on the supposition that, because of his *insufficiently thorough hypnotic treatments and their unsatisfactory results*, he as a theoretician, was constantly trying to find new methods.” Reviewer’s italics. A little earlier in his paper, the author says that “Freud has relinquished these methods *in spite of his successes*.” In connection with this contradiction it should be noted that Frank *utterly ignores* Freud’s later works, as well as the writings of other authors and the Zurich Clinic, otherwise he could not possibly assert—in 1908!—that the cathartic method and its results remained “unnoticed” and only “isolated verifications” were attempted.

[948] (The reviewer cannot refrain from pointing out how simple it is to obtain information on these seemingly difficult problems. If, for instance, an author is faced with the problem why Freud may have given up hypnosis, he need only compose a

letter to Professor Freud and inquire about it. On this point the reviewer is insistent because it is the basic sickness of German psychiatry that one is never eager to *understand*, but only to *misunderstand*. In these matters a *personal discussion* is needed in order to eliminate all unnecessary difficulties and misunderstandings. If this principle, which is fully accepted in America, were acknowledged on our continent, we would not see so many otherwise deserving authors making fools of themselves by their criticism, which is frequently couched in a language that renders any reply impossible.)

Fürst, see Jung: *Diagnost. Assoz. stud.*, X.

- [949] Hermann (Galkhausen): "Gefühlsbetonte Komplexe im Seelenleben des Kindes, im Alltagsleben und im Wahnsinn," *Zeitschrift für Kinderforschung*, XIII, 129–43. — Clearly written introduction to the theory of complexes and its application to various normal and pathological psychic states.
- [950] Isserlin (Munich): "Die diagnostische Bedeutung der Assoziationversuche," *Münchener medizinische Wochenschrift*, no. 27 (1907). — In this critical account of the association studies in Zurich, the author acknowledges the existence of several important findings. But where Freudian psychology begins, his approval ends.
- [951] Jung (Zurich): *Zur Psychologie und Pathologie sogenannter okkulten Phänomene*.² Leipzig 1902. — Besides clinical and psychological discussions on the nature of hysterical somnambulism, this work contains detailed observations on a case of spiritualistic mediumship. The splitting of the personality derives from its infantile tendencies and the fantasy systems are found to be rooted in sexual wish-deliria. Examples of neurotic automatisms include a case of cryptomnesia which the author discovered in Nietzsche's *Zarathustra*.
- [952] _____. "Ein Fall von hysterischem Stupor bei einer Untersuchungsgefangenen,"³ *Journ. f. Psychol, u. Neurol.*, I (1902).— Description of the patient's pathological intention, wish to be ill, Freudian repression of anything unpleasant, and wish-fulfilling delusions in a case of the Ganser-Raecke twilight state.
- [953] _____. "Die psychopathologische Bedeutung des Assoziationsexperimentes,"⁴ *Archiv für Kriminalanthropologie*, XX (1906), 145ff. — General introduction to the association experiment and the theory of complexes.
- [954] _____. "Experimentelle Beobachtungen über das Erinnerungsvermögen,"⁵ *Zentralbl. f. Nervenheilkunde u. Psychiatrie*, XXVIII (1905), 653ff. — The author describes the reproduction procedure he himself inaugurated. If, on completion of an association experiment, the subject is asked whether he can remember his previous reaction to each of the stimulus words, it is found that the forgetting usually occurs at or immediately after complex-disturbances. Hence it is a "Freudian forgetting." The procedure is of practical value in pin-pointing complex-indicators.

[955] _____. “Die Hysterielehre Freuds. Eine Erwiderung auf die Aschaffenburgsche Kritik,”⁶ (*Münchener medizinische Wochenschrift*, LIII:47 (1906). — As the title indicates, this is a piece of polemic the aim of which is to induce our opponent to get better acquainted with the psychoanalytic method before judging it. Today this paper is merely of historical value, marking, we might say, the starting-point of the now flourishing Freudian movement.

[956] _____. “Die Freudsche Hysterietheorie,”⁷ *Monatsschrift f. Psychiatrie u. Neurologie*, XXIII:4 (1908), 310ff. — A report written at the request of the president of the International Congress for Psychiatry in Amsterdam, 1907. The author confines his remarks to the most elementary principles in accordance with his knowledge at that time, which since then has been considerably enlarged with increasing experience. Historically, Freud’s theory may be regarded as a transformation of the cathartic method into psychoanalysis. The psychoanalytic conception of hysteria is illustrated with the help of a case which may serve as a paradigm. Summary (abbreviated): Certain precocious sexual activities of a more or less perverse nature grow up on a constitutional basis. At puberty, the fantasies tend in a direction constellated by the infantile sexual activity. The fantasies lead to the formation of complexes of ideas that are incompatible with the other contents of consciousness and are therefore repressed. This repression takes with it the transference of libido to a love-object, thus precipitating a great emotional conflict which then provides occasion for the outbreak of actual illness.

[957] _____. “Associations d’idées familiales”⁸ (avec 5 graphiques), *Archives de psychologie*, VII (1907). — With the help of Fürst’s material (see *Diagnostische Assoziationsstudien*, X) the author evaluates the average difference between various types of association. The results are given in percentages, with graphs.

[958] _____. “L’analyse des rêves,”⁹ *Année psychologique*, published by Alfred Binet, V (1909), 160ff. — Outline of the elements of Freud’s interpretation of dreams, based on examples from the author’s own experience.

[959] _____. *Über die Psychologie der Dementia praecox*.¹⁰ Halle, 1907. — The book consists of five chapters:

- I. Critical survey of theoretical views on the psychology of dementia praecox, as found in the literature up to 1909. In general, a central disturbance is assumed, given different names by different authors, some of whom also mention “fixation” and the “splitting-off of sequences of ideas.” Freud was the first to demonstrate the psychogenic mechanism of paranoid dementia.
- II. The feeling-toned complex and its general effects on the psyche. A distinction is made between the acute and the chronic effects of the complex, i.e., between the immediate

and long-lasting assimilation of its contents.

- III. The influence of the feeling-toned complex on the valency of associations. This question is discussed in some detail, the main accent falling on the biological problem of working through the complex and of psychological adaptation to the environment.
- IV. Dementia praecox and hysteria: a parallel. A comprehensive description of the similarities and differences of both diseases. Summary: Hysteria contains as its innermost core a complex that can never be overcome completely, though the possibility of overcoming it is present *in potentia*. Dementia contains a complex that has become permanently fixed and can never be overcome.
- V. Analysis of a case of paranoid dementia as a paradigm. An absolutely typical case of an elderly patient, presumed to be imbecilic, who produced masses of neologisms that could be satisfactorily explained under analysis and confirm the content of the preceding chapters.

[960] The book has been translated into English by Peterson and Brill, with an introduction by the translators. Title: C. G. Jung: *The Psychology of Dementia Praecox*. Nervous and Mental Diseases Monograph Series No. 3. Authorized translation with an introduction by Frederick Peterson, M.D., and A. A. Brill, Ph.B., M.D. New York, 1909.

[961] _____. *Diagnostische Assoziationsstudien*. Beiträge zur experimentellen Psychopathologie. Edited by C. G. Jung. Vol. I. [Leipzig,] 1906.¹¹ — This volume contains a selection of works from the Zurich Clinic on association and the association experiment which were previously published separately in the *Journal für Psychologie und Neurologie*. Quite apart from their psychological viewpoint, these works are of practical and medical interest because it was from these researches that the diagnostic association experiment was developed, an experiment which furnishes us with a quick and certain clue to the most important of the complexes. The diagnostic use of the experiment is of primary importance; of secondary importance is its use as a clinical aid to differential diagnosis in very many cases where the diagnosis is still uncertain. [Contents as follows.]

[962] Preface: by Professor Bleuler: “Über die Bedeutung von Assoziationsversuchen,” pp. 1–6.—Verbal association is one of the few psychological products that can be evaluated experimentally. Much may be expected from these experiments because the whole psychic past and present, with all their experiences and aspirations, are reflected in the associative activity. It is an “index of all psychic processes, and we need only decipher it in order to know the whole man.”

[963] I. C. G. Jung and Franz Riklin (Zurich): “Experimentelle Untersuchungen über Assoziationen Gesunder,”¹² pp. 7–145.— The aim of this paper was to collect and present a large amount of associations of normal subjects. In order to evaluate the material statistically, a system of classification was needed that would represent an extension and improvement of the Kraepelin-Aschaffenburg system. The system adopted by the two authors follows logical linguistic principles and allows a statistical evaluation which, though imperfect, is nevertheless sufficient for present purposes. The first question to be discussed was whether and if so what types of reaction occur in the normal state. It was found that, on average, educated subjects exhibit a shallower type of reaction than do the uneducated; further, that the subjects fall into two main types, which shade off into each other: an objective and an egocentric type. The first reacts with few signs of emotion, the second with many. The second type is of particular interest from the practical standpoint and falls into two further subdivisions: the so-called constellation or *complex-constellation type* and the *predicate type*. The first tries to suppress emotions, the second to display them.

[964] Fatigue, somnolence, alcoholic intoxication, and mania produce a shallow type of reaction. The shallowness is due primarily to disturbance of attention in these states. This was proved by conducting a special experiment designed to distract the subject’s attention and then continuing the association test under these conditions. The experiments yielded positive results.

[965] II. K. Wehrlin (Zurich): “Über die Assoziationen von Imbezillen und Idioten,” pp. 146–174. — The author reports the results of his association experiments with 13 imbeciles. The associations of the most feeble-minded exhibit a distinct type known as the *definition type*. Characteristic reactions:

Winter: consists of snow.

Singing: consists of notes and song-books.

Father: member beside the mother.

Cherry: a garden thing.

[966] Imbeciles thus display an extraordinarily intense attitude to the intellectual meaning of the stimulus word. It is characteristic that this type is found precisely among the feeble-minded.

[967] III. C. G. Jung: “Analyse der Assoziationen eines Epileptikers.”¹³ pp. 175–92. — The associations of this epileptic clearly belong to the definition type, having an awkward and cumbersome character that confirms and supplements the subject’s own reaction:

Fruit: that is a fruit, a fruity fruit.

Strong: am powerful, that's strong.

Jolly: I'm jolly. I'm merry.

[968] There are also an extraordinary number of feeling-toned, egocentric associations that are expressed undisguised. Certain indications support the conjecture that the epileptic feeling-tone has a markedly perseverating character.

[969] V. C. G. Jung: "Über das Verhalten der Reaktionszeit beim Assoziationsexperimente."¹⁴ pp. 193–228. — The hitherto unknown reasons for the abnormal prolongation of certain reaction-times are here investigated, with the following results: Educated subjects react, on average, quicker than the uneducated. Reaction-time of female subjects is, on average, considerably longer than that of male subjects. The grammatical quality of the stimulus word has a definite influence on reaction-time, and so has the logical linguistic quality of the association. *Reaction-times exceeding the probable mean are for the most part caused by the interference of an unconscious repressed complex.* Hence they are an important aid in the discovery of repressed complexes. This is documented with numerous examples of analyses of associations that have been constellated in this way.

[970] V. E. Bleuler: "Bewusstsein und Assoziation." pp. 229–57.— Drawing upon literary as well as case material, this paper sets out to prove that "so far as has been observed, no sharp distinction can be made between conscious and unconscious," and that the same functional structures and mechanisms that we find in our consciousness can be shown to exist outside it and to influence the psyche just as much as the analogous conscious processes. "In this sense there are unconscious sensations, perceptions, conclusions, feelings, fears and hopes, which differ from their conscious counterparts only because the quality of consciousness is absent." B. cites in particular the cases of multiple personality and remarks that we should not speak merely of *an* unconscious, but that an almost infinite number of different unconscious groupings is possible. The grouping of memory elements into different personalities is due without exception to the overriding influence of affects.

[971] B. regards the quality of consciousness as something subsidiary, since psychic processes need to become conscious only under certain conditions, that is to say when they enter into association with "those ideas, sensations, strivings which at a given moment constitute our personality."

[972] VI. Jung: "Psychoanalyse und Assoziationsexperiment,"¹⁵ pp. 258–81. — This paper still shows the strong influence of the original Breuer-Freud theory of neurosis, namely, the theory of the psychic trauma. Neurotic symptoms are essentially symbols

of repressed complexes. Disturbed reactions in the association experiment reveal the words and things that lead directly to the unknown complex. Thus far the experiment can be a valuable aid in analysis. This possibility is discussed by means of a practical example, a case of obsessional neurosis. The building up of disturbed reactions into a legend proves the existence of an extensive erotic complex containing a number of individual determinants. In this way we gain a deep insight into the actual personality. Subsequent psychoanalysis justified the expectations the association experiment had aroused, thus bearing out the conclusion that the experiment renders the complex hidden behind the neurotic symptoms accessible to investigation. Every neurosis harbours a complex that exerts considerable influence on the experiment and, as countless experiences show, it must have a causal significance.

*

Contributions VII to XI have now been published in Vol. II of *Diagnostische Assoziationsstudien*:

[973] VII. Riklin: "Kasuistische Beiträge zur Kenntnis hysterischer Assoziationsphänomene," pp. 1–30. — The author examines the association phenomena in eight hysterics and comes to the following conclusions: The hysterical type of reaction is dominated by more or less autonomous complexes of great affective power, the development of which seems to be much more pronounced than with normal subjects. One or the other complex dominates the reaction to the exclusion of everything else, so that the experiment is thickly studded with complex-disturbances. Domination by one complex is the hallmark of hysterical psychology; it is probable that all the symptoms can be derived directly from the complex.

[974] VIII. Jung: "Assoziation, Traum und hysterisches Symptom,"¹⁶ pp. 31–66. — This paper undertakes to describe and to determine the various ways in which the erotic complex manifests itself in a case of hysteria. First, analysis of the associations shows how they are constellated by the erotic complex, then follows an analysis of its transformations in a dream-series, and finally the complex is shown to be the root of the neurosis as well. In hysteria the complex possesses an abnormal degree of autonomy and tends to lead an active existence on its own, which progressively diminishes and replaces the power of the ego-complex. In this way a new, pathological personality comes into being, whose inclinations, judgments, and decisions tend only in the direction of the pathological will. The second personality consumes the normal ego-remnant and forces it into the role of a secondary (controlled) complex.

[975] IX. Jung: "Über die Reproduktionsstörungen beim Assoziationsexperiment,"¹⁷ pp. 67–76. — The subject of this paper is the reproduction method discussed above (Jung, "Experimentelle Beobachtungen über das Erinnerungsvermögen"). On the

basis of extensive pathological material it is shown that a faultily reproduced association has a reaction-time that exceeds the mean for the experiment, and exhibits an average of more than twice as many complex-indicators as a correctly reproduced association. From this it is evident that disturbance of reproduction is another indicator for the interference of a complex.

[976] X. Emma Fürst (Schaffhausen): “Statistische Untersuchungen über Wortassoziationen und über familiäre Überstimmung im Reaktionstypus bei Ungebildeten,” pp. 77–112. — Association experiments were made with 24 families totalling 100 subjects; this interim paper presents the results of the evaluation of only 9 of the uneducated families consisting of 37 subjects. Evaluation of the remaining material is not yet complete.

[977] It was found that husbands tend to produce rather more outer associations than their wives, and sons rather more than their sisters. 54% of the subjects, predominantly women, were pronounced predicate-types. The tendency to form value-judgments is greater in age than in youth; with women it begins at 40 and with men at 60. Relatives have a tendency to conform in reaction type to concordance of associations. The most striking and most regular conformity occurs between parents and children of the same sex.

[978] XI. Ludwig Binswanger (Kreuzlingen): “Über das Verhalten des psychogalvanischen Phänomens beim Assoziationsexperiment,” pp. 113–95. [Abstract, by Binswanger, omitted.]

*

The following works of the Zurich Clinic are concerned with the diagnostic use of the association experiment:

[979] Jung: *Die psychologische Diagnose des Tatbestandes*.¹⁸ Halle, 1906. — General description and interpretation of the experiment. Practical application to a case of theft.

[980] _____. “Le nuove vedute della psicologia criminale. Contributo al metodo della ‘Diagnosi della conoscenza del fatto,’”¹⁹ *Rivista di psicologia applicata*, IV (1908), pp. 285–304. — Practical application to an actual case of theft with several suspects.

[981] Philipp Stein (Budapest): “Tatbestandsdiagnostische Versuche bei Untersuchungsgefangenen,” *Zeitschrift für Psychologie und Physiologie der Sinnesorgane*, 1909. — Investigation of factual evidence presented by guilty, suspected, and innocent persons. The material was collected partly from the Psychiatric Clinic and partly from prisoners held in detention in Zurich, and is of particular interest as stemming from the living reality of criminal practice.

- [982] Jung: *Der Inhalt der Psychose*.²⁰ Freuds Schriften zur angewandten Seelenkunde. No. 3. 1908. — This paper, an academic lecture, discusses the great change which the introduction of Freudian psychology has wrought in our psychological conception of the psychoses. First a simple account is given of the switch from the anatomical to the psychological approach; then follows an outline of the psychological structure of dementia praecox, illustrated by a number of concrete cases. The paper does not purport to be anything more than an introduction to the modern problems of psychological psychiatry. It was published in Russian and Polish in 1909.
- [983] Ladame Geneva: “L’association des idées et son utilisation comme méthode d’examen dans les maladies mentales.” *L’Encéphale, journal mensuel de neurologie et de psychiatrie*. No. 8, 1908). — Extremely objective account of the results of association studies.
- [984] _____. Review of Jung’s *Psychologie der Dementia praecox*. *Archives de psychologie*. IX 1909), 76. — The author summarizes the content of the book in some detail, but refrains from criticism and only adds the following passage at the end: “In conclusion, let us remark how fruitful attempts of this kind ... are. After reading them it is impossible to go to sleep again mentally and to take a calm or desultory view of the innumerable dementia praecox patients who inhabit our asylums. One feels irresistibly compelled to look for something else behind the banal symptoms of psychosis, to discover the individual himself and his normal and abnormal personality.”
- [985] Alphonse Maeder Zurich: I. “Contributions à la psychopathologie de la vie quotidienne.” *Archives de psychologie*. VI. — II. “Nouvelles contributions à la psychopathologie,” *Archives de psychologie*. VII. I Simple analyses of Freudian slips of the tongue, forgetting, *faux pas*. demonstrating the existence of a repressed idea with negative feeling-tone. II The author gives examples of various kinds of forgetting caused by “isolation” and “derivation,” discusses abreaction “décharge émotionnelle” in relation to the concept of the complex, and offers evidence of dissociation in normal persons, including the mechanisms of displacement, “irradiation” and identification. Attention is drawn to “automatismes musicaux” and to the indirect means of expression employed by the unconscious. The author stresses the fruitfulness of this branch of psychopathology.
- [986] _____. “Essai d’interprétation de quelques rêves,” *Archives de psychologie*, VI. —A short introductory account of Freud’s theory of dream interpretation and of psychoanalysis, illustrated by four of the author’s dream analyses. He shows that the same symbols are frequently employed in dreams, legends, and myths in exactly the same way (notably the snake, dog, bird, garden, house, box).
- [987] _____. “Die Symbolik in den Legenden, Märchen, Gebräuchen und Träumen,” *Psychiatrisch-neurologische Wochenschrift*, X. — Thinking in symbols is an inferior

stage of association that equates similarity with identity; it is frequently a process of unconscious activity (hence its role in dreams, hallucinations, delusional ideas, as well as in poetry). Examples are taken from epileptic twilight states. Author discusses the assimilative tendency of the sexual complex in relation to symbol formation. Interpretation of the fish as a sexual symbol provides the clue to numerous customs, folk beliefs (fish on Friday, April fish = April fool, the game on Ash Wednesday), legends and fairytales (Grimm: "The Golden Fish").

[988] _____. *Une voie nouvelle en psychologie*. Coenobium Lugano-Milano, 1909. — Informative essay on Freudian psychology (excluding psychopathology). By uncovering unconscious motivations, psychoanalysis provides a coherent view of the way a person thinks and acts.

[989] Disturbances of unconscious activity are discussed with the help of the author's own analyses. These disturbances should be regarded as expressions of the unconscious, as revelations of unadmitted tendencies. The gradual transition to the pathological is stressed throughout. Dreams are intimately connected with the individual's actual conflicts; they are solutions offered by the unconscious which are often accepted later on and become realities. Conflicts are due partly to the stresses of civilization.

[990] Section III treats of symbols in dreams, hallucinations, fairytales, and legends, and in ordinary speech. The symbol is a special form of thought association characterized by its impreciseness: vague analogies are taken as identities. This is probably typical of the unconscious: it has something infantile and primitive about it. Symbolisms in popular speech (Rabelais, folklore), in legends, in the language of primitives show affinities with associations under fatigue, in *abaissement du niveau mental*, in symptomatic actions when attention is distracted, in dreams, psychoses, and neuroses.

[991] _____. "A propos des Symboles," *Journal de Psychologie normale et pathologique*, 1909. [Abstract, by Maeder, omitted.]

[992] Hermann Müller (Zurich): "Beiträge zur Kenntnis der Hyperemesis Gravidarum," *Psychiatrische-neurologische Wochenschrift*, X. — On the basis of careful clinical observations on a number of cases of hyperemesis²¹ the author comes to the following conclusions:

1. *Vomitus matutinus gravidarum* is a psychogenic symptom.
2. Hyperemesis is in the majority of cases psychogenic.

[993] Although the author does not put forward any complete analysis, in several of his cases he makes psychological insight possible. Attention is paid throughout to the views of the Freudian school.

- [994] _____. "Ein Fall von induziertem Irresein nebst anschliessenden Erörterungem," *Psychiatrisch-neurologische Wochenschrift*, XI. — A case of religious exaltation in a female religious fanatic induced a psychosis in a female hysteric who lived with her, by reason of the "same aetiological demand." The presentation of the two cases is elegant and lucid, thanks to the application of Freudian analysis.
- [995] Oskar Pfister (Zurich): "Wahnvorstellung und Schülerselbstmord. Auf Grund einer Traumanalyse beleuchtet," *Schweizerische Blätter für Schulgesundheitspflege*, I (1909). — "Psychoanalytische Seelsorge und experimentelle Moralpädagogik," *Protestantische Monatshefte*, I (1909). — "Ein Fall von psychoanalytischer Seelsorge und Seelenheilung," *Evangelische Freiheit. Monatsschrift für die kirchliche Praxis in der gegenwärtigen Kultur*, II–V (1909). [Abstract, by Pfister, covering all three items, omitted.]
- [996] Pototsky (Berlin): "Die Verwertbarkeit des Assoziationsversuches für die Beurteilung der traumatischen Neurosen," *Monatsschrift für Psychiatrie und Neurologie*, XXV, pp. 521ff. — The author applied the association experiment to two patients with neuroses due to an accident. In the first case there was an overwhelming predominance of the compensation complex, in the second a striking absence of the same complex. Prognostic conclusions are drawn from these findings.
- [997] Frank Riklin (Zurich): "Hebung epileptischer Amnesien durch Hypnose," *Journ. f. Psychol, u. Neurol.*, 1:5/6 (1903). — The author's success in clearing up the amnesias of epileptics under hypnosis demonstrates their affinity with hysterical amnesias. Association experiments of clinical, diagnostic interest are also reported.
- [998] _____. "Zur Anwendung der Hypnose bei epileptischen Amnesien," *Journ. f. Psychol, u. Neurol.*, II (1903). — Report of another case with epileptic twilight states and disappearance of amnesia, though it is to be regretted that no analysis is given of their content. During these states the patient lovingly stroked a cat, and sometimes a goat too. It has since been brought to my knowledge that this scene was a fragment of an infantile erotic experience.
- [999] _____. "Zur Psychologie hysterischer Dämmerzustände und des Ganserschen Symptoms," *Psychiatrisch-neurologische Wochenschrift*, No. 22 (1904). — Ganser has described the symptom of "irrelevant talk" in hysterical twilight states. Subsequently, the concept of Ganser's symptom has been taken by various authors (Raecke in particular) now in a broader and now in a narrower sense. Further, it was maintained that the symptom is exclusively associated with the outbreak of twilight states among prisoners in detention. The psychological affinity between the irrelevant talk of hysterics and the mechanism of simulation forced itself upon these authors largely because of this fact. Jung ("Ein Fall von hysterischem Stupor bei einer Untersuchungsgefangenen," *Journ. f. Psychol, u. Neurol.*, 1, 1902) was the first to

place the problem on the footing of Freudian psychology, thus facilitating the correct evaluation and interpretation of Ganser's symptom and the twilight state.^{21a}

[1000] The paper reports four cases of hysterical twilight states with Ganser's symptom. Only one of them was a prisoner in detention, the others not. The psychic situation of the detainee is exceptional: he is driven into a corner, gives false answers, tells lies, and in an extremity of distress falls into a twilight state; and only under these conditions will the symptom of "automatized simulation," of not knowing and not understanding, come markedly to the fore. The general situation at the onset of Ganser's twilight state is that a painful event is immediately repressed and thrust into oblivion because it is incompatible with the other contents of consciousness. The motive of not knowing or of not wanting to know produces the symptom of irrelevant talk. Disturbance of orientation proves to be a wish not to be oriented in regard to the existing situation. In twilight states, not knowing can also be replaced by compensatory wish-fantasies. The pronounced "restriction of consciousness" serves to split off the intolerably painful idea and to allow the emergence of censored, wish-fulfilling situations.

[1001] _____. "Analytische Untersuchungen der Symptome und Assoziationen eines Falles von Hysterie," *Psychiatrisch-neurologische Wochenschrift*, No. 46 (1905). — For the main part the analysis stems from the year 1902–3 and concerns a typical, severe case of conversion hysteria. At that time the Breuer-Freud *Studien über Hysterie* still served as a theoretical and technical model. The therapeutic results must be rated very good; during the 6–7 years since then, the patient's physical symptoms have come back only occasionally. Her personality, however, shows signs of moral deterioration. Nowadays, perhaps, we would no longer have the courage or the desire to analyse a personality of so little value and so poorly developed, and with so few hopes for the future. The results are therefore to be rated all the more highly. An important contributory factor was the transference to the analyst. While the author found that abreaction was not sufficient to account for the therapeutic result, he was handicapped by insufficient knowledge of the nature of the transference.

[1002] At the time of the analysis the author was also not familiar enough with dream interpretation to derive much benefit from it.

[1003] The structure of the symptoms was analysed and a number of psychic traumata were discovered. The patient's early childhood received scant attention; on the other hand the mechanism by which hysterical ailments of the body are produced is amply documented.

[1004] One section of the book is devoted to association experiments. At that time it was of great importance to show that the same mechanisms are at work in the association experiment as those which produce hysterical phenomena, and that the

laws governing the effects of the complex are the same in the experiment as in normal persons, but only emerge with greater clarity.

[1005] Another section is concerned with the association mechanism leading to conversion hysteria and with the theory of abreaction. The author was keenly aware of the gap between theory and fact, which has since been filled by introducing the concepts of transference, libido, and infantile sexuality.

[1006] _____. *Die diagnostische Bedeutung von Assoziationsversuchen bei Hysterischen*. — Lecture delivered at the 35th meeting of the Society for Swiss Psychiatrists in St. Urban, 1904. Abstract in the annual report of the Society and in the *Psychiatrisch-neurologische Wochenschrift*, No. 29 (1904).

[1007] _____. “Über Versetzungsbesserungen,” *Psychiatrisch-neurologische Wochenschrift*, Nos. 16/18 (1905). — The opening of the annexes to the Rheinau Sanatorium (Canton Zurich) affords an opportunity to observe the effect of transferring mentally ill patients from one institution to another. The observations relate to 85 patients of whom the author has previous knowledge at the Burghölzli. In more than half the cases an improvement was noted.

[1008] Adaptation to reality is helped by greater freedom of movement and, above all, by work therapy. Especially in the commonest disease, dementia praecox, this draws the patient out of his introversion and transfers his interest to reality. In order to show how the patients assimilate their new milieu, the author briefly discusses the psychological significance of the most important symptoms of this disease (negativism, blocking, wish-fulfilment in delusional ideas, servant-girl psychoses, fertility symbols, mistaken identity due to complexes, religious delusions as translation of wish fantasies into paranoid ideas; their elaboration, condensation, stereotypization, cathexis of the motor apparatus by complex-automatisms).

[1009] The best results are obtained through the exercise of complexes of ideas and functions that have remained normal. Equally effective are early discharge, replacement whenever possible of bed treatment, which only accentuates introversion and “dreaminess,” by work therapy which draws the patients out of themselves.

[1010] With the aid of two case histories it is shown how the introversion comes about, where the transference of interest to the outside world fails, and how the process of introversion goes much further than simple wish-fulfilment in fantasy would require. In the second case even the attempt at wish-fulfilment in reality was unable to check the introversion; the unconscious produced ideas of self-destruction to which the patient succumbed by committing suicide.

[1011] In about half the cases the transfer had no noticeable influence.

[1012] The effects of the transfer are illustrated by a series of excerpts from case histories analytically interpreted.

[1013] _____. "Beitrag zur Psychologie der kataleptischen Zustände bei Katatonie," *Psychiatrisch-neurologische Wochenschrift*, Nos. 32/33 (1906). — The author succeeded in making contact with a catatonic while in a severe cataleptic state and in discovering something of what was going on in this state. We learn from the anamnesis that this condition set in after a psychosis lasting for four years. The psychosis first manifested itself in the patient's autoerotic self-aggrandizement from the age of 18. He tried to win the hand of a relative's rich daughter, completely ignoring the impossibility of doing so. Despite being rebuffed he continued to press his suit undeterred. Cataleptic symptoms were already present on his admission to the clinic, along with a persistent tendency to break out and get to his cousin.

[1014] The patient's condition can be outlined as follows: underlying the catalepsy is a powerful tendency to sleep, to "be a dead man," as was evident from the patient's own statements. The result of this tendency resembles natural sleep, but actually it is more like hypnotic sleep. It is motivated by the repression of a complex, a wish to forget.

[1015] Although the author succeeded in breaking through this sleep tendency, the breakthrough was not complete, so that, side by side with adequate discharge of affect, for instance weeping over the utter hopelessness of ever reaching the beloved, a peculiar compromise between the discharge of affect and the sleep tendency could be observed in the patient's facial expression and demeanour. The two components were sometimes divided into the two halves of the face: one side weeping, one eye open. Keeping the eyes open meant rapport with the investigator; closing the eyes meant breaking off the rapport and the victory of the tendency to sleep or forget.

[1016] Throughout the investigation the thought perseverated, "I am going to marry Emma C.," or "I love Emma C.," counterbalanced by another thought which maintains the sleep tendency as a protective factor and which voices the cousin's reply, "Don't expect anything of the future."

[1017] The patient readily imagined wish-fulfilling situations in which he believed his beloved was standing before him, went towards her, tried to embrace her, took other persons present (doctor, warder) as substitutes (mistaken identity), but always through the veil of cataleptic sleep.

[1018] Through this veil it is possible to perceive quite adequate and profound discharges of affect.

[1019] Evaluation of the questions and modes of reaction follows the laws of complex-reactions in the association experiment.

[1020] This study suggests that the catatonic phenomena in dementia praecox have in general the significance attributed to them in the present case.

[1021] _____. "Über Gefängnispsychosen," *Psychiatrisch-neurologische Wochenschrift*, XI, Nos. 30/37. —An attempt to explain and classify the clinical pictures of prison psychosis along psychoanalytic lines. Prison is a psychological situation which, despite differences of constitution in the diagnostic sense, releases psychological and pathological reactions that are more or less uniform.

[1022] _____. "Psychologie und Sexualsymbolik der Märchen," *Psychiatrisch-neurologische Wochenschrift*, IX, Nos. 22/24. — Excerpts from the author's major work: *Wunscherfüllung und Symbolik im Märchen*.

_____. *Wunscherfüllung und Symbolik im Märchen*. (Schriften zur angewandten Seelenkunde, edited by Freud, No. 2, 1908.) [Abstract, by Riklin, omitted.]

[1023] Schnyder (Bern): *Définition et nature de l'hystérie*. (Congrès des médecins aliénistes et neurologistes de France et des pays de langue française, XVIIIème Session.) Geneva, 1907. — The doctrinal tenets of a wide-ranging literature are scrutinized in this volume. Among the reviews there is an objective account of the Breuer-Freud method, as well as of the theory of complexes. Schnyder rejects the modern viewpoints. "The ideas of Freud and his partisans are certainly an important contribution to the solution of the problem of hysteria. However, the sage of Vienna might be reproached for having introduced an arbitrary mechanization into the psychological conception of hysteria, and for relying on hypotheses which, however ingenious, are of too subjective a nature to lay claim to incontestable scientific value."

[1024] Schwarzwald (Lausanne): "Beitrag zur Psychopathologie der hysterischen Dämmerzustände und Automatismen," *Journ. f. Psychol., u. Neurol.*, XV (1909). — Investigation of a psychogenic twilight state in which the patient set fire to his house. The material allows glimpses into the psychological mechanism of the deed and of the case itself. The infantile history is unfortunately incomplete, but the author is mistaken in dispensing entirely with infantile development. The patient's childhood is of the greatest importance for the subsequent development of neurosis, at least as great as the situation at the moment, if not greater.

[1025] A refining of his psychoanalytic technique would convince the author of the soundness of this view. The dream of "Tom Thumb" which the patient had the day before the incendiarism is very significant and clearly indicates that the act was determined by infantile reminiscences. This has escaped the attention of the author. Analysis of childhood and the correct evaluation of its results is one of the most difficult parts of the psychoanalytical technique, particularly for the beginner.

[Jung contributed several abstracts to the periodical *Folia neuro-biologica* (Leipzig).²² for which he was an editorial consultant. As these are summaries without critical comment, they are not translated but merely listed here:

In Vol. 1:3 (1908):

(388) Jung, C. G. “Associations d’idées familiales,” *Archives de psychologie*. VII:26 (1907).

(389) Metrai, M. “Expériences scolaires sur la mémoire de l’orthographe.” *ibid.*

(394) Lombard. Emile. “Essai d’une classification des phénomènes de glossolalie.” *ibid.*. VII:25 (1907).

(395) Claparède. Ed. “Quelques mots sur la définition de l’hystérie,” *ibid.*, VII:26 (1907). [See above, par. 943.]

(396) Flournoy. Th. “Automatisme téléologique antisuicide. Un cas de suicide empêché par une hallucination,” *ibid.*

(397) Leroy, E.-Bernard. “Escroquerie et hypnose. Escroqueries prolongées pendant plusieurs mois à l’acide de manoeuvres hypnotiques pratiquées sur une des victimes,” *ibid.*

(398) Lemaître, Aug. “Un nouveau cycle somnambulique de Mlle Smith. Les peintures religieuses,” *ibid.*, VII:25 (1907).

In Vol. II:1 (1908):

(122) Piéron, H. “La Théorie des émotions et les données actuelles de la physiologie,” *Journal de psychologie normal et pathologique*, IV–V (1907–8).

(123) Revault d’Allones, G. “L’Explication physiologique de l’émotion,” *ibid.*

(124) Hartenberg, P. “Principe d’une physiognomie scientifique,” *ibid.*

(130) Dumas, G. “Qu’est-ce que la psychologie pathologique?,” *ibid.*

(131) Dromard, G. “De la dissociation de la mimique chez les aliénés,” *ibid.*

(132) Marie, A. “Sur quelques troubles fonctionnels de l’audition chez certains débiles mentaux,” *ibid.*

(133) Janet, P. “Le renversement de l’orientation ou l’allochirie des représentations.”

(134) Pascal, Constanza. “Les Maladies mentales de Robert Schumann,” *ibid.*

(135) Vigouroux, A., and Juquelier, P. “Contribution clinique à l’étude des délires du rêve,” *ibid.*

In Vol. II:3 (1908).

(348) Varendonck, J. “Les idéals des enfants,” *Archives de psychologie*, VII:28 (1908).

(349) Claparède, Ed. “Classification et plan des méthodes psychologiques,” *ibid.*

(350) Kataroff, Dimitre. (Travail du Laboratoire de psychologie de l'Université de Genève. 1 "Expériences sur le rôle de la récitation comme facteur de la mémorisation," *ibid.*

(351) Maeder, Alphonse. "Nouvelles contributions à la psychopathologie de la vie quotidienne," *ibid.*, VII:27 (1908). [See above, par. 985.]

(352) Rouma, Georges. "Un cas de mythomanie, Contribution à l'étude du mensonge et de la fabulation chez l'enfant," *ibid.*

EDITORS.]

REVIEW OF HITSCHMANN: "FREUD'S NEUROSENLEHRE"¹

[1026] Hitschmann's book meets a longfelt need. A book that introduces the beginner to the problems of psychoanalysis in a clear and simple way has long been wanted. Hitschmann has fulfilled this task most satisfactorily. It cannot have been easy to present the manifold discoveries and conclusions of psychoanalysis in systematic order, for, contrary to the prejudices of our opponents, it is not at all a question of a preconceived system that puts no difficulties in the way of further theoretical development, but of extraordinarily complicated material that throws into relief the whole laboriousness of patient empirical research (only, of course, if one works in this field oneself.) The content of the book is very diverse but in no way confusing. The author has confined himself to essentials and, where the problems are still fluid, has been satisfied with hints. He has thus succeeded in painting an excellent picture of the present state of psychoanalysis and its far-reaching problems. It is to be hoped that the book will reach the widest possible public, not least because it will dispel numerous prejudices and false opinions which have arisen among medical men through inadequate knowledge of the literature. We must also hope that it will soon be translated into foreign languages, for which purpose it is better suited than many original researches which are so specialized that they are difficult to understand.

ANNUAL REPORT (1910/11) BY THE PRESIDENT OF THE INTERNATIONAL PSYCHOANALYTIC ASSOCIATION¹

[1027] A year and a half ago at the Congress in Nuremberg it was decided to establish an International Association; the foundation of local branches in Vienna, Berlin, and Zurich followed in quick succession. The Berlin branch, with nine members, was set up in March 1910, with Dr. Abraham² as chairman; Vienna followed in April with twenty-four members, under the chairmanship of Dr. Adler.³ Zurich was established in June with nineteen members, under Dr. Binswanger⁴ as chairman. These branches formed the base of our International Psychoanalytic Association, though with its fifty-two members in three countries it was still a tender shoot. With great pleasure and satisfaction I now can announce that in the past year our Association has led a most vigorous life. In February the seed planted in America sprouted. A local branch was established in New York with twenty-one members under the chairmanship of Dr. Brill.⁵ And at long last South Germany joined in: the Munich branch was established in March with six members under Dr. Seif⁶ as chairman.

[1028] During 1911 the respective memberships grew as follows: Berlin, from 9 to 12; Vienna, from 24 to 38; Zurich, from 19 to 29. Thus the total membership rose from 52 to 106. In other words, we have slightly more than doubled.

[1029] The Zurich group is deeply grateful to the stimulus provided by Freud's scientific theories. It may to some extent lessen our debt of gratitude if we may be allowed to point out that the founders of the branches in Berlin, Munich, and New York have come out of the Zurich school.

[1030] This encouraging proliferation in the outside world is matched by the teeming scientific activity within the sections. I refer to the variety of topics on which lectures were given in the individual groups. Positive contributions to our scientific problems, however, can be expected only when an individual member's rich experience is brought to bear on the solution of the problem adduced. In general, such an ideal condition is difficult to bring about; specifically, groups with comparatively recent local traditions will consider it their foremost goal to instruct and educate their members. At this time psychoanalysis demands of anybody who wants to master it an uncommon amount of industry and scientific concentration, if it is to be more than the free-wheeling exercise of highly individualized talents. The temptation to eschew empirical evidence is very strong in psychoanalytic work, especially since scientific *pseudo-exactitude*, like all cultural absurdities, collapses before the gaze of the analysand into its own nothingness. Yet, this does not do away with the need for

systematic planning of scientific research and exposition, which must be well conceived and immediately convincing. We who are favoured with taking possession of these newly discovered territories are obliged to use self-discipline so as to prevent these goods from being jeopardized by an unbridled imagination. Let us never forget that everything we conceive and create is well conceived and well created only when it is addressed to mankind in a humanly intelligible language. What fate expects of us is that we faithfully husband the enormous store of knowledge provided by Freud's discoveries and pass it on to our fellow men, rather than pervert it for the gratification of our own ambitions. This task requires from each of us not only a high degree of self-criticism, but also a thorough psychoanalytic training. We know well that this training is hard to come by in isolation; it is easier to obtain it when many different heads work together. This task of teaching and training is one of the main purposes of the branches of our Association, and I should like to recommend it to the local chairmen with special emphasis. Next to the results of new research, discussions of elementary questions should be on the agenda of local meetings; they would enable younger members to acquire knowledge of fundamental ideas and principles with which a thorough familiarity is the *sine qua non* of the scientific method. Such basic discussions would make it possible to dispose of many theoretical and practical misconceptions. And it seems to me of great importance to expose deviations of opinion to immediate and thorough discussion in order to forestall any squandering of our strength on pointless side-issues. This possibility, as the events in Vienna⁷ have shown, lies not so far afield, inasmuch as the present unbridled ways of psychoanalytic investigation and the multitude of problems that are touched upon encourage changes, as revolutionary as they are unjustified, in the principles of neurosis theory that Freud discovered and elaborated in decades of hard work. I believe, vis-à-vis such temptations, that we must never forget that our Association also has the important purpose of discrediting "wild" psychoanalysis and not admitting it to its own ranks. We need not fear that dogmatism—long desired by our opponents—would surely invade psychoanalysis; but it rather means that we are holding tightly to the principles we have gained and to which we will adhere until they have been either entirely confirmed or else recognized as wholly false.

[1031] After these remarks and wishes concerning the cultivation of our science in the local branches, I must also call your attention to the publishing activities in the psychoanalytic field. The past year has seen the *Zentralblatt für Psychoanalyse*⁸ added to the *Jahrbuch*; under its alert editorship the new journal has already published a great deal of material and by its variety rendered a good account of the variety of psychoanalysis. Next year a further organ will be added,⁹ of a more general rather than strictly medical character.

[1032] This year I have witnessed with my own eyes the tremendous impression that the efforts on behalf of our cause have created in the world. Knowledge and appreciation of psychoanalysis are more widespread than is generally assumed.

[1033] This past year has brought us in Zurich a loss, a loss of special poignancy for the hopes for our scientific future. It is the death of our friend Honegger,¹⁰ who had recommended himself to the membership by his ingenious paper read at Nuremberg.

TWO LETTERS ON PSYCHOANALYSIS¹

10 January 1912

[1034] In the communication from Dr. Kesselring and Dr. B. of the Keplerbund, which appeared in this column, exception was taken to the following remark of the reporter: “Dr. Kesselring, as he himself observed, spoke as an opponent of Freud’s psychoanalytic method and at the request of the Keplerbund. This Society is opposed to a tendentious materialistic pursuit of the natural sciences and wishes to combat the erroneous view that scientific knowledge stands in the way of religious belief. Hence the impression which the speaker intended to make upon his audience is perfectly understandable.”

[1035] In saying this the reporter did not “discredit” Dr. Kesselring’s willingness to speak on Freud in the Keplerbund, nor did he discredit the general activity of that Society—he merely stated something that was self-evident. The Keplerbund has the following article in its programme, which it claims is based on a “scientifically and ethically unassailable foundation”: “The Keplerbund holds the conviction that the truth contains within itself the harmony of scientific facts with philosophical knowledge and with religious experience.” Further: “The Keplerbund differs quite consciously from the materialistic dogma of monism and combats the atheistic propaganda resulting therefrom, which wrongly seeks support in the findings of natural science.”

[1036] According to this programme, therefore, the Keplerbund is not merely a champion of enlightenment and popular education, but also a militant organization. Since Freud’s teachings likewise stand in sharpest contrast to the “harmony” sought for by the Keplerbund, every thinking person will know that the society must, on its own admission, fight against them. When an organization arranges a lecture, it usually makes sure beforehand of the point of view of the lecturer, no matter whether its interest in the theme is religious, political, artistic, or scientific. Anyone who knows that Dr. Kesselring was a pupil of Freud’s must also know—so at least one must assume—that he is Freud’s opponent in theory and in practice. Equally, a reporter engaged by the Keplerbund knows that he cannot defend Freud’s “pan-sexualism” within its precincts. The reporter, who incidentally is neither a Freudian nor against the Keplerbund, did not credulously rely on the opinions of others, but to the best of his ability oriented himself beforehand on the theme of the lecture, the principles of the Keplerbund, and the views of Dr. Kesselring.

[1037] In this same connection a correspondent wrote: "To the amazement of professional people Dr. Kesselring's lecture 'On Psychoanalysis' brought before the public at the Schwurgerichtssaal a recent line of medical research which, among other things, has to include within the scope of its analytical work the most intimate and repulsive of all human fantasies. Disputes over the results of this research are taking a violent form in professional circles, and opinions are very much divided. But however violent the scientific discussion may be, opponents and friends of psychoanalysis are alike agreed that such things, even if only for the sake of good taste, should not be paraded before the public at the Schwurgerichtssaal, quite apart from the fact that even the best educated public can exercise no competent judgment in these matters. One could, with as much right, hold gynaecological examinations at the Schwurgerichtssaal in order to arouse public feeling against some of the findings of medical research."

[1038] For the rest, the lecture, whose lack of objectivity must have struck even the layman, contained so many distortions that it seemed designed to spread confusion and error. Those who wish to find out what psychoanalysis is really about are recommended to read Freud's *Über Psychoanalyse*² (publ. Deuticke, Vienna and Leipzig), in which he gives an account of his views and methods in more or less popular language. Reference should also be made to the invaluable work *Die Psychoanalyse Freuds*³ (Deuticke) by Eugen Bleuler, professor of psychiatry at Zurich, who discusses in an objective and critical way the pros and cons of psychoanalysis. The authority and continental reputation of this excellent scholar should guarantee the educated public a more competent view of psychoanalysis than the statements of Dr. Kesselring.

DR. J.

17 January 1912

[1039] In connection with the article on "Psychoanalysis" that was published in your columns last Saturday, I would like to remark that the concept of sexuality used by Freud and me has a far wider range of meaning than it has in common usage. As I have often pointed out, we understand by "sexuality" all those instinctual forces which extend beyond the domain of the instinct of self-preservation. The scientific justification for this conception cannot be discussed here. It can be read about in Freud's and my writings. Confusion between the common conception and our biological conception of sexuality naturally leads to the greatest misunderstandings.

[1040] I further allow myself to remark that it is not permissible to lay at our door all the immature researches that have been undertaken by less qualified persons. We can accept responsibility only for what we ourselves have written, and not for the manifold sins of other writers. One could just as well hold Christianity responsible

for the abominations of the Inquisition, if one wished to adopt so summary a procedure. Naturally, I am not thinking of the invaluable researches of Dr. Riklin, with which I am in full agreement, but of the book by Michelsen,⁴ mentioned by my critic F. M.,⁵ and a number of other writings whose standpoints and method of exposition I must repudiate.

DR.JUNG

ON THE PSYCHOANALYTIC TREATMENT OF NERVOUS DISORDERS¹

[1041] Psychoanalysis differs from other psychotherapeutic methods in that, by preference, it takes as its starting point those products of the human psyche which originate outside the selective effect of attention—parapraxes, the seemingly pointless fantasies of daydreaming, nocturnal dreams. The founder of the method, Professor Freud of Vienna, has succeeded in demonstrating from this material the existence of a principle which governs psychic events, the principle of *determination*. These inferior products, accordingly, are not fortuitous, but clearly and demonstrably are causally conditioned, or in psychological terms determined. They are formed under the influence of feeling-toned, unconscious ideas.

[1042] The application of the method to the pathological formations of psychoneurotics has shown that these are built up in a similar way, only they are much more complicated. The first formulation of the newly won insights was the trauma theory, as propounded by Breuer and Freud in their *Studies on Hysteria*, published in 1895.

[1043] Further investigations showed, however, that the trauma is of less pathological significance than the *conflict*, or rather, that most experiences acquire traumatic force only when they release a conflict within the patient. These conflicts are in the overwhelming majority of cases between sexual wishes (in the widest sense) and opposing tendencies of a moral and aesthetic nature. The result of such conflicts, which affect the emotional life, is a series of pathological processes, mechanisms altogether comparable to the defensive measures which the body puts up against a noxious agent.

[1044] To trace these mechanisms is now the task of the therapy, the ultimate aim of which is to free the psyche from the conflict.

[1045] In the case of a 35-year-old female hysteric, married, mother of several children, who since her 20th year had exhibited a number of hysterical physical symptoms, psychoanalysis was carried out after numerous other treatments had failed. Three of her symptoms, which all affected the respiratory activity, could be traced back to a trauma at the age of puberty, an attempted rape, when the full impact of the man's body had compressed the thorax. But the ultimate determinant was to be found in the experiences of earliest childhood, when the patient had listened with sexual excitement to the nightly intercourse of her parents. Thus the symptom which seemed like a sudden involuntary expiration with simultaneous closure of the glottis was a repetition of the following scene: her mother once came to her bed, whereupon she

started violently and wanted to let out a scream, which she was just able to suppress. These two opposed innervations persisted in the form of the aforesaid symptom.

[1046] Now when, as a result of unfavourable experiences, the individual does not obtain sufficient sexual gratification in later life, a process occurs which Freud calls regression: as a substitute for the failure of gratification, the patient reverts to an earlier, infantile one.

[1047] This infantile gratification, however, is not re-experienced in its original form, but only in the form of its somatic, physiological concomitant. There is a *conversion* of sexual excitation into somatic-motor excitation.

[1048] So with this patient the respiratory disturbance induced by the two opposed innervations became fixated not because of the fright she had received, but because of the sexual excitement that had accompanied her listening.

[1049] The onset of the disorder was directly connected with her marriage, which had brought the patient disappointments, so that in intercourse she remained frigid. The libido that was nevertheless present consequently chose the way of regression and led to the reactivation of those past and forgotten experiences of gratification, or rather to their physiological concomitants.

[1050] The result of the treatment was that all symptoms disappeared but for a few traces.

[The discussion that followed did not deal specifically with Jung's case. The speakers, including Paul-Charles Dubois, of Bern,² recounted cases of their own that had been cured by nonpsychoanalytic means and made various hostile remarks. Jung concluded:]

[1051] It is regrettable that the discussion failed to deal more specifically with the analysis presented here. The method of psychoanalytic research and treatment cannot be rejected as a whole unless on examination it turns out to be defective, but this was not done here. Psychoanalysis represents a radical theory which should be used together with other methods.

[1052] The view that it should not be used because its usefulness has not been proved or theoretically established cannot be supported by the facts [of the case], and it would disregard the principle of scientific research that practical experimentation is to be given preference over theoretical considerations.

[1053] Failures, naturally, do occur, but just as in other fields they do not permit us to draw conclusions of a general validity.

[1054] The discussion of sexual matters is admittedly not easy and not to everyone's taste; tactfully employed, however, it is an essential ingredient of any psychotherapy. — Dreams are often inexactly reported or added to; these additions are, however, as Freud has shown, not fortuitous coincidences, but governed by the same unconscious

ideas that informed the dream itself. That childhood impressions persist throughout one's life, even if they seemingly are insignificant, is a certainty. The explanation for this is that such impressions have been repressed because of a certain significant conjunction of ideas, and for this very reason could survive in the unconscious until they were uncovered by analysis.

A COMMENT ON TAUSK'S CRITICISM OF NELKEN¹

[1055] In the first issue of this periodical there was a review by Tausk of Nelken's "Analytische Beobachtungen über Phantasien eines Schizophrenen."² In this review I came upon the following passage:

In the first catatonic attack the patient produced the fantasy that mice and rats were gnawing at his genitals. Nelken derives the symbolic significance of these animals from a suggestion of Jung's, who sees them as symbolizing nocturnal fear. There is no doubt that this interpretation is correct, but it comes from a later elaboration of this symbol and bars the way to deeper insight. Analysis of dreams and neuroses has taught me beyond question—and I find my view supported by other psychoanalysts—that mice and rats are cloacal animals and that they represent, in symbolic form, the defecation complex (anal complex).

[1056] I would like to defend Nelken's view against Tausk's. I do not doubt in the least that Tausk's view is also right. We have known this for a long time, and it has been completely confirmed once more by Freud's rat-man.³ Further, we know very well that catatonic introversion and regression reactivate all the infantile impulses, as is evident from numerous observations in Nelken's analysis. So there is no question of this aspect of the case having escaped us; it merely seemed unimportant because by now it is self-evident. It is no longer of vital importance to know that the anal complex can act as a substitute for normal modes of transference or adaptation, since we know already that the pathological regression of libido reactivates every variety of infantile sexualism and produces infantile fantasies of every conceivable kind. Anyone who still thinks that a definite group of fantasies, or a "complex" has been singled out just hasn't seen enough cases. We therefore consider it irrelevant that the castration is performed by cloacal animals. Incidentally, mice are not "cloacal animals" but animals that live in holes, and this is a more comprehensive concept than "cloacal animals."

[1057] The only thing we learn from this interpretation is that an infantile complex or infantile interest takes the place of the normal interest. It may be of some value for the specialist to know that in this particular case it was the anal fantasy that contributed a bit of symbolism for the purpose of expressing the introversion and regression of libido. But this interpretation does not supply a generally applicable principle of explanation when we come to the far more important task of discovering

the real functional significance of the castration motif. We cannot content ourselves with a simple reduction to infantile mechanisms and leave it at that.

[1058] I was once given a very impressive example of this kind of interpretation. In a discussion on the historical fish-symbol, one of those present remarked that the fish vanishing in the sea was simply the father's penis vanishing in his wife's vagina. This kind of interpretation, which I consider sterile, is what I call sexual concretism. It seems to me that psychoanalysts are confronted with the much greater and more important task of understanding what these analogies are trying to say. What did men of many different races and epochs mean by the symbol of the fish? Why—in the present case too, for that matter—were these infantile channels of interest reactivated? What does this fetching up of infantile material signify? For this obviously is the problem. The statement: "Infantile reminiscences are coming to the surface again" is vapid and self-evident. It also leads us away from the real meaning. In Nelken's case the problem is not the derivation of part of the rat-symbol from the anal complex, but the castration motif to which the fantasy obviously belongs. The rats and mice are the instrument of the castration. But there are many other kinds of castrating instrument which are by no means anally determined. Tausk's reduction of the rats is merely of value to the specialist and has no real significance as regards the problem of sacrifice, which is at issue here.

[1059] The Zurich school naturally recognizes that the material is reducible to simpler infantile patterns, but it is not content to let it go at that. It takes these patterns for what they are, that is, images through which the unconscious mind is expressing itself. Thus, with reference to the fish-symbol, we would argue as follows : We do not deny the Viennese school the possibility that the fish-symbol can ultimately be reduced to parental intercourse. We are ready to assume this provided there are fairly cogent reasons for doing so. But, because we are not satisfied with this relatively unimportant reduction, we ask ourselves what the evocation of parental intercourse or something similar means to the patient. We thus carry the assumption a stage further, because with the reduction to the infantile pattern we have not gained an understanding of the real significance of the fact that the reminiscence was regressively reactivated. Were we to remain satisfied with the reduction, we would come back again and again to the long-since-accepted truth that the infantile lies at the root of the mental world, and that adult mental life is built upon the foundations of the infantile psyche.

[1060] Even in the backwaters of the psychoanalytic school one should have got beyond marvelling over the fact that, for instance, the artist makes use of images relating to the incest complex. Naturally every wish has these infantile patterns which it makes use of in every conceivable variation in order to express itself. But if the pattern, the infantile element, were still absolutely operative (i.e., not just

regressively reactivated), all mental products would turn out to be unbelievably trivial and deadly monotonous. It would always be the same old infantile story that formed the essential core of all mental products. Fortunately, the infantile motifs are not the essential; that is to say, for the most part they are regressively reactivated, and are fittingly employed for the purpose of expressing currents and trends in the actual present—and most clearly of all when the things to be expressed are as far-off and intangible as the most distant childhood. Nor should it be forgotten that there is also a future. The reduction to infantile material makes the inessential in art—the limited human expression—the essence of art, which consists precisely in striving for the greatest variety of form and the greatest freedom from the limitations of the conventional and the given.

[1061] Herbert Silberer⁴ once made the very good observation that there is a mythological stage of cognition which *apprehends symbolically*. This saying holds good for the employment of infantile reminiscences: they aid cognition or apprehension and are expressive symbols. No doubt the infantile reminiscence or tendency is still partly operative and thus has an extraordinarily disturbing and obstructive effect in actual life. That is also the reason why it is so easy to find. But we would be wrong to regard it as a *source of energy* on that account; it is much more a limitation and an obstacle. But because of its undeniable existence it is at the same time a necessary means of expression by analogy, for the furthest reaches of fantasy cannot offer any other material for analogical purposes. Accordingly, even if we do approach the primitive images analytically, we are not content with reduction and with establishing their self-evident existence, but, by comparing them with similar material, we try rather to reconstruct the actual problem that led to the employment of these primitive patterns and seeks expression through them. In this sense we take incest primarily as a symbol, as a means of expression, as Adler too has suggested.

[1062] Hence I cannot agree with Tausk when he says that comparison with analogous material “bars the way to deeper insight.” We do not regard the discovery of the anal fantasy as an insight that could be compared in importance with an understanding of the castration motif. I must therefore defend Nelken’s attempt to establish general connections in a wider context. We can hardly expect proof of the self-evident existence of infantile fantasies to furnish any insight into the general problem of sacrifice, which makes use of the castration motif among others. That Nelken has this question in mind is clear from his footnote, in which he refers to the snake and scorpion as historical castration animals.

[1063] I have taken the liberty of dwelling at some length on Tausk’s comment because it seemed to offer a favourable opportunity to sketch out our different approach to these matters. We do not by any means deny the possibility of Tausk’s reduction, as should be obvious. But in this and all similar reductions we find nothing that seems

to us to offer a satisfactory explanation. We believe, on the contrary, that a satisfactory explanation must make clear the teleological significance of the castration motif. In psychology, as is generally known, you cannot get very far with purely causal explanations, since a very large number of psychic phenomena can be satisfactorily explained only in teleological terms. This does nothing to alter or to detract from the exceedingly valuable discoveries of the Freudian school. We merely add the factor of teleological observation to what already exists. I have devoted a special study to this question, which will shortly appear in the *Jahrbuch*.⁵

[1064] Our attempts to develop and broaden the previous insights have given rise to absurd talk of a schism. Anything of that sort can only be the invention of people who take their working hypotheses as articles of faith. This rather childish standpoint is one which I do not share. My scientific views change with my experience and insight, as has always been the case in science generally. It would be a matter for suspicion if this were not so.

ANSWERS TO QUESTIONS ON FREUD¹

On 24 July 1953. the representative of the *New York Times* in Geneva, Michael L. Hoffman, sent Jung the following questionnaire in connection with a projected article on Freud:

1. What part of Freud's work do you accept?

2. What was the role of Freud's work and views in the development of your own analytical psychology?

3. In your opinion does Freudian sexuality play any part in the aetiology of neuroses?

4. Would you care to make an estimate of Freud's contribution to our knowledge of the psyche?

5. Would you care to comment on the value of Freud's procedure as a therapeutic procedure?

[1065] As it is impossible to deal with a critique of Freud's work in a short article I have to restrict myself to concise answers.

[1066] 1. I accept the facts Freud has discovered, but accept his theory only partially.

[1067] 2. The facts of repression, substitution, symbolization, and systematic amnesia described by Freud coincided with the results of my association experiments (1902–4). Later on (1906) I discovered similar phenomena in schizophrenia. I accepted in those years all of Freud's views, but I could not make up my mind to accept the sexual theory of neurosis and still less of psychosis, no matter how much I tried. I came to the conclusion (1910) that Freud's one-sided emphasis on sex must be a subjective prejudice.

[1068] 3. It is obvious that the sexual instinct plays a considerable role everywhere in life, and thus also in neurosis, and it is equally obvious that the power-drive, the many forms of fear, and the individual necessities are of equal importance. I object only to the uniqueness of sexuality as suggested by Freud.

[1069] 4. Freud's contribution to our knowledge of the psyche is without doubt of the greatest importance. It yields an insight into the dark recesses of the human mind and character which can be compared only to Nietzsche's *Genealogy of Morals*. In this respect Freud was one of the great cultural critics of the nineteenth century. His specific resentment explains the one-sidedness of his explanatory principle.

[1070] One could not say that Freud is the discoverer of the unconscious—C. G. Carus and Eduard von Hartmann were before him and Pierre Janet was his contemporary—

but he certainly showed a way to the unconscious and a definite possibility of investigating its contents. In this respect his book on dream interpretation proved to be most helpful, although from a scientific standpoint it is most objectionable.

[1071] 5. The question of psychological therapy is exceedingly complex. We know for certain that just any method or any procedure or any theory, seriously believed, conscientiously applied and supported by a humanly congenial understanding, can have a most remarkable therapeutic effect. Therapeutic efficacy is by no means the prerogative of any particular system; what counts is the character and the attitude of the therapist. For this reason I tell my pupils: you must know the best you can about the psychology of neurotic individuals as well as of yourself. If it is the best, you are likely to believe it, and then you can be serious enough to apply what you know with devotion and responsibility. If it is the best *you* know, then you will always entertain a reasonable doubt whether somebody else might not know better than yourself, and out of sheer compassion with your patient you will make sure that you don't lead him astray. Therefore you will never forget to inquire how far he agrees or disagrees with you. When he disagrees you are stuck, and if this fact is overlooked both doctor and patient are fooled.

[1072] Theory is important in the first place for science. In practice you can apply as many theories as there are individuals. If you are honest you will preach your individual gospel, even if you don't know it. If you are right, it will be good enough. If you are wrong, even the best theory will be equally wrong. Nothing is worse than the right means in the hands of the wrong man. Never forget that the analysis of a patient analyses yourself, as you are just as much in it as he is.

[1073] I am afraid psychotherapy is a very responsible business and anything but an impersonal application of a convenient medical method. There was a time when the surgeon did not even think of washing his hands before an operation, and the time is still with us when doctors believe they are not personally concerned when they apply psychotherapeutic methods.

[1074] For this reason I object to any kind of prejudice in the therapeutical approach. In Freud's case I disagree with his materialism, his credulity (trauma theory), his fanciful assumptions (totem and taboo theory), and his asocial, merely biological point of view (theory of neurosis).

[1075] This is a mere outline of critical viewpoints. I myself regard such statements as futile, since it is much more important to put forward facts that demand an altogether different conception of the psyche, i.e., new facts unknown to Freud and his school.

[1076] It has never been my purpose to criticize Freud, to whom I owe so much. I have been far more interested in the continuation of the road he tried to build, namely the further investigation of the unconscious so sadly neglected by his own school.

VII

ON SYMBOLISM

(related to Volume 5 of the Collected Works)

[Though not recorded by Jung himself, these brief abstracts are included as evidence of Jung's preparatory work for *Wandlungen und Symbole der Libido* (1911–12), revised as *Symbols of Transformation* (1952). *The Freud/Jung Letters* contains references to preliminary drafts, e.g., the unrecovered "Herisau lecture," in 193J, par. 3, which Freud subjected to detailed criticism in 199aF.]

THE CONCEPT OF AMBIVALENCE¹

[1077] *Discussion.*² C. G. Jung: The concept of ambivalence is probably a valuable addition to our terminology. In one and the same thing the opposite may be contained. *Altus* = high and deep. Pleasure may derive from pain. This implies not a sequence of one after the other, but a simultaneous one-in-the-other: a uniform given. He [Jung] objects to the statement “Ambivalence is the driving force.” Ambivalence probably is not the driving force, but rather a formal aspect as we find it everywhere. Freud has adduced many examples from the history of language. Modern words too show ambivalence, e.g., *sacré*,³ *luge* (Irish) = contract;⁴ *bad* (English) = *bat* = *bass* (Middle High German) = good. Through the migration of language the meaning of a word is transformed into its historical opposite. Dreams make use of similarities as well as of opposites. Among the possibilities of similarity, contrast is closest at hand. He, Jung, had this dream: *He is a small man with a beard, wears no glasses and is no longer young.* Hence, everything the opposite. If we want to demonstrate our psychoanalytic view, we too, just like the anatomists, command an unambiguous kind of material that we find in the monuments of antiquity and in the field of mythology. For example, the fertility god is at the same time the destroyer (Indra). The sun means fertility and destruction. Therefore we have the lion as a zodiac sign standing for the intense heat of the sun. Ambivalence is evident in the mythological successions. Odin becomes the wild hunter who molests lonely girls on the highways. Freia has turned into a she-devil. Venus, as the philologists teach us, acquired a good aspect and turned into St. Verena (St. Verena, the patron saint of Baden, Ct. Aargau; watering places, as we know from history, were consecrated and subject to Venus). St. Verena, Venus, however, also lends her name to dangerous mountains (Verenelisgärtli near the Glärnisch; St. Verenakehle is the name of the great avalanche chute on the Schafburg in the Säntis mountains). *Devas* (Sanskrit, = angel) becomes the devil in Persian. The snake on the pole corresponds to the ambivalence of the concept of Christ.

[1078] The representation of libido oscillates between the symbols of the lion and the snake, the principle of dry and wet: both are opposite sexual or phallic symbols. Jung saw a stele of Priapus in Verona. The god smilingly holds a basket full of phalli on his arm and points with the other hand to a snake which bites off his erect penis.⁵

[1079] Nice examples of ambivalence are shown by the language of erotic jokes, such as occur in the *Golden Ass* of Apuleius;⁶ also in the language of mysticism; Mechtild of Magdeburg says: “By Christ’s love I have been wounded unto death.” Through the

killing of the bull (in the Mithras mythologies) creation is brought about. “The bull is the father of the snake and the snake is the father of the bull.”⁷ Our Christian religious ideas are likewise based on this principle. Through Christ’s death, man is redeemed for life eternal. We encounter the same idea in the cult of Mithras, which was of great importance in antiquity and helped spread the concepts of Christianity.

* * *

[1080] *Discussion.*⁸ C. G. Jung: The expression “taken off my chest”⁹ in reference to the discussion of the tormenting complex is very apt and characteristic of analytic therapy. An officer, whenever his complex was about to get the better of him, commanded: “Attention— halt! Six paces to the rear—march!” and every time felt very much relieved by this objectivation of his disease.

* * *

[1081] *Discussion.*¹⁰ As a contribution from child psychology to the significance of sacrifice, C. G. Jung tells about the “Tantalus Club” which was founded by some youngsters for the celebration of sexual mysteries. Their emblem depicted a man who hung from a gallows by a rope tied to his penis and his nose. The sacrificed and tormented were the youngsters themselves, just like Tantalus whose torment consists in constantly being denied satisfaction of his most ardent desires.

CONTRIBUTIONS TO SYMBOLISM¹

[1082] Starting from the contrast that exists between hysterical fantasies and those of dementia praecox, the lecturer points out that in order to understand the latter, historical parallels must be adduced, because in dementia praecox the patient suffers from the reminiscences of mankind. In contrast to hysteria, his language uses ancient images of universal validity, even though at first glance they seem incomprehensible to us.

[1083] The case of a 34-year-old female neurotic serves to illustrate how a recent fantasy can be documented and elucidated by historical material. The patient's fantasy deals with a man she loves unrequitedly who is suspended by the genitals, a fantasy which was also found in a 9-year-old boy as a symbolic expression of his unfulfilled libido ("Hanging and fearing, suspended in pain").² This fantasy, when taken together with corresponding ethnological traditions and mythological parallels of the sacrifice of the god of spring by hanging or flaying, signifies a sacrifice of sexuality which one hangs on to and cannot get rid of and which in ancient cults was offered to the Great Mother as a sacrifice of the phallus.³

VIII

TWO ESSAYS ON ANALYTICAL PSYCHOLOGY

(related to Volume 7 of the Collected Works)

ADAPTATION, INDIVIDUATION, COLLECTIVITY¹

1. Adaptation

[1084] A. *Psychological adaptation* consists of two processes:

1. Adaptation to outer conditions.
2. Adaptation to inner conditions.

[1085] By outer conditions are meant not only the conditions of the surrounding world, but also my conscious judgments, which I have formed of objective things.

[1086] By inner conditions are meant those facts or data which force themselves upon my inner perception from the unconscious, independently of my conscious judgment and sometimes even in opposition to it. Adaptation to inner conditions would thus be adaptation to the unconscious.

[1087] B. In *neurosis* the adaptation process is disturbed, or rather we might say that the neurosis is itself a disturbed or diminished process of adaptation that takes two basic forms:

1. Disturbance of adaptation to outer conditions.
2. Disturbance of adaptation to inner conditions.

[1088] In the first case we must again distinguish two different and fundamental situations:

1. Adaptation to outer conditions is disturbed because the subject tries to adapt entirely and exclusively to the outside, while entirely neglecting the inside, thereby upsetting the balance of the act of adaptation.

2. The disturbance arises from a preferential adaptation to the inside.

[1089] Equally, adaptation to inner conditions can be disturbed in two ways:

1. By exclusive adaptation to the outside.
2. By neglect of the outside in favour of adaptation to the inside.

[1090] C. *The Energetics of Adaptation*: These considerations lead to the energetics of the adaptation process. When the libido invested in a particular function cannot be equilibrated by the exercise of the function, it accumulates until it attains a value which exceeds that of the neighbouring functional system. Then a process of equilibration begins, because a potential is present. The energy flows over, as it were, into another system. When, therefore, adaptation to the inside is not achieved, the libido intended for that purpose accumulates until it begins to flow out of the system

of inner adaptation into the system of outer adaptation, with the result that characteristics belonging to inner adaptation are carried over into outer—that is to say, fantasies intervene in the relation to the real world. Conversely, when the system of outer adaptation overflows into the system of inner adaptation, characteristics belonging to the former are carried over into the latter, namely, qualities belonging to the reality-function.

[1091] D. *Adaptation in Analysis*: Adaptation in analysis is a special question. During the analysis, experience shows that, barring quite exceptional circumstances, the analysis is the main thing. There is no categorical imperative, “The analysis *must* be the main thing”; it is simply that, judging by the average run of experience, the analysis *is* the main thing. Hence the main achievement is in the first place adaptation to the analysis, which for one patient is represented by the person of the analyst, and for another by the “analytical idea.” The purpose in either case is to secure trust: the one who starts off with an unconscious mistrust of his fellow seeks above everything to make sure of the personality of the analyst; the other, whose main desire is to be instructed about the reliability of methods of thinking, seeks above everything to understand the basic ideas.

[1092] As the analysis proceeds, the former must naturally catch up in understanding the idea, the latter in learning to trust the analyst’s personality.

When adaptation has been carried thus far, the analysis is generally held to have come to an end for all practical purposes, in so far as it is assumed that this personal balance is the essential aim and demand. There is, on the fact of it, nothing to be said against this view.

[1094] Experience shows, however, that in certain and not too uncommon cases a demand is raised by the unconscious, which expresses itself to begin with in the extraordinary intensity of the transference, and in the influence thus exerted on the patient’s lifeline. This heightened transference seems, at first, to contain the demand for a particularly intensive adaptation to the analyst, and for the time being it should be accepted as such, though it is at bottom an over-compensation for a resistance to the analyst that is felt to be irrational. This resistance arises from the demand for individuation, which is *against* all adaptation to others. But since the breaking of the patient’s previous personal conformity would mean the destruction of an aesthetic and moral ideal, the first step in individuation is a tragic *guilt*. The accumulation of guilt demands *expiation*. This expiation cannot be offered to the analyst, for that would only restore the patient’s personal conformity. The guilt and its expiation call for a *new collective function*: just as before the object of faith and love, namely the image of the analyst, was a *representative* of humanity, so now humanity itself takes the place of the analyst and to it is offered the expiation for the guilt of individuation.

[1095] Individuation cuts one off from personal conformity and hence from collectivity. That is the guilt which the individuant leaves behind him for the world, that is the guilt he must endeavour to redeem. He must offer a ransom in place of himself, that is, he must bring forth values which are an equivalent substitute for his absence in the collective personal sphere. Without this production of values, final individuation is immoral and—more than that—suicidal. The man who cannot create values should sacrifice himself consciously to the spirit of collective conformity. In so doing, he is free to choose the collectivity to which he will sacrifice himself. Only to the extent that a man creates objective values can he and may he individuate. Every further step in individuation creates new guilt and necessitates new expiation. Hence individuation is possible only so long as substitute values are produced. Individuation is exclusive adaptation to inner reality and hence an allegedly “mystical” process. The expiation is adaptation to the outer world. It has to be offered to the outer world, with the petition that the outer world accept it.

[1096] The individuant has no *a priori* claim to any kind of esteem. He has to be content with whatever esteem flows to him from outside by virtue of the values he creates. Not only has society a right, it also has a duty to condemn the individuant if he fails to create equivalent values, for he is a deserter.

[1097] When, therefore, the demand for individuation appears in analysis under the guise of an exceptionally strong transference, it means farewell to personal conformity with the collective, and stepping over into solitude, into the cloister of the inner self. Only the shadow of the personality remains in the outer world. Hence the contempt and hate that come from society. But inner adaptation leads to the conquest of inner realities, from which values are won for the reparation of the collective.

[1098] Individuation remains a pose so long as no positive values are created. Whoever is not creative enough must re-establish collective conformity with a group of his own choice, otherwise he remains an empty waster and windbag. Whoever creates *unacknowledged* values belongs to the contemned, and he has himself to blame for this, because society has a right to expect *realizable* values. For the existing society is always of absolute importance as the point of transition through which all world development passes, and it demands the highest collaborative achievement from every individual.

2. Individuation and Collectivity

[1099] Individuation and collectivity are a pair of opposites, two divergent destinies.² They are related to one another by guilt. The individual is obliged by the collective demands to purchase his individuation at the cost of an equivalent work for the benefit of society. So far as this is possible, individuation is possible. Anyone who cannot do this must submit directly to the collective demands, to the demands of

society, or rather, he will be caught by them automatically. What society demands is *imitation* or conscious identification, a treading of accepted, authorized paths. Only by accomplishing an equivalent is one exempted from this. There are *very many people who at first* are altogether incapable of accomplishing this equivalent. They are therefore bound to the well-trodden path. If they are pushed off it, they are seized by helpless anxiety, from which only another of the prescribed paths can deliver them. Such people can achieve self-reliance only after imitating for a very long time one of the models they have chosen. A person who by reason of special capacities is entitled to individuate must accept the contempt of society until such time as he has accomplished his equivalent. Only a few are capable of individuating, because individuation rules out any renunciation of collective conformity until an equivalent has been accomplished whose objective value is acknowledged. Human relationship establishes itself automatically on the basis of an acknowledged equivalent, because the libido of society goes directly towards it. Without the equivalent, all attempts at conformity are foredoomed to failure.

[1100] Through imitation, one's own values become *reactivated*. If the way to imitation is cut off, they are nipped in the bud. The result is helpless anxiety. If the imitation is a demand made by the analyst, i.e., if it is a demand for the sake of adaptation, this again leads to a destruction of the patient's values, because imitation is an automatic process that follows its own laws, and lasts as long and goes as far as is necessary. It has quite definite limits which the analyst can never know. Through imitation the patient learns individuation, because it reactivates his own values.

[1101] The collective function may be divided into two functions, which from the "mystical" or metapsychological point of view are identical:

1. The collective function in relation to society.
2. The collective function in relation to the unconscious.

[1102] The unconscious is, as the collective psyche, the psychological representative of society. The persona can have no relation to the unconscious since it is collectively identical with it, being itself collective. Hence the persona must be extinguished or, in other words, restored to the unconscious. From this arises individuality as one pole that polarizes the unconscious, which in turn produces the counterpole, the God-concept.

[1103] The individual must now consolidate himself by cutting himself off from God and becoming wholly himself. Thereby and at the same time he also separates himself from society. Outwardly he plunges into solitude, but inwardly into hell, distance from God. In consequence, he loads himself with guilt. In order to expiate this guilt, he gives his good to the soul, the soul brings it before God (the polarized unconscious), and God returns a gift (productive reaction of the unconscious) which the soul offers to man, and which man gives to mankind. Or it may go another way:

in order to expiate the guilt, he gives his supreme good, his love, not to the soul but to a human being who stands for his soul, and from this human being it goes to God and through this human being it comes back to the lover, but only so long as this human being stands for his soul. Thus enriched, the lover begins to give to his soul the good he has received, and he will receive it again from God, in so far as he is destined to climb so high that he can stand in solitude before God and before mankind.

[1104] Thus I, as an individual, can discharge my collective function either by giving my love to the soul and so procuring the ransom I owe to society, or, as a lover, by loving the human being through whom I receive the gift of God.

[1105] But here as well there is a discord between collectivity and individuation: if a man's libido goes to the unconscious, the less it goes to a human being; if it goes to a human being, the less it goes to the unconscious. But if it goes to a human being, and it is a true love, then it is the same as if the libido went direct to the unconscious, so very much is the other person a representative of the unconscious, though only if this other person is truly loved.

[1106] Only then does love give him the quality of a mediator, which otherwise and in himself he would not possess.

FOREWORD TO THE HUNGARIAN EDITION OF JUNG: "ON THE PSYCHOLOGY OF THE UNCONSCIOUS"¹

[1107] The Hungarian translation of my book *On the Psychology of the Unconscious*,² by Dr. Peter Nagy, carefully collated and checked by Dr. Jolande Jacobi, deserves to be greeted as a novum since this is the first Hungarian publication of any of my writings. Except for a few translations into Russian, one of my earliest books now appears in a language of Eastern Europe for the first time. I am indebted to Dr. Jacobi not only for making this possible, but more particularly because she was closely associated with the revision of this book and its publication, and was ready with helpful suggestions and useful advice. It is also due to her conscientious collaboration that the Hungarian edition is equipped with an index, lacking in the Swiss edition, as well as with a short glossary to elucidate the terminology, which is often difficult and new, attaching to the theme.

[1108] For it is a particular pleasure that my book is now available in Hungary, a country from which signs of the liveliest interest have again and again come my way. I hope to pay off a little of my debt of gratitude, at least indirectly, with this foreword. Of my many pupils, who all come from the Western half of the world, Dr. Jacobi is the first Hungarian; she has worked for years under my personal direction in Zurich, and in so doing has acquired a profound knowledge of that very extensive and difficult territory, the psychology of the unconscious. In her book *The Psychology of C. G. Jung*,³ an excellent introduction to my work in general, she has given evidence of this. Her knowledge also guarantees the accuracy and fidelity of the translation, so very necessary in dealing with such tricky and delicate material as the psychology of the unconscious.

[1109] This essay makes no claim to be a comprehensive exposition; its aim is to acquaint the reader with the main problems of the psychology of the unconscious, and this only within the limits prescribed by direct medical experience. As it does not pretend to be more than an introduction, the manifold relations with the history of human thought, mythology, religion, philosophy, the psychology of primitives, and so on are only hinted at.

Küsnacht-Zurich, January 1944

IX

THE STRUCTURE AND DYNAMICS OF THE PSYCHE

(related to Volume 8 of the Collected Works)

FOREWORDS TO JUNG: “ÜBER PSYCHISCHE ENERGETIK UND DAS WESEN DER TRÄUME”¹

First Edition (1928)

[1110] In this volume, the second of the *Psychologische Abhandlungen*,² I am publishing four papers of which three have so far appeared only in English.³ One of the papers deals with the still unsolved problem of dream interpretation, while the others are concerned with—in my view—a question of central importance: the fundamental psychic factors, the *dynamic images*, which it seems to me express the nature of psychic energy. My concept of psychic energy, first put forward in *Wandlungen und Symbole der Libido* (1912),⁴ has met with so much opposition and misunderstanding that it seemed to me worth working over the problems of psychic energetics once again, this time not from the practical but from the theoretical side. The reader, therefore, need fear no repetitions.

Küsnacht-Zurich 1928

Second Edition (1948)

[1111] The papers in this volume are attempts to introduce some order into the chaotic profusion of psychic phenomena by means of concepts that are current in other fields of research besides psychology. Since our psychological knowledge is still in its infancy, our primary concern must be with elementary concepts and groups of facts, and not with the individual complications in which our case histories abound, and which can never be completely elucidated. The Freudian “model” of neurosis and dreams gives only a partial explanation of the empirical material. As medical psychologists, we must seek to refine our methods as well as our psychological concepts, more particularly because the “academic” psychologists have abandoned the attempt to investigate the unconscious empirically. It falls to the lot of the medical psychologist to probe more deeply into the compensatory relationship between conscious and unconscious which is so vital for an understanding of the psyche as a whole.

[1112] Except for some improvements I have made no drastic alterations to the text. The number of papers has been increased to six, as I have added a short “Review of the Complex Theory” and some recent aperçus on dream research, “On the Nature of Dreams.”¹

Küsnacht-Zurich, May 1947

ON HALLUCINATION¹

[1113] Hallucination is not merely a pathological phenomenon but one that also occurs in the sphere of the normal. The history of prophecy as well as experiences among primitives show that psychic contents not infrequently come to consciousness in hallucinatory form. In this respect only the form is worthy of note, not the function, which is nothing other than what is commonly called a “brain wave” [*Einfall*]. As the word itself indicates, a certain spontaneity attaches to the phenomenon; it is as though the psychic content had a life of its own and forced its way into consciousness by its own strength. This peculiarity probably explains the ease with which the brain wave assumes an hallucinatory character. Common speech is familiar with these transitions from brain wave to hallucination. In the mildest cases we say: “I thought”; “it occurred to me” is a little stronger; stronger still is “it was as though an inner voice said,” and finally “it was as though someone were calling to me,” or “I heard a voice quite distinctly.”

[1114] Hallucinations of this kind usually derive from the still subliminal, maturer personality which is not yet capable of direct consciousness, as observations of somnambulists show. In the case of primitive medicine-men they come from a subliminal thinking or intuiting which at that level is not yet capable of becoming conscious.

FOREWORD TO SCHLEICH: "DIE WUNDER DER SEELE"¹

[1115] When, after many years, I again took up the works of Carl Ludwig Schleich and tried to capture the mental world of this remarkable thinker in a telling image, what persistently came into my mind was the indelible impression which another powerful thinker—very unlike Schleich and yet so very like him—had made upon me: Paracelsus. Odd bedfellows indeed—the contemporary of the humanists and the modern, forward-looking Schleich, separated by four centuries of spiritual growth and change, not to speak of differences of personality. The very idea would have struck me as preposterous had I not been strangely moved just by the affinity of opposites. Above all, it seemed to me significant that Paracelsus stood at the beginning of an epoch in the history of medicine and Schleich at its end. Both were typical representatives of a period of transition, and both of them revolutionaries. Paracelsus cleared the way for scientific medicine, benighted at times by age-old animistic beliefs yet filled with the liveliest apprehension of an age in which the intangibles of the soul would be replaced by a massive materialism. Schleich was a revolutionary in the opposite sense. Although steeped in anatomical and physiological concepts, he boldly reached out towards the very same psychic realm upon which Paracelsus, obeying the dictates of his age, had half-reluctantly turned his back. Both were enthusiasts, uplifted and fortified by the certitudes of their vision, optimistically credulous, rejoicing in their hopes, pioneers of a new spiritual outlook who went their head-spinning way sure-footed and undismayed. Both gazed fearlessly into suprahuman, metaphysical abysses and both avowed their faith in the eternal images deeply engraved in the human psyche. Paracelsus' way took him down to the divine but essentially pre-Christian *prima materia*, the "Hyliaster."² Schleich, starting from the darkness of the blood vessels, ducts, and the labyrinth of the nerve-endings, mounted the ganglionic ladder of the sympathetic nervous system to a transcendental soul which appeared to him in all its Platonic glory in the "supracelestial place." Both were inspired by the effervescence of an age of decay and change. Both were born out of their time, eccentric figures eyed askance by their contemporaries. One's contemporaries are always dense and never understand that enthusiasm, and what appears to them to be unseemly ebullience come less from personal temperament than from the still unknown well-springs of a new age. How people looked askance at Nietzsche's volcanic emotion, and how long he will be spoken of in times to come! Even Paracelsus has now been gratefully disinterred after four hundred years in an attempt to resuscitate him in modern dress. What will

happen with Schleich? We know that he was aiming at that unitary vision of psychic and physical processes which has given the strongest impetus to medical and biological research today. Though hampered by a terminology inherited from an age of scientific materialism, he broke through the narrow confines of a de-psychized materiality and crossed the threshold, barricaded with thorny prejudices, which separated the soul from the body. And though he had no knowledge of my own efforts, which for a long time remained unknown to the scientific public in Germany, in his own way he fought shoulder to shoulder with me for the recognition of the soul as a factor *sui generis*, and thus broke a new path for psychology, which till then had been condemned to get along without a psyche.

[1116] The breakthrough initiated by Paracelsus led the way out of medieval scholasticism into the then unknown world of matter. This is the great and essential service which has placed medicine forever in his debt. And it is not isolated facts, methods, or laws which make Schleich important for us, but his pushing forward into a new field of vision where the mass of known facts appears in a new and different light. By syncretizing all our previous knowledge and seeking a standpoint from which to gain a view of the whole, he succeeded in escaping from the charmed circle of pure empiricism and touched upon the very foundation of the empirical method itself, though most people are quite unaware of it. This fundamental thing is the relation of the body's chemistry to psychic life. Paracelsus ultimately decided in favour of "chemism," despite his allegiance to a view of the world dominated by the spirit as the highest authority. Schleich, four hundred years later, decided in favour of psychic animation, and thus raised the psyche from its undignified position as a subsidiary product to that of the *auctor rerum*. With a bold stroke he put the mechanisms and chemisms of the body in a new hierarchy. The "vestigial" sympathetic nervous system, an apparently fortuitous tangle of ganglionic nodes that regulate the vegetative functions of the body in an astoundingly purposive way, becomes the matrix of the cerebrospinal system, whose crowning miracle, the brain, seems to our fascinated gaze the controller of all bodily processes. Nay more: the sympathetic system is, for Schleich, the mysterious "cosmic nerve," the true "ideoplast," the original and most immediate realization of a body-building and body-sustaining World Soul, which was there before mind and body came into existence. The Hyliaster of Paracelsus is thus stripped of its unfathomable creative secret. Once again the solidity and tangibility of matter, so fervently believed in and so convincing to the senses, dissolve into Maya, into a mere emanation of primordial thought and will, and all hierarchies and all values are reversed. The intangible, the psyche, becomes the ground and substrate, and the "merely vegetative" sympathetic system the possessor and realizer of unthinkable creative secrets, the vehicle of the life-giving World Soul, and, ultimately, the architect of the brain, this newest

achievement of the pre-existent creative will. What lay modestly hidden beneath the overwhelming grandeur of the cerebrospinal system, which, as the vehicle of consciousness, seems to be identical with the psyche as such—this same sympathetic system is “psyche” in a deeper and more embracing sense than is the interplay of the cortical fields of the cerebrum. Notwithstanding its quantitative and qualitative insignificance, it is the exponent of a psyche far excelling consciousness both in depth and scope, and is not, like this, defencelessly exposed to the potions of the endocrine system, but itself creates these magical secretions with single-minded purposiveness.

[1117] Just as Paracelsus laboured to concoct sylphids and succubi out of mandrakes, hangman’s amulets, and the blackest folk-medicine in his alchemical retort while yet having intimations of the truth, so Schleich spoke the language of the best “brain mythology” of the pre-war era and yet penetrated into the deepest problems and symbols of the human psyche, following his inner intuition and without knowing what he was doing. His soaring imagination transmuted figures of speech into forms which, unbeknownst to him, are actually archetypes of the collective unconscious that manifest themselves wherever introspection seeks to plumb the depths of the psyche, as for instance in Indian and Chinese yoga.

[1118] Schleich was thus a pioneer not only in somatic medicine but also in the remoter reaches of psychology, where it coalesces with the vegetative processes of the body. This is without doubt the darkest area of all, which scientific research has long sought to elucidate in vain. It is just this darkness which fascinated Schleich’s mind and let loose a spate of imaginative ideas. Though they were not based on any new facts, they will certainly stimulate new interpretations and new modes of observation. As the history of science shows, the progress of knowledge does not always consist in the discovery of facts but, just as often, in opening up new lines of inquiry and in formulating hypothetical points of view. One of Schleich’s favourite ideas was that of a psyche spread through the whole of the body, and dependent more on the blood than on grey matter. This is a brilliant notion of incalculable import. It enabled him to reach certain conclusions as to the way in which the psychic processes are determined, and these conclusions have independently confirmed my own research work. I am thinking chiefly of the historical factors determining the psychic background, as formulated in my theory of the collective unconscious. The same might be said of the mysterious connections between the psyche and the geographical locality, which Schleich linked up with dietetic differences—a possibility that should not be dismissed out of hand. When one considers the remarkable psychic and biological changes to which European immigrants are subject in America,³ one cannot help feeling that in this matter science has still a number of important problems to solve.

[1119] Although Schleich's thought and language were wholly dependent on the data of the body, he was nevertheless impressed by the incorporeal nature of the psyche. What struck him about dreams was their spacelessness and timelessness, and for him hysteria was a "metaphysical problem"—metaphysical because the "ideoplastic" capacities of the unconscious psyche were nowhere more palpably in evidence than in the neuroses. Marvelling he gazed at the bodily changes wrought by the unconscious in hysteria. One can see from this almost childlike amazement how new and unexpected such observations were for him, although for the psychopathologist they have long been truisms. But one also sees from what generation of medical men he came—a generation blinded by prejudice, that passed unheedingly by the workings of the psyche upon the body, and even with its first, groping steps in psychology believed that the psyche could be dispensed with. Considering this lack of psychological knowledge, it is all the more astonishing and greatly to Schleich's credit that he was able to break through to a recognition of the psyche and to a complete reversal of biological causality. His conclusions seem almost too radical to the psychologist, or at any rate over-audacious, since they trespass upon regions which philosophical criticism must put beyond the bounds of human understanding.

[1120] Schleich's limited knowledge of psychology and his enthusiasm for intuitive speculation are responsible for a certain lack of reflection and for the occasional shallow patches in his work, for instance, his blindness to the psychic processes in dreams, which he sees through the spectacles of materialistic prejudice. Again, there is no inkling of the philosophical and moral problems that are conjured up by his identification of conscience with the function of hormones. Schleich thus paid tribute to the scientific past and to the spirit of the Wilhelmine era, when the authority of science swelled into blind presumption and the intellect turned into a ravaging beast. But he saw very clearly that if medicine considered only the body and had no eyes for the living man, it was doomed to stultification. For this reason he turned away from the investigation of mere facts and used his knowledge of biology for wider purposes, to construct a bold synoptic view which would eradicate the grave errors of an obsolete materialism. The nineteenth century did everything it could to bring the psyche into disrepute, and it is Schleich's great achievement to have thrust the psychic meaning of vital processes into the light of day. His works may serve as an introduction to the revolution that has taken place in our general outlook and extricated us from the straitjacket of academic specialism.

FOREWORD TO JACOBI: "THE PSYCHOLOGY OF C. G. JUNG"¹

[1121] The present work, I believe, meets a generally felt need which I myself up to now have not been in a position to satisfy—the wish for a concise presentation of the elements of my psychological theories. My endeavours in psychology have been essentially pioneer work, leaving me neither time nor opportunity to present them systematically. Dr. Jacobi has taken this difficult task upon herself with a happy result, having succeeded in giving an account free from the ballast of technical particulars. It is a synopsis that includes or at least touches upon all essential points, so that it is possible for the reader—with the aid of the references and the bibliography of my writings—to orient himself readily wherever needful. An additional merit is that the text has been supplemented with a number of diagrams, which are a help in understanding certain functional relations.

[1122] It is a particular satisfaction to me that the author has been able to avoid furnishing any support to the opinion that my researches constitute a doctrinal system. Expositions of this kind slip all too easily into a dogmatic style which is wholly inappropriate to my views. Since it is my firm conviction that the time for an all-inclusive theory, taking in and describing all the contents, processes, and phenomena of the psyche from one central viewpoint, has not yet arrived, I regard my concepts as tentative attempts to formulate a scientific psychology based in the first place upon immediate experience with human beings. This is not a kind of psychopathology, but a general psychology which also takes cognizance of the empirical material of pathology.

[1123] I hope that it may be the lot of this book not only to give the general reader an insight into my researches, but also to save him much laborious searching in his study of them.

August 1939

Foreword to the Spanish Edition¹

[1124] It gives me particular pleasure to know that this book is now appearing in a Spanish translation. It will acquaint the Spanish public with the most recent developments of a psychology that has grown out of the experiences of the physician's art. This psychology is concerned with complex psychic phenomena that are continually encountered in daily life. It is not an abstract academic science, but a formulation of practical experiences which remains faithful to the scientific method.

As a result, this psychology includes within its scope wide areas of other sciences and of life in general. My very best wishes accompany this book on its journey through the world.

FOREWORD TO HARDING: "PSYCHIC ENERGY"¹

[1125] This book presents a comprehensive survey of the experiences of analytical practice, a survey such as anyone who has spent many years in the conscientious pursuit of professional duties may well feel the need of making. In the course of time, insights and recognitions, disappointments and satisfactions, recollections and conclusions mount to such proportions that one would gladly rid oneself of the burden of them in the hope not merely of throwing out worthless ballast but also of presenting a summation which will be useful to the world of today and of the future.

[1126] The pioneer in a new field rarely has the good fortune to be able to draw valid conclusions from his total experience. The efforts and struggles, the doubts and uncertainties of his voyage of discovery have penetrated his marrow too deeply to allow him the perspective and clarity of vision needed for a comprehensive survey. Those of the second generation, who base their work on the groping experiments, the lucky hits, the circuitous approaches, the half truths and mistakes of the pioneer, are less burdened and can take more direct roads, envisage more distant goals. They can cast off many doubts and hesitations, concentrate on essentials, and, in this way, map out a simpler and clearer picture of the newly discovered territory. This simplification and clarification redound to the benefit of those of the third generation, who are thus equipped from the outset with an over-all chart. With this chart they are enabled to formulate new problems and mark out the boundary lines more sharply than ever before.

[1127] We can congratulate the author on the success of her attempt to provide a general orientation on the problems of medical psychotherapy in its most modern aspects. Her many years of practical experience have stood her in good stead; without them her undertaking would not have been possible at all. For it is not a question, as many believe, of a "philosophy," but rather of facts and their formulation, which in turn must be tested in practice. Concepts like "shadow" and "anima" are in no sense intellectual inventions. They are designations for psychic facts of a complex nature which are empirically verifiable. These facts can be observed by anyone who takes the trouble to do so and who is able to lay aside his preconceived ideas. Experience shows how difficult this is. For instance, how many people still labour under the delusion that the term archetype denotes an inherited idea! Such completely unwarranted assumptions naturally make any understanding impossible.

[1128] It is to be hoped that Dr. Harding's book, with its simple and lucid exposition, will be especially suited to dispel such absurd misunderstandings. In this respect it

can be of the greatest service not only to the doctor but also to the patient. I should like to emphasize this point particularly. It is obviously necessary for a doctor to have an adequate understanding of the material laid before him; but if he is the only one who understands, it is of no great help to the patient, since he is actually suffering from lack of consciousness and should therefore become more conscious. To this end, he needs knowledge; and the more of it he acquires, the greater is his chance of overcoming his difficulties. For those of my patients who have reached the point where greater spiritual independence is necessary, Dr. Harding's book is one that I should unhesitatingly recommend.

Küsnacht-Zurich, July 8, 1947

ADDRESS ON THE OCCASION OF THE FOUNDING OF THE C. G. JUNG INSTITUTE, ZURICH, 24 APRIL 1948¹

[1129] It is a particular pleasure and satisfaction for me to have the privilege of speaking to you on this memorable day of the founding of an Institute for Complex Psychology. I am honoured that you have come here for the purpose of establishing this institute of research which is designed to carry on the work begun by me. I hope, therefore, I may be allowed to say a few words about what has been achieved up to the present, as well as about our aims for the future.

[1130] As you know, it is nearly fifty years since I began my work as a psychiatrist. At that time, the broad fields of psychopathology and psychotherapy were so much wasteland. Freud and Janet had just begun to lay the foundations of methodology and clinical observation, and Flournoy in Geneva had made his contribution to the art of psychological biography, which is still far from being appreciated at its true value. With the help of Wundt's association experiments, I was trying to evaluate the peculiarities of neurotic states of mind as exactly as possible. In the face of the layman's prejudice that the psyche was something immeasurably subjective and boundlessly capricious, my purpose was to investigate what appeared to be the most subjective and most complicated psychic process of all, namely, the associative reaction, and to describe its nature in numerically expressible quantities. This work led directly to the discovery of the *feeling-toned complex*, and indirectly to a new question, namely, the problem of *attitude*, which exerts a decisive influence upon the associative reaction. The answer to this question was found by clinical observation of patients and by analysis of their behaviour. From these researches there emerged a *psychological typology*, which distinguished two attitude-types, the extravert and the introvert, and four function-types corresponding to the four orienting functions of consciousness.

[1131] The existence of complexes and of typical attitudes could not be adequately explained without the hypothesis of the unconscious. From the beginning, therefore, the above-mentioned experiments and researches went hand in hand with an investigation of unconscious processes. This led, about 1912, to the actual discovery of the *collective unconscious*. The term itself is of a later date. If the theory of complexes and type psychology had already overstepped the bounds of psychiatry proper, with the hypothesis of the collective unconscious the scope of our researches was extended without limit. Not only the domain of normal psychology, but also those of racial psychology, folklore, and mythology in the widest sense became the

subject-matter of complex psychology. This expansion found expression in the collaboration with the sinologist Richard Wilhelm and the indologist Heinrich Zimmer. Both are now dead, but our science has not forgotten the inestimable contribution they made. Wilhelm above all introduced me to medieval Chinese alchemy and thus prepared the ground for an understanding of the rudiments of modern psychology that are to be found in the medieval texts. Into the painful gap left by the death of these two fellow workers there stepped, a few years ago, Karl Kerényi, one of the most brilliant philologists of our time. Thus a wish I personally had long cherished saw fulfillment, and our science was granted a new helper.^{1a}

[1132] The insights gained originally in the domains of psychopathology and normal psychology proved to be keys to the most difficult Taoist texts and to abstruse Indian myths, and Kerényi has now supplied such a wealth of connections with Greek mythology that the cross-fertilization of the two branches of science can no longer be doubted. In the same way that Wilhelm aroused an interest in alchemy and made possible a true interpretation of this little understood philosophy, Kerényi's work has stimulated a large number of psychological researches, in particular the investigation and elucidation of one of the most important problems in psychotherapy, namely, the *phenomenon of the transference*.²

[1133] Recently an unexpected and most promising connection has been forged between complex psychology and physics, or to be more accurate, *microphysics*. On the psychological side, it was first of all C. A. Meier who pointed out the common conception of complementarity. Pascual Jordan approached psychology from the physicist's side by drawing attention to the phenomenon of spatial relativity which applies equally to the phenomena of the unconscious. W. Pauli has taken up the new "psychophysical" problem on a much broader basis, examining it from the standpoint of the formation of scientific theories and their archetypal foundations.³ Recently, in two impressive lectures, he showed on the one hand how the archetypal triad or trinity formed the point of departure for Kepler's astronomy, and on the other how Fludd's polemics with Kepler were based on the alchemical thesis of the quaternity. The object at issue, the *proportio sesquitertia* or ratio of 3 : 1, is likewise a fundamental problem in the psychology of the unconscious. Thirty years ago, the problem first presented itself in psychology as a typological phenomenon, i.e., as the relation of three more or less differentiated functions to one inferior function which was contaminated with the unconscious. Since then it has been considerably widened and deepened by the study of Gnostic and alchemical texts. It appears there partly in the form of the social or folkloristic *marriage quaternio*, derived originally from the primitive cross-cousin-marriage, and partly in the form of a differentiation in the sequence of elements, in which one or the other element, usually fire or earth, is distinguished from the other three. The same problem appears in the controversy

between the trinitarian and the quaternarian standpoint in alchemy. In complex psychology the quaternity symbol has been shown to be an expression of psychic totality, and in the same way it could be established that the *proportio sesquitertia* commonly occurs in the symbolism produced by the unconscious. If, as conjectured, the quaternity or above-named proportion is not only fundamental to all concepts of totality but is also inherent in the nature of observed microphysical processes, we are driven to the conclusion that the space-time continuum, including mass, is psychically relative—in other words, that it forms a unity with the unconscious psyche. Accordingly, there must be phenomena which can be explained only in terms of a psychic relativity of space, time, and mass. Besides numerous individual observations the experiments conducted at Duke University by Rhine and elsewhere by other investigators have furnished sufficient proof of this. You will forgive me if I have dwelt on the latest connections of our psychology with physics at some length. It did not seem to me superfluous in view of the incalculable importance of this question.

[1134] To round out the position of complex psychology as it is at present, I would like to mention some major works by pupils. These include the “Einführung in die Grundlagen der komplexen Psychologie,” by Toni Wolff,⁴ a work distinguished for its philosophical clarity; the books of Esther Harding on feminine psychology;⁵ the analysis of the *Hypnerotomachia* of Francesco Colonna, by Linda Fierz-David,⁶ a showpiece of medieval psychology; the valuable introduction to our psychology by Jolande Jacobi;⁷ the books on child psychology by Frances Wickes,⁸ notable for their interesting material; the great book by H. G. Baynes, *Mythology of the Soul*;⁹ a synoptic study by Gerhard Adler;¹⁰ a large-scale work in several volumes by Hedwig von Roques and Marie-Louise von Franz;¹¹ and finally, a work of significant content and scope on the evolution of consciousness by Erich Neumann.¹²

[1135] Of particular interest are the repercussions of complex psychology in the psychology of religion. The authors here are not my personal pupils. I would draw attention to the excellent book by Hans Schaer¹³ on the Protestant side, and to the writings of W. P. Witcutt¹⁴ and Father Victor White¹⁵ concerning the relations of our psychology to Thomist philosophy, and finally to the excellent account of the basic concepts by Gebhard Frei,¹⁶ whose unusual erudition facilitates an understanding from all sides.

[1136] To the picture of the past and present I must now try to sketch out one for the future. This can naturally take the form only of programmatic hints.

[1137] The manifold possibilities for the further development of complex psychology correspond to the various developmental stages it has already passed through. So far as the experimental aspect is concerned, there are still numerous questions which need to be worked out by experimental and statistical methods. I have had to leave

many beginnings unfinished because of more pressing tasks that claimed my time and energies. The potentialities of the association experiment are by no means exhausted yet. For instance, the question of the periodic renewal of the emotional tone of complex-stimulators is still unanswered; the problem of familial patterns of association has remained stuck in its beginnings, promising though these were; and so has the investigation of the physiological concomitants of the complex.

[1138] In the medical and clinical field there is a dearth of fully elaborated case histories. This is understandable, because the enormous complexity of the material puts almost insurmountable difficulties in the way of exposition and makes the highest demands not only on the knowledge and therapeutic skill of the investigator but also on his descriptive capacity. In the field of psychiatry, analyses of paranoid patients coupled with research into comparative symbolism would be of the utmost value. Special consideration might be given to the collection and evaluation of dreams in early childhood and pre-catastrophal dreams, i.e., dreams occurring before accidents, illness, and death, as well as dreams during severe illnesses and under narcosis. The investigation of pre- and post-mortal psychic phenomena also comes into this category. These are particularly important because of the relativation of space and time that accompanies them. A difficult but interesting task would be research into the processes of compensation in psychotics and in criminals, and in general into the goal of compensation and the nature of its directedness.

[1139] In normal psychology, the most important subjects for research would be the psychic structure of the family in relation to heredity, the compensatory character of marriage and of emotional relationships in general. A particularly pressing problem is the behaviour of the individual in the mass and the unconscious compensation to which this gives rise.

[1140] A rich harvest is to be reaped in the field of the humanities. Here a tremendous prospect opens out, and at present we are standing only on its extreme periphery. Most of it is still virgin territory. The same applies to biographical studies, which are especially important for the history of literature. But above all, analytical work remains to be done on questions concerned with the psychology of religion. The study of religious myths would throw light not only on racial psychology but also on certain borderline problems such as the one I mentioned earlier. In this respect, particular attention would have to be paid to the quaternity symbol and the *proportio sesquitertia*, as exemplified in the alchemical axiom of Maria, both from the side of the psychologist and from that of the physicist. The physicist may have to consider revising his concept of space-time, and for the psychologist there is need of a more thorough investigation and description of triadic and tetradic symbols and their historical development, to which Frobenius has contributed valuable material. Comprehensive studies are also needed of symbols of the goal or of unity.

[1141] This list, put together more or less at random, makes no claim to completeness. What I have said may suffice to give you a rough idea of what has already been achieved in complex psychology and of the direction which future researches conducted by the Institute might be expected to take. Much will remain a mere desideratum. Not all of it will be fulfilled; the individual differences of our workers on the one hand, and the irrationality and unpredictability of all scientific development on the other, will see to that. Happily, it is the prerogative of any institution with limited means, and not run by the State, to produce work of high quality in order to survive.

DEPTH PSYCHOLOGY¹

[1142] “Depth psychology” is a term deriving from medical psychology, coined by Eugen Bleuler to denote that branch of psychological science which is concerned with the phenomenon of the unconscious.

[1143] As a philosophical and metaphysical concept, the unconscious occurs fairly early, for instance as “petites perceptions” in Leibniz,² “eternal unconscious” in Schelling, “unconscious Will” in Schopenhauer, and as the “divine Absolute” in von Hartmann.

[1144] In the academic psychology of the nineteenth century, the unconscious occurs as a basic theoretical concept in Theodor Lipps, who defines it as the “psychic reality which must necessarily be thought to underlie the existence of a conscious content”; and in F. H.W. Myers and William James, who stress the importance of an unconscious psyche. With Theodor Fechner, the unconscious becomes an empirical concept. Nevertheless, the empirical approach to the unconscious may properly be said to date from quite recent times, since up to the turn of the century the psyche was usually identified with consciousness, and this made the idea of the unconscious appear untenable (Wundt).

[1145] The real pioneers of experimental research into the unconscious were Pierre Janet and Sigmund Freud, two medical psychologists whose investigations of pathological psychic life laid the foundations of the modern science of the unconscious. Great credit is due to Janet for his investigation of hysterical states, which he developed in his theory of “partial psychic dissociation,” drawing a distinction between the “partie supérieure” and “partie inférieure” of a function. Equally fruitful was his experimental proof of “idées fixes” and “obsessions,” and of their autonomous effects upon consciousness.

[1146] The prominence given to the unconscious as a fundamental concept of empirical psychology, however, goes back to Freud, the true founder of the depth psychology which bears the name of psychoanalysis. This is a special method of treating psychic illnesses, and consists essentially in uncovering what is “hidden, forgotten, and repressed” in psychic life. Freud was a nerve specialist. His theory was evolved in the consulting room and always preserved its stamp. His fundamental premise was the pathological, neurotically degenerate psyche.

[1147] The development of Freud’s thought can be traced as follows. He began by investigating neurotic symptoms, more particularly hysterical symptom-formation,

whose psychic origin Breuer, employing a method borrowed from hypnotism, had previously discovered in the existence of a causal connection between the symptoms and certain experiences of which the patient was unconscious. In these experiences Freud recognized affects which had somehow got “blocked,” and from which the patient had to be freed. He found there was a meaningful connection between the symptom and the affective experience, so much so that conscious experiences which later became unconscious were essential components of neurotic symptoms. The affects remained unconscious because of their painful nature. In consequence, Freud made no further use of hypnosis in “abreacting” the blocked affects, but developed instead his technique of “free association” for bringing the repressed processes back to consciousness. He thus laid the foundations of a causal-reductive method, of which special use was to be made in his interpretation of dreams.

[1148] In order to explain the origin of hysteria, Freud established the theory of the sexual trauma. He found that traumatic experiences were especially painful because most of them were caused by instinctual impulses coming from the sexual sphere. He assumed to begin with that hysteria in general was due to a sexual trauma in childhood. Later he stressed the aetiological significance of infantile-sexual fantasies that proved to be incompatible with the moral values of consciousness and were therefore repressed. The theory of repression forms the core of Freud’s teaching. According to this theory, the unconscious is essentially a phenomenon of repression, and its contents are elements of the personal psyche that although once conscious are now lost to consciousness. The unconscious would thus owe its existence to a moral conflict.

[1149] The existence of these unconscious factors can be demonstrated, as Freud showed, with the help of parapraxes (slips of the tongue, forgetting, misreading) and above all with the help of dreams, which are an important source of information regarding unconscious contents. It is Freud’s particular merit to have made dreams once more a problem for psychologists and to have attempted a new method of interpretation. He explained them by means of the repression theory, and maintained that they consisted of morally incompatible elements which, though capable of becoming conscious, were suppressed by an unconscious moral factor, the “censor,” and could therefore appear only in the form of disguised wish-fulfillments.

[1150] The instinctual conflict underlying this phenomenon Freud described initially as the conflict between the pleasure principle and the reality principle, the latter playing the part of an inhibiting factor. Later he described it as the conflict between the sexual instinct and the ego-instinct (or between the life-instinct and the death-instinct). The obtaining of pleasure was correlated with the pleasure principle, and the culture-creating impulse with the reality principle. Culture required the sacrifice of instinctual gratification by the whole of mankind and the individual alike.

Resistance to this sacrifice led to secret wish-fulfillments distorted by the “censor.” The danger inherent in this theory was that it made culture appear a substitute for unsatisfied natural instincts, so that complex psychic phenomena like art, philosophy, and religion became “suspect,” as though they were “nothing but” the outcome of sexual repression. It would seem that Freud’s negative and reductive attitude towards cultural values was historically conditioned. His attitude towards myth and religion was that of the scientific materialism of the nineteenth century. As his psychology was mainly concerned with the neuroses, the pathological aspect of the transformation of instinct claims a disproportionately large place in his theory of the unconscious and of the neuroses themselves. The unconscious appears to be essentially an appendix of consciousness; its contents are repressed wishes, affects, and memories that owe their pathogenic significance to infantile sexuality. The most important of the repressed contents is the so-called Oedipus complex, which represents the fixation of infantile sexual wishes on the mother and the resistance to the father arising from feelings of envy and fear. This complex forms the core of a neurosis.

[1151] The question of the dynamics of unconscious fantasy-formations led Freud to a concept of great importance for the further development of depth psychology, namely, the concept of libido. At first he regarded this as the sexual instinct, but later broadened it by assuming the existence of “libidinal affluxes” due to the displacement and dissociability of the libido. Through the investigation of libido-fixations Freud discovered the “transference,” a fundamental phenomenon in the treatment of neurosis. Instead of recollecting the repressed elements, the patient “transfers” them to the analyst in the form of some current experience; that is, he projects them and thereby involves the analyst in his “family romance.” In this way his illness is converted into the “transference neurosis” and is then acted out between them.

[1152] Freud later expanded the concept of the unconscious by calling it the “id” in contradistinction to the conscious ego. (The term derives from Groddeck.) The id represents the natural unconscious dynamism of man, while the ego forms that part of the id which is modified under the influence of the environment or is replaced by the reality principle. In working out the relations between the ego and the id, Freud discovered that the ego contains not only conscious but also unconscious contents, and he was therefore compelled to frame a concept to characterize the unconscious portion of the ego, which he called the “super-ego” or “ego-ideal.” He regarded this as the representative of the parental authority, as the successor of the Oedipus complex, that impels the ego to restrain the id. It manifests itself as conscience, which, invested with the authority of collective morality, continues to display the

character of the father. The super-ego accounts for the activity of the censor in dreams.

[1153] Although Alfred Adler is usually included among the founders of depth psychology, his school of *individual psychology* represents only a partial continuation of the line of research initiated by his teacher Freud. Confronted with the same empirical material, Adler considered it from an entirely different point of view. For him, the primary aetiological factor was not sexuality but the power-drive. The neurotic individual appeared to him to be in conflict with society, with the result that his spontaneous development was blocked. On this view the individual never exists for himself alone; he maintains his psychic existence only within the community. In contrast to the emphasis Freud laid on instinctual strivings, Adler stressed the importance of environmental factors as possible causes of neurosis. Neurotic symptoms and disturbances of personality were the result of a morbidly intensified valuation of the ego, which, instead of adapting to reality, develops a system of "guiding fictions." This hypothesis gives expression to a finalistic viewpoint diametrically opposed to the causal-reductive method of Freud, in that it emphasizes the direction towards a goal. Each individual chooses a guiding line as a basic pattern for the organization of all psychic contents. Among the possible guiding fictions, Adler attached special importance to the winning of superiority and power over others, the urge "to be on top." The original source of this misguided ambition lies in a deep-rooted feeling of inferiority, necessitating an over-compensation in the form of security. A primary organ-inferiority, or inferiority of the constitution as a whole, often proves to be an aetiological factor. Environmental influences in early childhood play their part in building up this psychic mechanism, since it is then that the foundations are laid for the development of the guiding fiction. The fiction of future superiority is maintained by tendentiously distorting all valuations and giving undue importance to being "on top" as opposed to "underneath," "masculine" as opposed to "feminine," a tendency which finds its clearest expression in the so-called "masculine protest."

[1154] In Adler's individual psychology, Freud's basic concepts undergo a process of recasting. The Oedipus complex, for example, loses its importance in view of the increasing drive for security; illness becomes a neurotic "arrangement" for the purpose of consolidating the life-plan. Repression loses its aetiological significance when understood as an instrument for the better realization of the guiding fiction. Even the unconscious appears as an "artifice of the psyche," so that it may very well be asked whether Adler can be included among the founders of depth psychology. Dreams, too, he regarded as distortions aiming at the fictive security of the ego and the strengthening of the power drive. Nevertheless, the services rendered by Adler and his school to the phenomenology of personality disturbances in children should

not be overlooked. Above all, it must be emphasized that a whole class of neuroses can in fact be explained primarily in terms of the power drive.

[1155] Whereas Freud started out as a neurologist, and Adler later became his pupil, C. G. Jung was a pupil of Eugen Bleuler and began his career as a psychiatrist. Before he came into contact with Freud's ideas, he had, in treating a case of somnambulism in a fifteen-year-old girl (1899), observed that her unconscious contained the beginnings of a future personality development, which took the form of a split (or "double") personality. Through experimental researches on association (1903) he found that in normal individuals as well as in neurotics the reactions to word-tests were disturbed by split-off ("repressed") emotional *complexes* ("feeling-toned complexes of ideas"), which manifested themselves by means of definite symptoms ("complex-indicators"). These experiments confirmed the existence of the repressions described by Freud and their characteristic consequences. In 1906 Jung gave polemical support to Freud's discovery. The theory of complexes maintains that neurosis is caused by the splitting-off of a vitally important complex. Similar splinter-complexes can be observed in schizophrenia. In this disease the personality is, as it were, broken up into its complexes, with the result that the normal ego-complex almost disappears. The splinter-complexes are relatively autonomous, are not subject to the conscious will, and cannot be corrected so long as they remain unconscious. They lend themselves to personification (in dreams, for instance), and, with increasing dissociation and autonomy, assume the character of partial personalities (hence the old view of neuroses and psychoses as states of possession).

[1156] In 1907 Jung became personally acquainted with Freud, and derived from him a wealth of insights, particularly in regard to dream psychology and the treatment of neurosis. But in certain respects he arrived at views which differed from those of Freud. Experience did not seem to him to justify Freud's sexual theory of neurosis, and still less that of schizophrenia. The conception of the unconscious needed to be broadened, inasmuch as the unconscious was not just a product of repression but was the creative matrix of consciousness. Equally, he was of the opinion that the unconscious could not be explained in personalistic terms, as a merely personal phenomenon, but that it was also in part collective. Accordingly, he rejected the view that it possessed a merely instinctual nature, as well as rejecting the wish-fulfillment theory of dreams. Instead, he emphasized the compensatory function of the unconscious processes and their teleological character. For the wish-fulfillment theory he substituted the concept of development of personality and development of consciousness, holding that the unconscious does not consist only of morally incompatible wishes but is largely composed of hitherto undeveloped, unconscious portions of the personality which strive for integration in the wholeness of the individual. In the neurotic, this process of realization is manifested in the conflict

between the relatively mature side of the personality and the side which Freud rightly described as infantile. The conflict has at first a purely personal character and can be explained personalistically, as the patients themselves do, and moreover in a manner which agrees both in principle and in detail with the Freudian explanation. Their standpoint is a purely personal and egoistic one, and takes no account of the collective factors, this being the very reason why they are ill. In schizophrenics, on the other hand, the collective contents of the unconscious predominate strongly in the form of mythological motifs. Freud could not subscribe to these modifications of his views, so Jung and he parted company.

[1157] Such differences of viewpoint, further increased by the contradiction between Freud's and Adler's explanation of neurosis, prompted Jung to investigate more closely the important question of the conscious attitude, on which the compensatory function of the unconscious depends. Already in his association experiments he had found indications of an *attitude-type*, and this was now confirmed by clinical observations. As a general and habitual disposition in every individual, there proved to be a more or less pronounced tendency towards either *extraversion* or *introversion*, the focus of interest falling in the first case on the object, and in the second on the subject. These attitudes of consciousness determine the corresponding modes of compensation by the unconscious: the emergence in the first case of unconscious demands upon the subject, and in the second of unconscious ties to the object. These relationships, in part complementary, in part compensatory, are complicated by the simultaneous participation of the variously differentiated *orienting functions* of consciousness, namely, *thinking*, *feeling*, *sensation*, and *intuition*, which are needed for a whole judgment. The most differentiated ("superior") function is complemented or compensated by the least differentiated ("inferior") function, but at first only in the form of a conflict.

[1158] Further investigation of the collective material of the unconscious, presented by schizophrenics and by the dreams of neurotics and normal people, elicited typical figures or motifs which have their counterparts in myth and may therefore be called *archetypes*. These are not to be thought of as inherited ideas; rather, they are the equivalent of the "pattern of behaviour" in biology. The archetype represents a mode of psychic behaviour. As such, it is an "irrepresentable" factor which unconsciously arranges the psychic elements so that they fall into typical configurations, much as a crystalline grid arranges the molecules in a saturated solution. The specific associations and memory images forming these configurations vary endlessly from individual to individual; only the basic pattern remains the same. One of the clearest of these archetypal figures is the *anima*, the personification of the unconscious in feminine form. This archetype is peculiar to masculine psychology, since the unconscious of a man is by nature feminine, probably owing to the fact that sex is

determined merely by a preponderance of masculine genes, the feminine genes retreating into the background. The corresponding role in a woman is played by the *animus*. A figure common to both sexes is the *shadow*, a personification of the inferior side of the personality. These three figures appear very frequently in the dreams and fantasies of normal people, neurotics and schizophrenics. Less frequent is the archetype of the *wise old man* and of the *earth mother*. Besides these there are a number of functional and situational motifs, such as ascent and descent, the crossing (ford or strait), tension and suspension between opposites, the world of darkness, the breakthrough (or invasion), the creation of fire, helpful or dangerous animals, etc. Most important of all is the supposedly central archetype or *self*, which seems to be the point of reference for the unconscious psyche, just as the ego is the point of reference for consciousness. The symbolism associated with this archetype expresses itself on the one hand in circular, spherical, and quaternary forms, in the “squaring of the circle,” and in mandala symbolism; on the other hand in the imagery of the supraordinate personality (God-image, Anthropos symbolism).

[1159] These empirical findings show that the unconscious consists of two layers: a superficial layer, representing the *personal unconscious*, and a deeper layer, representing the *collective unconscious*. The former is made up of personal contents, i.e., things forgotten and repressed, subliminal or “extrasensory” perceptions and anticipations of future developments, as well as other psychic processes that never reach the threshold of consciousness. A neurosis originates in a conflict between consciousness and the personal unconscious, whereas a psychosis has deeper roots and consists in a conflict involving the collective unconscious. The great majority of dreams contain mainly personal material, and their protagonists are the ego and the shadow. Normally, the dream material serves only to compensate the conscious attitude. There are, however, comparatively rare dreams (the “big” dreams of primitives) which contain clearly recognizable mythological motifs. Dreams of this sort are of especial importance for the development of personality. Their psychotherapeutic value was recognized even in ancient times.

[1160] Since the personal unconscious contains the still active residues of the past as well as the seeds of the future, it exerts a direct and very considerable influence on the conscious behaviour of the individual. All cases of unusual behaviour in children should be investigated for their psychic antecedents through rigorous interrogation of both child and parents. The behaviour of the parents, whether they have open or hidden conflicts, etc., has an incalculable effect on the unconscious of the child. The causes of infantile neurosis are to be sought less in the children than in the parents or teachers. The teacher should be more conscious of his shadow than the average person, otherwise the work of one hand can easily be undone by the other. It is for

this reason that medical psychotherapists are required to undergo a training analysis, in order to gain insight into their own unconscious psyche.

[1160a] Thanks to the parallelism between mythological motifs and the archetypes of the unconscious, depth psychology has been applied in widely differing fields of research, especially by students of mythology, folklore, comparative religion, and the psychology of primitives (Richard Wilhelm, Heinrich Zimmer, Karl Kerényi, Hugo Rahner, Erich Neumann), as was also the case with the Freudian school earlier (Karl Abraham, Otto Rank, Ernest Jones). As the archetypes have a “numinous” quality and underlie all religious and dogmatic ideas, depth psychology is also of importance for theology.

[1161] The activity of the collective unconscious manifests itself not only in compensatory effects in the lives of individuals, but also in the mutation of dominant ideas in the course of the centuries. This can be seen most clearly in religion, and, to a lesser extent, in the various philosophical, social, and political ideologies. It appears in most dangerous form in the sudden rise and spread of psychic epidemics, as for instance in the witch hunts in Germany at the end of the fourteenth century, or in the social and political utopias of the twentieth century. How far the collective unconscious may be considered the efficient cause of such movements, or merely their material cause, is a question for ethnologists and psychologists to decide; but certain experiences in the field of individual psychology indicate the possibility of a spontaneous activity of archetypes. These experiences usually concern individuals in the second half of life, when it not infrequently happens that drastic changes of outlook are thrust upon them by the unconscious as a result of some defect in their conscious attitude. While the activity of the personal unconscious is confined to compensatory changes in the personal sphere, the changes effected by the collective unconscious have a collective aspect: they alter our view of the world, and, like a contagion, infect our fellow men. (Hence the astonishing effects of certain psychopaths on society!)

[1162] The regulating influence of the collective unconscious can be seen at work in the psychic development of the individual, or *individuation process*. Its main phases are expressed by the classic archetypes that are found in the ancient initiation mysteries and in Hermetic philosophy. These archetypal figures appear in projected form during the transference. Freud recognized only the personal aspect of this psychotherapeutically very important phenomenon. Despite appearances to the contrary, its real psychotherapeutic value does not lie in the sphere of personal problems (a misunderstanding for which the neurotic patient has to pay dearly), but in the projection of archetypal figures (anima, animus, etc.). The archetypal relationships thus produced during the transference serve to compensate the unlimited exogamy of our culture by a realization of the unconscious endogamous

tendency. The goal of the psychotherapeutic process, the self-regulation of the psyche by means of the natural drive towards individuation, is expressed by the above-mentioned mandala and Anthropos symbolism.

FOREWORD TO THE FIRST VOLUME OF STUDIES FROM THE C. G. JUNG INSTITUTE¹

[1163] The works which the Institute proposes to publish in this series derive from many different spheres of knowledge. This is understandable since they are predominantly psychological in character. Psychology, of its very nature, is the intermediary between the disciplines, for the psyche is the mother of all the sciences and arts. Anyone who wishes to paint her portrait must mingle many colours on his palette. In order to do justice to its subject, psychology has to rely on any number of auxiliary sciences, on whose findings its own growth and prosperity depend. The psychologist gratefully acknowledges his borrowings from other sciences, though he has neither the intention nor the ambition to usurp their domains or to “know better.” He has no wish to intrude into other fields but restricts himself to using their findings for his own purposes. Thus, for example, he will not use historical material in order to write history but rather to demonstrate the nature of the psyche—a concern which is foreign to the historian.

[1164] The forthcoming publications in this series will show the great diversity of psychological interests and needs. Recent developments in psychological research, in particular the psychology of the collective unconscious, have confronted us with problems which require the collaboration of other sciences. The facts and relationships unearthed by the analysis of the unconscious offer so many parallels to the phenomenology of myths, for example, that their psychological elucidation may also shed light on the mythological figures and their symbols. At all events, we must gratefully acknowledge the invaluable support psychology has received from students of myths and fairy-tales, as well as from comparative religion, even if they on their part have not yet learnt how to make use of its insights. The psychology of the unconscious is still a very young science which must first justify its existence before a critical public. This is the end which the publications of the Institute are designed to serve.

September 1948

FOREWORD TO FRIEDA FORDHAM: "INTRODUCTION TO JUNG'S PSYCHOLOGY"¹

[1165] Mrs. Frieda Fordham has undertaken the by no means easy task of producing a readable résumé of all my various attempts at a better and more comprehensive understanding of the human psyche. As I cannot claim to have reached any definite theory explaining all or even the main part of the psyche's complexities, my work consists of a series of different approaches, or one might call it a circumambulation of unknown factors. This makes it rather difficult to give a clear-cut and simple account of my ideas. Moreover, I always felt a particular responsibility not to overlook the fact that the psyche does not reveal itself only in the doctor's consulting-room, but above all in the wide world, as well as in the depths of history. What the doctor observes of its manifestations is an infinitesimal part of the psychic world, and moreover often distorted by pathological conditions. I was always convinced that a fair picture of the psyche could be obtained only by a comparative method. But the great disadvantage of such a method is that one cannot avoid the accumulation of comparative material, with the result that the layman becomes bewildered and loses his tracks in the maze of parallels.

[1166] The author's task would have been much simpler if she had been in possession of a neat theory for a *point de départ*, and of well-defined case material without digressions into the immense field of general psychology. The latter, however, seems to me to form the only safe basis and criterion for the evaluation of pathological phenomena, even as normal anatomy and physiology are an indispensable precondition for a study of their pathological aspects. Just as human anatomy has a long evolution behind it, the psychology of modern man depends upon its historical roots and can only be judged by its ethnological variants. My works offer innumerable possibilities of side-tracking the reader's attention with considerations of this sort.

[1167] Under those somewhat trying conditions the author has nevertheless succeeded in extricating herself from all the opportunities to make mis-statements. She has presented a fair and simple account of the main aspects of my psychological work. I am indebted to her for this admirable piece of work.

September 1952

FOREWORD TO MICHAEL FORDHAM: "NEW DEVELOPMENTS IN ANALYTICAL PSYCHOLOGY"¹

[1168] It is not easy to write a foreword to a book consisting of a collection of essays, especially when each essay requires one to take up an attitude or stimulates the reader into discursive comments. But this is just what Dr. Fordham's papers do: every single one of them is so carefully thought out that the reader can hardly avoid holding a conversation with it. I do not mean in a polemical sense, but rather in the sense of affirmation and in the desire to carry the objective discussion a stage further and collaborate on the solution of the problems involved. Opportunities for such enjoyable dialogues are unfortunately rather rare, so that one feels it as a distinct loss when one has to forgo them. A foreword ought not to make remarks to the author and, so to speak, buttonhole him for a private conversation. It ought, rather, to convey to the reader something of the impressions which the writer of the foreword received when reading the manuscript. If I may be forgiven a somewhat frivolous expression, the foreword should be content with the role of an intellectual aperitif.

[1169] Thus I can confess myself grateful for the stimulation the book has brought me, and salute the author's collaboration in the field of psychotherapy and analytical psychology. For in this territory questions arise of a practical and theoretical kind, which are so difficult to answer that they will continue to exercise our minds for a long time to come. Above all I would like to draw attention to Dr. Fordham's discussion of the problem of synchronicity, first mooted by me and now dealt with by him in a masterly manner. I must rate his achievement all the higher because it demands not only understanding, but courage too, not to let oneself be prevented from going more deeply into this problem by the prejudices of our intellectual compeers. Also I must acknowledge that the author has in no wise succumbed to the very understandable temptation to underestimate the problem, to pass off one's own lack of comprehension as the stupidity of others, to substitute other terms for the concepts I have proposed and to think that something new has been said. Here Dr. Fordham's feeling for essentials is confirmed in the finest way.

[1170] The paper on the transference merits attentive reading. Dr. Fordham guides his reader through the multifarious aspects of this "problem with horns"—to use an expression of Nietzsche's—with circumspection, insight, and caution, as befits this in every respect delicate theme. The problem of the transference occupies a central position in the dialectical process of analytical psychology and therefore merits quite special interest. It makes the highest demands not only on the doctor's knowledge

and skill but also on his moral responsibility. Here the truth of the old alchemical dictum is proved yet again: “ars totum requirit hominem” (the art requires the total man). The author takes full account of the overriding importance of this phenomenon and accordingly devotes to it a particularly attentive and careful exposition. The practising psychologist would be very wrong if he thought he could dismiss general considerations of this kind based on broader principles, and dispense with all deeper reflection. Even if psychotherapy admits of numerous provisional and superficial solutions in practice, the practising analyst will nevertheless come up against cases from time to time that challenge him as a man and a personality in a way that may be decisive. The usual interim solutions and other banal expedients, such as appeals to collective precepts, which are invariably constructed with “must” or “ought,” then have a habit of breaking down, and the question of ultimate principles, or of the ultimate meaning of the individual, arises. This is the moment when dogmatic tenets and pragmatic rules of thumb must make way for a creative solution issuing from the total man, if his therapeutic endeavours are not to get miserably silted up and stuck. In such cases he will need reflection and will be thankful to those who have been farsighted enough to struggle for an all-round understanding.

[1171] For it is not only a routine performance that is expected of the analyst, but also a readiness and ability to master unusual situations. This is particularly true of psychotherapy, where in the last analysis we are concerned with the whole of the human personality and not merely with life in its partial aspects. Routine cases can be disposed of in a variety of ways—with good advice, with suggestion, with a bit of training, with confession of sin, with any more or less plausible system of views and methods. It is the uncommon cases that set us the master test, by forcing us into fundamental reflections and demanding decisions of principle. From this vantage point we shall then discover that even in ordinary cases there is adumbrated a line that leads to the central theme, namely, the individuation process with its problem of opposites.

[1172] This level of insight cannot be reached without the dialectical discussion between two individuals. Here the phenomenon of the transference forcibly brings about a dialogue that can only be continued if both patient and analyst acknowledge themselves as partners in a common process of approximation and differentiation. For, in so far as the patient frees himself from his infantile state of unconsciousness and its restrictive handicaps, or from its opposite, namely unbounded egocentricity, the analyst will see himself obliged to diminish the distance between them (hitherto necessary for reasons of professional authority), to a degree that does not prevent him from displaying that measure of humanity which the patient needs in order to assure himself of his right to exist as an individual. Just as it is the duty of parents and educators not to keep children on the infantile level but to lead them beyond it, so it

is incumbent on the analyst not to treat patients as chronic invalids but to recognize them, in accordance with their spiritual development and insight, as more or less equal partners in the dialogue, with the same rights as himself. An authority that deems itself superior, or a personality that remains *hors concours*, only increases the patient's feelings of inferiority and of being excluded. An analyst who cannot risk his authority will be sure to lose it. In order to maintain his prestige he will be in danger of wrapping himself in the protective mantle of a doctrine. But life cannot be mastered with theories, and just as the cure of neurosis is not, ultimately, a mere question of therapeutic skill, but is a moral achievement, so too is the solution of problems thrown up by the transference. No theory can give us any information about the ultimate requirements of individuation, nor are there any recipes that can be applied in a routine manner. The treatment of the transference reveals in a pitiless light what the healing agent really is: it is the degree to which the analyst himself can cope with his own psychic problems. The higher levels of therapy involve his own reality and are the acid test of his superiority.

[1173] I hope Dr. Fordham's book, which is distinguished for its farsightedness, carefulness, and clarity of style, will meet with the interest it so much deserves.

June 1957

AN ASTROLOGICAL EXPERIMENT¹

[1174] In the Swiss edition² I purposely set out the results of the astrological statistics in tabular form in this chapter, so that the reader could gain some insight into the behaviour of the figures—in other words, see for himself how fortuitous these results were. Subsequently, I wanted to suppress that account of the experiment in the English edition and for a very peculiar reason indeed. That is, it has been forcibly borne in on me that practically nobody has understood it the right way, despite—or perhaps because—of the fact that I took the trouble to describe the experiment in great detail and in all its vicissitudes. Since it involved the use of statistics and comparative frequencies, I had the (as it now seems) unlucky idea that it would be helpful to present the resultant figures in tabular form. But evidently the suggestive effect emanating from statistical tables is so strong that nobody can rid himself of the notion that such an array of figures is somehow connected with the tendentious desire to *prove* something. Nothing could have been further from my mind, because all I intended to do was to describe a certain sequence of events in all its aspects. This altogether too unassuming intention was misunderstood all round, with the consequence that the meaning of the whole exposition went by the board.

[1175] I am not going to commit this mistake again, but shall make my point at once by anticipating the result: the experiment shows how synchronicity plays havoc with statistical material. Even the choice of my material seems to have thrown my readers into confusion, since it is concerned with *astrological* statistics. One can easily imagine how obnoxious such a choice must be to a prudish intellectualism. Astrology, we are told, is unscientific, absolute nonsense, and everything to do with it is branded as rank superstition. In such a dubious context, how could columns of figures mean anything except an attempt to furnish proofs in favour of astrology, proofs whose invalidity is a foregone conclusion? I have already said that there was never any question of that—but what can words do against numerical tables?

[1176] We hear so much of astrology nowadays that I determined to inquire a little more closely into the empirical foundations of this intuitive method. For this reason I picked on the following question: *How do the conjunctions and oppositions of the sun, moon, Mars, Venus, ascendant, and descendant behave in the horoscopes of married people?* The sum of all these aspects amount to fifty.

[1177] The material to be examined, namely, marriage horoscopes, was obtained from friendly donors in Zurich, London, Rome, and Vienna. The horoscopes, or rather the birth data, were piled up in chronological order just as the post brought them in. The

misunderstanding already began here, as several astrological authorities informed me that my procedure was quite unsuited to evaluating the marriage relationship. I thank these amiable counsellors, but on my side there was never any intention of evaluating marriage astrologically but only of investigating the question raised above. As the material only trickled in very slowly I was unable to restrain my curiosity any longer, and I also wanted to test out the methods to be employed. I therefore took the 360 horoscopes (i.e., 180 pairs) that had so far accumulated and gave the material to my coworker, Dr. Liliane Frey-Rohn, to be analysed. I called these 180 pairs the “first batch.”

[1178] Examination of this batch showed that the conjunction of sun (masculine) and moon (feminine) was the most frequent of all the 50 aspects, occurring in 10% of all cases. The second batch, evaluated later, consisted of 440 additional horoscopes (220 pairs) and showed as the most frequent aspect a moon-moon conjunction (10.9%). A third batch, consisting of 166 horoscopes (83 pairs), showed as the most frequent aspect the ascendant-moon conjunction (9.6%).

[1179] What interested me most to begin with was, of course, the question of probability: were the maximum results obtained “significant” figures or not; that is, were they improbable or not? Calculations undertaken by a mathematician showed unmistakably that the average frequency of 10% in all three batches is far from representing a significant figure. Its probability is much too great; in other words, there is no ground for assuming that our maximum frequencies are more than mere dispersions due to chance. Thus far the result of our statistics (which nevertheless cover nearly one thousand horoscopes) is disappointing for astrology. The material is, however, much too scanty for us to be able to draw from it any conclusions either for or against.

[1180] But if we look at the results qualitatively, we are immediately struck by the fact that in all three batches it is a *moon conjunction*, and what is more—a point which the astrologer will doubtless appreciate—a conjunction of moon and sun, moon and moon, moon and ascendant, respectively. The sun indicates the month, the moon the day, and the ascendant the “moment” of birth. The positions of sun, moon, and ascendant form the three main pillars of the horoscope. It is altogether probable that a moon conjunction should occur once, but that it should occur three times is extremely improbable (the improbability increases by the square each time), and that it should single out precisely the three main positions of the horoscope from among 47 other possibilities is something supranormal and looks like the most gorgeous falsification in favour of astrology.

[1181] These results, as simple as they are unexpected, were consistently misunderstood by the statisticians. They thought I wanted to prove something with my set of figures, whereas I only wished to give an ocular demonstration of their

“chance” nature. It is naturally a little unexpected that a set of figures, meaningless in themselves, should “arrange” a result which everybody agrees to be improbable. It seems in fact to be an instance of that possibility which Spencer-Brown has in mind when he says that “the results of the best-designed and most rigorously observed experiments in psychical research are chance results after all,” and that “the concept of chance can cover a wider natural field than we previously suspected.”³ In other words what the previous statistical view obliged us to regard as “significant,” that is, as a quasi-intentional grouping or arrangement, must be regarded equally as belonging to the realm of chance, which means nothing less than that the whole concept of probability must be revised. One can also interpret Spencer-Brown’s view as meaning that under certain circumstances the quality of “pseudo-intention” attaches to chance, or—if we wish to avoid a negative formulation—that chance can “create” meaningful arrangements that look as if a causal intention had been at work. But that is precisely what I mean by “synchronicity,” and what I wanted to demonstrate in the report on my astrological experiment. Naturally I did not embark on the experiment for the purpose of achieving, or in anticipation of, this unexpected result, which no one could have foreseen; I was only curious to find out what sort of numbers would turn up in an investigation of this kind. This wish seemed suspicious not only to certain astrologers but also to my friendly mathematical adviser, who saw fit to warn me against thinking that my maximal figures would be a proof of the astrological thesis. Neither before nor afterwards was there any thought of such proof, besides which my experiment was arranged in a way most unsuited to that purpose, as my astrological critics had already pointed out.

[1182] Since most people believe that numbers have been *invented* or thought out by man, and are therefore nothing but concepts of quantities, containing nothing that was not previously put into them by the human intellect, it was naturally very difficult for me to put my question in any other form. But it is equally possible that numbers were *found* or discovered. In that case they are not only concepts but something more—autonomous entities which somehow contain more than just quantities. Unlike concepts they are based not on any psychic assumption but on the quality of being themselves, on a “so-ness” that cannot be expressed by an intellectual concept. Under these circumstances they might easily be endowed with qualities that have still to be discovered. Also one could, as with all autonomous beings, raise the question of their behaviour; for instance one could ask what numbers do when they are intended to express something as archetypal as astrology. For astrology is the last remnant, now applied to the stars, of that fateful assemblage of gods whose numinosity can still be felt despite the critical procedures of our scientific age. In no previous age, however “superstitious,” was astrology so widespread and so highly esteemed as it is today.

[1183] I must confess that I incline to the view that numbers were as much found as invented, and that in consequence they possess a relative autonomy analogous to that of the archetypes. They would then have, in common with the latter, the quality of being pre-existent to consciousness, and hence, on occasion, of conditioning it rather than being conditioned by it. The archetypes too, as *a priori* forms of representation, are as much found as invented: they are *discovered* inasmuch as one did not know of their unconscious autonomous existence, and *invented* by the mind inasmuch as their presence was inferred from analogous representational structures. Accordingly it would seem that natural numbers must possess an archetypal character. If that is so, then not only would certain numbers have a relation to and an effect on certain archetypes, but the reverse would also be true. The first case is equivalent to number magic, but the second is equivalent to my question whether numbers, in conjunction with the numinous assemblage of gods which the horoscope represents, would show a tendency to behave in a special way.

[1184] All reasonable people, especially mathematicians, are acutely concerned with the question of what we can do by means of numbers. Only a few devote any attention to the question of what, in so far as they are autonomous, numbers do in themselves. The question sounds so absurd that one hardly dares to utter it in decent intellectual society. I could not predict what result my scandalous statistics would show. I had to wait and see. And as a matter of fact my figures behaved in so obliging a fashion that an astrologer can probably appreciate them far better than a mathematician. Owing to their excessively strict adherence to reason, mathematicians seem unable to see beyond the fact that in each separate case my result has too great a probability to prove anything about astrology. Of course it doesn't, because it was never intended to do any such thing, and I never for a moment believed that the maximum, falling each time on a moon conjunction, represented a so-called significant figure. Yet in spite of this critical attitude a number of mistakes were made in working out and computing the statistics, which all without exception contrived to bring about the most favourable possible result for astrology. As though to punish him for his well-meaning warning, the worst mistake of all fell to the lot of my mathematician, who at first calculated far too small a probability for the individual maxima, and was thus unwittingly deceived by the unconscious in the interests of astrological prestige.

[1185] Such lapses can easily be explained by a secret support for astrology in face of the violently prejudiced attitude of the conscious mind. But this explanation does not suffice in the case of the extremely significant over-all result, which with the help of quite fortuitous numbers produced the picture of the classical marriage tradition in astrology, namely the conjunction of the moon with the three principal positions of the horoscope, when there were 47 other possibilities to choose from. Tradition since the time of Ptolemy predicts that the moon conjunction with the sun or moon of the

partner is the marriage characteristic. Because of its position in the horoscope, the ascendant has just as much importance as the sun and moon. In view of this tradition one could not have wished for a better result. The figure giving the probability of this predicted concurrence, unlike the first-obtained maximum of 10%, is indeed highly significant and deserves emphasizing, although we are no more able to account for its occurrence and for its apparent meaningfulness than we can account for the results of Rhine's experiments, which prove the existence of a perception independent of the space-time barrier.

[1186] Naturally I do not think that this experiment or any other report on happenings of this kind proves anything; it merely points to something that even science can no longer overlook—namely, that its truths are in essence statistical and are therefore not absolute. Hence there is in nature a background of acausality, freedom, and meaningfulness which behaves complementarily to determinism, mechanism, and meaninglessness; and it is to be assumed that such phenomena are observable. Owing to their peculiar nature, however, they will hardly be prevailed upon to lay aside the chance character that makes them so questionable. If they did this they would no longer be what they are—acausal, undetermined, meaningful.⁴

[1187] [Pure causality is only meaningful when used for the creation and functioning of an efficient instrument or machine by an intelligence standing outside this process and independent of it. A self-running process that operates entirely by its own causality, i.e., by absolute necessity, is meaningless. One of my critics accuses me of having too rigid a conception of causality. He has obviously not considered that if cause and effect were not necessarily⁵ connected there would hardly be any meaning in speaking of causality at all. My critic makes the same mistake as the famous scientist⁶ who refuses to believe that God played dice when he created the world. He fails to see that if God did not play dice he had no choice but to create a (from the human point of view) meaningless machine. Since this question involves a transcendental judgment there can be no final answer to it, only a paradoxical one. *Meaning arises not from causality but from freedom, i.e., from acausality.*

[1188] [Modern physics has deprived causality of its axiomatic character. Thus, when we explain natural events we do so by means of an instrument which is not quite reliable. Hence an element of uncertainty always attaches to our judgment, because—*theoretically, at least*—we might always be dealing with an exception to the rule which can only be registered negatively by the statistical method. No matter how small this chance is, it nevertheless exists. Since causality is our only means of explanation and since it is only relatively valid, we explain the world by applying causality in a paradoxical way, both positively and negatively: A is the cause of B and possibly not. The negation can be omitted in the great majority of cases. But it is my contention that it cannot be omitted in the case of phenomena which are relatively

independent of space and time. As the time-factor is indispensable to the concept of causality, one cannot speak of causality in a case where the time-factor is eliminated (as in precognition). *Statistical truth leaves a gap open for acausal phenomena.* And since our causalistic explanation of nature contains the possibility of its own negation, it belongs to the category of *transcendental judgments*, which are paradoxical or antinomian. That is so because nature is still beyond us and because science gives us only an average picture of the world, but not a true one. If human society consisted of average individuals only, it would be a sad sight indeed.]

[1189] From a rational point of view an experiment like the one I conducted is completely valueless, for the oftener it is repeated the more probable becomes its lack of results. But that this is also *not* so is proved by the very old tradition, which would hardly have come about had not these “lucky hits” often happened in the past. They behave like Rhine’s results: they are exceedingly improbable, and yet they happen so persistently that they even compel us to criticize the foundations of our probability calculus, or at least its applicability to certain kinds of material.

[1190] When analysing unconscious processes I often had occasion to observe synchronistic or ESP phenomena, and I therefore turned my attention to the psychic conditions underlying them. I believe I have found that they nearly always occur in the region of archetypal constellations, that is, in situations which have either activated an archetype or were evoked by the autonomous activity of an archetype. It is these observations which led me to the idea of getting the combination of archetypes found in astrology to give a quantitatively measurable answer. In this I succeeded, as the result shows; indeed one could say that the organizing factor responded with enthusiasm to my prompting. The reader must pardon this anthropomorphism, which I know positively invites misinterpretation; it fits in excellently well with the psychological facts and aptly describes the emotional background from which synchronistic phenomena emerge.

[1191] I am aware that I ought at this point to discuss the psychology of the archetype, but this has been done so often and in such detail elsewhere⁷ that I do not wish to repeat myself now.

[1192] I am also aware of the enormous impression of improbability made by events of this kind, and that their comparative rarity does not make them any more probable. The statistical method therefore excludes them, as they do not belong to the average run of events.

LETTERS ON SYNCHRONICITY

*To Markus Fierz*¹

21 February 1950

Dear Professor Fierz,

[1193] You were kind enough to read through my MS on synchronicity, for which I have never thanked you sufficiently. I have been too engrossed in working out this idea.

[1194] Today I take the liberty of burdening you with yet another portion of this manuscript, my excuse being that I am in great perplexity as regards the mathematical evaluation of the results worked out. I enclose the Tables, together with the commentary. For your general orientation I would only remark that the peculiar nature of the material has necessitated a somewhat peculiar arrangement of the Tables. The basis of the experiment consists of 180 married pairs, whose horoscopes were compared for the frequency of the so-called classical marriage aspects, namely, the conjunction and opposition of sun and moon, Mars and Venus, ascendant and descendant. These yield 50 aspects. The results obtained for married pairs were compared with $180 \times 180 - 1 = 32,220$ combinations of unmarried pairs. To the original material of 180 married pairs another 145 were added later, which were also included in the statistics. They were examined in part separately, in part together with the 180, as you can see from the Tables.

[1195] The most interesting seems to me to be Table VI,² which shows the dispersions in the frequency values of the aspects. I would now be most grateful if you would give me your criticism and view of the Tables as a whole, and, in particular, answer a question arising out of Table VI. We have here some aspects which considerably exceed the probable mean value of the combinations. I would now like to know what is the probability of these deviations from the probable mean. I know that for this purpose a calculation is used which is based on the so-called "deviation standard."³ But this method is beyond my mathematical capacity and here I am wholly dependent on your help. I would be very glad if you would concentrate mainly on this question. For outside reasons there is some urgency with these Tables, as the book is soon to go to press. Failing all else it would be enough for me if you could simply confirm that the Tables as a whole are in order, and if you could give me the probability at least for the two highest values in Table VI, column 1. All the rest, I

devoutly hope, you will be able to see from the Tables themselves. After brooding on them for a long time they have become clear to me, and I must confess I would not know how to make them any clearer.

[1196] Should you be interested in the whole of the manuscript, or think it desirable to read it for the present purpose, it is naturally at your disposal. But I wouldn't like to send such an avalanche crashing down on you without warning.

Thanking you in advance for the trouble you are taking,

Yours sincerely, C. G. JUNG

2 March 1950

Dear Professor Fierz,

[1197] My best thanks for all the trouble you have taken. You have given me just what I hoped for from you—an objective opinion as to the significance of the statistical figures obtained from my material of now 400 marriages. Only I am amazed that my statistics have amply confirmed the traditional view that the sun-moon aspects are marriage characteristics, which is further underlined by the value you give for the moon-moon conjunction, namely 0.125%.

For myself I regard the result as very unsatisfactory and have therefore stopped collecting further material, as the approximation to the probable mean with increasing material seems to me suspicious.

[1198] Although the figure of 0.125% is still entirely within the bounds of possibility, I would nevertheless like to ask you, for the sake of clarity, whether one may regard this value as “significant” in so far as it represents a relatively low probability that coincides with the historical tradition? May one at least *conjecture* that it argues for rather than against the tradition (since Ptolemy)? I fully share your view of divinatory methods as *catalysts* of intuition. But the result of these statistics has made me somewhat sceptical, especially in connection with the latest ESP experiments which have obtained probabilities of 10^{-31} . These experiments and the whole experience of ESP are sufficient proof that meaningful coincidences do exist. There is thus some probability that the divinatory methods actually produce synchronistic phenomena. These seem to me most clearly discernible in astrology. The statistical findings undoubtedly show that the astrological correspondences are nothing more than chance. The statistical method is based on the assumption of a continuum of uniform objects. But synchronicity is a qualified individual event which is ruined by the statistical method; conversely, synchronicity abolishes the assumption of [a continuum of] uniform objects and so ruins the statistical method. It seems, therefore, that a *complementarity relationship* exists between synchronicity and causality. Rhine's statistics have proved the existence of synchronicity *in spite of unsuitable methods*. This aroused false hopes in me as regards astrology. In Rhine's experiments

the phenomenon of synchronicity is an extremely simple matter. The situation in astrology is incomparably more complicated and is therefore more sensitive to the statistical method, which emphasizes just what is least characteristic of synchronicity, that is, uniformity. Now my results, mischievously enough, exactly confirm the old tradition although they are as much due to chance as were the results in the old days. So again something has happened that shows all the signs of synchronicity, namely a “meaningful coincidence” or “Just So” story. Obviously the ancients must have experienced the same thing quite by chance, otherwise no such tradition could ever have arisen. I don’t believe any ancient astrologer statistically examined 800 horoscopes for marriage characteristics. He always had only small batches at his disposal, which did not ruin the synchronistic phenomenon and could therefore, as in my case, establish the prevalence of moon-moon and moon-sun conjunctions, although these are bound to diminish with a higher range of numbers. All synchronistic phenomena, which are more highly qualified than ESP, are as such unprovable, that is to say a single authenticated instance is sufficient proof in principle, just as one does not need to produce ten thousand duckbilled platypi in order to prove they exist. It seems to me synchronicity represents a *direct act of creation* which manifests itself as chance. The statistical proof of natural conformity to law is therefore only a very limited way of describing nature, since it grasps only uniform events. But nature is essentially discontinuous, i.e., subject to chance. To describe it we need a principle of discontinuity. In psychology this is the drive to individuation, in biology it is differentiation, but in nature it is the “meaningful coincidence,” that is to say synchronicity.

[1199] Forgive me for putting forward these somewhat abstruse-looking reflections. They are new to me too and for that reason are still rather chaotic like everything *in statu nascendi*.

Thanks again for your trouble! I should be glad to have your impressions.

Best regards, C. G. JUNG

20 October 1954

Dear Professor Fierz,

[1200] Just now an English version of my book on synchronicity is being prepared. I would like to take this opportunity to make the necessary corrections for the probabilities of the maximal figures which you have so kindly calculated for me. My publishers now want to see the details of your calculation, as they don’t understand what method you have employed. If it would be possible for you to let me have this report fairly soon I should be most grateful. Unfortunately I must still add a special request, namely the answer to the question: What is the probability of the total result that the 3 conjunctions, moon-sun, moon-moon, moon asc., all come out together?⁴

This result (though consisting of chance figures) corresponds to the traditional astrological prediction and at least *imitates* that picture, and if it consisted of “significant figures” would prove the rightness of astrological expectations.

[1201] I hope I have succeeded in expressing myself clearly. I am indeed extremely sorry to bother you with this question and take up your valuable time. Perhaps you can assign the task to a student. Naturally in this matter I am helpless and am therefore quite prepared to recompense you or the student for the expenses involved. Please do not be offended at this practical suggestion.

Best thanks in advance!

Yours sincerely, C. G. JUNG

28 October 1954

Dear Professor Fierz,

[1202] Let me thank you most cordially for your kind and prompt fulfilment of my request. There is, of course no need for you to repeat your exposition; I will send it direct to Dr. Michael Fordham.

[1203] A misunderstanding seems to have arisen over my question about the moon-sun, moon-moon, moon-asc. triad:

1. The fact that my figures are due to chance was something I myself had noticed when putting my tables together. That is why I had the Tables printed in full; they express the chance nature of the figures quite clearly and so enable the non-mathematical reader to take it in at a glance. For the sake of accuracy I then asked you to give me the probability of my maxima. Your answer is more or less in line with what I expected. It was never my intention to prove that the astrological prediction is correct—I know the unreliability of astrology much too well for that. I only wanted to find out the exact degree of probability of my figures. You have already warned me twice about the impossibility of proving anything. That, if you will permit me to say so, is carrying coals to Newcastle. It doesn't matter to me at all whether astrology is right or not, but only (as said) what degree of probability those figures (“maxima”) have, which *simulate* an apparent proof of the rightness of the astrological prediction.

2. The astrological prediction consists in the *traditional* assertion that my three moon conjunctions are specifically characteristic of marriage. (Sun, moon, asc. are the main pillars of the horoscope.) So this triad is not arbitrarily selected at all, for which reason I consider the analogy of the three white ants⁵ entirely to the point. With all due respect, you seem to me to go very wide of the mark if you imagine that I regard my results as other than statistically determined. Naturally they fall within the limits of mathematical probability, but that does not stop my maxima from occurring at the very places the astrologer would expect. The only thing that interests

me is the degree of probability to be attributed to this coincidence, merely for the sake of accuracy! I don't want to *prove* anything with my figures but only to *show what has happened* and what I have done. *Quite by chance*, as I have tried to show with all possible clarity, a configuration resulted which, if it consisted of significant figures, would argue in favour of astrology. The whole story is in other words a case like the scarab⁶ and simply shows what chance can do—a “Just So” story in fact! That such coincidences are in principle more than merely statistically determined is proved by Rhine's results, but not by an isolated instance like my statistics.

[1204] Naturally I speak in favour of chance in one respect, because I contest the absolute validity of statistical statements in so far as they dismiss all exceptions as unimportant. This gives us an abstract, average picture of reality which is to some extent a falsification of it, and this cannot remain a matter of indifference to the psychologist since he has to cope with the pathological consequences of this abstract substitute for reality.

[1205] The exception is actually more real than the average since it is the vehicle of reality *par excellence*, as you yourself point out in your letter of October 24th.

[1206] I am sorry to have caused you so much work, and that you now have to read this long letter as well. But I really do not know what could have led you to believe that I wanted to prove the truth of astrology. I only wanted to present a case of “meaningful coincidence” which would illustrate the main idea of my paper on synchronicity. This fact has been generally overlooked. In London they have called in a top statistician⁷ to solve the riddle of my Tables. That is rather like a peasant not being able to open his barn door and then sending for an expert on safes, who naturally can't open it either. Regrettably, he too has succumbed to the error that I wanted to prove something in favour of astrology, although I disclaim this at some length in my book.

[1207] Unfortunately I am unable to understand how you can consider any other constellations (among my 50) just as “meaningful” as the three moon conjunctions. None of the others are “classical predictions.” Nor does just any ant appear, but only the “predicted” white ant. I am interested to know the probability of this meaningful occurrence precisely because it is not very probable that the white ant will be the first to come out of the box three times in succession. If the probability of a single time is 1:50, wouldn't the probability of three times be 1:50³? A quite appreciable figure, it seems to me. This result may surely be taken as complying with my intention to present a case of synchronicity, even though it proves nothing about astrology, which was never my intention anyway.

Hoping that I have succeeded this time in clearing up the misunderstanding,
I remain with best thanks and cordial greetings,

Yours, C. G. JUNG

1st July 1955

Dear Fordham,

[1208] Synchronicity tells us something about the nature of what I call the *psychoid* factor, i.e., the unconscious archetype (not its conscious representation!). As the archetype has the tendency to gather suitable forms of expression round itself, its nature is best understood when one imitates and supports this tendency through amplification. The natural effect of an archetype and its amplification can be certainly understood as an analogy of the synchronistic effect, inasmuch as the latter shows the same tendency of arranging collateral and coincidental facts which represent suitable expressions of the underlying archetype. It is difficult or even impossible, however, to prove that amplificatory associations are *not causal*, whereas amplificatory facts coincide in a way that defies causal explanation. That is the reason why I call spontaneous and artificial amplification a mere analogy of synchronicity. It is true, however, that we cannot prove a causal connection in every case of amplification, and thus it is quite possible that in a number of cases, where we assume causal “association,” it is really a matter of synchronicity. What is “association” after all? We don’t know. It is not impossible that psychic arrangement in general is based upon synchronicity with the exception of the secondary rational “enchaînement” of psychic events in consciousness. This is analogous to the natural course of events, so different from our scientific and abstract reconstruction of reality based upon the statistical average. The latter produces a picture of nature consisting of mere probabilities, whereas reality is a crisscross of more or less impracticable events. Our psychic life shows the same phenomenological picture. This is the reason why I am rather inclined to think that it would be presumptuous to suppose the psyche is based exclusively upon the synchronistic principle, at least in our present state of knowledge.

[1209] I quite agree with your idea of the two complementary attitudes of understanding, viz., rational and irrational or synchronistic. But it remains to be seen whether all irrational events are *meaningful coincidences*. I doubt it.

[1210] It is refreshing to see you at work with these interesting problems and to hear something intelligent from you instead of the amazing stupidities dished out by our contemporaries.

[1211] I am sorry that I cannot come over to England to celebrate with you. I am writing in hospital, where I am nursing some prostatic trouble. Tomorrow I shall be dismissed for the time being. Old age is not exactly my idea of a joke.

My best wishes, Yours cordially, C. G. JUNG

[1212] P.S. As you are going to celebrate my 80th birthday in London and I am unfortunately unable to attend I thought it might be a nice gesture if you could send an invitation to the Swiss Ambassador to Great Britain. I am sure that he would appreciate at least your friendly gesture to one of his countrymen.

THE FUTURE OF PARAPSYCHOLOGY

The *International Journal of Parapsychology* (New York), in its 1963 autumn issue (V:4, pp. 450f.), published Jung's answers to a questionnaire which had been circulated in June 1960 among various authorities in connection with a survey on "The Future of Parapsychology."

How do you define parapsychology?

[1213] Parapsychology is the science dealing with those biological or psychological events which show that the categories of matter, space, and time (and thus of causality) are not axiomatic.

Which areas of research, in your opinion, should be classified as belonging within parapsychology?

[1214] The psychology of the unconscious.

Do you anticipate that future research would emphasize quantitative or qualitative work?

[1215] Future research will have to emphasize both.

Do you believe that a repeatable experiment is essential to strengthen the position of parapsychological studies within the scientific community?

[1216] The repeatable experiment is desirable but, inasmuch as most of the events are spontaneous and irregular, the experimental method will not be generally applicable.

Have you any comments on recent criticisms with regard to statistical methods employed in parapsychological studies?

[1217] The statistical method is most desirable and indispensable to scientific research, where and when it can be applied. But this is only possible when the material shows a certain regularity and comparability.

Do you believe that certain qualitative researches may be quantified in order to gain wider acceptance?

[1218] The quantification of qualitative research is surely the best means of conviction.

In the qualitative area, where do you foresee the greatest potential for future research progress—spontaneous phenomena, crisis telepathy, survival studies, out-of-the-body experiences, or any other?

[1219] The greatest and most important part of parapsychological research will be the careful exploration and qualitative description of spontaneous events.

Do you feel that during the past decade parapsychology has become more widely accepted among scientists active in other areas?

[1220] My impression is that, in Europe, at least, open-mindedness has increased.

Have you any comments regarding the psychological significance of certain psychic phenomena?

[1221] The psychological significance of parapsychological events has hardly been explored yet.

Have you any comments regarding the special psychological conditions that seem to favour, or reduce, the likelihood of an occurrence of psychic phenomena?

[1222] The factor which favours the occurrence of parapsychological events is the presence of an active archetype, i.e., a situation in which the deeper, instinctual layers of the psyche are called into action. The archetype is a borderline phenomenon, characterized by a relativation of space and time, as already pointed out by Albertus Magnus (*De mirabilibus mundi*),¹ whom I have mentioned in my paper "Synchronicity: An Acausal Connecting Principle."

THE ARCHETYPES AND THE COLLECTIVE UNCONSCIOUS

(related to Volume 9 of the Collected Works)

THE HYPOTHESIS OF THE COLLECTIVE UNCONSCIOUS¹

[1223] Indications of the concept of a collective psyche are to be found in Leibniz's theory of "petites perceptions," also in Kant's anthropology. In Schelling the "eternally unconscious" is the absolute ground of consciousness. Despite different terminology Hegel's view is similar. C. G. Carus was the first to base a developed philosophical system on the concept of the unconscious. Related features may be found in Schopenhauer. Eduard von Hartmann exalted the unconscious to the concept of an absolute, universal Spirit. The scientific investigation of the psychological unconscious began with the discovery of hypnotism and was continued via the Salpêtrière school in the works of Janet and Flournoy. Independently of this, it was the Breuer-Freud discovery of the aetiology of neurosis that led to Freud's sexual theory of the unconscious. Independent, again, of the Freudian school was the discovery of the so-called "complexes" and "autonomous contents" of the unconscious by the author.

[1224] Whereas for Freud the unconscious is essentially a function of consciousness, the author holds the unconscious to be an independent psychic function prior to consciousness and opposed to it. According to this view the unconscious may be divided into a *personal* and a *collective* unconscious. The latter is a psychic propensity to a regular functioning, independent of time and race. Its products may be compared with "mythological motifs." Despite the autochthonous origin of the former, the two are analogous in principle, which may be taken as an indication of their conforming to psychological law.

[1225] In the further course of the lecture the author, with the help of a special department of symbology, the so-called mandala symbolism, demonstrated the parallelism between the symbol of the circle, as produced by educated patients undergoing treatment, and the ritual mandalas of lamaism and *kundalini* yoga, as well as the parallels with the views of the Tantrists, of classical Chinese philosophy, and Chinese yoga. Further parallels are children's drawings, the prehistoric mandalas of Rhodesia, the sand-paintings from the healing ceremonies (*yaibichy* dances) of the Navaho (Arizona),² the visions of Hildegard of Bingen from the Codex Lucca³ (12th to 13th cent.), and the eschatological views of Jacob Boehme.⁴ The modern pictorial material was derived from people who produced it spontaneously and were not in any way influenced.

FOREWORD TO ADLER: "ENTDECKUNG DER SEELE"¹

[1226] This book is a systematic account of the three different approaches now current in psychotherapy: Freud's, Alfred Adler's, and my own. Drawing on his wide professional knowledge, the author has carefully elaborated the principal viewpoints underlying each approach, and thus gives the reader, who may have neither the time nor the opportunity to study the originals, a complete and rigorously objective survey of this controversial field. The exposition and manner of expression are such that the educated layman can follow the argument without difficulty.

[1227] Psychological theories, which at the outset seemed destined for use only in the strictly delimited domain of medical psychotherapy, have long since burst the bounds of a specialized science, and have not only penetrated into the provinces of its sister sciences but become—even if fragmentary—the common property of all educated persons. This means, however, that informed public opinion has been infected with the same confusion which still prevails today in medical psychology. What distinguishes Dr. Adler's work in particular is his thoroughly reliable and comprehensive account of my own views, which differ in so radical and characteristic a way from those of the other two investigators. His book, sober, lucid, and systematic, is a worthy companion to the earlier works by Kranefeldt² and Heyer.³ It is a milestone in the slow but sure conquest of the crises and confusions that hang over the psychological views of our day.

December 1933

FOREWORD TO HARDING: "WOMAN'S MYSTERIES"¹

[1228] Esther Harding, the author of this book, is a physician and specialist in the treatment of psychogenic illness. She is a former pupil of mine who has endeavoured not only to understand the modern psyche but also, as the present book shows, to explore its historical background. Preoccupation with historical subjects may at first glance seem to be merely a physician's personal hobby, but to the psychotherapist it is a necessary part of his mental equipment. The psychology of primitives, folklore, mythology, and the science of comparative religion open our eyes to the wide horizons of the human psyche and give us that indispensable aid we so urgently need for an understanding of unconscious processes. Only when we see in what shape and what guise dream symbols, which seem to us unique, appear on the historical and ethnic scene, can we really understand what they are pointing at. Also, once equipped with this extensive comparative material, we can comprehend more nearly that factor which is so decisive for psychic life, the archetype. Of course this term is not meant to denote an inherited idea, but rather an inherited mode of psychic functioning, corresponding to the inborn way in which the chick emerges from the egg, the bird builds its nest, a certain kind of wasp stings the motor ganglion of the caterpillar, and eels find their way to the Bermudas. In other words, it is a "pattern of behaviour." This aspect of the archetype, the purely biological one, is the proper concern of scientific psychology.

[1229] But the picture changes at once when looked at from the inside, from within the realm of the subjective psyche. Here the archetype appears as a numinous factor, as an experience of fundamental significance. Whenever it clothes itself in suitable symbols (which is not always the case), it seizes hold of the individual in a startling way, creating a condition amounting almost to possession, the consequences of which may be incalculable. It is for this reason that the archetype is so important in the psychology of religion. All religious and metaphysical concepts rest upon archetypal foundations, and, to the extent that we are able to explore them, we can cast at least a superficial glance behind the scenes of world history, and lift a little the veil of mystery which hides the meaning of metaphysical ideas. Metaphysics is, as it were, a physics or physiology of the archetypes, and its dogmas formulate the insights that have been gained into the nature of these dominants—the unconscious leitmotifs that characterize the psychic happenings of a given epoch. The archetype is "metaphysical" because it transcends consciousness.

[1230] Dr. Harding's book is an attempt to describe some of the archetypal foundations of feminine psychology. In order to understand the author's intention, the reader must overcome the prejudice that psychology consists merely of what Mr. Smith and Mrs. Jones happen to know about it. The psyche consists not only of the contents of consciousness, which derive from sensory impressions, but also of ideas apparently based on perceptions which have been modified in a peculiar way by preexistent and unconscious formative factors, i.e., by the archetypes. The psyche can therefore be said to consist of consciousness plus the unconscious. This leads us to conclude that one part of the psyche is explicable in terms of recent causes, but that another part reaches back into the deepest layers of our racial history.

[1231] Now the one certain fact about the nature of neurosis is that it is due to a disturbance of the primary instincts, or at least affects the instincts to a considerable degree. The evolution of human anatomy and of human instincts extends over geological periods of time. Our historical knowledge throws light upon only a few stretches of the way, whose total length would have to be reckoned in millions of miles. However, even that little bit is a help when, as psychotherapists, we are called upon to remedy a disturbance in the sphere of instinct. Here it is the therapeutic myths offered by religion that teach us the most. The religions might indeed be considered as psychotherapeutic systems which assist our understanding of instinctual disturbances, for these are not a recent phenomenon but have existed from time immemorial. Although certain types of disease, notably infectious ones like *typhus antiquorum*, may disappear and others take their place, it is still not very probable that tuberculosis, shall we say, was an entirely different disease five or ten thousand years ago. The same is true of psychic processes. Therefore, in the descriptions of abnormal psychic states left us by antiquity, we are able to recognize certain features that are familiar to us; and when it comes to the fantasies of neurotic and psychotic patients, it is just here, in ancient literature, that we find the most illuminating parallels.

[1232] From the empirical evidence, it has now been known for some time that any one-sidedness of the conscious mind, or a disturbance of the psychic equilibrium, elicits a compensation from the unconscious. The compensation is brought about by the constellation and accentuation of complementary material which assumes archetypal forms when the *fonction du réel*, or correct relation to the surrounding world, is disturbed. When, for instance, a woman develops too masculine an attitude—something that may very easily happen owing to the social emancipation of women today—the unconscious compensates this one-sidedness by a symptomatic accentuation of certain feminine traits. This process of compensation takes place within the personal sphere so long as the vital interests of the personality have not been harmed. But if more profound disturbances should occur, as when a women

alienates herself from her husband through her insistence on always being in the right, then archetypal figures appear on the scene. Difficulties of this kind are very common, and once they have grown to pathological proportions they can be remedied only by psychotherapeutic methods. For this reason, it has long been the endeavour of analytical psychologists to acquire as wide a knowledge as possible of the network of archetypal images produced by the unconscious, with a view to understanding the nature of the archetypal compensation in each individual case.

[1233] Dr. Harding's systematic survey of the archetypal material of feminine compensation comes as a most welcome contribution to these endeavours, and we must be grateful to her for having devoted herself to this task with such self-sacrificing effort in addition to her professional work. Her investigation is valuable and important not only for the specialist but for the educated layman who is interested in a psychology founded on experience of life and a knowledge of human nature. Our times, characterized as they are by an almost total disorientation in regard to the ends of human existence, stand in need, above all else, of a vast amount of psychological knowledge.

August 1948

FOREWORD TO NEUMANN: "THE ORIGINS AND HISTORY OF CONSCIOUSNESS"¹

[1234] The author has requested me to preface his book with a few words of introduction, and to this I accede all the more readily because I found his work more than usually welcome. It begins just where I, too, if I were granted a second lease of life, would start to gather up the *disjecta membra* of my own writings, to sift out all those "beginnings without continuations" and knead them into a whole. As I read through the manuscript of this book it became clear to me how great are the disadvantages of pioneer work: one stumbles through unknown regions; one is led astray by analogies, forever losing the Ariadne thread; one is overwhelmed by new impressions and new possibilities; and the worst disadvantage of all is that the pioneer only knows afterwards what he should have known before. The second generation has the advantage of a clearer, if still incomplete, picture; certain landmarks that at least lie on the frontiers of the essential have grown familiar, and one now knows what must be known if one is to explore the newly discovered territory. Thus forewarned and forearmed, a representative of the second generation can spot the most distant connections; he can unravel problems and give a coherent account of the whole field of study, whose full extent the pioneer can only survey at the end of his life's work.

[1235] This difficult and meritorious task the author has performed with outstanding success. He has woven his facts into a pattern and created a unified whole, which no pioneer could have done nor could ever have attempted to do. As though in confirmation of this, the present work opens at the very place where I unwittingly made landfall on the new continent long ago, namely, the realm of *matriarchal symbolism*; and, as a conceptual framework for his discoveries, the author uses a symbol whose significance first dawned on me in my recent writings on the psychology of alchemy: the *uroboros*. Upon this foundation he has succeeded in constructing a unique history of the evolution of consciousness, and at the same time is representing the body of myths as the phenomenology of this same evolution. In this way he arrives at conclusions and insights which are among the most important ever to be reached in this field.

[1236] Naturally to me, as a psychologist, the most valuable aspect of the work is the fundamental contribution it makes to a psychology of the unconscious. The author has placed the concepts of analytical psychology—which for many people are so bewildering—on a firm evolutionary basis, and erected upon this a comprehensive

structure in which the empirical forms of thought find their rightful place. No system can ever dispense with an over-all hypothesis which in its turn depends upon the temperament and subjective assumptions of the author as well as upon objective data. This factor is of the greatest importance in psychology, for the “personal equation” colours the mode of seeing. Ultimate truth, if there be such a thing, demands the concert of many voices.

[1237] I can only congratulate the author on his achievement. May this brief foreword convey to him my heartfelt thanks.

1 March 1949

FOREWORD TO ADLER: "STUDIES IN ANALYTICAL PSYCHOLOGY"¹

[1238] It gave me particular pleasure to hear that Dr. Gerhard Adler's admirable book *Studies in Analytical Psychology* is now to appear in German. The author is a skilled psychotherapist and therefore in a position to handle his theme on the basis of practical experience. This advantage can hardly be overrated, for therapeutic work means not only the daily application of psychological views and methods to living people and to sick people in particular, but also a daily criticism which success or failure brings to bear upon the therapy and its underlying assumptions. We may therefore expect from the author a well-pondered judgment amply backed by experience. In this expectation we are not disappointed. Everywhere in these essays we come across nicely balanced opinions and never upon prejudices, bigotries, or forced interpretations.

[1239] With a happy choice the author has picked out a number of problems which must inevitably engage the attention of every thinking psychotherapist. First and foremost he has been concerned—very understandably—to stress the peculiarity of analytical psychology as compared with the materialistic and rationalistic tendencies of the Freudian school—an undertaking which, in view of the latter's delight in sectarian seclusion, has still lost nothing of its topicality. This is by no means a matter of specialist or merely captious differences that would not interest a wider public; it is more a matter of principle. A psychology that wants to be scientific can no longer afford to base itself on so-called philosophical premises such as materialism or rationalism. If it is not to overstep its competence irresponsibly, it can only proceed phenomenologically and abandon preconceived opinions. But the opinion that we can pass transcendental judgments, even when faced with highly complicated material like that presented by psychological experience, is so ingrown that philosophical statements are still imputed to analytical psychology, although this is completely to misunderstand its phenomenological standpoint.

[1240] A major interest of psychotherapy is, for practical reasons, the psychology of dreams, a field where theoretical assumptions have not only suffered the greatest defeats but are applied at their most odious. The dream analysis in the third essay is exemplary.

[1241] It is much to be welcomed that the author pays due attention to the important role of the ego. He thus counters the common prejudice that analytical psychology is only interested in the unconscious, and at the same time he gives instructive examples of the relations between the unconscious and the ego in general.

[1242] The controversial question of whether, and if so how, the raising to consciousness of unconscious contents is therapeutically effective meets with adequate treatment. Although their conscious realization is a curative factor of prime importance, it is by no means the only one. Besides the initial “confession” and the emotional “abreaction” we have also to consider transference and symbolization. The present volume gives excellent illustrations of the latter two from case histories.

[1243] It is much to the credit of the author that he has also turned to the religious aspect of psychic phenomena. This question is not only delicate—it is particularly apt to irritate philosophical susceptibilities. But, provided that people are able to read and to give up their prepossessions, I truly have no idea how anybody could feel himself affronted by the author’s remarks—provided, again, that the reader is able to understand the phenomenological viewpoint of science. Unhappily this understanding, as I often had occasion to know, does not appear to be particularly widespread—least of all, it would seem, in professional medical circles. The theory of knowledge does not of course figure in the medical curriculum, but is indispensable to the study of psychology.

[1244] Not only on account of the lucidity of its exposition, but also because of its wealth of illustrative case histories, this book fills a gap in psychological literature. It gives both the professional and the psychologically minded layman a welcome set of bearings in territory which—at any rate to begin with—most people find rather hard of access. But the examples drawn direct from life offer an equally direct approach, and this is an aid to understanding. I would therefore like to recommend this book most cordially to the reading public.

May 1949

FOREWORD TO JUNG: "GESTALTUNGEN DES UNBEWUSSTEN" (1950)¹

[1245] In so far as poetry is one of those psychic activities that give shape to the contents of the unconscious, it seems to me not unfitting to open this volume with an essay which is concerned with a number of fundamental questions affecting the poet and his work.^{1a} This discussion is followed by a lecture on the rebirth motif,² given on the occasion of a symposium on this theme. Drama, the principal theme of poetic art, had its origin in ceremonial, magically effective rites which, in form and meaning, represented a *δρωμένον* or *δράμα*, something "acted" or "done." During this time the tension builds up until it culminates in a *περπέτεια*, the *dénouement*, and is resolved. Menacingly, the span of life narrows down to the fear of death, and out of this *angustiae* (straits, quandary, wretchedness, distress) a new birth emerges, redemptive and opening on to larger horizons. It is evident that drama is a reflection of an eminently psychological situation which, infinitely varied, repeats itself in human life and is both the expression and the cause of a universally disseminated archetype clothed in multitudinous forms.

[1246] The third contribution is a case history.³ It is the description of a process of transformation illustrated by pictures. This study is supplemented by a survey of mandala symbolism drawn from case material.⁴ The interpretation of these pictures is in the main formal and, unlike the preceding essay, lays more emphasis on the common denominators in the pictures than on their individual psychology.

[1247] The fifth and last contribution is a psychological study of E.T.A. Hoffmann's tale "The Golden Pot," by Aniela Jaffé.⁵ This tale of Hoffmann's has long been on my list of literary creations which cry out for interpretation and deeper understanding. I am greatly indebted to Mrs. Jaffé for having undertaken the not inconsiderable labour of investigating the psychological background of "The Golden Pot," thus absolving me from a task which I felt to be an obligation.

January 1949

FOREWORD TO WICKES: "VON DER INNEREN WELT DES MENSCHEN"¹

[1248] Frances G. Wickes' book, which first appeared in America in 1938,² is now available in a German translation. It is the fruit of a long and industrious life, uncommonly rich in experience of people of all classes and ages. Anyone who wishes to form a picture of the inner life of the psyche and broaden his knowledge of psychic phenomena in general is warmly recommended to read this book. The author has taken the greatest pains to express the inner experiences of her patients with the help of the viewpoints I have introduced into psychology. Her collection of case histories is of the greatest value to the skilled psychotherapist and practising psychologist, not to mention the layman, for whom she opens vistas into a world of experience hitherto inaccessible to him.

[1249] If, as in this book, fantasy is taken for what it is—a natural expression of life which we can at most seek to understand but cannot correct—it will yield possibilities of psychic development that are of the utmost importance for the cure of psychogenic neuroses and of the milder psychotic disturbances. Fantasies should not be negatively valued by subjecting them to rationalistic prejudices; they also have a positive aspect as creative compensations of the conscious attitude, which is always in danger of incompleteness and one-sidedness. Fantasy is a self-justifying biological function, and the question of its practical use arises only when it has to be channeled into so-called concrete reality. So long as this situation has not arisen, it is completely beside the point to explain fantasy in terms of some preconceived theory and to declare it invalid, or to reduce it to some other biological process. Fantasy is the natural life of the psyche, which at the same time harbours in itself the irrational creative factor. The neurotic's involuntary over- or undervaluation of fantasy is as injurious to the life of the psyche as its rationalistic condemnation or suppression, for fantasy is not a sickness but a natural and vital activity which helps the seeds of psychic development to grow. Frances Wickes illustrates this in exemplary fashion by describing the typical figures and phases that are encountered in involuntary fantasy processes.

September 1953

FOREWORD TO JUNG: "VON DEN WURZELN DES BEWUSSTSEINS" (1954)¹

[1250] In this ninth volume of the "Psychologische Abhandlungen" I have put together a number of works which for the most part grew out of Eranos lectures. Some have been revised, some augmented, and some completely reworked. The essay on "The Philosophical Tree" is new, although I have dealt with this theme earlier in a sketchy way. The central theme of this book is the *archetype*, the nature and significance of which are described and elucidated from various angles: history, psychology both practical and theoretical, case material. In spite of the fact that this theme has often been discussed by me as well as by other authors, such as Heinrich Zimmer, Karl Kerényi, Erich Neumann, Mircea Eliade, etc., it has proved to be both inexhaustible and particularly difficult to comprehend, if one may give credence to criticisms vitiated by prejudice and misunderstanding. One is left with the suspicion that the psychological standpoint and its consequences are felt in many quarters to be disagreeable and for this reason are not permitted a hearing. The simplistic approach is instantly assured of the applause of the public because it pretends to make the answering of difficult questions superfluous, but well-founded observations that cast doubt on things which appear simple and settled arouse displeasure. The theory of archetypes seems to come into this category. For some it is self-evident and a welcome aid in understanding symbol-formation, individual as well as historical and collective. For others it seems to epitomize an annoying aberration that has to be extirpated by all possible means, however ridiculous.

[1251] Although it is easy to demonstrate the existence and efficacy of the archetypes, their phenomenology leads to really difficult questions of which I have given a few samples in this book. For the present there is still no possibility of simplification and of building highways "that fools may not err."

May 1953

FOREWORD TO VAN HELSDINGEN: "BEELDEN UIT HET ONBEWUSTE"¹

[1252] Dr. R. J. van Helsdingen has asked me to write a foreword to his book. I am happy to comply with his request for a particular reason: the case that is discussed and commented on was one that I treated many years ago, as can now be said publicly with the kind permission of my former patient. Such liberality is not encountered everywhere, because many one-time patients are understandably shy about exposing their intimate, tormenting, pathogenic problems to the eye of the public. And indeed one must admit that their drawings or paintings do not as a rule have anything that would recommend them to the aesthetic needs of the public at large. If only for technical reasons the pictures are usually unpleasant to look at and, lacking artistic power, have little expressive value for outsiders. These shortcomings are happily absent in the present case: the pictures are artistic compositions in the positive sense and are uncommonly expressive. They communicate their frightening, daemonic content to the beholder and convince him of the terrors of a fantastic underworld.

[1253] While it was the patient's own mother country that produced the great masters of the monstrous, Hieronymus Bosch and others, who opened the flood-gates of creative fantasy, the pictures in this book show us imaginative activity unleashed in another form: the Indomalaysian phantasmagoria of pullulating vegetation and of fear-haunted, stifling tropical nights. Environment and inner disposition conspired to produce this series of pictures which give expression to an infantile-archaic fear. Partly it is the fear of a child who, deprived of her parents, is defencelessly exposed to the unconscious and its menacing, phantasmal figures; partly the fear of a European who can find no other attitude to everything that the East conjures up in her save that of rejection and repression. Because the European does not know his own unconscious, he does not understand the East and projects into it everything he fears and despises in himself.

[1254] For a sensitive child it is a veritable catastrophe to be removed from her parents and sent to Europe after the unconscious influence of the Oriental world had moulded her relation to the instincts, and then, at the critical period of puberty, to be transported back to the East, when this development had been interrupted by Western education and crippled by neglect.² The pictures not only illustrate the phase of treatment that brought the contents of her neurosis to consciousness, they were also an instrument of treatment, as they reduced the half conscious or unconscious images floating about in her mind to a common denominator and fixated them. Once an

expression of this kind has been found, it proves its “magical” efficacy by putting a spell, as it were, on the content so represented and making it relatively innocuous. The more complex this content is, the more pictures are needed to depotentiate it. The therapeutic effect of this technique consists in inducing the conscious mind to collaborate with the unconscious, the latter being integrated in the process. In this way the neurotic dissociation is gradually remedied.

[1255] The author is to be congratulated on having edited this valuable and unusual material. Although only the initial stages of the analysis are presented here, some of the pictures indicate possibilities of a further development. Even with these limitations, however, the case offers a considerable enrichment of the literature on the subject, which is still very meagre.

May 1954

FOREWORD TO JACOBI: "COMPLEX/ARCHETYPE/SYMBOL"¹

[1256] The problem this book is concerned with is one in which I, too, have been interested for a long time. It is now exactly fifty years since I learned, thanks to the association experiment, the role which complexes play in our conscious life. The thing that most impressed me was the peculiar autonomy the complexes display as compared with the other contents of consciousness. Whereas the latter are under the control of the will, coming or going at its command, complexes either force themselves on our consciousness by breaking through its inhibiting effect, or else, just as suddenly, they obstinately resist our conscious intention to reproduce them. Complexes have not only an obsessive, but very often a possessive, character, behaving like imps and giving rise to all sorts of annoying, ridiculous, and revealing actions, slips of the tongue, and falsifications of memory and judgment. They cut across the adapted performance of consciousness.

[1257] It was not difficult to see that while complexes owe their relative autonomy to their emotional nature, their expression is always dependent on a network of associations grouped round a centre charged with affect. The central emotion generally proved to be individually acquired, and therefore an exclusively personal matter. Increasing experience showed, however, that the complexes are not infinitely variable, but mostly belong to definite categories, which soon began to acquire their popular, and by now hackneyed, names—inferiority complex, power complex, father complex, mother complex, anxiety complex, and all the rest. This fact, that there are well-characterized and easily recognizable types of complex, suggests that they rest on equally typical foundations, that is, on emotional aptitudes or *instincts*. In human beings instincts express themselves in the form of unreflected, involuntary fantasy images, attitudes, and actions, which bear an inner resemblance to one another and yet are identical with the instinctive reactions specific of *Homo sapiens*. They have a dynamic and a formal aspect. Their formal aspect expresses itself, among other things, in fantasy images that are surprisingly alike and can be found practically everywhere at all epochs, as might have been expected. Like the instincts, these images have a relatively autonomous character; that is to say, they are “numinous” and can be found above all in the realm of numinous or religious ideas.

[1258] For reasons that I cannot enter into here, I have chosen the term “archetype” for this formal aspect of the instinct. Dr. Jacobi has made it her task, in this book, to expound the important connection on the one hand between the individual complex and the universal, instinctual archetype, and on the other hand between this and the

symbol. The appearance of her study is the more welcome to me in that the concept of the archetype has given rise to the greatest misunderstandings and—if one may judge by the adverse criticisms—must be presumed to be very difficult to comprehend. Anyone, therefore, who has misgivings on this score can seek information in this volume, which also takes account of much of the literature. My critics, with but few exceptions, usually do not take the trouble to read over what I have to say on the subject, but impute to me, among other things, the opinion that the archetype is an inherited idea. Prejudices seem to be more convenient than seeking the truth. In this respect, too, I hope that the author's endeavours, especially the theoretical considerations contained in [Part I](#), illustrated by examples of the archetype's mode of manifestation and operation in [Part II](#), may shed a little illumination. I am grateful to her for having spared me the labour of having constantly to refer my readers to my own writings.

February 1956

FOREWORD TO BERTINE: "HUMAN RELATIONSHIPS"¹

[1259] The author of this book has undertaken the important task of investigating the problems of human relationship from the standpoint of analytical psychology, an undertaking which will be welcome not only to the psychotherapist but also to those interested in the wider field of general psychology. Facts that are of the greatest significance for an understanding of human relationships have undoubtedly come to light in the course of my own and my colleagues' researches. While the conclusions which Freud and Adler had drawn from their intensive studies of neurosis were based on the personal psychology of their neurotic patients, which they tried to apply to the psychology of society, analytical psychology has called attention to more general human facts which also play an important role in neurosis but are not specifically characteristic of it, being a normal part of the human constitution. I would mention in particular the existence of differences in type, such as extraversion and introversion, which are not difficult for a layman to recognize. It is obvious that these two diametrically opposed attitudes must have a very decisive influence on the relationship of individuals, and the psychology of the function types—thinking, feeling, sensation, and intuition—further differentiates the general effects of extraversion and introversion.

[1260] These attitude and function types belong mainly to man's conscious psychology. The researches of analytical psychology have shown, further, that it is not only the data of the senses and unconscious personal repressions which exert an influence of consciousness. It is also profoundly affected by unconscious, instinctive—that is, innate—patterns of psychic behaviour. These patterns are just as characteristic of man as are the instincts in the behaviour of animals. But while we know about the instinctive patterns in animals only by observing their outward behaviour, the human psyche offers a great advantage in that—thanks to ideas and language—the instinctive process can be visualized in the form of fantasy images, and this inner perception can be communicated to an outside observer by means of speech. If the animal psyche were capable of such an accomplishment, we would be able to recognize the mythology which the weaver bird is expressing when it builds its nest, and the yucca moth when it deposits its eggs in the yucca flower.² That is, we would know what kind of fantasy images trigger off their instinctive actions. This insight, however, is possible only in the case of human beings, where it opens up the boundless world of myth and folklore that spans the globe with analogies and parallel

motifs. The images which appear here conform with those in dreams and hallucinations to an astonishing degree, to say the least.

[1261] This discovery was actually made by Freud, and he erected a monument to it in his concept of the Oedipus complex. He was gripped by the numinosity of this motif, or archetype, and accordingly gave it a central place in his theory-building. But he failed to draw the further and inescapable conclusion that there must be another, “normal” unconscious beyond the one produced by arbitrary repressions. This “normal” unconscious consists of what Freud described as “archaic remnants.” But if the Oedipus complex represents a universal type of instinctive behaviour independent of time, place, and individual conditioning, it follows inevitably that it cannot be the only one. Although the incest complex is undoubtedly one of the most fundamental and best known complexes, it must obviously have its feminine counterpart which will express itself in corresponding forms. (At the time I proposed calling it the Electra complex.)³ But incest, after all, is not the only complication in human life, though this sometimes seems to be the case according to Freudian psychology. There are also other typical patterns which regulate the relation of father to son, mother to daughter, parents to children, brothers and sisters to each other, and so on. Oedipus is only one of the existing patterns and determines only the behaviour of the son, and this only up to a point. Mythology, folklore, dreams, and psychoses do not fall short in this respect. They offer a veritable plethora of patterns and formulas not only for family relationships but also for man and woman, individual and society, conscious and unconscious, dangers to body and soul, and so forth.

[1262] These archetypes exert a decisive influence on human relationships. Here I would mention only the eminently practical significance of the animus (the archetype of man in woman) and anima (the archetype of woman in man), which are the source of so much fleeting happiness and long-drawn-out suffering in marriage and friendship.

[1263] The author has much to say about these things, based on her medical practice and on her arduous but rewarding work with people. She deserves to be heard, and I hope her book will find a large number of attentive readers.

August 1956

PREFACE TO DE LASZLO: "PSYCHE AND SYMBOL"¹

[1264] Dr. de Laszlo has risked shocking the American reader by including some of my most difficult essays in her selection from my writings. In sympathy with the reader I acknowledge how tempting if not unavoidable it is to fall into the trap of appearances as the eye wanders over the pages in a vain attempt to get at the gist of the matter in the shortest possible time. I know of so many who, opening one of my books and, stumbling upon a number of Latin quotations, shut it with a bang, because Latin suggests history and therefore death and unreality. I am afraid my works demand some patience and some thinking. I know: it is very hard on the reader who expects to be fed by informative headlines. It is not the conscientious scientist's way to bluff the public with impressive résumés and bold assertions. He tries to explain, to produce the necessary evidence, and thus to create a basis for understanding. In my case, moreover, understanding is not concerned with generally known facts, but rather with those that are little known or even new. It was therefore incumbent upon me to make these facts known. In so far as such unexpected novelties demand equally unexpected means of explanation I found myself confronted with the task of explaining the very nature of my evidential material.

[1265] The facts are experiences gained from a careful and painstaking analysis of certain psychic processes observed in the course of psychic treatment. As these facts could not be satisfactorily explained by themselves, it was necessary to look round for possible comparisons. When, for instance, one comes across a patient who produces symbolic mandalas in his dreams or his waking imagination and proceeds to explain these circular images in terms of certain sexual or other fantasies, this explanation carries no conviction, seeing that another patient develops wholly different motivations. Nor is it permissible to assume that a sexual fantasy is a more likely motivation than, for instance, a power drive, since we know from experience that the individual's disposition will of necessity lead him to give preference to the one or the other. Both patients, on the other hand, may have one fact in common—a state of mental and moral confusion. We would surely do better to follow up this clue and try to discover whether the circular images are connected with such a state of mind. Our third case producing mandalas is perhaps a schizophrenic in such a disturbed state that he cannot even be asked for his accompanying fantasies. This patient is obviously completely dissolved in a chaotic condition. Our fourth case is a little boy of seven who has decorated the corner of the room where his bed stands with numerous mandalas without which he cannot go to sleep. He only feels safe

when they are around him. His fantasy tells him that they protect him against nameless fears assailing him in the night. What is his confusion? His parents are contemplating divorce.² And what shall we say of a hard-boiled scientific rationalist who produced mandalas in his dreams and in his waking fantasies? He had to consult an alienist, as he was about to lose his reason because he had suddenly become assailed by the most amazing dreams and visions. What was *his* confusion? The clash between two *equally real* worlds, one external, the other internal: a fact he could no longer deny.³

[1266] There is no need to prolong this series since, leaving aside all theoretical prejudices, the underlying reason for producing a mandala seems to be a certain definable mental state. But have we any evidence which might explain why such a state should produce a mandala? Or is this mere chance? Consequently we must ask whether our experiences are the only ones on record and, if not, where we can find comparable occurrences. There is no difficulty in finding them; plenty of parallels exist in the Far East and the Far West, or right here in Europe, several hundred years ago. The books of reference can be found in our university libraries, but for the last two hundred years nobody has read them, and they are—oh horror!—written in Latin and some even in Greek. But are they dead? Are those books not the distant echo of life once lived, of minds and hearts quick with passions, hopes, and visions, as keen as our own? Does it matter so much whether the pages before us tell the story of a patient still alive, or dead for fifty years? Does it really matter whether their confessions, their anguish, their strivings speak the English of today or Latin or Greek? No matter how much we are of today, there has been a yesterday, which was just as real, just as human and warm, as the moment we call Now, which—alas—in a few hours will be a yesterday as dead as the first of January anno Domini 1300. A good half of the reasons why things now are what they are lies buried in yesterday. Science in its attempt to establish causal connections has to refer to the past. We teach comparative anatomy, why not comparative psychology? The psyche is not only of today, it reaches right back to prehistoric ages. Has man really changed in ten thousand years? Have stags changed their antlers in this short lapse of time? Of course the hairy man of the Ice Ages has become unrecognizable when you try to discover him among the persons you meet on Fifth Avenue. But you will be amazed when you have talked with them for a hundred hours about their intimate life. You will then read the mouldy parchments as if they were the latest thrillers. You will find the secrets of the modern consulting room curiously expressed in abbreviated mediaeval Latin or in an intricate Byzantine hand.

[1267] What the doctor can hear, when he listens attentively, of fantasies, dreams, and intimate experiences is not mentioned in the Encyclopaedia Britannica or in textbooks and scientific journals. These secrets are jealously guarded, anxiously

concealed, and greatly feared and esteemed. They are very private possessions, never divulged and talked about, because they are feared as ridiculous and revered as revelations. They are numinous, a doubtful treasure, perhaps comical, perhaps miraculous, at all events a painfully vulnerable spot, yet presiding over all the crossroads of one's individual life. They are officially and by general consent just as unknown and despised as the old parchments with their indecipherable and unaesthetic hieroglyphics, evidence of old obscurantisms and foolishness. We are ignorant of their contents, and we are equally ignorant of what is going on in the deeper layers of our unconscious, because "those who know do not talk, those who talk do not know."⁴ As inner experiences of this kind increase, the social nexus between human beings decreases. The individual becomes isolated for no apparent reason. Finally this becomes unbearable and he has to confide in someone. Much will then depend on whether he is properly understood or not. It would be fatal if he were to be misinterpreted. Fortunately, such people are instinctively careful and as a rule do not talk more than necessary.

[1268] When one hears a confession of this kind, and the patient wants to understand himself better, some comparative knowledge will be most helpful. When the hard-boiled rationalist mentioned above came to consult me for the first time, he was in such a state of panic that not only he but I myself felt the wind blowing over from the lunatic asylum! As he was telling me of his experiences in detail he mentioned a particularly impressive dream. I got up and fetched an ancient volume from my bookshelf and showed it to him, saying: "You see the date? Just about four hundred years old. Now watch!" I opened the book at the place where there was a curious woodcut, representing his dream almost literally. "You see," I said, "your dream is no secret. You are not the victim of a pathological insult and not separated from mankind by an inexplicable psychosis. You are merely ignorant of certain experiences well within the bounds of human knowledge and understanding." It was worth seeing the relief which came over him. He had seen with his own eyes the documentary evidence of his sanity.

[1269] This illustrates why historical comparison is not a mere learned hobby but very practical and useful. It opens the door to life and humanity again, which had seemed inexorably closed. It is of no ultimate advantage to deny or reason away or ridicule such seemingly abnormal or out-of-the-way experiences. They should not get lost, because they contain an intrinsic individual value, the loss of which entails definite damage to one's personality. One should be aware of the high esteem which in past centuries was felt for such experiences, because it explains the extraordinary importance that we ignorant moderns are forced to attribute to them in spite of ourselves.

[1270] Understanding an illness does not cure it, but it is a definite help because you can cope with a comprehensible difficulty far more easily than with an incomprehensible darkness. Even if in the end a rational explanation cannot be reached, you know at least that you are not the only one confronted by a “merely imaginary” wall, but one of the many who have vainly tried to climb it. You still share the common human lot and are not cut off from humanity by a subjective defect. Thus you have not suffered the irreparable loss of a personal value and are not forced to continue your way on the crutches of a dry and lifeless rationalism. On the contrary, you find new courage to accept and integrate the irrationality of your own life and of life in general.

[1271] Instincts are the most conservative determinants of any kind of life. The mind is not born a *tabula rasa*. Like the body, it has its predetermined individual aptitudes: namely, patterns of behaviour. They become manifest in the ever-recurring patterns of psychic functioning. As the weaver-bird will infallibly build its nest in the accustomed form, so man despite his freedom and superficial changeability will function psychologically according to his original patterns—up to a certain point; that is, until for some reason he collides with his still living and ever-present instinctual roots. The instincts will then protest and engender peculiar thoughts and emotions, which will be all the more alien and incomprehensible the more man’s consciousness has deviated from its original conformity to these instincts. As nowadays mankind is threatened with self-destruction through radioactivity, we are experiencing a fundamental reassertion of our instincts in various forms. I have called the psychological manifestations of instinct “archetypes.”

[1272] The archetypes are by no means useless archaic survivals or relics. They are living entities which cause the preformation of numinous ideas or dominant representations. Insufficient understanding, however, accepts these prefigurations in their archaic form, because they have a numinous fascination for the underdeveloped mind. Thus Communism is an archaic, highly insidious pattern of life which characterizes primitive social groups. It implies lawless chieftainship as a vitally necessary compensation, a fact which can be overlooked only by means of a rationalistic bias, the prerogative of a barbarous mind.

[1273] It is important to remember that my concept of the archetypes has been frequently misunderstood as denoting inherited ideas or as a kind of philosophical speculation. In reality they belong to the realm of instinctual activity and in that sense they represent inherited patterns of psychic behaviour. As such they are invested with certain dynamic qualities which, psychologically speaking, are characterized as “autonomy” and “numinosity.”

[1274] I do not know of any more reliable way back to the instinctual basis than through an understanding of these psychological patterns, which enable us to

recognize the nature of an instinctive attitude. The instinct to survive is aroused as a reaction against the tendency to mass suicide represented by the H-bomb and the underlying political schism of the world. The latter is clearly man-made and due to rationalistic distortions. Conversely, if understood by a mature mind, the archetypal preformations can yield numinous ideas ahead of our actual intellectual level. That is just what our time is in need of. This, it seems to me, is an additional incentive to pay attention to the unconscious processes which in many persons today anticipate future developments.

[1275] I must warn the reader: this book will not be an easy pastime. Once in a while he will meet with thoughts which demand the effort of concentration and careful reflection—a condition unfortunately rare in modern times. On the other hand, the situation today seems to be serious enough to cause at least uneasy dreams if nothing else.

August 1957

FOREWORD TO BRUNNER: "DIE ANIMA ALS SCHICKSALSPROBLEM DES MANNES"¹

[1276] The antecedents of this book are such that it might give rise to misunderstandings unless the reader is acquainted with them beforehand. Let me therefore say at once that its subject-matter is a dialogue extending over a period of eight years. The partners to this dialogue made it a condition from the start that the record they kept of it should be as honest and complete as was humanly possible. In order to fulfil this condition, and not restrict it to the conscious aspects of the situation, they made it their task to take note also of the unconscious reactions that accompanied or followed the dialogue. Obviously, this ambitious project could be completed only if the unconscious reactions of *both* partners were recorded. A "biographical" debate of such a nature would indeed be something unique in our experience, requiring exceptionally favourable circumstances for its realization. In view of the unusual difficulties she was faced with, the author deserves our thanks for having reproduced, scrupulously and in all the necessary detail, at least three-quarters of the dialogue. Her experiment will be acclaimed by all those who are interested in the real life of the psyche, and more particularly because it gives a vivid account of a typical masculine problem which invariably arises in such a situation.

[1277] Although every case of this kind follows an archetypal ground plan, its value and significance lie in its uniqueness, and this uniqueness is the criterion of its objectivity. The true carrier of reality is the individual, and not the "statistical average" who is a mere abstraction. So if the author confines her observations to two persons only, this shows her feeling for the psychological facts. The value of the personality, too, lies in its uniqueness, and not in its collective and statistical qualities, which are merely those of human species and, as such, irreducible factors of a suprapersonal nature. Although the limitation to two persons creates an "unscientific" impression of subjectivity, it is actually a guarantee of psychological objectivity: this is how real psychic life behaves, this is what happens in reality. That part of it which can be formulated theoretically belongs to the common foundations of psychic life and can therefore be observed just as easily under other conditions and in other individuals. Scientific insight is essentially a by-product of a psychological process of dialectic. During this process, "true" and "untrue," "right" and "wrong" are valid only in the moral sense and cannot be judged by any general criterion of "truth" or "rightness." "True" and "right" simply tell us whether what is happening is "true" or "right" for the person concerned.

[1278] The reader of this book is thus an invisible listener at a serious dialogue between two cultivated persons of our time, who discuss the various questions that come their way. Both of them make their contribution in complete freedom and remain true to their purpose throughout. I lay particular emphasis on this because it is by no means certain at the outset that such a dialogue will be continued. Often these discussions come to an abrupt stop for lack of enthusiasm in one partner or both, or for some other reason, good or bad. Very often, too, they give up at the first difficulty. The circumstances must have been unusually favourable for the dialogue to have continued over such a long period of time. Special credit is due to the author for having recorded the proceedings on two levels at once and successfully communicated them to the outside world. The thoughts and interior happenings she describes form a most instructive *document humain*, but its very uniqueness exposes it to the danger of being misunderstood and contemptuously brushed aside as a “subjective fantasy.” For it is concerned mainly with that special relationship which Freud summed up under the term “transference,” whose products he regarded as “infantile fantasies.” As a result of this devaluation and rationalistic prejudice, their importance as phenomena of psychic transformation was not recognized. This scientific sin of omission is only one link in the long chain of devaluation of the human psyche that has nothing to justify it. It is a symptom of profound unconsciousness that our scientific age has lost sight of the paramount importance of the psyche as a fundamental condition of human existence. What is the use of technological improvements when mankind must still tremble before those infantile tyrants, ridiculous yet terrible, in the style of Hitler? Figures like these owe their power only to the frightening immaturity of the man of today, and to his barbarous unconsciousness. Truly we can no longer afford to underestimate the importance of the psychic factor in world affairs and to go on despising the efforts to understand psychic processes. We are still very far from understanding where we ourselves are at fault, and this book should grant us a deep insight. It is, indeed, only a random sample, but all experience consists of just that. Without individual experience there can be no general insight.

[1279] The author has done well to take a well-known case from the history of literature as an introduction to the real *pièce de résistance* of her book. The case is that of Rider Haggard, who was afflicted with a similar problem. (One might also mention Pierre Benoît and Gérard de Nerval.) Rider Haggard is without doubt the classic exponent of the anima motif, though it had already appeared among the humanists of Renaissance, for instance, as the nymph Polia in the *Hypnerotomachia* of Francesco Colonna,² or as a psychological concept in the writings of Richard White of Basingstoke,³ or as a poetic figure among the “fedeli d’amore.”⁴

[1280] The motif of the anima is developed in its purest and most naïve form in Rider Haggard. True to his name, he remained her faithful knight throughout his literary life and never wearied of his conversation with her. He was a spiritual kinsman of René d'Anjou, a latter-day troubadour or knight of the Grail, who had somehow blundered into the Victorian Age and was himself one of its most typical representatives. What else could he do but spin his strange tale of past centuries, harking back to the figures of Simon Magus and Helena, Zosimos and Theosebeia, in the somewhat sorry form of a popular "yarn?" Psychology, unfortunately, cannot take aesthetic requirements into account. The greatness and importance of a motif like that of the anima bear no relation to the form in which it is presented. If Rider Haggard uses the modest form of a yarn, this does not detract from the psychological value of its content. Those who seek entertainment or the higher art can easily find something better. But anyone who wants to gain insight into his own anima will find food for thought in *She*, precisely because of the simplicity and naïveté of presentation, which is entirely devoid of any "psychological" intent.

[1281] Rider Haggard's literary work forms an excellent introduction to the real purpose of this book, since it provides a wealth of material illustrating the symbolism of the anima and its problems. Admittedly, *She* is only a flash in the pan, a beginning without continuation, for at no point does the book come down to earth. Everything remains stuck in the realm of fantasy, a symbolic anticipation. Rider Haggard was unaware of his spiritual predecessors, so did not know that he had been set a task at which the philosophical alchemists had laboured, and which the last of the Magna Opera, Goethe's *Faust*, could bring to fruition not in life but only after death, in the Beyond, and then only wistfully. He followed in the footsteps of the singers and poets who enchanted the age of chivalry. The romantic excursions of his German contemporary, Richard Wagner, did not pass off so harmlessly. A dangerous genius, Friedrich Nietzsche, had a finger in the pie and Zarathustra raised his voice, with no wise woman at his side as partner to the dialogue. This mighty voice emanated from a migraine-ridden bachelor, "six thousand feet beyond good and evil," who met his "Dudu and Suleika"⁵ only in the tempests of madness and penned those confessions which so scandalized his sister that traces of them can be found only in his clinical history. This sounds neither good nor beautiful, but it is part of the business of growing up to listen to the fearful discords which real life grinds out and to include them among the images of reality. Truth and reality are assuredly no music of the spheres—they are the beauty and terror of Nature herself.

[1282] The richest yield of all is naturally to be found in the primary material itself, that is to say in the dreams, which are not thought up or "spun" like a yarn. They are involuntary products of nature, spontaneously expressing the psychic processes without the interference of the conscious will. But this richness reveals itself, one

might say, only to him who understands the language of animals and plants. Although this is a tall order, it is not putting too great a burden on the learning capacity of an intelligent person who has a moderate amount of intuition and a healthy aversion for doctrinal opinions. Following its instinct for truth, intuition goes along with the stream of images, feels its way into them until they begin to speak and yield up their meaning. It rediscovers forgotten or choked-up paths where many have wandered in distant times and places—perhaps even one’s partner in the dialogue. Picking up the trail, he will pursue a parallel path and in this way learn the natural structure of the psyche.

[1283] The author has successfully evoked in the dreamer the intuitive attitude he needs in order to follow the unconscious process of development. The “interpretation” does not adhere to any particular theory, but simply takes up the symbolic hints given by the dreams. Even though use is made of psychological concepts such as the anima, this is not a theoretical assumption, because “anima” is merely a name for a special group of typical psychic happenings that anyone can observe. In an extensive dialogue like this, interpretations can only be passing phases and tentative formulations, but they do have to prove themselves correct when taken as a whole. Only at the end of the journey will it be discovered whether they have done so, and whether one was on the right path or not. The dialectical process is always a creative adventure, and at every moment one has to stake one’s very best. Only then, and with God’s help, can the great work of transformation come to pass.

April 1959

XI

CIVILIZATION IN TRANSITION

(related to Volume 10 of the Collected Works)

REPORT ON AMERICA¹

[1284] Lecturer described a number of impressions he had gained on two journeys in North America.² The psychological peculiarities of the Americans exhibit features that would be accessible to psychoanalysis, since they point to intense sexual repression. The reasons for repression are to be sought in the specifically American complex, namely, living together with lower races, more particularly the Negroes. Living together with barbarous races has a suggestive effect on the laboriously subjugated instincts of the white race and drags it down. Hence strongly developed defensive measures are necessary, which manifest themselves in the particular aspects of American culture.

NO THE PSYCHOLOGY OF THE NEGRO¹

[1285] The psychoses of Negroes are the same as those of white men. In milder cases the diagnosis is difficult because one is not sure whether one is dealing with superstition. Investigation is complicated by the fact that the Negro does not understand what one wants of him, and besides that is ignorant [does not know his age, has no idea of time].² He shows a great inability to look into his own thoughts, a phenomenon that is analogous to resistance among our patients. Little is said of hallucinations, and equally little of delusional ideas and dreams. — The Negro is extraordinarily religious: his concepts of God and Christ are very concrete. The lecturer has pointed out on an earlier occasion³ how certain qualities of the Americans (for instance, their self-control) may be explained by their living together with the (uncontrolled) Negroes. In the same way this living together also exerts an influence on the Negro. For him the white man is pictured as an ideal: in his religion Christ is always a white man. He himself would like to be white or to have white children; conversely, he is persecuted by white men. In the dream examples given by the lecturer, the wish or the task of the Negro to adapt himself to the white man appears very frequently. One is struck by the large number of sacrificial symbols that occur in the dreams, just as the lecturer has mentioned in his book *Wandlungen und Symbole der Libido*.⁴ This is yet another indication that such symbols are not only Christian but have their origin in a biological necessity.

A RADIO TALK IN MUNICH¹

[1286] Your question is not so easy to answer. My interest in these matters was not the result of a primary interest in Chinese philosophy, from a study of which, it might be supposed, I had learnt all sorts of valuable things for my psychology. On the contrary, Chinese thought was very alien to me to begin with. I owe my relations to China and to Richard Wilhelm simply and solely to certain psychological discoveries. In the first place, it was the discovery of the collective unconscious, that is to say, of impersonal psychic processes, that aroused my interest in primitive and Oriental psychology. Among these impersonal psychic processes there are quite a number which seem absolutely strange and incomprehensible and cannot be brought into connection with any of the historical symbols known to us, but for which we can find plenty of unquestionable analogies in the psychologies of the Orient. Thus a whole group or layer of impersonal contents can only be understood in terms of the psychology of primitives, while others have their nearest analogies in India or China. It had previously been supposed that mythological symbols were disseminated by migration. But I have found that the occurrence of the same symbols in different countries and continents does not depend on migration, but rather on the spontaneous revival of the same contents.

[1287] Years of observing such processes has convinced me that—for the present at least—the unconscious psyche of Europeans shows a distinct tendency to produce contents that have their nearest analogies in the older Chinese philosophy and the later Tantric philosophy. This prompted me to submit my observations to the eminent sinologist Richard Wilhelm, who thereupon confirmed the existence of some astonishing parallels. The fruit of our collaboration is the recently published book called *The Secret of the Golden Flower*.² These parallels bear out a conjecture I have long held, that our psychic situation is now being influenced by an irruption of the Oriental spirit, and that this is a factor to be reckoned with. What is going on is analogous to the psychic change that could be observed in Rome during the first century of our era. As soon as the Romans, beginning with the campaigns of Pompey, made themselves the political masters of Asia Minor, Rome became inundated with Hellenistic-Asiatic syncretism. The cults of Attis, Cybele, Isis, and the Magna Mater spread throughout the Roman Empire. Mithras conquered Roman officialdom and the entire army, until all these cults were overthrown by Christianity. I do not know how much the spiritual and political decline of Spain and Portugal had to do with their conquest of the primitive South American continent, but the fact remains that the two

countries which first established their rule in East Asia, namely Holland and England, were also the first to be thoroughly infected with theosophy. It seems to be a psychological law that though the conquerer may conquer a country physically, he will secretly absorb its spirit. Today the old China has succumbed to the West, and my purely empirical findings show that the Chinese spirit is making itself clearly perceptible in the European unconscious. You will understand that this statement is no more for me than a working hypothesis, but one which can claim a considerable degree of probability in view of the historical analogies.

*

[1288] My journey to Africa³ arose from the same need that had taken me to New Mexico⁴ the year before. I wanted to get to know the psychic life of primitives at first hand. The reason for this is the aforementioned fact that certain contents of the collective unconscious are very closely connected with primitive psychology. Our civilized consciousness is very different from that of primitives, but deep down in our psyche there is a thick layer of primitive processes which, as I have said, are closely related to processes that can still be found on the surface of the primitive's daily life. Perhaps I can best illustrate this difference by means of an example. When I ask an employee to deliver a letter to a certain address, I simply say to him: "Please take this letter to Mr. X." In Africa I lived for a time with a very primitive tribe, the Elgonis, who inhabit the primeval forests of Mount Elgon, in East Africa, and are still partly troglodytes. One day I wanted to send some letters. The nearest white men were some engineers who were working at the terminus of a branch line of the Uganda railway, two and a half days' journey away. In order to reach them, I needed a runner, and at my request the chief put a man at my disposal. I gave him a bundle of letters, telling him in Swahili (which he understood) to take the letters to the white *bwana*s. Naturally, everybody within a radius of a hundred miles would know where to find them, for news travels fast in Africa. But after receiving my order, the man remained standing before me as though struck dumb and did not stir from the spot. I thought he was waiting for baksheesh in the form of cigarettes, and gave him a handful, but he stood there as dumb and stiff as before. I had no idea what this meant, and, looking round me in perplexity, my eye fell on my safari headman Ibrahim, a long thin Somali, who, squatting on the ground, was watching the scene, grinning. In his frightful English he said to me: "You no do it like so, Bwana, but like so—" And he sprang up, seized his rhinoceros whip, cracked it through the air a couple of times in front of the runner, then gripped him by the shoulders, and with shouts and gesticulations delivered himself of the following peroration: "Here, the great bwana M'zee, the wise old man, gives you letters. See, you hold them in your hand. But you must put them in a cleft stick. Ho boys"—this to my servants—"bring a cleft stick,

give it to this pagan. Hold it in your hand so—put the letters in the cleft here—bind it tight with grass—so—and now hold it high, so that all will see you are the runner of the great bwana. And now go to the bwanas at the waterfall and seek one till you find him, and then go to him and say to him: ‘The great bwana M’zee has given me letters, they are in my stick here, take them!’ And the white bwana will say: ‘It is well.’ Then you can return home. And now run, but so—” and Ibrahim began running with upraised whip—“so must you run and run, until you come to the place where the little houses go on wheels. Run, run, you dog, run like hell!” The runner’s face had gradually lit up as though witnessing a great revelation. Grinning all over, he raised his stick and hurtled away from us, as though shot from a cannon, Ibrahim close behind him with cracking whip and a flood of curses. The man ran 74 miles in 36 hours without stopping.

[1289] Ibrahim had succeeded, with an enormous expenditure of mime and words, in putting the man into the mood of the runner, hypnotizing him into it, so to speak. This was necessary because a mere order from me could not conjure up a single movement. Here you see the chief difference between primitive and civilized psychology: with us a word is enough to release an accumulation of forces, but with primitives an elaborate pantomime is needed, with all manner of embellishments which are calculated to put the man into the right mood for acting. If these primitive vestiges still exist in us—and they do—you can imagine how much there is in us civilized people that cannot catch up with the accelerated tempo of our daily life, gradually producing a split and a counter-will that sometimes takes a culturally destructive form. That this really is so, is clearly shown by the events of the last few decades.

[1290] Naturally, the purpose of my travels was not to investigate only the differences, but also the similarities between the civilized and the primitive mind. Here there are many points of connection. For instance, in dreams we think in very much the same way as the primitive thinks consciously. With primitives, waking life and dream life are less divided than with us—so little, in fact, that it is often difficult to find out whether what a primitive tells you was real or a dream. Everything that we reject as mere fantasy because it comes from the unconscious is of extraordinary importance for the primitive, perhaps more important than the evidence of his senses. He values the products of the unconscious—dreams, visions, fantasies, and so on—quite differently from us. His dreams are an extremely important source of information, and the fact that he has dreamt something is just as significant for him as what happens in reality, and sometimes very much more significant. My Somali boys, those of them that could read, had their Arabic dream books with them as their only reading matter on the journey. Ibrahim assiduously instructed me in what I ought to

do if I dreamt of Al Khidr, the Verdant One,⁵ for that was the first angel of Allah, who sometimes appeared in dreams.

[1291] For primitives, certain dreams are the voice of God. They distinguish two types of dream: ordinary dreams that mean nothing, and the dreams they call the great vision. So far as I was able to judge, the “big dreams” are of a kind that we too would consider significant. The only dream that occurred while I was there—at least, the only one that was reported to me—was the dream of an old chief, in which he learnt that one of his cows had calved, and was now standing with her calf down by the river, in a particular clearing. He was too old to keep track of his many cattle that pastured in the various open places in the forest, so he naturally didn’t know this cow was going to calve, let alone where. But the cow and the calf were found just where he had dreamt they would be. These people are extraordinarily close to nature. Several other things happened which made it quite clear to me why they were so convinced that their dream told the truth. Part of the reason is that their dreams often fulfil the thinking function over which they still do not have full conscious control. They themselves say that the appearance of the white man in their country has had a devastating effect on the dream life of their medicine-men and chiefs. An old medicine-man told me with tears streaming down his face: “We have no dreams any more since the white man is in the land.” After many talks on this subject, I finally discovered that the leading men owed their leadership chiefly to dreams that came true. Since everything is now under British control, the political leadership has been taken out of the hands of the chiefs and medicine-men. They have become superfluous, and the guiding voice of their dreams is silenced.

FOREWORDS TO JUNG: "SEELENPROBLEME DER GEGENWART"

First Edition (1931)

[1292] The lectures and essays contained in this volume¹ owe their existence primarily to questions addressed to me by the public. These questions are enough in themselves to sketch a picture of the psychological problems of our time. And, like the questions, the answers have come from my personal and professional experience of the psychic life of our so remarkable era. The fundamental error persists in the public that there are definite answers, "solutions," or views which need only be uttered in order to spread the necessary light. But the most beautiful truth—as history has shown a thousand times over—is of no use at all unless it has become the innermost experience and possession of the individual. Every unequivocal, so-called "clear" answer always remains stuck in the head and seldom penetrates to the heart. The needful thing is not to *know* the truth but to *experience* it. Not to have an intellectual conception of things, but to find our way to the inner, and perhaps wordless, irrational experience—that is the great problem. Nothing is more fruitless than talking of how things must or should be, and nothing is more important than finding the way to these far-off goals. Most people know very well how things should be, but who can point the way to get there?

[1293] As the title of this book shows, it is concerned with problems, not solutions. The psychic endeavours of our time are still caught in the realm of the problematical; we are still looking for the essential question which, when found, is already half the solution. These essays may open the reader's eyes to our wearisome struggle with that tremendous problem, the "soul," which perhaps torments modern man in even higher degree than it did his near and distant ancestors.

Küsnacht-Zurich, December 1930

Second Edition (1933)

[1294] As only one and a half years have gone by since the appearance of the first edition, there are no reasons for essential alterations in the text. The collection of my essays therefore appears in unaltered form. And as no fundamental objections or misunderstandings that might have provided occasion for an explanatory answer have become known to me, there is no need either of a longer foreword. At any rate, the reproach of psychologism so often levelled at me would be no excuse for a long

disquisition, for no fair-minded person will expect me to prefer the attitude of a metaphysician or a theologian in my own field of work. I shall never stop seeing and judging all observable psychic phenomena psychologically. Every reasonable man knows that this does not express any final and ultimate truth. Absolute assertions belong to the realm of faith—or of immodesty.

Küsnacht-Zurich, July 1932

Italian New Edition (1959)²

[1295] This book is a collection of lectures and essays which originated in the 1920's and constitute volume III of my "Psychologische Abhandlungen." They are for the most part popular expositions of certain fundamental questions of practical psychology, which concerns itself not only with the sick but with the healthy. The latter also have "problems," the same in principle as those of the neurotic, but because practically everybody has them and knows them they are counted as "contemporary questions," while in their neurotic form they appear rather as biographical *curiosa*. The treatment of the neuroses has naturally confronted doctors with many questions they could not answer by medical means alone. They had to resort to an academic psychology that had never concerned itself with living human beings, or only under restrictive experimental conditions which were a direct hindrance to the natural expression of the psyche as a whole. Since the doctors received no help from outside (with the exception of a few philosophers like C. G. Carus, Schopenhauer, Eduard von Hartmann, Nietzsche), they saw themselves compelled to build up a medical psychology of real human beings. The essays in this volume bear witness to these efforts.

March 1959

FOREWORD TO ALDRICH: "THE PRIMITIVE MIND AND MODERN CIVILIZATION"¹

[1296] The author of this book, who studied analytical psychology in Zurich a few years ago, has asked me for a few introductory words to his work. I accede to his request with all the more pleasure as I was not bored but decidedly delighted by reading his book. Books of this kind are often of a very dry, though learned and useful, character. There are indeed not a few of them, because, together with the discovery of a new empirical psychology, the modern scientific mind has become interested in what were formerly called "curiosités et superstitions des peuples sauvages," a field formerly left to missionaries, traders, hunters, and geographical and ethnographical explorers. A rich harvest of facts has been gleaned and gathered up in long rows of volumes even more formidable than Sir James Frazer's *Golden Bough* series. As everywhere in the science of the nineteenth century, the collection type of method has prevailed, producing an accumulation of disconnected and undigested facts which in the long run could not fail to make a survey almost impossible. Such an ever increasing accumulation, here as well as in other sciences, has hindered the formation of judgment. It is a truism that there are never facts enough, but, on the other hand, there is only one human brain, which only too easily gets swamped by the boundless flood of material. This happens particularly to the specialist, whose mind is trained to a careful consideration of facts. But when judgment is required the mind must turn away from the impression of the facts and should lift itself to a higher level from which a survey becomes possible. One might almost say: as a rule the higher standpoint is not given by the specialized science but by a convergence of viewpoints from other scientific realms.

[1297] Thus the understanding of primitive psychology would have remained an almost insoluble task without the assistance of mythology, folklore, history, and comparative religion. Sir James Frazer's work is a splendid example of this composite method. It is rather astonishing that among the co-operating sciences psychology seems to be lacking. It was, however, not completely absent. Among the many who tried to tackle the problems of the primitive mind, no one has done so without psychology. But the psychological point of view employed by each investigator was his own—just as if there were only one psychological standpoint, i.e., the author's own psychology. Seen from Tylor's point of view, animism is quite obviously his individual bias. Lévy-Bruhl measures primitive facts by means of his extremely rational mind. From his standpoint it appears quite logical that the primitive mind should be an "état

prélogique.” Yet the primitive is far from being illogical and is just as far from being “animistic.” He is by no means that strange being from whom the civilized man is separated by a gulf that cannot be bridged. The fundamental difference between them is not a difference in mental functioning, but rather in the premises upon which the functioning is based.

[1298] The reason why psychology has hitherto rendered so little assistance to the explorer in the vast field of primitive psychology is not so much the natural disinclination of the specialist to appeal to principles outside his particular domain as the fact that a psychology which would be really helpful simply did not exist. The psychology that is needed must be a psychology of the complex functions, i.e., a psychology that does not reduce the complexities of the mind to their hypothetical elements, which is the method of experimental or physiological psychology. The first attempt at a complex psychology was made by Freud, and his essay *Totem and Taboo* was one of the first direct contributions of the new psychology to the investigation of the primitive mind. It matters little that his attempt is nothing more than an application of his sexual theory, originally gleaned from pathological minds. His essay nevertheless demonstrates the possibility of a *rapprochement* between psychology and the problem of the primitive mind. Sometime before the work above mentioned, I undertook a similar task² that eventually led me to the primitive mind, but with a very different method. While Freud’s method consisted in the application of an already existing theory, my method was a comparative one. I have reason to believe that the latter yields better results. The main reason is that our new psychology is in no way advanced enough to present a theory of the mind that would have universal application. With modesty we can claim no more than the possession of sound facts and some rules of thumb which might prove useful in the attempt to master the problem of the primitive mind.

[1299] Mr. Aldrich, I observe, has made use of his studies in analytical psychology, to the advantage of his research. His sane and balanced opinions, equally distant from the Charybdis of dry empirical enumeration of facts and the Scylla of deduction from arbitrary premises, owe their vitality and colour in no small measure to a consideration of analytical psychology. I am sure that the analytical psychologist will welcome Mr. Aldrich’s book as one of the most vivid and clear presentations of the primitive mind in its relation to civilized psychology. I may also express the hope that the co-operation of the psychologist will prove its usefulness to all students of primitive psychology who approach their subject from the ethnological standpoint.

PRESS COMMUNIQUÉ ON VISITING THE UNITED STATES¹

September 1936

[1300] The reason why I come to the United States is the fact that Harvard University has bestowed upon me the great honour of inviting me to its Tercentenary Celebration. Being a psychopathologist as well as psychologist, I have been asked to participate in a symposium about “Psychological Factors Determining Human Behaviour.”²

[1301] This is not my first visit to the United States, though my last visit dates back as far as 1924. I am eagerly looking forward to observing the changes which the last eventful decade has brought to public as well as to private life over here and to compare them with those of our own profoundly upset Europe. It is my sincere hope to find more common sense, more social peace, and less insanity in the United States than in the old countries. As a psychologist I am deeply interested in mental disturbances, particularly when they infect whole nations. I want to emphasize that I despise politics wholeheartedly: thus I am neither a Bolshevik, nor a National Socialist, nor an Anti-Semite. I am a neutral Swiss and even in my own country I am uninterested in politics, because I am convinced that 99 per cent of politics are mere symptoms and anything but a cure for social evils. About 50 per cent of politics is definitely obnoxious inasmuch as it poisons the utterly incompetent mind of the masses. We are on our guard against contagious diseases of the body, but we are exasperatingly careless when it comes to the even more dangerous collective diseases of the mind.

[1302] I make this statement in order to disillusion any attempt to claim me for any particular political party. I have some reason for it, since my name has been repeatedly drawn into the political discussion, which is, as you best know, in a feverish condition actually. It happened chiefly on account of the fact that I am interested in the undeniable differences in national and racial psychology, which chiefly account for a series of most fatal misunderstandings and practical mistakes in international dealings as well as in internal social frictions. In a politically poisoned and overheated atmosphere the sane and dispassionate scientific discussion of such delicate, yet most important problems has become well-nigh impossible. To discuss such matters in public would be about as successful as if the director of a lunatic asylum were to set out to discuss the particular delusions of his patients in the midst of them. You know, the tragicomical thing is that they are all convinced of their normality as much as the doctor himself of his own mental balance.

[1303] It will soon be thirty years since my first visit to the United States. During this time I watched the tremendous progress of the country, and I learned to appreciate also the enormous change America has undergone and is still undergoing, namely the transition from a still pioneering mood to the very different attitude of a people confined to a definite area of soil.

[1304] I shall spend my time chiefly at Harvard, and after a short visit to the museums of New York I intend to sail again in the first days of October.

PSYCHOLOGY AND NATIONAL PROBLEMS¹

[1305] The question of psychology and national problems with which I have been asked to deal is indeed of some topicality. It is a question, however, that would not have been asked before the World War. People in general were then not aware of any disturbance in the mental or psychic atmosphere of Europe, although the psychological critic or a philosopher of the antique style could have found enough to talk about. It was a prosperous world then and one which believed in what the eye saw and the ear heard and in what rationalism and philosophical positivism had to say. Even the rational possibility of a great war seemed, in spite of historical evidence, a far-fetched and artificial nightmare, nothing more than a theoretical scarecrow occasionally conjured up by politicians and newspapers when they had nothing else to say. One was thoroughly convinced that international, financial, commercial, and industrial relations were so tightly knit together as to exclude the mere possibility of a war. The Agadir incident² and similar gestures seemed to be mere pranks of a psychopathic monarch, otherwise safely enmeshed in an international network of financial obligations, whose gigantic proportions were supposed to rule out any attempts of a serious military nature. Moreover the fabulous development of science, the high standard of public education in most European countries, and a public opinion organized as never before in history, allowed European humanity to believe in man's conscious achievements, in his reason, intelligence and will-power. It almost appeared as if man and his ideals were going to possess the earth and rule it wisely for the welfare of all peoples.

[1306] The World War has shattered this dream and has crushed most of the ideals of the preceding era. In this postwar mood originated the doubt: Is everything right with the human mind? One began to question its sanity because thinking people grew more and more astonished at all the things humanity could do. The benevolent god of science that had done such marvellous things for the benefit of man had uncovered his dark face. He produced the most diabolical war machinery, including the abomination of poison gases, and human reason got more and more obscured by strange and absurd ideas. International relations turned into the most exaggerated nationalism, and the very God of the earth, the *ultima ratio* of all things worldly—money—developed a more and more fictitious character never dreamt of before. Not only the security of the gold standard but also that of treaties and other international arrangements, already badly shaken by the War, did not recover but became increasingly illusory. Nearly all major attempts at reduction of armaments and at

stabilization of international finances went wrong. Slowly it dawned upon mankind that it was caught in one of the worst moral crises the world had ever known.

[1307] It is natural enough that in many quarters the doubt arose as to whether the human mind had not changed. It did not appear preposterous any more to assume that possibly there were peculiar psychological reasons for all these disquieting developments which otherwise could hardly be explained. Many people wondered what psychology would have to say about the world situation. Such questions, as a matter of fact, have often been put to me, and I must confess I always felt not only definitely uncomfortable but singularly incompetent to give a satisfactory answer. The subject is really too complicated. The predominant and immediate reasons for the crisis are factors of an economic and political nature. Inasmuch as these are activities of the human mind they should be subject to certain psychological laws. But the economic factors especially are not wholly psychological in character; they depend to a great extent on conditions that can hardly be linked up with psychology. In politics on the other hand psychology seems to prevail, but there is an ultimate factor of numbers, of sheer force and violence, that corresponds to a caveman's or an animal's psychology rather than to anything human. There is no psychology yet of such infinitely complex matters as economics or politics. It is still quite questionable whether there is any hope at all that psychology can be applied to things due to non-psychological factors. I don't consider myself competent to deal with the ultimate meaning of our world crisis. There are certain sides to it, however, that possess a definitely psychological aspect, offering an opportunity for comment. It seems to be within the reach of contemporary psychology to produce a certain point of view at least.

[1308] Before entering upon this subject I want to say a few words about psychology in general:

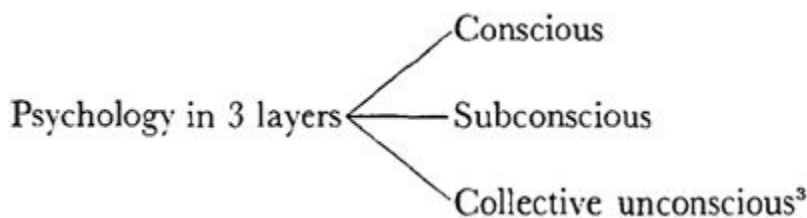

[1309] Having given you a short account of what I understand psychology consists of, let me turn now to our subject. First of all a negative statement: I exclude from psychological consideration the strictly economic and political aspect of present-day events. I am doing this because they are, partly at least, non-psychological. Whatever the psychological reasons for the Great War may have been, they transcend my psychological competence. I shall concern myself chiefly with the psychological situation brought about by the War. That there is a so-called psychological situation

at all appears to be borne out by a great number of phenomena which we have to call symptoms. You call a certain phenomenon a symptom when it is obvious that it does not function as a logical means to an end but rather stands out as a mere result of chiefly causal conditions without any obvious purposiveness. Thus the yellow colour of the skin in a case of jaundice is a phenomenon with no purposiveness and we therefore call it a symptom, as contrasted with the war-paint of a Red Indian which is a purposive part of the war ceremonial. Or a man drives a nail into the wall and we ask him why he is doing it; if he answers that it is to hang his coat there, then what he does is purposive because it makes sense. But if he answers that it is because he happened to hold a hammer and a nail in his hands, then his action is a symptom, or at least he wants it to appear as such.

[1310] Likewise we could imagine mass organizations without the Roman salute, lictor bundles, swastikas, neo-paganism, and other paraphernalia because our political parties as well as Standard Oil or Dutch Shell can do without them. Therefore it appears to us as if such peculiarities were chiefly symptoms of a particular causal condition of the mind. On the other hand we know that symbols and ceremonies mainly occur in religious organizations where it is indeed a matter of a peculiar mental state. Of course if you are in that frame of mind you would not talk of symptomatology. On the contrary, you would call those peculiarities purposive and meaningful, because to you they appear to serve a definite end. As long as one is within a certain phenomenology one is not astonished and nobody wonders what it is all about. Such philosophical doubt only comes to the man who is outside the game.

[1311] The countries where the most remarkable symptoms occur are chiefly those that have been actually at war and have therefore found themselves afterwards in a state of appalling misery and disorder. I mean particularly Russia, Germany, Austria, and Italy. No matter what the cause, misery is a definite psychological condition characterized by definite emotions, such as depression, fear, despair, insecurity, unrest, and resentments of every description.

[1312] Since our empirical psychology is based entirely on the experience of individual cases, our argument must necessarily start from the individual. This leads us to the question: What will an individual do when under the strain of acute misery? There is a positive and a negative reaction to such a condition:

1. *Positive.* A greater effort is called forth. The individual will show more strength and will-power and will try to overcome the obstacle or the cause of misery through physical, intellectual, and moral effort. It will be an entirely conscious and rational attempt supported by all the means at an individual's disposal. If the strength of *one* individual is not sufficient he will seek the help of others; perhaps a greater number of individuals will form some sort of organization in order to remove the cause of

suffering. If such an ultimate attempt fails, or if an individual is too weak from the start to show fight, then a negative reaction takes place.

II. *Negative*. Instead of suitable measures of defence, and instead of a concentration of energy, of efforts of the will, and of all the rational ways and methods applicable to such a condition, an emotional reaction will take place. Emotional reaction always denotes an inferior adjustment. This does not necessarily mean that the adjustment is ineffectual. It merely denotes that, if the individual comes through successfully, the success is due to the fact that he has been passively carried through on the crest of an emotional wave rather than by conscious and deliberate effort of the will. In other words the success has been reached in a primitive and inferior way, in the main through a merely instinctive reaction. But more often the emotional reaction is not successful just because it is too primitive and therefore a maladjustment to a perhaps highly complicated situation. In either case the individual is passive and he is more the object of the emotion than its subject. The emotional reaction as a rule consists of depression, fear, and even panic. Emotional conditions always call up instinctive reactions. The hierarchy of human reason becomes weakened and disintegrated, leaving a door open for the intrusion of primitive instinctive forces. *Emotional reaction always means regression*. The first effect of regression is as a rule the reawakening of infantile methods and attitudes. People under the influence of fear and despair very often become infantile, exaggeratedly helpless and demoralized.⁴ Helplessness and panic also lead to group formation, or rather to a clustering together in masses for the sake of gregarious security.

[1313] Group formation under the influence of panic cannot be called an organization because it is not an attempt based on reason and will but on a fundamentally emotional movement. It is an accumulation rather than an organization. Such group formations all show unmistakable traces of infantile and archaic psychology, infantile inasmuch as they always look for the father, and archaic inasmuch as the father-image appears in a mythological setting. It seems to be unavoidable that such group formations regress to primitive tribal associations that are held together on the one hand by a chief or medicine-man, and on the other by a sort of mystical doctrine, the tribal teaching.

[1314] We turn now to the question: What would a nation do when in a state of psychological misery? Since a multitude of people or a nation is nothing but an accumulation of individuals, its psychology is likewise an accumulation of individual psychologies. The individual psyche, however, is characterized by individual differences, partly congenital, partly acquired. Nearly every individual shows certain specific achievements which add to his relative uniqueness. On the other hand each individual is partly similar to any other, a fact that produces the aspect of human

equality. Thus individuals are like each other inasmuch as they have qualities in no way different from those of others, but unlike each other inasmuch as they develop qualities and achievements that cannot be compared with those of other people. Whatever people have in common can accumulate in a group formation, but their individual achievements never accumulate—rather they extinguish each other. Thus a large group, considered as *one* being, exhibits merely the traits common to all people but none of their individual achievements. The traits common to all people consist chiefly of instinctual qualities; these are of a relatively primitive character and indubitably inferior in comparison with the mental level of most of the members of the group. Thus a hundred intelligent people together make one hydrocephalus.

[1315] The psychology of masses is always inferior, even in their most idealistic enterprises. The whole of a nation never reacts like a normal modern individual, but always like a primitive group being. Therefore masses are never properly adjusted except on very primitive levels. Their reactions belong to our second category—the negative form. Man in the group is always unreasonable, irresponsible, emotional, erratic, and unreliable. Crimes the individual alone could never stand are freely committed by the group being. A society woman would rather die than appear at a dinner in an obscene dress, but if it were the fashion in the group she would not hesitate for a second to put on the most shocking monstrosity. Think for a moment of the famous *cul de Paris* that embellished the youth of our older generation. And men are no better. The larger an organization the lower its morality. The leader of a great religious movement, when caught out in a lie, said, “Oh! for Christ you may even lie.”

[1316] Nations being the largest organized groups are from a psychological point of view clumsy, stupid, and amoral monsters like those huge saurians with an incredibly small brain. They are inaccessible to reasonable argument, they are suggestible like hysterical patients, they are childish and moody, helpless victims of their emotions. They are caught in every swindle, called slogans, they are stupid to an amazing degree, they are greedy, reckless, and blindly violent, like a rhino suddenly aroused from sleep. They persevere in every nonsense, in every emotion and resentment, in every prejudice, far beyond the psychological moment, and they get ensnared by the cheapest of all obvious tricks. Most of the time they live in dreams and primitive illusions usually rigged out as “isms.” As long as they can feed on open ground in an undisturbed way they are sleepy and harmless. But if their food gets scarce and they begin to migrate and to encroach upon neighbouring territory, they resort to violence. They are not to be convinced that human beings have evolved much better methods in many thousands of years and that these individual men believe in reason and intelligence.

[1317] Monster groups have a natural leaning to leaders. But a leader always means a group within the nation, and such a group is more greedy and eats more than the other groups it leads. And as all greedy monsters are jealous they get rid of their leaders and call the new condition a democracy, in which nobody rules and nobody is ruled. The logic of this procedure closely resembles the story of the man who got stranded on an uninhabited island. The first thing he did was an act of statesmanship: he called himself a democracy and consequently felt extraordinarily free and in full possession of all political rights.

[1318] Even a group being can't help noticing that in living in a democracy you run your head against remarkably unintelligent restrictions of freedom, imposed upon each free, self-ruling citizen by an invisible, wholly legendary being called the "State." When a monster group first called itself a "democracy" it surely did not think that its former ruler, now dethroned, would turn into a ghost. Yet he did. He became the State.

[1319] The State is the psychological mirror-image of the democracy monster. As the nation always rises as *one man*, the State is just as good as one man. As a matter of fact it is quite a person, of unlimited means, more exacting than any tyrant ever was, greedy to the limit and biologically dangerous. It, the State, is not like a Roman Caesar, enslaving prisoners of war on the lower strata of the population; it squeezes its contributions out of the most vital and most gifted individuals of its domain, making slaves of them for its own wasteful devices. It does not know that energy only works when accumulated. Its energy is *money*. It taps all carefully prepared and studied accumulations of this energy and dissipates it so that it becomes ineffectual, thereby causing an artificial entropy.

[1320] It seems that "democracy" was a suitable name only in the very youth of the State-ghost. In order to support its boundless ambitions two brand-new "isms" had to be invented: Socialism and Communism. They enhance its ultra-democratic character to an extraordinary degree: the man on the lonely island is now the communistic social democracy. Together with these illusions goes another helpful procedure, the hollowing out of money, which in the near future will make all savings illusory and, along with cultural continuity, guaranteed by individual responsibility. The State takes over responsibility and enslaves every individual for its own ridiculous schemes. All this is done by what one calls inflation, devaluation, and, most recently, "dilution," which you should not mix up with the unpopular term "inflation." Dilution is now the right word and only idiots can't see the striking difference between this concept and inflation. Money value is fast becoming a fiction guaranteed by the State. Money becomes paper and everybody convinces everybody else that the little scraps are worth something because the State says so.

[1321] I am by no means sure that what I am saying is not fictitious too. I don't know exactly what has gone wrong, but I have a strong and most uncomfortable feeling that something has gone wrong and that it is even getting worse. I am also certain that I am not the only one to experience such a queer feeling. There must be hundreds of people who have lost their confidence in the direction in which things are apparently moving. As group beings we are all befogged in the same way, but as individuals we might just as well apply as much of our psychiatric knowledge as seems to befit the peculiar symptomatology of our bewildering epoch.

[1322] As I mentioned at the beginning, we find the symptoms chiefly in those nations that have been mangled the most by the war beast. There is for instance the German case. As far back as 1918 I published a paper⁵ in which I called the attention of my contemporaries to an astounding development in the German edition of the collective unconscious. I had caught hold of certain collective dreams of Germans which convinced me that they portrayed the beginning of a national regression analogous to the regression of a frightened and helpless individual, becoming first infantile and then primitive or archaic. I saw Nietzsche's "blond beast" looming up, with all that it implies. I felt sure that Christianity would be challenged and that the Jews would be taken to account. I therefore tried to start the discussion in order to forestall the inevitable violence of the unconscious outburst of which I was afraid—though not enough, as subsequent events have unfortunately shown only too clearly. I don't need to say that I was not heard at all. The fog of war-psychology was just too dense.

[1323] Germany was the first country to experience the miracles worked by democracy's ghost, the State. She saw her money becoming elastic and expanding to astronomical proportions and then evaporating altogether. She experienced all in one heap what the ghosts of other democracies are trying to do to us in a sort of slow-motion picture, probably hoping that nobody understands the eyewash. Germany got it right in the neck and there was no joke about it. The whole educated middle class was utterly ruined, but the State was on top, putting on more and more of the "-istic" rouge as war-paint. The country was in a condition of extreme misery and insecurity, and waves of panic swept over the population. In an individual case these are the symptoms of an oncoming outburst. Any such outburst would bring up archaic material, archetypes that join forces with the individual as well as with the people. There is some teleology about this: it creates strength where there was weakness, conviction instead of doubt, courage instead of fear. But the energy needed to bring about such a transformation is taken away from many old values and the success gained is paid for dearly. Such an outburst is always a regression into history and it always means a lowering of the level of civilization.

[1324] Through Communism in Russia, through National Socialism in Germany, through Fascism in Italy, the State became all-powerful and claimed its slaves body

and soul. Democracy became its own mirror-image, its own ghost, while the ghost became appallingly real, an all-embracing mystical presence and personality that usurped the throne a pious theocratic Christianity had hoped God would take. The old totalitarian claim of the *Civitas Dei* is now voiced by the State: one sheep as good as another and the whole herd crowded together, guarded by plain-clothed and uniformed wolf-dogs, utterly deprived of all the rights which the man on the island who called himself a democracy had dreamt of. There are no rights left, only duties. Every source of energy, industry, commerce, money, even private enterprise, is sucked up into the new slave-owner, the State.

[1325] And a new miracle happened. Out of nowhere certain men came, and each of them said like Louis XIV, “L’état c’est moi.” They are the new leaders. The State has proved its personal reality by incarnating itself in men that came from Galilee, inconspicuous nobodies previously, but equipped with the great spirit voice that cowed the people into soundless obedience. They are like Roman Caesars, usurpers of empires and kingdoms, and like those incarnations of a previously invisible deity devoutly invoked and believed in by everybody. They are the State that has superseded the medieval theocracy.

[1326] This process of incarnation is particularly drastic in Hitler’s case. Hitler himself as an ordinary person is a shy and friendly man with artistic tastes and gifts. As a mere man he is inoffensive and modest, and has nice eyes. But he comes from Braunau, a little town that has already produced two famous mediums—the Schneider brothers. (Harry Price has written a book about one of them.⁶) Hitler is presumably the third and the most efficient medium from Braunau. When the State-spirit speaks through him, he sends forth a voice of thunder and his word is so powerful that it sweeps together crowds of millions like fallen autumn leaves.

[1327] There is obviously no power left in the world and particularly no State-loving “-ism” which is capable of resisting this incredible force. Of course you will say, as everybody does, “One must be a German to understand such miracles.” Yes, this is just as true as that you must be an Italian to understand the mythology of the Fascio, or a Russian to appreciate the charms of Stalin’s paternal regime. Of course you can’t understand those funny foreigners, Sir Oswald Mosley and Colonel de la Rocque⁷ being still babes in arms. But if you carefully study what President Roosevelt is up to and what the famous N.R.A.⁸ meant to the world of American commerce and industry, then you get a certain idea of how near the great State in America is to becoming Roosevelt’s incarnation. Roosevelt is the stuff all right, only the circumstances are not bad enough. Great Britain seems to be pretty conservative, yet you have a taxation which makes the great estates uninhabitable. That is exactly how things began in Italy. You have devalued your money, this is the second step. You could not stop the boastful march of Roman legions through the bottleneck of Suez,

and Sir Samuel⁹ meekly and wisely took all the air out of that magnificent gesture of a proud British fleet adorning the entrance to Italy's triumph. This was the third step. England comes perhaps so late into the paradise of a new age that she arrives there with many old-world values well preserved by sheer lack of interest. Being Swiss I heartily sympathize with this attitude. Knowing of nothing that would be better, we hang on to the rear of events and muddle along as we have been used to do for six hundred years. We can't imagine our dictator yet, but already an unfortunate majority believes in the mighty ghost to whom we have sacrificed all our railways and the gold standard on top of that.

[1328] The incarnation of the State-ghost is no mean affair. It competes with famous historical parallels; it even challenges them. Just as Christianity had a cross to symbolize its essential teaching, so Hitler has a swastika, a symbol as old and widespread as the cross. And just as it was a star over Bethlehem that announced the incarnation of God, so Russia has a red star, and instead of the Dove and the Lamb a hammer and sickle, and instead of the sacred body a place of pilgrimage with the mummy of the first witness. Even as Christianity challenged the Roman Imperium, enthroned ambitious Roman bishops as *Pontifices Romani*, and perpetuated the great Empire in the theocracy of the Church and the Holy Roman Empire, so the Duce has produced once more all the stage scenery of the Imperium which will soon reach from Ethiopia to the Pillars of Hercules as of old.

[1329] Again it is Germany that gives us some notion of the underlying archetypal symbolism brought up by the eruption of the collective unconscious. Hitler's picture has been erected upon Christian altars. There are people who confess on their tombstones that they died in peace since their eyes had beheld not the Lord but the Führer. The onslaught on Christianity is obvious; it would not even need corroboration through a neo-pagan movement incorporating three million people. This movement can only be compared with the archetypal material exhibited by a case of paranoid schizophrenia. You find in neo-paganism the most beautiful Wotanistic symbolism, Indogermanic speculation, and so on. In North Germany there is a sect that worships Christ in the form of a rider on a white horse.¹⁰ It does not go as far as collective hallucinations, though the waves of enthusiasm and even ecstasy are running high.

[1330] Nations in a condition of collective misery behave like neurotic or even psychotic individuals. First they get dissociated or disintegrated, then they pass into a state of confusion and disorientation. As it is not a question of psychotic disintegration in an individual case, the confusion affects mainly the conscious and subconscious layers but does not touch the fundamental instinctual structure of the mind, the collective unconscious. On the contrary, the confusion in the top layers produces a compensatory reaction in the collective unconscious, consisting of a

peculiar personality surrogate, an archaic personality equipped with superior instinctive forces. This new constellation is at first completely unconscious, but as it is activated it becomes perceptible in the form of a projection. It is usually the doctor treating a patient who unwittingly assumes the role of the projected figure. The mechanism of this projection is the transference. By transference the doctor appears in the guise of the father, for instance, as that personality who symbolizes superior power and intelligence, a guarantee of security and a protection against overwhelming dangers. So long as the disintegration has not reached the deeper layers, the transference will not produce more than the projection of the father-image. But once the confusion has stirred up these unknown depths, the projection becomes more collective and takes on mythological forms. In this case the doctor appears as a sort of sorcerer or saviour. With actively religious persons the doctor would be superseded by an activated image of Christ or by that of an invisible divine presence.

[1331] Mystical literature abounds in descriptions of such experiences. You also find detailed records in William James' *Varieties of Religious Experience*. But if you observe the dreams of such patients you will find peculiar symbolic images, often long before the patients themselves become conscious of any so-called mystical experiences. These images always show a specific pattern: they are circular or square, or like a cross or a star, or are composites of such elements. The technical term I use for such figures is the *mandala*, the Sanskrit word for "circle."¹¹ The corresponding medieval Latin term is the *circulus quadratus* or *rosa*. In Hindu literature you also find the terms *padma* (lotus) and *chakra*, meaning the flowerlike centres of different localizations of consciousness.¹²

[1332] Because of its circular form the mandala expresses roundness, that is, completeness or integration. In Tantrism and Lamaism it is used as an instrument of concentration and as a means of uniting the individual consciousness, the human ego-personality, with the superior divine personality of the non-ego, i.e., of the unconscious. Mandalas often have the character of *rotating* figures. One such figure is the swastika. We may therefore interpret it as a projection of an unconscious collective attempt at the formation of a compensatory unified personality. This unconscious attempt plays a great role in the general personification of the State. It gives it its ghostlike quality and bestows upon it the faculty of incarnating itself in a human personality. The almost personal authority and apparent efficiency of the State are, in a sense, nothing else than the unconscious constellation of a superior instinctual personality which compensates the obvious inefficiency of the conscious ego-personality.

[1333] When Nietzsche wrote his prophetic masterpiece, *Thus Spake Zarathustra*, he certainly had not the faintest notion that the superman he had created out of his personal misery and inefficiency would become a prophetic anticipation of a Führer

or Duce. Hitler and Mussolini are more or less ordinary human beings, but ones who, curiously enough, assume that they themselves know what to do in a situation which practically nobody understands. They seem to have the superhuman courage or the equally superhuman recklessness to shoulder a responsibility which apparently nobody else is willing or able to carry. Only a superman could be entrusted with faculties that are equal to the difficulties of the actual situation. But we know that mystical experience as well as identification with an archetypal figure lend almost superhuman force to the ordinary man. Not in vain do the Germans call their Führer “our Joan of Arc.” He is very much the character that is open to unconscious influences. I am told that Hitler locked himself in his room for three days and nights when his whole staff beseeched him not to leave the League of Nations. When he appeared again he said without any explanation, “Gentlemen, Germany must leave the League.” This story sounds as if German politics were not made but revealed.

[1334] Hitler’s unconscious seems to be female. Mussolini’s Latin and very masculine temperament does not allow a comparison with Hitler. As an Italian he is imbued with Roman history, and indeed in every gesture he betrays his identity with the Caesar. It is most characteristic what rumour has to say about him. I am told—I don’t know whether there is any truth in it or not—that not very long ago he appeared at a reception in the Roman toga and the golden laurel wreath of the Caesar, creating a panic that could only be hushed up by the most drastic measures. Even if this is a mere legend it shows beautifully how rumour interprets the Duce’s role. Gossip is surely a bad thing, but I confess I always find it interesting because it is often the only means of getting information about a public figure. Gossip does not need to be true in order to be of value. Even if it gives an entirely twisted picture of a man, it clearly shows the way in which his persona, that is his public appearance, functions. The persona is never the true character; it is a composite of the individual’s behaviour and of the role attributed to him by the public.¹³ Most of the biography of a public figure consists of the persona’s history and often of very little individual truth. Well, this is the penalty the man in the limelight has to pay!

[1335] It seems as if in nearly all the countries of Europe the gulf between the right and left wing were widening, in so far as these countries are not already Fascist. It is so in Spain and it soon might be as obvious in France. Since Socialism and Communism merely enhance the attributes of democracy, i.e., of a Constitution where there is a ruler without subjects and subjects without a ruler, they only serve to hollow out the meaning of Parliament, of government, of money, and of the so-called rights of the free citizen. The only possible synthesis seems to be the eventual incarnation of the State-ghost in a superman with all his mythological paraphernalia. Recently Ramsay MacDonald made a very clear statement. Speaking of the Labour Party he literally said: “Its members are a flock without a shepherd and with a plethora of sheep-dogs

in disagreement with one another about the fold in which the flock should be penned. Is it not time for Labour policy to be realistic? By its fumbling with the cardinal issues of defence and peace, it is casting doubt on the competence of democracy and playing straight into the hands of Fascism. The problems of modern life are too urgent to remain the playthings of shortsighted partisans.”¹⁴

[1336] It is doubtful whether the European nations would remain for any length of time in the chaotic disorder of the childish Communistic doctrine. They rather revert to type, to a state of enforced order which is nothing else than dictatorship and tyrannical oligarchy. At least this form has come to light even in sluggish Russia, where 170 million people are kept in order by a few million members of the Communist Party. In Italy it is the Fascio, and in Germany the S.S. is fast on the way to becoming something like a religious order of knights that is going to rule a colony of sixty million natives. In the history of the world there has never been a case where order was established with sweet reasonableness in a chaos. Chaos yields only to enforced order.

[1337] In the dictator and his oligarchical hierarchy the State-ghost appears in the flesh. Yet such statesmen are human beings who assume power over their fellow beings, and instantly the latter feel suppressed, which they did not feel as long as they were called democrats. Of course this State slavery is just as bad as before, but now they remember they might have to say something political and are told to shut up. Then they feel as if something dreadful had happened to them. They don't realize that whatever they talked about in the democracy was just as futile as anything they might talk about now. It is true that democrats talk and socialists talk more and communists beat them all at talk. It is just that sort of thing that has led them to disintegration, and that's why in a condition of enforced order talk comes abruptly to an end.

[1338] Disorder is destructive. Order is always a cage. Freedom is the prerogative of a minority and it is always based on the disadvantage of others. Switzerland, the oldest democracy in the world, calls herself a free country because no foreigner ever enjoyed a liberty to her disadvantage until America and Great Britain went off the gold standard. Since then we have felt like victims. Now we play the same trick on the other countries that hold Swiss bonds (mind you, Switzerland is the third biggest banker in Europe!) and we probably feel better for it. But are we really free? We are weak and unimportant and we try to be so; our style of life is narrow and our outlook hampered not only by ordinary hills but by veritable mountains of prejudice against anything and everybody that exceeds our size. We are locked in the cage of order and we enjoy just enough air not to suffocate. We have one virtue yet: we are modest and our ambitions are small. That is why we can stick to order and why we don't believe much in talk. But our freedom is exceedingly limited—fortunately enough. It may save us from a dictator.

[1339] In continental Europe today, I am afraid it is hardly a question of whether we are going to enjoy more freedom or less. As a matter of fact things have gone so far that soon even the problem of freedom will be obsolete. The question is rather that of “to be or not to be.” The dilemma is now between chaos and enforced order. Will there be civil war or not? — that is what we anxiously ask the dark Fates of Europe. I would like to quote here Miguel de Unamuno, one of those Spanish liberals who undermined the traditional order in the hope of creating greater freedom. Here is his most recent confession: “Times have changed. It is not any more a question of Liberalism and Democracy, Republic or Monarchy, Socialism or Capitalism. It is a question of civilization and barbarity. Civilization is now represented in Spain by General Franco’s Army.”¹⁵

[1340] Compulsory order seems to be preferable to the terrors of chaos, at all events the lesser of two great evils. Orders, I am afraid, have to be heard in silence.

[1341] But there is a majority of people to whom it seems the most serious matter in the world when they can’t talk any more. This appears to be the reason why even the most []¹⁶ dictatorships are eventually talked out of existence, and why the senseless and lamentable gamble of politics is meandering its way through history—a sad comedy to the thinking mind and to the feeling heart.

[1342] If we are stumbling into an era of dictators, Caesars, and incarnated States, we have accomplished a cycle of two thousand years and the serpent has again met with its own tail. Then our era will be a near replica of the first centuries A.D., when Caesar was the State and a god, and divine sacrifices were made to Caesar while the temples of the gods crumbled away. You know that thousands in those days turned their eyes away from this visible world, filled with horror and disgust, and adopted a philosophy which healed their souls. Since history repeats itself and the spiral of evolution seemingly returns to the point where it took off, there is a possibility that mankind is approaching an epoch when enough will be said about things which are never what we wish them to be, and when the question will be raised why we were ever interested in a bad comedy.

RETURN TO THE SIMPLE LIFE¹

What are your views on a return of the Swiss people to the simple life?

[1300] The return to the simple life can be regarded as an unhoped-for piece of good fortune even though it demands considerable self-sacrifice and is not undertaken voluntarily. Thanks to the mass media and the cheap sensationalism offered by the cinema, radio, and newspapers, and thousands of amusements of all kinds, life in the recent past has rapidly been approaching a condition that was not far removed from the hectic American tempo. Indeed, in the matter of divorces, Zurich has already reached the American record. All time-saving devices, amongst which we must count easier means of communication and other conveniences, do not, paradoxically enough, save time but merely cram our time so full that we have no time for anything. Hence the breathless haste, superficiality, and nervous exhaustion with all the concomitant symptoms—craving for stimulation, impatience, irritability, vacillation, etc. Such a state may lead to all sorts of other things, but never to any increased culture of the mind and heart.

Do you think we should turn more and more to the treasures of our culture?

[1344] As the booming book trade in many countries shows, if the worst comes to the worst people will even turn to a good book. Unfortunately, such a decision always needs a compelling external cause. Unless driven by necessity, most people would never dream of “turning to the treasures of our culture.” The delusion of steady social improvement has been dinned into them so long that they want to forget the past as quickly as possible so as not to miss the brave new world that is constantly being dangled before their eyes by unreformable world-reformers. Their neurasthenic craving for the latest novelty is a sickness and not culture. The essence of culture is continuity and conservation of the past; craving for novelty produces only anti-culture and ends in barbarism. The inevitable outcome is that eventually the whole nation will yearn for the very culture which, owing to the delusion of better conditions in the future (which seldom if ever materialize), has almost (or entirely) disappeared. Unfortunately our world, or perhaps the moral structure of man, is so constituted that no progress and no improvement are consistently good, since sooner or later the corresponding misuse will appear which turns the blessing into a curse. Can anyone seriously maintain that our wars are in any way “better” than those of the Romans?

[1345] The craze for mass organization wrenches everyone out of his private world into the deafening tumult of the market-place, making him an unconscious, meaningless particle in the mass and the helpless prey of every kind of suggestion. The never failing bait is the alleged “better future,” which prevents him from adapting himself to the actual present and making the best of it. He no longer lives in the present and *for* the future, but—in a totally unrealistic way—already in the future, defrauded of the present and even more of the past, cut off from his roots, robbed of his continuity, and everlastingly duped by the mocking *fata morgana* of a “better future.” A tremendous disillusionment is needed to save people from wishful thinking and bring them back to the sound bases of tradition, and to remind them of the blessings of a spiritual culture which the “age of progress” has destroyed with its nihilistic criticism. One has only to think of the spiritual devastation that has already been wrought by materialism, the invention of would-be intellectuals equipped with truly infantile arguments. It will be difficult to get rid of the kind of thinking whose very stupidity makes it so popular.

Do you believe that happiness is found not in material but in spiritual things?

[1346] To remove the ideal from the material to the spiritual world is a tricky business, because material happiness is something tangible (if ever it is attained), and the spirit an invisible thing which it is difficult to find or to demonstrate. It is even supposed that most of what goes by the name of “spirit” is so much empty talk and a clattering of words. An attainable sausage is as a rule more illuminating than a devotional exercise; in other words, to find happiness in the spirit one must be possessed of a “spirit” to find happiness in. A life of ease and security has convinced everyone of all the material joys, and has even compelled the spirit to devise new and better ways to material welfare, but it has never *produced* spirit. Probably only suffering, disillusion, and self-denial do that. Anyone who can live under such stresses and still find life worth while already has spirit, or at least has some inklings of it. But at all times there are only very few who are convinced from the bottom of their hearts that material happiness is a danger to the spirit, and who are able to renounce the world for its sake.

[1347] I hope, therefore, that the scourge which is now lashing Europe will bring the nations to realize that this world, which was never the best of all possible worlds in the past, will not be so in the future either. It is, as always, compounded of day and night, light and darkness, brief joys and abiding sorrows, a battleground without respite or peace, because it is nothing but the melting-pot of human desires. But the spirit is another world within this world. If it is not just a refuge for cowards, it comes only to those who *suffer* life in this world and accept even happiness with a gesture of polite doubt. Had the Christian teachings not been so utterly forgotten in the face of all this technological “progress,” the avalanches that now threaten to

engulf Europe would never have started rolling. Belief in this world leaves room neither for the spirit of Christianity nor for any other good spirit. The spirit is always hidden and safe from the world, an inviolable sanctuary for those who have forsworn, if not the world, at least their belief in it.

Can there be an optimism of austerity?

[1348] Instead of “optimism,” I would have said an “optimum” of austerity. But if “optimism” is really meant, very much more would be required, for “austerity” is anything but enjoyable. It means real suffering, especially if it assumes acute form. You can be “optimistic” in the face of martyrdom only if you are sure of the bliss to come. But a certain minimal degree of austerity I regard as beneficial. At any rate, it is healthier than affluence, which only a very few people can enjoy without ill effects, whether physical or psychic. Of course one does not wish anything unpleasant for anybody, least of all oneself, but, in comparison with other countries, Switzerland has so much affluence to spare (however honourably earned) that we are in an excellent position to give some of it away. There is an “optimum” of austerity which it is dangerous to exceed, for too much of it does not make you good but hard and bitter. As the Swiss proverb trenchantly puts it: “Behind every rich man stands a devil, and behind every poor man two.”

[1349] Since “optimism” seems to have been meant, and hence an optimistic attitude towards something unpleasant, I would add that in my view it would be equally instructive to speak of a “pessimism” of austerity. Human temperaments being extremely varied, indeed contradictory, we should never forget that what is good for one man is harmful for another. One man, because of his inner weakness, needs encouragement; another, because of his inner assurance, needs the restraint of austerity. Austerity enforces simplicity, which is true happiness. But to live simply, without regret and bitterness, is a moral task which many people will find very hard.

Will turning away from material things foster the team-spirit?

[1350] A common need naturally strengthens the team-spirit, as we can see in England at this moment. But the very existence of many moral weaklings increases the danger of selfishness. All extraordinary conditions bring men’s badness as well as their goodness to light. However, since the majority of our people may be regarded as morally healthy, there is ground for hope that a common need will cause their virtues to shine more brightly.

[1351] Believing as I do in the virtues and diligence of the Swiss, I am convinced that they have an absolute will to preserve their national independence and are ready to make the heaviest sacrifices. At any rate, the team-spirit in Switzerland is not undeveloped and hardly needs special strengthening. Above all, we do not have those

social contrasts between a solid upper crust or party on the one hand and an anonymous mass on the other, which in other countries keep citizens apart. Class conflicts with us are mainly imported from abroad. Instead of pushing the team-spirit artificially to the fore, it seems to me more important to stress the development of the personality, since this is the real vehicle of the team. Faced with the question of *what* a man does, one should never forget *who* is doing it. If a community consists of nothing but trash, then it amounts to nothing, for a hundred imbeciles still do not add up to anything sensible. The noisy and insistent preaching of the team-spirit only causes them to forget that their contribution to society consists of nothing but their own uselessness. If I belong to an organization with 100,000 members it does not prove in the least that I am any good, let alone if there are millions of them. And if I pat myself on the back for being a member, I am merely adding to my non-value the illusion of excessive value. Since, in accordance with the laws of mass psychology, even the best man loses his value and meaning in the mass, it is doubly important for him to be in secure possession of his good qualities in order not to damage the community of which he is a member. Instead of talking so much about the team-spirit it would be more to the point to appeal to the spiritual maturity and responsibility of the individual. If a man is capable of leading a responsible life himself, then he is also conscious of his duties to the community.

[1352] We Swiss believe in quality; let us therefore use our national belief for improving the value of the individual, instead of letting him become a mere drop in the ocean of the community. Self-knowledge and self-criticism are perhaps more necessary for us in Switzerland, and more important for the future, than a great herd of social irresponsibles. In Switzerland we could do nothing anyway with masses welded together and controlled by iron discipline; our country is far too small. What counts with us are the virtues, the stoutheartedness and toughness of the individual who is conscious of himself. In the case of extreme necessity everyone has to do his bit in his allotted place. It is nice to hope for a helper in time of need, but self-reliance is better. The community is not anything good in itself, as it gives countless weaklings a wonderful opportunity to hide behind each other and palm off their own incompetence on their fellows. People are only too willing to expect the community to do what they themselves are incapable of doing, and they hold it responsible when they as individuals fail to fulfil their necessary obligations.

[1353] Although we Swiss do undoubtedly have a fairly well-developed team-spirit, most of our attempts at community are miserable specimens. They grow on stony ground and are divided by thorny hedges. One and all suffer from the Swiss national vices of obstinacy and mistrustfulness—at least, these national qualities are called vices when people get annoyed about them, as very often happens. But from another point of view they could almost be extolled as virtues. It is quite impossible to say

how much of our political, intellectual, and moral independence of the powerful world around us we owe to these unpleasant qualities. Fortunately—I am almost inclined to say—their roots penetrate into the deepest recesses of every Swiss heart. We are not easily fooled. How many poisonous infections, how many fantastic ideas may we not have avoided in the course of the centuries thanks to these qualities! The fact that we are in some respects a hundred years behind the times, and that many reforms are desperately overdue, is the price we have to pay for such useful national failings.

[1354] Hence I expect more from the Swiss national character than from an artificially fostered team-spirit, because it has deeper roots in our native soil than an enthusiasm which wanes with the words that conjure it up. It is all very fine to be swept along on a tide of enthusiasm, but one cannot enthuse indefinitely. Enthusiasm is an exceptional state, and human reality is made up of a thousand vulgarities. Just what these are is the decisive thing. If the ordinary Swiss makes very sure that he himself has it good and can summon up no enthusiasm whatever for the joys of having nothing in glorious solidarity with everybody else, that is certainly unromantic—worse, it is selfish, but it is sound instinct. The healthy man does not torture others—generally it is the tortured who turn into torturers. And the healthy man also has a certain amount of goodness which he is the more inclined to expend since he does not enjoy a particularly good conscience on account of his obvious selfishness. We all have a great need to be good ourselves, and occasionally we like to show it by the appropriate actions. If good can come of evil self-interest, then the two sides of human nature have cooperated. But when in a fit of enthusiasm we begin with the good, our deep-rooted selfishness remains in the background, unsatisfied and resentful, only waiting for an opportunity to take its revenge in the most atrocious way. Community at all costs, I fear, produces the flock of sheep that infallibly attracts the wolves. Man's moral endowment is of so dubious a nature that a stable condition seems possible only when every sheep is a bit of a wolf and every wolf a bit of a sheep. The truth is that a society is more secure the more the much maligned instincts can, of their own accord, start off the counterplay of good and evil. "Pure good" and "pure evil" are both superhuman excesses.

[1355] Although there is naturally no need to preach self-interest, since it is omnipresent, it should not be needlessly slandered; for when the individual does not prosper neither does the whole. And when he is driven to unnatural altruism, self-interest reappears in monstrous, inhuman form—"changing shape from hour to hour, I employ my savage power"²—for the instincts cannot be finally suppressed or eradicated. Excessive sacrifice of the individual for the sake of the community makes no sense in our case anyway, since, our country being so small, we are in no position

to assert our self-interest in nationalistic form, that is, by the conquest of foreign countries.

[1356] In sober scepticism as opposed to propaganda talk, in sure instinct and closeness to nature, in self-limitation grounded in self knowledge, I see more health for our Fatherland than in fervent speeches about regeneration and hysterical attempts at a reorientation. Sooner or later it will be found that nothing really “new” happens in history. There could be talk of something really novel only if the unimaginable happened: if reason, humanity, and love won a lasting victory.

EPILOGUE TO JUNG: "L'HOMME À LA DÉCOUVERTE DE SON ÂME"¹

[1357] The fundamental concepts of my psychology have been set forth in the course of this book. Helped by the perceptive translation of M. Cahen-Salabelle, the reader will not have failed to take note that this psychology does not rest on academic postulates, but on my experiences of man, in health and in sickness. That is why it could not be confined to a study of the contents and functions of consciousness: it had to concern itself also with that part of the psyche we call the unconscious. Everything we say about the unconscious should be taken with a grain of salt; we have only indirect evidence for its existence since it is not open to direct observations; whatever conceptions we form of it are but logical deductions from its effects. These deductions possess only a hypothetical validity because it cannot be determined beforehand whether the nature of the unconscious can be adequately grasped by the conscious mind. I have always endeavoured, therefore, to find a formulation which brings together in a logical relationship the greatest possible number of observed facts, or else, on the basis of my knowledge of a given psychic state, to predict its probable future development, which is also a method for proving the correctness of a given hypothesis. Many a medical diagnosis, as we know, can hardly be proved right at the moment the doctor formulates it, and can be confirmed only when the disease takes its predicted course. It is in this way that my views concerning the unconscious have little by little been built up.

[1358] It is my conviction that the investigation of the psyche is the science of the future. Psychology is the youngest of the sciences and is only at the beginning of its development. It is, however, the science we need most. Indeed, it is becoming ever more obvious that it is not famine, not earthquakes, not microbes, not cancer but man himself who is man's greatest danger to man, for the simple reason that there is no adequate protection against psychic epidemics, which are infinitely more devastating than the worst of natural catastrophes. The supreme danger which threatens individuals as well as whole nations is a *psychic danger*. Reason has proved itself completely powerless, precisely because its arguments have an effect only on the conscious mind and not on the unconscious. The greatest danger of all comes from the masses, in whom the effects of the unconscious pile up cumulatively and the reasonableness of the conscious mind is stifled. Every mass organization is a latent danger just as much as a heap of dynamite is. It lets loose effects which no man wants and no man can stop. It is therefore in the highest degree desirable that a knowledge of psychology should spread so that men can understand the source of the

supreme dangers that threaten them. Not by arming to the teeth, each for itself, can the nations defend themselves in the long run from the frightful catastrophes of modern war. The heaping up of arms is itself a call to war. Rather must they recognize those psychic conditions under which the unconscious bursts the dykes of consciousness and overwhelms it.

[1359] It is my hope that this book will help to throw light on this fundamental problem for mankind.

MARGINALIA ON CONTEMPORARY EVENTS¹

[1360] Until a few centuries ago those regions of the world which have since been illuminated by science were shrouded in deepest darkness. Nature was still in her original state, as she had been from time immemorial. Although she had long since been bereft of gods, she had not by any means been *de-psychized*. Demonic spirits still haunted the earth and water, and lingered in the air and fire; witchcraft and prophecies cast their shadows over human relationships, and the mysteries of faith descended deep into the natural world. In certain flowers there could be found images of the martyrs' instruments of torture, and of Christ's blood; the clockwise spiral of the snail's shell was a proof of the existence of God; in alchemy the Virgin birth was figured in the awakening of the *infans mercurialis* in the womb of the earth; Christ's passion was represented by the *separatio*, *solutio*, and *digestio* of the arcane substance; his death and resurrection were reproduced in the processes of chemical transformation. These depicted the otherwise unimaginable transubstantiation. The secret of the baptismal water was rediscovered in the marvellous properties of the solvent *par excellence*, the ὕδωρ θεῖον or *aqua permanens*. Christ's crucifixion was like a prefiguration of the task of natural science, for the tree of the Cross corresponded to the *arbor philosophica*, which in turn stood for the *opus alchymicum* in general.

[1361] Today we can scarcely imagine this state of mind any more, and we can form no proper conception of what it meant to live in a world that was filled from above with the mysteries of God's wonder, down to the very crucible of the smelter, and was corrupted from below by devilish deception, tainted by original sin, and secretly animated by an autochthonous demon or an *anima mundi*—or by those “sparks of the World Soul” which sprang up as the seeds of life when the Ruach Elohim brooded on the face of the waters.

[1362] One can scarcely imagine the unspeakable change that was wrought in man's emotional life when he took farewell from that almost wholly antique world. Nevertheless, anyone whose childhood was filled with fantasy can feel his way back to it to a certain extent. Whether one laments or welcomes the inevitable disappearance of that primordial world is irrelevant. The important thing is the question that nobody ever asks: What happens to those figures and phantoms, those gods, demons, magicians, those messengers from heaven and monsters of the abyss, when we see that there is no mercurial serpent in the caverns of the earth, that there are no dryads in the forest and no undines in the water, and that the mysteries of faith

have shrunk to articles in a creed? Even when we have corrected an illusion, it by no means follows that the psychic agency which produces illusions, and actually needs them, has been abolished. It is very doubtful whether our way of rectifying such illusions can be regarded as valid. If, for example, one is content to prove that there is no whale that could or would like to swallow a Jonah, and that, even if it did, a man would rapidly suffocate under those conditions and could not possibly be spewed forth alive again—when we criticize in this way we are not doing justice to the myth. Indeed, such an argument is decidedly ridiculous because it takes the myth literally, and today this seems a little bit too naïve. Already we are beginning to see that enlightened correction of this kind is painfully beside the point. For it is one of the typical qualities of a myth to fabulate, to assert the unusual, the extraordinary, and even the impossible. In the face of this tendency, it is quite inappropriate to trot out one's elementary-school knowledge. This sort of criticism does nothing to abolish the mythologizing factor. Only an inauthentic conception of the myth has been corrected. But its real meaning is not touched, even remotely, and the mythologizing psychic factor not at all. One has merely created a new illusion, which consists in the belief that what the myth says is not true. Any elementary-school child can see that. But no one has any idea of what the myth is really saying. It expresses psychic facts and situations, just as a normal dream does or the delusion of a schizophrenic. It describes, in figurative form, psychic facts whose existence can never be dispelled by mere explanation. We have lost our superstitious fear of evil spirits and things that go bump in the night, but, instead, are seized with terror of people who, possessed by demons, perpetrate the frightful deeds of darkness. That the doers of such deeds think of themselves not as possessed, but as “supermen,” does not alter the fact of their possession.

[1363] The fantastic, mythological world of the Middle Ages has, thanks to our so-called enlightenment, simply changed its place. It is no longer incubi, succubi, wood-nymphs, melusines, and the rest that terrify and tease mankind; man himself has taken over their role without knowing it and does the devilish work of destruction with far more effective tools than the spirits did. In the olden days men were brutal, now they are dehumanized and possessed to a degree that even the blackest Middle Ages did not know. Then a decent and intelligent person could still—within limits—escape the devil's business, but today his very ideals drag him down into the bloody mire of his national existence.

[1364] The development of natural science as a consequence of the schism in the Church continued the work of the dedeification of Nature, drove away the demons and with them the last remnants of the mythological view of the world. The result of this process was the gradual dissolution of projections and the withdrawal of projected contents into the human psyche. Thus the rabble of spooks that were

formerly outside have now transported themselves into the psyche of man, and when we admire the “pure,” i.e., depsychized, Nature we have created, we willy-nilly give shelter to her demons, so that with the end of the Middle Ages *anno* 1918 the age of total blood baths, total demonization, and total dehumanization could begin. Since the days of the Children’s Crusade, of the Anabaptists and the Pied Piper of Hamelin, no such psychic epidemics have been seen, especially not on a national scale. Even the torture chamber—that staggering achievement of modern times!—has been reintroduced into Europe. Everywhere Christianity has proved incapable² of stopping the abomination, although many Christians have set their lives at stake. Finally, the invention of human slaughterhouses—compared with which the Roman circuses of 2,000 years ago were but a piffling prelude—is a scarcely surpassable achievement of the neo-German spirit.

[1365] These facts make one think. The demonism of Nature, which man had apparently triumphed over, he has unwittingly swallowed into himself and so become the devil’s marionette. This could happen only because he believed he had abolished the demons by declaring them to be superstition. He overlooked the fact that they were, at bottom, the products of certain factors in the human psyche. When these products were unreal and illusory, their sources were in no way blocked up or rendered inoperative. On the contrary, after it became impossible for the demons to inhabit the rocks, woods, mountains, and rivers, they used human beings as much more dangerous dwelling places. In natural objects much narrower limits were drawn to their effectiveness: only occasionally did a rock succeed in hitting a hut, only rarely was it possible for a river to overflow its banks, devastate the fields, and drown people. But a man does not notice it when he is governed by a demon; he puts all his skill and cunning at the service of his unconscious master, thereby heightening its power a thousandfold.

[1366] This way of looking at the matter will seem “original,” or peculiar, or absurd, only to a person who has never considered where those psychic powers have gone which were embodied in the demons. Much as the achievements of science deserve our admiration, the psychic consequences of this greatest of human triumphs are equally terrible. Unfortunately, there is in this world no good thing that does not have to be paid for by an evil at least equally great. People still do not know that the greatest step forward is balanced by an equally great step back. *They still have no notion of what it means to live in a de-psychized world.* They believe, on the contrary, that it is a tremendous advance, which can only be profitable, for man to have conquered Nature and seized the helm, in order to steer the ship according to his will. All the gods and demons, whose physical nothingness is so easily passed off as the “opium of the people,” return to their place of origin, Man, and become an intoxicating poison compared with which all previous dope is child’s play. What is

National Socialism³ except a vast intoxication that has plunged Europe into indescribable catastrophe?

[1367] What science has once discovered can never be undone. The advance of truth cannot and should not be held up. But the same urge for truth that gave birth to science should realize what progress implies. Science must recognize the as yet incalculable catastrophe which its advances have brought with them. The still infantile man of today has had means of destruction put into his hands which require an immeasurably enhanced sense of responsibility, or an almost pathological anxiety, if the fatally easy abuse of their power is to be avoided. The most dangerous things in the world are immense accumulations of human beings who are manipulated by only a few heads. Already those huge continental blocs are taking shape which, from sheer love of peace and need of defence, are preparing future catastrophes. The greater the equalized masses, the more violent and calamitous their movement!

[1368] When mankind passed from an animated Nature into an exanimated Nature, it did so in the most discourteous way: animism was held up to ridicule and reviled as superstition. When Christianity drove away the old gods, it replaced them by one God. But when science de-psychized Nature, it gave her no other soul, merely subordinating her to human reason. Under the dominion of Christianity the old gods continued to be feared for a long time, at least as demons. But science considered Nature's soul not worth a glance. Had it been conscious of the world-shattering novelty of what it was doing, it would have reflected for a moment and asked itself whether the greatest caution might not be indicated in this operation, when the original condition of humanity was abolished. If yes, then a "rite de sortie," a ceremonial proclamation to the gods it was about to dethrone, and a reconciliation with them, would have been necessary. That at least would have been an act of reverence. But science and so-called civilized man never thought that the progress of scientific knowledge would be a "peril of the soul" which needed forestalling by a powerful rite. This was presumed impossible, because such a "rite de sortie" would have been nothing but a polite kowtowing to the demons, and it was the triumph of the Enlightenment that such things as nature-spirits did not exist at all. But it was merely that what one *imagined* such spirits to be did not exist. They themselves exist all right, here in the human psyche, unperturbed by what the ignorant and the enlightened think. So much so that before our very eyes the "most industrious, efficient, and intelligent" nation in Europe could fall into a state of *non compos mentis* and put a poorly gifted housepainter, who was never distinguished by any particular intelligence but only by the use of the right means of mass intoxication, quite literally on the altar of totalitarianism, otherwise reserved for a theocracy, and leave him there. Evidently neither knowledge nor preparation of any kind is needed for the direction of the State, and without any military training one can be a great

Field Marshal. Even intelligence blanches at the sight of it and cannot but marvel at the unprecedented “genius.” It was indeed something quite out of the ordinary when a person came along and cold-bloodedly stated that *he* would take over the responsibility. It was so stupefying that nobody thought of asking *who* was accepting the responsibility, or of taking the necessary precautions against public mischief. At all events the thing promised far too much for anyone to take serious offence. The psychopathologist is familiar with this particular “genius” of irresponsible promises: it is called *pseudologia phantastica*, and it is considered quite a feat not to be duped by such people, especially when they exhibit in a high degree symptoms of possession, such as divinatory phenomena (hunches, thought-reading, etc.), and fits of pathological affect (the classic frenzy of the prophets). Nothing is so infectious as affect and nothing is so disarming as the promised fulfillment of one’s own selfish wishes. I do not dare to think of what might have happened to us Swiss if we had had the misfortune to be a nation of eighty millions. According to all the psychological precedents our stupidity would have been multiplied, and our morality divided, by twenty. The greater the accumulation of masses, the lower the level of intelligence and morality. And if any further proof were needed of this truth, the descent of Germany into the underworld would be an example. We should not delude ourselves that we would not have succumbed too. The presence of traitors in our midst shows how easily we succumb to suggestion, even without the mitigating excuse of being a nation of eighty millions.

[1369] What protected us was above all our *smallness* and the inevitable psychological consequences of this. First the *distrust* of the little man, whose one thought day and night is to ensure that the big man shall not bully or cheat him—for this, if one is small, must be expected of the big man. Hence, the more hectoring his words, the more they arouse *defiance* and *obstinacy*: “Now I certainly won’t,” says the honest citizen. Whether he is accused of being a misoneist or a conservative or a numskull has no effect on his instinctive reaction—at the moment; in the long run, however, the Swiss is so “reasonable” that he is secretly ashamed of his stolidity, his pigheadedness, his being a hundred years behind the times and consequently runs the risk of involving himself after all in the tumult of “world organization,” “living space,” “economic blocs,” or whatever the nostrums today are called. In this respect it is no mistake to be stuck in the past. It is as a rule better to postpone the future, since it is doubtful whether what comes afterwards will be so much better. Usually it is so with reservations, or not at all.

[1370] Far be it from me to encourage such nasty things as envy and stinginess, but the fact is they exist and contribute to the heightening of distrust and not wanting to get “with it.” Yet, like harmful animals, they have their uses. Naturally I don’t want to speak in favour of the bad qualities, but I enjoy studying them just because, in a

collectivity, they prove to be so much more effective than the virtues. They have the great advantage of piling up in proportion to the size of the population while the virtues have the disadvantage of extinguishing each other under the same conditions. They suffer from the same drawback as famous galleries, where the accumulated masterpieces kill each other stone dead. Virtue is jealous, but vice seeks companions (and the evil one loves large numbers, small ones he despises, and therefore occasionally overlooks them).

[1371] In times of unrest such as these, we are protected by our deep roots, by tradition, which—thank God—is still alive and cherished, by love of country, by a profound conviction that no tree ever reaches up to heaven, and that the higher it grows the closer its roots approach to hell, by a taste that likes the middle, the *μηδὲν ἄγαν* (“do nothing to excess”) of the Greek sages, who knew only their *polis* and presumably never even dreamt of a nation of eighty millions, and lastly by the aforesaid bad qualities, which we certainly don’t wish to conceal. We have had enough of this from the other side of the Rhine: “The healthiest, most industrious, most efficient, and staunchest nation”—how the fish rise to this bait! Anyone who is really convinced of his own and his nation’s imperfections will not fall for the power of the superlative, the whopping lie. He knows, or should know, that the statesman who toys with unlawful measures is ultimately working for the ruin of the nation. The demand for the probity of the nation’s leaders must be the fundamental principle of all politics, however humdrum, undiplomatic, unmodern, and short-sighted that may sound. Success that is obtained by bad means sooner or later ends in ruin. The history of the German Reich since 1871 is an object lesson in this respect. But the danger that one will learn nothing from history is great.

[1372] Just as ruinous, it seems to me, as the worship of success and the belief in superlatives is the fashionable tendency to turn man into a mere function of economic factors. Moleschott’s celebrated dictum. “Man is what he eats,” cannot claim to be even a physiological truth, for although he depends on his food, he is not what this is but how he digests it. All schemes for world improvement, world communications, economic spheres of influence, national alliances, etc., stand or fall by the way man deals with them. And if there is anyone who does not believe that even the best idea will in all probability be sabotaged by man’s notorious short-comings, by his stupidity, laziness, unscrupulousness, egotism, etc., he can safely pack up his statistical tables. Even in a system patched together out of countless compromises, and weighed down with all sorts of impractical and seemingly unnecessary historical appendages, the State will prosper tolerably well if the majority of its citizens still possess an unatrophied sense of justice. Nobody can deny the importance of economic conditions, but what is far more important is how the public reacts to their inevitable ups and downs. Over and above all external factors the ultimate decisions

always rest with the human psyche. Whether one had a large or a small “living space” matters little in comparison with whether one has a sound or a gullible psyche. In this respect the “leaders,” with sure grasp, have understood what is so crucially lacking: an unquestionable spiritual and moral authority. The pope or the Church could say they are such an authority, but how many people believe it? No doubt one *ought* to believe it, but doesn’t one always use this little word “ought” when one is forced to admit that one simply doesn’t know how the necessary remedy is to be brought about?

[1373] I think the appeal to the religious conscience of humanity no longer arouses any response worth mentioning today. The modern peddlers of poisonous intoxicants have replaced this “opium” with far more effective drugs. Nowadays it is science more than anything that is the great power for good or ill. Science has done more than usher in a new age of unbelief: it *is* that age. When anything is labelled “scientific,” you can be quite sure that it will be given a welcome hearing by everyone who values his intelligence and his intellectual reputation. Here, then, we would have a quite passable authority which has given proof not only of its iconoclastic but also of its positive powers.

[1374] For about half a century now science has been examining under the microscope something that is more invisible than the atom—the human psyche—and what it discovered at first was very far from enjoyable. If one had the necessary imagination one would actually be shattered by these discoveries. But the psychologist today is in the same position as the physicist, who has discovered the elements of a future atomic bomb capable of turning the earth into a nova. He sees it merely as an interesting scientific problem, without realizing that the end of the world has come tangibly closer. In the case of psychology things are not quite as bad as that, but all the same it has discovered where those demons, which in earlier ages dominated nature and man’s destiny, are actually domiciled, and, what is more, that they are none the worse for enlightenment. On the contrary, they are as sprightly as ever, and their activity has even extended its scope so much that they can now get their own back on all the achievements of the human mind. We know today that in the unconscious of every individual there are instinctive propensities or psychic systems charged with considerable tension. When they are helped in one way or another to break through into consciousness, and the latter has no opportunity to intercept them in higher forms, they sweep everything before them like a torrent and turn men into creatures for whom the word “beast” is still too good a name. They can then only be called “devils.” To evoke such phenomena in the masses all that is needed is a few possessed persons, or only one. Possession, though old-fashioned, has by no means become obsolete; only the name has changed. Formerly they spoke of “evil spirits,” now we call them “neuroses” or “unconscious complexes.” Here as everywhere the

name makes no difference. The fact remains that a small unconscious cause is enough to wreck a man's fate, to shatter a family, and to continue working down the generations like the curse of the Atrides. If this unconscious disposition should happen to be one which is common to the great majority of the nation, then a single one of these complex-ridden individuals, who at the same time sets himself up as a megaphone, is enough to precipitate a catastrophe. The good people, in their innocence and unconsciousness, do not know what is happening to them when they are changed overnight into a "master race" (a work of the devil, who has so often changed horse-apples into gold), and an amazed Europe is hard put to accommodate itself to the "new order" where anything so monstrous (one thinks of Maidenek⁴ in relation to Eckhart, Luther, Goethe, and Kant!) is not merely a possibility but a *fait accompli*.⁵

[1375] Countless people have asked themselves how it was possible for a civilized nation like Germany to fall into this hellish morass. I once wrote that Germany is the land of spiritual catastrophes.⁶ If the neo-German madness proclaims that the Germans are the chosen people, and if they then, out of envious rivalry, persecute the Jews with whom they have certain psychological peculiarities in common (behind every persecution there lurks a secret love, as doubt behind every fanaticism), we are indeed confronted with something quite apart, a state of being "elect." For nobody can fall so low unless he has a great depth. If such a thing can happen to a man, it challenges his best and highest on the other side; that is to say, this depth corresponds to a potential height, and the blackest darkness to a hidden light. This light is certainly invisible today, because it is blocked up in the depths of the psyche. Indeed everything has gone so desperately awry in Germany, and what has happened is an infernal caricature of the answer the German spirit should have given to the question put to Europe by a new age. Instead of reflecting on this question, it was taken in by that fake figure of the Superman, which the neurotically degenerate mind of Nietzsche invented as a compensation for his own weakness. (Not without some excuse, however, since the Faust that made the pact with the devil was his godfather.) Germany has soiled her name and her honour with the blood of the innocent and brought upon her own head the curse of election. She has aroused such hatred in the world that it is difficult to make the scales of justice balance. And yet the first to enter with the Saviour into paradise was the thief. And what does Meister Eckhart say? "For this reason God is willing to bear the brunt of sins and often winks at them, mostly sending them to people for whom he has prepared some high destiny. See! Who was dearer to our Lord or more intimate with him than his apostles? Not one of them but fell into mortal sin, and all were mortal sinners."⁷

[1376] Nowhere are the opposites wrenched further apart than in the German. He is like a sick man who has fallen a victim to his unconscious and no longer knows himself.

[1377] The psychiatrist knows that certain dangerous unconscious forces can be rendered harmless, or at least held in check, if they are made conscious, that is. if the patient can assimilate them and integrate them with his personality. In so far as psychiatrists are concerned with the psychic treatment of such complexes, they have to do every day with “demons,” i.e., with psychic factors that display demonic features when they appear as a mass phenomenon. To be sure, a bloodless operation of this kind is successful only when a single individual is involved. If it is a whole family, the chances are ten to one against, and only a miracle can provide the remedy. But when it is a whole nation the artillery speaks the final word. If this is to be avoided one must begin with the individual—and a lamentably long-drawn-out and hopeless labour of Sisyphus this may seem. At any rate people are so impressed by the suggestive power of megaphone oratory that they are inclined to believe that this bad means—mass hypnotism—could be put to a good purpose by “inflammatory” speeches, “pungent” words, and soul-stirring sermons. Though I don’t want to dismiss altogether the saying about the end justifying the means, I must emphasize that mass persuasion for the sake of the good compromises its end and aim, because at bottom it is simply a whipped-up mood whose effect peters out at the earliest opportunity. The innumerable speeches and articles on the “renewal” are futile, so much chatter that hurts nobody and bores everyone.

[1378] *If the whole is to change, the individual must change himself.* Goodness is an individual gift and an individual acquisition. In the form of mass suggestion it is mere intoxication, which has never yet been counted a virtue. Goodness is acquired only by the individual as his own achievement. No masses can do it for him. But evil needs masses for its genesis and continued existence. The mastermen of the S.S. are all, when segregated each by himself, indescribably small and ugly. But the good man shines like a jewel that was lost in the Sahara. The scientist knows that no epidemic can be sealed off by a *cordon sanitaire* unless the individual is prevented from breaking it. Nor can one hope for the cleanliness of a people unless the individual is induced to wash himself daily. Perhaps in a more enlightened era a candidate for governmental office will have to have it certified by a psychiatric commission that he is not a bearer of psychic bacilli. How much this would have spared the world had it been done before 1933!

[1379] The disinfection of the upper echelons would certainly be merely a palliative, for a real cure would consist in the immunization of individuals. The snag here is that the alteration of the individual seems to be such an infinitely long and discouraging way round. It should be remembered, however, that only two other possibilities exist. First, the undoubtedly successful method of mass suggestion, which unfortunately works best only when you want to make something slide downhill or collapse. All that can be built with it are houses of cards or concentration camps or death pits. This

method, therefore, is not to be recommended. Second, you can fold your hands in your lap, stick your head in the sand, and let things run on in God's or the devil's name. But it is extremely difficult and irritating to let a thing run on. If anything sensible came of it in the end, it would be like a *lèse-majesté* of man. So this way, too, is out.

[1380] What then remains? *Only with the individual can anything be done.* The rise and spread of Christianity show that something of the kind is not altogether impossible. Even a sceptic will have to admit that Christianity has brought about a psychic change of sorts, even if only a superficial one.⁸ It expelled many demons (and piled them up somewhere else), and it actually effected the dedeification of nature. If we disregard the mass conversions, its spread was due mainly to the work of one individual upon another. The individual was directly appealed to in early Christian times, and this appeal has continued down through the centuries in the ecclesiastical cure of souls. (In the case of Protestantism one has to ask oneself where, for sheer kerygmatics, the cure of souls has got to!) Without a personal appeal there is no personal influence, which alone can change the attitude of the individual for the better. This requires the personal commitment not only of the one to be changed, but above all of the one who wants to do the changing. Words and gestures influence only the man who is ready to go downhill and is merely waiting for the final push.

[1381] What we need are a few illuminating truths, but no articles of faith. Where an intelligible truth works, it finds in faith a willing ally; for faith has always helped when thinking and understanding could not quite make the grade. Understanding is never the handmaiden of faith—on the contrary, faith completes understanding. To educate men to a faith they do not understand is doubtless a well-meant undertaking, but one runs the risk of creating an attitude that believes everything it does not understand. This—it seems to me—unwittingly prepared the ground for the “genius of the Führer.” It is so convenient to be able to believe when one fears the effort of understanding.

[1382] The medical name for make-believe and preaching faith is suggestion therapy. It has the disadvantage of adding something to a person, or taking it away from him, without his insight and decision. Childlike faith, when it occurs naturally, is certainly a charisma. But when “joyful faith” and “childlike trust” are instilled by religious education, they are no charisma but a gift of the ambiguous gods, because they can be manipulated only too easily and with greater effect by other “saviours” as well. Hence the lament of many Germans about the shameful misuse that was made of the best qualities of the German people, their faith, their loyalty, and their idealism.

[1383] Since the Church is still the greatest institution for mass education, with nothing of comparable value to set beside it, it will probably have to consider refining its methods if it wants to appeal to the educated person. The latter is by no means a

quantité négligeable, as statistics show that what he thinks and writes percolates down to the broad masses within rather less than a generation. Thus, for example, that outstandingly stupid book by Herr Büchner, *Kraft und Stoff*,⁹ became in the course of twenty years the most-read book in the public libraries of Germany. The educated man is and remains a leader of the people, whether he knows it or not and whether he wants it or not. The people seek, despite everything, to understand. Although it was not clearly provided for in the original plan of creation that our first parents would eat of the tree of knowledge, it seems nevertheless to have happened, and since then the wheel of history cannot be turned back. The people want still more of those fruits. This is a hopeful sign, for besides stratospheric bombs and the alluring possibilities of uranium there are also, perhaps, salutary truths which instruct man on his true nature and demonstrate its dangerousness as incontestably as modern hygiene demonstrates the aetiology of typhus and virulent smallpox. At the same time, they lend renewed plausibility to an attitude which it has been the constant endeavour of all the higher religions to inculcate into humanity.

ANSWERS TO “MISHMAR” ON ADOLF HITLER¹

Eugen Kolb, Geneva correspondent of *Mishmar* (*The Daily Guardian*) of Tel Aviv, wrote to Jung on 4 September 1945 for his answers to the following questions. Jung replied on 14 September.

How do you, as a psychiatrist, judge Hitler as a “patient”?

[1384] Hitler was in my view primarily an *hysteric*. (Already in the first World War he had been officially diagnosed as such.) More particularly he was characterized by a subform of hysteria: *pseudologia phantastica*. In other words he was a “pathological liar.” If these people do not start out directly as deceivers, they are the sort of idealists who are always in love with their own ideas and who anticipate their aims by presenting their wish-fantasies partly as easily attainable and partly as having been attained, and who believe these obvious lies themselves. (Quisling, as his trial showed, was a similar case.) In order to realize their wish-fantasies *no means is too bad* for them, just because they believe they can thereby attain their beloved aim. They “believe” they are doing it for the benefit of humanity, or at least of the nation or their party, and cannot under any circumstances see that their aim is invariably egoistic. Since this is a common failing, it is difficult for the layman to recognize such cases as psychopathic. Because only a convinced person is immediately convincing (by psychic contagion), he exercises as a rule a devastating influence on his contemporaries. Almost everybody is taken in by him.

How could this “psychopath” influence whole nations to such an extent?

[1385] If his maniacal wish-system is a socio-political one, and if it corresponds to the pet ideas of a majority, it produces a psychic epidemic that swells like an avalanche. The majority of the German people were discontented and hugged feelings of revenge and resentment born of their national inferiority complex and identified themselves with the underdogs. (Hence their special hatred and envy of the Jews, who had anticipated them in their idea of a “chosen people”!)

Do you consider his contemporaries, who executed his plans, equally “psychopathic”?

[1386] Suggestion works only when there is a secret wish to fulfil it. Thus Hitler was able to work on all those who compensated their inferiority complex with social aspirations and secret dreams of power. As a result he collected an army of social

misfits, psychopaths, and criminals around him, to which he also belonged. But at the same time he gripped the unconscious of normal people, who are always naïve and fancy themselves utterly innocent and right. The majority of normal people (quite apart from the 10 per cent or so who are inferior) are ridiculously unconscious and naïve and are open to any passing suggestion. So far as lack of adaptation is a disease, one can call a whole nation diseased. But this is normal mass psychology; it is a herd phenomenon, like panic. The more people live together in heaps, the stupider and more suggestible the individual becomes.

If that is so, how can they be cured?

[1387] Education for fuller consciousness! Prevention of social herd-formations, of proletarianization and mass-mindedness! No one-party system! No dictatorship! Communal autonomy!

TECHNIQUES OF ATTITUDE CHANGE CONDUCTIVE TO WORLD PEACE¹

Memorandum to Unesco

I

[1388] Psychotherapy as it is taught and practised at the C. G. Jung Institute for Analytical Psychology, Zurich, can be described as a technique for changing the mental attitude. It is a method by which not only neuroses and functional psychoses can be treated, but also all sorts of mental and moral conflicts in normal people. It consists chiefly in the integration of unconscious contents into consciousness. As the unconscious mind complements or—more accurately—compensates the conscious attitude, it becomes of considerable practical importance when the attitude of consciousness deviates to one side to such a degree that the mental balance is upset. This is the case in neuroses and psychoses. The mental and moral conflicts of normal people show a disturbance of balance of a somewhat different kind: the conflicting opposites are both conscious, whereas in the neuroses the opposing half is mostly unconscious. But even with normal people the mental attitude is only partially based upon conscious and rational motives. Quite a number of—often decisive—motives remain unconscious.

[1389] The unconscious mind consists of:

- a. Previously conscious but forgotten or repressed contents.
- b. Subliminal elements and combinations of elements not yet conscious.
- c. Inherited instinctual patterns, so-called archetypes determining human behaviour.

All these contents and elements form together a matrix of the conscious mind, which would not be able to function without their continuous collaboration. A dissociation between conscious and unconscious immediately causes pathological disturbances. The unconscious, therefore, is a factor of the greatest biological importance. Its physiological aspect consists of the functioning of all the subcortical centres, which cannot be influenced by the will, and its psychological aspect of those dominant emotional tendencies in human nature which cannot be ruled by reason. These tendencies are exceedingly dynamic and of an ambivalent nature. If properly understood, they form a most welcome and useful support and *vis a tergo* to conscious convictions and decisions. If misunderstood or misdirected they paralyse

and blindfold people, pushing them into a mass-psychosis. It is, therefore, of vital importance in medical psychology to gain access to this reservoir of energy, and no attempt to change mental attitudes can be permanently successful without first establishing a new contact with the unconscious. Hitler's enormous psychological effect was based upon his highly ingenious method of playing on the well-known national inferiority complex of the Germans, of which he himself was the most outstanding example. A similar yet positive release of unconscious dynamism was the overwhelming expansion of Christianity in the second and third centuries, and the explosive spread of Islam in the seventh century. An instructive example of epidemic insanity was the witch-hunting mania in Germanic countries in the fifteenth century. This was the cause of a veritable campaign of enlightenment initiated by the Papal Bull *Summis desiderantes* in 1484.

[1390] It must be emphasized that "mental attitude" is a concept which does not describe or define accurately enough what we understand by this term. The attitude our method is concerned with is not only a mental but a *moral* phenomenon. An attitude is governed and sustained by a dominant conscious idea accompanied by a so-called "feeling-tone," i.e., an *emotional value*, which accounts for the efficacy of the idea. The mere idea has no practical or moral effect whatever if it is not supported by an emotional quality having as a rule an *ethical value*. More often than not a neurotic dissociation is due to the effect of an intellectual or moral idea that forms an ideal incompatible with human nature. The contrary is also true, since a dominant immoral idea suppresses the better nature of an individual. In either case the attitude is determined by mental as well as moral factors. This explains why a change of attitude is by no means an easy task, since it always involves considerable moral effort. Should this be lacking, the attitude would not really be changed and the old ways would persist under the disguise of new slogans.

[1391] The *method* can be described only in its general outlines:

- a. The patient gives an honest account of his biography.
- b. He collects his dreams and other products of the unconscious and submits them to analysis.
- c. The analytical procedure tries to establish the *context* surrounding each item of the dream, etc. This is done by collecting the associations to a given item. This part of the work is carried out chiefly by the patient.
- d. The context elucidates the incomprehensible dream-text in the same way as corrupt or mutilated texts become readable with the help of philological parallels.
- e. In this way it is possible to establish a *reading of the dream-text*. This, however, does not imply an understanding of the *dream's meaning*. Determination of its meaning is a matter of practice, i.e., the apparent meaning has to be related to and

compared with the conscious attitude. Without such a comparison it is impossible to understand the functional meaning of the dream.

f. As a rule the meaning of a dream is compensatory to the conscious attitude, i.e., it adds to the latter what was lacking in it. The dream is a *natural attempt to redress a lack of balance*, and it changes the conscious attitude to such an extent that a state of equilibrium is restored.

g. The method can be applied only in individual cases and only if the individual voluntarily submits to it.

h. A change of attitude can be brought about only when there is a motive strong enough to enforce a serious submission to the method. In pathological cases it is, as a rule, the illness itself and its intolerable consequences that provide the necessary motivation. In normal cases of conflict it is strong depression, despair, or a religious problem which enables an individual to make a sustained effort to achieve an ultimate change of attitude. A provisional or experimental application of the method rarely produces the desired effect, i.e., a complete change of attitude.

i. It is, however, possible that an earnest and conscientious person with a trained mind and a scientific education can acquire sufficient knowledge through a careful study of the existing literature to apply the method to himself to a certain extent. By this means he can at least obtain some understanding of its possibilities. But as the method is in essence a *dialectical procedure*, he will not be able to progress beyond a certain point without the help of an experienced teacher. Since the method does not involve intellectual factors only, but also feeling values and above all the important question of *human relationship*, the principle of collaboration becomes imperative.

II

[1392] The applicability and efficacy of the method described above are severely restricted to the individual. A change of attitude can be brought about this way only in the individual and through individual treatment. Moreover, one can apply this method with reasonable hope of success only to individuals endowed with a certain degree of intelligence and sound sense of morality. A marked lack of education, a low degree of intelligence and a moral defect are prohibitive. As 50 per cent of the population are below normal in one or other of these respects, the method could not have any effect on them even under ideal circumstances. Since the most intimate and delicate problems have to be confronted the moment one begins to delve into the meaning of dreams, a man's attitude cannot be changed unless he takes account of the most questionable and painful aspects of his own character. One cannot, therefore, expect much from the application of such a method to a *group*. A change of attitude never starts with a group but only with an individual.

[1393] If a number of individuals were to undergo such treatment separately, and—provided their motive was strong enough—were to experience a change of attitude, they could subsequently form a group, a *leading minority*, which might become the nucleus of a larger body of people. Their numbers could be increased

- a. by individual treatment,
- b. by suggestion through authority.

The great mass of the people is led by its suggestibility. It cannot be changed in its *attitude*, only in its *behaviour*. The latter depends upon the *authority of leaders* whose attitude has been really changed.

[1394] In this way the ideas of modern psychology have spread and in a similar way religious and all sorts of intellectual, moral, and immoral movements have gained ground. Such a development seems to be theoretically possible as long as we can be sure that the causes of human attitude are of a psychological nature and can be reached by psychological means. On the other hand we have to remember that psychology in our days is still a very young science and might be still in its cradle. We have to admit, therefore, the possibility of causal factors beyond our rational expectations.

[1395] Within the above-mentioned limits a change of attitude is something that can be taken for granted. Success is not easily attainable and the method is neither infallible nor foolproof. It requires a considerable amount of education and training of physician and teacher and a very strong motive on the part of the patient or pupil. But it is also a fact that the interest of the general public in psychology had rapidly increased in spite of the marked resistance of academic authority. Psychological ideas and concepts have spread far and wide, which is irrefutable proof of real need to know more about psychology. Under these circumstances it would not be unreasonable to consider the possibility of a wider application of the said method.

[1396] The first thing needed would be *teachers*. But here we come up against the inevitable question of motive. The motive must be a vital one and stronger than any prejudice. This is a very serious obstacle. It needs more than mere idealism—the teacher has to be absolutely convinced that his personal attitude is in need of revision, even of actual change. Nobody will condescend to this unless he feels that there really is something wrong. In view of the actual condition of the world every intelligent person is ready to admit that there is something utterly wrong with our attitude. Yet this inclusive statement rarely ever includes the individual in question, namely, the would-be teacher. His attitude is surely right and only needs confirmation and support, but no change. It is a very long step from this conviction to the conclusion: the world is wrong and therefore I am wrong too. To pronounce such words is easy, but to feel their truth in the marrow of one's bones is a very different

proposition, yet it is the *sine qua non* of the true teacher. In other words, it is a question of personalities, without which no method and no organization make sense. *A man whose heart is not changed will not change any other's*. Unfortunately the world of today is inclined to belittle and to ridicule such a simple and evident truth as this and thereby proves its own psychological immaturity, which is one of the prime causes of the present state of affairs as well as of numberless neuroses and individual conflicts.

[1397] Since the Middle Ages our mental horizon has been immensely enlarged, but unfortunately in a one-sided way. The object without prevails over the condition within. We know very little of ourselves, we even hate to know more. Yet it is man that experiences the world and any experience is determined by the subject as well as by the object. Logically the subject should be just as important as the object. But actually we know infinitely less of our psyche than of external objects. This fact cannot fail to impress anybody who tries to understand the motivation of human attitudes. The unconscious of highly educated people is often well-nigh incredible in certain respects, not to mention their prejudices and their irresponsible ways of dealing—or rather not dealing—with them. Naturally they set a suggestive example to the masses with disastrous results, but they are little concerned with the *trahison des clercs*. Our insight and our self-education have not kept pace with the ever-expanding external horizon. On the contrary, we know in some ways less of the psyche than in the Middle Ages.

[1398] It is evident that a better knowledge of man's psyche begins with a better understanding of oneself. If the method is successful it often integrates a vast amount of hitherto unconscious material into consciousness, enlarging both its range of vision and its moral responsibility. When parents know which of their unconscious tendencies and habits are injurious to their children's psyches, they will feel a moral obligation to do something about it, provided their sense of duty and their love are normally developed. The same law will operate in groups and, last but not least, in nations, that is, in the leading minorities, in so far as these consist of individuals who are conscious of certain tendencies which could seriously endanger human relationships. The main danger is *direct and indirect egotism*, i.e., unconsciousness of the ultimate equality of our fellow men. Indirect egotism manifests itself chiefly in an abnormal altruism, which is even capable of forcing something that seems right or good to us upon our neighbour under the disguise of Christian love, humanity and mutual help. Egotism always has the character of *greed*, which shows itself chiefly in three ways: the power-drive, lust, and moral laziness. These three moral evils are supplemented by a fourth which is the most powerful of all—*stupidity*. Real intelligence is very rare and forms statistically an infinitesimal part of the average mind. Viewed from the level of a more highly qualified mind, the average

intelligence is very low. Unfortunately unusual intelligence is often—as an uncommon individual quality—dearly paid for by a corresponding moral weakness or even defect, and is thus a doubtful gift of the gods.

[1399] Greed is uncontrollable except when counteracted by an equally violent morality. Morality, however, if it exceeds the norm, becomes a real danger to human relationship, because it is the direct instigator of compensatory immoral behaviour and thus reveals its secret root, greed.

[1400] A nation consists of the sum of its individuals, and its character corresponds to the moral average. Nobody is immune to a nationwide evil unless he is unshakably convinced of the danger of his own character being tainted by the same evil. But the immunity of the nation depends entirely upon the existence of a leading minority immune to the evil and capable of combatting the powerful suggestive effect of seemingly possible wish-fulfilments. If the leader is not absolutely immune, he will inevitably fall a victim to his own will-to-power.

[1401] The accumulated greed of a nation becomes utterly uncontrollable unless counteracted by all the forces (civil and military) a government is equipped with. No suggestion works unless one is convinced of its power. Arguments are ineffectual.

III

[1402] As to the next step for further development of the aforesaid method we propose:

a. Giving publicity to the ideas mentioned above in circles likely to influence the few who are capable of drawing their own conclusions.

b. If there are some who share the conviction that their own attitude is really in need of revision, they should be given the opportunity to submit to individual treatment.

c. Since a great deal of self-deception is to be expected as to the seriousness of one's motivations, some would soon drop out while others would need more time than was foreseen. In this case the financial allowance granted to the former would go to the latter, so that they could continue their work for as long as from six months to a year.

d. As “a change of attitude” is a rather indefinite term, we must emphasize that we understand by this the change brought about through the integration of formerly unconscious contents into consciousness. Such an addition inevitably involves a change that is felt as such. The change is never neutral. It is essentially an increase of consciousness and it depends entirely upon the individual's character what form it will ultimately take. It is, when it comes to the worst, an inoculation with one's own virtue. It is a challenge to the whole man, and it must be considered a risk—the risk involved in the further development of man's consciousness.²

THE EFFECT OF TECHNOLOGY ON THE HUMAN PSYCHE¹

[1403] The question you ask me, concerning the effect of technology on the human psyche, is not at all easy to answer, as you may well imagine. The problem is a very complicated one.

[1404] Since technology consists of certain procedures invented by man, it is not something that somehow lies outside the human sphere. One may therefore conjecture that certain modes of human adaptation also exist which would meet the requirements of technology. Technological activities mostly consist in the identical repetition of rhythmical procedures. This corresponds to the basic pattern of primitive labour, which is never performed without rhythm and an accompanying chant. The primitive, that is, the man who is relatively instinctive, can put up with an extraordinary amount of monotony. There is even something fascinating about it for him. When the work is accompanied by drumming, he is able to heat himself up into an ecstasy, or else the monotony of the action makes him fall into a semi-unconscious condition, which is not so unpleasant either. The question naturally is: What is the effect of these primitive techniques on modern man, who no longer has the capacity to transport himself into semi-unconscious or ecstatic states for any length of time?

[1405] In general it can be said that for modern man technology is an imbalance that begets dissatisfaction with work or with life. It estranges man from his natural versatility of action and thus allows many of his instincts to lie fallow. The result is an increased resistance to work in general. The remedy would presumably be to move industry out of the towns, a four-hour day, and the rest of the time spent in agricultural work on one's own property—if such a thing could be realized. In Switzerland it might be, given time. Naturally it is different with the slum mentality of huge worker-populations, but that is a problem in itself.

[1406] Considered on its own merits, as a legitimate human activity, technology is neither good nor bad, neither harmful nor harmless. Whether it be used for good or ill depends entirely on man's own attitude, which in turn depends on technology. The technologist has something of the same problem as the factory worker. Since he has to do mainly with mechanical factors, there is a danger of his other mental capacities atrophying. Just as an unbalanced diet is injurious to the body, any psychic imbalances have injurious effects in the long run and need compensating. In my practice I have observed how engineers, in particular, very often developed philosophical interests, and this is an uncommonly sound reaction and mode of compensation. For this reason I have always recommended the institution of

Humanistic Faculties at the Federal Polytechnic, to remind students that at least such things exist, so that they can come back to them if ever they should feel a need for them in later life.

[1407] Technology harbours no more dangers than any other trend in the development of human consciousness. The danger lies not in technology but in the possibilities awaiting discovery. Undoubtedly a new discovery will never be used only for the good, but will certainly be used for ill as well. Man, therefore, always runs the risk of discovering something that will destroy him if evilly used. We have come very close to this with the atom bomb. Faced with such menacing developments, one must ask oneself whether man is sufficiently equipped with reason to be able to resist the temptation to use them for destructive purposes, or whether his constitution will allow him to be swept into catastrophe. This is a question which experience alone can answer.

FOREWORD TO NEUMANN: "DEPTH PSYCHOLOGY AND A NEW ETHIC"¹

[1408] The author has asked me if I would write a foreword to the present book. I am happy to comply with this request, although it is only as an empiricist, and never as a philosopher, that I have been concerned with depth psychology, and cannot boast of ever having tried my hand at formulating ethical principles. My professional work has certainly given me plenty of opportunities to do this, since the chief causes of a neurosis are conflicts of conscience and difficult moral problems that require an answer. The psychotherapist thus finds himself in an extremely awkward situation. Having learnt by long and often painful experience the relative ineffectiveness of trying to inculcate moral precepts, he has to abandon all admonitions and exhortations that begin with "ought" and "must." In addition, with increasing experience and knowledge of psychic relationships, the conviction dwindles away that he knows exactly what is good and bad in every individual case. His *vis-à-vis*, the other person, is indeed "another," a profound stranger, if ever the discussion should penetrate to the core of the problem, namely, the unique individuality of the patient. What is then meant by "good"? Good for him? Good for me? Good for his relatives? Good for society? Our judgment becomes so hopelessly caught in a tangle of subsidiary considerations and relationships that, unless circumstances compel us to cut through the Gordian knot, we would do better to leave it alone, or content ourselves with offering the sufferer what modest help we can in unravelling the threads.

[1409] For these reasons it is particularly difficult for the medical psychologist to formulate any ethical principles. I do not mean that such a task does not exist, or that its solution is absolutely impossible. I fully recognize that there is an urgent need today to formulate the ethical problem anew, for, as the author aptly points out, an entirely new situation has arisen since modern psychology broadened its scope by the study of unconscious processes. Concurrently with this, things have happened in Europe, and still go on happening, that far surpass the horrors of imperial Rome or the French reign of terror; things that have ruthlessly revealed the weakness of our whole system of ethics.

[1410] Moral principles that seem clear and unequivocal from the standpoint of ego-consciousness lose their power of conviction, and hence their applicability, when we consider the *compensatory significance of the shadow* in the light of ethical responsibility. No man endowed with any ethical sense can avoid doing this. Only a man who is repressed or morally stupid will be able to neglect this task, though he

will not be able to get rid of the evil consequences of such behaviour. (In this respect the author utters some heartening truths.)

[1411] The tremendous revolution of values that has been brought about by the discovery of the unconscious, with repercussions still to come, is scarcely understood today or even noticed. The psychological foundation of all philosophical assertions, for example, is still assiduously overlooked or deliberately obscured, so much so that certain modern philosophies unconsciously lay themselves open to psychological attack. The same is true of ethics.

[1412] It is, understandably enough, the medical psychologist who is the first to be impressed by the shortcomings or evils of the epoch, for he is the first to have to deal with its casualties. The treatment of neurosis is not, in the last resort, a technical problem, but a moral one. There are, admittedly, interim solutions that are technical, but they never result in the kind of ethical attitude that could be described as a real cure. Although every act of conscious realization is at least a step forward on the road to individuation, to the “making whole” of the individual, the integration of the personality is unthinkable without the responsible, and that means moral, relation of the parts to one another, just as the constitution of a state is impossible without mutual relations between its members. The ethical problem thus poses itself, and it is primarily the task of the psychologist to provide an answer or to help his patient find one. Often this work is wearisome and difficult, because it cannot be accomplished by intellectual shortcuts or moral recipes, but only by careful observation of the inner and outer conditions. Patience and time are needed for the gradual crystallization of a goal and a direction for which the patient can take responsibility. The analyst learns that ethical problems are always intensely individual and can convince himself again and again that the collective rules of conduct offer at most provisional solutions, but never lead to those crucial decisions which are the turning-points in a man’s life. As the author rightly says: “The diversity and complexity of the situation make it impossible for us to lay down any theoretical rule of ethical behaviour.”

[1413] The formulation of ethical rules is not only difficult but actually impossible because one can hardly think of a single rule that would not have to be reversed under certain conditions. Even the simple proposition “Conscious realization is good” is only of limited validity, since we not infrequently meet with situations in which conscious realization would have the worst possible consequences. I have therefore made it a rule to take the “old ethic” as binding only so long as there is no evidence of its injurious effects. But if dangerous consequences threaten, one is then faced with a problem of the first order,² the solution of which challenges the personality to the limit and demands the maximum of attention, patience and time. The solution, in my experience, is always individual and is only subjectively valid. In such a situation, all those reflections which the author passes under review have to be

considered very seriously. Despite their subjective nature, they cannot very well be formulated except as collective concepts. But since these reflections constantly recur in practice—for the integration of unconscious contents continually poses such questions—it necessarily follows that, in spite of individual variation, they will exhibit certain regular features which make it seem possible to abstract a limited number of rules. I do not, myself, think that any of these rules are absolutely valid, for on occasion the opposite may be equally true. That is what makes the integration of the unconscious so difficult: we have to learn to think in antinomies, constantly bearing in mind that every ultimate truth turns into an antinomy if it is thought out to the end. All our statements about the unconscious are “eschatological” truths, that is, borderline concepts which formulate a partially apprehended fact or situation, and are therefore only conditionally valid.

[1414] The ethical problems that cannot be solved in the light of collective morality or the “old ethic” are *conflicts of duty*, otherwise they would not be ethical. Although I do not share Friedrich Theodor Vischer’s optimistic view that morality is always self-evident, I am nevertheless of the opinion that in working out a difficult problem the moral aspect of it has to be considered if one is to avoid a repression or a deception. He who deceives others deceives himself, and vice versa. Nothing is gained by that, least of all the integration of the shadow. Indeed, its integration makes the highest demands on an individual’s morality, for the “acceptance of evil” means nothing less than that his whole moral existence is put in question. Decisions of the most momentous kind are called for. The alchemical dictum “The art requires the whole man” is particularly true of the integration of the unconscious, and this process was in fact symbolically anticipated by the alchemists. It is evident, therefore, that the solution will be satisfactory only if it expresses the whole of the psyche. This is not possible unless the conscious mind takes account of the unconscious, unless desire is confronted with its possible consequences, and unless action is subjected to moral criticism.

[1415] Nor should it be forgotten that moral law is not just something imposed upon man from outside (for instance, by a crabbed grandfather). On the contrary, it expresses a psychic fact. As the regulator of action, it corresponds to a preformed image, a pattern of behaviour which is archetypical and deeply embedded in human nature. This has no fixed content; it represents the specific form which any number of different contents may take. For one person it is “good” to kill those who think differently from him; for another the supreme law is tolerance; for a third it is a sin to skin an animal with an iron knife; for a fourth it is disrespectful to step on the shadow of a chief. Fundamental to all these rules is “religious observation” or “careful consideration,” and this involves a moral effort which is indispensable for the development of consciousness. A saying of Jesus in the Codex Bezae (referring to

Luke 6: 4) expresses it in lapidary form: “Man, if thou knowest what thou doest, thou art blessed. But if thou knowest not, thou art accursed and a transgressor of the law.”

[1416] We might therefore define the “new ethic” as a development and differentiation within the old ethic, confined at present to those uncommon individuals who, driven by unavoidable conflicts of duty, endeavour to bring the conscious and the unconscious into responsible relationship.

[1417] In so far as ethics represent a system of moral demands, it follows that any innovations within or outside this system would also possess a “deontological” character. But the psychic situation to which the new admonition “you ought” would be applicable is so complicated, delicate and difficult that one wonders who would be in a position to make such a demand. Nor would it be needed at all since the ethically minded person who gets into a situation of this sort has already been confronted with this same demand, from within, and knows only too well that there is no collective morality that could extricate him from his dilemma. If the values of the old ethic were not seated in the very marrow of his bones, he would never have got into this situation in the first place. Let us take as an example the universally valid commandment: Thou shalt not lie. What is one to do if, as frequently happens to a doctor, one finds oneself in a situation where it would be a catastrophe to tell the truth or to suppress it? If one does not want to precipitate the catastrophe directly, one cannot avoid telling a convincing lie, prompted by psychological common sense, readiness to help, Christian charity, consideration for the fate of the other people concerned—in short, by ethical motives just as strong as if not stronger than those which compel one to tell the truth. One comforts oneself with the excuse that it was done in a good cause and was therefore moral. But anyone who has insight will know that on the one hand he was too cowardly to precipitate a catastrophe, and on the other hand that he has lied shamelessly. He has done evil but at the same time good. No one stands beyond good and evil, otherwise he would be out of this world. Life is a continual balancing of opposites, like every other energetic process. The abolition of opposites would be equivalent to death. Nietzsche escaped the collision of opposites by going into the madhouse. The yogi attains the state of *nirvandva* (freedom from opposites) in the rigid lotus position of non-conscious, non-acting *samadhi*. But the ordinary man stands between the opposites and knows that he can never abolish them. There is no good without evil, and no evil without good. The one conditions the other, but it does not become the other or abolish the other. If a man is endowed with an ethical sense and is convinced of the sanctity of ethical values, he is on the surest road to a conflict of duty. And although this looks desperately like a moral catastrophe, it alone makes possible a higher differentiation of ethics and a broadening of consciousness. A conflict of duty forces us to examine our conscience and thereby to discover the shadow. This, in turn, forces us to come to terms with the

unconscious. The ethical aspect of this process of integration is described with praiseworthy clarity by the author.

[1418] Those who are unfamiliar with the psychology of the unconscious will have some difficulty in envisaging the role which the unconscious plays in the analytical process. The unconscious is a living psychic entity which, it seems, is relatively autonomous, behaving as if it were a personality with intentions of its own. At any rate it would be quite wrong to think of the unconscious as mere “material,” or as a passive object to be used or exploited. Equally, its biological function is not just a mechanical one, in the sense that it is merely *complementary* to consciousness. It has far more the character of *compensation*, that is, an intelligent choice of means aiming not only at the restoration of the psychic equilibrium but at an advance towards wholeness. The reaction of the unconscious is far from being merely passive; it takes the initiative in a creative way, and sometimes its purposive activity predominates over its customary reactivity. As a partner in the process of conscious differentiation, it does not act as a mere opponent, for the revelation of its contents enriches consciousness and assists differentiation. A hostile opposition takes place only when consciousness obstinately clings to its one-sidedness and insists on its arbitrary standpoint, as always happens when there is a repression and, in consequence, a partial dissociation of consciousness.

[1419] Such being the behaviour of the unconscious, the process of coming to terms with it, in the ethical sense, acquires a special character. The process does not consist in dealing with a given “material,” but in negotiating with a psychic minority (or majority, as the case may be) that has equal rights. For this reason the author compares the relation to the unconscious with a parliamentary democracy, whereas the old ethic unconsciously imitates, or actually prefers, the procedure of an absolute monarchy or a tyrannical one-party system. Through the new ethic, the ego-consciousness is ousted from its central position in a psyche organized on the lines of a monarchy or totalitarian state, its place being taken by *wholeness* or the *self*, which is now recognized as central. The self was of course always at the centre, and always acted as the hidden director. Gnosticism long ago projected this state of affairs into the heavens, in the form of a metaphysical drama: ego-consciousness appearing as the vain demiurge, who fancies himself the sole creator of the world, and the self as the highest, unknowable God, whose emanation the demiurge is. The union of conscious and unconscious in the individuation process, the real core of the ethical problem, was projected in the form of a drama of redemption and, in some Gnostic systems, consisted in the demiurge’s discovery and recognition of the highest God.

[1420] This parallel may serve to indicate the magnitude of the problem we are concerned with, and to throw into relief the special character of the confrontation with the unconscious on an ethic plane. The problem is indeed a vital one. This may

explain why the question of a new ethic is of such serious and urgent concern to the author, who argues his case with a boldness and passion well matched by his penetrating insight and thoughtfulness. I welcome this book as the first notable attempt to formulate the ethical problems raised by the discovery of the unconscious and to make them a subject for discussion.

March 1949

FOREWORD TO BAYNES : “ANALYTICAL PSYCHOLOGY AND THE ENGLISH MIND”¹

[1421] I write these few introductory words to this collection of essays and lectures in affectionate memory of their author. The late H. G. Baynes was my assistant for several years, my travelling companion on our African expedition, and my faithful friend till his all too early death, which has left a painful gap in the circle of his friends and colleagues.

[1422] His first published work was his most excellent translation of my book *Psychological Types*.² Later he became well known as the author of two important works, *Mythology of the Soul*³ and *Germany Possessed*.⁴ The first of these deals with the daily reality of the psychotherapist, and the second with contemporary events.

[1423] In *Mythology of the Soul* the author uses raw material—such as the psychotherapist meets with daily in his consulting hours—as a clue to guide the reader through the maze of individual reflections, opinions, interpretations, and attempts at explanation which a psychologist gathers in the course of his experience. The empirical material stimulates such considerations, and they are also indispensable in order to integrate it in consciousness.

[1424] *Germany Possessed* is concerned with the great contemporary problems which form a direct challenge to the psychologically minded doctor. This book made the author known to a very wide public.

[1425] His shorter writings, which have been collected in this present volume, deal with the complex psychic conditions characteristic of medical psychology. Psychology is thus a discipline which obliges the medical psychologist to deal with complex psychic factors, for the psychotherapeutic process can only take place on this level. Therefore analytical psychology is also rightly called “complex psychology.”

[1426] A simplifying theory is naturally exceedingly popular in this highly complicated field, but the author has wisely resisted any such temptation. In its place he has drawn from a really remarkable wealth of theoretical and practical points of view and has opened up possibilities and connections worthy of further discussion.

[1427] H. G. Baynes left us too soon. May this volume, which he has left to us, become a milestone on the road of psychological research.

THE RULES OF LIFE¹

[1428] In reply to your kind enquiry about “rules of life,” I would like to remark that I have had so much to do with people that I have always endeavoured to live by no rules as far as possible. Non-observance of rules requires, of course, far less effort, for usually one makes a rule in order to repress the tendency in oneself not to follow it. In psychology, above all, rules are valid only when they can be reversed. Also, they are not without their dangers, since they consist of words and our civilization is largely founded on a superstitious belief in words. One of the supreme religious assumptions is actually the “Word.” Words can take the place of men and things. This has its advantages but it is also a menace. One can then spare oneself the trouble of thinking for oneself or making any effort, to one’s own advantage or disadvantage and that of one’s fellows.

[1429] I have, for instance, a tendency to make a principle of doing what I want to do or should do as soon as possible. This can be very unwise and even stupid. The same applies to practically all adages and “rules of life.” Take, for example, the saying, “Quid-*quid id est, prudenter agas et respice finem*” (Whatever it be, act prudently and consider the end). But in this way, however praiseworthy the principle is, you can let a vitally important decision of the moment slip through your fingers.

[1430] No rules can cope with the paradoxes of life. Moral law, like natural law, represents only one aspect of reality. It does not prevent one from following certain “regular” habits *unconsciously*—habits which one does not notice oneself but can only discover by making-careful inquiries among one’s fellows. But people seldom enjoy having what they don’t know about themselves pointed out to them by others, and so they prefer to lay down rules which are the exact opposite of what they are doing in reality.

ON FLYING SAUCERS¹

[1431] Your wish to bring up the “Flying Saucers” for discussion is certainly a timely one. But though you may not have overshot the mark in questioning me, I must tell you that in spite of the interest I have taken in the subject since about 1946, I have still not been able to establish an empirical basis sufficient to permit any conclusions to be drawn. In the course of years I have accumulated a voluminous dossier on the sightings, including the statements of two eyewitnesses well-known to me personally (I myself have never seen anything!) and have read all the available books, but I have found it impossible to determine even approximately the nature of these observations. So far only one thing is certain: it is not just a rumour, *something is seen*. What is seen may in individual cases be a subjective vision (or hallucination), or, in the case of several observers seeing it simultaneously, a collective one. A psychic phenomenon of this kind would, like a rumour, have a compensatory significance, since it would be a spontaneous answer of the unconscious to the present conscious situation, i.e., to fears created by an apparently insoluble political situation which might at any moment lead to a universal catastrophe. At such times men’s eyes turn to heaven for help, and marvellous signs appear from on high, of a threatening or reassuring nature. (The “round” symbols are particularly suggestive, appearing nowadays in many spontaneous fantasies directly associated with the threatening world situation.)

[1432] The possibility of a purely psychological explanation is illusory, for a large number of observations point to a natural phenomenon, or even a physical one—for instance, those explicable by reflections from “temperature inversions” in the atmosphere. Despite its contradictory statements, the American Air Force, as well as the Canadian, consider the sightings to be “real,” and have set up special bureaux to collect the reports. The “disks,” however, that is, the objects themselves, do not behave in accordance with physical laws but as though they were weightless, and they show signs of *intelligent guidance* such as would suggest quasi-human pilots. Yet the accelerations are so tremendous that no human being could survive them.

[1433] The view that the disks are real is so widespread (in America) that reports of landings were not long in coming. Recently I read accounts of this kind from two different sources. In both of them the mystical element in the vision or fantasy was very much in evidence: they described half-human, idealized human beings like angels who delivered the appropriate edifying messages.² Unfortunately, there is a total lack of any useful information. And in both cases the photographs failed to

come out. Reports of landings, therefore, must for the time being be taken with considerable caution.

[1434] What astonishes me most of all is that the American Air Force, despite all the information it must possess, and despite its alleged fear of creating a panic similar to the one which broke out in New Jersey on the occasion of Welles's radio play,³ is systematically working towards that very thing by refusing to release an authentic and reliable account of the facts.⁴ All we have to go on is the occasional information squeezed out by journalists. It is therefore impossible for the uninitiated to form an adequate picture of what is happening. Although for eight years I have been collecting everything that came within my reach, I must admit I am no further forward today than I was at the beginning. I still do not know what we are up against with these "flying saucers." The reports are so weird that, granted the reality of these phenomena, one feels tempted to compare them with parapsychological happenings.

[1435] Because we lack any sure foundation, all speculation is worthless. We must wait and see what the future brings. So-called "scientific" explanations, such as Menzel's reflection theory, are possible only if all the reports that fail to fit the theory are conveniently overlooked.

[1436] That is all I have to say on the subject of Flying Saucers. An interview would therefore not be worthwhile.

[Supplementary Questions Addressed to Jung by Letter]

Supposing it should turn out that we are being spied upon by non-human, intelligent beings, do you think that this could be assimilated into the existing world-picture without harmful results? Or do you think it would necessarily lead to a kind of Copernican revolution, and that consequently the panic you fear would be a legitimate counteraction?

Further, should the responsible authorities take steps to prevent a panic, and what psychohygienic measures seem suitable to you for this purpose?

[1437] These questions are entirely legitimate today, since there are responsible persons—better informed than I—who are of the opinion that the phenomena we are discussing are of extraterrestrial origin. As I have said, I cannot, or cannot yet, share this view, because I have not been able to obtain the necessary confirmation. If these "objects" are, as claimed, of extraterrestrial or possibly planetary origin (Mars, Venus), we still have to consider the reports of Saucers rising out of the sea or the earth. We must also take account of numerous reports of phenomena resembling ball lightning, or strange, stationary will-o'-the-wisps (not to be confused with St. Elmo's fire). In rare cases ball lightning can attain considerable dimensions, appearing as a dazzling ball of light, half as big as the moon, moving slowly from cloud to cloud, or

ripping a path about five yards wide and 200 yards long through a forest, smashing all the trees in its way. It is either soundless, like the Saucers, or it can vanish with a clap of thunder. It is possible that ball lightning in the form of isolated charges of electricity (so-called “bead-lightning”) is the origin of those Saucers arranged in a row which have been photographed on several occasions. Other electrical phenomena have frequently been reported in connection with the Saucers.

[1438] If, despite this still unclarified possibility, the extraterrestrial origin of the Saucers should be confirmed, this would prove the existence of intelligent interplanetary communication. What such a fact might mean for humanity cannot be imagined. But there is no doubt we would find ourselves in the same critical situation as primitive societies confronted with the superior culture of the white man. The reins of power would be wrenched from our hands, and, as an old witch doctor once told me with tears in his eyes, we would have “no dreams any more”—the lofty flights of our spirit would have been checked and crippled forever.

[1439] Naturally, the first thing to be consigned to the rubbish heap would be our science and technology. What the moral effects of such a catastrophe would be can be seen from the pitiful decay of primitive cultures taking place before our eyes. That the construction of such machines would be evidence of a scientific technology immensely superior to ours admits of no two opinions. Just as the Pax Britannica put an end to tribal warfare in Africa, so our world could roll up its Iron Curtain and use it as so much scrap along with all the billions of tons of armaments, warships, and munitions. That wouldn't be such a bad thing, but we would have been “discovered” and colonized—reason enough for universal panic!

[1440] If we wish to avoid such a catastrophe, the officials in possession of authoritative information should not hesitate to enlighten the public as speedily and thoroughly as possible, and above all stop this stupid game of mystification and suggestive allusion. Instead, they have allowed a lot of fantastic and mendacious publicity to run riot—the best possible preparation for panic and psychic epidemics.

[Further Supplementary Questions]

The idea of a possible parallel with parapsychological processes is extremely interesting. Presumably you are thinking of apparitions?

You write that in times like these men's eyes turn to heaven for help. Are you thinking of some period of upheaval in the past, which produced comparable phenomena? Is there evidence of other collective visions or hallucinations with a similar content?

How do you explain the fact that with few exceptions Saucers have so far been observed only over the North American continent? Does this, in your view, suggest

that they are more likely to be psychic—specifically American “apparitions,” as it were—or, on the contrary, that they are of an objective nature?

[1441] It is hardly possible to answer your question about the analogy of the Saucers with parapsychological phenomena, since a basis for comparison is totally lacking. If we wished to take such a possibility seriously, it would first have to be shown that the “apparitions” are causally connected with psychic states; in other words, that under the influence of certain emotional conditions a major population group experiences the same psychic dissociation and the same exteriorization of psychic energy as does a single medium. All we know at present is that collective visions do exist. But whether collective *physical* phenomena, such as levitations, apparitions of light, materializations, etc., can also be produced is a moot question. At present any reference to the parapsychological aspect only demonstrates the boundless perplexity in which we find ourselves today.

[1442] I cannot refrain from remarking, however, that the whole collective psychological problem that has been opened up by the Saucer epidemic stands in compensatory antithesis to our scientific picture of the world. In the United States this picture has if possible an even greater dominance than with us. It consists, as you know, very largely of statistical or “average” truths. These exclude all rare borderline cases, which scientists fight shy of anyway because they cannot understand them. The consequence is a view of the world composed entirely of normal cases. Like the “normal” man, they are essentially *fictions*, and particularly in psychology fictions can lead to disastrous errors. Since it can be said with a little exaggeration that reality consists mainly of exceptions to the rule, which the intellect then reduces to the norm, instead of a brightly coloured picture of the real world we have a bleak, shallow rationalism that offers stones instead of bread to the emotional and spiritual hungers of the world. The logical result is an insatiable hunger for anything extraordinary. If we add to this the great defeat of human reason, daily demonstrated in the newspapers and rendered even more menacing by the incalculable dangers of the hydrogen bomb, the picture that unfolds before us is one of universal spiritual distress, comparable to the situation at the beginning of our era or to chaos that followed A.D. 1000, or the upheavals at the turn of the fifteenth century. It is therefore not surprising if, as the old chroniclers report, all sorts of signs and wonders appear in the sky, or if miraculous intervention, where human efforts have failed, is expected from heaven. Our Saucer sightings can be found—*mutatis mutandis*—in many reports that go back to antiquity, though not, it would seem, with the same overwhelming frequency. But then, the possibility of destruction on a global scale, which has been given into the hands of our so-called politicians, did not exist in those days.

[1443] McCarthyism and the influence it has exerted are evidence of the deep and anxious apprehensions of the American public. Therefore most of the signs in the skies will be seen in North America.

[1444] At the beginning of this century I was firmly convinced that nothing heavier than air could fly and that the atom was really “a-tomic” (indivisible). Since then I have become very cautious and will only repeat what I said at the beginning of our correspondence: Despite a fairly thorough knowledge of the available literature (six books and countless reports and articles, including two eyewitness reports), I still do not know what kind of reality the Flying Saucers may have. So I am not in a position to draw conclusions and to form any reliable judgment. I just don’t know what one should make of this phenomenon.

*Statement to the United Press International*⁵

[1445] As a result of an article published in the *APRO Bulletin*, the report has been spread by the press that in my opinion the Ufos are physically real. This report is altogether false. In a recently published book (*Ein Moderner Mythos*, Zurich, 1958),⁶ I expressly state that I cannot commit myself on the question to the physical reality or unreality of the Ufos since I do not possess sufficient evidence either for or against. I therefore concern myself solely with the psychological aspect of the phenomenon, about which a great deal of material is available. I have formulated the position I take on the question of the reality of Ufos in the following sentence: “Something is seen, but it isn’t known what.” This formulation leaves the question of “seeing” open. Something material could be seen, or something psychic could be seen. Both are realities, but of different kinds.

[1446] My relations with APRO are confined to the following: while I was collecting material for the above-mentioned book, the *APRO Bulletin* approached me in a friendly manner. When this organization recently asked me if they might consider me to be an honorary member, I consented. I have sent my book to APRO to inform them of my position in regard to the Ufo question. APRO advocates the physical reality of the Ufo with much zeal and idealism. I therefore regard its misleading article as a regrettable accident.

*Letter to Keyhoe*⁷

16 August 1958

Major Donald E. Keyhoe
National Investigation Committee on Aerial Phenomena
1536 Connecticut Avenue

Washington 6, D. C.

Dear Major Keyhoe,

[1447] Thank you very much for your kind letter! I have read all you have written concerning Ufos and I am a subscriber to the *NICAP Bulletin*. I am grateful for all the courageous things you have done in elucidating the thorny problem of Ufo-reality.

[1448] The article in *APRO Bulletin* July 1958, which caused all that stir in the press, is unfortunately inaccurate. As you know I am an alienist and medical psychologist. I have never seen a Ufo and I have no first-hand information either about them or about the dubious attitude of the AAF [American Air Force]. On account of this regrettable lack I am unable to form a definite opinion concerning the physical nature of the Ufo-phenomenon. As I am a scientist, I only say what I can prove and reserve my judgment in any case where I doubt my competence. Thus I said: "Things are seen, but one does not know what." I neither affirm, nor deny. But it is certain beyond all possible doubt that plenty of statements about Ufos are made and they are of all sorts. I am chiefly concerned with this aspect of the phenomenon. It yields a rich harvest of insight into its universal significance. My special preoccupation precludes neither the physical reality of the Ufos nor their extraterrestrial origin, nor the purposefulness of their behaviour, etc. But I do not possess sufficient evidence which would enable me to draw definite conclusions. The evidence available to me however is convincing enough to arouse a continuous and fervent interest. I follow with my greatest sympathy your exploits and your endeavours to establish the truth about the Ufos.

[1449] In spite of the fact that I hold my judgment concerning the nature of the Ufos—temporarily let us hope—in abeyance, I thought it worth while to throw a light upon the rich fantasy material which has accumulated round the peculiar observations in the skies. Any new experience has two aspects: (1) the pure fact and (2) the way one conceives of it. It is the latter I am concerned with. If it is true that the AAF or the Government withholds telltale facts, then one can only say that this is the most unpsychological and stupid policy one could invent. Nothing helps rumours and panics more than ignorance. It is self-evident that the public ought to be told the truth, because ultimately it will nevertheless come to the light of day. There can be hardly any greater shock than the H-bomb and yet everyone knows of it without fainting.

[1450] As to your question about the possible hostility of the Ufos, I must emphasize that I have no other knowledge about them than that which everybody can get out of printed reports. That is the reason why I am still far from certain about the Ufos' physical reality.

[1451] Thank you for your kind offer to send me clippings. I have got enough of them.
It is a curious fact that whenever I make a statement it is at once twisted and falsified.
The press seems to enjoy lies more than the truth.

I remain, dear Major,

Yours, C. G. JUNG

HUMAN NATURE DOES NOT YIELD EASILY TO IDEALISTIC ADVICE¹

[1452] There is little to criticize in Mr. Roberts' article since its author is obviously a man of good will and optimistic enthusiasm. Moreover, he points in the right direction, and he gives proper value to man's mental and moral attitude. He hopes and believes, it seems to me, that saying the right and good thing will be enough to produce the desired effect. Unfortunately, human nature is a bit more complicated and does not yield to a well-meaning hint or to idealistic advice.

[1453] It always has been and still is the great question how to get the ordinary human to the point where he can make up his mind to draw the right conclusion and to do the right thing, or how to make him listen at all. His moral and mental inertia and his notorious prejudices are the most serious obstacle to any moral or spiritual renaissance. If he had been inclined to resist the overwhelming impact of his emotional entanglements, passions, and desires, and to put a stop to the haste and rush of his daily activities, and to try at least to get out of his lamentable yet cherished unconsciousness about himself, the world and its sad history of intrigue, violence, and cruelty would have reached a state of peace and humanity long before Christ—in the time of Buddha or Socrates. But to get him there, that's just the trouble.

[1454] It is perhaps a good idea to liberate man from all inhibitions and prejudices that hamper, torment, and disfigure him. But the question is less to liberate from something, than rather, as Nietzsche asked, to which end? In certain cases it looks as if in getting rid of one's inhibitions and burdens, one had "thrown away one's best." Liberation can be a good or a very bad solution. It largely depends upon the choice of one's further goal whether the liberation has been a boon or a fatal mistake.

[1455] I don't want to go further into the complexities of this problem, and moreover it would be unfair to criticize the author for something he obviously is not aware of, viz., the fact that this formulation of the problem dates from about forty years ago. Since that time, a voluminous literature thoroughly dealing with the point in question has come into existence. I don't know which circumstances have prevented the author from informing himself about the more modern developments in the discussion between religion and psychology. In view of Freud's notorious inability to understand religion, the reader would have welcomed, if not expected, a summary at least of the main work done along this line during the past four decades. Goodwill and enthusiasm are not to be underrated, but ignorance is regrettable.

ON THE HUNGARIAN UPRISING¹

I

[1456] 1. The bloody suppression of the Hungarian people by the Russian army is a vile and abominable crime, to be condemned forthwith.

2. The Egyptian dictator has by unlawful measures provoked Great Britain and France to a warlike act. This is to be deplored as a relapse into obsolete and barbarous methods of politics.

II

[1457] The crushing of Hungary is one more link in the chain of iniquitous events which make the middle of the twentieth century one of the blackest chapters in history, rich in infamies as it is. Western Europe had to endure the spectacle of a civilized European country being throttled and, conscious of its own miserable impotence, be content to play the Good Samaritan. Though the great storm of indignation unleashed by outraged public feeling was unable to blow away the Russian tanks, it at least brought with it the relief everyone feels when guilt can be laid beyond all doubt at somebody else's door. In the worldwide moral outcry we scarcely heard the voice of our own conscience, reminding the West of those wicked deeds of Machiavellianism, short-sightedness, and stupidity without which the events in Hungary would not have been possible. The focus of the deadly disease lies in Europe.

ON PSYCHODIAGNOSTICS¹

Can one, with today's psychodiagnostic methods, determine the suitability of a candidate for a job, in a matter of hours or days, more efficiently than the employer could with the help of his general knowledge of human nature?

[1458] The employer may have a very good knowledge of human nature, able to size up the total situation intuitively in a few seconds. Naturally you can't acquire a knack like this from any method. There are, however, employers who are anything but good judges of men. In this case a careful and conscientious psychodiagnosis is the only right thing. Anyway, it is better than nothing, and certainly better than the employer's illusions and projections.

Are we right to oppose the use of psychodiagnostics in the selection of candidates, or is it simply another futile attempt to turn back the wheel of history?

[1459] It would be plain stupid to oppose the use of psychodiagnostics, for these tests are so widely used today that nobody can fight against them. By refusing them one puts oneself in a false position from the start, as in certain cases of refusal to testify in court. But if you are faced with a good judge of men, he will extract your painful secrets from your trouser pocket with the greatest skill without your knowing it, and do it much better than was ever done by a psychodiagnostic method.

We would like to ask you for a short prognosis concerning the further development of these methods and their influence on society.

[1460] I am no prophet, and I cannot predict the future of our society. I can only tell you that I hope for a further improvement in psychodiagnostic methods and in the understanding of man in general, as contrasted with the other possibility that any man may be pushed into any kind of job anywhere. Anything that promotes the understanding of one's fellow men is welcome to me.

IF CHRIST WALKED THE EARTH TODAY¹

[1461] It is absolutely certain that if a Christ should reappear in the world he would be interviewed and photographed by the press and would not live longer than one month. He would die being fed up with himself, as he would see himself banalized beyond all endurance. He would be killed by his own success, morally and physically.

FOREWORD TO "HUGH CRICHTON-MILLER, 1877-1959"¹

[1462] It is more than thirty years ago—on the occasion of a short stay in England—that I became acquainted with Dr. Hugh Crichton-Miller. Being a stranger and, on account of my unorthodox views, a psychiatric outsider, I was deeply impressed by the friendly, open, and unprejudiced manner of his welcome. Not only did he introduce me to the staff of his clinic, he also invited me to give them a short address—much to my embarrassment, since I never felt particularly certain of myself when called upon to talk to an entirely unknown audience. But I soon felt the presence of an atmosphere of mutual trust and confidence between chief and staff, so that I could talk to them in a more or less natural way—at least I hope so. Talking to Crichton-Miller was easy. I felt we were speaking the same language, though our views were not always the same. But they were reasonably different, so that a satisfactory discussion was possible. Whenever I had a chance in the course of many years, I very much enjoyed discussing controversial points with him. He was for I don't know how many years the only man of my age with whom I could talk as man to man, without constantly fearing that my partner would suddenly throw a fit or become otherwise impolite. We took each other at our face value and in the course of years we grew slowly into the conviction that we had a good relationship. Such a silent conviction can be, in spite of everything, an illusion as long as it has not come to an actual showdown. The proof of this came in the last years before the second World War.

[1463] We then had an international Society for Psychotherapy on the continent consisting of a Dutch, Danish, Swiss, and a very large German group. The president of the Society had been Professor Kretschmer up to 1933, when he resigned in the fatal year of Hitler's usurpation of power. I had been up to then in the inactive role of an honorary vice-president. The German group, afraid of getting amalgamated with, i.e., overshadowed by, the far more influential "Society for Psychiatry" with its well-known anti-psychological prejudice, asked me to take over the function of president, just because I was non-German and would therefore emphasize the international character of the organization. They hoped in that way to escape complete annihilation, even if they had to survive in a society of herb addicts and believers in "natural healing." I knew it would be a very difficult task if I were to accept this proposition. But having been vice-president for a number of years, I did not consider it particularly honourable conduct to get cold feet, and so I stepped in.

[1464] The first task confronting me was to increase the non-German membership in order to form an adequate counterweight. We added a Swedish group, and I opened

negotiations with French representatives, but I looked most toward England and America. The first person I approached was Crichton-Miller, and I did not find him wanting. He understood the situation and my motives. The Germans became more and more difficult and tried to overwhelm us with a large Italian and even a Japanese membership. Since nothing was known of modern medical psychology in either of those countries, the long lists of new members were composed by order and consisted of people who were absolutely innocent of the slightest professional knowledge of modern psychotherapy. Shortly before the outbreak of the war, it came to a decisive showdown with the Germans in Zurich. Being the British representative, Crichton-Miller lent me personally his invaluable help to ward off the German intrigue. I am forever grateful to him for his sturdy co-operation and his truly loyal friendship. That was the man I shall never forget.

[1465] During the war we naturally saw nothing of each other, and it was only afterwards that I received the shocking news of his fatal disease. I wanted very much to see him again but was overburdened with urgent work and hampered by the consequences of an injury to my heart. I found no occasion to go to England. Fortunately enough, in 1949 he could manage to come out to Switzerland, to the Bernese Oberland, where I went to meet him and his wife. I found him in an advanced stage of his illness. As he had expressed the urgent wish to talk to me, I was eager to hear from him what it was. After lunch we withdrew. He took out a sheet of paper with a closely written text. As our talks hitherto had never been intimate or personal, I was surprised when he plunged straight *in medias res* and asked me to answer a number of questions on religion. It was a complete survey of the *religio medici*, of all the religious conclusions an old doctor might draw from his innumerable experiences of suffering and death and from the inexorable reality of life's reverses. I knew we were talking *in conspectu mortis* of ultimate things, at the end of days. Then we took leave of each other, shook hands amiably and politely, as if after a delightful lunch with a distant yet friendly acquaintance. *Vale amice!*

January 1960

XII

PSYCHOLOGY AND RELIGION

(related to Volume II of the Collected Works)

WHY I AM NOT A CATHOLIC¹

[1466] *Firstly:* Because I am a practical Christian to whom love and justice to his brother mean more than dogmatic speculations about whose ultimate truth or untruth no human being can ever have certain knowledge. The relation to my brother and the unity of the true “catholic” Christendom is to me infinitely more important than “justification by *fide sola*.” As a Christian I have to share the burden of my brother’s wrongness, and that is most heavy when I do not know whether in the end he is not more right than I. I hold it to be immoral, in any case entirely unchristian, to put my brother in the wrong (i.e., to call him fool, ass, spiteful, obdurate, etc.) simply because I suppose myself to be in possession of the absolute truth. Every totalitarian claim gradually isolates itself because it excludes so many people as “defectors, lost, fallen, apostate, heretic,” and so forth. The totalitarian maneuvers himself into a corner, no matter how large his original following. I hold all confessionalism to be completely unchristian.

[1467] *Secondly:* Because I am a doctor. If I possessed the absolute truth I could do nothing further than to press into my patient’s hand a book of devotion or confessional guidance, just what is no longer of any help to him. When, on the other hand, I discover in his untruth a truth, in his confusion an order, in his lostness something that has been found, then I have helped him. This requires an incomparably greater self-abnegation and self-surrender for my brother’s sake than if I assessed, correctly from the standpoint of one confession, the motivations of another.

[1468] You underestimate the immense number of those of goodwill, but to whom confessionalism blocks the doors. A Christian has to concern himself, especially if he is a physician of souls, with the spirituality of the reputedly unspiritual (spirit = confessionalism!) and he can do this only if he speaks their language and certainly not if, in the deterrent way of confessionalism, he sounds the kerygmatic trumpet, hoarse with age. Whoever talks in today’s world of an absolute and single truth is speaking in an obsolete dialect and not in any way in the language of mankind. Christianity possesses a *εὐαγγέλιον*, good tidings from God, but no textbook of a dogma with claim to totality. Therefore it is hard to understand why God should never have sent more than one message. Christian modesty in any case strictly forbids assuming that God did not send *εὐαγγέλια* in other languages, not just in Greek, to other nations. If we think otherwise our thinking is in the deepest sense unchristian. The Christian—my idea of Christian—knows no curse formulas; indeed

he does not even sanction the curse put on the innocent fig-tree by the rabbi Jesus, nor does he lend his ear to the missionary Paul of Tarsus when he forbids cursing to the Christian and then he himself curses the next moment.

[1469] *Thirdly:* Because I am a man of science.

[1470] The Catholic doctrine, as you present it to me so splendidly, is familiar to me to that extent. I am convinced of its “truth” in so far as it formulates determinable psychological facts, and thus far I accept this truth without further ado. But where I lack such empirical psychological foundations it does not help me in the least to believe in anything beyond them, for that would not compensate for my missing knowledge; nor could I ever surrender to the self-delusion of knowing something where I merely believe. I am now nearly seventy years old, but the charisma of belief has never arisen in me. Perhaps I am too overweening, too conceited; perhaps you are right in thinking that the cosmos circles around the God Jung. But in any case I have never succeeded in thinking that what I believe, feel, think, and understand is the only and final truth and that I enjoy the unspeakable privilege of God-likeness by being the possessor of the sole truth. You see that, although I can estimate the charisma of faith and its blessedness, the acceptance of “faith” is impossible for me because it says nothing to me.

[1471] You will naturally remonstrate that, after all, I talk about “God.” I do this with the same right as humanity has from the beginning equated the numinous effects of certain psychological facts with an unknown primal cause called God. This cause is beyond my understanding, and therefore I can say nothing further about it except that I am convinced of the existence of such a cause, and indeed with the same logic by which one may conclude from the disturbance of a planet’s course the existence of a yet unknown heavenly body. To be sure, I do not believe in the absolute validity of the law of causality, which is why I guard against “positing” God as cause, for by this I would have given him a precise definition.

[1472] Such restraint is surely an offense to confessors of the Faith. But according to the fundamental Christian commandment I must not only bear with and understand my schismatic Protestant brother, but also my brothers in Arabia and India. They, too, have received strange but no less notable tidings which it is my obligation to understand. As a European, I am burdened most heavily by my unexpectedly dark brother, who confronts me with his antichristian Neo-Paganism. This extends far beyond the borders of Germany as the most pernicious schism that has ever beset Christianity. And though I deny it a thousand times, *it is also in me*. One cannot come to terms with this conflict by imputing wrong to someone else and the undoubted right to oneself. This conflict I can solve first of all only within myself and not in another.

THE DEFINITION OF DEMONISM¹

[1473] Demonism (synonymous with daemonomania = possession) denotes a peculiar state of mind characterized by the fact that certain psychic contents, the so-called complexes, take over the control of the total personality in place of the ego, at least temporarily, to such a degree that the free will of the ego is suspended. In certain of these states ego-consciousness is present, in others it is eclipsed. Demonism is a primordial psychic phenomenon and frequently occurs under primitive conditions. (Good descriptions in the New Testament, Luke 4:34, Mark 1:23, 5:2, etc.) The phenomenon of demonism is not always spontaneous, but can also be deliberately induced as a “trance,” for instance in shamanism, spiritualism, etc. (Cf. J. Hastings, *Encyclopaedia of Religion and Ethics*; Schürer. “Zur Vorstellung von der Besessenheit im Neuen Testament,” *Jahrbuch für protestantische Theologie*, 1892.)

[1474] Medically, demonism belongs partly to the sphere of the psychogenic neuroses, partly to that of schizophrenia. Demonism can also be epidemic. One of the most celebrated epidemics of the Middle Ages was the possession of the Ursulines of London, 1632. The epidemic form includes the induced collective psychoses of a religious or political nature, such as those of the twentieth century. (Cf. G. le Bon, *The Crowd, a Study of the Popular Mind*, 1896; Otto Stoll, *Suggestion und Hypnotismus in der Völkerpsychologie*, 2nd edn., 1904.)

FOREWORD TO JUNG: "SYMBOLIK DES GEISTES" (1948)

[1475] The present volume, the sixth of the *Psychologische Abhandlungen*, contains five essays which are concerned with the symbolism of the spirit: a study of Satan in the Old Testament by Dr. Riwkah Schärf,¹ and four essays from my pen. The first essay in the book, "The Phenomenology of the Spirit in Fairytales,"² gives an account of the "spirit archetype," or rather, of a dream and fairytale motif whose behaviour is such that one has to conceive of it as "spirit." Examples are also given of the dramatic entanglements to which the appearance of this motif leads. The second essay describes how, in the medieval natural philosophy of the alchemists, the primitive "nature-spirit" developed into the "Spirit Mercurius."³ As the original texts show, a spirit-figure came into being that was directly opposed to the Christian view of the spirit. The third contribution, by Dr. Schärf, describes the historical development of the ungodly spirit, Satan, as depicted in the texts of the Old Testament. The fourth essay, "A Psychological Approach to the Dogma of the Trinity,"⁴ gives a brief sketch of the historical development of the trinitarian concept before and after Christ, followed by a synopsis of psychological viewpoints that need to be taken into account for a rational comprehension of the idea of the Trinity. It goes without saying that in any such discussion, metaphysical views cannot be considered, because, within the confines of a scientific psychology and its tasks, an idea characterized as "metaphysical" can claim the significance only of a psychic phenomenon. Equally the psychologist does not presume to say anything "metaphysical," i.e., transcending his proper province, about his subject-matter—that lies outside his competence. In so far—and only so far—as the Trinity is not merely an object of belief but, over and above that, a human concept falling within the purview of psychology, can it be subjected to scientific observation. This does not affect the object of belief in any way. The reader will do well to keep this limitation of the theme constantly in mind.

[1476] The final contribution⁵ is a description and analysis of a Chinese, but originally Indian, text which describes a way of meditation for the attainment of Buddhahood. I have added this essay for the purpose of rounding out the picture for my reader, showing him an Eastern aspect of it.

[1477] It now remains for me to correct an error. In my book *The Psychology of the Transference*⁶ I promised to publish my new work, *Mysterium Coniunctionis*,⁷ as volume 6 of the "Psychologische Abhandlungen." Owing to illness and other causes I

had to alter plans and am therefore publishing *Symbolik des Geistes* in its stead. The above-mentioned work will not go to press until later.

June 1947

FOREWORD TO QUIPEL: "TRAGIC CHRISTIANITY"¹

[1478] The author of this essay has asked me to start off his book with a few introductory words. Although I am not a philologist, I gladly accede to this request because Dr. Quispel has devoted particular attention to a field of work which is familiar also to me from the psychological standpoint. Gnosticism is still an obscure affair and in need of explanation, despite the fact that sundry personages have already approached it from the most diverse angles and tried their hands at explanations with doubtful success. One even has the impression that the ban on heresy still hangs over this wide domain, or at least the disparagement which specialists are accustomed to feel for annoying incomprehensibilities. We have an equivalent of this situation in psychiatry, which has ostentatiously neglected the psychology of the psychoses and shows pronounced resistances to all attempts in this direction. This fact, though astonishing in itself, is, however, comprehensible when one considers the difficulties to be overcome once one tries to fathom the psychology of delusional ideas. We can understand mental illness only if we have some understanding of the mind in general. Delusional ideas cannot be explained in terms of themselves, but only in terms of our knowledge of the normal mind. Here the only phenomenological method that promises success, as opposed to philosophical and religious prejudice, has made next to no headway, indeed it has still not even been understood. The fundamental reason for this is that the doctor, to whom alone psychopathological experiences are accessible, seldom or never has the necessary epistemological premises at his command. Instead of which, if he reflects at all and does not merely observe and register, he has usually succumbed to a philosophical or religious conviction and fills out the gaps in his knowledge with professions of faith.

[1479] What is true of psychopathology can—*mutatis mutandis*—be applied directly to the treatment which Gnosticism has undergone. Its peculiar mental products demand the same psychological understanding as do psychotic delusional formations. But the philologist or theologian who concerns himself with Gnosticism generally possesses not a shred of psychiatric knowledge, which must always be called upon in explaining extraordinary mental phenomena. The explanation of Gnostic ideas “in terms of themselves,” i.e., in terms of their historical foundations, is futile, for in that way they are reduced only to their less developed forestages but not understood in their actual significance.

[1480] We find a similar state of affairs in the psychopathology of the neuroses, where, for instance, Freud's psychoanalysis reduces the neurotic symptomatology only to its

infantile forestages and completely overlooks its functional, that is, its *symbolic* value. So long as we know only the causality or the historical development of a normal biological or psychic phenomenon, but not its functional development, i.e., its purposive significance, it is not really understood. The same is true of Gnostic ideas: they are not mere symptoms of a certain historical development, but creative new configurations which were of the utmost significance for the further development of Western consciousness. One has only to think of the Jewish-Gnostic presuppositions in Paul's writings and of the immense influence of the "gnostic" gospel of John. Apart also from these important witnesses, and in spite of being persecuted, branded as heresy, and pronounced dead within the realm of the Church, Gnosticism did not die out at once by any means. Its philosophical and psychological aspects went on developing in alchemy up to the time of Goethe, and the Jewish syncretism of the age of Philo² found its continuation within orthodox Judaism in the Kabbala. Both these trends, if not exactly forestages of the modern psychology of the unconscious, are at all events well-nigh inexhaustible sources of knowledge for the psychologist. This is no accident inasmuch as parallel phenomena to the empirically established contents of the collective unconscious underlie the earliest Gnostic systems. The archetypal motifs of the unconscious are the psychic source of Gnostic ideas, of delusional ideas (especially of the paranoid schizophrenic forms), of symbol-formation in dreams, and of active imagination in the course of an analytical treatment of neurosis.

[1481] In the light of these reflections, I regret Dr. Quispel's quotations from the Gnostics, that the "Autopator contained in himself all things, in [a state of] unconsciousness (*ἐν ἀγνώσῃα*)"³ and that "The Father was devoid of consciousness (*ἀνευνόητος*),"⁴ as a fundamental discovery for the psychology of Gnosticism. It means nothing less than that the Gnostics in question derived the knowable *ὑπερκόσμος* from the unconscious, i.e., that these represented unconscious contents. This discovery results not only in the possibility but also in the necessity of supplementing the historical method of explanation by one that is based on a scientific psychology.

[1482] Psychology is indebted to the author for his endeavours to facilitate the understanding of Gnosticism, not merely because we psychologists have made it our task to explain Gnosticism, but because we see in it a *tertium comparationis* which affords us the most valuable help in the practical understanding of modern individual symbol-formation.

May 1949

FOREWORD TO ABEGG: "OSTASIEN DENKT ANDERS"¹

[1483] The author of this book, the entire text of which unfortunately I have not seen, has talked to me about her project and about her ideas with regard to the difference between Eastern and Western psychology. Thus I was able to note many points of agreement between us, and also a competence on her part to make judgments which is possible only to one who is a European and at the same time possesses the invaluable advantage of having spent more than half a lifetime in the Far East, in close contact with the mind of Asia. Without such first-hand experience it would be a hopeless task to approach the problem of Eastern psychology. One must be deeply and directly moved by the strangeness, one might almost say by the incomprehensibility, of the Eastern psyche. Decisive experiences of this kind cannot be transmitted through books; they come only from living in immediate, daily relationship with the people. Having had unusual advantages in this respect, the author is in a position to discuss what is perhaps the basic, and is in any case an extremely important, question of the difference between Eastern and Western psychology. I have often found myself in situations where I had to take account of this difference, as in the study of Chinese and East Indian literary texts and in the psychological treatment of Asiatics. Among my patients, I am sorry to say, I have never had a Chinese or a Japanese, nor have I had the privilege of visiting either China or Japan. But at least I have had the opportunity to experience with painful clarity the insufficiency of my knowledge. In this field we still have everything to learn, and whatever we learn will be to our immense advantage. Knowledge of Eastern psychology provides the indispensable basis for a critique of Western psychology, as indeed for any objective understanding of it. And in view of the truly lamentable psychic situation of the West, the importance of a deeper understanding of our Occidental prejudices can hardly be overestimated.

[1484] Long experience with the products of the unconscious has taught me that there is a very remarkable parallelism between the specific character of the Western unconscious psyche and the "manifest" psyche of the East. Since our experience shows that the biological role which the unconscious plays in the psychic economy is compensatory to consciousness, one can venture the hypothesis that the mind of the Far East is related to our Western consciousness as the unconscious is, that is, as the left hand to the right.

[1485] Our unconscious has, fundamentally, a tendency toward wholeness, as I believe I have been able to prove. One would be quite justified in saying the same thing

about the Eastern psyche, but with this difference: that in the East it is consciousness that is characterized by an apperception of totality, while the West has developed a differentiated and therefore necessarily one-sided attention or awareness. With it goes the Western concept of causality, a principle of cognition irreconcilably opposed to the principle of synchronicity which forms the basis and the source of Eastern “incomprehensibility,” and explains as well the “strangeness” of the unconscious with which we in the West are confronted. The understanding of synchronicity is the key which unlocks the door to the Eastern apperception of totality that we find so mysterious. The author seems to have devoted particular attention to just this point. I do not hesitate to say that I look forward to the publication of her book with the greatest interest.

March 1949

FOREWORD TO ALLENBY: "A PSYCHOLOGICAL STUDY OF THE ORIGINS OF MONOTHEISM"¹

[1486] It can no longer be doubted today that meaningful connections are discoverable in dreams and other spontaneous manifestations of the unconscious. This raises the question of the origin of unconscious contents. Are they genuine creations of the unconscious psyche, or thoughts that were originally conscious but subsequently became unconscious for one reason or another?

[1487] The individual dream-thoughts, or at least their elements, are always of conscious origin, otherwise they could not be represented or recognized. Also, a whole sequence of images connected together in a meaningful way, or an entire scene, frequently derives from the conscious memory. But when we consider the meaning of the dream as a whole, the question of derivation becomes much more difficult to answer. So far as can be established empirically, the function of dreams is to compensate the conscious situation, as though there were a natural drive to restore the balance. The more one-sided the conscious situation is, the more the compensation takes on a *complementary* character. Obvious examples of this can be found in people who naïvely deceive themselves or who hold to some fanatical belief. As we know, the most lurid scenes of temptation are depicted in the dreams of ascetics. In such cases it would be very difficult to prove that the meaning of the dream derives from a conscious thought that subsequently became unconscious, for obviously no such reflection or self-criticism ever took place and for that very reason had to be performed by the dream. The hypothesis becomes completely untenable when the dreams produce meaningful connections which are absolutely unknown to the dreamer or which *cannot* be known to him. The clearest phenomena of this kind, convincing even to the layman, are telepathic dreams which give information concerning events at a distance or in the future, beyond the range of sense-perception.

[1488] These phenomena offer striking proof that there are meaningful connections in the unconscious which are not derived from conscious reflection. The same is true of dream motifs found otherwise only in myths and fairytales, and exhibiting characteristic forms of which the dreamer has no conscious knowledge. Here we are not dealing in any sense with ideas, but with instinctual factors, the fundamental forms that underlie all imaginative representation; in short, with a pattern of mental behaviour which is ingrained in human nature. This accounts for the universal occurrence of these archetypes of the imagination. Their *a priori* presence is due to

the fact that they, like the instincts, are inherited, and therefore constantly produce mythological motifs in every individual as soon as his imagination is given free play, or whenever the unconscious gains the upper hand.

[1489] Modern psychological experience has shown that not only the meaning of the dream, but also certain dream-contents, must derive entirely from the unconscious, for the simple reason that they could not have been known to consciousness and therefore cannot be derived from it.

[1490] However slight the effect of a particular dream may be, the unconscious compensation is of great importance for a man's conscious life and for what one calls his "fate." The archetypes naturally play a considerable role here, and it is no accident that these determining factors have always been personified in the form of gods and demons.

[1491] Since the relation of the unconscious to consciousness is not a mechanical one and not purely complementary, but performs a meaningful and compensatory function, the question arises as to who might be the "author" of the effects produced. In our ordinary experience, phenomena of this kind occur only in the realm of the thinking and willing ego-consciousness. There are, however, very similar "intelligent" acts of compensation in nature, especially in the instinctual activities of animals. For us, at least, they do not have the character of conscious decisions, but appear to be just like human activities that are exclusively controlled by the unconscious. The great difference between them is that the instinctual behaviour of animals is predictable and repetitive, whereas the compensatory acts of the unconscious are individual and creative.

[1492] The "author" in both cases seems to be the pattern of behaviour, the archetype. Although in human beings the archetype represents a collective and almost universal mode of action and reaction, its activity cannot as a rule be predicted; one never knows when an archetype will react, and which archetype it will be. But once it is constellated, it produces "numinous" effects of a determining character. Thus Freud not only stumbled on the Oedipus complex but also discovered the dual-mother motif of the hero myth in Leonardo da Vinci. But he made the mistake of deriving this motif from the fact that Leonardo had two mothers in reality, namely, his real mother and a stepmother. Actually, the dual-mother motif occurs not only in myths but also in the dreams and fantasies of individuals who neither have two mothers nor know anything about the archetypal motifs in mythology. So there is no need of two mothers in reality to evoke the dual-mother motif. On the contrary, the motif shows the tendency of the unconscious to reproduce the dual-mother situation, or the story of double descent or child-substitution, usually for the purpose of compensating the subject's feelings of inferiority.

[1493] As the archetypes are instinctive, inborn forms of psychic behaviour, they exert a powerful influence on the psychic processes. Unless the conscious mind intervenes critically and with an effort of will, things go on happening as they have always happened, whether to the advantage or disadvantage of the individual. The advantages seem to preponderate, for otherwise the development of consciousness could hardly have come about. The advantage of “free” will is indeed so obvious that civilized man is easily persuaded to leave his whole life to the guidance of consciousness, and to fight against the unconscious as something hostile, or else dismiss it as a negligible factor. Because of this, he is in danger of losing all contact with the world of instinct—a danger that is still further increased by his living an urban existence in what seems to be a purely manmade environment.

[1494] This loss of instinct is largely responsible for the pathological condition of our contemporary culture. The great psychotherapeutic systems embodied in religion still struggle to keep the way open to the archetypal world of the psyche, but religion is increasingly losing its grip with the result that much of Europe today has become dechristianized or actually anti-Christian. Seen in this light, the efforts of modern psychology to investigate the unconscious seem like salutary reactions of the European psyche, as if it were seeking to re-establish the connection with its lost roots. It is not simply a matter of rescuing the natural instincts (this seems to have been Freud’s particular preoccupation), but of making contact again with the archetypal functions that set bounds to the instincts and give them form and meaning. For this purpose a knowledge of the archetypes is indispensable.

[1495] The question of the existence of an archetypal *God-image* is naturally of prime importance as a factor determining human behaviour. From the history of symbols as well as from the case histories of patients it can be demonstrated empirically that such a God-image actually exists, an image of wholeness which I have called the symbol of the *self*. It occurs most frequently in the form of *mandala* symbols. The author of this book has made it her task to investigate the psychological aspect of the God-image on the one hand and the theological aspect of the self on the other—a task which in my view is as necessary as it is timely. At a time when our most valuable spiritual possessions are being squandered, we would do well to consider very carefully the meaning and purpose of the things we so heedlessly seek to cast overboard. And before raising the cry that modern psychology destroys religious ideas by “psychologizing” them, we should reflect that it is just this psychology which is trying to renew the connection with the realities of the psyche, lest consciousness should flutter about rootlessly and helplessly in the void, a prey to every imaginable intellectualism. Atrophy of instinct is equivalent to pathological suggestibility, the devastating effects of which may be witnessed in the recurrent psychic epidemics of totalitarian madness.

[1496] I can only hope this book finds a wide circle of serious readers.

May 1950

THE MIRACULOUS FAST OF BROTHER KLAUS¹

[1497] The fact that Brother Klaus, on his own admission and according to the reports of reliable witnesses, lived without material sustenance for twenty years is something that cannot be brushed aside however uncomfortable it may be. In the case of Therese of Konnersreuth² there are also reports, whose reliability of course I can neither confirm nor contest, that for a long period of time she lived simply and solely on holy wafers. Such things naturally cannot be understood with our present knowledge of physiology. One would be well advised, however, not to dismiss them as utterly impossible on that account. There are very many things that earlier were held to be impossible which nevertheless we know and can prove to be possible today.

[1498] Naturally I have no explanation to offer concerning such phenomena as the fast of Brother Klaus, but I am inclined to think it should be sought in the realm of parapsychology. I myself was present at the investigation of a medium who manifested physical phenomena. An electrical engineer measured the degree of ionization of the atmosphere in the immediate vicinity of the medium. The figures were everywhere normal except at one point on the right side of the thorax, where the ionization was about sixty times the normal. At this point, when the (parapsychological) phenomena were in progress, there was an emission of ectoplasm capable of acting at a distance. If such things can occur, then it is also conceivable that persons in the vicinity of the medium might act as a source of ions—in other words, nourishment might be effected by the passage of living molecules of albumen from one body to another. In this connection it should be mentioned that in parapsychological experiments decreases of weight up to several kilograms have been observed during the (physical) phenomena, in the case both of the medium and of some of the participants, who were all sitting on scales. This seems to me to offer a possible approach to an explanation. Unfortunately these things have been far too little investigated at present. This is a task for the future.

CONCERNING “ANSWER TO JOB”¹

[1498a] This is not a “scientific” book but a personal confrontation with the traditional Christian world view, occasioned by the impact of the new dogma of the Assumption. It echoes the reflections of a physician and theological layman, who had to find the answers to many questions on religious matters and was thus compelled to wrestle with the meaning of religious ideas from his particular, non-confessional standpoint. In addition, the questions were motivated by contemporary events: falsehood, injustice, slavery, and mass murder engulfed not only major parts of Europe but continue to prevail in vast areas of the world. What has a benevolent and almighty God to say to these problems? This desperate question, asked a thousand times, is the concern of this book.

RELIGION AND PSYCHOLOGY: A REPLY TO MARTIN BUBER¹

[1499] Some while ago the readers of your magazine were given the opportunity to read a posthumous article by Count Keyserling,² in which I was characterized as “unspiritual.” Now, in your last issue, I find an article by Martin Buber³ which is likewise concerned with my classification. I am indebted to his pronouncements at least in so far as they raise me out of the condition of unspirituality, in which Count Keyserling saw fit to present me to the German public, into the sphere of spirituality, even though it be the spirituality of early Christian Gnosticism, which has always been looked at askance by theologians. Funnily enough this opinion of Buber’s coincides with another utterance from an authoritative theological source accusing me of agnosticism—the exact opposite of Gnosticism.

[1500] Now when opinions about the same subject differ so widely, there is in my view ground for the suspicion that none of them is correct, and that there has been a misunderstanding. Why is so much attention devoted to the question of whether I am a Gnostic or an agnostic? Why is it not simply stated that I am a psychiatrist whose prime concern is to record and interpret his empirical material? I try to investigate facts and make them more generally comprehensible. My critics have no right to slur over this in order to attack individual statements taken out of context.

[1501] To support his diagnosis Buber even resorts to a sin of my youth, committed nearly forty years ago, which consists in my once having perpetrated a poem.⁴ In this poem I expressed a number of psychological *aperçus* in “Gnostic” style, because I was then studying the Gnostics with enthusiasm. My enthusiasm arose from the discovery that they were apparently the first thinkers to concern themselves (after their fashion) with the contents of the collective unconscious. I had the poem printed under a pseudonym and gave a few copies to friends, little dreaming that it would one day bear witness against me as a heretic.

[1502] I would like to point out to my critic that I have in my time been regarded not only as a Gnostic and its opposite, but also as a theist and an atheist, a mystic and a materialist. In this concert of contending opinions I do not wish to lay too much stress on what I consider myself to be, but will quote a judgment from a leading article in the *British Medical Journal* (9 February 1952), a source that would seem to be above suspicion. “Facts first and theories later is the keynote of Jung’s work. He is an empiricist first and last.” This view meets with my approval.

[1503] Anyone who does not know my work will certainly ask himself how it is that so many contrary opinions can be held about one and the same subject. The answer to

this is that they are all thought up by “metaphysicians,” that is, by people who for one reason or another think they know about unknowable things in the Beyond. I have never ventured to declare that such things do *not* exist; but neither have I ventured to suppose that any statement of mine could in any way touch them or even represent them correctly. I very much doubt whether our conception of a thing is identical with the nature of the thing itself, and this for very obvious scientific reasons.

[1504] But since views and opinions about metaphysical or religious subjects play a very great role in empirical psychology,⁵ I am obliged for practical reasons to work with concepts corresponding to them. In so doing I am aware that I am dealing with anthropomorphic ideas and not with actual gods and angels, although, thanks to their specific energy, such (archetypal) images behave so autonomously that one could describe them metaphorically as “psychic daimonia.” The fact that they are autonomous should be taken very seriously; first, from the theoretical standpoint, because it explains the dissociability of the psyche as well as actual dissociation, and second, from the practical one, because it forms the basis for a dialectical discussion between the ego and the unconscious, which is one of the mainstays of the psychotherapeutic method. Anyone who has any knowledge of the structure of a neurosis will be aware that the pathogenic conflict arises from the counterposition of the unconscious relative to consciousness. The so-called “forces of the unconscious” are not intellectual concepts that can be arbitrarily manipulated, but dangerous antagonists which can, among other things, work frightful devastation in the economy of the personality. They are everything one could wish for or fear in a psychic “Thou.” The layman naturally thinks he is the victim of some obscure organic disease; but the theologian, who suspects it is the devil’s work, is appreciably nearer to the psychological truth.

[1505] I am afraid that Buber, having no psychiatric experience, fails to understand what I mean by the “reality of the psyche” and by the dialectical process of individuation. The fact is that the ego is confronted with psychic powers which from ancient times have borne sacred names, and because of these they have always been identified with metaphysical beings. Analysis of the unconscious has long since demonstrated the existence of these powers in the form of archetypal images which, be it noted, *are not identical with the corresponding intellectual concepts*. One can, of course, believe that the concepts of the conscious mind are, through the inspiration of the Holy Ghost, direct and correct representations of their metaphysical referent. But this conviction is possible only for one who already possesses the gift of faith. Unfortunately I cannot boast of this possession, for which reason I do not imagine that when I say something about an archangel I have thereby confirmed that a metaphysical fact. I have merely expressed an opinion about something that can be experienced, that is, about one of the very palpable “powers of the unconscious”.

These powers are numinous “types”—unconscious contents, processes, and dynamisms—and such types are, if one may so express it, immanent-transcendent. Since my sole means of cognition is experience I may not overstep its boundaries, and cannot therefore pretend to myself that my description coincides with the portrait of a real metaphysical archangel. What I have described is a psychic factor only, but one which exerts a considerable influence on the conscious mind. Thanks to its autonomy, it forms the counterposition to the subjective ego because it is a piece of the *objective psyche*. It can therefore be designated as a “Thou.” For me its reality is amply attested by the truly diabolical deeds of our time: the six million murdered Jews, the uncounted victims of the slave labour camps in Russia, as well as the invention of the atom bomb, to name but a few examples of the darker side. But I have also seen the other side which can be expressed by the words beauty, goodness, wisdom, grace. These experiences of the depths and heights of human nature justify the metaphorical use of the term “daimon.”

[1506] It should not be overlooked that what I am concerned with are psychic phenomena which can be proved empirically to be the bases of metaphysical concepts, and that when, for example, I speak of “God” I am unable to refer to anything beyond these demonstrable psychic models which, we have to admit, have shown themselves to be devastatingly real. To anyone who finds their reality incredible I would recommend a reflective tour through a lunatic asylum.

[1507] The “reality of the psyche” is my working hypothesis, and my principal activity consists in collecting factual material to describe and explain it. I have set up neither a system nor a general theory, but have merely formulated auxiliary concepts to serve me as tools, as is customary in every branch of science. If Buber misunderstands my empiricism as Gnosticism, it is up to him to prove that the facts I describe are nothing but inventions. If he should succeed in proving this with empirical material, then indeed I am a Gnostic. But in that case he will find himself in the uncomfortable position of having to dismiss all religious experiences as self-deception. Meanwhile I am of the opinion that Buber’s judgment has been led astray. This seems especially evident in his apparent inability to understand how an “autonomous psychic content” like the God-image can burst upon the ego, and that such a confrontation is a living experience. It is certainly not the task of an empirical science to establish how far such a psychic content is dependent on and determined by the existence of a metaphysical deity. That is the concern of theology, revelation, and faith. My critic does not seem to realize that when he himself talks about God, his statements are dependent firstly on his conscious and then on his unconscious assumptions. Of *which* metaphysical deity he is speaking I do not know. If he is an orthodox Jew he is speaking of a God to whom the incarnation in the year 1 has not yet been revealed. If he is a Christian, then his deity knows about the incarnation of which Yahweh still

shows no sign. I do not doubt his conviction that he stands in a living relationship to a divine Thou, but now as before I am of the opinion that this relationship is primarily to an autonomous psychic content which is defined in one way by him and in another by the Pope. Consequently I do not permit myself the least judgment as to whether and to what extent it has pleased a metaphysical deity to reveal himself to the devout Jew as he was before the incarnation, to the Church Fathers as the Trinity, to the Protestants as the one and only Saviour without co-redemptrix, and to the present Pope as a Saviour with co-redemptrix. Nor should one doubt that the devotees of other faiths, including Islam, Buddhism, Hinduism, and so on, have the same living relationship to “God,” or to Nirvana and Tao, as Buber has to the God-concept peculiar to himself.

[1508] It is remarkable that he takes exception to my statement that God cannot exist apart from man and regards it as a transcendental assertion. Yet I say expressly that everything asserted about “God” is a human statement, in other words a psychological one. For surely the image we have or make for ourselves of God is never detached from man? Can Buber show me where, apart from man, God has made an image of himself? How can such a thing be substantiated and by whom? Here, just for once, and as an exception, I shall indulge in transcendental speculation and even in “poetry”: God has indeed made an inconceivably sublime and mysteriously contradictory image of himself, without the help of man, and implanted it in man’s unconscious as an archetype, an *ἀρχέτυπον φῶς*, archetypal light: not in order that theologians of all times and places should be at one another’s throats, but in order that the unpretentious man might glimpse an image, in the stillness of his soul, that is akin to him and is wrought of his own psychic substance. This image contains everything he will ever imagine concerning his gods or concerning the ground of his psyche.

[1509] This archetype, whose existence is attested not only by ethnology but by the psychic experience of individuals, satisfies me completely. It is so humanly close and yet so strange and “other”; also, like all archetypes, it possesses the utmost determinative power with which it is absolutely necessary that we come to terms. The dialectical relationship to the autonomous contents of the collective unconscious is therefore, as I have said, an essential part of therapy.

[1510] Buber is mistaken in thinking that I start with a “fundamentally Gnostic viewpoint” and then proceed to “elaborate” metaphysical assertions. One should not misconstrue the findings of empiricism as philosophical premises, for they are not obtained by deduction but from clinical and factual material. I would recommend him to read some autobiographies of the mentally ill, such as John Custance’s *Wisdom, Madness and Folly* (1951), or D. P. Schreber’s *Memoirs of My Nervous Illness* (first published 1903), which certainly do not proceed from Gnostic

hypotheses any more than I do; or he might try an analysis of mythological material, such as the excellent work of Dr. Erich Neumann, his neighbour in Tel Aviv: *Amor and Psyche* (1952). My contention that the products of the unconscious are analogous and related to certain metaphysical ideas is founded on my professional experience. In this connection I would point out that I know quite a number of influential theologians, Catholics as well as Protestants, who have no difficulty in grasping my empirical standpoint. I therefore see no reason why I should take my method of exposition to be quite so misleading as Buber would have us believe.

[1511] There is one misunderstanding which I would like to mention here because it comes up so often. This is the curious assumption that when a projection is withdrawn nothing more of the object remains. When I correct my mistaken opinion of a man I have not negated him and caused him to vanish; on the contrary, I see him more nearly as he is, and this can only benefit the relationship. So if I hold the view that all statements about God have their origin in the psyche and must therefore be distinguished from God as a metaphysical being, this is neither to deny God nor to put man in God's place. I frankly confess that it goes against the grain with me to think that the metaphysical God himself is speaking through everyone who quotes the Bible or ventilates his religious opinions. Faith is certainly a splendid thing if one has it, and knowledge by faith is perhaps more perfect than anything we can produce with our laboured and wheezing empiricism. The edifice of Christian dogma, for instance, undoubtedly stands on a much higher level than the somewhat wild "philosophoumena" of the Gnostics. Dogmas are spiritual structures of supreme beauty, and they possess a wonderful meaning which I have sought to fathom in my fashion. Compared with them our scientific endeavors to devise models of the objective psyche are unsightly in the extreme. They are bound to earth and reality, full of contradictions, incomplete, logically and aesthetically unsatisfying. The empirical concepts of science and particularly of medical psychology do not proceed from neat and seemly principles of thought, but are the outcome of our daily labours in the sloughs of ordinary human existence and human pain. They are essentially irrational, and the philosopher who criticizes them as though they were philosophical concepts tilts against windmills and gets into the greatest difficulties, as Buber does with the concept of the self. Empirical concepts are names for existing complexes of facts. Considering the fearful paradoxicality of human existence, it is quite understandable that the unconscious contains an equally paradoxical God-image which will not square at all with the beauty, sublimity, and purity of the dogmatic concept of God. The God of Job and of the 89th Psalm is clearly a bit closer to reality, and his behaviour does not fit in badly with the God-image in the unconscious. Of course this image, with its Anthropos symbolism, lends support to the idea of the incarnation. I do not feel responsible for the fact that the history of

dogma has made some progress since the days of the Old Testament. This is not to preach a new religion, for to do that I would have to follow the old-established custom of appealing to a divine revelation. I am essentially a physician, whose business is with the sickness of man and his times, and with remedies that are as real as the suffering. Not only Buber, but every theologian who baulks at my odious psychology is at liberty to heal my patients with the word of God. I would welcome this experiment with open arms. But since the ecclesiastical cure of souls does not always produce the desired results, we doctors must do what we can, and at present we have no better standby than that modest “gnosis” which the empirical method gives us. Or have any of my critics better advice to offer?

[1512] As a doctor one finds oneself in an awkward position, because unfortunately one can accomplish nothing with that little word “ought.” We cannot demand of our patients a faith which they reject because they do not understand it, or which does not suit them even though we may hold it ourselves. We have to rely on the curative powers inherent in the patient’s own nature, regardless of whether the ideas that emerge agree with any known creed or philosophy. My empirical material seems to include a bit of everything—it is an assortment of primitive, Western, and Oriental ideas. There is scarcely any myth whose echoes are not heard, nor any heresy that has not contributed an occasional oddity. The deeper, collective layers of the human psyche must surely be of a like nature. Intellectuals and rationalists, happy in their established beliefs, will no doubt be horrified by this and will accuse me of reckless eclecticism, as though I had somehow invented the facts of man’s nature and mental history and had compounded out of them a repulsive theosophical brew. Those who possess faith or prefer to talk like philosophers do not, of course, need to wrestle with the facts, but a doctor is not at liberty to dodge the grim realities of human nature.

[1513] It is inevitable that the adherents of traditional religious systems should find my formulations hard to understand. A Gnostic would not be at all pleased with me, but would reproach me for having no cosmogony and for the cluelessness of my gnosis in regard to the happenings in the Pleroma. A Buddhist would complain that I was deluded by Maya, and a Taoist that I was too complicated. As for an orthodox Christian, he can hardly do otherwise than deplore the nonchalance and lack of respect with which I navigate through the empyrean of dogmatic ideas. I must, however, once more beg my unmerciful critics to remember that I start from *facts* for which I seek an interpretation.

ADDRESS AT THE PRESENTATION OF THE JUNG CODEX¹

Mr. President, viri magnifici, Ladies and Gentlemen!

[1514] It gives me much pleasure to accept this precious gift in the name of our Institute. For this I thank you, and also for the surprising and undeserved honour you have done me in baptising the Codex with my name. I would like to thank Dr. Meier personally for his persistent and successful efforts to acquire the Codex, and for organizing this celebration. He has asked me to say something about the psychological significance of Gnostic texts.

[1515] At present, unfortunately, I know only three of the treatises contained in the Codex. One of these is an important, so it seems, early Valentinian text that affords us some insight into the mentality of the second century A.D. It is called "The Gospel of Truth,"² but it is less a gospel than a treatise explaining the Christian message, its purpose being to assimilate this strange and hardly understandable message to the Hellenistic-Egyptian world of thought. It is evident that the author was appealing to the intellectual understanding of his reader, as if in remembrance of the words: "We preach Christ crucified, unto the Jews a stumbling-block, and unto the Greeks foolishness" (I Cor. 1:23). For him Christ was primarily a light-bringer, who went forth from the Father in order to illuminate the stupidity, darkness, and unconsciousness of mankind. This deliverance from *agnosia* relates the text to the accounts which Hippolytus has left of the Gnostics, and of the Naassenes and Peratics in particular, in his *Elenchos*.³ There we also find most of what I call the "phenomena of assimilation." They consisted partly of allegories and partly of genuine symbols, and their purpose was to shed light on the essentially metaphysical figure of Christ and make it more comprehensible to the mentality of that epoch. For the modern mind this accumulation of symbols, parables, and synonyms has just the opposite effect, since it only deepens the darkness and entangles the light-bringer in a network of barely intelligible analogies. It is not likely that the Gnostic attempts at elucidation met with much success in the pagan world, especially as the Church very soon opposed them and whenever possible suppressed them. Luckily during this process some of the best pieces (to judge by their content) were preserved for posterity, so that today we are in a position to see in what way the Christian message was taken up by the unconscious of that age.

[1516] These phenomena are naturally of especial significance for psychologists and psychiatrists, who are professionally concerned with the psychic background, and

this is the reason why our Institute is so interested in acquiring and translating Gnostic texts. Although suppressed and forgotten, the process of assimilation that began with Gnosticism continued all through the Middle Ages, and it can still be observed in modern times whenever the individual consciousness is confronted with its own shadow, or the inferior part of the personality. This happens spontaneously in certain cases, whether they be normal or pathological. The general rule, however, is that modern man needs expert help to become conscious of his darkness, because in most cases he has long since forgotten this basic problem of Christianity: the moral and intellectual *agnosia* of the merely natural man. Christianity, considered as a psychological phenomenon, contributed a great deal to the development of consciousness, and wherever this dialectical process has not come to a standstill we find new evidence of assimilation. Even in medieval Judaism a parallel process took place over the centuries, independently of the Christian one, in the Kabbala. Its nearest analogy in the Christian sphere was philosophical alchemy, whose psychological affinities with Gnosticism can easily be demonstrated.

[1517] The urgent therapeutic necessity of confronting the patient with his own dark side is a continuation of the Christian development of consciousness and leads to phenomena of assimilation similar to those found in Gnosticism, the Kabbala, and Hermetic philosophy. Since comparison with these earlier historical stages is of the greatest importance in interpreting the modern phenomena, the discovery of authentic Gnostic texts is of the utmost practical value to us in our researches. These few hints must suffice to explain our interest in a Gnostic codex. A detailed account of these relationships may be found in a number of studies that have already been published.

LETTER TO PÈRE BRUNO¹

5 November 1953

Dear Fr. Bruno,

[1518] Your questions interested me extremely. You ask for information about the method to be followed in order to establish the existence of an archetype. Instead of a theoretical discourse, I propose to give you a practical demonstration of my method by trying to tell you what I think about that probably historical personage, Elijah.

[1519] If the tradition were concerned with a person characterized rather by individual and more or less unique traits, to whom few or no legends, miraculous deeds, and exploits or relations or parallels with mythological figures were attached, there would be no reason to suppose the presence of an archetype. If on the other hand the biography of the person concerned contains mythical motifs and parallels, and if posterity has added elements that are clearly mythological, then there is no longer any doubt that we are dealing with an archetype.

[1520] *The prophet Elijah is a highly mythical person*, though that does not prevent his being a historical one at the same time, like for example St. John the Baptist or even Jesus, the rabbi of Nazareth. I call the mythical attributes “phenomena of assimilation.” (I have just published a study on the astrological assimilation of Christ as fish in my book *Aion*, 1951.)

[1521] There is no need to repeat to you the well-known Old Testament traditions. Let us rather glance at the Christian tradition in the New Testament and later. As a “hairy” man [2 Kings 1:8] Elijah is analogous to St. John the Baptist [Mark 1:6]. His calling of an apostle (Elisha), walking on the water, the discouragement (I Kings 19: 4ff.) prefigure analogous incidents in the life of Christ, who is also interpreted as a reappearance of Elijah, and his saying on the cross: “Eli, Eli ...” as an invocation of Elijah. The name derives from El (= God). Chrysostom derives the name Elias [= Elijah] from Helios: “quod sicut sol ex oceano emergens versus supremum coelus tendit.”² At his birth he was hailed by angels. He was wrapped in fiery swaddling clothes and nourished by flames. He had *two souls* (!). (See J. Fr. Mieg, *De raptu Eliae*, 1660, and Schulinus, *De Elia corvorum alumno*, 1718.) In Roman days, there was a pagan sanctuary on Carmel, which seems to have consisted only of an altar (Tacitus, *Hist.* II, 78, “tantum ara et reverentia”).³ Vespasian is said to have obtained an oracle in this sanctuary. Iamblichus (*Vita Pythagorica* III, 15) says that the

mountain is sacred and represents a taboo area and that Pythagoras often stayed in the sacred solitude of Carmel. It is possible that the Druses have preserved in their sanctuary on the mountain the place of the altar of Elijah.

[1522] In *Pirkê Eliezer* 31, Elijah is the incarnation of an eternal soul-substance and is of the same nature as the angels. It was his spirit that called up the ram which was substituted for Isaac. He wears the ram's skin as a girdle or apron. He is present at the circumcision as the "Angel of the Covenant" (*Pirkê Eliezer* 29). Even in our own day, a special chair is reserved for Elijah at the rite of circumcision, and at the feast of the Passover a goblet of wine is placed on the table and the head of the family opens the door to invite Elijah to enter and share the feast.

[1523] Legend calls him "violent," "quarrelsome," and "merciless." It was because of these unfavourable qualities that he had to yield up his office of prophet to Elisha. He caused the sun to stand still during the sacrifice of Carmel. In the time to come he will awaken the dead. The boy he raised to life was Jonah (later swallowed by the monster). Since his ascension to heaven he is among the angels, and he hovers over the earth like an eagle spying out the secrets of men.

[1524] He is also considered to be a parallel of Moses. They have in common the murder of a man, their flight, being nourished by a woman, the vision of God, the calling together of the people by a mountain. Elijah and Moses were present at the transfiguration on Tabor.

[1525] Elijah helped Rabbi Meir by transforming himself into a hetaira. He is generally a helper in all sorts of human difficulties (healing even the toothache, enriching the poor, bringing leaves from paradise, building magic palaces, etc.) He also plays tricks by making people lose their purses. He slays on the spot a man who does not pray properly. Thus Elijah is identical with the figure of Khadir or Khidr in Islamic tradition.⁴ When, yielding to the prayer of Rabbi Hiyya, he reveals the secret of resurrecting the dead, the angels intercede, carry the rabbi off, and give him a good hiding with fiery whips. The village dogs bark joyously when Elijah appears (in disguise). Three days before the appearing of the Messiah, Elijah will manifest himself on the *mountains* of Israel.

[1526] According to Moses ben Leon, Elijah belongs to the category of angels who recommended the creation of man. Moses Cordovero compares him to Enoch, but whereas the latter's body is consumed by fire, Elijah retains his earthly form so as to be ready to appear again. His body descends from the Tree of Life. Since he was not dead, he was supposed to dwell invisibly on Mount Carmel; for example, the Shunamite went to look for him and found him at Carmel (II Kings 4:25). (For the Jewish tradition, see Strack and Billerbeck, *Kommentar zum N.T.*, vol. IV, [part 2](#), pp. 764ff. Also *Encyclopedia Judaica*, 1930, vol. 6.) In Hasidic tradition, Elijah was endowed with the *collective soul* of Israel. Every male child, when presented for the

covenant with God, receives a part of the soul of Elijah and after attaining adult age and developing this soul, Elijah appears to him. Abraham ibn Ezra of Toledo is said to have been unable to develop this soul completely. (It is evident that Elijah represents both the collective unconscious and the “self,” atman, purusha, of man. It is a question of the *individuation process*. See M. Buber, *Die Erzählungen der Chassidim* (1949), p. 402.⁵ M. Buber is one of my relentless adversaries. He has not understood even what he wrote himself!).⁶

[1527] Islamic tradition depends in the first place on the Jewish commentaries. Ilyās (Elijah) has received from God power to control the rain. He causes a great drought. He ascends to heaven on a fiery horse and God transforms him into a half-human angel (according to al-Tabari). In the Koran, Sura 18, 64ff., he is replaced by al-Khadir. (In a Jewish legend it is Elijah who travels with Joshua ben Levi, in the Koran it is al-Khadir with Joshua ben Nun.) Ordinarily, Ilyās and al-Khadir are immortal twins. They spend Ramadan at Jerusalem every year and afterwards they take part in the pilgrimage to Mecca without being recognized. Ilyās is identified with Enoch and Idrīs (= Hermes Trismegistus). Later Ilyas and al-Khadir are identified with St. George (see *Encyclopedia of Islam*, Leiden and Leipzig, 1913).

[1528] In medieval Christian tradition, Elijah continues to haunt the imagination. For example, it is specially fascinated by his ascent to heaven, which is frequently represented. In illuminated MSS, the model is followed of the Mithraic representation of the ascent of Sol inviting Mithras to join him in the fiery chariot. (See Bousset, “Die Himmelsreise der Seele,” *Arch. f. Relig. wiss.*, 1901, IV, p. 160ff., Cumont, *Textes et monuments*, I, p. 178, fig. 11.) Tertullian (*De praescriptione hereticorum* 40) says of Mithras: “imaginem resurrectionis inducit.”⁷ The Mandaeen hero-saviour Saoshyant, the next to come in the series of millennial saviours or prophets, is fused with Mithras, as is the latter with Idris (Hermes, Mercurius; see Dussaud, “Notes de myth, syrienne,” pp. 23ff.⁸ In these circumstances, it is not very surprising that Elijah should become “Helyas Artista” in medieval alchemy (e.g., Dorn, “De transmut. met.,” *Theatr. chem.*, 1602, I, p. 610: “usque in adventum Heliae Artistae quo tempore nihil tam occultum quod non revelabitur”).⁹ This passage has its origin in the treatise “De tinctura physicorum” of Paracelsus. (See also Helvetius, *Vitulus aureus*, 1667; Glauber, *De Elia Artista*, 1668, and Kopp, *Die Alchemie*, 1886, I, pp. 250ff.)¹⁰

[1529] It is unnecessary to continue this long list of *phenomena of assimilation* which follow without interruption, so to speak, from the remotest times to our own day. This proves irrefutably that Elijah is a *living archetype*. In psychology, we call it a *constellated archetype*, that is to say one that is more or less generally active, giving birth to new forms of assimilation. One of these phenomena was the choice of Carmel for the foundation of the first convent in the twelfth century. The mountain

had long been a numinous place as the seat of the Canaanite deities Baal and Astarte. (Cf. the duality of Elijah, the transformation into a hetaira.) YHWH supplants them as inhabitant of the sacred place (Eli-yah like Khadir a kind of personification of YHWH or Allah. Cf. the temperament and the fire of the prophet!). The numinous inhabitant of Carmel is chosen as the patron of the order. The choice is curious and unprecedented. According to the empirical rule, an archetype becomes active and chooses itself when a certain lack in the conscious sphere calls for a compensation on the part of the unconscious. What is lacking on the conscious side is the immediate relation with God: in so far as Elijah is an angelic being fortified with divine power, having the magic name of Eli-YHWH, delivered from corruptibility, omniscient and omnipresent, he represents the ideal compensation not only for Christians but for Jews and Moslems also. He is the typical *θεόςανθρωπος*, more human than Christ inasmuch as he is begotten and born in *peccatum originale*, and more universal in that he included even the pre-Yahwist pagan deities like Baal, El-Elyon, Mithras, Mercurius, and the personification of Allah, al-Khadir.

[1530] I have already said that the archetype “gets itself chosen” rather than is deliberately chosen. I prefer this way of putting it because it is almost the rule that one follows unconsciously the attraction and suggestion of the archetype. I think that the legend of Elijah and the unique atmosphere of Mount Carmel exercised an influence from which the founder of the order could no more withdraw himself than could the Druses, the Romans, Jews, Canaanites, or Phoenicians. It was not only the *place* which favoured the choice for the adoption of a compensatory figure but the *time*. The twelfth century and the beginning of the thirteenth were just the period which activated the spiritual movements brought into being by the new aeon which began with the eleventh century.¹¹ These were the days of Joachim of Flora and the Brethren of the Free Spirit, of Albertus Magnus and Roger Bacon, of the beginning of Latin alchemy and of the natural sciences and also of a feminine religious symbol, the Holy Grail. (For the significance of the year 1000, see my *Aion*. chs. VI and X, 3.)

[1531] To complete the establishment of a living archetype, the historical proofs do not wholly suffice, since one can explain the historical documentation by tradition (whose beginnings, however, always remain unexplained). That the archetype also manifests itself spontaneously outside tradition needs to be added to the evidence. God as collective soul, as spirit of nature, eternally renewed, incorruptible, archetype of the spirit even in the form of the “Trickster,” pagan divinity, is encountered in ancient and medieval alchemy having nothing to do with the local tradition of Carmel. The *Deus absconditus* of alchemy has the same compensating function as the figure of Elijah. Lastly—as is little known—the psychology of alchemy has become comprehensible to us thanks to the fact that we observe analogous

compensations in pathological and normal individuals in modern times. In calling themselves “atheists” or “agnostics,” people dissatisfied with the Christian tradition are not being merely negative. In many cases it is easy to observe the phenomenon of the “compensating God,” as I have demonstrated in my most recent works.

I hope, dear Fr. Bruno, that I have shown you the way an archetype is established and have answered your question concerning the choice of the archetype.

Yours sincerely, C. G. JUNG

LETTER TO PÈRE LACHAT¹

Küsnacht, 27 March 1954

Dear Sir,

[1532] It was very kind of you to send me your booklet² on the reception and action of the Holy Spirit. I have read it with special interest since the subject of the Holy Spirit seems to me one of current importance. I remember that the former Archbishop of York, Dr. Temple, admitted, in conversation with me, that the Church has not done all that it might to develop the idea of the Holy Spirit. It is not difficult to see why this is so, for *τὸ πνεῦμα πνεῖ ὅπου θέλει*³—a fact which an institution may find very inconvenient! In the course of reading your little book a number of questions and thoughts have occurred to me, which I set out below, since my reactions may perhaps be of some interest to you.

[1533] I quite agree with your view that one pauses before entrusting oneself to the “unforeseeable action” of the Holy Spirit. One feels afraid of it, not, I think, without good reason. Since there is a marked difference between the God of the Old Testament and the God of the New, a definition is desirable. You nowhere explain your idea of God. Which God have you in mind: The New Testament God, or the Old? The latter is a paradox; good and demonlike, just and unjust at the same time, while the God of the New Testament is by definition perfect, good, the Summum Bonum even, without any element of the dark or the demon in him. But if you identify these two Gods, different as they are, the fear and resistance one feels in entrusting oneself unconditionally to the Holy Spirit are easy to understand. The divine action is so unforeseeable that it may well be really disastrous. That being so, the prudence of the serpent counsels us not to approach the Holy Spirit too closely.

[1534] If, on the other hand, it is the New Testament God you have in mind, one can be absolutely certain that the risk is more apparent than real since the end will always be good. In that event the experiment loses its venturesome character; it is not really dangerous. It is then merely foolish not to give oneself up entirely to the action of the Holy Spirit. Rather one should seek him day by day, and one will easily lay hold of him, as Mr. Horton⁴ assures us. In the absence of a formal statement on your part, I assume that you identify the two Gods. In that case the Holy Spirit would not be easy to apprehend; it would even be highly dangerous to attract the divine attention by specially pious behaviour (as in the case of Job and some others). In the Old

Testament Satan still has the Father's ear, and can influence him even against the righteous. The Old Testament furnishes us with quite a number of instances of this kind, and they warn us to be very careful when we are dealing with the Holy Spirit. The man who is not particularly bold and adventurous will do well to bear these examples in mind and to thank God that the Holy Spirit does not concern himself with us overmuch. One feels much safer under the shadow of the Church, which serves as a fortress to protect us against God and his Spirit. It is very comforting to be assured by the Catholic Church that it "possesses" the Spirit, who assists regularly at its rites. Then one knows that he is well chained up. Protestantism is no less reassuring in that it represents the Spirit to us as something to be sought for, to be easily "drunk," even to be possessed. We get the impression that he is something passive, which cannot budge without us. He has lost his dangerous qualities, his fire, his autonomy, his power. He is represented as an innocuous, passive, and purely beneficent element, so that to be afraid of him would seem just stupid.

[1535] This characterization of the Holy Spirit leaves out of account the terrors of YHWH. It does not tell us what the Holy Spirit is, since it has failed to explain to us clearly what it has done with the *Deus absconditus*. Albert Schweitzer naïvely informs us that he takes the side of the ethical God and avoids the *absconditus*, as if a mortal man had the ability to hide himself when faced with an almighty God or to take the other, less risky side. God can implicate him in unrighteousness whenever he chooses.

[1536] I also fail to find a definition of Christ; one does not know whether he is identical with the Holy Spirit, or different from him. Everyone talks about Christ; but who is this Christ? When talking to a Catholic or Anglican priest, I am in no doubt. But when I am talking to a pastor of the Reformed Church, it may be that Christ is the Second Person of the Trinity and God in his entirety, or a divine man (the "supreme authority," as Schweitzer has it, which doesn't go too well with the error of the parousia), or one of those great founders of ethical systems like Pythagoras, Confucius, and so on. It is the same with the idea of God. What is Martin Buber talking about when he discloses to us his intimate relations with "God"? YHWH? The olden Trinity, or the modern Trinity, which has become something more like a Quaternity since the *Sponsa* has been received into the *Thalamus*?⁵ Or the rather misty God of Protestantism? Do you think that everyone who says that he is surrendering himself to Christ has really surrendered himself to Christ? Isn't it more likely that he has surrendered himself to the image of Christ which he has made for himself, or to that of God the Father or the Holy Spirit? Are they all the same Christ—the Christ of the Synoptics, of the *Exercitia Spiritualia*, of a mystic of Mount Athos, of Count Zinzendorf,⁶ of the hundred sects, of Caux⁷ and Rudolf Steiner, and—last but not least—of St. Paul? Do you really believe that anyone, be he who he

may, can bring about the real presence of one of the Sacred Persons by an earnest utterance of their name? I can be certain only that someone has called up a psychic image, but it is impossible for me to confirm the real presence of the Being evoked. It is neither for us nor for others to decide *who* has been invoked by the holy name and to whom one has surrendered oneself. Has it not happened that the invocation of the Holy Spirit has brought the devil on the scene? What are invoked are in the first place images, and that is why images have a special importance. I do not for a moment deny that the deep emotion of a true prayer may reach transcendence, but it is above our heads. There would not even be any transcendence if our images and metaphors were more than anthropomorphism and the words themselves had a magical effect. The Catholic Church protects itself against this insinuation *expressis verbis*, insisting on its teaching that God cannot go back on his own institutions. He is morally obliged to maintain them by his Holy Spirit or his grace. All theological preaching is a mythologem, a series of archetypal images intended to give a more or less exact description of the unimaginable transcendence. It is a paradox, but it is justified. The totality of these archetypes corresponds to what I have called the *collective unconscious*. *We are concerned here with empirical facts, as I have proved.* (Incidentally, you don't seem to be well informed about either the nature of the unconscious or my psychology. The idea that the unconscious is the abyss of all the horrors is a bit out of date. The collective unconscious is neutral; it is only nature, both spiritual and chthonic. To impute to my psychology the idea that the Holy Spirit is "only a projection of the human soul" is false. He is a transcendental fact which presents itself to us under the guise of an archetypal image (e.g. [])⁸, or are we to believe that he is really "breathed forth" by the Father and the Son?). There is no guarantee that this image corresponds exactly to the transcendental entity.

[1537] The unconscious is ambivalent; it can produce both good and evil effects. So the image of God also has two sides, like YHWH or the God of Clement of Rome with two hands; the right is Christ, the left Satan, and it is with these two hands that he rules the world.⁹ Nicholas of Cusa calls God a *complexio oppositorum* (naturally under the apotropaic condition of the *privatio boni!*). YHWH's paradoxical qualities are continued in the New Testament. In these circumstances it becomes very difficult to know what to make of *prayer*. Can we address our prayer to the good God to the exclusion of the demon, as Schweitzer recommends? Have we the power of dissociating God like the countrywoman who said to the child Jesus, when he interrupted her prayer to the Virgin: "Shhh, child, I'm talking to your mother"? Can we really put on one side the God who is dangerous to us? Do we believe that God is so powerless that we can say to him: "Get out, I'm talking to your better half?" Or can we ignore the *absconditus*? Schweitzer invites us to do just this; we're going to

have our bathe in the river, and never mind the crocodiles. One can, it seems, brush them aside. Who is there who can produce this “simple faith”?

[1538] Like God, then, the unconscious has two aspects; one good, favourable, beneficent, the other evil, malevolent, disastrous. The unconscious is the immediate source of our religious experiences. This psychic nature of all experience does not mean that the transcendental realities are also psychic; the physicist does not believe that the transcendental reality represented by his psychic model is also psychic. He calls it *matter*, and in the same way the psychologist in no wise attributes a psychic nature to his images or archetypes. He calls them “psychoids”¹⁰ and is convinced that they represent transcendental realities. He even knows of “simple faith” as that *conviction which one cannot avoid*. It is vain to seek for it; it comes when it wills, for it is the gift of the Holy Spirit. There is only one divine spirit—an immediate presence, often terrifying and in no degree subject to our choice. There is no guarantee that it may not just as well be the devil, as happened to St. Ignatius Loyola in his vision of the *serpens oculatus*, interpreted at first as Christ or God and later as the devil.¹¹ Nicholas of Flüe had his terrifying vision of the *absconditus*, and transformed it later into the kindly Trinity of the parish church of Sachseln.¹²

[1539] Surrender to God is a formidable adventure, and as “simple” as any situation over which man has no control. He who can risk himself wholly to it finds himself directly in the hands of God, and is there confronted with a situation which makes “simple faith” a vital necessity; in other words, the situation becomes so full of risk or overtly dangerous that the deepest instincts are aroused. An experience of this kind is always numinous, for it unites all aspects of totality. All this is wonderfully expressed in Christian religious symbolism: the divine will incarnate in Christ urges towards the fatal issue, the catastrophe followed by the fact or hope of resurrection, while Christian faith insists on the deadly danger of the adventure; but the Churches assure us that God protects us against all danger and especially against the fatality of our character. Instead of taking up our cross, we are told to cast it on Christ. He will take on the burden of our anguish and we can enjoy our “simple faith” at Caux. We take flight into the Christian collectivity where we can forget even the will of God, for in society we lose the feeling of personal responsibility and can swim with the current. One feels safe in the multitude, and the Church does everything to reassure us against the fear of God, as if it did not believe that He could bring about a serious situation. On the other hand psychology is painted as black as possible, because it teaches, in full agreement with the Christian creed, that no man can ascend unless he has first descended. A professor of theology once accused me publicly that “in flagrant contradiction to the words of Christ” I had criticized as *childish* the man who remains an infant retaining his early beliefs. I had to remind him of the fact that Christ never said “remain children” but “become like children.” This is one small

example of the way in which Christian experience is falsified; it is prettied up, its sombre aspects are denied, its dangers are hidden. But the action of the Holy Spirit does not meet us in the atmosphere of a normal, bourgeois (or proletarian!), sheltered, regular life, but only in the insecurity outside the human economy, in the infinite spaces where one is alone with the *providentia Dei*. We must never forget that Christ was an innovator and revolutionary, *executed with criminals*. The reformers and great religious geniuses were *heretics*. It is there that you find the footprints of the Holy Spirit, and no one asks for him or receives him *without having to pay a high price*. The price is so high that no one today would dare to suggest that he possesses or is possessed by the Holy Spirit, or he would be too close to the psychiatric clinic. The danger of making oneself ridiculous is too real, not to mention the risk of offending our real god: *respectability*. There one even becomes very strict, and it would not be at all allowable for God and his Spirit to permit themselves to give advice or orders as in the Old Testament. Certainly everyone would lay his irregularities to the account of the unconscious. One would say: God is faithful, he does not forsake us, God does not lie, he will keep his word, and so on. We know it isn't true, but we go on repeating these lies ad infinitum. It is quite understandable that we should seek to hold the truth at arm's length, because it seems impossible to give oneself up to a God who doesn't even respect his own laws when he falls victim to one of his fits of rage or forgets his solemn oath. When I allow myself to mention these well-attested facts the theologians accuse me of blasphemy, unwilling as they are to admit the ambivalence of the divine nature, the demonic character of the God of the Bible and even of the Christian God. Why was that cruel immolation of the Son necessary if the anger of the "deus ultionum" is not hard to appease? One doesn't notice much of the Father's goodness and love during the tragic end of his Son.

[1540] True, we ought to abandon ourselves to the divine will as much as we can, but admit that to do so is difficult and dangerous, so dangerous indeed that I would not dare to advise one of my clients to "take" the Holy Spirit or to abandon himself to him until I had first made him realize the risks of such an enterprise.

[1541] Permit me here to make a few comments. On pp. 11f.: The Holy Spirit is to be feared. He is revolutionary *especially* in religious matters (not at all "perhaps even religious," p. 11 bottom). Ah, yes, one does well to refuse the Holy Spirit, because people would like to palm him off on us without telling us what this sacred fire is which killeth and maketh to live. One may get through a battle without being wounded, but there are some unfortunates who do not know how to avoid either mutilation or death. Perhaps one is among their number. One can hardly take the risk of that without the most convincing necessity. It is quite normal and reasonable to refuse oneself to the Holy Spirit. Has M. Boegner's¹³ life been turned upside down? Has he taken the risk of breaking with convention (e.g., eating with Gentiles when

one is an orthodox Jew, or even better with women of doubtful reputation), or been immersed in darkness like Hosea, making himself ridiculous, overturning the traditional order, etc.? It is deeds that are needed, not words.

[1542] p. 13. It is very civil to say that the Holy Spirit is “uncomfortable and sometimes upsetting,” but very characteristic.

[1543] p. 16. It is clear that the Holy Spirit is concerned in the long run with the collectivity (*ecclesia*), but in the first place with the individual, and to create him he isolates him from his environment, just as Christ himself was thought mad by his own family.

[1544] p. 19. The Holy Spirit, “the accredited bearer of the holiness of God.” But who will recognize him as such? Everyone will certainly say that he is drunk or a heretic or mad. To the description “bearer of the holiness” needs to be added the holiness which God himself sometimes sets on one side (Ps. 89).

[1545] p. 21. It is no use for Mr. Horton to believe that receiving the Holy Spirit is quite a simple business. It is so to the degree that we do not realize what is at issue. We are surrendering ourselves to a Spirit with two aspects. That is why we are not particularly ready to “drink” of him, or to “thirst” for him. We hope rather that God is going to pass us by, that we are protected against his injustice and his violence. Granted, the New Testament speaks otherwise, but when we get to the Apocalypse the style changes remarkably and approximates to that of older times. Christ’s kingdom has been provisional; the world is left thereafter for another aeon to Antichrist and to all the horrors that can be envisaged by a pitiless and loveless imagination. This witness in favour of the god with two faces represents the last and tragic chapter of the New Testament which would like to have set up a god exclusively good and made only of love. This Apocalypse—was it a frightful gaffe on the part of those Fathers who drew up the canon? I don’t think so. They were still too close to the hard reality of things and of religious traditions to share our mawkish interpretations and prettily falsified opinions.

[1546] p. 23. “Surrender without the least reserve.” Would Mr. Horton advise us to cross the Avenue de l’Opéra blindfold? His belief in the good God is so strong that he has forgotten the fear of God. For Mr. Horton God is dangerous no longer. But in that case—what is the Apocalypse all about? He asks nevertheless, “To what interior dynamism is one surrendering oneself, natural or supernatural?” When he says, “I surrender myself wholly to God,” how does he know what is “whole”? Our wholeness is an unconscious fact, whose extent we cannot establish. God alone can judge of human wholeness. We can only say humbly: “As wholly as possible.”

[1547] There is no guarantee that it is really *God* when we say “god.” It is perhaps a word concealing a demon or a void, or it is an act of grace coincident with our prayer.

[1548] This total surrender is disturbing. Nearly twenty years ago I gave a course at the Ecole Polytechnique Suisse for two semesters on the *Exercitia Spiritualia* of St. Ignatius.¹⁴ On that occasion I received a profound impression of this total surrender, in relation to which one never knows whether one is dealing with sanctity or with spiritual pride. One sees too that the god to whom one surrenders oneself is a clear and well-defined prescription given by the director of the Exercises. This is particularly evident in the part called the “colloquium,” where there is only one who speaks, and that is the initiand. One asks oneself what God or Christ would say if it were a real dialogue, but no one expects God to reply.

[1549] p. 26. The identity of Christ with the Holy Spirit seems to me to be questionable, since Christ made a very clear distinction between himself and the paraclete, even if the latter’s function resembles Christ’s. The near-identity of the Holy Spirit with Christ in St. John’s Gospel is characteristic of the evangelist’s Gnosticism. It seems to me important to insist on the chronological sequence of the Three Persons, for there is an evolution in three stages:

1. The Father. The opposites not yet differentiated; Satan is still numbered among the “sons of God.” Christ then is only hinted at.

2. God is incarnated as the “Son of Man.” Satan has fallen from heaven. He is the other “son.” The opposites are differentiated.

3. The Holy Spirit is One, his prototype is the Ruach Elohim, an emanation, an active principle, which proceeds (as quintessence) *a Patre Filioque*. Inasmuch as he proceeds also from the Son he is different from the Ruach Elohim, who represents the active principle of Yahweh (not incarnate, with only angels in place of a son). The angels are called “sons,” they are not begotten and there is no mother of the angels. Christ on the other hand shares in human nature, he is even man by definition. In this case it is evident that the Holy Spirit proceeding from the Son does not arise from the divine nature only, that is, from the second Person, but also from the human nature. Thanks to this fact, human nature is included in the mystery of the Trinity. Man forms part of it.

[1550] This “human nature” is only figuratively human, for it is exempt from original sin. This makes the “human” element definitely doubtful inasmuch as man without exception, save for Christ and his mother, is begotten and born bearing the stamp of the *macula peccati*. That is why Christ and his mother enjoy a nature divine rather than human. For the Protestant there is no reason to think of Mary as a goddess. Thus he can easily admit that on his mother’s side Christ was contaminated by original sin; this makes him all the more human, at least so far as the *filioque* of the Protestant confession does not exclude the true man from the “human” nature of Christ. On the other hand it becomes evident that the Holy Spirit necessarily proceeds *from the two natures* of Christ, not only from the God in him, but also from the man in him.

[1551] There were very good reasons why the Catholic Church has carefully purified Christ and his mother from all contamination by the *peccatum originale*. Protestantism was more courageous, even daring or—perhaps?—more oblivious of the consequences, in not denying—*expressis verbis*—the human nature (in part) of Christ and (wholly) of his mother. *Thus the ordinary man became a source of the Holy Spirit*, though certainly not the only one. It is like lightning, which issues not only from the clouds but also from the peaks of the mountains. This fact signifies the continued and progressive divine incarnation. Thus man is received and integrated into the divine drama. He seems destined to play a decisive part in it; that is why he must receive the Holy Spirit. I look upon the receiving of the Holy Spirit as a highly revolutionary fact which cannot take place until the ambivalent nature of the Father is recognized. If God is the *summum bonum*, the incarnation makes no sense, for a good god could never produce such hate and anger that his only son had to be sacrificed to appease it. A Midrash says that the Shofar is still sounded on the Day of Atonement to remind YHWH of his act of injustice towards Abraham (by compelling him to slay Isaac) and to prevent him from repeating it. A conscientious clarification of the idea of God would have consequences as upsetting as they are necessary. They would be indispensable for an interior development of the trinitarian drama and of the role of the Holy Spirit. The Spirit is destined to be incarnate in man or to choose him as a transitory dwelling-place. “Non habet nomen proprium,” says St. Thomas;¹⁵ because he will receive the name of man. That is why he must not be identified with Christ. We cannot receive the Holy Spirit unless we have accepted our own individual life as Christ accepted his. Thus we become the “sons of god” fated to experience the conflict of the divine opposites, represented by the crucifixion.

[1552] Man seems indispensable to the divine drama. We shall understand this role of man’s better if we consider the paradoxical nature of the Father. As the Apocalypse has alluded to it (*evangelium aeternum*) and Joachim of Flora¹⁶ has expressed it, the Son would seem to be the intermediary between the Father and the Holy Spirit. We could repeat what Origen said of the Three Persons, that the Father is the greatest and the Holy Spirit the least. This is true inasmuch as the Father by descending from the cosmic immensity became the least by incarnating himself within the narrow bounds of the human soul (cult of the child-god, Angelus Silesius). Doubtless the presence of the Holy Spirit enlarges human nature by divine attributes. Human nature is the divine vessel and as such the union of the Three. This results in a kind of quaternity which always signifies *totality*, while the triad is rather a process, but never the natural division of the *circle*, the natural symbol of wholeness. The quaternity as union of the Three seems to be aimed at by the *Assumption of Mary*. This dogma adds the feminine element to the masculine Trinity, the terrestrial element (*virgo terra!*) to the spiritual, and thus sinful man to the Godhead. For Mary in her character

of *omnium gratiarum mediatrix* intercedes for the sinner before the judge of the world. (She is his “paraclete.”) She is *φιλανθρωπος* like her prefiguration, the Sophia of the Old Testament.¹⁷ Protestant critics have completely overlooked the symbolic aspect of the new dogma and its emotional value, which is a capital fault.

[1553] The “littleness” of the Holy Spirit stems from the fact that God’s *pneuma* dissolves into the form of little flames, remaining none the less intact and whole. His dwelling in a certain number of human individuals and their transformation into *ὕψω τοῦ θεοῦ* signifies a very important step forward beyond “Christocentrism.” Anyone who takes up the question of the Holy Spirit seriously is faced with the question whether Christ is identical with the Holy Spirit or different from him. With dogma, I prefer the independence of the Holy Spirit. The Holy Spirit is *one*, a *complexio oppositorum*, in contrast to YHWH after the separation of the divine opposites symbolized by God’s two sons, Christ and Satan. On the level of the Son there is no answer to the question of good and evil; there is only an incurable separation of the opposites. The annulling of evil by the *privatio boni* (declaring to be *μη ὄν*) is a *petitio principii* of the most flagrant kind and no solution whatever.¹⁸ It seems to me to be the Holy Spirit’s task and charge to reconcile and reunite the opposites in the human individual through a special development of the human soul. The soul is paradoxical like the Father; it is black and white, divine and demon-like, in its primitive and natural state. By the discriminative function of its conscious side it separates opposites of every kind, and especially those of the moral order personified in Christ and Devil. Thereby the soul’s spiritual development creates an enormous tension, from which man can only suffer. Christ promised him redemption. But in what exactly does this consist? The *imitatio Christi* leads us to Calvary and to the annihilation of the “body,” that is, of biological life, and if we take this death as symbolic it is a state of suspension between the opposites, that is to say, an unresolved conflict. That is exactly what Przywara has named the “rift,”¹⁹ the gulf separating good from evil, the latent and apparently incurable dualism of Christianity, the eternity of the devil and of damnation. (Inasmuch as good is real so also is evil.)

[1554] To find the answer to this question we can but trust to our mental powers on the one hand and on the other to the functioning of the unconscious, that spirit which we cannot control. It can only be hoped that it is a “holy” spirit. The cooperation of conscious reasoning with the data of the unconscious is called the “transcendent function” (cf. *Psychological Types*, par. 828).²⁰ This function progressively unites the opposites. Psychotherapy makes use of it to heal neurotic dissociations, but this function had already served as the basis of Hermetic philosophy for seventeen centuries. Besides this, it is a natural and spontaneous phenomenon, part of the process of individuation. Psychology has no proof that this process does not unfold itself at the instigation of God’s will.

[1555] The Holy Spirit will manifest himself in any case in the psychic sphere of man and will be presented as a psychic experience. He thus becomes the object of empirical psychology, which he will need in order to translate his symbolism into the possibilities of this world. Since his intention is the incarnation, that is, the realization of the divine being in human life, he cannot be a light which the darkness comprehendeth not. On the contrary, he needs the support of man and his understanding to comprehend the *mysterium iniquitatis* which began in paradise before man existed. (The serpent owes his existence to God and by no means to man. The idea: *omne bonum a Deo, omne malum ab homine* is an entirely false one.) YHWH is inclined to find the cause of evil in men, but he evidently represents a moral antinomy accompanied by an almost complete lack of reflection. For example, he seems to have forgotten that he created his son Satan and kept him among the other “sons of God” until the coming of Christ—a strange oversight!

[1556] The data of the collective unconscious favour the hypothesis of a paradoxical creator such as YHWH. An entirely good Father seems to have very little probability; such a character is difficult to admit, seeing that Christ himself endeavoured to reform his Father. He didn't completely succeed, even in his own logia. Our unconscious resembles this paradoxical God. That is why man is faced with a psychological condition which does not let him differentiate himself from the image of God (YHWH). Naturally we can believe that God is different from the image of him that we possess, but it must be admitted on the other side that the Lord himself, while insisting on the Father's perfect goodness, has given a picture of him which fits in badly with the idea of a perfectly moral being. (A father who tempts his children, who did not prevent the error of the immediate parousia, who is so full of wrath that the blood of his only son is necessary to appease him, who left the crucified one to despair, who proposes to devastate his own creation and slay the millions of mankind to save a very few of them, and who before the end of the world is going to replace his Son's covenant by another gospel and complement the love by the fear of God.) It is interesting, or rather tragic, that God undergoes a complete relapse in the last book of the New Testament. But in the case of an antinomian being we could expect no other development. The opposites are kept in balance, and so the kingdom of Christ is followed by that of Antichrist. In the circumstances the Holy Spirit, the third form of God, becomes of extreme importance, for it is thanks to him that the man of good will is drawn towards the divine drama and mingled in it, and the Spirit is *one*. In him the opposites are separated no longer.

[1557] Begging you to excuse the somewhat heretical character of my thoughts as well as their imperfect presentation. I remain, dear monsieur, yours sincerely,

C. G. JUNG

NON RESURRECTION¹

[1558] You are quite right: I have never dealt with all aspects of the Christ-figure for the simple reason that it would have been too much. I am not a theologian and I have had no time to acquire all the knowledge that is wanted in order to attempt the solution of such problems as that of the Resurrection.

[1559] Indubitably resurrection is one of the most—if not the most—important item in the myth or the biography of Christ and in the history of the primitive church.

1. Resurrection as a historical fact in the biography of Jesus

[1560] Three Gospels have a complete report about the postmortal events after the Crucifixion. Mark, however, mentions only the open and empty tomb and the presence of the angel, while the apparition of the visible body of Christ has been reported by a later hand in an obvious addendum. The first report about the resurrected Christ is made by Mary Magdalene, from whom Christ had driven out seven devils. This annotation has a peculiarly cursory character (cf. in particular Mark 11:19),² as if somebody had realized that Mark's report was altogether too meagre and that the usual things told about Christ's death ought to be added for the sake of completeness.

[1561] The earliest source about the Resurrection is St. Paul, and he is no eyewitness, but he strongly emphasizes the absolute and vital importance of resurrection as well as the authenticity of the reports. (Cf. I Cor. 15:14ff and 15:5ff.) He mentions Cephas (Peter) as the first witness, then the twelve, then the five hundred, then James, then the apostles, and finally himself. This is interesting, since his experience was quite clearly an understandable vision, while the later reports insist upon the material concreteness of Christ's body (particularly Luke 24:42 and John 20:24ff.). The evangelical testimonies agree with each other only about the emptiness of the tomb, but not at all about the chronology of the eyewitnesses. There the tradition becomes utterly unreliable. If one adds the story about the end of Judas, who must have been a very interesting object to the hatred of the Christians, our doubts of the Resurrection story are intensified: there are two absolutely different versions of the way of his death.

[1562] *The fact of the Resurrection is historically doubtful.* If we extend the *beneficium dubii* to those contradictory statements we could consider the possibility of an individual as well as collective vision (less likely of a materialization).

[1563] The conclusion drawn by the ancient Christians—since Christ has risen from the dead so shall we rise in a new and incorruptible body—is of course just what St. Paul has feared most,³ viz., invalid and as vain as the expectation of the immediate parousia, which has come to naught.

[1564] As the many shocking miracle-stories in the Gospels show, spiritual reality could not be demonstrated to the uneducated and rather primitive population in any other way but by crude and tangible “miracles” or stories of such kind. Concretism was unavoidable with all its grotesque implications—for example, the believers in Christ were by the grace of God to be equipped with a glorified body at their resurrection, and the unbelievers and unredeemed sinners were too, so that they could be plagued in hell or purgatory for any length of time. An incorruptible body was necessary for the latter performance, otherwise damnation would have come to an end in no time.

[1565] Under those conditions, resurrection as a historical and concrete fact cannot be maintained, whereas the vanishing of the corpse could be a real fact.

2. *Resurrection as a psychological event*

[1566] The facts here are perfectly clear and well documented: The life of the God-man on earth comes to an end with his resurrection and transition to heaven. This is firm belief since the beginning of Christianity. In mythology it belongs to the hero that he conquers death and brings back to life his parents, tribal ancestors, etc. He has a more perfect, richer, and stronger personality than the ordinary mortal. Although he is also mortal himself, death does not annihilate his existence: he continues living in a somewhat modified form. On a higher level of civilization he approaches the type of the dying and resurrected god, like Osiris, who becomes the greater personality in every individual (like the Johannine Christ), viz., his *τέλειος ἄνθρωπος*, the complete (or perfect) man, the self.

[1567] The self as an archetype represents a numinous wholeness, which can be expressed only by symbols (e.g., mandala, tree, etc.). As a collective image it reaches beyond the individual in time and space⁴ and is therefore not subjected to the corruptibility of *one* body: the realization of the self is nearly always connected with the feeling of timelessness, “eternity,” or immortality. (Cf. the personal and superpersonal ātman.) We do not know what an archetype is (i.e., consists of), since the nature of the psyche is inaccessible to us, but we know that archetypes exist and work.

[1568] From this point of view it is no longer difficult to see to what degree the story of the Resurrection represents the projection of an indirect realization of the self that had appeared in the figure of a certain man, Jesus of Nazareth, of whom many rumors were circulating.⁵ In those days the old gods had ceased to be significant.

Their power had already been replaced by the concrete one of the visible god, the Caesar, whose sacrifices were the only obligatory ones. But this substitution was as unsatisfactory as that of God by the communistic state. It was a frantic and desperate attempt to create—out of no matter how doubtful material—a spiritual monarch, a *pantokrator*, in opposition to the concretized divinity in Rome. (What a joke of the *esprit d'escalier* of history—the substitution for the Caesar of the pontifical office of St. Peter!)

[1569] Their need of a spiritual authority then became so particularly urgent, because there was only one divine individual, the Caesar, while all the others were anonymous and hadn't even private gods listening to their prayers.⁶ They took therefore to magic of all kinds. Our actual situation is pretty much the same: we are rapidly becoming the slaves of an anonymous state as the highest authority ruling our lives. Communism has realized this ideal in the most perfect way. Unfortunately our democracy has nothing to offer in the way of different ideals; it also believes in the concrete power of the state. There is no spiritual authority comparable to that of the state anywhere. We are badly in need of a spiritual counterbalance to the ultimately bolshevistic concretism. It is again the case of the “witnesses” against the Caesar.

[1570] The gospel writers were as eager as St. Paul to heap miraculous qualities and spiritual significances upon that almost unknown young rabbi, who after a career lasting perhaps only one year had met with an untimely end. What they made of him we know, but we don't know to what extent this picture has anything to do with the truly historical man, smothered under an avalanche of projections. Whether he was the eternally living Christ and Logos, we don't know. It makes no difference anyhow, since the image of the God-man lives in everybody and has been incarnated (i.e., projected) in the man Jesus, to make itself visible, so that people could realize him as their own interior *homo*, their self.

[1571] Thus they had regained their human dignity: everybody had divine nature. Christ had told them: *Dii estis*: “ye are gods”; and as such they were his brethren, of his nature, and had overcome annihilation either through the power of the Caesar or through physical death. They were “resurrected with Christ.”

[1572] Since we are psychic beings and not entirely dependent upon space and time, we can easily understand the central importance of the resurrection idea: we are not completely subjected to the powers of annihilation because our psychic totality reaches beyond the barrier of space and time. Through the progressive integration of the unconscious we have a reasonable chance to make experiences of an archetypal nature providing us with the feeling of continuity before and after our existence. The better we understand the archetype, the more we participate in its life and the more we realize its eternity or timelessness.

[1573] As roundness signifies completeness or perfection, it also expresses rotation (the rolling movement) or progress on an endless circular way, an identity with the sun and the stars (hence the beautiful confession in the “Mithraic Liturgy”; *ἐγὼ εἰμι σύμπλανος ὑμῖν ἀστήρ* (“I am a Star following his way like you”). The realization of the self also means a re-establishment of Man as the microcosm, i.e., man’s cosmic relatedness. Such realizations are frequently accompanied by synchronistic events. (The prophetic experience of vocation belongs to this category.)

[1574] To the primitive Christians as to all primitives, the Resurrection had to be a concrete, materialistic event to be seen by the eyes and touched by the hands, as if the spirit had no existence of its own. Even in modern times people cannot easily grasp the reality of a psychic event, unless it is concrete at the same time. Resurrection as a psychic event is certainly not concrete, it is just a psychic experience. It is funny that the Christians are still so pagan that they understand spiritual existence only as a body and as a physical event. I am afraid our Christian churches cannot maintain this shocking anachronism any longer, if they don’t want to get into intolerable contradictions. As a concession to this criticism, certain theologians have explained St. Paul’s glorified (subtle) body given back to the dead on the day of judgment as the authentic individual “form,” viz., a spiritual idea sufficiently characteristic of the individual that the material body could be skipped. It was the evidence for man’s survival after death and the hope to escape eternal damnation that made resurrection in the body the mainstay of Christian faith. We know positively only of the fact that space and time are relative to the psyche.

ON THE DISCOURSES OF THE BUDDHA¹

[1575] It was neither the history of religion nor the study of philosophy that first drew me to the world of Buddhist thought, but my professional interests as a doctor. My task was the treatment of psychic suffering, and it was this that impelled me to become acquainted with the views and methods of that great teacher of humanity whose principal theme was the “chain of suffering, old age, sickness, and death.” For although the healing of the sick naturally lies closest to the doctor’s heart, he is bound to recognize that there are many diseases and states of suffering which, not being susceptible of a direct cure, demand from both patient and doctor some kind of attitude to their irremediable nature. Even though it may not amount to actual incurability, in all such cases there are inevitably phases of stagnation and hopelessness which seem unendurable and require treatment just as much as a direct symptom of illness. They call for a kind of moral attitude such as is provided by religious faith or a philosophical belief. In this respect the study of Buddhist literature was of great help to me, since it trains one to observe suffering objectively and to take a universal view of its causes. According to tradition, it was by objectively observing the chain of causes that the Buddha was able to extricate his consciousness from the snares of the ten thousand things, and to rescue his feelings from the entanglements of emotion and illusion. So also in our sphere of culture the suffering and the sick can derive considerable benefit from this prototype of the Buddhist mentality, however strange it may appear.

[1576] The discourses of the Buddha, here presented in K. E. Neumann’s new translation, have an importance that should not be underestimated. Quite apart from their profound meaning, their solemn, almost ritual form emits a penetrating radiance which has an exhilarating and exalting effect and cannot fail to work directly upon one’s feelings. Against this use of the spiritual treasures of the East it might be—and indeed, often has been—objected from the Christian point of view that the faith of the West offers consolations that are at least as significant, and that there is no need to invoke the spirit of Buddhism with its markedly rational attitude. Aside from the fact that in most cases the Christian faith of which people speak simply isn’t there, and no one can tell how it might be obtained (except by the special providence of God), it is a truism that anything known becomes so familiar and hackneyed by frequent use that it gradually loses its meaning and hence its effect; whereas anything strange and unknown, and so completely different in its nature, can open doors hitherto locked and new possibilities of understanding. If a Christian insists so much

on his faith when it does not even help him to ward off a neurosis, then his faith is vain, and it is better to accept humbly what he needs no matter where he finds it, if only it helps. There is no need for him to deny his religion convictions if he acknowledges his debt to Buddhism, for he is only following the Pauline injunction: “Prove all things; hold fast that which is good” (I Thess. 5:21).

[1577] To this good which should be held fast one must reckon the discourses of the Buddha, which have much to offer even to those who cannot boast of any Christian convictions. They offer Western man ways and means of disciplining his inner psychic life, thus remedying an often regrettable defect in the various brands of Christianity. The teachings of the Buddha can give him a helpful training when either the Christian ritual has lost its meaning or the authority of religious ideas has collapsed, as all too frequently happens in psychogenic disorders.

[1578] People have often accused me of regarding religion as “mental hygiene.” Perhaps one may pardon a doctor his professional humility in not undertaking to prove the truth of metaphysical assertions and in shunning confessions of faith. I am content to emphasize the importance of having a *Weltanschauung* and the therapeutic necessity of adopting some kind of attitude to the problem of psychic suffering. Suffering that is not understood is hard to bear, while on the other hand it is often astounding to see how much a person can endure when he understands the why and the wherefore. A philosophical or religious view of the world enables him to do this, and such views prove to be, at the very least, psychic methods of healing if not of salvation. Even Christ and his disciples did not scorn to heal the sick, thereby demonstrating the therapeutic power of their mission. The doctor has to cope with actual suffering for better or worse, and ultimately has nothing to rely on except the mystery of divine Providence. It is no wonder, then, that he values religious ideas and attitudes, so far as they prove helpful, as therapeutic systems, and singles out the Buddha in particular, the essence of whose teaching is deliverance from suffering through the maximum development of consciousness, as one of the supreme helpers on the road to salvation. From ancient times physicians have sought a panacea, a *medicina catholica*, and their persistent efforts have unconsciously brought them nearer to the central ideas of the religion and philosophy of the East.

[1579] Anyone who is familiar with methods of suggestion under hypnosis knows that plausible suggestions work better than those which run counter to the patient’s own nature. Consequently, whether he liked it or not, the doctor was obliged to develop conceptions which corresponded as closely as possible with the actual psychological conditions. Thus, there grew up a realm of theory which not only drew upon traditional thought but took account of the unconscious products that compensated its inevitable one-sidedness—that is to say, all those psychic factors which Christian

philosophy left unsatisfied. Among these were not a few aspects which, unknown to the West, had been developed in Eastern philosophy from very early times.

[1580] So if, as a doctor, I acknowledge the immense help and stimulation I have received from the Buddhist teachings, I am following a line which can be traced back some two thousand years in the history of human thought.

FOREWORD TO FROBOESE-THIELE: "TRÄUME—EINE QUELLE RELIGIÖSER ERFAHRUNG?"¹

[1581] This book has the merit of being the first to investigate how the unconscious of Protestants behaves when it has to compensate an intensely religious attitude. The author examines this question with the help of case material she has collected in her practical work. She has evidently had the good fortune to come upon some very instructive cases who, moreover, did not object to the publication of their material. Since we owe our knowledge of unconscious processes primarily to dreams, the author is mainly concerned with the dreams of her patients. Even for one familiar with this material, the dreams and symbols reported here are remarkable. As a therapist, she handles the dreams in a very felicitous manner, from the practical side chiefly, so that a reciprocal understanding of the meaning of the dream is gradually built up between her and the patient. This puts the reader in the advantageous position of listening in on a dialogue, so to speak. The method is as instructive as it is satisfying, since it is possible to present in this way several fairly long sequences of dreams. A detailed scientific commentary would take up a disproportionate amount of space without making the dream interpretation any more impressive. If the interpretation is at times uncertain, or disregards various details, this in no way affects the therapeutic intention to bring the meaning of the dream nearer to consciousness. In actual practice, one can often do full justice to a dream if one simply puts its general tendency, its emotional atmosphere, and its approximate meaning in the right light, having first, of course, assured oneself of the spontaneous approval of the dreamer. With intelligent persons, this thoughtful feeling of one's way into the meaning of the dream can soon be left to the patient himself.

[1582] The author has been entirely successful in bringing out the religious meaning of the dreams and so demonstrating her thesis. A religious attitude does in fact offer a direct challenge to the unconscious, and the more inimical the conscious attitude is to life, the more forceful and drastic will be this unconscious reaction. It serves the purpose, firstly, of compensating the extremism of the conscious attitude and, secondly, of individuation, since it re-establishes the approximate wholeness of the personality.

[1583] The material which Dr. Froboese-Thiele has made available in her book is of considerable importance for doctors and theologians alike, since both of them have here an opportunity to assure themselves that the unconscious possesses a religious aspect against which no cogent arguments can be mustered. One is left with a feeling

of shame that so little of the empirical case material which would give the layman an adequate idea of these religious processes has been published. The author deserves our special thanks for having taken the trouble to write up these exacting cases *in extenso*. I hope her book will come into the hands of many thoughtful persons whose minds are not stopped up with needless prejudices, and who would be in a position to find a satisfactory answer to religious questions, or at least to come by those experiences which ought to underlie any authentic religious convictions.

JUNG AND RELIGIOUS BELIEF¹

1. Questions to Jung and His Answers²

QUESTION 1. *You say that religion is psychically healthy and often for the latter part of life essential, but is it not psychically healthy only if the religious person believes that his religion is true?*

Do you think that in your natural wish to keep to the realm of psychology you have tended to underestimate man's search for truth and the ways in which he might reach this as, for example, by inference?

[1584] Nobody is more convinced of the importance of the search for truth than I am. But when I say: something transcendental is true, my critique begins. If I call something true, it does not mean that it is absolutely true. It merely seems to be true to myself and/or to other people. If I were not doubtful in this respect it would mean that I implicitly assume that I am able to state an absolute truth. This is an obvious hybris. When Mr. Erich Fromm³ criticizes me for having a wrong idea and quotes Judaism, Christianity, and Buddhism he demonstrates how illogical his standpoint is, as are the views of those religions themselves, i.e., their truths contradict each other. Judaism has a morally ambivalent God; Christianity a Trinity and Summum Bonum; Buddhism has no God but has interior gods. Their truth is relative and not an absolute truth—if you put them on the same level, as Mr. Fromm does. I naturally admit, and I even strongly believe, that it is of the highest importance to state a “truth.” I should be prepared to make transcendental statements, but on one condition: that I state at the same time the possibility of their being untrue. For instance “God is,” i.e., is as I think he is. But as I know that I could not possibly form an adequate idea of an all-embracing eternal being, my idea of him is pitifully incomplete; thus the statement “God is not” (so) is equally true and necessary. To make absolute statements is beyond man's reach, although it is ethically indispensable that he give all the credit to his subjective truth, which means that he admits being bound by his conviction to apply it as a principle of his actions. Any human judgment, no matter how great its subjective conviction, is liable to error, particularly judgments concerning transcendental subjects. Mr. Fromm's philosophy has not transcended yet—I am afraid—the level of the twentieth century; but the power-drive of man and his hybris are so great that he believes in an absolutely valid judgment. No scientifically minded person with a sense of intellectual responsibility can allow himself such arrogance. These are the reasons why I insist upon the criterion of *existence*, both in the realm of

science and in the realm of religion, and upon immediate and primordial *experience*. Facts are facts and contain no falsity. It is our judgment that introduces the element of deception. To my mind it is more important that an idea exists than that it is true. This despite the fact that it makes a great deal of difference subjectively whether an idea seems to me to be true or not, though this is a secondary consideration since there is no way of establishing the truth or untruth of a transcendental statement other than by a subjective belief.

QUESTION 2. *Is it possible that you depreciate consciousness through an overvaluation of the unconscious?*

[1585] I have never had any tendency to depreciate consciousness by insisting upon the importance of the unconscious. If such a tendency is attributed to me it is due to a sort of optical illusion. Consciousness is the “known,” but the unconscious is very little known and my chief efforts are devoted to the elucidation of our unconscious psyche. The result of this is, naturally, that I talk more about the unconscious than about the conscious. Since everybody believes or, at least, tries to believe in the unequivocal superiority of rational consciousness, I have to emphasize the importance of the unconscious irrational forces, to establish a sort of balance. Thus to superficial readers of my writings it looks as if I were giving the unconscious a supreme significance, disregarding consciousness. As a matter of fact the emphasis lies on consciousness as the *conditio sine qua non* of apperception of unconscious contents, and the supreme arbiter in the chaos of unconscious possibilities. My book about *Types* is a careful study of the empirical structure of consciousness. If we had an inferior consciousness, we should all be crazy. The ego and ego-consciousness are of paramount importance. It would be superfluous to emphasize consciousness if it were not in a peculiar compensatory relationship with the unconscious.

[1586] People like Demant⁴ start from the prejudiced idea that the unconscious is something more or less nasty and archaic that one should get rid of. This is not vouched for by experience. The unconscious is neutral, rather like nature. If it is destructive on the one side, it is as constructive on the other side. It is the source of all sorts of evils and also the matrix of all divine experience and—paradoxical as it may sound—it has brought forth and brings forth consciousness. Such a statement does not mean that the source *originates*, i.e., that the water is created just at the spot where you see the source of a river; it comes from deep down in the mountain and runs along its secret ways before it reaches daylight. When I say, “Here is the source,” I only mean the spot where the water becomes visible. The water-simile expresses rather aptly the nature and importance of the unconscious. Where there is no water nothing lives; where there is too much of it everything drowns. It is the task of consciousness to select the right place where you are not too near and not too far

from water; but the water is indispensable. An unfavourable opinion about the unconscious does not enable proper Christians, like Demant, to realize that religious experience, so far as the human mind can grasp it, cannot be distinguished from the experience of so-called unconscious phenomena. A metaphysical being does not as a rule speak through the telephone to you; it usually communicates with man through the medium of the soul, in other words, our unconscious, or rather through its transcendental “psychoid” basis.⁵ If one depreciates the unconscious one blocks the channels through which the *aqua gratiae* flows, but one certainly does not incapacitate the devil by this method. Creating obstacles is just his métier.

[1587] When St. Paul had the vision of Christ, that vision was a psychic phenomenon—if it was anything. I don’t presume to know what the psyche is; I only know that there is a psychic realm in which and from which such manifestations start. It is the place where the *aqua gratiae* springs forth, but it comes, as I know quite well, from the immeasurable depths of the mountain and I don’t pretend to know about the secret ways and places the water flows through before it reaches the surface.

[1588] As the general manifestations of the unconscious are ambivalent or even ambiguous (“It is a fearful thing to fall into the hands of the living God,” Heb. 10:31), decision and discriminating judgment are all-important. We see that particularly clearly in the development of the individuation process, when we have to prevent the patient from either rejecting blindly the data of the unconscious or submitting to them without criticism. (Why has Jacob to fight the angel of the Lord? Because he would be killed if he did not defend his life.) There is no development at all but only a miserable death in a thirsty desert if one thinks one can rule the unconscious by our arbitrary rationalism. That is exactly what the German principle, “Where there is a will, there is a way,” tried to do, and you know with what results.

QUESTION 3. *In your “Answer to Job” you state, page 463 (Collected Works, Vol. 11): “I have been asked so often whether I believe in the existence of God or not that I am somewhat concerned lest I be taken for an adherent of ‘psychologism’ far more commonly than I suspect.” You go on to say, “God is an obvious psychic and non-physical fact,” but I feel in the end you do not actually answer the question as to whether or not you believe in the existence of God other than as an archetype. Do you?*

This question is important because I should like to answer the kind of objection raised by Glover in his Freud or Jung, page 163: “Jung’s system is fundamentally irreligious. Nobody is to care whether God exists, Jung least of all. All that is necessary is to ‘experience’ an “attitude’ because it ‘helps one to live.’”

[1589] An archetype—so far as we can establish it empirically—is an *image*. An image, as the very term denotes, is a picture of something. An archetypal image is like the

portrait of an unknown man in a gallery. His name, his biography, his existence in general are unknown, but we assume nevertheless that the picture portrays a once living subject, a man who was real. We find numberless images of God, but we cannot produce the original. There is no doubt in my mind that there is an original behind our images, but it is inaccessible. We could not even be aware of the original since its translation into psychic terms is necessary in order to make it perceptible at all. How would Kant's *Critique of Pure Reason* look when translated into the psychic imagery of a cockroach? And I assume that the difference between man and the creator of all things is immeasurably greater than between a cockroach and man. Why should we be so immodest as to suppose that we could catch a universal being in the narrow confines of our language? We know that God-images play a great role in psychology, but we cannot prove the physical existence of God. As a responsible scientist I am not going to preach my personal and subjective convictions which I cannot prove. I add nothing to cognition or to a further improvement and extension of consciousness when I confess my personal prejudices. I simply go as far as my mind can reach, but to venture opinions beyond my mental reach would be immoral from the standpoint of my intellectual ethics. If I should say, "I believe in such and such a God," it would be just as futile as when a Negro states his firm belief that the tin-box he found on the shore contains a powerful fetish. If I keep to a statement which I think I can prove, this does not mean that I deny the existence of anything else that might exist beyond it. It is sheer malevolence to accuse me of an atheistic attitude simply because I try to be honest and disciplined. Speaking for myself, the question whether God exists or not is futile. I am sufficiently convinced of the effects man has always attributed to a divine being. If I should express a belief beyond that or should assert the existence of God, it would not only be superfluous and inefficient, it would show that I am not basing my opinion on facts. When people say that they believe in the existence of God, it has never impressed me in the least. Either I know a thing and then I don't need to believe it; or I believe it because I am not sure that I know it. I am well satisfied with the fact that I know experiences which I cannot avoid calling numinous or divine.

QUESTION 4. *Do you ignore the importance of other disciplines for the psyche?*

Goldbrunner in his Individuation, page 161, says that your treatment of "what God is in Himself" is a question which you regard as beyond the scope of psychology, and adds: "This implies a positivistic, agnostic renunciation of all metaphysics." Do you agree that your treatment amounts to that? Would you not agree that such subjects as metaphysics and history have their place in the experience of the psyche?

[1590] I do not ignore the importance of other disciplines for the psyche. When I was professor at the E.T.H. in Zurich I lectured for a whole year about Tantrism⁶ and for another year about the *Spiritual Exercises* of St. Ignatius of Loyola.⁷ Moreover, I have written a number of books about the peculiar spiritual discipline of the alchemists.

[1591] What Goldbrunner says is quite correct. I don't know what God is in himself. I don't suffer from megalomania. Psychology to me is an honest science that recognizes its own boundaries, and I am not a philosopher or a theologian who believes in his ability to step beyond the epistemological barrier. Science is made by man, which does not mean that there are not occasionally acts of grace permitting transgression into realms beyond. I don't depreciate or deny such facts, but to me they are beyond the scope of science as pointed out above. I believe firmly in the intrinsic value of the human attempt to gain understanding, but I also recognize that the human mind cannot step beyond itself, although divine grace may and probably does allow at least glimpses into a transcendental order of things. But I am neither able to give a rational account of such divine interventions nor can I prove them. Many of the analytical hours with my patients are filled with discussions of "metaphysical" intrusions, and I am in dire need of historical knowledge to meet all the problems I am asked to deal with. For the patient's mental health it is all-important that he gets some proper understanding of the numina the collective unconscious produces, and that he assigns the proper place to them. It is, however, either a distortion of the truth or lack of information when Goldbrunner calls my attitude "positivistic," which means a one-sided recognition of scientific truth. I know too well how transitory and sometimes even futile our hypotheses are, to assume their validity as durable truths and as trustworthy foundations of a *Weltanschauung* capable of giving man sure guidance in the chaos of this world. On the contrary, I rely very much on the continuous influx of the numina from the unconscious and from whatever lies behind it. Goldbrunner therefore is also wrong to speak of an "agnostic renunciation of all metaphysics." I merely hold that metaphysics cannot be an object of science, which does not mean that numinous experiences do not happen frequently, particularly in the course of an analysis or in the life of a truly religious individual.

QUESTION 5. *If my reading of your views is correct, I should judge that you think evil to be a far more active force than traditional theological views have allowed for. You appear unable to interpret the condition of the world today unless this is so. Am I correct in this? If so, is it really necessary to expect to find the dark side in the Deity? And if you believe that Satan completes the quaternity does this not mean that the Deity would be amoral?*

Victor White in his *God and the Unconscious* writes at the end of his footnote on page 76: “On the other hand, we are unable to find any intelligible, let alone desirable, meaning in such fundamental Jungian conceptions as the ‘assimilation of the shadow’ if they are not to be understood as the supplying of some absent good (e.g., consciousness) to what is essentially valuable and of itself ‘good.’”

[1592] I am indeed convinced that evil is as positive a factor as good. Quite apart from everyday experience it would be extremely illogical to assume that one can state a quality without its opposite. If something is good, then there must needs be something that is evil or bad. The statement that something is good would not be possible if one could not discriminate it from something else. Even if one says that something exists, such a statement is only possible alongside the other statement that something does not exist. Thus when the Church doctrine declares that evil is not (*μη ὄν*) or is a mere shadow, then the good is equally illusory, as its statement would make no sense.

[1593] Suppose one has something 100-per-cent good, and if anything evil comes in it is diminished, say by 5 per cent. Then one possesses 95 per cent of goodness and 5 per cent is just absent. If the original good diminished by 99 per cent, one has 1 per cent good and 99 per cent is gone. If that 1 per cent also disappears, the whole possession is gone and one has nothing at all. To the very last moment one had only good and oneself was good, but on the other side there is simply nothing and nothing has happened. Evil deeds simply do not exist. The identification of good with *ousia* is a fallacy, because a man who is thoroughly evil does not disappear at all when he has lost his last good. But even if he has 1 per cent of good, his body and soul and his whole existence are still *thoroughly good*; for, according to the doctrine, evil is simply identical with non-existence. This is such a horrible syllogism that there must be a very strong motive for its construction. The reason is obvious: it is a desperate attempt to save the Christian faith from dualism. According to this theory [of the *privatio boni*] even the devil, the incarnate evil, must be good, because he exists, but inasmuch as he is thoroughly bad, he does not exist. This is a clear attempt to annihilate dualism in flagrant contradiction to the dogma that the devil is eternal and damnation a very real thing. I don't pretend to be able to explain the actual condition of the world, but it is plain to any unprejudiced mind that the forces of evil are dangerously near to a victory over the powers of good. Here Basil the Great would say, “Of course that is so, but all evil comes from man and not from God,” forgetting altogether that the serpent in Paradise was not made by man, and that Satan is one of the sons of God, prior to man. If man were positively the origin of all evil, he would possess a power equal or almost equal to that of the good, which is God. But we don't need to inquire into the origin of Satan. We have plenty of evidence in the Old Testament that Yahweh is moral and immoral at the same time, and Rabbinic

theology is fully aware of this fact. Yahweh behaves very much like an immoral being, though he is a guardian of law and order. He is unjust and unreliable according to the Old Testament. Even the God of the New Testament is still irascible and vengeful to such a degree that he needs the self-sacrifice of his son to quench his wrath. Christian theology has never denied the identity of the God of the Old Testament with that of the New Testament. Now I ask you: what would you call a judge that is a guardian of the Law and is himself unjust? One would be inclined to call such a man immoral. I would call him both immoral and moral, and I think I express the truth with this formula. Certainly the God of the Old Testament is good and evil. He is the Father or Creator of Satan as well as of Christ. Certainly if God the Father were nothing else than a loving Father, Christ's cruel sacrificial death would be thoroughly superfluous. I would not allow my son to be slaughtered in order to be reconciled to my disobedient children.

[1594] What Victor White writes about the assimilation of the shadow is not to be taken seriously. Being a Catholic priest he is bound hand and foot to the doctrine of his Church and has to defend every syllogism. The Church knows all about the assimilation of the shadow, i.e., how it is to be repressed and what is evil. Being a doctor I am never too certain about my moral judgments. Too often I find that something that is a virtue in one individual is a vice in another, and something that is good for the one is poison for another. On the other hand, pious feeling has invented the term of *felix culpa* and Christ preferred the sinner. Even God does not seem particularly pleased with mere righteousness.

[1595] Nowhere else is it more important to emphasize that we are speaking of our traditional image of God (which is not the same as the original) than in the discussion of the *privatio boni*. We don't produce God by the magic word or by representing his image. The word for us is still a fetish, and we assume that it produces the thing of which it is only an image. What God is in himself nobody knows; at least I don't. Thus it is beyond the reach of man to make valid statements about the divine nature. If we disregard the short-comings of the human mind in assuming a knowledge about God, which we cannot have, we simply get ourselves into most appalling contradictions and in trying to extricate ourselves from them we use awful syllogisms, like the *privatio boni*. Moreover our superstitious belief in the power of the word is a serious obstacle to our thinking. That is the historical reason why quite a number of shocking contradictions have been heaped up, offering facile opportunities to the enemy of religion. I strongly advocate, therefore, a revision of our religious formulas with the aid of psychological insight. It is the great advantage of Protestantism that an intelligent discussion is possible. Protestantism should make use of this freedom. Only a thing that changes and evolves, lives, but static things mean spiritual death.⁸

2. Final Questions and Answers⁹

QUESTION 1. *If Christ, in His Incarnation, concentrated, as you contend, on goodness (“Answer to Job,” pp. 414, 429f.) what do you mean by “Christ preferred the sinner” and “Even God does not seem particularly pleased with mere righteousness”? Is there not an inconsistency here?*

[1596] Of course there is. I am just pointing it out.

QUESTION 2. *You stress the principle of the opposites and the importance of their union. You also write of enantiodromia in relation to the opposites but this (in the sense in which Heraclitus used the term) would never produce a condition of stability which could lead to the union of the opposites. So is there not a contradiction in what you say about the opposites?*

[1597] “Enantiodromia” describes a certain psychological fact, i.e., I use it as a psychological concept. Of course it does not lead to a union of opposites, has—as a matter of fact—nothing to do with it. I see no contradiction anywhere.

QUESTION 3. *If the principle of enantiodromia, a perpetual swinging of the pendulum, is always present would we not have a condition in which there would be no sense of responsibility, but one of amorality and meaninglessness?*

[1598] Naturally life would be quite meaningless if the enantiodromia of psychological states kept on for ever. But such an assumption would be both arbitrary and foolish.

QUESTION 4. *When we come into close contact with pharisaism, theft or murder, involving uncharitableness, ruthless and selfish treatment of others, we know that they are evil and very ugly. In actual life what we call goodness—loyalty, integrity, charitableness—does not appear as one of a pair of opposites but as the kind of behavior we want for ourselves and others. The difficulty is that we cannot judge all the motives involved in any action with certainty. We are unable to see the complete picture and so we should be cautious and charitable in our judgments. But this does not mean that what is good is not good, or what is evil is not evil. Do you not think that what you have to say about the quaternity and enantiodromia ultimately blurs the distinction between good and evil? Is not what is blurred only our capacity always to see the real moral issues clearly?*

[1599] It only means that moral judgment is human, limited, and under no condition metaphysically valid. Within these confines good is good, and evil is evil. One must have the courage to stand up for one’s convictions. We cannot imagine a state of wholeness (quaternity) which is good and evil. It is beyond our moral judgment.

QUESTION 5. *Theologians who believe in Satan have maintained that he was created good but that through the use of his free will he became evil. What necessity is there to assume that he is the inevitable principle of evil in the Godhead—the fourth member of the quaternity?*

[1600] Because the Three are the Summum Bonum, and the devil is the principle and personification of evil. In a Catholic quaternity the fourth would be the Mother, 99-per-cent divine. The devil would not count, being *μη̄ ὄν*, an empty shadow owing to the *privatio boni*, in which the Bonum is equal to *οὐσία*.

QUESTION 6. *You build much on the existence of four functions, thinking, feeling, sensation, and intuition. Is this a final or satisfactory typology? If feeling is included, why not conation?*

[1601] The four functions are a mere model for envisaging the qualities of *consciousness*. Conation is a term applicable to the creative process starting in the unconscious and ending in a conscious result, in other words a dynamic aspect of psychic life.

QUESTION 7. *By different approaches in your later writings you add Satan and the Blessed Virgin Mary to the Trinity, but this would make a quinary. Who compose the quaternity?*

[1602] The quaternity can be a hypothetical structure, depicting a wholeness. It is also not a logical concept, but an empirical fact. The *quinarius* or *quinio* (in the form of 4 + 1, i.e., quincunx) does occur as a symbol of wholeness (in China and occasionally in alchemy) but relatively rarely. Otherwise the *quinio* is not a symbol of wholeness, quite the contrary (e.g., the five-rayed star of the Soviets or of U.S.A.). Rather, it is a chaotic *prima materia*.

QUESTION 8. *Would not the quaternity involve not only a revision of doctrine but of moral issues as well, for it would appear inevitably to mean complete moral relativity and so amorality having its source in the Godhead Itself?*

[1603] Man cannot live without moral judgment. From the fact of the empirical quaternary structure of 3 + 1 (3 = good, 1 = evil) we can conclude that the unconscious characterizes itself as an unequal mixture of good and evil.

[1604] There are also not a few cases where the structure is reversed: 1 + 3 (1 = good, 3 = evil). 3 in this case would form the so-called “lower triad.” Since the quaternity as a rule appears as a unity, the opposites annul each other, which simply means that our anthropomorphic judgment is no more applicable, i.e., the divinity is beyond good and evil, or else metaphysical assertion is not valid. In so far as the human mind and

its necessities issue from the hands of the Creator, we must assume that moral judgment was provided by the same source.

QUESTION 9. *What exactly are you referring to when you use the word “quaternity” in relation to religion? Are you using “quaternity” purely for images which men form of the Godhead? You sometimes give the impression that you are referring to God-images alone. At other times you write as if you have in mind the Godhead itself. This is especially so when you stress the necessity of including Satan and also the Blessed Virgin Mary in the Godhead. If you do not refer to the Godhead itself, there seems to me to be no explanation of the urgency of your words about recognizing the evil principle in God and your welcome of the promulgation of the Assumption.*

[1605] I use the term “quaternity” for the mandala and similar structures that appear *spontaneously* in dreams and visions, or are “invented” (from *invenire* = to find), to express a totality (like four winds and seasons or four sons, seraphim, evangelists, gospels, fourfold path, etc.). The quaternity is of course an image or picture, which does not mean that there is no original!

[1606] If the opposites were not contained in the image, it would not be an image of totality. But it is meant to be a picture of ineffable wholeness, in other words, its symbol. It has an importance for the theologian only in so far as the latter attributes significance to it. If he assumes that his images or formulations are not contents of his consciousness (which is a *contradictio in adiecto*), he can only state that they are exact replicas of the original. But who could suggest such a thing? In spite of the fact that the Church long ago discouraged the idea of a quaternity, the fact remains that Church symbolism abounds in quaternity allusions. As Three (Trinity) is only one (albeit the main) aspect of the Deity, the remaining fourth principle is wiped out of existence by the *privatio boni* syllogism. But the Catholic Church was aware that the picture without opposites is not complete. It therefore admitted (at least tentatively) the existence of a feminine factor within the precincts of the masculine Trinity (*Assumptio Beatae Virginis*). For good reasons the devil is still excluded, and even annihilated, by the *privatio boni*.

[1607] The admission of the *Beata Virgo* is a daring attempt, in so far as she belongs to *lubricum illud genus*¹⁰ (St. Epiphanius), so suspect to the moralistic propensities of the said Church. However, she has been spiritually “disinfected” by the dogma of *Conceptio immaculata*. I consider the Assumption as a cautious approach to the solution of the problem of opposites, namely, to the integration of the fourth metaphysical figure into the divine totality. The Catholic Church has almost succeeded in creating a *quaternity without shadow*, but the devil is still outside. The Assumption is at least an important step forward in Christian (?) symbolism. This evolution will be completed when the dogma of the Co-Redemptrix is reached. But

the main problem will not be solved, although one pair of opposites (♂ and ♀) has been smuggled into the divine wholeness. Thus the Catholic Church (in the person of the Pope) has at least seen fit to take the Marianic movement in the masses, i.e., a *psychological fact*, so seriously that he did not hesitate to give up the time-hallowed principle of apostolic authority.

[1608] Protestantism is free to ignore the spiritual problems raised by our time, but it will remove itself from the battlefield and thereby lose its contact with life.

[1609] Being a natural and spontaneous symbol, the quaternity has everything to do with human psychology, while the trinitarian symbol (though equally spontaneous) has become cold, a remote abstraction. Curiously enough, among my collection of mandalas I have only a small number of trinities and triads. They stem one and all from Germans!¹¹ (Unconscious of their shadows, therefore unaware of collective guilt!)

[1610] I do not know at all to what extent human formulas, whether invented or spontaneous, correspond with the original. I only know that we are profoundly concerned with them, whether people know it or not, just as you can be with an illness of which you are unaware. It makes an enormous practical difference whether your dominant idea of totality is three or four. In the former case all good comes from God, all evil from man. Then man is the devil. In the latter case man has a chance to be saved from devilish possession, in so far as he is not inflated with evil. What happened under National Socialism in Germany? What is happening under Bolshevism? With the quaternity the powers of evil, so much greater than man's, are restored to the divine wholeness, whence they originated, even according to Genesis. The serpent was not created by man.

[1611] The quaternity symbol has as much to do with the Godhead as the Trinity has. As soon as I begin to think at all about the experience of "God," I have to choose from my store of images between [concepts representing him as a] monad, dyad, triad, tetrad or an indistinct multiplicity. In any serious case the choice is limited by the kind of revealed image one has received. Yahweh and Allah are monads, the Christian God a triad (historically), the modern experience presumably a tetrad, the early Persian deity a dyad. In the East you have the dyadic monad Tao and the monadic Anthropos (*purusha*), Buddha, etc.

[1612] In my humble opinion all this has very much to do with psychology. We have nothing to go by but these images. Without images you could not even speak of divine experiences. You would be completely inarticulate. You only could stammer "mana" and even that would be an image. Since it is a matter of an ineffable experience the image is indispensable. I would completely agree if you should say: God approaches man in the form of symbols. But we are far from knowing whether the symbol is correct or not.

- [1613] The *privatio boni* cannot be compared to the quaternity, because it is not a revelation. On the contrary, it has all the earmarks of a “doctrine,” a philosophical invention.
- [1614] It makes no difference at all whether I say “God” or “God-head.” Both are in themselves far beyond man’s reach. To us they are revealed as psychic images, i.e., symbols.
- [1615] I am far from making any statements about God himself. I am talking about images, which it is very important to think and talk about, and to criticize, because so much depends upon the nature of our dominant ideas. It makes all the difference in the world whether I think that the source of evil or good is myself, my neighbour, the devil, or the supreme being.
- [1616] Of course I am pleading the cause of the *thinking* man, and, inasmuch as most people do not think, of a small minority. Yet it has its place in creation and presumably it makes sense. Its contribution to the development of consciousness is considerable and since Nature has bestowed the highest premium of success on the *conscious* being, consciousness must be more precious to Nature than unconsciousness. Therefore I think that I am not too far astray in trying to understand the symbol of the Deity. My opinion is that such an attempt—whether successful or not—could be of great interest to theology which is built on the same primordial images, whether one likes it or not. At all events you will find it increasingly difficult to convince the educated layman that theology has nothing to do with psychology, when the latter acknowledges its indebtedness to the theological approach.
- [1617] My discussion with theology starts from the fact that the naturally revealed central symbols, such as the quaternity, are not in harmony with trinitarian symbols. While the former includes the darkness in the divine totality, the Christian symbol excludes it. The Yahwistic symbol of the star of David is a *complexio oppositorum*: ▽, fire △ and water ☆, a mandala built on three, an unconscious acknowledgment of the Trinity but including the shadow. Properly so, because Satan is still among the *benê Elohim* [sons of God], though Christ saw him falling out of heaven [Luke 10:18]. This vision points to the Gnostic abscission of the shadow, mentioned by Irenaeus.¹² As I have said, it makes a great and vital difference to man whether or not he considers himself as the source of evil, while maintaining that all good stems from God. Whether he knows it or not, this fills him with satanic pride and hybris on the one side and with an abysmal feeling of inferiority on the other. But when he ascribes the immense power of the opposites to the Deity, he falls into his modest place as a small image of the Deity, not of Yahweh, in whom the opposites are unconscious, but of a quaternity consisting of the main opposites: male and female, good and evil, and reflected in human consciousness as confirmed by psychological experience and by the historical evidence. Or have I invented the idea of Tao, the living spiritual symbol

of ancient China? Or the four sons of Horus in ancient Egypt? Or the alchemical quaternity that lived for almost a thousand years? Or the Mahayana mandala which is still alive?

QUESTION 10. *One of your objections to the privatio boni doctrine is that it minimizes evil, but does not your view of the quaternity, which includes both good and evil, minimize evil much more surely and assume its existence for ever?*

[1618] The quaternity symbol relativizes good and evil, but it does not minimize them in the least.

QUESTION 11. *You argue in "Answer to Job" (pp. 399, 430) that, because of his virgin birth, Christ was not truly man and so could not be a full incarnation in terms of human nature. Do you believe that Christ was born of a virgin? If not, the argument in "Answer to Job" falls to pieces. If you believe in the Virgin Birth, would it not be logical to accept the whole emphasis of the Christian Creeds, for they would not appear to be more difficult to believe in than the Virgin Birth?*

[1619] The dogma of the Virgin Birth does not abolish the fact that "God" in the form of the Holy Ghost is Christ's father. If Yahweh is his father, then it is a matter of an *a priori* union of opposites. If the Summum Bonum is his father, then the powers of darkness are missing and the term "good" has lost its meaning and Christ has not become man, because man is afflicted with darkness.

QUESTION 12. *Christ, so the Gospel narratives assert, was born in a manger because there was no room for Him in the inn at Bethlehem; His early life included the Slaughter of the Innocents and His family lived for a time exiled in Egypt; He faced temptation in the wilderness; His ministry was carried on under such hard conditions that He "had not where to lay His head" (Matt. 8:20). He met and ministered to numerous sufferers; sinners received His sympathy and understanding; He endured an agony of suffering in the Garden of Gethsemane and this was followed by His trials, and finally the cruellest of deaths by crucifixion. On what grounds then can you argue that Christ was an incarnation of the light side of God and that He did not enter fully into the dark aspects of existence? ("Answer to Job," pp. 398f., 414, 430.) On the contrary, traditionally He has often been thought of as "a man of sorrows, and acquainted with grief."*

[1620] All that has nothing to do with the dark side of man. Christ is on the contrary the innocent and blameless victim without the *macula peccati*, therefore not really a human being who has to live without the benefit of the Virgin Birth and is crucified in a thousand forms.

QUESTION 13. *What do you mean when in “Answer to Job” you refer to Antichrist and his reign, and state that this was astrologically foretold?*

[1621] It is potentially foretold by the aeon of the Fishes (♓) then beginning, and in fact by the Apocalypse. Cf. my argument in *Aion*, ch. VI.; also Rev. 20:7: “And when the thousand years are expired, Satan shall be loosed out of his prison.”

QUESTION 14. *What do you mean by “divine unconsciousness” in “Answer to Job” (footnote on page 383)? Is God more limited than man?*

[1622] This is just the trouble. From Job it is quite obvious that Yahweh behaves like a man with inferior consciousness and an absolute lack of moral self-reflection. In this respect God-image is more limited than man. Therefore God must incarnate.

QUESTION 15. *One of Job’s greatest problems was: Can I believe in a just God? Individuation, “the Christification of many,” the solution given in “Answer to Job” [p. 470], does not do justice to Job’s question. Did not Job want meaning, a good God and not simply individuation? He was concerned with metaphysical and theological issues, and the modern Job is too, and just as man cannot live by bread alone, so is he unlikely to feel that he can live by individuation alone which, at its most successful, would appear to be little more than a preparatory process enabling him to face these issues more objectively.*

[1623] Job wanted justice. He saw that he could not obtain it. Yahweh cannot be argued with. He is unreflecting power. What else is left to Job but to shut his mouth? He does not dream of individuation, but he knows what kind of God he is dealing with. It is certainly not Job drawing further conclusions but God. He sees that incarnation is unavoidable because man’s insight is a step ahead of him. He must “empty himself of his Godhead and assume the shape of the *δοῦλος*¹³ i.e., man is his lowest form of existence, in order to obtain the jewel which man possesses in his self-reflection. Why is Yahweh, the omnipotent creator, so keen to have his “slave,” body and soul, even to the point of admitted jealousy?

[1624] Why do you say “by individuation alone”? *Individuation is the life in God*, as mandala psychology clearly shows. Have you not read my later books? You can see it in every one of them. The symbols of the self coincide with those of the Deity. The self is not the ego, it symbolizes the totality of man and he is obviously not whole without God. That seems to be what is meant by incarnation and incidentally by individuation.

3. *Answers to Questions from the Rev. David Cox:*¹⁴

This question concerned Jung's statement in Two Essays on Analytical Psychology (par. 327) that Western culture has no name or concept for the "union of opposites by the middle path" which could be compared to the concept of Tao. It was suggested that the Christian doctrine of justification by faith is such a concept.

[1625] Not being a theologian I cannot see a connection between the doctrine of justification and Tao. Tao is the cooperation of opposites, bright-dark, dry-humid, hot-cold, south-north, dragon-tiger, etc., and has nothing to do with moral opposites or with a reconciliation between the Summum Bonum and the devil. Christian doctrine—so far as I know—does not recognize dualism as the constitution of Tao, but Chinese philosophy does.

[1626] It is certainly true that natural man always tries to increase what seems "good" to him and to abolish "evil." He depends upon his consciousness, which, however, may be crossed by "conscience" or by some unconscious intention. This factor can occasionally be stronger than consciousness, so that it cannot be fought. We are very much concerned in psychotherapy with such cases.

[1627] The "Will of God" often contradicts conscious principles however good they may seem. Penitence or remorse follows the deviation from the superior will. The result is—if not a chronic conflict—a *coniunctio oppositorum* in the form of the symbol (*symbolum* = the two halves of a broken coin), the expression of totality.

[1628] I did not know that you understand Christ as the new centre of the individual. Since this centre of the individual appears empirically as a union of opposites (usually a quaternity), Christ must be beyond moral conflict, thus representing ultimate decision. This conception coincides absolutely with my view of the self (= Tao, *nirdvandva*). But since the self includes my consciousness as well as my unconscious, my ego is an integral part of it. Is this also your view of Christ? If this should be so, I could completely agree with you. Life then becomes a dangerous adventure, because I surrender to a power beyond the opposites, to a superior or divine factor, without argument. His supreme decision may be what I call good or what I call bad, as it is unlimited. What is the difference between my behaviour and that of an animal fulfilling the will of God unreservedly? The only difference I can see is that I am conscious of, and reflect on, what I am doing. "If thou knowest what thou art doing, thou art blessed."¹⁵ You have acted.

[1629] (*Unjust steward.*) This is Gnostic morality but not that of the decalogue. The true servant of God runs risks of no mean order. *Entendu!* Thus, at God's command, Hosea marries a whore. It is not beyond the bounds of possibility that such orders could be issued even in modern times. Who is ready to obey? And what about the fact that anything coming from the unconscious is expressed in a peculiar language (words, thoughts, feelings, impulses) that might be misinterpreted? These questions are not meant as arguments against the validity of your view. They merely illustrate

the enormity of the risk. I ventilate them only to make sure we really believe in a Christ beyond good and evil. I am afraid of unreflecting optimism and of secret loopholes, as for instance, “Oh, you can trust in the end that everything will be all right.” *Id est*: “God is good” (and not beyond good and evil). Why has God created consciousness and reason and doubt, if complete surrender and obedience to his will is the *ultima ratio*? He was obviously not content with animals only. He wants reflecting beings who are at the same time capable of surrendering themselves to the primordial creative darkness of his will, unafraid of the consequences.

[1630] I cannot help seeing that there is much evidence in primitive Christianity for your conception of Christ, but none in the later development of the Church. Nevertheless there are the seemingly unshakable scriptural testimonies to the essential goodness of God and Christ and there is—to my knowledge—no positive statement in favour of a beyond-good-and-evil conception, not even an implied one. This seems to me to be a wholly modern and new interpretation of a revolutionary kind, at least in view of the *Summum Bonum*, as you add the *Malum* and transcend both. In this I completely agree with you. I only want to make sure that we understand each other when we reach the conclusion that man’s true relation to God must include both love and fear to make it complete. If both are true, we can be sure that our relation to him is adequate. The one relativizes the other: in fear we may hope, in love we may distrust. Both conditions appeal to our consciousness, reflection, and reason. Both our gifts come into their own. But is this not a relativization of complete surrender? Or at least an acceptance after an internal struggle? Or a fight against God that can be won only if he himself is his advocate against himself, as Job understood it? And is this not a tearing asunder of God’s original unity by man’s stubbornness? A disruption sought by God himself, or by the self itself? As I know from my professional experience, the self does indeed seek such issues because it seeks *consciousness*, which cannot exist without discrimination (differentiation, separation, opposition, contradiction, discussion). The self is empirically in a condition we call unconscious in our three-dimensional world. What it is in its transcendental condition, we do not know. So far as it becomes an object of cognition, it undergoes a process of discrimination and so does everything emanating from it. The discrimination is intellectual, emotional, ethical, etc. That means: the self is subject to our free decision thus far. But as it transcends our cognition, we are its objects or slaves or children or sheep that cannot but obey the shepherd. Are we to emphasize consciousness and freedom of judgment or lay more stress on obedience? In the former case can we fulfil the divine will to consciousness, and in the latter the primordial instinct of obedience? Thus we represent the intrinsic Yea and Nay of the *opus divinum* of *creatio continua*. We ourselves are in a certain respect “beyond good and evil.” This is very dangerous indeed (cf. Nietzsche), but no

argument against the truth. Yet our inadequacy, dullness, inertia, stupidity, etc. are equally true. Both are aspects of one and the same being.

[1631] Accordingly the alchemists thought of their opus as a continuation and perfection of creation, whereas the modern psychological attempt confronts the opposites and submits to the tension of the conflict: “Expectans naturae operationem, quae lentissima est, aequo animo,”¹⁶ to quote an old master. We know that a *tertium quid* develops out of an opposition, partly aided by our conscious effort, partly by the co-operation of the unconscious effort, partly by the co-operation of the unconscious (the alchemists add: *Deo concedente*). The result of this opus is the *symbol*, in the last resort the self. The alchemists understood it to be as much physical as spiritual, being the *filius macrocosmi*, a parallel to Christ, the *υἱος τοῦ ἀνθρώπου*. The Gnostics understood the serpent in paradise to be the *λόγος*, and in the same way the alchemists believed that their *filius philosophorum* was the chthonic *serpens mercurialis* transformed (taking the serpent on the *σταυρός* [cross] as an *allegoria ad Christum spectans*).¹⁷ Their naïveté shows a hesitation (which I feel too) to identify the self with Christ. Their symbol is the *lapis*. It is incorruptible, *semel factus* (from the *increatum*, the primordial chaos), everlasting, our tool and master at the same time (“*artifex non est magister lapidis, sed potius eius minister*”),¹⁸ the redeemer of creation in general, of minerals, plants, animals, and of man’s physical imperfection. Hence its synonyms: panacea, *alexipharmacum*, *medicina catholica*, etc. (and hellebore, because it heals insanity).

[1632] Of course if you understand Christ by definition as a *complexio oppositorum*, the equation is solved. But you are confronted with a terrific historical counterposition. As it concerns a point of supreme importance, I wanted to clarify the problem beyond all doubt. This may explain and excuse my long-winded argument.

II

In “Answer to Job” Jung claims that Jesus “incarnates only the light” side of God. This may represent the way in which Jesus is thought of by the majority of Western men and women today, but is it not false to the New Testament and to Christian thought over the centuries?

[1633] You must consider that I am an alienist and practical psychologist, who has to take things as they *are* understood, not as they *could* or *should* be understood. Thus the Gnostics thought that Christ had cut off his shadow, and I have never heard that he embodies evil as Yahweh explicitly does. Catholic as well as Protestant teaching insists that Christ is without sin. As a scientist I am chiefly concerned with what is generally believed, although I can’t help being impressed by the fact that the ecclesiastical doctrines do not do justice to certain facts in the New Testament. I have however to consider the *consensus omnium* that Christ is without the *macula peccati*.

If I should say that Christ contains some evil I am sure to have the Churches against me. As a psychologist I cannot deal with the theological conception of truth. My field is people's common beliefs.

[1634] Since I am not chiefly concerned with theology but rather with the layman's picture of theological concepts (a fact you must constantly bear in mind), I am liable to make many apparent contradictions (like the medieval mind acquainted with funny stories about Jesus, as you rightly point out). The Gospels do indeed give many hints pointing to the dark side, but this has not affected the picture of the *lumen de lumine*, which is the general view. I am thinking—as a psychologist—about all sorts of erroneous notions which do exist in spite of higher criticism and accurate exegesis and all the achievements of theological research. My object is the general condition of the Christian mind, and not theology, where I am wholly incompetent. Because the *lumen de lumine* idea is paramount in the layman's mind, I dare to point to certain scriptural evidence (accessible to the layman) showing another picture of Christ. I am certain that your conception of Christ would have a hard time getting through certain thick skulls. It is the same with the idea of evil contained in God. I am concerned with dogmas, prejudices, illusions, and errors and every kind of doubt in the layman's mind, and I try to get a certain order into that chaos by the means accessible to a layman, i.e., to myself as a representative of the humble “ignoramus.”

III

This question deals with the relationship between faith and projection. Has Jung, in his writing, treated faith as being connected with an outward form of religion?

[1635] This I do not properly understand. Of course “faith” is a relationship to projected contents. But I cannot see how that “corresponds for all practical purposes to a withdrawal of the projection.” Faith on the contrary—as it seems to me—maintains the conviction that the projection is a reality. For instance, I project saintly qualities on to somebody. My faith maintains and enhances this projection and creates a worshipful attitude on my part. But it is quite possible that the bearer of the projection is nothing of the kind, perhaps he is even an unpleasant hypocrite. Or I may project, i.e., hypostatize, a religious conviction of a certain kind which I maintain with faith and fervour. Where is the “withdrawal of the projection”?

[1636] In case of doubt you had better refer to *Symbols of Transformation*. Once I was at the beginning of things, at the time when I separated from Freud in 1912. I found myself in great inner difficulties, as I had no notion of the collective unconscious or of archetypes. My education was based chiefly on science, with a modest amount of the humanities. It was a time of *Sturm und Drang*. The so-called *Psychology of the Unconscious*¹⁹ was an intuitive leap into the dark and contains no end of inadequate formulations and unfinished thoughts.

[1637] I make a general distinction between “religion” and a “creed” for the sake of the layman, since it is chiefly he who reads my books and not the academic scholar. He (the scholar) is not interested in the layman’s mind. As a rule he nurses resentments against psychology. I must repeat again: I am a psychologist and thus people’s minds interest me in the first place, although I am keen to learn the truth the specialist produces. The layman identifies religion with a creed, that is, with the “things done in the church.” Thus Islam, Judaism, Buddhism, etc. are simply religions like Christianity. That there is a genuine inner life, a communion with transcendental powers, a possibility of religious *experience* is mere hearsay. Nor are the churches over-sympathetic to the view that the alpha and omega of religion is the subjective individual experience, but put community in the first place, without paying attention to the fact that the more people there are the less individuality there is. To be alone with God is highly suspect, and, mind you, it is, because the will of God can be terrible and can isolate you from your family and your friends and, if you are courageous or foolish enough, you may end up in the lunatic asylum. And yet how can there be religion without the experience of the divine will? Things are comparatively easy as long as God wants nothing but the fulfilment of his laws, but what if he wants you to break them, as he may do equally well? Poor Hosea could believe in the symbolic nature of his awkward marriage, but what about the equally poor little doctor who has to swear his soul away to save a human life? He cannot even begin to point out what an affliction his act of lying is, although in his solitude with God he may feel justified. But in case of discovery he has to face the ignominious consequences of his deed and nobody will believe him to be a witness for the divine will. To be God’s voice is not a social function anymore. *Si parva licet componere magnis*—what did I get for my serious struggle over *Job*, which I had postponed for as long as possible? I am regarded as blasphemous, contemptible, a fiend, whose name is mud. It fell to my lot to collect the victims of the Summum Bonum and use my own poor means to help them. But I could not say that a church of any denomination has encouraged my endeavours. You are one of the *very few* who admit the *complexio oppositorum* in the Deity. (Cusanus does not seem to have really known what he was talking about, nor anybody else in those days, otherwise he would have been roasted long ago.) That is the reason why I don’t identify religion with a creed. I can have a real communion only with those who have the same or similar religious experience, but not with the believers in the Word, who have never even taken the trouble to understand its implications and expose themselves to the divine will unreservedly. They use the Word to protect themselves against the will of God. Nothing shields you better against the solitude and forlornness of the divine experience than community. It is the best and safest substitute for individual responsibility.

[1638] The self or Christ is present in everybody *a priori*, but as a rule in an *unconscious condition* to begin with. But it is a definite *experience* of later life, when this fact becomes *conscious*. It is not really understood by teaching or suggestion. It is only real when it *happens*, and it can happen only when you withdraw your projections from an *outward* historical or metaphysical Christ and thus *wake up* Christ within. This does not mean that the unconscious self is inactive, only that we do not understand it. The self (or Christ) cannot become conscious and real without the withdrawal of external projections. An act of *introjection* is needed, i.e., the realization that the self lives in you and not in an external figure separated and different from yourself. The self has always been, and will be, your innermost centre and periphery, your *scintilla* and *punctum solis*. It is even biologically the archetype of order and—dynamically—the source of life.

IV

Here the question is concerned with Jung's objections to the view that God is the Summum Bonum and sin is a privatio boni.

[1639] Well, I have noticed that it seems to be a major difficulty for the theological mind to accept the fact that (1) “good” and “evil” are man-made judgments. Somebody’s “good” may be bad or evil for another *et vice versa*. (2) One cannot speak of “good” if one does not equally speak of “evil,” any more than there can be an “above” without a “below,” or “day” without “night.” (3) The *privatio boni* appears to me a syllogism. If “good” and *οὐσία* are one without an equally valid counterpart, then “good” is also a *μη ὄν* because the term “good” has lost its meaning; it is just “being” and evil is just “not-being” and the term means “nothing.” Of course you are free to call “nothing” evil, but nothing is just nothing and cannot bear another name, making it into “something.” Something non-existing has no name and no quality. The *privatio boni* suggests that evil is *μη ὄν*, not-being or nothing. It is not even a shadow. There remains only the *ὄν*, but it is not good, since there is no “bad.” Thus the epithet “good” is redundant. You can call God the Summum, but not the Bonum, since there is nothing else different from “being,” from the Summum *qua* being! Although the *privatio boni* is not the invention of the Church Fathers, the syllogism was most welcome to them on account of the Manichaean danger of dualism. Yet without dualism there is no cognition at all, because discrimination is impossible.

[1640] I have never [as you state] understood from my study of the Fathers that God is the highest good *with reference to man*, no matter what he is in himself. This is certainly new to me. Obviously my critique of the Summum Bonum does not apply in this case. The Bonum then would be an anthropomorphic judgment, “God is good for me,” leaving it an open question whether he is the same for other people. If one

assumes him to be a *complexio oppositorum*, i.e., beyond good and evil, it is possible that he may appear equally well as the source of evil which you believe to be ultimately good for man. I am convinced, as I have seen it too often to doubt it, that an apparent evil is really no evil at all if you accept and obediently live it as far as possible, but I am equally convinced that an apparent good is in reality not always good at all but wholly destructive. If this were not the case, then everything would be ultimately good, i.e., good in its essence, and evil would not really exist, as it would be a merely transitory appearance. In other words: the term “good” has lost its meaning, and the only safe basis of cognition is our world of experience, in which the power of evil is very real and not at all a mere appearance. One can and does cherish an optimistic hope that ultimately, in spite of grave doubts, “all will be well.” As I am not making a metaphysical judgment, I cannot help remarking that at least in our empirical world the opposites are inexorably at work and that, without them, this world would not exist. We cannot even conceive of a thing that is not a form of energy, and energy is inevitably based upon opposites.

[1641] I must however pay attention to the psychological fact that, so far as we can make out, *individuation* is a natural phenomenon, and in a way an inescapable goal, which we have reason to call *good for us*, because it liberates us from the otherwise insoluble conflict of opposites (at least to a noticeable degree). It is not invented by man, but Nature herself produces its archetypal image. Thus the credo “in the end all will be well” is not without its psychic foundation. But it is more than questionable whether this phenomenon is of any importance to the world in general, or only to the individual who has reached a more complete state of consciousness, to the “redeemed” man in accordance with our Christian tenet of eternal damnation. “Many are called, but few are chosen” is an authentic logion and not characteristic of Gnosticism alone.

V

Jung has been given the title “Gnostic” which he has rejected. This term has probably been used about him [and his system] because he appears to believe that salvation is for the few and that the many cannot and ought not to attempt individuation. Is it possible that he is a “Gnostic” in this sense?

[1642] The designation of my “system” as “Gnostic” is an invention of my theological critics. Moreover I have no “system.” I am not a philosopher, merely an empiricist. The Gnostics have the merit of having raised the problem of *πόθεν τὸ κακόν*; [whence evil?]. Valentinus as well as Basilides are in my view great theologians, who tried to cope with the problems raised by the inevitable influx of the collective unconscious, a fact clearly portrayed by the “gnostic” gospel of St. John and by St. Paul, not to mention the Book of Revelation, and even by Christ himself (unjust

steward and Codex Bezae to Luke 6:4). In the style of their time they hypostatized their ideas as metaphysical entities. Psychology does not hypostatize, but considers such ideas as psychological statements about, or models of, essential unconscious factors inaccessible to immediate experience. This is about as far as scientific understanding can go. In our days there are plenty of people who are unable to believe a statement they cannot understand, and they appreciate the help psychology can give them by showing them that human behaviour is deeply influenced by numinous archetypes. That gives them some understanding of why and how the religious factor plays an important role. It also gives them ways and means of recognizing the operation of religious ideas in their own psyche.

[1643] I must confess that I myself could find access to religion only through the psychological understanding of inner experiences, whereas traditional religious interpretations left me high and dry. It was only psychology that helped me to overcome the fatal impressions of my youth that everything untrue, even immoral, in our ordinary empirical world *must* be believed to be the eternal truth in religion. Above all, the killing of a human victim to placate the senseless wrath of a God who had created imperfect beings unable to fulfil his expectations poisoned my whole religion. Nobody knew an answer. "With God all things are possible." Just so! As the perpetrator of incredible things he is himself incredible, and yet I was supposed to believe what every fibre of my body refused to admit! There are a great many questions which I could elucidate only by psychological understanding. I loved the Gnostics in spite of everything, because they recognized the necessity of some further *raisonnement*, entirely absent in the Christian cosmos. They were at least human and therefore understandable. But I have no *γνώσις τοῦ θεοῦ*. I know the reality of religious experience and of psychological models which permit a limited understanding. I have Gnosis so far as I have immediate experience, and my models are greatly helped by the *représentations collectives* of all religions. But I cannot see why one creed should possess the unique and perfect truth. Each creed claims this prerogative, hence the general disagreement! This is not very helpful. Something must be wrong. I think it is the immodesty of the claim to god-almightiness of the believers, which compensates their inner doubt. Instead of basing themselves upon immediate experience they believe in words for want of something better. The *sacrificium intellectus* is a sweet drug for man's all-embracing spiritual laziness and inertia.

[1644] I owe you quite a number of apologies for the fact that my layman's mental attitude must be excruciatingly irritating to your point of view. But you know, as a psychologist I am not concerned with theology directly, but rather with the incompetent general public and its erroneous and faulty convictions, which are however just as real to it as their competent views are to the theologians. I am

continually asked “theological” questions by my patients, and when I say that I am only a doctor and they should ask the theologian, then the regular answer is, “Oh, yes, we have done so,” or “we do not ask a priest because we get an answer we already know, which explains nothing.”

[1645] Well this is the reason why I have to try for better or worse to help my patients to some kind of understanding at least. It gives them a certain satisfaction as it has done to me, although it is admittedly inadequate. But to them it sounds as if somebody were speaking their language and understanding their questions which they take very seriously indeed. Once, for instance, it was a very important question to me to discover how far modern Protestantism considers that the God of the Old Testament is identical with the God of the New Testament. I asked two university professors. They did not answer my letter. The third (also a professor) said he didn't know. The fourth said, “Oh, that is quite easy. Yahweh is a somewhat more archaic conception contrasted with the more differentiated view of the New Testament.” I said to him, “That is exactly the kind of psychologism you accuse me of.” My question must have been singularly inadequate or foolish. But I do not know why. I am speaking for the layman's psychology. The layman is a reality and his questions do exist. My “Answer to Job” voices the questions of thousands, but the theologians don't answer, contenting themselves with dark allusions to my layman's ignorance of Hebrew, higher criticism, Old Testament exegesis, etc., but there is not a single answer. A Jesuit professor of theology asked me rather indignantly how I could suggest that the Incarnation has remained incomplete. I said, “The human being is born under the *macula peccati*. Neither Christ nor his mother suffers from original sin. They are therefore not human, but superhuman, a sort of God.” What did he answer? Nothing.

[1646] Why is that so? My layman's reasoning is certainly imperfect, and my theological knowledge regrettably meagre, but not as bad as all that, at least I hope not. But I do know something about the psychology of man now and in the past, and as a psychologist I raise the questions I have been asked a hundred times by my patients and other laymen. Theology would certainly not suffer by paying attention. I know you are too busy to do it. I am all the more anxious to prevent avoidable mistakes and I shall feel deeply obliged to you if you take the trouble of showing me where I am wrong.

[1647] Gnosis is characterized by the hypostatizing of psychological apperceptions, i.e., by the integration of archetypal contents beyond the revealed “truth” of the Gospels. Hippolytus still considered classical Greek philosophy along with Gnostic philosophies as perfectly possible views. Christian Gnosis to him was merely the best and superior to all of them. The people who call me a Gnostic cannot understand that I am a psychologist, describing modes of psychic behaviour precisely like a biologist

studying the instinctual activities of insects. He does not *believe* in the tenets of the bee's philosophy. When I show the parallels between dreams and Gnostic fantasies I *believe* in neither. They are just facts one does not need to believe or to hypostatize. An alienist is not necessarily crazy because he describes and analyses the delusions of lunatics, nor is a scholar studying the *Tripitaka* necessarily a Buddhist.

4. Reply to a Letter from the Rev. David Cox²⁰

[1648] The crux of this question is: "Within your own personality." "Christ" can be an external reality (historical and metaphysical) or an archetypal image or idea in the collective unconscious pointing to an unknown background. I would understand the former mainly as a projection, but not the latter, because it is immediately evident. It is not projected upon anything, therefore there is no projection. Only, "faith" in Christ is different from faith in anyone else, since in this case, "Christ" being immediately evident, the word "faith," including or alluding to the possibility of doubt, seems too feeble a word to characterize that powerful presence from which there is no escape. A general can say to his soldiers, "You must have faith in me," because one might doubt him. But you cannot say to a man lying wounded on the battlefield, "You ought to *believe* that this a real battle," or "Be sure that you are up against the enemy." It is just too obvious. Even the historical Jesus began to speak of "faith" because he saw that his disciples had no immediate evidence. Instead they had to believe, while he himself being identical with God had no need to "have faith in God."

[1649] As one habitually identifies the "psyche" with what one knows of it, it is assumed that one can call certain (supposed or believed) metaphysical entities non-psyche. Being a responsible scientist I am unable to pass such a judgment, for all I know of regular religious phenomena seems to indicate that they are psychic events. Moreover I do not know the full reach of the psyche, because there is the limitless extent of the unconscious. "Christ" is definitely an archetypal image (I don't add "only") and that is all I actually know of him. As such he belongs to the (collective) foundations of the psyche. I identify him therefore with what I call the self. The self rules the whole of the psyche. I think our opinions do not differ essentially. You seem to have trouble only with the theological (and self-inflicted) devaluation of the psyche, which you apparently believe to be ultimately definable.

[1650] If my identification of Christ with the archetype of the self is valid, he is, or ought to be, a *complexio oppositorum*. Historically this is not so. Therefore I was profoundly surprised by your statement that Christ contains the opposites. Between my contention and historical Christianity there stretches that deep abyss of Christian dualism—Christ and the Devil, good and evil, God and Creation.

[1651] “Beyond good and evil” simply means: we pass no moral judgment. But in fact nothing is changed. The same is true when we state that whatever God is or does is *good*. Since God does everything (even man created by him is his instrument) everything is good, and the term “good” has lost its meaning. “Good” is a relative term. There is no good without bad.

[1652] I am afraid that even revealed truth has to evolve. Everything living changes. We should not be satisfied with unchangeable traditions. The great battle that began with the dawn of consciousness has not reached its climax with any particular interpretation, apostolic, Catholic, Protestant, or otherwise. Even the highly conservative Catholic Church has overstepped its ancient rule of apostolic authenticity with the *Assumptio Beatae Virginis*. According to what I hear from Catholic theologians, the next step would be the Coredemptrix. This obvious recognition of the female element is a very important step forward. It means psychologically the recognition of the unconscious, since the representative of the collective unconscious is the *anima*, the archetype of all divine mothers (at least in the masculine psyche).

[1653] The equivalent on the Protestant side would be a confrontation with the unconscious as the counterpart or consort of the masculine Logos. The hitherto valid symbol of the supreme spiritual structure was Trinity + Satan, the so-called 3 + 1 structure, corresponding to three conscious functions versus the one unconscious, so-called inferior function; or 1 + 3 if the conscious side is understood as one versus the so-called inferior or chthonic triad, mythologically characterized as three mother figures.²¹ I suppose that the negative evaluation of the unconscious has something to do with the fact that it has been hitherto represented by Satan, while in reality it is the female aspect of man’s psyche and thus not wholly evil in spite of the old saying: *Vir a Deo creatus, mulier a simia Dei*.

[1654] It seems to me of paramount importance that Protestantism should integrate psychological experience, as for instance Jacob Boehme did. With him God does not only contain love, but, on the other side and in the same measure, the fire of wrath, in which Lucifer himself dwells. Christ is a revelation of his love, but he can manifest his wrath in an Old Testament way just as well, i.e., in the form of evil. Inasmuch as out of evil good may come, and out of good evil, we do not know whether creation is ultimately good or a regrettable mistake and God’s suffering. It is an ineffable mystery. At any rate we are not doing justice either to nature in general or to our own human nature when we deny the immensity of evil and suffering and turn our eyes from the cruel aspect of creation. Evil should be recognized and one should not attribute the existence of evil to man’s sinfulness. Yahweh is not offended by being feared.

[1655] It is quite understandable why it was an *εὐαγγέλιον* [evangel, “good tidings”] to learn of the *bonitas Dei* and of his son. It was known to the ancients that the *cognito sui-ipsius* [self-knowledge]²² was a prerequisite for this, not only in the Graeco-Roman world but also in the Far East. It is to the individual aptitude that the man Jesus owes his apotheosis: he became the symbol of the self under the aspect of the infinite goodness, which was certainly the symbol most needed in ancient civilization (as it is still needed today).

[1656] It can be considered a fact that the dogmatic figure of Christ is the result of a condensation process from various sources. One of the main origins is the age-old god-man of Egypt: Osiris-Horus and his four sons. It was a remodeling of the unconscious archetype hitherto projected upon a divine non-human being. By embodying itself in a historical man it came nearer to consciousness, but in keeping with the mental capacity of the time it remained as if suspended between God and man, between the need for good and the fear of evil. Any doubt about the absolute *bonitas Dei* would have led to an immediate regression to the former pagan state, i.e., to the amorality of the metaphysical principle.

[1657] Since then two thousand years have passed. In this time we have learned that good and evil are categories of our moral judgment, therefore relative to man. Thus the way was opened for a new model of the self. Moral judgment is a necessity of the human mind. The Christ (*ὁ Χριστός*) is the Christian model that expresses the self, as the *Ἄνθρωπος* is the corresponding Egypto-Judaic formula. Moral qualification is withdrawn from the deity. The Catholic Church has almost succeeded in adding femininity to the masculine Trinity. Protestantism is confronted with the psychological problem of the unconscious.

[1658] It is, as far as I can see, a peculiar process extending over at least four thousand years of mental evolution. It can be contemplated in a “euhemeristic” way as a development of man’s understanding of the supreme powers beyond his control. [The process consists of the following stages:] (1) Gods. (2) A supreme Deity ruling the gods and demons. (3) God shares our human fate, is betrayed, killed or dies, and is resurrected again. There is a feminine counterpart dramatically involved in God’s fate. (4) God becomes man in the flesh and thus historical. He is identified with the abstract idea of the Summum Bonum and loses the feminine counterpart. The female deity is degraded to an ancillary position (Church). Consciousness begins to prevail against the unconscious. This is an enormously important step forward in the emancipation of consciousness and in the liberation of thought from its involvement in things. Thus the foundation of science is laid, but on the other hand, that of atheism and materialism. Both are inevitable consequences of the basic split between spirit and matter in Christian philosophy, which proclaimed the redemption of the

spirit from the body and its fetters. (5) The whole metaphysical world is understood as a psychic structure projected into the sphere of the unknown.

[1659] The danger of this viewpoint is exaggerated scepticism and rationalism, since the original “supreme powers” are reduced to mere representations over which one assumes one has complete control. This leads to a complete negation of the supreme powers (scientific materialism).

[1660] The other way of looking at it is from the standpoint of the archetype. The original chaos of multiple gods evolves into a sort of monarchy, and the archetype of the self slowly asserts its central position as the archetype of order in chaos. One God rules supreme but apart from man. It begins to show a tendency to relate itself to consciousness through a process of penetration: the humanizing effect of a feminine intercession, expressed for instance by the Isis intrigue. In the Christian myth the Deity, the self, penetrates consciousness almost completely, without any visible loss of power and prestige. But in time it becomes obvious that the Incarnation has caused a loss among the supreme powers: the indispensable dark side has been left behind or stripped off, and the feminine aspect is missing. Thus a further act of incarnation becomes necessary. Through atheism, materialism, and agnosticism, the powerful yet one-sided aspect of the Summum Bonum is weakened, so that it cannot keep out the dark side, and incidentally the feminine factor, any more. “Antichrist” and “Devil” gain the ascendancy: God asserts his power through the revelation of his darkness and destructiveness. Man is merely instrumental in carrying out the divine plan. Obviously he does not want his own destruction but is forced to it by his own inventions. He is entirely unfree in his actions because he does not yet understand that he is a mere instrument of a destructive superior will. From this paradox he could learn that—*nolens volens*—he serves a supreme power, and that supreme powers exist in spite of his denial. As God lives in everybody in the form of the *scintilla* of the self, man could see his “daemonic,” i.e., ambivalent, nature in himself and thus he could understand how he is penetrated by God or how God incarnates in man.

[1661] Through his further incarnation God becomes a fearful task for man, who must now find ways and means to unite the divine opposites in himself. He is summoned and can no longer leave his sorrows to somebody else, not even to Christ, because it was Christ that has left him the almost impossible task of his cross. Christ has shown how everybody will be crucified upon his destiny, i.e., upon his self, as he was. He did not carry his cross and suffer crucifixion so that we could escape. The bill of the Christian era is presented to us: we are living in a world rent in two from top to bottom; we are confronted with the H-bomb and we have to face our own shadows. Obviously God does not want us to remain little children looking out for a parent who will do their job for them. We are cornered by the supreme power of the incarnating Will. God really wants to become man, even if he rends him asunder.

This is so no matter what we say. One cannot talk the H-bomb or Communism out of the world. We are in the soup that is going to be cooked for us, whether we claim to have invented it or not. Christ said to his disciples “Ye are gods.” This word becomes painfully true. If God incarnates in the empirical man, man is confronted with the divine problem. Being and remaining man he has to find an answer. It is the question of the opposites, raised at the moment when God was declared to be good only. Where then is his dark side? Christ is the model for the human answers and his symbol is the *cross*, the union of the opposites. This will be the fate of man, and this he must understand if he is to survive at all. We are threatened with universal genocide if we cannot work out the way of salvation by a symbolic death.

[1662] In order to accomplish his task, man is inspired by the Holy Ghost in such a way that he is apt to identify him with his own mind. He even runs the grave risk of believing he has a Messianic mission, and forces tyrannous doctrines upon his fellow-beings. He would do better to dis-identify his mind from the small voice within, from dreams and fantasies through which the divine spirit manifests itself. One should listen to the inner voice attentively, intelligently and critically (*Probate spiritus!*), because the voice one hears is the *influxus divinus* consisting, as the *Acts of John* aptly state, of “right” and “left” streams, i.e., of opposites.²³ They have to be clearly separated so that their positive and negative aspects become visible. Only thus can we take up a middle position and discover a middle way. That is the task left to man, and that is the reason why man is so important to God that he decided to become a man himself.

[1663] I must apologize for the length of this exposition. Please do not think that I am stating a truth. I am merely trying to present a hypothesis which might explain the bewildering conclusions resulting from the clash of traditional symbols and psychological experiences. I thought it best to put my cards on the table, so that you get a clear picture of my ideas.

[1664] Although all this sounds as if it were a sort of theological speculation, it is in reality modern man’s perplexity expressed in symbolic terms. It is the problem I so often had to deal with in treating the neuroses of intelligent patients. It can be expressed in a more scientific, psychological language; for instance, instead of using the term God you say “unconscious,” instead of Christ “self,” instead of incarnation “integration of the unconscious,” instead of salvation or redemption “individuation,” instead of crucifixion or sacrifice on the Cross “realization of the four functions or of “wholeness.” I think it is no disadvantage to religious tradition if we can see how far it coincides with psychological experience. On the contrary it seems to me a most welcome aid in understanding religious traditions.

[1665] A myth remains a myth even if certain people believe it to be the literal revelation of an eternal truth, but it becomes moribund if the living truth it contains

ceases to be an object of belief. It is therefore necessary to renew its life from time to time through a *new interpretation*. This means re-adapting it to the changing spirit of the times. What the Church calls “prefigurations” refer to the original state of the myth, while the Christian doctrine represents a new interpretation and re-adaptation to a Hellenized world. A most interesting attempt at re-interpretation began in the eleventh century,²⁴ leading up to the schism in the sixteenth century. The Renaissance was no more a rejuvenation of antiquity than Protestantism was a return to the primitive Christianity: it was a new interpretation necessitated by the devitalization of the Catholic Church.

[1666] Today Christianity is devitalized by its remoteness from the spirit of the times. It stands in need of a new union with, or relation to, the atomic age, which is a unique novelty in history. The myth needs to be retold in a new spiritual language, for the new wine can no more be poured into the old bottles than it could in the Hellenistic age. Even conservative Jewry had to produce an entirely new version of the myth in its Cabalistic Gnosis. It is my practical experience that psychological understanding immediately revivifies the essential Christian ideas and fills them with the breath of life. This is because our worldly light, i.e., scientific knowledge and understanding, coincides with the symbolic statement of the myth, whereas previously we were unable to bridge the gulf between knowing and believing.

[1667] Coming back to your letter (pp. 2–3, 25 September) I must say that I could accept your definition of the Summum Bonum, “Whatever God is, that is good,” if it did not interfere with or twist our sense of good. In dealing with the moral nature of an act of God, we have either to suspend our moral judgment and blindly follow the dictates of this superior will, or we have to judge in a human fashion and call white white and black black. In spite of the fact that we sometimes obey the superior will blindly and almost heroically, I do not think that this is the usual thing, nor is it commendable on the whole to act blindly, because we are surely expected to act with conscious moral reflection. It is too dangerously easy to avoid responsibility by deluding ourselves that our will is the will of God. We can be forcibly overcome by the latter, but if we are not we must use our judgment, and then we are faced with the inexorable fact that humanly speaking some acts of God are good and some bad, so much so that the assumption of a Summum Bonum becomes almost an act of hubris.

[1668] If God can be understood as the perfect *complexio oppositorum*, so can Christ. I can agree with your view about Christ completely, only it is not the traditional but a very modern conception which is on the way to the desired new interpretation. I also agree with your understanding of Tao and its contrast to Christ, who is indeed the paradigm of the reconciliation of the divine opposites in man brought about in the process of individuation. Thus Christ stands for the treasure and the supreme “good.” (In German “good” = *gut*, but the noun *Gut* also means “property” and “treasure.”)

[1669] When theology makes metaphysical assertions the conscience of the scientist cannot back it up. Since Christ never meant more to me than what I could understand of him, and since this understanding coincides with my empirical knowledge of the self, I have to admit that I mean the self in dealing with the idea of Christ. As a matter of fact I have no other access to Christ but the self, and since I do not know anything beyond the self I cling to his archetype. I say, "Here is the living and perceptible archetype which has been projected upon the man Jesus or has historically manifested itself in him." If this collective archetype had not been associated with Jesus he would have remained a nameless Zaddik. I actually prefer the term "self" because I am talking to Hindus as well as Christians, and I do not want to divide but to unite.

[1670] Since I am putting my cards on the table, I must confess that I cannot detach a certain feeling of dishonesty from any metaphysical assertion—one may speculate but not assert. One cannot reach beyond oneself, and if somebody assures you he can reach beyond himself and his natural limitations, he overreaches himself and becomes immodest and untrue.

[1671] This may be a *deformation professionnelle*, the prejudice of a scientific conscience. Science is an honest-to-God attempt to get at the truth and its rule is never to assert more than one can prove within reasonable and defensible limits. This is my attitude in approaching the problem of religious experience.

[1672] I am unable to envisage anything beyond the self, since it is—by definition—a borderline concept designating the unknown totality of man: there are no known limits to the unconscious. There is no reason whatsoever why you should or should not call the beyond-self Christ or Buddha or Purusha or Tao or Khidr or Tifereth. All these terms are recognizable formulations of what I call the "self." Moreover I dislike the insistence upon a special name, since my human brethren are as good and as valid as I am. Why should their name-giving be less valid than mine?

[1673] It is not easy for a layman to get the desired theological information, because even the Church is not at one with herself in this respect. *Who* represents authentic Christianity? Thus the layman whether he likes it or not has to quote Protestant or Catholic statements *pêle-mêle* as Christian views because they are backed up by some authority. In my case I believe I have been careful in quoting my sources.

[1674] You as a theologian are naturally interested in the best possible view or explanation, while the psychologist is interested in all sorts of opinions because he wants to acquire some understanding of mental phenomenology and cares little for even the best possible metaphysical assertion, which is beyond human reach anyhow. The various creeds are just so many phenomena to him, and he has no means of deciding about the truth or the ultimate validity of any metaphysical statement. I cannot select the "best" or the "ultimate" opinions because I do not know which kind

of opinion to choose from which Church. Also I do not care particularly where such opinions come from, and it is quite beyond my capacity to find out whether they are erroneous or not. I would be wrong only if I attributed, for instance, the idea of the *conceptio immaculata* to Protestantism or the *sola fide* standpoint to Catholicism. The many misunderstandings attributed to me come into this category. In either case it is plain to see that someone has been careless in his assumptions. But if I attribute Ritschl's christological views to Protestantism, it is no error in spite of the fact that the Church of England does not subscribe to the opinions of Mr. Ritschl or of Mr. Barth.^{24a} I hope I have not inadvertently been guilty of some misquotation.

[1675] I can illustrate the problem by a typical instance. My little essay on Eastern Meditation²⁵ deals with the popular tract *Amitāyur Dhyāna Sūtra*, which is a relatively late and not very valuable Mahāyāna text. A critic objected to my choice: he could not see why I should take such an inconspicuous tract instead of a genuinely Buddhist and classical Pāli text in order to present Buddhist thought. He entirely overlooked the fact that I had no intention whatever of expounding classical Buddhism, but that my aim was to analyse the psychology of this particular text. Why should I not deal with Jacob Boehme or Angelus Silesius as Christian writers, even though they are not classical representatives either of Catholicism or of Protestantism?

[1676] A similar misunderstanding appears in your view that I am not doing justice to the *ideal* of community. Whenever possible I avoid *ideals* and much prefer *realities*. I have never found a community which would allow "full expression to the individual within it." Suppose the individual is going to speak the truth regardless of the feelings of everybody else: he would not only be the most abominable enfant terrible but might equally well cause a major catastrophe. Edifying examples of this can be observed at the meetings of Buchman's so-called Oxford Group Movement. At the expense of truth the individual has to "behave," i.e., suppress his reaction merely for the sake of Christian charity. What if I should get up after a sermon about ideals and ask the parson how much he himself is able to live up to his admonitions? In my own case the mere fact that I am seriously interested in psychology has created a peculiar hostility or fear in certain circles. What has happened to those people in the Church, that is in a Christian community, who ventured to have a new idea? No community can escape the laws of mass psychology. I am critical of the community in the same way as I suspect the individual who builds his castles in Spain while anxiously avoiding the expression of his own convictions. I am shy of ideals which one preaches and never lives up to, simply because one cannot. I want to know rather what we *can* live. I want to build up a possible human life which carries through God's experiment and does not invent an ideal scheme knowing that it will *never* be fulfilled.

[1677] I am much obliged to you for telling me exactly what you think and for criticizing my blunt ways of thinking and writing (also of talking, I am afraid). It seems, however, to be the style of natural scientists: we simply state our proposition, assuming that nobody will think it to be more than a disputable hypothesis. We are so imbued with doubts concerning our assumptions that scepticism is taken for granted. We are therefore apt to omit the conventional *captatio benevolentiae lectoris* with its “With hesitation I submit ...,” “I consider it a daring hypothesis ...,” etc. We even forget the preamble: “This is the way I look at it...”

[1678] The case of the Jesuit²⁷ was that he put the direct question to me: “How on earth can you suggest that Christ was not human?” The discussion was naturally on the *dogmatic* level, as there is no other basis on which this question can be answered. It is not a question of *truth*, because the problem itself is far beyond human judgment. My “Answer to Job” is merely a reconstruction of the psychology discernible in this and other Old Testament texts for the interested layman. He knows very little of Higher Criticism, which is historical and philological in the main, and it is but little concerned with the layman’s reactions to the paradoxes and moral horrors of the Old Testament. He knows his Bible and hears the sermons of his parson or priest. As a Catholic he has had a dogmatic education.

[1679] When talking of “Job” you must always remember that I am dealing with the psychology of an archetypal and anthropomorphic image of God and not with a metaphysical entity. As far as we can see, the archetype is a psychic structure with a life of its own to a certain extent.

[1680] God in the Old Testament is a guardian of law and morality, yet is himself unjust. He is a moral paradox, unreflecting in an ethical sense. We can perceive God in an infinite variety of images, yet all of them are anthropomorphic, otherwise they would not get into our heads. The divine paradox is the source of unending suffering to man. Job cannot avoid seeing it and thus he sees more than God himself. This explains why the God-image has to come down “into the flesh.” The paradox, expressed of course with many hesitations in the particularities of the myth and in the Catholic dogma, is clearly discernible in the fact that the “Suffering Righteous man” is, historically speaking, an erroneous conception, not identical with the suffering God, because he is Jesus Christ, worshipped as a separate God he is a mere prefiguration, painfully included in a triunity and not an ordinary man who is forced to accept the suffering of intolerable opposites he has not invented. They were preordained. He is the victim, because he is capable of three-dimensional consciousness and ethical decision. (This is a bit condensed. Unlike Yahweh, man has self-reflection.)

[1681] I don't know what Job is supposed to have seen. But it seems possible that he unconsciously anticipated the historical future, namely the evolution of the God-image. God had to become man. Man's suffering does not derive from his sins but from the maker of his imperfections, the paradoxical God. The righteous man is the instrument into which God enters in order to attain self-reflection and thus consciousness and rebirth as a divine child trusted to the care of adult man.

[1682] Now this is not the statement of a truth, but the psychological reading of a mythological text—a model constructed for the purpose of establishing the psychological linking together of its contents. My aim is to show what the results are when you apply modern psychology to such a text. Higher Criticism and Hebrew philology are obviously superfluous, because it is simply a question of the text which the layman has under his eyes. The Christian religion has not been shaped by Higher Criticism.

[1683] The trouble I have with my academic reader is that he cannot see a psychic structure as a relatively autonomous entity, because he is under the illusion that he is dealing with a concept. But in reality it is a living thing. The archetype? all have a life of their own which follows a biological pattern. A Church that has evolved a masculine Trinity will follow the old pattern: 3 + 1, where 1 is a female and, if 3 = good, 1 as a woman will mediate between good and evil, the latter being the devil and the shadow of the Trinity. The woman will inevitably be the Mother-Sister of the Son-God, with whom she will be united *in thalamo*, i.e., in the *ἱερός γάμος*, *quod est demonstratum* by the second Encyclical concerning the Assumption.”²⁸

[1684] A passionate discourse between the man Job and God will logically lead to a mutual rapprochement: God will be humanized, man will be “divinized.” Thus Job will be followed by the idea of the Incarnation of God and the redemption and apotheosis of man. This development, however, is seriously impeded by the fact that the “woman,” as always, inevitably brings in the problem of the shadow. Therefore *mulier taceat in ecclesia*. The arch-sin the Catholic Church is ever after is sexuality, and the ideal *par excellence* virginity, which puts a definite stop to life. But if life should insist on going on, the shadow steps in and sin becomes a serious problem, because the shadow cannot be left to eternal damnation any more. Consequently, at the end of the first millennium of the Christian aeon, as predicted in the Apocalypse, the world was suspected of being created by the devil.²⁹ The impressive and still living myth of the Holy Grail came to life with its two significant figures of Parsifal and Merlin. At the same time we observe an extraordinary development of alchemical philosophy with its central figure of the *filius macrocosmi*, a chthonic equivalent of Christ.

[1685] This was followed by the great and seemingly incurable schism of the Christian Church, and last but not least by the still greater and more formidable schism of the

world towards the end of the second millennium.

[1686] A psychological reading of the dominant archetypal images reveals a continuous series of psychological transformations, depicting the autonomous life of archetypes behind the scenes of consciousness. This hypothesis has been worked out to clarify and make comprehensible our religious history. The treatment of psychological troubles and the inability of my patients to understand theological interpretations and terminology have given me my motive. The necessities of psychotherapy have proved to me the immense importance of a religious attitude, which cannot be achieved without a thorough understanding of religious tradition, just as an individual's troubles cannot be understood and cured without a basic knowledge of their biographical antecedents. I have applied to the God-image what I have learned from the reconstruction of so many human lives through a knowledge of their unconscious. All this is empirical and may have nothing to do with theology, if theology says so. But if theology should come to the conclusion that its tenets have something to do with the empirical human psyche, I establish a claim. I think that in those circumstances my opinion should be given a hearing. It cannot be argued on the level of metaphysical assertions. It can be criticized only on its own psychological level, regardless of whether it is a psychologically satisfactory interpretation of the facts or not. The "facts" are the documented historical manifestations of the archetype, however "erroneous" they may be.

[1687] I have stated my point of view bluntly (for which I must ask your forgiveness!) in order to give you a fair chance to see it as clearly as possible. The end of your letter, where you deal with Christ, leaves me with a doubt. It looks to me as if you were trying to explain the empirical man Jesus, while I am envisaging the archetype of the Anthropos and its very general interpretation as a collective phenomenon and not as the best possible interpretation of an individual and historical person. Christianity as a whole is less concerned with the historical man Jesus and his somewhat doubtful biography than with the mythological Anthropos or God-Son figure. It would be rather hazardous to attempt to analyse the historical Jesus as a human person. "Christ" appears from a much safer (because mythological) background, which invites psychological elucidation. Moreover it is not the Jewish rabbi and reformer Jesus, but the archetypal Christ who touches upon the archetype of the Redeemer in everybody and carries conviction.

[1688] My approach is certainly not theological and cannot be treated as a theologoumenon. It is essentially a psychological attempt based upon the archetypal, amoral God-image, which is not a concept but rather an irrational and phenomenal experience, an *Urbild*. But in so far as theologians are also concerned with the adult human psyche (perhaps not as much as medical psychology). I am convinced that it would be of advantage to them to become acquainted with the psychological aspects

of the Christian religion. I will not conceal the fact that theological thinking is very difficult for me, from which I conclude that psychological thinking must be an equally laborious undertaking for the theologian. This may explain why I inundate you with such a long letter.

[1689] When I see how China (and soon India) will lose her old culture under the impact of materialistic rationalism. I grow afraid that the Christian West will succumb to the same malady, simply because the old symbolic language is no longer understood and people cannot see any more where and how it applies. In Catholic countries anyone leaving the Church becomes frankly atheistic. In Protestant countries a small number become sectarians, and the others avoid the churches for their cruelly boring and empty sermons. Not a few begin to believe in the State—not even knowing that they themselves are the State. The recent broadcasts of the B.B.C.³⁰ give a good picture of the educated layman's mind with regard to religion. What an understanding! All due to the lack of a psychological standpoint, or so it seems to me.

[1690] I am sorry that I am apparently a *petra scandali*. I do not mean to offend. Please accept my apologies for my bluntness. I am sincerely grateful to you for giving me your attention.

Faithfully yours, C. G. JUNG

XIII

ALCHEMICAL STUDIES

(related to Volumes 12, 13, and 14 of the Collected Works)

FOREWORD TO A CATALOGUE ON ALCHEMY¹

[1691] Alchemy is the forerunner or even the ancestor of chemistry, and is therefore of historical interest to the student of chemistry, in so far as it can be proved to contain recognizable descriptions of chemical substances, reactions, and technical procedures. How much may be gained in this respect from alchemical literature is shown by the comprehensive work of E. O. von Lippmann, *Entstehung und Ausbreitung der Alchemie* (Berlin, 1919). The peculiar character of this literature lies, however, in the fact that there exists a comparatively large number of treatises from which, apart from the most superficial allusions, absolutely nothing of a chemical nature can be extracted. It was therefore supposed—and many of the alchemists themselves wanted us to believe—that their mysterious sign-language was nothing but a skilful way of disguising the chemical procedures which lay behind it. The adept would see through the veil of hieroglyphics and recognize the secret chemical process. Unfortunately, alchemists of repute destroyed this legend by their admission that they were unable to read the riddle of the Sphinx, complaining that the old authors, like Geber and Raymundus Lullius, wrote too obscurely. And indeed, a careful study of such treatises, which perhaps form the majority, will reveal nothing of a chemical nature but something which is purely symbolic, i.e., *psychological*. Alchemical language is not so much *semeiotic* as *symbolic*: it does not disguise a known content but suggests an unknown one, or rather, this unknown content *suggests itself*. This content can only be psychological. If one analyses these symbolic forms of speech, one comes to the conclusion that archetypal contents of the collective unconscious are being projected. Consequently, alchemy acquires a new and interesting aspect as a *projected psychology of the collective unconscious*, and thus ranks in importance with mythology and folklore. Its symbolism has the closest connections with dream symbolism on the one hand, and the symbolism of religion on the other.

FAUST AND ALCHEMY¹

[1692] The drama of *Faust* has its primary sources in alchemy; these are on the one hand dreams, visions, and parables, on the other, personal and biographical notes regarding the Great Opus. One of the latest and most perfect examples of this sort is the *Chymische Hochzeit* of Christian Rosencreutz (1616), actually written by Johann Valentin Andreae (1586–1634), a theologian of Württemberg who was also the author of *Turbo* (1616), a comedy written in Latin.² The hero of this play is a learned know-it-all who, disillusioned with the sciences, finally returns to Christianity. The *Chymische Hochzeit* represents the *opus Alchymicum* under the aspect of the *hierosgamos* of brother and sister (Venus gives birth to a hermaphrodite). But these things are only hinted at in veiled terms. Because the royal children are still too infantile (identification with the parents, incest with the mother), they are slain, purified, and put together again, by being subjected to every alchemical procedure. To be restituted, the bridal pair is taken over the sea, and a kind of Aegean festival is celebrated with nymphs and sea-goddesses and a paean to love is sung. Rosencreutz is revealed as the father of the young king or, respectively, the royal couple.

[1693] Alchemy had long known that the mystery of transformation applies not only to chemical materials but to man as well. The central figure is Mercurius, to whom I have devoted a special study.³ He is a chthonic spirit, related to Wotan and the Devil.

[1694] Faust is introduced like Job, but it is not he who suffers; it is others who suffer through him, and even the Devil is not left unscathed. Mercurius enters in the shape of Mephistopheles (Devil and Satan), as a dog to begin with, son of Chaos, and fire (alch. *filius canis*, arises out of chaos, *natura ignea*). He becomes the servant of Faust (*familiaris, servus fugitivus*). Mephisto has two ravens (cf. Wotan)¹. He is the “northern phantom” and has his “pleasure-ground” in the “north-west.”

[1695] The axiom of Maria (3 + 1) pervades the whole work (4 main phases, 4 thieves, 4 (-1) grey women, 4 elements, Pluto’s four-in-hand team of horses, 3 + 1 boys, 1 + 2 + 3 + 4 = 10 in the witches’ tables, 3–4, 7–8 Kabiri, “Three and one and one and three,” etc.).

[1696] Mephisto brings about the projection onto the anima with its tragic end (child murder. There follows the suppression of Eros by the power drive Walpurgisnacht = overpowering by the shadow). In the fire magic and the gold swindle there appears the Boy Charioteer, a Mercurius *juvenis*, on the one hand hermaphrodite like his preform, the Devil, a *kyllenios*, and on the other an analogy to Christ and the Holy Spirit; at the same time he brings the wild host (Wotan!).

[1697] The underworld tripod embodies the feminine chthonic trinity, Diana, Luna, Hecate, and Phorkyads). It corresponds to the *vas hermeticum* (and the early Christian communion table of the catacombs with 3 loaves and 1 fish. The *Tripus Aureus* of alchemy is the one that Hephaestus cast into the sea.

[1698] Faust falls into a faint when he tries to possess Helen. This is the beginning of Phase II, and the second upsurge of Eros. Faust is again rejuvenated (as in Phase I) as the Baccalaureus; the Devil, however, is “old.” The Homunculus corresponds to the Boy Charioteer. His father is Wagner (Rosencreutz); his cousin is the Devil, hence Mercurius in a younger shape. Faust is taken to the classic “world of fable” (collective unconscious) for “healing.” The “water” heals (*aqua permanens, mare nostrum*). From it emerges the mountain (rebirth of the personality, alch. arising of the *terra firma* out of the sea). The Aegean Festival is the *hierosgamos* of Homunculus and Galatea (both are “stones brought to life”) in the sea. Touching the tripod with the key and the *hierosgamos* prefigure the “chymical” marriage of Faust to Helen, the sister anima. Their child Euphorion is the third renewal form of Mercurius.

[1699] Phase III ends with the death of Euphorion, and once again the next and last phase begins with the power drive. The devout Philemon and Baucis are murdered. After Faust’s death the Devil is cheated. The conflict goes on. Faust’s place is taken by his “entelechy,” the *puer aeternus*, who never can realize his united double nature because Faust is always the victim of whatever his shape may be at the time. He loses himself in smatterings of knowledge, in autoerotic Eros, in magic and deception, in the delusion of being a demigod (Helena), and finally in the inflation of thinking himself the saviour of the whole world. He is always blind about himself, does not know what he is doing, and lacks both responsibility and humour. But the Devil knows who he himself is; he does not lie to himself, he has humour and the small kind of love (insects), all of which Faust lacks. The shadow cannot be redeemed unless consciousness acknowledges it as a part of its own self—that is, understands its compensatory significance. The “blessed boy” is therefore only a representation of a prenatal state that in no way throws light on what the experience of earthly life was really for. Dr. Marianus is the “son of the mother.” A possible parallel might be an eighth-century alchemist, Morienes, Morienus, Marianus,⁴ who was one of the most spiritual of all alchemists and understood the *opus* as a human transformation system. He says: “Temporum quidem longa mutatio hominem sub tempore constitutum confundit et mutat ... ultimam autem mutationem mors dira subsequitur.”⁵

ALCHEMY AND PSYCHOLOGY¹

[1700] Throughout the history of alchemy we find—besides a considerable knowledge of substances (minerals and drugs) and a limited knowledge of the laws of chemical processes—indications of an accompanying “philosophy” which received the name “Hermetic” in the later Middle Ages. This natural philosophy appears first and particularly clearly in the Greek alchemists of the first to the sixth centuries A.D. (Pseudo-Demokritus, Zosimos of Panopolis, and Olympiodorus). It was also especially evident in the sixteenth and seventeenth centuries, when it reached its full development. This development owed a great deal to Paracelsus and his pupils (Gerard Dorn and Heinrich Khunrath). In the interval between these two periods, philosophical speculation gave way to a more religious tendency (ideas were produced which ran parallel to the dogmatic concepts), hand in hand with a “mystical” tendency which gives alchemy its peculiar character. As the alchemists had no real knowledge of the nature and behaviour of chemical substances, they drew conscious parallels between the unknown processes and mythological motifs and thus “explained” the former (cf. Dom Pernety, *Dictionnaire mytho-hermétique*, 1756) and they amplified these unknown processes by the projection of unconscious contents. This explains a peculiarity of the texts: on the one hand, the authors repeat what was said by their predecessors again and again and, on the other, they give a free rein to unlimited subjective fantasy in their symbolism. Comparative research has proved that the alchemical symbols are partly variations of mythological motifs, belonging to the conscious world of the alchemists, and partly spontaneous products of the unconscious. This becomes evident in the parallel character of the symbolism in modern dreams and that of alchemy. The alchemical symbols portray partly the substances or their unknown “mystical” nature and partly the process which leads to the goal of the work. It is the latter aspect that gives rise to the most highly pictorial development. The principal symbol of the substance that is transformed during the process is *Mercurius*. His portrait in the texts agrees in all essentials with the characteristics of the unconscious.

[1701] At the beginning of the process, he is in the *massa confusa*, the chaos or *nigredo* (blackness). In this condition, the elements are fighting each other. Here Mercurius plays the role of the *prima materia*, the transforming substance. He corresponds to the Nous or Anthropos, sunk in Physis, of Greek alchemy. In later days he is also called the “world soul in chains,” a “system of the higher powers in the lower,” etc. This depicts a dark (“unconscious”) condition of the adept or of a psychic content.

The procedures in the next phase have the purpose of illuminating the darkness by a *union of the opposed elements*. This leads to the *albedo* (whitening), which is compared to the sunrise or to the full moon. The white substance is also conceived as a pure body which has been refined by the fire but which still lacks a soul. It is considered to be feminine and is therefore called *sponsa* (bride), silver, or moon. Whereas the transformation of the darkness into light is symbolized by the theme of the fight with the dragon, it is the motif of the *hierosgamos* (sacred marriage of sister and brother or mother and son) which appears in this phase. The quaternity (*quaternio*) of the elements here becomes a duality (*binarius*). The reddening (*rubedo*) follows the whitening. By means of the *coniunctio* the moon is united with the sun, the silver with the gold, the female with the male.

[1702] The development of the *prima materia* up to the *rubedo* (*lapis rubeus*, *carbunculus*, *tinctura rubra*, *sanguis spiritualis s. draconis*, etc.) depicts the conscious realization (*illuminatio*) of an unconscious state of conflict which is henceforth kept in consciousness. During this process, the scum (*terra damnata*) which cannot be improved must be thrown out. The white substance is compared to the *corpus glorificationis*, and another parallel is the *ecclesia*. The feminine character of the *lapis albus* corresponds to that of the unconscious, symbolized by the moon. The sun corresponds to the “light” of consciousness.

[1703] Becoming conscious of an unconscious content amounts to its integration in the conscious psyche and is therefore a *coniunctio Solis et Lunae*. This process of integration is one of the most important, helpful factors in modern psychotherapy, which is pre-eminently concerned with the psychology of the unconscious, for both the nature of consciousness and that of the unconscious are altered by it. As a rule the process is accompanied by the phenomenon of the *transference*, that is, the projection of unconscious contents on to the doctor. We also meet this phenomenon in alchemy, where a woman adept often plays the role of the *soror mystica* (Zosimos and Theosebeia, Nicolas Flamel and Peronelle, John Pordage and Jane Leade, and in the nineteenth century Mr. South and his daughter, Mrs. Atwood).

[1704] The *coniunctio* produces the *lapis philosophorum*, the central symbol of alchemy. This lapis has innumerable synonyms. On the one hand, its symbols are quaternary or circular figures and, on the other, the *rebis* or the hermaphroditic Anthropos who is compared to Christ. He has a trichotomus form (*habat corpus, animam et spiritum*) and is also compared to the Trinity (*trinus et unus*). The symbolism of the *lapis* corresponds to the mandala (circle) symbols in dreams, etc., which represent wholeness and order and therefore express the personality that has been altered by the integration of the unconscious. The alchemical *opus* portrays the process of individuation but in a projected form because the alchemists were unconscious of this psychic process.²

XIV

THE SPIRIT IN MAN, ART, AND LITERATURE

(related to Volume 15 of the Collected Works)

MEMORIAL TO J. S.¹

[1705] Death has laid its hand upon our friend. The darkness out of which his soul had risen has come again and has undone the life of his earthly body, and has left us alone in pain and sorrow.

[1706] To many death seems to be a brutal and meaningless end to a short and meaningless existence. So it looks, if seen from the surface and from the darkness. But when we penetrate the depths of the soul and when we try to understand its mysterious life, we shall discern that death is not a meaningless end, the mere vanishing into nothingness—it is an accomplishment, a ripe fruit on the tree of life. Nor is death an abrupt extinction, but a goal that has been unconsciously lived and worked for during half a lifetime.

[1707] In the youthful expansion of our life we think of it as an ever-increasing river, and this conviction accompanies us often far beyond the noonday of our existence. But if we listen to the quieter voices of our deeper nature we become aware of the fact that soon after the middle of our life the soil begins its secret work, getting ready for the departure. Out of the turmoil and terror of our life the one precious flower of the spirit begins to unfold, the four-petaled flower of the immortal light, and even if our mortal consciousness should not be aware of its secret operation, it nevertheless does its secret work of purification.

[1708] When I met J. S. for the first time I found in him a man of rare clarity and purity of character and personality. I was deeply impressed with the honesty and sincerity of his purpose. And when I worked with him, helping him to understand the intricacies of the human psyche, I could not but admire the kindness of his feeling and the absolute truthfulness of his mind. But though it was a privilege to teach a man of such rare human qualities, it was not the thing that touched me most. Yes, I did teach him, but he taught me too. He spoke to me in the eternal language of symbols, which I did not grasp until the awe-inspiring conclusion, the culmination in death, became manifest. I shall never forget how he liberated his mind from the turmoil of modern business life, and how, gradually working back, he freed himself from the bonds that held him fast to his earthly parents and to his youth; and how the eternal image of the soul appeared to him, first dimly, then slowly taking shape in the vision of his dreams, and how finally, three weeks before his death, he beheld the vision of his own sarcophagus from which his living soul arose.

[1709] Who am I that I should dare say one word beyond this vision? Is there a human word that could stand against the revelation given to the chosen one? There is none.

[1710] Let us return, therefore, to the external language and let us hear the words of the sacred text. And as the ancient words will give truth to us, we will give life to them. (I Corinthians 13; 15:31–55.)

FOREWORD TO SCHMID-GUISAN: "TAG UND NACHT"¹

[1711] The atmosphere of this book is only too familiar to me. On reading the manuscript, I found it difficult at first to extricate myself from the toils of day-to-day psychotherapeutic practice—until I succeeded in viewing the book against its historical background. It is indeed something of a literary orphan, seeming to have no affinities with the present. Its strange form—the adventures of an allegorical hero—reminds one of the eighteenth century. But this is no more than a reminder, for the book is quite alien to the eighteenth century in its feeling. The problem of feeling is altogether modern, and the book opens up a world of experience that seems to have been locked away since the time of René d'Anjou—the whole sensuous world of Eros, which the latest Papal Encyclical on Christian marriage² and the penalistic conscience of modern man have conspired to suppress in a quite terrifying manner. Actually it is an esoteric book, a petal fallen from the unfading mystic rose which the troubadours accused the Church of hiding under a veil of secrecy. As though any Church had ever known the secret, or knowing it could have tolerated it! This book is neither for nor of the masses. For the multitude, it had better not been written, or should be read only because of its bad reputation. They will be lucky if they emerge unscathed. Nearly five hundred years ago a similar book was written, again at a cultural turning-point, and again a petal from that mystic rose—a knightly adventure and a stumbling-block to the vulgar, the *Hypnerotomachia*³ of that celebrated Poliphilo, who for a moment twitched the veil from the psychic background of the Cinquecento. From the preface to that book I would like to set down a classical passage which shows how the Knights of the Rose join hands across the centuries:

From this it is evident that all wise men have practised their sciences beneath the shadow of the fairest, innermost secrets of Love. Love was, and is still, the graceful brush which traces out all that is strange and appointed by Fate, as much among the higher as the lower powers, and all that is subject to them....

Know, see and hear, and you will wisely remark that the most splendid, sublime, and precious mysteries are hidden beneath the beauties of Love, from which they issue anew, for Love is the joyful soul of everything that lives....

Should I discover that some profane person had put forth his odious hand to this book to finger it, or that some unworthy creature should make bold to turn its pages, or that some shameless dissembler, under the cloak of piety, should derive a vulgar pleasure from it, or that some evil-minded spectator of these sovereign gifts should seek, from boredom, the profit that by right belongs only to loving hearts, I would

break the pen which has described so many configurations of the great secret, and, utterly forgetful of myself, would expunge all memory of the satisfaction I have found in the narration, delicately veiled in the semblance of pretty fictions, of things most wonderful and rare, which serve but to elevate a man to all that is virtuous, and denying myself the very life of my life, I would abstain from the eager pursuit of those voluptuous charms which draw men towards the sacred delights.⁴

[1712] Since witless literal-mindedness has not died out in four hundred years, I would like to impress upon the reader the classical warning which the unconscious gave Poliphilo on his journey into the darkness: “Whoever thou mayest be, take of this treasure as much as thou wilt. Yet I warn thee, take from the head and touch not the body.”⁵

*Hans Schmid-Guisan: In Memoriam*⁶

[1713] Life is in truth a battle, in which friends and faithful companions-in-arms sink away, struck by the wayward bullet. Sorrowfully I see the passing of a comrade, who for more than twenty years shared with me the experiment of life and the adventure of the modern spirit.

[1714] I first met Hans Schmid-Guisan at a conference of psychiatrists in Lausanne,^{6a} where I discussed for the first time the impersonal, collective nature of psychic symbols. He was then assistant physician at the Mahaim Clinic in Cery. Not long afterwards he came to Zurich, in order to study analytical psychology with me. This collaborative effort gradually broadened into a friendly relationship, and the problems of psychological practice frequently brought us together in serious work or round a convivial table. At that time we were especially interested in the question of the relativity of psychological judgments, or, in other words, the influence of temperament on the formation of psychological concepts. As it turned out, he developed instinctively an attitude type which was the direct opposite of my own. This difference led to a long and lively correspondence,⁷ thanks to which I was able to clear up a number of fundamental questions. The results are set forth in my book on types.

[1715] I remember a highly enjoyable bicycle tour which took us to Ravenna, where we rode along the sand through the waves of the sea. This tour was a continual discussion which lasted from coffee in the morning, all through the dust of the Lombardy roads, to the round-bellied bottle of Chianti in the evening, and continued even in our dreams. He stood the test of this journey: he was a good companion and always remained so. He battled valiantly with the hydra of psychotherapy and did his best to inculcate into his patients the same humanity for which he strove as an ideal. He never actually made a name for himself in the scientific world, but shortly before his death he had the pleasure of finding a publisher for his book *Tag und Nacht*,⁸ in

which he set down many of his experiences in a form peculiarly his own. Faithful to his convictions, he wrote it as he felt he had to write it, pandering to nobody's prejudices. His humanity and his sensitive psychological understanding were not gifts that dropped down from heaven, but the fruit of unending work on his own soul. Not only relatives and friends stand mourning today by his bier, but countless people for whom he opened the treasure-house of the psyche. They know what this means to them in a time of spiritual drought.

ON THE TALE OF THE OTTER¹

[1716] In writing a few introductory words to this publication, one of his last, I am discharging a duty to my dead friend, Oskar A. H. Schmitz. I am not a literary man, nor am I competent to pass judgment on aesthetic questions. Moreover, the literary value of “The Tale of the Otter” is of little concern to me. I readily admit that, as a fairytale, it is as good or as bad as any other that a writer has invented. Such tales, as we know, even though invented by a great writer, do not breathe the flowery, woodland magic of the popular fairytale. Usually they can be shown to be products of the author’s personal psychology, and they have a problematical air that makes them slightly unnatural. This is true also of “The Tale of the Otter.” It is only a literary form for a content that could have been expressed in quite other words and in quite another way. Nevertheless, it was not chosen fortuitously. The content clothed itself in fairytale form not with the secret pretence of being an allegory, but because in this guise it could find the simplest and most direct access to the reader’s heart. Childlike simplicity of heart was a basic trait of Schmitz’s nature, known to very few people, and one which he himself recognized only late in life. Thanks to this simplicity, he could speak to the hearts of those he wished to touch.

[1717] I happen to know how the tale came to be written. It was not born of any conscious intention to reach a particular kind of public; it was never even thought out, but flowed unconsciously from his pen. Schmitz had learnt how to switch off his critical intellect for certain purposes and to place his literary powers at the disposal of the heart’s wisdom. In this way he was able to say things that are infinitely far removed from the usual style of his writings. At times, it became a real necessity for him to express himself in this way. For many things which reason wrestles with in vain flow easily and effortlessly into a pen emptied of all critical intentions.

[1718] The result may seem very simple, indeed naïve, and anyone who read it as one reads a popular fairytale would be disappointed. It is equally idle to take it as an allegory. Schmitz himself did not really know what his tale meant. He told me so himself, for we often talked about it.

[1719] The utterances of the heart—unlike those of the discriminating intellect—always relate to the whole. The heartstrings sing like an Aeolian harp only under the gentle breath of a mood, an intuition, which does not drown the song but listens. What the heart hears are the great, all-embracing things of life, the experiences which we do not arrange ourselves but which happen to us. All the pyrotechnics of reason and literary skill pale beside this, and language returns to the naïve and childlike.

Simplicity of style is justified only by significance of content, and the content acquires its significance only from the revelation of experience. The decisive experience of Schmitz's life was his discovery of the reality of the psyche and the overcoming of rationalistic psychologism. He discovered that the psyche is something that really exists. This changed his life and his work outlook.

[1720] For those who are vouchsafed such a discovery, the psyche appears as something objective, a psychic non-ego. This experience is very like the discovery of a new world. The supposed vacuum of a merely subjective psychic space becomes filled with objective figures, having wills of their own, and is seen to be a cosmos that conforms to law, and among these figures the ego takes its place in transfigured form. This tremendous experience means a shattering of foundations, an overturning of our arrogant world of consciousness, a cosmic shift of perspective, the true nature of which can never be grasped rationally or understood in its full implications.

[1721] An experience of this kind induces an almost frightening need to communicate with sympathetic fellow-beings, to whom one then turns with naïve words. "The Tale of the Otter" describes an experience of the unconscious and the resultant transformation both of the personality and of the figures in the psyche. The King stands for the ruling principle of consciousness, which strays further and further away from the unconscious. (The fish disappear from the waters of the kingdom.) The stagnation of consciousness finally compels the King to make contact with the unconscious again. (The King's pilgrimage.) The otter, the unconscious partner of the ego, seeks to bring about a reconciliation with consciousness. (Gilgamesh-Eabani motif.) This is successful, and a new world of consciousness arises on an apparently firm foundation. But as the King represents only the best part of the personality, and not the inferior part, the shadow, which should also be included in the transformation, the old King dies and his good-for-nothing nephew succeeds to the throne. The second half of the tale is concerned with the far more difficult task of including the weaknesses of the personality and its useless, adolescent traits in the process of transformation. This is especially difficult because the shadow is burdened with a still more inferior, feminine component, a negative anima figure (Brolante, the harlot). While the masculine components are successfully brought into harmony with the vital instincts (represented by animals), there is a final separation between the spiritual and the physical nature of the anima. The masculine half is rescued from evil, but the feminine half becomes its victim.

[1722] "The Tale of the Otter" gives touching and modest expression to an all-embracing and all-transforming initiation. Read it with care and meditate upon it! For when all this has been fulfilled in him, Schmitz died. In this little fairytale he tells posterity how it fared with him and what transformations his soul had to undergo before it was ready to lay aside its garment and end its lifelong experiment.

IS THERE A FREUDIAN TYPE OF POETRY?¹

[1723] Poetry, like every product of the human mind, is naturally dependent on a man's general psychological attitude. If a writer is sick, psychically sick, it is highly probable that whatever he produces will bear the stamp of his sickness. This is true with reservations, of course; for there actually are cases where the creative genius so far transcends the sickness of the creator that only a few traces of human imperfection are to be seen in the work. But these are exceptions; the general rule is that a neurotic poet will make neurotic poems. The more neurotic a poem is, the less it is a creative work of art and the more it is a symptom. It is therefore very easy to point out infantile symptoms in such cases and to view the product in the light of a particular theory; indeed, it is sometimes possible to explain a work of art in the same way as one can explain a nervous illness in terms of Freud's theory or Adler's. But when it comes to great poetry the pathological explanation, the attempt to apply Freudian or Adlerian theory, is in effect a ridiculous belittlement of the work of art. The explanation not only contributes nothing to an understanding of the poetry, but, on the contrary, deflects our gaze from that deeper vision which the poet offers. The Freudian and the Adlerian theory alike formulate nothing but the human-all-too-human aspects of the commonplace neurosis. So when one applies this point of view to great poetry, one is dragging it down to the level of dull ordinariness, when actually it towers above it like a high mountain. It is quite obvious that all human beings have father and mother complexes, and it therefore means nothing if we discern traces of a father or mother complex in a great work of art; just as little as would the discovery that Goethe had a liver and two kidneys like any other mortal.

[1724] If the meaning of a poetic work can be exhausted through the application of a theory of neurosis, then it was nothing but a pathological product in the first place, to which I would never concede the dignity of a work of art. Today, it is true, our taste has become so uncertain that often we no longer know whether a thing is art or a disease. I am convinced, however, that if a work of art can be explained in exactly the same way as the clinical history of a neurosis, either it is not a work of art, or the explainer has completely misunderstood its meaning. I am quite convinced that a great deal of modern art, painting as well as poetry, is simply neurotic and that it can, consequently, be reduced like an hysterical symptom to the basic, elementary facts of neurotic psychology. But so far as this is possible, it ceases to be art, because great art is man's creation of something superhuman in defiance of all the ordinary,

miserable conditions of his birth and childhood. To apply to this the psychology of neurosis is little short of grotesque.

FOREWORD TO GILBERT: "THE CURSE OF INTELLECT"¹

[1725] The author has kindly given me a chance of reading his book in manuscript. I must say, I have read it with the greatest interest and pleasure. It is most refreshing, after the whole nineteenth century and a stretch of the twentieth, to see the intellect once more turned loose upon herself, not exactly in the dispassionate form of a "Critique of Pure Reason," but in the rather impassioned way of a most temperamental onslaught on herself. As a matter of fact, it is a wholesome and vitalizing tearing into sorry shreds of what all "healthy-minded" people believed in as their most cherished securities. I am human enough to enjoy a juicy piece of injustice when it comes in the right moment and in the right place. Sure enough, Intellect has done her worst in our "Western Civilization," and she is still at it with undoubted force. Kant could still afford to deal with the contemporaneous intellect in a polite, careful, and gentle way, because she then was but a mere fledgling. But our time is concerned with a monster completely grown up and so fat that it can easily begin to devour itself.

[1726] At the funeral somebody will be allowed to say only something nice about the deceased. In anticipation of that future event I will say it now: The chief trouble seems to be that the intellect escaped the control of man and became his obsession, instead of remaining the obedient tool in the hands of a creator, shaping his world, adorning it with the colourful images of his mind.

January 1934

FOREWORD TO JUNG: "WIRKLICHKEIT DER SEELE" (1934)¹

[1727] This, the fourth volume of my "Psychologische Abhandlungen," contains a number of essays that faithfully reflect the manifold facets of the more recent psychology. It is not long since the psychology of the personality broke free from the all too narrow confines of the consulting room on the one hand, and of materialistic and rationalistic assumptions on the other. It is therefore no wonder if much still clings to it that is in need of clarification. Until recently the worst chaos prevailed in the realm of theory, and only now have serious attempts been made to clear away the confusion. Dr. Kranefeldt's contributions² are devoted to this task. Dr. Rosenthal's contribution³ is an application of the typological viewpoint to the scientific study of religion. The archetypical figures of anima and animus form a special department of depth psychology. Emma Jung discusses the phenomenology of the animus complex.⁴

[1728] My own contributions are concerned on the one hand with the philosophical problems of modern psychology, and on the other hand with its applications. Since this time, too, my essays came into being as answers to questions addressed to me by the public,⁵ their unusual diversity may be taken as an indication that recent psychological insights have left their mark on as many diverse realms of the mind. Not only doctors and teachers, but writers and educated laymen, and—last but not least—even publishers are now evincing an interest in things psychological.

[1729] These many facets of complex psychology, lighting up the most varied walks of life and domains of the mind, are in turn a much simplified reflection of the measureless diversity and iridescence of the psyche itself. Although one could never dream of exhausting its mysteries and fathoming all its secrets, it nevertheless seems to me one of the foremost tasks of the human mind to labour without cease for an ever deeper knowledge of man's psychic nature. For the greatest enigma in the world, and the one that is closest to us, is man himself.

September 1933

FOREWORD TO MEHLICH: "J. H. FICHTE'S SEELENLEHRE UND IHRE BEZIEHUNG ZUR GEGENWART"¹

[1730] Although I owe not a little to philosophy, and have benefited by the rigorous discipline of its methods of thought, I nevertheless feel in its presence that holy dread which is inborn in every observer of facts. The unending profusion of concepts spawning yet other concepts, rolling along like a great flood in the history of philosophy, is only too likely to inundate the little experimental gardens of the empiricist, so carefully marked out, swamping his well-ploughed fields, and swallowing up the still unexplored virgin land. Confronting the flux of events with unprejudiced gaze, he must fashion for himself an intellectual tool stripped of all preconceptions, and anxiously eschew as perilous temptations all those modes of thinking which philosophy offers him in such excessive abundance.

[1731] Because I am an empiricist first and foremost, and my views are grounded in experience, I had to deny myself the pleasure of reducing them to a well-ordered system and of placing them in their historical and ideological context. From the philosophical standpoint, of whose requirements I am very well aware, this is indeed a painful omission. Even more painful to me, however, is the fact that the empiricist must also forswear an intellectual clarification of his concepts such as is absolutely imperative for the philosopher. His thinking has to mould itself to the facts, and the facts have as a rule a distressingly irrational character which proves refractory to any kind of philosophical systematization. Thus it comes about that empirical concepts are concerned for the most part with the chaos of chance events, because it is their function to produce a provisional order amid the disorder of the phenomenal world. And because they are wholly bent on this urgent task, they neglect—sometimes only too readily—their own philosophical development and inner clarification, for a thinker who performs the first task satisfactorily will seldom be able to complete the second.

[1732] These two aspects became overwhelmingly clear to me as I read this admirable study of Fichte's psychology: on the one hand the apparent carelessness and vagueness of my own concepts when it comes to systematic formulation, and on the other the precision and clarity of a philosophical system which is singularly unencumbered by empirical impedimenta. The strange but undeniable analogy between two points of view derived from totally different sources certainly gives one food for thought. I am not aware of having plagiarized Fichte, whom I have not read. Naturally I am familiar with Leibniz, C. G. Carus, and von Hartmann, but I never

knew till now that my psychology is “Romantic.” Unlike Rickert² and many other philosophers and psychologists, I hold that, in spite of all abstraction, objectivity, absence of bias, and empiricism, everyone thinks as *he* thinks and sees as *he* sees. Accordingly, if there is a type of mind, or a disposition, that thinks and interprets “romantically,” analogous conclusions will emerge no matter whether they are coloured by the subject or by the object. It would be vain to imagine—gamely competing with Baron Münchhausen—that one could disembarass oneself of one’s own weight and thus get rid of the ultimate and most fundamental of all premises—one’s own disposition. Only an isolated and hypertrophied psychic function is capable of cherishing such an illusion. But a function is only a part of the human whole, and its limited character is beyond all doubt. Were it not for these considerations the analogy between Fichte and me would certainly have to be regarded as a minor miracle.

[1733] It is a bold undertaking—for which the author deserves all the more credit—to bring Fichte into line with a modern empirical psychology based on facts that were wholly inaccessible to this philosopher—an empiricism, moreover, which has unearthed conceptual material that is singularly unsuited to philosophical evaluation. But it seems that this undertaking has been successful, for I learn to my amazement that the Romantic Movement has not been relegated to the age of fossils, but still has living representatives. This is probably no accident, for it appears that besides the self-evident experience of the “objective” world there is an *experience of the psyche*, without which an experience of the world would not be possible at all. It seems to me that the secret of Romanticism is that it confronted the all-too-obvious *object* of experience with a *subject* of experience, which it proceeded to objectify thanks to the infinite refractive powers of consciousness. There is a psychology that always has another person or thing for an object—a fairly well-differentiated kind of behaviourism which might be described as “classical.” But besides this there is a psychology which is a knowing of the knower and an experiencing of the experiment.

[1734] The indirect influence of the type of mind exemplified by Hume, Berkeley, and Kant can hardly be overestimated. Kant in particular erected a barrier across the mental world which made it impossible for even the boldest flight of speculation to penetrate into the object. Romanticism was the logical counter-movement, expressed most forcefully, and most cunningly disguised, in Hegel, that great psychologist in philosopher’s garb. Nowadays it is not Kant but natural science and its de-subjectivized world that have erected the barrier against which the speculative tendency rebounds. Its essentially behaviourist statements about the object end in meaninglessness and nonsense. That is why we seek the meaning in the statements of the subject, believing we are not in error if we assume that the subject will first of all make statements about itself. Is it the empiricist in me, or is it because analogy is not

identity, that makes me regard the “Romantic” standpoint simply as a point of departure and its statements as “comparative material”?

[1735] I admit that this attitude is disappointingly sober, but the psychic affinity with a romantic philosopher prompts me to a critical utterance which seems to me the more in place as there are only too many people for whom “Romantic” always means something out of a romance.

[1736] Apart from this critical proviso, which the author herself stresses, her book is a welcome contribution of the study of a specific attitude of mind which has recurred many times in the course of history and presumably will also recur in the future.

FOREWORD TO VON KOENIG-FACHSENFELD: "WANDLUNGEN DES TRAUMPROBLEMS VON DER ROMANTIK BIS ZUR GEGENWART"¹

[1737] The author has asked me to write a foreword to her dissertation. I am happy to comply with her request because this comprehensive and well-documented work deserves to be known to a wider scientific public. Although we already possess a number of valuable "synoptic" studies which give a fairly complete account of the various doctrines prevalent in modern psychology—I would mention in particular the works of W. Kranefeldt, G. R. Heyer, and Gerhard Adler—there was always a noticeable gap as regards the historical and philosophical side of complex psychology. The more conscious it became of the magnitude of its task—the study of the human psyche in its totality—the more contacts it made with other fields of thought where the psyche has an equal right to speak, above all with philosophy. For whenever a science begins to grow beyond its narrow specialist boundaries, the need for fundamental principles is forced upon it, and with this it moves into the sovereign sphere of philosophy. If the science happens to be psychology, a confrontation with philosophy is unavoidable for the very reason that it had been a philosophic discipline from the beginning, resolutely breaking away from philosophy only in quite recent times, when it established itself within the philosophical and the medical faculties as an independent empirical science with mechanistic techniques. The experimental psychology inaugurated by W. Wundt was succeeded by the psychology of the neuroses, which had been developed almost simultaneously by Freud in Vienna and by Pierre Janet in Paris. My own course of development was influenced primarily by the French school and later by Wundt's psychology. Later, in 1906, I made contact with Freud, only to part company with him in 1913, after seven years of collaboration, owing to differences of scientific opinion. It was chiefly considerations of principle that brought about the separation, above all the recognition that psychopathology can never be based exclusively on the psychology of psychic disease, which would restrict it to the pathological, but must include normal psychology and the full range of the psyche. Modern medicine quite rightly adheres to the principle that pathology must be based on a thorough knowledge of normal anatomy and physiology. The criterion by which we judge disease does not and cannot lie in the disease itself, as most of the medieval physicians thought, but only in the normal functioning of the body. Disease is a variation of the normal. The same considerations apply to therapy.

[1738] For a long time it seemed as though experimental and medical psychologists could get along with purely scientific methods. But the view gradually gained ground that a critique of certain ideals originating in the humanistic disciplines was not out of place, since a careful investigation of the aetiology of pathological states had shown how the general attitude of the patient which led to the morbid variation depended on just these ideal or moral premises, not to mention the interpretation of facts and the theories resulting therefrom. But as soon as medical psychology reached this point, it turned out that the principles which had hitherto held unlimited sway over men's minds were of a purely rationalistic or materialistic nature, and, in spite of their "scientific" pretensions, had to be subjected to philosophical criticism because the object of their judgment was the *psyche itself*. The psyche is an extremely complex factor, so fundamental to all premises that no judgment can be regarded as "purely empirical" but must first indicate the premises by which it judges. Modern psychology can no longer disguise the fact that the object of its investigation is its own essence, so that in certain respects there can be no "principles" or valid judgments at all, but only *phenomenology*—in other words, *sheer experience*. On this level of knowledge, psychology has to abdicate as a science, though only on this very high level. Below that, judgments and hence science are still possible, provided that the premises are always stated, and to that extent the prospects for psychology as a science are by no means hopeless. But once it ceases to be conscious of the factors conditioning its judgments, or if it has never attained to this consciousness, it is like a dog chasing his own tail.

[1739] So far, then, as psychology takes its own premises into account, its relevance to philosophy and the history of ideas is self-evident, and this is where the present book comes in. No one can deny that certain of these premises are a restatement of ideas dating back to the time of the Romantics. However, it is not so much the ideal premises that justify the author's historical approach as the supposedly "modern" phenomenological standpoint of "sheer experience," which was not only anticipated by the Romantics but actually pertains to their very nature. It was the essence of Romanticism to "experience" the psyche rather than to "investigate" it. This was once again an age of philosopher-physicians, a phenomenon that was observed for the first time in the post-Paracelsan era, more especially in philosophical alchemy, whose most important practitioners were usually doctors. In keeping with the pre-scientific spirit of the times, the Romantic psychology of the early nineteenth century was a child of Romantic natural philosophy—one thinks of C. G. Carus—although the beginnings of empiricism were already discernible in Justinus Kerner. The psychology of the sixteenth century, on the other hand, still had occult and religious undercurrents, and though it called itself "philosophy" a later, "enlightened" age would hardly have countenanced the name. The psyche as experience is the hallmark

of the Romantics who sought the blue flower,² as well as of the philosophical alchemists who sought the *lapis noster*.

[1740] This book performs the valuable service of unlocking a veritable treasure-house of contemplative Romantic poetry for modern psychology. The parallelism with my psychological conceptions is sufficient justification for calling them “Romantic.” A similar inquiry into their philosophical antecedents would also justify such an epithet, for every psychology that takes the psyche as “experience” is from the historical point of view both “Romantic” and “alchemystical.” Below this experimental level, however, my psychology is scientific and rationalistic, a fact I would beg the reader not to overlook. The premise underlying my judgments is the *reality of everything psychic*, a concept based on the appreciation of the fact that the psyche can also be pure experience.

[1741] The author has carried out her task with great professional expertise, and I warmly recommend her book to everyone who is interested in the problems of modern complex psychology.

FOREWORD TO GILLI: "DER DUNKLE BRUDER"¹

[1742] By writing a foreword to Gertrud Gilli's drama in verse, I do not wish to evoke the impression that it needs a psychological explanation in order to heighten its effect. Works of art are their own interpretation. *The Dark Brother* does not share the modern obscurantism of certain contemporary paintings, nor is it a direct product of unconscious activity which would require interpretation and transcription into generally intelligible language.

[1743] The play is modern, however, in so far as the central process of Christianity, the divine drama, is reflected in the sphere of human motivations. A bold stroke indeed! But has not the personality of Judas always been a problematical figure in the redemption mystery? For certain Protestant theologians and historians, Christ himself has been stripped of his divine incarnation and become simply a founder of religion, a very superior and exemplary one, it is true, and his passion mere human suffering for the sake of an ideal, thus lending considerably more plausibility to the human protagonists and antagonists. Only in the mythological phase of the mind are heroes representatives of light and purity, and their adversaries embodiments of absolute evil. The real man is a mixture of good and bad, of self-determination and supine dependence, and the borderline between genuine ideals and personal striving for power is often very difficult to draw. As for the genius, his role as the mouthpiece and proclaimer of new truths is not always felt as an unmixed blessing by ordinary mortals, especially where religious beliefs are concerned.

[1744] In one form or another, the figure of the redeemer is universal because it partakes of our common humanity. It invariably emerges from the unconscious of the individual or the people when an intolerable situation cries out for a solution that cannot be implemented by conscious means alone. Thus the Messianic expectations of the Jews were bound to rise to fever pitch when, as a result of the corruption that followed in the wake of Herod the Great, all hope of an independent sacerdotal order or kingdom had vanished, and the country had become a Roman province lacking any form of autonomy. It is therefore readily understandable that these Messianic expectations centred on a political redeemer, and that more than one enthusiastic patriot sought to fulfil this role—above all Judas of Galilee, whose insurrection is reported by Flavius Josephus,² and who, boldly but quite logically, entangles the eponymous hero of this drama in a similar task.

[1745] But underlying the divine drama there is a different plan, which is not concerned with man's outward, social, or political liberation. It focuses rather on the inner man

and his psychic transformation. What is the use of changing the external conditions if man's inner attitude remains the same? It is all the same, psychologically, whether his subjection is the result of external circumstances or of intellectual or moral systems. True "redemption" comes about only when he is led back to that deepest and innermost source of life which is generally called God. Jesus was the channel for a new and direct experience of God, and how little this depends on external conditions is amply demonstrated by the history of Christianity.

[1746] Man lives in a state of continual conflict between the truth of the external world in which he has been placed and the inner truth of the psyche that connects him with the source of life. He is pulled now to one side and now to the other until he has learnt to see that he has obligations to both. In this sense Gertrud Gilli's play gives expression to a universal and timeless human fact: beyond our personal and time-bound consciousness, in our interior selves, there is enacted the everlasting drama in which the all-too-human players reach out, yearning and shrinking at once, for the deeper truth, and seek to bend it to their own purposes and their own ruin.

[1747] If Judas in Gilli's play is depicted as the dark brother of Jesus, and if his character and fate are reminiscent of Hamlet's, there may well be deeper reasons for this. One could imagine him more active and aggressive, for instance as a fiery patriot who has to get rid of Jesus from inner necessity, because Jesus as the corrupter of the people obstructs his plans for their liberation, or else because Judas sees him as the political Messiah and then betrays him out of disappointment and rage. In this sense, too, Judas would be his dark brother, since in the story of the Temptation the devil of worldly power stepped up to Jesus in much the same way as Mara tempted the Buddha. Judas might easily have become a hero after the manner of classical drama. But because his dependence catches him on every side and he can scarcely act on his own initiative, he becomes an exponent of the human drama which, though played out within the confines of the earth's shadow, has at all times accompanied the divine drama and often eclipsed it.

GÉRARD DE NERVAL¹

[1748] Gérard de Nerval (pseudonym of Gérard Labrunie, 1808–1853) was a lyric poet and translator of Goethe and Heine. He is best known by his posthumously published novel *Aurélia*, in which he relates the history of his anima and at the same time of his psychosis. The dream at the beginning, of a vast edifice and the fatal fall of a winged daemon, deserves special attention. The dream has no lysis. The daemon represents the self, which no longer has any room to unfold its wings. The disastrous event preceding the dream is the projection of the anima upon “une personne ordinaire de notre siècle,” with whom the poet was unable to work on the *mysterium* and in consequence jilted Aurélia. Thus he lost his “pied à terre” and the collective unconscious could break in. His psychotic experiences are largely descriptions of archetypal figures. During his psychosis the real Aurélia appears to have died, so that his last chance of connecting the unconscious with reality, and of assimilating its archetypal contents, vanished. The poet ended by suicide. The MS of *Aurelia* was found on his body.

FOREWORD TO FIERZ-DAVID: "THE DREAM OF POLIPHILLO"¹

[1749] It must be twenty-five years since Francesco Colonna's *Hypnerotomachia Poliphili* first came my way in the French translation published by Béroalde de Verville in 1600. Later, in the Morgan Library, New York, I saw and admired the first Italian edition² with its superb woodcuts. I set about reading the book, but soon got lost in the mazes of its architectural fantasies, which no human being can enjoy today. Probably the same thing has happened to many a reader, and we can only sympathize with Jacob Burckhardt, who dismissed it with a brief mention while bothering little about its contents. I then turned to the "Recueil Stéganographique," Béroalde's Introduction, and in spite of its turgid and high-flown verbiage I caught fleeting glimpses which aroused my curiosity and encouraged me to continue my labours, for labours they are in a case like this. My efforts found their reward, for plodding on, chapter by chapter, I sensed, rather than recognized, more and more things I was later to encounter in my study of alchemy. Indeed, I cannot even say how far it was this book that put me on the track of the royal art. In any case, not long afterwards I began to collect the old Latin treatises of the alchemists, and in a close study of them lasting many years I did eventually succeed in unearthing those subterranean processes of thought from which sprang not only the world of alchemical imagery but also Poliphilo's dream. What first found expression in the poetry of the minnesingers and troubadours can be heard here as a distant echo of a dreamlike past, but it is also a premonition of the future. Like every proper dream, the *Hypnerotomachia* is Janus-faced: it is a picture of the Middle Ages on the brink of the Renaissance—a transition between two eras, and therefore highly relevant to the world today, which is even more obviously a time of transition and change.

[1750] So it was with considerable interest that I read the manuscript sent me by Mrs. Linda Fierz-David, for it is the first serious attempt to unlock Poliphilo's secret and to unravel its crabbed symbolism with the help of modern psychology. In my opinion, her undertaking has been entirely successful. She has pursued the psychological problem which forms the central theme of the book through all the twists and turns of the story, demonstrating its personal and suprapersonal character as well as bringing to light its significance for the world of that time. Many of her interpretations are so astute and illuminating that this seemingly outlandish and baroque tale, eagerly read in the sixteenth and seventeenth centuries, is once more brought within the intellectual orbit of the modern reader. With an intelligence equalled only by her intuition, she has painted a picture of that peculiar Renaissance

psychology whose literary monument is the *Hypnerotomachia*, while giving that picture a timeless background. Thus, the tale reappears in all the freshness of its original colours and makes a direct appeal to the man of today by virtue of its imperishable psychological truth.

[1751] On its voyage through uncharted seas, the book owes some of its happiest discoveries to the sensitiveness of the feminine mind, which, delicately indiscreet, can take a peep behind Francesco Colonna's richly ornate baroque façade. It was because of this feminine gift that St. Catherine was consulted by the heavenly assembly "in all difficult cases," as we learn from Anatole France's amusing account in *Penguin Island*. "While on earth, St. Catherine had confounded fifty very learned doctors. She was versed in the philosophy of Plato as well as the Scriptures, and possessed rhetoric." Hence, it is no matter for surprise if Mrs. Fierz-David has brought off some dazzling feats of interpretation which throw considerable light on the obscurities of Poliphilo's symbolism. The tortuous ways of the masculine mind, setting traps for itself with its own vanities, are here exposed and illuminated, and modern man would do well to learn from this example.

[1752] In her commentary, she takes us deep into psychological problems that remain unfathomable to the modern mind and set it a hard task. The book is not easy reading—indeed, it requires some effort. But it is a rich and stimulating repast, and will amply reward the attentive reader who comes to meet it halfway. For myself, I am grateful to the author for the enriched knowledge and insight her book has brought me.

February 1946

FOREWORD TO CROTTET: "MONDWALD"¹

[1753] The author of this book is no ordinary explorer, of whom there is no lack nowadays, but one who still understands the almost forgotten art of travelling with all his senses open. This art or, as we might also say, this gift bestowed by the grace of heaven, enables the traveller to bring back from distant shores more than can ever be captured by cameras and tape-recorders, to wit, his own experience through which we glimpse the lure of foreign lands and peoples. This alone makes them come alive for us as we listen to the tale of the clash of two worlds. The "subjectivity" so rightly feared by science here becomes a source of illumination, conveying to us flashes of insight which no description of facts however complete can attain. This is a matter of taking notes with scrupulous objectivity. Instead, the "sensitive traveller" creates an experience which does not, like a factual record, consist merely of the data of the senses and the intellect, but of those countless, indescribable, subliminal impressions which hold the traveller captive in a foreign land. Certainly his objective description tells us a great deal, but his emotion, his being carried away, means far more. It reveals something that cannot be expressed in words: the wholeness of prehistoric nature and preconscious humanity, which for the civilized man and inhabitant of a virtually enslaved earth is utterly alien and unfathomable. All sorts of possibilities hang invisibly in the air, yet somehow we have always known of them; realities of which an age-old, nearly forgotten knowledge in us evokes a distant echo; a longing that looks back to the golden haze of a childhood morning, and forward to fulfilment at the millennium. It is the intimation of a pristine wholeness, lost and now hoped for again, that hovers over the primeval landscape and its inhabitants, and only the storyteller's emotion can bring it home to us. We understand and share his passionate desire to preserve and perpetuate this fathomless splendour, for which a National Park would be but a feeble substitute, and we lament with him the devastation that threatens it because of our civilizing barbarism. In Kenya an old squatter once said to me: "This ain't man's country, it's God's country." Today it is dotted with goldmines, schools, mission stations—and where are the slow rivers of grazing herds, the human dwellings clustering like wasps' nests on yellow and red cliffs beneath the shade of acacias, the soundless eternity of a life without history?

[1754] The author's aim is to preserve the life of a primitive people, the Lappish Skolts in northern Finland, who have been robbed of their reindeer herds, and thus protect at least a little bit of that primeval age from irremediable disaster. May his wish be granted.

March 1949

FOREWORD TO JACOBI: "PARACELSUS: SELECTED WRITINGS"¹

[1755] The author has asked me for some introductory words to the English edition of her book on Paracelsus. I am more than willing to comply with this request, for Paracelsus, an almost legendary figure in our time, was a preoccupation of mine when I was trying to understand alchemy, especially its connection with natural philosophy. In the sixteenth century, alchemical speculation received a strong impetus from this master, notably from his singular doctrine of "longevity"—a theme ever dear to the alchemist's heart.

[1756] In her book, Dr. Jacobi emphasizes the moral aspect of Paracelsus. She wisely lets the master speak for himself on crucial points, so that the reader can gain first-hand information about this strange Renaissance personality, so amply endowed with genius. The liberal use of original texts, with their vivid, imaginative language, helps to develop a striking picture of the man who exerted a powerful influence not only on his own time but on succeeding centuries.

[1757] A contradictory and controversial figure, Paracelsus cannot be brought into line with any stereotype—as Sudhoff,² for instance, sought to do when, arbitrarily and without a shadow of evidence, he declared that certain aberrant texts were spurious. Paracelsus remains a paradox, like his contemporary, Agrippa von Nettesheim. He is a true mirror of his century, which even at this late date presents many unsolved mysteries.

[1758] An excellent feature of Dr. Jacobi's book is her glossary of Paracelsus' concepts, each furnished with a succinct definition. To follow the language of this physician, this natural philosopher and mystic—a language freighted with technical terms and neologisms—is not easy for readers unfamiliar with alchemical writings.

[1759] The book abounds in pictorial material which, coming for the most part from Paracelsus' time and from the places where he lived, rounds out and sharpens the presentation.

May 1949

FOREWORD TO KANKELEIT: “DAS UNBEWUSSTE ALS KEIMSTÄTTE DES SCHÖPFERISCHEN”¹

[1760] Dr. Otto Kankeleit has given me the manuscript of his book and has asked me to write a foreword. It is not a scientific study of a theoretical nature, but a descriptive survey of the multitudinous phenomena and problems which beset the practising psychotherapist in his daily work. It is a kaleidoscopic assortment of images, visions, flickerings on the edge of the mind—a phantasmagoria of all the things the doctor wonders about. He finds himself confronted with a mass of problems stretching into a limitless horizon. That is the particular value of this book: it opens vistas into reaches of the psyche extending far beyond the confines of the consulting room, giving the reader a glimpse into a world hitherto unknown to him. It does not stop short at the pathological and does not apply to the sick the psychopathology of the sick. It leads beyond that to the wide realm of psychic life in general, to an abiding concern with the sick person, for the principal aim of modern medicine is not so much to eliminate the symptoms of sickness as to guide the patient back to a normal and balanced life.

[1761] Naturally this can be done only if he is given a balanced picture of the human psyche to offset his morbid and limited experience of it. For this purpose, as the author very rightly points out, it is necessary for doctor and patient to come to terms with the nature of the unconscious, since, for good or ill, they are both involved in its mysterious reality.

[1762] The book is in many respects extremely instructive for the doctor, and a very sympathetic one because of its unbiased standpoint.

Jung's Contribution

Among the “testimonials from scholars, writers, and artists” (subtitle of Dr. Kankeleit’s book) are Jung’s answers (ibid., pp. 68f.) to the following questionnaire:

What is the respective share of the conscious and the unconscious in the creative process?

[1763] Like all psychic life the creative process stems from the unconscious. If you identify with the creative process you usually end up by imagining that you yourself are the creator.

Have you, at the onset of a new period of creativity, observed in yourself exceptional states of any kind, in which the unconscious took the lead?

[1764] Speaking for myself, I must confess that I always notice the strangest things at the onset of a new period of creativity. (I don't doubt that there are people who never notice such things.) The unconscious takes the lead nightly in our dreams, so it is not at all surprising that it should usher in the creative process with all sorts of spontaneous phenomena.

Do you occasionally resort to stimulants of any kind (alcohol, morphine, hashish, etc.)?

[1765] Oh no! Never! A new idea is intoxicating enough.

Do you think dreams play a part in the creative process?

[1766] For years my dreams used to anticipate my creative activities as well as other things.

Have you ever experienced exceptional states of any kind (precognition, telepathy, etc.) which are not dependent on the creative process?

[1767] On closer analysis, I don't think any exceptional states can be separated from the creative process, because life itself is creativity par excellence.

I would like very much to have a detailed description of a creative process.

[1768] I could give you a detailed description but will not do so because for me the whole thing is too mysterious. I stand in such awe of the great mysteries that I am unable to talk about them. In any case, a close study of any dream series will provide perfect examples.

FOREWORD TO SERRANO: "THE VISITS OF THE QUEEN OF SHEBA"¹

[1769] This book is an extraordinary piece of work. It is dreams within dreams, highly poetic I should say, and most unlike the spontaneous products of the unconscious I am used to, although well-known archetypal figures are clearly discernible. The poetic genius has transformed this primordial material into almost musical shapes, just as, conversely, Schopenhauer understood music as the movement of archetypal ideas. The principal formative factor seems to be a strong aesthetic tendency. The reader is caught in an endlessly proliferating dream, in ever-expanding space and immeasurable depths of time. On the other hand the cognitive element plays no significant role—it even recedes into a misty background, yet alive with the wealth of colourful images. The unconscious or whatever we designate by this name presents itself to the author under its poetic aspect, while I envisage it chiefly under its scientific and philosophical or, to be more accurate, its religious aspect. The unconscious is surely the *Pammeter*, the Mother of All (i.e., of all psychic life), being the matrix, background, and foundation of all the differentiated phenomena we call psychic—religion, science, philosophy, art. The experience of the unconscious, whatever form it may take, is an approach to wholeness, the one experience lacking in our modern civilization. It is the *via regia* to the *Unus Mundus*.

IS THERE A TRUE BILINGUALISM?¹

[1770] You have asked me a question which I cannot answer precisely. I would not be able to define what you understand by “bilingualism.”

[1771] There are certainly people living abroad who have become so used to a new language that they not only think but even dream in the idiom of the country. I, personally, have experienced this after a rather long stay in England. I suddenly caught myself definitely thinking in English.

[1772] This has never happened to me with the French language, but I noticed that after a comparatively short stay in France my vocabulary unexpectedly increased. This was caused not so much by intense reading of French nor by conversation with French people, but was more the influence of the atmosphere—if this expression is permissible. This is a fact that has been observed quite often. But once one returns to one’s country these riches generally disappear.

[1773] I am absolutely convinced that in many cases a second language can be implanted in this fashion—even at the expense of the original language. But as one’s memory is not without limit, a bi- or tri-lingual state ends by damaging the scope of one’s vocabulary as well as the greatest potential use of each language.

XV

THE PRACTICE OF PSYCHOTHERAPY

(related to Volume 16 of the Collected Works)

REVIEWS OF BOOKS BY HEYER

*Der Organismus der Seele*¹

[1774] The author of this book has performed the grateful service of giving a comprehensive account of the chaos—one can hardly say less—that reigns in the field of psychotherapy. I know of no book that grasps the essential problems of modern therapy and its conflicting views in just this knowledgeable, unprejudiced, and wholly impartial manner. Unfortunately, most other books of the kind are written in the interests of some system and therefore suffer from that distressing theoretical narrow-mindedness which, on occasion, borders on sectarian bigotry. Many of these authors appear to have forgotten that psychology, of all the sciences, demands the most constant self-criticism. Every psychologist should realize first and foremost that his point of view is his own subjective prejudice. This particular prejudice is certainly no worse than any other, moreover it is extremely likely to be a fundamental assumption with many other people as well. Hence it is generally worth while pursuing one's point of view as far as possible. It will doubtless bear fruit that have a certain usefulness. But under no circumstances should one indulge in the unscientific delusion that one's own subjective prejudice represents a universal and fundamental psychological truth. No true science can spring from this, only a faith whose shadow is intolerance and fanaticism. Contradictory views are necessary for the evolution of any science; they must not be set up in opposition to each other, but should seek the earliest possible synthesis. Books like Heyer's have long been wanting. They are absolutely indispensable if we are ever to create an objective psychology, which can never be the work of a single individual but only the result of the concerted labours of many. Heyer's book offers a conspectus of the main contemporary doctrines of Freud, Adler, and myself. Separate accounts of these may be known to the reader, but until now they have not, as a rule, been related to one another, so that each formed a closed system. Heyer's book thus fills a long-felt need. It is written in a lively style and is richly interspersed with the author's own practical experiences—perhaps the most commendable book I know on this subject.

Praktische Seelenheilkunde²

[1775] One is often tempted to think that it was a fatal error of medical psychology in the days of its infancy to suppose that the neuroses were quite simple things which could be explained by a single hypothesis. This optimism was probably inevitable; had it been otherwise, perhaps nobody would have plucked up courage to venture any theory about the psyche at all. The difficulties and complications that beset the psychology of neuroses are nowhere more apparent than in the great variety of possible methods of treatment. There are so many of them that the layman in psychiatry may easily be driven to despair when it comes to choosing the method which suits not only the neurosis to be treated but the doctor treating it. We are familiar enough, nowadays, with the idea that physical illnesses derive from all sorts of causes and are subject to all sorts of conditions and therefore generally need treating from various angles; but it is still taken too much for granted that, among all these physical illnesses, a neurosis is just another illness or, at best, another category of illness. The reason for this prejudice is that modern medicine has only recently discovered the “psychological factor” in illness, and now clings to the idea that this “factor” is a simple quantity, one of the many conditioning factors or causes of physical disease. The psyche is thus vested with the kind of reality we concede to a toxin, a bacillus, or a cancer cell; but we are altogether disinclined to attribute to the psyche anything like the real existence with which we unthinkingly endow the body.

[1776] In this book, Heyer again presents us, as he did with such signal success in his earlier work *Organismus der Seele*, with a synoptic view, not of theories this time, but of the practical methods of treatment. He offers a survey, richly documented with case histories, of all the techniques which the psychotherapist requires for his everyday medical work and which are therefore also of great interest to the general practitioner. The latter regards his neurotic patients as being physically ill, like the other patients who are suffering from predominantly physical disturbances. Illnesses that are psychogenic in origin are naturally, to his way of thinking, physical, and so his first thought will be of a physical cure. The attitude of the orthodox psychotherapist who makes a sharp cut between neurosis and the pathology of the body is foreign to him. But neuroses, too, are unorthodox things and do not always prove resistant to physical treatment. The truth is that some neuroses are predominantly physical and others predominantly psychological. And often it is a diagnostic feat to make out to which category a particular case belongs. Thus psychotherapy is inevitably, at least for the time being, a curious mixture of psychological and physiological therapeutics. On all this Heyer's book provides a

wealth of information that should be of the greatest value to the psychotherapist as well as to the general practitioner and the medical student.

[1777] It is sometimes said that when many remedies are prescribed for a certain disease, none of them can claim to be particularly efficacious. The multitude of views in psychotherapy does not, however, arise from this source of confusion, but rather from the fact that neurosis is not so much *one* disease as an amalgam of several diseases which require an equal number of remedies. It is exceedingly probable that the psyche is analogous to the body and is capable of having as many diseases. The future has still to discover a pathology of the psyche to match that of the body. That modest “psychological factor” will, in time, broaden out and cover a field of medical experience no whit inferior to that of the body in scope and significance. Hence we would do well to infer, from the diversity of psychotherapeutic methods, a corresponding diversity of psychopathological states. Every one of the types of treatment mentioned corresponds, up to a point, to one aspect of the so-called “neurosis”—in other words, to a genuine form of sickness. But our present knowledge of psychopathology is not yet sufficiently advanced for us to specify without a doubt what particular form of psychic sickness calls for what treatment. We are still in the position of the physicians in the Middle Ages who, lacking the requisite knowledge of anatomy, physiology, and pathological anatomy, were solely dependent on practical experience, intuition, and the *physician’s art*. They were not necessarily bad doctors for that, any more than primitive medicine-men are bad doctors. It is precisely through the various kinds of treatment, their successes and failures, that we shall get to know the various kinds of psychic pathology, psychic biology, and psychic structure.

[1778] Heyer’s book is an important milestone on the road to the discovery of the diseases of the psyche and their specific remedies. It is written from practical experience and will be particularly valuable to the general practitioner. In its arrangement it relies on clinical pictures of illness; thus Chapter II deals with disturbances in the respiratory and circulatory systems, Chapter III with digestive disturbances, Chapter IX with sexual disturbances, and Chapter X with insomnia. Chapters I, IV, and V form an introduction to psychology. Three chapters deal with the various kinds of therapy. The book is equipped with a very readable appendix by Lucy Heyer, giving an account of the physical aids to psychotherapy, such as gymnastics, breathing, massage, etc.

[1779] I regret the absence of a similar account dealing with the artistic and spiritual remedies, for in practice these play no small part along with the purely physical ones. Maldevelopment and inhibitedness exist in the psyche as well as in the body and are in just as much need of exercise and reeducation.

ON THE “ROSARIUM PHILOSOPHORUM”¹

[1780] The *Rosarium* is one of the first, if not *the* first, synoptic texts covering the whole field of alchemy. It may have originated about 1350. The author is anonymous. It has been attributed to Peter of Toledo, who is supposed to have been an older brother of the famous Arnaldus de Villanova (1235–1313). Certain parts of it may date back to the former, but not the whole text, which was first printed in 1550 and contains numerous quotations from Arnaldus. The 1550 edition is a compilation consisting of two different parts, each a separate treatise. There are also interpolations of some length from various authors, for instance a letter of Raymundus Lullius to Rupertum Regem Franciae. (This Rupertus may be identical with Robert I, the Wise, 1309–1343.)

[1781] The text begins with a kind of preface or introduction in which the author discusses the “art” in general terms. He emphasizes that the art operates only “within Nature.” Only *one* thing is needed for the procedure, and not several things. Operating “outside Nature” leads nowhere. The author stresses that the laborant must have a sound mental disposition. The art consists in *uniting the opposites*, which are represented as male and female, form and matter. In addition the *4 roots* (radices, rhizomata, elements) are needed. The *prima materia* (initial material) is found everywhere. It is also called *lapis* = stone, or “salt” or “water.” The water (*aqua permaens*) is identical with *argentum vivum* (quicksilver). The elements are likewise represented as pairs of opposites:

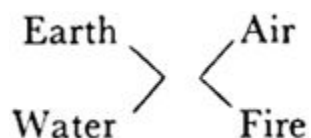

The author warns against taking the terminology *literally*; only fools would do this.

[1782] In the preface we find the following verses:

Hic lapis exilis extat, precio quoque vilis,
Spernitur a stultis, amatur plus ab edoctis.
(Here stands the mean, uncomely stone,
'Tis very cheap in price!
The more it is despised by fools,
The more loved by the wise.)²

[1783] The “lapis exilis” may correspond to the “lapisit exillis,” Wolfram von Eschenbach’s name for the Grail.³

[1784] The text proper opens with a pictorial representation of the alchemical process:⁴ a fountain from which the *aqua permanens* flows out of three pipes in the form of *lac virginis* (virgin's milk), *acetum fontis* (vinegar of the fount), and *aqua vitae* (water of life). Above the fountain is a star, with the sun to the left and the moon to the right (as opposites). Surmounting the star is the two-headed Mercurial Serpent, symbolizing the contamination of opposites in the unconscious. The picture is flanked by two columns of cloud or smoke, an indication of the "spiritual" (volatile) nature of the process. In the corners are four stars, alluding to the quaternity of the elements. The three springs form the *material Trinity* (the spirit of God, brooding over the chaos, penetrated into matter and became water). Together with inert matter (earth) they constitute the unity which is indicated by the quaternity of the elements ($3 + 1 = 4$).

[1785] For some alchemists the *prima materia* is something that can be found everywhere, for others it has first to be produced out of the "imperfect body" or substance. The contradiction resolves itself when one takes account of the amply documented theory of the *humidum radicale*: all chemical substances contain, in greater or lesser degree, the moisture, the water of the beginning that was brooded over by the spirit of God. This water was the *prima materia*. The opening words of the first chapter can thus be understood without difficulty:

The imperfect body has been changed into the *prima materia*, and this water, combined with our water (*aqua permanens*), produces *one* pure, clear water (solvent) that purifies everything and contains within itself everything needful (i.e., for the process of self-transformation)... Out of this water and with this water our procedure is brought to completion. But it dissolves the bodies not by means of the common solvent (*solutione vulgari*), as transmitted by the ignorant who transform the body into rain-water, but by means of the true philosophical solvent in which the body is transformed into the original water whence it arose in the beginning. This same water reduces the bodies themselves to ashes. You must know that the art of alchemy is a gift of the Holy Spirit.

[1786] The dissolution of the imperfect body transforms it back into the watery initial state, i.e., into the *prima materia*. The *aqua nostra* (our water), as is evident from the text and from numerous other sources, is also *fire*, the baptismal water, and at the same time the Holy Spirit this contains. *Aqua nostra* is therefore a "spirit water," which is united with the *prima materia* in the same way as the spirit of God brooded over the water of the beginning and from it created the world.

[1787] The process of creation is performed outwardly through a chemical operation and inwardly through *active imagination*: "And imagine this with the true and not with the fantastic imagination," the text enjoins.⁵ Matter was thought of as entirely passive; everything creative and active proceeded from the mind. *Aqua nostra* as

“spirit water” was a chemical body endowed with spirit, which was produced by the art; it was named the “tincture” or “quintessence.” Medieval man thought in terms of spirit, whereas we always start with matter. We can understand how matter alters mind, but cannot see how mind can transform matter, although logically there is a reciprocal relationship between the two processes.

[1788] The second chapter is concerned mainly with the secret of the *aqua nostra*. This water, as we have said, is the *humidum radicale*, a *spirituale corpus* also named *sapo sapientum* (“soap of the wise,” a play on words). It is so named in *Clavis sapientiae* of Alfonso X, king of Castile, who reigned 1252–1284. His treatise is said to be a translation from the Arabic. The *humidum radicale* is identical with the *serpens mercurialis*, the dragon, hence is also named “dragon’s blood.” The body to be transformed must be dissolved in its own liquid, its “blood”; this tincture, the elixir or *lapis*, is identical with *aqua nostra*. The texts are very confused on this point. But the confusion is not so bad if one bears in mind that the “water” is either extracted by sublimation from a body that contains a particularly large amount of it, or that the elixir already extracted is used for dissolving the body. The texts deal sometimes with the one and sometimes with the other, or more generally with both at once, as does the *Rosarium*. Other synonyms for the water are *pinguedo* (fat), *unctuositas*, *vapor unctuosus* (fatty vapour).

[1789] These basic ideas are developed and embroidered on in the following chapters, particularly the idea of the *coniunctio*. By this is meant the reunion of the imperfect body with its soul (*anima*), of which it had been deprived.⁶ Here the *anima* (= *humidum radicale*) serves as a vehicle for the spirit, which through active imagination permeates the watery solution. Usually the spirit is active and male, the material body passive and female. (Occasionally it is the other way round!) The male is red (red tincture, red slave, sun, red rose), the female white (white tincture, white spouse, moon, lily, white rose). The myth of Gabricus and Beya is the model for the *coniunctio* symbolism,⁷ one of the commonest and most impressive motifs in alchemy. It is concerned with the problem of opposites projected into matter, with the union of opposites for the purpose of producing a third thing, the Hermaphroditus or Rebis (“consisting of two”),⁸ or the “living” Stone of the Wise. This symbol is something that originates in man, like a child, and continues to exist in him, as an ancient treatise, probably of Arabic origin and attributed to Rosinus (Zosimos), says. (“Rosinus ad Sarratantam,” *Artis auriferae*, II, 1593, p. 311.) The stone has the significance of a panacea, of a drink of immortality, of a redeemer in general, and hence is an *allegoria Christi*.

PREFACE TO AN INDIAN JOURNAL OF PSYCHOTHERAPY¹

[1790] Dr. Bannerjee has kindly asked me to write a foreword to the special number of this journal devoted to my psychological work. It is a great pleasure to express my appreciation of the attentive interest given to my modest attempts at furthering the development of psychological understanding in general and the deepening of insight into the workings of the unconscious. India with her highly differentiated spiritual culture enjoys certain advantages over the European mind, inasmuch as the latter, owing to its origin in ancient Greek culture, is more handicapped by its dependence upon the sensory aspects of the external world. We expect of India and her spiritual attitude a unique contribution—an introspection originating in a different point of view which would compensate the one-sidedness of the European outlook. We look forward hopefully to a collaboration with the Indian mind, knowing that the mystery of the psyche can be understood only when approached from opposite sides.

[1791] I believe that the coming age will be in desperate need of a common basic understanding of man, which would enable mankind to become a brotherhood rather than a chaos of power-driven usurpers.

ON PICTURES IN PSYCHIATRIC DIAGNOSIS¹

[1792] The case that you lay before me presents every ground for thinking of latent schizophrenia. This diagnosis is confirmed by the pictures. There is a distinct tendency to translate living reality into abstractions in order to cut off the emotional rapport with the object. This forces the ego into an unsuitable power stance with the sole aim of domination. His (the artist's) commentary is very enlightening in this respect. Under these conditions there naturally can be no point in looking for symbols of the self,² since there is an overwhelming tendency to push the ego into the foreground and suppress the self. The ego is an arbitrary fragment, and the self the unwanted whole. No trace of the latter can be seen in the pictures.

XVI

THE DEVELOPMENT OF PERSONALITY

(related to Volume 17 of the Collected Works)

FOREWORD TO EVANS: "THE PROBLEM OF THE NERVOUS CHILD"¹

[1793] I have read the manuscript of Mrs. Evans' book, *The Problem of the Nervous Child*, with great pleasure and interest. Mrs. Evans' knowledge of her subject-matter is based on a solid foundation of practical experience, an experience gained in the difficult and toilsome treatment and education of nervous children. Whoever has had to deal with nervous children knows what an amount of patience, as well as skill, is needed to guide a child out of a wrong pathological attitude into a normal life. This book, as the reader can see on almost every page, is the fruit of extensive work in the field of neuroses and abnormal characters. Despite the fact that there are numerous books on education, there are very few that concern themselves with a child's most intimate problems in such a careful and painstaking way. It is self-evident that this contribution will be of great value to anyone interested in educational questions. The physician should be particularly indebted to the author, as her book will be a valuable ally in the fight against the widespread evil of neuroses in adults. More and more the neurologist of today realizes that the origin of the nervousness of his patients is very rarely of recent date, but goes back to the early impressions and developments in childhood. There lies the source of many later nervous diseases. Most of the neuroses originate from a wrong psychological attitude which hinders adjustment to the environment or to the individual's own requirements. This wrong psychological position which is at the bottom of almost every neurosis has, as a rule, been built up during the course of the years and very often began in early childhood as a consequence of incompatible familial influences. Knowing this, Mrs. Evans lays much stress on the parent's mental attitude and its importance for the child's psychology. One easily overlooks the enormous power of imitation in children. Parents too easily content themselves with the belief that a thing hidden from the child cannot influence it. They forget that infantile imitation is less concerned with action than with the parent's state of mind from which the action emanates. I have frequently observed children who were particularly influenced by certain unconscious tendencies of the parents, and, in such cases, I have often advised the treatment of the mother rather than of the child. Through the enlightenment of the parents, their wrong influences can at least be avoided, and thus much can be done for the prevention of later neuroses in the children.

[1794] The author particularly insists upon the importance of watching the manifestations of the sexual instinct in childhood. Anyone concerned with the education of abnormal children will confirm the existence and the frequency of

sexual symptoms in these children. Despite the fact that sexual activity does not belong to the infantile period, it frequently manifests itself in a symptomatic way, as a symptom of abnormal development. An abnormal development does not provide sufficient opportunity for the normal display of the child's energies. Thus, the normal outlet being blocked, the energy accumulates and forcibly seeks an abnormal outlet in premature and perverted sexual interests and activities. Infantile sexuality is the most frequent symptom of a morbid psychological attitude. In my view, it is wrong to consider sexual phenomena in early childhood as the expression of an organic disposition; most of the cases are due to an environment unsuited to the child's psychological nature. The attitude of the child towards life is certainly determined by the inherited disposition, but only to a certain extent; on the other side it is the result of the immediate parental influences and of education. While the inherited disposition cannot be changed, these latter influences can be improved by suitable methods, and thus the original unfavourable disposition can be overcome. Mrs. Evans' book shows the way, and how to treat even the most intricate cases.

October 1919

FOREWORD TO HARDING: "THE WAY OF ALL WOMEN"¹

[1795] It is a pleasure to comply with the author's wish that I should write an introduction to her book. I have read her work with the greatest interest, and am gratified to find that it does not come into the category of those sententious books, bristling with prejudices, which expatiate on the psychology of women with gushing eloquence, and finally overflow in a sentimental hymn to "holy motherhood." Such books have another unpleasant characteristic: they never speak of things as they are, but only as they should be, and instead of taking the problem of the feminine psyche seriously, they conveniently gloss over all the dark and disagreeable truths with advice that is as ineffectual as it is patently good. Such books are not always written by men—if they were they might be excusable—but many are written by women who seem to know as little about feminine feelings as men do.

[1796] It is a foregone conclusion among the initiated that men understand nothing of women's psychology as it actually is, but it is astonishing to find that women know nothing of themselves either. However, we are only surprised as long as we naïvely and optimistically imagine that mankind understands anything fundamental about the psyche. This is indeed one of the most difficult tasks the investigating mind can set itself. The latest developments in psychology show with ever-increasing clarity not only that there are no simple formulas from which the world of the psyche might be derived, but that we have never yet succeeded in defining the field of psychic experience with sufficient exactitude. Despite the immense surface area, scientific psychology has not even begun to break down the mountain of prejudices that persistently block the way to the psyche as it really is. Psychology is the youngest of the sciences and is suffering from all those childhood ailments which afflicted the adolescence of other sciences in the late Middle Ages. There still exist psychologies which limit the field of psychic experience to the consciousness and its contents, or understand the psyche as a purely reactive phenomenon without any trace of autonomy. The fact of an unconscious psyche has not yet gained undisputed acceptance, despite an overwhelming mass of empirical material which proves beyond all doubt that there can be no psychology of consciousness without a recognition of the unconscious. Lacking this foundation, it is impossible to deal with a psychological datum that is in any way complex, and the actual psyche we have to deal with in real life is complexity itself. Consequently, a psychology of woman cannot be written without an adequate knowledge of the unconscious background of the mind.

[1797] Drawing on her rich psychotherapeutic experience, Dr. Harding has sketched a picture of the feminine psyche which, in scope and thoroughness, far surpasses previous works in this field. Her presentation is refreshingly free from prejudice and remarkable for the love of truth it displays. Her arguments never lose themselves in dead theories and fanatical fads, which unfortunately are so frequently met with in this field of work, and she has succeeded in penetrating with the light of knowledge into crannies and depths where before darkness prevailed. Only one half of feminine psychology can be grasped with the aid of biological and social concepts, and in this book it becomes clear that woman possesses a peculiar spirituality very strange to man, to which Dr. Harding has devoted a special chapter. Without a knowledge of the unconscious this new aspect, so essential for an understanding of the psychology of woman, could never have been brought out with such clarity and completeness. The fructifying influence of the psychology of the unconscious is also evident in many other places in the book.

[1798] At a time when the divorce rate has broken all records, when the relation of the sexes has become a perplexing problem, a book like this seems to me of the greatest help. To be sure, it does not provide the one thing everybody expects—a generally acceptable recipe for solving this dreadful tangle of questions in a simple and practical way, so that we need rack our brains about it no longer. On the other hand, the book contains an ample store of what we actually need very badly, and that is understanding—understanding of psychic facts and conditions with the help of which we can orient ourselves in the complicated situations of life.

[1799] Why after all do we have a psychology? Why is it that we are especially interested in psychology just now? The answer is that everyone is in desperate need of it. Humanity seems to have reached a point where the concepts of the past are no longer adequate, and we begin to realize that our nearest and dearest are actually strangers to us, whose language we no longer understand. It is beginning to dawn on us that the people living on the other side of the mountain are not made up exclusively of red-headed devils who are responsible for all the evil on this side of the mountain. A little of this uneasy suspicion has filtered through into the relations between sexes; not everyone is utterly convinced that everything good is in “me” and everything evil in “you.” Already we can find super-moderns who ask themselves in all seriousness whether there may not be something wrong with us, whether perhaps we are too unconscious, too antiquated, and whether this may not be the reason why when confronted with difficulties in sexual relationships we still continue to employ with disastrous results the methods of the Middle Ages if not those of the caveman. There are indeed people who have read with horror the Pope’s Encyclical on Christian marriage,² and yet must admit that for cavemen our so-called “Christian” marriage is a cultural step forward. Although we are still far from having overcome

our prehistoric mentality, which enjoys its most signal triumphs just in the sphere of sex, where man is made most vividly aware of his mammalian nature, certain ethical refinements have nevertheless crept in which permit anyone with ten to fifteen centuries of Christian education behind him to progress towards a slightly higher level.

[1800] On this level the spirit—from the biological point of view an incomprehensible psychic phenomenon—plays a not unimportant role psychologically. It had a weighty word to say on the subject of Christian marriage, and it still participates vigorously in the discussion whenever marriage is doubted and depreciated. It appears in a negative capacity as counsel for the instincts, and in a positive one as the defender of human dignity. Small wonder, then, that a wild and confusing conflict breaks out between man as an instinctual creature of nature and man as a spiritual and cultural being. The worst thing about it is that the one is forever trying violently to suppress the other in order to bring about a so-called harmonious solution of the conflict. Unfortunately, too many people still believe in this procedure, which is all-powered in politics; there are only a few here and there who condemn it as barbaric and would like to set up in its place a just compromise whereby each side of man's nature is given a hearing.

[1801] But unhappily, in the problem between the sexes, no one can bring about a compromise by himself alone; it can only be achieved in relation to the other sex. Hence the need for psychology! On this level, psychology becomes a kind of special pleading—or rather, a *method of relationship*. It guarantees real knowledge of the other sex instead of arbitrary opinions, which are the source of the incurable misunderstandings now undermining in increasing numbers the marriages of our time.

[1802] As a weighty contribution to this striving for a deeper knowledge of human nature and for a clarification of the confusion in the relations between the sexes, Dr. Harding's book is heartily to be welcomed.

February 1932

DEPTH PSYCHOLOGY AND SELF-KNOWLEDGE¹

Is depth psychology a new way to self-knowledge?

[1803] Yes, depth psychology must be termed a new way, because in all the methods practised up to now no account was taken of the existence of the unconscious. Thus a new factor entered our field of vision, which has seriously complicated and fundamentally altered the situation. Formerly, the fact had not been reckoned with that man is a “twofold” being—a being with a conscious side which he knows, and an unconscious side of which he knows nothing but which need be no secret to his fellows. How often one makes all sorts of mistakes without being conscious of them in the least, while they are borne in upon others all the more painfully! Man lives as a creature whose one hand doesn’t know what the other is doing. The recognition that we have to allow for the existence of an unconscious is a fact of revolutionary importance. Conscience as an ethical authority extends only as far as consciousness extends. When a man lacks self-knowledge he can do the most astonishing or terrible things without calling himself to account and without ever suspecting what he is doing. Unconscious actions are always taken for granted and are therefore not critically evaluated. One is then surprised at the incomprehensible reactions of one’s neighbours, whom one holds to be responsible; that is, one fails to see what one does oneself and seeks in others the cause of all the consequences that follow from one’s own actions.

[1804] Marriages furnish an instructive example of how easily one sees the mote in another’s eye but not the beam in one’s own. Of far greater, indeed truly monstrous, proportions are the projections of war propaganda, when the lamentably bad manners of civil life are exalted into a principle. Our unwillingness to see our own faults and the projection of them on to others is the source of most quarrels, and the strongest guarantee that injustice, animosity, and persecution will not easily die out. When one remains unconscious of oneself one is frequently unaware of one’s own conflicts; indeed the existence of unconscious conflicts is actually held to be impossible. There are many marriages in which the partners skirt round every possible conflict with the greatest caution, the one actually imagining himself to be immune from such things, while the other is filled to the neck with laboriously repressed complexes and almost choked by them. Such a situation often has injurious effects on the children too. We know that children often have dreams dealing with the unconfessed problems of their parents. These problems weigh upon the children because the parents, being themselves unconscious of them, have never attempted to come to grips with their

own difficulties, and this creates something like a poisoning of the atmosphere. For this reason the neuroses of childhood depend to a considerable degree upon the parents' conflicts.

How is depth psychology distinguished from the previous methods of psychological research? Where does it coalesce with other disciplines?

[1805] Psychology up till now took no account of the motivation of conscious contents due to the existence of the unconscious. Once the unconscious is included in the calculation, everything suddenly gets a double bottom, as it were. We have to look at everything from two sides, whereas the old psychology was satisfied with the contents of consciousness. Thus the old method of explaining the appearance of psychogenic (psychologically caused) symptoms could rest content with the supposition that they were auto-suggested figments of the imagination. The modern explanation, which lets the unconscious psyche of the patient have its say, investigates his dreams, fantasies, and complexes, i.e., that segment of his life-history which is responsible for the formation of the symptoms. No one questions today that neurotic symptoms are produced by processes in the unconscious. The conscious realization of the unconscious causative factors therefore has a definite therapeutic value. Psychogenic symptoms are products of the unconscious. These symptom also include various opinions and convictions which, though they may be uttered consciously enough, nevertheless are determined in reality by unconscious motives. Thus a too importunate and one-sided assertion of principles can often be traced back to an unconscious failure to live up to them. I knew someone, for instance, who, on every occasion, suitable or not, paraded his principle of honesty and truthfulness before the public. As I soon discovered, he suffered from a rather too lively imagination, which now and then seduced him into gross lies. The whole question of truth therefore occasioned in him a not undeserved "sentiment d'incomplétude," which in turn moved him to exceptionally loud ethical protestations, no small part of whose aim was to beget in himself a conviction of honesty.

[1806] With the recognition that every conscious process rests in part upon an unconscious one and may represent it symbolically, our previous views of psychic causality are radically called into question. Direct causal sequences in consciousness appear doubtful, and every experience of psychic contents urgently requires them to be supplemented by their unconscious aspect. Although depth psychology is a discipline in itself, it lurks invisibly, thanks to the fact of the unconscious, in the background of all other disciplines. Just as the discovery of radioactivity overthrew the old physics and necessitated a revision of many scientific concepts, so all disciplines that are in any way concerned with the realm of the psychic are broadened out and at the same time remoulded by depth psychology. It raises new problems for philosophy; it greatly enriches pedagogics and still more the study of human

character; it also poses new problems for criminology, especially as regards criminal motives; for medicine it opens up an unsuspected store of fresh insights and possibilities through the discovery of the interdependence of bodily and psychic processes and the inclusion of the neurotic factor; and it has richly fecundated, less closely related sciences such as mythology, ethnology, etc.

Are the various schools of depth psychology similar in their aims?

[1807] The difference between the principal schools of depth psychology up to date are based upon as many different aspects of the unconscious. The unconscious possesses a biological, a physiological, a mythical, a religious aspect, and so on. This means that the most varied conceptions are not only possible but even necessary. Each has its own justification, though none to the exclusion of others, for the unconscious is a highly complex phenomenon to which one single concept can never do justice. One cannot judge a person from a moral standpoint *only*, for example, but has to regard him from this standpoint *too!* Certain contents of the unconscious can be understood as strivings for power, others as the expression of sexual or other drives, while yet others allow no explanation in terms of biological drives under any circumstances.

Has "analytical psychology," i.e., the Jungian school of depth psychology, definite guiding principles?

[1808] I should prefer not to use the term "guiding principles" in this connection. Just because of the extreme variety and complexity of the aspects of the unconscious and its possible meanings, every "guiding principle" works as an arbitrary assumption, as an actual prejudice that tries to anticipate its irrational manifestations, though these cannot be determined in advance, and perhaps force them into an unsuitable mould. One must avoid all assumptions so far as possible in order to grasp the pure manifestation itself. This must carry its own interpretation with it, to such an extent that its significance is immediately evident from the nature of the phenomenon and is not forced upon it by the observer. He must, in fact, accustom himself to be guided more by the material than by his own opinions, however well founded they may appear to him. Every item of psychic experience presents itself in an individual form, even though its deeper content may be collective. One can never determine in advance, however, which of its principal aspects lies concealed behind the individual form. "Guiding principles" are therefore admissible at most as working hypotheses, and this only in the realm of scientific research. The practical material is best accepted *mente vacua* (without any preconceived theories).

What are the principal tools of analytical psychology? Does the interpretation of dreams occupy a central place?

[1809] The analytical situation has a fourfold aspect: (a) The patient gives me in his own words a picture of the situation as he consciously sees it. (b) His dreams give me a compensating picture of the unconscious aspect of it. (c) The relational situation in which the patient is placed vis-à-vis the analyst adds an objective side to the two other subjective ones, (d) Working through the material collected under a, b, and c fills out the total picture of the psychological situation. The necessity of working through it arises from the fact that the total picture often stands in the liveliest contrast to the views of the ego-personality and therefore leads to all sorts of intellectual and emotional reactions and problems, which in their turn clamour for solution and answer. Since the final goal of the undertaking can only consist in restoring the original wholeness of the personality in a viable form, one cannot dispense with a knowledge of the unconscious. The purest product of the unconscious is the dream. The dream points directly to the unconscious, for it “happens” and we have not invented it. It brings us unfalsified material. What has passed through consciousness is already sifted and remodelled. As we can deduce from the lava ejected by a volcano the constitution of the strata from which it comes, so we can draw deductions as to the unconscious situation from the contents of dreams. Only dream material plus conscious material reveals the picture of the *whole* man. And only in this way can we find out who our antagonist is.

[1810] Although dreams disclose the unconscious to us with perhaps the nearest approach to faithfulness we can attain, we also come upon its traces in every form of creative activity, such as music and poetry, and in all other forms of art. It appears in all manifestations of a spontaneous and creative kind, the further these are removed from everything mechanical, technical, and intellectual. As well as from dreams we can therefore draw conclusions from such things as drawings in which patients are encouraged to reveal their inner images. Although obviously the personality of the patient holds the centre of our attention, and introspection is an indispensable instrument of our work in common, yet this is anything rather than *brooding*. Brooding is a sterile activity which runs round in a circle and never reaches a reasonable goal. It is not *work* but a weakness, even a vice. On the other hand, if you feel out of sorts, you can legitimately make yourself an object of serious investigation, just as you can earnestly search your conscience without lapsing into moral weakness. Anyone who is in bad odour with himself and feels in need of improvement, anyone who in brief wishes to “grow,” must take counsel with himself. Unless you change yourself inwardly too, outward changes in the situation are worthless or even harmful. It is not enough to jump up, puff yourself out, and shout: “I take the responsibility!” Not only mankind but fate itself would like to know *who* promises to take this weighty step and whether it is someone who *can* take the responsibility. We all know that anyone can *say* so. It is not the position that makes

the man, but the man who does his work. Therefore self-searching, with the help of one or more persons, is—or rather should be—the essential condition for taking on a higher responsibility, even if it is only that of realizing the meaning of individual life in the best possible form and to the fullest possible degree. Nature always does that, but *without responsibility*, for this is the fated and divinely allotted task of man.

Is not an important milestone in the development of self-knowledge, which has increased the difficulties of the “way to oneself,” to be found in the Reformation and in the loss of confession for Protestants, and so for millions of people? Has not self-searching become keener and deeper because of the loss of the dialogue that the Catholic has with his confessor, and the loss of absolution?

[1811] The difficulties have indeed become enormously greater, as evidenced by the increased prevalence of complexes among Protestants, which has been statistically established. But these increased difficulties constitute—if the Protestant will really face and grapple with them—an exceptionally advantageous basis for self-knowledge. They can, however, just as easily lead, precisely because a confessor is lacking, either to sterile brooding or to thoughtless superficiality. Most people need someone to confess to, otherwise the basis of experience is not sufficiently real. They do not “hear” themselves, cannot contrast themselves with something different, and thus they have no outside “control.” Everything flows inwards and is answered only by oneself, not by another, someone different. It makes an enormous difference whether I confess my guilt only to myself or to another person. This being thrown back upon themselves often leads Protestants to spiritual arrogance and to isolation in their own ego. Although analytical psychology guards against being considered a substitute for confession, in practice it must often function willy-nilly as such. There are so many Catholics who no longer go to confession, and still more Protestants who do not even know what confession is, that it is not surprising some of them yield to their need of communication and share their burdens with an analyst in a way which could almost be called confession. The difference, however, is considerable, inasmuch as the doctor is no priest, no theological and moral authority, but, at best, a sympathetically listening confidant with some experience of life and knowledge of human nature. There is no admonition to repentance unless the patient does it himself, no penance unless—as is almost the rule—he has got himself in a thorough mess, and no absolution unless God has mercy on him. Psychology is admittedly only a makeshift, but at the present time a necessary one. Were it not a necessity it would have collapsed long ago from inner emptiness. It meets a need that unquestionably exists.

Does a knowledge of the “other side,” that is, one’s own unconscious side, bring relief, release? Does not self-knowledge rather increase the tension between what

one is and what one would like to be?

[1812] Being able to talk things over freely can in itself be a great relief. In general, working with the unconscious brings an increase of tension at first, because it activates the opposites in the psyche by making them conscious. This entirely depends, though, on the situation from which one starts. The carefree optimist falls into a depression because he has now become conscious of the situation he is in. On the other hand, the pressure on the inward brooding person is released. The initial situation decides whether a release or increase of pressure will result. Through self-searching in analysis people suddenly become aware of their real limitations. How often a woman has previously felt herself a snow-white dove and had no suspicion of the devil concealed within her! Without this knowledge she can neither be healed nor attain wholeness. For one person deeper knowledge of himself is a punishment, for another a blessing. In general, every act of conscious realization means a tensing of opposites. It is in order to avoid this tension that people repress their conflicts. But if they become conscious of them, they get into a corresponding state of tension. This supplies in turn the driving power for a solution of the problems they are faced with.

Doesn't a systematic preoccupation with oneself lead to egocentricity?

[1813] At first glance, from an external and superficial point of view, it does make one egocentric. But I consider this justifiable up a point. One *must* occupy oneself with oneself; otherwise one does not grow, otherwise one can never develop! One must plant a garden and give it increasing attention and care if one wants vegetables; otherwise only weeds flourish. "Egocentric" has an unpleasant undertone of pathological egoism. But as I have said, occupation with and meditation on one's own being is an absolutely legitimate, even necessary activity if one strives after a real alteration and improvement of the situation. Outwardly changing the situation, doing something else, forgetting what one was, alters nothing essential. Indeed, even when a bad man does good, he is nevertheless not good but suffers from a good symptom without being altered in character. How many drinkers, for example, have turned teetotalers without being freed from their psychic alcoholism! And only too soon they succumbed again to their vice. There are essentially bad natures that actually specialize in being good and, if they chance to become some kind of educator, the results are catastrophic. A *systematic* preoccupation with oneself serves a purpose. It is work and achievement. Often, in fact, it is much better to educate oneself first before one educates others. It is by no means certain that the man with good intentions is under all circumstances a good man. If he is not, then his best intentions will lead to ruin as daily experience proves.

Doesn't an exact knowledge of one's own nature with all its contradictions and absurdities, make one unsure? Doesn't it weaken selfconfidence and so lessen the

ability to survive in the battle of life?

[1814] Much too often people have a pathetic cocksureness which leads them into nothing but foolishness. It is better to be unsure because one then becomes more modest, more humble. It is true that an inferiority complex always harbours within it the danger of outdoing itself and compensating the supposed lack by a flight into the opposite. Wherever an inferiority complex exists, there is good reason for it. There actually is an inferiority of some kind, though not precisely where one is persuaded it is. Modesty and humility are not the signs of an inferiority complex. They are highly estimable, indeed admirable, virtues and not complexes. They prove that their fortunate possessor is not a presumptuous fool, but knows his own limitations, and will therefore never stumble beyond the bounds of humanity, dazzled and intoxicated by his imagined greatness. The people who fancy they are sure of themselves are the ones who are truly unsure. Our life is unsure, and therefore a feeling of unsureness is much nearer to the truth than the illusion and the bluff of sureness. In the long run it is the better-adapted man who triumphs, not the wrongly self-confident, who is at the mercy of dangers from without and within. Measure not by money or power! Peace of soul means more.

Can depth psychology assist social adaptation and increase the capacity for human contacts?

[1815] The increased self-knowledge which depth psychology necessitates also creates greater possibilities of communication: you can interpret yourself in the analytical dialogue and learn through self-knowledge to understand others. In that way you become more just and more tolerant. Above all, you can remedy your own mistakes, and this is probably the best chance of making a proper adaptation to society. Naturally you can also make wrong use of self-knowledge, just as any other knowledge.

Has self-knowledge a healing, liberating effect?

[1816] Repentance, confession, and purification from sin have always been the conditions of salvation. So far as analysis helps confession, it can be said to bring about a kind of renewal. Again and again we find that patients dream of the analysis as of a refreshing and purifying bath, or their dreams and visions present symbols of rebirth, which show unmistakably that knowledge of their unconscious and its meaningful integration in their psychic life give them renewed vitality, and do indeed appear to them as a deliverance from otherwise unavoidable disaster or from entanglement in the skeins of fate.

How does the integration of the unconscious express itself in the actual psychic situation?

[1817] This question can be answered only in a very general sense. Individuality is so varied that in each single case the integration of the unconscious takes place in a different and unforeseen way. One could describe this only with the help of concrete examples. The human personality is incomplete so long as we take simply the ego, the conscious, into account. It becomes complete only when supplemented by the unconscious. Therefore knowledge of the unconscious is indispensable for every true self-investigation. Through its integration, the centre of the personality is displaced from the limited ego into the more comprehensive self, into that centre which embraces both realms, the conscious and the unconscious, and unites them with each other. This self is the mid-point about which the true personality turns. It has therefore been since remotest times the goal of every method of development based upon the principle of self-knowledge, as, for example, Indian yoga proves. From the Indian standpoint our psychology looks like a “dialectical” yoga. I must remark, however, that the yogi has quite definite notions as to the goal to be reached and does everything to attain this postulated goal. With us, intellectualism, rationalism, and voluntarism are such dangerous psychic forces that psychotherapy must whenever possible avoid setting itself any such goal. If the goal of wholeness and of realizing his originally intended personality should grow naturally in the patient, we may sympathetically assist him towards it. If it does not grow of itself, it cannot be implanted without remaining a permanent foreign body. Therefore we renounce such artifices when nature herself is clearly not working to this end. As a medical art, equipped only with human tools, our psychotherapy does not presume to preach salvation or a way thereto, for that does not lie within its power.

FOREWORD TO SPIER: "THE HANDS OF CHILDREN"¹

[1818] Chirology is an art which dates back to very ancient times. The ancient physicians never hesitated to make use of such auxiliary techniques as chiromancy and astrology for diagnostic purposes, as is shown, for instance, by the little book written by Dr. Goclenius,² who lived at the end of the sixteenth century in Würzburg. The rise of the natural sciences and hence of rationalism in the eighteenth century brought these ancient arts, which could look back on a thousand or more years of history, into disrepute, and led to the rejection of everything that, on the one hand, defied rational explanation and verification by experiment or, on the other, made too exclusive a claim on intuition. On account of the uncertainty and paucity of scientific knowledge in the Middle Ages, even the most conscientious thinkers were in danger of applying their intuition more to the promotion of superstition than of science. Thus all early, and particularly medieval, treatises on palmistry are an inextricable tangle of empiricism and fantasy. To establish a scientific method and to obtain reliable results it was necessary, first of all, to make a clean sweep of all these irrational procedures. In the twentieth century, after two hundred years of intensive scientific progress, we can risk resurrecting these almost forgotten arts which have lingered on in semi-obscurity and can test them in the light of modern knowledge for possible truths.

[1819] The view of modern biology that man is a totality, supported by a host of observations and researches, does not exclude the possibility that *hands*, those organs so intimately connected with the psyche, might reveal by their shape and functioning the psychic peculiarities of the individual and thus furnish eloquent and intelligible clues to his character. Modern science is steadily abandoning the medieval conception of the dichotomy of body and mind, and just as the body is now seen to be something neither purely mechanical nor chemical, so the mind seems to be but another aspect of the living body. Conclusions drawn from one as to the nature of the other seem therefore to be within the realm of scientific possibility.

[1820] I have had several opportunities of observing Mr. Spier at work, and must admit that the results he has obtained have made a lasting impression on me. His method, though predominantly intuitive, is based on wide practical experience. Experiences of this nature can be rationalized to a large extent, that is to say they admit of a rational explanation once they have happened. Apart from routine, however, the manner in which they are obtained depends at all decisive points on a finely differentiated, creative intuition which is in itself a special talent. Hence persons with nothing but an

average intelligence can hardly be expected to master the method. There is, nevertheless, a definite possibility that people who are intuitively gifted will be able to obtain similar results provided they are properly taught and trained. Intuition is not by any means an isolated gift but a regular function which is capable of being developed. Like the functions of seeing and hearing it has a specific field of experience and a specific range of knowledge based upon this.

[1821] The findings presented in this book are of fundamental importance for psychologists, doctors, and teachers. Spier's chiromancy is a valuable contribution to the study of human character in its widest sense.

FOREWORD TO THE HEBREW EDITION OF JUNG: "PSYCHOLOGY AND EDUCATION"¹

[1822] I have before me the Hebrew edition of my essays on psychology and education.² Not knowing this language, I am unable to appreciate the merits of the translation, so I can only bid it welcome as a "firstling" that is unique in my experience.

[1823] As the study of the child psyche and the question of education may fairly be said to occupy a privileged position today, it does not seem inappropriate that the contributions of analytical psychology should receive some attention. I have never made the child psyche an object of special research, but have merely collected experiences from my psychotherapeutic practice. These do however give rise to a number of interesting observations, firstly in regard to adults who have not yet rid themselves of their disturbing infantilism, secondly in regard to the complex relations between parents and children, and thirdly in regard to the children themselves.

[1824] The complex psychology of the child and in particular the psychic disorders of children are more often than not causally connected with the psychology of the parents, and in most cases one would do well to pay more attention to the faulty attitude of parents and educators than to the child's psyche, which in itself would function correctly if it were not disturbed by the harmful influence of the parents. The most important question next to the education of the child is the education of the educator. I hope these essays will prove stimulating in this respect, which is the one I would recommend to the especial consideration of the reader.

ADDENDA

FOREWORD TO "PSYCHOLOGISCHE ABHANDLUNGEN," VOLUME I¹

[1825] The *Psychologische Abhandlungen* (Psychological Papers) comprise the works of my friends and pupils as well as other colleagues, and also my own contributions to psychology. In accordance with the character of our psychological interests, this series will include not only works in the area of psychopathology, but also investigations of a general psychological nature. The present state of psychology seems to make it advisable that schools or movements have their own organs of publication; in this way a troublesome scattering of works among many different periodicals can be avoided, and mutuality of outlook can achieve suitable expression through publication in one consistent place.

Küsnacht-Zurich, May 1914

The Editor:
C. G. JUNG

ADDRESS AT THE PRESENTATION OF THE JUNG CODEX¹

Mr. President, Mr. Minister, viri magnifici, Ladies and Gentlemen!

[1826] It gives me much pleasure to accept this precious gift in the name of our Institute. For this I thank you, and also for the surprising and undeserved honour you have done me in baptising the Codex with my name. I would like to express my special thanks both to Mr. Page, who through generous financial assistance made the purchase of the papyrus possible, and to Dr. Meier, who through unflagging efforts has given it a home.

[1827] Dr. Meier has asked me to say a few words to you about the psychological significance of Gnostic texts. Of the four tracts contained in this codex, I should like to single out especially the *Evangelium Veritatis*, an important Valentinian text that affords us some insight into the mentality of the second century A.D. “The Gospel of Truth” is less a gospel than a highly interesting commentary on the Christian message. It belongs therefore to the series of numerous “phenomena of assimilation,” its purpose being to assimilate this strange and hardly understandable message to the Hellenistic-Egyptian world of thought. It is evident that the author was appealing to the intellectual understanding of his reader, as if in remembrance of the words: “We preach Christ crucified, unto the Jews a stumbling-block, and unto the Greeks foolishness” (I Cor. 1.23). For him Christ was primarily a metaphysical figure, a light-bringer, who went forth from the Father in order to illuminate the stupidity, darkness, and unconsciousness of mankind and to lead the individual back to his origins through self-knowledge. This deliverance from *agnosia* relates the text to the accounts which Hippolytus, in his *Elenchos*, has left of the Gnostics, and of the Naassenes and Peratics in particular. There we also find most of what I call the “phenomena of assimilation.” By this term I mean to delineate those specifically psychic reactions aroused by the impact that the figure and message of Christ had on the pagan world, most prominently those allegories and symbols such as fish, snake, lion, peacock, etc., characteristic of the first Christian centuries, but also those much more extensive amplifications due to Gnosticism, which clearly were meant to illuminate and render more comprehensible the metaphysical role of the Saviour. For the modern mind this accumulation of symbols, parables, and synonyms has just the opposite effect, since it only deepens the darkness and entangles the light-bringer in a network of barely intelligible analogies.

[1828] Gnostic amplification, as we encounter it in Hippolytus, has a character in part hymn-like, in part dream-like, which one invariably finds where an aroused imagination is trying to clarify an as yet still unconscious content. These are, on the one hand, intellectual, philosophical—or rather, theosophical—speculations, and, on the other, analogies, synonyms, and symbols whose psychological nature is immediately convincing. The phenomenon of assimilation mainly represents the reaction of the psychic matrix, i.e., the unconscious, which becomes agitated and responds with archetypal images, thereby demonstrating to what degree the message has penetrated into the depths of the psyche and how the unconscious interprets the phenomenon of Christ.

[1829] It is not likely that the Gnostic attempts at elucidation met with success in the pagan world, quite aside from the fact that the Church very soon opposed them and whenever possible suppressed them. Luckily during this process some of the best pieces (to judge by their content) were preserved for posterity, so that today we are in a position to see in what way the Christian message was taken up by the unconscious of that age. These assimilation phenomena are naturally of especial significance for psychologists and psychiatrists, who are professionally concerned with the psychic background, and this is the reason why our Institute is so interested in acquiring and translating authentic Gnostic texts.

[1830] Although suppressed and forgotten, the process of assimilation that began with Gnosticism continued all through the Middle Ages, and it can still be observed in modern times whenever individual consciousness is confronted with its own shadow, or the inferior part of the personality. This aspect of human personality, which is most often repressed owing to its incompatibility with one's self-image, does not consist only of inferior characteristics but represents the entire unconscious; that is, it is almost always the first form in which unconsciousness brings itself to the attention of consciousness. Freud's psychology occupied itself exclusively, so to speak, with this aspect. Behind the shadow, however, the deeper layers of the unconscious come forward, those which, so far as we are able to ascertain, consist of archetypal, sometimes instinctive, structures, so-called "patterns of behaviour." Under the influence of extraordinary psychic situations, especially life crises, these archetypal forms or images may spontaneously invade consciousness, in the case of sick persons just as in the case of healthy ones. The general rule, however, is that modern man needs expert help to become conscious of his darkness, because in most cases he has long since forgotten this basic problem of Christianity: the moral and intellectual *agnosia* of the merely natural man. Christianity, considered as a psychological phenomenon, contributed a great deal to the development of consciousness, and wherever this dialectical process has not come to a standstill we find new evidence of assimilation. Even in medieval Judaism a parallel process took place over the

centuries, independently of the Christian one, in the Kabbala. Its nearest analogy in the Christian sphere was philosophical alchemy, whose psychological affinities with Gnosticism can easily be demonstrated.

[1831] The urgent therapeutic necessity of confronting the individual with his own dark side is a secular continuation of the Christian development of consciousness and leads to phenomena of assimilation similar to those found in Gnosticism, the Kabbala, and Hermetic philosophy.

[1832] The reactions of the matrix that we observe these days are not only comparable, both in form and in content, with Gnostic and medieval symbols, but presumably are also of the same sort, and have the same purpose as well, in that they make the figure of *Hyios tou anthropou*, Son of Man, the innermost concern of the individual, and also expand it into a magnitude comparable with that of the Indian *purusha-atman*, the *anima mundi*. At this time, however, I would prefer not to go any further into these modern tendencies, which indeed were developing among the Gnostics.

[1833] Since comparison with these earlier historical stages is of the greatest importance in interpreting the modern phenomena, the discovery of authentic Gnostic texts is, especially for the direction our research is taking, of the greatest interest, all the more so in that it is not only of a theoretical but also of a practical nature. If we seek genuine psychological understanding of the human being of our own time, we must know his spiritual history absolutely. We cannot reduce him to mere biological data, since he is not by nature merely biological but is a product also of spiritual presuppositions.

[1834] I must unfortunately content myself with these bare outlines in attempting to explain our interest in a Gnostic text. Further proof of our interest in Gnosticism and detailed explanations may be found in a number of studies that have already been published.

BIBLIOGRAPHY

BIBLIOGRAPHY

The bibliography does not, as a rule, list works that are the source of contents of this volume. Details of such works are given in the initial footnote of the respective items of contents.

ADAMSKI, GEORGE, with DESMOND LESLIE. *Flying Saucers Have Landed*. London, 1953.

ADLER, GERHARD. *Entdeckung der Seele; Von Sigmund Freud und Alfred Adler zu C. G. Jung*. Zurich, 1934.

_____. *Studies in Analytical Psychology*. New edn., London, 1966; New York, 1967. (Original: *Zur analytischen Psychologie*. Zurich, 1952.)

_____. See also JUNG, *Letters*.

AKSAKOW, A. N. *Animismus und Spiritismus*. Leipzig, 1894.

Amitāyur Dhyāna Sūtra. Translated by F. Max Müller and Junjiro Takakusu. In: *Buddhist Mahāyāna Sūtras*, Part II. (Sacred Books of the East, 49.) Oxford, 1894.

AMMIANUS MARCELLINUS. *History*. Translated by John C. Rolfe. (Loeb Classical Library.) London and Cambridge, Mass., 1956.

L'Année psychologique (Paris), XIV (1908).

ANONYMOUS. *Die Tyroler ekstatischen Jungfrauen. Leitsterne in die dunklen Gebiete der Mystik*. Regensburg, 1843.

APULEIUS. *The Golden Ass*. Translated by W. Adlington, revised by S. Gaselee. (Loeb Classical Library.) London and Cambridge, Mass., 1915.

AUGUSTINE, SAINT. *Tractatus in Johannis Evangelium*. In MIGNE. *P.L.*, vol. 35.

AVALON, ARTHUR, pseud. (Sir John Woodroffe), ed. and trans. *The Serpent Power, being the Sat-Cakra-Nirūpana and Pādukā-Pancaka*. (Tantrik Texts.) London, 1919. 6th edn., Madras, 1958.

BALLET, GILBERT. *Swedenborg: Histoire d'un visionnaire au XVIII siècle*. Paris, 1899.

BAYNES, H. G. *Germany Possessed*. London, 1941.

_____. *Mythology of the Soul*. London, 1940.

BEIT, HEDWIG VON. *Gegensatz und Erneuerung im Märchen*. (Symbolik des Märchen, 2.) Bern and Munich, 1957; 2nd edn., rev., 1965.

_____. *Symbolik des Märchens. Versuch einer Deutung*. Bern, 1952.

BENOÎT, PIERRE. *L'Atlantide*. Paris, 1919. Trans. by M. C. Tongue and M. Ross: *Atlantida*. New York, 1920.

BÉROALDE DE VERVILLE, FRANÇOIS (trans.). *Le tableau des riches inventions ... représentées dans le Songe de Poliphile*. Paris, 1600. (Contains the "Recueil Stéganographique.") See also COLONNA; FIERZ-DAVID.

- BERTHELOT, MARCELLIN. *Collection des anciens alchimistes grecs*. Paris, 1887–88. 3 vols.
- BLANKE, FRITZ. *Bruder Klaus von Flüe*. Zurich, 1948.
- BLEULER, PAUL EUGEN. *Die Psychoanalyse Freuds*. Leipzig and Vienna, 1911. (Original: *Jahrbuch für psychoanalytische und psychopathologische Forschungen*, 11:2 (1910).)
- BOURGET, PAUL. *L'Étape*. Paris, 1902.
- BOUSSET, WILHELM. “Die Himmelsreise der Seele,” *Archiv für Religionswissenschaft* (Tübingen and Leipzig), IV (1901), 136–69.
- British Medical Journal* (London). Leading article, 9 Feb. 1952.
- BUBER, MARTIN. *Eclipse of God: Studies in the Relation Between Religion and Philosophy*. New York, 1952.
- _____. *Die Erzählungen der Chassidim*. Zurich, 1949. Translated by Olga Marx: *Tales of the Hasidim*. New York, 1947.
- _____. “Religion und modernes Denken,” *Merkur*, VI: 2 (Feb. 1952). Translated as “Religion and Modern Thought” in *Eclipse of God*, supra.
- BÜCHNER, LUDWIG. *Kraft und Stoff*. Leipzig, 1871.
- BUDGE, E. A. WALLIS. *Egyptian Literature*. Vol. 1: *Legends of the Gods*. (Books on Egypt and Chaldea, 32.) London, 1912.
- CAPRON, E. W. *Modern Spiritualism; Its Facts and Fanaticisms, Its Consistencies and Contradictions*. New York and Boston, 1855.
- CASSINI, JACQUES DOMINIQUE, COMTE DE THURY. *Les Tables parlantes au point de vue de la physique générale*. Geneva, 1855.
- CODEX:
Oxford. Bodleian Library. MS. Bruce 96. (Codex Brucianus).
- COLONNA, FRANCESCO. *Hypnerotomachia Poliphili*... Venice, 1499. For French translation, see BÉROALDE DE VERVILLE; for English paraphrase, see FIERZ-DAVID.
- CORBIN, HENRY. *Creative Imagination in the Ṣūfism of Ibn Arabī*. Translated by Ralph Manheim. Princeton (Bollingen Series XCI) and London, 1969.
- CROOKES, WILLIAM. “Notes of an Enquiry into the Phenomena called Spiritual, during the years 1870–73,” *Quarterly Journal of Science* London, XI (n.s., IV) (1874).
- CUMONT, FRANZ. *Textes et monuments figurés relatifs aux mystères de Mithra*. Brussels, 1894–99. 2 vols.
- CUSTANCE, JOHN. *Wisdom, Madness and Folly*. New York and London, 1951.
- DAVIE, T. M. “Comments upon a Case of ‘Periventricular Epilepsy,’” *British Medical Journal* (London), 11 (Aug. 17, 1935).
- DEMANT, VIGO AUGUSTE. *The Religious Prospect*. London, 1941.
- DESSOIR, MAX. *Das Doppel-Ich*. Leipzig, 1890.

- DIETERICH, ALBRECHT. *Eine Mithrasliturgie*. Leipzig, 1903; 2nd edn., 1910. Translated by G.S.R. Mead: *A Mithraic Ritual*. London and Benares, 1907.
- DORN, GERARD. "Congeries Paracelsicae chemicae de transmutationibus metallorum," in: *Theatrum chemicum*, vol. I. Ursel, 1602.
- DUNS SCOTUS, JOANNES. *Quaestiones Scoti super Universalibus Porphyrii...* Venice, 1520.
- DUSSAUD, RENÉ. *Notes du mythologie syrienne*. Paris, 1903–5.
- [ECKHART, MEISTER.] [*Works of*] *Meister Eckhart*. Translated by C. de B. Evans. London, 1924–52. 2 vols.
- ELIADE, MIRCEA. *Shamanism: Archaic Techniques of Ecstasy*. Translated by W. R. Trask. New York (Bollingen Series LXXVI) and London, 1964.
- [ELIEZER BEX HYRCANUS.] *Pirkê de Rabbi Eliezer*. Translated and edited by Gerald Friedlander. London and New York, 1916.
- ELLENBERGER, HENRI F. *The Discovery of the Unconscious*. New York and London, 1970.
- Encyclopedia of Islam*. Edited by M. Th. Houtsma et al. Leiden and Leipzig, 1913–34.
- Encyclopedia Judaica*. Edited by Jacob Klatzkin. Berlin, 1928–34.
- EPIPHANIUS. *Panarium, sive Arcula (Contra Octoginta Haereses)*. In MIGNE, P.G., vol. 41, col. 173, to vol. 42, col. 852.
- EVANS-WENTZ, W. Y. *The Tibetan Book of the Dead*. London, 1927; 3rd edn., with commentary by C. G. Jung, 1957.
- FIERZ-DAVID, LINDA. *The Dream of Poliphilo*. Translated by Mary Hottinger. With a foreword by C. G. Jung. New York (Bollingen Series XXV) and London, 1950.
- FLAVIUS JOSEPHUS. *The Jewish War*, Translated by H. St.J. Thackeray. (Loeb Classical Library.) London and Cambridge, Mass., 1956.
- FOUCART, P. F. *Les Mystères d'Eleusis*. Paris, 1914.
- FRANCE, ANATOLE. *Penguin Island*. Translated by A. W. Evans. New York, 1909.
- _____. *The White Stone*. Translated by C. E. Roche. (Works of Anatole France, Autograph Edition, 14.) New York, 1924.
- FRAZER, JAMES G. *The Golden Bough*. London, 1911—15. 12 vols.
- FREI, GEBHARD. *Probleme der Parapsychologie: Gesammelte Aufsätze*. Edited by A. Resch. Munich, 1969.
- FREUD, SIGMUND. *Five Lectures on Psychoanalysis*. In: Standard Edition of the Complete Psychological Works, translated under the editorship of James Strachey, 11. London, 1957. (Original: *Über Psychoanalyse*, 1910.)
- _____. *The Interpretation of Dreams*. Standard Edition, 4, 5. London, 1953. (Original: *Die Traumdeutung*, 1900.)
- _____. "Notes upon a Case of Obsessional Neurosis." In: Standard Edition, 10. London, 1955. (Original: "Bemerkungen über einen Fall von Zwangsneurose," 1909.)
- _____. *An Outline of Psycho-Analysis*. In: Standard Edition, 23. London, 1964. (Original: *Abriss der Psychoanalyse*, 1940.)

- _____. and C. G. JUNG. *The Freud/Jung Letters*. Edited by William McGuire. Translated by R.F.C. Hull and Ralph Manheim. Princeton (Bollingen Series XCIV) and London, 1974.
- FREUNDLICH, JAKOB. Article in *Deutsches Archiv für klinische Medizin* (Berlin), 177:4 (1934).
- FROMM, ERICH. *Psychoanalysis and Religion*. (The Terry Lectures.) New Haven, 1950.
- GAYOT DE PITAVAL, FRANÇOIS. *Causes célèbres et intéressantes avec les jugements qui les ont décidés (1734–43)*. Paris, 1772–88.
- GILLI, GERTRUD. “C. G. Jung in seiner Handschrift,” in *Die kulturelle Bedeutung der komplexen Psychologie*. (Festschrift for Jung’s 60th Birthday.) Berlin, 1935.
- GLAUBER, JOHANN RUDOLF. *De Elia Artista*. Amsterdam, 1668.
- GLOVER, EDWARD. *Freud or Jung*. London, 1950.
- GNOSIUS, DOMINICUS. *Hermetis Trismegisti Tractatus vere Aureus ... cum scholiis Dominici Gnosii*. Leipzig, 1610.
- GOELENIUS, RODOLPHUS. *Uranoscopiae, chirosopiae, metoposcopiae et ophthalmoscopiae contemplatio*. Frankfurt a. M., 1608.
- GÖRRES, JOHAN JOSEPH VON. *Die christliche Mystik*. Regensburg and Landshut, 1836–42. 4 vols.
- _____. *Emanuel Swedenborg, seine Visionen und sein Verhältnis zur Kirche*. Speyer, 1827.
- GOETHE, JOHANN WOLFGANG VON. *Egmont*. Leipzig, 1788. For translation see: *Dramatic Works of Goethe*. Translated by Sir Walter Scott and revised by Henry G. Bohn. London, 1872.
- _____. *Faust, Part Two*. Translated by Philip Wayne. (Penguin Classics.) Harmondsworth, 1959.
- GOLDBRUNNER, JOSEF. *Individuation: A Study of the Depth Psychology of Carl Gustav Jung*. Translated by Stanley Godman. London and New York, 1955. (Original: *Individuation: Die Tiefenpsychologie in Carl Gustav Jung*. Munich, 1949.)
- GRENFELL, BERNARD P., and ARTHUR S. HUNT (eds. and trans.). *New Sayings of Jesus and Fragment of a Lost Gospel from Oxyrhynchus*. New York and London, 1904.
- GUILLAUME DE DIGULLEVILLE. *Le Pèlerinage de la vie humaine. Le Pèlerinage de l’ame. Le Pèlerinage de Jésus Christ*. In: JOSEPH DELACOTTE. *Guillaume de Digulleville ... Trois romans-poèmes du XIV^e siècle*. Paris, 1932.
- GURNEY, EDMUND, FREDERIC W. H. MYERS, and FRANK PODMORE. *Phantasms of the Living*. London, 1886. 2 vols.
- HAGGARD, HENRY RIDER. *She: A History of Adventure*. London and New York, 1887.
- HARDING, M. ESTHER. *The Way of All Women*. With a foreword by C. G. Jung. New York, 1933.
- _____. *Woman’s Mysteries: Ancient and Modern*. New York, 1935. 2nd edn., with foreword by C. G. Jung, New York, 1955.
- HARRISON, JANE E. *Prolegomena to the Study of Greek Religion*. 3rd edn., Cambridge, 1922.
- HASTINGS, JAMES. *Encyclopedia of Religion and Ethics*. New York, 1908–27. 13 vols.
- HELVETIUS, JOHANN FRIEDRICH. “Vitulus aureus,” in *Musaeum hermeticum*, pp. 815–63. Amsterdam, 1667.

- HERMAS. *The Shepherd*. In: *The Apostolic Fathers*. With an English translation by Kirsopp Lake. (Loeb Classical Library.) London and New York. 1917. 2 vols. (Vol. 2, pp. 6–305.)
- HERODOTUS. *The Histories*. Translated by Aubrey de Selincourt. (Penguin Classics.) Harmondsworth, 1954.
- HEYER, GUSTAV RICHARD. *The Organism of the Mind*. Translated by E. and C. Paul. London, 1933.
- HIPPOLYTUS. *Elenchos (Refutatio omnium haeresium)*. (*Werke*, Vols. III and IV.) Edited by Paul Wendland. (Griechische christliche Schriftsteller.) Leipzig, 1916. For translation, see: *Philosophoumena, or The Refutation of All Heresies*. Translated by Francis Legge. London and New York, 1921. 2 vols.
- HOCHE, AIFRED E. *Handbuch der gerichtlichen Psychiatrie* Berlin, 1901; 3rd edn., rev., 1934.
- HUBERT, HENRI, and MARCEL MAUSS. *Mélanges d'histoire des religions*. Paris, 1909.
- IAMBlichus. *Vita Pythagorica*. Edited by L. Deubner. Leipzig, 1937.
- IBSEN, HENRIK. *The Lady from the Sea*. In *Plays*. Translated by U. Ellis-Fermor and P. Watts. (Penguin Classics.) Harmondsworth, 1950ff. (Original, 1888.)
- IGNATIUS OF LOYOLA, SAINT. *Exercitia Spiritualia*. Translated and edited by Joseph Rickaby, S.J., as *The Spiritual Exercises*. 2nd edn., London, 1923.
- Imago: Zeitschrift für Anwendung der Psychoanalyse auf die Geisteswissenschaften*. Leipzig and Vienna, 1912–1937.
- IRENAEUS, SAINT. *Contra [or Adversus] haereses libri quinque*. See MIGNE, P.G., vol. 7, cols. 433–1224. For translation, see *Five Books of Irenaeus against Heresies*. Translated by John Keble. (Library of Fathers of the Holy Catholic Church.) Oxford, 1872. Also: *The Writings of Irenaeus*. Translated by Alexander Roberts and W. H. Rambaut. Vol. I. (Ante-Nicene Christian Library, 5.) Edinburgh, 1868.
- JACOBI, JOLANDE. *Complex/Archetype/Symbol in the Psychology of C. G. Jung*. Translated by Ralph Manheim. With a foreword by C. G. Jung. New York (Bollingen Series LVII) and London, 1959.
- _____. *The Psychology of C. G. Jung*. Translated by K. W. Bash. London, 1942; New Haven, 1943. Revised edition, translated by Ralph Manheim, 1958. (Several later editions.) (Original: *Die Psychologie von C. G. Jung*. Zurich, 1940.)
- JAFFÉ, ANIELA. “Bilder und Symbole aus E. T. A. Hoffmanns Märchen ‘Der goldne Topf,’” in: C. G. JUNG. *Gestaltungen des Unbewussten*. Zurich, 1950.
- Jahrbuch für psychoanalytische und psychopathologische Forschungen*. Edited by C. G. Jung under the direction of Eugen Bleuler and Sigmund Freud. Leipzig and Vienna, 1909–1913.
- JAMES, MONTAGUE RHODES, trans. *The Apocryphal New Testament*. Oxford, 1924.
- JAMES, WILLIAM. *The Varieties of Religious Experience*. New York and London, 1902.
- JOSEPHUS, FLAVIUS. *The Jewish War*. (Loeb Classical Library.) London and Cambridge, Mass., 1927.
- Journal für Psychologie und Neurologie*. Leipzig, 1903.
- JUNG, CARL GUSTAV. “The Aims of Psychotherapy.” In: *The Practice of Psychotherapy*. Coll. Works, 16.
- _____. *Aion: Researches into the Phenomenology of the Self*. Coll. Works, 9, ii.

- _____. *Alchemical Studies*. Coll. Works, 13.
- _____. "Answer to Job." In: *Psychology and Religion: West and East*. Coll. Works, 11.
- _____. *The Archetypes and the Collective Unconscious*. Coll. Works, 9, i.
- _____. "Archetypes of the Collective Unconscious." In: *The Archetypes and the Collective Unconscious*. Coll. Works, 9, i.
- _____. *Aufsätze zur Zeitgeschichte*. Zurich, 1946.
- _____. "Brother Klaus." In: *Psychology and Religion: West and East*. Coll. Works, 11.
- _____. "A Case of Hysterical Stupor in a Prisoner in Detention." In: *Psychiatric Studies*. Coll. Works, 1.
- _____. *Civilization in Transition*. Coll. Works, 10.
- _____. *Collected Papers on Analytical Psychology*. Edited by Constance E. Long. London and New York, 1916.
- _____. "Commentary on 'The Secret of the Golden Flower'." In: *Alchemical Studies*. Coll. Works, 13.
- _____. "The Complications of American Psychology." In: *Civilization in Transition*. Coll. Works, 10.
- _____. "Concerning Mandala Symbolism." In: *The Archetypes and the Collective Unconscious*. Coll. Works, 9, i.
- _____. "Concerning Psychoanalysis." In: *Freud and Psychoanalysis*. Coll. Works, 4.
- _____. "Concerning Rebirth." In: *The Archetypes and the Collective Unconscious*. Coll. Works, 9, i.
- _____. "The Content of the Psychoses." In: *The Psychogenesis of Mental Disease*. Coll. Works, 3.
- _____. *Contributions to Analytical Psychology*. Translated by H. G. and C. F. Baynes. London and New York, 1928.
- _____. *The Development of Personality*. Coll. Works, 17.
- _____. *Diagnostische Assoziationsstudien*. 2 vols. Leipzig, 1906–9.
- _____. "Dream Symbols of the Process of Individuation." In: *The Integration of Personality*. Translated by Stanley Dell. New York, 1939; London, 1940. Revised as "Individual Dream Symbolism in Relation to Alchemy," in: *Psychology and Alchemy*. Coll. Works, 12.
- _____. *Essays on Contemporary Events*. Translated by Barbara Hannah et al. London, 1947.
- _____. *Experimental Researches*. Coll. Works, 2.
- _____. "Ein Fall von hysterischem Stupor bei einer Untersuchungsgefangenen," in *Journal für Psychologie und Neurologie*, 1:3 (1902).
- _____. "The Familial Constellations." In: *Experimental Researches*. Coll. Works, 2.
- _____. "Flying Saucers: A Modern Myth of Things Seen in the Skies." In: *Civilization in Transition*, Coll. Works, 10.
- _____. Foreword to White's *God and the Unconscious*. In: *Psychology and Religion: West and East*. Coll. Works, 11.
- _____. *Freud and Psychoanalysis*. Coll. Works, 4.
- _____. "General Aspects of Dream Psychology." In: *The Structure and Dynamics of the Psyche*. Coll. Works, 8.
- _____. *Gestaltungen des Unbewussten*. (With a contribution by Aniela Jaffé.) Zurich, 1950.
- _____. *L'Homme à la découverte de son âme*. Edited by Roland Cahen. Geneva, 1944; 6th edn., Paris, 1962.
- _____. "Instinct and the Unconscious." In: *The Structure and Dynamics of the Psyche*. Coll. Works, 8.

- _____. *Letters*. Selected and edited by Gerhard Adler, in collaboration with Aniela Jaffé. Translated by R. F. C. Hull. Princeton (Bollingen Series XCV) and London, 1973, 1975. 2 vols.
- _____. *Memories, Dreams, Reflections*. Recorded and edited by Aniela Jaffé. New York and London, 1963.
- _____. "Mind and Earth." In: *Civilization in Transition*. Coll. Works, 10.
- _____. *Ein Moderner Mythos: Von Dingen, die am Himmel gesehen werden*. Zurich, 1958.
- _____. *Modern Man in Search of a Soul*. New York and London, 1933.
- _____. *Mysterium Coniunctionis*. Coll. Works, 14.
- _____. "New Paths in Psychology." In: *Two Essays on Analytical Psychology*. Coll. Works, 7.
- _____. "On the Importance of the Unconscious in Psychopathology." In: *The Psychogenesis of Mental Disease*. Coll. Works, 3.
- _____. "On the Nature of Dreams." In: *The Structure and Dynamics of the Psyche*. Coll. Works, 8.
- _____. "On the Nature of the Psyche." In: *The Structure and Dynamics of the Psyche*. Coll. Works, 8.
- _____. "On the Practical Use of Dream Analysis." In: *The Practice of Psychotherapy*. Coll. Works, 16.
- _____. "On Psychic Energy." In: *The Structure and Dynamics of the Psyche*. Coll. Works, 8.
- _____. "On the Psychogenesis of Schizophrenia." In: *The Psychogenesis of Mental Disease*. Coll. Works, 3.
- _____. "On Psychological Understanding." In: *The Psychogenesis of Mental Disease*. Coll. Works, 3.
- _____. "On the Psychology and Pathology of So-Called Occult Phenomena." In: *Psychiatric Studies*. Coll. Works, 1.
- _____. *Paracelsica*. Zurich, 1942.
- _____. "Paracelsus as a Spiritual Phenomenon." In: *Alchemical Studies*. Coll. Works, 13.
- _____. "The Phenomenology of the Spirit in Fairytales." In: *The Archetypes and the Collective Unconscious*. Coll. Works, 9, i.
- _____. "The Philosophical Tree." In: *Alchemical Studies*. Coll. Works, 13.
- _____. *The Practice of Psychotherapy*. Coll. Works, 16.
- _____. *Psychiatric Studies*. Coll. Works, 1.
- _____. *The Psychogenesis of Mental Disease*. Coll. Works, 3.
- _____. "A Psychological Approach to the Dogma of the Trinity." In: *Psychology and Religion: West and East*. Coll. Works, 11.
- _____. "Psychological Factors Determining Human Behaviour." In: *The Structure and Dynamics of the Psyche*. Coll. Works, 8.
- _____. "The Psychological Foundations of Belief in Spirits." In: *The Structure and Dynamics of the Psyche*. Coll. Works, 8.
- _____. *Psychological Types*. Coll. Works, 6.
- _____. *Die Psychologie der Übertragung*. Zurich, 1946.
- _____. *Psychologie und Alchemie* Zurich, 1944.
- _____. *Psychologie und Erziehung*. Zurich, 1946.

- _____. *Psychology and Alchemy*. Coll. Works, 12.
- _____. "Psychology and Literature." In: *The Spirit in Man, Art, and Literature*. Coll. Works, 15.
- _____. *Psychology and Religion*. (The Terry Lectures.) New Haven and London, 1938. Cf. "Psychology and Religion." In: Coll. Works, 11.
- _____. *Psychology and Religion: West and East*. Coll. Works, 11.
- _____. "The Psychology of Dementia Praecox." In: *The Psychogenesis of Mental Disease*. Coll. Works, 3. Cf. *The Psychology of Dementia Praecox*. (Nervous and Mental Diseases Monograph Series No. 3.) Translated by A. A. Brill and F. Peterson. New York, 1909.
- _____. "The Psychology of Eastern Meditation." In: *Psychology and Religion: West and East*. Coll. Works, 11.
- _____. "The Psychology of the Transference." In: *The Practice of Psychotherapy*. Coll. Works, 16.
- _____. *Psychology of the Unconscious: A Study of the Transformations and Symbolisms of the Libido. A Contribution to the History of the Evolution of Thought*. Translated by B. M. Hinkle. New York and London, 1916.
- _____. "Psychotherapy Today." In: *The Practice of Psychotherapy*. Coll. Works, 16.
- _____. "The Reaction-Time in the Association Experiment." In: *Experimental Researches*. Coll. Works, 2.
- _____. "Realities of Practical Psychotherapy." In: *The Practice of Psychotherapy*. Coll. Works, 16.
- _____. "The Relations between the Ego and the Unconscious." In: *Two Essays on Analytical Psychology*. Coll. Works. 7.
- _____. "A Review of the Complex Theory." In: *The Structure and Dynamics of the Psyche*. Coll. Works, 8.
- _____. "Richard Wilhelm: In Memoriam." In: *The Spirit in Man, Art, and Literature*. Coll. Works, 15.
- _____. "The Role of the Unconscious." In: *Civilization in Transition*. Coll. Works. 10.
- _____. "Septem Sermones ad Mortuos." In: *Memories, Dreams, Reflections*, revised edn., appendix V.
- _____. "The Significance of the Father in the Destiny of the Individual." In: *Freud and Psychoanalysis*. Coll. Works, 4.
- _____. "The Soul and Death." In: *The Structure and Dynamics of the Psyche*. Coll. Works, 8.
- _____. *The Spirit in Man, Art, and Literature*, Coll. Works, 15.
- _____. "The Spirit Mercurius." In: *Alchemical Studies*. Coll. Works, 13.
- _____. *The Structure and Dynamics of the Psyche*. Coll. Works, 8.
- _____. "The Structure of the Unconscious." In: *Two Essays on Analytical Psychology*. Coll. Works, 7.
- _____. (ed.). *Studies in Word-Association*. Translated by M. D. Eder. London and New York. 1918.
- _____. "A Study in the Process of Individuation." In: *The Archetypes and the Collective Unconscious*. Coll. Works, 9, i.
- _____. *Symbolik des Geistes*. Zurich, 1948.
- _____. *Symbols of Transformation*. Coll. Works, 5.

- _____. "Synchronicity: An Acausal Connecting Principle." In: *The Structure and Dynamics of the Psyche*. Coll. Works, 8.
- _____. "The Theory of Psychoanalysis." In: *Freud and Psychoanalysis*. Coll. Works, 4.
- _____. "The Therapeutic Value of Abreaction." In: *The Practice of Psychotherapy*. Coll. Works, 16.
- _____. "The Transcendent Function." In: *The Structure and Dynamics of the Psyche*. Coll. Works, 8.
- _____. "Transformation Symbolism in the Mass." In: *Psychology and Religion: West and East*. Coll. Works, 11.
- _____. "Traumsymbole des Individuationsprozesses," *Eranos Jahrbuch 1935*. Zurich, 1936. For translation, see "Dream Symbols of the Process of Individuation."
- _____. *Two Essays on Analytical Psychology*. Coll. Works, 7.
- _____. *Über psychische Energetik und das Wesen der Träume*. Zurich, 1948.
- _____. *Über die Psychologie des Unbewussten*. Zurich, 1943.
- _____. "Versuch einer Darstellung der psychoanalytischen Theorie," *Jahrbuch für psychoanalytische und psychopathologische Forschungen* (Leipzig and Vienna), V:1 (1913).
- _____. *Wandlungen und Symbole der Libido*. Leipzig, 1912.
- _____. "Wotan." In: *Civilization in Transition*. Coll. Works, 10.
- ____—, and M.-L. VON FRANZ, JOSEPH L. HENDERSON, JOLANDE JACOBI, and ANIELA JAFFÉ. *Man and His Symbols*. London and New York, 1964.
- _____. and W. PAULI. *The Interpretation of Nature and the Psyche*. Translated by R.F.C. Hull. New York (Bollingen Series LI), 1955. (Original: *Naturerklärung und Psyche*. Zurich, 1952.)
- _____. and FREDERICK PETERSON. "Psychophysical Investigations with the Galvanometer and Pneumograph in Normal and Insane Individuals." In: *Experimental Researches*. Coll. Works, 2.
- _____. and CHARLES RICKSHER. "Further Investigations on the Galvanic Phenomenon and Respiration in Normal and Insane Individuals." In: *Experimental Researches*. Coll. Works, 2.
- _____. and RICHARD WILHELM. *The Secret of the Golden Flower*. See WILHELM.
- JUNG, EMMA. "On the Nature of the Animus." Translated by Cary F. Baynes. In: EMMA JUNG. *Animus and Anima*. New York (The Analytical Psychology Club of New York), 1957. (Original: "Ein Beitrag zum Problem des Animus," in: C. G. JUNG. *Wirklichkeit der Seele*. Zurich, 1934.)
- KANT, IMMANUEL. *Anthropologie in pragmatischer Hinsicht*. Königsberg, 1798.
- _____. *Critique of Pure Reason*. Translated by Norman Kemp Smith. London, 1964.
- _____. *Dreams of a Spirit-Seer, Illustrated by Dreams of Metaphysics*. Translated by E. F. Goerwitz. New York and London, 1900.
- KARDEC, ALLAN. *Buch der Medien*. See translation by Emma A. Wood: *Experimental Spiritism. A Book on Mediums: Or, Guide for Mediums and Invocators*. Boston, 1874.
- KERNER, JUSTINUS. *Blätter aus Prevorst; Originalien und Lesefrüchte für Freunde des inneren Lebens ...* Karlsruhe, 1831–39. 12 vols, in 3.

- _____. *Die Geschichte des Thomas Ignaz Martin, Landsmanns zu Gallardon, über Frankreich und dessen Zukunft im Jahre 1816 geschaut*. Heilbronn, 1835.
- _____. *Die somnambulen Tische. Zur Geschichte und Erklärung dieser Erscheinungen*. Stuttgart, 1853.
- KEYHOE, DONALD EDWARD. *Flying Saucers from Outer Space*. New York, 1953; London, 1954.
- KEYSERLING, COUNT HERMANN. "Begegnungen mit der Psychoanalyse," *Merkur*, IV: 11 (Nov. 1950), 1151–68.
- KOPP, HERMANN. *Die Alchemie in älterer und neuerer Zeit*. Heidelberg, 1886. 2 vols.
- KRAFFT-EBING, RICHARD VON. *Lehrbuch der Psychiatrie auf klinischer Grundlage*. Stuttgart, 1879. Authorized translation by C. G. Chaddock: *Text-book of Insanity based on Clinical Observations*. Philadelphia, 1904.
- KRANEFELDT, W. M. "'Ewige Analyse.' Bemerkungen zur Traumdeutung und zum Unbewussten," in: C. G. JUNG. *Wirklichkeit der Seele*. Zurich, 1934.
- _____. "Der Gegensatz von Sinn und Rhythmus im seelischen Geschehen," in *ibid*.
- _____. "'Komplex' und Mythos," in: C. G. JUNG. *Seelenprobleme der Gegenwart*. Zurich, 1930.
- _____. *Secret Ways of the Mind*. With an introduction by C. G. Jung. Translated by Ralph M. Eaton. New York, 1932; London, 1934.
- LAGHAT, PÈRE WILLIAM. *La Réception et l'action du Saint-Esprit dans la vie personnelle et communautaire*. Neuchâtel, 1953.
- LANGE, WILHELM. *Hölderlin: eine Pathographie*. Stuttgart, 1909.
- LAO-TZU. *Tae-te-ching*. See: ARTHUR WALEY. *The Way and Its Power*. London, 1934.
- LE BON, GUSTAVE. *The Crowd, a Study of the Popular Mind*. New York, 1896; London, 1897. (Original: *Psychologie des foules*. Paris, 1895.)
- LEIBNIZ, GOTTFRIED WILHELM. *Nouveaux Essais sur l'entendement humain*. Paris, 1704. Translation by A. G. Langley: *New Essays concerning Human Understanding*. LaSalle, Ill., 1949.
- LÉVY-BRUHL, LUCIEN. *How Natives Think*. Translated by Lilian A. Clare. London, 1926. (Original: *Les Fonctions mentales dans les sociétés inférieures*. Paris, 1912.)
- LIPPMANN, E. O. VON. *Entstehung und Ausbreitung der Alchemie*. Berlin, 1919.
- LÖWENFELD, LEOPOLD. *Der Hypnotismus: Handbuch der Lehre von der Hypnose und der Suggestion*. Wiesbaden, 1901.
- MALININE, M., H. C. PUECH, and G. QUISPÉL, eds. *Evangelium Veritatis*. Zurich, 1956.
- MANGET, JEAN JACQUES, ed. *Bibliotheca chemica curiosa*. Geneva, 1702. 2 vols.
- MEAD, G.R.S. *The Gnostic John the Baptizer*. London, 1924.
- MICHELSSEN, JOHANN. *Ein Wort an geistigen Adel deutscher Nation*. Munich, 1911.
- MIEG, JOANNES FRIDERICUS. *De raptu Eliae*. 1660.
- MORIENUS ROMANUS. "Sermo de transmutatione metallorum," in: *Artis auriferae*, vol. II. Basel, 1610. 2 vols.
- MOSER, FANNY. *Der Okkultismus: Täuschungen und Tatsachen*. Zurich, 1935.

- MURRAY, HENRY A., ed. (directing workers at the Harvard Psychological Clinic). *Explorations in Personality: A Clinical and Experimental Study of Fifty Men of College Age*. New York and London, 1938.
- NELKEN, JAN. "Analytische Beobachtungen über Phantasien eines Schizophrenen," *Jahrbuch für psychoanalytische und psychopathologische Forschungen*, IV: 1 (1912).
- NERVAL, GÉRARD DE, pseud. (Gérard Labrunie). *Aurélia*. Paris, 1926.
- NEUMANN, ERICH. *Amor and Psyche*. Translated by Ralph Manheim. New York (Bollingen Series LIV) and London, 1952.
- _____. *The Origins and History of Consciousness*. Translated by R.F.C. Hull. New York (Bollingen Series XLII) and London, 1954. (Original: *Ursprungsgeschichte des Bewusstseins*. Zurich, 1949.)
- NIETZSCHE, FRIEDRICH WILHELM. *On the Genealogy of Morals*. Translated by Walter Kaufmann and R.J. Hollingdale. New York, 1967.
- _____. *Thus Spake Zarathustra*. Translated by Thomas Common and revised by Oscar Levy and J. L. Beevers. 6th edn., London, 193².
- The Observer* (London), 11 Oct. 1936.
- PARACELUS (Theophrastus Bombast of Hohenheim). *De vita longa*. Edited by Adam von Bodenstein. Basel, 1562.
- _____. *Sämmtliche Werke*. Edited by Karl Sudhoff and Wilhelm Matthiessen. Munich and Wiesbaden, 1922–35. 14 vols.
- PERNETY, A.J. *Dictionnaire mytho-hermétique*. Paris, 1756.
- PHILO JUDAEUS. *Works*. Translated by F. H. Colson. (Loeb Classical Library.) London and Cambridge, Mass., 1956–62.
- Pirkê de Rabbi Eliezer*. See ELIEZER BEN HYRCANUS.
- PIUS XI, POPE. *Casti Connubii*. 31 Dec. 1930.
- PIUS XII, POPE. *Apostolic Constitution "Munificentissimus Deus."* Translated into English. Dublin (Irish Messenger Office), 1950.
- PRICE, HARRY. *An Account of Some Further Experiments with Willy Schneider*. New York, 1925.
- _____. *The Phenomena of Rudi Schneider*. New York, 1926.
- PRYZWARA, ERICH. *Deus semper maior*. Freiburg im Breisgau, 1938. 3 vols.
- RASMUSSEN, KNUD. *Across Arctic America*. New York, 1927.
- RHINE, J. B. *New Frontiers of the Mind*. New York, 1937; London, 1938.
- _____. *The Reach of the Mind*. New York and London, 1948.
- ROSENCREUTZ, CHRISTIAN. *Chymische Hochzeit*. (1616.) Edited by Richard van Dülmen. Stuttgart, 1973.
- ROSENTHAL, HUGO. "Der Typengegensatz in der jüdischen Religionsgeschichte," in: C. G. JUNG. *Wirklichkeit der Seele*. Zurich, 1934.
- "Rosinus ad Sarratantam episcopum," in: *Artis auriferae quam chemiam vocant....*, vol. I. Basel, [1593]. 2 vols.

- Samyutta-Nikaya*. See: *The Book of the Kindred Sayings*. (Sangyutta-Nikaya.) Translated by Mrs. C.A.F. Rhys Davids. London and New York, 1917–20.
- SCHAER, HANS. *Religion and the Cure of Souls in Jung's Psychology*. Translated by R.F.C. Hull, New York (Bollingen Series XXI) and London, 1950. (Original: *Religion und Seele in der Psychologie C. G. Jungs*. Zurich, 1946.)
- _____. *Erlösungsvorstellungen und ihre psychologischen Aspekte*. (Studien aus dem C. G. Jung-Institut, II.) Zurich, 1950.
- SCHÄRF (-KLUGER), RIWKAH. *Satan in the Old Testament*. Translated by Hildegard Nagel. Evanston, Ill., 1967. (Original: "Die Gestalt Satans im Alten Testament," in: C. G. JUNG. *Symbolik des Geistes*. Zurich, 1948.)
- SCHMALTZ, GUSTAV. *Östliche Weisheit und westliche Psychotherapie*. Stuttgart, 1951.
- SCHOPENHAUER, ARTHUR. *Parerga und Paralipomena*. Leipzig, 1874; new edn., Oxford, 1974.
- _____. *The World as Will and Idea*. Translated by R. B. Haidane and J. Kemp. (English and Foreign Philosophical Library, 22–24.) London, 1883–86. 3 vols. London, 6th edn., 1957.
- SCHREBER, DANIEL PAUL. *Memoirs of My Nervous Illness*. Translated by Ida Macalpine and Richard A. Hunter. (Psychiatric Monograph Series, 1.) London, 1955. (Original: *Denkwürdigkeiten eines Nervenkranken*. Leipzig, 1903.)
- SCHULINUS (Johann Heinrich Schuelin). *Dissertatio philologica de Elia corvorum alumno*. Altorfli Noricorum, 1718.
- SCHÜRER, EMIL. "Zur Vorstellung von der Besessenheit im Neuen Testament," *Jahrbuch für protestantische Theologie* (Leipzig), 1892.
- SHAW, GEORGE BERNARD. *Man and Superman: A Comedy and A Philosophy*. London, 1903. (Penguin edn., 1952.)
- SILBERER, HERBERT. *Problems of Mysticism and Its Symbolism*. Translated by Smith Ely Jelliffe. New York, 1917. (Original: *Probleme der Mystik und ihrer Symbolik*. Leipzig, 1914.)
- _____. "Über die Symbolbildung," *Jahrbuch für psychoanalytische und psychopathologische Forschungen*, III:1 (1911).
- _____. "Von den Kategorien der Symbolik," *Zentralblatt für Psychoanalyse und Psychotherapie* (Wiesbaden), 11:4 (1912).
- [SOPHOCLES.] "Life of Sophocles," in: *Sophoclis Fabulae*. Edited by A. C. Pearson. Oxford, 1924.
- SPENCER-BROWN, G. "Statistical Significance in Psychical Research," *Nature*, 175 (25 July 1953).
- STOLL, OTTO. *Suggestion und Hypnotismus in der Völkerpsychologie*. 2nd edn., Leipzig, 1904.
- STRACK, HERMANN L., and PAUL BILLERBECK. *Kommentar zum Neuen Testament aus Talmud und Midrasch*. Munich, 1922–28. 4 vols.
- TACITUS. *Historiae*. Translated by C. H. Moore. (Loeb Classical Library.) London and Cambridge, Mass., 1956.
- TERENCE. *Heauton Timorumenos*. Translated by J. Sargeant. (Loeb Classical Library.) London and Cambridge, Mass., 1953.
- TERTULLIAN. *De praescriptione hereticorum 40*. Edited by T. Herbert Bindley. Oxford, 1893.

- Theatrum chemicum, praecipuos selectorum auctorum tractatus ... continens.* Ursel and Strasbourg, 1602–61. 6 vols.
- THOMAS AQUINAS, SAINT. *The Summa Theologica*. Literally translated by the Fathers of the English Dominican Province. London, 1911–22. 18 vols.
- THOMPSON, R. CAMPBELL (trans.). *The Epic of Gilgamesh*. London, 1928.
- THURY, PROFESSOR. See CASSINI.
- TYRRELL, G.N.M. *The Personality of Man*. London, 1947.
- VIRGIL. *Eclogues*. Translated by H. R. Fairclough. (Loeb Classical Library.) London and Cambridge, Mass., 1967.
- WAGNER, RICHARD. *The Flying Dutchman*. Original, 1843.
- _____. *Parsifal*. Original, 1882.
- WALSER, HANS H. “An Early Psychoanalytical Tragedy: J. J. Honegger and the Beginnings of Training Analysis” (translated by A. K. Donoghue), *Spring* (Zurich and New York), 1974.
- WELLS, HERBERT GEORGE. *The Time Machine*. New York, 1895.
- _____. *The War of the Worlds*. London, 1898.
- WHITE, STEWART EDWARD. *Across the Unknown*. New York, 1939.
- _____. *The Betty Book*. New York, 1937; London, 1945.
- _____. *The Road I Know*. New York, 1942; London, 1951.
- _____. *The Unobstructed Universe*. New York, 1940; London, 1949.
- WHITE, VICTOR. *God and the Unconscious*. With a foreword by C. G. Jung. London, 1952; Chicago, 1953.
- WHYTE, LANCELOT LAW. *The Unconscious before Freud*. New York, 1960; London, 1962.
- WICKES, FRANCES G. *The Inner World of Childhood*. New York and London, 1927.
- _____. *The Inner World of Man*. New York and Toronto, 1938.
- WILHELM, RICHARD (trans.). *The I Ching or Book of Changes*. Rendered into English by Cary F. Baynes. With a foreword by C. G. Jung. New York (Bollingen Series XIX) and London, 1950; 3rd edn., Princeton and London, 1967.
- _____. (trans.). *The Secret of the Golden Flower*. With a Commentary and Memorial by C. G. Jung. Translated by Cary F. Baynes. London and New York, 1931; new edn., 1962. (Original: *Das Geheimnis der goldenen Blüte*. Zurich, 1929.)
- WILLCOX, A. R. *The Rock Art of South Africa*. Johannesburg, 1963.
- WITCUTT, W. P. *Catholic Thought and Modern Psychology*. London, 1943.
- _____. *Return to Reality*. London, 1954; New York, [?1956].
- WOLFF, TONI. “Einführung in die Grundlagen der komplexen Psychologie.” in: *Die kulturelle Bedeutung der Komplexen Psychologie*. Berlin, 1935. Reprinted in *Studien zu C. G. Jungs Psychologie*. Zurich, 1959.
- Zentralblatt für Psychoanalyse*. Wiesbaden, 1910–1914.

INDEX

INDEX OF TITLES

The titles of articles in this volume are here listed alphabetically, with beginning page number, except for reviews, abstracts, forewords, etc., which are readily located in the main index under the name of the subject author.

Abstracts of the Psychological Works of Swiss Authors, [398](#)

Adaptation, Individuation, Collectivity, [449](#)

Address at the Presentation of the Jung Codex, [671](#), [828](#)

Address on the Occasion of the Founding of the C. G. Jung Institute, [471](#)

Alchemy and Psychology, [751](#)

Analytical Psychology: Theory and Practice, [1](#)

Answers to Questions on Freud, [438](#)

Approaching the Unconscious, [183](#)

Astrological Experiment, An, [494](#)

Concept of Ambivalence, The, [443](#)

Concerning *Answer to Job*, [662](#)

Contributions to Symbolism, [446](#)

Crime and the Soul, [343](#)

Definition of Demonism, The, [648](#)

Depth Psychology, [477](#)

Depth Psychology and Self-Knowledge, [811](#)

Effect of Technology on the Human Psyche, The, [614](#)

Faust and Alchemy, [748](#)

Foreword to a Catalogue on Alchemy, [747](#)

Foreword to the First Volume of Studies from the C. G. Jung Institute, [487](#)

Future of Parapsychology, The, [510](#)

Human Nature Does Not Yield Easily to Idealistic Advice, [634](#)

Hypothesis of the Collective Unconscious, The, [515](#)

If Christ Walked the Earth Today, [638](#)

Individuation and Collectivity, [452](#)

Is There a Freudian Type of Poetry?, [765](#)

Is There a True Bilingualism?, [789](#)

Jung and Religious Belief, [702](#)

Letters on Synchronicity, [502](#)

Man and His Symbols, [183](#)

Marginalia on Contemporary Events, [591](#)

Memorial to J. S., [757](#)

Miraculous Fast of Brother Klaus, The, [660](#)

Munich, A Radio Talk in, [553](#)

On Dementia Praecox, [335](#)

On the Discourses of the Buddha, [697](#)

On Flying Saucers, [626](#)

On Hallucination, [461](#)

On the Hungarian Uprising, [636](#)

On Pictures in Psychiatric Diagnosis, [802](#)

On the Psychoanalytic Treatment of Nervous Disorders, [430](#)

On Psychodiagnostics, [637](#)

On the Psychology of the Negro, [552](#)

On Resurrection, [692](#)

On the *Rosarium Philosophorum*, [797](#)

On Spiritualistic Phenomena, [293](#)

On the Tale of the Otter, [762](#)

Preface to an Indian Journal of Psychotherapy, [801](#)

Present Status of Applied Psychology, The, [333](#)

Press Communiqué on Visiting the United States, [564](#)

Psychology and National Problems, [566](#)

Psychology and Spiritualism, [312](#)

Question of Medical Intervention, The, [347](#)

Radio Talk in Munich, A, [553](#)

Religion and Psychology: A Reply to Martin Buber, [663](#)

Report on America, [551](#)

Return to the Simple Life, [582](#)

Reviews of Psychiatric Literature, [374](#)

Rules of Life, The, [625](#)

Significance of Freud's Theory for Neurology and Psychiatry, The, [388](#)

Symbolic Life, The, [265](#)

Symbols and the Interpretation of Dreams, [183](#)

Tavistock Lectures, The, [1](#)

Techniques of Attitude Change Conducive to World Peace, [606](#)

Two Letters on Psychoanalysis, [427](#)

Why I Am Not a Catholic, [645](#)

INDEX

A

- Aalders, C., [826n](#)
- abaissement du niveau mental*, [67](#), [74](#), [79](#), [222](#), [335](#)
- in schizophrenia, [351](#)
- abdomen, crab as representation of, [92](#)
- Abegg, Lily: *Ostasien denkt anders*, J.'s foreword, [654–55](#)
- Abraham and Isaac, [688](#)
- Abraham Ibn Ezra, [675](#)
- Abraham, Karl, [398&n](#), [423&n](#), [485](#)
- absolution, [287](#)
- and cure, [273](#)
- Abyssinians, [46](#)
- active imagination, [6](#), [169](#), [170](#), [172](#), [530–31](#), [799](#), [800](#)
- archetypal motifs in, [653](#)
 - and dream-series, [174](#), [176](#)
- Adam, and Christ, [231](#), [280](#)
- Adam Kadmon, [280](#)
- Adamski, George: *Flying Saucers Have Landed*, [627n](#)
- adaptation: in analysis, [450](#), [451](#)
- energetics of, [450](#)
 - psychological, [449–52](#)
- Adler, Alfred/Adlerian, [6](#), [62](#), [124–26](#), [128](#), [423&n](#), [517](#), [534](#)
- confession, [126](#)
 - on “guiding fictions,” [481](#)
 - on masculine protest, [481](#)
 - on power-drive, [480](#)
 - psychology/school of psychology, [125](#), [127](#), [423n](#), [480](#)
 - theory, [61](#)
 - ed. (with Stekel), *Zentralblatt für Psychoanalyse*, [425&n](#)

Adler, Gerhard, [474](#), [773](#)
 Entdeckung der Seele, [127n](#);
 J.'s foreword, [517](#)
 Studies in Analytical Psychology, [474n](#);
 J's foreword, [523](#), [524](#)

adolescence, [233](#)

adumbratio, [234](#)

advice, idealistic, [634](#)

Aerial Phenomena Research Organization (APRO), [626n](#), [632](#)
 Bulletin, [632](#)

aesthetics, [341](#)

affect(s), [23](#), [43](#)
 blocking of, [478](#)
 emotion as, [25](#)
 infectiousness of, [596](#)
 influence of, on psyche, [375](#)
 and intellectual feelings, distinguished, [375](#)
 and invasions, [32](#)
 James-Lange theory of, [25](#), [27](#)

affectivity, [375](#)

Africa, [46](#)
 “going native” in, [148](#)
 J.'s journey to, [554–57](#), [623](#)

Africa, Central, [15](#)

Africa, East, Elgonyi tribe in, *see* Elgonyi

Africa, South, rock-carvings in, [39n](#)

Agadir, Morocco, [566&n](#)

agnosia, [671](#), [672](#), [826](#)

agnosticism, [734](#)

agoraphobia, [365](#)

Agrippa von Nettesheim, Cornelius, [784](#)

Aion, god, [121](#), [122](#)

aischrologia, [121&n](#)

Aksakow, A. N.: *Animismus und Spiritismus*, [293n](#)

Albertus Magnus, 678

De mirabilis mundi, 511

alchemist(s)/alchemy, 120, 167, 280, 286, 546

art of, “requires the whole man,” 619

Byzantine, 211

and chemistry, 40, 747;

Faust and, 748–50

foreword by J. to a catalogue on, 747

German, 11

Gnosticism and, 652, 672

Greek, 751

J.’s rediscovery of, 211

Latin, 232, 678

natural philosophy of, 649

philosophical, philosophy of, 742

and pre-Christian rites, 270

and psychology, 751–53

psychology of, 678

spiritual discipline of, 707

symbolism of, 747, 751

trinitarian and quaternarian standpoints, 473

R. Wilhelm and, 472

alcoholic “cured by Jesus,” 242, 272

Aldrich, Charles Roberts: *The Primitive Mind and Modern Civilization*, J.’s foreword, 561–63

Alexander the Great, 221, 222

Alexandria, 121n

Alexandros, 108, 109

Alfonso X, King of Castile: *Clavis sapientiae*, 799

Alfred the Great, King, 282

alienist(s), see psychiatrist(s)

Allah, as monad, 715

Allenby, Amy I.: “A Psychological Study of the Origins of Monotheism” (unpubl.), J.’s foreword, 656–60

Allendy, R., 765n

altar, [234](#)

altruism, abnormal, [612](#)

ambivalence, [443](#), [444](#)

America/Americans, [10](#), [14](#), [96](#), [139](#), [149](#)

commerce and industry in, [575](#)

European immigrants in, [465](#)

J.'s journey to, [214](#), [551](#)&*n*;

Negro complex in, [551](#)

primitive layer in, [47](#), [148](#)

self-control in, [552](#)

sexual repression in, [551](#)

spiritualism in, [293](#), [294](#)

university "psychologies," [127](#)

unrest in, [275](#)

woman patient, [147](#)

women's colleges in, [147](#)

American Indians, [552](#)*n*;

Navaho sand-paintings and *yaibichy* dances, [516](#)

Pueblo, [247](#)

—, and Father Sun, [247](#), [274](#), [288](#)

—, on thinking, [10](#)

—, sand-paintings of, [123](#)

South, [205](#)

Amitāyur Dhyāna Sūtra, [739](#)

Ammianus Marcellinus, [296](#)

amnesia, infantile, [258](#), [259](#)

amplification, [83](#), [84](#)

Anabaptists, [593](#)

anaesthesia, cutaneous and sensory, [388](#)

anal: complex, [433](#), [434](#)

fantasy, [436](#)

analysis: adaptation in, [450](#), [451](#)

danger of, for analyst, [153](#)

of pupil, [251](#)

as quickened maturation, 172
and return to a church, 285
training, 485

analyst(s): analysis of, 140
challenges to, 492
neurotic, 149
not a superman, 217
own psychic problems of, 493
and patient, as partners, 493
patients' resistance to, 220
and patients' sexual fantasy about, 144
personality of, and transference, 143
projections into, 140, 161
provocation by, 151
as saviour, 165
"snake's eyes" of, 142

analytical psychology, 523, 563, 608, 814; *see also* depth psychology

Anatomical Institute, 214

Andreae, Johann Valentin, 748

angels in hell, 229, 233

Angelus Silesius, 688, 739

anger, 26

Angola, 39n

anima (J.'s concept), 72n, 189, 190, 351, 484, 536
as archetype, of divine mothers, 731
-figure, in schizophrenic's painting, 179
motif, 545, 546
as personification: of collective unconscious, 89
of inferior functions, 89
projection on to, 749

anima mundi, 591

animal(s): cloacal, 433, 434
in dream-series of eight-year-old girl, 229
in dreams, symbolize sympathetic system, 92, 95

emotional manifestations in, [234](#)
founding, [233](#)
and “intelligent” acts of compensation, [657](#)
magnetism, [294](#), [295](#), [340](#)
psyche in, [235](#)
sense of smell in, [326](#)
symbols of evangelists, [185](#)
taboo to Church, [99](#)

ANIMALS (separate species):

beetle, in dream, [94](#), [95](#)
bull: “father of the snake,” [444](#)
 in Gilgamesh epos, [106](#), [107](#)
 in Mithras legend, [444](#)
cat, Egyptian sculpture of, [142](#)
catfish, [33n](#)
cockroach, [706](#)
cow and calf, in dream, [556](#), [557](#)
crab, represents abdomen, [92](#)
crab-lizard, in dream, [82](#), [86](#), [87](#), [90–94](#)
dog “Clever Hans,” [377&n](#)
dove, sacred to Church, [99](#)
dragon: in cave, [117](#), [120](#), [123](#)
 motif, [38](#), [91](#), [92](#)
 link with snake, [117](#), [232](#)
fish: aeon of (astrology), [718](#)
 as historical symbol, [434](#), [827](#)
 Ichthys, Christ as, [115](#), [157](#)
 sacred, to early Church, [99](#)
insects, symbiotic functions of, [234](#)
lamb, sacred in early Church, [99](#)
lion, [827](#)
 as libido symbol, [444](#)
mastodon, in dream, [65n](#), [66](#), [91](#)
mice, in catatonic patient’s fantasy, [433](#)

monster: motif, 38
symbol of, 102
namazu, 33n
oxen, in dream of Archelaos, 108
parrots, araras, 205
peacock, 827
platypus, 248
ram, and Isaac, 674
rats, in catatonic patient's fantasy, 433
ravens, two, 749
rhinoceros, with tick-birds, 39&n
salamander, 33
scarab, 506
serpent/snake: -bite, cure for, in Egypt, 102, 103
biting phallus in stele of Priapus, 444
in cave, 116–18, 123
as Christ symbol, 444, 827
on cross as allegory of Christ, 722
in dream of Toledo cathedral, 112, 113
eyes of, and hero's eyes, 92
in Gilgamesh epic, 107
healing, 116
as historical castration animal, 436
horned, 229, 232
as libido symbol, 444
mercurialis, 232, 722
in paradise, 690, 709, 715, 722
primitives and, 125
python at Delphi, 117
quadricornutus/ four-horned, 232
represents cerebrospinal system, 91
in schizophrenic's painting, 179
serpens oculatus, in vision of Ignatius Loyola, 683
Shakti as, 120

train's movement and, [82](#), [87](#)
as winter symbol, [122](#)
snail, shell of, as proof of existence of God, [591](#)
uroboros, [522](#)
wasp, [518](#)
weaver bird, [535](#), [541](#)
whale, [38](#)
worm, poisonous, in myth of Isis and Ra, [102](#), [103](#)
yucca moth, [535](#)
animism, [595](#)
animus, [72n](#), [89](#), [484](#), [536](#)
incubators, [147](#)
L'Année psychologique, [406n](#)
Anthropos, [122](#)
Christ and, [743](#)
as monad, [715](#)
and unconscious God-image, [669](#)
Antichrist, [685](#), [691](#)
antimony: truth as, [619](#)
YHWH as, [690](#)
antiquity: dreams in, [107](#), [111](#), [236](#), [237](#)
medicine in, [102](#)
anxiety: equivalents of, [390](#)
hysteria, [390](#)
neurosis, [278](#), [279](#), [390](#)
neurotic, and sexuality, [390](#), [391](#)
Aosta, [115](#)
aphasia, [376](#)
apocatastasis, [231](#)
Apollo, [117](#), [120](#)
apperception, [12](#), [186](#), [370](#)
fantastic, [371](#)
state of, [371](#)
apraxia, [383](#)

Apuleius: *Golden Ass*, 444

aqua gratiae, 705

aqua permanens, 270

and baptismal water, 591

arbor philosophica, and tree of Cross, 591

arcane substance, 591

Archelaos, Roman governor of Palestine, 108, 109

archetype(s), 37, 38, 236, 529, 574

as *a priori* forms of representation, 497, 657

autonomy of, 244, 742

choice of, 677, 678

of collective unconscious, 464

constellation of, 658, 677

in dream symbolism, 227–43

emotional value of, 260

etymology of, 228*n*;

existence of, denied, 259, 260

—, establishing, 673–78

fascination of, 238

as formal aspect of instinct, 533, 541

and Germany, 576

and history, 163, 164

identification with, 153, 578

as image, 706

—, and emotion, 257

and individuation, 486

inherited instinctual patterns of behaviour, 483, 518, 541, 607, 657, 658

as inherited tendency to form mythological motifs, 228

not inherited idea, 229, 470, 483, 518

initiative of, 238

intervention of, 161

as living matter, 257

of lover in a remote land, 159

numinosity of, 238, 259, 260, 485, 518, 541, 658

and organic illness, 103, 133, 134
in practical experience, 257
and projection, 141, 152, 153, 156
specific energy of, 238
spontaneous activity of, 485
timelessness/eternity of, 695
unconscious, 508

Areopagus, 112

Aristophanes: *The Frogs*, 117

Arnaldus de Villanova, 797

art/artists: difficulty in thinking, 169
galleries, 274
inspiration and invasion, 34, 35
modern, and neurosis, 766

Artemidoros of Daldis, 237

artifex, and lapis, 722&n

Artis auriferac, 753n

“Rosinus ad Sarratantam,” 800

ascetics, and dreams of temptation, 656

Asia, Europe as peninsula of, 67

Asklepios, 116

Assagioli, Roberto, 398n

assimilation: and Gnosticism, 672, 826
of irrational ideas, 356
of lost contents, 259
phenomena of, 671, 672, 677, 826–27
work of, 259

association(s): categories/classification of, 74
familial patterns of, 475
free, 82, 84, 187, 188, 190–92, 478
method, 6

association experiments/tests, 48–56, 191, 353, 406, 471, 482

and complexes, *see* complex(es) s.v.; and Freudian unconscious, 61
and hysterics, 410

participation in, 77
potentialities of, 475
respiration in, 63–65
and schizophrenia, 54, 353
vowel sequences in, 401

Ast the Shepherd, 339

Astarte, 677

Asterios, Bishop, 120, 121*n*

astrology: Jung's experiment, 494–501
and statistics, 494
and synchronicity, 497, 504, 506
unconscious, 179

ataxia-abasia, 371

atheism, 733, 734

Athens, 92, 118, 120

Athos, Mount, 681

Atman/atman, 280, 694, 828
Elijah as, 675

atom bomb, 615, 666

atomic age, 736

Atonement, Day of, 688

Atrides, curse of, 599

attention, oscillating, 196

Attis cult, 554

attitude(s): change of, 608–10, 613
mental and moral, 607, 608
of understanding, rational and irrational, 508

Augustine, St., 10, 37, 288
In Johannis Evang., *ion*, 288*n*

Augustus, 108

austerity, optimism of, 584

Australians, primitive, 41, 282

Austria, 569

autoerotic insulation, 149

automatic wiring, [302](#), [304](#)
automatisms, [244](#)
autonomy, conscious, [74](#)
Autopator, [653](#)
autosuggestion, [302](#)
Avalon, Arthur: *The Serpent Power*, [578n](#)

B

Baal, [677](#)
Babinski, Joseph, [400](#)
Babylon: Creation Myth, [105](#)
 Gilgamesh Epic, [105&n](#), [106](#), [107](#)
 —, Eabani in, [764](#)
 —, Enkidu in, [105–7](#)
 —, Humbaba in, [106](#), [110](#)
 rite of temple prostitution in, [159](#)
 “whore of,” patient’s nickname, [146](#)
Bacon, Roger, [678](#)
Ballet, Gilbert: *Swedenborg: Histoire d’un visionnaire au XVIII siècle*, [299n](#)
Bannerjee, Samiran, [801](#)
baptism: font/piscina, [116](#), [117](#), [158](#)
 —, *benedictio fontis*, [158](#), [270](#)
 as initiation, [116](#), [156](#)
 as *mysteria*, [115](#)
 symbolism of, [158](#)
 water in, and *aqua permanens*, [591](#)
Bardo existence, [95](#)
Barker, Mary, [3](#), [4](#)
Barmen, Pomerania, [296](#)
Barth, Karl, [739&n](#)
Basel: leprosy, [87](#)
 Société de Psychologie, [3](#)
Basil the Great, [709](#)
Basilides (Gnostic), [727](#)

Basilides of Alexandria, [663n](#)
Basler Nachrichten, [293n](#)
Baudouin, (Louis) Charles, [673n](#), [765n](#)
Bavarian Board of Physicians, [307](#)
Baynes, Cary F. (trans. into English): *The I Ching, or Book of Changes*, [69n](#)
Baynes, Helton Godwin, [168](#), [623n](#)
 Analytical Psychology and the English Mind, J.'s foreword, [623–24](#)
 Germany Possessed, [623](#)
 Mythology of the Soul, [474](#), [613n](#), [623](#)
Bechterew, W. von: *Psyche und Leben*, J.'s review, [385](#)
Becker, Th.: *Einführung in die Psychiatrie*, J.'s review, [386](#)
Beit, Hedwig von (H. von Roques), [474](#)
 Gegensatz und Erneuerung im Märchen, [474n](#)
 Symbolik des Märchens, [474n](#)
belief, and illusion, [247](#)
Belilios, A. D., [287](#)
belly, thinking thoughts in, [10](#)
Bender, Hans, [494n](#)
Bendit, L. J., [34](#)
Benedictines, and psychotherapy, [269](#)
benedictio fontis, [158](#), [270](#)
Bennet, E. A., [3](#), [31](#), [176](#), [179](#)
Benoît, Pierre, [545](#)
 L'Atlantide, [201](#)
Bergson, Henri, [121](#)
Berkeley, George, [772](#)
Berlin, [58](#)
Bern Winter Meeting of Swiss Psychiatrists, 1910, [443n](#)
Bernese Alps, [170](#)
Berneuchener movement, in Germany, [285&n](#)
Béroalde de Verville, *see under* Colonna
Berthelot, Marcellin: *Collections des anciens alchimistes grecs*, [753n](#)
Bertine, Eleanor: *Human Relationships*, J.'s foreword, [534–36](#)
Bethlehem, massacre of innocents, [274](#)

Betty, medium, *see* White, Betty

bewitchings, 328

Beyond, the, 315

Bezzola, Dumeng: “Zur Analyse psychotraumatischer Symptome,” J.’s abstract, 398

BIBLE:

Old Testament: Daniel, 109

Kings, First Book of, 673

Kings, Second Book of, 673, 675

Zachariah, 677*n*

New Testament: Acts of the Apostles, 231

Corinthians, First Epistle to, 231, 671, 692, 693*n*, 758, 826

Hebrews, 705

John, Gospel of, 679*n*, 686, 693

Luke, 648, 693, 716

Mark, 648, 673, 692

Matthew, Gospel of, 280*n*

Philippians, 718*n*

Revelation, Book of/Apocalypse, 232, 685, 686, 688&*n*, 718, 727, 742

Thessalonians, First Epistle to, 698

Apocrypha/Pseudepigrapha: *Acts of John*, 735

James, M. R.: *The Apocryphal New Testament*, 735*n*

Bibliotheca chemica curiosa, ed. Manget, 753*n*

bilingualism, 789

Binet, Alfred, 341

ed., *L’Année psychologique*, 406*n*

Binswanger, Ludwig, 423&*n*

“Über das Verhalten des psychogalvanischen Phänomens beim Assoziations-
experiment,” 411

biography, psychological, 471

Bion, Wilfred R., 29, 65, 66

birth-chamber: baptismal font as, 158

Egyptian, 157

bladder disturbances, 374

Blanke, Fritz: *Bruder Klaus von Flüe*, 660*n*

J.'s letter to, [660n](#)

Bleikeller, in Bremen, [214](#)

Bleuler, (Paul) Eugen, [314](#), [334](#), [375&nn](#), [392n](#), [481](#)
co-director of *Jahrbuch*, [392n](#)
on depth psychology, [477](#)
unpublished paper on ambivalence, [443n](#)
Affektivität, Suggestibilität, Paranoia, J.'s abstract, [399–400](#)
—, J.'s review, [375–76](#)
“Bewusstsein und Assoziation,” J.'s abstract, [408](#), [409](#)
“Freudsche Mechanismen in der Symptomatologie von Psychosen,” [399](#)
and J., “Komplexe und Krankheitsursache bei Dementia praecox,” J.'s abstract, [399](#)
Die Psychoanalyse Freuds, [429](#)
“Sexuelle Abnormitäten der Kinder,” J.'s abstract, [400](#)
“Über die Bedeutung von Assoziationsversuchen,” J.'s abstract, [406–7](#)

blindness: hysterical, [298](#)
of St. Paul, [298](#)

“blond beast,” [163](#)

body: evolution of embryonic, [258](#)
and mind, relation between, [33](#), [34](#), [65](#)
as personification of shadow of ego, [23](#)

Boegner, M., [685](#)

Boehme, Jacob, [516](#), [732–39](#)

Bollingen, J.'s “Tower” at, [798n](#)

Bolshevism, [715](#)

Bolte, Richard: “Assoziationsversuche als diagnostisches Hilfsmittel,” J.'s abstract, [400](#)

bomb(s): atom, [615](#), [666](#)
hydrogen, [260](#), [541](#), [630](#), [734](#)
stratospheric, [603](#)

Boniface VIII, Pope, [99](#)

bonitas Dei, [732](#), [733](#)

Borobudur, [178](#)

Bosch, Hieronymus, [530](#)

Boss, Medard, [347&n](#), [348](#)

Bourget, Paul: *L'Étape*, [88](#)

Bousset, Wilhelm: “Die Himmelfahrt der Seele,” 676

bowl(s): golden, in dream of Toledo cathedral, 112, 113, 118, 121, 166
in schizophrenic patient’s picture, 176

brain: anatomy, 376
at birth, 41
meaning of, 350
mythology, 464
wave (*Einfall*), 461

Braunau, 575

breaking lines, 177

Bremen, 214

Brethren of the Free Spirit, 678

Breuer, Josef, 187, 388, 515
on hysterical symptoms, 478

Brill, Abraham A., 423&n

British and American Society for Psychical Research, 317

British Anthropological Society, 68

British Broadcasting Corporation, 744

British Medical Journal, 65, 664

British Museum, 67, 121

British Union of Fascists (“Blackshirts”), 575n

Brogie, Louis Victor de, 33, 34n

Bronze Age, 39

brooding, 815, 816

brother and sister, *hierosgamos* of, 748

Brother Klaus/Nicholas von der Flüe, 99&n
fast of, 660–61
vision of, 683

Browne, Leonard F., 96

Brunner, Cornelia: “Die Anima als Schicksalsproblem des Mannes,” J.’s foreword, 543–47

Bruno de Jésus-Marie, Père, J.’s letter to, 673–78
ed. *Élie le prophète*, 673n

Bruns, L.: *Die Hysterie im Kindesalter*, J.’s review, 374–75

Brunton, Charles, 94

Bubastis, [121](#)

Buber, Martin, [681](#)

Die Erzählungen der Chassidim, [675](#)

“Religion und modernes Denken,” [663n](#)

J.’s reply, [663–70](#)

Tales of the Hasidim, [675n](#)

Buchman, Frank, [739](#)

Büchner, Ludwig: *Kraft und Stoff*, [603&n](#)

Buddha, [178](#), [181](#), [311](#)

Pali Canon, [697n](#), [739](#)

Buddhahood, attainment of, [650](#)

Buddhism/Buddhists, [246](#), [261](#), [262](#), [667](#), [697–99](#), [703](#)

Mahayana, [739](#)

—, mandala, [717](#)

and suffering, [697](#)

Zen, *koans* in, [234](#)

Budge, E. A. Wallis: *Egyptian Literature*, [103n](#)

Bulletin or Korrespondenzblatt der internationalen psychoanalytischen Vereinigung,
[423n](#)

Bumke, Oswald: *Landläufige Irrtümer in der Beurteilung von Geisteskranken*, J.’s
review, [383](#)

Burckhardt, Jacob, [780](#)

Burghölzli Mental Hospital, Zurich, [353n](#), [361n](#)

Burgundy, Duke of, [87](#)

Byzantine alchemy, [211](#)

C

Caesar, as god, [165](#), [581](#), [694](#), [695](#)

Cahen (Cahen-Salabelle), Roland, ed. and trans., J.’s essays in *L’homme à la découverte
de son âme*, [3](#), [589&n](#)

Cairo, tombs of Khalifs in, [315](#)

Camps, P. W. L., [130](#)

Canaanite deities, [677](#)

cancer/carcinoma, [321](#)

phobia, [206](#), [242](#)
candle, plunged into font, [158](#)
Capron, E. W.: *Modern Spiritualism, Its Facts and Fanaticisms*, [293n](#)
cardiac disorder, [357](#)
Carmel: Elijah and, [674](#), [675](#), [677](#), [678](#)
 pagan sanctuary on, [674](#)
Carus, C. G., [439](#), [515](#), [560](#), [771](#), [775](#)
Cassini, Jacques Dominique, comte de Thury, [296](#) (“Professor Thury”)
Castalia, Fountain of, [116](#), [117](#)
Castel, William, [297](#)
castration: complex, *see* complex s.v.; motif, [434](#), [436](#)
 —, teleological significance, [436](#)
 as numinous mutilation, [348](#)
 as treatment for transvestism, [347](#), [348](#)
catalepsy: crimes committed in state of, [345](#)
 hypnoid, [325](#)
 psychology of, [418](#), [419](#)
catastrophe, [316](#)
catatonia: akinetic motility psychosis, [378](#), [382](#)
 cerebral localizations, [382](#)
 consciousness of, [371](#)
 and hypnotic states, [377](#)
cathartic method, [378](#), [398](#), [402](#)
cathedrals, Gothic, [114](#)
 see also Chartres; Toledo
Catherine of Alexandria, St., [781](#)
Catholic Church, [246](#), [263](#)
 and analysis, [271](#)
 benedictio fontis, [158](#), [270](#)
 and cure, [273](#)
 and dogma of infallibility, [283](#)
 and Holy Spirit, [680](#)
 marriage rite in, [157](#)
 and meaningful life, [275](#)

quaternity in, 712, 714
and sexuality, 742
and spiritualism, 294
as therapeutic institution, 162
Catholicism: J.'s reasons for not joining, 645–47
and truth, 646
Catholics, 246
less subject to neurosis, 267, 269
as patients, 162
causality, 499, 500
law of, 647
relativeness of, 68
Western concept of, 655
Caux, *see* Moral Re-Armament Movement
cave: descent into, 38, 113, 120
dragon in, 117, 120, 123
serpent in, 116–18, 123
Cecrops, 92, 118
centre: of consciousness, *see* ego s.v.; non-ego, 167, 173, 178
cerebrospinal system, serpent as, 91
cerebrum, origin of, 9
chakra, 578
manipura, *see* *manipura* Chalewsky, Fanny: “Heilung eines hysterischen Bellens durch Psychoanalyse,” 400
Charcot, Jean Martin, 370, 374
charisma, faith as, 603, 646
Chartres cathedral, 115, 116
child (ren): and archetypal images, 232
born in the East, 145
and collective unconscious, 95
criminal, 96
drawings by, 516
dreams of, 40, 229, 362, 363, 368
—, archetypal, 95
ethereal, 95

- god, 688
- parents make neuroses of, 133, 358, 485
- substitution, 658
- unconscious in, 130
- childhood: early, unconscious, 8, 10
 - memories about, 199
 - and neurosis in later life, 420
 - sexuality in, 806
- childishness, Western, 245
- Children's Crusades, 593
- China/Chinese, 45, 46, 69, 148, 162
 - Book of Wisdom, 131
 - literature, 68
 - loss of old culture, 743
 - mind, 69
 - philosophy, 119, 516, 553
- chirology, 820
- Chladni, Ernst Florens Friedrich, 307&n
- choreic affections, hysterical, 374
- Christ/Jesus, 638
 - as archetype, 730, 731, 737
 - astrological assimilation of, 673
 - beyond good and evil, 720, 721
 - as brother, 280
 - in childhood, 682
 - as *complexio oppositorum*, 722, 731, 737
 - crucifixion of, 688, 734
 - death of, 444
 - and devil/Satan, 682, 687, 689
 - , as opposites, 689
 - and Elijah, 673, 674, 677
 - evil and, 723
 - executed with criminals, 97, 684
 - and fig-tree, 646

as Fish/Ichthys, 115, 157, 673
and healing the sick, 699
as Holy Spirit, 686, 687, 689
imitatio Christi, 123, 689
as innocent victim, 718, 741
as light-bringer, 671, 826
and myth of God-man, 247
name of, not to be mentioned, 115
opposites contained in, 731
passion of, in alchemy, and arcane substance, 591
and projections, 695, 730
the Redeemer, 97, 231
and Redeemer archetype, 743
resurrection of, 591, 692–96
as rider on white horse, 577
sacrifice of, 275, 276
sayings of, 122, 619
self as, 722, 725, 731–33, 737, 738
sources for, 732
as totality, 123
and tree, 239
and unjust steward, 727
and virgin birth, 717, 718
within, 280

Christian: dogma, truth of, 288

and unconscious, 262

Christianity, 703

and development of consciousness, 672

devitalization of, 736

dualism of, 689, 690

and end of the world, 246

esoteric meaning of, 267, 280

expansion of, 607

Hitler and, 576

impotence of, [593](#)&*n*
philosophy, [699](#)
problem of, [127](#)
and psychic change, [602](#)
and Roman Imperium, [576](#)
and technological progress, [584](#)
Christian Science, [341](#)
Christmas tree, [235](#), [239](#)
Christocentrism, [689](#)
Church: Catholic, *see* Catholic Church
fanatical sects in, [154](#)
and fear of God, [683](#)
and mass education, [603](#)
church(es), robbed of magical images, [274](#)
Church of England: Holy Communion in, [281](#)
a real church, [281](#)
Churches, Free, [283](#)
Church Fathers, [726](#)
Greek, [231](#)
circle: magic, [123](#), [178](#), [179](#)
symbol of, [515](#)
as symbol of “all-round” man, [280](#)
circulus quadratus, [577](#)
circumambulatio, [178](#), [179](#)
circumcision, [674](#)
cistern, in dream, [112](#), [113](#), [119](#)
city: as synonym for self, [122](#)
walk round circumference, [178](#)
civilization, [208](#)
Civitas Dei, [574](#)
clairvoyance, [295](#), [296](#), [304](#), [306](#)
Claparède, Edouard: “Classification et plan des méthodes psychologiques,” [421](#)*n*
“Quelques mots sur la définition de l’hystérie,” [420](#)*n*
J.’s abstract, [400](#)

Clausura, [272](#)

Clavis sapientiae, [799](#)

Clement of Rome, [682](#)

clergy, as *directeur de conscience*, [284](#)

Cockin, F. A., [744n](#)

Code Napoléon, [273](#)

Codices and MSS: Bezae, [619](#), [720n](#), [727](#)

Jung Codex (*Evangelium Veritatis*), [671&n](#), [826–28](#),

Lucca: Hildegard of Bingen, [516](#)

Oxford: Bodleian Library, Bruce, [96](#) (Codex Brucianus), [122&n](#)

cognitio sui ipsius, [732](#)

cognition, [27](#), [186](#)

mystic powers of, [306](#)

mythological stage of, [435](#)

theory of, [60](#)

collectivity: Christian, [683](#)

individuation and, [452–54](#)

Colonna, Francesco: *Hypnerotomachia Poliphili*, [474](#), [545](#), [759&n](#), [760&n](#), [780](#)

trans. Béroalde de Verville, *Le Tableau des riches inventions*, containing *Recueil steganographique*, [760n](#), [780](#); see also Fierz-David, Linda

colour, as oscillations, [9](#)

Communism, [573](#), [574](#), [579](#), [580](#), [735](#)

an archaic pattern of life, [541](#)

Communist use of language, [203](#)

Communitic state, as substitute for God, [694](#), [695](#)

community: and divine experience, [725](#)

individual and, [585–88](#), [739](#)

comparative method, see method s.v.

compensation: archetypal, [520](#)

Elijah as, [677](#)

feminine, [520](#)

goal of, [475](#)

complementarity, [472](#)

complex(es), [188](#), [515](#)

in association experiments, [71](#), [353](#)

autonomous, 73, 238, 532, 533
castration, 57, 58, 61
among Catholics, 268, 269
consciousness of, 73, 74
-constellation type, 407
in demonism, 648
dreams and, 72, 82, 190, 191
ego as, *see* ego s.v.; father, 278, 279
feeling-toned, 376, 388, 482
as fragmentary personalities, 72, 73
incest, 58, 84, 126
-indicators, 482
inferiority, 144, 221, 222
among Jews, 268
money, 49
personal, 238
personification of, 72
power, 125–27
among Protestants, 268
psychic functional, and their executive organs, 383
psychology, 562
of representations, 388
saviour, 152–55, 161
social, 238
split-off, 168
theory, 482
tormenting, 444
complexio oppositorum: Christ as, 722, 731, 737
God/Deity as, 682, 725, 726, 737
Holy Spirit as, 689
star of David as, 716
compulsion neurosis, 128–30
conation, 27, 712
concentration camp, 599&n, 602; *see also* Maidenek

conceptio immaculata, see Mary

concretism, 693

 bolshevistic, 695

confession, religious, 223, 269, 271

 analytical psychology and, 816

 public, 242

confessionalism, 645

conflict, and neurosis, 283, 284

coniunctio oppositorum, 719

conscience: exploration of, 244

 and neurosis, 616

conscious mind: lopsidedness of, 190

 in mania, 351

 narrowness of, 9, 316

 onesideness of, 316

consciousness: alterations of, 302

 beginning of, 133

 and the “Beyond,” 315

 clouding of, 305

 collective, of our time, 6

 dawn of, 95

 definition of, 11

 development of, 193, 658

 —, in Buddhism, 699

 differentiation of, 156

 dimming of, 328

 dissociability of, 197

 dissociation of, 194, 621

 eclipse of, 32, 197

 ectopsychic contents of, 36

 ego and, see ego s.v.; emancipation of, 733

 emptiness of, 371

 evolution of, 522

 exclusive belief in, 243

experimental state of, 194
extension of, 259, 316
and feeling, 10
fringe of, 21, 205, 209, 223
functions and, *see* function(s) s.v.; an intermittent phenomenon, 8
invasion of, by strange contents, 355
localization(s) of, 9, 11, 578
and loss of numinous symbols, 254, 255
lowered threshold of, 351
not the whole psyche, 262, 340
onesidedness of, 621
and physical world, 8, 9
in primitives, 10, 316
psyche and, 193, 262, 340, 519
psychology of, 7
reflective, origin of, 236
restricted/narrow, 9
subjective, entanglement in, 262
as surface or skin, 8
and unconscious, *see* unconscious and consciousness; and union with “Orthos,” 316
unity of, 72, 195
value of, 316
Western, 245

consensus: gentium, 276
omnium, 247

contagion, mental, 26, 75, 138
contamination through mutual unconsciousness, 141, 149
contradictio in adiecto, 714
conversion, and hysterical symptom, 431
Coptic Museum (Cairo), 826n
Coptic treatise (Codex Brucianus), 122
Corbin, Henry: *Creative Imagination in the Sufism of Ibn Arabi*, 545n
Correspondenz-Blatt für Schweizer Ärzte, 374n
Cosmopolitan, 638n

Cox, David: J.'s letters/answers to, [719–44](#)

Jung and St. Paul, [702n](#)

Cramer, A.: *Gerichtliche Psychiatrie*, J.'s review, [386](#)

creatio continua, [721](#)

creation: cruel aspect of, [732](#)

of world, myth of, [231](#)

creed, as *symbolum*, [719](#)

Cretan monuments, [185](#)

Crichton-Miller, Hugh, [1](#), [134](#), [135](#)

Hugh Crichton-Miller, 1877–1959, J.'s foreword, [639–41](#)

crime, inner urge to, [344](#)

criminal(s): children, [96](#)

dual personality of, [343](#)

soul of, [345](#)

use of association tests, [49](#), [51](#), [63](#)

criticism, higher, [740](#), [741](#)

Croix de Feu, [575n](#)

Crookes, Sir William, [299](#), [301](#), [306](#), [307](#), [314](#)

“Notes of an Enquiry into the Phenomena called Spiritual, during the years 1870–73,” [300n](#)

Quarterly Journal of Science, [299](#)

cross: of Christ, [683](#)

four arms of, [123](#)

of functions, [17](#)

and swastika, analogy, [576](#)

as symbol, [244–45](#), [257](#)

tree of, and *arbor philosophica*, [591](#)

as union of opposites, [735](#)

see also crucifixion

Crottet, Robert: *Mondwald*, J.'s foreword, [782–83](#)

crowd, emotion in, [138](#)

crucifixion: of thieves, with Christ, [97](#)

on wheel, [38–39](#)

see also cross

crypt, [115](#), [116](#)

cryptomnesia, [15](#), [200](#), [201](#)

cul de Paris, [571](#)

culture: contemporary, pathological nature of, [658](#)

essence of, [583](#)

Freud's theory of, [479](#)

Cumont, Franz: *Textes et monuments*, [676](#)

cura animarum/care of souls, [246](#)

curses, Christianity and, [646](#)

Cusanus, Nicholas, [682](#), [725](#)

Custance, John: *Wisdom, Madness, and Folly*, [667](#)

J.'s foreword, [349–352](#)

Cybele cult, [554](#)

Cyrillic script, [188](#)

D

dagger, in dream of Toledo cathedral, [112–13](#), [118](#), [121](#), [166](#)

daimonia, psychic, [664](#)

damnation, eternity of, [690](#), [693](#), [727](#)

Dana, Martha, [692n](#)

dances, *yaibichy*, of Navaho, [516](#)

Dante and Beatrice, [545n](#)

Darshana, [265](#)

Darwin, Charles, [213](#)

Davenport brothers, mediums, [299](#)

Davie, T. M., [133](#)

“Comments upon a Case of ‘Periventricular Epilepsy’,” [65n](#)

dead, return of, [328](#)

Dead Sea, [108](#)

death: fear of, [107](#)

as goal, [757](#)

philosophy and, [315](#)

preparation for, [234](#), [315](#)

spectre of, [246](#)

symbolic, as salvation, [735](#)

unknown approach of, [234](#)
Déesse Raison, [261](#)
deities, *see* god(s)
Delphi, [117](#)
 oracle at, [239](#)
delusional ideas: and archetypal motifs, [652](#)
 understanding of, [651](#)
delusions, and mythological motifs, [354](#)
Demant, V. A., [704](#)
 The Religious Prospect, [704n](#)
dementia praecox, *see* schizophrenia
Demeter, [120](#), [121n](#)
demiurge, Gnostic, [622](#)
democracy, [572–74](#), [580](#), [695](#)
Democritus, pseudo, [270](#), [751](#)
demon(s): autochthonous, [591](#)
 metaphorical, [666](#)
 possession by, [593](#)
 psychic powers embodied in, [587](#), [593](#), [594](#), [599](#), [601](#)
demonism, [648](#)
 of nature, [593](#)
 demotivation, [370](#)
Deo concedente, [722](#)
depression, [32](#)
depth psychology, [616](#), [811–13](#), [818](#)
 J.’s encyclopedia article on, [477–86](#)
descensus ad inferos, [38](#)
descent, double, [658](#)
Dessoir, Max, [341](#)
 Das Doppel-Ich, [341n](#)
determination, principle of, [430](#)
deus absconditus, [678](#), [680](#), [682](#)
“deus ultionum,” [684](#)
Devas, angel (Sanskrit)/devil (Persian), [444](#)

devil/Satan, [680](#)

Christ and, *see* Christ s.v.; eternity of, [690](#)

as fourth member of quaternity, [712](#), [732](#)

as left hand of God, [682](#)

as son of God, [687](#), [689](#), [690](#), [709](#), [710](#)

—, *benê Elohim*, [716](#)

Dharma, [261](#)

diagnosis, and paintings of patients, [181](#)

dialectical discussion with unconscious, [664](#), [667](#)

diaphragm, seat of psychic activity, [10](#)

Dicks, Henry V., [26](#), [168](#)

dictator (ship), [318](#), [580](#), [581](#)

Dieterich, Albrecht, [42](#)

Eine Mithrasliturgie, [42n](#)

differentiation, [621](#)

Diocletian, [116](#)

Dionysus, [117](#), [121n](#)

directeur de conscience, [269](#), [284](#)

discontinuity, principle of, [504](#), [505](#)

diseases, as disturbed normal processes, [6](#)

disorientation, worldwide, [254](#)

dissociability of psyche, [195](#), [664](#)

dissociation, [309](#)

between conscious and unconscious, [607](#)

of consciousness, [194](#), [621](#)

in hysteria, [100](#)

of modern mind, [243](#)

neurotic, [167](#), [209](#), [608](#), [690](#)

in schizophrenia, *see* schizophrenia s.v.

worldwide, [254](#)

divination, experiments in, [296](#)

divining rod, [295](#), [296](#), [302](#)

divorce rate, [582](#)

doctor: and faith, [669](#)

and incurable disease, 697
intuition in, 16
as saviour, 577
as sorcerer, 577
dogmas: as spiritual structures, 668
truth of, 271
Dorn, Gerard, 232n, 676n, 651
“De transmutatione metallorum” in *Theatrum chemicum*, 676
Dost, Max: *Kurzer Abriss der Psychologie, Psychiatrie und gerichtlichen Psychiatrie*,
J.’s review, 384
drama, and rebirth motif, 525
dream(s), 68
affects in, 364–65
of Africans, 557, 629
analyst’s, of patient, 144, 146,
anticipatory, 15, 237
in antiquity, 107, 112, 236
archetypal, of children, *see* child(ren) s.v. dreams
archetypal contents of, 104, 227–43, 259
“big,” 85, 111, 193, 484, 556
-books, Arabic, 556
censorship in, 366, 367
of children, *see* child(ren) s.v.
on collective level, 111
compensating function, 110, 207, 220, 227, 233, 608, 656, 657
and complexes, *see* complex(es) s.v.
composition, 366
condensation in, 364, 368
and context, 110, 213, 608
of convenience, 363
and creative process, 787
and diagnosis of physical disorder, 65&n, 66 (*see also below* organic)
displacement in, 365, 368
and distortion, 84–86
-elements, 364–66

façade, 366
fear in, 367, 368
feelings in, 364
Freud on, 361–68
functional meaning of, 187
of Germans, collective, 573
in girl, with progressive muscular atrophy, 66
God speaks through, 262
(*see also below* sent by God)
as guardian of sleep, 222, 363, 367, 368
historical, 110
-images, 187, 191, 204, 206, 222, 228, 363, 366
—, context of, 213, 220, 227
and immortality, 288
instigator, 365
is its own interpretation, 83, 248,
language of, 203–15, 227, 279, 285
and language of nature, 255
latent and manifest content, 362–65, 368
in later stages of analyses, 104
localized “down below,” 11
meaning of, 657
-motifs, 207, 210, 231
mythological, III
of Negroes, 37, 38, 40
new thoughts in, 198
and “nothing but” explanation, 192
obsessive, 227
organic representations in, 66 (*see also above* and diagnosis)
of personal exaltation, 224
picture-language of, 204
precatastrophal, 475
of primitives, *see* primitive(s) s.v.
and prognostication of the future, 236, 237

and recollection of prehistoric world, 258
recurrent, 210, 211, 227
religious meaning of, 700, 701
replaced by objectivation of images, 172
repression in, 366, 367
scene changes in, 90
and self-regulating psychic system, 110
“sent by God”/*somnia a Deo missa*, 193, 263, 286 (see also above God speaks through)
-series, 40, 78, 174–76, 229, 236
sexual allusions in, 249
significance of, 185–95
as source of natural symbols, 217
-statement, manifest, 190
as statements about the unconscious, 313
subliminal, 210, 222, 223
symbols/symbolism in, 40, 186, 190, 223, 248, 653
symbol-producing function of, 257
teleological explanation of, 368
telepathic, 656
theories of, 361
-thought, 364, 367, 656
in transference, 148
two aspects of, 259
universal language in, 111
waking, 367
wish-, 363, 367
wish-fulfilment theory, 188, 479
-work, 362, 365, 366

dream-analysis/interpretation, 6, 40, 77–96, 814, 815
and archetypal image, 102
before Freud, 190
and causal-reductive method, 478
complexes in, 73
as confrontation of two minds, 217

and feelings, 364, 365
incompetent application of, 210
and individuality of dreamer, 250
interpretation of one's own dreams, 109
intricacies of, 7
and intuitive attitude, 547
and mutual dream of interpreter and dreamer, 251
and self-awareness of interpreter, 250
and types problem, 216–43

dreams: instances (in order of appearance in the text): Negro's, of man crucified on wheel, 38
lubricating machinery, and drainage of pond, with mastodon, 65n, 66
patient wearing black coat, in small Swiss village, with former classmates, 79
dreamer is late for a conference, and misses his train looking for his portfolio—the train is derailed, 79–81
a peasant woman is told of a great walk planned—a monstrous crab-lizard appears and is killed, 86ff
a rolling wheel which burns (5-year-old's dream), 94
beetle that pinches, 5-year-old's dream), 94, 95
Archelaos', of oxen eating ears of wheat, 108
Glaphyra's, of murdered husband, 108–109
Nebuchadnezzar's, of hewn tree. 109
Roman senator's daughter's, of Minerva, 111
Sophocles', of Herakles' vessel, 111, 112
cistern beneath Toledo cathedral, with serpent guarding golden bowl, 112–15, 117–19, 121, 122, 123, 166
J.'s, of devalued patient as woman in castle tower, 146
custom-house at frontier (three dreams), 150
Mr X tries to jump on dreamer's back (J.'s own dream), 204
prejudiced and stubborn woman is invited into a cowshed, 207
stepping off a mountain into the air, 207
discovery of wing or guest house containing old library (J.'s own dream), 211
A house with historical layers with prehistoric tomb beneath the lowest (J.'s own dream), 213–15
man with exalted opinion of himself dreams of drunken tramps, 221

intelligent woman's dream of dishonest intriguer as "sister" or shadow, 221
the leading horseman clears a ditch and his companions fall in (dreamt by two
separate patients, one young, one old, 225
eight-year old girl's series of "uncanny" dreams, 229–34, 239
related by Artemidorus of Daldis, of man who dreamt his father died in flames, 237
patient's dream that ill doctor perished in a great fire, 237
J. as size of a god, in cornfield, holding patient in his arms, 278
J.'s dream of pretty girl with father complex, 278
dreamer (J. himself) is a small man with a beard, with no glasses, and is no longer
young, 443
African chief's dream of cow and calf, 556, 557
eagle circling over concentration camp, 677n
dying man's, of his own sarcophagus, 758
Dreyfus, —, M.D., 385
Dromard, G.; "De la dissociation de la mimique chez les aliénés," 421n
drugs, 598
Druses, 674, 678
dualism: and Christianity, 709, 731
Manichaeism, 726
Dubois, Paul, 214, 431
Die Einbildung als Krankheitsursache, J.'s review, 380
Duce, the (Mussolini), 165
Dudu and Suleika (Nietzsche), 546&n
Duke University, 313
Dumas, G.: "Qu'est-ce que la psychologie pathologique?," 421n
Duns Scotus, Johannes: *Super universalibus Porphyrii*, 9n
durée créatrice (Bergson), 121
Dürr, —, Prof., 333
Dussaud, René: *Notes de mythologie syrienne*, 676n
duty, conflict of, 620
dyad, Persian deity as, 715

E

East/Eastern/Oriental, 173

aim of detachment, 166
European's fear of, 530
and Golden Age, 245
mandala in, 123, 178
mind, 69, 233
philosophy(-ies), 69, 95, 232
religions, 213, 232
symbolism, 67
—, of greeting, 20
therapy, 103
thinking, 68
white man in, 145
will to power of, 244

East and West: mind of, 68–69
 psychology of, 654, 655

Easter, 158
 coloured eggs at, 235

Eberschweiler, A.: “Untersuchungen über die sprachliche Komponente der
 Assoziation,” J.'s abstract, 401

echolalia, 377

Eckhart, Meister, 280, 600
 Works, trans. C. de B. Evans, 600n

eclecticism, 669

ecstasy, 304

Ecstatic Virgins of the Tyrol, The / Die Tyroler ekstatischen Jungfrauen ... (anon.),
 295&n

ectoplasm, 660

ectopsyche, 12, 43

educated man as leader of the people, 603

education: Christian, 602&n
 for fuller consciousness, 605

Edwards, H. M., 287

ego: is centre of consciousness, 11
 is a complex, 11
 -complex, 43, 45, 72, 73

-consciousness, [621](#)
—, in demonism, [648](#)
consciousness and, [8](#), [11](#)
constituents of, [11](#)
and cross of functions, [17](#)
dark side of, [22](#)
in Freud's theory, [480](#)
-personality, [202](#)
realization of, [8](#)
shadow-world of, [23](#)
and unconscious, [159–60](#), [664](#)
egocentricity and meditation, [817](#)
egotism, [612](#)
Egypt/Egyptians, [109](#)
 cat sculpture, [142](#)
 Christianity in, [694n](#)
 Essene sect in, [108](#)
 Horus, *see* Horus
 Isis mysteries in, *see* Isis s.v.
 and snake-bite, treatment for, [102](#), [103](#)
 symbolism, [173](#)
 temples, [157](#)
Ehrenfels, Christian von: *Grundbegriffe der Ethik*, J.'s review, [383](#)
 Sexualethik, J.'s review, [384](#)
Eid, Albert, Estate, [826n](#)
Eidgenössische Technische Hochschule, *see* Zurich s.v.
Einfall, [15](#), [172](#)
Einstein, Albert, [67](#), [499n](#)
Electra complex, [535](#)
electrocardiogram experiments, [29n](#)
electrons, [34n](#)
El-Elyon, [677](#)
Eleusinian mysteries, [239](#), [270](#)
Eleusis, [120](#)

Elgonyi tribe, East Africa, [240](#), [554](#)

and dreams, [192](#), [286](#)

and *selelteni* (ghosts), [318](#)

sun worship of, [240](#)

Eliade, Mircea, [253](#), [529](#)

Shamanism: Archaic Techniques of Ecstasy, [253n](#)

Elijah: in alchemy, [676](#)&[n](#)

as angel, [674](#), [675](#)

ascension of, [676](#)

and Elisha, [673](#), [674](#)

as “hairy” man, [673](#)

as mythical/archetypal figure, [673](#)–[78](#)

two souls of, [674](#)

walking on water, [673](#)

Elimelekh of Litzhensk: “Elijah,” [675n](#)

Ellenberger, Henri F.: *The Discovery of the Unconscious*, [374n](#), [427n](#)

Ellis, Havelock, [380](#)

Emmerich, Katherina, [295](#)

emotion(s), [23](#)–[26](#)

contagious, [138](#) (*see also* contagion)

and feeling, differentiated, [26](#), [27](#), [29](#), [219](#)

Ossianic, [294](#)

overwhelming, [138](#)

of patients, [140](#)

and symbol, [249](#)

empiricism, [463](#)

J.’s, [666](#)–[68](#)

and philosophy, [770](#), [771](#)

enantiodromia, [711](#)

Encyclopedia Hebraica, [751n](#)

Encyclopedia of Islam, [676](#)

Encyclopedia Judaica, [675](#)

endogamy, [486](#)

endopsyché, [12](#), [43](#)

energetics of adaptation, 450
energetic conception of psyche, 314
energetic tension, 222
energy: emotional, of numinous phenomena, 254
 and opposites, 727
 and psyche, relation, 385
 psychic, 459
 specific, of functions, 16
engineers, and philosophy, 615
England, 13, 14, 41, 49, 130, 161, 185
 theosophy in, 554
England, Canon H., 281, 283
Enkidu, *see* Babylon s.v. Gilgamesh Epic
Enlightenment, 595
Ennemoser, Joseph, 340&n
Enoch: and Elijah, 675
 and Ilyās, 676
Epidaurus, 116
epidemic, psychic/mental, 46, 290, 485, 590, 604, 659
 demonism as, 648
 and insanity, 607
epilepsy: prodromal symptoms of, 95
 as repression of criminal instinct, 344
Epiphanius, St., 714
 Panarium, 653n
Eranos-Jahrbuch, 285n
Eranos lectures/Tagung, 67n, 529
Erechtheus, 118
Eschenmayer, Karl August, 340&n
Eschle, Franz C. R.: *Grundzüge der Psychiatrie*, J.'s review, 379–80
Eskimos, Polar, 286
Essenes, 108
E.T.H., *see* Zurich s.v.
Eidgenössische Technische Hochschule, *see* Zurich s.v.

ethic(s): differentiation of, 620

“new,” 619, 622

“old,” 618–20

ethical problem, 617, 618

and psychology, 616, 617

etymology (-ies): archetype, 228n

“invent,” 239

Europe: history of, 81

a peninsula of Asia, 67

Evangelium Veritatis, see Codices and MSS: Jung Codex

Evans, Elida: *The Problem of the Nervous Child*, J.’s foreword, 805–6

Evans-Wentz, W. Y.: *The Tibetan Book of the Dead*, 95n

Eve, “hidden in the body,” 189

evil: as non-existence, 709, 726

as positive factor, 708

Exercitia Spiritualia, see Ignatius Loyola

existence, criterion of, 703

existentialism, 347

exogamy of our culture, 486

expiation for guilt of individuation, 451, 453

extra ecclesiam, 276

nulla salus, 284

extra-sensory perception (ESP): experiments, 504

phenomena and archetypes, 500

extraversion, 483, 534

types, 217

Ezekiel, vision of, 185, 205

F

fairy tales, [38](#), [111](#), [230](#), [649](#), [657](#)

J.'s foreword to "The Tale of the Otter," [762–64](#)

faith, [683](#):

charisma of, [646](#)

and consolation, [698](#)

knowledge by, [668](#)

and projection, [723](#), [730](#)

and thought, [254](#)

family-ies: murder, [386](#)

research into, [74](#)

romance, [480](#)

fanaticism. [154](#), [600](#)

fantasy-ies: and active imagination, differentiated, [171](#)

creative, [212](#)

localized "down below," [11](#)

positive aspect of, [527](#)

Fascism, [164](#), [165](#), [574](#), [570](#), [580](#)

fasting of Brother Klaus, [660](#), [661](#)

fate, dreams and, [657](#)

father: complex, *see* complexes

doctor as, [577](#)

fixation, [277](#)

-image, and group formations. [570](#)

—, projection of, [159–60](#), [277](#), [577](#)

-transference, [160](#), [277](#)

Father: of All, [255](#)

"devoid of consciousness" in Gnosticism, [653](#)

paradoxical nature of, [688](#), [690](#)

Sun, [247](#), [274](#), [288](#)

Faust, *see* Goethe

Fechner, Theodor, [477](#)

"fedeli d'amore." [545](#)

Federal Polytechnic. *see* Zurich s.v.

Eidgenössische Technische Hochschule

feeling s: and affects, 26, 210

emotion and, *see* emotion s.z.

function, 12–14, 16–17, 43, 48. 88

—, of evaluation value, 25 30. 219

—, rational. 29. 219,

lesion of, 357

type, :18, 26, 139–40

-values, 13, 17

feeling-tone(d), 13

and idea, 608

feeling-toned complex, 376, 405, 471

repressed, 388, 482

felix culpa, 710

Feminine. Eternal, 106

feminine psychology, 808

fertility of the earth, 120–21

Fichte J. H., 771

Fierz, Jürg, 616n

Fierz, Markus: J.'s letters to, on

synchronicity, 502–7

Fierz-David, Linda: *The Dream of Poliphilo*, 474, 545, 760n

J.'s foreword, 759n, 780–81

filioque clause, 687

filius macrocosmi, 722, 742

filius philosophorum, 722

fire and water, in star of David, 716

Flammarion, Camille, 314

Flinker, Martin. 789n

Almanac, 789n

Flournoy, Théodore, 471, 515

“Automatisme téléologique antisuicide,” 420

Des Indes à la Planète Mars, J.'s abstract, 401

“Nouvelles observations sur un cas de somnambulisme avec glossolalie,” J.’s abstract, [401](#)

flower(s), [591](#)

blue, [775](#)

Fludd, Robert, polemics with Kepler, [473](#)

flying saucers, *see* Ufos

Folia neuro-biologica, [420&n](#)

fonction du reel, *see* Janet

Fordham. Frieda: Introduction to Jung’s Psychology, J.’s foreword, [489–90](#)

Fordham, Michael, [506](#)

J.’s letter to, on synchronicity, [508–9](#)

New Development in Analytical Psychology, J.s foreword, [491–03](#)

Forel, Auguste Henri, [341&n](#), [387&n](#)

Ethische und rechtliche Konflikte im Sexualleben in- und ausserhalb der Ehe, J.’s review, [387](#)

forgetting, definition of, [198](#)

Förster-Nietzsche, Elizabeth. [201](#)

Foucart, P. F.: *Les Mystères d’Eleusis*, [121n](#)

four: corners, in child’s dream, [229](#), [232](#)

dimensions, [28](#), [58–59](#)

Fox family, Hydesville New York. [293](#)

France French, [52](#), [579](#)

and Germany Germans, [46](#), [47](#), [48](#)

language, [14](#), [219](#)

psychologists, [9](#), [12](#), [138](#), [143](#)

France, Anatole, [394](#)

Penguin Island, [337n](#), [781](#)

The White Stone. [394n](#)

Francis of Assisi, St., [99](#)

Franco, Francisco, [581&n](#)

Frank, Ludwig: “Zur Psychoanalyse,” J.’s abstract, [402–3](#)

Frankfurt a. M., Saalburg near, [117](#)

Franz, Marie-Louise von, [183](#), [474&n](#), [825n](#)

Frazer, Sir James G.: *The Golden Bough*, [561](#), [562](#)

Frederick the Great, clock of, [211](#)

free association, *see* association(s) s.v.

freedom, 580, 581

as emotion, 310, 311

Freeman, John, 183

Frei, Gebhard, 475

Probleme der Parapsychologie: Gesammelte Aufsätze, 475n

Freia, 444

frequency, 314, 315

Freud, Sigmund, 6, 132, 199, 337, 342, 354, 380, 381, 392, 471, 517, 534, 773

and Adler, 125–26, 127

on ambivalence in language, 443

J.'s answers to questions on, 438–40

on archaic remnants, 206, 227, 535

biological point of view, 440

on castration complex, 61

causal-reductive method of, 481

and causes of psychosis, 381

on censor, 222, 366, 367, 479, 480

on counter transference, 140

credulity of, 440

on death-instinct, 479

on determination, 430

on dream-interpretation, 84, 85, 187, 377

on ego-ideal, 480

on ego-instinct, 479

on hysteria, 369, 372, 375, 381, 388

on Id, 61, 62, 128, 131, 480

on incest-wish, 91

and instincts, 658

on introverted type, 218

and Jung: analysis of Jung's dream, 213–15

—, collaboration, 125, 354

—, loss of friendship, 214

—, disagreement, 125, 483

on Leonardo da Vinci, [658](#)
materialism of, [440](#)
and memories, [258](#)
negative, reductive attitude of, [479](#)
neurosis theory of, [425](#), [652](#)
and “nothing but” explanation, [277](#), [479](#)
and objective side, [160](#)
on obsessional neurosis, [388](#)
on Oedipus complex, [535](#), [658](#)
one-sidedness of his views, [438](#)
on pleasure principle, [479](#)
on pre-conscious, [57](#)
on primitive mind, [562](#)
and psychoanalysis, [478](#)
psychology, [126](#)
and religion, [635](#)
on repression, [188](#), [478](#), [479](#)
scientific materialism of, [479](#)
sectarianism of, [523](#)
and sex, exclusive interest, [215](#)
and shadow, [828](#)
static view of, [62](#)
on subconscious, [377](#)
on super-ego, [480](#)
three-dimensional, [59](#)
totem and taboo theory, [440](#)
on transference, [136](#), [141](#), [151](#), [544](#)
on unconscious, [10](#), [61](#), [62](#), [124](#), [127](#), [128](#), [263](#), [515](#)
WORKS: “Five Lectures on Psychoanalysis,” [428n](#)
“Fragment of an Analysis of a Case of Hysteria,” [382n](#)
The Freud/Jung Letters, see Jung: WORKS; *The Interpretation of Dreams*, [354](#), [361n](#)
“Notes upon a Case of Obsessional Neurosis,” [433n](#)
“On Dreams,” [361n](#)
J.’s report, [361–68](#)

- “An Outline of Psychoanalysis,” 535n
preface to Stekel, *Nervöse Angstzustände und ihre Behandlung*, 390n
(with Breuer) *Studies on Hysteria*, 378&n, 430
“Three Essays on the Theory of Sexuality,” 382n
Totem and Taboo, 562
Über Psychoanalyse, 428
Zur Psychopathologie des Alltagslebens, J.’s review, 381–82
- Freudlicher, —, 29
- Freundlich, Jakob: *Deutsches Archiv für klinische Medizin*, 29n
- Frey-Rohn, Liliane, 495
- Fribourg, Bishop of, 270
- Frobenius, Leo, 476
- Froboese-Thiele, Felicia; *Träume—eine Quelle religiöser Erfahrung*, J.’s foreword, 700–701
- Fromm, Erich, 634n, 702, 703
Psychoanalysis and Religion, 702n
- Führer, see Hitler
- function(s): collective, 453
conscious, subjective components of, 22
in consciousness, 12, 36
cross of, 17
differentiated, 351
ectopsychic, 12
endopsychic, 21, 22, 37
four, 28, 43, 57, 97–98, 122, 483, 712
inferior, 19–21, 98, 732
psychological, 16
rational, 13
of religious symbols, 244–52
subjective components of, 43
thinking, 12–4, 16, 17, 43, 219
-types, four, 219, 471, 534
- Fürst, Emma: “Statistische Untersuchungen über Wortassoziationen,” J.’s abstract, 410–11
- Fürth, first German railway to, 308n

future: historic, [281](#)

unconscious concern with, [236](#)

G

Game, Margaret, [3](#), [4](#)

Ganser's symptom, [415](#), [416](#)

gas, poison, [567](#)

Gaul, [108](#)

Gayot de Pitaval, François, [397&n](#)

Geber (Jabir ibn Hayyan) [747](#)

Gemütlichkeit, [48](#)

genitals, suspension by, [445](#), [446](#)

George, St., [676](#)

Germany/German(s), [48](#), [161](#), [164](#), [569](#). [573](#). [574](#), [596](#), [597](#), [600](#)

and collective guilt, [715](#)

France and, *see* France s.v.

inferiority complex of, [604](#), [605](#), [607](#)

language, [14](#), [15](#), [30](#), [87](#), [136](#), [176](#)

national character of, [603](#)

Nazis in, *see* Nazism

philosophy, [62](#)

and prejudice, [241](#)

primitivity of, [254](#)

psychology, *see* psychology s.v.

sentimentality of, [47](#), [152](#)

southern, [121](#)

S.S. in, [580](#), [601](#)

and triadic mandalas, [715](#)

see also National Socialism

Gerry, Peggy, [692n](#)

Gerster, Georg, [626n](#)

ghosts, [319](#), [328](#)

explanation of, [326](#)

primitive fear of, [318](#), [319](#)

selelteni, Elgyonyi and, 318
stories, 318, 319, 326–28
as symbol, 328

Gilbert, J. Allen, 767n
“The Curse of Intellect” (unpublished), J.’s preface, 767

Gilgamesh, *see* Babylon s.v. Gilgamesh Epic

Gilli, Gertrud: *Der dunkle Bruder*, J.’s foreword, 776–78
“C. G. Jung in seiner Handschrift,” 776n

Glaphyra, 100–101

Glauber, Johann: *De Elia Artista*, 676

Glover, A.S.B., 589n, 673n, 679n

Glover, Edward: *Freud or Jung*, 706

gnosis, 730
of empirical method, 669

Gnosius, Dominicus: *Hermetis Trismegisti Tractatus vere Aureus de Lapide philosophici secreto*, 189n

Gnosticism, 280, 621, 651–53, 663
and assimilation, 672, 827
and collective unconscious, 652, 664
and evil, 727
father in, “devoid of consciousness,” 653
and Holy Ghost as feminine, 99
in John’s Gospel, 652, 686, 727
Jung considered as, 663, 664, 666, 727, 728, 730
morality, 720
“philosophoumena” of, 668
psychological significance of, 671, 826–28
and shadow (of Christ), cut off, 716, 722

Goclenius, Rodolphus: *Uranoscopiae, chirosocopiae, metoposcopiae*, 820&n

God: as Begetter, 156
belief in, Jung’s own, 706
child of, 279
compensating, 678
as *complexio oppositorum*, *see* *complexio oppositorum*; devil and, *see* devil s.v.
evil principle in, 709, 710, 712, 713, 723

fear of, 206, 279
feminine counterpart, 733
and Godhead, 715
help of the lonely, 286
incarnation of, 687
metaphysical, 668
of Old and New Testaments, 679, 680, 729
the one who made the sun (St. Augustine), 10, 288
pneuma of, 689
self as, 621
speaks through dreams and visions, 262, 263
as *summum bonum*, 688, 726, 733, 736, 737
a symbol of symbols, 283
is terrible, 289
two aspects/ambivalence/paradox of, 682–84, 686, 688, 690, 691, 709, 710, 740, 741
two sons of, 689
as unknown primal cause, 646
will of, 719, 720, 724, 725, 737

god(s): dying, 239
—, and resurrected, 694
psychopompic, 122
of Spring, sacrifice of, 446
sun-, 121
turned into philosophical ideas, 316
unconscious need for, 278

god-almightiness, 728

Godet, E., see Jung: WORKS s.v. *Phénomènes occultes*

godfather and godmother, 156, 157

Godhead, priest in, 274

God-image, 706
amoral, 743
archaic, 155
archetypal, 659, 667, 743
as autonomous psychic content, 666

evolution of, [741](#)
in man, [690](#)
as symbol of the self, [659](#)
two sides of, [682](#)
in the unconscious, [669](#)

Godlikeness, [646](#)

god-man, [238](#), [239](#), [247](#)
Christ as, [693](#), [695](#)
disappearance of, into unconscious, [261](#)

Goerwitz, E. F., *see under* Kant, [1](#).

Goethe, J. W. von, [30](#)
Egmont, Klärchen's song, [446n](#)
Faust, [241](#), [318](#), [546](#), [587n](#)
—, Aegean festival, [748](#), [749](#)
—, and alchemy, [748–50](#)
—, axiom of Maria in, [749](#)
—, Mephistopheles, [748](#), [749](#)

gold, [118](#)

Goldbrunner, Josef, [707](#), [708](#)
Individuation, [707](#)

Golden Age, [245](#)

good and evil, [620](#), [689](#), [708](#), [709](#), [716](#), [731](#)
beyond good and evil, [731](#)
—, Christ as, *see* Christ
in quaternity, [717](#)
relative, [717](#), [733](#)

good and *ousia*, identification, [709](#)

goodness, an individual acquisition, [601](#)

Görres, Johan Joseph von, [294](#)
Die christliche Mystik, [294](#)
Emanuel Swedenborg, seine Visionen und sein Verhältnis zur Kirche, [294](#)

gospel, *everlasting/evangelium aeternum*, [688&n](#)

“Gospel of Truth” (Gnostic), [671](#), [826](#)

Graham, Billy, [638n](#)

Grail, Holy, [678](#), [742](#), [798](#)

and spear, [118](#), [120](#)

graphology, [77](#)

Gray, Sidney, [3](#)

Great War, [46](#), [69](#), [163](#)

Greece/Greek: essence and spirit of, [239](#)

gods, [248](#)

language, [82](#)

medicine in, [103](#)

mythology, [40](#), [118](#), [472](#)

philosophy, [214](#)

greed: egotism and, [612](#)

Grenfell, Bernard P., and Arthur S. Hunt: *New Sayings of Jesus and Fragment of a Lost Gospel*, [122n](#)

Grimm brothers (Jacob, Wilhelm): *Fairy Tales*, [103](#)

Groddeck, Georg, [480](#)

group (s): formations, [570](#), [571](#)

and psychotherapeutic method, [609](#), [610](#)

Guild of Pastoral Psychology (London), [265](#)

Guillaume de Digulleville, [99](#)

Pèlerinage de l'âme de Jésus Christ, [99](#)

guilt, in individuation, [451](#), [453](#)

Gurney, Edmund, F.W.H. Myers, and Frank Podmore: *Phantasms of the Living*, [296](#)

H

Hades, [109](#)

Hadfield, J. A., [1](#), [25](#), [36](#), [169](#)

Haggard, H. Rider: anima motif in, [545](#), [546](#)

She, [201](#), [545](#), [546](#)

Hall, G. Stanley, [172](#)

hallucinations, [298](#), [38g](#), [461](#)

hypnagogic, [325](#)

olfactory, [321](#), [326](#)

verbal, [312](#)

see also voices

Haloa festival, [121n](#)

Hamelin, Pied Piper of, [593](#)

hands, and character, [820](#)

Hans, Clever, [377&n](#)

Harding, M. Esther, [474](#)

Psychic Energy, J.'s foreword, [469–70](#)

The Way of All Women, [474n](#)

—, J.'s foreword, [807–10](#)

Woman's Mysteries, [474n](#)

—, J.'s foreword, [518–20](#)

Harling, Ann, [283](#)

Harrison, Jane E.: *Prolegomena to the Study of Greek Religion*, [121n](#)

Hartenberg, P.: "Principe d'une physiognomie scientifique," [421n](#)

Hartmann, Eduard von, [62](#), [439](#), [560](#), [771](#)

on "divine Absolute," [477](#), [515](#)

Harvard Psychological Clinic, [269n](#)

Harvard University, [564&n](#)

Hasidic, [279](#), [675](#)

Hastings, James: *Encyclopedia of Religion and Ethics*, [648](#)

Hauffe, Friederike, clairvoyante of Prévorst, [294](#), [295](#)

haunted house, [320–26](#), [328](#)

Havet, J., [606n](#)

head, abstract existence of, [310](#)

healing the "split," [253–64](#)

heart: and memory, [310](#)

thinking in, [10](#)

hebephrenic fantasies, [389](#)

Hecate, [122](#)

Hegel, G.W.F., [515](#), [772](#)

Helena, and Simon Magus, [545](#)

Helios, and Elias/Elijah, [674](#)

hellebore, lapis as, [722](#)

Hellpach, Willy: *Grundlinien einer Psychologie der Hysterie*, J.'s review, [369–73](#)

Helsdingen, R. J. van: “Beeiden uit het onbewuste,” J.’s foreword, [530](#), [531](#)

Helvetius: “Vitulus aureus,” in *Musaeum hermeticum*, [676](#)

Hendy, B. D., [33](#)

Hephaestus, [749](#)

Heraclitus, on enantiodromia, [711](#)

Herakles, [112](#) heresy, [669](#)

heretics, religious geniuses as, [684](#)

Hermann, —: “Gefühlsbetonte Komplexe in Seelenleben des Kindes, im Alltagsleben und im Wahnsinn,” J.’s abstract, [403](#)

Hermas: *The Shepherd*, [115](#), [116](#)

Hermes Trismegistus: as Idris, [676](#)
Tractatus aureus, [286](#)

Hermetic philosophy, [232](#), [672](#), [690](#), [751](#), [828](#)

hero: as archetype, [232](#)
and conquest of death, [694](#)
-dragon conflict, [105](#), in, [231](#), [238](#)
and dual mother motif, [658](#)
identical with dragon, [92](#)
identification with, [238](#)
motif, [38](#), [91](#), [92](#)
myth, [102](#), [238](#)

Herod the Great, [777](#)

Herodotus, [121](#)&n

Herrnhuter Brüdergemeinde, [681](#)n

hetaira, transformation into, [674](#), [677](#)

Heyer, Gustav R., [517](#), [773](#)
The Organism of the Mind, [127](#)n
Der Organismus der Seele, [794](#)
—, J.’s review, [793](#)
Praktische Seelenheilkunde, J.’s review, [794–96](#)

Heyer, Lucy, [796](#)

hierosgamos: [120](#), [121](#)n
of Homunculus and Galatea, [749](#)
of Spiritus Sanctus and baptismal water, [158](#)

Hilarius, [296](#)

Hildegard of Bingen: Codex Lucca, 516

visions of, 516

Hillman, James, ed.: *Studies in Jungian Thought*, 487n

Himalayas, 153

Hindu(-ism), 97, 185, 667

lingam, 249, 250

literature, 67, 68

psychology, 11

Hippolytus, 730, 827

Elenchos, 653n, 671, 827

Hitler, Adolf/the Führer, 544, 576, 578, 595, 596, 602, 604, 605

as hysteric, 596, 604

as incarnation, 575

like Mohammed, 281

and *pseudologia phantastica*, 604

psychological effect of, 607

Hitlerism, 164

Hitschmann, Eduard: *Freuds Neurosenlehre*, J.'s review, 422

Hoare, Sir Samuel, *later* Viscount Templewood, 576&n

Hoche, Alfred E., 386

Handbuch der gerichtlichen Psychiatrie, 386n

Hoffman, Michael L., 438&n

Hoffmann, Ernst Theodor Wilhelm: “The Golden Pot,” 327&n, 525&n

Holy Communion, 273, 281

Holy Ghost/Spirit, 679–91

as Christ's father, *see* Christ s.v.; as *complexio oppositorum*, 689

as feminine, in Gnosticism, 99

identification with, 735

invocation of, 681

as psychic experience, 690

as revolutionary, 685

as transcendental fact, 682

two aspects of, 685

and union of opposites, 689, 691

Holy Roman Empire, [576](#)
Home, Mr., spiritualistic medium, [299](#), [300](#)
Homeric age, [10](#)
homo interior, Christ as, [695](#)
homo sapiens, [215](#)
homosexuality and law in Germany, [382](#)
Honegger, Johann Jakob, [426](#)*&n*
Hopkins, W., [289](#), [290](#)
Horst, Georg Conrad, [340](#)*&n*
Horton, —, [680](#), [685](#), [686](#)
Horus, [185](#)
 four sons of, [717](#), [732](#)
Hosea, [685](#), [720](#), [724](#)
Hottentots, [158](#)
Howe, Eric Graham, [27](#), [28](#), [58–60](#), [62](#)
Hubert, Henri, and M. Mauss: *Mélanges d'histoire des religions*, [38](#)*&n*
Hull, R.F.C., [183](#), [449](#)*n*
human mind, medical approach to, [354](#)
humanities and psychology of neuroses, [357](#)
Humbaba, *see* Babylon s.v. Gilgamesh Epic
Hume, David, [772](#)
Hungarian uprising, [636](#)
Hunt, Arthur S., *see under* Grenfell, B. P.
Huxley, Aldous, [638](#)*n*
hydrogen bomb, *see* bomb(s)
hygiene, psychic, [310](#)
Hyious tou anthropou/Son of Man, [828](#)
Hyliaster, *see* Paracelsus
hypnosis, [295](#), [303](#), [379](#)
 movement, [377](#)
 and rapport, [143](#), [144](#)
 and suggestion method, [699](#)
hypnotic: methods of treatment, [215](#), [378](#)
 sleep, [379](#)

hypnotism, [339](#), [340](#), [515](#)
forensic significance of, [378](#)
forms and techniques of, [377](#)
mass, [601](#)

hypothesis, fulfilment/living of, [280](#), [281](#)

hysteria, [58](#)
aetiology, [374](#)
anaesthesia in, [388](#)
and association tests, [353](#)
in childhood, [374](#)
complex in, [410](#)
differential diagnosis, [374](#)
dissociation in, [100](#)
among mediums, [302](#)
a “metaphysical problem,” [465](#)
psychic symptoms in, [374](#)
psychogenesis, [374](#), [388](#)
psychology of, [369](#)
riddle of, [369](#)
root phenomena of, [372](#)
sexual trauma theory, [478](#)
sociological and historical aspects, [372](#)
theory, [370](#)
treatment for, [375](#)

hysterical: anaesthesia, [187](#)
choreic affections, [374](#)
disturbance of sensation, [371](#)
hyperaesthesias, [371](#)
intellect, [371](#)
pain, [27](#)
pain-apraxia, [371](#)
paralysis, [371](#), [374](#)
psychogenesis of symptom, [388](#), [478](#)

hysterics: analysis of, [430](#), [431](#)

and lies, 197

spontaneous phenomena in, 303

I

Iamblichus: *Vita Pythagorica*, 674

Ibsen, Henrik: *Lady from the Sea*, 159

I Ching, trans. Wilhelm/Baynes, 69n

Ichthys/fish, Christ as, *see* Christ

icons, 181

“Id,” *see* Freud s.v.

idea(s): association of, 354

as entity, 309

flight of, 351

as golden vessels, 310

mythological, essentially real, 399

as phenomenon, 309

symbolic, 248, 249

unconscious, 303

universal, 309–11

identity, psychic, 194&n, 205

idols, reason for, 181

Idris, 676

Ignatius Loyola: *Exercitia Spiritualia*, 681, 686, 707&n

vision of *serpens oculus*, 683

image(s): parental, 156, 157, 159

primordial, 39, 228

imagination: active, *see* active imagination

a priori categories of, 38

pathological effects of, 380

Imago: Zeitschrift für Anwendung der Psychoanalyse auf die Geisteswissenschaften,
425n

imitatio Christi, *see* Christ/Jesus s.v.

imitation, 452, 453

“imitative illnesses,” 377

immortality, [288](#), [309](#), [310](#)

magic herb of, [107](#)

psychology of belief in, [309](#)

and realization of self, [694](#)

of soul, [319](#)

imps, complexes as, [532](#)

incarnation, [669](#)

further, [734](#)

incompleteness of, [729](#), [734](#)

and individuation, [719](#)

as integration of unconscious, [736](#)

incest: complex, *see* complex s.v.

among Hottentots, [158](#)

wish, [91](#), [94](#)

India, [45](#), [68](#)

castes in, [157](#)

and loss of old culture, [743](#)

performance of rites in, [273](#)

see also Hindu (-ism)

Indian Journal of Psychotherapy, J.'s foreword, [801](#)

individual: change to goodness in, [601](#), [602](#)

collectivization of, [216](#)

and group formation, [571](#)

need for change in, [261](#)

individuality, [453](#), [493](#)

individuation, [123](#), [166](#), [351](#), [618](#), [675](#), [690](#), [701](#), [705](#)

and adaptation, [451](#), [452](#)

and collectivity, [452–54](#)

a dialectical process, [665](#)

drive to, [505](#)

guilt in, [451](#), [452](#)

inescapable, [727](#)

interpretation of symbols in, [259](#)

as life in God, [719](#)

and problem of opposites, [493](#)
as salvation/redemption, [736](#)
union of conscious and unconscious in, [622](#)

Indomalaysia, [530](#)

Indra, [443](#)

infans mercurialis, [591](#)

infection, moral and mental, [245](#)

inflation, [573](#)
 psychotherapist and, [154](#)

influx divinus, [735](#)

initiation(s): and baptism, [116](#), [156](#)
 doctrines taught at, [233](#), [234](#)
 rites, [157](#)

insanity, [337](#), [350](#), [379](#)
 see also psychosis
 schizophrenia

insight, scientific, [544](#)

insomnia, J.'s own, [322](#), [323](#)

instinct(s): animal, [234](#)
 atrophy of, [659](#)
 language of, [209](#)
 loss of, [658](#)
 lost contact with consciousness, [244](#)

Institute of Medical Psychology (The Tavistock Clinic), J.'s lectures to, [3](#), [566n](#)

insulation, autoerotic, [149](#)

integration: ethical aspect of, [621](#)
 of personality, [617](#)
 of unconscious contents, [606](#), [613](#), [618](#)

intellect: incapable of understanding ritual, [271](#)
 murderous, [279](#)
 and neurosis, [284](#)

intellectual(s), [328](#)
 rationalist, [262](#)

intelligence testing, [384](#)

intercessio: divina, 157

sacerdotis, 157

International Congress for Psychiatry, Amsterdam, 1907, J.'s report, 404–5

International Journal of Parapsychology, 510

International Psychoanalytic Association, 423&n, 606n

interpretation, and emotional value, 260

introjection, 725

introspection, 241

introversion, 38, 217, 483, 534

in dementia praecox, 417, 418

intuition, 14–16, 43, 56

as fourth dimension, 28

and interpretation of symbols, 251

irrational, 219

and nose, link, 326, 327

as perception, 15, 219

in physics, 251

subliminal, 326

intuitive type, 19

invasion(s), 43

and affects, 32, 33

and artistic inspiration, 34

as endopsychic factor, 24

invent, etymology of, 239

inventions, and mythological anticipations, 39

invisibles, 312, 314–16

ions/ionization, and mediums, 660

Irenaeus, 716

Adversus haereses, 716n

Irminger, H., 645n

Iron Curtain, 244–45

Ishtar, in Gilgamesh Epic, 106–7

Isis: cult, 554

as feminine intercession, 734

mysteries, [121](#)
and Ra, [102](#), [103n](#)
Islam, [607](#), [667](#)
and Elijah (Ilyās), [675](#)
and Elijah (Khidr/al-Khadir), *see* Khidr
new, [281](#)
Isserlin, Max: “Die diagnostische Bedeutung der Assoziationversuche,” [403](#)
Italy, [161](#), [569](#)
conquest of Ethiopia, [576n](#)
tiled roofs, [118](#)
Ixion, [40](#), [95](#)

J

J. S., J.’s memorial to, [757](#)
Jacob, in fight with angel, [705](#)
Jacob, St., lazar-house (leproser), and battle of 1444, [87](#), [91](#), [102](#)
Jacobi, Jolande, [455](#), [474](#), [606n](#), [811n](#)
Complex/Archetype/Symbol, [96n](#), [229n](#), [474n](#)
—, J.’s foreword, [532–33](#)
Paracelsus: Selected Writings, J.’s foreword, [784](#), [785](#)
The Psychology of C. G. Jung, [455](#), [474n](#), [613n](#)
—, J.’s foreword, [467–68](#)
Jaffé, Aniela, [327](#), [825n](#)
Apparitions and Precognition, [327&n](#)
—, J.’s foreword, [327–29](#)
“Bilder und Symbole aus E.T.A. Hoffmanns Märchen *Der Goldene Topf*,” [327n](#),
[525&n](#)
Jahrbuch für psychoanalytische und psychopathologische Forschungen (ed. Jung),
[125n](#), [129](#), [392&n](#), [398n](#), [436](#), [551n](#)
James, William, [25&n](#), [205](#), [209](#)
on unconscious psyche, [477](#)
Varieties of Religious Experience, [577](#)
James-Lange theory of affect, [25](#), [33](#)
Janet, Pierre, [67](#), [74](#), [187](#), [222](#), [244](#), [341](#), [388](#), [439](#), [471](#), [477](#), [515](#), [773](#)

fonction du réel, [12](#), [520](#)
on “idées fixes,” [477](#)
on obsessions, [477](#)
on “partie supérieure” and “partie inférieure” of a function, [477](#)
“Le renversement d’orientation ou l’allochirie des représentations,” [421](#)

Japanese: and earthquakes, [33&n](#)
 Government, [69](#)

Java, [145](#), [178](#)

Jena, [287](#)

Jerusalem, [107](#)

Jesuit(s): and psychotherapy, [269](#), [287](#)
 theologian, [729](#), [740](#)

Jews, [162](#), [246](#), [665](#)
 complexes in, *see* complexes s.v.
 and consultation of rabbi for psychological troubles, [268](#)
 in Germany, [573](#), [600](#), [605](#)
 and tradition of Elias, [231](#); *see also* Judaism

Joachim of Flora, [678](#), [688&n](#)

Joan of Arc, Maid of Orleans, [299](#)

Job, [680](#), [741](#)
 God Yahweh of, [699](#), [718](#), [719](#), [721](#), [742](#)
 and individuation, [718](#)

John the Baptist, St., [108](#), [673](#)

John Chrysestoni, [674&n](#)

John the Evangelist, St., “Gnostic” gospel of, [652](#), [686](#)

Jonah, and whale, [592](#), [674](#)

Jones, Ernest, [399n](#), [485](#)

Jordan, Pascual, [473](#)

Josephus, Flavius, [107](#), [777](#)
 De bello Judaico, The Jewish War, [107n](#) [694n](#), [777n](#)

Judaism: God in, [703](#)
 medieval, and Kabbala, [672](#), [828](#)
 see also Jews

Judas of Galilee, [777](#), [778](#)

death of, 693

JUNG, CARL GUSTAV:

CASES IN SUMMARY in *order of presentation, numbered for reference*:

- [1] Widow with hysteria, wrongly diagnosed as sarcomatosis of the spinal cord.—58
- [2] Man aged 40 suffering from vertigo, with dream-series.— 78–82, 86–94, 96
- [3] Girl of 10 with mythological dreams, who gave her father a book of them for Christmas and died a year later.—96, 229–34, 239, 259
- [4] Schizophrenic woman who painted pictures to objectify her condition.—100–101
- [5] Young Frenchman whose depression began following journey to Spain and dream of Toledo cathedral.—112–23, 166
- [6] Young man with compulsion neurosis, living off a woman's savings, who wrote analysis of his case.— 128–30
- [7] Woman doctor aged 58 whose previous analyst had shown no emotions.—139
- [8] Man who bought Egyptian sculpture of cat, illustrating projection of feminine image.—141–42
- [9] Lady forced to come to consultation by transference.—143
- [10] Girl of 24, born in Java. Before her three attempts to start analysis she had three dreams of a customs house at the frontier. Jung's own dream of her in castle tower showed his misplaced devaluation of her sister of Case, 30.— 43–46, 150, 531n
- [11] American woman analyst threatened by her patient with a revolver, unable to accept her feelings as a woman.—147
- [12] Young artist who had difficulty in using active imagination.—169–71
- [13] University scientist who drank and was lonely: he recorded his own dream-series illustrating archetypal symbolism.— 173–76, 285&nn, 538, 540
- [14] Woman in stupor, who remembered events under hypnosis.—197
- [15] Professor of philosophy and psychology with cancer phobia.—206, 242
- [16] Man trying to “get above himself” whose dream foreshadows his death in mountain accident.—207
- [17] Woman whose dreams foreshadowed attack on her by sexual pervert.—208
- [18] Man whose cause of neurosis was circumvented for ten years.—224–25
- [19] Professor who had vision repeated in old woodcut.—229, 540
- [20] Alcoholic cured temporarily by Oxford Group, sent to Jung after relapse.—242, 272
- [21] Woman of the nobility who discussed her analysis with a Jesuit father-confessor.—269

- [22] Catholic lady from Rome who was helped back into full confession by Jung, after over-involvement with father-confessor.—271–72
- [23] Woman student of philosophy with father-transference to Jung.—277
- [24] Jewish girl with anxiety neurosis.—278–79
- [25] Somnambulistic girl.—309, 482
- [26] Boy aged, 9 who stabbed his sister after a “little man” appeared to him.—343–44
- [27] Man who murdered his family; his wife, a member of a religious sect, instilled the criminal impulse into him.—344–45
- [28] 35-year-old female hysteric with respiratory disturbances. —430–31
- [29] 34-year-old female neurotic with fantasy of man suspended by genitals.—446
- [30] Woman, later treated by van Helsing, whose paintings reflect her childhood divided between Indomalaysia and Holland (sister of Case 10).—530–31
- [31] Seven-year-old son of unhappy marriage who put pictures of mandalas round his bed.—538

WORKS: “The Aims of Psychotherapy,” 166n

Aion, 89n, 121n, 673, 678, 682n, 688n, 688n, 689n, 711n, 716n, 718, 732n, 736n, 742n, 825n

Alchemical Studies, 68n

“Answer to Job,” 681n, 689n, 702n, 705, 711&n, 717, 725, 729, 740

The Archetypes and the Collective Unconscious, 37n, 42n

“Archetypes of the Collective Unconscious,” 683n

“Associations d’idées familiales,” 420

Aufsätze zur Zeitgeschichte, 591n

“Beiträge zur Symbolik,” untraced lecture at Weimar Congress, Rank’s abstract, 446n

“Blick in die Verbrecherseele,” 343n

“Brother Klaus,” 39n, 99n, 683n

“A Case of Hysterical Stupor in a Prisoner in Detention,” 415n

Civilization in Transition, 47n

Collected Papers on Analytical Psychology, 459n

“Commentary on ‘The Secret of the Golden Flower’,” 166n, 179n

“The Complications of American Psychology,” 465n, 552n

“Concerning Mandala Symbolism,” 145n, 179n, 525n, 538n, 577n

“Concerning Psychoanalysis,” 427n

“Concerning Rebirth,” 525n, 556n, 675n

“The Content of the Psychoses,” 354n
Contributions to Analytical Psychology, 459n, 623n
Diagnostische Assoziationsstudien, 398, 400
“Dream Symbols of the Process of Individuation,” 67n
Essays on Contemporary Events, 591n
Experimental Researches, 48n
“Ein Fall von hysterischem Stupor bei einer Untersuchungsgefangenen,” 415
“The Familial Constellations,” 74n
“Flying Saucers: A Modern Myth,” 631n, 715n
Foreword to White’s *God and the Unconscious*, 474
The Freud/Jung Letters, 333nn, 335n, 339, 375n, 376n, 377nn, 380n, 381n, 383n, 386n, 387n, 388n, 392n, 398n, 406n, 420n, 422n, 423nn, 426n, 427n, 430n, 441, 443n, 551n, 552n, 761n
“Further Investigations on the Galvanic Phenomenon and Respiration in Normal and Insane Individuals” (with Ricksher), 27n
“General Aspects of Dream Psychology,” 78n, 459n
Gestaltungen des Unbewussten, 327n, 825n
“Herisau lecture,” 441
L’Homme à la découverte de son âme, 123n, 613n
“Instinct and the Unconscious,” 459n, 535n
The Interpretation of Nature and the Psyche (with Pauli), 473n
Letters, ed. G. Adler, 285n, 312n, 494n, 502n, 561n, 616n, 673n, 679n, 702n, 762n, 767n, 773n, 788n, 789n
Man and His Symbols (with von Franz et al.), 183
Memories, Dreams, Reflections, 214n, 278n, 361, 554n, 798n
“Mind and Earth,” 552n
Ein Moderner Mythos, 631
Modern Man in Search of a Soul, 589n
Mysterium Coniunctionis, 545n, 650, 683n, 825n
Naturerklärung und Psyche (with Pauli), 494n
“New Paths in Psychology,” 427n
“Le nuove vedute della psicologia criminale,” 411
“On the Importance of the Unconscious in Psychopathology,” 70n
“On the Nature of Dreams,” 78n, 460
“On the Nature of the Psyche,” 501n, 683n, 705n

“On the Practical Use of Dream Analysis,” 78n

“On Psychic Energy,” 459n

“On the Psychogenesis of Schizophrenia,” 69n

“On Psychological Understanding,” 70n

“On the Psychology and Pathology of So-called Occult Phenomena,” 309n

Paracelsica, 753n

“Paracelsus as a Spiritual Phenomenon,” 462n

Phénomènes occultes, trans. E. Godet and Y. Le Lay, 309n

“The Phenomenology of the Spirit in Fairytales,” 649, 732n

“The Philosophical Tree,” 529, 677n

The Practice of Psychotherapy, 66n

Il problema dell’inconscio nella psicologia moderna, trans. A. Vita and G. Bollea, 559n

The Process of Individuation, 707n

Psychiatric Studies, 200n

“A Psychological Approach to the Dogma of the Trinity,” 649, 711n

“The Psychological Diagnosis of Evidence,” 307n

“Psychological Factors Determining Human Behaviour,” 564&n

“The Psychological Foundations of Belief in Spirits,” 309n; 459n

Psychological Types, 12n, 13n, 14n, 17n, 43n, 89n, 115n, 166n, 613n, 623&n, 690, 704, 761n

Die Psychologie der Übertragung, 613n, 753n

Psychologie und Alchemie, 753n, 825n

Psychologie und Erziehung, 613n

“Psychologie und Spiritismus,” 312n

Psychologische Abhandlungen, 459, 525, 529, 558, 625, 649, 825

Die Psychologische Diagnose des Tatbestandes, 411

Psychology and Alchemy, 11n, 67n, 99n, 121n, 122n, 167n, 171n, 174n, 175n, 285n, 516n, 538n, 711n, 722n, 775n, 798n, 799n

“Psychology and Literature,” 39n, 525n

Psychology and Religion, 11n, 39n, 613n

“The Psychology of Dementia Praecox,” 349, 354, 376n, 406

“The Psychology of Dictatorship,” 566n

“The Psychology of Eastern Meditation,” 650n, 739n

“The Psychology of the Transference,” 154n, 650, 748n, 797n, 798n, 800n

Psychology of the Unconscious, 38n, 355, 459n, 552n, 697n, 724

“Psychophysical Investigations with the Galvanometer and Pneumograph in Normal and Insane Individuals” (with Peterson), 27n

“Psychotherapy Today,” 269n

“The Reaction-time Ratio in the Association Experiment,” 303

“The Realities of Practical Psychotherapy,” 11n, 145n, 531n, 578n

“The Relations between the Ego and the Unconscious,” 613n

“A Review of the Complex Theory,” 460

“Richard Wilhelm: In Memoriam,” 553n

“The Role of the Unconscious,” 163n, 465n, 573n

The Secret of the Golden Flower (with Wilhelm), 753n

Seelenprobleme der Gegenwart, 825n

forewords, 558–60

VII Sermones ad Mortuos, 663n

“The Significance of the Father in the Destiny of the Individual,” 74n

“The Soul and Death,” 309n

“The Spirit Mercurius,” 649, 732nn

The Structure and Dynamics of the Psyche, 42n, 109n

“The Structure of the Unconscious,” 449n

Studies in Word Association, 48n

“A Study in the Process of Individuation,” 166n, 525n, 577n

Symbolik des Geistes, 753n, 825n

Symbols of Transformation, 10n, 38n, 42n, 91n, 105n, 17n, 121n, 355, 44n, 446n, 724

“Synchronicity: An Acausal Connecting Principle,” 34n, 477n, 494n, 511

“The Theory of Psychoanalysis,” 436n, 535n

“The Therapeutic Value of Abreaction,” 69n

“The Transcendent Function,” 449n, 690n

“Transformation Symbolism in the Mass,” 735n

“Traumsymbole des Individuationsprozesses,” 67n

Two Essays on Analytical Psychology, 49n, 72n, 89n, 155n, 160n, 166n, 277n, 579n, 623n, 719

Über die Energetik der Seele, 825n

Über psychische Energetik und das Wesen der Träume, 613n

Über die Psychologie des Unbewussten, 613n

“Versuch einer Darstellung der psychoanalytischen Theorie,” 436n

“Von den Wurzeln des Bewusstseins,” 825n

Wandlungen und Symbole der Libido, 354n, 459, 552, 562n, 697n

Wirklichkeit der Seele, 825n

“Wotan,” 164n, 577n, 600n

“Zur Umerziehung des deutschen Volkes,” 599n

ed., see also *Jahrbuch für psychoanalytische und psychopathologische Forschungen*

Jung Codex, see CODICES

Jung, C. G. Institute for Analytical Psychology, Zurich, 606&n

J.’s address at founding of, 471–76

address on presentation of J. Codex, 671&n, 826&n

foreword to first volume of *Studies*, 487–88

Jung, Emma, 768, 825n

“Ein Beitrag zum Problem des Animus”/trans. Cary F. Baynes, “On the Nature of the Animus,” 768n

Jupiter, planet, 67

jus primae noctis, 159

justification by faith, 719

“Just So Story,” 230, 504, 506

K

Kabbala, 652, 672, 736, 828

Kankeleit, Otto: *Das Unbewusste als Keimstätte des Schöpferischen*, J.’s foreword and contribution, 786–87

Kant, Immanuel, 7, 62, 213, 299, 318, 772

Anthropologie in pragmatischer Hinsicht, 7n

and anthropology, 515

Critique of Pure Reason, 706

Dreams of a Spirit-Seer, trans. E. F. Goerwitz, 217n, 318n

on Swedenborg, 297–99

psychology of, 379

Kardec, Allan: *Buch der Medien*, 304

katabasis, 38, 120

Kataroff, Dimitre: “Expériences sur le rôle de la récitation comme facteur de la mémorisation,” 421n

Kepler, Johann: astronomy of, and archetypal triad, [473](#)
Keplerbund, [427–29](#)
Kerényi, Karl, [472](#), [485](#), [529](#)
Kerner, Justinus, [201](#), [294](#), [340](#), [775](#)
 Blätter aus Prevorst, [200&n](#)
 Die Geschichte des Thomas Ignaz Martin, [299n](#)
 The Somnambulant Tables/Die somnambulen Tische, [296&n](#)
kerygmatics, [602](#)
Kesselring, Max, [427–29](#)
key: in dream of Toledo, [122](#)
 and mysteries, [121](#)
Keyhoe, Donald E., [626n](#)
 J.'s letter to, [632–33](#)
 Flying Saucers from Outer Space, [627n](#)
Keyserling, Count Hermann, [663](#)
 “Begegnungen mit der Psychoanalyse, [663n](#)
Khidr/Al-Khadir, [556](#)
 Elijah and, [675–77](#)
Khunrath, Heinrich, [751](#)
Kingdom of God, on earth, [245](#)
Kirsch, James, [692n](#)
Kitchin, Derek, [265](#), [287](#)
Kleist, Karl: *Untersuchungen zur Kenntnis der psychomotorischen
 Bewegungsstörungen bei Geistkranken*, J.'s review, [382](#)
Knapp, Albert, [376](#)
 Die polyneuritischen Psychosen, J.'s review, [378](#)
Koenig-Fachsenfeld, Olga von: *Wandlungen des Traumproblems von der Romantik bis
 zur Gegenwart*, J.'s foreword, [773–75](#)
Kolb, Eugen, [604](#)
Kopp, Hermann: *Die Alchemie in älterer und neuerer Zeit*, [676](#)
Korrespondenzblatt der internationalen psychoanalytischen Vereinigung (Bulletin).
 [423n](#)
Kraepelin, Emil, [370](#)
 diagnostics of, [385](#)
Krafft-Ebing, Richard von: case of servant-girl aged, 24 with hallucinations, [298](#)

Lehrbuch der Psychiatrie/Textbook of Insanity, 298n

Kranefeldt, W. M., 517, 768, 773, 825n

“‘Ewige Analyse’,” 768n

“Der Gegensatz von Sinn und Rhythmus in seelischen Geschehen,” 768n

“‘Komplex’ und Mythos,” 558n

Secret Ways of the Mind. 127n. 517n

Kretschmer, Ernst, 639

“Kreuzungen episode,” in Freud/Jung relationship, 430n

Kundalini, see yoga s.v.

Künkel, Fritz, 312n

L

labour camps in Russia, 665

Labour Party, 579

Lachat, Père William: J.’s letter to, 679–91

La Réception et Faction du Saint-Esprit dans la vie personnelle et communautaire, 679n

Ladame, —: “L’Association des idées et son utilisation comme méthode d’examen dans les maladies mentales,” 412

review of J.’s *Psychologie der Dementia praecox*, 412

Laforgue, René, 673n

lamaism, mandalas of, 181, 516, 578

Lang, Josef, 825n

Lange, C. G., 25n

Lange, Wilhelm, 336n

Hölderlin: eine Pathographie, 336n

language, history of, 443

Lao-tzu: “high stands on low,” 233

Tao-te-ching, 539n

lapis: as *alexipharmacum*, 722

and artifex, 722&n

exilis, 798

noster, 775

philosophorum, symbolism of, 753

semel factus, 722

La Rocque, François de, 575n

Laszlo, Violet S. de: *Psyche and Symbol*, J.'s foreword, 537–42

Latin spirit, 47

League of Nations, 578

“least of your brethren.” 280

Le Bon, Gustave: *The Crowd: A Study of the Popular Mind*, 138, 648

Leibniz, G. W., 62, 771

Nouveaux Essais sur l’entendement humain, 9n

“petites perceptions,” 305, 477, 515

Leipzig, 78n, 86, 87, 89, 94

Le Lay, Yves, *see* Jung, C. G., WORKS: *Phénomènes occultes*

Lemaitre, A.: “Un nouveau cycle somnambulique de Mlle. Smith,” 421n

Leo, zodiacal sign, 121

Leroy. E.-Bernard: “Escroquerie et hypnose,” 421n

Leslie, Desmond, 627n

Levi, Herta, 820n

levitation, 300

Lévy-Bruhl, Lucien: *How Natives Think*, 42n

on “l’état prélogique,” 562

on *participation mystique*, 42, 194&n, 205

see also *représentations collectives*

Lexicon der Paedagogik, 477n

liberation, 635

libido: and adaptation, 450

-fixations, 480

Freud’s concept, 480

infantile fixation of, 124

lion and snake as symbols of, 444

Liébeault, Auguste Ambroise, 340&n

Liepmann, H. K., 376

life: after death, 287, 288, 294

banal, 274

divine drama of, 274, 275

meaningful, 275
meaning of, 246, 263
rules of, 625
second half of, 315, 485
symbolic, 282
too rational, 274

light, wave and particle theory of, 33, 34n
light-bringer, Christ as, 671, 826
lightning, 628
lingam as symbol, 249, 250
Lippmann, E. O. von: *Entstehung und Ausbreitung der Alchemie*, 747
Lipps, Theodor, 477
Locke, John, 9n
Lodge, Sir Oliver, 314
Löwenfeld, Leopold, 378&n
 Homosexualität und Strafgesetz, J.'s review, 382
 Der Hypnotismus: Handbuch der Lehre von der Hypnose und der Suggestion, 378&n
 and H. Kurella, eds., *Grenzfragen des Nerven- und Seelenlebens*, 361n
Logos, 121, 731
Lombard, Emile: "Essai d'une classification des phénomènes de glossolalie," 420n
Lomer, George: *Liebe und Psychose*, J.'s review, 380
London, 70
loneliness, 276
lotus (padma), 578
Louis XIV, 574
love, and transference, 143
lubricum illud genus/"that slippery sex," 714&n
Lucifer, 732
lucus a non lucendo, 318
Luff, Mary C., 32
Luke, Gospel of, 133n
Lullius, Raymundus/Lull, Ramon, 238, 747, 797
lumen de lumine, 723
Luna, 180

Lutherans in Sweden, [281](#)

lying/lies: doctor's telling of, [620](#)

pathological/pseudologia phantastica, [596](#), [604](#)

M

Mabbott, J. D., [744n](#)

McCarthyism, [631](#)

MacDonald, Ramsay, [579&n](#)

McDougall, William, [69&n](#)

MacIntyre, Alasdair, [744n](#)

Mackenzie, Marion, [132](#)

macula peccati, [687](#), [718](#), [723](#), [729](#)

Madeleine, Mme., [377&n](#)

Maeder, Alphonse: "À propos des symboles," [414](#)

"Contributions à la psychopathologie de la vie quotidienne," J.'s abstract, [412](#)

"Essai d'interprétation de quelques rêves," [413](#)

"Nouvelles contributions à la psychopathologie de la vie quotidienne," J.'s abstract, [412](#), [421n](#)

"Die Symbolik in den Legenden, Märchen, Gebräuchen und Träumen," J.'s abstract, [413](#)

Une voie nouvelle en psychologie, J.'s abstract, [413](#), [414](#)

magic: sexual, [92](#)

today, [328](#)

magnetism, animal, *see* animal s.v.

Mahaim Clinic, Cery, [761](#)

Mahatmas, [153](#)

Mahyāna, mandala, [717](#), [739](#)

Maidenek, concentration camp at, [599&n](#)

male and female: as opposites, [714](#), [716](#)

principle. [118–20](#). [122](#)

Malinine, M., with H. C. Puech and G. Quispel, eds., *Evangelium Veritatis*, is. [671n](#)

Malinowski, Bronislaw, [561n](#)

man: archaic, [228](#)

dehumanization of, [593](#)

governed by demon, 594
isolated in *cosmos*, 255
“is what he eats,” 598
modern, 205, 256
original, 280
scientific and inventive mind of, 260
as totality, 317
mana, 240, 241, 715
Mandaean(s), 676
mandala(s), 178, 179, 537, 538, 577, 578
 healing purpose of, 123
 and individuation, 719
 Lamaic, *see* Lamaism
 Mahāyāna, 717
 motif, 67*n*
 of Rhodesia, prehistoric, 516
 as rotating figure, 578
 swastika as, 578
 symbolism of, 178, 515
 —, and God-image. 659
 trinity and triad in, 714, 716
Manget. J. J.: *Bibliotheca chemica curiosa*, 733*n*
manic depression, 31, 351, 375, 385
Manichaeism, 726
manipura chakra, 67, 95
mankind, as one individual, 244
Mann, Thomas, 697*n*
Marduk, spring-god in Babylonian myth, 105
Maria, axiom of, and *propertio sesquitertia*, 476
Marie, A.: “Sur quelques troubles fonctionnels de l’audition chez certains débiles mentaux,” 421*n*
Mark, St., 247
marriage: Christian, 157, 809
 compensatory character of, 476
 cross-cousin, 473

heavenly, [299](#)
horoscopes, [495](#), [502](#), [503](#)
psychology of, [77](#)
quaternio, [473](#)
Marseilles, [113n](#)
Marti, Fritz, [420&n](#)
Martin. P.W., [606n](#)
Martin, Thomas Ignaz, [299](#)
 Die Geschichte des Thomas Ignaz Martin, by J. Kemer, [299n](#)
Mary, Mother of God: Assumption of, [689](#), [713](#), [714](#), [742](#)
 Assumptio Beatae Virginis, [714](#), [731](#)
 as bride in bridal-chamber, [681&n](#) [742n](#)
 as Co-Redemptrix, [714](#), [731](#)
 Immaculate Conception/*conceptio immaculata*, [714](#), [738](#)
 and Marianic movement, [714](#)
 as *omnium gratiarum mediatrix*, [689](#)
 Protestant view of, [687](#)
 as *virgo terra*, [689](#)
Mary Magdalene, [692](#)
Mass, the: Host in, and Mithras cult, [270](#)
 as living mystery, [270](#)
 miracle of, [276](#)
mass(es): conversions, [602](#)
 danger of, [590](#)
 evil and, [601](#)
 hypnotism, [601](#)
 individual in, and unconscious compensation, [476](#)
 -mindedness, [605](#)
 phenomenon, demonic features in, [601](#)
 politics and, [564](#)
 psychology of, [161](#), [571](#), [586](#), [605](#)
 psychosis, [607](#)
 suggestion, [595](#), [596](#), [601](#), [602](#)
Mater Magna, [554](#)

materialism, [603n](#), [733](#). [734](#)
and psychology, [523](#)
scientific, [314](#), [463](#), [734](#)
and spiritual devastation, [583](#)

matriarchal symbolism, [521](#)

matter, physical, [255](#)

Matthew, Book of, [231](#)

maturation, analysis as, [172](#)

Matuta, goddess of death, [91](#)

Mauss, M., *see under* Hubert, H.

Maya, [464](#), [670](#)

Mead, G.R.S.: *The Gnostic John the Baptizer*, [694n](#)

mechanization, [370](#)

Mechtild of Magdeburg. [444](#)

medicina catholica, [699](#)
lapis as, [722](#)
medicine: ancient Egyptian, *see* Egypt s.v.
ancient Greek, *see* Greek s.v. and borrowing from other sciences, [357](#), [358](#)
lack of psychological understanding, [355](#)

medicine-man, [285](#), [286](#), [570](#)
ability to “smell.” [325](#)
on dreams, [557](#)

mediums, [294](#), [299](#), [301](#), [304–7](#), [313](#)
controls, [312](#)
hysterical symptoms among, [302](#)
see also White, Betty

megalomania, [144](#)

megaphone oratory, [601](#)

Mehlich, Rose: *J. H. Fichtes Seelenlehre und ihre Beziehung zur Gegenwart*, J.’s
foreword, [770–72](#)

Meier, C. A., [472](#), [671](#), [826&n](#)
Antike Inkubation und moderne Psychotherapie, [487n](#)

Meir, Rabbi, [674](#)

melancholia, [31](#)

Mellon, Paul and Mary, Collection, [747n](#)

melothesia, 11n

memory(-ies): as function, 22

- healing effect of, 258
- infantile, recollection of, 259

Menninger, Karl, 634n

mental disease/disturbance, 353

- social definition of, 35

Menzel, reflection theory of, 628

Mephistopheles, *see* Goethe: *Faust*

Mercurius, 752

- and Elijah legend, 676, 677
- Kyllenios*, 749
- as Mephistopheles, 748
- and Mithras, 676
- and *serpens mercurialis*, 232, 722
- and transformation, 748

Merlin, 742

Mesmer, Franz Anton, 295, 339, 340

mesmerism, 294, 339, 340

Mesolithic Age, 39

Mesopotamia, 109

Messina earthquake, 92&n

metaphysical: assertions, dishonesty of, 737, 738

- principle, amorality of, 733

metaphysics: and archetypes, 519

- and science, 707, 708

meteors/meteorites, 307&n

method: analytical, 608

- causal-reductive, 478
- comparative, 7
- scientific, 309
- statistical, 319
- teaching of, 251

Métral, M.: “Expériences scolaires sur la mémoire de l’orthographe,” 420n

Meyer, E.: *Die Ursachen der Geisteskrankheiten*, J.'s review, [381](#)

Meyer, Konrad Ferdinand, [336n](#)

periodic melancholia of, [336](#)

see also under Sadger

Michelsen, Johann: [429](#)

Ein Wort an geistigen Adel deutscher Nation, [429n](#)

microbes, [262](#)

microcosm, man as, [695](#), [696](#)

Middle Ages, [67](#), [232](#)

art in, [173](#)

dreams in, [66](#), [112](#), [236](#)

and *jus primae noctis*, [159](#)

mythological world of, [593](#)

secret traditions in, [115](#), [120](#)

Weltanschauung of, [115](#)

Midrash, [688](#)

Mieg, Joannes Fridericus: *De raptu Eliae*, [674](#)

migration, and dissemination of mythological symbols, [553](#)

Miller, Emanuel, [102](#)

mind: archetypal, [45](#)

basic conformity of, [42](#)

between death and birth, [95](#)

growth to consciousness of, [241](#)

history and phenomenology of, [356](#)

not born a *tabula rasa*, [540](#)

original, [258](#), [259](#)

structure of, [36](#)

Minerva, goddess, [111](#)

miracle-stories, in Gospel, [693](#)

Mishmar, *The Daily Guardian*, [604](#)

misoneism, [192](#), [194](#)

Mithras/Mithraism: Aion (key god) in, [121](#)

bells in, [270](#)

bread stamped with cross/divided into four, [270](#)

and Christianity, [115](#), [117](#)
and Elijah myth, [676](#), [677](#)
killing of bull in, [444](#)
liturgy, star in, [695](#)
Roman army and, [554](#)
Sol and, [676](#)
Tauroktonos, [117](#)
water/springs in, [117](#), [270](#)

Moebius/Möbius, Paul Julius, [336&n](#), [388](#)
on hysterical symptom, [375](#), [388](#)

Mohammed(-ans), [289](#)

Moleschott, Jacob, [598](#)

Moll, Albert, [341&n](#)
Der Hypnotismus, mit Einschluss der Haupt punkte der Psychotherapie und des Occultismus, J.'s review, [377](#), [378](#)

monad, Anthropos as, [715](#)

Monakow, Constantin von, [333&n](#)

monasteries, [282](#)

money: devaluation of, [576](#)
dilution of, [573](#)
fictitious character of, [567](#)
hollowing out of, [573](#)
the State and, [572–4](#)

Monogenes, [122](#)

moon: conjunction, in marriage horoscopes, [495](#), [496](#), [498](#), [499](#), [502–7](#)
as symbol of unconscious, [180](#)

Moorish Kingdom, [114](#)

moral law as psychic fact, [619](#)

morality: and greed, [612](#)
in large organizations, [571](#)
relativity of, [713](#)
sexual, and psychoanalysis, [394](#), [395](#)
social v. individual, [383](#)

Moral Re-Armament movement, Caux centre, [681&n](#), [683](#)

Morgan, D. Glan, [283–85](#)

Morienus Romanus, 750&n

“De transmutatione metallorum,” in *Artis auriferae*, 750n

Moroney, M. J., 507n

Moser, Fanny: *Okkultismus: Täuschungen und Tatsache*, 317n

Spuk: Irrlaube oder Wahrglaube?, 317

—, J.’s foreword, 317–26

Moses, 205

and Elijah, parallels, 674

Moses ben Leon, 675

Moses Cordovero, 675

Mosley, Sir Oswald, 575&n

mother-dragon, 91, 105

mother: dual, motif of, 658

earth-, 484

and feeling function, 89

figures, three, 732

fixation, 277

-love, crushing weight of, 338

significance of, in life of K. F. Meyer, 337, 338

terrible, 91

Mother: all-compassionate, 276

Earth, 255

of God, as arch-saint, 99

Great, 239, 255

—, sacrifice to, 446

motif: of hostile brothers, 228

mythological, *see* myth s.v.

motivation, and psychotherapy: of patient, 609, 613

of teacher, 610, 611

mountain: climbing, and dream, 207

sickness, 78, 79, 88, 89, 96

movement(s), automatic, 303–5

mulier taceat in ecclesia, 742

Müller, Hermann: “Beiträge zur Kenntnis der Hypermesis Gravidarum,” J.’s abstract,

414

“Ein Fall von induzierten Irresein nebst anschliessenden Erörterungen,” 414

mulungu, 240

mungu, 240

Murray, Henry A.: “Conclusions” to *Explorations in Personality*, 269n

Mürren, advertisement for, 170

Mussolini, Benito/Il Duce, 127, 165, 576, 578, 579

mutilation, numinous, 348

Myers, F.H.W., 477

mysteria of early Christianity, 115

mysterium: iniquitatis, 690

tremendum, 270

mystery(-ies): ancient, 120, 122

 as expression of psychological condition, 270

mystical experiences, 577

 mysticism, 98

 medieval, 280

 mystics, and experience of archetypes, 98

myth(s), 38

 and collective unconscious, 487

 as mental therapy, 238

 motifs, 38, 39, 228, 515

 and mythologizing factor, 592

 reinterpretation of, 736

 as symbols that happened, 247

mythologem, theological preaching as, 682

mythology, 41, 91, 354

 ambivalence in, 443

 archetypal motifs in, 658

 Greek, see Greek s.v.

 opposites in, 443, 444

 a psychic phenomenon of the present, 327

 Scandinavian, 92

 truth of, 328

N

Naassenes, [671](#), [827](#)

Näcke, Paul: *Ueber Familienmord durch Geistesranke*, J.'s review, [386](#)

Nagel, Hildegard, [645n](#), [654n](#)

Nägeli, —, (Freiburg im Breisgau), [296](#)

Nag Hamadi, Upper Egypt, [671n](#)

Nagy, Peter: trans. into Hungarian of Jung's *On the Psychology of the Unconscious*, J.'s foreword, [455–56](#)

namazu, [33n](#)

Napoleon I, [221](#), [222](#)

Napoleon III, [299](#)

nation(s): in collective misery, [577](#)

 psychology of, [571](#)

National Industrial Recovery Act (U.S.A.), [575n](#)

National Investigations Committee on Aerial Phenomena (NICAP), [626n](#)

 J.'s statement to, [631](#), [632](#)

nationalism, [567](#)

National Recovery Administration (U.S.A.), [575&n](#)

National Socialism/Nazi(sm), [165](#), [289](#), [574](#), [594](#), [715](#)

Nature, [156](#)

 conquest of, [261](#)

 de-deification of, [593](#), [602](#)

 demands death, [275](#)

 demonism of, [593](#), [594](#)

 de-psychization of, [591](#), [593–95](#)

 man and, [255](#), [260](#)

 populated with monstrous machines, [260](#)

 -spirit, [649](#)

Navaho, *see* American Indians: North

Nazi(s), *see* National Socialism

Neanderthalensis, [214](#)

Near East, symbolism of dying god in, [239](#)

Nebuchadnezzar, dream of, [109](#), [110](#)

negativism, 371

Negro(es), 35, 46, 47, 148

dreams of, 37–40, 552&n

myth, 119

psychoses of, 552

religion of, 552

thoughts “in the belly,” 10

and white man, idealization of, 552

Neiditsch, Jeanne, 398n

Nekyia, 38, 107

Nelken, Jan, 433n

“Analytische Beobachtungen über Phantasien eines Schizophrenen,” J.’s comment on
Tausk’s criticism, 433–37

neo-paganism, 569, 576, 647

Nerval, Gérard de (pseudonym of Gérard Labrunie), 545

J.’s lecture on, 779

nervous system, of analyst, 154

Neue Preussische Zeitung, 296

Neue Zürcher Zeitung, J.’s letters in, 427n

Neumann, Erich, 474, 485, 529

Amor and Psyche, 668

Depth Psychology and a New Ethic, J.’s foreword, 616–20

The Origins and History of Consciousness, 474n

J.’s foreword, 474–75

Neumann, Karl Eugen: *Die Reden Gotamo Buddhos*, J.’s comment on, 697&n

Neumann, Therese, see Therese of Konnersreuth neuralgia, 374

neurology (-ists), 341

Freud’s theories and, 388

neurosis, 24, 340

adaptation process in, 449

as attempt at self-cure, 168, 169

childhood as origin of, in later life, 420

compulsion, see compulsion

definition, 167

as expression of affections of whole man, 357

a moral problem, 617
psychogenic nature of, 380
psychological conception of, 341, 390
psychology and therapy of, 357, 358
reason for, 274
sexual theory of, 388, 402, 438
structure of, 665
symbolic value of, 652
a terra incognita, 354
as transitory phase, 284
neurotic(s): behaviour of, 197
 complexes in, 353
 isolation of, 105
 symptoms, 187
New Mexico, J.'s visit to, 123, 554
New York *Times*, 438, 564n
Nicholas of Cusa, 682
Nicholas von der Flüe, *see* Brother Klaus
Niehus-Jung, Marianne, 566n
Nietzsche, Friedrich Wilhelm, 31, 199, 233, 394, 395, 463, 492, 546, 560, 634, 721
 and "blond beast," 573
 Dudu and Suleika, 546&n
 Genealogy of Morals, Freud's work compared to, 439
 madness of, 620
 and Superman, 600
 Thus Spake Zarathustra, 31, 202, 546&n, 578
 —, and Kerner, parallel, 200, 201
nihil est in intellectu. . ., 9
Nile, 121
nirdvandva, 620, 720
Nirvana, 667
Nonconformists, 283
normality: mental and moral conflicts of, 606
 and neurosis, closeness of, 251

“nothing but”: Freud’s explanation, [277](#)
people as, [274](#)
nuclear deterrent, [245](#)
numbers: archetypes and, [497](#), [498](#)
as autonomous entities, [497](#), [498](#)
as mythological entities, [203](#)
in table-tilting experiment, [305](#), [306](#)
see also four; thirteen; three
numina, flight of, [261](#)
numinosity: of cultural symbols, [253](#)
destruction of, [254](#)
loss of, [254](#)
of words, [257](#)
Nuremberg: first German railway from, [308n](#)
see also Psychoanalytic Congresses s.v. Second

O

obedience, primordial instinct of, [721](#)
object: and subject, *see* subject
and withdrawal of projection, [668](#)
objectivation of impersonal images, [166](#), [173](#), [179](#)
observation, sources of error in, [307](#)
Observer (London), [581n](#)
obsession (s), [206](#)
psychotherapy of, [362](#)
obsessional neurosis, [388](#)
Occam’s Razor, [371n](#)
occult phenomena, [293–329](#), [378](#)
Odin, [443](#)
Odyssey, [38](#)
Oedipus complex, [479](#)
olfactory organ, degeneration of, in man, [325](#), [326](#)
Olympiodorus, [751](#)
one-sidedness, [6](#)

of conscious mind, 316, 621
of Western attitude, 655

operations, cosmetic, 347

opposites, 245
balancing of, 620
collision of, 620
conflict of: crucifixion as, 688
—, and individuation, 727
—, in normal people, 607
cooperation of, 719
divine, 689
functions as, 18
inner confrontation of, 351
pairs of, *see below*: problem of, and Assumption of Mary, 714
structure of, 351
suspension between, 689
symbolism of, 351
system of, in mania, 351
union of, *see below*; wrenched apart, in Germans, 600

opposites, pairs of: contained in one word, 443
instances, 245, 443, 444, 719 (*see also* Christ s.v. and devil; good and evil; male and female; right and left)
and symbols, 226

opposites, union of, 118, 119, 122
and enantiodromia, 711
and Holy Spirit, 689, 691
in man, 689, 734
in symbol, 259
in transcendent function, 690

opus alchymicum/alchemical, 591
as creation of world, repeated, 721, 722
as *hierosgamos*, 748

opus divinum, 721
opus nostrum, 171
organ-inferiority, 481

organic disease, and archetypal symbols, [103](#), [133](#), [134](#)
Oriental, *see* East/Eastern
Origen, [231](#), [688](#)
Orphic cult, [117](#)
Orthodox Church, [281](#), [282](#)
Orthos, [315](#), [316](#)
Osiris, [694](#)
 and Horus, [239](#)
Oxford Group Movement, [162](#), [272](#), [739](#)
Oxyrhynchus sayings of Jesus, [122](#)

P

padma (lotus), [578](#)
Page, George H., [826](#)
paintings/drawings, by patients: in psychiatric diagnosis, [802](#)
 value of, [530](#)
Paleolithic Age, [39](#)
paleontology, [214](#)
Palestine, [108](#)
Pali Canon, *see* Buddha s.v.
palmistry, [820](#)
Pammeter, [788](#)
pantokrator, [694](#)
Papal Bull: *Summis desiderantes*, [607](#)
papyrus, Gnostic, in Coptic (Jung Codex), [671](#)
Paracelsus, [751](#), [784](#), [785](#)
 “De tinctura physicorum,” [676](#)
 De vita longa, ed. Adam v. Bodenstein, [676](#)
 on Hyliaster, [462](#)–[64](#)
 Sämmtliche Werke, ed. K. Sudhoff, [784](#)
 and scientific medicine, [462](#)
paraesthesia, [389](#)
paralysis: and unconscious memory, [303](#)
 of the will, [329](#)

paranoia, 379

parapraxes, 479

parapsychological experiences, 317, 660, 694ⁿ

parapsychological phenomena: Jung's own, 322

- sources of, 319
- truth of, 329

parapsychology, 320, 326, 327

- future of, 510, 511

parents: influence of, in childhood neurosis/hysteria, 374, 485, 805, 806, 822

- liberation from, 156, 157
- psychic situation of, 358, 611

Paris, 47, 52

parousia, 681, 691, 693

Parsifal, 742

participation mystique, see Lévy-Bruhl

Pascal, Constanza: "Les Maladies mentales de Robert Schumann," 421ⁿ

Passover, feast of, 674

pathography, 336

pathology, psychosexual, 380, 381

patient(s): in auto-erotic insulation, 146

- face to face with therapist, 139, 140
- language of, 225, 276
- own need for knowledge, 470

Patricius and Hilarius, soothsayers, 296

Patristic literature, 283

patterns of behaviour, 828

Paul, St., 247, 280, 298, 695, 696, 727

- and cursing, 646
- Jewish-Gnostic presuppositions of, 652
- on resurrection of Christ, 692, 693
- vision of Christ, 705

Pauli, Wolfgang, 285ⁿ, 473

- "The Influence of Archetypal Ideas on the Scientific Theories of Kepler,"

Peale, Norman Vincent, 638ⁿ 473ⁿ

pendulum, automatic, [295](#), [296](#), [302](#)

penis: amputation of, [347](#)

and *lingam* symbolism, [249](#), [250](#)

penitence, [719](#)

Peratics, [671](#), [827](#)

perception: olfactory, [325](#)

unconscious, [28](#), [313](#)

perineum, [11](#)

Pernety, A. J.: *Dictionnaire mythohermétique*, [751](#)

perpetuum mobile, [174](#)

Perry, John Weir: *The Self in Psychotic Process*, J.'s foreword, [353–56](#)

persecution, and secret love, [600](#)

Persian religion, [117](#)

persona, [49](#), [579](#)&*n*

of public figure, [579](#)

and unconscious, [453](#)

personality: activated portions of the unconscious as, [312](#)

archaic, in ourselves, [20](#)

centre of, [179](#)

fragmentary, [73](#), [100](#)

future, [22](#)

magic, [155](#)

splinter-, [309](#)

personification of unconscious contents, [312](#)

Peter, St., [122](#), [692](#)

Peter of Toledo, [796](#)

Peterson, Frederick, [27n](#)

“petites perceptions,” *see* Leibniz

petitio principii, [689](#)

petra scandali, [744](#)

Pfister, Oskar: “Ein Fall von psychoanalytischer Seelsorge und Seelenheilung,” [414](#)

“Psychoanalytische Seelsorge und experimentelle Moralpädagogik,” [414](#)

“Wahnvorstellung und Schülerselbstmord,” [414](#)

Pharaoh, [104](#)

twice-born, [157](#)
pharmakon athanasias, [107](#)
phenomenology, [289](#)
Philo Judaeus, [652](#)&*n*
philosophy: Chinese, *see* China/Chinese s.v.
 medieval, [174](#)
 and psychology, [87](#), [355](#), [617](#)
 spiritualistic, [315](#)
Philp, H. L.: *Jung and the Problem of Evil*, extracts, [702](#)–19
phlegmone, [237](#)
Phocaeans, [113](#)&*n*
Phorkyade, [749](#)
physics, microphysics, and complex psychology, [472](#), [473](#)
Piéron, H.: “La Théorie des émotions et les données actuelles de la physiologie,” [421](#)*n*
Pilcz, Alexander: *Lehrbuch der speziellen Psychiatrie für Studierende und Aerzte*, J.’s
 review, [384](#)
pioneer work, [521](#)
Pirkê Eliezer, [674](#)
piscina, [116](#), [117](#)
“Pitch-birds”/*Pechvögel*, [23](#)
Pithecanthropus, [214](#)
Pius, Roman bishop, [116](#)
Pius XI, Pope, [759](#)*n*
 Encyclical: *Casti Connubii*, [759](#)&*n*, [809](#)&*n*
Pius XII, Pope: *Apostolic Constitution*, [681](#)*n*, [742](#)*n*
Plato, [280](#), [315](#)
Pleroma, [670](#)
Plokker, J. H., [826](#)*n*
 pneuma, [155](#)
poetry, Freudian type of, [765](#), [766](#)
Poimen, Shepherd, in vision of Hermas, [116](#)
poisonings, [381](#)
Pöldinger, Walter: “Zur Bedeutung bildernischen Gestaltens in der psychiatrischen
 Diagnostik,” [802](#)*n*
Polia, [545](#)

Poliphilo, *see under* Colonna

politeness, archaic, [20](#)

political economy, [355](#)

politics, [564](#), [565](#), [567](#)

poltergeists, [294](#)

Polynesians, [240](#)

Pompey, [554](#)

Pope: private blessing for J., [271](#), [272](#)

see also Boniface VIII; Pius XI; Pius XII

population, over-, [260](#), [261](#)

Porphyry, [117](#)

Portugal, [554](#)

possession, [599](#)

demonic, [228](#)

states of, [374](#)

Pototsky, —: “Die Verwertbarkeit des Assoziationsversuches für die Beurteilung der traumatischen Neurosen,” J.’s abstract, [414](#)

power complex, *see* complex(es) s.v.

powers, supreme, [733](#), [734](#)

prayer, [681](#), [682](#)

prejudices, positive or negative, [253](#)

Priapus, stele of, in Verona, [444](#)

Price, Harry, [575&n](#)

An Account of Some Further Experiments with Willy Schneider, [575n](#)

The Phenomena of Rudi Schneider, [575n](#)

priests: Catholic, trained as psychotherapists, [287](#)

vs. doctor, consulted for psychological trouble, [268](#)

as sacrifice, [274](#)

primitive (s): anger in, [24](#)

consciousness in, [10](#), [316](#)

and dreams, [85](#), [111](#), [192](#), [193](#), [285](#), [286](#), [556](#), [557](#)

and initiation rites, [157](#)

and intuition, [15](#)

loss of numinosity in, [254](#)

meaning of ceremonies, [240](#)

and monotony, 614
and pain, 104
politeness of, 20
psyche unsynthesized in, 194
psychology, 11, 42, 159, 192, 354, 553–56, 562, 563
and sexual intercourse, 128
and snake, 125
soul among, 24
storytellers, 247, 248
superstitions of, 241
thinking of, 10, 204
primitivity in inner world of man, 256
privatio boni, 682, 689, 709, 710, 712, 714, 715, 726
progress, age of, 583
projection, 136, 137
of archaic personality, 577
of archetypes, *see* archetype(s) s.v.
and Christ, *see* Christ
in dream-analysis, 220
of emotional contents, 138
of father-image, 159, 160, 277, 577
impersonal, 155, 160, 161
integration of, 316
mutual, 140
mythological forms of, 577
of personal images, 160
an unconscious mechanism, 137, 138
withdrawal of, 593, 668
prophecy, 295, 296, 298
and hallucination, 461
prophets, frenzy of, 596
proportio sesquitercia/ratio of 3:1, 473, 476
prostitution, 384
Protestantism, 711

and care of souls, [602](#)

God in, [729](#)

and integration of psychological experience, [732](#)

ritual life of, [273](#)

splitting of into new denominations, [273](#)

uncertainty of, [273](#)

Protestants, [231](#), [246](#), [263](#), [714](#)

and Holy Spirit, [680](#)

neurosis among, [284](#)

as patients, [162](#)

—, complexes among, *see* complexes s.v.

and self-knowledge, [816](#)

Provençal, [115](#)

Provence, [117](#)

providentia Dei, [684](#)

Przywara, Erich, [689](#)

Deus semper maior, [689n](#)

pseudologia phantastica, [596](#), [604](#)

psychoanalysis, [388](#); *see also* psychoanalysis

psyche, [347n](#)

American, [316](#)

basic function of, [166](#)

and biological causality, [466](#)

“comparative anatomy” of, [228](#)

and consciousness, *see* consciousness s.v.

dissociability of, [195](#), [664](#)

and geographical locality, [465](#)

as historical structure, [356](#)

and loss of moral and spiritual values, [255](#)

man’s greatest danger, [320](#)

man’s greatest instrument, [263](#)

and matter, [314](#)

not a *tabula rasa*, [235](#)

not atom, is primary, [349](#)

as object and subject, 7, 126
objective, 665, 763
of patient, 349, 355
phenomenology of, 309
prehistoric, identity with, 259
primitive, loss of, 258
primordial, 111
reality of, 351, 665, 666
relation to physiology and biology, 385
study of, 5
and sympathetic system, 464
theological devaluation of, 731
and time and space, 287
unconscious, 7, 36, 78, 193
undervaluation of, 263
psychiatrist/alienist, 349, 350, 352
and patients' psychology, 356
and psychological aspect of his cases, 356
psychiatry, 354, 355, 367, 368, 372, 373, 375
and documentary evidence, 350
Freud's importance for, 388
German, 403
judicial, 386
psychic reality, 351
"psychic smells," 326
psychoanalysis: and empirical evidence, 424
goal of, 395
and morality, 395
"wild," 425
psychoanalytic training, need for, 424
Psychoanalytic Congresses: First, Salzburg, 335*n*, 392
Second, Nuremberg, 423&*n*, 426, 551*n*
Third, Weimar, 423*n*, 446*n*
psychodiagnostics, 637

psychogalvanic effect, [26](#), [27](#)
psychography/automatic writing, [302](#), [304](#), [337](#)
psychoid(s), [683](#), [705](#)
 factor, [508](#)
psychological institute, Bern, [333](#)
psychologism, [559](#), [705](#), [729](#)
psychology/psychologist (s): academic, [249](#), [460](#), [559](#)
 of the ages, [133](#)
 analytical, [563](#)
 of ancient Egyptians, [103](#)
 chaos in, [127](#)
 collective, [163](#)
 comparative, [539](#)
 compartment, [153](#), [242](#)
 of consciousness, [7](#)
 empirical, [309](#), [561](#), [569](#), [664](#)
 —, and Holy Spirit, [690](#)
 English, [9](#)
 exile, [282](#)
 experimental, [307](#)
 and factor of value, [260](#)
 and feeling, [14](#)
 four-dimensional, [59](#)
 French, *see* France/French s.v.
 German, [12](#)
 Hindu, *see* Hindu s.v.
 introspective, [67](#)
 medical, [6](#)
 medieval, [163](#)
 modern, [7](#), [103](#), [316](#), [599](#), [610](#), [617](#)
 national and racial, [565](#)
 and national problems, [566–81](#)
 needs widening of its horizon, [320](#)
 normal, [375](#)

- objective, [125](#)
- pathological, [353](#), [354](#)
- philosophical, [242](#)
- and philosophy, [773–75](#)
- practical, [19](#)
- primitive, *see* primitive (s) s.v.
- public interest in, [610](#)
- as real life adventure, [249](#)
- the science of the future, [589](#)
- of the statement, [307](#)
- psychopath, Hitler as, [605](#)
- psychopathology, [6](#), [353](#), [376](#)
- psychophysical parallelism, [34](#), [65](#)
- psychosis, [353](#), [383](#)
 - aetiology of, [381](#)
 - affective, [365](#) (*see also* manic-depression)
 - autochthonous descriptions, [350](#)
 - classification of, [379](#), [386](#)
 - and collective unconscious, [484](#)
 - confusional, [32](#)
 - motility, *see* catatonia
 - mythological fragments in, [259](#)
 - outbreak of, [355](#)
 - psychology of, [349](#), [651](#)
 - see also* insanity; schizophrenia
- psychosomatic medicine, [355](#), [357](#)
- psychosynthesis, [398](#), [399](#)
- psychotherapists: physical illness among, [154](#)
 - priests trained as, [287](#)
- psychotherapy, [223](#), [390](#)
 - aims of, [316](#)
 - a craft, [126](#)
 - description of, [606](#)
 - as dialectical discussion with the unconscious, [664](#), [667](#)

and emotions of patient, [138](#)
goal of, [819](#)
hypnotic, [378](#)
puberty, [233](#)
rites, [157](#)
Pueblo Indians, *see* American Indians s.v.
purusha, [828](#)
Elijah as, [675](#)
Pythagoras, [674](#)
Pythagoreans, [203](#)

Q

quaternity: alchemical, [717](#)
Catholic, [712](#), [714](#)
devil/Satan as fourth member, [712](#), [732](#)
divine, [232](#)
and Godhead, [715](#)
and shadow, [714](#)
as symbol of psychic totality, [473](#)
totality as, [688](#), [713](#)
Trinity and, [688](#)
as unity, [713](#)
Quest, the, [285](#), [289](#)
quinarius/quinio/quincunx, [712](#), [713](#)
Quisling, Vidkun, [604](#)
Quispel, Gilles, [651&n](#), [671n](#), [826n](#)
“Tragic Christianity,” J.’s foreword to, [651–53](#)

R

races, study of, [47](#)
racial inheritance, [37](#)
radioactivity, [541](#)
Rahner, Hugo, [485](#)
railways, [308&n](#)

Rank, Otto, [446n](#), [485](#), [551n](#)

ed. *Imago*, [425n](#)

rapport between doctor and patient, [144](#), [168](#), [224](#), [225](#)

Rasmussen, Knud, [286](#)

Across Arctic America, [286n](#)

rationalism, [273](#), [705](#)

materialistic, [743](#)

and superstition, complementary, [318](#)

rationality, [318](#)

Ravenna, [761](#)

reaction time, prolongation of, [49](#)

redeemer, [38](#), [743](#)

reductio in primam figuram, [84](#), [85](#)

reduction to infantile material, [435](#), [436](#)

Rees, J. R., [135](#)

regression, [431](#), [570&n](#)

infantile, [159](#)

into history, [574](#)

national, [573](#)

Reibmayer, Albert: *Die Entwicklungsgeschichte des Talentes und Genies*, J.'s review, [385–86](#)

Reichhardt, M.: *Leitfaden zur psychiatrischen Klinik*, J.'s review, [378–79](#)

Reith, Marian, [692n](#)

relativism, [7](#)

relativity, theory of, [68](#)

relativization of moral values, [233](#)

religio medici, [641](#)

religion, [167](#)

an absolute experience, [289](#)

anaemia of, [261](#)

archetypes and, [519](#)

comparative, [354](#)

and creed, distinction, [724](#), [725](#)

cultural symbols in, [253](#)

Fascism as, [165](#)

future, [277](#)
as mental hygiene, [698](#)
“psychologizing” of, [659](#)
psychology of, [474](#), [476](#)
as psychotherapeutic systems, [162](#), [519](#), [658](#), [699](#)
and science, conflict, [289](#)
symbols in, [212](#)
world, [246](#)

religious: conversion, [259](#)
development, [267](#)

Renaissance, [545](#), [736](#)

René d’Anjou, [545](#), [759](#)

reparation, of the collective, [452](#)

representations, “dim,” [7](#)

représentations collectives (Lévy-Bruhl), [201](#), [228](#), [233](#), [238](#), [253](#)
origins of, [240](#)
of religions, [728](#)
symbols as, [212](#)

repression, [188](#), [478](#), [479](#)

respectability, [684](#)

Revault d’Allones, G.: “L’Explication physiologique de l’émotion,” [421n](#)

revelation, new, [267](#)

Rheinau Sanatorium (Canton Zurich), [417](#)

Rhine, J. B., [319](#), [473](#), [499](#), [500](#), [504](#)
New Frontiers of the Mind, [313n](#)
The Reach of the Mind, [313n](#)

Rhodesia: prehistoric sun-wheel mandalas of, [39&n](#), [516](#)

Richet, Alfred, [314](#)

Rickert, Heinrich, [771&n](#)

Ricksher, Charles, [27n](#)

right and left, in John (Acts of Peter), [735&n](#)

Riklin, Franz, [429](#)
J.’s abstracts: “Analytische Untersuchungen der Symptome und Assoziationen eines Falles von Hysterie,” [416–17](#)
“Beitrag zur Psychologie der kataleptischen Zustände bei Katatonie,” [418–19](#)

- “Die diagnostische Bedeutung von Assoziationsversuchen bei Hysterischen,” 417
- “Hebung epileptischer Amnesien durch Hypnose,” 415
- “Kasuistische Beiträge zur Kenntnis hysterischer Assoziationsphänomene,” 410
- “Psychologie und Sexualsymbolik der Märchen,” 419
- “Über Gefängnispsychosen,” 419
- “Über Versetzungsbesserungen,” 417
- Wunscherfüllung und Symbolik im Märchen*, 419
- “Zur Psychologie hysterischer Dämmerzustände und des Ganserschen Symptoms,” 415
- unpublished lecture on omnipotence of thoughts, 445n
- Rippon, T. S., 287
- rite de sortie*, 595
- Ritsehl, Albrecht, 739&n
- ritual: of life, 273
- psychology of, 271
- Robert I, the Wise, 797
- Roberts, William A., 634
- “Analysis and Faith,” 634n
- Roman Catholic Church, *see* Catholic Church
- Romantic Movement, 294, 771, 772, 775
- Rome/Roman(s): Mithraeum, 117
- pestilence in, 116
- psychic change in, 554
- Senate, 111
- Tarpeian rock, 117
- Roosevelt, Franklin Delano, 575&n
- Roques, Hedwig von, *see* Beit
- Rosarium philosophorum*, 797–800
- rose, mystic, 759
- Rosenbach, —, 379
- Rosencreutz, Christian: *Chymische Hochzeit*, 748
- Rosenthal, Hugo, 768, 825n
- “Der Typengegensatz in der jüdischen Religionsgeschichte,” 768n
- “Rosinus ad Sarratantam,” 800
- Ross, T. A., 129

Rothe, Frau, [302](#)

Rouma, Georges: “Un cas de mythomanie, Contribution à l’étude du mensonge et de la fabulation chez l’enfant,” [421n](#)

Ruach, Elohim, [592](#), [687](#)

Russia, [188](#), [569](#), [580](#)

Freudian psychology in, [398n](#)

primitivity of, [254](#)

S

Saalburg, [117](#)

Sachs, Hanns: ed. *Imago*, [425n](#)

sacrifice: of Christ, [275](#), [276](#)

of god of spring, [446](#)

of phallus, in ancient cults, [446](#)

priest as, *see* priest

problem of, [434](#), [436](#)

sacrificial symbols in Negroes’ dreams, [552&n](#)

sacrificium intellectus, [728](#)

Sadger, Isidor: *Konrad Ferdinand Meyer, Eine pathographisch-psychologische Studie*, J.’s review, [336–38](#)

St. Moritz, [129](#)

Salpêtrière school, [515](#)

Salzburg, *see* Psychoanalytic Congresses s.v. First *samadhi*, [620](#)

Samyutta-Nikaya, [311n](#)

San Clemente Church, Rome, [117](#)

Sanskrit, [67](#), [82](#), [178](#)

Sans Souci, [211](#)

Saoshyant, [676](#)

sarcomatosis, case of, [58](#)

sarcophagus, vision of, [758](#)

Satan, *see* devil/Satan

saviour: complex, *see* complex s.v.

expectation, [161](#)

sayings of Jesus, *see* Christ s.v.

Scandinavian mythology, [92](#)

scapegoats, [97](#)

Schaer, Hans, [474](#)

Erlösungsvorstellungen und ihre psychologischen Aspekte, [474n](#)

Religion and the Cure of Souls in Jung's Psychology, [474n](#)

Schärf (-Kluger), Riwkah, [825n](#)

“Die Gestalt Satans im Alten Testament”/*Satan in the Old Testament*, [649n](#), [711n](#)

Schelling, F.W.J. von: on “eternal unconscious,” [477](#), [515](#)

Schemer, K. A., [361](#)

Schiaparelli, Giovanni, [314](#)

Schiller, Johann Christoph Friedrich von, [30](#)

in servant-girl's hallucinations, [298](#)

schizophrenia/dementia praecox, [335](#), [353–55](#)

and association experiment, [54](#), [353](#)

and collective contents of the unconscious, [483](#)

complexes in, [72](#)

and cure, [101](#)

and demonism, [648](#)

diagnosis of, [385](#)

dissociation in, [100](#)

ego split in, [11](#)

fantasies in, and historical parallels, [446](#)

Freud's theory and, [388](#), [389](#)

hallucinations in, [389](#)

and hysteria, [406](#)

neologisms, [349](#)

organic factor in, [335](#)

paintings in, [176](#), [177](#)

patient's vision, [41](#)

personality changes in, [12](#)

psychology of, [354](#)

regional variations in diagnosis, [384](#)

splinter-complexes in, [482](#)

unconscious in, [353](#)
uncultivated deserts of, [371](#)
world in state of, [254](#)

Schleich, Carl Ludwig: *Those Were Good Days*, [462n](#)
Die Wunder der Seele, J.'s foreword, [462–66](#)

Schloss, Jerome, J.'s memorial, [757](#)

Schmaltz, Gustav: *Komplexe Psychologie und körperliches Symptom*, J.'s foreword, [357–58](#)
Östliche Weisheit und westliche Psychotherapie, [664n](#)

Schmid-Guisan, Hans, [825n](#)
J.'s *In Memoriam*, [760–61](#)
Tag und Nacht, [761](#)
—, J.'s foreword, [759–60](#)

Schmitz, Oskar A. H.: *Märchen aus dem Unbewussten*, J.'s foreword, [762–64](#)

Schneider brothers, [575](#)

Schneiter, C., [825n](#)

Schnyder, —: *Définition et nature de l'hystérie*, J.'s abstract, [419](#)

scholasticism, [463](#)

Schopenhauer, Arthur, [168](#), [213](#), [515](#), [560](#), [788](#)
on sanctity, [294](#)
on “unconscious will,” [477](#)
Parerga und Paralipomena, [294](#)
The World as Will and Idea, [294n](#)

Schreber, Daniel Paul: *Memoirs of My Nervous Illness*, [667–68](#)

Schrenck-Notzing, Albert von, [341&n](#)

Schubert, Gotthilf Heinrich von, [361](#)

Schulinus (Johann Heinrich Schuelin): *De Elia corvorum alumno*, [674](#)

Schumann, —, Professor, [333](#)

Schürer, Emil: “Zur Vorstellung von der Besessenheit im Neuen Testament,” [648](#)

Schwarzwald, —: “Beitrag zur Psychopathologie der hysterischen Dämmerzustände und Automatismen,” J.'s abstract, [420](#)

Schweitzer, Albert, [680–82](#), [697n](#)

Schweizer Gesellschaft für Psychiatrie, [461n](#)
Schweizerischer Beobachter, [327](#)
Schweizer Lexikon, J.'s article in, [648n](#)

science: authority of, [466](#)
as power for good or ill, [598](#), [599](#)
psychic consequences of, [594](#), [595](#)
and religious experience, [289](#), [738](#)
scintilla, self as, [725](#), [734](#)
séances, educated people and, [319](#)
Seif, Leonhard, [423](#)
sejunction theory (Wernicke), [376](#)
self: as archetype, [484](#), [694](#), [725](#), [734](#)
city as synonym for, [122](#)
Elijah as, [675](#)
in four dimensions, [60](#)
-interest, [587](#)
-knowledge, [588](#), [818](#), [819](#)
loss of, [24](#)
realization of, [694](#), [695](#)
seeks consciousness, [721](#)
symbols of, and symbols of Deity, [719](#)
theological aspect of, [659](#)
as totality of man, [719](#)
sensation: extinction of, [370](#), [371](#)
function, [12–14](#), [16–18](#), [28](#), [43](#), [219](#)
type, [18](#), [19](#)
sense-perceptions, subliminal, [199](#)
sensitiveness, intensification of, [50](#)
Serrano, Miguel: *The Visits of the Queen of Sheba*, J.'s foreword, [788](#)
sex: and neurosis, [128](#)
pathology of, [380](#)
sexual: concretism, [434](#)
ethics, [384](#)
misdemeanours, [393](#)
morality, natural/cultural, [384](#)
mysteries, [445](#)
sexuality: biological conception of, [429](#)

and neurosis, 388
shadow, 280, 484, 620
 assimilation of, 708, 710
 compensatory significance of, 617
 confrontation with, 728
 destructive, 254
 in Gnosticism, 716
 integration of, 619
 and Iron Curtain, 245
 living one's own, 23
 loss of, 23
 our own, 245
 projection of, 160
 -side, 24, 221
 in Trinity, 716, 741
 -world, 21
Shakti, 120
shamanism, 253&n, 648
Shaw, George Bernard: *Man and Superman*, 164&n
Shiva, 120, 181
Shunamite, 675
Sicily, *see* Messina
sight, second, 328
Silberer, Herbert, 435
 Problems of Mysticism and Its Symbolism, 753n
 "Über die Symbolbildung," 435n
 "Von den Kategorien der Symbolik," 435n
similia similibus curantur, 6
Simon the Essene, 108, 109
Simon Magus, 108, 545
simulation, 375
sin, original/*peccatum originale*, 687
Sisyphus, labour of, 601
Skolts, Lappish, of Finland, 783

sleep: magnetic, [295](#)

“waking,” [295](#)

Socialism, [573](#), [579](#)

society, individual’s separation from, [453](#)

Society for Freudian Researches, Zurich, [334](#)

Society for Psychotherapy, [639](#), [640](#)

Soho, [70](#)

Sol, and Luna, [120](#)

sola fide, [738](#)

somnambulism (-ists), [295](#), [296](#), [317](#), [340](#), [374](#)

hallucinations in, [461](#)

Son, as intermediary between Father and Holy Spirit, [688](#)

Son of Man, [829](#)

soothsaying, [296](#)

Sophia, [689](#)

Sophocles, [111](#), [112](#)

Sophoclis Fabulae, ed. Pearson, [112n](#)

Sorbonne, [52](#)

sorcerer, [156](#)

sorcery, [328](#)

Sorokin, Pitirim A., [638n](#)

soul: bush-, [194](#), [205](#)

and collective function, [454](#)

cure of, [602](#), [669](#)

daily need of, [274](#)

existence of, after death, [309](#)

language of, [284](#)

lonely, [276](#)

loss of, [46](#), [194](#), [195](#), [277](#)

paradoxical, [689](#)

part-, [309](#)

problem of, [558](#)

spiritual development of, [689](#)

vision of, rising from sarcophagus, [758](#)

world-, 464
—, sparks of, 591
sound, as oscillations, 9
Southwark, Bishop of (Richard Parsons), 281–84, 286, 289
space and time: an illusion, 287
 as limiting factors, 315
 and psychic totality, 695
 relativation of, 313, 319, 473, 475, 511, 696
 unconscious independent of, 315
Spain, 112, 116, 122, 554, 579
speech, modern, 255
Spencer-Brown, G., 496
 “Statistical Significance in Psychical Research,” 496n
Speyr, — von, Professor, 444n
Spier, Julius: *The Hands of Children*, J.’s foreword, 820–21
spirit(s): aim of, 314
 archetype, 649
 communicating with, 293, 313
 of the departed, as personified unconscious content, 314
 existence of, 313
 God as, 155
 happiness in, 583, 584
 and matter, split between, 733
 as psychic phenomena, 312
spiritism, 293n; *see also* spiritualism
spiritualism, 73, 293–307, 312, 648
 American, 299, 314
 compensatory significance of, 314
 dual nature of, 293
 and ionization investigation, 660
 physical phenomena in, 306
 primitive projection in, 316
 reality of phenomena in, 307, 319
 a religious belief, 293

spiritualists, [302](#), [306](#), [308](#)

Spiritus, [155](#)

Spiritus Sanctus, [158](#); see also Holy Ghost

spittle, magical effect of, [240](#)

springs of water, [117](#)

Stalin, Joseph, [575](#)

star: over Bethlehem, [576](#)

of David, [716](#)

red, of Russia, [576](#)

State: belief in, [744](#)

as ghost, [572–76](#), [579](#), [580](#)

as highest authority, [695](#)

personification of, [578](#)

Stein, Philipp: “Tatbestandsdiagnostische Versuche bei Untersuchungsgefangenen,” J.’s abstract, [411](#)

Steiner, Rudolf, [681](#)

Stekel, Wilhelm, [390n](#)

Nervöse Angstzustände und ihre Behandlung, J.’s review, [390](#), [391](#)

ed. with A. Adler, *Zentralblatt für Psychoanalyse*, [425n](#)

stella matutina, [226](#)

Stenia festival, [121n](#)

Stern, William, [307&n](#)

Stoll, Otto: *Suggestion und Hypnotismus in der Völkerpsychologie*, [648](#)

Strack, H. L., and Paul Billerbeck: *Kommentar zum Neuen Testament*, [675](#)

Strauss, E. B., [29](#), [57](#), [58](#), [60](#), [62](#), [63](#), [133](#), [134](#)

subject and object: of equal importance, [611](#)

oneness of, [42](#)

psyche as, [7](#)

subliminality, [222](#)

suffering, [697–99](#)

Sufism, [545n](#)

suggestibility, [370–72](#)

during sleep (Moll), [377](#)

suggestion, [605](#)

definition of, [377](#)

under hypnosis, [699](#)
and masses, [610](#)
method, [295](#)
therapy, [340](#), [603](#)
suicide, [260](#)
Summis desiderantes, Papal Bull, [607](#)
Summum Bonum, [721](#)
 as Christ's father, [717](#)
 and dark side, [734](#)
 God as, *see* God
 Three/trinity as, [712](#)
 victims of, [725](#)
sun: Father, [247](#), [274](#), [288](#)
 -god, [121](#)
 -image, archetypal, [39](#)
 -wheel, [39](#), [95](#), [186](#)
 —, in paleolithic (?) Rhodesian rock-drawings, [39](#)*&n*
 worshippers: Elgonyi, [240](#)
 —, Pueblo Indians, [10](#)
Sunday Referee, [343](#)*n*
Superman, [578](#), [579](#), [600](#)
superstition, [327](#)
 of modern man, [241](#)
Supreme Being, [246](#)
Sutras: Amitayur Dhyana Sutra, [739](#)
Suttie, Ian, [60–62](#)
Swahili, [240](#)
swastika(s), [569](#), [576](#)
 as mandala, [578](#)
Swedenborg, Emanuel, [297](#)*&n*, [299](#)
Switzerland/Swiss, [161](#)
 at battle of St. Jacob, [87](#)
 dialect, [23](#)
 and freedom, [580](#)

frontier, in dream, [150](#)
and Great War, [46](#)
and harvest blessing, [178](#)
journey from, in dream, [86](#)
national character/temperament, [127](#), [328](#), [585–87](#), [596](#)
village, in dream, [79](#)

sword, ancient, in dream, [113](#)

Sylvester, St., [117](#)

symbol (s): interpretation of, [225](#)
 natural vs. cultural, [253](#)
 as natural products, [211](#)
 religious, [244–52](#), [827](#)
 and reunion of opposites, [259](#)
 and sign, differentiated, [212](#)

symbolic life, need for, [273](#), [274](#)

symbolism: of collective unconscious, [38](#)
 of manners, [20](#)
 mythological, [240](#)
 Oriental, [67](#)
 study of, [264](#)
 taking refuge in, [282](#)

symbolum, [719](#)

sympathetic system, [134](#), [464](#)
 animal symbols of, [179](#)

symptom, definition of, [568](#)

synchronicity, [34](#), [69](#), [319](#), [491](#), [655](#), [696](#)
 and archetypes, [500](#), [501](#), [508](#)
 and astrology, [497](#), [504](#), [506](#)
 J.'s letter to Fierz on, [502–7](#)
 and statistical material, [494](#)

syncretism: Hellenistic-Asiatic, [554](#)
 Jewish, [652](#)

T

table-turning, [294–96](#), [299](#), [302](#), [304](#)
Tabor, transfiguration on, [674](#)
Tacitus: *Historiae*, [674](#)
Tagus river, [112](#)
Talmud, [83](#), [248](#)
Tantalus Club, [445](#)
Tantra *chakra*, [578](#)
Tantric (-ism), [95](#), [120](#)
 J.'s seminar on, [707](#)
 mandala in, [578](#)
 philosophy, [553](#)
 Yoga, [11](#), [516](#)
Tao, [69](#), [119](#), [667](#), [717](#)
 and Christ, contrasted, [737](#)
 as dyadic monad, [715](#)
 and opposites, cooperation of, [719](#)
 as self, [720](#)
Taoist, [68](#)
Tao-te-ching (Lao-tzu), [539n](#)
Tarpeian rock, [117](#)
Tausk, Victor, [433–37](#), [433n](#)
Tavistock Clinic, *see* Institute of Medical Psychology
Tavistock Institute of Human Relations, [606n](#)
teacher, and shadow, [485](#)
team-spirit, [585–87](#)
technology, effect of, on psyche, [614](#), [615](#)
telepathic phenomena, [15](#)
temenos, [123](#), [178](#), [179](#)
Temple, Frederick, Archbishop, [679](#)
temple: in magic circle, [178](#)
 prostitution rite in Babylon, [159](#)
Terence: *Heauton Timorumenos*, [45n](#)
tertium comparationis, [364](#), [653](#)
Tertullian: *De praescriptione hereticorum*, [676](#)

tetrad, God as, 715
Tetrarch of Palestine, 108
Thayer, Ellen, 654n
Theatrum chemicum, 753n
theologoumenon, 743
theology: and the practical man, 268
 and primordial images, 716
 and psychology, 354, 716, 742, 743
Theosebeia, 545
theosophy, 554
 primitive projection in, 316
Therapeutai, 108
therapist, character of, 439
 see also analyst; doctor
Therese of Konnersreuth (Therese Neumann), 660&n
Thesmophoria, 121n
thinking: in the belly, 10
 function, 12, 13, 16, 17, 43, 219
 in the heart, 10
 mechanistic, 316
 of primitives, 10
 subliminal, 461
 type, *see* type s.v.
 see also thought(s)
thirteen, 256
Thomas Aquinas, St., 688
 Summa theologica, 688n
Thomist philosophy, 475
Thompson, R. Campbell: *The Epic of Gilgamesh*, 105n
thought (s): a late discovery, 241
 -patterns, collective, 234
 see also thinking
three plus one, 713, 732, 741
 ratio/*proportio sesquitertia*, 473, 476

Thury, Professor, *see* Cassini

Tiamat, dragon in Babylonian myth, [105](#)

Tibetan philosophy, [95](#)

Tifereth, [738](#)

time machine, [28](#)

time and space, *see* space and time

timelessness, and realization of self, [694](#)

Tiresias, [38](#)

Toledo, [121](#), [122](#)
 cathedral, [112–15](#)

Toletum, [114](#)

tongue, slips of, [532](#)

totalitarianism, [596](#), [659](#)

totality: Eastern apperception of, [655](#)
 as four, [715](#)
 image of, [9](#)
 of man, [122](#)
 psychic, and quaternity symbol, [473](#)
 as three, [715](#)

tractability, [371](#), [372](#)

trance: and demonism, [648](#)
 speaking in, [302](#), [304](#)

transcendence, prayer and, [681](#)

transcendent function, [690](#)

transference, [134–37](#), [472](#), [492](#), [577](#)
 aetiology of, [143](#)
 in alchemy, [753](#)
 to animals, [141](#)
 and archetypes, [164](#), [486](#)
 collapse of, [142](#)
 as compensation, [168](#)
 counter-, [140](#), [142](#), [150](#)
 as dialogue between partners, [493](#)
 dreams in, *see* dreams s.v.

erotic, 141
father, 160, 277
Freud on, 480, 486
heightened, 451, 452
as hindrance, 151
intensity of, 142, 152
mutual unconsciousness in, 149
neurosis, 480
as projection, 136–38, 151, 152, 155
teleological value of, 168
therapy of, 154, 160
transformation, in alchemy, 591
transubstantiation, 591
Transvaal, 39n
transvestism, 347–48
trauma theory, 430
treasure, 166
 in the depths, 118
 integration of, 152
 singular feeling as, 329
 in transference, 143
treatment, reductive, 224
tree(s): fig-tree, 646
 of knowledge, 603
 of Life, 675
 symbol: and Christ, 239
 —, of Great Mother, 239
tremors, intended, 303
triad: and Kepler's astronomy, 473
 lower/inferior, 713, 732
Trinity: as archetype, 99
 devil/Satan as fourth in, *see* devil s.v.
 man as part of, 687, 689
 and Mary as fourth, 681, 687, 689, 712, 714

masculine, [99](#), [689](#), [714](#), [733](#), [741](#)
and psychological viewpoint, [649](#)
and quaternity, [688](#)
shadow of, [716](#), [741](#)
as symbol, [714](#)

Tripitaka, [730](#)

Tripus aureus, [749](#)

truth: eschatological, [618](#)
experience of, [558](#)
how we know it, [288](#)
relative or absolute, [703](#)

Turbo, [748](#)

twilight states, [302](#)
hysterical, [415](#), [416](#)

Tylor, E. B., [562](#)

type(s): attitude-, [471](#), [483](#)
classification into, [220](#)
complex-constellation, [407](#)
and dream-analysis, [217](#), [218](#)
function-, [219](#), [471](#), [534](#)
intellectual, [20](#)
predicate, [407](#)
thinking, [17](#), [43](#), [56](#)

typology, psychological, [471](#)

typos (imprint), [37](#)

Die Tyroler ekstatischen Jungfrauen (anon.), [295n](#)

Tyrrell, G.N.M.: *The Personality of Man*, [313n](#)

U

ὕδωρ Θεῖον (*hudor theion*), [591](#)

Ufos/flying saucers, [626–33](#)
and American Air Force, [627](#), [632](#), [633](#)
extra-terrestrial origin of, [628](#), [629](#), [632](#)
Flying Saucer Review, [626n](#)

in history, [631](#)
and parapsychological processes, [628](#), [630](#)
as psychic phenomenon, [626](#), [630](#), [631](#)
as symbols, [626](#)

Ulysses, [38](#)

Unamuno, Miguel de, [581](#)&*n*

unconscious (the): ambivalence/two aspects of, [682](#), [683](#)

apprehension, [305](#), [306](#)

capriciousness of, [306](#)

and Christ-phenomenon, [828](#)

combination, [305](#)

continuous, [9](#)

as creative matrix of consciousness, [482](#)

deliberations of, [237](#)

depreciation of, [206](#)

different conceptions of, [62](#), [124](#)

discovery of, [317](#)

as dustbin of the conscious mind, [206](#)

empirical approach to, [477](#)

energetic charge of, [353](#)

energy of, compared with consciousness, [314](#), [315](#)

extent of, unknown, [316](#)

goodwill of, [235](#)

has no known limits, [738](#)

has no time, [287](#)

integration of, [695](#)

interventions of, [249](#)

as land of dreams, [315](#)

language of, [279](#), [285](#)

localization of, [319](#)

in manic state, [351](#)

meaning of term, [8](#)

message of, [207](#)

neutrality of, [704](#)

physiological aspect of, [607](#)
powers of, [665](#)
powers of perception of, [326](#)
problems, exteriorization of, [322](#)
religious aspect of, [701](#)
Satan as representative of, [732](#)
in schizophrenia, is dreamlike, [353](#)
spectral world of, [318](#)
and subliminal perceptions, [313](#)
symbolic language of, [356](#)
symbol-producing, [262](#), [279](#)
a treasure-house of lost memories, [313](#)

unconscious, collective, [41](#), [482](#), [483](#)
activation of, [161](#), [162](#), [164](#)
and anima, *see* anima s.v. personification
archetypes and, [38](#)
children's awareness of, [95](#)
contents of, [37](#)
—, activated, [46](#)
discovery of, [472](#)
Elijah as, [675](#)
in Germans, [573](#)
and Gnosticism, [652](#), [664](#)
and mutation of dominant ideas, [485](#)
and nations, [577](#)
patient's, onslaught of, [153](#)
and primitive psychology, [553](#), [554](#)
processes of, [6](#)
—, and mystics, [98](#)
and psychosis, [484](#)
regulating influence of, [486](#)
symbolism in, [38](#)
as totality of archetypes, [682](#)

unconscious, personal, [37](#), [484](#), [515](#)

- contents of, [57](#), [58](#)
- is relative, [45](#), [58](#)
- unconscious and consciousness: collaboration, [235](#)
 - consciousness arises from, [10](#)
 - conscious surrounded by sea of unconscious, [315](#)
 - compensating, [621](#), [655](#), [657](#), [704](#)
 - in Freud's theory, [515](#)
 - independent and opposed, [515](#)
 - as nonsense and sense, [262](#)
 - relative importance of, [704](#)
 - united, [120](#), [122](#)
- unconscious contents: autonomous, [515](#)
 - emotionality of, [258](#)
 - fascination of, [74](#)
 - in Freud's theory, [479](#)
 - integration of, with consciousness, [606](#), [613](#), [618](#)
 - origin of, [656](#)
 - projection of, [316](#)
- unconscious mind: and compensation of conscious attitude, [606](#)
 - as matrix of conscious mind, [607](#)
 - products of, [8](#)
 - storehouse of relics, [41](#)
 - structure of, [6](#)
- unconscious processes, [36](#)
 - compensatory function of, [482](#)
 - exteriorization of, [319](#)
 - investigation of, [7](#)
 - teleological character of, [482](#)
- unconsciousness: in our civilization, [45](#)
 - mutual, [140](#)
 - through mutual contamination, *see* contamination s.v.
 - original condition of, [120](#)
 - as treasure, [120](#)
- underworld: psychic, [254](#)

and water, [117](#), [123](#)

Unesco (United Nations Educational, Scientific and Cultural Organization): Second General Conference, [606n](#)

J.'s memorandum to, [606–13](#)

Royaumont Conference, [606n](#)

universe, unobstructed, [315](#)

Urstein, M.: *Die Dementia praecox und ihre Stellung zum manischdepressiven Irresein*, J.'s review, [385](#)

Ursulines of London, [648](#)

V

Valens, Emperor, [296](#)

Valentinus (Gnostic), [727](#), [826](#)

value: feeling and, [13](#)

idea of, [5](#)

reactivation of, [453](#)

subjective, of transference, [154](#), [160](#)

Varendonck, J.: “Les idéals des enfants,” [421n](#)

vase, in patient's drawing, [176](#), [179](#)

Venus, [444](#)

Veraguth, Otto, [339&n](#)

Verena, St., [444](#)

Vespasian, [674](#)

vessel, [121](#)

as container, [176–78](#)

ideas as, [310](#)

motif, as archetypal image, [176](#)

Vienna Psychoanalytic Society, [423&n](#), [425n](#)

Vigouroux, A., and Juquelier, P.: “Contribution clinique à l'étude des délires du rêve,” [421n](#)

Virgil: *Eclogue V*, [165n](#)

Virgin birth: in alchemy, [591](#)

and rationalization, [271](#)

virginity, secret of, [271](#)

Vischer, Friedrich Theodor, 619

Visigoths, 114

vision(s), 295, 298

collective, 626, 630

dying man's, of sarcophagus, 758

of female saints, 298

as morbid symptoms, 205

of Paul on road to Damascus, 298

of professor, repeated in old woodcut, 229

and Resurrection, 693

of schizophrenic patient, 41

warning, 327

visionaries, 298

vita somnium breve, 233

vocation, prophetic experience of, 696

Vodoz, J., 825n

Vogt, Oskar, 341&n

Vogt, Ragnar, 377

voices, heard by the insane, 312

volition, 370, 375

Volkelt, J., 361

voyeurism, 394

W

Wagner, Richard, 546

Flying Dutchman, 159

Parsifal, 118, 120, 742

Waldstein, Louis: *Das Unbewusste Ich/The Subconscious Self*, J.'s review, 339–42

Walser, Hans H.: "An Early Psychoanalytical Tragedy," 426n

Walton, Robert C., 744n

wand, as dream symbol, 86, 92, 93

war: wish for, 274

World War I, 567, 568

water: divine, rite of, 270

healing, 749
and unconscious, 118
and underworld, 117, 123

Wehrlin, K.: “Über die Assoziationen von Imbezillen und Idioten,” J.’s abstract, 407, 408

Welfare State, 245

Welles, Orson, 627n

Wells, Herbert George: *The Time Machine*, 28
The War of the Worlds, 627&n

Weltanschauung: Christian, 116
of Middle Ages, 115
need for, 698

Weltwoche, 625n, 626n

Wernicke, Carl, 378, 382
Grundriss der Psychiatrie in klinischen Vorlesungen, J.’s review, 376

West/western: Christian tradition in, 231
civilization, 245
consciousness, 245
and Iron Curtain, 244, 245
unease of, 254

wheel, as sun-symbol, 95, 186

White, Betty, medium, 313–16

White, Richard (of Basingstoke), 545

White, Stewart Edward, 312n
Across the Unknown, 314n
The Betty Book, 314n, 316
The Road I Know, 314n
The Unobstructed Universe/Uneingeschränktes Weltall, 312&n, 314
—, J.’s foreword to German trans., 312–16

White, Victor, 474, 710
God and the Unconscious, 474n, 708

White House, 219

wholeness, 621
meaning of, 123
of symbol-producing individual, 250

as unconscious fact, 686
unconscious tendency toward, 655

Whyte, Lancelot Law: *The Unconscious before Freud*, 477n

Wiekes, Frances G., 474
The Inner World of Childhood, 474n, 613n
Inner World of Man, 613n
Von der inneren Welt des Menschen, J.'s foreword, 527–28

Wilhelm, Richard, 68, 472, 485, 553&n
The Secret of the Golden Flower, 68n, 553&n

will: and control of functions, 16
free, 21, 658
fulfilment of, 281
-power, 17
—, of complexes, 72
to power, of the East, 244

Willcox, A. R.: *The Rock Art of South Africa*, 39n

Wilmann, —, 385

wise old man archetype, 484

wish-fulfilment, dream as, 363, 367, 479

witch: burning of, 318
-craft, 591
-hunts, 485, 607
warlocks and worricows, 256

Witcutt, W. P., 474
Catholic Thought and Modern Psychology, 474n
Return to Reality, 474n

Wittels, Fritz: *Die sexuelle Not*, J.'s marginal notes on, 393–96

Wolff, Toni, 4
Einführung in die Grundlagen der komplexen Psychologie, 474&n

Wolfram von Eschenbach, 798

woman, masculine attitude in, 520

word(s): as fetish, 710
superstitious belief in, 625, 710

work therapy, 417

world: dehumanized, [255](#)
principle, male or female, [254](#)
Soul, [464](#)
—, sparks of, [591](#)
Teacher, new incarnation of, [267](#)

Wotan, [749](#)

and Germany, [576](#)

Wreschner, Arthur, [333&n](#)

Wright, Maurice B., [70](#)

Wulffen, Erich: *Der Sexualverbrecher*, J.'s review, [397](#)

Wundt, Wilhelm, [78&n](#), [370](#), [477](#), [773](#)

association experiments of, [471](#)

Y

Yahweh/YHWH, [682](#), [690](#)

active principle of, [687](#)

consciousness of, [718](#)

Elijah and, [677](#)

as monad, [715](#)

moral and immoral, [709](#)

opposites unconscious in, [716](#)

paradoxical, [690](#)

Yellowlees, David, [124](#)

Yoga, [120](#)

Chinese, [516](#)

consciousness in, [72](#)

Indian and Chinese, [465](#)

Kundalini, [120](#), [516](#)

Tantric, [11](#) [515](#)

yogi, [620](#)

Z

Zeitschrift für angewandte Psychologie und psychologische Sammelforschung, [333n](#)

Zen: see Buddhism s.v.

Zentralblatt für Psychoanalyse, [423n](#), [425&n](#), [551n](#)

Zeus, [40](#)

Ziegler, K. A. (bookseller): *Alchemie*, [747n](#)

Zilboorg, Gregory, [634n](#)

Zimmer, Heinrich, [472](#), [485](#), [529](#)

Zinzendorf, Count Nikolaus Ludwig von, [681&n](#)

zodiac, sign of Leo, [121](#)

Zöllner, Friedrich, [314](#)

Zoroaster, [117](#)

Zosimus of Panopolis, [545](#), [751](#)

Zürcher Student, [614n](#), [637n](#)

Zurich, [49](#), [51](#), [67](#), [139](#), [301](#)

branch of the International Psychoanalytic Association, [423](#), [424](#)

Eidgenössische Technische Hochschule/Federal Polytechnic (E.T.H.), [3](#), [515n](#), [614n](#),
[615](#), [686n](#), [707](#)

Psychoanalytic Society, [552n](#)

Psychological Club, [748n](#), [779n](#), [797n](#)

school of psychoanalysis, [381](#), [433n](#), [434](#)

—, abstracts of works, [398–421](#)

University Psychiatric Clinic, [333](#); *see also* Burghölzli Mental Hospital

Zwinglian Church, [273](#)

THE COLLECTED WORKS OF C. G. JUNG

THE PUBLICATION of the first complete edition, in English, of the works of C. G. Jung was undertaken by Routledge and Kegan Paul, Ltd., in England and by Bollingen Foundation in the United States. The American edition is number XX in Bollingen Series, which since 1967 has been published by Princeton University Press. The edition contains revised versions of works previously published, such as *Psychology of the Unconscious*, which is now entitled *Symbols of Transformation*; works originally written in English, such as *Psychology and Religion*; works not previously translated, such as *Aion*; and, in general, new translations of virtually all of Professor Jung's writings. Prior to his death, in 1961, the author supervised the textual revision, which in some cases is extensive. Sir Herbert Read (d. 1968), Dr. Michael Fordham, and Dr. Gerhard Adler compose the Editorial Committee; the translator is R. F. C. Hull (except for Volume 2) and William McGuire is executive editor.

The price of the volumes varies according to size; they are sold separately, and may also be obtained on standing order. Several of the volumes are extensively illustrated. Each volume contains an index and in most a bibliography; the final volumes will contain a complete bibliography of Professor Jung's writings and a general index to the entire edition.

In the following list, dates of original publication are given in parentheses (of original composition, in brackets). Multiple dates indicate revisions.

*1. PSYCHIATRIC STUDIES

On the Psychology and Pathology of So-Called Occult Phenomena (1902)

On Hysterical Misreading (1904)

Cryptomnesia (1905)

On Manic Mood Disorder (1903)

A Case of Hysterical Stupor in a Prisoner in Detention (1902)

On Simulated Insanity (1903)

A Medical Opinion on a Case of Simulated Insanity (1904)

A Third and Final Opinion on Two Contradictory Psychiatric Diagnoses (1906)

On the Psychological Diagnosis of Facts (1905)

†2. EXPERIMENTAL RESEARCHES

STUDIES IN WORD ASSOCIATION (1904–7, 1910)

The Associations of Normal Subjects (by Jung and F. Riklin)

An Analysis of the Associations of an Epileptic

The Reaction-Time Ratio in the Association Experiment

Experimental Observations on the Faculty of Memory

Psychoanalysis and Association Experiments

The Psychological Diagnosis of Evidence

Association, Dream, and Hysterical Symptom

The Psychopathological Significance of the Association Experiment

Disturbances in Reproduction in the Association Experiment

The Association Method

The Family Constellation

PSYCHOPHYSICAL RESEARCHES (1907–8)

On the Psychophysical Relations of the Association Experiment

Psychophysical Investigations with the Galvanometer and Pneumograph in Normal and Insane Individuals (by F. Peterson and Jung)

Further Investigations on the Galvanic Phenomenon and Respiration in Normal and Insane Individuals (by C. Ricksher and Jung)

Appendix: Statistical Details of Enlistment (1906); New Aspects of Criminal Psychology (1908); The Psychological Methods of Investigation Used in the Psychiatric Clinic of the University of Zurich (1910); On the Doctrine of Complexes ([1911] 1913); On the Psychological Diagnosis of Evidence (1937)

*** 3. THE PSYCHOGENESIS OF MENTAL DISEASE**

The Psychology of Dementia Praecox (1907)

The Content of the Psychoses (1908/1914)

On Psychological Understanding (1914)

A Criticism of Bleuler's Theory of Schizophrenic Negativism (1911)

On the Importance of the Unconscious in Psychopathology (1914)

On the Problem of Psychogenesis in Mental Disease (1919)

Mental Disease and the Psyche (1928)

On the Psychogenesis of Schizophrenia (1939)

Recent Thoughts on Schizophrenia (1957)

Schizophrenia (1958)

† 4. FREUD AND PSYCHOANALYSIS

Freud's Theory of Hysteria: A Reply to Aschaffenburg (1906)

The Freudian Theory of Hysteria (1908)

The Analysis of Dreams (1909)

A Contribution to the Psychology of Rumour (1910–11)

On the Significance of Number Dreams (1910–11)

Morton Prince, "The Mechanism and Interpretation of Dreams": A Critical Review (1911)

On the Criticism of Psychoanalysis (1910)

Concerning Psychoanalysis (1912)

The Theory of Psychoanalysis (1913)

General Aspects of Psychoanalysis (1913)

Psychoanalysis and Neurosis (1916)

Some Crucial Points in Psychoanalysis: A Correspondence between Dr. Jung and Dr. Loÿ (1914)

Prefaces to "Collected Papers on Analytical Psychology" (1916, 1917)

The Significance of the Father in the Destiny of the Individual (1909/1949)

Introduction to Kranefeldt's "Secret Ways of the Mind" (1930)

Freud and Jung: Contrasts (1929)

‡ 5. SYMBOLS OF TRANSFORMATION (1911–12/1952)

PART I

Introduction

Two Kinds of Thinking

The Miller Fantasies: Anamnesis

The Hymn of Creation

The Song of the Moth

PART II

Introduction

The Concept of Libido

The Transformation of Libido

The Origin of the Hero

Symbols of the Mother and of Rebirth

The Battle for Deliverance from the Mother

The Dual Mother

The Sacrifice

Epilogue

Appendix: The Miller Fantasies

* 6. PSYCHOLOGICAL TYPES (1921)

Introduction

The Problem of Types in the History of Classical and Medieval Thought

Schiller's Ideas on the Type Problem

The Apollinian and the Dionysian

The Type Problem in Human Character

The Type Problem in Poetry

The Type Problem in Psychopathology

The Type Problem in Aesthetics

The Type Problem in Modern Philosophy

The Type Problem in Biography

General Description of the Types

Definitions

Epilogue

Four Papers on Psychological Typology (1913, 1925, 1931, 1936)

† 7. TWO ESSAYS ON ANALYTICAL PSYCHOLOGY

On the Psychology of the Unconscious (1917/1926/1943)

The Relations between the Ego and the Unconscious (1928)

Appendix: New Paths in Psychology (1912);

The Structure of the Unconscious (1916) (new versions, with variants, 1966)

‡ 8. THE STRUCTURE AND DYNAMICS OF THE PSYCHE

On Psychic Energy (1928)

The Transcendent Function ([1916]/1957)

A Review of the Complex Theory (1934)

The Significance of Constitution and Heredity in Psychology (1929)

Psychological Factors Determining Human Behavior (1937)

Instinct and the Unconscious (1919)

The Structure of the Psyche (1927/1931)
On the Nature of the Psyche (1947/1954)
General Aspects of Dream Psychology (1916/1948)
On the Nature of Dreams (1945/1948)
The Psychological Foundations of Belief in Spirits (1920/1948)
Spirit and Life (1926)
Basic Postulates of Analytical Psychology (1931)
Analytical Psychology and *Weltanschauung* (1928/1931)
The Real and the Surreal (1933)
The Stages of Life (1930–1931)
The Soul and Death (1934)
Synchronicity: An Acausal Connecting Principle (1952)
Appendix: On Synchronicity (1951)

*** 9. PART I. THE ARCHETYPES AND THE COLLECTIVE UNCONSCIOUS**

Archetypes of the Collective Unconscious (1934/1954)
The Concept of the Collective Unconscious (1936)
Concerning the Archetypes, with Special Reference to the Anima Concept
(1936/1954)
Psychological Aspects of the Mother Archetype (1938/1954)
Concerning Rebirth (1940/1950)
The Psychology of the Child Archetype (1940)
The Psychological Aspects of the Kore (1941)
The Phenomenology of the Spirit in Fairytales (1945/1948)
On the Psychology of the Trickster-Figure (1954)
Conscious, Unconscious, and Individuation (1939)
A Study in the Process of Individuation (1934/1950)
Concerning Mandala Symbolism (1950)
Appendix: Mandalas (1955)

*** 9. PART II. AION (1951)**

RESEARCHES INTO THE PHENOMENOLOGY OF THE SELF

The Ego
The Shadow
The Syzygy: Anima and Animus

The Self

Christ, a Symbol of the Self

The Sign of the Fishes

The Prophecies of Nostradamus

The Historical Significance of the Fish

The Ambivalence of the Fish Symbol

The Fish in Alchemy

The Alchemical Interpretation of the Fish

Background to the Psychology of Christian Alchemical Symbolism

Gnostic Symbols of the Self

The Structure and Dynamics of the Self

Conclusion

* 10. CIVILIZATION IN TRANSITION

The Role of the Unconscious (1918)

Mind and Earth (1927/1931)

Archaic Man (1931)

The Spiritual Problem of Modern Man (1928, 1931)

The Love Problem of a Student (1928)

Woman in Europe (1927)

The Meaning of Psychology for Modern Man (1933'1934)

The State of Psychotherapy Today (1934)

Preface and Epilogue to "Essays on Contemporary Events" (1946)

Wotan (1936)

After the Catastrophe (1945)

The Fight with the Shadow (1946)

The Undiscovered Self (Present and Future) (1957)

Flying Saucers: A Modern Myth (1958)

A Psychological View of Conscience (1958)

Good and Evil in Analytical Psychology (1959)

Introduction to Wolff's "Studies in Jungian Psychology" (1959)

The Swiss Line in the European Spectrum (1928)

Reviews of Keyserling's "America Set Free" (1930) and "La Révolution
Mondiale" (1934)

The Complications of American Psychology (1930)

The Dreamlike World of India (1939)

What India Can Teach Us (1939)

Appendix: Documents (1933–1938)

† 11. PSYCHOLOGY AND RELIGION: WEST AND EAST

WESTERN RELIGION

Psychology and Religion (The Terry Lectures) (1938/1940)

A Psychological Approach to the Dogma of the Trinity (1942/1948)

Transformation Symbolism in the Mass (1942/1954)

Forewords to White's "God and the Unconscious" and Werblowsky's "Lucifer and Prometheus" (1952)

Brother Klaus (1933)

Psychotherapists or the Clergy (1932)

Psychoanalysis and the Cure of Souls (1928)

Answer to Job (1952)

EASTERN RELIGION

Psychological Commentaries on "The Tibetan Book of the Great Liberation" (1939/1954) and "The Tibetan Book of the Dead" (1935/1953)

Yoga and the West (1936)

Foreword to Suzuki's "Introduction to Zen Buddhism" (1939)

The Psychology of Eastern Meditation (1943)

The Holy Men of India: Introduction to Zimmer's "Der Weg zum Selbst" (1944)

Foreword to the "I Ching" (1950)

* 12. PSYCHOLOGY AND ALCHEMY (1944)

Prefatory note to the English Edition ([1951?] added 1967)

Introduction to the Religious and Psychological Problems of Alchemy

Individual Dream Symbolism in Relation to Alchemy (1936)

Religious Ideas in Alchemy (1937)

Epilogue

† 13. ALCHEMICAL STUDIES

Commentary on "The Secret of the Golden Flower" (1929)

The Visions of Zosimos (1938/1954)

Paracelsus as a Spiritual Phenomenon (1942)

The Spirit Mercurius (1943/1948)

The Philosophical Tree (1945/1954)

‡ 14. MYSTERIUM CONIUNCTIONIS (1955-56)

AN INQUIRY INTO THE SEPARATION AND SYNTHESIS OF PSYCHIC OPPOSITES IN ALCHEMY

The Components of the Coniunctio

The Paradoxa

The Personification of the Opposites

Rex and Regina

Adam and Eve

The Conjunction

* 15. THE SPIRIT IN MAN, ART, AND LITERATURE

Paracelsus (1929)

Paracelsus the Physician (1941)

Sigmund Freud in His Historical Setting (1932)

In Memory of Sigmund Freud (1939)

Richard Wilhelm: In Memoriam (1930)

On the Relation of Analytical Psychology to Poetry (1922)

Psychology and Literature (1930/1950)

“Ulysses”: A Monologue (1932)

Picasso (1932)

† 16. THE PRACTICE OF PSYCHOTHERAPY

GENERAL PROBLEMS OF PSYCHOTHERAPY

Principles of Practical Psychotherapy (1935)

What Is Psychotherapy? (1935)

Some Aspects of Modern Psychotherapy (1930)

The Aims of Psychotherapy (1931)

Problems of Modern Psychotherapy (1929)

Psychotherapy and a Philosophy of Life (1943)

Medicine and Psychotherapy (1945)

Psychotherapy Today (1945)

Fundamental Questions of Psychotherapy (1951)

SPECIFIC PROBLEMS OF PSYCHOTHERAPY

The Therapeutic Value of Abreaction (1921/1928)
The Practical Use of Dream-Analysis (1934)
The Psychology of the Transference (1946)
Appendix: The Realities of Practical Psychotherapy ([1937] added, 1966)

‡ 17. THE DEVELOPMENT OF PERSONALITY

Psychic Conflicts in a Child (1910/1946)
Introduction to Wickes's "Analyses der Kinderseele" (1927/1931)
Child Development and Education (1928)
Analytical Psychology and Education: Three Lectures (1926/1946)
The Gifted Child (1943)
The Significance of the Unconscious in Individual Education (1928)
The Development of Personality (1934)
Marriage as a Psychological Relationship (1925)

18. THE SYMBOLIC LIFE

Miscellaneous Writings

19. BIBLIOGRAPHY OF C. G. JUNG'S WRITINGS

20. GENERAL INDEX TO THE COLLECTED WORKS

See also:

C. G. JUNG: LETTERS

Selected and edited by Gerhard Adler, in collaboration with Aniela Jaffé. Translations from the German by R.F.C. Hull.

VOL. 1: 1906–1950

VOL. 2: 1951–1961

THE FREUD/JUNG LETTERS

Edited by William McGuire, translated by
Ralph Manheim and R.F.C. Hull

* The contents of each part are related to volumes of the Collected Works as indicated. Dates are of first publication or, when known, of writing.

¹ [The charts and diagrams have been re-executed, and photographs of the drawings (actually water-colours) have kindly been furnished by Dr. E. A. Bennet.]

- ¹ [*Anthropologie in pragmatischer Hinsicht* (1798), Pt. I, Bk. I, sec. 5.]
- ² [“There is nothing in the mind that was not in the senses.” Cf. Leibniz, *Nouveaux Essais sur l’Entendement humain*, Bk. II, ch. 1, sec. 2, in response to Locke. The formula was scholastic in origin; cf. Duns Scotus, *Super universalibus Porphyrii*, qu. 3.]
- ³ [*In Johannis Evang.*, XXXIV, 2. Cf. *Symbols of Transformation* (C.W., vol. 5), par. 162 and n. 69.]
- ⁴ [Cf. “The Realities of Practical Psychotherapy” (C.W., vol. 16, 2nd edn.), pars. 558ff.]
- ⁵ [What Jung may have had in mind are the *melothesia*e, explained in “Psychology and Religion” (C.W., vol. 11), par. 113, n. 5; cf. *Psychology and Alchemy*, fig. 156.]
- ⁶ [*Psychological Types* (C.W., vol. 6), Definition 47.]
- ⁷ [*Ibid.*, Def. 53.]
- ⁸ [*Ibid.*, Def. 5.]
- ⁹ [*Ibid.*, Def. 21.]
- ¹⁰ [*Ibid.*, Def. 44.]
- ¹¹ [*Ibid.*, Def. 35.]
- ¹² [*Ibid.*, Def. 30.]
- ¹³ [*Ibid.*]

¹⁴ [The theory was independently advanced by William James and by the Danish physiologist C. G. Lange, and is commonly referred to by both their names.]

¹⁵ [Jung and Peterson, “Psychophysical Investigations with the Galvanometer and Pneumograph in Normal and Insane Individuals” (1907); Jung and Ricksher, “Further Investigations on the Galvanic Phenomenon and Respiration in Normal and Insane Individuals” (1907); in C.W., vol. 2.]

¹⁶ [Possibly a stenographic slip for Jakob Freundlich, who conducted electrocardiogram experiments; see his article in *Deutsches Archiv für klinische Medizin* (Berlin), 177:4 (1934), 449–57.]

¹⁷ [According to a Japanese legend, the *namazu*, a kind of catfish of monstrous size, carries on its back most of Japan, and when annoyed it moves its head or tail, thus provoking earthquakes. The legend is often depicted in Japanese art.]

¹⁸ [Louis Victor de Broglie, French physicist, recipient of Nobel Prize for physics (1929), discovered the wave character of electrons. In the preceding sentence of the text, instead of “oscillations” and “corpuscles” the more usual terms would be “waves” and “particles.”]

¹⁹ [Cf. “Synchronicity: An Acausal Connecting Principle” (C.W., vol. 8).]

- ¹ [Cf. *The Archetypes and the Collective Unconscious* (C.W., vol. 9, i), par. 5.]
- ² See *Psychology of the Unconscious* [or *Symbols of Transformation* (C.W., vol. 5), index, s.v.].
- ³ [Henri Hubert and Marcel Mauss, *Mélanges d'histoire des religions*, p. xxix.]
- ⁴ [Cf. *Symbols of Transformation*, par. 154.]
- ⁵ [Cf. “Psychology and Literature” (C.W., vol. 15), par. 150; “Psychology and Religion” (C.W., vol. 11), par. 100, and “Brother Klaus” (ibid.), par. 484. Documentation of the Rhodesian “sun-wheels” has not been possible, though such rock-carved forms are noted in Angola and South Africa: cf. Willcox, *The Rock Art of South Africa*, fig. 23 and pls. xvii–xx. Their dating is in doubt. The “rhino with tick-birds” is from the Transvaal and is in a museum in Pretoria. It was discovered in 1928 and widely publicized.]
- ⁶ [Albrecht Dieterich, *Eine Mithrasliturgie*.]
- ⁷ [*Symbols of Transformation*, pars. 151ff.; *The Archetypes and the Collective Unconscious*, par. 105; *The Structure and Dynamics of the Psyche* (C.W. vol. 8), pars. 228 and 318f.]
- ⁸ *How Natives Think*, trans. by Lilian A. Clare.
- ⁹ For general description of types and functions, see *Psychological Types*, Chap. X.
- ¹⁰ [Cf. Terence, *Heauton Timorumenos*, 1.1.25: “Homo sum; humani nil a me alienum puto” (I am a man; I count nothing human alien to me).]
- ¹¹ [*Civilization in Transition* (C.W., vol. 10), pars. 94ff. and 946ff.]
- ¹² *Studies in Word Association*, trans. by Eder. [Also in *Experimental Researches* (C.W., vol. 2).]
- ¹³ *Two Essays on Analytical Psychology* (C.W., vol. 7), pars. 245f., 304f.

¹⁴ [Cf. supra, par. 48, n. 15.]

¹⁵ [Cf. T. M. Davie, “Comments upon a Case of ‘Periventricular Epilepsy,’ ” *British Medical Journal*, no. 3893 (Aug. 17, 1935), 293–297. The dream is reported by a patient of Davie as follows: “Someone beside me kept on asking me something about oiling some machinery. Milk was suggested as the best lubricant. Apparently I thought that oozy slime was preferable. Then a pond was drained, and amid the slime there were two extinct animals. One was a minute mastodon. I forgot what the other one was.”

Davie’s comment: “I thought it would be of interest to submit this dream to Jung to ask what his interpretation would be. He had no hesitation in saying that it indicated some organic disturbance, and that the illness was not primarily a psychological one, although there were numerous psychological derivatives in the dream. The drainage of the pond he interpreted as the damming-up of the cerebrospinal fluid circulation.”]

¹⁶ [*The Practice of Psychotherapy* (C.W., vol. 16), pars. 344f.]

¹⁷ [Cf. supra, par. 17, n. 4.]

¹⁸ [The mandala motif, in a lecture, “Traumsymbole des Individuationsprozesses,” that Jung delivered a few weeks previously at the Eranos Tagung. It was published the next year in *Eranos-Jahrbuch 1935*; in translation, as “Dream Symbols of the Process of Individuation,” *The Integration of the Personality*, 1939; revised as Part II of *Psychologie und Alchemie*, 1944 (= C.W., vol. 12). See also *infra*, par. 406, n. 15.]

¹⁹ *The Secret of the Golden Flower*. [The Chinese text was translated by Richard Wilhelm. The commentary by Jung is contained in *Alchemical Studies* (C.W., vol. 13).]

²⁰ [William McDougall (1871–1938). American psychiatrist. Cf. Jung’s “On the Psychogenesis of Schizophrenia” (C.W., vol. 3), par. 504, and “The Therapeutic Value of Abreaction” (C.W., vol. 16), par. 255.]

²¹ [Cf. *The I Ching, or Book of Changes*, trans. by Wilhelm/Baynes, 3rd edn., introduction, p. liii.]

¹ [Cf. “On the Importance of the Unconscious in Psychopathology,” and “On Psychological Understanding,” both delivered in 1914 (C.W., vol. 3).]

² For example, the figures of *anima* and *animus*. [See *Two Essays on Analytical Psychology* (C.W., vol. 7), pars. 296ff.]

³ “The Familial Constellations” (C.W., vol. 2) and “The Significance of the Father in the Destiny of the Individual” (C.W., vol. 4), pars. 698–702.

⁴ “On the Practical Use of Dream Analysis” (C.W., vol. 16). [Also “General Aspects of Dream Psychology” and “On the Nature of Dreams” (C.W., vol. 8).]

⁵ [The reference is to Wilhelm Wundt, of Leipzig (1832–1920).]

⁶ *Psychological Types*, Def. 48. See also *Two Essays*, pars. 296ff. [Also *Aion* (C.W., vol. 9, ii), ch. 3.]

⁷ [E.g., *Symbols of Transformation*, Part II, ch. V, especially par. 395.]

⁸ [The reference is to the disaster of 1908, when 90 per cent of the Sicilian city was destroyed, with a loss of 60,000 lives.]

⁹ Cf. W. Y. Evans-Wentz. *The Tibetan Book of the Dead*.

¹⁰ [Cf. infra, pars. 525ff. The case is also discussed in Jacobi, *Complex/Archetype Symbol*, pp. 139ff.]

¹¹ ["Brother Klaus" (C.W., vol. 11).]

¹² [*Psychology and Alchemy* (C.W., vol. 12), pars. 315ff.]

¹ “And Isis, the great lady of enchantments, said, ‘Flow on, poison, and come forth from Rā. ... I have worked, and I make the poison to fall on the ground, for the venom hath been mastered.... Let Rā live, and let the poison die; and if the poison live then Rā shall die.’ And similarly, a certain man, the son of a certain man, shall live, and the poison shall die.” E. A. Wallis Budge, *Egyptian Literature*, I, p. 55.

² [*Symbols of Transformation*, pars. 375ff.]

³ R. Campbell Thompson, *The Epic of Gilgamesh*.

⁴ [Josephus, *The Jewish War* 2.111–115.]

⁵ [Cf. *The Structure and Dynamics of the Psyche* (C.W., vol. 8), frontispiece and refs. with it.]

⁶ [Thus far, the dream is documented in the “Life of Sophocles,” sec. 12, in *Sophoclis Fabulae*, ed. Pearson, p. xix.]

⁷ [The people of ancient Phocaea, on the western coast of Asia Minor, founded Massilia (Marseilles) and colonies on the east coast of Spain.]

⁸ [Cf. *Psychological Types*, ch. V, 4a.]

⁹ [*Symbols of Transformation*, pars. 572f.]

¹⁰ [Cf. *Psychology and Alchemy*, par. 105, n. 35, citing Foucart, *Les Mystères d’Eleusis*. According to classicists, Asterios’ report referred to rituals of Demeter celebrated at Alexandria in which a priest (not of Apollo) and a priestess performed the *hierosgamos*. The narration of *aischrologia* to please Demeter occurred during the Thesmophoria, an autumn festival in her honour, the Stenia, celebrating her return, and the mid-winter Haloa, sacred to Demeter and Dionysus. Cf. Harrison, *Prolegomena*, ch. IV, esp. pp. 136, 148f.]

¹¹ [Herodotus 2.60 (Penguin edn., pp. 125f.).]

¹² [See *Aion* (C.W., vol. 9, ii), frontispiece, and *Symbols of Transformation*, index, s.v.]

¹³ *New Sayings of Jesus and Fragment of a Lost Gospel*, ed. by Grenfell and Hunt [pp. 36 and 15].

¹⁴ [It is MS. Bruce 96, Bodleian Library, Oxford. Cf. *Psychology and Alchemy*, par. 138f.]

¹⁵ [For further analysis of this dream, from the Basel Seminar (supra, p. 3), see Jung's *L'Homme à la découverte de son âme*, pp. 214ff.]

15 [*Jahrbuch für psychoanalytische und psychopathologische Forschungen* (Leipzig and Vienna); Jung withdrew from the editorship in 1913.]

¹⁶ W. M. Kranefeldt, *Secret Ways of the Mind*; G. R. Heyer, *The Organism of the Mind*; Gerhard Adler, *Entdeckung der Seele*.

¹⁷ [Luke 18:19.]

¹⁸ [See supra, par. 135, n. 15.]

- ¹ [The case is discussed more fully in “The Realities of Practical Psychotherapy” (C.W., vol. 16, 2nd edn.), appendix. See also “Concerning Mandala Symbolism” (C.W., vol. 9, i), pars. 656–659 and figs. 7, 8, and 9, showing mandalas painted by this patient.]
- ² [Supra, pars. 322f.]
- ³ [This is actually the same case that was discussed supra, pars. 334f.]
- ⁴ [For Jung’s later views on this problem, see “The Psychology of the Transference” (C.W., vol. 16).]
- ⁵ *Two Essays* (C.W., vol. 7), pars. 374ff.
- ⁶ *Two Essays*, pars. 206ff.
- ⁷ “The Role of the Unconscious” (C.W., vol. 10), par. 17.
- ⁸ “Wotan” (C.W., vol. 10).
- ⁹ [Act III. in a speech by Don Juan (Penguin edn., 1952, p. 149).]
- ¹⁰ [Cf. Virgil, *Eclogue V*, 64: “ipsa sonant arbusta: ‘deus, deus ille, Menalca!’” (the very groves ring out: “A god is he, a god, Menalcas!”).]
- ¹¹ See particularly the “Commentary on *The Secret of the Golden Flower*” (C.W., vol. 13, and “The Aims of Psychotherapy” (C.W., vol. 16).
- ¹² See *Psychological Types*, Def. 29, and *Two Essays*, pars, 266ff. [Also “A Study in the Process of Individuation” C.W., vol. 9. iv.]
- ¹³ [Cf. *Psychology and Alchemy*, pars. 44, 126, 129, 135, 325ff.]
[Cf. *Psychology and Alchemy* (C.W., vol. 12), par. 360.]

¹⁴ This case provided the material for Part II of *Psychology and Alchemy*.]

¹⁵ “Traumsymbole des Individuationsprozesses,” in the *Eranos-Jahrbuch 1935*. [Now Part II of *Psychology and Alchemy*.]

¹⁶ [Cf. “Commentary on *The Secret of the Golden Flower*” (C.W., vol. 13) and “Concerning Mandala Symbolism” (C.W. vol. 9, 1).]

¹ [Dominicus Gnosius, *Hermetis Trismegisti Tractatus vere Aureus de Lapide philosophici secreto* (1610), p. 101.—
EDITORS.]

² Lévy-Bruhl later retracted this term under the pressure of adverse criticism, to which he unfortunately succumbed.
His critics were wrong inasmuch as unconscious identity is a well-known psychological fact.

¹ Ch. XL, “Great Events” (trans. Common, p. 180, slightly modified). [For other discussions, see *Psychiatric Studies*, pars. 140ff. and 180ff.—EDITORS.]

² Vol. IV. p. 57, headed “An Extract of Awe-Inspiring Import from the Log of the Ship *Sphinx* in the Year 1686, in the Mediterranean.”

¹ For further details, see my *Memories, Dreams, Reflections*, pp. 156ff. (London edn., pp. 152ff.).

¹ From Gk. *arche*, 'origin', and *tupos*, 'blow, imprint'.

² [For another analysis of this case, see Jacobi, *Complex/Archetype/Symbol*, Part II.—EDITORS.]

³ [Gerard Dorn, of Frankfurt, a 17th-century physician and alchemist.]

¹ [Henry A. Murray, in his “Conclusions” to *Explorations in Personality: A Clinical and Experimental Study of Fifty Men of College Age*, by the Workers at the Harvard Psychological Clinic, under Murray’s direction (1938), p. 739, sec. 17. Cited also in “Psychotherapy Today” (1941), C.W., vol. 16. par. 218.]

² [“tremendous mystery.”]

³ [The part of the religious house from which those of the opposite sex are excluded.]

⁴ [Cf. *Two Essays on Analytical Psychology* (C.W., vol. 7), pars. 206ff.]

⁵ “[Cf. *Memories, Dreams, Reflections*, pp. 138f./137f.]

⁶ [Cf. Matthew 25:40.]

⁷ [A German Protestant movement (founded at Berneuchen, Neumark) aiming at a deepening of religious life. See *Letters*, ed. G. Adler, vol. 1. p. 215, n. 1.]

⁸ [Cf. “Traumsymbole des Individuationsprozesses,” *Eranos Jahrbuch 1935*. The material was subsequently incorporated in *Psychology and Alchemy*, Part II.]

⁹ Wolfgang Pauli (1900–1958), Swiss physicist and Nobel Prize winner.]

¹⁰ [Cf. Knud Rasmussen, *Across Arctic America*, ch. III: “A Wizard and His Household.”]

¹¹ [This offensive term was not invariably derogatory in earlier British and Continental usage, and definitely not in this case.]

¹² [In *Johannis Evang.*, XXXIV, 2.]

- ¹ [Lecture delivered at the Bernoullianum, Basel, 5 Feb. 1905. Published serially as “Ueber spiritistische Erscheinungen” in the *Basler Nachrichten*, nos. 311—316 (12–17 Nov. 1905). Jung’s original footnotes are given in full.]
- ^{1a} [While “spiritism” (for *Spiritismus*) is the form now preferred by specialists, “spiritualism,” the form in general currency, has been used in this paper and those that follow.]
- ² Detailed report in Capron, *Modern Spiritualism, Its Facts and Fanaticisms* (Boston, 1885); résumé in Aksakow, *Animismus und Spiritismus* (1894).
- ³ [*The World as Will and Idea*.]
- ⁴ *Die Tyroler ekstatischen Jungfrauen. Leitsterne in die dunklen Gebiete der Mystik* (Regensburg, 1843).
- ⁵ *Die somnambulen Tische: Zur Geschichte und Erklärung dieser Erscheinungen*.
- ⁶ [*Dreams of a Spirit-Seer*, trans. by E. F. Goerwitz, pp. 158ff. The unidentified text quoted by Jung gives the date 1756 for Swedenborg’s experience. In the Goerwitz edn. the date 1759 is justified in Appendix III, pp. 160–61.]
- ⁷ Krafft-Ebing. *Lehrbuch der Psychiatrie* [Buch III, Teil III. cap. 3, Beob. 68; cf. trans. by C. G. Chaddock, *Text-book of Insanity*. p. 495, case 52].
- ⁸ Cf. Kerner, *Die Geschichte des Thomas Ignaz Martin, Landsmanns zu Gallardon, über Frankreich und dessen Zukunft im Jahre 1816 geschaut* (Heilbronn, 1835).
- ⁹ Cf. Gilbert Ballet, *Swedenborg: Histoire d’un visionnaire au XVIII siècle* (Paris, 1899).
- ¹⁰ [“Notes of an Enquiry into the Phenomena called Spiritual, during the years 1870–73,” *Quarterly Journal of Science* (London), XI (n.s., IV) (1874), 85–86.]
- ¹¹ [C.W., vol. 2.]
- ¹² For a detailed account of these phenomena, see my “On the Psychology and Pathology of So-Called Occult Phenomena” C.W., vol. 1. pars. 79ff.
- ¹³ [(1871–1938), professor of applied psychology, Breslau U.; at Duke U., in the U.S.A., 1934–38. See *The Freud/Jung Letters*, index, s.v., and “The Psychological Diagnosis of Evidence” (C.W., vol. 2), par. 728.]
- ¹⁴ [Correctly, meteorites, which even into the 19th cent. astronomers believed of terrestrial origin. The German physicist E.F.F. Chladni (1756–1827) advocated the theory of extra-terrestrial origin.]
- ¹⁵ [When the first German railway was opened, in 1835, from Nuremberg to Fürth, the Board of Physicians held that the speed of the trains would cause dizziness in travellers and onlookers and would sour the milk of cows grazing near the tracks.]

¹ [Paris, 1939. The book is a trans., by E. Godet and Y. Le Lay, of “On the Psychology and Pathology of So-Called Occult Phenomena” (C.W., vol. 1), “The Soul and Death,” and “The Psychological Foundations of Belief in Spirits” (both in C.W., vol. 8). The present trans. of the foreword is from the original German MS.]

² *Samyutta-Nikaya*, 12. II.

¹ [First published as the foreword to Stewart Edward White, *Uneingeschränktes Weltall* (Zurich, 1948), the German trans. of *The Unobstructed Universe* (New York, 1940), in which a foreword by Jung had not appeared. It was subsequently published as “Psychologie und Spiritismus,” *Neue Schweizer Rundschau*, n.s., XVI: 7 (Nov., 1948), 430–35. White (1873–1946), American author, chiefly wrote adventure stories with a frontier background; he became involved with spiritualism later in life. Jung was introduced to his books in 1946 by Fritz Künkel, American psychotherapist; see his letter to Künkel, 10 July 1946, discussing *The Unobstructed Universe* at length, in *C. G. Jung: Letters*, ed. G. Adler, vol. 1.]

² J. B. Rhine, *New Frontiers of the Mind* (1937); *The Reach of the Mind* (1948). Also G.N.M. Tyrrell, *The Personality of Man* (1947).

³ [*The Betty Book* (1937); *Across the Unknown* (1939); *The Road I Know* (1942).]

¹ [Baden, 1950. By Fanny Moser. (“Ghost: False Belief or True?”)]

² [*Okkultismus: Täuschungen und Tatsachen* (1935).]

³ [*Dreams of a Spirit-Seer*, trans. by Goerwitz, p. 92.]

⁴ [Ibid., p. 88.]

⁵ [Pp. 253ff.]

¹ [Aniela Jaffé, *Geistererscheinungen und Vorzeichen* (Zurich, 1958). Trans., New Hyde Park, New York, 1963, with the present trans. of the foreword, here somewhat revised.]

² “Bilder und Symbole aus E.T.A. Hoffmanns Märchen ‘Der goldne Topf,’” in Jung, *Gestaltungen des Unbewussten* (1950).

¹ [(Translated by W. S.) “Der gegenwärtige Stand der angewandten Psychologie in den einzelnen Kulturländern,” under “Nachrichten” in *Zeitschrift für angewandte Psychologie und psychologische Sammelforschung* (Leipzig), I (1907–8), 466ff. There were contributions from France, French Switzerland, and the United States, as well as Jung’s (pp. 469–70).]

² [Arthur Wreschner, German experimental psychologist and physician, practising in Zurich. See *The Freud/Jung Letters*, 124J, n. 9.]

³ [See *The Freud/Jung Letters*, 198J, n. 2a.]

⁴ [Constantin von Monakow, Swiss neurologist. See *The Freud/Jung Letters*, index, s.v. Monakow.]

⁵ [See *The Freud/Jung Letters*, 46J, 47J.]

¹ [Jung's abstract contributed to Otto Rank's report of the First International Psychoanalytic Congress (Salzburg, 27 Apr. 1908), in *Zentralblatt für Psychoanalyse* (Wiesbaden), I:3 (Dec. 1910), 128. The original paper is lost. Cf. *The Freud/Jung Letters*, 85J, n. 4.]

¹ [Basler Nachrichten, Nov. 1909. Isidor Sadger, *Konrad Ferdinand Meyer: Eine pathographisch-psychologische Studie* (Grenzfragen des Nerven- und Seelenlebens, 59; Wiesbaden, 1908). For the Viennese psychoanalyst Sadger, see *The Freud/Jung Letters*, 75J, n. 1. In his study he discussed the influence of the mother and sister on the sexual life of the Zurich poet Meyer (1825–98).]

² [Paul Julius Möbius (1854–1907), Leipzig neurologist, published on the psychopathology of these and other writers.]

³ [Wilhelm Lange (1875–1950), *Hölderlin: eine Pathographie* (1909).]

⁴ A well-known sage writes: “If you have a fresh view or an original idea, if you present men and things from an unexpected point of view, you will surprise the reader. And the reader does not like being surprised. He never looks in a history for anything but the stupidities that he knows already. If you try to instruct him you only humiliate him and make him angry. Do not try to enlighten him; he will only cry out that you insult his beliefs.” [Anatole France, preface to *Penguin Island* (1908; trans. by A. W. Evans, 1909), preface, p. vii.]

¹ [Basler Nachrichten, 9 Dec. 1909. Louis Waldstein, *Das unbewusste Ich und sein Verhältnis zur Gesundheit und Erziehung* (Wiesbaden, 1908); trans. from the English (*The Subconscious Self and Its Relation to Education and Health*, New York, 1897) by Gertrud Veraguth. Waldstein (1853–1915) was an American neurologist.]

² [Otto Veraguth (1870–1944), Zurich neurologist, husband of the translator. For Jung’s comments on him and on the book (“abysmally insignificant”), see *The Freud/Jung Letters*, 115J, par. 2.]

³ [(1734–1815), Austrian physician, experimenter with animal magnetism.]

⁴ [For Kerner (1786–1862), German poet and student of occultism, see “On the Psychology and Pathology of So-Called Occult Phenomena” (C. W., vol. 1), par. 140. Joseph Ennemoser (1787–1854), Karl August Eschenmayer (1768–1852), and Georg Conrad Horst (1767–1838) wrote on magic, mesmerism, etc.]

⁵ [Auguste Ambroise Liébeault (1823–1904), French physician and hypnotist.].

⁶ [Max Dessoir (author of *Das Doppel-Ich*, 1890), August Forel (infra, par. 921, n. 201, Albert Moll (infra, par. 893), Oskar Vogt, Albert von Schrenck-Notzing: all psychiatrists.]

¹ [Published in the *Sunday Referee* (London), 11 Dec. 1932. A German version, “Blick in die Verbrecherseele,” which may have been the original of the English, appeared in the *Wiener Journal*, 15 Jan. 1933. The present text contains some minor changes taken over from the German.]

¹ [*Psyche* (Heidelberg), IV:8 (1950–51), 464–65.]

² [Ibid., 448ff.]

³ [Ibid., IV:4, 229ff.]

⁴ [Ibid., IV:7, 394ff.]

¹ [New York, 1952. By John Custance. The foreword (not included in the British edition, 1951) was translated by an unknown hand from a German MS written in 1951 and is given here in revised form. The German original was published in Custance, *Weisheit und Wahn* (Zurich, 1954).]

² [C.W., vol. 3.]

¹ [Berkeley and Los Angeles: University of California Press; London: Cambridge University Press, 1953. By John Weir Perry. The foreword appears to have been written in English.]

² The Burghölzli, Zurich.]

³ [The second paper is probably “The Content of the Psychoses” (C.W., vol. 3.) Cf. below, par. 982.]

⁴ [*Wandlungen und Symbole der Libido* (1911–12).]

¹ [Stuttgart, 1955. By Gustav Schmalz. (“Complex Psychology and Somatic Symptom.”)]

¹ [Trans. from a typescript discovered in Jung's posthumous papers; apparently a report given to his colleagues on the staff of the Burghölzli Mental Hospital, where Jung had taken up his first professional post, as assistant physician, on 10 Dec. 1900. (Cf. *Memories, Dreams, Reflections*, end of Ch. III, "Student Years.") The subject was Freud's *Über den Traum* (trans., "On Dreams," Standard Edn., V), published as part (pp. 307–344) of a serial publication, *Grenzfragen des Nerven- und Seelenlebens*, ed. L. Löwenfeld and H. Kurella (Wiesbaden, 1901); it was a summary of *Die Traumdeutung* (1900; trans., *The Interpretation of Dreams*, Standard Edn., IV–V). The present trans. was published in *Spring*, 1973.]

² [Standard Edn., V, p. 641.]

³ [Ibid., p. 647.]

⁴ [Ibid., p. 651.]

¹ [*Zentralblatt für Nervenheilkunde und Psychiatrie* (Berlin), XXVIII (1905), 318–21. Willy Hellpach, *Grundlinien einer Psychologie der Hysterie* (Leipzig, 1904). (“Basics of a Psychology of Hysteria.”) See *The Freud/Jung Letters*, 230J, n. 7.]

² [Occam’s Razor: “Entia praeter necessitatem non sunt multiplicanda.”]

- ¹ [Twenty-five reviews published in the *Correspondenz-Blatt für Schweizer Ärzte* (Basel). XXVI-XL (1906–10), rediscovered by Henri F. Ellenberger in the course of research for his book *The Discovery of the Unconscious*. The Editors are grateful to Professor Ellenberger for informing them of these articles, which Jung wrote for the *Correspondenz-Blatt* (“Bulletin for Swiss Physicians”) during his association with the psychoanalytic movement, and which often express his partiality for Freud’s work.]
- ² [See above, par. 795, n. 2.]
- ³ [Eugen Bleuler (1857–1939), director of the Burghölzli. See *The Freud/Jung Letters*, 2J, no. 8; 40F, n. 6; 41J; and *infra*, par. 938.]
- ⁴ [Originating in childhood, a term later rejected by Bleuler.]
- ⁵ [See *The Freud/Jung Letters*, 33J, n. 8.]
- ⁶ [See “The Psychology of Dementia Praecox” (C.W., vol. 3), par. 55.]
- ⁷ [See *The Freud/Jung Letters*, 94F, n. 1.]
- ⁸ [A talking dog. Cf. C.W., vol. 8, par. 364, n. 27.]
- ⁹ [See the *Freud/Jung Letters*, 102F, n.3]
- ¹⁰ [*Studies on Hysteria*.]
- ¹¹ [See *The Freud/Jung Letters*, 11F, n. 3.]
- ¹² [*Der Hypnotismus: Handbuch der Lehre von der Hypnose und der Suggestion*.]
- ¹³ [See *The Freud/Jung Letters*, 115J, n. 8, and *infra*, following par. 1050.]
- ¹⁴ [See *The Freud/Jung Letters*, 27F, n. 11.]
- ¹⁵ [This probably refers to “Fragment of an Analysis of a Case of Hysteria,” and “Three Essays on the Theory of Sexuality,” both in Standard Edn., vol. 7.]
- ¹⁶ [See n. 11, *supra*.]
- ¹⁷ [See *The Freud/Jung Letters*, 196J, n. 2.]
- ¹⁸ [See *The Freud/Jung Letters*, 49J, n. 2.]
- ¹⁹ [Alfred E. Hoche, *Handbuch der gerichtlichen Psychiatrie*.]
- ²⁰ [August (or Auguste) Henri Forel (1848–1931), director of the Burghölzli before Bleuler. See *The Freud/Jung Letters*, index, s.v.]

¹ [(Translated by W. S.) “Über die Bedeutung der Lehre Freud’s für Neurologie und Psychiatrie,” a lecture to the Zurich Cantonal Medical Society, autumn meeting, 26 Nov. 1907: Jung’s abstract, *Correspondenz-Blatt für Schweizer Ärzte*, XXXVIII (1908), 218. See *The Freud/Jung Letters*, 54J.]

¹ [(Translated by W. S.) *Medizinische Klinik* (Berlin), IV:45 (8 Nov. 1908), 1735–36. Wilhelm Stekel's book, with a preface by Freud (in Standard Edn., vol. IX), was published in Berlin and Vienna, 1908. The preface was omitted after the 2nd edn. (1912) in view of Stekel's defection from orthodox psychoanalysis. Trans., *Conditions of Nervous Anxiety and Their Treatment* (London, 1922). For Jung's relations with Stekel 1907–13, see *The Freud/Jung Letters*, index, s.v. Stekel.]

¹ [*Jahrbuch für psychoanalytische und psychopathologische Forschungen* (Leipzig and Vienna), I:1 (1909), of which Jung was editor and Freud and Bleuler co-directors. For its founding and history, see *The Freud/Jung Letters*, index, s.v. The *Jahrbuch*, V:2 (1913), contained Jung's and Bleuler's statements of resignation; see *The Freud/Jung Letters*, comment following 357J, 27 Oct. 1913.]

¹ [*Jahrbuch für psychoanalytische und psychopathologische Forschungen*, II: 1 (1910), 312–15. Fritz Wittels, *Die sexuelle Not* (“Sexual Privation”), (Vienna and Leipzig, 1909). See *The Freud/Jung Letters*, 209F and n. 1. The present translation was published in *Spring*, 1973.]

² [*The White Stone* (1905; trans. by C. E. Roche, 1924), p. 133.]

¹ [*Jahrbuch für psychoanalytische und psychopathologische Forschungen*, II:2 (1910), 747. Erich Wulffen, *Der Sexualverbrecher* (“The Sexual Offender,” subtitled “A Handbook for Jurists, Magistrates, and Doctors, with numerous original criminological photographs”) (Berlin, 1910).]

² [François Gayot de Pitaval (1673–1743), French juriconsult, compiler of *Causes célèbres et intéressantes* (1734–43), in 20 vols.]

¹ [“Referate über psychologische Arbeiten schweizerischen Autoren (bis Ende 1909),” *Jahrbuch für psychoanalytische und psychopathologische Forschungen*, II:1 (1910), 356–88. The authors and many of the publications mentioned are commented on in *The Freud/Jung Letters* (see index), except the following, on whom information is unavailable: Eberschweiler, Hermann, Ladame, H. Müller, Pototsky, Schnyder, and Schwarzwald. For references by Freud and Jung to the abstracts in general, see *ibid.*, 91J and 209F. The *Jahrbuch*, under Jung’s editorship, also published abstracts or survey articles on Freud’s writings (by Abraham), the Austrian and German psychoanalytic literature (Abraham), English and American literature on clinical psychology and psychopathology (Jones), Freudian psychology in Russia (Neiditsch), and Freud’s theories in Italy (Assagioli).]

² [= “On the Psychology and Pathology of So-called Occult Phenomena” (C.W., vol. 1).]

³ [= “A Case of Hysterical Stupor in a Prisoner in Detention” (*ibid.*).]

⁴ [= “The Psychopathological Significance of the Association Experiment” (C.W., vol. 2).]

⁵ [= “Experimental Observations on the Faculty of Memory” (*ibid.*).]

⁶ [= “Freud’s Theory of Hysteria: A Reply to Aschaffenburg” (C.W. vol. 4).]

⁷ [= “The Freudian Theory of Hysteria” (*ibid.*).]

⁸ [Omitted from the Collected Works. See C.W., vol. 2, par. 999, n. 1.]

⁹ [= “The Analysis of Dreams” (C.W., vol. 4).]

¹⁰ [= “The Psychology of Dementia Praecox” (C.W., vol. 3).]

¹¹ [Jung also abstracted Vol. I of the *Diagnostische Assoziationsstudien* in *L’Année psychologique* (Paris), XIV (1908), 453–55, at the invitation of its editor, Alfred Binet. (See *The Freud/Jung Letters*, 59J and n. 2.) As the abstracts are similar to, but briefer than, those translated here, they are omitted.]

¹² [= “The Associations of Normal Subjects” (C.W., vol. 2).]

¹³ [= “An Analysis of the Associations of an Epileptic” (*ibid.*).]

¹⁴ [= “The Reaction Time Ratio in the Association Experiment” (*ibid.*).]

¹⁵ [= “Psychoanalysis and Association Experiments” (*ibid.*).]

¹⁶ [= “Association, Dream, and Hysterical Symptom” (*ibid.*).]

¹⁷ [= “Disturbances of Reproduction in the Association Experiment” (*ibid.*).]

¹⁸ [= “The Psychological Diagnosis of Evidence” (*ibid.*).]

¹⁹ [= “New Aspects of Criminal Psychology” (*ibid.*, appendix).]

²⁰ [= “The Content of the Psychoses” C.W., vol. 3.]

²¹ [Excessive vomiting in pregnancy.]

^{21a} [Cf. “A Case of Hysterical Stupor in a Prisoner in Detention,” pars. 278ff.]

²² [For Freud’s disparagement of this journal, see *The Freud/Jung Letters*, 55F and n. 3.]

¹ [*Jahrbuch für psychoanalytische und psychopathologische Forschungen*, III:1 (1911), 480. Eduard Hitschmann, *Freuds Neurosenlehre; nach ihrem gegenwärtigen Stande zusammenfassend dargestellt* (“Freud’s Theory of Neurosis: a Comprehensive Interpretation of Its Present Status”) (Leipzig and Vienna, 1911). See *The Freud/Jung Letters*, 194F, n. 3.]

¹ [(Translated by W. S.) Part of the Report on the Third Psychoanalytic Congress, Weimar, 21–22 Sept. 1911, in the *Bulletin*, or *Korrespondenzblatt der internationalen psychoanalytischen Vereinigung*, in *Zentralblatt für Psychoanalyse* (Wiesbaden), II:3 (Dec. 1911), 233–34. Jung had been elected president of the International Psychoanalytic Association upon its founding at the Second Psychoanalytic Congress at Nuremberg, 30–31 Mar. 1910. For the Congress programmes, see *The Freud/Jung Letters*, appendix 4, pp. 473–76.]

² [Karl Abraham: see *The Freud/Jung Letters*, 35J, n. 7.]

³ [Alfred Adler: see *ibid.*, 20F, n. 5, and 260F, n. 3. Adler had resigned from the Vienna Society the previous June, but his resignation was not officially announced until 11 Oct. 1911.]

⁴ [Ludwig Binswanger: see *ibid.* 16J, n. 1.]

⁵ [Abraham A. Brill: see *ibid.*, 69J, n. 2, and 238F, n. 4.]

⁶ [Leonhard Seif: see *ibid.*, 137J, n. 1.]

⁷ [The allusion is to the secession of Adler and several of his followers from the Vienna Society in June.]

⁸ [The first issue appeared in Oct. 1910 under the direction of Freud and the joint editorship of Adler and Stekel.]

⁹ [*Imago: Zeitschrift für Anwendung der Psychoanalyse auf die Geisteswissenschaften* (“Journal for the Application of Psychoanalysis to the Humanities”), directed by Freud, edited by Otto Rank and Hanns Sachs; its first issue appeared in March 1912.]

¹⁰ [Johann Jakob Honegger, Jr., who committed suicide on 28 Mar. 1911. See *The Freud/Jung Letters*, 148J, n. 2, and 247J; and H. H. Walser, “An Early Psychoanalytical Tragedy,” *Spring*, 1974. The “paper read at Nuremberg” has not survived.]

¹ [*Neue Zürcher Zeitung*, on the dates given. Jung's article "Neue Bahnen der Psychologie" ("New Paths in Psychology," C.W., vol. 7, appendix), in *Raschers Jahrbuch für Schweizer Art und Kunst*, 1912 (issued in Dec. 1911), precipitated controversy which led to a public lecture attacking psychoanalysis by Max Kesselring, M.D., a neurologist of Zurich, on 15 Dec. 1911 in the Schwurgerichtssaal, sponsored by the Zurich branch of the Keplerbund. During Jan. 1912 articles in the *Zeitung* by Kesselring and others carried the polemic on; Jung contributed these two. He published an article designed to close the discussion, in *Wissen und Leben* (Zurich), 15 Feb. 1912: "Concerning Psychoanalysis," C.W., vol. 4. The entire controversy is summarized in H. F. Ellenberger, *The Discovery of the Unconscious*, pp. 810–14; see also *The Freud/Jung Letters*, 287J, n. 7; 293F. n. 7; 294J; 295J.]

² [Freud's Clark University lectures, pub. by Deuticke 1910: trans. as "Five Lectures on Psychoanalysis" (Standard Edn., XI).]

³ [Originally in the *Jahrbuch für psychoanalytische und psychopathologische Forschungen*, II:2 (1910). Trans. by C. R. Payne, *Freud's Theories of the Neuroses* (1913).]

⁴ [Johann Michelsen, *Ein Wort an geistigen Adel deutscher Nation* (Munich, 1911) (from Ellenberger, p. 877, n. 270).]

⁵ [Fritz Marti, literary editor of the *Neue Zürcher Zeitung*, who signed ("F.M.") some of the articles.]

¹ [Jung's abstract of a report to the Medical-Pharmaceutical Society of Bern at a meeting on 4 June 1912. The abstract, including the discussion, was published in the *Correspondenzblatt für Schweizer Ärzte*, XLII (1 Oct. 1912), 1079–84. Cf. *The Freud/Jung Letters*, 318J, last par., and 319F, for the “Kreuzlingen episode,” which occurred shortly before this occasion.]

² [See *ibid.*, 116F, n. 8.]

¹ [“Eine Bemerkung zur Tauskschen Kritik der Nelkenschen Arbeit,” *Internationale Zeitschrift für ärztliche Psychoanalyse* (Vienna and Leipzig), I:3 (1913), 285–88. For Victor Tausk, of Vienna, see *The Freud/Jung Letters*, 348J, n. 4. For Jan Nelken, a psychiatrist of the Zurich School, see *ibid.*, 305J, n. 3. The present trans. was published in *Spring*, 1973.]

² [In the *Jahrbuch für psychoanalytische und psychopathologische Forschungen*, IV:1 (1912). (“Analytical Observations on the Fantasies of a Schizophrenic.”)]

³ [Freud, “Notes upon a Case of Obsessional Neurosis” (orig., 1909), Standard Edn., X.]

⁴ [Cf. Herbert Silberer, “Über die Symbolbildung,” *Jahrbuch*, III: 1 (1911) and “Von den Kategorien der Symbolik,” *Zentralblatt für Psychoanalyse*, II: 4 (1912).]

⁵ [“Versuch einer Darstellung der psychoanalytischen Theorie.” *Jahrbuch*, V:1 (1913): trans., “The Theory of Psychoanalysis” (C.W., vol. 4.)]

¹ [Jung wrote this reply (in English) to Hoffman's questions on 7 Aug. 1953. So far as is known, Jung's answers were not published by the *New York Times*. First published in *Spring*, 1968.]

¹ [(Translated by W. S.) Abstract of remarks by Jung at the Winter Meeting of Swiss Psychiatrists, Bern, 27 Nov. 1910, reported in the *Zentralblatt für Psychoanalyse*, 1:5/6 (Feb./Mar. 1911), 267–68. The report, more or less abbreviated, appeared also in the *Psychiatrisch-neurologische Wochenschrift* (Halle), XII:43 (21 Jan. 1911), and the *Correspondenzblatt für Schweizer Ärzte*, XLI:6 (20 Feb. 1911). See *The Freud/Jung Letters*, 222J (29 Nov. 1910), n. 1.]

² [Of a paper by Eugen Bleuler, “Über Ambivalenz” (“On Ambivalence”); its publication, if any, could not be traced.]

³ [In French, *sacré* can mean both “blessed” and “cursed.”]

⁴ [The word intended is probably *luige*, “oath,” but the point of this example is obscure.]

⁵ [Cf. *Symbols of Transformation* (C.W., vol 5). par. 680 and pl. LXIb; also in 1911/12 edn. See also *The Freud/Jung Letters*, 215J, par. 1.]

⁶ [Cf. *Symbols of Transformation*, par. 439, n. 43.]

⁷ [Cf. *ibid.*, par. 671.]

⁸ [Of a lecture by Prof. von Speyr, “Zwei Fälle von eigentümlicher Affektverschiebung” (“Two Cases of the Displacement of Affect”): its publication could not be traced.]

⁹ [“vom Leibe gerückt,” lit., “removed from my body.”]

¹⁰ [Of a lecture by Franz Riklin, “Die ‘Allmacht der Gedanken’ bei der Zwangsneurose” (“The ‘Omnipotence of Thoughts’ in Compulsion Neurosis”); its publication could not be traced.]

¹ [(Translated by W. S.) An abstract, recorded by Otto Rank, of Jung's lecture, entitled "Beiträge zur Symbolik," at the Third Psychoanalytic Congress in Weimar, 21–22 Sept. 1911. Abstracts of the twelve papers read at the Congress were published in the *Zentralblatt für Psychoanalyse*, II:2 (Nov. 1911), 100–104. A MS of Jung's lecture has not been found.]

² [Goethe, *Egmont*, Klärchen's song, Act III.]

³ [For the parallels, see *Symbols of Transformation*, index, s.v. "Attis" and "castration." (also in 1911/12 edn.)]

1 [Translated from typescripts discovered 1964 in the archives of the Psychological Club, Zurich. The papers are signed and dated “Oct. 1916” in Jung’s handwriting, and would thus have been written about the same time as “The Transcendent Function” (C.W., vol. 8) and “The Structure of the Unconscious” (C.W., vol. 7, 2nd edn., Appendix 2). Their content appears to be, in part, a further elaboration of the Addendum to the latter, pars. 503ff. The present trans., with a prefatory note and postscript by R.F.C. Hull, was published in *Spring*, 1970.]

2 [*Bestimmungen*; could also mean “destinations.”]

¹ [*Bevezetés a Tudattalan Pszichológiájába*, trans. by Peter Nagy (Budapest: Bibliotheca, 1948).]

² [C.W., vol. 7.]

³ [See infra, par. 1121, n. 1.]

¹ [Originally titled *Über die Energetik der Seele*.]

² [A series of psychological publications edited by Jung. See addenda, par. 1825.]

³ ["General Aspects of Dream Psychology," first published as "The Psychology of Dreams," in *Collected Papers on Analytical Psychology* (1916); "Instinct and the Unconscious," first published in the *British Journal of Psychology*, X:1 (1919); "The Psychological Foundations of Belief in Spirits," first published in *Proceedings of the Society for Psychical Research*, XXXI:79 (May, 1920). The latter two papers were reprinted in *Contributions to Analytical Psychology* (1928), together with the fourth paper, "On Psychic Energy." All four papers are in C.W., vol. 8.]

⁴ [Trans. as *Psychology of the Unconscious* (1916); revised edn., *Symbols of Transformation*, C.W., vol. 5.]

⁵ [Both in C.W., vol. 8.]

¹ [Contribution to a discussion at a meeting of the Schweizerische Gesellschaft für Psychiatrie, Prangins (near Geneva), 1933. Trans. from the Proceedings in *Schweizer Archiv für Neurologie und Psychiatrie*, XXXII (1933): 2, 382.]

¹ [Berlin. 1934. A collection of essays. Schleich (1859–1922). German surgeon and writer, discovered local anaesthesia. Cf. his autobiographical *Those Were Good Days!* trans. by B. Miall (1936).]

² [“Paracelsus as a Spiritual Phenomenon” (C.W., vol. 13). pars. 170f. (“Iliaster”).]

³ [“The Role of the Unconscious,” par. 18; “Mind and Earth,” pars. 94f; “The Complications of American Psychology,” pars. 947ff, 970f. (all in C.W., vol. 10).]

¹ [Jolan (or Jolande) Jacobi, *Die Psychologie von C. G. Jung* (Zurich: Rascher, 1940). Concerning the author (1890–1973), see *infra*, par. 1134. The foreword was trans. by K. W. Bash in *The Psychology of C. G. Jung* (New Haven: Yale University Press, 1942); an edition published the same year by Routledge & Kegan Paul, London, omits the foreword. A revised edn. of the entire book, including the foreword, was retrans. by Ralph Manheim and published by both houses, 1962; 8th edn., revised, 1973. The version published here has been revised by R.F.C. Hull.]

² [Jolan Jacobi, *La Psicología de C. G. Jung*, trans. by José M. Sacristan (Madrid, 1947). The present trans. is from the German MS.]

¹ [M. Esther Harding, *Psychic Energy: Its Source and Goal* (New York, Bollingen Series X, and London, 1947). The author (1889–1971), originally English, practiced in New York. The foreword was trans. for the 1947 edn. by Hildegard Nagel; republished in 2nd edn., 1963, with subtitle of the book changed to “Its Source and Its Transformation.” The Nagel trans. is published here with minor revisions. For forewords to other works of Harding’s, see *infra*, pars. 1228ff. and 1795ff.]

- ¹ [Trans. from the unpublished German MS. A translation by Hildegard Nagel appeared in the *Bulletin* of the Analytical Psychology Club of New York, 10:7 (Oct. 1948), Supplement. The present trans. is new.]
- ^{1a} [The work of Richard Wilhelm (1873–1930), Heinrich Zimmer (1890–1943), and Karl Kerényi (1897–1973) has been widely translated.]
- ² [Cf. *Mysterium Coniunctionis*, pp. xiii and xv.]
- ³ [“The Influence of Archetypal Ideas on the Scientific Theories of Kepler,” in Jung and Pauli, *The Interpretation of Nature and the Psyche* (trans., 1955).]
- ⁴ [In *Die kulturelle Bedeutung der Komplexen Psychologie* (1935); reprinted posthumously in *Studien zu C. G. Jungs Psychologie* (1959), with introduction by Jung (in C.W., vol. 10).]
- ⁵ [*Woman’s Mysteries* and *The Way of All Women*. Cf. infra, pars. 1228ff. and 1795ff.]
- ⁶ [*The Dream of Poliphilo*. Cf. infra, pars. 1749ff.]
- ⁷ [*The Psychology of C. G. Jung*. Cf. supra, pars. 1121ff. Also *Complex/Archetype/Symbol*, infra, pars. 1256ff.]
- ⁸ [*The Inner World of Childhood*. Cf. C.W., vol. 17.]
- ⁹ [London, 1940. Cf. infra, pars. 1421ff.]
- ¹⁰ [*Studies in Analytical Psychology*. Cf. infra, pars. 1238ff.]
- ¹¹ [*Symbolik des Märchens* and *Gegensatz und Erneuerung im Märchen* (Bern, 1959), by Hedwig von Beit, maiden name of Frau von Roques; the publications are based on the work of Dr. von Franz.]
- ¹² [*The Origins and History of Consciousness*. Cf. infra, pars. 1234ff.]
- ¹³ [(1910–1968), professor of philosophy and the psychology of religion, Bern U. The reference is to his *Religion and the Cure of Souls in Jung’s Psychology* (trans. by R.F.C. Hull, 1950). Cf. his *Erlösungsvorstellungen und ihre psychologischen Aspekte* (1950).]
- ¹⁴ [English priest, at that time a Roman Catholic convert; after 1949, Anglican. Cf. his *Catholic Thought and Modern Psychology* (1943), and his account of his reconversion, *Return to Reality* (1954).]
- ¹⁵ [*God and the Unconscious*. Cf. Jung’s foreword, C.W., vol. 11.]
- ¹⁶ [(1905–68), professor of philosophy and comparative religion, Theological Seminary of Schöneck (Cant. Nidwalden). Cf. his *Probleme der Parapsychologie: Gesammelte Aufsätze*, ed. A. Resch (1969).]

¹ [Article written (in 1948) for the *Lexicon der Paedagogik* (Bern, 1951), vol. II, pp. 768–73: “Tiefenpsychologie.”]

² [That is, subliminal perceptions which are not apperceived. Cf. “Synchronicity” (C.W., vol. 8), pars. 931, 937. For the references in this and the following par., cf. L. L. Whyte, *The Unconscious before Freud*, index, ss.vv.]

¹ [Vol. I of Studien aus dem C. G. Jung Institut, Zurich, 1949: C. A. Meier, *Antike Inkubation und moderne Psychotherapie*. The foreword was published in a trans. by Ralph Manheim, in the first vol. of Studies in Jungian Thought, James Hillman, General Editor: *Evil: Essays by Carl Kerényi* [and others] (Evanston, Ill., 1967), and (same series, same year), in a trans. of Meier's book: *Ancient Incubation and Modern Psychotherapy*. The present trans. is by R.F.C. Hull.]

¹ [Penguin Books, 1953. The foreword was written in English.]

¹ [London, 1957. The foreword was written in English.]

¹ [A condensed version of ch. II of “Synchronicity: An Acausal Connecting Principle” (C.W., vol. 8). Published as “Ein astrologisches Experiment,” *Zeitschrift für Parapsychologie und Grenzgebiete der Psychologie* (Bern), I:2/3 (May 1958), 81–92. A long prefatory note by the editor, Hans Bender, quoted a letter to him from Jung, 12 Feb. 1958, in further clarification; it is in *Letters*, ed. G. Adler, vol. 2.]

² [Jung and Pauli, *Natureerklärung und Psyche*, 1952.]

³ [G. Spencer-Brown, “Statistical Significance in Psychological Research,” *Nature*, vol. 172, 25 July 1953, p. 154.]

⁴ [The following two paragraphs, not represented in the *Zeitschrift* version, were added by Jung respectively to the German MS and to a letter containing queries sent to him by the translator, 23 April 1954.]

⁵ With all due respect to their statistical nature! (C.G.J.)

⁶ [Albert Einstein.]

⁷ [Cf. “On the Nature of the Psyche” (C.W., vol. 8), pars. 397ff.]

¹ [Cf. “Synchronicity: An Acausal Connecting Principle” (C.W., vol. 8). See other letters to Fierz in *Jung: Letters*, ed. G. Adler.]

² [Table II in the English edn.]

³ [English in the original.]

⁴ [The report is summarized in “Synchronicity,” pp. 483f.]

⁵ [Cf. *ibid.*, par. 902.]

⁶ [*Ibid.*, par. 843.]

⁷ [M. J. Moroney, Fellow of the Royal Statistical Society.]

⁸ [Handwritten, in English.]

¹ [Incunabulum, undated, Zentralbibliothek, Zurich. Cf. C.W., vol. 8, par. 859.]

¹ [Author's abstract of a lecture delivered at the Federal Polytechnic Institute (ETH), Zurich, 1 Feb. 1932. Published in the *Vierteljahrschrift der Naturforschenden Gesellschaft in Zurich*, LXXVII. Pt. 2 (1932), iv–v. The MS of the original lecture has not been found. Cf. supra, pars. 1143–45.]

² [Cf. *Psychology and Alchemy*, C.W., vol. 12, fig. 110.]

³ [Ibid., fig. 195.]

⁴ [Ibid., pars. 214–16.]

¹ [Zurich, 1934. By Gerhard Adler, at that time in Berlin; after 1936, in England. (“Discovery of the Soul.”)]

² [See infra, pars. 1727f., and Jung’s introduction to W.M. Kranefeldt’s *Secret Ways of the Mind* (C.W., vol. 4, pars. 745ff.).]

³ [See infra, pars. 1774ff.]

¹ [M. Esther Harding, *Woman's Mysteries: Ancient and Modern; A Psychological Interpretation of the Feminine Principle as Portrayed in Myth, Story, and Dreams*. The original edn. (New York, 1935) did not contain this foreword, which was written for the German trans., *Frauen-Mysterien* (Zurich, 1949): trans. by Edward Whitmont for the revised edn. of the book (New York, 1955). The present version is revised. See supra, pars. 1125ff.]

¹ [New York (Bollingen Series XLII), 1954; London, 1955. Trans. by R.F.C. Hull (including the foreword) from *Ursprungsgeschichte des Bewusstseins* (Zurich, 1949). Erich Neumann (1905–1960), originally German, later lived in Israel.]

¹ [The foreword, not in the original edn. (London and New York, 1948), was written for the German edition, *Zur analytischen Psychologie* (Zurich, 1952), and is included (trans. by R.F.C. Hull) in the new English edition (London, 1966; New York, 1967).]

¹ [(“Configurations of the Unconscious.”) *Psychologische Abhandlungen*, VII. For contents, see the following notes.]

^{1a} [“Psychology and Literature” (in C.W., vol. 15).]

² [“Concerning Rebirth” (in C.W., vol. 9, i).]

³ [“A Study in the Process of Individuation” (ibid.).]

⁴ [“Concerning Mandala Symbolism” (ibid.).]

⁵ [“Bilder und Symbole aus E.T.A. Hoffmanns Märchen ‘Der goldne Topf.’”]

¹ [Zurich, 1953. Frances G. Wickes (1875–1967), American psychotherapist, was influenced by Jung’s theories. Cf. Jung’s introduction to her *Analyse der Kinderseele* (*The Inner World of Childhood*, 1927), C.W., vol. 17, pars. 8off.]

² [*The Inner World of Man* (New York and Toronto), without this foreword (which was also published in E. D. Kirkham’s trans. in the *Bulletin of the Analytical Psychology Club of New York*, 16:2, Feb. 1954).]

¹ [(“From the Roots of Consciousness.”) Contents: “Archetypes of the Collective Unconscious,” “Concerning the Archetypes, with Special Reference to the Anima Concept,” “Psychological Aspects of the Mother Archetype” (all in C.W., vol. 9, i); “The Visions of Zosimos” (in C.W., vol. 13); “Transformation Symbolism in the Mass” (in C.W., vol. II); “The Philosophical Tree” (in C.W., vol. 13); “On the Nature of the Psyche” (in C.W., vol. 8).]

¹ [Arnhem (Netherlands), 1957. (“Pictures from the Unconscious.”) Foreword in German.]

² [This case is not to be confused with the similar case—the patients were in fact sisters—discussed in “The Realities of Practical Psychotherapy,” appendix to *The Practice of Psychotherapy* (C.W., vol. 16, 2nd edn.).]

¹ [Jolande Jacobi, *Komplex/Archetypus/Symbol in der Psychologie C. G. Jungs* (Zurich, 1957), trans. by Ralph Manheim (New York, Bollingen Series LVII, and London, 1959). The foreword was trans. by R.F.C. Hull. For Jacobi, see supra, pars. 1121ff.]

¹ [New York and London, 1958. Jung wrote the foreword for the Swiss edn., *Menschliche Beziehungen* (Zurich, 1957), and it was trans. by Barbara Hannah for the English edn. It appears here in slightly revised form. Eleanor Bertine (1887–1968) was an American analytical psychologist.]

² [Cf. “Instinct and the Unconscious” (C.W., vol. 8), pars. 268, 277.]

³ [“The Theory of Psychoanalysis” (1912), (C.W., vol. 4), pars. 347ff. Cf. Freud’s comment, “An Outline of Psycho-Analysis” (1940), Std. Edn., XXIII, p. 194.]

¹ [A selection from the writings of C. G. Jung, ed. by Violet S. de Laszlo (Anchor Books, New York, 1958). The foreword appears here in slightly revised form.]

² [Cf. “Concerning Mandala Symbolism” (C.W., vol. 9, i), par. 687 and fig. 33.]

³ [Cf. the dream series in *Psychology and Alchemy*, C.W., vol. 12, Part II.]

⁴ [*Tao-te-ching*, ch. 56.]

¹ [Vol. XIV of *Studien aus dem C. G. Jung Institut* (Zurich, 1963), by Cornelia Brunner. (“The Anima as a Problem in the Man’s Fate.”)]

² [Cf. *infra*, pars, 1749ff.]

³ [Cf. Jung, *Mysterium Coniunctionis*, C.W., vol. 14, pars. 91ff.]

⁴ [Mystical cult in Sufism; its attitudes are compared to those of Dante toward Beatrice. See Corbin, *Creative Imagination in the Sūfism of Ibn Arabī*, esp. Part II, pp. 136ff.]

⁵ [In Nietzsche, *Thus Spake Zarathustra*, Part IV.]

¹ [An abstract, recorded by Otto Rank, of Jung's "Bericht über Amerika," at the Second Psychoanalytic Congress in Nuremberg, 30–31 Mar. 1910. Abstracts of the papers read at the Congress were published in the *Jahrbuch für psychoanalytische und psychopathologische Forschungen*, II:2 (1910). Rank also published a briefer abstract in the *Zentralblatt für Psychoanalyse*, I:3 (Dec. 1910), 130; trans. in *The Freud/Jung Letters*, 223F, n. 6. Also see *ibid.*, index, s.v. Jung: "Report on America," for evidence that a report on the psychoanalytic movement in the U.S.A. had originally been planned. A MS of Jung's report has not been found.]

² [In Aug–Sept. 1909, to the Clark Conference, and in Mar. 1910, to Chicago.]

¹ [Abstract of a lecture to the Zurich Psychoanalytic Society on 22 Nov. 1912, published in the *Internationale Zeitschrift für ärztliche Psychoanalyse*, I:1 (1913), 115 (*Bulletin* section). See *The Freud/Jung Letters*, 323J, n. 3. For Jung's later views on the influence of Negroes and American Indians on American behaviour, see "Mind and Earth" and "The Complications of American Psychology" (C.W., vol. 10). A MS of the present lecture has not been discovered.]

² [So bracketed in the abstract.]

³ [Not traced; perhaps an earlier lecture to the Society, but cf. the preceding "Report on America."]

⁴ [Neither this work (trans. by Hinkle, *Psychology of the Unconscious*) nor its revision, C.W., vol. 5, contains reference to sacrificial symbols in the dreams of Negroes. Concerning the dreams of psychotic Negroes otherwise, see C.W., vol. 6, par. 747, and C.W., vol. 5, par. 154.]

¹ [Unpublished; from a MS in Jung's hand, dated 19 Jan. 1930. The background of Jung's remarks could not be ascertained.]

² [*Das Geheimnis der goldenen Blüte* (late 1929); trans. by Cary F. Baynes, *The Secret of the Golden Flower* (1931; revised edn., 1962). See Jung's commentary, C.W., vol. 13, and his memorial address for Wilhelm (who died 1 Mar. 1930), C.W., vol. 15.]

³ [In 1925; see *Memories, Dreams, Reflections*, ch. IX, iii.]

⁴ [In 1924–25; *ibid.*, ch. IX, ii.]

⁵ [Cf. "Concerning Rebirth" (C.W., vol. 9, i), par. 250.]

¹ [(“Contemporary Psychic Problems.”) *Psychologische Abhandlungen*, III. Thirteen articles by Jung, originally published from 1925 on, and assigned to seven C.W. vols.; and one essay, “‘Komplex’ und Mythos,” by W. M. Kranefeldt.]

² [*Il problema dell’inconscio nella psicologia moderna*, trans. by Arrigo Vita and Giovanni Bollea (Turin), originally published 1942; new edn., 1959, with the present foreword, here trans. from the German original.]

¹ [With an introduction by Bronislaw Malinowski (London and New York, 1931). Aldrich's trans. of the foreword is reproduced here with minor changes. The original appears to have been lost. See Jung's letter to the author, 5 Jan. 1931, in *Letters*, ed. G. Adler, vol. 1. Charles Roberts Aldrich, who resided in California, died in 1933.]

² [*Wandlungen und Symbole der Libido* (1912).]

¹ [Unpublished typescript, written in English. While it apparently was intended for the New York press, no instance of its publication or quotation has been discovered. For an interview that Jung gave the *New York Times* (4 Oct. 1936) upon leaving New York, see “The 2,000,000 Year Old Man,” in *C. G. Jung Speaking*.]

² [For Jung’s contribution, under this title, see C.W., vol. 8. The symposium at Harvard was actually entitled *Factors Determining Human Behavior*.]

- ¹ [A lecture delivered in English at the Institute of Medical Psychology (The Tavistock Clinic), London, 14 Oct. 1936, when Jung had just returned from his visit to the United States (see the preceding article). He had written the lecture during the voyage, according to his daughter Marianne Niehus-Jung. The text, based on a holograph MS, has not been previously published, though similar ideas are found in an interview with Jung in the *Observer* (London, date undetermined), reprinted in *Time*, 9 Nov. 1936, *The Living Age* (New York), Dec. 1936, and as “The Psychology of Dictatorship” in *C. G. Jung Speaking*.]
- ² [Arrival of a German warship at the port of Agadir, Morocco, which precipitated an international crisis in 1911.]
- ³ [Jung evidently elaborated this schema in his lecture.]
- ⁴ [As examples of regression, presumably elaborated in the lecture, the holograph itemizes: 1. Father and mother complex. 2. Complex of infantile religion. 3. Regression to infantile criminality. 4. Regression to archetypes: schizophrenia, mystical experience, and analytical experience.]
- ⁵ [Cf. “The Role of the Unconscious” (C.W., vol. 10), pars. 17ff.]
- ⁶ [Cf. Price, *An Account of Some Further Experiments with Willy Schneider* (1925), *The Phenomena of Rudi Schneider* (1926), and other books on these Austrian mediums.]
- ⁷ [Mosley founded the British Union of Fascists (“Blackshirts”) in 1932. Col. François de la Rocque was leader of the French reactionary group “Croix de Feu.”]
- ⁸ [National Recovery Administration, established to administer the National Industrial Recovery Act (13 June 1933), recognizing a “national emergency” and vesting in the President (F. D. Roosevelt) authority to approve codes of fair competition for various trades and industries, regulate wages, hours of labour, etc.]
- ⁹ [Sir Samuel Hoare, later Viscount Templewood (1880–1959), British foreign secretary in 1935, when he sought to appease Italy in its conquest of Ethiopia.]
- ¹⁰ [Cf. “Wotan” (C.W., vol. 10), par. 373.]
- ¹¹ [Cf. “A Study in the Process of Individuation” and “Concerning Mandala Symbolism” (C.W., vol. 9, i).]
- ¹² [Cf. “The Realities of Practical Psychotherapy” (C.W., vol. 16, 2nd edn., Appendix), par. 560. Also Arthur Avalon, *The Serpent Power*.]
- ¹³ [Concerning the persona, cf. *Two Essays on Analytical Psychology*, C.W., vol. 7, pars. 243ff., 305ff.]
- ¹⁴ [Source unidentifiable. MacDonald (1886–1937) was Great Britain’s first Labour prime minister, 1924, and again 1929–1935.]
- ¹⁵ [*The Observer* (London), 11 Oct. 1936, in an article written from Salamanca 3 Oct. 1936. Unamuno (1891–1936) repudiated the Franco regime in a moving speech at Salamanca on 12 Oct. 1936.]
- ¹⁶ [Illegible in holograph.]

¹ [Translated from “Rückkehr zum einfachen Leben,” *DU: Schweizerische Monatsschrift*, Jhg. I, no. 3 (May 1941). An editorial note in *DU* states that it is a summation of Jung’s reply to a questionnaire sent out by the Schweizer Feuilleton-Dienst (features service) to various eminent Swiss, on the effects of wartime conditions in Switzerland.]

² [*Faust II*, Act 5.]

¹ [(Translated from the French by A.S.B.G.) The volume for which this was written (in the series Collection Action et Pensée, no. 10, Geneva, 1944) contained five essays by Jung, translated, with a preface, by Roland Cahen-Salabelle, together with extracts from Jung's Basel Seminar (1934) and "Tavistock Lectures" (supra, pars. 1ff.), edited by Dr. Cahen (later form of his name). Only two of the essays are among the eleven that composed *Modern Man in Search of a Soul* (New York and London, 1933).]

¹ [Translated from a typescript, “Randglossen zur Zeitgeschichte,” dated 1945, unpublished except for the last nine paragraphs (see below, par. 1374, n. 5). Cf. Jung, *Aufsätze zur Zeitgeschichte* (1946); trans. as *Essays on Contemporary Events* (1947); its contents (in C.W., vols. 10 and 16) were published originally 1936–45.]

² This can be disputed, since it is the Christian *organizations* that have demonstrated their impotence. But if you identify the Church with Christianity, this distinction collapses.

³ All -isms that promise a “better” world are to be distrusted on principle, for this world only becomes different, but not better. Man can, however, to a certain extent adopt a better or worse *attitude*, one that is more reasonable or less. Of the basic evils of existence, inner and outer, he will never be freed. He would do better to realize that this world is a battleground, and at any time only a short span between birth and death.

⁴ [Nazi concentration camp of World War II, near Lublin, Poland.]

⁵ [Pars. 1375–83 were published in the *Basler Nachrichten*, no. 486 (16 Nov. 1946), under the title “Zur Umerziehung des deutschen Volkes” (“On the Re-education of the German People”).]

⁶ [“Wotan” C. W., vol. 10, par. 391.]

⁷ [*Works*, trans. by C. de B. Evans. II, pp. 18f.]

⁸ In view of the most recent events in Europe one must guard against the assumption that a Christian education has penetrated to the marrow.

⁹ [Ludwig Büchner (1824–99), German physician and philosopher, apostle of extreme materialism.]

¹ [Not published until 15 Nov. 1974, when Kolb's and Jung's letters were printed in *Mishmar* (in Hebrew), with editorial comments, under the heading, "What Did Jung Say to Mishmar's Correspondent in Switzerland 29 Years Ago?" The publication was the consequence of an inquiry sent to *Mishmar* by the editors of the C.W., attempting to learn whether the late Eugen Kolb had published Jung's letter.]

¹ [From a holograph, with typescript passages, written (in English) in 1948 in response to a request from the United Nations Educational, Scientific and Cultural Organization (Unesco). The Second General Conference of Unesco, in Nov.–Dec. 1947, had adopted a resolution instructing the Director General to promote “enquiries into modern methods which have been developed in education, political science, philosophy and psychology for changing mental attitudes and into the social and political circumstances which favour the employment of particular techniques.” Accordingly, memoranda were commissioned from individuals at specialized institutes, including the International Psychoanalytic Association, the Tavistock Institute of Human Relations, and the C. G. Jung Institute for Analytical Psychology. Mr. P. W. Martin, an official of Unesco, conducted the arrangements with the Jung Institute. Jung’s memorandum, published here (with minor stylistic revisions), was later partially incorporated in a text prepared by Dr. Jolande Jacobi on behalf of the Jung Institute, which was sent to Unesco on 23 June 1948 for discussion at the Conference on Methods of Attitude Change Conducive to International Understanding in October 1948, at Royaumont (near Paris). The Jung Institute’s memorandum was not, however, included in the agenda of the Royaumont Conference. Acknowledgment is made to the Unesco Press for permission to publish this memorandum and to Mr. J. Havet, Director of the Unesco Department of Social Sciences, for his advice and assistance in 1974.]

² Here a list of “books of reference” was appended: (1) Attitude: *Psychological Types*. (2) Method: *The Relations between the Ego and the Unconscious*; *L’Homme à la découverte de son âme*; Baynes, *Mythology of the Soul*; Wickes, *Inner World of Childhood* and *Inner World of Man*; *Psychologie und Erziehung*. (3) Psychology: *Über die Psychologie des Unbewussten*; *Psychology and Religion*; *Über psychische Energetik und das Wesen der Träume*; *Psychologie der Übertragung*; Jacobi, *The Psychology of C. G. Jung*.

¹ [Letter, of 14 Sept. 1949, to the editors of the *Zürcher Student* (Eidgenössische Technische Hochschule = Federal Polytechnic Institute), published in the Nov. 1949 issue, Jhg. 27.]

¹ [Written in 1949 for a proposed English edition of Erich Neumann, *Tiefenpsychologie und neue Ethik* (Zurich, 1949). An English edition was published only in 1969 (New York and London), trans. by Eugene Rolfe, with the present trans. of the foreword by R.F.C. Hull (here slightly revised). For Jung's appraisal of the book when it was published in German, see *Letters*, ed. G. Adler, vol. 1, to Neumann, Dec. 1948, and to J. Fierz, 13 Jan. 49.]

² "The most wretched of inventors are those who invent a new morality: they are always immoralists," says a French aphorist. [Untraceable.]

¹ [London, 1950. The foreword was written in English. Helton Godwin Baynes (1882–1943), English analytical psychologist, accompanied Jung on his expedition to East Africa in 1925–26.]

² [London and New York, 1923. The version in C.W., vol. 6, is the Baynes trans. revised by R.F.C. Hull. Baynes also translated, in collaboration with his then wife Cary F. Baynes, Jung's *Contributions to Analytical Psychology* (London and New York, 1928) and *Two Essays on Analytical Psychology* (London and New York, 1928).]

³ [London, 1940.]

⁴ [London, 1941.]

¹ [*Weltwoche* (Zurich), Jhg. 22, no. 1100 (10 Dec. 1954). Jung was one of several prominent persons asked to comment on this subject.]

¹ [Letter to *Weltwoche* (Zurich), Jhg. 22, no. 1078 (9 July 1954), in reply to the editor's request for an interview by Georg Gerster. It was followed by further questions and answers, printed in the same issue. Extracts subsequently appeared as an article (not submitted to Jung before publication) in the *Flying Saucer Review* (London), May–June 1955, which was reprinted by the Aerial Phenomena Research Organization in the *APRO Bulletin* (Alamogordo, New Mexico), July 1958. The extracted version of the *Weltwoche* letters resulted in misunderstandings which were given much publicity, and on 13 August Jung released a statement to the United Press International (UPI) and to the National Investigations Committee on Aerial Phenomena (NICAP), of which an English version was published in the Sept. issue of the *APRO Bulletin*. A further statement, in the form of a letter to the director of NICAP, Major Donald E. Keyhoe (infra. pars. 1447f.), was published by NICAP in the *UFO Investigator*, 1:5 (Aug.–Sept. 1958). All these documents were republished in *CSI of New York*, Publication No. 27 (July 1959).]

² George Adamski's book (with Desmond Leslie), *Flying Saucers Have Landed*, appeared in 1953 (London). In it he tells the story of how he met a saucer-man in the California desert.

³ [*The War of the Worlds*, adapted by Orson Welles (1938) from H. G. Wells's novel. It is about Martians invading the United States.]

⁴ The report by Major Donald E. Keyhoe concerning his struggle with the Pentagon for recognition of the interplanetary origin of the Ufos was published in 1953 under the title *Flying Saucers from Outer Space*.

⁵ [See above, n. 1. This text is translated from the *Badener Tageblatt*, 29 Aug. 1958, and differs in some respects from the translation in the *APRO Bulletin*.]

⁶ [Trans. by R.F.C. Hull as *Flying Saucers: A Modern Myth of Things Seen in the Skies* (New York and London, 1959) : in C.W., vol. 10.]

⁷ [Original in English. See above, n. 1.]

¹ [Written in English as an invited comment on an article, “Analysis and Faith,” by William H. Roberts, which together with comments by Jung and others—including Gregory Zilboorg, Erich Fromm, and Karl Menninger—was published in *The New Republic* (Washington), 132:20 (16 May 1955). The article was subtitled: “How close are religion and psychiatry in their approaches to sin and salvation?” Roberts was professor of philosophy and religion at Philander Smith College, a Black college in Little Rock, Arkansas.]

¹ [Contributions to symposia: (I) “Das geistige Europa und die ungarische Revolution,” *Die Kultur* (Munich), Jhg. 5, no. 73 (1 Dec. 1956); (II) *Aufstand der Freiheit: Dokumente zur Erhebung des ungarischen Volkes* (Zurich, 1957).]

¹ [Letter of 27 June 1958, answering questions from the editors of the *Zürcher Student* (see above, par. 1403, n. 1) and published in the July 1958 issue, Jhg. 36.]

¹ [Contribution, written in English, to a symposium published in *Cosmopolitan* (New York), CXLV:6 (Dec. 1958), and consisting of “ten highly individual opinions from noted thinkers who have devoted their lives to problems of the spirit.” These also included Norman Vincent Peale, Aldous Huxley, Pitirim A. Sorokin, and Billy Graham.]

¹ [The book (Dorchester, 1961) had the subtitle “A Personal Memoir by His Friends and Family.” The foreword, written in English, is published here with minor stylistic changes.]

¹ [(Translated by H. N.) Written as part of a letter to H. Irringer of Zurich, 22 Sept. 1944, but not sent; instead, Jung retained it in his literary papers. For the letter to Irringer, see *Jung: Letters*, ed. G. Adler, vol. 1.]

¹ [Written July 1945, at the request of Encyclios-Verlag, Zurich, publishers of the *Schweizer Lexikon*. The first sentence and the references at the end of the article were published (without attribution) as the definition of “Dämonie” in the *Lexikon* (1949), vol. I.]

- ¹ ["Die Gestalt Satans im Alten Testament"; trans., *Satan in the Old Testament* (Evanston, 1967).]
- ² [In *The Archetypes and the Collective Unconscious*, C.W., vol. 9, i.]
- ³ [In *Alchemical Studies*, C.W., vol. 13.]
- ⁴ [In *Psychology and Religion: West and East*, C.W., vol. II.]
- ⁵ ["The Psychology of Eastern Mediation," *ibid.*]
- ⁶ [*Die Psychologie der Übertragung*, p. xi. Cf. foreword to "The Psychology of the Transference" (C.W., vol. 16).]
- ⁷ [C.W., vol. 14.]

¹ [According to information from Gilles Quispel (professor of ancient church history, Utrecht University, Netherlands), in 1949 he planned to publish in Bollingen Series a volume of his lectures given at the Eranos conferences. The projected title was *Tragic Christianity*, and Jung consented to write this foreword. The book was never published.]

² [Philo Judaeus (fl. A.D. 39). Graeco-Judaic philosopher of Alexandria. His works include commentaries on the Old Testament, which he interpreted allegorically, finding in it the source of the main doctrines of Plato, Aristotle, and other Greek philosophers.]

³ Epiphanius, *Panarium*, XXXI, cap V. [The quotation is here abbreviated; for Jung's fuller version of the Greek text see *Aion* (C.W., vol. 9, ii), par. 298 and n. 16.]

⁴ Hippolytus, *Elenchos*, VI, 42, 4. [This quotation, also abbreviated here, comes immediately after the one from Epiphanius in *Aion*, par. 298, where Jung cites Quispel's French trans. of the Greek text.]

¹ [Zurich, 1950. (“East Asia Thinks Otherwise.”) The foreword was not included in the English-language edition of the book, by Lily Abegg, *The Mind of East Asia* (London and New York, 1952). It is reproduced here, in a translation by Hildegard Nagel and Ellen Thayer, titled “The Mind of East and West,” from the *Inward Light* (Washington, D.C.), no. 49, (autumn 1955), having previously appeared in the *Bulletin of the Analytical Psychology Club of New York* vol. 15, no. 3 (Mar. 1953).]

¹ [Written for Amy I. Allenby's book (Ph.D. dissertation, Oxford U.), which was not published. Dr. Allenby is an analytical psychologist in Oxford.]

¹ [Translated from “Das Fastenwunder des Bruder Klaus,” *Neue Wissenschaft* (Baden. Switzerland). 1950/51, no. 7; revised from a letter to Fritz Blanke, 10 Nov. 1948, thanking him for his book *Bruder Klaus von Flüe* (Zurich, 1948). Cf. *Letters*, ed. G. Adler, vol. 1. A prefatory note by the editor of *Neue Wissenschaft* states: “The period of Brother Klaus’s fast lasted from 1467 to 1487. All contemporary witnesses, even those in the immediate neighbourhood of the saint, agree that during this time he took no nourishment.”]

² [Therese Neumann (1889–1962), generally known as Therese of Konnersreuth. Switzerland, stigmatized since 1926, when she claimed to have re-experienced Christ’s Passion.]

¹ [(Translated by R. H.) Author's description, printed on the dust jacket of the original edn. of *Antwort auf Hiob*, which was published in Zurich around 1 Apr. 1952. It was reprinted in the appendix to *Gesam. Werke*, XI, p. 687, but not in C.W., vol. II (which contains "Answer to Job".)]

¹ [Written 22 Feb. 1952 as a letter to the editor, published as “Religion und Psychologie” in *Merkur* (Stuttgart), VI: 5 (May 1952), 467–73, and reprinted as “Antwort an Martin Buber” in *Gesam. Werke*, XI, Anhang. The present translation was published in *Spring*, 1973.]

² [Hermann Keyserling (1880–1946). “Begegnungen mit der Psychoanalyse,” *Merkur*, IV: II (Nov. 1950), 1151–68.]

³ [“Religion und modernes Denken,” *Merkur* VI: 2 (Feb. 1952). Trans., “Religion and Modern Thinking,” together with Buber’s reply to Jung (in the same issue with Jung’s reply, *Merkur*, VI:5), in *Eclipse of God* (1953).]

⁴ [*VII Sermones ad Mortuos*, by Basilides of Alexandria (n.d. [1916]), privately printed. English trans. by H. G. Baynes, privately printed 1925; reprinted in the 2nd edn. of *Memories, Dreams, Reflections*, appendix.]

⁵ Cf. G. Schmaltz, *Östliche Weisheit und westliche Psychotherapie* (1951).

¹ [Draft written for a convocation at the Gesellschaftshaus zum Rüden, Zurich, 15 Nov. 1953. For Jung's final version, see the Addenda. The Jung Codex is a Gnostic papyrus in Coptic found in 1945 near the village of Nag Hamadi in Upper Egypt and acquired in 1952 for the C. G. Jung Institute.]

² [Published under the editorship of M. Malinine, H. C. Puech, and G. Quispel, *Evangelium Veritatis* (Zurich, 1956).]

³ [Otherwise known as *Philosophoumena*, or *The Refutation of All Heresies*, trans. by F. Legge (1921).]

¹ [(Translated from the French by A.S.B.G. and J.A.P.) Published in *Élie le prophète*, ed. by Père Bruno de Jésus-Marie, O.C.D., vol. II (Les Études Carmélitaines, Paris, 1956), pp. 13–18. Comments were supplied by Charles Baudouin, René Laforgue, and Father Bruno to form a chapter entitled “Puissance de l’archétype,” signed by the four. See also Jung’s letter of 20 Nov. 1956 to Père Bruno in *Letters*, ed. G. Adler, vol. 2.]

² [“which extends toward the highest heaven as the sun rising from the ocean.”]

³ [“only an altar and the worship (of the god)”]

⁴ [Cf. “Concerning Rebirth” (C.W., vol. 9, i), pars. 240ff.]

⁵ [Buber, *Tales of the Hasidim*, vol. I: “Elijah,” by Elimelekh of Lizhensk, p. 257.]

⁶ [Cf. supra, “Reply to Buber,” pars. 1499fl.]

⁷ [“he offers an image of the resurrection.”]

⁸ [René Dussaud. *Notes du mythologie syrienne* (Paris. 1903–5.)

⁹ [“until the coming of Helyas Artista, in whose time all that is hidden will be revealed”]

¹⁰ [Following this letter. Bruno quoted another letter from Jung of 22 Dec. 1954 (misdated by Bruno 1953; here trans. by J.A.P.) :

“So far as concerns the Helias of the alchemists, let me remind you of the text by Gerardus Dorneus [quoted as above]. Instead of saying ‘usque ad adventum Christi,’ the alchemist prefers an earlier form of the anthropos, Elijah, who is one of the four persons raised to heaven with their bodies: Enoch, Elijah, Christ, and Mary.

“The reason why the alchemist preferred Elijah, a figure or condition prior to Christ, is probably because in Paracelsus Elijah, like Enoch, belongs among the ‘Enochdiani and Heliezati,’ that is, among those whose bodies are capable of longevity (up to a thousand years) or else incorruptible, like the bodies of Enoch and Elijah. The prolongation of life was a very special interest of the master’s, whereas the premature death of Christ did not seem interesting to him. (Certainly Paracelsus verged on the scientific materialism of the eighteenth century! Cf. *Theophrasti Paracelsi Tract. De Vita Longa*, edit. by Adam v. Bodenstein, 1562.)

“Jewish tradition says that Elijah remained in the corporeal state so as to be visible to mortal eyes during his peregrinations on earth. After reading a little book I had just written (which had to do among other things with the archetypal nature of Yahweh as revealed in the Book of Job), an intellectual and agnostic (or materialistic) Jew had a dream which was sent to me. In his dream he was back in a concentration camp (where he had actually been during the war). Suddenly he perceived an extraordinarily large eagle circling over the camp. He felt spied upon and watched by the menacing bird and, in a highly emotional state, wanted to defend himself by attacking it. To this end, he was looking for a combat plane with which to bring the animal down.

“Thanks to my book, he had realized that in reality it is possible to abolish the idea of a god by means of reason, yet not possible to free oneself from it when one is dealing with an archetype innate in the structure of the psyche itself. (This dream is discussed in “The Philosophical Tree” [C.W. 13], pars. 466ff.) Elijah in the shape of an eagle represents the eye of Yahweh which sees all—‘oculi Dei qui discurrent in universam terram’ (Zach. 4:10). The fear of God had seized him. Thus the theriomorphic attribute of the ancient prophet still plays its part in our time.”]

¹¹ [Cf. *Aion*. pars, 137ff.]

- ¹ [(Translated from the French by A.S.B.G.) See Jung's letters of 18 Jan. and 29 June 1955 to Père William Lachat in *Letters*, ed. G. Adler, vol. 2.]
- ² [*La Réception et l'action du Saint-Esprit dans la vie personnelle et communautaire* (Neuchâtel, 1953).]
- ³ ["The spirit bloweth where it listeth." John 3:8.]
- ⁴ [Unidentified.]
- ⁵ [*Apostolic Constitution* ("Munificentissimus Deus") of Pius XII (1950), sec. 33: "... on this day the Virgin Mother was taken up to her heavenly bridal-chamber." Cf. "Answer to Job" (C.W., vol. II), par. 743, n. 4.]
- ⁶ [Count Nikolaus Ludwig von Zinzendorf (1700–60), founder of the Herrnhuter Brüdergemeinde, a community of Moravian Brethren.]
- ⁷ [Caux-sur-Montreux, Switzerland, a conference centre of the Moral Re-Armament movement. A World Assembly was held there in 1949.]
- ⁸ [Lacuna in the file copy of the letter.]
- ⁹ [Cf. *Aion*, C.W., vol. 9, ii, pars. 99ff.]
- ¹⁰ [Cf. *Mysterium Coniunctionis*, C.W., vol. 14, pars. 786f.]
- ¹¹ [Cf. "On the Nature of the Psyche" (C.W., vol. 8), par. 395.]
- ¹² [Cf. "Brother Klaus" (C.W., vol. II) and "Archetypes of the Collective Unconscious" (C.W., vol. 9, i), pars. 12ff.]
- ¹³ [Unidentified.]
- ¹⁴ [Lectures at the Federal Polytechnic Institute (ETH), Zurich, June 1939 to March 1940. Privately issued.]
- ¹⁵ ["He has no proper name." *Summa theologica*, I, xxvi, art. 1.]
- ¹⁶ [The "everlasting gospel" in Rev. 14: 7 is "Fear God." For Joachim's view, see *Aion*, pars. 137ff.]
- ¹⁷ [Cf. "Answer to Job," pars. 613ff.]
- ¹⁸ [Cf. *Aion*, pars. 89ff.]
- ¹⁹ [Erich Przywara, *Deus semper maior*, I, pp. 71f.]
- ²⁰ [Cf. also "The Transcendent Function" (C.W., vol. 8).]

¹ [Written in English, 19 Feb. 1954, in reply to an inquiry from Martha Dana, Peggy Gerry, and Marian Reith, members of a seminar on Jung's *Aion* led by Dr. James Kirsch, Los Angeles, 1953–54, during which (Dr. Kirsch has stated) “every line of the book was read and commented upon. While the seminar was in progress Mrs. Dana, Mrs. Gerry, and Mrs. Reith became curious about the fact that in all of the writings of Jung they had not found any commentary on the idea of Resurrection ... [which] seemed to be the central event in the Christ story, and they therefore wondered why Jung had not said anything about it.”]

² [Evidently an error for 16:9ff.]

³ “If Christ be not risen, then is our preaching vain, and your faith is also vain” (I Cor. 15:14).

⁴ Cf. the so-called parapsychological phenomena.

⁵ Cf. the passage about Christ in the Church Slavonic text of Josephus, *The Jewish War*, in G.R.S. Mead, *The Gnostic John the Baptizer*, pp. 97ff. [= ch. III: “The Slavonic Josephus’ Account of the Baptist and Jesus,” pp. 106ff.]

⁶ Their condition was worse than that of the Egyptians in the last pre-Christian centuries: these had already acquired an individual Osiris. As a matter of fact, Egypt turned Christian at once with no hesitation.

¹ [Statement in the publisher's prospectus for *Die Reden Gotamo Buddhos*, translated from the Pali Canon by Karl Eugen Neumann, 3 vols. Zurich, Stuttgart, Vienna, 1956). Statements were also contributed to the prospectus by Thomas Mann and Albert Schweitzer. Neumann (1865–1915) had published an earlier version of his translation in 1911, which Jung cited in *Wandlungen und Symbole der Libido* (1911–12): cf. *Psychology of the Unconscious* (New York, 1916), p. 538, n. 25. The present statement was published as “Zu *Die Reden Gotamo Buddhos*” in *Gesam. Werke*, XI, Anhang.]

¹ [Göttingen, 1957. By Felicia Froboese-Thiele. (“Dreams—a Source of Religious Experience?”)]

¹ [Extracts from H. L. Philp, *Jung and the Problem of Evil* (London, 1958). The book consists of correspondence between the author and Jung in the form of questions and answers (in English), and an extended critical attack of 175 pages on Jung's writings on religion, with particular reference to *Answer to Job*. It concludes with Jung's answers to questions sent by another correspondent, the Rev. David Cox (author of *Jung and St. Paul*, 1959). In both cases the answers are reproduced here with minor stylistic revisions and additional footnotes. The bibliographical references to Jung's works have been brought up to date. For other letters from Jung to Philp, see *Letters*, ed. G. Adler, vol. 2.]

² [Philp, pp. 8–21. (9 Nov. 1956.)]

³ [In his question, Philp quoted the following passage from Fromm, *Psychoanalysis and Religion*, pp. 23f.: “Before I present Jung's analysis of religion a critical examination of these methodological premises seems warranted. Jung's use of the concept of truth is not tenable. He states that ‘truth is a fact and not a judgment,’ that ‘an elephant is true because it exists.’ But he forgets that truth always and necessarily refers to a judgment and not to a description of a phenomenon which we perceive with our senses and which we denote with a word symbol. Jung then states that an idea is ‘psychologically true inasmuch as it exists.’ But an idea ‘exists’ regardless of whether it is a delusion or whether it corresponds to fact. The existence of an idea does not make it ‘true’ in any sense. Even the practising psychiatrist could not work were he not concerned with the truth of an idea, that is, with its relation to the phenomena it tends to portray. Otherwise, he could not speak of a delusion or a paranoid system. But Jung's approach is not only untenable from a psychiatric standpoint; he advocates a standpoint of relativism which though on the surface more friendly to religion than Freud's, is in its spirit fundamentally opposed to religions like Judaism, Christianity, and Buddhism. These consider the striving for truth as one of man's cardinal virtues and obligations and insist that their doctrines whether arrived at by revelation or only by the power of reason are subject to the criterion of truth.”]

⁴ [Cf. *The Religious Prospect*, pp. 188ff., quoted by Philp in his question.]

⁵ [Cf. “On the Nature of the Psyche” (C.W., vol. 8), par. 368.]

⁶ [Seminar on Buddhism and Tantric Yoga (Oct. 1938 to June 1939), in *The Process of Individuation*. Notes on Lectures at the ETH, Zurich, trans. and ed. by Barbara Hannah. Privately issued.]

⁷ [Exercitia Spiritualia of St. Ignatius of Loyola (June 1939 to Mar. 1940), in *ibid.*]

⁸ For the comprehension of the problems here mentioned, I recommend: “Answer to Job”; “A Psychological Approach to the Dogma of the Trinity” (ch. 5, “The Problem of the Fourth”); *Aion* (ch. 5, “Christ, A Symbol of the Self”); *Psychology and Alchemy* (Introduction, especially par. 36). For the biography of Satan, see R. Schärf-Kluger, *Satan in the Old Testament*.

⁹ [Philp, pp. 214–25. (8 Oct. 1957.) Page references for “Answer to Job” are to C.W., vol.11.]

¹⁰ [“that slippery sex.”]

¹¹ [Cf. “Flying Saucers: A Modern Myth” (C.W., vol. 10), par. 775.]

¹² [*Adversus haereses*, II, 5, 1. Cf. *Aion*, C.W., vol. 9,ii, par. 75 and n. 23.]

¹³ [Cf. Philippians 2:6.]

¹⁴ [Philp, pp. 226–39. (Aug. 1957.) The questions were not directly quoted because of the personal way in which some of them were framed.]

¹⁵ [Codex Bezae to Luke 6:4.]

- ¹⁶ [“Patiently awaiting a work of nature, which is very slow.”]
- ¹⁷ [Cf. *Psychology and Alchemy*, C.W., vol. 12, fig. 217.]
- ¹⁸ [“The artifex is not the master of the stone, but rather its minister.”]
- ¹⁹ [The translation (1916) of the original (1912) version of *Symbols of Transformation*.]
- ²⁰ [Philp, pp. 239–50. (25 Sept. 1957.)]
- ²¹ [Cf. “The Phenomenology of the Spirit in Fairytales” (C.W., vol. 9, i), pars. 425f., 436ff.; *Aion*, par. 351; and “The Spirit Mercurius” (C.W., vol. 13), pars. 270ff.]
- ²² [Cf. “The Spirit Mercurius,” par. 301.]
- ²³ [James, *The Apocryphal New Testament*, p. 255: “The Acts of Peter.” Cf. “Transformation Symbolism in the Mass” (C.W., vol. II), par. 429.]
- ²⁴ [Cf. *Aion*, pars, 139ff.]
- ^{24a} [Albrecht Ritschl (1822–1889) and Karl Barth (1886–1968), resp. German and Swiss Protestant theologians.]
- ²⁵ [“The Psychology of Eastern Meditation” (C.W., vol. II).]
- ²⁶ [Philp, pp. 250–54. (12 Nov. 1957.)]
- ²⁷ [Cf. *supra*, par. 1645.]
- ²⁸ [*Apostolic Constitution (“Munificentissimus Deus”) of Pius XII*, sec. 22: “The place of the bride whom the Father had espoused was in the heavenly courts.” Sec. 33: “... on this day the Virgin Mother was taken up to her heavenly bridal-chamber.”]
- ²⁹ [*Aion*, pars. 225ff.]
- ³⁰ [Probably a series of five talks on “Religion and Philosophy,” by Robert C. Walton, J. D. Mabbott, Alasdair MacIntyre, and the Rev. F. A. Cockin, broadcast in Sept.—Oct. 1957, according to information from the B.B.C.]

¹ [K. A. Ziegler (bookseller): *Alchemie* II, List No. 17 (Bern, May 1946). Foreword published in both German and English (here slightly revised). Reprinted as a prefatory note to Ian MacPhail, comp., *Alchemy and the Occult, A Catalogue of Books and Manuscripts from the Collection of Paul and Mary Mellon Given to Yale University Library* (New Haven, 1968).]

¹ [(Translated by H. N.) Author's abstract of a lecture given to the Psychological Club, Zurich, on 8 Oct. 1949; published in the Club's *Jahresbericht*, 1949–50. A typescript (38 pp.) of the entire lecture, made from a stenogram and evidently not corrected by Jung, is in the Jung archives.]

² [See “The Psychology of the Transference” (C.W., vol. 16), par. 407 and n. 18.]

³ [“The Spirit Mercurius” (C.W., vol. 13), orig. 1942.]

⁴ [In the alchemical literature, usually Morienus Romanus. See *Psychology and Alchemy*, C.W., vol. 12, par. 386 and n. 88, and par. 558.]

⁵ [“For the long lapse of time upsets man, who is under the law of time, and transforms him ... after the final transformation, however, fearful death follows.”—Morienus Romanus, “De transmutatione metallorum,” *Artis auriferae* (Basel, 1610), II, p. 14.]

¹ [Written in English for *Encyclopedia Hebraica* (Tel Aviv, 1951; Hebrew year 5711), where it was published in vol. III, in a Hebrew translation. Nearly all the allusions are explained in *Psychology and Alchemy*, C.W., vol. 12. The English original is published here with minor stylistic changes.]

² [Jung appended the following bibliography:] Berthelot, *Collection des anciens alchimistes grecs* (1887); *Artis auriferae*, II (1593); *Theatrum chemicum* (1602–61), VI; Manget, *Bibliotheca chemica curiosa* (1702), II; Herbert Silberer, *Problems of Mysticism and Its Symbolism* (New York, 1917); R. Wilhelm and Jung, *The Secret of the Golden Flower* (1931); Jung, *Paracelsica* (1942), *Psychologie und Alchemie* (1944), *Die Psychologie der Uebertragung* (1946), *Symbolik des Geistes* (1948).

¹ [Published in *Spring*, 1955 (Analytical Psychology Club of New York), with the note: “These words, spoken in 1927. are printed here with ... permission of Dr. Jung.” Evidently written in English. Club records indicate that J. S. was Jerome Schloss. of New York, but no other details have been available.]

¹ [Zurich and Munich, 1931. For Hans Schmid-Guisan (1881–1932), see Jung’s letter of 6 Nov. 1915, in *Letters*, ed. G. Adler, vol. 1.]

² [*Casti Connubii* of Pius XI, 31 Dec. 1930.]

³ [By Francesco Colonna, 1499. Cf. *infra*, pars. 1751ff., “Foreword to Fierz-David: *The Dream of Poliphilo*.”]

⁴ [This is from the “Receuil stéganographique,” the introduction to Béroalde de Verville’s French translation of 1600, and is not represented in the above-cited English version. The trans. here, by A.S.B. Glover, is from the French.]

⁵ “Quisquis es quantumque libuerit, huius thesauri sume: at moneo, aufer caput, corpus ne tangiot.” [Cf. *The Dream of Poliphilo*, p. 39.]

⁶ [*Basler Nachrichten*, 25 Apr. 1932.]

^{6a} [Cf. *The Freud/Jung Letters*, 259J, of 12 June 1911.]

⁷ [See *Psychological Types*, C.W., vol. 6, p. xii.]

⁸ [Cf. *supra*.]

¹ ["Vorwort zum Märchen vom Fischotter," i.e., foreword to one tale in Oscar A. H. Schmitz, *Märchen aus dem Unbewussten* (Munich, 1932), with drawings by Alfred Kubin. For Schmitz (1873—1931), see Jung's letter of 26 May 1923 in *Letters*, ed. G. Adler, vol. 1.]

¹ [Written originally in German, in answer to the question “Existe-t’il une poésie de signe freudien?” and published in a French trans. in the *Journal des poètes* (Brussels), III:5 (11 Dec. 1932), under the heading “La Psychanalyse devant la poésie,” with answers also from R. Allendy and Louis Charles Baudouin.]

¹ [Written in English. The book was never published. For J. Allen Gilbert, M.D. (1867–1948), American psychotherapist, see Jung's letters of 19 June 1927 and 8 Jan. 1934 (relevant to this MS) in *Letters*, ed. G. Adler, vol. 1.]

¹ [(“Reality of the Soul”; subtitled “Applications and Advances of the New Psychology.”) Besides the four contributions of other writers, there are nine essays by Jung, which were assigned to several vols. of the C.W.]

² [W. M. Kranefeldt, “Der Gegensatz von Sinn und Rhythmus im seelischen Geschehen,” and “‘Ewige Analyse’. Bemerkung zur Traumdeutung und zum Unbewussten.”]

³ [Hugo Rosenthal, “Der Typengegensatz in der jüdischen Religionsgeschichte.”]

⁴ [Emma Jung, “Ein Beitrag zum Problem des Animus.” Trans. by Cary F. Baynes, “On the Nature of the Animus,” in *Animus and Anima* (Analytical Psychology Club of New York, 1957).]

⁵ [Cf. “Foreword to *Seelenprobleme der Gegenwart*,” supra, par. 1292.]

¹ [Zurich and Leipzig. 1935. (“Fichte’s Psychology and Its Relation to the Present.” The author, Dr. Rose Mehlich, closed her book with a chapter on Fichte and Jung.)]

² [Heinrich Rickert (1863–1936), German philosopher, taught that an individual’s bias influences what he learns.]

¹ [Stuttgart, 1935. (“Transformations of Dream Problems from Romanticism to the Present.”) For Dr. Olga von Koenig-Fachsenfeld, see Jung’s letter of 5 May 1941 in *Letters*, ed. G. Adler, vol. I.]

² [A symbol of the poet’s search, in German romantic poetry. Cf. *Psychology and Alchemy*, C.W., vol. 12, pars. 99ff.]

¹ [Zurich, 1938. (“The Dark Brother.”) Gertrud Gilli was a graphologist. Cf. her article, “C. G. Jung in seiner Handschrift,” in *Die kulturelle Bedeutung der komplexen Psychologie* (1935).]

² [*The Jewish War*, II, 56; A.D. 6 or 7.]

¹ [Author's abstract of a lecture given to the Psychological Club, Zurich, on 9 June 1945; published in the Club's *Jahresbericht*, 1945–46. A typescript (24 pp.) of the entire lecture, made from a stenogram and evidently not corrected by Jung, is in the Jung archives.]

¹ [Linda Fierz-David. *Der Liebestraum des Poliphilo, ein Beitrag zur Pyschologie der Renaissance und der Moderne* (Zurich, 1947); trans. by Mary Hottinger, *The Dream of Poliphilo* (Bollingen Series XXV, New York, 1950). The translation of the foreword is revised here.]

² [Venice, 1499.]

¹ [Zurich, 1949. By Robert Crottet. (“Moon-Forest,” subtitled “Lappish Stories.”)]

¹ [Written in German; trans., with the entire book, by Norbert Guterman (Bollingen Series XXVIII, New York, 1951), and slightly revised here. The original book, edited by Jolande Jacobi (see supra, par. 1121, n. 1) was *Theophrastus Paracelsus: Lebendiges Erbe* (“Living Heritage”) (Zurich, 1942).]

² [Karl Sudhoff, editor of the *Sämtliche Werke* of Paracelsus, in 14 vols. (1922–1935).]

¹ [Munich and Basel, 1959. (“The Unconscious as Seedbed of the Creative,” subtitled “Testimonials from Scholars, Poets, and Artists.”)]

¹ [Bombay and London (Asia Publishing House), 1960; republished by Routledge & Kegan Paul, London, 1972. For Miguel Serrano, see Jung's letter of 31 Mar. 1960 in *Letters*, ed. G. Adler, vol. 2. The present foreword was originally a letter in English to Serrano, 14 Jan. 1960; here somewhat revised.]

¹ [Letter in answer to this question published (in French) in the *Flinker Almanac 1961* (Librairie Française et Etrangère, Paris). For another letter to Martin Flinker, 17 Oct. 1957, published in his *Almanac 1958*, see *Letters*, ed. G. Adler, vol. 2.]

¹ [*Europäische Revue* (Berlin), IX: 10 (Oct. 1933), 639. Gustav Richard Heyer, *Der Organismus der Seele* (Munich, 1932); trans. by E. and C. Paul, *The Organism of the Mind* (London, 1933). For Heyer (1890–1967), see Jung’s letter of 20 Apr. 1934, in *Letters*, ed. G. Adler, vol. 1.]

² [Zentralblatt für Psychotherapie, IX:3 (1936), 184–86. Heyer, *Praktische Seelenheilkunde* (Munich, 1935).]

¹ [Author's abstract of two lectures given at the Psychological Club, Zurich, on unknown dates; published in the Club's *Jahresbericht*, 1936–37. The symbolic illustrations of the *Rosarium philosophorum* are used by Jung as a parallel to the modern psychotherapeutic process in "The Psychology of the Transference" (C.W., vol. 16), first published as *Die Psychologie der Übertragung* (Zurich, 1946). The present lectures were an early exercise toward that publication.]

² [Jung carved the Latin text on a cube of hewn stone at his "Tower" in Bollingen, in 1950. Cf. *Memories, Dreams, Reflections*, pp. 226f./215f.]

³ [Cf. *Psychology and Alchemy*, par. 246, n. 125.]

⁴ [Cf. "The Psychology of the Transference," Fig. 1.]

⁵ [*Psychology and Alchemy*, par. 360.]

⁶ ["The Psychology of the Transference," Fig. 9.]

⁷ [Ibid., par. 457.]

⁸ [Ibid., Fig. 10.]

¹ [*Psychotherapy*, I: 1 (April 1956), organ of the Indian Psychotherapeutical Society, Calcutta. Dr. Samiran Bannerjee was honorary secretary. Jung's typescript, in English, is dated 7 Sept. 1955.]

¹ [(Translated by H. N.) Commentary on Walter Pöldinger, “Zur Bedeutung bildnerischen Gestaltens in der psychiatrischen Diagnostik,” *Die Therapie des Monats* (Mannheim), IX:2 (1959), with reproductions of pictures by a patient. Pöldinger was on the staff of a mental hospital in Lucerne.]

² [Refers to a question asked in regard to one picture.]

¹ [New York, 1920; London, 1921. By Elida Evans, an American child specialist. The foreword appears to have been written in English.]

¹ [New York and London, 1933. The foreword, written in German, was trans. for the book by Cary F. Baynes. The present version is somewhat revised. For Esther Harding, see supra, par. 1125, n. 1.]

² [*Casti Connubii* of Pius XI, 31 Dec. 1930.]

¹ [Written in answer to questions from Dr. Jolande Jacobi. Published in *DU: Schweizerische Monatsschrift* (Zurich), III: 9 (Sept. 1943), and in an English trans. by an unknown hand in *Horizon* (London), VIII:48 (Dec. 1943). This trans. is reproduced here in revised form. It was previously published in *Spring*, 1969.]

¹ [Translated from a German MS by Victor Grove for the English trans. of Julius Spier, *The Hands of Children: An Introduction to Psycho-chirology* (London, 1944); 2nd edn., 1955, with an appendix, “The Hands of the Mentally Diseased,” by Herta Levi. The trans. has been revised.]

² [Rodolphus Goelenius, *Uranoscopiae, chiroscopiae, metoposcopiae et ophthalmoscopiae contemplatio* (Frankfurt, 1608).

¹ [Tel-Aviv. 1958. Trans. here from the original German MS.]

² ["Psychic Conflicts in a Child," "Analytical Psychology and Education," and "The Gifted Child" (C.W., vol. 17), the contents of *Psychologie und Erziehung* (1946).]

¹[(Translated by L. R.) Leipzig and Vienna: Deuticke, 1914. The volume contained papers by Josef Lang, J. Vodoz, Hans Schmid, and C. Schneiter. The series was not used again until 1928, when Jung published *Über die Energetik der Seele* as vol. II (Zurich: Rascher, henceforward). This and the succeeding volumes were devoted to Jung's writings, sometimes with contributions by colleagues: III (1931), *Seelenprobleme der Gegenwart*, with a contribution by W. M. Kranefeldt; IV (1934), *Wirklichkeit der Seele*, with contributions by Hugo Rosenthal, Emma Jung, and W. M. Kranefeldt; V (1944), *Psychologie und Alchemie*; VI (1948), *Symbolik des Geistes*, with a contribution by R. Schärf; VII (1950), *Gestaltungen des Unbewussten*, with a contribution by Aniela Jaffé; VIII (1951), *Aion*, with a contribution by M.-L. von Franz; IX (1954), *Von den Wurzeln des Bewusstseins*; X–XII (1955–56), *Mysterium Coniunctionis*, with a contribution by M.-L. von Franz (= an edition of *Aurora Consurgens*, constituting vol. XII).]

¹ [(Translation revised and augmented by L. R.) The text of this address given above, pars. 1514–1517 (q.v.), was obtained by the Editors from the Jung archives at Küsnacht in the early 1960's and was assigned to R.F.C. Hull for translation on the assumption that it represented the text that Jung read at the convocation in Zurich, 15 Nov. 1953. In 1975, when the present vol. was in page proof, a considerably augmented version was published (in German) by Professor Gilles Quispel as an appendix to the volume *C. G. Jung: een mens voor deze tijd* (Rotterdam), consisting of essays (in Dutch) on Jung's work by Quispel ("Jung and Gnosis"), C. Aalders, and J. H. Plokker. Quispel had obtained this text of the Address some years earlier from one of the persons who had arranged the convocation. Subsequently, Professor C. A. Meier provided an even fuller version of Jung's actual remarks, and that is translated here (the added material being indicated by a vertical line in the left margin). Jung had first written the shorter version, then had expanded it prior to the occasion, but the shorter version had been circulated.

George H. Page, of Switzerland, donated funds that enabled the Jung Institute to purchase the Codex from the estate of Albert Eid, a Belgian dealer in antiquities who had acquired it in Egypt. Professor Meier, then director of the Institute, had played the leading role in tracing and negotiating for the Codex. In accordance with the original agreement, the Codex was eventually given to the Coptic Museum in Cairo.]

- * Published 1957; 2nd edn., 1970.
- † Published 1973.
- * Published 1960.
- † Published 1961.
- ‡ Published 1956; 2nd edn., 1967. (65 plates, 43 text figures.)
- * Published 1971.
- † Published 1953; 2nd edn., 1966.
- ‡ Published 1960; 2nd edn., 1969.
- * Published 1959; 2nd edn., 1968. (Part I: 79 plates, with 29 in colour.)
- * Published 1964; 2nd edn., 1970. (8 plates.)
- † Published 1958; 2nd edn., 1969.
- * Published 1953; 2nd edn., completely revised, 1968. (270 illustrations.)
- † Published 1968. (50 plates, 4 text figures.)
- ‡ Published 1963; 2nd edn., 1970. (10 plates.)
- * Published 1966.
- † Published 1954; 2nd edn., revised and augmented, 1966. (13 illustrations.)
- ‡ Published 1954.

B O L L I N G E N S E R I E S X X

THE COLLECTED WORKS

OF

C. G. JUNG

VOLUME 19

EDITORS

† SIR HERBERT READ

MICHAEL FORDHAM, F.R.C.PSYCH., HON. F.B.P.S.S

GERHARD ADLER, PH.D.

WILLIAM MC GUIRE, *executive editor*

GENERAL
BIBLIOGRAPHY
of C. G. Jung's Writings

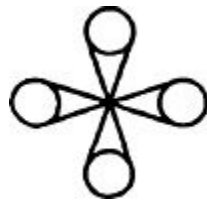

COMPILED BY LISA RESS

WITH COLLABORATORS

BOLLINGENSERIESXX

PRINCETON UNIVERSITY PRESS

COPYRIGHT © 1979 BY PRINCETON UNIVERSITY PRESS, PRINCETON, N.J

THIS EDITION IS BEING PUBLISHED IN THE UNITED STATES OF AMERICA FOR BOLLINGEN FOUNDATION BY PRINCETON UNIVERSITY PRESS AND IN ENGLAND BY ROUTLEDGE & KEGAN PAUL, LTD. IN THE AMERICAN EDITION, ALL THE VOLUMES COMPRISING THE COLLECTED WORKS CONSTITUTE NUMBER XX IN BOLLINGEN SERIES. THE PRESENT VOLUME IS NUMBER 19 OF THE COLLECTED WORKS AND IS THE LAST TO BE PUBLISHED.

LIBRARY OF CONGRESS CATALOGUE CARD NUMBER: 75-156

ISBN 0-691-09893-X

MANUFACTURED IN THE U.S.A.

EDITORIAL NOTE

In the compilation of the following list of published writings, it has been the intention to record (through 1975) the initial publication of each original work of C. G. Jung, each translation, and subsequent substantial revisions and/or expansions thereof, with reciprocal cross-references. The items are ordered chronologically by years of publication, and within the year to the best of our knowledge (books first); items that cannot be dated closely enough appear at the end of the year's listings. Unless otherwise indicated (by an initial asterisk), each publication in German, English, and French has been examined by the compilers and described accordingly. This principle could not, practically, be observed for works in other languages, though these have been examined insofar as possible. Translations are related by cross-references to the work from which the translation was made, though it has not been possible to ascertain this in every case.

Unrevised reprintings of a text are not recorded unless brought out by a different publisher or altered in format, as in the case of a paperback edition. In such instances, the reissue is noted under the original entry. Separately reprinted brief extracts have generally been omitted as well. The proliferation of reprints, particularly in paperback, and of extract and anthologized use of Jung's writings both in brief and in extenso has made a policy of inclusiveness unrealistic.

In addition to all books and articles written by Jung solely or in collaboration with others, it has been the intention to record all forewords and the like written for other authors' works, letters included in other writers' publications, book reviews, newspaper articles both popular and scholarly, published texts of lectures appearing either in full or as summarized by their author ("Autoreferat"), and announcements issued in his capacity as editor.

In order to give as nearly complete a record as possible of Jung's publication, as well as to throw light on the sequence of development of his ideas, we have included, duly distinguished and with the permission of the responsible organizations, those items issued initially for private circulation. For the same reasons, we have included whatever information became available to us in regard to the delivery of a publication on some occasion in lecture form, and other useful secondary information. A separate list records chronologically the volumes of Seminar Notes, for the most part issued privately and under restriction. The numerous interviews with Jung—either published in periodicals and books or recorded for radio, television, or film, or by tape—have not been listed. Those of most interest and value are published in a volume, outside the *Collected Works*, entitled *C. G. Jung Speaking: Interviews and Encounters*.

The *Collected Works* (in English) and the *Gesammelte Werke* (in German) are separately listed, in volume sequence, with the necessary reciprocal cross-references. (Lists of contents of volumes 2 and 13 in the *Gesammelte Werke*, though still in press, were added in proof but could not be included in the indexes.)

While we have aimed at citing every substantial publication of Jung's writings, we are aware that in the case of items appearing in newspapers, books by other authors, etc., and particularly in the case of translations, omissions undoubtedly have occurred. We shall be grateful to be informed of these—and of any omissions and errors whatever—looking toward a revised edition of the General Bibliography.

*

This bibliography of Jung's writings was originally compiled, as a working tool for the English collection edition at the outset, by Michael Fordham, who based it on a list published by Jolande Jacobi in her *The Psychology of C. G. Jung*; he was indebted also, for advice, to Professor Jung's secretary at that time, Marie-Jeanne Schmid. This "draft bibliography," more or less in the form of the present publication, underwent revision and augmentation by the Editors and staff in a printed version that was privately distributed to workers in the field. The project of compiling a definitive General Bibliography was undertaken by A.S.B. Glover. After his death, in 1966, the work was carried on, under William McGuire's supervision, first by Jasna P. Heurtley and then by Lisa Ress, who is responsible for the present comprehensive state of the Bibliography.

The editors and publishers of the *Gesammelte Werke*, in Switzerland, have been of assistance throughout. Others to whom the compilers are especially indebted are Doris Albrecht, Roland Cahen, Aldo Carotenuto, G. Dreifuss, Aniela Jaffé, and Mihoko Okamura. The resources of two collections have been of particular value: the library of Professor C. G. Jung, at his house in Küsnacht/Zürich, subsequently in the care of Mr. and Mrs. Franz Jung, and the Kristine Mann Library of the Analytical Psychology Club of New York.

*

ABBREVIATIONS AND SYMBOLS. The bibliographical abbreviations will, it is assumed, be obvious to users of the Bibliography. Abbreviations of titles of periodicals are explained in the index of periodicals. CW = *Collected Works*; GW = *Gesammelte Werke* (both listed by volumes in [Part II](#)). BS = Bollingen Series. An asterisk preceding an entry in the German, English, and French sections indicates that the publication could not be examined.

VOLUME 19 GENERAL BIBLIOGRAPHY

CONTENTS

EDITORIAL NOTE

I. THE PUBLISHED WRITINGS OF C. G. JUNG:

Original Works and Translations

German

English

Danish

Dutch

Finnish

French

Greek

Hebrew

Hungarian

Italian

Japanese

Norwegian

Portuguese

Russian

Serbo-Croatian

Slovenian

Spanish

Swedish

Turkish

II. THE COLLECTED WORKS OF C. G. JUNG / DIE GESAMMELTEN WERKE VON C. G. JUNG

III. SEMINAR NOTES

INDEXES

1. Titles (of all English and German items and of original works in other languages)

2. Personal Names

3. Congresses, Organizations, Societies, etc.

4. Periodicals

ADDENDA

I

THE PUBLISHED WRITINGS OF C. G. JUNG

Original Works and Translations

GERMAN

- 1902a *Zur Psychologie und Pathologie sogenannter occulter Phänomene. Eine psychiatrische Studie.* Leipzig: Oswald Mutze. pp. 121. Repub. as GW 1,1. Inaugural dissertation for the doctoral degree, presented to the Universität Zürich, Medizinische Fakultät. TR.—English: 1916a,2/CW 1,1//French: 1939a,2/1956a,4//Russian: 1939a.
- 1902b “Ein Fall von hysterischem Stupor bei einer Untersuchungsgefangenen.” *J. Psychol. Neurol.*, I:3, 110–22. Repub. as GW 1,5. TR.—English: CW 1,5.
- 1903a “Über manische Verstimmung.” *Allgemeine Zeitschrift für Psychiatrie und psychisch-gerichtliche Medizin*, LXI:1, 15–39. Repub. as GW 1,4. TR.—English: CW 1,4.
- 1903b “Über Simulation von Geistesstörung.” *J. Psychol. Neurol.*, II:5, 181–201. Repub. as GW 1,6. TR.—English: CW 1,6.
- 1904a With F. Riklin: “Experimentelle Untersuchungen über Assoziationen Gesunder.” (Diagnostische Assoziationsstudien, I. Beitrag.) *J. Psychol. Neurol.*, as follows: Pt. I—III:1/2, 55–83; Pt. II—III:4, 145–64; Pt. III—III:5, 193–215; Pt. IV—III:6, 283–308; Pt. V—IV: 1/2, 24–67. Combined and pub. as G.1906a, 1 with slight title change.
- 1904b “Über hysterisches Verlesen: eine Erwiderung an Herrn Hahn (pr. Arzt in Zürich).” *Archiv für die gesamte Psychologie*, III:4 (May), 347–50. Repub. as GW 1,2. TR.—English: CW 1,2.
- 1904c “Ärztliches Gutachten über einen Fall von Simulation geistiger Störung.” *Schweiz. Z. Strafrecht*, XVII, 55–75. Repub. as GW 1,7. TR.—English: CW 1,7.
- 1905a “Kryptomnesie.” *Die Zukunft*, Jhg. 13, L (25 Feb.), 325–34. Repub., slightly rev., as GW 1,3. TR.—English: CW 1,3.
- 1905b Review of Willy Hellpach: *Grundlinien einer Psychologie der Hysterie.* *Zbl. Nervenhk.*, XXVIII (n.s. XVI) (15 Apr.), 318–21. TR.—English: CW 18,19.
- 1905c “Experimentelle Beobachtungen über das Erinnerungsvermögen.” *Zbl. Nervenhk.*, XXVIII (n.s. XVI): 196 (1 Sept.), 653–66. Repub. as GW 2,4. TR.—English: CW 2,4.
- 1905d “Zur psychologischen Tatbestandsdiagnostik.” *Zbl. Nervenhk.*, XXVIII (n.s. XVI):200 (1 Nov.), 813–15. Repub. as GW 1,9. TR.—English: CW 1,9.

- 1905e “Über spiritistische Erscheinungen.” *Basl. Nach.*, Nos. 311–16 (12–17 Nov.). Extract pub. in *Volksrecht* (22 Nov.). Given as lecture at the Bernoullianum, Basel, 5 Feb. 1905. TR.—English: CW 18,4.
- 1905f “Die psychologische Diagnose des Tatbestandes.” *Schweiz, Z. Strafrecht*, XVIII, 369–408. Repub. as G. 1906k with last (minor) sentence omitted.
- 1905g “Analyse der Assoziationen eines Epileptikers.” (Diagnostische Assoziationsstudien, III. Beitrag.) *J. Psychol. Neurol.*, V:2, 73–90. Repub. as G. 1906a,2.
- 1905h “Über das Verhalten der Reaktionszeit beim Assoziationsexperimente.” (Diagnostische Assoziationsstudien, IV. Beitrag.) *J. Psychol. Neurol.*, VI: 1/2, 1–36. Also issued as pamphlet, Leipzig: Barth. pp. 38. Jung’s “Habilitationsschrift,” Universität Zürich, Medizinische Fakultät. Repub. as G. 1906a,3.
- 1906a *Diagnostische Assoziationsstudien: Beiträge zur experimentellen Psychopathologie*. Ed. by C. G. Jung. Vol. I. Leipzig: Barth. pp. 281. Subsequently issued bound as one with G. 1909a. Contains the following works wholly or partly by Jung:
1. With F. Riklin: “Experimentelle Untersuchungen über Assoziationen Gesunder.” (7–145) G. 1904a repub. with slight title change. Repub. as GW 2,1. TR.—English: 1918a,1/CW 2,1.
 2. “Analyse der Assoziationen eines Epileptikers.” (175–92) G. 1905g repub. Repub. as GW 2,2. TR.—English: 1918a,2/CW 2,2.
 3. “Über das Verhalten der Reaktionszeit beim Assoziations-experimente.” (193–228) G. 1905h repub. Repub. as GW 2,3. TR.—English: 1918a,3/CW 2,3.
 4. “Psychoanalyse und Assoziationsexperiment.” (258–81) G. 1906i repub. Repub. as GW 2,5. TR.—English: 1918a,4/CW 2,5.
- Contents also summarized in French by Jung. Cf. Fr. 1908a.
- 1906b “Die psychopathologische Bedeutung des Assoziationsexperimentes.” *Archiv für Kriminalanthropologie und Kriminalistik*, XXII:2–3 (15 Feb.), 145–62. Given as inaugural lecture upon Jung’s appointment as Lecturer in Psychiatry, Universität Zürich, 21 Oct. 1905. Repub. as GW 2,8. TR.—English: CW 2,8.
- 1906c “Statistisches von der Rekrutenaushebung.” *CorrespBl. schweizer Ärzte*, XXXVI:4 (15 Feb.), 129–30. Repub. as GW 2,15. TR.—English: CW 2,15.

- 1906d “Obergutachten über zwei sich widersprechende psychiatrische Gutachten.” *Monatsschrift für Kriminalpsychologie und Strafrechtsreform*, II:11/12 (Feb.-Mar.), 691–98. Repub. as GW 1,8 with minor title change. TR.—English: CW 1,8.
- 1906e Review of L. Bruns: *Die Hysterie im Kindesalter*. *CorrespBl. schweizer Ärzte*, XXXVI:19 (1 Oct.), 634–35. TR.—English: CW 18,20.
- 1906f Review of E. Bleuler: *Affektivität, Suggestibilität, Paranoia*. *CorrespBl. schweizer Ärzte*, XXXVI:21 (1 Nov.), 694–95. TR.—English: CW 18,20.
- 1906g “Die Hysterielehre Freuds. Eine Erwiderung auf die Aschaffenburgsche Kritik.” *Münchener medizinische Wochenschrift*, LIII:47 (20 Nov.), 2301–02. Repub. as GW 4,1. TR.—English: CW 4,1.
- 1906h Review of Carl Wernicke: *Grundriss der Psychiatrie in klinischen Vorlesungen*. *CorrespBl. schweizer Ärzte*, XXXVI:23 (1 Dec), 790–91. TR.—English: CW 18,20.
- 1906i “Psychoanalyse und Assoziationsexperiment.” (Diagnostische Assoziationsstudien, VI. Beitrag.) *J. Psychol. Neurol.*, VII: 1/2, 1–24. Also pub. in *Schweiz. Z. Strafrecht*, XVIII, 396–403. Repub. as G. 1906a,4. TR.—English: 1918a,4.
- 1906j “Assoziation, Traum und hysterisches Symptom.” *J. Psychol. Neurol.*, VIII: 1/2, 25–60. Repub. as G. 1909a,1.
- 1906k “Die psychologische Diagnose des Tatbestandes.” *Juristisch-psychiatrische Grenzfragen*, IV:2, 3–47. Also pub. as pamphlet (bound with article by another author). Halle: Carl Marhold. At head of title: “Aus der psychiatrischen Universitätsklinik in Zürich.” G. 1905f repub. with omission of last (minor) sentence. Repub. as monograph: G. 1941d; and as GW 2,6. TR.—English: CW 2,6.
- 1907a *Über die Psychologie der Dementia praecox: Ein Versuch*. Halle a. S.: Carl Marhold. pp. 179. 1972: (Frühe Schriften II; “Studienausgabe.”) Olten: Walter. pp. 180.

Vorwort. (Dated July 1906.)

- I. Kritische Darstellung theoretischer Ansichten über die Psychologie der Dementia praecox.
- II. Der gefühlsbetonte Komplex und seine allgemeinen Wirkungen auf die Psyche.
- III. Der Einfluss des gefühlsbetonten Komplexes auf die Association.

IV. Dementia praecox und Hysterie. Eine Parallele.

V. Analyse eines Falles von paranoider Demenz, als Paradigma.

Schlusswort.

Repub. as GW 3,1. TR.—English: 1909a/CW 3,1//Russian: 1939a.

- 1907b Review of Albert Moll: *Der Hypnotismus, mit Einschluss der Hauptpunkte der Psychotherapie und des Occultismus*. *CorrespBl. schweizer Ärzte*, XXXVII:11 (1 June), 354–55. TR.—English: CW 18,20.
- 1907c Review of Albert Knapp: *Die polyneuritischen Psychosen*. *CorrespBl. schweizer Ärzte*, XXXVII: 11 (1 June), 355. TR.—English: CW 18,20.
- 1907d Review of M. Reichhardt: *Leitfaden zur psychiatrischen Klinik*. *CorrespBl. schweizer Ärzte*, XXXVII:23 (1 Dec.), 742–43. TR.—English: CW 18,20.
- 1907e “Über die Reproduktionsstörungen beim Assoziationsexperiment.” (Diagnostische Assoziationsstudien, IX. Beitrag.) *J. Psychol. Neurol.*, IX:4, 188–97. Repub. as G. 1909a,2.
- 1907f Contribution to discussion of paper by Frank and Bezzola: “Über die Analyse psychosomatischer Symptome,” p. 185, in “II. Vereinsbericht. 37. Versammlung südwestdeutscher Irrenärzte in Tübingen am 3. und 4. November 1906.” *Zbl. Nervenhk.*, n.s. XVIII:5, 176–91.
- 1908a *Der Inhalt der Psychose*. (Schriften zur angewandten Seelenkunde, 3.) Leipzig and Vienna: Franz Deuticke. pp. 26. Repub. with supplement as G. 1914a. Academic lecture, given at the Rathaus, Zurich, 16 Jan. 1908. TR.—Russian: 1909a.
- 1908b With E. Bleuler: “Komplexe und Krankheitsursachen bei Dementia praecox.” *Zbl. Nervenhk.*, XXXI (n.s. XIX), (Mar.), 220–27.
- 1908c 7 abstracts. *Folia neuro-biol.*, 1:3 (Mar.), 493–94, 497–99. Listed but not trans. at the end of CW 18,26. Articles abstracted by Jung:
1. 388) Jung, C. G. “Associations d’idées familiales.”
 2. 389) Métral, M. “Expériences scolaires sur la mémoire de l’orthographe.”
 3. 394) Lombard, Emile. “Essai d’une classification des phénomènes de glossolalie.”
 4. 395) Claparède, Ed. “Quelques mots sur la définition de l’hystérie.”
 5. 396) Flournoy, Th. “Automatisme téléologique antisuicide....”
 6. 397) Leroy, E.-Bernard. “Escroquerie et hypnose. ... ”

7. 398) Lemaître, Aug. “Un nouveau cycle somnambulique de Mlle. Smith. Les peintures religieuses.”

All of the above articles reviewed appeared originally in the *Archives de psychologie* 1907, VII:25&26. Cf. CW 18,26,ii.

1908d “Über die Bedeutung der Lehre Freuds für Neurologie und Psychiatrie” (Autoreferat). *CorrespBl. schweizer Ärzte*, XXXVIII:7 (1 Apr.), 218.

Summary of lecture given to the Gesellschaft der Ärzte des Kantons Zürich, autumn meeting, 26 Nov. 1907. TR.—English: CW 18,21.

1908e Review of Franz C. R. Eschle: *Grundzüge der Psychiatrie*. *CorrespBl. schweizer Ärzte*, XXXVIII:8 (15 Apr.), 264–65. TR.—English: CW 18,20.

1908f Review of P. Dubois: *Die Einbildung als Krankheitsursache*. *CorrespBl. schweizer Ärzte*, XXXVIII: 12 (15 June), 399. TR.—English: CW 18,20.

1908g Review of Georg Lomer: *Liebe und Psychose*. *CorrespBl. schweizer Ärzte*, XXXVIII: 12 (15 June), 399–400. TR.—English: CW 18,20.

1908h Review of E. Meyer: *Die Ursachen der Geisteskrankheiten*. *CorrespBl. schweizer Ärzte*, XXXVIII, 706. TR.—English: CW 18,20.

1908i 9 abstracts. *Folia neuro-biol.*, II: 1 (Oct.), 124–25, 132–35. Listed but not trans. at the end of CW 18,26. Articles abstracted by Jung:

1. 122) Piéron, H. “La théorie des émotions et les données actuelles de la physiologie.”
2. 123) Revault d’Allones, [G.] “L’explication physiologique de l’émotion.”
3. 124) Hartenberg, P. “Principe d’une physiognomie scientifique.”
4. 130) Dumas, G. “Qu’est-ce que la psychologie pathologique?”
5. 131) Dromard, [G.] “De la dissociation de la mimique chez les aliénés.”
6. 132) Marie, A. “Sur quelques troubles fonctionnels de l’audition chez certains débiles mentaux.”
7. 133) Janet, P. “Le renversement de l’orientation ou l’allochirie des représentations.”
8. 134) Pascal, [Constanza]. “Les maladies mentales de Robert Schumann.”
9. 135) Vigouroux, [A.] et Juquelier, [P.] “Contribution clinique à l’étude des délires du rêve.”

All the articles reviewed appeared originally in the *Journal de psychologie normal et pathologique*, IV (Sept.-Oct. 1907), V (Mar.-Apr. 1908). Cf. CW 18,26,ii.

- 1908j Review of Wilhelm Stekel: *Nervöse Angstzustände und ihre Behandlung*. *Medizinische Klinik*, IV:45 (8 Nov.), 1735–36. TR.—English: CW 18,22.
- 1908k Review of Sigmund Freud: *Zur Psychopathologie des Alltagslebens*. *CorrespBl. schweizer Ärzte*, XXXVIII:23 (1 Dec.), 775–76. TR.—English: CW 18,20.
- 1908l 5 abstracts. *Folia neuro-biol.*, II:3 (Dec.), 366–68. Listed but not trans. at the end of CW 18,26. Articles abstracted by Jung:
1. 348) Varendonck, J. “Les idéals des enfants.”
 2. 349) Claparède, Ed. “Classification et plan des méthodes psychologiques.”
 3. 350) Kataroff, Dimitre. “Expériences sur le rôle de la récitation comme facteur de la mémorisation.”
 4. 351) Maeder, Alphonse. “Nouvelles contributions à la psychopathologie de la vie quotidienne.”
 5. 352) Rouma, Georges. “Un cas de Mythomanie. ... ”
- All of the above articles reviewed appeared originally in the *Archives de psychologie 1908*, VII:27&28. Cf. CW 18,26,ii.
- 1908m “Die Freudsche Hysterietheorie.” *Monatsschrift für Psychiatrie und Neurologie*, XXIII:4, 310–22. Repub. as GW 4,2. Lecture given to the First International Congress of Psychiatry and Neurology, Amsterdam, Sept. 1907. TR.—English: CW 4,2//Dutch: 1908a.
- 1908n “Zur Tatbestandsdiagnostik.” *Z. angew. Psychol.*, I:1/2, 163.
- 1908o Contribution entitled “Deutsche Schweiz” to “Der gegenwärtige Stand der angewandten Psychologie in den einzelnen Kulturländern.” *Z. angew. Psychol.*, I, 469–70. TR.—English: CW 18,9.
- 1909a *Diagnostische Assoziationsstudien: Beiträge zur experimentellen Psychopathologie*. Ed. by C. G. Jung. Vol. II. Leipzig: Barth. Subsequently issued bound as one with G. 1906a. Contains the following works by Jung:
1. “Assoziation, Traum und hysterisches Symptom.” (31–66) G. 1906j repub. Repub. as GW 2,7. TR.—English: 1918a,5/CW 2,7.
 2. “Über die Reproduktionsstörungen beim Assoziationsexperiment.” (67–76) G. 1907e repub. Repub. as GW 2,9. TR.—English: 1918a,6/CW 2,9.
- 1909b “Vorbemerkung der Redaktion.” *Jb. psychoanal. psychopath. Forsch.*, I:1. 1 p. Dated Jan. 1909. TR.—English: CW 18,23.

- 1909c “Die Bedeutung des Vaters für das Schicksal des Einzelnen.” *Jb. psychoanal. psychopath. Forsch.*, I:1, 155–73. Also pub. as pamphlet, Leipzig and Vienna: Franz Deuticke. pp. 19. “Zweite, unveränderte, mit einer Vorrede versehene Auflage.” Pub., rev. and exp., as G. 1949a. TR.—English: 1916a,4/ (Pts. only) CW 4,14// French: 1935a,3.
- 1909d Review of Karl Kleist: *Untersuchungen zur Kenntnis der psychomotorischen Bewegungsstörungen bei Geisteskranken*. *CorrespBl. schweizer Ärzte*, XXXIX: 1 (1 Jan.), 176. TR.—English: CW 18,20.
- 1909e Review of L. Loewenfeld: *Homosexualität und Strafgesetz*. *CorrespBl. schweizer Ärzte*, XXXIX: 1 (1 Jan.), 176. TR.—English: CW 18,20.
- 1909f Review of Oswald Bumke: *Landläufige Irrtümer in der Beurteilung von Geisteskranken*. *CorrespBl. schweizer Ärzte*, XXXIX:6 (15 Mar.), 205. TR.—English: CW 18,20.
- 1909g Review of Christian von Ehrenfels: *Grundbegriffe der Ethik*. *CorrespBl. schweizer Ärzte*, XXXIX:6 (15 Mar.), 205. TR.—English: CW 18,20.
- 1909h Review of Isidor Sadger: *Konrad Ferdinand Meyer. Eine pathographisch-psychologische Studie*. *Basl. Nach.* (Nov.), 1 p. TR.—English: CW 18,11.
- 1909i Review of Louis Waldstein: *Das unbewusste Ich und sein Verhältnis zur Gesundheit und Erziehung*. *Basl. Nach.* (9 Dec.), 1 p. TR.—English: CW 18,12.
- 1910a Review of Christian v. Ehrenfels: *Sexualethik*. *CorrespBl. schweizer Ärzte*, XL:6 (20 Feb.), 173. TR.—English: CW 18,20.
- 1910b Review of Alexander Pilcz: *Lehrbuch der speziellen Psychiatrie für Studierende und Aerzte*. *CorrespBl. schweizer Ärzte*, XL:6 (20 Feb.), 174. TR.—English: CW 18,20.
- 1910c Review of Max Dost: *Kurzer Abriss der Psychologie, Psychiatrie und gerichtlichen Psychiatrie ...* *CorrespBl. schweizer Ärzte*, XL:6 (20 Feb.), 174. TR.—English: CW 18,20.
- 1910d Review of W. v. Bechterew: *Psyche und Leben*. *CorrespBl. schweizer Ärzte*, XL:7 (1 Mar.), 206. TR.—English: CW 18,20.
- 1910e Review of M. Urstein: *Die Dementia praecox und ihre Stellung zum manisch-depressiven Irresein*. *CorrespBl. schweizer Ärzte*, XL:7 (1 Mar.), 206. TR.—English: CW 18,20.

- 1910f Review of Albert Reibmayer: *Die Entwicklungsgeschichte des Talentés und Genies*. I. Band. *CorrespBl. schweizer Ärzte*, XL:8 (10 Mar.), 237. TR.—English: CW 18,20.
- 1910g Review of P. Näcke: *Ueber Familienmord durch Geisteskranke*. *CorrespBl. schweizer Ärzte*, XL:8 (10 Mar.), 237–38. TR.—English: CW 18,20.
- 1910h Review of Th. Becker: *Einführung in die Psychiatrie*. *CorrespBl. schweizer Ärzte*, XL:29, 942. TR.—English: CW 18,20.
- 1910i Review of A. Cramer: *Gerichtliche Psychiatrie*. *CorrespBl. schweizer Ärzte*, XL:29, 942. TR.—English: CW 18,20.
- 1910j Review of August Forel: *Ethische und rechtliche Konflikte im Sexualleben in- und ausserhalb der Ehe*. *CorrespBl. schweizer Ärzte*, XL:29, 942–43. TR.—English: CW 18,20.
- 1910k “Über Konflikte der kindlichen Seele.” *Jb. psychoanal. psychopath. Forsch.*, II: 1, 33–58. Also pub. as monograph: Leipzig and Vienna: Franz Deuticke. pp. 26. Repub., with addn. of new foreword, as G. 1916b. Cf. E. 1910a,3 for English version. Lecture delivered to the Depts. of Psychology and Pedagogy, Clark University, Worcester, Mass., Sept. 1909. TR.—Russian: 1939a.
- 1910l “Randbemerkungen zu dem Buch von [Fritz] Wittels: *Die sexuelle Not*.” *Jb. psychoanal. psychopath. Forsch.*, II: 1, 312–15. TR.—English: 1973d,2.
- 1910m “Referate über psychologische Arbeiten schweizerischer Autoren (bis Ende 1909).” *Jb. psychoanal. psychopath. Forsch.*, II: 1, 356–88. TR.—English: CW 18,26.
- 1910n “Bericht über Amerika.” In “Bericht über die II. private psychoanalytische Vereinigung in Nürnberg am 30. und 31. März.” *Jb. psychoanal. psychopath. Forsch.*, 11:2, 737. Abstract, recorded by Otto Rank, of Jung’s paper. Briefer abstract, also by Rank, pub. in *Zbl. Psychoanal.*, 1:3 (Dec.), 130. TR.—English: CW 18,64.
- 1910o “Zur Kritik über Psychoanalyse.” *Jb. psychoanal. psychopath. Forsch.*, 11:2, 743–46. Repub. as GW 4,7. TR.—English: CW 4,7.
- 1910p “Buchanzeige.” Review of Erich Wulffen: *Der Sexualverbrecher*. *Jb. psychoanal. psychopath. Forsch.*, II:2, 747. TR.—English: CW 18,25.
- 1910q “Ein Beitrag zur Psychologie des Gerüchtes.” *Zbl. Psychoanal.*, I:1/2, 81–90. Repub. as GW 4,4. TR.—English: 1916a,5/CW 4,4//French: 1935a,2.

- 1910r “Die an der psychiatrischen Klinik in Zürich gebräuchlichen psychologischen Untersuchungsmethoden.” *Z. angew. Psychol*, III, 390. Contribution to a survey of clinical methods. Repub. as GW 2,17. TR.—English: CW 2,17.
- 1910s “Über Dementia praecox.” *Zbl. Psychoanal*, I:3 (Dec.), 128. Summary of lecture given at the I. private Psychoanalytische Vereinigung, Salzburg, 27 Apr. 1908. TR.—English: CW 18,10.
- 1911a “Wandlungen und Symbole der Libido. Beiträge zur Entwicklungsgeschichte des Denkens.” [Pt. I.] *Jb. psychoanal. psychopath. Forsch.*, III:1, 120–227. Contents:
1. Einleitung.
 2. Über die zwei Arten des Denkens.
 3. Vorbereitende Materialien zur Analyse der Millerschen Phantasien.
 4. Der Schöpferhymnus.
 5. Das Lied von der Motte.
- Repub., with G. 1912c, as G. 1912a. The 1st of 2 pts.
- 1911b “Morton Prince, M.D.: *The Mechanism and Interpretation of Dreams*. Eine kritische Besprechung.” *Jb. psychoanal. psychopath. Forsch.*, III:1, 309–28. Repub. as GW 4,6. TR.—English: CW 4,6.
- 1911c “Kritik über E. Bleuler: ‘Zur Theorie des schizophrenen Negativismus.’” *Jb. psychoanal. psychopath. Forsch.*, III:1, 469–74. Repub. as GW 3,3. TR.—English: 1916a,7/CW 3,4.
- 1911d “Buchanzeige.” Review of Eduard Hitschmann: *Freuds Neurosenlehre*. *Jb. psychoanal. psychopath. Forsch.*, III:1, 480. TR.—English: CW 18,27.
- 1911e “Ein Beitrag zur Kenntnis des Zahlentraumes.” *Zbl. Psychoanal.*, I:12, 567–72. Repub. as GW 4,5. TR.—English: 1916a,6/CW 4,5// French: 1956a,3.
- 1911f “Beiträge zur Symbolik.” *Zbl. Psychoanal.*, II:2 (Nov.), 103–04. Summary by Otto Rank of lecture given at the 3d Congress of the Internationale Psychoanalytische Vereinigung, Weimar, 22 Sept. 1911. (Ms. of lecture never discovered.) TR.—English: CW 18,34.
- 1911g “Bericht über das Vereinsjahr 1910–11.” *Korrespondenzblatt der Internationalen Psychoanalytischen Vereinigung*, pp. 16–17, in *Zbl. Psychoanal.*, II:3 (Dec), 233–34. Annual report by the president, delivered to the 3d Congress of the Internationale Psychoanalytische Vereinigung, Weimar, 21–22 Sept. 1911. TR.—English: CW 18,28.

- 1911h Contribution on ambivalence to the discussion following a paper by E. Bleuler. *Psychiatrisch-neurologische Wochenschrift*, XII:43 (21 Jan.), 406. (Also pub. in *Zbl. Psychoanal.*, 1:5 (Feb.-Mar.), 267–68, and in *CorrespBl. schweizer Ärzte*, XLI:6 (20 Feb.)) Brief remarks to papers by Von Speyr and Riklin follow. Recorded at a Winter Meeting of the Verein schweizer Irrenärzte, Bern, 27 Nov. 1910. TR.—English: CW 18,33.
- 1912a *Wandlungen und Symbole der Libido. Beiträge zur Entwicklungsgeschichte des Denkens*. Leipzig and Vienna: Franz Deuticke. pp. 422. With 8 text illus. G. 1911a and 1912c repub., combined as one. Repub., with addn. of new foreword, as G. 1925a. TR.—English: 1916b.
- 1912b *“Über Psychoanalyse beim Kinde.” I^{er} congrès international de Pédagogie, Brussels, August, 1911. [Published Papers.] Vol. II, pp. 332–43. Brussels: Librairie Misch et Thron. Subsequently incorporated into G. 1913a.
- 1912c “Wandlungen und Symbole der Libido. Beiträge zur Entwicklungsgeschichte des Denkens.” [Pt. II] *Jb. psychoanal. psychopath. Forsch.*, IV: 1, 162–464. Contents:
1. Einleitung.
 2. Über den Begriff und die genetische Theorie der Libido.
 3. Die Verlagerung der Libido als mögliche Quelle der primitiven menschlichen Erfindungen.
 4. Die unbewusste Entstehung des Heros.
 5. Symbole der Mutter und der Wiedergeburt.
 6. Der Kampf um die Befreiung von der Mutter.
 7. Das Opfer.
- Repub., with G. 1911a, as G. 1912a. The 2d of 2 pts.
- 1912d “Neue Bahnen der Psychologie” *Raschers Jahrbuch für schweizer Art und Kunst* (Zurich), III, 236–72. Repub. as GW 7,3. Pub., rev. and exp., with title change, as G. 1917a. TR.—English: 19168,15/CW 7,3 (2d edn.).
- 1912e “Psychoanalyse.” *Neue Zur. Z.*, CXXXIII:38 (10 Jan.). Jung’s response to article by J[ohann] M[ichelsen], “Psychoanalyse,” which appeared earlier in the same paper, 2 Jan. 1912. Cf. G. 1912f and 1912g. TR.—English: CW 18,29.
- 1912f “Zur Psychoanalyse.” *Neue Zur. Z.*, CXXXIII:72 (17 Jan.). Jung’s reply to a response to his G. 1912e. Cf. G. 1912e and 1912g. TR.—English: CW 18,29.
- 1912g “Zur Psychoanalyse.” *Wissen und Leben*, IX: 10 (15 Feb.), 711–14. Jung’s reply to the editor’s request for a concluding word on the controversy carried

in the *Neue Zur. Z.* (cf. G. 1912e and 1912t) in the form of a letter to the editor, dated 28 Jan. 1912. Repub. as GW 4,8. TR.—English: CW 4,8.

† *Neue Schweizer Rundschau* published as *Wissen und Leben*, 1907–1918.

- 1912h “Über die psychoanalytische Behandlung nervöser Leiden,” (Autoreferat.) *CorrespBl. schweizer Ärzte*, XLII, 28 (1 Oct.), 1079–84. Abstract of a report given at a meeting of the Medizinisch-pharmazeutischer Bezirksverein, Bern, 4 June 1912. TR.—English: CW 18,30.
- 1913a “Versuch einer Darstellung der psychoanalytischen Theorie. Neun Vorlesungen, gehalten in New-York im September 1912.” *Jb. psychoanal. psychopath. Forsch.*, V: 1, 307–441. The text of 9 lectures written in German but given in an English trans. as an Extension Course at Fordham University, Sept. 1912. Cf. E. 1913b. Repub. as monograph: Leipzig and Vienna: Franz Deuticke. pp. 135. Pub. with addns. as G. 1955b. Incorporates G. 1912b. TR.—English: 1913b/1914a/igi5b/CW 4,9//French: 1932a//Spanish: 1935b.
- 1913b “Erklärung der Redaktion.” *Jb. psychoanal. psychopath. Forsch.*, V-2, 757. Repub. in G. 1974a following 357J. TR.—English: 1974b.
- 1913c “Zur Psychologie des Negers.” *Korrespondenzblatt der Internationalen Psychoanalytischen Vereinigung*, p. 8, in *Internationale Zeitschrift für ärztliche Psychoanalyse*, 1:1, 115. Abstract of lecture given to the Zurich Branch Society of the Internationale Psychoanalytische Vereinigung, Zurich, 22 Nov. 1912. TR.—English: CW 18,65.
- 1913d “Eine Bemerkung zur Tauskschen Kritik der Nelkenschen Arbeit.” *Internationale Zeitschrift für ärztliche Psychoanalyse*, 1:3, 285–88. TR.—English: 1973d,3/CW 18,31.
- 1914a *Der Inhalt der Psychose*. (Schriften zur angewandten Seelenkunde, 3) Leipzig and Vienna: Franz Deuticke. pp. 44. G. 1908a exp. by the addn. of the rev. German version of E. 1915c as Suppl. Repub. as GW 3,2. TR.—English: 1916a,14/CW 3,2&3//Russian: 1939a.
- 1914b *Psychotherapeutische Zeitfragen. Ein Briefwechsel mit Dr. C. G. Jung*. Ed. by Dr. R. Loy. Leipzig and Vienna: Franz Deuticke. pp. 51. Repub. as GW 4,12. TR.—English: 1916a,10/CW 4,12//French: 1953a,7.
- 1914c Editorial note to *Psychologische Abhandlungen*, 1, ed. by C. G. Jung. Leipzig and Vienna: Franz Deuticke. 1 p. TR.—English: CW 18,134.
- 1916a *VII Sermones ad Mortuos. Die sieben Belehrungen der Toten*. Geschrieben von Basilides in Alexandria, der Stadt, wo der Osten den Westen berührt.

Übersetzt aus dem griechischen Urtext in die deutsche Sprache. Printed for private circulation by the author. pp. XXVIII. Repub. as G. 1962a,i5,x. TR.—English: 19253/19663,19 //Portuguese: 1969a//Spanish: 1966b. Presentation copy examined, inscribed: “To R.F.C. Hull. A souvenir from C. G. Jung. June, 1959.”

- 1916b *Über Konflikte der kindlichen Seele*. Leipzig and Vienna: Franz Deuticke. pp. 35. G. 1910k repub. with the addn. of the “Vorwort zur zweiten Auflage,” dated Dec. 1915. Pub. with further addns. as G. 1939a. TR.—French: 1935a,1//Russian: 1939a.
- 1917a *Die Psychologie der unbewussten Prozesse. Ein Überblick über die moderne Theorie und Methode der analytischen Psychologie*. (Schweizer Schriften für allgemeines Wissen, 1.) Zurich: Rascher. pp. 135. G. 1912d, rev. and exp., with title change and the addn. of a preface dated Dec. 1916. Repub., slightly rev. and with new preface, as G. 1918a. TR—English: 1917a, 15.
- 1918a *Die Psychologie der unbewussten Prozesse. Ein Überblick über die moderne Theorie und Methode der analytischen Psychologie*. Zurich: Rascher, pp. 149. G. 1917a, slightly rev., pub. with the addn. of a preface to the second edition, dated Oct. 1918. Pub., further rev. and exp., with title change, as G. 1926a.
- 1918b “über das Unbewusste.” *Schweizerland*, IV:9, 464–72; IV:11–12, 548–58. In 2 pts. Repub. as GW 10,1. TR.—English: CW 10,1.
- 1921a *Psychologische Typen*. Zurich: Rascher, pp. 704. Repr. with varying pp. Index added 1930. Contents:
- Einleitung. (7–13)
 - I. Das Typenproblem in der antiken und mittelalterlichen Geistesgeschichte. (17–94)
 - II. Über Schillers Ideen zum Typenproblem. (97–189)
 - III. Das Apollinische und das Dionysische. (193–207)
 - IV. Das Typenproblem in der Menschenkenntnis. (211–36)
 - V. Das Typenproblem in der Dichtkunst. (239–380)
 - VI. Das Typenproblem in der Psychiatrie. (383–404)
 - VII. Das Problem der typischen Einstellungen in der Ästhetik. (407–21)
 - VIII. Das Typenproblem in der modernen Philosophie. (425–55)
 - IX. Das Typenproblem in der Biographik. (459–70)
 - X. Allgemeine Beschreibung der Typen. (473–583)
 - XI. Definitionen. (587–691)

Schlusswort. (693–704)

Repub. as GW 6,1&3. TR.—Dutch: 1949b // English: ig23a/CW 6,1,2,8:4 // French: 1950a // Greek: 19353/19543 // Italian: 1948a // Japanese: (Pts. only) 1957a // Portuguese: 1967b // Russian: (Pts. only) 1924a/1929a//Spanish: 1934a//Swedish: 1941a.

- 1922a “über die Beziehungen der analytischen Psychologie zum dichterischen Kunstwerk.” *Wissen und Leben*, XV: 19 (1 Sept.), 914–25; XV:20 (15 Sept.), 964–75. (Parts I and II respectively.) Repub. as G. 1931a,3. Given as lecture to the Gesellschaft für deutsche Sprache und Literatur, Zurich, May 1922, and to the Psychologischer Club Zurich, same year. TR.—English: 1923b/CW 15,6//French: 1931a,4.
- 1925a *Wandlungen und Symbole der Libido. Beiträge zur Entwicklungsgeschichte des Denkens*. Leipzig and Vienna: Franz Deuticke. pp. 428. G. 1912a repub., with addn. of the “Vorrede zur zweiten Auflage,” dated Nov. 1924, which appears on the recto and verso of the unnumbered page between the title page and the table of contents. Pub., greatly rev. and exp., with title change, as G. 1952d. TR.—French: ig3ib//Spanish: 1953b.
- 1925b “Die Ehe als psychologische Beziehung.” *Das Ehebuch*. pp. 294–307. Ed. by Hermann Keyserling. Celle: Kampmann. Repub. as G. 1931a,11. TR.—English: 1926a/1928a,6//French: 1931a,5.
- 1925c “Psychologische Typen.” *Zeitschrift für Menschenkunde; Blätter für Charakterologie ...*, I:1 (May), 45–65. Repub. as GW 6,5. Lecture given at the Congrès international de Pedagogic Territet/Montreux, 1923. TR.—English: 1925b/CW 6,6.
- 1926a *Das Unbewusste im normalen und kranken Seelenleben... Ein Überblick über die moderne Theorie und Methode der analytischen Psychologie*. “III. vermehrte und verbesserte Auflage.” Zurich: Rascher, pp. 166. Contents:
- Vorworten. (5–10)
 - I. Die Anfänge der Psychoanalyse. (11–28)
 - II. Die Sexualtheori. (29–45)
 - III. Der andere Gesichtspunkt. Der Wille zur Macht. (46–59)
 - IV. Die zwei psychologischen Typen. (60–92)
 - V. Das persönliche und das überpersönliche oder kollektive Unbewusste. (93–115)
 - VI. Die synthetische oder konstruktive Methode. (116–29)
 - VII. Die Dominanten des kollektiven Unbewussten. (130–58)

VIII. Zur Auffassung des Unbewussten. Allgemeines zur Therapie. (159–64)

Schlusswort. (165–66)

G. 1918a rev. and exp. with title change. Again rev. and exp., with title change, as G. 1943a. TR—English: 1928b,1/CW 7,1//French: 1928a//Spanish: 1938a//Swedish: 1934a.

1926b *Analytische Psychologie und Erziehung. 3 Vorlesungen gehalten in London im Mai 1924.* Heidelberg: N. Kampmann. pp. 95. Repr. 1936: Zurich: Rascher, pp. 95. First written and given as lectures in English (cf. E. 19283,13, Lectures II-IV, London, May 1924). First pub., however, in this German version. Pub., rev. and exp., as G. 1946b,!. TR.—Dutch: 1928a.

1926c “Geist und Leben.” *Form und Sinn*, II:2 (Nov.), 33–44. Repub. as G. 1931a,13. Lecture given to the Literarische Gesellschaft Augsburg, 29 Oct. 1926, contributed to the series “Natur und Geist.” TR.—English: 1928a,2.

1927a “Die Erdbedingtheit der Psyche.” *Mensch und Erde*. pp. 83–137. Ed. by Hermann Keyserling. (Der Leuchter; Weltanschauung und Lebensgestaltung, 8.) Darmstadt: Otto Reichl. Subsequently divided and largely rewritten as G. 1931a,8 and G. 1928d. Originally given as lecture to the Conference of the Gesellschaft für freie Philosophie, Darmstadt, 1927. TR.—French: 1931a,3.

1927b “Die Frau in Europa.” *Europ. Rev.*, III:7 (Oct.), 481–99. Repub. as G. 1929a. TR.—English: 1928a,5.

1928a *Die Beziehungen zwischen dem Ich und dem Unbewussten.* Darmstadt: Reichl. pp. 208. Repr. 1933: Zurich: Rascher. Half title: *Das Ich und das Unbewusste.* Contents:

I. Die Wirkungen des Unbewussten auf das Bewusstsein.

1. Das persönliche und das kollektive Unbewusste. (11–30)

2. Die Folgeerscheinungen der Assimilation des Unbewussten. (31–60)

3. Die Persona als ein Ausschnitt aus der Kollektivpsyche. (61–73)

4. Die Versuche zur Befreiung der Individualität aus der Kollektivpsyche. (74–88)

II. Die Individuation.

1. Die Funktion des Unbewussten. (91–116)

2. Anima und Animus. (117–58)

3. Die Technik der Unterscheidung zwischen dem Ich und den Figuren des Unbewussten. (159–83)

4. Die Mana-Persönlichkeit. (184–208)

Orig. given as lecture, in German, and pub. in trans. as Fr. 1916a.

Subsequently much rev. and exp. from the German ms., and pub. as above.

Pub. with the addn. of a new foreword as G. 1935a. TR.—Dutch:

1935a//English: 1928b,2.

1928b *über die Energetik der Seele*. (Psychologische Abhandlungen, 2.) Zurich: Rascher, pp. 224. Contents:

1. Vorwort. Repub. as G. 1948b,1.

2. “Über die Energetik der Seele.” (9–111) Repub. as G. 1948b,2. TR.—English: 1928a,1.

3. “Allgemeine Gesichtspunkte zur Psychologie des Traumes.” (112–84) First pub. in an English trans. (cf. E. 1916a,13). Orig. German text considerably rev. and exp., and pub. here. Subsequently pub., rev. and exp., as G. 1948b,4. TR.—French: 1944a,6.

4. “Instinkt und Unbewusstes.” (185–99) First pub. in an English trans. (cf. E. 1919b). Pub., rev. and with the addn. of brief concluding note, as G. 1948b,6. Contribution to symposium, “Instinct and the Unconscious,” presented at a joint meeting of the Aristotelian Society, The Mind Association, and the British Psychological Association, London, July 1919. TR.—English: 1919b.

5. “Die psychologischen Grundlagen des Geisterglaubens.” (200–24) Pub., rev., as G. 1948b,7. Paper read in an English trans. before the Society for Psychical Research, London, 4 July 1919. TR.—English: 1920b//French: 1939a,4.

Whole book pub., exp., with addns. and title change, as G. 1948b.

1928c “Heilbare Geistesranke? Organisches oder funktionelles Leiden?” *Berliner Tageblatt*, 189 (21 Apr.), 1. Beiblatt. The orig. ms. bears the title “Geisteskrankheit und Seele” and was presumably given as a lecture before a meeting of the III. Allgemeiner Ärztlicher Kongress für Psychotherapie, Baden-Baden, 20–22 Apr. 1928. Repub. under the orig. title as GW 3,6. TR.—English: CW 3,7.

1928d “Die Struktur der Seele.” *Europ. Rev.*, IV: 1 (Apr.), 27–37; and IV:2 (May), 125–35. (In two parts.) Derived from G. 1927a. Pub., rev. and exp., as G. 1931a,7.

1928e “Die Bedeutung der schweizerischen Linie im Spektrum Europas.” *Neue Schw. R.*, XXXIV:6 (June), 1–11, 469–79. A retort to Keyserling’s *Das*

Spektrum Europas. Repub. as GW 10,19. TR.—English: 1959k/CW 10,19 // French: 1948a,3.

1928f “Das Seelenproblem des modernen Menschen.” *Europ. Rev.*, IV:9. (Dec.), 700–15. Brief, much simplified version pub. as G. 1929e. Pub., rev. and exp., as G. 1931a,14. Read before the Tagung des Verbandes für intellektuelle Zusammenarbeit, Prague, Oct. 1928. TR.—English: 1931c // French: 1931a,2.

1928g “Psychoanalyse und Seelsorge.” *Ethik (Sexual- und Gesellschafts-Ethik)* (Halle), V:1, 7–12. Repub. as GW 11,8. TR.—English: CW 11,8.

1929a *Die Frau in Europa*. Zurich: Verlag der Neuen Schweizer Revue, pp. 46. Reset, 1932: “Zweite Auflage.” Zurich: Rascher, pp. 39. Reset, 1965: “Rascher Paperback,” pp. 25. G. 1927b repub. as monograph. Repub. as G. 19713,2. TR.—Dutch: 1949c //English: CW 10,6 // French: 1931a,6 //Italian: 1963a,4 // Japanese: 1956b,3 //Spanish: 1940a.

1929b With Richard Wilhelm: *Das Geheimnis der goldenen Blüte. Ein chinesisches Lebensbuch*. Munich: Dorn. pp. 161. A 1929 Berlin edn. with 150 pp. has been reported but not seen. Contains the following work by Jung:

I. “Einführung.” (7-[88])

1. Einleitung. (9–27)

2. Die Grundbegriffe. (28–40)

3. Die Erscheinungen des Weges. (41–57)

4. Die Loslösung des Bewusstseins vom Objekt. (58–64)

5. Die Vollendung. (65–73)

6. Schlusswort. (74–75)

7. Beispiele europäischer Mandalas. ([77–88]) Includes 10 black and white plates.

G. 1929h pub., rev. and exp. Pub., rev. and with addns., as G. 1938a. TR.—English: 1931a.1&2 // Italian: 1936a.

1929c * “Ziele der Psychotherapie.” *Bericht über den IV. allgemeinen ärztlichen Kongress für Psychotherapie in Bad Neuheim* [April], pp. 1–14. Given as lecture to the Congress, 12 Apr. 1929. Repub. as G. 1931a,5.

1929d “Die Probleme der modernen Psychotherapie.” *Schweizerisches medizinisches Jahrbuch*, pp. 74–86. Repub. as G. 1931a,2. Lecture given to the Ärztlicher Verein and to the Psychotherapeutische Gesellschaft, Munich, 21 March 1929. TR.—English: 1931d.

- 1929e “Das Seelenproblem des modernen Menschen.” *Allgemeine Neueste Nachrichten* (23 Jan.). A much abbreviated, simplified version of G. 1928f
- 1929f “Der Gegensatz Freud und Jung.” *Kölnische Zeitung*, Saturday, 4 May and Tuesday, 7 May. (In two parts.) Repub. as G. 1931a,4.
- 1929g “Paracelsus. Ein Vortrag gehalten beim Geburtshaus an der Teufelsbrücke bei Einsiedeln am 22. Juni 1929.” *Lesezirkel*, XVI: 10 (Sept.), 117–25. Repub. as G. 1934b,5. Lecture given at Paracelsus’ birthplace to the Literarische Club Zurich, 22 June 1929.
- 1929h With Richard Wilhelm: “Tschang Scheng Schu. Die Kunst das menschliche Leben zu verlängern.” *Europ. Rev.*, V:8 (Nov.), 530–56. Contains the following work by Jung:
1. “Einleitung.” (530–42)
Pub., rev. and exp., as G. 1929b.
- 1929i “Die Bedeutung von Konstitution und Vererbung für die Psychologie.” *Die Medizinische Welt*, III:47 (Nov.), 1677–79. Repub. as GW 8,4. TR.—English: CW 8,4.
- 1930a “Psychologie und Dichtung.” *Philosophie der Literaturwissenschaft*. pp. 315–30. Ed. by Emil Ermatinger. Berlin: Junker und Dünnhaupt. Pub., rev. and exp., as G. 1950a,2. TR.—English: 1930c / 1933a,8.
- 1930b “Einführung.” W. M. Kranefeldt: *Die Psychoanalyse*, pp. 5–16. (Sammlung Göschen, 1034.) Berlin and Leipzig: Walter de Gruyter. Reset, 1950: new title: *Therapeutische Psychologie*. Jung’s introduction, pp. 5–17. Repub. as GW 4,15. TR.—English: 1932a / CW 4,15.
- 1930c “Nachruf für Richard Wilhelm.” *Neue Zür. Z.*, CLI:422 (6 Mar.), 1. Repub. as G. 1931b. Delivered as contribution to a memorial service for Wilhelm, Munich, 10 May 1930. Cf. G. 1931b and 1938a,2. TR.—English: 1931a,3.
- 1930d “Die seelischen Probleme der menschlichen Altersstufen.” *Neue Zür. Z.* (14 and 16 Mar.). (In 2 pts.) Pub., largely rewritten, as G. 1931a,10, with title change, TR.—French: 1931a,1.
- 1930e “Der Aufgang einer neuen Welt.” A review of Hermann Keyserling: *Amerika; der Aufgang einer neuen Welt*. *Neue Zür. Z.*, no. 2378, iv (7 Dec.), Bücherbeilage, p. 6. Repub. as GW 10,20. TR.—English: CW 10,20.
- 1931a *Seelenprobleme der Gegenwart*. (Psychologische Abhandlungen, 3.) Zurich: Rascher, pp. 435. 1950: rev. edn. pp. 392. Reset, 1969: “Rascher Paperback.” pp. 323. Repr., 1973: (“Studienausgabe.”) Olten: Walter, pp. 323. Contents:

1. Vorwort(e). (v–vii) Dated Dec. 1930 and July 1932. TR—English: CW 18,67 with addn. // Japanese: 1955a // Swedish: 1936a,1.
2. “Die Probleme der modernen Psychotherapie.” (1–39) G. 1929d repub. Repub. as GW 16,6. TR.—English: CW 16,6 // French: 1953a,3 // Japanese: 1955a // Swedish: 1936a,2.
3. “über die Beziehungen der analytischen Psychologie zum dichterischen Kunstwerk.” (40–73) G. 1922a repub. Repub. as GW 15,6. TR.—Danish: 1964a //English: CW 15,6 // Japanese: 1955a // Serbo-Croat: 1969a,8 // Swedish: 1936a,3.
4. “Der Gegensatz Freud und Jung.” (74–86) G. 1929f repub. Repub. as GW 4,16. TR.—English: 1933a,6 / CW 4,16 // French: 1953a,8 // Swedish: 1936a,4.
5. “Ziele der Psychotherapie.” (87–114) G. 1929c repub. Repub. as GW 16,5. TR.—English: 1933a,3 / CW 16,5//French: 1953a,6.
6. “Psychologische Typologie.” (115–43) A lecture to a meeting of the Schweizer Irrenärzte, Zurich, 1928. Repub. as GW 6,6. TR.—English: 1933a,4 / CW 6,7 // French: 1961b,7 // Swedish: 1936a,5.
7. “Die Struktur der Seele.” (144–75) G. 1928d rev. and exp. Repub. as GW 8,7. TR.—English: CW 8,7 // French: 1961b,I // Japanese: 1955a //Swedish: 1936a,6.
8. “Seele und Erde.” (176–210) Derived from G. 1927a; title changed. Repub. as GW 10,2. TR.—English: 1928a,3 / CW 10,2 //Japanese: 1955a.
9. “Der archaische Mensch.” (211–47) G. 1931f. somewhat rev. Repub. as GW 10,3. TR.—Dutch: 1940a,5 // English: 1933a,7 / CW 10,3 //French: 1961b,5//Japanese: 1955a//Swedish: 19363,7.
10. “Die Lebenswende.” (248–74) G. 1930d, much rev., with title change. Repub. as GW 8,16. TR.—Dutch: 1940a,3 // English: 1933a,5 / CW 8,16 // French: 1961b,8 // Swedish: 1936a,8.
11. “Die Ehe als psychologische Beziehung.” (275–95) G. 1925b repub. Repub. as GW 17,8. TR.—Dutch: 1940a,2 //English: CW 17,8//Japanese: 1955a//Swedish: 1936a,9.
12. “Analytische Psychologie und Weltanschauung.” (296–335) A rev. and exp. version of the orig. unpub. ms, 1st pub. in trans. as E. 1928a,4. Repub. as GW 8,14. Lecture given in Karlsruhe, 1927, and to the Philosophische Gesellschaft, Zurich, 4 March 1930. TR.—Dutch: 1940a,7//English: CW 8,14//French: 1961 b,4 // Swedish: 1936a,10.

13. "Geist und Leben." (369–400) G. 1926c repub. Repub. as GW 8,12. TR.—English: CW 8,12 // French: 1961b,3 // Japanese: 1955a.
14. "Das Seelenproblem des modernen Menschen." (401–35) G. 1928f, rev. and exp. Repub. as GW 10,4. TR.—Dutch: 1940a,I // English: 1933a,10 / CW 10,4 // ?Greek: 1949a // Japanese: 1955a // Spanish: 1932a // Swedish: 1936a,11.
- TR. of entire work: Dutch: 1956a // ?Greek: 1962c // Italian: 1942a.
- 1931b * "Richard Wilhelm." *Chinesisch-Deutscher Almanach für das Jahr 1931*, pp. 7–14. Frankfurt a. M.: China-Institut. G. 1930c repub.? Repub. as G. 1938a,2 with title change.
- 1931c * "Die praktische Verwendbarkeit der Traumanalyse." *Bericht über den VI. allgemeinen ärztlichen Kongress für Psychotherapie*. Dresden. Delivered as a lecture to the 6th Congress of the Allgemeine ärztliche Gesellschaft für Psychotherapie, Dresden, 31 Apr. 1931. Cf. G. 1934b,4. TR.—English: 1933a,1.
- 1931d "Vorwort." H. Schmid-Guisan: *Tag und Nacht*, pp. vi-x. Zurich and Munich: Rhein, TR.—English: CW 18,108.
- 1931e "Einführung." Francis [error for Frances] G. Wickes: *Analyse der Kindesseele. Untersuchung und Behandlung nach den Grundlagen der Jungschen Theorie*, pp. 13–20. Stuttgart: Julius Hoffmann. The first 3½ paragraphs only of the above were previously pub. in trans. as E. 1927a. Repub. as GW 17,2. TR.—Dutch: 1957b // English: (Pt. only) 1927a / 1966c / CW 17,2 // Italian: 1948e.
- 1931f "Der archaische Mensch." *Europ. Rev.*, VII:3 (Mar.), 182–203. Pub., rev. somewhat, as G. 1931a,9. Lecture delivered to the Hottinger Lesezirkel, Zurich, 22 Oct. 1930, and pub. abridged as the above. TR.—Spanish: 1931a.
- 1931g "Die Entschleierung der Seele." *Europ. Rev.*, VII:7 (July), 504–22. Pub. with minor alterations and title change as G. 1934b,2. Lecture given to the Kulturbund, Vienna, 1931. TR.—English: 1933a,9.
- 1932a *Die Beziehung der Psychotherapie zur Seelsorge*. Zurich: Rascher. pp. 30. Reset, 1948; pp. 39. Repub. as GW 11,7 with title change. Text of lecture to the Elsässische Pastoralkonferenz, Strassburg, May 1932, and to the Psychologischer Club Zurich, 1932. TR.—Dutch: 1935b // English: 1933a,11 / CW 11,7 // French: 1953a,13.

- 1932b “Vorwort zum Märchen vom Fischotter.” O. A. Schmitz: *Märchen aus dem Unbewussten*. pp. 7–12. Munich: Hanser. TR.—English: CW 18,110.
- 1932c * Answers to questions on Goethe. *Kölnische Zeitung*, (22 Mar.) Letter to the editor, Max Rychner (28 Feb. 1932). Letter pub. in G. 1972a, and trans. in E. 1973b.
- 1932d “Dr. Hans Schmid-Guisan.” *Basl. Nach.*, (25 Apr.). Obituary article. TR.—English: CW 18,109.
- 1932e “Ulysses.” *Europ. Rev.*, VIII:2/9 (Sept.), 547–68. Pub. with the addn. of “forenote” as G. 1934b,7. TR.—Spanish: 1933a.
- 1932f “Sigmund Freud als kulturhistorische Erscheinung.” *Charakter*, 1:2 (Sept.), 65–70. Repub. as G. 1934b,6. Excerpts pub. as “Entlarvung der viktorianischen Epoche. Freud kulturhistorisch gesehen.” *Vossische Zeitung* (4 Aug.). Simultaneously issued in trans. in the U.S. edn. of this journal as E. 1932b. TR.—English: 1932b //Spanish: 1935c.
- 1932g “Picasso.” *Neue Zür Z.*, CLIII.-2 (Sun., 13 Nov.), 1. Repub. as G. 1934b,8. TR.—Spanish: 1933b / 1934b.
- 1932h “Wirklichkeit und Überwirklichkeit.” *Querschnitt*, XII: 12 (Dec), 844–45. Repub. as GW 8,15. TR.—English: CW 8,15.
- 1932i “Die Hypothese des kollektiven Unbewussten.” (Autoreferat.) *Vierteljahresschrift der Naturforschenden Gesellschaft in Zürich*, LXXVII:2, “Sitzungsberichte,” IV–V. Abstract of lecture read before a meeting of the Naturforschende Gesellschaft held at the Eidgenössische Technische Hochschule, Zurich, 1 Feb. 1932. Lecture ms not discovered. TR.—English: CW 18,51.
- 1933a “Blick in die Verbrechenseele. Das Doppelleben des Kriminellen. Ungewöhnliche Fälle von Übertragung verbrecherischer Absichten auf Andere. ... Aus einem Gespräch.” *Neues Wiener Journal*, (15 Jan.). 1 p. For English versions, see E. 1932c.
- 1933b “Über Psychologie” *Neue Schw. R.*, n.s. I:1 (May), 21–28 and 1:2 (June), 98–106. (In 2 pts.) Rev. and expanded into G. 1934b,3 with change of title. An expanded version of a lecture originally delivered in Dresden, 1931, then at a conference, Town Hall, Zurich, 18 Dec. 1932, and in Cologne and Essen, Feb. 1933. TR.—French: (Pts. only) 1933a.
- 1933c “Bruder Klaus.” *Neue Schw. R.*, n.s. I:4 (Aug.), 223–29. Repub. as GW 11,6. TR.—English: 1946c / CW 11,6.

- 1933d Review of Gustav Richard Heyer: *Der Organismus der Seele. Europ. Rev.*, IX: 10 (Oct.), 639. TR.—English: CW 18,124.
- 1933e “Geleitwort des Herausgebers.” *Zbl. Psychotherap.*, VI:3 (Dec.), 139–40. Repub. as GW 10,25. TR.—English: CW 10,25.
- 1933f Contribution on hallucination to the “Discussion-Aussprache” following papers on “Das Problem der Sinnestäuschungen” in “Bericht über die Wissenschaftlichen Sitzungen der 84. Versammlung der Schweizerischen Gesellschaft für Psychiatrie in Prangins près Nyon, 7–8 Octobre 1933.” *Schweizer Archiv für Neurologie und Psychiatrie ...*, XXXII: 2, 382. TR.—English: CW 18,38.
- 1934a *Allgemeines zur Komplextheorie*. (Kultur- und staatswissenschaftliche Schriften der Eidgenössischen Technischen Hochschule, 12.) Aarau: Sauerländer. pp. 20. Pub., slightly rev. and with minor title change, as G. 1948b,3. Text of lecture originally entitled “Über Komplextheorie,” given as “Antrittsvorlesung,” at the Eidgenössische Technische Hochschule, 5 May 1934, and at the 7. [Allgemeiner ärztlicher] Kongress für Psychotherapie, Bad Nauheim, 10–13 May 1934. Summary of lecture pub. in *Zbl. Psychotherap.*, VII: 3, 139–42. TR. of whole—French: 1944a,5.
- 1934b *Wirklichkeit der Seele. Anwendungen und Fortschritte der neueren Psychologie*. With contributions by Hugo Rosenthal, Emma Jung and W. M. Kranefeldt. (Psychologische Abhandlungen, 4.) Zurich: Rascher. pp. 409. Reset, ig6g: Olten: Walter, pp. 265. Contains the following works by Jung:
1. Vorwort. Dated Sept. 1933. TR.—English: CW 18,113 // Japanese: 1955b.
 2. “Das Grundproblem der gegenwärtigen Psychologie” (1–31) G. 1931g, slightly rev. and with title change. Repub. as GW 8,13. TR.—English: CW 8,13 // French: 1944a,1 // Japanese: 1955b // Spanish: 1935a.
 3. “Die Bedeutung der Psychologie für die Gegenwart.” (32–67) G. 1933b, rev. and exp. with title change. Repub. as GW 10,7. TR.—English: CW 10,7 // French: 1944a,2 // Japanese: 1955b.
 4. “Die praktische Verwendbarkeit der Traumanalyse.” (68–103) Cf. G. 1931c. Repub. as GW 16,12. TR.—English: 1933a,1 / CW 16,12 // French: 1944a,7 // Japanese: 1955b.
 5. “Paracelsus.” (104–18) G. 1929g repub. Repub. as G. 1952c. TR.—English: CW 15,1 // French: 1961b,14.
 6. “Sigmund Freud als kulturhistorische Erscheinung.” (119–31) G. 1932f repub. Repub. as GW 15,3. TR.—English: CW 15,3 // French: 1961b,15

// Japanese: 1955b.

7. "Ulysses." (132–69) G. 1932e pub. with the addn. of a forenote. Repub. as GW 15,8. TR.—English: 1949c / CW 15,8 // French: 1961b,16 // Japanese: 1955b // Spanish: 1933a / ?1944a.

8. "Picasso." (170–79) G. 1932g repub. Repub. as GW 15,9. TR.—English: 1940a / 1953i / CW 15,9 // French: 1961b,17 // Italian: 1946a // Japanese: 1955b // Spanish: 1933b / 1934b.

9. "Vom Werden der Persönlichkeit." (180–211) Lecture delivered to the Kulturbund, Vienna, Nov. 1932, titled "Die Stimme des Innern." Repub. as GW 17,7. TR.—Dutch: 1940a,4. // English: 1939a,6 / CW 17,7 // French: 1955b // Japanese: 1955b.

10. "Seele und Tod." (212–30) G. 1934h repub. Pub., abridged and with title change, as G. 1935i. Repub. as whole as GW 8,17. TR.—Dutch: 1940b,6 // English: 1945a / 1959c / CW 8,17 // French: 1939a,3 / 1956a,5 // Japanese 1955b.

TR. of entire work—Dutch: 1957a // Italian: 1949b // Spanish: 1935a / (Pts. only?) 1940a.

1934c "Zur Empirie des Individuationsprozesses." *Eran. Jb.* 1933. pp. 201–14. Includes 5 black and white plates. (The *Eranos Jahrbuch* articles were originally given as lectures at the Eranos Tagung, Ascona, in August of the year indicated.) Pub., completely rewritten and exp., as G. 1950a,4. TR.—English: 1939a,2.

1934d "Geleitwort." Gerhard Adler: *Entdeckung der Seele. Von Sigmund Freud und Alfred Adler zu C. G. Jung.* pp. vii-viii. Zurich: Rascher. Dated Dec. 1933. TR.—English: CW 18,52.

1934e "Geleitwort." Carl Ludwig Schleich: *Die Wunder der Seele*, pp. 3–11. Berlin: S. Fischer. Reset, 1953: Frankfurt: G. B. Fischer. pp. 5–11. TR.—English: CW 18,39.

1934f Rejoinder to Dr. Bally's article "Deutschstämmige Psychotherapie," headlined "Zeitgenössisches." *Neue Zür. Z.*, CLV:437,1 (13 Mar.) and CLV:443,1 (14 Mar.). (In 2 pts.) Cf. G. 1934g. Repub., with G. 1934g, as GW 10,26. TR.—English: CW 10,26 (with trans. of G. 1934g).

1934g "Ein Nachtrag." *Neue Zur. Z.*, CLV:457 (15 Mar.). Second and third paragraphs *only* by Jung. Cf. G. 1934f. Repub., with G. 1934f. as GW 10,26. TR.—English: CW 10,26 (p. 544, last 3 parags., ftnote 5) with trans. of G. 1934f.

- 1934h “Seele und Tod.” *Europ. Rev.*, X:4 (Apr.), 229–38. Extract pub. in *Berliner Tageblatt*, (17 Apr.). Entire article repub. as G. 1934b,10.
- 1934i “Ein neues Buch von Keyserling.” Review of Hermann Keyserling: *La Révolution mondiale*. *Basl. Nach.*, Sonntagsblatt, XXVIII: 19 (13 May), 78–79. Repub. as GW 10,21. TR.—English: CW 10,21.
- 1934j Circular letter: “Sehr geehrte Kollegen! ... Zürich-Küsnacht 1.12.34.” *Zbl. Psychotherap.*, VII:6 (Dec), 1p. (separatum). Repub. as GW 10,27. TR.—English: 1946d,1 / CW 10,27.
- 1934k “Zur gegenwärtigen Lage der Psychotherapie.” *Zbl. Psychotherap.*, VII:1, 1–16. Repub. as GW 10,8. TR.—English: CW 10,8 // French: 1953a,9.
- 1934l With M. H. Göring: “Geheimrat Sommer zum 70. Geburtstag.” *Zbl. Psychotherap.*, VII, 313–14.
- 1935a *Die Beziehungen zwischen dem Ich und dem Unbewussten*. Zurich: Rascher. pp. 208. 1966: 7th rev. edn. (“Rascher Paperback.”) pp. 151. 1971: (“Studienausgabe.”) Olten: Walter, pp. 160. G. 1928a pub. with addn. of the “Vorrede zur zweiten Auflage,” dated Oct. 1934, on 4 unnumbered pp. between the title page and the table of contents. (An insignificant, prefatory parag. was added to the 1938 repr.) Repub. as GW 7,2, with slight title change, TR.—Danish: 1962a // English: CW 7,2 // French: 1938a / 1964a // ? Greek: 1962a,2 // Hebrew: 1973a // Italian: 1948a // Norwegian: 1966a // Spanish: 1936a // Swedish: 1967a.
- 1935b “Über die Archetypen des kollektiven Unbewussten.” *Eran. Jb. 1934*. pp. 179–229. (See G. 1934c.) Pub., rev., as G. 1954b,2. TR.—English: 1939a,3.
- 1935c “Einleitung.” M. Esther Harding: *Der Weg der Frau*. pp. 9–13. Zurich: Rhein. The original German version, of which an English trans. was previously pub. as E. 1933b. TR.—English: 1933b / CW 18,130.
- 1935d “Geleitwort.” Olga von Koenig-Fachsenfeld: *Wandlungen des Traumproblems von der Romantik bis zur Gegenwart*, pp. iii–vi. Stuttgart: F. Enke. TR.—English: CW 18,115.
- 1935e “Vorwort.” Rose Mehlich: *J. H. Fichtes Seelenlehre und ihre Beziehung zur Gegenwart*, pp. 7–11. Zurich: Rascher, TR.—English: (Pts. only) 1950e / CW 18,114.
- 1935f “Einführung.” *Das tibetanische Totenbuch*. pp. 15–35. Ed. by W. Y. Evans-Wentz. Zurich: Rascher. Jung’s “Einführung” consists of:
1. “Geleitwort.” (15–16)

2. "Psychologischer Kommentar zum Bardo Thödol." (17–35)

Repub. as GW 11,11. TR.—English: 1957f.

- 1935g "Was ist Psychotherapie?" *Schweizerische Ärztezeitung für Standesfragen*, XVI: 26 (28 June), 335–39. Repub. as GW 16,3. Contribution to a symposium of the Allgemeine ärztliche Gesellschaft für Psychotherapie, "Psychotherapie in der Schweiz," May 1935. Cf. G. 1935h. TR.—English: CW 16,3 // French: 1953a,1.
- 1935h "Votum C. G. Jung." *Schweizerische Ärztezeitung für Standesfragen*, XVI:26 (28 June), 345–46. Repub. as GW 10,31, with sl. title change. Contribution to discussion at symposium, "Psychotherapie in der Schweiz," May 1935. Cf. G. 1935g. TR.—English: CW 10,31.
- 1935i "Von der Psychologie des Sterbens." *Münchener Neueste Nachrichten*, 269 (2 Oct.), 3. G. 1934b, 10 abridged and with title change.
- 1935j "Geleitwort." *Zbl. Psychotherap.*, VIII: 1, 1–5. Repub. as GW 10,28. TR.—English: CW 10,28.
- 1935k "Vorbemerkung des Herausgebers." *Zbl. Psychotherap.*, VIII:2, 65. Repub. as GW 10,29. TR.—English: CW 10,29.
- 1935l "Grundsätzliches zur praktischen Psychotherapie." *Zbl. Psychotherap.*, VIII:2, 66–82. Repub. as GW 16,2. Given as lecture to the Medizinische Gesellschaft, Zurich, 1935. TR.—English: CW 16,2 // French: 1953a,5.
- 1936a "Traumsymbole des Individuationsprozesses ..." *Eran. Jb. 1935*. pp. 13–133. (See G. 1934c.) Pub., rev. and exp., as G. 1944a,3. TR.—English: 1939a,4 / 1959d.
- 1936b "Psychologische Typologie." *Süddeutsche Monatshefte*, XXXIII:5 (Feb.), 264–72. Repub. as GW 6,7. TR.—English: CW 6,8.
- 1936c "Wotan." *Neue Schw. R.*, n.s. III: 11 (Mar.), 657–69. Repub. as G. 1946a,2. TR.—English: (abridged) 1937c / 1947a,3 / CW 10,10.
- 1936d Review of Gustav Richard Heyer: *Praktische Seelenheilkunde*. *Zbl. Psychotherap.*, IX:3, 184–86. TR.—English: CW 18,125.
- 1936e "Über den Archetypus, mit besonderer Berücksichtigung des Anima-begriffes." *Zbl. Psychotherap.*, IX:5, 259–74. Pub., rev., as G. 1954b,3.
- 1937a "Die Erlösungsvorstellungen in der Alchemie." *Eran. Jb. 1936*. pp. 13–111. (See G. 1934c.) Pub., rev. and exp., as G. 1944a,4. TR.—English: 1939a,5.

- 1937b “Zur psychologischen Tatbestandsdiagnostik. Das Tatbestandsexperiment im Schwurgerichtsprozess Näf.” *Archiv für Kriminologie*, C (Jan.–Feb.), 123–30. Repub. as GW 2,19. TR.—English: CW 2,19.
- 1938a With Richard Wilhelm: *Das Geheimnis der goldenen Blüte. Ein chinesisches Lebensbuch*. “II. Auflage.” Zurich: Rascher, pp. 150. Contains the following works by Jung:
1. “Vorrede zur II. Auflage.” (v–viii) TR.—English: 1962b,1.
 2. “Zum Gedächtnis Richard Wilhelms.” (ix–xviii) G. 1930c repub. with title change, TR.—English: 1962b,3.
 3. Europäischer Kommentar. (1–66) (Untitled here) G. 1928b,1, 1–6 rev. and exp. TR.—English: 1962b,2.
 4. “Beispiele europäischer Mandalas.” (67–68 + 10 plates) Plates (excepting #2) incorporated into G. 1950a,5. TR.—English: 1962b,2. G. 1929b pub. rev. and with addns. Pub. reset and with further addns. as G. 1957b. TR.—Dutch: 1953a // English: 1962b // Spanish: 1955a.
- 1938b “Ueber das Rosarium Philosophorum.” *Aus d. Jhrsb. 1937/38*. pp. 25–29. Printed for private circulation. Summary of 2 lectures to the Psychologischer Club Zürich, given presumably late in 1937 or early in 1938. TR.—English: CW 18,126.
- 1938c “Einige Bemerkungen zu den Visionen des Zosimos.” *Eran. Jb. 1937*. pp. 15–54 (See G. 1934c.) Pub., rev. and considerably exp., with title change, as G. 1954b,5.
- 1938d “Begleitwort.” Gertrud Gilli: *Der dunkle Bruder*. 2 pp. Zurich/Elgg: Volksverlag, TR.—English: CW 18,116.
- 1939a *Über Konflikte der kindlichen Seele*. “Dritte Auflage.” Zurich: Rascher. pp. 36. G. 1916b pub. as a pamphlet with a new foreword and supplement, Pub., slightly rev. and exp., as G. 1946b,2. TR.—Spanish: 1945a.
- 1939b “Die psychologischen Aspekte des Mutterarchetypus.” *Eran. Jb. 1938*. pp. 403–43. (See G. 1934c.) Pub., rev., as G. 1954b,4. TR.—English: 1943a.
- 1939c “Geleitwort.” D. T. Suzuki: *Die grosse Befreiung. Einführung in den Zen-Buddhismus*. pp. 7–37. Leipzig: Curt Weller. Repub. as GW 11,13. TM—English: 1949d/CW 11,13//?Spanish: 1964c.
- 1939d “† Sigmund Freud.” *Basl. Nach.*, Sonntagsblatt, XXXIII:40 (1 Oct.), 157–59. Obituary article. Repub. as GW 15,4. TR.—English: CW 15,4 // Norwegian: 1956a.

- 1939e “Bewusstsein, Unbewusstes und Individuation.” *Zbl. Psychotherap.*, XI:5, 257–70. Orig. written in English and pub. as E. 1939a,1. Subsequently rev. considerably and pub. in this German version. Repub. as GW 9,1,10. TR.—English: CW 9,1,10 // French: 1953a,12.
- 1940a *Psychologie und Religion. Die Terry Lectures 1937 gehalten an der Yale University*. Zurich: Rascher. pp. 192. 1962: 4th edn., rev. and reset. (“Rascher Paperback.”) pp. 125. Orig. written in English and trans. from E. 1938a by Felicia Froboese and Toni Wolff. Subsequently rev. and exp. and pub. in this version. Contents:
- Vorrede. (Oct. 1939)
1. Die Autonomie des Unbewussten. (9–61)
 2. Dogma und natürliche Symbole. (63–116)
 3. Geschichte und Psychologie eines natürlichen Symbols. (117—90)
- Repub. as GW 11,1. TR.—Danish: 1968a // Dutch: 1951a // English: CW 11,1 // French: 1958b // Greek: 1962b // Italian: 1948c // Japanese: 1956b,1 // Norwegian: 1965a//Portuguese: 1956a // Spanish: 1949b//Turkish: 1965a (from English).
- 1940b “Die verschiedenen Aspekte der Wiedergeburt.” *Eran. Jb.* 1939. pp. 399–447. (See G. 1934c.) Pub., rev. and exp., with title change, as G. 19508,3. TR.—English: 1944a.
- 1940c “Geleitwort.” Jolande Jacobi: *Die Psychologie von C. G. Jung*. pp. 17–18. Zurich: Rascher. Dated Aug. 1939. Paging varies in successive edns. TR.—Danish: 1963a / English: 1942c / 1962c / CW 18,40 // Italian: 1949c//Spanish: 1947a.
- 1941a With K. Kerényi: *Das göttliche Kind in mythologischer und psychologischer Beleuchtung*. (Albae Vigiliae, 6/7.) Amsterdam: Pantheon Akademische Verlagsanstalt, pp. 124. Contains the following work by Jung:
- “Zur Psychologie des Kind-Archetypus.” (85–124)
- Pub. rev., together with G. 1941b, as G. 1941c.
- 1941b With K. Kerényi: *Das göttliche Mädchen. Die Hauptgestalt der Mysterien von Eleusis in mythologischer und psychologischer Beleuchtung*. (Albae Vigiliae, 8/9.) Amsterdam: Pantheon Akademische Verlagsanstalt, pp. 109. Contains the following work by Jung:
- “Zum psychologischen Aspekt der Korefigur.” (85–109)
- Pub. rev., together with G. 1941a, as G. 1941c.

- 1941c With K. Kerényi: *Einführung in das Wesen der Mythologie*. Amsterdam: Pantheon Akademische Verlagsanstalt; Zurich: Rascher. pp. 251. Contains the following works by Jung:
1. "Zur Psychologie des Kind-Archetypus." (105–44)
 2. "Zum psychologischen Aspekt der Korefigur." (217–41)
- G. 1941a and 1941b rev. and pub. as one vol. Repub. as G. 1951b. TR.—English: 1949a // Italian: 1948b.
- 1941d *Die psychologische Diagnose des Tatbestandes*. Zurich: Rascher. pp. 47. G. 1906k repub. Repub. as GW 2,6. TR.—English: CW 2,6.
- 1941e "Rückkehr zum einfachen Leben." *Du*, Jhg. L3 (May), 6–7, 56. Summation of answers to a questionnaire on the effect of wartime conditions in Switzerland. TR.—English: (Pts. only) 1945b / CW 18,71.
- 1941f "Paracelsus als Arzt." *Schweizerische medizinische Wochenschrift*, LXXI:40 (Oct.), 1153–70. Repub. as G. 1942a,1. Simplified version pub. in *Basler Nachrichten* (21 Sept.). Lecture given at the annual meeting of the Naturforschende Gesellschaft Basel, of the Schweizerische Gesellschaft zur Geschichte der Medizin und der Naturwissenschaften, Basel, 7 Sept. 1941 and to the Psychologischer Club Zürich, 21 Feb. 1942.
- 1942a *Paracelsica. Zwei Vorlesungen über den Arzt und Philosophen Theophrastus*. Zurich: Rascher, pp. 188. With 3 plates and 5. text illus. Contents:
- Vorwort. (7–8)
1. "Paracelsus als Arzt." (9–41) G. 1941t repub. Repub. as GW 15,2. TR.—English: CW 15,2.
 2. "Paracelsus als geistige Erscheinung." (43–178) Lecture contributed to the Schweizerische Paracelsus Gesellschaft Celebration, Einsiedeln, 5 Oct. 1941. Repub. as GW 13,3. TR.—English: CW 13,3.
- Two lectures delivered on the occasion of the 400th anniversary of Paracelsus' death, Autumn 1941.
- 1942b "Zur Psychologie der Trinitätsidee." *Eran. Jb. 1940/41*. pp. 31–64. (See G. 1934c.) Pub., rev. and exp. with title change, as G. 1948a,4. Lecture given also to the Psychologischer Club Zurich, 5 Oct. 1940.
- 1942c "Das Wandlungssymbol in der Messe." *Eran. Jb. 1940/41*. pp. 67–155. (See G. 1934c.) Pub., rev. and exp., as G. 1954b,6. Lecture given also to the Psychologischer Club Zurich, 17 May 1941. TR.—English: 1955b / 1955l (Pt. only).

- 1943a *Über die Psychologie des Unbewussten*. Zurich: Rascher, pp. 213. ig6o: reset, “7. vermehrte und verbesserte Auflage.” pp. 135. 1966: reset. (“Rascher Paperback.”) pp. 148. Contents:
- Vorworte. (7–15)
 - 1. Die Psychoanalyse. (17–34)
 - 2. Die Erosththeorie. (35–53)
 - 3. Der andere Gesichtspunkt: Der Wille zur Macht. (54–73)
 - 4. Das Problem des Einstellungstypus. (74–115)
 - 5. Das persönliche und das überpersönliche oder kollektive Unbewusste. (116–44)
 - 6. Die synthetische oder konstruktive Methode. (145–60)
 - 7. Die Archetypen des kollektiven Unbewussten. (161–202)
 - 8. Zur Auffassung des Unbewussten: Allgemeines zur Therapie. (203–11)
 - Schlusswort. (212–13)
- G. 1926a rev. and exp. with title change. Repub. as GW 7,1. TR.—Danish: 1961a//Dutch: 1950b//English: CW 7,1 // Finnish: 1966a // French: 1952a // ?Greek: 1956a / 1962a,1 // Hebrew: 1973b // Hungarian: 1948a // Italian: 1947b / 1968a // Norwegian: 1963a // Portuguese: 1967a // Swedish: 1965a.
- 1943b “Der Geist Mercurius.” *Eran. Jb.* 1942. pp. 179–236. (See G. 1934c.) Pub., rev. and exp., as G. 19483,3.
- 1943c “Zur Psychologie östlicher Meditation.” *Mitteilungen der Schweizerischen Gesellschaft der Freunde ostasiatischer Kultur*, V, 33–53. Repub. as G. 1948a,5. Lecture given to the Psychologischer Club Zurich, 8 May 1943, and to the Schweizerische Gesellschaft der Freunde ostasiatischer Kultur, Zurich/Basel/Bern, Mar.-May 1943. TR.—English: 1947b.
- 1943d * “Votum. Zum Thema: Schule und Begabung.” *Schweizer Erziehungsrundschau*, XVI: 1 (Apr.), 3–8. Lecture presented as contribution to a meeting of the Basler staatliche Schulsynode, 4 Dec. 1942. Repub. with title change as G. 1946b,3.
- 1943e “Psychotherapie und Weltanschauung.” *Schweizerische Zeitschrift für Psychologie und ihre Anwendungen*, I:3, 157–64. Repub. as G. 1946a,4. Contribution to the Tagung für Psychologie, Zurich, 26 Sept. 1942.
- 1943f “Ein Gespräch mit C. G. Jung. Über Tiefenpsychologie und Selbsterkenntnis.” *Du*, III:9 (Sept.), 15–18. Written in answer to questions from Jolande Jacobi. Repub. as G. 1947c with title change. TR.—English: 1943b.

- 1944a *Psychologie und Alchemie* (Psychologische Abhandlungen, 5.) Zurich: Rascher, pp. 696. Contents:
1. Vorwort. (7–8)
 2. Einleitung in die religionspsychologische Problematik der Alchemie. (13–62) Repub. as G. 1957a,2.
 3. Traumsymbole des Individuationsprozesses. (69–305) G. 1936a rev. and exp.
 4. Die Erlösungsvorstellungen in der Alchemie. (313–631) G. 1937a rev. and exp.
 5. Epilog. (635–46)
- Pub., rev. and with addn. of new foreword, as G. 1952d. TR.—English: CW 12 (1st edn.) // Italian: 1949a.
- 1944b “Vorwort” and essay: “Über den indischen Heiligen.” Heinrich Zimmer: *Der Weg zum Selbst*, pp. 5–6, and pp. 11–24. Ed. by C. G. Jung. Zurich: Rascher. Essay repub. as GW 11,15. TR.—Dutch: 1948b // English: (essay only) CW 11,15.
- 1945a *Psychologische Betrachtungen*. A selection from the writings of C. G. Jung, comp. and ed. by Jolande Jacobi. Zurich: Rascher, pp. 455. A collection of short passages from a wide range of writings; contains no new material. Pub., rev. and exp. with title change, as G. 1971b. TR.—Dutch: 1949a//English: 1953a // French: 1965a.
- 1945b “Das Rätsel von Bologna.” *Festschrift Albert Oeri*. pp. 265–79. Basel: Basler Nachrichten. Cf. G. 1955a,11,3. TR.—English: 1946f.
- 1945c “Nach der Katastrophe.” *Neue Schw. R.*, n.s. XIII:2 (June), 67–88. Repub. as G. 19463,5. TR.—English: 1946a.
- 1945d “Vom Wesen der Träume.” *Ciba Zeitschrift* (Basel), IX:99 (July), 3546–57. Repub. as G. 1952i. Pub., rev. and exp., as G. 1948b,5. TR.—Dutch: 1947b // English: 1948a // French: 1945a / 1953a,4 // Portuguese: 1947a / 1948a // Spanish: 1946a.
- 1945e “Medizin und Psychotherapie.” *Bulletin der schweizerischen Akademie der medizinischen Wissenschaften*, 1:5, 315–28. Repub. as GW 16,8. Lecture delivered to a scientific meeting of the Senate of the Academy, Zurich, 12 May 1945. TR.—English: CW 16,8 // French: 1953a,2.
- 1945f “Die Psychotherapie in der Gegenwart.” *Schweizerische Zeitschrift für Psychologie und ihre Anwendungen*, IV: 1, 3–18. First pub. in an English trans., E. 1942b. Repub. as G. 19463,3. Given as the opening address to the

Kommission für Psychotherapie, Schweizerische Gesellschaft für Psychiatrie, Zurich, 4th annual meeting, 19 July 1941. TR.—English: 1942b / 1947a,4 / CW 16,9.

1945g “Der philosophische Baum.” *Verhandlungen der Naturforschenden Gesellschaft Basel*, LVI:2, 411–23. Pub., greatly rev. and exp., as G. 1954b,7. Written as contribution to a Festschrift for Gustav Senn, professor of botany, which was never published.

1946a *Aufsätze zur Zeitgeschichte*. Zurich: Rascher. pp. 147. Contents:

1. Vorwort. (vii–ix) Repub. as GW 10,9. TR.—English: 1947a,1 / CW 10,9.
2. “Wotan.” (3–23) Repub. as GW 10,10. G. 1936c repub. TR.—English: (abridged) 1937c / 19473,3 / CW 10,10 // French: 1948a,2.
3. “Die Psychotherapie in der Gegenwart.” (25–55) G. 1945f repub. with slight title change. Repub. as GW 16,9. TR.—English: 1947a,4 / CW 16,9 // French: 1953a,10.
4. “Psychotherapie und Weltanschauung.” (57–72) G. 1943e repub. Repub. as G. 1954c,3 and GW 16,7. TR.—English: 1947a, 5 / CW 16,7 // French: 1953a,14.
5. “Nach der Katastrophe.” (73–116) G. 1945c repub. Repub. as GW 10,11. TR.—English: 1947a,6 / CW 10,11 // French: 1948a,4.
6. “Nachwort.” (117–47) Repub. as GW 10,13. TR.—English: 1947a,7 / CW 10,13 // ?French: 1948a,5.

TR. of entire work—Dutch: 1947a // Spanish: 1968a.

1946b *Psychologie und Erziehung*. Zurich: Rascher. pp. 204. 1963: (“Rascher Paperback.”) pp. 135. Contents:

1. “Analytische Psychologie und Erziehung: Drei Vorlesungen.” (3–124) G. 1926b rev. and exp., with addn. of new foreword dated June 1945. Repub. as GW 17,4. TR.—English: CW 17,4 // French: 1963a,1 // Japanese: 1956a,1.
2. “Über Konflikte der kindlichen Seele.” (125–81) G. 1939a slightly exp. Repub. as GW 17,1. TR.—English: CW 17,1 // French: 1963a,2 // Japanese: 1956a,2.
3. “Der Begabte.” (183–203) G. 1943d repub. with title change. Repub. as GW 17,5. TR.—English: CW 17,5 // French: 1963a,5 // Japanese: 1956a,3.

TR. of entire work—Dutch: 1948a//Hebrew: 1958a//Italian: 1947a // Norwegian: 1967a // Spanish: 1949a.

1946c *Die Psychologie der Übertragung. Erläutert anhand einer alchemistischen Bilderserie. Für Ärzte und praktische Psychologen.* Zurich: Rascher, pp. 283.

Contents:

Vorrede, (vii-xii) Dated Fall 1945.

I. Einleitende Überlegungen zum Problem der Übertragung. (1–63)

II. Die Bilderserie des Rosarium Philosophorum als Grundlage für die Darstellung der Übertragungsphänomene. (65–253)

1. Der Mercurbrunnen.

2. König und Königin.

3. Die nackte Wahrheit.

4. Das Eintauchen im Bade.

5. Die Conjunction.

6. Der Tod.

7. Der Aufstieg der Seele.

8. Die Reinigung.

9. Die Wiederkehr der Seele.

10. Die neue Geburt.

Schlusswort. (255–60)

Repub. as GW 16,13. TR.—English: CW 16,13 // Italian: 1962a // Spanish: 1954a.

1946d “Gérard de Nerval.” (Autoreferat.) *Aus d. Jhrsb. 1945/46.* p. 18. Printed for private circulation. Summary of lecture to the Psychologischer Club Zurich, 9 June 1945. TR.—English: CW 18,117.

1946e “Zur Psychologie des Geistes.” *Eran. Jb. 1945.* pp. 385–448. (See G. 1934c.) Pub., rev. and exp., with title change, as G. 19483,2. TR.—English: 1948d.

1946f Foreword to K. A. Ziegler: “Alchemie II,” List no. 17 (May), pp. 1–2. Printed in Bern. Foreword, in both German and English, to a bookseller’s catalog. For English version, see E. 1946b.

1946g “Zur Umerziehung des deutschen Volkes.” *Basl. Nach.*, No. 486, “Sondernummer ...” (Centennial edn.) (ca. 16 Nov.), 85. The last 9 paragraphs of an essay, “Randglossen zur Zeitgeschichte,” dated 1945, never pub. as a whole in German, although trans. and pub. in its entirety in English as CW 18,73. TR.—English: (full text) CW 18,73.

1946h Excerpts of letter (published to anon.) to James Kirsch (26 May 1934), pp. 225–27. Ernest Harms: “Carl Gustav Jung—Defender of Freud and the

Jews.” *Psychiatric Quarterly*, 20:2 (Apr.), 199–233. Entire letter pub. in G. 1972a and trans. in E. 1973b. TR.—English: 1946d,2.

1947a “Der Geist der Psychologie.” *Eran. Jb.* 1946. pp. 385–490. (See G. 1934c.) Pub., rev. and with title change, as G. 19540,8. TR.—English: 1954b,2 / (sl. abbrev.) 1957e.

1947b “Vorwort.” Linda Fierz-David: *Der Liebestraum des Poliphilo; ein Beitrag zur Psychologie der Renaissance und der Moderne*, pp. 5–7. Zurich: Rhein. Dated Feb. 1946. TR.—English: 1950c.

1947c “Über Tiefenpsychologie und Selbsterkenntnis. Ein Gespräch zwischen Prof. C. G. Jung und Dr. Jolan Jacobi.” *Hamburger Akademische Rundschau*, II: 1/2, 11–19. G. 1943f repub. with title change.

1948a *Symbolik des Geistes. Studien über psychische Phänomenologie...* With a contribution by Riwkah Schärf. (Psychologische Abhandlungen, 6.) Zurich: Rascher, pp. 500. 1965: (“Rascher Paperback.”) pp. 206. Contains the following works by Jung:

1. Vorwort, (vii-viii) Dated June 1947. TR.—English: CW 18,90.
2. “Zur Phänomenologie des Geistes im Märchen.” (3–67) G. 1946e, rev. and exp., with title change. Repub. as G. 1957a,3 and GW 9,i,8. TR.—English: 1954b,1 / CW 9,i,8 // Japanese: 1956a,4.
3. “Der Geist Mercurius.” (69–149) G. 1943b rev. and exp. Repub. as GW 13,4. TR.—English: 1953b / CW 13,4.
4. “Versuch zu einer psychologischen Deutung des Trinitäts-dogms.” (321–446) G. 1942b, greatly rev. and exp., with title change. Repub. as GW 11,2, with slight title change, TR.—English: CW 11,2 // French: (1 eh., “Das Problem des Vierten,” sl. abridged, in 2 pts.) 1957b and 1958c.
5. “Zur Psychologie östlicher Meditation,” (447–72) G. 1943c repub. Repub. as G. 19573,4 and GW 11,14. TR.—English: CW 11,14 // Japanese: 1956b,2.

TR. of entire work—Dutch: 1955a//Italian; 1959a // Spanish: 1962a.

1948b *Über psychische Energetik und das Wesen der Träume.* (Psychologische Abhandlungen, 2.) “2., vermehrte und verbesserte Auflage.” Zurich: Rascher, pp. 311. 1965: 3d edn., rev. and reset. (“Rascher Paperback.”) pp. 206. Contents:

1. Vorwort(en). (1–3) G. 1928b,1 repub. with new foreword (dated May 1947) added for this edn. TR.—English: CW 18,37.

2. “Über die Energetik der Seele.” (5–117) G. 1928b,2 repub. Repub. as GW 8,1. TR.—English: CW 8,1 // French: 1956a,1.
3. “Allgemeines zur Komplextheorie.” (119–43) G. 1934a, sl. rev. and with minor title change. Repub. as GW 8,3, with reversion to title of G. 1934a. TR.—English: CW 8,3 // French: 1962a,5.
4. “Allgemeine Gesichtspunkte zur Psychologie des Traumes.” (145–225) G. 1928b,3, rev. and exp. Repub. as GW 8,9. TR.—English: 1956b / CW 8,9 // French: 1962a,6.
5. “Vom Wesen der Träume.” (227–57) G. 1945d, rev. and exp. Repub. as G. 1954c,1 and GW 8,10. TR.—English: CW 8,10.
6. “Instinkt und Unbewusstes.” (259–76) G. 1928b,4, rev. and with addn. of brief concluding note. Repub. as GW 8,6. TR.—English: CW 8,6 // French: 1956a,2.
7. “Die psychologischen Grundlagen des Geisterglaubens.” (277–311) G. 1928b,5 rev. Repub. as GW 8,11. TR.—English: CW 8,11 // French: 1956a,6.

G. 1928b exp., with title change. New foreword and items 2. and 4. added, TR. of entire work—Danish: 1969a // Norwegian: 1968a // Spanish: 1954b.

1948c “De Sulphure.” *Nova Acta Paracelsica*, V. pp. 27–40. Pub., exp., as part of G. 1955a,III,3. TR.—English: ?1947c.

1948d “Vorwort.” Esther Harding: *Das Geheimnis der Seele*, pp. 9–10. Zurich: Rhein. Written in German as introduction for the original English pub. and first pub. in trans. TR.—English: 1947e.

1948e “Vorwort.” Stuart Edward White: *Uneingeschränktes Weltall*. pp. 7–14. Zurich: Origo. Written in German to accompany the German trans. of White’s *The Unobstructed Universe* (New York, 1940). Dated July 1948. Also pub. as “Psychologie und Spiritismus.” *Neue Schw. R.*, n.s. XVI:7 (Nov.), 430–35. TR.—English: CW 18,6.

1948f “Schatten, Animus und Anima.” *Wiener Zeitschrift für Nervenheilkunde* ..., 1:4 (June), 295–307. Incorporated as part of G. 1951a,II & III. Lecture given to the Schweizerische Gesellschaft für praktische Psychologie, Zurich, 1948. TR.—English: 1950a.

1949a *Die Bedeutung des Vaters für das Schicksal des Einzelnen*. “Dritte, umgearbeitete Auflage.” Zurich: Rascher, pp. 38. G. 1909c rev. and exp., with addn. of new foreword. Repub. as GW 4,14. TR.—English: CW 4,14 (with addns. from G. 1909c) // French: 1963a,4.

- 1949b “Über das Selbst.” *Eran. Jb.* 1948. pp. 285–315. Incorporated into G. 1951a.IV. Lecture given also to the Psychologischer Club Zurich, 22 May 1948. TR.—English: 1951a.
- 1949c “Vorwort.” Robert Crottet: *Mondwald. Lappengeschichten*. pp. 7–9. Zurich: Fretz und Wasmuth. Dated March 1949. TR.—English: CW 18,119.
- 1949d “Geleitwort.” Esther Harding: *Frauen-Mysterien, einst und jetzt*. pp. viii-xii. Zurich: Rascher. Dated Aug. 1948. TR.—Dutch: 1938a// English: 1955e / CW 18,53 // French: 1953d.
- 1949e “Geleitwort zu den ‘Studien aus dem C. G. Jung-Institut Zürich’.” C. A. Meier: *Antike Inkubation und moderne Psychotherapie*. (Studien aus dem C. G. Jung-Institut Zürich, 1.) Zurich: Rascher. 2 unno.’d pp. after title page. Introduction to the series, of which Jung was the editor. Dated Sept. 1948. TR.—English: (Pts. only) 1950e / 1967d / CW 18,45.
- 1949f “Vorwort.” Erich Neumann: *Ursprungsgeschichte des Bewusstseins*. pp. 1–2. Zurich: Rascher. Dated 1 March 1949. TR.—English: 1954f.
- 1949g Letter to the editors on the effect of technology on the psyche. *Zürcher Student*, Jhg. 27:5 (Nov.), 129–30. Written in reply to the eds.’ question and dated 14 Sept. 1949. TR.—English: CW 18,76.
- 1949h * “Dämonie.” (Definition.) *Schweizer Lexikon*, Vol. I. Zurich: Encyclios. Written July 1945 at the request of the publishers. Only the 1st sentence and the references appear here as the definition, which is published without attribution, TR.—Full text of Jung’s definition pub. in trans. as CW 18,89.
- 1950a *Gestaltungen des Unbewussten*. With a contribution by Aniela Jaffé. (Psychologische Abhandlungen, 7.) Zurich: Rascher, pp. 616. Contains the following works by Jung:
1. Vorwort. (1–2) Dated Jan. 1949. TR.—English: CW 18,56.
 2. “Psychologie und Dichtung.” (5–36) G. 1930a, rev. and exp. Repub. as G. 19540,2 and GW 15,7. Excerpt pub. 1955 as “Der Dichter.” *Internationale Bodensee-Zeitschrift für Literatur ...*, IV:6 (July), 88–91. TR.—English: (with addn.) CW 15,7 // French: 1955a.
 3. “Über Wiedergeburt.” (37–91) G. 1940b, rev. and exp. with title change. Repub. as GW 9,i,5. TR.—English: CW 9,1,5.
 4. “Zur Empirie des Individuationsprozesses.” (93–186) G. 1934c, rev. and exp. Repub. as GW 9,i,11. TR.—English: CW g.i.11.
 5. “Über Mandalasymbolik.” (187–235) Contains 9 of the plates pub. in G. 1938a,4. Repub. as GW 9,i,12. TR.—English: CW 9,i,12.

- 1950b “Faust und die Alchemie.” (Autoreferat.) *Aus d. Jhrsb. 1949/50.* pp. 29–32. Printed for private circulation. Summary of lecture to the Psychologischer Club Zurich, 8 Oct. 1949. TR.—English: CW 18,105.
- 1950d “Geleitwort.” Lily Abegg: *Ostasien denkt anders*, pp. 3–4. Zurich: Atlantis. Dated Mar. 1949. Omitted from pub. of the English trans., *The Mind of East Asia* (London and New York, 1952). TR.—English: 1953f.
- 1950e “Vorrede” and “Fall von Prof. C. G. Jung.” Fanny Moser: *Spuk. Irrglaube oder Wahrglaube*. pp. 9–12 and pp. 253–61. Baden bei Zurich: Gyr. “Vorrede” dated Apr. 1950. “Vorrede” pub. as G. 1956b, with the omission of the first few sentences and the addn. of a title. TR. of both—English: CW 18,7.
- 1950f “Wo leben die Teufel? Zur Psychologie der Ehe.” *Welt*, (26 July). 1 p.
- 1950g Contribution to “Rundfrage über ein Referat auf der 66. Wanderversammlung der südwestdeutschen Psychiater und Neurologen in Badenweiler.” pp. 464–65. *Psyche*, Jhg. 4:8 (Nov.), 448–80. Answer to questionnaire concerning a report given by Dr. Medard Boss at the above congress and sent out by the editors to Boss’s colleagues. TR.—English: CW 18,14.
- 1951a *Aion. Untersuchungen zur Symbolgeschichte*. With a contribution by Marie-Louise von Franz. (Psychologische Abhandlungen, 8.) Zurich: Rascher. pp. 561. Contains the following work by Jung:
- “Beiträge zur Symbolik des Selbst.”
 - I. Das Ich. (15–21)
 - II. Der Schatten. (22–26) Incorporates G. 1948!.
 - III. Die Syzygie: Anima und Animus. (27–43) Incorporates G. 1948f.
 - IV. Das Selbst. (44–62) Incorporates G. 1949b.
 - V. Christus, ein Symbol des Selbst. (63–110)
 - VI. Das Zeichen der Fische. (111–41)
 - VII. Die Prophezeiung des Nostradamus. (142–51)
 - VIII. ber die geschichtliche Bedeutung des Fisches. (152–71)
 - IX. Die Ambivalenz des Fischsymbols. (172–83)
 - X. Der Fisch in der Alchemie. (184–224)
 - XI. Die alchemistische Deutung des Fisches. (225–50)
 - XII. Allgemeines zur Psychologie der christlich-alchemistischen Symbolik. (251–66)
 - XIII. Gnostische Symbole des Selbst. (267–320)

XIV. Die Struktur und Dynamik des Selbst. (321–78)

XV. Schlusswort. (379–84)

I–IV repub. as G. 1954c,4. Jung's work repub. with rearranged title as GW 9,ii.

On the advice of Dr. von Franz, it is construed that the title *Aion* belongs to Prof. Jung's part of the book rather than to hers. The present entry, however, records the title-page data of the Swiss edn. The CW trans. bears the title *Aion* as well. TR.—English: CW 9,ii.

1951b With K. Kerényi: *Einführung in das Wesen der Mythologie. Das göttliche Kind; Das göttliche Mädchen*. "4. revidierte Auflage." Zurich: Rhein, pp. 260. Contains the following works by Jung:

1. "Zur Psychologie des Kind-Archetypus." (105–47) Repub. as GW 9,i,6. TR.—English: CW 9,i,6.

2. "Zum psychologischen Aspekt der Korefigur." (223–50) Repub. as GW 9,i,7. TR.—English: CW 9,1,7.

G. 1941c repub. with the addn. of new foreword by Kerényi. TR.—French: 1953b // Italian: 1972a.

1951c "Tiefenpsychologie." (Definition.) *Lexikon der Pädagogik*. Vol. II, pp. 768–73. Bern: A. Francke. Written in 1948. TR.—English: CW 18,44.

1951d "Grundfragen der Psychotherapie." *Dialéctica*, V:i (15 Mar.), 8–24. Repub. as GW 16,10. TR.—English: CW 16,10 // French: 1953a,11.

1951e "Das Fastenwunder des Bruder Klaus." *Neue Wissenschaft*, Jhg. 1950/51:7 (Apr.), 14. Rev. from letter written 10 Nov. 1948 in response to Fritz Blanke's "Bruder Klaus von der Flüe." *Neue Wissenschaft*, Jhg. 1950/51:4. Orig. text of letter pub. in G. 1972b and trans. in E. 1973b. TR.—English: CW 18,94.

1952a *Antwort auf Hiob*. Zurich: Rascher, pp. 169. Pub. with addn. as G. 1961a. TR.—English: 1954a/CW 11,9 // French: 1964b // Italian: 1965d // Norwegian: 1969b // Spanish: 1964a // Swedish: 1954a. Note: A paragraph written by Jung describing the book was printed as a blurb on the dust jacket of this edn. Repub. as GW 11,23, and trans. into English as CW 18,95.

1952b With W. Pauli: *Naturerklärung und Psyche*. (Studien aus dem C. G. Jung-Institut Zürich, 4.) Zurich: Rascher, pp. 194. Contains the following work by Jung:

"Synchronizität als ein Prinzip akausaler Zusammenhänge." (1–107) Ch. 2 of Jung's article pub. rev. as G. 1958f. Whole article repub. as GW 8,18. TR.

—Dutch: 1954a.

A rev. version with addns. by the author was trans. and pub. as E. 1955a. TR. of entire work—Spanish: 1964b.

1952c * *Paracelsus*. (Der Bogen, 25.) St. Gallen: Tschudy. pp. 24. G. 1934b.5 repub. Repub. as GW 15,1. TR.—English: CW 15,1.

1952d *Psychologie und Alchemie*. 2d rev. edn. Zurich: Rascher, pp. 708. G. 1944a pub. rev. and with the addn. of “Vorwort zur 2. Auflage.” Repub. as GW 12. TR.—English: CW 12 // French: 1970a // Spanish: 1953a.

1952e *Symbole der Wandlung. Analyse des Vorspiels zu einer Schizophrenie*. With 300 illus., selected and comp. by Jolande Jacobi. “Vierte, umgearbeitete Auflage ...” Zurich: Rascher, pp. 821. 1971: “Sonderausgabe.” Ölten: Walter. (Same edn., in boards.) Contents:

Vorreden (vii-xviii)

Part I:

- I. Einleitung. (3–8) TR.—English: 1954d.
- II. Über die zwei Arten des Denkens. (9–51)
- III. Vorgeschichte. (52–58)
- IV. Der Schöpferhymnus. (59–129)
- V. Das Lied von der Motte. (130–96)

Part II:

- I. Einleitung. (199–217)
- II. Über den Begriff der Libido. (218–33)
- III. Die Wandlung der Libido. (234–83)
- IV. Die Entstehung des Heros. (284–345)
- V. Symbole der Mutter und der Wiedergeburt. (346–468)
- VI. Der Kampf um die Befreiung von der Mutter. (469–528)
- VII. Das Opfer. (529–763)
- VIII. Schlusswort. (764–69)

G. 1925a, greatly rev. and exp. with title change. Repub. as GW 5. TR.—English: GW 5 // French: 1953c // Italian: 1965b / 1970a // Spanish: 1962b.

1952f “Über Synchronizität.” *Eran. Jb.* 1951. pp. 271–84. (See G. 1934c.) Repub. as GW 8,19. Lecture given in 2 pts. also to the Psychologischer Club Zurich, 20 Jan. and 3 Feb. 1951. TR.—English: 1953c / 1957b / CW 8,19.

- 1952g “Vorwort.” Gerhard Adler: *Zur analytischen Psychologie*. pp. 7–9. Zurich: Rascher. Dated May 1949. Not in orig. edn.: London and New York: Norton, 1948. TR.—English: 1966e / CW 18,55 // French: 1957a.
- 1952h “Zu unserer Umfrage ‘Leben die Bücher noch?’ “ [Contribution] *Jungkaufmann; schweizer Monatsschrift für die kaufmännische Jugend*, XXVII:3 (Mar.), 51–52. Jung’s reply to Hölderlin’s famous question, written as a letter to the editor, A. Galliker (29 Jan. 1952). Text of letter pub. in G. 1972b and trans. in E. 1976a.
- 1952i * “Vom Wesen der Träume.” *Ciba-Zeitschrift* (Wehr-Baden), V:55 (May), 1830–37. G. 1945d repub. Pub., rev. and exp., as G. 1948b,5.
- 1952j “Religion und Psychologie.” *Merkur*, VI:5 (May), 467–73. Repub, with title change as GW 11,17. A reply to Prof. Buber. TR.—English: 1957d / 1973e.
- 1953a Contribution to *Trunken von Gedichten. Eine Anthologie geliebter deutscher Verse*, p. 63. Ed. by Georg Gerster. Zurich: Verlag der Arche. Partial trans. in E. 1976a, p. 193.
- 1953b “Vorwort.” Frances G. Wickes: *Von der inneren Welt des Menschen*. pp. vii–viii. Zurich: Rascher. Dated Sept. 1953. Not included in original English publication: *The Inner World of Man* (New York: Farrar and Rinehart, 1938). TR.—English: 1954g / CW 18,57.
- 1954a With Paul Radin and Karl Kerényi: *Der göttliche Schelm. Ein indianischer Mythen-Zyklus*. Zurich: Rhein, pp. 219. Contains the following work by Jung:
 “Zur Psychologie der Schelmenfigur.” (185–207) Repub. as GW 9,i,9. TR.—English: 1955d / 1956a.
 TR. of entire work—English: 1956a // French: 1958a // Italian: 1965a.
- 1954b *Von den Wurzeln des Bewusstseins. Studien über den Archetypus*. (Psychologische Abhandlungen, 9.) Zurich: Rascher, pp. 681. Contents:
 1. Vorrede. (ix-x) Dated May 1953. TR.—Dutch: 1962a,1 // English: CW 18,58.
 2. “Über die Archetypen des kollektiven Unbewussten.” (1–56) G. 1935b rev. Repub. as G. 1957a,1 and GW 9,i,1. TR.—Dutch: 1962a,2 // English: CW 9,1,1 // Spanish: 1970a,1.
 3. “Über den Archetypus mit besonderer Berücksichtigung des Animabegriffes.” (57–85) G. 1936e rev. Repub. as GW 9,i,3. TR.—Dutch: 1962a,3 // English: CW 9,i,3 // Spanish: 1970a,2.

4. “Die psychologischen Aspekte des Mutterarchetypus.” (87–135) G. 1939b rev. Repub. as GW 9,i,4. TR.—Dutch: 1962a,4 // English: (with pts. of E. 1943a) CW 9,i,4 // Spanish: 1970a,3.
5. “Die Visionen des Zosimos.” (135–216) G. 1938c, rev. and considerably exp., with title change. Repub. as GW 13,2. TR.—English: CW 13,2.
6. “Das Wandlungssymbol in der Messe.” (217–350) G. 1942c, rev. and exp. Repub. as GW 11,3. TR.—English: CW 11,3.
7. “Der philosophische Baum.” (351–496) G. 1945g, greatly rev. and exp. Repub. as GW 13,5. TR.—English: CW 13,5.
8. “Theoretische Überlegungen zum Wesen des Psychischen.” (497–608) G. 1947a, sl. rev. & with title change. Repub. as GW 8,8. Excerpts repub. as G. 1954c,5. TR.—Dutch: 1962a,5 // English: 1954b,2 / CW 8,8 // Spanish: 1970a,4.

TR. of entire work—French: 1971b.

1954c *Welt der Psyche. Eine Auswahl zur Einführung*. Ed. by A. Jaffé and G. P. Zacharias. Zurich: Rascher, pp. 165. 1965: reset. (“Geist und Psyche.”) Munich: Kindler. pp. 149. Contains the following works by Jung:

1. “Vom Wesen der Träume.” (9–32) G. 1948b,5 repub. Repub. as GW 8,10.
2. “Psychologie und Dichtung.” (33–61) G. 1950a,2 repub. Repub. as GW 15,7.
3. “Psychotherapie und Weltanschauung.” (63–73) G. 1946a,4 repub. Repub. as GW 16,7.
4. “Beiträge zur Symbolik des Selbst.” (75–120) G. 1951a, Chs. I–IV, repub. Repub. as GW 9,ii, chs. I–IV.
5. “Theoretische Überlegungen zum Wesen des Psychischen.” (121–59) G. 1954b,8, Section 7 and “Nachwort,” repub. Cf. GW 8,8.

TR. of entire work—Dutch: 1955b // Norwegian: 1969a.

1954d Preface to John Custance: *Weisheit und Wahn*. pp. vii–xi. Zurich: Rascher. Written in German in 1951, according to ms. in Jung Library, Küsnacht. First pub., however, in an English trans. TR—English: 1952a / CW 18,15.

1954e Two letters to the author. Georg Gerster: “C. G. Jung zu den fliegenden Untertassen.” *Weltwoche*, Jhg. 22: 1078 (9 July). Interview request not granted. These letters used in article instead, TR.—English: 1954h / (Pts. only) 1955i / 1959i,3 / CW 18,80.

1954f “Mach immer alles ganz und richtig.” *Weltwoche*, Jhg. 22:1100 (10 Dec.), 31.
Answer to question on the rules of life. TR.—English: CW 18,79.

1955a *Mysterium coniunctionis. Untersuchung über die Trennung und Zusammensetzung der seelischen Gegensätze in der Alchemie*. With the collaboration of M.-L. von Franz. Pt. I. (Psychologische Abhandlungen, 10.) Zurich: Rascher. pp. 284. Contents:

Die Symbolik der Polarität und Einheit.

Vorwort.

I. Die Komponenten der Coniunctio.

1. Die Gegensätze. (1–4)

2. Der Quaternio. (5–15)

3. Die Waise und die Witwe. (16–37)

4. Alchemie und Manichäismus. (38–42)

II. Die Paradoxa.

1. Die Arkansubstanz und der Punkt. (43–50)

2. Die Scintilla. (50–55)

3. Das Enigma Bolognese. (56–95) Cf. G. 1945b.

III. Die Personifikationen der Gegensätze.

1. Einleitung. (96–99)

2. Sol. (100–20)

3. Sulphur. (121–40) Includes an exp. G. 1948c.

4. Luna. (141–200)

5. Sal. (200–84)

Repub. as GW 14, vol. I. The 1st of 2 pts. Cf. G. 1956a for Pt. II. TR.—
English: CW 14.

1955b *Versuch einer Darstellung der psychoanalytischen Theorie*. Zurich: Rascher, pp. 195. G. 1913a pub. with the addn. of a foreword. Repub. as GW 4,9. TR.—
—English: CW 4,9.

1955c “Geleitwort.” Gustav Schmaltz: *Komplexe Psychologie und körperliches Symptom*, pp. 7–8. Stuttgart: Hippokrates. TR.—English: CW 18,17.

1955d “Psychologischer Kommentar.” *Das tibetische Buch der grossen Befreiung*, pp. 13–54. Ed. by W. Y. Evans-Wentz. Munich: Barth. “Kommentar” trans. from E. 1954e by M. Niehus-Jung; written in English in 1939. Repub. as GW 11,10.

1955e “Mandalas.” *Du*, Jhg. 15:4 (Apr.), 16, 21. Repub. as GW 9,i,13. TR.—
English: 1955g / CW 9,i,13.

1955f Letter to Hans A. Illing (10 Feb. 1955). Hans A. Illing: “Jung und die
moderne Tendenz in der Gruppentherapie.” *Heilkunst*, no. 7 (July), 233. Full
text of letter pub. in G. 1972b and trans. in E. 1976a. Excerpt pub. as G.
1956d,1. TR.—English: (excerpts) 1957i.

1956a *Mysterium coniunctionis*. ... Pt. II. (Psychologische Abhandlungen, 11.)
Zurich: Rascher, pp. 418. Contents:

Die Symbolik der Polarität und Einheit, (cont.)

IV. Rex und Regina.

1. Einleitung. (1–5)
2. Gold und Geist. (5–9)
3. Die königliche Wandlung. (9–19)
4. Die Heilung des Königs. (19–81)
5. Die dunkle Seite des Königs. (82–96)
6. Der König als Anthropos. (96–109)
7. Die Beziehung des Königssymbols zum Bewusstsein. (109–21)
8. Die religiöse Problematik der Königserneuerung. (121–33)
9. Regina. (134–39)

V. Adam und Eva.

1. Adam als Arkansubstanz. (140–49)
2. Die Statue. (150–57)
3. Adam als erster Adept. (157–67)
4. Die Gegensätzlichkeit Adams. (168–76)
5. Der “alte Adam.” (176–78)
6. Adam als Ganzheit. (179–85)
7. Die Wandlung. (186–99)
8. Das Runde, Kopf und Gehirn. (199–223)

VI. Die Konjunktion.

1. Die alchemistische Anschauung der Gegensatzvereinigung. (224–
38)
2. Stufen der Konjunktion. (238–47)
3. Die Herstellung der Quintessenz. (247–53)
4. Der Sinn der alchymischen Prozedur. (253–59)
5. Die psychologische Deutung der Prozedur. (259–69)

6. Die Selbsterkenntnis. (270–80)
7. Der Monoculus. (280–96)
8. Inhalt und Sinn der zwei ersten Konjunktionsstufen. (296–311)
9. Die dritte Stufe der Konjunktion: der unus mundus. (312–23)
10. Das Selbst und die erkenntnistheoretische Beschränkung. (324–34)
Nachwort. (335–337)

Repub. as GW 14, vol. II. The 2d of 2 pts. Cf. G. 1955a for Pt. I. (A third part was written by M.-L. von Franz. Cf. note under GW 14.) TR.—English: CW 14.

- 1956b “Die Parapsychologie hat uns mit unerhörten Möglichkeiten bekanntgemacht.” *Gibt es Geister? Rundfrage—beantwortet von Psychologen, Schriftstellern, Philosophen ...* pp. 17–22. Bern: Viktoria. G. 1950e (“Vorrede” only) pub. with omission of the 1st few sentences, and addn. of title.
- 1956c Statement in publisher’s brochure (with other statements) announcing publication of Karl Eugen Neumann’s translation of *Die Reden Gotamo Buddhos*. 2 pp. Zurich and Stuttgart: Artemis; Vienna: Paul Zsolnay. Undated, but probably written in Jan. 1956. Repub. as GW 11,26. TR.—English: CW 18,101.
- 1956d Excerpts of letters to Hans A. Illing. Georg R. Bach and Hans A. Illing: “Historische Perspektive zur Gruppenpsychotherapie.” *Zeitschrift für psychosomatische Medizin*, Jhg. 2 (Jan.), 141–42. Contains excerpts from the following letters by Jung:
1. 10 Feb. 1955 (141) Excerpted from G. 1955f.
 2. 26 Jan. 1955 (141–42)
- Full text of letters pub. in G. 1972b and trans. in E. 1976a. TR.—English: 1957i.
- 1956e “Wotan und der Rattenfänger. Bemerkungen eines Tiefenpsychologen.” *Der Monat*, IX:97 (Oct.), 75–76. Letter to the editor, Melvin J. Lasky (Sept. 1956). Text of letter pub. in G. 1973a and trans. in E. 1976a.
- 1956f Contribution to symposium, “Das geistige Europa und die ungarische Revolution.” *Die Kultur*, V:73 (1 Dec.), 8. Ca. 50 words long. TR.—English: CW 18,84,i.
- 1957a *Bewusstes und Unbewusstes. Beiträge zur Psychologie*. Ed. by Aniela Jaffé. (“Bücher des Wissens.”) Frankfurt am Main and Hamburg: Fischer. pp. 184. Contents:

1. “Über die Archetypen des kollektiven Unbewussten.” (11–53) G. 1954b,2 repub. Repub. as GW 9,i,1.
2. “Einleitung in die religionspsychologische Problematik der Alchemie.” (54–91) G. 1944a,2 repub. Repub. as GW 12,3,1.
3. “Zur Phänomenologie des Geistes im Märchen.” (92–143) G. 1948a,2 repub. Repub. as GW 9,i,8.
4. “Zur Psychologie östlicher Meditation.” (144–63) G. 1948a, 5 repub. Repub. as GW 11,14.

1957b * With Richard Wilhelm: *Das Geheimnis der goldenen Blüte. Ein chinesisches Lebensbuch*. “Fünfte Auflage.” Zurich: Rascher. pp. 161.

Contains the following works by Jung:

1. “Vorrede zur II. Auflage, (vii-x) Repub. as part of GW 13,1. TR.—English: CW 13,1.
2. “Zum Gedächtnis Richard Wilhelms.” (xiii-xxvi) Repub. as GW 15,5. TR.—English: CW 15,5.
3. “Europäischer Kommentar.” (1–68 + 10 plates) Repub. as part of GW 13,1. TR.—English: CW 13,1.

G. 1938a reset, with new foreword by Salomé Wilhelm (xi-xii) and the addn. of the text of the *Hui Ming Ging*. (148–67). TR. of entire work—English: 1962b.

1957c * Contribution to symposium: *Aufstand der Freiheit. Dokumente zur Erhebung des ungarischen Volkes*. p. 104. Zurich: Artemis. Ca. 175 words long. TR.—English: CW 18.84.ii.

1957d “Vorwort.” Eleanor Bertine: *Menschliche Beziehungen; eine psychologische Studie*, pp. 5–7. Zurich: Rhein. Dated Aug. 1956. TR.—English: 1958e / CW 18,61 // Italian: 1961a.

1957e * “Vorrede.” Felicia Froboese-Thiele: *Träume—eine Quelle religiöser Erfahrung?* pp. 18–19. Göttingen: Vandenhoeck and Ruprecht. TR.—English: CW 18,102.

1957f “Vorwort.” René J. van Heisdingen: *Beelden uit het onbewuste. Een geval van Jung*. pp. 7–8. Arnhem: Van Loghum Slaterus. Written for this pub. and dated May 1954. Foreword is in German, while the rest of the book is in Dutch. TR.—English: CW 18,59.

1957g “Vorwort.” Jolande Jacobi: *Komplex, Archetypus, Symbol in der Psychologie C. G. Jungs*, pp. ix-xi. Zurich: Rascher. Dated Feb. 1956. TR.—English: 1959e // French: 1961c.

- 1957h “Vorwort.” Victor White: *Gott und das Unbewusste*. pp. xi-xxvi. Zurich: Rascher. Repub. as GW 11,4. Originally written in German in 1952, but 1st pub. in an English trans. “Anhang” by Gebhard Frei contains extracts of letters written by Jung to Frei, reprinted from *Annalen der Philosophischen Gesellschaften Innerschweiz und Ostschweiz*, TR.—English: 1952c / CW 11,4.
- 1957i * “Gegenwart und Zukunft.” *Schweizer Monatshefte*, Supplement, XXXVI:12 (Mar.), 5–55. Also pub. as paperback: Zurich: Rascher. pp. 55. 1964: reset. (“Rascher Paperback.”) pp. 68. Repub. as GW 10,14. TR.—Danish: 1959a // Dutch: 1958a // English: 1958b / CW 10,14//Finnish: 1960a // French: 1962b//Italian: 1963a,10 // Norwegian: 1966c // Spanish: 1957a.
- 1957j * Contribution to *Flinker Almanac 1958*. pp. 52–53. Paris: Librairie Française et Etrangère. Ca. 500 words long. Letter to the editor, Martin Flinker (17 Oct. 1957). Text of letter pub. in G. 1973a and trans. in E. 1976a.
- 1958a *Ein moderner Mythos. Von Dingen, die am Himmel gesehen werden*. Zurich: Rascher. pp. 122. 1964: reset. (“Rascher Paperback.”) pp. 143. Repub., with addns., as GW 10,15. Contents:
- Vorrede. (7–9)
 - 1. Das Ufo als Gerücht. (11–25)
 - 2. Das Ufo im Traum. (26–75)
 - 3. Das Ufo in der Malerei. (76–93)
 - 4. Zur Geschichte des Ufophänomens. (94–98)
 - 5. Zusammenfassung. (99–104)
 - 6. Das Ufophänomen in nicht-psychologischer Beleuchtung. (105–09)
 - Epilog. (110–22)
- Dedicated to Walter Niehus. TR.—English: (with addns.) 1959b // French: 1961a // Italian: 1960a // Portuguese: ?1962b // Spanish: 1961a.
- 1958b “Die transzendente Funktion.” *Geist und Werk. Aus der Werkstatt unserer Autoren. Zum 75. Geburtstag von Dr. Daniel Brody*. pp. 3–33. Zurich: Rhein. A rev. version of the original 1916 ms. first pub. in an English trans. as E. 1957a. Repub. as GW 8,2. TR.—English: CW 8,2.
- 1958c “Das Gewissen in psychologischer Sicht.” *Das Gewissen*. pp. 185–207. (Studien aus dem C. G. Jung-Institut, Zurich, 7.) Zurich: Rascher. Repub. as GW 10,16. Also pub. in *Universitas* (June). Lecture contributed to the series “Das Gewissen,” C. G. Jung Institute, Zurich, Winter Semester 1957/58. TR.—English: CW 10,16 // French: 1971a,4.

- 1958e “Vorwort.” Aniela Jaffé: *Geistererscheinungen und Vorzeichen. Eine psychologische Deutung*. pp. 9–12. Zurich: Rascher. Dated August 1957. TR.—English: 1963b / CW 18,8.
- 1958f “Ein astrologisches Experiment.” *Zeitschrift für Parapsychologie und Grenzgebiete der Psychologie*, 1:2/3 (May), 81–92. G. 1952b, ch. 2 extensively rev. and condensed. Prefatory note includes letter to the editor, Hans Bender (12 Feb. 1958), repub. in G. 1973a and trans. in E. 1976a. TR.—English: CW 18,48 (with addns.).
- 1958g “Drei Fragen an Prof. C. G. Jung.” *Zürcher Student*, Jhg. 36:4 (July), 151. Dated 27 June 1958. Answers to questions on psycho-diagnostic methods. TR.—English: CW 18,85.
- 1958h “Zeichen am Himmel. C. G. Jung und die physische Realität der UFOs.” *Badener Tagblatt* (29 Aug.). Ca. 220 words long. Press release to United Press International, probably also pub. in other newspapers. TR.—English: 1958h / 1958j / 1959i,1 / CW 18,81.
- 1958i “Die Schizophrenie.” *Schweizer Archiv für Neurologie und Psychiatrie*, LXXXI: 1/2, 163–77. Repub. as GW 3,9. Paper presented to the II. Internationaler Kongress für Psychiatrie, Zurich, 1957. Brief summary (in German, English, French, Spanish, and Italian) pub. as “Schizophrenia.” *Synopses, Lectures to the Full Assemblies and Lectures to the Symposia. [Proceedings] Zurich, II. International Congress for Psychiatry, 1957*. pp. 49–52. [Zurich, ?1958.] TR.—English: CW 3,10.
- 1958j “‘Nationalcharakter’ und Verkehrsverhalten.” *Zentralblatt für Verkehrs-Medizin, Verkehrs-Psychologie und angrenzende Gebiete*, IV:3, 131–33. A letter written at the request of the editor, F. v. Tischendorf (19 Apr. 1958). Text of letter pub. in G. 1973a and trans. in E. 1976a. TR.—English: 1959j.
- 1959a “Über Psychotherapie und Wunderheilungen. Aus einem Brief von C. G. Jung.” *Magie und Wunder in der Heilkunde. Ein Tagungsbericht*. pp. 8–9. Ed. by Wilhelm Bitter. (7. Kongressbericht der Stuttgarter Gemeinschaft “Arzt und Seelsorger.”) Stuttgart: Klett. Letter (17 Apr. 1959), written at the request of the editor, Wilhelm Bitter, pub. with minor omissions. Entire letter pub. in G. 1973a and trans. in E. 1976a.
- 1959b “Gut und Böse in der analytischen Psychologie.” *Gut und Böse in der Psychotherapie. Ein Tagungsbericht*. pp. 29–42. Ed. by Wilhelm Bitter. (8. Kongressbericht der Stuttgarter Gemeinschaft “Arzt und Seelsorger.”) Stuttgart: “Arzt und Seelsorger.” Extemporaneous address to the

Gemeinschaft, Zurich, Fall 1958. Transcript prepared for pub. by Gebhard Frei, and approved, with corrections, by Jung. Repub. as GW 10,17 and GW 11,19. TR—English: 1960e / CW 10,17. Also contains on pp. 56–57 the first 2 parags. of a letter to the editor (12 July 1958), the full text of which appears in G. 1973a and is trans. in E. 1976a.

- 1959c * Foreword to Frieda Fordham: *Eine Einführung in die Psychologie C. G. Jungs*. pp. 7–8. Zurich: Rascher. Trans. from E. 1953d by J. Meier.
- 1959d * “Geleitwort” and answers to questions. Otto Kankleit: *Das Unbewusste als Keimstätte des Schöpferischen. Selbstzeugnisse von Gelehrten, Dichtern, und Künstlern*. pp. 9 and 68–69. Munich and Basel: Ernst Reinhardt. TR.—English: CW 18,121.
- 1959e “Vorrede.” Toni Wolff: *Studien zu C. G. Jungs Psychologie*. pp. 7–14. Ed. by C. A. Meier. Zurich: Rhein. Dated Aug. 1958. Repub. as GW 10,18. TR.—English: 1960d / CW 10,18.
- 1959f “Neuere Betrachtungen zur Schizophrenie.” *Universitas*, XIV: 1 (Jan.), 31–38. Trans. from the original English text (cf. E. 1957h) by H. Degen. Repub. as GW 3,8. Text of contribution to the “Voice of America” symposium, “The Frontiers of Knowledge and Humanity’s Hopes for the Future,” broadcast 16 Dec. 1956; written up at the request of the Bollingen Foundation.
- 1959g Contribution to “Eine Tat-Umfrage: Das Interview mit dem anonymen Stimmbürger. Psychologen legen das unbewusste Nein des Bürgers bloss.” *Tat* (23 Jan.). 1 p. Ca. 350 words long.
- 1959h Commentary on Walter Pöldinger: “Zur Bedeutung bildnerischen Gestaltens in der psychiatrischen Diagnostik,” *Die Therapie des Monats*, IX:2, 67. TR.—English: CW 18,128.
- 1961a *Antwort auf Hiob*. 3d rev. edn. Zurich: Rascher. pp. 122. 1967: reset. (“Rascher Paperback.”) pp. 143. 1973: (“Studienausgabe.”) Olten: Walter, pp. 143. G. 1952a repub. with the addn. of a “Nachwort” trans. from E. 1956c by Marianne Niehus-Jung. Repub. as GW 11,9. TR.—Finnish: 1974a.
- 1961b “Nachwort.” Arthur Koestler: *Von Heiligen und Automaten*, pp. 363–68. Zurich: Büchergilde Gutenberg. Bern, Stuttgart, Vienna: Scherz. 1965: Zurich: Buchclub Ex Libris. Trans. from E. 1961c by Hans Flesch-Brunningen. Written in English as a letter to Melvin J. Lasky, editor of *Encounter* (19 Oct. 1960), in response to excerpts of Koestler’s book pub. therein, and itself pub. in a subsequent issue. Text of letter trans. into German in G. 1973a.

1961c “Ein Brief zur Frage der Synchronizität.” *Zeitschrift für Parapsychologie und Grenzgebiete der Psychologie*, V:1 (Mar.), 1–8. Trans. from the English ms. by H. Bender, with corrections and additions by Jung. Originally written in English as letter to A.D. Cornell (9 Feb. 1960). TR.—English: 1961a.

1962a *Erinnerungen, Träume, Gedanken*. Recorded and ed. by Aniela Jaffé. Zurich: Rascher. pp. 422. 1968: Zurich: Buchclub Ex Libris. pp. 423. ?1971: Olten: Walter, pp. 423. Contents:

1. Prolog. (10–12)
2. Kindheit. (13–30)
3. Schuljahre. (31–88)
4. Studienjahre. (89–120)
5. Psychiatrische Tätigkeit. (121–50)
6. Sigmund Freud. (151–73)
7. Die Auseinandersetzung mit dem Unbewussten. (174–203)
8. Zur Entstehung des Werkes. (204–26)
9. Der Turm. (227–41)
10. Reisen. (242–92)
11. Visionen. (293–301)
12. Über das Leben nach dem Tode. (302–29)
13. Späte Gedanken. (330–56)
14. Rückblick. (357–61)
15. Appendix.
 - i. Aus den Briefen Jungs an seine Frau aus den USA. 1909 (363–70)
 - ii. Aus Briefen von Freud an Jung. 1909–11. (370–73) Cf. G 1974a.
 - iii. Brief an seine Frau aus Sousse, Tunis. 1920. (373–75)
 - iv. Aus einem Brief an einen jungen Gelehrten. 1952. (375–76) To Zwi Werblowsky (17 June 1952). Entire letter pub. in G. 1972b and trans. in E. 1975a.
 - v. Aus einem Brief an einen Kollegen. 1959. (376–78) To Erich Neumann (10 Mar. 1959). Entire letter pub. as G. 1967a and trans. in E. 1975a.
 - vi. “Théodore Flournoy.” (378–79)
 - vii. “Richard Wilhelm.” (380–84) Cf. G. 1930c and G. 1931b.
 - viii. “Heinrich Zimmer.” (385–86)
 - ix. Nachtrag zum “Roten Buch.” (387)
 - x. “VII Sermones ad Mortuos.” (389–98) G. 1916a repub.

Also contains excerpts of letter to Gustav Steiner (30 Dec. 1957), pp. 3–4. Cf. G. 1964b. TR. (Appendix content varies)—Dutch: 1963a // English: 1962a / 1966a // French: 1966a // ?Japanese: 1972a and 1973a // Norwegian: 1966b // Portuguese: 1969a // Spanish: 1966b // Swedish: 1964a. See E. 1962a for Danish and Italian trans.’s. Uncertain whether Japanese trans. from German or English.

- 1963a “Vorwort.” Cornelia Brunner: *Die Anima als Schicksalsproblem des Mannes*. pp. 9–14. (Studien aus dem C. G. Jung-Institut, Zürich, 14.) Zurich: Rascher. Dated April 1959. TR.—English: CW 18,63.
- 1963b “Geleitbrief.” *Der Mensch als Persönlichkeit und Problem*. Gedenkschrift for Ildefons Betschart on his 60th birthday. pp. 14–15. Ed. by Elisabeth Herbrich. Munich: Anton Pustet. Letter to the editor (30 May 1960). Entire text of letter pub. in G. 1973a and trans. in E. 1976a.
- 1964a “Brief von Prof. C. G. Jung an den Verfasser.” Josef Rudin: *Psychotherapie und Religion*. pp. 11–13. 2d edn. Olten: Walter. Letter to the author written 30 Apr. 1960 in response to Jung’s reading of the 1st edn. of the above, and subsequently included in the 2d. Text of letter pub. in G. 1973a and trans. in E. 1976a. TR.—English: 1968c.
- 1964b Letter to Gustav Steiner (30 Dec. 1957), pp. 125–28. Gustav Steiner: “Erinnerungen an Carl Gustav Jung. Zur Entstehung der Autobiographie.” *Basler Stadtbuch 1965*. Basel: Helbing und Lichtenhahn. A facsimile of the 1st part of the ms. appears on p. 127. Pub. with omissions in G. 1962a, pp. 3–4. Repub. in G. 1973a. TR.—English: (Pt. only) 1962a / 1976a.
- 1967a Letter to Erich Neumann (10 March 1959). Aniela Jaffé: *Der Mythos vom Sinn im Werk von C. G. Jung*. pp. 182–84. Paperback. Zurich: Rascher. Repub. in G. 1973a. Pub. in abbrev. form as G. 1962a, 15,v. TR.—English: 1976a.
- 1967b * Excerpt of letter to Ernst Hanhart (18 Feb. 1957). *Katalog der Autographen-Auktion* (Marburg), no. 425 (23–24 May). Also pub. in the *Tagesanzeiger für Stadt und Kanton Zürich* (27 May). TR.—English: 1976a.
- 1967c Letters to Richard Evans. Richard I. Evans: *Gespräche mit C. G. Jung und Äusserungen von Ernest Jones*. Zurich: Rhein. pp. 168. Trans. from E. 1964b by Lucy Heyer-Grote. Contains 2 letters dated April 1957 and one dated 30 May 1957. Also contains a lengthy interview.
- 1968a “Zugang zum Unbewussten.” *Der Mensch und seine Symbole*. pp. 20–103. [Ed. by Carl G. Jung and after his death by M.-L. von Franz; coordinating

editor, John Freeman.] Olten: Walter. pp. 320. Trans. from E. 1964a by Klaus Thiele-Dohrmann.

1968b Letters to August Forel. August Forel: *Briefe. Correspondance 1864–1927*. Ed. by Hans W. Walser. Bern: Hans Huber. Contains the following letters from Jung:

1. 1 Apr. 1906. (381–82)
2. 12 Oct. 1909. (403) Repub. in G. 1972a.

TR.—English: 1973b.

1969a *Über Grundlagen der analytischen Psychologie. Die Tavistock Lectures*. Zurich: Rascher, pp. 218. Trans. from E. 1968a by Hilde Binswanger. 1975: (“Studienausgabe.”) Olten: Walter. TR.—Norwegian: 1972a.

1971a *Der Einzelne in der Gesellschaft*. (“Studienausgabe.”) Olten: Walter. pp. 117. Contents:

1. “Die Bedeutung des Vaters für das Schicksal des Einzelnen.” (7–31) GW 4,14 repub.
2. “Die Frau in Europa.” (33–55) G. 1929a repub. Repub. as GW 10,6.
3. “Das Liebesproblem des Studenten.” (57–77) First pub. in English trans. Repub. as GW 10,5. Lecture to the student body, Universität Zürich, prob. in Dec. 1922. TR.—English: 1928a,7 / CW 10,5.
4. “Die Bedeutung der analytischen Psychologie für die Erziehung.” (79–96) GW 17,3 prepub. Orig. German here pub. for the first time. Cf. E. 1928a, 13, Lecture I, for English version. Lecture given at the Congrès international de Pédagogie, Territet / Montreux, 1923.
5. “Die Bedeutung des Unbewussten für die individuelle Erziehung.” (97–115) GW 17,6 prepub. Orig. German here pub. for the 1st time. Lecture given at the International Congress of Education, Heidelberg, 1925. TR.—English: 1928a,14 / CW 17,6.

1971b *Mensch und Seele. Aus dem Gesamtwerk 1905 bis 1961*. Selected and ed. by Jolande Jacobi. Olten: Walter, pp. 391. “Dritte, erweiterte Auflage von *Psychologische Betrachtungen*.” G. 1945a, rev. and exp. Cf. E. 1970b for details. TR. (in effect)—English: 1970b.

1971c *Psychiatrie und Okkultismus*. (Frühe Schriften I; “Studienausgabe.”) Olten: Walter, pp. 155. Contents:

1. “Zur Psychologie und Pathologie sogenannter okkultur Phänomene.” (7–102) GW 1,1 repub.
2. “Über hysterisches Verlesen.” (103–06) GW 1,2 repub.

3. "Kryptomnesie." (107–19) GW 1,3 repub.

4. "Über manische Verstimmung." (121–49) GW 1,4 repub.

1971d *Psychologie und Religion*. ("Studienausgabe.") Olten: Walter, pp. 280.

Contents:

1. "Psychologie und Religion." (7–127) GW 11,1 repub.

2. "Über die Beziehung der Psychotherapie zur Seelsorge." (129–52) GW 11,7 repub.

3. "Psychoanalyse und Seelsorge." (153–61) GW 11,8 repub.

4. "Das Wandlungssymbol in der Messe." (163–267) GW 11,3 repub.

1972a *Briefe. Erster Band, 1906–1945*. Ed. by Aniela Jaffé in collaboration with Gerhard Adler. Olten: Walter, pp. 530. English and French letters trans. by Aniela Jaffé. The 1st of 3 vols. Cf. G. 1972b and G. 1973a. Letters arranged chronologically. Contains 381 letters. "With a very few exceptions ... the selection of letters in the Swiss and American editions is identical." Cf. E. 1973b. TR.—English: 1973b and 1976a // French: 1975a.

1972b *Briefe. Zweiter Band, 1946–1955*. pp. 560. Bibliographical information the same as for G. 1972a. The 2d of 3 vols. Cf. G. 1972a and G. 1973a. Contains 333 letters. TR.—English: 1973b and 1976a // French: 1975a.

1972c *Probleme der Psychotherapie*. ("Studienausgabe.") Olten: Walter, pp. 107.

Contents:

1. "Grundfragen der Psychotherapie." (7–22) GW 16,10 repub.

2. "Grundsätzliches zur praktischen Psychotherapie." (23–42) GW 16,2 repub.

3. "Was ist Psychotherapie?" (43–51) GW 16,3 repub.

4. "Einige Aspekte der modernen Psychotherapie." (52–59) GW 16,4 repub.

5. "Der therapeutische Wert des Abreagierens." (60–70) GW 16,11 repub.

6. "Psychotherapie und Weltanschauung." (71–78) GW 16,7 repub.

7. "Medizin und Psychotherapie." (79–88) GW 16,8 repub.

8. "Die Psychotherapie in der Gegenwart." (89–106) GW 16,9 repub.

1972d *Typologie*. ("Studienausgabe.") Olten: Walter, pp. 208. Contents:

1. "Zur Frage der psychologischen Typen." (7–17) GW 6,4 repub.

2. "Allgemeine Beschreibung der Typen." (18–104) GW 6,3,10 repub.

3. "Definitionen." (105–89) GW 6,3,11 repub.

4. "Psychologische Typen." (190–205) GW 6,5 repub.

1972e *Zur Psychoanalyse*. (Frühe Schriften III; "Studienausgabe.") Olten: Walter, pp. 121. Contents:

1. "Die Hysterielehre Freuds. Eine Erwiderung auf die Aschaffenburgsche Kritik." (7–14) GW 4,1 repub.
2. "Die Freudsche Hysterietheorie." (15–30) GW 4,2 repub.
3. "Die Traumanalyse." (31–40) GW 4,3 repub.
4. "Ein Beitrag zur Psychologie des Gerüchtes." (41–55) GW 4,4 repub.
5. "Ein Beitrag zur Kenntnis des Zahlentraumes." (56–64) GW 4,5 repub.
6. "Morton Prince M.D. *The Mechanism and Interpretation of Dreams*. Eine kritische Besprechung." (65–85) GW 4,6 repub.
7. "Zur Kritik über Psychoanalyse." (86–89) GW 4,7 repub.
8. "Zur Psychoanalyse." (90–93) GW 4,8 repub.
9. "Allgemeine Aspekte der Psychoanalyse." (94–108) GW 4,10 repub.
10. "Über Psychoanalyse." (109–18) GW 4,11 repub.

1973a *Briefe. Dritter Band, 1956–61*. pp. 431. Bibliographical information the same as for G. 1972a. The last of 3 vols. Cf. G. 1972a and G. 1972b. Contains 258 letters and a general index to the 3 vols. TR.—English: 1976a.

1973b *Versuch einer Darstellung der psychoanalytischen Theorie*. (Frühe Schriften IV; "Studienausgabe.") Olten: Walter, pp. 209. Contents:

1. "Versuch einer Darstellung der psychoanalytischen Theorie." (9–161) GW 4,9 repub.
2. "Psychotherapeutische Zeitfragen. Ein Briefwechsel zwischen C. G. Jung und R. Loy.á (163–206) GW 4,12 repub.

1973c *Zum Wesen des Psychischen*. ("Studienausgabe.") Olten: Walter, pp. 149. Contents:

1. "Die transzendente Funktion." (7–36) GW 8,2 repub.
2. "Die Bedeutung von Konstitution und Vererbung für die Psychologie." (37–46) GW 8,4 repub.
3. "Psychologische Determinanten des menschlichen Verhaltens." (47–62) GW 8,5 repub.
4. "Theoretische Überlegungen zum Wesen des Psychischen." (63–145) GW 8,8 repub.

1973d *Zur Psychogenese der Geisteskrankheiten*. ("Studienausgabe.") Olten: Walter, pp. 100. Contents:

1. "Der Inhalt der Psychose." (7–49) GW 3,2 repub.

2. “Über das Problem der Psychogenese bei Geisteskrankheiten.’ (51–66) GW 3,5 repub.
3. “Über die Bedeutung des Unbewussten in der Psychopathologie.” (67–74) GW 3,4 repub.
4. “Geisteskrankheit und Seele.” (75–79) GW 3,6 repub.
5. “Die Schizophrenie.” (81–98) GW 3,9 repub.

1974a With Sigmund Freud: *Briefwechsel*. Edited by William McGuire and Wolfgang Sauerländer. Frankfurt a. M.: S. Fischer. pp. 766. Contains 294 letters by Jung, dated 1906–1914 (+ 1 from 1923), of which 8 prev. appeared in G. 1972a. Editorial apparatus translated from E. 1974b by W. Sauerländer, TR.—English: 1974b // French: 1975a // Italian: 1974a.

1975a Address at the presentation of the Jung Codex and letters to G. Quispel. Gilles Quispel: “Jung en de Gnosis.” pp. 85–146. *Jung—een mens voor deze tijd*. Rotterdam: Lemniscaat. Contains the following works by Jung:

Letters to Quispel:

1. 18 Feb. 1953. (139)
2. 21 Apr. 1950. (140–41) Also pub. in G. 1972b. TR.—English: 1973b.
3. 22 July 1951. (142–43)
4. [Address at the presentation of the Jung Codex]. (144–46) Given in Zurich, 15 Nov. 1953. Dutch summary included. TR.—English: CW 18,97.

ENGLISH

- 1907a “On Psychophysical Relations of the Associative Experiment.” *J. abnorm. Psychol.*, 1:6 (Feb.), 247–55. Repub., slightly rev., with slight title change as CW 2,12. TR.—GW 2,12.
- 1907b With F. Peterson: “Psycho-physical Investigations with the Galvanometer and Pneumograph in Normal and Insane Individuals.” *Brain*, XXX:2 (pt. 118) (July), 153–218. Repub., slightly rev., as CW 2,13. TR.—GW 2,13.
- 1908a With Charles Ricksher: “Further Investigations on the Galvanic Phenomenon and Respiration in Normal and Insane Individuals.” *J. abnorm. Psychol.*, II:5 (Dec. 1907–Jan. 1908), 189–217. Repub., slightly rev., as CW 2,14. TR.—GW 2,14.
- 1909a *The Psychology of Dementia Praecox*. (Nervous and Mental Disease Monograph Series No. 3.) New York: The Journal of Nervous and Mental Disease Publishing Co. pp. 153. 1971: facsimile edn. New York: Johnson Reprint Corp. pp. 150. Trans. from G. 1907a by Frederick W. Peterson and A. A. Brill. Contents:
- Author’s Preface. (xix–xx) Dated July 1906.
 - I. Critical Presentation of Theoretical Views on the Psychology of Dementia Praecox.
 - II. The Emotional Complex and Its General Action on the Psyche.
 - III. The Influence of the Emotional Complex on Association.
 - IV. Dementia Praecox and Hysteria, a Parallel.
 - V. Analysis of a Case of Paranoid Dementia as a Paradigm.
- Pub. in dif. trans.’s as E. 1936b and CW 3,1.
- 1910a “The Association Method.” *American Journal of Psychology*, XXI:2 (Apr.), 219–69. Trans. from a largely unpub. German text by A. A. Brill. Contents:
1. Lecture I. (Untitled) (219–40) Pub. in a dif. trans. as CW 2,10. Partially incorporates It. 1908a.
 2. Lecture II. “Familial [printed as “Familiar”] Constellations. (240–51) Pub. in a dif. trans. as CW 2,11. Cf. Fr. 1907a.
 3. Lecture III. “Experiences Concerning the Psychic Life of the Child.” (251–69) German version pub. as G. 1910k. Cf. CW 17,1.
- Repub. in *Lectures and Addresses Delivered before the Departments of Psychology and Pedagogy in Celebration of the Twentieth Anniversary of the*

Opening of Clark University—September, 1909. Worcester, Mass.: The University. pp. 39–89. Pub. with stylistic alterations as E. 1916a,3.

- 1913a “On the Doctrine of Complexes.” *Australasian Medical Congress, Transactions of the 9th Session*, II, 835–39. Sydney: Wm. Applegate Gullick, Government Printer, under the direction of the Literary Committee. Repub., slightly rev., as CW 2,18. Paper contributed to the Congress, Sydney, Australia, Sept. 1911. TR.—GW 2,18.
- 1913b “The Theory of Psychoanalysis.” [1st section: Introduction and Chs. I–III.] *Psychoanal. Rev.*, I:1 (Nov.), 1–40. Trans. from G. 1913a by Edith and M. D. Eder and Mary Moltzer. The 1st of 5 sections. Repub., with E. 1914a and 1915b, as E. 1915a. Pub., together with E. 1914a and 1915b, with addns., in a dif. trans. as CW 4,9. First part of a series of 9 lectures given in English as an Extension Course at Fordham University, New York City, Sept. 1912.
- 1913c “Letter from Dr. Jung.” (To *The Psychoanalytic Review*, Nov. 1913.) *Psychoanal. Rev.*, I:1 (Nov.), 117–18. Repub. in E. 1973b. TR.—German: 1972a.
- 1913d “Psycho-Analysis.” *Transactions of the Psycho-Medical Society*, IV: 2. pp. 19. Trans. (by ?) from the orig. German ms., a version of which was ultimately pub. as GW 4,10. Repub. with slight title change as E. 1915d. Read before the Psycho-Medical Society, London, 5 Aug. 1913. TR.—Dutch: 1914a.
- 1914a “The Theory of Psychoanalysis.” *Psychoanal. Rev.* [2d–4th sections: Chs. IV-VII: 1:2 (Feb.), 153–77; Ch. VIII: I:3 (July), 260–84; Ch IX: 1:4 (Oct.), 415–30.] Trans. from G. 1913a by Edith and M. D. Eder and Mary Moltzer. The 2d, 3d, and 4th of 5 sections. Cf. E 1913b and E. 1915b. Repub., with E. 1913b and 1915b, as E. 1915a. Pub., with E. 1913b and 1915b, with addns., in a dif. trans. as CW 4,9. The middle portion of a series of 9 lectures. Cf. E. 1913b.
- 1914b “On the Importance of the Unconscious in Psychopathology.” *British Medical Journal*, II (5 Dec.), 964–66. Repub. as E. 1916a,11. Paper read in the Section of Neurology and Psychological Medicine, 82d Annual Meeting of the British Medical Association, Aberdeen, 29–31 July 1914. (Discussion with Ernest Jones follows ?) Summary appeared in *The Lancet*, II (1914) (5 Sept.), 650.
- 1915a *The Theory of Psychoanalysis.* (Nervous and Mental Disease Monograph Series No. 19.) New York: Journal of Nervous and Mental Disease

Publishing Co. pp. 135. 1971: Facsimile edn. New York: Johnson Reprint Corp. Contents:

Introduction. (1–3)

I. Consideration of Early Hypotheses. (4–16)

II. The Infantile Sexuality. (17–26)

III. The Conception of Libido. (27–44)

IV. The Etiological Significance of the Infantile Sexuality. (45–54)

V. The Unconscious. (55–59)

VI. The Dream. (60–66)

VI. The Dream. (60–66)

VII. The Content of the Unconscious. (67–71)

VIII. The Etiology of the Neuroses. (72–95)

IX. The Therapeutical Principles of Psychoanalysis. (96–110)

X. Some General Remarks on Psychoanalysis, (111–33)

E. 1913b, 1914a, and 1915b repub. as a monograph. Pub. in a dif. trans. as CW 4,9.

1915b “The Theory of Psychoanalysis.” [5th section: Ch. X.] *Psychoanal. Rev.*, II:1 (Jan.), 29–51. Trans. from G. 1913a by Edith and M. D. Eder and Mary Moltzer. The last of 5 sections. Cf. E. 1913b and 1914a. Repub., with E. 1913b and 1914a, as E. 1915a. Pub., with E. 1913b and 1914a, with addns., in a dif. trans. as CW 4,9. The last of a series of lectures. Cf. E. 1913b.

1915c “On Psychological Understanding.” *J. abnorm. Psychol.* IX:6 (Feb.-Mar.), 385–99. German version, rev. and slightly exp., pub. as supplement in G. 1914a. ?Incorporated in E. 1916a, 14. English version read before the Psycho-Medical Society, London, 24 July 1914.

1915d “Psychoanalysis.” *Psychoanal. Rev.*, II:3 (July), 241–59. E. 1913d repub. with slight title change. Repub. as E. 1916a,8. Pub. in a dif. trans., with title change, as CW 4,10.

1916a *Collected Papers on Analytical Psychology*. Ed. by Constance E. Long. New York: Moffat, Yard; London: Bailliére, Tindall & Cox. pp. 392. Some copies bear the title: *Analytical Psychology*. Contents:

1. Author’s Preface. (vii–x) Probably trans. from a German ms. by Constance E. Long. Dated Jan. 1916. Repub. as E. 1917a, 1, and in a dif. trans. as CW 4,13, “First Edition.” TR.—German: GW 4,13,a.
2. “On the Psychology and Pathology of So-called Occult Phenomena.” (1–93) Trans. from G. 1902a by M. D. Eder. Repub. as E. 1917a,2, and, in a

- dif. trans., as CW 1,1.
3. "The Association Method." (94–155) E. 1910a pub. with stylistic alterations. Consists of 3 lectures, the 1st 2 pub. in a dif. trans. as CW 2,10 and 11. In regard to the 3d, cf. CW 17,1. Repub. as E. 1917a,3.
 4. "The Significance of the Father in the Destiny of the Individual." (156–75) Trans. from G. 1909c by M. D. Eder. Repub. as E. 1917a,4. Cf. CW 4,14.
 5. "A Contribution to the Psychology of Rumour." (176–90) Trans. from G. 1910q. Repub. as E. 1917a,5. Pub. in a dif. trans. as CW 4,4.
 6. "On the Significance of Number-Dreams." (191–99) Trans. from G. 1911e by M. D. Eder. Repub. as E. 1917a,6. Pub. in a dif. trans. as CW 4,5.
 7. "A Criticism of Bleuler's 'Theory of Schizophrenic Negativism'." (200–05) Trans. from G. 1911c by M. D. Eder. Repub. as E. 1917a,7. Pub. in a dif. trans. as CW 3,4.
 8. "Psychoanalysis." (206–25) E. 1915d repub. Repub. as E. 1917a,8. Pub. in a dif. trans., with title change, as CW 4,10.
 9. "On Psychoanalysis." (226–35) Repub. as E. 1917a,g, and with minor revs. and title change as CW 4,11. Read in English before the New York Academy of Medicine, 8 Oct. 1912, and to the 17th International Medical Congress, London, 1913.
 10. "On Some Crucial Points in Psychoanalysis." (236–77) Trans. from G. 1914b by Edith Eder. Repub. as E. 1917a,10. Pub. in a dif. trans. with minor title change as CW 4,12.
 11. "On the Importance of the Unconscious in Psychopathology." (278–86) E. 1914b repub. Repub. as E. 1917a,11. Pub., slightly rev., as CW 3,5.
 12. "A Contribution to the Study of Psychological Types." (287–98) Trans. from Fr. 1913a by Constance E. Long. Repub. as E. 1917a,12. Pub. in a dif. trans. as CW 6,5.
 13. "The Psychology of Dreams." (299–311) Trans. from an unpub. ms. (greatly exp. and pub. as G. 1928b,2) by Dora Hecht. Repub. as E. 1917a,13. Cf. E. 1956b and CW 8,9 for dif. trans.'s of an exp. version.
 14. "The Content of the Psychoses." (312–51) Trans. from G. 1914a by M. D. Eder. Repub. as E. 1917a,14. Pub. in a dif. trans. as CW 3,2. ? Incorporates E. 1915c.
 15. "New Paths in Psychology." (352–77) Trans. from G. 1912d by Dora Hecht. Pub., rev. and exp., with title change, as E. 1917a,15. Pub. in a dif. trans. as CW 7,3.

TR.—Japanese: (7 articles only) 1926a.

1916b *Psychology of the Unconscious. A Study of the Transformation and Symbolisms of the Libido. A Contribution to the History of the Evolution of Thought.* New York: Moffat, Yard; London: Kegan Paul, Trench, Trubner. pp. Ivi + 566. (Lengthy front matter contains intro. by the translator.) Trans. from G. 1912a by Beatrice M. Hinkle. The American edn. was imported, presumably as sheets, into Great Britain by Kegan Paul, who substituted their title page. Publication date for the London edn. is considered to be 1917, although copies bear only the 1916 copyright date by Moffat Yard. In 1919, Moffat Yard issued a “new edn.,” xxxvi + 339 pp. Kegan Paul reprinted this last version in 1921, continuing to do so through the 6th impression, 1951. (In 1947, the imprint became Routledge & Kegan Paul.) Dodd Mead (New York) acquired the book from Moffat Yard in 1925, reprinting the 1916 edn. which was in print until 1972. Contents (the first pagination given is that of the 1916 edn., the second, that of the 1919 edn.):

1. Author’s Note. (xlvii) (xxix) Cf. CW 5, 2d edn., 2d pr.

Part I.

2. Introduction. (3–7) (1–3)

3. Concerning the Two Kinds of Thinking. (8–41) (4–21)

4. The Miller Phantasies. (42–48) (22–25)

5. The Hymn of Creation. (49–86) (26–46)

6. The Song of the Moth. (87–126) (47–69)

Part II.

7. Aspects of the Libido. (127–38) (70–76)

8. The Conception and the Genetic Theory of Libido. (139–56) (77–86)

9. The Transformation of the Libido. A Possible Source of Primitive Human Discoveries. (157–90) (87–105)

10. The Unconscious Origin of the Hero. (191–232) (106–28)

11. Symbolism of the Mother and of Rebirth. (233–306) (129–168)

12. The Battle for Deliverance from the Mother. (307–40) (169–87)

13. The Dual Mother Role. (341–427) (188–236)

14. The Sacrifice. (428–83) (237–67)

Entire work pub., rev. and expanded, in a dif. trans. with change of title, as CW 5. TR.—Japanese: 1931b.

1917a *Collected Papers on Analytical Psychology.* Ed. by Constance E. Long. 2d edn. New York: Moffat, Yard; London: Baillière, Tindall & Cox. pp. 492.

Contents conform to those of the 1st edn. (cf. E. 1916a) with the following addns. and substitution:

- 1a. Author's Preface to the Second Edition. (ix-xii) Probably trans. from the German ms. by Constance E. Long. Dated June 1917. Repub. in a dif. trans. as CW 4,13,b.
15. "The Psychology of the Unconscious Processes." (352–444) Trans. from G. 1917a by Dora Hecht. Replaces E. 1916a,15, of which this is a rev. and exp. version. Cf. E. 1928b,1 and CW 7,1 for trans.'s of further rev. versions.
16. "The Conception of the Unconscious." (445–74) Trans. from a German ms. subsequently lost, a French trans. of which was pub. as Fr. 1916a. The orig. ms. was found posthumously and a dif. trans. pub. as CW 7,4 (2d edn.). Cf. E. 1928,2 and CW 7,2 for trans. of further rev. versions. Delivered as a lecture to the Zurich School of Analytical Psychology, 1916.

1918a *Studies in Word-Association. Experiments in the Diagnosis of Psychopathological Conditions Carried Out at the Psychiatric Clinic of the University of Zurich, under the direction of C. G. Jung.* New York: Moffat, Yard; London: Heinemann, 1919. pp. 575. 1969: New York: Russell & Russell; London: Routledge & Kegan Paul. Trans. by M. D. Eder. Contains the following works by Jung:

1. With F. Riklin: "The Associations of Normal Subjects." (8–172) Trans. from G. 1906a,1. Pub. in a dif. trans. as CW 2,1.
2. "Analysis of the Associations of an Epileptic." (206–26) Trans. from G. 1906a,2. Pub. in a dif. trans. as CW 2,2.
3. "Reaction-Time in Association Experiments." (227–65) Trans. from G. 1906a,3. Pub. in a dif. trans. as CW 2,3.
4. "Psycho-Analysis and Association Experiments." (297–321) Trans. from G. 1906a,4. Pub. in a dif. trans. with slight title change as CW 2,5.
5. "Association, Dream, and Hysterical Symptoms." (354–95) Trans. from G. 1909a,1. Pub. in a dif. trans. with slight title change as CW 2,7.
6. "On Disturbances in Reproduction in Association Experiments." (396–406) Trans. from G. 1909a,2. Pub. in a dif. trans. with slight title change as CW 2,9.

1919a "On the Problem of Psychogenesis in Mental Diseases." *Proceedings of the Royal Society of Medicine* (Section of Psychiatry), XII:9 (Aug.), 63–76. Repub., slightly rev., as CW 3,6. Written in English and read to the Section of Psychiatry, The Society, Annual Meeting, London, 11 July 1919.

- 1919b “Instinct and the Unconscious.” *British Journal of Psychology*, X:1 (Nov.), 15–26. Trans. by H. G. Baynes from a German ms. subsequently pub. as G. 1928b,4. Repub. as E. 1928a,10. *Also issued as a pamphlet including other authors’ papers, Cambridge, England: Cambridge University Press. Pub. in a dif. trans. as CW 8.6. A contribution to the Symposium of the same name, presented at the joint meeting of the British Psychological Society, the Aristotelian Society, and the Mind Association, London, 12 July 1919.
- 1920a “Introduction.” Elida Evans: *The Problem of the Nervous Child*. pp. v-viii. New York: Dodd Mead; London: Kegan Paul [1921]. Dated Oct. 1919. Repub. as CW 18,129.
- 1920b “The Psychological Foundations of Belief in Spirits.” *Proceedings of the Society for Psychical Research*, XXXI:79 (May), 75–93. Trans. by H. G. Baynes from a German ms. subsequently pub. as G. 1928b, 5. Repub. as E. 1928a,9. Pub. in a dif. trans. as CW 8,11. Read before a general meeting of the Society, London, 4 July 1919.
- 1921a “The Question of the Therapeutic Value of ‘Abreaction’.” *British Journal of Psychology* (Medical Section), II:1 (Oct.), 13–22. Pub., slightly rev., as E. 1928a,11. TR.—German: GW 16,11.
- 1923a *Psychological Types, or, The Psychology of Individuation*. New York: Harcourt Brace; London: Kegan Paul, Trench, Trubner. pp. 654. 1959: New York: Pantheon; London: Routledge & Kegan Paul. Trans. from G. 1921a by H. G. Baynes. Contents:
1. Introduction. (9–14)
 2. The Problem of Types in the History of Classical and Medieval Thought. (15–86)
 3. Schiller’s Ideas upon the Type Problem. (87–169)
 4. The Apollonian and the Dionysian. (170–83)
 5. The Type Problem in the Discernment of Human Character. (184–206)
 6. The Problem of Types in Poetry. (207–336)
 7. The Type Problem in Psychiatry. (337–57)
 8. The Problem of Typical Attitudes in Aesthetics. (358–71)
 9. The Problem of Types in Modern Philosophy. (372–400)
 10. The Type Problem in Biography. (401–11)
 11. General Description of the Types. (412–517)
 12. Definitions. (518–617)
 13. Conclusion. (618–28)

Repub., trans. rev., as CW 6. Items 1, 11, 12 pub. as E. 1959a,4.

1923b “On the Relation of Analytical Psychology to Poetic Art.” *British Journal of Medical Psychology*, III:3, 213–31. Trans. from G. 1922a by H. G. Baynes. Repub. as E. 1928a,8. Pub. in a dif. trans. as CW 8,11.

1925a *VII Sermones ad Mortuos. The Seven Sermons to the Dead Written by Basilides in Alexandria, the City Where the East Toucheth the West*. Edinburgh: Neill. pp. 28. Trans. from G. 1916a by H. G. Baynes. Printed for private circulation. Repub. as E. 1966a,19 and E. 1967b. Cf. E. 1967a. Presentation copy examined inscribed “To R. F. C. Hull. C. G. Jung. June 1959. Translation by H. G. Baynes.”

1925b “Psychological Types.” *Problems of Personality. Studies Presented to Morton Prince, Pioneer in American Psychopathology*. pp. 289–302. Ed. by C. MacFie Campbell, et al. New York: Harcourt Brace; London: Kegan Paul, Trench, Trubner. Trans. from G. 1925c by H. G. Baynes. Pub. in dif. trans.’s as E. 1928a,12 and CW 6,6. Lecture delivered at the International Congress of Education, Territet, 1923.

1926a “Marriage as a Psychological Relationship.” *The Book of Marriage*. pp. 348–62. Ed. by Hermann Keyserling. New York: Harcourt Brace. Trans. from G. 1925b by Therese Duerr. Pub. in dif. trans.’s as E. 1928a,6 and CW 17,8.

1927a “Introduction.” Frances G. Wickes: *The Inner World of Childhood*. pp. xiii–xiv. New York: D. Appleton. Trans. from a ms. subsequently expanded into G. 1931e, of which the above comprises the 1st 3½ pars. Entire text of G. 1931e trans. and pub. as E. 1966c. Cf. CW 17,2.

1928a *Contributions to Analytical Psychology*. New York: Harcourt Brace; London: Kegan Paul, Trench, Trubner. pp. 410. Trans. by H. G. and Cary F. Baynes. Contents:

1. “On Psychical Energy.” (1–76) Trans. from G. 1928b,2. Pub. in a dif. trans. with slight title change as CW 8,1.
2. “Spirit and Life.” (77–98) Trans. from G. 1926c. Pub. in a dif. trans. as CW 8,12.
3. “Mind and the Earth.” (99–140) Trans. from a German ms. subsequently pub. as G. 1931a,8. Pub. in a dif. trans. with minor title change as CW 10,2.
4. “Analytical Psychology and Weltanschauung.” (141–63) Trans. from a German ms. subsequently rev. and exp. into G. 1931a,12. Cf. CW 8,14.
5. “Woman in Europe.” (164–88) Trans. from G. 1927b. Prepub. as E. 1928c. Excerpt pub. as E. 1930d. Pub. in a dif. trans. as CW 10,6.

6. "Marriage as a Psychological Relationship." (189–203) Trans. from G. 1925b. Pub. in dif. trans.'s as E. 1926a and CW 17,8.
7. "The Love Problem of the Student." (204–24) Trans. from a German ms. subsequently pub. as G. 1971a,3. Pub. in a dif. trans. with minor title change as CW 10,5. Lecture delivered to the student body, University of Zurich, 1924.
8. "On the Relation of Analytical Psychology to Poetic Art." (225–49) E. 1923b repub. Pub. in a dif. trans. with minor title change as CW 15,6.
9. "The Psychological Foundations of Belief in Spirits." (250–69) E. 1920b repub. Pub. in a dif. trans. as CW 8,11.
10. "Instinct and the Unconscious." (270–81) E. 1919b repub. Pub. in a dif. trans. as CW 8,6.
11. "The Question of the Therapeutic Value of 'Abreaction'." (282–94) E. 1921a, slightly rev. Repub., slightly rev. and with minor title change, as CW 16,11.
12. "Psychological Types." (295–312) Trans. from G. 1925c. Pub. in dif. trans.'s as E. 1925b and CW 6,6.
13. "Analytical Psychology and Education." (313–82) Consists of 4 lectures. Lecture 1 trans. from the unpub. German ms. subsequently pub. as G. 1971a,4. Repub., slightly rev., as CW 17,3. Delivered to the International Congress of Education, Territet, 1923. Lectures II–IV drafted in English and rev. by Roberts Aldrich. Cf. CW 17,4. Delivered to the International Congress of Education, London, May 1924.
14. "The Significance of the Unconscious in Individual Education." (383–402) Trans. from a German ms. subsequently pub. as G. 1971a,5. Delivered as a lecture to the International Congress of Education, Heidelberg, 1925. Pub. in a dif. trans. as CW 17,6. Excerpt pub. as "Analysis of Two Homosexual Dreams." pp. 286–93. *The Homosexuals as Seen by Themselves and Thirty Authorities*. Ed. by A. M. Krich. New York: Citadel Press., 1957.

1928b *Two Essays on Analytical Psychology*. New York: Dodd, Mead; London: Baillière, Tindall & Cox. pp. 280. Trans. by H. G. and C. F. Baynes.

Contents:

1. "The Unconscious in the Normal and Pathological Mind." (1–121) Trans. from G. 1926a. Cf. E. 1917a,15 and CW 7,1 for trans.'s of earlier and later versions. Extracts (Chs. V & VII; pt. of last par. omitted) pub. in *Classics in Psychology*, pp. 715–55. Ed. by Thorne Shipley. New York: Philosophical Library, 1961.

2. "The Relation of the Ego to the Unconscious." (125–269) Trans. from G. 1928a. Pub. in a dif. trans. with slight title change as CW 7,2.

1928c "Woman in Europe." *New Adelphi*, n.s. II: 1 (Sept.), 19–35. E. 1928a,5 prepub.

1930a "Your Negroid and Indian Behavior." *Forum*, LXXXIII:4 (Apr.), 193–99. Repub., slightly rev. and with title change, as CW 10,22. Written in English.

1930b "Some Aspects of Modern Psychotherapy." *Journal of State Medicine*, XXXVIII:6 (June), 348–54. Repub. as CW 16,3. Written in English and delivered before the Congress of the Society of Public Health, Zurich, 1929. TR.—German: GW 16,4.

1930c "Psychology and Poetry." *transition*, no. 19/20 (June), 23–45. Trans. from G. 1930a by Eugene Jolas. Pub. in a dif. trans. with title change as E. 1933a,8. Cf. CW 15,7.

1930d "The Plight of Woman in Europe." *The 1930 European Scrap Book*. pp. 213–16. New York: Forum Press. Excerpted from E. 1928,5.

1931a With Richard Wilhelm: *The Secret of the Golden Flower*. New York: Harcourt Brace; London: Kegan Paul, Trench, Trubner. pp. 151. 1955: New York: Wehman Bros. pp. 151. Trans. by Cary F. Baynes. Pub., rev. and augmented, as E. 1962b. Contains the following works by Jung:

1. "Commentary." (77–137) Trans. from G. 1929b,I,1–6. Cf. CW 13,1.
2. "Examples of European Mandalas." (137–38 + 10 plates) Trans. from G. 1929b,I,7. Cf. CW 13,1, pp. 56 ff and CW 9,i,12.
3. "In Memory of Richard Wilhelm." (139–51) Trans. from G. 1930c. Cf. E. 1958a,9 and CW 15,5.

1931b "Foreword." Charles Roberts Aldrich: *The Primitive Mind and Modern Civilization*. pp. xv-xvii. New York: Harcourt Brace; London: Kegan Paul, Trench, Trubner. Trans. by Aldrich from the German ms. Repub., trans. slightly rev., as CW 18,69.

1931c "The Spiritual Problem of Modern Man." *Prabuddha Bharala*, 36:8 (Aug.), 377–84; 36:9 (Sept.), 435–43. Trans. from G. 1928t by? Also pub. as monograph: Mayavati Almora, Himalayas: Advaiti Ashrama. pp. 15. Cf. E. 1933a,10 and CW 10,4 for trans.'s of rev. version.

1931d "Problems of Modern Psychotherapy." *Schweizerisches Medizinisches Wochenschrift*, LXL35 (29 Aug.) 810–32. Trans. from G. 1929d by Cary [F.] Baynes. Repub. as E. 1933a,2. Pub. in a dif. trans. as CW 16,6.

- 1932a “Introduction.” W. M. Kranefeldt: *Secret Ways of the Mind*. pp. xxv-xl. New York: Henry Holt; London: Kegan Paul, Trench, Trubner, 1934. Trans. from G. 1930b by Ralph M. Eaton. Pub. in a dif. trans. as CW 4,15.
- 1932b “Sigmund Freud in His Historical Setting.” *Character and Personality*, 11 (Sept.), 48–55. Trans. from G. 1932! by Cary F. Baynes. English trans. issued simultaneously with the orig. German (cf. G. 1932i) which was pub. in the German edn. of this journal. Pub. in a dif. trans. as CW 15,3.
- 1932c “Crime and the Soul. The Mystery of Dual Personality in the Lawbreaker. Inoffensive People Who Become Criminals.” *Sunday Referee* (London) (11 Dec). For German version, see G. 1933a. Pub., with minor rev. in accordance with G. 1933a, as CW 18,13.
- 1933a *Modern Man in Search of a Soul*. New York: Harcourt Brace; London: Kegan Paul. pp. 282. 1955: Paperback edn. (Harvest Books) New York: Harcourt Brace Jovanovich. pp. 244. 1961: London: Routledge & Kegan Paul. pp. 282. Trans. by W. S. Dell and Cary F. Baynes. Contents:
1. “Dream Analysis in Its Practical Application.” (1–31) Trans. from G. 1931c. Pub. in a dif. Trans. with title change as CW 16,12.
 2. “Problems of Modern Psychotherapy.” (32–62) E. 1931a repub. Pub. in a dif. trans. as CW 16,6.
 3. “The Aims of Psychotherapy.” (63–84) Trans. from G. 1931a, 5. Pub. in a dif. trans. as CW 16,5.
 4. “A Psychological Theory of Types.” (85–108) Trans. from G. 1931a,6. Repub., trans. slightly rev., as CW 6,7.
 5. “The Stages of Life.” (109–31) Trans. from G. 1931a,10. Pub. in a dif. trans. as CW 8,16.
 6. “Freud and Jung: Contrasts.” (132–42) Trans. from G. 1931a, 4. Pub. in a dif. trans. as CW 4,16.
 7. “Archaic Man.” (143–74) Trans. from G. 1931a,9. Pub. in a dif. trans. as CW 10,3.
 8. “Psychology and Literature.” (175–99) Trans. from G. 1930a. Pub. in a dif. trans. with title change as E. 1930c. Cf. CW
 9. “The Basic Postulates of Analytical Psychology.” (200–25) Trans. from G. 1931g. Pub., trans. slightly rev., as CW 8,13.
 10. “The Spiritual Problem of Modern Man.” (226–54) Trans. from G. 1931a,14. Pub. in a dif. trans. as CW 10,4. Cf. E. 1931c for a trans. of earlier version.

11. "Psychotherapists or the Clergy." (255–82) Trans. from G. 1932a.
Repub. as E. 1956d. Pub. in a dif. trans. as CW 11,7.

1933b "Introduction." M. E. Harding: *The Way of All Women*, pp. ix-xiii. London: Longmans, Green. 1970: Rev. edn. New York: G. P. Putnam's Sons for the C. G. Jung Foundation for Analytical Psychology. pp. xv-xviii. Trans. by Cary F. Baynes from the German ms. subsequently pub. as G. 1935c Repub., somewhat rev., as CW 18,130. Dated Feb. 1932. TR.—Italian: 1947c//Swedish: 1934b.

1936a *The Concept of the Collective Unconscious*. (Papers of the Analytical Psychology Club of New York.) New York: Analytical Psychology Club. pp. 20. Mimeographed for private circulation, Dec. 1936. Reissued in 2 pts. as E. 1936d and 1937b. Cf. CW 9,i,2. Text of lecture delivered to the Analytical Psychology Club, Plaza Hotel, New York, 2 Oct. 1936, and in London (cf. E. 1936d).

1936b *The Psychology of Dementia Praecox*. (Nervous and Mental Disease Monograph Series No. ?3.) New York and Washington: Journal of Nervous and Mental Disease Pub. Co. pp. 150. Trans. from G. 1907a by A. A. Brill. Pub. in dif. trans.'s as E. 1909a and CW 3,1. For contents, see E. 1909a.

1936c "Yoga and the West." *Prabuddha Bharata*, Section III, Sri Rama-krishna Centenary Number (Feb.), 170–77. Trans. from a German ms. by Cary F. Baynes. Pub. in a dif. trans. (based on this one) as CW 11,12. For German version, see GW 11,12. TR.—French: 1949a.

1936d "The Concept of the Collective Unconscious." (Pt. I.) *St. Bartholomew's Hospital Journal*, XLIV.3 (Dec), 46–49. The 1st part of E. 1936a repub. The 1st of 2 pts. Cf. E. 1937b. Repub., slightly rev., with E. 1937b, as CW 9,i,2. Text of lecture previously delivered in New York (cf. E. 1936a) given before the Abernethian Society, St. Bartholomew's Hospital, London, 19 Oct. 1936.

1936e See 1968a.

1937a "Psychological Factors Determining Human Behavior." *Factors Determining Human Behavior*, pp. 49–63. (Harvard Tercentenary Publications.) Cambridge, Mass.: Harvard U. P.; London: Humphrey Milford/Oxford U. P. Pub., with slight alterations and title change, as E. 1942a, and with above title and slight alterations as CW 8,5. For German version based on the orig. ms., cf. GW 8,5. Paper delivered in English as contribution to the Harvard Tercentenary Conference of Arts and Sciences, September 1936.

- 1937aa Letter to the author (24 Sept. 1926). Louis London: *Mental Therapy: studies in fifty cases*. Vol. 2, p. 637. New York: Covici, Friede. Excerpts only. Written in English. Full text pub. in E. 1973b and trans. in G. 1972a.
- 1937^b “The Concept of the Collective Unconscious.” (Pt. II.) *St. Bartholomew’s Hospital Journal*, XLIV:4 (Jan.), 64–66. The 2d pt. of E. 1936a repub. The 2d of 2 pts. Cf. E. 1936b. Repub., slightly rev., with E. 1936b, as CW 9,1,2.
- 1937c “Wotan.” *Saturday Review of Literature*, XVI:25 (16 Oct.), 3–4, 18, 20. Trans. from G. 1936c by Barbara Hannah and altered by the editors. Pub. unaltered in dif. trans.’s, as E. 1947a,3 and CW 10,10.
- 1938a *Psychology and Religion*. (The Terry Lectures.) New Haven, Conn.: Yale U. P.; London: Oxford U. P. pp. 131. 1960: Paperback edn. (Yale Paperbound), New Haven: Yale U. P. Contents:
1. The Autonomy of the Unconscious Mind. (1–39)
 2. Dogma and Natural Symbols. (40–77)
 3. The History and Psychology of a Natural Symbol. (78–114)
- Cf. CW 11,1. Written in English and delivered as the 15th series of “Lectures on Religion in the Light of Science and Philosophy,” Yale University, New Haven, Connecticut, 1937. Subsequently trans. into German, rev. by Toni Wolff and exp. by Jung, to form G. 1940a. TR.—Turkish: 1965a.
- 1938b “Presidential Address. Views Held in Common by the Different Schools of Psychotherapy Represented at the Congress, July, 1938.” *Journal of Mental Science*, LXXXIV:353 (Nov.), 1055. Summary of Jungs address delivered to the Tenth International Medical Congress for Psychotherapy, Oxford, 29 July-2 Aug. 1938. Cf. CW 10,33.
- 1939a *The Integration of the Personality*. New York: Farrar and Rinehart; London: Kegan Paul, 1940. pp. 313. Trans. by Stanley M. (i.e., W. Stanley) Dell. Contents:
1. “The Meaning of Individuation.” (3–29) Written in English for this volume, and pub. here with some addns. of material from other of Jung’s writing by the translator. Subsequently rewritten in German, considerably rev., and pub., with the deletion of Dell’s addns., as G. 1939e. Cf. CW 9,i,10 for a trans. of the rev. version.
 2. “A Study in the Process of Individuation.” (30–51) Trans. from G. 1934c. Cf. CW 9,i,11 for a trans. of the rev. version.
 3. “Archetypes of the Collective Unconscious.” (52–95) Trans. from G. 1935b. Cf. CW g,i,i for a trans. of the rev. version.

4. "Dream Symbols of the Process of Individuation." (96–204) Trans. from G. 1936a. Pub. in a dif. trans., with slight title change, as E. 1959d. Cf. CW 12,3, pt. II (2d edn.) for a trans. of the rev. version.
5. "The Idea of Redemption in Alchemy." (205–80) Trans. from G. 1937a. Cf. CW 12,3, pt. III (2d edn.) for a trans. of the rev. version.
6. "The Development of the Personality." (281–305) Trans. from G. 1934b,9. Pub. in a dif. trans. with slight title change as CW 17,7.

1939b "The Dreamlike World of India." *Asia*, XXXIX: 1 (Jan.), 5–8. Repub. as CW 10,23. Written in English, TR.—German: GW 10,23.

1939c "What India Can Teach Us." *Asia*, XXXIX: 2 (Feb.), 97–8. Repub. as CW 10,24. Written in English, TR.—German: GW 10,24.

1939d "On the Psychogenesis of Schizophrenia." *Journal of Mental Science*, LXXXV:358 (Sept.), 999–1011. Repub. as E. 19598,8. Written in English and read at a meeting of the Section of Psychiatry, Royal Society of Medicine, London, 4 April 1939. TR.—German: GW 3,7.

1940a *Picasso*. (Papers of the Analytical Psychology Club.) New York: Analytical Psychology Club. pp. 8. Trans. from G. 1934b,8 by Alda F. Oertly. Printed for private circulation. Pub. in dif. trans.'s as E. 1953i and CW 15,9.

1942a "Human Behaviour." *Science and Man. Twenty-Four Original Essays . . .* pp. 423–35. Ed. by Ruth Nanda Anshen. New York: Harcourt Brace. E. 1937a pub. with minor alterations, omission of last par., and title change. Pub. with slight alterations and reversion to title of E. 1937a as CW 8,5. Author given as "Charles Gustav Jung."

1942b "Psychotherapy Today." *Spring 1942*. pp. 1–12. New York; Analytical Psychology Club. Trans. by Hildegard Nagel from a German ms. pub. as G. 1945f. Printed for private circulation. Pub. in dif. trans.'s as E, 1947a,4 and CW 16,9.

1942c "Foreword." Jolande Jacobi: *The Psychology of C. G. Jung*. pp. vii-viii. London: Kegan Paul, Trench, Trubner. 1943: New Haven, Conn.: Yale U. P.; London: Kegan Paul, Trench, Trubner. pp. v-vi. Trans. from G. 1940c by K. W. Bash. Dated Aug. 1939. Pub. in a dif. trans. as E. 1962c. Repub., trans. rev., as CW 18,40.

1943a "The Psychological Aspects of the Mother Archetype." *Spring 1943*). pp. 1–31. New York: Analytical Psychology Club. Trans. from G. 1939b by Cary F. Baynes and Ximena de Angulo. Printed for private circulation. Cf. CW 9,1,4 for a trans. of a rev. version, which incorporates parts of the above.

- 1943b “An Interview with C. G. Jung.” *Horizon*, VIII;48 (Dec), 372–81. Trans. from G. 1943f by an unknown hand. Repub., trans. rev. and with title change, as E. 1969t and CW 18,131. Answers written by Jung to questions from Jolande Jacobi.
- 1944a “The Different Aspects of Rebirth.” *Spring 1944*. pp. 1–25. New York: Analytical Psychology Club. Trans. from G. 1940b by Theodor Lorenz and Ximena de Angulo. Printed for private circulation. Cf. CW 9,1,5 for a trans. of the rev. version.
- 1944b “Introduction.” Julius Spier: *The Hands of Children; An Introduction to Psychochirology*. pp. xv-xvi. London: Kegan Paul, Trench, Trubner. 1955: 2d edn. London: Routledge & Kegan Paul. Trans. from the German ms. by Victor Grove (who trans. the entire book). Repub., trans. rev., as CW 18,132.
- 1945a “The Soul and Death.” *Spring 1945*. pp. 1–9. New York: Analytical Psychology Club. Trans. from G. 1934b,10 by Eugene H. Henley. Printed for private circulation. Repub., trans. slightly rev., as E. 1959c. Cf. CW 8,17.
- 1945b “Return to the Simple Life. Excerpts from a Swiss Newspaper Article.” *Bull. APC*, 7:1 (Jan.), Supplement, 1–6. Excerpts of G. 1941e trans. by Eugene H. Henley. Printed for private circulation. Full text pub. in a dif. trans. as CW 18,72.
- 1946a “After the Catastrophe.” *Spring 1946*. pp. 4–23. New York: Analytical Psychology Club. Trans. from G. 1945c by Elizabeth Welsh. Printed for private circulation. Repub. as E. 1947a,6. Pub. in a dif. trans. as CW 10,11.
- 1946b Foreword to K. A. Ziegler: “Alchemie II,” List No. 17 (May), pp. 1–2. Bern. Written both in English and in German as a foreword to a bookseller’s catalog. English text repub. as E. 1968d, and, slightly rev., as CW 18,104. Cf. G. 1946f for the German version.
- 1946c Contribution entitled “Jung’s Commentary.” pp. 372–77. Horace Gray: “Brother Klaus, With a Translation of Jung’s Commentary.” *Journal of Nervous and Mental Diseases*, CII,4 (Apr.), 359–77. Trans. from G. 1933c by Horace Gray; title omitted. Pub. in a dif. trans. with inclusion of title as CW 11,6.
- 1946d Two letters. (1 Dec, and 26 May 1934) Ernest Harms: “Carl Gustav Jung—Defender of Freud and the Jews.” *Psychiatric Quarterly*, 20:2 (Apr.), 199–233. Trans. by Ernest Harms.
1. Circular letter to *Zentralblatt* subscribers (1 Dec. 1934). (222–23) Trans. from G. 1934j. Pub. in a dif. trans. as CW 10,27.

2. Excerpts from letter “to a Jewish pupil and friend” (James Kirsch, 26 May 1934) (227–30) Trans. from the German ms., parts of which are included here on pp. 225–27. Cf. G. 1946h. Repub. as E. 1972c,7, and, in a dif. trans., in E. 1973b. Cf. G. 1972a for text of the original letter.

1946e “The Fight with the Shadow.” *Listener*, 37:930 (7 Nov.), 615–16, 641.

Repub. with title change as E. 1947t and 1947a,2. Repub. slightly rev. and with reversion to above title as CW 10,12. Text of talk broadcast in the Third Programme, British Broadcasting Corp., 3 Nov. 1946.

1946f “The Bologna Enigma.” *Ambix*, 11:3/4 (Dec), 182–91. Trans. from G. 1945b by Miss Marmorstein. Incorporated, in a dif. trans., into CW 14,11,3.

1947a *Essays on Contemporary Events*. London: Kegan Paul, Trench, Trubner. pp. 90. Contents:

1. Preface, (vii-viii) Trans. from G. 1946a,1 by Elizabeth Welsh. Pub. in a dif. trans. as CW 10,9.
2. Introduction: “Individual and Mass Psychology.” (ix-xviii) E. 1946e repub. with title change. Repub. with title above as E. 1947f and, slightly rev. and with reversion to title of E. 1946e, as CW 10,12.
3. “Wotan.” (1–16) Trans. from G. 1946a,2 by Barbara Hannah. Pub. in dif. trans.’s as E. 1937c and CW 10,10.
4. “Psychotherapy Today.” (17–35) Trans. from G. 1946a,3 by Mary Briner. Pub. in dif. trans.’s as E. 1942b and CW 16,9.
5. “Psychotherapy and a Philosophy of Life.” (36–44) Trans. from G. 1946a,4 by Mary Briner. Pub. in a dif. trans. as CW 16,7.
6. “After the Catastrophe.” (45–72) E. 1946a,5 repub. Pub. in a dif. trans. as CW 10,11.
7. “Epilogue.” (73–90) Trans. from G. 1946a,6 by Elizabeth Welsh. Pub. in a dif. trans. as CW 10,13.

1947b “On the Psychology of Eastern Meditation.” *Art and Thought*. (Issued in honor of Dr. Ananda K. Coomaraswamy.) pp. 169–79. Ed. by K. Bharatha Iyer. London: Luzac. Trans. from G. 1943c by Carol Baumann. Reprint issued, dated Feb. 1948. Repub. as E. 1949b. Pub. in a dif. trans. with slight title change as CW 11,14.

1947c “An Alchemistic Text Interpreted As If It Were a Dream.” *Spring 1947*. PP.3–10. New York: Analytical Psychology Club. Trans. and slightly condensed from G. 1955a, III,3 by Carol Baumann. Printed for private circulation.

- 1947d “Jungian Method of Dream Analysis.” *World of Dreams. An Anthology*, pp. 634–59. Ed. by Ralph L. Woods. New York: Random House. Extracts compiled from E. 1916a,8&13; E. 1939a,3; E. 1928b,2 and E. 1933a,1.
- 1947e “Foreword.” M. Esther Harding: *Psychic Energy: Its Source and Goal*. pp. xi-xii, (B. S. 10.) New York: Pantheon. 1963: 2d edn., rev. 8c enl. pp. xix-xx. Retitled *Psychic Energy: Its Source and Its Transformation*, pp. xix-xx. 1973: (Princeton/Bollingen Paperback.) Princeton University Press. Trans. by Hildegard Nagel from a German ms. pub. as G. 1948d. Dated 8 July 1947. Repub., trans. si. rev., as CW 18,42. TR.—French: 1952b.
- 1947f “Individual and Mass Psychology.” *Chimera*, V:S (Spring), 3–11. E. 1946e repub. Repub. with title change as E. 1947a,2.
- 1948a “On the Nature of Dreams.” *Spring 1948*. pp. 1–12. New York: Analytical Psychology Club. Trans. from G. 194sd by Ethel Kirk-ham. Also issued separately for private circulation as mimeographed pamphlet: (Papers of the Analytical Psychology Club of New York. 6.) New York: The Club. 12 pp. Cf. CW 8,10 for trans. of rev. & exp. version.
- 1948b “Address Given at the Opening Meeting of the C. G. Jung Institute of Zurich, April 24, 1948.” *Bull. APC*, 10:7 (Oct.), Suppl., 1–7. Trans. by Hildegard Nagel from the unpub. German ms. Pub. in a dif. trans. as CW 18,43.
- 1948c “Letter to Miss Pinckney.” *Bull. APC*, 10:7 (Oct.), 3. Written in English at the request of the editor, Sally M. Pinckney; dated 30 Sept. 1948. Repub. in E. 1973b. TR.—German: 1972b.
- 1948d *On the Psychology of the Spirit*. (Papers of the Analytical Psychology Club of New York, 6.) New York: The Club. 43 pp. Trans. from G. 1946e by Hildegard Nagel. Printed for private circulation.
- 1949a With C. Kerényi: *Essays on a Science of Mythology. The Myth of the Divine Child and the Mysteries of Eleusis*. (B. S. 22.) New York: Pantheon, pp. 289. 1950: British edn. *Introduction to a Science of Mythology*. London: Routledge & Kegan Paul. pp. 289. Trans. from G. 1941c by R. F. C. Hull. Repub., trans. rev., as E. 1963a. Contains the following works by Jung:
1. “The Psychology of the Child Archetype.” (95–138) Repub. as E. 1958a,4, and, trans. rev., as CW 9,i,6.
 2. “The Psychological Aspects of the Kore.” (215–56) Repub., trans. rev., as CW 9,i,7.
- 1949b *On the Psychology of Eastern Meditation*. New York: Analytical Psychology Club. pp. 19. E. 1947b repub. Printed for private circulation. Pub. in a dif.

trans. with slight title change as CW 11,14.

- 1949c “Ulysses, a Monologue.” *Spring 1949*. pp. 1–20. New York: Analytical Psychology Club. Trans. from G. 1934b,7 by W. Stanley Dell. Printed for private circulation. Repub. as E. 1953h. Pub. in a dif. trans. as CW 15,8. Unauthorized facsimile of this edn. without indication of source pub. 1972: Folcroft, Pa.: Folcroft Library Editions, pp. 22.
- 1949d “Foreword.” Daisetz Suzuki: *An Introduction to Zen Buddhism*. pp. 9–29. New York: Philosophical Library; London: Rider. * 1959: Paperback edn. London: Arrow Books. 1964: Paperback edn. (Evergreen Black Cat) New York: Grove Press. Trans. from G. 1939c by Constance Rolfe. Pub. in a dif. trans. as CW 11,13. (1st edn.—Kyoto, 1934—lacks Foreword.) TR.—Dutch: 1958b.
- 1950a “Shadow, Animus and Anima.” *Spring 1950*. pp. 1–11. New York: Analytical Psychology Club. Trans. from G. 1948f by William H. Kennedy. Incorporated, in a dif. trans., into CW g.ii, Chs. II-III.
- 1950b “Foreword.” H. G. Baynes: *Analytical Psychology and the English Mind and Other Papers*, p. v. London: Methuen. Written in English. Repub. as CW 18,78.
- 1950c “Foreword.” Linda Fierz-David: *The Dream of Poliphilo*. pp. xiii-xv. (B. S. 25.) New York: Pantheon. Trans. from G. 1947b by Mary Hottinger. Repub., trans. rev., as CW 18,118.
- 1950d “Foreword.” *The I Ching, or Book of Changes*. The Richard Wilhelm translation ... p. i-xx. New York: Pantheon (B. S. 19); London: Routledge 8c Kegan Paul. (In 2 vols.) 1961: 2d edn. (In 1 vol.) pp. i-xx. 1967: 3d edn. (In 1 vol.) Princeton University Press. pp. xxi-xxxix. Trans. from the German ms. by Cary F. Baynes. Written for the English edn. and dated 1949. Repub. as E. 1958a,6 and, trans. slightly rev., as CW 11,16. Cf. GW 11,16 for original German version. TR.—Dutch: 1953b.
- 1950e “Introductions by C. G. Jung.” *Bull. APC*, 12:5 (May), 10–13. Excerpts from G. 1935e and G. 1949e trans. by Hildegard Nagel. Entire text of G. 1935e pub. in dif. trans.’s as E. 1967a and CW 18,45. Entire text of G. 1949e pub. in a dif. trans. as CW 18,45.
- 1951a “Concerning the Self.” *Spring 1951*. pp. 1–20. New York: Analytical Psychology Club. Trans. from G. 1949b by Hildegard Nagel. Also issued for private circulation as mimeographed pamphlet. (Papers of the APC of NY, 7.) 20 pp. Cf. CW 9.ii, Chs. IV-V for trans. of exp. version.

- 1951b “Foreword to the English Edition.” *Paracelsus: Selected Writings*. pp. 23–24. Ed. by Jolande Jacobi. (B. S. 28.) New York: Pantheon. 1958: 2d edn. pp. xxi-xxii. Trans. from the German ms. by Norbert Guterman. Dated May 1949. Repub., slightly rev., as CW 18,120.
- 1952a “Preface.” John Custance: *Wisdom, Madness and Folly. The Philosophy of a Lunatic*, pp. [1–4]. New York: Pellegrini and Cudahy. Trans. by an unknown hand from a German ms. pub. as G. 1954d. Written in 1951. Repub., trans. rev., as CW 18,15. (British edn., 1951, lacks this Preface.) TR.—French: 1954a.
- 1952b “Introduction.” R. J. Zwi Werblowsky: *Lucifer and Prometheus. A Study of Milton’s Satan*, pp. ix-xii. London: Routledge & Kegan Paul. Trans. from a German ms. pub. as GW 11,5 by R.F.C. Hull. Dated March 1951. Repub., trans. slightly rev., as CW 11,5.
- 1952c “Foreword.” Victor White: *God and the Unconscious*, pp. xiii-xxv. London: Harvill Press; Chicago: Henry Regnery, 1953. Trans. by Victor White from a German ms. pub. as G. 1957h. Dated May 1952. Pub. slightly rev. as CW 11,4. Also contains extracts from Iet ters to Gebhard Frei (13 Jan. 1948 and 17 Jan. 1949), Appendix, pp. 235–62, the full texts of which appear in G. 1972b and are trans. in E. 1973b. TR.—Portuguese: 1964a // Spanish: 1955b.
- 1953a *Psychological Reflections. An Anthology of the Writings of C. G. Jung*. Selected and ed. by Jolande Jacobi. New York: Pantheon (B. S. 31); London: Routledge & Kegan Paul. pp. 342. 1961: Paperback edn. (Harper Torchbooks: The Bollingen Library.) New York: Harper. pp. 340. In effect, a trans. of G. 1945a: “R.F.C. Hull’s translations for the *Collected Works* have been drawn upon insofar as possible ... (supplemented by those of S. Dell, H. G. and C. F. Baynes and others; see p. xxi). ... The passages for which no English translation is cited have been translated especially ... by J. Verzar and revised by Elizabeth Welsh.” Pub., rev. and exp., as E. 1970b.
- 1953b *The Spirit Mercury*. New York: Analytical Psychology Club. pp. 63. Trans. from G. 1948a,3 by Gladys Phelan and Hildegard Nagel. Printed for private circulation. Pub. in a dif. trans. with slight title change as CW 13,4.
- 1953c “Concerning Synchronicity.” *Spring* 1953. pp. 1–10. New York: Analytical Psychology Club. Trans. from G. 1952f by Alice H. Dunn. Printed for private circulation. Pub. in a dif. trans. with title change as E. 1957b.
- 1953d “Foreword.” Frieda Fordham: *An Introduction to Jung’s Psychology*, p. 10. Harmondsworth, England and Baltimore, Md.: Penguin. 1966: 3d edn. p. 11.

Written in English and dated Sept. 1952. Repub. as CW 18,46. TR.—Dutch: 1961a // German: 1959c // Italian: 1961b // Norwegian: 1964a.

- 1953e “Foreword.” John Weir Perry: *The Self in Psychotic Process; Its Symbolization in Schizophrenia*, pp. v-viii. Berkeley and Los Angeles: University of California Press; London: Cambridge University Press. Apparently written in English. Repub. as CW 18,16.
- 1953f “Preface by C. G. Jung. *Ostasien Denkt Anders. ...*” *Bull. APC*, 15:3 (Mar.), Supplement, 1–3. Trans. from G. 1950d by Hildegard Nagel and Ellen Thayer. Printed for private circulation. Repub. with title change as E. 1955j.
- 1953g “The Challenge of the Christian Enigma. A Letter ... to Upton Sinclair.” (3 Nov. 1952) *New Repub.*, 128:17 (27 Apr.), 18–19. Repub., with omission of some minor changes, in E. 1976a. Written in English, TR.—German: 1972b.
- 1953h “Ulysses: A Monologue.” *Nimbus*, II: 1 (June-Aug.), 7–20. E. 1949c repub. Pub. in a dif. trans. as CW 15,8.
- 1953i “Picasso.” *Nimbis*, 11:2 (Autumn), 25–27. Trans. from G. 1932g by Ivo Jarosy. Pub. in dif. trans.’s as E. 1940a and CW 15,9.
- 1954a *Answer to Job*. London: Routledge & Kegan Paul; Great Neck, N.Y.: Pastoral Psychology Book Club, 1955. pp. 194. Trans. from G. 1952a by R.F.C. Hull. Repub. with the addn. of E. 1956c si. rev. and titled “Prefatory Note,” as CW 11,9.
- 1954b *Spirit and Nature*. (Papers from the Eranos Yearbooks, 1.) New York: Pantheon (B. S. 30); London: Routledge & Kegan Paul, 1955. Trans. by R.F.C. Hull, Contains the following works by Jung:
1. “The Phenomenology of the Spirit in Fairy Tales.” (3–48) Trans. from G. 1948a,2. Repub. as E. 1958a,3, and, trans. slightly rev., as CW 9,i,8.
 2. “The Spirit of Psychology.” (371–444) Trans. from G. 1947a. Pub., slightly abbreviated, as E. 1957e. Cf. CW 8,8 for trans. of the rev. and exp. version.
- 1954c *The Symbolic Life*. (Guild Lecture No. 80.) London: Guild of Pastoral Psychology. pp. 30. Pub. in abbrev. form as E. 1961d. Printed for private circulation. Repub., sl. rev., as CW 18,3. Transcript from the shorthand notes of Derek Kitchin of a seminar talk given to the Guild, London, 5 April 1939.
- 1954d “Foreword to *Symbols of Transformation*.” *Spring 1954*. pp. 13–15. New York: Analytical Psychology Club. Trans. from G. 1952e, Pt. 1,1 by R.F.C. Hull. Repub. as CW 5,4, I,I.

- 1954e “Psychological Commentary.” *The Tibetan Book of the Great Liberation*. ... pp. xxix-lxiv. Ed. by W. Y. Evans-Wentz. London, New York: Oxford University Press. Repub., slightly rev., as CW 11,10. 1st 21 pp. of the commentary pub., very slightly rev. and with title change, as E. 1955k. Written in English in 1939. TR.—French: 1960a // German: 1955d.
- 1954f “Foreword.” Erich Neumann: *The Origins and History of Consciousness*, pp. xiii-xiv. New York: Pantheon (B. S. 42.); London: Routledge & Kegan Paul, 1955. 1962: Paperback edn. (Harper Torchbooks: The Bollingen Library.) New York: Harper. 2 vols. Trans. from G. 1949f by R.F.C. Hull. Repub. as CW 18,54.
- 1954g “Preface by C. G. Jung.” *Bull. APC*, 16:2 (Feb.), 7–8. Trans. from G. 1953b by Ethel D. Kirkham. Printed for private circulation. Pub. in a dif. trans. as CW 18,57.
- 1954h “C. G. Jung on Flying Saucers.” *Bull. APC*, 16:7 (Oct.), 7–14. Trans. from G. 1954e by Ellen Thayer with the help of Hildegard Nagel. Printed for private circulation. Pub. in dif. trans.’s as E. 1959i,3 and CW 18,80. Extracts pub. in a dif. trans. as E. 1955l.
- 1955a With W. Pauli: *The Interpretation of Nature and the Psyche*. New York: Pantheon (B. S. 51.); London: Routledge & Kegan Paul. pp. 247. Contains the following work by Jung:
- “Synchronicity: An Acausal Connecting Principle.” (5–146) G. 1952b, rev. and exp. by the author, and trans. by R.F.C. Hull. Dated August 1950. Repub., trans. slightly rev., as CW 8,18.
- 1955b “Transformation Symbolism in the Mass.” *The Mysteries*. (Papers from the Eranos Yearbooks, 2.) pp. 274–336. New York: Pantheon (B. S. 30.); London: Routledge & Kegan Paul, 1956. Trans. from G. 1942c by R.F.C. Hull. Includes certain of the rev.’s of G. 1954a,6. Repub. as E. 1958a,5 and in a slightly dif. trans. as CW 11,3. Cf. E. 1955l.
- 1955c “Memorial to J. S.” *Spring 1955*. p. 63. New York: Analytical Psychology Club. Written in English and delivered in 1927. (J. S. = Jerome Schloss—Ed. note.) Repub. as CW 18,107.
- 1955d “On the Psychology of the Trickster.” *Spring 1955*. pp. 1–14. New York: Analytical Psychology Club. Trans. from G. 1954a by Hildegard Nagel. Pub. in a dif. trans., with slight title change, as E. 1956a. Cf. CW 9,i,9.
- 1955e “Introduction.” M. Esther Harding: *Woman’s Mysteries*, pp. ix-xii. New and rev. edn. New York: Pantheon. Trans. from G. 1949d by Edward Whitmont.

Repub., trans. rev., as CW 18,53. (1st edn'—London, 1935—pub. without this introduction, which was written for the Swiss edn.) TR.—French: 1953d.

- 1955f “The Christian Legend. An Interpretation.” (Letter to Upton Sinclair, 7 Jan. 1955.) *New Repub.*, 132:8 (21 Feb.), 30–31. Written in English. Letter pub. with minor changes and some omissions. Full text pub. in E. 1976a. Title appears thus on cover only. Titled “A Communication.” on p. 30. TR.—German: 1972b.
- 1955g “Mandalas.” *Du*, Jhg. XV:4 (Apr.), 1 p. Trans. from G. 1955e by E. W. [Elizabeth Welsh]. This English trans. accompanied the pub. of the German original in the same issue. Pub. in a dif. trans. as CW 9,i,13. TR.—Turkish: 1954a.
- 1955h “Human Nature Does Not Yield Easily to Idealistic Advice.” *New Repub.*, 132:20 (16 May), 18–19. Written in English as an invited comment on a previous article. Repub. as CW 18,83.
- 1955i * “C. G. Jung on the Question of Flying Saucers.” *Flying Saucer Review*, May-June. Extracts trans. from G. 1954e. (Extracts selected give misleading impression of Jung’s views.) Repub. as E. 1958f Entire text pub. in dif. trans.’s as E. 1954h, E. 1959i,3 and CW 18,81.
- 1955j “The Mind of East and West.” *Inward Light*, no. 49 (Fall), 3–4. E. 1953f repub. with title change. Repub. with title change as CW 18,92.
- 1955k “Psychology, East and West.” *Tomorrow*, IV: 1 (Autumn), 5–23. The 1st 21 pp. of E. 1954e pub., very slightly rev. and with title change.
- 1955l “The Mass and the Individuation Process.” *The Black Mountain Review* (Bañalbufar, Mallorca), no. 5 (Summer), 90–147. Trans. from G. 1942c, last part, by Elizabeth Welsh. Cf. E. 1955b.
- 1956a “On the Psychology of the Trickster Figure.” Paul Radin and Karl Kerényi: *The Trickster. A Study of American Indian Mythology*. pp. 193–211. New York: Philosophical Library; London: Routledge & Kegan Paul. Trans. from G. 1954a by R.F.C. Hull. Repub., trans. slightly rev., as CW g,i,9, and in a dif. trans. with slight title change as E. 1955d.
- 1956aa * *Answer to Job*. Great Neck, N.Y.: Pastoral Psychology Book Club. pp. ? 194. E. 1954a pub. with new title page. Repub. as CW 11,9.
- 1956b “General Aspects of the Psychology of the Dream.” *Spring 1956*. pp. 1–25. New York: Analytical Psychology Club, Trans. from G. 1948b,4 by Robert A. Clark. Pub. in a dif. trans. with slight title change as CW 8,9. Cf. E. 1916a,13 for trans. of an earlier version.

- 1956c “Why and How I Wrote My ‘Answer to Job’.” *Pastoral Psychology*, VI:60 (Jan.), 80–81. Written in English as a letter to the ed., Simon Doniger (Nov. 1955). Repub. in *Bull. APC*, 18:4 (Apr.), 1–3. Included as “Prefatory Note,” with minor stylistic rev., in CW 11,9. Pub. with the restoration of “an important phrase” in E. 1973a. Original letter pub. in E. 1976a. TR.—German: 1961a (“Nachwort”) / 1972b (text of letter).
- 1956d “Psychotherapists or the Clergy.” *Pastoral Psychology*, VII:60 (Apr.), 27–42. E. 1933a,11 repub. Pub. in a dif. trans. as CW 11,7.
- 1956e “Preface.” *Psychotherapy*, I:1 (Apr.), 1 p. Typescript written in English and dated 7 Sept. 1955. Inaugural issue of Calcutta journal devoted to Analytical Psychology. Repub. as CW 18,127.
- 1957a *The Transcendent Function*. Zurich; Students’ Association, C. G. Jung-Institut. pp. 23. Trans. by A. R. Pope from a German ras. written in 1916 and pub., ms. and exp., as G. 1958b. Printed for private circulation. Cf. CW 8,2 for a trans. of the rev. version.
- 1957b “On Synchronicity.” *Man and Time*. (Papers from the Eranos Yearbooks, 3.) pp. 201–11. New York: Pantheon (B. S. 30); London: Routledge & Kegan Paul, 1958. Trans. from G. 1952f by R.F.C. Hull. Repub., trans. slightly rev., as CW 8,19. Pub. in a dif. trans. with title change as E. 1953c.
- 1957c “The Mind of Man Reaches Out.” *New Frontiers of Knowledge: A Symposium*, pp. 53–55. Ed. by M. B. Schnapper. Washington: Public Affairs Press. E. 1957h condensed and re-edited, with title change.
- 1957d “Answer to Buber.” *Spring 1957* pp. 1–9. New York: Analytical Psychology Club. Trans. from G. 1952j by Robert A. Clark. Printed for private circulation. Pub. in a dif. trans. with title change as E. 1973e.
- 1957e “The Spirit of Psychology.” *This Is My Philosophy*, pp. 115–67. Ed. by Whit Burnett. New York: Harper; London: Allen and Unwin. E. 1954b,2, slightly abbreviated, TR.—Italian: 1959b.
- 1957f “Psychological Commentary.” *The Tibetan Book of the Dead ...* pp. xxxv–lii. Ed. by W. Y. Evans-Wentz. 3d edn. London: Oxford University Press. Trans. from G. 1935f by R.F.C. Hull. Repub. with slight title change as E. 1958a,8, and, with minor alterations, as CW 11,11. (1st and 2d edn.’s lack commentary.)
- 1957g “Foreword.” Michael Fordham: *New Developments in Analytical Psychology*, pp. xi–xiv. London: Routledge & Kegan Paul. Written in English and dated June 1957. Repub. as CW 18,47.

1957h “Dr. Jung’s Contribution to the Voice of America Symposium ‘The Frontiers of Knowledge and Humanity’s Hopes for the Future’.” *Bull. APC*, 19:4 (Apr.), Supplement, 1–8. Text of contribution, written in English, to the United States Information Agency broadcast in 30 languages the week of the 16th Dec. 1956. Printed for private circulation. Repub. as E. 1959f Pub., slightly rev. in accordance with the German version (G. 1959f) and with title change, as CW 3,9. Pub., condensed and re-edited, with title change, as E. 1957c. TR—German: 1959f.

1957i Letters to the author (26 Jan. and 10 Feb. 1955). Hans A. Illing: “C. G. Jung on the Present Trends in Group Psychotherapy.” *Human Relations*, X:1, 78ff. Trans. from the orig. German mss. by Hans A. Illing. Letter of 10 Feb. repub., with slight deletions, on p. 394, in Illing’s “Jung’s Theory of the Group as a Tool in Psychotherapy.” *International Journal of Group Psychotherapy*, VII:4 (Oct.), 392–97. Letters pub. in a dif. trans. in E. 1976a. German originals pub. in full in G. 1972b, and with deletions as G. 1956d (both letters), and G. 1955t (letter of 10 Feb. only).

1957i Excerpt of letter to the author. Patricia Hutchins: *James Joyce’s World*, pp. 184–85, footnote i. London: Methuen. Written in English to Patricia Graecen (Hutchins) (29 June 1955). Repub. as E. 19591,2. Entire letter pub. in E. 1976a.

1958a *Psyche and Symbol. A Selection from the Writings of C. G. Jung*. Ed. by Violet S. de Laszlo. Paperback. (Anchor Books.) Garden City, N.Y.: Doubleday. pp. 363. Contents:

1. “Preface.” (xi-xvii) Dated August 1957. Repub., slightly rev., as CW 18,62.
2. “Five Chapters from: *Aion*.” (1–60) CW 9.ii, Chs. I-V prepub.
3. “The Phenomenology of the Spirit in Fairy Tales.” (61–112) E. 1954b,1 repub. Repub., trans. slightly rev., as CW 9,i,8.
4. “The Psychology of the Child Archetype.” (113–47) E. 1949a, 1 repub. Repub., trans. rev., as CW 9,i,6 (1st edn.).
5. “Transformation Symbolism in the Mass.” (148–224) E. 1955b repub. Repub., trans. slightly rev., as CW 11,3.
6. “Foreword to the *I Ching*.” (225–44) E. 1950d repub. Repub., trans. slightly rev., as CW 11,16.
7. “Two Chapters from: *The Interpretation of Nature and the Psyche*.” (245–82) E. 1955a, Chs. III-IV repub. Repub., along with rest of text, trans. slightly rev., as CW 8,18.

8. “Psychological Commentary on *The Tibetan Book of the Dead*.” (283–301) E. 1957f repub. Repub., trans. slightly rev., as CW 11,11.

9. “Commentary on The Secret of the Golden Flower.” (302–51) E. 1962b,2 prepub. Pub. in a dif. trans. as CW 13,1.

1958b *The Undiscovered Self*. (Atlantic Monthly Press Book.) Boston: Little, Brown; London: Routledge & Kegan Paul. pp. 113. 1959: Paperback edn. New York: Mentor Books/New American Library, pp. 125. 1971: (Atlantic Monthly Press Book.) Boston: Little, Brown. pp. 113. Trans. from G. 1957i by R.F.C. Hull, and rev. by the American editors. Repub., trans. further rev., as CW 10,14. Extract prepub. as “God, the Devil, and the Human Soul.” *Atlantic Monthly*, CC:5 (Nov.), 57–63. “... prompted by conversations between Dr. Jung and Dr. Carleton Smith, Director of the National Arts Foundation, which brought it to the attention of the editors of the Atlantic Monthly Press.” TR.—Portuguese: 1961a.

1958c Answers to questions of, and correspondence with, the author and David Cox. Howard L. Philp: *Jung and the Problem of Evil*. pp. 5–21, 209–54. London: Rockliff. Repub., with minor stylistic rev. and addn. of title, as CW 18,103. Letter of 11 June 1957 repub. in E. 1976a.

1958d “Message of the Honorary President.” *Chemical Concepts of Psychosis*, p. xxi. Ed. by Max Rinkel with Herman C. B. Denber. New York: McDowell/Obolensky. Letter to Max Rinkel (Apr. 1957), chairman of a Symposium on Chemical Concepts of Psychosis, pub. in the volume above, which comprises the “Proceedings of the Symposium ... held at the Second International Congress of Psychiatry in Zurich ... 1 to 7 September 1957.” Repub. with title change as CW 3,11. TR.—German: 1973a.

1958e “Foreword.” Eleanor Bertine: *Human Relationships: In the Family, in Friendship, in Love*. pp. v–vii. New York, London: Longmans, Green. 1963: New York: David MacKay. Trans. from G. 1957d by Barbara Hannah. Repub., trans. slightly rev., as CW 18,61,

1958f “Dr. Carl Jung on Unconventional Aerial Objects.” *A.P.R.O. Bulletin* (July), 1,5. E. 1955i repub. Repub. in E. 1959i,3. Cf. E. 1954h and CW 18,81.

1958g “Dr. Jung Sets the Record Straight.” *UFO Investigator*, 1:5 (Aug.-Sept.), 1 p. Letter written (in English) to Major Keyhoe (NICAP) (16 Aug. 1958). Repub. with title change as E. 1959g. Pub. condensed as E. 1959i,2.

1958h “Released to United Press from Dr. Jung.” *Bull. APC*, 20:6 (Oct.), 10, Trans. from G. 1958h by Henny Carioba. Pub. in dif. trans.’s as E. 1958j, 1959i,I

and CW 18,81. Repudiates statement attributed to him in an *A.P.R.O. Bulletin* article. Cf. E. 1955i.

- 1958i “Banalized beyond Endurance.” Contribution to symposium, “If Christ Walked the Earth Today.” *Cosmopolitan*, CXLV:6 (Dec), 30. Title added by editors. Repub. under title of the symposium as CW 18,86.
- 1958i Statement to United Press International. *A.P.R.O. Bulletin* (Sept.), 7. Trans. from G. 1958h. Repub. in dif. trans.’s as E. 1958h, 1959i,1 and CW 18,81.
- 1959a *The Basic Writings of C. G. Jung*. Ed. by Violet Staub de Laszlo. New York: Modern Library (Div. of Random House). pp. 552. Contents:
1. from *Symbols of Transformation*. (3–36) CW 5,1&4, Pt. I, Ch. I-II repub.
 2. from “On the Nature of the Psyche.” (37–104) CW 8,8 repub. with some omissions.
 3. from “The Relations between the Ego and the Unconscious.” (105–82) CW 7,2: Preface to 2d edn.; Pt. I, Chs. 1–3; Pt. II, Chs. 1–2, repub.
 4. from *Psychological Types*. (183–285) E. 1923a: Introduction, and Chs. 10–11 (abridged), repub. Cf. CW 6.
 5. “Archetypes of the Collective Unconscious.” (286–326) CW 9,i,1 repub.
 6. “Psychological Aspects of the Mother Archetype.” (327–60) CW 9,i,4 repub.
 7. “On the Nature of Dreams.” (363–79) CW 8,10 prepub.
 8. “On the Psychogenesis of Schizophrenia.” (380–97) E. 1939a repub. Repub. as CW 3,8.
 9. from “The Psychology of the Transference.” (398–429) CW 16,13 (1st edn.): Introduction, repub.
 10. “Introduction to the Religious and Psychological Problems of Alchemy.” (433–68) CW 12,2, Pt. I (1st edn.) repub.
 11. “Psychology and Religion.” (469–528) CW 11,1 repub.
 12. “Marriage as a Psychological Relationship.” (531–44) CW 17,8 repub.
- 1459b *Flying Saucers. A Modern Myth of Things Seen in the Skies*. New York: Harcourt Brace; London: Routledge & Kegan Paul. pp. 184. 1969: Paperback edn. New York: Signet Books/New American Library. pp. 144. Trans. from G. 1958a by R.F.C. Hull. Pts. 1 & 9 below not included in the text of G. 1958a. Repub., trans. slightly rev., as CW 10,15. Much abbreviated version pub. with title change as E. 1959h. Contents:
1. Preface to the English Edition. (ix–x) Dated Sept. 1958. TR.—German: GW 10,15.
 2. Introductory. (xi–xiv)

3. Ufos as Rumours. (1–24)
4. Ufos in Dreams. (25–101)
5. Ufos in Modern Painting. (102–27)
6. Previous History of the Ufo Phenomenon. (128–45)
7. Ufos Considered in a Non-Psychological Light. (146–53)
8. Epilogue. (154–74)
9. Supplement. (174–76) Added to the English edition, TR.—German: GW 10,15, PP- 471–73.

1959c “The Soul and Death.” *The Meaning of Death*, pp. 3–15. Ed. by Herman Feifel. New York: McGraw-Hill, Blakiston Division. E. 1945a repub., trans. slightly rev. by R.F.C. Hull. Repub. as CW 8,17.

1959d “Dream Symbols of the Individuation Process.” *Spiritual Disciplines*. (Papers from the Eranos Yearbooks, 4.) pp. 341–423. New York: Pantheon (B. S. 30); London: Routledge & Kegan Paul. Trans. from G. 1936a by R.F.C. Hull. Pub. in a dif. trans. with slight title change as E. 1939a,4. Cf. CW 12,3, Pt. II (2d edn.) for a trans. of the rev. version.

1959e “Foreword.” Jolande Jacobi: *Complex/Archetype/Symbol in the Psychology of C. G. Jung*, pp. ix-xi. New York: Pantheon (B. S. 57); London: Routledge & Kegan Paul. 1971: Paperback edn. (Prince-ton/Bollingen Paperback.) Princeton University Press. Trans. from G. 1957g by R.F.C. Hull. Repub. as CW 18,60.

1959f “New Thoughts on Schizophrenic” *Universitas*, III: 1 (Jan.), 53–58. E. 1957h repub. with title change. Repub., slightly rev., with title change, as CW 3,9. Cf. E. 1957c for condensed version. Pub. simultaneously with the German trans. Cf. G. 1959f

1959g “UFO.” *Bull. APC*, 21:2 (Feb.), 6–8. E. 1958g repub. with title change. Printed for private circulation. Repub. with title change as CW 18,83. Pub. condensed as E. 1959i,2.

1959h “A Visionary Rumour.” *Journal of Analytical Psychology*, IV: 1 (Apr.), 5–19. E. 1959b much abbreviated.

1959i “Jung on the UFO ...” *CSI of New York*, No. 27 (July), var. pp. Contains the following works by Jung:

1. Statement on UFO’s to UPI (13 Aug. 1958). (4) Trans. from G. 1958h by “CSI.” Pub. in dif. trans.’s as E. 1958h, 1958j and CW 18,81.
2. Letter to Maj. Donald Keyhoe (NICAP), (16 Aug. 1958). (5) E. 1959g Pub. condensed. Full text pub. as E. 1958g, 1959g and CW’ 18,82.

3. "C. G. Jung on the Question of Flying Saucers." (Appendix 1: 1–5) Consists of a trans. by "CSI" of G. 1954e together with E. 1955i repub. for purpose of comparison. Includes in brackets "material omitted [from E. 1955]. When [these translations] differ appreciably, the CSI version appears [on left, the other] in the right-hand column." Pub. in dif. trans.'s as E. 1954h and CW 18,80.

- 1959j "'National Character' and Behavior in Traffic. A Letter from Dr. Jung." *Bull. APC*, 21:8 (Dec), Supplement, 1–4. Trans. from G. 1958j by Hildegard Nagel. Printed for private circulation. Letter to F. von Tischendorf (19 April 1958). Pub. in a dif. trans. in E. 1976a.
- 1959k "The Swiss National Character." *Adam*, 275 (27th year), 13–16. Trans. from G. 1928e by Gwen Mountford and Miron Grindea. Pub. in a dif. trans. with title change as CW 10,19. A retort to Keyserling's *Das Spectrum Europa*.
- 1959l Two letters. Richard Ellmann: *James Joyce*. New York: Oxford University Press. Contains the following letters from Jung:
1. To James Joyce (27 Sept. 1932) (642) Repub. as E. 1966d.
 2. To Patricia Graecen (Hutchins) (29 June 1955) (692) E. 1957 repub. Entire letter pub. in E. 1975a and trans. in G. 1972b.
- 1960a *Answer to Job*. Paperback edn. New York: Meridian, pp. 223. CW 11,9 repub. (reset) with omission of "Prefatory Note."
- 1960b "Foreword." Miguel Serrano: *The Visits of the Queen of Sheba*. 2 pp. Bombay: Asia Publishing House. 1972: London: Routledge & Kegan Paul. Paperback edn. New York: Harper. Written in English as letter to Serrano (14 Jan, 1960) and pub. here slightly rev. Repub., somewhat rev., as CW 18,122. Entire letter pub. in full as E. 1966b,I. TR.—Spanish: 1960a.
- 1960c Letter to the Editor (Jan. 1960). *Listener*, XLIII:1608 (21 Jan.), 133. Written in English in response to reaction to his interview on the B.B.C. program "Face to Face," 22 Oct. 1959. Cf. E. 1975a, letters to Hugh Burnett (5 Dec. 1959) and M. Leonard (5 Dec. 1959)-TR.—German: GW 11, 25/1973a.
- 1960d "Preface by Dr. Jung." *Bull. APC*, 22:5 (May), 20–28. Trans. from G. 1959e by Edith Wallace. Pub. in a dif. trans. with title change as CW 10,18.
- 1960e "Good and Evil in Analytical Psychology." *Journal of Analytical Psychology*, V.-2 (July), 91–99. Trans. from G. 1959b by R.F.C. Hull. Repub., trans. rev., as CW 10,17.
- 1961a "A Letter on Parapsychology and Synchronicity. Dr. Jung's Response to an Inquiry." *Spring 1961*. pp. 50–57. New York: Analytical Psychology Club.

Trans. from G. 1961b by Hildegard Nagel. Written in English to A. D. Cornell (9 Feb. 1960) and trans., with addns. and corrections by Jung, as G. 1961c, from which the above has been trans. in turn. Repub., slightly rev., in E. 1976a. (In lieu of the orig. English ms., which had been lost.) *Spring 1961* reissued, photocopied and bound as one with *Spring 1960* and *Spring 1962*, in 1973.

1961b “Foreword.” *Hugh Crichton-Miller, 1877–1959, A Personal Memoir by His Friends and Family*. pp. 1–2. Dorchester (England): Longmans Ltd. Written in English and dated Jan. 1960. Repub., slightly rev., as CW 18,87.

1961c “Yoga, Zen, and Koestler.” *Encounter*, XVI:2 (Feb.), 56–58. Letter written in English to the editor, Melvin J. Lasky (19 Oct. 1960) in response to 2 articles by Koestler. Repub. as E. 1963f. TR.—German: 1961b / 1973a.

1961d “The Symbolic Life.” *Darshana*, I:3 (Aug.) (C. G. Jung memorial issue.) 11–22. E. 1954c abbrev. Cf. CW 18,3.

1962a *Memories, Dreams, Reflections*. Recorded and ed. by Aniela Jaffé. New York: Pantheon (Div. of Random House). pp. 398. London: Collins and Routledge & Kegan Paul, 1963. pp. 383. 1965: Paperback edn. New York: Vintage (Div. of Random House), pp. 398 (index added). 1973: Rev. edn., with corrections. Trans. from G. 1962a by Richard and Clara Winston. Pub. with addn. as E. 1966a. Contents (2d pagination refers to London edn.):

1. Prologue. (3–5) (17–19) Extracts prepub, as pt. of “Jung on Freud.” *Atlantic Monthly*, CCX;5 (Nov.), 47–56. Cf. no. 6 below.
2. First Years. (6–23) (21–36)
3. School Years. (24–83) (37–89)
4. Student Years. (84–113) (90–115)
5. Psychiatric Activities. (114–45) (116–43)
6. Sigmund Freud. (146–69) (144–64) Extracts pub. as pt. of “Jung on Freud.” Cf. no. 1 above.
7. Confrontation with the Unconscious. (170–99) (165–91)
8. The Work. (200–22) (1Q2–211)
9. The Tower. (223–37) (212–24)
10. Travels. (238–88) (224–69)
11. Visions. (289–98) (270–77)
12. On Life after Death. (299–326) (278–301) Extracts pub. as “Jung on Life after Death.” *Atlantic Monthly*, CCX:6 (Dec), 39–44.
13. Late Thoughts. (327–54) (302–26) 1st par. and Pt. I pub. as “Jung’s View of Christianity.” *Atlantic Monthly*, CCXI:1 (Jan. ‘63), 61–66.

14. Retrospect. (355–59) (327–30)

Appendixes (contents differ somewhat from Anhang of G. 1962a):

15. Freud to Jung. (Letters: 16 Apr. 1909; 12 May 1911; 15 June 1911)
(361–64) (333–35) Cf. E. 1974b.

16. Letters to Emma Jung from America (1909). (365–70) (336–40)

17. Letters to Emma Jung from North Africa (1920). (371–72) (340–41)

18. “Richard Wilhelm.” (373–77) (342–45)

Also contains pts. of letter to Gustav Steiner (30 Dec. 1957). (viii-ix) (11–12) Cf. E. 1975a. TR.—Danish: 1965/66a // Italian: 1965c // ?Japanese: 1972a and 1973a.

1962b With Richard Wilhelm: *The Secret of the Golden Flower. A Chinese Book of Life*. New York: Harcourt Brace. pp. 149. 1962: Paperback edn. New York: Harvest Books. Trans. from G. 1938a by Cary F. Baynes. E. 1931a, rev. and augmented by the addn. of “part of the Chinese meditation text ‘The Book of Consciousness and Life’ with a Foreword by Salome Wilhelm.” Cf. G. 1957b. Contains the following works by Jung:

1. “Foreword to the Second German Edition.” (xiii-xiv) Trans. from G. 1938a, 1. Pub. in a dif. trans. as pp. 3–5, CW 13,1.
2. “Commentary.” (81–137) Trans. from G. 1938a,38:4, here combined. Pub. in a dif. trans. as CW 13,1. Prepub. as E. 1958a,9.
3. “In Memory of Richard Wilhelm.” (138–49) Trans. from G. 1938a,2. Pub. in a dif. trans. with title change as CW 15,5.

1962c “Foreword.” Jolande Jacobi: *The Psychology of C. G. Jung*. p. vii. New Haven: Yale University Press. Trans. from G. 1940c by Ralph Manheim. Repub., trans. rev., as CW 18,40. Pub. in a dif. trans. as E. 1942c.

1963a With C. Kerényi: *Essays on a Science of Mythology: The Myth of the Divine Child and The Mysteries of Eleusis*. Paperback edn. (Harper Torchbooks/Bollingen Library.) New York: Harper & Row. pp. 200. E. 1949a, trans. rev. Cf. E. 1969a. Contains the following works by Jung:

1. “The Psychology of the Child Archetype.” (70–100) CW 9,1,6 (1st edn.) repub. Repub., trans. further slightly rev., as CW 9,i,6 (2d edn.).
2. “The Psychological Aspects of the Kore.” (156–77) CW 9,i,7 (1st edn.) repub. Repub., trans. further slightly rev., as CW 9,i,7 (2d edn.).

1963b “Foreword.” Aniela Jaffé: *Apparitions and Precognition; A Study from the Point of View of C. G. Jung’s Analytical Psychology*. pp. v-viii. New Hyde Park, N.Y.: University Books. Trans. from G. 1958e by R.F.C. Hull. Repub., trans. si. rev., as CW 18,8.

- 1963c Letter to Emanuel Maier (24 March 1950). Benjamin Nelson: “Hesse and Jung. Two Newly Recovered Letters.” p. 15. *Psychoanal. Rev.*, 50:3 (Fall), 11–16. Repub. in E. 1973b. TR.—German: 1972b.
- 1963d Letter to Wm. G. Wilson (30 Jan. 1961), pp. 6–7, “The Bill W. Carl Jung Letters.” *A A Grapevine*, XIX: 8 (Jan.), 2–7. Also pub. in *Bull. APC*, 25:3 (Mar.), 6–13. Repub. as E. 1968e. TR.—German: 1973a.
- 1963e Answers to questionnaire, “The Future of Parapsychology,” added as “Appendix,” pp. 450–51, to Martin Ebon, “The Second Soul of C. G. Jung.” *International Journal of Parapsychology*, V:4 (Autumn), 427–58. Dated 23 June 1960. Repub. with addn. of title as CW 18,50.
- 1963f Letter to Melvin Lasky, editor of *Encounter*, *Bull. APC*, 25:6 (Oct.), 16–20. Dated 19 Oct. 1960. E. 1961c repub. without title. Repub. in *Bull. APC*, 25:6 (Oct.), 16–20, and in E. 1976a.
- 1964a “Approaching the Unconscious.” *Man and His Symbols*, pp. 18–103. Ed. by Carl G. Jung and after his death M.-L. von Franz. Co-ordinating ed., John Freeman. London: Aldus Books; Garden City, N.Y.: Doubleday. 1968: Paperback edn. New York: Dell. pp. 1–94. Written in English in 1961 and extensively rev. and rearranged under the supervision of John Freeman in collaboration with Marie-Louise von Franz. Jung’s original text pub. with title change as CW 18,2. “The remaining chapters were written by the various authors to Jung’s direction and under his supervision.” TR.—Dutch: 1966a//French: 1964c//German: 1968a//Italian: 1967a// Spanish: 1966c//Swedish: 1966a.
- 1964b Letters to Richard Evans. Richard I. Evans: *Conversations with Carl Jung and Reactions from Ernest Jones*. Princeton, N.J.: D. Van Nostrand. pp. 173. Contains the following letters:
1. April 1957. (7)
 2. April 1957. (9)
 3. 30 May 1957. (10)
- Also contains a lengthy interview, rev. by Evans. Repub. 1976: *Jung on Elementary Psychology: A Discussion between Carl Jung and Richard Evans*. New York: Dutton. A verbatim transcript of the interview added in appendix. TR.—French: 1964e. German: 1967c.
- 1965aa *Answer to Job*. Paperback edn. London: Hodder and Stoughton. pp. 192. E. 1954a repub. (offset). Repub. with the addn. of “Prefatory Note” as E. 1971a,15.

- 1965a Letter to the author (7 July 1958), pp. 141–42. Edward Thornton: “Jungian Psychology and the Vedanta.” pp. 131–42. *Spectrum Psychologiae. Eine Freundesgabe*. Festschrift zum 60. Geburtstag C. A. Meier. Ed. by C. T. Frey-Wehrlin. Zurich: Rascher. Written in English.
- 1966a *Memories, Dreams, Reflections*. Recorded and ed. by Aniela JafÉ. Paperback edn. New York: Vintage Books (Div. of Random House), pp. 430. E. 1962a (New York edn., 1965 paperback) repub. with the following addn.:
19. “Septem Sermones ad Mortuos.” (378–90) E. 1925a repub. Cf. hardcover, E. 1967a.
- 1966b Letters to the author. Miguel Serrano: *C. G. Jung and Hermann Hesse. A Record of Two Friendships*. London: Routledge & Kegan Paul. pp. 112. 1968: Paperback edn. New York: Schocken, pp. 112. Written in English. Letters repub. along with Spanish trans. in Sp. 1965a. Contains the following letters by Jung, with minor corrections:
1. 14 January 1960. (68) Pub. with minor deletions and alteration as E. 1960b.
 2. 16 June 1960. (69–70)
 3. 31 March 1960. (74–75) Repub. in E. 1975a. TR.—German: 1973a.
 4. 14 September 1960. (83–88) Repub. in E. 1975a. TR.—German: 1973a. TR.—Spanish: 1965a.
- 1966c “Introduction.” Frances G. Wickes: *The Inner World of Childhood. A Study in Analytical Psychology*, pp. xvii–xxv. Rev. edn. New York: Appleton-Century. 1968: Paperback edn. (Signet) New York: New American Library. pp. 304. CW 17,2 repub. Original brief version pub. as E. 1927a.
- 1966d Letter to James Joyce (27 Sept. 1932)’ *Letters of James Joyce*. Ed. by Richard Ellmann. Vol. 3, pp. 253–54. New York: Viking. E. 1959,1 repub. Repub. in CW 15,8, pp. 133–34 and E. 1973b.
- † Date given as “? August 1932.”
- 1966e “Foreword.” Gerhard Adler: *Studies in Analytical Psychology*. pp. 3–5. New edn. London: Hodder & Stoughton. 1967: New York: G. P. Putnam’s Sons for the C. G. Jung Foundation for Analytical Psychology. 1969: Paperback edn. New York: Capricorn. Trans. from G. 1952g by R.F.C. Hull. Repub. as CW 18,55. (1st edn. — London & New York, 1948—lacks Foreword.)
- 1967a *Memories, Dreams, Reflections*. Recorded and ed. by Aniela Jaffé. 4th ptg. New York: Pantheon (Div. of Random House), pp. 430. E. 1962a repub. with same addn. as E. 1966a. TR.—Japanese: 1972a and 1973a.

- 1967b *VII Sermones ad Mortuos. The Seven Sermons to the Dead Written by Basilides in Alexandria.* ... London: Stuart & Watkins. pp. 34. E. 1925a repub. Cf. 1966a, 19.
- 1967d “Foreword to Studies from the C. G. Jung Institute, Zurich.” *Evil*. pp. xi-xii. Ed. by the Curatorium of the C. G. Jung Institute, Zurich. (Studies in Jungian Thought.) Evanston, Ill.: Northwestern University Press. Trans. from G. 1949e by Ralph Manheim. Also pub. in C. A. Meier: *Ancient Incubation and Modern Psychotherapy*, pp. ix-x. (Studies in Jungian Thought.) Evanston, Ill.: Northwestern University Press. Pub. in a dif. trans. with slight title change as CW 18,45. Excerpt pub. in a dif. trans. as pt. of E. 1950e.
- 1967e “Preface.” John Trinick: *The Fire-Tried Stone*, pp. [8–11]. Marazion, Cornwall: Wordens of Cornwall, in association with London: Stuart & Watkins. Two letters to the author, written in English (13 Oct. 1956 and 15 Oct. 1957), pub. as Preface. Letter of 15 Oct. 1957 repub. in E. 1975a.
- 1967f Letter to the author (1 Dec. 1960). Edward Thornton: *Diary of a Mystic*, p. 14. London: George Allen & Unwin. Written in English. Repub. in E. 1975a. TR.—German: 1973a.
- 1968a *Analytical Psychology; Its Theory and Practice. The Tavistock Lectures*. New York: Pantheon (Div. of Random House); London: Routledge & Kegan Paul. pp. 224. 1970: Paperback edn. New York: Vintage Books (Div. of Random House), pp. 224. 5 lectures, each with transcript of ensuing discussion, given for the Institute of Medical Psychology, London, 30 Sept-4 Oct. 1935. Stenographic transcript ed. by Mary Barker and Margaret Game, mimeographed for private circulation by the Analytical Psychology Club of London, 1936, entitled *Fundamental Psychological Conceptions: A Report of Five Lectures* ... and here slightly rev. by R.F.C. Hull. Repub. as CW 18,1. TR.—French: (excerpts only, from 1936 version) 1944a,34&8 // German: 1969a.
- 1968b Letter to the author (27 April 1959). Joseph F. Rychlak: *A Philosophy of Science for Personality Theory*, pp. 342–43. Boston: Houghton Mifflin. Written in English. Repub. in E. 1975a. TR.—German: 1973a
- 1968c “Letter of Professor C. G. Jung to the Author.” Josef Rudin: *Psychotherapy and Religion*, pp. xi-xiii. Notre Dame, Ind.: Notre Dame University Press. Trans. from G. 1964a by Elisabeth Reinecke and Paul C. Bailey. Dated 30 Apr. 1960. Pub. in a dif. trans. in E. 1976a.
- 1968d Prefatory note. *Alchemy and the Occult. A Catalogue of Books and Manuscripts from the Collection of Paul and Mary Mellon Given to Yale*

University Library. Vol. 1, 1 p. Compiled by Ian MacPhail. New Haven, Conn.: Yale University Library. (In 2 vols.) E. 1946b repub. Repub., slightly rev. and with addn. of title, as CW 18,104.

1968e Letter to Wm. G. Wilson (30 Jan. 1961), pp. 20–21, “The Bill W. Carl Jung Letters.” *AA Grapevine*, XXIV:8 (Jan.), 16–21. E. 1963d repub. Repub. in E. 1975a.

1968f “Answers to Questions on Freud.” *Spring 1968*. pp. 46–48. New York: Analytical Psychology Club. Written in English in reply to questions sent by Michael L. Hoffman, Geneva representative of the *New York Times*, and dated 7 Aug. 1953. Repub. as CW 18,32.

1968g “A 1937 Letter from C. G. Jung.” *Journal of Religion and Health*, V:3 (July), 275. Written in English to the Rev. Kendig Cully (25 Sept. 1937). Repub. in E. 1973b. TR.—German: 1972a.

1969a With C. Kerényi: *Essays on a Science of Mythology ...* Rev. edn. (Princeton/Bollingen Paperback.) Princeton University Press, pp. 200. CW 9,i,6 and 7 (2d edn.) repub.

1969b *On the Nature of the Psyche*. (Princeton/Bollingen Paperback.) Princeton University Press. pp. 175. Contents:

1. “On Psychic Energy.” (3–66) CW 8,1 repub.
2. “On the Nature of the Psyche.” (67–144) CW 8,8 repub.

1969c *Psychology and Education*. (Princeton/Bollingen Paperback.) Princeton University Press. pp. 161. Contents:

1. “Psychic Conflicts in a Child.” (1–35) CW 17,1 repub.
2. “Child Development and Education.” (37–52) CW 17,3 repub.
3. “Analytical Psychology and Education.” (53–122) CW 17,4 repub.
4. “The Gifted Child.” (123–35) CW 17,5 repub.

1969d *The Psychology of the Transference*. (Princeton/Bollingen Paperback.) Princeton University Press, pp. 207. CW 16,13 (2d edn.) repub.

1969e “Foreword.” Erich Neumann: *Depth Psychology and a New Ethic*. pp. 11–18. New York: G. P. Putnam’s Sons for the C. G. Jung Foundation for Analytical Psychology. Trans. from the German *ms.* by R.F.C. Hull. Written for a proposed English edn. not pub. until 1969. Dated March 1949. Repub., trans. slightly rev., as CW 18,77. German edn. lacks this Foreword.

1969f “Depth Psychology and Self-Knowledge. Dr. Jung’s Answers to Questions Asked by Dr. Jolande Jacobi.” *Spring 1969*. pp. 129–39. New York:

Analytical Psychology Club. E. 1943b repub. with title change; trans. rev. by R.F.C. Hull. Repub. as CW 18,131.

1970a *Four Archetypes: Mother, Rebirth, Spirit, Trickster*. (Princeton/Bollingen Paperback.) Princeton University Press, pp. 173. 1972, London: Routledge & Kegan Paul. Contents:

1. "Psychological Aspects of the Mother Archetype." (7–44) CW 9,i,4 repub.
2. "Concerning Rebirth." (45–81) CW 9,i,5 repub.
3. "The Phenomenology of the Spirit in Fairytales." (83–132) CW 9,i,8 repub.
4. "On the Psychology of the Trickster-Figure." (133–52) CW 9,i,9 repub.

1970b *Psychological Reflections. A New Anthology of His Writings 1904–1961*. Selected and ed. by Jolande Jacobi in collaboration with R.F.C. Hull. Princeton University Press (B. S. 31); London: Routledge & Kegan Paul. pp. 391. 1973: (Princeton/Bollingen Paperback.) Princeton University Press, pp. 379. Trans. by R.F.C. Hull. ("... all but relatively few of the quotations are taken from the Collected Works. ... " This revision, prepared in English, adds passages from 1945–61 and omits some older material. The Swiss edn. [G. 1971b] is based on this one.) E. 1953a rev. and exp. Extracts pub, as E. 1972e.

1970c "Two Posthumous Papers. 1916." *Spring 1970*. pp. 170–76. Zurich: Analytical Psychology Club of New York. Trans. by R.F.C. Hull from the unpub. German typescripts found posthumously. Dated Oct. 1916. Contents:

1. "Adaptation," (170–73)
2. "Individuation and Collectivity." (174–76)

Repub. as CW 18,35.

1970d *Letter to André Barbault (26 May 1954). *Aquarian Agent*, I:13 (Dec.). Trans. from Fr. 1954b by an unknown hand. Pub. in a dif. Trans. in E. 1976a.

1971a *The Portable Jung*. Ed. with an intro. by Joseph Campbell. New York: Viking. pp. 650. (Published simultaneously in paperback.) Trans. by R.F.C. Hull. Contents:

Part I,

1. "The Stages of Life." (3–22) CW 8,16 repub.
2. "The Structure of the Psyche." (23–46) CW 8,7 repub.
3. "Instinct and the Unconscious." (47–58) CW 8,6 repub.

4. "The Concept of the Collective Unconscious." (59–69) CW 9,i,2 repub.
5. "The Relations between the Ego and the Unconscious." (70–138) CW 7,2 repub.
6. "Aion: Phenomenology of the Self." (139–62) CW 9,ii, Chs. I—III, repub.
7. "Marriage as a Psychological Relationship." (163–77) CW 17,8 repub.
8. "Psychological Types." (178–269) CW 6, Ch. X, repub.

Part II.

9. "The Transcendent Function." (273–300) CW 8,2 repub.
10. "On the Relation of Analytical Psychology to Poetry." (301–22) CW 15,6 repub.
11. "Individual Dream Symbolism in Relation to Alchemy." (323–455) CW 12,3, Pt. II (2d edn.) repub.
12. "The Spiritual Problem of Modern Man." (456–79) CW 10,4 repub.
13. "The Difference between Eastern and Western Thinking." (480–502) CW 11,10, pars. 759–87, repub.

Part III.

14. "On Synchronicity." (505–18) CW 8,19 repub.
15. "Answer to Job." (519–650) CW 11,9 repub. Cf. E. 1973a.

1971b "Excerpts from Selected Letters." *Spring 1971*. pp. 121–35. Zurich: Analytical Psychology Club of New York. Excerpts from E. 1973b and 1976a prepub. Contents:

- †1. "... to a little daughter." (1 July 1919) To Marianne Jung.
- †2. "to a solicitous colleague." (6 Nov, 1926) To Frances G. Wickes, †Prepub. from E. 1973b.
- †3. "... to Freud." (5 Oct. 1906) Also prepub. from E. 1974b.
- †4. "Recollections of ... the U. S." (23 July 1949) To Virginia Payne.
- †5. "On Einstein and Synchronicity." (25 Feb. 1953) To Carl Seelig.
- †6. "On Mescaline." (15 Feb. 1955) To A. M. Hubbard.
- †7. "On the Shadow and Protestantism." (9 Nov. 1955) To Theodor Bovet.
- †8. "To a Colleague on Suicide." (25 July 1946) To Eleanor Bertine.
- †9. "On Suicide." (19 Nov. 1955) To an anonymous recipient.
- †10. "In Old Age." (10 Aug. 1960) To the Earl of Sandwich.
- †Prepub. from E. 1973b.
- ‡Prepub. from E. 1976a.

1972a *Mandala Symbolism*. (Princeton/Bollingen Paperback.) Princeton University Press. pp. 121. Contents:

1. "Mandalas." (3–5) CW 9,i,13 repub.
2. "A Study in the Process of Individuation." (6–70) CW 9.i.11 repub.
3. "Concerning Mandala Symbolism." (71–100) CW 9,1,12 repub.

1972b Letters to the author (4 Mar. and 3 Dec. 1957). Frederic Spiegelberg: *Images from Tibetan Art*. pp. [4–5]. A folio collection of eight reproductions for coloring and meditation with an essay and commentaries by Frederic Spiegelberg and additional commentaries by C. G. Jung. San Francisco: Lodestar Press. Trans. by Frederic Spiegelberg from the German letters.

1972c "Letters to a Friend: Part I." *Psychological Perspectives*, III: 1 (Spring), 9–18. To James Kirsch. Trans. by James Kirsch from the German mss. except as otherwise noted. The 1st of 2 pts. Cf. E. 1972d. Contents:

1. 19 Aug. 1929. Pub. in a dif. trans. in E. 1976a. German letter pub. in G. 1973a.
2. 15 Aug. 1930.
3. 12 Aug. 1931.
4. 12 Mar. 1932.
5. 20 Jan. 1933.
6. 20 Feb. 1934.
7. 26 May 1934. E. 1946d,2 repub. Trans. by Ernest Harms. Pub. in a dif. trans. in E. 1973b. German letter pub. in G. 1972a.
8. 16 Aug. 1934.
9. 29 Sept. 1934. Last par. only. Entire letter pub. in a dif. trans. in E. 1973b. German letter pub. in G. 1972a.
10. 17 Feb. 1935.
11. 25 July 1946. Written in English.
12. 12 July 1951.
13. 18 Nov. 1952. Written in English. Repub. in E. 1976a. TR.—German: 1972b.
14. 23 Nov. 1952.
15. 28 Nov. 1952. Written in English.

1972d "Letters to a Friend: Part II." *Psychological Perspectives*, III:2 (Fall), 167–78. To James Kirsch, except no. 15 below, to Hildegard Kirsch. Trans. by James Kirsch from the German mss. except as otherwise noted. The last of 2 pts. Cf. E. 1972c. Contents:

1. 29 Jan. 1953. Pub. in a dif. trans. in E. 1976a. German letter pub. in G. 1972b.
2. 28 May 1953. Pub. in a dif. trans. in E. 1976a. German letter pub. in G. 1972b.
3. 6 Aug. 1953.
4. 2 Oct. 1953.
5. 16 Feb. 1954. Pub. in a dif. trans. in E. 1976a. German letter pub. in G. 1972b.
6. 5 Mar. 1954. Pub. in a dif. trans. in E. 1976a. German letter pub. in G. 1972b.
7. 23 June 1954.
8. 11 Sept. 1954.
9. Summer 1957.
10. 29 Apr. 1958. Pub. in a dif. trans. in E. 1976a. German letter pub. in G. 1973a.
11. 3 Nov. 1958.
12. 10 Dec. 1958. Pub. in a dif. trans. in E. 1976a. German letter pub. in G. 1973a.
13. 12 Nov. 1959. Pub. in a dif. trans. in E. 1976a. German letter pub. in G. 1973a.
14. 10 Jan. 1960.
15. 2 Nov. 1960. To Hildegard Kirsch.

1972e “‘Psychological Reflections’ on Youth and Age.” *University*, 51 (Winter), 18–22. Extracts of E. 1970b.

1973a *Answer to Job*. (Princeton/Bollingen Paperback.) Princeton University Press. pp. 121. CW 11,9, 2d edn., 2d ptg. (1973) repub.

1973b *Letters. 1: 1906–1950*. Selected and ed. by Gerhard Adler in collaboration with Aniela Jaffé. Princeton University Press (B. S. 95); London: Routledge & Kegan Paul. pp. 596. German letters trans. by R.F.C. Hull, French letters by Jane A. Pratt. The 1st of 2 vols. Cf. E. 1976a. Contains 522 letters, of which 152 are in the orig. English. Contents arranged chronologically. “With a very few exceptions ... the selection of letters in the Swiss and American editions is identical.” Cf. G. 1972a and 1972b for the German version. TR.— (English originals) German: 1972a/1972b.

1973c *Synchronicity: An Acausal Connecting Principle*. (Princeton/Bollingen Paperback.) Princeton University Press; London: Routledge & Kegan Paul.

pp. 135. Contents:

1. "Synchronicity: An Acausal Connecting Principle." (1–103) CW 8,18 repub.
2. "On Synchronicity." (104–15) E. 1971a,14 repub,

1973d "Three Early Papers." *Spring 1973*. pp. 171–87. Zurich: Analytical Psychology Club of New York. Trans. by R.F.C. Hull. Contents:

1. "Sigmund Freud: *On Dreams* (1901)." (171–79) Trans. from a typescript apparently of a report given at Burghölzli and dated 25 Jan. 1901. CW 18,18 prepub.
2. "Marginal Note on F. Wittels: *Die sexuelle Not*. (1910)." (179–82) Trans. from G. 1910l. CW 18,24 prepub.
3. "A Comment on Tausk's Criticism of Nelken (1913)." (182–87) Trans. from G. 1913d. CW 18,31 prepub.

1973e "Religion and Psychology: A Reply to Martin Buber." *Spring 1971* pp. 196–203. Zurich: Analytical Psychology Club of New York. Trans. from G. 1952j by R.F.C. Hull. Repub. as CW 18,96. Pub. in a dif. trans. with title change as E. 1957d.

1974a *Dreams*. (Princeton/Bollingen Paperback.) Princeton University Press. pp. 337. Contents:

Part I: Dreams and Psychoanalysis.

1. "The Analysis of Dreams." (3–12) CW 4,3 repub.
2. "On the Significance of Number Dreams." (13–20) CW 4,5 repub.

Part II: Dreams and Psychic Energy.

3. "General Aspects of Dream Psychology." (23–66) CW 8,9 repub.
4. "On the Nature of Dreams." (67–83) CW 8,10 repub.

Part III: The Practical Use of Dream-Analysis.

5. "The Practical Use of Dream-Analysis." (87–109) CW 16,12 repub.

Part IV: Individual Dream Symbolism in Relation to Alchemy.

6. "Individual Dream Symbolism in Relation to Alchemy." (111–297) CW 12,3, Part II (2d edn.) repub.

1974b With Sigmund Freud: *The Freud / Jung Letters. The Correspondence between Sigmund Freud and C. G. Jung*. Ed. by William McGuire. Princeton University Press (B. S. 94); London: Hogarth Press and Routledge & Kegan Paul. pp. 650. Freud letters trans. by Ralph Manheim, Jung letters trans. by R.F.C. Hull, from the German mss. (pub. simultaneously as G. 1974a). Contains 196 letters by Jung to Freud written 1906–1914 (+ 1 from 1923); 8 were prepub. in E. 1973b, 8 in E. 1974d, and 1 as E. 1971b,3. Intro, includes

2 letters to Ernest Jones (22 Feb. 1952) p. xxi and (19 Dec. 1953) p. xxiii, and 1 to K. R. Eissler (20 July 1958) pp. xxvii-xxviii, the full texts of which appear in E. 1976a.

1974c *The Psychology of Dementia Praecox*. (Princeton/Bollingen Paperback.) Princeton University Press, pp. 222. CW 3,1 repub.

1974d Letters to Freud, pp. 40–42, 86–94. “The Freud/Jung Letters.” Ed. by William McGuire. *Psychology Today*, VIL9 (Feb.), 37–42, 86–94. Extracts of E. 1974b prepub. 8 letters dated 18 Jan. 1911–6 Jan. 1913, selected and ed. by Elizabeth Hall, with an introduction by William McGuire.

1974e Letters to Mary Foote. pp. 259–66. Edward Foote: “Who Was Mary Foote?” *Spring 1914*. pp. 256–68. Zurich: Analytical Psychology Club of New York. Contents:

1. 19 Mar. 1927. Prepub. from E. 1976a.
2. 12 Dec. 1929.
3. 18 Dec. 1929. Prepub. from E. 1976a.
4. 29 Mar. 1933. Prepub. from E. 1976a.
5. 12 July 1937. Prepub. from E. 1976a.
6. 22 July 1939.
7. 28 July 1942.
8. 11 May 1944.

1975a “To Oskar Schmitz (1921–1931)” *Psychological Perspectives*, 6:1 (Spring), 79–95. Trans. from the German, with the aid of an anon, trans., by James Kirsch, except as noted below. Contains the following letters from Jung to Schmitz:

1. 15 Mar. 1921 (80)
2. 26 May 1923 (80–83) Repub. from E. 1973b. For orig. German, see G. 1972a.
3. 2 Nov. 1926 (83–84)
4. 13 Nov. 1926 (84–85)
5. 7 Jan. 1927 (85–86) †Prepub. from E. 1976a.
6. 21 July 1927 (86–87) †Prepub. from E. 1976a.
7. 3 Mar. 1928 (87)
8. 20 Sept. 1928 (89–90) †Repub. from E. 1973b.
9. 5 Apr. 1929 (91)
10. 5 Apr. 1929 (92)
11. 8 Sept. 1929 (92)

12. 24 Sept. 1929 (93)

Also contains a letter from Jung to Keyserling (25 Aug. 1928), pp. 87–88, †repub. from E. 1973b, as well as letters to Schmitz from Emma Jung, pp. 90–91, 93–95.

†Trans. by R.F.C. Hull.

1976a *Letters. 2: 1951–1961*. Selected and ed. by Gerhard Adler in collaboration with Aniela Jaffé. Princeton University Press (B. S. 95); London: Routledge & Kegan Paul. pp. 716. German letters trans. by R.F.C. Hull (8 trans. by Hildegard Nagel), French letters by Jane A. Pratt. The 2d of 2 vols. Cf. E. 1973b. Contains 463 letters, of which 214 are in the orig. English. In addition, the 1914–50 Addenda consist of 16 letters, of which 9 are in the orig. English. Contents arranged chronologically. Cf. G. 1972b and 1973a for the German version, TR.—(English originals) G. 1972b/1973a.

DANISH

- 1957a “Menneskets sjæleliv.” *Perspektiv*, IV:6 (Mar.), 34–37. Trans. from the German ms. by Hans Reitzel. Written as contribution to a series of articles entitled “Mennesket og fremtiden—En international enquete” (Man and the Future—An international symposium), ed. through the agency of the American Cultural Attaché in Copenhagen.
- 1959a *Natid og fremtid*. Copenhagen: Gyldendal. pp. 100. Trans. from G, 1957i by Mogens Boisen.
- 1961a *Det ubevidste*. Copenhagen: Gyldendal. pp. 160. Trans. from G. 1943a by Mogens Boisen.
- 1962a *Jeget og det ubevidste*. Copenhagen: Gyldendal. pp. 160. Trans. from G. 1935a by Mogens Boisen.
- 1963a Foreword to Jolande Jacobi: *C. G. Jungs psykologi*. pp. 7–8. Copenhagen: Gyldendal. Trans. from G. 1940c by Mogens Boisen.
- 1964a “Af den analytiske psykologis forhold til det digteriske kunstværk.” *Vindrosen*, XI:3, 13–24. Trans. from G. 1931d,3 by Erik Nielsen.
- 1–6a *Erindringer, drømme og tanker*. Recorded and ed. by Aniela Jaffé. Copenhagen: Biilmann og Eriksen. Vol. I, pp. 198. 1966: Vol. 2, pp. 319. Trans. from E. 1962a by Jon Kilje.
- 1968a *Psykologi og religion*. (Uglebøger, 213.) Copenhagen: Gyldendal. pp. 156. Trans. from G. 1940a by Christian Kock.
- 1969a *Den psykiske energetik og drømmenes væsen*. (Uglebøger.) Copenhagen: Gyldendal. pp. 220. Trans. from G. 1948b by Christian Kock.

DUTCH

- 1908a “De theorie van Freud over hysteric” *Geneeskundige Courant*, XLII, 225–58. Trans. from G. 1908m by ?.
- 1914a “Over Psychoanalyse.” *Nederlandsch Tijdschrift voor Geneeskunde*, II: 19 (7 Nov.), 1512–23. Trans. from E. 1913d by J. H. van der Hoop.
- 1928a *Analytische psychologie en opvoeding. Drie voordrachten gehouden te Londen in Mei 1924*. Zutphen: W. J. Thieme. pp. 87. Trans. from G. 1926b by J. L. Gunning. Cf. Du. 19483,1–3, for trans. of rev. version.
- 1935a *De banden tussen het ik en het onbewuste*. (Psychologische biblio-theek, 5.) Hague: Servire, pp. 179. 1960, paperback edn. *Het ik en het onbewuste*. (Luxe-pockets, 92.) pp. 135. Trans. from G. 1928a by A. M. Meerlo.
- 1935b *Theoloog of medicus?* Zutphen: G.J.A. Ruys. pp. 44. Trans. from G. 1932a by ?.
- 1938a Foreword to Esther Harding: *Vrouwen Lewensweg*. pp. xi-xiv. Leiden: E. J. Brill. Trans. from G. ig4gd by W.E.D. Sterek.
- 1940a *Zielsproblemen van deze tijd*. Amsterdam: Meulenhoff. pp. 202. Trans. from G. 1931a and 1934b by Frank de Vries. Cf. Du. 1956a. Contents:
1. “De ziel als probleem voor den modernen mens.” (1–33) Trans. from G. 19313,14. Cf. Du. 19563,13.
 2. “Het huwelijk als psychologische verhouding.” (34–52) Trans. from G. 1931a,11. Cf. Du. 19563,10.
 3. “Het leven op een keerpunt.” (53–78) Trans. from G. 19313,10. Cf. Du. 19563,9.
 4. “Over de wording der persoonlijkheid.” (79–109) Trans. from G. 1934b,g. Cf. Du. 1957a.
 5. “De archaische mens.” (110–45) Trans. from G. 19313,9. Cf. Du. 1956a,8.
 6. “De ziel en de dood.” (146–163) Trans. from G. 19340,10. Cf. Du. 1957a.
 7. “Analytische psychologie en wereldbeschouwing.” (164–202) Trans. from G. 19313,12. Cf. Du. 19563,11.
- 1947a *De catastrophe. Psychologische beschouwingen over Europa’s jongste geschiedenis*. Arnhem: Van Loghum Slaterus. pp. 152. Trans. from G. 1946a by C. L. de Ligt-van Rossem.

- 1947b “De betekenis der Dromen.” *Ciba-Tijdschrift*, 22 (Mar.), 714–26. Trans. from G. 1945d by M. C. Schoute.
- 1948a *Psychologie en opvoeding ...* Arnhem: Van Loghum Slaterus. pp. 187. Trans. from G. 1946b by G. Ringeling. Contents:
1–3. “Drie Voordrachten.” Cf. Du. 1928a for trans. of earlier version.
4. “Conflicten in de Kinderziel.”
5. “Het begaafde Kind.”
- 1948b “Voorwoord” and essay: “Over de Indische heilige.” Heinrich Zimmer: *De weg tot het zelf*. p. 5, and pp. 225–37. Hague: De Driehoek. Trans. from G. 1944b by Madeion de Man.
- 1949a *Psychologische beschouwingen. Een keur uit zijn werken*. Comp, and ed. by Jólán Jacobi. Antwerp: Het Kompas; Amsterdam: L. J. Veen, 1950. pp. 362. Trans. from G. 1945a by Elisabeth Camerling.
- 1949b *Psychologische typen*. Hague: Servire, pp. 473. Trans. from G. 1921a by Rob Limburg.
- 1949c *De vrouw in Europa*. Lochern: H. Buys. Trans. from G. 1929a by ?.
- 1949d “Woord ten geleide.” Jólán Jacobi: *De psychologie van C. G. Jung*. p. 7. Amsterdam: Contact, pp. 198. 1963: Antwerp: Zeist. p. 7. Trans. from G. 1940c by M. Drukker.
- 1950a *De mens op weg naar zelf-ontdekking. Structuur en functie van het onbewuste geestesleven*. Amsterdam: Meulenhoff. pp. 298. Trans. from Fr. 1944a by J. Kassies.
- 1950b *De psychologie van het onbewuste*. Arnhem: Van Loghum Slaterus. pp. 192. Trans. from G. 1943a by G. Ringeling.
- 1951a *Psychologie en godsdienst. De Terry Lectures 1937 gehouden aan de Yale University*. Amsterdam: L. J. Veen; Antwerp: Het Kompas, pp. 151. Trans. from G. 1940a by Elisabeth Camerling.
- 1953a With Richard Wilhelm: *Het geheim van de gouden bloem. Een Chinees levensboek*. Amsterdam: L. J. Veen. pp. 159. 1975: Deven-ter: Ankh-Hermes. Trans. from G. 1938a by J. M. Hondius and R. de Jong-Belinfante.
- 1953b “Voorwoord.” *I Tjing: Het boek der veranderingen*. Vol. I, pp. vi-xxiii. Amsterdam: L. J. Veen. 2 vols. Trans. from E. 1950d by A. Hochberg-van Wallinga.
- 1954a *Synchroniciteit als beginsel van acausale samenhangen*. Amsterdam: L. J. Veen. pp. 141. Trans. from G. 1952b by J. M. Hondius.

- 1955a *De symboliek van de geest*. Amsterdam: L. J. Veen. pp. 361. Trans. from G. 1948a by Elisabeth Camerling.
- 1955b *De wereld der ziel*. Arnhem: Van Loghum Slaterus. pp. 188. Trans. from G. 1954c by G. Ringeling.
- 1956a *Zielsproblemen van onze tijd*. Amsterdam: L. J. Veen. pp. 272. Trans. from G. 1931a by Elisabeth Camerling and Fr. de Vries. Cf. Du. 1940a. Contents:
1. "Problemen der moderne psychotherapie." (9–31)
 2. "Over de relaties van de analytische psychologie tot het kunst-werk van de dichter. (32–52)
 3. "De tegenstelling Freud en Jung." (53–60)
 4. "Doelstellingen van de psychotherapie." (61–77)
 5. "Psychologische typologie." (78–95)
 6. "De structuur van de ziel." (96–115)
 7. "Ziel en aarde." (116–136)
 8. "De archaïsche mens." (137–158) Cf. Du. 1940a,5.
 9. "Het leven op een keerpunt." (159–174) Cf. Du. 1940,3.
 10. "Het huwelijk als psychologische verhouding." (175–86)
 - 11 "Analytische psychologie en wereldbeschouwing." (187–230) Cf. Du. 1940a,7.
 12. "Geest en leven." (231–249)
 13. "Het zielsprobleem van de moderne mens." (250–?72) Cf. Du. 1940a,1.
- 1957a *De werkelijkheid van de ziel*. Amsterdam: L. J. Veen. pp. 247. Trans. from G. 1934b by Elisabeth Camerling and Frank de Vries. Cf. Du. 1940a,4&6.
- 1957b Foreword to Frances G. Wickes: *De innerlijke wereld van het kind*. pp. 13–19. Amsterdam: L. J. Veen. Trans. from G. 1931e by Elisabeth Camerling and Frank de Vries.
- 1958a *Onze tijd en zijn toekomst*. Amsterdam: L. J. Veen. pp. 86. Trans. from G. 1957i by Elisabeth Camerling.
- 1958b "Voorwoord." D. T. Suzuki; *Inleiding tot het Zen-Boeddhisme*. pp. 1–27. Deventer: N. Kluwer. pp. 162. 1972: Deventer: Ankh-Hermes. Trans. from E. 1949d by William B. Moens.
- 1961a Foreword to Frieda Fordham: *Inleiding tot de psychologie van Jung*. pp. 5–6. Amsterdam: Wereldbibliothek. Trans. from E. 1953d by Annie J. Blits.
- 1962a *Archetypen*. (Luxe-pockets, 93.) Hague: Servire, pp. 240. Trans. from G. 1954b,1–4,8 by Elisabeth Camerling. Contents:

1. “Voorwoord.” (7–8)
2. “Over de archetypen van het collectieve onbewuste.” (9–56)
3. “Over het archetype met speciale belichting van het begrip ‘anima.’
“(57–78)
4. “De psychologische aspecten van het moederarchetype.” (79–118)
5. “Over het wezen van het psychische.” (119–205)
6. Appendices (226–240)

1963a *Herinneringen, dromen, gedachten*. Recorded and ed. by Aniela Jaffé. Arnhem: Van Loghum Slaterus. pp. 356. Trans. from G. 1962a by Agaath van Ree. Contents conform to those of G. 1962a, with the exception of those of the appendix, which are as follows:

1. “Uit brieven van Freud aan Jung.” (329–31)
2. “Uit brieven aan Emma Jung.” (333–37)
3. “Richard Wilhelm.” (338–42)
4. “Heinrich Zimmer.” (343–56)

1966a “Die benadering van het onbewuste.” *De mens en zijn Symbolen*. pp. 17–111. With M.-L. von Franz, Joseph L. Henderson, Jolande Jacobi, and Aniela Jaffé. Rotterdam: Lemniscaat. pp. 368. Trans. from E. 1964a by Elisabeth Camerling and Annie J. Blits.

FINNISH

- 1960a *Nykyhelki ja tulevaisuus*. Helsinki: Kirjayhtymä. pp. 102. Trans. from G. 1957i by Kaj Kauhanen.
- 1966a *Piilotajunnan psykologiaa*. (Forum Kirjaston, 13.) Helsinki: Tammi. pp. 158. Trans. from G. 1943a by Erkki Rutanen.
- 1974a *Job saa Vastauksen*. Helsinki: Kustannusosakeyhtiö Otava. pp. 159. Trans. from G. ?1961a by Sinikka Kallio.

FRENCH

*In the French entries, an asterisk marks a work not examined.

- 1907a “Associations d’idées familiales.” *Archs. psychol.*, VII:26 (Oct.), 160–68. The content of this paper considerably overlaps that of E. 1910a,2; in addition, “some material reused in ETH lectures, *Modern Psychology*, April 1934–July 1935.”
- 1908a A summary of *Diagnostische Associationsstudien*, Vol. I. *Année psychologique*, XIV, 453–55. Summarized from G. 1906a. Each article summarized individually in 1 or 2 paragraphs.
- 1909a “L’Analyse des rêves.” *Année psychologique*, XV, 160–67. TR.—English: CW 4,3.
- 1913a “Contribution à l’étude des types psychologiques.” *Archs. psychol.*, XIII: 52 (Dec), 289–99. Lecture delivered to the Fourth Psychoanalytic Congress, Munich, 7–8 Sept. 1913, in German and then rev. into French by the author. Cf. GW 6,4 for the German version. TR.—English: 1916a, 12.
- 1913b “La Psycho-analyse.” *Encéphale*, VIII, 263–66. Summary of a report read in English to the 17th International Congress of Medicine, London, August 1913. Cf. E. 1916a,9.
- 1916a “La Structure de l’inconscient.” *Archs. psychol.*, XVI:62 (Dec), 152–79. Trans. by M. Marsen from a German ms. subsequently pub. as GW 7,4. Cf. Fr. 1938a for a trans. of a rev. version. Delivered in German as a lecture to the Zurich School of Analytical Psychology, 1916. TR.,—English: CW 7,4 (1st edn.).
- 1928a *L’Inconscient dans la vie psychique normale et anormale*. Paris: Payot. pp. 190. Trans. from G. 1926a by E. Grandjean-Bayard Cf. Fr. 1952a for trans. of rev. version.
- 1931a *Essais de psychologie analytique*. Paris: Stock, Delamain et Boutelleau. pp. 198. Trans. by Yves Le Lay. Cf. Fr. 1961b for a rev. and exp. version.
Contents:
1. “Les problèmes psychiques des différents âges de l’homme.” (1–26)
Trans. from G. 1930d. Cf. Fr. 1961b,8.
 2. “Le problème psychique de l’homme moderne.” (27–59) Trans. from G. 1928f. Repub. as Fr. 1961b,6.

3. “Le conditionnement terrestre de l’âme.” (60–114) Trans. from G. 1927a, Repub. as Fr. 1961b,2 with title change.
4. “La psychologie analytique dans ses rapports avec l’œuvre poétique.” (115–46) Trans. from G. 1922a. Repub. as Fr. 1961b,13.
5. “Le mariage, relation psychologique.” (147–66) Trans. from G. 1925b, Repub, as Fr. 1961b,11.
6. “La femme en Europe.” (167–98) Trans. from G. 1929a. Repub. as Fr. 19610,10.

1931b **Métamorphoses et symboles de la libido*. Paris: Montaigne (Aubier); Geneva: Kundig. pp. 488. Trans. from G. 1925a by Louis de Vos. Cf. Fr. 1953c for trans. of a rev. and exp. version.

1932a **La théorie psychanalytique*. Paris: Montaigne (Aubier); Geneva: Kundig, pp. 125. Trans. from G. 1913a by Marthe Schmid-Guisan.

1932b “La psychanalyse devant la poésie. Existe-t-il une poésie de signe ‘freudien’?” *Journal des poètes*, III: 5 (11 Dec), 1, Written in German in reply to the question in the title and trans. by ?. Cf. CW 18,111.

1933a “Sur la psychologie” *Revue d’Allemagne*, VII70 (15 Aug.: “No. spécial sur C. G. Jung”), 690–708. Parts of G. 1933b trans. by—Decourdemanche. Cf. Fr. 1944a,2.

1935a *Conflits de l’Ame enfantine. La rumeur.—L’influence du père*. Paris: Montaigne (Aubier), pp. 77. Trans. by L. de Vos and Olga Raesvsky. Cf. Fr. 1963a for trans. of rev. and exp. version. Contents:

1. “Conflits de l’âme enfantine.” (9–42) Trans. from G. 1916b by L. DeVos. Cf. Fr. 1963a,2.
2. “Contribution à la psychologie de la ‘rumeur publique’.” (43–58) Trans. from G. 1910g by Olga Raesvsky. Repub. as Fr. 19633,3 with title change.
3. “L’influence du père sur la destinée de ses enfants.” (59–77) Trans. from G. 1909c by Olga Raesvsky. Cf. Fr. 1963,4.

1938a *Le moi et l’inconscient*. (Psychologie, 5.) Paris: Gallimard, pp. 254. Trans. from G. 1935a by A. Adamov. Pub. in a dif. trans. with title change as Fr. 1964a. Cf. Fr. 1916a for trans. of earlier version.

1939a *Phénomènes occultes*. Paris: Montaigne (Aubier), pp. 122. Trans. by E. Godet and Yves Le Lay. Contents:

1. Préface, (v-vii) Trans. from the German ms., written for this edn. Dated 1938. Cf. CW 18,5.

2. “A propos de certains phénomènes dits occultes.” (1–94) Trans. from G. 1902a. Cf. Fr. 1956a,4.
3. “Âme et mort.” (95–106) Trans. from G. 1934b,10. Cf. Fr. 1956a,5.
4. “Croyance aux esprits.” (107–22) Trans. from G. 1928b,5. Cf. Fr. 1956a,6.

1943a *L’homme à la découverte de son âme. Structure et fonctionnement de l’inconscient.* (Action et Pensée, 10.) Geneva: Éditions du Mont-Blanc, pp. 403. 1946: 2d edn., rev. & corrected, pp. 354. Trans. by R. Cahen-Salabelle. Pub., rev. & exp., as Fr. 1962a. Extract prepub. as Fr. 1944a. Contents:

1. “Le problème fondamental de la psychologie contemporaine.” (3–31) Trans. from G. 1934b,2. Cf. Fr. 1962a, 1 for rev. version with title change.
2. “La psychologie et le temps présent.” (33–67) Trans. from G. 1934b,3. Cf. Fr. 1962a,2 for rev. version with title change and Fr. 1933a for trans. of extracts.
- †3. Conférence I: “Introduction à la psychologie analytique. Notions fondamentales, Pt. 1. Psychologie générale.” (71–134) The 1st of 6 seminars given to the “Société de Psychologie,” Basel, 1934, and at the Institute of Medical Psychology, London, 1935. The remainder follow as noted. Trans. from a lecture later pub. in E. 1968a. Cf. Fr. ig62a,3 for rev. version with title change.
- †4. Conférence II: “Introduction à la psychologie analytique. Notions fondamentales, Pt. II. Les complexes.” (135–87) Trans. from a lecture later pub. in E. 1968a. Cf. Fr. 19628,4 for rev. version with title change.
5. “Considérations générales sur la théorie des complexes.” (189–211) Trans. from G. 1934a. Cf. Fr. 19623,5 for trans. of rev. version.
6. “La psychologie du rêve.” (215–80) Trans. from G. 19280,3. Cf. Fr. 1962a,6 for trans. of rev. version.
7. “L’utilisation pratique de l’analyse onirique.” (281–314) Trans. from G. 1934b,4. Repub., trans. rev., as Fr. 1962a,7.
- †8. Conférences IV-VI: “Introduction à la psychologie analytique. Notions fondamentales, Pt. III. Les rêves.” (315–400) Trans. from a lecture later pub. in E. 1968a. Cf. Fr. 19623,8 for rev. version with title change.
9. “Epilogue.” (401–03) Written for this edn. and dated Jan. 1944. Repub., trans. rev., as Fr. 19623,9. TR.—English: CW 18,72.

TR—Dutch: 1950a // Portuguese: 1962a.

† Items marked are composed of a seminar report edited by Dr. Cahen, who takes responsibility for the contents of these chapters.—M. F. (Cf. details

above under item no. 3.)

- 1944a “L’expérience des associations.” *Action et Pensée*, XX: 1 (Feb.), 1–11. A prepub. extract of Fr. 1943a.
- 1945a “De la nature des rêves.” *Revue Ciba* (Basel), 46 (Sept.), 1602–13. Trans. from G. 1945d by René Kaech. Pub. in a dif. trans., with title change, as Fr. 1953a,4.
- 1948a *Aspects du drame contemporain*. Geneva: Georg. pp. 233. Trans. from the German by Roland Cahen-Salabelle. Pub., exp. and trans. rev., as Fr. 1971a. Contents:
1. “Avertissement de l’auteur.” (69–74) Written for this edn.
 2. “Wotan.” (75–106) Trans. from G. 19463,2.
 3. “Signification de la ligne suisse dans l’analyse spectrale de l’Europe.” (107–32) Trans. from G. 1928e.
 4. “Après la catastrophe.” (133–90) Trans. from G. 19463,5 in collaboration with M. B. Besson. Extracts pub. in Henri Stierlin, “Les solutions de Bertrand Russell et de Carl Gustav Jung.” *Tribune de Genève* (19 July 1955). 1 p.
 5. “Epilogue.” (191–233) Trans. from G. 1946a,6.
- 1949a “Le yoga et l’occident.” *Approches de l’Inde. Textes et études*. pp. 320–29. Ed. by Jacques Masui. Paris: Cahiers du Sud. Trans. from E. 1936c by ?.
- 1950a *Types psychologiques*. Geneva: Georg; Paris: Albin Michel. pp. 523. 1958: 2d edn. Geneva: Georg; Paris: Buchet/Chastel. pp. 507. Trans. from G. 1921a by Yves Le Lay. Contents (paging of ist edn.):
1. Avant-propos. (1–2)
 2. Avant-propos de la 7^e édition allemande. (3)
 3. Introduction. (5–9)
 4. Le problème des types dans l’histoire de la pensée antique et médiévale, (u–69)
 5. Les idées de Schiller sur le problème des types. (70–136)
 6. L’Apollinien et le Dionysien. (137–48)
 7. Le problème des types dans la connaissance des hommes. (149–68)
 8. Le problème des types dans la poésie. (169–277)
 9. Le problème des types dans la psychiatrie. (278–93)
 10. Le problème de l’attitude typique dans l’esthétique. (294–304)
 11. Le problème des types dans la philosophie moderne. (305–27)
 12. Le problème des types dans la biographie. (328–36)

13. Description générale des types. (337–419)

14. Définitions. (420–500)

15. Epilogue. (501–510)

1950b “Introduction.” Jolan Jacobi: *La psychologie de C. G. Jung*. p. 12. Neuchâtel: Delachaux et Niestlé. 1964: Rev. and enl. edn. Geneva: Editions du Mont-Blanc, pp. 19–20. Trans. from G. 1940c by V. Baillods.

1952a *Psychologie de l'inconscient*. Geneva: Georg; Paris: Buchet/Chastel. pp. 235. 1963: 2d edn. pp. 228. 1973: new edn. pp. 220. Trans. from G. 1943a by Roland Cahen. Cf. Fr. 1928a for trans. of earlier version.

1952b “Préface.” M. Esther Harding: *Réalité de l'âme. L'énergie psychique, son origine et son but*. pp. 7–8. Neuchâtel: La Baconnière. Trans. from E. 1947e by Elisabeth Huguenin.

1952c “Psychothérapie pratique. Fondements généraux.” *Encéphale*, XL, 407–30. A prepub. extract of Fr. 1953a,5.

1953a *La guérison psychologique*. Geneva: Georg, pp. 337. 1970: Rev. edn. Geneva: Georg; Paris: Buchet/Chastel. pp. 342. Trans. by Roland Cahen. Contents:

1. “Qu'est-ce que la psychothérapie?” (3–13) Trans. from G. 1935g.
2. “Médecine et psychothérapie.” (14–28) Trans. from G. 1945e.
3. “Les problèmes de la psychothérapie moderne.” (29–59) Trans. from G. 19318,2.
4. “De la nature des rêves.” (60–79) Trans. from G. 1943d. Pub. in a dif. trans. as Fr. 1945a.
5. “Psychothérapie pratique.” (80–104) Trans. from G. 1935l. Excerpt prepub. as Fr. 1952c.
6. “Moyens et buts de la psychothérapie.” (105–26) Trans. from G. 1931a,5.
7. “Des méthodes suggestives à la psychanalyse.” (129–76) Trans. from G. 1914b.
8. “L'opposition entre Freud et Jung.” (177–87) Trans. from G. 1931a,4.
9. “La névrose et l'auto-régulation psychologique.” (188–208) Trans. from G. 1934k.
10. “Des images parentales au totalitarisme étatique.” (209–30) Trans. from G. 1946a,3.
11. “Le relativisme essentiel de la psychothérapie.” (231–51) Trans. from G. 1951d.

12. “Conscience, inconscient et individuation.” (255–72) Trans. from G. 1939e.

13. “Des rapports de la psychothérapie et de la direction de conscience.” (273–300) Trans. from G. 1932a.

14. “Psychothérapie et conception du monde.” (301–11) Trans. from G. 1946a,4.

1953b With Charles Kerényi: *Introduction à l'essence de la mythologie. L'enfant divin.—La jeune fille divine*. Paris: Payot. pp. 221. Trans. from G. 1951b by Henri E. Del Medico.

1953c *Métamorphoses de l'âme et ses symboles*. ... Geneva: Georg. pp. 770. 1967: Repr. Geneva: Georg; Paris: Buchet/Chastel. pp. 770. Trans. from G. 1952e by Yves Le Lay. Cf. Fr. 1931b for trans. of earlier version.

1953d “Introduction.” M. Esther Harding: *Les mystères de la femme dans les temps anciens et modernes*, pp. 5–7. Paris: Payot. Trans. from G. 1949d by Eveline Mahyere.

1954a “Avant-propos.” John Custance: *Le livre de la sagesse et de la folie*. pp. 7–11. Paris: Plon. Trans. from E. 1952a by Michel Tournier.

1954b “C. G. Jung et l'astrologie.” *Astrologie moderne*. Pub. here in the form of an “Interview du 26 Mai 1954 de André Barbault et Jean Carteret” but actually taken from a letter in French to André Barbault (26 May 1954), written in response to a questionnaire. Letter trans. as E. 1970d and in E. 1976a.

1955a “Psychologie et poésie.” *Le Disque vert: C. G. Jung*. pp. 9–39. Brussels: Le Disque vert. 1964: Facsimile. (Les Cahiers pensée et action, 23/24, Jan.-May.) Paris, Brussels: Editions “Pensée et Action.” Trans. from G. 1950a,2 by Roland Cahen. Repub. as Fr. 1961b,12. TR.—Turkish: 1964a.

1955b “Devenir de la personnalité.” *Synthèses: Revue Européenne* (Brussels), 10th yr: 115 (Dec.), 354–72, Trans. from G. 1934b.9 by Yves Le Lay. Repub. as Fr. 1961b,9.

1956a *L'Énergétique psychique*. Geneva: Georg; Paris: Albin Michel?. pp. 253. Trans. by Yves Le Lay. Contents:

1. “Énergétique psychique.” (17–93) Trans. from G. 1948b,2.
2. “Instinct et inconscient.” (94–105) Trans. from G. 1948b,6.
3. “Contribution à la connaissance du rêve de nombres.” (107–17) Trans. from G. 1911e.
4. “Psychologie et pathologie des phénomènes dits occultes.” (118–218) Trans. from G. 1902a. Cf. Fr. 1939a,2.

5. “Âme et mort.” (219–31) Trans. from G. 1934b,10. Cf. Fr. 1939a,3.

6. “Fondements psychologiques de la croyance aux esprits.” (232–52)
Trans. from G. 1948b. Cf. Fr. 19393,4.

1956b Letters to Père Bruno. Père Bruno de Jésus-Marie, with the collaboration of Ch. Baudouin, C. G. Jung, and R. Laforgue: “Puissance de l’archétype.” pp. 13–18. *Élie le prophète*. Vol. II, pp. 11–33. Ed. by Père Bruno de Jésus-Marie. (Les Études Carmélitaines.) Paris: Desclée de Brouwer. Written in French to Père Bruno and dated 5 Nov. 1953 (pp. 13–17) and 22 Dec. 1953 (error for 1954) (pp. 17–18). TR.—English: CW 18,98.

1957a “Préface,” Gerhard Adler: *Essais sur la théorie et pratique de l’analyse jungienne*. pp. 3–6. Geneva: Georg. Trans. from G. 1952g by Liliane Fearn and Jenny Leclerq.

1957b “Le problème du quatrième.” *La Table Ronde*, 120 (Dec), 183–96. Trans., slightly abridged, from G. 19483,4, “Das Problem des Vierten,” by Yves Le Lay. The 1st of 2 pts. Cf. Fr. 1958c.

1958a With Paul Radin and Charles Kerényi: *Le fripon divin. Un mythe indien*. (Analyse et Synthèse, 3.) Geneva: Georg; Paris: Buchet/Chastel. pp. 205. Trans. from G. 1954a by Arthur Reiss. Contains the following work by Jung:
1. “Contribution à l’étude de la psychologie du fripon.” (175–99)

1958b *Psychologie et religion*. Paris: Buchet/Chastel, Corrêa. pp. 220. Trans. from G. 1940a by Marthe Bernson and Gilbert Cahen.

1958c “Le problème du quatrième.” (Pt. 2.) *La Table Ronde*, 121 (Jan.), 89–101. Trans., slightly abridged, from G. 19483,4, “Das Problem des Vierten,” by Yves Le Lay. The 2d of 2 pts. Cf. Fr. 1957b.

1958d “Hors des lieux communs.” *Le Jura libre*, 8 Aug. 1 p.

1959a “Préface.” Georges Duplain: *Aux frontières de la connaissance. Entretien avec le professeur C.-G. Jung à propos d’une étude sur les “soucoupes volantes.”* Lausanne: Gazette de Lausanne. 1 p. (t.p. verso) Reprint (“separatum”) of interview by Duplain, pub. in the *Gazette*, Aug. 24, Sept. 1 and 8, 1959, with addition of Jung’s “Préface,” which appears only in this reprint, not in the original articles. TR.—English: *C. G. Jung Speaking* (1977), pp. 410–11.

1960a “Commentaire psychologique.” *Le livre tibétain de la grande libération*. pp. 15–49. Ed. by W. Y. Evans-Wentz. Paris: Adyar. Trans. from E. 1957e by Margurite La Fuente, with the assistance of Constance Lounsbery.

1960b * “Psychoanalyse d’une réalité: l’âme.” *Arts, Lettres, Spectacles, Musique*, 790 (5–11 Oct.), 1–2. An excerpt of Fr. 1961b, prepub. TR.—Slovenian: 1961a.

1961a *Un mythe moderne. Des “signes du ciel.”* (Les Essais, XCVIII.) Paris: Gallimard. pp. 306. Trans. from G. 1958a by Roland Cahen, with the collaboration of René and Françoise Baumann.

1961b *Problèmes de l’âme moderne*. Paris: Buchet/Chastel, Corrèa. pp. 466. Trans. by Yves Le Lay, with the exception of no. 12 below, as noted. Fr. 1931a, rev. and exp. Excerpt prepub. as Fr. 1960b. Contents:

Pt. I: L’Âme et l’esprit.

1. “La structure de l’âme.” (11–38) Trans. from G. 19313,7.
2. “Âme et terre.” (39–67) Fr. 19313,3 repub. with title change.
3. “L’esprit et la vie.” (69–94) Trans. from G. 19313,13.
4. “Psychologie analytique et conception du monde (Weltanschauung).” (95–129) Trans. from G. 19313,12.

Pt. II: L’Homme et l’existence.

5. “L’homme archaïque.” (133–64) Trans. from G. 19313,9.
6. “Le problème psychique de l’homme moderne.” (165–93) Fr. 1931a,2 repub.
7. “Typologie psychologique.” (195–219) Trans. from G. 1931a,6.
8. “Au solstice de la vie.” (221–43) Trans. from G. 19313,10. Cf. Fr. 1931a,1.
9. “Le devenir de la personnalité.” (245–70) Fr. 1955b repub.

Pt. III; La Femme et le couple.

10. “La femme en Europe.” (273–300) Fr. 1931a,6 repub.
11. “Le mariage, relation psychologique.” (301–17) Fr. 1931a,5 repub.

Pt. IV: La Poésie et l’art.

12. “Psychologie et poésie.” (321–52) Trans. by Roland Cahen. Fr. 1955a repub. Repub. as Fr. 1964d.
13. “La psychologie analytique dans ses rapports avec l’oeuvre poétique.” (353–80) Fr. 1931a,4 repub.
14. “Paracelse.” (381–93) Trans. from G. 19340,5.
15. “Freud.” (395–405) Trans. from G. 1934b,6.
16. “Ulysse.” (407–39) Trans. from G. 19340,7.
17. “Picasso.” (441–49) Trans. from G. 1934b,8.

- 1961c “Préface.” Jolande Jacobi: *Complexe, archétype, symbole*, pp. 5–6.
Neuchâtel: Delachaux et Niestlé. Trans. from G. 1957g by Jacques Chavy.
- 1961d * “Réponse à la question du bilinguisme.” *Flinker Almanac 1961*. pp. ai.
Paris: Librairie Française et Etrangère. Letter to the editor, Martin Flinker,
written in response to a question, TR.—English: CW 18,123.
- 1962a *L’homme à la découverte de son âme. Structure et fonctionnement de
l’inconscient*. (Action et Pensée, 10.) 6th edn., rev. and exp. Geneva: Éditions
du Mont-Blanc, pp. 354. 1963: Reset. (Petite Bibliothèque Payot, 53.) Paris:
Payot. pp. 341. (Lacks index.) Trans. by Roland Cahen. Fr. 1943a, rev. and
exp. Contents (pagination of 1962 and 1963 edns. respectively):
- Livre I: Exposition.
1. “Visages de l’âme contemporaine.” (49–68) (35–56) Fr. 1944a,1,
trans. rev. and with title change.
 2. “Reconquête de la conscience.” (69–93) (57–83) Fr. 19443,2, trans.
rev. and with title change.
- Livre II: Les Complexes.
3. “Fonctions et structures du conscient et de l’inconscient.” (97–142)
(85–133) Fr. 1944a,3, rev. and with title change.
 4. “L’expérience des associations.” (143–80) (135–74) Fr. 1944a,4,
rev. and with title change.
 5. “Théorie des complexes.” (181–97) (175–92) Trans. from G.
1948b,3. Cf. Fr. 1944a,5 for trans. of earlier version.
- Livre III: Les Rêves.
6. “Les enseignements du rêve.” (201–46) (193–243) Trans. from G.
1948b,4. Cf. Fr. 1944a,6 for trans. of earlier version.
 7. “Signification individuelle du rêve.” (247–71) (245–71) Fr. 1944a,7
repub., trans. rev., with title change,
 8. “Du rêve au mythe.” (273–332) (273–337) Fr. 1944a,8 rev., with
title change.
 9. “Épilogue.” (333–34) (339–40) Fr. 1944a,9 repub., trans. rev.
TR.—Spanish: 1969a.
- 1962b *Présent et avenir*. Paris: Buchet/Chastel. pp. 213. 1970: Paris: Denoël,
Gonthier. pp. 189. Trans. from G. 1957i by Roland Cahen, with the
collaboration of René and Françoise Baumann. Extract prepub. as “Malheur à
l’homme normal dans le monde moderne.” *Arts, Lettres, Spectacles,
Musique*, 881 (12–18 Sept.), 9.

- 1963a *Psychologie et éducation*. Paris: Buchet/Chastel. pp. 266. Trans. by Yves Le Lay, with the collaboration of L. de Vos and Olga Raesvski. Cf. Fr. 1935a for trans. of earlier version. Contents:
1. “Psychologie analytique et éducation.” (11–117) Trans. from G. 1946b,1 by Yves Le Lay.
 2. “Conflits de l’âme enfantine.” (119–77) Trans. from G. 1946b,2 by L. de Vos. Cf. Fr. 1935a,1.
 3. “La rumeur.” (179–204) Fr. 1935a,2 repub. with title change,
 4. “De l’importance du père pour la destinée de l’individu.” (205–40) Trans. from G. 1949a by Olga Raesvski; trans. rev. and completed by Yves Le Lay. Cf. Fr. 1935,3.
 5. “L’enfant doué.” (241–59) Trans. from G. 1946b,3 by Yves Le Lay.
- 1963b *L’âme et la vie. Ouvrages de C. G. Jung*. Compiled and ed. by Jolande Jacobi. Paris: Buchet/Chastel. pp. 534. Trans. from G. 1945a by Roland Cahen and Yves Le Lay.
- 1964a *Dialectique du moi et de l’inconscient*. (Les Essais, CXIII.) Paris: Gallimard. pp. 334. 1973: rev. and corr. edn. pp. 274. Trans. from G. 1935a by Roland Cahen. Pub. in a dif. trans. with title change as Fr. 1938a.
- 1964b *Réponse à Job*. Paris: Buchet/Chastel. pp. 301. 1971: new edn. Trans. from G. 1952a by Roland Cahen.
- 1964c * “Essai d’exploration de l’inconscient.” *L’Homme et ses symboles*. pp. 18–103. Conceived and realized by C. G. Jung and M.-L. von Franz, Joseph L. Henderson, Jolande Jacobi, Aniela Jaffé. Paris: Editions Laffont. pp. 320. Also pub. as paperback monograph: *Essai d’exploration de l’inconscient*. Paris: Editions Gonthier. pp. 155. Trans. from E. 1964a by Laure Deutschmeister.
- 1964d “Psychologie et poésie.” *Le Disque Vert: C. G. Jung*. pp. 9–39. (Les cahiers Pensée et Action, 23–24.) Brussels, Paris: Le Disque Vert, Fr. 1961b, 12 repub.
- 1964e Letters to Richard Evans. Richard I. Evans: *Entretiens avec Jung*. Paris: Payot. pp. 144. Trans. from E. 1964b by Philip Coussy. Contains 2 letters dated April 1957 and one dated 30 May 1957 (and a lengthy interview).
- 1966a “Ma vie.” *Souvenirs, rêves et pensées*. Recorded and ed. by Aniela Jaffé. (Collection “Témoins.”) Paris: Gallimard. pp. 464. 1973: new edn. with index. (Coll. Vécu.) pp. 528. Trans. from G. 1962a by Roland Cahen and Yves Le Lay, with the collaboration of Salomé Burckhardt. Contents conform

to those of G. 1962a with the omission of G. 19623,15, x: “Septem sermones ad mortuos.”

1970a *Psychologie et alchimie*. Paris: Buchet/Chastel. pp. 705. Trans. from G. 1952d by Henry Pernet and Roland Cahen.

1971a *Aspects du drame contemporain*. Geneva: Georg; Paris: Buchet/Chastel. pp. 270. Trans. by Roland Cahen. Fr. 1948a, exp. and trans. rev. Contents: 1–3 as in Fr. 1948a with the addition of:
4. “La Conscience morale d’un point de vue psychologique.” Trans. from G. 1958c.

1971b *Racines de la conscience*. Paris: Buchet/Chastel. pp. 630. Trans. from G. 1954b by Yves Le Lay and Etienne Perrot.

1975a With Sigmund Freud: *Correspondance*. Edited by William McGuire. (Collection “Connaissance de l’inconscient,” directed by J.-B. Pontalis.) Paris: Gallimard. Vol. I, pp. 365; Vol. II, pp. 409. Trans. from G. 1974a and E. 1974b by Ruth Fivaz-Silbermann.

GREEK

- 1935a *Charakteres e Psychologikoi Typoi*. Athens: Embo Tinos oinos ... pp. ?
Trans. from G. 1921a by ? Cf. Gr. 1954a.
- 1949a *To Themeliödes Problema tés Synchrones Psychologias*. Athens: Avgi. pp.
72. Trans. from G. ?1931a,14 by K. L. Méranaios.
- 1950a *Eisagògē stēn Analytikē Psychologia*. Athens: Avgi. pp. 160. Trans. from G.
? by K. L. Méranaios and Minas Zographou.
- 1954a *Psychologikoi Typoi*. Athens: Maris, pp. 480. Trans. from G. 1921a by Minas
Zographou and K. L. Méranaios. Cf. Gr. 1935a.
- 1956a *E Psychologia tou Asyneidetou*. Athens: Karavia. pp. 160. Trans. from ?G.
1943a by K. B. Nikolaou. Pub. in a dif. trans. as Gr. 1962a,1.
- 1962a *Analytike Psychologia*. Athens: Kovostes. pp. 288. Trans. by Pen
Ieromnemonos. Contents:
1. “E. Psychologia tou Asyneidetou.” Trans. from G. ?1943a. Pub. in a dif.
trans. as Gr. 1956a.
 2. “Scheseis Metaxy tou ‘Ego’ kai tou Asyneidetou.” Trans. from G. ?
1935a.
- 1962b *Psychologia kai Threskeia*. Athens: Maris, pp. 160. Trans. from G. 1940a by
K. L. Méranaios.
- 1962c *Ta Problemata tes Synchrones Psyches*. Athens: Bibliotheke ĩia Olous. pp. ?
Trans. from ?G. 1931a by E. Androvliake.

HEBREW

- 1950/51a “Alkhimiah we-psykhologiah.” *Encyclopaedia Hebraica*. Vol. 3, pp. 606–08. Jerusalem: Encyclopedia Publishing Co. Written especially for this volume and trans. by a member of the editorial board from the English text pub., slightly rev., as CW 18,106.
- 1958a *Psykhologiah analytit we-khinukh*. Tel Aviv: Dvir. pp. 143. Trans. from G. 1946b by Netta Blech. Contains a foreword dated 1955 especially written for this edition, TR.—English: (foreword only) CW 18,133.
- 1973a *Ha-any we-ha-lo-muda*. Tel Aviv: Dvir. pp. 140. Trans. from G. 1935a by Haym Yzak.
- 1973b *Ha-psykhologiah shel ha-lo-muda*. Tel Aviv: Dvir. pp. 115. Trans. from G. 1943a by Haym Yzak.
- 1974a “Ma-amar Jung le-ktav Mishmar be-shweits lifnei 29 shanim.” *Al Hamishmar*, 15 Nov. [What did Jung say to *Mishmar*’s correspondent in Switzerland 29 years ago?] Trans. by an unknown hand from a letter written in German to Eugen Kolb (14 Sept. 1945), Swiss correspondent for *Al Hamishmar*, in response to questions on Hitler. Cf. CW 18,74.

HUNGARIAN

1948a *Bevezetés a tudattalan pszichológiájába*. Budapest: Bibliotheca. pp. 177.
Trans. from G. 1943a by Peter Nagy. Contains a foreword written especially
for the Hungarian edn., dated Jan. 1944. Cf. CW 18,36.

ITALIAN

- 1908a “Le nuove vedute della psicologia criminale. Contributo al metodo della ‘Diagnosi della conoscenza del fatto’ (Tatbestandsdiagnose).” *Rivista di psicologia applicata*, IV:4 (July-Aug.), 285–304. Trans. from a German ms. by L. Baroncini. Partially incorporated into E. 1910a.1. TR.—English: CW 2,16 // German: GW 2,16.
- 1936a With Richard Wilhelm: *Il mistero del fiore d’oro*. Bari: Laterza. pp. 154. Trans. from G. 1929b by Mario Gabrieli.
- 1942a *Il problema dell’inconscio nella psicologia moderna*. (La cultura, 51.) Turin: Einaudi. pp. 297. Trans. from G. 1931a by Arrigo Vita and Giovanni Bollea. Pub. with the addn. of a foreword as It. 1959c.
- 1946a “Picasso alla luce della psicologia analitica.” *Lettere ed arti*, 11:6, 8–13. Trans. from G. 1934b,8 by C. L. Musatti.
- 1947a *Psicologia e educazione*. (Psiche e coscienza, 8.) Rome: Astrolabio. pp. 147. Trans. from G. 1946b by Roberto Bazlen.
- 1947b *Sulla psicologia dell’inconscio*. (Psiche e coscienza, 3.) Rome: Astrolabio. pp. 153. Trans. from G. 1943a by B. Veneziani and M. Viva-relli. Pub. in a dif. trans., with title change, as It. 1968a.
- 1947c Introduction to M. Esther Harding: *La strada della donna*, pp. 12–15. (Psiche e coscienza, 7.) Rome: Astrolabio. Trans. from E. 1933b by Adriana and Tomaso Carini.
- 1948a *L’io e l’inconscio*. Turin: Einaudi. pp. 156. Repub. 1967, Turin: Boringhieri. Trans. from G. 1935a by Arrigo De Vita.
- 1948b With K. Kerényi: *Prolegomeni allo studio scientifico della mitologia*. Turin: Einaudi. pp. 250. 1964, Turin: Boringhieri. pp. 257. Trans. from G. 1941c by Angelo Brelich.
- 1948c *Psicologia e religione*. Milan: Edizioni di Comunità, pp. 151. Trans. from G. 1940a by Bruno Veneziani.
- 1948d *Tipi psicologici*. (Psiche e coscienza, 5.) Rome: Astrolabio. pp. 523. Trans. from G. 1921a by Cesare L. Musatti. Pub., trans. rev., as It. 1969a.
- 1948e Introduction to Frances G. Wickes: // *mondo psichico dell’infanzia*. pp. 15–22. Rome: Astrolabio. Trans. from G. 1931e by Olga Aqua-rone.

- 1949a *Psicologia e alchimia*. (Psiche e coscienza, 12.) Rome: Astrolabio. pp. 535. Trans. from G. 1944a by Roberto Bazlen.
- 1949b *La realtà dell'anima*. (Psiche e coscienza, 4.) Rome: Astrolabio. pp. 210. Trans. from G. 1934b by Paolo Santarcangeli. Repub. with additions as It. 1963a. Excerpts pub. as It. 1961c.
- 1949c Foreword to Jolande Jacobi: *La psicologia di Carl G. Jung*. pp. [11–12]. Turin: Einaudi. Trans. from G. 1940c by Arrigo Vita.
- 1950a “Prefazione alla traduzione inglese ...” *I King*. pp. 11–28. Rome: Astrolabio. Trans. by Bruno Veneziani from the German ms. pub. as GW 11,16.
- 1959a *La simbolica dello spirito*. Turin: Einaudi. pp. 349. Trans. from G. 1948a by Olga Bovero Caporali.
- 1959b “Lo spirito della psicologia.” *Questa è la mia filosofia*. Ed. by Whit Burnett, pp. 163–229. Milan: Bompiani. Trans. from E. 1957e by Gianni Di Benedetto.
- 1959c *Il problema dell'inconscio nella psicologia moderna*. Turin: Einaudi. It. 1942a repub. with the addn. of a foreword to this Italian repr. dated March 1959. Only Jung's typescript has been seen. Poss. reissued 1964. pp. 307. TR. —(Foreword only) English: CW 18,68.
- 1960a *Su cose che si vedono nel cielo*. Milan: Bompiani. pp. 193. Trans from G. 1958a by Silvano Daniele.
- 1961a “Presentazione.” Eleanor Bertine: *Le relazioni tra le persone*. pp. 7–9. Milan: Ed. di Comunità. Trans. from G. 1957d by Margherita Allievi Clerici.
- 1961b “Premessa.” Frieda Fordham: *Introduzione a Carl Gustav Jung*. pp. 19–20. Florence: Ed. Universitaria. Trans. from E. 1959d by Vera Nozzoli.
- 1961c “L'individuo e la massa nel pensiero di Carl G. Jung. Il rischio della personalità.” *Espresso* (18 June), 4 pp. Excerpts of It. 1949b.
- ?1962a *La psicologia del transfert*. Rome: Mondadori, pp. 184. 1962: Milan: Il Saggiatore. 1963: Milan: Club degli Editori, pp. 188. 1968: New edn. Milan: Il Saggiatore, pp. 236. Trans. from G. 1946c by Silvano Daniele.
- 1963a *Realtà dell'anima*. (Biblioteca de cultura scientifica. Serie viola, 36.) Turin: Boringhieri. pp. 262, Trans. by Paolo Santarcangeli. It. 1949b repub. with addns. Contents:
1. “Il problema fondamentale della psicologia contemporanea.” (10–35) Repub. from It. 1949b.

2. "Il significato della psicologia per i tempi moderni." (36–63) Repub. from It. 1949b.
3. "L'applicabilità pratica dell'analisi dei sogni." (64–92) Repub, from It. 1949b.
4. "La donna in Europa." (93–118) Trans. from G. 1929a.
5. "Paracelso." (119–30) Repub. from It. 1949b.
6. "Sigmund Freud come fenomeno culturale." (131–40) Repub. from It. 1949b.
7. "Ulisse—Monolog." (141–71) Repub. from It. 1949b.
8. "Picasso." (172–79) Repub. from It. 1949b.
9. "Anima e morte." (180–93) Repub. from It. 1949b.
10. "Presente e futuro." (194–262) Trans. from G. 1957i.

Note: Omits a trans. of G. 1934b,9.

1965a With Paul Radin and Karl Kerényi: *Il briccone divino*. Milan: Bompiani, pp. 234. Trans. from G. 1954a by Nini Dalmaso and Silvano Daniele. Contains the following work by Jung:

1. "Contributo allo studio psicologico della figura del Briccone." (175–201)

1965b *La libido. Simboli e trasformazioni*. (Opere di C. G. Jung, 5.) Turin: Boringhieri. pp. 602. Trans. from G. 1952e by Renato Raho. Cf. It. 1970a and 1975d.

1965c *Ricordi, sogni, riflessioni*. Recorded and ed. by Aniela Jaffé. (La cultura, 104.) Milan: Il Saggiatore, pp. 432. Trans. from E. 1962a by Guido Russo. Contents conform to those of E. 1962a with the omission of E. 1962a,18, "Richard Wilhelm."

1965d *Risposta a Giobbe*. Milan: Il Saggiatore. pp. 188. Trans. from G. 1952a by Alfredo Viz.

1967a "Introduzione all'inconscio." *L'uomo e i suoi simboli*. pp. 18–103. Ed. by C. G. Jung, and after his death M.-L. von Franz. Florence: Casini, pp. 320. Trans. from E. 1964a by Roberto Tatucci.

1968a *Psicologia dell'inconscio*. Turin: Boringhieri. pp. 185. Trans. from G. 1943a by Silvano Daniele. Also pub. in a dif. trans. with change of title as It. 1947b.

1969a *Tipi psicologici*. (Opere di C. G. Jung, 6.) Turin: Boringhieri. pp. 606. Trans. from GW 6 by Cesare Luigi Musatti and Luigi Aurigemma. It. 1948d repub., trans. rev. Cf. It. 1972d,8.

- 1970a *Simboli della trasformazione*. (Opere di C. G. Jung, 5.) Turin: Boringhieri. pp, 581. Trans. from G. 1952e by Renato Raho. Cf. It. 1965b and 1975a.
- 1970b *Studi psichiatrici*. (Opere di C. G. Jung, 1.) Turin: Boringhieri. pp. 258. Trans. from GW 1 by Guido Bistolfi.
- 1971a *Psicogenesi delle malattie mentali*. (Opere di C. G. Jung, 3.) Turin: Boringhieri. pp. 307. Trans. from GW 3 by Lucia Personeni and Luigi Aurigemma.
- 1972a With Károly Kerényi: *Prolegomeni allo studio scientifico della mitologia*. (Universale scientifica, 74.) Turin: Boringhieri. pp. 267. Trans. from G. 1951b by Angelo Brelich. Contains the following works by Jung:
1. "Psicologia dell'archetipo del Fanciullo."
 2. "Aspetto psicologico della figura di Kore."
- 1972b "Prefazione." Jolande Jacobi: *Complesso archetipo simbolo*, pp. 7–9. Turin: Boringhieri. pp. 201. Trans. from G. 1957g by Giuseppe Zappone.
- 1973a *Freud e la psicoanalisi*. (Opere di C. G. Jung, 4.) Turin: Boringhieri. pp. 397. Trans. from GW 4 by Lucia Personeni and Silvano Daniele. Pts. pub. in a dif. trans. as It. 1971d.
- 1974a With Sigmund Freud: *Lettere tra Freud e Jung*. Ed. by William McGuire with the collaboration of Wolfgang Sauerländer. Turin: Boringhieri. pp. 645. Jung's letters trans. from G. 1974a by Silvano Daniele. Conforms to G. 1974a and E. 1974b with the following omissions: "Acknowledgments," "Appendix 1," the Freud and Jung entries in the index, and 1 photo and 2 facsimiles. Additions consist of the last appendix (6) and a chronological table.

See addenda at the end of this volume.

JAPANESE

Entries marked † are taken from photocopies of title pages and tables of contents collected, transliterated, and identified by Mihoko Okamura.

- 1926a *Jung ronbunshu, renso jikkenho sonota*. (Kinsei hentai. Shinrigaku taikan, 10.) Tokyo: Nihon seishin igakkai and Nihon hentai shinrigaku taikan. pp. 302. 7 articles trans. from E. 1916a by Kokyo Nakamura.
- 1931b *Seimeiryoku no hatten*. (Sekai dai-shiso zenshu, 44.) Tokyo: Shun-jusha. pp. 298. Trans. from E. 1916b by Kokyo Nakamura.
- 1955a † *Gendaijin no tamashii*. (Jung chosakushu, 2.) Tokyo: Nihon kyobun-sha. pp. 307. Trans. from G. 1931a by Yoshitaka Takahashi and Senjirô Eno. Consists of 1–3,7–9,11,13, and 14.
- 1955b *Kokoro no kôzô—kindai shinrigaku no oyo to shinpo*. (Jung chosakushu, 3.) Tokyo: Nihon kyôbun-sha. pp. 254. Trans. from G. 1934b,1–4,6–10 by Senjirô Eno.
- 1956a † *Ningen shinri to kyôiku*. (Jung chosakushu, 5.) Tokyo: Nihon kyôbun-sha. pp. 253. Trans. from G. 1946b and 1948a,2 by Shihô Nishimaru. Contains the following works by Jung:
1. “Bunsekiteki shinrigaku to kyoiku.” Trans. from G. 1946b,1.
 2. “Kodomo no kokoro no katto ni tsuite.” Trans. from G. 1946b,2.
 3. “Shusai.” Trans. from G. 1946b,3.
 4. “Otogo-banashi no seishin no gensho-gaku.” Trans. from G. 1948a,2.
- 1956b † *Ningen shinri to shûkyô*. (Jung chosakushu, 4.) Tokyo: Nihon kyôbun-sha. pp. 306. Trans. by Sakae Hamakawa. Contains the following works by Jung:
1. “Ningen shinri to shûkyô.” Trans. from G. 1940a.
 2. “Toyo-teki meiso no shinri.” Trans. from G. 1948a,5.
 3. “Yoroppa no josei.” Trans. from G. 1929a.
- 1957a † *Ningen no taipu*. (Jung chosakushu, 1.) Tokyo: Nihon kyôbun-sha. pp. 305. Trans. from G. 1921a,X–XII, by Yoshitaka Takahashi.
- 1972a *Yungu Jiden: Omoide, Yume, Shiso*. Vol. 1. Tokyo: Misuzo Shobo. pp. 290. Trans. from E. 1967a and/or G. 1962a by Hayao Kawai, Akira Fujinawa, and Yoshiko Idei.
- 1973a *Yungu Jiden: Omoide, Yume, Shiso*. Vol. 2. Tokyo: Misuzu Shobo. pp. 284. Trans. from E. 1967a and/or G. 1962a by Hayao Kawai, Akira Fujinawa, and

Yoshiko Idei.

NORWEGIAN

- 1956a “Om Sigmund Freud.” *Horisont*, 2:7 (Oct.), 225–29. Trans. from G. 1939a by André Bjerke.
- 1963a *Det ubevisste*. (Cappelen's realbøker, 4.) Oslo: Cappelen. pp. 140. Trans. from G. 1943a by Carl-Martin Borgen.
- 1964a Foreword to Frieda Fordham: *Innføiring i Jungs psykologi*. pp. 5–6. Oslo: Gyldendal. Trans. from E. 1953d by Jan Brøgger.
- 1965a *Psykologi og religion*. Oslo: Cappelen. pp. 140. Trans. from G. 1940a by Hedvig Wergeland.
- 1966a *Jeg'et og det ubevisste*. Oslo: Cappelen. pp. 144. Trans. from G. 1935a by Hedvig Wergeland.
- 1966b *Mitt liv. Minner, drømmer, tanker*. Recorded and ed. by Aniela Jaffé. (Fakkelt-bok, 88.) Oslo: Gyldendal. pp. 280. Trans. from G. 1962a by Ole Grepp. Contents conform to those of G. 1962a, except that G. 1962a,9–11 are combined into one chapter. “Drømmer og visjoner,” and the appendix consists solely of G. 1962a,15,ii.
- 1966c *Nåtid og fremtid*. Oslo: Cappelen. pp. 88. Trans. from G. 1957i by Hedvig Wergeland.
- 1967a *Psykologi og oppdragelse*. (Ugle-bøkene, 2.) Oslo: Cappelen. pp. 132. Trans. from G. 1946b by Trond Winje.
- 1968a *Psykisk energi*. (Ugle-bøkene, 15.) Oslo: Cappelen. pp. 195. Trans. from G. 1948b by Hedvig Wergeland.
- 1969a *Psykens Verden*. (Ugle-bøkene, 22.) Oslo: Cappelen. pp. 116. Trans. from G. 1954c by Hedvig Wergeland.
- 1969b *Svar på Job*. (Ugle-bøkene, 35.) Oslo: Cappelen. pp. 116. Trans. from G. 1952a by Hedvig Wergeland.
- 1972a *Analytisk psykologi*. Oslo: Cappelen. pp. 234. Trans. from G. 1969a by Trond Winje.

PORTUGUESE

- 1947a “A natureza dos sonhos.” *Actas Ciba* (Rio de Janeiro), XIV:2/3 (Feb.-Mar.), 51–63. Trans. from G. 1945d. Repub. as Port. 1948a in a trans. identical save for minor verbal differences.
- 1948a “Da natureza dos sonhos.” *Actas Ciba* (Lisbon), IV (Jan.), 132–43. Trans. from G. 1945d by Teresa Bandara. Port. 1947a repub. in a trans. identical save for minor verbal differences.
- 1956a *Psicología e religião*. Rio de Janeiro: Zahar. pp. 119, Trans. from G. 1940a by Fausto Guimarães.
- 1961a *O eu desconhecido*. Rio de Janeiro: Editora Fundo de Cultura. pp. 131. Trans. from E. 1958b by Fausto Cunha.
- 1962a *O homem à descoberta da alma*. (Filosofia e religiao [new series], 15.) Porto: Livraria Tavares Martins, pp. 507. Trans. from Fr. 1944a by Camilo Alves Pais.
- ?1962b *Um mito moderno*. Lisbon: Minotauro. pp. 293. Trans. from G. 1958a by José Blanc de Portugal. Book lacks date.
- 1962c *Psicología e educação*. Rio de Janeiro: Fundo de Cultura, pp. ?. Trans. from ?G. 1946b by ?.
- 1964a “Prologo.” Victor White: *Deus e a psicanálise*. pp. 15–32. (Circulo de humanismo cristão. Pessoa e cultura, 7.) Lisbon: Moráis. Trans. from E. 1952c by Belmiro Masino Figueiro. Frei’s appendix also contains extracts from letters written by Jung to the author.
- 1967a *Acerca da psicologia do inconsciente*. Lisbon: Edições Delfos. pp. 206. Trans. from G. 1943a by Ingrid Bauner Trigo Trindade.
- 1967b *Tipos psicológicos*. Rio de Janeiro: Zahar. pp. 567. Trans. from G. 1921a by Alvaro Cabrai.
- 1967c *Sobre a psicologia do inconsciente*. Lisbon: Delfos, pp. ???. Trans. from G. 19?? by ?.
- 1972a *Fundamentos de psicologia analítica*. Petropolis, Brazil: Vozes. pp. 239. Trans. from E. 1968a by Araceli Elman.
- 1975a *Memorias, Sonhos, Reflexões*. Rio de Janeiro: Nova Frontiera. pp. 360. Trans. from 1962a by Dora Ferreira da Silva.

RUSSIAN

- 1909a *Psikhoz i ego sodержanie*. St. Petersburg: Obshchestvennaia Pol'za. pp. 32. Trans. from G. 1908a by Vera Epelbaum. Cf. Rus. 1939a for trans. of later version (G. 1914a).
- 1924a *Psikhologicheskie tipy*. Moscow: Moskovskoie Gosudarstvennoie Izdatel'stvo. pp. 96. Trans. from a part of G. 1921a by E. I. Ruzer. Entire work pub. in a dif. trans. as Rus. 1929a.
- 1929a *Psikhologicheskie tipy*. Ed. by Emil Medtner. (Izbrannye trudy po analiticheskoi psikhologii, 1.) Berlin: Petropolis ("Musaget"). pp. 475. Trans. from G. 1921a by Sophia Lorie. Parts of G. 1921a pub. in a dif. trans. as Rus. 1924a.
- 1939a *Psikhologiya dementia praecox; Konflikty dietskoi dushi; Psikhoz i ego sodержanie, i drugii stat'i*. Ed. by Emil Medtner. (Izbrannye trudy po analiticheskoi psikhologii.) Paris: Les Éditeurs Réunis. pp. 365. Trans. from G. 1907a, 1910k, 1914a, 1902a, and "4 short papers (mainly on diagnostic methods) originally published between 1902 and 1914" by Olga Raevskaia, et al. "A Publication of the Psychology Club, Zurich." Cf. Rus. 1909a for trans. of an earlier version of G. 1914a.

SERBO-CROATIAN

1938a *Psihološki tipovi*. (Karijatide. Filozofska Biblioteka, 5.) Belgrade: Kosmos, pp. 411. 1963: 2d edn. (Karijatide. Filozofska Biblioteka, 12.) pp. 425. Trans. from G. 1921a by Miloš Djuric.

1969a *Lavirint u Đoveku*. (Biblioteka "Zodijak," 16.) Belgrade: Vuk Karadžić. pp. 188. Trans. from the German by Slobodan Janković. Contents:

1. "Predgovor." (7–46)
2. "Primena energetskeg stanovista." (47–61)
3. "Osnovni pojmovi teorije o libidu." (62–75)
4. "Arhaični Novek." (76–98)
5. "O bičnu sna." (99–109)
6. "Prilozi simbolični Jastva." (110–128)
7. "Ciljevi psihoterapije." (129–145)
8. "O odnosima analitičke psihologije prema umetničkom delu." (146–165) Trans. from G. 1931a,3.
9. "Psihologija i poezija." (166–186) Trans. from G. ?1950a,2.

Except as indicated, sources have not been ascertained.

SLOVENIAN

1961a “Psihoanaliza neke realnosti. Duševnost.” *Naši Razgledi*, X:12 (June), 280–81. Trans from Fr. 1960b by Vladimir Bartol.

SPANISH

- 1925a “Tipos psicológicos.” *Revta. Occid.*, 10 (Nov.), 161–83. Trans. from ?G. 1925c by an unknown hand.
- 1927a *Lo inconsciente en la vida psíquica normal y patológica*. Madrid: Revista de Occidente, pp ?. 1938: Buenos Aires: Losada, pp. 136. 1965: pp. 142. Trans. from G. 1926a by E. Rodriguez Sadia.
- 1931a “El hombre arcaico.” *Revta. Occid.*, 32 (Apr.), 1–36. Trans. from G. 1931f by an unknown hand.
- 1932a “El problema psíquico del hombre moderno.” *Revta. Occid.*, 36 (May), 202–34. Trans. from G. 1931aS,14 by an unknown hand.
- 1933a “Ulises.” *Revta. Occid.*, 39 (Feb.), 113–49. Trans. from G. 1932e by an unknown hand. Cf. Sp. 1944a.
- 1933b “Picasso.” *Atenea*, XXIV:99, 105–10. Trans. from G. 1932g by Luisa Frey and Juan Uribe Echevarría. Cf. Sp. 1934b.
- 1934a *Tipos psicológicos*. (Col. Piragra, 23.) Buenos Aires: Sudamericana. pp. 566. Trans. from G. 1921a by Ramón Gómez de la Serna. In later edns., paging and format vary. 1945: pp. 552; 1960: pp. 483; 1964: pp. 659; 1965: 2 vols. Contains a foreword written for this edn. and dated October 1934. TR.— (Foreword only) English: CW 6,3.
- 1934b “Picasso.” *Revta. Occid.*, 44 (Apr.), 113–22. Trans. from G. 1932g, by an unknown hand. Cf. Sp. 1933b.
- 1935a *La psique y sus problemas actuales*. Madrid and Buenos Aires: Pöblet, pp. 376. Trans. from G. 1934b by Eugenio Imaz. 1944: 2nd edn. Cf. Sp. 1940a.
- 1935b *Teoría del psicoanálisis*. Barcelona: Apolo, pp. 240. 1961: Barcelona: Plaza Janes, pp. 194. Trans. from G. 1913a by F. Oliver Brachfeld.
- 1935c “Ubicación histórica de Sigmund Freud.” Abraham Meyer: *Critica de la teoría sexual de Freud*, pp. 7–18, Buenos Aires: Inman. Trans. from G, 1932f by ?.
- 1936a *El yo y el inconsciente*. (Biblioteca de psicoanálisis y caracterología, 3.) Barcelona: Luis Miracle, pp. 255. Trans. from G. 1935a by S. Montserrat Esteve.
- 1936b “Los arquetipos del inconsciente colectivo.” *Revta. Occid.*, 54 (July), 1–56. Trans. from G. 1935b by ?.

- 1938a *Lo inconsciente*. (Colección Biblioteca Contemporánea.) Buenos Aires: Losada, pp. 142. Trans. from G. 1926a by Emilio Rodríguez Sadia.
- 1940a *Realidad del alma*. (Colección Cristal del Tiempo.) Buenos Aires: Losada, pp. 200. Trans. from G. 1929a and 1934b by Fernando Vela and Felipe Jiménez de Asúa. Cf. Sp. 1935a.
- 1944a *¿Quién es Ulises?* Buenos Aires: Santiago Rueda, pp. 91. Trans. from G. ? 1934b,7 by an unknown hand. Cf. Sp. 1933a.
- 1945a *Conflictos del alma infantil*. Buenos Aires: Paidós. pp. 123. 1972: 5th ptg. or edn. pp. 126. Trans. from G. 1939a by Ida Germán de Butelman.
- 1946a “La naturaleza de los sueños.” *Actas Ciba* (Buenos Aires), 10 (Oct.), 279–93. Trans. from G. 1945d by Antonio Hernández.
- 1947a “Prefacio” and “Prólogo ... a la edición española.” Jolande Jacobi: *La psicología de C. G. Jung*. pp. 25–26 and p. 27. Madrid: Espasa-Calpe. Preface trans. from G. 1940c and the prologue (written especially for this edn.) from the German ms. by José M. Sacristán. TR.—English: (Prologue only) CW 18,41.
- 1949a *Psicología y educación*. Buenos Aires: Paidós. pp. 111. 1974: 5th ptg. or edn. Trans. from G. 1946b by Ludovico Rosenthal.
- 1949b *Psicología y religión*. Buenos Aires: Paidós. 1972: 5th ptg. or edn. pp. 168. Trans. from G. 1940a by Enrique Butelman.
- 1953a *Psicología y alquimia*. Buenos Aires: Santiago Rueda, pp. 501. Trans. from G. 1952d by Alberto Luis Bixio.
- 1953b *Transformaciones y símbolos de la libido*, Buenos Aires: Paidós. pp. 441. Trans. from G. 1925a by Ludovico Rosenthal. Rev. version pub. as Sp. 1962b.
- 1954a *La psicología de la transferencia*. Buenos Aires: Paidós. pp. 198. 1972: 3d ptg. or edn. pp. 200. Trans. from G. 1946c by J. Kogan Albert.
- 1954b *Energética psíquica y esencia del sueño*. (Biblioteca de Psicología Profunda.) Buenos Aires: Paidós. pp. 218. 1973: 3d edn. or ptg. pp. 238. Trans. from G. 1948b by Ludovico Rosenthal and Blas Sosa.
- 1955a With Richard Wilhelm: *El secreto de la flor de oro*. (Biblioteca de Psicología Profunda, 10.) Buenos Aires: Paidós. pp. 136. 1972: 3d ptg. or edn. Trans. from G. 1938a by Roberto Pope.
- 1955b “Prólogo.” Victor White: *Dios y el inconsciente*, pp. 19–34. Madrid; Gredos. Trans. from E. 1952c by Fr. Acacio Fernández.

- 1957a *Presente y futuro*. (Otras Publicaciones, Ensayos, 23.) Buenos Aires: Sur. pp. 104. Trans. from G. 1957i by Pablo Simon.
- 1960a “Prólogo.” Miguel Serrano: *Las visitas de la reina de Saba*. p. vii. Santiago: Nacimiento. Trans. from E. 1960b by Miguel Serrano. Written as letter to the author. Cf. Sp. 1965a,1 for trans. of whole letter.
- 1961a *Sobre cosas que se ven en el cielo*. Buenos Aires: Sur. pp. 206. Trans. from G. 1958a by Alberto Luis Bixio.
- 1962a *Simbología del espíritu*. (Biblioteca de Psicología y Psicoanálisis.) Mexico: Fondo de Cultura Económica, pp. 325. Trans. from G. 1948a by Matilde Rodríguez Cabo,
- 1962b *Símbolos de transformación*. Buenos Aires: Paidós. pp. 444. Trans. from G. 1952e by Enrique Butelman. A rev. version of Sp. 1953b.
- 1964a *Respuesta a Job*. Mexico: Fondo de Cultura Económica, pp. 132. Trans. from G. 1952a by Andrés Pedro Sánchez Pascual.
- 1964b *La interpretación de la naturaleza y la psique*. (Biblioteca de Psicología Profunda, 12.) Buenos Aires: Paidós. pp. 130. Contains the following work by Jung:
“La sincronicidad como principio de conexión acausal.” Trans. from G. 1952b by Haraldo Kanemann.
- 1964c “Prólogo.” D. T. Suzuki: *Introducción al Budismo zen*. pp. ?. Buenos Aires: Paidós. Trans. from ?G. 1939c by ?.
- 1965a Letters to the author. Miguel Serrano: *El círculo hermético, de Hermann Hesse a C. G. Jung*. Santiago: Zig-Zag. Letters trans. from the English by Miguel Serrano. Contains the following letters from Jung (pp. of facsimiles follow those of trans. text):
1. 14 Jan. 1960 (139, 143–44) (141) English letter pub., si. rev., as E. 1960b, and in orig. form as E. 1966c,1. Spanish trans. pub., si. rev., as Sp. 1960a.
 2. 16 June 1960 (145, 149) (147) English letter repub. as E. 1966c,2.
 3. 31 Mar. 1960 (159–60) (157) English letter repub. as E. 1966c,3.
 4. 14 Sept. 1960 (175, 187–96) (177–86) English letter repub. as E. 1966c,4.
- 1966a *Paracelsica*. Buenos Aires: Sur. pp. 138. Trans. from G. 1942a by Eduardo García Belsunce.

- 1966b *Recuerdos, sueños y pensamientos*. Ed. by Aniela Jaffé. (Biblioteca Breve, Ciencias Humanas, 233.) Barcelona: Seix Barrai, pp. 424. Trans. from G. 1962a by Ma. Rosa Borrás. Contents conform to those of G. 1962a.
- 1966c “Acercamiento al inconsciente.” *El hombre y sus símbolos*, pp. 18–103. Madrid: Aguilar. pp. 320. Trans. from E. 1964a by Luis Escolar Bareño.
- 1968a *Consideraciones sobre la historia actual*. (Colección Punto Omega, 14.) Madrid: Guadarrama, pp. 162. Trans. from G. 1946a by Luis Alberto Martín Baro.
- 1969a *Los complejos y el inconsciente*. Madrid: Alianza, pp. 452. Trans. from Fr. 1962a by Jesús López Pacheco.
- 1970a *Arquetipos e inconsciente colectivo*. Buenos Aires: Paidós. pp. 217. Trans. from G. 1954b.2,3,4,8, by Miguel Murmis.

SWEDISH

1934a *Det omedvetna i normalt och sjukt själsliv*. Stockholm: Natur och Kultur, pp. 139. Trans. from G. 1926a by Gunnar Nordstrand.

1934b "Inledning." Esther Harding: *Vi kvinnor. En psykologisk tolkning*. pp. 7–11. Stockholm: Hökerberg. Trans. from E. 1933b by Signe Hallström.

1936a *Själens och dess problem i den moderna människans liv*. Stockholm: Natur och Kultur, pp. 232. Partial trans. of G. 1931a by Gunnar Nordstrand (omits G. 1931a,5,8, and 13). Contents:

1. "Författarens förord." Trans. from G. 1931a,1.
2. "Den moderna psykoterapiens problema." Trans. from G. 1931a,2.
3. "Den analytiska psykologiens förhållande till det litterära konstverket." Trans. from G. 19313,3.
4. "Freud och Jung som motsatser." Trans. from G. 19313,4.
5. "Psykologiska typer," Trans. from G. 19313,6.
6. "Själens struktur." Trans. from G. 19318,7.
7. "Den arkaistiska människan." Trans. from G. 1931a,9.
8. "Livets höjdpunkt." Trans. from G. 1931a,10.
9. "Äktenskapet som psykologiskt förhållande." Trans. from G. 1931a,11.
10. "Varldsåskådningen och den analytiska psykologien." Trans. from G. 1931a,12.
11. "Själens problem i den moderna människans liv." Trans. from G. 1931a,14.

1941a *Psykologiska typer*. Stockholm: Natur och Kultur, pp. 350. Trans. from (?pts. of) G. 1921a by Ivar Alm. Contents:

Inledning.

- I. Allmän beskrivning av typerna.
- II. Typproblemet i idéhistorian.
- III. Individualitet och kollektivitet.
- IV. Den förenande Symbolen.

Definitioner.

Anmärkningar.

Noter.

- 1954a *Svar på Job*. Stockholm: Natur och Kultur, pp. 137. Trans. from G. 1952a by Hjalmar Sundén.
- 1964a *Mitt liv. (Minnen, drömmar, tankar.)* Recorded and ed. by Aniela Jaffé. Stockholm: Natur och Kultur, pp. 304. Trans. from G. 1962a by Ivar Alm. Contents conform to those of G. 1962a, except that G. 1962a, 9–11 have been combined into one chapter, “Drömmar och visioner,” and the appendix consists solely of G. 1962a, 15,ii.
- 1965a *Det omedvetna*. Stockholm: Wahlström & Widstrand. pp. 143. Trans. from G. 1943a by Heidi Parland.
- 1966a “Mötet med det omedvetna.” *Människan och hennés symboler*. pp. 18–103. In collaboration with M.-L. von Franz, Joseph L. Henderson, Jolande Jacobi, and Aniela Jaffé. Stockholm: Forum, pp. 320. Trans. from E. 1964a by Karin Stolpe.
- 1967a *Jaget och det omedvetna*. Stockholm: Wahlström & Widstrand. pp. 149. Trans. from G. 1935a by Heidi Parland.

TURKISH

- 1954a “Remiz (Symbole).” *Mason Dergisi*, IV:16 (4 Oct.), 803–09. Trans. from E. 1955g by S. T. Türk.
- 1964a “Psikoloji ve edebiyat.” *Psikanaliz acisinden edebiyat*. pp. 52–78. Istanbul: Atac Kitabevi. pp. 78. Trans. from Fr. 1955a by Selâhattin Hilâv. Also contains an article by Freud and one by Adler.
- 1965a *Psikoloji ve din*. Istanbul: Olus Yayınevi. pp. 128. Trans. from E. 1938a by Ender Gürol.

II

THE COLLECTED WORKS OF C. G. JUNG DIE GESAMMELTEN WERKE VON C. G. JUNG

The contents of the two editions are coordinated on facing pages. Paragraph numbers (column at right) are given only for the *Collected Works*; they are the same for the *Gesammelte Werke* except for discrepancies in volumes 6, 8, 11, and 14, which are explained in each volume. Page numbers are given in () following each title. The cross-references indicate, in general, the immediate derivation of each work, with further references as may be useful. Republications (chiefly paperback reprints) derived *from* the texts in the collected volumes are also indicated.

The Collected Works of C. G. Jung. Edited by †Herbert Read, Michael Fordham, and Gerhard Adler; executive editor (from 1967), William McGuire. Translated by †R.F.C. Hull, except as otherwise noted. New York: Pantheon Books for Bollingen Foundation, 1953–1960; Bollingen Foundation (distributed by Pantheon Books, a Division of Random House), 1961–1967. Princeton, New Jersey: Princeton University Press, 1967–1978. (Bollingen Series XX.) London: Routledge & Kegan Paul, 1953–1978. (The New York/Princeton and London edns. are identical except for title-pages and binding. Reprintings vary.)

CW 1 *Psychiatric Studies.* (Collected Works, 1.) 1957: 1st edn. 1970: 2d edn.

1. “On the Psychology and Pathology of So-Called Occult Phenomena.” (3–88) Trans. from G. 1902a.
2. “On Hysterical Misreading,” (89–92) Trans. from G. 1904b.
3. “Cryptomnesia.” (95–106) Trans. from G. 1905a.
4. “On Manic Mood Disorder.” (109–34) Trans. from G. 1903a.
5. “A Case of Hysterical Stupor in a Prisoner in Detention.” (137–56) Trans. from G. 1902b.
6. “On Simulated Insanity.” (159–87) Trans. from G. 1903b.
7. “A Medical Opinion on a Case of Simulated Insanity.” (188–205) Trans. from G. 1904c.
8. “A Third and Final Opinion on Two Contradictory Psychiatric Diagnoses.” (209–18) Trans. from G. 1906d.
9. “On the Psychological Diagnosis of Facts.” (219–21) Trans. from G. 1905d.

CW 2 *Experimental Researches.* (Collected Works, 2.) 1973. Trans. by Leopold Stein in collaboration with Diana Riviere.

1. “The Associations of Normal Subjects.” (3–196) By C. G. Jung and Franz Riklin. Trans. from G. 1906a,1.

Die gesammelten Werke von C. G. Jung. Edited by †Marianne Niehus-Jung, †Lena Hurwitz-Eisner, †Franz Riklin, Lilly Jung-Merker, and Elisabeth Ruf. Zurich: Rascher, 1958–1970. Olten: Walter, 1971–

GW 1 *Psychiatrische Studien.* (Gesammelte Werke, 1.) 1966. TR.—Italian: 1970b.

1. “Zur Psychologie und Pathologie sogenannter okkultur Phänomene.” (1–98) G. 1902a repub. Repub. as G. 1971c,1.
2. “Über hysterisches Verlesen.” (99–102) G. 1904b repub. Repub. as G. 1971c.2.

3. "Kryptomnesie." (103–15) G. 1905a, slightly rev. Repub. as G. 1971c,3.
4. "Über manische Verstimmung." (117–46) G. 1903a repub. Repub. in G. 1971c,4.
5. "Ein Fall von hysterischem Stupor bei einer Untersuchungs gefangenen." (147–67) G. 1902b repub.
6. "Über Simulation von Geistesstörung." (169–201) G. 1903b repub.
7. "Ärztliches Gutachten über einen Fall von Simulation geistiger Störung." (203–21) G. 1904c repub.
8. "Obergutachten über zwei widersprechende psychiatrische Gutachten." (223–33) G. 190öd repub., with minor title change.
9. "Zur psychologischen Tatbestandsdiagnostik." (235–37) G. 1905d repub.

GW 2 *Experimentelle Untersuchungen*. (Gesammelte Werke, 2.) 1978? With translations from the English by Sabine Lucas.

1. "Experimentelle Untersuchungen über Assoziationen Gesunder." (.....) By C. G. Jung and Franz Riklin. G. 1906a,1 repub.
2. "An Analysis of the Associations of an Epileptic." (197–220) Trans. from G. 1906a,2.
3. "The Reaction-time Ratio in the Association Experiment." (221–71) Trans. from G. 1906a,3.
4. "Experimental Observations on the Faculty of Memory." (272–87) Trans. from G. 1905c.
5. "Psychoanalysis and Association Experiments." (288–317) Trans. from G. 1906a,4.
6. "The Psychological Diagnosis of Evidence." (318—52) Trans. from G. 1941a.
7. "Association, Dream, and Hysterical Symptom." (353–407) Trans. from G. 1909a.1.
8. "The Psychopathological Significance of the Association Experiment." (408–25) Trans. from G.1906b.
9. "Disturbances of Reproduction in the Association Experiment." (426–38) Trans. from G. 1909a,2.
10. "The Association Method." (439–65) Trans. from an unpub. German ms. in part by Leopold Stein, completed by Jean Rhees and rev. by Diana Riviere. Contents partly derived from It. 1908a. Cf. CW 2,16.
11. "The Family Constellation." (466–79) Trans. from an unpub. German ms. in part by Leopold Stein, completed by Jean Rhees and rev. by Diana Riviere. Contents resemble those of Fr. 1907a.

12. "On the Psychophysical Relations of the Association Experiment." (483–91) E. 1907a repub. with slight title change.
 13. "Psychophysical Investigations with the Galvanometer and Pneumograph in Normal and Insane Individuals." (492–553) By Frederick Peterson and C. G. Jung. E. 1907b repub., slightly rev.
 14. "Further Investigations on the Galvanic Phenomenon and Respiration in Normal and Insane Individuals." (554–80) By Charles Ricksher and C. G. Jung. E. 1908a repub., slightly rev. Appendix:
 15. "Statistical Details of Enlistment." (583–85) Trans. from G. 1906c.
 2. "Analyse der Assoziationen eines Epileptikers." (.....) G.1906a,2 repub.
 3. "Über das Verhalten der Reaktionszeit beim Assoziationsexperimente." (.....) G. 1906a,3 repub.
 4. "Experimentelle Beobachtungen über das Erinnerungsvermögen." (.....) G. 1905c repub.
 5. "Psychoanalyse und Assoziationsexperiment." (.....) G.1906a,4 repub.
 6. "Die psychologische Diagnose des Tatbestandes." (.....) G.1941c! repub.
 7. "Assoziation, Traum und hysterisches Symptom." (.....) G.1909a, 1 repub.
 8. "Die psychopathologische Bedeutung des Assoziationsexperimentes." (.....) G 1906b repub.
 9. "Über die Reproduktionsstörungen beim Assoziationsexperiment." (.....) G. 1909a,2 repub.
 10. "Die Assoziationsmethode." (.....) First pub., from a manuscript.
 11. "Die familiäre Konstellation." (.....) First pub., from a manuscript.
 12. "Über die psychophysischen Beziehungen des Assoziations experimentes." (.....) Trans. from CW 2,12.
 13. "Psychophysische Untersuchungen mit dem Galvanometer und Pneumographen bei Normalen und Geisteskranken." By Frederick Peterson and C. G. Jung. (.....) Trans. from CW 2,13.
 14. "Weitere Untersuchungen über das galvanische Phänomen und die Respiration bei Normalen und Geisteskranken." By Charles Ricksher and C. G. Jung. (.....) Trans. from CW 2,14.
- Anhang:
15. "Statistisches von der Rekrutenaushebung." (.....) G. 1906c repub.
 16. "New Aspects of Criminal Psychology." (586–96) Trans. from It. 1908a. Cf. CW 2,10.
 17. "The Psychological Methods of Investigation Used in the Psychiatric Clinic of the University of Zurich." (597) Trans. from G. 1910r.
 18. "On the Doctrine of Complexes." (598–604) E. 1913a repub., slightly rev.

19. "On the Psychological Diagnosis of Evidence: The Evidence-Experiment in the Näf Trial." (605–14) Trans. from G. 1937b.

CW 3 *The Psychogenesis of Mental Disease*. (Collected Works, 3.) 1960.

1. "The Psychology of Dementia Praecox." (1–151) Trans. from G. 1907a. Repub. as E. 1974c.
2. "The Content of the Psychoses." (153–78) Trans. from G. 1914a.
3. "On Psychological Understanding." (179–93) Trans. from G. 1914a ("Supplement").
4. "A Criticism of Bleuler's Theory of Schizophrenic Negativism." (197–202) Trans. from G. 1911c.
5. "On the Importance of the Unconscious in Psychopathology." (203–10) E. 1916a.11 repub.
6. "On the Problem of Psychogenesis in Mental Disease." (211–25) E. 1919a repub., slightly rev.
7. "Mental Disease and the Psyche." (226–30) Trans. 496–503 from G. 1928c.
8. "On the Psychogenesis of Schizophrenia." (233–49) E. 1939d repub. Prepub. as E. 195ga,8.
9. "Recent Thoughts on Schizophrenia." (250–55) Cf. E. 1957h.
10. "Schizophrenia." (256–71) Trans. from G. 1958i.
11. "Letter to the Second International Congress of Psychiatry Symposium on Chemical Concepts of Psychosis, 1957." (272) E. 1958d repub. Written to Max Rinkel (Apr. 1957). TR.—German: 1973a.

CW 4 *Freud and Psychoanalysis*. (Collected Works, 4.) 1961.

1. "Freud's Theory of Hysteria: A Reply to Aschaffenburg." (3–9) Trans. from G. 1906g.
16. "Neue Aspekte der Kriminalpsychologie." (.....) Trans. from CW 2,16.
17. "Die an der Psychiatrischen Klinik in Zürich gebräuchlichen psychologischen Untersuchungsmethoden." (.....) G. 1910r repub.
18. "Ein kurzer Überblick über die Komplexlehre." (.....) First pub., from a ms.
19. "Zur psychologischen Tatbestandsdiagnostik: Das Tatbestandsexperiment im Schwurgerichtsprozess Näf." (.....) G. 1937b repub.

GW 3 *Psychogenese der Geisteskrankheiten*. (Gesammelte Werke, 3.) 1968. TR.—Italian: 1971a.

1. "Über die Psychologie der Dementia praecox: Ein Versuch." (1–170) G. 1907a repub,
2. "Der Inhalt der Psychose." (171–215) G. 1914a repub. Repub. as G. 1973d,1. (Including Nachtrag: "Über das psychologische Verständnis

- pathologische Vorgänge.”)
3. “Kritik über E. Bleuler: Zur Theorie des schizophrenen Negativismus.” (217–224) G. 1911c repub.
 4. “Über die Bedeutung des Unbewussten in der Psychopathologie.” (225–34) Trans. from E. 1914b by Klaus Thiele-Dohrmann, and slightly rev. Repub. as G. 1973d,3.
 5. “Über das Problem der Psychogenese bei Geisteskrankheiten.” (235–52) Trans. from E. 1919a by Klaus Thiele-Dohrmann. Repub. as G. 1973d,2.
 6. “Geisteskrankheit und Seele.” (253–60) G. 1928c repub. with change to the original title of ms. Repub. as G. 1973d,4.
 7. “Über die Psychogenese der Schizophrenie.” (261–81) Trans. from E. 1939d by Klaus Thiele-Dohrmann.
 8. “Neuere Betrachtungen zur Schizophrenie.” (283–91) G. 195gf repub.
 9. “Die Schizophrenie.” (293–312) G. 1958i repub. Repub. as G.

GW 4 *Freud und die Psychoanalyse*. (Gesammelte Werke, 4.) 1969.

1. “Die Hysterielehre Freuds. Eine Erwiderung auf die Aschaffenburgsche Kritik.” (1–10) G. 1906g repub. Repub. as G. 1973e,1.
2. “The Freudian Theory of Hysteria.” (10–24) Trans. from G. 1908m.
3. “The Analysis of Dreams.” (25–34) Trans. from Fr. 1909a by Philip Mairet and rev. by R.F.C. Hull. Repub. as E. 1974a,1.
4. “A Contribution to the Psychology of Rumour.” (35–47) Trans. from G. 1910q.
5. “On the Significance of Number Dreams.” (48–55) Trans. from G. 1911e. Repub. as E. 19743,2.
6. “Morton Prince, *The Mechanism and Interpretation of Dreams*: A Critical Review.” (56–73) Trans. from G. 1911b.
7. “On the Criticism of Psychoanalysis.” (74–77) Trans. from G. 19100.
8. “Concerning Psychoanalysis.” (78–81) Trans. from G. 1912g.
9. “The Theory of Psychoanalysis.” (83–226) Trans. from G. 1955b.
10. “General Aspects of Psychoanalysis.” (229–42) Trans. from the German ms., a version of which was subsequently pub. as GW 4,10.
11. “Psychoanalysis and Neurosis.” (243–51) E. 1916a,9, trans. slightly rev., with title change.
12. “Some Crucial Points in Psychoanalysis: A Correspondence between Dr. Jung and Dr. Loÿ.” (252–89) Trans. from G. 1914b.
13. a and b. “Vreiaees to *Collected Papers on Analytical Psychology*.” (290–97) E. 1916a,1 and E. 19178,1, trans. slightly rev.

14. "The Significance of the Father in the Destiny of the Individual." (301–23) Trans. from G. 1949a, with the addition of material trans. from the 1st edn., i.e. G. 1909c.
15. "Introduction to Kranefeldt's *Secret Ways of the Mind*." (324–32) Trans. from G. 1930b.
16. "Freud and Jung: Contrasts." (333–40) Trans. from G. 1931a,4.
2. "Die Freudsche Hysterietheorie." (11–28) G. 1908m repub. Repub. as G. 1972e,2.
3. "Die Traumanalyse." (29–40) Trans. from Fr. 1909a by Klaus Thiele-Dohrmann. Repub. as G. 1972e,3.
4. "Ein Beitrag zur Psychologie des Gerüchtes." (41–57) G. 1910q repub. Repub. as G. 1972e,4.
5. "Ein Beitrag zur Kenntnis des Zahlentraumes." (59–69) G. 1911e repub. Repub. as G. 1972e,5.
6. "Morton Prince, M.D. *The Mechanism and Interpretation of Dreams*. Eine kritische Besprechung." (71–93) G. 1911b repub. Repub. as G. 1972e,6.
7. "Zur Kritik über Psychoanalyse." (95–100) G. 19100 repub. Repub. as G. 1972e,7.
8. "Zur Psychoanalyse." (101–06) G. 1912g repub. Repub. as G. 1972e,8.
9. "Versuch einer Darstellung der psychoanalytischen Theorie." (107–255) G. 1955b repub. Repub. as G. 1973b,1.
10. "Allgemeine Aspekte der Psychoanalyse." (257–73) Based on the original, unpub. German ms. Repub. as G. 1972e,9. Cf.E 1913d.
11. "Über Psychoanalyse." (275–86) Trans. from E. 1916a,8 by Klaus Thiele-Dohrmann. Repub. as G. 1972e,10.
12. "Psychotherapeutische Zeitfragen. Ein Briefwechsel zwischen C. G. Jung und R. Loy." (287–331) G. 1914b repub. Repub. as G. 1973b,2.
13. "Vorreden zu den *Collected Papers on Analytical Psychology*." (333–44) (Text of 2d preface based on the original German ms.) Trans. from E. 1916a,1 and E. 1917a,1 by Klaus Thiele-Dohrmann.
14. "Die Bedeutung des Vaters für das Schicksal des Einzelnen." (345–70) G. 1949a repub. Repub. as G. 1971a,1.
15. "Einführung zu W. M. Kranefeldt: *Die Psychoanalyse*." (371–82) G. 1930b repub.
16. "Der Gegensatz Freud und Jung." (383–93) G. 1931a,4 repub.

CW 5 *Symbols of Transformation. An Analysis of the Prelude to a Case of Schizophrenia*. (Collected Works, 5.) 1956: 1st edn. 1962: Paperback edn. New York: Harper. 2 vols. 1967: 2d edn. 1974: 2d edn., 2d ptg., with addn. of

Author's Note to the First American/English Edition (p. xxx), from E. 1916b.
With 65 plates and 43 text illus. Trans. from G. 1952e.

- †1. Foreword to the Fourth Swiss Edition, (xxiii-xxvi)
2. Foreword to the Third Swiss Edition, (xxvii)
3. Foreword to the Second Swiss Edition, (xxviii-xxix)
4. Symbols of Transformation.

Part One:

- †I. Introduction. (3–6)
- †II. Two Kinds of Thinking (7–33)
- III. The Miller Fantasies: Anamnesis. (34–38)
- IV. The Hymn of Creation. (39–78)
- V. The Song of the Moth. (79–117)

Part Two:

- I. Introduction. (121–31)
- II. The Concept of Libido. (132–41)
- III. The Transformation of Libido. (142–70)
- IV. The Origin of the Hero. (171–206)
- V. Symbols of the Mother and of Rebirth. (207–73)
- VI. The Battle for Deliverance from the Mother. (274–305)
- VII. The Dual Mother. (306–93)
- VIII. The Sacrifice. (394–440)
- IX. Epilogue. (441–44)

Appendix: "Some Instances of Subconscious Creative Imagination," by Miss Frank Miller. (447–62) † Repub. as E. 1959a,1.

CW 6 Psychological Types. (Collected Works, 6.) 1971. [No. 4:] A revision by R.F.C. Hull of the trans. by H. G. Baynes (cf. E. 1923a). Trans. from G. 1921a.

1. Foreword to the First Swiss Edition, (xi–xii)
2. Foreword to the Seventh and Eighth Swiss Editions, (xii–xiii)

GW 5 *Symbole der Wandlung. Analyse des Vorspiels zu einer Schizophrenie.* (Gesammelte Werke, 5.) 1973. With 123 text illus. G. 1952e repub. with fewer illus. and additional end matter.

1. Vorrede zur vierten Auflage. (11–15) Dated Sept. 1950.
2. Vorrede zur dritten Auflage. (16) Dated Nov. 1937.
3. Vorrede zur zweiten Auflage. (17–18) Dated Nov. 1924.
4. Symbole der Wandlung.

Erster Teil:

I. Einleitung. (21–24)

II. über die zwei Arten des Denkens. (25–54)

III. Vorgeschichte. (55–59)

IV. Der Schöpferhymnus. (60–105)

V. Das Lied von der Motte. (106–54)

Zweiter Teil:

I. Einleitung. (157–69)

II. Über den Begriff der Libido. (170–81)

III. Die Wandlung der Libido. (182–215)

IV. Die Entstehung des Heros. (216–60)

V. Symbole der Mutter und der Wiedergeburt. (261–351)

VI. Der Kampf um die Befreiung von der Mutter. (352–92)

VII. Die Zweifache Mutter. (393–500)

VIII. Das Opfer. (501–57)

IX. Schlusswort. (558–61)

Anhang: Übersetzungen. (565–93)

GW 6 *Psychologische Typen*. (Gesammelte Werke, 6.) 1960: “Neunte, rev. Auflage.”
1967: “Zehnte, rev. Auflage.” tr.—Italian: 1969a.

1. Vorworte zur 7. und 8. Auflage. (xi–xii)

2. Vorrede. (xv–xvi)

3. Foreword to the Argentine Edition, (xiv–xv) Trans. from Sp. 1934a.

4. Psychological Types.

Introduction. (3–7)

I. The Problem of Types in the History of 8–100 Classical and Medieval
Thought. (8–66)

II. Schiller’s Ideas on the Type Problem. (67–135)

III. The Apollonian and the Dionysian. (136–46)

IV. The Type Problem in Human Character. (147–65)

V. The Type Problem in Poetry. (166–372)

VI. The Type Problem in Psychopathology. (273–88)

VII. The Type Problem in Aesthetics. (289–99)

VIII. The Type Problem in Modern Philosophy. (300–21)

IX. The Type Problem in Biography. (322–29)

X. General Description of the Types. (330–407) Repub. as E. 1971a,8.

XI. Definitions. (408–86)

Epilogue. (487–95)

Appendix: Four Papers on Psychological Typology.

5. “A Contribution to the Study of Psychological Types (1913).” (499–509)
Trans. from the German ms. Cf. GW 6,4. and Fr. 1913a.
6. “Psychological Types (1923).” (510–23) Trans. from GW 6,5 (2d edn.).
7. “A Psychological Theory of Types (1931)” (524–41) E. 19338,4, repub.
trans. slightly rev.
8. “Psychological Typology (1936).” (542–55) Trans. from GW 6,7 (2d edn.)
3. Psychologische Typen. G. 1921a repub. with addn. of a def. of “Selbst” in
chap. 11.

Einleitung. (1–6)

1. Das Typenproblem in der antiken und mittelalterlichen Geistesgeschichte.
(7–69)
2. Über Schillers Ideen zum Typenproblem. (70–143)
3. Das Apollinische und das Dionysische. (144–55)
4. Das Typenproblem in der Menschenkenntnis. (156–76)
5. Das Typenproblem in der Dichtkunst. (177–292)
6. Das Typenproblem in der Psychopathologie. (293–309)
7. Das Problem der typischen Einstellungen in der Ästhetik. (310–21)
8. Das Typenproblem in der modernen Philosophie. (322–46)
9. Das Typenproblem in der Biographik. (347–56)
10. Allgemeine Beschreibung der Typen. (357–443) Repub. as G. 1972d,2.
11. Definitionen. (444–528) Repub. as G. 1972d,3.
12. Schlusswort. (529–37)

Anhang:

4. “Zur Frage der psychologischen Typen.” (541–51) Lecture given at the
Psychoanalytische Kongress, Munich, Sept. 1913. Repub. as G. 1972d,1. Cf.
Fr. 1913a and E. 1916a,12.
5. “Psychologische Typen.” (552–67) G. 1925c repub. Repub. as G. 1972d,4.
6. “Psychologische Typologie.” (568–86) G. 1931a,6 repub.
7. “Psychologische Typologie.” (587–601) G. 1936b repub.

CW 7 *Two Essays on Analytical Psychology*. (Collected Works, 7.) 1953: 1st edn.
1956: Paperback 1st edn. New York: Noonday (Meridian). 1966: 2d edn. (fully
reset). 1972: Paperback 2d edn. Princeton U. P. First Edition:

1. “The Psychology of the Unconscious.” (3–117) Trans. from G. 1943a, with
omission of some prefatory matter.
 - a) “Preface to the First Edition.” (3–4) Dated Dec. 1916.

- b) "Preface to the Second Edition." (4–5) Dated Oct. 1918.
 - c) "from Preface to the Third Edition." (5–6) Dated 1925.
 - e) "Preface to the Fifth Edition." (6–7) Dated Apr. 1942.
2. "The Relations between the Ego and the Unconscious." (121–239) Trans. from G. 1935a. Excerpts repub. as E. 19593,3.
- a) "Preface to the Second Edition." (121–32) Dated Oct. 1934.

Appendixes:

3. "New Paths in Psychology." (243–62) A trans. of an incomplete version of G. 1912d. For trans. of complete version, see CW 7,3, 2d edn.
4. "The Structure of the Unconscious." (263–92) Trans. from Fr. 1916a by Philip Mairet. For a trans. of the orig. German ms., see CW 7,4, 2d edn.

Second Edition:

1. "On the Psychology of the Unconscious." (1–119) Contains the same prefaces as CW 7, 1st edn., although paging differs, with the following addition:
- d) "Preface to the Fourth Edition (1936)." (7) Trans. from G. 1943a.

Cf. CW 7,3, below.

2. "The Relations between the Ego and the Unconscious." (121–241) Trans. from G. 1935a. Repub. as E. 19713,5.

GW 7 *Zwei Schriften über Analytische Psychologie*. (Gesammelte Werke, 7.) 1964.

1. "Über die Psychologie des Unbewussten." (1–130) G. 1943a repub.
2. "Die Beziehungen zwischen dem Ich und dem Unbewussten." (131–264) G. 1935a repub.

Anhang:

3. "Neue Bahnen der Psychologie." (267–91) G. 1912d repub.
4. "Die Struktur des Unbewussten." (292–337) Given as lecture to the Zürcher Schule für Analytische Psychologie, 1916. Original ms. titled: "Über das Unbewusste und seine Inhalte." Cf. CW 7,4. First pub. in a French trans. Pub., rev. and exp., as G. 1928a. TR.—English: CW 7,4 (2d edn.) //French: 1916a.

Appendixes;

3. "New Paths in Psychology." (245–68) Trans. from G. 1912d. Cf. CW 7,1, above.
4. "The Structure of the Unconscious." (269–304) Trans. from the orig. unpub. German ms., for a version of which, see GW 7,4. Cf. CW 7,4, 1st edn.

CW 8 *The Structure and Dynamics of the Psyche*. (Collected Works, 8.) 1960: 1st edn. 1969: 2d edn. (no. 18 extensively revised). With 1 plate (frontisp.).

1. "On Psychic Energy." (3–66) Trans. from G. 1948b,2. Repub. as E. 1969b,1.
2. "The Transcendent Function." (67–91) Trans. largely from G. 1958b.
(Prefatory note partially rewritten for this publication.) Repub. as E. 1971a,9.
3. "A Review of the Complex Theory." (92–104) Trans. from G. 1948b,3.
4. "The Significance of Constitution and Heredity in Psychology." (107–13)
Trans. from G. 1929i.
5. "Psychological Factors Determining Human Behaviour." (114–25) E. 1942a
repub. with slight alterations based on the orig. German typescript (cf. GW 8,5) and reversion to the title of E. 1937a.
6. "Instinct and the Unconscious." (129–38) Trans. from G. 1948b,6. Repub. as E. 19713,3.
7. "The Structure of the Psyche." (139–58) Trans from G. 1931a,7. Repub. as E. 1971a,2.
8. "On the Nature of the Psyche." (159–234) E. 1954b,2, trans. rev., with title change. Prepub., with some omissions, as E. 19598,2. Repub. as E. 1969b,2.
9. "General Aspects of Dream Psychology." (237–80) Trans. from G. 1948b,4.
Repub. as E. 1974a,3.
10. "On the Nature of Dreams." (281–97) Trans. from G. 1948b,5. Repub. as E. 1959a,7 and as E.1974a,4.
11. "The Psychological Foundations of Belief in Spirits." (301–18) Trans. from G. 1948b,7.

GW 8 *Die Dynamik des Unbewussten*. (Gesammelte Werke, 8.) 1967.

1. "über die Energetik der Seele." (1–73) G. 1948b,2 repub.
2. "Die transzendente Funktion." (75–104) G. 1958b repub. Repub. as G. 1973c,1.
3. "Allgemeines zur Komplextheorie." (105–20) G. 1948b,3 repub.
4. "Die Bedeutung von Konstitution und Vererbung für die Psychologie." (121–29) G. 1929i repub. Repub. as G. 1973c,2.
5. "Psychologische Determinanten des menschlichen Verhaltens." (131–45)
Originally delivered in English as a lecture (cf. E. 1937a) based on an unpub. German ms. Repub. as G. 1973c,3.
6. "Instinkt und Unbewusstes." (147–59) G. 1948b,6 repub.
7. "Die Struktur der Seele." (161–83) G. 1931a,7 repub.
8. "Theoretische Überlegungen zum Wesen des Psychischen." (185–267) G. 1954b,8 repub. Repub. as G. 1973c,4.
9. "Allgemeine Gesichtspunkte zur Psychologie des Traumes." (269–318) G. 1948b,4 repub.

10. "Vom Wesen der Träume." (319–38) G. 1948b,5 repub.
11. "Die psychologischen Grundlagen des Geisterglaubens." (339–60) G. 1948b,7 repub.
12. "Spirit and Life." (319–37) Trans. based on E. 1928a,2.
13. "Basic Postulates of Analytical Psychology." (338–57) E. 1933a,9, trans. slightly rev.
14. "Analytical Psychology and *Weltanschauung*." (358–81) Trans. from G. 1931a,12. Cf. E. 1928a,4 for earlier version.
15. "The *Real* and the Surreal." (382–84) Trans. from G. 1932h.
16. "The Stages of Life." (387–403) Trans. from G. 1931 a, 10, and based on E. 1933a,5. Repub. as E.1971a,1.
17. "The Soul and Death." (404–15) E. 1959c repub.
18. "Synchronicity: An Acausal Connecting Principle." (417–519) E. 1955a, trans. slightly rev. Repub. as E. 1973c,1.

Appendix:

19. "On Synchronicity." (520–31) E. 1957b, trans. slightly rev. Repub. as E. 1971a,14 and E. 1973c,2.

CW 9,i *The Archetypes and the Collective Unconscious*. (Collected Works, 9,i.) 1959: 1st edn. 1968: 2d edn. With 79 plates (29 col.).

1. "Archetypes of the Collective Unconscious." (3–41) Trans. from G. 1954b,2. Repub. as E. 1959a, 5. Cf. E. 1939a,3.
2. "The Concept of the Collective Unconscious." 87–110 (42–53) E. 1936d and E. 1937b, combined, slightly rev. Repub. as E. 1971a,4.tr.—German: GW 9,i,2.
3. "Concerning the Archetypes." (54–72) Trans. from G. 1954b,3.
4. "Psychological Aspects of the Mother Archetype." 148–98 (75–110) Trans. from G. 1954b,4 with parts incorporated from E. 1943a. Repub. as E. 1959a,6 and E. and E. 1970,a,1.
5. "Concerning Rebirth." (113–47) Trans. from 199–258 G. 19503,3. Repub. as E. 19703,2.
6. "The Psychology of the Child Archetype." (151–81) E. 1949a,1 repub., trans. rev. (Trans. further rev. for 2d edn.) 1st edn. version repub. as E. 1963a,1. 2d edn. version repub. as E. 1969a.
12. "Geist und Leben." (361–83) G. 1931a,13 repub.
13. "Das Grundproblem der gegenwärtigen Psychologie." (385–406) G. 1934b,2 repub.
14. "Analytische Psychologie und Weltanschauung." (407–34) G. 1931a, 12 repub.

15. "Wirklichkeit und Überwirklichkeit." (435–39) G. 1932h repub.
16. "Die Lebenswende." (441–60) G. 19313,10 repub.
17. "Seele und Tod." (461–74) G. 19340,10 repub.
18. "Synchronizität als ein Prinzip akausaler Zusammenhänge." (475–577) G 1952b rePub
19. "Über Synchronizität." (579–91) G. 1952f repub.

GW 9,i *Die Archetypen und das kollektive Unbewusste.* (Gesammelte Werke, g,i.) 1976.

1. "Über die Archetypen des kollektiven Unbewussten." (11–51) G. 1954b,i repub.
2. "Der Begriff des kollektiven Unbewussten." (53–66) Trans. from CW 9,i,2 by Elisabeth Rüd.
3. "Über den Archetypus mit besonderer Berücksichtigung des Animabegriffes." (67–87) G. 1954b,3 repub.
4. "Die psychologischen Aspekte des Mutterarchetypus." (89–123) G. 1954b,4 repub.
5. "Über Wiedergeburt." (125–161) G. 1950a,3 repub.
6. "Zur Psychologie des Kindarchetypus." (163–195) G. 1951b,1 repub.
7. "The Psychological Aspects of the Kore." (182–203) E. 1949a,2 repub., trans. rev. further as in no. 6.
8. "The Phenomenology of the Spirit in Fairytales." (207–54) Trans. from G. 19483,2. Repub. as E. 19703,3. Trans. also pub. in slightly dif. form as E. 1954b,i.
9. "On the Psychology of the Trickster-Figure." (255–72) E. 1956a, trans. slightly rev. Repub. as E. 1970a,4.
10. "Conscious, Unconscious, and Individuation." (275–89) E. 19393,1, rev. in accordance with G. 1939e (later German version).
11. "A Study in the Process of Individuation." 525–626 (290–354) Trans. from G. 19503,4. Repub. as E. 1972a,2. Cf. E. 1939a>2
12. "Concerning Mandala Symbolism." (355–84) Trans. from G. 1950a,5. Repub. as E. 1972a,3.
13. "Mandalas." (387–90) Trans. from G. 1955e. Repub. as E. 19723,1.

CW 9,ii *Aion: Researches into the Phenomenology of the Self.* (Collected Works, g,ii.) 1959: 1st edn. 1968: 2d edn. With 3 plates. Trans. from G. 1951a.

Foreword, (ix–xi)

†I. The Ego. (3–7)

†II. The Shadow. (8–10)

†III. The Syzygy: Anima and Animus, (u-22)

†IV. The Self. (23–35)

†V. Christ, a Symbol of the Self. (36–71)

VI. The Sign of the Fishes. (72–94)

VII. The Prophecies of Nostradamus. (95–102)

VIII. The Historical Significance of the Fish. (103–17)

IX. The Ambivalence of the Fish Symbol. (“8–25)

X. The Fish in Alchemy. (126–53)

XI. The Alchemical Interpretation of the Fish. (154–72)

†Chs. I–V prepub. as E. 1958,2, slightly rev. Chs. I–III repub. as E. 1971a,6.

7. “Zum psychologischen Aspekt der Korefigur.” (197–220) G. 1951b,2 repub.

8. “Zur Phänomenologie des Geistes im Märchen.” (221–269) G. 1948a,2 repub.

9. “Zur Psychologie der Tricksterfigur.” (271–290) G. 1954a repub.

10. “Bewusstsein, Unbewusstes und Individuation.” (291–307) G. 1939e repub.

11. “Zur Empirie des Individuationsprozesses.” (309–372) G. 1950a,4 repub.

12. “Über Mandalasymbolik.” (373–407) G. 19503,5 repub.

13. “Mandalas (Anhang).” (409–414) G. 1955e repub.

GW 9,ii *Aion; Beiträge zur Symbolik des Selbst.* (Gesammelte Werke, 9.ii.) 1976.

Jung’s contribution to G. 1951a repub. with rearrangement of title.

Vorrede. (9–)

I. Das Ich. (12–16)

II. Der Schatten. (17–19)

III. Die Syzygie: Anima und Animus. (20–31)

IV. Das Selbst. (32–45)

V. Christus, ein Symbol des Selbst, (46–80)

VI. Das Zeichen der Fische. (81–103)

VII. Die Prophezeiung des Nostradamus. (104–111)

VIII. Über die geschichtliche Bedeutung des Fisches. (112–126)

IX. Die Ambivalenz des Fischsymbols. (127–135)

X. Der Fisch in der Alchemie. (136–165)

XI. Die alchemistische Deutung des Fisches. (166–185)

XII. Background to the Psychology of Christian Alchemical Symbolism.
(173–83)

XIII. Gnostic Symbols of the Self. (184–221)

XIV. The Structure and Dynamics of the Self. (222–65)

XV. Conclusion. (266–69)

CW 10 *Civilization in Transition*. (Collected Works, 10.) 1964: 1st edn. 1970: 2d edn.
With 8 plates.

1. “The Role of the Unconscious.” (3–28) Trans. from G. 1918b.
2. “Mind and Earth.” (29–49) Trans. from G. 1931a,8
3. “Archaic Man.” (50–73) Trans. from G. 1931a,9.
4. “The Spiritual Problem of Modern Man.” (74–94) Trans. from G. 1931a,14.
Repub. as E. 1971a,12.
5. “The Love Problem of a Student,” (97–112) Trans. from an unpub. ms. also
pub. as G. 1971a,3.
6. “Woman in Europe.” (113–33) Trans. from G. 1927a.
7. “The Meaning of Psychology for Modern Man.” (134–56) from G. 1934b,3.
8. “The State of Psychotherapy Today.” (157–73) Trans. from G. 1934k.
9. “Preface to *Essays on Contemporary Events*.” (177–78) Trans. from G.
1946a,1.
- .
10. “Wotan.” (179–93) Trans. from G. 19463,2.
11. “After the Catastrophe.” (194–217) Trans. from G. 1946a,5.
12. “The Fight with the Shadow.” (218–26) E. 19478,2, slightly rev.
13. “Epilogue to *Essays on Contemporary Events*.” (227–43) Trans. from G.
1946a,6.
14. “The Undiscovered Self (Present and Future).” (245–305) E. 1958b repub.,
trans. further rev.
15. “Flying Saucers: A Modern Myth of Things Seen in the Skies.” (307–433)
E. 1959b repub., trans. slightly rev.

XII. Allgemeines zur Psychologie der christlich-alchemistischen
Symbolik. (186–196)

XIII. Gnostische Symbole des Selbst. (197–237)

XIV. Die Struktur und Dynamik des Selbst. (238–280)

XV. Schlusswort. (281–284)

GW 10 *Zivilisation im Übergang*. (Gesammelte Werke, 10.) 1974.

1. “Über das Unbewusste.” (15–42) G. 1918b repub.
2. “Seele und Erde.” (43–65) G. 1931a,8 repub.
3. “Der archaische Mensch.” (67–90) G. 1931a,9 repub.
4. “Das Seelenproblem des modernen Menschen.” (91–113) G. 1931a,14
repub.

5. "Das Liebesproblem des Studenten." (115–33) G. 1971a,3 repub.
6. "Die Frau in Europa." (135–56) G. 1971a,2 repub.
7. "Die Bedeutung der Psychologie für die Gegenwart." (157–180) G. 1934b,3 repub.
8. "Zur gegenwärtigen Lage der Psychotherapie." (181–99) G 1934k repub.
9. "Vorwort zu *Aufsätze zur Zeitgeschichte*." (201–02) G. 1946a,1 repub.
10. "Wotan." (203–218) G. 1946a,2 repub.
11. "Nach der Katastrophe." (219–44) G. 1946a,5 repub.
12. "Der Kampf mit dem Schatten." (245–54) Trans. from CW 10,12 by Elisabeth Rüb. Lecture broadcast in English, B.B.C., 3d Programme, 3 Nov. 1946, and 1st pub. as E. 1946e.
13. "Nachwort zu *Aufsätze zur Zeitgeschichte*." (255–273) G. 1946a,6 repub.
14. "Gegenwart und Zukunft." (275–336) G. 1957i repub.
15. "Ein moderner Mythos: Von Dingen, die am Himmel gesehen werden." (337–473) G. 1958a repub. with the addn. of a trans. of E. 1959b,1 and 9 by Elisabeth Rüb.
16. "A Psychological View of Conscience." (437–55) Trans. from G. 1958c.
17. "Good and Evil in Analytical Psychology." (456–68) E. 1960e repub., trans. rev.
18. "Introduction to Toni Wolff's *Studies in Jungian Psychology*." (469–76) Trans. from G. 1959e.
19. "The Swiss Line in the European Spectrum." (479–88) Trans. from G. 1928e.
20. "The Rise of a New World." (489–95) Trans. from G. 1930e.
21. "La Révolution Mondiale." (496–501) Trans. from G. 1934i
22. "The Complications of American Psychology." (502–14) E. 1930a, stylistically slightly rev., with title change.
23. "The Dreamlike World of India." (515–24) E. 1939b repub.
24. "What India Can Teach Us." (525–30) E. 1939c repub.
25. "Editorial. *Zentralblau*, VI (1933)." (533–34) Trans. from G. 1933e.
26. "A Rejoinder to Dr. Bally." (535–44) Trans. from G. 1934t and (last 3 paragraphs, p. 544) G. 1934g.
27. "Circular Letter." (545–46) Trans. from G. 1934j.
28. "Editorial. *Zentralblatt*, VIII (1935)." (547–51) Trans. from G. 1935j.
29. "Editorial Note. *Zentralblatt*, VIII (1935)." (552–53) Trans. from G. 1935k.
30. "Presidential Address to the 8th General Medical Congress for Psychotherapy, Bad Nauheim, 1935." (554–56) Trans. from a German ms. pub. as GW 10,30.

31. "Contribution to a Discussion on Psychotherapy." (557–60) Trans. from G. 1935h.
32. "Presidential Address to the 9th International Medical Congress for Psychotherapy, Copenhagen, 1937." (561–63) Trans. from a German ms. pub. as GW 10,32. Congress held 2–4 Oct. 1937.
16. "Das Gewissen in psychologischer Sicht." (475–95) G. 1958c repub.
17. "Gut und Böse in der analytischen Psychologie." (497–510) GW 11,19 repub.
18. "Vorrede zu: Toni Wolff, *Studien zu C. G. Jungs Psychologie*." (511–18) G. 1959e repub.
19. "Die Bedeutung der schweizerischen Linie im Spektrum Europas." (519–30) G. 1928e repub.
20. "Der Aufgang einer neuen Welt." Eine Besprechung von: H. Keyserling *Amerika. Der Aufgang einer neuen Welt*. (531–37) G. 1930e repub.
21. "Ein neues Buch von Keyserling *La Révolution mondiale et la responsabilité de l'esprit*." (539–45) G. 1934i repub.
22. "Komplikationen der amerikanischen Psychologie." (547–61) Trans. from CW 10,22 by Elisabeth Rüb.
23. "Die träumende Welt Indiens." (563–74) Trans. from E. 1939b by Elisabeth Rüb.
24. "Was Indien uns lehren kann." (575–80) Trans. from E. 1939c by Elisabeth Rüb.
"Verschiedenes."
25. "Geleitwort." (*Zentralblatt* VI, 1933) (581–82) G. 1933e repub.
26. "Zeitgenössisches." (*Neue Zürcher Zeitung* CLV, 1934) (583–93) G. 1934f and G. 1934g repub.
27. "Rundschreiben." (*Zentralblatt* VII, 1934) (595–96) G. 1934j repub.
28. "Geleitwort." (*Zentralblatt* VIII, 1935) (597–602) G. 1935j repub.
29. "Vorbemerkung des Herausgebers." (*Zentralblatt* VIII, 1935) (603–04) G. 1935k repub.
30. "Begrüßungsansprache zum Achten Allgemeinen Ärztlichen Kongress in Bad Nauheim (1935)." (605–07) Presidential address to the Congress, 27–30 Mar. 1935. TR.—English: CW 10,30.
31. "Votum." (*Schweizerische Ärztezeitung* XVI, 1935) (609–12) G. 1935h repub. with sl. title change.
32. "Begrüßungsansprache zum Neunten Internationalen Ärztlichen Kongress für Psychotherapie in Kopenhagen (1937)." (613–15) Presidential address to the Congress, Copenhagen, 2–4 Oct. 1937. TR.—English: CW 10,32.

33. "Presidential Address to the 10th International Medical Congress for Psychotherapy, Oxford, 1938." (564–67) Given in English. Summary pub. as E. 1938b. TR.—German: GW 10,33.

CW 11 *Psychology and Religion: West and East*. (Collected Works, 11.) 1958: 1st edn. 1969: 2d edn. With 1 plate (frontisp.).

1. "Psychology and Religion." (3–105) E. 1938a, combined with a trans. of G. 1940a. Repub. as E. 1959a.11.
2. "A Psychological Approach to the Dogma of the Trinity." (107–200) Trans. from G. 1948a,4.
3. "Transformation Symbolism in the Mass." (201–96) Trans. from G. 1954b. Cf. E. 1955b.
4. "Foreword to White's *God and the Unconscious*." (299–310) E. 1952c, trans. slightly rev.
5. "Foreword to Werblowsky's *Lucifer and Prometheus*." (311–15) E. 1952b, trans. slightly rev.
6. "Brother Klaus." (316–23) Trans. from G. 1933c.
7. "Psychotherapists or the Clergy." (327–47) Trans. from G. 1932a.
8. "Psychoanalysis and the Cure of Souls." (348–54) Trans. from G. 1928g.
9. "Answer to Job." (355–470) E. 1954a repub. with the addn. of E. 1956c as "Prefatory Note," both sl. rev. Repub. as E. 1971a,15. Pub. without "Prefatory Note" as E. 1960a and E. 1965aa. "Important phrase" restored to "Prefatory Note" (2d sentence, 4th par.) in the 2d ptg. of the 2d edn. of this vol. (1973) and repub. in this form as E. 1973a. Cf. E. 1976a, letter to S. Doniger (Nov. 1955), for orig. version of "Prefatory Note."
10. "Psychological Commentary on *The Tibetan Book of the Great Liberation*." (509–26) E. 1954e repub. Pt. 1 (par. 759–87) repub. as E. 1971a,13.
11. "Psychological Commentary on *The Tibetan Book of the Dead*." (509–26) E. 1957f repub.
33. "Begrüßungsansprache zum Zehnten Internationalen Ärztlichen Kongress für Psychotherapie in Oxford (1938)." (617–20) Presidential address delivered in English to the Congress, Oxford, 29 July-2 Aug. 1938. Trans. from CW 10,33 by Elisabeth Rüb.

GW 11 *Zur Psychologie westlicher und östlicher Religion*. (Gesammelte Werke, 11.) 1963.

1. "Psychologie und Religion." (XVII-117) G. 1940a repub. Repub. as G. 1971d, 1.
2. "Versuch einer psychologischen Deutung des Trinitätsdogmas." (119–218) G. 1948a,4 repub. with slight title change.

3. "Das Wandlungssymbol in der Messe." (219–323) G. 1954–6 repub. Repub. as G. 1971d,4.
4. "Vorwort zu V. White: *Gott und das Unbewusste.*" (325–39) G. 1957h repub.
5. "Vorwort zu Z. Werblowsky: *Lucifer und Prometheus.*" (340–44) The original text of the German ms. first pub. in an English trans. TR.—English: 1952b / CW 11,5.
6. "Bruder Klaus." (345–52) G. 1933c repub.
7. "Über die Beziehung der Psychotherapie zur Seelsorge." (355–76) G. 1932a repub. with slight title change. Repub. as G. 1971d,2.
8. "Psychoanalyse und Seelsorge." (377–83) G. 1928g repub. Repub. as G. 1971d,3.
9. "Antwort auf Hiob." (385–506) G. 1961a repub. "Nachwort" (pp. 505–506) lacks paragraph nos. and is taken from a letter to Simon Doniger (Nov. 1955). For full text of letter, see E. 1976a.
10. "Psychologischer Kommentar zu: *Das tibetische Buch der grossen Befreiung.*" (511–49) G. 1955d repub.
11. "Psychologischer Kommentar zum Bardo Thödol (Das tibetanische Totenbuch)." (550–67) G. 1935f repub.
12. "Yoga and the West." (529–37) Cf. E. 1936c for a dif. trans. on which this one is based.
13. "Foreword to Suzuki's *Introduction to Zen 877–907 Buddhism.*" (538–57) Trans. from G. 1939c.
14. "The Psychology of Eastern Meditation." 908–49 (558–75) Trans. from G. 1943c.
15. "The Holy Men of India." (576–86) Trans. from 950–63 G. 1944b. (Brief "Vorwort" omitted.)
16. "Foreword to the *Ching.*" (589–608) E. 1950d, 964–1018 trans. slightly rev.
12. "Yoga und der Westen." (571–80) The original text of a German ms. first pub. in English. TR.—English: 1936c / CW 11,12.
13. "Geleitwort zu D. T. Suzuki: *Die grosse Befreiung.*" (581–602) G. 1939c repub.
14. "Zur Psychologie östlicher Meditation." (603–21) G. 1948a,5 repub.
15. "Über den indischen Heiligen. Einführung zu H. Zimmer: *Der Weg zum Selbst.*" (622–32) G. 1944b repub.
16. "Vorwort zum *Ging.*" (633–54) Text of the original German ms. Differs from the English version, E. 1950d. TR.—English: 1950d // Italian: 1950a. Anhang (not in CW 11):

17. "Antwort an Martin Buber." (657–65) G. 1952j repub. with title change, TR.—English: 1957d / 1973e.
18. "Zu *Psychologie und Religion*." (665–67) From a letter to a Protestant theologian written in 1940.
19. "Gut und Böse in der analytischen Psychologie" (667–81) G. 1959b repub. Repub. as GW 10,17.
20. "Zum Problem des Christussymbols." (681–85) Trans. by Aniela Jaffé from a letter written in English to Victor White (24 Nov. 1953). Text of orig. letter pub. in E. 1976a.
21. "Zu *Antwort auf Hiob*." (685–86) From a letter to Hans Schär (16 Nov. 1951). Entire text of letter pub. in G. 1972b and trans. in E. 1976a.
22. "Zu *Antwort auf Hiob*." (687) From a letter to Dorothée Hoch (28 May 1952). Entire text of letter pub. in G. 1972b and trans. in E. 1976a.
23. "Klappentext zur ersten Auflage von *Antwort auf Hiob*." (687) Jung's description printed on the dust jacket of the 1st edn., ca. Apr. 1952. TR.—English: CW 18,95.
24. "Aus einem Brief an einen protestantischen Theologen." (688) From a letter to Hans Wegmann (19 Dec. 1943). Entire text pub. in G. 1972a and trans. in E. 1973b.
25. "Brief an *The Listener*. Januar 1960." (689–90) Trans. from E. 1960c by Marianne Niehus-Jung. Repub. in G. 1973a.
26. "Zu *Die Reden Gotamo Buddhos*." (690–93) G. 1956c repub. with title change. TR.—English: CW 18,101.

CW 12 *Psychology and Alchemy*. (Collected Works, 12.) 1953: 1st edn. 1968: 2d edn. (fully reset). With 270 text illus. Trans. from G. 1952d, except no. 1 in 2d edn.

First Edition:

1. Foreword to the Swiss Edition. (vii)

2. Psychology and Alchemy.

I. Introduction to the Religious and Psychological Problems of Alchemy. (1–37)

Repub. as E. 1959a,10.

II. Individual Dream Symbolism in Relation to Alchemy. (39–213).

III. Religious Ideas in Alchemy. (215–451)

Epilogue. (453–63)

Second Edition:

1. "Prefatory Note to the English Edition." (v) Trans. from the unpublished ms.

2. "Foreword to the Swiss Edition." (x)

3. Psychology and Alchemy.

- I. Introduction to the Religious and Psychological problems of Alchemy. (1–37)
- II. Individual Dream Symbolism in Relation to Alchemy. (39–223)
Repub. as E. 1971a, 11 and E. 19743,6.
- III. Religious Ideas in Alchemy. (225–471) 332–554
Epilogue. (473–83)

CW 13 *Alchemical Studies*. (Collected Works, 13.) 1967. With 50 plates (1 col.) and 4 text illus.

1. “Commentary on *The Secret of the Golden Flower*.” (1–56) Trans. from G. 1957b,1 and 3.
2. “The Vision of Zosimos.” (57–108) Trans. from G. 1954b,5.
3. “Paracelsus as a Spiritual Phenomenon.” (109–89) Trans. from G. 1942a,2, with the addition of 2 footnotes derived from posthumous papers.
4. “The Spirit Mercurius.” (191–200) Trans. from G. 1948a,3.
5. “The Philosophical Tree.” (251–349) Trans. from G. 1954b,7.

GW 12 *Psychologie und Alchemie*. (Gesammelte Werke, 12.) 1972. With 271 text illus. G. 1952d repub.

1. Vorwort. (11) Dated January 1943.
2. Vorwort zur zweiten Auflage. (12) Dated July 1951.
3. [Psychologie und Alchemie]
 - I. Einleitung in die religionspsychologische Problematik der Alchemie (15–54)
 - II. Traumsymbole des Individuationsprozesses. (57–260)
 - III. Die Erlösungsvorstellungen in der Alchemie (263–537) Epilog. (539–51)

GW 13 *Studien über alchemistische Vorstellungen*. (Gesammelte Werke, 13.) 1978. With 38 plates and 4 text figures.

1. “Kommentar zu *Das Geheimnis der Goldenen Blüte*.” (11–63) G. 1957b,i and 3 repub.
2. “Die Visionen des Zosimos.” (65–121) G. 1954b,5 repub.
3. “Paracelsus als geistige Erscheinung.” (123–209) G. 1942a,2 repub., with the addition of 2 footnotes derived from posthumous papers.
4. “Der Geist Mercurius.” (211–269) G. 1948a,3 repub.
5. “Der philosophische Baum.” (271–376) G. 1954b,6 repub.

CW 14 *Mysterium Coniunctionis. An Inquiry into the Separation and Synthesis of Psychic Opposites in Alchemy.* (Collected Works, 14.) 1963: 1st edn. 1970: 2d edn. With 10 plates. Trans. from G. 1955a and 1956a

Foreword, (xiii–xix)

I. The Components of the Coniunctio. (3–41)

II. The Paradoxa. (42–88)

III. The Personification of the Opposites. (89–257)

IV. Rex and Regina. (258–381)

V. Adam and Eve. (382–456)

VI. The Conjunction. (457–553)

Epilogue. (554–56)

CW 15 *The Spirit in Man, Art, and Literature.* (Collected Works, 15.) 1966. 1971: Paperback edn. Princeton U. P.

1. “Paracelsus.” (3–12) Trans. from G. 1934b,5.

2. “Paracelsus the Physician.” (13–30) Trans. from G. 1942a,1.

3. “Sigmund Freud in His Historical Setting.” (33–40) Trans. from G. 1934b,6.

4. “In Memory of Sigmund Freud.” (41–49) Trans. 60–73 from G. 1939d.

5. “Richard Wilhelm: In Memoriam.” (53–62) Trans. from G. 1957b,2.

6. “On the Relation of Analytical Psychology to Poetry.” (65–83) Trans. from G. 19313,3. Repub. as E. 1971a,10.

7. “Psychology and Literature.” (84–105) Trans. from G. 1950a,2, with the addition of an introduction trans. from a ms. found posthumously and pub. as the “Vorrede” to GW 15,7.

8. “‘Ulysses’: A Monologue.” (109–34) Trans. from G. 1934b,7. Letter to James Joyce (27 Sept. 1932), included in the Appendix, pp. 133–34, is E. 1966d repub. Repub. as E. 1975a.

9. “Picasso.” (135–41) Trans. from G. 1932g.

GW 14 *Mysterium Coniunctionis. Untersuchung über die Trennung und Zusammensetzung der seelischen Gegensätze in der Alchemie.* Unter Mitarbeit von Marie-Louise von Franz. (Gesammelte Werke, 14.) In two volumes. 1968. Vol. 2 contains 7 plates and 3 text illus. G. 1955a and 1956a reprinted, front matter reset, and with the addn. of a trans. of Greek and Latin texts, bibliography, and an editor’s foreword. For contents, see G. 1955a and G. 1956a. Paragraph nos. conform to those of G. 1955a and G. 1956a and vary from CW 14.

Note: Ergänzungsband: “*Aurora Consurgens.*” *Ein dem Thomas von Aquin zugeschriebenes Dokument der alchemistischen Gegensatzproblematik*, von

Dr. M.-L. von Franz. (Gesammelte Werke, 14, Ergänzungsband.) Olten:
Walter. 1973. Published as a supplemental volume to the *Gesammelte Werke*.

GW 15 *Über das Phänomen des Geistes in Kunst und Wissenschaft*. (Gesammelte Werke, 15.) 1971.

1. "Paracelsus." (11–20) G. 1934b,5 repub. Cf. G. 1952c.
2. "Paracelsus als Arzt." (21–41) G. 1942a,1 repub.
3. "Sigmund Freud als kulturhistorische Erscheinung." (43–51) G. 1934b,6 repub.
4. "Sigmund Freud." (53–62) G. 1939d repub.
5. "Zum Gedächtnis Richard Wilhelms." (63–73) G. 1957b,2 repub.
6. *Über die Beziehungen der analytischen Psychologie zum dichterischen Kunstwerk.* (75–96) G. 1931a,3 repub.
7. "Psychologie und Dichtung." (97–120) G. 1950a,2 repub. with the addition of a "Vorrede" pub. here for the first time in the original German, found posthumously. TR. (including "Vorrede")—English: CW 15,7.
8. "'Ulysses' Ein Monolog." (121–49) G. 1934b,7 repub, "Anhang" (pp. 146–49) includes a trans. by Elisabeth Rief of a letter written to James Joyce in English (27 Sept. 1932). For text of orig. letter, see CW 15,8 and E. 1973b.
9. "Picasso." (151–57) G. 1934b,8 repub.

CW 16 *The Practice of Psychotherapy. Essays on the Psychology of the Transference and Other Subjects*. (Collected Works, 16.) 1954: 1st edn. 1966: 2d edn. (no. 13 fully reset). With 3 plates and 10 text illus.

1. "Foreword to the Swiss Edition (1958)." Trans. from GW 16,1. (2d edn. only.)

Part One.

2. "Principles of Practical Psychotherapy." (3–20)
 3. "What is Psychotherapy?" (21–28) Trans. from G. 1935g.
 4. "Some Aspects of Modern Psychotherapy." (29–35) E. 1930b repub. TR.—German: GW 16,4.
 5. "The Aims of Psychotherapy." (36–52) Trans. from G. 1931a,5.
 6. "Problems of Modern Psychotherapy." (53–75) Trans. from G. 1931a,2.
 7. "Psychotherapy and a Philosophy of Life." (76–83) Trans. from G. 1943e.
 8. "Medicine and Psychotherapy." (84–93) Trans. from G. 1945e.
 9. "Psychotherapy Today." (94–110) Trans. from G. 1945f.
 10. "Fundamental Questions of Psychotherapy." (111–25) Trans. from G. 1951d.
- Part Two.

11. "The Therapeutic Value of Abreaction." (129–38) E. 1928a,11, trans. slightly rev. and with title change.
12. "The Practical Use of Dream-Analysis." (139–61) Trans. from G. 1934b,4. Repub. as E. 1974a,5.
13. "The Psychology of the Transference." (163–321) 1st edn. [(163–323) 2d edn.] Trans. from G. 1946c. (Trans. rev. for 2d edn.) Repub. (2d edn. version) as E. 1969d. Introduction (1st edn. version) repub. as E. 1959a,9. Appendix (2d edn. only):
14. "The Realities of Practical Psychotherapy." (327–38) Trans. from an unpub. ms. Lecture given to II. Tagung für Psychotherapie, Bern, 28 May 1937

GW 16 *Praxis der Psychotherapie. Beiträge zum Problem der Psychotherapie und zur Psychologie der Übertragung.* (Gesammelte Werke, 16.) 1958. With 3 plates and 11 text illus.

1. "Geleitwort des Autors." (ix–x) Dated Aug. 1957. TR.—English: CW 16,1.
2. "Grundsätzliches zur praktischen Psychotherapie." (1–20) G. 1935g repub. Repub. as G. 1972c,2.
3. "Was ist Psychotherapie?" (21–29) G. 1935g repub. Repub. as G. 1972c,3.
4. "Einige Aspekte der modernen Psychotherapie." (30–37) Trans. from CW 16,4 by the editors. Repub. as G. 1972c,4.
5. "Ziele der Psychotherapie." (38–56) G. 1931a,5 repub.
6. "Die Probleme der modernen Psychotherapie." (57–81) G. 1931a,2 repub.
7. "Psychotherapie und Weltanschauung." (82–89) G. 1946a,4 repub. Repub. as G. 1972c,6.
8. "Medizin und Psychotherapie." (90–99) G. 1945e repub. Repub. as G. 1972c,7.
9. "Die Psychotherapie in der Gegenwart." (100–17) G. 1946a,3 repub. Repub. as G. 1972c,8
10. "Grundfragen der Psychotherapie." (118–33) G. 1951d repub. Repub. as G. 1972c,1.
11. "Der therapeutische Wert des Abreagierens." (137–47) Trans. from E. 1921a by the editors. Repub. as G. 1972c,5.
12. "Die praktische Verwendbarkeit der Traumanalyse." (148–71) G. 1934b,4 repub.
13. "Die Psychologie der Übertragung." (173–345) G. 1946c repub.

CW 17 *The Development of Personality.* (Collected Works, 17.) 1954.

1. "Psychic Conflicts in a Child." (1–35) Trans. from G. 1946b,2. Repub. as E. 1969c,1.

2. "Introduction to Wickes's *Analyse der Kinderseele*." (37–46) Trans. from G. 1931e. Repub. as E. 1966c.
3. "Child Development and Education." (47–62) E. 1928a,13, Lecture I, slightly rev. Repub. as E. 1969c,2. TR.—German: GW 17,3.
4. "Analytical Psychology and Education." (63–132) Trans. from G. 1946b,1. Repub. as E. 1969c,3.
5. "The Gifted Child." (133–45) Trans. from G. 1946b,3. Repub. as E. 1969c,4.
6. "The Significance of the Unconscious in Individual Education." (149–64) Trans. from a German ms. subsequently pub. as G. 1971a,5.
7. "The Development of Personality." (165–86) Trans. from G. 1934b,9.
8. "Marriage as a Psychological Relationship." (187–201) Trans. from G. 1931a,11. Repub. as E. 1959a,12 and as E. 1971a,7.

CW 18 *The Symbolic Life; Miscellaneous Writings*. (Collected Works, 18.) 1975. Trans. by R.F.C. Hull with contributions from others. (Translations are Hull's except as otherwise noted.)

1. "The Tavistock Lectures." (1–18) E. 1968a repub.
2. "Symbols and the Interpretation of Dreams." (18–264) Written in English in 1961. English ms. here rev. by R.F.C. Hull. Pub., extensively rev. and rearranged under the supervision of John Freeman in collaboration with Marie-Louise von Franz, with title change, as E. 1964a.
3. "The Symbolic Life." (267–90) E. 1954c repub., sl. rev.
4. "On Spiritualistic Phenomena." (293–308) Trans. from G. 1905e.
5. "Foreword to Jung: *Phénomènes occultes*." (309–11) Trans. from the German ms. Cf. Fr. 1939a,1.

GW 17 *Über die Entwicklung der Persönlichkeit*. (Gesammelte Werke, 17.) 1972.

1. "Über Konflikte der kindlichen Seele." (11–47) G. 1946b,2 repub.
2. "Einführung zu Frances G. Wickes *Analyse der Kindesseele*." (49–58) G. 1931e repub. with title change.
3. "Die Bedeutung der Analytischen Psychologie für die Erziehung." (59–76) G. 1971a,4 repub.
4. "Analytische Psychologie und Erziehung." (77–153) G. 1946b,1 repub.
5. "Der Begabte." (155–68) G. 1946b,3 repub.
6. "Die Bedeutung des Unbewussten für die individuelle Erziehung." (169–87) G. 1971a,5 repub.
7. "Vom Werden der Persönlichkeit." (189–211) G. 1934b,9 repub.
8. "Die Ehe als psychologische Beziehung." (213–27) G. 1931a,11 repub.

GW 18 *Das symbolische Leben*. (Gesammelte Werke, 18.) [Not yet published.]

6. "Psychology and Spiritualism." (312–16) Trans. from G. 1948e.
7. "Foreword to Moser: *Spuk: Irrglaube oder Wahrglaube?* (317–20) Jung's Contribution. (320–26) Trans. from G. 1950e.
8. "Foreword to Jaffé: *Apparitions and Precognition.*" (327–29) E. 1963b repub., trans. sl. rev.
9. "The Present Status of Applied Psychology." (333–34) Trans. from G. 1908o by Wolfgang Sauerländer.
10. "On Dementia Praecox." (335) Trans. from G. 1910s.
11. "Review of Sadger: *Konrad Ferdinand Meyer.*" (336–38) Trans. from G. 1909h.
12. "Review of Waldstein: *Das unbewusste Ich.*" (339–42) Trans. from G. 1909i.
13. "Crime and the Soul." (343–46) E. 1932c repub. with minor rev. in accordance with the German version, G. 1933a.
14. "The Question of Medical Intervention." 822–25 (347–48) Trans. from G. 1950g.
15. "Foreword to Custance: *Wisdom, Madness and Folly.*" (349–52) E. 1952a repub., trans. rev.
16. "Foreword to Perry: *The Self in Psychotic Process.*" (353–56) E. 1953e repub.
17. "Foreword to Schmaltz: *Komplexe Psychologie und körperliches Symptom.*" (357–58) Trans. from G. 1955c.
18. "Sigmund Freud: *On Dreams.*" (361–68) Trans. from a German ms. found posthumously and dated 25 January 1901. Prepub. as E. 1973d,1. Apparently a report given to colleagues at Burghölzli Mental Hospital.
19. "Review of Hellpach: *Grundlinien einer Psychologie der Hysterie.*" (369–73) Trans. from G.1905b.
20. "Reviews of Psychiatric Literature (1906–1910)." (374–87) Trans. from G. 1906e, f, and h; 1907b,c, and d; 1908e, f, g, h, and k; 1909d-g; and 1910a-j.
21. "The Significance of Freud's Theory for Neurology and Psychiatry." (388–89) Trans. from G. 1908d by Wolfgang Sauerlander.
22. "Review of Stekel: *Nervöse Angstzustände und ihre Behandlung.*" (390–91) Trans. from G.igo8j by Wolfgang Sauerlander.
23. "Editorial Preface to the *Jahrbuch* (1909)." (392) Trans. from G. 1909b.
24. "Marginal Notes on Wittels: *Die sexuelle Not.*" (393–96) Trans. from G. 1910l. Prepubas E.1973d'2
25. "Review of Wulffen: *Der Sexualverbrecher.*" (397) Trans. from G. 1910p.

26. "Abstracts of the Psychological Works of Swiss Authors." (398–421) Trans. from G. 1910m. List of abstracts made for the *Folia-Neurobiologica* follows. Cf. G. 1908c,i, and l.
27. "Review of Hitschmann: *Freuds Neurosenlehre*." (422) Trans. from G. 1911d.
28. "Annual Report by the President of the International Psychoanalytic Association." (423–26) Trans. from G. 1911g by Wolfgang Sauerländer.
29. "Two Letters on Psychoanalysis." (427–29) Trans. from G. 1912e and f.
30. "On the Psychoanalytic Treatment of Nervous Disorders." (430–32) Trans. from G. 1912h.
31. "A Comment on Tausk's Criticism of Nelken." (433–37) Trans. from G. 1913d. Prepub. as E.1973d'3
32. "Answers to Questions on Freud." (438–40) E. 1968f repub. Written in English and dated 7 Aug. 1953
33. "The Concept of Ambivalence." (443–45) Trans. from G. 1911h by Wolfgang Sauerlander.
34. "Contributions to Symbolism." (446) Trans. from G. 191 if by Wolfgang Sauerlander.
35. "Adaptation, Individuation, Collectivity." (449–54) Trans. from the unpub. German typescripts found posthumously and dated Oct. 1916. Prepub. as E. 1970c.
36. "Foreword to the Hungarian Edition of *On the Psychology of the Unconscious*." (455–56). Trans. from the German ms. dated Jan. 1944. Cf. Hu 1948a.
37. "Forewords to Jung: *Über psychische Energetik und das Wesen der Träume*." (459–60) Trans. from G. 19480,1.
38. "On Hallucination." (461) Trans. from G. 1933t.
39. "Foreword to Schleich: *Die Wunder der Seele*." (462–66) Trans. from G. 1934e.
40. "Foreword to Jacobi: *The Psychology of C. G. Jung*." (467–68) E. 1962c repub., trans. rev. Pub. in a dif. trans. as E. 1942c.
41. "Foreword to the Spanish Edition." (See no. 40.) (468) Trans. from the German ms. Cf. Sp. 1947a.
42. "Foreword to Harding: *Psychic Energy*." (469–70) E. 1947e repub., trans. sl. rev.
43. "Address on the Occasion of the Founding of the C. G. Jung Institute, Zurich, 24 April 1948." (471–76) Trans. from the unpub. German typescript (471–76) Trans. from the unpub. German typescript.

44. "Depth Psychology." (477–86) Trans. from G. 1951c
45. "Foreword to the First Volume of Studies from 1163–64 the C. G. Jung Institute." (487–88) Trans. from G. 1949e
46. "Foreword to F. Fordham: *Introduction to Jung's Psychology*." (489–90) E. 1953d repub.
47. "Foreword to M, Fordham: *New Developments in Analytical Psychology*." (491–93) E. 1957g repub.
48. "An Astrological Experiment." (494–501) Trans. from G. 1958f with the exception of par. 1187, which was subsequently added to the German ms., and par. 1188, added to a letter by the translator, dated 23 Apr. 1954.
49. "Letters on Synchronicity." (502–09) To Markus Fierz (21 Feb. 1950; 2 Mar. 1950; 20 Oct. 1954; 28 Oct. 1954). ?Trans. from the orig. German letters. To Michael Fordham (1 July 1955). Written in English.
50. "The Future of Parapsychology." (510–11) E. 1213–22 1963e repub.
51. "The Hypothesis of the Collective Unconscious." (515–16) Trans. from G. 1932i.
52. "Foreword to Adler: *Entdeckung der Seele*." (517) Trans. from G. 1934d.
53. "Foreword to Harding: *Woman's Mysteries*." (518–20) E. 1955e repub., trans. rev.
54. "Foreword to Neumann: *The Origins and History of Consciousness*." (521–22) E. 1954f repub.
55. "Foreword to Adler: *Studies in Analytical Psychology*." (523–24) E. 1966e repub.
56. "Foreword to Jung: *Gestaltungen des Unbewussten*." (525–26) Trans. from G. 1950a,1.
57. "Foreword to Wickes: *Von der inneren Welt des Menschen*." (527–28) Trans. from G. 1953b.
58. "Foreword to Jung: *Von den Wurzeln des Bewusstseins*." (529) Trans. from G. 1954b,1.
59. "Foreword to van Heisdingen: *Beelden uit het onbewuste*." (530–31) Trans. from G. 1957f.
60. "Foreword to Jacobi: *Complex/Archetype/Symbol*" (532–33) E. 1959e repub.
61. "Foreword to Bertine: *Human Relationships*." (534–36) E. 1958e repub., trans. sl. rev.
62. "Preface to de Laszlo: *Psyche and Symbol*." (537–42) E. 1958a,1 repub., sl. rev.
63. "Foreword to Brunner: *Die Anima als Schicksals-problem des Mannes*." (543–47) Trans. from G. 1963a.

64. "Report on America." (551) Trans. from G.1910.
65. "On the Psychology of the Negro." (552) Trans. from G. 1913c.
66. "A Radio Talk in Munich." (553–57) Trans. from an unpub. German ms. dated 19 Jan. 1930.
67. "Forewords to Jung: *Seelenprobleme der Gegenwart.*" (558–60) Trans. from G. 1931a, 1 and from the orig. German ms. pub. in trans. as the Foreword to It. 1959c. Dated Dec. 1930, July 1932, and March 1959.
68. "Foreword to Aldrich: *The Primitive Mind and Modern Civilization.*" (561–63) E. 1931b repub., trans. si. rev.
69. "Press Communiqué on Visiting the United States (1936)." (564–65) Unpub. typescript written in English and dated Sept. 1936.
70. "Psychology and National Problems." (566–81) Unpublished typescript written in English. Lecture given at the Institute of Medical Psychology (Tavistock Clinic), London, 14 Oct. 1936
71. "Return to the Simple Life." (582–88) Trans. from G. 1941e.
72. "Epilogue to Jung: *L'Homme à la découverte de son âme.*" (589–90) Trans. from Fr. 1944a,9 by A.S.B. Glover.
73. "Marginalia on Contemporary Events." (591–603) Trans. from a German typescript dated 1945, the last 9 pars. of which were pub. as G.1946g.
74. "Answers to *Mishmar* on Hitler." (604–05) Trans. from a letter written 14 Sept. 1945 in German to Eugen Kolb, Swiss representative for the Israeli newspaper, *Al Hamishmar*. Cf. He. 1974a.
75. "Techniques of Attitude Change Conducive to World Peace (Memorandum to UNESCO)." (606–13) Unpublished typescript/manuscript written in English in response to a request from UNESCO.
76. "The Effect of Technology on the Human Psyche." (614–15) Trans. from G. 1949g.
77. "Foreword to Neumann: *Depth Psychology and a New Ethic.*" (616–22) E. 1969e repub., trans. sl. rev.
78. "Foreword to Baynes: *Analytical Psychology and the English Mind.*" (623–24) E. 1950b repub.
79. "Rules of Life." (625) Trans. from G. 1954f
80. "On Flying Saucers." (626–31) Trans. from G. 1954e.
81. "Statement to the United Press International." (631–32) Trans. from G. 1958h.
82. "Letter to Keyhoe." (632–33) E. 1959g repub.
83. "Human Nature Does Not Yield Easily to Idealistic Advice." (634–35) E. 1955h repub.

84. "On the Hungarian Uprising." (636) Trans. from G. 1956f and G. 1957c, here combined.
85. "On Psychodiagnostics." (637) Trans. from G.1958g.
86. "If Christ Walked the Earth Today." (638) E. 19581 repub. with title change.
87. "Foreword to *Hugh Crichton Miller 1877–1959.*" (639–41) E. 1961b repub., si. rev.
88. "Why I Am Not a Catholic." (645–47) Trans. by Hildegard Nagel from a letter written in German to H. Irminger (22 Sept. 1944) and never sent.
89. "The Definition of Demonism." (648) Trans. from a definition written in July 1945, of which only the first sentence and the references were pub. as G. 1949h.
90. "Foreword to Jung: *Symbolik des Geistes.*" (649–50) Trans. from G. 1948a,1.
91. "Foreword to Quispel: *Tragic Christianity.*" (651–53) Trans. from an unpub. German ms.
92. "Foreword to Abegg: *Ostasien denkt anders.*" (654–55) E- 1955j; rePub
93. "Foreword to Allenby: *The Origins of Monotheism.*" (656–59) Trans. from an unpub. German ms.
94. "The Miraculous Fast of Brother Klaus." (660–61) Trans. from G. 1951e. Rev. from a letter to Fritz Blanke (10 Nov. 1948). Cf. E. 1973b for a trans. of entire orig. letter.
95. "Concerning 'Answer to Job'." (662) Trans. from GW 11,23 by Ruth Horine. Jung's description, printed on the dust jacket of the orig. edn., ca. 1 April 1952. Cf. G. 1952a.
96. "Religion and Psychology: A Reply to Martin Buber." (663–70) E. 1973e repub. (German text pub. in GW 11.)
97. "Address at the Presentation of the Jung Codex." (671–72) Given in Zurich, 15 Nov. 1953. Trans. from a German ms. pub. as G. 1975a,4. (Cf. no. 135, below.)
98. "Letter to Père Bruno." (673–78) Trans. from Fr. 1956b by A.S.B. Glover and Jane A. Pratt. Dated 5 Nov. 1953. Cf. letters to Bruno (22 Dec. 1954; 20 Nov. 1956) in E. 1975a.
99. "Letter to Père Lachat." (679–91) Trans. from the French by A.S.B. Glover. Dated 27 March 1954. Cf. letters to Lachat (18 Jan. and 29 June 1955) in E. 1975a.
100. "On Resurrection." (692–96) Written in English in reply to an inquiry and dated 19 Feb. 1954.

101. "On the Discourses of the Buddha." (697–99) Trans. from G. 1956c.
(German text pub. as GW 11,26.)
102. "Foreword to Froboese-Thiele: *Träume—eine Quelle religiöser Erfahrung?*"
(700–01) Trans. from G. 1957e.
103. "Jung and Religious Belief." (702–44) E, 1958c repub., with minor stylistic
rev, addl, footnotes, and addn. of title. Cf. letter to H. L. Philp (11 June
1957) in E, 1976a
104. "Foreword to a Catalogue on Alchemy." (747) E. 1968d repub., si. rev. and
with the addn. of a title.
105. "Faust and Alchemy." (748–50) Trans. from G. 1950b by Hildegard Nagel.
106. "Alchemy and Psychology." (751–53) Written in English for the
Encyclopedia Hebraica, and pub. here with minor stylistic rev. TR.—
Hebrew: 1950/5
107. "Memorial to J. S." (757–58) E. 1955c repub. Spoken in English in memory
of Jerome Schloss, 1927.
108. "Foreword to Schmid-Guis: *Tag und Nacht.*" (759–60) Trans. from G.1931a.
109. "Hans Schmid-Guisan: In Memoriam." (760–61)—15 Trans. from G. 1932d.
110. "On the Tale of the Otter." (762–64) Trans. from G.1932b.
111. "Is There a Freudian Type of Poetry?" (765–66) Trans. from the unpub.
German ms. Cf. Fr.1932b.
112. "Foreword to Gilbert: *The Curse of the Intellect.*" (767) Written in English
for the book, which was never pub., and dated Jan. 1934.
113. "Foreword to Jung: *Wirklichkeit der Seele.*" (768–69) Trans. from G.
1934b,1.
114. "Foreword to Mehlich: *J. H. Fichtes Seelenlehre und ihre Beziehung zur
Gegenwart.*" (770–72) Trans. from G. 1935e.
115. "Foreword to von Koenig-Fachsenfeld: *Wand-hingen des Traumproblems
von der Romantik bis zur Gegenwart.*" (773–75) Trans. from G. 1935-d
116. "Foreword to Gilli: *Der dunkle Bruder.*" (776–78) Trans. from G. 1938d.
117. "Gérard de Nerval." (779) Trans. from G. 1946d.
118. "Foreword to Fierz-David: *Dream of Poliphilo.*" (780–81) E.1950c repub.,
trans. rev.
119. "Foreword to Crottet: *Mondwald.*" (782–83) Trans. from G.1949c.
120. "Foreword to Jacobi: *Paracelsus: Selected Writings.*" (784–85) E.1951b
repub., sl. rev.
121. "Foreword to Kankleit: *Das Unbewusste als Keimstätte des
Schöpferischen.*" (786) "Jung's Contribution." (786–87) Trans. from G.
1959d.

122. "Foreword to Serrano: *The Visits of the Queen of Sheba.*" (788) E.1960b repub., somewhat rev. Cf. E.19660,1.
123. "Is There a True Bilingualism?" (789) Trans. from Fr. 1961d by R.F.C. Hull.
124. "Review of Heyer: *Der Organismus der Seele.*" (793–94) Trans, from G.1933d.
125. "Review of Heyer: *Praktische Seelenheilkunde.*" (794–96) Trans. from G. 193Öd.
126. "On the *Rosarium Philosophorum.*" (797–800) Trans. from G. 1938b.
127. "Preface to an Indian Journal of Psychotherapy." (801) E. 1956e repub.
128. "On Pictures in Psychiatric Diagnosis." (802) Trans. from G. 1959h by Hildegard Nagel.
129. "Foreword to Evans: *The Problem of the Nervous Child.*" (805–06) E. 1920a repub.
130. "Foreword to Harding: *The Way of All Women.*" (807–10) E. 1933b repub.
131. "Depth Psychology and Self-Knowledge." (811–19) E. 196gf repub.
132. "Foreword to Spier: *The Hands of Children.*" (820–21) E. 1944b repub., trans. rev.
133. "Foreword to the Hebrew Edition of Jung: *Psychologie und Erziehung.*" (822) Trans. from an unpub. German ms. Cf. He. 1958a. Appendix.
134. "Foreword to *Psychologische Abhandlungen, Volume I.*" (825) Trans. from G. 1914c by Lisa Ress.
135. "Address at the Presentation of the Jung 1826–34 Codex." (8?6-??) Item no. 97, above, the trans. revised and augmented by Lisa Ress, from a German ms.

III

SEMINAR NOTES

SEMINAR NOTES

References are added, in square brackets, to the copies in the Kristine Mann Library, Analytical Psychology Club of New York, * = not examined.

1923 [*Human Relationships in Relation to the Process of Individuation.*] Unpub. typescript. 27 + 11 pp. Given at Polzeath, Cornwall, England, July 1923. Unauthorized longhand notes taken for their own use by M. Esther Harding and Kristine Mann. Also known as the “Cornwall Seminar.” [KML 1]

1925a [*Analytical Psychology.*] *Notes on the Seminar in Analytical Psychology ...* [Comp. by Cary F. de Angulo and rev. by C. G. Jung.] Arranged by members of the class. Zurich: multigraphed typescript. 227 pp. Figs. Given in Zurich, 23 Mar.-6 July 1925. Indexed. Cf. Sem. 1939 index. Spine title: *Analytical Psychology.* [KML 2]

1925b [*Dreams and Symbolism.*] Lectures at Swanage. Xeroxed typescript. 101 pp. Given at Swanage, England, July-Aug. 1925. Unauthorized longhand notes taken by M. Esther Harding. Also known as the “Swanage Seminar.” [KML 3]

1928–30 *Dream Analysis.* Notes of the Seminars in Analytical Psychology ... [1930: 1st edn.] Zurich: multigraphed typescript. 6 pts. in 5 vols. * 1938: 2d [unalt.] edn. Ed. by Carol S. Baumann. 1958: 3d [unalt.] edn. Zurich: Privately printed [typewriter comp., offset] for the Psychology Club Zurich. 2 vols. Given in Zurich, 7 Nov. 1928–25 June 1930.

Contents of 1st edn. (vols.):

1: 7 Nov.-12 Dec. 1928. Arranged by Anne Chapin. 68 pp.

2/3: 23 Jan.-26 June 1929. Comp. and ed. by Charlotte H. Deady. 285 pp.

4: 9 Oct.-11 Dec. 1929. Comp. and ed. by Mary Foote. 212 pp.

5: 22 Jan.-26 Mar. 1930. Comp. and ed. by Mary Foote. 190 pp.

6: 7 May-25 June 1930. Arranged and ed. by Mary Foote. 219 pp. Includes index of dreams in all vols., pp. 218–19.

Indexed in Sem. 1932b index and in Sem. 1939 index.

Contents of 3d edn. (vols.):

1: 7 Nov. 1928–26 June 1929. 215 pp. Notes with this edn. say that the material was comp. and ed. by Mary Foote from the notes of Anne Chapin and Ethel Taylor.

2: 9 Oct. 1929–25 June 1930. 298 pp. Notes with this edn. say that the material was comp. and ed. by Charlotte H. Deady and reed. by Carol F. Baumann. [KML 6, S. 3 & 4]

1930–31 *Bericht über das deutsche Seminar ...* Comp. and ed. by Olga von Koenig-Fachsenfeld. 1931–32, 2d ptg. Stuttgart: Privately printed. 2 vols. Given in Küsnacht/Zurich, 6 Oct. 1930–10 Oct. 1931. Contents (vols.):

1: 6–11 Oct. 1930. 113 pp. Figs + 21 plates. Also contains R. Heyer: “Bericht über C. G. Jungs analytisches Seminar.” *Zentralblatt für Psychotherapie.*, ... 4:1, 104–10.

2: 5–10 Oct. 1931. 153 pp. Figs. + 16 plates.

Spine title: *Deutsches Seminar*. ?Also known as *Zur Psychologie der Individuation*. [KML 8,9]

1930–34 [*Interpretation of Visions.*] Notes of the Seminars in Analytical Psychology. Ed. by Mary Foote. Autumn 1930–Winter 1934. Zurich: multigraphed typescript. 11 vols. + 1 of 29 plates. * 1939–41: New edn. Given in Zurich, 15 Oct. 1930–21 Mar. 1934. Indexed in Sem. 1932b index and Sem. 1939 index. Spine title: *Visions*. [KML ?]

Excerpts pub. in 10 installments, each titled “The Interpretation of Visions. Excerpts from the Notes of Mary Foote.” Selected and ed. by Jane A. Pratt. *Spring 1960–69*. New York: Analytical Psychology Club. Installments:

1. 30 Oct.-5 Nov. 1930. *Spring 1960*. pp. 107–48.

2. 12 Nov.-9 Dec. 1930. *Spring 1961*. pp. 109–51.

3. 13 Jan.-25 Mar. 1931. *Spring 1962*. pp. 107–57.

4. 6 May-24 June 1931. *Spring 1963*. pp. 102–47.

5. 11 Nov.-16 Dec. 1931. *Spring 1964*. pp. 97–138.

6. 16 Dec.-10 Feb. 1932. *Spring 1965*. pp. 100–41.

7. 17 Feb.-9 Mar. 1932. *Spring 1966*. pp. 121–53.

8. 9 Mar.-22 June 1932. *Spring 1967*. pp. 86–147.

9. 1 June 1932–18 Jan. 1933. *Spring 1968*. pp. 53–132.

10. 25 Jan-21 June 1933. *Spring 1969*. pp. 7–72.

Republ. as *The Visions Seminars*. With parts 11–13 ed. by Patricia Berry. Zurich: Spring Pubis., 1976. 2 vols. pp. 534, 28 pls.

1932a With J. W. Hauer: *The Kundalini Yoga*. Notes on the seminar given by J. W. Hauer with Psychological Commentary by C. G. Jung. Comp. by Mary Foote. Autumn 1932. [1st edn.] Zurich: multigraphed typescript. 216 pp. illus. *1940: 2d edn. Given at the Psychologischer Club Zurich, by Hauer 3–8 Oct. and by Jung 12, 19, and 26 Oct. and 2 Nov. 1932. 1st edn. contains the following material of Jung's:

1. "Psychological Commentary." Lectures I-IV. (131–216) Lectures I—III given in English. Lecture IV given in German, "arranged by [Toni] Wolff for the report of the German seminar, with additional material from Dr. Jung," and trans. by Cary F. Baynes.

Also known as the "Tantra Yoga Seminars." [KML 10]

1st 2 lectures republ., sl. rev., as "Psychological Commentary on Kundalini Yoga. Lectures One and Two." *Spring 1975*. pp. 1–32. Zurich: Analytical Psychology Club of New York.

Also issued in a German version: *Bericht über das Seminar von Prof. Dr. J. W. Hauer*. 3–8 Oktober 1932 im Psychologischer Club Zurich. 1933: Zurich: multigraphed typescript. Contains the following Jung material:

1. "Erstes-Viertes englische(s) Seminar(e)." (105–48) [?Trans. and] ed. by Linda Fierz and Toni Wolff from the notes of the English seminars, with the exception of the fourth seminar, as noted above under the English version.
2. "Westliche Parallelen zu den tantrischen Symbolen." (153–58) Condensed version of seminar given during the same period as those above.

1932b [*Index to Dream Analysis and Interpretation of Visions; Notes of the English Seminars*,] Autumn 1928–Spring 1932. Comp. by Carol Sawyer [Baumann]. 1932: Zurich: multigraphed typescript. 36 pp. Includes chronological list of dreams and visions, and list of reference books mentioned. Incorporated in Sem. 1939, index. Paging corresponds to that of the first edns. Spine title: *Index to Dreams and Visions, 1928–32*.

1933 *Bericht über das Berliner Seminar ...* 1933. [1st edn.]. Berlin: multigraphed typescript. 199 pp. 1950's, 2d ptg. Zurich. 165 pp. Given in Berlin, 26 June-1 July 1933. Contains the following Jung material:

1. "Stenogramm des Seminars ..." (1–165) Shorthand notes of the seminars.

2. "Stenogramm des Zwiegesprächs von ... Jung und A. Weizsäcker in der Funkstunde Berlin," 26 June 1933. (166–73) Interview broadcast over Berlin radio on 26 June 1933.

Also known as the "Berliner Seminare" and possibly as "Über Träume." A 2d vol. of seminars given in Berlin in 1934 is said to exist.

1933–41 *Modern Psychology*. Notes on lectures ... [1934?–42, 1st edn.] Zurich: multigraphed typescript. 6 vols. 1959–60: 2d edn. Zurich: Privately printed [typewriter comp., offset]. 6 vols. in 3. Given at the Eidgenössische Technische Hochschule, Zurich, 20 Oct. 1933–11 July 1941.

Arrangement of contents in the 1st edn. (vols.):

- 1: *Modern Psychology*. 20 Oct. 1933–23 Feb. 1934. 77 pp.
- 2: *Modern Psychology*. 20 Apr. 1934–12 July 1935. 163 pp. Both these vols. comp. and trans., from shorthand notes, by Elizabeth Welsh and Barbara Hannah.
- 3: *Process of Individuation: [Eastern Texts]*. 28 Oct. 1938–23 June 1939. 166 pp. Comp. and trans. by Barbara Hannah.
- 4: *Process of Individuation: Exercitia Spiritualia of St. Ignatius of Loyola*. 16 June 1939–8 Mar. 1940. 42 pp. Comp. and trans. from the shorthand notes of Riwkah Schärf by Barbara Hannah.
- 5: *Process of Individuation: Alchemy I*. 8 Nov. 1940–28 Feb. 1941. pp. 157. Comp. and trans. from the shorthand notes of Riwkah Schärf by Barbara Hannah.
- 6: *Process of Individuation: Alchemy II*. 2 May–11 July 1941. pp. 152. Comp. and trans. from the shorthand notes of Riwkah Schärf by Barbara Hannah.

Arrangement of contents in the 2d edn. (vols.):

- 1/2: *Modern Psychology*.
- 3/4: *The Process of Individuation: [Eastern Texts]*. (11–101) *The Process of Individuation: Exercitia Spiritualia of St. Ignatius of Loyola*. (102–264)
- 5/6: *The Process of Individuation: Alchemy I*. (11–130) *The Process of Individuation: Alchemy II*. (135–231). Index (235–53). [KML 15, 16]

1934–39 *Psychological Analysis of Nietzsche's Zarathustra*. Notes on Seminars ... Ed. by Mary Foote. Spring 1934–Winter 1939. 1st edn. Zurich: multigraphed typescript. 10 vols. + index vol. *[n.d.: 2d edn.] Given in Zurich. Vol. 1–3

typed double-spaced; 4–10 single-spaced.* In the 2d edn., spacing is the same in all vols. [KML 17, 18]

Extracts of vol. 7 pub. as follows: [1] “Answer by Dr. Jung to a Question Concerning the Archaic Elements in the Self. Zurich Seminar June 3, 1936.” *Bull. APC*, 30:5 (May), 14–19. A version, taken from some student’s notes, of Jung’s spoken reply given in the course of his seminar, Zurich, 3 June 1936. (The seminar notes above contain a dif. version, Pt. 7, pp. 80–85.) [2] “Comments on a Passage from Nietzsche’s Zarathustra (1936).” *Spring* 1972. pp. 149–61. Zurich: Analytical Psychology Club of New York. Excerpted from the seminar notes, Pt. 7, Lecture 2 (13 May 1936), pp. 18–29, and slightly re-edited.

Index vol.: *Index of the Notes on Psychological Analysis of Nietzsche’s Zarathustra ... Vols. 1–10, 1934–1939* [1st edn.]. Comp. by Mary Briner. 1942, Zurich: multigraphed typescript. 58 pp. [KML 19]

1934 * [*Bericht über das Basler Seminar.*] 1–6 October 1934. No editor named. Basel, 1935: multigraphed typescript, untitled. pp. 89.

1935 *Fundamental Psychological Conceptions. A Report of Five Lectures ...* Ed. by Mary Barker and Margaret Game for the Analytical Psychology Club, London, 1936. London: multigraphed typescript. 235 pp. Given under the auspices of the Institute of Medical Psychology, London, 30 Sept.-4 Oct. 1935. Pub., sl. rev., with title change, as E. 1968a and CW 18,1. Also known as the “London Lectures” and as the “Tavistock Lectures.” [KML 20]

1936–37a Lectures at the ETH, Zurich, Oct. 1935–July 1936. Comp. by Barbara Hannah, Una Gauntlett Thomas, and Elizabeth Baumann.

1936–37a *Dream Symbols of the Individuation Process.* Ed. from members’ notes by Kristine Mann, M. Esther Harding, and Eleanor Bertine, with the help of Sallie Pinckney. New York: multigraphed typescript. 1937–38. 2 vols. Based on shorthand transcripts “as near verbatim as possible.” Contents (vols.):

1: Seminar at Bailey Island, Maine. 20–25 Sept. 1936. Also known as the “Bailey Island Seminar.”

2: Seminar in New York City, 16–18, 25–26 Oct. 1937. Also known as the “New York Seminar.” [KML 22]

1936–37b *Seminar über Kinderträume und ältere Literatur über Traum-Interpretation.* Ed. by Hans H. Baumann. [?1937] Zurich: multi-graphed typescript. 115 pp. Given at the Eidgenössische Technische Hochschule, Zurich, Winter Semester 1936–37. Spine title: *Kinderträume. W.S. 1936–37.* [KML 21]

Excerpt trans. and pub. as follows: "A Seminar with C. G. Jung: Comments on A Child's Dream (1936–37)." *Spring 1074*. pp. 200–23. Zurich: Analytical Psychology Club of New York. Trans. by Eugene H. Henley from the seminar above.

1937 * *Bericht über die Berliner Vorträge*. 28–29 September 1937. Ed. by Marianne Stark. Berlin, 1937: multigraphed typescript. pp. 55, with 52 photographs.

1938–39 *Psychologische Interpretation von Kinderträumen und ältere Literatur über Träume*. Ed. by Liliane Frey and Riwkah Schärf from stenographic transcripts. [n.d. 1st edn.] [1950's] 2d edn. Zurich: [Privately printed for the C. G. Jung-Institut] Eidgenössische Technische Hochschule. 217 pp. Given at the ETH, Zurich, 25 Oct. 1938–7 Mar. 1939. Spine title: *Kinderträume, W.S. 1938/39*. A supplementary vol. of students' papers, made up for the 1st edn., has been added to the 2d edn. as an "Anhang." [KML 24, 25] Trans. as follows: *Psychological Interpretation of Children's Dreams*. Notes on Lectures ... 1938–39. Zurich: multigraphed typescript. 143 pp. Trans. from the German above by Mary Foote, with the help of Cornelia Brunner. Spine title: *Children's Dreams*. [KML 23]

1939 [*Index to Analytical Psychology, Dream Analysis, and Interpretation of Visions; Notes of the English Seminars, 1925–Winter 1934.*] Comp. by Mary Briner. 1939. Zurich: multigraphed typescript. 59 pp. Incorporates Sem. 1932b index. Includes list of dreams and visions, list of reference books mentioned, and word index. Paging corresponds to that of the 1st edns. Spine title: *Index 1925–1934*. [KML 4]

1939–40 *Psychologische Interpretation von Kinderträumen*. Ed. by Liliane Frey and Aniela Jaffé from the stenographic transcripts of Riwkah Schärf. Date of 1st edn. not known. 1950's: 2d edn. Zurich: [Privately printed for the C. G. Jung-Institut] Eidgenössische Technische Hochschule. 195 pp. Given at the Hochschule, Zurich, Winter Semester 1939–40. Spine title: *Kinderträume, W.S. 1939/40*. A supplementary vol. of students' papers, made up for the 1st edn., has been added to the 2d edn. as an "Anhang." [KML 26, 27]

INDEXES

INDEX 1: TITLES

Including the titles of all English and German items and of original works in other languages. Also see Index 2 under names of authors for whose book Jung wrote a preface, etc.

A

Abstracts, *Folia neuro-biologica*: Jung, Métral, Lombard, Claparède, Flournoy, Leroy Lemaître, G. [1908c](#)

Piéron, Revault d'Allones, Hartenberg, Dumas, Dromard, Marie, Janet, Pascal, Vigouroux et Juquelier, G. [1908i](#)

Varendonck, Claparède, Katzaroff, Maeder, Rouma, G. [1908l](#)

“Abstracts of the Psychological Works of Swiss Authors (1910)”: CW 18,26

“Adaptation”: E. [1970c,1](#), CW 18,35

“Adaptation, Individuation, Collectivity (1916)”: CW 18,35

“Address at the Presentation of the Jung Codex”: G. [1975a,4](#), CW 18,97

“Address Given at the Opening Meeting of the C. G. Jung Institute of Zurich, 24 April 1948”: E. [1948b](#)

“Ärztliches Gutachten über einen Fall von Simulation geistiger Störung”: G. [1904c](#), [GW 1,7](#)

“After the Catastrophe”: E. [1946a](#), [1947a,6](#), CW 10,11

“Aims of Psychotherapy, The”: E. [1933a,3](#), CW 16,5

Aion: G. [1951a](#), GW 9.ii; CW 9,ii

Excerpts: E. [1950a](#), [1958a,2](#), [1971a,6](#)

Alchemical Studies: CW 13

“Alchemistic Text Interpreted As If It Were a Dream, An”: E. [1947c](#)

“Alchemy and Psychology”: CW 18,106

Alchemy and the Occult. A Catalogue ..., Prefatory Note: E. [1968d](#), CW 18,104

“Alhemiya upesyhologiya”: He. [1950/51a](#)

“Allgemeine Aspekte der Psychoanalyse”: G. [1972e,9](#), GW 4,10

“Allgemeine Beschreibung der Typen”: G. [1972d,2](#), GW 6,3,10

“Allgemeine Gesichtspunkte zur Psychologie des Traumes”: G. [1928b,3](#), [1948d,4](#), GW 8,9

Allgemeines zur Komplextheorie: G. [1934a](#), [1948b.3](#), GW 8,3

“An der psychiatrischen Klinik in Zürich gebräuchlichen psychologischen Untersuchungsmethoden, Die”: G. 1910r

“Analyse der Assoziationen eines Epileptikers”: G. 1905g, 1906a,2

“Analyse des rêves, L’”: Fr. 1909a

“Analysis of Dreams, The”: E. 1974a,1, CW 4,3

“Analysis of the Associations of an Epileptic, An”: E. 1918a,2, CW 2,2

Analytical Psychology: E. 1916a

Analytical Psychology: Seminar Notes, 1925a

“Analytical Psychology and Education”: E. 1928a,13, 1969c,3, CW 17,4

“Analytical Psychology and Weltanschauung”: E. 1928a,4, CW 8,14

Analytical Psychology Club: E. 1942b, 1949b, 1950a, 1953b

Analytical Psychology Club, Papers of: E. 1940a, 1948a&d, 1951a

Analytical Psychology; Its Theory and Practice. The Tavistock Lectures: E. 1968a

Analytische Psychologie und Erziehung: G. 1926b, G. 1946b,1, GW 17,4

“Analytische Psychologie und Weltanschauung”: G. 1931a,12, GW 8,14

“Annual Report by the President of the International Psychoanalytic Association”: CW 18,28

“Answer by Dr. Jung to a Question Concerning the Archaic Elements in the Self ... ”: Seminar Notes, 1934–39

“Answer to Buber”: E. 1957d

Answer to Job: E. 1954a, 1960a, 1965a, 1971a,15, 1973a, CW 11,9

“Answers to *Mishmar* on Adolf Hitler”: CW 18,74

Answers to questionnaire, “The Future of Parapsychology”: E. 1963e

Answers to questions on Goethe: G. 1932c

“Answers to Questions on Freud”: E. 1968f, CW 18,32

“Antrittsvorlesung”: G. 1934a

“Antwort an Martin Buber”: GW 11,17

Antwort auf Hiob: G. 1952a, 1961a, GW 11,9

“Klappentext zur ersten Auflage”: GW 11,22

“Approaching the Unconscious”: E. 1964a

“Archaic Man”: E. 1933a,7, CW 10,3

“Archaische Mensch, Der”: G. 1931a,9, 1931f, GW 10,3

Archetypes and the Collective Unconscious, The: CW 9,i

“Archetypes of the Collective Unconscious,” E. 1939a,3, 1959a,5, CW 9,i,1

“Association, Dream, and Hysterical Symptom”: CW 2,7

“Association, Dream, and Hysterical Symptoms”: E. 1918a,5
“Association Method, The”: E. 1910a, 1916a,3, 1917a,3, CW 2,10
“Associations d’idées familiales”: Fr. 1907a
“Associations of Normal Subjects, The”: E. 1918a,1, CW 2,1
“Assoziation, Traum und hysterisches Symptom”: G. 1906j, 1909a,1
“Astrological Experiment, An (1958)”: CW 18,48
“Astrologisches Experiment, Ein”: G. 1958f
“Aufgang einer neuen Welt, Der”: G. 1930e, GW 10,20
Aufsätze zur Zeitgeschichte: G. 1946a
 Vorwort zu: GW 10,9
 Nachwort zu: GW 10,13
“Aus einem Brief an einen protestantischen Theologen”: GW 11,24
Aux frontières de la connaissance ..., “Préface”: Fr. 1959a

B

“Bailey Island Seminar”: Seminar Notes, 1936–37a
“Banalized beyond Endurance”: E. 1958i
“Basic Postulates of Analytic Psychology, The”: E. 1933a,9, CW 8,13
Basic Writings of C. G. Jung: E. 1959a
“Bedeutung der Analytischen Psychologie für die Erziehung, Die”: G. 1971a,4, GW 17,3
“Bedeutung der Psychologie für die Gegenwart, Die”: G. 1934b,3, GW 10,7
“Bedeutung der schweizerischen Linie im Spektrum Europas, Die”: G. 1928e, GW 10,19
“Bedeutung des Unbewussten für die individuelle Erziehung, Die”: G. 1971a,5, GW 17,6
Bedeutung des Vaters für das Schicksal des Einzelnen, Die: G. 1909c, 1949a, 1971a,1, GW 4,14
“Bedeutung von Konstitution und Vererbung für die Psychologie, Die”: G. 1929i, 1973c,2, GW 8,4
“Begabte, Der”: G. 1946b,3 GW 17,5
“Begriff des kollektiven Unbewussten, Der”: GW 9,1,2
“Begrüßungsansprache zum Achten Internationalen Ärztlichen Kongress für Psychotherapie, Bad Nauheim (1935)”: GW 10,30

- “Begrüßungsansprache zum Neunten Internationalen Ärztlichen Kongress für Psychotherapie, Kopenhagen (1937)”: GW 10,32
- “Begrüßungsansprache zum Zehnten Internationalen Ärztlichen Kongress für Psychotherapie, Oxford (1938)”: GW 10,33
- “Beispiele europäischer Mandalas”: G. [1929b](#),1,7, [1938a](#),4
- “Beitrag zur Kenntnis des Zahlenraumes, Ein”: G. [1911e](#), [1972e](#),5, GW 4,5
- “Beitrag zur Psychologie des Gerüchtes, Ein”: G. [1910q](#), [1972e](#),4, GW 4,4
- “Beiträge zur Symbolik”: G. [1911f](#)
- “Beiträge zur Symbolik des Selbst”: G. [1951a](#), [1954c](#).4, GW 9.ii
- “Bemerkung zur Tauskschen Kritik der Nelkenschen Arbeit, Eine”: G. [1913d](#)
- “Bericht über Amerika”: G. [1910n](#)
- Bericht über das Basler Seminar*: Seminar Notes, [1934](#)
- Bericht über das Berliner Seminar ...* : Seminar Notes, [1933](#)
- Bericht über das deutsche Seminar ...* : Seminar Notes, [1930](#)–31
- “Bericht über das Vereinsjahr 1910–11”: G. [1911g](#)
- Bericht über die Berliner Vorträge*: Seminar Notes, [1937](#)
- “Berliner Seminare”: Seminar Notes, [1933](#)
- Bewusstes und Unbewusstes*: G. [1957a](#)
- “Bewusstsein, Unbewusstes und Individuation”: G. [1939e](#)
- Beziehung der Psychotherapie zur Seelsorge, Die*: G. [1932a](#)
- Beziehungen zwischen dem Ich und dem Unbewussten, Die*: G. [1928a](#), [1935a](#), GW 7,2
- “Blick in die Verbrecherseele. Das Doppelleben des Kriminellen...”: G. [1933a](#)
- “Bologna Enigma, The”: E. [1946f](#)
- “Brief an *The Listener*. Januar 1960”: GW 11,25
- “Brief von Prof. C. G. Jung an den Verfasser”: G. [1964a](#)
- “Brief zur Frage der Synchronizität, Ein”: G. [1961c](#)
- Briefe*: I, 1906–45: G. [1972a](#); II, [1946](#)–55: G. [1972b](#); III, [1956](#)–61: G. [1973a](#)
- Briefwechsel* (with Freud): G. [1974a](#)
- “Brother Klaus”: E. [1946c](#), CW 11,6
- “Bruder Klaus”: G. [1933c](#), GW 11,6
- “Buchanzeige.” Review of Hitschmann: G. [1911d](#)
- “Buchanzeige.” Review of Wulffen: G. [1910p](#)

C

- “C. G. Jung et l’astrologie”: Fr. [1954b](#)

“C. G. Jung on Flying Saucers”: E. [1954h](#)

“C. G. Jung on the Question of Flying Saucers”: E. [1955i](#), [1959i,3](#)

“Case of Hysterical Stupor in a Prisoner in Detention, A”: CW 1,5

“Challenge of the Christian Enigma, The. A Letter ... to Upton Sinclair”: E. [1953g](#)

“Child Development and Education”: E. [1969c,2](#), CW 17,3

Children’s Dreams: Seminar Notes, [1938–39](#)

“Christian Legend, The. An Interpretation”: E. [1955f](#)

“Circular letter (1934)”: CW 10,27

Circular letter: “Sehr geehrte Kollegen ... (1.12.34)”: G. [1934j](#)

Circular letter to *Zentralblatt* subscribers (1 Dec. 1934): E. [1946d,1](#)

Civilization in Transition: CW 10

Collected Papers on Analytical Psychology: E. [1916a](#), [1917a](#)

 Prefaces to: CW 4,13

 Vorreden zu den: GW 4,13

“Comment on Tausk’s Criticism of Nelken, A”: E. [1973d,3](#), CW 18,31

“Commentary” (*The Secret of the Golden Flower*): E. [1931a,1](#), [1962b,2](#)

“Commentary on *The Secret of the Golden Flower*”: E. 1958a,9, CW 13,1

Commentary on W. Pödlinger: “Zur Bedeutung bildnerischen Gestaltens in der psychiatrischen Diagnostik”: G. [1959h](#)

“Comments on a Passage from Nietzsche’s *Zarathustra*. (1936)”: Seminar Notes, [1934–39](#)

“Communication, A”: E. [1955f](#)

“Complications of American Psychology, The”: CW 10,22

“Concept of Ambivalence, The”: CW 18,33

“Concept of the Collective Unconscious, The”: E. [1936a&d](#), [1937b](#), [1971a,4](#), CW 9,1,2

“Conception of the Unconscious, The”: E. [1917a,16](#)

“Concerning ‘Answer to Job’”: CW 18,95

“Concerning Mandala Symbolism”: E. [1972a,3](#), CW 9,1,12

“Concerning Psychoanalysis”: CW 4, 8

“Concerning Rebirth”: E. [1970a,2](#), CW 9,i.5

“Concerning Synchronicity”: E. [1953c](#)

“Concerning the Self”: E. [1951a](#)

“Conscious, Unconscious, and Individuation”: CW 9,i,10

“Content of the Psychoses, The”: G. [1916a,14](#), [1917a,14](#), CW 3,2

Contribution entitled “Deutsche Schweiz” ... : G. [19080](#)
Contribution on hallucination ... : G. [1933f](#)
“Contribution to a Discussion on Psychotherapy”: CW 10,31
Contribution to discussion of paper by Frank and Bezzola ... : G. [1907f](#)
Contribution to “Eine Tat-Umfrage ...”: G. [1959g](#)
Contribution to “Rundfrage überein Referat...”: G. [1950g](#)
Contribution to symposium: *Aufstand der Freiheit*: G. [1957c](#)
Contribution to symposium: “The Frontiers of Knowledge”: G. [1959f](#); E. [1957h](#)
Contribution to symposium: “Das geistige Europa und die ungarische Revolution”: G. [1956f](#)
“Contribution to the Psychology of Rumour, A”: E. [1916a,5](#), [1917a,5](#), CW 4,4
“Contribution to the Study of Psychological Types, A”: E. [1916a,12](#), [1917a,12](#), CW 6,5
Contribution to *Trunken von Gedichten* ... : G. [1953a](#)
Contributions to Analytical Psychology: E. [1928a](#)
“Contributions to Symbolism”: CW 18,34
“Cornwall Seminar”: Seminar Notes, [1923](#)
“Crime and the Soul”: E. [1932c](#), CW 18,13
“Criticism of Bleuler’s ‘Theory of Schizophrenic Negativism,’ A”: E. [1916a,7](#), [1917a,7](#), CW 3,4
“Cryptomnesia”: CW 1,3

D

“Dämonie”: G. [1949h](#)
“De Sulphure”: G. [1948c](#)
“Definition of Demonism, The”: CW 18,89
“Depth Psychology (1948)”: CW 18,44
“Depth Psychology and Self-Knowledge”: E. [1969f](#), CW 18,131
“Deutsche Schweiz,” contribution to “Der gegenwärtige Stand ...”: G. [19080](#)
Deutsches Seminar: Seminar Notes, [1930–31](#)
Development of Personality, The: CW 17
“Development of the Personality, The”: E. [1939a,6](#), CW 17,7
Diagnostische Assoziationsstudien, I. Beitrag: G. [1904a](#)
 III. Beitrag: G. [1905g](#)
 IV, Beitrag: G. [1905h](#), [1906i](#)

IX. Beitrag: G. [1907e](#)

Diagnostische Assoziationsstudien: Beiträge zur experimentellen Psychopathologie:

Vol. I: G. [1906a](#)

Summary, Fr. [1908a](#); Vol. II: G. [1909a](#)

“Dichter, Der”: G. [1950a,2](#)

“Difference between Eastern and Western Thinking, The”: E. [1971a,13](#)

“Different Aspects of Rebirth, The”: E. [1944a](#)

Dissertation: G. [1902a](#)

“Disturbances of Reproduction in the Association Experiment”: CW 2,9

“Dr. Hans Schmid-Guissn”: G. [1932d](#)

“Dr. Jung on Unconventional Aerial Objects”: E. [1958f](#)

“Dr. Jung Sets the Record Straight”: E. [1958g](#)

“Dr. Jung’s Contribution to the Voice of America Symposium...” E. [1957h](#)

Dream Analysis: Seminar Notes, [1928–30](#)

“Dream Analysis in Its Practical Application”: E. [1933a,1](#)

“Dream Symbols of the Individuation Process”: E. [1959d](#); Seminar Notes, [1936–37a](#)

“Dream Symbols of the Process of Individuation”: E. [1939a,4](#)

“Dreamlike World of India, The”: E. [1939b](#), CW 10,23

Dreams: E. [1974a](#)

Dreams and Symbolism: Seminar Notes, [1925b](#)

“Drei Fragen an Prof. C. G. Jung”: G. [1958g](#)

Dynamik des Unbewussten, Die: GW 8

E

“Editorial. *Zentralblatt*, VI (1933)”: CW 10,25

“Editorial. *Zentralblatt*, VIII (1935)”: CW 10,28

“Editorial Note. *Zentralblatt*, VIII (1935)”: CW 10,29

Editorial note to the series: *Psychologische Abhandlungen*: G. [1914c](#)

“Editorial Preface to the *Jahrbuch*”: CW 18,23

“Effect of Technology on the Human Psyche, The”: CW 18,76

“Ehe als psychologische Beziehung, Die”: G. [1925b](#), [1931a,11](#), GW 17,8

Einführung in das Wesen der Mythologie: G. [1941c](#), [1951b](#)

“Einführung zu Frances G. Wickes ‘Analyse der Kindesseele’ “: GW 17,2

“Einführung zu W. M. Kranefeldt: ‘Die Psychoanalyse’ “: G. [1930b](#), GW 4,15

“Einige Aspekte der modernen Psychotherapie”: G. [1972c,4](#), GW 16,4

“Einige Bemerkungen zu den Visionen des Zosimos”: G. [1938c](#)
 “Einleitung in die religionspsychologische Problematik der Alchemie”: G. [1944a,2](#),
[1957a,2](#), GW 12,3,I
Einzelne in der Gesellschaft, Der: G. [1971a](#)
 “Entlarvung der viktorianischen Epoche. Freud kulturhistorisch gesehen”: G. [1932f](#)
 “Entschleierung der Seele, Die”: G. [1931g](#)
 “Epilogue to ‘Essays on Contemporary Events’ “: E. [1947a,7](#), CW 10,13
 “Epilogue to Jung: *L’Homme à la découverte de son âme*”: CW 18,72
 Fr. [1944a,g](#), [1962a,g](#)
 “Erdbedingtheit der Psyche, Die”: G. [1927a](#)
Erinnerungen, Träume, Gedanken: G. [1962a](#)
 “Erklärung der Redaktion”: G. [1913b](#)
 “Erlösungsvorstellungen in der Alchemie, Die”: G. [1937a](#), [1944a,4](#), GW 12,3,III
Essays on a Science of Mythology ... : E. [1949a](#), [1963a](#), [1969a](#)
Essays on Contemporary Events: E. [1947a](#); “Preface”: E. [1947a,1](#), CW 10,9
 “Europäischer Kommentar.” *Das Geheimnis der goldenen Blüte*: G. [1938a,3](#), [1957b,3](#)
 “Examples of European Mandals”: E. [1931a,2](#), CW 13,1, pp. 56ff.
 “Excerpts from Selected Letters”: E. [1971b](#)
 Excerpts of letters to Illing (26 Jan. 8c 10 Feb. 1955): G. [1956d](#)
 “Experiences Concerning the Psychic Life of the Child”: E. [1910a,3](#)
 “Experimental Observations on the Faculty of Memory”: CW 2,4
Experimental Researches: CW 2
 “Experimentelle Beobachtungen über das Erinnerungsvermögen”: G. [1905c](#)
 “Experimentelle Untersuchungen über Assoziationen Gesunder”: G. [1904a](#), [1906a,1](#)

F

“Face to Face” (22 Oct. 1959): E. [1960c](#)
 “Fall von C. G. Jung”: G. [1950e](#)
 “Fall von hysterischem Stupor bei einer Untersuchungsgefangenen, Ein”: G. [1902b](#),
 GW 1,5
 “Familial Constellations”: E. [1910a,2](#)
 “Family Constellation, The”: CW 2,11
 “Fastenwunder des Bruder Klaus, Das”: G. [1951e](#)
 “Faust and Alchemy”: CW 18,105
 “Faust und die Alchemie”: G. [1950b](#)

“Fight with the Shadow, The”: E. 1946e, CW 10,12

“Flying Saucers: A Modern Myth of Things Seen in the Skies”; CW 10,15
Flying Saucers. A Modern Myth of Things Seen in the Skies: E. 1959b

“Foreword to a Catalogue on Alchemy”: CW 18,104

“Foreword to Abegg: *Ostasien denkt anders*”: CW 18,92

“Foreword to Adler: *Entdeckung der Seele*”: CW 18,52

“Foreword to Adler: *Studies in Analytical Psychology*”: CW 18,55

“Foreword to Aldrich: *The Primitive Mind and Modern Civilization*”: CW 18,68

“Foreword to Allenby: *The Origins of Monotheism*”: CW 18,93

“Foreword to Baynes: *Analytical Psychology and the English Mind*”: CW 18,78

“Foreword to Bertine: *Human Relationships*”: CW 18,61

“Foreword to Brunner: *Die Anima als Schicksalsproblem des Mannes*”: CW 18,63

“Foreword to Crottet: *Mondwald*”: CW 18, 119

“Foreword to Custance: *Wisdom, Madness and Folly*”: CW 18,15

“Foreword to Evans: *The Problem of the Nervous Child*”: CW 18,129

“Foreword to Fierz-David: *Dream of Poliphilo*”: CW 18,118

“Foreword to F. Fordham: *Introduction to Jung’s Psychology*”: CW 18,46

“Foreword to M. Fordham: *New Developments in Analytical Psychology*”: CW 18,47

“Foreword to Froboese-Thiele: *Träume—eine Quelle religiöser Erfahrung?*”: CW 18,102

“Foreword to Gilbert: *The Curse of the Intellect*”: CW 18,112

“Foreword to Gilli: *Der dunkle Bruder*”: CW 18,116

“Foreword to Harding: *Psychic Energy*”: CW 18,42

“Foreword to Harding: *The Way of All Women*”: CW 18,130

“Foreword to Harding: *Woman’s Mysteries*”: CW 18,53

“Foreword to Hugh Crichton-Miller 1877–1959”: CW 18,87

“Foreword to Jacobi: *Complex/Archetype/Symbol*”: CW 18,60

“Foreword to Jacobi: *Paracelsus: Selected Writings*”: CW 18,120

“Foreword to Jacobi: *The Psychology of C. G. Jung*”: CW 18,40

“Foreword to Jaffé: *Apparitions and Precognition*”: CW 18,8

“Foreword to Jung: *Gestaltung des Unbewussten*”: CW 18,56

“Foreword to Jung: *Phénomènes occultes*”: CW 18,5

“Foreword to Jung: *Symbolik des Geistes*”: CW 18,90

“Foreword to Jung: *Von den Wurzeln des Bewusstseins*”: CW 18,58

“Foreword to Jung: *Wirklichkeit der Seele*”: CW 18,113

- “Foreword to Kankeleit: *Das Unbewusste als Keimstätte des Schöpferischen*”: CW 18,121
- “Foreword to Koenig-Fachsenfeld: *Wandlungen des Traumproblems ...*”: CW 18,115
- “Foreword to Mehlich: *J. H. Fichtes Seelenlehre und ihre Beziehung zur Gegenwart*”: CW 18,114
- “Foreword to Moser: *Spuk*”: CW 18,7
- “Foreword to Neumann: *Depth Psychology and a New Ethic*”: CW 18,77
- “Foreword to Neumann: *The Origins and History of Consciousness*”: CW 18,54
- “Foreword to Perry: *The Self in Psychotic Process*”: CW 18,16
- “Foreword to Quispel: *Tragic Christianity*”: CW 18,91
- “Foreword to Schleich: *Die Wunder der Seele*”: CW 18,3g
- “Foreword to Schmaltz: *Komplexe Psychologie und körperliches Symptom*”: CW 18,17
- “Foreword to Schmid-Guisan: *Tag und Nacht*”: CW 18,108
- “Foreword to Serrano: *The Visits of the Queen of Sheba*”: CW 18,122
- “Foreword to Spier: *The Hands of Children*”: CW 18,132
- “Foreword to Studies from the C. G. Jung Institute, Zurich”: E. [1967d](#)
- “Foreword to Suzuki’s *Introduction to Zen Buddhism*”: CW 11,13
- “Foreword to *Symbols of Transformation*”: E. [1954d](#)
- “Foreword to the First Volume of Studies from the C. G. Jung Institute. ([1948](#))”: CW 18,45
- “Foreword to the Hebrew edition of Jung: *Psychology and Education*”: CW 18,133
- “Foreword to the Hungarian Edition of Jung: *On the Psychology of the Unconscious*”: CW 18,36
- “Foreword to the *I Ching*”: E. [1958a,6](#), CW 11,16
- “Foreword to the Spanish Edition” [of Jacobi: *The Psychology of C. G. Jung*]: CW 18,41
- “Foreword to van Helsdingen: *Beelden uit het onbewuste*”: CW 18,59
- “Foreword to Werblowsky’s *Lucifer and Prometheus*”: CW 11,5
- “Foreword to White’s *God and the Unconscious*”: CW 11,4
- “Foreword to Wickes: *Von der inneren Welt des Menschen (1953)*”: CW 18,57
- Foreword to K. A. Ziegler: “*Alchemie II*”: E. [1946b](#), [1968d](#), CW 18,104
- “Forewords to Jung: *Seelenprobleme der Gegenwart (1930, 1932, 1959)*”: CW 18,67
- “Forewords to Jung: *Über psychische Energetik und das Wesen der Träume (1928, 1947)*”: CW 18,37

Four Archetypes: Mother, Rebirth, Spirit, Trickster: E. [1970a](#)
Frau in Europa, Die: G. [1927b](#), [1929a](#), [1971a,2](#), GW 10,6
“Freud and Jung: Contrasts”: E. [1933a,6](#), CW 4,16
Freud and Psychoanalysis: CW 4
Freud/Jung Letters, The: E. [1974b](#)
Freud und die Psychoanalyse: GW 4
“Freudian Theory of Hysteria, The”: CW 4,2
“Freud’s Theory of Hysteria: A Reply to Aschaffenburg”: CW 4,1
“Freudsche Hysterietheorie, Die”: G. [1908m](#), [1972e](#), GW 4,2
Fundamental Psychological Conceptions: A Report of Five Lectures: E. [1968a](#);
Seminar Notes, [1935](#)
“Fundamental Questions of Psychotherapy”: CW 16,10
“Further Investigations on the Galvanic Phenomenon and Respiration in Normal and
Insane Individuals”: E. [1908a](#), CW 2,14
“Future of Parapsychology, The”: E. [1963e](#), CW 18,50

G

“Gegensatz Freud und Jung, Der”: G. [1929f](#), [1931 a,4](#), GW 4,16
“Gegenwart und Zukunft”: G. [1957i](#), GW 10,14
“Gegenwärtige Stand der angewandten Psychologie in den einzelnen Kulturländern,”
Contribution G. [1908o](#)
Geheimnis der Goldenen Blüte, Das. Ein chinesisches Lebensbuch: G. [1929b](#), [1938a](#),
[1957b](#)
“Geheimrat Sommer zum 70. Geburtstag”: G. [1934l](#)
“Geist der Psychologie, Der”: G. [1947a](#)
“Geist Mercurius, Der”: G. [1943b](#), [1948a,3](#)
“Geist und Leben”: G. [1926c](#), [1931a,13](#), GW 8,12
“Geisteskrankheit und Seele”: G. [1928c](#), [1973d,4](#), GW 3,6
“Geleitbrief.” *Mensch als Persönlichkeit und Problem, Der*: G. [1963b](#)
“Geleitwort.” *Praxis der Psychotherapie*: GW 16,1
“Geleitwort.” (*Zentralblatt VI*, 1933): GW 10,25
“Geleitwort.” (*Zentralblatt VIII*, 1935): G. [1935j](#). GW 18,28
“Geleitwort des Herausgebers”: G. [1933e](#), GW 10,25
“Geleitwort zu den ‘Studien aus dem C. G. Jung-Institut Zürich’ “: G. [1949e](#)
“General Aspects of Dream Psychology”: E. [1974a,3](#), CW 8,9

“General Aspects of Psychoanalysis”: CW 4,10
“General Aspects of the Psychology of the Dream”: E. 1956b
“Gérard de Nerval”: G. 1946d; CW 18,117
“Gespräch mit C. G. Jung. über Tiefenpsychologie und Selbsterkenntnis”: G. 1943f
Gestaltungen des Unbewussten: G. 1950a
Foreword to: CW 18,56
“Gewissen, Das.” Lecture series, C. G. Jung Institute, Zurich: G. 1958c
“Gewissen in psychologischer Sicht, Das”: G. 1958c, GW 10,16
“Gifted Child, The”: E. 1969c,4, CW 17,5
“God, the Devil, and the Human Soul”: E. 1958b
Göttliche Kind in mythologischer und psychologischer Beleuchtung, Das: G. 1941a
Göttliche Mädchen, Das: G. 1941b
Göttliche Schelm, Der: G. 1954a
“Good and Evil in Analytical Psychology”: E. 1960e, CW 10,17
“Grundfragen der Psychotherapie”: G. 1951d, 1972c,1, GW 16,10
“Grundproblem der gegenwärtigen Psychologie, Das”: G. 1934b,2, GW 8,13
“Grundsätzliches zur praktischen Psychotherapie”: G. 1935l, 1972c,2, GW 16,2
“Gut und Böse in der analytischen Psychologie”: G. 1959b, GW 10,17, GW 11,19

H

Habilitationsschrift: G. 1905h
“Hans Schmid-Guisan: In Memoriam”: CW 18,109
“Heilbare Geistesranke? Organisches oder funktionelles Leiden?": G. 1928c
“Heinrich Zimmer”: G. 1962a,15,viii
“Holy Men of India, The”: CW 11,15
“Hors des lieux communs”: Fr. 1958d
Hugh Crichton-Miller, 1877–1959, A Personal Memoir ..., “Foreword”: E. 1961b, CW 18,87
“Human Behaviour”: E. 1942a
“Human Nature Does Not Yield Easily to Idealistic Advice”: E. 1955h, CW 18,83
Human Relationships in Relation ... : Seminar Notes, 1923
“Hypothese des kollektiven Unbewussten, Die”: G. 1932i
“Hypothesis of the Collective Unconscious (1932)": CW 18,51
“Hysterielehre Freuds, Die ...": G. 1906g, 1972e,1, GW 4,1

I

- I Ching, The, or Book of Changes*, “Foreword”: E. [1950d](#), [1958a,6](#), CW 11,16
I Ging: “Vorwort zum”: GW 11,16
Ich und das Unbewusste, Das: G. [1928a](#)
“Idea of Redemption in Alchemy The”: E. [1939a,5](#)
“If Christ Walked the Earth Today”: E. [1958i](#), CW 18,86
“In Memory of Richard Wilhelm”: E. [1931a,3](#), [1962b,3](#)
“In Memory of Sigmund Freud”: CW 15,4
“In Old Age”: E. [1971b,10](#)
Index of the Notes on ... Zarathustra: Seminar Notes, [1934–39](#)
Index to Analytical Psychology ... : Seminar Notes, [1939](#)
Index to Dream Analysis and Interpretation of Visions ... Seminar Notes, [1932b](#)
Index to Dreams and Visions, 1928–32: Seminar Notes, [1932b](#)
Index 1925–1934: Seminar Notes, [1939](#)
“Individual and Mass Psychology”: E. [1947a,2](#), [1947f](#)
“Individual Dream Symbolism in Relation to Alchemy”: E. [1971a](#), 11, [1974a,6](#), CW 12,2, Pt. II
“Individuation and Collectivity”: E. [1970c,2](#)
Inhalt der Psychose, Der: G. [1908a](#), [1914a](#), [1973d,1](#), GW 3,2
“Instinct and the Unconscious”: E. [1919b](#), [1928a,10](#), [1971a,3](#), CW 8,6
“Instinkt und Unbewusstes”: G. [1928b,4](#), [1948b,6](#), GW 8,6
Integration of the Personality, The: E. [1939a](#)
Interpretation of Nature and the Psyche, The: E. [1955a](#)
Interpretation of Visions, The: Seminar Notes, [1930–34](#)
“Interview with C. G. Jung, An”: E. [1943b](#)
Introduction to a Science of Mythology: E. [1949a](#)
“Introduction to the Religious and Psychological Problems of Alchemy”: E. [1959a,10](#), CW 12,2,1 (1st edn.), 3,1 (2nd edn.)
“Introduction to Toni Wolff’s *Studies in Jungian Psychology*”: CW 10,18
“Introductions by C. G. Jung”: E. [1950e](#)
“Is There a Freudian Type of Poetry?": CW 18,111
“Is There a True Bilingualism?": CW 18,123

J

- “Jung and Religious Belief”: CW 18,103

“Jung on Freud”: E. [1962a](#), 1&6
“Jung on Life after Death”: E. [1962a](#),12
“Jung on the UFO ...”: E. [1959i](#)
“Jungian Method of Dream Analysis”: E. [1947d](#)
“Jung’s Commentary to *Brother Klaus*”: E. [1946c](#)
“Jung’s View of Christianity”: E. [1962a](#),13

K

“Kampf mit dem Schatten, Der”: GW 10,12
Kinderträume. W.S. 1936–37: Seminar Notes, [1936–37b](#)
Kinderträume. W.S. 1938/39: Seminar Notes, 1938–39
Kinderträume. W.S. 1939/40: Seminar Notes, 1939–40
“Klappentext zur ersten Auflage von *Antwort auf Hiob*”; GW 11–23
“Komplexe und Krankheitsursachen bei Dementia praecox”: G. [1908b](#)
Kranefeldt, W. M.: *Psychoanalyse*, “Einführung”: G. [1930b](#), GW 4,15
Secret Ways of the Mind, “Introduction”: E. [1932a](#), CW 4,15
“Kritik über E. Bleuler: ‘Zur Theorie des schizophrenen Negativismus’”: G. [1911c](#),
GW 3,3
“Kryptomnesie”: G. [1905a](#), [1971c](#),3, GW 1,3
Kundalini Yoga, The: Seminar Notes, [1932a](#)

L

“Leben die Bücher noch?": G. [1952h](#)
“Lebenswende, Die”: G. [1931a](#),10, GW 8,16
Lectures at the ETH: Seminar Notes, [1935–36](#)
“Letter from Dr, Jung”: E. [1913c](#)
“Letter of Professor C. G. Jung to the Author”: E. [1968c](#)
“Letter on Parapsychology and Synchronicity, A ... ”: E. [1961a](#)
“Letter to Keyhoe”: CW 18,82
“Letter to Miss Pinckney”: E. [1948c](#)
“Letter to Père Lachat”: CW 18,99
“Letter to the editor (Jan. 1960)”: E. [1960c](#)
Letter to the editors on the effect of technology on the psyche: G. [1949g](#)
“Letter to the Second International Congress for Psychiatry ... 1957”: CW 3,11
Letters.1: 1906–1950: E. [1973b](#); Excerpts: E. [1971b](#),1–4,8

Letters.2: 1951–1961: E. [1976a](#); Excerpts: E. [1971b](#),5–7,9–10

“Letters on Synchronicity”: CW 18,49

“Letters to a Friend: Part I”: E. [1972c](#); Part II: E. [1972d](#)

“Letter to Père Bruno”: CW 18,98

Lexikon der Pädagogik: G. [1951c](#)

“Liebesproblem des Studenten, Das”: G. [1971a](#),3, GW 10,5

“London Lectures”: Seminar Notes, [1935](#)

“Love Problem of the Student, The”: E. [1928a](#),7, CW 10,5

M

“Mach immer alles gut und richtig”: G, 1954f

Man and the Future. An international symposium. Copenhagen: Dan. 1957a

Mandala Symbolism: E. [1972a](#)

“Mandates”: G. [1955e](#), GW 9,i,13: E. [1955g](#), [1972a](#),1. CW 9,i,13

“Marginal Note on F. Wittels: *Die sexuelle Not* (1910)”: E. [1973d](#),2, CW 18,24

“Marginalia on Contemporary Events”: CW 18,73

“Marriage as a Psychological Relationship”: E. [1926a](#), [1928a](#),6, [1959a](#),12, [1971a](#),7, CW 17,8

“Mass and the Individuation Process, The”: E. [1955](#)

“Meaning of Individuation, The”; E. [1939a](#),1

“Meaning of Psychology for Modern Man, The”: CW 10,7

“Medical Opinion on a Case of Simulated Insanity, A”: CW 1,7

“Medicine and Psychotherapy”: CW 16,8

“Medizin und Psychotherapie”: G. [1945e](#), [1972c](#),7, GW 16,8

Mehlich, R.: *J. H. Fichtes Seelenlehre ...*, “Vorwort”: G. [1935e](#)

Foreword to: E. [1950e](#), CW 18,114

Meier, C. A., *Antike Inkubation und moderne Psychotherapie*, “Geleitwort zu den ‘Studien aus dem C. G. Jung-Institut Zürich’”: G. [1949e](#)

“Memorial to J. S.”: E. [1955c](#), CW 18,107

Memories, Dreams, Reflections: E. [1962a](#), [1966a](#)

Mensch und Seele ...: G. [1971b](#)

Mensch und seine Symbole, Der: G. 1968a

“Mental Disease and the Psyche”: CW 3,7

“Message of the Honorary President”: E. 1958d

“Mind and Earth”: CW 10,2

“Mind and the Earth”: E. [1928a,3](#)
“Mind of East and West, The”: E. [1955j](#)
“Mind of Man Reaches Out, The”: E. [1957c](#)
“Miraculous Fast of Brother Klaus, The”: CW 18,94
Modern Man in Search of a Soul: E. [1933a](#)
Modern Psychology: Seminar Notes, [1933–41](#): cf Fr. [1907a](#)
“Moderner Mythos, Ein ...”: CW 10,15
Moderner Mythos, Ein ... : G. [1958a](#)
“Morton Prince, M.D.: *The Mechanism and Interpretation of Dreams ...*”: G. [1911b](#),
[1972e,6](#), GW 4,6
CW 4,6
Moser, Fanny, *Spuk*, “Foreword to”: CW 18,7;
“Vorrede” and contribution: G. [1950e](#)
Mysterium Coniunctionis ... : G. [1955a](#), [1956a](#), GW 14, vols. 1 & 2 CW 14

N

“Nach der Katastrophe”: G. [1945c](#), [1946a,5](#), GW 10,11
“Nachtrag, Ein”: G. [1934g](#)
“Nachwort.” (*Aufsätze zur Zeitgeschichte*): G. [1946a,6](#)
“Nachwort.” Koestler, Arthur, *Von Heiligen und Automaten*: G. [1961b](#)
“ ‘National Character’ and Behavior in Traffic. A Letter from Dr. Jung”: E. [1959j](#)
“ ‘Nationalcharakter’ und Verkehrsverhalten”: G. [1958j](#)
Naturerklärung und Psyche: G. [1952b](#)
“Neue Bahnen der Psychologie”: G. [1912d](#), GW 7,3
“Neuere Betrachtungen zur Schizophrenie”: G. [1959f](#), GW 3,8
“Neues Buch von Keyserling, Ein”: G. [1934i](#), GW 10,21
Neumann, Erich, *Depth Psychology and a New Ethic*, “Foreword”: E. [1969e](#), CW
[18,77](#);
Origins and History of Consciousness, “Foreword”: E. [1954f](#), CW 18,54
Ursprungsgeschichte des Bewusstseins, “Vorwort”: G. [1949f](#)
“New Aspects of Criminal Psychology”: CW 2,16
“New Paths in Psychology”: E. [1916a,15](#), CW 7,3
“New Thoughts on Schizophrenia”: E. [1959f](#)
“New York Seminar”: Seminar Notes, [1936–373](#)
“1937 Letter from C. G. Jung, A”: E. [1968g](#)

“Nuove redute della psicologia criminale, Le”: It. [1908a](#)

O

“Obergutachten über zwei (sich) widersprechende psychiatrische Gutachten”: G. [1906d](#), GW 1,8

“On Dementia Praecox”: CW 18,10

“On Disturbances in Reproduction in Association Experiments”: E. [1918a,6](#)

“On Einstein and Synchronicity”: E. [1971b,5](#)

“On Flying Saucers”: CW 18,80

“On Hallucination”: CW 18,38

“On Hysterical Misreading”: CW 1,2

“On Manic Mood Disorder”: CW 1,4

“On Mescaline”: E. [1971b,6](#)

“On Pictures in Psychiatric Diagnosis”: CW 18,128

“On Psychic Energy”: E. [1969b,1](#), CW 8,1

“On Psychical Energy”: E. [1928a,1](#)

“On Psychoanalysis”: E. [1916a,9](#), [1917a,9](#)

“On Psychodiagnostics”: CW 18,85

“On Psychological Understanding”: E. [1915c](#), CW 3,3

“On Psychophysical Relations of the Associative Experiment”: E. [1907a](#)

“On Resurrection”: CW 18,100

“On Simulated Insanity”: CW 1,6

“On Some Crucial Points in Psychoanalysis”: E. [1916a,10](#), [1917a,10](#)

“On Spiritualistic Phenomena”: CW 18,4

“On Suicide”: E. [1971b,9](#)

“On Synchronicity”: E. [1957b](#), [1971a,14](#), [1973c.2](#), CW 8,19

“On the Criticism of Psychoanalysis”: CW 4,7

“On the Discourses of the Buddha”: CW 18,101

“On the Doctrine of Complexes”: E. [1913a](#), CW 2,18

“On the Hungarian Uprising”: CW 18,84

“On the Importance of the Unconscious in Psychopathology”: E. [1914b](#), [1916a.11](#), [1917a.11](#), CW 3,5

“On the Nature of Dreams”: E. [1948a](#), [1959a,7](#), [1974a,4](#), CW 8,10

“On the Nature of the Psyche”: E. [1969b,2](#), CW 8,8

Excerpts: E. [1959a,2](#)

On the Nature of the Psyche: E. [1969b](#)

“On the Problem of Psychogenesis in Mental Diseases”: E. [1919a](#), CW 3,6

“On the Psychoanalytic Treatment of Nervous Disorders”: CW 18,30

“On the Psychogenesis of Schizophrenia”: E. [1939d](#), [1959a,8](#), CW 3,8

“On the Psychological Diagnosis of Evidence”: CW 2,19

“On the Psychological Diagnosis of Facts”: CW 1,9

“On the Psychology and Pathology of So-Called Occult Phenomena”: E. [1916a,2](#),
[1917a,2](#), CW 1,1

On the Psychology of Eastern Meditation: E. [1947b](#), [1949b](#)

“On the Psychology of the Negro”: CW 18,65

“On the Psychology of the Spirit”: E. [1948d](#)

“On the Psychology of the Trickster”: E. [1955d](#)

“On the Psychology of the Trickster Figure”: E. [1956a](#), [1970a,4](#), CW 9,i,9

“On the Psychology of the Unconscious”: CW 7,1 (2nd edn.)

On the Psychology of the Unconscious, Foreword to the Hungarian edn. of: CW 18,36

“On the Psychophysical Relations of the Association Experiment”: CW 2,12

“On the Relation of Analytical Psychology to Poetic Art”: E. [1923b](#), [1928a,8](#)

“On the Relation of Analytical Psychology to Poetry”: E. [1971a,10](#), CW 15,6

“On the Rosarium Philosophorum”: CW 18,126

“On the Shadow and Protestantism”: E. [1971b,7](#)

“On the Significance of Number-Dreams”: E. [1916a,6](#), [1917a,6](#), [1974a,2](#), CW 4,5

“On the Tale of the Otter”: CW 18,110

P

Paracelsica. Zwei Vorlesungen ... : G. [1942a](#)

“Paracelsus”: G. [1929g](#), [1934b,5](#), GW 15,1

Paracelsus: G. [1952c](#)

Paracelsus: Selected Writings, “Foreword to the English Edition”: E. [1951b](#)

Foreword to: CW 18,120

“Paracelsus als Arzt”: G. [1941f](#), [1942a,1](#), GW 15,2

“Paracelsus als geistige Erscheinung”: G. [1942a,2](#)

“Paracelsus as a Spiritual Phenomenon”: CW 13,3

“Paracelsus the Physician”: CW 15,2

“Parapsychologie hat uns mit unerhörten Möglichkeiten bekanntgemacht, Die”: G.
[1956b](#)

Perry, John Weir: *The Self in Psychotic Process* ..., "Foreword": E. [1953e](#), CW 18,16
Phénomènes occultes, Foreword to: CW 18,5
"Phenomenology of the Spirit in Fairy Tales, The": E. [1954b,1](#), [1958a,3](#), [1970a,3](#), CW 9,1,8
"Philosophical Tree, The": CW 13,5
"Philosophische Baum, Der": G. [1945g](#), [1954b,7](#)
"Picasso": G. [1932g](#), [1934a,8](#), GW 15,9
E. [1940a](#), E. [1953i](#), CW 15,9
"Plight of Woman in Europe, The": E. [1930d](#)
Portable Jung, The: E. [1971a](#)
"Practical Use of Dream-Analysis, The": E. [1974a,5](#), CW 16,12
Practice of Psychotherapy, The ... : CW 16
"Praktische Verwendbarkeit der Traumanalyse, Die": G. [1931c](#), [1934b,4](#), GW 16,12
Praxis der Psychotherapie. Beiträge zum Problem der Psychotherapie und zur Psychologie der Übertragung: GW 16
"Preface," *Psychotherapy* (Calcutta): E. [1956e](#), CW 18,127
"Preface by C. G. Jung": E. [1954g](#)
"Preface by C. G. Jung. *Ostasien Denkt Anders* ...": E. [1953f](#)
"Preface by Dr. Jung": E. [1960d](#)
"Preface to an Indian Journal of Psychotherapy": CW 18, 127
"Preface to de Laszlo: *Psyche and Symbol*": CW 18,62
"Preface to 'Essays on Contemporary Events' ": CW 10,9
"Prefaces to *Collected Papers on Analytical Psychology*": CW 4,13
"Present State of Applied Psychology, The": CW 18,9
"Presidential Address ... 1935": CW 10,30
"Presidential Address ... 1937": CW 10,32
"Presidential Address ... 1938": E. [1938b](#), CW 10,33
"Press Communiqué on Visiting the United States": CW 18,69
"Principles of Practical Psychotherapy": CW 16,2
"Probleme der modernen Psychotherapie, Die": G. [1929d](#), [1931a,2](#), GW 16,6
Probleme der Psychotherapie: G. [1972c](#)
"Problems of Modern Psychotherapy": E. [1931d](#), [1933a,2](#), CW 16,6
Process of Individuation: Alchemy I: Seminar Notes, [1933](#)–41
Process of Individuation: Alchemy II: Seminar Notes, [1933](#)–41
Process of Individuation: [Eastern Texts]: Seminar Notes, [1933](#)–41

Process of Individuation: Exercitia Spiritualia ...: Seminar Notes, 1933–41
Psyche and Symbol. A Selection from the Writings of C. G. Jung: E. 1958a; “Preface”:
E. 1958a,1 CW 18,62
Psychiatric Studies: CW 1
Psychiatrie und Okkultismus: G. 1971c
Psychiatrische Studien: GW 1
“Psychic Conflicts in a Child”: E. 1969c,1, CW 17,1
“Psychoanalyse”: G. 1912e
“Psychoanalyse und Assoziations-experiment”: G. 1906a,4, 1906i
“Psychoanalyse und Seelsorge”: G. 1928g, 1971d,3, GW 11,8
“Psycho-analysis”: E. 1913d, 1915d
“Psycho-analysis”: E. 1915d, 1916a,8, 1917a,8
“Psycho-Analysis and Association Experiments”: E. 1918a,4
“Psychoanalysis and Association Experiments”: CW 2,5
“Psychoanalysis and Neurosis”: CW 4,11
“Psychoanalysis and the Cure of Souls”: CW 11,8
Psychogenese der Geisteskrankheiten: GW 3
Psychogenesis of Mental Disease, The: CW 3
Psychological Analysis of Nietzsche’s Zarathustra. Notes on the Seminar: Seminar
Notes, 1934–39
“Psychological Approach to the Dogma of the Trinity, A”: CW 11,2
“Psychological Aspects of the Kore, The”: E. 1949a,2, 1963a,2, 1969a, CW 9,1,7
“Psychological Aspects of the Mother Archetype, The”: E. 1943a, 1959a,6, 1970a,1,
CW 9,1,4
“Psychological Commentary.” *The Kundalini Yoga*: Seminar Notes, 1932a
“Psychological Commentary.” *The Tibetan Book of the Great Liberation*: E. 1954e,
CW 11,10
“Psychological Commentary on ‘The Tibetan Book of the Dead,’ “E. 1957f, 1958a,8,
CW 11,11
“Psychological Diagnosis of Evidence, The”: CW 2,6
“Psychological Factors Determining Human Behavior”: E. 1937a, CW 8,5
“Psychological Foundations of Belief in Spirits, The”: E. 1920b, 1928a,9, CW 8,11
Psychological Interpretation of Children’s Dreams ... : Seminar Notes, 1938–39
“Psychological Methods of Investigation. ... The”: CW 2,17
Psychological Reflections ... : E. 1953a. 1970b

“ ‘Psychological Reflections’ on Youth and Age”: E. 1972e

“Psychological Theory of Types, A”: E. 1933a,4, CW 6,7

“Psychological Types”: E. 1925b, 1928a,12, CW 6,6

Psychological Types, or, The Psychology of Individuation: E. 1923a, CW 6

Excerpts: E. 1959a,4, 1971a,8

“Psychological View of Conscience, A”: CW 10,16

Psychologie der Übertragung, Die: G. 1946c, GW 16,13

Psychologie der unbewussten Prozesse, Die. Ein Überblick ... : G. 1917a, 1918a

Psychologie und Alchemie: G. 1944a, 1952d, GW 12

“Psychologie und Dichtung”: G. 1930a, 1950a,2, 1954c,2, GW 15,7

Psychologie und Erziehung: G. 1946b; Foreword to the Hebrew edn. of: He. 1958a; CW 18,133

“Psychologie und Religion”: G. 1971d,1, GW 11,1

Psychologie und Religion ... : G. 1940a, 1971d

“Psychologie und Spiritismus”: G. 1948e

Psychologische Abhandlungen: 1: G. 1914c; 3: G. 1931a; 4: G. 1934b; 5: G. 1944a; 6: G. 1948a; 7: G. 1950a; 8: G. 1951a; 9: G. 1954b; 10: G. 1955a; 11: G. 1956a

Psychologische Abhandlungen. Editorial note to the series: G. 1914c

Psychologische Betrachtungen: G. 1945a

“Psychologische Determinanten des menschlichen Verhaltens”: G. 1973c,3, GW 8,5

“Psychologische Diagnose des Tatbestandes, Die”: G. 1905f, 1906k

Psychologische Diagnose des Tatbestandes, Die: G. 1941d

Psychologische Interpretation von Kinderträumen ... : Seminar Notes, 1938–39

“Psychologische Typen”: G. 1925c, 1972d,4, GW 6,5

Psychologische Typen: G. 1921a, GW 6

“Psychologische Typologie” (1931): G. 1931a,6, GW 6,6

“Psychologische Typologie” (1936): G. 1936b, GW 6,7

“Psychologischen Aspekte des Mutterarchetypus, Die”: G. 1939b, 1954b,4, GW 9,i,4

“Psychologischen Grundlagen des Geisterglaubens, Die”: G. 1928b,5, 1948b,7, GW 8,11

“Psychologischer Kommentar zum Bardo Thödol”: G. 1935f,2, GW 11,11

“Psychologischer Kommentar.” *Das tibetische Buch der grossen Befreiung*: G. 1955d

“Psychologischer Kommentar zu: *Das tibetische Buch der grossen Befreiung*”: GW 11,10

Psychology and Alchemy: CW 12

Psychology and Education: E. [1969c](#)

“Psychology and Literature”: E. [1933a,8](#), CW 15,7

“Psychology and National Problems”: CW 18,70

“Psychology and Poetry”: E. [1930c](#)

“Psychology and Religion”: E. [1959a,11](#), CW 11.1

Psychology and Religion: E. [1938a](#)

Psychology and Religion: West and East: CW 11

“Psychology and Spiritualism”: CW 18,6

“Psychology, East and West”: E. [1955k](#)

“*Psychology of Dementia Praecox, The*”: CW 3,1

Psychology of Dementia Praecox, The: E. [1909a](#), [1936b](#), [1974c](#)

“Psychology of Dreams, The”: E. [1916a,13](#), [1917a,13](#)

“Psychology of Eastern Meditation, The”: CW 11,14

“Psychology of the Child Archetype, The”: E. [1949a,1](#), [1958a,4](#), [1963a,1](#), CW 9,i,6

“Psychology of the Transference, The”: CW 16,13

Excerpts: E. [1959a,9](#)

Psychology of the Transference, The: E. [1969d](#)

“Psychology of the Unconscious, The”: CW 7,1 (1st edn.)

Psychology of the Unconscious, The. A Study of the Transformation Symbolisms of the Libido ... : E.1916b

“Psychology of the Unconscious Processes, The”: E. [1917a,15](#)

“Psychopathological Significance of the Association Experiment, The”: CW 2,8

“Psychopathologische Bedeutung des Assoziationsexperimentes, Die”: G. [1906b](#)

“Psycho-physical Investigations with the Galvanometer and Pneumograph in Normsl and Insane Individuals”: E. [1907b](#), CW 2,13

“Psychotherapeutische Zeitfragen. Ein Briefwechsel ...”: G. [1973b,2](#), GW 4,12

Psychotherapeutische Zeitfragen. Ein Briefwechsel ... : G. [1914b](#)

“Psychotherapie in der Gegenwart, Die”: G. [1945f](#), [1946a,3](#), [1972c,8](#), GW 16,9

“Psychotherapie und Weltanschauung”: G. [1943e](#), [1946a,4](#), [1954c,3](#), [1972c,6](#), GW 16,7

“Psychotherapists or the Clergy”: E. [1933a,11](#)’ [1956d](#). CW 11,7

“Psychotherapy and a Philosophy of Life”: E. [1947a,5](#), CW 16,7

“Psychotherapy Today”: E. [1942b](#), [1947a,4](#), CW 16,9

“Question of Medical Intervention, The”: CW 18,14

“Question of the Therapeutic Value of Abreaction, The”: E. [1921a](#), [1928a](#),[11](#)

R

“Radio Talk in Munich, A (1930)”: CW 18,66

“Rätsel von Bologna, Das”: G. [1945b](#)

“Randbemerkungen zu dem Buch von [Fr.] Wittels: *Die sexuelle Not*”: G. [1910l](#)

“Randglossen zur Zeitgeschichte”: G. [1946g](#)

“Reaction-Time in Association Experiments, The”: E. [1918a](#),[3](#)

“Reaction-time Ratio in the Association Experiment, The”: CW 2,3

“Real and the Surreal, The”: CW 8,15

“Realities of Practical Psychotherapy, The”: CW 16,14

“Recent Thoughts on Schizophrenia”: CW 3,9

“Recollections of ... the U. S.”; E. [1971b](#),[4](#)

Reden Gotamo Buddhos, Die: Statement in publisher’s brochure (on): G. [1956c](#), GW 11,26

“Referate über psychologische Arbeiten schweizerischer Autoren (bis Ende 1909)”: G. [1910m](#)

“Rejoinder to Dr. Bally”: G. [1934f](#); CW 10,26

“Relation of the Ego to the Unconscious, The”: E. [1928b](#),[2](#)

“Relations between the Ego and the Unconscious, The”: E. [1971a](#),[5](#), CW 7,2 Excerpts: [E. 1959a](#),[3](#)

“Released to United Press from Dr. Jung”: E. [1958h](#)

“Religion and Psychology: A Reply to Martin Buber”: E. [1973e](#). CW 18,96

“Religion und Psychologie”: G. 1952j

“Réponse à la question du bilinguisme”: Fr. [1961d](#)

“Report on America (1910)”: CW 18,64

“Return to the Simple Life”: E. [1945b](#), CW 18,71

Review of Bechterew: G. [1910d](#)

Review of Becker: G. [1910h](#)

Review of Bleuler: *Affektivität ...* : G. 1906f

Review of Bleuler: *Zur Theorie des schizophrenen Negativismus*: G. 1911c

Review of Bruns: G. [1906e](#)

Review of Bumke: G. [1909f](#)

Review of Cramer: G. [1910i](#)

Review of Dost: G. [1910c](#)

Review of Dubois: G. [1908f](#)

Review of Ehrenfels: *Grundbegriffe der Ethik*: G. [1909g](#)

Review of Ehrenfels: *Sexualethik*: G. [1910a](#)

Review of Eschle: G. [1908e](#)

Review of Forel: G. [1910j](#)

Review of Freud: *Zur Psychopathologie ...* : G. [1908k](#)

Review of Hellpach: *Grundlinien einer Psychologie der Hysterie*: G. [1905b](#); CW 18,19

Review of Heyer; *Der Organismus der Seele*: G. [1933d](#); CW 18,124

Review of Heyer: *Praktische Seelenheilkunde*: G. [1936d](#); CW 18,125

Review of Hitschmann: *Freuds Neurosenlehre*: G. [1911d](#), CW 18,27

Review of Keyserling: *Amerika ...* : G. [1930e](#)

Review of Kleist: G. [1909d](#)

Review of Knapp: G. [1907c](#)

Review of Loewenfeld: G. [1909e](#)

Review of Lomer: G. [1908g](#)

Review of Meyer: G. [1908h](#)

Review of Moll: G. [1907b](#)

Review of Näcke: G. [1910g](#)

Review of Pilez: G. [1910b](#)

Review of Prince: G. [1911b](#)

Review of Reibmayer: G. [1910f](#)

Review of Reichardt: G. [1907d](#)

Review of Sadger: *Konrad Ferdinand Meyer*: G. [1909h](#); CW 18,11

Review of Stekel: *Nervöse Angstzustände*: G. [1908j](#); CW 18,22

“Review of the Complex Theory, A”: CW 8,3

Review of Urstein: G. [1910e](#)

Review of Waldstein: *Das unbewusste Ich*: G. [1909i](#); CW 18,12

Review of Wernicke: G. [1906h](#)

Review of Wulffen: *Der Sexualverbrecher*: G. [1910p](#); CW 18,25

“Reviews of Psychiatric Literature (1906–10)”: CW 18,20

“Revolution Mondiale, La”: CW 10,21

“Richard Wilhelm”: G. [1930c](#), [1931b](#), [1962a](#), [15](#), [vii](#)

“Richard Wilhelm: In Memoriam”: CW 15,5

“Rise of a New World, The”: CW 10, 20
“Role of the Unconscious, The”: CW 10,1
“Rückkehr zum einfachen Leben”: G. 1941e
“Rules of Life”: CW 18,79
“Rundschreiben” (*Zentralblatt* VII, 1934): GW 10,27

S

“Schatten, Animus und Anima”: G. 1948f
“Schizophrenia”: CW 3,10
“Schizophrenie Die”: G. 1958i,1973d,5 GW 3,9
Schweizer Lexikon: G. 1949h
Secret of the Golden Flower, The: E. 1931a, 1962b
“Seele und Erde”: G. 1931a,8, GW 10,2
“Seele und Tod:” G. 1934b,10&h, GW 8,17
“Seelenproblem des modernen Menschen, Das”: G. 1928f, 1929e, 1931a,4. GW 10,4
Seelenprobleme der Gegenwart: G. 1931a; Forewords to: CW 18,67
“Seelischen Probleme der menschlichen Altersstufen, Die”: G. 1930d
Seminar über Kinderträume ...: Seminar Notes, 1936–37b
“A Seminar with C. G. Jung ...”: Seminar Notes, 1936–37b
VII Sermones ad Mortuos ...: G. 1916a; E. 1925a, 1967b
“VII Sermones ad Mortuos”: G. 1962a, 15,x
E. 1966a,19
“Shadow, Animus and Anima”: E. 1950a
“Sigmund Freud”: G. 1939d, GW 15,4
“Sigmund Freud als kulturhistorische Erscheinung”: G. 1932f, 1934b,6, GW 15,3
Sigmund Freud/C. G. Jung: Briefwechsel, G. 1974a
“Sigmund Freud in His Historical Setting”: E. 1932b, CW 15,3
“Sigmund Freud: *On Dreams*”: E. 1973d,1, CW 18,18
“Significance of Constitution and Heredity in Psychology, The”: CW 8,4
“Significance of Freud’s Theory for Neurology and Psychiatry, The”: CW 18,21
“Significance of the Father in the Destiny of the Individual, The”: E. 1916a,4,
1917a,4, CW 4,14
“Significance of the Unconscious in Individual Education, The”: E. 1928a,14, CW
17,6
“Some Aspects of Modern Psychotherapy”: E. 1930b, CW 16,3

“Some Crucial Points in Psychosynthesis: A Correspondence ...”: CW 4,12
“Soul and Death, The”: E. [1945a](#), [1959c](#), CW 8,17
“Spirit and Life”: E. [1928a,2](#), CW 8,12
Spirit and Nature. Papers from the Eranos Yearbooks, I: E. [1954b](#)
Spirit in Man, Art, and Literature, The: CW 15
“Spirit Mercurius, The”: CW 13,4
Spirit Mercury, The: E. [1953b](#)
“Spirit of Psychology, The”: E. [1954b,2](#), [1957e](#)
“Spiritual Problem of Modern Man, The”: E. [1931c](#), [1933a,10](#), [1971a,12](#), CW 10,4
“Stages of Life, The”: E. [1933a,5](#),[1971a,1](#), CW 8,16
“State of Psychotherapy Today, The”: CW 10,8
Statement in publisher’s brochure (on) ... *Die Reden Gotamo Buddhos*: G. [1956c](#)
Statement on UFO’s to UPI (13 Aug. 1958): E. [1959i,1](#)
“Statement to United Press International”: E. [1958j](#), CW 18,81
“Statistical Details of Enlistment”: CW 2,15
“Statistisches von der Rekrutenaushebung”: G. [1906c](#)
“Stenogramm des Zwiegesprächs von ... Jung ...”: Seminar Notes, [1933](#)
“Stimme des Innern, Die”: G. [1934b,9](#)
Structure and Dynamics of the Psyche, The: CW 8
“Structure of the Psyche, The”: E. [1971a,2](#), CW 8,7
“Structure of the Unconscious, The”: CW 7,4
“Struktur der Seele, Die”: G. [1928d](#), [1931a,7](#), GW 8,7
“Struktur des Unbewussten, Die”: GW 7,4
Studien aus dem C. G. Jung-Institut Zürich: 1: G. [1949e](#); 4: G. [1952b](#); 7: G. [1958c](#); 14: G. [1963a](#).
Studien aus dem C. G. Jung-Institut Zürich, “Geleitwort zu den ...”: G. [1949e](#)
Studies from the C. G. Jung Institute, Zurich, Foreword to: E. [1967d](#), CW 18,45
Studies in Word-Association ... : E. [1918a](#)
“Study in the Process of Individuation, A”: E. [1939a,2](#), [1972a,2](#), CW 9,i,11
“Swanage Seminar”: Seminar Notes, [1925b](#)
“Swiss Line in the European Spectrum, The”: CW 10,19
“Swiss National Character, The”: E. [1959k](#)
Symbole der Wandlung: G. [1952e](#), GW 5
“Symbolic Life, The”: E. [1961d](#), CW 18,3
Symbolic Life, The: E. [1954c](#)

Symbolik des Geistes: G. [1948a](#); Foreword to: CW 18, go

“Symbols and the Interpretation of Dreams”: CW 18,2

Symbols of Transformation: CW 5

Excerpts: E. [1959a.1](#); Foreword to: E. [1954d](#)

“Synchronicity: An Acausal Connecting Principle”: E. [1955a](#), [1973c,1](#), CW 8,18

Synchronicity: An Acausal Connecting Principle: E. [1973c](#)

“Synchronizität als ein Prinzip akausaler Zusammenhänge”: G. [1952b](#), GW 8,18

T

“Tatitra Yoga Seminars”: Seminar Notes, [1932a](#)

Tavistock Lectures, Die: G. [1969a](#)

Tavistock Lectures, The: E. [1968a](#)

“Tavistock Lectures, The”: CW 18,1

Seminar Notes, [1935](#)

“Techniques of Attitude Change Conducive to World Peace (Memorandum to UNESCO) (1948)”: CW 18,75

Terry Lectures, The; Yale University: E. [1938a](#)

“Théodore Flournoy”: G. [1962a](#), 15,vi

“Theoretische Überlegungen zum Wesen des Psychischen”: G. [1954b,8](#), [1954c,5](#), [1973c,4](#), GW 8,8

“Theory of Psychoanalysis, The”: E. [1913b](#), [1914a](#), [1915b](#), CW 4,9

Theory of Psychoanalysis, The: E. [1915a](#)

“Therapeutic Value of Abreaction, The”: CW 16,11

“Therapeutische Wert des Abreagierens, Der”: G. [1972c,5](#), GW 16,11

“Third and Final Opinion on Two Contradictory Psychiatric Diagnoses, A”: CW 1,8

“Three Early Papers”: E. [1973d](#)

Tibetanische Totenbuch, Das, “Einführung”: G. [1935f](#)

“Tiefenpsychologie”: G. [1951c](#)

“To a Colleague on Suicide”: E. [1971b,8](#)

“... to a little daughter”: E. [1971b,1](#)

“to a solicitous colleague”: E. [1971b,2](#)

“... to Freud”: E. [1971b,3](#)

“Träumende Welt Indiens, Die”: GW 10,23

“Transcendent Function, The”: E. [1971a,9](#), CW 8,2

Transcendent Function, The: E. [1957a](#)

“Transformation Symbolism in the Mass”: E. [1955b](#), [1958a,5](#), CW 4–3
“Transzendente Funktion, Die”: G. [1958b](#), [1973c](#), GW 8,2
“Traumanalyse, Die”: G. [1972e,3](#), GW 4,3
“Traumsymbole des Individuations-prozesses”: G. [1936a](#), [1944a,3](#), GW 12,3,II
“Tschang Scheng Schu. Die Kunst das menschliche Leben ...”: G. [1929h](#)
“Two Chapters from *The Interpretation of Nature and the Psyche*”: E, [1958a,7](#)
Two Essays on Analytical Psychology: E. [1928b](#), CW 7
“Two Letters on Psychoanalysis ... ”: CW 18,29
Two letters to the author. Gerster, Georg: G. [1954e](#)
“Two Posthumous Papers. 1916”: E. [1970c](#)
Typologie: G. [1972d](#)

U

Über das Phänomen des Geistes in Kunst und Wissenschaft: GW 15
“Über das Problem der Psychogenese bei Geisteskrankheiten”: G. [1973d,2](#), GW 3,5
“Über das Rosrium Philoso-phorum”: G. [1938b](#)
“Über das Selbst”: G. [1949b](#)
“Über das Unbewusste”: G. [1918b](#), GW 10,1
“Über das Unbewusste und seine Inhalte”: GW 7,4
“Über das Verhalten der Reaktionszeit beim Assoziationsexperimente”: G. [1905h](#),
[1906a,3](#)
“über den Archetypus, mit besonderer Berücksichtigung ... ”: G. [1936e](#), [1954b,3](#), GW
9,1,3
“Über den indischen Heiligen”: G. [1944b](#), GW 11,15
“Über die Archetypen des kollektiven Unbewussten”: G. [1935b](#), [1954b,2](#), [1957a,1](#),
GW 9,i,1
“Über die Bedeutung der Lehre Freuds für Neurologie und Psychiatrie”: G. [1908d](#)
“Über die Bedeutung des Unbewussten in der Psychopathologie”: G. [1973d,3](#), GW 3,4
“Über die Beziehung der analytischen Psychologie zum dichterischen Kunstwerk”: G.
[1922a](#), [1931a,3](#), GW 15,6
“Über die Beziehung der Psychotherapie zur Seelsorge”: G. [1971d,2](#), GW 11,7
“Über die Energetik der Seele”: G. [1928b,2](#), [1948b,2](#), GW 8,1
Über die Energetik der Seele: G. [1928b](#)
Über die Entwicklung der Persönlichkeit: GW 17
“Über die psychosnslytische Behsndlung nervöser Leiden”: G, [1912h](#)

“Über die Psychogenese der Schizophrenie”: GW 3,7
Über die Psychologie der Dementia praecox: Ein Versuch: G. 1907a, GW 3,1
Über die Psychologie des Unbewussten: G. 1943a, GW 7,1
 Foreword to the Hungarian Edn. of: CW 18,36
 “Über die Reproduktionsstörungen beim Assoziationsexperiment”: G. 1907e, 1909a,2
Über Grundlagen der analytischen Psychologie: G. 1969a
 “Über hysterisches Verlesen ...”: G. 1904b, 1971c,2, GW 1,2
 “Über Komplextheorie”: G. 1934a
Über Konflikte der kindlichen Seele: G. 1910k, 1916b, 1939a, 1946b,2, GW 17,1
 “Über Mandalasymbolik”: G. 1950a,5, GW 9,1,12
 “Über manische Verstimmung”: G. 1903a, 1971c,4, GW 1,4
Über psychische Energetik und das Wesen der Träume: G. 1948b
 “Über Psychoanalyse”: G. 1972e,10, GW 4,11
 “Über Psychoanalyse beim Kinde”: G. 1912b
 “Über Psychologie”: G. 1933b
 “Über Psychotherapie und Wunderheilungen”: G. 1959a
 “Über Simulation von Geistesstörung”: G. 1903b, GW 1,6
 “Über spiritistische Erscheinungen”: G. 1905e
 “Über Synchronizität”: G. 1952f, GW 8,19
 “... Über Tiefenpsychologie und Selbsterkenntnis”: G. 1943f, 1947c
 “Über Träume”: Seminar Notes, 1933
 “Über Wiedergeburt”: G. 1950a,3, GW 9,1,5
 “UFO”: E. 1959g
 “Ulysses: A Monologue”: E. 1953h, CW 15,8
 “Ulysses, A Monologue”: E. 1949c
 “Ulysses ... ”: G. 1932e, 1934b,7, GW 15,8
Unbewusste im normalen und kranken Seelenleben, Das... Ein Überblick ... : G. 1926a
 “Unconscious in the Normal and Pathological Mind, The”: E. 1928b,1
Undiscovered Self, The: E. 1958b
 “Undiscovered Self (Present and Future), The”: CW 10,14

V

“Verschiedenen Aspekte der Wiedergeburt, Die”: G. 1940b

Versuch einer Darstellung der psychoanalytischen Theorie. Neun Vorlesungen ... : G. 1913a, 1955b, 1973b, 1973b,1, GW 4,9

“Versuch einer psychologischen Deutung des Trinitätsdogmas”: GW 11,2

“Versuch zu einer psychologischen Deutung des Trinitätsdogmas”: G. 1948a,4

“Visionary Rumour, A”: E. 1959h

“Visionen des Zosimos, Die”: G. 1954b,5

Visions: Seminar Notes, 1930–34

“Visions of Zosimos, The”: CW 13,2

“Vom Werden der Persönlichkeit”: G. 1934b,9, GW 17,7

“Vom Wesen der Träume”: G. 1945d, 1948b,5, 1952i, 1954c,1, GW 8,10

Von den Wurzeln des Bewusstseins: G. 1954b; Foreword to: CW 18,58

“Von der Psychologie des Sterbens”: G. 1935i

“Vorbemerkung der Redaktion”: G. 1909b

“Vorbemerkung des Herausgebers.” (*Zentralblatt VII*, 1935): G. 1935k, GW 10,29

“Vorrede.” F. Froboese-Thiele, *Träume—eine Quelle religiöser Erfahrung?*: G. 1957e

“Vorrede” and contribution to F. Moser, *Spuk*: G. 1950e

“Vorrede zu: Toni Wolff: *Studien zu C. G. Jungs Psychologie*”: GW 10,18

“Vorreden zu den *Collected Papers on Analytical Psychology*”: GW 4,13

“Vorwort.” E. Neumann, *Ursprungsgeschichte des Bewusstseins*: G. 1949f

“Vorwort zu D. T. Suzuki: *Die grosse Befreiung*”: GW 11,13

“Vorwort zu V. White: *Gott und das Unbewusste*”: GW 11,4

“Vorwort zu Z. Werblowsky: *Lucifer und Prometheus*”: GW 11,5

“Vorwort zum I Ging”: GW 11,16

“Votum. (*Schweizerische Ärztezeitung XVI*, 1935)”: GW 10,81

“Votum. Zum Thema: Schule und Begabung”: G. 1943d

“Votum C. G. Jung”: G. 1935h

W

“Wandlungen und Symbole der Libido. Beiträge zur Entwicklungsgeschichte des Denkens”: pt. I: G. 1911a; pt. II: 1912c

Wandlungen und Symbole der Libido. Beiträge zur Entwicklungsgeschichte des Denkens. G. 1912a, 1925a

“Wandlungssymbol in der Messe, Das”: G. 1942c, 1954b,6, 1971d,4, GW 11,3

“Was Indien uns lehren kann”: GW 10,24

“Was ist Psychotherapie?": G. 1935g, 1972c,3, GW 16,3

Welt der Psyche: G. 1954c

“Westliche Parallelen zu den tantrischen Symbolen”: Seminar Notes, [1932a](#)

“What India Can Teach Us”: E. [1939c](#), CW 10,24

“What Is Psychotherapy?": CW 16,3

“Why and How I Wrote My *Answer to Job*”: E. [1956c](#)

“Why I Am Not a Catholic”: CW 18,88

Wirklichkeit der Seele: G. [1934b](#); Foreword to: CW 18,113

“Wirklichkeit und Überwirklichkeit”: G. [1932h](#), GW 8,15

“Wo leben die Teufel?...”: G 1950f

“Woman in Europe”: E. [1928a,5](#), [1928c](#), CW 10,6

“Wotan”: G. [1936c](#), [1946a,2](#), GW 10,10; E. [1937c](#), [1947a,3](#), CW 10,10

“Wotan und der Rattenfänger ...”: G. [1956e](#)

Y

“Yoga and the West”: E. [1936c](#), CW 11,12

“Yoga und der Westen”: GW 11,12

“Yoga, Zen, and Koestler”: E. [1961c](#)

“Your Negroid and Indian Behavior”: E. [1930a](#)

Z

“Zeichen am Himmel...”: G. [1958h](#)

“Zeitgenössisches. (*Neue Zürcher Zeitung*, CLV, 1934)”: G. [1934f](#); CW 10,26

“Ziele der Psychotherapie”: G. [1929c](#), [1931a,5](#), GW 16,5

Zivilisation im Übergang: GW 10

“Zu *Antwort auf Hiob*” (1951): GW 11,21

“Zu *Antwort auf Hiob*” (1952): GW 11,22

“Zu *Die Reden Gotamo Buddhos*”: GW 11,26

“Zu *Psychologie und Religion*”: GW 11,18

“Zu unserer Umfrage ‘Leben die Bücher noch?’ ”: G. [1952h](#)

“Zugang zum Unbewussten”: G. [1968a](#)

“Zum Gedächtnis Richard Wilhelms”: G. [1938a,2](#), [1957b,2](#), GW 15,5

“Zum Problem des Christus-symbols”: GW 11,20

“Zum psychologischen Aspekt der Korefigur”: G. [1941b](#), [1941c,2](#), [1951b,2](#), GW 9,1,7

Zum Wesen des Psychischen: G. [1973c](#)

“Zur Empirie des Individuations-prozesses”: G. [1934c](#), [1950a,4](#), GW 9,1,11

“Zur Frage der psychologischen Typen”: G. [1972d,1](#), GW 6,4

“Zur gegenwärtigen Lage der Psychotherapie”: G. [1934k](#), GW 10,8

“Zur Kritik über Psychoanalyse”: G. [19100](#), [1972e,7](#), GW 4,7

“Zur Phänomenologie des Geistes im Märchen”: G. [1948a,2](#), [1957a,3](#), GW 9,1,8

“Zur Psychoanalyse.” (17 Jan.): G. [1912f](#)

“Zur Psychoanalyse.” (15 Feb.): G. [1912g](#), [1972e,8](#), GW 4,8

Zur Psychoanalyse: G. [1972e](#)

Zur Psychogenese der Geisteskrankheiten: G. [1973d](#)

“Zur Psychologie der Schelmenfigur”: G. [1954a](#)

“Zur Psychologie der Trickster-figur”: GW 9,1,9

“Zur Psychologie der Trinitätsidee”: G. [1942b](#)

“Zur Psychologie des Geistes”: G. [1946e](#)

Zur Psychologie des Individuation: Seminar Notes, [1930–31](#)

“Zur Psychologie des Kind-Archetypus”: G. [1941a](#), [1941c,1](#), [1951b,1](#), GW 9,1,6

“Zur Psychologie des Negers”: G. [1913c](#)

“Zur Psychologie östlicher Meditation”: G. [1943c](#), [1948a,5](#), [1957a,4](#), GW 11,14

Zur Psychologie und Pathologie sogenannter occulter Phänomene : G. [1902a](#)

“Zur Psychologie und Pathologie sogenannter okkulter Phänomene”: G. [1971c,1](#), GW 1,1

Zur Psychologie westlicher und östlicher Religion: GW 11

“Zur psychologischen Tatbestandsdiagnostik”: G. [1905d](#), GW 1,9

“Zur psychologischen Tatbestandsdiagnostik. Das Tatbestandsexperiment im Schwurgerichts-prozess Näf”: G. [1937b](#)

“Zur Tatbestandsdiagnostik”: G. [1908n](#)

“Zur Umerziehung des deutschen Volkes”: G. [1946g](#)

Zwei Schriften über analytische Psychologie: GW 7

INDEX 2: PERSONAL NAMES

Names of editors, compilers, co-authors, authors for whose books Jung wrote reviews or forewords, persons eulogized, translators, and recipients of letters published elsewhere than in the *Letters* or *Briefe* (which are separate from the CW)—in the German and English entries.

A

Abegg, Lily: G. [1950d](#); E. [1953f](#); CW 18,92

Adler, Alfred: G. [1934d](#)

Adler, Gerhard: G. [1934d](#), [1952g](#); E. [1966e](#), [1973b](#), [1976a](#), CW 18,52, CW 18,55; Fr. [1957a](#); CW ed.

Aldrich, Charles Roberts: E. [1928a,13](#), [1931b](#), CW 18,68

Allenby, Amy I: CW 18,93

Anshen, Ruth Nanda: E. [1942a](#)

Aschaffenburg, Gustav: G. [1906g](#), GW 4,1; CW 4,1

B

Bach, Georg R.: G. [1956d](#)

Bailey, Paul C.: E. [1968c](#)

Bally, Gustav: G. [1934f](#); CW 10,26

Barbault, André: G. [1972b](#); E. [1970d](#), [1976a](#); Fr. [1952b](#)

Barker, Mary: E. [1968a](#), Seminar Notes, [1935](#)

Bash, K. W.: E. [1942c](#)

Baumann, Carol: E. [1947b](#), [1947c](#), Seminar Notes, [1928–30](#), [1932b](#)

Baumann, Elizabeth: Seminar Notes, 1935–36

Baumann, Hans H.: Seminar Notes, [1936–37b](#)

Baynes, Cary F.: E. [1928a&b](#), [1931a&d](#), [1932b](#), [1933a&b](#), [1936c](#), [1943a](#), [1950d](#), [1953a](#), [1962b](#), Seminar Notes, [1932a](#)

Baynes, H. G.: E. [1920b](#), [1923a](#), [1923b](#), [1924a&b](#), [1928a&b](#), [1950b](#), [1953a](#), CW 6, CW 18,78

Bechterew, W. von: G. [1910d](#); CW 18,20

Becker, Th.: G. [1910h](#); CW 18,20

Bender, Hans: G. [1958f](#), [1961c](#), [1973a](#); E. [1976a](#)

Bertine, Eleanor: G. 1957d, 1972b; E. 1958e, 1971b,8, 1973b, CW 18,61, Seminar Notes, 1936–37a; It. 1961a
Betschart, Ildefons: G. 1963b
Bezzola, Dumeng: G. 1907f
Binswanger, Hilde: G. 1969a
Bitter, Wilhelm: G. 1959a&b, 1973a; E. 1976a
Blanke, Fritz: G. 1951e, 1972b; E. 1973b, CW 18,94
Bleuler, Eugen: G. 1906f, 1908b, 1911c&h, GW 3,3; E. 1916a,7, CW 3,4, CW 18,34
Boss, Medard: G. 1950g
Bovet, Theodor: G. 1972b; E. 1971b,7, 1976a
Brill, A. A.: E. 1909a, 1910a, 1936b
Briner, Mary: E. 1947a,4&8:5, Seminar Notes, 1934–39, 1939
Brody, Daniel: G. 1958b
Bruder Klaus, *see* Niklaus von Flüe
Brunner, Cornelia: G. 1963a; CW 18,63, Seminar Notes, 1938–39
Bruno de Jésus-Marie, Père: CW 18,98
Fr. 1956b
Bruns, L.: G. 1906e; CW 18,20
Buber, Martin: G. 1952j, GW 11,17
E. 1957d, 1973e, CW 18,96
Bumke, Oswald: G. 1909f; CW 18,20
Burnett, Hugh: G. 1973a; E. 1960c, 1976a
Burnett, Whit: E. 1957e

C

Campbell, C. MacFie: E. 1925b
Campbell, Joseph: E. 1971a
Carioba, Henny: E. 1958h
Chapin, Anne: Seminar Notes, 1928–30
Claparède, Edouard: G. 1908c,4, 1908l,2
Clark, Robert A.: E. 1956b, 1957d
Coomaraswamy, Ananda K.: E. 1947b
Cornell, A. D.: G. 1961c; E. 1961a, 1976a
Cox, David: E. 1958c, CW 18,103
Cramer, A.: G. 1910i; CW 18,20

Crichton-Miller, Hugh: E. [1961b](#), CW 18,87
Crottet, Robert: G. [1949c](#); CW 18,119
Cully, Kendig: G. [1972a](#); E. [1968g](#), [1973b](#)
Custance, John: G. [1954d](#); E. [1952a](#), CW 18,15

D

Deady, Charlotte H.: Seminar Notes, [1928–30](#)
de Angulo, Cary F.: Seminar Notes, [1925a](#)
de Angulo, Ximena: E. [1943a](#), [1944a](#)
Degen, Hans: G. [1959f](#)
de Laszlo, Violet Staub: E. [1958a](#), [1959a](#), CW 18,62
Dell, W. Stanley: E. [1933a](#), [1939a](#), [1949c](#), [1953a](#)
Denber, Herman C. B.: E. [1958d](#)
Doniger, Simon: G. [1972b](#), GW 11,9; E. [1956c](#), [1976a](#), CW 11,9
Dost, Max: G. [1910c](#); CW 18,20
Dromard, G.: G. [1908i,5](#)
Dubois, P.: G. [1908f](#); CW 18,20
Duerr, Therese: E. [1926a](#)
Dumas, G.: G. [1908i,4](#)
Dunn, Alice H.: E. [1953c](#)

E

Eaton, Ralph M.: E. [1932a](#)
Ebon, Martin: E. [1963e](#)
Eder, Edith: E. [1913b](#), [1914a](#), [1915b](#), [1916a](#)
Eder, M. D.: E. [1913b](#), [1914a](#), [1915b](#), [1916a](#), [1918a](#)
Ehrenfels, Christian von: G. [1909g](#), [1910a](#); CW 18,20
Einstein, Albert: E. [1971b,5](#)
Eissler, Kurt R.: G. [1973a](#), [1974a](#); E. [1974b](#), [1976a](#)
Ellmann, Richard: E. [1959l](#)
Ermatinger, Emil: G. [1930a](#)
Eschle, Franz: G. [1908e](#); CW 18,20
Evans, Elida: E. [1920a](#), CW 18,129
Evans, Richard I.: G. [1967c](#); E. [1964b](#)
Evans-Wentz, W. Y.: G. [1935f](#), [1955d](#); E. [1954e](#), [1957f](#)

F

- Feifel, Herman: E. [1959c](#)
- Fichte, J. H.: G. [1935e](#)
- Fierz, Markus: CW 18,49,i
- Fierz-David, Linda: G. [1947b](#); E. [1950c](#), CW 18,118, Seminar Notes, [1932a](#)
- Flesch-Brunningen, Hans: G. [1961b](#)
- Flinker, Martin: G. [1957j](#), [1973a](#); E. [1976a](#); Fr. [1961d](#)
- Flournoy, Théodore: G. [1908c,5](#), [1962a,15](#),vi
- Foote, Mary: E. [1974e](#), [1976a](#), Seminar Notes, [1928–30](#), [1930–34](#), [1932a](#), 1934–39, 1938,39
- Fordham, Frieda: G. [1959c](#); E. 19,53d, CW 18,46: CW cd.
- Fordham, Michael: E. [1957g](#), CW 18,47&49,ii
- Forel, August: G. [1910j](#), [1968b](#), [1972a](#); E. [1973b](#), CW 18,20
- Frank, Ludwig: G. [1907f](#)
- Franz, Marie-Louise von: G. [1951a](#), [1955a](#), [1968a](#), GW 14; E. [1964a](#)
- Freeman, John: G. [1968a](#); E. [1964a](#)
- Frei, Gebhard: G. [1957h](#), [1972b](#); E. [1952c](#), [1973b](#)
Port. [1964a](#); Sp.[1955b](#)
- Freud, Sigmund: G. [1906g](#), [1908d,k&m](#), [1932f](#), [1934d](#), [1939d](#), [1962a,15](#),ii, [1972a](#), [1974a](#), GW 4
E. [1932b](#), [1933a,6](#), [1962a,15](#), [1968f](#), [1971b,3](#), [1973b&d,i](#), [1974b&d](#), CW 4, CW 18,32
Du. [1963a,1](#); It. [1974a](#)
- Frey, Liliane: Seminar Notes, [1938–39](#), 1939–40
- Frey-Wehrlin, C. T.: E. [1965a](#)
- Froboese-Thiele, Felicia: G. [1940a](#), [1957e](#), CW 18,102

G

- Galliker, A.: G. [1952h](#), [1972b](#); E. [1976a](#), Seminar Notes, [1935](#)
- Game, Margaret: E. [1968a](#)
- Gerster, Georg: G. [1953a](#), [1954e](#)
- Gilbert, J. Allen: CW 18,112
- Gilli, Gertrud: G. [1938d](#); CW 18,116
- Glover, A.S.B.: CW 18,72,98,&99
- Göring, M. H.: G. [1934l](#)

Goethe, Johann Wolfgang von: G. [1932c](#).
Graecen, Patricia: G. [1972b](#); E. [1957j](#), [1959,1,2](#), [1976a](#)
Gray, Horace: E. [1946c](#)
Grindea, Miron: E. [1959k](#)
Grove, Victor: E. [1944b](#)
Guterman, Norbert: E. [1951b](#)

H

Hahn, R.: G. [1904b](#)
Hanhart, Ernst: G. [1967b](#); E. [1976a](#)
Hannah, Barbara: E. [1937c](#) [1947a,3](#), [1958e](#), Seminar Notes, [1933–41](#), [1935–36](#)
Harding, M. Esther: G. [1935c](#), [1948d](#), [1949d](#); E. [1933b](#), [1947e](#), [1955e](#) CW
[18,42,53,&130](#), Seminar Notes, [1923](#), [1925b](#), [1936–37a](#)
[Du. 1938a](#); Fr. [1953d](#)
Harms, Ernest: G. [1946h](#); E. [1946d](#)
Hartenberg, P.: G. [1908i,3](#)
Hauer, J. W.: Seminar Notes, [1932a](#)
Hecht, Dora: E. [1916a,13&15](#), [1917a,15](#)
Hellpach, Willy: G. [1905b](#); CW [18,19](#)
Helsdingen, René J. van: G. [1957f](#); CW [18,59](#)
Henley, Eugene H.: E. [1945a&b](#), Seminar Notes, [1936—37b](#)
Herbrich, Elisabeth: G. [1963b](#), [1973a](#); E. [1976a](#)
Hesse, Hermann: E. [1963c](#), [1966b](#)
Heyer, Gustav Richard: G. [1933d](#), [1936d](#); CW [18,124&125](#)
Heyer-Grote, Lucy: G. [1967c](#)
Hinkle, Beatrice: E. [1916b](#)
Hitschmann, Eduard: G. [1911d](#); CW [18,27](#)
Hoch, Dorothee: G. [1972b](#), GW [11,22](#); E. [1976a](#)
Hoffman, Michael L.: E. [1968f](#)
Horine, Ruth: CW [18,95](#)
Hottinger, Mary: E. [1950c](#)
Hubbard, A. M.: G. [1972b](#); E. [1971b,6](#), [1976a](#)
Hull, R.F.C.: E. [1925a](#), [1949a](#), [1952b](#), [1953a](#), [1954a,b,d&f](#), [1955a&b](#), [1956a](#),
[1957b&f](#), [1958b](#), [1959b,d&e](#), [1960e](#), [1963b](#), [1966e](#), [1968a](#), [1969e&f](#), [1970b&c](#),
[1971a](#), [1973b,d&e](#), [1974b](#), [1976a](#), CW [1](#), CW [3–18](#)

Hurwitz-Eisner, Lena: GW ed.

Hutchins, Patricia, *see* Graecen, Patricia

I

Illing, Hans A.: G. [1955f](#), [1956d](#), [1972b](#); E. [1957i](#), [1976a](#)

Irminger, H.: E. [1973b](#), CW 18,88

Iyer, K. Bharatha: E. [1947b](#)

J

Jacobi, Jolande: G. [1940c](#), [1943f](#), [1945a](#), [1947c](#), [1952e](#), [1957g](#),[1971b](#); E. [1942c](#),
[1943b](#),[1951b](#), [1953a](#),[1959e](#),[1962c](#),[1969f](#),[1970b](#), CW 28,40,41,60,120

Du. [1949a](#)

Fr. 1961e, 1965a

It. [1949c](#)

Sp. [1947a](#)

Jaffé, Aniela: G. [1950a](#), [1954c](#), [1957a](#), [1958e](#), [1962a](#), [1972a&b](#), [1973a](#), GW 11,20

E. [1962a](#), [1963b](#), [1966a](#), [1967a](#), CW 18,8, Seminar Notes, [1939–40](#)

Janet, Pierre: G. [1908i](#),7

Jarosy, Ivo: E. [1953i](#)

Jolas, Eugene: E. [1930c](#)

Jones, Ernest: G. [1972b](#), [1974a](#); E. [1914b](#), [1974b](#), [1976a](#)

Joyce, James: G. [1972a](#), GW 15,8

E. [1959l](#), [1966d](#), [1973b](#), CW 15,8

Jung, Emma: G. [1934b](#), [1962a](#),15, [i&iii](#); E. [1962a](#),16&17, [1975a](#)

Jung, Marianne, *see* Nielius-Jung, Marianne

Jung-Merker, Lilly: GW ed.

Juquelier, P.: G. [1908i](#),9

K

Kankeleit, Otto: G. [1959d](#); CW 18,121

Katzaroff, Dimitre: G. [1908l](#),3

Kennedy, William H.: E. [1950a](#)

Kerényi, Karl: G. [1941a](#),b,&c, [1951b](#), [1954a](#); E. [1949a](#), [1956a](#), [1963a](#), [1969a](#); Fr.
[1953b](#), [1958a](#)

It. [1948b](#), [1965a](#), [1972a](#)

Keyhoe, Donald: E. [1958g](#), [1959i,2](#), CW 18,82
Keyserling, Hermann, Graf: G. [1925b](#), [1927a](#), [1928e](#), [1930e](#), [1934i](#); E. [1926a](#), [1959k](#),
[1975a](#)
Kirkham, Ethel D.: E. [1948a](#), [1954g](#)
Kirsch, Hildegard: E. [1972d](#)
Kirsch, James: G. [1946h](#), [1972a&b](#), [1973a](#); E. [1946d,2](#), [1972c&d](#), [1973b](#). [1975a](#),
[1976a](#)
Kitchin, Derek: E. [1954c](#)
Klaus, Bruder, *see* Niklaus von der Flüe
Kleist, Karl: G. [1909d](#); CW 18,20
Knapp, Albert: G. [1907c](#); CW 18,20
Koenig-Fachsenfeld, Olga von: G. [1935d](#); CW 18,115, Seminar Notes, [1930–31](#)
Koestler, Arthur: G. [1961b](#), [1973a](#); E. [1961c](#)
Kolb, Eugen: CW 18,74; He. [1974a](#)
Kranefeldt, W. M.: G. [1930b](#), [1934b](#), GW 4,15; E. [1932a](#), CW 4,15
Krich, A. M.: E. [1928a](#), 14

L

Lachat, Père William: G. [1972b](#); E. [1976a](#), CW 18,99
Lasky, Melvin J.: G. [1956e](#), [1961b](#), [1973a](#); E. [1961c](#), [1963f](#), [1976a](#)
Lemaitre, Aug.: G. [1908c,7](#)
Leonard, M.: G. [1973a](#); E. [1960c](#), [1976a](#)
Leroy, E.-Bernard: G. [1908c,6](#)
Loewenfeld, L.: G. [1909e](#); CW 18,20
Lombard, Emile: G. [1908c,3](#)
Lomer, Georg: G. [1908g](#); CW 18,20
London, Louis S.: G. [1972a](#); E. [1937aa](#), [1973b](#)
Long, Constance E.: E. [1916a](#), [1917a](#)
Lorenz, Theodor: E. [1944a](#)
Loÿ, R.: G. [1914b](#), [1973b,2](#), GW 4,12; CW 4,12

M

McGuire, William: E. [1974b&d](#), CW ed.
MacPhail, Ian: E. [1968d](#)
Maeder, Alphonse: G. [19081,4](#)

Maier, Emanuel: G. [1972b](#); E. [1963c](#), [1973b](#)
Mairet, Philip: CW 4,3
Manheim, Ralph: E. [1962c](#), [1967d](#), [1974b](#)
Mann, Kristine: Seminar Notes, [1923](#), [1936–37a](#)
Marie, A.: G. [1908i,6](#)
Marmorstein, Miss: E. [1946f](#)
Mehlich, Rose: G. [1935e](#); E. [1950e](#), CW 18,114
Meier, C. A.: G. [1949e](#), [1959e](#); E. [1965a](#), [1967d](#)
Meier, J.: G. [1959c](#)
Mellon, Mary: E. [1968d](#)
Mellon, Paul: E. [1968d](#)
Métraï, M.: G. [1908c,2](#)
Meyer, E.: G. [1908h](#); CW 18,20
Meyer, Konrad F.: G. [1909h](#); CW 18,11
Michelson, Johann: G. [1912e](#)
Miller, Frank: CW 5
Moll, Albert: G. [1907b](#); CW 18,20
Moltzer, Mary: E. [1913b](#), [1914a](#), [1915b](#), [1916a](#)
Moser, Fanny: G. [1950e](#); CW 18,7
Mountford, Gwen: E. [1959k](#)

N

Näcke, P.: G. [1910g](#); CW 18,20
Nagel, Hildegard: E. [1942b](#), [1947e](#), [1948b&d](#), [1950e](#), [1951a](#), [1953b&f](#), [1954h](#), [1955d](#),
[1959j](#), [1961a](#), CW 18,88,105,&:128
Nelken, Jan: G. [1913d](#); E. [1973d,3](#), CW 18,31
Nelson, Benjamin: E. [1963c](#)
Nerval, Gérard de: G. [1946d](#); CW 18,117
Neumann, Erich: G. [1949f](#), [1962a,15,v](#), [1967a](#), [1973a](#); E. [1954f](#). [1969e](#). [1976a](#), CW
18,54&77
Neumann, Karl Eugen: G. [1956c](#)
Niehus, Walter: G. [1958a](#)
Niehus-Jung, Marianne: G. [1955d](#), [1972a](#), GW 11,25 GW ed. E. [1971b,i](#), [1973b](#)
Niklaus von Flüe: G. [1933c](#), GW 11,6; E. [1946c](#), CW 11,6

O

Oeri, Albert: G. [1945b](#)

Oertley, Alda F.: E. [1940a](#)

P

Pascal, Constanza: G. [19081,8](#)

Pauli, Wolfgang: G. [1952b](#); E. [1955a](#); Sp. [1961a](#)

Payne, Virginia: G. [1972b](#); E. [1971b,4](#), [1973b](#)

Perry, John Weir: E. [1953e](#), CW 18,16

Peterson, Frederick: E. [1907b](#), CW 2,13

Phelan, Gladys: E. [1953b](#)

Philp, Howard L.: G. [1973a](#); E. [1958c](#), [1976a](#), CW 18,103

Picasso, Pablo: G. [1932g](#), [1934b,8](#), GW 15,9; E. [1940a](#), [1953i](#), CW 15,9

Piéron, H.: G. [1908i,1](#)

Pilcz, Alexander: G. [1910b](#); CW 18,20

Pinckney, Sallie M.: G. [1972b](#); E. [1948c](#), [1973b](#), Seminar Notes, [1936–37a](#)

Pöldinger, Walter: G. [1959h](#), CW 18,128

Pope, A. R.: E. [1957a](#)

Pratt, Jane A.: E. [1973b](#), [1976a](#), CW 18,98, Seminar Notes, [1930–34](#)

Prince, Morton: G. [1911b](#), GW 4,6; E. [1925b](#), CW 4,6

Q

Quispel, Gilles: G. [1975a](#); CW 18,91

R

Radin, Paul: G. [1954a](#); E. [1956a](#); Fr. [1958a](#); It. [1965a](#)

Ramakrishna, Sri: E. [1936c](#)

Rank, Otto: G. [1910n](#), [1911f](#)

Reibmayer, Albert: G. [1910f](#); CW 18,20

Reichardt, M.: G. [1907d](#); CW 18,20

Reinecke, Elisabeth: E. [1968c](#)

Ress, Lisa: CW 18,134&135

Revault d'Aliones, G.: G. [1908i,2](#)

Rhees, Jean, CW 2,10&11

Ricksher, Charles: E. [1908a](#), CW 2,14

Riklin, Franz: G. [1904a](#), [1906a,1](#) [1911h](#); GW ed.; E. [1918a,1](#)

Rinkel, Max: G. [1973a](#); E. [1958d](#), CW 3,11
Riviere, Diana: CW 2
Rolfe, Constance: E. [1949d](#)
Rosenthal, Hugo: G. [1934b](#)
Rouma, Georges: G. [19081,5](#)
Rudin, Joseph: G. [1964a](#), [1973a](#); E. [1968c](#), [1976a](#)
Rüf, Elisabeth: GW 10,12,15,22, &33, GW 15,8; GW ed.
Rychlak, Joseph F.: G. [1973a](#); E. [1968b](#), [1976a](#)
Rychner, Max: G. [1932c](#), [1972a](#); E. [1973b](#)

S

Sadger, Isidor: G. [1909h](#); CW 18,11
Sandwich, Earl of: G. [1973a](#); E. [1971b,10](#), [1976a](#)
Sauerlander, Wolfgang: G. [1974a](#); CW 18,9,[21](#),[22](#),[28](#),[33&34](#)
Schär, Hans: G. [1972b](#), GW 11,21; E. [1976a](#)
Schärf, Riwkah: G. [1948a](#); Seminar Notes, [1933–41](#), [1938–39](#); [1939–40](#)
Schleich, Carl Ludwig: G. [1934e](#); CW 18,39
Schloss, Jerome: E. [1955c](#); CW 18,107
Schmaltz Gustav: G. [1955e](#); CW 18,17
Schmid-Guisan, Hans: G. [1931d](#), [1932d](#); CW 18,108&109
Schmitz, Oskar A. H.: G. [1932b](#); E. [1975a](#)
Schnapper, M. B.: E. [1957c](#)
Seelig, Carl: G. [1972b](#); E. [1971b,5](#), [1975a](#)
Senn, Gustav: G. [1945g](#)
Serrano, Miguel: G. [1973a](#); E. [1960b](#), [1966b](#), [1976a](#); Sp. [1965a](#)
Shipley, Thorne: E. [1928b,l](#)
Sinclair, Upton: G. [1972b](#); E. [1953g](#), [1955f](#), [1976a](#)
Smith, Carleton: E. [1958b](#)
Sommer, Robert: G. [19341](#)
Speyr, von: G. [1911h](#)
Spiegelberg, Frederic: E. [1972b](#)
Spier, Julius: E. [1944b](#), CW 18,132
Stein, Leopold: CW 2
Steiner, Gustav: G. [1964b](#), [1973a](#); E. [1962a](#), [1976a](#)
Stekel, Wilhelm: G. [1908j](#); CW 18,22

Suzuki, Daisetz T.: G. [1939c](#), GW 11,13; E. [1949d](#), CW 11,13

T

Tausk, Victor: G. [1913d](#); E. [1973d,3](#), CW 18,31

Taylor, Ethel: Seminar Notes, [1928–30](#)

Thayer, Ellen: E. [1953f](#), [1954h](#)

Thiele-Dohrmann, Klaus: G. [1968a](#), GW 3,5&7, GW 4,3,11,&13

Thomas, Una Gauntlett: Seminar Notes, [1935–36](#)

Thornton, Edward: G. [1973a](#); E. [1965a](#), [1967f](#), [1976a](#)

Tischendorf, F. von: G. [1958j](#), [1973a](#); E. [1959j](#), [1976a](#)

Trinick, John: G. [1973a](#); E. [1967e](#), [1976a](#)

U

Urstein, M.: G. [1910e](#); CW 18,20

V

Varendonck, J.: G. [19081,i](#)

Verzar, J.: E. [1953a](#)

Vigouroux, A.: G. [1908i,9](#)

W

W., E. [Elizabeth Welsh]: E. [1955g](#); *see also* Welsh, Elizabeth

Waldstein, Louis: G. [1909i](#); CW 18,12

Wallace, Edith: E. [1960d](#)

Walser, Hans W.: G. [1968b](#)

Wegmann, Hans: G. [1972a](#), GW 11,24; E. [1973a](#)

Welsh, Elizabeth: E. [1946a](#), [1947a,1&7](#), [1953a](#), [1955g&l](#), Seminar Notes, [1933–41](#)

Werblowsky, R. J. Zwi: G. [1962a](#), 15,iv, [1972b](#), GW 11,5; E. [1952b](#), [1976a](#), CW 11,5

Wernicke, Carl: G. [1906h](#); CW 18,20

White, Stuart E.: G. [1948e](#)

White, Victor: G. [1957h](#), [1972b](#), GW 11,4&20; E. [1952c](#), [1976a](#), CW 11,4; Port.

[1964a](#); Sp. [1955b](#)

Whitmont, Edward: E. [1955e](#)

Wickes, Frances G.: G. [1931e](#), [1953b](#), [1972a](#) GW 17,2; E. [1927a](#), [1966c](#), [1971b,2](#),

[1973b](#), CW 17,2, CW 18,57

Wilhelm, Richard: G. [1929b&h](#), [1930c](#), [1931b](#), [1938a](#), [1957b](#), [1962a](#),15,vii; E. [1931a](#),
[1950d](#), [1962a](#),18, [1962b](#); Du. [1963a](#),3; It. [1936a](#)

Wilhelm, Salome: E. [1962b](#)

Wilson, William G.: G. [1973a](#); E. [1963d](#), [1968e](#), [1976a](#)

Winston, Clara: E. [1962a](#)

Winston, Richard: E. [1962a](#)

Wittels, Fritz: G. [1910l](#); E. [1973d](#),2

Wolff, Toni: G. [1940a](#), [1959e](#), GW 10,18, GW 11,1; E. [1938a](#), CW 10,18, Seminar
Notes, [1932a](#)

Woods, Ralph L.: E. [1947d](#)

Wulffen, Erich: G. [1910p](#); CW 18,25

Z

Zacharias, Gerhard P.: G. [1954c](#)

Ziegler, K. A.: G. [1946f](#); E. [1946b](#)

Zimmer, Heinrich: G. [1944b](#), [1962a](#), 15,viii, GW 11,15

Zosimos: G. [1938c](#), [1954b](#),5; CW 13,2

**INDEX 3:
CONGRESSES, ORGANIZATIONS, SOCIETIES, ETC.**

Cited in the German and English sections only.

A

Abernethian Society, London: E. [1936d](#)

Ärztlicher Verein, ? Munich: G. [1929d](#)

Allgemeine ärztliche Gesellschaft für Psychotherapie: G. [1931c](#), [1935g](#); *see also*
International Medical Congress for Psychotherapy

Allgemeiner ärztlicher Kongress für Psychotherapie, *see* International Medical
Congress for Psychotherapy

Alsatian Pastoral Conference, *see* Elsässische Pastoral konferenz

Analytical Psychology Club, London: E. [1968a](#)

Analytical Psychology Club of New York: E. [1936a](#), [1940c](#), [1948a+d](#), [1949c](#), [1951a](#)

Aristotelian Society, London: E. [1919b](#)

“Arzt und Seelsorger,” *see* Stuttgarter Gemeinschaft...

Australasian Medical Congress, 9th Session, Sydney, Sept. 1911: E. [1913a](#)

B

B.B.C., *see* British Broadcasting Corporation

Basel School Council, *see* Basler staatliche Schulsynode

Basler staatliche Schulsynode: G. [1943d](#)

Bericht über den ... allgemeinen ärztlichen Kongress ..., *see* Allgemeiner ärztlicher
Kongress...

Bernoullianum, Basel: G. [1905e](#)

British Broadcasting Corporation, London: E. [1946e](#), [1960c](#)

British Medical Association. Section of Neurology & Psychological Medicine, 82nd
annual meeting, Aberdeen, 29–31 July 1914: E. [1914b](#)

British Psychological Association, London, 12 July 1919: E. [1919b](#)

C

C. G. Jung Institute, Zurich: G. [1958c](#); E. [1948b](#)

Clark University, Worcester, Mass.: E. [1910a](#)

Conference for Psychology, *see* Tagung für Psychologie

Congrès des Unions Intellectuels, *see* Verband für Intellektuelle Zusammenarbeit

Congrès international de Pédagogie, *see* International Congress of Education

Congress for Psychotherapy, *see* Tagung für Psychotherapie

D

Dresden, 1931: G. [1933b](#)

E

E.T.H., *see* Eidgenössische Technische Hochschule

Eidgenössische Technische Hochschule, Zurich: G. [1932i](#), [1934a](#)

Seminar Notes, [1933](#)–41. [1936](#)–37b, [1938](#)–39, [1939](#)–40

Elsässische Pastoralkonferenz, Strassburg, May 1932: G. [1932a](#)

Eranos Tagung, Ascona: 1939, G. [1940b](#); 1940, G. [1942b](#); 1941, G. [1942c](#); 1942, G. [1943b](#); 1945, G. [1946e](#); 1946, G. [1947a](#); 1948, G. [1949b](#); 1951, G. [1952f](#)

F

Federal Polytechnic Institute, *see* Eidgenössische Technische Hochschule

Fordham University, New York: G. [1913a](#); E. [1913b](#)

G

General Medical Congress for Psychotherapy, *see* International Medical Congress for Psychotherapy

Gesellschaft der Aerzte des Kantons Zürich: G. [1908d](#)

Gesellschaft für deutsche Sprache und Literatur, Zurich: G. [1922a](#)

Gesellschaft für freie Philosophie, Darmstadt: G. [1927a](#)

Guild of Pastoral Psychology, London, seminar talk, 5 Apr. 1939: E. [1954c](#)

H

Harvard University, Cambridge, Mass. Tercentenary Conference of Arts and Sciences, Sept. 1936: E. [1937a](#)

Hottinger Lesezirkel, Zurich: G. [1931f](#)

I

Institute of Medical Psychology, London: E. [1968a](#)

International Congress for Psychiatry, *see* Internationaler Kongress für Psychiatrie

International Congress of Education / Congrès international de Pédagogie: I, Brussels, Aug. 1911, G. [1912b](#)

Territet/Montreux, 1923, G. [1925c](#)

London, May 1924, E. [1928a](#), 13, II–IV Heidelberg, 1925, E. [1928a,14](#)

International Congress of Pedagogy, *see* International Congress of Education

International Congress of Psychiatry and Neurology, Amsterdam, Sept. 1907: G. [1908m](#)

International General Medical Society for Psychotherapy, Swiss section, *see* Allgemeine ärztliche Gesellschaft für Psychotherapy

International Medical Congress, 17th, London, 1913: E. [1916a,9](#)

International Medical Congress for Psychotherapy / Allgemeiner ärztlicher Kongress für Psychotherapie: III, Baden-Baden, 20–22 April 1928, G. [1928c](#)

IV, Bad Nauheim, 12 April 1929, G. [1929c](#)

VI, Dresden, 31 April 1931, G. [1931c](#)

VII, Bad Nauheim, 10–13 May 1934

VIII, Bad Nauheim, 27–30 Mar. 1935, CW 10,30

IX, Copenhagen, 2–4 Oct. 1937, CW 10,32

X, Oxford, 29 July–2 Aug. 1938, E. [1938b](#); *see also* Allgemeine ärztliche Gesellschaft für Psychotherapie

International Psychoanalytic Association, *see* Internationale psychoanalytische Vereinigung

Internationale psychoanalytische Vereinigung: 3. Kongress, Weimar, 21–22 Sept. 1911, G. [1911f+g](#)

Zurich Branch Society, Zurich, 22 Nov. 1912, G. [1913c](#)

Congress, Munich, 7–8 Sept. 1913, Fr. [1913a](#)

Internationaler Kongress für Psychiatrie II, Zurich, 1–7 Sept. 1957: G. [1958i](#); E. [1958d](#)

K

Karlsruhe, 1927: G. [1931a,12](#)

Kulturbund, Vienna: G. [1931g](#), [1934b,9](#)

L

Literarische Gesellschaft, Augsburg: G. [1926c](#)

Literarischer Club, Zurich: G. [1929g](#)

M

Medical-Pharmaceutical Society, *see* Medizinisch-Pharmaceutischer Bezirksverein

Medizinische Gesellschaft, Zurich: G. [1935l](#)

Medizinisch-pharmaceutischer Bezirksverein, Bern: G. [1912h](#)

Mind Association, London: E. [1919b](#)

N

Naturforschende Gesellschaft: G. [1945g](#)

Zurich, 1 Feb. 1932, G. [1932i](#)

Basel, 7 Sept. 1941, G. [1941f](#)

New York Academy of Medicine, 8 Oct. 1912: E. [1916a,9](#)

P

Philosophische Gesellschaft, Zurich: G. [1931a,12](#)

Private psychoanalytische Vereinigung: I, Salzburg, 27 April 1908, G. [1910s](#)

II, Nürnberg, 30–31 March [1910](#), G. [1910n](#)

Psychoanalytic Congress, *see* Internationale psychoanalytische Vereinigung

Psychologischer Club Zürich: G. [1922a](#), [1932a](#), [1938b](#), [1941f](#), [1942b+c](#), [1943c](#),
[1946d](#), [1949b](#), [1950b](#), [1952f](#)

Psycho-medical Society, London: E. [1913d](#). [1915c](#)

Psychotherapeutische Gesellschaft, Munich: G. [1929d](#)

R

Royal Society of Medicine, Section of Psychiatry: Annual! Meeting, London, 11 July
1919, E. [1919a](#)

Meeting, London, 4 April 1939, E. [1939d](#).

S

Schweizerische Akademie der medizinischen Wissenschaft: G. [1945e](#)

Schweizerische Gesellschaft der Freunde ostasiatischer Kultur: G. [1943c](#)

Schweizerische Gesellschaft für praktische Psychologie: G. [1948f](#)

Schweizerische Gesellschaft für Psychiatrie: 84. Versammlung, Prangins, 7–8 Oct.
1933, G. [1933f](#)

Kommission für Psychotherapie, 4th annual meeting, Zurich, 19 July 1941, G.
[1945f](#)

Schweizerische Gesellschaft zur Geschichte der Medizin und der
Naturwissenschaften: G. [1941f](#)

Schweizerische Paracelsus Gesellschaft. Einsiedeln: G. [1942a,2](#), [1948c](#)

Society for German Language and Literature, *see* Gesellschaft für deutsche Sprache ...
Society for Nature Research, *see* Naturforschende Gesellschaft...
Society for Psychological Research, London: E. [1920b](#)
Society of Public Health, Congress, Zurich, 1929: E. [1930b](#)
Stuttgarter Gemeinschaft "Arzt und Seelsorger": 7. Kongress, 1958, G. [1959a](#); 8.
Kongress, 1959, Fall, Zurich, 1959b
Südwestdeutsche Irrenärzte: 37. Versammlung, Tübingen, 3–4 Nov. 1906, G. [1907f](#)
Swiss Academy of Medical Science, *see* Schweizerische Gesellschaft für Psychiatrie,
Kommission für Psychotherapie
Swiss Psychiatrists, Winter Meeting, *see* Verein schweizer Irrenärzte
Swiss Society for the History of Medicine and the Natural Sciences, *see*
Schweizerische Gesellschaft zur Geschichte der Medizin ...

T

Tagung für Psychologie, Zurich, 26 Sept. 1942: G. [1943e](#)
Tagung für Psychotherapie, II, Bern, 28 May 1937: CW 16,14

U

United States Information Agency: E. [1957h](#)
Universität Zürich: G. [1902a](#), [1905h](#), [1906b&k](#), 1971a,3
Universitätsklinik, Zürich, *see* Universität Zürich
University of Zurich, *see* Universität Zürich

V

Verband für intellektuelle Zusammenarbeit, Tagung, Prague, Oct. 1928: G. [1928f](#)
Verein schweizer Irrenärzte: Winter Meeting, Bern, 27 Nov. 1910, G. [1911h](#)
Zurich, 1928, G. [1931a,6](#)

W

Wanderversammlung der Südwestdeutschen Psychiater und Neurologen, 66.,
Badenweiler, 1950: G. [1950g](#)

Y

Yale University, New Haven, Conn.: E. [1938a](#)

Z

Zurich Cantonal Medical Society, *see* Gesellschaft der Aerzte des Kantons Zürich

Zurich Medical Society, *see* Medizinische Gesellschaft, Zurich

Zurich Psychoanalytic Society, *see* Internationale psychoanalytische Vereinigung.

Zurich Branch Society

Zurich, Rathaus: G. [1908a](#), [1933b](#)

Zurich School of Analytical Psychology: Fr. 1916a

Zurich Town Hall, *see* Zurich, Rathaus

INDEX 4: PERIODICALS

ABBREVIATIONS USED IN THE BIBLIOGRAPHY

Aus d. Jhrsb. = Aus dem Jahresbericht.

Basl. Nach. = Basler Nachrichten.

Bull. APC = Analytical Psychology Club of New York. Bulletin.

CorrespBl. schweizer Ärzte = Correspondenzblatt für schweizer Ärzte.

Eran. Jb. = Eranos-Jahrbuch.

Europ. Rev. = Europäische Revue.

J. abnorm. Psychol. = Journal of Abnormal Psychology.

J. Psychol. Neurol. = Journal für Psychologie und Neurologie.

Jb. Psychoanal. psychopath. Forsch. = Jahrbuch für psychoanalytische und psychopathologische Forschungen.

Neue Schw. R. = Neue schweizer Rundschau.

Neue Zür. Z. = Neue Zürcher Zeitung.

New Repub. = New Republic.

Psychoanal. Rev. = Psychoanalytic Review.

Schweiz. Z. Strafrecht. = Schweizerische Zeitschrift für Strafrecht.

Revta Occid. = Revista de Occidente.

Z. angew. Psychol. = Zeitschrift für angewandte Psychologie und psychologische Sammelforschung.

Zbl. Nervenhk. = Zentralblatt für Nervenheilkunde und Psychiatrie.

Zbl. Psychoanal. = Zentralblatt für Psychoanalyse.

Zbl. Psychotherap. = Zentralblatt für Psychotherapie und ihre Grenzgebiete.

A

AA Grapevine; International Monthly Journal of Alcoholics Anonymous (New York):

E. [1963d](#), [1968e](#)

A.P.R.O. Bulletin (Alamogordo, N.M.), Organ of the Aerial Phenomena Research Organization: E. [1958f&j](#)

Actas Ciba (Buenos Aires): Sp. [1946a](#)

(Lisbon): Port. [1948a](#)

(Rio de Janeiro): Port. [1947a](#); *see also* Ciba Zeitschrift and Revue Ciba

Action et Pensée (Geneva): Fr. [1944b](#)

Adam; International Journal (Bucharest; London): E. [1959k](#)
Al Hamishmar (Tel Aviv): He. [1974a](#)
Allgemeine Neueste Nachrichten (Munich): G. [1929e](#)
Allgemeine Zeitschrift für Psychiatrie und psychisch-gerichtliche Medizin (Berlin): G. [1903a](#)
Ambix (London): E. [1946f](#)
American Journal of Psychology (Ithaca, N.Y.): E. [1910a](#)
Analytical Psychology Club of New York, Bulletin (New York): E. [1945b](#), [1948b+c](#),
[1950e](#), [1953f](#), [1954g+h](#), [1956c](#),[1957](#), [1958h](#), [1959g+j](#), [1960d](#), [1963d+f](#)
Annalen der Philosophischen Gesellschaften. ... See Philosophische Gesellschaften ...
Année psychologique (Paris): Fr. [1908a](#), [1909a](#)
Archiv für die gesamte Psychologie (Leipzig): G. [1904b](#)
Archiv für Kriminalanthropologie und Kriminalistik (Leipzig): G. [1906b](#)
Archiv für Kriminologie (Leipzig): G. [1937b](#)
Archives de psychologie (Geneva): Fr. [1907a](#), [1913a](#), [1916a](#)
Arts, Lettres, Spectacles, Musique (Paris): Fr. [1960b](#), [1962b](#)
Asia (New York): E. [1939b+c](#)
Astrologie moderne, L' (Paris): Fr. [1954b](#)
Atenea (Santiago, Chile): Sp. [1933b](#)
Atlantic Monthly, The (Boston): E. [1958b](#), [1962a](#),[1,6,12,13](#)
Aus dem Jahresbericht (Zurich), Annual pub. of the Psychologischer Club Zurich: G. [1938b](#), [1946d](#), [1950b](#)
Australasian Medical Congress. Transactions. (Sydney): E. [1913a](#)

B

Badener Tagblatt (Baden, Switzerland): G. [1958h](#)
Basler Nachrichten (Basel): G. [1905e](#), [1909h+i](#), [1932d](#), [1934i](#), [1939d](#), [1946g](#)
Basler Stadtbuch; Jahrbuch für Kultur und Geschichte, ed. by Fritz Griebler, Valentin
Lötscher, Adolf Portmann. (Basel): G. [1964b](#)
Berliner Tageblatt (Berlin): G. [1928c](#), [1934h](#)
Black Mountain Review (Bañalbufar, Mallorca): E. [19551](#)
Brain; A Journal of Neurology (London): E. [1907b](#)
British Journal of Medical Psychology (London): E. [1923b](#)
British Journal of Psychology (London): E. [1919b](#), [1921a](#)
British Medical Journal (London): E. [1914b](#)

C

Centralblatt, *see listings under* Zentralblatt

Character and Personality; An International Quarterly of Psychodiagnostics and Allied Studies (Durham, North Carolina): E. [1932b](#)

Charakter (Berlin): G. [1932f](#)

Chimera (N.Y.; Princeton, N.J.): E. [1947f](#)

Chinesisch-deutscher Almanach (Frankfurt am Main): G. [1930a](#)

Ciba, *see Actas Ciba and* Revue Ciba

Ciba-Tijdschrift (Basel): Du. [1947b](#)

Ciba Zeitschrift (Basel): G. [1945d](#)

(Baden): G. [1952i](#)

Correspondenzblatt für schweizer Ärzte (Basel): G. [1906c,e,f,+h](#), [1907b,c,+d](#), [1908d-h,+k](#), [1909d-g](#). [1910a-j](#), [1911h](#). [1912h](#)

Cosmopolitan (New York): E. [1958i](#)

C.S.I. of New York (New York) (Civilian Saucer Intelligence): E. [1959i](#)

D

Darshana (Moradabad, India): E. [1961d](#)

Dialectica (Neuchâtel): G. [1951d](#)

Du; schweizerische Monatsschrift (Zurich): G. [1941e](#), [1943f](#), [1955e](#); E. [1955g](#)

E

Encéphale, L'; Journal de Psychiatrie (Paris): Fr. [1913b](#), [1952c](#)

Encounter (London): E. [1961c](#)

Eranos-Jahrbuch, ed. by Olga Froebe-Kapteyn (Zurich): G. [1934c](#), [1935b'](#) [1936a](#), [1937a](#). [1938c](#), [1939b](#), [1940b](#), [1942b+c](#), [1943b](#), [1946e](#), [1947a](#), [1949b](#), [1952f](#)

Espresso, L' (Rome): It. [1961c](#)

Ethik (Sexual- und Gesellschafts-Ethik) (Halle): G. [1928g](#)

Europäische Revue (Berlin): G. [1927b](#), [1928d+f](#), [1929h](#), [1931f+g](#), [1932e](#), [1933d](#), [1934h](#)

F

Flinker Almanac (Paris): G. [1957j](#); Fr. [1961d](#)

Flying Saucer Review (London): E. [1955i](#)
Folia neuro-biologica (Leipzig): G. [1908c,i,+l](#)
Form und Sinn (Augsburg): G. [1926c](#)
Forum (New York): E. [1930a](#)

G

Geneeskundige Courant (Amsterdam): Du. [1908a](#)
Guild of Pastoral Psychology, Lectures (London): E. [1954c](#)

H

Hamburger akademische Rundschau (Hamburg): G. [1947c](#)
Horisont (Oslo): Nor. [1956a](#)
Horizon (London): E. [1943b](#)
Human Relations (London; Ann Arbor, Mich.): E. [1957i](#)

I

International Congress for Psychiatry (Proceedings) (Zurich): G. [1958i](#)
International Journal of Group Psychotherapy (New York), Organ of the American Group Psychotherapy Association: E. [1957i](#)
International Journal of Parapsychology (New York): E. [1963e](#)
Internationale Zeitschrift für ärztliche Psychoanalyse (Leipzig): G. [1913c+d](#)
Inward Light (Washington, D.C.): E. [1955j](#)

J

Jahrbuch für psychoanalytische und psychopathologische Forschungen (Leipzig): G. [1909b+c](#), [1910k-p](#), [1911a-d](#), [1912c](#), [1913a+b](#)
Journal des poètes, Le (Brussels): Fr. [1932b](#)
Journal für Psychologie und Neurologie (Leipzig): G. [1902b](#), [1903b](#), [1904a](#), [1905g+h](#), [1906i+j](#), [1907e](#)
Journal of Abnormal Psychology (Boston): E. [1907a](#), [1908a](#), [1915c](#)
Journal of Analytical Psychology (London): E. [1959h](#), [1960e](#)
Journal of Mental Science (London): E. [1938b](#), [1939d](#)
Journal of Nervous and Mental Disease (New York; Richmond; London): E. [1946c](#)
Journal of Religion and Health (New York), Organ of the Academy of Religion and Mental Health: E. [1968f](#)

Journal of State Medicine (London): E. [1930b](#)

Jungkaufmann, Der; Schweizer Monatschrift für die kaufmännische Jugend (Zurich):
G. [1952h](#)

Jura libre, Le (Delémont, Switz.): Fr. [1958d](#)

Juristisch-psychiatrische Grenzfragen (Halle): G. [1906k](#)

K

Katalog der Autographen-Auktion (Marburg): G. [1967b](#)

Kölnische Zeitung (Cologne): G. [1929f](#), [1932c](#)

Kultur, Die (Munich): G. [1956f](#)

L

Lancet, The (London): E. [1914b](#)

Lesezirkel, Der (Zurich): G. [1929g](#)

Lettere ed arti (Venice): It. [1946a](#)

Listener, The (London): E. [1946e](#), [1960c](#)

M

Mason Dergisi (Istanbul): Turk. [1954a](#)

Medizinische Klinik (Berlin): G. [1908j](#)

Medizinische Welt (Berlin): G. [1929i](#)

Mercur (Stuttgart): G. [1952j](#)

Mitteilungen der Schweizerischen Gesellschaft ..., *see* Schweizerische Gesellschaft...
Mitteilungen

Monat, Der (Frankfurt am Main): G. [1956e](#)

Monatsschrift für Kriminal-psychologie und Strafrechts-reform (Heidelberg): G.
[1906d](#)

Monatsschrift für Psychiatrie und Neurologie (Basel): G. [1908m](#)

Münchener medizinische Wochen-schrift (Munich): G. [1906g](#)

Münchener neueste Nachrichten (Munich): G. [1935i](#)

N

Naüi Razgledi (Ljubljana): Sl. [1961a](#)

Naturforschende Gesellschaft in Zürich, Vierteljahrschrift (Zurich): G. [1932i](#)

Naturforschende Gesellschaft. Verhandlungen (Basel): G. [1945g](#)

Nederlandsch Tijdschrift voor Geneeskunde (Amsterdam): Du. [1914a](#)

Neue Schweizer Rundschau (Zurich) (published as Wissen und Leben, 1907–18): G. [1928e](#), [1933b+c](#), [1936c](#), 1945c, 1948e
Neue Wissenschaft; Zeitschrift für Parapsychologie (Oberengstringen / Zurich): G. [1951e](#)
Neue Zürcher Zeitung (Zurich): G. [1912e+f](#), 1930c–e 1932g, 1934f+g
Neues Wiener Journal (Vienna): G. [1933a](#)
New Adelphi (London): E. [1928c](#)
New Republic, The (New York): E. [1953g](#). 1955f+h
Nimbus (London): E. [1953h+i](#)
Nova Acta Paracelsica (Basel), Yearbook of the Schweizerische Paracelsus Gesellschaft Einsiedeln: G. [1948c](#)

P

Pastoral Psychology (Great Neck, N.Y.): E. [1956c+d](#)
Perspektiv (Copenhagen): Dan. [1957a](#)
Philosophische Gesellschaften Innerschweiz und Ostschweiz, Annalen: G. [1957h](#)
Prabuddha Bharata (Calcutta): E. [1931c](#), [1936c](#)
Proceedings of the International Congress..., *see* International Congress...
Proceedings of the Royal Society ..., *see* Royal Society ...
Proceedings of the Society ..., *see* Society ...
Psyche (Heidelberg): G. [1950g](#)
Psychiatric Quarterly (Utica, N.Y.): G. [1946h](#); E. [1946d](#)
Psychiatrisch-Neurologische Wochenschrift (Halle): G. [1911h](#)
Psychoanalytic Review (New York): E. [1913b+c](#), [1914a](#), 1915b+d, 1963g
Psychological Perspectives (Los Angeles) Organ of the Analytical Psychology Club:
E. [1972c+d](#)
Psychology Today (Del Mar, Cal.): E. [1974b](#)
Psycho-Medical Society, Transactions (Cockermouth, England): E. [1913d](#)
Psychotherapy (Calcutta): E. [1956e](#)

Q

Querschnitt (Berlin): G. [1932h](#)

R

Raschers Jahrbuch für schweizer Art und Kunst (Zurich): G. [1912d](#)

Revista de Occidente (Madrid): Sp. [1925a](#), [1931a](#), [1932a](#), [1933a](#), [1934b](#), [1936b](#)

Revue Ciba (Basel): Fr, [1945a](#); *see also* *Actas Ciba and Ciba Zeitschrift*

Revue d'Allemagne et des pays de langue allemande (Paris): Fr. [1933a](#)

Rivista di psicologia applicata (Florence): It. [1908a](#)

Royal Society of Medicine, Proceedings (London): E. [1919a](#)

S

St. Bartholomew's Hospital Journal (London): E. [1936d](#), [1937d](#)

Saturday Review of Literature, The (New York): E. [1937c](#)

Schweizer Archiv für Neurologie und Psychiatrie (Zurich): G. [1933f](#). [1958i](#)

Schweizer Bücherverzeichnis (Zurich): G. 1950c

Schweizer Erziehungs-Rundschau (Zurich): G. [1943d](#)

Schweizer Monatshefte (Zurich): G. [1957i](#)

Schweizerische Ärztezeitung für Standesfragen (Bern): G. [1935h+i](#)

Schweizerische Akademie der medizinischen Wissenschaften. Bulletin (Basel): G. [1945e](#)

Schweizerische Gesellschaft der Freunde ostasiatischer Kultur. Mitteilungen (St. Gallen): G. [1943c](#)

Schweizerische Medizinische Wochenschrift (Basel): G. [1941f](#); E. [1931d](#)

Schweizerische Paracelsus Gesellschaft, Yearbook, *see* *Nova Acta Paracelsica*

Schweizerische Zeitschrift für Psychologie und ihre Anwendung (Bern): G. [1943e](#), [1945f](#)

Schweizerische Zeitschrift für Strafrecht (Bern): G. [1904c](#), [1905f](#), [1906i](#)

Schweizerisches medizinisches Jahrbuch (Basel): G. [1929d](#)

Schweizerland (Zurich): G. [1918b](#)

Society for Psychological Research, Proceedings (London): E. [1920b](#)

Spring (through 1969, New York; 1970–, Zurich), Annual of the Analytical Psychology Club of New York, New York. E. [1942b](#), [1943a](#), [1944a](#), [1945a](#), [1946a](#), [1947c](#), [1948a](#), [1949c](#), [1950a](#), [1951a](#), [1953c](#), [1954d](#), [1955c+d](#), [1956b](#), [1957d](#), [1961a](#), [1968f](#), [1969f](#), [1970c](#), [1971b](#), [1973d+e](#), [1974e](#)

Süddeutsche Monatshefte (Munich): G. [1936b](#)

Sunday Referee (London): E. [1932c](#)

Synthèses: Revue européenne (Brussels): Fr, [1955b](#)

T

Table Ronde, La (Paris): Fr. [1957b](#), [1958c](#)

Tagesanzeiger für Stadt und Kanton Zürich (Zurich): G. [1967b](#)

Tat, Die (Zurich): G. [1959g](#)

Therapie des Monats, Die (Mannheim): G. [1959h](#)

Tomorrow (New York): E. [1955k](#)

Transactions of the Australasian ..., *see* Australasian Medical Congress ...

Transactions of the Psycho-Medical ..., *see* Psycho-Medical Society ...

transition (Paris): E. [1930c](#)

Tribune de Genève (Geneva): Fr. [1948a,4](#)

U

UFO Investigator; Facts about Flying Saucers (Washington, D.C.), Organ of the National Investigations Committee on Aerial Phenomena: E. [1958g](#)

Universitas (Stuttgart): G. [1958c](#), [1959f](#); E. [1959f](#)

University; A Princeton Magazine (Princeton, N.J.): E. [1972e](#)

V

Verhandlungen der Naturforschenden. ... *see* Naturforschende Gesellschaft ...

Vierteljahrschrift der Naturforschenden ..., *see* Naturforschende Gesellschaft ...

Vindrosen (Copenhagen): Dan. [1964a](#)

Volksrecht (Zurich): G. [1905e](#)

Vossische Zeitung (Berlin): G. [1932f](#)

W

Welt, Die (Hamburg): G. [1950f](#)

Weltwoche, Die (Zurich): G. [1954e+f](#)

Wiener Zeitschrift für Nervenheilkunde ... und deren Grenzgebiete (Vienna): G. [1948f](#)

Wissen und Leben (Zurich) (replaces Neue Schweizer Rundschau, 1907–18): G. [1912g](#)

Z

Zeitschrift für angewandte Psychologie und psychologische Sammelforschung (Leipzig): G. [1908n+o](#), [1910r](#)

Zeitschrift für Menschenkunde; Blätter für Charakterologie und angewandte Psychologie (Munich): G. [1925b](#)

Zeitschrift für Parapsychologie und Grenzgebiete der Psychologie (Bern): G. [1958f](#),
[1961b](#)

Zeitschrift für psychosomatische Medizin (Göttingen): G. [1956d](#)

Zentralblatt für Nervenheilkunde und Psychiatrie (Leipzig): G. [1905b–d](#), [1907f](#), [1908b](#)

Zentralblatt für Psychoanalyse und Psychotherapie (Wiesbaden): G. [1910a+s](#), [1911e–h](#)

Zentralblatt für Psychotherapie und ihre Grenzgebiete einschliesslich der
medizinischen Psychologie und psychischen Hygiene (Leipzig): G. [1910n](#),[1933e](#),
[1934a,j-l](#), [1935j–l](#), [1936d+e](#), [1939e](#)

Zentralblatt für Verkehrs-Medizin, Verkehrs-Psychologie und angrenzende Gebiete
(Alfeld/Leine and Bad Godesberg): G. [1958j](#)

Zukunft, Die (Berlin): G. [1905a](#)

Zürcher Student (Zurich), Organ of the student body, University of Zurich: G. [1949g](#),
[1958g](#)

ADDENDA

ITALIAN

These entries were received from a correspondent in Italy too late for inclusion in the Italian section. They have not been integrated into the cross-references in the German and English sections, and some attributions to sources are tentative.

- 1949d “Introduzione.” Charles Robert Aldrich: *Mente primitiva e civiltà moderna*, pp. 13, 16. Turin: Einaudi. Trans. from E. 1931b by Tullio Tentori.
- 1962b “Sulla sincronicità.” *Il Verri*, VII:3 (Aug.), 3–14. Trans. from G. 1952f by C. R.
- 1962c “L’uomo arcaico.” *Magia e civiltà*, pp. 124–51. Ed. by Ernesto de Martino. Milan: Garzanti. Trans. from G. 1931a,9 by ?
- 1970c “Prefazione.” D. T. Suzuki: *Introduzione al Buddismo Zen*. pp. 15–33. Rome: Ubaldini. Trans. from E. 1949d by Grazia Marchianô.
- 1970d *Psicologia della schizofrenia*. Rome: Newton Compton Italiana. pp. 219. Trans. from G. 1907a by Celso Balducci.
- 1971b *La malattia mentale*. Rome: Newton Compton Italiana. pp. 235. Trans. by Celso Balducci. Contents:
1. “Simulazione dell’alienazione mentale.” (31–72) Trans. from G. 1903b. Pub. in a dif. trans. as It. 1974b,3.
 2. “Parere medico su un caso di simulazione di malattia mentale.” (73–98) Trans. from G. 1904c. Pub. in a dif. trans. as It. 1974b,5.
 3. “Il contenuto delle psicosi.” (99–132) Trans. from G. 1908a.
 4. “Critica alla teoria del negativismo schizofrenico secondo Bleuler.” (133–42) Trans. from G. 1911c.
 5. “Attualità in tema di psicoterapia. Carteggio con il dottor C. G. Jung, a cura di R. Loy.” (143–96) Trans. from G. 1914b.
 6. “Il problema della psicogenesi della malattia mentale.” (197–218) Trans. from GW 3,6.
 7. “Importanza terapeutica dell’abreazione.” (219–35) Trans. from GW 16,11.

1971c *Inconscio, occultismo e magia*. Rome: Newton Compton Italiana. pp. 251.

Trans. by Celso Balducci. Contents:

1. "Psicologia e patologia dei cosiddetti fenomeni occulti." (39–140) Trans. from G. 1902a. Pub. in a dif. Trans. as It. 1974b,1.
2. "Importanza dell'inconscio in psicopatologia." (141–50) Trans. from GW 3,5.
3. "La struttura dell'inconscio." (151–84) Trans. from GW 7,4.
4. "L'inconscio." (185–216) Trans. from G. 1918b.
5. "Istinto ed inconscio." (217–28) Trans. from G. 1928b,4.
6. "I fondamenti psicologici della credenza negli spiriti." (229–51) Trans. from G. 1928b,5.

1971d *La psicoanalisi e Freud*. Rome: Newton Compton Italiana, pp. 225. Trans. by Liliana Grosso. Pub. in a dif. Trans. with addns. as It. 1973a. Contents:

1. "La teoria di Freud sull'isteria: una risposta ad Aschaffenburg." (33–44) Trans. from GW 4,1.
2. "La teoria freudiana dell'isteria." (45–66) Trans. from GW 4,2.
3. "L'analisi dei sogni." (67–80) Trans. from GW 4,3.
4. "Un contributo alla psicologia del pettegolezzo." (81–100) Trans. from GW 4,4.
5. "Sull'importanza dei sogni dei numeri." (101–12) Trans. from GW 4,5.
6. "Morton Prince: 'il meccanismo e l'interpretazione dei sogni'—una revisione critica." (113–38) Trans. from GW 4,6.
7. "Sulla critica alla psicoanalisi." (139–46) Trans. from GW 4,7.
8. "Riguardo alla psicoanalisi." (147–52) Trans. from GW 4,8.
9. "Aspetti generali della psicoanalisi." (153–72) Trans. from GW 4,10.
10. "Psicoanalisi e nevrosi." (173–86) Trans. from GW 4,11.
11. "Prefazione alla 'Raccolta di scritti sulla psicologia analitica.'" (187–98) Trans. from GW 4,13.
12. "L'importanza del padre nel destino dell'individuo." (199–225) Trans. from GW 4,14.

1972c *La dimensione psichica*. Turin: Boringhieri. pp. 345. Trans. by ?Luigi Aurigemma. Contents:

1. "Psicoterapia e concezione del mondo." (37–45) Trans. from G. 1943e.
2. "L'essenza dei sogni." (46–66) Trans. from G. 1948b,5.
3. "Psicologia e poesia." (67–89) Trans. from G. 1950a,2.
4. "La funzione trascendente." (90–119) Trans. from G. 1958b.

5. "Gli archetipi dell'inconscio collettivo." (120–161) Trans. from G. 1954b,2.
6. "La struttura della psiche (da 'Aion')." (162–97) Trans. from G. 1951a,I–IV.
7. "Wotan." (198–213) Trans. from G. 1936c.
8. "La schizofrenia." (214–32) Trans. from G. 1958i.
9. "Riflessioni teoriche sull'essenza della psiche." (233–318) Trans. from G. 1954b,8.
10. "La coscienza dal punto di vista psicologico." (319–40) Trans. from G. 1958c.

1972d *Psicologia e psichiatria*. Rome: Newton Compton Italiana. pp. 247. Trans. by Celso Balducci. Contents:

1. "Caso di stupore isterico in una detenuta sottoposta ad istruttoria." (19–46) Trans. from GW 1,5. Pub. in a dif. trans. as It. 1974b,2.
2. "Squilibrio affettivo maniacale." (47–84) Trans. from GW 1,4.
3. "Paralessia isterica." (85–92) Trans. from GW 1,2. Pub. in a dif. trans. as It. 1974b,4.
4. "Criptomnesia." (93–110) Trans. from GW 1,3. Pub. in a dif. trans. as It. 1974b,6.
5. "Diagnostica psicologica dei fatti." (111–116) Trans. from GW 1,9.
6. "Terza e definitiva perizia su due diagnosi psichiatriche contraddittorie." (117–32) Trans. from GW 1,8. Pub in a dif. trans. as It. 1974b,7.
7. "Conflitti psichici in una bambina." (133–74) Trans. from GW 17,1.
8. "Contributo allo studio dei tipi psicologici." (175–90) Trans. from GW 6,4.
9. "La comprensione psicologica dei problemi patologici." (191–212) Trans. from GW 3,2, Nachtrag.
10. "Nuove vie della psicologia." (213–47) Trans. from GW 7,3.

1973b "Introduzione." M. Esther Harding: *I misteri della donna*. pp. 7–9. Rome: Astrolabio. Trans. from E. 1955e by Aldo Giuliani.

1974b *Psicologia e patologia dei cosiddetti fenomeni occulti e altri scritti*. Turin: Boringhieri. pp. 223. Trans. by Guido Bistolfi. Contents:

1. "Psicologia e patologia dei cosiddetti fenomeni occulti." (3–98) Trans. from G. 1902a. Pub. in a dif. Trans. as It. 1971c,1.
2. "Caso di stupore isterico in una detenuta in carcere preventivo." (99–122) Trans. from G. 1902b. Pub. in a dif. trans. as It. 1972d,1.

3. "Simulazione di malattia mentale." (123–54) Trans. from G. 1903b. Pub. in a dif. trans. as It. 1971b, 1.
4. "Paralessia isterica." (155–58) Trans. from G. 1904b. Pub. in a dif. trans. as It. 1972d,3.
5. "Perizia medica su un caso di simulazione di malattia mentale." (159–78) Trans. from G. 1904c. Pub. in a dif. trans. as It. 1971b,2.
6. "Criptomnesia." (179–91) Trans. from G. 1905a, Pub. in a dif. Trans. as It. 1972d,4.
7. "Superperizia su due perizie psichiatriche contraddittorie." (192–202) Trans. from G. 1906d. Pub. in a dif. trans. as It. 1972d,6.

1975a *Psicologia analitica. Le conferenze alla Clinica Tavistock 1935*. Milan: Mondadori. pp. 184. Trans. from G. 1969a by Sergio Chiappori.

1975b "Commento psicologico." *Il libro tibetano della Grande Liberazione*. pp. 39–40. Ed. by W. Y. Evans-Wentz. Rome: Newton Compton. Trans. from E. 1954e by Carla Cipollini and Sabatino Piovani.

1975c *Psicologia, linguaggio e associazione verbale*. Rome: Newton Compton. pp. 399. Trans. by Marina Beer. Contents:

1. "Le associazione dei soggetti normali." (11–189) Trans. from GW 2,1.
2. "Analisi delle associazioni di un epilettico." (190–210) Trans. from GW 2,2.
3. "Il coefficiente del tempo di reazione nell-esperimento di associazione." (211–56) Trans. from GW 2,3.
4. "Osservazioni sperimentali sulla facoltà della memoria." (257–71) Trans. from GW 2,4.
5. "Psicoanalisi ed esperimenti di associazione." (272–99) Trans. from GW 2,5.
6. "Associazione, sogni e sintomo isterico." (300–47) Trans. from GW 2,7.
7. "L'importanza dell' esperimento di associazione per la psicopatologia." (348–63) Trans. from GW 2,8.
8. "Disturbi della riproduzione negli esperimenti di associazione." (364–75) Trans. from GW 2,9.
9. "Il metodo dell'associazione." (376–99) Trans. from GW 2,10.

1975d *La libido. Simboli e trasformazioni*. Rome: Newton Compton. pp. 389. Trans. from G. 1912a by Girolamo Mancuso. Cf. It. 1965b and 1970a.

THE COLLECTED WORKS OF

C. G. JUNG

THE PUBLICATION of the first complete edition, in English, of the works of C. G. Jung was undertaken by Routledge and Kegan Paul, Ltd., in England and by Bollingen Foundation in the United States. The American edition is number XX in Bollingen Series, which since 1967 has been published by Princeton University Press. The edition contains revised versions of works previously published, such as *Psychology of the Unconscious*, which is now entitled *Symbols of Transformation*; works originally written in English, such as *Psychology and Religion*; works not previously translated, such as *Aion*; and, in general, new translations of virtually all of Professor Jung's writings. Prior to his death, in 1961, the author supervised the textual revision, which in some cases is extensive. Sir Herbert Read (d. 1968), Dr. Michael Fordham, and Dr. Gerhard Adler compose the Editorial Committee; the translator is R. F. C. Hull (except for Volume 2) and William McGuire is executive editor.

The price of the volumes varies according to size; they are sold separately, and may also be obtained on standing order. Several of the volumes are extensively illustrated. Each volume contains an index and in most a bibliography; the final volumes will contain a complete bibliography of Professor Jung's writings and a general index to the entire edition.

In the following list, dates of original publication are given in parentheses (of original composition, in brackets). Multiple dates indicate revisions.

*1. PSYCHIATRIC STUDIES

On the Psychology and Pathology of So-Called Occult Phenomena (1902)

On Hysterical Misreading (1904)

Cryptomnesia (1905)

On Manic Mood Disorder (1903)

A Case of Hysterical Stupor in a Prisoner in Detention (1902)

On Simulated Insanity (1903)

A Medical Opinion on a Case of Simulated Insanity (1904)

A Third and Final Opinion on Two Contradictory Psychiatric Diagnoses
(1906)

On the Psychological Diagnosis of Facts (1905)

†2. EXPERIMENTAL RESEARCHES

Translated by Leopold Stein in collaboration with Diana Riviere

STUDIES IN WORD ASSOCIATION (1904–7, 1910)

The Associations of Normal Subjects (by Jung and F. Riklin)

An Analysis of the Associations of an Epileptic

The Reaction-Time Ratio in the Association Experiment

Experimental Observations on the Faculty of Memory

Psychoanalysis and Association Experiments

The Psychological Diagnosis of Evidence

Association, Dream, and Hysterical Symptom

The Psychopathological Significance of the Association Experiment

Disturbances in Reproduction in the Association Experiment

The Association Method

The Family Constellation

PSYCHOPHYSICAL RESEARCHES (1907–8)

On the Psychophysical Relations of the Association Experiment

Psychophysical Investigations with the Galvanometer and Pneumograph in
Normal and Insane Individuals (by F. Peterson and Jung)

Further Investigations on the Galvanic Phenomenon and Respiration in
Normal and Insane Individuals (by C. Ricksher and Jung)

Appendix: Statistical Details of Enlistment (1906); New Aspects of Criminal
Psychology (1908); The Psychological Methods of Investigation Used in the
Psychiatric Clinic of the University of Zurich (1910); On the Doctrine of
Complexes ([1911] 1913); On the Psychological Diagnosis of Evidence
(1937)

*3. THE PSYCHOGENESIS OF MENTAL DISEASE

The Psychology of Dementia Praecox (1907)

The Content of the Psychoses (1908/1914)

On Psychological Understanding (1914)

A Criticism of Bleuler's Theory of Schizophrenic Negativism (1911)

On the Importance of the Unconscious in Psychopathology (1914)

On the Problem of Psychogenesis in Mental Disease (1919)

Mental Disease and the Psyche (1928)

On the Psychogenesis of Schizophrenia (1939)

Recent Thoughts on Schizophrenia (1957)

Schizophrenia (1958)

†4. FREUD AND PSYCHOANALYSIS

Freud's Theory of Hysteria: A Reply to Aschaffenburg (1906)
The Freudian Theory of Hysteria (1908)
The Analysis of Dreams (1909)
A Contribution to the Psychology of Rumour (1910–11)
On the Significance of Number Dreams (1910–11)
Morton Prince, "The Mechanism and Interpretation of Dreams": A Critical Review (1911)
On the Criticism of Psychoanalysis (1910)
Concerning Psychoanalysis (1912)
The Theory of Psychoanalysis (1913)
General Aspects of Psychoanalysis (1913)
Psychoanalysis and Neurosis (1916)
Some Crucial Points in Psychoanalysis: A Correspondence between Dr. Jung and Dr. Loÿ (1914)
Prefaces to "Collected Papers on Analytical Psychology" (1916, 1917)
The Significance of the Father in the Destiny of the Individual (1909/1949)
Introduction to Kranefeldt's "Secret Ways of the Mind" (1930)
Freud and Jung: Contrasts (1929)

‡5. SYMBOLS OF TRANSFORMATION (1911–12/1952)

PART I

Introduction
Two Kinds of Thinking
The Miller Fantasies: Anamnesis
The Hymn of Creation
The Song of the Moth

PART II

Introduction
The Concept of Libido
The Transformation of Libido
The Origin of the Hero
Symbols of the Mother and of Rebirth
The Battle for Deliverance from the Mother
The Dual Mother
The Sacrifice

Epilogue

Appendix: The Miller Fantasies

*6. PSYCHOLOGICAL TYPES (1921)

Introduction

The Problem of Types in the History of Classical and Medieval Thought

Schiller's Ideas on the Type Problem

The Apollinian and the Dionysian

The Type Problem in Human Character

The Type Problem in Poetry

The Type Problem in Psychopathology

The Type Problem in Aesthetics

The Type Problem in Modern Philosophy

The Type Problem in Biography

General Description of the Types

Definitions

Epilogue

Four Papers on Psychological Typology (1913, 1925, 1931, 1936)

†7. TWO ESSAYS ON ANALYTICAL PSYCHOLOGY

On the Psychology of the Unconscious (1917/1926/1943)

The Relations between the Ego and the Unconscious (1928)

Appendix: New Paths in Psychology (1912); The Structure of the Unconscious (1916) (new versions, with variants, 1966)

‡8. THE STRUCTURE AND DYNAMICS OF THE PSYCHE

On Psychic Energy (1928)

The Transcendent Function ([1916]/1957)

A Review of the Complex Theory (1934)

The Significance of Constitution and Heredity in Psychology (1929)

Psychological Factors Determining Human Behavior (1937)

Instinct and the Unconscious (1919)

The Structure of the Psyche (1927/1931)

On the Nature of the Psyche (1947/1954)

General Aspects of Dream Psychology (1916/1948)

On the Nature of Dreams (1945/1948)

The Psychological Foundations of Belief in Spirits (1920/1948)

Spirit and Life (1926)

Basic Postulates of Analytical Psychology (1931)
Analytical Psychology and *Weltanschauung* (1928/1931)
The Real and the Surreal (1933)
The Stages of Life (1930–1931)
The Soul and Death (1934)
Synchronicity: An Acausal Connecting Principle (1952)
Appendix: On Synchronicity (1951)

*9. PART I. THE ARCHETYPES AND THE COLLECTIVE UNCONSCIOUS

Archetypes of the Collective Unconscious (1934/1954)
The Concept of the Collective Unconscious (1936)
Concerning the Archetypes, with Special Reference to the Anima Concept
(1936/1954)
Psychological Aspects of the Mother Archetype (1938/1954)
Concerning Rebirth (1940/1950)
The Psychology of the Child Archetype (1940)
The Psychological Aspects of the Kore (1941)
The Phenomenology of the Spirit in Fairytales (1945/1948)
On the Psychology of the Trickster-Figure (1954)
Conscious, Unconscious, and Individuation (1939)
A Study in the Process of Individuation (1934/1950)
Concerning Mandala Symbolism (1950)
Appendix: Mandalas (1955)

*9. PART II. AION (1951)

RESEARCHES INTO THE PHENOMENOLOGY OF THE SELF

The Ego
The Shadow
The Syzygy: Anima and Animus
The Self
Christ, a Symbol of the Self
The Sign of the Fishes
The Prophecies of Nostradamus
The Historical Significance of the Fish
The Ambivalence of the Fish Symbol
The Fish in Alchemy
The Alchemical Interpretation of the Fish

Background to the Psychology of Christian Alchemical Symbolism
Gnostic Symbols of the Self
The Structure and Dynamics of the Self
Conclusion

*10. CIVILIZATION IN TRANSITION

The Role of the Unconscious (1918)
Mind and Earth (1927/1931)
Archaic Man (1931)
The Spiritual Problem of Modern Man (1928/1931)
The Love Problem of a Student (1928)
Woman in Europe (1927)
The Meaning of Psychology for Modern Man (1933/1934)
The State of Psychotherapy Today (1934)
Preface and Epilogue to “Essays on Contemporary Events” (1946)
Wotan (1936)
After the Catastrophe (1945)
The Fight with the Shadow (1946)
The Undiscovered Self (Present and Future) (1957)
Flying Saucers: A Modern Myth (1958)
A Psychological View of Conscience (1958)
Good and Evil in Analytical Psychology (1959)
Introduction to Wolff’s “Studies in Jungian Psychology” (1959)
The Swiss Line in the European Spectrum (1928)
Reviews of Keyserling’s “America Set Free” (1930) and “La Révolution
Mondiale” (1934)
The Complications of American Psychology (1930)
The Dreamlike World of India (1939)
What India Can Teach Us (1939)
Appendix: Documents (1933–1938)

†11. PSYCHOLOGY AND RELIGION: WEST AND EAST

WESTERN RELIGION

Psychology and Religion (The Terry Lectures) (1938/1940)
A Psychological Approach to the Dogma of the Trinity (1942/1948)
Transformation Symbolism in the Mass (1942/1954)

Forewords to White's "God and the Unconscious" and Werblowsky's "Lucifer and Prometheus" (1952)

Brother Klaus (1933)

Psychotherapists or the Clergy (1932)

Psychoanalysis and the Cure of Souls (1928)

Answer to Job (1952)

EASTERN RELIGION

Psychological Commentaries on "The Tibetan Book of the Great Liberation" (1939/1954) and "The Tibetan Book of the Dead" (1935/1953)

Yoga and the West (1936)

Foreword to Suzuki's "Introduction to Zen Buddhism" (1939)

The Psychology of Eastern Meditation (1943)

The Holy Men of India: Introduction to Zimmer's "Der Weg zum Selbst" (1944)

Foreword to the "I Ching" (1950)

*12. PSYCHOLOGY AND ALCHEMY (1944)

Prefatory note to the English Edition ([1951?] added 1967)

Introduction to the Religious and Psychological Problems of Alchemy

Individual Dream Symbolism in Relation to Alchemy (1936)

Religious Ideas in Alchemy (1937)

Epilogue

†13. ALCHEMICAL STUDIES

Commentary on "The Secret of the Golden Flower" (1929)

The Visions of Zosimos (1938/1954)

Paracelsus as a Spiritual Phenomenon (1942)

The Spirit Mercurius (1943/1948)

The Philosophical Tree (1945/1954)

‡14. MYSTERIUM CONIUNCTIONIS (1955–56)

AN INQUIRY INTO THE SEPARATION AND

SYNTHESIS OF PSYCHIC OPPOSITES IN ALCHEMY

The Components of the Coniunctio

The Paradoxa

The Personification of the Opposites

Rex and Regina

Adam and Eve
The Conjunction

*15. THE SPIRIT IN MAN, ART, AND LITERATURE

Paracelsus (1929)

Paracelsus the Physician (1941)

Sigmund Freud in His Historical Setting (1932)

In Memory of Sigmund Freud (1939)

Richard Wilhelm: In Memoriam (1930)

On the Relation of Analytical Psychology to Poetry (1922)

Psychology and Literature (1930/1950)

“Ulysses”: A Monologue (1932)

Picasso (1932)

†16. THE PRACTICE OF PSYCHOTHERAPY

GENERAL PROBLEMS OF PSYCHOTHERAPY

Principles of Practical Psychotherapy (1935)

What Is Psychotherapy? (1935)

Some Aspects of Modern Psychotherapy (1930)

The Aims of Psychotherapy (1931)

Problems of Modern Psychotherapy (1929)

Psychotherapy and a Philosophy of Life (1943)

Medicine and Psychotherapy (1945)

Psychotherapy Today (1945)

Fundamental Questions of Psychotherapy (1951)

SPECIFIC PROBLEMS OF PSYCHOTHERAPY

The Therapeutic Value of Abreaction (1921/1928)

The Practical Use of Dream-Analysis (1934)

The Psychology of the Transference (1946)

Appendix: The Realities of Practical Psychotherapy ([1937] added, 1966)

‡17. THE DEVELOPMENT OF PERSONALITY

Psychic Conflicts in a Child (1910/1946)

Introduction to Wickes’s “Analyse der Kinderseele” (1927/1931)

Child Development and Education (1928)

Analytical Psychology and Education: Three Lectures (1926/1946)

The Gifted Child (1943)

The Significance of the Unconscious in Individual Education (1928)

The Development of Personality (1934)

Marriage as a Psychological Relationship (1925)

*18. THE SYMBOLIC LIFE

Miscellaneous Writings

†19. GENERAL BIBLIOGRAPHY OF C. G. JUNG'S WRITINGS

†20. GENERAL INDEX TO THE COLLECTED WORKS

- * Published 1957; 2nd edn., 1970.
- † Published 1973.
- * Published 1960.
- † Published 1961.
- ‡ Published 1956; 2nd edn., 1967. (65 plates, 43 text figures.)
- * Published 1971.
- † Published 1953; and edn., 1966.
- ‡ Published 1960; 2nd edn., 1969.
- * Published 1959; and edn., 1968. (Part I: 79 plate, with 29 in colour.)
- * Published 1964; 2nd edn., 1970. (8 plates.)
- * Published 1958; 2nd edn., 1969.
- * Published 1953; 2nd edn., completely revised, 1968. (270 illustrations.)
- † Published 1968. (50 plates, 4 text figures.)
- ‡ Published 1963; 2nd edn., 1970. (10 plates.)
- * Published 1966.
- † Published 1954; 2nd edn., revised and augmented, 1966. (13 illustrations.)
- † Published 1954.
- * Published 1976.
- † Published 1979.